

3

3

Xerox® VersaLink® C415 Multifunction Color Printer Service Manual

Xerox® VersaLink® C415 Color MFP

Xerox® VersaLink® C415 Color MFP Service Manual

705P01475

Initial Release

July 2023

Prepared By:

Xerox Corporation

800 Phillips Road

Webster, New York 14580

© 2023 Xerox Corporation. All Rights Reserved. Xerox® and VersaLink® are the trademarks of Xerox Corporation in the United States and/or other countries.

Other company trademarks are also acknowledged.

NOTICE

All service documentation is supplied to Xerox external customers for informational purposes only. Xerox service documentation is intended for use by certified, product trained service personnel only. Xerox does not warrant or represent that such documentation is complete, nor does Xerox represent or warrant that it will notify or provide to such customer any future changes to this documentation. Customer performed service of equipment, or modules, components or parts of such equipment may affect the warranty offered by Xerox with respect to such equipment. You should consult the applicable warranty for its terms regarding customer or third party service.

If the customer self-services any Xerox equipment, modules, components or parts thereof, the customer releases Xerox from all liability of the customer actions. The customer agrees to indemnify, defend, and hold Xerox harmless, from any third party claims that arise directly or indirectly from such service.

While Xerox has tried to make this documentation accurate, Xerox will have no liability arising out of any inaccuracies or omissions.

Introduction

About This Manual ii
How To Use This Manual ii
Change Historyiii
Mod/Tag Identificationiii
Voltages Resistances and Tolerancesiv
Safety Information v
Health and Safety Incident reportingvi
Translation of Warningsvii

About This Manual

This manual is part of a multinational service documentation system that is structured in the standard Xerox service manual format.

Organization

The service manual is the document used as the primary information source for repairing and maintaining this family of products and is available as EDOC on a CDROM, or in PDF format on a CDROM. The information within the manual is divided into an introduction and 8 other sections.

Section 1 Service Call Procedures

This section is used to start and complete a service call. The procedures in this section will either direct you to a Repair Analysis Procedure (RAP), or identify a faulty component or subassembly.

Section 2 Status Indicator Repair Analysis Procedures

This section contains the Repair Analysis Procedures (RAPs) and checkouts necessary to diagnose, isolate and repair faults other than image quality faults.

Section 3 Image Quality

This section contains the Image Quality Repair Analysis Procedures (IQ RAPs), checkouts and setup procedures necessary to diagnose, isolate and repair image quality faults.

Section 4 Repairs and Adjustments

This section contains the instructions for removal, replacement, and adjustment of parts within the machine.

Section 5 Parts List

This section contains the detailed and illustrated spare parts list. Any part that is spared or that must be removed to access a spared part is illustrated.

Section 6 General Procedures and Information

This section contains all other procedures, product specifications and general information. It also contains Tag/MOD information. The abbreviations used in this Manual are in [GP 40 Glossary of Terms, Acronyms and Abbreviations](#).

Section 7 Wiring Data

This section contains the PJ locations, wiring diagrams and block schematic diagrams (BSDs).

Section 8 Product Technical Overview

This section contains technical details of the machine.

Publication Comments Sheet

A Publication Comment Sheet is provided at the rear of the PDF version of the manual.

How To Use This Manual

Always start with the Service Call Procedures, Section 1. Perform Initial Actions to verify the problem, then follow the directions given.

How to Differentiate Between Machine Variants

When a procedure, parts list description, artwork, or other reference is unique across different machine variants, the applicable variant is identified. For example, VLC415:

1. VL = VersaLink
2. C = Color
3. 4 = Workteam Mid Laser Printer
4. 1 = 1st Family
5. 5 = MultiFunctional Printer (MFP)

VLC415 includes the following model variants:

- Xerox® VersaLink® C415 Color MultiFunctional Printer

Warnings, Cautions And Notes



WARNING: A warning is used whenever an operating or maintenance procedure, practice, condition or statement, if not strictly observed, could result in personal injury.

A translated version of all warnings is in [Translation of Warnings](#).



CAUTION: A caution is used whenever an operation or maintenance procedure, practice, condition or statement, if not strictly observed, could result in damage to the equipment.

Note: A note is used where it is essential to highlight a procedure, practice, condition or statement.

Change History

Change History provides changes to the service manual after the launch version, initial release.

September 2023.

- GP 4 Software Upgrade

Mod/Tag Identification

Figure 1 shows the Mod/Tag identification symbols.



F-1-0628-A

Figure 1 Mod/Tag identification symbols

Voltages Resistances and Tolerances

DC Voltage Levels and Tolerances

DC voltages should be measured between an available test point and a machine ground. Table 1 shows the range of the common voltages.

Table 1 DC Voltage Levels

Nominal Voltage	Voltage Tolerance Range
0V	0.00 to 0.10V
+3.3V standby	+3.23V to +3.43V
+3.3V	+3.23V to +3.43V
+5V and +5V standby	+4.75V to +5.25V
+12V	+11.4V to +12.6V
+24V	+23.28V to +25.73V

Non-standard voltage levels will be quoted on the relevant wiring diagram or BSD. All other voltage levels are plus or minus 10 %.

Resistance Tolerances

All resistance measurement tolerances are plus or minus 10 %, unless otherwise stated in the procedure.

DC Signal Nomenclature

Figure 1 shows the signal nomenclature used in the BSDs.

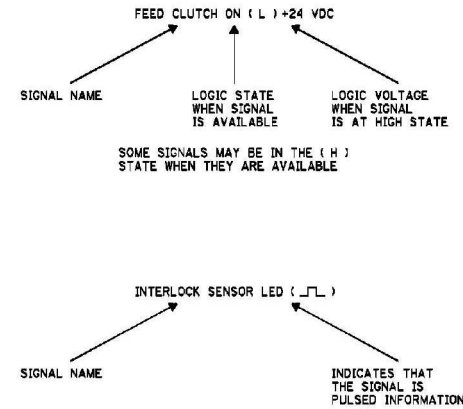

TF-1-0629-A

Figure 1 Signal Nomenclature

Table 2 shows the signal tolerances.

Table 2 Signal tolerances

Signal Voltage	(H) Logic Level	(L) Logic Level
+5V	+3.85V or greater	At or near 0.8V
+3.3V	+2V or greater	At or near 0.8V

Non standard signal tolerances will be quoted on the relevant circuit diagram.

Note: The logic level shown with the signal name will be the actual signal as measured with a service meter. This will not necessarily be the same as the logic state shown on the diagnostic screen.

Safety Information

The WARNING that follows is for general guidance when live working.



WARNING: Do not work in a confined space. 1m (39 inches) space is needed for safe working.

Safety Icons

The safety icons that follow are displayed on the machine:

ESD Caution Symbol



CAUTION: Certain components in this product are susceptible to damage from electrostatic discharge. Observe all ESD procedures to avoid component damage.

Location Arrow Symbol

The location arrow symbol points to the location to install, to gain access to, or to release an object.



Hot Surface Symbol

This symbol indicates hot surfaces. Take care when servicing the machine.



Lethal Voltage Symbol

This symbol indicates potentially lethal voltages. Take care when servicing the machine when the power cord is connected.



Toner Cartridge

The product contains a toner cartridge that is recyclable. Under various state and local laws, it may be illegal to dispose of the cartridge into the municipal waste. Check with the local waste officials for details on recycling options or the proper disposal procedures.

Fuses



WARNING: Do not install a fuse of a different type or rating. Installing the wrong type or rating of fuse can cause overheating and a risk of fire.

Part Replacement

Only use genuine Xerox approved spare parts or components to maintain compliance with legislation and safety certification.

Disassembly Precautions

Do not leave the machine with any covers removed at a customer location.

Reassembly Precautions

Use extreme care during assembly. Check all harnesses to ensure they do not contact moving parts and do not get trapped between components.

General Procedures

Observe all warnings displayed on the machine and written in the service procedures. Do not attempt to perform any task that is not specified in the service procedures.

Health and Safety Incident reporting

I. Summary

This section defines requirements for notification of health and safety incidents involving Xerox products (equipment and materials) at customer locations.

II. Scope

Xerox Corporation and subsidiaries worldwide.

III. Objective

To enable prompt resolution of health and safety incidents involving Xerox products and to ensure Xerox regulatory compliance.

IV. Definitions

Incident:

An event or condition occurring in a customer account that has resulted in injury, illness or property damage. Examples of incidents include machine fires, smoke generation, physical injury to an operator or service representative. Alleged events and product conditions are included in this definition.

V. Requirements

Initial Report:

1. Xerox organizations shall establish a process for individuals to report product incidents to Xerox Environment Health and Safety within 24 hours of becoming aware of the event.
2. The information to be provided at the time of reporting is contained in Appendix A (Health and Safety Incident Report involving a Xerox product).
3. The initial notification may be made by the method that follows:
 - Email Xerox EH&S at: usa.product.incident@xerox.com.
 - Fax Xerox EH&S at: 585-422-2249.

Note: If sending a fax, please also send the original via internal mail.

Responsibilities for resolution:

1. Business Groups/Product Design Teams responsible for the product involved in the incident shall:
 - a. Manage field bulletins, customer correspondence, product recalls, safety retrofits.
 - b. Fund all field retrofits.
2. Field Service Operations shall:

- a. Preserve the Xerox product involved and the scene of the incident inclusive of any associated equipment located in the vicinity of the incident.
 - b. Return any affected equipment/part(s) to the location designated by Xerox EH&S and/or the Business Division.
 - c. Implement all safety retrofits.
3. Xerox EH&S shall:
 - a. Manage and report all incident investigation activities.
 - b. Review and approve proposed product corrective actions and retrofits, if necessary.
 - c. Manage all communications and correspondence with government agencies.
 - d. Define actions to correct confirmed incidents.

VI. Appendices

The Health and Safety Incident Report involving a Xerox Product (Form # EH&S-700) is available in the following location:

- [GSN Library 1789](#)

Translation of Warnings



WARNING: A warning is used whenever an operating or maintenance procedure, practice, condition or statement, if not strictly observed, could result in personal injury.

DANGER: Une note Danger est utilisée chaque fois qu'une procédure d'utilisation ou de maintenance peut être cause de blessure si elle n'est pas strictement respectée.

AVVERTENZA: Un segnale di avvertenza è utilizzato ogni volta che una procedura operativa o di manutenzione, una pratica, una condizione o un'istruzione, se non strettamente osservata, potrebbe causare lesioni personali.

VORSICHT: Weist darauf hin, dass ein Abweichen von den angeführten Arbeits- und Wartungsanweisungen gesundheitliche Schäden, möglicherweise sogar schwere Verletzungen zur Folge haben kann.

AVISO: Un aviso se utiliza siempre que un procedimiento de operación o mantenimiento, práctica o condición puede causar daños personales si no se respetan estrictamente.



WARNING: Do not work in a confined space. 1 m (39 inches) space is needed for safe working.

DANGER : Ne pas travailler dans un espace restreint. 1 mètre d'espace est nécessaire pour un dépannage en toute sécurité.

AVVERTENZA: Non lavorare in uno spazio limitato; è necessario uno spazio di almeno un metro attorno alla macchina per la sicurezza dell'operatore.

VORSICHT: Nur mit ausreichendem Bewegungsspielraum (1 m) arbeiten.

AVISO: No trabaje en un espacio reducido. Se necesita 1 metro de espacio para trabajar con seguridad.



WARNING: Do not install a fuse of a different type or rating. Installing the wrong type or rating of fuse can cause overheating and a risk of fire.

DANGER : Ne pas installer de fusible de type ou de calibre différent. Il existe un risque de surchauffe voire d'incendie.

AVVERTENZA: per evitare rischi di surriscaldamento o d'incendio, non installare un fusibile di tipo o carica diversi da quelli esistenti.

VORSICHT: Keine Sicherungen anderer Art oder anderer Leistung auf dem IOT-PWB installieren - Überhitzungs- und Brandgefahr.

AVISO: No instale un fusible de potencia o tipo distinto. Un fusible de potencia o tipo distinto puede producir sobrecalentamiento y el riesgo de incendio.



WARNING: Ensure that the electricity to the machine is switched off while performing tasks that do not need electricity. Refer to GP XX. Disconnect the power cord. Electricity can cause death or injury. Moving parts can cause injury.

DANGER : Assurez-vous que la machine est hors tension lorsque vous effectuez des tâches ne nécessitant pas d'alimentation électrique. Reportez-vous à GP XX. Débranchez le câble d'alimentation pour prévenir tout risque d'électrocution. Les chocs électriques peuvent présenter un danger de mort ou entraîner des blessures graves. De plus, certaines pièces, lorsqu'elles sont en mouvement, peuvent être source de blessures graves.

AVVERTENZA: Accertarsi di isolare la macchina dall'alimentazione elettrica quando si eseguono attività che non richiedono elettricità. Vedere GP XX. Scollegare il cavo di alimentazione. L'elettricità può causare morte o lesioni personali. Le parti in movimento possono causare lesioni personali.

VORSICHT: Sicherstellen, dass die Stromversorgung des Geräts bei Arbeiten, die keinen Strom erfordern, ausgeschaltet ist. Siehe auch GP XX. Den Netzstecker ziehen. Andernfalls besteht Stromschlaggefahr und Verletzungsgefahr durch bewegliche Teile.

AVISO: Asegúrese de mantener la máquina aislada de la energía eléctrica mientras realiza tareas que no necesitan electricidad. Consulte GP XX. Desconecte el cable de alimentación. La energía eléctrica puede producir lesiones o incluso la muerte. Las piezas sueltas pueden producir lesiones.



WARNING: Switch off the electricity to the machine. Refer to **GP 10** . Disconnect the power cord from the customer supply while performing tasks that do not need electricity. Electricity can cause death or injury. Moving parts can cause injury.

DANGER : Mettez la machine hors tension. Reportez-vous à **GP 10** . Déconnectez le cordon d'alimentation de l'alimentation du client lorsque vous réalisez des tâches qui ne nécessitent pas d'électricité. L'électricité peut être à l'origine de blessures, voire d'un accident mortel. Les pièces amovibles peuvent être à l'origine de blessures.

AVVERTENZA: Spegner la macchina. Vedere **GP 10** . Scollegare il cavo di alimentazione dall'alimentatore quando si eseguono attività che non richiedono elettricità. L'elettricità può causare morte o lesioni personali. Le parti in movimento possono causare lesioni personali.

VORSICHT: Schalten Sie die Stromversorgung der Maschine ab. Siehe auch **GP 10** . Ziehen Sie das Stromkabel ab, wenn Sie Aufgaben ausführen, für die keine Stromversorgung benötigt wird. Stromschläge können Todesfällen oder Verletzungen verursachen. Bewegliche Teile können zu Verletzungen führen.

AVISO: Apague la electricidad de la máquina. Consulte el **GP 10** . Desconecte el cable de alimentación eléctrica de la toma de pared mientras esté realizando tareas que no necesiten corriente. La electricidad puede causar daños o la muerte. Las partes móviles pueden causar daños.



WARNING: Take care when measuring AC mains (line) voltage. Electricity can cause death or injury.

DANGER : Prendre des précautions lors du relevé de la tension de la prise de courant alternatif. L'électricité peut entraîner des blessures graves voire mortelles.

AVVERTENZA: Procedere con cautela durante la misurazione della tensione CA della rete. L'elettricità può causare infortuni o morte.

VORSICHT: Bei der Netzspannungsprüfung stets vorsichtig vorgehen

AVISO: Tenga cuidado al medir la tensión de la línea de alimentación de corriente alterna. La electricidad puede causar lesiones e incluso la muerte.



WARNING: Ensure that the electricity to the machine is switched off while performing tasks that do not need electricity. Refer to **GP 10** . Disconnect the power cord. Electricity can cause death or injury. Moving parts can cause injury.

DANGER : Assurez-vous que la machine est hors tension lorsque vous effectuez des tâches ne nécessitant pas d'alimentation électrique. Reportez-vous à **GP 10** . Débranchez le câble d'alimentation pour prévenir tout risque d'électrocution. Les chocs électriques peuvent présenter un danger de mort ou entraîner des blessures graves. De plus, certaines pièces, lorsqu'elles sont en mouvement, peuvent être source de blessures graves.

AVVERTENZA: Accertarsi di isolare la macchina dall'alimentazione elettrica quando si eseguono attività che non richiedono elettricità. Vedere **GP 10** . Scollegare il cavo di alimentazione. L'elettricità può causare morte o lesioni personali. Le parti in movimento possono causare lesioni personali.

VORSICHT: Sicherstellen, dass die Stromversorgung des Geräts bei Arbeiten, die keinen Strom erfordern, ausgeschaltet ist. Siehe auch **GP 10** . Den Netzstecker ziehen. Andernfalls besteht Stromschlaggefahr und Verletzungsgefahr durch bewegliche Teile.

AVISO: Asegúrese de mantener la máquina aislada de la energía eléctrica mientras realiza tareas que no necesitan electricidad. Consulte **GP XX** . Desconecte el cable de alimentación. La energía eléctrica puede producir lesiones o incluso la muerte. Las piezas sueltas pueden producir lesiones.



WARNING: Do not touch the fuser while it is hot.

DANGER : Ne pas toucher au four pendant qu'il est encore chaud.

AVVERTENZA: Non toccare il fonditore quando è caldo.

VORSICHT: Fixierbereich erst berühren, wenn dieser abgekühlt ist.

AVISO: No toque el fusor mientras está caliente.



WARNING: Do not touch the fuser while it is hot.

DANGER : Ne pas toucher au four pendant qu'il est encore chaud.

AVVERTENZA: Non toccare il fonditore quando è caldo.

VORSICHT: Fixierbereich erst berühren, wenn dieser abgekühlt ist.

AVISO: No toque el fusor mientras está caliente.



WARNING: Take care during this procedure. Sharp edges may be present that can cause injury.

DANGER : Exécuter cette procédure avec précaution. La présence de bords tranchants peut entraîner des blessures.

AVVERTENZA: procedere con cautela durante questa procedura. Possono essere presenti oggetti con bordi taglienti pericolosi.

VORSICHT: Bei diesem Vorgang vorsichtig vorgehen, damit keine Verletzungen durch die scharfen Kanten entstehen.

AVISO: Tenga cuidado al efectuar este procedimiento. Puede haber bordes afilados que podrían producir lesiones.



WARNING: Do not use the power button as a safety disconnect device. The power button is not a disconnect device. Disconnect the power cord from the supply to isolate the equipment.

DANGER : Ne vous servez pas de l'interrupteur comme d'un dispositif de déconnexion. L'interrupteur n'est pas un dispositif de déconnexion. Débranchez le câble d'alimentation de la prise électrique pour isoler l'appareil.

AVVERTENZA: L'interruttore di alimentazione non è un dispositivo di disconnessione di sicurezza e pertanto non va utilizzato come tale. Per isolare la macchina, scollegare il cavo di alimentazione dalla presa elettrica.

VORSICHT: Zur Unterbrechung der Gerätestromzufuhr nicht den Betriebsschalter verwenden, sondern das Netzkabel aus der Steckdose ziehen, an die das Gerät angeschlossen ist. Nur dann ist der Drucker vollständig vom Stromnetz getrennt.

AVISO: No utilice el botón de encendido/apagado como dispositivo de desconexión de seguridad. El botón de encendido/apagado no es un dispositivo de desconexión. Desconecte el cable de alimentación de la fuente de energía para aislar el equipo.

1 Service Call Procedures

SCP 1 Initial Actions.....11
SCP 2 Call Actions11
SCP 3 Fault Analysis12
SCP 4 Subsystem Maintenance.....13
SCP 5 Final Actions14

SCP 1 Initial Actions

Service Call Procedures are used at the beginning of a service call. Use Initial Actions to collect information about the machine performance.

Procedure



WARNING: Switch off the electricity to the machine, [GP 10](#). Disconnect the power lead from the customer supply while performing tasks that do not need electricity. Electricity can cause death or injury. Moving components can cause injury.



CAUTION: Do not work in a confined space. 1m (39 inches) space is needed for safe working.

1. Take note of problems, error messages or error codes. If necessary, refer to [dC122](#) Fault Codes and History Files.
2. Switch off, then switch on the machine, [GP 10](#).
3. Ask the operator to describe or demonstrate the problem.
4. If the problem is the result of an incorrect action by the operator, refer the operator to the user documentation.
5. Check the steps that follow:
 - a. The power lead is connected to the wall outlet and to the machine.
 - b. The paper is loaded correctly.
 - c. All paper trays are closed.
 - d. All doors are closed.
6. Check the machine service log book for previous actions that are related to this call.
7. Go to [SCP 2](#) Call Actions.

SCP 2 Call Actions

Use Call Actions to perform any general actions before starting to diagnose the fault.

Procedure

1. If this is the first service call to this machine, if possible, perform the actions that follow:
 - a. Check the machine configuration with the customer. Check that all the required hardware and software is installed. Check that all the required hardware and software is enabled.
 - b. Check that all the machine settings are entered correctly.
 - c. Mark off the hardware options, software options or Tags installed on the Tag matrix cards.
 - d. Enter the machine information and the customer information in the service log book.
2. Review the print samples.
3. Ensure the user access settings are correct. If necessary refer to the user documentation.
4. If necessary, perform [GP 13](#) Cloning Network Configurations.

Note: The clone file must be taken whenever the customer changes the network controller setting or after the system software is changed.
5. Before switching off the machine or clearing the memory, check for a customer job in the memory.
6. Check and record the total impressions usage counter.
7. Go to [SCP 3](#) Fault Analysis.

SCP 3 Fault Analysis

Use Fault Analysis to identify the appropriate RAP to perform based on the machine fault or symptoms.

- For network printing issues refer to, [OF 8](#), Network Printing Problems RAP.

Procedure



CAUTION: Do not expose the drum cartridges, to light for more than 30 minutes. If necessary, remove the drum cartridges, then place in a black bag.

Fault Codes

If a fault code is displayed, go to the relevant RAP.

Image Quality Defects

If the image quality is defective, go to the [IQ 1](#) IOT Image Quality Entry RAP.

Unresolved Faults

If a fault cannot be resolved using the appropriate RAP, and only if instructed by next level support, obtain a device log. Refer to [GP 19](#), Obtaining Audit and Device Logs. Escalate the problem to next level support.

Other Problems

- For suspected power distribution faults, refer to the following:
 - [7 Wiring Data](#)
- If the customer requires a billing plan change, go to [GP 26](#), PagePack Plan Activation.

Additional Information

If necessary, refer to the general procedures and information that follow:

- [GP 1](#) Diagnostics Entry
- [GP 2](#) Fault Codes and Fault History
- [GP 3](#) Service Information.
- [GP 4](#) Machine Software
- [GP 5](#) Miscellaneous Checks
- [GP 6](#) How to Check a Motor
- [GP 7](#) How to Check a Sensor
- [GP 8](#) How to Check a Solenoid or Clutch
- [GP 9](#) How to Check a Switch
- [GP 10](#) How to Switch Off the Machine or Switch On the Machine
- [GP 11](#) How to Safely Lift or Move Heavy Modules
- [GP 12](#) Machine Lubrication
- [GP 13](#) Network Clone Procedure
- [GP 14](#) Printing Reports
- [GP 15](#) Cleaning the Printhead Lenses
- [GP 16](#) Installation Space Requirements
- [GP 17](#) Electrical Power Requirements
- [GP 18](#) Cleaning the Scanner

- [GP 19](#) Obtaining Audit and Device Logs
- [GP 20](#) First Copy/Print Out Time and Power On Time
- [GP 21](#) Restriction of Hazardous Substances (RoHS)
- [GP 22](#) Back Up and Restore Settings
- [GP 23](#) Customer Administration Tools
- [GP 24](#) How to Set the Date and Time
- [GP 25](#) Ethernet Crossover Cable Setup
- [GP 26](#) PagePack Plan Activation
- [GP 27](#) Intermittent or Noise Problem
- [GP 28](#) System Administrator Password Reset
- [GP 29](#) Print/Copy Orientation Definitions
- [GP 30](#) Paper and Media Size Specifications
- [GP 31](#) Environmental Data
- [GP 32](#) Device Specification
- [GP 33](#) Restoring Customer Mode
- [GP 34](#) How to Re-Enter Optional Feature Installation Keys
- [GP 35](#) Serial Number Synchronization Procedure
- [GP 36](#) Xerox USB Wireless Printing Troubleshooting
- [GP 37](#) Supplies Plan Conversion
- [GP 40](#) Glossary of Terms, Acronyms and Abbreviations

SCP 4 Subsystem Maintenance

Use Subsystem Maintenance to identify potentially worn components that should be replaced to prevent further faults, and to perform routine cleaning and lubrication of the machine.



WARNING: Switch off the electricity to the machine, GP 10. Disconnect the power lead from the customer supply while performing tasks that do not need electricity. Electricity can cause death or injury. Moving components can cause injury.

Go to the correct procedure:

- [Service Checks](#)
- [HFSI](#)
- [How to Clean the Machine](#)
- [Drum Cartridge Handling](#)

Service Checks

Perform the actions in [Table 1](#) at the indicated service interval.

Table 1 Service Check Intervals

Servicing Items	Service Details	Service Interval
IQ check	Check the overall print quality using a test chart. Check for uneven density, blank areas, drum scratches, heat roll scratches, etc. in A3 halftone.	Every visit
Clean the machine interior	Check and clean the paper transport roller (including the bypass tray). Clean any toner residue in the paper transport path. Clean any contamination and paper dust from the jam sensors.	150K feeds
	Clean the operating parts around the toner cartridges.	Every visit
Safety Check	Ensure that the power cords are not damaged and no wires are exposed. Ensure that an extension cord with insufficient length or power cord outside the specification, such as an off-the-shelf power strip, is not being used. Ensure that a single socket does not have multiple power plugs plugged into it.	Every visit

HFSI

For High Frequency Service Items (HFSI), refer to [dC135 HFSI Counters](#) and [Table 2](#), below.

Part Name	Part Number	Kit Contents	Life	Manual Counter Reset	PL Ref.
Fuser (110V)	126N00519	Fuser (110V)	150K prints	Yes	PL 10.05 item 2
Fuser (220V)	126N00520	Fuser (220V)	150K prints	Yes	PL 10.05 item 2
Paper Tray*	022N02894	Tray pick tires*	150K prints	Yes	PL 70.05 item 2
Optional 550-Sheet + 100-sheet Tray 2 (650-sheet tray)	022N02895	Optional 650-sheet tray pick rollers (bypass tray)	150K prints	Yes	PL 70.15 item 2
Optional 550-Sheet + 100-sheet Tray 2 (650-sheet tray)	022N02894	Optional 650-sheet pick tires	150K prints	Yes	PL 70.15 item 4
Optional 550 Sheet Tray 3	022N02894	Optional 550-sheet pick tires	150K prints	Yes	PL 70.15 item 3
DADF Maintenance Kit	116R00039	Separator Assembly DADF Pick Roller Assembly	110K feeds	Yes**	PL 5.05

*Tray pick tires: For a single tray only; Common with optional trays.
 **Customers will reset counters in Admin menu: Device > Tools > Supplies > Supply Counter Reset > select the counter to reset > Reset Counter.
 Service will reset counters in Diagnostics, [dC135](#).
 Available resettable HFSI counters may vary with device software version.

How to Clean the Machine

Use a dry lint free cloth or a lint free cloth moistened with water for all cleaning unless directed otherwise. Wipe with a dry lint free cloth if a moistened cloth is used.

1. Feed Components (Rolls and Pads)

Use a dry lint free cloth or a lint free cloth moistened with water. Wipe with a dry lint free cloth if a moistened cloth is used.

2. Toner Dispense Units

Vacuum the toner dispense units.

3. Jam Sensors

Clean the sensors with a dry cotton swab.

Drum Cartridge Handling

- The drum cartridges must be protected from light shock and mechanical damage.
- Do not expose the photoreceptor drum to bright lights for extended periods.
- Whenever the drum cartridge is removed, place the drum cartridge in the black plastic bag supplied with the machine. Store the drum cartridge in a safe place on a clean flat surface, to avoid damage to the photoreceptor drum surface.
- Place the drum cartridge in the black bag if the left door is opened for long periods.

SCP 5 Final Actions

Use Final Actions to verify the correct operation of the machine and to complete the service call.

Procedure

Perform the steps that follow. If a fault is identified, go to [SCP 3](#) Fault Analysis:

1. If necessary, re-connect the machine to the customer's network.
2. If necessary, perform [GP 13](#) Cloning Network Configurations.

Note: The clone file will need to be taken whenever the system software is changed.
3. Perform the relevant maintenance procedures. Refer to [SCP 4](#) Subsystem Maintenance.
4. Ensure that the machine has the latest available software loaded.
5. Operate the machine in all modes. Make the copies and prints from all trays.
6. Make prints from all trays. Check the registration quality. To reset the registration, perform [dC126](#) System Registration Adjustment.
7. Make a proof print of a customer document.
8. If some of the customer's selections were changed, return the selections to the customer settings.
9. Mark off the hardware options, software options or Tags installed on the Tag matrix cards.
10. If some changes were made to the configuration or options were added, print the configuration report. Store the configuration report with the machine log book. Discard the previous version of the configuration report.
11. Log the usage counters.
12. If necessary, provide the customer with training.
13. Remove and destroy all copies of test patterns.
14. Ensure the machine and service area are clean.

2 Status Indicator RAPs

Chain 301	18	305-300-00 Sensor (DADF cover) Service Check RAP	44
301-100-00, 305-104-00, 305-105-00 IRCloseAllDoors RAP	18	Chain 310	44
Chain 302	19	310-327-00, 310-341-00, 310-361-00, 310-362-00, 310-364-00, 310-368-00 to 310-374-00, 310-376-00 to 310-379-00, 310-383-00 Fuser Error Service Check RAPs	45
302-302-00, 302-306-00, 302-308-00 Flash Failure RAP	19	310-473-00 to 310-476-00, 310-517-00 900 Error Service Check RAP	46
302-312-00 Application SW Checksum Failure RAP	20	310-670-00, 310-418-00, 310-419-00, 310-422-00 to 310-430-00, 310-488-00, 305-211-00, 305-212-00 Printhead Error Service Check RAPs	46
302-315-00 Service Registry Bad Data / Corrupted RAP	20	Chain 316	47
302-316-00 and 302-317-00 Service Registry Not Responding RAP	21	316-000-00 to 316-016-99 Network Faults 1 RAP	47
302-318-00 Touch Device not Available RAP	21	316-023-09 to 316-153-19 Network Faults 2 RAP	48
302-320-00 UI Data Time Out Error RAP	22	316-165-01 to 316-165-04 SLC and MLC Wear Level RAP	48
302-380-00 and 302-381-00 UI Communication Fault RAP	22	316-330-00 System Startup Process Crash RAP	49
302-390-00 Power Up Fault RAP	23	316-331-00 and 316-331-01 UI Panel Communication Failure RAP	49
Chain 303	23	316-333-00 Device DLM Process Unloaded After Causing Repeated Resets RAP	50
303-306-00 Downgrade Not Permitted	24	316-338-00 and 316-339-00 Platform Death Faults RAP	50
303-307-00 Upgrade Synchronization Failure	24	316-340-00 UI Power On Failure RAP	51
303-315-00 DC Platform Internal Interface Fault RAP	25	316-400-19 NVM Connection Failure RAP	51
303-316-00 CCM Cannot Communicate With IOT RAP	25	316-428-00, 316-430-00 NVM Save Failure RAP	52
303-317-00 IOT NVM Save Failure	26	316-435-00, 316-435-01, 316-436-00 UI Faults RAP	52
303-319-00 IOT NVM Restore Failure	26	316-501-00 to 316-544-00 Network Faults 4 RAP	53
303-320-00 Incompatible Product Type	27	316-600-35 to 316-608-105 Network Faults 5 RAP	53
303-324-00 Software Upgrade File Transfer Failure	27	316-609-19 to 316-612-68 Network Faults 5 RAP	54
303-325-00 Wall Clock Time-out During Power Up	28	316-613-09 to 316-617-19 Network Faults 6 RAP	55
303-326-00 Upgrade is not Required	28	316-620-92 to 316-625-90 Network Faults 7 RAP	55
303-327-00 Upgrade Failure	29	316-626-00 to 316-635-99 Network Faults 8 RAP	56
303-329-00 Upgrade Request During Diagnostics	29	316-629-92 No Acknowledgment To RPC Message and RPC Timeout RAP	57
303-330-00 Upgrade Request During Active Security Feature	30	316-636-35 to 316-647-26 Network Faults 9 RAP	58
303-331-00 Communication Fault With NC	30	316-640-00 System Date Is Invalid For The Apache HTTPS Device Certificate RAP	59
303-332-00 NC Communications Timeout	31	316-649-35 to 316-668-95 Network Faults 10 RAP	59
303-333-00 Invalid Value Detected for NVM 616-004 RAP	31	316-650-68 Network Or Authentication Server Setup RAP	60
303-338-00 and 303-338-01 CCS/Controller Reset RAP	32	316-652-68 Configuration of Remote Server Incorrect RAP	61
303-346-00 Communication Fault with UI RAP	32	316-653-68 Smart Card Error RAP	61
303-347-00 UI Communications Lost RAP	33	316-656-68 OCSP Error RAP	62
303-355-00 CCM POST Failure During NVM Integrity Test	33	316-657-68 Non Compliant FIPS 140-2 Certificate RAP	62
303-380-00 Distribution PWB Missing or Disconnected RAP	34	316-658-68 Expired Certificate RAP	63
303-381-00, 303-382-00, 303-383-00 Critical Parameter Write Fail RAP	34	316-659-68 Certificate Key Length Error RAP	63
303-397 System Configuration is Lost	35	316-660-68 Card Locked Out RAP	64
303-401 Basic FAX Not Detected or Confirmed	35	316-662-68 Authentication Credentials Locked RAP	64
303-403 Extended FAX Not Detected or Confirmed	36	316-663-68 Authentication Server Clock Mismatch RAP	65
303-406-00 FIK Does Not Match Machine Class RAP	36	316-664-68 Invalid Authentication Server Certificate RAP	65
303-417-00 Incompatible FAX SW Detected at Power Up	37	316-667-68 to 316-672-68 SMB Error RAP	66
303-450-00 Unexpected IOT reset RAP	37	316-669-28 to 316-730-66 Network Faults 11 RAP	66
303-777-00 Power Loss Detected	38	316-679-68 Device User Database Unavailable RAP	67
303-788-00 Failed to Exit Power Save Mode RAP	38	316-697-68 to 316-702-68 Server Error RAP	68
303-790-00 Time Zone File Cannot be Set	39	316-718-00, 316-720-01 thru 04, 316-732-01 thru 07 Disk Partition Faults RAP	68
303-805-00 GPU is Hung RAP	39	316-727-00 RPC Connections Approaching Limit RAP	69
Chain 305	40	316-732-01 to 316-732-03 Disk Partition Threshold Exceeded (threshold=See FS 26-003 System Partitioning spec) RAP	69
305-101-00, 305-102-00, 305-124-00, 305-125-00, 305-906-00, 305-922-00 Sensor (DADF scan 1) Jam RAP	40	316-732-05, 316-732-07 Disk Partition Threshold Exceeded (threshold=See FS 26-003 System Partitioning spec) RAP	70
305-103-00, 362-358-00, 362-397-00 to 362-399-00, 362-463-00, 362-476-00, 362-798-00 Scanner Communication Error Service Check RAPs	41	316-742-19 Hard Disk ODIO Failure RAP	70
305-106-00 DADF top cover open service check RAP	42	316-747-00 Productivity Kit Error RAP	71
305-121-00 DADF Paper Undetected Service Check RAP	42	316-748-00 Remote Services Download Failed RAP	71
305-126-00 to 305-129-00, 305-175-00 to 305-177-00 Sensor (DADF scan 2) Jam Service Check RAPs	43	316-750-07 to 316-750-95 Network Faults 12 RAP	72
305-210-00 DADF Imagepipe Jam Service Check RAP	43		

316-751-00 to 316-753-95 Network Faults 13 RAP	73	343-360-00 to 343-366-00 Motor (CMY) Drive Failure Service Check RAPs.....	104
316-754-09 to 316-756-93 Network Faults 14 RAP	74	Chain 352	104
316-757-09 to 316-760-99 Network Faults 15 RAP	75	352-214-00 to 352-228-00, 352-314-00 to 352-322-00, 353-214-00 to 353-228-00, 353-314-00 to 353-328-00, 372-114-00 to 372-140-00, 372-321-00, 373-114-00 to 373-140-00, 374-114-00 to 374-140-00 Optional Tray Motors Jam Service Check	105
316-761-14 to 316-765-93 Network Faults 16 RAP	76	Chain 371	106
316-766-09 to 316-772-95 Network Faults 17 RAP	77	371-107-00, 371-108-00, 372-151-00, 372-152-00, 373-153-00, 373-154-00, 374-100-01, 374-950-00, 375-950-00, 375-951-00, 376-104-00, 376-105-00, 377-950-00, 377-951-00 Mismatched paper size and paper printer setting error service check RAPs	107
316-773-19 to 316-779-95 Network Faults 18 RAP	78	371-210-00, 371-212-00, 371-214-00, 371-216-00, 371-218-00, 371-220-00, 371-222-00 Motor (tray 1 pick) Lifting Error Service Check RAPs	107
316-780-00 to 316-789-47 Network Faults 19 RAP	78	371-300-00, 371-308-00, 371-310-00, 371-316-00, 371-322-00, 374-300-00 Sensor (input): Paper Arrived Too Early or Failed to Arrive Jam Service Check RAPs.....	108
316-816-09 EIP Service Not Responding RAP	79	371-302-00, 371-306-00 Sensor (input): Paper Arrived Too Early From The MPF Jam Service Check RAPs.....	108
316-972-08, 316-972-09, 316-972-15 Software Upgrade Failure RAP.....	80	371-304-00 Sensor (input): Paper Failed to Clear from the MPF Jam Service Check RAP	109
316-990-19 Lockdown Security Remediation Failed RAP.....	80	371-312-00 Sensor (input): Paper Failed to Clear Jam Service Check RAP	109
316-991-19 and 316-992-19 Configuration Watchdog Feature RAP.....	81	371-314-00 Tray 1 Pick Error Service Check RAP.....	110
316E Network Fault Checkout RAP	81	371-316-00, 371-322-00, 374-300-00 Sensor (input): Paper Arrived Too Early From Optional Tray Jam Service Check RAPs.....	110
Chain 319	82	371-317-00, 371-331-00, 371-346-00, 374-317-00 Motor (tray 1 pick) Jam Service Check RAPs.....	111
319-200-00 Node Tree Settings Corrupted/Invalid RAP	82	371-318-00, 371-324-00, 374-318-00 Sensor (input): Paper Failed to Arrive from Optional Tray Jam Service Check RAPs.....	111
319-300-00 and 319-301-00 Hard Disk Read/Write Error RAP.....	83	371-320-00, 371-326-00, 374-320-00 Sensor (input): Paper Failed to Clear from Optional Tray Jam Service Check RAPs.....	112
319-340-00 SIC Crash RAP.....	83	371-328-00, 371-100-00 Sensor (input): Static Jam Service Check RAPs	112
319-401-00 Out Of Memory RAP	84	371-339-00 Sensor (input): Paper Cleared Too Early Jam Service Check RAP.....	113
319-409-01, 319-409-02, 319-409-03, 319-409-04 Video Errors RAP	84	Chain 372	113
319-410-00 to 319-410-18 Imaging Errors RAP	85	372-100-00 to 372-150-00, 372-330-00, 372-331-00, 372-900-00, 372-902-00, 373-100-00 to 373-152-00, 373-330-00, 373-900-00, 374-112-00 to 374-150-00, 374-334-00 to 374-338-00, 377-149-00, 377-274-00 to 377-278-00 Optional Tray Sensors Jam Service Check RAP.....	114
319-411-01 to 319-411-08 and 319-412-01 Scan Image Faults RAP.....	85	372-210-00 to 372-222-00 Optional Tray Pick Drive Error Service Check RAPs.....	115
319-420-00 to 319-426-00 Image Processing Errors RAP.....	86	372-300-00 to 372-312-00, 373-210-00 to 373-222-00, 373-300-00 to 373-312-00, 374-218-00 to 374-231-00 Optional Tray Motor Error Service Check RAPs.....	116
319-750-00 to 319-754-00 Power On Sequence Faults RAP	86	372-305-00, 373-305-00, 374-305-00 Sensor (input): Paper Cleared Too Early from Optional Tray Jam Service Check RAPs.....	117
319-760-00 Test Patterns Missing From EPC RAP.....	87	Chain 376	117
319-761-00, 319-762-00 Generic Engine Fault RAP.....	87	Chain 377	118
Chain 320	88	374-232-00, 377-402-00, 377-404-00, 377-407-00, 377-410-00, 377-419-00 Paper (duplex job) Failed to Arrive Jam Service Check RAPs	118
320-200-00, 320-302-00 to 320-345-00, 320-713-00 Fax Errors RAP	88	374-233-00, 377-402-00, 377-405-00, 377-408-00, 377-411-00, 377-420-00 Sensor (input): Paper (duplex job) Failed to Clear Jam Service Check RAPs.....	119
320-710-00 and 320-711-00 Fax Image Overwrite Error RAP	89	377-102-00, 377-109-00, 377-204-00 Sensor (fuser exit): Paper Failed to Arrive from Optional Tray Jam Service Check RAPs.....	119
Chain 322	89	377-103-00, 377-113-00 Sensor (fuser exit): Paper Failed to Clear Jam Service Check RAPs.....	120
322-300-05 Image Complete Not Received from Video RAP	90	377-105-00 Sensor (fuser exit): Paper Failed to Arrive Jam Service Check RAP	120
322-300-10, 322-301-05 Image Transfer Errors RAP.....	90	377-106-00 Sensor (fuser exit): Paper Failed to Arrive from MPF Jam Service Check RAP	121
322-300-16 Clock Overflow Fault RAP	91	377-108-00, 377-111-00, 377-205-00 Sensor (fuser exit): Paper Failed to Clear from Optional Tray Jam Service Check RAPs.....	121
322-309-04 NO Accepts Received Fault RAP.....	91	377-112-00 Sensor (fuser exit): Static Jam Service Check RAP	122
322-310-04 to 322-318-04 Paper Supply Errors RAP	92	377-202-00 Paper Size Mismatch (Duplex Print) Service Check RAP	122
322-311-04 Sequencer Response Fault RAP	92	Chain 391	123
322-314-04, 322-315-05 Module Errors RAP.....	93		
322-316-04, 322-317-04, 322-318-04 Job Faults RAP	93		
322-319-04 IOT Integrity Problem While Printing a Job RAP.....	94		
322-320-00 to 322-325-00, 322-335-00 to 322-340-00 Software Install Failed RAP	94		
322-328-00 Incomplete System Information RAP.....	95		
322-330-00 and 322-332-00 PagePack and Supplies Plan Errors RAP.....	95		
322-350-02 Software Detects non-Valid Xerox SOK 2 or 3 RAP	96		
322-352-00 Serial Number Missing From Memory RAP	96		
322-360-00 to 322-363-00 3-way Sync (Service Plan) Faults RAP.....	97		
322-364-00 Critical Parameters Restored from Mirror RAP	98		
322-365-00 Engine Serial Number Needs Recovery RAP.....	98		
322-370-00 Unable To Communicate With XSA Database RAP	99		
322-371-00, 322-407-00, 322-417-00, 322-419-00, 322-421-00 Embedded Fax Errors RAP.....	99		
322-701-04, 322-720-00, 322-721-00, 322-751-04, 322-754-17 Configuration Mismatch Fault RAP	100		
Chain 341	100		
341-368-00, 341-369-00 Firmware Mismatch Fail RAP	101		
341-395-00 MDM F1 Fuse Broken RAP	101		
Chain 342	102		
342-200-00 to 342-204-00, 342-208-00 LVPS Error Service Check RAP.....	102		
Chain 343	103		
343-342-00 to 343-348-00 Motor (black) Drive Failure Service Check RAPs.....	103		

391-126-00 to 391-129-00, 391-402-00, 391-403-00 Replace the black or color imaging kit RAPs.....	123
391-314-00, 391-328-00, 391-921-00 to 391-921-08 Imaging Unit (K) Error Service Check RAPs.....	124
391-318-01 to 391-318-09, 393-969-01 to 393-969-05 Imaging Unit (CMY) Error Service Check RAPs.....	124
391-400-00, 391-911-00, 391-912-00, 391-954-00, 391-955-00 Waste Toner Bottle Full- Waste Toner Counter Triggered RAPs.....	125
391-913-00, 393-425-00, 393-428-00, 393-442-00 to 393-464-00, 393-912-00 Drum Cartridge K Life End RAPs.....	125
391-952-00 WTB Smartchip or Sensor Common Problem RAP.....	126
Chain 393	126
391-125-00, 393-100-00 to 393-124-00, 393-335-01, 393-923-01 to 393-923-10, 393-983-00 Toner Cartridge (K) Error Service Check RAPs.....	127
391-942-00, 393-100-00 to 393-126-00, 393-113-00, 393-117-00, 393-121-00, 393-125-00, 393-947-00 to 393-954-00, 393-336-01, 393-337-01, 393-944-01 to 393-944-09, 393-946-00 to 393-946-09, 393-988-00 to 393-988-09 Toner Cartridge (CMY) Error Service Check RAPs.....	128
393-426-00, 393-427-00, 393-432-00 to 393-434-00, 393-438-00 to 393-441-00 Cartridge Out of Quanta - Toner Very Low RAPs.....	129
393-901-00 Waste Toner Bottle Error Service Check RAP.....	130
393-964-00 to 393-967-00, 393-964-01 to 393-967-01 Toner Meter Card Error Service Check RAPs.....	130
Chain 395	131
395-001-00 to 395-009-00 DC Software Upgrade Fail RAP.....	131
395-300-00 to 395-304-00, 395-318-00, 395-319-00, 395-321-00 to 395-324-00 Software Upgrade Failure (Hardware) RAP.....	132
395-171-00 to 395-174-00 Software Upgrade Failure (Memory) RAP.....	132
395-313-00 to 395-313-03 DLM Installation Fail RAP.....	133
Chain 399	133
399-350-00, 399-355-00, 399-364-00, 399-373-00, 399-375-00, 399-377-00, 399-395-00, 399-350-10, 399-355-10, 399-364-10, 399-373-10, 399-375-10, 399-377-10, 399-395-10 Motor (fuser) Error Service Check RAPs.....	134
Chain OF	134
OF1 Machine Not Ready RAP.....	135
OF2 UI Touch Screen Failure RAP.....	135
OF3 AC Power RAP.....	136
OF4 +5VDC Power Fault RAP.....	136
OF5 +24VDC Power Fault RAP.....	137
OF6 Power On Self Test RAP.....	137
OF7 USB Operation RAP.....	140
OF8 Network Printing Problems RAP.....	141
OF9 TCP/IP Checkout RAP.....	142
OF10 Problem Printing Job RAP.....	143
OF 11 Job Prints Incorrectly RAP.....	144
OF12 Modem/Fax PWB Service RAP.....	144
OF13 Secure Access RAP.....	145
OF 14 Troubleshooting Possible Restart Faults RAP.....	147

301-100-00, 305-104-00, 305-105-00 IRCloseAllDoors RAP

The machine detects a door is open and the interlock is active.

301-100-00 IRCloseAllDoors

305-104-00 Front Cover Open

305-105-00 Rear Cover Open



WARNING: Switch off the electricity to the machine, [GP 10](#). Disconnect the power lead from the customer supply while performing tasks that do not need electricity. Electricity can cause death or injury. Moving components can cause injury.

1. Check the doors for the following:
 - Obstructions
 - Damage
 - Improper operation
2. Close the doors properly.

Note: Make sure that there is no gap between the door and the printer.
3. Make sure that the door links and hinges are properly interlocked and the sensor actuator is not damaged.
4. Press the power button to turn off the printer, and then disconnect the power cord from the electrical outlet.
5. Wait for 30 seconds to make sure that all electrical charges have dissipated from the printer.
6. Connect the power cord to the electrical outlet, and then press the power button to turn on the printer.
7. Wait for the printer to completely boot up and initialize all its components before sending the print job again.
8. Check the front door sensor, for damage and improper installation.
9. Make sure that the front door sensor, is functional, do the following:
 - a. Enter the Diagnostics Menu, [GP 1](#).
 - b. Touch Diagnostics > [dC330](#) Component Control > Print Engine > Sensor Tests.
 - c. Touch the appropriate test for the Sensor in question.
10. Make sure that the connections between the controller PWB, [PL 3.05 item 1](#) and front door sensor are properly connected.
11. Install new components, in order, as required:
 - a. Front door sensor.
 - b. Controller PWB, [PL 3.05 item 1](#).

302-302-00, 302-306-00, 302-308-00 Flash Failure RAP

302-302-00 Flash Rewrite Failure.

302-306-00 Flash Erase Failure.

302-308-00 Flash Download Failure.



WARNING: Switch off the electricity to the machine, GP 10. Disconnect the power lead from the customer supply while performing tasks that do not need electricity. Electricity can cause death or injury. Moving components can cause injury.

1. Switch OFF, then switch on the machine, GP 10.
2. Perform a software upgrade, GP 4, using the Altboot method.
3. If the fault persists, install new components in order, as required:
 - a. If installed, Optional 500+GB Hard Disk, PL 25.05 item 2.
 - b. Controller PWB, PL 3.05 item 1.

302-312–00 Application SW Checksum Failure RAP



WARNING: Switch off the electricity to the machine, GP 10. Disconnect the power lead from the customer supply while performing tasks that do not need electricity. Electricity can cause death or injury. Moving components can cause injury.

1. Switch OFF, then switch ON the machine, GP 10.
2. Perform a software upgrade, GP 4.
3. If the fault persists, install new components in order, as required:
 - a. If installed, Optional 500+GB Hard Disk, PL 25.05 item 1.
 - b. Controller PWB, PL 3.05 item 1.

302-315–00 Service Registry Bad Data / Corrupted RAP

302–315–00 is an internal machine fault code, and is never displayed or logged in the fault history.



WARNING: Switch off the electricity to the machine, GP 10. Disconnect the power lead from the customer supply while performing tasks that do not need electricity. Electricity can cause death or injury. Moving components can cause injury.

1. Switch OFF, then switch ON the machine, GP 10.
2. Enter Diagnostics, GP 1.
 - a. Touch **Adjustments**, then touch dC301.
 - b. Follow the procedures to initialize NVM.
3. If the fault persists, perform Software Upgrade, GP 4, using the USB FORCED_ALTBOOT method.

302-316-00 and 302-317-00 Service Registry Not Responding RAP

302-316-00 SRS returns to UI “invalid fields, invalid data, or missing data”.

302-317-00 UI gets no response from SRS.

Procedure



WARNING: Switch off the electricity to the machine, GP 10. Disconnect the power lead from the customer supply while performing tasks that do not need electricity. Electricity can cause death or injury. Moving components can cause injury.

Perform the following in order:

1. Upgrade software, GP 4.
2. Install a new Controller PWB, PL 3.05 item 1.

302-318-00 Touch Device not Available RAP

LUI gets stuck after upgrade or popo (home/power button works).



WARNING: Switch off the electricity to the machine, GP 10. Disconnect the power lead from the customer supply while performing tasks that do not need electricity. Electricity can cause death or injury. Moving components can cause injury.

Switch OFF, then switch ON the machine, GP 10. If the fault persists, call 2nd level support.

302-320-00 UI Data Time Out Error RAP

A software error has occurred. User intervention is required to Power Off/Power On the machine. Printing may be disabled.

1. Switch OFF, then switch ON the machine, [GP 10](#).
2. Perform a software upgrade, [GP 4](#), using the Altboot method.
3. If the fault persists, perform RAP, [303-347-00 UI Communications Lost RAP](#) UI Communication Lost RAP.

302-380-00 and 302-381-00 UI Communication Fault RAP

302-380-00 Communication via H-H USB netpath connection between SBC and UI panel is not working.

302-381-00 Communication via USB connection between CC and UI panel is not working.



WARNING: Switch off the electricity to the machine, [GP 10](#). Disconnect the power lead from the customer supply while performing tasks that do not need electricity. Electricity can cause death or injury. Moving components can cause injury.

Perform the following in order:

1. Switch OFF, then switch ON the machine, [GP 10](#).
2. Upgrade the software, [GP 4](#).
3. Install a new control panel cable, [PL 2.05 item 2](#).
4. Install a new controller PWB, [PL 3.05 item 1](#).

302-390–00 Power Up Fault RAP

During power up all configurable services have not achieved a stable state after 5 minutes from power up.

Perform RAP, [OF 1 Machine Not Ready RAP](#).

303–306–00 Downgrade Not Permitted

Downgrade not permitted. A Customer upgrade was attempted, which would result in a software downgrade, which is not allowed.

Procedure



WARNING: Switch off the electricity to the machine, GP 10. Disconnect the power lead from the customer supply while performing tasks that do not need electricity. Electricity can cause death or injury. Moving components can cause injury.



CAUTION: Software downgrades cannot be performed by a customer. When using the FORCED_ALTBOOT method, follow the procedure in GP 4, Software Upgrade. Inform the customer that customer data will not be retained using the FORCED_ALTBOOT method for downgrading machine software.

If a software downgrade is required by the customer, perform the downgrade using the FORCED_ALTBOOT method, GP 4.

303-307–00 Upgrade Synchronization Failure

SW Upgrade Synchronization Failure. Customer or CSE tried to perform upgrade resulting in a SW Upgrade Synchronization problem.

Initial Actions



WARNING: Switch off the electricity to the machine, GP 10. Disconnect the power lead from the customer supply while performing tasks that do not need electricity. Electricity can cause death or injury. Moving components can cause injury.



CAUTION: Software downgrades cannot be performed by a customer. When using the FORCED_ALTBOOT method, follow the procedure in GP 4, Software Upgrade. Inform the customer that customer data will not be retained using the FORCED_ALTBOOT method for downgrading machine software.

Switch off, then switch on the machine GP 10.

Procedure

Perform the following in order:

1. Check connections and cables and perform Software Upgrade again using Altboot in GP 10.
2. If the upgrade fails again, use Altboot to upgrade the SW version that existed on the machine prior to attempting the upgrade.
3. If the previous version loads correctly, download the upgrade SW again, verify that the files are correct for the machine, and attempt the upgrade using different media.

303-315–00 DC Platform Internal Interface Fault RAP

303-315-00 The DC platform software interface has timed out.

Procedure



WARNING: Switch off the electricity to the machine, GP 10. Disconnect the power lead from the customer supply while performing tasks that do not need electricity. Electricity can cause death or injury. Moving components can cause injury.

Check the fault history file for other 303-XXX fault codes.

303-XXX fault codes occur randomly.

Y	N	
		Switch OFF, then switch ON the machine, GP 10 .
		The fault persists.
Y	N	
		Perform SCP 5 Final Actions.

The cause may be due to electrical noise, perform the GP 28 Intermittent Failure RAP.

303–316–00 CCM Cannot Communicate With IOT RAP

WD1 Controller PWB Wiring Diagram

Controller cannot communicate with IOT.

Scanning and FAX are available, printing and copying are disabled.



WARNING: Switch off the electricity to the machine, GP 10. Disconnect the power lead from the customer supply while performing tasks that do not need electricity. Electricity can cause death or injury. Moving components can cause injury.

1. Switch OFF, then switch ON the , GP 10.
2. Perform a Software Upgrade, GP 4, using the Forced Altboot method.
3. Install new components in order as required:



CAUTION: Never install a new drive PWB, new controller PWB, or black toner cartridge at the same time. First install one of the parts, then switch on the machine, GP 10, to allow the components to sync. If the installation is successful, switch off the machine, then install another part item, if necessary.

- a. Controller PWB, PL 3.05 item 1.
 - b. Drive PWB, PL 1.05 item 4.
4. If the fault persists, contact next level support.

303–317–00 IOT NVM Save Failure

303–317–00 IOT NVM Save Failure

Procedure



WARNING: Switch off the electricity to the machine, [GP 10](#). Disconnect the power lead from the customer supply while performing tasks that do not need electricity. Electricity can cause death or injury. Moving components can cause injury.

Switch OFF, then switch ON the machine [GP 10](#).

Fault Code 303-317 is still declared.

Y N

If intermittent performance is suspected, inspect the Drive PWB for loose connections or any obvious electrical/mechanical cause for malfunction.

This fault can be caused by IOT software corruption or a software version mismatch between the IOT module and the rest of the software:

- If the fault occurred after replacing the Drive PWB, it is probably a software mismatch; perform a Software Upgrade [GP 4](#).
- If the fault is unrelated to Drive PWB replacement it may be corrupt software; perform a Forced Upgrade.

If this does not resolve the problem replace the following in order,

1. Upgrade SW using [GP 4](#).
2. Install a new Drive PWB, [PL 1.05 item 2](#).

303–319–00 IOT NVM Restore Failure

303–319–00 IOT NVM Restore Failure



WARNING: Switch off the electricity to the machine, [GP 10](#). Disconnect the power lead from the customer supply while performing tasks that do not need electricity. Electricity can cause death or injury. Moving components can cause injury.

Procedure

Perform [dC361](#) NVM Restore for the IOT Critical NVM.

If this does not resolve the problem replace the following in order,

1. Install a new Drive PWB [PL 1.05 item 2](#).

303–320–00 Incompatible Product Type

Incompatible Product Type. SW Upgrade Aborted due to incompatible product type - software set does not match hardware.



WARNING: Switch off the electricity to the machine, GP 10. Disconnect the power lead from the customer supply while performing tasks that do not need electricity. Electricity can cause death or injury. Moving components can cause injury.

Procedure

Perform GP 4 Software Upgrade with the correct Software module or select the correct .dlm file using the Web UI to upgrade the machine.

303–324–00 Software Upgrade File Transfer Failure

SW Upgrade File Transfer failure

Initial Actions



WARNING: Switch off the electricity to the machine, GP 10. Disconnect the power lead from the customer supply while performing tasks that do not need electricity. Electricity can cause death or injury. Moving components can cause injury.

Switch OFF, then switch ON the machine GP 10.

Procedure

Perform the following in order:

1. Check connections and cables and perform SW Upgrade again using Altboot in GP 4.
2. Download and upgrade the SW again, verify that the files are correct for the machine, and attempt the upgrade using different media.

303–325–00 Wall Clock Time-out During Power Up

System detects that the Wall Clock has not incremented within 1.5 seconds during Power On.

Procedure



WARNING: Switch off the electricity to the machine, [GP 10](#). Disconnect the power lead from the customer supply while performing tasks that do not need electricity. Electricity can cause death or injury. Moving components can cause injury.

Switch OFF, then switch ON the machine [GP 10](#).

If the problem continues, call service support for assistance.

303–326–00 Upgrade is not Required

Upgrade not required, since the SW Upgrade version is the same as the SW version on the machine.



WARNING: Switch off the electricity to the machine, [GP 10](#). Disconnect the power lead from the customer supply while performing tasks that do not need electricity. Electricity can cause death or injury. Moving components can cause injury.



CAUTION: Software downgrades cannot be performed by a customer. When using the FORCED_ALTBOOT method, follow the procedure in [GP 4](#), Software Upgrade. Inform the customer that customer data will not be retained using the FORCED_ALTBOOT method for downgrading machine software.

Procedure

If a software reinstallation is required, perform [GP 4](#) using Forced Altboot Method.

303–327–00 Upgrade Failure

Upgrade Failed. this problem could be caused by an internal timing issue (Front side BUS speed set incorrectly), hardware error, user error and others.

Initial Actions



WARNING: Switch off the electricity to the machine, GP 10. Disconnect the power lead from the customer supply while performing tasks that do not need electricity. Electricity can cause death or injury. Moving components can cause injury.



CAUTION: Software downgrades cannot be performed by a customer. When using the FORCED_ALTBOOT method, follow the procedure in GP 4, Software Upgrade. Inform the customer that customer data will not be retained using the FORCED_ALTBOOT method for downgrading machine software.

Check connections and reconnect Drive PWB, and Controller PWB and attempt another upgrade using GP 4 Forced Altboot for the system or platform that failed.

Procedure

The problem is still present:

Y N

| Return to Service Call Procedures.

Call service support for assistance.

303–329–00 Upgrade Request During Diagnostics

Upgrade request received during active diagnostics.



WARNING: Switch off the electricity to the machine, GP 10. Disconnect the power lead from the customer supply while performing tasks that do not need electricity. Electricity can cause death or injury. Moving components can cause injury.

Procedure

Exit Diagnostics and perform GP 4 Software Upgrade.

303–330–00 Upgrade Request During Active Security Feature

Upgrade request received during active Security function.



WARNING: Switch off the electricity to the machine, [GP 10](#). Disconnect the power lead from the customer supply while performing tasks that do not need electricity. Electricity can cause death or injury. Moving components can cause injury.

Procedure

Wait until Security function (Image Overwrite) is completed and perform [GP 4](#) Software Upgrade.

303–331–00 Communication Fault With NC

Main controller board cannot communicate with Network Controller and unable to reestablish communications for 12 minutes. This problem could be caused by loose connections or improperly seated PWBs.



WARNING: Switch off the electricity to the machine, [GP 10](#). Disconnect the power lead from the customer supply while performing tasks that do not need electricity. Electricity can cause death or injury. Moving components can cause injury.

The printer is currently busy. Normal operations should resume momentarily. The controller will continue to try to re-establish communication for 12 minutes.

If the fault persists, go to [303–332–00 NC Communications Timeout](#).

303–332–00 NC Communications Timeout

CCS unable to reestablish communication with the Network Controller after 5 minutes.

Procedure



WARNING: Switch off the electricity to the machine, GP 10. Disconnect the power lead from the customer supply while performing tasks that do not need electricity. Electricity can cause death or injury. Moving components can cause injury.

1. Switch OFF, then switch ON the machine, GP 10
2. Remove, then reseal all connections on the controller PWB.
3. Install a new controller PWB, PL 3.05 item 1.

303-333–00 Invalid Value Detected for NVM 616-004 RAP

Invalid value has been detected for NVM 616–004 System configuration.

Initial Actions



WARNING: Switch off the electricity to the machine, GP 10. Disconnect the power lead from the customer supply while performing tasks that do not need electricity. Electricity can cause death or injury. Moving components can cause injury.

Power OFF and power ON the machine GP 10.

Procedure

Enter diagnostics and check the 616–004 NVM value

- Default = 1
- Min = 0
- Max = 8
- 0 = Unknown (not set)
- 1 = ST (Networked)
- 8 = Network Suppressed

If the value is not correct perform the following-

1. NVM Initialization dC301.
2. NVM save and restore dC361.

303–338–00 and 303–338–01 CCS/Controller Reset RAP

303–338–00 CCS has been reset; either the watch dog timer timed out or the application SW wrote to an illegal address.

303–338–01 System detects that CCS has been reset unexpectedly due to a crash.

Initial Actions

Check that the customer does not have another device configured with the same IP address.



WARNING: Switch off the electricity to the machine, **GP 10**. Disconnect the power lead from the customer supply while performing tasks that do not need electricity. Electricity can cause death or injury. Moving components can cause injury.

1. Switch OFF, then switch On the machine **GP 10**.
2. Perform **dC361** to restore NVM.
3. If the fault persists, perform **GP 4** software upgrade using the Altboot method.

303–346–00 Communication Fault with UI RAP

UI dead- Unable to establish communication with the UI after 5 minutes

Perform RAP **303–347–00 UI Communications Lost RAP**, Communication Fault with UI.

303–347–00 UI Communications Lost RAP

WD1 Controller PWB Wiring Diagram

C415 Wiring Diagrams

The controller PWB cannot communicate with UI PWBA.

If communication is not reestablished within 30 seconds, fault code 303-346–00 will be declared.

1. Switch OFF, then switch ON the machine, GP 10.
2. Perform GP 4, Software Upgrade using the Altboot method.
3. If the fault persists perform OF 2, UI Touch Screen Failure RAP.

303–355–00 CCM POST Failure During NVM Integrity Test

Power On Self-Test failure detected during the NVM Integrity Test.

An error message will be displayed on the LUI for the power on cycle when the fault is raised.

Initial Actions



WARNING: Switch off the electricity to the machine, GP 10. Disconnect the power lead from the customer supply while performing tasks that do not need electricity. Electricity can cause death or injury. Moving components can cause injury.

Switch OFF, then switch ON the machine GP 10.

Procedure

Report the Billing Meter reset GP 26.

303–380–00 Distribution PWB Missing or Disconnected RAP

PWB is missing or disconnected.

1. Switch OFF, then switch ON the machine, [GP 10](#).
2. If the fault persists, contact next level support for assistance.

303–381–00, 303–382–00, 303–383–00 Critical Parameter Write Fail RAP

303–381–00 MCB Critical Parameter Write Fail

303–382–00 Mirror Critical Parameter Write Fail

303–383–00 CRUM Critical Parameter Write Fail

A memory write error occurred. When a memory location needs to be updated to match the others, a write may be attempted up to two tries before raising an error.

Switch OFF, then switch ON the machine, [GP 10](#).

303–397 System Configuration is Lost

This fault occurs when the System Configuration is lost and an attempted recovery made.



WARNING: Switch off the electricity to the machine, GP 10. Disconnect the power lead from the customer supply while performing tasks that do not need electricity. Electricity can cause death or injury. Moving components can cause injury.

Procedure

Refer to GP 8

303–401 Basic FAX Not Detected or Confirmed

Basic FAX not detected/confirmed

Procedure



WARNING: Switch off the electricity to the machine, GP 10. Disconnect the power lead from the customer supply while performing tasks that do not need electricity. Electricity can cause death or injury. Moving components can cause injury.

Switch the power OFF then ON GP 10. If the problem continues, go to the OF 12.

303–403 Extended FAX Not Detected or Confirmed

Extended FAX not detected/confirmed

Procedure



WARNING: Switch off the electricity to the machine, GP 10. Disconnect the power lead from the customer supply while performing tasks that do not need electricity. Electricity can cause death or injury. Moving components can cause injury.

Switch the power OFF then ON GP 10. If the problem continues, go to the OF 12.

303-406–00 FIK Does Not Match Machine Class RAP

FIK speed does not match machine class.

1. Switch OFF, then switch ON the machine, GP 10.
2. Install a new controller PWB, PL 3.05 item 1.

303–417–00 Incompatible FAX SW Detected at Power Up

Incompatible FAX software detected at power on

Procedure



WARNING: Switch off the electricity to the machine, GP 10. Disconnect the power lead from the customer supply while performing tasks that do not need electricity. Electricity can cause death or injury. Moving components can cause injury.

Switch OFF, then switch ON the machine. If the problem continues, reload FAX software GP 10.

303–450–00 Unexpected IOT reset RAP

Unexpected IOT reset has occurred.



WARNING: Switch off the electricity to the machine, GP 10. Disconnect the power lead from the customer supply while performing tasks that do not need electricity. Electricity can cause death or injury. Moving components can cause injury.

Switch OFF, then switch ON the machine. If the problem persists, reload System software GP 10.

303–777–00 Power Loss Detected

Input Power loss detected or software corruption.

Power on Self test has detected that the previous shutdown was abnormal. Possible causes include the following:



WARNING: Switch off the electricity to the machine, GP 10. Disconnect the power lead from the customer supply while performing tasks that do not need electricity. Electricity can cause death or injury. Moving components can cause injury.

- The main power switch was used to power off the machine instead of the software switch.
- Power outage / unplugging power cord / poor voltage quality.

Procedure

- Verify customer power outlet voltage is correct.
- Perform customer training on proper power down process.

303–788–00 Failed to Exit Power Save Mode RAP

CCS Runtime could not enter power saver mode S3.

Note: The CC USB could not re-enumerate the UI panel coming out of sleep, which keeps parts of the system in power saver mode S3 and parts awake. This prevents system entry into power saver mode S3 at the next attempt to do so.



WARNING: Switch off the electricity to the machine, GP 10. Disconnect the power lead from the customer supply while performing tasks that do not need electricity. Electricity can cause death or injury. Moving components can cause injury.

Switch OFF, then switch ON the machine, GP 10, to allow system to enter power save.

303–790–00 Time Zone File Cannot be Set

Timezone file cannot be set. At power up, the time zone setting is not valid due to NVM corruption, or OS file system problem. Time Zone overridden to GMT: DST Disabled.

Procedure



WARNING: Switch off the electricity to the machine, GP 10. Disconnect the power lead from the customer supply while performing tasks that do not need electricity. Electricity can cause death or injury. Moving components can cause injury.

1. Switch OFF, then switch ON GP 10.
2. Perform dC361 to restore NVM.
3. If the problem continues, perform GP 4 SW upgrade.

303–805–00 GPU is Hung RAP

The Graphical Processing Unit is hung. Kernel logs a critical error in the logs.

1. Switch OFF, then switch ON the machine, GP 10.
2. Install a new controller PWB, PL 3.05 item 1.

305-101-00, 305-102-00, 305-124-00, 305-125-00, 305-906-00, 305-922-00 Sensor (DADF scan 1) Jam RAP

305-101-00 First Scan Sensor not reached

305-102-00 First Scan Sensor not cleared

305-124-00 First Scan Off Jam

305-125-00 First Scan On Jam

305-906-00 Remainder Jam First Scan

305-922-00 Remainder Jam - First Scan Sensor



WARNING: Switch off the electricity to the machine, GP 10. Disconnect the power lead from the customer supply while performing tasks that do not need electricity. Electricity can cause death or injury. Moving components can cause injury.

1. Make sure that paper is supported and loaded properly.
2. Check the DADF pick rollers and separator rollers for wear, damage, contamination, and improper installation.
3. Check the DADF paper path for debris and foreign object.
4. Make sure that the DADF top cover and the DADF is properly closed.
5. Make sure that the sensor (DADF scan 1) is functional. Do the following:
 - a. Enter the Diagnostics, GP 1
 - b. Touch Diagnostics > dC330 Component Control > Print Engine > Sensor Tests.
 - c. Touch the appropriate test for the Sensor in question.
6. Make sure that the connections between the sensor (DADF scan 1) and the controller board are properly connected.
7. Check the sensor (DADF scan 1) and its actuator for damage and improper installation.
8. Make sure that the connections between the DADF and the controller board are properly connected.
9. Check the DADF pick drive for improper operation.
10. Check the DADF pick drive rollers and gears for wear and damage. Install a new, DADF maintenance kit PL 5.05 item 4.

305-103-00, 362-358-00, 362-397-00 to 362-399-00, 362-463-00, 362-476-00, 362-798-00 Scanner Communication Error Service Check RAPs

305-103-00 Scanner Disabled by any other reason (invalid license, too many hw errors, etc.)

362-358-00 Backside Cable error

362-397-00 IIT Comm Failure - Logical Protocol

362-398-00 Scanner Comm Failure- HW Protocol

362-399-00 IIT Comm Failure - No Response

362-463-00 IIT Mech Failure - DADF

362-476-00 IIT Mech Failure - Flatbed carriage failed to home

362-798-00 Frontside FFC cable is unplugged



WARNING: Switch off the electricity to the machine, [GP 10](#). Disconnect the power lead from the customer supply while performing tasks that do not need electricity. Electricity can cause death or injury. Moving components can cause injury.

1. Enable the scanner via the control panel or EWS.
 - a. From the home screen, touch **Settings > Device > Maintenance > Configuration Menu > Scanner Configuration > Disabled Scanner** .
 - b. Select **Enabled** .
2. Switch OFF, then switch ON the machine, [GP 10](#).
3. If an 84y.xx error code persists, then check if the DADF or the flatbed scanner is causing the error.
4. Check the error logs in the Print Log Summary.
 - a. Enter the Diagnostics menu, and then touch **Event Log > Print Log Summary** .
 - b. If the printer has encountered successive scanner errors, then perform the appropriate service check.

Note: Before replacing an DADF or flatbed scanner, perform a sensor test and motor test to validate which scanner is causing the error.
5. Make sure that the DADF sensors and motors are functional, do the following:
 - a. Enter the Diagnostics menu, and then touch **Scanner diagnostics** .
 - b. Perform all DADF sensor and motors tests.
6. Make sure that the connections between the DADF and the controller board are properly connected.
7. Check the DADF for wear, damage, and improper installation. For more information, see [REP 5.1](#).
8. Make sure that the flatbed scanner sensors and motors are functional, do the following:
 - a. Enter the Diagnostics menu [GP 1](#), and then touch dC330 component control (scan engine).
 - b. Perform all flatbed scanner sensor and motors tests.

9. Make sure that the connections between the flatbed scanner and the controller board are properly connected.
10. Check the flatbed scanner for wear, damage, and improper installation. For more information, see [REP 60.2](#) .

305-106-00 DADF top cover open service check RAP

305-106-00 IRScanAdfCoverOpen: Scanner DADF Cover Open



WARNING: Switch off the electricity to the machine, [GP 10](#). Disconnect the power lead from the customer supply while performing tasks that do not need electricity. Electricity can cause death or injury. Moving components can cause injury.

1. Check the DADF doors for the following:
 - Obstructions
 - Damage
 - Improper operation
2. Close the DADF doors properly.

Note: Make sure that there is no gap between the door and the DADF.
3. Make sure that the DADF door links and hinges are properly interlocked and the sensor actuator is not damaged.
4. Press the power button to turn off the printer, and then disconnect the power cord from the electrical outlet.
5. Wait for 30 seconds to make sure that all electrical charges have dissipated from the printer.
6. Connect the power cord to the electrical outlet, and then press the power button to turn on the printer.
7. Wait for the printer to completely boot up and initialize all its components before sending the print job again.
8. Check the sensor (DADF top door interlock) actuator for damage and improper installation.
9. Make sure that the sensor (DADF top door interlock) is functional, do the following:
 - a. Enter the Diagnostics, [GP 1](#)
 - b. Touch Diagnostics > dC330 Component Control > Print Engine > Sensor Tests.
 - c. Touch the appropriate test for the Sensor in question.
10. Make sure that the connections between the controller board and sensor (DADF top door interlock) are properly connected.

305-121-00 DADF Paper Undetected Service Check RAP

305-121-00 Feed Sensor Off



WARNING: Switch off the electricity to the machine, [GP 10](#). Disconnect the power lead from the customer supply while performing tasks that do not need electricity. Electricity can cause death or injury. Moving components can cause injury.

1. Make sure that paper is supported and loaded properly.
2. Make sure that the sensor (DADF media present) is functional. Do the following:
 - a. Enter the Diagnostics, [GP 1](#)
 - b. Touch Diagnostics > dC330 Component Control > Print Engine > Sensor Tests.
 - c. Touch the appropriate test for the Sensor in question.
3. Make sure that the connections between the sensor (DADF media present) and the controller board are properly connected.
4. Check the sensor (DADF media present) and its actuator for damage and improper installation.

305-126-00 to 305-129-00, 305-175-00 to 305-177-00 Sensor (DADF scan 2) Jam Service Check RAPs

305-126-00 Second Scan Dup Off Jam

305-127-00 Second Scan Dup On Jam

305-129-00 Remainder Dup / Second Scan Jam

305-175-00 Remainder Jam - Second Scan/Duplex Sensor

305-176-00 Second Scan/Duplex Sensor not reached

305-177-00 Second Scan/Duplex Sensor not cleared



WARNING: Switch off the electricity to the machine, GP 10. Disconnect the power lead from the customer supply while performing tasks that do not need electricity. Electricity can cause death or injury. Moving components can cause injury.

1. Make sure that paper is supported and loaded properly.
2. Check the DADF pick rollers and separator rollers for wear, damage, contamination, and improper installation.
3. Check the DADF paper path for debris and foreign object.
4. Make sure that the DADF top cover and the DADF is properly closed.
5. Make sure that the sensor (DADF scan 2) is functional. Do the following:
 - a. Enter the Diagnostics, GP 1.
 - b. Touch Diagnostics > dC330 Component Control > Print Engine > Sensor Tests.
 - c. Touch the appropriate test for the Sensor in question.
6. Make sure that the connections between the sensor (DADF scan 2) and the controller board are properly connected.
7. Check the sensor (DADF scan 2) and its actuator for damage and improper installation.
8. Make sure that the connections between the DADF and the controller board are properly connected.
9. Check the DADF pick drive for improper operation.
10. Check the DADF pick drive rollers and gears for wear and damage. For more information, see REP 5.2.

305-210-00 DADF Imagepipe Jam Service Check RAP

305-210-00 Imagepipe Error



WARNING: Switch off the electricity to the machine, GP 10. Disconnect the power lead from the customer supply while performing tasks that do not need electricity. Electricity can cause death or injury. Moving components can cause injury.

1. Make sure that paper is supported and loaded properly.
2. Remove the jammed paper in the DADF.
3. Perform a Switch OFF, then switch ON the machine, GP 10.
4. Resent the copy job.

Note: While scanning multiple documents with different sizes using the DADF, set the Scan Size option to **Mixed** or **Auto-size**.

305-300-00 Sensor (DADF cover) Service Check RAP

305-300-00 Platen cover interlock opened during run



WARNING: Switch off the electricity to the machine, [GP 10](#). Disconnect the power lead from the customer supply while performing tasks that do not need electricity. Electricity can cause death or injury. Moving components can cause injury.

1. Make sure that paper is supported and loaded properly.
2. Make sure that the sensor (DADF cover) is functional. Do the following:
 - a. Enter the Diagnostics, [GP 1](#)
 - b. Touch Diagnostics > [dC330](#) Component Control > Print Engine > Sensor Tests.
 - c. Touch the appropriate test for the Sensor in question.
3. Make sure that the connections between the sensor (DADF cover) and the controller board are properly connected.
4. Check the sensor (DADF cover) and its actuator for damage and improper installation.
5. Make sure that the connections between the DADF and the controller board are properly connected.
6. Check the DADF top cover for foreign objects.
7. Check the DADF top cover for damage and improper installation.. For more information, see [REP 5.2](#).

310-327-00, 310-341-00, 310-361-00, 310-362-00, 310-364-00, 310-368-00 to 310-374-00, 310-376-00 to 310-379-00, 310-383-00 Fuser Error Service Check RAPs

310-327-00 Fuser On Time Fail

310-341-00 Fuser powerup Fail

310-361-00 Fuser relay comm fail

310-362-00 Fuser relay open fail

310-364-00 Fuser warm up fail

310-368-00 Fuser EWC line temp fail

310-369-00 Fuser EWC / Line long

310-370-00 Fuser EWC / Line too fast

310-371-00 Fuser Open relay

310-372-00 Fuser power up undertemp too long

310-373-00 Fuser feed undertemp too long

310-374-00 Fuser under temp fail

310-376-00 Fuser under temp check

310-377-00 Fuser On Time Fail

310-378-00 Fuser Main temp fail

310-379-00 Fuser Main therm open

310-383-00 Fuser heater was too cold when page entered fuser nip



WARNING: Switch off the electricity to the machine, GP 10. Disconnect the power lead from the customer supply while performing tasks that do not need electricity. Electricity can cause death or injury. Moving components can cause injury.

1. Make sure that the printer is placed in a location with the following temperature and humidity:
 - 60°F to 90°F temperature range
 - 8% to 80% relative humidity
2. If the printer needs to be placed in a below freezing environment, then do the following:
 - a. Remove the fuser, and then allow it to slowly warm above freezing temperature.
 - b. Reinstall the fuser, and then turn on the printer.
 - c. Disable the Sleep mode setting. From the home screen, touch **Settings > Device > Power Management > Timeouts > Sleep Mode**.
3. Make sure that the printer is plugged into an appropriately rated and properly grounded electrical outlet.
4. Switch OFF, then switch ON the machine, GP 10.
5. Make sure that the cooling fan is functional. Do the following:
 - a. Enter the Diagnostics, GP 1.
 - b. Touch Diagnostics > dC330 Component Control > Print Engine > Motor Tests.
 - c. Touch the appropriate test for the Motor in question.
6. Make sure that the connections between the cooling fan and the controller board are properly connected.
7. Check the cooling fan for damage, contamination, and improper installation.
8. Make sure that the correct voltage is supplied to the fuser from the power supply.
9. Make sure that the connections between the controller board and the fuser are properly connected.
10. Check the fuser for damage, contamination, and improper installation. For more information, see REP 10.1.

310-473-00 to 310-476-00, 310-517-00 900 Error Service Check RAP

310-473-00 NVRAM chip failure with mirror part

310-474-00 System Board NAND Failure

310-475-00 The engine timed out waiting for a mechanical reset or an intervention required clear to complete after tray insert

310-476-00 The engine timed out waiting for an option to quiescent

310-517-00 Engine cable error: No video communication between RIP & engine cards



WARNING: Switch off the electricity to the machine, [GP 10](#). Disconnect the power lead from the customer supply while performing tasks that do not need electricity. Electricity can cause death or injury. Moving components can cause injury.

1. Clear all jobs in the printer and computer print queue.
2. Switch OFF, then switch ON the machine, [GP 10](#).
3. Turn off the printer.
4. Disconnect the USB cable, fax line, and network cable from the printer.
5. Turn on the printer.
6. If the error does not occur, then install each cable one at a time and perform a POR after each cable installation.
7. Make sure that the printer is running the latest firmware version.
If the printer cannot connect to the network due to a 900 error, then do the following:
 - a. Enter Recovery mode. For more information, see [GP 4](#).
 - b. Flash the firmware code through a USB cable that is directly connected to a computer.
8. Turn off the printer.
9. Remove all electronic options (hard disk, ISD, wireless module, ISP, and memory options).
10. Turn on the printer.
11. If the error does not occur, then install the electronic options one at a time and perform a POR after each electronic option installation.
12. Replace the electronic option that causes the error.
13. Make sure that the connections between the engine board and the controller board are properly connected.
14. Check the controller board for the following:
 - Foreign debris (dust, dirt, or any accumulated material)
 - Circuit board expansion due to heat and humidity
 - Damaged pins, burnt-out components, and signs of overheating and bulging
 - Missing components and solder joint connection issues
 - Contamination issues (corrosion, degradation, metallization, and chemical leakage)
 - Incorrect input or output voltages. See the wiring diagram.

For more information, see [REP 3.1](#).

310-670-00, 310-418-00, 310-419-00, 310-422-00 to 310-430-00, 310-488-00, 305-211-00, 305-212-00 Printhead Error Service Check RAPs

310-670-00 Weather station data not valid

310-418-00 Mirror motor lock is asserted before the motor is turned on

310-419-00 The printhead +5v power was not on when starting the laser servo

310-422-00 The printhead error (no first Hysnc) was detected

310-423-00 The printhead error (lost first Hysnc) was detected

310-424-00 The printhead error (lost first Hysnc) was detected during servo

310-425-00 The printhead error (mirror motor lost lock) was detected

310-426-00 The printhead error (mirror motor no first lock) was detected

310-427-00 The printhead error (mirror motor never stabilized) was detected

310-428-00 Unable to determine printhead type from printhead NVRAM

310-429-00 Failure to read NVRAM

310-430-00 Printhead NVRAM contents are incorrect

310-488-00 Printhead NVRAM checksum mismatch. The calculated checksum does not match the checksum stored in the printhead NVRAM

305-211-00 Laser Safety interlock

305-212-00 Mirror motor lock fail



WARNING: Switch off the electricity to the machine, [GP 10](#). Disconnect the power lead from the customer supply while performing tasks that do not need electricity. Electricity can cause death or injury. Moving components can cause injury.

1. Switch OFF, then switch ON the machine, [GP 10](#).
2. Make sure that the connections between the controller board and the printhead are properly connected.
3. Check the printhead for damage, contamination, and improper installation. For more information, see [REP 60.1](#).

316-000-00 to 316-016-99 Network Faults 1 RAP

316-000-00 Format services non shutdown ESS faults.

316-000-01 ENS service non shutdown ESS faults.

316-000-09 Cannot create RPC connection with ENS.

316-000-19 Cannot create RPC connection with ENS.

316-001-09 Unable to do startup synchronization.

316-001-14 Unable to do startup synchronization.

316-001-19 Unable to do startup synchronization.

316-001-26 Unable to startup and synchronize with SC.

316-003-09 Too many IPC handles.

316-003-14 Too many IPC handles.

316-003-19 Too many IPC handlers.

316-004-14 RPC call failure to ESS registration service.

316-004-19 RPC connect failure to ESS registration service.

316-005-14 RPC call failure to ESS registration service.

316-005-19 RPC call failure to ESS registration service.

316-005-68 RPC call failure to ESS registration service (to register with).

316-005-92 RPC call failure to ESS registration service (to register with).

316-006-09 Cannot register for events.

316-006-19 Cannot register for events.

316-009-09 Invalid IPC data received.

316-010-14 Unable to send IPC.

316-010-99 IPC open, create, signal queue failed.

316-012-00 Rolling reboot has been detected.

316-015-14 SESS data store environmental variable not set.

316-015-19 SESS data store environmental variable not set.

316-016-14 Data store initialization failed.

316-016-19 Data store initialization failed.

316-016-99 Data store initialization failed.

1. If a single occurrence, take no action.
2. For multiple occurrences, go to [316E Network Fault Checkout RAP](#) Network Fault Checkout RAP.

316-023-09 to 316-153-19 Network Faults 2 RAP

316-023-09 RPC call failure to ENS.

316-026-09 Memory allocation failure.

316-026-14 Memory allocation error.

316-030-19 Unable to obtain client RPC handle to EJS.

316-031-09 Invalid event notification received.

316-048-09 Unable to set binding.

316-048-14 Cannot set ESS client binding.

316-048-99 Unable to set client binding.

316-051-00 File Descriptor (FD) Threshold Exceeded.

316-101-93 Swap memory usage exceeds 90 percent

316-150-19 Unable to sync peer (within ESS) infrastructure services.

316-150-26 Fault service failed to write log.

316-151-09 Invalid IPC command.

316-151-26 Fault service failed to get a log handle.

316-152-09 Internal IPC failure.

316-152-14 Empty internal event received by ENS.

316-152-19 Unable to send request to SESS.

316-152-26 Fault service could not open fault log.

316-153-09 Unable to obtain IPC queue.

316-153-14 Can not initialize internal event list.

316-153-19 NVM save failure.

1. If a single occurrence, take no action.
2. For multiple occurrences, perform the [316E Network Fault Checkout RAP](#) Network Fault Check-out RAP.

316-165-01 to 316-165-04 SLC and MLC Wear Level RAP

316-165-01 SLC wear level at 90 %

316-165-02 MLC wear level at 90 %

316-165-03 SLC wear level at 100 %

316-165-04 MLC wear level at 100 %

Procedure



WARNING: Switch off the electricity to the machine, [GP 10](#). Disconnect the power lead from the customer supply while performing tasks that do not need electricity. Electricity can cause death or injury. Moving components can cause injury.

1. Switch OFF, then switch ON the machine, [GP 10](#).
2. If the fault persists, contact next level support.

316-330-00 System Startup Process Crash RAP

A process not owned by a platform crashed.

No action required. The machine will self-restart. The UI should display the message: System Startup Process Crash.

316-331-00 and 316-331-01 UI Panel Communication Failure RAP

316-331-00 UI Panel Communication Failure.

316-331-01 UI Panel Communication Failure After Retry

The UI panel stopped communication with the controller PWB.

Procedure



WARNING: Switch off the electricity to the machine, GP 10. Disconnect the power lead from the customer supply while performing tasks that do not need electricity. Electricity can cause death or injury. Moving components can cause injury.

1. Switch OFF, then switch ON the machine, GP 10.
2. If the fault persists, perform the 302-380-00 and 302-381-00 UI Communication Fault RAP UI Communication Fault RAP.

316-333-00 Device DLM Process Unloaded After Causing Repeated Resets RAP

A device dlm was unloaded after causing repeated resets.

No action required.

316-338-00 and 316-339-00 Platform Death Faults RAP

316-338-00 NC Platform Death. An element of the network Controller has crashed.

316-339-00 UI Platform Death. An element of the UI has crashed.

No actions required. The machine will self-restart. The UI should display the message:

- NC Platform Death — 316-338-00
- UI Platform Death — 316-339-00

316-340-00 UI Power On Failure RAP

UI power on timer expired.

No action required, The machine will self-restart. The UI should display the message: UI Power On Failure.

316-400-19 NVM Connection Failure RAP

Invalid System Config; SW Error; NVM Corrupted; NVM Non existent.

No action required. The UI should display the message: NVM Failure - Init performed.

316-428-00, 316-430-00 NVM Save Failure RAP

316-428-00 NVM Save to FPGA Failure

316-430-00 NVM Save to SPI Failure

1. Switch OFF, then switch ON the machine, [GP 10](#).
2. If the fault persists, install a new controller PWB, [PL 3.05 item 1](#).

316-435-00, 316-435-01, 316-436-00 UI Faults RAP

316-435-00 UI thread not running 10s warning.

316-435-01 UI thread not running 30s warning.

316-436-00 UI Serial Comm Not Present.

No action required.

316-501-00 to 316-544-00 Network Faults 4 RAP

- 316-501-00 Ethernet cable not connected.
 - 316-502-00 USB WiFi adapter not installed.
 - 316-503-00 Ethernet 802.1X connection failure.
 - 316-504-00 WiFi connection failure. Cannot connect to the WiFi network.
 - 316-505-00 WiFi connection lost.
 - 316-506-00 Ethernet DHCP/BOOTP Error: DHCP/BOOTP failure.
 - 316-507-00 Ethernet DHCP/BOOTP Error: DHCP/BOOTP failure.
 - 316-508-00 Ethernet DHCP/BOOTP Error: DHCP/BOOTP failure.
 - 316-509-00 Ethernet DHCP/BOOTP Error: DHCP/BOOTP failure.
 - 316-514-00 Ethernet DHCP/BOOTP Error: DHCP/BOOTP failed to obtain an address.
 - 316-517-00 WiFi DHCP/BOOTP Error: DHCP/BOOTP failed to obtain an address.
 - 316-518-00 Ethernet DHCP/BOOTP Error: DHCP/BOOTP failed to obtain an address.
 - 316-519-00 WiFi DHCP/BOOTP Error: DHCP/BOOTP failed to obtain an address.
 - 316-524-00 Ethernet: Duplicate IPv4 address detected.
 - 316-525-00 WiFi Duplicate IPv4 address detected.
 - 316-526-00 Ethernet: No IPv4 router configured.
 - 316-527-00 WiFi: No IPv4 router configured.
 - 316-528-00 Ethernet: No IPv6 router advertisement. No routable IPv6 address configured.
 - 316-529-00 WiFi: No IPv6 router advertisement. No routable IPv6 address configured.
 - 316-531-00 Ethernet: Duplicate IPv6 address detected.
 - 316-533-00 WiFi: Duplicate IPv6 address detected.
 - 316-535-00 Ethernet DHCPv6 Error: DHCPv6 failed to obtain an address.
 - 316-536-00 WiFi DHCPv6 Error: DHCPv6 failed to obtain an address.
 - 316-540-00 Ethernet DHCPv6 Error: DHCPv6 failed to obtain an address.
 - 316-544-00 WiFi DHCPv6 Error: DHCPv6 failed to obtain an address.
1. If a single occurrence, take no action.
 2. For multiple occurrences, perform, [316E Network Fault Checkout RAP](#).

316-600-35 to 316-608-105 Network Faults 5 RAP

- 316-600-35 Can not create RPC connection to ENS.
- 316-600-66 Unable to Create RPC Connection with ENS.
- 316-600-67 Unable to Create RPC Connection with ENS.
- 316-600-19 Client Bridge Communication Timeout(EAGAIN).
- 316-601-26 Fault Service Failed IPC Queue Setup.
- 316-601-35 System Control initialization failed.
- 316-601-47 Diag Service Failed IPC Queue Setup.
- 316-601-66 Unable to do start up synchronization.
- 316-601-67 Unable to do start up synchronization.
- 316-601-68 Unable to start up & sync with SC.
- 316-602-19 UI Client Bridge Communication Timeout (EAGAIN).
- 316-602-28 RPC Server Registration failed.
- 316-602-35 RPC Server Registration.
- 316-602-38 RPC Server Registration failed.
- 316-602-66 Unable to Register as an RPC Server.
- 316-602-67 Unable to Register as an RPC Server.
- 316-602-68 Unable to Register as an RPC Server.
- 316-602-105 Unable to Register as an RPC Server.
- 316-603-11 Replace handler call failed.
- 316-603-28 Replace handler call failed.
- 316-603-46 Too many IPC handlers.
- 316-603-66 Too many IPC handlers.
- 316-603-67 Too many IPC handlers.
- 316-603-68 Replace handler call failed.
- 316-603-105 RPC call failure to network controller registration service.
- 316-604-14 Unable to unregister as RPC service during shutdown. Registration failed.
- 316-604-38 Could not register with registration service.
- 316-604-99 Could not register with registration service.
- 316-604-105 SESS data store environmental variable not set.
- 316-605-07 Unable to register with registration service.
- 316-605-14 RPC call failure to ESS registration service.

316-605-26 Fault service timed out registering with registration service.

316-605-35 RPC call failure to NC registration service.

316-605-47 RPC call failure to NC registration service (to register with).

316-605-66 RPC call failure to NC registration service.

316-605-67 RPC call failure to NC registration service.

316-605-105 Unable to unregister as RPC service during shutdown.

316-606-07 Cannot register for events.

316-606-35 Cannot register for events.

316-606-46 Cannot register for events.

316-606-99 Cannot register for events.

316-606-105 OS problem.

316-607-19 Invalid RPC data received.

316-607-46 Invalid RPC data received.

316-607-47 Invalid RPC disk diagnostic data received.

316-607-92 Invalid RPC data received.

316-607-105 Service run loop failed.

316-608-09 Unable to free IPC resources.

316-608-11 IPC unregister failed.

316-608-14 Unable to free IPC resources.

316-608-26 Fault service failed to unbind with SC.

316-608-28 IPC unregister fail.

316-608-35 Unable to free IPC resources.

316-608-66 Unable to free IPC resources.

316-608-67 Unable to free IPC resources.

316-608-68 Unable to Free IPC Resources.

316-608-105 Unable build UI SVC, obtain client failed.

1. If a single occurrence, take no action.
2. For multiple occurrences, go to the [316E Network Fault Checkout RAP](#) Network Fault Checkout RAP.

316-609-19 to 316-612-68 Network Faults 5 RAP

316-609-19 Invalid RPC data received.

316-609-26 Fault service encountered error trying to get IPC message.

316-609-47 Invalid IPC data received. Get SC diagnostics handle failed.

316-609-92 Invalid IPC data received.

316-609-105 Too many IPC handlers.

316-610-00 IPC send failure to ESS AAA service for queue command authorization.

316-610-09 Cannot send IPC message to ESS platform manage.

316-610-11 IPC communication failed.

316-610-19 Unable to send IPC message.

316-610-26 Unable to send IPC message.

316-610-28 IPC communication failed.

316-610-35 Unable to send IPC message.

316-610-92 Failure to send queue status.

316-610-99 Unable to send IPC message.

316-611-14 Unable to remove RPC connection.

316-611-19 Unable to remove RPC connection.

316-611-26 Unable to remove RPC connection.

316-611-38 Client removal failure.

316-611-47 Unable to remove RPC connection.

316-611-66 Unable to remove RPC connection.

316-611-67 Unable to remove RPC connection.

316-611-99 Unable to remove RPC connection.

316-612-09 Unable to do shutdown synchronization.

316-612-14 Unable to do shutdown synchronization.

316-612-35 Unable to do shutdown synchronization.

316-612-68 Unable to do shutdown synchronization.

1. If a single occurrence, take no action.
2. For multiple occurrences, go to the [316E Network Fault Checkout RAP](#) Network Fault Checkout RAP.

316-613-09 to 316-617-19 Network Faults 6 RAP

316-613-09 DC registration synchronization error.

316-613-14 DC ENS synchronization error.

316-613-19 DC sys mgr sync error.

316-614-09 DC registration communications error.

316-614-14 Digital copier ENS registration error.

316-614-19 DC sys mgr communications error.

316-615-35 SESS data store environmental variable not set.

316-615-66 SESS data store environmental variable not set.

316-615-67 SESS data store environmental variable not set.

316-616-35 Data Store initialization failure.

316-616-38 Error - Shared Memory Failure.

316-616-67 Submission of Email or IFax Job Failed.

316-617-19 Send Event Failure Unable to send event to NC ENS.



WARNING: Switch off the electricity to the machine, GP 10. Disconnect the power lead from the customer supply while performing tasks that do not need electricity. Electricity can cause death or injury. Moving components can cause injury.

1. If a single occurrence, take no action.
2. For multiple occurrences, go to the [316E Network Fault Checkout RAP](#) Network Fault Checkout RAP.

316-620-92 to 316-625-90 Network Faults 7 RAP

316-620-92 Unable to unregister with network controller registration service due to registration service failure.

316-620-93 Unable to unregister with network controller registration service due to registration service failure.

316-620-99 Registration service failed.

316-621-00 Unable to get host name. Configuration error.

316-621-07 Unable to get host name. Configuration error.

316-621-11 Unable to get host name. Configuration error.

316-621-28 Unable to get host name. Configuration error.

316-621-35 Failed to get host name using GetHostName call.

316-621-38 Failed to get host name using GetHostName call.

316-621-47 Failed to get host name using GetHostName call.

316-621-66 Unable to get host name.

316-621-67 Unable to get host name.

316-621-93 Failed to get host name using GetHostName call.

316-621-99 Failed to get host name using GetHostName call.

316-622-07 Corrupt O/S RPC table.

316-622-09 Corrupt O/S table.

316-622-11 Corrupt O/S table.

316-622-14 Corrupt O/S table.

316-622-19 Corrupt O/S table.

316-622-26 Corrupt O/S table.

316-622-28 Corrupt O/S table.

316-622-35 Corrupt O/S table.

316-622-38 Corrupt O/S table.

316-622-46 Corrupt O/S table.

316-622-47 Software upgrade file failure.

316-622-66 Unable to unregister as RPC service during shutdown.

316-622-67 Unable to register as RPC service during shutdown.

316-622-68 Unable to register as RPC service during shutdown.

316-623-35 ENS Service failed to respond in time.

316-623-47 ENS service failed to respond in time.

316-624-46 RPC corrupted o/s failure.

316-625-35 Unknown message received. Software version mismatch.

316-625-46 Software version mismatch.

316-625-66 Invalid IPC message type.

316-625-67 Invalid IPC message type.

316-625-90 Known service sends message that does not make sense.

Procedure



WARNING: Ensure that the electricity to the machine is switched off while performing tasks that do not need electricity. Refer to GP 4 . Disconnect the power cord. Electricity can cause death or injury. Moving parts can cause injury.

1. If a single occurrence, take no action.
2. For multiple occurrences, go to the [316E Network Fault Checkout RAP](#) Network Fault Checkout RAP.

316-626-00 to 316-635-99 Network Faults 8 RAP

316-626-00 Memory leak, software bug memory corrupt. Virtual memory exhausted. Process size exceeding system limits.

316-626-11 Memory leak, software bug memory corrupt. Virtual memory exhausted. Process size exceeding system limits.

316-626-38 Memory leak, software bug memory corrupt. Virtual memory exhausted. Process size exceeding system limits.

316-626-47 Memory leak, software bug memory corrupt. Virtual memory exhausted. Process size exceeding system limits.

316-626-66 Memory allocation failed.

316-626-67 Memory allocation failed.

316-628-07 Range environment variable not set. Set to invalid numeric string.

316-628-09 Unable to complete RPC call.

316-628-35 Range environment variable not set. Set to invalid numeric string.

316-628-46 Range environment variable not set. Set to invalid numeric string.

316-628-66 Range environment variable not set. Set to invalid numeric string.

316-628-67 Range environment variable not set. Set to invalid numeric string.

316-629-11 Fault service call to PSW callback failed.

316-629-26 Fault service call to PSW callback failed.

316-629-46 No acknowledgment for RPC message.

316-629-66 No acknowledgement for RPC message.

316-629-67 No acknowledgment for RPC message.

316-629-68 No acknowledgment for RPC message.

316-629-92 No acknowledgment for RPC message. RPC timeout calling program received void response due to corrupt RPC.

316-629-93 No acknowledgment for RPC message. RPC timeout calling program received void response due to corrupt RPC.

316-630-09 Corrupt O/S RPC table.

316-630-26 Corrupt system configuration.

316-630-35 Unable to get RPC client handle. Corrupt system configuration.

316-630-38 Null pointer returned when obtain client attempted.

316-630-46 Corrupt system configuration.

316-630-47 Corrupt system configuration.

316-630-66 Unable to get RPC client handle.

316-630-67 Unable to get RPC client handle.

316-630-68 Unable to get RPC client handle.

316-630-99 Corrupt system configuration.

316-631-19 Software error in the ENS service or in the service generating the fault.

316-631-46 Software error in the ENS or in the service generating the fault.

316-633-19 Invalid system configuration. NVM corrupted.

316-634-46 Unable to specify shutdown routine during initialization.

316-635-07 Cannot free XDR data.

316-635-35 Cannot free XDR data.

316-635-46 Unable to free XDR data.

316-635-99 Unable to convert serialized data to internal data structure.

Procedure



WARNING: Ensure that the electricity to the machine is switched off while performing tasks that do not need electricity. Refer to [GP 4](#). Disconnect the power cord. Electricity can cause death or injury. Moving parts can cause injury.

1. If a single occurrence, take no action.
2. For multiple occurrences, go to the [316E Network Fault Checkout RAP](#) Network Fault Checkout RAP.

316-629-92 No Acknowledgment To RPC Message and RPC Timeout RAP

No Acknowledgment to RPC Message.

RPC timeout calling program received void response due to one or more of the following conditions:

- Corrupt RPC
- Corrupt System Configuration
- Service being communicated with died
- Loose Cable

Procedure



WARNING: Switch off the electricity to the machine, [GP 10](#). Disconnect the power lead from the customer supply while performing tasks that do not need electricity. Electricity can cause death or injury. Moving components can cause injury.

1. If a single occurrence, take no action.
2. For multiple occurrences perform, [316E Network Fault Checkout RAP](#).
3. If the fault persists, contact 2nd level support.

316-636-35 to 316-647-26 Network Faults 9 RAP

316-636-35 Unable to convert serialized data to internal data structure. Unable to free XDR data.

316-636-99 Unable to convert serialized data to internal structure. Unable to free XDR data.

316-637-11 Failed to open system jobs file.

316-637-26 Failed to open system jobs file.

316-637-38 Disk write error.

316-637-47 Failed to open a file. Bad disk.

316-637-66 File I/O error.

316-637-67 File I/O error.

316-637-93 File I/O error.

316-637-95 File I/O error.

316-638-66 Unable to initialize with queue library.

316-638-67 Unable to initialize with queue library.

316-639-38 O/S failure memory.

316-639-46 O/S failure memory.

316-640-00 Invalid system date for Apache HTTPS device certificate.

316-640-28 Calling program received void.

316-640-35 RPC send corrupt.

316-640-46 O/S failure.

316-641-00 Cannot log fault to network controller fault log. Either registration or network controller fault service is not available.

316-641-26 Unable to log a fault on the network controller.

316-641-46 Cannot log fault to network controller fault service.

316-642-46 Software error.

316-642-47 Software error.

316-643-19 Disk write error.

316-643-26 Failed to close system jobs file.

316-643-47 Failed to close a file.

316-644-11 Common logging utility failed to get log size.

316-644-26 Common logging utility failed to get log size.

316-644-47 Failed while trying to get data for next process to be verified.

316-644-66 File I/O error.

316-644-67 File I/O error.

316-645-11 Failed write to system jobs file.

316-645-26 Failed write to system jobs file.

316-645-46 Failed to write to a file.

316-645-47 Failed to write to a file.

316-645-66 File I/O error.

316-645-67 File I/O error.

316-646-26 Failed to delete system jobs file.

316-647-19 Lynx OS not responding.

316-647-26 Diagnostic failure, O/S failure.

Procedure



WARNING: Ensure that the electricity to the machine is switched off while performing tasks that do not need electricity. Refer to GP 4 . Disconnect the power cord. Electricity can cause death or injury. Moving parts can cause injury.

1. If a single occurrence, take no action.
2. For multiple occurrences, go to the [316E Network Fault Checkout RAP](#) Network Fault Checkout RAP.

316-640-00 System Date Is Invalid For The Apache HTTPS Device Certificate RAP

The system date was reset by the system to default, or, the customer manually set the date older than the certificate's start date.

Procedure



WARNING: Switch off the electricity to the machine, GP 10. Disconnect the power lead from the customer supply while performing tasks that do not need electricity. Electricity can cause death or injury. Moving components can cause injury.

1. System date needs to be updated to current date. Refer to, GP 24 How to Set the Date and Time.

316-649-35 to 316-668-95 Network Faults 10 RAP

316-649-35 Software error.

316-650-35 Service making invalid attribute request.

316-650-99 Service making invalid attribute request.

316-651-19 IPC, OS, SESS or SC operation.

316-651-35 IPC and OS failure. SESS not responding.

316-651-99 IPC and OS failure. SESS not responding.

316-652-38 SPI enroll failed. Unable to enroll SPI callbacks.

316-652-98 SPI enroll failed. Unable to enroll SPI callbacks.

316-652-99 SPI enroll failed. Unable to enroll SPI callbacks.

316-653-38 When DM passes completed job logged an invalid job.

316-654-14 Log_Init/Log_Close Fault.

316-654-38 DM returned from SPI register function because of error.

316-654-99 DM returned from log function because of error.

316-655-38 DM returned to SPI register function because of error.

316-656-38 RPC processing fault.

316-658-07 Unable to get host name. Configuration error.

316-659-11 Parser utility open failure.

316-659-28 Parser utility open failure.

316-659-93 Parser utility open failure.

316-659-95 Parser utility open failure.

316-660-95 Cannot read local directory entries.

316-660-99 Service initialization failed.

316-661-95 Cannot create spool directory.

316-662-11 Parser utility template failed to parse.

316-662-28 Parser utility template failed to parse.

316-662-93 Parser utility template failed to parse.

316-662-95 Parser utility template failed to parse.

316-663-11 Parser utility template failed to parse.

316-663-28 Parser utility template failed to parse.

316-663-93 Parser utility template failed to parse.

316-663-95 Parser utility template failed to parse.

- 316-664-11 Parser utility parser closing failed.
- 316-664-28 Parser utility parser closing failed.
- 316-664-93 Parser utility parser closing failed.
- 316-664-95 Parser utility parser closing failed.
- 316-665-95 Unable to detach from child thread.
- 316-666-11 Parser utility invocation failed.
- 316-666-28 Parser utility invocation failed.
- 316-666-93 Parser utility invocation failed.
- 316-666-95 Parser utility invocation failed.
- 316-667-11 Parser utility set status failed.
- 316-667-28 Parser utility set status failed.
- 316-667-95 Parser utility set status failed.
- 316-668-47 Failed to write NVM.
- 316-668-93 Unable to determine local file statistics.
- 316-668-95 Unable to determine local file statistics.

Procedure



WARNING: Ensure that the electricity to the machine is switched off while performing tasks that do not need electricity. Refer to GP 4 . Disconnect the power cord. Electricity can cause death or injury. Moving parts can cause injury.

1. If a single occurrence, take no action.
2. For multiple occurrences, go to the [316E Network Fault Checkout RAP](#) Network Fault Checkout RAP.

316-650-68 Network Or Authentication Server Setup RAP

When accessing the network server an authentication error notification was issued from the server.

Procedure



WARNING: Switch off the electricity to the machine, GP 10. Disconnect the power lead from the customer supply while performing tasks that do not need electricity. Electricity can cause death or injury. Moving components can cause injury.

Advise the customer to have the system administrator confirm the server settings.

316-652-68 Configuration of Remote Server Incorrect RAP

The remote server cannot be accessed.

Procedure



WARNING: Switch off the electricity to the machine, GP 10. Disconnect the power lead from the customer supply while performing tasks that do not need electricity. Electricity can cause death or injury. Moving components can cause injury.

Advise the customer to have the system administrator test the communication between the remote server and the machine.

316-653-68 Smart Card Error RAP

The device has detected a smart card error.

Procedure



WARNING: Switch off the electricity to the machine, GP 10. Disconnect the power lead from the customer supply while performing tasks that do not need electricity. Electricity can cause death or injury. Moving components can cause injury.

Advise the customer to have the system administrator confirm the configuration of the smart card authentication settings.

316-656-68 OCSP Error RAP

The device has detected an expired certificate, FIPS configuration incompatibility, or other configuration issue.

Procedure



WARNING: Switch off the electricity to the machine, GP 10. Disconnect the power lead from the customer supply while performing tasks that do not need electricity. Electricity can cause death or injury. Moving components can cause injury.

Advise the customer to have the system administrator validate the certificates on the domain controller.

316-657-68 Non Compliant FIPS 140-2 Certificate RAP

The device has detected the security certificate is not FIPS 140-2 compliant.

Procedure



WARNING: Switch off the electricity to the machine, GP 10. Disconnect the power lead from the customer supply while performing tasks that do not need electricity. Electricity can cause death or injury. Moving components can cause injury.

Advise the customer to have the system administrator run the FIPS 140-2 configuration check.

316-658-68 Expired Certificate RAP

The device has detected the security certificate has expired.

Procedure



WARNING: Switch off the electricity to the machine, GP 10. Disconnect the power lead from the customer supply while performing tasks that do not need electricity. Electricity can cause death or injury. Moving components can cause injury.

Advise the customer to have the system administrator:

- Ensure that the time, date and the time zone are set correctly.
- Check that the security certificate is trusted and has not expired.

316-659-68 Certificate Key Length Error RAP

The length of the encryption key on the certificate does not meet the requirements set by the system administrator.

Procedure



WARNING: Switch off the electricity to the machine, GP 10. Disconnect the power lead from the customer supply while performing tasks that do not need electricity. Electricity can cause death or injury. Moving components can cause injury.

Advise the customer to raise the issue with the system administrator.

316-660-68 Card Locked Out RAP

The the user's authorization card is locked out of the device.

Procedure



WARNING: Switch off the electricity to the machine, GP 10. Disconnect the power lead from the customer supply while performing tasks that do not need electricity. Electricity can cause death or injury. Moving components can cause injury.

Advise the customer to raise the issue with the system administrator.

316-662-68 Authentication Credentials Locked RAP

The user has exceeded the number of invalid login attempts and is locked out of the device.

Procedure



WARNING: Switch off the electricity to the machine, GP 10. Disconnect the power lead from the customer supply while performing tasks that do not need electricity. Electricity can cause death or injury. Moving components can cause injury.

Try logging in again after allowing the minimum time for the system to reset the lock.

Note: The number of invalid login attempts and the lock out time period (30 minutes default) may vary for each machine as both these features are adjustable and set by the system administrator. Advise the customer to raise the issue with the system administrator.

316-663-68 Authentication Server Clock Mismatch RAP

There is a mismatch between the time and date setting on the machine and the authentication time or date setting.

Procedure



WARNING: Switch off the electricity to the machine, GP 10. Disconnect the power lead from the customer supply while performing tasks that do not need electricity. Electricity can cause death or injury. Moving components can cause injury.

Advise the customer to raise the issue with the system administrator.

316-664-68 Invalid Authentication Server Certificate RAP

Authentication server certificate is invalid, expired, or revoked.

Procedure



WARNING: Switch off the electricity to the machine, GP 10. Disconnect the power lead from the customer supply while performing tasks that do not need electricity. Electricity can cause death or injury. Moving components can cause injury.

Advise the customer to raise the issue with the system administrator.

316-667-68 to 316-672-68 SMB Error RAP

316-667-68 SMB Error on local system

316-668-68 SMB Error on remote system

316-669-68 Parameter error to SMB client

316-670-68 SMB internal system error

316-671-68 SMB server error

316-672-68 SMB authentication error RAP

Procedure



WARNING: Switch off the electricity to the machine, GP 10. Disconnect the power lead from the customer supply while performing tasks that do not need electricity. Electricity can cause death or injury. Moving components can cause injury.

1. Verify usernames and passwords for access are correct.
2. Advise the customer to raise the issue with the system administrator.

316-669-28 to 316-730-66 Network Faults 11 RAP

316-669-28 Unable to write job template to network controller disk.

316-669-93 Unable to write job template to network controller disk.

316-669-95 Unable to write job template to network controller disk.

316-670-00 Unable to lock/unlock data store.

316-670-11 Unable to decode template file.

316-670-28 Unable to decode template file.

316-670-47 Failed to save NVM.

316-670-93 Unable to decode template file.

316-671-00 Sort jobs failed.

316-671-47 Failed to initialize NVM.

316-671-93 Unable to encode template file.

316-671-95 Unable to encode template file.

316-672-09 Software error. File system corruption.

316-672-95 Software error. File system corruption.

316-673-95 Software error. File system corruption.

316-674-00 RPC server not responding.

316-675-00 Database server not responding.

316-700-00 In a list job request, an unknown attribute was requested.

316-700-35 Unknown attribute requested passes into a function.

316-701-00 LOA failure. Unable to communicate with XSA database.

316-701-68 Printing prohibited. Unable to communicate with postgres database.

316-701-99 LOA failure. Unable to communicate with XSA database.

316-701-110 Unable to communicate with XSA Database.

316-702-00 LOA failure. Unable to communicate with XSA database.

316-702-95 LOA failure. Unable to communicate with XSA database.

316-707-00 Unknown queue request received.

316-709-00 Unknown modify request received.

316-710-00 Service being communicated to is dead. System resource corrupted.

316-710-35 Service trying to communicate to is dead. System resources corrupted.

316-716-00 Data store not created. Corrupt environment variable.

316-728-00 Range environment variable set to invalid numeric string.

316-730-00 Unable to create client handle.

316-730-28 Unable to create client handle.

316-730-35 Unable to create client handle.

316-730-66 Unable to create client handle.

Procedure



WARNING: Ensure that the electricity to the machine is switched off while performing tasks that do not need electricity. Refer to [GP 4](#). Disconnect the power cord. Electricity can cause death or injury. Moving parts can cause injury.

1. If a single occurrence, take no action.
2. For multiple occurrences, go to the [316E Network Fault Checkout RAP](#) Network Fault Checkout RAP.

316-679-68 Device User Database Unavailable RAP

The user cannot access the user database of the machine.

Procedure



WARNING: Switch off the electricity to the machine, [GP 10](#). Disconnect the power lead from the customer supply while performing tasks that do not need electricity. Electricity can cause death or injury. Moving components can cause injury.

Advise the customer to raise the issue with the system administrator.

316-697-68 to 316-702-68 Server Error RAP

316-697-68 Kerberos error RAP

316-698-68 LDAP Error RAP

316-699-68 Failed to open Azure IoT Hub Connection RAP

316-700-68 gSOAP Server Error RAP

316-702-68 gSOAP Client Error RAP

Procedure

Advise the customer to raise the issue with the system administrator.

316-718-00, 316-720-01 thru 04, 316-732-01 thru 07 Disk Partition Faults RAP

316-718-00 Data store threshold exceeded.

316-720-01 Disk partition root threshold exceeded.

316-720-02 Disk partition /OPT threshold exceeded.

316-720-03 Disk partition /TMP threshold exceeded.

316-720-04 Disk partition /PERSISTENT threshold exceeded.

316-722-01 Disk partition /VAR threshold exceeded.

316-732-01 Disk Partition /var/spool/nc/scan Threshold Exceeded.

316-732-02 Disk Partition /var/spool/nc/image_store: "File Cabinet Service" Threshold Exceeded.

316-732-03 Disk Partition /var/spool/nc/image_store: "Transfer service" Threshold Exceeded.

316-732-05 Disk Partition /var/spool/CIPS/image_store Threshold Exceeded.

316-732-07 Disk Partition /var/fonts Threshold Exceeded.

Procedure



WARNING: Switch off the electricity to the machine, GP 10. Disconnect the power lead from the customer supply while performing tasks that do not need electricity. Electricity can cause death or injury. Moving components can cause injury.

1. If a single occurrence take no action.
2. For multiple occurrences, perform Software Upgrade, GP 10.
3. Delete all files possible from memory.
4. If that isn't possible, delete the job with a new job termination reason that will list in both the completed job history and the audit log.
5. Perform GP 19, Obtaining Audit and Device Logs.
6. If the fault persists, contact 2nd Level Support with the required logs for review.

316-727-00 RPC Connections Approaching Limit RAP

316-727-00 RPC connections approaching limit RAP

Procedure



WARNING: Switch off the electricity to the machine, GP 10. Disconnect the power lead from the customer supply while performing tasks that do not need electricity. Electricity can cause death or injury. Moving components can cause injury.

Advise the customer to contact the system administrator.

316-732-01 to 316-732-03 Disk Partition Threshold Exceeded (threshold=See FS 26-003 System Partitioning spec) RAP

316-732-01 Disk Partition /var/spool/nc/scan Threshold Exceeded (threshold=See FS 26-003 System Partitioning spec) RAP

316-732-02 Disk Partition /var/spool/nc/image_store: "File Cabinet Service" Threshold Exceeded (threshold=See FS 26-003 System Partitioning spec) RAP

316-732-03 Disk Partition /var/spool/nc/image_store: "Transfer service" Threshold Exceeded (threshold=See FS 26-003 System Partitioning spec) RAP

Procedure



WARNING: Switch off the electricity to the machine, GP 10. Disconnect the power lead from the customer supply while performing tasks that do not need electricity. Electricity can cause death or injury. Moving components can cause injury.

1. Delete all files possible from memory.
2. If that isn't possible, delete the job with a new job termination reason that will list in both the completed job history and the audit log.
3. Perform GP 19, Obtaining Audit and Device Logs.
4. If the fault persists, contact 2nd Level Support with the required logs for review.

316-732-05, 316-732-07 Disk Partition Threshold Exceeded (threshold=See FS 26-003 System Partitioning spec) RAP

316-732-05 Disk Partition /var/spool/CIPS/image_store Threshold Exceeded (threshold=See FS 26-003 System Partitioning spec) RAP

316-732-07 Disk Partition /var/fonts Threshold Exceeded (threshold=See FS 26-003 System Partitioning spec) RAP

Procedure



WARNING: Switch off the electricity to the machine, **GP 10**. Disconnect the power lead from the customer supply while performing tasks that do not need electricity. Electricity can cause death or injury. Moving components can cause injury.

Switch OFF, then switch ON the machine, **GP 10**. If the fault persists, call 2nd level support.

316-742-19 Hard Disk ODIO Failure RAP

316-742-19 Hard disk ODIO failure.

Procedure



WARNING: Switch off the electricity to the machine, **GP 10**. Disconnect the power lead from the customer supply while performing tasks that do not need electricity. Electricity can cause death or injury. Moving components can cause injury.

1. Print a configuration report.
2. If the configuration report shows Image Overwrite as installed/disabled, perform the following:
 - a. Enter Customer Administration Tools, **GP 2**.
 - b. Select the **Tools** tab.
 - c. Select **Security Settings**.
 - d. Select **Image Overwrite Security**.
 - e. Enable the required feature.

316-747-00 Productivity Kit Error RAP

Paired Optional Hard Drive has errors (such as mount errors, corrupted partition, unrecognized partition).



WARNING: Switch off the electricity to the machine, GP 10. Disconnect the power lead from the customer supply while performing tasks that do not need electricity. Electricity can cause the death or injury. Moving components can cause the injury.

Switch OFF, then switch ON the machine, GP 10. If the fault persists, call 2nd level support.

316-748-00 Remote Services Download Failed RAP

When Remote Services has detected content available for this device but is unable to complete a download.

Procedure



WARNING: Switch off the electricity to the machine, GP 10. Disconnect the power lead from the customer supply while performing tasks that do not need electricity. Electricity can cause death or injury. Moving components can cause injury.

Switch OFF, then switch ON the machine, GP 10. If the fault persists, call 2nd level support.

316-750-07 to 316-750-95 Network Faults 12 RAP

316-750-07 Message received from DM not processed correctly.

316-750-09 Service tried to register and service is already registered.

316-750-11 Template cache file is missing.

316-742-19 Hard disk ODIO failure.

316-750-14 Too many messages sent to SESS system control.

316-750-19 Invalid request data from calling service.

316-750-26 Invalid number of faults requested.

316-750-35 Data store failure.

316-750-38 Initialization of SPI and job tracking table failed in SVC initialize service.

316-750-46 Client requested an unknown object or invalid object type.

316-750-47 Bad parameter returned.

316-750-66 Failure to set service state.

316-750-67 Failure to set service state.

316-750-90 Unexpected service sends this message.

316-750-92 Unable to open bit map captured to disk. Bad or full disk.

316-750-93 IFS error when requesting memory.

316-750-95 Local spool area does not exist.

Procedure



WARNING: Switch off the electricity to the machine, **GP 10**. Disconnect the power lead from the customer supply while performing tasks that do not need electricity. Electricity can cause death or injury. Moving components can cause injury.

1. If a single occurrence, take no action.
2. For multiple occurrences, go to the **316E Network Fault Checkout RAP** Network Fault Checkout RAP.

316-751-00 to 316-753-95 Network Faults 13 RAP

- 316-751-00 Database error known by service registry or registry not available.
- 316-751-07 Message received from network controller AAA not processed correctly.
- 316-751-11 Initialization procedure fails.
- 316-751-14 SC not responding.
- 316-751-19 Invalid permission to change date.
- 316-751-26 Unrecognized code. Service raises code that the fault service doesn't know how to handle.
- 316-751-28 Templates attributes are invalid, or syntax error.
- 316-751-35 Invalid queue ID.
- 316-751-38 Unknown attribute returned for completed job list.
- 316-751-46 Client requested an unknown object or invalid object type.
- 316-751-47 Failed to replace the current directory with directory from alt. partition.
- 316-751-66 Unable to send event to network controller ENS.
- 316-751-67 Unable to send event to network controller ENS.
- 316-751-92 Cannot set job to complete.
- 316-751-93 Invalid template attribute.
- 316-751-112 Database Error or Service Registry not available.
- 316-752-00 File cabinet application registration error.
- 316-752-07 Data store error.
- 316-752-09 Configuration control problem.
- 316-752-14 SC not responding. SC IPC queue does not exist.
- 316-752-19 RPC failure.
- 316-752-26 Unrecognized SESS error code.
- 316-752-28 Template cache file is missing.
- 316-752-35 Invalid queue ID.
- 316-752-46 Invalid row of table object.
- 316-752-47 Invalid test pattern source.
- 316-752-66 Scan to fax services registration error.
- 316-752-67 Scan to fax services registration error.
- 316-752-92 Configuration problem.
- 316-752-93 Error accessing jobs in job list.

- 316-752-95 File transfer failure.
- 316-753-00 File cabinet application un-registration error.
- 316-753-09 Software bug.
- 316-753-14 Calling service used an invalid event number.
- 316-753-19 Invalid event information or data. ENS failure. System RPC information corrupt.
- 316-753-26 PSW failure. O/S failure. CCM failure.
- 316-753-28 Cannot communicate with UI for template list request.
- 316-753-35 Unable to change EJS status to offline.
- 316-753-46 Invalid table row.
- 316-753-47 Failed to close a directory during verification check. Corrupt disk.
- 316-753-66 Data store read failure.
- 316-753-67 Data store read failure.
- 316-753-90 Software error.
- 316-753-92 Configuration problem.
- 316-753-93 Error adding jobs in job list.
- 316-753-95 Requested transfer protocol not supported.

Procedure



WARNING: Switch off the electricity to the machine, GP 10. Disconnect the power lead from the customer supply while performing tasks that do not need electricity. Electricity can cause death or injury. Moving components can cause injury.

1. If a single occurrence, take no action.
2. For multiple occurrences, go to the [316E Network Fault Checkout RAP](#) Network Fault Checkout RAP.

316-754-09 to 316-756-93 Network Faults 14 RAP

- 316-754-09 Still registered services after timeout.
- 316-754-14 Receipt is not there. Failure on ENS side.
- 316-754-19 Shutdown request reason unknown.
- 316-754-26 Fault service encountered error reading fault log. File system corrupted.
- 316-754-28 Initialization procedure fails.
- 316-754-35 OS corrupt.
- 316-754-46 Attempted to write a read only object. Software configuration error.
- 316-754-47 Failed to replace a file that was missing with file from alt. partition.
- 316-754-66 OS problem.
- 316-754-67 OS problem.
- 316-754-68 Initialize procedure fails.
- 316-754-90 Software bug.
- 316-754-92 Data store failure.
- 316-754-93 Error deleting jobs from job list.
- 316-754-95 Unable to remove advisory lock on network server.
- 316-755-00 Service registry cannot initialize database.
- 316-755-09 Cannot register new service due to too many entries in SRV table.
- 316-755-14 Message buffer full. Full queue.
- 316-755-19 SESS system control broken or too many IPC messages.
- 316-755-26 Disk write error. Software error.
- 316-755-28 Cancel request failed.
- 316-755-35 OS corrupt. Software corrupt. Data store corrupt.
- 316-755-46 Mismatched data type during object write. Software configuration error or request mis-handled configuration index data.
- 316-755-47 Failed to repair the permission of the current file being checked.
- 316-755-67 Cancel request failed.
- 316-755-90 Software limit reached.
- 316-755-92 Invalid IPC data received.
- 316-755-93 Unable to initialize with IFS.
- 316-755-99 Unable to abort job fault.
- 316-755-112 Unable to initialize the service registry table.

- 316-756-09 Service not registered.
- 316-756-14 Client provided wrong binding information. Client not required as RPC server.
- 316-756-26 Software error.
- 316-756-28 Range String Error.
- 316-756-35 OS corrupt. Software error. NVM error.
- 316-756-46 Poll select failed.
- 316-756-47 Executable missing or corrupt. Invalid test parameters.
- 316-756-67 Unable to read NVM value.
- 316-756-92 Invalid IPC Data Received.
- 316-756-93 IPA operation failed.

Procedure



WARNING: Switch off the electricity to the machine, GP 10. Disconnect the power lead from the customer supply while performing tasks that do not need electricity. Electricity can cause death or injury. Moving components can cause injury.

1. If a single occurrence, take no action.
2. For multiple occurrences, go to the [316E Network Fault Checkout RAP](#) Network Fault Checkout RAP.

316-757-09 to 316-760-99 Network Faults 15 RAP

316-757-09 System RPC corrupt.

316-757-14 Programming bug. Attempted to shorten timeout.

316-757-19 System manager died or communications link failed.

316-757-26 Software error. Bad disk.

316-757-28 Unknown Message Received.

316-757-35 OS corrupt. Software error. NVM corrupt.

316-757-46 O/S failure.

316-757-47 Failed while trying to replace the file with a file from alt. partition. Configuration error.

316-757-66 Unable to write NVM.

316-757-67 Unable to write NVM.

316-757-92 Invalid IPC Data Received.

316-757-93 Unable to set ICS document state.

316-758-09 Invalid service failure reported.

316-758-14 RPC communications error to client.

316-758-19 Unable to unregister registration service.

316-758-26 Fault service encountered error trying to access its own queue ID.

316-758-28 State Error.

316-758-35 Unable to change EJS state to offline.

316-758-46 Failed setting up monitor routine with registration service.

316-758-47 Error searching for job ID during print job submission. Print submission tool failed.

316-758-66 Service run loop failed.

316-758-67 Service loop failed.

316-758-93 Unable to obtain data store object handle.

316-759-14 Request for wildcard from non-NC

316-759-19 Network controller failed cold reset 3 times in a row.

316-759-26 Service requesting information of fault service. Software error.

316-759-28 SC Init Fault.

316-759-46 Process no in correct state, O/S failure.

316-759-47 Failed to abort the requested process.

316-759-66 OA event register failed.

316-759-67 OA event register failed.

316-759-93 Unable to create.dat file.

316-760-14 Software error. Calling service not registered.

316-760-19 Any network controller startup.

316-760-26 Software failure.

316-760-28 Unable to Ack SC.

316-760-46 Software failure.

316-760-47 Found incorrect checksum partition 1 during software verify check. Bad disk and bad software.

316-760-67 Create list failed.

316-760-68 SRS returns to login service. Invalid fields, invalid data or missing data.

316-760-93 Job report failure from CCM.

316-760-99 RPC failure. CCM not responding.

Procedure



WARNING: Switch off the electricity to the machine, GP 10. Disconnect the power lead from the customer supply while performing tasks that do not need electricity. Electricity can cause death or injury. Moving components can cause injury.

1. If a single occurrence, take no action.
2. For multiple occurrences, go to the [316E Network Fault Checkout RAP](#) Network Fault Checkout RAP.

316-761-14 to 316-765-93 Network Faults 16 RAP

316-761-14 Invalid RPC data.

316-761-19 Any network controller shut down.

316-761-26 Unable to become client of UI.

316-761-28 Unable to submit a job.

316-761-46 Hardware failure.

316-761-47 Failed to initialize. Files needed for software verify.

316-761-67 Failed to retrieve public list.

316-761-68 Login gets no response from SRS.

316-761-93 Image conversion to TIFF failed.

316-761-95 Unable to read template pool configuration information.

316-762-09 Netware process failed. Software error. Check fault log for more specific reasons.

316-762-14 Invalid internal table type.

316-762-19 DC platform mgr communication error.

316-762-26 Unable to become client of SCS diagnostic service.

316-762-46 Hardware failure.

316-762-47 Missing file found during software verify check. Disk access problem. Configuration problem.

316-762-67 Invalid index for recipient list.

316-762-68 Service registry bad data corrupted.

316-762-93 IFS Image done call failed.

316-762-95 Unable to read document repository configuration information.

316-763-14 Reached internal limit for events.

316-763-19 System manager died, its platform crashed or RPC comm corrupt.

316-763-26 No acknowledgment to RPC message. RPC timeout.

316-763-46 Hardware failure.

316-763-47 Invalid permission found during software verify check.

316-763-67 Failed to retrieve LDAP list.

316-763-93 Document image count not found.

316-763-95 Internal destination error.

316-764-09 Apple talk process failure. Software error. Check fault log for more specific reasons.

316-764-14 Internal logic error.

316-764-19 System call to signal failed.

316-764-26 Fault Service Encountered Error Trying to get IPC Message.

316-764-46 Hardware failure.

316-764-47 Found incorrect checksum during software verify check. Bad disk and bad software.

316-764-67 Create list failed.

316-765-09 Software error. Check fault log for more specific reasons.

316-765-19 Set status failed.

316-765-26 Fault Service Call to PSW Callback failed.

316-765-46 Software failure.

316-765-47 Novell daemon not running.

316-765-67 Failed to retrieve recipient list.

316-765-93 Unable to access data store.

Procedure



WARNING: Switch off the electricity to the machine, GP 10. Disconnect the power lead from the customer supply while performing tasks that do not need electricity. Electricity can cause death or injury. Moving components can cause injury.

1. If a single occurrence, take no action.
2. For multiple occurrences, go to the [316E Network Fault Checkout RAP](#) Network Fault Checkout RAP.

316-766-09 to 316-772-95 Network Faults 17 RAP

316-766-09 Adobe process failure. Check faults log for more specific reasons.

316-766-19 DM admin error.

316-766-26 Fault Service Call to UI Callback failed.

316-766-46 Software failure.

316-766-47 No servers responded.

316-766-67 Failed to bind to LDAP server.

316-766-93 TIFF handle has become null.

316-766-95 Cannot create image file name.

316-767-19 Request to cancel spooling job error. Job map library unable to cancel job.

316-767-26 Fault Service Call to RDT Callback failed.

316-767-46 Software failure.

316-767-47 Server name in configuration list is not up.

316-767-67 Error performing LDAP search.

316-767-93 Get document image count failed.

316-767-95 Cannot determine filing policy for transfer.

316-768-19 Job map library unable to hold or release jobs.

316-768-46 Software failure.

316-768-47 Network controller not attached to server.

316-768-67 Error performing public search.

316-768-93 Increment image count failed.

316-768-95 Cannot get network advisory lock file name.

316-769-19 Novell network failed to respond to request.

316-769-46 Software failure.

316-769-47 Network controller not attached to the print queue.

316-769-67 Failed to cancel search request.

316-769-93 IFS de-register call failed.

316-769-95 Cannot determine appropriate lock name and address.

316-770-19 SESS/DM job command not processed.

316-770-46 Software failure.

316-770-47 Network controller attached to both queue and server.

316-770-67 Required attribute missing.

316-771-19 UI/PSW/RDT/ RPC corrupt.

316-771-46 Software failure.

316-771-47 Failed to configure novell network.

316-772-19 Software error.

316-772-46 TCPIP address already being used.

316-772-47 Failed doing registration or RPC call.

316-772-95 Invalid transfer request.

Procedure



WARNING: Switch off the electricity to the machine, GP 10. Disconnect the power lead from the customer supply while performing tasks that do not need electricity. Electricity can cause death or injury. Moving components can cause injury.

1. If a single occurrence, take no action.
2. For multiple occurrences, go to the [316E Network Fault Checkout RAP](#) Network Fault Checkout RAP.

316-773-19 to 316-779-95 Network Faults 18 RAP

- 316-773-19 Software error.
- 316-773-46 Failed requesting platform reset.
- 316-774-19 Client provided wrong binding info. Client not registered as RPC server. System RPC info is corrupt.
- 316-774-46 BOOTP status file error.
- 316-775-19 Data store not configured. Software error.
- 316-775-46 TCPIP missing configuration data.
- 316-775-95 Cannot create temporary file name.
- 316-776-19 Software error.
- 316-776-46 TCPIP invalid interface.
- 316-776-95 Cannot clean up after job completion.
- 316-777-19 Software error. Data store corrupt, missing configuration.
- 316-777-46 TCPIP invalid addressing.
- 316-777-95 Cannot log requested network server.
- 316-778-19 Software error.
- 316-778-46 TCPIP socket failure.
- 316-778-95 Cannot generate confirmation sheet.
- 316-779-00 System manager power saver complete callback failed. System manager failed or communications link failed.
- 316-779-19 System manager callback SM power save completed failed.
- 316-779-46 TCPIP interface attach.
- 316-779-47 SESS diagnostic failure.
- 316-779-95 Cannot create the template/job log name.

Procedure



WARNING: Switch off the electricity to the machine, GP 10. Disconnect the power lead from the customer supply while performing tasks that do not need electricity. Electricity can cause death or injury. Moving components can cause injury.

1. If a single occurrence, take no action.
2. For multiple occurrences, go to the [316E Network Fault Checkout RAP](#) Network Fault Checkout RAP.

316-780-00 to 316-789-47 Network Faults 19 RAP

- 316-780-00 Power save request timeout.
- 316-780-19 Power saver request timeout.
- 316-780-46 TCPIP enable interface.
- 316-780-47 SESS diagnostic failure.
- 316-780-95 Cannot determine the remote directory.
- 316-781-19 Customer software upgrade file is corrupted on transfer.
- 316-781-46 TCPIP NVRAM failure.
- 316-781-47 SESS diagnostic failure.
- 316-782-09 Network controller configuration synchronization process failure. Software error. check fault log for more specific reasons.
- 316-782-19 Software upgrade manifest file does not match software upgrade files.
- 316-782-46 TCPIP gateway failure.
- 316-782-47 SESS diagnostic failure.
- 316-783-09 Software error. IPC failure. SC not processing IPC.
- 316-783-19 Network controller does not enter upgrade mode. Network controller does not respond to upgrade prep command.
- 316-783-46 TCPIP host file failure.
- 316-783-47 SESS diagnostic failure.
- 316-784-09 Software error. Registration service out of date.
- 316-784-19 Software upgrade aborted, IOT failed to enter upgrade mode. IOT does not respond to upgrade prep command.
- 316-784-46 TCPIP resolve file failure.
- 316-784-47 SESS diagnostic failure.
- 316-785-09 Network controller agent process failure. Software error. Check fault log for more specific reasons.
- 316-785-19 UI does not respond to upgrade prep command.
- 316-785-46 TCPIP resolve file failure.
- 316-785-47 SESS diagnostic failure.
- 316-786-09 Software error. Check alt log for more specific reasons.
- 316-786-19 Network controller ntar of upgrade file fails.
- 316-786-46 TCPIP ELT file failure.
- 316-786-47 SESS diagnostic failure.
- 316-787-19 Network controller times out. Cannot communicate with IOT.

316-787-46 TCP/IP failure.

316-787-47 SESS diagnostic failure.

316-788-19 Option load failure software.

316-788-46 Failed performing dynamic DNS update.

316-788-47 SESS diagnostic failure.

316-789-19 Option load failure software.

316-789-46 Failed performing autonet IP process.

316-789-47 SESS diagnostic failure.

Procedure



WARNING: Switch off the electricity to the machine, **GP 10**. Disconnect the power lead from the customer supply while performing tasks that do not need electricity. Electricity can cause death or injury. Moving components can cause injury.

1. If a single occurrence, take no action.
2. For multiple occurrences, go to the **316E Network Fault Checkout RAP** Network Fault Checkout RAP.

316-816–09 EIP Service Not Responding RAP

The EIP service failed to respond to the machine's request.

Procedure



WARNING: Switch off the electricity to the machine, **GP 10**. Disconnect the power lead from the customer supply while performing tasks that do not need electricity. Electricity can cause death or injury. Moving components can cause injury.

1. If a single occurrence, take no action.
2. For multiple occurrences, go to the **316E Network Fault Checkout RAP** Network Fault Checkout RAP.

316-972-08, 316-972-09, 316-972-15 Software Upgrade Failure RAP

316-972-08 Boot manager software verification failure.

316-972-09 SWUP signature verification failure.

316-972-15 DLM signature failure.

Procedure



WARNING: Switch off the electricity to the machine, [GP 10](#). Disconnect the power lead from the customer supply while performing tasks that do not need electricity. Electricity can cause death or injury. Moving components can cause injury.



CAUTION: Software downgrades cannot be performed by a customer. When using the FORCED_ALTBOOT method, follow the procedure in [GP 4](#), Software Upgrade. Inform the customer that customer data will not be retained using the FORCED_ALTBOOT method for downgrading machine software.

1. Ensure the correct DLM file for the device is used.
2. If the fault persists, perform a Software Upgrade, [GP 4](#), using the FORCED_ALTBOOT method.

316-990-19 Lockdown Security Remediation Failed RAP

At least one of the Lockdown security settings is not compliant.

Procedure

Advise the customer to request the system administrator check the customer Lockdown and Remediate Security feature.

316–991–19 and 316-992-19 Configuration Watchdog Feature RAP

316-991-19 Xerox Configuration Watchdog Remediation Failed.

316-992-19 A security related item being monitored by the Xerox Configuration Watchdog feature has changed.

Procedure

No service action is required. Advise the customer to notify the system administrator to check the settings of the configuration watchdog feature.

316E Network Fault Checkout RAP

Initial Actions

Switch off, then switch on the machine, [GP 10](#).

Procedure

Refer to the Active Messages and Fault History to determine under what situation the fault is occurring.

The fault is related to a specific job, client or Page Description Language (PDL).

Y N

| Reload the software, [GP 4](#).

The fault persists.

Y N

| Perform [SCP 5](#) Final Actions.

Install new components as necessary:

- Optional 500+GB Hard Disk, if installed, [PL 25.05 item 2](#).
- Controller PWB [PL 3.05](#).

If the fault persists, perform the [OF 1](#) Machine Not Ready RAP.

The fault occurs on one particular job from one particular client.

Y N

The fault occurs on all jobs sent from one client.

Y N

The fault occurs with one job from any client.

Y N

| Install new components as necessary:

- Optional 500+GB Hard Disk, if installed, [PL 25.05 item 2](#).
- Controller PWB [PL 3.05](#).

If the fault persists, perform the [OF 1](#) Machine Not Ready RAP.

Another VersaLink® machine is available.

Y N

| Escalate the service call.

Perform the job causing the fault on another VersaLink® machine

The fault is repeatable on both machines.

Y N

| Reload the software, [GP 4](#), on the faulty machine. If the fault persists, escalate the service call.

Contact next level support, then explain that a Software Problem Action Report (SPAR) needs to be generated.

Ask the System Administrator to:

- Check the network configuration on the client (compare to a working client).
- Ensure that the client has the required resources.
- Reload the print driver on the client.

If the fault persists, ask the customer to contact the customer support centre.

Ask the customer to reload the print driver on the affected workstation.

319–200–00 Node Tree Settings Corrupted/Invalid RAP

The configuration settings in the node tree is invalid/corrupted.

No intervention required. The node tree settings will be recovered after auto reboot of the machine.

319-300-00 and 319-301-00 Hard Disk Read/Write Error RAP

319-300-00 Unable to read or write data from the Image Disk

319-301-00 Unable to write data to the Image Disk RAP

Procedure



WARNING: Switch off the electricity to the machine, [GP 10](#). Disconnect the power lead from the customer supply while performing tasks that do not need electricity. Electricity can cause death or injury. Moving components can cause injury.

Switch OFF, then switch ON the machine, [GP 10](#).

The fault persists.

Y N

| Perform, [SCP 5](#) Final Actions, then log the problem in the [Logbook](#).

- Perform Software Upgrade, [GP 4](#), using the Altboot method.
- If installed, verify the harness between the optional 500Gb+ hard disk, [PL 25.05 item 2](#), and the controller PWB [PL 3.05 item 1](#), is fully seated and has no damage. Repair any damage to the harness as required.
- If the fault persists, install new components as required:
 1. Optional 500Gb+ hard disk, [PL 25.05 item 2](#).
 2. Controller PWB, [PL 3.05 item 1](#).

319-340-00 SIC Crash RAP

Scan Image Controller (SIC) detects that it has recovered from a crash.

Procedure



WARNING: Switch off the electricity to the machine, [GP 10](#). Disconnect the power lead from the customer supply while performing tasks that do not need electricity. Electricity can cause death or injury. Moving components can cause injury.

Switch OFF, then switch ON the machine, [GP 10](#). If the fault persists, call 2nd level support.

319-401-00 Out Of Memory RAP

Out of memory caused by a stress document

1. Switch OFF, then switch ON the machine, **GP 10**.
2. If the fault persists, perform a software upgrade, **GP 4**, using the Altboot method.

319-409-01, 319-409-02, 319-409-03, 319-409-04 Video Errors RAP

319-409-01 Video determines that it cannot guarantee the integrity of the job being processed due to an Overflow condition.

319-409-02 Video determines that it cannot guarantee the integrity of the job being processed due to an underflow condition.

319-409-03 Video determines that it cannot guarantee the integrity of the job being processed due to a No Block List error.

319-409-04 Video determines that it cannot guarantee the integrity of the job being processed due to End of Block List error.

Switch OFF, then switch ON the machine, **GP 10**, then rerun the job causing the fault.

319-410-00 to 319-410-18 Imaging Errors RAP

319-410-00 Mark Output Timeout.

319-410-01 Mark Output Timeout.

319-410-02 Compress Image timeout.

319-410-03 Decompress Image timeout.

319-410-04 Merge Image timeout.

319-410-05 Rotate Image timeout.

319-410-06 Network Input Failure.

319-410-07 E-Fax Send/Receive Failure.

319-410-08 Scan Input Failure.

319-410-09 Byte Count Error.

319-410-10 Set Up Too Late.

319-410-11 DMA Master Abort.

319-410-12 Huffman Error.

319-410-13 EOR ERROR.

319-410-14 Scan Output Timeout.

319-410-15 Image Path Response Error from CIPS.

319-410-17 Insufficient Memory for video operation.

319-410-18 Video Fatal error from CIPS.

Switch OFF, then switch ON the machine **GP 10**. Rerun the job causing the fault.

319-411-01 to 319-411-08 and 319-412-01 Scan Image Faults RAP

319-411-01 Scan Image Capture DMA Setup Too Late RAP

319-411-02 Scan Image Capture IIT Setup Too Early RAP

319-411-03 Scan Image Capture DMA Overflow RAP

319-411-04 Scan Image Capture DMA Incomplete RAP

319-411-05 Scan Image Capture DMA Timeout RAP

319-411-06 Scan Image Capture Planar Data Missing RAP

319-411-07 Scan Image Capture DMA Failure due to Master Abort RAP

319-411-08 Scan Image Capture Setup Failure RAP

319-412-01 Scan Image Capture IIT Line Sync Integrity Error RAP

Switch OFF, then switch ON the machine, **GP 10**. Rerun the job causing the fault.

319-420-00 to 319-426-00 Image Processing Errors RAP

319-420-00 Image Processing Error (at Power UP).

319-422-00 Image Processing Error (at Standby).

319-424-00 Image Processing Error (with Job).

319-426-00 Image Processing Error (during print).

1. Switch OFF, then switch ON the machine, **GP 10**. Rerun the job causing the fault.
2. If the fault persists, upgrade the software, **GP 4**, using the Altboot method.

319-750-00 to 319-754-00 Power On Sequence Faults RAP

319-750-00 When the System detects that the EPC Memory Size configuration has changed during the Power On Sequence.

319-752-00 When the System detects that the Image Rotation Configuration has changed during Power On Sequence.

319-754-00 When the System detects that the Image Disk Configuration (Present vs Not Present) has changed during the Power On Sequence.

Switch OFF, then switch ON the machine, **GP 10**. Rerun the job causing the fault.

319-760-00 Test Patterns Missing From EPC RAP

When test patterns are missing from EPC a 319-760-00 fault should be declared.

1. Switch OFF, then switch ON the machine, GP 10. Rerun the job causing the fault.
2. Contact next level support, then raise status 09-582.

319-761-00, 319-762-00 Generic Engine Fault RAP

319-761-00 Generic Scan Engine Fault.

319-762-00 Generic Print Engine Fault.

No user intervention required.

320-200-00, 320-302-00 to 320-345-00, 320-713-00 Fax Errors RAP

320-200-00 Fault for Fax Engine Crash.

320-302-00 Fax Card Hardware or Software Error.

320-303-00 Fax Card Hardware or Software Error.

320-305-00 Fax Card Hardware or Software Error.

320-320-00 5 instances of an unrecoverable fax fault and has not been cleared by a card reset.

320-322-00 NV device not fitted to basic fax card.

320-323-00 Fax system memory is low.

320-331-00 No comms via PSTN1 port.

320-338-00 Fax communication error at power up or re-boot.

320-339-00 Internal fax card fault.

320-341-00 Miscellaneous Basic Card problems.

320-342-00 Error accessing file on a NV device.

320-345-00 FaxPort1ModemFailure.

320-713-00 Fax Job Data Removal Error.

Initial Actions

Print a Configuration Sheet.

Perform, [OF 12](#), Modem/Fax PWB Service RAP.

320-710-00 and 320-711-00 Fax Image Overwrite Error RAP

320-710-00 IIO Error has occurred on the fax card when overwriting the job

320-711-00 ODIO Error has occurred on the fax card when overwriting the compact flash memory

Initial Actions

Print a Configuration Sheet and a Software Failure Report. Refer to, [GP 14](#) Printing Reports.



WARNING: Switch off the electricity to the machine, [GP 10](#). Disconnect the power lead from the customer supply while performing tasks that do not need electricity. Electricity can cause death or injury. Moving components can cause injury.

1. Ensure the FAX is enabled.
2. Perform, [GP 4](#) Software Upgrade, using the FORCED_ALTBOOT method.
3. Perform, [OF 12](#) Modem/Fax PWB Service RAP, to verify the Fax settings are correct.
4. If the fault persists, install a new fax PWB [PL 20.05](#) item 1.

322-300-05 Image Complete Not Received from Video RAP

A complete image was not received from the scanner.

Initial Actions

Print a Configuration Report for later comparison of software version and machine configurations.



CAUTION: Inform the customer that all customer configuration settings will be lost if the DISABLE_DATA_BACKUP flag is required during software upgrade. Perform an NVM Save and Restore, [dC361](#), saving all platforms to USB for potential restore at the end of this procedure.



WARNING: Switch off the electricity to the machine, [GP 10](#). Disconnect the power lead from the customer supply while performing tasks that do not need electricity. Electricity can cause death or injury. Moving components can cause injury.

1. Check the job log in the UI, delete the job causing the fault.
2. Switch OFF, then switch ON the machine, [GP 10](#).
3. Check the job log in the UI, make sure the job is not there. Delete the job again if the job exists.
4. Upgrade the software, [GP 4](#), using the FORCED_ALTBOOT method with the DISABLE_DATA_BACKUP flag.



CAUTION: The DISABLE_DATA_BACKUP intentionally prevents backup of the data on the machine. There is nothing for the Revert to previous settings operation to restore. A Forced Altboot enables the Revert to previous settings feature to display. This feature restores machine-specific information, IF, the DISABLE_DATA_BACKUP flag is used, all machine-specific information will be lost.

5. If the fault persists, install new components in order as required:
 - a. Controller PWB, [PL 3.05 item 1](#).
 - b. Flatbed scanner, [PL 60.10 item 1](#).

322-300-10, 322-301-05 Image Transfer Errors RAP

322-300-10 DVMA Transfer Fault.

322-301-05 Scan resource Fault.

Initial Actions

Rerun job after the machine recovers.

Check the Service Log for the frequency of occurrence of this fault.

Check [dC122](#) Fault History for the frequency of occurrence of this fault.



WARNING: Switch off the electricity to the machine, [GP 10](#). Disconnect the power lead from the customer supply while performing tasks that do not need electricity. Electricity can cause death or injury. Moving components can cause injury.

Switch OFF, then switch ON the machine, [GP 10](#). Rerun the job.

Record the fault in the [Logbook](#).

If the fault persists, install new items in order as required:

1. Controller PWB, [PL 3.05 item 1](#).
2. Flatbed scanner, [PL 60.10 item 1](#).

322–300–16 Clock Overflow Fault RAP

The machine determines that it needs to do a reset in order to avoid an impending real time clock overflow

No action required. The machine will reset on it's own to ovoid an overflow condition.

322-309-04 NO Accepts Received Fault RAP

Consecutive NO accepts received from a module exceeds threshold value (currently 20).

Five consecutive 322-309-04 will cause 322-319-04.

Procedure

Switch OFF, then switch ON the machine, GP 10.

If the fault persists, go to the [322-319-04 IOT Integrity Problem While Printing a Job RAP](#) IOT Integrity Problem While Printing a Job RAP.

322-310-04 to 322-318-04 Paper Supply Errors RAP

322-310-04 Pages received from extended job service out of sequence.

322-311-04 Sequencer failed to respond with proposal within the required time.

322-314-04 Module registration error.

322-315-04 One or more modules failed to respond with a completion message.

322-316-04 Job required paper tray that does not exist.

322-317-04 Job required finishing capability that does not exist.

322-318-04 Job required an IOT capability that does not exist.

Procedure



WARNING: Switch off the electricity to the machine, GP 10. Disconnect the power lead from the customer supply while performing tasks that do not need electricity. Electricity can cause death or injury. Moving components can cause injury.

1. Verify the UI control panel tray settings and the tray configuration are correct for the job requested.
2. Switch OFF, then switch ON the machine, GP 10.
3. Delete the original job, then rerun the job causing the fault.

322-311-04 Sequencer Response Fault RAP

Sequencer did not respond with proposal within the required time

Initial Actions

Check the Service Log for the frequency of occurrence of this fault.

Check dC122 Fault History for the frequency of occurrence of this fault.

Procedure



WARNING: Switch off the electricity to the machine, GP 10. Disconnect the power lead from the customer supply while performing tasks that do not need electricity. Electricity can cause death or injury. Moving components can cause injury.

Switch OFF, then switch ON the machine, GP 10.

The fault persists.

Y N

Return to SCP 3.

Note: Record the fault in the Logbook. If the same fault recurs frequently, perform the actions listed in the Y branch of this RAP.

Perform the following in order:

1. Perform Software Upgrade, GP 4.
2. Install a new drive PWB, PL 1.05 item 2.
3. Install a new controller PWB, PL 3.05 item 1.

322-314-04, 322-315-05 Module Errors RAP

322-314-04 Module Registration Error.

322-315-04 Module Completion Fault.

Initial Actions

Check the Service Log for the frequency of occurrence of this fault.

Check **dC122** Fault History for the frequency of occurrence of this fault

1. delete the job causing the fault.
2. Switch OFF, then switch ON the machine, **GP 10**.
3. Rerun the job causing the fault.

322-316-04, 322-317-04, 322-318-04 Job Faults RAP

322-316-04 Job Paper Tray Fault.

322-317-04 Job Finishing Fault.

322-318-04 Job IOT Fault.

Initial Actions

Verify the settings in the UI and the paper in the trays match the job requested.

Check the Service Log for the frequency of occurrence of this fault.

Check **dC122** Fault History, for the frequency of occurrence of this fault

1. Switch OFF, then switch ON the machine, **GP 10**.
2. Enter job in the Job Log as terminated.
3. Mark Service broadcasts an event identifying the Job ID and the reason for the time out.

Note: If the deleted job is a Copy job, the UI uses the event information to inform the user.

322-319-04 IOT Integrity Problem While Printing a Job RAP

This fault can result in two ways:

1. IOT Cycles down and back up 10 times without printing a page within the same job causing a 322-319-04.
2. 5 consecutive 322-309-04 will also cause a 322-319-04. Please refer to fault code [322-309-04 NO Accepts Received Fault RAP](#) for more information.

Procedure

1. Switch OFF, then switch ON the machine [GP 10](#).
2. If the fault persists, check fault history for 322-309-04. Perform RAP [322-309-04 NO Accepts Received Fault RAP](#) to resolve the fault.

Note: If the deleted job is a Copy job, the UI uses the event information to inform the user that the job has been deleted and needs to be rescanned.

If the deleted job is a Print Job, the ESS uses the information to delete the job.

322-320-00 to 322-325-00, 322-335-00 to 322-340-00 Software Install Failed RAP

322-320-00 SM Failed to install scan to file.

322-321-00 SM Failed to remove Scan to file.

322-322-00 SM Failed to install LAN FAX.

322-323-00 SM Failed to remove LAN FAX.

322-324-00 SM Failed to install Scan to Email.

322-325-00 SM Failed to remove Scan to Email.

322-326-00 SM Failed to install IFAX.

322-327-00 SM Failed to remove IFAX.

322-335-00 SM Failed to install Job Based Accounting.

322-336-00 SM Failed to remove Job Based Accounting.

322-337-00 SM Failed to install disk overwrite.

322-338-00 SM Failed to remove Disk Overwrite.

322-339-00 SM Failed to install Job Overwrite.

322-340-00 SM Failed to remove Job Overwrite.

Initial Actions

Check the Service Log for the frequency of occurrence of this fault.

Check [dC122](#) Fault History for the frequency of occurrence of this fault.



WARNING: Switch off the electricity to the machine, [GP 10](#). Disconnect the power lead from the customer supply while performing tasks that do not need electricity. Electricity can cause death or injury. Moving components can cause injury.

Switch OFF, then switch ON the machine, [GP 10](#).

1. Perform, Software Upgrade [GP 4](#), using the FORCED_ALTBOOT method.
2. Install a new controller PWB, [PL 3.05](#).

322-328-00 Incomplete System Information RAP

Incomplete System Information. Accounting Service Data is corrupt. User must POPO to clear.

Procedure

Switch OFF, then switch ON the machine, [GP 10](#).

322-330-00 and 322-332-00 PagePack and Supplies Plan Errors RAP

322-330-00 PagePack PIN (Supplies Plan Activation Code) Entry Locked RAP

322-332-00 Invalid Plan Conversion RAP

Plan conversion invalid due to repeated incorrect entry attempts.

Initial Actions

Ensure that this fault code did not occur during an attempt to perform plan conversion. Refer to, [GP 26](#) PagePack Plan Activation.

Check the [Service Log](#) for the frequency of occurrence of this fault.

Check [dC122](#) Fault History for the frequency of occurrence of this fault

1. Fault code 322-330-00: perform, [GP 26](#) PagePack Plan Activation.
2. Fault code 322-332-00: perform, [GP 37](#) Supplies Plan Conversion.

If the fault persists, contact next level support.

322–350–02 Software Detects non-Valid Xerox SOK 2 or 3 RAP

Software detects non-valid Xerox SOK 2 or 3.

1. Switch OFF, then switch ON the machine, [GP 10](#).
2. If the fault persists, contact next level support.

322-352-00 Serial Number Missing From Memory RAP

Serial Number Update Required or Serial number lost/missing. A password routine may be required to write serial number to machine.

Initial Actions

1. Confirm that the machine serial number displayed on the UI and on the label on machine frame match. If they do not match notify the FE/NTS.
 - a. Select, **Machine Status > Machine Information Screen**.
 - b. Print a Configuration Sheet, [GP 14](#) Printing Reports, if the UI is unavailable.

Check all P/J connectors for loose or unseated connectors on the following PWBs.

1. Drive PWB, [PL 1.05 item 2](#).
2. Controller PWB, [PL 3.05 item 1](#).
3. Check the Fault History, [dC122](#), for communications faults. These can prevent serial number synchronization and must be addressed before proceeding.
4. Enter Diagnostics, [GP 1](#), then touch **[Clear Counters]**. **[Exit and Reboot]** at Diagnostics Exit.
5. If the fault persists, order new PWBs as per listed below before troubleshooting the fault.
 - Drive PWB, [PL 1.05 item 2](#).
 - Controller PWB, [PL 3.05 item 1](#).



WARNING: Do not swap PWBs between machines.



WARNING: Do not remove the batteries from any PWBs while making voltage checks in this RAP.



CAUTION: The serial number is stored and synchronized between the controller PWB, drive PWB, and black toner cartridge. Always install these items individually. After installation of one of these items, switch on the machine, [GP 1](#), to allow the serial number to synchronize before proceeding to install the next part. Refer to [dC132](#) Machine Serial Number.



CAUTION: Never install a new drive PWB, new controller PWB, or black toner cartridge at the same time. First install one of the parts, then switch on the machine, [GP 10](#), to allow the components to sync. If the installation is successful, switch off the machine, then install another part item, if necessary.



WARNING: Switch off the electricity to the machine, [GP 10](#). Disconnect the power lead from the customer supply while performing tasks that do not need electricity. Electricity can cause the death or injury. Moving components can cause the injury.

Switch OFF, then switch ON the machine, [GP 10](#). If the fault persists, wait 5 minutes, then perform [GP 10](#) again.

Procedure

Match the serial numbers on the UI. Select, **[Machine Status > Machine Information]**, and the serial number on the plate inside the front cover and the Configuration Report printed at the beginning of this RAP.



WARNING: Do not remove the black (K) toner cartridge or the imaging unit from the machine unless instructed to do so. Removing may cause the serial number synchronization to fail. The black (K) CRUM holds serial number information and is synced with the drive PWB and controller PWB.

The serial numbers match.

Y N

1. Switch OFF the machine, [GP 10](#), then disconnect the power cord for the source.
2. Contact next level support, then go to [GP 35](#) Serial Number Synchronization Procedure.

A new drive PWB and controller PWB were installed at the same time.

Y N

Install the original controller PWB back into the machine, then perform, [GP 10](#).

The fault persists.

Y N

1. Check the Fault History, [dC122](#). If no other fault codes exist perform, [SCP 5](#) Final Actions.
2. If more faults are listed, perform the corresponding RAP to clear the fault.

Reseat all connectors between the controller PWB, [PL 3.05 item 1](#) and the drive PWB, [PL 1.05 item 2](#).

The fault persists.

Y N

Perform, [SCP 5](#) Final Actions.
Perform, [dC132](#) to restore serial number integrity.

The fault persists.

Y N

1. Check the Fault History, [dC122](#). If no other fault codes exist perform, [SCP 5](#) Final Actions.
2. If more faults are listed, perform the corresponding RAP to clear the fault.

1. Enter Diagnostics, [GP 1](#), then perform [dC122](#). If other fault codes are present, go to the specific fault code RAP.
2. Switch off the machine, [GP 10](#).
3. Install the original drive PWB back into the machine.
4. Perform, [dC132](#) to restore serial number integrity.
5. Perform Software Upgrade, [GP 4](#). If the fault persists, contact next level support for assistance.
6. Check the fault log for fault code 322-365-00. If the fault is listed, perform RAP, [322-365-00](#) Engine Serial Number Needs Recovery RAP.
7. Perform, [SCP 5](#), Final Actions.

322-360-00 to 322-363-00 3-way Sync (Service Plan) Faults RAP

322-360-00 Service Plan Mismatch

Three way sync of Service Plan could not be resolved or is associated with incorrect Region.

322-361-00 Product ID Mismatch RAP

Three way sync of ProductID could not be resolved

322-362-00 Product Class Mismatch RAP

Three way sync of Product Class could not be resolved

322-363-00 Billing Counter Mismatch RAP

Three way sync of Billing Counters could not be resolved

Primary Causes

Typically these faults are caused by the installation of a new controller PWB, new drive PWB, black (K) toner cartridge, or a combination of these installed in the same task.

1. Perform, [GP 35](#), Serial Number Synchronization Procedure.
2. If the fault persists, contact next level support.

322-364-00 Critical Parameters Restored from Mirror RAP

Three way sync determined that the primary NVM storage has been replaced or corrupted.

Perform, [GP 35](#) Serial Number Synchronization Procedure.

322-365-00 Engine Serial Number Needs Recovery RAP

Three way sync determined that the engine Critical Parameter File is lost or corrupted.

Initial Actions

1. If possible, perform, [dC361](#) NVM Save and Restore, to save all machine data files to hard drive.
2. Immediately, backup all machine data files to USB for safe keeping if the machine data backed up to hard drive is unavailable during the following procedure.

Procedure

322-352-00 is present.

Y N

Perform, [dC361](#) NVM Save and Restore, to restore machine print engine data.

Note: If a backup to USB was performed at the beginning of service, this should be used to restore machine data. If this is not available, save machine NVM to hard drive, then pick the engine settings file and restore to machine.

Note: If the 322-365-00 fault persists, then contact next level support to obtain a Manufacturing Recovery File to be attempted. If the fault continues to persists escalate to next level support for further instruction.

Check for other engine faults; these should be corrected before attempting GP 35.

Other engine faults exist.

Y N

Perform, [GP 35](#) Serial Number Synchronization Procedure, then restart the machine.

322-365-00 fault persists.

Y N

| Perform, [SCP 5](#) Final Actions.

Perform, [dC361](#) NVM Save and Restore, to restore machine data.

Note: If a backup to USB was performed at the beginning of service, this should be used to restore machine data. If this is not available, save machine NVM to hard drive, then pick the engine settings file and restore to machine.

Note: If the 322-365-00 fault persists, then contact next level support to obtain a Manufacturing Recovery File to be attempted. If the fault continues to persists escalate to next level support for further instruction.

Clear all other faults, perform, [GP 35](#) Serial Number Synchronization Procedure, then restart the machine.

322-365-00 fault persists.

Y N

| Perform, [SCP 5](#) Final Actions.

Contact next level support.

322-370-00 Unable To Communicate With XSA Database RAP

XSA communication lost, SW issue internal to the device.

1. Switch OFF, then switch ON the machine, [GP 10](#).
2. Upgrade the software, [GP 4](#), using the Forced Altboot method and FORCED_UPGRADE tag.

322-371-00, 322-407-00, 322-417-00, 322-419-00, 322-421-00 Embedded Fax Errors RAP

322-371-00 Fax Application Registration Error RAP

322-407-00 SM Failed To Install Embedded Fax RAP

322-417-00 SM Failed To Removal Embedded Fax RAP

322-419-00 SM Failed To Enable Embedded Fax RAP

322-421-00 SM Failed To Disable Embedded Fax RAP

Set by Fax Service when it gets no response from Service Registry when trying to Register.

Initial Actions

- If the Fax Card is installed, go to [OF 12](#).
- Check the Service Log for the frequency of occurrence of this fault.
- Check [dC122](#) Fault History for the frequency of occurrence of this fault.

Procedure



WARNING: Switch off the electricity to the machine, [GP 10](#). Disconnect the power lead from the customer supply while performing tasks that do not need electricity. Electricity can cause the death or injury. Moving components can cause the injury.

Switch OFF, then switch ON the machine [GP 10](#).

The fault code reappears.

Y N

Return to [SCP 3](#).

Note: Record the fault in the [Logbook](#). If the same fault recurs frequently, perform the actions listed in the Y branch of this RAP.

Perform the following in order:

1. Upgrade SW using [GP 4](#).
2. Install a new Fax PWB, [PL 20.05 item 1](#).
3. Install a new controller PWB, [PL 3.05 item 1](#).

322-701-04, 322-720-00, 322-721-00, 322-751-04, 322-754-17 Configuration Mismatch Fault RAP

322-701-04 Module completion message received after IOT returned to standby.

322-720-00 Service Registry Bad data / Corrupted.

322-721-00 Triple A gets no response from SRS.

322-751-04 Paper Tray Configuration Mismatch.

322-754-17 When the System detects the UI Configuration has changed during the Power On Sequence.

1. Verify the tray configuration is the same in the UI control panel as is physically configured in the machine.
2. Change the UI control panel configuration to match the job required.
3. Switch OFF, then switch ON the machine, **GP 10**.
4. Check the UI control panel input tray required is set correctly, then run the job again causing the fault.
5. If the fault persists, contact next level support.

341–368–00, 341–369–00 Firmware Mismatch Fail RAP

WD1 Controller PWB Wiring Diagram

341-368-00 MCU-SW Firmware Mismatch RAP

341-369-00 MD Type Mismatch RAP

Procedure

Perform Software Upgrade, [GP 4](#), using the FORCED_ALTBOOT method.

341–395–00 MDM F1 Fuse Broken RAP

MM F1 fuse is broken or blown.

Initial Actions



CAUTION: Back up ALL Device Platform Settings files to the hard drive AND USB thumb drive, if possible, before any PWB changes. Refer to, [dC361](#) NVM Save and Restore.

Note: If possible, print a Configuration Report before performing and removal procedures.



CAUTION: Never install a new controller PWB, drive PWB, or black toner cartridge at the same time. First install one of the parts, then switch on the machine, [GP 10](#), to synchronize machine settings. If the installation is successful, switch off the machine, then install another part item if necessary.

1. Switch OFF, then switch ON the machine, [GP 10](#).
2. If the fault persists, install a new drive PWB, [PL 1.05 item 4](#).



CAUTION: If the black toner cartridge is removed during the replacement, reinstall the black tone cartridge before switching on the machine. The machine settings are synchronized between the controller PWB, drive PWB, and black toner CRUM. If any one of these items is not installed when the machine is switched on, the machine may lose serial number sync, rendering the machine inoperable.

3. Print a new Configuration Report or verify in the UI, the software is the latest version after the replacement. Compare the Configuration Report software version printed during Initial Actions to the new Configuration Report or the UI. Upgrade the software, [GP 4](#), if necessary, using the Altboot Method.

342-200-00 to 342-204-00, 342-208-00 LVPS Error Service Check RAP

342-200-00 LVPS/controller (switched power rails that determine the PGOOD signal state) dropped while not sleeping

342-201-00 LVPS/controller (switched power rails that determine the PGOOD signal state) line not up by timeout from POR/sleep exit

342-202-00 Sensor rail down at POR

342-203-00 No line frequency detected

342-204-00 Line Frequency outside operating range of device

342-208-00 LVPS relay is stuck closed.



WARNING: Switch off the electricity to the machine, GP 10. Disconnect the power lead from the customer supply while performing tasks that do not need electricity. Electricity can cause death or injury. Moving components can cause injury.

1. Make sure that the printer is plugged into an appropriately rated and properly grounded electrical outlet..
2. Switch OFF, then switch ON the machine, GP 10.
3. Make sure that the connections between the controller board and the LVPS are properly connected.
4. Make sure that the printer is plugged into an outlet.
5. Make sure that voltage output of the electrical outlet matches the voltage rating of the printer.

Note: A poor power source may trigger a false fuser error.

343-342-00 to 343-348-00 Motor (black) Drive Failure Service Check RAPs

343-342-00 ITB Motor On Fail

343-343-00 ITB Motor Off Fail

343-344-00 ITB Motor Speed Fail

343-345-00 Transfer Belt Motor loss of encoders (motor stall)

343-346-00 Transfer Belt Motor underspeed

343-347-00 Transfer Belt Motor over speed

343-348-00 Transfer Belt Motor move too long



WARNING: Switch off the electricity to the machine, [GP 10](#). Disconnect the power lead from the customer supply while performing tasks that do not need electricity. Electricity can cause death or injury. Moving components can cause injury.

1. Switch OFF, then switch ON the machine, [GP 10](#).
2. Make sure that the motor (K developer-transfer) is functional. Do the following:
 - a. Remove the imaging kit.
 - b. Enter the Diagnostics, [GP 1](#)
 - c. Touch Diagnostics > dC330 Component Control > Print Engine > Motor Tests.
 - d. Touch the appropriate test for the Motor in question.
3. Make sure that the connections between the motor (K developer-transfer) and the controller board are properly connected.
4. Check the EP drive for damage, contamination, and improper installation. For more information, see [REP 40.1](#).
5. Check the transfer rollers and belt for contamination, wear, damage, and improper installation.
6. Check the transfer module for improper operation. Manually turn the gear, and then make sure it is not stuck.

343-360-00 to 343-366-00 Motor (CMY) Drive Failure Service Check RAPs

343-360-00 PC Motor On Fail

343-361-00 PC Motor Off Fail

343-362-00 PC Motor Speed Fail

343-463-00 PC Motor Stall

343-364-00 PC Motor low speed

343-365-00 PC Motor high speed

343-366-00 PC Motor long Fail



WARNING: Switch off the electricity to the machine, [GP 10](#). Disconnect the power lead from the customer supply while performing tasks that do not need electricity. Electricity can cause death or injury. Moving components can cause injury.

1. Switch OFF, then switch ON the machine, [GP 10](#).
2. Make sure that the motor (CMY developer) is functional. Do the following:
 - a. Remove the imaging kit.
 - b. Enter the Diagnostics, [GP 1](#)
 - c. Touch Diagnostics > dC330 Component Control > Print Engine > Motor Tests.
 - d. Touch the appropriate test for the Motor in question.
3. Make sure that the connections between the motor (CMY developer) and the controller board are properly connected.
4. Check the EP drive for damage, contamination, and improper installation. For more information, see [REP 40.1](#)
5. Check the transfer rollers and belt for contamination, wear, damage, and improper installation.
6. Check the transfer module for improper operation. Manually turn the gear, and then make sure it is not stuck.

352-214-00 to 352-228-00, 352-314-00 to 352-322-00, 353-214-00 to 353-228-00, 353-314-00 to 353-328-00, 372-114-00 to 372-140-00, 372-321-00, 373-114-00 to 373-140-00, 374-114-00 to 374-140-00 Optional Tray Motors Jam Service Check

352-214-00 Tray 2 Pick Motor failed to achieve expected speed

352-216-00 Tray 2 Pick Motor loss of encoders (motor stall)

352-218-00 Tray 2 pick Motor underspeed

352-220-00 Tray 2 Pick Motor overspeed

352-222-00 Tray 2 pick Motor moved too long

352-226-10 Tray 2 Pick Motor does not turn on

352-228-00 Tray 2 Pick Motor does not turn off

352-314-00 Tray 2 Pass Through Motor failed to achieve expected speed

352-316-00 Tray 2 Pass Through Motor loss of encoders (motor stall)

352-318-00 Tray 2 Pass Through Motor underspeed

352-326-10 Tray 2 Pass Through Motor does not turn on

352-328-00 Tray 2 Pass Through Motor does not turn off

352-320-00 Tray 2 Pass Through Motor overspeed

352-322-00 Tray 2 Pass Through Motor moved too long

353-214-00 Tray 3 Pick Motor failed to achieve expected speed

353-216-00 Tray 3 pick Motor loss of encoders (motor stall)

353-218-00 Tray 3 pick Motor underspeed

353-220-00 Tray 3 Pick Motor overspeed

353-222-00 Tray 3 Pick Motor moved too long

353-226-10 Tray 3 pick Motor does not turn on

353-228-00 Tray 3 Pick Motor does not turn off

353-314-00 Tray 3 Pass Through Motor failed to achieve expected speed

353-316-00 Tray 3 Pass Through Motor loss of encoders (motor stall)

353-318-00 Tray 3 Pass Through Motor underspeed

353-320-00 Tray 3 Pass Through Motor overspeed

353-322-00 Tray 3 Pass Through Motor moved too long

353-326-10 Tray 3 Pass Through Motor does not turn on

353-328-00 Tray 3 Pass Through Motor does not turn off

372-114-00 Tray 2 Transport (550) or lift (HCIT) Motor does not turn on

372-116-00 Tray 2 Transport (550) or lift (HCIT) Motor does not turn off

372-118-00 Tray 2 Transport (550) or lift (HCIT) Motor failed to achieve expected speed

372-120-00 Tray 2 Transport (550) or lift (HCIT) Motor loss of encoders (motor stall)

372-122-00 Tray 2 Transport (550) or lift (HCIT) Motor underspeed

372-124-00 Tray 2 Transport (550) or lift (HCIT) Motor overspeed

372-126-00 Tray 2 Transport (550) or lift (HCIT) Motor moved too long

372-128-00 Tray 2 Motor does not turn on

372-130-00 Tray 2 Motor does not turn off

372-132-00 Tray 2 Motor failed to achieve expected speed

372-134-00 Tray 2 Motor loss of encoders (motor stall)

372-138-00 Tray 2 Motor overspeed

372-140-00 Tray 2 Motor moved too long

372-321-00 Tray 2 Motor underspeed

373-114-00 .70 = Tray 3 Transport (550) or lift (HCIT) Motor does not turn on

373-116-00 Tray 3 Transport (550) or lift (HCIT) Motor does not turn off

373-118-00 Tray 3 Transport (550) or lift (HCIT) Motor failed to achieve expected speed

373-120-00 Tray 3 Transport (550) or lift (HCIT) Motor loss of encoders (motor stall)

373-122-00 The motor (tray 3 pass-through) is running too slow.

373-122-00 Tray 3 Transport (550) or lift (HCIT) Motor underspeed

373-124-00 Tray 3 Transport (550) or lift (HCIT) Motor overspeed

373-126-00 Tray 3 Transport (550) or lift (HCIT) Motor moved too long

373-128-00 Tray 3 Motor does not turn on

373-130-00 Tray 3 Motor does not turn off

373-132-00 Tray 3 Motor failed to achieve expected speed

373-134-00 Tray 3 Motor loss of encoders (motor stall)

373-136-00 Tray 3 Motor underspeed

373-138-00 Tray 3 Motor overspeed

373-140-00 Tray 3 Motor moved too long

374-114-00 .70 = Tray 4 Transport (550) or lift (HCIT) Motor does not turn on

374-116-00 .71 = Tray 4 Transport (550) or lift (HCIT) Motor does not turn off

374-118-00 .72 = Tray 4 Transport (550) or lift (HCIT) Motor failed to achieve expected speed

374-120-00 .73 = Tray 4 Transport (550) or lift (HCIT) Motor loss of encoders (motor stall)

374-122-00 .74 = Tray 4 Transport (550) or lift (HCIT) Motor underspeed

374-124-00 .75 = Tray 4 Transport (550) or lift (HCIT) Motor overspeed

374-126-00 .76 = Tray 4 Transport (550) or lift (HCIT) Motor moved too long

374-128-00 .80 = Tray 4 Motor does not turn on

374-130-00 .81 = Tray 4 Motor does not turn off

374-132-00 .82 = Tray 4 Motor failed to achieve expected speed

374-134-00 .83 = Tray 4 Motor loss of encoders (motor stall)

374-136-00 .84 = Tray 4 Motor underspeed

374-138-00 .85 = Tray 4 Motor overspeed

374-140-00 .86 = Tray 4 Motor moved too long



WARNING: Switch off the electricity to the machine, GP 10. Disconnect the power lead from the customer supply while performing tasks that do not need electricity. Electricity can cause death or injury. Moving components can cause injury.

1. Make sure that paper is supported and loaded properly.
2. Switch OFF, then switch ON the machine, GP 10.
3. Identify the tray that causes the paper jam error. Place the affected tray insert at the bottom. For example, If tray 2 is causing the paper jam error in a 4-tray configuration, then swap tray 2 and tray 4.
4. Remove the tray insert.
5. Check the tray insert and its lift plate gears for damage and improper operation.
6. Make sure that the following motors are functional:
 - Motor (pick (tray (x)))
 - Motor (pass-through (tray(x)))Do the following:
 - a. Enter the Diagnostics, GP 1.
 - b. Touch Diagnostics > dC330 Component Control > Print Engine > Motor Tests.
 - c. Touch the appropriate test for the Motor in question.
7. Make sure that the connections between the motors and the controller board are properly connected.
8. Check the motors for damage, and improper installation.

371-107-00, 371-108-00, 372-151-00, 372-152-00, 373-153-00, 373-154-00, 374-100-01, 374-950-00, 375-950-00, 375-951-00, 376-104-00, 376-105-00, 377-950-00, 377-951-00 Mismatched paper size and paper printer setting error service check RAPs

371-107-00 IRLoad: Load tray 1 with media (orientation not supported)

371-108-00 IRLoad: Load tray 1 with media (orientation supported)

372-151-00 IRLoad: Load tray 2 with media (orientation not supported)

372-152-00 IRLoad: Load tray 2 with media (orientation supported)

373-153-00 IRLoad: Load tray 3 with media (orientation not supported)

373-154-00 IRLoad: Load tray 3 with media (orientation supported)

374-100-01 Change tray 4 to different media (orientation supported)

374-950-00 IRChange: Load tray 4 to different media (orientation not supported)

375-950-00 Change tray 5 to different media (orientation not supported) RAP

375-951-00 IRChange: Load tray 5 to different media (orientation not supported) RAP

376-104-00 Load MP feeder with media (orientation not supported) RAP

376-105-00 Load MP feeder with media (orientation supported) RAP

377-950-00 Change MP feeder to different media (orientation not supported) RAP

377-951-00 Change MP feeder to different media (orientation supported) RAP



WARNING: Switch off the electricity to the machine, [GP 10](#). Disconnect the power lead from the customer supply while performing tasks that do not need electricity. Electricity can cause death or injury. Moving components can cause injury.

1. Set the paper size in the Paper menu to match the paper loaded. From the home screen, touch **Settings > Paper > Tray Configuration**.
2. Adjust the paper guides in the tray to correct position for the paper loaded.
Make sure that the guides fit snugly against the paper.
3. Replace with correct paper type or size.

371-210-00, 371-212-00, 371-214-00, 371-216-00, 371-218-00, 371-220-00, 371-222-00 Motor (tray 1 pick) Lifting Error Service Check RAPs

371-210-00 Tray 1 Lift On Fail

371-212-00 Tray 1 Lift Off Fail

371-214-00 Autocomp Pick / Lift Motor failed to achieve expected speed

371-216-00 Autocomp Pick / Lift Motor loss of encoders (motor stall)

371-218-00 Autocomp Pick / Lift Motor underspeed

371-220-00 Autocomp Pick / Lift Motor overspeed

371-222-00 Autocomp Pick / Lift Motor moved too long



WARNING: Switch off the electricity to the machine, [GP 10](#). Disconnect the power lead from the customer supply while performing tasks that do not need electricity. Electricity can cause death or injury. Moving components can cause injury.

1. Check the tray insert (non-lift) for damage and improper installation.
2. Check the tray guides for improper operation and damage.
3. Switch OFF, then switch ON the machine, [GP 10](#).
4. Make sure that the motor (tray 1 pick) is functional. Do the following:
 - a. Remove the imaging kit.
 - b. Enter the Diagnostics, [GP 1](#)
 - c. Touch Diagnostics > dC330 Component Control > Print Engine > Motor Tests.
 - d. Touch the appropriate test for the Motor in question.
5. Make sure that the connections between the motor (tray 1 pick) and the controller board are properly connected.
6. Check the media feeder for damage, contamination, and improper installation. For more information, see [REP 80.1](#).

371-300-00, 371-308-00, 371-310-00, 371-316-00, 371-322-00, 374-300-00 Sensor (input): Paper Arrived Too Early or Failed to Arrive Jam Service Check RAPs

371-300-00 MFP S1/Input sensor covered too soon

371-308-00 Tray 1 bump exit sensor covered too soon

371-310-00 Sensor never made by leading edge of page

371-316-00 S1/Input sensor covered too soon. Source is tray 2.

371-322-00 S1/Input sensor covered too soon. Source is tray 3.

374-300-00 S1/Input sensor covered too soon. Source is tray 4.



WARNING: Switch off the electricity to the machine, GP 10. Disconnect the power lead from the customer supply while performing tasks that do not need electricity. Electricity can cause death or injury. Moving components can cause injury.

1. Make sure that paper is supported and loaded properly.
2. Make sure that the paper is free of debris and obstructions.
3. Switch OFF, then switch ON the machine, GP 10.
4. Check if the paper jam error occurs when using other trays.

371-302-00, 371-306-00 Sensor (input): Paper Arrived Too Early From The MPF Jam Service Check RAPs

371-302-00 Sensor never made by leading edge of page . Source is mpf/manual

371-306-00 Fail to pick detected from mpf/manual by s1/Input sensor/stage. Source is mpf/manual



WARNING: Switch off the electricity to the machine, GP 10. Disconnect the power lead from the customer supply while performing tasks that do not need electricity. Electricity can cause death or injury. Moving components can cause injury.

1. Set the paper size in the Paper menu to match the paper loaded. From the home screen, touch **Settings> Paper> Tray Configuration**.
2. Adjust the paper guides in the tray to correct position for the paper loaded.
Make sure that the guides fit snugly against the paper.
3. Replace with correct paper type or size.
4. Make sure that paper is supported and loaded properly.
5. Make sure that the paper is free of debris and obstructions.
6. Switch OFF, then switch ON the machine, GP 10.
7. Check if the paper jam error occurs when using other trays.
8. If the paper jam error occurs regardless of the paper source or even after restarting the printer when the paper path is cleared, then do the following:
 - a. Check the sensor (duplex) actuator for damage and improper installation.
 - b. Make sure the sensor (duplex) actuator is functional, do the following:
 1. Enter the Diagnostics, GP 1
 2. Touch Diagnostics > dC330 Component Control > Print Engine > Sensor Tests.
 3. Touch the appropriate test for the Sensor in question.
 - c. Make sure that the cables and connectors are properly connected.

371-304-00 Sensor (input): Paper Failed to Clear from the MPF Jam Service Check RAP

371-304-00 S1/Input/Stage sensor never cleared by trailing edge of page. Source is mpf/manual (bump exit sensor for CA/MM)



WARNING: Switch off the electricity to the machine, [GP 10](#). Disconnect the power lead from the customer supply while performing tasks that do not need electricity. Electricity can cause death or injury. Moving components can cause injury.

1. Make sure that paper is supported and loaded properly.
2. Make sure that the paper is free of debris and obstructions.
3. Switch OFF, then switch ON the machine, [GP 10](#).
4. Check if the paper jam error occurs when using other trays.
5. If the paper jam error occurs only when using the MPF, then do the following:
 - a. Check the MPF pick roller and separator roller for wear, damage, and contamination.
 - b. Make sure that the MPF solenoid is functional. Do the following:
 1. Enter the Diagnostics, [GP 1](#)
 2. Touch Diagnostics > dC330 Component Control > Print Engine > Motor Tests.
 3. Touch the appropriate test for the Motor in question.
 - c. Check the MPF gearbox for wear, damage, and improper mesh.
6. If the paper jam error occurs regardless of the source tray, then do the following:
 - a. Identify the location of the leading edge of the paper.
 - b. If the leading edge of the paper did not reach the fuser, then check the imaging unit and transfer roller for damage and improper installation.
 - c. If the leading edge of the paper reached the fuser, then check the fuser for wear, damage, and improper installation. For more information, see [REP 10.1](#)

371-312-00 Sensor (input): Paper Failed to Clear Jam Service Check RAP

371-312-00 Bump exit/stage sensor never cleared by trailing edge of page. Source is tray 1.



WARNING: Switch off the electricity to the machine, [GP 10](#). Disconnect the power lead from the customer supply while performing tasks that do not need electricity. Electricity can cause death or injury. Moving components can cause injury.

1. Make sure that paper is supported and loaded properly.
2. Make sure that the paper is free of debris and obstructions.
3. Switch OFF, then switch ON the machine, [GP 10](#).
4. Check if the paper jam error occurs when using other trays.
5. If the paper jam error occurs only when using tray 1, then do the following:
 - a. Check the pick roller for wear, damage, contamination, and improper installation.
 - b. Check the separator pad or separator roller for wear, damage, contamination, and improper installation.
6. If the paper jam error occurs regardless of the source tray, then do the following:
 - a. Check the input sensor actuator for damage, and improper installation.
 - b. Make sure that the sensor (duplex and input) is functional. Do the following:
 1. Enter the Diagnostics, [GP 1](#)
 2. Touch Diagnostics > dC330 Component Control > Print Engine > Sensor Tests.
 3. Touch the appropriate test for the Sensor in question.
 4. Make sure that the connections between the sensor (duplex and input) and the controller board are properly connected.
 5. Check the sensor (duplex and input) for damage and improper installation. For more information, see [REP 80.2](#)
 - c. If the paper jam error occurs regardless of the source tray, then do the following:
 1. Identify the location of the leading edge of the paper.
 2. If the leading edge of the paper did not reach the fuser, then check the imaging unit and transfer roller for damage and improper installation.
 3. If the leading edge of the paper reached the fuser, then check the fuser for wear, damage, and improper installation. For more information, see [REP 10.1](#)

371-314-00 Tray 1 Pick Error Service Check RAP

371-314-00 Fail to pick detected from tray1 by s1/Input/Stage sensor



WARNING: Switch off the electricity to the machine, [GP 10](#). Disconnect the power lead from the customer supply while performing tasks that do not need electricity. Electricity can cause death or injury. Moving components can cause injury.

1. Make sure that paper is supported and loaded properly.
2. Make sure that the paper is free of debris and obstructions.
3. Switch OFF, then switch ON the machine, [GP 10](#).
4. Check if the paper jam error occurs when using other trays.
5. If the paper jam error occurs only when using tray 1, then do the following:
 - a. Check the pick roller for wear, damage, contamination, and improper installation.
 - b. Check the separator pad or separator roller for wear, damage, contamination, and improper installation.
6. Check the pick arm and pick roller for damage and improper installation.

371-316-00, 371-322-00, 374-300-00 Sensor (input): Paper Arrived Too Early From Optional Tray Jam Service Check RAPs

371-316-00 S1/Input sensor covered too soon. Source is tray 2.

371-322-00 S1/Input sensor covered too soon. Source is tray 3.

374-300-00 S1/Input sensor covered too soon. Source is tray 4.



WARNING: Switch off the electricity to the machine, [GP 10](#). Disconnect the power lead from the customer supply while performing tasks that do not need electricity. Electricity can cause death or injury. Moving components can cause injury.

1. Make sure that paper is supported and loaded properly.
2. Make sure that the paper is free of debris and obstructions.
3. Switch OFF, then switch ON the machine, [GP 10](#).
4. Check if the paper jam error occurs when using other trays.
5. If the paper jam error occurs regardless of the source tray, then do the following:
 - a. Check the input sensor actuator for damage, and improper installation.
 - b. Make sure that the sensor (duplex and input) is functional. Do the following:
 1. Enter the Diagnostics, [GP 1](#)
 2. Touch Diagnostics > dC330 Component Control > Print Engine > Sensor Tests.
 3. Touch the appropriate test for the Sensor in question.
 4. Make sure that the connections between the sensor (duplex and input) and the controller board are properly connected.
 5. Check the sensor (duplex and input) for damage and improper installation. For more information, see [REP 80.2](#)
6. Check the pick arm and pick roller for damage and improper installation.

371-317-00, 371-331-00, 371-346-00, 374-317-00 Motor (tray 1 pick) Jam Service Check RAPs

371-331-00 MFS Input sensor did not clear; source = MFS

371-317-00 Autocomp Motor underspeed; source = tray 2

371-346-00 Tray1- Autocomp Motor underspeed

374-317-00 Autocomp Motor underspeed



WARNING: Switch off the electricity to the machine, [GP 10](#). Disconnect the power lead from the customer supply while performing tasks that do not need electricity. Electricity can cause death or injury. Moving components can cause injury.

1. Make sure that paper is supported and loaded properly.
2. Make sure that the paper is free of debris and obstructions.
3. Switch OFF, then switch ON the machine, [GP 10](#).
4. Check if the paper jam error occurs when using other trays.
5. Check the pick arm and pick roller for damage and improper installation.

371-318-00, 371-324-00, 374-318-00 Sensor (input): Paper Failed to Arrive from Optional Tray Jam Service Check RAPs

371-318-00 Jam at S1/Input/stage - never reached s1/Input/stage sensor. Source is Tray 2

371-324-00 Jam at Bump Exit - never reached bump exit sensor. Source is Tray 3

374-318-00 Jam at Bump Exit - never reached bump exit sensor. Source is Tray 4



WARNING: Switch off the electricity to the machine, [GP 10](#). Disconnect the power lead from the customer supply while performing tasks that do not need electricity. Electricity can cause death or injury. Moving components can cause injury.

1. Make sure that paper is supported and loaded properly.
2. Make sure that the paper is free of debris and obstructions.
3. Switch OFF, then switch ON the machine, [GP 10](#).
4. Check if the paper jam error occurs when using other trays.
5. If the paper jam error occurs when using optional trays (tray 2 to tray 4), then do the following:
 - a. Check the pick roller for wear, damage, contamination, and improper installation.
 - b. Check the separator pad or separator roller for wear, damage, contamination, and improper installation.
 - c. Check the paper path above the tray for debris and foreign object.
6. If the paper jam error occurs regardless of the source tray, then do the following:
 - a. Check the input sensor actuator for damage, and improper installation.
 - b. Make sure that the sensor (duplex and input) is functional. Do the following:
 1. Enter the Diagnostics, [GP 1](#)
 2. Touch Diagnostics > dC330 Component Control > Print Engine > Sensor Tests.
 3. Touch the appropriate test for the Sensor in question.
 - c. Make sure that the connections between the sensor (duplex and input) and the controller board are properly connected.
 - d. Check the sensor (duplex and input) for damage and improper installation. For more information, see [REP 80.2](#)
7. If the paper jam error occurs regardless of the source tray, then do the following:
 - a. Identify the location of the leading edge of the paper.
 - b. If the leading edge of the paper did not reach the fuser, then check the imaging unit and transfer roller for damage and improper installation.
 - c. If the leading edge of the paper reached the fuser, then check the fuser for wear, damage, and improper installation. For more information, see [REP 10.1](#)

371-320-00, 371-326-00, 374-320-00 Sensor (input): Paper Failed to Clear from Optional Tray Jam Service Check RAPs

371-320-00 S1/Input sensor never cleared by trailing edge of page. Source is tray 2

371-326-00 S1/Input sensor never cleared by trailing edge of page. Source is tray 3

374-320-00 S1/Input sensor never cleared by trailing edge of page. Source is tray 4



WARNING: Switch off the electricity to the machine, [GP 10](#). Disconnect the power lead from the customer supply while performing tasks that do not need electricity. Electricity can cause death or injury. Moving components can cause injury.

1. Make sure that paper is supported and loaded properly.
2. Make sure that the paper is free of debris and obstructions.
3. Switch OFF, then switch ON the machine, [GP 10](#).
4. Check if the paper jam error occurs when using other trays.
5. If the paper jam error occurs when using optional trays (tray 2 to tray 4), then do the following:
 - a. Check the pick roller for wear, damage, contamination, and improper installation.
 - b. Check the separator pad or separator roller for wear, damage, contamination, and improper installation.
 - c. Check the paper path above the tray for debris and foreign object.
6. If the paper jam error occurs regardless of the source tray, then do the following:
 - a. Check the input sensor actuator for damage, and improper installation.
 - b. Make sure that the sensor (duplex and input) is functional. Do the following:
 1. Enter the Diagnostics, [GP 1](#)
 2. Touch Diagnostics > dC330 Component Control > Print Engine > Sensor Tests.
 3. Touch the appropriate test for the Sensor in question.
 - c. Make sure that the connections between the sensor (duplex and input) and the controller board are properly connected.
 - d. Check the sensor (duplex and input) for damage and improper installation. For more information, see [REP 80.2](#)
7. If the paper jam error occurs regardless of the source tray, then do the following:
 - a. Identify the location of the leading edge of the paper.
 - b. If the leading edge of the paper did not reach the fuser, then check the imaging unit and transfer roller for damage and improper installation.
 - c. If the leading edge of the paper reached the fuser, then check the fuser for wear, damage, and improper installation. For more information, see [REP 10.1](#)

371-328-00, 371-100-00 Sensor (input): Static Jam Service Check RAPs

371-328-00 S1/Input sensor covered at warmup

371-100-00 S1 sensor / Pick sensor / MFS sensor covered on warmup



WARNING: Switch off the electricity to the machine, [GP 10](#). Disconnect the power lead from the customer supply while performing tasks that do not need electricity. Electricity can cause death or injury. Moving components can cause injury.

1. Make sure that paper is supported and loaded properly.
2. Make sure that the paper is free of debris and obstructions.
3. Switch OFF, then switch ON the machine, [GP 10](#).
4. Check if the paper jam error occurs when using other trays.
5. If the paper jam error occurs regardless of the source tray, then do the following:
 - a. Check the input sensor actuator for damage, and improper installation.
 - b. Make sure that the sensor (duplex and input) is functional. Do the following:
 1. Enter the Diagnostics, [GP 1](#)
 2. Touch Diagnostics > dC330 Component Control > Print Engine > Sensor Tests.
 3. Touch the appropriate test for the Sensor in question.
 - c. Make sure that the connections between the sensor (duplex and input) and the controller board are properly connected.
 - d. Check the sensor (duplex and input) for damage and improper installation. For more information, see [REP 80.2](#)

371-339-00 Sensor (input): Paper Cleared Too Early Jam Service Check RAP

371-339-00 Bump exit sensor cleared by page too soon. Source is tray 1.



WARNING: Switch off the electricity to the machine, **GP 10**. Disconnect the power lead from the customer supply while performing tasks that do not need electricity. Electricity can cause death or injury. Moving components can cause injury.

1. Make sure that paper is supported and loaded properly.
2. Make sure that the paper is free of debris and obstructions.
3. Switch OFF, then switch ON the machine, **GP 10**.
4. Check if the paper jam error occurs when using other trays.
5. Check the pick roller for wear, damage, contamination, and improper installation.
6. Make sure that the reverse solenoid is functional. Do the following:
 - a. Enter the Diagnostics, **GP 1**
 - b. Touch Diagnostics > dC330 Component Control > Print Engine > Motor Tests.
 - c. Touch the appropriate test for the Motor in question.
7. Check the reverse solenoid and its actuator for wear, damage, and improper operation.
8. Check the redrive assembly for wear, damage, and improper mesh.

372-100-00 to 372-150-00, 372-330-00, 372-331-00, 372-900-00, 372-902-00, 373-100-00 to 373-152-00, 373-330-00, 373-900-00, 374-112-00 to 374-150-00, 374-334-00 to 374-338-00, 377-149-00, 377-274-00 to 377-278-00 Optional Tray Sensors Jam Service Check RAP

372-100-00 Tray2 Misfeed_Empty RAP

372-102-00 EARLY ARRIVING JAM (Paper reaches the sensor too soon, or unexpected). Source was tray2. RAP

372-105-00 Tray 2 late jam RAP

372-108-00 EARLY ARRIVING JAM (Paper reaches the sensor too soon, or unexpected). Source was tray3. RAP

372-110-00 NEVER ARRIVING JAM FROM NORMAL PATH (Paper didnt reach the specified sensor, but did reach the previous sensor). Source was tray3. RAP

372-112-00 LATE LEAVING JAM (Paper reaches sensor but clears it late. (Long media, double feed). Source was tray3. RAP

372-142-00 STATIC JAM (Paper at sensor at start, cover closed or idle. Jam not cleared). Option declared jam, or warmup jam with no known page source. RAP

372-144-00 EARLY ARRIVING JAM (Paper reaches the sensor too soon, or unexpected). Option declared jam, or warmup jam with no known page source. RAP

372-146-00 NEVER ARRIVING JAM FROM NORMAL PATH (Paper didnt reach the specified sensor, but did reach the previous sensor). Option declared jam, or warmup jam with no known page source. RAP

372-148-00 LATE LEAVING JAM (Paper reaches sensor but clears it late. (Long media, double feed). Option declared jam, or warmup jam with no known page source. RAP

372-150-00 FAIL TO PICK FROM TRAY (Paper did not reach first sensor; Miss-feed, tray empty). Option declared jam, or warmup jam with no known page source. RAP

372-330-00 FAIL TO PICK FROM TRAY (Paper did not reach first sensor; Miss-feed, tray empty). Source was tray3. RAP

372-331-00 EARLY ARRIVING JAM (Paper reaches the sensor too soon, or unexpected). Source was tray4. RAP

372-900-00 Tray 2 static jam RAP

372-902-00 STATIC JAM (Paper at sensor at start, cover closed or idle. Jam not cleared). Source was tray3. RAP

373-100-00 Tray 3 Misfeed_Empty RAP

373-102-00 Tray 3 early jam RAP

373-105-00 Regi Senor On Jam (Tray3) RAP

373-142-00 STATIC JAM (Paper at sensor at start, cover closed or idle. Jam not cleared). Option declared jam, or warmup jam with no known page source. RAP

373-144-00 EARLY ARRIVING JAM (Paper reaches the sensor too soon, or unexpected). Option declared jam, or warmup jam with no known page source. RAP

373-146-00 NEVER ARRIVING JAM FROM NORMAL PATH (Paper didnt reach the specified sensor, but did reach the previous sensor). Option declared jam, or warmup jam with no known page source. RAP

373-148-00 LATE LEAVING JAM (Paper reaches sensor but clears it late. (Long media, double feed). Option declared jam, or warmup jam with no known page source. RAP

373-150-00 FAIL TO PICK FROM TRAY (Paper did not reach first sensor; Miss-feed, tray empty). Option declared jam, or warmup jam with no known page source. RAP

373-152-00 The paper fed from an unknown source did not clear the sensor (tray 3 pass-through). RAP

373-330-00 EARLY ARRIVING JAM (Paper reaches the sensor too soon, or unexpected). Source was tray4. RAP

373-900-00 Tray 3 static jam RAP

374-112-00 LATE LEAVING JAM (Paper reaches sensor but clears it late. (Long media, double feed). Source was tray4. RAP

374-142-00 STATIC JAM (Paper at sensor at start, cover closed or idle. Jam not cleared). Source was tray4. RAP

374-143-00 STATIC JAM (Paper at sensor at start, cover closed or idle. Jam not cleared). Source was tray4. RAP

374-146-00 NEVER ARRIVING JAM FROM NORMAL PATH (Paper didnt reach the specified sensor, but did reach the previous sensor). Source was tray4. RAP

374-147-00 NEVER ARRIVING JAM FROM NORMAL PATH (Paper didnt reach the specified sensor, but did reach the previous sensor). Source was tray4. RAP

374-148-00 LATE LEAVING JAM (Paper reaches sensor but clears it late. (Long media, double feed). Source was tray4. RAP

374-150-00 FAIL TO PICK FROM TRAY (Paper did not reach first sensor; Miss-feed, tray empty). Source was tray4. RAP

374-334-00 STATIC JAM (Paper at sensor at start, cover closed or idle. Jam not cleared). Source was tray4. RAP

374-335-00 EARLY ARRIVING JAM (Paper reaches the sensor too soon, or unexpected). Source was tray4. RAP

374-338-00 LATE LEAVING JAM (Paper reaches sensor but clears it late. (Long media, double feed). Source was tray4. RAP

377-149-00 STATIC JAM (Paper at sensor at start, cover closed or idle. Jam not cleared). Option declared jam, or warmup jam with no known page source. RAP

377-274-00 EARLY ARRIVING JAM (Paper reaches the sensor too soon, or unexpected). Option declared jam, or warmup jam with no known page source. RAP

377-275-00 NEVER ARRIVING JAM FROM NORMAL PATH (Paper didnt reach the specified sensor, but did reach the previous sensor). Option declared jam, or warmup jam with no known page source. RAP

377-276-00 LATE LEAVING JAM (Paper reaches sensor but clears it late. (Long media, double feed). Option declared jam, or warmup jam with no known page source. RAP

377-277-00 FAIL TO PICK FROM TRAY (Paper did not reach first sensor; Miss-feed, tray empty). Option declared jam, or warmup jam with no known page source. RAP

377-278-00 SENSOR DID NOT CLEAR (Previous sheet did not clear sensor so next sheet could look for an input make). Option declared jam, or warmup jam with no known page source. RAP



WARNING: Switch off the electricity to the machine, GP 10. Disconnect the power lead from the customer supply while performing tasks that do not need electricity. Electricity can cause death or injury. Moving components can cause injury.

1. Make sure that paper is supported and loaded properly.
2. Switch OFF, then switch ON the machine, GP 10.
3. Identify the tray that causes the paper jam error. Place the affected tray insert at the bottom. For example, If tray 2 is causing the paper jam error in a 4-tray configuration, then swap tray 2 and tray 4.
4. Make sure the following sensors are functional:
 - Sensor (pass-through)
 - Sensor (index)
 - Sensor (trailing edge)
 - Sensor (media present)
 Do the following:
 - a. Enter the Diagnostics, GP 1.
 - b. Touch Diagnostics > dC330 Component Control > Print Engine > Sensor Tests.
 - c. Touch the appropriate test for the Sensor in question.
5. Make sure that the connections between the listed sensors and the controller board are properly connected.
6. Check the sensors and its actuators for damage and improper installation.
7. Check the tray insert for damage and improper installation.
8. Check the tray guides for damage and improper operation.
9. Check the lift plate for damage and improper operation.

372-210-00 to 372-222-00 Optional Tray Pick Drive Error Service Check RAPs

372-210-00 Tray 2 Lift ON Fail

372-212-00 Tray 2 Lift Off Fail

372-214-00 Tray 2 Pick Motor failed to achieve expected speed

372-216-00 Tray 2 Pick Motor loss of encoders (motor stall)

372-218-00 Tray 2 pick Motor underspeed

372-220-00 Tray 2 Pick Motor overspeed

372-222-00 Tray 2 pick Motor moved too long



WARNING: Switch off the electricity to the machine, GP 10. Disconnect the power lead from the customer supply while performing tasks that do not need electricity. Electricity can cause death or injury. Moving components can cause injury.

1. Turn off the printer.
2. Check the optional tray for improper installation.
3. Remove the optional tray, and then check the connectors on the printer and optional tray for damage and improper connection.
4. Reinstall the optional tray, and then turn on the printer.
5. Remove the tray insert.
6. Check the tray insert and its lift plate gears for damage and improper operation.
7. Make sure that the following motors are functional:
 - Motor (pick (tray (x))
 - Motor (pass-through (tray(x))
 Do the following:
 - a. Enter the Diagnostics, GP 1
 - b. Touch Diagnostics > dC330 Component Control > Print Engine > Motor Tests.
 - c. Touch the appropriate test for the Motor in question.
8. Make sure that the connections between the motors and the controller board are properly connected.
9. Check the motors for damage, and improper installation.

372-300-00 to 372-312-00, 373-210-00 to 373-222-00, 373-300-00 to 373-312-00, 374-218-00 to 374-231-00 Optional Tray Motor Error Service Check RAPs

372-300-00 Tray 2 transport Motor On Fail

372-302-00 Tray 2 transport Motor Off Fail

372-304-00 Tray 2 transport Motor Speed Fail

372-306-00 Tray 2 transport Motor loss of encoders (motor stall)

372-308-00 Tray 2 transport Motor underspeed

372-310-00 Tray 2 transport Motor overspeed

372-312-00 Tray 2 transport Motor moved too long

373-210-00 Tray3 Lift On Fail

373-212-00 Tray 3 Off Fail

373-214-00 Tray 3 Pick Motor failed to achieve expected speed

373-216-00 Tray 3 pick Motor loss of encoders (motor stall)

373-218-00 Tray 3 pick Motor underspeed

373-220-00 Tray 3 Pick Motor overspeed

373-222-00 Tray 3 Pick Motor moved too long

373-300-00 Tray 3 transport Motor On Fail

373-302-00 Tray 3 transport Motor Off Fail

373-304-00 Tray 3 transport Motor Speed Fail

373-306-00 Tray 3 transport Motor loss of encoders (motor stall)

373-308-00 Tray 3 transport Motor underspeed

373-310-00 Tray 3 transport Motor overspeed

373-312-00 Tray 3 transport Motor moved too long

374-218-00 Tray 4 Pick Motor does not turn on

374-219-00 Tray 4 pick Motor does not turn off

374-220-00 Tray 4 pick Motor failed to achieve expected speed

374-221-00 Tray 4 Pick Motor loss of encoders (motor stall)

374-222-00 Tray 4 pick Motor underspeed

374-223-00 Tray 4 pick Motor overspeed

374-224-00 Tray 4 Pick Motor moved too long

374-225-00 Tray 4 transport Motor does not turn on

374-226-00 Tray 4 transport Motor does not turn off

374-227-00 Tray 4 transport Motor failed to achieve expected speed

374-228-00 Tray 4 transport Motor loss of encoders (motor stall)

374-229-00 Tray 4 transport Motor underspeed

374-230-00 Tray 4 transport Motor overspeed

374-231-00 Tray 4 transport Motor moved too long



WARNING: Switch off the electricity to the machine, GP 10. Disconnect the power lead from the customer supply while performing tasks that do not need electricity. Electricity can cause death or injury. Moving components can cause injury.

1. Make sure that the printer is placed in a location with the recommend airflow, ventilation, and clearance around the printer. For more information, see GP 16 .
2. Make sure that the cooling fan is functional. Do the following:
 - a. Enter the Diagnostics, GP 1
 - b. Touch Diagnostics > dC330 Component Control > Print Engine > Motor Tests.
 - c. Touch the appropriate test for the Motor in question.
3. Make sure that the connections between the cooling fan and the controller board are properly connected.
4. Check the cooling fan for damage, contamination, and improper installation.

372-305-00, 373-305-00, 374-305-00 Sensor (input): Paper Cleared Too Early from Optional Tray Jam Service Check RAPs

372-305-00 S1/Input sensor cleared by page too soon. Source is tray 2

373-305-00 S1/Input sensor cleared by page too soon. Source is tray 3

374-305-00 S1/Input sensor cleared by page too soon. Source is tray 4



WARNING: Switch off the electricity to the machine, **GP 10**. Disconnect the power lead from the customer supply while performing tasks that do not need electricity. Electricity can cause death or injury. Moving components can cause injury.

1. Set the paper size in the Paper menu to match the paper loaded. From the home screen, touch **Settings> Paper**.
2. Make sure that paper is supported and loaded properly.
3. Make sure that the paper is free of debris and obstructions.
4. Switch OFF, then switch ON the machine, **GP 10**.
5. Check if the paper jam error occurs when using other trays.
6. If the paper jam error occurs when using optional trays (tray 2 to tray 4), then do the following:
 - a. Check the pick roller for wear, damage, contamination, and improper installation.
 - b. Check the separator pad or separator roller for wear, damage, contamination, and improper installation.
 - c. Check the paper path above the tray for debris and foreign object.

374-232-00, 377-402-00, 377-404-00, 377-407-00, 377-410-00, 377-419-00 Paper (duplex job) Failed to Arrive Jam Service Check RAPs

374-232-00 S1/Input/stage sensor never made by leading edge of page during duplex pass; source = tray 4

377-402-00 S1/Input/stage sensor never cleared by trailing edge of page during duplex pass. source = MPF

377-404-00 S1/Input/stage sensor never made by leading edge of page during duplex pass; source = tray 1

377-407-00 S1/Input/stage sensor never made by leading edge of page during duplex pass; source = tray 2

377-410-00 S1/Input/stage sensor never made by leading edge of page during duplex pass; source = tray 3

377-419-00 S1/Input/stage sensor never made by leading edge of page during duplex pass; source = unknown

Procedure



WARNING: Switch off the electricity to the machine, GP 10. Disconnect the power lead from the customer supply while performing tasks that do not need electricity. Electricity can cause death or injury. Moving components can cause injury.

1. Make sure that paper is supported and loaded properly.
2. Make sure that the paper is free of debris and obstructions.
3. Switch OFF, then switch ON the machine, GP 10.
4. Check if the paper jam error occurs when using other trays.
5. Check the printed page count.
 - a. Enter the Diagnostics menu, and then touch **Printer Setup**.
 - b. If the page count is near 400K, then replace the duplex.
6. Check the duplex paper path for jammed paper, debris, and obstructions.
7. Check the duplex rollers for debris, wear, damage, contamination, and improper installation.
8. Check the duplex linkage and belt for damage and improper installation.

374-233-00, 377-402-00, 377-405-00, 377-408-00, 377-411-00, 377-420-00 Sensor (input): Paper (duplex job) Failed to Clear Jam Service Check RAPs

374-233-00 S1/Input/stage sensor never cleared by trailing edge of page during duplex pass. source = tray 4

377-402-00 S1/Input/stage sensor never cleared by trailing edge of page during duplex pass. source = MPF

377-402-00 377-405-00 S1/Input/stage sensor never cleared by trailing edge of page during duplex pass. source = tray 1

377-408-00 S1/Input/stage sensor never cleared by trailing edge of page during duplex pass. source = tray 2

377-411-00 S1/Input/stage sensor never cleared by trailing edge of page during duplex pass. source = tray 3

377-420-00 S1/Input/stage sensor never cleared by trailing edge of page during duplex pass. source = unknown



WARNING: Switch off the electricity to the machine, GP 10. Disconnect the power lead from the customer supply while performing tasks that do not need electricity. Electricity can cause death or injury. Moving components can cause injury.

1. Make sure that paper is supported and loaded properly.
2. Make sure that the paper is free of debris and obstructions.
3. Switch OFF, then switch ON the machine, GP 10.
4. Check if the paper jam error occurs when using other trays.
5. Check the printed page count.
 - a. Enter the Diagnostics menu, and then touch **Printer Setup**.
 - b. If the page count is near 400K, then replace the duplex.
6. Check the duplex paper path for jammed paper, debris, and obstructions.
7. Check the duplex rollers for debris, wear, damage, contamination, and improper installation.
8. Check the duplex linkage and belt for damage and improper installation.
9. Check the isolation roller for wear, damage, and contamination.

377-102-00, 377-109-00, 377-204-00 Sensor (fuser exit): Paper Failed to Arrive from Optional Tray Jam Service Check RAPs

377-102-00 Fuser exit sensor never made by leading edge of page. Source is tray 2

377-109-00 Fuser Exit Sensor late (Tray 3)

377-204-00 Fuser exit sensor never made by leading edge of page. Source is tray 4



WARNING: Switch off the electricity to the machine, GP 10. Disconnect the power lead from the customer supply while performing tasks that do not need electricity. Electricity can cause death or injury. Moving components can cause injury.

1. Make sure that paper is supported and loaded properly.
2. Make sure that the paper is free of debris and obstructions.
3. Switch OFF, then switch ON the machine, GP 10.
4. Check if the paper jam error occurs when using other trays.
5. If the paper jam error occurs when using optional trays (tray 2 to tray 4), then do the following:
 - a. Check the pick roller for wear, damage, contamination, and improper installation.
 - b. Check the separator pad or separator roller for wear, damage, contamination, and improper installation.
 - c. Check the paper path above the tray for debris and foreign object.
6. If the paper jam error occurs regardless of the source tray, then do the following:
 - a. Check the input sensor actuator for damage, and improper installation.
 - b. Make sure that the sensor (duplex and input) is functional. Do the following:
 1. Enter the Diagnostics, GP 1
 2. Touch Diagnostics > dC330 Component Control > Print Engine > Sensor Tests.
 3. Touch the appropriate test for the Sensor in question.
 - c. Make sure that the connections between the sensor (duplex and input) and the controller board are properly connected.
 - d. Check the sensor (duplex and input) for damage and improper installation. For more information, see REP 80.2
7. If the paper jam error occurs regardless of the source tray, then do the following:
 - a. Identify the location of the leading edge of the paper.
 - b. If the leading edge of the paper did not reach the fuser, then check the imaging unit and transfer roller for damage and improper installation.
 - c. If the leading edge of the paper reached the fuser, then check the fuser for wear, damage, and improper installation. For more information, see REP 10.1

377-103-00, 377-113-00 Sensor (fuser exit): Paper Failed to Clear Jam Service Check RAPs

377-103-00 Fuser Exit trailedge (MPF)

377-113-00 Fuser exit sensor never cleared by trailing edge of page. Source is tray 1



WARNING: Switch off the electricity to the machine, [GP 10](#). Disconnect the power lead from the customer supply while performing tasks that do not need electricity. Electricity can cause death or injury. Moving components can cause injury.

1. Make sure that paper is supported and loaded properly.
2. Make sure that the paper is free of debris and obstructions.
3. Switch OFF, then switch ON the machine, [GP 10](#).
4. Check if the paper jam error occurs when using other trays.
5. If the paper jam error occurs regardless of the source tray, then do the following:
 - a. Make sure that the fuser is functional. Do the following:
 1. Enter the Diagnostics, [GP 1](#)
 2. Touch Diagnostics > dC330 Component Control > Print Engine > Sensor Tests.
 3. Touch the appropriate test for the Sensor in question.
 - b. Make sure that the connections between the fuser and the controller board are properly connected.
 - c. Check the fuser for wear, damage, and improper installation. For more information, see [REP 10.1](#)
 - d. Check the fuser actuator for wear, damage, and improper installation.
 - e. Check the redrive assembly for wear, damage, and improper mesh.

377-105-00 Sensor (fuser exit): Paper Failed to Arrive Jam Service Check RAP

377-105-00 Fuser Exit late (Tray 1)



WARNING: Switch off the electricity to the machine, [GP 10](#). Disconnect the power lead from the customer supply while performing tasks that do not need electricity. Electricity can cause death or injury. Moving components can cause injury.

1. Make sure that paper is supported and loaded properly.
2. Make sure that the paper is free of debris and obstructions.
3. Switch OFF, then switch ON the machine, [GP 10](#).
4. Check if the paper jam error occurs when using other trays.
5. If the paper jam error occurs only when using tray 1, then do the following:
 - a. Check the pick roller for wear, damage, contamination, and improper installation.
 - b. Check the separator pad or separator roller for wear, damage, contamination, and improper installation.
6. If the paper jam error occurs regardless of the source tray, then do the following:
 - a. Identify the location of the leading edge of the paper.
 - b. If the leading edge of the paper did not reach the fuser, then check the imaging unit and transfer roller for damage and improper installation.
 - c. If the leading edge of the paper reached the fuser, then check the fuser for wear, damage, and improper installation. For more information, see [REP 10.1](#)

377-106-00 Sensor (fuser exit): Paper Failed to Arrive from MPF Jam Service Check RAP

377-106-00 Fuser Exit Sensor Early (MPF)



WARNING: Switch off the electricity to the machine, [GP 10](#). Disconnect the power lead from the customer supply while performing tasks that do not need electricity. Electricity can cause death or injury. Moving components can cause injury.

1. Make sure that paper is supported and loaded properly.
2. Make sure that the paper is free of debris and obstructions.
3. Switch OFF, then switch ON the machine, [GP 10](#).
4. Check if the paper jam error occurs when using other trays.
5. If the paper jam error occurs only when using the MPF, then do the following:
 - a. Check the MPF pick roller and separator roller for wear, damage, and contamination.
 - b. Make sure that the MPF solenoid is functional. Do the following:
 1. Enter the Diagnostics, [GP 1](#)
 2. Touch Diagnostics > dC330 Component Control > Print Engine > Motor Tests.
 3. Touch the appropriate test for the Motor in question.
 - c. Check the MPF gearbox for wear, damage, and improper mesh.
6. If the paper jam error occurs regardless of the source tray, then do the following:
 - a. Identify the location of the leading edge of the paper.
 - b. If the leading edge of the paper did not reach the fuser, then check the imaging unit and transfer roller for damage and improper installation.
 - c. If the leading edge of the paper reached the fuser, then check the fuser for wear, damage, and improper installation. For more information, see [REP 10.1](#)

377-108-00, 377-111-00, 377-205-00 Sensor (fuser exit): Paper Failed to Clear from Optional Tray Jam Service Check RAPs

377-108-00 Fuser exit sensor never cleared by trailing edge of page. Source is tray 2

377-111-00 Fuser exit sensor never cleared by trailing edge of page. Source is tray 3

377-205-00 Fuser exit sensor never cleared by trailing edge of page. Source is tray 4



WARNING: Switch off the electricity to the machine, [GP 10](#). Disconnect the power lead from the customer supply while performing tasks that do not need electricity. Electricity can cause death or injury. Moving components can cause injury.

1. Make sure that paper is supported and loaded properly.
2. Make sure that the paper is free of debris and obstructions.
3. Switch OFF, then switch ON the machine, [GP 10](#).
4. Check if the paper jam error occurs when using other trays.
5. If the paper jam error occurs when using optional trays (tray 2 to tray 4), then do the following:
 - a. Check the pick roller for wear, damage, contamination, and improper installation.
 - b. Check the separator pad or separator roller for wear, damage, contamination, and improper installation.
 - c. Check the paper path above the tray for debris and foreign object.
6. If the paper jam error occurs regardless of the source tray, then do the following:
 - a. Check the input sensor actuator for damage, and improper installation.
 - b. Make sure that the sensor (duplex and input) is functional. Do the following:
 1. Enter the Diagnostics, [GP 1](#)
 2. Touch Diagnostics > dC330 Component Control > Print Engine > Sensor Tests.
 3. Touch the appropriate test for the Sensor in question.
 - c. Make sure that the connections between the sensor (duplex and input) and the controller board are properly connected.
 - d. Check the sensor (duplex and input) for damage and improper installation. For more information, see [REP 80.2](#)
7. If the paper jam error occurs regardless of the source tray, then do the following:
 - a. Identify the location of the leading edge of the paper.
 - b. If the leading edge of the paper did not reach the fuser, then check the imaging unit and transfer roller for damage and improper installation.
 - c. If the leading edge of the paper reached the fuser, then check the fuser for wear, damage, and improper installation. For more information, see [REP 10.1](#)

377-112-00 Sensor (fuser exit): Static Jam Service Check RAP

377-112-00 Fuser exit sensor covered at warmup



WARNING: Switch off the electricity to the machine, GP 10. Disconnect the power lead from the customer supply while performing tasks that do not need electricity. Electricity can cause death or injury. Moving components can cause injury.

1. Turn off the printer.
2. Check the optional tray for improper installation.
3. Remove the optional tray, and then check the connectors on the printer and optional tray for damage and improper connection.
4. Reinstall the optional tray, and then turn on the printer.
5. Remove the tray insert.
6. Check the tray insert and its lift plate gears for damage and improper operation.
7. Make sure that the following motors are functional:
 - Motor (pick (tray (x)))
 - Motor (pass-through (tray(x)))Do the following:
 - a. Enter the Diagnostics, GP 1
 - b. Touch Diagnostics > dC330 Component Control > Print Engine > Motor Tests.
 - c. Touch the appropriate test for the Motor in question.
8. Make sure that the connections between the motors and the controller board are properly connected.
9. Check the motors for damage, and improper installation.

377-202-00 Paper Size Mismatch (Duplex Print) Service Check RAP

377-202-00 Paper size mismatch (duplex print) service check RAP



WARNING: Switch off the electricity to the machine, GP 10. Disconnect the power lead from the customer supply while performing tasks that do not need electricity. Electricity can cause death or injury. Moving components can cause injury.

1. Make sure that the paper size is supported for duplex printing.

Note:

- Narrow or short paper may not be supported for duplex printing.
 - Heavy paper may not be supported for duplex printing.
- For more information, see GP 30

391-126-00 to 391-129-00, 391-402-00, 391-403-00 Replace the black or color imaging kit RAPs

391-126-00 Replace Black imaging unit / Photoconductor , 0 estimated pgs remain AEOL due to PC Rev counter

391-127-00 Replace Black imaging unit / Photoconductor , 0 estimated pgs remain AEOL due to Quanta exhausted

391-128-00 Replace Color Imaging unit / Photoconductor , 0 estimated pgs remain AEOL due to PC Rev counter

391-129-00 Replace Color imaging unit / Photoconductor , 0 estimated pgs remain AEOL due to Quanta exhausted

391-402-00 Black Imaging Unit End of Life

391-403-00 Color Imaging Unit End of Life



WARNING: Switch off the electricity to the machine, **GP 10**. Disconnect the power lead from the customer supply while performing tasks that do not need electricity. Electricity can cause death or injury. Moving components can cause injury.

Replace the black or color imaging kit.

391-314-00, 391-328-00, 391-921-00 to 391-921-08 Imaging Unit (K) Error Service Check RAPs

391-314-00 Black IU or Photoconductor smartchip or sensor common problem - Write Failure

391-328-00 Image Unit CRUM K Auth IC Error

391-921-00 Black IU or Photoconductor smartchip or sensor common problem

391-921-01 Black IU or Photoconductor smartchip or sensor common problem - Missing

391-921-02 Black IU or Photoconductor smartchip or sensor common problem - Missing Mux

391-921-03 Black IU or Photoconductor smartchip or sensor common problem - Read Failure

391-921-04 Black IU or Photoconductor smartchip or sensor common problem - Write Failure

391-921-05 Black IU or Photoconductor smartchip or sensor common problem - Device Info Read Fail

391-921-07 Black IU or Photoconductor smartchip or sensor common problem - Read Failure

391-921-08 Black IU or Photoconductor smartchip or sensor common problem - Data Integrity error



WARNING: Switch off the electricity to the machine, GP 10. Disconnect the power lead from the customer supply while performing tasks that do not need electricity. Electricity can cause death or injury. Moving components can cause injury.

1. Check if the printer is using a genuine and supported Xerox imaging unit or imaging kit.

Note: If the printer is using a third-party imaging unit or imaging kit, then refer the users to the supplier.

2. Check the imaging unit or imaging kit for damage.
3. Make sure that the imaging unit or imaging kit is free of toner buildup. Using an approved toner vacuum cleaner, completely clean the supplies.
4. When installing a genuine after market supply for the first time and a supplies message error occurs, install the latest firmware version available for your printer.
5. Clean the toner cartridge contacts for any toner contamination.
6. Check the toner cartridge contacts for damage.
7. Make sure that the connections between the controller board and the toner cartridge are properly connected.

391-318-01 to 391-318-09, 393-969-01 to 393-969-05 Imaging Unit (CMY) Error Service Check RAPs

391-318-01 Black IU or Photoconductor smartchip or sensor common problem - Authentication error

391-318-02 Black & Color Image Unit smartchip or sensor common problem - Missing Mux

391-318-03 Black & Color Image Unit smartchip or sensor common problem - Read Failure

391-318-04 Black & Color Image Unit smartchip or sensor common problem - Write Failure

391-318-05 Black & Color Image Unit smartchip or sensor common problem - Device Info Read Fail

391-318-06 Black & Color Image Unit smartchip or sensor common problem - Authentication Error

391-318-07 Black & Color Image Unit smartchip or sensor common problem - Read Failure

391-318-08 Black & Color Image Unit smartchip or sensor common problem - Data Integrity error

391-318-09 Black & Color Image Unit: Fail to replenish

393-969-01 Black & Color IU or Photoconductor Unsupported Error: - Unsupported memory map version in smartchip

393-969-02 Black & Color IU or Photoconductor Unsupported Error: - Fail capacity class/model compatibility check

393-969-03 Black & Color IU or Photoconductor Unsupported Error: - Fail OEM check.

393-969-04 Black & Color IU or Photoconductor Unsupported Error: - Supply is on the revoked list.

393-969-05 Black & Color IU or Photoconductor Unsupported Error: - IU is MICR, and this FW release doesn't support MICR



WARNING: Switch off the electricity to the machine, GP 10. Disconnect the power lead from the customer supply while performing tasks that do not need electricity. Electricity can cause death or injury. Moving components can cause injury.

1. Check if the printer is using a genuine and supported Xerox imaging unit or imaging kit.

Note: If the printer is using a third-party imaging unit or imaging kit, then refer the users to the supplier.

2. Check the imaging unit or imaging kit for damage.
3. Make sure that the imaging unit or imaging kit is free of toner buildup. Using an approved toner vacuum cleaner, completely clean the supplies.
4. When installing a genuine after market supply for the first time and a supplies message error occurs, install the latest firmware version available for your printer.
5. Clean the waste toner bottle contacts for any toner contamination.
6. Check the waste toner bottle contacts for damage.
7. Make sure that the connections between the controller board and the waste toner bottle are properly connected.

391-400-00, 391-911-00, 391-912-00, 391-954-00, 391-955-00 Waste Toner Bottle Full- Waste Toner Counter Triggered RAPs

391-400-00 Waste Toner Bottle Full- Waste Toner counter triggered

391-911-00 Waste Toner Bottle Full - Absolute EOL State User set point via EWS triggered

391-912-00 Waste Toner Bottle Full - Claimed EOL state

391-954-00 Waste Toner Bottle Absolute EOL State

391-955-00 Waste Toner Bottle Absolute EOL StateWaste Toner counter triggered



WARNING: Switch off the electricity to the machine, GP 10. Disconnect the power lead from the customer supply while performing tasks that do not need electricity. Electricity can cause death or injury. Moving components can cause injury.

Replace the waste toner bottle.

391-913-00, 393-425-00, 393-428-00, 393-442-00 to 393-464-00, 393-912-00 Drum Cartridge K Life End RAPs

391-913-00 Drum Cartridge K Life End

393-425-00 Black toner cartridge isNear Empty state ("replace soon.." message)

393-428-00 Replace cartridge – quanta – hard stop

393-442-00 Replace Cyan cartridge – fresh toner

393-443-00 Replace Black cartridge – fresh toner

393-444-00 Replace Magenta cartridge – fresh toner

393-445-00 Replace Yellow cartridge – fresh toner

393-446-00 Cyan Cartridge at End of Life via Failure to Replenish Image Unit

393-447-00 Black Cartridge at End of Life via Failure to Replenish Image Unit

393-448-00 Magenta Cartridge at End of Life via Failure to Replenish Image Unit

393-449-00 (88.37Y) Yellow Cartridge at End of Life via Failure to Replenish Image Unit

393-450-00 Cyan Cartridge out of Quanta (end of life)

393-451-00 Black Cartridge out of Quanta (end of life)

393-452-00 Magenta Cartridge out of Quanta (end of life)

393-453-00 Yellow Cartridge out of Quanta (end of life)

393-454-00 Replace Cyan cartridge – fresh toner – hard stop

393-455-00 Replace Black cartridge – fresh toner – hard stop

393-456-00 Replace Magenta cartridge – fresh toner – hard stop

393-457-00 ReplaceYellow cartridge – fresh toner – hard stop

393-458-00 Cyan Cartridge at Absolute End of Life via Failure to Replenish Image Unit

393-459-00 Black Cartridge at Absolute End of Life via Failure to Replenish Image Unit

393-460-00 Magenta Cartridge at Absolute End of Life via Failure to Replenish Image Unit

393-461-00 Yellow Cartridge at Absolute End of Life via Failure to Replenish Image Unit

393-462-00 Replace Cyan cartridge – quanta – hard stop (absolute end of life)

393-463-00 Replace Magenta cartridge – quanta – hard stop (absolute end of life)

393-464-00 Replace Yellow cartridge – quanta – hard stop (absolute end of life)

393-912-00 Black toner cartridge is empty



WARNING: Switch off the electricity to the machine, GP 10. Disconnect the power lead from the customer supply while performing tasks that do not need electricity. Electricity can cause death or injury. Moving components can cause injury.

Replace the cartridge.

391-952-00 WTB Smartchip or Sensor Common Problem RAP

391-952-00 WTB smartchip or sensor common problem



WARNING: Switch off the electricity to the machine, GP 10. Disconnect the power lead from the customer supply while performing tasks that do not need electricity. Electricity can cause death or injury. Moving components can cause injury.

1. Open door A.



CAUTION: The inside of the printer might be hot. To reduce the risk of injury from a hot component, allow the surface to cool before touching it.

2. Open door B.
3. Remove the right cover.
4. Remove the waste toner bottle.
5. Align, and then insert the waste toner bottle.
6. Align, and then attach the right cover.
7. Close door B, and then close door A.

391-125-00, 393-100-00 to 393-124-00, 393-335-01, 393-923-01 to 393-923-10, 393-983-00 Toner Cartridge (K) Error Service Check RAPs

391-125-00 Non-genuine supply - Black cartridge

393-100-00 Black Toner Bottle Unsupported Error: Unsupported memory map version in smartchip

393-102-00 Black Toner Bottle Unsupported Error: Fail OEM check.

393-103-00 Black Toner Bottle Unsupported Error: Fail SWE marriage check

393-104-00 Black Toner Bottle Unsupported Error: Supply is on the revoked list.

393-105-00 Black Toner Bottle Unsupported Error: Bottle is MICR, and this FW release does not support MICR

393-112-00 Black Toner Bottle Unsupported Error: Used, Metered, Aftermarket cartridge was installed into a printer with Service Plan : Learning and Region Learning

393-116-00 Black Toner Bottle Unsupported Error: A Metered, Aftermarket cartridge was installed into a printer with Service Plan Sold and Region Learning or Worldwide

393-120-00 Black Toner Bottle Unsupported Error: A Metered, Aftermarket cartridge was installed into a printer with Service Plan Sold and Region X (not Learning and not Worldwide)

393-124-00 Black Toner Bottle Unsupported Error: A Used, Metered, Aftermarket cartridge was installed into a printer with Service Plan Learning and Region X (not Learning and not Worldwide)

393-335-01 Toner CRUM K Auth IC Error

393-923-00 Toner CRUM Comm Fail K1

393-923-01 Black Toner Bottle smartchip or sensor common problem - Missing

393-923-02 Black Toner Bottle smartchip or sensor common problem - Missing Mux

393-923-03 Black Toner Bottle smartchip or sensor common problem - Read Failure

393-923-04 Black Toner Bottle smartchip or sensor common problem - Write Failure

393-923-05 Black Toner Bottle smartchip or sensor common problem - Device Info Read Fail

393-923-06 Black Toner Bottle smartchip or sensor common problem - Authentication Error

393-923-07 Black Toner Bottle smartchip or sensor common problem - Read Failure

393-923-08 Black Toner Bottle smartchip or sensor common problem - Data Integrity error

393-923-09 Fail to replenish due to bad auger gear and bottle gear mesh

393-923-10 Black Cartridge Invalid Reman detected

393-983-00 Fail to replenish due to bad auger gear and bottle gear mesh



WARNING: Switch off the electricity to the machine, GP 10. Disconnect the power lead from the customer supply while performing tasks that do not need electricity. Electricity can cause death or injury. Moving components can cause injury.

1. Check if the printer is using a genuine and supported Xerox toner cartridge.

Note: If the printer is using a third-party toner cartridge, then refer the users to the supplier.

2. Make sure that the cartridge region matches the printer region.
3. Make sure that the toner cartridge is not damage and not leaking.
4. Make sure that the toner cartridge is free of toner buildup. Using an approved toner vacuum cleaner, completely clean the supplies.
5. When installing a genuine after market supply for the first time and a supplies message error occurs, install the latest firmware version available for your printer.
6. Clean the toner cartridge contacts for any toner contamination.
7. Check the toner cartridge contacts for damage.
8. Make sure that the connections between the controller board and the toner cartridge are properly connected.

391-942-00, 393-100-00 to 393-126-00, 393-113-00, 393-117-00, 393-121-00, 393-125-00, 393-947-00 to 393-954-00, 393-336-01, 393-337-01, 393-944-01 to 393-944-09, 393-946-00 to 393-946-09, 393-988-00 to 393-988-09 Toner Cartridge (CMY) Error Service Check RAPs

391-942-00 Non-genuine supply - Black and color (CMY) imaging unit or kit, or photoconductor

393-113-00 Cyan Toner Bottle Unsupported Error: A Used, Metered, Aftermarket cartridge was installed into a printer with Service Plan Learning and Region Learning

393-114-00 Magenta Toner Bottle Unsupported Error: A Used, Metered, Aftermarket cartridge was installed into a printer with Service Plan Learning and Region Learning

393-115-00 Yellow Toner Bottle Unsupported Error: A Used, Metered, Aftermarket cartridge was installed into a printer with Service Plan Learning and Region Learning

393-117-00 Cyan Toner Bottle Unsupported Error: A Metered, Aftermarket cartridge was installed into a printer with Service Plan Sold and Region Learning or Worldwide

393-118-00 Magenta Toner Bottle Unsupported Error: A Metered, Aftermarket cartridge was installed into a printer with Service Plan Sold and Region Learning or Worldwide

393-119-00 Yellow Toner Bottle Unsupported Error: A Metered, Aftermarket cartridge was installed into a printer with Service Plan Sold and Region Learning or Worldwide

393-121-00 Cyan Toner Bottle Unsupported Error: A Metered, Aftermarket cartridge was installed into a printer with Service Plan Sold and Region X (not Learning and not Worldwide)

393-122-00 Magenta Toner Bottle Unsupported Error: A Metered, Aftermarket cartridge was installed into a printer with Service Plan Sold and Region X (not Learning and not Worldwide)

393-123-00 Yellow Toner Bottle Unsupported Error: A Metered, Aftermarket cartridge was installed into a printer with Service Plan Sold and Region X (not Learning and not Worldwide)

393-125-00 Cyan Toner Bottle Unsupported Error: A Used, Metered, Aftermarket cartridge was installed into a printer with Service Plan Learning and Region X (not Learning and not Worldwide)

393-126-00 Magenta Toner Bottle Unsupported Error: A Used, Metered, Aftermarket cartridge was installed into a printer with Service Plan Learning and Region X (not Learning and not Worldwide)

393-127-00 Yellow Toner Bottle Unsupported Error: A Used, Metered, Aftermarket cartridge was installed into a printer with Service Plan Learning and Region X (not Learning and not Worldwide)

393-336-01 Toner CRUM Y Auth IC Error

393-337-01 Toner CRUM M Auth IC Error

393-944-01 Cyan Toner Bottle smartchip or sensor common problem - Missing

393-944-02 Cyan Toner Bottle smartchip or sensor common problem - Missing Mux

393-944-03 Cyan Toner Bottle smartchip or sensor common problem - Read Failure

393-944-04 Cyan Toner Bottle smartchip or sensor common problem - Write Failure

393-944-05 Cyan Toner Bottle smartchip or sensor common problem - Device Info Read Fail

393-944-06 Cyan Toner Bottle smartchip or sensor common problem - Authentication Error

393-944-07 Cyan Toner Bottle smartchip or sensor common problem - Read Failure

393-944-08 Cyan Toner Bottle smartchip or sensor common problem - Data Integrity error

393-944-09 Cyan Cartridge Invalid Reman detected

393-946-00 Yellow Toner Bottle smartchip or sensor common problem - Missing

393-946-01 Yellow Toner Bottle smartchip or sensor common problem - Missing

393-946-02 Yellow Toner Bottle smartchip or sensor common problem z = B: Missing Mux

393-946-03 Yellow Toner Bottle smartchip or sensor common problem - Read Failure

393-946-04 Yellow Toner Bottle smartchip or sensor common problem - Write Failure

393-946-05 Yellow Toner Bottle smartchip or sensor common problem - Device Info Read Fail

393-946-06 Yellow Toner Bottle smartchip or sensor common problem - Authentication Error

393-946-07 Yellow Toner Bottle smartchip or sensor common problem - Read Failure

393-946-08 Yellow Toner Bottle smartchip or sensor common problem - Data Integrity error

393-946-09 Yellow Cartridge Invalid Reman detected

393-947-00 Cyan Toner Bottle Unsupported Error: - Unsupported memory map version in smartchip

393-948-00 Cyan Toner Bottle Unsupported Error: - Fail OEM check.

393-949-00 Cyan Toner Bottle Unsupported Error: - Supply is on the revoked list.

393-950-00 Cyan Toner Bottle Unsupported Error: - IU is MICR, and this FW release does not support MICR

393-951-00 Magenta Toner Bottle Unsupported Error: - Unsupported memory map version in smartchip

393-952-00 Magenta Toner Bottle Unsupported Error: - Fail OEM check.

393-953-00 Magenta Toner Bottle Unsupported Error: - Supply is on the revoked list.

393-954-00 Magenta Toner Bottle Unsupported Error: - IU is MICR, and this FW release does not support MICR

393-955-00 Yellow Toner Bottle Unsupported Error: - Unsupported memory map version in smartchip

393-957-00 Yellow Toner Bottle Unsupported Error: - Supply is on the revoked list.

393-958-00 Yellow Toner Bottle Unsupported Error: - IU is MICR, and this FW release does not support MICR

393-968-00 Yellow Toner Bottle Unsupported Error: - Fail OEM check.

393-988-00 Magenta Toner Bottle smartchip or sensor common problem

393-988-01 Magenta Toner Bottle smartchip or sensor common problem - Missing

393-988-02 Magenta Toner Bottle smartchip or sensor common problem - Missing Mux

393-988-03 Magenta Toner Bottle smartchip or sensor common problem - Read Failure

393-988-04 Magenta Toner Bottle smartchip or sensor common problem - Write Failure

393-988-05 Magenta Toner Bottle smartchip or sensor common problem - Device info read failure

393-988-06 Magenta Toner Bottle smartchip or sensor common problem - Read Failure

393-988-07 Magenta Toner Bottle smartchip or sensor common problem - Read Failure

393-988-08 Magenta Toner Bottle smartchip or sensor common problem - Data Integrity error

393-988-09 Magenta Cartridge Invalid Reman detected



WARNING: Switch off the electricity to the machine, GP 10. Disconnect the power lead from the customer supply while performing tasks that do not need electricity. Electricity can cause death or injury. Moving components can cause injury.

1. Check if the printer is using a genuine and supported Xerox toner cartridge.

Note: If the printer is using a third-party toner cartridge, then refer the users to the supplier.

2. Make sure that the cartridge region matches the printer region.
3. Make sure that the toner cartridge is not damaged and not leaking.
4. Make sure that the toner cartridge is free of toner buildup. Using an approved toner vacuum cleaner, completely clean the supplies.
5. When installing a genuine after market supply for the first time and a supplies message error occurs, install the latest firmware version available for your printer.
6. Clean the waste toner bottle contacts for any toner contamination.
7. Check the waste toner bottle contacts for damage.
8. Make sure that the connections between the controller board and the waste toner bottle are properly connected.

393-426-00, 393-427-00, 393-432-00 to 393-434-00, 393-438-00 to 393-441-00 Cartridge Out of Quanta - Toner Very Low RAPs

393-426-00 Cartridge out of Quanta - Toner very Low

393-427-00 Cartridge out of Quanta - Toner Life Ended

393-432-00 C Toner Cartridge out of Quanta (low)

393-433-00 M Toner Cartridge out of Quanta (low)

393-434-00 Y Toner Cartridge out of Quanta (low)

393-438-00 Cyan Cartridge out of Quanta (very low)

393-439-00 Black Cartridge out of Quanta (very low)

393-440-00 Magenta Cartridge out of Quanta (very low)

393-441-00 Yellow Cartridge out of Quanta (very low)



WARNING: Switch off the electricity to the machine, GP 10. Disconnect the power lead from the customer supply while performing tasks that do not need electricity. Electricity can cause death or injury. Moving components can cause injury.

Touch **Continue** to clear the message.

393-901-00 Waste Toner Bottle Error Service Check RAP

393-901-00 Waste toner bottle error service check



WARNING: Switch off the electricity to the machine, GP 10. Disconnect the power lead from the customer supply while performing tasks that do not need electricity. Electricity can cause death or injury. Moving components can cause injury.

1. Make sure that the waste toner bottle is properly installed and not full.
2. Clean the sensor (waste toner bottle) with a cloth, and then print a test page.

Note: Sensor contamination can cause communication errors.

3. Clean the waste toner bottle contacts for any toner contamination.
4. Check the waste toner bottle contacts for damage.
5. Make sure that the connections between the controller board and the waste toner bottle are properly connected.

393-964-00 to 393-967-00, 393-964-01 to 393-967-01 Toner Meter Card Error Service Check RAPs

393-964-00 Black Bottle Toner Meter Cycle Error:z = Y: 1st error, Recoverable

393-964-01 Black Bottle Toner Meter Cycle Error:z = Z: 2nd error, Non-Recoverable

393-965-00 Cyan Bottle Toner Meter Cycle Error:z = Y: 1st error, Recoverable

393-965-01 Cyan Bottle Toner Meter Cycle Error:z = Z: 2nd error, Non-Recoverable

393-966-00 Magenta Bottle Toner Meter Cycle Error:z = Y: 1st error, Recoverable

393-966-01 Magenta Bottle Toner Meter Cycle Error:z = Z: 2nd error, Non-Recoverable

393-967-00 Yellow Bottle Toner Meter Cycle Error:z = Y: 1st error, Recoverable

393-967-01 Yellow Bottle Toner Meter Cycle Error:z = Z: 2nd error, Non-Recoverable



WARNING: Switch off the electricity to the machine, GP 10. Disconnect the power lead from the customer supply while performing tasks that do not need electricity. Electricity can cause death or injury. Moving components can cause injury.

1. Make sure that the toner meter card is properly installed.
2. Check the sensor (toner meter) for contamination.
3. Make sure that the printer is free of toner buildup. Using an approved toner vacuum cleaner, completely clean the supplies.
4. Make sure that the sensor (toner meter) is functional. Do the following:
 - a. Enter the Diagnostics, GP 1
 - b. Touch Diagnostics > dC330 Component Control > Print Engine > Sensor Tests.
 - c. Touch the appropriate test for the Sensor in question.

395–001–00 to 395–009–00 DC Software Upgrade Fail RAP

395–001–00 Software Upgrade Failure : DC software failed to upgrade.

395-002-00 Software Upgrade Failure : DC Application RAP.

395-008-00 Software Upgrade Failure : DC OS RAP

395-009-00 Software Upgrade Failure : DC CIPS RAP



WARNING: Switch off the electricity to the machine, [GP 10](#). Disconnect the power lead from the customer supply while performing tasks that do not need electricity. Electricity can cause death or injury. Moving components can cause injury.



CAUTION:

1. Verify the correct DLM for the device is being used.
 2. Obtain the correct Launch DLM Recovery Patch (LDRP) for the device being upgraded from GSN Library 16910 or Library 500 for Approved Service Providers
1. Verify all connections on the controller PWB and to the UI, drive PWB, and 500 GB Hard Drive if installed, are all seated properly and no damage to harnesses or connectors exists. Repair or replace as required.
 2. Perform a Software Upgrade, [GP 4](#), using the FORCED_ALTBOOT method.
 3. If the fault persists install a new controller PWB, [PL 3.05 item 1](#).

395-300-00 to 395-304-00, 395-318-00, 395-319-00, 395-321-00 to 395-324-00 Software Upgrade Failure (Hardware) RAP

395-300-00 Software Upgrade Failure : Incompatible Product.

395-301-00 Software Upgrade Failure : Incompatible Hardware.

395-302-00 Software Upgrade Failure : Incompatible Firmware.

395-303-00 Software Upgrade Failure : DLM Downgrade.

395-304-00 Software Upgrade Failure : DLM Sidegrade.

395-318-00 Software Upgrade Failure : USB pendrive not detected.

395-319-00 Software Upgrade Failure : USB pendrive not detected 2nd time.

395-321-00 Software Upgrade Failure : Failure to revert flash contents.

395-322-00 USB drive filesystem unsupported.

395-323-00 Multiple USB drives detected.

395-324-00 Disk is blank or cannot be mounted.



WARNING: Switch off the electricity to the machine, [GP 10](#). Disconnect the power lead from the customer supply while performing tasks that do not need electricity. Electricity can cause death or injury. Moving components can cause injury.



CAUTION:

1. Verify the correct DLM for the device is being used.
 2. Obtain the correct Launch DLM Recovery Patch (LDRP) for the device being upgraded from GSN Library 16910 or Library 500 for Approved Service Providers
1. Verify all connections on the controller PWB and to the UI, drive PWB, and 500 GB Hard Drive if installed, are all seated properly and no damage to harnesses or connectors exists. Repair or replace as required.
 2. If the 500+GB Hard Disk, [PL 25.05 item 2](#) is installed, check the connections at the controller PWB are firmly seated and no damage to the harness exists. Repair or install a new 500+GB Hard Disk as required.
 3. If a USB drive is used, verify the drive:
 - a. Is formatted in FAT32 only.
 - b. The USB drive mounts and is readable in another machine or PC.
 - c. Only one USB device is attached to the machine during the software upgrade.
 4. Perform a Software Upgrade, [GP 4](#), using the FORCED_ALTBOOT method.
 5. If the fault is 395–324–00, perform software upgrade [GP 4](#), using the Special Alboot method.
 6. If the fault persists install a new controller PWB, [PL 3.05 item 1](#).

395–171–00 to 395–174–00 Software Upgrade Failure (Memory) RAP

395–171–00 Software Upgrade Failure : Insufficient RAM.

395–172–00 Software Upgrade Failure : Insufficient memory.

395–173–00 Software Upgrade Failure : Failed to decrypt DLM.

395–174–00 Software Upgrade Failure : Failed to run Recovery software.



WARNING: Switch off the electricity to the machine, [GP 10](#). Disconnect the power lead from the customer supply while performing tasks that do not need electricity. Electricity can cause death or injury. Moving components can cause injury.

1. Switch off, then switch on the machine, [GP 10](#).
2. Perform Software Upgrade, [GP 4](#) using the FORCED_ALTBOOT method.
3. If the fault persists, perform Software Upgrade, [GP 4](#) using the FORCED_ALTBOOT method with DISABLE_DATA_BACKUP flag.

395–313–00 to 395–313–03 DLM Installation Fail RAP

395-313-00 Differential DLM Installation Failure: Launch DLM Missing.

395-313-01 Differential DLM Installation Failure: Launch DLM Corrupt.

395-313-02 Differential DLM Installation Failure: Launch DLM Mismatch.

395-313-03 Launch DLM Installation Failure.



CAUTION: Obtain the correct Launch DLM Recovery Patch (LDRP) for the device being upgraded from GSN Library 16910 or Library 500 for Approved Service Providers

1. Verify the correct Recovery Patch file is being used for the machine.
2. Reinstall the Recovery Patch file.

399-350-00, 399-355-00, 399-364-00, 399-373-00, 399-375-00, 399-377-00, 399-395-00, 399-350-10, 399-355-10, 399-364-10, 399-373-10, 399-375-10, 399-377-10, 399-395-10
Motor (fuser) Error Service Check RAPs

399-350-00 Fuser Motor does not turn on

399-355-00 Fuser Motor does not turn off

399-364-00 Fuser Motor Stall

399-373-00 Fuser Motor underspeed

399-375-00 Fuser Motor overspeed

399-377-00 Fuser Motor moved too long

399-395-00 Fusing Mot Current Fail

399-350-10 Fuser Motor does not turn on

399-355-10 Fuser Motor does not turn off

399-364-10 Fuser Motor loss of encoders (motor stall)

399-373-10 Fuser Motor underspeed

399-375-10 Fuser Motor overspeed

399-377-10 Fuser Motor moved too long

399-395-10 Fuser Motor failed to achieve expected speed



WARNING: Switch off the electricity to the machine, [GP 10](#). Disconnect the power lead from the customer supply while performing tasks that do not need electricity. Electricity can cause death or injury. Moving components can cause injury.

1. Switch OFF, then switch ON the machine, [GP 10](#).
2. Make sure that the motor (fuser) is functional. Do the following:
 - a. Enter the Diagnostics, [GP 1](#).
 - b. Touch Diagnostics > dC330 Component Control > Print Engine > Motor Tests.
 - c. Touch the appropriate test for the Motor in question.
3. Make sure that the connections between the motor (main) and the controller board are properly connected.
4. Check the motor (fuser) for wear, damage, and improper mesh connection. For more information, see [REP 10.2](#)
5. Make sure that the correct voltage is supplied to the fuser from the power supply.
6. Make sure that the connections between the controller board and the fuser are properly connected.
7. Check the fuser for damage, contamination, and improper installation. For more information, see [REP 10.1](#)

OF1 Machine Not Ready RAP

C415 Wiring Diagrams

Machine Not Ready, is defined as any condition where the machine is not capable of performing its basic tasks (Copy or Print). **Not Ready**, ranges from a machine that is totally inert, without any indication of power, to a machine that appears ready but does not respond to either Control Panel commands or network input.

Initial Actions

- Switch off the machine, [GP 10](#).
- Check all connections on the LVPS, [PL 1.05 item 3](#), Drive PWB, and Controller PWB, [PL 3.05 item 1](#).

Procedure

The first step is to categorize the problem. Decide which of the following condition best describes the problem:

- [Dead Machine](#)
- [Boots up; does not respond to Control Panel](#)
- [Boots up; does not print \(or other Network problem\)](#)

Dead Machine

1. If the machine shows no sign of power (fans or motors running, backlight on UI display, LEDs on Control Panel), check for AC line voltage at the customer supply outlet. Refer to, [OF 3](#).
2. If AC voltage is measured within specifications, [GP 17](#), measure the voltage at the connector on the LVPS.
3. If the voltage is within specification, measure the voltage at the connector on the drive PWB, [PL 1.05 item 4](#).
4. If the voltage at each connector is within specification, measure the voltage at [JPWR2](#), and [JPWR1](#) on the Controller PWB.

Install new components as required:

1. LVPS, [PL 1.05 item 3](#).
2. Drive PWB, [PL 1.05 item 4](#).
3. Controller PWB, [PL 3.05 item 1](#).

Boots up; does not respond to Control Panel

Perform the following:

1. Switch off, then switch on the machine, [GP 10](#)
2. Perform RAP, [OF 2](#).
3. Install new components as required:
 - Control panel display, [PL 2.05](#).
 - Controller PWB, [PL 3.05 item 1](#).

Boots up; does not print (or other Network problem)

Perform RAP, [OF 11](#), Job Prints Incorrectly RAP.

OF2 UI Touch Screen Failure RAP

C415 Wiring Diagrams

Use this RAP to solve user interface touch screen problems when the machine has power but either the display is Black, blank, too dark, responds incorrectly or does not refresh.

Procedure

1. Switch OFF, then switch ON the machine, [GP 10](#).
2. Check the, control panel FCC, [PL 2.05 item 3](#), is fully seated at the control panel and the controller PWB. Verify no damage or severe creasing to the FFC exists and the connector-ends are not frayed. Install a new components as required:
 - a. Control panel FFC, [PL 2.05 item 3](#).
 - a.
 - If no problems are found, install new components as required:
 - Control panel FFC, [PL 2.05 item 3](#).
 - Controller PWB, [PL 3.05 item 1](#).
 - Control panel, [PL 2.05](#).

OF3 AC Power RAP

C415 Wiring Diagrams

Use this procedure to identify AC power input and output failures.

Procedure



WARNING: Switch off the electricity to the machine, [GP 10](#). Disconnect the power lead from the customer supply while performing tasks that do not need electricity. Electricity can cause the death or injury. Moving components can cause the injury.



WARNING: Take care when measuring AC mains (line) voltage. Electricity can cause death or injury.

1. Switch off the machine, [GP 10](#).
2. Measure the voltage connecting the LVPS, [PL 1.05 item 3](#) to the drive PWB, [PL 1.05 item 4](#).

The voltage measured is within electrical power requirements, [GP 11](#).

Y N

Disconnect the power cord from the outlet. Check the AC mains (line) voltage at the customer's power outlet.

The voltage measured is within electrical power requirements, [GP 17](#).

Y N

The voltage is incorrect, or the wiring of the main supply is found to be defective, inform your technical manager and the customer. Do not attempt to repair or adjust the customer supply.

Verify the power cord is not frayed or damaged and is fully seated into the machine socket.

The main power cord is good.

Y N

Install a new power cord.

Install a new LVPS, [PL 1.05 item 3](#).

1. Switch ON the machine, [GP 10](#).
2. Measure the voltage connecting the LVPS, [PL 1.05 item 3](#) to the drive PWB, [PL 1.05 item 4](#).

The AC power supply is within specification, [GP 17](#).

Y N

Install a new LVPS, [PL 1.05 item 3](#).

- Install a new drive PWB, [PL 1.05 item 4](#).
- Install a new controller PWB, [PL 3.05 item 1](#).

OF4 +5VDC Power Fault RAP

C415 Wiring Diagrams

Procedure



WARNING: Switch off the electricity to the machine, [GP 10](#). Disconnect the power lead from the customer supply while performing tasks that do not need electricity. Electricity can cause death or injury. Moving components can cause injury.



WARNING: Take care when measuring AC mains (line) voltage. Electricity can cause death or injury.

Check the voltage between the LVPS pin 1 and ground.

+5VDC is measured.

Y N

Check the voltage between pin 1 and pin 4 on the LVPS, [PL 1.05 item 3](#).

The AC power supply is within specification, [GP 17](#).

Y N

Perform the [OF 3 AC Power RAP](#).

Switch off the machine, [GP 10](#). Disconnect the harness from the LVPS. Wait 15 seconds, then switch on the machine, [GP 10](#). Check the voltage between the LVPS [PL 1.05 item 3](#), pin 1 and ground.

+5VDC is measured.

Y N

Install a new LVPS, [PL 1.05 item 3](#).

Check the +5VDC circuit for a short circuit to frame.

Check the wiring of the suspect component for an open circuit or poor contact.

OF5 +24VDC Power Fault RAP

C415 Wiring Diagrams

Procedure



WARNING: Switch off the electricity to the machine, [GP 10](#). Disconnect the power lead from the customer supply while performing tasks that do not need electricity. Electricity can cause death or injury. Moving components can cause injury.



WARNING: Take care when measuring AC mains (line) voltage. Electricity can cause death or injury.

Check the voltage between the LVPS pin 1 and ground.

+24VDC is measured.

Y	N	
		Check the voltage between pin 1 and pin 4 on the LVPS, PL 1.05 item 3 .
		The AC power supply is within specification, GP 17.
Y	N	
		Perform the OF 3 AC Power RAP .
		Switch off the machine, GP 10 . Disconnect the harness from the LVPS. Wait 15 seconds, then switch on the machine, GP 10 . Check the voltage between the LVPS pin 1 and ground.
		+24VDC is measured.
Y	N	
		Install a new LVPS, PL 1.05 item 3 .
		Check the +24VDC circuit for a short circuit to frame.

Check the wiring of the suspect component for an open circuit or poor contact.

OF6 Power On Self Test RAP

Power on Self Test (POST) runs each time the machine is powered On. POST checks the function of key subsystems on the SBC PWB before starting the operating system. As POST executes, progress codes appear on the SBC PWB 7-segment display.

This procedure uses POST to help diagnose SBC PWB faults preventing the machine from powering up correctly. On power up, the 7-segment displays progress codes for short periods of time dependent on how long each test takes. Following POST testing, normal operation is indicated by a flashing decimal point. If any other code remains after testing, this may point to a problem component. Refer to the [Table 1](#) for POST codes and corresponding service procedure.

Note: When reading the codes shown on the seven segment display, be sure to read them looking straight at them while sitting, kneeling or squatting next to the machine. Do not attempt to read them “upside down” while bending over.

Note: If a fault occurs during POST, it may be helpful to refer to the [OF 1](#) for additional trouble shooting aides. The [OF 1](#) lists possible service actions that can be performed based on the state of various LEDs on the SBC PWB.

The Power On Self Test consists of three segments:



CAUTION: The serial number is stored and synchronized between the Controller PWB, [PL 3.05 item 1](#) and Drive PWB, [PL 1.05 item 4](#). Always install a new Controller PWB and Drive PWB individually. Power on the machine to allow the serial number to synchronize before proceeding to replace a second listed component. Unrecoverable NVM corruption or billing data loss results if listed parts are installed together. Refer to [dC132 Serial Number Synchronize](#) and [GP 27 Billing Impression Mode Verification](#).

1. Hardware POST: The 7-segment display steps through the following sequence: 8->1->2->3->4->0->6->7->9->u (only if HDD not available). A problem is indicated if any additional codes are displayed, or if the cycle stops on one of the codes.
2. OS Loading: u - Displayed while the operating system is initializing.
3. Subsystem Synchronization: The seven segment display cycles through the following letters in sequence: blank->A->b->C->d->e->E->F. Each of these codes represents one of the CCS software “platforms”. The display steps through all CCS software platforms and clears them as they become available. Any code left remaining is a platform that did not complete its initialization and synchronization.



CAUTION: If a new Controller PWB, [PL 3.05 item 1](#), is installed perform an AltBoot, [GP 4](#), at the first power-up.

Procedure

Note: If boot failure occurs after new components are installed, make sure the new components are compatible with the machine and all connectors are secure.

Note: To power down the machine, press the UI Power Button and then respond to the on-screen prompts. Wait until the Power Button LED turns off, then switch off the machine, [GP 10](#).

1. Locate the SBC PWB 7-segment display, [Figure 1](#), then cycle system power.
2. Observe activity on the 7-segment display and compare it with the expected display sequence. A failure is indicated by additional codes being displayed during the test, or by stopping on one or more codes. Pay careful attention to the codes as they display, since failure codes may not persist and may clear if the test is able to proceed. Follow the indicated service action.



Figure 1 7-Segment display location

Refer to [Table 1](#) for an overview of the tests performed and possible resolutions for POST failures.

Table 1 Power On Self-Tests

POST Code Name	Code Description	SBC LED Code	Decimal Point	Service Action if Fault Persists
7-segment display test	BIOS starts. No stop on segment failure.	8	Off	Install a new Controller PWB
System Memory Initialization check	Initialize DDR3 Memory and stop on failure.	1	Off	Install a new Controller PWB
BIOS flash memory Initialization check	Testing BIOS private NVM area in BIOS flash chip	3	Off	Install a new Controller PWB
Initialize Real-time Clock	Initialize RTC and stop on failure	4	Off	Install a new Controller PWB
Initialize the Video	Initialize Video (IGD processor h/w) and stop on failure	0	Off	Install a new Controller PWB

POST Code Name	Code Description	SBC LED Code	Decimal Point	Service Action if Fault Persists
NVRAM corruption in EFI DXE drivers area	NVRAM corruption detected: reload BIOS	7	Off	Perform Special Altboot or PWS Altboot, GP 4 If the fault persists, Install a new Controller PWB.
Boot to OS	Boot to OS	9	Off	Perform Special Altboot or PWS Altboot, GP 4 If the fault persists, Install a new Controller PWB.
Trusted Boot Failed	Secure Boot or the OS Boot Manager failed verification for Chain of Trust.	U	Off	Perform Special Altboot or PWS Altboot, GP 4 If the fault persists, Install a new Controller PWB.
Kernel starting user space	Kernel starting user space	u	heart beat @ 1 puls-e/sec	Perform Special Altboot or PWS Altboot, GP 4 If the fault persists, Install a new Controller PWB.
TPM key read	Read encryption key(s) from the TPM and stop on failure	e	heart beat @ 1 puls-e/sec	Perform Special Altboot or PWS Altboot, GP 4 If the fault persists, Install a new Controller PWB.
HHD/SSD boot	Boot from HDD/SSD and stop on failure	6	heart beat @ 1 puls-e/sec	Perform Special Altboot or PWS Altboot, GP 4 If the fault persists, Install a new Controller PWB.
FPGA check	Initialize FPGA FPGA load failure disables IOT communications (303–315), IIT communications (362–310), and disables the Ethernet port (316–501)	2	heart beat @ 1 puls-e/sec	Refer to 303-315–00 DC Platform Internal Interface Fault RAP , 305-103-00 , 316-501-00 to 316-544-00 Network Faults 4 RAP RAPs, Perform Special Altboot or PWS Altboot, GP 4 If the fault persists, Install a new Controller PWB PL 3.05 item 1.
Ready mode	None, no faults detected	blank	heart beat @ 1 puls-e/sec	None, no fault detected

After Application start the 7-segment display cycles around displaying this set of codes suppressing the codes of platforms that are fully synchronized with the system. Any code left displayed after power on indicates this event has not been detected in the software and is a probable software issue. Refer to [Table 2](#).

Table 2 Machine Level Self-Test Codes

POST Code Name	Code Description	SB-C LE-D code	Decimal point	Service Action if Fault Persists	Comments
UI platform availability	UI platform not available	A	heart-beat @ 1 pulse/sec	Check Controller PWB to UI cable connection, Reload software: perform PWS Altboot with Disable_Data_Backup, GP 4 Install a new Control Panel Display, 7-inch, PL 2.05 Install a new Controller PWB, PL 3.05 item 1	'A' code clears when UI apps communication is established. The system auto-reboots if 'A' is not cleared.
IIT comms established	IIT comms not established	b	heart-beat @ 1 pulse/sec	Check Fault History, dC122 for any 362-xxx fault codes. Follow RAPs as applicable.	'b' code clears when IIT communication is established. 'b' code does not prevent bootup.
NC platform availability	NC platform not available	C	heart-beat @ 1 pulse/sec	Reload software: perform PWS Altboot with Disable_Data_Backup, GP 4 Install a new Controller PWB, PL 3.05 item 1	'C' code clears when network controller app completes startup. System auto-reboots if 'C' is not cleared.
Dc platform availability	Dc platform not available	d	heart-beat @ 1 pulse/sec	Reload software: perform PWS Altboot with Disable_Data_Backup, GP 4	'd' code clears when DC app completes startup. 'd' code does not prevent bootup.

POST Code Name	Code Description	SB-C LE-D code	Decimal point	Service Action if Fault Persists	Comments
IOT comms established	IOT comms not established	E	heart-beat @ 1 pulse/sec	Check Fault History, dC122 for any IOT fault codes. Follow RAPs as applicable.	'E' code clears when IOT communications are established. 'E' does not prevent bootup.
Fax comms established	Fax comms not established	F	heart-beat @ 1 pulse/sec	Perform OF 12 Fax Entry RAP	'F' code clears when Fax app is available. 'F' code does not prevent bootup.
Entry to Deep Sleep	OS suspending drivers, entering Deep Sleep	L	heart-beat → Off	Reload software (Altboot), GP 4 Install a new Controller PWB, PL 3.05 item 1	On system sleep entry the OS puts up an 'L' briefly while it suspends drivers, then it puts an 'r' when in deep sleep (suspend to memory/S3 mode).
Semi-conscious	Running in semi-conscious mode	t	heart-beat @ 1 pulse/sec	None, for diagnostic information only	When leaving deep sleep (suspend to memory/S3 mode), the OS POST display will transition from 'H' to 't'. From semi-conscious the machine will either wake up fully and the OS will blank the POST display, or the machine will go back to deep sleep (the OS POST display shall transition from 'L' to 'r')
Exit from deep sleep	Waking up: OS Resuming drivers	H	Off → heart-beat	Reload software (Altboot), GP 4 Install a new Controller PWB, PL 3.05 item 1	When leaving deep sleep, the OS POST display will transition from 'H' to 't'. From semi-conscious the machine either wake up fully and the OS will blank the POST display, or the machine go back to deep sleep (the OS POST display will transition from 'L' to 'r')
Deep sleep (suspend to memory/S3 mode)	Resting in deep sleep	Blank	Off		Machine is in sleep mode (maximum power saving mode)

POST Code Name	Code Description	SB-C LE-D code	Decimal point	Service Action if Fault Persists	Comments
System Entropy Health check	Checks the processor DRNG hardware	j	Off	Reload software (Special Altboot), GP 4 Install a new Controller PWB, PL 3.05 item 1	
Rolling Reset	A rolling reset condition has occurred, and System start-up has been halted to prevent additional reboots	n	Off	Use the accompanying POST codes to determine cause of reboot	

OF7 USB Operation RAP

Use this RAP if a USB connected device fails to communicate with the machine.

Initial Actions

- Print a configuration report, [GP 14](#).
- Connect USB device to one of the two USB ports on the machine.

Procedure

If the device is not detected, perform the following procedure:

- EWS USB Device Enabled:
 - Open a web browser.
 - Enter the machine IP address in the browser address line to enter EWS.
 - Click **Admin**, then login in as admin.
 - Click; **Properties**, on the left menu click **Connectivity > Setup**.
 - Scroll down to **USB Setting** and verify **Port Management (A and B)** is checked.
 - Insert the USB drive in the UI port. The screen for the USB options should appear on the UI control panel.
 - Remove the USB drive, then insert the same USB drive in the rear USB port. The same screen should appear on the UI control panel.
 - If no response to either or both ports from the USB drive insertion, use a known good USB drive, then repeat Steps **f.** and **g.**.
 - If the same result, Upgrade the Software, [GP 4](#), using a FORCED_ALTBOOT method.



CAUTION: Carefully read the procedure to understand the tags to either wipe user setting or retain user settings. Notify the customer that if both USB ports are not functioning, use settings may be lost.

- Repeat Steps **a.** through **e.** above.
If either USB port is not functional:

- Reseat the UI control panel harness on the controller PWB and at the UI control panel.
- Repeat Steps **1a.** through **1c.** If either port continues not functioning, install new components in order:
-



CAUTION: Restart the machine after each new component installation before installing the next component in the list.

- Controller PWB, [PL 3.05 item 1](#).
- Control panel display, [PL 2.05 item 2](#).
- Control panel harness, [PL 2.05 item 1](#).

OF8 Network Printing Problems RAP

This Procedure is provided to help identify and diagnose network printing problems.

Initial Actions

- Ensure the machine is online.
- Ensure that no IOT faults exist that prevent the IOT from functioning. That is, copies can be made, or prints can be printed from the UI.

Determine the following:

- Are any jobs printing on the printer?
- Is the problem related to one workstation?
- Is the problem related to one job?
- Have any changes been made to the network prior to a printing problem?
- Was a backup log of network configuration data created? If so, was it last created by a CSE or the customer/SA?

If there are multiple protocols enabled on the printer, and the problems are ONLY occurring with one network protocol, go to the procedure appropriate for that protocol:

- Switch OFF, then switch ON the machine, [GP 10](#).
- TCP/IP: [OF 9](#), TCP/IP Checkout RAP.

Procedure

No printing occurs (jobs won't print, can't see printer, or can't connect to printer)

Y N
| If, instead of job printing normally, there is a literal printing of the PDL (many pages of code, or the job prints, but looks wrong fonts, missing fonts, other image quality problems), go to the [OF 10](#).

The problem occurs in all print jobs from all clients.

Y N
| **The problem occurs in a specific job from all clients.**

Y N
| **The problem occurs in all jobs from a specific client or group of clients,**

Y N
| If the problem is with a specific job from a specific client, the problem is likely with the client; either not connected to the network, wrong or old driver, bad application files or a hardware failure in the client.

If no printing can be done from a specific client or group, while other clients or group function normally, the likely cause is a problem in the customer's network.

If the problem is specific to a single application or group of applications, ensure that current drivers are loaded.

If the problem occurs in only one job, go to the [OF 10](#).

Check that the printer is physically connected to the network cable and that the cable/connections are OK. Disconnect and reseal the cable at both ends. Check to see if the problem is corrected.

The fault persists.

Y N
| Return to [SCP 1](#).

Go to [GP 14](#) (Network Printing Simulation) and send a print job.

An acceptable print is produced:

Y N
|

- verify machine settings .
- reload system software, [GP 9](#).
- If the fault persists, install a new, Controller PWB [PL 3.05 item 1](#).

Print out a Configuration Report, [GP 14](#). Review the, TCP/IP, and Microsoft Networking (NETBIOS) settings.

At least one networking protocol is enabled.

Y N
| The printer is not installed properly. Inform the customer/system administrator that the printer needs to be installed and setup for the appropriate networking protocol.

Enter Diagnostics, [GP 1](#), then go to [dC312](#). Check for a selectable protocol (not grayed out).

There is at least one selectable protocol.

Y N
| Switch OFF, then switch ON the machine, [GP 10](#). When machine is ready, reenter Diagnostics, [GP 1](#), the select [dC312](#) again. Check for a selectable protocol (not grayed out).

There is at least one selectable protocol.

Y N
| Open software update, [GP 4](#), then perform the Regular AltBoot procedure.

If the fault persists, return to the start of this procedure.

Select **Start**. Observe the test results.

The test passed.

Y N
| Enter Diagnostics, [GP 1](#), then go to [dC312](#). Check for a selectable protocol (not grayed out).

The test passed.

Y N
| Perform the following:

- Ask the system administrator to test the network port.
- Open software update, [GP 4](#), then perform the Regular AltBoot procedure.
- Install a new Ethernet cable from the machine to the source connector.
- Check fault history for faults related to networking, then perform the RAP associated with any faults listed.
- TCP/IP: [OF 9](#), TCP/IP Checkout RAP
- If the fault persists, install a new Controller PWB, [PL 3.05](#).

Verify that the problem is corrected. If the problem continues, go to [GP 4](#) and perform the Regular AltBoot procedure.



CAUTION: The AltBoot procedure in Software Upgrade, [GP 4](#), will delete all stored data on the System Disk Drive, including E-mail addresses, Xerox Standard Accounting data, and network configuration information. **ALWAYS** backup the machine, [GP 22](#), if possible, before performing AltBoot. If the machine failure is such that cloning is not possible, ensure that the customer is aware of the data loss.

Reload software via AltBoot, [GP 4](#).

The problem continues.

Y N
| Return to [SCP 1](#).

Select the most appropriate from the following:

- Jobs Won't Print, Can't See Printer, Can't Connect to Printer

- TCP/IP: OF 9, TCP/IP Checkout RAP
- A particular job isn't printing, go to the Problem Printing Job RAP, OF 10
- Instead of job printing normally, there is a literal printing of the PDL (many pages of cryptic code) - Go to the OF 10
- Job prints, but looks wrong. Wrong fonts, missing fonts, other image quality problems - Go to the OF 11

OF9 TCP/IP Checkout RAP

Use this RAP if the printer is enabled for TCP/IP protocol, but there are problems printing to it.

Initial Actions

- Perform OF 8, Network Printing Problems RAP.
- It is assumed that before entering here that the IOT is known to be OK.
- Ensure that the printer is properly configured for the TCP/IP Network. Verify with the system administrator that the following printer settings are correct:
 - Printer IP address
 - Subnet mask
 - Broadcast Address
 - Default Gateway
- For Solaris 2.5 and above, the key operator or system administrator must have root privilege to install the printer.
- For SunOs, have the system administrator ensure that the /etc/printcap file is properly configured.
- Switch OFF, then switch ON the machine, GP 10.

Procedure

Determine if problem is occurring on multiple workstations.

Only one workstation is unable to print (answer no if unsure)

Y N

Print a Configuration Report, GP 14 . Review the TCP/IP settings.

TCP/IP is enabled.

Y N

Inform the customer's system administrator that the printer needs TCP/IP added.

Enter Diagnostics, GP 1. Select dC312 , then check if TCP/IP is selectable.

TCP/IP is selectable (not grayed out).

Y N

Switch OFF, then switch ON the machine, GP 10. Reenter Diagnostics, GP 1. When machine is ready, select dC312 again. Check if TCP/IP is selectable.

TCP/IP is selectable (not grayed out).

Y N

Go to GP 4, then perform the Regular AltBoot procedure.

If the fault persists, return to the start of this procedure.

Enter Diagnostics, GP 1. Select dC312, select TCP/IP and select Start . Observe the test results.

The test passed.

Y N

In Echo Test, dC312, select Internal TCP/IP and select Start.

Observe the test results.

The test passed.

B

A

A	B	Y	N
			Perform the following:
			<ul style="list-style-type: none"> There may be a problem with the network port. Ask the system administrator to test the port. If the fault persists, request the customer's system administrator install a new Ethernet cable. Go to GP 4 and perform the Regular AltBoot procedure. If the fault persists, install a new Controller PWB, PL 3.05.
			Request the system administrator install the printer.
			<ul style="list-style-type: none"> Ensure that all configurations and IP addresses are valid.
			Request the system administrator install the printer.
			<ul style="list-style-type: none"> Ensure that all configurations and IP addresses are valid.
			The problem occurs only on one job
		Y	N
			Have the customer's system administrator Ping the IP address of the printer from the affected workstation.
			Observe results.
			The workstation can ping the printer successfully.
		Y	N
			Have the customer's system administrator Ping another known good static IP address on the network.
			The workstation can successfully ping another static IP address on the network.
		Y	N
			Inform the customer's system administrator there is a problem with the workstation.
			Request the system administrator check the workstation configuration is correct for the network.
			Request the system administrator check the workstation configuration is correct for the network.
			The same job prints ok from another workstation.
		Y	N
			Have the customer's system administrator reload the print driver on the affected workstation.
			If the problem continues, escalate the call to the Customer Service Center (CSC).
			There is an application problem. Request the customer contact the Customer Service Center.

OF10 Problem Printing Job RAP

Use this RAP when a particular job won't print. Other jobs print OK.

Procedure

Check the output to see if a PDL error sheet was printed.

An error sheet was printed.

Y N

On the machine UI, select Job Status, Other Queues, All Completed Jobs, Save.

Check the queue for the job in question.

The job is in the log.

Y N

Select Other Queues, All Incomplete Jobs, Save.

The job is stuck in the queue.

Y N

Check for a fault listed against the job in question.

There is a fault(s) listed with the job.

Y N

Go to Software Upgrade, [GP 4](#), and perform the Regular AltBoot procedure.

Go to the appropriate RAP for the fault(s) listed with the job.

Switch the machine power off/on to reboot the SBC PWB.

The job printed OK.

Y N

Inform the customer the job must be deleted. Delete the job. Instruct the customer to recreate and re-send the job.

The job printed OK.

Y N

Go to Software Upgrade, [GP 4](#), and perform the Regular AltBoot procedure.

If the problem continues, there may be a problem with the job. See if other jobs print OK. If not, instruct the customer/System administrator to reload the print driver on the affected workstation.

If the problem continues have the customer call the Customer Service Center.

Done. Return to [SCP 1](#).

Done. Return to [SCP 1](#).

The job must have been printed. Check for the possibility that the job was removed from the printer by another user.

Go to Software Upgrade, [GP 4](#), and perform the Regular AltBoot procedure.

If the problem continues, there may be a problem with the job. See if other jobs print OK. If not, instruct the customer/System administrator to reload the print driver on the affected workstation.

If the problem continues have the customer call the Customer Service Center.

OF 11 Job Prints Incorrectly RAP

The job prints, but incorrectly.

Procedure

Discuss the problem with the customer and/or inspect the incorrect output.

There is a font problem.

Y N

The problem is occurring on all jobs from all clients.

Y N

The problem is occurring on jobs from one particular client.

Y N

The problem is related to a particular job. Have the customer call the Customer Support Center.

There may be a problem with the client workstation. Check/perform the following:

- See if problem is related to a particular job. If so, go to the **OF 10**.
- Ensure that the client meets minimum specifications for the Embedded Web Server software drivers.
- Ensure the latest printer drivers are loaded.
- Have the customer/System administrator reload the printer driver.

Have the customer/system administrator replace the print drivers. Ensure that the latest drivers available are loaded.

The problem persists.

Y N

Return to **SCP 3**.

Go to **GP 4** and perform the Regular AltBoot procedure.

Have the customer view the job in Print Preview of the application.

The problem appears in Print Preview.

Y N

There may be a font substitution that is not acceptable to the customer. In the Printer Setup for the print driver, if Always Send to Printer is selected, the actual fonts will be sent to the printer from the workstation. This will slow down the printer performance, but will usually solve the font problem.

There may be a problem with the client workstation. Check/perform the following:

- See if problem is related to a particular job. If so, go to the **OF 10**.
- Ensure the client meets minimum specifications for the Embedded Web Server drivers.
- Ensure the latest printer drivers are loaded.
- Have the customer/System administrator reload the printer driver.

OF12 Modem/Fax PWB Service RAP

There is a problem with the FAX. The primary causes of Fax problems, **in order of likelihood**, are:

- Phone line problems
- Customer operation problems
- PBX setup problems
- Machine configuration problems
- Fax hardware problems

Initial Actions

- If the problem is FAX not printing the Date and Time stamp, enter **dC131** and change the setting in NVM location 200-143 from a 0 to a 1.
- Check the phone line connection is active.
- Check the Configuration Sheet to confirm that the FAX PWB is detected.
- If the FAX icon is not present, check cable connection from the FAX PWB to the Controller PWB.
- Verify the presence of the FAX PWB.
- If the fault persists, or the FAX is inoperable, proceed to the following procedure.

Procedure



WARNING: Switch off the electricity to the machine, **GP 10**. Disconnect the power lead from the customer supply while performing tasks that do not need electricity. Electricity can cause death or injury. Moving components can cause injury.

Actions	Yes	No
Step 1 Reseat the telephone cable on the LINE port of the printer and on the wall jack. The fault persists.	Go to step 2.	Perform SCP 5 , Call Closeout.
Step 2 Check if the telephone cable sends and receives calls. Does the cable send and receive calls?	Go to step 4.	Go to step 3.
Step 3 Connect the telephone cable to a working wall jack. The fault persists.	Go to step 4.	Perform SCP 5 Final Actions.
Step 4 Reseat the fax PWB harness and on the JFAX1 connector, on the controller PWB, PL 3.05 item 1. The fault persists.	Go to step 5.	Perform SCP 5 Final Actions.
Step 5 Check the fax PWB harness for continuity.	Go to step 7.	Go to step 6.

Actions	Yes	No
Does the cable have continuity?		
Step 6 Install a new fax PWB, PL 20.05 item 1. Note: The fax PWB harness is not seperately spared. The fax PWB harness is part of the fax PWB. The fault persists.	Go to step 7.	Perfrom SCP 5 Final Actions.
Step 7 Measure the voltages of pins 4, 5, and 7 of the JFAX1 connector, on the controller PWB, PL 3.05 item 1. Note: Pins 9, 11, 13, 15, 17, and 19 are GND. Are the voltages of pins 4 and 5 equal to +3.3VDC and pin 7 equal to +5VDC?	Go to step 8.	Go to step 9.
Step 8 Install a new fax PWB, PL 20.05 item 1. The fault persists.	Go to step 9.	Perfrom SCP 5 Final Actions.
Step 9 Install a new controller PWB, PL 3.05 item 1. The fault persists.	Contact the next level of support.	Perfrom SCP 5 Final Actions.

OF13 Secure Access RAP

Overview

Xerox Secure Access uses an external device, such as a card reader or biometric device, to authorize access to the machine. This reader then passes the information to the controller, which handles the authentication process including, which GUI screens are displayed, accepting GUI responses, that defines their content and order. The controller can pass user identities and passwords directly to the machine after gathering the data from an external server. All communication is via a secure network link, Figure 1 Network Diagnostic.

Xerox Secure Access shall be controlled via the Embedded Web Server GUI. The active status is displayed in tools within Access Control. If communication cannot be established with the Xerox Secure Access Server the service may be temporarily disabled by touching the now enabled Off button within the Xerox Secure Access tools window. Once communication is reestablished the stored Xerox Secure Access setting shall be restored.

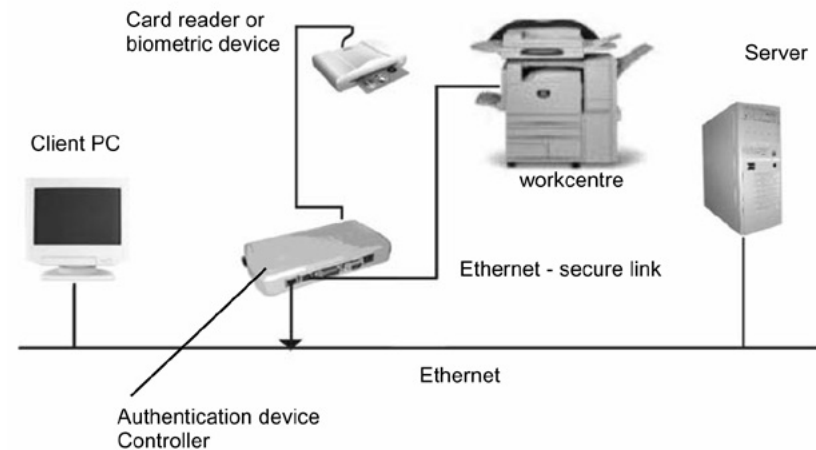

Q-1-4271-A

Figure 1 Network Diagnostic

Initial Action

Before working on the Xerox Secure Access, check out the machine in the service mode to insure no faults are displayed and that the machine is functioning properly. If it is not, repair any problems before proceeding with diagnosing the Secure Access Accessory. Diagnostics can be entered to test copier functionality when Secure Access is installed.

Note: To power down the machine, press the UI Power Button and then respond to the on-screen prompts. Wait until the Power Button LED turns off, then switch off the Main Power Switch (GP 4).

Perform the following steps

- Check the connection between the Card Reader and the Secure Access Authentication Device.
- Check for the LEDs are on or blinking on the Secure Access Authentication Device. If the LEDs on the Secure Access Authentication Device are not operating, go to Secure Access Authentication Device Failure.
- Check for the LEDs are on or blinking on the Card Reader. If the LEDs on the Card Reader are not operating, go to Card Reader Failure.

- If customers have problems of install / setting up, or any other problems related to their Secure Access Administrator, they should refer to the Secure Access System Administrator's Guide or contact Xerox Technical Support.

Secure Access Authentication Device Failure

The primary failure modes are power problems or failed hardware components. The symptom of these failures can be detected by observing the LEDs on the Secure Access Authentication Device, [Figure 2](#).

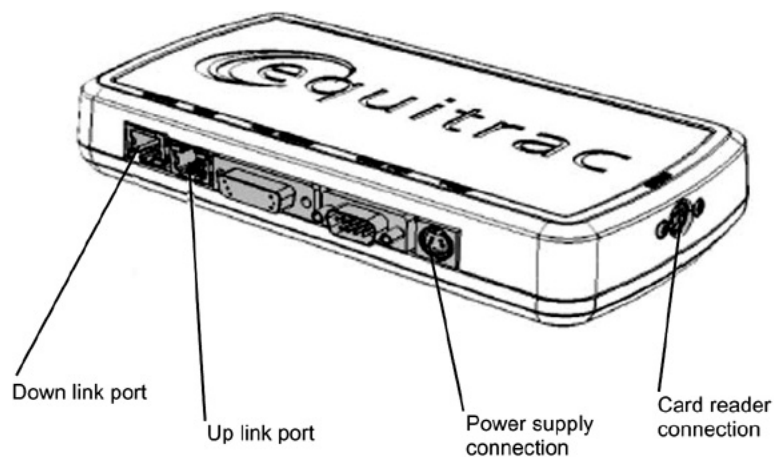

Figure 2 Authentication Device

Check the power to the Secure Access Authentication Device.

- Check the power supply at the wall socket. If there is no power at the wall socket, have the customer restore power and continue when confirmed.
- Disconnect the power cord from the wall socket and the power supply. Check the power cord for continuity and damage. If necessary install a new power cord. Disconnect the power cord from the power supply and plug the power cord into the wall outlet. Using a multi meter, check for line voltage at the end of the power cord disconnected from the power supply. If there is power at the wall but not at the end of the power cord. Install a new power cord.
- Disconnect the small power cord from the Secure Access Authentication Device. Check there is +5V at the connector that plugs into the Secure Access Authentication Device. If there is no +5V, install a new power supply.
- There is a 'Keyed' switch on the end of the Secure Access Authentication Device. Obtain the key from the customer. Insert the key into the 'keyed' switch and cycle the switch 1 quarter turn clockwise and then back to its start position. Observe the LEDs and listen for an audible tone.
- If the LEDs on the Secure Access Authentication Device "Uplink" and "Downlink" Ethernet ports do not cycle on and off as the controller goes through its boot-up process, or if the audible tone is not heard. Install a new Secure Access Authentication Device.

Note: A new device will require the Secure Access Administrator to reconfigure the server with the new MAC address for the new part. Be sure to inform the Secure Access Administrator of the MAC address of the device being removed and the MAC address of the new device.

Card Reader Failure

The primary failure modes are power problems or failed hardware components. The symptom of these failures can be detected by observing the LED on the Card Reader. Refer to [Figure 2](#).

- The Green LED on the Card Reader is On
- The Green LED on the Card Reader Flashes Rapidly
- The Red LED on the Card Reader is On
- The Red LED on Card Reader Flashes Slowly
- The Red LED on Card Reader Flashes Rapidly
- The Card Reader LEDs are not On or Blinking

Table 1 Fault Indications

When the LED on the card Reader is	Description
Red	The authentication device is in idle mode; there is no active session.
Green	The authentication device is in ready mode; a session is active.
Slow Flashing Red	The authentication device has no connection to the server.
Slow Flashing Green	The authentication device is communicating to the server.
Fast flashing red	Invalid card / password; access denied.

The Green LED on the Card Reader is On

- This indicates an active Secure Access Session and the Card Read correctly corresponds to a valid Secure Access Account.
- If the UI on the machine is locked, check with the customer for a second PIN number for additional security. This PIN number will need to be entered via the soft keys on the UI.
- Ensure that the card corresponds to a valid Secure Access Account.

The Green LED on the Card Reader Flashes Rapidly

- This indicates a valid card swipe and in the process of authentication on the server.
- If the UI on the machine is locked, check with the customer for a second PIN number for additional security. This PIN number will need to be entered via the soft keys on the UI.
- If the UI on the machine is locked and no secondary PIN is required. Check that the Xerox Secure Access is installed correctly, and ask customer to check the configuration at the server.

The Red LED on the Card Reader is On

- This indicates the Card Reader is in an idle state. If the red LED remains on, and the UI remains locked after a card is swiped, re-orient the card and re-swipe.
- Try a known good card in the reader. If the other card is working on the problem Card Reader. Ask customer to make sure the card corresponds to a valid Secure Access Account.
- Try the card in a known good reader. If the card is working on a known good Card Reader, it may be a problem with the Secure Access Authentication Device. Check to see if the LEDs on the Secure Access Authentication Device are on.

The Red LED on Card Reader Flashes Slowly

- This indicates the reader is connected to the controller but the controller is not connected to the server. Check the Ethernet green LED on the Authentication Device.

A	B	<p>Y N</p> <p>Contact Next Level Support to obtain a Print Engine Recovery File and instructions.</p> <p>Recover file installed, the fault persists.</p> <p>Y N</p> <ol style="list-style-type: none"> 1. Sync is successful. Now other parts can be installed as required. 2. Perform, SCP 5, Final Actions. <p>Engine SN Restore Failed Machine inoperable Escalate to Next Level Support.</p> <ol style="list-style-type: none"> 1. Insert the USB drive with the backed up Print Engine machine settings. 2. Enter Diagnostics, GP 1. 3. Touch Adjustments. 4. Touch , dC361NVM Save and Restore 5. Touch Print Engine. 6. Touch Restore from USB Drive. 7. Touch Restore Machine NVM. <p>Restore is Successful.</p> <p>Y N</p> <p>Contact Next Level Support to obtain a Print Engine Recovery File and instructions.</p> <p>Recover file installed, the fault persists.</p> <p>Y N</p> <ol style="list-style-type: none"> 1. Sync is successful. Now other parts can be installed as required. 2. Perform, SCP 5, Final Actions. <p>Engine SN Restore Failed Machine inoperable Escalate to Next Level Support.</p> <p>Restart the machine, 322-365-00 fault cleared.</p> <p>Y N</p> <p>Engine SN Restore Failed Machine inoperable Escalate to next level of support. Perform, SCP 5, Final Actions.</p> <ol style="list-style-type: none"> 1. Sync is successful. Now other parts can be installed as required. 2. Perform, SCP 5, Final Actions.
---	---	---

Refer to, [dC132](#)Machine Serial Number, to fix serial sync issue.

The 322-352-00 fault persists.

Y	N	<ol style="list-style-type: none"> 1. Sync is successful. Now other parts can be installed as required. 2. Perform, SCP 5, Final Actions. <ol style="list-style-type: none"> 1. Check the UI fault list for any active faults other than the fault causing the issue. Resolve all faults possible. Then, perform dC132 Machine Serial Number. 2. If no other active faults are found in the UI fault list, dC132 is unsuccessful, and the fault causing the issue persists, contact next level support for further instruction.
---	---	---

3 Image Quality

Image Quality RAPs	150
IQ1 IOT Image Quality Entry RAP.....	150
IQ2 IIT (Scanner) Image Quality Entry RAP.....	152
IQ3 Misaligned Color RAP.....	153
IQ4 Toner Easily Rubs Off RAP.....	154
IQ5 Gray or Solid Background RAP.....	154
IQ6 Solid Color or Black Image RAP.....	155
IQ7 Blank or White Pages RAP.....	156
IQ8 Horizontal White Lines RAP.....	157
IQ9 Horizontal Colored Lines or Banding RAP.....	158
IQ10 Text or Images Cut Off RAP.....	158
IQ11 Mottled Print and Dots RAP.....	159
IQ12 Vertical White Lines RAP.....	160
IQ13 Ghost Images RAP.....	161
IQ14 Vertical Colored Lines or Banding RAP.....	161
IQ15 Dark Print RAP.....	162
IQ16 Missing Color RAP.....	162
IQ17 Uneven Print Density RAP.....	163
IQ18 Repeating Defects RAP.....	164
IQ19 Light Print RAP.....	165
IQ20 Print Crooked or Skewed RAP.....	166
IQ21 Toner Patch Sensing Service Check RAP.....	166
IQ22 Auto Alignment Service Check RAP.....	167
IQ23 Blurred Print RAP.....	168
Scan Quality RAPs	169
SQ1 Dark Image Quality (using the DADF or scanner) RAP.....	170
SQ2 Vertical Lines (process direction using the DADF) RAP.....	170
SQ3 Spots (using the flatbed scanner) RAP.....	171
SQ4 DADF Skew Check RAP.....	171
SQ5 Media Damage (using the DADF) RAP.....	172
SQ6 Blank Page Copy RAP.....	172
SQ7 Solid Black Page Copy RAP.....	173

IQ1 IOT Image Quality Entry RAP

Use this RAP to identify the causes of Image Quality defects and provides steps to working through each Image Quality RAP.

Copy and Print Mode Definitions:

- Print Mode document images are submitted electronically from a Fax, USB, or network source. They do not use any of the IIT components (DADF or Scanner) and there is no hard copy original.
- Copy Mode document images are made from a hard copy original. They use the IIT components (DADF and/or Scanner) to introduce the image into the machine.
- For Copy Mode images made using the DADF, side 1 is defined as the visible side of the document as it sits in the DADF document tray. Side 2 is the side that faces the document tray and is not visible without removing the document from the tray and turning it over. It is useful to label the two sides on the originals used for testing.
- For Copy Mode images made using the Platen Glass, some different parts of the IIT are used to make the image.

Initial Actions

During initial actions, a set of copies and prints are produced. These, along with any copies or prints from the customer, enable you to analyze and correct image quality problems.

1. Ensure that fresh dry paper that meets Xerox specifications is loaded in all paper trays. If necessary, refer to the User Guide to find the approved list of papers and part numbers. 8.5 x 11 and A4 should be loaded. If possible, use paper listed in, [Table 1 Recommended Papers](#).
2. Set the machine UI settings to the corresponding settings listed in, [Table 2 Basic Copier Mode Settings](#), to ensure that the machine is set to a standard state.
3. Make copies of hard copy originals to check for copy mode problems. If a customer original is not available, make the copies from the Color Test Pattern 82E13120
 - a. Make 2-sided copies using the DADF. Use the following process to ensure that both the scanner (for side 1) and the CIS (for side 2) are tested. Set the Copy mode for 2-sided to 2-sided copying.

Set the number of copies to 10.

1. If possible, use a 2-sided original. If the customer original is not 2 sided, use the Color Test Pattern and feed it through the DADF twice. When using the Color Test Pattern use the following process. Be sure to keep track of whether the copies are side one or side two.
 - 1) Place the Test Pattern in the DADF document tray face up with the top on the left. This will produce a set of side 1 copies.
 - 2) Place the Test Pattern in the DADF document tray face down with the top on the left. This will produce a set of side 2 copies.
2. Make copies using the platen. Be sure to register the original correctly on the platen with the top on the left. Use either the customer original, or the Color Test Pattern.
4. Ask the customer to make ten 2-sided prints of the file that is showing the defect. If possible, ask that the file be printed from several different computers.
5. If step 4 cannot be completed, make ten 2-sided prints of an appropriate test pattern using [dC612](#).

Table 1 Recommended Papers

Paper	Size / Weight
Bold Digital Printing	8.5 x11 or A4
ColoTech Plus Gold	8.5 x 11 or A4

Table 2 Basic Copier Mode Settings

Item Name	Sub-Item	Sub-Item	Setting
Output Color	-	-	Auto Detect
Reduce/Enlarge	-	-	Auto
Original Type	More	Content Type	Photo and Text
Original Type	More	How Original was Produced	Printed Original
Lighten/Darken	-	-	Normal
Sharpness	-	-	Normal
Saturation	-	-	Normal
Automatic Background Suppression	-	-	Off (unchecked)
Contrast	Contrast: Manual Contrast	-	Normal
Color Presets	-	-	Off
Color Balance	-	-	Normal
Image Shift	-	-	Off

Procedure

Check the set of copies and prints for the presence of the defect in Copy Mode and in Print Mode.

If the problem only occurs in Copy Mode, go to the [IQ2 RAP](#).

1. Check machine customer selectable image quality settings on the UI and the Print Driver. Determine if adjustments to these settings should be made to tune image output to meet customer IQ requirements.
2. Refer the customer to user documentation to review settings that affect copy and print image quality. In particular, ask that they review the following settings for Copy image quality:
 - Output Color
 - Original Type
 - Lighten / Darken
 - Sharpness
 - Saturation

- Automatic Background Suppression
 - Color Presets
 - Color Balance
3. Make a set of prints using dC612 to aid in further defect analysis.
 4. Examine the complete set of copies and prints to determine which Image Quality RAP to perform listed in, [Table 3 Image Quality Defects: Process \(Slow Scan\) Direction Streaks and Lines](#).

Table 3 Image Quality Defects: Process (Slow Scan) Direction Streaks and Lines

Defect	Description	Corrective Action
IQ3 Misaligned Color RAP	Color misalignment	Go to the RAP IQ3
IQ4 Toner Easily Rubs Off RAP	The print is poorly fused to the page.	Go to the RAP IQ4
IQ5 Gray or Solid Background RAP	The page background appears greyed or having a tint of color	Go to the RAP IQ5
IQ6 Solid Color or Black Image RAP	The page prints a solid color or black.	Go to the RAP IQ6
IQ7 Blank or White Pages RAP	The page prints a Blank or White page	Go to the RAP IQ7
IQ8 Horizontal White Lines RAP	Horizontal white lines or missing print appears on the page.	Go to the RAP IQ8
IQ9 Horizontal Colored Lines or Banding RAP	Horizontal lines appear across the page at intervals top to bottom.	Go to the RAP IQ9
IQ10 Text or Images Cut Off RAP	The print is incomplete or cut off the page.	Go to the RAP IQ10
IQ11 Mottled Print and Dots RAP	Dots and irregular print appearing at the top and bottom of the page.	Go to the RAP IQ11
IQ12 Vertical White Lines RAP	Vertical white lines or missing print appears on the page.	Go to the RAP IQ12
IQ13 Ghost Images RAP	Images appear washed out and overlaid.	Go to the RAP IQ13
IQ14 Vertical Colored Lines or Banding RAP	Colored lines or bands appear vertically across the page.	Go to the RAP IQ14
IQ15 Dark Print RAP	The page appears horizontal dark gradient starting from top to bottom.	Go to the RAP IQ15
IQ16 Missing Color RAP	The print has missing colors	Go to the RAP IQ16

Defect	Description	Corrective Action
IQ17 Uneven Print Density RAP	The print is unevenly delivered to the page.	Go to the RAP IQ17
IQ18 Repeating Defects RAP	Lines or dots repeat at regular intervals down the page.	Go to the RAP IQ18
IQ19 Light Print RAP	The print is washed out at 20 % to 30 % print density.	Go to the RAP IQ19
IQ20 Print Crooked or Skewed RAP	The print is skewed or crooked.	Go to the RAP IQ20
IQ21 Toner Patch Sensing Service Check RAP	Toner Patch Sensing Service Check	Go to the RAP IQ21
IQ22 Auto Alignment Service Check RAP	Auto Alignment Service Check	Go to the RAP IQ22
IQ23 Blurred Print RAP	The color print is blurred and not crisp.	Go to the RAP IQ23

IQ2 IIT (Scanner) Image Quality Entry RAP

Use this RAP to troubleshoot scanner and DADF problems only. Before proceeding verify that the defect is present in Copy mode only. If the defect is present on the page printed from the IOT go to, [IQ 1](#) Image Quality Entry RAP.

Initial Actions

1. Clean the scanner, [GP 18](#).
2. Recheck for the problem by repeating the copy mode print generation process from [IQ 1](#). If the problem remains continue with this procedure. Otherwise return to Call Flow.

Procedure

Examine the copies made during Initial Actions of [IQ 1](#). Compare the defective copies with the descriptions listed in [Table 1](#). Perform the corrective action listed for that defect.

Note: The defects listed in [Table 1](#) are for problems that occur in copy mode only. If the problem occurs in both copy and print mode, refer to [IQ 1](#).

Table 1 IIT/IPS Image Quality Problems

Defect	SubSystem	Corrective Action	Description
Dark image quality (using the DADF or scanner)	DADF or Scanner	Check print quality samples Correct any print quality issues using RAP, IQ 1 Image Quality Entry RAP Clean the scanner Clean the white reference strips Perform a copy job using the DADF Perform a copy using the scanner If the fault persists, install a new controller PWB, PL 3.05	The image is dark using either the DADF or the scanner.
Vertical lines (process direction using the DADF) check	DADF	Clean the Platen Glass Clean the Platen Cushion Calibrate the IIT dC945 . Perform RAP IQ14	Vertical lines appear on the page.
Spots (using the flatbed scanner) check	Scanner	Perform RAP IQ 1 Image Quality Entry RAP	Spots on the printed page appear after scanning a document.
DADF skew check	DADF	Clean the CIS Install a new scanner assembly, PL 60.10 item 1	Images and print are skewed or crooked.

Defect	SubSystem	Corrective Action	Description
Media Damage (using the DADF)	DADF	Check the DADF paper path for debris or foreign objects. Clean the DADF pick and separator rollers. Install new DADF rollers, PL 5.05 item 4	Highlight density too light
Black Or Blank Page Copy	DADF/Scanner	Perform RAP IQ7 for blank pages. Perform IQ6 for black pages.	Highlight density too dark

IQ3 Misaligned Color RAP

Note: Before proceeding with this print quality check, see [IQ 1](#)

Initial Actions

1. Determine the color misalignment.
 - a. Enter the Diagnostics menu [GP 1](#), and then touch **Advanced Print Quality Samples > Advanced Print Quality Test Pages**.
 - b. Check pages G and H on the test pages to determine the color misalignment.
2. Adjust the color. From the home screen, touch **Settings > Print > Quality > Advanced Imaging > Color Adjust**.
3. Perform the auto alignment service check. For more information, see [IQ22](#).
4. Check the printhead for damage, contamination, and improper installation.

IQ4 Toner Easily Rubs Off RAP



Figure 1 Toner Easily Rubs Off

Note: Before proceeding with this print quality check, see [IQ 1](#)

Initial Actions

1. Depending on your operating system, specify the paper type from the Printing Preferences or Print dialog.
 - a. Make sure that the setting matches the paper loaded.
 - b. Change the setting on the printer control panel.
2. Perform the service check for any log error codes.
 - a. From the home screen, touch **Settings > Device > Maintenance > Configuration Menu > Reports > Event Log**.
 - b. Check the log history for fuser error codes.
3. Check the LVPS for damage, contamination, and improper installation. For more information, see [REP 1.2](#).

IQ5 Gray or Solid Background RAP

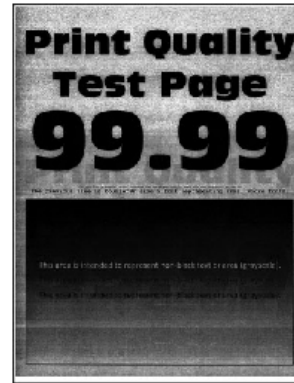

Figure 1 Gray Background

Note: Before proceeding with this print quality check, see [IQ 1](#)

Initial Actions

1. Check the imaging kit for damage, contamination, and improper installation. For more information, see [REP 60.4](#).
2. Check for missing colors. Do the following:
 - a. Place a narrow strip of paper over the gap between the developer units. **Note:** Make sure that the paper stays in place when inserting the imaging kit to prevent the laser from discharging the photoconductor units.
 - b. From the home screen, touch **Settings > Reports > Print Quality Pages**.
 - c. Check the test pages for solid colors.

If there are missing solid colors on the test pages, do the following:

 - a. Make sure that the cables connecting the printhead to the controller board are properly connected.
 - b. Check the printhead for damage, contamination, and improper installation.
 - c. Check the controller board for damage, contamination, and improper installation.
3. Check the FFC connection between the controller board and the engine board for the following:
 - Improper connection
 - Damage
4. Check the HVPS cable for discontinuity, damage, contamination, and improper installation.
5. Make sure that the HVPS contacts are properly positioned and can freely move up and down.
 - a. Remove the transfer module. For more information, see [REP 90.6](#).
 - b. Make sure that the three HVPS contacts are properly positioned and can freely move up and down.

Note: If the contracts are improperly positioned and stuck, do the following:

- a. Check the HVPS for damage, contamination, and improper installation.

- b. Check the controller board for damage, contamination, and improper installation.

IQ6 Solid Color or Black Image RAP



Figure 1 Solid Color or Black Image

Note: Before proceeding with this print quality check, see [IQ 1](#)

Initial Actions

1. Check the imaging kit for damage, contamination, and improper installation. For more information, see [REP 60.4](#).
2. Check for missing colors. Do the following:
 - a. Place a narrow strip of paper over the gap between the developer units. **Note:** Make sure that the paper stays in place when inserting the imaging kit to prevent the laser from discharging the photoconductor units.
 - b. From the home screen, touch **Settings > Reports > Print Quality Pages**.
 - c. Check the test pages for solid colors.If there are missing solid colors on the test pages, do the following:
 - a. Make sure that the cables connecting the printhead to the controller board are properly connected.
 - b. Check the printhead for damage, contamination, and improper installation.
 - c. Check the controller board for damage, contamination, and improper installation.
3. Check the FFC connection between the controller board and the engine board for the following:
 - Improper connection
 - Damage
4. Check the HVPS cable for discontinuity, damage, contamination, and improper installation.
5. Make sure that the three HVPS contacts are properly positioned and can freely move up and down. Do the following:
 - a. Remove the transfer module. For more information, see [REP 90.6](#).
 - b. Make sure that the three HVPS contacts are properly positioned and can freely move up and down.If the contracts are improperly positioned and stuck, do the following:
 - a. Check the HVPS for damage, contamination, and improper installation.

- b. Check the controller board for damage, contamination, and improper installation.

IQ7 Blank or White Pages RAP

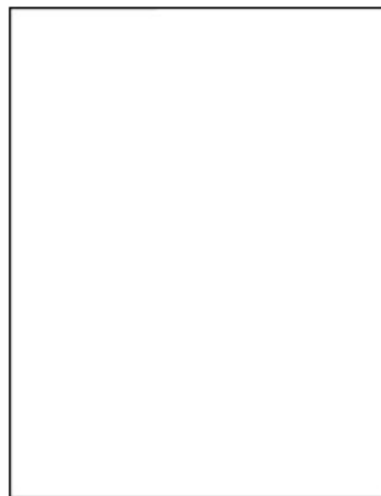

Figure 1 Blank Page

Initial Actions

Precheck procedure

1. From the home screen, navigate to **Settings > Troubleshooting > Print Quality Test Pages**.
2. Check page A to determine any missing colors.
3. If any one color or black is missing, then perform the missing color check. See [IQ16](#).

Service check

1. Check the imaging kit for damage, contamination, and improper installation. For more information, see [REP 60.4](#).
2. Make sure that the contacts between the developer units and the PCUs on the imaging kit are clean. Do the following:
 - a. Remove the imaging kit. For more information, see [REP 60.4](#).
 - b. Remove the developer units.
 - c. Check the contacts between the developer units and the PCUs on the imaging kit for damage and contamination. For more information, see [IQ 1](#).
3. Check the printhead cable for damage, contamination, and improper installation.
4. Check the printhead for damage, contamination, and improper installation.
5. Check the HVPS cable for discontinuity.
6. Check the FFC connection between the controller board and the engine board for the following:
 - Improper connection
 - Damage
7. Make sure that the three HVPS contacts are properly positioned and can freely move up and down. Do the following:

- a. Remove the transfer module. For more information, see [REP 90.6](#).
- b. Make sure that the three HVPS contacts are properly positioned and can freely move up and down.

If the contacts are improperly positioned and stuck, do the following:

- a. Check the HVPS for damage, contamination, and improper installation.
- b. Check the controller board for damage, contamination, and improper installation.

IQ8 Horizontal White Lines RAP



Figure 1 Horizontal White Lines

Note: Before proceeding with this print quality check, see [IQ 1](#)

Initial Actions

1. Depending on your operating system, specify the paper type from the Printing Preferences or Print dialog.
 - a. Make sure that the setting matches the paper loaded.
 - b. Change the setting on the printer control panel.
2. Check the imaging kit for damage, contamination, and improper installation. For more information, see [REP 60.4](#).
3. Check the HVPS for damage, contamination, and improper installation.
4. Check the HVPS cable if it is pinched or damaged.
5. Make sure that the cables connecting the HVPS to the controller board are properly connected.

IQ9 Horizontal Colored Lines or Banding RAP



Figure 1 Horizontal Colored Lines

Note: Before proceeding with this print quality check, see [IQ 1](#)

Initial Actions

1. Depending on your operating system, specify the paper type from the Printing Preferences or Print dialog.
 - a. Make sure that the setting matches the paper loaded.
 - b. Change the setting on the printer control panel.
2. Check the imaging kit for damage, contamination, and improper installation. For more information, see [REP 60.4](#).
3. Make sure that the lines appear in equal intervals. Do the following:
 - a. From the home screen, enter the Diagnostics menu [GP 1](#), and then touch **Settings > Troubleshooting > Print Quality Test Pages**.
 - b. Check the test page.

If the lines do not appear in equal intervals, perform the repeating defects check. For more information, see [IQ18](#).

IQ10 Text or Images Cut Off RAP



Figure 1 Image Cut Off

Note: Before proceeding with this print quality check, see [IQ 1](#)

Initial Actions

1. Make sure to adjust the paper guides in the tray to the correct position for the paper loaded.
2. Depending on your operating system, specify the paper type from the Printing Preferences or Print dialog.
 - a. Make sure that the setting matches the paper loaded.
 - b. Change the setting on the printer control panel.
3. Check the imaging kit for damage, contamination, and improper installation. For more information, see [REP 60.4](#).
4. Check the developer units for damage, contamination, and improper installation.
5. Check for packing material left on the imaging components.
6. Make sure that the developer unit hold downs are in their proper position and are properly operating. Do the following:
 - a. Remove the imaging kit.
 - b. Check the hold downs for improper position.

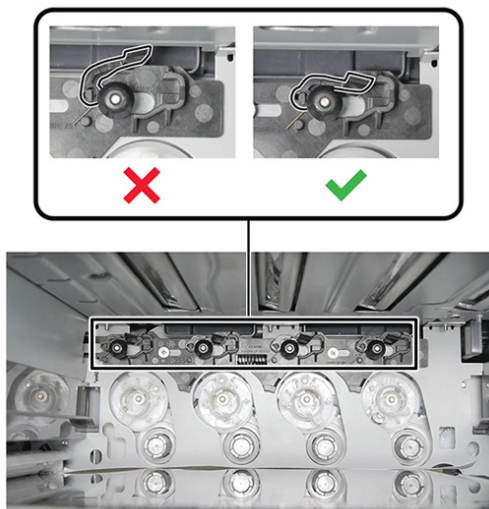

Figure 2 Developer Unit

IQ11 Mottled Print and Dots RAP



VLC4155_3002

Figure 1 Random Dark Spots

Note: Before proceeding with this print quality check, see [IQ 1](#)

Initial Actions

1. Check the printer for leaked toner contamination.
2. Make sure that the settings match. Do the following:
 - a. From the home screen, touch **Settings > Paper > Tray Configuration > Paper Size/Type**.
 - b. Make sure that the paper type and paper size settings match the paper loaded.
 - c. Check the paper for a textured or rough finish.
If the paper is textured or has rough finish, replace it with plain paper.
3. Depending on your operating system, specify the paper type from the Printing Preferences or Print dialog.
 - a. Make sure that the setting matches the paper loaded.
 - b. Change the setting on the printer control panel.
4. Check the imaging kit for damage, contamination, and improper installation. For more information, see [REP 60.4](#).
5. To clean the printer of toner leakage, do the following:
 - a. Using a toner vacuum, clean the printer thoroughly.
 - b. Perform a print job to clear the remaining toner from the imaging components.
 - c. Replace the developer unit of the leaking color. For more information, see [IQ 1](#).
6. Check the photoconductor unit for damage, contamination, and improper installation. For more information, see [IQ 1](#).
7. Make sure that the fuser is free from contamination. Do the following:

- a. From the home screen, touch **Settings > Reports > Menu Settings Page**.

Note: Perform this step twice to clear any debris.

- b. Check the fuser for toner contamination.

If the fuser is contaminated, replace the fuser. For more information, see [REP 10.1](#).

8. Check the transfer module for damage, contamination, and improper installation. For more information, see [REP 90.6](#).

IQ12 Vertical White Lines RAP



Figure 1 Vertical White Lines

Note: Before proceeding with this print quality check, see [IQ 1](#)

Initial Actions

1. Depending on your operating system, specify the paper type from the Printing Preferences or Print dialog.
 - a. Make sure that the setting matches the paper loaded.
 - b. Change the setting on the printer control panel.
2. Check the imaging kit for damage, contamination, and improper installation. For more information, see [REP 60.4](#).
3. Make sure that the printhead lenses are clean. Do the following:
 - a. Perform the waste toner bottle service check.
 - b. Remove the imaging kit.
 - c. Clean the printhead lenses. For more information, see [GP 15](#)
4. Check the test pages and identify the affected color. Do the following:
 - a. From the home screen, touch **Settings > Troubleshooting > Print Quality Test Pages**.
 - b. Identify the developer unit of the affected color. Replace the affected developer unit.
 - c. If all colors are affected, then replace the transfer module. For more information, see [REP 90.6](#).
5. Check the photoconductor unit for damage, contamination, and improper installation. For more information, see [IQ 1](#).
6. Check the transfer module for damage, contamination, and improper installation. For more information, see [REP 90.6](#).
7. Check the printhead for damage, contamination, and improper installation.

IQ13 Ghost Images RAP

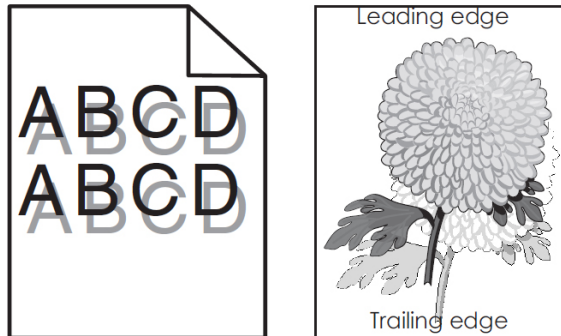

Figure 1 Ghost Image

Note: Before proceeding with this print quality check, see [IQ 1](#)

Initial Actions

- Depending on your operating system, specify the paper type from the Printing Preferences or Print dialog.
 - Make sure that the setting matches the paper loaded.
 - Change the setting on the printer control panel.
- Adjust the color. From the home screen, touch **Settings > Print > Quality > Advanced Imaging > Color Adjust**.
- Check the imaging kit for damage, contamination, and improper installation. For more information, see [REP 60.4](#).
- From the home screen, check the status of the black and color imaging kit.
- Measure the distance from one point of the original image to the same point on the ghost image.
If the distance is 43.9 mm, then replace the imaging kit. For more information, see [REP 60.4](#).
- Check the developer unit for damage, contamination, and improper installation. For more information, see [IQ 1](#).
- Make sure that the fuser is free from contamination. Do the following:
 - From the home screen, touch **Settings > Reports > Menu Settings Page**. **Note:** Perform this step twice to clear any debris.
 - Check the fuser for toner contamination.
If the fuser is contaminated, replace the fuser. For more information, see [REP 10.1](#).

IQ14 Vertical Colored Lines or Banding RAP



Figure 1 Vertical Colored Lines

Note: Before proceeding with this print quality check, see [IQ 1](#)

Initial Actions

- If the printer is an MFP, use a blank sheet of paper to make a two-sided copy on the DADF. If the vertical dark lines appear, clean the DADF scanner glass. For more information, see [GP 18](#).
- Depending on your operating system, specify the paper type from the Printing Preferences or Print dialog.
 - Make sure that the setting matches the paper loaded.
 - Change the setting on the printer control panel.
- Check the imaging kit for damage, contamination, and improper installation. For more information, see [REP 60.4](#).
- Check the developer unit for damage, contamination, and improper installation. For more information, see [IQ 1](#).
- Check the transfer module for damage, contamination, and improper installation. For more information, see [REP 90.6](#).
Note: Make sure there is no debris under the transfer module when it is removed.
- Check the fuser for damage, contamination, and improper installation. For more information, see [REP 10.1](#).

IQ15 Dark Print RAP

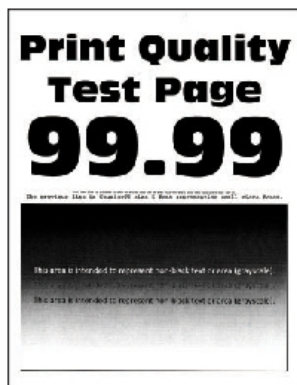

Figure 1 Dark Print

Note: Before proceeding with this print quality check, see [IQ 1](#)

Initial Actions

1. Adjust the color. From the home screen, touch **Settings > Print > Quality > Advanced Imaging > Color Adjust**.
2. Depending on your operating system, reduce the toner darkness from the Printing Preferences or Print dialog. Note: You can also change the setting on the printer control panel.
3. Depending on your operating system, specify the paper type from the Printing Preferences or Print dialog.
 - a. Make sure that the setting matches the paper loaded.
 - b. Change the setting on the printer control panel.
4. Check the paper for a textured or rough finish.
If the paper is textured or has rough finish, replace it with plain paper.
5. Identify the color affected. Do the following:
 - a. From the home screen, touch **Settings > Troubleshooting > Print Quality Test Pages**.
 - b. Check the test pages.
If only one color is affected, do the following:
 - a. Enter the Diagnostics menu [GP 1](#), and then touch **Printer diagnostics & adjustments > Color alignment adjust > AA adjustment row**.
 - b. Perform the toner patch sensing service check. For more information, see [IQ21](#).
6. Check the HVPS cable for discontinuity, damage, contamination, and improper installation.
7. Check the HVPS for damage, contamination, and improper installation.
8. Check the transfer module and its contacts for damage, contamination, and improper installation. For more information, see [REP 90.6](#).

IQ16 Missing Color RAP

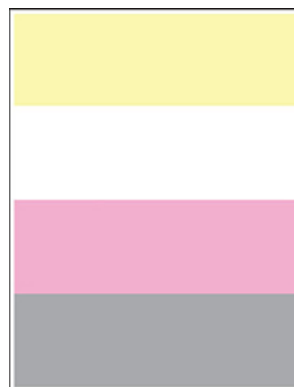

Figure 1 Missing Color

Note: Before proceeding with this print quality check, see [IQ 1](#)

Initial Actions

1. Adjust the color. From the home screen, touch **Settings > Print > Quality > Advanced Imaging > Color Adjust**.
2. Check for packing material left in the imaging kit.
3. Make sure that the toner cartridges and developer units are properly installed.
4. Check the imaging kit for damage, contamination, and improper installation. For more information, see [REP 60.4](#).
5. Check the waste toner bottle for damage, contamination, and improper installation. For more information, see [REP 90.4](#).
6. Check the printhead cable for damage, contamination, and improper installation.
7. Identify the color affected. Do the following:
 - a. From the home screen, touch **Settings > Troubleshooting > Quality Tests Pages**.
 - b. Check the test pages.
If the missing color is yellow, do the following:
 - a. Removing the imaging kit.
 - b. Make sure that the transfer module cleaning blade is in the correct position. For more information, see [REP 90.6](#).
8. Check the contacts on the imaging kit and the developer unit of the missing color for dust or debris.
If the contacts are not free of dust and debris, clean the contacts between the developer unit and the imaging kit.
9. Check the developer unit for damage, contamination, and improper installation.
10. Make sure that the pins in the HVPS can freely move in and out with an equal amount of spring force.
If the pins do not freely move, replace the HVPS.

11. Make sure that the motor of the affected developer unit runs. Do the following:
 - a. Remove the imaging kit. For more information, see [REP 60.4](#).
 - b. Enter the Diagnostics menu [GP 1](#), and then touch **Printer diagnostics & adjustments > Motor tests**.
 - c. Go to the appropriate developer unit motor test for the missing color, and then run the test. If the motor does not run, replace the defective Main Drive Gearbox [REP 40.1](#).
12. Make sure that the imaging kit couplers move. Do the following:
 - a. Remove the imaging kit. For more information, see [REP 60.4](#).
 - b. While manually turning the motors, check if the couplers that drive the imaging kit move. If the couplers do not move, replace the Main Drive Gearbox. For more information, see [REP 40.1](#).
13. Check the Print Quality Test Pages if the black plane or the CMY plane is missing. If the black plane or the CMY plane is missing, replace the HVPS.
14. Check the printhead for damage, contamination, and improper installation.
15. Check the controller board for damage, contamination, and improper installation.
16. Check the FFC connection between the controller board and the engine board for the following:
 - Improper connection
 - Damage

IQ17 Uneven Print Density RAP

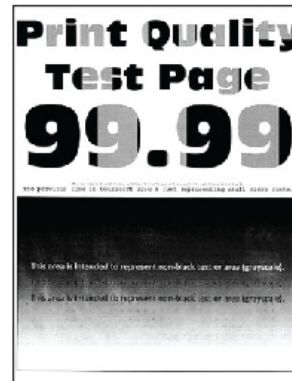

Figure 1 Uneven Print

Note: Before proceeding with this print quality check, see [IQ 1](#)

Initial Actions

1. Check the imaging kit for damage, contamination, and improper installation. For more information, see [REP 60.4](#).
2. Adjust the color. From the home screen, touch **Settings > Print > Quality > Advanced Imaging > Color Adjust**.
3. Make sure that the settings match. Do the following:
 - a. Touch **Settings > Device > Preferences**.
 - b. Make sure that the paper type and size settings match the paper type and size set on the tray.

If the settings do not match, change the paper size and type or adjust the size settings in the tray.
4. Check the paper for a textured or rough finish.

If the paper is textured or has rough finish, replace it with plain paper.
5. Make sure to clean the printhead lenses.
6. Check the imaging kit for damage, contamination, and improper installation. For more information, see [REP 60.4](#).

IQ18 Repeating Defects RAP



Figure 1 Repeating Defects

Note: Before proceeding with this print quality check, see [IQ 1](#)

Initial Actions

1. Check the rollers along the paper path for dust or debris.
If there is dust or debris on the rollers, clean the affected rollers.
2. Check the distance between the repeating defects. Do the following:
 - a. From the home screen, touch **Settings > Troubleshooting > Print Quality Test Pages**.
 - b. Measure the distance between the repeating defects on the affected color page.
3. Check the measurement against the following components. If there is a match, replace the component that matches the measurement. **Imaging kit**
 - 94.20 mm (3.71 in.)
 - 29.80 mm (1.17 in.)
 - 23.20 mm (0.91 in.)

Developer unit

 - 43.90 mm (1.73 in.)
 - 45.50 mm (1.79 in.)

Transfer module

 - 37.70 mm (1.48 in.)
 - 78.50 mm (3.09 in.)
 - 55 mm (2.17 in.)

Fuser

 - 79.80 mm (3.14 in.)
 - 94.30 mm (3.71 in.)
4. In addition, refer to the following list of interval measurements with their corresponding affected components.

Notes:

- Replace the parts one at a time in the order indicated.
- Print a test page after replacing each part to check if the problem has been solved.
- For more information on the supplies, see [IQ 1](#).

99 mm interval

- Fuser

94 mm interval

- Imaging kit

79 mm interval

- Developer unit of the affected color

75 mm interval

- Fuser

55–56 mm interval

- Developer unit
- Transfer module
- EP drive

44–45 mm interval

- Developer unit

33 mm interval

- Developer unit
- EP drive

28 mm, 24 mm, 16 mm, 12–14 mm, 9 mm, and 4-5 mm interval

- EP drive

6–7 mm interval

- Fuser motor
- EP drive

1–3 mm interval

- Developer unit
- Fuser
- EP drive
- MFP redrive

Less than 1 mm interval

- EP drive
- Fuser motor

IQ19 Light Print RAP

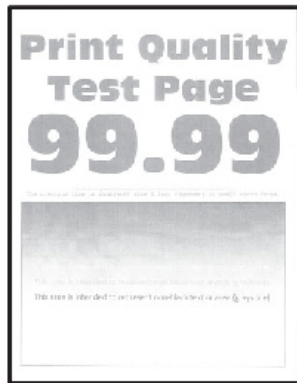

Figure 1 Light Print

Note: Before proceeding with this print quality check, see [IQ 1](#)

Initial Actions

1. Adjust the color. From the home screen, touch **Settings > Print > Quality > Advanced Imaging > Color Adjust**.
2. Depending on your operating system, reduce the toner darkness from the Printing Preferences or Print dialog.
3. Check the color saver setting. Do the following:
 - a. From the home screen, touch **Settings > Print > Quality > Color Saver**.
 - b. Turn off Color Saver.
4. Depending on your operating system, specify the paper type from the Printing Preferences or Print dialog.
 - a. Make sure that the setting matches the paper loaded.
 - b. Change the setting on the printer control panel.
5. Check the paper for a textured or rough finish.
If the paper is textured or has rough finish, replace it with plain paper.
6. Check the imaging kit for damage, contamination, and improper installation. For more information, see [REP 60.4](#).
7. Check the developer units for damage, contamination, and improper installation.
8. Make sure that the motor of the affected developer unit runs. Do the following:
 - a. From the home screen, enter the Diagnostics menu [GP 1](#), and then touch **Printer diagnostics & adjustments > Motor tests**.
 - b. Select the motor of the affected color, and then run the test.
If the motor does not run, make sure that the motor cable is properly installed.
9. Make sure to clean the printhead lenses. Do the following:
 - a. Perform the waste toner bottle service check.
 - b. Remove the imaging kit.
 - c. Clean the printhead lenses.
10. Check the HVPS cable for discontinuity, damage, contamination, and improper installation.
11. Make sure that the HVPS contacts are visible and can freely move up and down:
 - a. Remove the transfer module. For more information, see [REP 90.6](#).
 - b. Make sure that the three HVPS contacts are visible and can freely move up and down.
If the contacts are not visible and they cannot freely move, replace the imaging kit. For more information, see [REP 60.4](#).
12. Check the transfer module for damage, contamination, and improper installation. For more information, see [REP 90.6](#).
13. Check the HVPS for damage, contamination, and improper installation.

IQ20 Print Crooked or Skewed RAP



Figure 1 Skewed Print

Note: Before proceeding with this print quality check, see [IQ 1](#)

Initial Actions

1. Adjust the paper guides in the tray to the correct position for the paper loaded.

Note: Make sure that the paper stack is below the maximum paper fill line.

2. Load paper from a fresh package.

Note: Make sure that the paper loaded is supported by the printer. For more information, see [GP 30](#)

3. Check the transfer module for damage, contamination, and improper installation.
4. Perform printhead adjustment. For more information, see [ADJ 90.1](#).
5. Check the pick rollers for dust or debris.
6. If the paper in tray 1 are straight but the paper in the other tray/s is skewed, then do the following:
 - a. Make sure that the paper guides in the tray/s are free to move and properly adjusted.
 - b. Enter the Diagnostics menu [GP 1](#), and then touch **Printer diagnostics & adjustments > Registration adjust**.
 - c. Select **Duplex Skew** or **Option Skew**.

Notes:

 - Duplex Skew affects the duplex side of the paper.
 - Option Skew affects the paper in tray 2, tray 3, and MPF.
 - Raising the value of the skew setting rotates the horizontal lines clockwise while the vertical lines remain vertical.
 - d. Print a test page.

IQ21 Toner Patch Sensing Service Check RAP

Initial Actions

Precheck procedure

Note: Perform this procedure before performing the service check.

1. Enter the Diagnostics menu, and then navigate to:
Printer diagnostics & adjustments > Color alignment adjust
2. On the AA adjustment row, touch **Start**.

Note:

- This triggers the auto align routine which performs the color alignment error corrections (0.42 mm, 0.84 mm, and 3 mm range).
 - If the AA adjustment is successful, an AA adjustment passed message appears on the screen. If an AA adjustment passed message does not appear, skip the next pre-check step, and then go directly to step 4 in the service check.
3. Enter the Diagnostics menu, and then navigate to:
Printer setup > EP setup > Toner patch sensor adjust > Full calibration

Note: This triggers the auto align routine (0.42 mm range only) and the solid area and linearization adjustments.

Service check

1. Check if the CalSet values are equal to 0. Do the following:
 - a. From the home screen, touch **Settings > Troubleshooting > Print Quality Test Pages**.
 - b. On the Device Information section of the test page, check the CalSet values of the following:
 - C developer unit operating point
 - C laser operating point
 - C linearization stat
 - M developer unit operating point
 - M laser operating point
 - M linearization stat
 - Y developer unit operating point
 - Y laser operating point
 - Y linearization stat
 - K developer unit operating point
 - K laser operating point
 - K linearization stat
2. Perform the blank or white pages service check. For more information, see [IQ7](#).
If there is an issue found and resolved, perform the auto alignment service check. For more information, see [IQ22](#).
3. Make sure that the results of the following tests approximately match the expected values and fall within the requirements:

- a. Enter the Diagnostics menu, and then touch **Printer setup > EP setup > Toner patch sensor adjust**.
- b. On the sensor gain characterization, touch **Start**.
- c. On the sensor gain verification, touch **Start**.
- d. On the sensor gain verification section of the test page, check the average signal values of the patch number.

If the results do not match with the expected value and do not fall within the requirements, perform the auto alignment service check. For more information, see [IQ22](#)

4. Make sure that the JTPS_C1 connector on the engine board is properly connected to the toner patch sensor [REP 90.2](#).
5. Make sure that the results of the following tests approximately match the expected values and fall within the requirements:
 - a. Replace the toner patch sensor. For more information, see [REP 90.2](#)
 - b. Enter the Diagnostics menu, and then touch **Printer setup > EP setup > Toner patch sensor adjust**
 - c. On the sensor gain characterization, touch **Start**.
 - d. On the sensor gain verification, touch **Start**.
 - e. On the sensor gain verification section of the test page, check the average signal values of the patch number.

IQ22 Auto Alignment Service Check RAP

Initial Actions

Pre check procedure

Note: Perform this procedure before performing the service check.

1. Enter the Diagnostics menu [GP 1](#), and then navigate to: **Printer Setup > EP setup > Toner patch sensor adjust > Full calibration**
2. Navigate to **Advanced Print Quality Samples > Advanced Print Quality Test Pages**.
3. Check pages G and H on the test pages to determine the color misalignment.
4. If colors are misaligned, then navigate to **Printer diagnostics & adjustments > Color alignment adjust > Auto align**.
5. Find AA adjustment, and then press **OK** or touch **Start**.

Note: This triggers the auto align routine which performs the color alignment error corrections for the 0.42 mm, 0.84 mm, and 3 mm ranges.

6. Navigate to **Advanced Print Quality Samples > Advanced Print Quality Test Pages**.
7. Check pages G and H on the test pages to determine the color misalignment.
8. If colors are still misaligned, then navigate to **Printer diagnostics & adjustments > Color alignment adjust > Auto align**.

Note: Ignore the AA adjustment performed earlier.

Service check

1. Check if the color alignment stat value is equal to 0. Do the following:
 - a. From the home screen, touch **Settings > Troubleshooting > Print Quality Test Pages**.
 - b. On the CalSet section of the test page, check the color alignment stat value.
2. Perform the Blank or white pages check or Missing color check. For more information, see [IQ7](#) or [IQ16](#).
3. Make sure that the results of the following tests approximately match the expected values and fall within the requirements:
 - a. Enter the Diagnostics menu [GP 1](#), and then touch **Printer setup > EP setup > Toner patch sensor adjust**.
 - b. Find Sensor gain characterization, and then press **OK** or touch **Start**.
 - c. Find Sensor gain verification, and then press **OK** or touch **Start**.
 - d. On the TPS Sensor Characterization and Verification Information Page section of the print out, check the values of the following:
 - The PaperLeft-NDS Volts and PaperRight-DS Volts in the Patch Average from the TPS Verification Page section.
 - The Left-NDS Volts and Right-DS Volts in the High Gain Bare Belt Characterization Results section.
 - The mV value in the Amplifier Offset Characterization Result section.

If the results do not match with the expected value and do not fall within the requirements, check the sensor (toner patch) cables on the controller board for improper connection.

4. Check the transfer module for damage, contamination, and improper installation. For more information, see [REP 90.6](#).
5. Make sure that the sensors (toner patch) are free of dust or debris.
6. Replace the sensors (toner patch).
7. Make sure that the results of the following tests approximately match the expected values and fall within the requirements:
 - a. Enter the Diagnostics menu [GP 1](#), and then touch **Printer setup > EP setup > Toner patch sensor adjust**.
 - b. Find Sensor gain characterization, and then press **OK** or touch **Start**.
 - c. Find Sensor gain verification, and then press **OK** or touch **Start**.
 - d. On the TPS Sensor Characterization and Verification Information Page section of the print out, check the values of the following:
 - The PaperLeft-NDS Volts and PaperRight-DS Volts in the Patch Average from the TPS Verification Page section.
 - The Left-NDS Volts and Right-DS Volts in the High Gain Bare Belt Characterization Results section.
 - The mV value in the Amplifier Offset Characterization Result section.

Post-check procedure (as necessary)

Note: Perform this procedure only if the sensors (toner patch) were replaced during the service check.

1. Enter the Diagnostics menu [GP 1](#), and then navigate to: **Printer diagnostics & adjustments > Color alignment adjust**
2. Find AA adjustment, and then press **OK** or touch **Start**.

Note: This action triggers the auto align routine which performs the color alignment error corrections for the 0.42 mm, 0.84 mm, and 3 mm ranges.
3. Enter the Diagnostics menu [GP 1](#), and then navigate to: **Printer Setup > EP setup > Toner patch sensor adjust > Full calibration**

Note: This action triggers the auto align routine which performs the color alignment error corrections for the 0.42 mm range only.
4. From the home screen, navigate to **Settings > Troubleshooting > Print Quality Test Pages**.
5. On the CalSet section of the test page, check if the color alignment stat value is equal to 0. If the value is 0, then contact the next level of support.

IQ23 Blurred Print RAP

Note: Before proceeding with this print quality check, see [IQ 1](#)

Initial Actions

1. Adjust the color. From the home screen, touch **Settings > Print > Quality > Advanced Imaging > Color Adjust**.
2. Check the imaging kit for damage, contamination, and improper installation. For more information, see [REP 60.4](#).
3. Make sure the printhead lenses are clean. Do the following:
 - a. Remove the imaging kit.
 - b. Clean the printhead lenses.
4. Make sure that the temperature and humidity levels in the printer and in the room are similar. Do the following:
 - a. Enter the Diagnostics menu [GP 1](#), and then touch **Printer diagnostics & adjustments > Weather Station**.
 - b. Press **OK** or touch **Start**.
5. Perform the weather station service check.
6. Make sure that the HVPS cable is properly connected to the HVPS connector on the controller board.
7. Check the HVPS cable for discontinuity and damage.
8. Remove the transfer module. For more information, see [REP 90.6](#). Make sure that the three HVPS contacts (1) are properly positioned and can freely move up and down.

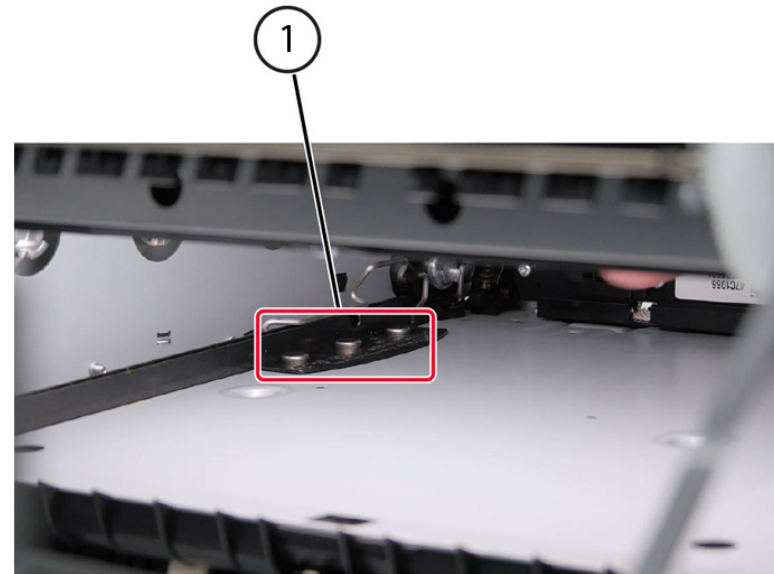

VLC415S_3006

9. Check the HVPS for damage, contamination, and improper installation.
10. Check the transfer module for damage, contamination, and improper installation. For more information, see [REP 90.6](#).
11. Check the controller board for damage, contamination, and improper installation.

SQ1 Dark Image Quality (using the DADF or scanner) RAP

Procedure

1. Check if the scan defect is visible on the print quality samples. Enter the Diagnostics menu [GP 1](#), and then touch Advanced Print Quality Samples > Advanced Print Quality Test Pages.
If the scan defect is visible, identify, and then resolve the print quality defect. For more information, see [IQ 1](#).
2. Perform a color adjust. From the home screen, touch Settings > Print > Quality > Advanced Imaging > Color Adjust.
3. Make sure that the following parts are clean:
 - DADF Glass
 - Scanner Glass
 - DADF Glass Pad
 - Scanner Glass Pad
 - DADF Glass Pad in Door C
 - DADF Glass in Door CFor more information, see [GP 18](#).
4. Check the controller board for damage and improper installation. For more information, see [REP 3.1](#).

SQ2 Vertical Lines (process direction using the DADF) RAP

Procedure

1. Check if the scan defect is visible on the print quality samples. Enter the Diagnostics menu [GP 1](#), and then touch Advanced Print Quality Samples > Advanced Print Quality Test Pages.
If the scan defect is visible, identify, and then resolve the print quality defect. For more information, see [IQ 1](#).
2. Make sure that the following parts are clean:
 - DADF Glass
 - Scanner Glass
 - DADF Glass Pad
 - Scanner Glass Pad
 - DADF Glass Pad in Door C
 - DADF Glass in Door CFor more information, see [GP 18](#).
3. Check the DADF Glass on the scanner for cracks or damage.
4. Check inside the flatbed scanner for dust and contamination.
5. Identify which side of the paper the scan defect occurs. Perform a duplex copy job using the DADF.

Note:

- If the scan defect occurs on the front side, then check the Flatbed Scanner for damage and improper installation. For more information, see [REP 60.2](#).
- If the scan defect occurs on the back side, then check the DADF for damage and improper installation. For more information, see [REP 5.1](#).

SQ3 Spots (using the flatbed scanner) RAP

Procedure

1. Check if the scan defect is visible on the print quality samples. Enter the Diagnostics menu [GP 1](#), and then touch Advanced Print Quality Samples > Advanced Print Quality Test Pages.

If the scan defect is visible, identify, and then resolve the print quality defect. For more information, see [IQ 1](#).

2. Make sure that the following parts are clean:

- Scanner Glass
- Scanner Glass Pad

For more information, see [GP 18](#).

3. Check the scanner glass pad for damage and improper installation. For more information, see [REP 5.3](#).
4. Check inside the flatbed scanner for dust and contamination.
5. Check the flatbed scanner for damage and improper installation. For more information, see [REP 60.2](#).

SQ4 DADF Skew Check RAP

Procedure

1. Check if the scan defect is visible on the print quality samples. Enter the Diagnostics menu [GP 1](#), and then touch Advanced Print Quality Samples > Advanced Print Quality Test Pages.

If the scan defect is visible, identify, and then resolve the print quality defect. For more information, see [IQ 1](#).

2. Make sure that the printer is placed on a flat, sturdy, and stable surface.
3. Make sure that the document is properly loaded in the DADF tray.

Note: The guides in the DADF tray must match the width of the document.

4. Make sure that the DADF paper path is free of debris and obstruction.
5. Make sure that the DADF top cover is properly closed.
6. Enable the DADF electronic deskew setting. From the home screen, touch Settings > Device > Maintenance > Configuration Menu > Scanner Configuration > DADF Deskew > DADF Electronic Deskew > On.
7. Check the DADF pick roller and separator roller for wear and damage. For more information, see [REP 5.5](#).

SQ5 Media Damage (using the DADF) RAP

Procedure

1. Make sure that the document is properly loaded in the DADF tray.

The guides in the DADF tray should match the width of the document.

2. Make sure that the DADF paper path is free of debris and obstruction.
3. Make sure that the DADF top cover is properly closed.
4. Check the DADF pick roller and separator roller for wear and damage. For more information, see [REP 5.5](#).

SQ6 Blank Page Copy RAP

Procedure

1. Check if the issue is a blank page print quality issue. Enter the Diagnostics menu [GP 1](#), and then touch Advanced Print Quality Samples > Advanced Print Quality Test Pages.

If the test page is blank, then resolve the print quality defect. For more information, see [IQ7](#).

2. Make sure that the orientation of the document is correct.

Note:

- When copying from the DADF, load the document faceup.
 - When copying from the flatbed scanner, load the document facedown.
3. Make sure that the connections between the DADF and the controller board are properly connected.
 4. Make sure that the connections between the flatbed scanner and the controller board are properly connected.
 5. Check the DADF and its FFC for damage and improper Installation. For more information, see [REP 5.1](#).
 6. Check the flatbed scanner and its FFC for damage and improper Installation. For more information, see [REP 60.2](#).
 7. Check the controller board for damage and improper installation. For more information, see [REP 3.1](#).

SQ7 Solid Black Page Copy RAP

Procedure

1. Check if the issue is a solid black page print quality issue. Enter the Diagnostics menu, and then touch Advanced Print Quality Samples > Advanced Print Quality Test Pages.

If the test page is solid black, then resolve the print quality defect. For more information, see [IQ6](#).

2. Make sure that the following parts are clean:

- DADF Glass Pad
- Scanner Glass Pad
- DADF Glass Pad in Door C
- DADF Glass in Door C

For more information, see [GP 18](#).

3. Make sure that the connections between the DADF and the controller board are properly connected.
4. Make sure that the connections between the flatbed scanner and the controller board are properly connected.
5. Check the DADF and its FFC for damage and improper Installation. For more information, see [REP 5.1](#).
6. Check the flatbed scanner and its FFC for damage and improper Installation. For more information, see [REP 60.2](#).
7. Check the controller board for damage and improper installation. For more information, see [REP 3.1](#).

4 Repairs- Adjustments

Chain 1 REPs - Standby Power	175	ADJ 90.1 Registration Adjustment.....	236
REP 1.1 HVPS PWB	175		
REP 1.2 LVPS	178		
REP 1.3 Drive PWB.....	179		
Chain 2 REPs - User Interface	180		
REP 2.1 UI Control Panel.....	180		
REP 2.2 UI Control Panel Hinge.....	181		
Chain 3 REPs - Machine Run Control	183		
REP 3.1 Controller PWB	184		
Chain 5 REPs- DADF	185		
REP 5.1 DADF Assembly	186		
REP 5.2 DADF Access Door	187		
REP 5.3 Scanner Glass Pad	188		
REP 5.4 DADF Left and Right Hinges	189		
REP 5.5 DADF Roller	190		
Chain 10 REPs- Print Transport and Fusing	191		
REP 10.1 Fuser	192		
REP 10.2 Fuser Drive Motor	194		
REP 10.3 Fuser Exit Sensor	195		
Chain 28 REPs Covers	197		
REP 28.1 Left Cover.....	197		
REP 28.2 Lower Left Subframe.....	198		
REP 28.3 Lower Right Subframe	202		
REP 28.4 Top Cover	205		
REP 28.5 Rear Cover	206		
REP 28.6 Front Door Assembly.....	207		
REP 28.7 Front Door Inner Paper Feed Guide	209		
Chain 40 REPs - Main Drives	210		
REP 40.1 Main Drive Gearbox.....	210		
Chain 60 REPs - Imaging and NOHAD	212		
REP 60.1 Printhead	212		
REP 60.2 Flatbed Scanner.....	213		
REP 60.3 Scanner Right Support.....	215		
REP 60.4 Imaging Kit	218		
Chain 70 REPs - Paper Supply	219		
REP 70.1 Pick Tires.....	220		
Chain 80 REPs- Paper Transport	221		
REP 80.1 Media Feeder.....	221		
REP 80.2 Duplex Sensor	223		
Chain 90 REPs- Xerographics	224		
REP 90.1 Toner Meter PWB	225		
REP 90.2 Toner Patch Sensor.....	226		
REP 90.3 Toner Cartridge Contact	228		
REP 90.4 Waste Toner Bottle.....	229		
REP 90.5 Toner Contact Block.....	230		
REP 90.6 Transfer Module.....	231		
REP 90.7 Transfer Module Guide.....	234		
Chain 5 ADJs - DADF/Scanner	235		
ADJ 5.1 DADF Registration Adjustment	235		
Chain 60 ADJs - Imaging	236		
ADJ 60.1 Scanner Manual Registration Adjustment.....	236		
Chain 90 ADJs - Xerographics	236		

REP 1.1 HVPS PWB

Parts List on [PL 1.05](#)

Removal



WARNING: Switch off the electricity to the machine, [GP 10](#). Disconnect the power lead from the customer supply while performing tasks that do not need electricity. Electricity can cause death or injury. Moving components can cause injury.



Figure 1 ESD Symbol

1. Remove the eight screws (1), and then remove the rear cover.



2. Disconnect all the connectors (2).

VLC415S_4266

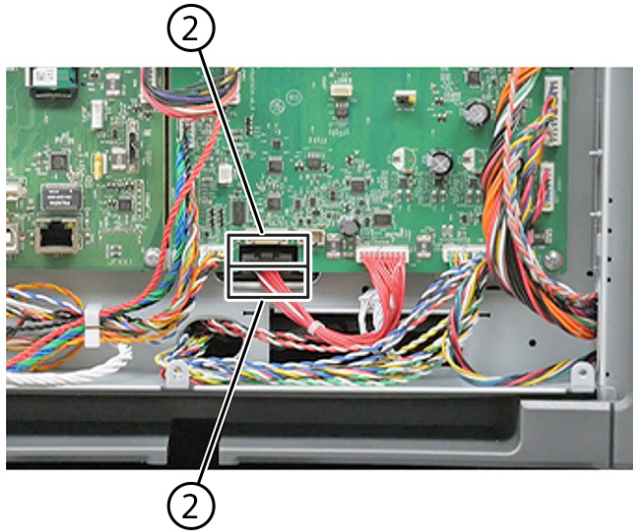

VLC415S_4267

3. Remove the six screws (3).

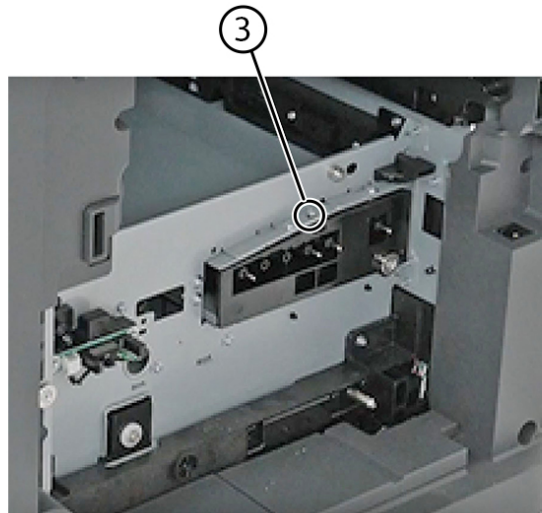

VLC415S_4268

4. Remove the engine board (4).

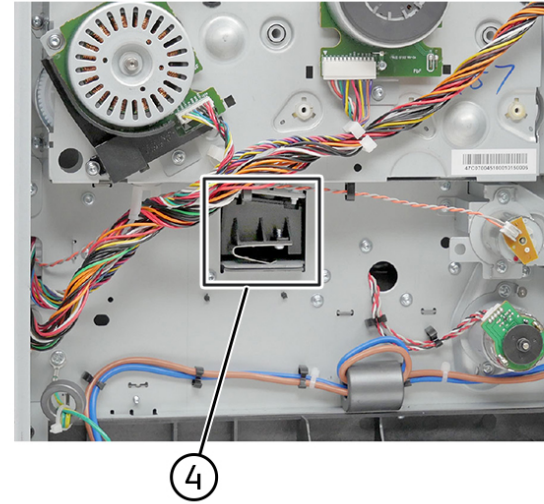

VLC415S_4269

5. Remove the transfer module. See [REP 90.6](#)

6. Disconnect the connector.

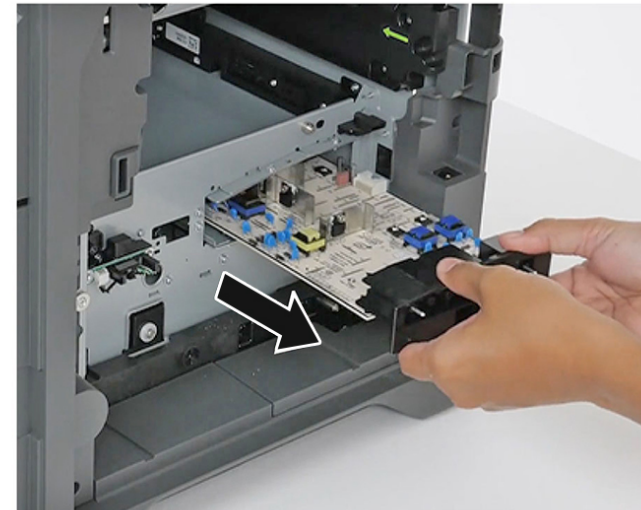

VLC415S_4270

7. Remove the screw (6).

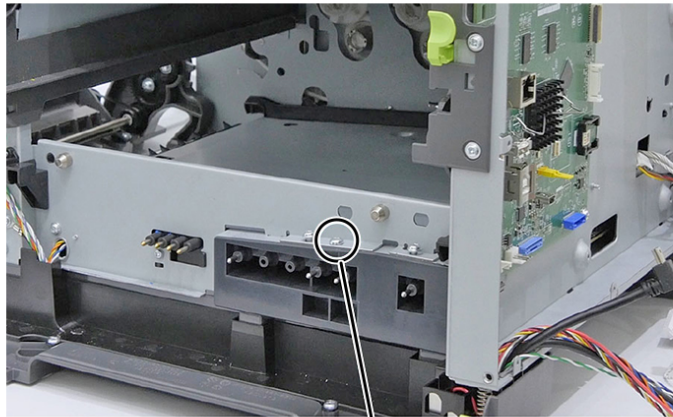

6

VLC4155_4271

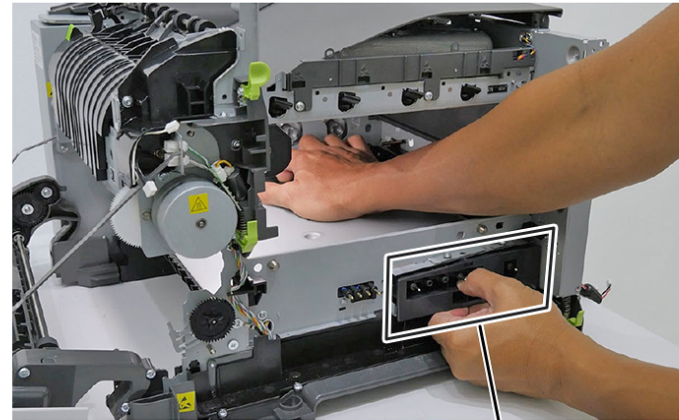

8

VLC4155_4273

8. Press and hold the three transfer module contacts (7).

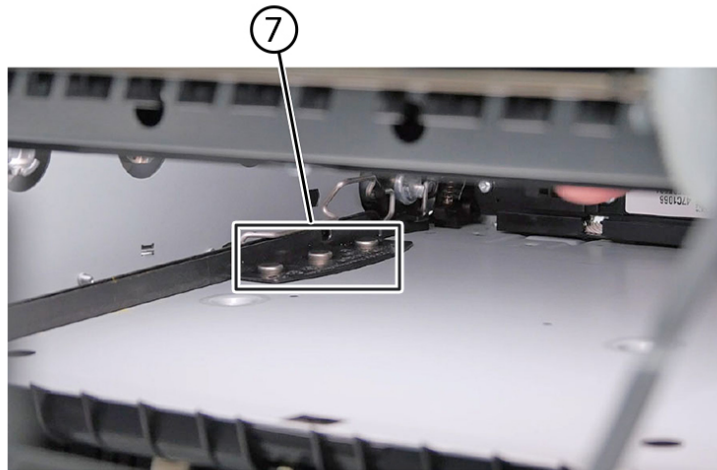

7

VLC4155_4272

9. While pressing on the contacts, carefully pull out the HVPS (8).

Replacement

Note: To avoid breaking the HVPS, make sure to insert it carefully during installation.

Replacement is the reverse of the removal procedure.

REP 1.2 LVPS

Parts List on [PL 1.05](#)

Removal



WARNING: Switch off the electricity to the machine, [GP 10](#). Disconnect the power lead from the customer supply while performing tasks that do not need electricity. Electricity can cause death or injury. Moving components can cause injury.



Figure 1 ESD Symbol

1. Turn off the printer, and then unplug the power cord.
2. Remove the left cover. See [REP 28.1](#)
3. Disconnect the three cables (1).

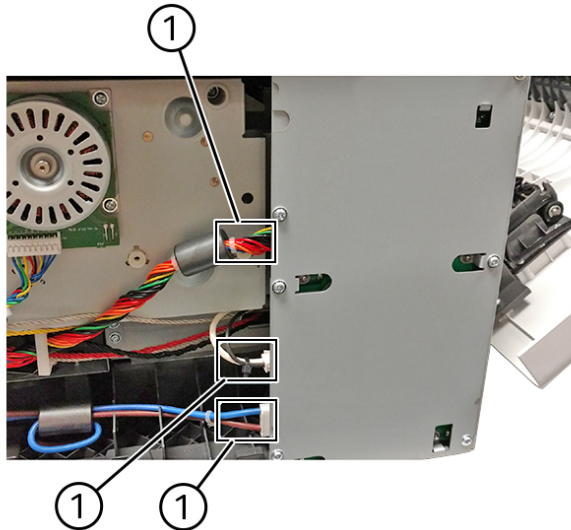

VLC415S_4013

4. Remove the seven screws (2), and then remove the LVPS.

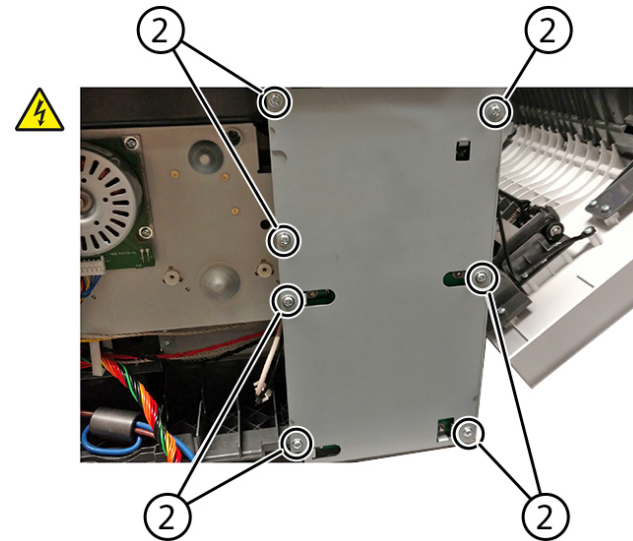

VLC415S_4014

Replacement

Replacement is the reverse of the removal procedure.



WARNING: Make sure to set the switch (3) to the correct setting for your voltage requirements before installing the LVPS. The switch can be set to either 115 V or 230 V.

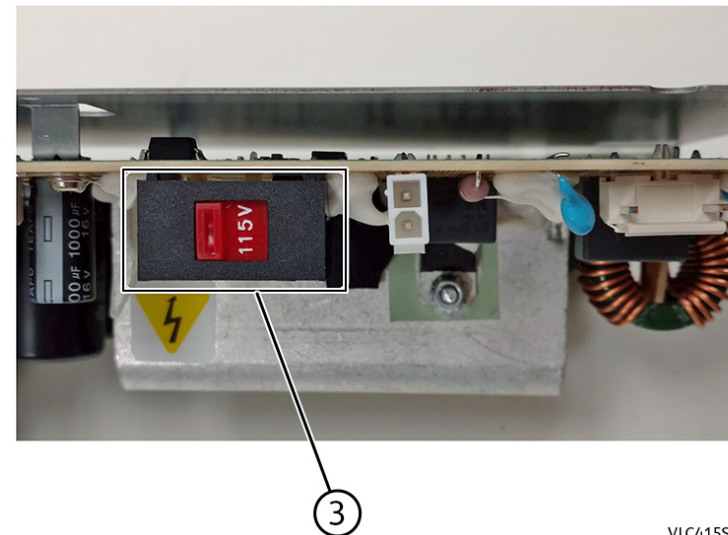

VLC415S_4015

REP 1.3 Drive PWB

Parts List on [PL 1.05](#)



CAUTION: The serial number is stored and synchronized between the controller PWB, drive PWB, and black toner cartridge. Always install these items individually. After installation of one of these items, switch on the machine, [GP 1](#), to allow the serial number to synchronize before proceeding to install the next part. Refer to [dC132](#) Machine Serial Number.

Initial Actions

Pre-Removal Requirements

If Possible, collect the machine data in dC361 before proceeding with removal of the drive PWB procedure.

1. Check the UI control panel, if available, for any active faults. Resolve as required in the corresponding RAP.
2. Enter Diagnostics, [GP 1](#). Perform, [dC361](#) NVM Save and Restore, to **Save** customer settings to the hard drive.
3. While still in dC361, click on each file listed, then select **Copy to USB device** as a second backup.
4. Exit Diagnostics, [GP 1](#).
5. Shutdown the machine, [GP 10](#).

Removal



WARNING: Switch off the electricity to the machine, [GP 10](#). Disconnect the power lead from the customer supply while performing tasks that do not need electricity. Electricity can cause death or injury. Moving components can cause injury.



Figure 1 ESD Symbol



CAUTION: Mark to identify the original PWBs and Black Toner Cartridge, if removed from machine. DO NOT dispose of or return those items until the machine is completely recovered.

1. Remove the rear cover, [REP 28.5](#).
2. Disconnect all cables, then remove six screws (1).



VLC625S_4150

3. Remove the drive PWB.

Replacement



CAUTION: The serial number is stored and synchronized between the controller PWB, drive PWB, and black toner cartridge. Always install these items individually. After installation of one of these items, switch on the machine, [GP 1](#), to allow the serial number to synchronize before proceeding to install the next part. Refer to [dC132](#) Machine Serial Number.

The replacement is the reverse of the removal procedure.

Post—Replacement Requirements

Perform the following steps to return the machine to **Customer Mode** after installation of a new controller PWB.

1. Switch on the machine, [GP 10](#).
 - Note:** While the machine is booting up for the first time after a new drive PWB is installed, encryption will initiate. Allow time for encryption to complete before the machine comes to **Ready**.
2. After the machine completes encryption and comes to **Ready**, perform, [GP 4](#) Software Upgrade, using the **Special ALTBOOT** procedure.
3. After the machine restarts from the software upgrade, enter Diagnostics, [GP 1](#).
4. Enter [dC131](#) NVM Read/Write.
 - a. Enter the chain-link **[616-014]**, then change the value to **4** and save.
 - b. Exit Diagnostics, [GP 1](#).
5. Restart the machine, [GP 10](#).
6. If the machine restarts to a 322-365-00 Fault Code error, follow the procedure in [322-365-00](#).

REP 2.1 UI Control Panel

Parts List on [PL 2.05](#)

Removal



WARNING: Switch off the electricity to the machine, [GP 10](#). Disconnect the power lead from the customer supply while performing tasks that do not need electricity. Electricity can cause death or injury. Moving components can cause injury.



Figure 1 ESD Symbol

1. Release the hinge (1).



VLB415S_4051

2. Remove the screws (2).

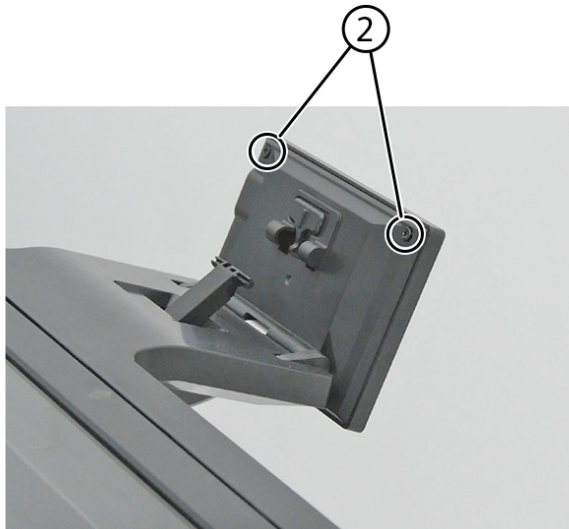

3. Disconnect the connector (3).

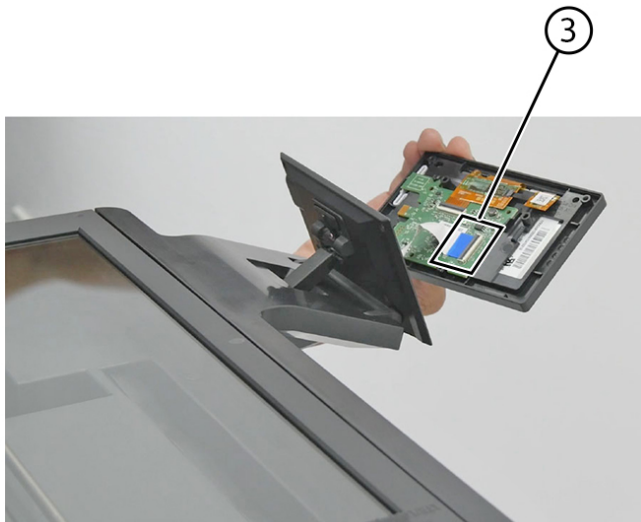

4. Remove the control panel.

Replacement

Replacement is the reverse of the removal procedure.

REP 2.2 UI Control Panel Hinge

Parts List on [PL 2.05](#)

Removal



WARNING: Switch off the electricity to the machine, [GP 10](#). Disconnect the power lead from the customer supply while performing tasks that do not need electricity. Electricity can cause death or injury. Moving components can cause injury.



Figure 1 ESD Symbol

1. Remove the right cover.
2. Remove the DADF. See [REP 5.1](#)
3. Remove the control panel. See [REP 2.1](#)
4. Remove the cover (1).

VLB415S_4052

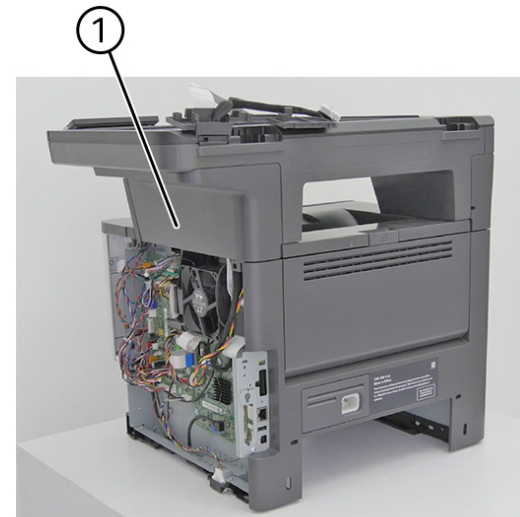

5. Remove the cover (2).

VLB415S_4054

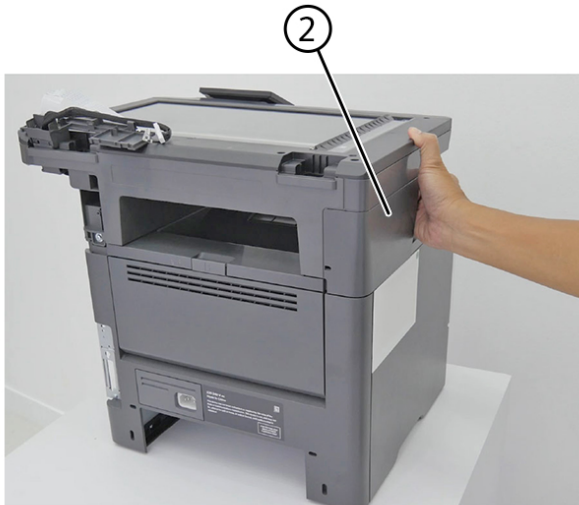

VLB415S_4055



VLB415S_4057

6. Remove the screws (3).

8. Remove the screws (5).

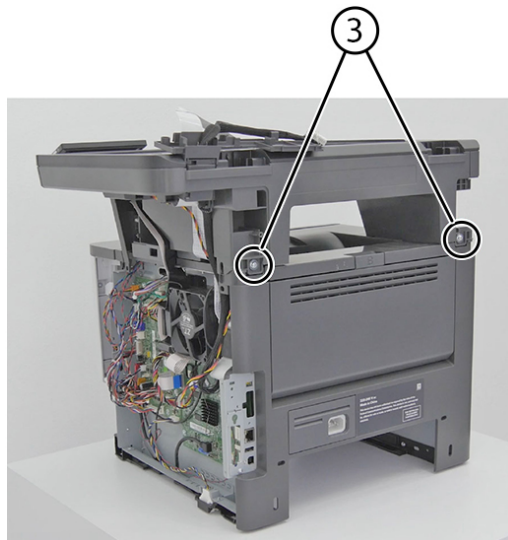

VLB415S_4056

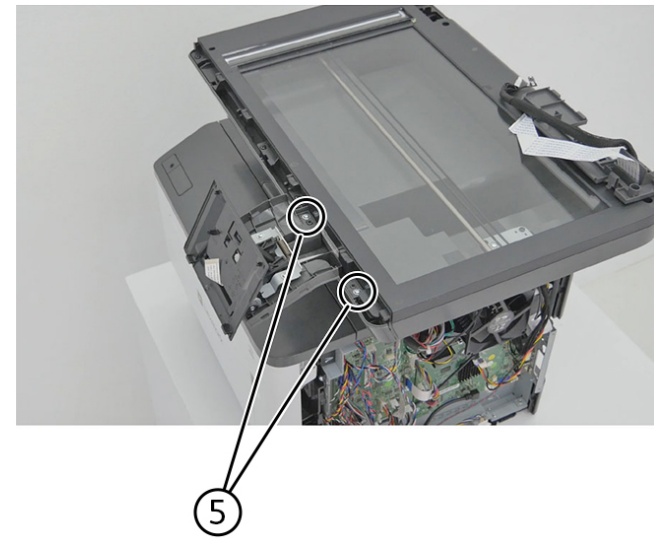

VLB415S_4058

7. Remove the top front cover (4).

9. Remove the screws (6).

10. Disconnect the connector (7), and then unroute the cable.

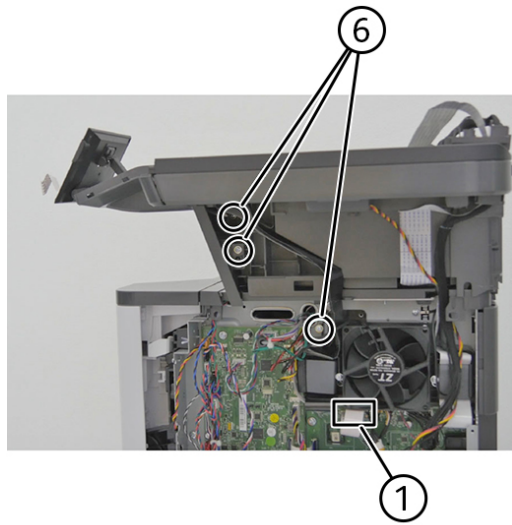

VLB415S_4059

11. Remove the control panel hinge.

Replacement

Replacement is the reverse of the removal procedure.

REP 3.1 Controller PWB

Parts List on [PL 3.05](#)

Initial Actions

Pre-Removal Requirements

1. Check the UI control panel, if available, for any active faults. Resolve as required in the corresponding RAP.
2. Enter Diagnostics, [GP 1](#). Enter, [dC361](#) NVM Save and Restore, then touch **Machine NVM** to save all device platform settings to the hard drive.
3. While still in dC361, click on each file listed, then select **Copy to USB device** as a second backup.
4. Exit Diagnostics, [GP 1](#).
5. Shutdown the machine, [GP 10](#).



Figure 1 ESD Symbol



CAUTION: Never install a drive PWB and controller PWB in the same task. Install one, then check if the issue is resolved before installing the other PWB.

Removal



WARNING: Switch off the electricity to the machine, [GP 10](#). Disconnect the power lead from the customer supply while performing tasks that do not need electricity. Electricity can cause death or injury. Moving components can cause injury.

1. Remove the rear cover, [REP 28.5](#).
2. Disconnect all the cables from the controller PWB (1).

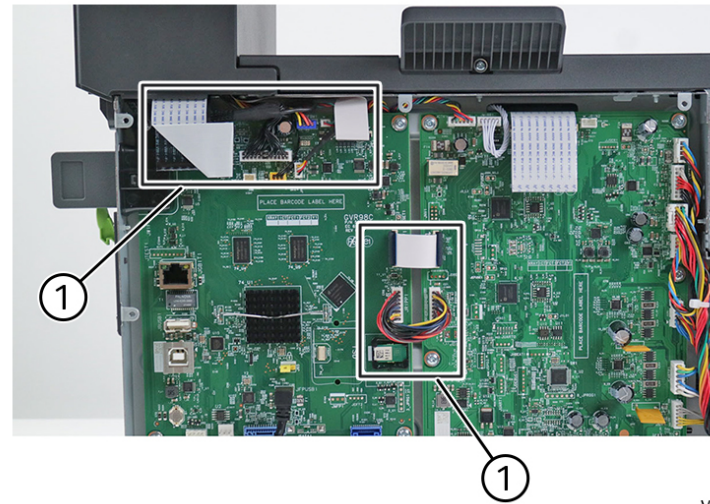

VLC415S_4290

3. Remove the wireless module (2).

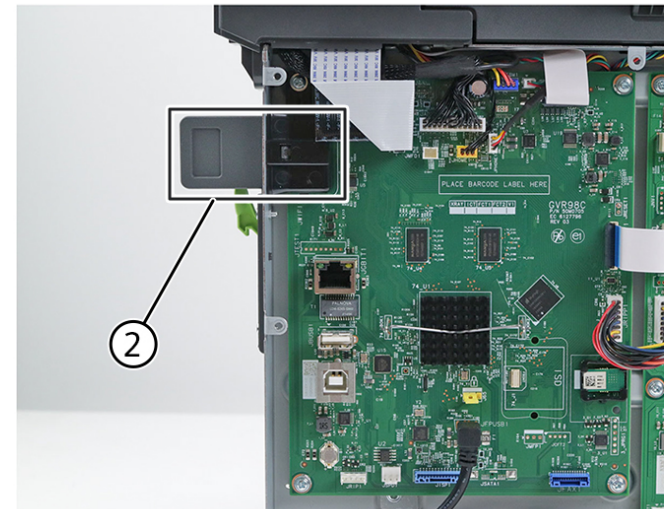

VLC415S_4291

4. Remove four screws (3).

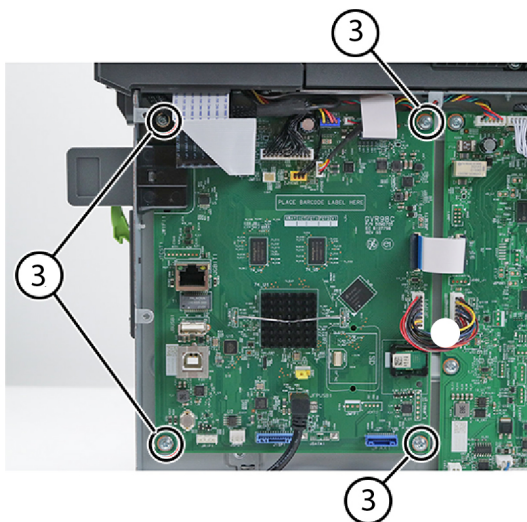

VLC415S_4293

5. Remove the controller PWB.

Replacement



CAUTION: The serial number is stored and synchronized between the controller PWB, drive PWB, and black toner cartridge. Always install these items individually. After installation of either one of these items, ensure the black toner cartridge is installed, then switch on the machine, [GP 10](#), to allow the serial number to synchronize before proceeding to install the next item. Refer to [dC132](#) Machine Serial Number.

Replacement is the reverse of the removal procedure.

Post—Replacement Requirements

Perform the following steps to return the machine to **Customer Mode** after installation of a new controller PWB.

1. Switch on the machine, [GP 10](#).

Note: While the machine is booting up for the first time after a new controller PWB is installed, encryption will initiate. Allow time for encryption to complete before the machine comes to **Ready**.

2. After the machine completes encryption and comes to **Ready**, perform, [GP 4](#) Software Upgrade, using the **Special ALTBOOT** procedure.
3. After the machine restarts from the software upgrade, enter Diagnostics, [GP 1](#).
4. Enter [dC131](#) NVM Read/Write.
 - a. Enter the chain-link [\[616–014\]](#), then change the value to **4** and save.
 - b. Exit Diagnostics, [GP 1](#).
5. Restart the machine, [GP 10](#).

Note: For any software issues resulting in failed restarts after installing a new controller PWB, refer to, [322-365-00](#), to resolve issues.

REP 5.1 DADF Assembly

Parts List on [PL 5.05](#)

Removal



WARNING: Switch off the electricity to the machine, [GP 10](#). Disconnect the power lead from the customer supply while performing tasks that do not need electricity. Electricity can cause death or injury. Moving components can cause injury.



Figure 1 ESD Symbol

1. Release the latches, and then remove the cover.

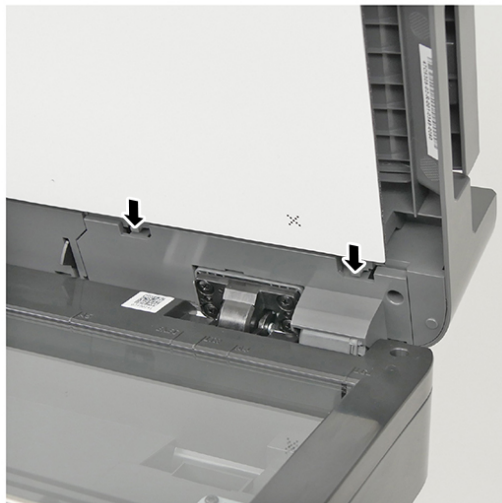

VLC415S_4255

2. Disconnect the FFC (1).

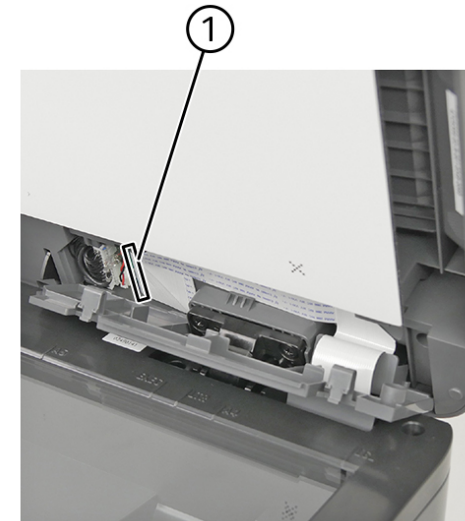

VLC415S_4256

3. Slightly lift the DADF, and then disconnect the cables (2).

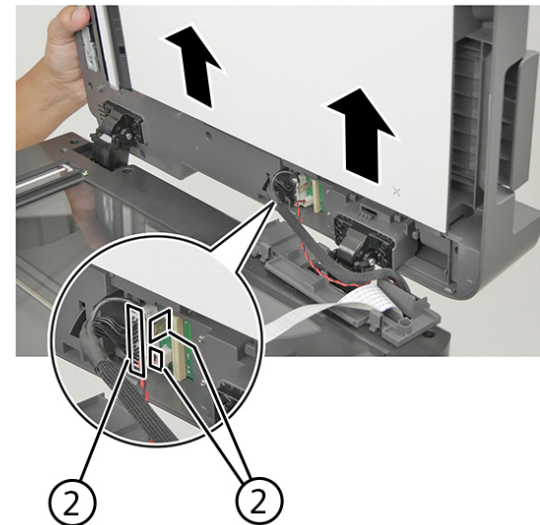

VLC415S_4257

4. Remove the DADF.

Replacement

Replacement is the reverse of the removal procedure.

REP 5.2 DADF Access Door

Parts List on [PL 5.05](#)

Removal



WARNING: Switch off the electricity to the machine, [GP 10](#). Disconnect the power lead from the customer supply while performing tasks that do not need electricity. Electricity can cause death or injury. Moving components can cause injury.

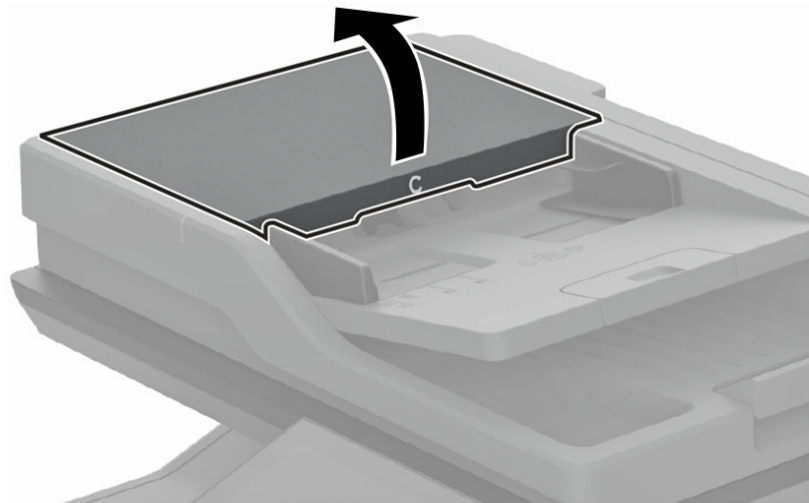

Figure 1 ESD Symbol

1. Open door (3).



WARNING: To prevent damage from electrostatic discharge, touch any exposed metal frame of the printer before accessing or touching interior areas of the printer.



VLC415S_4248

2. Disconnect the cable (1).



VLC415S_4258

3. Using a flat-blade screwdriver, release the hinges (2).

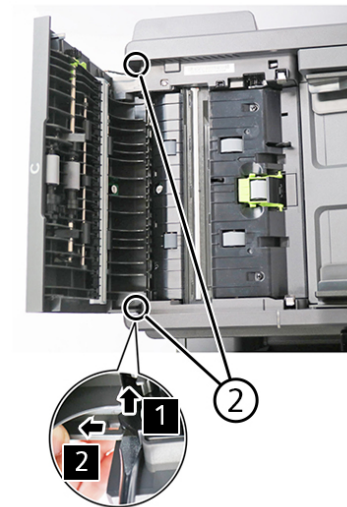

VLC415S_4259

4. Remove the cover.

Replacement

Replacement is the reverse of the removal procedure.

REP 5.3 Scanner Glass Pad

Parts List on [PL 5.05](#)

Removal



WARNING: Switch off the electricity to the machine, [GP 10](#). Disconnect the power lead from the customer supply while performing tasks that do not need electricity. Electricity can cause death or injury. Moving components can cause injury.



Figure 1 ESD Symbol

1. Open the scanner cover.

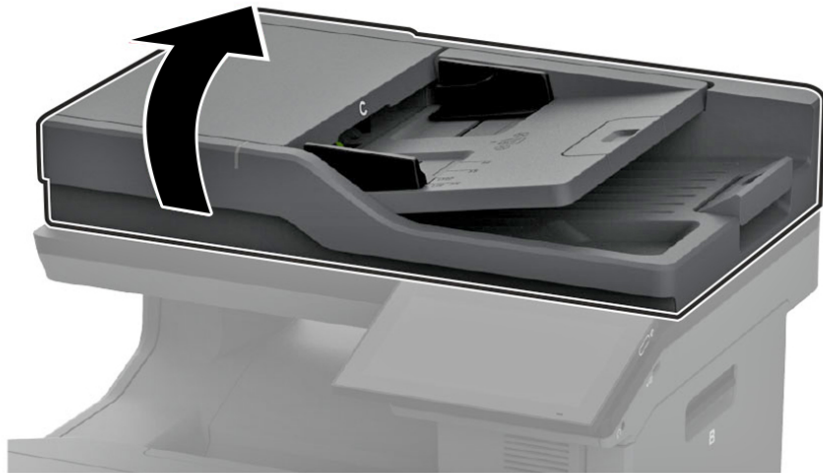

VLC415S_4251

2. Slowly remove the scanner glass pad.

Note: The adhesive should not tear off the pad.

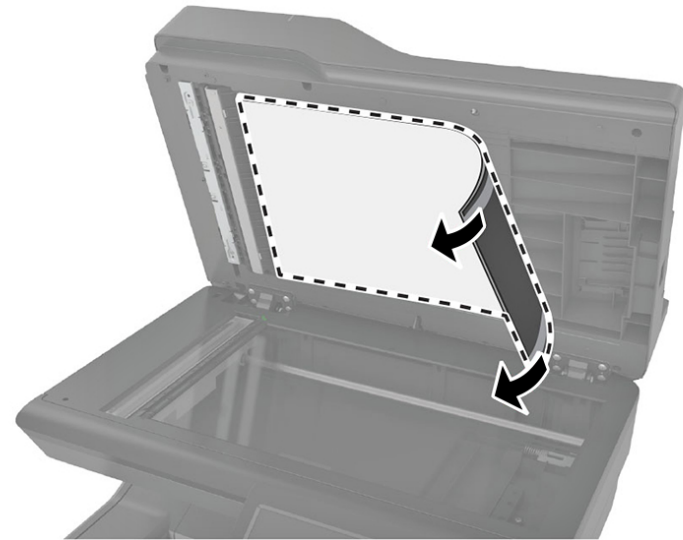

VLC415S_4252

Replacement

Installation notes:

1. Place the white area of the new scanner glass pad facedown on the scanner glass, and then remove the backing on the tape.



VLC415S_4253

Note: Make sure that the scanner glass pad is aligned correctly on the edges of the scanner glass.

2. Close the scanner cover to stick the new scanner glass pad to the cover.

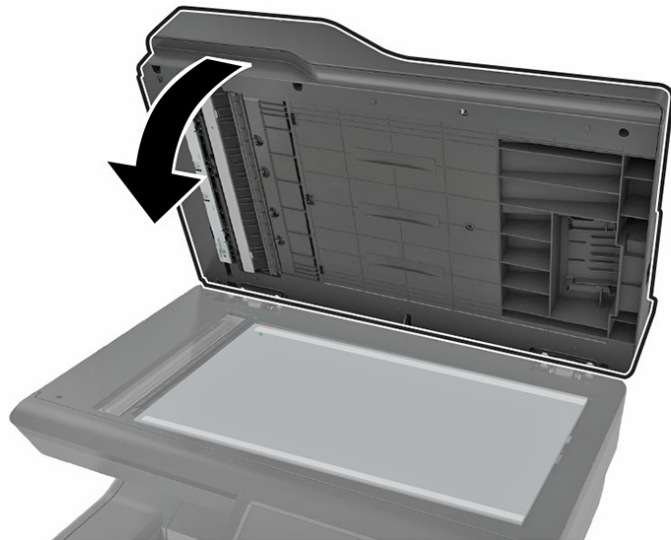

VLC415S_4254

3. Open the scanner cover to check if the new scanner glass pad is properly attached to the cover.

REP 5.4 DADF Left and Right Hinges

Parts List on [PL 5.05](#)

Removal



WARNING: Switch off the electricity to the machine, [GP 10](#). Disconnect the power lead from the customer supply while performing tasks that do not need electricity. Electricity can cause death or injury. Moving components can cause injury.



Figure 1 ESD Symbol

DADF Left Hinge Removal

1. Remove the DADF. See [REP 5.1](#)
2. Remove the four screws (1), and then remove the hinge.

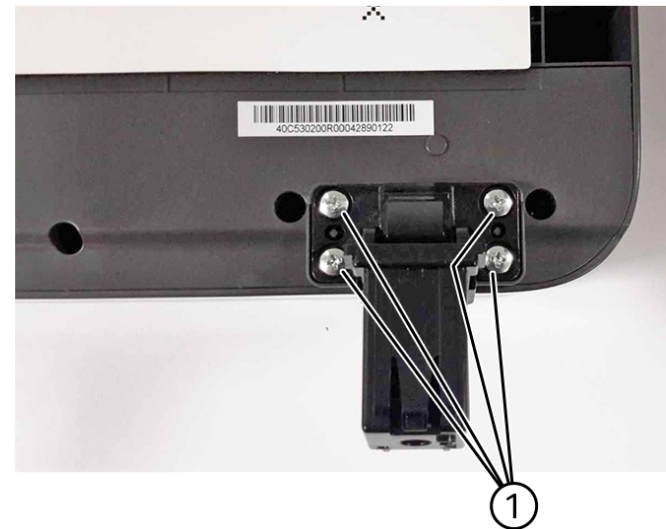

VLC415S_4260

DADF Left Hinge Removal

1. Remove the DADF. See [REP 5.1](#)
2. Remove the four screws (1), and then remove the hinge.

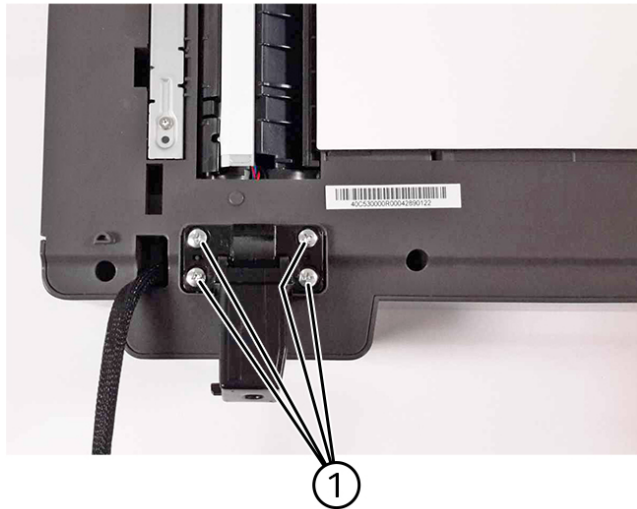

Replacement

Replacement is the reverse of the removal procedure.

REP 5.5 DADF Roller

Parts List on [PL 5.05](#)

Removal



WARNING: Switch off the electricity to the machine, [GP 10](#). Disconnect the power lead from the customer supply while performing tasks that do not need electricity. Electricity can cause death or injury. Moving components can cause injury.

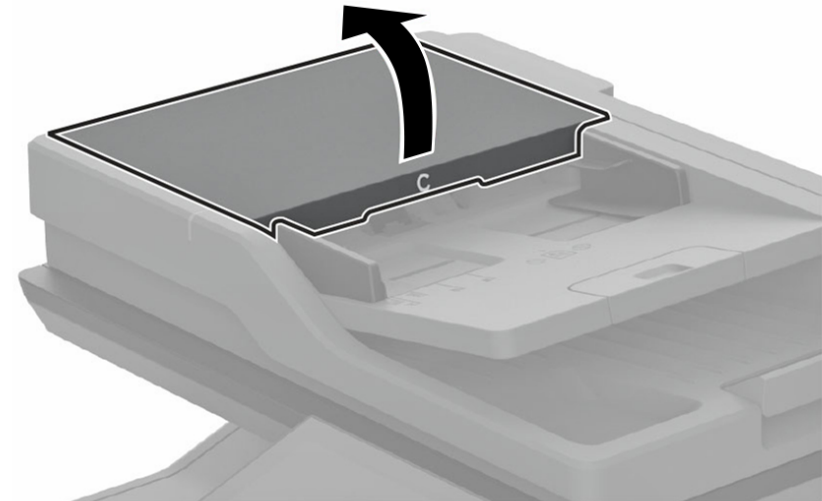

Figure 1 ESD Symbol

1. Open door (3).



WARNING: To prevent damage from electrostatic discharge, touch any exposed metal frame of the printer before accessing or touching interior areas of the printer.



2. Remove the DADF pick roller.

VLC415S_4248

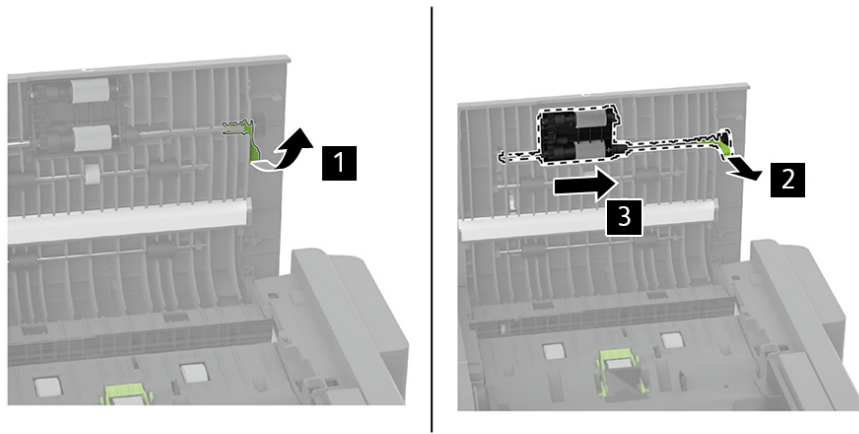

VLC415S_4249

3. Remove the DADF separator roller.

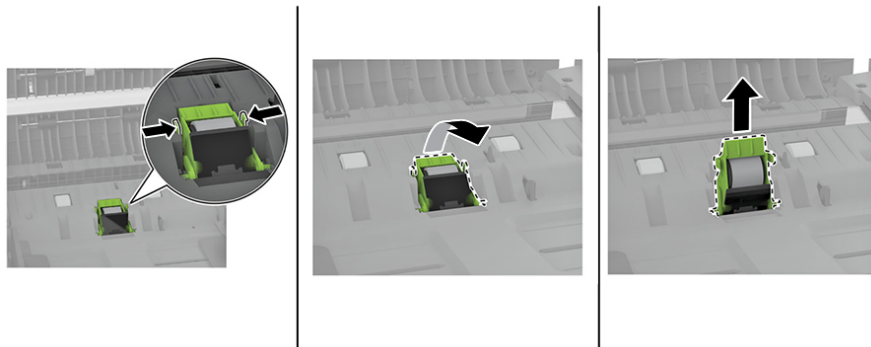

VLC415S_4250

Replacement

Replacement is the reverse of the removal procedure.

REP 10.1 Fuser

Parts List on [PL 10.05](#)

Removal



WARNING: Switch off the electricity to the machine, [GP 10](#). Disconnect the power lead from the customer supply while performing tasks that do not need electricity. Electricity can cause death or injury. Moving components can cause injury.

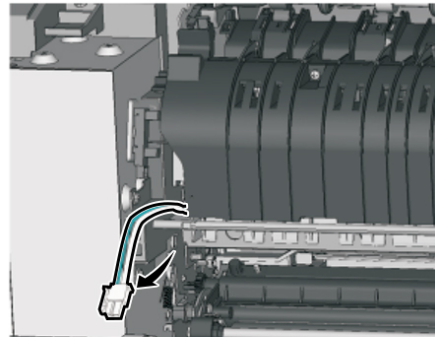
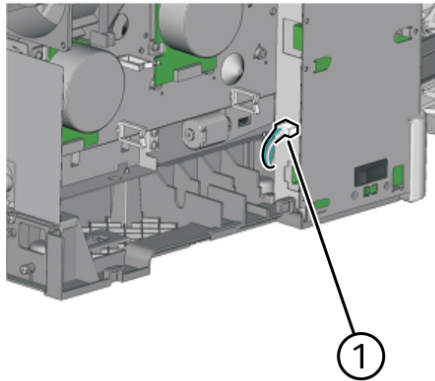

Figure 1 ESD Symbol

1. Remove the right cover.
2. Remove the left cover. See [REP 28.1](#)
3. Disconnect the cable (1) from the LVPS.
4. Position the fuser cable so that it can be pulled through from the front of the printer, and then guide the cable through the front.



CAUTION: Do not pull the cable too hard or cut the cable insulation.



VLC415S_4102

5. Remove the redrive belt (2) from the redrive pulley.

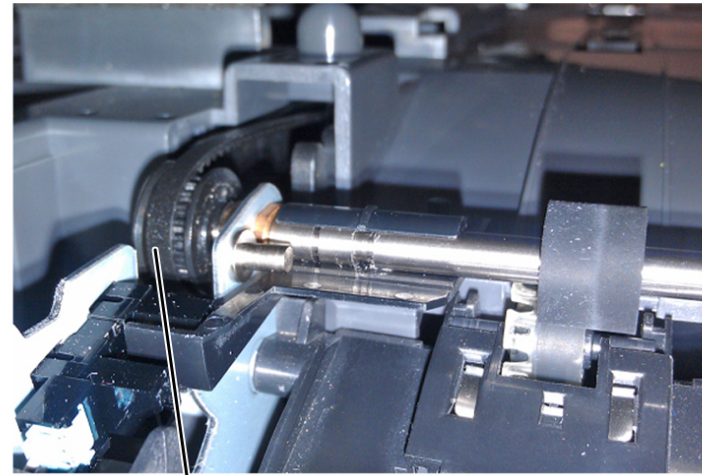

2

VLC415S_4103

6. Remove the bin full/narrow media sensor flag.
7. Remove the right output bin deflector.
8. Disconnect the cable (3), and then remove it from its retainer.

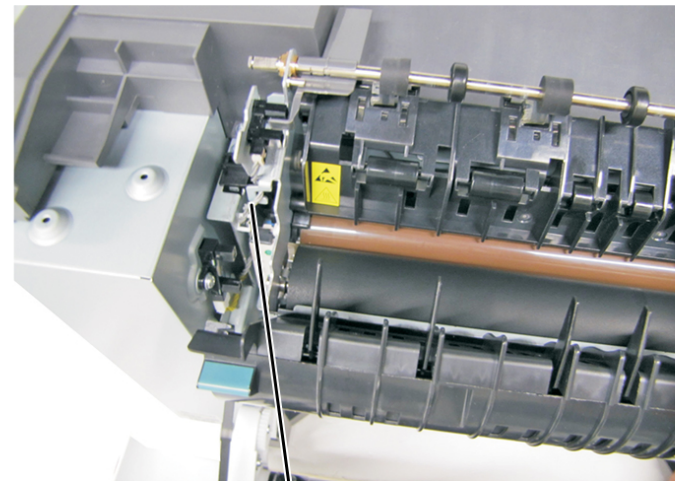

3

VLC415S_4104

9. Unhook the two springs (4) from both sides of the fuser.

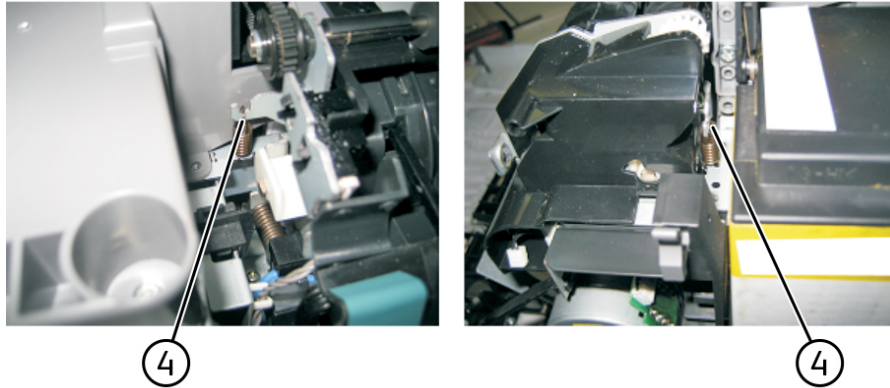

VLC415S_4105

10. Disconnect the two cables (5), and then pull them over the retainer.

11. Remove the screw (6).

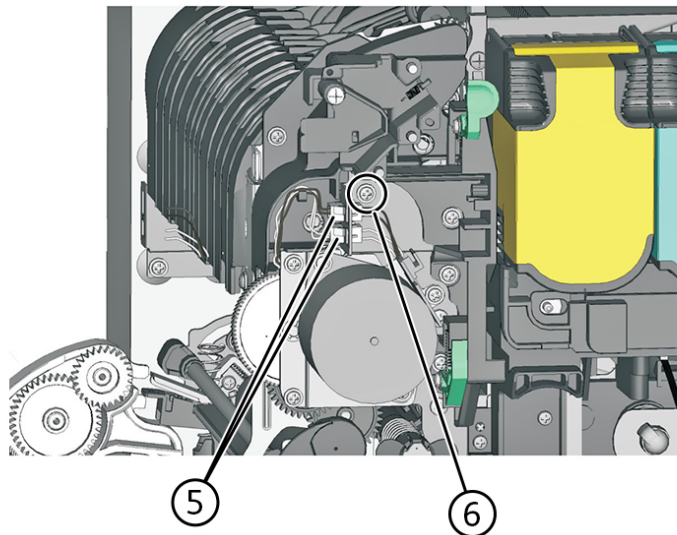

VLC415S_4106

Note: Do not lose the grounding washer.

12. Rotate the top of the fuser toward the front, and then slide the fuser to the left to align the fuser side frames with the flat area of the shaft.



CAUTION: Do not damage the sensor (fuser exit) on the left of the fuser when rotating.

13. Lift, and then remove the fuser.

Note:

- a. Install the flags (1) from the old fuser into the new fuser.

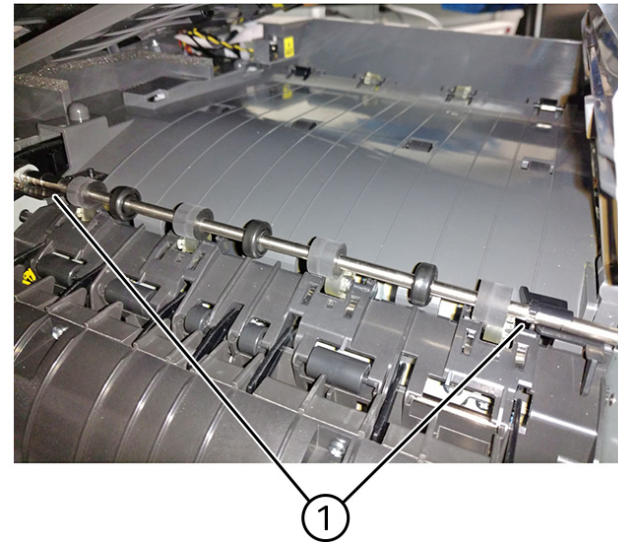

VLC415S_4107

- b. Enter the Diagnostics menu, and then navigate to: **Printer diagnostics & adjustments > Supply Reset > Fuser Reset**
- c. Select **Start**.
- d.
- e. Print approximately 15 test pages each in simplex and duplex modes to make sure that the belt is properly working and the flags are properly installed.
- f. Pay attention to noise that may indicate an improper belt installation.
- g. If a Remove media from output bin or a 34.04 error appears, check the fuser flags for proper installation.

Replacement

Replacement is the reverse of the removal procedure.

REP 10.2 Fuser Drive Motor

Parts List on [PL 10.05](#)

Removal



WARNING: Switch off the electricity to the machine, [GP 10](#). Disconnect the power lead from the customer supply while performing tasks that do not need electricity. Electricity can cause death or injury. Moving components can cause injury.



Figure 1 ESD Symbol

1. Remove the right cover.
2. Disconnect the cable (1).

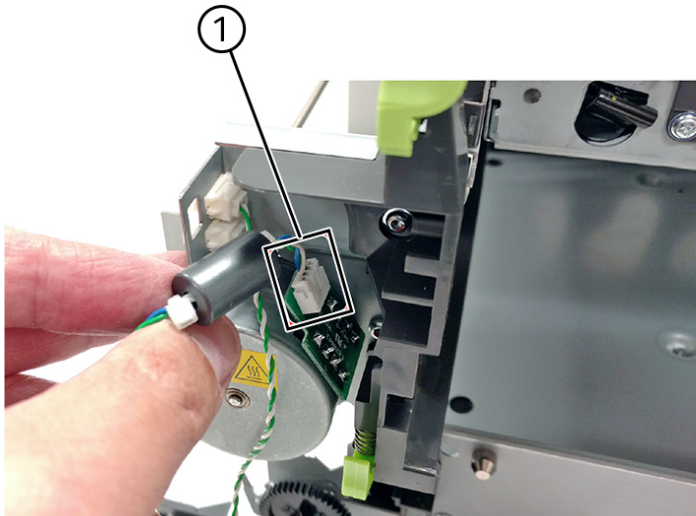

VLC4155_4024

3. Remove the two screws (2), and then remove the motor.

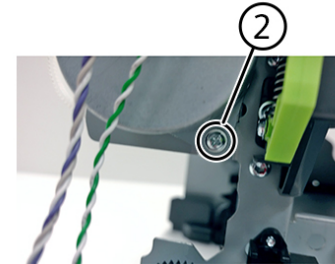
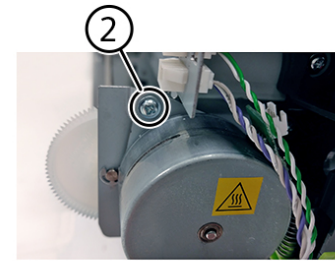

VLC4155_4025

Replacement

Replacement is the reverse of the removal procedure.

REP 10.3 Fuser Exit Sensor

Parts List on [PL 10.05](#)

Removal



WARNING: Switch off the electricity to the machine, [GP 10](#). Disconnect the power lead from the customer supply while performing tasks that do not need electricity. Electricity can cause death or injury. Moving components can cause injury.



Figure 1 ESD Symbol

1. Remove the left cover. See [REP 28.1](#)
2. Remove the cable (1) from its retainer (2).

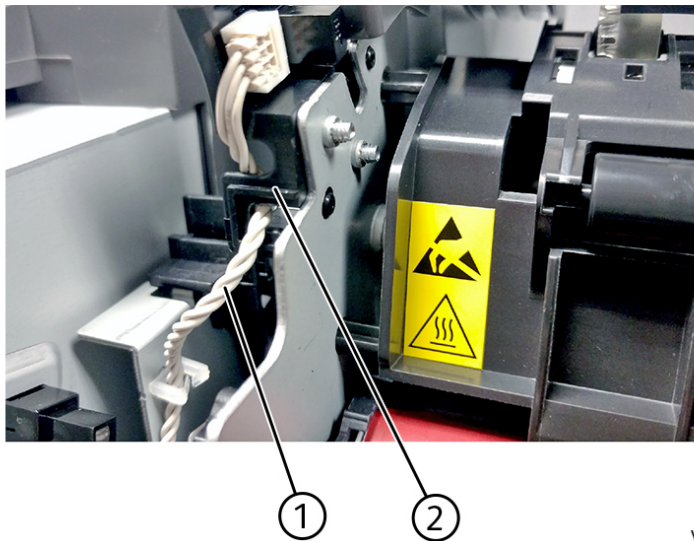

VLC415S_4016

3. Disconnect the cable (3).

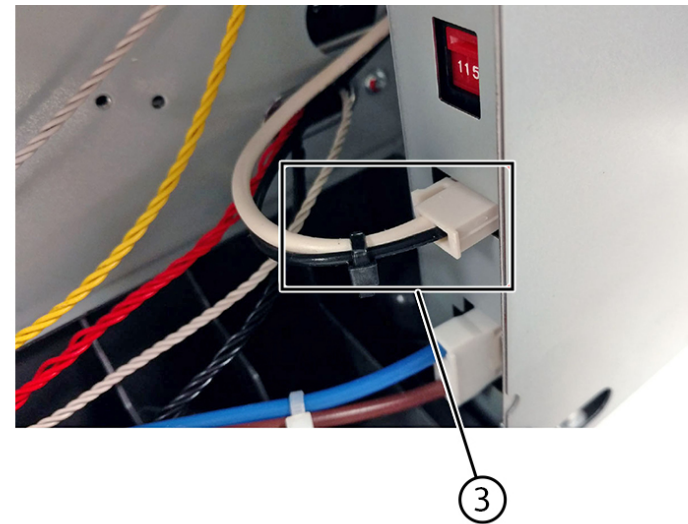

VLC415S_4017

4. Disconnect the cable (4).

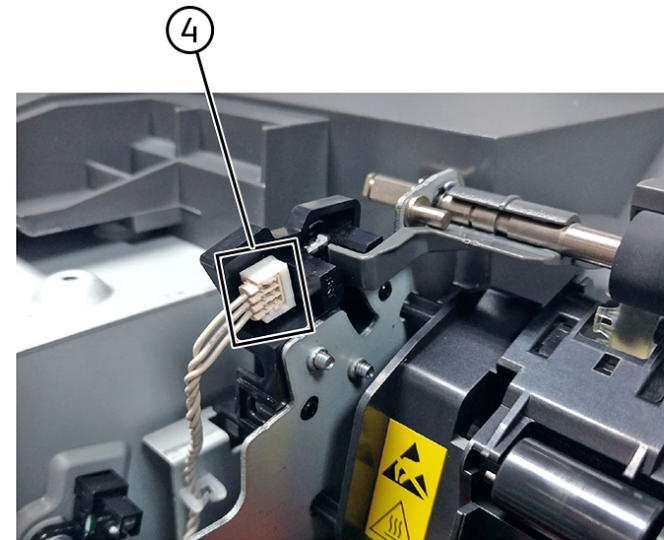

VLC415S_4018

5. Unhook the two springs (5) from both sides of the fuser.

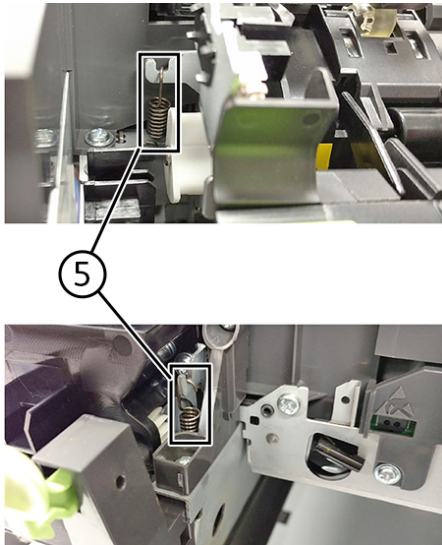

6. Disconnect the two thermistor cables (6), and then remove the screw (7).

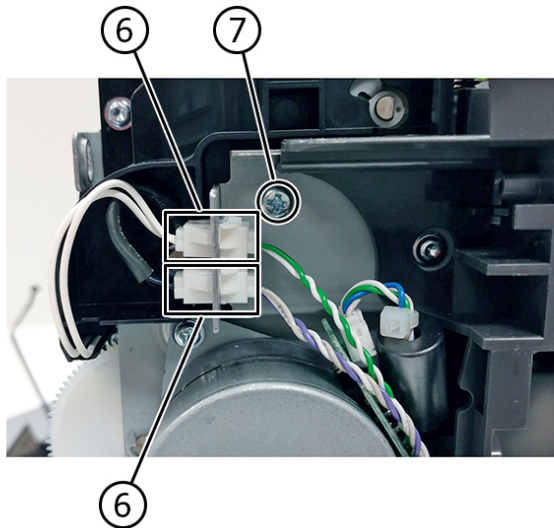

7. If the printer is an MFP, then remove the belt (8) from the pulley.

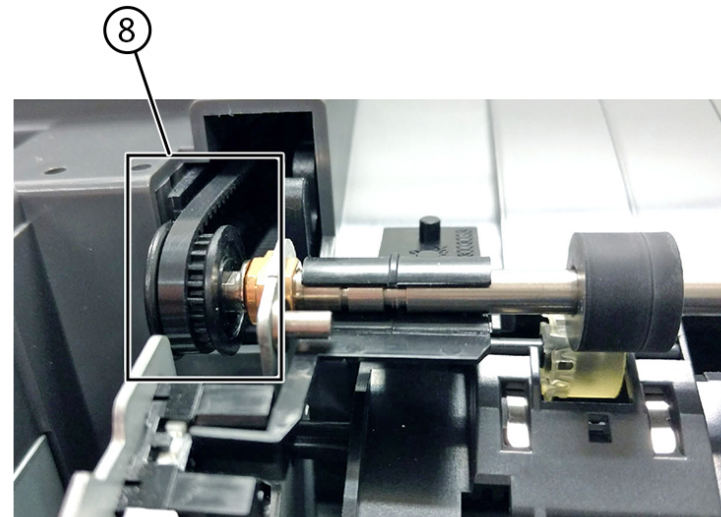

8. Rotate the fuser toward the front, disconnect the cable (9), and then remove the screw (10).

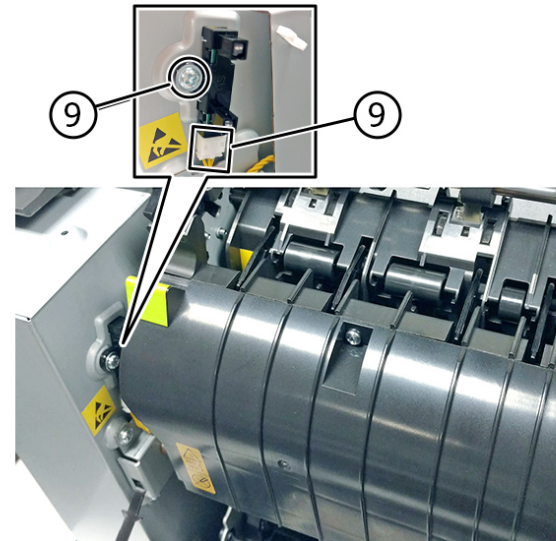

9. Using a flat-head screwdriver, remove the lower end of the sensor, and then gently pull the sensor from the frame.

REP 28.1 Left Cover

Parts List on [PL 28.10](#)

Removal



WARNING: Switch off the electricity to the machine, [GP 10](#). Disconnect the power lead from the customer supply while performing tasks that do not need electricity. Electricity can cause death or injury. Moving components can cause injury.



Figure 1 ESD Symbol

1. Remove the two screws (1).

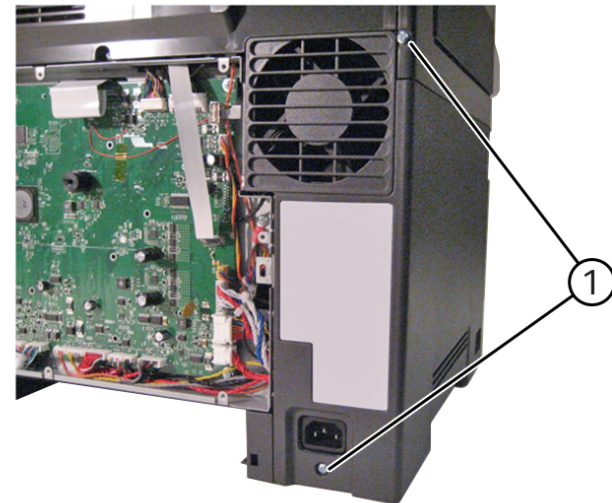

VLC415S_4004

2. Remove one screw (2).



VLC415S_4005

3. Place the left side of the printer on the edge of the table, and then remove the cover.

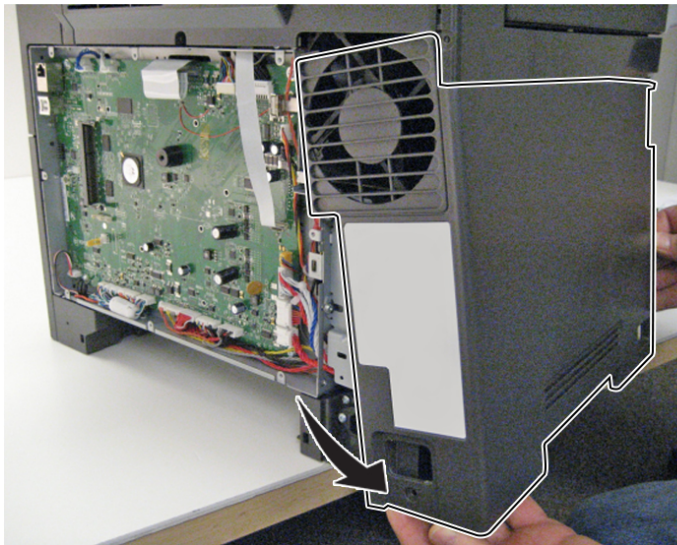

VLC415S_4006

Note: When replacing the left cover, flex the cover slightly to engage the tab near the power switch.

REP 28.2 Lower Left Subframe

Parts List on [PL 28.10](#)

Removal



WARNING: Switch off the electricity to the machine, [GP 10](#). Disconnect the power lead from the customer supply while performing tasks that do not need electricity. Electricity can cause death or injury. Moving components can cause injury.



Figure 1 ESD Symbol

Note: The lower left frame and lower right frame are in the same FRU.

1. Remove the tray insert.
2. Remove the screw (1).

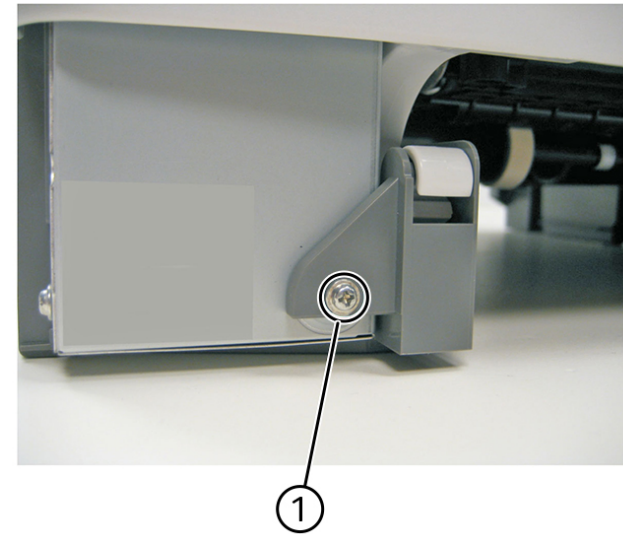

VLC415S_4111

3. Remove the waste toner bottle. See [REP 90.4](#)
4. Remove the imaging kit. See [REP 60.4](#)
5. Remove the left cover. See [REP 28.1](#)
6. Disconnect the three cables (2).

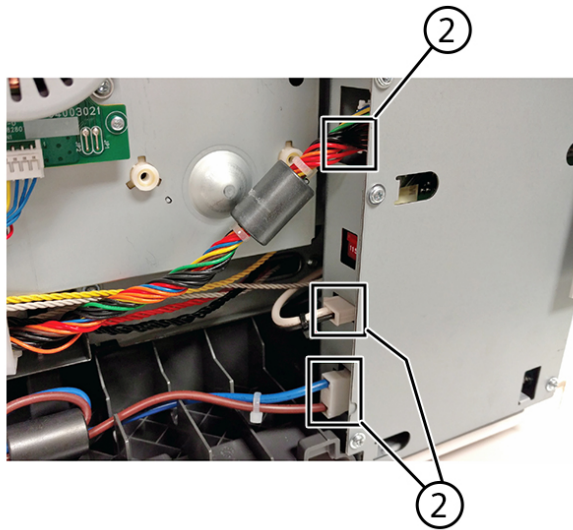

- 7. Remove the flatbed scanner assembly.
- 8. Remove the five screws (3).

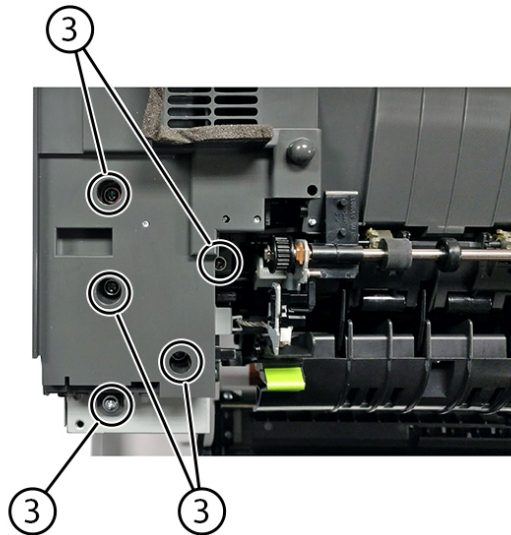

- 9. Position the fuser cable (4) so that it can be pulled through from the front of the printer, and then guide the cable through the front.



WARNING: Do not pull the cable too hard or cut the cable insulation.

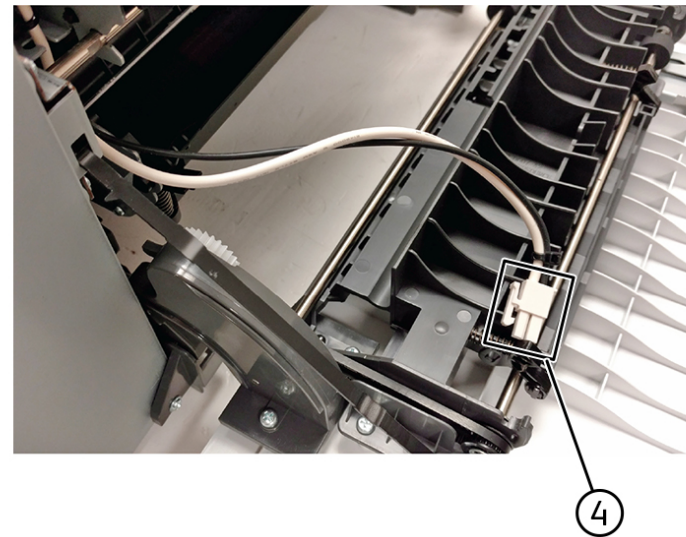

- 10. Remove the bin full/narrow media sensor flag.
- 11. Disconnect the cable (5), and then remove it from its retainer.

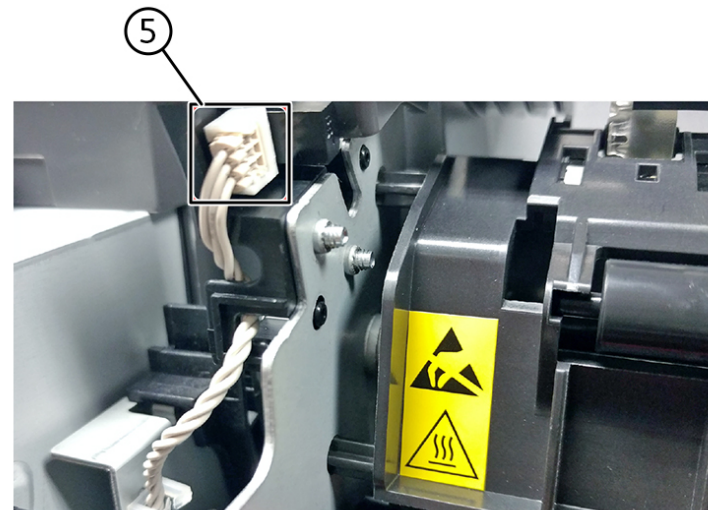

- 12. Unhook the two springs (6) from both sides of the fuser.

VLC415S_4112

VLC415S_4114

VLC415S_4113

VLC415S_4115

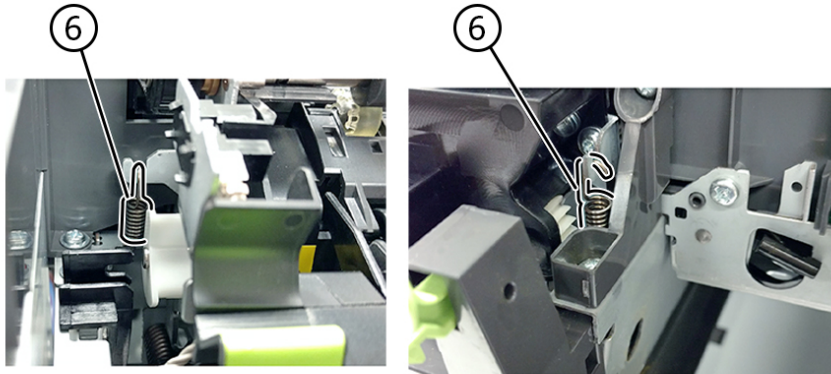

VLC415S_4116

13. Disconnect the two cables (7), and then pull them over the retainer.
 14. Remove the screw (8).

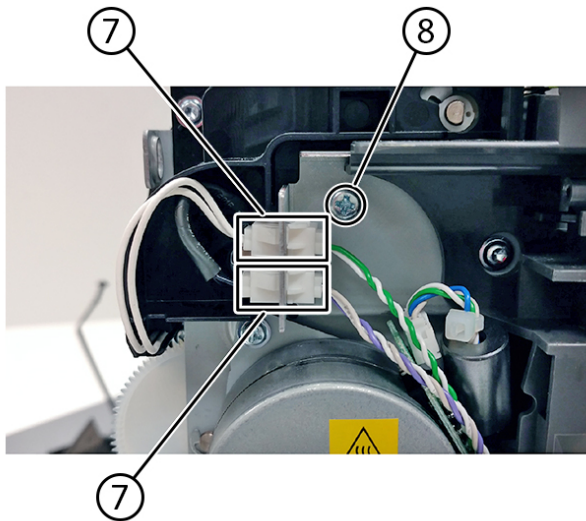

VLC415S_4117

- Note:** Do not lose the grounding washer.
 15. Remove the two screws (9).

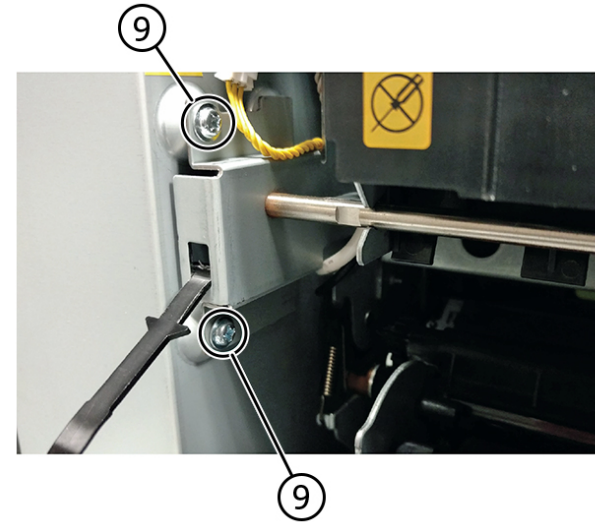

VLC415S_4118

16. Rotate the top of the fuser toward the front, and then slide the fuser to the left to align the fuser side frames with the flat area of the shaft.
 17. Disconnect the cable (10).



VLC415S_4119

18. Lift the front left corner of the top cover, and then tilt the LVPS cage (11) to remove the cage.

- Note:**
- At the bottom of the cage on the left side, disengage the two posts.

- Pay attention to the sensor (fuser exit) which remains on the cage.

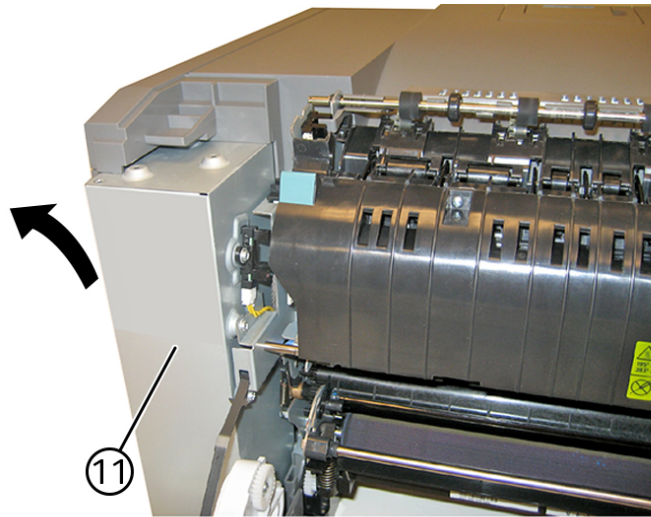

VLC415S_4120

19. Place the printer on its right side.
20. Remove the connector (12).

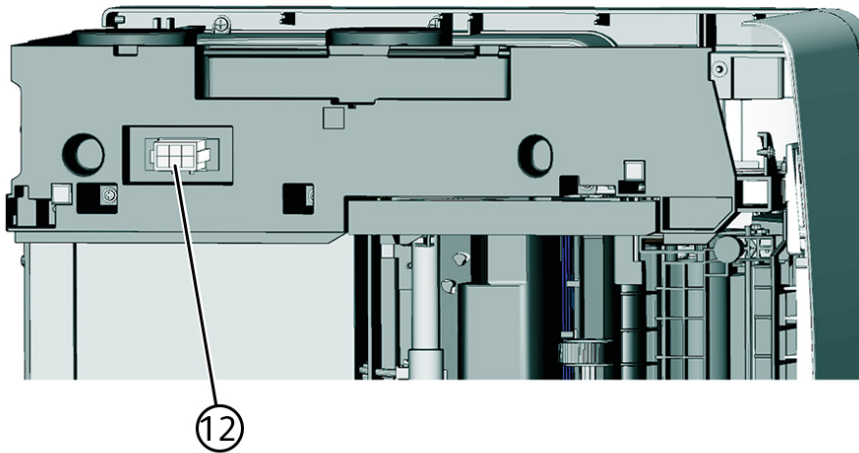

VLC415S_4121

21. At the rear of the printer, remove the five screws (13).

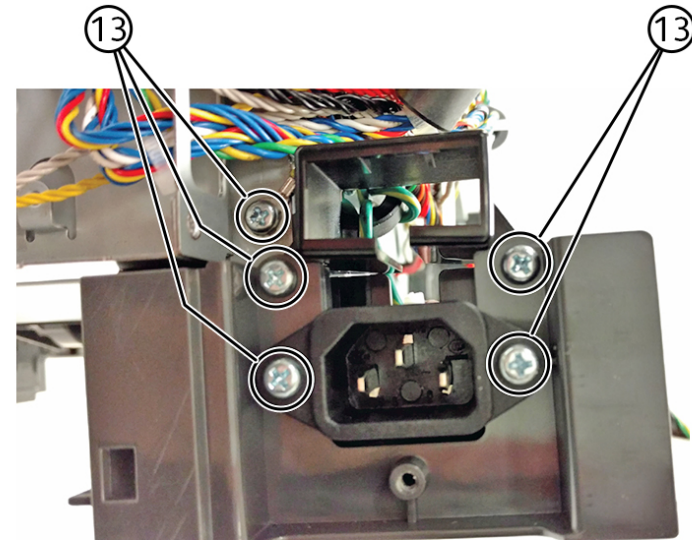

VLC415S_4122

22. Remove the AC receptacle from the lower left frame.
23. Remove the three screws (14).

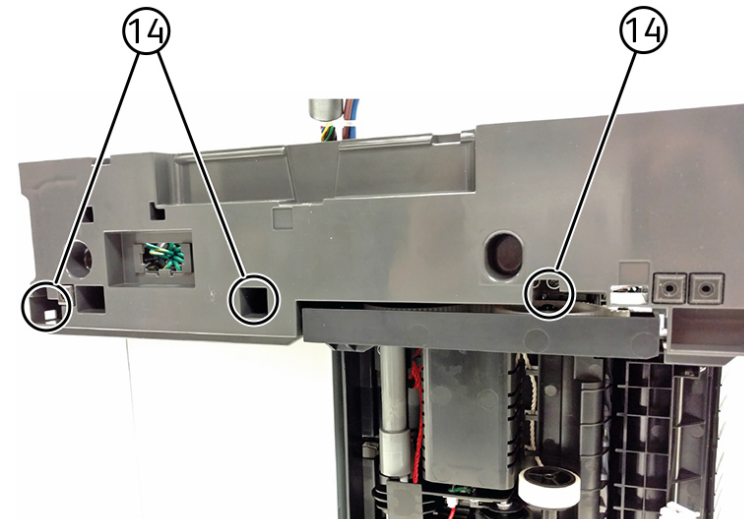

VLC415S_4123

24. Tilt the front door down, detach the door from the frame, and then remove the screw (15).

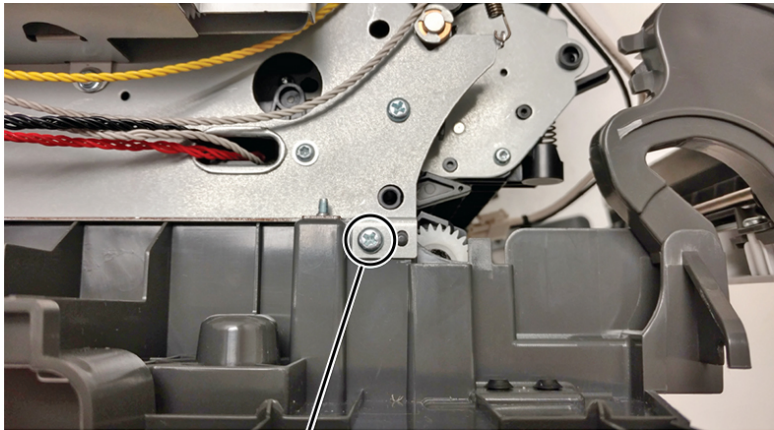

15

25. Swing the lower left frame away from the printer to remove it.

VLC415S_4124

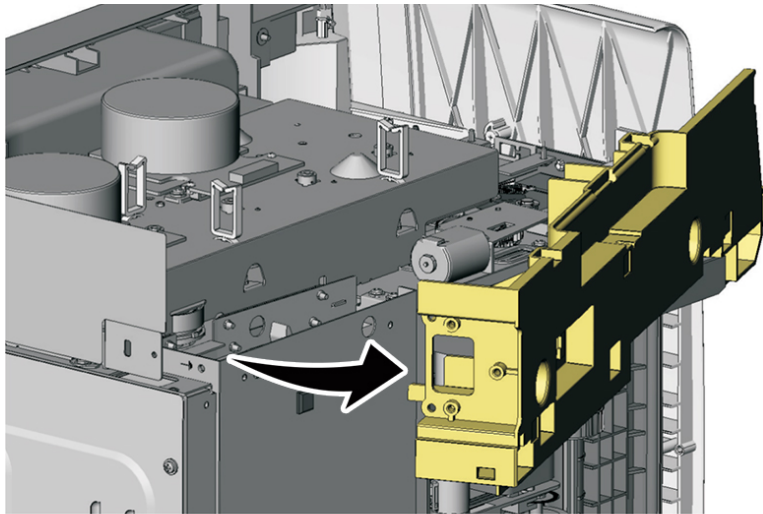

VLC415S_4125

Replacement

Replacement is the reverse of the removal procedure.

REP 28.3 Lower Right Subframe

Parts List on [PL 28.10](#)

Removal



WARNING: Switch off the electricity to the machine, [GP 10](#). Disconnect the power lead from the customer supply while performing tasks that do not need electricity. Electricity can cause death or injury. Moving components can cause injury.



Figure 1 ESD Symbol

1. Remove the tray insert.
2. Remove the waste toner bottle. See [REP 90.4](#)
3. Remove the imaging kit. See [REP 60.4](#)
4. Remove the screw (1), and then remove the four screws (2).

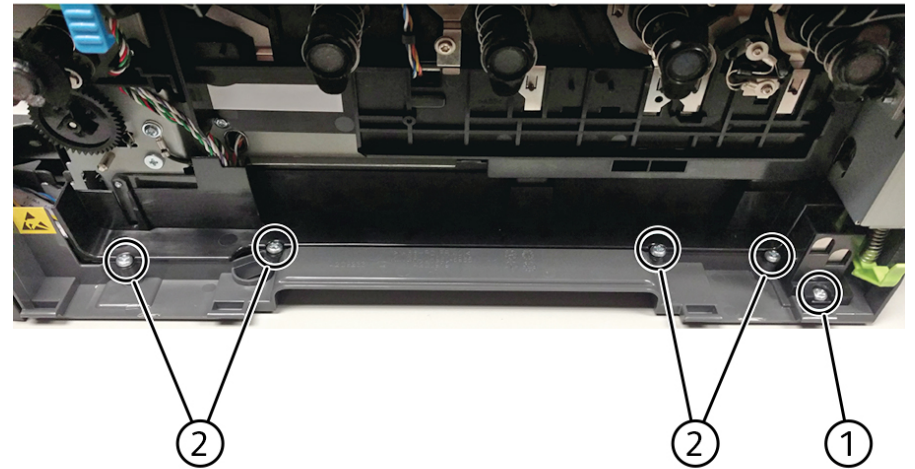

VLC415S_4126

Note:

- Do not unplug the waste toner bottle sensor contact.
 - The cable cover is part of the lower right frame.
5. Place the printer on its left side.
 6. Remove the four screws (3).

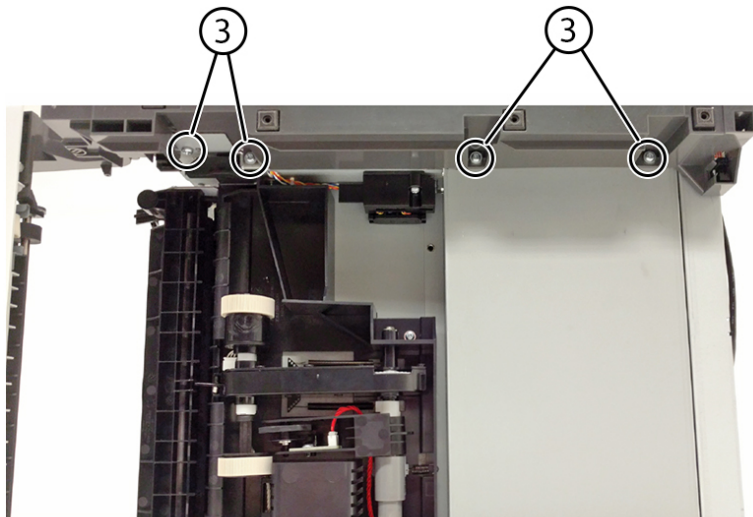

VLC415S_4127

7. Lift the lower right frame pin (4) out of the hole on the printer frame.

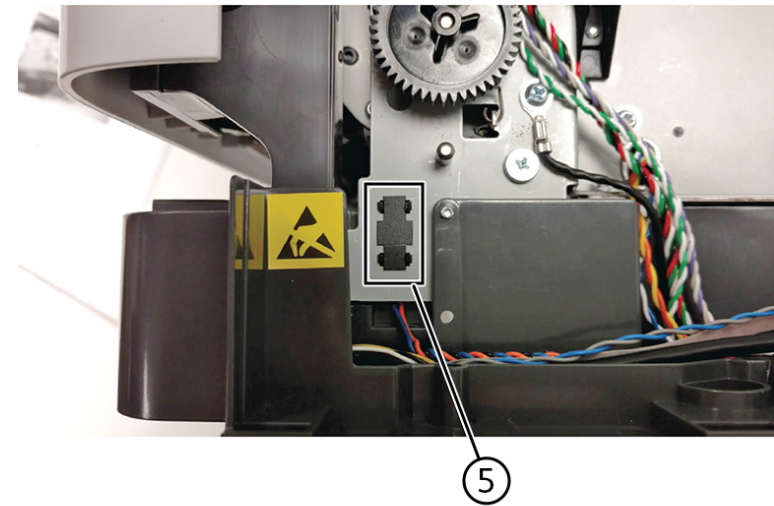

VLC415S_4129

9. Remove the sensor, and then disconnect the cable (6).

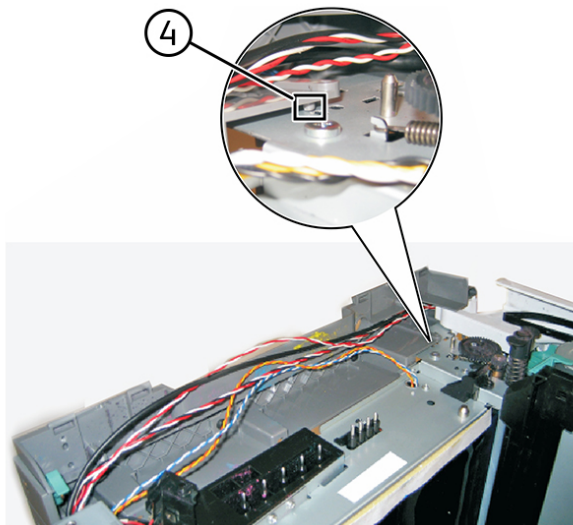

VLC415S_4128

8. Remove the sensor retainer plate (5).

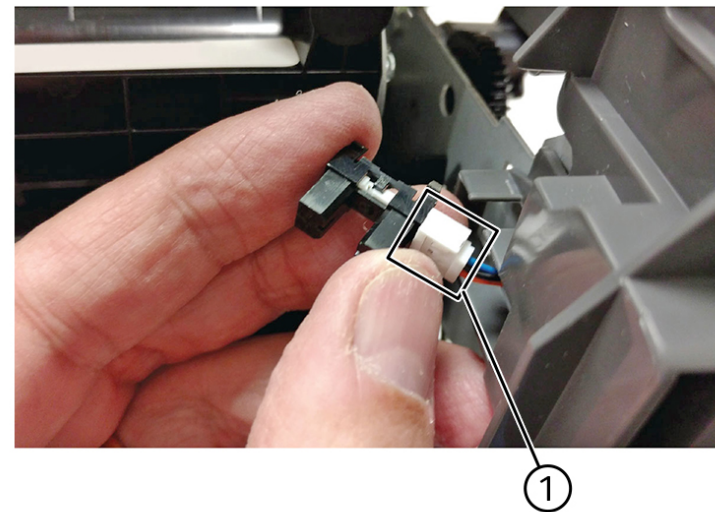

VLC415S_4130

10. Swing the rear part away from the printer, and then remove the spring (7).

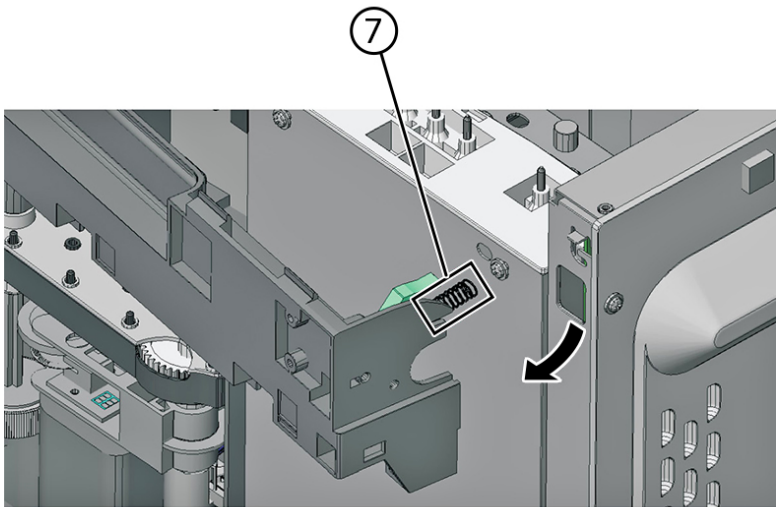

VLC415S_4131

11. Disconnect the cable (8).

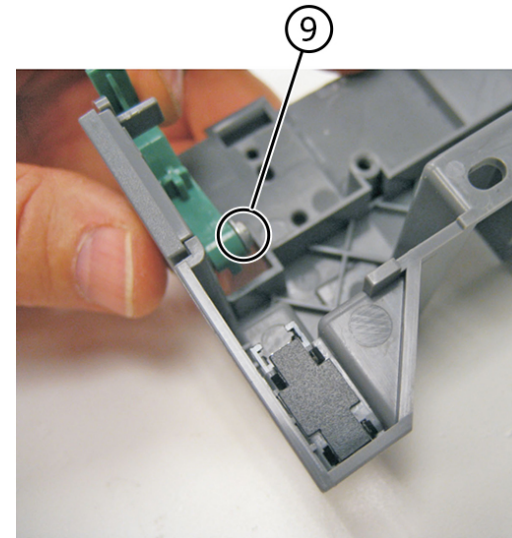

VLC415S_4133

14. Disconnect the cable (10), remove the screw (11), and then remove the sensor (12).

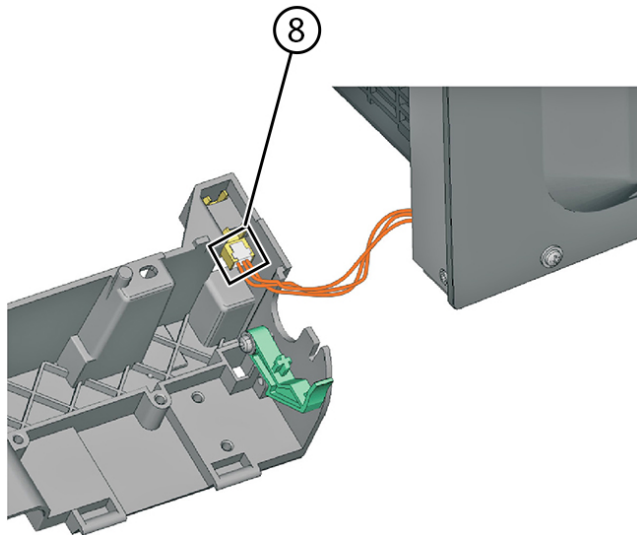

VLC415S_4132

12. Swing the rear of the lower right frame away from the printer to remove it.

13. From inside the lower right frame, remove the screw (9), and then remove the spring bracket.

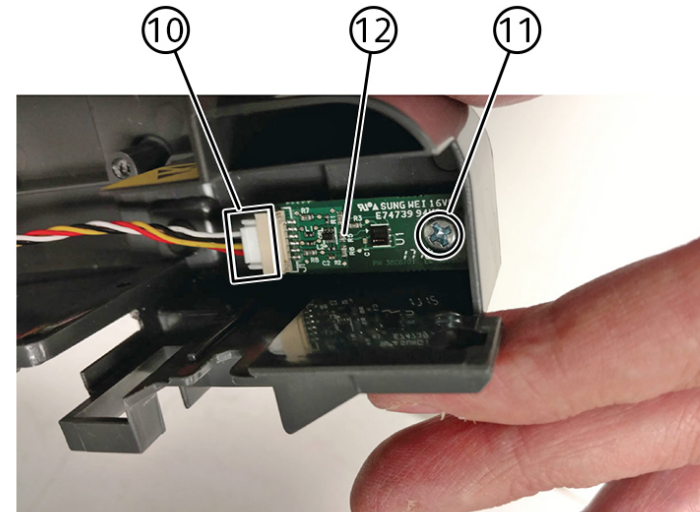

VLC415S_4134

Note:

- a. Reinstall the spring bracket and the weather station.
- b. Before installing the lower right frame, connect the cable to the sensor (tray present), and then put the spring in place.
- c. Install the weather station on the new lower right frame.

Replacement

Replacement is the reverse of the removal procedure.

REP 28.4 Top Cover

Parts List on [PL 28.05](#)

Removal



WARNING: Switch off the electricity to the machine, [GP 10](#). Disconnect the power lead from the customer supply while performing tasks that do not need electricity. Electricity can cause death or injury. Moving components can cause injury.



Figure 1 ESD Symbol

1. Remove the flatbed scanner. See [REP 60.2](#)
2. Remove the two screw (1).

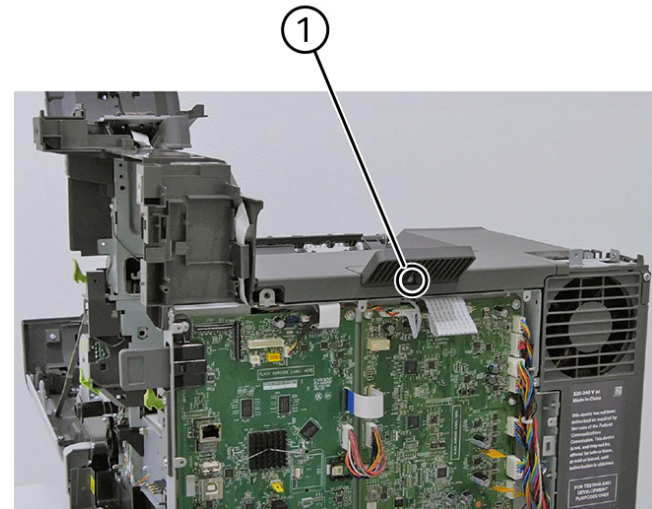

VLC415S_4162

3. Remove the bin extender (2).

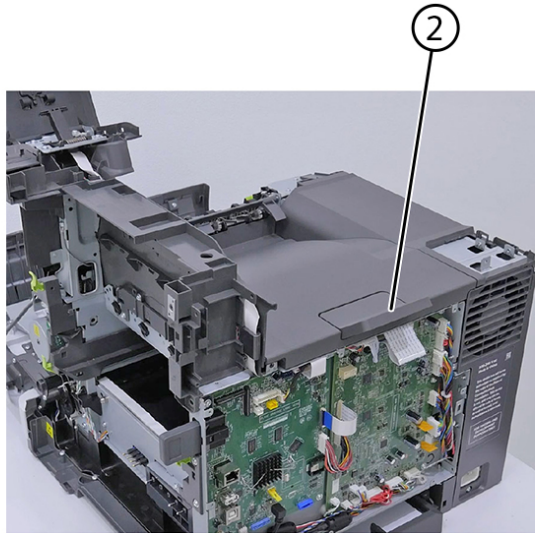

4. Remove the screw (3).

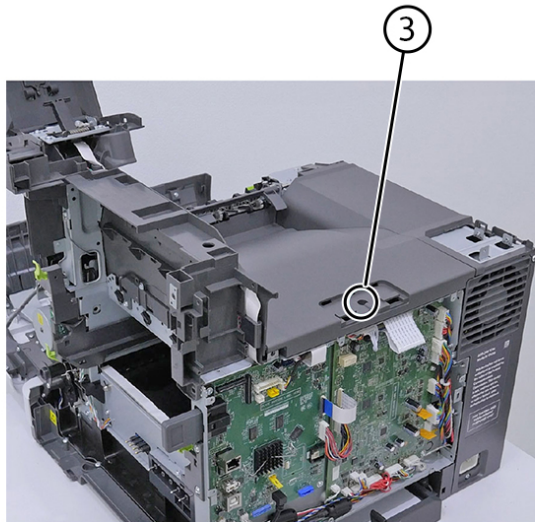

5. Remove the top cover.

Replacement

Replacement is the reverse of the removal procedure.

REP 28.5 Rear Cover

Parts List on [PL 28.05](#)

Removal



WARNING: Switch off the electricity to the machine, [GP 10](#). Disconnect the power lead from the customer supply while performing tasks that do not need electricity. Electricity can cause death or injury. Moving components can cause injury.



Figure 1 ESD Symbol

1. Remove the eight screws (1).

VLC415S_4163

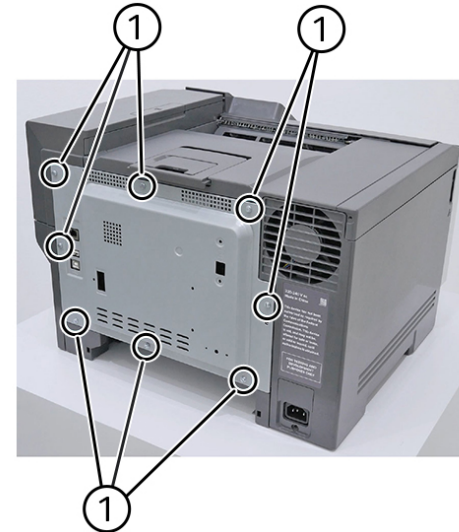

2. Remove the rear cover.

VLC415S_4266

REP 28.6 Front Door Assembly

Parts List on [PL 28.05](#)

Removal



WARNING: Switch off the electricity to the machine, [GP 10](#). Disconnect the power lead from the customer supply while performing tasks that do not need electricity. Electricity can cause death or injury. Moving components can cause injury.



Figure 1 ESD Symbol

1. Remove the tray insert.
2. Open the front door.
3. Remove the six screws (1).

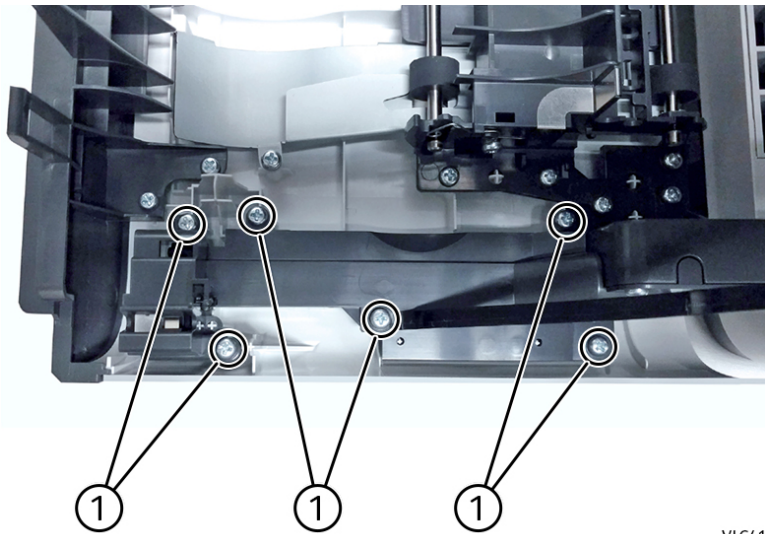

VLC415S_4061

4. Remove the three screws (2).

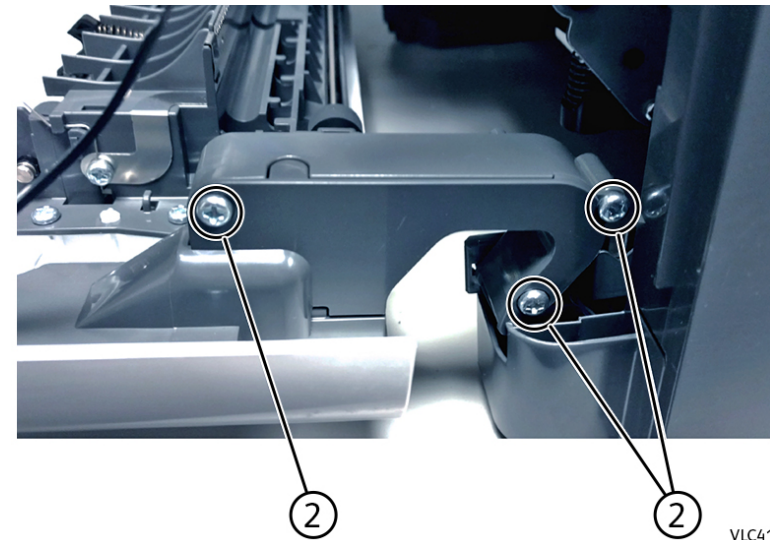

VLC415S_4062

5. Release the left and right door straps.

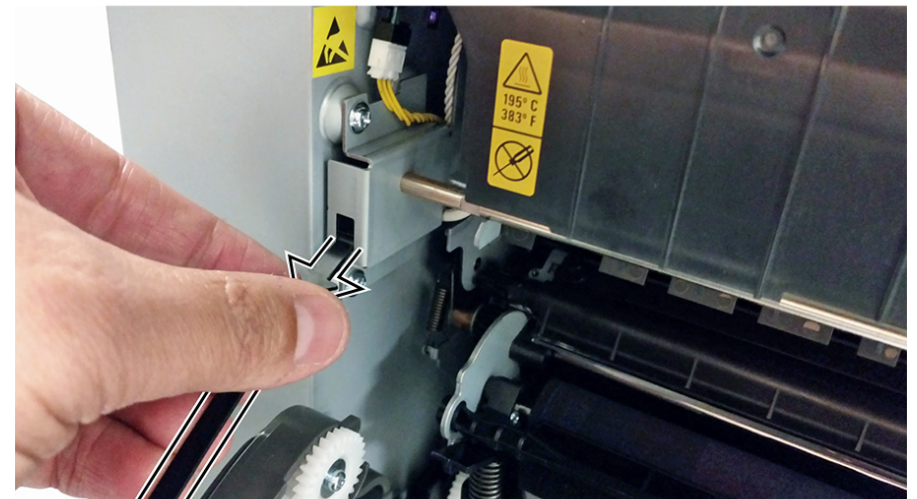

VLC415S_4063

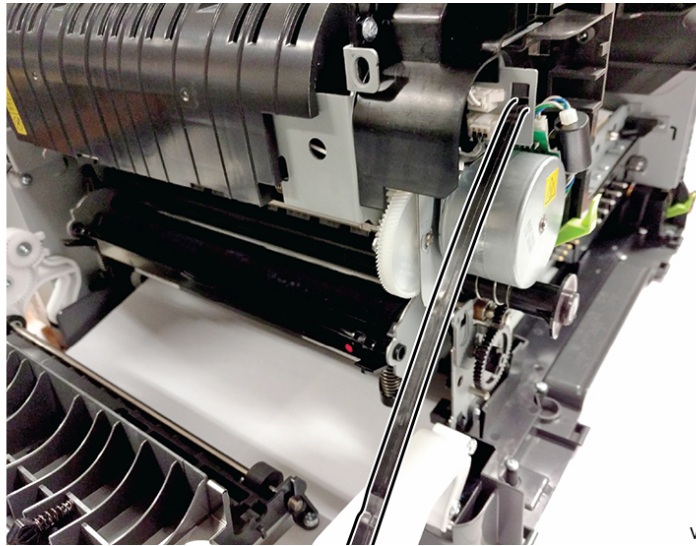

6. Remove the wireless card.
7. Route the interlock switch cover assembly (3) away from the door.

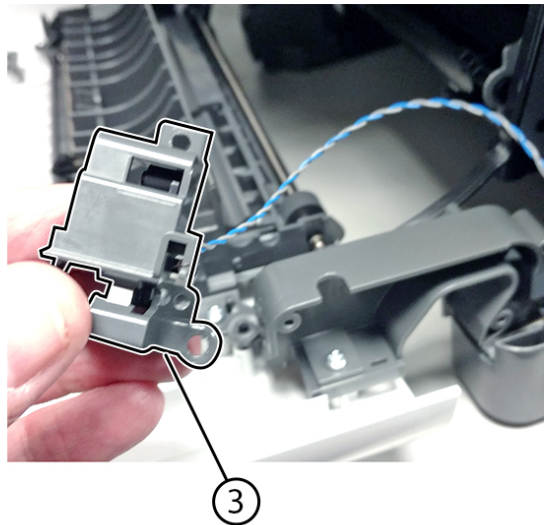

8. Remove the left hinge (4) from the left subframe.

VLC415S_4064

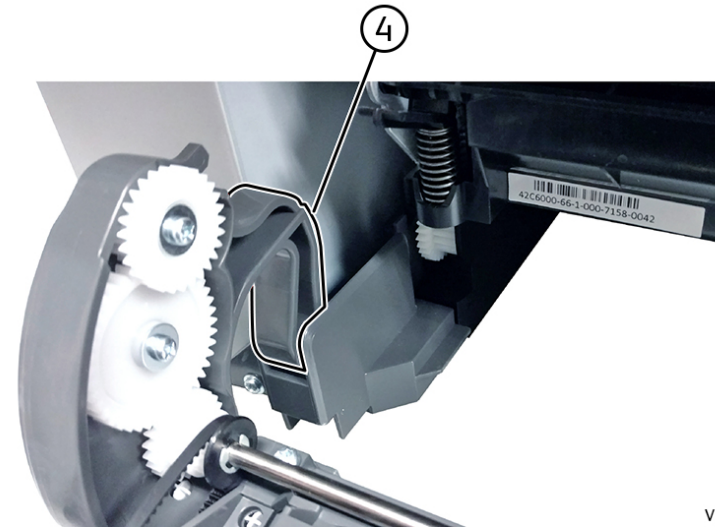

9. Remove the right hinge (5) from the right subframe.

VLC415S_4066

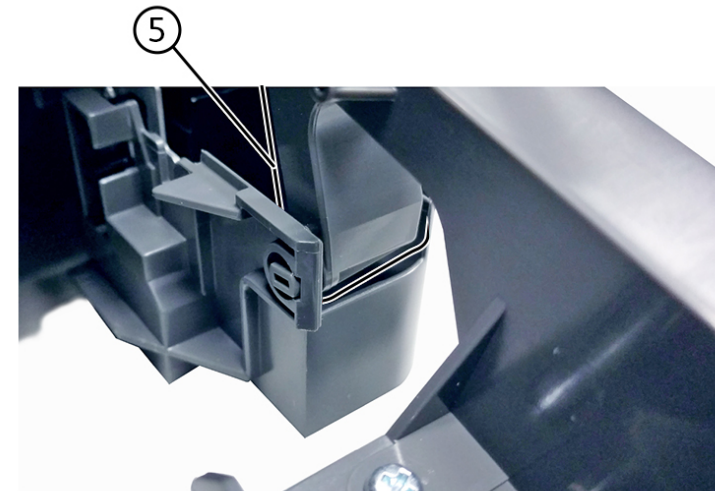

10. Remove the front middle cover.

VLC415S_4067

Replacement

Replacement is the reverse of the removal procedure.

REP 28.7 Front Door Inner Paper Feed Guide

Parts List on [PL 80.05](#)

Removal



WARNING: Switch off the electricity to the machine, [GP 10](#). Disconnect the power lead from the customer supply while performing tasks that do not need electricity. Electricity can cause death or injury. Moving components can cause injury.



Figure 1 ESD Symbol

1. Open the front door.
2. Release the two door straps (1) from the frame.

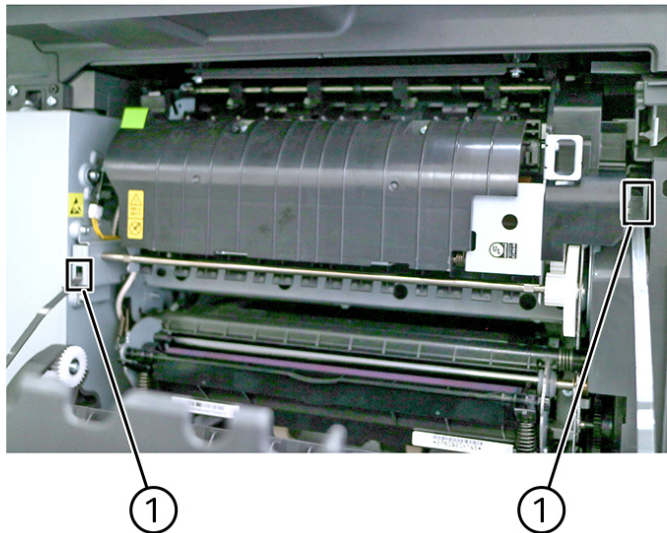

VLC415S_4068

3. Remove the nine screws (2), and then remove the deflector.

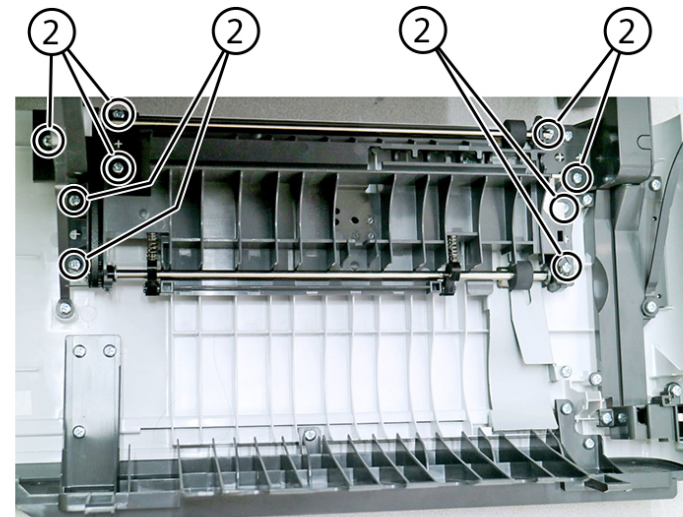

VLC415S_4069

Replacement

Replacement is the reverse of the removal procedure.

REP 40.1 Main Drive Gearbox

Parts List on [PL 40.05](#)

Removal



WARNING: Switch off the electricity to the machine, [GP 10](#). Disconnect the power lead from the customer supply while performing tasks that do not need electricity. Electricity can cause death or injury. Moving components can cause injury.



Figure 1 ESD Symbol

1. Open the front door.
2. Remove the right cover.
3. Remove the toner cartridges.
4. Remove the waste toner bottle.
5. Remove the imaging kit.
6. Remove the two screws (1) at the back.



VLC415S_4223

7. Remove the screw (2) on the left side, and then remove the left cover.

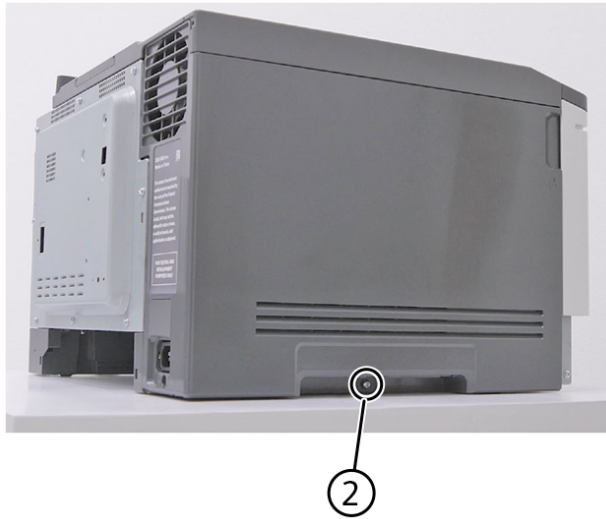

VLC415S_4224

8. Disconnect the connectors (3) from the EP drive.

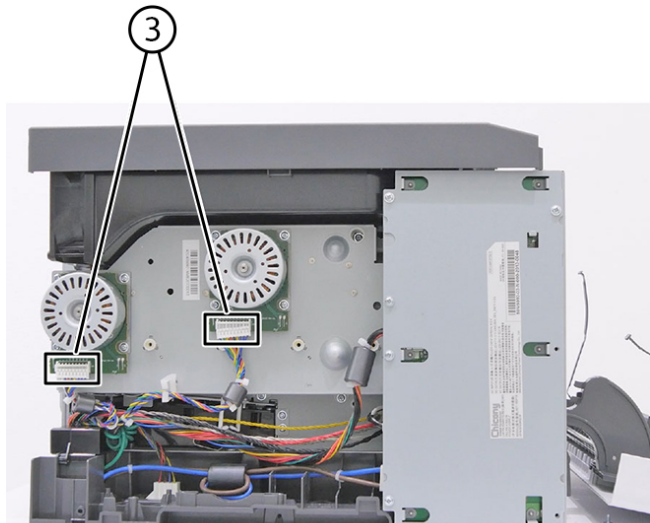

VLC415S_4225

9. Remove the three screws (4).

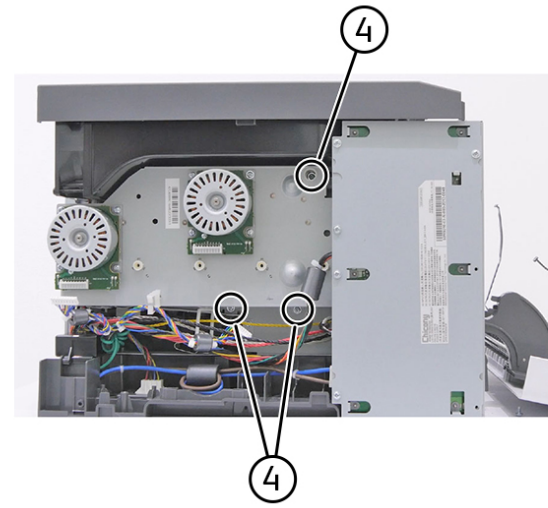

VLC415S_4226

10. Remove the two screws (5).

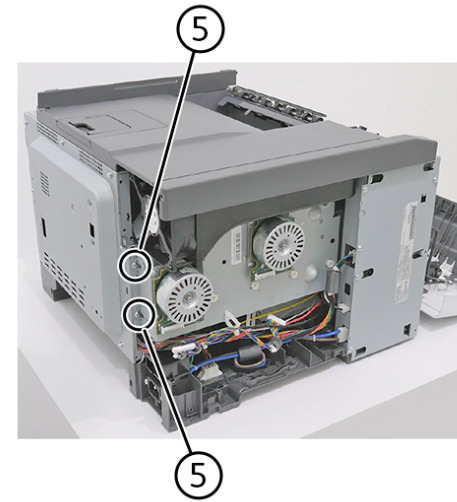

VLC415S_4227

11. Remove the EP drive.

REP 60.1 Printhead

Parts List on [PL 60.05](#)

Removal



WARNING: Switch off the electricity to the machine, [GP 10](#). Disconnect the power lead from the customer supply while performing tasks that do not need electricity. Electricity can cause death or injury. Moving components can cause injury.



Figure 1 ESD Symbol

1. Remove the top cover. See [REP 28.4](#)
2. Remove the three screws (2), and then remove the printhead.

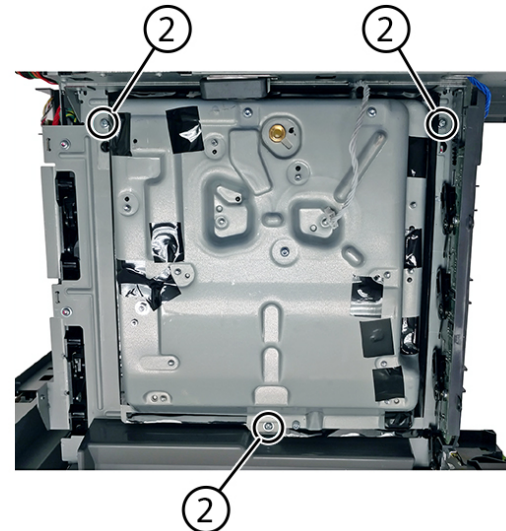

VLC415S_4175

Replacement

Replacement is the reverse of the removal procedure.

REP 60.2 Flatbed Scanner

Parts List on [PL 60.10 item 1](#)

Removal



WARNING: Switch off the electricity to the machine, [GP 10](#). Disconnect the power lead from the customer supply while performing tasks that do not need electricity. Electricity can cause death or injury. Moving components can cause injury.



Figure 1 ESD Symbol

1. Remove the DADF. See [REP 5.1](#)
2. Remove the control panel base cover (1).



2

VLC415S_4212

4. Remove the three screws (3).

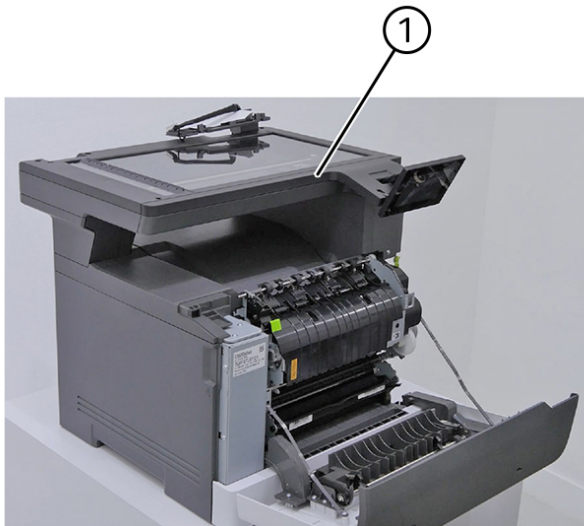

1

VLC415S_4211

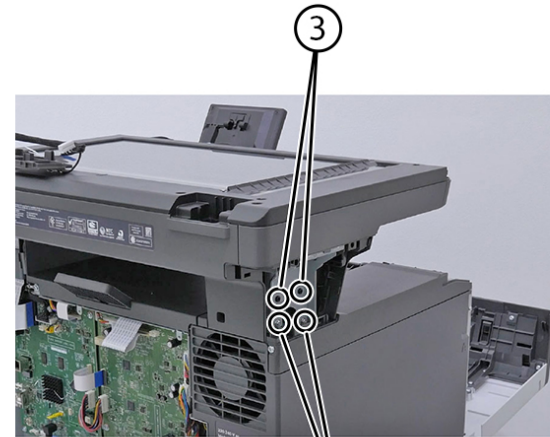

3

3

VLC415S_4213

3. Remove the scanner left rear access cover (2).

5. Remove the scanner right rear access cover (4).

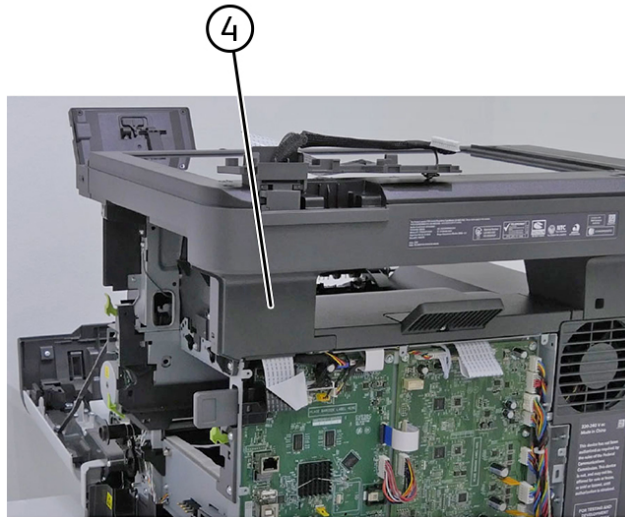

VLC415S_4214

6. Disconnect the connector (5).

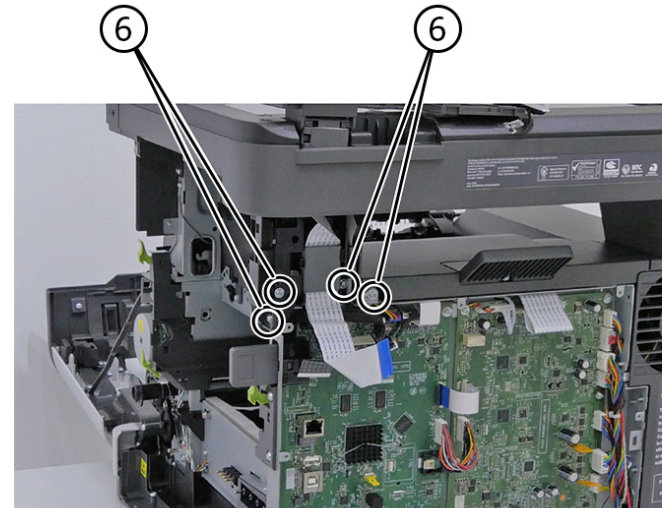

VLC415S_4216

8. Remove the three screws (7).

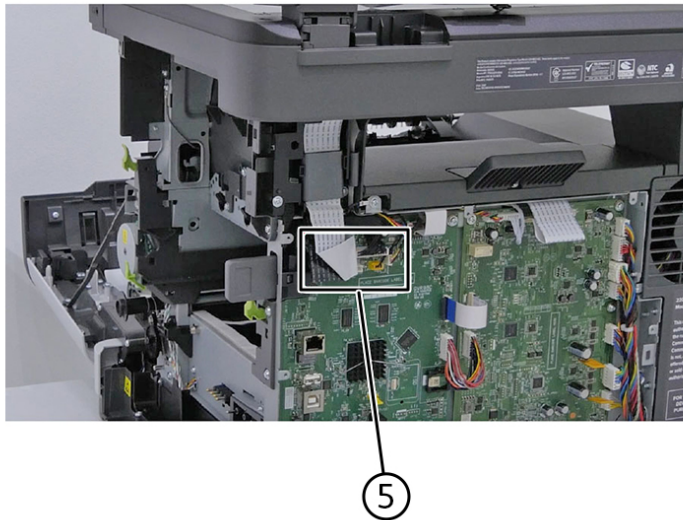

VLC415S_4215

7. Remove the three screws (6).

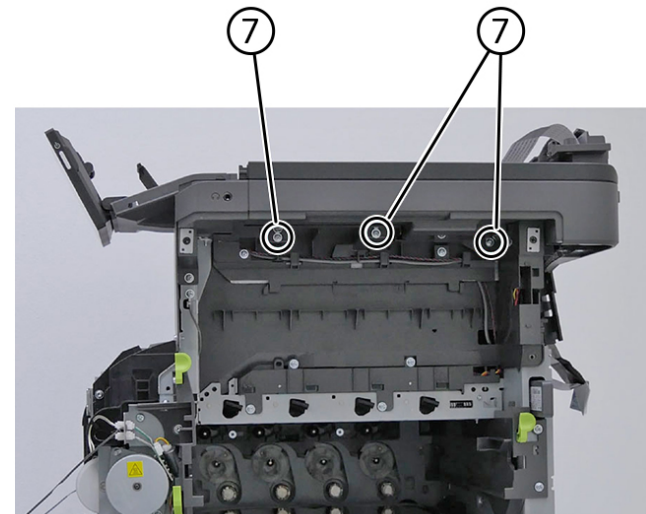

VLC415S_4217

9. Remove the two screws (8).

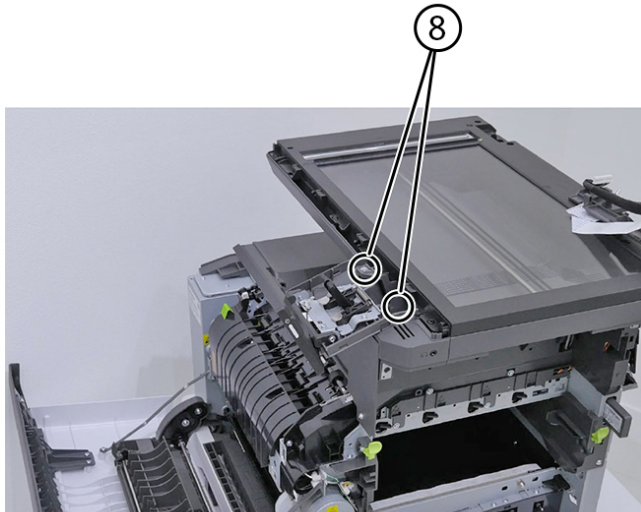

VLC415S_4218

10. Remove the flatbed scanner (9).

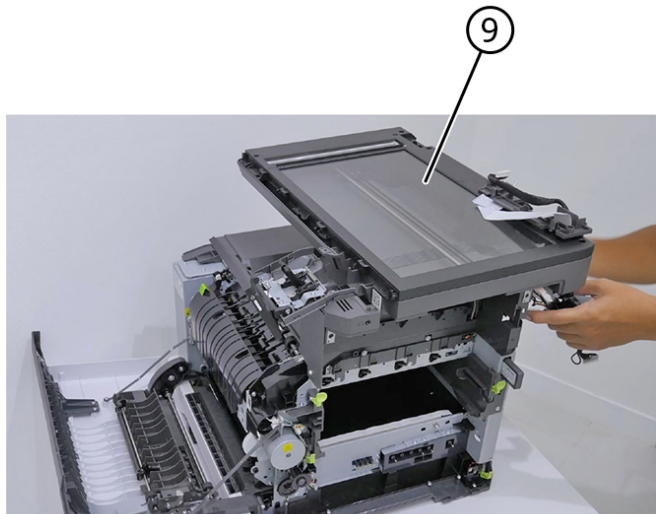

VLC415S_4219

Replacement

Replacement is the reverse of the removal procedure.

REP 60.3 Scanner Right Support

Parts List on [PL 28.10](#)

Removal



WARNING: Switch off the electricity to the machine, [GP 10](#). Disconnect the power lead from the customer supply while performing tasks that do not need electricity. Electricity can cause death or injury. Moving components can cause injury.



Figure 1 ESD Symbol

1. Remove the top cover. See [REP 28.4](#)
2. Disconnect the connectors (1).

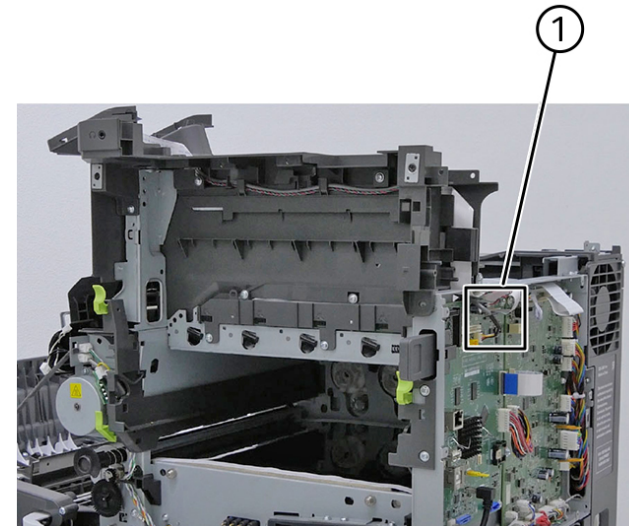

VLC415S_4201

3. Remove the six screws (2).

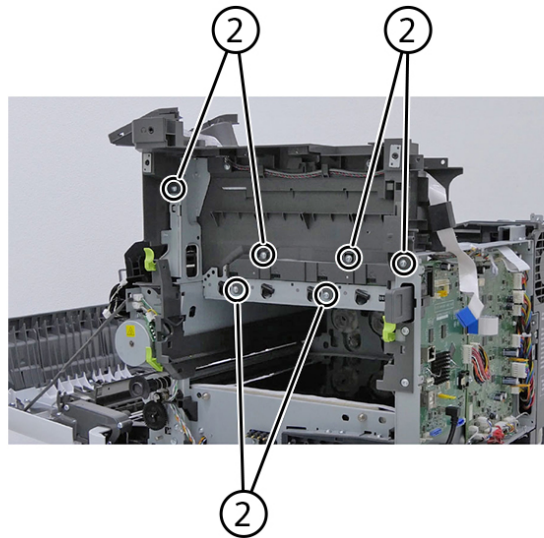

4. Remove the scanner support right cover (3).

VLC415S_4202

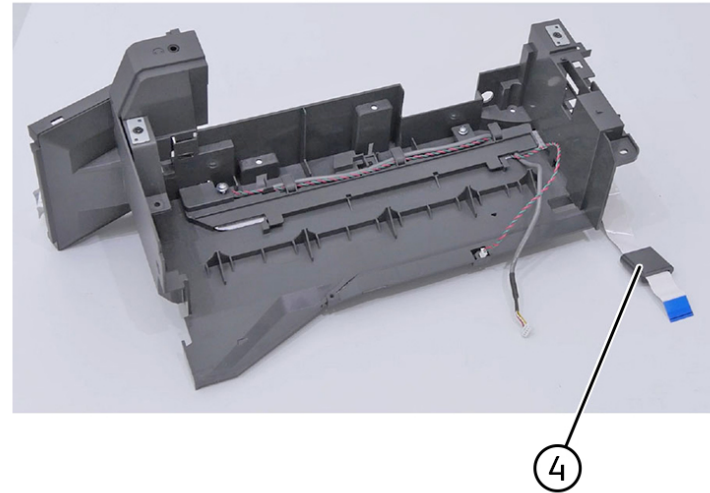

VLC415S_4204

6. Remove the two screws (5).

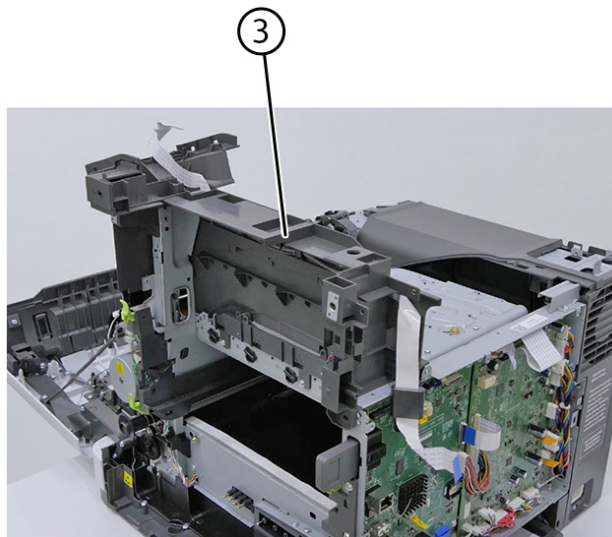

5. Remove the toroid (4).

VLC415S_4203

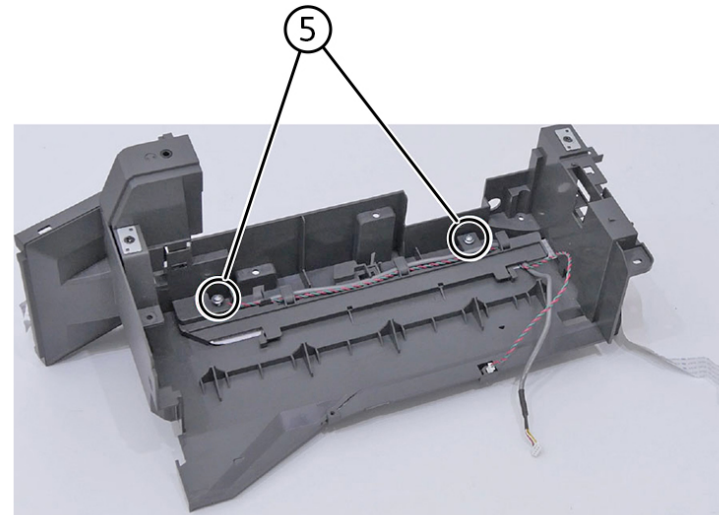

VLC415S_4205

7. Remove the cable cover (6).

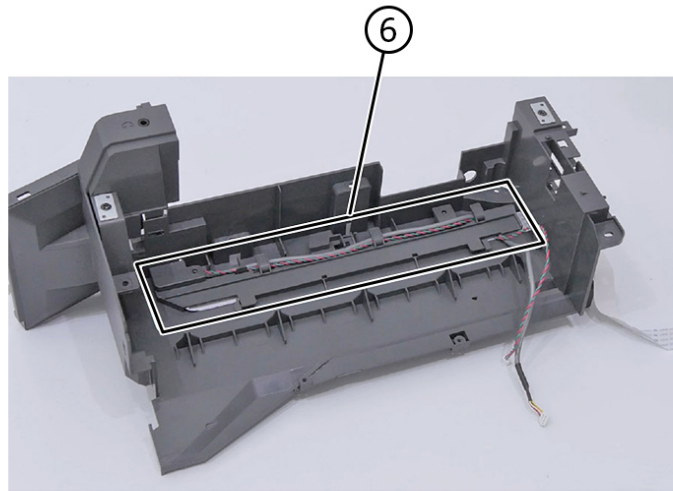

VLC415S_4206

8. Unroute the cables (7).

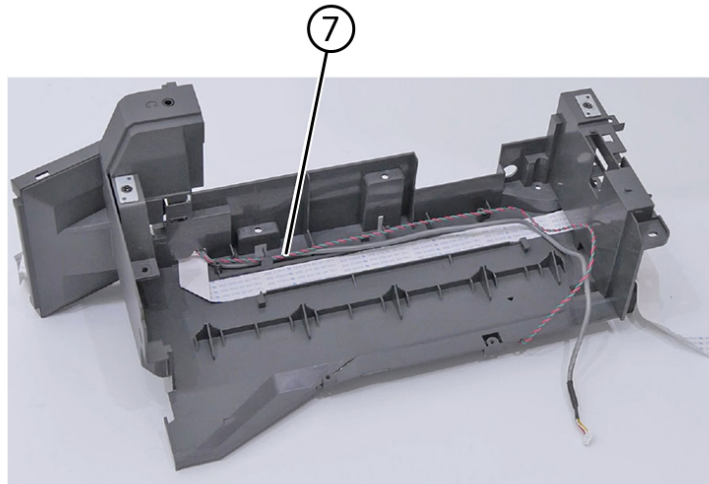

VLC415S_4207

9. Release the latch, and then remove the speaker cover (8).

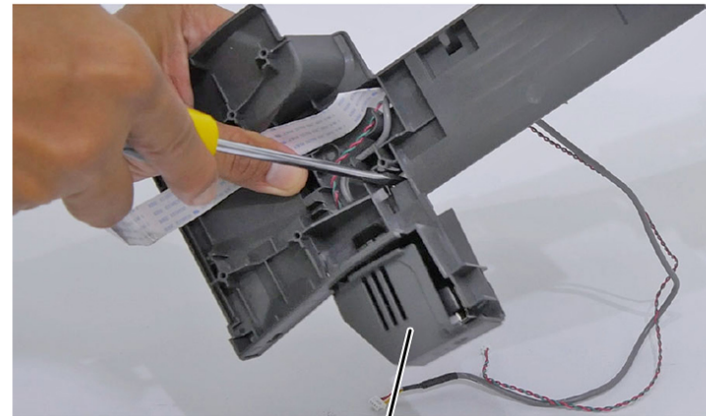

VLC415S_4208

10. Remove the speaker (9).

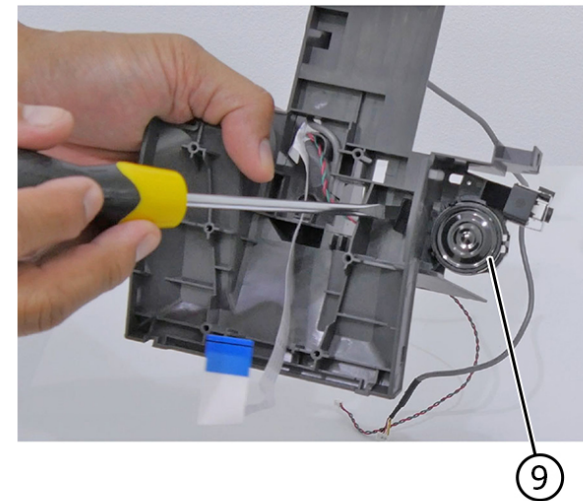

VLC415S_4209

11. Disconnect the connector (10) from the speaker, and then unroute the cables.

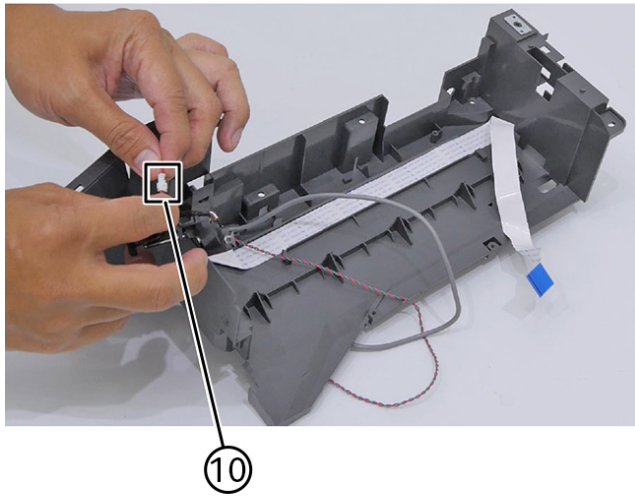

Replacement

Replacement is the reverse of the removal procedure.

REP 60.4 Imaging Kit

Removal



WARNING: Switch off the electricity to the machine, GP 10. Disconnect the power lead from the customer supply while performing tasks that do not need electricity. Electricity can cause death or injury. Moving components can cause injury.



Figure 1 ESD Symbol

Note: This is not a FRU.

Note: The imaging kit contains the photoconductor unit and developer units. When you replace the imaging kit, you are replacing the photoconductor unit and developer units.

VLC415S_4210

1. Remove the waste toner bottle. See REP 90.4
2. Remove the toner cartridges.
3. Lift the two latches (1) to unlock the imaging kit.

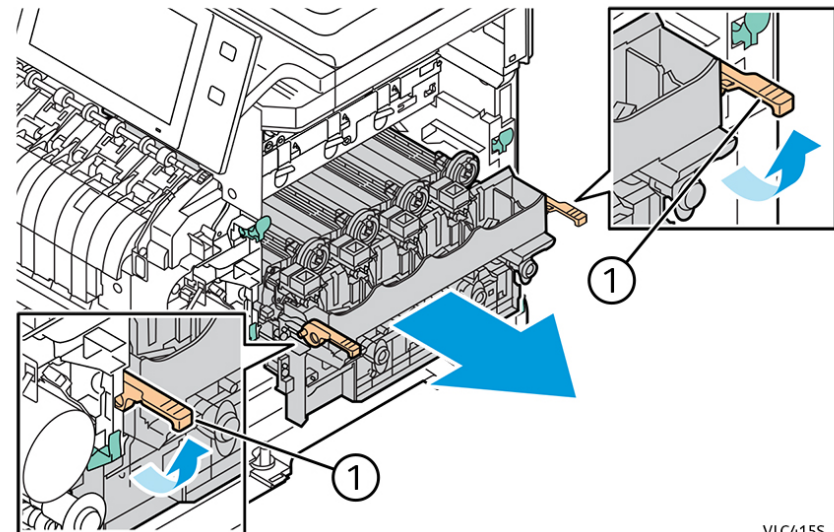

4. Pull the two latches.

VLC415S_4051

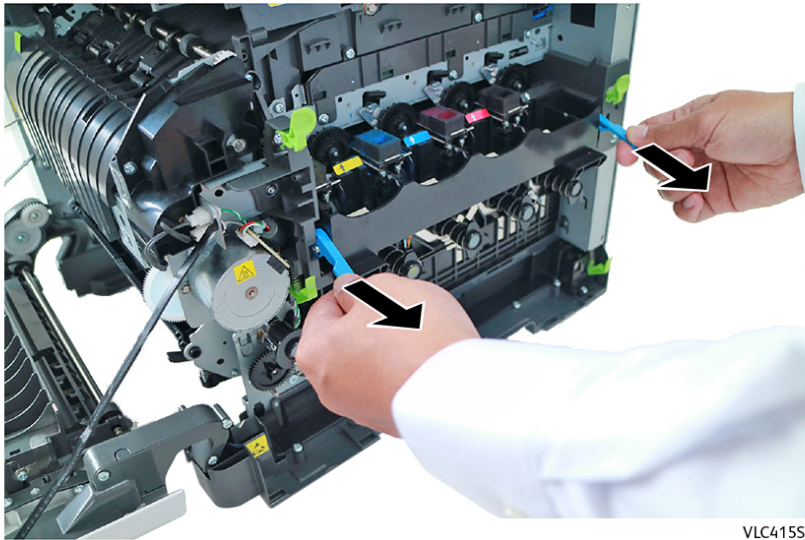

VLC415S_4052

5. Press and hold the two handles (2) and the latch (3), and then pull the imaging kit to remove.

Note: Do not touch the underside of the imaging kit.

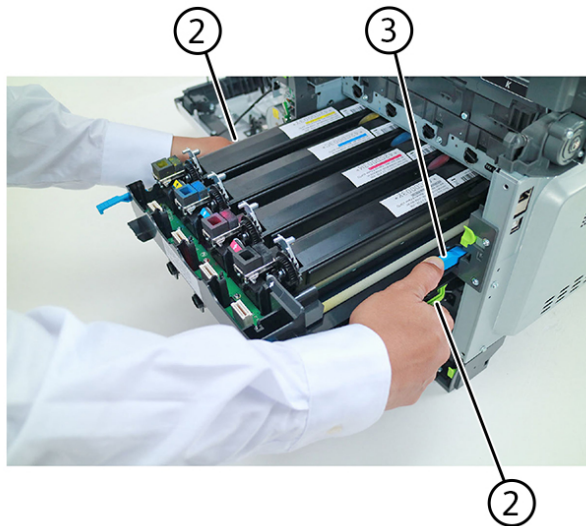

VLC415S_4053

REP 70.1 Pick Tires

Parts List on [PL 70.05 item 2](#)

Removal



WARNING: Switch off the electricity to the machine, [GP 10](#). Disconnect the power lead from the customer supply while performing tasks that do not need electricity. Electricity can cause death or injury. Moving components can cause injury.

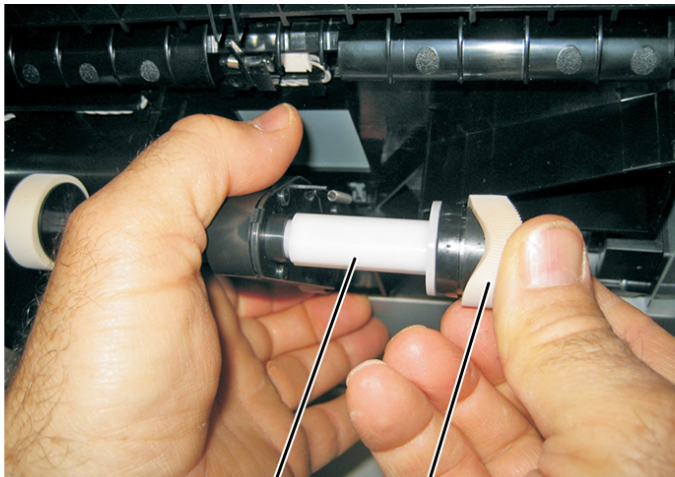

Figure 1 ESD Symbol



CAUTION: Remove only the rubber tires and not the paper pick tire assembly to avoid losing small parts.

1. Lower the paper pick motor drive assembly.
2. Remove the rubber tire (1) from the pick roll assembly (2). Repeat for the other tire.



②

①

VLC415S_4109

Replacement

Replacement is the reverse of the removal procedure.

Note: Install the new rubber tires with the surface texture turning in the direction as shown in the following:

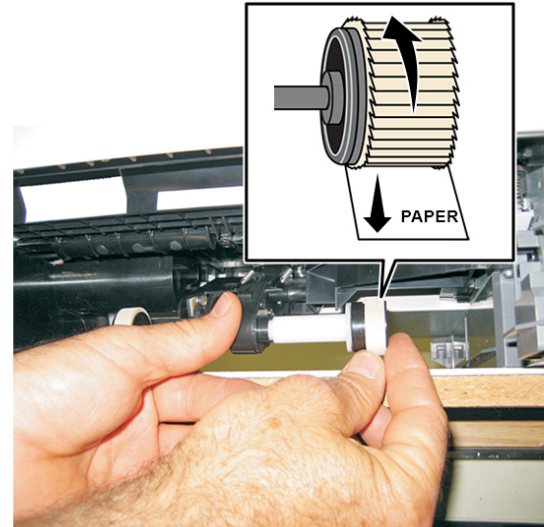

VLC415S_4110

Note: Feel each rubber surface to verify that it turns in the proper direction. The smoother surface pushes the paper toward the front of the printer.

REP 80.1 Media Feeder

Parts List on [PL 70.05 item 1](#)

Removal



WARNING: Switch off the electricity to the machine, [GP 10](#). Disconnect the power lead from the customer supply while performing tasks that do not need electricity. Electricity can cause death or injury. Moving components can cause injury.



Figure 1 ESD Symbol

1. Remove the waste toner bottle. See [REP 90.4](#)
2. Remove the imaging kit. See [REP 60.4](#)
3. Remove the left cover. See [REP 28.1](#)
4. Remove the rear cover. See [REP 28.5](#)
5. Disconnect the cable (1) from the JSP1 connector on the controller board.
6. Route the cable through the opening (2), and then remove the cable from its retainer (3).

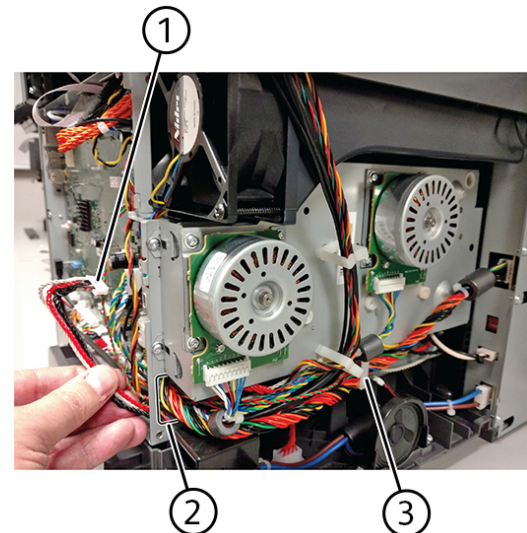

VLC415S_4145

7. Partially reinstall the rear cover to protect the controller board.
8. Place the printer on its rear, and then remove the two screws (4).

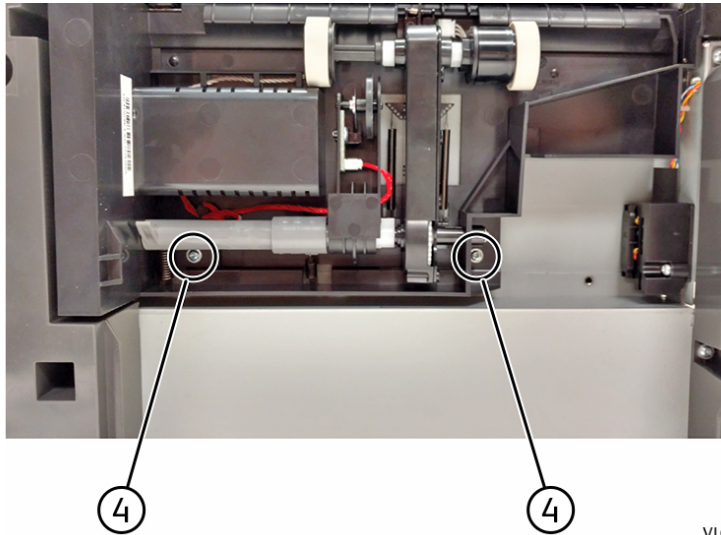

VLC415S_4146

9. On the right side, loosen the screw (5) with a screwdriver, and then remove it while holding the paper feed roller assembly.

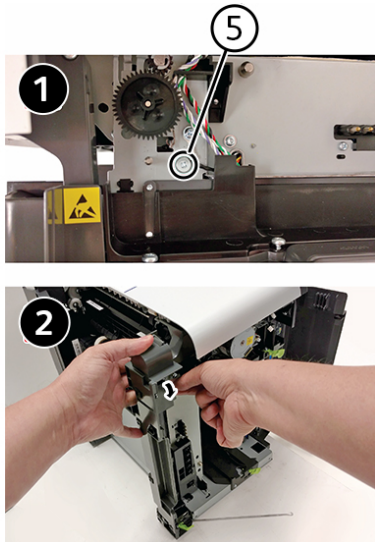

VLC415S_4147

10. Move the right side of the paper feed roller assembly out to free the shaft from the opening in the frame.

Note: Pay attention to the location of the shaft and the opening in the frame.

11. Remove the paper feed roller assembly.

Installation notes:

Note:

- Place the left side of the paper feed roller assembly in the printer. Make sure that the shaft on the left side aligns with the hole in the frame.
- Reinstall the three screws holding the paper feed roller assembly to the printer.
- Place the printer on the upright position.
- Reroute the cable, and then make sure to secure the cable in its retainer on the left side.
- Remove the rear cover, and then reconnect the cable on the controller board.
- Replace the rear cover.

REP 80.2 Duplex Sensor

Parts List on [PL 80.05](#)

Removal



WARNING: Switch off the electricity to the machine, [GP 10](#). Disconnect the power lead from the customer supply while performing tasks that do not need electricity. Electricity can cause death or injury. Moving components can cause injury.



Figure 1 ESD Symbol

1. Remove the imaging kit. See [REP 60.4](#)
2. Remove the two screws (1).

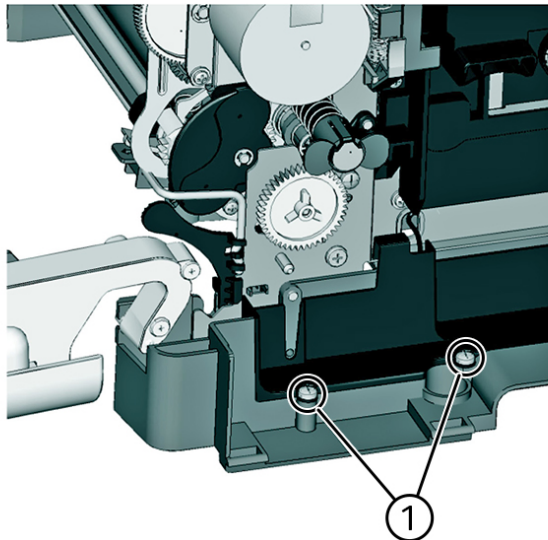

VLC415S_4135

3. Pull the corner of the cable cover (2) away from the right side to access the two sensor posts (3).

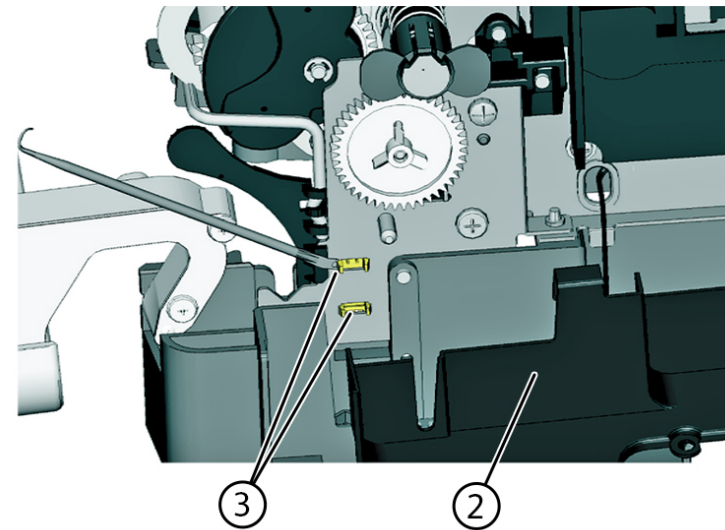

VLC415S_4136

4. Remove the sensor plate (4).

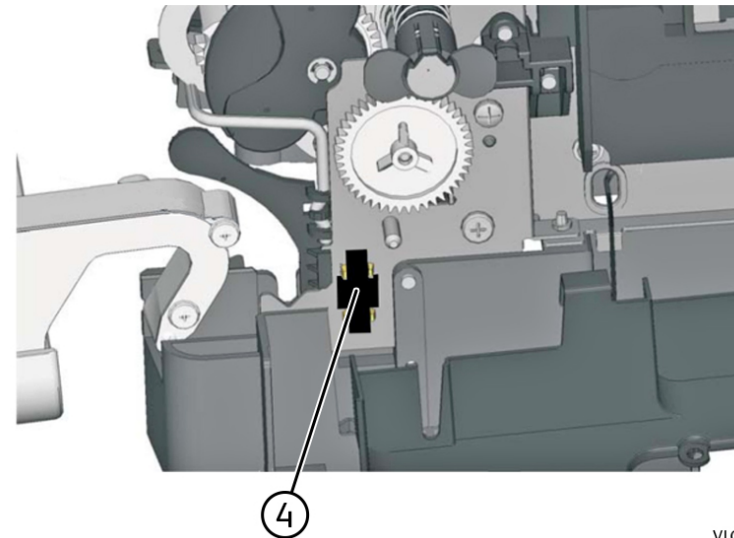

VLC415S_4137

5. Press on the latches to detach the sensor from the printer frame.
6. Disconnect the cable (5).

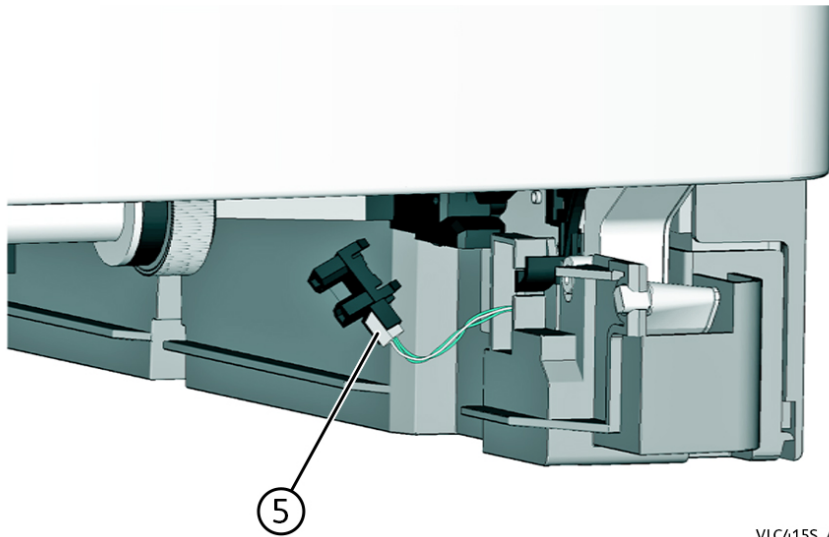

Replacement

Replacement is the reverse of the removal procedure.

Installation Notes

1. Clean the contact surface where the sensor retaining plate was removed before installing the new sensor.
Make sure that the clamps on the sensor legs are securely attached to the printer frame.
Note: Make sure that the clamps on the sensor legs are securely attached to the printer frame.
2. Remove the backing from the new sensor retaining plate, and then place the plate on the surface between the sensor mounting latches.

REP 90.1 Toner Meter PWB

Parts List on [PL 1.05](#)

Removal



WARNING: Switch off the electricity to the machine, [GP 10](#). Disconnect the power lead from the customer supply while performing tasks that do not need electricity. Electricity can cause death or injury. Moving components can cause injury.



Figure 1 ESD Symbol

1. Remove the imaging kit. See [REP 60.4](#)
2. Remove the rear cover. See [REP 28.5](#)
3. Disconnect the cable (1), and then push the TMC card cable through the frame opening.

Note: Pay attention to the cable routing.

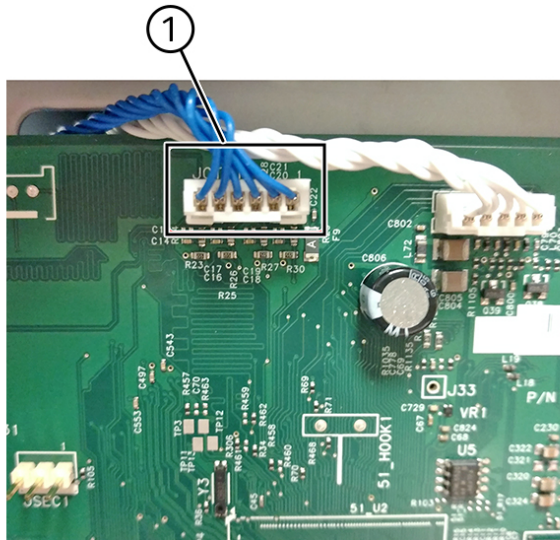

VLC415S_4026

4. Remove the four screws (2).

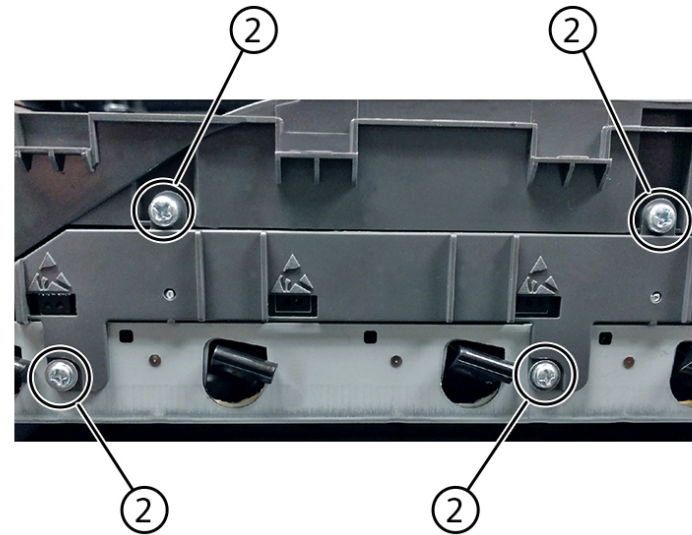

VLC415S_4027

5. Insert a flat-head screwdriver into the left side of the frame, and then pry the card loose to remove it.

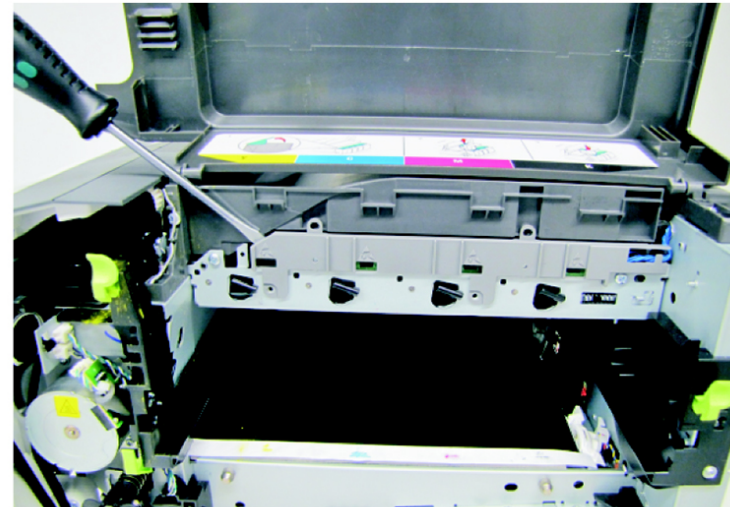

VLC415S_4028

Replacement

Replacement is the reverse of the removal procedure.

Installation Notes

- Make sure to run the cable (3) through the retainer.

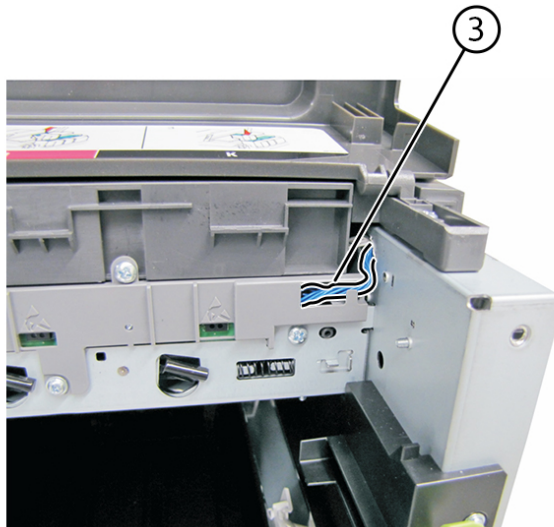

VLC415S_4029

- The TMC card is a tight fit. Insert the bottom edge inside the frame first, and then push down on the top edge to clear the top cover.

REP 90.2 Toner Patch Sensor

Parts List on [PL 90.05](#)

Removal



WARNING: Switch off the electricity to the machine, [GP 10](#). Disconnect the power lead from the customer supply while performing tasks that do not need electricity. Electricity can cause death or injury. Moving components can cause injury.



Figure 1 ESD Symbol

- Remove the transfer module. See [REP 90.6](#)
- Remove the spring (1).

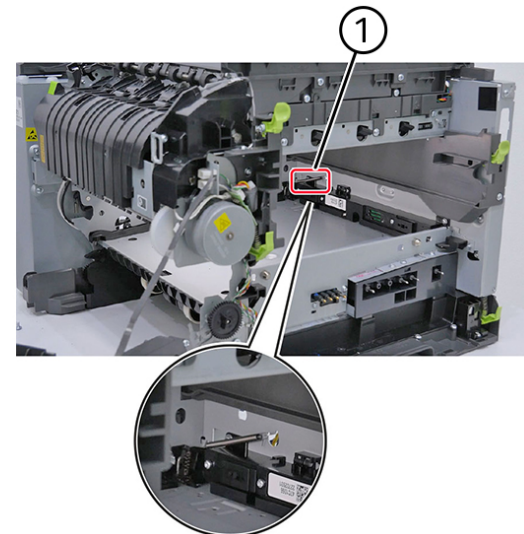

VLC415S_4262

- Remove the three screws (2).

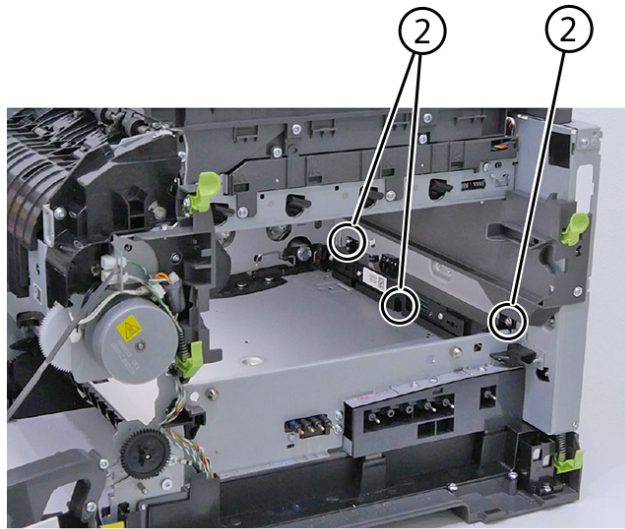

VLC4155_4263

4. Remove the sensor (toner patch) (3).

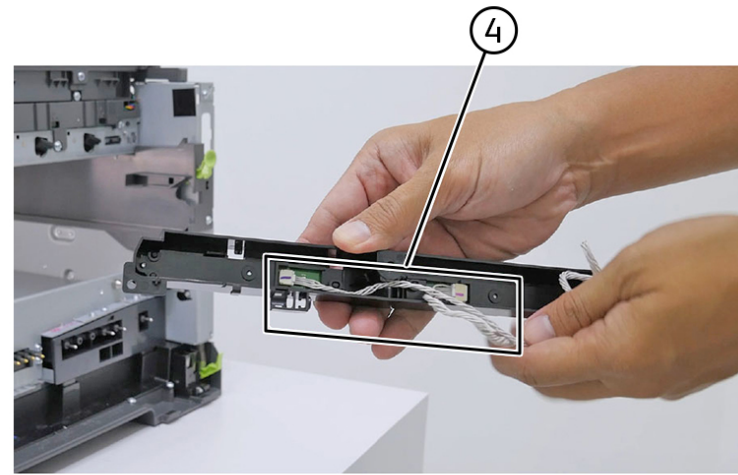

VLC4155_4265

Replacement

Replacement is the reverse of the removal procedure.

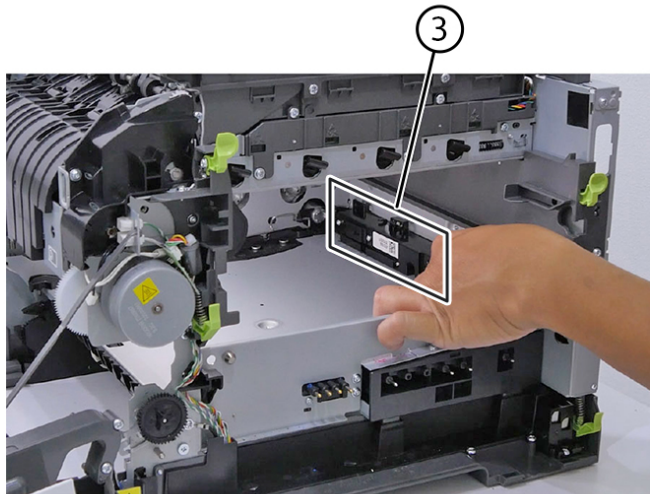

VLC4155_4264

5. Disconnect the connector, and then unroute the cable (4).

REP 90.3 Toner Cartridge Contact

Parts List on [PL 90.05](#)

Removal



WARNING: Switch off the electricity to the machine, [GP 10](#). Disconnect the power lead from the customer supply while performing tasks that do not need electricity. Electricity can cause death or injury. Moving components can cause injury.



Figure 1 ESD Symbol

1. Remove the right cover.
 2. Remove the waste toner bottle. See [REP 90.4](#)
 3. Remove the imaging kit. See [REP 60.4](#)
 4. Remove the rear cover. See [REP 28.5](#)
 5. Remove the screw (1) to allow access to the cable cover.
- Note:** Do not remove the waste toner bottle contact block.
6. Remove the four screws (2), and then remove the cable cover.

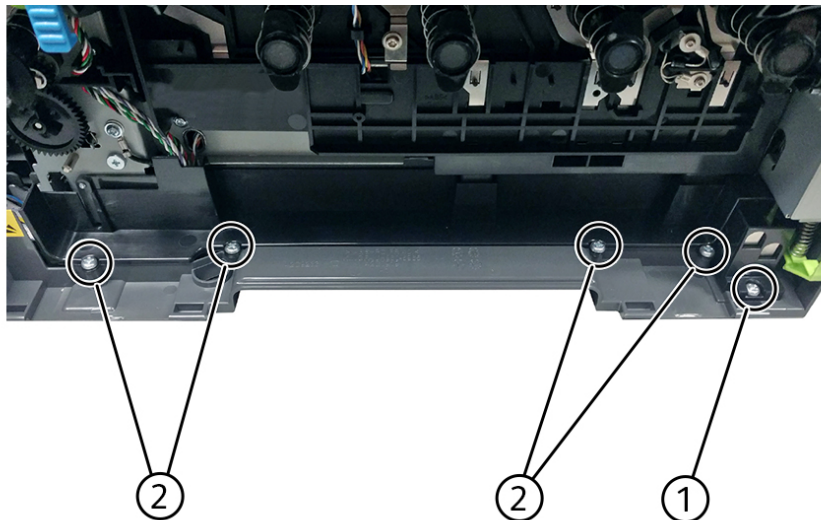

VLC415S_4054

7. Place the printer on its left side.
8. Remove the screw (3), and then release the two tabs (4).

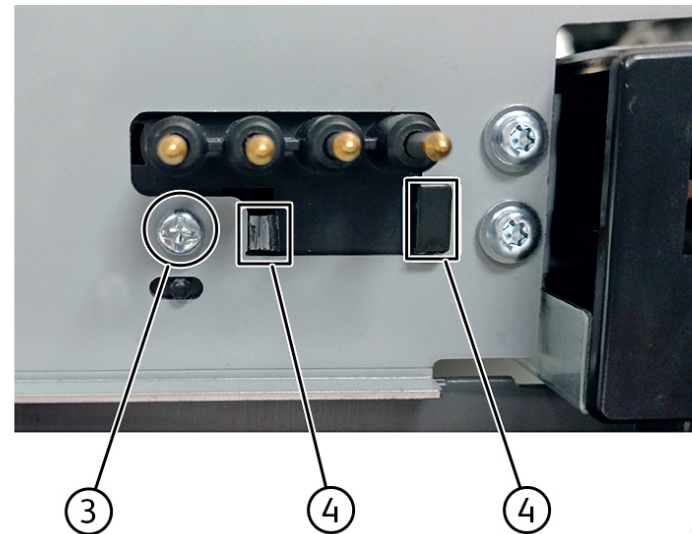

VLC415S_4055

9. Slide the toner cartridge contacts to the left to remove it.
10. Disconnect the cable (5) from the controller board.

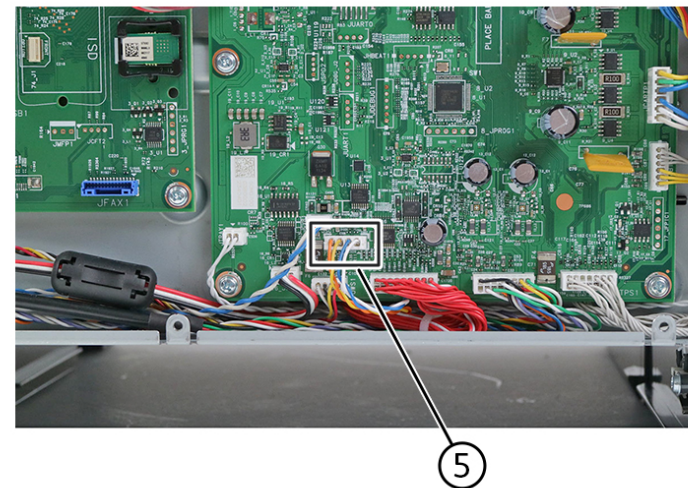

VLC415S_4275

- Note:** If used, pay attention to the assembly of the cable and toroid.
11. Remove the cable from its retainer at the bottom of the printer.
 12. Extract the cable through the frame, and then remove the cable with the spring contacts.

Note: If the cable has a toroid, unwrap the cable from the toroid, and then make sure to use the same number of wraps on the new cable.

Replacement

Replacement is the reverse of the removal procedure.

REP 90.4 Waste Toner Bottle

Removal



WARNING: Switch off the electricity to the machine, GP 10. Disconnect the power lead from the customer supply while performing tasks that do not need electricity. Electricity can cause death or injury. Moving components can cause injury.



Figure 1 ESD Symbol

1. Remove the right cover.
2. Press the two tabs (1) to release the waste toner bottle.

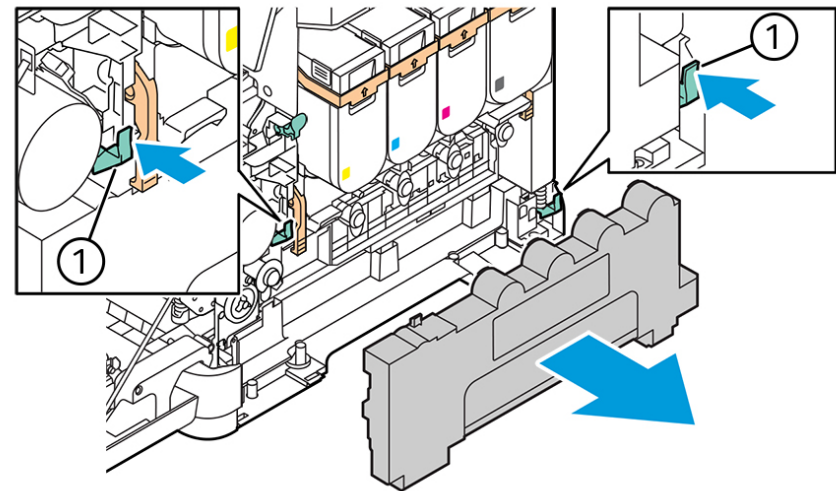

VLC415S_4057

Replacement

Replacement is the reverse of the removal procedure.

REP 90.5 Toner Contact Block

Parts List on [PL 90.05](#)

Removal



WARNING: Switch off the electricity to the machine, [GP 10](#). Disconnect the power lead from the customer supply while performing tasks that do not need electricity. Electricity can cause death or injury. Moving components can cause injury.



Figure 1 ESD Symbol

1. Open the front door.
2. Remove the right cover.
3. Remove the toner cartridges.
4. Remove the waste toner bottle.
5. Remove the imaging kit.
6. Remove the eight screws (1), and then remove the rear cover.

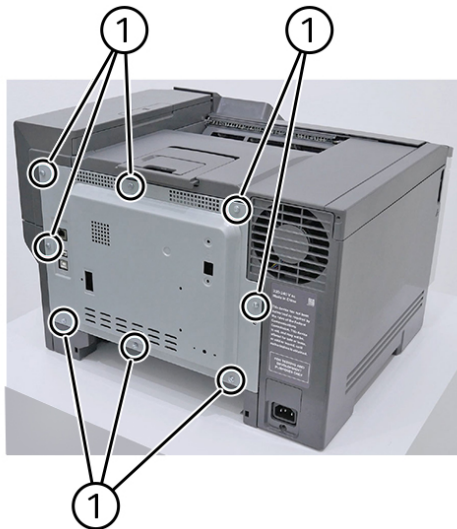

VLC415S_4243

7. Disconnect the connector (2) from the engine board.

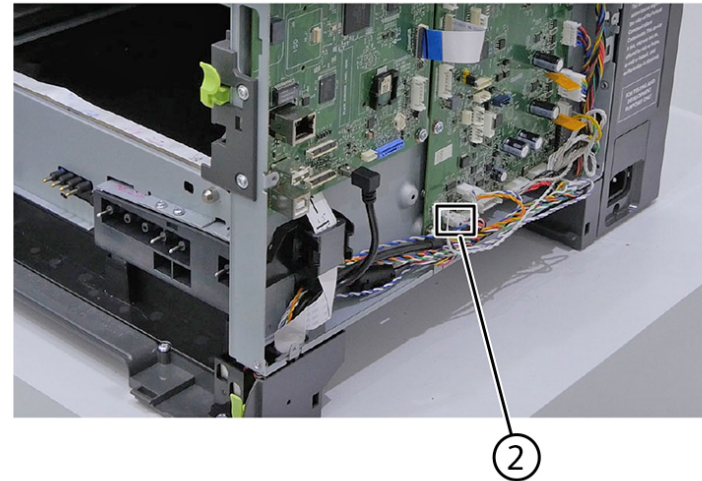

VLC415S_4244

8. Unroute the cable, and then remove the toroid (3) from the cable.

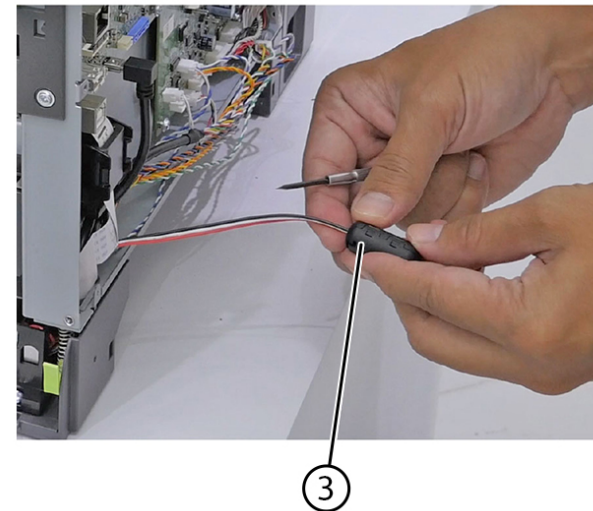

VLC415S_4245

9. Remove the screw (4).

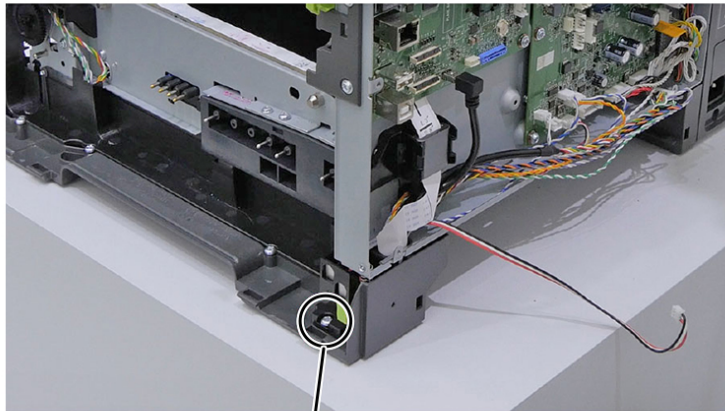

4

10. Remove the waste toner bottle contact block (5).

VLC415S_4246

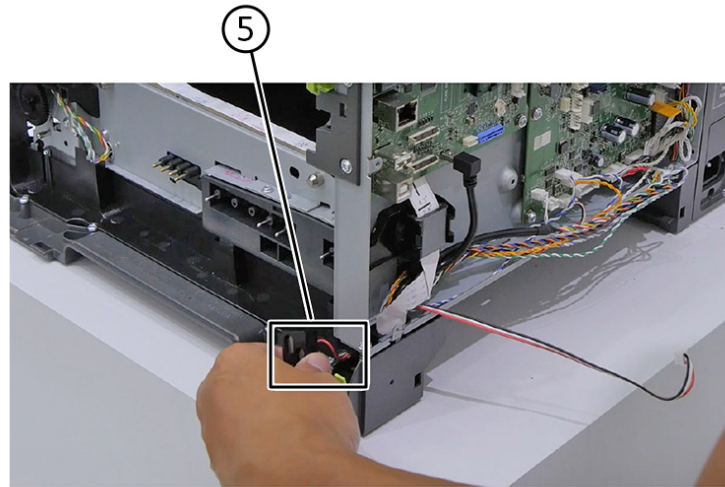

VLC415S_4247

Replacement

Replacement is the reverse of the removal procedure.

REP 90.6 Transfer Module

Parts List on [PL 90.10](#)

Removal



WARNING: Switch off the electricity to the machine, [GP 10](#). Disconnect the power lead from the customer supply while performing tasks that do not need electricity. Electricity can cause death or injury. Moving components can cause injury.



Figure 1 ESD Symbol

1. Remove the right cover.
2. Remove the waste toner bottle.
3. Remove the imaging kit. See [REP 60.4](#)
4. Disconnect the spring (1) on the right side.

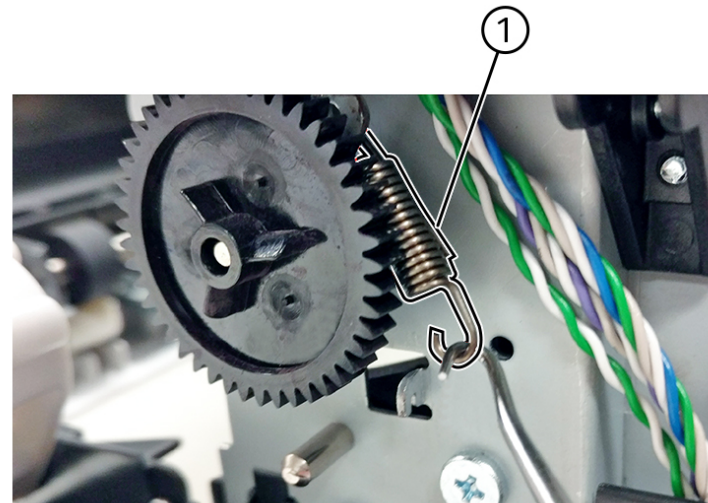

VLC415S_4044

5. Release the left and right door straps (2).

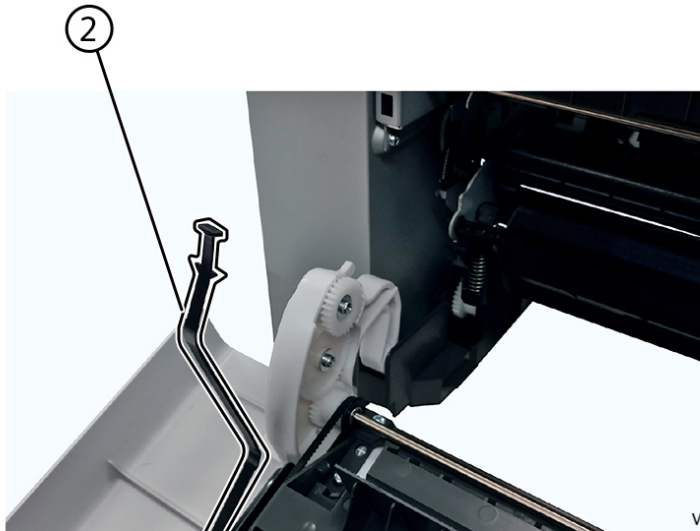

VLC415S_4045

6. Disconnect the spring (3).

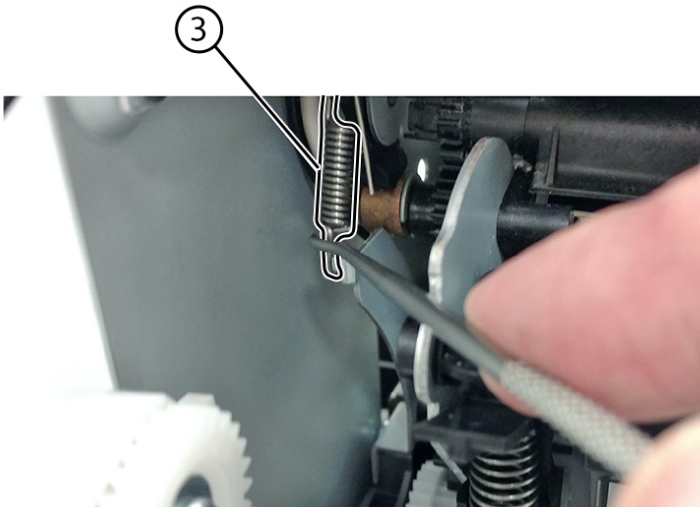

VLC415S_4046

7. Raise the cam (4) and spring (5).

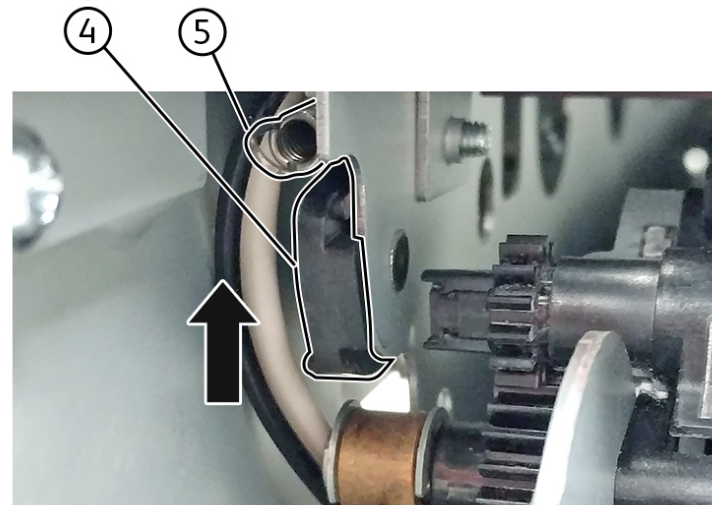

VLC415S_4047

8. Place the tip of a flat-head screwdriver in between the release lever (6) and the frame, and then rotate the screwdriver to rotate the release lever and decouple the transfer module while pulling it toward the front.



CAUTION: Make sure that the lever is in the fully released position before removing the transfer module.

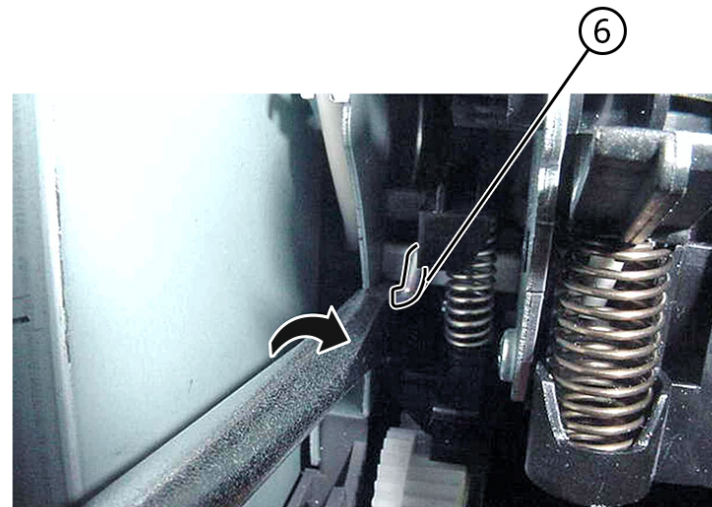

VLC415S_4048

9. Hold the release lever as you pull out the transfer module for the first four inches (100 mm). A quick and firm pull should overcome the latch at this point.

10. Remove the transfer module.

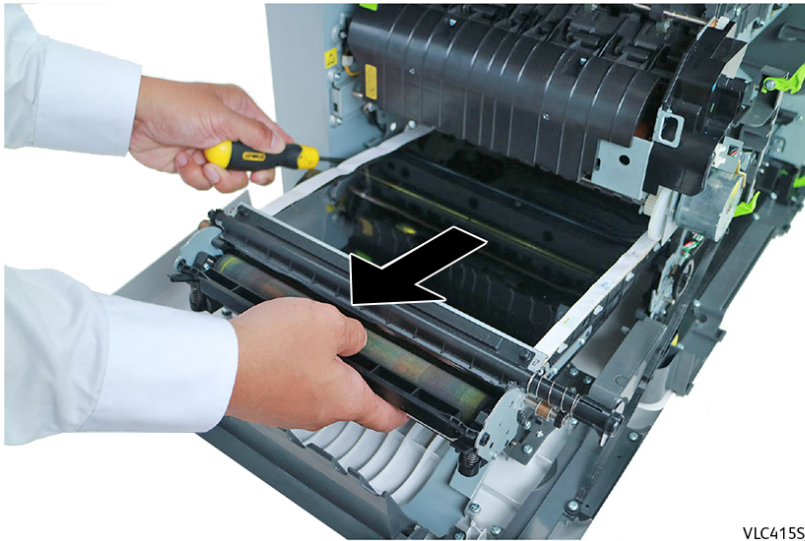

VLC415S_4049

Replacement

Replacement is the reverse of the removal procedure.

Installation Notes

1. Do not rotate the release lever again to install the new transfer module. Doing so may cause the incorrect seating of the transfer module. The coupler is rotated out of the way as the transfer module slides in.
2. Rotate the right side spring clamp (7) and left side cam back to their original positions, and then rehook the springs.

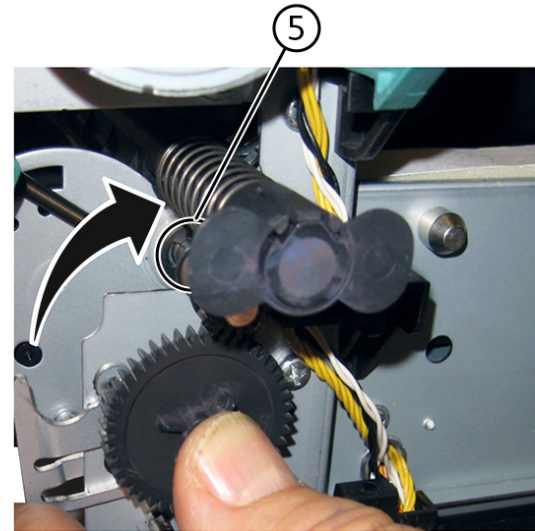

VLC415S_4050

3. Make sure to reset the ITM counter after installing the new transfer module. Enter the Diagnostics menu, and then navigate to:
Printer diagnostics & adjustments > Supply reset > ITM reset

REP 90.7 Transfer Module Guide

Parts List on [PL 90.10](#)

Removal



WARNING: Switch off the electricity to the machine, [GP 10](#). Disconnect the power lead from the customer supply while performing tasks that do not need electricity. Electricity can cause death or injury. Moving components can cause injury.



Figure 1 ESD Symbol

1. Remove the tray insert.
2. Remove the right cover.
3. Remove the waste toner bottle. See [REP 90.4](#)
4. Remove the imaging kit. See [REP 60.4](#)
5. Remove the transfer module. See [REP 90.6](#)
6. Remove the fuser. See [REP 10.1](#)
7. Remove the left cover. See [REP 28.1](#)
8. Remove the LVPS. See [REP 1.2](#)
9. Remove the lower right frame. See [REP 28.3](#)
10. Remove the screw (1).

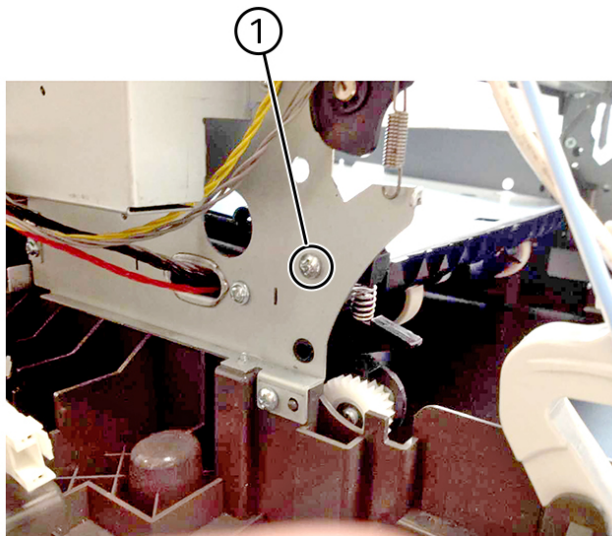

VLC415S_4139

11. Remove the two screws securing the transfer module guide to the frame.

Note: Use either a short #2 Phillips or a right angle screwdriver.

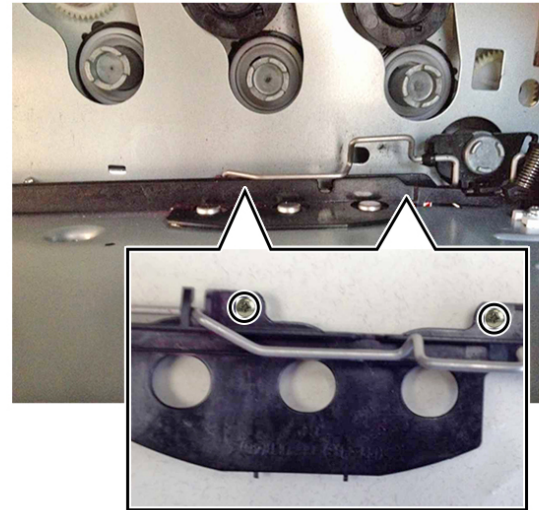

VLC415S_4140

12. Remove the spring (2).

Note: Pay attention to how the spring is attached to the bail.

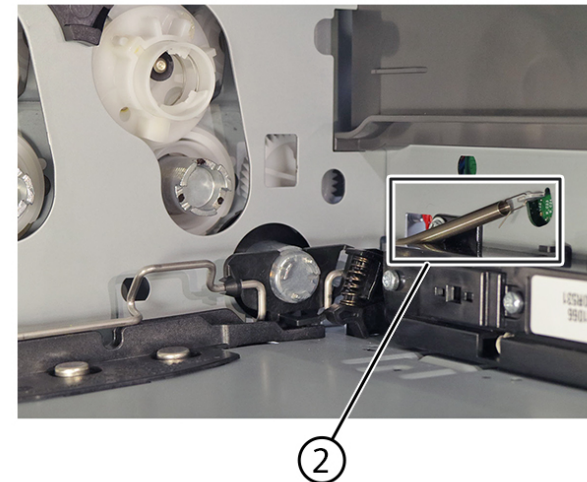

VLC625S_4061

13. Using a spring hook or screwdriver, press and hold the transfer module drive coupling (3), and then tilt the guide up from the side with the screw holes to remove it.

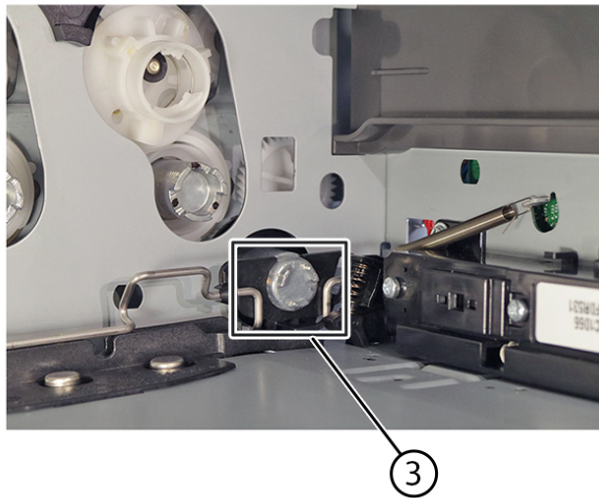

VLC4155_4289

ADJ 5.1 DADF Registration Adjustment

1. Login as Administrator
2. From the **Home** screen click on **Tools > Troubleshooting > Calibration > Scanner Manual Registration**
3. Select **Side 1, Side 2** for the correct DADF registration test.
4. Follow the on screen procedure.

ADJ 60.1 Scanner Manual Registration Adjustment

1. Login as Administrator
2. From the **Home** screen click on **Tools > Troubleshooting > Calibration > Scanner Manual Registration**
3. Select **Document Glass** (scanner).
4. Follow the on screen procedure.

ADJ 90.1 Registration Adjustment

Image misalignments can occur after printhead replacement. Perform this procedure to correct the position of the image relative to the paper edges.

Note: You cannot perform mechanical registration or skew adjustments on this printhead.

Before performing the procedure, make sure that the tray guides are properly set and the paper settings on the printer match the paper size loaded in the tray.

ADJ 90.1.1 Skew Adjustment

The skew adjustment changes the angle of the horizontal lines so that the lines can be aligned with the leading edge of the page. As the skew setting is changed, the top line on the test page stays in place at the left end, while its right end tilts up or down. All horizontal lines on the page will tilt at that same angle while the vertical lines will remain vertical. Changing the skew setting moves the right edge of the page up and down, and changes the angle of the top and bottom lines. If the skew is properly adjusted, the horizontal lines at the top of the page will be parallel to the leading edge of the page.

To check for skew:

1. Enter the Diagnostics menu **GP 1**, and then navigate to:
Adjustments > dC126 System Registration > Registration Adjust
2. Select **Quick Test**, and then touch **Start**.

The printer prints a test page.

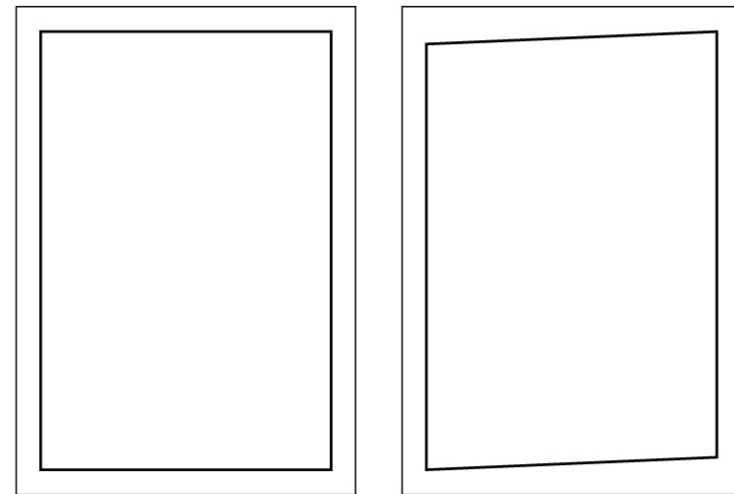

Normal

Skewed

v1c625s_4013

Note: If there is no skew on the page, then see [Top and Bottom Margins Adjustment](#)

To adjust the skew:

1. Enter the Diagnostics menu **GP 1**, and then navigate to:

Adjustments > dC126 System Registration > Registration Adjust > Top Skew

- Specify the value. The value range is from -100 to 100.

Note:

- Raising the value of the skew rotates the horizontal lines clockwise. The left end of the line remains in the same place and the right end moves downward.
 - Decreasing the value of the skew rotates the horizontal lines counter clockwise. The left end of the line remains in the same place and the right end moves upward.
- Touch **OK**.
 - Print a Quick test page to verify the change.
 - Repeat step 1 through step 4 until the horizontal line is properly aligned with the leading edge of the page.
 - Check for proper margin alignment. see [Top and Bottom Margins Adjustment](#).

ADJ 90.1.2 Top and Bottom Margins Adjustment

- Load Letter or A4-size paper into tray 1.
- Verify that the paper type and size settings match the paper type and size loaded in the tray.
- Enter the Diagnostics menu **GP 1**, and then navigate to **dC126 System Registration > Registration Adjust**.
- Touch **Quick Test**, and then touch **Start**.
The printer prints a test page.
- Check the top and bottom margins of the test page for correct alignment.

Note:

- The arrows should be completely visible along the edges.
- The tip of the arrows should point to the edges of the paper.

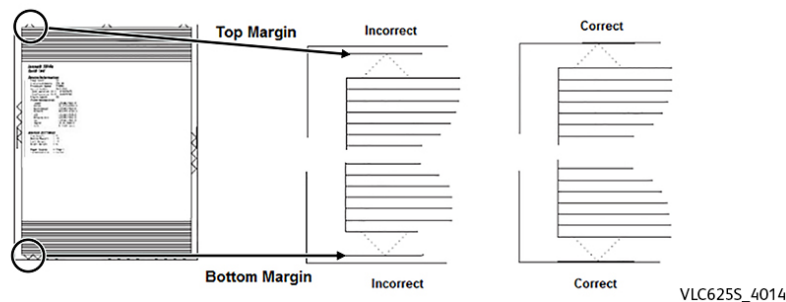

- Change the value of the top margin or bottom margin as needed.
 - Select the margin that needs adjustment.
 - Enter a value in the field.

Note:

- The value range is from -80 to 80.
- Increasing the value of the top margin pushes the top edge of the image downward. Increasing the value of the bottom margin pushes the bottom edge of the image upward.

- Touch **Start**.
- Print a test page to verify the changes.
 - Repeat step 7 through step 8 as needed.
 - Check for proper color alignment. See [Color Alignment Adjustment](#).

ADJ 90.1.3 Color Alignment Adjustment

- Enter the Diagnostics menu **GP 1**, and then navigate to:

Adjustments > dC919 Color Balance Adjustment

On the AA Adjustment row, touch **Start**.

Note: Note: The Color alignment procedure is performed on the cyan, magenta, and yellow colors

- Enter the Diagnostics menu **GP 1**, and then navigate to:
Adjustments > dC919 Color Balance Adjustment > Color alignment adjust > Cyan > Quick test
Check the alignment markings on the test page generated. Follow the instructions on the test page to correct the color misalignment.
- Enter the Diagnostics menu **GP 1**, and then navigate to:
Adjustments > dC919 Color Balance Adjustment > Color alignment adjust > Yellow > Quick test
Check the alignment markings on the test page generated. Follow the instructions on the test page to correct the color misalignment.
- Enter the Diagnostics menu **GP 1**, and then navigate to:
Adjustments > dC919 Color Balance Adjustment > Color alignment adjust > Magenta > Quick test
Check the alignment markings on the test page generated. Follow the instructions on the test page to correct the color misalignment.
- If color misalignment still occurs, then repeat step 1 through step 4.

5 Parts List

PL 1 - Standby Power	239
PL 1.05 Electrical	240
PL 2 - User Interface	241
PL 2.05 User Interface.....	242
PL 3 - Machine Run Control	243
PL 3.05 Controller PWB Assembly	244
PL 5 - DADF	245
PL 5.05 DADF Components	246
PL 10 - Print Transport and Fusing	247
PL 10.05 Fuser	248
PL 20 - Fax	249
PL 20.05 Fax	250
PL 25 - Accessories	251
PL 25.05 Accessories	252
PL 26- Consumables and Tools	253
PL 26.05 Consumables and tools	254
PL 28- Covers	255
PL 28.05 Covers 1.....	256
PL 28.10 Covers 2.....	257
PL 31 – Maintenance/Installation/Removal Kits	258
PL 31.05 Harness	259
PL 40 – Main Drive Assembly	260
PL 40.05 Drive Components	261
PL 40.10 NOHAD	262
PL 60 - Imaging	263
PL 60.05 Printhead	264
PL 60.10 Scanner	265
PL 70 - Paper Supply	266
PL 70.05 Paper Feed.....	267
PL 70.10 250 Sheet Tray 1	268
PL 70.15 650 Sheet Tray 2 (Option).....	269
PL 70.20 550 Sheet Tray 3 (Option).....	270
PL 80 - Paper Transport	271
PL 80.05 Paper Path.....	272
PL 90 - Xerographics	273
PL 90.05 Xerographic Components.....	274
PL 90.10 Transfer Module Assembly.....	275

PL 1.05 Electrical

Item	Part	Description
1	140N63970	Toner meter PWB (REP 90.1)
2	105N02414	HVPS (REP 1.1)
3	105N02413	LVPS 220V (REP 1.2)
—	105N02412	LVPS 110V (REP 1.2)
4	140N63971	Drive PWB (Engine Board) (REP 1.3)

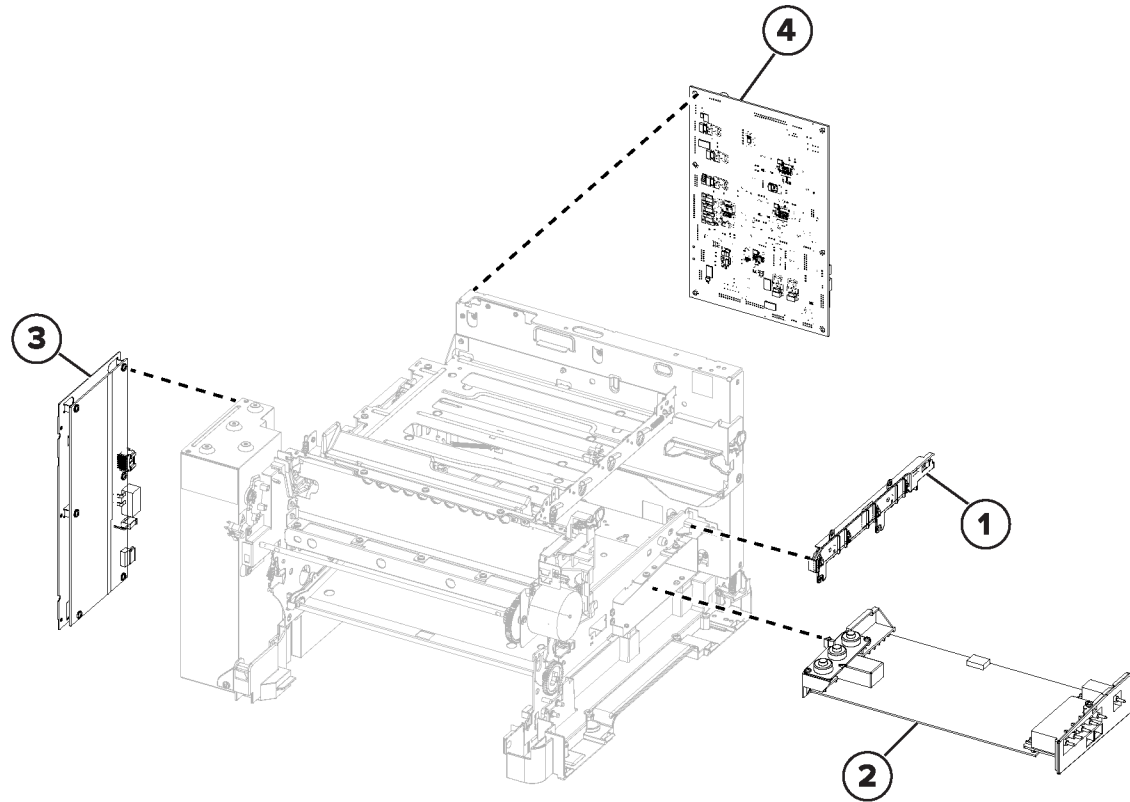

vlc415s5001a

PL 2.05 User Interface

Item	Part	Description
1	003N01207	Control panel hinge (REP 2.2)
2	002N03701	Control panel (REP 2.1)
3	109N00929	Control panel FFC

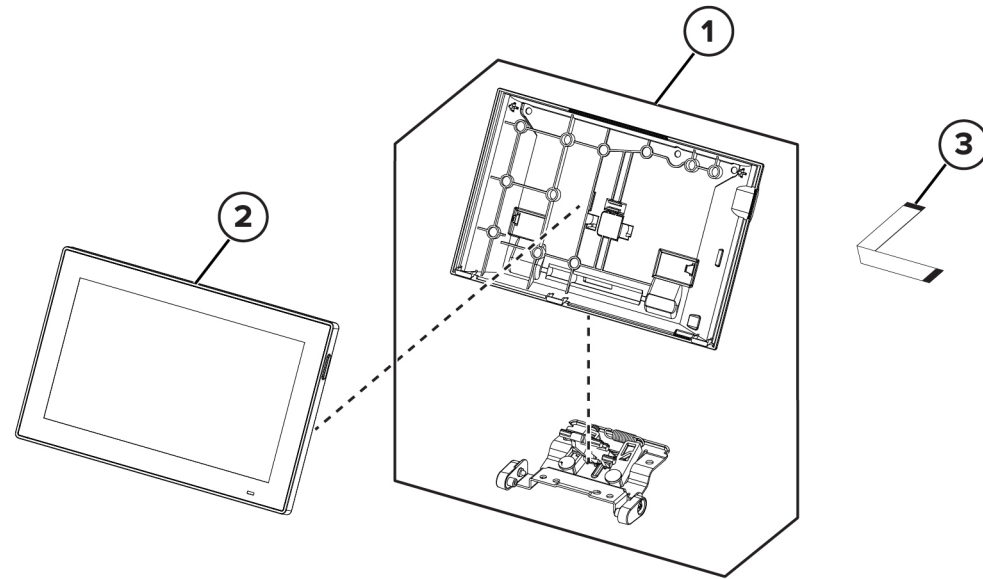

vlc415s5002a

PL 3.05 Controller PWB Assembly

Item	Part	Description
1	109N00927	Controller PWB (REP 3.1)
2	133N23278	Trusted platform module (TPM)

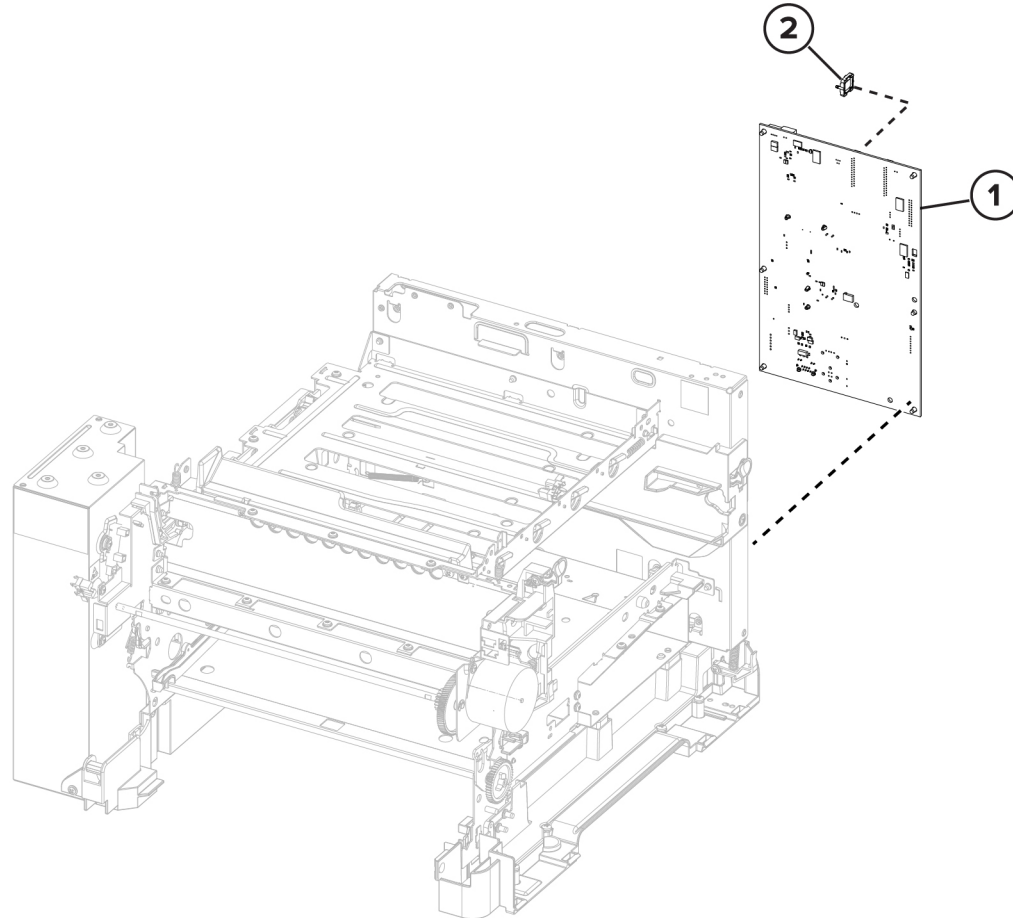

vlc415s5003a

PL 5.05 DADF Components

Item	Part	Description
1	022N02978	DADF assembly (REP 5.1)
2	002N03741	DADF top cover (P/O PL 5.05 Item 1) (REP 5.2)
3	050N00757	DADF tray (P/O PL 5.05 Item 1)
4	116R00039	DADF maintenance kit (P/O PL 5.05 Item 1) (REP 5.5) (See Note)
5	019N01167	Scanner glass pad (REP 5.3)
6	003N01200	DADF right hinge (REP 5.4)
7	003N01202	DADF left hinge (REP 5.4)
8	117N02408	DADF harness kit

Note: HFSI. To reset HFSI counter, refer to [dC135](#)

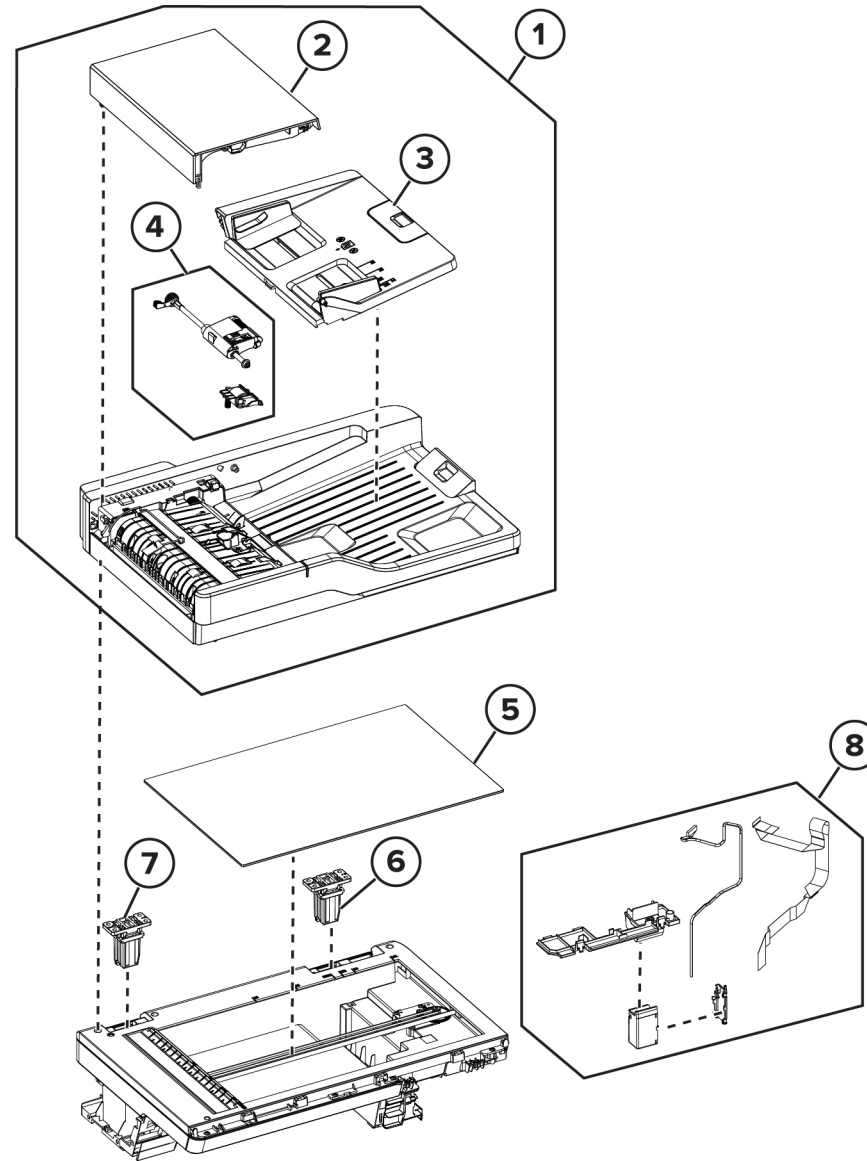

vlc415s5004a

PL 10.05 Fuser

Item	Part	Description
1	126N00514	Fuser deflector
2	126N00519	Fuser, 110 V (REP 10.1) (See Note)
—	126N00520	Fuser, 220 V (REP 10.1) (See Note)
3	130N01895	Fuser exit sensor (REP 10.3)

Note: HFSI. To reset HFSI counter, refer to [dC135](#)

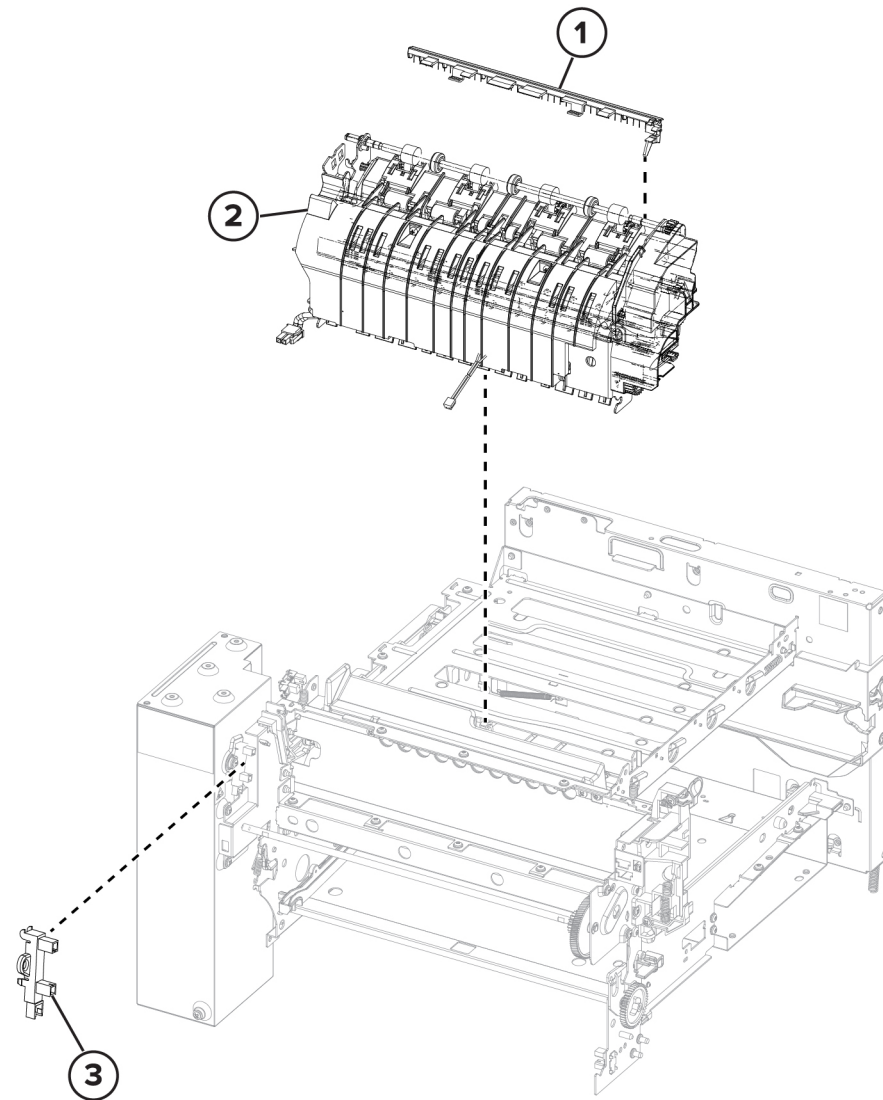

vlc415s5005a

PL 20.05 Fax

Item	Part	Description
1	091N80393	Fax PWB
2	497K24460	Optional Fax Disable Kit (Not Shown) (See Note)
3	497K24470	Optional Fax Removal Kit (Not Shown) (See Note)

Note: For special request only.

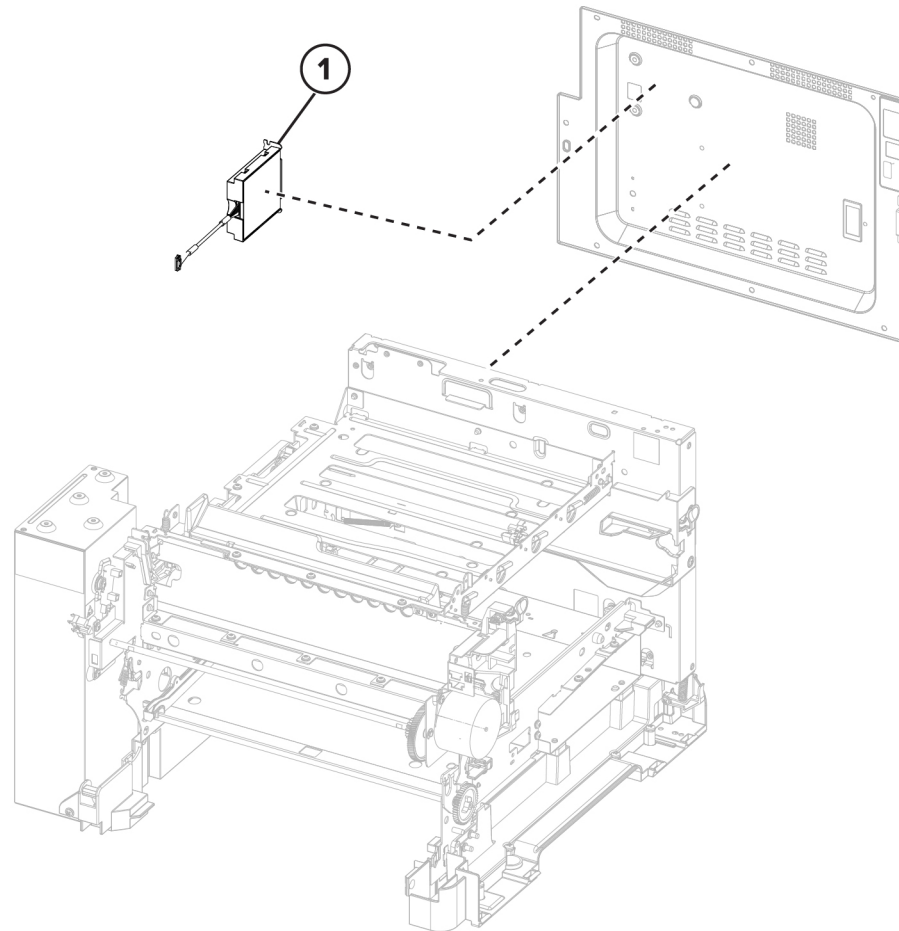

vlc415s5023a

PL 25.05 Accessories

Item	Part	Description
1	097N02470	Optional wireless network adapter
2	097N02466	500+GB Hard Disk Drive
3	097N02442	Convenience stapler (110V)
—	097N02463	Convenience stapler (220V)
4	019N01170	Staple cartridge holder
5	497N07994	Adjustable Stand (Not Shown)
6	497N05244	Printer Stand (Not Shown)
7	017N00320	Adjustable stand nonlocking caster (Not Shown)
8	017N00319	Adjustable stand locking caster (Not Shown)
9	097N02465	550 Sheet Tray (Not Shown)
10	097N02468	650 Sheet Duo Tray (Not Shown)

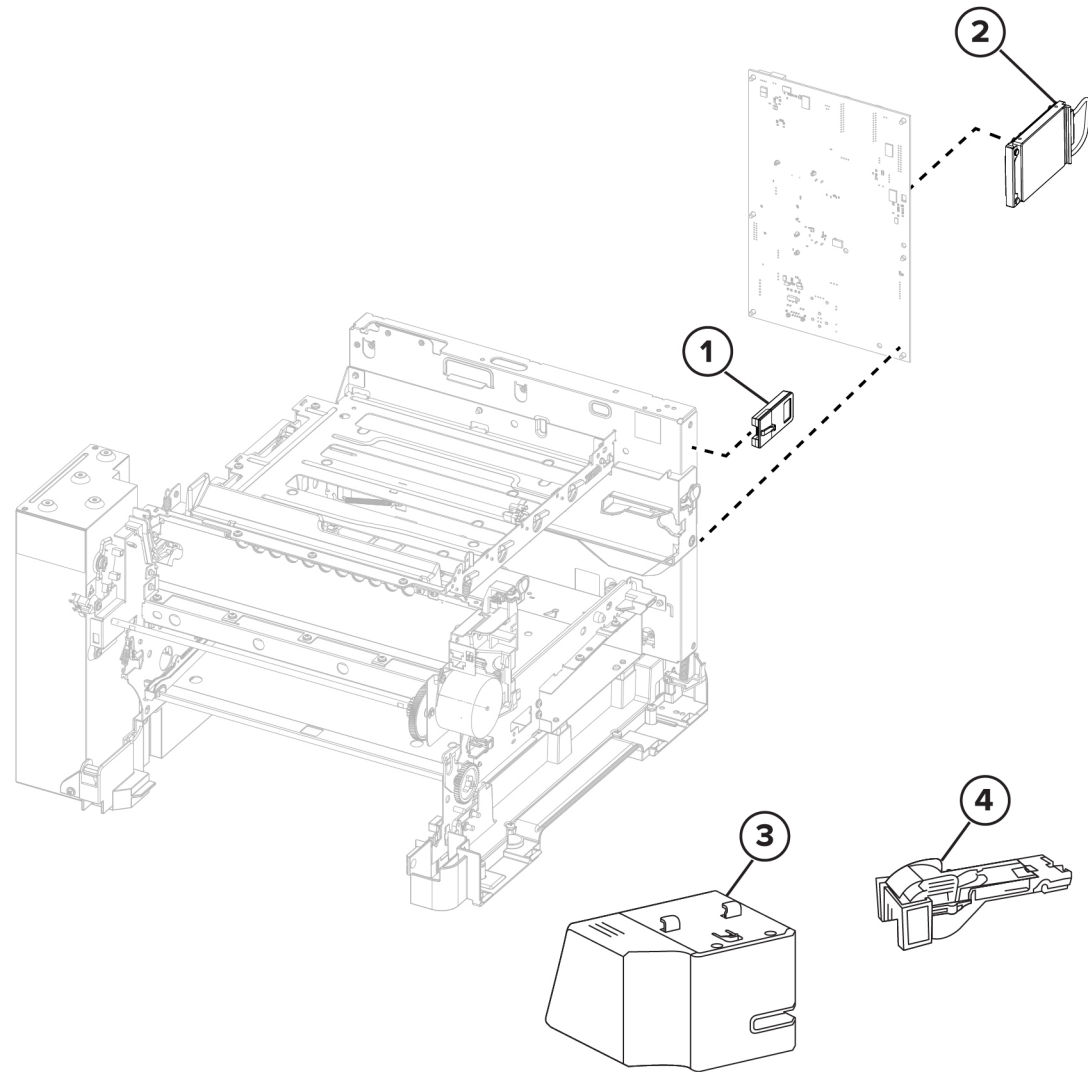

vlc415s5024a

PL 26.05 Consumables and tools

Item	Part	Description
1	006R04694	Cyan WW Metered
2	006R04695	Magenta WW Metered
3	006R04696	Yellow WW Metered
4	006R04693	Black WW Metered
5	006R04678	Cyan Std WW Sold
6	006R04679	Magenta Std WW Sold
7	006R04680	Yellow Std WW Sold
8	006R04677	Black Std WW Sold
9	006R04686	Cyan High-Capacity NA Sold
10	006R04765	Cyan High-Capacity XE Sold
11	006R04687	Magenta High-Capacity NA Sold
12	006R04766	Magenta High-Capacity XE Sold
13	006R04688	Yellow High-Capacity NA Sold
14	006R04767	Yellow High-Capacity XE Sold
15	006R04685	Black High-Capacity NA Sold
16	006R04764	Black High-Capacity XE Sold
17	006R04698	Cyan WW Sold (See Note)
18	006R04699	Magenta WW Sold (See Note)
19	006R04700	Yellow WW Sold (See Note)
20	006R04697	Black WW Sold (See Note)
21	013R00700	Black Imaging Kit
22	013R00701	Black and color imaging Kit
23	008R13325	Waste Toner Bottle
24	008R13347	Staple Cartridges

**No exploded
View Provided**

Note: Not widely distributed. For specific accounts only.

vlc415s5020a

PL 28.05 Covers 1

Item	Part	Description
1	002N03751	Top cover (REP 28.4)
2	002N03760	Rear cover (REP 28.5)
3	002N03752	Connectivity cover
4	002N03750	Toner access door
5	002N03745	Right cover
6	003N01189	Door straps
7	002N03754	Front door (REP 28.6)
8	002N03753	Top access cover
9	002N03746	Left side cover (REP 28.1)
10	002N03749	Bezel (C415)
11	—	Front Door Inner Paper Feed Guide (P/O PL 28.05 Item 7) (REP 28.7)

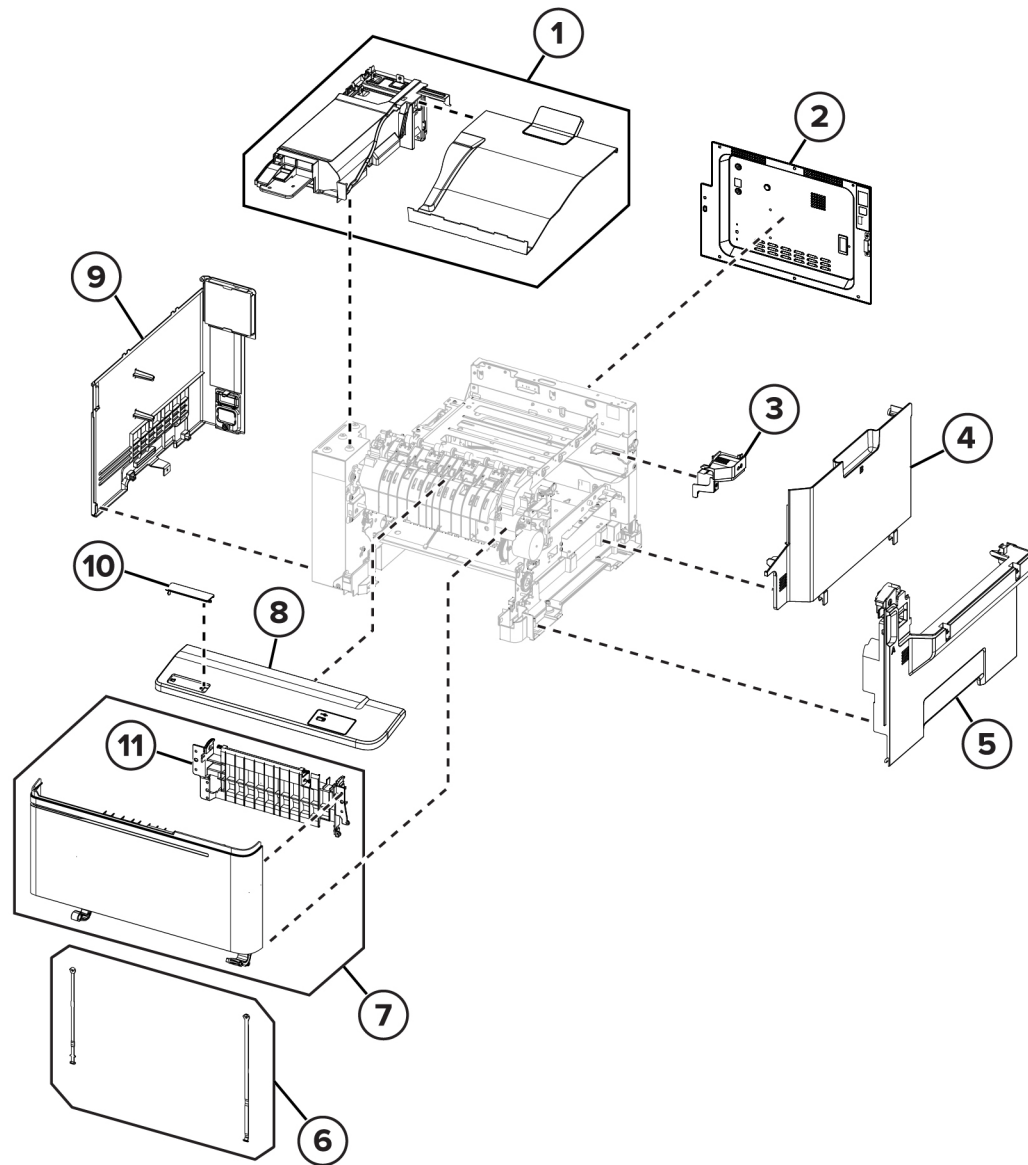

vlc415s5007a

PL 28.10 Covers 2

Item	Part	Description
1	002N03748	Control panel base cover
2	109N00924	Scanner rear access (left and right) cover
3	109N00925	Scanner right support (REP 60.3)
4	001N00610	Lower right subframe (REP 28.3)
5	117N02189	Subframe cable cover
6	001N00609	Lower left subframe (REP 28.2)
7	053N00378	Bin full flag
8	002N03757	Interlock switch cover

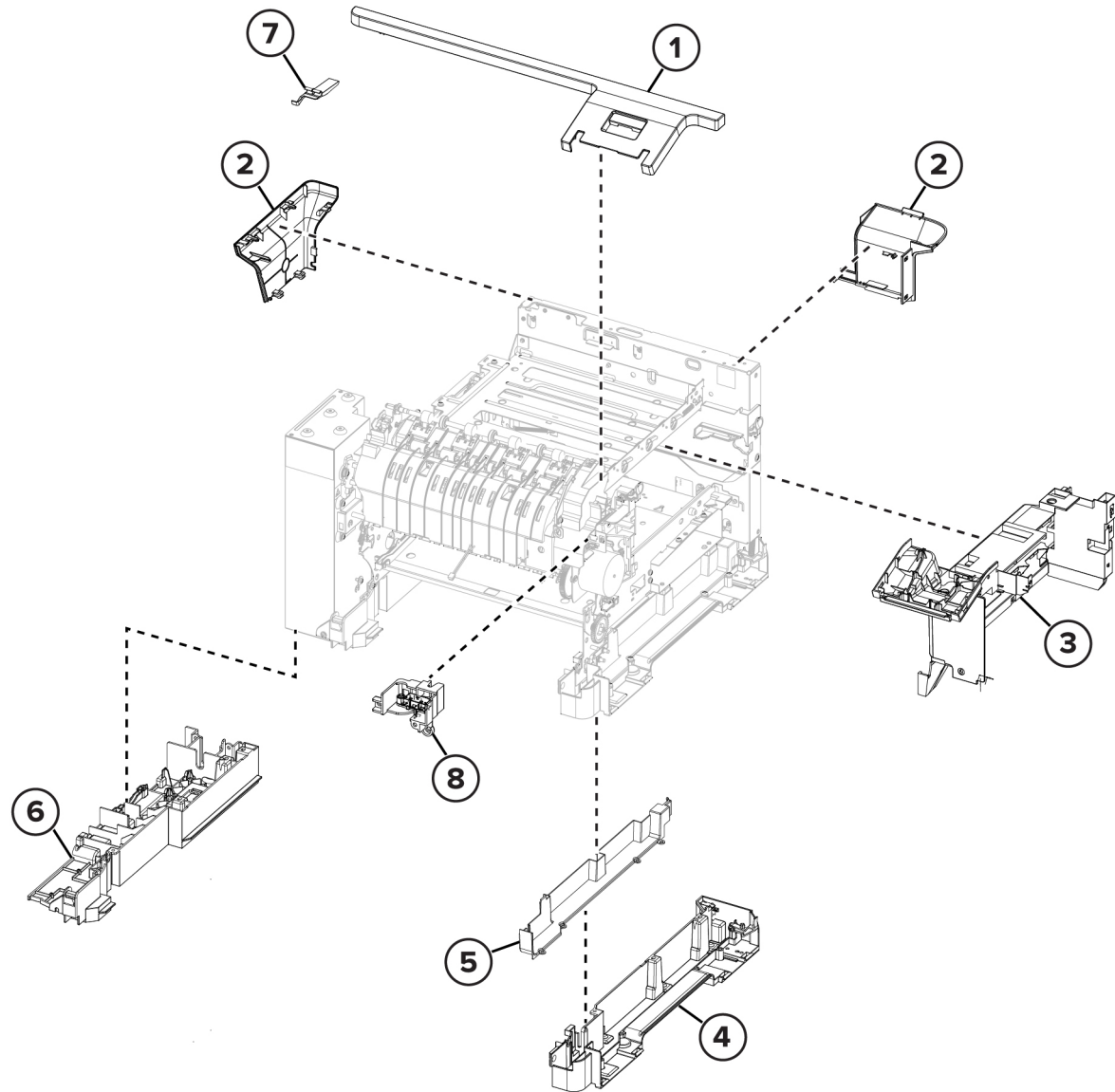

vlc415s5008a

PL 31.05 Harness

Item	Part	Description
1	117N02410	Weather station harness
2	126N00450	Fuser exit narrow media to controller PWB harness
3	117N02414	Fuser/Input sensor harness
4	117N02413	LVPS to controller PWB harness
5	117N02190	EP motor to controller PWB harness
6	117N02412	Tray 2 to controller PWB harness
7	117N02193	HVPS to controller PWB harness
8	117N02411	Tray present sensor harness
9	112N00258	AC power to LVPS harness
10	117N02415	Front USB harness

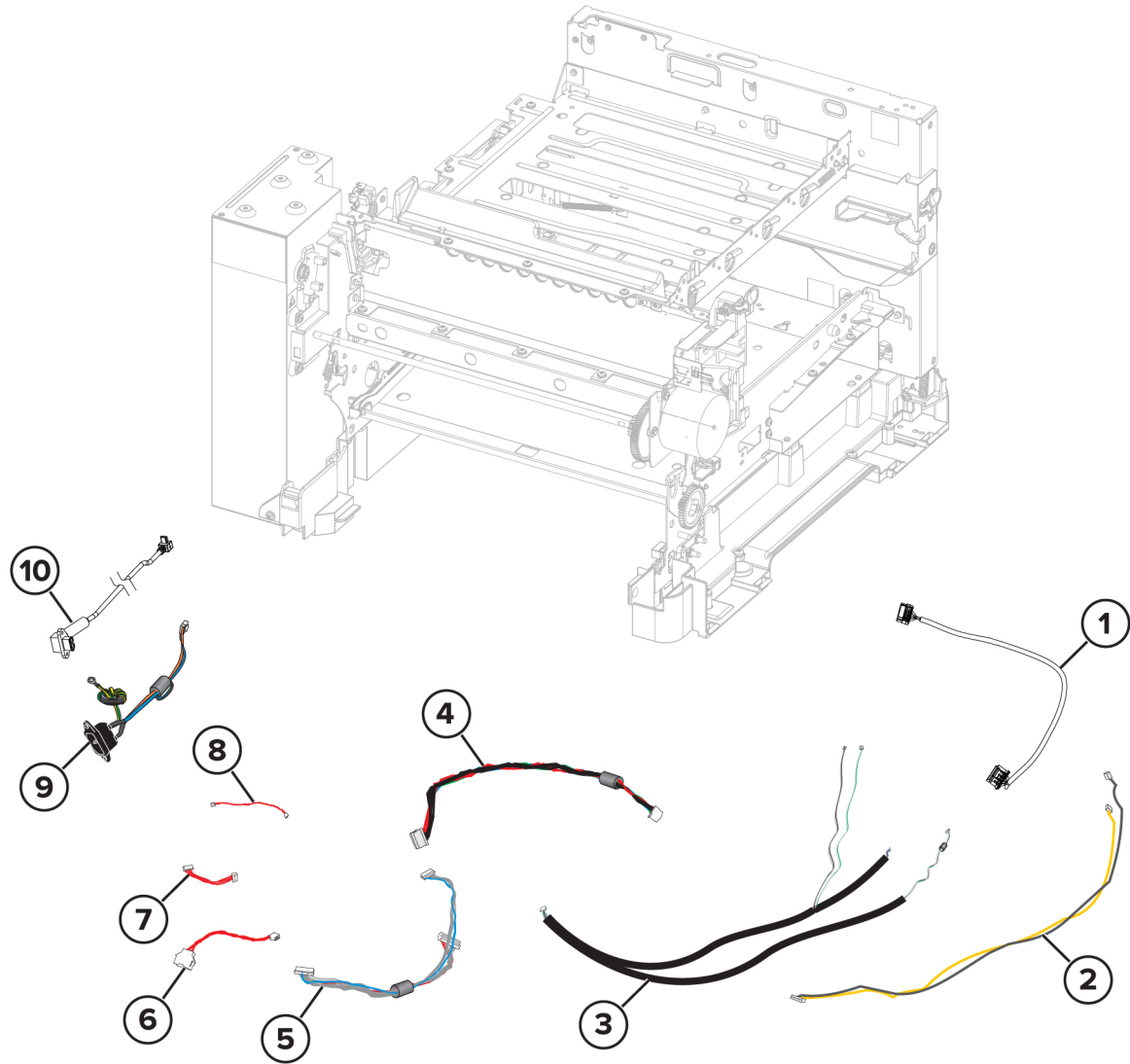

vlc415s5021a

PL 40.05 Drive Components

Item	Part	Description
1	127N07961	Fuser drive motor (REP 10.2)
2	007N01851	EP drive assy (REP 40.1)

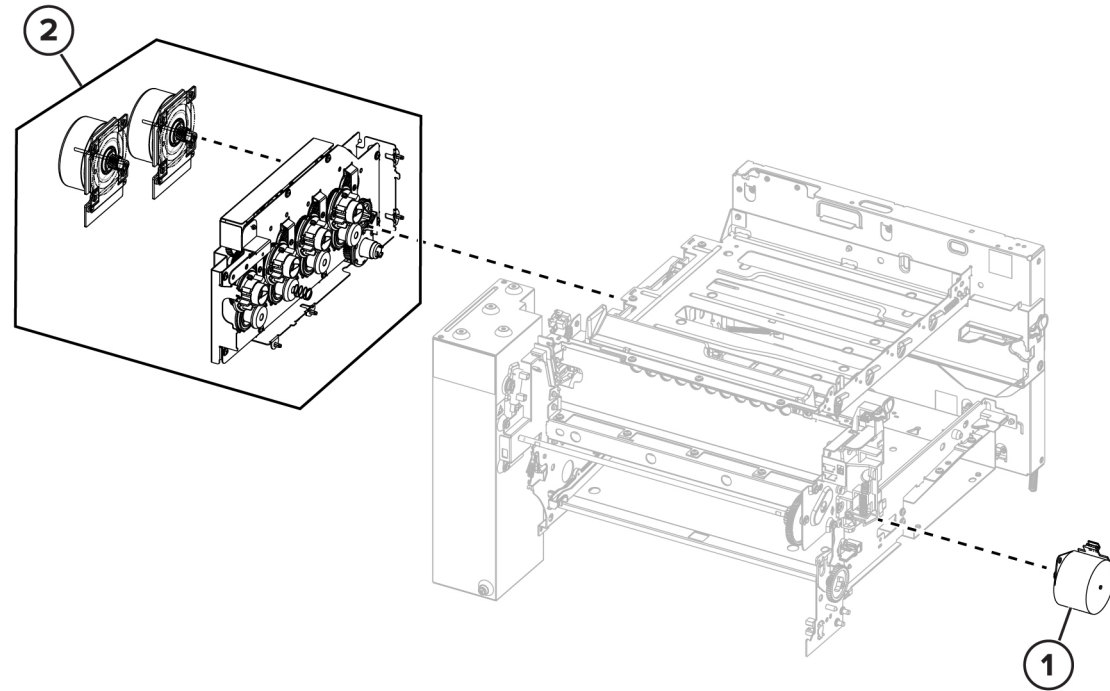

vlc415s5009a

PL 40.10 NOHAD

Item	Part	Description
1	127N07965	System fan
2	130N01909	Weather station

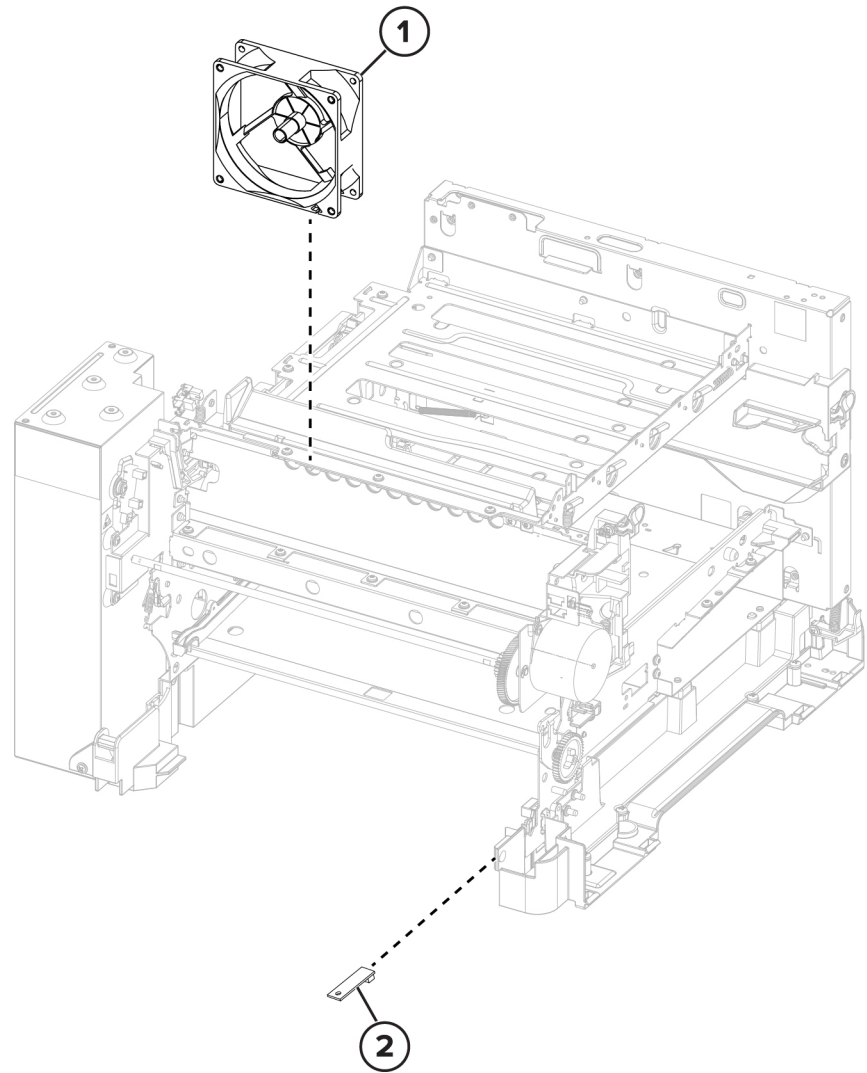

vlc415s5010a

PL 60.05 Printhead

Item	Part	Description
1	046N00246	Printhead (REP 60.1)

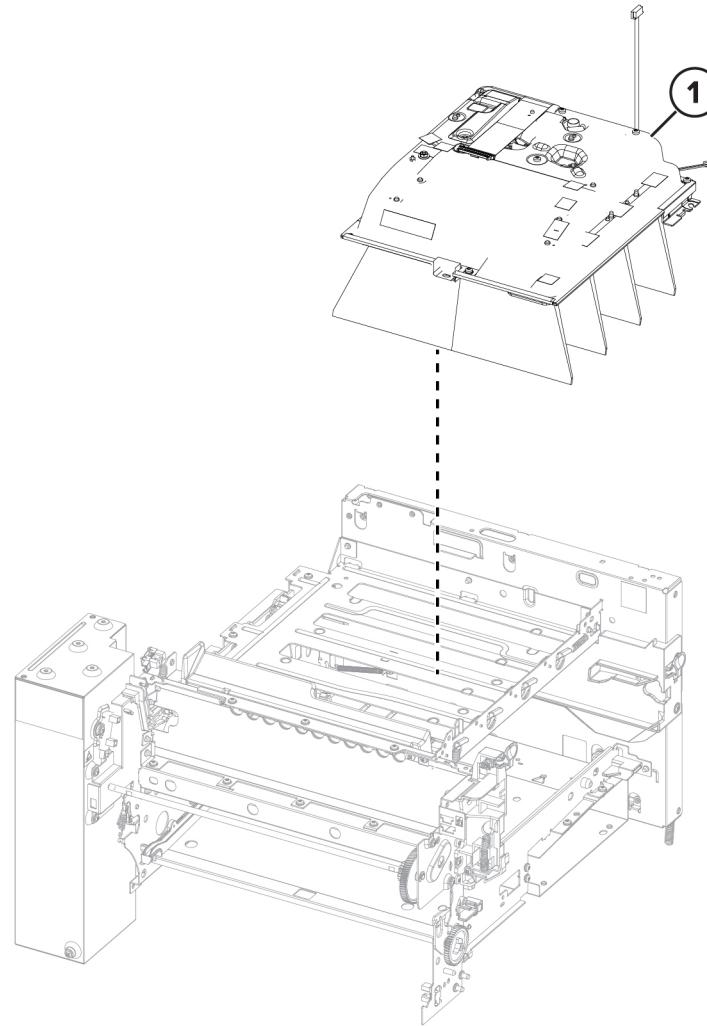

vlc415s5011a

PL 60.10 Scanner

Item	Part	Description
1	109N00923	Flatbed scanner (REP 60.2)

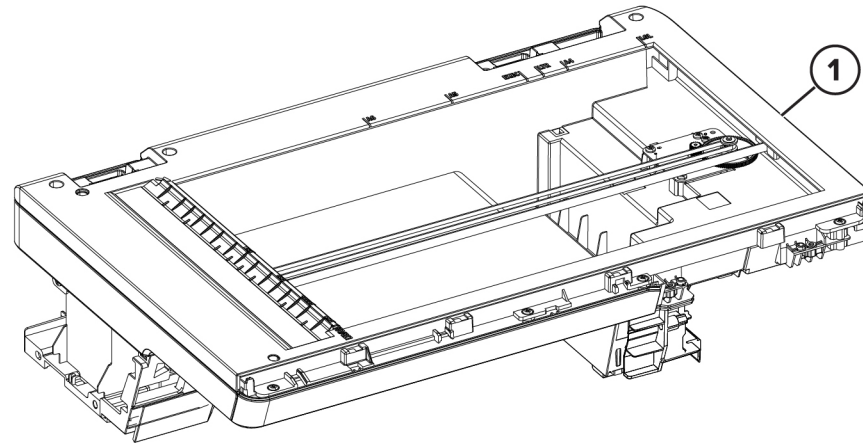

vlc415s5022a

PL 70.05 Paper Feed

Item	Part	Description
1	022N02898	Media feeder (REP 80.1)
2	022N02894	Pick Tires (REP 70.1) (See Note)

Note: HFSI. To reset HFSI counter, refer to [dC135](#)

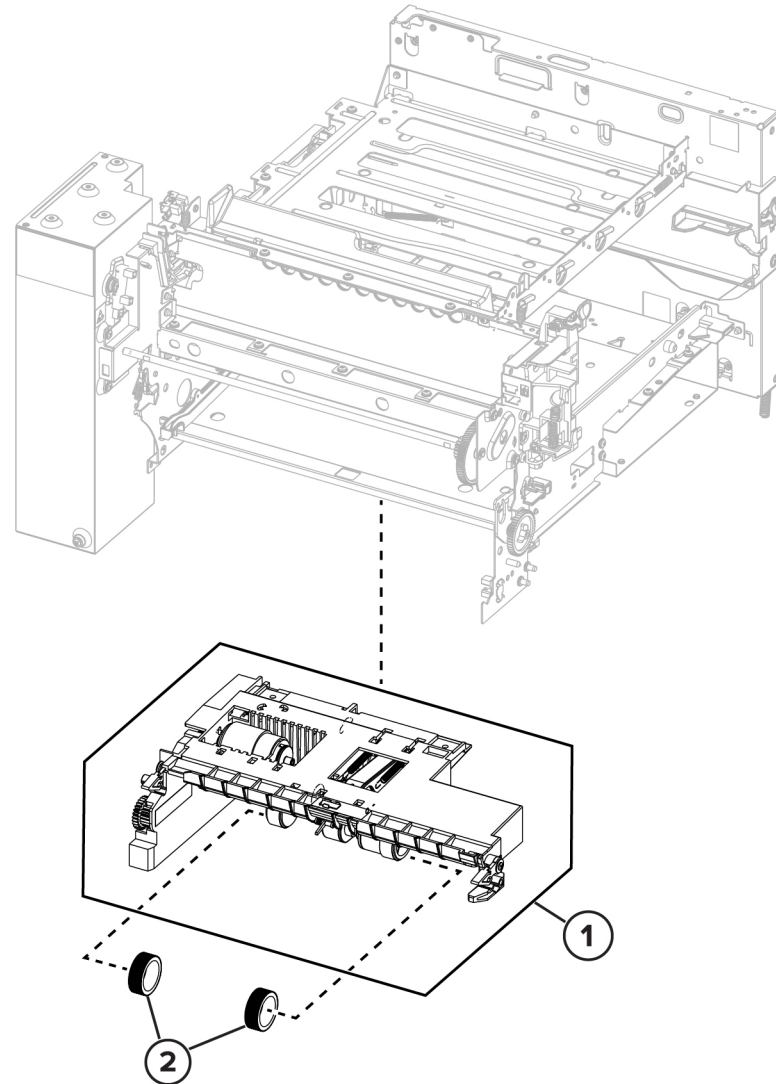

vlc415s5012a

PL 70.10 250 Sheet Tray 1

Item	Part	Description
1	050N00765	250-sheet tray

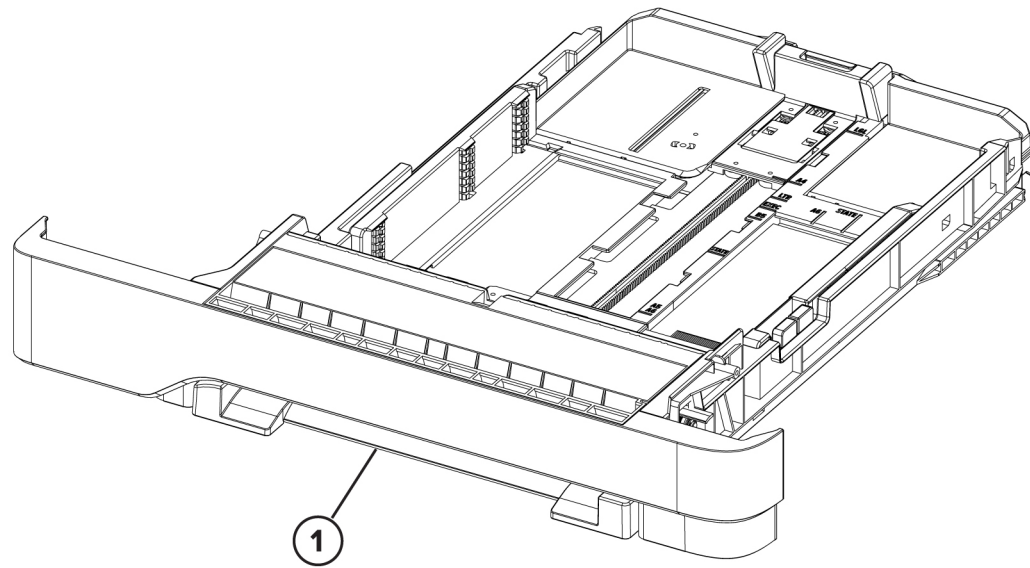

vlc415s5013a

PL 70.15 650 Sheet Tray 2 (Option)

Item	Part	Description
1	—	Optional 650-sheet duo tray
2	022N02895	Optional 650-sheet tray bypass pick rollers (P/O PL 70.15 Item 1) (See Note)
3	050N00767	Optional 650-sheet duo tray insert (P/O PL 70.15 Item 1)
4	022N02894	Pick tires (P/O PL 70.15 Item 1) (REP 70.1) (See Note)

Note: HFSI. To reset HFSI counter, refer to [dC135](#)

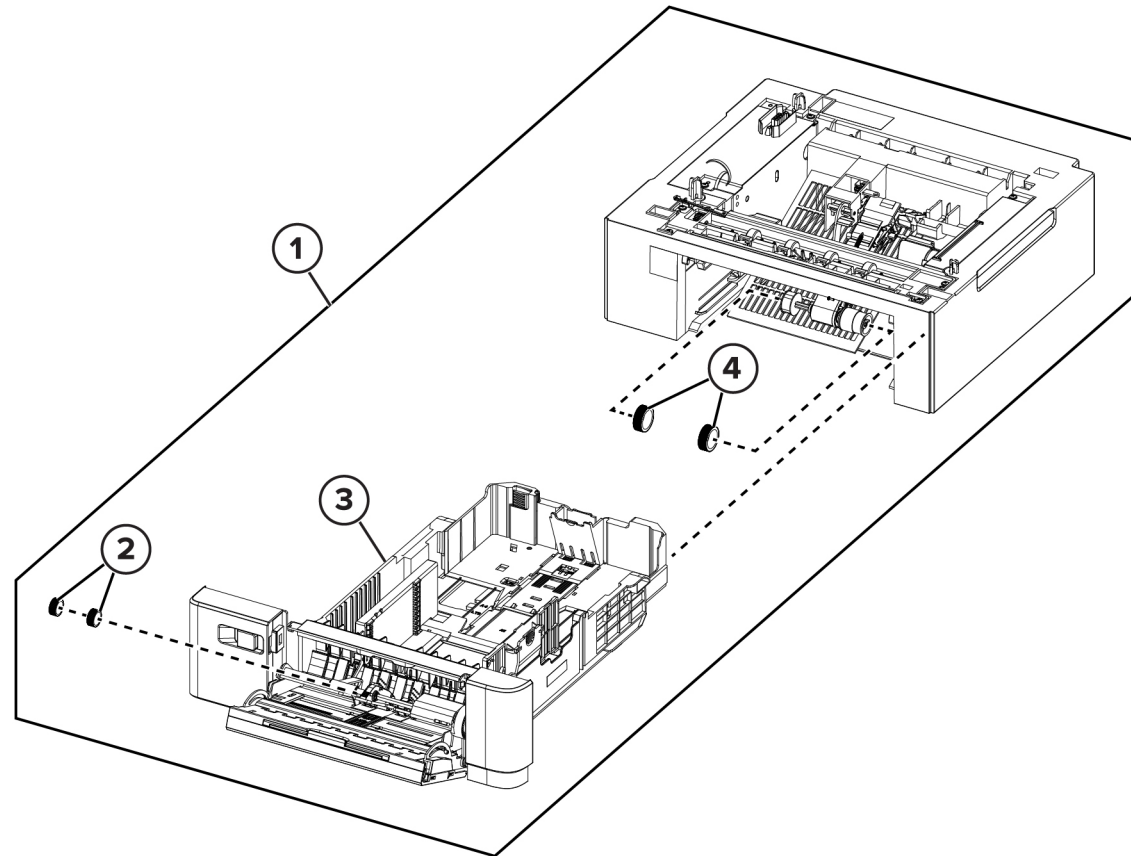

vlc415s5015a

PL 70.20 550 Sheet Tray 3 (Option)

Item	Part	Description
1	—	Optional 550-sheet tray
2	050N00766	Optional 550-sheet tray insert (P/O PL 70.20 Item 1)
3	022N02894	Pick tires (P/O PL 70.20 Item 1) (REP 70.1) (See Note)

Note: HFSI. To reset HFSI counter, refer to dC135

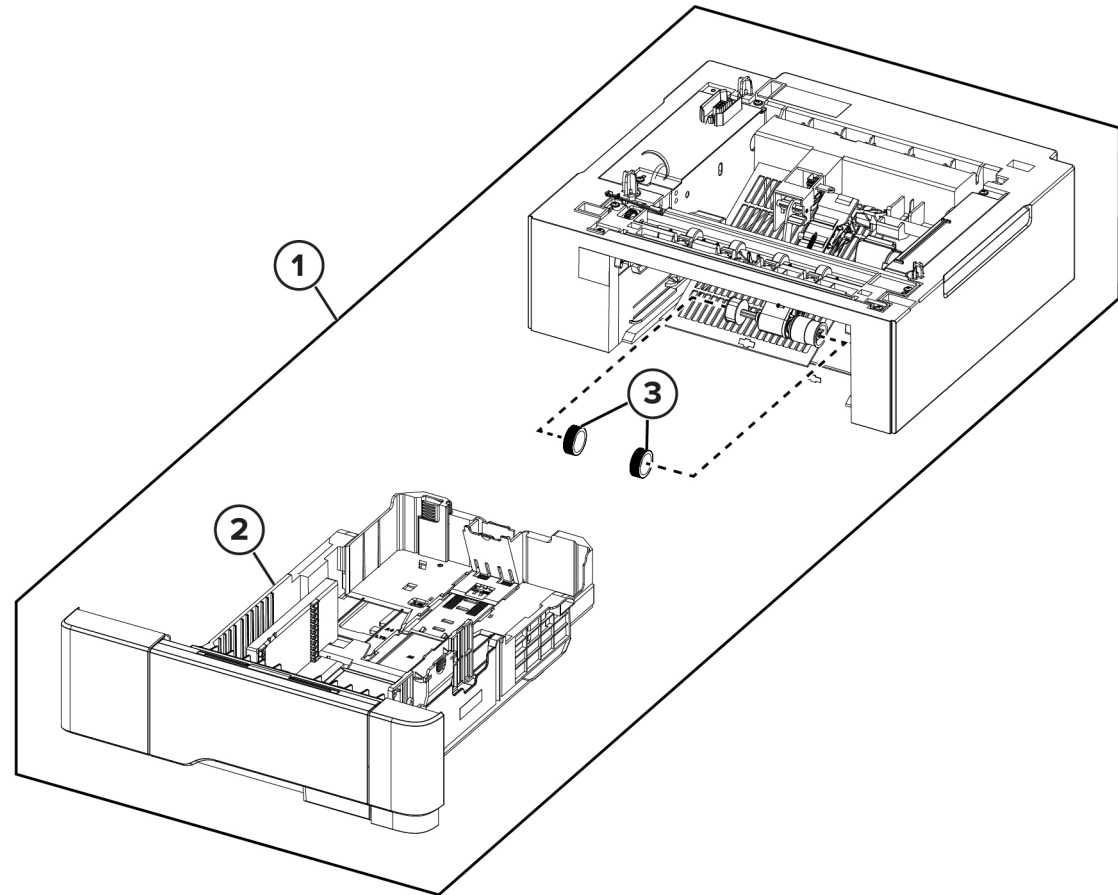

vlc415s5014a

PL 80.05 Paper Path

Item	Part	Description
1	130N01896	Sensors (narrow media/bin full) 1a/Sensors (narrow media/bin full) 1b (REP 80.2)

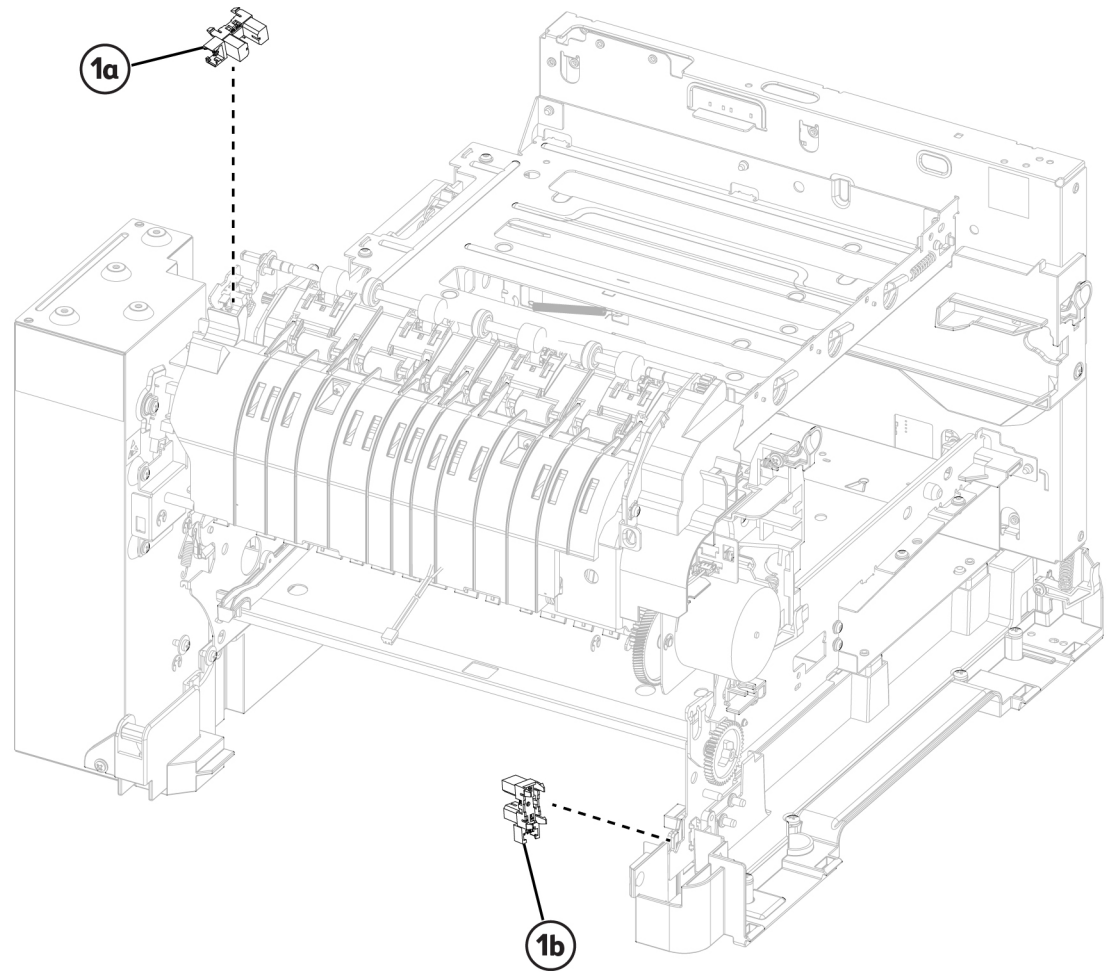

vlc415s5016a

PL 90.05 Xerographic Components

Item	Part	Description
1	130N02009	Toner patch sensor (REP 90.2)
2	014N00528	Waste toner bottle contact block (REP 90.5)
3	108N00643	Toner cartridge contact (REP 90.3)

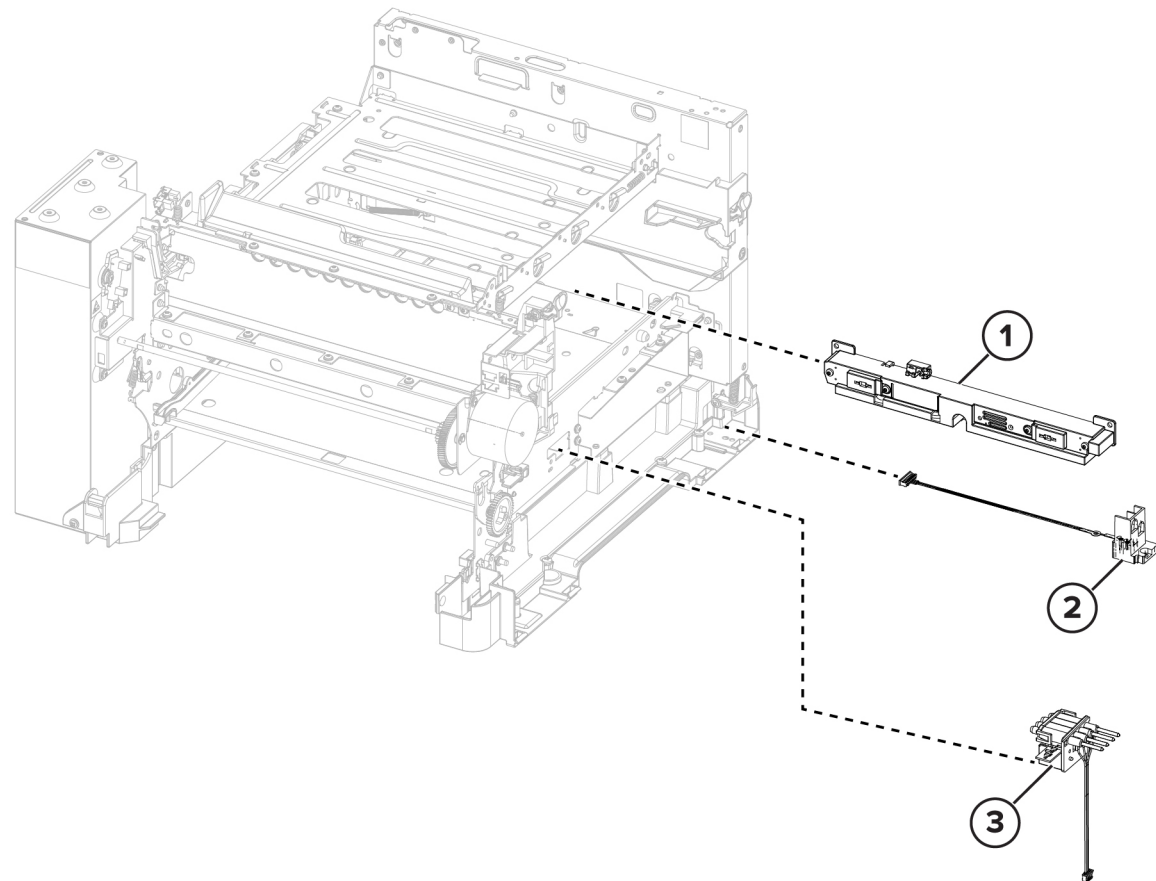

vlc415s5018a

PL 90.10 Transfer Module Assembly

Item	Part	Description
1	133N23274	Transfer module guide (REP 90.7)
2	133N23275	Transfer module (REP 90.6)

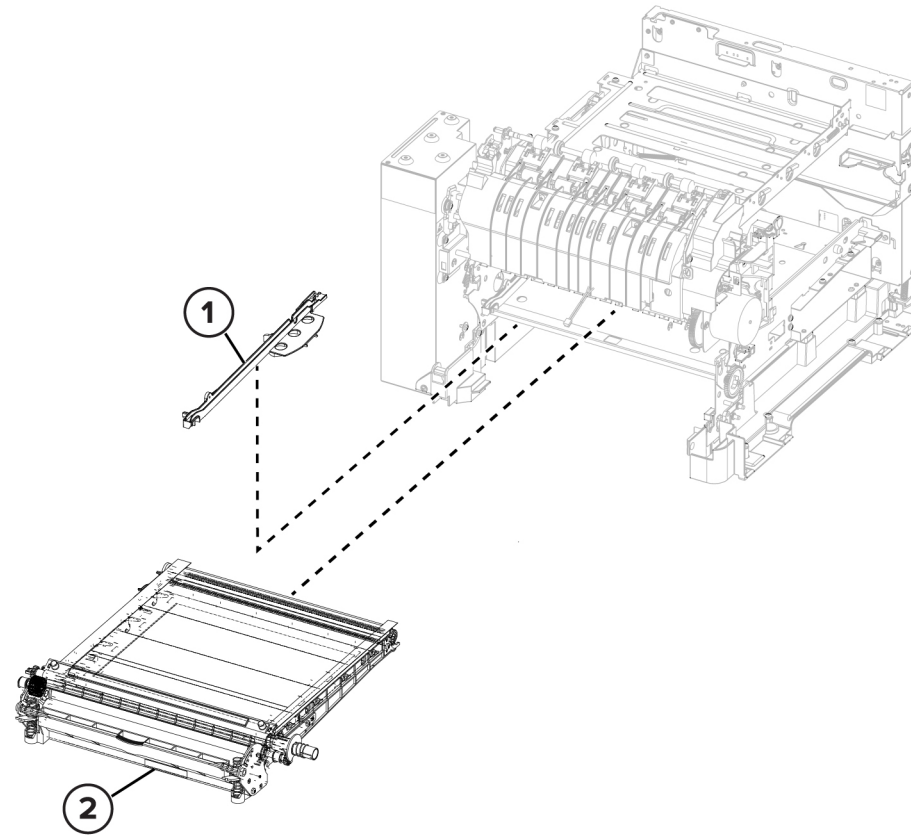

vlc415s5019a

6 General Procedures and Information

General Procedures	277	dC612 Print Test Patterns	368
GP 1 Diagnostics Mode Entry	277	dC727 Tray Quick Print Tests.....	369
GP 2 Fault Codes and History Files	279	dC919 Color Balance Adjustment	370
GP 3 Service Information	280	dC925 Printer Setup.....	371
GP 4 Software Upgrade	283	dC927 Toner Patch Sensor (TPS) Setup	372
GP 5 Miscellaneous Checks	303	dC945 IIT Calibration	373
GP 6 How to Check a Motor	304	Change Tags	374
GP 7 How to Check a Switch	305	Change Tags	374
GP 8 How to Check a Solenoid or Clutch	306		
GP 9 How to Check a Sensor	307		
GP 10 How to Switch Off the Machine or Switch On the Machine	308		
GP 11 How to Safely Lift or Move Heavy Modules	309		
GP 12 Machine Lubrication	309		
GP 13 Cloning	310		
GP 14 Printing Reports and Information Pages.....	312		
GP 15 Cleaning the Printhead Lense	313		
GP 16 Installation Space Requirements.....	314		
GP 17 Electrical Power Requirements.....	316		
GP 18 Cleaning the Scanner	319		
GP 19 Obtaining Audit and Device Logs	320		
GP 20 First Copy/Print Out Time and Power On Time	322		
GP 21 Restriction of Hazardous Substances (RoHS)	322		
GP 22 Backup & Restore Settings.....	323		
GP 23 Customer Administration Tools.....	324		
GP 24 How to Set the Date and Time.....	325		
GP 25 Ethernet Crossover Cable Setup.....	326		
GP 26 Supplies Plan Activation	328		
GP 27 Intermittent or Noise Problem	331		
GP 28 System Administrator Password Reset	332		
GP 29 Print/Copy Orientation Definitions.....	333		
GP 30 Paper and Media Size Specifications.....	334		
GP 31 Environmental Data.....	340		
GP 32 Device Specification	341		
GP 33 Restoring Customer Mode.....	342		
GP 34 How to Re-Enter Optional Feature Installation Keys	343		
GP 35 Serial Number Synchronization Procedure.....	344		
GP 36 Xerox Wireless Printing Troubleshooting.....	345		
GP 37 Supplies Plan Conversion	346		
GP 40 Glossary of Terms, Acronyms and Abbreviations	349		
Diagnostics	355		
Service Copy (Tools) Mode	355		
dC104 Usage Counters.....	355		
dC108 Software Version	356		
dC122 Fault History	356		
dC126 Paper Registration.....	357		
dC131 NVM Read/Write	357		
dC132 Machine Serial Number	358		
dC135 HFSI Counters	359		
dC301 NVM Initialization.....	359		
dC312 Network Echo Tests.....	360		
dC330 Component Control	360		
dC361 NVM Save and Restore.....	367		

GP 1 Diagnostics Mode Entry

Purpose

This procedure describes how to enter and exit diagnostics mode and the available diagnostics routines.

Note: When diagnostics mode is entered, all existing copy jobs are cancelled and an 'Offline' screen message is displayed.

How to Enter Service Mode

Note: Do not enter diagnostics mode if the Replace Toner Cartridge dialog box is displayed. Entry to diagnostics mode with the dialog box displayed will stop the machine printing test patterns. Confirm either yes or no, then enter diagnostics mode.

1. Switch on the machine, [GP 10](#).
2. When the machine is ready press and hold the **Home** button for 7 seconds. The passcode screen will display when the button is released.
3. Enter the passcode, 6789. Press the **OK** button on the UI.

Note: Five incorrect entries cause the entry screen to lock for 3 minutes.

4. Select the relevant tab:
 - [General Information Tab](#)
 - [Service Information Tab](#)
 - [Diagnostics Tab](#)
 - [Adjustments Tab](#)
 - [Maintenance Tab](#)

Call Closeout Button

Note: Do not exit service mode until the machine has recovered from all diagnostic routines.

1. Select the Call Closeout button to exit service mode.
2. If necessary, select Reset Counters.
3. Select Exit or Exit and Reboot.

General Information Tab

- Product code
- Serial number
- Total images

- Images since last call
- System software version
- IPV4 address
- Device name
- IPV6 address

Service Information Tab

The service info tab contains routines used to track; use counts, SW versions, fault history, and consumable status. Refer to [Table 1](#) Service Information Tab.

Table 1 Service Information Tab

Routine	Description
dC104 dC104	Usage Counters
dC108 dC108	Software Version
dC122 dC122	Fault History
dC135 dC135	CRU / HSF1 Status

Diagnostics Tab

The diagnostic tab contains routines used to test specific areas of the machine. Refer to [Table 2](#) Diagnostics Tab.

Table 2 Diagnostics Tab

Routine	Description
dC312 dC312	Network Echo Test
dC330 dC330	Component Control (Fax Engine)
dC330 dC330	Component Control (Print Engine)
dC330 dC330	Component Control (Scan Engine)

Routine	Description
dC612 dC612	Print Test Pattern
dC727 dC727	Tray Quick Print Tests

Adjustments Tab

The adjustment tab contains routines used to modify the set-up or to calibrate specific areas of the machine. Refer to [Table 3 Adjustments Tab](#).

Table 3 Adjustments Tab

Routine	Description
dC126 dC126	System Registration
dC131 dC131	NVM Read/Write
dC301 dC301	NVM Initialization
dC361 dC361	NVM Save and Restore
dC919 dC919	Color Balance Adjustment
dC925 dC925	Printer Setup
dC927 dC927	Toner Patch Sensor Setup
dC945 dC945	IIT Calibration

Maintenance Tab

The maintenance tab contains routines that give information about the fault history of the machine, serial number, and consumable. Refer to [Table 4 Maintenance Tab](#).

Table 4 Maintenance Tab

Routine	Description
dC122 dC122	Fault History
dC132 dC132	Machine Serial Number
dC135 dC135	CRU / HSF1

Service Copy Mode

Service copy mode provides access to the machine that is greater than that of a user, but less than that of the System Administrator. This mode allows the CSE to perform a number of checks and run copies without compromising the customer's security settings. This mode can be used if the Administrator user name and passcode are not at the default, and the Administrator is not available to enter the admin passcode. Perform the steps that follow:

1. Press and hold the **Home** button for 7 seconds. The passcode screen will display when the button is released.
2. Enter the passcode 2732. press the **OK** button on the UI.
3. The **Log In** button will change to display **CSE**.

Note: Five incorrect entries cause the entry screen to lock for 3 minutes.

Note: The tools available in this mode are a subset of those available in Administrator mode. CSE service copy mode remains active until the **login/CSE** button is pressed again. When finished with always log out of service copy mode by pressing the **CSE** button and confirming log out.

GP 2 Fault Codes and History Files

Purpose

To describe access to fault history information and explain the fault code structure.

- Fault History files can be accessed from the UI:
 - Touch Device > Notifications > Fault History.

Fault Data Available from Service Mode

- Enter Service Mode, [GP 1](#):
- Touch Service Information > dC122 Fault History, [dC122](#).

Function, Fault, Component Codes

Refer to, [Table 1](#), Function and fault code prefixes. Also known as the chain code.

For example. displayed code 373-215-00, Tray 3 hoist failure.

- 3 - Indicates that this is an Atlantis software platform fault code.
- 73 - The fault is located in chain 7 — paper supply, tray 3.
- 215 - This is the link code.
- 00 - This is the extension code.

Table 1 Function and fault code prefixes

Chain Code	Function
301	Standby power
302	User interface
303	Machine run control
305	Document transportation
310	Fusing and copy/print transportation
312	Finishers
316	Network controller
319	Video image manipulation
320	Fax
322	System Errors
340	Main drives
36X	LED print head, scanners

Chain Code	Function
37X (X = tray No.)	Paper supply (paper trays and bypass)
38X	Paper feed and transport
39X	Xerographics
395	Software upgrade errors

GP 3 Service Information

Purpose

To provide machine hardware and software information.

Diagnostics Mode Screen

Enter service/diagnostics mode, [GP 1](#). The screen displays the following selections:

- **Initial View:**
 - [General Information Tab.](#)
 - [Service Information Tab.](#)
 - [Diagnostics Tab](#)
 - [Adjustments Tab.](#)
 - [Maintenance Tab.](#)
- **General Information:**
 - Product Code:
 - Serial Number:
 - Total Images:
 - Images Since Last Call:
 - System Software Version:
 - IPV4 Address:
 - Device Name:
 - IPV6 Address:
- **Service Information:**
 - [dC104](#) Usage Counters
 - [dC108](#) Software Version
 - [dC122](#) Fault History
 - [dC135](#) CRU/HFSI

Machine Serial Number

To locate the machine serial number, open the front door, the serial number plate is located on the lower left frame of the machine, [Figure 1](#).

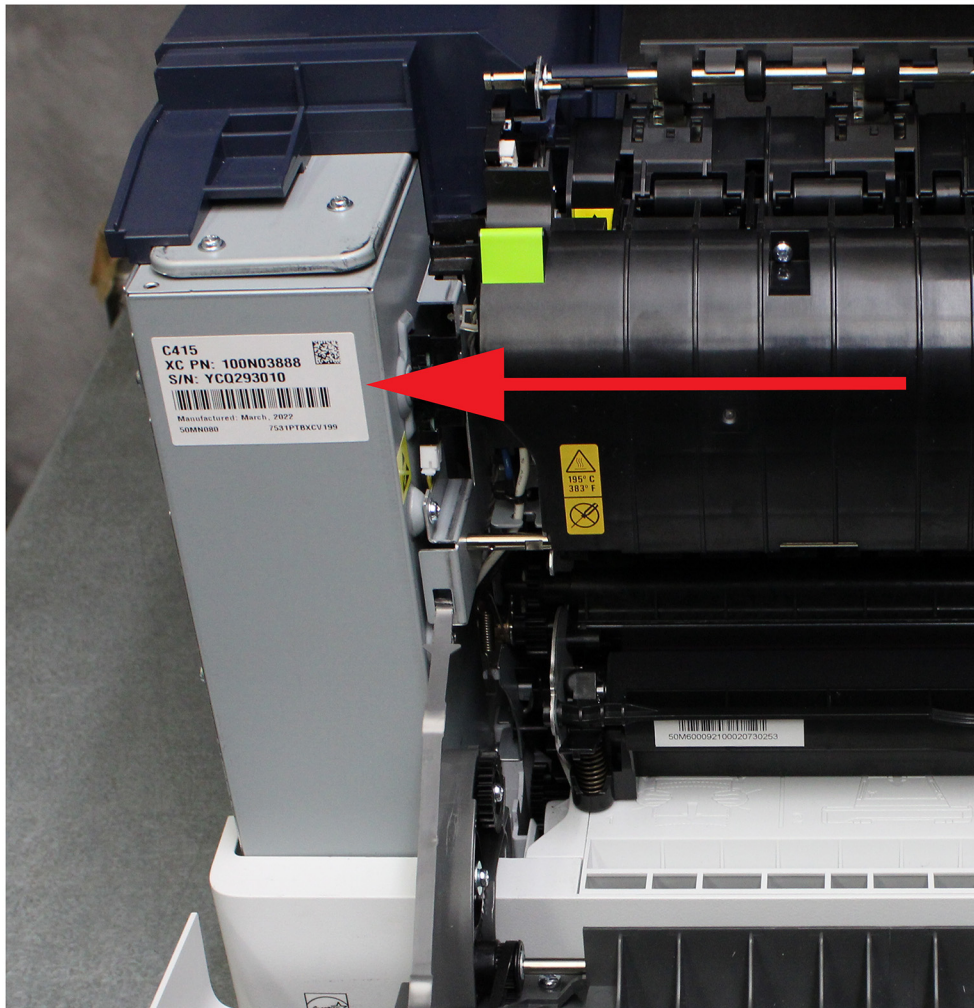

vlc415s6004

Figure 1 Machine Serial Number

The serial number for the NA markets is in the format: XXX #####. Where XXX is the product code (see [Product Code](#)) and ##### is the serial number.

The serial number for the XE markets is in the format: MMM#####C. MMM is the manufacturing location code, ##### is the serial number and C is the check digit, for example 2327020103.

Product Code

The machine product codes are shown below, [Table 1](#).

Table 1 Machine product codes

Machine Configuration	Product Code	Comments
C415_DN, (110VAC)	YCQ	
C415V_DN, (220VAC)	YDZ	
C415_YDN, (110VAC)	YQCN	TAA configuration
C415V_YDN, (220VAC)	YDZN	TAA configuration

GP 4 Software Upgrade

Preparation



CAUTION: The Altboot procedure may delete all stored data on the System Disk Drive, including e-mail addresses, Xerox Standard Accounting data, and network configuration information. If possible, clone the machine, [GP 13](#), and back up customer settings, [GP 22](#), before performing Altboot. If the machine failure is such that a Backup and Restore cannot be performed, notify the customer that data will be lost.

Perform the following, if possible:

1. Save NVM to a USB drive, [dC361](#).
2. Print a Configuration Report, [GP 14](#).
3. Clone the network configuration, [GP 13](#).
4. Create a backup file of customer settings, [GP 22](#).

Purpose

This procedure provides installation instructions for upgrading, downgrading, or restoring system software:

Additional software installation options are available using EWS when software updates are enabled. Customers can upload system software using EWS or they can configure EWS to monitor an FTP site and automatically upgrade when a newer version is detected. [Table 1](#) lists the available software installation procedures and their effects on each module.

Note: If a newly installed component has a different version of software than the software set that is on the controller PWB, the software on the new component may be upgraded or downgraded at system startup.

Note: To power down the machine, press the UI Power Button and then respond to the on-screen prompts. Wait until the Power Button LED turns off, then switch off the Main Power Switch, [GP 10](#).

Note: The following table provides an overview of the procedures that follow. The table is not intended as a procedure for the type of software installation. A link to the procedure is provided in the table.

Table 1 Software Loading Options

Software Loading Options														
HW Location		Controller (SBC)												
Platform Components		OS kernel & FPG-As	SW Upgrade	BIOS	Net-work Controller	Fax	Copy Controller	UI App	OS	OS kernel & FPG-As	UI Panel Firm-ware	IIT Apps	DADF	IOT
Physical location of the software component.		eMMC		eMM-C	eMMC					UI PWB	eMM-C	DADF PWB	Con-troller PWB	
Full DLM download location: GSN Library 17823														
Software Platform	Procedure Overview	Operation												
USB Altboot (Standard Altboot) Used for software upgrade or downgrade. Based on the drive setup, the printer reads the folders, finds the Altboot folder, checks the versions of software against the .DLM file, and then installs the .DLM file associated with the printer. The printer retains the customer data.	<p>Standard USB Altboot Procedure</p> <p>Also called standard Altboot, this is the base procedure:</p> <p>Based on the drive setup, the printer reads the folders, finds the Altboot folder, checks the versions of software against the .DLM file, and then installs the .DLM file associated with the printer. The printer retains the customer data.</p> <ul style="list-style-type: none"> • USB Port on the machine must be Enabled. • Do not partition the USB drive. • Format the USB drive for FAT32 (other formats are not supported). 	Upgrade Downgrade Reload					none							

Software Loading Options			
	<ul style="list-style-type: none"> • Only place one .DLM file per product number in the folder. • Altboot .DLMs are larger files. 		
<p>Forced USB Altboot: Method used for failed SW Upgrade recovery.</p>	<p style="color: green;">Forced USB Altboot Procedure</p> <p>In a USB drive formatted for Altboot, add a blank text file in the Altboot directory and call it FORCED_UPGRADE (the filename is case-sensitive).</p> <ul style="list-style-type: none"> • This flag bypasses the printer's version checks and verification of each option and accessory, and installs the whole software package at once. FORCED_UPGRADE also overwrites the customer settings and sets the printer back to factory defaults. • Use this method when the printer is refusing to update, if the customer wants the 	<p>Upgrade Downgrade Reload</p>	

Software Loading Options		
	printer settings re-set, or to revert the printer back to an older software version.	
Special Altboot: Use in the event of EMMC or Controller Board failure, the machine may lose the encryption keys for the EMMC.	<p style="color: green;">Special Altboot Procedure</p> <p>In the event of EMMC or Controller Board failure, the machine may lose the encryption keys for the EMMC.</p> <ul style="list-style-type: none"> • Place the swup_usb file in the Altboot folder to restore the keys and recover the printer. • This file is version and product specific, so be sure to download a fresh version of this file when you download the .DLM file from where you get firmware files. Both files are packaged together in the same folder. 	Upgrade Downgrade Reload
PWS ALTBOOT: Allows upgrade when USB is not available at the customer site.	<p style="color: green;">PWS Altboot Procedure</p> <p>Sometimes the need to perform an Altboot procedure but the customer does not</p>	Upgrade Downgrade Reload

Software Loading Options														
<p>allow USB drives to be connected with their network.</p> <ul style="list-style-type: none"> In this case, connect the laptop (with PWS software installed) using a standard crossover Ethernet cable. <p>Note: Unlike Alta-Link products, there is no special custom serial or USB cable needed.</p> <ul style="list-style-type: none"> Run the PWS Altboot utility to connect with the printer and download the software. There are settings for Forced, Special or Secure, and regular Altboot processes. <p>Note: When connecting with a crossover cable, assign both the printer and computer, a static IP address on the same subnet (like 192.168.1.1 and 192.168.1.2). When finished, return the printer to its previous IP address settings.</p>														
Other software upgrade methods (for reference only).														
<p>Normal USB Upgrade</p> <p>Note: Recommended CSE method, customer data should always be preserved.</p>	<p>DLM file placed in \Upgrade folder on a USB drive and inserted after the machine has come to ready.</p> <ul style="list-style-type: none"> Uses smaller "differential" DLM (only changes 	Version Check: Up/Down	Version Check: Up/Down	Version Check: Up/Down	Up/Down / Re-load	Up/Down / Re-load	Up/Down / Re-load	Up/Down / Re-load	Up/Down / Re-load	Up/Down / Re-load	Up/Down / Re-load	Up/Down / Re-load	Version Check: Up Only	Version Check: Up Only

Software Loading Options													
	from Launch DLM) <ul style="list-style-type: none"> Machine must be Online USB Ports must be Enabled Software Upgrade must be enabled 												
Customer Manual Upgrade via EWS	DLM file is loaded through [EWS Properties > General Setup > Machine Software > Manual Upgrade] <ul style="list-style-type: none"> Both the Customer DLM, downloaded from Xerox.com, and the full DLM file types can be used during EWS upgrade. Machine must be Online Software Upgrade must be enabled 												
SWUP Utility	DLM file is loaded through SWUP utility. <ul style="list-style-type: none"> Uses smaller differential DLM (only changes from Launch DLM) Machine must be Online 												

Software Loading Options													
	<ul style="list-style-type: none"> Software Upgrade must be enabled 												
Customer Automatic FTP Upgrade	<p>DLM file is placed on an FTP server and EWS is configured [Properties > General Setup > Machine Software > Auto Upgrade) to periodically check the FTP site for updated SW.</p> <ul style="list-style-type: none"> Uses smaller "differential" DLM (only changes from Launch DLM) Machine must be Online Software Upgrade must be enabled 												

Software Loading Options													
Remote Services	<p>New major SW releases are automatically pushed to connected machines.</p> <ul style="list-style-type: none"> • Uses smaller "differential" DLM (only changes from Launch DLM) • Machine must be Online • Software Upgrade via Remote Services must be enabled with device communicating with Xerox. 												
Fleet Orchestrator	<p>Contents of the different platform behaviors (upgrade/downgrade/reload) is same as all customer upgrades (EWS/Normal USB upgrade/Etc).</p>												

Software Installation Types

- Loading Software Using a USB Flash Drive
- Embedded Web Server (EWS) upgrade using the network
- Altboot Software Loading using a USB Flash Drive
 - Standard Altboot Procedure
 - Forced Altboot Procedure
 - Special Altboot Procedure
- PWS Altboot Procedure using PWS Altboot tools

Additional Tools

- Troubleshooting
- Fleet Orchestrator

System software sets are compilations of software modules and a software compatibility database (SCD). The SCD lists software versions suitable for the system and its installed options. System software is supplied as a .DLM file.

Two versions of the software DLM file are available.



CAUTION: The full DLM is required for all forms of Altboot Software Updates.

1. The full Altboot versions of the DLM files will be made available on the TCP/IP Site and [GSN Library 17823](#) for Service to use during Altboot upgrades:

Note: Example: XeroxVersaLink_X415_ALTBOOT_system-sw#11802400220120#.DLM (The X =: B if mono, C if Color)

- Product Type: VersaLink
- Product Number: X415
- Version number is a numeric series to identify product, version, and release date.
-



CAUTION: The software will not load if no pound (#) signs appear in the file name.



CAUTION: Do not attempt to open this file. Attempting to open the file may corrupt it, making it unusable.

Note: The Altboot DLM can be used even when the shipped DLM is missing in the machine.

2. The smaller, Thin/BDC or Customer File, DLM files downloaded from Xerox.com, contain changes from the manufactured release software that ships in the machine:

Note: Example: XeroxVersaLink_X415_system-sw#11902500304611# (The X =: B if mono, C if Color)

- Product Type: VersaLink
- Product Number: X415

- Version number is a numeric series to identify product, version, and release date.
- If the Launch DLM is missing from the drive, the BDC upgrade will fail and the launch DLM recovery patch (LDRP) will be required.
- Software upgrade instructions and instructions on how to recover from failed upgrades are posted with the upgrade files on Xerox.com.

Note: Software version information appears in **Service Information > Service Mode, dC108** .

Note: If the screen displays the message **The device is in non-customer mode** after completing Power On, it will be necessary to perform **GP 33** to restore the machine to customer mode. If the Billing Counters have been lost, follow **GP 26** to report Billing Meter reset.

At Power On, the system checks the version information for each installed module and compares it to locally stored SCDs.

Software Installation Procedures

Note: Depending on the procedure used, the software installation could require up to 60 minutes. If the installation fails, refer to **OF 1**, Machine Not Ready RAP .

Initial Actions:

- Verify the machine is fully operational, if possible. Clear any active faults or jams.
- Obtain a USB Flash drive with a minimum capacity of 1GB, formatted for FAT32.
- Print a Configuration Report, if possible, to check the software version on the machine.
- Download the current version .dlm file from Xerox.com
- USB port must be enabled.
- Software updating must be enabled.

Software Upgrade Installation

Customer USB DLM Software Upgrade

1. Either allow all pending print jobs to finish or delete the pending jobs from the que.

Note: If the print jobs cannot be deleted, inform the customer that all pending jobs will be lost.



CAUTION:

Check the Release Notes to ensure upgrades can be applied.

Note: Before inserting the USB drive, ensure the machine is in a **[Ready]** state.

2. Log in as Admin.
3. Enable SW Upgrade via UI Tools or the EWS.
4. Connect the USB Flash drive containing the .DLM file to one of the USB ports.



CAUTION: The USB should only contain the DLM for the machine being updated. No other DLM should exist.

Note: Use a USB thumb drive that is compatible with Xerox approved models.

Note: It is not necessary to switch off the system to perform a software upgrade.

5. Touch **[Install File]** on the USB Drive Detected popup, then select the .DLM file for the upgrade to initiate.
6. Do not remove the USB drive until the message **[Software upgrade is completed. Remove the USB drive to restart the system]**, displays on the UI.
7. If the upgrade fails, use the **Forced Altboot** procedure to recover.
8. The system may restart several times completing the installation before returning to a ready state.
9. After the software has been upgraded a software upgrade report will print automatically.

Embedded Web Server (EWS) upgrade using the network

1. Open a web browser, enter the machine IP address in the address field, then press **Enter** on the keyboard. The system EWS will open.

Note: The machine IP address is listed at the top-center of the UI screen.

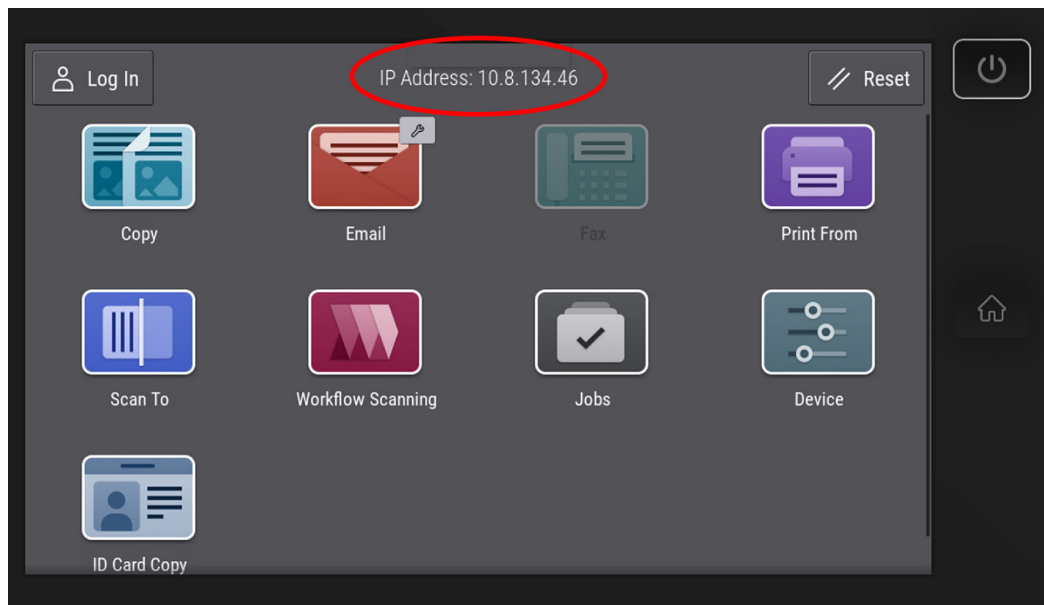

vlc625s6005

Figure 1 UI Home Screen IP Address

2. Click **[Properties]**, then login as Admin.
3. Select **General Setup > Software Upgrade**.
The Screen will open to **[Fleet Orchestrator]**.
4. Select **Create / Install File**.

5. Select **Software Upgrade File**
6. Scroll to **[Details]** > **[Installation Policy]**. Verify the link is set to **[Allowed]**.
To set to Allowed from Not Allowed:
 - a. Click on the link, **[Not Allowed]**.
 - b. Check the box **[Allow Software Upgrade]**.
 - c. Click **[Apply]**.
7. Select **Install a File**, then **Browse**. Select the .DLM file from the upgrade directory.

Note: Both the Customer DLM downloaded from Xerox.com and the full DLM file types can be used for EWS upgrade. Download the full DLM file here: [GSN Library 17823](#)

8. Select **Install**.
Note: All network connectivity is lost. Progress can be monitored from the UI.
9. The system reboots several times before returning to a ready state.

Altboot Software Installation

There are four altboot software configurations. Each is listed below:

- [Altboot Software Loading using a USB Flash Drive](#)
 - [Standard Altboot Procedure](#)
 - [Forced Altboot Procedure](#)
 - [Special Altboot Procedure](#)
- [PWS Altboot Procedure using PWS Altboot tools](#)

Additional Tools

- [Troubleshooting](#)
- [Fleet Orchestrator](#)

Altboot Software Loading using a USB Flash Drive

Altboot reloads system software. It is used to upgrade, downgrade, or reload software on systems that will not come to a ready state. It also can be used to upgrade or downgrade the software on system options.



CAUTION: Altboot should only be used when a loss of operation occurs and the standard customer software upgrade is not possible.

Note: If the customer purchased Adobe PS or McAfee Trellix features, perform the following:

- Login as Admin. Refer to, [GP 23](#).
- Install features as required. Refer to, [GP 35](#) How to Re-Enter Optional Feature Installation Keys.

 **CAUTION:** The system may appear to hang during the Altboot process while loading software in the background. Wait a minimum of 10 minutes before switching the system off. Switching the system off while software is loading will corrupt the software installation requiring the Altboot installation to be restarted.

Standard Altboot Procedure

1. Perform [dC361](#) NVM Save and Restore.
2. USB Port must be **[Enabled]**.
3. Format the USB drive for **FAT32** (other formats not supported).

Note: Do not partition the USB drive.

4. Confirm USB file and directory structure is configured correctly. The below structure is required in the root level of the USB drive.

Note: It is best practice to start the procedure with a clean formatted USB drive having no files or folders.

Table 2 USB structure at root level

```
\...  
  
\Altboot\XeroxVersaLink_X415_ALTBOOT_system-sw#11802400227150#.DLM (example only)(The X =: B if mono, C if Color)
```

Note: Ensure the Microsoft Windows Safely remove hardware procedure is followed before the USB Flash drive is removed.

5. Copy the required .DLM software file into the \altboot folder of the USB drive.
- Note:** Typically, only one .DLM file per product number should be in the folder.
6. Switch OFF the machine, [GP 10](#).
7. Insert the USB into an active port in the machine.
8. Switch ON the machine, then immediately press and hold the **[Home]** button as soon as the printer starts.
9. The installation progress indicator appears on the UI.
10. When the installation is complete, the UI will state, Remove the USB drive for the system to restart.
11. After restart, the machine will print a Software Upgrade Report.
12. Touch the altboot file to be installed, then touch **[OK]**.

Note: The printer may restart several times during the installation.

Forced Altboot Procedure

 **CAUTION:** Use Forced Altboot with extreme caution! Forced Altboot replaces boot and application code. Power failure during a Forced Altboot may result in PWBs becoming unrecoverable.

1. Perform [dC361](#) NVM Save and Restore.
2. Start with a USB drive as per the [Standard Altboot Procedure](#).
3. Create a flag labeled **FORCED_UPGRADE** inside the \altboot folder.

 **CAUTION:** Forced Altboot uses the available .DLM file to upgrade or downgrade every component in the system, regardless of installed software. Forced Altboot is required to recover from corrupt application code for all machine devices.

Note: This is an empty file and must not have an extension. The Altboot routine checks to see that a file with this name is present.

4. **To create the FORCED_UPGRADE flag:**

- a. Open the \altboot folder on USB drive.
- b. Right click on a blank area of the screen and select **New**.
- c. Select **Text Document**.
- d. The name [New Text Document.txt] will be highlighted.
- e. Type **FORCED_UPGRADE** (the file name is case-sensitive), then press **Enter**.
- f. A pop-up with the message, **If you change a file name extension, the file might become unusable. Are you sure you want to change it?**, will appear.
- g. Click **Yes**.
- h. The folder structure should be as below:

Table 3 Structure at root level

```

\...

\altboot\XeroxVersaLink_X415_ALTBOOT_system-sw#11802400227150#.DLM (example only)(The X =: B if mono, C if Color)

\altboot\FORCED_UPGRADE

```

5. **To create the DISABLE_DATA_BACKUP flag:**

- a. Open the \altboot folder
- b. In a blank area of the screen, right click and select **New**.
- c. Select **Text Document**.
- d. The name **New Text Document.txt** will be highlighted.
- e. Type **DISABLE_DATA_BACKUP** (the file name is case sensitive), then press **Enter**.
- f. A pop-up with the message, **If you change a file name extension, the file might become unusable. Are you sure you want to change it?** will appear.
- g. Click on **Yes**.
- h. The folder structure should be as below:

Table 4 Structure at root level

```

\...

\altboot\XeroxVersaLink_X415_ALTBOOT_system-sw#11802400227150#.DLM (example only)(The X =: B if mono, C if Color)

```

\altboot\FORCED_UPGRADE

\altboot\DISABLE_DATA_BACKUP

 **CAUTION:** The **DISABLE_DATA_BACKUP** intentionally prevents backup of the data on the machine. There is nothing for the **Revert to previous settings** operation to restore. A Forced Altboot enables the **Revert to previous settings** feature to display. This feature restores machine-specific information, **IF**, the **DISABLE_DATA_BACKUP** flag is used, all machine-specific information will be lost.

6. Installation of the altboot .DLM:

- a. Switch OFF the machine, [GP 10](#)
- b. Insert the USB drive into an available USB port on the machine.
- c. Switch on the machine, immediately press and hold the **[HOME]** button.
- d. Release the **[HOME]** button when the UI screen shows the installation starting.
- e. The installation progress indicator appears on the UI.
- f. When the installation is complete, the UI will state, **Remove the USB drive for the system to restart.**
- g. After restart, the machine will print a Software Upgrade Report.
- h. When the machine is at Ready, on the UI control panel touch the **Device** icon, then touch **Tools > General > Revert to previous settings.**
- i. The machine will restart to the ready UI screen.

*

Special Altboot Procedure

Perform this step **ONLY** if executing a Special Altboot:

 **CAUTION:** Only perform Special Altboot procedure when a new Optional Hard Disk Drive (HDD) or controller PWB is installed or the files have become corrupted

1. Download the **SpecialAltboot\X415_SpecialAltboot_.zip** (example) file that is specific to the product from [GSN Library 17823](#).

Note: Example: X415_105.0xx.009.34422_SpecialAltboot.zip. These files are product specific and **MUST** match the Altboot system software DLM being used.

Note: Special Altboot files will only be provided for general releases. Recovering to a SPAR is a two step upgrade.

2. Extract the SpecialAltboot.zip content into the root folder of USB drive, **not the \altboot folder.**

Note: The default extract location for a specific unzip tool used may not be at the root level. Verify the root level of the USB drive is the destination for the extracted files before proceeding.

3. **Perform this step ONLY if executing a Disable_Data_Backup:** This prevents the NC from keeping data normally retained through an Altboot. This file is used to eliminate backup of corrupt customer settings.

To create the DISABLE_DATA_BACKUP flag:

- a. Open the \altboot folder

- b. In a blank area of the screen, right click and select **New**.
 - c. Select **Text Document**.
 - d. The name **New Text Document.txt** will be highlighted.
 - e. Type **DISABLE_DATA_BACKUP** (the file name is case sensitive), then press **Enter**.
 - f. A pop-up with the message, **If you change a file name extension, the file might become unusable. Are you sure you want to change it?** will appear.
 - g. Click on **Yes**.
 - h.
4. **Confirm USB file and directory structure is configured correctly. Below structure is required in the root level of the USB drive.**

Confirm:

Note: It is best practice to start the procedure with a clean formatted USB drive having no files or folders.

Table 5 Structure at root level

```

\...

\altboot\XeroxVersaLink_X415_ALTBOOT_system-sw#11802400227150#.DLM (example only)(The X =: B if mono, C if Color)

\altboot\FORCED_UPGRADE

\altboot\DISABLE_DATA_BACKUP

\swup_usb

\XeroxVersaLink_X415_118.024.002.27150 (example only)(The X =: B if mono, C if Color)

```

Note: Ensure the Microsoft Windows Safely remove hardware procedure is followed before the USB Flash drive is removed.

5. Insert the USB Flash drive into the system.
 6. Save the NVM settings, **dC361**. Verify that the NVM data were saved to the USB Flash drive before proceeding.
- Note:** The same USB Flash drive that has the .dlm file can be used to store NVM data.
7. Perform Backup and Restore of customer settings through EWS, **GP 22**.
 8. Complete or delete all pending print jobs. If the jobs cannot be deleted, inform the customer that all pending jobs will be lost.
 9. Switch OFF, then switch ON the machine, **GP 10**. The Altboot process starts automatically. No button presses are required to initiate the Altboot.
 10. The upgrade start screen displays.

Note: If the USB Flash drive is incompatible with the system, the upgrade start screen will display continuously. If the screen has not changed after 10 minutes, use a different known compatible USB drive, then restart the process.

11. The upgrade begins and the progress screen opens in about 2 minutes.

Note: If the upgrade process screen is not displayed after 4 minutes, restart the process.

12. The Altboot process may take up to 60 minutes to complete. When the Altboot complete screen opens, follow the on screen instructions.

13. If the Altboot process fails, the Altboot failed screen opens. Follow the on screen instructions. Restart the procedure and troubleshoot as necessary.

Note: Do not switch the machine Off unless directed to on the UI.

14. The system may reboot several times before returning to a ready state.

15. Check that the software set has installed. Refer to the printed software upgrade report or press the **Status** button.

16. Restore the customer settings, [GP 12](#).

17. When performing a Forced Altboot, select the **Device** icon, then **Tools > General > Revert to previous settings**.



CAUTION: The **DISABLE_DATA_BACKUP** intentionally prevents backup of the data on the machine. There is nothing for the **Revert to previous settings** operation to restore. A Forced Altboot enables the **Revert to previous settings** feature to display. This feature restores machine-specific information, **IF**, the **DISABLE_DATA_BACKUP** flag is used, all machine-specific information will be lost.

PWS Altboot Procedure

PWS-Altboot function is to perform full functional recovery of an MFP or printer with damaged SW and other recovery methods had failed. Also, it is used to provide a viable solution for customers that do not allow thumb drives and/or internet connectivity to perform software upgrades.

Before beginning the procedure perform the following:

1. Go to [GSN Library 17823](#), then download the following items:

- **VersaLink_X415X_Family_Altboot_Tool_PWS**
- **Altboot_SW_and_support_files_VersaLink_X415X_system_sw**. Download the version for the machine you are working on and store it in a folder named **Altboot_SW_and_support_files** on the PWS. The support files are paired with the software version. The support files will only work for that specific software version.

2. Connect an Ethernet crossover cable to the PWS Ethernet port and to the printer Ethernet port.

3. Install the Altboot tool downloaded in Step 1 on the PWS. Use the instructions in the Readme file included with the tool.

Note: Before loading system software, the system should be fully operational and the UI control panel fully operational. If possible, clear any active faults or jams before starting this procedure.

1. Perform an NVM Save, [dC361](#).

2. Back up customer settings, [GP 22](#).

3. Print a Configuration Report, [GP 14](#).

4. If possible, complete or delete all pending print jobs. If jobs cannot be deleted, warn the customer that all pending jobs will be lost.

5. If the machine is equipped with a Wireless Network Interface, enter Tools mode using CSE Tools (Service Copy Mode), [Service Copy \(Tools\) Mode](#), disable wireless, then Switch OFF and Switch ON the Machine, [GP 10](#).

6. Use these steps to configure a PWS LAN connection so the PWS can communicate with the system Network Controller. Once established, settings remain in effect until changed.



CAUTION: Record the original data for every place you make a change. You may or may not need to reset the IP address, depending on PWS usage and local network practice.

- a. Right click on the **My Network Places** icon.
 - b. Select **Properties** to bring up the Network and Dial-up Connections window.
 - c. Right click on **Local Area Connection** and select **Properties**.
 - d. Select the **General** tab and scroll down to Internet Protocol (TCP/IP). Highlight **TCP/IP** and select **Properties**.
 - e. Select the **Use the following IP address** radio button.
 - f. Enter the IP address 192.168.0.2.
 - g. Enter 255.255.255.0 for Subnet mask.
 - h. Select **OK** to close the **TCP/IP Properties** window
 - i. Select **OK** to close the **Local Area Connection Properties** window.
 - j. You may need to reboot the PWS to load the settings.
7. Disable the customer's WiFi network connection if enabled.
 8. Connect the PWS to the printer Ethernet port using an Ethernet crossover cable.
 9. Start the PWS Altboot tool on the PWS and follow the instruction in the file AltaLink-PWS-Altboot-Instructions.pdf to configure the Altboot tool. The file is in the Altboot tool package that was downloaded at the beginning of the PWS Altboot Procedure.
 10. Switch on the machine using the Main Power Switch. After approximately 10 seconds, the transfer of the uImage and uboot files begins.
 11. After file transfer, the settings menu appears in the terminal window. Check that the 'Received packet' line is displayed and that the IP address is set one digit away from the packet was received from address.
Press **Y** at the prompt and continue. If the valid netmask is not set, press **n** and change it to 255.255.255.0
 12. From the next menu, select **5 > Install SBC software**.
 13. At the **Proceed?** prompt, select **Y**.
 14. At the second **Proceed?** prompt, select **Y**.
 15. From the next menu, select **4 > Continue**.
 16. A list will display the .DLM file in the directory identified in step 2, select the DLM file to download to the machine. A transfer progress window will then open.
 17. After the DLM file has been downloaded to the machine, the Software Upgrade start screen will display on the UI.
 18. After approximately 1 minute the upgrade will begin and the Software Upgrade in progress screen will open. If the upgrade process screen is not displayed after 2 minutes, restart the process.
 19. The Altboot process should complete after approximately 5 minutes, and the Upgrade Complete screen will open. Ignore the instruction to remove the USB flash drive, only press **0** to continue.
 20. The machine will reboot several times before returning to a ready state. During the reboot, the Hard Disk Drive is encrypted. Switching off the machine can cause only partial encryption of the Hard Disk's partitions. The Altboot process may need to be re-run if power is removed at this step. The UI displays the Data Encryption/Decryption in Progress screen.
 21. After the reboots have finished the machine will come to ready. In the SBC-AlternateBoot window on the PWS should display SBC System is OPERATIONAL.

22. Disconnect the crossover Ethernet cable from the PWS network and the machine.
23. Connect the customer's network cable to the machine or re-enable the WiFi card adapter if installed.
24. Compare the configuration report printed at the start of the procedure to the software version in the **[Device]** UI control panel settings to verify the software upgrade is successful.
25. Perform an NVM Restore, [dC361](#).
26. Restore the customer settings, [GP 22](#).

Note: If the screen displays the message the device is in a non-customer mode, perform [GP 33](#) Restoring Customer Mode.

Additional Tools

- [Troubleshooting](#)
- [Fleet Orchestrator](#)

Troubleshooting

Listed below are possible problems that may stop Altboot software loading:

Possible causes and solutions are:

- Incompatible/or not working USB drive. Change the USB drive to a known good USB drive, or, use a Xerox approved model of USB drive.
- Corrupt.dlm file. Install a new .dlm file.
- Incorrect spelling of the \altboot directory on USB drive. Correct the spelling of the \altboot folder.
- Altboot and upgrade folders on the USB drive.
- Bad data connection to the optional hard disk drive. Reseat the optional hard disk drive harnesses.
- Hard disk drive corruption or failure.
- USB port or cable damage. Use a different USB port or cable.
- UI failure. Troubleshoot the UI control panel failure to resolve.
- Controller PWB failure. Troubleshoot the controller PWB.
- Check the +5V supply to the USB ports on the controller PWB. Troubleshoot the controller PWB.
- Failure to disable wireless networking when using a PWS. Disable the WiFi card.
- Pound [#] signs missing from the .dlm file name. Correct the .dlm file name.

Fleet Orchestrator

The Fleet Orchestrator feature allows you to configure many devices in similar ways, automatically. After you configure one device, you can distribute any of the configuration settings to other devices, as needed. You can set up schedules to share configuration settings regularly and automatically. The Fleet Orchestrator feature enables you to share the following types of configuration files

- **Software upgrade files:** A software upgrade file contains the latest firmware for the device. Xerox releases upgrades when needed. **Refer to the System Administrator Guide**
- **Clone files:** A clone file contains configuration settings from a device. When you install a clone file on another device, the clone file changes the configuration settings to match the settings on the cloned device. **Refer to the System Administrator Guide**

- **1-Touch Add-On files:** A 1-Touch Add-On file adds workflows to a device without overwriting existing apps or workflows. **Refer to the System Administrator Guide**

Software Upgrade Files: When Xerox releases a new version of software for the device, Fleet Orchestrator can be used to install the software upgrade file. Software upgrade files do not overwrite printer configuration settings.

GP 5 Miscellaneous Checks

Purpose

To indicate which types of problems to look for when checking or inspecting parts of the machine.

Procedure

1. Assess the fault. Check if the part is broken, too loose or too tight. Check if it needs cleaning or lubricating.
2. Check the components that follow as appropriate:
 - [Actuators](#)
 - [Bearings](#)
 - [Drive Belts](#)
 - [Gears](#)
 - [Gravity Fingers and Stripper Fingers](#)
 - [Harnesses and Wiring](#)
 - [Rollers](#)
 - [Shafts](#)

Actuators

- Free movement.
- Damage
- Contamination.

Bearings

- Wear.
- Damage.
- Contamination.

Drive Belts

- Wear.
- Damaged teeth.
- Correct tension.
- Contamination of tension rollers and support shafts.

Gears

- Contamination.

- Chips or cracks.
- Wear.
- Misalignment.

Gravity Fingers and Stripper Fingers

- Free movement.
- Missing fingers.
- Damage.
- Contamination on the fingers, rollers or on the pivot shaft.

Harnesses and Wiring

- Continuity.
- Short circuits caused by physical damage or contamination of conductors, terminals or connectors.
- Overheated insulation.
- Damaged insulation near moving parts and sharp edges.
- Pin and receptacle damage on connectors.

Rollers

- Flats.
- Tears.
- Contamination.
- Secure E-clips and other retainers.

Shafts

- Contamination.
- Misalignment.
- Rotates without binding.

GP 6 How to Check a Motor

This procedure describes how to check a motor:

Initial Actions



WARNING: Isolate the machine from the electrical supply while performing tasks that do not need electricity. Refer to GP 10. Electricity can cause death or injury. Moving parts can cause injury.

1. Check that the motor is free to rotate.
2. Check that all the motors mechanisms are clean, free to move and lubricated correctly.
3. Enable 24V with chain-link 041-001 and test motor operability using dC330. Run the motor for 30 seconds, if the motor shows signs of or can be heard to slow down, the motor is defective. Install a new motor.
4. Perform the appropriate procedure:
 - Two Wire DC Motor
 - DC Motor with Integral Encoder
 - Four Wire Stepper Motor

Note: The voltages, PJ numbers, pin numbers and PWB names shown are an example only. Go to the wiring diagram associated with the RAP for the correct information.

Note: In cases where the motor may be driven forward or backward, the same two feed wires are used, but the voltages on them are reversed, to reverse the motor direction. Such motors may have two component control codes, for forward and reverse. A typical application is a tray lift motor with a tray-up and a tray-down direction.

1. Check the drive voltage when the component control code for the motor is entered. If the drive voltage is present at the motor, but the motor does not turn, install a new motor. If the drive voltage is not present, go to step 2.
2. Check that the drive voltage is correct at the driver output pins of the PWB when the component control code for the motor is entered. If the drive voltage is present, check the wiring and connectors to the motor. If the drive voltage is not present, check the power to the driver PWB. If the power to the PWB is good, install a new driver PWB.

Note: This type of motor has the normal drive voltages for a DC motor, plus the +3.3VDC and 0V lines for the encoder. The encoder has two outputs, A and B, producing pulses when the motor is on. When the motor is running in one direction, the encoder A pulses lead the encoder B pulses. In the other direction, encoder B pulses lead encoder A pulses. In this way the controller can detect that the motor is running in the correct direction.

Check the operation of the motor as follows:

1. Check the drive voltage when the component control code for the motor is entered. If the drive voltage is present at the motor, but the motor does not turn, install a new motor. If the drive voltage is not present, go to step 2.
2. Check that the drive voltage is correct at the output pins of the driver PWB when the component control code for the motor is entered. If the drive voltage is present, check the wiring and connectors to the motor. If the drive voltage is not present, check the power to the driver PWB. If the power to the PWB is good, install a new driver PWB.

Note: When checking for pulses, use a standard digital multimeter. Using the DC volts range, or the AC volts range, expect to obtain a reading greater than 1V and less than 4 volts, while the motor is running. The actual value depends on the meter's reaction to square waves and to the particular frequency of the pulses. It is common to obtain a reading of 2 to 3 volts. If the meter has a minimum and maximum recording facility, expect a maximum value of around +4.9 volts DC, and a minimum value of around +0.2 volts DC.

Check the operation of the encoder as follows:

Check for pulses when the motor is running. If pulses are present at the motor, but not present at the PWB, check the wiring to the motor and repair or install new wiring. If pulses are present at the PWB, but there is still an error indicating that the motor is failing, install a new driver PWB.

Note: A stepper motor with an internal open circuit may appear to be fully functional under dC330 component control. However, under normal operation it will run with intermittent failure. Use the multimeter to check stepper motor coil resistance.

1. Refer to Figure 1 as an example. Disconnect PJ111. Check the +24VDC supply and the phase pulses to GND when the component control code for the motor is entered. If the supply and pulses are present, install a new motor.
2. Check the connectors and wiring to the motor. Repair or install new wiring, as necessary.
3. Disconnect PJ111. Check the +24VDC. If +24VDC is not present, check the power to the PWB. If the power is good, install a new PWB. Check the phase pulses at the PWB. If the phase pulses are not present at the PWB, install a new PWB.

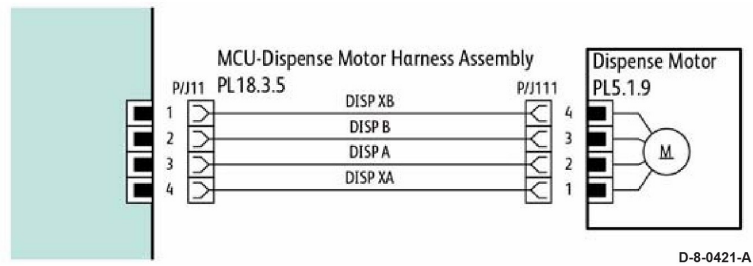

Figure 1 Motor wiring diagram

GP 7 How to Check a Switch

Use this procedure to check the operation of a switch.

Note: Figure 1 shows an interlock switch actuated by the closing of a door.

Initial Actions



WARNING: Isolate the machine from the electrical supply while performing tasks that do not need electricity. Refer to GP 10. Electricity can cause death or injury. Moving parts can cause injury.

Manually check that the switch operates. Ensure that the magnet or other actuator has enough mechanical movement to operate the switch.

Note: The voltages, PJ numbers, pin numbers and PWB names shown are an example only. Go to the wiring diagram associated with the RAP for the correct information.

Procedure

1. Enter Diagnostics, GP 1, then dC330 to enable the switch to test. Actuate the switch. If the display changes, the switch operates correctly. If the display does not change, perform the following steps.
2. Inspect the mechanism intended to actuate the switch. Adjust, repair or install a new part as needed if it is not actuating the switch.
3. Disconnect the switch and measure the resistance between the two connector pins. If it does not change from infinite to 0 ohms as the switch is actuated, install a new switch. If the resistance changes correctly, go to the next step.
4. Check the continuity of the wire harness between the switch and its control PWB. If open, repair or install a new harness.
5. If the switch and wire harness have tested good, install a new PWB that the switch is connected to.

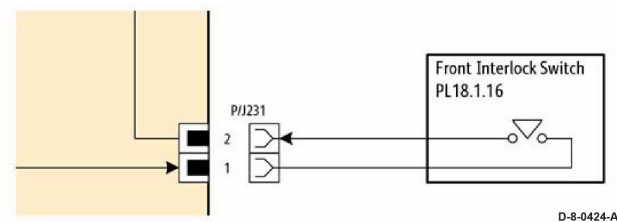

Figure 1 Switch wiring diagram

GP 8 How to Check a Solenoid or Clutch

Use this procedure to check a clutch or solenoid.

Initial Actions



WARNING: Isolate the machine from the electrical supply while performing tasks that do not need electricity. Refer to GP 10. Electricity can cause death or injury. Moving parts can cause injury.

1. For a clutch, check that the shafts, gears, rolls etc., associated with the clutch are free to rotate, clean and lubricated where applicable.
2. For a solenoid, check that the solenoid is free to actuate and that the mechanisms associated with the solenoid are free to move.

Procedure

Note: The voltages, PJ numbers, pin numbers and PWB names shown are an example only. Go to the wiring diagram associated with the RAP for the correct information.

Note: When a solenoid is energized in diagnostics, movement is seen. When a clutch is energized in diagnostics, the sound of the clutch action is heard. If possible, run the motor connected to the clutch to confirm when the clutch is energized.

1. Enter the dC330 output code for the clutch or solenoid. If the clutch or solenoid does not energize, continue with step 2.
2. Refer to Figure 1 (as an example). Disconnect PJ17, check for +24VDC at pin 1 on the wiring side of the connector. If the voltage is correct, install a new solenoid or clutch.
3. Reconnect PJ17, enter the dC330 output code for the clutch or solenoid, while measuring the voltage between pin 1 and ground. If the voltage does not change when the code is entered, install a new PWB.
4. If the fault is intermittent, perform the actions that follow:
 - a. Check the wiring. Repair or replace as necessary.
 - b. Operate the clutch or solenoid under normal running conditions. If the clutch or solenoid operates intermittently or with hesitation, install new parts.
 - c. Check that the clutch or solenoid has enough drive to operate the mechanism to which it is attached; if necessary, install a new clutch or solenoid.

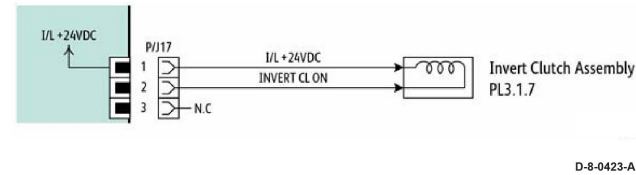

Figure 1 Clutch wiring diagram

GP 9 How to Check a Sensor

Use this procedure to check the operation of all types of sensors.

Note: Some sensors have a resistor within the sensor and other sensors require a resistor on the PWB. The resistor limits the current through the LED. The voltage to the sensor LED with an external resistor, is typically 1.2V

Note: The voltages, PJ numbers, pin numbers and PWB names shown are an example only. Go to the wiring diagram associated with the RAP for the correct information.

Note: In some cases, two sensors are used to form an interruptible beam of light. In these cases, the LED of one sensor and the sensing element of the other sensor are used. Treat the two sensors as if they were housed in the same body for diagnostic purposes, ignoring the unused part of each sensor. If the combined sensors do not operate correctly and the beam path is clear of obstruction, it may be necessary to install both new sensors.

Quick Sensor Check

Enter the component control code for the sensor, refer to [dC330](#). Actuate the sensor. If the display changes, the sensor operates correctly. If the display does not change, perform the procedure.

Procedure



WARNING: Isolate the machine from the electrical supply while performing tasks that do not need electricity. Refer to [GP 10](#). Electricity can cause death or injury. Moving parts can cause injury.

For the sensor in the example wiring diagram shown in [Figure 1](#) :

1. Actuate the sensor and check for a change in voltage at PJ27, pin 3. If the voltage changes, install a new PWB. If the voltage does not change, continue to the next step.
2. Disconnect PJ271 at the sensor. Check for +3.3VDC and 0V (GND) on the harness (between pins 2 and 3). If the voltage is correct, install a new sensor. If voltage is not present, go to the next step.
3. Disconnect PJ27 and PJ271. Check the harness and the connectors for continuity. Repair or install a new harness if continuity test indicates an open wire. If harness is good, go to the next step.
4. Check for +3.3VDC and 0V (GND) between pins 2 and 3. If voltage is not correct, install a new PWB.

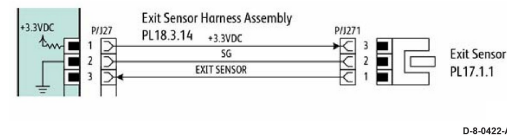

Figure 1 Sensor wiring diagram

GP 10 How to Switch Off the Machine or Switch On the Machine

Purpose

To properly instruct the user how to switch off or switch on the machine. The following procedures will provide the greatest security of customer data and prevent damage to the machine.

Refer to:

- [Switch Off Procedure](#)
- [Power Off Procedure](#)
- [Restart](#)
- [Switch On Procedure](#)
- [Sleep Mode](#)

Switch Off Procedure

1. Press and hold the **power button** on the UI control panel for 5 seconds, then release the **power button**.
2. After 5 seconds from releasing the power button, the machine will switch OFF automatically

Power Off Procedure

Note: Do not disconnect the power cord or interrupt the electricity supply before the power down is complete unless advised. The data and software can become damaged.

1. Press then release the **power button** on the UI control panel.
2. Touch **Power Off**.
3. When the power button stops blinking and is fully dark, remove the power cord from the customer's power supply outlet.

Restart

1. Press the **power button** once on the UI control panel.
2. Touch **Restart** from the power down options window.

Note: The machine will restart within 2–3 minutes.

Switch On Procedure

Note:

- After the machine has been switched off, wait a **minimum of 2 minutes** before the machine is switched on.
- After a service call, ensure that all service tools are removed from the machine.

1. Connect the power cord from the customer's power supply outlet to the machine.
2. Press the **power button** on the UI control panel.
3. The machine will perform a power on self test (POST) as it comes to Ready.

Sleep Mode

1. Press the **power button** on the UI control panel.
2. Touch **Sleep** to enter sleep mode.

Note: When sleep is touched, the machine should immediately enter sleep mode.

Note: Issues that may cause the machine to not enter sleep mode:

1. There is an active fault or status needing attention. Check the UI for a page up arrow or UI fault log for active faults.
2. The system is busy doing something in the back ground (e.g. a data push, or there is a software bug and some process is hung).
3. An active job is in process of completion. Check the UI Jobs for activity.
4. Check the DADF for paper in the feeder and remove if found.

GP 11 How to Safely Lift or Move Heavy Modules

Purpose

Use this procedure when lifting or moving heavy modules.

Procedure

When removing heavy modules from the machine, the instructions that follow must be observed:

1. Ensure that a suitable stable surface to support the module after removal is located in close proximity to the machine.

Note: Other parts of the machine are not a suitable stable surface.

2. Ensure that the height of the support surface is between 750mm and 1000mm (30 inches and 39 inches).
3. Ensure that there are no hazards or obstacles between the machine and the support surface.
4. If instructed to remove the module toward the rear of the machine and only 1 person is available, the module must be removed while standing at the rear of the machine. If 2 people are available, the module may be removed while standing at the front of the machine.
5. Two people are required if the module is to be lifted on to the floor or lifted from the floor.

GP 12 Machine Lubrication

Purpose

To give information on the use of lubricants.

Procedure



WARNING: Switch off the electricity to the machine, GP 10. Disconnect the power lead from the customer supply while performing tasks that do not need electricity. Electricity can cause the death or injury. Moving components can cause the injury.



CAUTION: Only use lubricants as directed. Incorrect use of lubricants could seriously affect the performance of the machine.

Take the precautions that follow when performing machine lubrication:

- Wear disposable gloves.
- Only use lubricants that are specified in the Parts List.
- Only lubricate parts of the machine as directed in the relevant RAPs, Repairs, Adjustments and General Procedures.
- Apply only the smallest amount of lubricant, sufficient to lubricate the parts. To prevent contamination, remove any surplus lubricant before the machine is run.
- Take great care not to contaminate other parts of the machine with the lubricant.

GP 13 Cloning

Use this procedure to create or install a clone file in order to duplicate one machine setting's configuration to other machines or restore settings following Forced AltBoot using the DISABLE_DATA_BACKUP flag.

Create a Clone File

1. Open a web browser
2. Enter the machine's IP address in the **Address** line.
3. The Embedded Web Server window opens to the **Home** screen.
4. Select the **Properties** tab.
5. Login as **admin** at the prompt.
6. The **Fleet Orchestrator** screen opens, [Figure 1](#).
7. Click the **+ Create/Install File** button, then select **Create a File** from the drop down list.

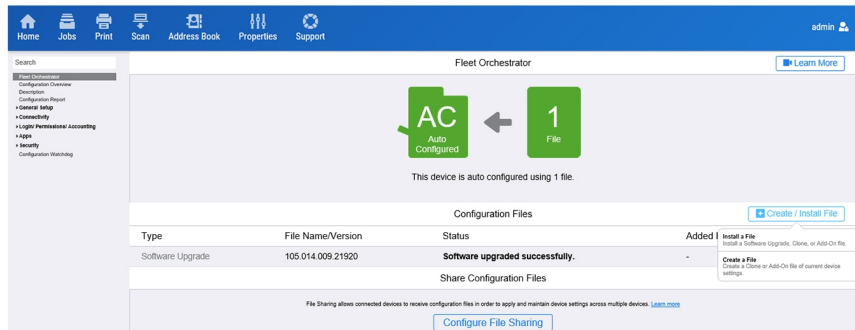

Q-1-0018-A

Figure 1 Fleet Orchestrator Screen

8. The **Create Configuration File** screen opens. Select **Clone File**, [Figure 2](#).

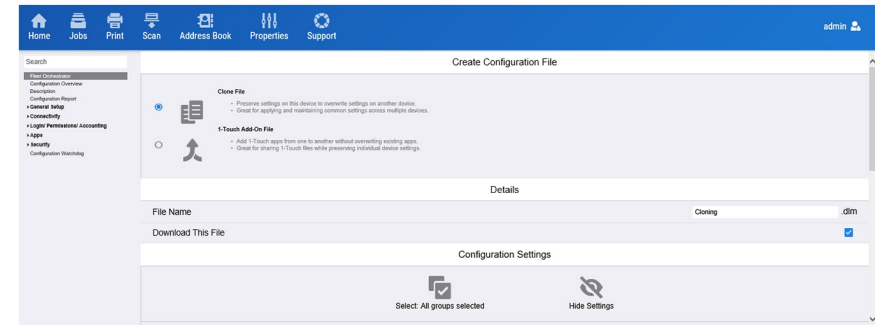

Q-1-0019-A

Figure 2 Clone File

9. The **Configuration Settings**, [Figure 3](#), allows the user to turn off, or on, those settings required for the clone file.

Note: Click the **(Details...)** link next to each selectable component to view the data within that component.

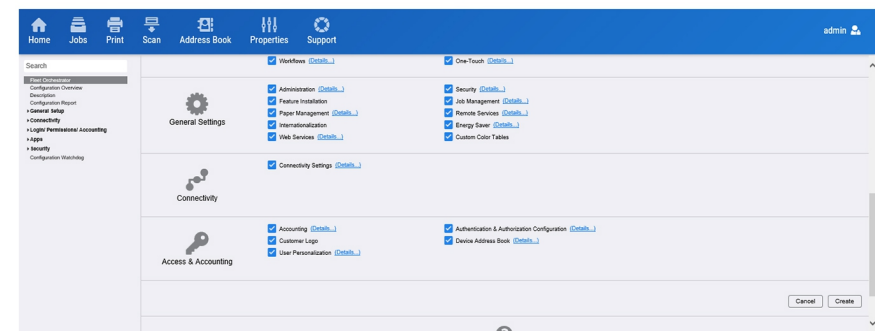

Q-1-0020-A

Figure 3 Features and Feature Details

10. Click the **Create** button at the bottom right corner of the screen.
11. Click the file name link to download into the Downloads folder on the computer.

Note: It may take several minutes to create the cloning.dlm file. Do not make any changes or attempt to do anything with the machine such as power off until the process is complete.

Note: After the clone file has been created, do not attempt to open the clone file as it may corrupt it.

12. Click on **Close** to return to the Fleet Orchestrator screen.

Installing a Clone file

Note: This procedure can be done from ANY PC connected to the network or the PWS connected to the machine using a crossover Ethernet cable. The only requirement is an Internet browser.

1. Open a web browser.
2. Enter the machine's IP address in the **Address** line.
3. The Embedded Web Server window opens to the **Home** screen.
4. Select the **Properties** tab.
5. Login as **admin** at the prompt.
6. The **Fleet Orchestrator** screen opens.
7. Click the **+ Create/Install File** button, then select **Create a File** from the drop down list.
8. On the **Install Configuration File** screen, select **Clone File**, [Figure 4](#).

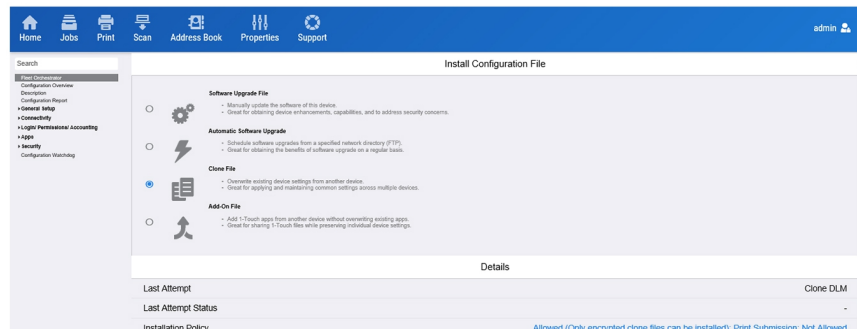

Q-1-0021-A

Figure 4 Clone File Selection

9. Click the **Browse** button, then navigate to the clone file, [Figure 5](#).

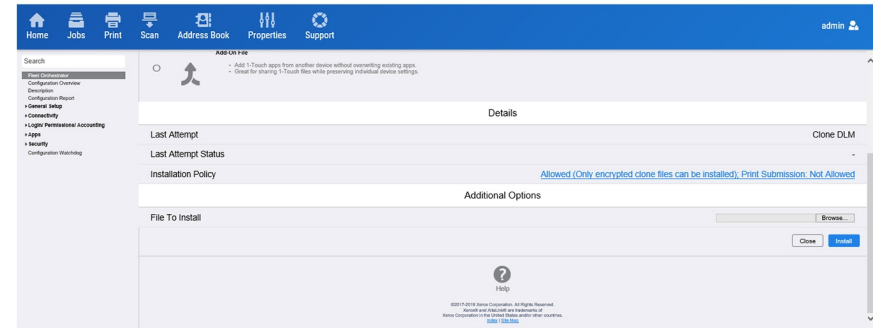

Q-1-0022-A

Figure 5 Browse to the Clone File

Click the **Install** button.

Note: If the machine does not reboot after five minutes, switch off, then switch on the machine, [GP 10](#).

10. Print a Configuration Report [GP 14](#), then verify the clone file installation is successful.

GP 14 Printing Reports and Information Pages

Reports and Information can be printed or viewed by two methods:

1. The Embedded Web Server.
2. The UI Control Panel.

Embedded Web Server (EWS)

The EWS Configuration Report.

1. Enter the machine IP address found at the top of the UI Control Panel.
2. At the **Home** screen, click on the **Properties** tab.
3. Enter the username and password for **admin** access at the prompt.
4. On the left menu, click **Configuration Report**.
5. The Configuration Report is listed on screen, can be downloaded to the computer's Downloads folder, or printed to the printer output bin.

The UI Control Panel:

Note: Depending on policy setting, you may have to enter SA mode to print reports.

- [Basic Configuration Report](#)
- [Detailed Configuration Report](#)
- [Billing Summary](#)
- [Getting Started](#)
- [Troubleshooting Print Quality](#)
- [Supplies Usage Page](#)
- [Graphics Demo Page](#)
- [PCL Font List](#)
- [PostScript Font List](#)

1. At the UI panel **Home** screen:
2. Touch the **Device** icon on the UI.
3. Touch **Information Pages**.
4. Touch the Configuration Report or Information Page required, then press **Print**.

Available Reports and Information in the UI Control Panel

Basic Configuration Report

Lists the current state of pertinent system configuration parameters including installed options and network settings.

Detailed Configuration Report

Details the current state of all system configuration parameters including installed options and network settings.

Billing Summary

Lists Billing Meter impression counters (for customers on billing meter supplies plans only) and Sheet Count by Paper Type.

Getting Started

Provides steps and information to basic settings for printer operation.

Troubleshooting Print Quality

Provides steps to resolve print quality issues.

Supplies Usage Page

Includes the current status of printer consumable and routine maintenance items. Installation dates and replacement part numbers are listed.

Graphics Demo Page

Shows a brief synopsis of the device graphics capabilities.

PCL Font List

This report provides a list of the installed PCL fonts.

PostScript Font List

This report provides a list of the installed PostScript fonts.

GP 15 Cleaning the Printhead Lens

Cleaning the Printhead Lens

1. Remove the waste toner bottle, [PL 26.05 item 23](#)
2. Remove the four imaging kits, [PL 26.05](#)
3. Using a lint-free cloth, wipe the printhead lenses (1).

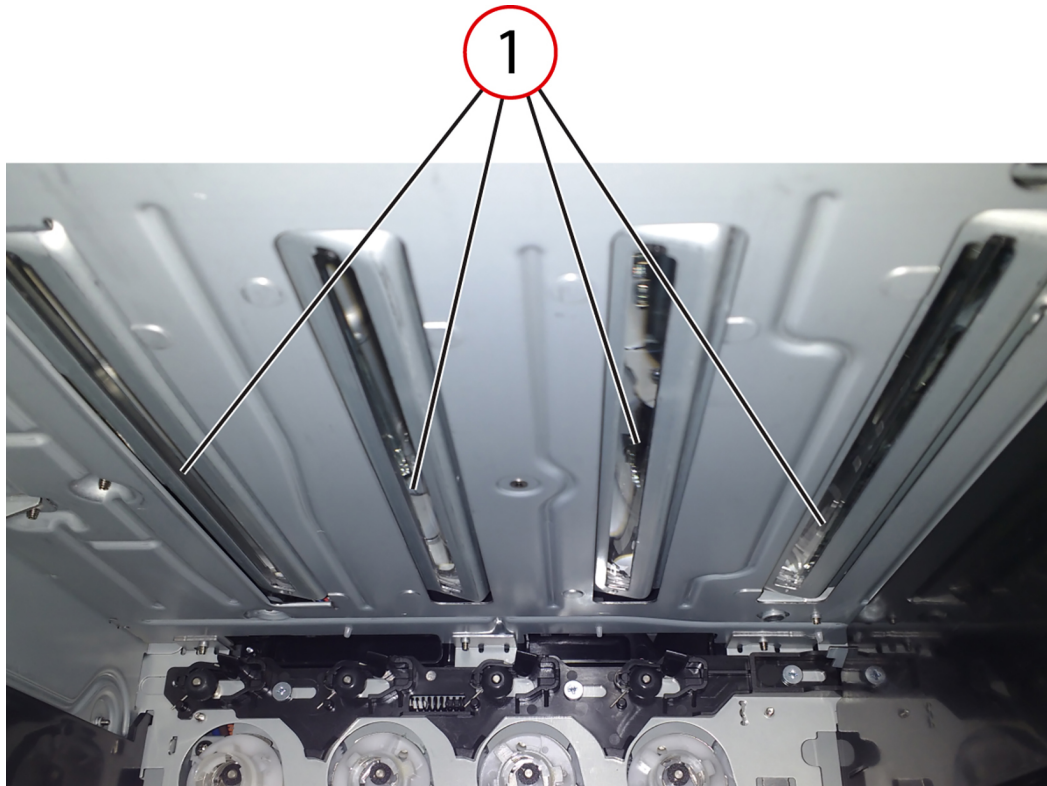

vlc625s_6006

Figure 1 Printhead lenses

GP 16 Installation Space Requirements

To outline the general space requirements to enable safe use and adequate access for service.



WARNING: Do not work in a confined space. 1 m (39 inches) space is needed for safe working.



WARNING: USA and Canada. Do not install this machine in a hallway or exit route that does not have 1.12 m (44 inches) of space additional to the normal space requirements in front of the machine. To conform with fire regulations this additional 1.12 m (44 inches) of space is needed in front of the machine in hallway and exit routes

Machine Height

Machine Configuration	Height
IOT + DADF (lowered)	491mm (19.3 inches)
IOT + DADF (raised)	796mm (31.3 inches)
IOT + DADF + Optional 550+100-sheet tray, DADF (lowered)	624mm (24.5 inches)
IOT + DADF + Optional 550+100-sheet tray, DADF (raised)	902mm (36.5 inches)
IOT + DADF + Optional 550+100-sheet tray + 550-sheet tray, DADF (lowered)	757mm (29.7 inches)
IOT + DADF + Optional 550+100-sheet tray + 550-sheet tray, DADF (raised)	1035mm (41.7 inches)
IOT + DADF + Optional 550+100-sheet tray + 550-sheet tray + Adjustable Stand, DADF (lowered)	1012mm (39.8 inches)
IOT + DADF + Optional 550+100-sheet tray + 550-sheet tray + Adjustable Stand, DADF (raised)	1317mm (51.8 inches)

Machine Weight

Machine Configuration	Weight
IOT + DADF	27.1kg (47.9lb)
IOT + DADF + Optional 550+100-sheet tray	31.3kg (69lb)
IOT + DADF + Optional 550+100-sheet tray + 550-sheet tray	35.2kg (77.6lb)
IOT + DADF + Optional 550+100-sheet tray + 550-sheet tray + Adjustable Stand	57.7kg (127.2lb)

Paper Trays

Configuration	Weight
Optional 550+100-sheet tray	4.2kg (9.3lb)
Optional 550-sheet tray	3.9kg (8.6lb)

Minimum Clearance Requirements

The minimum clearance requirements are for the minimum safety work space around the machine. To acquire this minimum safety work space, it may be necessary to move the machine within the area specified. A gap of 100mm (3.94 inches) is required at the rear for airflow to fans. This is also sufficient for the DADF when raised. Refer to, [Table 1](#), Minimum Clearance Requirements.

Table 1 Minimum Clearance Requirements

Area	Dimensions
Top	305mm/12 inches
Left Side	65mm/12 inches
Right Side	110mm/4.33 inches
Rear	100mm/3.94 inches
Front	305mm/12 inches

Note: These clearance values are for the most compact operating configuration of the product. Additional clearance (especially from the front) may be needed for clearing misfeeds or for replacement of the toner cartridges and imaging unit.

Installation Space Requirements

The table and figures below provide the recommended minimum installation space requirements by machine configuration. Following these recommended minimums will ensure safe operation of the machine. Refer to, [Table 2](#) Minimum Installation Space Requirements.

Configuration	Machine Width	Machine Depth	Machine Height
IOT + DADF (raised) Figure 1	860mm / 33.9 inches	1085mm / 42.7 inches	796mm / 31.3 inches
IOT + DADF (raised) with 550 +100-sheet tray and 550-sheet tray Figure 2	860mm / 33.9 inches	1085mm / 42.7 inches	1062mm / 41.8 inches
IOT + DADF (raised) with 550 +100-sheet tray+550-sheet tray and Adjustable Stand Figure 3	891mm / 35.1 inches	1143mm / 45 inches	1502mm / 59.1 inches

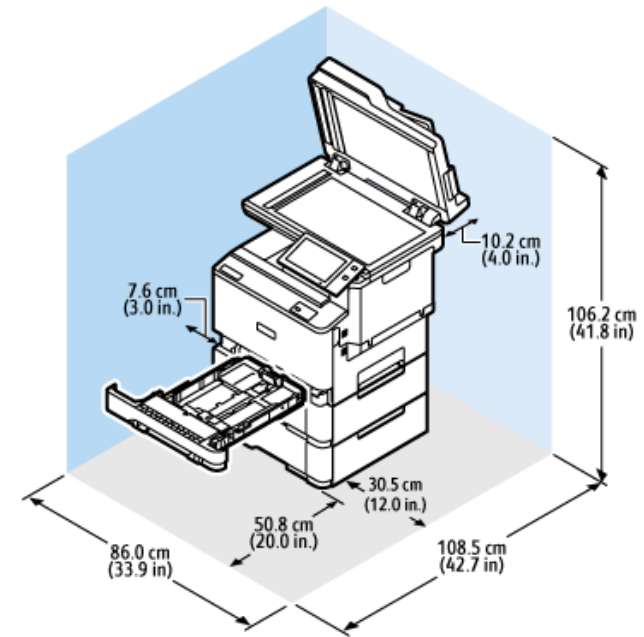

Figure 2 IOT + DADF with 550+100-sheet tray and 550-sheet tray Dimensions

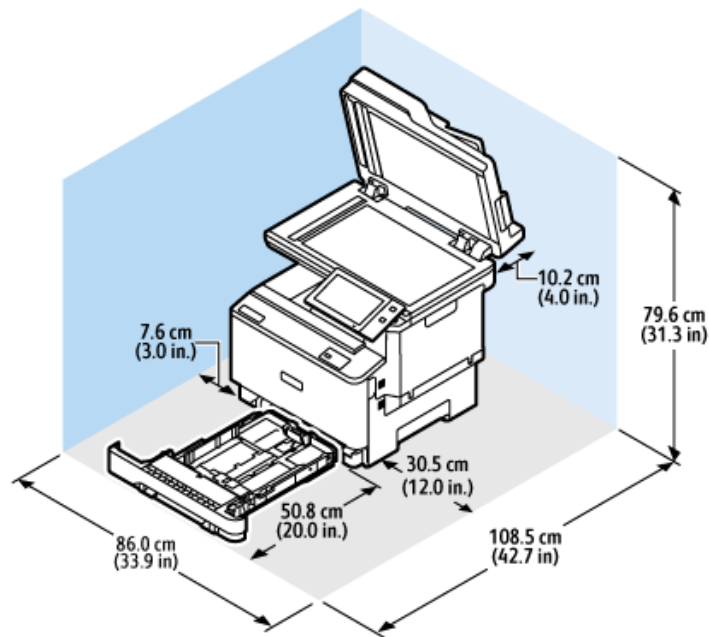

Figure 1 IOT + DADF Dimensions

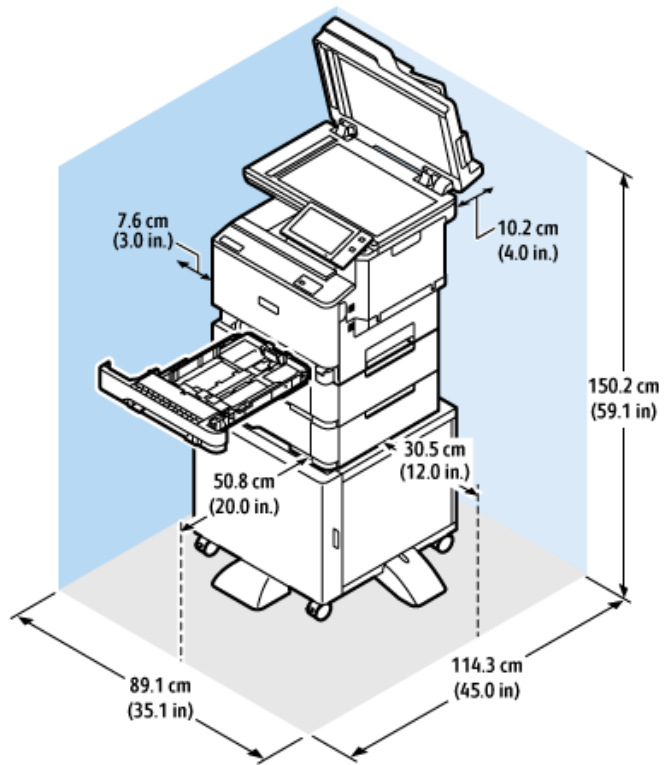

Figure 3 IOT + DADF with 550+100-sheet tray + 550-sheet tray and Adjustable Stand Dimensions

GP 17 Electrical Power Requirements

List of Tables:

1. [Table 1](#), Electrical Power Usage.
2. [Table 2](#), Power Modes, supports up to six (6) power modes.
3. [Table 3](#), Operation Modes.

Power Usage

Table 1 Power Usage

Power State	Value
Off (W)	0.2
Hibernate (W)	0.2
Sleep State (W)	1.3
Ready Low Power State - Tier 2 (W)	29
Ready State - Tier 1/ first ~5 min (W)	NA
Simplex Printing (W)	587
Duplex Printing (W)	402
Typical Electricity Consumption (kwh) Default Mode	0.57
Average Current While Operating 100-110V (A)	8.18
Average Current While Operating 110-127V (A)	7.03
Average Current While Operating 220-240V (A)	3.66
Rated (Maximum) Current 100-110V (A)	8.8
Rated (Maximum) Current 110-127V (A)	7.8
Rated (Maximum) Current 220-240V (A)	3.9

Power Modes

Table 2 Operation modes

Mode	State
<p>Active Mode:</p> <ul style="list-style-type: none"> Machine producing output. 	<ul style="list-style-type: none"> Power Used: Varies with job and includes maximum AC power. Active Mode Entry: From Ready or Sleep Modes, upon receipt of a print or scan job Active Mode Exit: Upon job complete UI state: By default, the UI is active, with backlight on, and indicator light blinking blue.
<p>Ready Mode:</p> <ul style="list-style-type: none"> Machine can respond to jobs with minimal delay. 	<ul style="list-style-type: none"> Ready Mode Entry: <ul style="list-style-type: none"> From Active Mode, on job completion. From Sleep Mode upon wake event* From Hibernate Mode, upon scheduled wake, or touch of Power Button From Off Mode via touch of Power Button Ready Mode Exit: <ul style="list-style-type: none"> To Sleep Mode, upon Power Button touch, Sleep timeout of scheduled Sleep event. To Hibernate Mode, upon scheduled event. To Off Mode, via a 5 second press of the Power Button. UI state: <ul style="list-style-type: none"> At home screen, by default, with the indicator light illuminated blue.
<p>Sleep Mode:</p> <ul style="list-style-type: none"> Primary power saving mode. UI dark. Machine can respond to jobs with some delay. 	<ul style="list-style-type: none"> Sleep Mode Entry. <ul style="list-style-type: none"> From Ready Mode only, via Sleep mode timeout, power button press, or scheduled day/time. Sleep Mode Exit. <ul style="list-style-type: none"> To Ready Mode, via wake events*, or cycling AC power. To Deep Sleep Mode, via a 6 minute timeout from entering Sleep mode. To Hibernate Mode, via scheduled Hibernate, or Hibernate inactivity timeout. To Off Mode, via a 5 second press of the Power Button. UI State: <ul style="list-style-type: none"> Indicator light is lit solid amber with panel dark. Touch screen is active, in Sleep.

Mode	State
<p>Deep Sleep Mode:</p> <ul style="list-style-type: none"> Enhanced power saving mode. UI is dark. Machine can respond to jobs with some delay. 	<ul style="list-style-type: none"> Deep Sleep Mode Entry <ul style="list-style-type: none"> From Sleep Mode only, via 6-minute timeout after entering Sleep Mode Deep Sleep Mode Exit <ul style="list-style-type: none"> To Ready Mode, via wake events*, or cycling AC power. To Hibernate Mode, via scheduled Hibernate, or Hibernate inactivity timeout To Off Mode, via a 5 second press of the Power Button UI State: <ul style="list-style-type: none"> Indicator light blinks amber, with panel dark Touch screen is active, in Deep Sleep
<p>Hibernate Mode:</p> <ul style="list-style-type: none"> Panel not lit. Touch not active. Minimal wake events recognized. MACHINE IS NOT RESPONSIVE TO PRINT OR FAX JOBS IN THE HIBERNATE STATE. Supports ultra-low power, via scheduled times when printer is not being actively used. 	<ul style="list-style-type: none"> Hibernate Mode Entry <ul style="list-style-type: none"> Via scheduled date/time Via inactivity timeout. <ul style="list-style-type: none"> 3 days, by default By default, the inactivity timer is disabled, if the machine is connected via network, USB, or FAX Hibernate Mode Exit <ul style="list-style-type: none"> Press of the Power Button Scheduled Wake Cycling AC power. UI State: The indicator light will pulse amber, otherwise, the machine appears to be unpowered.

Mode	State
<p>Off (Soft Off) Mode:</p> <ul style="list-style-type: none"> Lowest Power machine state. MACHINE IS NOT RESPONSIVE TO PRINT OR FAX JOBS IN THE OFF MODE. 	<ul style="list-style-type: none"> Off Mode Entry: <ul style="list-style-type: none"> Via sustained, five second, Power Button Press <ul style="list-style-type: none"> After five second press, UI will turn off If the machine is in Off Mode, and AC power is cycled <ul style="list-style-type: none"> Machine will return to Off Mode The Power Button LED will pulse for 30 seconds, after AC power is reapplied, before the machine re-enters Off Mode. Off Mode Exit to Ready Mode: <ul style="list-style-type: none"> Via momentary Power Button press only. UI State: Panel, buttons, and all lights, are off, in Off Mode. The machine is unpowered, except for low power uC and some portions of the Low Voltage Power Supply (LVPS).
<p>Wake:</p> <ul style="list-style-type: none"> The device is in the Wake state during printing, scanning, copying, or any time the display is active. Responsiveness and performance are most important in Wake, thus fewer power savings features are enabled in this state. 	<p>Device may transition to a Wake State upon:</p> <ul style="list-style-type: none"> Physical activity: <ul style="list-style-type: none"> Wake sources vary depending on prior state, but may include <ul style="list-style-type: none"> Cover/Door open Touch Screen Press Power Button Press: always active Print or Scan Jobs initiated via USB, Ethernet, WiFi, FAX <ul style="list-style-type: none"> Note that some devices support ISP's (Internal Solutions Ports) to provide IEEE 1284 Parallel Port, Serial, and Fiber. These would also remain active during Sleep and wake the machine upon job receipt.

Note: * Wake events from Sleep include: Touching op panel screen; pressing power button; physical sensors, such as opening covers and doors, opening tray 1, or lifting the scan lid; inserting paper into the DADF; inserting a thumb drive (front USB-Host); inserting a keyboard (rear USB-Host); activity from a CAC [Xerox] / FSM [Lexmark] (front USB-Host); receiving a USB, network or fax job.

These products have a default behavior to reduce energy consumption called Sleep-Print-Sleep (SPS). When the device is in Sleep mode any subsequent job will awaken the printer. Once the job is completed the device immediately returns to the Sleep state.

Sleep-Print-Sleep mode can be disabled in the Settings Menu under Sleep Mode Profile by setting "Stay awake after printing".

Table 3 IOT states

Sub-System	Run Mode	Ready Mode	Low Power Mode	Sleep Mode	Sub Power Off Mode
Fuser	Maintaining operating temperature	Maintaining standby temperature	Maintaining low temperature	Off	Off
Xerographics	Operating state	Off	Off	Off	Off
Print Head Assembly	Operating state	Off	Off	Off	Off
Fusing Fan	Temperature controlled slow or fast rotation	Temperature control in stop or rotate (slow)	Temperature control in stop or rotate (slow)	Off	Off
Marking Fan	Temperature controlled, either stopped or slow or fast rotation	Temperature control led either stop or slow rotation	Temperature control led either stop or slow rotation	Off	Off
ESS (Reference only)	Operating state	Standby	Standby	Ready to receive	Inactive

GP 18 Cleaning the Scanner

Procedure

1. Lift the scanner cover, [Figure 1](#).

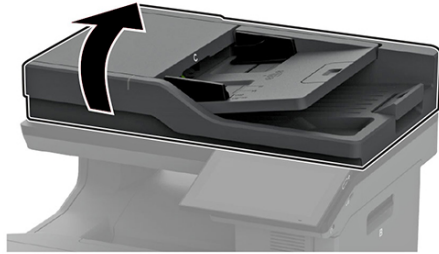

Figure 1 DADF

2. Using a damp, soft, lint-free cloth, wipe the following areas:

- DADF glass pad, [Figure 2](#).

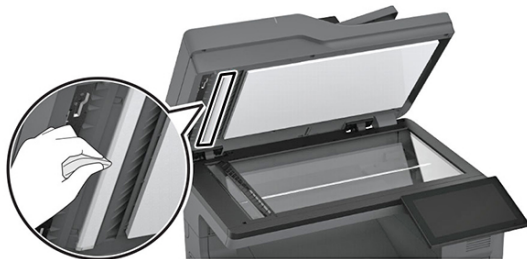

Figure 2 DADF glass pad

- Scanner glass pad, [Figure 3](#).



Figure 3 Scanner glass pad

VLC625S_1001

VLC625S_1002

VLC625S_1003

- DADF glass, [Figure 4](#).



Figure 4 DADF glass

- Scanner glass, [Figure 5](#).



Figure 5 Scanner glass

3. Close the scanner cover.
4. Open door C.
5. Using a damp, soft, lint-free cloth, wipe the following areas:
 - DADF glass pad in door C, [Figure 6](#).

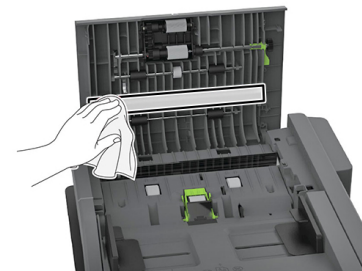

Figure 6 DADF glass pad in door C

VLC625S_1004

VLC625S_1005

VLC625S_1006

- DADF glass in door C, [Figure 7](#).



VLC625S_1007

Figure 7 DADF glass in door C

6. Close door C.

GP 19 Obtaining Audit and Device Logs

Purpose

To obtain then download device data for analysis by 2nd level support. The machine needs to be out of Diagnostics [GP 1](#), if you need to enable HTTPS or you will get an error.

Note: It may not be possible to obtain a device log if the device executed a reboot after an error occurred. To enable the device log collection enter Diagnostics, enter [dC131](#), then set the NVM chain-link code 700-530 value to 0. Repeat the device log procedure then reset the NVM chain-link code 700-530 value back to 1.

Initial Actions

- Print a configuration report, [GP 14](#) Printing Reports, to locate the machine's IPv4 address.
- The machine IPv4 address is also located at the top of the UI screen.

Procedure

User Panel (UI) on the Machine

1. Login as Admin.
2. Touch, **Device > Tools > Network Settings > Advanced Network Settings > HTTP Settings**.
3. Verify HTTP is **[Enabled]**.

Audit Log

- Enter the **IPv4 address** from the Configuration Report, into the address line in a web browser, then press **Enter** on the keyboard to access the WebUI.

Note: The computer accessing the WebUI must be on the same TCP/IP network address as the machine.

- Within the WebUI, login to admin mode, [GP 23](#) Customer Administration Tools.

1. Click the tab, **[Properties]**, at the top of the screen.
2. On the left side of the screen click, **Connectivity > Setup**.
3. Scroll down to **[Protocol]**, then **[HTTP]**, verify the **[Enabled]** box is checked.

If unchecked:

- a. Click **[Edit]**, to open the HTTP settings.
- b. In the **[Configuration]** section, click **[Enabled]**.
- c. Enter the port number, **[80]** is the default.
- d. **[Force Traffic over Secure Connection (HTTPS)]**, check **[Yes]**, port number **[443]** is default.
- e. Click **[Save]** to save settings.

1. Within EWS, click the tab, **[Properties]**, at the top of the screen.
2. On the left side of the screen, open the **Security** menu.
3. Open the **[Logs]** menu, then click **[Audit Log]**.
 - a. Click the **Export Audit Log** radio button.
 - b. Click the **Download Log** link. A file named [UQA188055_2022-12-28T15_46-0800_audifile.zip], **example**, is downloaded to the **Downloads** folder on the computer.

Note: The instructions state to **Right click on the link to download**. This is a typo and should be ignored. Left click the link to download the log file.
 - c. Extract the zip file, then find the file named "auditfile.txt".

Note: To view the file, open with a text editor such as; Notepad, Notepad ++, Wordpad, or other text editing/viewing application.
4. If uploading to the **SFTP Transfer Server**, check the box to enable **[Automatic Log Transfer]**.
 - a. Enter the **[Log Transfer SFTP Server]**:
 - **[IPv4 Address]**, [xxx][xxx][xxx][xxx] and port :[xxxx].or
 - **[Host Name]**, [xxx.xxx.xxx.xxx] :[xxxx].
 - b. **[Path]**, enter the HTTPS server address, if known.
 - c. **[Authentication]**, select the appropriate method.
 - d. Enter the **[Login Name]** and **[Password]**.
 - e. Click, **[Apply]**.

Support Logs

1. Obtain the machine's IP address by printing a configuration report. Refer to **GP 14** Printing Reports.
2. Access the web UI by entering the IP address into a web browser on a PC on the same network as the machine.
3. Log in to the web UI as an administrator. Refer to **GP 23** Customer Administration Tools.
4. Click **Properties**, at the top of the screen.
5. On the left side screen menu, click **Security > Logs > Support Logs**.
6. Click **Start Download**.

7. Click **Download File Now**. A file named [UMQ000530_20230208_153932.zip], **example** is downloaded to the **Downloads** folder on the computer.
8. Support Logs can also be downloaded to a USB drive by using the Control Panel (UI):
 - a. Login as admin.
 - b. At the Control Panel (UI), Touch; **Device > Tools > Network Settings > Support Logs > Download Log Files**.

Note: If a USB drive is not detected, the **USB Drive Not Found** screen appears. Insert a USB drive or remove, then insert the USB drive again. Select **OK**, the download will begin to the USB drive.

GP 20 First Copy/Print Out Time and Power On Time

Time to Ready and Time to First Print

Ready State: The printer's "Ready State" is when all Op-Panel, Engine, and RIP functions are "Active", and the printer is ready to print.

Hibernate State: The printer's "Hibernate State" is an ultra-low power state that only "Wakes" (comes out of a low power state or off) the printer for programmed "Wake Events" or a Soft Off button press.

Table 1 Power On, FPOT, and FCOT Specifications

Process	Type	Time In Seconds
Power On		129.75
First Page Out Time (FPOT)	Color – PS	7.17
	Mono – PS	7.92
	Color – PCL	6.62
	Mono – PCL	7.27
First Copy Out Time (FCOT)	Color	6.23
	Mono	7.06

GP 21 Restriction of Hazardous Substances (RoHS)

Purpose

To provide information on the RoHS Directive.

The RoHS Directive restricts the use of certain hazardous substances in electrical and electronic equipment. It applies to equipment placed in the European Union (EU) market. The directive takes effect from 1st July 2006.

Note: Currently these restrictions are only for the European Union (EU) market and some associated countries. For more information go to www.Xerox.com. However, Xerox has mandated that all Xerox® VersaLink® machines must be maintained as RoHS compliant.

The hazardous substances are:

- Lead (Pb)
- Mercury (Hg)
- Cadmium (Cd)
- Hexavalent Chromium (Cr 6+, Cr [VI])
- Polybrominated Diphenyl Ethers (PBDEs)
- Polybrominated Biphenyls (PBBs)

Identification of a RoHS Compliant Machine

Xerox will maintain a central list of RoHS compliant machines.

All Xerox® VersaLink® machines are RoHS compliant at time of manufacture.

Procedure



CAUTION: Failure to comply with RoHS guidelines can result in product recalls, imprisonment, fines or penalties.

Use only spares that are listed in the Xerox® VersaLink® Spare Parts List. Do not use spare parts from other similar machines, even if the parts look identical. All Xerox® VersaLink® machines are RoHS compliant at time of manufacture and must be maintained as RoHS compliant.

GP 22 Backup & Restore Settings

The Backup & Restore feature takes a snapshot of your device's settings and saves them as a backup file to the device itself. Xerox recommends backing up your device settings when the device is operating as desired. This practice is useful for restoring (applying settings) to your device, such as when the settings have changed in error. Note that settings contained in the Daily backup file will be reapplied after a software upgrade. Updating this file before upgrading software will maintain your device's most recent settings.



CAUTION: Before starting the procedure, inform the system administrator when any service procedure may result in the loss of saved customer settings.

Setting the Security Installation Policy for Backup & Restore

1. Open a web browser, then enter the machine IP address in the browser address line.
2. When EWS loads, click on **Login** in the upper right of the screen.
3. Enter the username **admin** and password to log in as admin.

Note: The default Password is the **device serial number**. If the admin password is changed, contact the owner for the admin password or follow the instructions in, [GP 28](#), Resetting the System Administrator Password. If changed during the service call, make sure the admin password is set back to the owner created password, before performing, [SCP 5](#), Final Actions.

4. Click **Properties > Security > Installation Policies**.
5. **Backup & Restore** is the first policy listed. Check the box, then click **Take me there...**, to the right.
6. The first line, highlighted in blue, lists the active Security Installation Policy.
 - [Figure 1](#), shows backup and restore as not allowed. Click the **Allow Installation** button to allow installation.

Backup & Restore Settings

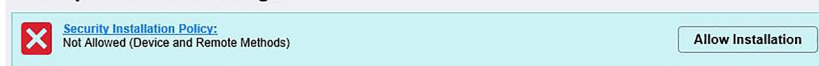

Q-1-0017-A

Figure 1 Allow Installation

Setting the Security Installation Policy for Backup & Restore (continued)

- [Figure 2](#), shows backup and restore as allowed. Click the **Restrict Installation** button to not allow installation.

Backup & Restore Settings

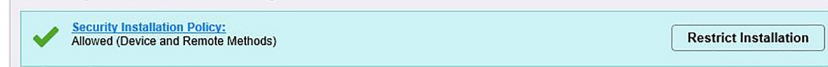

Q-1-0016-A

Figure 2 Restrict Installation

Locally Stored Backup Files

Backup files stored in the machine's memory are listed by, [Figure 3](#):

- **File Type**
 - **Daily File** is a backup file that is created automatically every day around midnight. This file can not be deleted, but it will be overwritten by a new file.
 - **Automatic – Upgrade File** is a backup file that is created when a SW upgrade is performed. This file can not be deleted, but it will be overwritten by a new file.
 - **Manual File** is a File that the customer can choose to create at any time.
- **Backup Date/Time**
- **Action**
 - **Backup:** backup/update files immediately.
 - **Restore:** restore files immediately.
 - **Other Actions:** delete Manual backups immediately.

File Type	Backup Date/Time	Backup	Restore	Other actions
Daily	2023-04-24T00-00-13	Update Now	Restore	
Automatic - Upgrade	2023-02-21T13-47-31		Restore	
Manual	2023-04-24T15-05-10	Update Now	Restore	Delete

vid256008

Figure 3 Locally Stored Backup Files and Actions

Import & Restore Backup File

1. In the Embedded Web Server, click **Properties > General Setup > Backup & Restore Settings**.

Import & Restore Backup File (continued)

2. Click **Browse**, then navigate to the file to be restored. The file name appears in the **[Choose File]** window.
3. Click the **Import & Restore** button to restore the machine settings from the selected file.

Create & Export Backup File Creating and Downloading a Backup File

1. In the Embedded Web Server, click **Properties > General Setup > Backup & Restore Settings**.
2. Click **Create and Export**.
3. The **Backup Instructions** page appears with a checked box stating **The backup file has been successfully created**.
4. To download the new backup file, click the file name link **[2023-04-24T15-47-49_UPQ100574.bkup]** example. The file begins downloading to the computer's Downloads folder.

GP 23 Customer Administration Tools

Purpose

To gain access to Customer Administration Tools in the UI control panel or to login as an administrator via the Embedded Web Server (EWS).

Refer to the relevant procedure:

- [How to Enter Customer Administration Tools](#)
- [How to Enter Admin Mode via the EWS](#)

How to Enter Customer Administration Tools

1. Switch on the machine, [GP 10](#).
2. When the machine completes startup to ready, touch **Log In** in the top left corner of the UI.
3. Touch the keys in the UI to type the user name, **admin**, in the box.
4. Touch **Next**.
5. Enter the password.

Note: The default password is the machine serial number (case sensitive). If the machine serial number does not work, request the customer created password for admin user. Be sure to change the password back to the customer created password if the password is changed during the service call.

Note: A new device will have a default password of the device Serial Number (case sensitive).

Refer to, [GP 28](#) Resetting the System Administrator Password.

6. Touch **Done**.
7. The user **Admin** is displayed in the top left corner of the UI control panel.

Admin User Logout

1. Touch **Admin** in the top left corner of the UI control panel.
2. Touch **Log Out**, then at the next screen touch:
 - a. **Cancel** to remain in admin mode.
 - b. **Log Out** to exit admin mode.

How to Enter Admin Mode via the EWS

1. Type the device IP address into a web browser.

Note: The machine IP address can be found:

- At the top center of the UI control panel.
 - The EWS Home Screen.
 - The machine Configuration Report, refer to [GP 14](#) Printing Reports.
2. Select **Login** at the top right corner.
 3. The **Login** screen is displayed:
 - a. In the **User ID** box enter **admin**.
 - b. Enter the password.

Note: The default password is the machine serial number (case sensitive). If the machine serial number does not work, request the customer created password for admin user. Be sure to change the password back to the customer created password if the password is changed during the service call.

Note: A new device will have a default password of the device Serial Number (case sensitive).

Refer to, [GP 28](#) Resetting the System Administrator Password.

- c. Click **Login**.
4. The user **admin** is displayed in the top right corner of the EWS screen.

Admin User Logout

1. Select **admin** in the top right corner of the UI control panel.
2. Select **Logout** from the pull down menu.

GP 24 How to Set the Date and Time

Purpose

To set the machine's date and time.

Procedure

Perform the steps that follow:

1. Enter Customer Administration Tools, [GP 23](#).
2. Touch **Device**.
3. Touch **General**.
4. Touch **Date & Time**.
5. Again, touch **Date & Time**.
6. Correctly set the date and time. Touch **OK**.
7. Log out of Customer Administration Tools.

GP 25 Ethernet Crossover Cable Setup

Purpose

To connect and then configure the PWS to communicate with a device via a ethernet crossover cable (600T02252).

Procedure



WARNING: Switch off the electricity to the machine, GP 10. Disconnect the power lead from the customer supply while performing tasks that do not need electricity. Electricity can cause death or injury. Moving components can cause injury.

1. Print a configuration report, GP 14.
2. Ensure that Windows firewall and wireless network connectivity on the PWS are turned off.
3. Record the IP address and Subnet Mask of the PWS.



CAUTION: Before changing the value of a setting ensure the original value is recorded. All the original values will need to be restored to the PWS at the end of the procedure.

- a. Open a command window on the PWS:
 - Select **Start** and in the Search box above the Start button, type **CMD**, then press **Enter**.
 - b. Type **ipconfig** at the command prompt, then record the Local Area Connection: IPv4 Address and Subnet Mask.
4. Configure the LAN connection of the PWS to enable communication with the device. Go to the relevant procedure:
 - [Windows 7](#).
 - [Windows 10](#).

Windows 7

Perform the steps that follow:

1. Select the Windows **Start** button, then **Control Panel**, then **Network and Sharing Center**.
2. From the left pane, select **Change adapter settings**.
3. Right-click on the **Local Area Connection** icon. Select **Properties**. The Local Area Connection Properties window will open.
4. Select **Internet Protocol Version 4 (TCP/IPv4)**. Select **Properties**, [Figure 1](#). The Internet Protocol Version 4 (TCP/IPv4) Properties window will open.

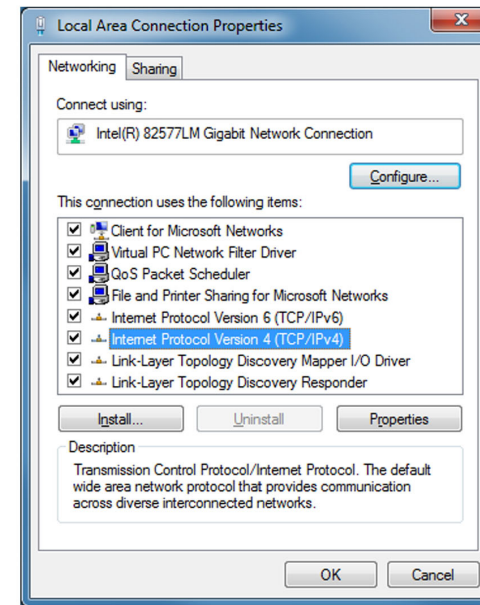

Y-1-0546-A

Figure 1 Properties window

5. Double-click the entry **Internet Protocol Version 4 (TCP/IPv4)**.
6. Select **Use the following IP address**, then enter the IP address and subnet mask.

Refer to the configuration report then:

- Set the IP address of the laptop one number higher than the device. For example, if the IP address of the device is 192.168.196.112, set the IP address of the laptop to 192.168.196.113.
- Set the Subnet mask of the laptop to the same as the Subnet mask of the device, [Figure 2](#).

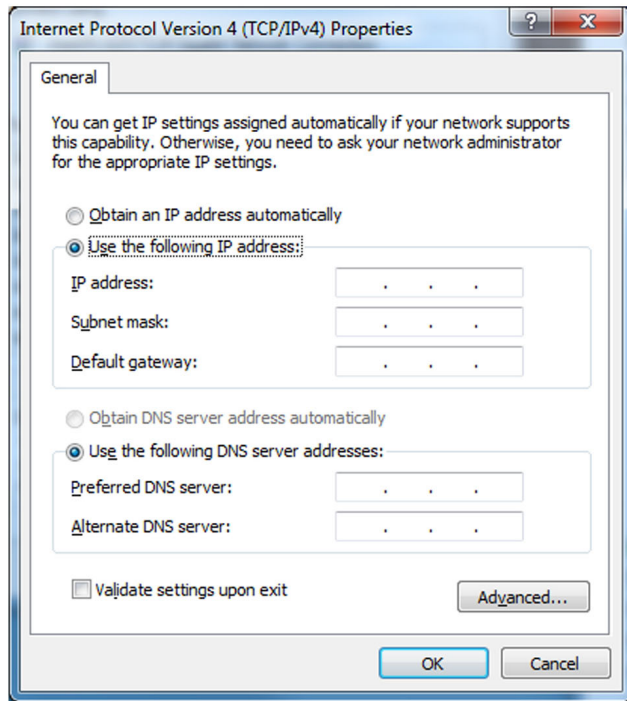

Y-1-0547-A

Figure 2 Properties window

7. Click on **OK** to close the properties dialog box, then **OK** to close the second properties dialog box.
8. Close the Local Area Connection Status dialog box.
9. Connect the ethernet crossover cable to the device, then continue with your procedure.

Windows 10

Perform the steps that follow:

1. Select the Windows **Start** button, then select **Settings**.
2. Select **Network & Internet**.
3. Under Related settings select **Network and Sharing Center**, then from the task list on the left of the screen select **Change adapter settings**.
4. Right click on **Local Area Connection (Ethernet)**, then select **Properties**.

5. Select **Internet Protocol Version 4(TCP/IPv4)**, then select **Properties**. The Internet Protocol Version 4 (TCP/IPv4) Properties window will open.
6. Select **Use the following IP address**, then enter the IP address and subnet mask.

Refer to the configuration report then:

- Set the IP address of the laptop one number higher than the device. For example, if the IP address of the device is 192.168.196.112, set the IP address of the laptop to 192.168.196.113.
 - Set the Subnet mask of the laptop to the same as the Subnet mask of the device.
7. Select **OK** to close the properties dialog box, then **OK** to close the second properties dialog box.
 8. Close the Local Area Connection Status dialog box.
 9. Connect the ethernet crossover cable to the device, then continue with your procedure.

GP 26 Supplies Plan Activation

To assist in activation of a new or changed Supplies Plan (formerly known as PagePack).

Introduction

The machine is typically shipped with a Neutral and Factory supplies plan coded CRUM in the toner cartridge. Refer to, [Table 1](#), Supplies Plan Variables and Regional Differentiations. When the first replacement toner cartridge is installed, the Regional Differentiation Code and Toner Cartridge Type in the machine settings are automatically changed to the same settings as the cartridge.

Note: Factory Learning Mode is Service Plan = **Neutral** and Regional Differentiation = **Factory**. It is also possible on this product to be in Regional Learning Mode, where a Service Plan = Sold or Metered and the Region = Factory.

Note: US devices will automatically set to metered without a PIN entry when a metered toner is inserted as the first toner after SWE.

Note: When a device has been set to sold, possibly upon a Sold cartridge inserted as the first toner after SWE, then any metered toner should be disallowed. Once Sold is set, only a Supplies Plan (formerly known as PagePack) PIN or a Plan Conversion, [GP 37](#), can be used to set Metered/Supplies Plan (formerly known as PagePack).

There are four service Plan Variables and six Regional Differentiations:

Plan Variables

- Neutral — as shipped
- Sold
- Metered
- Supplies Plan (formerly known as PagePack)

Regional Differentiations

- NA
- XE
- NAXE
- DMO
- Metered
- Factory – as shipped

Note: Refer to, [PL 26.05](#) for part numbers.

Verify the Current Machine Supplies Plan (formerly known as PagePack) Plan Configuration

At the machine UI:

1. Print a Configuration Report [GP 14](#).
2. The supplies plan is shown on the configuration report under the General Setup heading.

In EWS:

1. Open a web browser.
2. Enter the machine IP address.
3. On the **Home** screen scroll to the bottom and select **Configuration Report**.
4. The screen displays the configuration report in alphabetical order. Select **General Setup**.
5. The **Service Plan** is shown in the list. Typical **as shipped** service Supplies Plan is **Neutral**.

Note: Do not attempt to change the NVM settings in [Table 1](#), they are for reference only.

Table 1 Supplies Plan Variables and Regional Differentiations

Device Configuration (all possible) Xerox NVM	Xerox Toner						
	SWE (starter toner) (Sold_WW)	Metered_WW	Sold_NA	Sold_XE	Sold_DMO	Sold_NAXE	Sold_WW
Plan Variables: Neutral Sold Metered Supplies Plan (formerly known as Page-Pack)*							
Regional Differentiation: NA XE NAXE DMO WW Factory							
Metered_WW Metered_NA Metered_XE Metered_NA/XE	Y	Y	Y	Y	Y	Y	Y

Device Configuration (all possible) Xerox NVM	Xerox Toner						
	Metered_DMO						
Sold_NA	Y	N	Y	N	N	Y	Y
Sold_XE	Y	N	N	Y	N	Y	Y
Sold_DMO	Y	N	N	N	Y	N	Y
Sold_WW	Y	N	Y	Y	Y	Y	Y
Sold_NA/XE	Y	N	Y	Y	N	Y	Y

*Supplies Plan (formerly known as PagePack) and Metered configurations have the same behavior

Note: If a problem occurs after several toner replacements, the customer may have received the wrong toner in a consumable order; either because the wrong part number was ordered, or the shipment did not match the order. Resolution in this case is simple; the customer should exchange the toner for the correct part.

Note: If an incorrect toner cartridge was installed at the first toner replacement after install, or if the machine’s configuration changed due to software or NVM corruption, resolve the issue, then perform the following procedure:

Note: 220VAC machines:

- May ask for a Supplies Plan (formerly known as PagePack) Activation Code with a courtesy print time.
- This may happen when a metered toner is inserted into a neutral machine still running on SWE toner.
- This will appear automatically in Europe.
- A Supplies Plan (formerly known as PagePack) Activation Code can also be entered at any time by navigating through the following procedures.

Obtaining a Supplies Plan (formerly known as PagePack) Activation Code

- **XE:** Contact: office.europe.page.pack.pin@xerox.com.
- **NA:** Follow Local Process.

Note: The machine Serial Number and the Supplies Plan (formerly known as PagePack) Sequence number are required.

Supplies Plan (formerly known as PagePack) Activation via Web UI (EWS)

1. In the Embedded Web Server window, enter the machine IP address, then login as **[admin]**.
2. Select the **[Properties]** tab, then in the left column select **[General Setup]**.
3. Select **[Supplies Plan Activation Code]**.



CAUTION: Compare the serial number on the screen with the serial number on the configuration report to ensure the correct machine is being changed.

4. Enter the 6-character Supplies Plan (formerly known as PagePack) Activation Code provided above, in **[Supplies Plan Activation Code]**, then select **[Apply]**.

The Geographic Differentiation Code and Toner Cartridge Type will be reset to the values of the customer's agreed-to supplies plan.

Supplies Plan (formerly known as PagePack) Activation via Remote Control Panel (RPC)

1. Open a browser window, then enter the machine IP address to open Embedded Web Server.
2. Scroll down to remote control panel and start remote session, then login at the admin login screen.
3. At the **[Home]** screen, select **[Device]**.
4. Select **[Tools]**.
5. Select **[Device Settings]**.
6. Scroll down, touch **[Supplies]**, then select **[Enter Supplies Plan Activation Code]**.



CAUTION: Compare the serial number on the screen with the serial number on the configuration report to ensure the correct machine is being changed.

7. Enter the 6-character Supplies Plan Activation Code provided.
8. Select **[OK]**.

The Geographic Differentiation Code and Toner Cartridge Type will be reset to the values of the customer's agreed-to supplies plan.

Supplies Plan Activation via Machine UI

1. At the **[Home]** screen, (Log In to Admin mode is not required).
2. Touch **[Device]** on the UI, touch **[Tools]**.
3. Touch **[Device Settings]**.
4. Scroll down, touch **[Supplies]**, then touch **[Enter Supplies Plan Activation Code]**.



CAUTION: Compare the serial number on the screen with the serial number on the configuration report to ensure the correct machine is being changed.

5. Enter the 6-character Supplies Plan Activation Code provided in step above.
6. Touch **[OK]**.

The Geographic Differentiation Code and Toner Cartridge Type will be reset to the values of the customer's agreed-to supplies plan.

GP 27 Intermittent or Noise Problem

Purpose

The purpose of this RAP is to provide guidance for resolving an intermittent or noise problem. This is not an exact procedure, but a set of recommended actions that use the resources of the service manual to help locate the cause of an intermittent or noise problem.

Procedure

1. Check the service log. Recent service actions may provide information about the problem. For example, a component that was recently replaced to correct another problem may be the cause of the new intermittent problem.
2. Noise problems may be due to improper installation. Check for packing materials that have not been removed. Check for loose or missing hardware.
3. Run the machine in a mode that vigorously exercises the function that is suspected. The machine may fail more frequently or may fail completely under these conditions. Look for signs of failure or abnormal operation.

An intermittent problem can usually be associated with a RAP, since when it does fail, it results in a fault code, a jam code, or some other observable symptom.

4. Using the RAP that is associated with the symptom of the intermittent problem, examine all of the components that are referenced in the RAP. Look for:
 - contamination, such as a feed roller that has a build up of dirt or toner
 - wear, such as gear teeth that are rounded or have excessive backlash
 - HFSI, even if they are not near or have not exceeded the SPEC LIFE or COPY COUNT value
 - wires chafing against components of the machine, especially against moving components
 - misaligned, maladjusted, or incorrectly installed components
 - slow or slipping clutches; slow or binding solenoids
 - damaged components
 - excessive heat, or symptoms of excessive heat, such as the discoloration of a component
 - loose cables or wires
5. Using the RAP that is associated with the symptom of the intermittent problem, perform all of the adjustments for the components or functions that are referred to in the RAP. Check to ensure that the adjustment can be made and that there is an adequate range of adjustment, and that it can be set to or near the nominal value. Any abnormality that is observed may be an

indication of the cause of the problem. For example, a component can be adjusted to the nominal value, but it is at the limit of the adjustment range. This is not normal and may be an indication of the cause of the problem.

6. Operate all of the components in the appropriate RAP that is associated with the symptom of the intermittent problem with Component Control. Observe the components for any symptoms of abnormal operation, such as a hesitation or an unusual sound.
7. Check that the AC and DC power are within specification.
8. Get technical advice or assistance when it is appropriate. This will depend upon the situation and the established local procedures.
9. Examine the components that are not in the RAP, but are associated with the function that is failing. Refer to the BSDs. Look for:
 - contamination, such as a feed roller that has a build up of dirt or toner
 - wear, such as gear teeth that are rounded or have excessive backlash
 - HFSI, even if they are not near or have not exceeded the SPEC LIFE or COPY COUNT value
 - wires chafing against components of the machine, especially against moving components
 - misaligned, maladjusted, or incorrectly installed components
 - slow or slipping clutches; slow or binding solenoids
 - damaged components
 - excessive heat, or symptoms of excessive heat, such as the discoloration of a component
 - loose cables or wires
10. Perform the adjustments for the components that are not in the RAP, but are associated with the function that is failing. Refer to the BSDs. Check to ensure that the adjustment CAN BE MADE and that there is an adequate range of adjustment, and that it can be set to or near the nominal value. Any abnormality that is observed may be an indication of the cause of the problem. For example, a component can be adjusted to the nominal value, but it is at the limit of the adjustment range. This is not normal and may be an indication of the cause of the problem.
11. Operate all of the components that are not in the RAP, but are associated with the function that is failing with Component Control. Refer to the BSDs. Observe the components for any symptoms of abnormal operation, such as a hesitation, or an unusual sound.
12. Replace any components or consumables that are known to be a frequent cause of the problem. When doing this, consider the cost and time required. If the suspected item is inexpensive, can be installed quickly, and has a high probability of resolving the problem, then it is reasonable to replace it.

13. Leave an accurate and detailed record of your actions in the service log. Describe what you have observed, what actions you took, and the recommended next steps.

GP 28 System Administrator Password Reset

When the customer has forgotten the administrator password and so needs a new one, the customer must call the Welcome Center and request an administrator password reset.

Note: Check to see if the machine password is set at the default. The default password is the Serial Number and is case sensitive.

1. The Welcome Center will request the machine serial number and current total impressions.
2. The Welcome Center generates a Feature Installation Key number.
3. Press the **Device** icon, then select **Tools**.
4. If necessary, select **Device Settings**, then select **General > Feature Installation**.

Note: The UI control panel **Feature Installation** menu is accessible without logging in to the admin account.

5. Enter the Feature Key on the Feature Installation Key screen to reset the admin log in credentials to the values **admin** and **1111**.
 - a. Test the credentials by trying to log in and the Control Panel or EWS.



CAUTION: The next step calls for a Forced AltBoot procedure to be performed. In this case, **DO NOT** back up or restore customer settings using [GP 22](#). Doing so will relock the administrator password. Instead, tell the customer that the settings will need to be restored manually. Ask the customer to record all appropriate settings so that they can restore them after the procedure is complete.

6. If, after performing Steps 1–5 above, the password is not reset, check EWS to verify the password reset has been disabled by the customer, [Figure 1](#). The password can only be reset by a CSE arriving on site and performing a **Forced AltBoot**. Refer to, [GP 4 Software Upgrade](#).

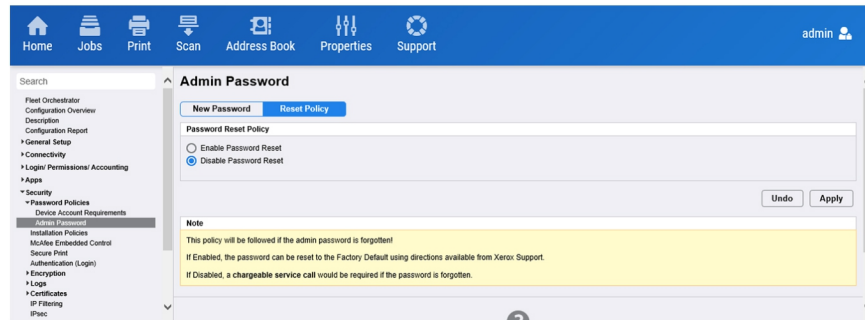

Figure 1 Disable Password Reset EWS screen

Q-1-0015-A

GP 29 Print/Copy Orientation Definitions

To describe print/copy orientation definitions.

Definitions

- **Lead-edge** - the edge of the paper first entering the paper path.
- **Trail-edge**, - the edge of the paper last entering the paper path.
- **In process direction** - can also be described as the slow scan direction.
- **Cross process direction** - can also be described as the fast scan direction.

1. **Figure 1**, Manual and Bypass Tray Feed Orientation, depicts the correct orientation for simplex printing from either the manual sheet feeder or bypass tray.

Manual Feed and Bypass Tray Feed Orientation

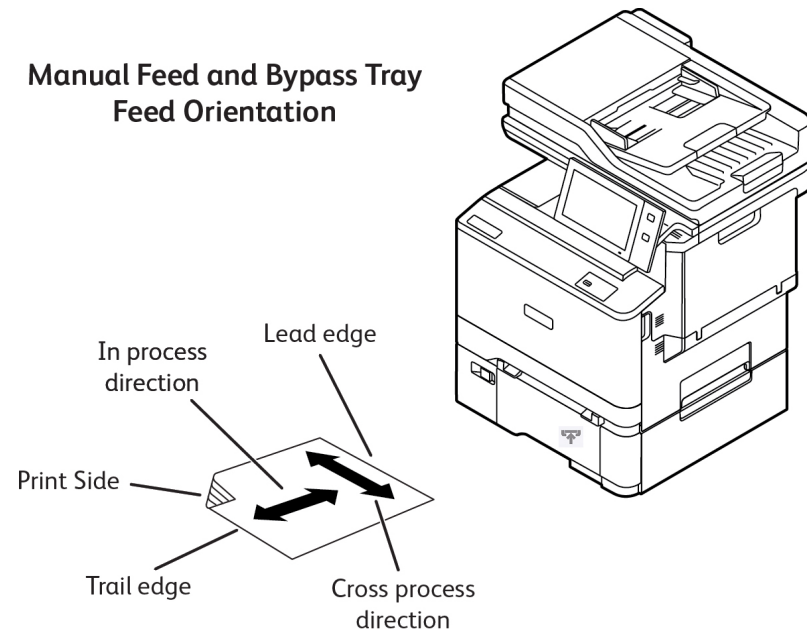

vfc415s6008

Figure 1 Manual and Bypass Tray Feed Orientation

2. **Figure 2**, Tray Feed Orientation, depicts the correct orientation for simplex printing from tray 1, 2, or 3.

Tray Feed Orientation

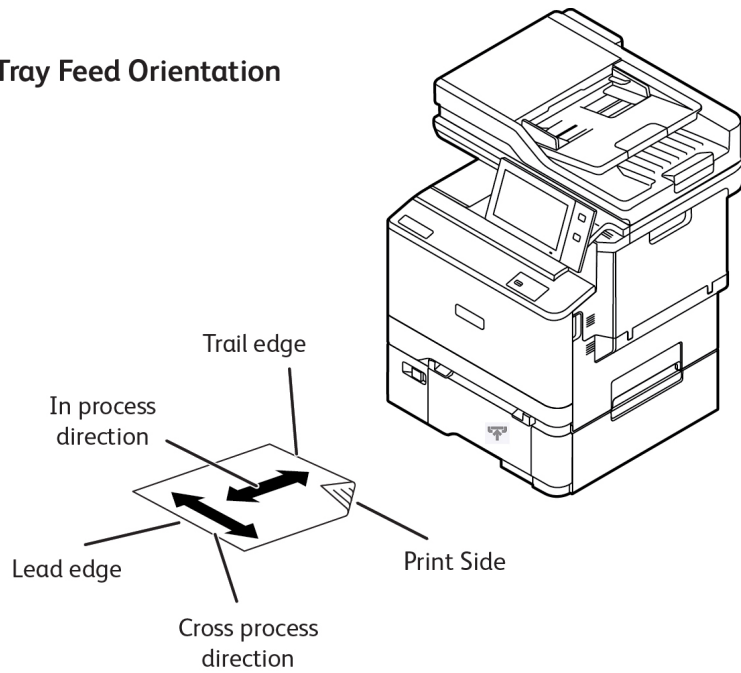

vle415e6009

Figure 2 Tray Feed Orientation

GP 30 Paper and Media Size Specifications

Purpose

As a reference of Xerox supported I/O media capacities, media types, media sizes, and media bonds and weights.

Specifications

Note: Check that the paper tray settings match the paper size in the tray.

Refer to the tables that follow:

- [Table 1](#) Input/Output Media Capacities.
- [Table 2](#) Media Sizes.
- [Table 3](#) Media Bonds and Weights.

Table 1 Input/Output Media Capacities

Input/Output Capacity by Media and Source			
Source	Media	Stack Height	Approximate Reference Capacity
Input			
Standard Tray ² : 250-sheet Tray	Plain Paper ¹	59 mm	250 sheets (75 g/m ²)
	Labels		200 labels (131 gm) ³
Single Sheet Manual Feeder ²	Plain Paper ¹	N/A	1 sheet (75 g/m ²)
	Labels		1 label (131 gm) ³
Optional Tray 2 ² : 550 + 100-sheet Tray (550-sheet data only)	Plain Paper ¹	59 mm	550 sheets (75 g/m ²)
	Labels		200 labels (131 gm) ³
Bypass Tray ² (part of the Optional 550 + 100-Sheet Tray)	Plain Paper ¹	11 mm	100 sheets (75 g/m ²)
	Envelopes, Other		Various quantities ⁴
Optional Tray 3 ² : 550-sheet Tray	Plain Paper ¹	59 mm	550 sheets (75 g/m ²)
	Labels		200 labels (131 gm) ³

Input/Output Capacity by Media and Source			
Output			
Center Tray ^{1,2}	Plain Paper	~ 44 mm	250 sheets (75 g/m ²)
¹ 20 lb. xerographic paper at ambient environment.			

Input/Output Capacity by Media and Source
² Capacity may vary and is subject to media specifications and printer operating environment.
³ Capacity will vary with label material and construction.
⁴ Capacity will vary depending on weight and type of media.

Table 2 Media Sizes

Name	Duplex	250-sheet Tray	Manual Single-sheet Feeder	550 + 100-sheet Option Tray 2	Bypass Tray (part of Tray 2)	550-sheet Option Tray 3	Center Tray	DADF Detection	Platen Detection
Letter (8.5 x 11") 215.9mm x 279.4mm	•	•	•	•	•	•	•	•	•1
Legal (8.5 x 14") 215.9mm x 355.6mm	•	•	•	•	•	•	•	•	•2
3 x 5" 76.2mm x 127.0mm			•		•		•		
Postcard (4 x 6") 101.6mm x 152.4mm		•	•		•		•		
Postcard (4.25 x 5.5") 108.0mm x 139.7mm			•		•		•		
5 x 7" 127.0mm x 177.8mm		•	•		•		•		
Statement (5.5 x 8.5") 139.7mm x 215.9mm		•	•		•		•	•	
Executive (7.25 x 10.5") 187.2mm x 266.7mm		•	•	•	•	•	•		
8 x 10" 202.3mm x 254.0mm		•	•	•	•	•	•		
8.5 x 13" 215.9mm x 330.2mm	•	•	•	•	•	•	•	•	•2
8.5 x 13.4" 215.9mm x 340.2mm	•	•	•	•	•	•	•	•	•2
A4 (210 x 297 mm)	•	•	•	•	•	•	•	•	•1
A5 SEF(148 x 210 mm)		•	•	•	•	•	•	•1	
A5 LEF(148 x 210 mm)		•	•		•		•		
A6 (105 x 148 mm)		•	•		•		•		
B5 (176 x 250 mm)		•	•	•	•	•	•		

Name	Duplex	250-sheet Tray	Manual Single-sheet Feeder	550 + 100-sheet Option Tray 2	Bypass Tray (part of Tray 2)	550-sheet Option Tray 3	Center Tray	DADF Detection	Platen Detection
JIS B5 (182 x 257 mm)		•	•	•	•	•	•		
215 x 315 mm	•	•	•	•	•	•	•		• ²
C5 Envelope (162 x 229 mm)		•	•		•		•		
C6 Envelope (114 x 162 mm)		•	•		•		•		
DL Envelope (110 x 220 mm)		•	•		•		•		
Envelope (6 x 9") 152.4mm x 228.6mm		•	•		•		•		
Monarch Envelope (3.9 x 7.5") 98.4mm x 190.5mm		•	•		•		•		
No. 9 Envelope (3.9 x 8.9") 98.4mm x 225.4mm		•	•		•		•		
No. 10 Envelope (4.1 x 9.5") 104.8mm x 241.3mm		•	•		•		•		
<p>Note: These constraints apply only to size. In respect of Envelopes, the size may be able to be duplex or invert, where the type may not. To fully understand the constraint for a given media, both size and type must be taken into account.</p>								<p>1 The size detected will be based on the Paper Size Preference setting</p> <p>2 The size detected will be based on the Default Legal Size setting.</p>	

Table 3 Media Bonds and Weights.

Media Types	Weight Range	Duplex	250-sheet Tray	Manual Single-sheet Feeder	Optional 550 + 100-sheet Tray 2	Bypass Tray	Optional 550-sheet Tray 3	Center Tray	DADF
Plain	75 - 90 gsm	•	•	•	•	•	•	•	•
Hole Punched	75 - 90 gsm	•	•	•	•	•	•	•	•
Letterhead	75 - 105 gsm	•	•	•	•	•	•	•	•
Lightweight Cardstock	120 – 176 gsm		•	•	•	•	•	•	
Cardstock	177 – 216 gsm		•	•				•	
Recycled	75 - 90 gsm	•	•	•	•	•	•	•	•
Bond	75 - 105 gsm	•	•	•	•	•	•	•	•
Labels	75 - 131 gsm		•	•	•	•	•	•	
Pre-Printed	75 - 90 gsm	•	•	•	•	•	•	•	•
Envelope	60 - 105 gsm		•	•		•		•	
Light Glossy Cardstock	105 – 176 gsm		•	•	•	•	•	•	
Glossy Cardstock	177 - 200 gsm		•	•				•	
Lightweight	60 - 74 gsm	•	•	•	•	•	•	•	•
Custom Type 1	75 - 90 gsm	•	•	•	•	•	•	•	
Custom Type 2	75 - 90 gsm	•	•	•	•	•	•	•	
Custom Type 3	75 - 90 gsm	•	•	•	•	•	•	•	
Custom Type 4	75 - 90 gsm	•	•	•	•	•	•	•	
Custom Type 5	75 - 90 gsm	•	•	•	•	•	•	•	
Custom Type 6	75 - 90 gsm	•	•	•	•	•	•	•	

Media Types	Weight Range	Duplex	250-sheet Tray	Manual Single-sheet Feeder	Optional 550 + 100-sheet Tray 2	Bypass Tray	Optional 550-sheet Tray 3	Center Tray	DADF
Custom Type 7	75 - 90 gsm	•	•	•	•	•	•	•	
<p>Note: These constraints apply only to type. In respect of Envelopes, the size may be able to be duplex or invert, where the type may not. To fully understand the constraint for a given media, both size and type must be taken into account.</p>									<p>Note: The weight range supported in the DADF shall be from 52–120 gsm and must be non-coated media.</p>

GP 31 Environmental Data

Operating Environment

Table 1 Temperature and Humidity, lists the minimum and maximum range of temperature and humidity limitations during normal operation of the machine.

Table 1 Temperature and Humidity

Environment	Specifications
Operating Temperature and Relative Humidity ^a	10 to 32.2°C (50 to 90°F) and 15 to 80 % RH 15.6 to 32.2°C (60 to 90°F) and 8 to 80 % RH Maximum wet-bulb temperature ^c (2): 22.8°C (73°F), non-condensing environment.
Operating Altitude Altitude – Packaged	0 – 2,896 meters (0 - 9,500 ft.) 0 - 10,363 meters (0 - 34,000 ft.)
Printer / Cartridge / IU Long-Term Storage ^b	15.6 to 32.2°C (60 to 90°F) and 8 to 80 % RH Maximum wet-bulb temperature (2): 22.8°C (73°F)
Printer / Cartridge / IU Short-Term Shipping	-40 to 40°C (-40 to 104°F)
^a In some cases performance specifications (such as paper OCF, EP cartridge usage) are specified to be measured at an Lab Ambient condition. ^b Supplies shelf-life is approximately 2 years. This shelf-life estimate is based on storage in standard office environment at 720 F (22.20 C) and 45 % humidity. ^c Wet-bulb temperature is determined by the air temperature and the relative humidity.	

Noise

- **Table 2** Sound Pressure Levels, contains the maximum sound pressure in decibels.
- **Table 3** Sound Power Levels, contains the maximum audible power in decibels during operation.

Table 2 Sound Pressure Levels

Sound Pressure Levels	dB Value
Idle	14
Simplex Print - Mono	51
Simplex Print - Color	53
Duplex Print - Mono	52
Duplex Print - Mono	54
Quiet Mode Print (Simplex) Mono	46

Sound Pressure Levels	dB Value
Quiet Mode Print (Simplex) Color	47
Quiet Mode Print (Duplex) Mono	48
Quiet Mode Print (Duplex) Color	48
Scan to file - Mono	51
Scan to file - Color	44
DADF Copy - Mono	55
DADF Copy - Color	52

Table 3 Sound Power Levels

Sound Power Levels	dB Value
Idle	3.1
Simplex Print - Mono	6.5
Simplex Print - Color	6.7
Duplex Print - Mono	6.7
Duplex Print - Mono	6.8
Quiet Mode Print (Simplex) Mono	6.1
Quiet Mode Print (Simplex) Color	6.2
Quiet Mode Print (Duplex) Mono	6.3
Quiet Mode Print (Duplex) Color	6.3
DADF Scan to file - Mono	6.6
DADF Scan to file - Color	5.9
DADF Copy - Mono	6.9
DADF Copy - Color	6.6

GP 32 Device Specification

Provide an over view of the The Xerox® VersaLink® C415 Color Multifunction Printer features and available options.

MFP/IOT Base Features

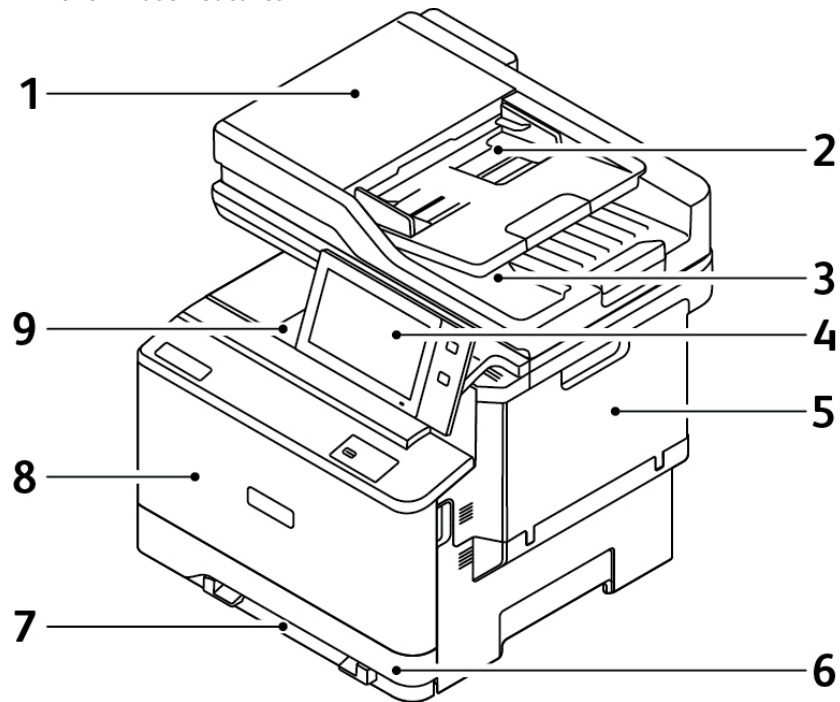

vlc415s6005

Figure 1 MFP/IOT Base Features Identification

1. DADF Cover
2. DADF Input Tray
3. DADF Output Tray
4. UI Control Panel
5. Toner Door
6. 250-sheet Tray
7. Manual Tray

8. Front Door
9. Center Tray

Accessories

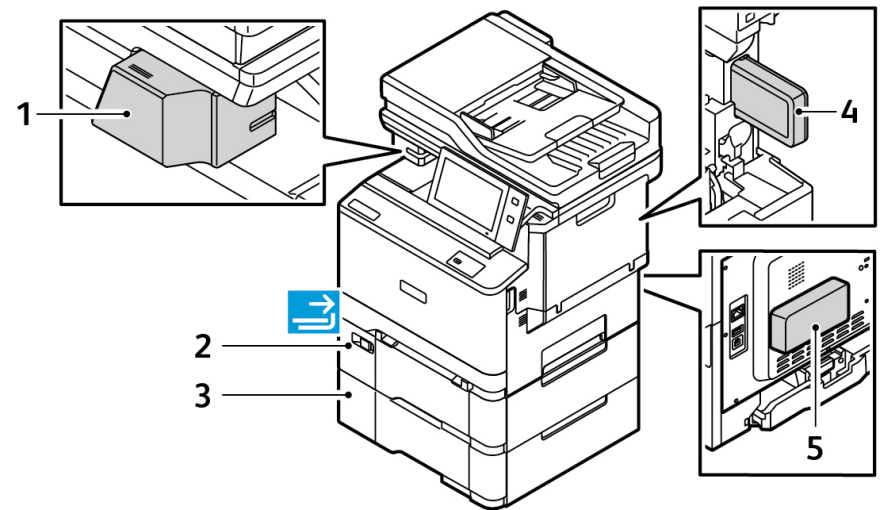

vlc415s6005

Figure 2 VLC415 Optional Accessories

1. Convenience stapler, [PL 25.05 item 3](#)
2. Optional 550-sheet + 100-sheet Tray (650-sheet tray) with Bypass Tray, [PL 25.05 item 10](#).
3. Optional 550 Sheet Tray, [PL 25.05 item 9](#)
4. Wifi Network Adapter, [PL 25.05 item 1](#).
5. 500+GB Hard Disk, [PL 25.05 item 2](#).

GP 33 Restoring Customer Mode

Purpose

This procedure provides a method to restore normal customer mode in the event that a procedure such as a software load, or NVM initialization has reset NVM 616-014 system install phase to the default value of 0 (non-customer mode).



CAUTION: NEVER change the controller PWB, control panel display, or start the machine with the black toner cartridge out of the machine while NVM 616-014 is set to 0, as three-way synchronization is not performed.

Overview

During some service procedures, NVM 616-014 may be set to the default value of 0. When this occurs, the screen will display the message **The device is in a non-customer mode**, Figure 1.

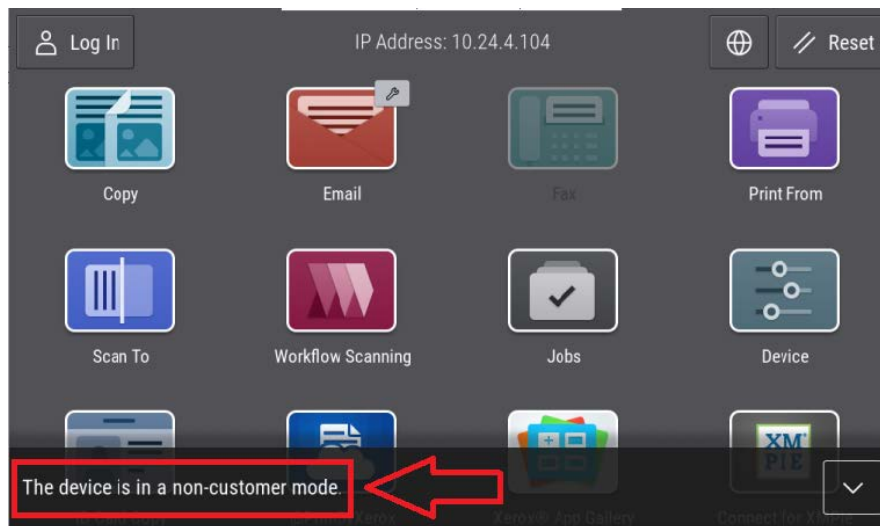

Figure 1 UI Display

The EWS UI screen will show no serial number, Figure 2.

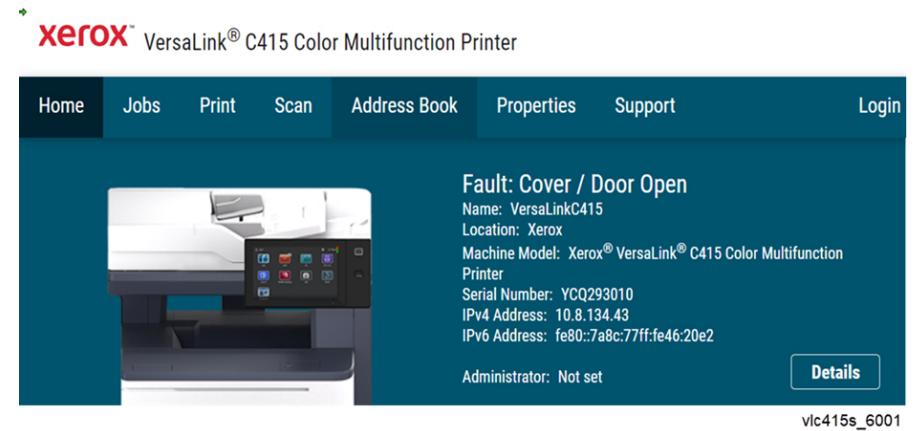

Figure 2 EWS UI Screen

When the NVM value is reset to 2, using the procedure listed below, it will cause the machine to re-start in Install Wizard mode. Re-running the Install Wizard will restore other customer data that also may have been lost.

After the Install Wizard completes, the value of NVM 616-014 is automatically set to 4.



CAUTION: POSU will NOT run if the machine is in non-customer mode, even though it may appear that SW load has completed successfully. For some SW upgrades, it is necessary for POSU to run to finish installing upgrades in all platforms.

Procedure

1. Enter Diagnostics, GP 1.
2. Select **Adjustments**.
3. Select **dc131**.
4. Enter **616-014** and select **Read**.
5. Set the NVM value to 2. Figure 3.

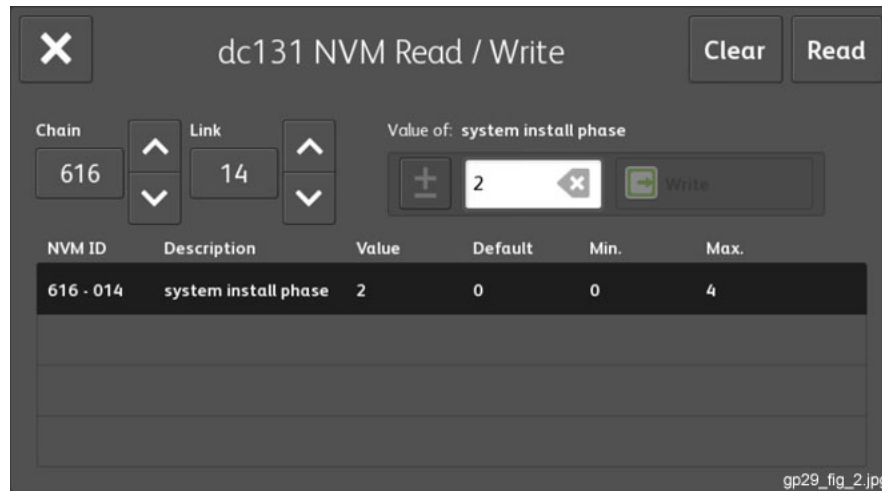

Figure 3 NVM 616-014 set to 2

6. Touch **Write**.
7. Touch the **X** to close , then select the **Call Closeout** button.
8. Select **Exit & Reboot**.

When the machine completes rebooting the Install Wizard will prompt to enter the initial settings. Follow the instructions on the screen to enter appropriate values as required. When the Install Wizard process completes the machine will reboot and the value of **NVM 616-014** will automatically be set to 4 (customer mode). During this reboot, if POSU is required, it will be performed.

Note: There is no indication on the screen when the machine is in customer mode. The only time any indication appears on the UI screen is when the machine is in non-customer mode.

GP 34 How to Re-Enter Optional Feature Installation Keys

Purpose

To explain how to re-enter optional feature installation keys.

Procedure

Perform the following:

1. Obtain the valid Feature Installation key(s) by either:
 - a. Asking the customer.
 - b. Logging into the SWAP portal, <https://www.xeroxlicensing.xerox.com/fik/>.
From the Welcome screen, select **Find** and existing key.
Enter the machine serial number in the window, then select **Next**.
 - c. Contacting the Licensing Admin Centre (USSG/XCL) or the Xerox sales representative (XE/DMO).
2. Enter the Feature Installation keys(s). Perform the following:
 - a. Select the **Device** icon on the UI.
 - b. Select **Tools**.
 - c. Select **Device Settings > General**.
 - d. Select **Feature Installation**. Enter the Feature Installation key, then select **OK**. If necessary, enter the second Feature Installation key.
 - e. Feature Installation Keys can also be entered via the EWS. Properties / General / Feature Installation.

GP 35 Serial Number Synchronization Procedure

Purpose

This procedure is used to maintain serial number and billing data integrity when certain PWBs must be replaced. This data is stored at three locations; drive PWB , controller PWB , and the black (K) toner cartridge. This procedure instructs how the data in all three locations is synchronized when one or more of the part items is replaced, or when data corruption associated when the 322–352-00 Serial Number Missing From Memory fault occurs.

Initial Actions

If possible, print a Configuration Report. Refer to, [GP 14 Printing Reports](#).

Note: Compare the serial number displayed on the control panel display with the serial number on the configuration report and the serial number on the data plate inside the front cover. If the serial numbers do not match, contact next level support.

Procedure



CAUTION: Check the machine is in **Customer Mode** before removing the controller PWB, control panel display, or the black toner cartridge. Refer to, [GP 33](#).

Note: To maintain the integrity of the serial number and billing data, never install all three part items listed below in the same task.

- Drive PWB, [PL 1.05 item 4](#).
- Controller PWB, [PL 3.05 item 1](#).
- Black (K) Toner Cartridge.

Install **ONE ITEM AT A TIME**, as per the following procedure steps.



CAUTION: Installing all three part items in the same task **will cause** unrecoverable NVM corruption. After installing **one of the new part items**, restart the machine, [GP 10](#), then check the machine for the fault cleared. If the fault persists, reinstall the original part item, restart the machine, [GP 10](#), then if required re-enter the serial number, [dC132 Machine Serial Number](#), before attempting installation of the next part item.

Controller PWB Replacement Precautions



CAUTION: Spare controller PWBs are shipped in Manufacturing Mode NVM **616–14**, value = **0**.

1. When a machine is in Manufacturing Mode, three way sync is inhibited.
 - a. During the install phase, NVM 616-14 is Saved and Restored, as long as, [dC361](#) is performed restoring from the USB drive backup immediately after installing a new controller PWB.
 - b. The install phase should return to Customer Mode, NVM **616–14 = 4**.
 - c. the system will sync thereafter.
2. In the case that a new controller PWB was installed:
 - a. An immediate machine startup and [dC361](#) must immediately be performed for the NVM change to take affect and cause a sync to occur.
3. In the event that a machine is found in such a condition that an NVM Save cannot be performed before any work on the machine is done, then a manual NVM write to **616-14 = 4** will be necessary following the installation of a new controller PWB. Refer to, [dC131 NVM Read/Write](#).

1. Check the fault log on the control panel display, [PL 2.05 item 2](#), if available, for any active faults. Resolve all faults possible before removing the controller PWB, control panel display, or black toner cartridge, as required in the corresponding RAP.



CAUTION:

- a. When fault code 322–352–00 is active, reinstall the **original** controller PWB, control panel display, black toner cartridge, or any combination of these as required, then restart the machine to allow synchronization.
 - b. if the fault persists, continue this procedure as outlined below.
2. Enter Diagnostics, [GP 1](#). Enter, [dC361 NVM Save and Restore](#), then touch **Machine NVM** to save all device platform settings to the hard drive.
 3. While still in [dC361](#), click on each file listed, then select each device platform setting and **Copy to USB device** as a second backup.
 4. Exit Diagnostics, [GP 1](#).
 5. Shutdown the machine, [GP 10](#).
 6. Remove the suspect failed part, then install the new part in the machine.



CAUTION: Mark the original part item removed from the machine, if replaced.

7. Install the first suspected failed item, switch ON the machine, GP 10, then check the machine for the fault cleared.
8. If the installation is successful and no fault remains, compare the serial number displayed on the control panel display with the serial number on the configuration report and the serial number on the data plate inside the front cover.

Note: When any one of the following conditions occurs, escalate the call to next level support:

- The serial number displayed on the control panel display does not match the data plate inside the front cover of the machine.
 - The serial number displayed on the control panel display does not match the configuration report printed in, **Initial Actions**.
 - Fault code 322–365–00 is raised.
9. If the fault persists, or, the fault code 322–365–00 is raised, reinstall the original part item, restart the machine, GP 10, then if required, re-enter the serial number, dC132 Machine Serial Number, before attempting installation of the next part item.

Fault code 322–365–00 may flag when the device platform settings restore is unsuccessful or the

Note: When any one of the following conditions occurs, escalate the call to next level support:

- The serial number displayed on the control panel display does not match the data plate inside the front cover of the machine.
- The serial number displayed on the control panel display does not match the configuration report printed in, **Initial Actions**.
- Fault code 322–365–00 is raised.

After contacting next level support, perform, dC132 Machine Serial Number.

GP 36 Xerox Wireless Printing Troubleshooting

Use this troubleshooting guide when the customer reports wireless network failures when using the Xerox wireless print kit.

Initial Actions

Consult your manager before troubleshooting the customer's network, as the policy varies according to region.

Perform the following:

1. Check that the wireless network adapter is properly installed in the machine.
2. Print a configuration report.
 - a. Check with the customer that printing of configuration reports is enabled. If necessary, ask the customer to enable printing of the configuration report.
3. Ensure that the machine is configured for wireless printing.
 - a. Check the configuration report under the heading Connectivity Physical Connections.
 - b. If wireless is disabled, ask the customer to enable wireless printing. Or enter Customer Administration Tools:
 1. Touch **Network Settings**.
 2. Touch **Network Connectivity**.
 3. Touch **Wireless**.
 4. Touch **OK**.
 - c. Check the network name listed next to SSID on the configuration report.
 - d. If the network name does not match the customer's wireless network, ask the customer to configure the wireless network setup before continuing.
 - e. Check the network name under the heading Connectivity Protocols.
 - f. If an IP address is not listed under TCP/IPv4 or TCP/IPv6, ask the customer to configure the wireless network setup before continuing.
4. Confirm that the customer's wireless network can be detected at the machine's location.
 - a. Ask the customer to confirm that the wireless network is switched on and can be received at the machine's location. Use the PWS/laptop or a smartphone to detect the customer's wireless network.

5. If the wireless network signal strength is weak, try repositioning the device away from walls/obstructions or temporarily removing/opening covers near the wireless adapter. To view the signal strength, enter System Administration Tools and perform the following:
 - a. Touch **Network Settings**.
 - b. Touch **Network Connectivity**.
 - c. Touch **Wireless**.
 - d. The signal strength is displayed in the text frame.
6. Install a new wireless network adapter.

GP 37 Supplies Plan Conversion

Purpose

The procedure explains how to convert the Supplies Plan (formerly known as PagePack) from Sold to Metered or Metered to Sold.

Introduction

Unless special ordered, machines are shipped with Factory-Neutral toner cartridges. The machine supplies plan is set by the toner cartridges. When toner cartridges are first replaced, the Geographic Differentiation Code and Toner Cartridge Type in NVM are automatically changed to the same settings as the replacement cartridge. Once these NVM are set, the toner configuration can only be changed with a Supplies Plan Conversion PIN

Table 1 Supplies Plan Variables and Regional Differentiations

Device Configuration (all possible) Xerox NVM	Xerox Toner						
	SWE (Starter toner) Sold_WW	Metered_WW	Sold_NA	Sold_XE	Sold_DMO	Sold_NAXE	Sold_WW
Plan Variables: Neutral Sold Metered Supplies Plan (formerly known as PagePack)* Regional Differentiation: NA XE NAXE DMO Factory							
Metered_WW Metered_NA Metered_XE	Y	Y	Y	Y	Y	Y	Y

Device Configuration (all possible) Xerox NVM	Xerox Toner						
	Metered_NA/XE Metered_DMO						
Sold_NA	Y	N	Y	N	N	Y	Y
Sold_XE	Y	N	N	Y	N	Y	Y
Sold_DMO	Y	N	N	N	Y	N	Y
Sold_WW	Y	N	Y	Y	Y	Y	Y
Sold_NA/XE	Y	N	Y	Y	N	Y	Y

*Supplies Plan (formerly known as PagePack) and Metered configurations have the same behavior

Check the current Supply Plan:

At the Machine UI:

1. Print Configuration Report [GP 14](#).
2. The supplies plan is shown on the configuration report under the **General Setup** heading.

At the Web UI:

1. Enter the machine IP address.
2. On the **Home** screen scroll to the bottom and select **Configuration Report**.
3. The screen displays the configuration report in alphabetical order. Select **General Setup**.
4. The **Supplies Plan** is shown in the list. Typical **as shipped** supplies plan is **Neutral**.

Obtain the Supplies Plan Conversion PIN

1. Press the **Device** icon on the UI and select **About**.

2. Record the Serial Number.
3. Select **X**
4. Select **Billing/Usage** and record the number of Total Impressions
5. Contact the relevant OPCO, provide the machine Serial Number and the number of Total Impressions.
 - **US:** Call Xerox Corporate Licensing Systems (XDSS) directly on 1-800-890-3260 or 1-800-635-8054 prompt 8 (license strings) for toner conversions. Provide the machine serial number and the number of total impressions.
 - **Xerox Business Solution (XBS):** All requests for such conversions must be approved by the XBS Headquarter VP of Service. Technicians should request that their field service manager contact their XBS Company VP of Service for directions. The XBS Core Company VP of Service will require authorization to convert the machine from sold to metered and provide a status of your request. Do not call field engineering to obtain a Service Plan Conversion PIN.
 - **US Authorized Service Provider (ASP):** Call PageConnect at 1-888-892-6483 or send an email to pageconnectprogram@xerox.com requesting a PIN. Provide the machine serial number and the total number of impressions.
 - **Canada:** Call the Customer Delivery Organization (CDO) field support number 1-800-647-1331 prompt 8 (license strings) for a Supplies Plan Conversion PIN. Provide the machine serial number and the total number of impressions.
 - **LATAM (Latin America):** Follow Local Process.
6. You will be given a 6-character Supplies Plan Conversion PIN.

Note: The Supplies Plan Conversion PIN must be entered within 500 Total Impressions counts of when it was issued, or it will not be valid.

Supplies Plan Conversion via Machine UI

1. Log in to **Admin** mode.
2. At the **Home** screen touch **Device > Tools > Device Settings > Supplies**.
3. Touch **Enter Plan Conversion**.

Note: The current Service Plan and Supplies Plan Number are listed.
4. Touch **+ Convert Supplies Plan**.
5. Enter the 6-character **Convert Supplies Plan** PIN provided.
6. Select **OK**.

The Geographic Differentiation Code and Toner Cartridge Type will be reset to the values of the customer's agreed-to supplies plan.

Supplies Plan Conversion via Remote Control Panel

1. Open a web browser then enter the machine IP in the address bar.
2. At the EWS Home screen, click on **Support > Remote Control Panel > Start Remote Session**.
3. Log in to **Admin** mode.
4. At the **Home** screen touch **Device > Tools > Device Settings > Supplies**.
5. Touch **Enter Plan Conversion**.

Note: The current Service Plan and Supplies Plan Number are listed.
6. Touch **+ Convert Supplies Plan**.
7. Enter the 6-character **Convert Supplies Plan** PIN provided.
8. Select **OK**.

The Geographic Differentiation Code and Toner Cartridge Type will be reset to the values of the customer's agreed-to supplies plan.

GP 40 Glossary of Terms, Acronyms and Abbreviations

Where possible unit designations as appear in ISO 1000 (International Organization for Standardization) and Xerox Standard MN2-905 have been used. All measurements appear in ISO units followed by any conversion in brackets e.g.; 22.5mm (0.885 inches)

Refer to [Table 1](#).

Table 1 Abbreviations

Term	Description
1TM	One Tray Module
3TM	Three Tray Module
AAA	Authentication, Authorisation and Accounting
ABS	Automatic Background Suppression.
AC	Alternating Current
ACAST	Anti Counterfeiting Activities Support/Strategy Team
ACL	Alternating Current Live
ACN	Alternating Current Neutral
AGC	Automatic Gain Control
AHA	Advanced Hardware Architecture
AMPV	Average Monthly Print Volume
ANSAM	Answer Tone, Amplitude Modulated
APS	Auto Paper Selection
ARP	Address Resolution Protocol. Converts an IP address to a MAC address. See RARP.
ASIC	Application Specific Integrated Circuit
B	Bels (applies to sound power level units)
Binding	Part of the communication between modules.
BM	Booklet Maker
BootP	Boot Protocol. AN IP protocol for automatically assigning IP addresses.
BPS	Bits Per Second
BS	Behavior Specification

Term	Description
BT	Busy Tone
BCR	Bias Charge Roll
BTR	Bias Transfer Roll
C	Celsius
CAT	Customer Admin Tool
CBC	Customer Business Center
CCD	Charged Coupled Device
CCM	Copy Controller Module
CCS	Copy Controller Service
CentreWare	CentreWare internet services is the embedded HTTP server application that is available on network enabled machines. It enables access to printing, faxing and scanning over the internet.
CIPS	Common Image Path Software
CIS	Contact Image Sensor
CL	Copy Lighter. A copy density setting
CQ	Copy Quality
CRC	Cyclic Redundancy Check
CRU	Customer Replaceable Unit
CRUM	Customer Replaceable Unit Monitor
CSE	Customer Service Engineer
CVT	Constant Velocity Transport
CWIS	CentreWare Internet Services (also known as Web UI)
DADF	Dual Auto Document Feeder
dB	Decibel (applies to sound pressure level units)
dC	Diagnostic code
DC	Device Controller, generic term for any module that acts as a image handling device e.g., SIP. Digital Copier
DC	Direct Current
DCN	Disconnect

Term	Description
DCS	Digital Command Signal
DDNS	Dynamic Domain Name System
DH	Document Handler
DHCP	Dynamic Host Config Protocol (similar to BootP)
DIMM	Dual In-line Memory Module
DIP	Dual In-line Package (switch)
DIS	Digital Identification Signal
DLM	Dynamically Loadable Module
DM	Document Manager
DMA	Direct Memory Access
DMO	Developing Markets Operations
DMO-E	Developing Markets Operations East
DMO-W	Developing Markets Operations West
DPI	Dots per inch
DRAM	Dynamic Random Access Memory
DST	Daylight Saving Time
DT	Dial Tone
DTMF	Dual Tone Multiple Frequency
DTS	Detack Saw
Dust Off	Routine to return machine to pre-install state
DVMA	Direct Virtual Memory Access
EH&S	Environmental Health and Safety
EJS	Easy Java Simulation
ELT	Extract, Load, Transform
Embedded Fax	A fax system included in a system device
EMC	Electromagnetic Compatibility
EME	Electromagnetic Emission

Term	Description
ENS	Event Notification Service. Used by a software module to alert another module of an event.
EOM	End Of Message
EOP	End Of Procedure
EOR	End Of Retransmission
EPA	Environmental Protection Agency
EPC	Electronic Page Collation (memory dedicated to temporary retention of images captured from the scanner and network controller)
EPROM	Erasable / Programmable Read Only Memory
ERR	End Retransmission Response
ERU	Engineer Replaceable Unit
ESD	Electrostatic Discharge
ESS	Electronic Sub-System (equivalent to NC)
EU	European Union
EUR	Europe
FAR	Fully Active Retard feeder
Fax	Facsimile
FCOT	First Copy Out Time
FDI	Foreign Device Interface
FIFO	First In First Out
Firmware	Software in a ROM
FLASH	On board erasable and re-programmable non volatile memory
FOIP	Fax Over Internet Protocol
FPGA	Field Programmable Gate Array
FPOT	First Print Out Time
FRU	Field Replaceable Unit
FRU	Fuser Replacement Unit
FTP	File Transfer Protocol

Term	Description
FX	Fuji Xerox
G3	Group 3
GMT	Greenwich Mean Time
GND	Ground
GSM	Grams per square metre
GUI	Graphical User Interface
HCF	High Capacity Feeder
HDD	Hard Disk Drive
HFSI	High Frequency Service Intervals
HTTP	Hyper Text Transfer Protocol
HVPS	High Voltage Power Supply
Hz	Hertz
I/O	Input/Output
I2C-bus	Inter Integrated Circuit bus. This provides a simple bidirectional 2-wire bus for efficient inter-IC control. All I2C-bus compatible devices incorporate an interface which allows them to communicate directly with each other via the I2C-bus.
ID	Identification
IDG	Inter document gap
IFax	Internet Fax
IIT	Image Input Terminal
Intlk	Interlock
ioctl	input/output control
IOT	Image Output Terminal
IP	Internet Protocol
IPA	Image Processing Accelerator. Used by the machine scanning services to convert scanned images to a standard format e.g. for scan to file / scan to E-mail for network transmission.
IPS	Image Processing Service
IPSec	Internet Protocol Security

Term	Description
IPX	Internetwork Protocol eXchange
IQ	Image Quality
IQS	Image Quality Specification
IR	Intelligent Ready
ISDN	Integrated Services Digital Network / International Standard Data Network
ISO	International Standards Organization
ITP	Internal Test Pattern
JBA	Job Based Accounting (Network Accounting)
JIS	Japanese Industrial Standards
kg	kilogram
kHz	kilohertz
Kill All	Routine to return all NVM, including protected NVM, to a virgin state. Factory use only
KO	Key Operator
LAN	Local Area Network
LCD	Liquid Crystal Display
LCSS	Low Capacity Stapler Stacker
LDAP	Lightweight Directory Access Protocol (allows sharing of corporate phone book information)
LE	Lead edge
LED	Light Emitting Diode
LEF	Long Edge Feed
LOA	Load Object Attributes
LPD	Line Printer Daemon
LPH	LED Print Head. An LED array in close proximity to and the same width as the photoreceptor. Individual LEDs are switched on/off to develop the image on the xerographic drum.
lpi	Lines per inch
LVF BM	Low Volume Finisher Booklet maker

Term	Description
LVDS	Low Voltage Differential Signal
LVPS	Low Voltage Power Supply
LUI	Local user Interface
m	metre
MAC Address	Media Access Code. This is the basic, unique identifier of a networked device. An incoming message is analysed and an address in another form, such as an IP address, is resolved by a lookup table to a MAC address. The message is then directed to, and accepted by the equipment thus identified. It is the burnt-in, hardware address of a NIC.
Mark Service	Mark Service is the software module that tells the hardware to put toner on paper.
MB	Megabyte (one MB = 1,048,576 bytes = 1024 kilobytes). Mail Box
Mb	Mega bit (one million bits)
MCF	Message Confirmation
MF	Multifunction
mm	millimeter
Modem	MOdulator/DEModulator. Hardware unit that converts the 'one' and 'zero' binary values from the computer to 2 frequencies for transmission over the public telephone network (modulation). It also converts the 2 frequencies received from the telephone network to the binary values for the computer (demodulation).
Moire	Image quality defect caused by interference between patterned originals and the digital imaging process. Moire patterns are repetitive and visible as bands, plaids or other texture.
MSG	Management Steering Group
ms	millisecond
N	Newton
NA	North America
NC	Network Controller (equivalent to ESS)
NC	Normal Contrast. Copy contrast setting
NCR	No Copying Required
NetBIOS	Network Basic Input / Output System. Software developed by IBM that provides the interface between the PC operating system, the I/O bus, and the network. Since its design, NetBIOS has become a de facto standard.

Term	Description
Nm	Newton metre
NOHAD	Noise, Ozone, Heat, Airflow and Dust
NTP	Network Time Protocol
NVM	Non-Volatile Memory
OA	Open Architecture
OCT	Offsetting Catch Tray
ODIO	On Demand Image Overwrite
OEM	Original Equipment Manufacturer
OPC	Organic Photo Conductor
OpCo	Operating Company
OS	Operating System
P/R	Photoreceptor
PABX	Private Automatic Branch Exchange
PC	Personal Computer
PC Fax	Personal Computer Fax
PCI	Peripheral Component Interface
PCL	Printer Control Language
PDF	Adobe Acrobat Portable Document Format
PFM	Paper Feed Module
PIN	Procedural Interrupt Negative
PIN	Personal Identification Number
ping	Packet InterNet Groper. Tool to test connections between nodes by sending and returning test data.
PME	Power Management Event
POPO	Power Off Power On
POO or P of O	Principles of Operation
POST	Power On Self Test

Term	Description
POTS	Plain Old Telephone System
PPM	Prints per minute / Parts Per Million
PR	Photo-Receptor
Process Death	A process has stopped working.
PS	Post Script
PS	Power Supply
PSTN	Private Switched Telephone Network
PSW	Portable Service Workstation
Pthread	Process Thread. A very low level operating system concept for code execution.
PWB	Printed Wiring Board
PWBA	Printed Wiring Board Assembly
PWM	Pulse-Width Modulation
PWS	Portable Work Station
RAM	Random Access Memory
RARP	Reverse Address Resolution. Reverse of ARP. Converts a MAC address to an IP address. The document centre resolves its address using RARP. See also MAC, NIC and ARP.
RDT	Remote Data Transfer
Reg	Registration
Registration Service	Monitors when RPC services go on and offline.
RF	Radio Frequency
RFID	Radio Frequency Identification
RPC	Remote Procedure Call. How the device communicates internally between software modules.
RH	Relative humidity
RMS	Root Mean Square (AC effective voltage)
RNR	Receive Not Ready
RoHS	Restriction of Hazardous Substances

Term	Description
ROM	Read Only Memory
RR	Receive Ready
RS-232, RS-423, RS-422, RS-485	Series of standards for serial communication of data by wire. RS-232 operates at 20kbits/s, RS-423 operates at 100kbits/s, RS-422 and RS-485 operate at 10Mbits/s. See FireWire and USB.
RTC	Real Time Clock
Rx	Receive
S2F	Scan-to-File
SA	Systems Administration
SAKO	Systems Administration Key Operator
SAR	Semi-Active Retard feeder
SBC	Single board controller. Copy, print and UI controllers all on one PWB within the image processing module.
SCD	Software Compatibility Database
SD	Secure Digital, memory card format
Server Fax	A fax system that uses a remote Fax server. Faxes transmit as a Scan to File job sent to the server. Fax receive as print jobs submitted to the Connection Device.
SEF	Short Edge Feed
Semaphore	A variable or abstract data type.
SESS	Strategic Electronic Sub-System
SH	Staple Head
SIM	Subscriber Identity Module (also known as a SOK-Software Option Key)
SIM	Scanner Input Module
SIP	Scanning and Image Processing
SIR	Standard Image Reference
SLP	Service Location Protocol (finds servers)
SM	Scheduled Maintenance
SMART	Systematic Material Acquisition Release Technique
SMB	Server Message Block. Microsoft Server / Client Communications protocol

Term	Description
SMP	Service Maintenance Pack (contains a software package)
SNMP	Simple Network Management Protocol
Snr	Sensor
SOK	Software Option Key (also known as a SOIM-Subscriber Identity Module)
SPAR	Software Problem Action Request
spi	Spots per inch
SPI	Service Provider Interface. Steps to process a job.
SR	Service Representative
SRS	Service Registry Service
SS or S/S	Sub System
SSDP	Simple Service Discovery Protocol
SSID	Service Set Identifier (wireless network name)
STM	Single Tray Module
SU	Staple Unit
SW	Switch
SW or S/W	Software
sync	synchronize
TAR	Take Away Roll
TAR or tar	An archive file format, derived from Tape ARchive
TBC	To Be Confirmed
TBD	To Be Defined
TC	Toner Concentration
TCF	Training Check Field
TCO	Thermal Cutout
TCP/IP	Transmission Control Protocol/Internet Protocol
TE	Trail Edge
Template	A collection of Scan to File attributes that can be conveniently re-used.

Term	Description
TIFF	Tagged Image File Format
TP	Test Point
TRC	Toner Reproduction Curve
TTM	Tandem Tray Module
TTY	Teletype Terminal
Tx	Transmit
UART	Universal Asynchronous Receiver Transmitter
U-boot	Universal Boot Loader
UI	User Interface (display screen)
UK	United Kingdom
UM	Unscheduled Maintenance
USB	Universal Serial Bus. High speed successor to parallel port for local device communications. Operates at 12Mbps/s. See FireWire and RS-232.
USCO	United States Customer Operations
USSG	United States Solutions Group
V.17 / V.29 / V.34	Modem standards
VOIP	Voice Over Internet Protocol
WC	WorkCentre
WEB UI	CentreWare Internet Services
XCL	Xerox Canada Limited
XE	Xerox Europe
XEIP	Xerox Extensible Interface Platform
XLA	Xerox Latin America
XML	eXtensible Markup Language
XPS	XML Paper Specification (printing format)
XRU	Xerographic Replacement Unit
XSA	Xerox Standard Accounting

Service Copy (Tools) Mode

Service Copy Mode

Service copy mode provides access to the machine that is greater than that of a user, but less than that of the System Administrator. This mode allows the CSE to perform a number of checks and run copies without compromising the customer's security settings. This mode can be used if the Administrator user name and passcode are not at the default, and the Administrator is not available to enter the admin passcode. Perform the steps that follow:

1. Press and hold the **Home** button for 7 seconds. The passcode screen will display when the button is released.
2. Enter the passcode 2732. press the **OK** button on the UI.

Note: Five incorrect entries cause the entry screen to lock for 3 minutes.

3. The **Log In** button will change to display **CSE**.

Note: The tools available in this mode are a subset of those available in Administrator mode. CSE service copy mode remains active until the **login/CSE** button is pressed again. When finished with always log out of service copy mode by pressing the **CSE** button and confirming log out.

dC104 Usage Counters

Purpose

Displays a history of system usage.

Procedure

1. Enter **GP 1**.
2. Select **Service Information**.
3. Select **dc104 Usage Counters**.
4. Touch the **Diagnostic Counters** button to filter the results:
 - **Diagnostic Counters** - lists sheet counters for service operations and tray totals.
 - **Impression Counters** - lists all impressions, categorized by B/W, Color, Large, Small, Print, Copy.
 - **Sheet Counters** - Color and B/W for copied and printed sheets.
 - **Images Sent Counters** - Server Fax, Internet Fax, E-mail images, and Network Scan.
 - **Fax Impressions Counters** - If Fax is enabled, lists the number of received Faxes that were printed.
 - **All Usage Counters** - all the above.

Press the **Update** button for the most current count.

dC108 Software Version

Purpose

Displays the installed software versions for the various modules installed in the system.

Procedure

1. Enter **GP 1**.
2. Select **Service Information**.
3. Select **dc108 Software Version**. Depending on installed options, software version information appears for these modules:
 - Software Upgrade
 - Copy Controller
 - Copy Controller OS
 - UI Panel Firmware
 - Fax
 - Imaging Output Terminal
 - Network Controller
 - Image Input Terminal
 - Document Feeder
 - User Interface
 - XUI Language Version
 - Finisher

dC122 Fault History

Purpose

Displays the Last 40 faults.

Note:

1. Faults detected while in Service Mode are not counted.
2. An Interlock open while the machine is stopped is not counted.
3. If multiple faults occurred in the machine, the primary fault is recorded.

Procedure

1. Enter **GP 1**.
2. Select **Service Information**.
3. Select **dc122 Fault History**.

Note: In dC122 Fault History, you can print in the right upper corner depending on software release 105.xxx.009.34422.

4. A five-column table will appear, listing the **Fault Name**, **Code**, **Date/Time**, **Total Impression**, and **Size** of the last 40 machine faults.
5. To clear the fault history, select **Reset Counters** on the **Call Closeout** screen.

dC126 Paper Registration

Purpose

This procedure is used to align the Lead Edge and Side Edge of the developed image with media fed from the various paper trays.

For instructions, refer to [ADJ 90.1](#).

dC131 NVM Read/Write

Note: NVM values are listed in the procedures where they are called out.

To access the complete [VCL415 and VLB415 NVM Tables](#).

Procedure

1. Enter Diagnostics, [GP 1](#).
2. Select **Adjustments**.
3. Select **dc131 NVM Read/Write**.
4. Enter the NVM Chain and Link in the **Chain** and **Link** windows.

Note: It is not necessary to re-enter NVM locations that have already been entered. You can select previously entered locations by touching the row in the table where that location is listed. If more than four NVM locations are entered, a scroll bar will appear on the right side of the table.

5. Select the **Read** button.

Note: When an NVM is displayed in the table, it will remain displayed until **Clear** is selected. The **Clear** button only clears the table display, not an NVM value.

6. Touch the **Value of:** window and use the keypad to enter the new NVM Value. Use the **+/-** button to enter negative numbers.
7. Select **Write** to load the new value.

dC132 Machine Serial Number

Purpose

This procedure synchronizes the serial number information on the components where it is stored.

Serial number information is stored at these locations:

- **Controller PWB, PL 3.05.**
- **Drive PWB, PL 1.05.**



CAUTION: When installing a new Controller PWB and Drive PWB in the same call, each must be installed independently, then the machine restarted to see if the fault persists. The new component's serial number data will synchronize automatically with the data on the other components. In such instances, dC132 need not be performed. **When both PWBs are installed at the same time, then the machine restarted, serial number mismatch and machine inoperability will occur, and dC132 must be performed.**

Initial Action

Check dC122 for Communications faults (Chain 303 and 316). These faults can prevent serial number synchronization. Resolve these faults before continuing. Please obtain a serial number re-synchronization request form from GSN Library 15053.

Procedure

Part 1 - Notify service support.

Note: It may take up to 24 – 72 hours to receive a password from A-CAST.

1. Enter **GP 1**.
2. Select **Maintenance**.
3. Select **dc132 Machine Serial Number**.
4. Select **Generate New Identifier Code**. Record the Unique Machine Identifier.



CAUTION: After the Unique Machine Identifier is generated, **DO NOT** touch the **Generate New Identifier Code** button a second time, as this will invalidate the Password that will be provided.

5. Contact service support for instructions on how to complete the form.

Note: Follow all instructions included in the form. You must complete the form, print it, obtain required signatures and data, then scan it. There is a cost for this service.

6. Have the National Technical Specialist (NTS, RSE or FE) forward a copy of service log and proof of the location of the machine to A-CAST. This information must indicate machine location, customer name and address.

The proof must be a screen capture of the NTS/FE/RSE customer support database (account management database), FWSS, ICSS, DFM BT, VQMS, VALE, STPR, eSAP, etc. The information on the proof must match the information on the form.

Part 2 - Re-serialize machine

1. Enter Diagnostics, **GP 1**.
2. Select **Maintenance**.
3. Select **dc132 Machine Serial Number**.
4. Select **Enter Passcode**.
5. Enter the Passcode received from A-CAST in the box named **Enter Passcode**.
6. Select **OK**.
7. Please verify UI screen indicated **Serial Number Verification Complete, Your machine serial number has been verified**.
8. Exit Diagnostic mode and select Reboot.
9. Print a configuration report and verify that the serial number is corrected. The serial numbers are now synchronized.

dC135 HFSI Counters

Purpose

This routine displays the percentage of service life remaining for periodic replacement parts.

Procedure

1. Enter Diagnostics, [GP 1](#).
2. Select **Maintenance**.
3. Select **dc135 CRU/HFSI**.
4. The CRU/HFSI screen lists the serviceable items and displays **Estimated Pages Remaining**.
5. Refer to [SCP 4](#) Subsystem Maintenance. Perform the listed Service Action for all HFSI counters that are at or near end of life.
6. To reset the count after replacing the parts, select the appropriate HFSI item, then select **Reset Counter**.

dC301 NVM Initialization

Purpose

This procedure may be needed when the machine cannot recover for some unknown reason, including problems such as producing blank copies/prints, continuously declaring system faults, etc.



CAUTION: Before Initializing NVM on any subsystem, perform [dC361](#) NVM Save and Restore. Performing NVM Initialization on any subsystem may cause damage or degradation of machine performance.

Initial Actions

- Disconnect any Foreign Interface devices.
- Obtain all of the following information:
 - Save Machine Settings, if possible.
 - NVM value factory setting report (typically it is located in the Tray 1 pocket).
 - Any customer setting Auditron account from the system administrator.
 - Any setting changes (specifically NVM settings) shown on the machine's service log.
 - Any customer settings in the Tools mode.
- If possible, perform [dC361](#) NVM Save and Restore.

Procedure

1. Enter Diagnostics, [GP 1](#).
2. Select **Adjustments**.
3. Select **dC301 NVM Initialization**.
4. Select the desired **Controller** and **NVM Data** using the features on the UI screen.
5. Select **Initialize** to run the routine. Select the **[X]** button to exit the routine without running it.
6. When prompted by the message **Are you sure you want to initialize NVM?**, select **Initialize**.

Note: If the screen displays the message **The device is in a non-customer mode** after completing this step, perform [dC361](#) to restore the machine to customer mode.

7. After the initialization is complete, the machine will restart into the Startup Wizard.

dC312 Network Echo Tests

Purpose

Tests the machine's ability to communicate on the network.

Procedure

1. Enter Diagnostics, [GP 1](#).
2. Select **Diagnostics**.
3. Select **dC312 Network Echo Test**.
4. Select the **Protocol** to be tested.

Note: Protocols not available will be greyed out.

5. Select the **Start Network Echo Test** button. The test will run. A message will be displayed on the UI indicating whether the test was successful.

dC330 Component Control

Purpose

To show the status of input components e.g. sensors, and to run or energize output components e.g. motors, solenoids.

Description

Output and input component codes are entered into the Component Control Table on the UI, and then checked individually or in permitted groups. The codes in the tables are grouped in function chain order. Refer to [GP 2](#) Fault Codes and History Files.

Go to the appropriate procedure:

- [Input Components](#)
- [Output Components](#)

Input Components

Component control codes are not used with the VLC415 dC330 procedures. Direct access to components are listed in the dC330 procedures of the Control Panel interface.

The displayed status of the input component can be changed by causing the component status to change, e.g. operating a sensor with a sheet of paper.

Output Components

Component control codes are not used with the VLC415 dC330 procedures. Direct access to components are listed in the dC330 procedures of the Control Panel interface.

Procedure

1. Enter Diagnostics, [GP 1](#).
2. Touch Diagnostics.
3. Touch:
 - a. dC330 Component Control (Fax Engine).
 - b. dC330 Component Control (Print Engine).
 - c. dC330 Component Control (Scan Engine).
1. Touch the dC330 component control list desired.
2. Scroll the list for the component to be checked.
3. Touch the component name.
4. Touch Start.

Note:

- Some motors require automatic deactivation in order to avoid secondary issues such as possible damage and contamination.
 - Some tests require a special action to activate a motor such as removing a major component.
 - If the motor fails, the test failure may not indicate a failed motor. Further troubleshooting may be required. Check PWBs and cables for possible issues.
 - The component status.
 - The component change state.
 - Operation counter.
5. Toggle Cyclic Motion to repeat the operation.
 6. Touch Stop All to stop component operation.
 7. Touch Close to return to the Diagnostics screen.
 8. Exit diagnostics, [GP 1](#).

Fax Engine Tests

Table 1 Fax Engine Tests

Test	Sub Menu	Sub Menu	Action	General
Agency Test				
	Go Off-Hook		Start	
	Ring Detect		Touch Start	
	Generate Tones	Generate GNC Tone 1100 Hz	Touch To Open Tones Menu	
		Generate ANS Tone 2100 Hz		
		Generate ANSam Tone		
		Generate DTMF Tone 0-9, *, #		
	Generate Modulations	V.21 300 bps	Touch To Open Modulations Menu	

Test	Sub Menu	Sub Menu	Action	General
		V.22 1200 bps ORG		
		V.22 1200 bps ANS		
		V.27ter 2400 bps		
		V.27ter 4800 bps		
		V.29 7200 bps		
		V.29 9600 bps		
		V.17 7200 bps		
		V.17 9600 bps		
		V.17 12000 bps		
		V.17 14400 bps		
		V.22 1200 bps org		
		V.22 1200 bps ans		
		V.34 2400 bps		
		V.34 4800 bps		
		V.34 7200 bps		
		V.34 9600 bps		
		V.34 12000 bps		
		V.34 14400 bps		
		V.34 16800 bps		
		V.34 19200 bps		
		V.34 21600 bps		
		V.34 24000 bps		
		V.34 26400 bps		
		V.34 28800 bps		

Test	Sub Menu	Sub Menu	Action	General
		V.34 31200 bps		
		V.34 33600 bps		
Fax Settings				
	General User Settings		Touch to Open	
		Behind PABX	Enable/Disable	
		Single Ring	Enable/Disable	
		Double Ring	Enable/Disable	
		Triple Ring	Enable/Disable	
		Enable Line Connection Detection	Enable/Disable	
		Enable Line In Wrong Jack Detection	Enable/Disable	
		Enable Extension Support	Enable/Disable	
	Homologation General Settings		Touch to Open	
		Detect EOLs	Increase/Decrease: Range 0 – 6	
		Dial Wait Time	Increase/Decrease: Range -255 – 255	
		Pause Timeout	Increase/Decrease: Range 0 – 255	
		Pulse Dial Type	Normal/One Pulse/ Ten Mins	
		Caller ID Pattern	None/DTAS_FSK/ RPAS_FSK/LR_FSK/	

Test	Sub Menu	Sub Menu	Action	General
			NTT/FSK/LR_DTFM/ DTFM	
		Fax Low Power	Auto/DisableSleep/ PermitSleep	
		JBIG	Enable/Disable	
		JBIG2	Enable/Disable	
		MMR	Enable/Disable	
		MR	Enable/Disable	
		Fax Image Confirmation	Enable/Disable	
		Partial Page Heartbeat	Enable/Disable	
		Partial Page Heartbeat Interval		
		Fax Image Width		
		Fax Receive Resolutions		
		Disable Sending CRP		
		Send Max Speed		
		Send - Allow V.34		
		Send - Allow V.17		
		Send - Allow V.29		
		Send - Allow V.27		
		Receive Max Speed		
		Receive - Allow V.34		
		Receive - Allow V.17		
		Receive - Allow V.29		

Test	Sub Menu	Sub Menu	Action	General
		Receive - Allow V.27		
	Homologation Con- exant Settings	Dial Tone Timeout	Touch to Open	
		Max Busy Check		
		Positive Twist Control		
		Negative Twist Control		
		ARA EQM Bias		
		Pulse Interdigit Delay		
		Enable CEQ		
		Disable V.17 TX Filter		
		Digital Line Guard		
		Digital Line Threshold		
		Off Hook Line Settle Time		
		Volume Level Low		
		Volume Level Medium		
		Volume Level High		
		Dial Timeout		
		Transmit Level		
		Receive Threshold		
		DTMF Low Power Level		
		DTMF High Power Level		

Test	Sub Menu	Sub Menu	Action	General
		Progress Threshold		
		Dial Tone Threshold		
		Adjust Power FSK		
		DC Characteristics		
		Impedance		
		High Ring Impedance		
		Pulse Make Time		
		Pulse Break Time		
		Pulse Fall Time		
		Busy Tone - Cycles		
		Busy Tone - Min On Time		
		Busy Tone - Max On Time		
		Busy Tone - Min Off Time		
		Busy Tone - Max Off Time		
		Congest Tone - Cycles		
		Congest Tone - Min On Time		
		Congest Tone - Max On Time		
		Congest Tone - Min Off Time		
		Congest Tone - Max Off Time		
Reset Fax Settings	Reset Fax User Settings			

Test	Sub Menu	Sub Menu	Action	General
	Reset Fax Modem Settings			
	Reset All Fax Settings			
	Reset to Compatibility Mode			
Fax Logs	Clear All T.30 Logs			
	Clear All T.30 Error Logs			
	Clear Fax Call Log			
	Clear Caller ID Log			

Print Engine Tests

Table 2 Print Engine Tests

Test	Sub Menu	Action	Sub Menu	General
Sensor Tests				
	MPF Media Present			
	Pick Roller Index (tray 1)			
	Tray 1 Media Out			
	Tray 1 pick			
	Tray 1 Pass-through			
	Input			
	Narrow media			

Test	Sub Menu	Action	Sub Menu	General
	Fuser exit			
	Duplex path			
	Duplex interlock			
	Output bin full			
	Front door interlock			
	Rear door interlock			
	Media size (tray 1) switch 1			
	Media size (tray 1) switch 2			
	Media size (tray 1) switch 3			
	Media size (tray 1) switch 4			
Additional Trays Sensor Tests				
	Tray 2 pick roller index			
	Tray 2 media out			

Test	Sub Menu	Action	Sub Menu	General
	Tray 2 pass-through			
	Tray 2 media size switch 1			
	Tray 2 media size switch 2			
	Tray 2 media size switch 3			
	Tray 2 media size switch 4			
Motor Tests				
	MPF pick			
	Pick (tray 1) picking			
	Pick (tray 1) lifting			
	Fuser (fusing)			
	Fuser (retracing)			
	Redrive (forward)			
	Redrive (reverse)			
	Imaging unit			
	K toner add			
	Fan (main)			

Test	Sub Menu	Action	Sub Menu	General
	Fan (cartridge)			
Additional Trays Motor Tests				
	Pick (tray 2) picking			
	Pick (tray 2) lifting			
	Pass-through (tray 2)			

Scanner Diagnostics

Table 3 Scanner diagnostics

Test	Sub Menu	Sub Menu	Action	General
Sensor Tests			Start	
Motor				
	Flatbed scanner		Start	
	DADF Transport			

Test	Sub Menu	Sub Menu	Action	General
		Run DADF transport forward	Start	
		Run DADF transport backward	Start	
		DADF stop transport	Start	
	DADF Pick		Start	
	DADF Tray Lift			
		Raise DADF Tray	Start	
		Lower DADF Tray	Start	
	DADF Deskew			
		DADF Deskew On	Start	
		DADF Deskew Off	Start	
	DADF Calibration		Start	
Feed				
	Select paper size			
	Feed test			
DA-DF Rolling Cleaning Cycle			Start	

FAX Engine

Table 4 FAX Engine

Test	Sub Menu	Sub Menu	Action	General
Agency Test				
	Go Off Hook		Start	
	Ring Detect		Start	
	Generate Tones			
	Modulations			
FAX Settings				
	Fax Modulations			
	Miscellaneous Settings			
	Reset Fax Settings			
Modem Settings				

Test	Sub Menu	Sub Menu	Action	General
	Caller ID Pattern Note: Changing the value of this setting also changes the value of the Caller ID setting in the Fax Settings.			
	Pulse Dial Type			
	Disable Sending CRP			
Reboot System	N/A			

dC361 NVM Save and Restore

Purpose

1. To capture the state of NVM to a file stored on the machine's controller PWB.
2. Copy the selected NVM to a USB device or restore NVM back to the device when required.

This routine supports the save and restore of the following NVM platforms:

- Print Engine
- Fax
- Fax Engine
- Scan Engine
- Copy Controller

Procedure



CAUTION: In this procedure it is important to follow the steps in order, read and understand all notes, and perform all actions correctly for each step. Failure to do so may result in saving an old and/or incorrect NVM file, then inadvertently reloading it when NVM is restored.

Note:

- NVM data files are first saved to the controller PWB.
Saved NVM platforms can be copied to a USB device by selecting the saved platform, then selecting **[Copy to USB Device]**.
- When an AltBoot or Forced AltBoot is performed, the files are first copied to the controller PWB from the USB drive, then written to the machine.

Note: Always save NVM data to a USB drive before performing an AltBoot or Forced AltBoot. Performing an AltBoot or Forced AltBoot deletes all data from the controller PWB.

To Save NVM

1. Enter Diagnostics, [GP 1](#).
2. If you are saving NVM to a USB device, connect the USB device to one of the USB ports on the machine.
3. Select **[Adjustments]**.
4. Select **[dc361 NVM Save and Restore]**.

Note: The top line represents the NVM data stored in the various locations in the machine. Subsequent lines represent the NVM platform saved in the controller PWB. Each time NVM is saved to the controller PWB a new file is created on the controller PWB. Each file displays as a separate line in the window with a unique date and time. Upon controller PWB replacement or a AltBoot or Forced AltBoot is performed, these files persist each time dc361 is accessed. When inserted, the USB device files are listed at the bottom.

5. Touch the **[Machine NVM]** line. A popup menu will open.
6. Select **[Save To Hard Drive]** from the popup menu.
A screen with a progress bar will display and the NVM data will be saved to the HDD/SSD immediately. No confirmation popup displays.
7. New line(s) are added to the screen in date and time order.
8. If it is necessary to copy the NVM files to a USB drive, touch the **[Hard Drive]** line from the save you just made. A popup menu displays.
9. Select **[Copy To USB Device]** from the popup menu.
A screen with a progress bar will display and the NVM data will be saved to the USB device immediately. No confirmation popup displays.

To Restore NVM

1. Enter Diagnostics, [GP 1](#).
2. If restoring NVM from a USB drive, connect the USB Drive to a USB port on the machine.
3. Select **[Adjustments]**.
4. Select **[dc361 NVM Save and Restore]**.

Note: The top line represents the NVM data stored in the various locations in the machine. Subsequent lines represent the data stored on the controller PWB and USB drive. Each time NVM is saved to the controller PWB a new file is created on the controller PWB. Each file displays as a separate line in the window with a unique date and time. Unless the controller PWB is replaced, or an AltBoot or Forced AltBoot is performed, these files persist each time dc361 is accessed. The USB Device files are always listed at the bottom.

5. Touch the **[Hard Drive]** line corresponding to either the save made previously or to the copy just made from the USB drive.
6. Select **[Restore Machine NVM]**.

Note: You must switch OFF, then switch ON the machine, [GP 10](#).

dC612 Print Test Patterns

Purpose

Prints the built-in test patterns to help identify Image Quality problems, [Table 1](#).

Procedure

1. Enter Diagnostics, [GP 1](#).
2. Select **Diagnostics**.
3. Select **dc612 Print Test Patterns**.
4. Select **[Start]** from the **[Advanced Print Quality Samples]** menu.

Table 1 Test Patterns

#	Description	Paper Size	Color Mode
1	Vertically repeating defects - [Print Cartridges]	8.5x11/A4	Y, M, C, K
2	Vertically repeating defects - [Transfer Module]	8.5x11/A4	Y, M, C, K
3	PQTEST-A	8.5x11/A4	Y, M, C, K
4	PQTEST-B	8.5x11/A4	C
5	PQTEST-C	8.5x11/A4	M
6	PQTEST-D	8.5x11/A4	Y
7	PQTEST-E	8.5x11/A4	K
8	PQTEST-F	8.5x11/A4	Blank
9	PQTEST-G	8.5x11/A4	Y, M, C, K
10	PQTEST-H	8.5x11/A4	Y, M, C, K
11	PQTEST-I	8.5x11/A4	Y, M, C, K
12	PQTEST-J	8.5x11/A4	Y, M, C, K

dC727 Tray Quick Print Tests

Purpose

Performs a single or continuous Quick Print Test.

Procedure

1. Enter Diagnostics, [GP 1](#).
2. Touch **[Diagnostics]** to open the diagnostics procedures menu.
3. Touch **[dc727 Tray Quick Print Tests]**.
4. Select the desired test from one of the three available options:
 - a. Touch **>Duplex**, to open the Duplex Quick Print Test menu.
 1. **[Paper size]**, touch the button to change the paper size.
 - Letter (default).
 - A4
 2. Two quick print test options are available:
 - **[Single]**, prints a single page.
 - **[Continuous]**, prints a minimum of 20 continuous pages.

Note: Load the MPF tray with a minimum of 20 sheets of the desired paper size, **[Letter]** or **[A4]**, before touching **[Start]**.
 3. **[Single]**, touch **[Start]** to print a single quick print test page.
 4. **[Continuous]**, touch **[Start]** to print continuous quick print test pages.
 - b. Touch **>MPF Tray**, to open the MPF Tray tests:
 1. Two quick print test options are available:
 - **[Single]**, prints a single page.
 - **[Continuous]**, prints a minimum of 20 pages.

Note: Load Tray 1 with a minimum of 20 sheets of the desired paper size, **[Letter]** or **[A4]**, before touching **[Start]**.
 2. **[Single]**, touch **[Start]** to print a single quick print test page.
 3. **[Continuous]**, touch **[Start]** to print continuous quick print test pages.

- A4
 2. Two quick print test options are available:
 - **[Single]**, prints a single page.
 - **[Continuous]**, prints a minimum of 20 continuous pages.

Note: Load the MPF tray with a minimum of 20 sheets of the desired paper size, **[Letter]** or **[A4]**, before touching **[Start]**.
 3. **[Single]**, touch **[Start]** to print a single quick print test page.
 4. **[Continuous]**, touch **[Start]** to print continuous quick print test pages.
- c. Touch **>Tray 1**, to open the Tray 1 tests:
 1. Two quick print test options are available:
 - **[Single]**, prints a single page.
 - **[Continuous]**, prints a minimum of 20 continuous pages.

Note: Load Tray 1 with a minimum of 20 sheets of the desired paper size, **[Letter]** or **[A4]**, before touching **[Start]**.
 2. **[Single]**, touch **[Start]** to print a single quick print test page.
 3. **[Continuous]**, touch **[Start]** to print continuous quick print test pages.

dC919 Color Balance Adjustment

Purpose

Adjustment of color alignment and to print or reset the default settings.

Procedure

1. Enter the Diagnostics, [GP 1](#).
2. Touch **[Adjustments]** to open the adjustments list.
3. Touch **[dc919 Color Balance Adjustment]**.
4. The following settings are available:

- **Color alignment adjust**
 - Touch the **[next]** button to open the procedure.

The color alignment adjust provides seven adjustments for each color C,Y,M,K independently. Perform the required adjustment for the color required.

- a. Select the required color for adjustment: **Cyan, Magenta, Yellow, or Black**:
 - **Top margin**, touch the **[+]** or **[-]** to the desired setting, then touch **[Save]**. The range is –100 to 100.
 - **Left margin**, touch the **[+]** or **[-]** to the desired setting, then touch **[Save]**. The range is –600 to 600.
 - **Right margin**, touch the **[+]** or **[-]** to the desired setting, then touch **[Save]**. The range is –600 to 600.
 - **Skew**, touch the **[+]** or **[-]** to the desired setting, then touch **[Save]**. The range is –50 to 50.
 - **Bow**, touch the **[+]** or **[-]** to the desired setting, then touch **[Save]**. The range is –50 to 50.
 - **Linearity**, touch the **[next]** button to open the linearity menu.
 - ◆ **Left adjustment**, touch the **[+]** or **[-]** to the desired setting, then touch **[Save]**. The range is –65 to 65.
 - ◆ **Center adjustment**, touch the **[+]** or **[-]** to the desired setting, then touch **[Save]**. The range is –65 to 65.
 - ◆ **Right adjustment**, touch the **[+]** or **[-]** to the desired setting, then touch **[Save]**. The range is –65 to 65.
 - ◆ **Quick test**, touch **[Start]** to initiate the Quick Test.

- **Quick test**, touch **[Start]** to initiate the Quick Test.
 - **Factory manual**, touch **[Start]** to begin the adjustment.
 - **Reset auto alignment margin**, touch **[Start]** to begin the adjustment.
 - **AA adjustment**, touch **[Start]** to begin the adjustment.
 - **Print AA information page**, touch **[Start]** to begin the adjustment.
5. Touch **[Back]**.
 6. Touch **[Call Closeout]**.
 7. Touch **[Exit & Reboot]**.

dC925 Printer Setup

Purpose

Adjusts the EP settings of the printer and calibrates the waste tone sensor for optimal accuracy.

Procedure

Three adjustments can be performed in dC925 Printer Setup:

1. Enter Diagnostics, [GP 1](#).
2. Scroll to **[Adjustments > dc925 Printer Setup]**, then touch **[dc925 Printer Setup]** to open the menu.
3. Touch the adjustment required:
 - a. **Engine Settings:** Not Used.
 - b. **EP Setup:** increase or reduce bias voltage on the drum from the bias charge roll.

Two settings are available for either **[Charge Adjust]** or **[Developer Adjust]**:

- **Charge Adjust:**

1. Black (DC bias votage)
 - 1) Touch the button to change the black bias voltage as required:
 - **[Low]**
 - **[Normal]** (default)
 - **[High]**
 - 2) Touch **[Save]** to set the change active.
2. Color (DC bias votage)
 - 1) Touch the button to change the color bias voltage as required:
 - **[Low]**
 - **[Normal]** (default)
 - **[High]**
 - 2) Touch **[Save]** to set the change active.

- **Developer Adjust:**

1. Black (DC bias votage)
 - 1) Touch the button to change the black bias voltage as required:

- **[Low]**
 - **[Normal]** (default)
 - **[High]**
 - 2) Touch **[Save]** to set the change active.
2. Color (DC bias votage)
 - 1) Touch the button to change the color bias voltage as required:
 - **[Low]**
 - **[Normal]** (default)
 - **[High]**
 - 2) Touch **[Save]** to set the change active.
 - c. **Waste toner sensor calibration:** calibrates the waste toner sensor, ensuring the accuracy of the waste toner level detection.
 1. Touch **[Start]** to begin the sensor calibration.
4. Exit Diagnostics, [GP 1](#).

dC927 Toner Patch Sensor (TPS) Setup

The Toner Patch Sensor (TPS) regulates the density of the toner fused to the print medium. dC927 is used when a new TPS sensor is installed or when toner density needs adjusting beyond the customer TPS setup allows.

Diagnostics Entry

Enter Diagnostics, [GP 1](#).

Calibration Frequency Preference

1. Touch the adjustment button to change the frequency of the auto-calibration process:
 - **[Disable]** stops auto-calibration entirely.
 - **[Fewest color adjustments]** sets the frequency of adjustment to the lowest number of auto-calibrations.
 - **[Fewer color adjustments]** sets the frequency of adjustment to a next lower number of auto-calibrations.
 - **[Normal]** sets the frequency of adjustment to the default number of auto-calibrations.
 - **[Better color accuracy]** sets the frequency of adjustment to a higher number of auto-calibrations.
 - **[Best color accuracy]** sets the frequency of adjustment to the highest number of auto-calibrations.
2. Touch **[Save]** to save settings.

TPS Characterization Data.



CAUTION: TPS characterization data is only used when a new TPS sensor kit is to be installed. Changing these values for any other reason could result in decreased print quality, possible damage, or machine failure.

1. Touch the **[next page]** button.
2. Enter the characterization data.

Note: The characterization data is provided with the TPS sensor kit.

- Select **[Left Sensor Data]**, then enter the corresponding strings.
- Select **[Right Sensor Data]**, then enter the corresponding strings.
- Select **[Shared Sensor Data]**, then enter the corresponding strings.
- Select **[Serial Number]**, then enter the corresponding strings.
- Select **[Save all TPS Sensor Data]**, then touch **[Start]**.

3. Remaining in dC927 Toner Patch Sensor Setup:
 - Touch **[Start]** to run the automated routine **[Sensor Gain Characterization]**.

Note: Engine will start up and stop to complete this automated routine, but no physical pages will be printed.

- Touch **[Start]** to run the automated routine **[Sensor Gain Verification]**.

Note: Check for red text indicating errors on the page printed by this automated routine. Contact the next level of support if needed.

- Touch **[Start]** to run the automated routine **[Full Calibration]**.

Note: Engine will start up and stop to complete this automated routine, but no physical pages will be printed.

Full Calibration

Touch **[Start]** to initiate all calibration procedures available for the TPS sensor.

Gap Calibration

Touch **[Start]** to initiate gap calibration procedures available for the TPS sensor.

Print TPS information page

Touch **[Start]** to print TPS sensor details.

Print Test Pages

Touch **[Start]** to print TPS sensor test pages.

Calibration Reference

Calibration reference decreases or increases the darkness of the print.

The Calibration reference section provides a menu for Black (K) and a menu for CMY.

- A negative number makes the print darker.
- A positive number makes the print lighter.

Note: Calibration Reference has CMY combined because the developer voltage controls are combined.

1. **Black:**
 - a. Touch **[-]** to make the print darker.
 - b. Touch **[+]** to make the print lighter.
2. **CMY:**

- a. Touch [-] to make the print darker.
- b. Touch [+] to make the print lighter.

Note: Make small adjustments, then test prints are suggested.

3. Touch [Save] to save changes.

Halftone Reference

Halftone reference increases or decreases the halftone darkness of the print.

Note: Halftone reference has four individual settings, One for C, one for M, one for Y, and one for K. This is because the laser power controls are all independent.

1. Touch the adjustment button for the desired color:

Note: Make small adjustments, then test prints are suggested.

- **[Low]** reduces the halftone reference.
- **[Normal]** is the default halftone reference.
- **[High]** increases the halftone reference.

2. Touch **[Save]** after each adjustment to save changes.

Reset Color Calibration

Touch **[Start]** to reset color calibration settings to default.

Sensor Gain Characterization

Touch **[Start]** to auto-adjust the TPS sensor gain characteristics.

Sensor Gain Verification

Touch **[Start]** to initiate system verification of the TPS sensor gain settings.

Exit Diagnostics, **GP 1**.

dC945 IIT Calibration

Purpose

The purpose of this procedure is to calibrate the optics in the IIT for optimal performance.

This procedure provides two functions:

1. Scanner Calibration Reset
2. Controller Calibration

Procedure

1. Enter Diagnostics, **GP 1**.
2. Touch the desired operation, then touch **[Start]** to begin.
3. Exit Diagnostics, **GP 1**, when complete.

Change Tags

Change Tag Introduction

This section describes tags associated with the printer, as well as multinational applicability, classification codes, and permanent or temporary modification information. Important modifications to the printer are identified by a tag number which is recorded on a tag matrix inside the front door.

Classification Codes

A tag number may be required to identify differences between parts that cannot be interchanged, or differences in diagnostic, repair, installation, or adjustment procedures.

A tag number may also be required to identify the presence of optional hardware, special non-volatile memory programming, or whether mandatory modifications have been installed. Each tag number is given a classification code to identify the type of change that the tag has made. The classification codes and their descriptions are listed in [Table 1](#).

Table 1 Classification codes

Classification Code	Description
M	Mandatory tag.
N	Tag not installed in the field.
O	Optional tag.
R	Repair tag.

7 Wiring Data

Wiring Diagrams	376
VLC415 Wiring Diagrams	377

VLC415 Wiring Diagrams

WD1 VLC415 Controller PWB Wiring Diagram

WD-1 VLC415 Controller PWB

Wiring Diagram

Location: [PL 3.05](#)

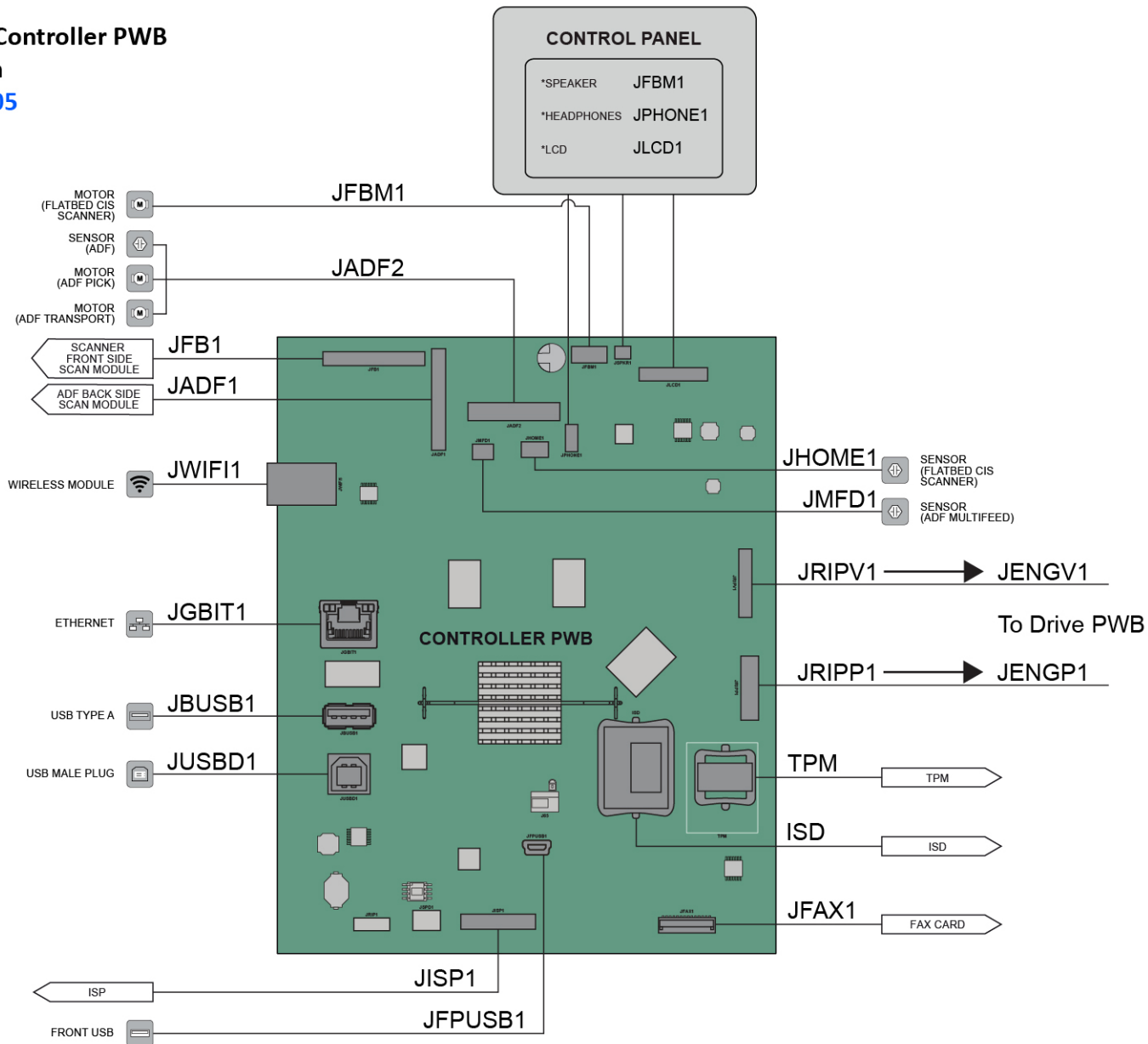

VLC415S_7001

WD2 VLC415 Drive PWB Wiring Diagram

**WD-2 VLC415 Drive PWB
Wiring Diagram
Location: [PL 1.05](#)**

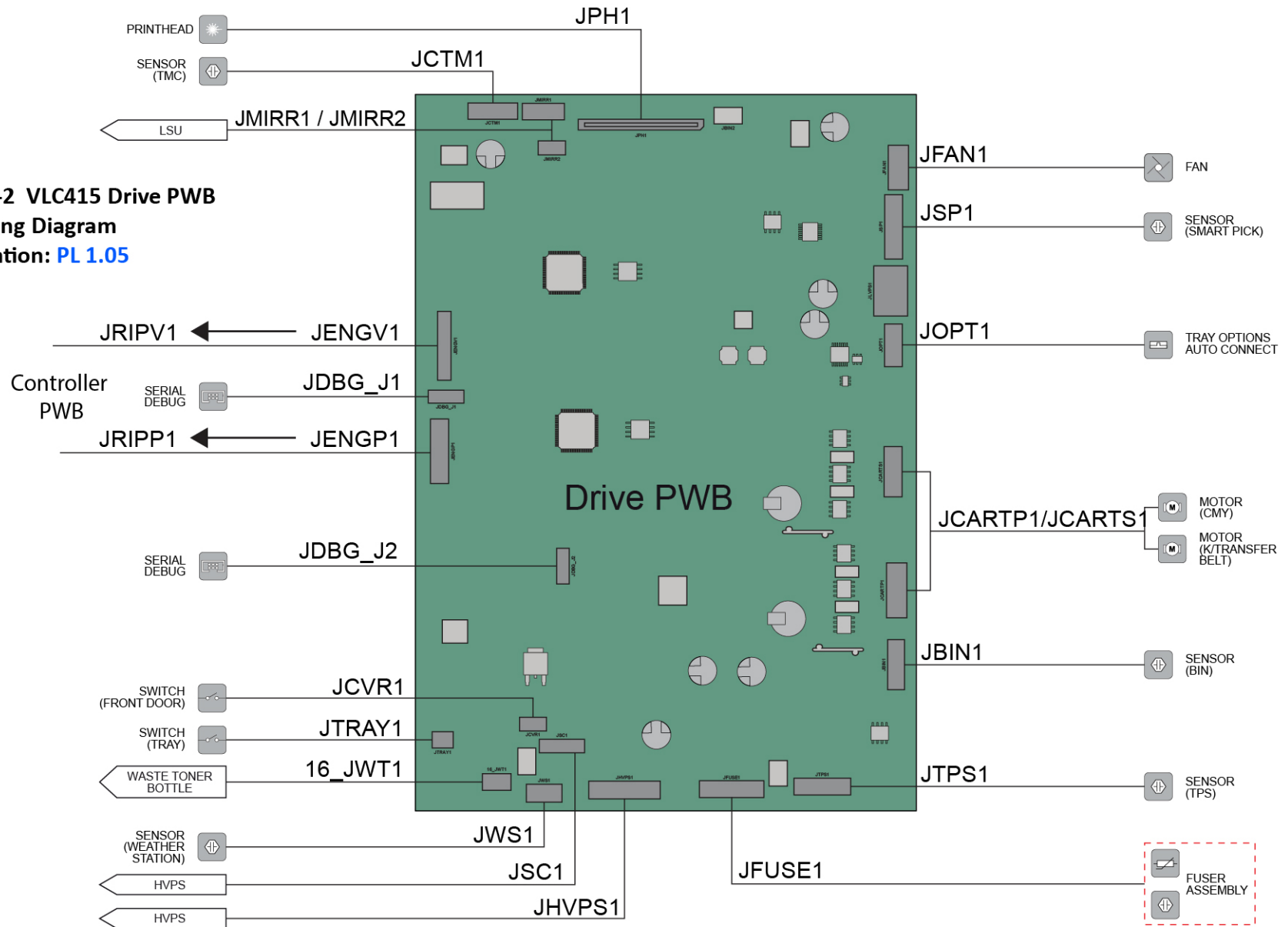

VLC415S_7002

WD4 VLC415 Wiring Diagram

WD-4 VLC415 System Wiring Diagram

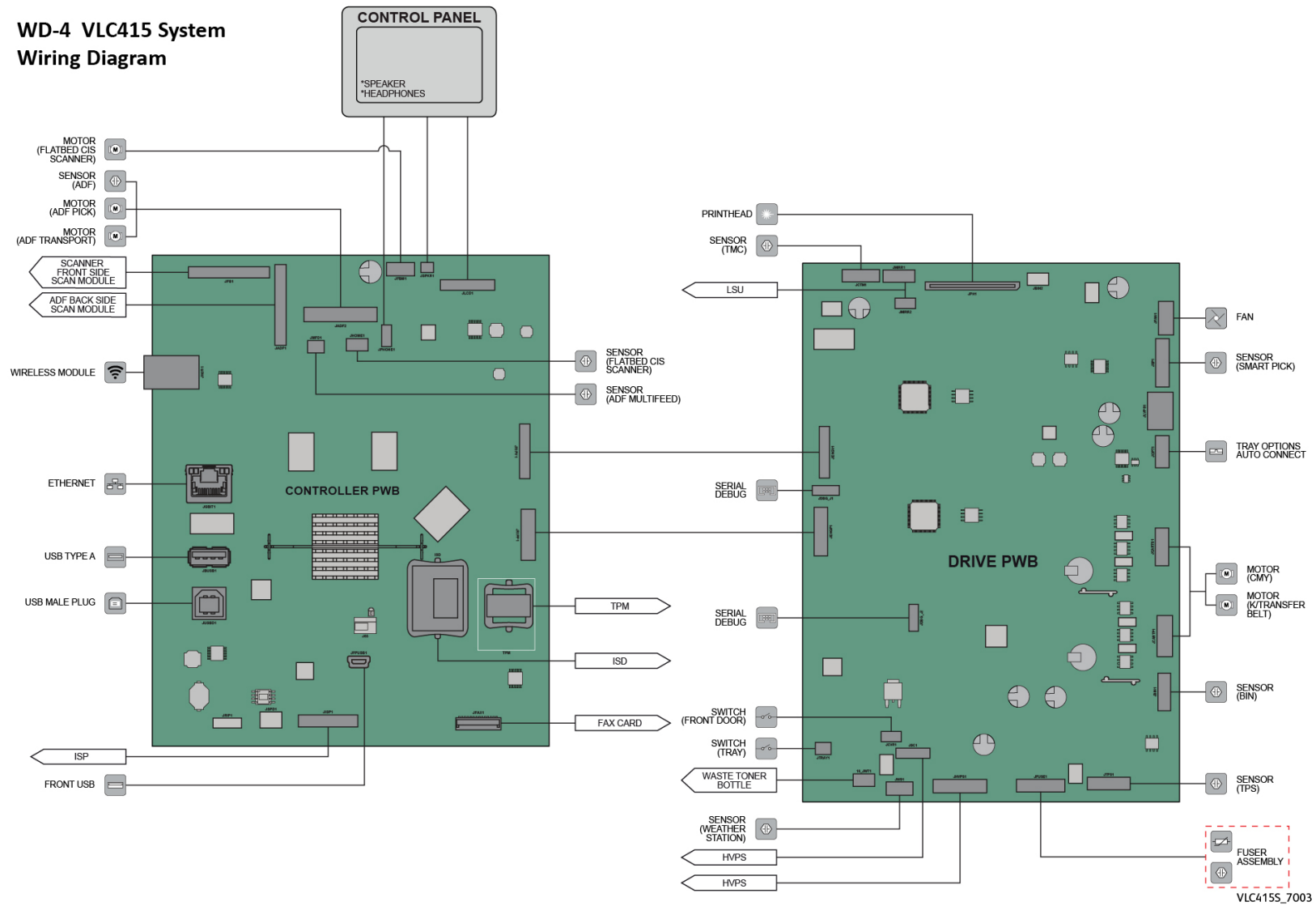

8 Product Technical Overview

- Product Technical Overview 381
 - POR Sequence 381
 - Printer Control 381
- Xerographics 382
 - Print Engine Layout 383
 - Flowchart 384
 - EP Process 385
- Printer Operation 393
 - Printer Sections 394
 - Printer Paper Path Rollers 395
 - Printer Paper Path Sensors 398
- DADF and Scanner Operation 399
 - Flatbed Scanner Drive 400
 - DADF Paper Path Rollers 402
 - DADF Paper Path Sensors 404
 - DADF Pick and Feed Drive 405
 - DADF Transport and Scan Drive 406
 - DADF Exit Drive 408

POR Sequence

As the printer is turned on, the engine code goes through a series of tests to verify hardware integrity. If a hardware failure is detected, then it is reported to the printer. If the POR sequence cannot be completed successfully, then the printer may post an error message. The message states that service may be needed.

Printer Control

The printer uses two boards, each with its own processor. The controller board handles system responsibilities such as PC connection, LAN, ISP attachments, and bitmap generation. The engine board performs tasks related to the operation of the electrical and mechanical device systems such as motors, lasers, power supplies, and fusers. There is an NVRAM device on each board to store system settings. Data on the NVRAM devices mirror each other automatically when one of the boards is replaced and printer is rebooted—if both boards are replaced together, critical data will be lost.

Print Engine Layout

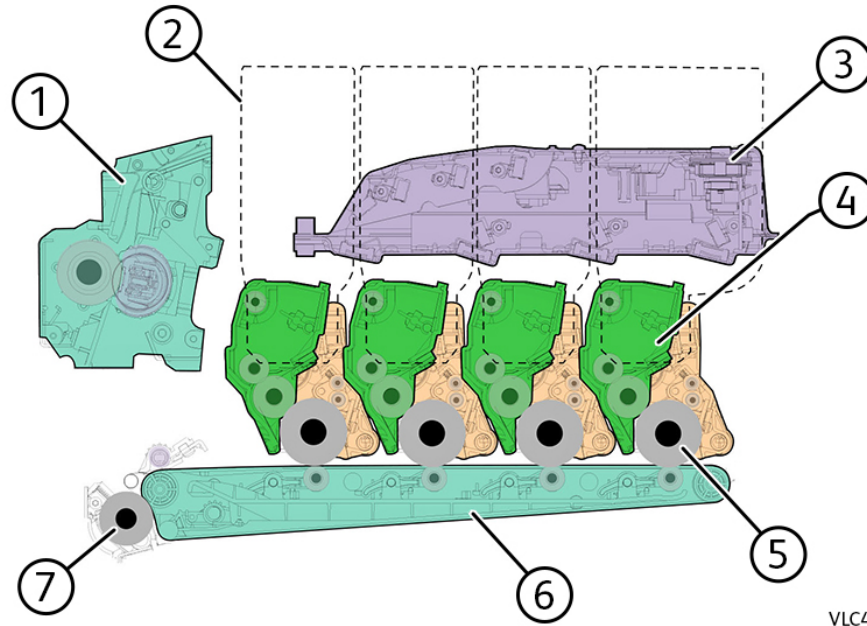

VLC415S_8001

Item Number	Description
1	Fuser
2	Toner Cartridges (C, M, Y, K)
3	Printhead
4	Developer Unit
5	Photoconductor Drum
6	Transfer Belt
7	Second Transfer Roller

Flowchart

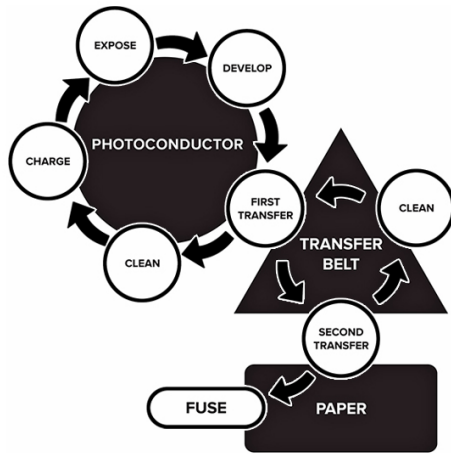

VLC415S_8002

EP Process

Charge

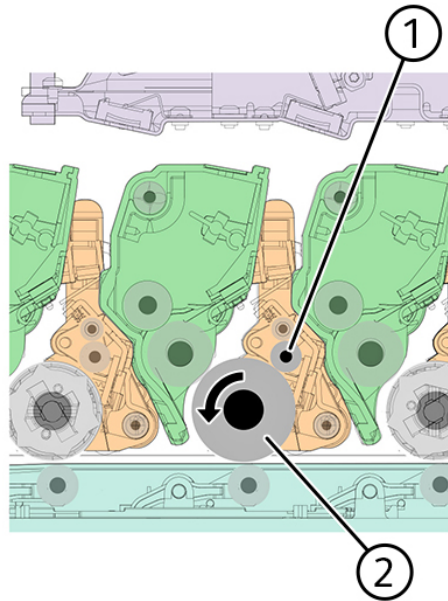

VLC415S_8003

Item Number	Description
1	Charge Roller
2	Photoconductor Drum

The charge roller applies a uniform negative electrical charge to the surface of the photoconductor drum. The photoconductor drum, because of its photoconductive properties, holds the charge as long as it is not exposed to light.

Service Tips

- If the surface of the charge roller is damaged, such as having a nick or pit, then the charge on the photoconductor drum is uneven. A repeating mark may appear on the printed page.
- If the charge roller is severely damaged, then the surface of the photoconductor drum is not properly charged. Excessive amounts of toner particles are deposited on the photoconductor drum. The printed page becomes saturated with 100% of the color from the supply with the defective charge roller. The affected imaging unit or kit must be replaced immediately.

Expose

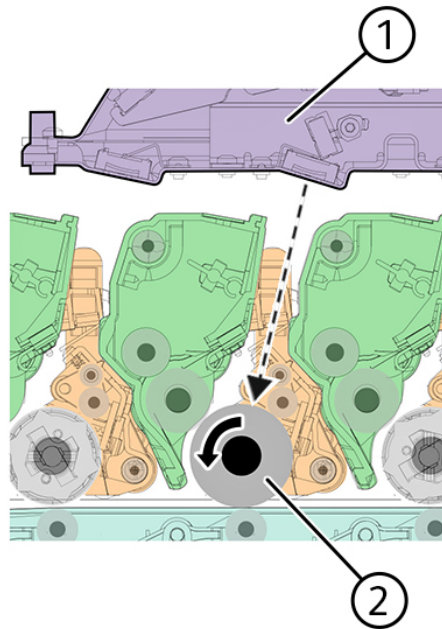

VLC415S_8004

Item Number	Description
1	Printhead
2	Photoconductor Drum

The printhead lasers emit the light that contacts the surface of the photoconductor drum. An invisible image, called digital latent image, is written as the light turns on or off. The light causes areas of the photoconductor drum surface to lose charge, resulting in a relative opposite polarity.

Service Tips

- Do not touch the surface of the photoconductor drum with your bare hand. The oil from your skin may cause a charge disparity on the surface, and the toner may no longer stick properly. The result can be repeating blotches or voids on the printed page or patches of light print. The affected imaging unit or kit may need to be replaced.
- The surface of the photoconductor drum is coated with an organic substance that makes it sensitive to light. Make sure to cover the photoconductor drum when you are working on the printer. If it is exposed to light for too long, then light or dark print quality problems may occur. The imaging unit or imaging kit may need to be replaced.
- Toner particles or dirt that get stuck on the printhead lens may obstruct the path of the laser beam. The result can be vertical light streaks on the printed page. If cleaning is not possible, then the printhead may need to be replaced.

Develop

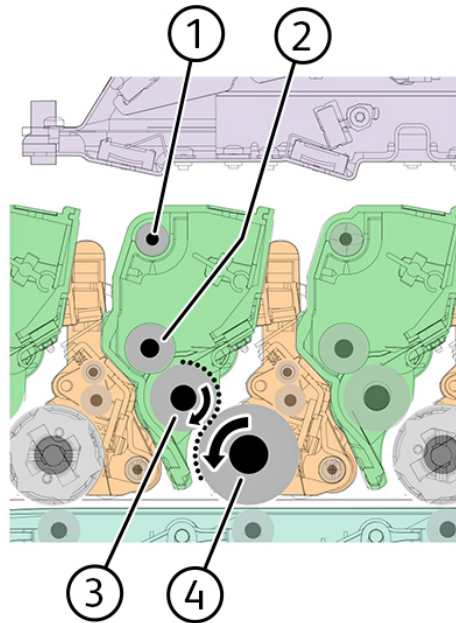

VLC415S_8005

Item Number	Description
1	Auger
2	Toner Add Roller
3	Developer Roller
4	Photoconductor Drum

The developer roller applies the toner from the toner cartridge to the photoconductor drum. The relative opposite polarity in charge causes the toner particles to attract to the photoconductor drum areas which were exposed to light.

This process is similar to using glue to write on a can, and then rolling the can over glitter. The glitter sticks to the glue but does not stick to the rest of the can.

Service Tips

- Do not touch the surface of the developer roller with your bare hand. The oil from your skin may cause a charge disparity on the surface, and the toner may no longer stick properly. The result can be repeating blotches or voids on the printed page or patches of light print. The affected developer unit may need to be replaced.
- If the developer roller is damaged, then it cannot contact the surface of the photoconductor drum properly. The result can be repeating marks, thin vertical voids, or thin vertical lines of color on the printed page. Check the surface of the developer roller for damage. For more information, see [IQ18](#).

First Transfer

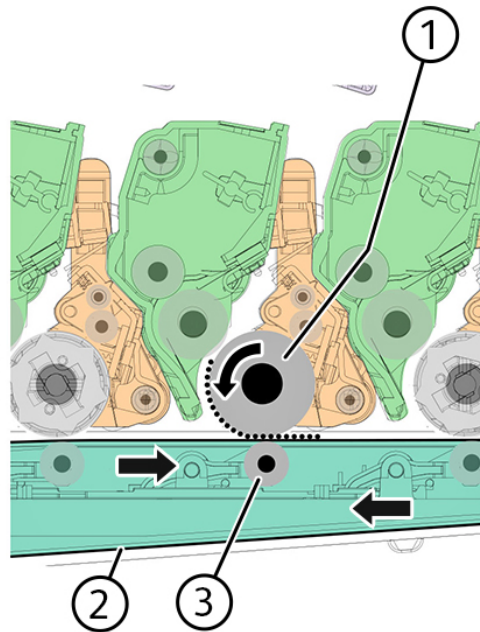

VLC415S_8006

Item Number	Description
1	Photoconductor Drum
2	Transfer Belt
3	First Transfer Roller

For each color, there is a charge difference between the developed toner image on the photoconductor drum surface and the first transfer roller. This difference causes the image to transfer to the surface of the transfer belt. This transfer occurs during a direct surface-to-surface contact between the photoconductor drum and the transfer belt.

Service Tips

- Do not touch the surface of the transfer belt with your bare hand. The oil from your skin may cause a charge disparity on the surface, and the toner may no longer stick properly. The result can be repeating blotches or voids on the printed page or patches of light print. The transfer module may need to be replaced. For more information, see [IQ18](#).
- Do not use solvents or other cleaners to clean the transfer belt surface. Their chemicals may result to scratches or charge disparities. Voids on the printed page or blotches of light print may occur. The transfer module may need to be replaced.
- Sharp and hard objects can damage the transfer belt surface. Be careful when using a screwdriver or prying tool near the transfer module. If the transfer belt has tears or cracks, then the transfer module may need to be replaced.

Second Transfer

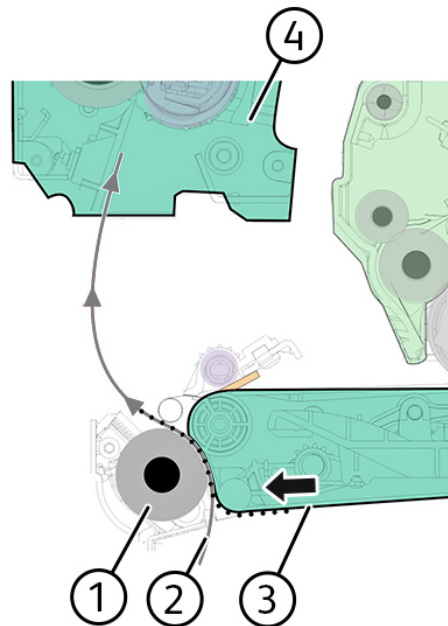

VLC415S_8007

Item Number	Description
1	Second Transfer Roller
2	Paper
3	Transfer Belt
4	Fuser

On the transfer belt, the four-color image is carried toward the second transfer roller until it reaches a set point. The paper pick is timed when the paper is at the exact position between the transfer belt and second transfer roller.

When the image on the transfer belt reaches the second transfer roller, the negatively charged toner clings to the paper. The entire image is then transferred from the transfer belt to the paper.

Service Tips

- If the second transfer roller has nicks, pits, or flat spots, then its surface cannot come into contact with the paper and transfer belt. The result can be voids on the printed page or spots of light print (or repeating voids or spots). For more information, see [IQ18](#).
- If the toner does not fully transfer, then the entire page may be very light or blank due to the following:
 - The second transfer roller does not properly engage the transfer belt.
 - The HVPS does not have voltage. Any toner that does transfer, is due to contact alone (without charge). Check the HVPS contacts to the second transfer roller.

Fuse

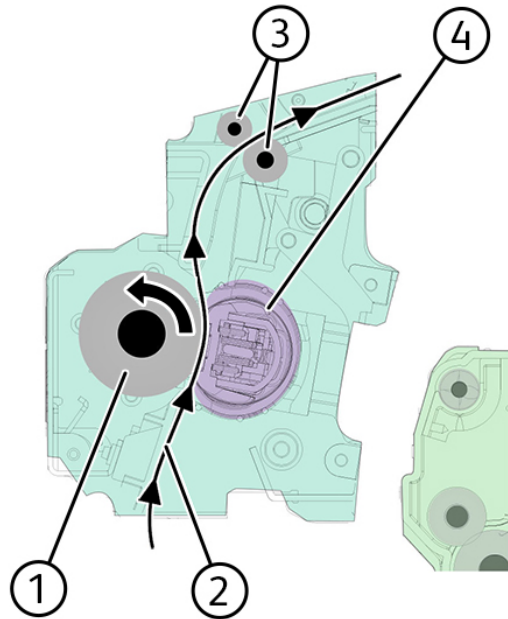

VLC415S_8008

Item Number	Description
1	Pressure Roller
2	Paper
3	Fuser Decurl Rollers
4	Heat Belt

Even if the toner image is already on the paper, the toner particles are not yet permanently bonded to the surface. Paper is transported from the second transfer roller to the fuser where heat and pressure are applied to it. As a result, the toner particles melt and permanently fuse with the paper, completing the print process. The cycle repeats for the succeeding pages.

Service Tips

- If the pressure roller or heat belt is damaged, then the toner may be pulled off the page. Paper jams may also occur.
- Toner rubbing off a printed page indicates a malfunctioning fuser or an incorrect paper type setting. Always check the paper type setting before replacing the fuser. A common mistake is to print on heavier paper, such as card stock, with the paper type set to plain paper.
- After a jam is called on the fuser area, the fuser roller automatically releases to relieve the pressure on the paper. If possible, never pull paper with unfused toner through the fuser. Try to pull the jammed paper out of the fuser in the opposite direction it was traveling.

Clean

Two cleaning processes take place during the EP process. Both processes remove the residual toner from the system.

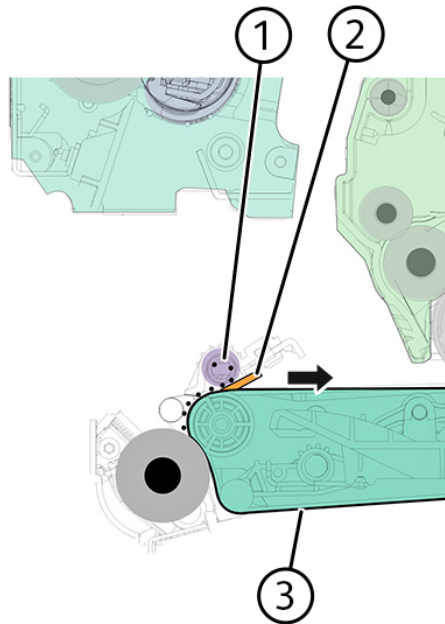

VLC415S_8009

Item Number	Description
1	Auger
2	Cleaning Blade
3	Transfer Belt

When the toner image on the transfer belt is transferred to the page, the transfer belt rotates and gets cleaned by the cleaning blade. The cleaning occurs for every page that is printed.

The removed toner is moved to the waste toner bottle using a rotating auger.

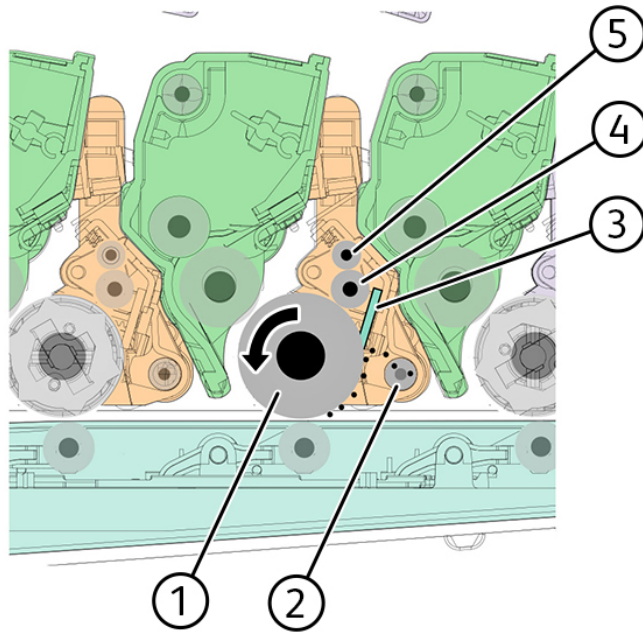

VLC415S_8010

Item Number	Description
1	Photoconductor Drum
2	Auger
3	Cleaning Blade
4	Charge Roller
5	Charge Roller Cleaner

After each plane of color is transferred to the transfer belt from the photoconductor drums, a cleaning blade scrapes the remaining toner from the drums.

The photoconductor drum surface is prepared to restart the EP process.

Printer Sections

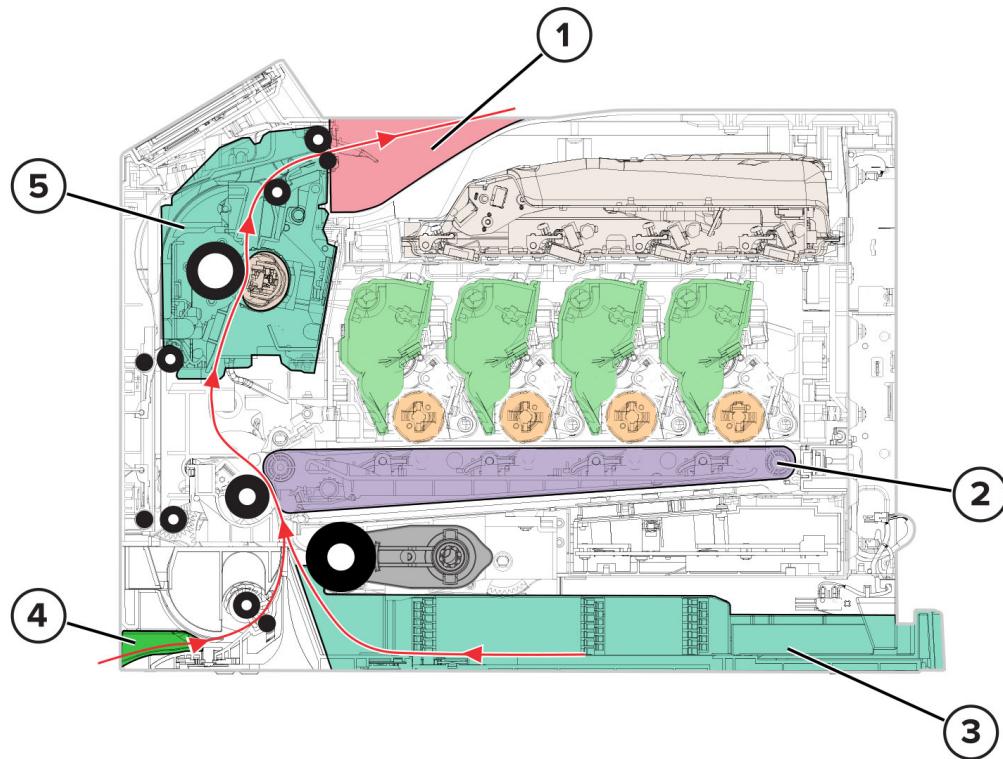

Item Number	Description
1	Output Bin
2	Transfer Module
3	Standard Tray
4	MPF
5	Fuser

Printer Paper Path Rollers

Standard Paper Path

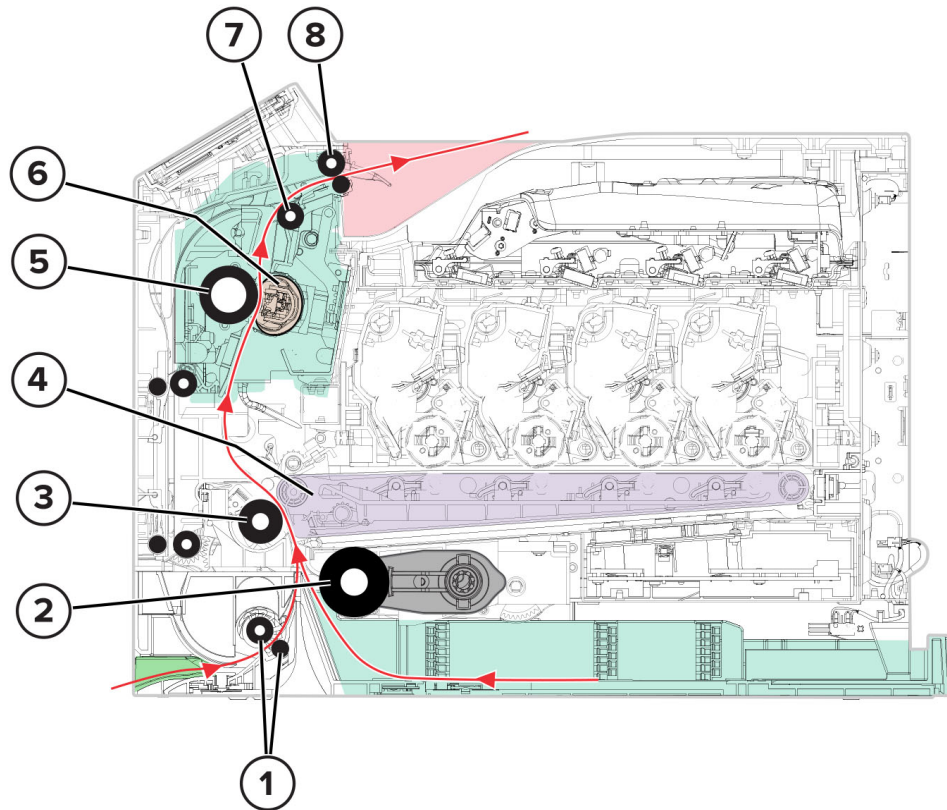

Item Number	Description
1	MPF Feed Rollers
2	Tray 1 Pick Roller
3	Second Transfer Roller
4	Transfer Belt
5	Fuser Roller
6	Fuser Belt

Item Number	Description
7	Fuser Decurl Roller
8	Fuser Exit Rollers

Paper is fed from the tray or MPF into the printer by pick or feed rollers.

The rollers push the paper to the transfer module where the image is transferred to the page.

The second transfer roller then moves the paper to the fuser, where heat and pressure are applied to the page to make the toner stick to the media.

The fuser roller pushes the paper towards the exit bin. The fuser exit rollers guide the paper into the exit bin.

Duplex Paper Path

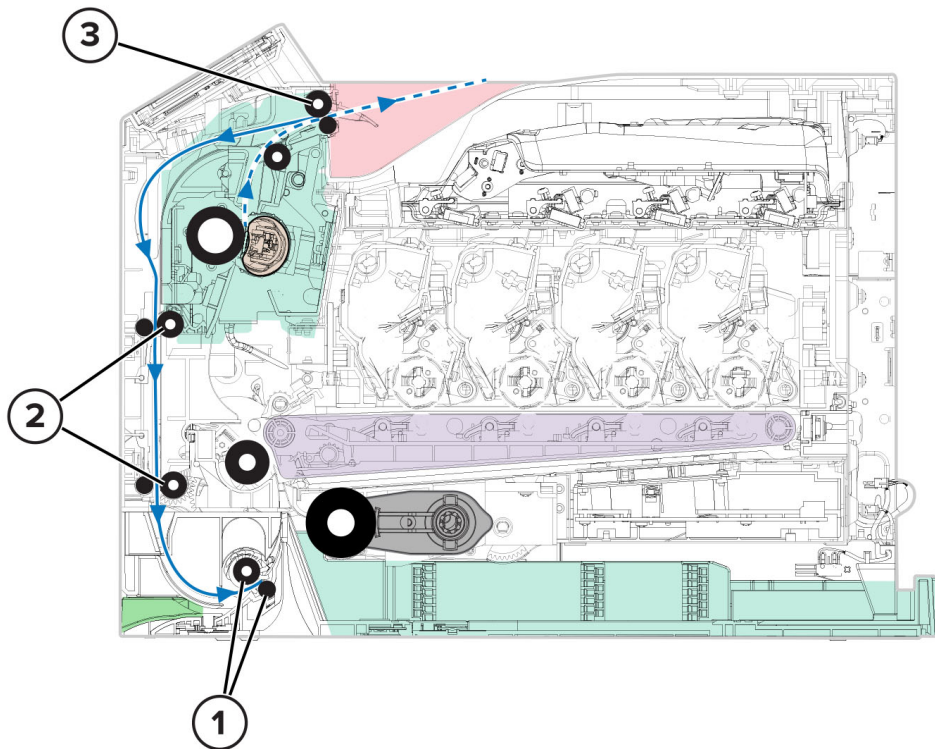

Item Number	Description
1	Duplex Staging Rollers
2	Duplex Transport Rollers
3	Fuser Exit Roller

Printers with duplex support use a secondary paper path to print on the second side of a sheet of paper.

After the first side of the paper is printed and the trailing edge of the paper clears the fuser exit sensor, the fuser motor engages to reverse the paper direction and feed it into the duplex unit. The pick motor also reverses.

The pick motor drives the duplex aligner rollers, which push the media down to the bottom turnaround in the paper tray and gate aligner.

When the trailing edge of the media clears the fuser, the fuser engine rotates forward to prepare the fuser for the page traveling through the duplex unit. As the media reaches the gate aligner, the speed of the pick motor is adjusted to accommodate the speed of the transfer belt, ensuring the proper registration of the image on the media.

The paper travels to the transfer module, and the second image is transferred to the reverse side of the media. Once the image is transferred, the media travels to the fuser, the fuser exit roller, and then on to the output bin.

Note: While the sheet is being transported through the duplex unit, it is the only sheet of paper being processed by the print engine. A user should not attempt to insert a sheet of paper into the manual paper feed while a duplex job is being processed to avoid a paper jam.

Printer Paper Path Sensors

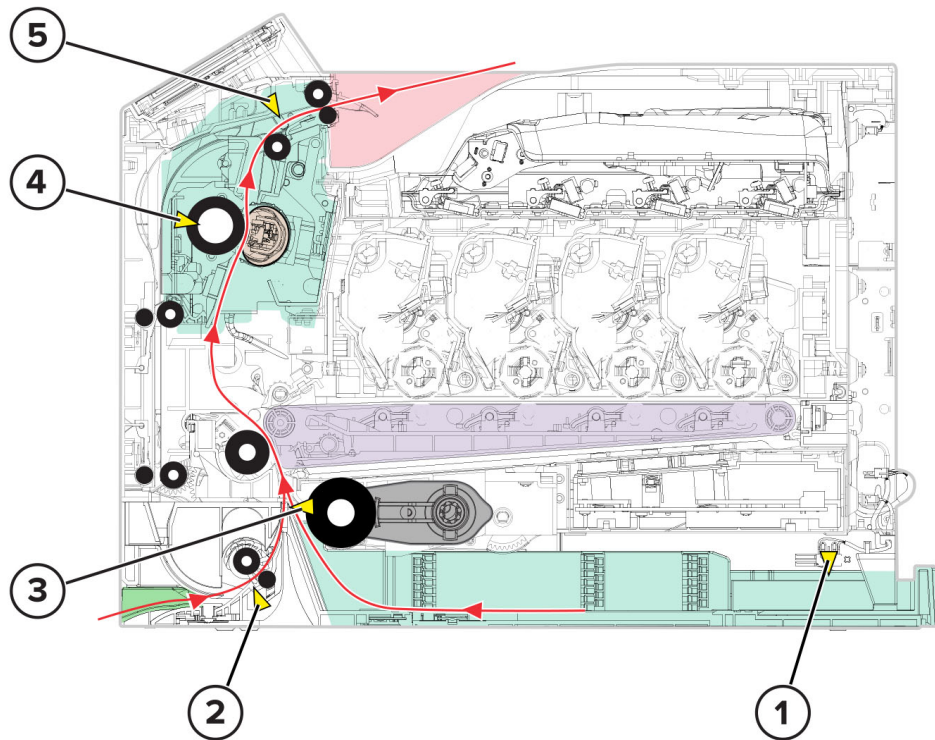

Item Number	Description
1	Sensor (tray present)
2	Sensor (duplex/manual feed)
3	Sensor (input)
4	Sensor (fuser exit)
5	Sensor (bin full)

Flatbed Scanner Drive

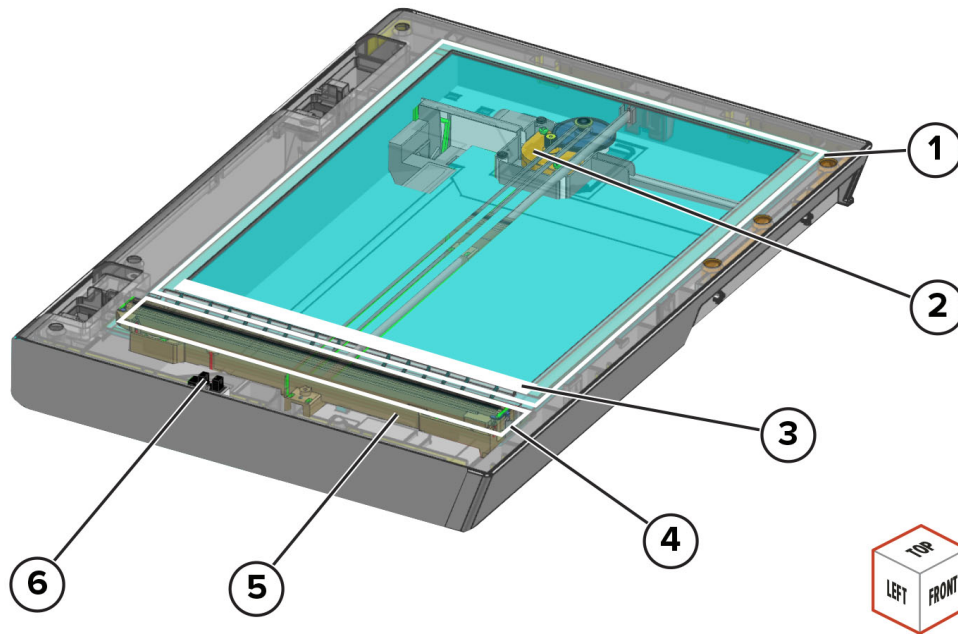

Item Number	Description
1	Scanner Glass Area
2	Motor (Flatbed CIS Scanner)
3	Calibration Reference Strip
4	DADF Glass Area
5	Flatbed CIS Scanner
6	Sensor (Flatbed CIS Scanner)

The flatbed scanner has a contact image sensor (CIS) scanner that illuminates the surface of the document. The reflections produced are detected by the CIS scanner to create the scan image.

For flatbed scan jobs, the CIS scanner moves across the scanner glass area to scan the front side of the document (facedown). The motor (flatbed CIS scanner) controls the CIS scanner position. The CIS scanner is detected at its home position by the sensor (flatbed CIS scanner). The position of the CIS scanner is also detected based on the computed distance relative to the calibration reference strip. To maintain the correct shading levels if needed, the CIS scanner scans the white surface of the calibration reference strip.

During DADF scan jobs, the CIS scanner stays at the DADF glass area to scan the front side of the document.

DADF Paper Path Rollers

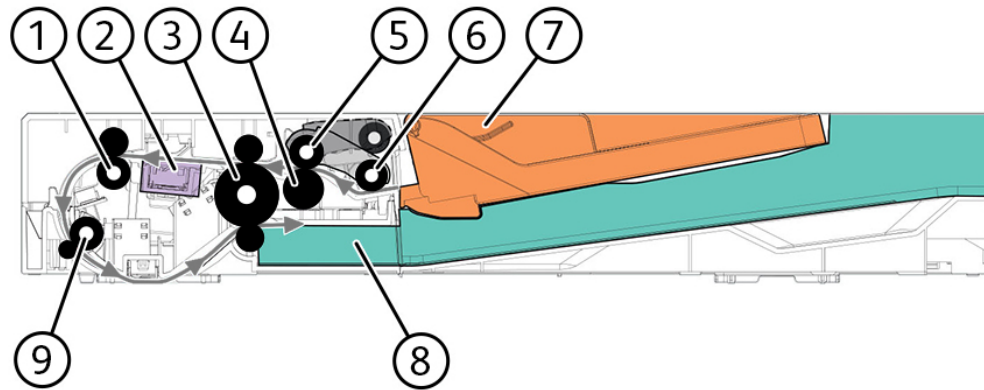

VLC4155_8016

Item Number	Description
1	DADF Transport Roller
2	DADF CIS Scanner
3	DADF Feed/Exit Roller
4	DADF Separator Roller
5	DADF Feed Roller
6	DADF Pick Roller
7	DADF Tray
8	DADF Bin
9	DADF Scan Roller

Paper from the DADF tray enters the DADF through the pick roller, feed roller, and separator roller.

The back side of the paper is scanned after the paper passes the DADF feed/exit roller. The front side of the paper is scanned after the paper passes the DADF scan roller.

After the paper is scanned, it is ejected by the feed/exit roller to the DADF bin.

DADF Paper Path Sensors

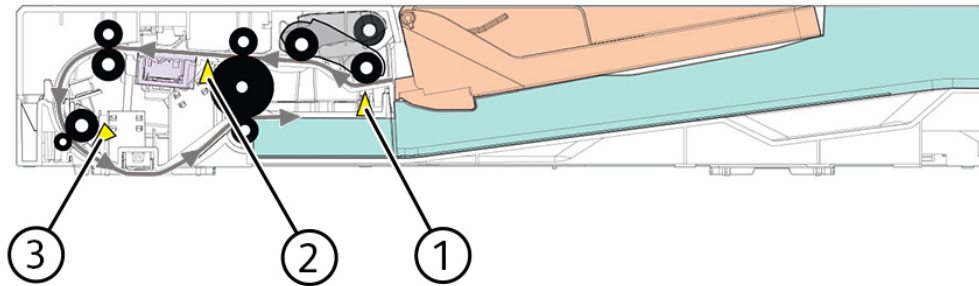

VLC415S_8017

Item Number	Sensor	Function
1	Sensor (DADF paper present)	Detects paper presence in the DADF tray
2	Sensor (DADF scan 2)	Detects the paper that is about to be scanned at its back side
3	Sensor (DADF scan 1)	Detects the paper that is about to be scanned at its front side

DADF Pick and Feed Drive

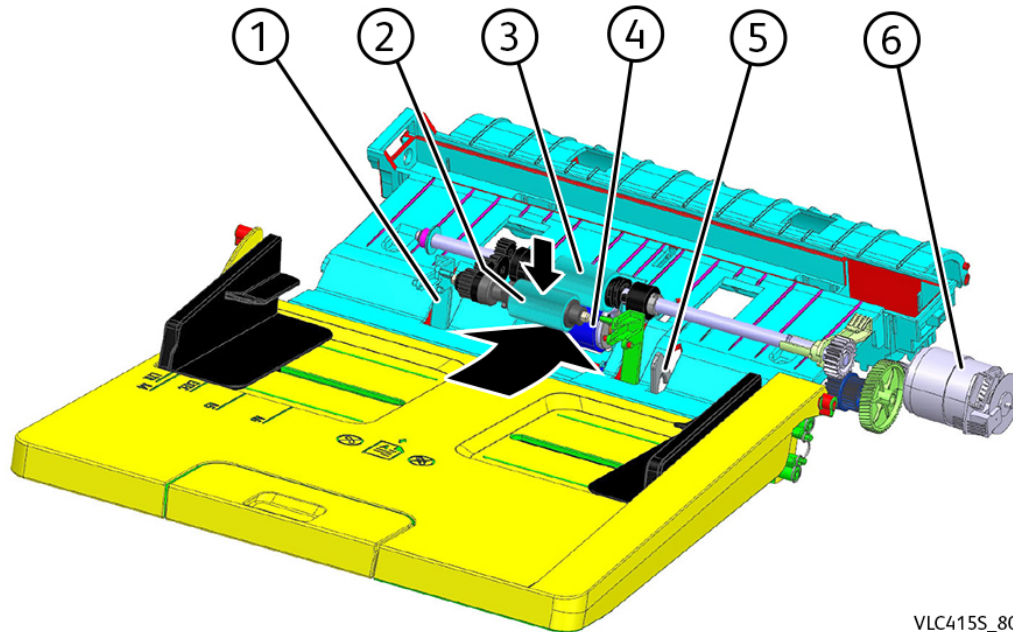

VLC415S_8018

Item Number	Description
1	Paper Stop
2	DADF Pick Roller
3	DADF Feed Roller
4	DADF Separator Roller
5	Sensor (DADF Paper Present)
6	Motor (DADF Pick)

The sensor (DADF paper present) detects if paper is loaded in the DADF tray. When the scan job command is signaled, the pick roller lowers to pick the paper from the DADF tray.

Note: When the pick roller is raised, the leading edges of the paper in the tray are aligned by the paper stops.

When paper reaches the feed roller, the resistance of the separator roller allows only the topmost sheet to feed.

The motor (DADF pick) drives the DADF pick and feed rollers.

DADF Transport and Scan Drive

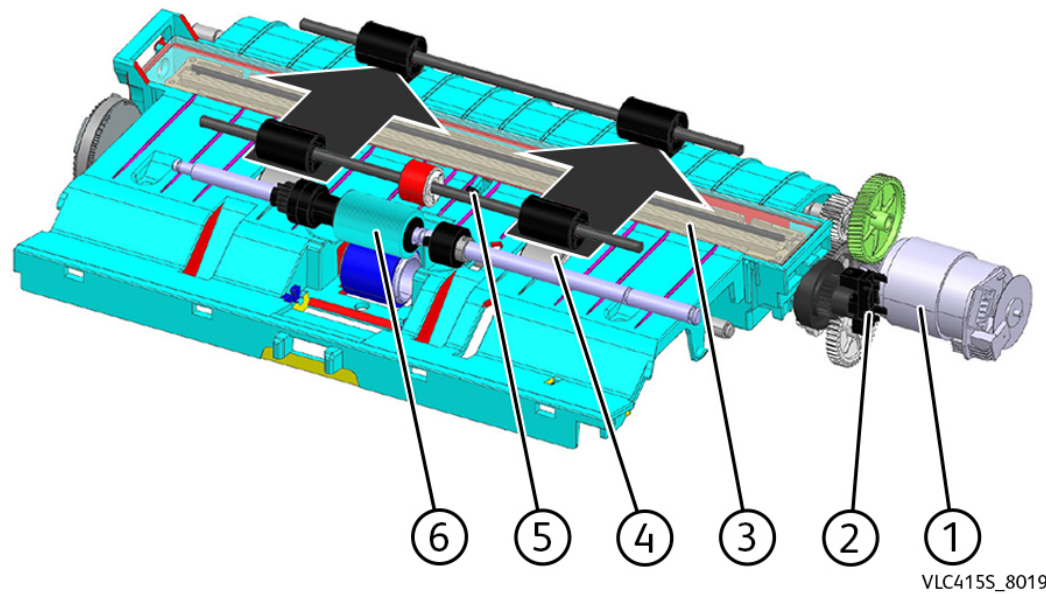

Item Number	Description
1	Motor (DADF Transport)
2	Sensor (DADF Calibration)
3	DADF CIS Scanner
4	DADF Feed/Exit Roller
5	Sensor (DADF Scan 2)
6	DADF Feed Roller

As paper enters the DADF, the DADF feed/exit roller receives it. The sensor (DADF scan 2) detects the paper to start the scan. The DADF CIS scanner scans the back side of the document.

The motor (DADF transport) drives the DADF feed/exit roller.

Note: If needed, calibration for the DADF CIS scanner occurs automatically before a job to adjust shading levels. During calibration, the DADF CIS scanner moves laterally to scan a reference white surface on the opposite side. The DADF CIS scanner is detected at its home position by the sensor (DADF calibration).

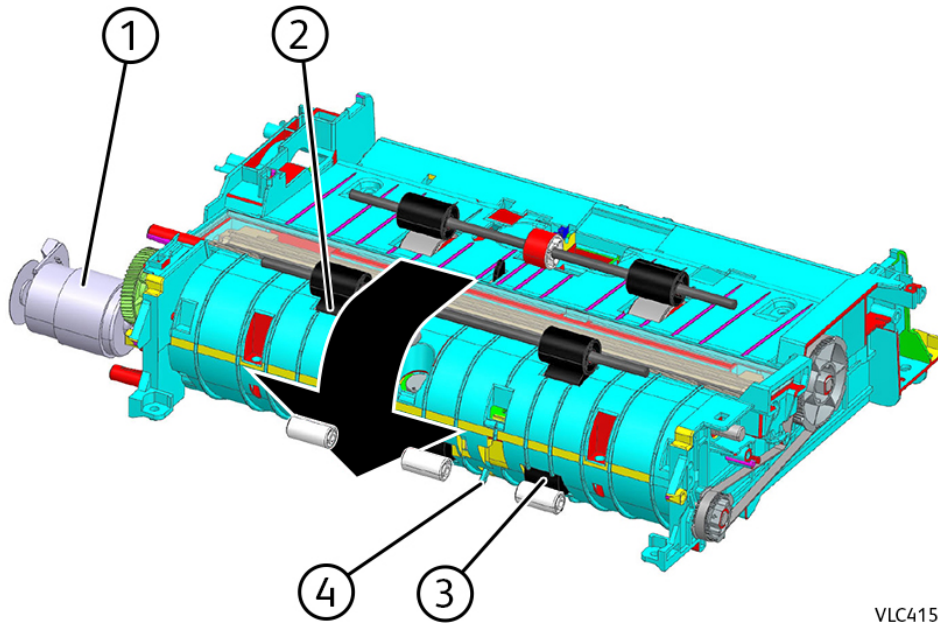

VLC415S_8020

Item Number	Description
1	Motor (DADF Transport)
2	DADF Transport Roller
3	DADF Scan Roller
4	Sensor (DADF Scan 1)

After the back side is scanned, the DADF transport roller transports paper to the DADF scan roller.

The motor (DADF transport) drives the DADF transport and scan rollers.

DADF Exit Drive

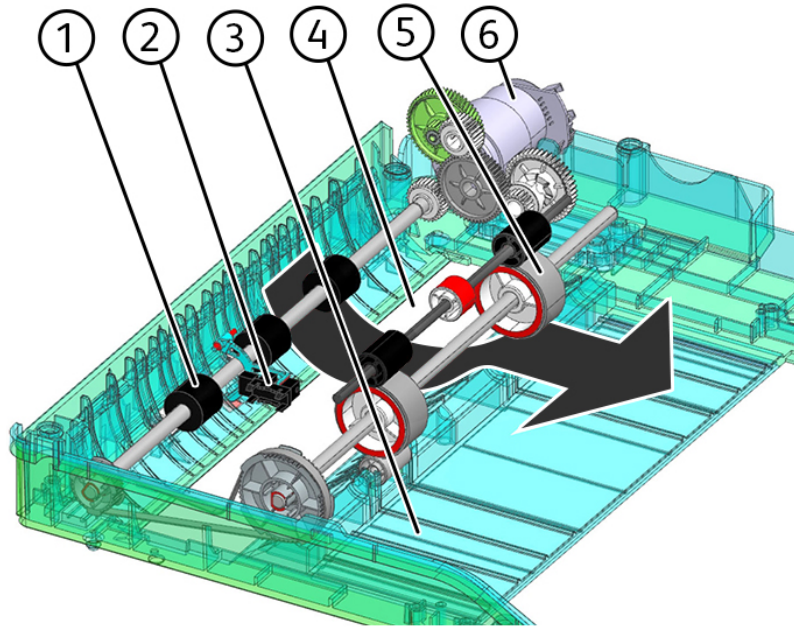

VLC415S_8021

Item Number	Description
1	DADF Scan Roller
2	Sensor (DADF Scan 1)
3	DADF Bin
4	DADF Glass
5	DADF Feed/Exit Roller
6	Motor (DADF Transport)

Paper is fed to the DADF scan roller for front-side scanning. At the DADF glass area, the flatbed scanner does the scan. The DADF feed/exit roller ejects the scanned document to the DADF bin.

The motor (DADF transport) drives the scan and exit rollers. The sensor (DADF scan 1) detects the paper entering the DADF glass area.

Reference Library

VLB415 and VLC415 NVM Tables	414
Log Book	547
EHS 700 - Health and Safety Incident Report Form	568

NVMID- Index	Tools		Display Mode	dc131 Display Name	Category	Type	Reset After Forced Altboot Software Installation	External Reference	Version	Machine Configure Parameter	Is part of Diagnostics Database?
	Description	Setting Information									
600-009	BlockSize in K		RW	BlockSize in K	NVMConfiguration	natural	No		1.686		
600-012	Frame Size		RW	Frame Size	NVMConfiguration	natural	No		1.686		
600-015	Fault Counter 19-750-00: VideoEPCSizeMisMatchCntr		RW	Ram Size Mismatch FaultFC	NVMFaultCounter	shortNatural	No	Fault Counter:19-750-00:	1.813		
600-016	Fault Counter 19-754-00: VideoDiskMismatchCntr		RW	Disk Mode Mismatch FaultFC	NVMFaultCounter	shortNatural	No	Fault Counter:19-754-00:	1.813		
600-017	Fault Counter 19-401-00: Out of Memory Fault - Stress Document		RW	Out Memory Fault - StrNC docFC	NVMFaultCounter	shortNatural	No	Fault Counter:19-401-00: Out of Memory Fault - Stress	1.153		
600-018	Fault Counter 19-402-00: FaultVideoDVMSTimeOutFault		RW	Compressor DVMA Timeout FaultFC	NVMFaultCounter	shortNatural	No	Fault Counter:19-402-00:	1.153		
600-020	Fault Counter 22-300-10: AHA End of Record Fault		RW	AHA End of Record Fault	NVMFaultCounter	shortNatural	No	Fault Counter:22-300-10: AHA End of Record Fault	1.000		
600-059	Toner Coverage Plane1-2		RO	Toner Coverage Plane1-2	NVMSystemUsageCounter	longNatural	No	System Usage	1.813		
600-060	Toner Coverage Plane1-3		RO	Toner Coverage Plane1-3	NVMSystemUsageCounter	longNatural	No	System Usage	1.813		
600-061	Toner Coverage Plane1-4		RO	Toner Coverage Plane1-4	NVMSystemUsageCounter	longNatural	No	System Usage	1.813		
600-071	Toner Coverage Plane1-14		RO	Toner Coverage Plane1-14	NVMSystemUsageCounter	longNatural	No	System Usage	1.813		
600-073	Toner Coverage Plane1-16		RO	Toner Coverage Plane1-16	NVMSystemUsageCounter	longNatural	No	System Usage Counter:226: Black	1.813		
600-074	Toner Coverage Plane1-17		RO	Toner Coverage Plane1-17	NVMSystemUsageCounter	longNatural	No	System Usage Counter:227: Black	1.813		
600-076	Toner Coverage Plane1-19		RO	Toner Coverage Plane1-19	NVMSystemUsageCounter	longNatural	No	System Usage Counter:229: Black >90 to 100% Area Coverage Impressions	1.813		
600-117	Toner Coverage Plane4-3		RO	Toner Coverage Plane4-3	NVMSystemUsageCounter	longNatural	No	System Usage Counter:278: Yellow >2 to 3% Area Coverage	1.813		
600-209	Fault Counter 19-420: Image Processing	no. of faults	RW	Fault Counter 19-420	NVMFaultCounter	shortNatural	No	Fault Counter:19-420-	1.660		
600-210	Fault Counter 19-422: Image Processing	no of faults	RW	Fault Counter 19-422	NVMFaultCounter	shortNatural	No	Fault Counter:19-422-	1.660		
600-211	Fault Counter 19-424: Image Processing	no of faults	RW	Fault Counter 19-424	NVMFaultCounter	shortNatural	No	Fault Counter:19-424-	1.660		
600-212	Fault Counter 19-426: Image Processing	no of faults	RW	Fault Counter 19-426	NVMFaultCounter	shortNatural	No	Fault Counter:19-426-	1.663		
600-213	Fault Counter 19-410-14: Scan Output	no of faults	RW	Fault Counter 19-410-14	NVMFaultCounter	shortNatural	No	Fault Counter:19-410-	1.668		
600-214	Fault Counter 19-340 :SIC Crash	no of faults	RW	Fault Counter 19-340-00	NVMFaultCounter	shortNatural	No	Fault Counter:19-340-	1.813		
603-002	Determines whether APS requires input to		RW	APSSStandardSizeRequired	NVMSAKOSetting	boolean	No		1.000		
603-013	Counter-COPYLargeSheets		ND		NVMBillingCounter	byteArray	No	Billing Counter:16:	1.799		
603-041	Counter-COPYLargeColorSheets		ND		NVMBillingCounter	byteArray	No	Billing Counter:19: Color Copied Large Sheets	1.799		
604-025	Counter-CollatedSheets		ND		NVMSystemUsageCounter	byteArray	No	System Usage Counter:186: All collated sheets	1.799		

604-028	Counter-DualStaples		ND		NVMSystemUsageCounter	byteArray	No	System Usage Counter:192: All dual staples	1.799		
604-037	Counter-PunchedSheets		ND		NVMSystemUsageCounter	byteArray	No	System Usage Counter:187: All punched sheets	1.799		
604-046	Counter-StapledSheets		ND		NVMSystemUsageCounter	byteArray	No	System Usage Counter:189: All stapled sheets	1.799		
604-055	Counter-All Uncollated Stapled sheets		ND		NVMSystemUsageCounter	byteArray	No	System Usage Counter:188: All uncollated stapled sheets	1.799		
604-061	Counter-DualPitchImages		ND		NVMSystemUsageCounter	byteArray	No	System Usage Counter:56: Number of developed dual-pitch images	1.799		
604-064	Counter-Stapled2_15		ND		NVMSystemUsageCounter	byteArray	No	System Usage Counter:180: Number of stapled output sets with 2 to 15 sheets	1.799		
604-067	Counter-Stapled16_30		ND		NVMSystemUsageCounter	byteArray	No	System Usage Counter:181: Number of stapled output sets with 16 to 30 sheets	1.799		
604-090	-Images During Service Call		ND		NVMDiagCounter	byteArray	No	Diagnostic Counter:299: Images During Service	1.799		
604-092	-Images Between Service Calls		ND		NVMDiagCounter	byteArray	No	Diagnostic Counter:300: Images Between Service	1.000		
604-094	Fault Counter 22-310-04:PageTKTSOutOfOrder (SheetsOutOfSequence)	no. of faults	ND		NVMFaultCounter	byteArray	No	Fault Counter:22-310-04: PageTKTSOutOfOrder	1.153		
604-099	Fault Counter 22-314-04: ModuleRegistrationError	no. of faults	ND		NVMFaultCounter	byteArray	No	Fault Counter:22-314-04: ModuleRegistrationError	1.000		
604-101	Fault Counter 22-315-04: NoCompletionsError	no. of faults	ND		NVMFaultCounter	byteArray	No	Fault Counter:22-315-04: NoCompletionsError	1.143		
604-105	Fault Counter 22-701-04: CompletionWhileIdle	no. of faults	ND		NVMFaultCounter	byteArray	No	Fault Counter:22-701-04: CompletionWhileIdle	1.000		

604-107	Fault Counter 22-316-04: trayDoesNotExist	no. of faults	ND		NVMFaultCounter	byteArray	No	Fault Counter:22-316-04: trayDoesNotExist	1.000		
604-109	Fault Counter 22-317-04: noFinisherCapabilityFound	no. of faults	ND		NVMFaultCounter	byteArray	No	Fault Counter:22-317-04: noFinisherCapabilityFound	1.000		
604-111	Fault Counter 22-318-04: noOTCapabilityFound	no. of faults	ND		NVMFaultCounter	byteArray	No	Fault Counter:22-318-04: noOTCapabilityFound	1.000		
604-127	Enable Offset policy	Enable Offset policy 0=Off 1=On	RW	MsoffsetEnabledPolicy	NVMSAKOSetting	boolean	No		1.754		
604-132	ProdCfgNvm	Northwood	RW	ProdCfgNvm	NVMConfiguration	shortNatural	No		1.266		
604-132	ProdCfgNvm	Burgundy	RW	ProdCfgNvm	NVMConfiguration	shortNatural	No		1.507		
604-132	ProdCfgNvm	Barolo	RW	ProdCfgNvm	NVMConfiguration	shortNatural	No		1.507		
604-135	Counter-Stapled31_50		ND		NVMSystemUsageCounter	byteArray	No	System Usage Counter:182: Number of stapled output sets with 31 to 50 sheets	1.799		
604-136	Counter-Stapled51_100		ND		NVMSystemUsageCounter	byteArray	No	System Usage Counter:183: Number of stapled output sets with 51 to 100 sheets	1.799		
604-160	Fault Counter 03-316: CCMCannotCommunicateWithlotFC		RW	CCMCannotCommunicateWithlotFC	NVMFaultCounter	shortNatural	No	Fault Counter:03-316-00: CCMCannotCommunicateWithlotFC	1.813		
604-161	Fault Counter 10-311: FuserHeatRollStsDisconnectFailCountFC		RW	FuserHeatRollStsDisconnectFC	NVMFaultCounter	shortNatural	No	Fault Counter:10-311-00: FuserHeatRollStsDisconnectFailCountFC	1.159		
604-162	Fault Counter 10-319: FuserNcSnrDifferentialFailCountFC		RW	FuserNcSnrDifferentialFC	NVMFaultCounter	shortNatural	No	Fault Counter:10-319-00: FuserNcSnrDifferentialFailCountFC	1.159		
604-163	Fault Counter 10-320: HeatRolloverTempFailCountFC		RW	HeatRolloverTempFailCountFC	NVMFaultCounter	shortNatural	No	Fault Counter:10-320-00: HeatRolloverTempFailCountFC	1.159		
604-164	Fault Counter 10-321: FuserNipFailCountFC		RW	FuserNipFailCountFC	NVMFaultCounter	shortNatural	No	Fault Counter:10-321-00: FuserNipFailCountFC	1.159		

604-165	Fault Counter 10-323: FuserRearNcSnrDisconnectFailCountFC		RW	FuserRearNcSnrDisconnectFC	NVMFaultCounter	shortNatural	No	Fault Counter:10-323-00: FuserRearNcSnrDisconnectFailCountFC	1.159		
604-166	Fault Counter 10-324: FuserNvmFailCountFC		RW	FuserNvmFailCountFC	NVMFaultCounter	shortNatural	No	Fault Counter:10-324-00: FuserNvmFailCountFC	1.159		
604-167	Fault Counter 10-326: WaitHeatRollFuserOnTimeFailCountFC		RW	WaitHeatRollFuserOnTimeFC	NVMFaultCounter	shortNatural	No	Fault Counter:10-326-00: WaitHeatRollFuserOnTimeFailCountFC	1.159		
604-168	Fault Counter 10-327: StandbyHeatRollFuserOnTimeFailCountFC		RW	StandbyHeatRollFuserOnTimeFC	NVMFaultCounter	shortNatural	No	Fault Counter:10-327-00: StandbyHeatRollFuserOnTimeFailCountFC	1.159		
604-169	Fault Counter 10-330: FuserMotorFailFC		RW	FuserMotorFailFC	NVMFaultCounter	shortNatural	No	Fault Counter:10-330-00: FuserMotorFailFC	1.813		
604-170	Fault Counter 12-112: HxportEntSnrOnJamFaultCountFC		RW	HxportEntSnrOnJamFaultCountFC	NVMFaultCounter	shortNatural	No	Fault Counter:12-112-00: HxportEntSnrOnJamFaultCountFC	1.813		
604-171	Fault Counter 12-113: BookletInSnrOnJamFaultCountFC		RW	BookletInSnrOnJamFaultCountFC	NVMFaultCounter	shortNatural	No	Fault Counter:12-113-00: BookletInSnrOnJamFaultCountFC	1.813		
604-172	Fault Counter 12-114: BookletInSnrOffJamFaultCountFC		RW	BookletInSnrOffJamFaultCountFC	NVMFaultCounter	shortNatural	No	Fault Counter:12-114-00: BookletInSnrOffJamFaultCountFC	1.813		
604-173	Fault Counter 12-115: BookletFolderRollExitSnrOnJamFaultCountFC		RW	BookletFolderRollExitSnrOnJamFC	NVMFaultCounter	shortNatural	No	Fault Counter:12-115-00: BookletFolderRollExitSnrOnJamFaultCountFC	1.813		
604-174	Fault Counter 12-125: GateSnrOnJamFaultCountFC		RW	GateSnrOnJamFaultCountFC	NVMFaultCounter	shortNatural	No	Fault Counter:12-125-00: GateSnrOnJamFaultCountFC	1.521		
604-175	Fault Counter 12-132: XportEntSnrOnJamFaultCountFC		RW	XportEntSnrOnJamFaultCountFC	NVMFaultCounter	shortNatural	No	Fault Counter:12-132-00: XportEntSnrOnJamFaultCountFC	1.813		
604-176	Fault Counter 12-142: BufferPathSnrOnJamFaultCountFC		RW	BufferPathSnrOnJamFaultCountFC	NVMFaultCounter	shortNatural	No	Fault Counter:12-142-00: BufferPathSnrOnJamFaultCountFC	1.521		
604-177	Fault Counter 12-151: CompileExitSnrOffJamFaultCountFC		RW	CompileExitSnrOffJamFC	NVMFaultCounter	shortNatural	No	Fault Counter:12-151-00: CompileExitSnrOffJamFaultCountFC	1.813		

604-178	Fault Counter 12-152: CompileExitSnrOnJamFaultCountFC		RW	CompileExitSnrOnJamFaultCountFC	NVMFaultCounter	shortNatural	No	Fault Counter:12-152-00: CompileExitSnrOnJamFaultCountFC	1.813		
604-179	Fault Counter 12-161: SetEjectJamFaultCountFC		RW	SetEjectJamFaultCountFC	NVMFaultCounter	shortNatural	No	Fault Counter:12-161-00: SetEjectJamFaultCountFC	1.813		
604-180	Fault Counter 12-162: HxportExitSnrOnJamFaultCountFC		RW	HxportExitSnrOnJamFaultCountFC	NVMFaultCounter	shortNatural	No	Fault Counter:12-162-00: HxportExitSnrOnJamFaultCountFC	1.521		
604-181	Fault Counter 12-171: TopTrayExitSnrOnJamFaultCountFC		RW	TopTrayExitSnrOnJamFaultCountFC	NVMFaultCounter	shortNatural	No	Fault Counter:12-171-00: TopTrayExitSnrOnJamFaultCountFC	1.813		
604-182	Fault Counter 12-172: TopTrayExitSnrOffJamFaultCountFC		RW	TopTrayExitSnrOffJamFaultCountFC	NVMFaultCounter	shortNatural	No	Fault Counter:12-172-00: TopTrayExitSnrOffJamFaultCountFC	1.813		
604-183	Fault Counter 12-180: BookletFolderRollExitSnrOffJamFaultCountFC		RW	BookletFolderRollExitSnrOffJamFC	NVMFaultCounter	shortNatural	No	Fault Counter:12-180-00: BookletFolderRollExitSnrOffJamFaultCountFC	1.813		
604-184	Fault Counter 12-211: StackerTrayFailFaultCountFC		RW	StackerTrayFailFaultCountFC	NVMFaultCounter	shortNatural	No	Fault Counter:12-211-00: StackerTrayFailFaultCountFC	1.813		
604-185	Fault Counter 12-212: StackerUpperLimitFailFaultCountFC		RW	StackerUpperLimitFailFC	NVMFaultCounter	shortNatural	No	Fault Counter:12-212-00: StackerUpperLimitFailFaultCountFC	1.813		
604-186	Fault Counter 12-213: StackerLowerLimitFailFaultCountFC		RW	StackerLowerLimitFailFC	NVMFaultCounter	shortNatural	No	Fault Counter:12-213-00: StackerLowerLimitFailFaultCountFC	1.813		
604-187	Fault Counter 12-221: FrontTamperHomeSnrOnFailFaultCountFC		RW	FrontTamperHomeSnrOnFailFC	NVMFaultCounter	shortNatural	No	Fault Counter:12-221-00: FrontTamperHomeSnrOnFailFaultCountFC	1.813		
604-188	Fault Counter 12-223: FrontTamperHomeSnrOffFailFaultCountFC		RW	FrontTamperHomeSnrOffFailFC	NVMFaultCounter	shortNatural	No	Fault Counter:12-223-00: FrontTamperHomeSnrOffFailFaultCountFC	1.813		
604-189	Fault Counter 12-224: RearTamperHomeSnrOffFailFaultCountFC		RW	RearTamperHomeSnrOffFailFC	NVMFaultCounter	shortNatural	No	Fault Counter:12-224-00: RearTamperHomeSnrOffFailFaultCountFC	1.813		
604-190	Fault Counter 12-225: BookletTamperFHomeSnrOnFailFaultCountFC		RW	BookletTamperFHomeSnrOnFailFC	NVMFaultCounter	shortNatural	No	Fault Counter:12-225-00: BookletTamperFHomeSnrOnFailFaultCountFC	1.813		

604-191	Fault Counter 12-226: BookletTamperFHomeSnrOffFailFaultCountFC		RW	BookletTamperFHomeSnrOffFailFC	NVMFaultCounter	shortNatural	No	Fault Counter:12-226-00: BookletTamperFHomeSnrOffFailFaultCountF	1.521		
604-192	Fault Counter 12-227: BookletEndGuideHomeSnrOffFailFaultCountFC		RW	BookletEndGuideHomeSnrOffFailFC	NVMFaultCounter	shortNatural	No	Fault Counter:12-227-00: BookletEndGuideHomeSnrOffFailFaultCount	1.813		
604-193	Fault Counter 12-228: BookletEndGuideHomeSnrOnFailFaultCountFC		RW	BookletEndGuideHomeSnrOnFailFC	NVMFaultCounter	shortNatural	No	Fault Counter:12-228-00: BookletEndGuideHomeSnrOnFailFaultCount	1.813		
604-194	Fault Counter 12-229: BookletTamperRHomeSnrOnFailFaultCountFC		RW	BookletTamperRHomeSnrOnFailFC	NVMFaultCounter	shortNatural	No	Fault Counter:12-229-00: BookletTamperRHomeSnrOnFailFaultCountF	1.521		
604-195	Fault Counter 12-230: BookletTamperRHomeSnrOffFailFaultCountFC		RW	BookletTamperRHomeSnrOffFailFC	NVMFaultCounter	shortNatural	No	Fault Counter:12-230-00: BookletTamperRHomeSnrOffFailFaultCountF	1.521		
604-196	Fault Counter 12-243: BookletKnifeHomeSnrOnFailFaultCountFC		RW	BookletKnifeHomeSnrOnFailFC	NVMFaultCounter	shortNatural	No	Fault Counter:12-243-00:	1.521		
604-197	Fault Counter 12-246: BookletStaplerFailCountFC		RW	BookletStaplerFailCountFC	NVMFaultCounter	shortNatural	No	Fault Counter:12-246-00: BookletStaplerFailCountFC	1.813		
604-198	Fault Counter 12-247: SideRegiSnrOffFailFaultCountFC		RW	SideRegiSnrOffFailFaultCountFC	NVMFaultCounter	shortNatural	No	Fault Counter:12-247-00:	1.813		
604-199	Fault Counter 12-260: EjectClampHomeSnrOnFailFaultCountFC		RW	EjectClampHomeSnrOnFailFC	NVMFaultCounter	shortNatural	No	Fault Counter:12-260-00: EjectClampHomeSnrOnFailFaultCountFC	1.813		
604-200	Fault Counter 12-261: BookletKnifeFoldingSnrFailFaultCountFC		RW	BookletKnifeFoldingSnrFailFC	NVMFaultCounter	shortNatural	No	Fault Counter:12-261-00: BookletKnifeFoldingSnrFailFaultCountFC	1.521		
604-201	Fault Counter 12-263: RearTsmperHomeSnrOnFailFaultCountFC		RW	RearTsmperHomeSnrOnFailFC	NVMFaultCounter	shortNatural	No	Fault Counter:12-263-00: RearTsmperHomeSnrOnFailFaultCountFC	1.813		
604-202	Fault Counter 12-264: BookletDrawerBrokenFailFaultCountFC		RW	BookletDrawerBrokenFailFC	NVMFaultCounter	shortNatural	No	Fault Counter:12-264-00: BookletDrawerBrokenFailFaultCountFC	1.521		
604-203	Fault Counter 12-265: BookletKnifeHomeSnrOffFailFaultCountFC		RW	BookletKnifeHomeSnrOffFailFC	NVMFaultCounter	shortNatural	No	Fault Counter:12-265-00:	1.813		
604-204	Fault Counter 12-266: BookletCompilerNoPaperSnrFailFaultCountFC		RW	BookletCompilerNoPaperSnrFailFC	NVMFaultCounter	shortNatural	No	Fault Counter:12-266-00: BookletCompilerNoPaperSnrFailFaultCountFC	1.813		
604-205	Fault Counter 12-270: TopOffsetHomeSnrOnFailCountFC		RW	TopOffsetHomeSnrOnFailCountFC	NVMFaultCounter	shortNatural	No	Fault Counter:12-270-00: TopOffsetHomeSnrOnFailCountFC	1.810		

604-205	Fault Counter 12-601: TopOffsetHomeSnrOnFailCountFC		RW	TopOffsetHomeSnrOnFailCountFC	NVMFaultCounter	shortNatural	No	Fault Counter:12-601-00: TopOffsetHomeSnrOnFailCountFC	1.813		
604-206	Fault Counter 12-271: TopOffsetHomeSnrOffFailCountFC		RW	TopOffsetHomeSnrOffFailCountFC	NVMFaultCounter	shortNatural	No	Fault Counter:12-271-00: TopOffsetHomeSnrOffFailCountFC	1.810		
604-206	Fault Counter 12-602: TopOffsetHomeSnrOffFailCountFC		RW	TopOffsetHomeSnrOffFailCountFC	NVMFaultCounter	shortNatural	No	Fault Counter:12-602-00: TopOffsetHomeSnrOffFailCountFC	1.813		
604-207	Fault Counter 12-282: EjectClampHomeSnrOffFailFaultCountFC		RW	EjectClampHomeSnrOffFailFC	NVMFaultCounter	shortNatural	No	Fault Counter:12-282-00: EjectClampHomeSnrOffFailFaultCountFC	1.813		
604-208	Fault Counter 12-283: SetClampHomeSnrOnFailFaultCountFC		RW	SetClampHomeSnrOnFailFC	NVMFaultCounter	shortNatural	No	Fault Counter:12-283-00: SetClampHomeSnrOnFailFaultCountFC	1.813		
604-209	Fault Counter 12-284: SetClampHomeSnrOffFailFaultCountFC		RW	SetClampHomeSnrOffFC	NVMFaultCounter	shortNatural	No	Fault Counter:12-284-00: SetClampHomeSnrOffFailFaultCountFC	1.813		
604-210	Fault Counter 12-291: StapleFailCountFC		RW	StapleFailCountFC	NVMFaultCounter	shortNatural	No	Fault Counter:12-291-00: StapleFailCountFC	1.813		
604-211	Fault Counter 12-295: StaplerMovePositionSnrOnFailFaultCountFC		RW	StaplerMovePositionSnrOnFailFC	NVMFaultCounter	shortNatural	No	Fault Counter:12-295-00: StaplerMovePositionSnrOnFailFaultCountFC	1.813		
604-212	Fault Counter 12-296: StaplerMovePositionSnrOffFailFaultCountFC		RW	StaplerMovePositionSnrOffFailFC	NVMFaultCounter	shortNatural	No	Fault Counter:12-296-00: StaplerMovePositionSnrOffFailFaultCountFC	1.813		
604-213	Fault Counter 12-320: PunchHomeSnrOnFailFaultCountFC		RW	PunchHomeSnrOnFailFaultCountFC	NVMFaultCounter	shortNatural	No	Fault Counter:12-320-00: PunchHomeSnrOnFailFaultCountFC	1.813		
604-214	Fault Counter 12-321: PunchHomeSnrOffFailFaultCountFC		RW	PunchHomeSnrOffFailFaultCountFC	NVMFaultCounter	shortNatural	No	Fault Counter:12-321-00: PunchHomeSnrOffFailFaultCountFC	1.813		
604-215	Fault Counter 12-322: PuncherMoveHomeSnrOffFailFaultCountFC		RW	PuncherMoveHomeSnrOffFailFC	NVMFaultCounter	shortNatural	No	Fault Counter:12-322-00: PuncherMoveHomeSnrOffFailFaultCountFC	1.813		
604-216	Fault Counter 12-323: PuncherMoveHomeSnrOnFailFaultCountFC		RW	PuncherMoveHomeSnrOnFailFC	NVMFaultCounter	shortNatural	No	Fault Counter:12-323-00: PuncherMoveHomeSnrOnFailFaultCountFC	1.813		

604-217	Fault Counter 12-330: DeculerHomeSnrOffFailFaultCountFC		RW	DeculerHomeSnrOffFailFC	NVMFaultCounter	shortNatural	No	Fault Counter:12-330-00: DeculerHomeSnrOffFailFaultCountFC	1.521		
604-218	Fault Counter 12-332: DecurlerHomeSnrOnFailFaultCountFC		RW	DecurlerHomeSnrOnFailFC	NVMFaultCounter	shortNatural	No	Fault Counter:12-332-00: DecurlerHomeSnrOnFailFaultCountFC	1.521		
604-219	Fault Counter 12-334: FinisherDownLoadFailCountFC		RW	FinisherDownLoadFailCountFC	NVMFaultCounter	shortNatural	No	Fault Counter:12-334-00: FinisherDownLoadFailCountFC	1.813		
604-220	SPARE (was Fault Counter 12-335: BookletSubCpuCommFailFaultCountFC)		RW	SPARE 604-220	NVMFaultCounter	shortNatural	No	Fault Counter:12-335-00: BookletSubCpuCommFailFaultCountFC	1.687		
604-221	Fault Counter 13-902: PaperRemainAtBookletCompileNoPaperSnrFaultCountFC		RW	PaperAtBookletCompileNoPaperSnrFC	NVMFaultCounter	shortNatural	No	Fault Counter:13-902-00: PaperRemainAtBookletCompileNoPaperSnrFa	1.159		
604-222	Fault Counter 13-903: PaperRemainAtBookletFolderRollExitSnrFaultCountFC		RW	PaperAtBookletFolderRollExitSnrFC	NVMFaultCounter	shortNatural	No	Fault Counter:13-903-00: PaperRemainAtBookletFolderRollExitSnrFault	1.159		
604-223	Fault Counter 42-313: RearCoolingFanFailCountFC		RW	RearCoolingFanFailCountFC	NVMFaultCounter	shortNatural	No	Fault Counter:42-313-00: RearCoolingFanFailCountFC	1.159		
604-224	Fault Counter 42-320: DrumMotorYFailCountFC		RW	DrumMotorYFailCountFC	NVMFaultCounter	shortNatural	No	Fault Counter:42-320-00: DrumMotorYFailCountFC	1.813		
604-225	Fault Counter 42-321: DrumMotorMFailCountFC		RW	DrumMotorMFailCountFC	NVMFaultCounter	shortNatural	No	Fault Counter:42-321-00: DrumMotorMFailCountFC	1.743		
604-226	Fault Counter 42-322: DrumMotorCFailCountFC		RW	DrumMotorCFailCountFC	NVMFaultCounter	shortNatural	No	Fault Counter:42-322-00: DrumMotorCFailCountFC	1.743		
604-227	Fault Counter 42-323: DrumMotorKFailCountFC		RW	DrumMotorKFailCountFC	NVMFaultCounter	shortNatural	No	Fault Counter:42-323-00: DrumMotorKFailCountFC	1.813		
604-228	Fault Counter 42-324: IBTDriveMotorFailCountFC		RW	IBTDriveMotorFailCountFC	NVMFaultCounter	shortNatural	No	Fault Counter:42-324-00: IBTDriveMotorFailCountFC	1.813		
604-229	Fault Counter 42-325: MainMotorFailCountFC		RW	MainMotorFailCountFC	NVMFaultCounter	shortNatural	No	Fault Counter:42-325-00: MainMotorFailCountFC	1.813		

604-230	Fault Counter 42-326: BeltHomePositionTooLongCountFC		RW	BeltHomePositionTooLongCountFC	NVMFaultCounter	shortNatural	No	Fault Counter:42-326-00: BeltHomePositionTooLongCountFC	1.159		
604-231	Fault Counter 42-327: BeltPositionFailCountFC		RW	BeltPositionFailCountFC	NVMFaultCounter	shortNatural	No	Fault Counter:42-327-00: BeltPositionFailCountFC	1.159		
604-232	Fault Counter 42-328: BeltEdgeSnrFailFC		RW	BeltEdgeSnrFailFC	NVMFaultCounter	shortNatural	No	Fault Counter:42-328-00: BeltEdgeSnrFailFC	1.159		
604-233	Fault Counter 42-330: FuserExhaustFanFailCountFC		RW	FuserExhaustFanFailCountFC	NVMFaultCounter	shortNatural	No	Fault Counter:42-330-00: FuserExhaustFanFailCountFC	1.813		
604-234	Fault Counter 42-331: BlowerMotorFanFailCountFC		RW	BlowerMotorFanFailCountFC	NVMFaultCounter	shortNatural	No	Fault Counter:42-331-00: BlowerMotorFanFailCountFC	1.159		
604-235	Fault Counter 42-600: BeltWalkFailCountFC		RW	BeltWalkFailCountFC	NVMFaultCounter	shortNatural	No	Fault Counter:42-600-00: BeltWalkFailCountFC	1.159		
604-236	Fault Counter 42-601: BeltEdgeLearnFailCountFC		RW	BeltEdgeLearnFailCountFC	NVMFaultCounter	shortNatural	No	Fault Counter:42-601-00: BeltEdgeLearnFailCountFC	1.159		
604-237	Fault Counter 42-602: BeltEdgeCheckFailCountFC		RW	BeltEdgeCheckFailCountFC	NVMFaultCounter	shortNatural	No	Fault Counter:42-602-00: BeltEdgeCheckFailCountFC	1.159		
604-238	Fault Counter 42-603: SuctionFilterLifeFailCountFC		RW	SuctionFilterLifeFailCountFC	NVMFaultCounter	shortNatural	No	Fault Counter:42-603-00: SuctionFilterLifeFailCountFC	1.159		
604-239	Fault Counter 45-310: ImageReadyNgCountFC		RW	ImageReadyNgCountFC	NVMFaultCounter	shortNatural	No	Fault Counter:45-310-00: ImageReadyNgCountFC	1.813		
604-240	Fault Counter 45-311: ControllerCommFailCountFC		RW	ControllerCommFailCountFC	NVMFaultCounter	shortNatural	No	Fault Counter:45-311-00:	1.813		
604-241	Fault Counter 47-210:		RW	OctOffsetFailCountFC	NVMFaultCounter	shortNatural	No	Fault Counter:47-210-	1.153		
604-241	Fault Counter 12-701: OctOffsetFailCountFC		RW	OctOffsetFailCountFC	NVMFaultCounter	shortNatural	No	Fault Counter:12-701-00: OutputFinisherCommFailCountFC	1.521		
604-242	Fault Counter 47-310: OutputFinisherCommFailCountFC		RW	OutputFinisherCommFailCountFC	NVMFaultCounter	shortNatural	No	Fault Counter:47-310-00: OutputFinisherCommFailCountFC	1.813		
604-243	Fault Counter 61-600: RosDataYFailCountFC		RW	RosDataYFailCountFC	NVMFaultCounter	shortNatural	No	Fault Counter:61-600-00: RosDataYFailCountFC	1.766		

604-244	Fault Counter 61-601: RosDataYFailCountFC		RW	RosDataMFailCountFC	NVMFaultCounter	shortNatural	No	Fault Counter:61-601-00: RosDataMFailCountFC	1.766		
604-245	Fault Counter 61-602: RosDataCFailCountFC		RW	RosDataCFailCountFC	NVMFaultCounter	shortNatural	No	Fault Counter:61-602-00: RosDataCFailCountFC	1.766		
604-246	Fault Counter 61-603: RosDataKFailCountFC		RW	RosDataKFailCountFC	NVMFaultCounter	shortNatural	No	Fault Counter:61-603-00: RosDataKFailCountFC	1.159		
604-247	Fault Counter 61-310: Clapper1FailCountFC		RW	Clapper1FailCountFC	NVMFaultCounter	shortNatural	No	Fault Counter:61-310-00: Clapper1FailCountFC	1.159		
604-248	Fault Counter 61-311: Clapper2FailCountFC		RW	Clapper2FailCountFC	NVMFaultCounter	shortNatural	No	Fault Counter:61-311-00: Clapper2FailCountFC	1.159		
604-249	Fault Counter 61-313: SOSLongMFailCountFC		RW	SOSLongMFailCountFC	NVMFaultCounter	shortNatural	No	Fault Counter:61-313-00: SOSLongMFailCountFC	1.159		
604-250	Fault Counter 61-315: SOSLongKFailCountFC		RW	SOSLongKFailCountFC	NVMFaultCounter	shortNatural	No	Fault Counter:61-315-00: SOSLongKFailCountFC	1.159		
604-251	Fault Counter 61-317: SOSShortMFailCountFC		RW	SOSShortMFailCountFC	NVMFaultCounter	shortNatural	No	Fault Counter:61-317-00: SOSShortMFailCountFC	1.159		
604-252	Fault Counter 61-319: SOSShortKFailCountFC		RW	SOSShortKFailCountFC	NVMFaultCounter	shortNatural	No	Fault Counter:61-319-00: SOSShortKFailCountFC	1.159		
604-253	Fault Counter 61-320: PolygonMotor1FailCountFC		RW	PolygonMotor1FailCountFC	NVMFaultCounter	shortNatural	No	Fault Counter:61-320-00: PolygonMotor1FailCountFC	1.159		
604-254	Fault Counter 61-321: PolygonMotor2FailCountFC		RW	PolygonMotor2FailCountFC	NVMFaultCounter	shortNatural	No	Fault Counter:61-321-00: PolygonMotor2FailCountFC	1.159		
604-255	Fault Counter 61-323: NoSOSMFailCountFC		RW	NoSOSMFailCountFC	NVMFaultCounter	shortNatural	No	Fault Counter:61-323-00: NoSOSMFailCountFC	1.159		
604-256	Fault Counter 61-325: NoSOSKFailCountFC		RW	NoSOSKFailCountFC	NVMFaultCounter	shortNatural	No	Fault Counter:61-325-00: NoSOSKFailCountFC	1.159		

604-257	Fault Counter 61-326: ROSCConnectYFailCountFC		RW	ROSCConnectYFailCountFC	NVMFaultCounter	shortNatural	No	Fault Counter:61-326-00: ROSCConnectYFailCountFC	1.766		
604-258	Fault Counter 61-327: ROSCConnectMFailCountFC		RW	ROSCConnectMFailCountFC	NVMFaultCounter	shortNatural	No	Fault Counter:61-327-00: ROSCConnectMFailCou	1.766		
604-259	Fault Counter 61-328: ROSCConnectCFailCountFC		RW	ROSCConnectCFailCountFC	NVMFaultCounter	shortNatural	No	Fault Counter:61-328-00: ROSCConnectCFailCou	1.766		
604-260	Fault Counter 61-329: ROSCConnectKFailCountFC		RW	ROSCConnectKFailCountFC	NVMFaultCounter	shortNatural	No	Fault Counter:61-329-00: ROSCConnectKFailCou	1.159		
604-261	Fault Counter 61-334: ROSYMVddFailCountFC		RW	ROSYMVddFailCountFC	NVMFaultCounter	shortNatural	No	Fault Counter:61-334-00:	1.159		
604-262	Fault Counter 61-335: ROSCKVddFailCountFC		RW	ROSCKVddFailCountFC	NVMFaultCounter	shortNatural	No	Fault Counter:61-335-00: ROSCKVddFailCountF	1.159		
604-263	Fault Counter 61-336: ROSYMVddDownFailCountFC		RW	ROSYMVddDownFailCountFC	NVMFaultCounter	shortNatural	No	Fault Counter:61-336-00: ROSYMVddDownFailC ountFC	1.159		
604-264	Fault Counter 61-337: ROSCKVddDownFailCountFC		RW	ROSCKVddDownFailCountFC	NVMFaultCounter	shortNatural	No	Fault Counter:61-337-00: ROSCKVddDownFailC ountFC	1.159		

604-265	Fault Counter 61-338: SOSStopMFailCountFC		RW	SOSStopMFailCountFC	NVMFaultCounter	shortNatural	No	Fault Counter:61-338-00: SOSStopMFailCountFC	1.159		
604-266	Fault Counter 61-339: SOSStopKFailCountFC		RW	SOSStopKFailCountFC	NVMFaultCounter	shortNatural	No	Fault Counter:61-339-00: SOSStopKFailCountFC	1.159		
604-267	Fault Counter 61-604: LDAalarmYCountFC		RW	LDAalarmYCountFC	NVMFaultCounter	shortNatural	No	Fault Counter:61-604-00: LDAalarmYCountFC	1.766		
604-268	Fault Counter 61-605: LDAalarmMCountFC		RW	LDAalarmMCountFC	NVMFaultCounter	shortNatural	No	Fault Counter:61-605-00: LDAalarmMCountFC	1.766		
604-269	Fault Counter 61-606: LDAalarmCCountFC		RW	LDAalarmCCountFC	NVMFaultCounter	shortNatural	No	Fault Counter:61-606-00: LDAalarmCCountFC	1.766		
604-270	Fault Counter 61-607: LDAalarmKCountFC		RW	LDAalarmKCountFC	NVMFaultCounter	shortNatural	No	Fault Counter:61-607-00: LDAalarmKCountFC	1.159		
604-271	Fault Counter 71-101: Tray1MisfeedJamCountFC		RW	Tray1MisfeedJamCountFC	NVMFaultCounter	shortNatural	No	Fault Counter:71-101-00: Tray1MisfeedJamCountFC	1.159		
604-272	Fault Counter 71-104: Tray1PreRegiSnrOnJamCountFC		RW	Tray1PreRegiSnrOnJamCountFC	NVMFaultCounter	shortNatural	No	Fault Counter:71-104-00:	1.159		
604-273	Fault Counter 71-105: Tray1RegiSnrOnJamCountFC		RW	Tray1RegiSnrOnJamCountFC	NVMFaultCounter	shortNatural	No	Fault Counter:71-105-00: Tray1RegiSnrOnJamCountFC	1.813		
604-274	Fault Counter 71-210: Tray1LiftUpFailCountFC		RW	Tray1LiftUpFailCountFC	NVMFaultCounter	shortNatural	No	Fault Counter:71-210-00: Tray1LiftUpFailCountFC	1.813		
604-275	Fault Counter 72-101:		RW	Tray2MisfeedJamCountFC	NVMFaultCounter	shortNatural	No	Fault Counter:72-101-	1.810		
604-276	Fault Counter 72-102: Tray2FeedOutSnr1OnJamCountFC		RW	Tray2FeedOutSnr1OnJamCountFC	NVMFaultCounter	shortNatural	No	Fault Counter:72-102-00: Tray2FeedOutSnr1OnJamCountFC	1.159		
604-277	Fault Counter 72-104:		RW	Tray2PreRegiSnrOnJamCountFC	NVMFaultCounter	shortNatural	No	Fault Counter:72-104-	1.159		
604-278	Fault Counter 72-105:		RW	Tray2RegiSnrOnJamCountFC	NVMFaultCounter	shortNatural	No	Fault Counter:72-105-	1.159		
604-279	Fault Counter 72-210: Tray2LiftUpFailCountFC		RW	Tray2LiftUpFailCountFC	NVMFaultCounter	shortNatural	No	Fault Counter:72-210-00: Tray2LiftUpFailCountFC	1.813		
604-280	Fault Counter 73-101:		RW	Tray3MisfeedJamCountFC	NVMFaultCounter	shortNatural	No	Fault Counter:73-101-	1.813		
604-281	Fault Counter 73-102:		RW	Tray3FeedOutSnr1OnJamCountFC	NVMFaultCounter	shortNatural	No	Fault Counter:73-102-	1.813		
604-282	Fault Counter 73-104:		RW	Tray3PreRegiSnrOnJamCountFC	NVMFaultCounter	shortNatural	No	Fault Counter:73-104-	1.159		
604-283	Fault Counter 73-105:		RW	Tray3RegiSnrOnJamCountFC	NVMFaultCounter	shortNatural	No	Fault Counter:73-105-	1.159		
604-284	Fault Counter 73-210:		RW	Tray3LiftUpFailCountFC	NVMFaultCounter	shortNatural	No	Fault Counter:73-210-	1.813		
604-285	Fault Counter 74-101:		RW	Tray4MisfeedJamCountFC	NVMFaultCounter	shortNatural	No	Fault Counter:74-101-	1.813		
604-286	Fault Counter 74-102:		RW	Tray4FeedOutSnr1OnJamCountFC	NVMFaultCounter	shortNatural	No	Fault Counter:74-102-	1.159		
604-287	Fault Counter 74-103:		RW	Tray4FeedOutSnr3OnJamCountFC	NVMFaultCounter	shortNatural	No	Fault Counter:74-103-	1.159		

604-288	Fault Counter 74-104: Tray4PreRegiSnrOnJamCountFC		RW	Tray4PreRegiSnrOnJamCountFC	NVMFaultCounter	shortNatural	No	Fault Counter:74-104-00: Tray4PreRegiSnrOnJamCountFC	1.159		
604-289	Fault Counter 74-105: Tray4RegiSnrOnJamCountFC		RW	Tray4RegiSnrOnJamCountFC	NVMFaultCounter	shortNatural	No	Fault Counter:74-105-00: Tray4RegiSnrOnJamCountFC	1.159		
604-290	Fault Counter 74-210: Tray4LiftUpFailCountFC		RW	Tray4LiftUpFailCountFC	NVMFaultCounter	shortNatural	No	Fault Counter:74-210-00: Tray4LiftUpFailCountFC	1.813		
604-291	Fault Counter 75-100:		RW	MSIMisfeedJamCountFC	NVMFaultCounter	shortNatural	No	Fault Counter:75-100-	1.813		
604-292	Fault Counter 75-109:		RW	MSIPreRegiSnrOnJamCountFC	NVMFaultCounter	shortNatural	No	Fault Counter:75-109-	1.159		
604-293	Fault Counter 75-135:		RW	MSIRegiSnrOnJamCountFC	NVMFaultCounter	shortNatural	No	Fault Counter:75-135-	1.813		
604-294	Fault Counter 75-210: MSILiftUpFailCountFC		RW	MSILiftUpFailCountFC	NVMFaultCounter	shortNatural	No	Fault Counter:75-210-00:	1.159		
604-295	Fault Counter 75-211:		RW	MSILiftDownFailCountFC	NVMFaultCounter	shortNatural	No	Fault Counter:75-211-	1.159		
604-296	Fault Counter 77-103: FuserExitSnrOffJamStraightCountFC		RW	FuserExitSnrOffJamStraightFC	NVMFaultCounter	shortNatural	No	Fault Counter:77-103-00: FuserExitSnrOffJamStraightCountFC	1.159		
604-297	Fault Counter 77-106: FuserExitSnrOnJamCountFC		RW	FuserExitSnrOnJamCountFC	NVMFaultCounter	shortNatural	No	Fault Counter:77-106-00: FuserExitSnrOnJamCountFC	1.159		
604-298	Fault Counter 77-107: FuserExitSnrOffJamInvertCountFC		RW	FuserExitSnrOffJamInvertCountFC	NVMFaultCounter	shortNatural	No	Fault Counter:77-107-00: FuserExitSnrOffJamInvertCountFC	1.159		
604-299	Fault Counter 77-109: IOTExitSnrOnJamStraightCountFC		RW	IOTExitSnrOnJamStraightCountFC	NVMFaultCounter	shortNatural	No	Fault Counter:77-109-00: IOTExitSnrOnJamStraightCountFC	1.813		
604-300	Fault Counter 77-111: IOTExitSnrOnJamInvertCountFC		RW	IOTExitSnrOnJamInvertCountFC	NVMFaultCounter	shortNatural	No	Fault Counter:77-111-00: IOTExitSnrOnJamInvertCountFC	1.159		
604-301	Fault Counter 77-113: IOTExitSnrOffJamStraightCountFC		RW	IOTExitSnrOffJamStraightCountFC	NVMFaultCounter	shortNatural	No	Fault Counter:77-113-00: IOTExitSnrOffJamStraightCountFC	1.159		

604-302	Fault Counter 77-115: IOTExitSnrOffJamInvertCountFC		RW	IOTExitSnrOffJamInvertCountFC	NVMFaultCounter	shortNatural	No	Fault Counter:77-115-00: IOTExitSnrOffJamInvertCountFC	1.159		
604-303	Fault Counter 77-118:		RW	PreRegiSnrOnDuplexJamCountFC	NVMFaultCounter	shortNatural	No	Fault Counter:77-118-	1.159		
604-304	Fault Counter 77-120: Post2ndBTRSnrOnJamCountFC		RW	Post2ndBTRSnrOnJamCountFC	NVMFaultCounter	shortNatural	No	Fault Counter:77-120-00: Post2ndBTRSnrOnJamCountFC	1.159		
604-305	Fault Counter 77-123: RegiSnrOnDuplexJamCountFC		RW	RegiSnrOnDuplexJamCountFC	NVMFaultCounter	shortNatural	No	Fault Counter:77-123-00:	1.159		
604-306	Fault Counter 77-129:		RW	DuplexInSnrOnJamCountFC	NVMFaultCounter	shortNatural	No	Fault Counter:77-129-	1.159		
604-307	Fault Counter 77-130: DuplexOutSnrOnJamCountFC		RW	DuplexOutSnrOnJamCountFC	NVMFaultCounter	shortNatural	No	Fault Counter:77-130-00: DuplexOutSnrOnJamC	1.813		
604-308	Fault Counter 77-312: FeederCommFailCountFC		RW	FeederCommFailCountFC	NVMFaultCounter	shortNatural	No	Fault Counter:77-312-00:	1.813		
604-309	Fault Counter 77-909: IOTStaticJamCountFC		RW	IOTStaticJamCountFC	NVMFaultCounter	shortNatural	No	Fault Counter:77-909-00:	1.159		
604-310	Fault Counter 78-100: HCF1PreRegiSnrOnJamCountFC		RW	HCF1PreRegiSnrOnJamCountFC	NVMFaultCounter	shortNatural	No	Fault Counter:78-100-00:	1.159		
604-311	Fault Counter 78-101: HCF1FeedOutSnr1OnJamCountFC		RW	HCF1FeedOutSnr1OnJamCountFC	NVMFaultCounter	shortNatural	No	Fault Counter:78-101-00: HCF1FeedOutSnr1On	1.159		
604-312	Fault Counter 78-102: HCF1RegiSnrOnJamCountFC		RW	HCF1RegiSnrOnJamCountFC	NVMFaultCounter	shortNatural	No	Fault Counter:78-102-00:	1.159		
604-313	Fault Counter 78-151: HCF1FeedOutSnrOnJamCountFC		RW	HCF1FeedOutSnrOnJamCountFC	NVMFaultCounter	shortNatural	No	Fault Counter:78-151-00: HCF1FeedOutSnrOnJ	1.813		
604-314	Fault Counter 78-250: HCF1TrayLiftUpFailCountFC		RW	HCF1TrayLiftUpFailCountFC	NVMFaultCounter	shortNatural	No	Fault Counter:78-250-00:	1.813		
604-315	Fault Counter 78-901: HCF1FeedOutSnrStaticJamFC		RW	HCF1FeedOutSnrStaticJamFC	NVMFaultCounter	shortNatural	No	Fault Counter:78-901-00: HCF1FeedOutSnrStati	1.813		
604-316	Fault Counter 89-600: RCSampleLateralFailA1CountFC		RW	RCSampleLateralFailA1CountFC	NVMFaultCounter	shortNatural	No	Fault Counter:89-600-00: RCSampleLateralFailA	1.813		
604-317	Fault Counter 89-601: RCSampleBlockFailA1InCountFC		RW	RCSampleBlockFailA1InCountFC	NVMFaultCounter	shortNatural	No	Fault Counter:89-601-00: RCSampleBlockFailA1InCountFC	1.813		
604-318	Fault Counter 89-602: RCSampleBlockFailA1CntCountFC		RW	RCSampleBlockFailA1CntCountFC	NVMFaultCounter	shortNatural	No	Fault Counter:89-602-00:	1.159		
604-319	Fault Counter 89-603: RCSampleBlockFailA1OutCountFC		RW	RCSampleBlockFailA1OutCountFC	NVMFaultCounter	shortNatural	No	Fault Counter:89-603-00:	1.813		
604-320	Fault Counter 89-604: RCSampleBlockFailB1InCountFC		RW	RCSampleBlockFailB1InCountFC	NVMFaultCounter	shortNatural	No	Fault Counter:89-604-00:	1.813		
604-321	Fault Counter 89-605: RCSampleBlockFailB1CntCountFC		RW	RCSampleBlockFailB1CntCountFC	NVMFaultCounter	shortNatural	No	Fault Counter:89-605-00:	1.159		
604-322	Fault Counter 89-606: RCSampleBlockFailB1OutCountFC		RW	RCSampleBlockFailB1OutCountFC	NVMFaultCounter	shortNatural	No	Fault Counter:89-606-00:	1.813		

604-323	Fault Counter 89-607: RCSampleBlockFailB2InCountFC		RW	RCSampleBlockFailB2InCountFC	NVMFaultCounter	shortNatural	No	Fault Counter:89-607-00: RCSampleBlockFailB2I	1.813		
604-324	Fault Counter 89-608: RCSampleBlockFailB2CntCountFC		RW	RCSampleBlockFailB2CntCountFC	NVMFaultCounter	shortNatural	No	Fault Counter:89-608-00: RCSampleBlockFailB2	1.159		
604-325	Fault Counter 89-609: RCSampleBlockFailB2OutCountFC		RW	RCSampleBlockFailB2OutCountFC	NVMFaultCounter	shortNatural	No	Fault Counter:89-609-00:	1.813		
604-326	Fault Counter 89-610: RCSampleBlockFailB3InCountFC		RW	RCSampleBlockFailB3InCountFC	NVMFaultCounter	shortNatural	No	Fault Counter:89-610-00: RCSampleBlockFailB3I	1.813		
604-327	Fault Counter 89-611: RCSampleBlockFailB3CntCountFC		RW	RCSampleBlockFailB3CntCountFC	NVMFaultCounter	shortNatural	No	Fault Counter:89-611-00: RCSampleBlockFailB3 CntCountFC	1.159		
604-328	Fault Counter 89-612: RCSampleBlockFailB3OutCountFC		RW	RCSampleBlockFailB3OutCountFC	NVMFaultCounter	shortNatural	No	Fault Counter:89-612-00: RCSampleBlockFailB3	1.813		
604-329	Fault Counter 89-613: RCSampleBlockFailB4InCountFC		RW	RCSampleBlockFailB4InCountFC	NVMFaultCounter	shortNatural	No	Fault Counter:89-613-00: RCSampleBlockFailB4I	1.813		
604-330	Fault Counter 89-614: RCSampleBlockFailB4CntCountFC		RW	RCSampleBlockFailB4CntCountFC	NVMFaultCounter	shortNatural	No	Fault Counter:89-614-00: RCSampleBlockFailB4 CntCountFC	1.159		
604-331	Fault Counter 89-615: RCSampleBlockFailB4OutCountFC		RW	RCSampleBlockFailB4OutCountFC	NVMFaultCounter	shortNatural	No	Fault Counter:89-615-00: RCSampleBlockFailB4 OutCountFC	1.813		
604-332	Fault Counter 89-616: RCDataOverFlowFailCountFC		RW	RCDataOverFlowFailCountFC	NVMFaultCounter	shortNatural	No	Fault Counter:89-616-00: RCDataOverFlowFailC ountFC	1.813		
604-333	Fault Counter 89-617: RCDataOverRangeFailCountFC		RW	RCDataOverRangeFailCountFC	NVMFaultCounter	shortNatural	No	Fault Counter:89-617-00: RCDataOverRangeFail CountFC	1.813		
604-334	Fault Counter 91-311: BCRCCCleanerMotorFailCountFC		RW	BCRCCCleanerMotorFailCountFC	NVMFaultCounter	shortNatural	No	Fault Counter:91-311-00: BCRCCCleanerMotorF	1.159		
604-335	Fault Counter 91-312: CCHvpsBrokenFailCountFC		RW	CCHvpsBrokenFailCountFC	NVMFaultCounter	shortNatural	No	Fault Counter:91-312-00: CCHvpsBrokenFailCou	1.159		
604-336	Fault Counter 91-313:		RW	CrumAsicCommFailCountFC	NVMFaultCounter	shortNatural	No	Fault Counter:91-313-	1.813		
604-337	Fault Counter 91-320:		RW	CCWireCutFailCountFC	NVMFaultCounter	shortNatural	No	Fault Counter:91-320-	1.159		
604-338	Fault Counter 91-914:		RW	DrumKCrumCommFailCountFC	NVMFaultCounter	shortNatural	No	Fault Counter:91-914-	1.813		
604-339	Fault Counter 91-917: DrumYCrumCommFailCountFC		RW	DrumYCrumCommFailCountFC	NVMFaultCounter	shortNatural	No	Fault Counter:91-917-00:	1.813		
604-340	Fault Counter 91-918:		RW	DrumMCrumCommFailCountFC	NVMFaultCounter	shortNatural	No	Fault Counter:91-918-	1.813		
604-341	Fault Counter 91-919:		RW	DrumCCrumCommFailCountFC	NVMFaultCounter	shortNatural	No	Fault Counter:91-919-	1.813		
604-342	Fault Counter 92-649: ADCShutterOpenFailCountFC		RW	ADCShutterOpenFailCountFC	NVMFaultCounter	shortNatural	No	Fault Counter:92-649-00: ADCShutterOpenFailC	1.813		
604-343	Fault Counter 92-650:		RW	ADCShutterCloseFailCountFC	NVMFaultCounter	shortNatural	No	Fault Counter:92-650-	1.813		

604-344	Fault Counter 92-651:		RW	ADCSensorFailCountFC	NVMFaultCounter	shortNatural	No	Fault Counter:92-651-	1.813		
604-345	Fault Counter 92-652:		RW	ADCPatchFailCountFC	NVMFaultCounter	shortNatural	No	Fault Counter:92-652-	1.159		
604-346	Fault Counter 92-653:		RW	ATCSensorYOutputFailCountFC	NVMFaultCounter	shortNatural	No	Fault Counter:92-653-	1.766		
604-347	Fault Counter 92-654:		RW	ATCSensorMOutputFailCountFC	NVMFaultCounter	shortNatural	No	Fault Counter:92-654-	1.766		
604-348	Fault Counter 92-655:		RW	ATCSensorCOutputFailCountFC	NVMFaultCounter	shortNatural	No	Fault Counter:92-655-	1.766		
604-349	Fault Counter 92-656:		RW	ATCSensorKOutputFailCountFC	NVMFaultCounter	shortNatural	No	Fault Counter:92-656-	1.159		
604-350	Fault Counter 92-657:		RW	ATCSensorYAmplitudeFailCountFC	NVMFaultCounter	shortNatural	No	Fault Counter:92-657-	1.766		
604-351	Fault Counter 92-658:		RW	ATCSensorMAmplitudeFailCountFC	NVMFaultCounter	shortNatural	No	Fault Counter:92-658-	1.766		
604-352	Fault Counter 92-659:		RW	ATCSensorCAmplitudeFailCountFC	NVMFaultCounter	shortNatural	No	Fault Counter:92-659-	1.766		
604-353	Fault Counter 92-660:		RW	ATCSensorKAmplitudeFailCountFC	NVMFaultCounter	shortNatural	No	Fault Counter:92-660-	1.813		
604-354	Fault Counter 92-661:		RW	EnvironTemperatureSnrFailCountFC	NVMFaultCounter	shortNatural	No	Fault Counter:92-661-	1.813		
604-355	Fault Counter 92-662:		RW	EnvironHumiditySensorFailCountFC	NVMFaultCounter	shortNatural	No	Fault Counter:92-662-	1.813		
604-356	Fault Counter 92-663:		RW	MiniSetupADCFailCountFC	NVMFaultCounter	shortNatural	No	Fault Counter:92-663-	1.159		
604-357	Fault Counter 94-320:		RW	FistBTRRetractFailCountFC	NVMFaultCounter	shortNatural	No	Fault Counter:94-320-	1.159		
604-358	Fault Counter 94-321:		RW	FirstBTRContactFailCountFC	NVMFaultCounter	shortNatural	No	Fault Counter:94-321-	1.159		
604-359	Fault Counter 94-322:		RW	SecondBTRRetractFailCountFC	NVMFaultCounter	shortNatural	No	Fault Counter:94-322-	1.159		
604-360	Fault Counter 94-323:		RW	SecondBTRContactFailCountFC	NVMFaultCounter	shortNatural	No	Fault Counter:94-323-	1.159		
604-361	Fault Counter 12-100:		RW	DFinDeculerInSnrOnJamFC	NVMFaultCounter	shortNatural	No	Fault Counter:12-100-	1.521		
604-362	Fault Counter 12-101:		RW	DFinDeculerOutSnrOnJamFC	NVMFaultCounter	shortNatural	No	Fault Counter:12-101-	1.521		
604-363	Fault Counter 12-102:		RW	DFinPunchOutSnrOnJamFC	NVMFaultCounter	shortNatural	No	Fault Counter:12-102-	1.521		
604-364	Fault Counter 12-103:		RW	DFinPunchOutSnrOffJamFC	NVMFaultCounter	shortNatural	No	Fault Counter:12-103-	1.521		
604-365	Fault Counter 12-104:		RW	DFinInterposeFeedOutSnrOnJamFC	NVMFaultCounter	shortNatural	No	Fault Counter:12-104-	1.521		
604-366	Fault Counter 12-108:		RW	DFinFolderPathSnr3OffJamFC	NVMFaultCounter	shortNatural	No	Fault Counter:12-108-	1.813		
604-367	Fault Counter 12-109:		RW	DFinInterposerFeedOutSnrOffJamF	NVMFaultCounter	shortNatural	No	Fault Counter:12-109-	1.521		
604-368	Fault Counter 12-117:		RW	DFinFolderPathExitSnrOnJamFC	NVMFaultCounter	shortNatural	No	Fault Counter:12-117-	1.813		
604-369	Fault Counter 12-118: DFinFolderPathSnr2OnJamFC		RW	DFinFolderPathSnr2OnJamFC	NVMFaultCounter	shortNatural	No	Fault Counter:12-118- 00: DFinFolderPathSnr2O nJamFC	1.813		
604-370	Fault Counter 12-119: DFi FolderPathSnr3OnJamFC		RW	DFi FolderPathSnr3OnJamFC	NVMFaultCounter	shortNatural	No	Fault Counter:12-119- 00: DFi FolderPathSnr3OnJam FC	1.813		
604-371	Fault Counter 12-120: DFinFolderPathSnr4OnJamFC		RW	DFinFolderPathSnr4OnJamFC	NVMFaultCounter	shortNatural	No	Fault Counter:12-120- 00: DFinFolderPathSnr4O nJamFC	1.813		
604-372	Fault Counter 12-141: DFinBufferPathSnrOffJam FC		RW	DFinBufferPathSnrOffJam FC	NVMFaultCounter	shortNatural	No	Fault Counter:12-141- 00: DFinBufferPathSnrOffJ	1.521		
604-373	Fault Counter 12-159: DFinEjectSnrOnJamFC		RW	DFinEjectSnrOnJamFC	NVMFaultCounter	shortNatural	No	Fault Counter:12-159- 00: DFinEjectSnrOnJamF C	1.521		
604-374	Fault Counter 12-160:		RW	DFinEjectSnrOffJamFC	NVMFaultCounter	shortNatural	No	Fault Counter:12-160-	1.521		
604-375	Fault Counter 12-214: DFinEndWallHomeSnrOffFailFC		RW	DFinEndWallHomeSnrOffFailFC	NVMFaultCounter	shortNatural	No	Fault Counter:12-214- 00: DFinEndWallHomeSnr OffFailFC	1.521		
604-376	Fault Counter 12-215: DFinEndWallOpenSnrOnFailFC		RW	DFinEndWallOpenSnrOnFailFC	NVMFaultCounter	shortNatural	No	Fault Counter:12-215- 00: DFinEndWallOpenSnr OnFailFC	1.521		

604-377	Fault Counter 12-216: DFinEndWallHomeSnrOnFailFC		RW	DFinEndWallHomeSnrOnFailFC	NVMFaultCounter	shortNatural	No	Fault Counter:12-216-00: DFinEndWallHomeSnrOnFailFC	1.521		
604-378	Fault Counter 12-217: DFinEndWallOpenSnrOffFailFC		RW	DFinEndWallOpenSnrOffFailFC	NVMFaultCounter	shortNatural	No	Fault Counter:12-217-00: DFinEndWallOpenSnrOffFailFC	1.521		
604-379	Fault Counter 12-218: DFinShelfHomeSnrOnFailFC		RW	DFinShelfHomeSnrOnFailFC	NVMFaultCounter	shortNatural	No	Fault Counter:12-218-00: DFinShelfHomeSnrOnFailFC	1.521		
604-380	Fault Counter 12-219: DFinShelfHomeSnrOffFailFC		RW	DFinShelfHomeSnrOffFailFC	NVMFaultCounter	shortNatural	No	Fault Counter:12-219-00: DFinShelfHomeSnrOffFailFC	1.521		
604-381	Fault Counter 12-235: DFinStapleMoveHomeSnrOffFailFC		RW	DFinStapleMoveHomeSnrOffFailFC	NVMFaultCounter	shortNatural	No	Fault Counter:12-235-00: DFinStapleMoveHomeSnrOffFailFC	1.521		
604-382	Fault Counter 12-236: DFinStapleMoveHomeSnrOnFailFC		RW	DFinStapleMoveHomeSnrOnFailFC	NVMFaultCounter	shortNatural	No	Fault Counter:12-236-00: DFinStapleMoveHomeSnrOnFailFC	1.521		
604-383	Fault Counter 12-237: DFinStapleCenterPositionSnrOnFailFC		RW	DFinStapleCenterPositionSnrOnFailFC	NVMFaultCounter	shortNatural	No	Fault Counter:12-237-00: DFinStapleCenterPositionSnrOnFailFC	1.521		
604-384	Fault Counter 12-238: DFinStapleCenterPositionSnrOffFailFC		RW	DFinStapleCenterPositionSnrOffFailFC	NVMFaultCounter	shortNatural	No	Fault Counter:12-238-00: DFinStapleCenterPositionSnrOffFailFC	1.521		
604-385	Fault Counter 12-239: DFinSubPaddleHomeSnrOnFailFC		RW	DFinSubPaddleHomeSnrOnFailFC	NVMFaultCounter	shortNatural	No	Fault Counter:12-239-00: DFinSubPaddleHomeSnrOnFailFC	1.521		
604-386	Fault Counter 12-240: DFinSubPaddleHomeSnrOffFailFC		RW	DFinSubPaddleHomeSnrOffFailFC	NVMFaultCounter	shortNatural	No	Fault Counter:12-240-00: DFinSubPaddleHomeSnrOffFailFC	1.521		
604-387	Fault Counter 12-241: DFinBookletKnifeFoldingSnrFailFC		RW	DFinBookletKnifeFoldingSnrFailFC	NVMFaultCounter	shortNatural	No	Fault Counter:12-241-00: DFinBookletKnifeFoldingSnrFailFC	1.521		
604-388	Fault Counter 12-248: DFinCompileStackerTrayOffsetFailFC		RW	DFinCompileStackerTrayOffsetFailFC	NVMFaultCounter	shortNatural	No	Fault Counter:12-248-00: DFinCompileStackerTrayOffsetFailFC	1.521		
604-389	Fault Counter 12-250: DFinEndGuideMot1StartFailFC		RW	DFinEndGuideMot1StartFailFC	NVMFaultCounter	shortNatural	No	Fault Counter:12-250-00: DFinEndGuideMot1StartFailFC	1.521		
604-390	Fault Counter 12-251: DFinEndGuideMot2StartFailFC		RW	DFinEndGuideMot2StartFailFC	NVMFaultCounter	shortNatural	No	Fault Counter:12-251-00: DFinEndGuideMot2StartFailFC	1.521		

604-391	Fault Counter 12-252: DFinEndGuideMot1HomeFailFC		RW	DFinEndGuideMot1HomeFailFC	NVMFaultCounter	shortNatural	No	Fault Counter:12-252-00: DFinEndGuideMot1HomeFailFC	1.521		
604-392	Fault Counter 12-253: DFinEndGuideMot2HomeFailFC		RW	DFinEndGuideMot2HomeFailFC	NVMFaultCounter	shortNatural	No	Fault Counter:12-253-00:	1.521		
604-393	Fault Counter 12-254: DFinEnvelopeFolderTrayBrokenFC		RW	DFinEnvelopeFolderTrayBrokenFC	NVMFaultCounter	shortNatural	No	Fault Counter:12-254-00: DFinEnvelopeFolderTrayBrokenFC	1.813		
604-394	Fault Counter 12-255: DFinInterposerTrayUpFailFC		RW	DFinInterposerTrayUpFailFC	NVMFaultCounter	shortNatural	No	Fault Counter:12-255-00: DFinInterposerTrayUpFailFC	1.521		
604-395	Fault Counter 12-324: DFinSideRegiHomeSnrOffFailFC		RW	DFinSideRegiHomeSnrOffFailFC	NVMFaultCounter	shortNatural	No	Fault Counter:12-324-00: DFinSideRegiHomeSnrOffFailFC	1.521		
604-396	Fault Counter 12-325: DFinSideRegiHomeSnrOnFailFC		RW	DFinSideRegiHomeSnrOnFailFC	NVMFaultCounter	shortNatural	No	Fault Counter:12-325-00: DFinSideRegiHomeSnrOnFailFC	1.521		
604-402	KnownJamsinFinishingdevicesC31- KnownJamsinFinishingdevicesC31		ND		NVMBillingCounter	byteArray	No	Billing Counter:302: Known Jams in Finishing Devices	1.799		
604-403	AllsheetsfedfromTray1- AllsheetsfedfromTray1		ND		NVMDiagCounter	byteArray	No	Diagnostic Counter:59: All sheets fed from Tray #1	1.799		
604-404	AllsheetsfedfromTray2- AllsheetsfedfromTray2		ND		NVMDiagCounter	byteArray	No	Diagnostic Counter:60: All sheets fed from Tray #2	1.799		
604-405	AllsheetsfedfromTray3- AllsheetsfedfromTray3		ND		NVMDiagCounter	byteArray	No	Diagnostic Counter:61: All sheets fed from Tray #3	1.799		
604-406	AllsheetsfedfromTray4- AllsheetsfedfromTray4		ND		NVMDiagCounter	byteArray	No	Diagnostic Counter:62: All sheets fed from Tray #4	1.810		
604-407	AllsheetsfedfromBypassTray- AllsheetsfedfromBypassTray		ND		NVMDiagCounter	byteArray	No	Diagnostic Counter:41: All sheets fed from MSI	1.813		
604-408	TotalSheetsside1-TotalSheetsside1		ND		NVMDiagCounter	byteArray	No	Diagnostic Counter:184: Total Sheets (Side 1)	1.799		

604-409	TotalSheetsside1and2- TotalSheetsside1and2		ND		NVMDiagCounter	byteArray	No	Diagnostic Counter:185: Total Sheets (Side 1 and 2)	1.799		
604-415	# of bins		RW	MSDefaultPrintBin	NVMSAKOSetting	shortNatural	No		1.260		
604-415	# of bins		RW	MSDefaultPrintBin	NVMSAKOSetting	shortNatural	No		1.416		
604-416	# of bins		RW	MSDefaultCopyBin	NVMSAKOSetting	shortNatural	No		1.260		
604-416	# of bins		RW	MSDefaultCopyBin	NVMSAKOSetting	shortNatural	No		1.416		
604-416	# of bins		RW	MSDefaultCopyBin	NVMSAKOSetting	shortNatural	No		1.574		
604-417	# of bins		RW	MSDefaultFaxBin	NVMSAKOSetting	shortNatural	No		1.260		
604-417	# of bins		RW	MSDefaultFaxBin	NVMSAKOSetting	shortNatural	No		1.802		
604-418	# of bins		RW	MSDefaultOtherBin	NVMSAKOSetting	shortNatural	No		1.260		
604-418	# of bins		RW	MSDefaultOtherBin	NVMSAKOSetting	shortNatural	No		1.416		
604-438	-OCT Total Sheets		ND		NVMSystemUsageCounter	byteArray	No	System Usage	1.799		
604-439	1 Tiered billing (Traditional):	Stores the count of all	ND		NVMBillingCounter	byteArray	No	Billing Counter:8: Black	1.799		
604-441	TOTAL MARK COUNTER: Tier 1	TOTAL MARK	ND		NVMBillingCounter	byteArray	No	Billing Counter:10:	1.000		
604-442	Media Order Group	1 = MSGXc 2 = MSGXe 3 = MSGFx 4 = MSGFxap 5 = MSGGco	RW	MSMediaSizeGroup	NVMSAKOSetting	shortNatural	No		1.796		
604-444	Conditional Finisher Offset Policy OFF /	0=Off (No conditional	RW	ConditionalFinisherOffsetPolicy	NVMSAKOSetting	boolean	No		1.799		
604-833	Fault Counter 12-024: Paddle Home Fault	no. of faults	RW	PaddleHomeFC	NVMFaultCounter	shortNatural	No	Fault Counter:12-024-	1.521		
604-834	Fault Counter 12-025: Paddle Move Fault	no. of faults	RW	PaddleMoveFC	NVMFaultCounter	shortNatural	No	Fault Counter:12-025-	1.521		
604-835	Fault Counter 12-043: Hole Punch Motor Move Fault	no. of faults	RW	PunchMotorMoveFC	NVMFaultCounter	shortNatural	No	Fault Counter:12-043-00: Hole Punch Motor	1.521		

604-836	Fault Counter 12-044: Hole Punch Head	no. of faults	RW	PunchHeadHomeFC	NVMFaultCounter	shortNatural	No	Fault Counter:12-044-	1.521		
604-837	Fault Counter 12-045: Hole Punch Head Move Fault	no. of faults	RW	PunchHeadMoveFC	NVMFaultCounter	shortNatural	No	Fault Counter:12-045-00: Hole Punch Head	1.521		
604-838	Fault Counter 12-046: Hole Punch Motor Home Fault	no. of faults	RW	PunchMotorHomeFC	NVMFaultCounter	shortNatural	No	Fault Counter:12-046-00: Hole Punch Motor	1.521		
604-839	Fault Counter 12-047: Punch Unit Move Fault	no. of faults	RW	PunchUnitMoveFC	NVMFaultCounter	shortNatural	No	Fault Counter:12-047-00: Punch Unit Move	1.521		
604-840	Fault Counter 12-056: Inserter Bottom Plate Home Fault	no. of faults	RW	InserterBottPltHomeFC	NVMFaultCounter	shortNatural	No	Fault Counter:12-056-00: Inserter Bottom	1.521		
604-841	Fault Counter 12-057: Inserter Bottom Plate Lift Fault	no. of faults	RW	InserterBottPltLiftFC	NVMFaultCounter	shortNatural	No	Fault Counter:12-057-00: Inserter Bottom	1.521		
604-842	Fault Counter 12-061: Crease Blade Move	no. of faults	RW	CreaseBladeMoveFFC	NVMFaultCounter	shortNatural	No	Fault Counter:12-061-	1.521		
604-843	Fault Counter 12-062: Crease Roll Motor	no. of faults	RW	CreaseRollMotorFailFC	NVMFaultCounter	shortNatural	No	Fault Counter:12-062-	1.521		
604-844	Fault Counter 12-063: Booklet Maker	no. of faults	RW	BMStaplerMoveFC	NVMFaultCounter	shortNatural	No	Fault Counter:12-063-	1.521		
604-845	Fault Counter 12-065: Back Stop Motor	no. of faults	RW	BackStopMotorMoveFC	NVMFaultCounter	shortNatural	No	Fault Counter:12-065-	1.521		
604-846	Fault Counter 12-066: Tamper Move Fault	no. of faults	RW	TampermoveFC	NVMFaultCounter	shortNatural	No	Fault Counter:12-066-00: Tamper Move Fault	1.521		
604-847	Fault Counter 12-083: Paper Pusher Motor Stalled	no. of faults	RW	PaperPushMotorStalledFC	NVMFaultCounter	shortNatural	No	Fault Counter:12-083-00: Paper Pusher	1.521		
604-848	Fault Counter 12-126: Entrance Sensor OFF Jam	no. of faults	RW	EntSnsOfJamFC	NVMFaultCounter	shortNatural	No	Fault Counter:12-126-00: Entrance Sensor	1.521		
604-849	Fault Counter 12-127: Punch Sensor ON Jam	no. of faults	RW	PunchSnrOnJamFC	NVMFaultCounter	shortNatural	No	Fault Counter:12-127-00: Punch Sensor ON	1.521		
604-850	Fault Counter 12-157: Buffer Point Sensor ON Jam	no. of faults	RW	BuffPointSnsOnJamFC	NVMFaultCounter	shortNatural	No	Fault Counter:12-157-00: Buffer Point Sensor	1.521		
604-851	Fault Counter 12-158: Buffer Point Sensor OFF Jam	no. of faults	RW	BuffPointSnsOffJamFC	NVMFaultCounter	shortNatural	No	Fault Counter:12-158-00: Buffer Point Sensor	1.521		
604-852	Fault Counter 12-166: Booklet Compiler Exit Sensor OFF Jam	no. of faults	RW	BookletCompExitSenOffJamFC	NVMFaultCounter	shortNatural	No	Fault Counter:12-166-00: Booklet Compiler	1.521		
604-853	Fault Counter 12-181: Booklet Maker Exit	no. of faults	RW	BMExitSnrOnJamFC	NVMFaultCounter	shortNatural	No	Fault Counter:12-181-	1.521		
604-854	Fault Counter 12-182: Booklet Maker Exit Sensor OFF Jam	no. of faults	RW	BMExitSnrOffJamFC	NVMFaultCounter	shortNatural	No	Fault Counter:12-182-00: Booklet Maker Exit	1.521		
604-855	Fault Counter 12-183: Booklet Maker	no. of faults	RW	BMUnexpectedSheetFC	NVMFaultCounter	shortNatural	No	Fault Counter:12-183-	1.678		
604-856	Fault Counter 12-184: Booklet Maker Stray Sheet	no. of faults	RW	BMStraySheetFC	NVMFaultCounter	shortNatural	No	Fault Counter:12-184-00: BMStraySheet	1.678		
604-857	Fault Counter 12-185: Trifold Exit Sensor ON Jam	no. of faults	RW	TrifoldExitSnrOnJFC	NVMFaultCounter	shortNatural	No	Fault Counter:12-185-00: Trifold Exit Sensor	1.521		
604-858	Fault Counter 12-186: Trifold Exit Sensor OFF Jam	no. of faults	RW	TrifoldExitSnrOffJFC	NVMFaultCounter	shortNatural	No	Fault Counter:12-186-00: Trifold Exit Sensor	1.521		
604-859	Fault Counter 12-187: Trifold Assist Sensor ON Jam	no. of faults	RW	TrifoldAssistSnrOnJFC	NVMFaultCounter	shortNatural	No	Fault Counter:12-187-00: Trifold Assist	1.521		
604-860	Fault Counter 12-190: Sheet late to BB	no. of faults	RW	LELateBBEntrySnrFC	NVMFaultCounter	shortNatural	No	Fault Counter:12-190-	1.521		
604-861	Fault Counter 12-191: Lead edge late to	no. of faults	RW	LELateInserterTabStandbySFC	NVMFaultCounter	shortNatural	No	Fault Counter:12-191-	1.521		
604-862	Fault Counter 12-192: Sheet late from BB	no. of faults	RW	TELatefromBBentrySFC	NVMFaultCounter	shortNatural	No	Fault Counter:12-192-	1.521		
604-863	Fault Counter 12-193: Trail edge late from	no. of faults	RW	TELateInserterTabSnrFC	NVMFaultCounter	shortNatural	No	Fault Counter:12-193-	1.521		
604-864	Fault Counter 12-194: Lead edge late to Inserter Pick Up Sensor	no. of faults	RW	LeadedgelatetoInserterPickUpSFC	NVMFaultCounter	shortNatural	No	Fault Counter:12-194-00: Lead edge late to	1.521		
604-865	Fault Counter 12-196: Trail edge late from Inserter Tray Pick Up Sensor	no. of faults	RW	TELatefromInserterPickUpSFC	NVMFaultCounter	shortNatural	No	Fault Counter:12-196-00: Trail edge late from	1.521		
604-866	Fault Counter 12-198: Stray sheet is detected after jam clearance	no. of faults	RW	FinStraySheetFC	NVMFaultCounter	shortNatural	No	Fault Counter:12-198-00: Stray sheet is	1.521		
604-867	Fault Counter 12-199: Unexpected Sheet at Finisher Entry	no. of faults	RW	UnexpectedSheetatFinEntFC	NVMFaultCounter	shortNatural	No	Fault Counter:12-199-00: Unexpected Sheet	1.521		
604-868	Fault Counter 12-273: Offset Unit Init Fault	no. of faults	RW	OffsetUnitInitFC	NVMFaultCounter	shortNatural	No	Fault Counter:12-273-00: Offset Unit Init	1.521		

604-869	Fault Counter 12-274: Offset Unit Home Fault	no. of faults	RW	OffsetUnitHomeFC	NVMFaultCounter	shortNatural	No	Fault Counter:12-274-00: Offset Unit Home	1.521		
604-870	Fault Counter 12-275: Offset Unit Home	no. of faults	RW	OffsetUnitHomeMvFC	NVMFaultCounter	shortNatural	No	Fault Counter:12-275-	1.521		
604-871	Fault Counter 12-276: Offset Unit Away	no. of faults	RW	OffsetUnitAwayHomeFC	NVMFaultCounter	shortNatural	No	Fault Counter:12-276-	1.521		
604-872	Fault Counter 12-277: Offset Unit Away	no. of faults	RW	OffsetUnitAwayHomeMvFC	NVMFaultCounter	shortNatural	No	Fault Counter:12-277-	1.521		
604-873	Fault Counter 12-288: Nip Split Failure	no. of faults	RW	NipSplitFC	NVMFaultCounter	shortNatural	No	Fault Counter:12-288-	1.521		
604-874	Fault Counter 12-289: Nip Home Failure	no. of faults	RW	NipHomeFC	NVMFaultCounter	shortNatural	No	Fault Counter:12-289-	1.521		
604-875	Fault Counter 12-310: Finisher Undocked	no. of faults	RW	FinUndockedDuringRFC	NVMFaultCounter	shortNatural	No	Fault Counter:12-310-	1.521		
604-876	Fault Counter 12-312: Top Cover Open in Run	no. of faults	RW	TopCoverOpeninRFC	NVMFaultCounter	shortNatural	No	Fault Counter:12-312-00: Top Cover Open in	1.521		
604-877	Fault Counter 12-313: Finisher Door Open	no. of faults	RW	FinDoorOpenInRFC	NVMFaultCounter	shortNatural	No	Fault Counter:12-313-	1.521		
604-878	Fault Counter 12-316: Inserter Top Cover	no. of faults	RW	InserterTopCoverOpenInRFC	NVMFaultCounter	shortNatural	No	Fault Counter:12-316-	1.521		
604-879	Fault Counter 12-317: Trifold Cover Open In Run	no. of faults	RW	TrifoldCoverOpenInRFC	NVMFaultCounter	shortNatural	No	Fault Counter:12-317-00: Trifold Cover Open	1.521		
604-880	Fault Counter 12-318: Trifold Front Door Open In Run	no. of faults	RW	TrifoldFDDoorOpenInRFC	NVMFaultCounter	shortNatural	No	Fault Counter:12-318-00: Trifold Front Door	1.521		
604-881	Fault Counter 12-319: Inserter Hand Door Open In run	no. of faults	RW	InserterHandDoorOpenInRFC	NVMFaultCounter	shortNatural	No	Fault Counter:12-319-00: Inserter Hand Door	1.521		
604-882	Fault Counter 12-340: Compiler Home Fault	no. of faults	RW	CompHomeFC	NVMFaultCounter	shortNatural	No	Fault Counter:12-340-00: Compiler Home	1.521		
604-883	Fault Counter 12-341: Compiler Out Fault	no. of faults	RW	CompOutFC	NVMFaultCounter	shortNatural	No	Fault Counter:12-341-	1.521		
604-884	Fault Counter 12-342: Compiler Move	no. of faults	RW	CompMvFC	NVMFaultCounter	shortNatural	No	Fault Counter:12-342-	1.521		
604-885	Fault Counter 12-371: Stapler Move Fault	no. of faults	RW	StapleMvFC	NVMFaultCounter	shortNatural	No	Fault Counter:12-371-	1.521		
604-886	Fault Counter 12-372: Stapler Home Fault	no. of faults	RW	StapleHomeFC	NVMFaultCounter	shortNatural	No	Fault Counter:12-372-00: Stapler Home Fault	1.521		
604-887	Fault Counter 12-373: Stapler Middle	no. of faults	RW	StapleMiddleHomeFC	NVMFaultCounter	shortNatural	No	Fault Counter:12-373-	1.521		
604-888	Fault Counter 12-374: Stapler Middle	no. of faults	RW	StapleMiddleMvFC	NVMFaultCounter	shortNatural	No	Fault Counter:12-374-	1.521		
604-889	Fault Counter 12-375: Stapler Jaw Home	no. of faults	RW	StapleJawHomeFC	NVMFaultCounter	shortNatural	No	Fault Counter:12-375-	1.521		
604-890	Fault Counter 12-376: Stapler Jaw Move	no. of faults	RW	StapleJawMvFC	NVMFaultCounter	shortNatural	No	Fault Counter:12-376-	1.521		
604-891	Fault Counter 12-377: Stapler Priming Fault	no. of faults	RW	StaplePrimingFC	NVMFaultCounter	shortNatural	No	Fault Counter:12-377-00: Stapler Priming	1.521		
604-892	Fault Counter 12-378: LCSS Stapler index	no. of faults	RW	LCSSStapleIndexFC	NVMFaultCounter	shortNatural	No	Fault Counter:12-378-	1.521		
604-893	Fault Counter 12-380: Punch Unit Side	no. of faults	RW	PunchUnitSideEdgeDetectFC	NVMFaultCounter	shortNatural	No	Fault Counter:12-380-	1.521		
604-894	Fault Counter 12-383: Back Stop Home	no. of faults	RW	BackStopHomeFFC	NVMFaultCounter	shortNatural	No	Fault Counter:12-383-	1.521		
604-895	Fault Counter 12-384: Tamper Home Fault	no. of faults	RW	TampHomeFC	NVMFaultCounter	shortNatural	No	Fault Counter:12-384-	1.521		
604-896	Fault Counter 12-392: Front Tamper Move	no. of faults	RW	FTampMvFC	NVMFaultCounter	shortNatural	No	Fault Counter:12-392-	1.521		
604-897	Fault Counter 12-393: Front Tamper	no. of faults	RW	FTampHomeFC	NVMFaultCounter	shortNatural	No	Fault Counter:12-393-	1.521		
604-898	Fault Counter 12-394: Front Tamper Away	no. of faults	RW	FTampAwayFromHomeFC	NVMFaultCounter	shortNatural	No	Fault Counter:12-394-	1.521		
604-899	Fault Counter 12-395: Front Tamper Away	no. of faults	RW	FTampAwayFromHomeMvFC	NVMFaultCounter	shortNatural	No	Fault Counter:12-395-	1.521		
604-900	Fault Counter 12-396: Rear Tamper Move	no. of faults	RW	RTampMvFC	NVMFaultCounter	shortNatural	No	Fault Counter:12-396-	1.521		
604-901	Fault Counter 12-397: Rear Tamper Home	no. of faults	RW	RTampHomeFC	NVMFaultCounter	shortNatural	No	Fault Counter:12-397-	1.521		
604-902	Fault Counter 12-398: Rear Tamper Away	no. of faults	RW	RTampAwayFromHomeMvFC	NVMFaultCounter	shortNatural	No	Fault Counter:12-398-	1.521		
604-903	Fault Counter 12-399: Rear Tamper Away	no. of faults	RW	RTampAwayFromHomeFC	NVMFaultCounter	shortNatural	No	Fault Counter:12-399-	1.521		
604-904	Fault Counter 12-403: Booklet Staple	no. of faults	RW	BMStapleHead2MvFC	NVMFaultCounter	shortNatural	No	Fault Counter:12-403-	1.521		
604-905	Fault Counter 12-411: Booklet Stapler	no. of faults	RW	BMStapleHomeFC	NVMFaultCounter	shortNatural	No	Fault Counter:12-411-	1.521		
604-906	Fault Counter 12-413: Booklet Staple	no. of faults	RW	BMStapleHead2HomeFC	NVMFaultCounter	shortNatural	No	Fault Counter:12-413-	1.521		
604-907	Fault Counter 12-414: Booklet Stapler Not	no. of faults	RW	BMStapleNotHomeForInFC	NVMFaultCounter	shortNatural	No	Fault Counter:12-414-	1.521		
604-908	Fault Counter 12-415: Roll Gate Home	no. of faults	RW	RollGateHomeFC	NVMFaultCounter	shortNatural	No	Fault Counter:12-415-	1.521		
604-909	Fault Counter 12-416: Crease Blade Home Fault	no. of faults	RW	CreaseBladeHomeFC	NVMFaultCounter	shortNatural	No	Fault Counter:12-416-00: Crease Blade	1.521		
604-910	Fault Counter 12-417: Booklet Maker	no. of faults	RW	BMFlapperHomeFC	NVMFaultCounter	shortNatural	No	Fault Counter:12-417-	1.521		
604-911	Fault Counter 12-418: Booklet Maker	no. of faults	RW	BMFlappermvFC	NVMFaultCounter	shortNatural	No	Fault Counter:12-418-	1.521		
604-912	Fault Counter 12-419: Booklet Maker	no. of faults	RW	BMTamp2HomeFC	NVMFaultCounter	shortNatural	No	Fault Counter:12-419-	1.521		

604-913	Fault Counter 12-420: Booklet Maker	no. of faults	RW	BMTamp2MvFC	NVMFaultCounter	shortNatural	No	Fault Counter:12-420-	1.521		
604-914	Fault Counter 12-440: Paper Pusher	no. of faults	RW	PapPushHomeFC	NVMFaultCounter	shortNatural	No	Fault Counter:12-440-	1.521		
604-915	Fault Counter 12-441: Paper Pusher	no. of faults	RW	PapPushHomeMvFC	NVMFaultCounter	shortNatural	No	Fault Counter:12-441-	1.521		
604-916	Fault Counter 12-442: Paper Pusher Away	no. of faults	RW	PapPushAwayHomeFC	NVMFaultCounter	shortNatural	No	Fault Counter:12-442-	1.521		
604-917	Fault Counter 12-443: Paper Pusher Away	no. of faults	RW	PapPushAwayHomeMvFC	NVMFaultCounter	shortNatural	No	Fault Counter:12-443-	1.521		
604-918	Fault Counter 12-450: Ejector Module	no. of faults	RW	EjectModMotorStallFC	NVMFaultCounter	shortNatural	No	Fault Counter:12-450-	1.521		
604-919	Fault Counter 12-451: Ejector Plate Motor	no. of faults	RW	EjectPlateMotorStallFC	NVMFaultCounter	shortNatural	No	Fault Counter:12-451-	1.521		
604-920	Fault Counter 12-452: Ejector Plate Home	no. of faults	RW	EjectPlateHomeFC	NVMFaultCounter	shortNatural	No	Fault Counter:12-452-	1.521		
604-921	Fault Counter 12-453: Ejector Plate Move	no. of faults	RW	EjectPlateMvFC	NVMFaultCounter	shortNatural	No	Fault Counter:12-453-	1.521		
604-922	Fault Counter 12-454: Lower Paddle Home	no. of faults	RW	LwrPaddHomeFC	NVMFaultCounter	shortNatural	No	Fault Counter:12-454-	1.521		
604-923	Fault Counter 12-455: Lower Paddle Move	no. of faults	RW	LwrPaddMvFC	NVMFaultCounter	shortNatural	No	Fault Counter:12-455-	1.521		
604-924	Fault Counter 12-456: Ejector Module Home Fault	no. of faults	RW	EjectModHomeFC	NVMFaultCounter	shortNatural	No	Fault Counter:12-456-00: Ejector Module Home Fault	1.521		
604-925	Fault Counter 12-457: Ejector Module Home Move Fault	no. of faults	RW	EjectModHomeMvFC	NVMFaultCounter	shortNatural	No	Fault Counter:12-457-00: Ejector Module	1.521		
604-926	Fault Counter 12-458: Ejector Module Out	no. of faults	RW	EjectModOutPosFC	NVMFaultCounter	shortNatural	No	Fault Counter:12-458-	1.521		
604-927	Fault Counter 12-459: Ejector Module Out Position Move Fault	no. of faults	RW	EjectModOutPosMvFC	NVMFaultCounter	shortNatural	No	Fault Counter:12-459-00: Ejector Module	1.521		
604-928	Fault Counter 12-460: Stacker Bin 1 Motor Stall	no. of faults	RW	StackBin1MotorStallFC	NVMFaultCounter	shortNatural	No	Fault Counter:12-460-00: Stacker Bin 1	1.521		
604-929	Fault Counter 12-461: Stacker Bin 1 Level Fault	no. of faults	RW	StackBin1LevelFC	NVMFaultCounter	shortNatural	No	Fault Counter:12-461-00: Stacker Bin 1Level Fault	1.521		
604-930	Fault Counter 12-462: Stacker Bin 1 Elevator Failure	no. of faults	RW	StackBin1ElevatorFC	NVMFaultCounter	shortNatural	No	Fault Counter:12-462-00: Stacker Bin 1 Elevator Failure	1.521		
604-931	Fault Counter 12-463: Booklet Maker Power Not Present Fault	no. of faults	RW	BMPwrNotPresentFC	NVMFaultCounter	shortNatural	No	Fault Counter:12-463-00: Booklet Maker	1.521		
604-932	Fault Counter 12-464: Booklet Maker Power Fault	no. of faults	RW	BMPwrFC	NVMFaultCounter	shortNatural	No	Fault Counter:12-464-00: Booklet Maker	1.521		
604-933	Fault Counter 12-465: Paddle Upper Position Fault	no. of faults	RW	PaddUpprPosFC	NVMFaultCounter	shortNatural	No	Fault Counter:12-465-00: Paddle Upper	1.521		
604-934	Fault Counter 12-466: Paddle Upper Position Move Fault	no. of faults	RW	PaddUpprPosMvFC	NVMFaultCounter	shortNatural	No	Fault Counter:12-466-00: Paddle Upper	1.521		
604-935	Fault Counter 12-467: Paddle Lower Position Fault	no. of faults	RW	PaddLwrPosFC	NVMFaultCounter	shortNatural	No	Fault Counter:12-467-00: Paddle Lower	1.521		
604-936	Fault Counter 12-468: Paddle Lower Position Move Fault	no. of faults	RW	PaddLwrPosMvFC	NVMFaultCounter	shortNatural	No	Fault Counter:12-468-00: Paddle Lower	1.521		
604-937	Fault Counter 12-469: Curl Suppressor Home Fault	no. of faults	RW	CurlSupprHomeFC	NVMFaultCounter	shortNatural	No	Fault Counter:12-469-00: Curl Suppressor	1.521		
604-938	Fault Counter 12-470: Curl Suppressor Move Fault	no. of faults	RW	CurlSupprMvFC	NVMFaultCounter	shortNatural	No	Fault Counter:12-470-00: Curl Suppressor	1.521		
604-939	Fault Counter 12-471: Curl Suppressor	no. of faults	RW	CurlSupprAwayPosFC	NVMFaultCounter	shortNatural	No	Fault Counter:12-471-	1.521		
604-940	Fault Counter 12-472: Curl Suppressor	no. of faults	RW	CurlSupprAwayPosMvFC	NVMFaultCounter	shortNatural	No	Fault Counter:12-472-	1.521		
604-941	Fault Counter 12-473: Pressing Motor Init	no. of faults	RW	PressMotorInitFC	NVMFaultCounter	shortNatural	No	Fault Counter:12-473-	1.521		
604-942	Fault Counter 12-474: Pressing Motor Init	no. of faults	RW	PressMotorInitMvFC	NVMFaultCounter	shortNatural	No	Fault Counter:12-474-	1.521		
604-943	Fault Counter 12-475: Pressing Motor Home Fault	no. of faults	RW	PressMotorHomeFC	NVMFaultCounter	shortNatural	No	Fault Counter:12-475-00: Pressing Motor	1.521		

604-944	Fault Counter 12-476: Pressing Motor Home Move Fault	no. of faults	RW	PressMotorHomeMvFC	NVMFaultCounter	shortNatural	No	Fault Counter:12-476-00: Pressing Motor	1.521		
604-945	Fault Counter 12-477: Pressing Motor Out Position Fault	no. of faults	RW	PressMotorOutPosFC	NVMFaultCounter	shortNatural	No	Fault Counter:12-477-00: Pressing Motor Out	1.521		
604-946	Fault Counter 12-478: Pressing Motor Out Position Move Fault	no. of faults	RW	PressMtrOutPosMvFC	NVMFaultCounter	shortNatural	No	Fault Counter:12-478-00: Pressing Motor Out	1.521		
604-947	Fault Counter 12-479: Insert Sheet Too Short	no. of faults	RW	InsShitTooShortFC	NVMFaultCounter	shortNatural	No	Fault Counter:12-479-00: Insert Sheet Too	1.521		
604-951	Total no. of Black and Color Duplex (Copy sheets +	Stores the count when	ND		NVMBillingCounter	byteArray	No		1.810		
604-952	Total no. of Black and Color Simplex (Copy sheets +	Stores the count when	ND		NVMBillingCounter	byteArray	No		1.810		
604-953	Total no. of Black simplex and duplex (Copy sheets + Print Sheets , including Blank and Banner Sheets	Stores the count when traditional billing	ND		NVMBillingCounter	byteArray	No		1.810		
604-954	Total number of (embedded Fax Images Successfully Sent and Scanned Image using Platen	Stores the count when traditional billing	ND		NVMBillingCounter	byteArray	No		1.810		
604-979	Finisher Hole Punch Configuration		RW	HolePunchConfiguration	NVMConfiguration	shortNatural	No		1.299		
604-979	Finisher Hole Punch Configuration	Corvo and Kiska uses finisher NVM 763-605	RW	HolePunchConfiguration	NVMConfiguration	shortNatural	No		1.769		
604-980	Fault Counter 12-762-00: Cannot communicate with finisher.	no. of faults	RW	ImeFinCommsFailFC	NVMFaultCounter	shortNatural	No	Fault Counter:12-762-00: Cannot communicate with	1.521		
604-981	Fault Counter 12-764-00: Finisher is not present.	no. of faults	RW	ImeFinMissingFC	NVMFaultCounter	shortNatural	No	Fault Counter:12-764-00: Finisher is not present.	1.521		
604-995	Fault Counter 12-492-00: CDI communications failure with finisher.	no. of faults	RW	FINISHERCDICOMMSFAILFC	NVMFaultCounter	shortNatural	No	Fault Counter:12-492-00: CDI communications failure	1.521		
604-996	Fault Counter 12-493-00: Finisher failure to Cycle Up in time	no. of faults	RW	FINISHERFAILCYCLEUPFC	NVMFaultCounter	shortNatural	No	Fault Counter:12-493-00: Finisher failure to Cycle Up in time	1.521		
604-997	Fault Counter 12-494-00: Finisher failure to return prep time	no. of faults	RW	FINISHERFAILPREPTIMEFC	NVMFaultCounter	shortNatural	No	Fault Counter:12-494-00: Finisher failure to	1.521		
604-998	Fault Counter 12-100-00: Finisher Late to Entry Sensor	no. of faults	RW	DfFnlinkLateToEntry	NVMFaultCounter	shortNatural	No	Fault Counter:12-100-00: Finisher Late to	1.521		
604-999	Fault Counter 12-102-00: Late IME Exit	no. of faults	RW	DfFnlinkLateImeExit	NVMFaultCounter	shortNatural	No	Fault Counter:12-102-00: Late IME Exit	1.521		
605-011	Counter-MFPRINTLargeSheets		ND		NVMBillingCounter	byteArray	No	Billing Counter:31: Black Printed Large Sheets	1.799		
605-015	Counter-PrintIFAXJobs		ND		NVMSystemUsageCounter	byteArray	No	System Usage Counter:48: Total	1.799		
605-025	Counter-MFPRINTLargeColorSheets		ND		NVMBillingCounter	byteArray	No	Billing Counter:34: Color Printed Large	1.799		
605-027	Counter-MFPRINTSuccessfulFaxImagesReceived		ND		NVMBillingCounter	byteArray	No	Billing Counter:12: Internet Fax	1.799		
606-003	Tray 1 Media Weight		RW	Tray 1 Media Weight	NVMSAKOSetting	shortNatural	No		1.042		
606-005	Tray 1 Priority		RW	Tray 1 Priority	NVMSAKOSetting	shortNatural	No		1.730		
606-006	Tray 1 Width	Range and default size in	RW	Tray 1 Width	NVMSAKOSetting	natural	No		1.333		
606-006	Tray 1 Width	Range and default size in	RW	Tray 1 Width	NVMSAKOSetting	natural	No		1.380		
606-006	Tray 1 Width	Range and default size in	RW	Tray 1 Width	NVMSAKOSetting	natural	No		1.488		
606-006	Tray 1 Width	Range and default size in	RW	Tray 1 Width	NVMSAKOSetting	natural	No		1.495		
606-006	Tray 1 Width	Range and default size in	RW	Tray 1 Width	NVMSAKOSetting	natural	No		1.696		

606-007	Tray 1 Length	Range and default size in	RW	Tray 1 Length	NVMSAKOSetting	natural	No		1.333		
606-007	Tray 1 Length	Range and default size in	RW	Tray 1 Length	NVMSAKOSetting	natural	No		1.380		
606-007	Tray 1 Length	Range and default size in mm	RW	Tray 1 Length	NVMSAKOSetting	natural	No		1.629		
606-007	Tray 1 Length	Range and default size in	RW	Tray 1 Length	NVMSAKOSetting	natural	No		1.495		
606-007	Tray 1 Length	Range and default size in	RW	Tray 1 Length	NVMSAKOSetting	natural	No		1.568		
606-007	Tray 1 Length	Range and default size in	RW	Tray 1 Length	NVMSAKOSetting	natural	No		1.696		
606-007	Tray 1 Length	Range and default size in	RW	Tray 1 Length	NVMSAKOSetting	natural	No		1.787		
606-007	Tray 1 Length	Range and default size in	RW	Tray 1 Length	NVMSAKOSetting	natural	No		1.804		
606-023	Tray 2 Media Weight		RW	Tray 2 Media Weight	NVMSAKOSetting	shortNatural	No		1.042		
606-025	Tray 2 Priority		RW	Tray 2 Priority	NVMSAKOSetting	shortNatural	No		1.730		
606-026	Tray 2 Width		RW	Tray 2 Width	NVMSAKOSetting	natural	No		1.253		
606-026	Tray 2 Width	Range and default size in	RW	Tray 2 Width	NVMSAKOSetting	natural	No		1.380		
606-026	Tray 2 Width	Range and default size in	RW	Tray 2 Width	NVMSAKOSetting	natural	No		1.640		
606-026	Tray 2 Width		RW	Tray 2 Width	NVMSAKOSetting	natural	No		1.495		
606-026	Tray 2 Width		RW	Tray 2 Width	NVMSAKOSetting	natural	No		1.696		
606-026	Tray 2 Width	Range and default size in	RW	Tray 2 Width	NVMSAKOSetting	natural	No		1.787		
606-027	Tray 2 Length	Range and default size in	RW	Tray 2 Length	NVMSAKOSetting	natural	No		1.253		
606-027	Tray 2 Length	Range and default size in mm	RW	Tray 2 Length	NVMSAKOSetting	natural	No		1.380		
606-027	Tray 2 Length	Range and default size in	RW	Tray 2 Length	NVMSAKOSetting	natural	No		1.640		
606-027	Tray 2 Length	Range and default size in	RW	Tray 2 Length	NVMSAKOSetting	natural	No		1.495		
606-027	Tray 2 Length	Range and default size in	RW	Tray 2 Length	NVMSAKOSetting	natural	No		1.568		
606-027	Tray 2 Length	Range and default size in	RW	Tray 2 Length	NVMSAKOSetting	natural	No		1.696		
606-027	Tray 2 Length	Range and default size in mm	RW	Tray 2 Length	NVMSAKOSetting	natural	No		1.787		
606-027	Tray 2 Length	Range and default size in mm	RW	Tray 2 Length	NVMSAKOSetting	natural	No		1.804		
606-032	Tray 2 Usage: Standard Tray / Envelope	specialMaterials = 0,	RW	Tray 2 Usage:Standard/Envelope	NVMSAKOSetting	shortNatural	No		1.524		
606-043	Tray 3 Media Weight		RW	Tray 3 Media Weight	NVMSAKOSetting	shortNatural	No		1.042		
606-045	Tray 3 Priority		RW	Tray 3 Priority	NVMSAKOSetting	shortNatural	No		1.730		
606-045	Tray 3 Priority		RW	Tray 3 Priority	NVMSAKOSetting	shortNatural	No		1.462		
606-045	Tray 3 Priority		RW	Tray 3 Priority	NVMSAKOSetting	shortNatural	No		1.507		
606-045	Tray 3 Priority		RW	Tray 3 Priority	NVMSAKOSetting	shortNatural	No		1.561		
606-046	Tray 3 Width	Range and default size in mm	RW	Tray 3 Width	NVMSAKOSetting	natural	No		1.042		
606-046	Tray 3 Width	Range and default size in	RW	Tray 3 Width	NVMSAKOSetting	natural	No		1.380	Yes	
606-046	Tray 3 Width	Range and default size in	RW	Tray 3 Width	NVMSAKOSetting	natural	No		1.495		

606-046	Tray 3 Width	Range and default size in	RW	Tray 3 Width	NVMSAKOSetting	natural	No		1.787		
606-047	Tray 3 Length	Range and default size in	RW	Tray 3 Length	NVMSAKOSetting	natural	No		1.615		
606-047	Tray 3 Length	Range and default size in	RO	Tray 3 Length	NVMSAKOSetting	natural	No		1.380	Yes	
606-047	Tray 3 Length	Range and default size in	RW	Tray 3 Length	NVMSAKOSetting	natural	No		1.495		
606-047	Tray 3 Length	Range and default size in	RW	Tray 3 Length	NVMSAKOSetting	natural	No		1.787		
606-047	Tray 3 Length	Range and default size in	RW	Tray 3 Length	NVMSAKOSetting	natural	No		1.804		
606-049	Tray 3 User Type	0 = TAFixed 1 = TAAadjustableAll	RW	Tray 3 User Type	NVMSAKOSetting	shortNatural	No		1.448		
606-063	Tray 4 Media Weight		RW	Tray 4 Media Weight	NVMSAKOSetting	shortNatural	No		1.042		
606-065	Tray 4 Priority		RW	Tray 4 Priority	NVMSAKOSetting	shortNatural	No		1.730		
606-065	Tray 4 Priority		RW	Tray 4 Priority	NVMSAKOSetting	shortNatural	No		1.462		
606-065	Tray 4 Priority		RW	Tray 4 Priority	NVMSAKOSetting	shortNatural	No		1.507		
606-066	Tray 4 Width	Range and default size in	RW	Tray 4 Width	NVMSAKOSetting	natural	No		1.042		
606-066	Tray 4 Width	Range and default size in	RW	Tray 4 Width	NVMSAKOSetting	natural	No		1.380	Yes	
606-066	Tray 4 Width	Range and default size in	RW	Tray 4 Width	NVMSAKOSetting	natural	No		1.495		
606-066	Tray 4 Width	Range and default size in	RW	Tray 4 Width	NVMSAKOSetting	natural	No		1.787		
606-067	Tray 4 Length	Range and default size in mm	RW	Tray 4 Length	NVMSAKOSetting	natural	No		1.615		
606-067	Tray 4 Length	Range and default size in	RW	Tray 4 Length	NVMSAKOSetting	natural	No		1.380	Yes	
606-067	Tray 4 Length	Range and default size in mm	RW	Tray 4 Length	NVMSAKOSetting	natural	No		1.495		
606-067	Tray 4 Length	Range and default size in mm	RW	Tray 4 Length	NVMSAKOSetting	natural	No		1.787		
606-067	Tray 4 Length	Range and default size in mm	RW	Tray 4 Length	NVMSAKOSetting	natural	No		1.804		
606-069	Tray 4 User Type	0 = TAFixed 1 = TAAadjustableAll	RW	Tray 4 User Type	NVMSAKOSetting	shortNatural	No		1.380		
606-083	Tray 5 Media Weight		RW	Tray 5 Media Weight	NVMSAKOSetting	shortNatural	No		1.042		
606-084	Tray 5 Direct Select	TSDirectOnly = 0, TSDirectAndAuto = 1	RW	Tray 5 Direct Select	NVMSAKOSetting	shortNatural	No		1.380		
606-085	Tray 5 Priority		RW	Tray 5 Priority	NVMSAKOSetting	shortNatural	No		1.793		
606-085	Tray 5 Priority Note: Tray 5 is manual feed slot on		RW	Tray 5 Priority	NVMSAKOSetting	shortNatural	No		1.814		
606-086	Tray 5 Width	Range and default size in mm	RW	Tray 5 Width	NVMSAKOSetting	natural	No		1.332		
606-086	Tray 5 Width	Range and default size in mm	RW	Tray 5 Width	NVMSAKOSetting	natural	No		1.380		
606-086	Tray 5 Width	Range and default size in	RW	Tray 5 Width	NVMSAKOSetting	natural	No		1.495		
606-086	Tray 5 Width	Range and default size in	RW	Tray 5 Width	NVMSAKOSetting	natural	No		1.629		
606-086	Tray 5 Width	Range and default size in	RW	Tray 5 Width	NVMSAKOSetting	natural	No		1.629		
606-086	Tray 5 Width	Range and default size in mm	RW	Tray 5 Width	NVMSAKOSetting	natural	No		1.700		
606-086	Tray 5 Width	Range and default size in mm	RW	Tray 5 Width	NVMSAKOSetting	natural	No		1.793		
606-087	Tray 5 Length	Range and default size in mm	RW	Tray 5 Length	NVMSAKOSetting	natural	No		1.332		
606-087	Tray 5 Length	Range and default size in mm	RW	Tray 5 Length	NVMSAKOSetting	natural	No		1.380		
606-087	Tray 5 Length	Range and default size in mm	RW	Tray 5 Length	NVMSAKOSetting	natural	No		1.495		
606-087	Tray 5 Length	Range and default size in mm	RW	Tray 5 Length	NVMSAKOSetting	natural	No		1.629		

606-087	Tray 5 Length	Range and default size in mm	RW	Tray 5 Length	NVMSAKOSetting	natural	No		1.675		
606-087	Tray 5 Length	Range and default size in mm	RW	Tray 5 Length	NVMSAKOSetting	natural	No		1.793		
606-088	Tray 5 Percent Full		RW	Tray 5 Percent Full	NVMSAKOSetting	shortNatural	No		1.016		
606-089	Tray 5 User Type	TAFixed = 0,	RW	Tray 5 User Type	NVMSAKOSetting	shortNatural	No		1.793		
606-103	Tray 6 Media Weight		RW	Tray 6 Media Weight	NVMSAKOSetting	shortNatural	No		1.042		
606-104	Tray 6 Direct Select	TSDirectOnly = 0,	RW	Tray 6 Direct Select	NVMSAKOSetting	shortNatural	No		1.340		
606-105	Tray 6 Priority		RW	Tray 6 Priority	NVMSAKOSetting	shortNatural	No		1.793		
606-105	Tray 6 Priority		RW	Tray 6 Priority	NVMSAKOSetting	shortNatural	No		1.380		
606-106	Tray 6 Width	Range and default size in mm	RW	Tray 6 Width	NVMSAKOSetting	natural	No		1.253		
606-106	Tray 6 Width	Range and default size in mm	RW	Tray 6 Width	NVMSAKOSetting	natural	No		1.610	Yes	
606-106	Tray 6 Width	Range and default size in mm	RW	Tray 6 Width	NVMSAKOSetting	natural	No		1.610	Yes	
606-106	Tray 6 Width Note: In Melody tray 6 is Optional HCF 2	Range and default size in mm	RW	Tray 6 Width	NVMSAKOSetting	natural	No		1.793		
606-107	Tray 6 Length	Range and default size in mm	RW	Tray 6 Length	NVMSAKOSetting	natural	No		1.042		
606-107	Tray 6 Length	Range and default size in mm	RW	Tray 6 Length	NVMSAKOSetting	natural	No		1.610	Yes	
606-107	Tray 6 Length	Range and default size in mm	RW	Tray 6 Length	NVMSAKOSetting	natural	No		1.610	Yes	
606-107	Tray 6 Length	Range and default size in mm	RW	Tray 6 Length	NVMSAKOSetting	natural	No		1.793		
606-109	Tray 6 User Type	TAFixed = 0,	RW	Tray 6 User Type	NVMSAKOSetting	shortNatural	No		1.793		
606-109	Tray 6 User Type	TAFixed = 0,	RW	Tray 6 User Type	NVMSAKOSetting	shortNatural	No		1.268		
606-109	Tray 6 User Type	TAFixed = 0,	RW	Tray 6 User Type	NVMSAKOSetting	shortNatural	No		1.610		
606-121	Tray 7 Media Type	MTStandard = 0,	RW	Tray 7 Media Type	NVMSAKOSetting	shortNatural	No		1.670		
606-122	Tray 7 Media Color	MCWhite = 0,	RW	Tray 7 Media Color	NVMSAKOSetting	shortNatural	No		1.670		
606-123	Tray 7 Media Weight		RW	Tray 7 Media Weight	NVMSAKOSetting	shortNatural	No		1.268		
606-123	Tray 7 Media Weight		RW	Tray 7 Media Weight	NVMSAKOSetting	shortNatural	No		1.670		
606-124	Tray 7 Direct Select	TSDirectOnly = 0,	RW	Tray 7 Direct Select	NVMSAKOSetting	shortNatural	No		1.793		
606-125	Tray 7 Priority		RW	Tray 7 Priority	NVMSAKOSetting	shortNatural	No		1.380		
606-125	Tray 7 Priority		RW	Tray 7 Priority	NVMSAKOSetting	shortNatural	No		1.670		
606-125	Tray 7 Priority		RW	Tray 7 Priority	NVMSAKOSetting	shortNatural	No		1.793		
606-126	Tray 7 Width	Range and default size in mm	RW	Tray 7 Width	NVMSAKOSetting	natural	No		1.380		
606-126	Tray 7 Width Note : In FX product, this Tray 7 NVM's is	Range and default size in mm	RW	Tray 7 Width	NVMSAKOSetting	natural	No		1.670		
606-126	Tray 7 Width	Range and default size in mm	RW	Tray 7 Width	NVMSAKOSetting	natural	No		1.696		
606-126	Tray 7 Width	Range and default size in mm	RW	Tray 7 Width	NVMSAKOSetting	natural	No		1.793		
606-127	Tray 7 Length	Range and default size in mm	RW	Tray 7 Length	NVMSAKOSetting	natural	No		1.380		
606-127	Tray 7 Length Note : In FX product, this Tray 7 NVM's is	Range and default size in mm	RW	Tray 7 Length	NVMSAKOSetting	natural	No		1.670		
606-127	Tray 7 Length Note : In FX product, this Tray 7 NVM's is used by 3TM tray config for Tray 3 setting.	Range and default size in mm	RW	Tray 7 Length	NVMSAKOSetting	natural	No		1.696		
606-127	Tray 7 Length Note : In Melody, tray 7 is Optional HCF 3	Range and default size in mm	RW	Tray 7 Length	NVMSAKOSetting	natural	No		1.793		

606-128	Tray 7 Percent Full Note : In FX product, this Tray 7 NVM's is used by 3TM tray config for Tray 3 setting. TTM tray config will use the Tray 3 NVM similar to other products.		RW	Tray 7 Percent Full	NVMSAKOSetting	shortNatural	No		1.670		
606-129	Tray 7 User Type	TAFixed = 0, TAAdjustableAll = 1,	RW	Tray 7 User Type	NVMSAKOSetting	shortNatural	No		1.380		
606-129	Tray 7 User Type	TAFixed = 0,	RW	Tray 7 User Type	NVMSAKOSetting	shortNatural	No		1.793		
606-130	Tray 7 Modulus Note : In FX product, this Tray 7 NVM's is		RW	Tray 7 Modulus	NVMSAKOSetting	shortNatural	No		1.670		
606-131	Tray 7 Modulus Position Note : In FX product, this Tray 7 NVM's is		RW	Tray 7 Modulus Position	NVMSAKOSetting	shortNatural	No		1.670		
606-141	Tray 8 Media Type	MTStandard = 0,	RW	Tray 8 Media Type	NVMSAKOSetting	shortNatural	No		1.670		
606-142	Tray 8 Media Color Note : In FX product, this Tray 8 NVM's is	MCWhite = 0, MCGreen = 1,	RW	Tray 8 Media Color	NVMSAKOSetting	shortNatural	No		1.670		
606-143	Tray 8 Media Weight Note : In FX product, this Tray 8 NVM's is		RW	Tray 8 Media Weight	NVMSAKOSetting	shortNatural	No		1.670		
606-144	Tray 8 Direct Select Note : In FX product, this Tray 8 NVM's is	TSDirectOnly = 0, TSDirectAndAuto = 1	RW	Tray 8 Direct Select	NVMSAKOSetting	shortNatural	No		1.793		
606-145	Tray 8 Priority		RW	Tray 8 Priority	NVMSAKOSetting	shortNatural	No		1.670		
606-145	Tray 8 Priority Note : In Melody, Tray 8 is Optional HCF 4		RW	Tray 8 Priority	NVMSAKOSetting	shortNatural	No		1.793		
606-146	Tray 8 Width	Range and default size in	RW	Tray 8 Width	NVMSAKOSetting	natural	No		1.670		
606-146	Tray 8 Width	Range and default size in	RW	Tray 8 Width	NVMSAKOSetting	natural	No		1.696		
606-146	Tray 8 Width Note : In Melody, Tray 8 is Optional HCF 4	Range and default size in mm	RW	Tray 8 Width	NVMSAKOSetting	natural	No		1.793		
606-147	Tray 8 Length Note : In FX product, this Tray 8 NVM's is	Range and default size in mm	RW	Tray 8 Length	NVMSAKOSetting	natural	No		1.670		
606-147	Tray 8 Length Note : In FX product, this Tray 8 NVM's is	Range and default size in mm	RW	Tray 8 Length	NVMSAKOSetting	natural	No		1.696		
606-147	Tray 8 Length	Range and default size in	RW	Tray 8 Length	NVMSAKOSetting	natural	No		1.793		
606-148	Tray 8 Percent Full Note : In FX product, this Tray 8 NVM's is used by 3TM tray config for Tray 4 setting. TTM tray config will use the Tray 4 NVM similar to other products.		RW	Tray 8 Percent Full	NVMSAKOSetting	shortNatural	No		1.670		
606-149	Tray 8 User Type	TAFixed = 0,	RW	Tray 8 User Type	NVMSAKOSetting	shortNatural	No		1.793		
606-150	Tray 8 Modulus Note : In FX product, this Tray 8 NVM's is		RW	Tray 8 Modulus	NVMSAKOSetting	shortNatural	No		1.670		
606-151	Tray 8 Modulus Position Note : In FX product, this Tray 8 NVM's is		RW	Tray 8 Modulus Position	NVMSAKOSetting	shortNatural	No		1.670		
606-190	Plain Large Sheets Used Total of large size Plain media sheets since activation date numLargePlainMedia	Plain Large Sheets Used Total of large size Plain media sheets since activation date numLargePlainMedia	ND	Plain Large Sheets Used	NVMSystemUsageCounter	byteArray	No	System Usage Counter:98: Plain Large Sheets Used	1.799		
606-191	Bond Large Sheets Used Total of large size Bond media sheets since activation date	Bond Large Sheets Used Total of large size Bond media sheets since	ND	Bond Large Sheets Used	NVMSystemUsageCounter	byteArray	No	System Usage Counter:99: Bond Large Sheets Used	1.799		

606-192	LetterHead Large Sheets Used Total of large size Leterhead media sheets	LetterHead Large Sheets Used	ND	LetterHead Large Sheets Used	NVMSystemUsageCounter	byteArray	No	System Usage Counter:100:	1.799		
606-193	Pre-Printed Large Sheets Used Total of large size Pre-Printed media	Pre-Printed Large Sheets Used	ND	Pre-Printed Large Sheets Used	NVMSystemUsageCounter	byteArray	No	System Usage Counter:101: Pre-	1.799		
606-199	Gloss Coating Large Sheets Used Total of large size Gloss Coating media	Gloss Coating Large Sheets Used	ND	Gloss Coating Large Sheets Used	NVMSystemUsageCounter	byteArray	No	System Usage Counter:108: Gloss	1.799		
606-205	Recycled Large Sheets Used Total of large size Recycled media sheets	Recycled Large Sheets Used	ND	Recycled Large Sheets Used	NVMSystemUsageCounter	byteArray	No	System Usage Counter:114: Recycled	1.799		
606-206	Hole Punched Large Sheets Used Total of large size Holepunched media	Hole Punched Large Sheets Used	ND	Hole Punched Large Sheets Used	NVMSystemUsageCounter	byteArray	No	System Usage Counter:115: Punched	1.799		
606-207	Other Paper Type Large Sheets Used Total of large size Other media (not	Other Paper Type Large Sheets Used	ND	Other Paper Type Large Sheets	NVMSystemUsageCounter	byteArray	No	System Usage Counter:116: Other	1.799		
606-209	Tabloid (11 x 17") Sheets Used Total of 11x17" sheets since activation	Tabloid (11 x 17") Sheets Used	ND	Tabloid Sheets Used	NVMSystemUsageCounter	byteArray	No	System Usage Counter:118: Tabloid	1.799		
606-214	12 x 18" Sheets Used	12 x 18" Sheets Used	ND	12 x 18 Sheets Used	NVMSystemUsageCounter	byteArray	No	System Usage	1.799		
606-215	12 x 19" Sheets Used Total of 12x19" sheets since activation	12 x 19" Sheets Used Total of 12x19" sheets	ND	12 x 19 Sheets Used	NVMSystemUsageCounter	byteArray	No	System Usage Counter:124: 12 x 19"	1.799		
606-218	A3 Sheets Used Total of A3 sheets since activation date numA3Sheets	A3 Sheets Used Total of A3 sheets since activation date	ND	A3 Sheets Used	NVMSystemUsageCounter	byteArray	No	System Usage Counter:127: A3 Sheets Used	1.061		
606-219	SRA3 Sheets Used	SRA3 Sheets Used	ND	SRA3 Sheets Used	NVMSystemUsageCounter	byteArray	No	System Usage	1.799		
606-249	All sheets fed from Tray #7	All sheets fed from Tray	ND	All sheets fed from Tray #7	NVMSystemUsageCounter	byteArray	No	System Usage	1.061		
606-250	All sheets fed from Tray #8	All sheets fed from Tray	ND	All sheets fed from Tray #8	NVMSystemUsageCounter	byteArray	No	System Usage	1.061		
606-269	Service Plan (Contract - with leaning mode	Sold = 0, Metered =	RO	Service Plan	NVMcontrolledAccess	shortNatural	No		1.790	Yes	Yes, as Text
606-399	SPARED (was Tray 7 Jams - Usage	Tray 7 Jams	ND	SPARE 606-399	NVMSystemUsageCounter	longNatural	No	System Usage	1.044		
606-400	Tray 8 Jams - Usage Counter	Tray 8 Jams	RO	Tray 8 Jams	NVMSystemUsageCounter	longNatural	No	System Usage	1.044		
606-403	Protocol comm faults counter	Protocol comm faults	RO	Protocol comm faults counter	NVMSystemUsageCounter	longNatural	No	System Usage	1.678		
606-483	Tray 7 (PPI) Feed Rolls life counter	Feeds - counted by	RW	Tray7FeedRollsLifeCount	NVMHFSICounter	longNatural	No		1.426		
606-488	Tray 6 (PFP) Feed Rolls life counter	Feeds - counted by	RW	Tray6FeedRollsLifeCount	NVMHFSICounter	longNatural	No		1.426		
606-493	Tray 7 (PPI) Feed Rolls replacement counter	Replacements - incremented when user resets life counter	RW	Tray7FeedRollsRepCount	NVMSystemUsageCounter	natural	No	Unknown	1.426		
606-494	Tray 1 Feed Rolls replacement counter	Replacements - incremented when user resets life counter	RW	Tray1FeedRollsRepCount	NVMSystemUsageCounter	natural	No	Unknown	1.426		
606-495	Tray 2 Feed Rolls replacement counter	Replacements - incremented when user resets life counter	RW	Tray2FeedRollsRepCount	NVMSystemUsageCounter	natural	No	Unknown	1.426		
606-496	Tray 3 Feed Rolls replacement counter	Replacements - incremented when user resets life counter	RW	Tray3FeedRollsRepCount	NVMSystemUsageCounter	natural	No	Unknown	1.426		
606-497	Tray 5 (MSI) Feed Rolls replacement counter	Replacements - incremented when user	RW	Tray5FeedRollsRepCount	NVMSystemUsageCounter	natural	No	Unknown	1.426		
606-498	Tray 6 (PFP) Feed Rolls replacements	Replacements - incremented when user resets life counter	RW	Tray6FeedRollsRepCount	NVMSystemUsageCounter	natural	No	Unknown	1.426		
606-513	Transfer Roller replacements	system increments counter	RO	XferRollReplacements	NVMSystemUsageCounter	natural	No	Unknown	1.265		
606-514	Transfer Belt replacements	system increments	RO	XferBeltReplacements	NVMSystemUsageCounter	natural	No	Unknown	1.799		
606-514	Transfer Belt Cleaner replacements	system increments counter	RO	BeltCleanerReplacements	NVMSystemUsageCounter	natural	No	Unknown	1.799		

606-516	SPDH Feed Roll Life Expectancy	Modifiable via DC131	RW	SPDHRollLife	NVMConfiguration	longNatural	No		1.434		
606-516	SPDH Feed Roll Life Expectancy	Modifiable via DC131	RW	SPDHRollLife	NVMConfiguration	longNatural	No		1.600		
606-516	ADF Roller- Forward Roller – Separation	Feeds - adjustable by	RW	SPDHRollLife	NVMConfiguration	longNatural	No		1.805		
606-517	Tray 7 (PPI) Feed Rolls Life Expectancy	Feeds - adjustable by CSE	RW	Tray7FeedRollsExpLife	NVMConfiguration	longNatural	No		1.434		
606-518	Tray 1 Feed Rolls life expectancy	Feeds - adjustable by CSE	RW	Tray1FeedRollsExpLife	NVMConfiguration	longNatural	No		1.434		
606-518	Tray 1 Pick & Separator Roller life expectancy	Feeds - adjustable by CSE	RW	Tray1FeedRollsExpLife	NVMConfiguration	longNatural	No		1.805		
606-519	Tray 2 Feed Rolls life expectancy	Feeds - adjustable by CSE	RW	Tray2FeedRollsExpLife	NVMConfiguration	longNatural	No		1.434		
606-519	Tray 2 Pick & Separator Roller life expectancy	Feeds - adjustable by CSE	RW	Tray2FeedRollsExpLife	NVMConfiguration	longNatural	No		1.805		
606-520	Tray 3 Feed Rolls Life Expectancy	Feeds - adjustable by CSE	RW	Tray3FeedRollsExpLife	NVMConfiguration	longNatural	No		1.434		
606-520	Tray 3 Pick & Separator Roller Life Expectancy	Feeds - adjustable by CSE	RW	Tray3FeedRollsExpLife	NVMConfiguration	longNatural	No		1.805		
606-521	Tray 5 (MSI) Feed Rolls life expectancy	Feeds - adjustable by CSE	RW	Tray5FeedRollsExpLife	NVMConfiguration	longNatural	No		1.434		
606-522	Tray 6 (PFP) Feed Rolls life expectancy	Feeds - adjustable by CSE	RW	Tray6FeedRollsExpLife	NVMConfiguration	longNatural	No		1.434		
606-523	Fuser Life Expectancy	Modifiable via DC131	RW	FuserLife	NVMConfiguration	longNatural	No		1.206		
606-523	Fuser Life Expectancy	Modifiable via DC131	RW	FuserLife	NVMConfiguration	longNatural	No		1.805		
606-527	Tray 7 (PPI) Feed Rolls install date	unix timedate - set when user resets count	ND	Tray7FeedRollsInstDate	NVMConfiguration	longNatural	No		1.667		
606-528	Tray 1 Feed Rolls install date	unix timedate - set when user resets count	ND	Tray1FeedRollsInstDate	NVMConfiguration	longNatural	No		1.667		
606-529	Tray 2 Feed Rolls install date	unix timedate - set when user resets count	ND	Tray2FeedRollsInstDate	NVMConfiguration	longNatural	No		1.667		
606-530	Tray 3 Feed Rolls install date	unix timedate - set when user resets count	ND	Tray3FeedRollsInstDate	NVMConfiguration	longNatural	No		1.667		
606-531	Tray 5 (MSI) Feed Rolls install date	unix timedate - set when user resets count	ND	Tray5FeedRollsInstDate	NVMConfiguration	longNatural	No		1.667		
606-532	Tray 6 (PFP) Feed Rolls install date	unix timedate - set when user resets count	ND	Tray6FeedRollsInstDate	NVMConfiguration	longNatural	No		1.667		
606-538	Label Enablement for T1 / T2	0=disabled 1=enabled	RW	T1/ T2 Label Enablement	NVMConfiguration	shortNatural	No		1.510		

606-540	Bias Transfer Roll Install Date	Bias Transfer Roller installation date	ND		NVMConfiguration	longNatural	No		1.667		
606-572	Fault Counter 12-098: FinisherFlashROMFailFC	no. of faults	RW	FinisherFlashROMFailFC	NVMFaultCounter	shortNatural	No	Fault Counter:12-098-00:	1.521		
606-573	Fault Counter 12-099: FinisherCommErrorFC	no. of faults	RW	FinisherCommErrorFC	NVMFaultCounter	shortNatural	No	Fault Counter:12-099-00:	1.521		
606-578	Fault Counter 12-480:	no. of faults	RW	FinisherElevationDriveFailFC	NVMFaultCounter	shortNatural	No	Fault Counter:12-480-00:	1.521		
606-579	Fault Counter 12-481: FinisherPaperPressDriveFailFC	no. of faults	RW	FinisherPaperPressDriveFailFC	NVMFaultCounter	shortNatural	No	Fault Counter:12-481-00: FinisherPaperPressDriveFailFC	1.521		
606-580	Fault Counter 12-482: FinisherAlignPlateDriveFailFC	no. of faults	RW	FinisherAlignPlateDriveFailFC	NVMFaultCounter	shortNatural	No	Fault Counter:12-482-00: FinisherAlignPlateDriveFailFC	1.521		
606-581	Fault Counter 12-483: FinisherEjectRollerContactFailFC	no. of faults	RW	FinisherEjectRollerContactFailFC	NVMFaultCounter	shortNatural	No	Fault Counter:12-483-00: FinisherEjectRollerContactFailFC	1.521		
606-582	Fault Counter 12-484: FinisherStorageBeltContactFailFC	no. of faults	RW	FinisherStorageBeltContactFailFC	NVMFaultCounter	shortNatural	No	Fault Counter:12-484-00: FinisherStorageBeltContactFailFC	1.521		
606-583	Fault Counter 12-485: FinisherBundleEjectMotorFailFC	no. of faults	RW	FinisherBundleEjectMotorFailFC	NVMFaultCounter	shortNatural	No	Fault Counter:12-485-00: FinisherBundleEjectMo	1.521		
606-604	Fault Counter 12-487: JamFinisherTransportAreaFC	no. of faults	RW	JamFinisherTransportAreaFC	NVMFaultCounter	shortNatural	No	Fault Counter:12-487-00: JamFinisherTransport	1.521		
606-605	Fault Counter 12-488: JamFinisherUpperOutputTrayFC	no. of faults	RW	JamFinisherUpperOutputTrayFC	NVMFaultCounter	shortNatural	No	Fault Counter:12-488-00: JamFinisherUpperOutp	1.521		
606-606	Fault Counter 12-489: JamFinisherStackerOutputTrayFC	no. of faults	RW	JamFinisherStackerOutputTrayFC	NVMFaultCounter	shortNatural	No	Fault Counter:12-489-00: JamFinisherStackerOu	1.521		
606-607	Fault Counter 12-491: StaplerJamFC	no. of faults	RW	StaplerJamFC	NVMFaultCounter	shortNatural	No	Fault Counter:12-491-00: StaplerJamFC	1.521		
606-629	IOTTOTALXCRUREPLACEMENTS_C This supports the AIF counter Color Drum Cartridge in Position R2		ND		NVMSystemUsageCounter	natural	No	System Usage Counter:342: Color Drum Cartridge in	1.799		
606-630	IOTTOTALXCRUREPLACEMENTS_M This supports the AIF counter Color Drum Cartridge in Position R3		ND		NVMSystemUsageCounter	natural	No	System Usage Counter:343: Color Drum Cartridge in	1.799		
606-631	IOTTOTALXCRUREPLACEMENTS_Y This supports the AIF counter Color Drum Cartridge in Position R4		ND		NVMSystemUsageCounter	natural	No	System Usage Counter:344: Color Drum Cartridge in	1.799		
606-787	Default is the version number of the Excel	Table Version used to	RW	FS23.201 Table Version	NVMConfiguration	natural	No		1.707		
606-787	Default is the version number of the Excel	Table Version used to	RW	FS23.201 Table Version	NVMConfiguration	natural	No		1.781		
606-787	Default is the version number of the Excel table used to create the NVM	Table Version used to create the NVM ie V1.234 = 1234	RW	FS23.201 Table Version	NVMConfiguration	natural	No		1.781		
606-787	Default is the version number of the Excel table used to create the NVM	Table Version used to create the NVM ie V1.234	RW	FS23.201 Table Version	NVMConfiguration	natural	No		1.781		

606-787	Default is the version number of the Excel table used to create the NVM	Table Version used to create the NVM ie V1.774 = 1774	RW	FS23.201 Table Version	NVMConfiguration	natural	No		1.800		
606-787	Default is the version number of the Excel table used to create the NVM	Table Version used to create the NVM ie V1.774 = 1774	RW	FS23.201 Table Version	NVMConfiguration	natural	No		1.800		
606-787	Default is the version number of the Excel table used to create the NVM	Table Version used to create the NVM ie V1.765 = 1765	RW	FS23.201 Table Version	NVMConfiguration	natural	No		1.816		
606-787	Default is the version number of the Excel table used to create the NVM	Table Version used to create the NVM ie V1.791 = 1791	RW	FS23.201 Table Version	NVMConfiguration	natural	No		1.807		
606-787	Default is the version number of the Excel table used to create the NVM	Table Version used to create the NVM ie V1.791 = 1791	RW	FS23.201 Table Version	NVMConfiguration	natural	No		1.810		
606-801	Fault Counter 12-444: Paper Pusher Switch Fault	no. of faults	RW	PapPusherSwitchFC	NVMFaultCounter	shortNatural	No	Fault Counter:12-444-00: Paper Pusher	1.521		
606-806	Default Staple position (HVF only)	1 = Staple head moves to	RW	Default Staple Position	NVMSAKOSetting	shortNatural	No		1.189		
606-820	Number of Grams of toner in a Standard size cartridge - Burgundy	Grams	RW	TonerGramsStd	NVMConfiguration	natural	No		1.526		
606-821	Number of Grams of toner in a High Capacity cartridge - Burgundy	Grams	RW	TonerGramsHiCap	NVMConfiguration	natural	No		1.526		
606-821	Number of Grams of toner in a High Capacity cartridge - Barolo	Grams	RW	TonerGramsHiCap	NVMConfiguration	natural	No		1.526		
606-834	B4 Sheets Used Total of B4 sheets since activation date	B4 Sheets Used Total of B4 sheets since	ND	B4 Sheets Used	NVMSystemUsageCounter	byteArray	No	System Usage Counter:???: B4	1.799		
606-838	Number of Grams of toner in a Standard size cartridge - Yellow	Grams	RW	TonerGramsStdYellow	NVMConfiguration	natural	No		1.572		
606-839	Number of Grams of toner in a Standard size cartridge - Magenta	Grams	RW	TonerGramsStdMagenta	NVMConfiguration	natural	No		1.572		
606-840	Number of Grams of toner in a Standard size cartridge - Cyan	Grams	RW	TonerGramsStdCyan	NVMConfiguration	natural	No		1.572		
606-842	Number of Grams of toner in a High Capacity cartridge - Yellow	Grams	RW	TonerGramsHiCapYellow	NVMConfiguration	natural	No		1.572		
606-843	Number of Grams of toner in a High Capacity cartridge - Magenta	Grams	RW	TonerGramsHiCapMagenta	NVMConfiguration	natural	No		1.572		

606-844	Number of Grams of toner in a High Capacity cartridge - Cyan	Grams	RW	TonerGramsHiCapCyan	NVMConfiguration	natural	No		1.572		
606-845	Number of Grams of toner in a High Capacity cartridge - Black	Grams	RW	TonerGramsHiCapBlack	NVMConfiguration	natural	No		1.572		
606-867	Tray 1 Envelopes: Width	Range and default size in mm	RW	Tray 1 Envelopes: Width	NVMSAKOSetting	natural	No		1.354		
606-868	Tray 1 Envelopes: Length	Range and default size in mm	RW	Tray 1 Envelopes: Length	NVMSAKOSetting	natural	No		1.354		

606-874	Fault Counter 12-259-00: EJECTHOMESENSORONFAILCTR	no. of faults	RW	EjectHomeSensorONFail	NVMFaultCounter	shortNatural	No	Fault Counter:12-259-00:EJECTHOMESENSORONFAILCTR	1.813		
606-875	Fault Counter 12-280-00: EJECTHOMESENSOROFFFAILCTR	no. of faults	RW	EjectHomeSensorOFFFail	NVMFaultCounter	shortNatural	No	Fault Counter:12-280-00:EJECTHOMESENSOROFFFAILCTR	1.813		
606-876	Fault Counter 12-917-00: STACKERTRAYSTAPLESETOVERCOUN	no. of faults	RW	StackerTrayStapleSetOverCount	NVMFaultCounter	shortNatural	No	Fault Counter:12-917-00:STACKERTRAYST	1.521		
606-877	Fault Counter 12-928-00:	no. of faults	RW	ScratchSheetCompile	NVMFaultCounter	shortNatural	No	Fault Counter:12-928-	1.521		
606-878	Fault Counter 12-976-00: STAPLENGCTR	no. of faults	RW	StapleNG	NVMFaultCounter	shortNatural	No	Fault Counter:12-976-00:STAPLENGCTR	1.813		
606-879	Fault Counter 12-977-00:	no. of faults	RW	StaplerFeedReadyFail	NVMFaultCounter	shortNatural	No	Fault Counter:12-977-	1.813		
606-880	Fault Counter 12-982-00:	no. of faults	RW	StackerLowerSafetyWarning	NVMFaultCounter	shortNatural	No	Fault Counter:12-982-	1.521		

606-881	Fault Counter 12-269-00: BOOKLETSSUBCPUCOMMFAILCTR	no. of faults	RW	BookletSubCPUCommFail	NVMFaultCounter	shortNatural	No	Fault Counter:12-269-00:BOOKLETSSUBCPU COMMFAILCTR	1.813		
606-882	Fault Counter 12-111-00: H_XPORTENTSNROFFJAMCTR	no. of faults	RW	H_XportEntSnrOFFJam	NVMFaultCounter	shortNatural	No	Fault Counter:12-111-00:H_XPORTENTSNR OFFJAMCTR	1.521		

606-883	Fault Counter 12-249-00: BOOKLETFRONTSTAPLERFAILCTR	no. of faults	RW	BookletFrontStaplerFail	NVMFaultCounter	shortNatural	No	Fault Counter:12-249-00:BOOKLETFRONTST	1.813		
606-884	Fault Counter 12-268-00: BOOKLETREARSTAPLERFAILCTR	no. of faults	RW	BookletRearStaplerFail	NVMFaultCounter	shortNatural	No	Fault Counter:12-268-00:BOOKLETREARST	1.813		
606-885	Fault Counter 12-212-00: BOOKLETSTAPLEMOVEPOSI_SNRONF	no. of faults	RW	BookletStapleMovePosi_SnrONFail	NVMFaultCounter	shortNatural	No	Fault Counter:12-212-00:BOOKLETSTAPLE	1.813		
606-886	Fault Counter 12-213-00:	no. of faults	RW	BookletStapleMovePosi_SnrOFFFail	NVMFaultCounter	shortNatural	No	Fault Counter:12-213-	1.813		
606-887	IBT Cleaner Install Date	System sets this upon new unit detection or confirmation	ND		NVMConfiguration	longNatural	No		1.751		
606-887	IBT Cleaner Install Date	System sets this upon	ND		NVMConfiguration	longNatural	No		1.751		
606-888	Second BTR Unit Install Date	System sets this upon	ND		NVMConfiguration	longNatural	No		1.751		
606-888	Second BTR Unit Install Date	System sets this upon new unit detection or confirmation	ND		NVMConfiguration	longNatural	No		1.751		
606-922	Number of Grams of toner in a Extra High Capacity cartridge - Burgundy	Grams	RW	TonerGramsExtraHiCap	NVMConfiguration	natural	No		1.526		
606-923	Number of Grams of toner in previous cartridge - Burgundy	Grams	RW	TonerGramsPrevious	NVMConfiguration	natural	No		1.526		
606-923	Number of Grams of toner in previous K	Grams	RW	TonerGramsPreviousK	NVMConfiguration	natural	No		1.572		
606-925	Number of Grams of toner in previous Y cartridge - Barolo Default is Starter cartridge Size	Grams	RW	TonerGramsPreviousY	NVMConfiguration	natural	No		1.572		
606-926	Number of Grams of toner in previous M	Grams	RW	TonerGramsPreviousM	NVMConfiguration	natural	No		1.572		

606-927	Number of Grams of toner in previous C	Grams	RW	TonerGramsPreviousC	NVMConfiguration	natural	No		1.572		
606-928	Fan Filter replacements	system increments counter	RO	FanFilterReplacements	NVMSystemUsageCounter	natural	No	System Usage Counter:???: FANFILTERREPLACEMENTS	1.799		
606-930	Counter-DualStapleFreeStapled		ND		NVMSystemUsageCounter	byteArray	No	System Usage Counter 10884: All dual Staple Free Staples	1.799		
606-931	Counter-StapleFreeStapledSheets		ND		NVMSystemUsageCounter	byteArray	No	System Usage Counter:10883: All	1.799		
606-932	Counter-All Uncollated StapleFreeStapled		ND		NVMSystemUsageCounter	byteArray	No	System Usage	1.799		
606-933	Counter-StapleFreeStapled2_15		ND		NVMSystemUsageCounter	byteArray	No	System Usage	1.799		
606-934	Total of 3xA4 Long Banner Sheet Used that is Larger than A3 Total of 3xA4 Long Banner Sheet Used since activation date	3xA4 Long Sheets Used that is Larger than A3 Total of Long 3xA4 sheets since activation date	ND	3xA4 Long Sheets	NVMSystemUsageCounter	byteArray	No		1.799		
606-935	Total of 4xA4 Long Banner Sheet Used	4xA4 Long Sheets Used	ND	4xA4 Long Sheets	NVMSystemUsageCounter	byteArray	No		1.799		
606-936	Total of 5xA4 Long Banner Sheet Used	5xA4 Long Sheets Used	ND	5xA4 Long Sheets	NVMSystemUsageCounter	byteArray	No		1.799		

606-937	Total of 6xA4 Long Banner Sheet Used that is Larger than A3 Total of 6xA4 Long Banner Sheet Used since activation date	6xA4 Long Sheets Used that is Larger than A3 Total of Long 6xA4 sheets since activation date	ND	6xA4 Long Sheets	NVMSystemUsageCounter	byteArray	No		1.799		
606-938	Total of Extra Long Black Banner Sheet made that is Larger than A3 Total of Extra Long Black Banner Sheet made since activation date	Black Banner Sheets Used that is Larger than A3 Total of Black Banner sheets since activation date	ND	Black Extra Long Sheets	NVMSystemUsageCounter	byteArray	No		1.799		

606-939	Total of Extra Long Color Banner Sheet Made that is Larger than A3 Total of Extra Long Color Banner Sheet Made since activation date	Color Banner Sheets Used that is Larger than A3 Total of Color Banner sheets since activation	ND	Color Extra Long Sheets	NVMSystemUsageCounter	byteArray	No		1.799		
606-940	Fault Counter 12-128: H-tra ExtSnrOnJamFaultCountFC	no.of times fault occurred	RW	H-tra ExtSnrOnJamFaultCountFC	NVMFaultCounter	shortNatural	No	Fault Counter:12-128-00:	1.813		
606-941	Fault Counter 12-129: H-tra ExtSnrOnJamFaultCountFC	no.of times fault occurred	RW	S-tra ExtSnrOnJamFaultCountFC	NVMFaultCounter	shortNatural	No	Fault Counter:12-129-00: H-tra	1.813		
606-942	Fault Counter 12-110: H-tra	no.of times fault occurred	RW	V-tra ExtSnrOnJamFaultCountFC	NVMFaultCounter	shortNatural	No	Fault Counter:12-110-	1.813		
606-943	Fault Counter 12-355-00: STAPLELESSSUBCPUDOWNLOADMODEFAILFAULTCOUNT	no.of times fault occurred	RW	STAPLELESSCPUDOWNLOADMOD	NVMFaultCounter	shortNatural	No	Fault Counter:12-355-00: STAPLELESSSUBCPUDOWNLOADMODEFAILFAULTCOUNT	1.813		
606-944	Fault Counter 12-333-00:	no.of times fault occurred	RW	PUNCHCPUDOWNLOADMODEFAI	NVMFaultCounter	shortNatural	No	Fault Counter:12-333-	1.813		
606-945	Fault Counter 12-250-00:	no.of times fault occurred	RW	PUNCHSUBCPUCOMMFAILFAULT	NVMFaultCounter	shortNatural	No	Fault Counter:12-250-	1.813		
606-946	Fault Counter 12-991-00: STAPLELESSSUBCPUCOMMUNICATIONFAILFAULTCOUNT	no.of times fault occurred	RW	STAPLELESSSUBCPUCOMMFAILFAULTCNT	NVMFaultCounter	shortNatural	No	Fault Counter:12-991-00: STAPLELESSSUBCPUCOMMUNICATIONFAILFAULT	1.813		

606-947	Fault Counter 12-990-00: HNSTAPLEFAILFAULTCOUNT	no.of times fault occurred	RW	HNSTAPLEFAILFAULTCOUNT	NVMFaultCounter	shortNatural	No	Fault Counter:12-990-00: HNSTAPLEFAILFAULT	1.813		
606-948	Fault Counter 13-210-00: BOOKLETSTAPLEMOVEPOSITIONSNRONFAILFAULTCOUNT	no.of times fault occurred	RW	BOOKLETSTAPLEMOVEPOSSNRO NFAILFC	NVMFaultCounter	shortNatural	No	Fault Counter:13-210-00: BOOKLETSTAPLEMOVEPOSITIONSNRONFAILFAULT	1.813		
606-949	Fault Counter 13-211-00: BOOKLETSTAPLEMOVEPOSITIONSNROFFFAILFAULTCOUNT	no.of times fault occurred	RW	BOOKLETSTAPLEMOVEPOSSNRO FFFAILFC	NVMFaultCounter	shortNatural	No	Fault Counter:13-210-00: BOOKLETSTAPLEMOVEPOSITIONSNROFFFAILFAULT	1.813		
606-950	Fault Counter 12-992-00: HN Stacker Stapler Move Position SNR ON Fail	no.of times fault occurred	RW	HNSTACKERSTAPLEMOVEPOSSNRO NFC	NVMFaultCounter	shortNatural	No	Fault Counter:12-992-00: HNSTACKERSTAPLEMOVEPOSSNRONFAULT	1.813		
606-951	Fault Counter 12-993-00: Stacker Stapler Move Position SNR OFF Fail	no.of times fault occurred	RW	STACKERSTAPLEMOVEPOSSNRO FFFC	NVMFaultCounter	shortNatural	No	Fault Counter:12-993-00: STACKERSTAPLEMOVEPOSSNROFFFAULT	1.813		

606-952	No. of Print calibration attempts		RW	Print Calibration attempts	NVMSystemUsageCounter	natural	No		1.808		
606-953	No. of Copy calibration attempts		RW	Copy Calibration attempts	NVMSystemUsageCounter	natural	No		1.808		

606-954	Toner Darkness Control for Alexandra Mono Engines	1 (Lightest) to 10 (Darkest) Default = 8	RW	TonerDarknessCtrl	NVMSAKOSetting	shortNatural	No		1.797		
606-959	Bias Transfer Roller (BTR) Life Counter	Feeds - counted by system	RW	BTRLifeCount	NVMHFSICounter	longNatural	No		1.813		
606-960	Bias Transfer Roller (BTR) Life Expectancy	Modifiable via DC131	RW	BTRExpLife	NVMConfiguration	longNatural	No		1.805		
608-411	Fault Counter 12-370-00: Stapler End Home Failure	no. of faults	RW	Stapler End Home Failure	NVMFaultCounter	shortNatural	No	Fault Counter:12-370-00: Stapler End Home	1.521		
608-412	Fault Counter 12-369-00: Stapler Return End Home Failure	no. of faults	RW	Stapler Return End Home Failure	NVMFaultCounter	shortNatural	No	Fault Counter:12-369-00: Stapler Return End Home Failure	1.521		
608-413	Fault Counter 12-368-00: Punch Unit paper side edge 2 detecting failure	no. of faults	RW	Punch - side edge2 detect fail	NVMFaultCounter	shortNatural	No	Fault Counter:12-368-00: Punch Unit paper side edge 2 detecting failure	1.521		
608-414	Fault Counter 12-367-00: Punch Unit paper side edge 3 detecting failure	no. of faults	RW	Punch - side edge3 detect fail	NVMFaultCounter	shortNatural	No	Fault Counter:12-367-00: Punch Unit paper side edge 3 detecting failure	1.521		
608-565	Fault Counter 45-321-00:MK_Panel_NG	no. of faults	RW	MK_Panel_NG	NVMFaultCounter	shortNatural	No	Fault Counter:45-321-	1.254		
608-566	Fault Counter 45-322-00:MK_Pitch_NG	no. of faults	RW	MK_Pitch_NG	NVMFaultCounter	shortNatural	No	Fault Counter:45-322-	1.254		
608-567	Fault Counter 45-331-00:MK_MKIF_MSG_Reject	no. of faults	RW	MK_MKIF_MSG_Reject	NVMFaultCounter	shortNatural	No	Fault Counter:45-331-00:MK_MKIF_MSG_Reject	1.254		
608-568	Fault Counter 45-332-00:MK_MMIF_MSG_Reject	no. of faults	RW	MK_MMIF_MSG_Reject	NVMFaultCounter	shortNatural	No	Fault Counter:45-332-00:	1.254		
608-569	Fault Counter 45-350-00:MK_Emergency_Over_Wait	no. of faults	RW	MK_Emergency_Over_Wait	NVMFaultCounter	shortNatural	No	Fault Counter:45-350-00:	1.254		
608-570	Fault Counter 45-351-00:MK_Emergency_No_Timer	no. of faults	RW	MK_Emergency_No_Timer	NVMFaultCounter	shortNatural	No	Fault Counter:45-351-00:	1.254		
608-571	Fault Counter 45-352-00:MK_Emergency_Enforced_Stop	no. of faults	RW	MK_Emergency_Enforced_Stop	NVMFaultCounter	shortNatural	No	Fault Counter:45-352-00:	1.254		
608-572	Fault Counter 45-313-00:ENG_LOGIC_FAIL	no. of faults	RW	ENG_LOGIC_FAIL	NVMFaultCounter	shortNatural	No	Fault Counter:45-313-00:ENG_LOGIC_FAIL	1.254		
608-573	Fault Counter 72-108-00:Feed Out	no. of faults	RW	Feed Out Sensor2 On Jam_Tray3/4	NVMFaultCounter	shortNatural	No	Fault Counter:72-108-	1.254		
608-574	Fault Counter 72-109-00:Regi Sensor On	no. of faults	RW	Regi Sensor On Jam_Tray1-4	NVMFaultCounter	shortNatural	No	Fault Counter:72-109-	1.254		
608-575	Fault Counter 77-200-00:POB Sensor On	no. of faults	RW	POB Sensor On Jam	NVMFaultCounter	shortNatural	No	Fault Counter:77-200-	1.813		
608-576	Fault Counter 77-101-00:Regi Sensor Off Jam	no. of faults	RW	Regi Sensor Off Jam	NVMFaultCounter	shortNatural	No	Fault Counter:77-201-00: Regi Sensor Off Jam	1.813		
608-577	Fault Counter 77-202-00:Exit Sensor1 On	no. of faults	RW	Exit Sensor1 On Jam	NVMFaultCounter	shortNatural	No	Fault Counter:77-202-	1.254		
608-578	Fault Counter 77-203-00:Exit Sensor2 On	no. of faults	RW	Exit Sensor2 On Jam	NVMFaultCounter	shortNatural	No	Fault Counter:77-203-	1.254		

608-579	Fault Counter 77-204-00:Exit Sensor1 Off	no. of faults	RW	Exit Sensor1 Off Jam_Long	NVMFaultCounter	shortNatural	No	Fault Counter:77-204-	1.254		
608-580	Fault Counter 77-104-00:Exit Sensor1 Off	no. of faults	RW	Exit Sensor1 Off Jam_Short	NVMFaultCounter	shortNatural	No	Fault Counter:77-104-	1.813		
608-581	Fault Counter 77-105-00:Exit Sensor2 Off	no. of faults	RW	Exit Sensor2 Off Jam	NVMFaultCounter	shortNatural	No	Fault Counter:77-105-	1.813		
608-582	Fault Counter 77-131-00:Duplex Path	no. of faults	RW	Duplex Path Sensor On Jam	NVMFaultCounter	shortNatural	No	Fault Counter:77-131-	1.813		
608-583	Fault Counter 77-900-00:IOT Static Jam	no. of faults	RW	IOT Static Jam_Regi Sensor	NVMFaultCounter	shortNatural	No	Fault Counter:77-900-	1.813		
608-584	Fault Counter 77-903-00:IOT Static Jam	no. of faults	RW	IOT Static Jam_POB Sensor	NVMFaultCounter	shortNatural	No	Fault Counter:77-903-	1.813		
608-585	Fault Counter 77-901-00:IOT Static Jam	no. of faults	RW	IOT Static Jam_Exit Sensor1	NVMFaultCounter	shortNatural	No	Fault Counter:77-901-	1.813		
608-586	Fault Counter 77-902-00:IOT Static Jam (@Exit Sensor2)	no. of faults	RW	IOT Static Jam_Exit Sensor2	NVMFaultCounter	shortNatural	No	Fault Counter:77-902-00: IOT Static Jam (@Exit Sensor2)	1.813		
608-587	Fault Counter 77-907-00:IOT Static Jam (@Duplex Path Sensor)	no. of faults	RW	IOT StaticJam Duplex Path Sensor	NVMFaultCounter	shortNatural	No	Fault Counter:77-907-00: IOT Static Jam (@Duplex Path Sensor)	1.813		
608-588	Fault Counter 78-214-00:TTM #2 3 Lift Up Fail	no. of faults	RW	TTM #2 3 Lift Up Fail	NVMFaultCounter	shortNatural	No	Fault Counter:78-214-00: TTM #2 3 Lift Up Fail	1.254		
608-589	Fault Counter 78-211-00:TTM #3 4 Lift Up Fail	no. of faults	RW	TTM #3 4 Lift Up Fail	NVMFaultCounter	shortNatural	No	Fault Counter:78-211-00: TTM #3 4 Lift Up Fail	1.254		
608-590	Fault Counter 71-940-00:#1 Lift Up NG	no. of faults	RW	#1 Lift Up NG	NVMFaultCounter	shortNatural	No	Fault Counter:71-940-00: #1 Lift Up NG	1.254		
608-591	Fault Counter 72-940-00:#2 Lift Up NG	no. of faults	RW	#2 Lift Up NG	NVMFaultCounter	shortNatural	No	Fault Counter:72-940-00: #2 Lift Up NG	1.254		
608-592	Fault Counter 73-940-00:#3 Lift Up NG	no. of faults	RW	#3 Lift Up NG	NVMFaultCounter	shortNatural	No	Fault Counter:73-940-00: #3 Lift Up NG	1.254		
608-593	Fault Counter 74-940-00:#4 Lift Up NG	no. of faults	RW	#4 Lift Up NG	NVMFaultCounter	shortNatural	No	Fault Counter:74-940-00: #4 Lift Up NG	1.254		
608-594	Fault Counter 78-945-00:TTM #2 3 Lift Up NG	no. of faults	RW	TTM #2 3 Lift Up NG	NVMFaultCounter	shortNatural	No	Fault Counter:78-945-00: TTM #2 3 Lift Up NG	1.254		
608-595	Fault Counter 78-946-00:TTM #3 4 Lift Up NG	no. of faults	RW	TTM #3 4 Lift Up NG	NVMFaultCounter	shortNatural	No	Fault Counter:78-946-00: TTM #3 4 Lift Up NG	1.254		
608-596	Fault Counter 47-211-00:Exit1 OCT Home Fail	no. of faults	RW	Exit1 OCT Home Fail	NVMFaultCounter	shortNatural	No	Fault Counter:47-211-00: Exit1 OCT Home Fail	1.813		

608-597	Fault Counter 47-212-00:Exit2 OCT Home Fail	no. of faults	RW	Exit2 OCT Home Fail	NVMFaultCounter	shortNatural	No	Fault Counter:47-212-00: Exit2 OCT Home Fail	1.813		
608-598	Fault Counter 71-212-00:TRAY1 Sensor Fail	no. of faults	RW	TRAY1 Sensor Fail	NVMFaultCounter	shortNatural	No	Fault Counter:71-212-00: TRAY1 Sensor Fail	1.813		
608-599	Fault Counter 72-212-00:TRAY2 Sensor Fail	no. of faults	RW	TRAY2 Sensor Fail	NVMFaultCounter	shortNatural	No	Fault Counter:72-212-00: TRAY2 Sensor Fail	1.813		
608-600	Fault Counter 73-212-00:TRAY3 Sensor Fail	no. of faults	RW	TRAY3 Sensor Fail	NVMFaultCounter	shortNatural	No	Fault Counter:73-212-00: TRAY3 Sensor Fail	1.813		
608-601	Fault Counter 74-212-00:TRAY4 Sensor Fail	no. of faults	RW	TRAY4 Sensor Fail	NVMFaultCounter	shortNatural	No	Fault Counter:74-212-00: TRAY4 Sensor Fail	1.813		
608-602	Fault Counter 77-214-00:P/H Module Logic Fail	no. of faults	RW	P/H Module Logic Fail	NVMFaultCounter	shortNatural	No	Fault Counter:77-214-00: P/H Module Logic Fail	1.813		
608-603	Fault Counter 77-215-00:Tray Module Comm Fail	no. of faults	RW	Tray Module Comm Fail	NVMFaultCounter	shortNatural	No	Fault Counter:77-215-00: Tray Module Comm Fail	1.813		
608-604	Fault Counter 77-602-00:OHP Sensor Fail	no. of faults	RW	OHP Sensor Fail	NVMFaultCounter	shortNatural	No	Fault Counter:77-602-00: OHP Sensor Fail	1.813		
608-605	Fault Counter 77-212-00:Tray Module Reset Fail	no. of faults	RW	Tray Module Reset Fail	NVMFaultCounter	shortNatural	No	Fault Counter:77-212-00: Tray Module Reset	1.813		
608-606	Fault Counter 77-214-00:Tray Module Logic Fail	no. of faults	RW	Tray Module Logic Fail	NVMFaultCounter	shortNatural	No	Fault Counter:77-214-00: Tray Module Logic Fail	1.813		
608-607	Fault Counter 77-211-00:Tray Module Kind Mismatch	no. of faults	RW	Tray Module Kind Mismatch	NVMFaultCounter	shortNatural	No	Fault Counter:77-211-00: Tray Module Kind Mismatch	1.813		
608-608	Fault Counter 78-216-00:HCF Logic Fail	no. of faults	RW	HCF Logic Fail	NVMFaultCounter	shortNatural	No	Fault Counter:78-216-00: HCF Logic Fail	1.813		
608-609	Fault Counter 77-320-00:ALL Feed Tray Broken	no. of faults	RW	ALL Feed Tray Broken	NVMFaultCounter	shortNatural	No	Fault Counter:77-320-00: ALL Feed Tray Broken	1.813		
608-610	Fault Counter 47-320-00:ALL Destination Tray Broken	no. of faults	RW	ALL Destination Tray Broken	NVMFaultCounter	shortNatural	No	Fault Counter:47-320-00: ALL Destination Tray Broken	1.813		

608-611	Fault Counter 94-300-00:IBT Front Cover	no. of faults	RW	IBT Front Cover	NVMFaultCounter	shortNatural	No	Fault Counter:94-300-00: IBT Front Cover	1.254		
608-612	Fault Counter 78-219-00:HCF PF2 Soft Download Fail	no. of faults	RW	HCF PF2 Soft Download Fail	NVMFaultCounter	shortNatural	No	Fault Counter:78-219-00: HCF PF2 Soft Download Fail	1.813		
608-613	Fault Counter 78-213-00:Finisher Kind Mismatch	no. of faults	RW	Finisher Kind Mismatch	NVMFaultCounter	shortNatural	No	Fault Counter:78-213-00: Finisher Kind Mismatch	1.813		
608-614	Fault Counter 75-103-00:MSI Feed Out Sensor Off Jam	no. of faults	RW	MSI Feed Out Sensor Off Jam	NVMFaultCounter	shortNatural	No	Fault Counter:75-103-00: MSI Feed Out Sensor Off Jam	1.813		
608-615	Fault Counter 94-400-00:1st BTR Contact/Retract Fail	no. of faults	RW	1st BTR Contact/Retract Fail	NVMFaultCounter	shortNatural	No	Fault Counter:94-400-00: 1st BTR Contact/Retract Fail	1.813		
608-616	Fault Counter 94-401-00:2nd BTR Contact/Retract Fail	no. of faults	RW	2nd BTR Contact/Retract Fail	NVMFaultCounter	shortNatural	No	Fault Counter:94-401-00: 2nd BTR Contact/Retract Fail	1.254		
608-617	Fault Counter 94-417-00:IBT Unit Near End Warning	no. of faults	RW	IBT Unit Near End Warning	NVMFaultCounter	shortNatural	No	Fault Counter:94-417-00: IBT Unit Near End Warning	1.254		
608-618	Fault Counter 94-418-00:IBT CLN Unit Near End Warning	no. of faults	RW	IBT CLN Unit Near End Warning	NVMFaultCounter	shortNatural	No	Fault Counter:94-418-00: IBT CLN Unit Near End Warning	1.254		
608-619	Fault Counter 94-419-00:2nd BTR Unit Near End Warning	no. of faults	RW	2nd BTR Unit Near End Warning	NVMFaultCounter	shortNatural	No	Fault Counter:94-419-00: 2nd BTR Unit Near End Warning	1.254		
608-620	Fault Counter 94-420-00:IBT Unit End Warning	no. of faults	RW	IBT Unit End Warning	NVMFaultCounter	shortNatural	No	Fault Counter:94-420-00: IBT Unit End Warning	1.254		
608-621	Fault Counter 94-421-00:IBT CLN Unit End Warning	no. of faults	RW	IBT CLN Unit End Warning	NVMFaultCounter	shortNatural	No	Fault Counter:94-421-00: IBT CLN Unit End Warning	1.254		
608-622	Fault Counter 94-422-00:2nd BTR Unit End Warning	no. of faults	RW	2nd BTR Unit End Warning	NVMFaultCounter	shortNatural	No	Fault Counter:94-422-00: 2nd BTR Unit End Warning	1.254		
608-623	Fault Counter 91-310-00:Auger Broken	no. of faults	RW	Auger Broken	NVMFaultCounter	shortNatural	No	Fault Counter:91-310-00: Auger Broken	1.254		
608-624	Fault Counter 10-371-00:Heat Belt STS Center Disconnection Fail	no. of faults	RW	HeatBelt STSCenterDisconnectFail	NVMFaultCounter	shortNatural	No	Fault Counter:10-371-00: Heat Belt STS Center Disconnection Fail	1.813		

608-625	Fault Counter 10-372-00:Heat Belt STS Center Over Temperature Fail	no. of faults	RW	HeatBelt STSCenterOverTempFail	NVMFaultCounter	shortNatural	No	Fault Counter:10-372-00: Heat Belt STS Center Over Temperature Fail	1.813		
608-626	Fault Counter 10-375-00:Heat Belt STS Center Warm Up Time Fail	no. of faults	RW	HeatBeltSTSCenterWarmUpTimeFail	NVMFaultCounter	shortNatural	No	Fault Counter:10-375-00: Heat Belt STS Center Warm Up Time Fail	1.813		
608-627	Fault Counter 10-376-00:Heat Belt STS Rear Warm Up Time Fail	no. of faults	RW	HeatBeltSTSRearWarmUpTimeFail	NVMFaultCounter	shortNatural	No	Fault Counter:10-376-00: Heat Belt STS Rear Warm Up Time Fail	1.813		
608-628	Fault Counter 10-378-00:Heat Belt Rotation Fail	no. of faults	RW	Heat Belt Rotation Fail	NVMFaultCounter	shortNatural	No	Fault Counter:10-378-00: Heat Belt Rotation Fail	1.813		
608-629	Fault Counter 10-380-00:P/Roll Latch Motor Fail	no. of faults	RW	P/Roll Latch Motor Fail	NVMFaultCounter	shortNatural	No	Fault Counter:10-380-00: P/Roll Latch Motor Fail	1.813		
608-630	Fault Counter 10-381-00:Fuser Assy Illegal Fail	no. of faults	RW	Fuser Assy Illegal Fail	NVMFaultCounter	shortNatural	No	Fault Counter:10-381-00: Fuser Assy Illegal Fail	1.813		
608-631	Fault Counter 10-382-00:Fuser Thermostat Fail	no. of faults	RW	Fuser Thermostat Fail	NVMFaultCounter	shortNatural	No	Fault Counter:10-382-00: Fuser Thermostat Fail	1.813		
608-632	Fault Counter 61-350-00:LPH Power On Fail Y	no. of faults	RW	LPH Power On Fail Y	NVMFaultCounter	shortNatural	No	Fault Counter:61-350-00: LPH Power On Fail Y	1.813		
608-633	Fault Counter 61-351-00:LPH Power On Fail M	no. of faults	RW	LPH Power On Fail M	NVMFaultCounter	shortNatural	No	Fault Counter:61-351-00: LPH Power On Fail M	1.813		
608-634	Fault Counter 61-352-00:LPH Power On Fail C	no. of faults	RW	LPH Power On Fail C	NVMFaultCounter	shortNatural	No	Fault Counter:61-352-00: LPH Power On Fail C	1.813		
608-635	Fault Counter 61-353-00:LPH Power On Fail K	no. of faults	RW	LPH Power On Fail K	NVMFaultCounter	shortNatural	No	Fault Counter:61-353-00: LPH Power On Fail K	1.813		
608-636	Fault Counter 45-370-00:LPH Power On Fail Multi	no. of faults	RW	LPH Power On Fail Multi	NVMFaultCounter	shortNatural	No	Fault Counter:45-370-00: LPH Power On Fail Multi	1.813		

608-637	Fault Counter 61-354-00:LPH Download Data Fail Y	no. of faults	RW	LPH Download Data Fail Y	NVMFaultCounter	shortNatural	No	Fault Counter:61-354-00: LPH Download Data Fail Y	1.813		
608-638	Fault Counter 61-355-00:LPH Download Data Fail M	no. of faults	RW	LPH Download Data Fail M	NVMFaultCounter	shortNatural	No	Fault Counter:61-355-00: LPH Download Data Fail M	1.813		
608-639	Fault Counter 61-356-00:LPH Download Data Fail C	no. of faults	RW	LPH Download Data Fail C	NVMFaultCounter	shortNatural	No	Fault Counter:61-356-00: LPH Download Data Fail C	1.813		
608-640	Fault Counter 61-357-00:LPH Download Data Fail K	no. of faults	RW	LPH Download Data Fail K	NVMFaultCounter	shortNatural	No	Fault Counter:61-357-00: LPH Download Data Fail K	1.813		
608-641	Fault Counter 45-371-00:LPH Download Data Fail Multi	no. of faults	RW	LPH Download Data Fail Multi	NVMFaultCounter	shortNatural	No	Fault Counter:45-371-00: LPH Download Data Fail Multi	1.813		
608-642	Fault Counter 61-358-00:LPH Mismatch Fail Y	no. of faults	RW	LPH Mismatch Fail Y	NVMFaultCounter	shortNatural	No	Fault Counter:61-358-00: LPH Mismatch Fail Y	1.813		
608-643	Fault Counter 61-359-00:LPH Mismatch Fail M	no. of faults	RW	LPH Mismatch Fail M	NVMFaultCounter	shortNatural	No	Fault Counter:61-359-00: LPH Mismatch Fail M	1.813		
608-644	Fault Counter 61-360-00:LPH Mismatch Fail C	no. of faults	RW	LPH Mismatch Fail C	NVMFaultCounter	shortNatural	No	Fault Counter:61-360-00: LPH Mismatch Fail C	1.813		
608-645	Fault Counter 61-361-00:LPH Mismatch Fail K	no. of faults	RW	LPH Mismatch Fail K	NVMFaultCounter	shortNatural	No	Fault Counter:61-361-00: LPH Mismatch Fail K	1.813		
608-646	Fault Counter 45-372-00:LPH Mismatch Fail Multi	no. of faults	RW	LPH Mismatch Fail Multi	NVMFaultCounter	shortNatural	No	Fault Counter:45-372-00: LPH Mismatch Fail Multi	1.813		
608-647	Fault Counter 61-362-00:LPH Read Fail Y	no. of faults	RW	LPH Read Fail Y	NVMFaultCounter	shortNatural	No	Fault Counter:61-362-00: LPH Read Fail Y	1.813		
608-648	Fault Counter 61-363-00:LPH Read Fail M	no. of faults	RW	LPH Read Fail M	NVMFaultCounter	shortNatural	No	Fault Counter:61-363-00: LPH Read Fail M	1.813		

608-649	Fault Counter 61-364-00:LPH Read Fail C	no. of faults	RW	LPH Read Fail C	NVMFaultCounter	shortNatural	No	Fault Counter:61-364-00: LPH Read Fail C	1.813		
608-650	Fault Counter 61-365-00:LPH Read Fail K	no. of faults	RW	LPH Read Fail K	NVMFaultCounter	shortNatural	No	Fault Counter:61-365-00: LPH Read Fail K	1.813		
608-651	Fault Counter 45-373-00:LPH Read Fail Multi	no. of faults	RW	LPH Read Fail Multi	NVMFaultCounter	shortNatural	No	Fault Counter:45-373-00: LPH Read Fail Multi	1.813		
608-652	Fault Counter 61-366-00:LPH Write Fail Y	no. of faults	RW	LPH Write Fail Y	NVMFaultCounter	shortNatural	No	Fault Counter:61-366-00: LPH Write Fail Y	1.813		
608-653	Fault Counter 61-367-00:LPH Write Fail M	no. of faults	RW	LPH Write Fail M	NVMFaultCounter	shortNatural	No	Fault Counter:61-367-00: LPH Write Fail M	1.813		
608-654	Fault Counter 61-368-00:LPH Write Fail C	no. of faults	RW	LPH Write Fail C	NVMFaultCounter	shortNatural	No	Fault Counter:61-368-00: LPH Write Fail C	1.813		
608-655	Fault Counter 61-369-00:LPH Write Fail K	no. of faults	RW	LPH Write Fail K	NVMFaultCounter	shortNatural	No	Fault Counter:61-369-00: LPH Write Fail K	1.813		
608-656	Fault Counter 45-374-00:LPH Write Fail Multi	no. of faults	RW	LPH Write Fail Multi	NVMFaultCounter	shortNatural	No	Fault Counter:45-374-00: LPH Write Fail Multi	1.813		
608-657	Fault Counter 61-370-00:LPH Act Fail Y	no. of faults	RW	LPH Act Fail Y	NVMFaultCounter	shortNatural	No	Fault Counter:61-370-00: LPH Act Fail Y	1.813		
608-658	Fault Counter 61-371-00:LPH Act Fail M	no. of faults	RW	LPH Act Fail M	NVMFaultCounter	shortNatural	No	Fault Counter:61-371-00: LPH Act Fail M	1.813		
608-659	Fault Counter 61-372-00:LPH Act Fail C	no. of faults	RW	LPH Act Fail C	NVMFaultCounter	shortNatural	No	Fault Counter:61-372-00: LPH Act Fail C	1.813		
608-660	Fault Counter 61-373-00:LPH Act Fail K	no. of faults	RW	LPH Act Fail K	NVMFaultCounter	shortNatural	No	Fault Counter:61-373-00: LPH Act Fail K	1.813		
608-661	Fault Counter 45-375-00:LPH Act Fail Multi	no. of faults	RW	LPH Act Fail Multi	NVMFaultCounter	shortNatural	No	Fault Counter:45-375-00: LPH Act Fail Multi	1.813		
608-662	Fault Counter 61-374-00:LPH Chip Fail Y	no. of faults	RW	LPH Chip Fail Y	NVMFaultCounter	shortNatural	No	Fault Counter:61-374-00: LPH Chip Fail Y	1.813		

608-663	Fault Counter 61-375-00:LPH Chip Fail M	no. of faults	RW	LPH Chip Fail M	NVMFaultCounter	shortNatural	No	Fault Counter:61-375-00: LPH Chip Fail M	1.813		
608-664	Fault Counter 61-376-00:LPH Chip Fail C	no. of faults	RW	LPH Chip Fail C	NVMFaultCounter	shortNatural	No	Fault Counter:61-376-00: LPH Chip Fail C	1.813		
608-665	Fault Counter 61-377-00:LPH Chip Fail K	no. of faults	RW	LPH Chip Fail K	NVMFaultCounter	shortNatural	No	Fault Counter:61-377-00: LPH Chip Fail K	1.813		
608-666	Fault Counter 61-378-00:LPH Ltrg Fail Y	no. of faults	RW	LPH Ltrg Fail Y	NVMFaultCounter	shortNatural	No	Fault Counter:61-378-00: LPH Ltrg Fail Y	1.813		
608-667	Fault Counter 61-379-00:LPH Ltrg Fail M	no. of faults	RW	LPH Ltrg Fail M	NVMFaultCounter	shortNatural	No	Fault Counter:61-379-00: LPH Ltrg Fail M	1.813		
608-668	Fault Counter 61-384-00:LPH Ltrg Fail C	no. of faults	RW	LPH Ltrg Fail C	NVMFaultCounter	shortNatural	No	Fault Counter:61-384-00: LPH Ltrg Fail C	1.813		
608-669	Fault Counter 61-385-00:LPH Ltrg Fail K	no. of faults	RW	LPH Ltrg Fail K	NVMFaultCounter	shortNatural	No	Fault Counter:61-385-00: LPH Ltrg Fail K	1.813		
608-670	Fault Counter 61-386-00:LPH PLL Lock Fail Y	no. of faults	RW	LPH PLL Lock Fail Y	NVMFaultCounter	shortNatural	No	Fault Counter:61-386-00: LPH PLL Lock Fail Y	1.813		
608-671	Fault Counter 61-387-00:LPH PLL Lock Fail M	no. of faults	RW	LPH PLL Lock Fail M	NVMFaultCounter	shortNatural	No	Fault Counter:61-387-00: LPH PLL Lock Fail M	1.813		
608-672	Fault Counter 61-388-00:LPH PLL Lock Fail C	no. of faults	RW	LPH PLL Lock Fail C	NVMFaultCounter	shortNatural	No	Fault Counter:61-388-00: LPH PLL Lock Fail C	1.813		
608-673	Fault Counter 61-389-00:LPH PLL Lock Fail K	no. of faults	RW	LPH PLL Lock Fail K	NVMFaultCounter	shortNatural	No	Fault Counter:61-389-00: LPH PLL Lock Fail K	1.813		
608-674	Fault Counter 45-376-00:LPH PLL Lock Fail Multi	no. of faults	RW	LPH PLL Lock Fail Multi	NVMFaultCounter	shortNatural	No	Fault Counter:45-376-00: LPH PLL Lock Fail Multi	1.813		
608-675	Fault Counter 61-390-00:LPH FFC Connect Posi Fail Y	no. of faults	RW	LPH FFC Connect Posi Fail Y	NVMFaultCounter	shortNatural	No	Fault Counter:61-390-00: LPH FFC Connect Posi Fail Y	1.813		
608-676	Fault Counter 61-391-00:LPH FFC Connect Posi Fail M	no. of faults	RW	LPH FFC Connect Posi Fail M	NVMFaultCounter	shortNatural	No	Fault Counter:61-391-00: LPH FFC Connect Posi Fail M	1.813		
608-677	Fault Counter 61-392-00:LPH FFC Connect Posi Fail C	no. of faults	RW	LPH FFC Connect Posi Fail C	NVMFaultCounter	shortNatural	No	Fault Counter:61-392-00: LPH FFC Connect Posi Fail C	1.813		
608-678	Fault Counter 61-393-00:LPH FFC Connect Posi Fail K	no. of faults	RW	LPH FFC Connect Posi Fail K	NVMFaultCounter	shortNatural	No	Fault Counter:61-393-00: LPH FFC Connect Posi Fail K	1.813		
608-679	Fault Counter 61-394-00:LPH FFC Connect Nega Fail Y	no. of faults	RW	LPH FFC Connect Nega Fail Y	NVMFaultCounter	shortNatural	No	Fault Counter:61-394-00: LPH FFC Connect Nega Fail Y	1.813		
608-680	Fault Counter 61-395-00:LPH FFC Connect Nega Fail M	no. of faults	RW	LPH FFC Connect Nega Fail M	NVMFaultCounter	shortNatural	No	Fault Counter:61-395-00: LPH FFC Connect Nega Fail M	1.813		
608-681	Fault Counter 61-396-00:LPH FFC Connect Nega Fail C	no. of faults	RW	LPH FFC Connect Nega Fail C	NVMFaultCounter	shortNatural	No	Fault Counter:61-396-00: LPH FFC Connect Nega Fail C	1.813		

608-682	Fault Counter 61-397-00:LPH FFC Connect Nega Fail K	no. of faults	RW	LPH FFC Connect Nega Fail K	NVMFaultCounter	shortNatural	No	Fault Counter:61-397-00: LPH FFC Connect Nega Fail K	1.813		
608-683	Fault Counter 61-398-00:BITZ1 Initialize Fail	no. of faults	RW	BITZ1 Initialize Fail	NVMFaultCounter	shortNatural	No	Fault Counter:61-398-00: BITZ1 Initialize Fail	1.813		
608-684	Fault Counter 61-399-00:BITZ2 Initialize Fail	no. of faults	RW	BITZ2 Initialize Fail	NVMFaultCounter	shortNatural	No	Fault Counter:61-399-00: BITZ2 Initialize Fail	1.813		
608-685	Fault Counter 61-610-00:Bitz1 CONTIF Fail	no. of faults	RW	Bitz1 CONTIF Fail	NVMFaultCounter	shortNatural	No	Fault Counter:61-610-00: Bitz1 CONTIF Fail	1.813		
608-686	Fault Counter 61-611-00:Bitz2 CONTIF Fail	no. of faults	RW	Bitz2 CONTIF Fail	NVMFaultCounter	shortNatural	No	Fault Counter:61-611-00: Bitz2 CONTIF Fail	1.813		
608-687	Fault Counter 10-360-00:IH Driver Input High Voltage Fail	no. of faults	RW	IH Driver Input HighVoltage Fail	NVMFaultCounter	shortNatural	No	Fault Counter:10-360-00: IH Driver Input High Voltage Fail	1.813		
608-688	Fault Counter 10-361-00:IH Driver Input Low Voltage Fail	no. of faults	RW	IH Driver Input LowVoltage Fail	NVMFaultCounter	shortNatural	No	Fault Counter:10-361-00: IH Driver Input Low Voltage Fail	1.813		

608-689	Fault Counter 10-362-00:IH Driver Surge Fail	no. of faults	RW	IH Driver Surge Fail	NVMFaultCounter	shortNatural	No	Fault Counter:10-362-00: IH Driver Surge Fail	1.813		
608-690	Fault Counter 10-363-00:IGBT High Temperature Fail	no. of faults	RW	IGBT High Temperature Fail	NVMFaultCounter	shortNatural	No	Fault Counter:10-363-00: IGBT High Temperature Fail	1.813		
608-691	Fault Counter 10-364-00:IGBT Temperature Sensor Fail	no. of faults	RW	IGBT Temperature Sensor Fail	NVMFaultCounter	shortNatural	No	Fault Counter:10-364-00: IGBT temperature disconnect	1.813		
608-692	Fault Counter 10-367-00:Input Low Current Fail	no. of faults	RW	Input Low Current Fail	NVMFaultCounter	shortNatural	No	Fault Counter:10-367-00: Input Low Current Fail	1.813		
608-693	Fault Counter 10-368-00:Encoder Pulse Fail	no. of faults	RW	Encoder Pulse Fail	NVMFaultCounter	shortNatural	No	Fault Counter:10-368-00: Encoder Pulse Fail	1.813		
608-694	Fault Counter 10-369-00:IH Driver Communication Fail	no. of faults	RW	IH Driver Communication Fail	NVMFaultCounter	shortNatural	No	Fault Counter:10-369-00: IH Driver Communication Fail	1.813		

608-695	Fault Counter 10-370-00:IH Driver Freeze Fail	no. of faults	RW	IH Driver Freeze Fail	NVMFaultCounter	shortNatural	No	Fault Counter:10-370-00: IH Driver Freeze Fail	1.813		
608-696	Fault Counter 92-670-00:ADC Patch Fail [Y]	no. of faults	RW	ADC Patch Fail [Y]	NVMFaultCounter	shortNatural	No	Fault Counter:92-670-00: ADC Patch Fail [Y]	1.751		
608-697	Fault Counter 92-671-00:ADC Patch Fail [M]	no. of faults	RW	ADC Patch Fail [M]	NVMFaultCounter	shortNatural	No	Fault Counter:92-671-00: ADC Patch Fail [M]	1.751		
608-698	Fault Counter 92-672-00:ADC Patch Fail [C]	no. of faults	RW	ADC Patch Fail [C]	NVMFaultCounter	shortNatural	No	Fault Counter:92-672-00: ADC Patch Fail [C]	1.751		
608-699	Fault Counter 92-673-00:ADC Patch Fail [K]	no. of faults	RW	ADC Patch Fail [K]	NVMFaultCounter	shortNatural	No	Fault Counter:92-673-00: ADC Patch Fail [K]	1.813		
608-700	Fault Counter 92-675-00:ADC_MiniSetup_Fail [Y]	no. of faults	RW	ADC_MiniSetup_Fail [Y]	NVMFaultCounter	shortNatural	No	Fault Counter:92-675-00: ADC_MiniSetup_Fail [Y]	1.766		
608-701	Fault Counter 92-676-00:ADC_MiniSetup_Fail [M]	no. of faults	RW	ADC_MiniSetup_Fail [M]	NVMFaultCounter	shortNatural	No	Fault Counter:92-676-00: ADC_MiniSetup_Fail [M]	1.766		
608-702	Fault Counter 92-677-00:ADC_MiniSetup_Fail [C]	no. of faults	RW	ADC_MiniSetup_Fail [C]	NVMFaultCounter	shortNatural	No	Fault Counter:92-677-00: ADC_MiniSetup_Fail [C]	1.766		

608-703	Fault Counter 92-678-00:ADC_MiniSetup_Fail [K]	no. of faults	RW	ADC_MiniSetup_Fail [K]	NVMFaultCounter	shortNatural	No	Fault Counter:92-678-00: ADC_MiniSetup_Fail [K]	1.813		
608-704	Fault Counter 89-621-00:RC Temp Sensor Fail	no. of faults	RW	RC Temp Sensor Fail	NVMFaultCounter	shortNatural	No	Fault Counter:89-621-00: RC Temp Sensor Fail	1.254		
608-705	Fault Counter 89-622-00:RC Data Linearity Fail	no. of faults	RW	RC Data Linearity Fail	NVMFaultCounter	shortNatural	No	Fault Counter:89-622-00: RC Data Linearity Fail	1.254		
608-706	Fault Counter 89-624-00:PS Zphase Sensor Fail	no. of faults	RW	PS Zphase Sensor Fail	NVMFaultCounter	shortNatural	No	Fault Counter:89-624-00: PS Zphase Sensor Fail	1.254		
608-707	Fault Counter 89-625-00:RC Data Linearity Fail-#1	no. of faults	RW	RC Data Linearity Fail-#1	NVMFaultCounter	shortNatural	No	Fault Counter:89-625-00: RC Data Linearity Fail-#1	1.813		
608-708	Fault Counter 89-626-00:RC Data Linearity Fail-#2	no. of faults	RW	RC Data Linearity Fail-#2	NVMFaultCounter	shortNatural	No	Fault Counter:89-626-00: RC Data Linearity Fail-#2	1.813		
608-709	Fault Counter 89-627-00:RC Data Linearity Fail-#3	no. of faults	RW	RC Data Linearity Fail-#3	NVMFaultCounter	shortNatural	No	Fault Counter:89-627-00: RC Data Linearity Fail-#3	1.813		

608-710	Fault Counter 89-628-00:RC Data Linearity Fail-#4	no. of faults	RW	RC Data Linearity Fail-#4	NVMFaultCounter	shortNatural	No	Fault Counter:89-628-00: RC Data Linearity Fail-#4	1.813		
608-711	Fault Counter 42-319-00:Drum YMC Motor Fail	no. of faults	RW	Drum YMC Motor Fail	NVMFaultCounter	shortNatural	No	Fault Counter:42-319-00: Drum YMC Motor Fail	1.813		
608-712	Fault Counter 42-605-00:Drive Fan Fail	no. of faults	RW	Drive Fan Fail	NVMFaultCounter	shortNatural	No	Fault Counter:42-605-00: Drive Fan Fail	1.813		
608-713	Fault Counter 42-334-00:IBT Fan Fail	no. of faults	RW	IBT Fan Fail	NVMFaultCounter	shortNatural	No	Fault Counter:42-334-00: IBT Fan Fail	1.813		
608-714	Fault Counter 42-335-00:Process1 Fan Fail	no. of faults	RW	Process1 Fan Fail	NVMFaultCounter	shortNatural	No	Fault Counter:42-335-00: Process1 Fan Fail	1.813		
608-715	Fault Counter 42-336-00:Process2 Fan Fail	no. of faults	RW	Process2 Fan Fail	NVMFaultCounter	shortNatural	No	Fault Counter:42-336-00: Process2 Fan Fail	1.813		

608-716	Fault Counter 42-343-00:Rear Bottom Fan Fail	no. of faults	RW	Rear Bottom Fan Fail	NVMFaultCounter	shortNatural	No	Fault Counter:42-343-00: Rear Bottom Fan Fail	1.813		
608-717	Fault Counter 42-338-00:LVPS Exhaust Fan Fail	no. of faults	RW	LVPS Exhaust Fan Fail	NVMFaultCounter	shortNatural	No	Fault Counter:42-338-00: LVPS Exhaust Fan Fail	1.813		
608-718	Fault Counter 42-340-00:Cartridge Fan Fail	no. of faults	RW	Cartridge Fan Fail	NVMFaultCounter	shortNatural	No	Fault Counter:42-340-00: Cartridge Fan Fail	1.813		
608-719	Fault Counter 42-341-00:MHVPS Fan Fail	no. of faults	RW	MHVPS Fan Fail	NVMFaultCounter	shortNatural	No	Fault Counter:42-341-00: MHVPS Fan Fail	1.254		
608-720	Fault Counter 42-342-00:Suction Fan Fail	no. of faults	RW	Suction Fan Fail	NVMFaultCounter	shortNatural	No	Fault Counter:42-342-00: Suction Fan Fail	1.254		
608-721	Fault Counter 42-316-00:Front Fan Fail	no. of faults	RW	Front Fan Fail	NVMFaultCounter	shortNatural	No	Fault Counter:42-316-00: Front Fan Fail	1.254		
608-722	Fault Counter 43-344-00:C Exhaust Fan Fail	no. of faults	RW	C Exhaust Fan Fail	NVMFaultCounter	shortNatural	No	Fault Counter:43-344-00: C Exhaust Fan Fail	1.813		
608-723	Fault Counter 42-332-00:IH INTAKE Fan Fail	no. of faults	RW	IH INTAKE Fan Fail	NVMFaultCounter	shortNatural	No	Fault Counter:42-332-00: IH INTAKE Fan Fail	1.813		
608-724	Fault Counter 42-604-00:NOHAD Temperature Sensor Fail	no. of faults	RW	NOHAD Temperature Sensor Fail	NVMFaultCounter	shortNatural	No	Fault Counter:42-604-00: NOHAD Temperature Sensor Fail	1.813		
608-725	Fault Counter 42-337-00:NOHAD Logic Fail	no. of faults	RW	NOHAD Logic Fail	NVMFaultCounter	shortNatural	No	Fault Counter:42-337-00: NOHAD Logic Fail	1.254		
608-726	Fault Counter 42-609-00:B Fan Fail	no. of faults	RW	B Fan Fail	NVMFaultCounter	shortNatural	No	Fault Counter:42-609-00: B Fan Fail	1.254		

608-727	Fault Counter 42-400-00: Fan Filter Life End	no. of faults	RW	Fan Filter Life End	NVMFaultCounter	shortNatural	No	Fault Counter:42-400-00: FANFILTEREOLCOUN T	1.813		
608-825	Tray 1 Detected Width	Tray 1 Detected Width (Custom Size Support)	RW	Tray 1 Detected Width	NVMSAKOSetting	natural	No		1.503		
608-826	Tray 1 Detected Length	Tray 1 Detected Length (Custom Size Support)	RW	Tray 1 Detected Length	NVMSAKOSetting	natural	No		1.503		
608-827	Tray 2 Detected Width	Tray 2 Detected Width (Custom Size Support)	RW	Tray 2 Detected Width	NVMSAKOSetting	natural	No		1.503		
608-828	Tray 2 Detected Length	Tray 2 Detected Length (Custom Size Support)	RW	Tray 2 Detected Length	NVMSAKOSetting	natural	No		1.503		
608-829	Tray 3 Detected Width	Tray 3 Detected Width (Custom Size Support)	RW	Tray 3 Detected Width	NVMSAKOSetting	natural	No		1.503		
608-830	Tray 3 Detected Length	Tray 3 Detected Length (Custom Size Support)	RW	Tray 3 Detected Length	NVMSAKOSetting	natural	No		1.503		
608-831	Tray 4 Detected Width	Tray 4 Detected Width (Custom Size Support)	RW	Tray 4 Detected Width	NVMSAKOSetting	natural	No		1.503		
608-832	Tray 4 Detected Length	Tray 4 Detected Length (Custom Size Support)	RW	Tray 4 Detected Length	NVMSAKOSetting	natural	No		1.503		

608-931	Fault Counter 12-765-00: Incompatible Finisher detected.	no. of faults	RW	ImelIncompatibleFinisherFC	NVMFaultCounter	shortNatural	No	Fault Counter:12-765-00: Incompatible Finisher detected.	1.521		
608-933	Fault Counter 12-195: Paper Detect Sensor not made Jam	no. of faults	RW	PaperDetectSensorNotMade	NVMFaultCounter	shortNatural	No	Fault Counter:12-195-00: PaperDetectSensorNot Made	1.521		
608-934	Fault Counter 12-125: Finisher Entry Sensor not made Jam	no. of faults	RW	LELateEntrySensor	NVMFaultCounter	shortNatural	No	Fault Counter:12-125-00: Finisher Entry Sensor not made Jam	1.521		
608-935	Fault Counter 12-101: Finisher Entry Sensor no cleared Jam	no. of faults	RW	TELateEntrySensor	NVMFaultCounter	shortNatural	No	Fault Counter:12-125-00: Finisher Entry Sensor not made Jam	1.521		
608-936	Fault Counter 12-336: Rear Staple Door Opened in Run	no. of faults	RW	StapleDoorOpenIR	NVMFaultCounter	shortNatural	No	Fault Counter:12-125-00: Finisher Entry Sensor not made Jam	1.521		
608-937	Fault Counter 12-283: Ejector Clamp Motor Stall Failure	no. of faults	RW	EjectorClampMotorStall	NVMFaultCounter	shortNatural	No	Fault Counter:12-125-00: Finisher Entry Sensor not made Jam	1.521		
608-938	Fault Counter 12-284: Ejector Clamp Return Home Failure	no. of faults	RW	EjectorClampReturnHome	NVMFaultCounter	shortNatural	No	Fault Counter:12-125-00: Finisher Entry Sensor not made Jam	1.521		

608-939	Fault Counter 12-950: Preparation time violation on finisher entry sensor	no. of faults	RW	LEEntrySensorTriggered	NVMFaultCounter	shortNatural	No	Fault Counter:12-125-00: Finisher Entry Sensor not made Jam	1.521		
608-943	Lightweight Large Sheets Used Total of large size Lightweight media sheets since activation date numLargeLWMedia	Lightweight Large Sheets Used Total of large size Lightweight media sheets	ND	Lightweight Large Sheets Used	NVMSystemUsageCounter	byteArray	No	System Usage Counter:909: Heavyweight Large Sheets Used	1.799		
608-951	Tray 1 Top Edge Reg Simp (FD 3.2.2)	pixels (600 dpi)	RW	Top Edge Reg Tray 1 Simplex	NVMMachVarRegistration	natural	No		1.362		
608-951	Tray 1 Top Edge Reg Simp (FS23.604)	pixels (600 dpi)	RW	Top Edge Reg Tray 1 Simplex	NVMMachVarRegistration	natural	No		1.485		
608-952	Tray 2 Top Edge Reg Simp (FD 3.2.2)	pixels (600 dpi)	RW	Top Edge Reg Tray 2 Simplex	NVMMachVarRegistration	natural	No		1.362		
608-952	Tray 2 Top Edge Reg Simp (FS23.604)	pixels (600 dpi)	RW	Top Edge Reg Tray 2 Simplex	NVMMachVarRegistration	natural	No		1.485		
608-953	Tray 3 Top Edge Reg Simp (FD 3.2.2)	pixels (600 dpi)	RW	Top Edge Reg Tray 3 Simplex	NVMMachVarRegistration	natural	No		1.362		
608-953	Tray 3 Top Edge Reg Simp (FS23.604)	pixels (600 dpi)	RW	Top Edge Reg Tray 3 Simplex	NVMMachVarRegistration	natural	No		1.485		
608-954	Tray 4 Top Edge Reg Simp (FD 3.2.2)	pixels (600 dpi)	RW	Top Edge Reg Tray 4 Simplex	NVMMachVarRegistration	natural	No		1.362		
608-954	Tray 4 Top Edge Reg Simp (FS23.604)	pixels (600 dpi)	RW	Top Edge Reg Tray 4 Simplex	NVMMachVarRegistration	natural	No		1.485		
608-955	Tray 5 (MSI) Top Edge Reg Simp (FD 3.2.2)	pixels (600 dpi)	RW	Top Edge Reg Tray 5 Simplex	NVMMachVarRegistration	natural	No		1.438		

608-955	Tray 5 (MSI) Top Edge Reg Simp (FS23.604)	pixels (600 dpi)	RW	Top Edge Reg Tray 5 Simplex	NVMMachVarRegistration	natural	No		1.485		
608-956	Tray 6 (PFP) Top Edge Reg Simp (FD 3.2.2)	pixels (600 dpi)	RW	Top Edge Reg Tray 6 Simplex	NVMMachVarRegistration	natural	No		1.438		
608-956	Tray 6 (PFP) Top Edge Reg Simp (FS23.604)	pixels (600 dpi)	RW	Top Edge Reg Tray 6 Simplex	NVMMachVarRegistration	natural	No		1.485		
608-957	Tray 1 Top Edge Reg Dup (FD 3.2.2)	pixels (600 dpi)	RW	Top Edge Reg Tray 1 Duplex	NVMMachVarRegistration	natural	No		1.362		
608-957	Tray 1 Top Edge Reg Dup (FS23.604)	pixels (600 dpi)	RW	Top Edge Reg Tray 1 Duplex	NVMMachVarRegistration	natural	No		1.485		
608-958	Tray 2 Top Edge Reg Dup (FD 3.2.2)	pixels (600 dpi)	RW	Top Edge Reg Tray 2 Duplex	NVMMachVarRegistration	natural	No		1.362		
608-958	Tray 2 Top Edge Reg Dup (FS23.604)	pixels (600 dpi)	RW	Top Edge Reg Tray 2 Duplex	NVMMachVarRegistration	natural	No		1.485		

608-959	Tray 3 Top Edge Reg Dup (FD 3.2.2)	pixels (600 dpi)	RW	Top Edge Reg Tray 3 Duplex	NVMMachVarRegistration	natural	No		1.362		
608-959	Tray 3 Top Edge Reg Dup (FS23.604)	pixels (600 dpi)	RW	Top Edge Reg Tray 3 Duplex	NVMMachVarRegistration	natural	No		1.485		
608-960	Tray 4 Top Edge Reg Dup (FD 3.2.2)	pixels (600 dpi)	RW	Top Edge Reg Tray 4 Duplex	NVMMachVarRegistration	natural	No		1.362		
608-960	Tray 4 Top Edge Reg Dup (FS23.604)	pixels (600 dpi)	RW	Top Edge Reg Tray 4 Duplex	NVMMachVarRegistration	natural	No		1.485		
608-961	Tray 5 (MSI) Top Edge Reg Dup (FD 3.2.2)	pixels (600 dpi)	RW	Top Edge Reg Tray 5 Duplex	NVMMachVarRegistration	natural	No		1.438		
608-961	Tray 5 (MSI) Top Edge Reg Dup (FS23.604)	pixels (600 dpi)	RW	Top Edge Reg Tray 5 Duplex	NVMMachVarRegistration	natural	No		1.485		
608-962	Tray 6 (PFP) Top Edge Reg Dup (FD 3.2.2)	pixels (600 dpi)	RW	Top Edge Reg Tray 6 Duplex	NVMMachVarRegistration	natural	No		1.438		
608-962	Tray 6 (PFP) Top Edge Reg Dup (FS23.604)	pixels (600 dpi)	RW	Top Edge Reg Tray 6 Duplex	NVMMachVarRegistration	natural	No		1.485		

608-963	IOT Lead Edge Reg Simp (FD 23.110)	scan lines	RW	IOT LE Reg Simp	NVMMachVarRegistration	natural	No		1.362		
608-963	IOT Lead Edge Reg Simp (FS23.604)	scan lines @600dpi	RW	IOT LE Reg Simp	NVMMachVarRegistration	natural	No		1.485		
608-964	IOT Lead Edge Reg Dup (FD 23.110)	scan lines	RW	IOT LE Reg Dup	NVMMachVarRegistration	natural	No		1.362		
608-964	IOT Lead Edge Reg Dup (FS23.604)	scan lines @600dpi	RW	IOT LE Reg Dup	NVMMachVarRegistration	natural	No		1.485		
608-976	Fault Counter 12-484-00: BMENDSTOPMIDHOMESENSORNOTMADE	no. of faults	RW	BMENDSTOPMIDHOMESENSORNOTMADE	NVMFaultCounter	shortNatural	No	Fault Counter:12-484-00: BMENDSTOPMIDHOMESENSORNOTMADE	1.678		
608-977	Fault Counter 12-486-00: BMENDSTOPMIDHOMESENSORNOTCLEARED	no. of faults	RW	BMENDSTOPMIDHOMESENSORNOTCLEARED	NVMFaultCounter	shortNatural	No	Fault Counter:12-486-00: BMENDSTOPMIDHOMESENSORNOTCLEARED	1.678		
608-978	Fault Counter 12-488-00: BMSTAPLEUNITMOVETOHOMEFAULT	no. of faults	RW	BMSTAPLEUNITMOVETOHOMEFAULT	NVMFaultCounter	shortNatural	No	Fault Counter:12-488-00: BMSTAPLEUNITMOVETOHOMEFAULT	1.678		

608-979	Fault Counter 12-490-00: BMSTAPLEUNITMOVETOAWAYFAULT	no. of faults	RW	BMSTAPLEUNITMOVETOAWAYFA ULT	NVMFaultCounter	shortNatural	No	Fault Counter:12-490- 00: BMSTAPLEUNITMOV ETOAWAYFAULT	1.678		
608-980	Fault Counter 11-492-00: BMSTAPLEUNITNOTHOMEFAULT	no. of faults	RW	Fault Counter 11-492-00	NVMFaultCounter	shortNatural	No	Fault Counter:11-492- 00: BMSTAPLEUNITNOT HOMEFAULT	1.417		
608-981	Toner CRU install date	System sets this upon new unit detection or confirmation	ND		NVMConfiguration	longNatural	No		1.417		
608-982	XRU CRU install date	unix time (seconds since start of 1970)	ND	XruInstallDate	NVMSAKOSetting	longNatural	No		1.421		
608-993	Toner Waste Control	Set/changed by a tools setting. 0=disabled, 1=enabled	RW	TonerWasteControlEnabled	NVMConfiguration	boolean	No		1.443		
608-996	Custom display names - Custom media type List initialized flag	Refer to FS 16.027	RO	CMT List Initialized	NVMSAKOSetting	boolean	No		1.693		

608-999	Display Media Resource Screen for jobs held for resources	Refer to FS 16.020 0 = Disabled (SR3 Status, no pop-up) 1 = Enabled (SR3 Status and pop-up)	ND		NVMSAKOSetting	shortNatural	No		1.796		
609-001	Fault Counter 01-300-00: FrontCoverOpenInRunFault	no. of faults	RW	FrontCoverOpenInRunFC	NVMFaultCounter	shortNatural	No	Fault Counter:01-300-00: FrontCoverOpenInRun Fault	1.370		
609-002	Fault Counter 01-305-00: SideCoverOpenInRunFault	no. of faults	RW	SideCoverOpenInRunFC	NVMFaultCounter	shortNatural	No	Fault Counter:01-305-00: SideCoverOpenInRun Fault	1.370		
609-003	Fault Counter 10-101-00: LeadEdgeLateToPostFuserSensorSimpFault	no. of faults	RW	LELateToPostFuserSnsrSimpFC	NVMFaultCounter	shortNatural	No	Fault Counter:10-101-00: LeadEdgeLateToPostFuserSensorSimpFault	1.370		
609-004	Fault Counter 10-102-00: LeadEdgeLateToPostFuserSensorDup1Fault	no. of faults	RW	LELateToPostFuserSnsrDup1FC	NVMFaultCounter	shortNatural	No	Fault Counter:10-102-00: LeadEdgeLateToPostFuserSensorDup1Fault	1.370		
609-005	Fault Counter 10-103-00: LeadEdgeLateToPostFuserSensorDup2Fault	no. of faults	RW	LELateToPostFuserSnsrDup2FC	NVMFaultCounter	shortNatural	No	Fault Counter:10-103-00: LeadEdgeLateToPostFuserSensorDup2Fault	1.370		
609-006	Fault Counter 10-107-00: TrailEdgeLateFromPostFuserSensorSimpNonInvFault	no. of faults	RW	TELateFmPostFuseSnsrSimpNonInvFC	NVMFaultCounter	shortNatural	No	Fault Counter:10-107-00: TrailEdgeLateFromPostFuserSensorSimpNonInvFault	1.370		
609-007	Fault Counter 10-108-00: TrailEdgeLateFromPostFuserSensorSimpInvFault	no. of faults	RW	TELateFmPostFuserSnsrSimpInvFC	NVMFaultCounter	shortNatural	No	Fault Counter:10-108-00:	1.370		
609-008	Fault Counter 10-109-00:	no. of faults	RW	TELateFmPostFuserSnsrDup1FC	NVMFaultCounter	shortNatural	No	Fault Counter:10-109-	1.370		

609-009	Fault Counter 10-110-00: TrailEdgeLateFromPostFuserSensorDup2 Fault	no. of faults	RW	TELateFmPostFuserSnsrDup2FC	NVMFaultCounter	shortNatural	No	Fault Counter:10-110-00: TrailEdgeLateFromPostFuserSensorDup2Fault	1.370		
609-010	Fault Counter 10-120-00: LeadEdgeLateTolotExitSensorInvFault	no. of faults	RW	LELateTolotExitSnsrInvFC	NVMFaultCounter	shortNatural	No	Fault Counter:10-120-00: LeadEdgeLateTolotExitSensorInvFault	1.370		
609-011	Fault Counter 10-121-00: LeadEdgeLateTolotExitSensorNonInvFault	no. of faults	RW	LELateTolotExitSnsrNonInvFC	NVMFaultCounter	shortNatural	No	Fault Counter:10-121-00: LeadEdgeLateTolotExitSensorNonInvFault	1.370		
609-012	Fault Counter 10-126-00: TrailEdgeLateFromlotExitSensorFault	no. of faults	RW	TELateFmLotExitSnsrFC	NVMFaultCounter	shortNatural	No	Fault Counter:10-126-00:	1.370		
609-013	Fault Counter 10-130-00: LeadEdgeLateToTopExitSensorFault	no. of faults	RW	LELateToTopExitSnsrFC	NVMFaultCounter	shortNatural	No	Fault Counter:10-130-00: LeadEdgeLateToTopExitSensorFault	1.370		
609-014	Fault Counter 10-131-00: TrailEdgeLateFromTopExitSensorFault	no. of faults	RW	TELateFmTopExitSnsrFC	NVMFaultCounter	shortNatural	No	Fault Counter:10-131-00: TrailEdgeLateFromTopExitSensorFault	1.370		

609-015	Fault Counter 10-132-00: LeadEdgeLateToInvertSensorSimpFault	no. of faults	RW	LELateToInvertSnsrSimpFC	NVMFaultCounter	shortNatural	No	Fault Counter:10-132-00: LeadEdgeLateToInvertSensorSimpFault	1.370		
609-016	Fault Counter 10-133-00: LeadEdgeLateToInvertSensorDup1Fault	no. of faults	RW	LELateToInvertSnsrDup1FC	NVMFaultCounter	shortNatural	No	Fault Counter:10-133-00: LeadEdgeLateToInvertSensorDup1Fault	1.370		
609-017	Fault Counter 10-134-00: LeadEdgeLateToInvertSensorDup2Fault	no. of faults	RW	LELateToInvertSnsrDup2FC	NVMFaultCounter	shortNatural	No	Fault Counter:10-134-00: LeadEdgeLateToInvertSensorDup2Fault	1.370		
609-018	Fault Counter 10-135-00: TrailEdgeLateFromInvertSensorSimpNonInvertFault	no. of faults	RW	TELateFmInvertSnsrSimpNonInvFC	NVMFaultCounter	shortNatural	No	Fault Counter:10-135-00: TrailEdgeLateFromInvertSensorSimpNonInvertFault	1.370		
609-019	Fault Counter 10-136-00: TrailEdgeLateFromInvertSensorSimpInvFault	no. of faults	RW	TELateFmInvertSnsrSimpInvFC	NVMFaultCounter	shortNatural	No	Fault Counter:10-136-00: TrailEdgeLateFromInvertSensorSimpInvFault	1.370		
609-020	Fault Counter 10-137-00: TrailEdgeLateFromInvertSensorDup1Fault	no. of faults	RW	TELateFmInvertSnsrDup1FC	NVMFaultCounter	shortNatural	No	Fault Counter:10-137-00: TrailEdgeLateFromInvertSensorDup1Fault	1.370		

609-021	Fault Counter 10-138-00: TrailEdgeLateFromInvertSensorDup2Fault	no. of faults	RW	TELateFmInvertSnsrDup2FC	NVMFaultCounter	shortNatural	No	Fault Counter:10-138-00: TrailEdgeLateFromInvertSensorDup2Fault	1.370		
609-022	Fault Counter 10-315-00: FuserThermFaultFault	no. of faults	RW	FuserThermFCFC	NVMFaultCounter	shortNatural	No	Fault Counter:10-315-00: FuserThermFaultFault	1.370		
609-023	Fault Counter 10-320-00: FuserControlFailureFault	no. of faults	RW	FuserCtrlFailFC	NVMFaultCounter	shortNatural	No	Fault Counter:10-320-00: FuserControlFailureFault	1.370		
609-024	Fault Counter 10-321-00: FuserControlFailureStandbyOverTempFault	no. of faults	RW	FuserCtrlFailStandbyOverTempFC	NVMFaultCounter	shortNatural	No	Fault Counter:10-321-00: FuserControlFailureStandbyOverTempFault	1.370		
609-025	Fault Counter 10-322-00: FuserControlFailureStandbyUnderTempFault	no. of faults	RW	FuserCtrlFailStandbyUnderTempFC	NVMFaultCounter	shortNatural	No	Fault Counter:10-322-00: FuserControlFailureStandbyUnderTempFault	1.370		
609-026	Fault Counter 10-323-00: FuserControlFailureRunOverTempFault	no. of faults	RW	FuserCtrlFailRunOverTempFC	NVMFaultCounter	shortNatural	No	Fault Counter:10-323-00: FuserControlFailureRunOverTempFault	1.370		

609-027	Fault Counter 10-324-00: FuserControlFailureRunUnderTempFault	no. of faults	RW	FuserCtrlFailRunUnderTempFC	NVMFaultCounter	shortNatural	No	Fault Counter:10-324-00: FuserControlFailureRunUnderTempFault	1.370		
609-028	Fault Counter 10-325-00:	no. of faults	RW	FuserNotBeingCtrlledFC	NVMFaultCounter	shortNatural	No	Fault Counter:10-325-	1.370		
609-029	Fault Counter 10-330-00: FuserWarmupFailureFault	no. of faults	RW	FuserWarmupFailFC	NVMFaultCounter	shortNatural	No	Fault Counter:10-330-00: FuserWarmupFailureFault	1.370		
609-030	Fault Counter 10-340-00: FuserAOverTemperatureFault	no. of faults	RW	FuserAOverTemperatureFC	NVMFaultCounter	shortNatural	No	Fault Counter:10-340-00: FuserAOverTemperatureFault	1.370		
609-031	Fault Counter 10-350-00: FuserOverTempOrShortCircuitFault	no. of faults	RW	FuserOverTempOrShortCircuitFC	NVMFaultCounter	shortNatural	No	Fault Counter:10-350-00: FuserOverTempOrSho	1.370		
609-032	Fault Counter 10-360-00: FuserBOverTemperatureFault	no. of faults	RW	FuserBOverTemperatureFC	NVMFaultCounter	shortNatural	No	Fault Counter:10-360-00: FuserBOverTemperatureFault	1.370		
609-033	Fault Counter 10-365-00: FuserCOverTemperatureFault	no. of faults	RW	FuserCOverTemperatureFC	NVMFaultCounter	shortNatural	No	Fault Counter:10-365-00: FuserCOverTemperatureFault	1.370		

609-034	Fault Counter 10-370-00: FuserPowerSaveControlFailureFault	no. of faults	RW	FuserPowerSaveCtrlFailFC	NVMFaultCounter	shortNatural	No	Fault Counter:10-370-00: FuserPowerSaveControlFailureFault	1.370		
609-035	Fault Counter 10-380-00: FuserTempGradientTooHighFault	no. of faults	RW	FuserTempGradientTooHighFC	NVMFaultCounter	shortNatural	No	Fault Counter:10-380-00: FuserTempGradientTooHighFault	1.370		
609-036	Fault Counter 10-399-00: FruAuthorisationFailureFault	no. of faults	RW	FruAuthorisationFailFC	NVMFaultCounter	shortNatural	No	Fault Counter:10-399-00: FruAuthorisationFailureFault	1.370		
609-037	Fault Counter 10-821-00: SorFuserControlFailureStandbyOverTempFault	no. of faults	RW	SFuserCtrlFailStandbyOverTempFC	NVMFaultCounter	shortNatural	No	Fault Counter:10-821-00: SorFuserControlFailureStandbyOverTempFault	1.370		
609-038	Fault Counter 10-822-00: SorFuserControlFailureStandbyUnderTempFault	no. of faults	RW	SFuserCtrlFailStandbyUnderTempFC	NVMFaultCounter	shortNatural	No	Fault Counter:10-822-00: SorFuserControlFailureStandbyUnderTempFault	1.370		
609-039	Fault Counter 41-350-00: PfmCommsFailureFault	no. of faults	RW	PfmCommsFailFC	NVMFaultCounter	shortNatural	No	Fault Counter:41-350-00: PfmCommsFailureFault	1.370		
609-040	Fault Counter 41-351-00: PfmFeedBufferOverflowFault	no. of faults	RW	PfmFeedBufferOverflowFC	NVMFaultCounter	shortNatural	No	Fault Counter:41-351-00:	1.370		

609-041	Fault Counter 41-354-00: PfmI2CFrameFailureFault	no. of faults	RW	PfmI2CFrameFailFC	NVMFaultCounter	shortNatural	No	Fault Counter:41-354-00: PfmI2CFrameFailureFault	1.370		
609-042	Fault Counter 41-359-00: HcfCommsFailureFault	no. of faults	RW	FinisherCommsFailFC	NVMFaultCounter	shortNatural	No	Fault Counter:41-359-00:	1.370		
609-043	Fault Counter 03-360-00: FinisherCommsFailureFault	no. of faults	RW	FINCOMMSFAILFLT	NVMFaultCounter	shortNatural	No	Fault Counter:03-360-00: FINCOMMSFAILFLT	1.678		
609-044	Fault Counter 41-363-00: FinToBmCommsFailureFault	no. of faults	RW	PfpCommsFailFC	NVMFaultCounter	shortNatural	No	Fault Counter:41-363-00: FinToBmCommsFailureFault	1.370		
609-045	Fault Counter 03-350-00: PfpCommsFailureFault	no. of faults	RW	FruCommsFailFC	NVMFaultCounter	shortNatural	No	Fault Counter:03-350-00: PfpCommsFailure	1.678		
609-046	Fault Counter 41-371-00: FruCommsFailureFault	no. of faults	RW	XruCommsFailFC	NVMFaultCounter	shortNatural	No	Fault Counter:41-371-00: FruCommsFailureFault	1.370		

609-047	Fault Counter 41-372-00: XruCommsFailureFault	no. of faults	RW	IOTCycledInWithoutPrintingFC	NVMFaultCounter	shortNatural	No	Fault Counter:41-372-00: XruCommsFailureFault	1.370		
609-048	Fault Counter 41-395-00: IOTCycledInWithoutPrintingFault	no. of faults	RW	LaserOnWithoutPrTurningFC	NVMFaultCounter	shortNatural	No	Fault Counter:41-395-00: IOTCycledInWithoutPrintingFault	1.370		
609-049	Fault Counter 41-396-00: LaserOnWithoutPrTurningFault	no. of faults	RW	MainMtrNotBeingCtrlledFC	NVMFaultCounter	shortNatural	No	Fault Counter:41-396-00: LaserOnWithoutPrTurningFault	1.370		
609-050	Fault Counter 41-397-00: MainMotorNotBeingControlledFault	no. of faults	RW	HcfCommsFailFC	NVMFaultCounter	shortNatural	No	Fault Counter:41-397-00: MainMotorNotBeingControlledFault	1.370		
609-051	Fault Counter 41-423-00: PrintCommandLateToPageSyncSimplex3 Fault	no. of faults	RW	PrintCmdLateToPageSyncSplx3FC	NVMFaultCounter	shortNatural	No	Fault Counter:41-423-00: PrintCommandLateToPageSyncSimplex3Fault	1.370		
609-052	Fault Counter 41-480-00: Failure24VFault	no. of faults	RW	Fail24VFC	NVMFaultCounter	shortNatural	No	Fault Counter:41-480-00: Failure24VFault	1.370		

609-053	Fault Counter 41-805-00: IgnorestatFault	no. of faults	RW	IgnorestatFC	NVMFaultCounter	shortNatural	No	Fault Counter:41-805-00: IgnorestatFault	1.370		
609-054	Fault Counter 41-852-00: OutOfTimersFault	no. of faults	RW	OutOfTmrsFC	NVMFaultCounter	shortNatural	No	Fault Counter:41-852-00: OutOfTimersFault	1.370		
609-055	Fault Counter 91-365-00: IOTRelativeHumiditySensorFault	no. of faults	RW	IOTRelativeHumiditySnsrFC	NVMFaultCounter	shortNatural	No	Fault Counter:91-365-00: FAULT9_365	1.678		
609-056	Fault Counter 91-375-00: IOTAmbientTemperatureSensorFault	no. of faults	RW	IOTAmbientTemperatureSnsrFC	NVMFaultCounter	shortNatural	No	Fault Counter:91-375-00: FAULT9_375	1.678		
609-057	Fault Counter 46-060-00: HighVoltagePowerSupplyFailureFault	no. of faults	RW	HighVoltagePowerSupplyFailFC	NVMFaultCounter	shortNatural	No	Fault Counter:46-060-00: HighVoltagePowerSupplyFailureFault	1.370		

609-058	Fault Counter 61-020-00: RosMotorFailureFault	no. of faults	RW	RosMtrFailFC	NVMFaultCounter	shortNatural	No	Fault Counter:61-020-00: RosMotorFailureFault	1.370		
609-059	Fault Counter 61-340-00: RosSystemFailureFault	no. of faults	RW	RosSystemFailFC	NVMFaultCounter	shortNatural	No	Fault Counter:61-340-00: RosSystemFailureFault	1.370		
609-060	Fault Counter 61-350-00: RosLaserNotBeingControlledFault	no. of faults	RW	RosLaserNotBeingCtrlledFC	NVMFaultCounter	shortNatural	No	Fault Counter:61-350-00: RosLaserNotBeingControlledFault	1.370		
609-061	Fault Counter 92-399-00: XruAuthorisationFailureFault	no. of faults	RW	XruAuthorisationFailFC	NVMFaultCounter	shortNatural	No	Fault Counter:92-399-00: XruAuthorisationFailureFault	1.370		

609-062	Fault Counter 93-310-00: ReplenisherLevelSensorFailureFault	no. of faults	RW	ReplenisherLevelSnsrFailFC	NVMFaultCounter	shortNatural	No	Fault Counter:93-310-00: ReplenisherLevelSensorFailureFault	1.370		
609-063	Fault Counter 93-360-00: TonerConcentrationSensorFailureFault	no. of faults	RW	TonerConcSnsrFailFC	NVMFaultCounter	shortNatural	No	Fault Counter:93-360-00: TonerConcentrationSensorFailureFault	1.370		
609-064	Fault Counter 93-361-00: TonerConcentrationControlFailureLowFault	no. of faults	RW	TonerConcCtrlFailLowFC	NVMFaultCounter	shortNatural	No	Fault Counter:93-361-00: TonerConcentrationControlFailureLowFault	1.370		
609-065	Fault Counter 93-362-00: TonerConcentrationControlFailureHighFault	no. of faults	RW	TonerConcCtrlFailHighFC	NVMFaultCounter	shortNatural	No	Fault Counter:93-362-00: TonerConcentrationControlFailureHighFault	1.370		

609-066	Fault Counter 93-363-00: TonerConcentrationIsolatedControlFailLowFault	no. of faults	RW	TonerConclsolatedCtrlFailLowFC	NVMFaultCounter	shortNatural	No	Fault Counter:93-363-00: TonerConcentrationIsolatedControlFailLowFault	1.370		
609-067	Fault Counter 93-380-00: WasteTonerBottleMissingFault	no. of faults	RW	WasteTonerBottleMissingFC	NVMFaultCounter	shortNatural	No	Fault Counter:93-380-00: WasteTonerBottleMissingFault	1.370		
609-068	Fault Counter 93-390-00: TonerCartridgeEmptyFault	no. of faults	RW	TonerCartridgeEmptyFC	NVMFaultCounter	shortNatural	No	Fault Counter:93-390-00: TonerCartridgeEmptyFault	1.370		
609-069	Fault Counter 94-341-00: ScrotronCleaningFailedFault	no. of faults	RW	ScrotronCleaningFailedFC	NVMFaultCounter	shortNatural	No	Fault Counter:94-341-00: ScrotronCleaningFailedFault	1.370		

609-070	Fault Counter 94-342-00: ScorotronCleanngWarningFault	no. of faults	RW	ScorotronCleanngWarningFC	NVMFaultCounter	shortNatural	No	Fault Counter:94-342-00: ScorotronCleanngWarningFault	1.370		
609-071	Fault Counter 94-345-00: TransferDetackCleaningFailedFault	no. of faults	RW	TransferDetackCleaningFailedFC	NVMFaultCounter	shortNatural	No	Fault Counter:94-345-00: TransferDetackCleaningFailedFault	1.370		
609-072	Fault Counter 94-346-00: TransferDetackCleanngWarningFault	no. of faults	RW	TransferDetackCleanngWarningFC	NVMFaultCounter	shortNatural	No	Fault Counter:94-346-00: TransferDetackCleanngWarningFault	1.370		
609-073	Fault Counter 94-350-00: PhotoreceptorEraseLampFailureFault	no. of faults	RW	PhotoreceptorEraseLampFailFC	NVMFaultCounter	shortNatural	No	Fault Counter:94-350-00: PhotoreceptorEraseLampFailureFault	1.370		
609-074	Fault Counter 94-370-00: IOTDeveloperTemperatureSensorFault	no. of faults	RW	IOTDeveloperTemperatureSnsrFC	NVMFaultCounter	shortNatural	No	Fault Counter:94-370-00: IOTDeveloperTemperatureSensorFault	1.370		
609-075	Fault Counter 81-100-00: LeadEdgeLateToPfmWaitPointSensorFault	no. of faults	RW	LELateToPfmWaitPointSnsrFC	NVMFaultCounter	shortNatural	No	Fault Counter:81-100-00: LeadEdgeLateToPfmWaitPointSensorFault	1.374		
609-076	Fault Counter 81-101-00: LeadEdgeLateToTray1FeedSensorFault	no. of faults	RW	LELateToTray1FeedSnsrFC	NVMFaultCounter	shortNatural	No	Fault Counter:81-101-00: LeadEdgeLateToTray1FeedSensorFault	1.374		
609-077	Fault Counter 81-102-00: LeadEdgeLateToTray2FeedSensorFault	no. of faults	RW	LELateToTray2FeedSnsrFC	NVMFaultCounter	shortNatural	No	Fault Counter:81-102-00:	1.374		

609-078	Fault Counter 81-103-00: LeadEdgeLateToTray3FeedSensorFault	no. of faults	RW	LELateToTray3FeedSnsrFC	NVMFaultCounter	shortNatural	No	Fault Counter:81-103-00: LeadEdgeLateToTray3	1.374		
609-079	Fault Counter 81-104-00: LeadEdgeLateToTray4FeedSensorFault	no. of faults	RW	LELateToTray4FeedSnsrFC	NVMFaultCounter	shortNatural	No	Fault Counter:81-104-00: LeadEdgeLateToTray4	1.374		
609-080	Fault Counter 81-106-00: LeadEdgeLateToTray1SensorFromTray2Fault	no. of faults	RW	LELateToTray1SnsrFmTray2FC	NVMFaultCounter	shortNatural	No	Fault Counter:81-106-00: LeadEdgeLateToTray1	1.374		
609-081	Fault Counter 81-107-00: LeadEdgeLateToTray4SensorFromTray3Fault	no. of faults	RW	LELateToTray4SnsrFmTray3FC	NVMFaultCounter	shortNatural	No	Fault Counter:81-107-00: LeadEdgeLateToTray4	1.374		
609-082	Fault Counter 81-108-00: LeadEdgeLateToTray2SensorFromTray4Fault	no. of faults	RW	LELateToTray2SnsrFmTray4FC	NVMFaultCounter	shortNatural	No	Fault Counter:81-108-00: LeadEdgeLateToTray2	1.374		
609-083	Fault Counter 81-111-00: TrailEdgeLateFromTray1FeedSensorFault	no. of faults	RW	TELateFmTray1FeedSnsrFC	NVMFaultCounter	shortNatural	No	Fault Counter:81-111-00: TrailEdgeLateFromTra	1.374		
609-084	Fault Counter 81-112-00: TrailEdgeLateFromTray2FeedSensorFault	no. of faults	RW	TELateFmTray2FeedSnsrFC	NVMFaultCounter	shortNatural	No	Fault Counter:81-112-00: TrailEdgeLateFromTra	1.374		
609-085	Fault Counter 81-113-00: TrailEdgeLateFromTray3FeedSensorFault	no. of faults	RW	TELateFmTray3FeedSnsrFC	NVMFaultCounter	shortNatural	No	Fault Counter:81-113-00: TrailEdgeLateFromTra	1.374		
609-086	Fault Counter 81-114-00: TrailEdgeLateFromTray4FeedSensorFault	no. of faults	RW	TELateFmTray4FeedSnsrFC	NVMFaultCounter	shortNatural	No	Fault Counter:81-114-00: TrailEdgeLateFromTra	1.374		
609-087	Fault Counter 71-100-00: Tray1HoistFailureFault	no. of faults	RW	Tray1HoistFailFC	NVMFaultCounter	shortNatural	No	Fault Counter:71-100-00: Tray1HoistFailureFault	1.374		
609-088	Fault Counter 71-500-00: Tray1OpenWhileFeedingFault	no. of faults	RW	Tray1OpenWhileFeedingFC	NVMFaultCounter	shortNatural	No	Fault Counter:71-500-00:	1.374		
609-089	Fault Counter 72-100-00: Tray2HoistFailureFault	no. of faults	RW	Tray2HoistFailFC	NVMFaultCounter	shortNatural	No	Fault Counter:72-100-00: Tray2HoistFailureFault	1.374		
609-090	Fault Counter 72-500-00: Tray2OpenWhileFeedingFault	no. of faults	RW	Tray2OpenWhileFeedingFC	NVMFaultCounter	shortNatural	No	Fault Counter:72-500-00: Tray2OpenWhileFeedi	1.374		
609-091	Fault Counter 73-100-00: Tray3HoistFailureFault	no. of faults	RW	Tray3HoistFailFC	NVMFaultCounter	shortNatural	No	Fault Counter:73-100-00: Tray3HoistFailureFault	1.374		
609-092	Fault Counter 73-500-00: Tray3OpenWhileFeedingFault	no. of faults	RW	Tray3OpenWhileFeedingFC	NVMFaultCounter	shortNatural	No	Fault Counter:73-500-00: Tray3OpenWhileFeedi	1.374		
609-093	Fault Counter 74-100-00: Tray4HoistFailureFault	no. of faults	RW	Tray4HoistFailFC	NVMFaultCounter	shortNatural	No	Fault Counter:74-100-00: Tray4HoistFailureFault	1.374		
609-094	Fault Counter 74-500-00: Tray4OpenWhileFeedingFault	no. of faults	RW	Tray4OpenWhileFeedingFC	NVMFaultCounter	shortNatural	No	Fault Counter:74-500-00: Tray4OpenWhileFeedi	1.374		

609-095	Fault Counter 76-100-00: PfpTrayHoistFailureFault	no. of faults	RW	PfpTrayHoistFailFC	NVMFaultCounter	shortNatural	No	Fault Counter:76-100-00: PfpTrayHoistFailureFa	1.374		
609-096	Fault Counter 76-101-00: PfpTrayLowerFailureFault	no. of faults	RW	PfpTrayLowerFailFC	NVMFaultCounter	shortNatural	No	Fault Counter:76-101-00: PfpTrayLowerFailure	1.678		
609-097	Fault Counter 76-500-00: PfpOpenWhileFeedingFault	no. of faults	RW	PfpOpenWhileFeedingFC	NVMFaultCounter	shortNatural	No	Fault Counter:76-500-00: PfpOpenWhileFeeding	1.678		
609-098	Fault Counter 76-510-00: PfpUndockedInRunFault	no. of faults	RW	PfpUndockedInRunFC	NVMFaultCounter	shortNatural	No	Fault Counter:76-510-00: PfpUndockedInRun	1.678		
609-099	Fault Counter 81-115-00: LeadEdgeLateToPfpWaitPointSensorFault	no. of faults	RW	LELateToPfpWaitPointSnsrFC	NVMFaultCounter	shortNatural	No	Fault Counter:81-115-00: LeadEdgeLateToPfpW aitPointSensorFault	1.374		
609-100	Fault Counter 81-117-00: LeadEdgeLateToPfpFeedSensorFault	no. of faults	RW	LELateToPfpFeedSnsrFC	NVMFaultCounter	shortNatural	No	Fault Counter:81-117-00: LeadEdgeLateToPfpFe edSensorFault	1.374		
609-101	Fault Counter 81-150-00: LeadEdgeLateToRegistrationSensorFrom PfmFault	no. of faults	RW	LELateToRegSnsrFmPfmFC	NVMFaultCounter	shortNatural	No	Fault Counter:81-150-00: LeadEdgeLateToRegis trationSensorFromPfm Fault	1.374		
609-102	Fault Counter 81-151-00: TrailEdgeLateToRegSensorAfterClutchOn Fault	no. of faults	RW	TELateToRegSnsrAfterClutchOnFC	NVMFaultCounter	shortNatural	No	Fault Counter:81-151-00: TrailEdgeLateToRegS ensorAfterClutchOnFa ult	1.374		
609-103	Fault Counter 81-155-00: LeadEdgeLateToRegistrationSensorFrom MsiFault	no. of faults	RW	LELateToRegSnsrFmMsiFC	NVMFaultCounter	shortNatural	No	Fault Counter:81-155-00: LeadEdgeLateToRegis trationSensorFromMsi Fault	1.374		
609-104	Fault Counter 81-156-00: StraySheetFromMsiAtRegSensorFault	no. of faults	RW	StrayShtFmMsiAtRegSnsrFC	NVMFaultCounter	shortNatural	No	Fault Counter:81-156-00: StraySheetFromMsiAt RegSensorFault	1.374		
609-105	Fault Counter 81-171-00: UnexpectedTimeoutForSheetTypeFault	no. of faults	RW	UnexpTmoutForShtTypeFC	NVMFaultCounter	shortNatural	No	Fault Counter:81-171-00: UnexpectedTimeoutFo rSheetTypeFault	1.374		
609-106	Fault Counter 81-174-00: PpMissingPreReleasedSheetFault	no. of faults	RW	PpMissingPreReleasedShtFC	NVMFaultCounter	shortNatural	No	Fault Counter:81-174-00: PpMissingPreReleased SheetFault	1.374		
609-107	Fault Counter 81-180-00: UnableToFeedNextSheetFault	no. of faults	RW	UnableToFeedNextShtFC	NVMFaultCounter	shortNatural	No	Fault Counter:81-180-00: UnableToFeedNextSh	1.374		

609-108	Fault Counter 83-160-00: LeadEdgeLateToDuplexSensorFault	no. of faults	RW	LELateToDplxSnsrFC	NVMFaultCounter	shortNatural	No	Fault Counter:83-160-00: LeadEdgeLateToDuple	1.374		
609-109	Fault Counter 83-161-00: TrailEdgeLateToDuplexSensorAfterClutch	no. of faults	RW	TELateToDplxSnsrAfterClutchOnFC	NVMFaultCounter	shortNatural	No	Fault Counter:83-161-00:	1.374		
609-110	Fault Counter 83-181-00: PpUnexpectedTimeoutForSheetTypeSimplInvFault	no. of faults	RW	PpUnexpTmoutForShtTypeSimplInvFC	NVMFaultCounter	shortNatural	No	Fault Counter:83-181-00: PpUnexpectedTimeoutForSheetTypeSimplInvFault	1.374		
609-111	Fault Counter 83-182-00: PpUnexpectedTimeoutForSheetTypeDuplexFault	no. of faults	RW	PpUnexpTmoutForShtTypeDplxFC	NVMFaultCounter	shortNatural	No	Fault Counter:83-182-00: PpUnexpectedTimeoutForSheetTypeDuplexFault	1.374		
609-112	Fault Counter 83-190-00: StraySheetDetectedPostJamClearanceFault	no. of faults	RW	StrayShtDetectPostJamClearFC	NVMFaultCounter	shortNatural	No	Fault Counter:83-190-00: StraySheetDetectedPo	1.374		
609-113	Fault Counter 01-310-00: TopCoverOpenInRunFault	no. of faults	RW	TopCoverOpenInRunFC	NVMFaultCounter	shortNatural	No	Fault Counter:01-310-00: TopCoverOpenInRunF	1.374		
609-114	Fault Counter 11-005-00: FinTamper1FrontMoveFailureFault	no. of faults	RW	FinTamp1FrontMoveFailFC	NVMFaultCounter	shortNatural	No	Fault Counter:11-005-00: FinTamper1FrontMove	1.374		
609-115	Fault Counter 11-006-00: FinTamper1RearMoveFailureFault	no. of faults	RW	FinTamp1RearMoveFailFC	NVMFaultCounter	shortNatural	No	Fault Counter:11-006-00: FinTamper1RearMove	1.374		
609-116	Fault Counter 11-007-00: FinTamper2FrontMoveFailureFault	no. of faults	RW	FinTamp2FrontMoveFailFC	NVMFaultCounter	shortNatural	No	Fault Counter:11-007-00: FinTamper2FrontMove	1.374		
609-117	Fault Counter 11-008-00: FinTamper2RearMoveFailureFault	no. of faults	RW	FinTamp2RearMoveFailFC	NVMFaultCounter	shortNatural	No	Fault Counter:11-008-00: FinTamper2RearMove	1.374		
609-118	Fault Counter 11-012-00: FinCompilerCarriageHomeFailureFault	no. of faults	RW	FinCompilerCarriageHomeFailFC	NVMFaultCounter	shortNatural	No	Fault Counter:11-012-00: FinCompilerCarriageH	1.374		

609-119	Fault Counter 11-014-00: FinCompilerCarriageMoveFailureFault	no. of faults	RW	FinCompilerCarriageMoveFailFC	NVMFaultCounter	shortNatural	No	Fault Counter:11-014-00: FinCompilerCarriageM	1.374		
609-120	Fault Counter 11-024-00: FinPaddleRollHomeFailureFault	no. of faults	RW	FinPaddleRollHomeFailFC	NVMFaultCounter	shortNatural	No	Fault Counter:11-024-00: FinPaddleRollHomeFai	1.374		
609-121	Fault Counter 11-025-00: FinPaddleRollCycleFailureFault	no. of faults	RW	FinPaddleRollCycleFailFC	NVMFaultCounter	shortNatural	No	Fault Counter:11-025-00: FinPaddleRollCycleFail	1.374		
609-122	Fault Counter 11-026-00: FinPaddleRollerNotHomeFailureFault	no. of faults	RW	FinPaddleRollerNotHomeFailFC	NVMFaultCounter	shortNatural	No	Fault Counter:11-026-00: FinPaddleRollerNotHomeFailureFault	1.374		
609-123	Fault Counter 11-030-00: FinBin1MoveFailureFault	no. of faults	RW	FinBin1MoveFailFC	NVMFaultCounter	shortNatural	No	Fault Counter:11-030-00:	1.374		
609-124	Fault Counter 11-031-00: FinBin1OffsetMoveFailureFault	no. of faults	RW	FinBin1OffsetMoveFailFC	NVMFaultCounter	shortNatural	No	Fault Counter:11-031-00: FinBin1OffsetMoveFailureFault	1.374		
609-125	Fault Counter 11-036-00: FinBin2MoveFailureFault	no. of faults	RW	FinBin2MoveFailFC	NVMFaultCounter	shortNatural	No	Fault Counter:11-036-00: FinBin2MoveFailureFault	1.374		
609-126	Fault Counter 11-040-00: FinBin2OffsetMoveFailureFault	no. of faults	RW	FinBin2OffsetMoveFailFC	NVMFaultCounter	shortNatural	No	Fault Counter:11-040-00: FinBin2OffsetMoveFailureFault	1.374		
609-127	Fault Counter 11-043-00: FinPunchHeadCycleFailureFault	no. of faults	RW	FinPunchHeadCycleFailFC	NVMFaultCounter	shortNatural	No	Fault Counter:11-043-00: FinPunchHeadCycleFailureFault	1.374		

609-128	Fault Counter 11-044-00: FinPunchHeadReturnHomeFailureFault	no. of faults	RW	FinPunchHeadRtrnHomeFailFC	NVMFaultCounter	shortNatural	No	Fault Counter:11-044-00: FinPunchHeadReturnHomeFailureFault	1.374		
609-129	Fault Counter 11-045-00: FinPunchHeadStuckHomeFailureFault	no. of faults	RW	FinPunchHeadStuckHomeFailFC	NVMFaultCounter	shortNatural	No	Fault Counter:11-045-00:	1.374		
609-130	Fault Counter 11-046-00: FinPunchUnitHomeFlagFailureFault	no. of faults	RW	FinPunchUnitHomeFlagFailFC	NVMFaultCounter	shortNatural	No	Fault Counter:11-046-00:	1.374		
609-131	Fault Counter 11-047-00: FinPunchUnitHomeFailureFault	no. of faults	RW	FinPunchUnitHomeFailFC	NVMFaultCounter	shortNatural	No	Fault Counter:11-047-00: FinPunchUnitHomeFail	1.374		
609-132	Fault Counter 11-050-00: FinStapleHead1CycleFailureFault	no. of faults	RW	FinStapleHead1CycleFailFC	NVMFaultCounter	shortNatural	No	Fault Counter:11-050-00: FinStapleHead1CycleF ailureFault	1.374		
609-133	Fault Counter 11-053-00: FinStapleUnit1MoveFailureFault	no. of faults	RW	FinStapleUnit1MoveFailFC	NVMFaultCounter	shortNatural	No	Fault Counter:11-053-00: FinStapleUnit1MoveFai lureFault	1.374		
609-134	Fault Counter 11-056-00: FinPPIBottomPlateHomeFailureFault	no. of faults	RW	FinPPIBottomPlateHomeFailFC	NVMFaultCounter	shortNatural	No	Fault Counter:11-056-00: FinPPIBottomPlateHo meFailureFault	1.374		
609-135	Fault Counter 11-057-00: FinPPIBottomPlateLiftFailureFault	no. of faults	RW	FinPPIBottomPlateLiftFailFC	NVMFaultCounter	shortNatural	No	Fault Counter:11-057-00: FinPPIBottomPlateLiftF ailureFault	1.374		
609-136	Fault Counter 11-061-00: FinBBCreaseBladeMoveFailureFault	no. of faults	RW	FinBBCreaseBladeMoveFailFC	NVMFaultCounter	shortNatural	No	Fault Counter:11-061-00: FinBBCreaseBladeMov eFailureFault	1.374		
609-137	Fault Counter 11-062-00: FinBBCreaseRollFailureFault	no. of faults	RW	FinBBCreaseRollFailFC	NVMFaultCounter	shortNatural	No	Fault Counter:11-062-00: FinBBCreaseRollFailur eFault	1.374		
609-138	Fault Counter 11-063-00: FinBBStapleHead1MoveFailureFault	no. of faults	RW	FinBBStapleHead1MoveFailFC	NVMFaultCounter	shortNatural	No	Fault Counter:11-063-00: FinBBStapleHead1Mov eFailureFault	1.374		
609-139	Fault Counter 11-065-00: FinBBBackStopStartFailureFault	no. of faults	RW	FinBBBackStopStartFailFC	NVMFaultCounter	shortNatural	No	Fault Counter:11-065-00: FinBBBackStopStartFa ilureFault	1.374		
609-140	Fault Counter 11-066-00: FinBBTamp1MoveFailureFault	no. of faults	RW	FinBBTamp1MoveFailFC	NVMFaultCounter	shortNatural	No	Fault Counter:11-066-00: FinBBTamp1MoveFa ilureFault	1.374		
609-141	Fault Counter 11-072-00: FinBBTapeFeedMoveFaultFault	no. of faults	RW	FinBBTapeFeedMoveFCFC	NVMFaultCounter	shortNatural	No	Fault Counter:11-072-00: FinBBTapeFeedMoveF aultFault	1.374		

609-142	Fault Counter 11-073-00: FinBBCoolingFanFault	no. of faults	RW	FinBBCoolingFanFCFC	NVMFaultCounter	shortNatural	No	Fault Counter:11-073-00:	1.374		
609-143	Fault Counter 11-077-00:	no. of faults	RW	FinBBHeaterUnderTemperatureFC	NVMFaultCounter	shortNatural	No	Fault Counter:11-077-	1.374		
609-144	Fault Counter 11-078-00:	no. of faults	RW	FinBBHeaterOverTemperatureFC	NVMFaultCounter	shortNatural	No	Fault Counter:11-078-	1.374		
609-145	Fault Counter 11-083-00:	no. of faults	RW	FinPaperPusherMtrStalledFC	NVMFaultCounter	shortNatural	No	Fault Counter:11-083-	1.374		
609-146	Fault Counter 11-100-00:	no. of faults	RW	LELateToFinEntrySnsrFC	NVMFaultCounter	shortNatural	No	Fault Counter:11-100-	1.374		
609-147	Fault Counter 11-101-00:	no. of faults	RW	FinTELateFmEntranceSnsrFC	NVMFaultCounter	shortNatural	No	Fault Counter:11-101-	1.374		
609-148	Fault Counter 11-110-00:	no. of faults	RW	LELateToFinPunchSnsrFC	NVMFaultCounter	shortNatural	No	Fault Counter:11-110-	1.374		
609-149	Fault Counter 11-120-00:	no. of faults	RW	LELateToFinCompilerEntrySnsrFC	NVMFaultCounter	shortNatural	No	Fault Counter:11-120-	1.374		
609-150	Fault Counter 11-122-00: TrailEdgeLateFromFinCompilerEntrySnsrFault	no. of faults	RW	TELateFmFinCompilerEntrySnsrFC	NVMFaultCounter	shortNatural	No	Fault Counter:11-122-00: TrailEdgeLateFromFin	1.374		
609-151	Fault Counter 11-130-00: LeadEdgeLateToFinTopExitSensorFault	no. of faults	RW	LELateToFinTopExitSnsrFC	NVMFaultCounter	shortNatural	No	Fault Counter:11-130-00: LeadEdgeLateToFinTo	1.374		
609-152	Fault Counter 11-132-00: TrailEdgeLateFromFinTopExitSensorFault	no. of faults	RW	TELateFmFinTopExitSnsrFC	NVMFaultCounter	shortNatural	No	Fault Counter:11-132-00: TrailEdgeLateFromFin	1.374		
609-153	Fault Counter 11-140-00: LeadEdgeLateToFin2ndTopExitSensorFault	no. of faults	RW	LELateToFin2ndTopExitSnsrFC	NVMFaultCounter	shortNatural	No	Fault Counter:11-140-00: LeadEdgeLateToFin2n	1.374		
609-154	Fault Counter 11-142-00: TrailEdgeLateFromFin2ndTopExitSensorFault	no. of faults	RW	TELateFmFin2ndTopExitSnsrFC	NVMFaultCounter	shortNatural	No	Fault Counter:11-142-00: TrailEdgeLateFromFin	1.374		
609-155	Fault Counter 11-150-00: LeadEdgeLateToFin3rdTopExitSensorFault	no. of faults	RW	LELateToFin3rdTopExitSnsrFC	NVMFaultCounter	shortNatural	No	Fault Counter:11-150-00: LeadEdgeLateToFin3r	1.374		
609-156	Fault Counter 11-152-00: TrailEdgeLateFromFin3rdTopExitSensorFault	no. of faults	RW	TELateFmFin3rdTopExitSnsrFC	NVMFaultCounter	shortNatural	No	Fault Counter:11-152-00: TrailEdgeLateFromFin	1.374		
609-157	Fault Counter 11-157-00: FinLELateToBufferPositionSensorFault	no. of faults	RW	FinLELateToBufferPosSnsrFC	NVMFaultCounter	shortNatural	No	Fault Counter:11-157-00: FinLELateToBufferPosi	1.374		
609-158	Fault Counter 11-158-00: FinLELateToExitHVFIntoBMSensorFault	no. of faults	RW	FinLELateToExitHVFIntoBMSnsrFC	NVMFaultCounter	shortNatural	No	Fault Counter:11-158-00: FinLELateToExitHVFIn toBMSensorFault	1.374		
609-159	Fault Counter 12-160-00: LeadEdgeLateToBBEntrySensorFault	no. of faults	RW	LELateToBBEntrySnsrFC	NVMFaultCounter	shortNatural	No	Fault Counter:12-160-00: FAULT11_160	1.678		
609-160	Fault Counter 11-161-00: FinTELateFromBufferPositionSensorFault	no. of faults	RW	FinTELateFmBufferPosSnsrFC	NVMFaultCounter	shortNatural	No	Fault Counter:11-161-00: FinTELateFromBufferP ositionSensorFault	1.374		
609-161	Fault Counter 12-162-00: TrailEdgeLateFromBBEntrySensorFault	no. of faults	RW	TELateFmBBEntrySnsrFC	NVMFaultCounter	shortNatural	No	Fault Counter:12-162-00: TrailEdgeLateFromBB	1.678		
609-162	Fault Counter 11-163-00: FinTELateFromExitHVFIntoBMSensorFault	no. of faults	RW	FinTELateFmExitHVFIntoBMSnsrFC	NVMFaultCounter	shortNatural	No	Fault Counter:11-163-00: FinTELateFromExitHV	1.374		
609-163	Fault Counter 11-164-00: FinTELateFromBufferPathSensorFault	no. of faults	RW	FinTELateFmBufferPathSnsrFC	NVMFaultCounter	shortNatural	No	Fault Counter:11-164-00: FinTELateFromBufferP	1.374		

609-164	Fault Counter 11-165-00: FinLELateToBufferPathSensorFault	no. of faults	RW	FinLELateToBufferPathSnsrFC	NVMFaultCounter	shortNatural	No	Fault Counter:11-165-00: FinLELateToBufferPat	1.374		
609-165	Fault Counter 11-170-00: LeadEdgeLateToBBCompilerExitSensorFault	no. of faults	RW	LELateToBBCompilerExitSnsrFC	NVMFaultCounter	shortNatural	No	Fault Counter:11-170-00: LeadEdgeLateToBBCo	1.374		
609-166	Fault Counter 11-172-00: TrailEdgeLateFromBBCompilerSensorFault	no. of faults	RW	TELateFmBBCompilerSnsrFC	NVMFaultCounter	shortNatural	No	Fault Counter:11-172-00: TrailEdgeLateFromBB CompilerSensorFault	1.374		
609-167	Fault Counter 11-173-00: FinOffsetUnitInitializationFailureFault	no. of faults	RW	FinOffsetUnitInitFailFC	NVMFaultCounter	shortNatural	No	Fault Counter:11-173-00: FinOffsetUnitInitializati onFailureFault	1.374		
609-168	Fault Counter 11-174-00: FinOffsetUnitReturnHomeFailureFault	no. of faults	RW	FinOffsetUnitRtrnHomeFailFC	NVMFaultCounter	shortNatural	No	Fault Counter:11-174-00: FinOffsetUnitReturnHo	1.374		
609-169	Fault Counter 11-175-00: FinOffsetUnitHomeFailureFault	no. of faults	RW	FinOffsetUnitHomeFailFC	NVMFaultCounter	shortNatural	No	Fault Counter:11-175-00: FinOffsetUnitHomeFail ureFault	1.374		
609-170	Fault Counter 11-176-00: FinOffsetUnitReturnAwayHomeFailureFault	no. of faults	RW	FinOffsetUnitRtrnAwayHomeFailFC	NVMFaultCounter	shortNatural	No	Fault Counter:11-176-00: FinOffsetUnitReturnAw ayHomeFailureFault	1.374		
609-171	Fault Counter 11-177-00: FinOffsetUnitAwayHomeFailureFault	no. of faults	RW	FinOffsetUnitAwayHomeFailFC	NVMFaultCounter	shortNatural	No	Fault Counter:11-177-00: FinOffsetUnitAwayHom eFailureFault	1.374		
609-172	Fault Counter 12-180-00: LeadEdgeLateToBBExitSensorFault	no. of faults	RW	LELateToBBExitSnsrFC	NVMFaultCounter	shortNatural	No	Fault Counter:12-180-00: FAULT11_180	1.678		
609-173	Fault Counter 11-182-00: TrailEdgeLateFromBBExitSensorFault	no. of faults	RW	TELateFmBBExitSnsrFC	NVMFaultCounter	shortNatural	No	Fault Counter:11-182-00: TrailEdgeLateFromBB ExitSensorFault	1.374		
609-174	Fault Counter 11-183-00: FinBMUnexpectedSheetDetectedFault	no. of faults	RW	FinBMUnexpShtDetectFC	NVMFaultCounter	shortNatural	No	Fault Counter:11-183-00: FinBMUnexpectedShe etDetectedFault	1.374		
609-175	Fault Counter 11-184-00: FinBMStraySheetDetectedPostJamClearanceFault	no. of faults	RW	FinBMStryShtDetectPostJamClearFC	NVMFaultCounter	shortNatural	No	Fault Counter:11-184-00: FinBMStraySheetDetec	1.374		
609-176	Fault Counter 11-185-00: FinLELateToTFExitSensorFault	no. of faults	RW	FinLELateToTFExitSnsrFC	NVMFaultCounter	shortNatural	No	Fault Counter:11-185-00: FinLELateToTFExitSen	1.374		
609-177	Fault Counter 11-186-00: FinTELateFromTFExitSensorFault	no. of faults	RW	FinTELateFmTFExitSnsrFC	NVMFaultCounter	shortNatural	No	Fault Counter:11-186-00: FinTELateFromTFExit SensorFault	1.374		

609-178	Fault Counter 11-187-00: FinLELateToTFAssistSensorFault	no. of faults	RW	FinLELateToTFAssistSnsrFC	NVMFaultCounter	shortNatural	No	Fault Counter:11-187-00: FinLELateToTFAssistS	1.374		
609-179	Fault Counter 11-188-00: FinNipSplitFailureFault	no. of faults	RW	FinNipSplitFailFC	NVMFaultCounter	shortNatural	No	Fault Counter:11-188-00: FinNipSplitFailureFault	1.374		
609-180	Fault Counter 11-189-00: FinNipHomeFailureFault	no. of faults	RW	FinNipHomeFailFC	NVMFaultCounter	shortNatural	No	Fault Counter:11-189-00: FinNipHomeFailureFau lt	1.374		
609-181	Fault Counter 11-191-00: FinLELateToPPITabStandbySensorFault	no. of faults	RW	FinLELateToPPITabStandbySnsrFC	NVMFaultCounter	shortNatural	No	Fault Counter:11-191-00: FinLELateToPPITabSt	1.374		
609-182	Fault Counter 11-193-00: FinTELateFromPPITabStandbySensorFau lt	no. of faults	RW	FinTELateFmPPITabStandbySnsrFC	NVMFaultCounter	shortNatural	No	Fault Counter:11-193-00: FinTELateFromPPITab StandbySensorFault	1.374		
609-183	Fault Counter 11-194-00: FinLELateToPPIPickupSensorFault	no. of faults	RW	FinLELateToPPIPickupSnsrFC	NVMFaultCounter	shortNatural	No	Fault Counter:11-194-00: FinLELateToPPIPickup	1.374		
609-184	Fault Counter 11-196-00: FinTELateFromPPITrayPickupSensorFault	no. of faults	RW	FinTELateFmPPITrayPickupSnsrFC	NVMFaultCounter	shortNatural	No	Fault Counter:11-196-00: FinTELateFromPPITra yPickupSensorFault	1.374		
609-185	Fault Counter 11-198-00: FinStraySheetDetectedPostJamClearance Fault	no. of faults	RW	FinStrayShtDetectPostJamClearFC	NVMFaultCounter	shortNatural	No	Fault Counter:11-198-00: FinStraySheetDetected PostJamClearanceFaul t	1.374		
609-186	Fault Counter 11-199-00: UnexpectedSheetDetectedFault	no. of faults	RW	UnexpShtDetectFC	NVMFaultCounter	shortNatural	No	Fault Counter:11-199-00: UnexpectedSheetDete ctedFault	1.374		
609-187	Fault Counter 11-300-00: FinUnDockedInterlockInRunFault	no. of faults	RW	FinUnDockedIntlckInRunFC	NVMFaultCounter	shortNatural	No	Fault Counter:11-300-00: FinUnDockedInterlockl nRunFault	1.374		

609-188	Fault Counter 11-301-00: FinEntryGateInterlockOpenInRunFault	no. of faults	RW	FinEntryGateIntlckOpenInRunFC	NVMFaultCounter	shortNatural	No	Fault Counter:11-301-00: FinEntryGateInterlock OpenInRunFault	1.374		
609-189	Fault Counter 11-302-00: FinTopCoverInterlockOpenInRunFault	no. of faults	RW	FinTopCoverIntlckOpenInRunFC	NVMFaultCounter	shortNatural	No	Fault Counter:11-302-00: FinTopCoverInterlockO	1.374		
609-190	Fault Counter 11-303-00: FinFrontDoorInterlockOpenInRunFault	no. of faults	RW	FinFrontDoorIntlckOpenInRunFC	NVMFaultCounter	shortNatural	No	Fault Counter:11-303-00: FinFrontDoorInterlock	1.374		
609-191	Fault Counter 11-304-00: FinTopGateInterlockOpenInRunFault	no. of faults	RW	FinTopGateIntlckOpenInRunFC	NVMFaultCounter	shortNatural	No	Fault Counter:11-304-00: FinTopGateInterlockO	1.374		
609-192	Fault Counter 11-305-00: FinBottomExitGateInterlockOpenInRunFault	no. of faults	RW	FinBotExitGateIntlckOpenInRunFC	NVMFaultCounter	shortNatural	No	Fault Counter:11-305-00: FinBottomExitGateInter	1.374		
609-193	Fault Counter 11-306-00: FinPPITopCoverInterlockOpenInRunFault	no. of faults	RW	FinPPITopCoverIntlckOpenInRunFC	NVMFaultCounter	shortNatural	No	Fault Counter:11-306-00: FinPPITopCoverInterlo	1.374		
609-194	Fault Counter 11-307-00: FinTrifoldTopCoverOpenInRunFault	no. of faults	RW	FinTrifoldTopCoverOpenInRunFC	NVMFaultCounter	shortNatural	No	Fault Counter:11-307-00: FinTrifoldTopCoverOp enInRunFault	1.374		
609-195	Fault Counter 11-308-00: FinTrifoldFrontDoorOpenInRunFault	no. of faults	RW	FinTrifoldFrontDoorOpenInRunFC	NVMFaultCounter	shortNatural	No	Fault Counter:11-308-00:	1.374		
609-196	Fault Counter 11-309-00: FinInserterLeftHandDoorOpenInRunFault	no. of faults	RW	FinInsLeftHandDoorOpenInRunFC	NVMFaultCounter	shortNatural	No	Fault Counter:11-309-00: FinInserterLeftHandDo	1.374		
609-197	Fault Counter 11-310-00: FinTamper1FrontHomeFailureFault	no. of faults	RW	FinTamp1FrontHomeFailFC	NVMFaultCounter	shortNatural	No	Fault Counter:11-310-00: FinTamper1FrontHom	1.374		
609-198	Fault Counter 11-311-00: FinTamper1RearHomeFailureFault	no. of faults	RW	FinTamp1RearHomeFailFC	NVMFaultCounter	shortNatural	No	Fault Counter:11-311-00: FinTamper1RearHome	1.374		
609-199	Fault Counter 11-312-00: FinTamper2FrontHomeFailureFault	no. of faults	RW	FinTamp2FrontHomeFailFC	NVMFaultCounter	shortNatural	No	Fault Counter:11-312-00: FinTamper2FrontHom eFailureFault	1.374		
609-200	Fault Counter 11-313-00: FinTamper2RearHomeFailureFault	no. of faults	RW	FinTamp2RearHomeFailFC	NVMFaultCounter	shortNatural	No	Fault Counter:11-313-00: FinTamper2RearHome	1.374		
609-201	Fault Counter 11-315-00: FinCompilerCarriageOverTravelFailureUp Fault	no. of faults	RW	FinComplerCarriageTravelFailUpFC	NVMFaultCounter	shortNatural	No	Fault Counter:11-315-00: FinCompilerCarriageO	1.374		
609-202	Fault Counter 11-316-00: FinCompilerCarriageOverTravelFailureLo wFault	no. of faults	RW	FinComplrCarriageTravelFailLowFC	NVMFaultCounter	shortNatural	No	Fault Counter:11-316-00: FinCompilerCarriageO verTravelFailureLowFa	1.374		

609-203	Fault Counter 11-319-00: FinRearTamperAwayHomeSensorFailureFault	no. of faults	RW	FinRearTampAwayHomeSnsrFailFC	NVMFaultCounter	shortNatural	No	Fault Counter:11-319-00: FinRearTamperAwayHomeSensorFailureFault	1.374		
609-204	Fault Counter 11-320-00: FinCompilerEjectorHomeFailureFault	no. of faults	RW	FinCompilerEjectorHomeFailFC	NVMFaultCounter	shortNatural	No	Fault Counter:11-320-00: FinCompilerEjectorHo	1.374		
609-205	Fault Counter 11-322-00: FinCompilerEjectorCycleFailureFault	no. of faults	RW	FinCompilerEjectorCycleFailFC	NVMFaultCounter	shortNatural	No	Fault Counter:11-322-00: FinCompilerEjectorCyc	1.374		
609-206	Fault Counter 11-334-00: FinBin1OverTravelFailureUpperFault	no. of faults	RW	FinBin1OverTravelFailUpperFC	NVMFaultCounter	shortNatural	No	Fault Counter:11-334-00: FinBin1OverTravelFail	1.374		
609-207	Fault Counter 11-335-00: FinBin1OverTravelFailureLowerFault	no. of faults	RW	FinBin1OverTravelFailLowerFC	NVMFaultCounter	shortNatural	No	Fault Counter:11-335-00: FinBin1OverTravelFail	1.374		
609-208	Fault Counter 11-336-00: FinBin1HomeFailureFault	no. of faults	RW	FinBin1HomeFailFC	NVMFaultCounter	shortNatural	No	Fault Counter:11-336-00: FinBin1HomeFailureFault	1.374		
609-209	Fault Counter 11-337-00: FinBin1OffsetHomeFailureFault	no. of faults	RW	FinBin1OffsetHomeFailFC	NVMFaultCounter	shortNatural	No	Fault Counter:11-337-00: FinBin1OffsetHomeFailureFault	1.374		
609-210	Fault Counter 11-344-00: FinBin2OverTravelFailureUpperFault	no. of faults	RW	FinBin2OverTravelFailUpperFC	NVMFaultCounter	shortNatural	No	Fault Counter:11-344-00: FinBin2OverTravelFailureUpperFault	1.374		
609-211	Fault Counter 11-345-00: FinBin2OverTravelFailureLowerFault	no. of faults	RW	FinBin2OverTravelFailLowerFC	NVMFaultCounter	shortNatural	No	Fault Counter:11-345-00: FinBin2OverTravelFailureLowerFault	1.374		
609-212	Fault Counter 11-346-00: FinBin2HomeFailureFault	no. of faults	RW	FinBin2HomeFailFC	NVMFaultCounter	shortNatural	No	Fault Counter:11-346-00: FinBin2HomeFailureFault	1.374		
609-213	Fault Counter 11-347-00: FinBin2OffsetHomeFailureFault	no. of faults	RW	FinBin2OffsetHomeFailFC	NVMFaultCounter	shortNatural	No	Fault Counter:11-347-00: FinBin2OffsetHomeFailureFault	1.374		
609-214	Fault Counter 11-350-00: FinPunchHeadHomeFailureFault	no. of faults	RW	FinPunchHeadHomeFailFC	NVMFaultCounter	shortNatural	No	Fault Counter:11-350-00: FinPunchHeadHomeFailureFault	1.374		
609-215	Fault Counter 11-360-00:	no. of faults	RW	FinStapleHead1HomeFailFC	NVMFaultCounter	shortNatural	No	Fault Counter:11-360-	1.374		

609-216	Fault Counter 11-364-00: FinStapleHead1NotPrimedFault	no. of faults	RW	FinStapleHead1NotPrimedFC	NVMFaultCounter	shortNatural	No	Fault Counter:11-364-00: FinStapleHead1NotPri	1.374		
609-217	Fault Counter 11-370-00: FinStapleUnit1HomeFailureFault	no. of faults	RW	FinStapleUnit1HomeFailFC	NVMFaultCounter	shortNatural	No	Fault Counter:11-370-00: FinStapleUnit1HomeFa	1.374		
609-218	Fault Counter 11-371-00:	no. of faults	RW	FinStaplerHomeFailFC	NVMFaultCounter	shortNatural	No	Fault Counter:11-371-	1.374		
609-219	Fault Counter 11-372-00: FinStaplerReturnHomeFailureFault	no. of faults	RW	FinStaplerRtrnHomeFailFC	NVMFaultCounter	shortNatural	No	Fault Counter:11-372-00:	1.374		
609-220	Fault Counter 11-373-00: FinStaplerMiddleHomeFailureFault	no. of faults	RW	FinStaplerMiddleHomeFailFC	NVMFaultCounter	shortNatural	No	Fault Counter:11-373-00: FinStaplerMiddleHome	1.374		
609-221	Fault Counter 11-374-00: FinStaplerStuckMiddleHomeFailureFault	no. of faults	RW	FinStaplerStuckMiddleHomeFailFC	NVMFaultCounter	shortNatural	No	Fault Counter:11-374-00: FinStaplerStuckMiddle	1.374		
609-222	Fault Counter 11-375-00: FinStaplerJawHomeFailureFault	no. of faults	RW	FinStaplerJawHomeFailFC	NVMFaultCounter	shortNatural	No	Fault Counter:11-375-00: FinStaplerJawHomeFai	1.374		
609-223	Fault Counter 11-376-00: FinStaplerJawStuckHomeFailureFault	no. of faults	RW	FinStaplerJawStuckHomeFailFC	NVMFaultCounter	shortNatural	No	Fault Counter:11-376-00:	1.374		
609-224	Fault Counter 11-377-00: FinStaplerPrimingFailureFault	no. of faults	RW	FinStaplerPrimingFailFC	NVMFaultCounter	shortNatural	No	Fault Counter:11-377-00: FinStaplerPrimingFailu reFault	1.374		
609-225	Fault Counter 11-380-00: FinPunchUnitPaperSideEdgeDetectingFail ureFault	no. of faults	RW	FinPunchPaprSideEdgeDetectFailFC	NVMFaultCounter	shortNatural	No	Fault Counter:11-380-00: FinPunchUnitPaperSid eEdgeDetectingFailure	1.374		
609-226	Fault Counter 11-383-00: FinBBBackStopHomeFailureFault	no. of faults	RW	FinBBBackStopHomeFailFC	NVMFaultCounter	shortNatural	No	Fault Counter:11-383-00: FinBBBackStopHomeF ailureFault	1.374		
609-227	Fault Counter 11-384-00: FinBBTamper1HomeFailureFault	no. of faults	RW	FinBBTamp1HomeFailFC	NVMFaultCounter	shortNatural	No	Fault Counter:11-384-00: FinBBTamper1HomeF ailureFault	1.374		
609-228	Fault Counter 11-391-00: FinBBFlapperHomeFailureFault	no. of faults	RW	FinBBFlapperHomeFailFC	NVMFaultCounter	shortNatural	No	Fault Counter:11-391-00: FinBBFlapperHomeFail ureFault	1.374		
609-229	Fault Counter 11-392-00: FinFrontTamperTrayHomeFailureFault	no. of faults	RW	FinFrontTampTrayHomeFailFC	NVMFaultCounter	shortNatural	No	Fault Counter:11-392-00: FinFrontTamperTrayH omeFailureFault	1.374		
609-230	Fault Counter 11-393-00: FinFrontTamperTrayReturnHomeFailureF ault	no. of faults	RW	FinFrontTampTrayRtrnHomeFailFC	NVMFaultCounter	shortNatural	No	Fault Counter:11-393-00: FinFrontTamperTrayR eturnHomeFailureFault	1.374		
609-231	Fault Counter 11-394-00: FinFrontTamperTrayAwayHomeFailureFa ult	no. of faults	RW	FinFrontTampTrayAwayHomeFailFC	NVMFaultCounter	shortNatural	No	Fault Counter:11-394-00: FinFrontTamperTrayA wayHomeFailureFault	1.374		

609-232	Fault Counter 11-395-00: FinFrontTamperTrayStuckAwayHomeFailureFault	no. of faults	RW	FinFrontTampStuckAwayHomeFailFC	NVMFaultCounter	shortNatural	No	Fault Counter:11-395-00: FinFrontTamperTrayStuckAwayHomeFailureF	1.374		
609-233	Fault Counter 11-396-00: FinRearTamperTrayHomeFailureFault	no. of faults	RW	FinRearTampTrayHomeFailFC	NVMFaultCounter	shortNatural	No	Fault Counter:11-396-00:	1.374		
609-234	Fault Counter 11-397-00: FinRearTamperTrayReturnHomeFailureFault	no. of faults	RW	FinRearTampTrayRtrnHomeFailFC	NVMFaultCounter	shortNatural	No	Fault Counter:11-397-00: FinRearTamperTrayRe	1.374		
609-235	Fault Counter 11-398-00: FinRearTamperTrayAwayHomeFailureFault	no. of faults	RW	FinRearTampTrayAwayHomeFailFC	NVMFaultCounter	shortNatural	No	Fault Counter:11-398-00:	1.374		
609-236	Fault Counter 11-399-00: FinRearTamperTrayReturnAwayHomeFailureFault	no. of faults	RW	FinRearTampRtrnAwayHomeFailFC	NVMFaultCounter	shortNatural	No	Fault Counter:11-399-00: FinRearTamperTrayRe	1.374		
609-237	Fault Counter 11-403-00: FinBBStapleHead2MoveFailureFault	no. of faults	RW	FinBBStapleHead2MoveFailFC	NVMFaultCounter	shortNatural	No	Fault Counter:11-403-00: FinBBStapleHead2MoveFailureFault	1.374		
609-238	Fault Counter 11-411-00: FinBBStapleHead1HomeFailureFault	no. of faults	RW	FinBBStapleHead1HomeFailFC	NVMFaultCounter	shortNatural	No	Fault Counter:11-411-00: FinBBStapleHead1HomeFailureFault	1.374		
609-239	Fault Counter 11-413-00: FinBBStapleHead2HomeFailureFault	no. of faults	RW	FinBBStapleHead2HomeFailFC	NVMFaultCounter	shortNatural	No	Fault Counter:11-413-00: FinBBStapleHead2HomeFailureFault	1.374		
609-240	Fault Counter 11-414-00: FinBMStaplerModuleHomeFault	no. of faults	RW	FinBMStaplerModuleHomeFC	NVMFaultCounter	shortNatural	No	Fault Counter:11-414-00: FinBMStaplerModuleHomeFault	1.374		
609-241	Fault Counter 11-415-00: FinBBCreaseRollGateHomeFailureFault	no. of faults	RW	FinBBCreaseRollGateHomeFailFC	NVMFaultCounter	shortNatural	No	Fault Counter:11-415-00: FinBBCreaseRollGate	1.374		
609-242	Fault Counter 11-416-00: FinBBCreaseBladeHomeFailureFault	no. of faults	RW	FinBBCreaseBladeHomeFailFC	NVMFaultCounter	shortNatural	No	Fault Counter:11-416-00: FinBBCreaseBladeHomeFailureFault	1.374		
609-243	Fault Counter 11-417-00: FinBMFlapperHomeFailureFault	no. of faults	RW	FinBMFlapperHomeFailFC	NVMFaultCounter	shortNatural	No	Fault Counter:11-417-00: FinBMFlapperHomeFailureFault	1.374		
609-244	Fault Counter 11-418-00: FinBMFlapperMoveFailureFault	no. of faults	RW	FinBMFlapperMoveFailFC	NVMFaultCounter	shortNatural	No	Fault Counter:11-418-00: FinBMFlapperMoveFailureFault	1.374		
609-245	Fault Counter 11-419-00: FinBMTamper2HomeFailureFault	no. of faults	RW	FinBMTamp2HomeFailFC	NVMFaultCounter	shortNatural	No	Fault Counter:11-419-00: FinBMTamper2HomeFailureFault	1.374		
609-246	Fault Counter 11-420-00: FinBMTamper2MoveFailureFault	no. of faults	RW	FinBMTamp2MoveFailFC	NVMFaultCounter	shortNatural	No	Fault Counter:11-420-00: FinBMTamper2MoveFailureFault	1.374		

609-247	Fault Counter 11-430-00: FinKickerCycleFailureFault	no. of faults	RW	FinKickerCycleFailFC	NVMFaultCounter	shortNatural	No	Fault Counter:11-430-00: FinKickerCycleFailureFault	1.374		
609-248	Fault Counter 11-440-00: FinPaperPusherReturnHomeFailureFault	no. of faults	RW	FinPaperPusherRtrnHomeFailFC	NVMFaultCounter	shortNatural	No	Fault Counter:11-440-00: FinPaperPusherReturnHomeFailureFault	1.374		
609-249	Fault Counter 11-441-00: FinPaperPusherHomeFailureFault	no. of faults	RW	FinPaperPusherHomeFailFC	NVMFaultCounter	shortNatural	No	Fault Counter:11-441-00: FinPaperPusherHomeFailureFault	1.374		
609-250	Fault Counter 11-442-00: FinPaperPusherReturnAwayHomeFailureFault	no. of faults	RW	FinPaperPusherRtrnAwayHomeFailFC	NVMFaultCounter	shortNatural	No	Fault Counter:11-442-00: FinPaperPusherReturnAwayHomeFailureFault	1.374		
609-251	Fault Counter 11-443-00: FinPaperPusherAwayHomeFailureFault	no. of faults	RW	FinPaperPusherAwayHomeFailFC	NVMFaultCounter	shortNatural	No	Fault Counter:11-443-00: FinPaperPusherAwayHomeFailureFault	1.374		
609-252	Fault Counter 11-450-00: FinEjectorModuleMotorStallFault	no. of faults	RW	FinEjectorModuleMtrStallFC	NVMFaultCounter	shortNatural	No	Fault Counter:11-450-00: FinEjectorModuleMotorStallFault	1.374		
609-253	Fault Counter 11-451-00: FinEjectorPlateMotorStallFailureFault	no. of faults	RW	FinEjectorPlateMtrStallFailFC	NVMFaultCounter	shortNatural	No	Fault Counter:11-451-00: FinEjectorPlateMotorStallFailureFault	1.374		
609-254	Fault Counter 11-452-00: FinEjectorPlateReturnHomeFailureFault	no. of faults	RW	FinEjectorPlateRtrnHomeFailFC	NVMFaultCounter	shortNatural	No	Fault Counter:11-452-00: FinEjectorPlateReturnHomeFailureFault	1.374		
609-255	Fault Counter 11-453-00: FinEjectorPlateHomeFailureFault	no. of faults	RW	FinEjectorPlateHomeFailFC	NVMFaultCounter	shortNatural	No	Fault Counter:11-453-00: FinEjectorPlateHomeFailureFault	1.374		
609-256	Fault Counter 11-454-00: FinLowerPaddleReturnHomeFailureFault	no. of faults	RW	FinLowerPaddleRtrnHomeFailFC	NVMFaultCounter	shortNatural	No	Fault Counter:11-454-00: FinLowerPaddleReturnHomeFailureFault	1.374		
609-257	Fault Counter 11-455-00: FinLowerPaddleHomeFailureFault	no. of faults	RW	FinLowerPaddleHomeFailFC	NVMFaultCounter	shortNatural	No	Fault Counter:11-455-00: FinLowerPaddleHomeFailureFault	1.374		
609-258	Fault Counter 11-456-00: FinEjectorModuleReturnHomeFailureFault	no. of faults	RW	FinEjectorModuleRtrnHomeFailFC	NVMFaultCounter	shortNatural	No	Fault Counter:11-456-00: FinEjectorModuleReturnHomeFailureFault	1.374		

609-259	Fault Counter 11-457-00: FinEjectorModuleHomeFailureFault	no. of faults	RW	FinEjectorModuleHomeFailFC	NVMFaultCounter	shortNatural	No	Fault Counter:11-457-00: FinEjectorModuleHomeFailureFault	1.374		
609-260	Fault Counter 11-458-00: FinEjectorModuleReturnOutFailureFault	no. of faults	RW	FinEjectorModuleRtrnOutFailFC	NVMFaultCounter	shortNatural	No	Fault Counter:11-458-00: FinEjectorModuleReturnOutFailureFault	1.374		
609-261	Fault Counter 11-459-00: FinEjectorModuleOutFailureFault	no. of faults	RW	FinEjectorModuleOutFailFC	NVMFaultCounter	shortNatural	No	Fault Counter:11-459-00: FinEjectorModuleOutFailureFault	1.374		
609-262	Fault Counter 11-460-00: FinStackerMotorStallFailureFault	no. of faults	RW	FinStackerMtrStallFailFC	NVMFaultCounter	shortNatural	No	Fault Counter:11-460-00: FinStackerMotorStallF	1.374		
609-263	Fault Counter 11-461-00: FinStackerBinHomeFailureFault	no. of faults	RW	FinStackerBinHomeFailFC	NVMFaultCounter	shortNatural	No	Fault Counter:11-461-00: FinStackerBinHomeFai	1.374		
609-264	Fault Counter 11-462-00: FinStackerBinMoveFailureFault	no. of faults	RW	FinStackerBinMoveFailFC	NVMFaultCounter	shortNatural	No	Fault Counter:11-462-00: FinStackerBinMoveFailureFault	1.374		
609-265	Fault Counter 11-463-00: FinBM24vUnavailableAtInputFault	no. of faults	RW	FinBM24vUnavailableAtInputFC	NVMFaultCounter	shortNatural	No	Fault Counter:11-463-00: FinBM24vUnavailableA	1.374		
609-266	Fault Counter 11-464-00: FinBM24vInternalFailureFault	no. of faults	RW	FinBM24vInternalFailFC	NVMFaultCounter	shortNatural	No	Fault Counter:11-464-00:	1.374		
609-267	Fault Counter 11-465-00: FinPaddleUnitReturnUpperFailureFault	no. of faults	RW	FinPaddleUnitRtrnUpperFailFC	NVMFaultCounter	shortNatural	No	Fault Counter:11-465-00: FinPaddleUnitReturnUpperFailureFault	1.374		
609-268	Fault Counter 11-466-00: FinPaddleUnitNotUpperFailureFault	no. of faults	RW	FinPaddleUnitNotUpperFailFC	NVMFaultCounter	shortNatural	No	Fault Counter:11-466-00: FinPaddleUnitNotUpperFailureFault	1.374		
609-269	Fault Counter 11-467-00: FinPaddleUnitReturnLowerFailureFault	no. of faults	RW	FinPaddleUnitRtrnLowerFailFC	NVMFaultCounter	shortNatural	No	Fault Counter:11-467-00: FinPaddleUnitReturnLowerFailureFault	1.374		
609-270	Fault Counter 11-468-00: FinPaddleUnitNotLowerFailureFault	no. of faults	RW	FinPaddleUnitNotLowerFailFC	NVMFaultCounter	shortNatural	No	Fault Counter:11-468-00: FinPaddleUnitNotLowerFailureFault	1.374		

609-271	Fault Counter 11-469-00: FinCurlSuppressorReturnHomeFailureFault	no. of faults	RW	FinCurlSuppressorRtrnHomeFailFC	NVMFaultCounter	shortNatural	No	Fault Counter:11-469-00: FinCurlSuppressorReturnHomeFailureFault	1.374		
609-272	Fault Counter 11-470-00: FinCurlSuppressorHomeFailureFault	no. of faults	RW	FinCurlSuppressorHomeFailFC	NVMFaultCounter	shortNatural	No	Fault Counter:11-470-00: FinCurlSuppressorHo	1.374		
609-273	Fault Counter 11-471-00: FinCurlSuppressorReturnAwayFailureFault	no. of faults	RW	FinCurlSuppressorRtrnAwayFailFC	NVMFaultCounter	shortNatural	No	Fault Counter:11-471-00: FinCurlSuppressorRet	1.374		
609-274	Fault Counter 11-472-00: FinCurlSuppressorAwayFailureFault	no. of faults	RW	FinCurlSuppressorAwayFailFC	NVMFaultCounter	shortNatural	No	Fault Counter:11-472-00: FinCurlSuppressorAwa yFailureFault	1.374		
609-275	Fault Counter 11-473-00: FinPressingSupportMotorReturnInitFailureFault	no. of faults	RW	FinPressSupportMtrRtrnInitFailFC	NVMFaultCounter	shortNatural	No	Fault Counter:11-473-00: FinPressingSupportMo torReturnInitFailureFau lt	1.374		
609-276	Fault Counter 11-474-00: FinPressingSupportMotorInitFailureFault	no. of faults	RW	FinPressSupportMtrInitFailFC	NVMFaultCounter	shortNatural	No	Fault Counter:11-474-00: FinPressingSupportMo torInitFailureFault	1.374		
609-277	Fault Counter 11-475-00: FinPressingSupportMotorReturnHomeFailureFault	no. of faults	RW	FinPressSupportMtrRtrnHomeFailFC	NVMFaultCounter	shortNatural	No	Fault Counter:11-475-00: FinPressingSupportMo torReturnHomeFailure Fault	1.374		
609-278	Fault Counter 11-476-00: FinPressingSupportMotorHomeFailureFault	no. of faults	RW	FinPressSupportMtrHomeFailFC	NVMFaultCounter	shortNatural	No	Fault Counter:11-476-00: FinPressingSupportMo torHomeFailureFault	1.374		
609-279	Fault Counter 11-477-00: FinPressingSupportMotorReturnOutFailureFault	no. of faults	RW	FinPressSupportMtrRtrnOutFailFC	NVMFaultCounter	shortNatural	No	Fault Counter:11-477-00: FinPressingSupportMo torReturnOutFailureFa ult	1.374		
609-280	Fault Counter 11-478-00: FinPressingSupportMotorOutFailureFault	no. of faults	RW	FinPressSupportMtrOutFailFC	NVMFaultCounter	shortNatural	No	Fault Counter:11-478-00: FinPressingSupportMo torOutFailureFault	1.374		
609-281	Fault Counter 11-479-00: FinShortSheetFedFromInserterFault	no. of faults	RW	FinShortShtFedFmInserterFC	NVMFaultCounter	shortNatural	No	Fault Counter:11-479-00: FinShortSheetFedFro mInserterFault	1.374		

609-282	Fault Counter 11-701-00: OctNotInIndexPositionFault	no. of faults	RW	OctNotInIndexPosFC	NVMFaultCounter	shortNatural	No	Fault Counter:11-701-00: OctNotInIndexPosition Fault	1.374		
609-283	Tray 9 Media Type	MTStandard = 0, MTDrilled = 1, MTEvelope = 3, ... MTRoughStock = 58,	RW	Tray 9 Media Type	NVMSAKOSetting	shortNatural	No		1.554		
609-284	Tray 9 Media Color	MCWhite = 0, MCGreen = 1, MCBuff = 2, ... MCCustom6 = 19,	RW	Tray 9 Media Color	NVMSAKOSetting	shortNatural	No		1.380		
609-285	Tray 9 Media Weight		RW	Tray 9 Media Weight	NVMSAKOSetting	shortNatural	No		1.380		
609-286	Tray 9 Direct Select	TSDirectOnly = 0, TSDirectAndAuto = 1	RW	Tray 9 Direct Select	NVMSAKOSetting	shortNatural	No		1.380		
609-287	Tray 9 Priority		RW	Tray 9 Priority	NVMSAKOSetting	shortNatural	No		1.380		
609-288	Tray 9 Width	Range and default size in mm	RW	Tray 9 Width	NVMSAKOSetting	natural	No		1.380		
609-289	Tray 9 Length	Range and default size in mm	RW	Tray 9 Length	NVMSAKOSetting	natural	No		1.380		
609-290	Tray 9 Percent Full		RW	Tray 9 Percent Full	NVMSAKOSetting	shortNatural	No		1.380		
609-291	Tray 9 User Type	TAFixed = 0, TAAdjustableAll = 1, ----- [TAAdjustableSizeOnly = 2]	RW	Tray 9 User Type	NVMSAKOSetting	shortNatural	No		1.380		
609-292	Tray 9 Modulus		RW	Tray 9 Modulus	NVMSAKOSetting	shortNatural	No		1.380		
609-293	Tray 9 Modulus Position		RW	Tray 9 Modulus Position	NVMSAKOSetting	shortNatural	No		1.380		

609-294	Tray 10 Media Type	MTStandard = 0, MTDrilled = 1, MTEvelope = 3,	RW	Tray 10 Media Type	NVMSAKOSetting	shortNatural	No		1.554		
609-295	Tray 10 Media Color	MCWhite = 0, MCGreen = 1, MCBuff = 2, ... MCCustom6 = 19,	RW	Tray 10 Media Color	NVMSAKOSetting	shortNatural	No		1.380		
609-296	Tray 10 Media Weight		RW	Tray 10 Media Weight	NVMSAKOSetting	shortNatural	No		1.380		
609-297	Tray 10 Direct Select	TSDirectOnly = 0, TSDirectAndAuto = 1	RW	Tray 10 Direct Select	NVMSAKOSetting	shortNatural	No		1.380		
609-298	Tray 10 Priority		RW	Tray 10 Priority	NVMSAKOSetting	shortNatural	No		1.380		
609-299	Tray 10 Width	Range and default size in mm	RW	Tray 10 Width	NVMSAKOSetting	natural	No		1.380		
609-300	Tray 10 Length	Range and default size in mm	RW	Tray 10 Length	NVMSAKOSetting	natural	No		1.380		
609-301	Tray 10 Percent Full		RW	Tray 10 Percent Full	NVMSAKOSetting	shortNatural	No		1.380		
609-302	Tray 10 User Type	TAFixed = 0, TAAdjustableAll = 1, ----- [TAAdjustableSizeOnly =	RW	Tray 10 User Type	NVMSAKOSetting	shortNatural	No		1.380		
609-303	Tray 10 Modulus		RW	Tray 10 Modulus	NVMSAKOSetting	shortNatural	No		1.380		
609-304	Tray 10 Modulus Position		RW	Tray 10 Modulus Position	NVMSAKOSetting	shortNatural	No		1.380		
609-305	Tray 11 Media Type	MTStandard = 0, MTDrilled = 1, MTEvelope = 3, ...	RW	Tray 11 Media Type	NVMSAKOSetting	shortNatural	No		1.554		
609-306	Tray 11 Media Color	MCWhite = 0, MCGreen = 1, MCBuff = 2, ...	RW	Tray 11 Media Color	NVMSAKOSetting	shortNatural	No		1.380		

609-307	Tray 11 Media Weight		RW	Tray 11 Media Weight	NVMSAKOSetting	shortNatural	No		1.380		
609-308	Tray 11 Direct Select	TSDirectOnly = 0, TSDirectAndAuto = 1	RW	Tray 11 Direct Select	NVMSAKOSetting	shortNatural	No		1.380		
609-309	Tray 11 Priority		RW	Tray 11 Priority	NVMSAKOSetting	shortNatural	No		1.380		
609-310	Tray 11 Width	Range and default size in mm	RW	Tray 11 Width	NVMSAKOSetting	natural	No		1.380		
609-311	Tray 11 Length	Range and default size in mm	RW	Tray 11 Length	NVMSAKOSetting	natural	No		1.380		
609-312	Tray 11 Percent Full		RW	Tray 11 Percent Full	NVMSAKOSetting	shortNatural	No		1.380		
609-313	Tray 11 User Type	TAFixed = 0, TAAdjustableAll = 1, ----- [TAAdjustableSizeOnly = 2]	RW	Tray 11 User Type	NVMSAKOSetting	shortNatural	No		1.380		
609-314	Tray 11 Modulus		RW	Tray 11 Modulus	NVMSAKOSetting	shortNatural	No		1.380		
609-315	Tray 11 Modulus Position		RW	Tray 11 Modulus Position	NVMSAKOSetting	shortNatural	No		1.380		
609-316	PFP Kit Type installed in PFP	0=Standard (A4 & Letter LEF) 1=Kit A (A3 SEF & A4 LEF) 2=Kit A (11x17 SEF &	RW	PFP Kit Type	NVMSAKOSetting	shortNatural	No		1.380		
609-319	Tray 4 Feed Rolls life expectancy	Feeds - adjustable by CSE	RW	Tray4FeedRollsExpLife	NVMConfiguration	longNatural	No		1.434		
609-319	Tray 4 Pick & Separator Roller life expectancy	Feeds - adjustable by CSE	RW	Tray4FeedRollsExpLife	NVMConfiguration	longNatural	No		1.805		
609-320	Tray 4 Feed Rolls install date	unix timedate - set when	ND	Tray4FeedRollsInstDate	NVMConfiguration	longNatural	No		1.667		

609-321	Tray 4 Feed Rolls replacement counter	Replacements - incremented when user	RW	Tray4FeedRollsRepCount	NVMSystemUsageCounter	natural	No	Unknown	1.426		
609-322	Tray 1 Transport Rolls life counter	Feeds - counted by	RW	Tray1TransportRollsLifeCount	NVMHFSICounter	longNatural	No		1.426		
609-323	Tray 1 Transport Rolls life expectancy	Feeds - adjustable by	RW	Tray1TransportRollsExpLife	NVMConfiguration	longNatural	No		1.426		
609-324	Tray 1 Transport Rolls install date	unix timedate - set when user resets count	ND	Tray1TransportRollsInstDate	NVMConfiguration	longNatural	No		1.667		
609-325	Tray 1 Transport Rolls replacement counter	Replacements - incremented when user resets life counter	RW	Tray1TransportRollsRepCount	NVMSystemUsageCounter	natural	No	Unknown	1.426		
609-326	Tray 2 Transport Rolls life counter	Feeds - counted by system	RW	Tray2TransportRollsLifeCount	NVMHFSICounter	longNatural	No		1.426		
609-327	Tray 2 Transport Rolls life expectancy	Feeds - adjustable by CSE	RW	Tray2TransportRollsExpLife	NVMConfiguration	longNatural	No		1.426		
609-328	Tray 2 Transport Rolls install date	unix timedate - set when user resets count	ND	Tray2TransportRollsInstDate	NVMConfiguration	longNatural	No		1.667		
609-329	Tray 2 Transport Rolls replacement counter	Replacements - incremented when user resets life counter	RW	Tray2TransportRollsRepCount	NVMSystemUsageCounter	natural	No	Unknown	1.426		
609-330	Tray 3/4 Transport Rolls life counter	Feeds - counted by system	RW	Tray3/4TransportRollsLifeCount	NVMHFSICounter	longNatural	No		1.426		
609-331	Tray 3/4 Transport Rolls life expectancy	Feeds - adjustable by CSE	RW	Tray3/4TransportRollsLimit	NVMConfiguration	longNatural	No		1.426		
609-332	Tray 3/4 Transport Rolls install date	unix timedate - set when user resets count	ND	Tray3/4TransportRollsInstDate	NVMConfiguration	longNatural	No		1.667		

609-333	Tray 3/4 Transport Rolls replacement counter	Replacements - incremented when user resets life counter	RW	Tray3/4TransportRollsRepCount	NVMSystemUsageCounter	natural	No	Unknown	1.426		
609-334	Split Drive Rolls life counter	Feeds - counted by system	RW	SplitDriveRollsLifeCount	NVMHFSICounter	longNatural	No		1.426		
609-335	Split Drive Rolls life expectancy	Feeds - adjustable by CSE	RW	SplitDriveRollsExpLife	NVMConfiguration	longNatural	No		1.426		
609-336	Split Drive Rolls install date	unix timedate - set when user resets count	ND	SplitDriveRollsInstDate	NVMConfiguration	longNatural	No		1.667		
609-337	Split Drive Rolls replacement counter	Replacements - incremented when user resets life counter	RW	SplitDriveRollsRepCount	NVMSystemUsageCounter	natural	No	Unknown	1.426		
609-338	Duplex Sensor Rolls life counter	Feeds - counted by system	RW	DuplexSensorRollsLifeCount	NVMHFSICounter	longNatural	No		1.426		
609-339	Duplex Sensor Rolls life expectancy	Feeds - adjustable by CSE	RW	DuplexSensorRollsExpLife	NVMConfiguration	longNatural	No		1.426		

609-340	Duplex Sensor Rolls install date	unix timedate - set when user resets count	ND	DuplexSensorRollsInstDate	NVMConfiguration	longNatural	No		1.667		
609-341	Duplex Sensor Rolls replacement counter	Replacements - incremented when user resets life counter	RW	DuplexSensorRollsRepCount	NVMSystemUsageCounter	natural	No	Unknown	1.426		
609-342	Bias Foam life counter	Feeds - counted by system	RW	BiasFoamLifeCount	NVMHFSICounter	longNatural	No		1.426		
609-343	Bias Foam life expectancy	Feeds - adjustable by CSE	RW	BiasFoamExpLife	NVMConfiguration	longNatural	No		1.434		
609-344	Bias Foam install date	unix timedate - set when user resets count	ND	BiasFoamInstDate	NVMConfiguration	longNatural	No		1.667		
609-345	Bias Foam replacement counter	Replacements - incremented when user resets life counter	RW	BiasFoamRepCount	NVMSystemUsageCounter	natural	No	Unknown	1.426		
609-346	Developer Drive Gear life counter	Feeds - counted by system	RW	DeveloperDriveGearLifeCount	NVMHFSICounter	longNatural	No		1.426		
609-347	Developer Drive Gear life expectancy	Feeds - adjustable by CSE	RW	DeveloperDriveGearExpLife	NVMConfiguration	longNatural	No		1.426		
609-348	Developer Drive Gear install date	unix timedate - set when user resets count	ND	DeveloperDriveGearInstDate	NVMConfiguration	longNatural	No		1.667		
609-349	Developer Drive Gear replacement counter	Replacements - incremented when user resets life counter	RW	DeveloperDriveGearRepCount	NVMSystemUsageCounter	natural	No	Unknown	1.426		

609-350	Post Fuser Rolls life counter	Feeds - counted by system	RW	PostFuserRollsLifeCount	NVMHFSICounter	longNatural	No		1.426		
609-351	Post Fuser Rolls life expectancy	Feeds - adjustable by CSE	RW	PostFuserRollsExpLife	NVMConfiguration	longNatural	No		1.426		
609-352	Post Fuser Rolls install date	unix timedate - set when user resets count	ND	PostFuserRollsInstDate	NVMConfiguration	longNatural	No		1.667		
609-353	Post Fuser Rolls replacement counter	Replacements - incremented when user	RW	PostFuserRollsRepCount	NVMSystemUsageCounter	natural	No	Unknown	1.426		
609-354	HVF Paddle life counter	Feeds - counted by system	RW	HVFPaddleLifeCount	NVMHFSICounter	longNatural	No		1.426		
609-355	HVF Paddle life expectancy	Feeds - adjustable by CSE	RW	HVFPaddleExpLife	NVMConfiguration	longNatural	No		1.434		
609-356	HVF Paddle install date	unix timedate - set when user resets count	ND	HVFPaddleInstDate	NVMConfiguration	longNatural	No		1.667		
609-357	HVF Paddle replacement counter	Replacements - incremented when user resets life counter	RW	HVFPaddleRepCount	NVMSystemUsageCounter	natural	No	Unknown	1.426		
609-358	Fault Counter 12-494-00: BMLELateToBMDetectSensor	no. of faults	RW	BMLELateToBMDetectSensor	NVMFaultCounter	shortNatural	No	Fault Counter:12-494-00:	1.678		
609-359	Fault Counter 12-496-00: BMTELateFromBMDetectSensor	no. of faults	RW	BMTELateFromBMDetectSensor	NVMFaultCounter	shortNatural	No	Fault Counter:12-496-00:	1.678		
609-364	Total since activation date	Total since activation date	ND	LW Cardstock Large Sheets Used	NVMSystemUsageCounter	byteArray	No	System Usage Counter 926: Lightweight Cardstock Large Sheets Used	1.799		
609-368	Total since activation date	Total since activation date	ND	Cardstock Large Sheets Used	NVMSystemUsageCounter	byteArray	No	System Usage Counter 928: Cardstock Large Sheets Used	1.799		
609-372	Total since activation date	Total since activation date	ND	HW Cardstock Large Sheets Used	NVMSystemUsageCounter	byteArray	No	System Usage Counter 930: Heavyweight Cardstock Large	1.799		
609-373	Total since activation date	Total since activation date	ND	HW Cardstock LG Reload Sheets	NVMSystemUsageCounter	byteArray	No	System Usage Counter 931: Heavyweight Cardstock Reloaded	1.799		
609-374	Stores local density adjustment for DC1037	Degrees (Range -3 to +3)	RW	Density Adjustment	NVMSAKOSetting	shortInteger	No		1.513		
609-375	Fault Counter 12-352-00: BMSTAPLEHEAD1PRIMINGFAULT	no. of faults	RW	BMSTAPLEHEAD1PRIMINGFAULT	NVMFaultCounter	shortNatural	No	Fault Counter:12-352-00: BMSTAPLEHEAD1PRI	1.515		
609-376	Fault Counter 12-353-00: BMSTAPLEHEAD2PRIMINGFAULT	no. of faults	RW	BMSTAPLEHEAD2PRIMINGFAULT	NVMFaultCounter	shortNatural	No	Fault Counter:12-353-00: BMSTAPLEHEAD2PRI	1.515		

609-377	Fault Counter 61-100-00: LEDPRINTEADDDATAINTEGRITYFAILURE	no. of faults	RW	LEDPRINTEADDDATAINTEGRITYFAILURE	NVMFaultCounter	shortNatural	No	Fault Counter:61-100-00: LEDPRINTEADDDATA	1.515		
609-378	Fault Counter 10-702-00: OFFSETCENTRETRAYMOTORFAILURE	no. of faults	RW	OFFSETCENTRETRAYMOTORFAILURE	NVMFaultCounter	shortNatural	No	Fault Counter:10-702-00: OFFSETCENTRETRA	1.515		
609-379	Fault Counter 93-364-00: TCNOTINRANGEFAULT	no. of faults	RW	TCNOTINRANGEFAULT	NVMFaultCounter	shortNatural	No	Fault Counter:93-364-00: TCNOTINRANGEFAU	1.515		
609-380	Fault Counter 10-170-00: LELATETO HORIZONTALTRANSPORT	no. of faults	RW	LELATETO HORIZONTALTRANSPORT	NVMFaultCounter	shortNatural	No	Fault Counter:10-170-00: LELATETO HORIZONTAL	1.515		
609-381	Fault Counter 10-171-00: TELATEFROMHORIZONTALTRANSPORT	no. of faults	RW	TELATEFROMHORIZONTALTRANSPORT	NVMFaultCounter	shortNatural	No	Fault Counter:10-171-00: TELATEFROMHORIZ	1.515		
609-382	Fault Counter 10-338-00: HORIZONTALTRANSPORTOPENINRUN	no. of faults	RW	HORIZONTALTRANSPORTOPENINRUN	NVMFaultCounter	shortNatural	No	Fault Counter:10-338-00: HORIZONTALTRANSPORTOPENINRUN	1.515		
609-383	Fault Counter 81-151-00: LELATETO REGSENSORSIMPLEX	no. of faults	RW	LELATETO REGSENSORSIMPLEX	NVMFaultCounter	shortNatural	No	Fault Counter:81-151-00: LELATETO REGSENS	1.515		
609-384	Fault Counter 81-152-00:	no. of faults	RW	LELATETO REGSENSORSIMPLEX	NVMFaultCounter	shortNatural	No	Fault Counter:81-152-	1.515		
609-385	Fault Counter 10-153-00:	no. of faults	RW	LELATETOPOSTFUSERSENSORSIMPLEX	NVMFaultCounter	shortNatural	No	Fault Counter:10-153-	1.515		
609-386	Fault Counter 10-154-00: TELATEPOSTFUSERSENSORSIMPLEX	no. of faults	RW	TELATEPOSTFUSERSENSORSIMPLEX	NVMFaultCounter	shortNatural	No	Fault Counter:10-154-00:	1.515		
609-387	Fault Counter 83-155-00: LELATETODUPLEXSENSOR	no. of faults	RW	LELATETODUPLEXSENSOR	NVMFaultCounter	shortNatural	No	Fault Counter:83-155-00:	1.515		
609-388	Fault Counter 83-156-00: TELATETODUPLEXSENSOR	no. of faults	RW	TELATETODUPLEXSENSOR	NVMFaultCounter	shortNatural	No	Fault Counter:83-156-00: TELATETODUPLEXSENSOR	1.515		
609-389	Fault Counter 81-136-00: LELATETOFEEDHCFLH	no. of faults	RW	LELATETOFEEDHCFLH	NVMFaultCounter	shortNatural	No	Fault Counter:81-136-00: LELATETOFEEDHCFL	1.515		
609-390	Fault Counter 81-137-00: TELATETOFEEDHCFLH	no. of faults	RW	TELATETOFEEDHCFLH	NVMFaultCounter	shortNatural	No	Fault Counter:81-137-00: TELATETOFEEDHCF	1.515		
609-391	Fault Counter 81-159-00: LELATETOHCXFEXITFROMTRAY3	no. of faults	RW	LELATETOHCXFEXITFROMTRAY3	NVMFaultCounter	shortNatural	No	Fault Counter:81-159-00: LELATETOHCXFEXITF	1.515		
609-392	Fault Counter 81-160-00: TELATETOFEEDERRHTARSENSOR	no. of faults	RW	TELATETOFEEDERRHTARSENSOR	NVMFaultCounter	shortNatural	No	Fault Counter:81-160-00: TELATETOFEEDERR	1.515		
609-393	Fault Counter 81-146-00: LELATETOFEEDHCFRH	no. of faults	RW	LELATETOFEEDHCFRH	NVMFaultCounter	shortNatural	No	Fault Counter:81-146-00:	1.515		
609-394	Fault Counter 81-147-00: TELATETOFEEDHCFRH	no. of faults	RW	TELATETOFEEDHCFRH	NVMFaultCounter	shortNatural	No	Fault Counter:81-147-00:	1.515		

609-395	Fault Counter 81-106-00: LELATETOTAR1SENSORFROMTRAY1	no. of faults	RW	LELATETOTAR1SENSORFROMTRAY1	NVMFaultCounter	shortNatural	No	Fault Counter:81-106-00: LELATETOTAR1SENSORFROMTRAY1	1.515		
609-396	Fault Counter 81-126-00:	no. of faults	RW	LELATETOTAR2SENSORFROMTRAY1	NVMFaultCounter	shortNatural	No	Fault Counter:81-126-00:	1.515		
609-397	Fault Counter 81-107-00: TELATETOTAR1SENSORFROMTRAY1	no. of faults	RW	TELATETOTAR1SENSORFROMTRAY1	NVMFaultCounter	shortNatural	No	Fault Counter:81-107-00: TELATETOTAR1SEN	1.515		
609-398	Fault Counter 81-127-00: TELATETOTAR2SENSORFROMTRAY2	no. of faults	RW	TELATETOTAR2SENSORFROMTRAY2	NVMFaultCounter	shortNatural	No	Fault Counter:81-127-00: TELATETOTAR2SEN	1.515		
609-399	Fault Counter 10-400-00: FRUMISSINGORCOMMSFAILUREFAULT	no. of faults	RW	FRUMISSINGORCOMMSFAILUREFAULT	NVMFaultCounter	shortNatural	No	Fault Counter:10-400-00: FRUMISSINGORCOM	1.515		
609-400	Fault Counter 92-400-00: PCMISSINGORCOMMSFAILUREFAULT	no. of faults	RW	PCMISSINGORCOMMSFAILUREFAULT	NVMFaultCounter	shortNatural	No	Fault Counter:92-400-00: PCMISSINGORCOMM	1.515		
609-401	Fault Counter 10-163-00: LELATETOPOSTFUSERSENSORDUPL X	no. of faults	RW	LELATETOPOSTFUSERSENSORDUPL X	NVMFaultCounter	shortNatural	No	Fault Counter:10-163-00: LELATETOPOSTFUS ERSENSORDUPL X	1.515		
609-402	Fault Counter 10-164-00: TELATETOPOSTFUSERSENSORDUPL X	no. of faults	RW	TELATETOPOSTFUSERSENSORDUPL X	NVMFaultCounter	shortNatural	No	Fault Counter:10-164-00: TELATETOPOSTFUS ERSENSORDUPL X	1.515		
609-403	Fault Counter 71-217-00: TRAY1BUMPUPFAILURE	no. of faults	RW	TRAY1BUMPUPFAILURE	NVMFaultCounter	shortNatural	No	Fault Counter:71-217-00: TRAY1BUMPUPFAILU RE	1.515		
609-404	Fault Counter 81-161-00: LELATETOREGSENSORDUPL X	no. of faults	RW	LELATETOREGSENSORDUPL X	NVMFaultCounter	shortNatural	No	Fault Counter:81-161-00: LELATETOREGSENS	1.515		
609-405	Fault Counter 81-162-00: TELATETOREGSENSORDUPL X	no. of faults	RW	TELATETOREGSENSORDUPL X	NVMFaultCounter	shortNatural	No	Fault Counter:81-162-00: TELATETOREGSENS ORDUPL X	1.515		
609-406	Fault Counter 81-167-00: LELATETOHCFTTRANSPORT	no. of faults	RW	LELATETOHCFTTRANSPORT	NVMFaultCounter	shortNatural	No	Fault Counter:81-167-00: LELATETOHCFTTRAN SPORT	1.515		

609-407	SPARED (was Fault Counter 81-168-00: TELATETOHCFTTRANSPORT)	no. of faults	ND	SPARE 609-407	NVMFaultCounter	shortNatural	No	Fault Counter:81-168-00: TELATETOHCFTTRANSPORT	1.515		
609-408	Fault Counter 10-399-00: FUSERINCOMPATIBLEFAULT	no. of faults	RW	FUSERINCOMPATIBLEFAULT	NVMFaultCounter	shortNatural	No	Fault Counter:10-399-00: FUSERINCOMPATIBLEFAULT	1.515		
609-409	Fault Counter 10-340-00: FUSERTEMPERATUREREADINGFAILURE	no. of faults	RW	FUSERTEMPERATUREREADINGFAILURE	NVMFaultCounter	shortNatural	No	Fault Counter:10-340-00: FUSERTEMPERATUREREADINGFAILURE	1.515		
609-410	Fault Counter 81-155-00: LELATETOREGSENSORFROMTRAY5	no. of faults	RW	LELATETOREGSENSORFROMTRAY5	NVMFaultCounter	shortNatural	No	Fault Counter:81-155-00: LELATETOREGSENSORFROMTRAY5	1.515		
609-411	Fault Counter 93-401-00: TONEBOTTLERMISSINGFAULT	no. of faults	RW	TONEBOTTLERMISSINGFAULT	NVMFaultCounter	shortNatural	No	Fault Counter:93-401-00: TONEBOTTLERMISSINGFAULT	1.515		
609-412	Fault Counter 93-399-00: TONERCARTRIDGEINCOMPATIBLEFAULT	no. of faults	RW	TONERCARTRIDGEINCOMPATIBLEFAULT	NVMFaultCounter	shortNatural	No	Fault Counter:93-399-00: TONERCARTRIDGEINCOMPATIBLEFAULT	1.515		
609-413	Fault Counter 93-365-00: HIGHACMODERECOVERYFAULT	no. of faults	RW	HIGHACMODERECOVERYFAULT	NVMFaultCounter	shortNatural	No	Fault Counter:93-365-00: HIGHACMODERECOVERYFAULT	1.515		
609-414	Fault Counter 81-190-00: LELATETOREGFROMTRAY1	no. of faults	RW	LELATETOREGFROMTRAY1	NVMFaultCounter	shortNatural	No	Fault Counter:81-190-00: LELATETOREGFROMTRAY1	1.515		
609-415	Fault Counter 81-191-00: LELATETOREGFROMTRAY2	no. of faults	RW	LELATETOREGFROMTRAY2	NVMFaultCounter	shortNatural	No	Fault Counter:81-191-00: LELATETOREGFROMTRAY2	1.515		
609-416	Fault Counter 81-192-00: LELATETOREGFROMTRAY3	no. of faults	RW	LELATETOREGFROMTRAY3	NVMFaultCounter	shortNatural	No	Fault Counter:81-192-00: LELATETOREGFROMTRAY3	1.515		
609-417	Fault Counter 81-193-00: LELATETOREGFROMTRAY4	no. of faults	RW	LELATETOREGFROMTRAY4	NVMFaultCounter	shortNatural	No	Fault Counter:81-193-00: LELATETOREGFROMTRAY4	1.515		
609-418	Fault Counter 81-194-00: LELATETOTAR1FROMTRAY2	no. of faults	RW	LELATETOTAR1FROMTRAY2	NVMFaultCounter	shortNatural	No	Fault Counter:81-194-00: LELATETOTAR1FROMTRAY2	1.515		
609-419	Fault Counter 81-195-00: LELATETOTAR1FROMTRAY3	no. of faults	RW	LELATETOTAR1FROMTRAY3	NVMFaultCounter	shortNatural	No	Fault Counter:81-195-00: LELATETOTAR1FROMTRAY3	1.515		

609-420	Fault Counter 81-196-00: LELATETOTAR1FROMTRAY4	no. of faults	RW	LELATETOTAR1FROMTRAY4	NVMFaultCounter	shortNatural	No	Fault Counter:81-196-00: LELATETOTAR1FRO	1.515		
609-421	Fault Counter 81-197-00: LELATETOTAR2FROMTRAY3	no. of faults	RW	LELATETOTAR2FROMTRAY3	NVMFaultCounter	shortNatural	No	Fault Counter:81-197-00: LELATETOTAR2FRO	1.515		
609-422	Fault Counter 81-198-00: LELATETOTAR2FROMTRAY4	no. of faults	RW	LELATETOTAR2FROMTRAY4	NVMFaultCounter	shortNatural	No	Fault Counter:81-198-00: LELATETOTAR2FRO	1.515		
609-423	Fault Counter 81-199-00: LELATETOHCXFEXITFROMTRAY4	no. of faults	RW	LELATETOHCXFEXITFROMTRAY4	NVMFaultCounter	shortNatural	No	Fault Counter:81-199-00: LELATETOHCXFEXITF	1.515		
609-424	Fault Counter 81-200-00: UNEXPECTEDSHEETATREG	no. of faults	RW	UNEXPECTEDSHEETATREG	NVMFaultCounter	shortNatural	No	Fault Counter:81-200-00: UNEXPECTEDSHEET ATREG	1.515		
609-425	Fault Counter 10-201-00: UNEXPECTEDSHEETATPOSTFUSER	no. of faults	RW	UNEXPECTEDSHEETATPOSTFUSER	NVMFaultCounter	shortNatural	No	Fault Counter:10-201-00: UNEXPECTEDSHEET ATPOSTFUSER	1.678		
609-426	Fault Counter 83-157-00: UNEXPECTEDSHEETATDUPLEX	no. of faults	RW	UNEXPECTEDSHEETATDUPLEX	NVMFaultCounter	shortNatural	No	Fault Counter:83-157-00: UNEXPECTEDSHEET	1.515		
609-427	Fault Counter 10-172-00: UNEXPECTEDSHEETATFINXPOR	no. of faults	RW	UNEXPECTEDSHEETATFINXPOR	NVMFaultCounter	shortNatural	No	Fault Counter:10-172-00: UNEXPECTEDSHEET ATFINXPOR	1.515		
609-428	Fault Counter 75-100-00: TRAY5(MSI)HOISTFAILURE	no. of faults	RW	TRAY5(MSI)HOISTFAILURE	NVMFaultCounter	shortNatural	No	Fault Counter:75-100-00: TRAY5(MSI)HOISTFAI LURE	1.515		
609-429	Fault Counter 03-800-00: FINISHERCOMMSRESETAFTERACRASH	no. of faults	RW	FINISHERCOMMSRESETAFTERACRASH	NVMFaultCounter	shortNatural	No	Fault Counter:03-800-00: FINISHERCOMMSRE SETAFTERACRASH	1.678		
609-430	Fault Counter 12-984-00: BOOKLETLOWSTAPLEFRONTFAULTCOUNT	no. of faults	RW	BOOKLETLOWSTAPLEFRONTFAULTCOUNT	NVMFaultCounter	shortNatural	No	Fault Counter:12-984-00: BOOKLETLOWSTAPL EFRONTFAULTCOUN T	1.813		
609-431	Fault Counter 12-989-00: BOOKLETLOWSTAPLEREARFAULTCOUNT	no. of faults	RW	BOOKLETLOWSTAPLEREARFAULTCOUNT	NVMFaultCounter	shortNatural	No	Fault Counter:12-989-00: BOOKLETLOWSTAPL EREARFAULTCOUNT	1.813		

609-432	Fault Counter 12-130-00: FOLDERPATHSNR1ONJAMFAULTCOUNT	no. of faults	RW	FOLDERPATHSNR1ONJAMFAULTCOUNT	NVMFaultCounter	shortNatural	No	Fault Counter:12-130-00: FOLDERPATHSNR1ONJAMFAULTCOUNT	1.813		
609-433	Fault Counter 12-131-00: COMPILEEXITSNRONJAMBUFFERFAULTCOUNT	no. of faults	RW	COMPILEEXITSNRONJAMBUFFERFAULTCOUNT	NVMFaultCounter	shortNatural	No	Fault Counter:12-131-00: COMPILEEXITSNRONJAMBUFFERFAULTCOUNT	1.813		
609-434	Fault Counter 12-135-00: COMPILEEXITSNRONJAMSTRBUFFERFAULTCOUNT	no. of faults	RW	COMPILEEXITSNRONJAMSTRBUFFERFAULTCOUNT	NVMFaultCounter	shortNatural	No	Fault Counter:12-135-00: COMPILEEXITSNRONJAMSTRBUFFERFAULTCOUNT	1.813		
609-435	Fault Counter 12-136-00: FOLDEREXITSNRONJAMFOLDFAULTCOUNT	no. of faults	RW	FOLDEREXITSNRONJAMFOLDFAULTCOUNT	NVMFaultCounter	shortNatural	No	Fault Counter:12-136-00: FOLDEREXITSNRONJAMFOLDFAULTCOUNT	1.813		
609-436	Fault Counter 12-222-00: UPENDGUIDEHOMESNROFFFAILFAULTCOUNT	no. of faults	RW	UPENDGUIDEHOMESNROFFFAILFAULTCOUNT	NVMFaultCounter	shortNatural	No	Fault Counter:12-222-00: UPENDGUIDEHOMESNROFFFAILFAULTCOUNT	1.813		
609-437	Fault Counter 12-274-00: LOWENDGUIDEHOMESNROFFFAILFAULTCOUNT	no. of faults	RW	LOWENDGUIDEHOMESNROFFFAILFAULTCOUNT	NVMFaultCounter	shortNatural	No	Fault Counter:12-274-00: LOWENDGUIDEHOMESNROFFFAILFAULTCOUNT	1.813		
609-438	Fault Counter 12-279-00: UPENDGUIDEHOMESNRONFAILFAULTCOUNT	no. of faults	RW	UPENDGUIDEHOMESNRONFAILFAULTCOUNT	NVMFaultCounter	shortNatural	No	Fault Counter:12-279-00: UPENDGUIDEHOMESNRONFAILFAULTCOUNT	1.813		
609-439	Fault Counter 12-288-00: LOWENDGUIDEHOMESNRONFAILFAULTCOUNT	no. of faults	RW	LOWENDGUIDEHOMESNRONFAILFAULTCOUNT	NVMFaultCounter	shortNatural	No	Fault Counter:12-288-00: LOWENDGUIDEHOMESNRONFAILFAULTCOUNT	1.813		
609-440	Fault Counter 12-289-00: FOLDERFANBROKENFAILFAULTCOUNT	no. of faults	RW	FOLDERFANBROKENFAILFAULTCOUNT	NVMFaultCounter	shortNatural	No	Fault Counter:12-289-00: FOLDERFANBROKENFAILFAULTCOUNT	1.813		
609-441	Fault Counter 12-290-00: INTERLOCK24VDISCONNECTFAULTCOUNT	no. of faults	RW	INTERLOCK24VDISCONNECTFAULTCOUNT	NVMFaultCounter	shortNatural	No	Fault Counter:12-290-00: INTERLOCK24VDISCONNECTFAULTCOUNT	1.813		
609-442	Fault Counter 12-292-00: BOOKLETTAMPERHOMESNRONFAILFAULTCOUNT	no. of faults	RW	BOOKLETTAMPERHOMESNRONFAILFAULTCOUNT	NVMFaultCounter	shortNatural	No	Fault Counter:12-292-00: BOOKLETTAMPERHOMESNRONFAILFAULTCOUNT	1.813		
609-443	Fault Counter 12-297-00: BOOKLETTAMPERHOMESNROFFFAILFAULTCOUNT	no. of faults	RW	BOOKLETTAMPERHOMESNROFFFAILFAULTCOUNT	NVMFaultCounter	shortNatural	No	Fault Counter:12-297-00: BOOKLETTAMPERHOMESNROFFFAILFAULTCOUNT	1.813		

609-444	Fault Counter 12-298-00: FOLDERSUBCPUCOMMFAILFAULTCOU	no. of faults	RW	FOLDERSUBCPUCOMMFAILFAULT	NVMFaultCounter	shortNatural	No	Fault Counter:12-298-00:	1.813		
609-445	Fault Counter 12-299-00: COMPILENOPAPERSNRONFAILFAULTC	no. of faults	RW	COMPILENOPAPERSNRONFAILFAI	NVMFaultCounter	shortNatural	No	Fault Counter:12-299-00:	1.813		
609-446	Fault Counter 12-319-00: BOOKLETSCPUDOWNLOADMODEFAI LFAULTCOUNT	no. of faults	RW	BOOKLETSCPUDOWNLOADMODEFAI	NVMFaultCounter	shortNatural	No	Fault Counter:12-319-00: BOOKLETSCPUDOWN LOADMODEFAILF AULTCOUNT	1.813		
609-447	Fault Counter 12-326-00: FOLDERSUBCPUDOWNLOADMODEFAI	no. of faults	RW	FOLDERCPUDOWNLOADMODEFAI	NVMFaultCounter	shortNatural	No	Fault Counter:12-326-00:	1.813		
609-448	Fault Counter 12-912-00: FINISHERSTATICJAMFAULTCOUNT	no. of faults	RW	FINISHERSTATICJAMFAULTCOUN	NVMFaultCounter	shortNatural	No	Fault Counter:12-912-00:	1.813		
609-449	Fault Counter 13-300-00: FOLDERFRONTDOOROPENFAULTCOU	no. of faults	RW	FOLDERFRONTDOOROPENFAULT	NVMFaultCounter	shortNatural	No	Fault Counter:13-300-00:	1.813		
609-450	Punch errors	Punch errors	RO	Punch errors	NVMSystemUsageCounter	longNatural	No	System Usage Counter:933:	1.813		
609-455	Defines the period of time before beeping occurs when left side door is open.	seconds	RW	LSDOpenTimeBeforeBeep	NVMConfiguration	shortNatural	No		1.529		
609-456	Enables/Disables 3mm border on print	0= disable border, 1= enable border (default)	RW	IMAGEBORDERENABLE	NVMSAKOSetting	boolean	No		1.535		
609-457	Fault Counter 91-377: PC cooling event	no. of faults	RW	PcCoolingEventFC	NVMFaultCounter	shortNatural	No	Fault Counter:91-377-00: PcCoolingEvent	1.697		
609-459	Lead Edge Registration		RW	LE Registration	NVMMachVarRegistration	integer	No		1.543		
609-469	Provides capability for manufacturing to adjust color registration and also allows a CSE to set it via DC131.		RW	ManRegiConLeftYellow	NVMMachVarRegistration	shortInteger	No		1.565		
609-470	Provides capability for manufacturing to adjust color registration and also allows a CSE to set it via DC131.		RW	ManRegiConLeftMagenta	NVMMachVarRegistration	shortInteger	No		1.565		
609-471	Provides capability for manufacturing to adjust color registration and also allows a CSE to set it via DC131.		RW	ManRegiConLeftCyan	NVMMachVarRegistration	shortInteger	No		1.565		
609-472	Provides capability for manufacturing to adjust color registration and also allows a CSE to set it via DC131.		RW	ManRegiConRightYellow	NVMMachVarRegistration	shortInteger	No		1.565		
609-473	Provides capability for manufacturing to adjust color registration and also allows a CSE to set it via DC131.		RW	ManRegiConRightMagenta	NVMMachVarRegistration	shortInteger	No		1.565		
609-474	Provides capability for manufacturing to adjust color registration and also allows a CSE to set it via DC131.		RW	ManRegiConRightCyan	NVMMachVarRegistration	shortInteger	No		1.565		
609-475	Provides capability for manufacturing to adjust color registration and also allows a CSE to set it via DC131.		RW	ManRegiConProcessLeftYellow	NVMMachVarRegistration	shortInteger	No		1.565		
609-476	Provides capability for manufacturing to adjust color registration and also allows a CSE to set it via DC131.		RW	ManRegiConProcessLeftMagenta	NVMMachVarRegistration	shortInteger	No		1.565		
609-477	Provides capability for manufacturing to adjust color registration and also allows a CSE to set it via DC131.		RW	ManRegiConProcessLeftCyan	NVMMachVarRegistration	shortInteger	No		1.565		
609-478	Provides capability for manufacturing to adjust color registration and also allows a CSE to set it via DC131.		RW	ManRegiConProcessRightYellow	NVMMachVarRegistration	shortInteger	No		1.565		

609-479	Provides capability for manufacturing to adjust color registration and also allows a CSE to set it via DC131.		RW	ManRegiConProcessRightMagenta	NVMMachVarRegistration	shortInteger	No		1.565		
609-480	Provides capability for manufacturing to adjust color registration and also allows a CSE to set it via DC131.		RW	ManRegiConProcessRightCyan	NVMMachVarRegistration	shortInteger	No		1.565		
609-481	Fault Counter 81-132-00: LELATETOHCXFEXITSENSORFROMTRAY3	no. of faults	RW	LELATETOHCXFEXITSENSORFROMTRAY3	NVMFaultCounter	shortNatural	No	Fault Counter:81-132-00: LELATETOHCXFEXITSENSORFROMTRAY3	1.573		
609-482	Fault Counter 81-133-00: LELATETOHCXFEXITSENSORFROMTRAY4	no. of faults	RW	LELATETOHCXFEXITSENSORFROMTRAY4	NVMFaultCounter	shortNatural	No	Fault Counter:81-133-00: LELATETOHCXFEXITSENSORFROMTRAY4	1.573		
609-483	Fault Counter 93-974-00: GENUINETONERNULLSTRINGCOUNTERK		RO	NullStringCounterK	NVMFaultCounter	shortNatural	No	Fault Counter:93-974-00: GENUINETONERNULLSTRINGCOUNTERK	1.584		
609-484	Fault Counter 93-975-00: GENUINETONERNULLSTRINGCOUNTERC		RO	NullStringCounterC	NVMFaultCounter	shortNatural	No	Fault Counter:93-975-00: GENUINETONERNULLSTRINGCOUNTERC	1.810		
609-485	Fault Counter 93-976-00: GENUINETONERNULLSTRINGCOUNTERM		RO	NullStringCounterM	NVMFaultCounter	shortNatural	No	Fault Counter:93-976-00: GENUINETONERNULLSTRINGCOUNTERM	1.810		
609-486	Fault Counter 93-974-00: GENUINETONERNULLSTRINGCOUNTERY		RO	NullStringCounterY	NVMFaultCounter	shortNatural	No	Fault Counter:93-974-00: GENUINETONERNULLSTRINGCOUNTERY	1.810		
609-487	Fault Counter 93-974-00: GENUINETONERNONXEROXSTRINGCOUNTERK		RO	NonGenuineStringCounterK	NVMFaultCounter	shortNatural	No	Fault Counter:93-974-00: GENUINETONERNONXEROXSTRINGCOUNTERK	1.584		
609-488	Fault Counter 93-974-00: GENUINETONERNONXEROXSTRINGCOUNTERC		RO	NonGenuineStringCounterC	NVMFaultCounter	shortNatural	No	Fault Counter:93-974-00: GENUINETONERNONXEROXSTRINGCOUNTERC	1.810		
609-489	Fault Counter 93-974-00: GENUINETONERNONXEROXSTRINGCOUNTERM		RO	NonGenuineStringCounterM	NVMFaultCounter	shortNatural	No	Fault Counter:93-974-00: GENUINETONERNONXEROXSTRINGCOUNTERM	1.810		
609-490	Fault Counter 93-974-00: GENUINETONERNONXEROXSTRINGCOUNTERY		RO	NonGenuineStringCounterY	NVMFaultCounter	shortNatural	No	Fault Counter:93-974-00: GENUINETONERNONXEROXSTRINGCOUNTERY	1.810		
609-491	IOTCommunicationsTimeout If the IOT fails to respond within the period defined by this NVM then communication	Timer in milliseconds	RW	IOTCommunicationsTimeout	NVMcrashRecoveryType	natural	No		1.589		
609-492	Fault Counter 81-180-00: LELATETOTAR1FROMTRAY6	no. of faults	RW	LELateToTAR1FromTray6	NVMFaultCounter	shortNatural	No	Fault Counter:81-180-00: LELATETOTAR1FROMTRAY6	1.616		
609-493	Fault Counter 81-182-00: LELATETOREGFROMTRAY6	no. of faults	RW	LELateToRegFromTray6	NVMFaultCounter	shortNatural	No	Fault Counter:81-182-00: LELATETOREGFROMTRAY6	1.616		
609-494	Fault Counter 81-184-00: LELATETOFEEDTRAY6	no. of faults	RW	LELateToFEEDTray6	NVMFaultCounter	shortNatural	No	Fault Counter:81-184-00: LELATETOFEEDTRAY6	1.616		
609-496	Enable JobOffset policy	Enable JobOffset policy 0=Off 1=On	RW	MSJobOffsetEnabledPolicy	NVMSAKOSetting	boolean	No		1.754		

609-497	Tray 1 detected width Min	Range and default size in mm	RW	Tray 1 detected width Min	NVMSAKOSetting	natural	No		1.669		
609-498	Tray 1 detected width Max	Range and default size in mm	RW	Tray 1 detected width Max	NVMSAKOSetting	natural	No		1.669		
609-499	Tray 1 detected Length Min	Range and default size in mm	RW	Tray 1 detected Length Min	NVMSAKOSetting	natural	No		1.669		
609-500	Tray 1 detected Length Max	Range and default size in mm	RW	Tray 1 detected Length Max	NVMSAKOSetting	natural	No		1.669		
609-501	Tray 2 detected width Min	Range and default size in mm	RW	Tray 2 detected width Min	NVMSAKOSetting	natural	No		1.669		
609-502	Tray 2 detected width Max	Range and default size in mm	RW	Tray 2 detected width Max	NVMSAKOSetting	natural	No		1.669		
609-503	Tray 2 detected Length Min	Range and default size in mm	RW	Tray 2 detected Length Min	NVMSAKOSetting	natural	No		1.669		
609-504	Tray 2 detected Length Max	Range and default size in mm	RW	Tray 2 detected Length Max	NVMSAKOSetting	natural	No		1.669		
609-505	Tray 3 detected width Min	Range and default size in mm	RW	Tray 3 detected width Min	NVMSAKOSetting	natural	No		1.669		
609-506	Tray 3 detected width Max	Range and default size in mm	RW	Tray 3 detected width Max	NVMSAKOSetting	natural	No		1.669		
609-507	Tray 3 detected Length Min	Range and default size in mm	RW	Tray 3 detected Length Min	NVMSAKOSetting	natural	No		1.669		
609-508	Tray 3 detected Length Max	Range and default size in mm	RW	Tray 3 detected Length Max	NVMSAKOSetting	natural	No		1.669		
609-509	Tray 4 detected width Min	Range and default size in mm	RW	Tray 4 detected width Min	NVMSAKOSetting	natural	No		1.669		

609-510	Tray 4 detected width Max	Range and default size in mm	RW	Tray 4 detected width Max	NVMSAKOSetting	natural	No		1.669		
609-511	Tray 4 detected Length Min	Range and default size in mm	RW	Tray 4 detected Length Min	NVMSAKOSetting	natural	No		1.669		
609-512	Tray 4 detected Length Max	Range and default size in mm	RW	Tray 4 detected Length Max	NVMSAKOSetting	natural	No		1.669		
609-513	Tray 5 detected Length Min	Range and default size in mm	RW	Tray 5 detected Length Min	NVMSAKOSetting	natural	No		1.669		
609-514	Tray 5 detected Length Max	Range and default size in mm	RW	Tray 5 detected Length Max	NVMSAKOSetting	natural	No		1.669		

609-515	Tray 7 detected width	Range and default size in mm	RW	Tray 7 Last detected width	NVMSAKOSetting	natural	No		1.669		
609-516	Tray 7 detected Length	Range and default size in mm	RW	Tray 7 Last detected Length	NVMSAKOSetting	natural	No		1.669		
609-518	Fault Counter 03-450:IOT crash unexpectedly	no of faults	RW	Fault Counter 03-450	NVMFaultCounter	shortNatural	No	Fault Counter:03-450-00: IOTCRASHCOUNT	1.658		
609-519	Fault Counter 74-900:Tray4SheetOverFeedFault	no of faults	RW	Fault Counter 74-900	NVMFaultCounter	shortNatural	No	Fault Counter:74-900-00: TRAY4SHEETOVERFEEDSNRCOUNT	1.664		

609-520	Fault Counter 76-900: Tray6SheetOverFeedFault	no.of faults	RW	Fault Counter 76-900	NVMFaultCounter	shortNatural	No	Fault Counter:76-900-00: TRAY6SHEETOVERFEEDSNRCOUNT	1.664		
609-521	Transport Drive Belt replacement counter	Replacements - incremented when user	RW	TransportDriveBeltRepCount	NVMSystemUsageCounter	natural	No	Unknown	1.677		
609-522	Transport Roll replacement counter	Replacements -	RW	TransportRollRepCount	NVMSystemUsageCounter	natural	No	Unknown	1.677		
609-523	Drive Pulley replacement counter	Replacements - incremented when user	RW	DrivePulleyRepCount	NVMSystemUsageCounter	natural	No	Unknown	1.677		
609-524	Pressure Blade replacement counter	Replacements -	RW	PressureBladeRepCount	NVMSystemUsageCounter	natural	No	Unknown	1.677		
609-525	Transport Drive Belt Life Counter	Feeds - counted by system	RW	TransportDriveBeltLifeCount	NVMHFSICounter	longNatural	No	Unknown	1.677		
609-526	Transport Drive Belt Life Expectancy	Modifiable via DC131	RW	TransportDriveBeltExpLife	NVMConfiguration	longNatural	No	Unknown	1.677		
609-527	Transport Drive Belt Install Date	Transport Belt install date	ND	TransportDriveBeltInstallDate	NVMConfiguration	longNatural	No	Unknown	1.677		
609-528	Transport Roll Life Counter	Feeds - counted by system	RW	TransportRollLifeCount	NVMHFSICounter	longNatural	No	Unknown	1.677		
609-529	Transport Roll Life Expectancy	Modifiable via DC131	RW	TransportRollExpLife	NVMConfiguration	longNatural	No	Unknown	1.677		
609-530	Transport Roll Install Date	Transport Belt install date	ND	TransportRollInstallDate	NVMConfiguration	longNatural	No	Unknown	1.677		
609-531	Drive Pulley Life Counter	Feeds - counted by	RW	DrivePulleyLifeCount	NVMHFSICounter	longNatural	No	Unknown	1.677		
609-532	Drive Pulley Life Expectancy	Modifiable via DC131	RW	DrivePulleyExpLife	NVMConfiguration	longNatural	No	Unknown	1.677		

609-533	Drive Pulley Install Date	Transport Belt install date	ND	DrivePulleyInstallDate	NVMConfiguration	longNatural	No	Unknown	1.677		
609-534	Pressure Blade Life Counter	Feeds - counted by	RW	PressureBladeLifeCount	NVMHFSICounter	longNatural	No	Unknown	1.677		
609-535	Pressure Blade Life Expectancy	Modifiable via DC131	RW	PressureBladeExpLife	NVMConfiguration	longNatural	No	Unknown	1.677		
609-536	Pressure Blade Install Date	Transport Belt install date	ND	PressureBladeInstallDate	NVMConfiguration	longNatural	No	Unknown	1.677		
609-537	Fault Counter 72-217-00: TRAY2BUMPUPFAILURE	no. of faults	RW	TRAY2BUMPUPFAILURE	NVMFaultCounter	shortNatural	No	Fault Counter:72-217-00: T2BUMPUPFAILUREC OUNT	1.678		
609-538	Fault Counter 73-217-00: TRAY3BUMPUPFAILURE	no. of faults	RW	TRAY3BUMPUPFAILURE	NVMFaultCounter	shortNatural	No	Fault Counter:73-217-00: T3BUMPUPFAILUREC OUNT	1.678		
609-539	Fault Counter 74-217-00: TRAY4BUMPUPFAILURE	no. of faults	RW	TRAY4BUMPUPFAILURE	NVMFaultCounter	shortNatural	No	Fault Counter:74-217-00: T4BUMPUPFAILUREC OUNT	1.678		
609-540	Fault Counter 10-316: Fuser T1 or T2	no. of faults	RW	FUSERT1ORT2EXCEED250DEGC	NVMFaultCounter	shortNatural	No	Fault Counter:10-316-	1.810		
609-541	Fault Counter 10-317: Fuser T1 or T2 sensor reached or exceeded soft cycle out	no. of faults	RW	FUSERT1ORT2BEYONDCYCLOUT THRSHLD	NVMFaultCounter	shortNatural	No	Fault Counter:10-317-00:	1.679		
609-542	Fault Counter 10-318: Fuser T1 or T2 have not dropped to run temperature after	no. of faults	RW	FUSERT1ORT2NOTATRUNTMPAF TRCOOLNG	NVMFaultCounter	shortNatural	No	Fault Counter:10-318-00:	1.679		
609-543	Fault Counter 91-379: PC cooling event timeout	no. of faults	RW	PcCoolingTimeoutFC	NVMFaultCounter	shortNatural	No	Fault Counter:91-379-00: PcCoolingTimeout	1.697		
609-545	Enable OCT offset policy	Enable OCT Offset policy 0=Off	RW	OCT offset enablement	NVMSAKOSetting	boolean	No		1.761		
609-546	Plain paper type setting	KisyuPlainTypes PlainA = 0,	RW	Plain paper type setting	NVMConfiguration	shortNatural	No		1.741		
610-005	Auto Contrast level for platen		RW	Copy Auto Contrast Level Platen	NVMSAKOSetting	shortNatural	No		1.807		
610-006	Auto Contrast level for DADH		RW	Copy Auto Contrast Level DADH	NVMSAKOSetting	shortNatural	No		1.807		
610-007	Auto Color detection window fast scan start, defined in tenth of percentage point of document fast scan dimension. Values from 0 to 1000 (e.g. 1% is 10, 10% is 100,		ND	Copy Auto Color Detect FS Start	NVMSAKOSetting	natural	No		1.622		
610-007	Auto Color detection window fast scan start, defined in tenth of percentage point of document fast scan dimension. Values		ND	Copy Auto Color Detect FS Start	NVMSAKOSetting	natural	No		1.737		
610-008	Auto Color detection window slow scan start, defined in tenth of percentage point of document slow scan dimension. Values from 0 to 1000 (e.g. 1% is 10, 10% is 100,		ND	Copy Auto Color Detect SS Start	NVMSAKOSetting	natural	No		1.622		

610-008	Auto Color detection window slow scan start, defined in tenth of percentage point of document slow scan dimension. Values from 0 to 1000 (e.g. 1% is 10, 10% is 100,		ND	Copy Auto Color Detect SS Start	NVMSAKOSetting	natural	No		1.737		
610-009	Auto Color Detection Level for platen at pixel level. Defines a value that dictates how chromatic a pixel has to be in order to		ND	Copy Auto Color Level Pixel Plat	NVMSAKOSetting	shortNatural	No		1.737		
610-011	Auto Color Detection Level for DADH at pixel level. Defines a value that dictates how many color pixels have to be on a		ND	Copy Auto Color Level Pixel DADH	NVMSAKOSetting	shortNatural	No		1.737		
610-015	Defines the type of paper used		ND	Copy White Reference	NVMSAKOSetting	shortNatural	No		1.622		
610-021	Auto Contrast level for platen		RW	Scan Auto Contrast Level Platen	NVMSAKOSetting	shortNatural	No		1.807		
610-022	Auto Contrast level for DADH		RW	Scan Auto Contrast Level DADH	NVMSAKOSetting	shortNatural	No		1.807		
610-030	Defines the type of paper used (4024, 4200, Xpressions, recyclable, etc)		ND	Scan White Reference	NVMSAKOSetting	shortNatural	No		1.622		
610-035	Auto Contrast level for platen		RW	Fax Auto Contrast Level Platen	NVMSAKOSetting	shortNatural	No		1.019		
610-036	Auto Contrast level for DADH		RW	Fax Auto Contrast Level DADH	NVMSAKOSetting	shortNatural	No		1.019		
610-037	Photo/Text Segmentation Threshold will control the Galileo segmentation. When it changes, the part of the input that will be		ND	Fax Photo/Text Segment'n Control	NVMSAKOSetting	shortNatural	No		1.622		
610-038	Defines the type of paper used		ND	Fax White Reference	NVMSAKOSetting	shortNatural	No		1.622		
610-047	Defines the binary vs. contone image path/printing	1 to 16	RW	Print ImagePath Type (bit depth)	NVMConfiguration	shortNatural	No		1.019		
610-052	Toner Saver Mode	0=standard 1=eco	RW	Toner Saver Mode	NVMConfiguration	shortNatural	No		1.477		
610-053	Scan Graph with CST2	0 - Without CST2 1 - With CST2	RW	IQ PARAMETER FAMILY	NVMConfiguration	natural	No		1.714		
612-001	Fault Counter 22-330-02: Queue To ESSPrint Timeout		RW	Queue To NC Print TimeoutFC	NVMFaultCounter	shortNatural	No	Fault Counter:22-330-02: Queue To ESSPrint Timeout	1.153		
612-002	Fault Counter 22-330-03: Queue To S2F Timeout		RW	Queue To S2F Timeout	NVMFaultCounter	shortNatural	No	Fault Counter:22-330-03: Queue To S2F Timeout	1.000		
612-003	Fault Counter 22-330-04: Queue To FaxSend Timeout		RW	Queue To FaxSend Timeout	NVMFaultCounter	shortNatural	No	Fault Counter:22-330-04: Queue To FaxSend Timeout	1.000		
612-004	Fault Counter 22-330-05: Queue To DCCopy Timeout		RW	Queue To DCCopy Timeout	NVMFaultCounter	shortNatural	No	Fault Counter:22-330-05: Queue To DCCopy Timeout	1.000		

612-005	Fault Counter 22-330-06: Queue To S2Distr Timeout		RW	Queue To S2Distr Timeout	NVMFaultCounter	shortNatural	No	Fault Counter:22-330-06: Queue To S2Distr Timeout	1.000		
616-001	Defines market region	Market Region settings: 0=US (North America) 1=XCL(Canada)	RO	Market Region	NVMcontrolledAccess	shortNatural	No		1.324	Yes	
616-002	Enable Power Saver feature - Most Programs	0=Disabled 1=Enabled	RW	power saver enabled	NVMSAKOSetting	boolean	No		1.631		
616-003	Northwood Family - Defines Machine PPM Speed (Product Configuration) 255 (PC0) = No Run. Speed set according to the SIM or via Mfg tool	255 = No Run 119 = 30 ppm 120 = 35 ppm 121 = 45 ppm	RO	Product Configuration	NVMcontrolledAccess	shortNatural	No		1.266		
616-003	Luminance Family - Defines Product Configuration	Machine Speed (Nominal ppm NOT ACTUAL): 32 = A1 class 32ppm (PCF32)	RO	Product Configuration	NVMcontrolledAccess	shortNatural	No		1.390	Yes	
616-003	Burgundy Family - Defines Machine PPM Speed (Product Configuration) See also ID250	152 = 47 ppm standard 153 = 47 ppm with Fax	RO	Product Configuration	NVMcontrolledAccess	shortNatural	No		1.507		
616-003	Brilliance Family - Defines Product Configuration	Machine Speed (Nominal ppm NOT ACTUAL): 145 = 40ppm (PCB40)	RO	Product Configuration	NVMcontrolledAccess	shortNatural	No		1.476	Yes	
616-003	Barolo Family - Defines Machine PPM Speed (Product Configuration) See also ID250	154 = 36ppm	RO	Product Configuration	NVMcontrolledAccess	shortNatural	No		1.507		
616-003	Snowdon Family - Defines Product Configuration	Machine Speed (Nominal ppm NOT ACTUAL): 163 = 45ppm (PCSN45)	RO	Product Configuration	NVMcontrolledAccess	shortNatural	No		1.732	Yes	
616-003	Snowdon2 Family - Defines Product Configuration	Machine Speed (Nominal ppm NOT ACTUAL): 174 = 45ppm (PCSN245)	RO	Product Configuration	NVMcontrolledAccess	shortNatural	No		1.732	Yes	
616-004	Lexington family - Defines system Configuration (type of System)	0 = Unknown (Not set) 1 = ST (Networked) 8 = Network Suppressed	RW	System Configuration	NVMConfiguration	shortNatural	No		1.099		
616-004	Defines System Configuration (type of system)	0 = Unknown (Not set) 1 = ST (Networked) 8 = Network Suppressed	RW	System Configuration	NVMConfiguration	shortNatural	No		1.028		
616-010	Defines time in "normal" mode where system has been idle to enabled transition into power saver.	The idle time in minutes before the machine will enter Low power	RW	powersaver idletime	NVMSAKOSetting	shortNatural	No		1.790		Yes, as Integer Value
616-010	Defines time in "normal" mode where system has been idle to enabled transition into power saver.	The idle time in minutes before the machine will enter Low power	RW	powersaver idletime	NVMSAKOSetting	shortNatural	No		1.790		Yes, as Integer Value
616-010	Defines time in "normal" mode where system has been idle to enabled transition into power saver.	The idle time in minutes before the machine will enter Low power	RW	powersaver idletime	NVMSAKOSetting	shortNatural	No		1.790		Yes, as Integer Value
616-010	Defines time in "normal" mode where system has been idle to enabled transition into power saver.	The idle time in minutes before the machine will enter Low power	RW	powersaver idletime	NVMSAKOSetting	shortNatural	No		1.790		Yes, as Integer Value
616-010	Defines time in "normal" mode where system has been idle to enabled transition into power saver.	The idle time in minutes before the machine will enter Low power	RW	powersaver idletime	NVMSAKOSetting	shortNatural	No		1.790		Yes, as Integer Value

616-011	Defines time in "mode 1" before transitioning to "mode 3" for appropriate configurations.	The idle time in minutes the machine will remain in Low power before entering	RW	power saver in mode 1 time	NVMSAKOSetting	shortNatural	No		1.321		
616-011	Defines time in "mode 1" before transitioning to "mode 3" for appropriate	The idle time in minutes the machine will remain in	RW	power saver in mode 1 time	NVMSAKOSetting	shortNatural	No		1.531		
616-014	Defines system's current installation phase.	0 = Manufacturing 2 = Pre Install (Default) 4 = Complete	RW	system install phase	NVMConfiguration	shortNatural	No		1.820	Yes	
616-015	SMFCustomerServiceNumber		ND		NVMSAKOSetting	byteArray	No		1.000		
616-052	Product Identifier (e.g. Marketing product name)	0 = Unknown (Not set) Lexington Family 89 to	RW	Product Identifier	NVMcontrolledAccess	natural	No	Device Profile:403: Model	1.155	Yes	
616-052	Product Identifier (e.g. Marketing product name)	1000 = Unknown (Not set) (Luminance values) 191 = 35	RW	Product Identifier	NVMcontrolledAccess	natural	No	Device Profile:403: Model	1.357	Yes	
616-052	Product Identifier (e.g. Marketing product name)	1000 = Unknown (Not set) (Brilliance values) 204 = 40 (note that this	RO	Product Identifier	NVMcontrolledAccess	natural	No	Device Profile:403: Model	1.582	Yes	
616-052	Product Identifier (e.g. Marketing product name)	1000 = Unknown (Not set) (Snowdon values) 227 = 45	RO	Product Identifier	NVMcontrolledAccess	natural	No	Device Profile:403: Model	1.598	Yes	
616-052	Product Identifier (e.g. Marketing product name)	1000 = Unknown (Not set) (Skylight values) 221=25	RO	Product Identifier	NVMcontrolledAccess	natural	No	Device Profile:403: Model	1.734	Yes	
616-052	Product Identifier (e.g. Marketing product name)	1000 = Unknown (Not set) (Snowdon2 values) 238 = 45	RO	Product Identifier	NVMcontrolledAccess	natural	No	Device Profile:403: Model	1.598	Yes	
616-052	Product Identifier (e.g. Marketing product name)	1000 = Unknown (Not set) (Kiska values)	RO	Product Identifier	NVMcontrolledAccess	natural	No	Device Profile:403: Model	1.734		
616-166	Intelligent Ready Yesterday's Activity IR1b array	Byte array containing 24 hourly activity bins (hr0 -->	ND	Yesterday's Activity IR1b array	NVMSAKOSetting	byteArray	No		1.781		
616-167	Intelligent Ready Yesterday's Activity IR2b	Byte array containing 24	ND	Yesterday's Activity IR2b array	NVMSAKOSetting	byteArray	No		1.781		
616-168	Intelligent Ready Today's Activity IR1b array	Byte array containing 24 hourly activity bins (hr0 --> hr23)	ND	Today's Activity IR1b array	NVMSAKOSetting	byteArray	No		1.781		
616-169	Intelligent Ready Today's Activity IR2b array	Byte array containing 24 hourly activity bins (hr0 --> hr23)	ND	Today's Activity IR2b array	NVMSAKOSetting	byteArray	No		1.781		
616-170	Intelligent Ready IR3 week array	Byte array containing 168 hourly activity bins (hr0 --> hr167, 00=first bin Sunday 00hrs AM)	ND	IR3 week array	NVMSAKOSetting	byteArray	No		1.781		
616-171	Intelligent Ready Low Power Timeout	Used by IR1 algorithm	ND	IR Low Power Timeout	NVMSAKOSetting	shortNatural	No		1.781		
616-172	Intelligent Ready Sleep Timeout	Used by IR2 algorithm	ND	IR Sleep Timeout	NVMSAKOSetting	shortNatural	No		1.781		

616-173	Intelligent Ready - pre-populated array daily usage flags	Byte array containing 7 values indicating weekday use of IR3 data or initial pre-populated data	ND	IR pre-populated usage flags	NVMSAKOSetting	byteArray	No		1.781		
616-200	Fault Counter 22-330: number of times page pack pin has been locked out	no. of faults	RW	NumTimesPagePackPinlockedFC	NVMFaultCounter	shortNatural	No	Fault Counter:22-330-00: number of times page pack pin has been locked out	1.045		
616-206	Disk Encryption enabled/disabled	0 = disabled, 1 = enabled	RW	Disk Encryption Enabled/Disabled	NVMcontrolledAccess	boolean	No		1.130		
616-206	Disk Encryption enabled/disabled	0 = disabled, 1 = enabled	RW	Disk Encryption Enabled/Disabled	NVMcontrolledAccess	boolean	No		1.527		
616-206	Disk Encryption enabled/disabled	0 = disabled, 1 = enabled	RW	Disk Encryption Enabled/Disabled	NVMcontrolledAccess	boolean	No		1.744		
616-213	defines system manager full ODIO timeout	90 minutes	RW	FullODIOTimeout	NVMDebug	shortNatural	No		1.135		
616-214	defines system manager standard ODIO timeout	30 minutes	RW	StandardODIOTimeout	NVMDebug	shortNatural	No		1.135		
616-217	PagePack Grace Prints Left	0-6000	ND		NVMcontrolledAccess	longInteger	No		1.823		
616-217	PagePack Grace Prints Left	0-2000	ND		NVMcontrolledAccess	longInteger	No		1.341		
616-224	Intelligent Ready History Log	Byte array containing a circular log of Intelligent Ready bin values updated on a daily basis. Sized for	ND	IR log data	NVMSAKOSetting	byteArray	No		1.179		
616-225	IR1a byte array	Byte array containing IR1a: quarter hourly values for a day	ND	IR1a values day array	NVMSAKOSetting	byteArray	No		1.781		
616-226	IR2a byte array	Byte array containing IR2a: hourly values for a day	ND	IR2a values day array	NVMSAKOSetting	byteArray	No		1.781		
616-227	IR1a last updated binId	Identifies last bin updated with Ir1a value for the day	ND	IR1a last bin updated	NVMSAKOSetting	shortNatural	No		1.781		
616-228	IR2a last updated binId	Identifies last bin updated with Ir2a value for the day	ND	IR2a last bin updated	NVMSAKOSetting	shortNatural	No		1.781		
616-229	When the CCS instructs the IME to enter Snooze mode, it needs to remember that snooze was initiated since the IME does not report this mode. When a new unit is detected, the flag should be reset. Note	0 = IME Not in Snooze mode, 1 = IME in snooze mode	RW	Display Snooze Message	NVMConfiguration	boolean	No		1.183		

616-232	Defines time in "normal" mode where system has been idle to enabled transition into power saver WITH fast resume set. Only for Solid Ink programmes.	The idle time in minutes before the machine will enter Low power with Fast resume set	RW	powersaver fast resume idletime	NVMSAKOSetting	shortNatural	No		1.238		
616-233	Defines time in "mode 1" before transitioning to "mode 3" WITH fast resume set. Only for Solid Ink programmes; Only for Solid Ink	The idle time in minutes the machine will remain in Low power before entering Sleep with Fast Resume	RW	powersaver fast resume in mode1	NVMSAKOSetting	shortNatural	No		1.238		
616-234	UI system Timeout value	seconds	RW	UI system Timeout value	NVMSAKOSetting	integer	Yes		1.552		
616-235	Regional Differentiator value	NA_Classic = 1 (Default) NA_Enterprise = 2 XE_Classic = 3 XE_Enterprise = 4	RO	RegDiff	NVMcontrolledAccess	shortNatural	No		1.819		
616-241	Control for UI display of Energy Star Logo splash screen. Factory Default is not to display Logo and the appropriate value is set by the MITS tool as required per programme.	0 = Not ES compliant OR unknown - do not display ES Logo on LUI. 1 = ES compliant - do display ES Logo on LUI.	RO	Energy Star Compliant status	NVMcontrolledAccess	boolean	No		1.729		
616-242	S-Config Enablement Status. This was developed for Mamba+ and used to interact with ID5612 but is no longer required. DEPRECATED FOR D3.6.		RO	S-Config EStarEnablement status	NVMSAKOSetting	boolean	No		1.673		
616-245	Install Wizard (FS22.020):SIM Required screen	Set by CCS when a SIM is required but not yet detected. For Northwood this is whenever Market =	ND	#	NVMConfiguration	boolean	No		1.733	Yes	
616-255	S/W UGD Fault Counter 95-011-00: XUI Application	no. of faults	RW	Fault Counter 95-011-00	NVMFaultCounter	shortNatural	No	Fault Counter:95-011-00:XUI Application	1.813		
616-256	S/W UGD Fault Counter 95-001-00: DCSWUPCODEERROR	no. of faults	RW	Fault Counter 95-001-00	NVMFaultCounter	shortNatural	No	Fault Counter:95-001-00:DCSWUPCODEERROR	1.636		
616-257	S/W UGD Fault Counter 95-002-00: DCAPPERROR	no. of faults	RW	Fault Counter 95-002-00	NVMFaultCounter	shortNatural	No	Fault Counter:95-002-00:DCAPPERROR	1.636		
616-258	S/W UGD Fault Counter 95-008-00: DCOSERROR	no. of faults	RW	Fault Counter 95-008-00	NVMFaultCounter	shortNatural	No	Fault Counter:95-008-00:DCOSERROR	1.813		
616-259	S/W UGD Fault Counter 95-009-00: DCCIPSEERROR	no. of faults	RW	Fault Counter 95-009-00	NVMFaultCounter	shortNatural	No	Fault Counter:95-009-00:DCCIPSEERROR	1.636		
616-260	S/W UGD Fault Counter 95-019-00: SUIH8ERROR	no. of faults	RW	Fault Counter 95-019-00	NVMFaultCounter	shortNatural	No	Fault Counter:95-019-00:SUIH8ERROR	1.813		

616-261	S/W UGD Fault Counter 95-020-00: DADHAPPERROR	no. of faults	RW	Fault Counter 95-020-00	NVMFaultCounter	shortNatural	No	Fault Counter:95-020-00:DADHAPPERROR	1.810		
616-262	S/W UGD Fault Counter 95-038-00: EMBEDFAXERROR	no. of faults	RW	Fault Counter 95-038-00	NVMFaultCounter	shortNatural	No	Fault Counter:95-038-00:EMBEDFAXERROR	1.813		
616-263	S/W UGD Fault Counter 95-040-00: IOTBOOTSTRAPERROR	no. of faults	RW	Fault Counter 95-040-00	NVMFaultCounter	shortNatural	No	Fault Counter:95-040-00:IOTBOOTSTRAPERROR	1.636		
616-264	S/W UGD Fault Counter 95-041-00: IOTBOOTLOADERERROR	no. of faults	RW	Fault Counter 95-041-00	NVMFaultCounter	shortNatural	No	Fault Counter:95-041-00:IOTBOOTLOADERERROR	1.636		
616-265	S/W UGD Fault Counter 95-042-00: IOTAPPERROR	no. of faults	RW	Fault Counter 95-042-00	NVMFaultCounter	shortNatural	No	Fault Counter:95-042-00:IOTAPPERROR	1.813		
616-266	S/W UGD Fault Counter 95-060-00: LCSS2KAPPERROR	no. of faults	RW	Fault Counter 95-060-00	NVMFaultCounter	shortNatural	No	Fault Counter:95-060-00:LCSS2KAPPERROR	1.636		
616-267	S/W UGD Fault Counter 95-140-00: DCNCAPPERROR	no. of faults	RW	Fault Counter 95-140-00	NVMFaultCounter	shortNatural	No	Fault Counter:95-140-00:DCNCAPPERROR	1.813		
616-268	S/W UGD Fault Counter 95-150-00: IITAPPERROR	no. of faults	RW	Fault Counter 95-150-00	NVMFaultCounter	shortNatural	No	Fault Counter:95-150-00:IITAPPERROR	1.813		
616-269	S/W UGD Fault Counter 95-153-00: IITKERNELError	no. of faults	RW	Fault Counter 95-153-00	NVMFaultCounter	shortNatural	No	Fault Counter:95-153-00:IITKERNELError	1.813		
616-270	S/W UGD Fault Counter 95-180-00: HCFWWMODERROR	no. of faults	RW	Fault Counter 95-180-00	NVMFaultCounter	shortNatural	No	Fault Counter:95-180-00:HCFWWMODERROR	1.813		
616-271	S/W UGD Fault Counter 95-191-00: PFPWWMODERROR	no. of faults	RW	Fault Counter 95-191-00	NVMFaultCounter	shortNatural	No	Fault Counter:95-191-00:PFPWWMODERROR	1.636		
616-272	S/W UGD Fault Counter 95-192-00: HVFAPPERROR	no. of faults	RW	Fault Counter 95-192-00	NVMFaultCounter	shortNatural	No	Fault Counter:95-192-00:HVFAPPERROR	1.636		
616-273	S/W UGD Fault Counter 95-193-00: HVFBMAPPERROR	no. of faults	RW	Fault Counter 95-193-00	NVMFaultCounter	shortNatural	No	Fault Counter:95-193-00:HVFBMAPPERROR	1.636		
616-274	S/W UGD Fault Counter 95-195-00: HVFBMBCERROR	no. of faults	RW	Fault Counter 95-195-00	NVMFaultCounter	shortNatural	No	Fault Counter:95-195-00:HVFBMBCERROR	1.636		

616-275	S/W UGD Fault Counter 95-200-00: CFINAPPERROR	no. of faults	RW	Fault Counter 95-200-00	NVMFaultCounter	shortNatural	No	Fault Counter:95-200-00:CFINAPPERROR	1.636		
616-276	S/W UGD Fault Counter 95-007-00: CHFINAPPERROR	no. of faults	RW	Fault Counter 95-007-00	NVMFaultCounter	shortNatural	No	Fault Counter:95-007-00:CHFINAPPERROR	1.813		
616-277	S/W UGD Fault Counter 95-203-00: AFINAPPERROR	no. of faults	RW	Fault Counter 95-203-00	NVMFaultCounter	shortNatural	No	Fault Counter:95-203-00:AFINAPPERROR	1.813		
616-278	S/W UGD Fault Counter 95-204-00: SBFINAPPERROR	no. of faults	RW	Fault Counter 95-204-00	NVMFaultCounter	shortNatural	No	Fault Counter:95-204-00:SBFINAPPERROR	1.813		
616-279	S/W UGD Fault Counter 95-161-00: IITSINDOHBCERROR	no. of faults	RW	Fault Counter 95-161-00	NVMFaultCounter	shortNatural	No	Fault Counter:95-161-00:IITSINDOHBCERR	1.636		
616-280	S/W UGD Fault Counter 95-162-00: IITSINDOH2APPERROR	no. of faults	RW	Fault Counter 95-162-00	NVMFaultCounter	shortNatural	No	Fault Counter:95-162-00:IITSINDOH2APPERROR	1.636		
616-281	S/W UGD Fault Counter 95-163-00: SPDHBOOTSINDOHERRO	no. of faults	RW	Fault Counter 95-163-00	NVMFaultCounter	shortNatural	No	Fault Counter:95-163-00:IITSINDOH1FPGAE	1.636		
616-282	S/W UGD Fault Counter 95-164-00: SPDHAPPSINDOHERRO	no. of faults	RW	Fault Counter 95-164-00	NVMFaultCounter	shortNatural	No	Fault Counter:95-164-00:IITSINDOHFPGAE	1.636		
616-283	S/W UGD Fault Counter 95-228-00: DADHSPB0DAPPERROR	no. of faults	RW	Fault Counter 95-228-00	NVMFaultCounter	shortNatural	No	Fault Counter:95-228-00:DADHSPB0DAPPE	1.636		
616-284	S/W UGD Fault Counter 95-229-00: DADHSPB0DBCERROR	no. of faults	RW	Fault Counter 95-229-00	NVMFaultCounter	shortNatural	No	Fault Counter:95-229-00:DADHSPB0DBCER	1.636		
616-285	S/W UGD Fault Counter 95-216-00: DCGLUEERROR	no. of faults	RW	Fault Counter 95-216-00	NVMFaultCounter	shortNatural	No	Fault Counter:95-216-00:DCGLUEERROR	1.813		
616-286	S/W UGD Fault Counter 95-168-00: DADHSPERROR	no. of faults	RW	Fault Counter 95-168-00	NVMFaultCounter	shortNatural	No	Fault Counter:95-168-00:DADHSPERROR	1.813		
616-287	S/W UGD Fault Counter 95-152-00: SICAPPERROR	no. of faults	RW	Fault Counter 95-152-00	NVMFaultCounter	shortNatural	No	Fault Counter:95-152-00:SICAPPERROR	1.813		
616-288	S/W UGD Fault Counter 95-226-00: SOKAPPERROR	no. of faults	RW	Fault Counter 95-226-00	NVMFaultCounter	shortNatural	No	Fault Counter:95-226-00:SOKAPPERROR	1.813		
616-289	S/W UGD Fault Counter 95-222-00: LVFAPPERROR	no. of faults	RW	Fault Counter 95-222-00	NVMFaultCounter	shortNatural	No	Fault Counter:95-222-00:LVFAPPERROR	1.810		
616-290	S/W UGD Fault Counter 95-224-00: DCSCDERROR	no. of faults	RW	Fault Counter 95-224-00	NVMFaultCounter	shortNatural	No	Fault Counter:95-224-00:DCSCDERROR	1.810		
616-291	S/W UGD Fault Counter 95-255-00: DCSCDERROR	no. of faults	RW	Fault Counter 95-255-00	NVMFaultCounter	shortNatural	No	Fault Counter:95-255-00:DCSCDERROR	1.636		
616-292	S/W UGD Fault Counter 95-306-00: CCSSYNCERROR	no. of faults	RW	Fault Counter 95-306-00	NVMFaultCounter	shortNatural	No	Fault Counter:95-306-00:CCSSYNCERROR	1.813		

616-293	S/W UGD Fault Counter 95-307-00: NCSYNCERROR	no. of faults	RW	Fault Counter 95-307-00	NVMFaultCounter	shortNatural	No	Fault Counter:95-307-00:NCSYNCERROR	1.813		
616-294	S/W UGD Fault Counter 95-308-00: UISYNCERROR	no. of faults	RW	Fault Counter 95-308-00	NVMFaultCounter	shortNatural	No	Fault Counter:95-308-00:UISYNCERROR	1.813		
616-295	S/W UGD Fault Counter 95-309-00: IITSYNCERROR	no. of faults	RW	Fault Counter 95-309-00	NVMFaultCounter	shortNatural	No	Fault Counter:95-309-00:IITSYNCERROR	1.813		
616-296	S/W UGD Fault Counter 95-310-00: IOTSYNCERROR	no. of faults	RW	Fault Counter 95-310-00	NVMFaultCounter	shortNatural	No	Fault Counter:95-310-00:IOTSYNCERROR	1.813		
616-297	S/W UGD Fault Counter 95-311-00: FINSYNCERROR	no. of faults	RW	Fault Counter 95-311-00	NVMFaultCounter	shortNatural	No	Fault Counter:95-311-00:FINSYNCERROR	1.813		
616-298	S/W UGD Fault Counter 95-312-00: FDRSYNCERROR	no. of faults	RW	Fault Counter 95-312-00	NVMFaultCounter	shortNatural	No	Fault Counter:95-312-00:FDRSYNCERROR	1.813		
616-299	S/W UGD Fault Counter 95-300-00: SWUPINCOMPATPRODERROR	no. of faults	RW	Fault Counter 95-300-00	NVMFaultCounter	shortNatural	No	Fault Counter:95-300-00:SWUPINCOMPATPRODERROR	1.636		
616-300	S/W UGD Fault Counter 95-301-00: SWUPINCOMPATHWERROR	no. of faults	RW	Fault Counter 95-301-00	NVMFaultCounter	shortNatural	No	Fault Counter:95-301-00:SWUPINCOMPATHWERROR	1.636		
616-301	S/W UGD Fault Counter 95-302-00: SWUPINCOMPATFWERROR	no. of faults	RW	Fault Counter 95-302-00	NVMFaultCounter	shortNatural	No	Fault Counter:95-302-00:SWUPINCOMPATFWERROR	1.636		
616-302	S/W UGD Fault Counter 95-303-00: SWUPDLMDOWNGRADEERROR	no. of faults	RW	Fault Counter 95-303-00	NVMFaultCounter	shortNatural	No	Fault Counter:95-303-00:SWUPDLMDOWNGRADEERROR	1.636		
616-303	S/W UGD Fault Counter 95-304-00: SWUPDLMSIDEGRADEERROR	no. of faults	RW	Fault Counter 95-304-00	NVMFaultCounter	shortNatural	No	Fault Counter:95-304-00:SWUPDLMSIDEGRADEERROR	1.636		
616-304	S/W UGD Fault Counter 95-305-00: SWUPPLATSYNCERROR	no. of faults	RW	Fault Counter 95-305-00	NVMFaultCounter	shortNatural	No	Fault Counter:95-305-00:SWUPPLATSYNCERROR	1.636		
616-305	SPARE was s/w upgrade fault counter		ND	SPARE	NVMMachVar	shortNatural	No		1.636		

616-306	SPARE was s/w upgrade fault counter		ND	SPARE	NVMMachVar	shortNatural	No		1.636		
616-307	SPARE was s/w upgrade fault counter		ND	SPARE	NVMMachVar	shortNatural	No		1.636		
616-308	SPARE was s/w upgrade fault counter		ND	SPARE	NVMMachVar	shortNatural	No		1.636		
616-309	SPARE was s/w upgrade fault counter		ND	SPARE	NVMMachVar	shortNatural	No		1.636		
616-310	SPARE was s/w upgrade fault counter		ND	SPARE	NVMMachVar	shortNatural	No		1.636		
616-311	SPARE was s/w upgrade fault counter		ND	SPARE	NVMMachVar	shortNatural	No		1.636		
616-312	SPARE was s/w upgrade fault counter		ND	SPARE	NVMMachVar	shortNatural	No		1.636		
616-313	SPARE was s/w upgrade fault counter		ND	SPARE	NVMMachVar	shortNatural	No		1.636		
616-314	SPARE was s/w upgrade fault counter		ND	SPARE	NVMMachVar	shortNatural	No		1.636		
616-315	SPARE was s/w upgrade fault counter		ND	SPARE	NVMMachVar	shortNatural	No		1.636		
616-316	SPARE was s/w upgrade fault counter		ND	SPARE	NVMMachVar	shortNatural	No		1.636		
616-317	SPARE was s/w upgrade fault counter		ND	SPARE	NVMMachVar	shortNatural	No		1.636		
616-318	SPARE was s/w upgrade fault counter		ND	SPARE	NVMMachVar	shortNatural	No		1.636		
616-319	SPARE was s/w upgrade fault counter		ND	SPARE	NVMMachVar	shortNatural	No		1.636		

616-320	SPARE was s/w upgrade fault counter		ND	SPARE	NVMMachVar	shortNatural	No		1.636		
616-321	SPARE was s/w upgrade fault counter		ND	SPARE	NVMMachVar	shortNatural	No		1.636		
616-322	SPARE was s/w upgrade fault counter		ND	SPARE	NVMMachVar	shortNatural	No		1.636		
616-323	SPARE was s/w upgrade fault counter		ND	SPARE	NVMMachVar	shortNatural	No		1.636		
616-324	SPARE was s/w upgrade fault counter		ND	SPARE	NVMMachVar	shortNatural	No		1.636		
616-325	SPARE was s/w upgrade fault counter		ND	SPARE	NVMMachVar	shortNatural	No		1.636		
616-326	SPARE was s/w upgrade fault counter		ND	SPARE	NVMMachVar	shortNatural	No		1.636		
616-327	SPARE was s/w upgrade fault counter		ND	SPARE	NVMMachVar	shortNatural	No		1.636		
616-339	For Blue Angel when the energy saver is set to 0 minutes the system will take a	seconds	RW	power saver grace period	NVMSAKOSetting	shortNatural	No		1.726		
616-346	Touch Volume		RW	Touch Volume	NVMSAKOSetting	shortNatural	No		1.741		
616-347	Fault / Alert Volume		RW	Fault / Alert Volume	NVMSAKOSetting	shortNatural	No		1.741		
616-348	Job Completion Volume		RW	Job Completion Volume	NVMSAKOSetting	shortNatural	No		1.741		

616-349	Energy Saver Volume		RW	Energy Saver Volume	NVMSAKOSetting	shortNatural	No		1.741		
616-350	Power Volume		RW	Power Volume	NVMSAKOSetting	shortNatural	No		1.741		
616-351	Log In Volume		RW	Log In Volume	NVMSAKOSetting	shortNatural	No		1.741		
616-352	AirPrint Feature unhide/hide (for use in Manufacturing)	0 = Hidden 1 = Unhidden	ND		NVMcontrolledAccess	boolean	No		1.790		Yes, as Text
616-352	AirPrint Feature unhide/hide (for use in Manufacturing)	0 = Hidden 1 = Unhidden	ND		NVMcontrolledAccess	boolean	No		1.790		Yes, as Text
616-352	AirPrint Feature unhide/hide (for use in Manufacturing)	0 = Hidden 1 = Unhidden	ND		NVMcontrolledAccess	boolean	No		1.790		Yes, as Text
616-355	Policy for AdjustableTrayConfirmation Prompt	0 - Always show 1 - Delayed Close 2 - Auto confirmation	RW	AdjustableTrayConfirmationPolicy	NVMSAKOSetting	shortNatural	No		1.817		
616-361	Enable / Disable of the Reduced Power Print feature. (Default = disabled for D3.6-D4.0 programmes).	0=Disabled 1=Enabled	RW	Lower Power Print Feature Enable	NVMSAKOSetting	boolean	No		1.701	Yes	
616-363	Control for UI display of Energy Star Logo splash screen. Factory Default is not to display Logo and the appropriate value is set by the MITS tool as required for 22ppm machines	0 = Not ES compliant OR unknown - do not display ES Logo on LUI. 1 = ES compliant - do display ES Logo on LUI.	RO	Energy Star Compliant status 22	NVMcontrolledAccess	boolean	No		1.792	Yes	
616-364	Control for UI display of Energy Star Logo splash screen. Factory Default is not to display Logo and the appropriate value is set by the MITS tool as required for 25ppm	0 = Not ES compliant OR unknown - do not display ES Logo on LUI. 1 = ES compliant - do	RO	Energy Star Compliant status 25	NVMcontrolledAccess	boolean	No		1.792	Yes	
616-365	Control for UI display of Energy Star Logo splash screen. Factory Default is not to display Logo and the appropriate value is set by the MITS tool as required for 28ppm	0 = Not ES compliant OR unknown - do not display ES Logo on LUI. 1 = ES compliant - do	RO	Energy Star Compliant status 28	NVMcontrolledAccess	boolean	No		1.792	Yes	
616-366	Control for UI display of Energy Star Logo splash screen. Factory Default is not to display Logo and the appropriate value is set by the MITS tool as required for 35ppm machines	0 = Not ES compliant OR unknown - do not display ES Logo on LUI. 1 = ES compliant - do display ES Logo on LUI.	RO	Energy Star Compliant status 30	NVMcontrolledAccess	boolean	No		1.792	Yes	
616-367	Control for UI display of Energy Star Logo splash screen. Factory Default is not to display Logo and the appropriate value is set by the MITS tool as required for 35ppm machines	0 = Not ES compliant OR unknown - do not display ES Logo on LUI. 1 = ES compliant - do display ES Logo on LUI.	RO	Energy Star Compliant status 35	NVMcontrolledAccess	boolean	No		1.750	Yes	
616-368	Control for UI display of Energy Star Logo splash screen. Factory Default is not to display Logo and the appropriate value is set by the MITS tool as required for 45ppm	0 = Not ES compliant OR unknown - do not display ES Logo on LUI. 1 = ES compliant - do	RO	Energy Star Compliant status 45	NVMcontrolledAccess	boolean	No		1.750	Yes	

616-369	Control for UI display of Energy Star Logo splash screen. Factory Default is not to display Logo and the appropriate value is set by the MITS tool as required for 55ppm machines	0 = Not ES compliant OR unknown - do not display ES Logo on LUI. 1 = ES compliant - do display ES Logo on LUI.	RO	Energy Star Compliant status 55	NVMcontrolledAccess	boolean	No		1.750	Yes	
616-370	Control for UI display of Energy Star Logo splash screen. Factory Default is not to display Logo and the appropriate value is set by the MITS tool as required for 70ppm	0 = Not ES compliant OR unknown - do not display ES Logo on LUI. 1 = ES compliant - do	RO	Energy Star Compliant status 70	NVMcontrolledAccess	boolean	No		1.750	Yes	
616-372	Control for UI display of Energy Star Logo splash screen. Factory Default is not to	0 = Not ES compliant OR unknown - do not display	RO	Energy Star Compliant status 60	NVMcontrolledAccess	boolean	No		1.792	Yes	
616-373	Control for UI display of Energy Star Logo splash screen. Factory Default is not to display Logo and the appropriate value is set by the MITS tool as required for 65ppm	0 = Not ES compliant OR unknown - do not display ES Logo on LUI. 1 = ES compliant - do	RO	Energy Star Compliant status 65	NVMcontrolledAccess	boolean	No		1.792	Yes	
616-374	Control for UI display of Energy Star Logo splash screen. Factory Default is not to display Logo and the appropriate value is set by the MITS tool as required for 75ppm	0 = Not ES compliant OR unknown - do not display ES Logo on LUI. 1 = ES compliant - do	RO	Energy Star Compliant status 75	NVMcontrolledAccess	boolean	No		1.750	Yes	
616-375	Control for UI display of Energy Star Logo splash screen. Factory Default is not to display Logo and the appropriate value is set by the MITS tool as required for 90ppm machines	0 = Not ES compliant OR unknown - do not display ES Logo on LUI. 1 = ES compliant - do display ES Logo on LUI.	RO	Energy Star Compliant status 90	NVMcontrolledAccess	boolean	No		1.750	Yes	
616-377	Control for UI display of Energy Star Logo splash screen. Factory Default is not to display Logo and the appropriate value is set by the MITS tool as required for 42ppm	0 = Not ES compliant OR unknown - do not display ES Logo on LUI. 1 = ES compliant - do	RO	Energy Star Compliant status 42	NVMcontrolledAccess	boolean	No		1.816	Yes	
616-378	Control for UI display of Energy Star Logo splash screen. Factory Default is not to display Logo and the appropriate value is set by the MITS tool as required for 50ppm machines	0 = Not ES compliant OR unknown - do not display ES Logo on LUI. 1 = ES compliant - do display ES Logo on LUI.	RO	Energy Star Compliant status 50	NVMcontrolledAccess	boolean	No		1.792	Yes	
616-384	Starter cartridge inserted count: Cyan	Cyan: To store the number of times the starter cartridge inserted count.	RO	CyanStrtrCartInstCnt	NVMSystemUsageCounter	shortNatural	No		1.764		
616-385	Starter cartridge inserted count: Magenta	Magenta: To store the number of times the	RO	MagStrtrCartInstCnt	NVMSystemUsageCounter	shortNatural	No		1.764		
616-386	Starter cartridge inserted count: Yellow	Yellow: To store the number of times the starter cartridge inserted count.	RO	YelStrtrCartInstCnt	NVMSystemUsageCounter	shortNatural	No		1.764		
616-387	Starter cartridge inserted count: Black	Black: To store the number of times the starter cartridge inserted count.	RO	BlkStrtrCartInstCnt	NVMSystemUsageCounter	shortNatural	No		1.764		

616-388	Toner billing mode	Stores the billing mode value that comes from the IOT. Enum TonerBillingMode	RO	TonerBillingMode	NVMcontrolledAccess	shortNatural	No		1.764		
616-389	Toner service plan mode	Stores the service plan value that comes from the IOT.	RO	TonerSvcPlanMode	NVMcontrolledAccess	shortNatural	No		1.764		
616-390	Toner regional differentiator	Stores the toner regional differentiator value that comes from the IOT.	RO	TonerRgnDifferentiator	NVMcontrolledAccess	shortNatural	No		1.764		
616-398	Fault Counter 16-972-15:DLM signature fails	no. of faults	RW	DLMSIGFAILSFAULT	NVMFaultCounter	shortNatural	No	Fault Counter:16-972-15:DLM signature fails	1.768		
616-399	Fault Counter 16-972-08:Bootmgr's SW verify failed.	no. of faults	RW	SWVERIFYBOOTFAILED	NVMFaultCounter	shortNatural	No	Fault Counter:16-972-08:Bootmgr's SW verify failed.	1.771		
616-400	Fault Counter 16-972-09:SWUP Signature Verification Fails	no. of faults	RW	SWUPSIGNATUREVERIFICATION FAILS	NVMFaultCounter	shortNatural	No	Fault Counter:16-972-09:SWUP Signature Verification Fails	1.768		
616-402	Type of fuser	0 = Letter Fuser 1 = A4 Fuser	RO	FuserType	NVMcontrolledAccess	shortNatural	No		1.803	Yes	Yes, as Text
617-001	Displayed faults-Fault Log		ND	Displayable Fault Log	NVMFaultLog	byteArray	No	Log Data:657: Last 250 Faults	1.707		
617-008	Hidden faults-Fault Log		ND	Hidden Fault Log	NVMFaultLog	byteArray	No	Unknown	1.707		
620-034	Fault Counter 05-110:		RW	05-110 counter	NVMFaultCounter	shortNatural	No	Fault Counter:05-110-00: Unknown	1.159		
620-035	Fault Counter 05-111: SPARED (was IIT fault counter)		ND	SPARE 620-035	NVMFaultCounter	shortNatural	No	Fault Counter:05-111-00: Unknown	1.159		
620-036	Fault Counter 05-112:		RW	05-112 counter	NVMFaultCounter	shortNatural	No	Fault Counter:05-112-00: Unknown	1.159		
620-037	Fault Counter 05-113: SPARED (was IIT fault counter)		ND	SPARE 620-037	NVMFaultCounter	shortNatural	No	Fault Counter:05-113-00: Unknown	1.159		

620-038	Fault Counter 05-115: SPARED (was IIT fault counter)		ND	SPARE 620-038	NVMFaultCounter	shortNatural	No	Fault Counter:05-115-00: Unknown	1.159		
620-039	Fault Counter 05-116: SPARED (was IIT fault counter)		ND	SPARE 620-039	NVMFaultCounter	shortNatural	No	Fault Counter:05-116-00: Unknown	1.159		
620-040	Fault Counter 05-121:		RW	05-121 counter	NVMFaultCounter	shortNatural	No	Fault Counter:05-121-00: Unknown	1.159		
620-041	Fault Counter 05-122:		RW	05-122 counter	NVMFaultCounter	shortNatural	No	Fault Counter:05-122-00: Unknown	1.159		
620-042	Fault Counter 05-123:		RW	05-123 counter	NVMFaultCounter	shortNatural	No	Fault Counter:05-123-00: Unknown	1.159		
620-043	Fault Counter 05-124:		RW	05-124 counter	NVMFaultCounter	shortNatural	No	Fault Counter:05-124-00: Unknown	1.159		
620-044	Fault Counter 05-125:		RW	05-125 counter	NVMFaultCounter	shortNatural	No	Fault Counter:05-125-00: Unknown	1.159		
620-045	Fault Counter 05-126:		RW	05-126 counter	NVMFaultCounter	shortNatural	No	Fault Counter:05-126-00: Unknown	1.813		
620-046	Fault Counter 05-127:		RW	05-127 counter	NVMFaultCounter	shortNatural	No	Fault Counter:05-127-00: Unknown	1.813		
620-047	Fault Counter 05-128:		RW	05-128 counter	NVMFaultCounter	shortNatural	No	Fault Counter:05-128-00: Unknown	1.813		
620-048	Fault Counter 05-129:		RW	05-129 counter	NVMFaultCounter	shortNatural	No	Fault Counter:05-129-00: Unknown	1.813		
620-049	Fault Counter 05-130:		RW	05-130 counter	NVMFaultCounter	shortNatural	No	Fault Counter:05-130-00: Unknown	1.813		
620-050	Fault Counter 05-133: SPARED (was IIT fault counter)		ND	SPARE 620-050	NVMFaultCounter	shortNatural	No	Fault Counter:05-133-00: Unknown	1.159		
620-051	Fault Counter 05-135:		RW	05-135 counter	NVMFaultCounter	shortNatural	No	Fault Counter:05-135-00: Unknown	1.813		

620-052	Fault Counter 05-136:		RW	05-136 counter	NVMFaultCounter	shortNatural	No	Fault Counter:05-136-00: Unknown	1.813		
620-053	Fault Counter 05-137: SPARED (was IIT fault counter)		ND	SPARE 620-053	NVMFaultCounter	shortNatural	No	Fault Counter:05-137-00: Unknown	1.159		
620-054	Fault Counter 05-138: SPARED (was IIT fault counter)		ND	SPARE 620-054	NVMFaultCounter	shortNatural	No	Fault Counter:05-138-00: Unknown	1.159		
620-055	Fault Counter 05-141:		RW	05-141 counter	NVMFaultCounter	shortNatural	No	Fault Counter:05-141-00: Unknown	1.813		
620-056	Fault Counter 05-142: SPARED (was IIT fault counter)		ND	SPARE 620-056	NVMFaultCounter	shortNatural	No	Fault Counter:05-142-00: Unknown	1.159		
620-057	Fault Counter 05-143: SPARED (was IIT fault counter)		ND	SPARE 620-057	NVMFaultCounter	shortNatural	No	Fault Counter:05-143-00: Unknown	1.159		
620-058	Fault Counter 05-144:		RW	05-144 counter	NVMFaultCounter	shortNatural	No	Fault Counter:05-144-00: Unknown	1.159		
620-059	Fault Counter 05-150: SPARED (was IIT fault counter)		ND	SPARE 620-059	NVMFaultCounter	shortNatural	No	Fault Counter:05-150-00: Unknown	1.159		
620-060	Fault Counter 05-151: SPARED (was IIT fault counter)		ND	SPARE 620-060	NVMFaultCounter	shortNatural	No	Fault Counter:05-151-00: Unknown	1.159		
620-061	Fault Counter 05-152: SPARED (was IIT fault counter)		ND	SPARE 620-061	NVMFaultCounter	shortNatural	No	Fault Counter:05-152-00: Unknown	1.159		
620-062	Fault Counter 05-153:		RW	05-153 counter	NVMFaultCounter	shortNatural	No	Fault Counter:05-153-00: Unknown	1.159		
620-063	Fault Counter 05-154: SPARED (was IIT fault counter)		ND	SPARE 620-063	NVMFaultCounter	shortNatural	No	Fault Counter:05-154-00: Unknown	1.159		
620-064	Fault Counter 05-155: SPARED (was IIT fault counter)		ND	SPARE 620-064	NVMFaultCounter	shortNatural	No	Fault Counter:05-155-00: Unknown	1.159		
620-065	Fault Counter 05-156: SPARED (was IIT		ND	SPARE 620-065	NVMFaultCounter	shortNatural	No	Fault Counter:05-156-	1.159		

620-066	Fault Counter 05-157: SPARED (was IIT fault counter)		ND	SPARE 620-066	NVMFaultCounter	shortNatural	No	Fault Counter:05-157-00: Unknown	1.159		
620-067	Fault Counter 05-158: SPARED (was IIT fault counter)		ND	SPARE 620-067	NVMFaultCounter	shortNatural	No	Fault Counter:05-158-00: Unknown	1.159		
620-068	Fault Counter 05-160:		RW	05-160 counter	NVMFaultCounter	shortNatural	No	Fault Counter:05-160-00: Unknown	1.159		
620-069	Fault Counter 05-190: SPARED (was IIT fault counter)		ND	SPARE 620-069	NVMFaultCounter	shortNatural	No	Fault Counter:05-190-00: Unknown	1.159		
620-070	Fault Counter 05-194:		RW	05-194 counter	NVMFaultCounter	shortNatural	No	Fault Counter:05-194-00: Unknown	1.813		
620-071	Fault Counter 05-195: SPARED (was IIT fault counter)		ND	SPARE 620-071	NVMFaultCounter	shortNatural	No	Fault Counter:05-195-00: Unknown	1.159		
620-072	Fault Counter 05-196:		RW	05-196 counter	NVMFaultCounter	shortNatural	No	Fault Counter:05-196-00: Unknown	1.813		
620-073	Fault Counter 05-197:		RW	05-197 counter	NVMFaultCounter	shortNatural	No	Fault Counter:05-197-00: Unknown	1.813		
620-074	Fault Counter 05-198:		RW	05-198 counter	NVMFaultCounter	shortNatural	No	Fault Counter:05-198-00: Unknown	1.813		
620-075	Fault Counter 05-199:		RW	05-199 counter	NVMFaultCounter	shortNatural	No	Fault Counter:05-199-00: Unknown	1.813		
620-076	Fault Counter 05-280:		RW	05-280 counter	NVMFaultCounter	shortNatural	No	Fault Counter:05-280-00: Unknown	1.813		
620-077	Fault Counter 05-304: SPARED (was IIT fault counter)		ND	SPARE 620-077	NVMFaultCounter	shortNatural	No	Fault Counter:05-304-00: Unknown	1.159		
620-078	Fault Counter 05-305:		RW	05-305 counter	NVMFaultCounter	shortNatural	No	Fault Counter:05-305-00: Unknown	1.159		

620-079	Fault Counter 05-306: SPARED (was IIT fault counter)		ND	SPARE 620-079	NVMFaultCounter	shortNatural	No	Fault Counter:05-306-00: Unknown	1.159		
620-080	Fault Counter 05-309:		RW	05-309 counter	NVMFaultCounter	shortNatural	No	Fault Counter:05-309-00: Unknown	1.159		
620-081	Fault Counter 05-900:		RW	05-900 counter	NVMFaultCounter	shortNatural	No	Fault Counter:05-900-00: Unknown	1.159		
620-082	Fault Counter 05-902: SPARED (was IIT fault counter)		ND	SPARE 620-082	NVMFaultCounter	shortNatural	No	Fault Counter:05-902-00: Unknown	1.159		
620-083	Fault Counter 05-903: SPARED (was IIT fault counter)		ND	SPARE 620-083	NVMFaultCounter	shortNatural	No	Fault Counter:05-903-00: Unknown	1.159		
620-084	Fault Counter 05-904: SPARED (was IIT fault counter)		ND	SPARE 620-084	NVMFaultCounter	shortNatural	No	Fault Counter:05-904-00: Unknown	1.159		
620-085	Fault Counter 05-906:		RW	05-906 counter	NVMFaultCounter	shortNatural	No	Fault Counter:05-906-00: Unknown	1.159		
620-086	Fault Counter 05-907:		RW	05-907 counter	NVMFaultCounter	shortNatural	No	Fault Counter:05-907-00: Unknown	1.159		
620-087	Fault Counter 05-908:		RW	05-908 counter	NVMFaultCounter	shortNatural	No	Fault Counter:05-908-00: Unknown	1.813		
620-088	Fault Counter 05-909:		RW	05-909 counter	NVMFaultCounter	shortNatural	No	Fault Counter:05-909-00: Unknown	1.813		
620-089	Fault Counter 05-910:		RW	05-910 counter	NVMFaultCounter	shortNatural	No	Fault Counter:05-910-00: Unknown	1.813		
620-090	Fault Counter 05-911:		RW	05-911 counter	NVMFaultCounter	shortNatural	No	Fault Counter:05-911-00: Unknown	1.813		
620-091	Fault Counter 05-912: SPARED (was IIT fault counter)		ND	SPARE 620-091	NVMFaultCounter	shortNatural	No	Fault Counter:05-912-00: Unknown	1.159		
620-092	Fault Counter 05-913:		RW	05-913 counter	NVMFaultCounter	shortNatural	No	Fault Counter:05-913-00: Unknown	1.813		

620-093	Fault Counter 05-914: SPARED (was IIT fault counter)		ND	SPARE 620-093	NVMFaultCounter	shortNatural	No	Fault Counter:05-914-00: Unknown	1.159		
620-094	Fault Counter 05-918: SPARED (was IIT fault counter)		ND	SPARE 620-094	NVMFaultCounter	shortNatural	No	Fault Counter:05-918-00: Unknown	1.159		
620-095	Fault Counter 05-919:		RW	05-919 counter	NVMFaultCounter	shortNatural	No	Fault Counter:05-919-00: Unknown	1.159		
620-096	Fault Counter 62-211: SPARED (was IIT fault counter)		ND	SPARE 620-096	NVMFaultCounter	shortNatural	No	Fault Counter:62-211-00: Unknown	1.159		
620-097	Fault Counter 62-277:		RW	62-277 counter	NVMFaultCounter	shortNatural	No	Fault Counter:62-277-00: Unknown	1.813		
620-098	Fault Counter 62-278: SPARED (was IIT fault counter)		ND	SPARE 620-098	NVMFaultCounter	shortNatural	No	Fault Counter:62-278-00: Unknown	1.159		
620-099	Fault Counter 62-310:		RW	62-310 counter	NVMFaultCounter	shortNatural	No	Fault Counter:62-310-00: Unknown	1.813		
620-100	Fault Counter 62-311:		RW	62-311 counter	NVMFaultCounter	shortNatural	No	Fault Counter:62-311-00: Unknown	1.810		
620-511	200 x 100 Scanned Lifetime Documents Number of jobs (not impressions) since activation that were scanned where the user selected 200 x 100 resolution	200 x 100 Scanned Lifetime Documents Number of jobs (not impressions) since	ND	200 x 100 Scanned Lifetime Docs	NVMSystemUsageCounter	byteArray	No	System Usage Counter:469: 200 x 100 Scanned Lifetime Documents	1.061		
620-522	Fault Counter 05-300: DADH open during run	DADH down sensor detects DADH opened whilst DADH in operation	RW	DADH OpenDuringRunFC	NVMFaultCounter	shortNatural	No	Fault Counter:05-300-00: DADH open during run	1.037		
620-523	Fault Counter 05-307: DADH LH cover interlock opened during run	24 V LH cover interlock opened during DADH in operation.	RW	DADHLHCovIntlockOpenDuringRunFC	NVMFaultCounter	shortNatural	No	Fault Counter:05-307-00: DADH LH cover interlock opened during run	1.037		
620-524	Fault Counter 05-310: DADH Source Doc Too Short For DADH	DADH ReportsDocument <110mm in length. See FD 8.3	RW	DADH Source Doc Too Short FC	NVMFaultCounter	shortNatural	No	Fault Counter:05-310-00: DADH Source Doc Too Short For DADH	1.037		
620-525	Fault Counter 05-330: LE late to post feed sensor S5 (misfeed)	Lead edge of original does not make the post feed sensor S5 in time window	RW	LE late to post feed sensorS5 FC	NVMFaultCounter	shortNatural	No	Fault Counter:05-330-00: LE late to post feed sensor S5 (misfeed)	1.037		
620-526	Fault Counter 05-331: TE late to post feed sensor S5 (multifeed)	Trail edge of original does not make the post feed sensor S5 in time window	RW	TE late to post feed sensorS5 FC	NVMFaultCounter	shortNatural	No	Fault Counter:05-331-00: TE late to post feed sensor S5 (multifeed)	1.037		
620-527	Fault Counter 05-335: LE late to TAR sensor S6	Lead edge of original does not make the TAR sensor S6 in time window	RW	LE late to TAR sensor S6 FC	NVMFaultCounter	shortNatural	No	Fault Counter:05-335-00: LE late to TAR sensor S6	1.037		
620-528	Fault Counter 05-340: LE late to Reg. Sensor S7	Lead edge of original does not make the Reg. sensor S7 in time window	RW	LE late to Reg. Sensor S7 FC	NVMFaultCounter	shortNatural	No	Fault Counter:05-340-00: LE late to Reg. Sensor S7	1.037		
620-529	Fault Counter 05-342: IIT/Scan LE late to mid-scan sensor	Trail edge of original does not make the Reg. sensor	RW	LE late to Exit sensor S8 FC	NVMFaultCounter	shortNatural	No	Fault Counter:05-345-00: LE late to Exit	1.810		
620-530	Fault Counter 05-346: TE late to Exit sensor S8 (FWD)	Trail edge of original does not make the Reg. sensor S8 in time window	RW	TE late to Exit sensor S8 FC	NVMFaultCounter	shortNatural	No	Fault Counter:05-346-00: TE late to Exit sensor S8 (FWD)	1.037		

620-531	Fault Counter 05-350: LE late to CVT sensor S10 (FWD)	Lead edge (FWD) of original does not make CVT sensor S10 in time window.	RW	LE late to CVT sensor S10 FWD FC	NVMFaultCounter	shortNatural	No	Fault Counter:05-350-00: LE late to CVT sensor S10 (FWD)	1.037		
620-532	Fault Counter 05-352: LE late to CVT sensor S10 (REV)	Lead edge (REV) of original does not make CVT sensor S10 in time window.	RW	LE late to CVT sensor S10 REV FC	NVMFaultCounter	shortNatural	No	Fault Counter:05-352-00: LE late to CVT sensor S10 (REV)	1.037		
620-548	Fault Counter 05-250-00: Kernel Checksum Error	DADH m/c corrupted flash memory	RW	KernelChecksumErrorFC	NVMFaultCounter	shortNatural	No	Fault Counter:05-250-00: Kernel Checksum Error	1.092		
620-549	Fault Counter 05-251-00: Application checksum error	DADH m/c corrupted flash memory	RW	ApplicationChecksumErrorFC	NVMFaultCounter	shortNatural	No	Fault Counter:05-251-00: Application checksum error	1.092		
620-550	Fault Counter 05-252-00: Stepper Controller Comms Error	Error when communicating between the stepper motor and DADH	RW	StepperControllerCommsErrorFC	NVMFaultCounter	shortNatural	No	Fault Counter:05-252-00: Stepper Controller Comms Error	1.092		
620-551	Fault Counter 05-253-00: IIT- DADH Comms Error	Error in comms between IIT and DADH	RW	IIT-DADHcommsErrorFC	NVMFaultCounter	shortNatural	No	Fault Counter:05-253-00: IIT- DADH Comms Error	1.721		
620-552	Fault Counter 05-254-00: Comms Sequence Error	When communications between IIT and DADH are out of sequence.	RW	CommsSequenceErrorFC	NVMFaultCounter	shortNatural	No	Fault Counter:05-254-00: Comms Sequence Error	1.092		
620-553	Fault Counter 05-259-00: DADH Hotline Error	The DADH hotline is in the wrong state during the scan	RW	DADHhotlineErrorFC	NVMFaultCounter	shortNatural	No	Fault Counter:05-259-00: DADH Hotline Error	1.092		
620-554	Fault Counter 05-260-00: DADH not in standby	The DADH is not in standby at the start of the job	RW	DADHnotInStandbyFC	NVMFaultCounter	shortNatural	No	Fault Counter:05-260-00: DADH not in standby	1.092		
620-577	BES2toS1Calibration_1	For S1 to S2 color matching routine	RW	BES2toS1Calibration_1	NVMMachVar	natural	No		1.738		
620-578	BES2toS1Calibration_2	For S1 to S2 color matching routine	RW	BES2toS1Calibration_2	NVMMachVar	natural	No		1.738		
620-579	BES2toS1Calibration_3	For S1 to S2 color matching routine	RW	BES2toS1Calibration_3	NVMMachVar	natural	No		1.738		
620-580	BES2toS1Calibration_4	For S1 to S2 color matching routine	RW	BES2toS1Calibration_4	NVMMachVar	natural	No		1.738		

620-581	BES2toS1Calibration_5	For S1 to S2 color matching routine	RW	BES2toS1Calibration_5	NVMMachVar	natural	No		1.738		
620-582	BES2toS1Calibration_6	For S1 to S2 color matching routine	RW	BES2toS1Calibration_6	NVMMachVar	natural	No		1.738		
620-583	BES2toS1Calibration_7	For S1 to S2 color matching routine	RW	BES2toS1Calibration_7	NVMMachVar	natural	No		1.738		
620-584	BES2toS1Calibration_8	For S1 to S2 color matching routine	RW	BES2toS1Calibration_8	NVMMachVar	natural	No		1.738		
620-585	BES2toS1Calibration_9	For S1 to S2 color matching routine	RW	BES2toS1Calibration_9	NVMMachVar	natural	No		1.738		
620-588	Fault Counter 05-966-00: DOCNOTFULLYINSERTED	no. of faults	RW	Fault Counter 05-966-00	NVMFaultCounter	shortNatural	No	Fault Counter:05-966-00: Unknown	1.581		
620-589	Fault Counter 05-100: IIT/Scan IIT SPDH EEPROM	no. of faults	RW	Fault Counter 05-100	NVMFaultCounter	shortNatural	No	Fault Counter:05-100-00:	1.643		
620-590	Fault Counter 05-131: IIT/Scan CVT Invert Sensor On Jam while inverting (PF2)	no. of faults	RW	Fault Counter 05-131	NVMFaultCounter	shortNatural	No	Fault Counter:05-131-00: CVTINVERTSNRONPF2JAMINVERTINGCOUNT	1.813		
620-591	Fault Counter 05-132: IIT/Scan CVT Invert Sensor On Jam (PF2)	no. of faults	RW	Fault Counter 05-132	NVMFaultCounter	shortNatural	No	Fault Counter:05-132-00: CVTINVERTSNRONPF2JAM	1.813		
620-592	Fault Counter 05-134: IIT/Scan CVT Invert Sensor Off Jam (Inv) (PF2)	no. of faults	RW	Fault Counter 05-134	NVMFaultCounter	shortNatural	No	Fault Counter:05-134-00: CVTINVERTSNROFFPF2JAM	1.813		
620-593	Fault Counter 05-139: IIT/Scan CVT Invert Sensor Off Jam (PF2)	no. of faults	RW	Fault Counter 05-139	NVMFaultCounter	shortNatural	No	Fault Counter:05-139-00: CVTINVERTSNRPF2OFFJAMCOUNT	1.813		
620-594	Fault Counter 05-145: IIT/Scan CVT-DADF Registration Sensor Off - Jam on inverting	no. of faults	RW	Fault Counter 05-145	NVMFaultCounter	shortNatural	No	Fault Counter:05-145-00: CVTREGSNROFFINVERTINGJAMCOUNT	1.813		
620-595	Fault Counter 05-146: IIT/Scan CVT-DADF Pre Registration Sensor Off Jam	no. of faults	RW	Fault Counter 05-146	NVMFaultCounter	shortNatural	No	Fault Counter:05-146-00: CVTPREREKSNROFFJAMCOUNT	1.813		
620-596	Fault Counter 05-147: IIT/Scan CVT-DADF Pre Registration Sensor Off Jam - Jam on inverting	no. of faults	RW	Fault Counter 05-147	NVMFaultCounter	shortNatural	No	Fault Counter:05-147-00: CVTPREREKSNROFFINVERTINGJAMCOUNT	1.813		
620-597	Fault Counter 05-210: IIT/Scan DADF Download Fail	no. of faults	RW	Fault Counter 05-210	NVMFaultCounter	shortNatural	No	Fault Counter:05-210-00: DADFDOWNLOADFAILCOUNT	1.643		

620-598	Fault Counter 05-336: IIT/Scan Document Feeder: IIT/Scan Paper jam at TAR sensor.	no. of faults	RW	Fault Counter 05-336	NVMFaultCounter	shortNatural	No	Fault Counter:05-336-00: IITARSNRJAMCOUNT	1.643		
620-599	Fault Counter 05-341: IIT/Scan Document Feeder: IIT/Scan Paper jam at Pre-Scan sensor.	no. of faults	RW	Fault Counter 05-341	NVMFaultCounter	shortNatural	No	Fault Counter:05-341-00: IITPRESCANSNRJAMCOUNT	1.643		
620-600	Fault Counter 05-343: IIT/Scan Document Feeder: IIT/Scan Paper jam at Mid Scan sensor.	no. of faults	RW	Fault Counter 05-343	NVMFaultCounter	shortNatural	No	Fault Counter:05-343-00: IITMIDSCANSNRJAMCOUNT	1.643		
620-601	Fault Counter 05-905: IIT/Scan CVT Feedout Sensor Static Jam (PF1.5 & PF2.02)	no. of faults	RW	Fault Counter 05-905	NVMFaultCounter	shortNatural	No	Fault Counter:05-905-00: CVTFEEDSNRJAMCOUNT	1.813		
620-602	Fault Counter 05-915: IIT/Scan CVT APS No.1 Sensor Static Jam (PF2 & 2.01 & PF2.02 & PF2.03 & PF3.01)	no. of faults	RW	Fault Counter 05-915	NVMFaultCounter	shortNatural	No	Fault Counter:05-915-00: CVTAPS1SNRJAMCOUNT	1.813		
620-603	Fault Counter 05-916: IIT/Scan CVT APS No.2 Sensor Static Jam (PF2 & 2.01 & PF2.02 & PF2.03 & PF3.01)	no. of faults	RW	Fault Counter 05-916	NVMFaultCounter	shortNatural	No	Fault Counter:05-916-00: CVTAPS2SNRJAMCOUNT	1.813		
620-604	Fault Counter 05-917: IIT/Scan CVT APS No.3 Sensor Static Jam(PF2 & 2.01 & PF2.02 & PF2.03	no. of faults	RW	Fault Counter 05-917	NVMFaultCounter	shortNatural	No	Fault Counter:05-917-00: CVTAPS3SNRJAMCOUNT	1.813		
620-605	Fault Counter 05-940: IIT/Scan DADF Feeder Tray Empty Fail	no. of faults	RW	Fault Counter 05-940	NVMFaultCounter	shortNatural	No	Fault Counter:05-940-00: DADFFEEDTRAYEMPTYFAILCOUNT	1.813		
620-606	Fault Counter 05-941: IIT/Scan Not Enough Originals detected in the DADF during DADF Fault Recovery	no. of faults	RW	Fault Counter 05-941	NVMFaultCounter	shortNatural	No	Fault Counter:05-941-00: LESSORIGINALSINDADFA TFAULTRECVRYCOUNT	1.813		
620-607	Fault Counter 05-945: IIT/Scan Fast Scan - size mismatch	no. of faults	RW	Fault Counter 05-945	NVMFaultCounter	shortNatural	No	Fault Counter:05-945-00: IITFSSIZEMISMATCHCOUNT	1.813		
620-608	Fault Counter 05-946: IIT/Scan Slow Scan - size	no. of faults	RW	Fault Counter 05-946	NVMFaultCounter	shortNatural	No	Fault Counter:05-946-00:	1.813		
620-609	Fault Counter 05-947: IIT/Scan CVT FS - size mismatch	no. of faults	RW	Fault Counter 05-947	NVMFaultCounter	shortNatural	No	Fault Counter:05-947-00: CVTFSSIZEMISMATCHCOUNT	1.813		
620-610	Fault Counter 05-948: IIT/Scan CVT SS - size mismatch	no. of faults	RW	Fault Counter 05-948	NVMFaultCounter	shortNatural	No	Fault Counter:05-948-00: CVTSSSIZEMISMATCHCO	1.813		
620-611	Fault Counter 05-958: IIT/Scan Nisca Document Feeder: IIT/Scan Lift Home Sensor Error.	no. of faults	RW	Fault Counter 05-958	NVMFaultCounter	shortNatural	No	Fault Counter:05-958-00: IITLIFTHOMESNRFAILCOUNT	1.643		
620-612	Fault Counter 05-959: IIT/Scan Nisca Document	no. of faults	RW	Fault Counter 05-959	NVMFaultCounter	shortNatural	No	Fault Counter:05-959-00:	1.643		
620-613	Fault Counter 05-961: IIT/Scan Nisca Document Feeder: IIT/Scan Motor Fan Lock Alarm.	no. of faults	RW	Fault Counter 05-961	NVMFaultCounter	shortNatural	No	Fault Counter:05-961-00: IITMTRFANLOCKALARMCOUNT	1.643		
620-615	Fault Counter 62-396: Side1 IIT/Scan CIS 1	no. of faults	RW	Fault Counter 62-396	NVMFaultCounter	shortNatural	No	Fault Counter:62-396-00:	1.643		
620-616	Fault Counter 62-397: Side1 IIT/Scan CIS1 pixel clock missing	no. of faults	RW	Fault Counter 62-397	NVMFaultCounter	shortNatural	No	Fault Counter:62-397-00: IITCIS1PXLCLKMISSINGCOUNT	1.813		
620-617	Fault Counter 62-398: Side1 IIT/Scan IIT-Cont I/O Cable Connection Fail	no. of faults	RW	Fault Counter 62-398	NVMFaultCounter	shortNatural	No	Fault Counter:62-398-00: IITIOCABLECONNECTFAILCOUNT	1.643		
620-618	Fault Counter 62-399: Side1 IIT/Scan NISCA DADF	no. of faults	RW	Fault Counter 62-399	NVMFaultCounter	shortNatural	No	Fault Counter:62-399-00:	1.643		
620-619	Fault Counter 62-450: Side1 IIT/Scan Calibration	no. of faults	RW	Fault Counter 62-450	NVMFaultCounter	shortNatural	No	Fault Counter:62-450-00:	1.813		
620-620	Fault Counter 62-451: Side1 IIT/Scan Calibration	no. of faults	RW	Fault Counter 62-451	NVMFaultCounter	shortNatural	No	Fault Counter:62-451-00:	1.813		

620-621	Fault Counter 62-452: Side1 IIT/Scan Calibration Pixel Offset Not Clear	no. of faults	RW	Fault Counter 62-452	NVMFaultCounter	shortNatural	No	Fault Counter:62-452-00: IITCALSIDE1PXLOFFSETN OTCLEARCOUNT	1.813		
620-622	Fault Counter 62-453: Side1 IIT/Scan Calibration Pixel Offset Not Done	no. of faults	RW	Fault Counter 62-453	NVMFaultCounter	shortNatural	No	Fault Counter:62-453-00: IITCALSIDE1PXLOFFSETN OTDONECOUNT	1.813		
620-623	Fault Counter 62-454: Side1 IIT/Scan Calibration Gain Range Not Clear	no. of faults	RW	Fault Counter 62-454	NVMFaultCounter	shortNatural	No	Fault Counter:62-454-00: IITCALSIDE1GAINRNGNOT	1.813		
620-624	Fault Counter 62-455: Side1 IIT/Scan Calibration	no. of faults	RW	Fault Counter 62-455	NVMFaultCounter	shortNatural	No	Fault Counter:62-455-00:	1.813		
620-625	Fault Counter 62-457: Side1 IIT/Scan Calibration Pixel Gain Not Done	no. of faults	RW	Fault Counter 62-457	NVMFaultCounter	shortNatural	No	Fault Counter:62-457-00: IITCALSIDE1PXLGAINNOT DONECOUNT	1.813		
620-626	Fault Counter 62-458: Side1 IIT/Scan Calibration Dark Range Errors	no. of faults	RW	Fault Counter 62-458	NVMFaultCounter	shortNatural	No	Fault Counter:62-458-00: IITCALSIDE1PXLOFFSETN OTDONECOUNT	1.813		
620-627	Fault Counter 62-459: Side1 IIT/Scan Calibration Pixel Offset Hi Errors	no. of faults	RW	Fault Counter 62-459	NVMFaultCounter	shortNatural	No	Fault Counter:62-459-00: IITCALSIDE1PXLOFFSETHI GHERRORCOUNT	1.813		
620-628	Fault Counter 62-460: Side1 IIT/Scan Calibration	no. of faults	RW	Fault Counter 62-460	NVMFaultCounter	shortNatural	No	Fault Counter:62-460-00:	1.813		
620-629	Fault Counter 62-461: Side1 IIT/Scan Calibration Gain Range Errors	no. of faults	RW	Fault Counter 62-461	NVMFaultCounter	shortNatural	No	Fault Counter:62-461-00: IITCALSIDE1GAINRNGERR	1.813		
620-630	Fault Counter 62-462: Side1 IIT/Scan Calibration Pixel Gain Hi Errors	no. of faults	RW	Fault Counter 62-462	NVMFaultCounter	shortNatural	No	Fault Counter:62-462-00: IITCALSIDE1PXLGAINHIGH ERRORCOUNT	1.813		
620-631	Fault Counter 62-463: Side1 IIT/Scan Calibration Pixel Gain Lo Errors	no. of faults	RW	Fault Counter 62-463	NVMFaultCounter	shortNatural	No	Fault Counter:62-463-00: IITCALSIDE1PXLGAINLOW ERRORCOUNT	1.813		
620-632	Fault Counter 62-466: Side1 IIT/Scan Dark Range Rail Error	no. of faults	RW	Fault Counter 62-466	NVMFaultCounter	shortNatural	No	Fault Counter:62-466-00: IITSIDE1DARKRNGRAILER RORCOUNT	1.813		
620-633	Fault Counter 62-467: Side1 IIT/Scan Gain Range Rail Error	no. of faults	RW	Fault Counter 62-467	NVMFaultCounter	shortNatural	No	Fault Counter:62-467-00: IITSIDE1GAINRNGRAILER RORCOUNT	1.813		
620-634	Fault Counter 62-468: Side1 IIT/Scan Color State Errors	no. of faults	RW	Fault Counter 62-468	NVMFaultCounter	shortNatural	No	Fault Counter:62-468-00: IITSIDE1COLORSTATEER RORCOUNT	1.813		
620-635	Fault Counter 62-476: Side1 IIT/Scan Stepper Home Error	no. of faults	RW	Fault Counter 62-476	NVMFaultCounter	shortNatural	No	Fault Counter:62-476-00: IITSTEPPERHOMEERROR	1.813		

620-636	Fault Counter 62-481: Side1 IIT/Scan DADH Client Time Out	no. of faults	RW	Fault Counter 62-481	NVMFaultCounter	shortNatural	No	Fault Counter:62-481-00: DADHCLIENTTIMEOUTCOUNT	1.813		
620-637	Fault Counter 62-486: Side1 IIT/Scan Supply 24 Volt Error	no. of faults	RW	Fault Counter 62-486	NVMFaultCounter	shortNatural	No	Fault Counter:62-486-00: IIT24VERRORCOUNT	1.813		
620-638	Fault Counter 62-490: Side1 IIT/Scan Data Steerer Error - Taurus 1	no. of faults	RW	Fault Counter 62-490	NVMFaultCounter	shortNatural	No	Fault Counter:62-490-00: IITSIDE1DATASTEERERERRORCOUNT	1.813		
620-639	Fault Counter 62-491: Side1 IIT/Scan Data Steerer Tx Error - Taurus 1	no. of faults	RW	Fault Counter 62-491	NVMFaultCounter	shortNatural	No	Fault Counter:62-491-00: IITSIDE1DATASTEERERTXERRORCOUNT	1.813		
620-640	Fault Counter 62-492: Side1 IIT/Scan video failure	no. of faults	RW	Fault Counter 62-492	NVMFaultCounter	shortNatural	No	Fault Counter:62-492-00: IITSIDE1VIDEOFAILCOUNT	1.643		
620-641	Fault Counter 62-779: Side1 IIT/Scan FPGA not loaded	no. of faults	RW	Fault Counter 62-779	NVMFaultCounter	shortNatural	No	Fault Counter:62-779-00: IITSIDE1FPGANOTLOADEDFAILCOUNT	1.813		
620-642	Fault Counter 62-780: Side1 IIT/Scan FPGA CRC Error	no. of faults	RW	Fault Counter 62-780	NVMFaultCounter	shortNatural	No	Fault Counter:62-780-00: IITSIDE1FPGACRCERRORCOUNT	1.813		
620-643	Fault Counter 62-781: Side1 IIT/Scan IIT Remote Nvm Out of Range	no. of faults	RW	Fault Counter 62-781	NVMFaultCounter	shortNatural	No	Fault Counter:62-781-00: IITSIDE1REMOTENVMOUOFNRNGCOUNT	1.813		
620-644	Fault Counter 62-782: Side1 IIT/Scan IIT Remote Nvm Read Timeout	no. of faults	RW	Fault Counter 62-782	NVMFaultCounter	shortNatural	No	Fault Counter:62-782-00: IITSIDE1REMOTENVMRDTIMEOUTCOUNT	1.813		
620-645	Fault Counter 62-783: Side1 IIT/Scan SPDH hotline error.	no. of faults	RW	Fault Counter 62-783	NVMFaultCounter	shortNatural	No	Fault Counter:62-783-00: IITSIDE1SPDHHOTLINEERROR	1.813		
620-646	Fault Counter 62-784: Side1 IIT/Scan IIT Platen hotline error	no. of faults	RW	Fault Counter 62-784	NVMFaultCounter	shortNatural	No	Fault Counter:62-784-00: IITSIDE1PLATENHOTLINEERROR	1.813		
620-647	Fault Counter 62-785: Side1 IIT/Scan Taurus 2 capability retry	no. of faults	RW	Fault Counter 62-785	NVMFaultCounter	shortNatural	No	Fault Counter:62-785-00: IITSIDE1TAURUS2CAPBLTYRETRYCOUNT	1.813		
620-648	Fault Counter 62-786: Side1 IIT/Scan Taurus 2 capability timeout	no. of faults	RW	Fault Counter 62-786	NVMFaultCounter	shortNatural	No	Fault Counter:62-786-00: IITSIDE1TAURUS2CAPBLTYTIMEOUTCOUNT	1.813		
620-649	Fault Counter 62-790: Side1 IIT/Scan Side 1 doorbell reject	no. of faults	RW	Fault Counter 62-790	NVMFaultCounter	shortNatural	No	Fault Counter:62-790-00: IITSIDE1DOORBELLREJE	1.773		
620-650	Fault Counter 62-791: Side1 IIT/Scan Side 1 doorbell timeout	no. of faults	RW	Fault Counter 62-791	NVMFaultCounter	shortNatural	No	Fault Counter:62-791-00: IITSIDE1DOORBELLTIMEOUTCOUNT	1.813		
620-651	Fault Counter 62-792: Side1 IIT/Scan Side 1 doorbell failure	no. of faults	RW	Fault Counter 62-792	NVMFaultCounter	shortNatural	No	Fault Counter:62-792-00: IITSIDE1DOORBELLFAILC	1.773		
620-652	Fault Counter 66-396: Side2 IIT/Scan CIS 2 Communication failure	no. of faults	RW	Fault Counter 66-396	NVMFaultCounter	shortNatural	No	Fault Counter:66-396-00: IITCIS2COMMFAILCOUNT	1.772		
620-653	Fault Counter 66-397: Side2 IIT/Scan CIS 2 Pixel clock missing	no. of faults	RW	Fault Counter 66-397	NVMFaultCounter	shortNatural	No	Fault Counter:66-397-00: IITCIS2PXLCLKMISSINGC	1.813		
620-654	Fault Counter 66-450: Side2 IIT/Scan Calibration Dark Range Not Clear	no. of faults	RW	Fault Counter 66-450	NVMFaultCounter	shortNatural	No	Fault Counter:66-450-00: IITSIDE2CALDARKRNGNO	1.813		
620-655	Fault Counter 66-451: Side2 IIT/Scan Calibration Dark Range Not Done	no. of faults	RW	Fault Counter 66-451	NVMFaultCounter	shortNatural	No	Fault Counter:66-451-00: IITSIDE2CALDARKRNGNO	1.813		
620-656	Fault Counter 66-452: Side2 IIT/Scan Calibration Pixel Offset Not Clear	no. of faults	RW	Fault Counter 66-452	NVMFaultCounter	shortNatural	No	Fault Counter:66-452-00: IITCALSIDE2PXLOFFSETN	1.813		

620-657	Fault Counter 66-453: Side2 IIT/Scan Calibration Pixel Offset Not Done	no. of faults	RW	Fault Counter 66-453	NVMFaultCounter	shortNatural	No	Fault Counter:66-453-00: IITCALSIDE2PXLOFFSETN	1.813		
620-658	Fault Counter 66-454: Side2 IIT/Scan Calibration Gain Range Not Clear	no. of faults	RW	Fault Counter 66-454	NVMFaultCounter	shortNatural	No	Fault Counter:66-454-00: IITCALSIDE2GAINRNGNOT	1.813		
620-659	Fault Counter 66-455: Side2 IIT/Scan Calibration Gain Range Not Done	no. of faults	RW	Fault Counter 66-455	NVMFaultCounter	shortNatural	No	Fault Counter:66-455-00: IITCALSIDE2GAINRNGNOT DONECOUNT	1.813		
620-660	Fault Counter 66-457: Side2 IIT/Scan Calibration Pixel Gain Not Done	no. of faults	RW	Fault Counter 66-457	NVMFaultCounter	shortNatural	No	Fault Counter:66-457-00: IITCALSIDE2PXLGAINNOT DONECOUNT	1.813		
620-661	Fault Counter 66-458: Side2 IIT/Scan Calibration Dark Range Errors	no. of faults	RW	Fault Counter 66-458	NVMFaultCounter	shortNatural	No	Fault Counter:66-458-00: IITCALSIDE2PXLOFFSETN	1.813		
620-662	Fault Counter 66-459: Side2 IIT/Scan Calibration Pixel Offset Hi Errors	no. of faults	RW	Fault Counter 66-459	NVMFaultCounter	shortNatural	No	Fault Counter:66-459-00: IITCALSIDE2PXLOFFSETHIGHERRORCOUNT	1.813		
620-663	Fault Counter 66-460: Side2 IIT/Scan Calibration Pixel Offset Lo Errors	no. of faults	RW	Fault Counter 66-460	NVMFaultCounter	shortNatural	No	Fault Counter:66-460-00: IITCALSIDE2PXLOFFSETL	1.813		
620-664	Fault Counter 66-461: Side2 IIT/Scan Calibration Gain Range Errors	no. of faults	RW	Fault Counter 66-461	NVMFaultCounter	shortNatural	No	Fault Counter:66-461-00: IITCALSIDE2GAINRNGERRORCOUNT	1.813		
620-665	Fault Counter 66-462: Side2 IIT/Scan Calibration Pixel Gain Hi Errors	no. of faults	RW	Fault Counter 66-462	NVMFaultCounter	shortNatural	No	Fault Counter:66-462-00: IITCALSIDE2PXLGAINHIGH ERRORCOUNT	1.813		
620-666	Fault Counter 66-463: Side2 IIT/Scan Calibration Pixel Gain Lo Errors	no. of faults	RW	Fault Counter 66-463	NVMFaultCounter	shortNatural	No	Fault Counter:66-463-00: IITCALSIDE2PXLGAINLOW ERRORCOUNT	1.813		
620-667	Fault Counter 66-466: Side2 IIT/Scan Dark Range Rail Error	no. of faults	RW	Fault Counter 66-466	NVMFaultCounter	shortNatural	No	Fault Counter:66-466-00: IITSIDE2DARKRNGRAILER RORCOUNT	1.813		
620-668	Fault Counter 66-467: Side2 IIT/Scan Gain Range Rail Error	no. of faults	RW	Fault Counter 66-467	NVMFaultCounter	shortNatural	No	Fault Counter:66-467-00: IITSIDE2GAINRNGRAILER RORCOUNT	1.813		
620-669	Fault Counter 66-468: Side2 IIT/Scan Color State Errors	no. of faults	RW	Fault Counter 66-468	NVMFaultCounter	shortNatural	No	Fault Counter:66-468-00: IITSIDE2COLORSTATEER RORCOUNT	1.813		



Machine Log Book

602E91901

Service Record

Date: Time:	Eng. No.: Name:	Type of Call:	
Meter 1 _____	2 _____	3 _____	4 _____
Problem/Cause/Solution		Parts Replaced	
Notes:			

Date: Time:	Eng. No.: Name:	Type of Call:	
Meter 1 _____	2 _____	3 _____	4 _____
Problem/Cause/Solution		Parts Replaced	
Notes:			

Service Record

Date: Time:	Eng. No.: Name:	Type of Call:	
Meter 1 _____	2 _____	3 _____	4 _____
Problem/Cause/Solution		Parts Replaced	
Notes:			

Date: Time:	Eng. No.: Name:	Type of Call:	
Meter 1 _____	2 _____	3 _____	4 _____
Problem/Cause/Solution		Parts Replaced	
Notes:			

Service Record

Date: Time:	Eng. No.: Name:	Type of Call:	
Meter 1	2	3	4
Problem/Cause/Solution		Parts Replaced	
Notes:			

Date: Time:	Eng. No.: Name:	Type of Call:	
Meter 1	2	3	4
Problem/Cause/Solution		Parts Replaced	
Notes:			

Service Record

Date: Time:	Eng. No.: Name:	Type of Call:	
Meter 1 _____	2 _____	3 _____	4 _____
Problem/Cause/Solution		Parts Replaced	
Notes:			

Date: Time:	Eng. No.: Name:	Type of Call:	
Meter 1 _____	2 _____	3 _____	4 _____
Problem/Cause/Solution		Parts Replaced	
Notes:			

Service Record

Date: Time:	Eng. No.: Name:	Type of Call:	
Meter 1 _____	2 _____	3 _____	4 _____
Problem/Cause/Solution		Parts Replaced	
Notes:			

Date: Time:	Eng. No.: Name:	Type of Call:	
Meter 1 _____	2 _____	3 _____	4 _____
Problem/Cause/Solution		Parts Replaced	
Notes:			

Service Record

Date: Time:	Eng. No.: Name:	Type of Call:	
Meter 1	2	3	4
Problem/Cause/Solution		Parts Replaced	
Notes:			

Date: Time:	Eng. No.: Name:	Type of Call:	
Meter 1	2	3	4
Problem/Cause/Solution		Parts Replaced	
Notes:			

Service Record

Date: Time:	Eng. No.: Name:	Type of Call:	
Meter 1	2	3	4
Problem/Cause/Solution		Parts Replaced	
Notes:			

Date: Time:	Eng. No.: Name:	Type of Call:	
Meter 1	2	3	4
Problem/Cause/Solution		Parts Replaced	
Notes:			

Service Record

Date: Time:	Eng. No.: Name:	Type of Call:	
Meter 1 _____	2 _____	3 _____	4 _____
Problem/Cause/Solution		Parts Replaced	
Notes:			

Date: Time:	Eng. No.: Name:	Type of Call:	
Meter 1 _____	2 _____	3 _____	4 _____
Problem/Cause/Solution		Parts Replaced	
Notes:			

Service Record

Date: Time:	Eng. No.: Name:	Type of Call:	
Meter 1	2	3	4
Problem/Cause/Solution		Parts Replaced	
Notes:			

Date: Time:	Eng. No.: Name:	Type of Call:	
Meter 1	2	3	4
Problem/Cause/Solution		Parts Replaced	
Notes:			

Service Record

Date: Time:	Eng. No.: Name:	Type of Call:	
Meter 1	2	3	4
Problem/Cause/Solution		Parts Replaced	
Notes:			

Date: Time:	Eng. No.: Name:	Type of Call:	
Meter 1	2	3	4
Problem/Cause/Solution		Parts Replaced	
Notes:			

Service Record

Date: Time:	Eng. No.: Name:	Type of Call:	
Meter 1	2	3	4
Problem/Cause/Solution		Parts Replaced	
Notes:			

Date: Time:	Eng. No.: Name:	Type of Call:	
Meter 1	2	3	4
Problem/Cause/Solution		Parts Replaced	
Notes:			

Service Record

Date: Time:	Eng. No.: Name:	Type of Call:	
Meter 1	2	3	4
Problem/Cause/Solution		Parts Replaced	
Notes:			

Date: Time:	Eng. No.: Name:	Type of Call:	
Meter 1	2	3	4
Problem/Cause/Solution		Parts Replaced	
Notes:			

Service Record

Date: Time:	Eng. No.: Name:	Type of Call:	
Meter 1	2	3	4
Problem/Cause/Solution		Parts Replaced	
Notes:			

Date: Time:	Eng. No.: Name:	Type of Call:	
Meter 1	2	3	4
Problem/Cause/Solution		Parts Replaced	
Notes:			

Service Record

Date: Time:	Eng. No.: Name:	Type of Call:	
Meter 1	2	3	4
Problem/Cause/Solution		Parts Replaced	
Notes:			

Date: Time:	Eng. No.: Name:	Type of Call:	
Meter 1	2	3	4
Problem/Cause/Solution		Parts Replaced	
Notes:			

CONFIDENTIAL
(When filled in)



EHS 700 - Health & Safety Incident Report Form For Incidents Involving a Xerox Product

For incidents in Canada: PIPEDA consent given	<input type="checkbox"/> YES <input type="checkbox"/> NO	EH&S Office Use ONLY EH&S Incident Reference Number:
PIPEDA is the Canadian "Personal Information Protection and Electronic Documents Act."		
For incidents in the EU: Safe Harbour Complaint	<input type="checkbox"/> YES <input type="checkbox"/> NO	

*Date Of Incident (mm / dd / yyyy):		
Product Description		
*Model No. or Product Name:		
Product Serial Number:	Serial Number(s) of Accessory(ies):	
Installation Date:	Total Copy Meter:	
Date of last service maintenance:		
List damaged and affected part(s) of the machine by description and part number:		
*Description	Part Number	
*Location of product and affected part(s):		
Customer Identification		
*Customer Name:	*Name of Customer Contact Person:	
*Address:	E-mail:	*Telephone:
		Fax:
Customer Service Engineer Identification		
*Name (required for Xerox serviced equipment):	Employee:	E-mail:
Location:	*Phone (required for Xerox serviced equipment):	
Individual Providing Notification		
*Name:	*Title:	*Telephone Number:
*Organization:	E-Mail:	
Mailing Address:	*Date Report Submitted:	

Details of Incident

***Description Of Incident: (Check all that apply)**

Smoke

Describe quantity and duration of smoke:

Fire with open flames seen

Electric shock to operator or service representative

Physical injury/illness to operator or service representative

Describe:

Other, describe:

MANDATORY DESCRIPTION (above): Provide a detailed description of all valid factors that may have contributed to the incident. Hardware involved in the incident should be preserved and retained for further investigation should investigation be deemed necessary by EH&S.

LIST INCIDENT DESCRIPTIONS AND SUPPORT DIAGRAMS/DATA INCLUDED OR ATTACHED:

***Any damage to customer property?** No Yes Describe:

***Did external emergency response provider(s) such as a fire department, ambulance, etc. respond?**

No Yes Identify: (i.e., source, names of individuals)

Apparent cause of incident (identify part that is suspected to be responsible for the incident)

***Preliminary actions taken to mitigate incident:**

Instructions: E-mail or fax both pages of this completed form to EH&S:

e-mail: usa.product.incident@xerox.com or fax 585-422-2249

* Required information is preceded by asterisk, **title shown in red** with a tan wash background

COPYRIGHT © 2023, XEROX CORPORATION.
ALL RIGHTS RESERVED. UNPUBLISHED
RIGHTS RESERVED UNDER THE COPYRIGHT
LAWS OF THE UNITED STATES.

PART#: 705P01475

xerox[™]