

Phaser® 7400

XEROX®

color printer

# Service Manual (Book 1)

# Options Manual (Book 2)

Updated 8/24/2015 DAW



Book 1: Print Engine  
Book 2: Options





# Phaser<sup>®</sup> 7400 Color Printer

## Service Manual Book 1: Print Engine

### **Warning**

The following servicing instructions are for use by qualified service personnel only. To avoid personal injury, do not perform any servicing other than that contained in the operating instructions, unless you are qualified to do so.

First Printing: August 2005

071-0876-00



Copyright © 2005 Xerox Corporation. All Rights Reserved. Unpublished rights reserved under the copyright laws of the United States. Contents of this publication may not be reproduced in any form without permission of Xerox Corporation.

Copyright protection claimed includes all forms of matters of copyrightable materials and information now allowed by statutory or judicial law or hereinafter granted, including without limitation, material generated from the software programs which are displayed on the screen such as styles, templates, icons, screen displays, looks, etc.

XEROX<sup>®</sup>, The Document Company<sup>®</sup>, the digital X<sup>®</sup>, CentreWare<sup>®</sup>, infoSMART<sup>®</sup>, Made For Each Other<sup>®</sup>, PagePack<sup>™</sup>, Phaser<sup>®</sup>, PhaserSMART<sup>®</sup>, and Walk-Up<sup>™</sup> are trademarks of Xerox Corporation in the United States and/or other countries.

Acrobat<sup>®</sup>, Adobe<sup>®</sup> Reader<sup>®</sup>, Adobe Type Manager<sup>®</sup>, ATM<sup>™</sup>, Illustrator<sup>®</sup>, PageMaker<sup>®</sup>, Photoshop<sup>®</sup>, PostScript<sup>®</sup>, Adobe Brilliant<sup>®</sup> Screens, Adobe Garamond<sup>®</sup>, Adobe Jenson<sup>™</sup>, Birch<sup>®</sup>, Carta<sup>®</sup>, IntelliSelect<sup>®</sup>, Mythos<sup>®</sup>, Quake<sup>®</sup>, and Tekton<sup>®</sup> are trademarks of Adobe Systems Incorporated in the United States and/or other countries.

Apple<sup>®</sup>, AppleTalk<sup>®</sup>, EtherTalk<sup>®</sup>, LaserWriter<sup>®</sup>, LocalTalk<sup>®</sup>, Macintosh<sup>®</sup>, Mac OS<sup>®</sup>, TrueType<sup>®</sup>, Apple Chancery<sup>®</sup>, Chicago<sup>®</sup>, Geneva<sup>®</sup>, Monaco<sup>®</sup>, New York<sup>®</sup>, and QuickDraw<sup>®</sup> are trademarks of Apple Computer, Inc. in the United States and/or other countries.

HP-GL<sup>®</sup>, HP-UX<sup>®</sup>, and PCL<sup>®</sup> are trademarks of Hewlett-Packard Corporation in the United States and/or other countries.

IBM<sup>®</sup> and AIX<sup>®</sup> are trademarks of International Business Machines Corporation in the United States and/or other countries.

Windows<sup>®</sup>, Windows NT<sup>®</sup>, Windows Server<sup>™</sup>, and Wingdings<sup>®</sup> are trademarks of Microsoft Corporation in the United States and/or other countries.

Novell<sup>®</sup>, NetWare<sup>®</sup>, NDPS<sup>®</sup>, NDS<sup>®</sup>, Novell Directory Services<sup>®</sup>, IPX<sup>™</sup>, and Novell Distributed Print Services<sup>™</sup> are trademarks of Novell, Incorporated in the United States and/or other countries.

Sun<sup>SM</sup>, Sun Microsystems<sup>™</sup>, and Solaris<sup>®</sup> are trademarks of Sun Microsystems, Incorporated in the United States and/or other countries.

SWOP<sup>®</sup> is a trademark of SWOP, Inc.

UNIX<sup>®</sup> is a trademark in the United States and other countries, licensed exclusively through X/Open Company Limited.

As an ENERGY STAR<sup>®</sup> partner, Xerox Corporation has determined that this product meets the ENERGY STAR guidelines for energy efficiency. The ENERGY STAR name and logo are registered U.S. marks.

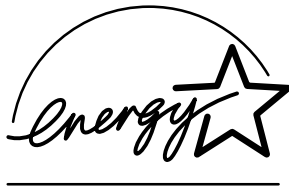

PANTONE<sup>®</sup> Colors generated may not match PANTONE-identified standards. Consult current PANTONE Publications for accurate color. PANTONE<sup>®</sup> and other Pantone, Inc. trademarks are the property of Pantone, Inc. © Pantone, Inc., 2000.

# Service Terms

## Manual Terms

Various terms are used throughout this manual to either provide additional information on a specific topic or to warn of possible danger present during a procedure or action. Be aware of all symbols and terms when they are used, and always read NOTE, CAUTION, and WARNING statements.

### Common Acronyms:

The following list defines the acronyms that may be found in this manual.

**ADC:** Automatic Density Control

**BTR:** Bias Transfer Roller

**CRUM:** Customer Replaceable Unit Monitor

**CTD:** Toner Density Control

**ESD:** Electrostatic Discharge

**IDT:** Intermediate Transfer Unit

**MCU:** Engine Control Board

**NCS:** Non-Contact Sensor

**PHD:** Imaging Unit

**PL:** Corresponds to the FRU Parts List.

**ROS:** Laser Scanning Unit

**RTC:** Charge Roller

### Note

A note indicates an operating or maintenance procedure, practice or condition that is necessary to efficiently accomplish a task.

A note can provide additional information related to a specific subject or add a comment on the results achieved through a previous action.

### Caution

A caution indicates an operating or maintenance procedure, practice or condition that, if not strictly observed, results in damage to, or destruction of, equipment.

### Warning

A warning indicates an operating or maintenance procedure, practice or condition that, if not strictly observed, results in injury or loss of life.

## Product Terms

**Caution:** A personal injury hazard exists that may not be apparent. For example, a panel may cover the hazardous area.

**Danger:** A personal injury hazard exists in the area where you see the sign.

# Symbols Marked on the Product



DANGER high voltage.



Protective ground (earth) symbol.



Hot surface on or in the printer. Use caution to avoid personal injury.



The surface is hot while the printer is running. After turning off the power, wait 30 minutes.



Avoid pinching fingers in the printer. Use caution to avoid personal injury.



Use caution (or draws attention to a particular component). Refer to the manual(s) for information.

# Power Safety Precautions

## Power Source

For 115 VAC printers, do not apply more than 135 volts RMS between the supply conductors or between either supply conductor and ground. For 230 VAC printers, do not apply more than 254 volts RMS between the supply conductors or between either supply conductor and ground. Use only the specified power cord and connector. This manual assumes that the reader is a qualified service technician.

Plug the three-wire power cord (with grounding prong) into a grounded AC outlet only. If necessary, contact a licensed electrician to install a properly grounded outlet. If the product loses its ground connection, contact with conductive parts may cause an electrical shock. A protective ground connection by way of the grounding conductor in the power cord is essential for safe operation.

## Disconnecting Power

### Warning

Turning the power off using the power switch does not completely de-energize the printer. You must also disconnect the power cord from the printer's AC inlet. Disconnect the power cord by pulling the plug, not the cord.

Disconnect the power cord in the following cases:

- if the power cord or plug is frayed or otherwise damaged,
- if any liquid or foreign material is spilled into the product,
- if the printer is exposed to any excess moisture,
- if the printer is dropped or damaged,
- if you suspect that the product needs servicing or repair,
- whenever you clean the product.

# Electrostatic Discharge (ESD) Precautions

Some semiconductor components, and the respective sub-assemblies that contain them, are vulnerable to damage by Electrostatic discharge (ESD). These components include Integrated Circuits (ICs), Large-Scale Integrated circuits (LSIs), field-effect transistors and other semiconductor chip components. The following techniques will reduce the occurrence of component damage caused by static electricity.

Be sure the power is off to the chassis or circuit board, and observe all other safety precautions.

- Immediately before handling any semiconductor components assemblies, drain the electrostatic charge from your body. This can be accomplished by touching an earth ground source or by wearing a wrist strap device connected to an earth ground source. Wearing a wrist strap will also prevent accumulation of additional bodily static charges. Be sure to remove the wrist strap before applying power to the unit under test to avoid potential shock.
- After removing a static sensitive assembly from its anti-static bag, place it on a grounded conductive surface. If the anti-static bag is conductive, you may ground the bag and use it as a conductive surface.
- Do not use freon-propelled chemicals. These can generate electrical charges sufficient to damage some devices.
- Do not remove a replacement component or electrical sub-assembly from its protective package until you are ready to install it.
- Immediately before removing the protective material from the leads of a replacement device, touch the protective material to the chassis or circuit assembly into which the device will be installed.
- Minimize body motions when handling unpacked replacement devices. Motion such as your clothes brushing together, or lifting a foot from a carpeted floor can generate enough static electricity to damage an electro-statically sensitive device
- Handle IC's and EPROM's carefully to avoid bending pins.
- Pay attention to the direction of parts when mounting or inserting them on Printed Circuit Boards (PCB's).

# Service Safety Summary

## General Guidelines

**For qualified service personnel only:** Refer also to the preceding Power Safety Precautions.

**Avoid servicing alone:** Do not perform internal service or adjustment of this product unless another person capable of rendering first aid or resuscitation is present.

**Use care when servicing with power:** Dangerous voltages may exist at several points in this product. To avoid personal injury, do not touch exposed connections and components while power is on. Disconnect power before removing the power supply shield or replacing components.

**Do not wear jewelry:** Remove jewelry prior to servicing. Rings, necklaces and other metallic objects could come into contact with dangerous voltages and currents.

## Warning Labels

Read and obey all posted warning labels. Throughout the printer, warning labels are displayed on potentially dangerous components. As you service the printer, check to make certain that all warning labels remain in place.

## Safety Interlocks

Make sure all covers are in place and all interlock switches are functioning correctly after you have completed a printer service call. If you bypass an interlock switch during a service call, use extreme caution when working on or around the printer.

## Servicing Electrical Components

Before starting any service procedure, switch off the printer power and unplug the power cord from the wall outlet. If you must service the printer with power applied, be aware of the potential for electrical shock.

### Warning

Do not touch any electrical component unless you are instructed to do so by a service procedure.



## Servicing Mechanical Components

When servicing mechanical components within the printer, manually rotate drive assemblies, rollers, and gears.

### Warning

Do not try to manually rotate or manually stop the drive assemblies while any printer motor is running.



## Servicing Fuser Components

### Warning

This printer uses heat to fuse the toner image to media. The Fuser is VERY HOT. Turn the printer power off and wait at least 5 minutes for the Fuser to cool before you attempt to service the Fuser or adjacent components.



# Regulatory Specifications

Xerox has tested this product to electromagnetic emission and immunity standards. These standards are designed to mitigate interference caused or received by this product in a typical office environment.

## United States (FCC Regulations)

This equipment has been tested and found to comply with the limits for a Class A digital device, pursuant to Part 15 of the FCC Rules. These limits are designed to provide reasonable protection against harmful interference when the equipment is operated in a commercial environment. This equipment generates, uses, and can radiate radio frequency energy. If it is not installed and used in accordance with these instructions, it may cause harmful interference to radio communications. Operation of this equipment in a residential area is likely to cause harmful interference in which case the user will be required to correct the interference at his/her own expense.

If this equipment does cause harmful interference to radio or television reception, which can be determined by turning the equipment off and on, the user is encouraged to try to correct the interference by one or more of the following measures:

- Reorient or relocate the receiver.
- Increase the separation between the equipment and receiver.
- Connect the equipment into an outlet on a circuit different from that to which the receiver is connected.
- Consult the dealer or an experienced radio/television technician for help.

Any changes or modifications not expressly approved by Xerox could void the user's authority to operate the equipment. To ensure compliance with Part 15 of the FCC rules, use shielded interface cables.

## Canada (Regulations)

This Class A digital apparatus complies with Canadian ICES-003.

Cet appareil numérique de la classe A est conforme à la norme NMB-003 du Canada.

## Warning

This is a class A product. In a domestic environment this product may cause radio interference in which case the user may be required to take adequate measures.

Xerox Corporation declares, under our sole responsibility, that the product to which this declaration relates is in conformity with the following standards and other normative documents:

### **Low Voltage Directive 73/23/EEC as amended**

---

EN 60950:2000

---

EN 60825-1:1994+A1:2001+A2:2002

---

### **Electromagnetic Compatibility Directive 89/336/EEC as amended**

---

EN 55022:1998 +A1:2000 +A2:2003

---

EN 55024:1998 +A1:2000 +A2:2003

---

EN 61000-3-2:2000

---

EN 61000-3-3:1995 +A1:2001

---

### **Radio & Telecommunications Terminal Equipment Directive 1999/5/EC as amended**

---

EN 300 330-2 V1.1.1

---

EN 300 440-2 V1.1.1

---

EN 300 489-3 V1.3.1

---

This product, if used properly in accordance with the user's instructions, is neither dangerous for the consumer nor for the environment.

A signed copy of the Declaration of Conformity for this product can be obtained from Xerox.

# Manual Organization

The *Phaser 7400 Color Printer Service Manual* is the primary document used for repairing, maintaining, and troubleshooting the printer. The manual is organized into two books. This volume, Book 1, focuses on the print engine with the exception of providing complete diagnostic and troubleshooting procedure for the printer and all its options. Book 2 focuses on option repair and includes an overview of option theory, option Field Replaceable Unit (FRU) replacement procedures, parts lists, and wiring diagrams. Use Book 2 after you've isolated a problem internal to a specific option or when a problem arises at the engine/option interface.

## Book 1 - Print Engine

Use Book 1 as your primary resource for understanding the operational characteristics of the print engine. Book 1 describes printer specifications, theory and includes information important to the diagnosis and repair of problems occurring in the print engine and attached options. Book 1 also provides detailed print engine replacement procedures, parts lists, and wiring diagrams.

Book 1 contains these sections:

**Introductory, Safety, and Regulatory Information:** This section contains important safety information and regulatory requirements.

**Section 1 - General Information:** This section contains an overview of the printer's operation, configuration, specifications, and consumables.

**Section 2 - Theory of Operation:** This section contains detailed functional information on print engine components.

**Section 3 - Error Codes and Messages:** This section describes the resident diagnostics available to assist the troubleshooting process. These diagnostics include error codes and messages and Service Usage Profile data stored in the printer. This section provides complete troubleshooting information for the print engine and all its options.

**Section 4 - General Troubleshooting:** Troubleshooting discussions cover the operation of Power On Self Test (POST), Service Diagnostics, In addition, this section includes troubleshooting methods for situations where no error indicator is available.

**Section 5 - Print-Quality Troubleshooting:** This section focuses on techniques to correct image quality problems associated with printer output.

**Section 6 - Adjustments and Calibrations:** This section provides procedures for the adjustment of print engine components.

**Section 7 - Cleaning and Maintenance:** This section provides periodic cleaning procedures for the printer.

**Section 8 - Service Parts Disassembly:** This section contains removal procedures for spare parts listed in the Parts List. A replacement procedure is included when necessary.

**Section 9 - Parts List:** This section contains exploded views of the print engine and option FRUs, as well as part numbers for orderable parts.

**Section 10 - Wiring Diagrams:** This section contains the plug/jack locations and the wiring diagrams for the print engine.

**Appendix A - Reference:** This section provides an illustration of the printer's menu structure, a listing of printer status codes, and a list of Service Diagnostics tests.

## Book 2 - Options

Use Book 2 as a reference when servicing printer options. Book 2 includes information important for the repair or replacement of option components. Use the troubleshooting procedures in Book 1 to diagnose and isolated the problem.

Book 2 contains these sections:

**Introductory, Safety, and Regulatory Information:** This section contains important safety information, regulatory requirements, and information about this manual.

**Section 1 - General Information:** This section contains an overview of the options available, configuration, specifications and consumables.

**Section 2 - Theory of Operation:** This section contains functional information on each option.

**Section 3 - General Troubleshooting:** This this section includes information and procedures for troubleshooting optional components.

**Section 4 - Adjustments and Calibrations:** This section provides procedures for the adjustment of print engine components.

**Section 5 - Service Parts Disassembly:** This section contains removal procedures for parts listed in the option's Field Replaceable Units (FRUs) Parts List. A replacement procedure is included when necessary.

**Section 6 - Parts Lists:** This section contains exploded views of the option FRUs, as well as FRU part numbers.

**Section 7 - Wiring Diagrams:** This section contains option plug/jack locations and wiring diagrams.

# Contents

Service Terms .....	iii
Symbols Marked on the Product .....	iv
Power Safety Precautions .....	v
Electrostatic Discharge (ESD) Precautions .....	vi
Service Safety Summary .....	vii
Regulatory Specifications .....	ix
Manual Organization .....	xi

## 1 General Information

Printer Introduction and Overview .....	1-2
Printer Configurations .....	1-3
Metered Printing .....	1-4
Parts of the Printer .....	1-5
Control Panel .....	1-7
Image Processor Board .....	1-8
Printer Options .....	1-9
Hard Drive .....	1-9
Additional Memory .....	1-9
Configuration Card .....	1-10
550-Sheet Feeder .....	1-10
1650-Sheet Feeder .....	1-10
Duplex Unit .....	1-11
Finisher .....	1-11
Maintenance Items .....	1-12
Consumables .....	1-12
Specifications .....	1-13
Memory Specifications .....	1-13
Consumable Life Specifications .....	1-13
Electrical Specifications .....	1-14
Physical Dimensions and Clearances .....	1-14
Functional Specifications .....	1-16
First Print Output Time .....	1-16
Image Specifications .....	1-17
Environmental Specifications .....	1-17
Media and Tray Specifications .....	1-18

## 2 Theory of Operation

Phaser 7400 Operational Overview . . . . .	2-2
Imaging Unit . . . . .	2-3
LED Heads . . . . .	2-4
Fuser . . . . .	2-4
Transfer Unit . . . . .	2-5
Print Process Summary . . . . .	2-6
Printer Controls . . . . .	2-10
Print-Quality Modes . . . . .	2-10
Color Registration Control . . . . .	2-10
Automatic Density Control . . . . .	2-13
Selective Control: Paper Pick . . . . .	2-13
Image Transfer Control . . . . .	2-14
Fuser Temperature Control . . . . .	2-14
Consumable Control . . . . .	2-14
Sensors . . . . .	2-15
Sensor Types . . . . .	2-15
Sensors in the Printer . . . . .	2-17
Sensor Functions . . . . .	2-19
Paper Level Detection . . . . .	2-21
Paper Present Detection . . . . .	2-21
Transparent Media Detection . . . . .	2-21
Automatic Media Thickness Detection . . . . .	2-21
Paper Size Detection . . . . .	2-22
Jam Detection . . . . .	2-23
Interlock Detection . . . . .	2-24
Toner Detection . . . . .	2-24
Input Paper Path . . . . .	2-27
Paper Fed from Tray 1 (MPT) . . . . .	2-27
Paper Fed from Tray 2 . . . . .	2-30
Paper Fed from Optional Trays . . . . .	2-33
Duplex Unit . . . . .	2-35
Output Paper Path . . . . .	2-37
Fuser and Exit . . . . .	2-37
Top Output Tray . . . . .	2-38
Side Output Tray . . . . .	2-38
Finisher/Inverter . . . . .	2-38
Drive Assemblies . . . . .	2-39
Imaging Unit Drive Motors . . . . .	2-39
Transfer Unit Motor . . . . .	2-41
Fuser Motor . . . . .	2-43
Toner Dispense Motors . . . . .	2-44
Duplex Drive Motors . . . . .	2-45

Chassis Assemblies . . . . .	2-46
Basket Assembly. . . . .	2-46
Waste Toner Recovery . . . . .	2-47
Registration Assembly . . . . .	2-48
Exit Assembly . . . . .	2-49
Job Offset Assembly. . . . .	2-51
Trays . . . . .	2-52
Tray 1 (MPT) . . . . .	2-52
Universal Trays . . . . .	2-53
Universal Feeder . . . . .	2-54
Side Output Tray. . . . .	2-54
Electrical. . . . .	2-55
Control Panel . . . . .	2-56
Image Processor Board . . . . .	2-56
Engine Control Board . . . . .	2-56
Registration Sensor Board . . . . .	2-56
LED Relay Board. . . . .	2-56
Imaging Unit Sensor Board. . . . .	2-57
Motor Driver Board. . . . .	2-57
Feeder Board. . . . .	2-57
HVPS . . . . .	2-58
LVPS. . . . .	2-59
Front Sensor Board. . . . .	2-59
Rear Sensor Board . . . . .	2-59
Fans . . . . .	2-60
Solenoids and Clutches . . . . .	2-61

### 3 Error Messages and Codes

Introduction . . . . .	3-2
Accessing Fault History . . . . .	3-2
Status Page. . . . .	3-3
Service Usage Profile . . . . .	3-3
Servicing Instructions . . . . .	3-4
Messages, Codes, and Procedures . . . . .	3-5
Error Message Abbreviations . . . . .	3-5
Jam Locator . . . . .	3-6
Error Message Summary . . . . .	3-7
Using the Troubleshooting Procedures. . . . .	3-15
Measurement Techniques. . . . .	3-16
Jam Error Procedures . . . . .	3-17
Jam at Door A Open Door A to Clear . . . . .	3-17
Jam at Door A Open Door A to Clear . . . . .	3-19
Jam at Door A Misfeed at Tray 1 (MPT) . . . . .	3-20
Jam at Door B Misfeed at Tray 2. . . . .	3-21
Jam at Door C for Tray [3][4][5][6] . . . . .	3-23
Jam at Door D Open Door D to Clear . . . . .	3-25

Jam in Duplex Unit . . . . .	3-26
Jam at Door E . . . . .	3-27
Jam Under Imaging Units . . . . .	3-29
Jam in Fuser . . . . .	3-31
Jam at Duplex Entrance . . . . .	3-33
Jam at Finisher Punch Unit . . . . .	3-35
Jam at Finisher Door H . . . . .	3-36
Jam at Finisher Door H . . . . .	3-37
Jam at Finisher Upper Output Tray . . . . .	3-38
Jam at Finisher Saddle Stapler . . . . .	3-39
Jam at Finisher Upper Output Tray . . . . .	3-40
Jam at Finisher Stapler . . . . .	3-41
Jam at Finisher Door G . . . . .	3-42
Jam at Finisher Saddle Stapler . . . . .	3-43
Jam at Finisher Upper Output Tray . . . . .	3-44
Jam Inside Finisher . . . . .	3-45
Jam at Finisher Entrance . . . . .	3-46
Finisher Output Tray Jammed . . . . .	3-47
Door and Cover Errors . . . . .	3-49
Close Top Cover . . . . .	3-49
Close Right Door A . . . . .	3-50
Close Right Door B . . . . .	3-51
Close Right Door C for Tray [3][4][5][6] . . . . .	3-53
Close Left Door D . . . . .	3-54
Close Left Door E . . . . .	3-55
Close Finisher Door F . . . . .	3-56
Close Finisher Door H . . . . .	3-57
Close Finisher Door J . . . . .	3-58
Consumable/Routine Maintenance Procedures . . . . .	3-59
Replace [C][M][Y][K] Toner Cartridge . . . . .	3-59
Replace [C][M][Y][K] Imaging Unit . . . . .	3-60
Replace Transfer Unit . . . . .	3-61
Replace Waste Cartridge . . . . .	3-62
Replace Fuser . . . . .	3-63
Install, Reseat or Lock [C][M][Y][K] Toner Cartridge . . . . .	3-64
Install or Reseat [C][M][Y][K] Imaging Unit . . . . .	3-65
Install or Reseat Transfer Unit . . . . .	3-66
Install or Reseat Waste Cartridge . . . . .	3-67
Install or Reseat Fuser . . . . .	3-68
Metered Toner Is not Enabled . . . . .	3-69
Replace Metered [C][M][Y][K] Toner Cartridge . . . . .	3-70



Tray and Media Errors	3-71
Clear Tray 1 (MPT) Riser Plate	3-71
Clear Tray [2][3][4][5][6] Riser Plate	3-73
Out of Paper Load Tray 1(MPT) with [size] [type]	3-74
Out of Paper Load Tray [2][3][4][5][6] with [size][type]	3-75
Manual Feed [size][type]	3-76
Top Output Tray Is Full, Unload Paper	3-77
Left Side Output Tray Is Full, Unload Paper	3-78
Finisher Lower Output Tray is Full, Unload Paper	3-79
Finisher Upper Output Tray is Full, Unload Paper	3-80
Open Left Side Output Tray	3-81
Media Mismatch Errors	3-82
Wrong Paper Size; Load Tray 1 (MPT) with [size][type]	3-82
Wrong Paper Size; Load Tray 2 with [size][type]	3-83
Wrong Paper Size; Load Tray [3][4][5][6] with [size][type]	3-84
Wrong Paper Type Load Tray [1 (MPT)][2][3][4][5][6] with [size][type]	3-85
Paper Not Available Load Tray 1 (MPT) with [size] [type]	3-86
Paper Not Available; Load Tray 2 with [size][type]	3-87
Paper Not Available Load Tray [3][4][5][6] with [size][type]	3-88
Configuration Errors	3-89
Invalid or Missing Configuration Card	3-89
Duplicate IP Address Detected	3-89
Fatal Error Procedures	3-90
Fuser Failure	3-90
Temp Sensor Failure	3-92
RH Sensor Failure	3-93
LED Over Temperature Failure	3-94
Motor Overheating Failure	3-95
Engine Failure	3-96
Power Supply Failure	3-97
Feeder Home Failure	3-98
Controller Fan Failure	3-99
Power Supply Fan Failure	3-100
Top Cover Cooling Fan Failure	3-101
Imaging Unit Fan Failure	3-102
Transfer Unit Fan Failure	3-103
Engine Cavity Fan Failure	3-104
Duplex Interface Failure	3-105
Tray [3][4][5][6] Interface Failure	3-106
Inverter Unit Interface Failure	3-107
[C][M][Y][K] LED Failure	3-108
[C][M][Y][K] Imaging Unit Failure	3-109
Flash Failure	3-111
Fuser Fan Failure	3-112
Fuser 110v/220v Mismatch Failure	3-113

Unsupported Duplex Unit ROM . . . . .	3-114
Unsupported Tray 2 ROM . . . . .	3-115
Unsupported Tray [3][4][5][6] ROM . . . . .	3-116
Unsupported Inverter Unit ROM . . . . .	3-117
Unsupported Finisher Unit ROM . . . . .	3-118
Hard Drive Failure . . . . .	3-119
Fuse Cut Error In Fuser . . . . .	3-120
Fuse Cut Error In Transfer Unit . . . . .	3-121
Fuse Cut Error In [C][M][Y][K] Imaging Unit. . . . .	3-122
Controller to Engine Communications Failure . . . . .	3-123
Finisher Fold Position Sensor Failure. . . . .	3-124
Finisher Paddle Failure. . . . .	3-125
Finisher Stapler Swing Motor Failure. . . . .	3-126
Finisher Stack Handling Motor Failure . . . . .	3-127
Finisher Staple Motor Failure . . . . .	3-128
Finisher Jog Motor Failure . . . . .	3-129
Finisher Lift Motor Failure . . . . .	3-130
Finisher Exit Failure . . . . .	3-132
Finisher Punch Side Registration Sensor Failure . . . . .	3-133
Finisher Punch Registration Sensor Failure . . . . .	3-134
Finisher Punch Backup RAM Failure . . . . .	3-135
Finisher Punch Communications Failure . . . . .	3-136
Finisher Punch Unit Transfer Motor Failure . . . . .	3-137
Finisher Punch Motor Failure. . . . .	3-138
Finisher Backup RAM Failure . . . . .	3-139
Finisher Punch Dust Sensor Failure . . . . .	3-140
Printer Error - Contact Service; report fault [n] . . . . .	3-141
Finisher Punch Unit Counter at End of Life . . . . .	3-141
Finisher Staple Unit Counter at End of Life. . . . .	3-142
Finisher Interface Error . . . . .	3-143
Inverter Power Supply Failure . . . . .	3-144
Fuser Thermistor Errors. . . . .	3-145
Job Offset Home Position Error . . . . .	3-146
Control Panel Communications Failure . . . . .	3-147
No Data to the [C][M][Y][K] LED Head . . . . .	3-148
Motor Driver Board Communications Error . . . . .	3-149
Tray [3][4][5][6] Firmware Error . . . . .	3-150
Duplex Unit Firmware Error . . . . .	3-151
Motor Driver Board Firmware Error . . . . .	3-152
Finisher Inverter Firmware Error . . . . .	3-153
CRUM Reader Board Failure . . . . .	3-154
Tray [3][4][5][6] Flash Memory Failure . . . . .	3-155
Duplex Unit Flash Memory Failure . . . . .	3-156
Motor Driver Board Flash Memory Failure . . . . .	3-157
Finisher Inverter Flash Memory Failure . . . . .	3-158
Tray 2 Lift Motor Failure . . . . .	3-159

Tray [3][4][5][6] Lift Motor Failure . . . . .	3-160
Error in the Transfer Unit Belt . . . . .	3-162
Duplex Unit Fan Failure . . . . .	3-163
+24V Not Available to the Duplex Unit . . . . .	3-164
Failure in the [C][M][Y][K] Imaging Unit Drum or Motor . . . . .	3-165
+24 V Not Available to Tray [3][4][5][6]. . . . .	3-167
Failure in the Fuser Motor . . . . .	3-168
Failure in the Waste Toner Motor . . . . .	3-169
Motor Driver Board Clock Frequency Error . . . . .	3-170
Duplex Unit Clock Frequency Error . . . . .	3-171
Finisher Inverter Clock Frequency Error . . . . .	3-172
Tray [3][4][5][6] Feeder Board Clock Frequency Error . . . . .	3-173
Waste Toner Transfer Error . . . . .	3-174
[CM][YK] Toner Supply Failure . . . . .	3-176
Warning Messages . . . . .	3-177
No Paper in Tray 1 (MPT) . . . . .	3-177
No Paper in Tray [2][3][4][5][6]. . . . .	3-178
Left Side Output Tray is Closed . . . . .	3-179
Waste Cartridge is Almost Full . . . . .	3-180
Non-Xerox [C][M][Y][K] Toner Cartridge . . . . .	3-181
Staple Cartridge Is Empty . . . . .	3-182
Punch Waste Box is Full or Missing . . . . .	3-183
Finisher Away From Base . . . . .	3-184
Finisher Away From Printer . . . . .	3-185

## 4 General Troubleshooting

Introduction . . . . .	4-2
System Startup . . . . .	4-2
Power On Self Test (POST) . . . . .	4-3
POST Soft Fault Messages . . . . .	4-4
POST Hard Fault Messages . . . . .	4-5
Fault Isolation . . . . .	4-6
Entry Level Fault Isolation Procedure . . . . .	4-6
Service Diagnostics . . . . .	4-7
Using Service Diagnostics . . . . .	4-7
Service Diagnostics Controls . . . . .	4-8
Service Diagnostics Utilities . . . . .	4-9
Status . . . . .	4-9
Test Prints . . . . .	4-10
Control Panel Troubleshooting . . . . .	4-10
No Control Panel Display after Power Is Turned On . . . . .	4-10
Control Panel LED Is On, Control Panel Display Is Blank . . . . .	4-11

Inoperable Printer Troubleshooting . . . . .	4-11
Engine Power-Up Sequence (BIST) . . . . .	4-12
Printer Continually Displays Warming Up. . . . .	4-13
Printer Displays Install or Reseat Imaging Unit . . . . .	4-13
Printer Displays Reseat Controller Board . . . . .	4-13
Printer Does Not Come to a Ready State . . . . .	4-14
Paper Size Switch Assembly . . . . .	4-14
Power Supply . . . . .	4-16
AC Power Supply Troubleshooting . . . . .	4-16
DC Power Supply Troubleshooting . . . . .	4-17
RAM Memory Fault Isolation . . . . .	4-17
Media Jams and the Paper Path . . . . .	4-19
Operating System and Application Problems . . . . .	4-21
Macintosh Printing Problems . . . . .	4-21
Windows Printing Problems . . . . .	4-23
Network Problems . . . . .	4-24
Network Diagnostics . . . . .	4-24
Network Logging . . . . .	4-26
USB Port Testing . . . . .	4-27

## 5 Print-Quality Troubleshooting

Print-Quality Problems Overview . . . . .	5-2
Defects Associated with Specific Printer Components . . . . .	5-3
Test Prints . . . . .	5-4
Analyzing the 100% Solid Fill Pages . . . . .	5-4
Analyzing the Color Test Pages . . . . .	5-5
Analyzing the PS Pattern . . . . .	5-6
Analyzing the Color Step Pages . . . . .	5-7
Print-Quality Troubleshooting . . . . .	5-8
Light Prints in All Colors . . . . .	5-8
Light Print in Only One Color . . . . .	5-10
Blank Prints . . . . .	5-12
Mottled or Splotchy Prints . . . . .	5-14
Unexpected Colors . . . . .	5-16
Repeating Bands, Lines, Marks, or Spots . . . . .	5-18
Random Bands, Lines, Marks, or Missing Spots . . . . .	5-19
Random Spots . . . . .	5-21
Background Contamination . . . . .	5-23
Residual Image, Ghosting or Hot Offset . . . . .	5-25
Incomplete Fusing or Cold Offset . . . . .	5-27
Mis-Registration, Color Layers Not Correctly Registered . . . . .	5-28
Toner on Back of Print . . . . .	5-31
Image Not Centered or Positioned Correctly . . . . .	5-32
Process Direction Bands, Voids, or Streaks . . . . .	5-34
Scan Direction Bands, Voids, or Streaks . . . . .	5-35
Scan Direction Dark Streaks . . . . .	5-37
Process Direction Bands, Voids, or Streaks . . . . .	5-38

## 6 Adjustments and Calibrations

Calibrations . . . . .	6-2
Color Calibration . . . . .	6-2
Margin Calibration . . . . .	6-2
Automatic Density Control (ADC) Calibration . . . . .	6-2
Automatic Thickness (ATS) Calibration . . . . .	6-4
Adjustments . . . . .	6-5
Vertical and Horizontal Color Registration . . . . .	6-5
Resetting NVRAM . . . . .	6-6
Restore Factory Color Settings . . . . .	6-6
Restore Previous Color Settings . . . . .	6-6
Restore Factory Margins Settings . . . . .	6-6
Resetting Connection Setup Defaults . . . . .	6-7
Resetting PostScript Setup Defaults . . . . .	6-7
Resetting PCL Setup Values to Default . . . . .	6-7
Resetting Control Panel Setup Values to Default . . . . .	6-8
Resetting Printer Controls Values to Default . . . . .	6-8
Resetting All Printer Defaults (PostScript NVRAM) . . . . .	6-8
Service Diagnostics NVRAM Utilities . . . . .	6-9
Postscript NVRAM Reset . . . . .	6-9
CRU Counter Read . . . . .	6-9
CRU Counter Reset . . . . .	6-9

## 7 Cleaning and Maintenance

Service Maintenance Procedures . . . . .	7-2
Cleaning . . . . .	7-2
Cleaning the Imaging Unit Contacts . . . . .	7-3
Cleaning the LED Heads . . . . .	7-5
Cleaning the Feed Rollers . . . . .	7-5
Maintenance . . . . .	7-6
RIP (Repair, Inspect, and Prevent) Procedures . . . . .	7-6

## 8 Service Parts Disassembly

Overview . . . . .	8-5
Standard Orientation of the Printer . . . . .	8-5
General Notes on Disassembly . . . . .	8-6
Preparation . . . . .	8-6
Notations in the Disassembly Text . . . . .	8-6
Fastener Types . . . . .	8-7
Maintenance Items and Consumables . . . . .	8-8
Imaging Unit Removal . . . . .	8-8
Toner Cartridge Removal . . . . .	8-9
Transfer Unit Removal . . . . .	8-10
Fuser Removal . . . . .	8-11

Print Engine Disassembly . . . . .	8-12
Covers . . . . .	8-13
Rear Cover . . . . .	8-13
Lower Rear Cover . . . . .	8-14
Right Rear Cover . . . . .	8-15
Right Side Cover . . . . .	8-16
Left Side Cover . . . . .	8-17
Front Door . . . . .	8-18
Door B . . . . .	8-19
Left Rear Cover . . . . .	8-20
Left Front Cover . . . . .	8-21
Upper Front Cover . . . . .	8-22
Right Front Cover . . . . .	8-23
Top Cover . . . . .	8-24
Trays . . . . .	8-25
Tray 1 (MPT) . . . . .	8-25
Tray 1 (MPT) Level Sensor . . . . .	8-28
Tray 1 (MPT) Home Position Sensor . . . . .	8-30
OHP Sensor . . . . .	8-31
Feed-Out Sensor #1 . . . . .	8-32
Tray 1 (MPT) No Paper Sensor . . . . .	8-33
Tray 1 (MPT) Feed Rollers . . . . .	8-34
Tray 2 Feeder . . . . .	8-38
Registration Motor . . . . .	8-39
Feed Motor . . . . .	8-40
Lift Motor . . . . .	8-41
Registration Clutch #2 . . . . .	8-42
Door B Detect Sensor . . . . .	8-43
Tray 2 No Paper Sensor . . . . .	8-45
Registration Sensor #2 . . . . .	8-47
Feed-Out Sensor #2 . . . . .	8-50
Feeder Board . . . . .	8-53
Tray 2 Feed Rollers . . . . .	8-54
Side Output Tray . . . . .	8-55
Chassis . . . . .	8-56
Job Offset Assembly . . . . .	8-56
Job Offset Motor . . . . .	8-59
Job Offset Home Position Sensor . . . . .	8-61
Top Output Chute . . . . .	8-63
Door A Latch Assembly . . . . .	8-64
Media Thickness Sensor . . . . .	8-66
Temperature/Humidity Sensor . . . . .	8-67
Exit Assembly . . . . .	8-68
Exit Gate Solenoid . . . . .	8-70
Fuser Exit Sensor and Actuator . . . . .	8-71
Top Output Tray Stack Full Sensor . . . . .	8-72

Side Output Tray Detect Sensor . . . . .	8-73
Side Output Tray Stack Full Sensor. . . . .	8-75
Door E Detect Sensor . . . . .	8-77
Fuser Release Sensor . . . . .	8-79
Registration Sensor Assembly . . . . .	8-80
Registration Shutter Solenoid. . . . .	8-81
ADC Sensor . . . . .	8-82
Media Slack Sensor and Actuator . . . . .	8-83
Registration Assembly . . . . .	8-84
Registration Clutch #1 . . . . .	8-85
Waste Toner Auger Assembly. . . . .	8-86
Waste Toner Reservoir Full Sensor. . . . .	8-88
Waste Toner Reservoir Auger Rotation Sensor. . . . .	8-89
Waste Toner Auger Rotation Sensor. . . . .	8-90
Transfer Unit Belt Rotation Sensor . . . . .	8-91
Lower Basket Assembly . . . . .	8-92
Basket Assembly. . . . .	8-93
LED Assembly. . . . .	8-100
Drive. . . . .	8-103
Transfer Unit Motor . . . . .	8-103
Toner Motors . . . . .	8-104
Imaging Unit Motors. . . . .	8-105
Fuser Motor . . . . .	8-106
Waste Toner Motor. . . . .	8-107
Imaging Unit Lift Uplink . . . . .	8-108
Electrical. . . . .	8-111
Control Panel . . . . .	8-111
Engine Control Board . . . . .	8-112
Image Processor Board . . . . .	8-113
Card Cage Fan Duct . . . . .	8-114
Card Cage Fan. . . . .	8-115
Card Cage . . . . .	8-117
HVPS Cover . . . . .	8-118
High Voltage Power Supply . . . . .	8-119
Housing Bias Assembly . . . . .	8-120
Low Voltage Power Supply . . . . .	8-121
LVPS Fan . . . . .	8-124
LED Head . . . . .	8-125
LED Relay Board. . . . .	8-126
Top Cover Interlock Switch. . . . .	8-127
Waste Toner Reservoir Detect Switch. . . . .	8-130
Door A Interlock Switch . . . . .	8-132
Imaging Unit Fan . . . . .	8-133
Transfer Unit Fan . . . . .	8-134
Top Cover Fan. . . . .	8-135
IP Fan . . . . .	8-138

Paper Size Switch . . . . .	8-139
Motor Driver Board . . . . .	8-141
Imaging Unit Sensor Board . . . . .	8-142
Toner Supply Camshaft . . . . .	8-144
Imaging Unit Motor Mounting Plate . . . . .	8-145
CRUM Reader Board . . . . .	8-146
CRUM Antenna . . . . .	8-147
Registration Sensor Board . . . . .	8-148
Fuser Fan . . . . .	8-149
Front Sensor Board . . . . .	8-150
Rear Sensor Board . . . . .	8-151

## 9 Parts List

Serial Number Format . . . . .	9-2
Using the Parts List . . . . .	9-3
Print Engine Parts . . . . .	9-4
Xerox Supplies and Accessories . . . . .	9-58
Service Kits . . . . .	9-60
Feed Roller Kit . . . . .	9-60
Sensor Kit . . . . .	9-61
Actuator Kit . . . . .	9-61
Hardware Kit . . . . .	9-62
Gear Kit . . . . .	9-63
Harness Kit . . . . .	9-64

## 10 Wiring Diagrams

Plug/Jack Locator Diagrams . . . . .	10-2
Print Engine Plug/Jack Designators . . . . .	10-2
Print Engine Plug/Jack Locators . . . . .	10-4
Wiring Diagrams . . . . .	10-17
Notations Used in Wiring Diagrams . . . . .	10-17
Print Engine Wiring Diagrams . . . . .	10-19
Print Engine General Wiring (1/7) . . . . .	10-19
Print Engine General Wiring (2/7) . . . . .	10-20
Print Engine General Wiring (3/7) . . . . .	10-21
Print Engine General Wiring (4/7) . . . . .	10-22
Print Engine General Wiring (5/7) . . . . .	10-23
Print Engine General Wiring (6/7) . . . . .	10-24
Print Engine General Wiring (7/7) . . . . .	10-25
Front Sensor Board (1/2) . . . . .	10-26
Front Sensor Board (2/2) . . . . .	10-27
Feeder Board . . . . .	10-28
Rear Sensor Board . . . . .	10-29
Registration . . . . .	10-30



Motor Driver Board (1/6) .....	10-31
Motor Driver Board (2/6) .....	10-32
Motor Driver Board (3/6) .....	10-33
Motor Driver Board (4/6) .....	10-34
Motor Driver Board (5/6) .....	10-35
Motor Driver Board (6/6) .....	10-36
LED Heads .....	10-37
Xerographics .....	10-38
LVPS .....	10-39
Fuser .....	10-40
Imaging Unit Sensor Board .....	10-41
Image Processor Board .....	10-42
Control Panel .....	10-43

## Reference

Phaser 7400 Menu Map .....	A-2
Printer Status Codes .....	A-4
Service Diagnostics Menu Map (1/2) .....	A-11
Service Diagnostics Menu Map (2/2) .....	A-12
Service Diagnostics Tests .....	A-13
Mode Select Port .....	A-28
Obtaining Serial Back Channel Traces .....	A-29
Preparing the Printer for Shipment .....	A-30

## Index



# General Information

## In this chapter...

- Printer Introduction and Overview
- Printer Configurations
- Parts of the Printer
- Printer Options
- Specifications

Section

1



# Printer Introduction and Overview

The *Xerox Phaser 7400 Color Printer Service Manual* is the primary document used to repair, maintain, and troubleshoot this printer. For manual updates, Service Bulletins, knowledge base, etc., see [www.xerox.com/office/7400support](http://www.xerox.com/office/7400support). For further technical support, contact your assigned Xerox Technical Support for this product.

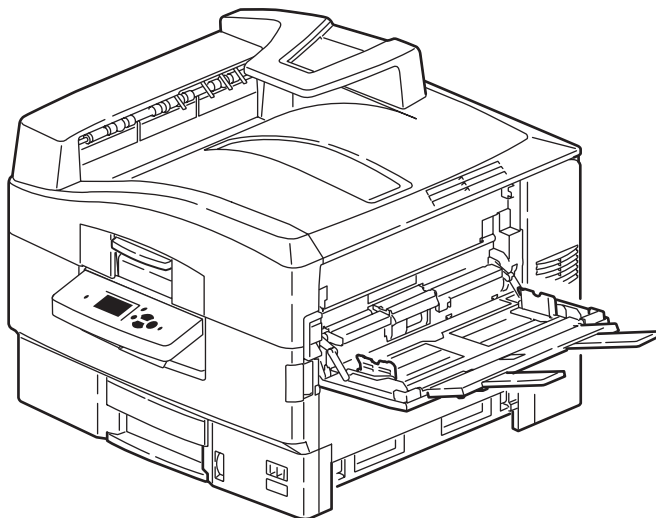

s7400-301

The Xerox Phaser 7400 Color Printer is a single pass, electrophotographic design, using light emitting diodes (LED) for image exposure. The Phaser 7400 supports PostScript 3 and PCL5c page description languages. Print performance for A4 paper is 40 pages per minute (ppm) monochrome, 36 ppm for full color in 1-sided or 2-sided modes. Full color prints are produced via consecutively transferring the subtractive primaries (cyan, magenta, yellow, and black) directly to paper. Resolutions of up to 600 x 1200 dots per inch (dpi), 32-level grayscale print is applicable at 600x600 dpi. The base configuration (Phaser 7400N) features USB 2.0 and 10/100baseT Ethernet Ports, 256 MB of memory, a 250-sheet multi-purpose Tray 1 (MPT), a 550-sheet input tray (Tray 2), a 500-sheet facedown Top Output Tray, and a 250-sheet faceup Side Output Tray.

Phaser 7400 printer options add memory, paper capacity and functionality. For configurations not originally equipped, an internal Hard Drive is available for font storage, storing print files, job collation, proof, personal, and secure print support. A selection of RAM memory upgrades are available to raise the installed quantity to the 1 GB maximum. A 1650-Sheet High-Capacity Feeder (HCF) is available with three, 550-sheet universal trays. A 550-Sheet Feeder (Tray 3) Lower Tray Assembly (LTA) is also available. On the output side, a 1000-Sheet Finisher provides punching, stapling, saddle stitch, and offset stacking raising the output total to 1750 sheets. A Duplex Unit is available to add automatic 2-sided printing for supported paper sizes from all trays.

# Printer Configurations

The Phaser 7400 Color Printer is available in five configurations. The main differences are standard memory, optional high-capacity feeders, duplexing (2-sided printing) capabilities, networking, and internal Hard Drive. The following table lists the available configurations.

Features	Printer Configuration				
	7400N	7400DN	7400DT	7400DX	7400DXF
Max Print Speed (ppm) color / monochrome	36/40	36/40	36/40	36/40	36/40
Hard Drive for Secure, Proof, Personal, and Saved Print Jobs	Optional	Optional	Yes	Yes	Yes
Standard Memory*	256 MB	256 MB	512 MB	512 MB	512 MB
USB Port	Yes	Yes	Yes	Yes	Yes
10/100 Ethernet Port	Yes	Yes	Yes	Yes	Yes
RAM Collation	Yes	Yes	Yes	Yes	Yes
Duplex Unit	Optional	Yes	Yes	Yes	Yes
PostScript / PCL Fonts	Yes	Yes	Yes	Yes	Yes
Banner Sizes	Yes	Yes	Yes	Yes	Yes
Photo Modes	Yes	Yes	Yes	Yes	Yes
Resolutions (dpi):					
Standard	600x600x1	600x600x1	600x600x1	600x600x1	600x600x1
Enhanced	1200x600x1	1200x600x1	1200x600x1	1200x600x1	1200x600x1
Photo	600x600x5	600x600x5	600x600x5	600x600x5	600x600x5
Tray 1 (MPT)**	Yes	Yes	Yes	Yes	Yes
Optional Trays **	Optional	Optional	1 x 550	3 x 550	4 x 550
550-Sheet Feeder**	Optional	Optional	Yes	Optional	Yes
1650-Sheet Feeder**	Optional	Optional	Optional	Yes	Yes
1000-Sheet Finisher***	Optional	Optional	Optional	Optional	Yes

\* All configurations have two memory slots supporting 256 MB and 512 MB cards, up to a maximum of 1 GB.

\*\* Trays 1 and 2 are standard on all configurations. All configurations support additional paper trays in the following combinations:

One 550-Sheet Feeder (Tray 3)

One 1650-Sheet Feeder (Trays 3, 4, and 5 or 4,5, and 6)

One 550-Sheet Feeder (Tray 3) and one 1650-Sheet Feeder (Trays 4, 5, and 6)

\*\*\* Requires a Hard Drive and a total of 4 optional trays for fitment.

# Metered Printing

Metered printing (PagePack), involves the combination of control software and specialized Toner Cartridges to meter printer activity for billing purposes. The Configuration page lists Metered Toner as Enabled when metering is enabled.

## Metered Operation

When a metered printer is initialized at first power-up, the customer sets the printer to Metered operation using a unique, factory-supplied, 4-digit PIN. Once set to Metered operation, the control software performs the following:

1. The Mode and PIN-entered values in Engine Control Board NVRAM are set.
2. The Control Panel momentarily displays “Metered Toner is now enabled”, then returns to “Ready” (if no other errors).
3. The First Time Tips pages and the Configuration page are printed.

If an incorrect PIN is entered, “Incorrect numeric password” displays with a prompt “Retry” or “Do not retry.” Retry returns to the enter prompt, “Do not retry” returns to the Replace [C][M][Y][K] Toner Cartridge error message. The error persists until the correct PIN is entered.

### Note

The Hidden Service menu provides an Enable Metered Toner option to restore the Metered mode parameters to NVRAM should they become lost or corrupt.

## Metered Toner Cartridges

To support metered printing, metered Toner Cartridges are available in all four colors. When a metered Toner Cartridge is installed in a printer not set to Metered operation, the printer displays the Replace [C][M][Y][K] Toner Cartridge error. If a metered Toner Cartridge is placed into a printer manufactured before metering was available, the printer displays Replace Incorrect Toner Cartridge. All other combinations of normal or metered printer and cartridges are accepted without warning or error.

## Diagnostics Mode

Service Diagnostics does not provide the utilities to set or clear Metered NVRAM values. Service Diagnostics does not check these values and does not display the current status of these values. However, the Configuration page does identify the printer setting as mentioned above.

### Note

When replacing the Engine Control Board from a metered printer, exchange NVRAM devices or use the Save/Restore utilities in Service Diagnostics to preserve the NVRAM settings. The Mode and PIN-entered values are not affected by NVRAM reset utilities.

# Parts of the Printer

## Front View

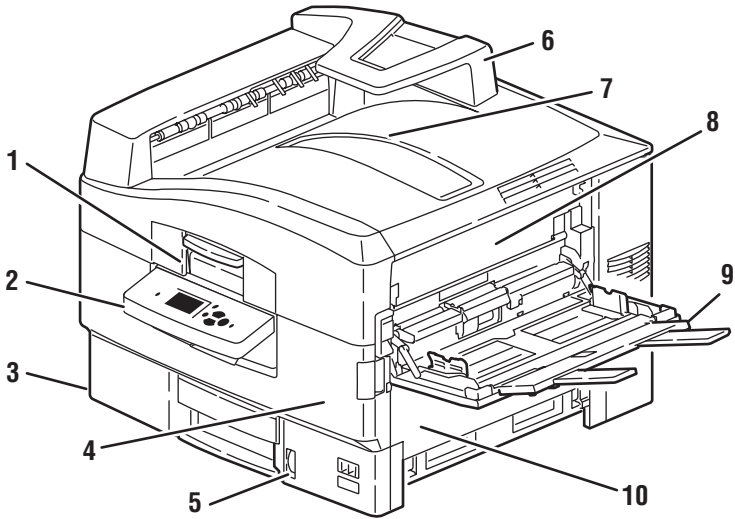

7400-001

- |                    |                    |
|--------------------|--------------------|
| 1. Top Cover latch | 6. Paper Catcher   |
| 2. Control Panel   | 7. Top Output Tray |
| 3. Tray 2          | 8. Door A          |
| 4. Front Door      | 9. Tray 1 (MPT)    |
| 5. Level Indicator | 10. Door B         |

# Rear View

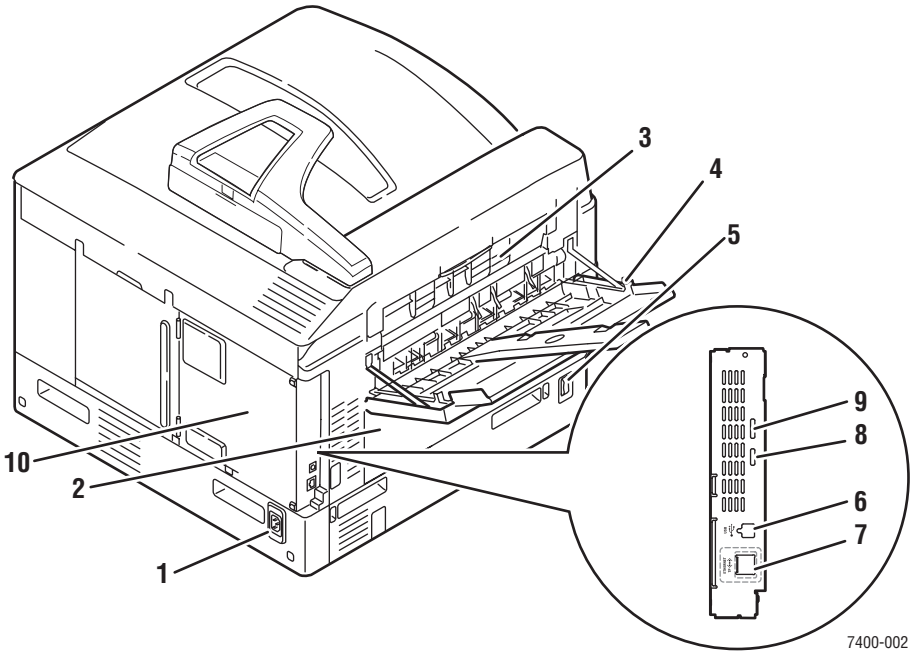

7400-002

- |                     |                      |
|---------------------|----------------------|
| 1. AC Receptacle    | 6. USB Port          |
| 2. Door D           | 7. Ethernet Port     |
| 3. Door E           | 8. Serial Debug Port |
| 4. Side Output Tray | 9. Mode Select Port  |
| 5. Power Switch     | 10. Rear Cover       |



# Control Panel

The Control Panel contains one tricolor LED, a display window, and six function buttons. These buttons navigate the menu system shown on the display, perform various functions, and select operational modes for the printer.

## LED Indicators:

LED State	Printer State
Green	Ready to Print
Flashing Yellow	Warning (but can still print)
Flashing Green	In Power Saver mode or busy (receiving or processing data)
Flashing Red	Error; cannot print

## Control Panel Button Descriptions

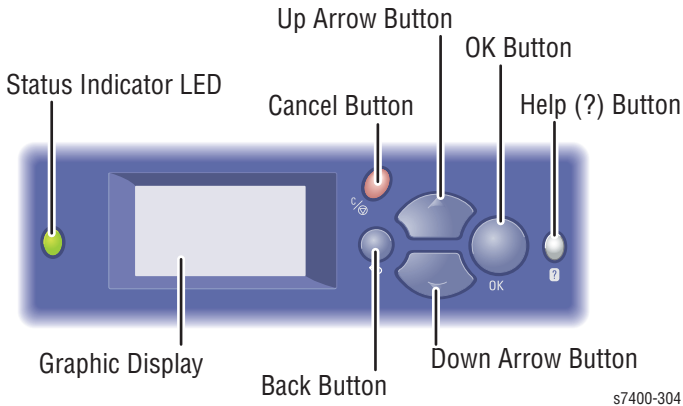

## Control Panel Shortcuts

Action	Press this at Power On
Skip Execution of POST Diagnostics	<b>OK</b>
Print Service Diagnostics Menu Map	<b>Help (?)</b>
Reset PostScript NVRAM	<b>Back + OK</b>
Password Bypass	<b>Up Arrow + Down Arrow</b>
Enter Service Diagnostics	<b>Back + Help (?)</b>

# Image Processor Board

Transfer the following components, if installed, to the new board when replacing the Image Processor Board.

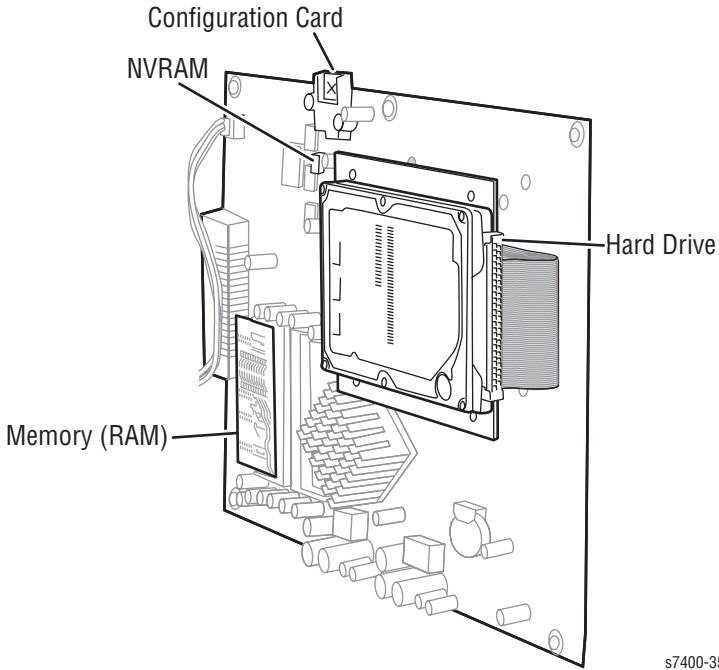

s7400-352

# Printer Options

Phaser 7400 Color Printer options include:

- 20 GB Hard Drive
- Additional Memory
- 550-Sheet Feeder (LTA)
- 1650-Sheet Feeder (HCF)
- Duplex Unit
- 1,000-Sheet Finisher (with hole punch, staple, saddle-stitch, and offset)

## Hard Drive

A 20 GB Hard Drive is available to enable the Job Collation, Saved Jobs, Proof, Personal, and Secure Print options. The Hard Drive installs on the Image Processor Board with stand-offs and connects to the board with a single data/power connector. Hard Drive utilization appears on the Configuration page.

## Additional Memory

The printer features two slots that accept 256 or 512 MB of high-speed DDR RAM. All combinations are allowed for 256, 512, 768 MB, up to the maximum of 1 GB. Memory modules must have the following characteristics:

- DDR PC2700 Memory Standard
- 200-Pin SODIMM
- Unbuffered, Non-parity
- Serial Presence Detect
- 2.5 Volt
- CL 2.5

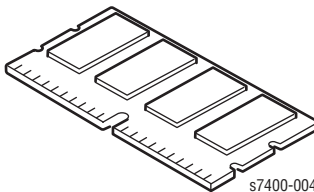

The Startup and Configuration pages list the amount of RAM installed in the printer. Installed memory not meeting the above specifications, is ignored by the printer.

# Configuration Card

A Configuration Card identifies the printer configuration, stores shadowed non-CRUM consumable data, consumable life counts, and network configuration parameters.

## 550-Sheet Feeder

The 550-Sheet Feeder increases the input capacity of the printer. The Lower Tray Assembly (LTA) attaches below Tray 2. When used in combination with the 1650-Sheet Feeder, the 550-Sheet Feeder is installed between the printer and 1650-Sheet Feeder. Up to four optional 550-Sheet Feeders per printer, totaling six universal trays (Trays 2~6), are allowed. However, when the 1650-Sheet Feeder High-Capacity Feeder (HCF) is installed, only one additional 550-Sheet Feeder is allowed between the HCF and printer. Electrical connection to the printer is made by a single interface connector.

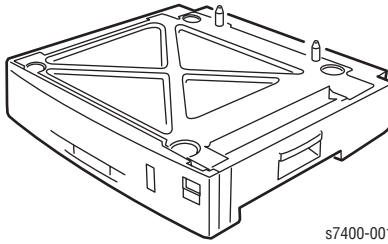

s7400-001

## 1650-Sheet Feeder

The 1650-Sheet Feeder adds three 550-sheet trays. Control signals reach the sheet feeder by a single connection.

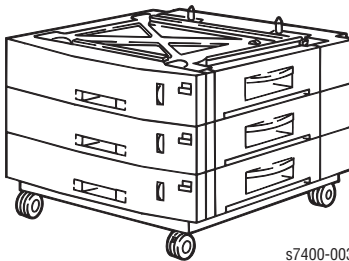

s7400-003

# Duplex Unit

The Duplex Unit adds two-sided printing. The Duplex Unit is inserted into the printer's left side just below the Side Output Tray. Electrical connection is made by an interface connector located inside the Duplex Unit cavity.

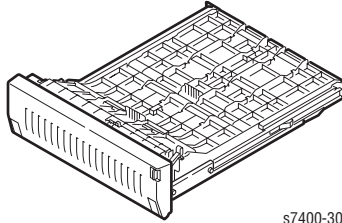

s7400-305

# Finisher

The Finisher increases the output capacity of the printer by 1,000 sheets. Printer output is directed to the Finisher by way of the side exit. Depending on the job specifications, as paper enters the Finisher it can be punched, stapled, offset and stacked depending on customer driver selections or Control Panel settings. The Finisher's Inverter is used to flip the media over. Control signals reach the Finisher through a single connector.

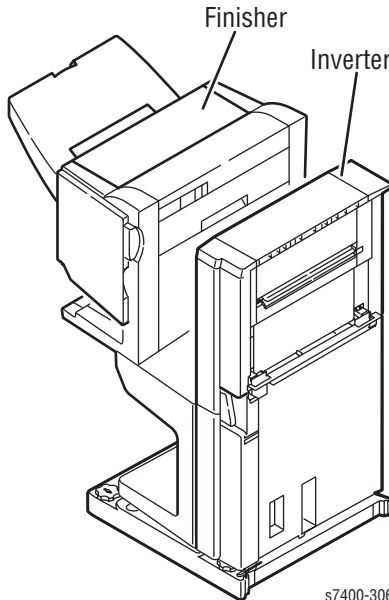

s7400-306

# Maintenance Items

A maintenance item is a printer part or assembly that has a limited life, and requires periodic replacement.

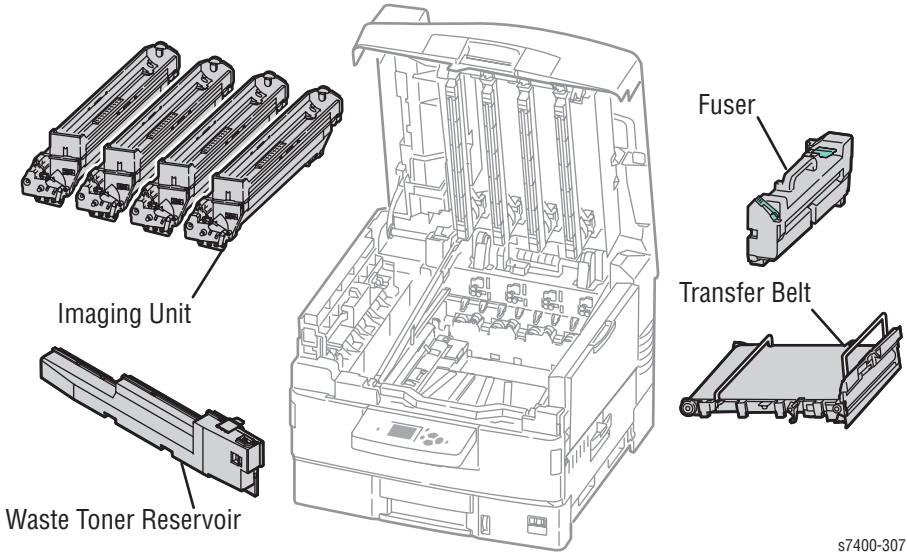

# Consumables

Consumables consist of the four toner cartridges used in the printer.

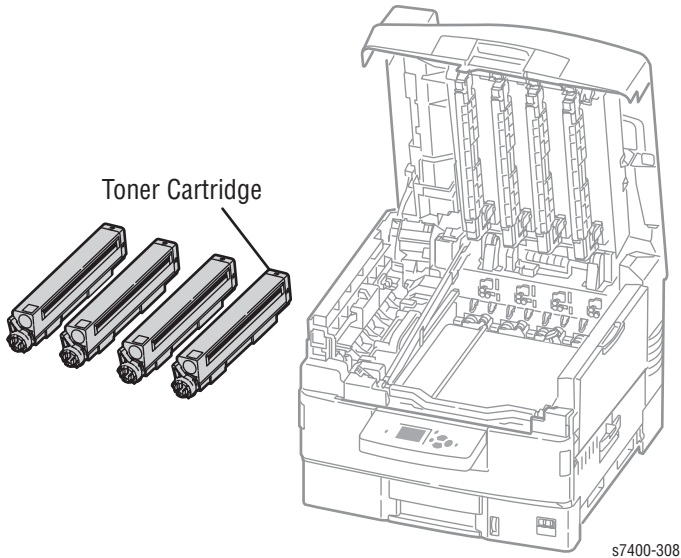

# Specifications

## Memory Specifications

Characteristic	Specification
Minimum RAM	256 MB
Maximum RAM	1 GB
Supported RAM	SODIMM 200-pin module of 256 or 512 MB. All combinations are allowed for configurations of 256, 512, 768 MB, and 1 GB.
NVRAM	Single chip of either PPROM or StrataFlash 16 MB

## Consumable Life Specifications

Internal counters track Consumables and Maintenance Items life usage. The Image Processor Board monitors these counters in order to display the near end-of-life and end-of-use messages.

Life ratings are based on A-size sheets at 5% coverage. Imaging Unit life ratings are based on average 3 page job length.

Toner Cartridges	Print Life
Black-Capacity	15,000
Color Capacity	7,500 or 15,000
Metered (PagePack) Capacity (all colors)	15,000

Maintenance Items	
Imaging Unit	30,000
Fuser	100,000
Transfer Unit	100,000
Feed Roller Kit	100,000
Waste Toner Reservoir	up to 30,000

# Electrical Specifications

Characteristic	Specification																
Primary line voltages	110-127 V Printer - (90 - 135 V) 13 amp circuit 220-240 V Printer - (198 - 254 V) 7-8 amp circuit																
Primary line voltage frequency range	100-120 V Printer - 50/60 Hz $\pm$ 2 Hz 220-240 V Printer - 50/60 Hz $\pm$ 2 Hz <b>NOTE:</b> Power the printer directly from the wall outlet. Do not use "Power Strips" as they may limit available current.																
Power consumption at rated voltage input	<table><thead><tr><th>Mode</th><th>Condition</th><th>100/120 VAC</th><th>220/240 VAC</th></tr></thead><tbody><tr><td><b>Print Mode</b></td><td><b>Maximum</b></td><td>1500 W or less</td><td>1500 W or less</td></tr><tr><td><b>Ready Mode</b></td><td><b>Fuser On</b></td><td>750 W or less</td><td>750 W or less</td></tr><tr><td><b>Sleep Mode</b></td><td><b>Fuser Off</b></td><td>55 W or less</td><td>55 W or less</td></tr></tbody></table>	Mode	Condition	100/120 VAC	220/240 VAC	<b>Print Mode</b>	<b>Maximum</b>	1500 W or less	1500 W or less	<b>Ready Mode</b>	<b>Fuser On</b>	750 W or less	750 W or less	<b>Sleep Mode</b>	<b>Fuser Off</b>	55 W or less	55 W or less
Mode	Condition	100/120 VAC	220/240 VAC														
<b>Print Mode</b>	<b>Maximum</b>	1500 W or less	1500 W or less														
<b>Ready Mode</b>	<b>Fuser On</b>	750 W or less	750 W or less														
<b>Sleep Mode</b>	<b>Fuser Off</b>	55 W or less	55 W or less														

# Physical Dimensions and Clearances

Print Engine	Value
Height:	47.1 cm (18.5 in.)
Width:	64.0 cm (25.2 in.)
Depth:	62.3 cm (24.5 in.)
Weight:	84 kg (185 lb.)
1650-Sheet Feeder	Value
Height:	40.1 cm (15.8 in.)
Width:	59.7 cm (23.5 in.)
Depth:	59.9 cm (23.6 in.)
Weight:	53 kg (117 lb.)
550-Sheet Feeder	Value
Height:	10.9 cm (4.3 in.)
Width:	59.7 cm (23.5 in.)
Depth:	59.9 cm (23.6 in.)
Weight:	16 kg (36 lb.)
Finisher	Value
Height:	101.6 cm (40.0 in.)
Width:	81.3 cm (32.0 in.)
Depth:	59.5 cm (23.6 in.)
Weight:	55 kg (122 lb.)
Surface	Value
Tilt tolerance:	Within 50 mm side to side.



## Minimum Clearances

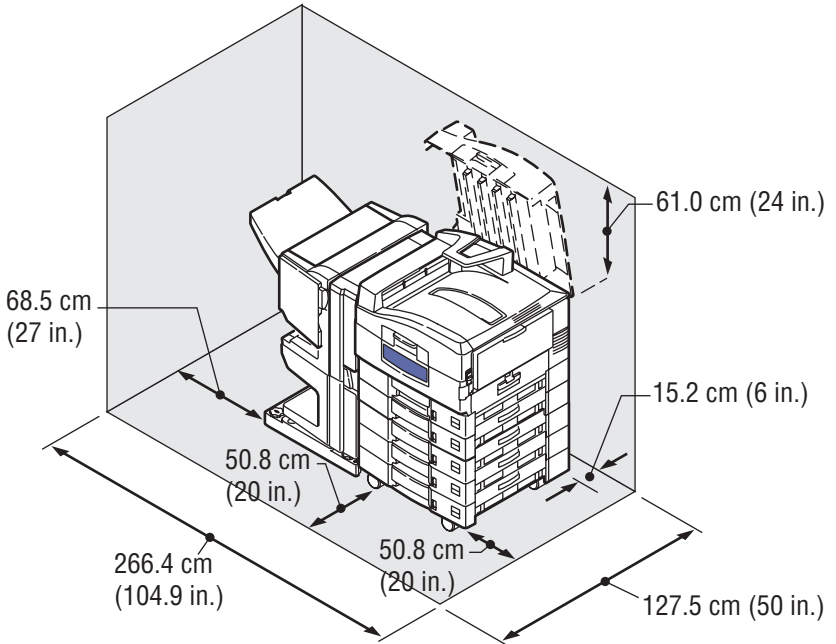
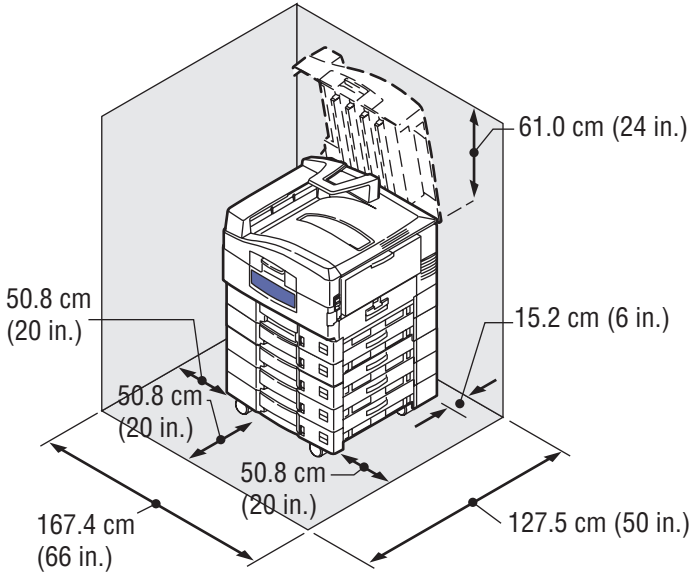

s7400-309

# Functional Specifications

## Functional Specifications

Characteristic	Specification
Printing Process	<b>Imaging System:</b> 4-tandem drums, electro-photographic system. <b>Exposure System:</b> Light-emitting Diode (LED), 4 beams. <b>Development System:</b> Dry type 2-component developer. <b>Fusing System:</b> Heat fusing, free nip-belt system.
Color Medium	Yellow, Magenta, Cyan, and Black Toner Cartridges
Resolution / Addressability	Standard 600 x 600 dpi (default) Enhanced 1200 x 600 dpi Photo 600 x 600 (5-bit) dpi
Operating Modes	<b>Print Mode:</b> Print Engine capable of making prints immediately. <b>Ready Mode:</b> 10 seconds from completion of a print. <b>Sleep / Power Saver Mode:</b> Entered after a specified period of Print Engine inactivity since completion of the last print.
Maximum Color Coverage	All configurations are 240%
Warm-up Time	< 85 seconds from cold start (power off condition) < 75 seconds from (Wake-up)

## First Print Output Time

First Print Output Time (FPOT) is defined as a time from receipt of the print command in Ready mode until the first page sourced from either Tray 1 or Tray 2 is delivered to the Output Tray. Sourcing media from the optional trays increases FPOT.

### Note

This does not include the execution times for the Boot Loader or POST which vary depending on printer configuration.

Print Mode	First Print Out Time* (maximum seconds)					
	Tray 1 (MPT)	Tray 2	Tray 3	Tray 4	Tray 5	Tray 6
Monochrome		12.0	13.5	14	15	16
Color		13	15.5	16.5	17.5	18.5

\*These conditions apply to the values in the table above:  
Printer at Ready  
A4 LEF paper  
Plain paper mode

# Image Specifications

Characteristic	Specification
Maximum Print Area	Minimum margins = 5 mm (0.2 in.) on all sides Maximum paper size = 328 mm x 1200 mm (12.9 in.x 47.25 in.) Minimum paper size = 105 mm x 148 mm (4.13 in. x 5.83 in.)
Guaranteed Print Area	The printer prints images meeting the Print Quality Specification except the margin area, which is 5.0 mm inside each edge of the paper.
Skew	< 1.0 mm across 220 mm image, < 1.5 mm from option trays
<b>Registration</b>	
Leading Edge	± 1.0 mm
Side Edge	± 1.0 mm
Duplex (front to back)	±1.5 mm (A size), 2.2 mm (B size)
Parallelism	± 0.5 mm across 220 mm image
<b>Linearity</b>	
Vertical	± 0.5 mm across 234 mm image
Horizontal	± 0.5 mm across 190 mm image
Slant	± 1.2 mm across 269 mm image

# Environmental Specifications

Characteristic	Specification
<b>Temperature</b>	
Operating	10 to 32°C (50 to 89.6 °F)
Storage	0 to 43°C (32 to 109.4 °F)
Transport	-10 to 43°C (-14 to 109.4 °F)
<b>Humidity (RH)</b>	Relative Humidity (50 - 70% to assure the best print-quality)
Operating	20 - 80%
Storage	10 - 90%
Transport	10 - 90%
<b>Altitude</b>	
Operating	0 to 2500 meters (8,000 ft.) at 25°C
Non-operating	0 to 6000 meters (20,000 ft.)
<b>Acoustic Noise (db)</b>	
Standby	45.0db or less
Power Saver	43.0db or less
Printing	55.0db or less

# Media and Tray Specifications

The following table lists the paper sizes and weights supported in the printer trays.

## Media and Tray Specifications

Specification		Trays	
Supported Media Sizes	<b>Paper Type</b>	<b>Size</b>	
	Letter	8.5 x 11 in.	All Trays
	Legal	8.5 x 14 in.	All Trays
	Executive	7.25 x 10.5 in.	All Trays
	Statement	5.5 x 8.5 in.	All trays
	US Folio	8.5 x 13 in.	All Trays
	A4	210 x 297 mm	All Trays
	A5	148 x 210 mm	All Trays
	A6	105 x 148 mm	Tray 1 Only
	B5 JIS	182 x 257 mm	All Trays
	ISO B5	176 x 250 mm	Tray 1 Only
Custom Size & Banner	8.5 x 35.4 in.	Tray 1 + 2	
Supported Envelopes*	Envelopes Weight	20 - 24 lb. Bond	Tray 1 Only
	Commercial #10	4.12 x 9.5 in.	
	Monarch Envelope	3.87 x 7.5 in.	
	A7 Envelope Custom	5.25 x 7.25 in.	
	DL Envelope	110 x 220 mm	
	C5 Envelope	162 x 229 mm	
	C6 Envelope	114 x 162 mm	
	B5 Envelope	175 x 250 mm	
Custom			
<b>NOTE:</b> Do not use envelopes with hot melt glue, windows, or metal clasps.			
Special Media	Phaser 35-Series		
	Premium Transparencies		
	Letter	216 x 279 mm (8.5 x 11 in.)	Tray 1 + 2
	A4	210 x 297 mm (8.27 x 11.69 in.)	Tray 1 + 2
	(Other sizes through Tray 1 using custom size option.)		
	Phaser Premium		
Postcards			
Letter	216 x 279 mm (8.5 x 11 in.)	Tray 1 Only	
A4	210 x 297 mm (8.27 x 11.69 in.)	Tray 1 Only	
Tray Capacity		<b>Universal Tray</b>	<b>Tray 1 (MPT)</b>
	<b>Standard Paper</b>	550 Sheets	100 Sheets
	<b>Transparency</b>	100 Sheets	50 Sheets
	<b>Envelopes</b>	N/A	10 each

## Media and Tray Specifications

	Specification		Trays
Supported Media Types and Weights	<b>Type</b>	<b>Weight</b>	
	Plain Paper	65 - 90 g/m <sup>2</sup> (17 - 24 lb. Bond)	All Trays
	Heavy Plain Paper	85 - 120 g/m <sup>2</sup> (22 - 32 lb. Bond)	All Trays
	Thin Card Stock	100 - 163 g/m <sup>2</sup> (30 - 60 lb. Cover)	All Trays
	Thick Card Stock	160 - 216 g/m <sup>2</sup> (59 - 80 lb. Cover)	All Trays
	Labels	N/A	Tray 1 Only
	Letterhead	85 - 120 g/m <sup>2</sup> (22 - 32 lb. Bond)	All Trays
	Glossy Paper	100 - 163 g/m <sup>2</sup> (81 - 110 lb. Text)	Tray 1 Only
	Digital Photo Paper	163 g/m <sup>2</sup> (60 lb. Cover)	Tray 1 Only
	Phaser Premium Post-cards	176 g/m <sup>2</sup> (65 lb. Cover)	Tray 1 Only
	Pre-printed	65 - 90 g/m <sup>2</sup> (17 - 24 lb. Bond)	All Trays
	Pre-punched	65 - 90 g/m <sup>2</sup> (17 - 24 lb. Bond)	All Trays
	Special	100 - 163 g/m <sup>2</sup> (30 - 60 lb. Cover)	All Trays

\*Some wrinkling and embossing may occur when printing envelopes.

### Note

For duplex configured printers, auto-duplex operation is available through all trays. Refer to the Paper Tips page for information on which paper types can be used for 2-sided printing.

For more details about supported paper and other media, print the Paper Tips page:

1. On the Control Panel, select **Information**, and then press the **OK** button.
2. Select **Information Pages**, and then press the **OK** button.
3. Select **Paper Tips**, and then press the **OK** button to print.



# Theory of Operation

## In this chapter...

- Overview
- Printer Controls
- Paper Path of the Printer
- Major Assemblies and Functions

Section

2

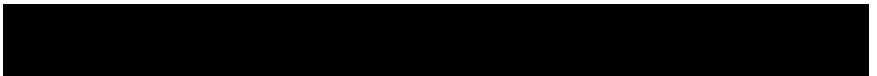

# Phaser 7400 Operational Overview

The Phaser 7400 Color Printer is a full-color LED printer using electrophotographic recording principals to place a full color image onto the print media. The system, as it appears in the following illustration, contains four Imaging Units comprised of a drum and developing unit for each color Cyan, Magenta, Yellow and Black (CMYK), and uses a Transfer Unit to transfer the toner image of each color onto print media producing full-color prints.

The figure below illustrates the relative position of components involved in the printing process.

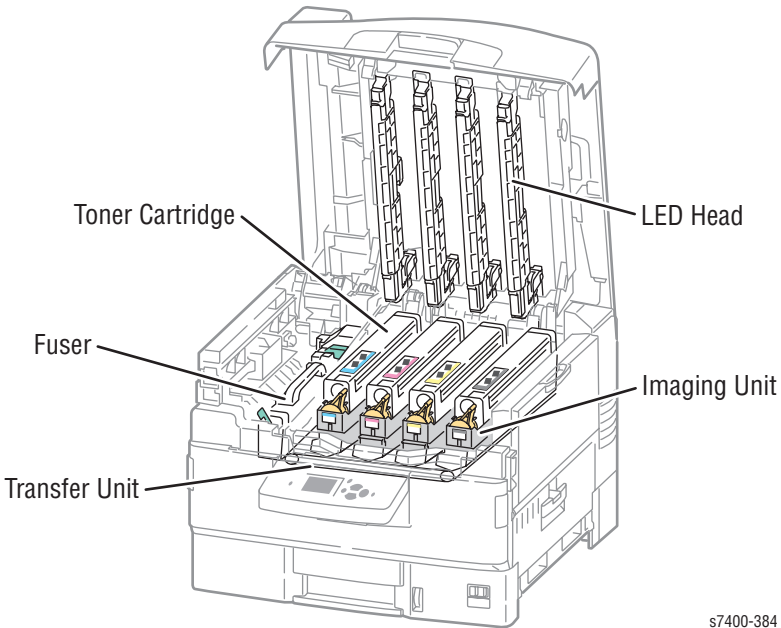

s7400-384



# Imaging Unit

The function of each Imaging Unit component is listed in the following table.

## Imaging Unit Components

Component	Function
Drum	The Drum is an aluminum cylinder coated with a layer of photoconductive material that retains electrical charges on its surface until exposed to light.
Bias Charge Roller (BCR)	The BCR uniformly distributes electrical charges over the drum surface, and erases the previous charge pattern.
Developer Roller	A thin layer of developer and toner adheres to the surface of this roller, which transports the toner to the Drum surface.
Sponge Roller	Transfers toner to the Developer Roller.
Agitation Bar	The Agitation Bar stirs the developer mixture to achieve a uniform distribution of toner.
Cleaning Blade	The Cleaning Blade removes toner remaining on the Drum.
Waste Toner Recovery	Moves excess toner from the Imaging Unit to the Waste Toner Recovery system for collection.

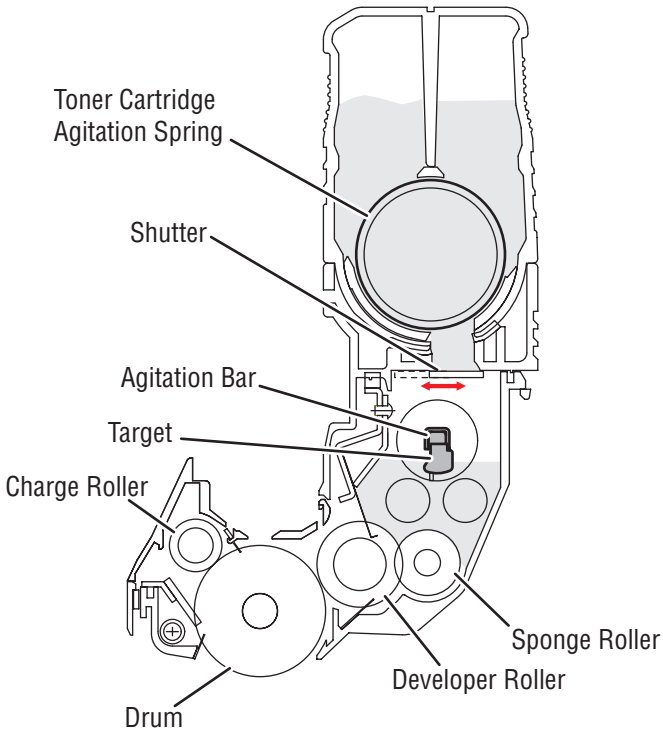

s7400-022

# LED Heads

The LED Heads receive signals from the Engine Control Board and scan the surface of the four Imaging Unit drums to create a latent image. The resolution is either 600 dpi or 1200 dpi and is determined by the customer setting.

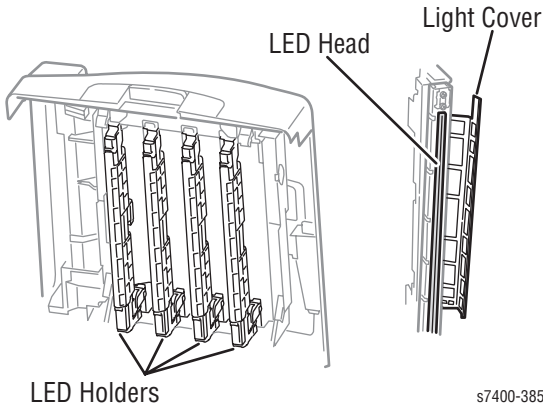

# Fuser

The Fuser, using a combination of heat and pressure, bonds the toner to the paper. The Fuser is replaced as a unit. The Heat Roller is heated by two internal halogen lamps, and the Pressure Roller is heated by a separate lamp. The Pressure Roller puts pressure against Fuser Belt, media, and Heat Roller to melt the toner and bond the image to the paper. After the toner image is fused to the paper, the paper passes through the Fuser Exit Sensor indicating the sheet's progress. To better understand Fuser errors, Fuser components are described in the following table.

## Fuser Components

Component	Function
Heat Roller	The Heat Roller is a metal tube with a coated surface and a Heater Assembly inside. As paper passes between the Heat Roller and Pressure Roller, the heat fuses the toner to the paper.
Pressure Roller	The Pressure Roller is a metal shaft coated with sponge rubber. The Pressure Roller maintains pressure on the paper passing between it and the Heat Roller. This pressure bonds the melted toner to the paper.
Heater Lamps	The Heater Lamps are quartz glass tubes containing heater coils. The Heater Lamps heat the Heat Roller.

## Fuser Components (Continued)

Component	Function
Temperature Sensors	These are Thermistors having a known value of resistance that varies with temperature. The sensors monitor the surface temperature of the Heat and Pressure Rollers.
Thermostats	The Thermostats provide a second-level of protection. If the Heat or Pressure Roller temperature exceeds the target temperature, AC power is cut-off to the Heater Rods. Once the Thermostats have opened, the Fuser must be replaced.
Fuser Exit Sensor	This sensor detects the arrival of the paper at the exit area of the Fuser. When paper is present, the signal /EXIT is Low.

## Fuser Life Expectancy

The life expectancy is 100,000 Letter/A4 size pages. Several factors reduce Fuser life:

- Paper use larger than letter size
- Printing on heavy media
- Printing short-edge feed
- Printing on transparencies or specialty media
- Repetitive image, long print runs

## Transfer Unit

The Transfer Unit transports the media under all four Imaging Unit drums using a belt. Transfer Rollers within the Transfer Unit receive biasing voltages from the HVPS to attract the toner from the drums to the media.

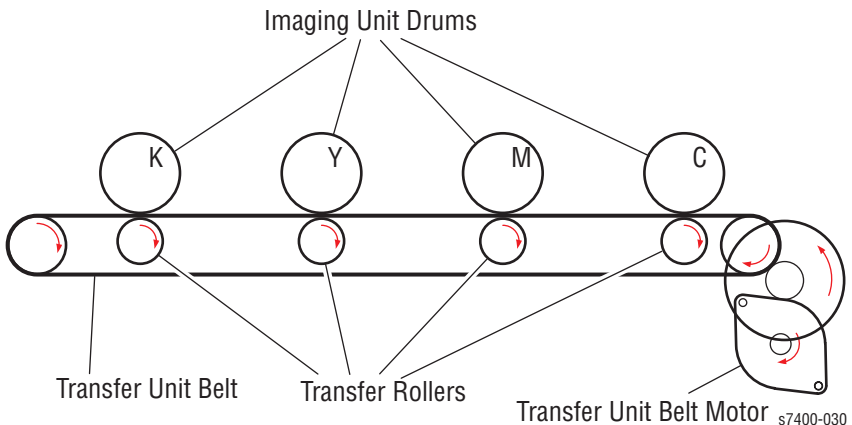

# Print Process Summary

The block diagram illustrates the steps involved in producing a full-color print. The (numbers) indicate the corresponding description provided in the Print Process Summary that follows this diagram.

## Print Process Block Diagram

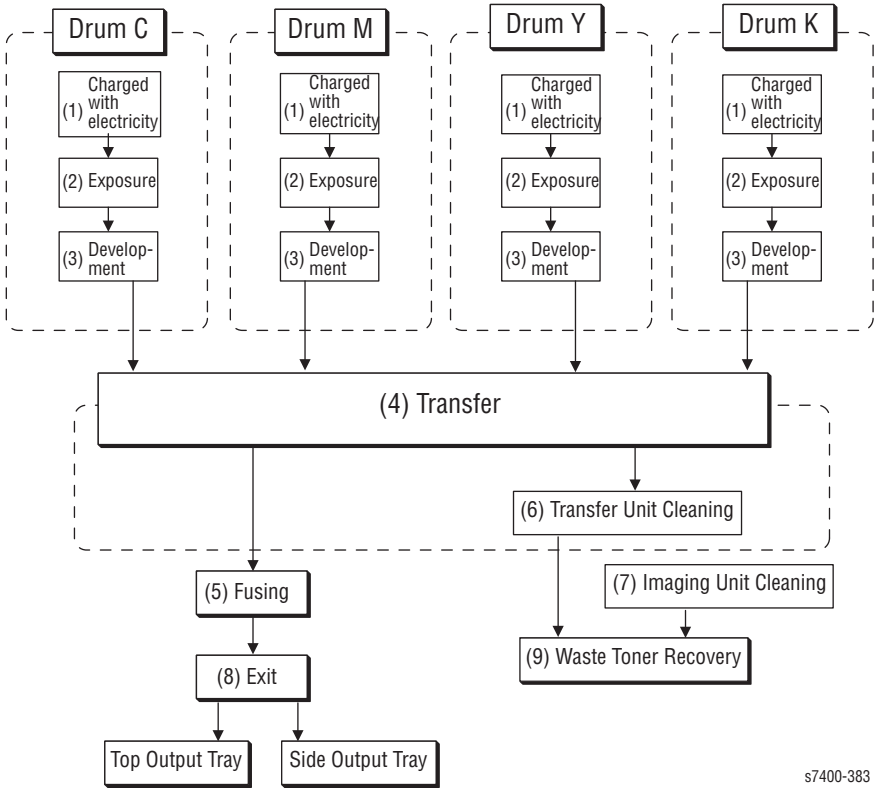

s7400-383

Refer to the Print Process Block Diagram above to relate each of the following process steps to an individual component.

- 1. Charging:** The charge roller (RTC) is negatively charged by the High-Voltage Power Supply (HVPS) and is kept in contact with the drum surface to provide a uniform negative charge on the drum as it rotates at a constant speed. This occurs simultaneously for CMYK.

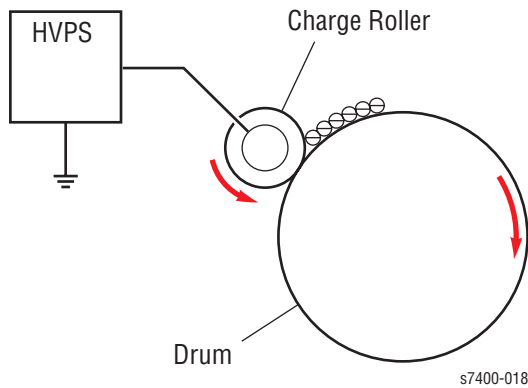

- 2. Exposure:** The Light Emitting Diode (LED) Head emits light to the negatively charged surface of the drum. Areas of the drum surface receiving the light attenuate the negative charge based on light intensity and surface potentials, forming the latent electrostatic image on the drum surface. This occurs simultaneously for CMYK.

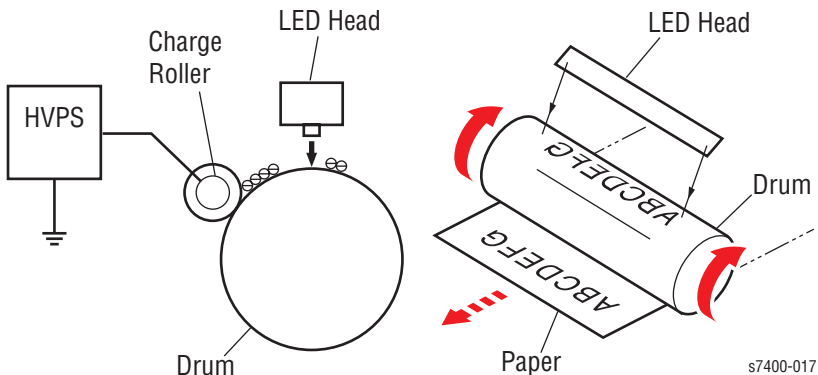

- 3. Development:** The Developer Roller applies toner to the latent image formed on the surface of the drum. Toner transfer occurs as follows:.

- The sponge roller transfers toner to the Developer Roller. The toner is negatively charged.
- The toner cleaning blade removes excess toner on the Developer Roller to form a thin film of toner on the surface of the Developer Roller.

- The toner is attracted to the latent image on the surface of the drum at the point where the drum is in contact with the developing roller.

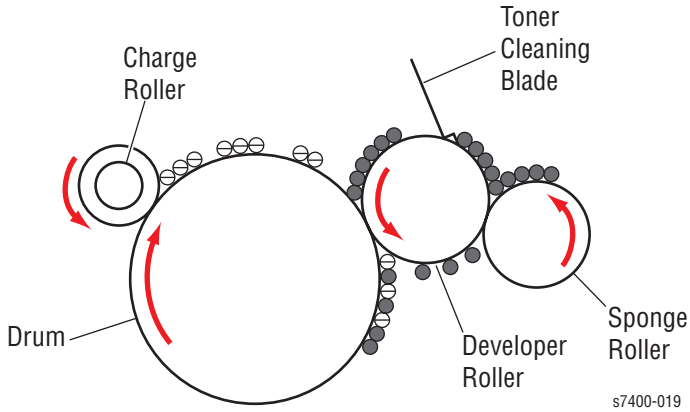

- 4. Transfer:** The Transfer Roller, made of a conductive sponge, presses the paper against the surface of the drum. This process sandwiches the paper between the drum and the Transfer Unit belt. A positive charge, supplied by the HVPS through contacts on the Transfer Unit, is applied to the Transfer Roller attracting the negatively-charged toner from the surface of the drum onto the paper.

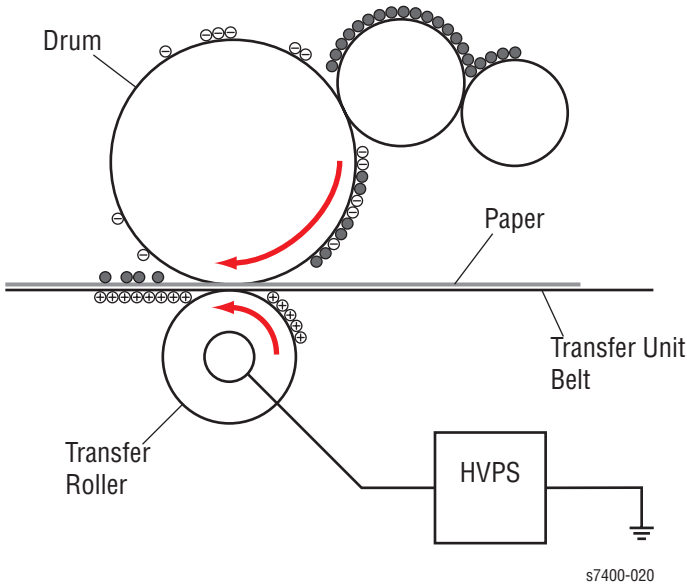

- 5. Fusing:** The Fuser uses a combination of heat and pressure to bond the toner image to the paper.

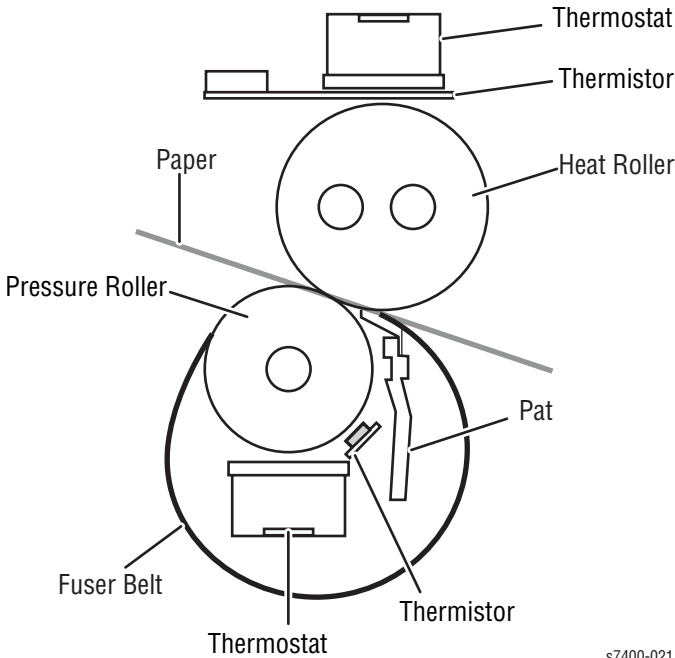

s7400-021

- 6. Transfer Unit Cleaning:** Toner remaining on the Transfer Unit belt is removed by a cleaning blade and transported by Auger to the toner waste port.

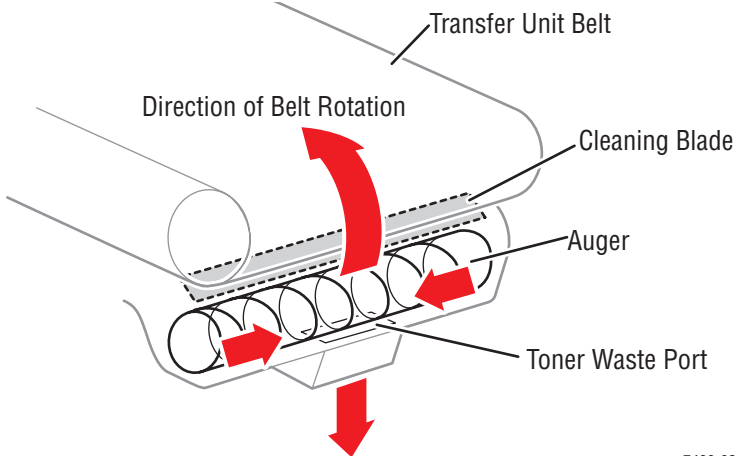

s7400-023

- 7. Imaging Unit Cleaning:** Toner remaining on the drum, following image transfer to the media, is scraped off by a cleaning blade and collected.
- 8. Paper Exit:** The paper is then advanced either upward to the Top Exit or downward towards the Side Exit depending on the Exit Gate position.
- 9. Waste Toner Recovery:** Excess toner collected from the Imaging Unit drums and the Transfer Unit belt is carried by an Auger Tube to the Waste Toner Reservoir located behind the Front Door.

# Printer Controls

## Print-Quality Modes

There are four print-quality modes:

Print-Quality Mode	Description
<b>Automatic</b>	Automatically selects the optimal print-quality mode for the paper type. For example, <b>Photo</b> print-quality mode is used when printing on Glossy Paper and <b>Standard</b> print-quality mode is used when printing on Plain Paper. (This setting is only available in the printer driver.)
<b>Standard</b>	600 X 600 dpi resolution. High-speed, general-purpose mode for crisp, bright, color prints. Recommended for most office use and quick prints.
<b>Enhanced</b>	600 X 1200 dpi resolution. High-quality mode for fine lines and detail. Recommended for vibrant, saturated, color prints. Balances printing speed with quality.
<b>Photo</b>	600 X 600 dpi resolution. Highest-quality mode for color prints and smoothest light colors. Recommended for photographs, smooth shaded drawings, and color.

## Color Registration Control

The printer uses a single-pass, quad system where each color (Yellow, Magenta, Cyan, and Black) has its own imaging drum. Images are formed on the drums, in the respective colors, and then layered on the media to form one image. To monitor color registration, photo-reflective, Color Registration Sensors are mounted inside the Registration Sensor Assembly. These sensors are positioned at the front and rear edges of the Transfer Unit belt as shown in the following figure.



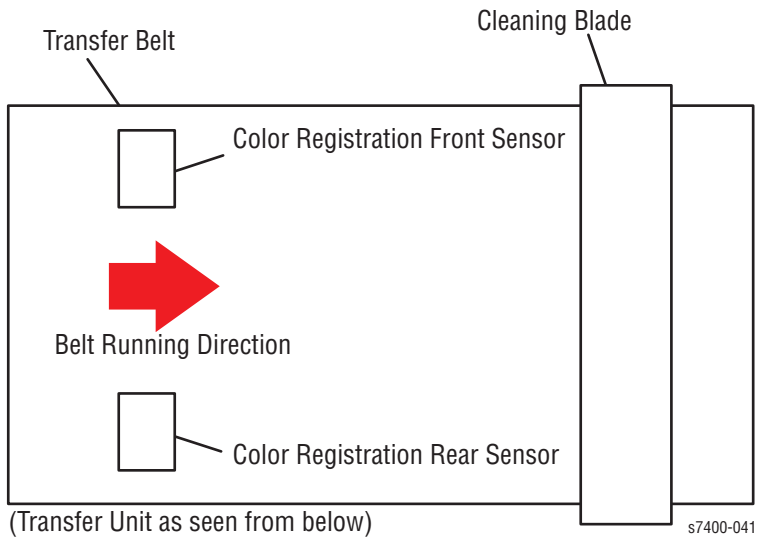
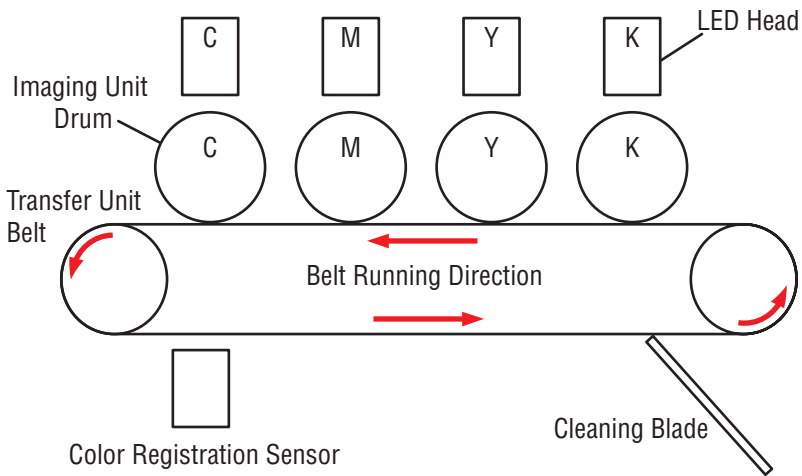

The Color Registration Sensors are used to measure the amount of misalignment based on the position of the color patches in relation to the black toner patch that precedes them. According to this measurement, the printer determines the correct value and automatically adjusts color registration in the main scanning, sub-scanning, and diagonal directions.

To avoid a positional shift between the different color images, the color registration control generates an alignment pattern (a series of primary color toner patches on either side of the Transfer Unit belt).

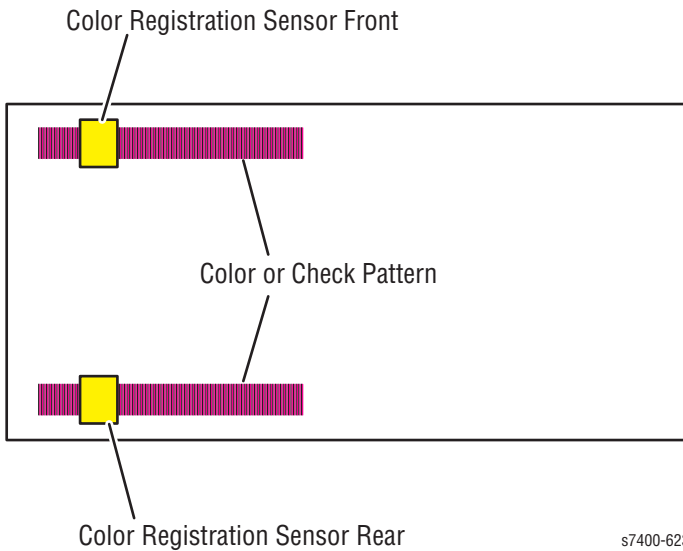

s7400-623

Color registration control is outlined below:

1. With no toner on the Transfer Unit, the output value of the Color Registration Sensors is measured to determine the reference value.
2. Patches for color registration control are generated on the edges of the Transfer Unit belt.
3. A solenoid-activated Registration Shutter opens so the sensors are exposed to the toner patches on the Transfer Unit belt.
4. The position of the patches generated is measured by the Color Registration Sensors.
5. The amount of registration shift is calculated from the reference value determined in Step 1, and the patch alignment measured in Step 4.
6. The image write timing is changed to compensate for any registration shift.

Color registration is checked when the power is turned On, a cover is closed, the printer is idle for more than 2 hours, or after printing 400 sheets.

# Automatic Density Control

The printer uses a series of test patches printed down the center of the Transfer Unit belt to monitor the density of toner being supplied to the Imaging Unit drums. The test patches consist of a grouping of all four colors applied repeatedly to the Transfer Unit belt at density levels of 15, 30, 50, 70, 85, and 100%. During the adjustment cycle, these patches are printed twice and the ADC Sensor voltage outputs are stored as reference values. During the status cycle, the test patches are generated once and the resulting ADC Sensor voltages are compared to the reference values obtained during the adjust cycle. Differences in the adjust and status ADC Sensor values indicate how much to adjust the amount of toner being dispensed for each color.

The following diagram depicts the Transfer Unit belt with the test patches.

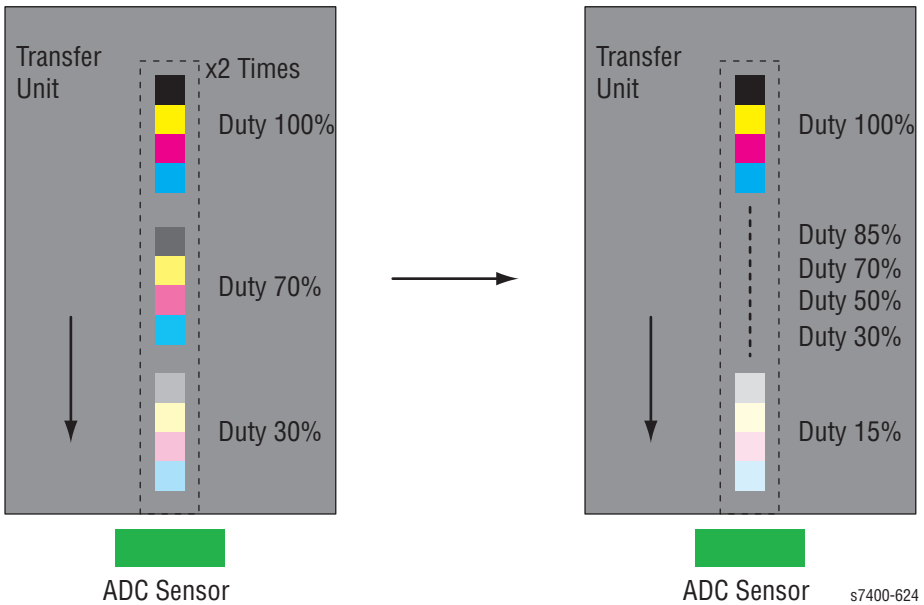

## Selective Control: Paper Pick

Unless changed in printer setup, the default tray is Tray 2. Trays in the optional 1650-Sheet Feeder are identified as Trays 3, 4, and 5. The tray in the optional 550-Sheet Feeder is identified as Tray 3. If both optional feeders are installed, the 550-Sheet Feeder tray is identified as Tray 3, and the trays of the 1650-Sheet Feeder are identified as Trays 4, 5, and 6.

### Note

The Phaser 7400 printer supports a maximum of 4 optional trays.

## Image Transfer Control

The printer monitors environmental conditions with the temperature and humidity sensors. The printer computes the optimal transfer voltage under the current environmental conditions (temperature and relative humidity), and applies the optimal transfer voltage to the Imaging Units and Transfer Unit Rollers.

## Fuser Temperature Control

During Fuser temperature control the printer's target temperature is set based on the media weight reported by the Media Thickness Sensor. The target temperature is also changed according to the printer's internal temperature and humidity detected with the Temperature and Humidity Sensor, print count, print mode, media type, and input power supply voltage. Different target temperatures are set for standby, printing, and process control. The Heat Roller surface temperature is controlled to match the target temperature by turning the heater rods On and Off.

Fuser temperature is regulated according to the sum of the temperatures detected at the Heat Roller and Pressure Roller surfaces. There is also a thermostat for safety purposes. When the Heat Roller temperature rises above a certain temperature, the thermostat opens and shuts down the power supplied to the heater rods.

## Consumable Control

The new/in-use condition of maintenance units is determined by the condition of a fuse. If the fuse in either the Fuser, Imaging Unit, or Transfer Unit is intact, the unit is recognized as a new. This fuse is checked when the printer is turned On, or a cover has been opened. When a new unit is detected, the printer resets the unit's life counter and blows the fuse indicating the unit is in-use. The count will not indicate it has been reset until two hundred pages have been printed.

## Consumable Life Counter Behavior

Internal counters track consumable life usage and store the values on the Engine Control Board EEPROM. The Image Processor Board stores the pixel count information in NVRAM and monitors these counters in order to display the consumable near end-of-life and at end-of-life messages.

The toner states displayed are OK, Low, and Empty. When an empty state is reached, the printer terminates printing at the end of the current page and displays the appropriate message on the Control Panel. No further jobs are accepted. All printer CRCs wait for the current print job to finish before declaring a Low or Empty state.

# Sensors

The printer contains sensors of various types that perform a variety of functions. One group of sensors track the progress of the paper along the paper path, and detect if a paper jam occurs. Other sensors detect the presence of the Toner Cartridges, stop printer activity if a door is open (interlock), detect the presence and size of media in the trays, and monitor the fusing temperature.

## Sensor Types

The types of sensors used vary with function. In general, there are four types in use:

### Photo Sensors

Two types of photo sensors are used, photo-reflective and photo-receptive. Photo-reflective sensors use light reflected back from an object to detect its presence. Photo-receptive sensors use an actuator or the object itself to block the light path to detect an object or condition.

Photo-reflective sensors have the light emitter and light receiver aligned on a single surface. Output of the photo-receptor is High ( $> +4.5\text{ V}$ ) when light is being reflected back and Low ( $< +3\text{ V}$ ) when it isn't. Photo-receptive sensors consist of a LED in one arm of a U-shaped holder, and a photo-transistor in the other arm. When the sensing area is unobstructed, light falls on the photo-receptor sending the signal High. If the light is interrupted, the photo-transistor goes Low. The figure below shows a typical photo-receptive sensor with the Hooks (catches) used to secure the sensor to its bracket.

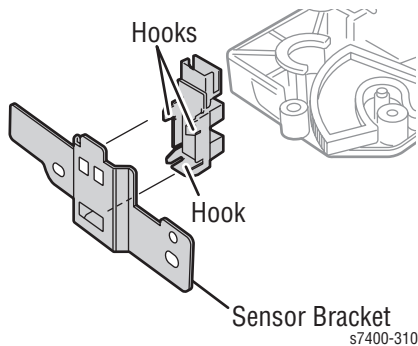

## Microswitches

Microswitches are used primarily as paper size sensors and cover or door interlocks. They are in a normally open state, and close when actuated. A bank of microswitches is used to detect paper size in the universal trays.

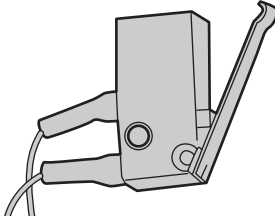

## Thermistors

Thermistors have a known value of resistance at a certain temperature. Used primarily in the Fuser for temperature sensing.

## Hall-Effect

Hall-Effect sensors detect the magnetic properties of the actuator. Hall-Effect sensors are used to monitor activity of the Waste Toner Recovery system and Transfer Unit belt. Use a magnetic source to actuate these sensors during testing.

## List of Sensor and Interlock Types

Name	Type	Function
Level Sensor	Photo-receptive	Detects paper stack height in Trays 2~6.
No Paper	Photo-receptive	Detects no paper condition in all trays.
Paper Size	Microswitch array	Detects the tray and the paper size.
Registration	Photo-receptive	Detects paper at the registration rollers.
Color Registration	Photo-reflective	Monitors color registration.
Feed-Out	Photo-receptive	Detects paper leaving the feeder.
Fuser Exit	Photo-receptive	Detects paper as it leaves the Fuser.
Stack Full	Photo-receptive	Detects when the output tray is full.
Temperature	Thermistor	Monitor Fuser roller temperatures.
Door Interlocks	Microswitch	Interrupts +24 V to the Motors.
Low Toner	photo-reflective	Detects toner in the Imaging Units.
Fuser Thermostats	Thermostatic switches	Interrupts AC power to the Fuser.
Offset Home	Photo-receptive	Detects Offset carriage position.
Temp/Humidity	Integrated circuit	Monitors the printer's environment.
Waste Toner	Hall-effect	Monitors waste augers and transfer belt.
CRUM antenna	RFID code reader	Communicates with the CRUMs.

# Sensors in the Printer

The following illustrations identifies the location of each sensor.

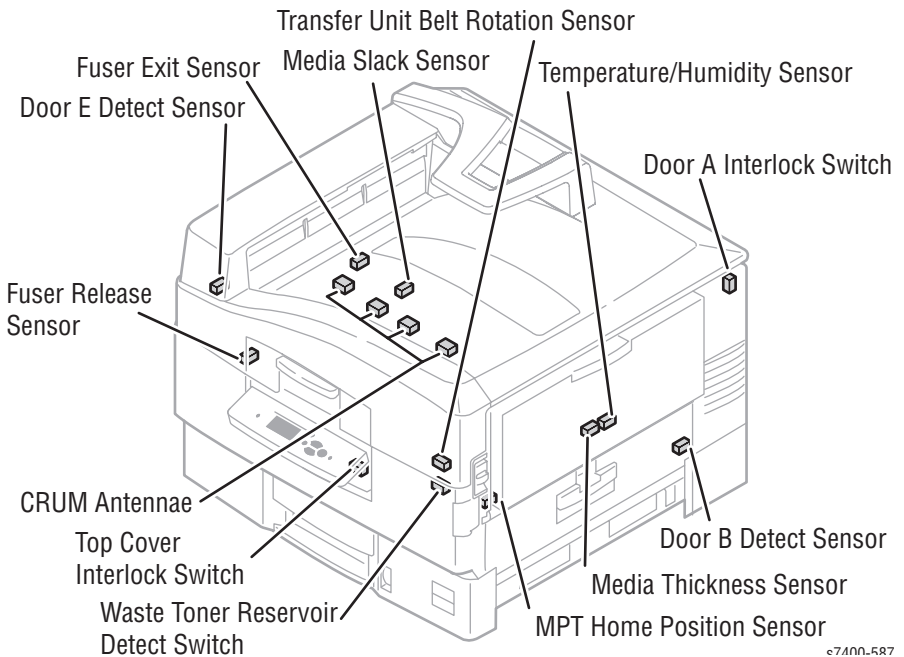
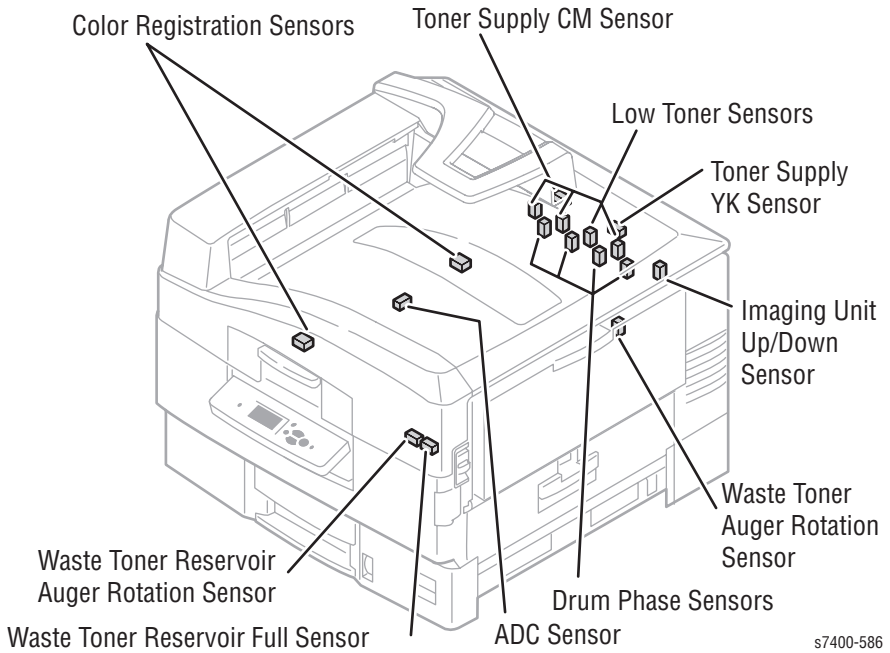

The diagram below identifies the paper feed sensors.

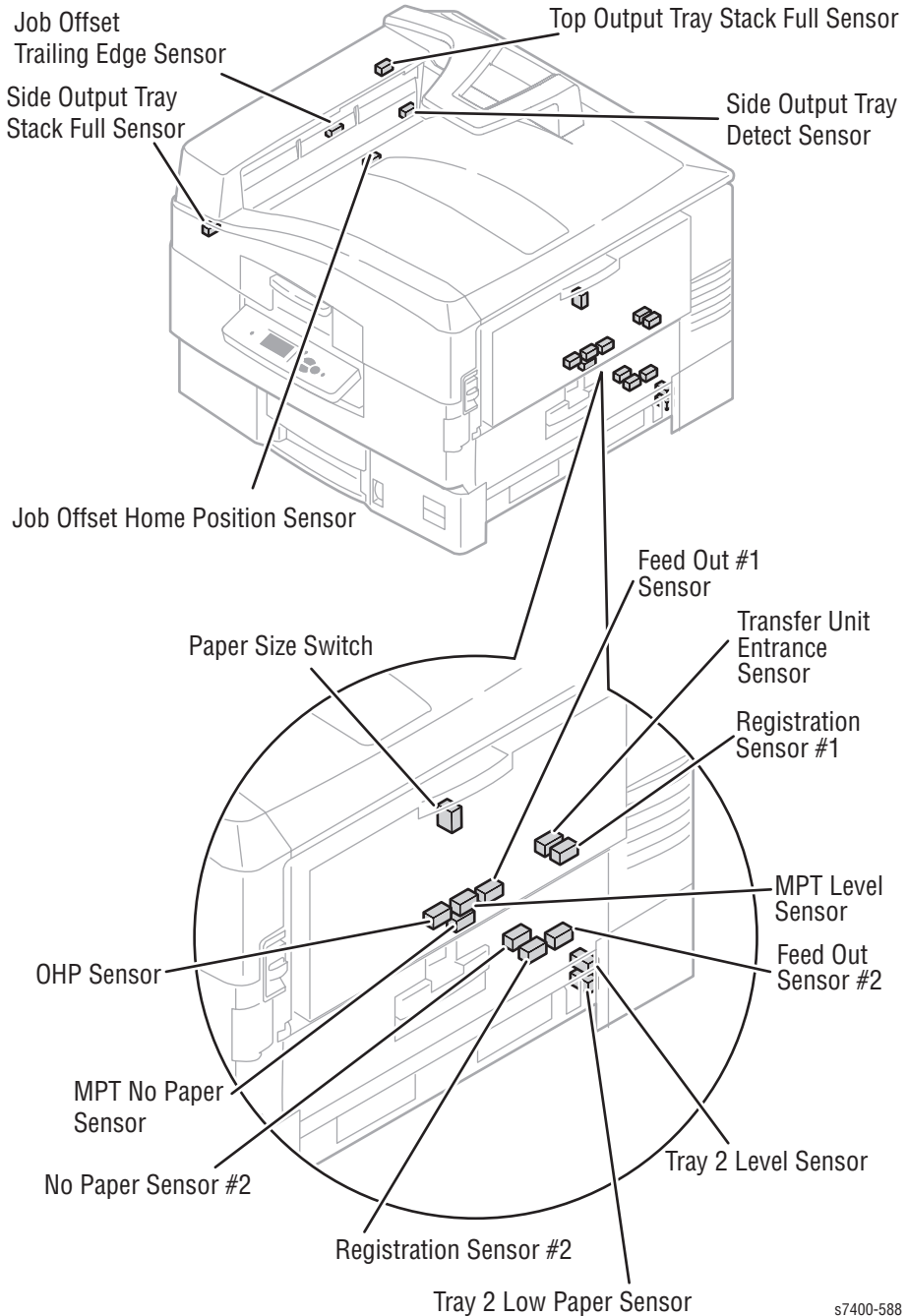

s7400-588



# Sensor Functions

The following table lists the function of each sensor.

## Sensor Functions

Sensor	Function	Sensor State
Top Output Tray Stack Full Sensor	Detects the Top Output Tray stack height.	On: not full Off: full
Side Output Tray Stack Full Sensor	Detects the Side Output Tray stack height.	On: not full Off: full
Side Output Tray Detect Sensor	Detects whether the Side Output Tray is open or closed.	On: open Off: closed
Job Offset Home Position Sensor	Detects the position of the Job Offset carriage.	On: not home Off: home
Job Offset Trailing Edge Sensor	Detects the trailing edge of the media for the Offset carriage.	On: media present Off: media absent
Top Cover Interlock	Detects the position of the Top Cover.	On: open Off: closed
Door A Interlock	Detects the position of Door A.	On: open Off: closed
Door B Detect	Detects the position of Door B.	On: open Off: closed
Door C Detect	Detects the position of Door C for Trays 3 ~ 6.	On: open Off: closed
Door D Detect	Detects the position of Door D.	On: open Off: closed
Door E Detect	Detects the position of Door E.	On: open Off: closed
Waste Toner Reservoir Detect Switch	Detects the presence of the Waste Toner Reservoir.	On: present Off: absent
Fuser Exit Sensor	Detects media at the Fuser Exit.	On: media present Off: media absent
Fuser Temperature	Monitors the Fuser process temperature.	Reference voltage
Media Slack Sensor	Detects media slack at the Fuser entrance.	On: slack Off: no slack
Media Thickness Sensor	Adjusts print parameters according to media thickness.	Reference voltage
Temperature/Humidity Sensor	Measures environmental conditions to calculate the optimal transfer voltage.	Reference voltage
Tray 1 (MPT) Feed-Out Sensor #1	Detects media leaving the Feed Rollers.	On: media present Off: media absent
Tray 1 (MPT) No Paper Sensor	Detects the absence of media in the tray.	On: media present Off: media absent
Tray 1 (MPT) Level Sensor	Detects the Tray 1 (MPT) media supply.	On: media present Off: media absent

## Sensor Functions (Continued)

Sensor	Function	Sensor State
Tray 1 (MPT) Home Position Sensor	Detects the position of the Tray 1 (MPT) Turn Clutch for pick operations.	On: not home Off: home
Transfer Unit Belt Rotation Sensor	Used to count Transfer Unit belt revolutions.	Voltage pulse
Color Registration Sensors	Monitors color registration pattern produced during automatic color registration processing.	Reference voltage
Fuser Release Sensor	Detects if the Fuser Rolls are separated or not.	On: Rollers separated Off: Pressure applied
Waste Toner Auger Rotation	Detects Waste Toner Manifold Auger rotation.	Voltage pulse
Waste Toner Reservoir Auger Rotation	Detects Waste Toner Reservoir Auger rotation. Provides count signal for cartridge life.	Voltage pulse
Waste Toner Reservoir Full	Detects when the Waste Toner Reservoir is full.	On: full Off: not full
Transfer Unit Entrance Sensor	Detects media leaving Registration Roller #1.	On: media present Off: media absent
Registration Sensor #1	Detects media at Registration Roller #1.	On: media present Off: media absent
Duplex Entrance Sensor	Detects media entering the Duplex Unit.	On: media present Off: media absent
Duplex Reverse Sensor	Detects the trailing edge and signals the Duplex Gate Solenoid to switch position.	On: media present Off: media absent
Duplex Front Sensor	Detects the trailing edge and exit from the Duplex Unit.	On: media present Off: media absent
Duplex Rear Sensor	Detects the leading edge following inversion.	On: media present Off: media absent
Toner Cartridge CRUMs	Detects the type of Toner Cartridge installed.	Data
Low Toner Sensors	Detects full, low, and empty state of Toner Cartridges.	Sensor state transition timing
Imaging Unit Drum Phase Sensors	Detect the position of the Imaging Unit drums.	On: absent Off: present
Lift Uplink Sensor	Detects the position of the Lift Uplink	On: IUs up Off: IUs down
OHP Sensor	Detects the presence of transparency media.	On: opaque Off: transparent
Paper Size Switches	Detects the size of media loaded in the universal trays.	See chart.
Feeder Registration Sensor	Detects media at the universal tray's Registration Roller.	On: media present Off: media absent
Feeder Level Sensor	Detects the lift position of media in the universal trays.	On: media present Off: media absent

## Sensor Functions (Continued)

Sensor	Function	Sensor State
Feeder Feed-Out Sensor	Detects media leaving the universal tray's Feed Rollers.	On: media present Off: media absent
Feeder No Paper Sensor	Detects the absence of media in the universal trays.	On: media present Off: media absent
Feeder Low Paper Sensor	Detects a low condition of media loaded in the universal trays.	On: media present Off: media absent

## Paper Level Detection

As paper is fed from the tray, the paper level drops. When the paper level reaches a certain point, an actuator unblocks the Level Sensor signaling the control logic to stop paper feed and raise the tray bottom. Raising the tray bottom pushes the paper up to achieve optimum force against the Feed Roller and blocks the Level Sensor resuming paper feed. This loop continues until the No Paper sensor is activated. Paper level sensing operates the same way for Trays 2 through 6. Tray 1 (MPT) uses No Paper sensing only.

## Paper Present Detection

When the last sheet is fed from any of the trays, the No Paper Sensor actuator drops into an opening in the paper tray, unblocking the sensor. Feeding is inhibited until paper is loaded into the tray.

## Transparent Media Detection

An Over Head Projector (OHP) Sensor is mounted on Door A at the Registration Assembly entrance. This sensor monitors media entering the Registration Assembly and signals when transparent media is being fed.

## Automatic Media Thickness Detection

The printer uses the Media Thickness Sensor to determine the thickness of media passing through the Registration Assembly. The printer automatically adjusts the Fuser temperature, Fuser speed, and electrophotographic parameters to accommodate the detected media weight. Automatic thickness detection (ATS) is available from any media source.

### Note

A special paper type is available in the **Tray Paper Type** menu that turns off ATS when selected. This allows manual configuration of print parameters if the automatic settings do not produce the desired result.

# Paper Size Detection

Trays 2 through 6 automatically sense the standard size media loaded in the printer by using the Paper Size Switches mounted on the frame at the back of the tray opening. When paper is loaded in the tray and the paper guides are adjusted, the levers on the bottom of the trays change the Paper Size Switch Actuators.

Actuating different combinations of the Paper Size Switches produces different combinations of high and low signals. These signals identify what size of paper has been loaded and what to display on the Control Panel. Also, any actuation of the size switches signals the Engine Control Board that the tray is present and closed.

## Universal Tray Paper Size Switch States

SW1	SW2	SW3	SW4	Media Size
0	0	0	0	No tray installed
1	1	1	1	A/Letter (LEF)
1	0	1	0	A/Letter (SEF)
1	0	0	1	A3
0	0	1	1	A3-Nobi
1	1	1	0	A4 (portrait)
0	0	1	0	A4 (landscape)
0	1	1	0	A5
0	1	1	1	A6
0	0	0	1	B4
1	1	0	0	B5 (LEF)
1	0	0	0	B5 (SEF)
1	0	1	1	B/Tabloid
1	1	0	1	Executive
0	1	0	0	Ledger 13 in.
0	1	0	1	Legal 14 in.

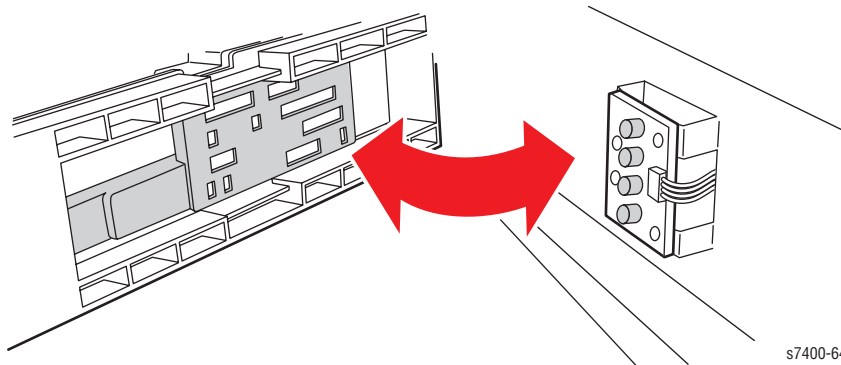

# Jam Detection

The printer checks for a paper jam when the printer is powered on and during printing. When a paper jam occurs, printing immediately stops. Below is a diagram of jam locations within the printer.

- Media Jams occur in the paper path if the associated sensor does not turn On within a specified amount of time, meaning the jam occurs prior to reaching the sensor, or if the sensor does not turn Off within a specified amount of time, meaning the jam occurs along the path of the sensor.
- Misfeeds occur when the paper can not be loaded from the tray.
- Paper size errors occur when the Registration Sensor does not turn Off within a specified amount of time based on paper size settings in NVRAM.

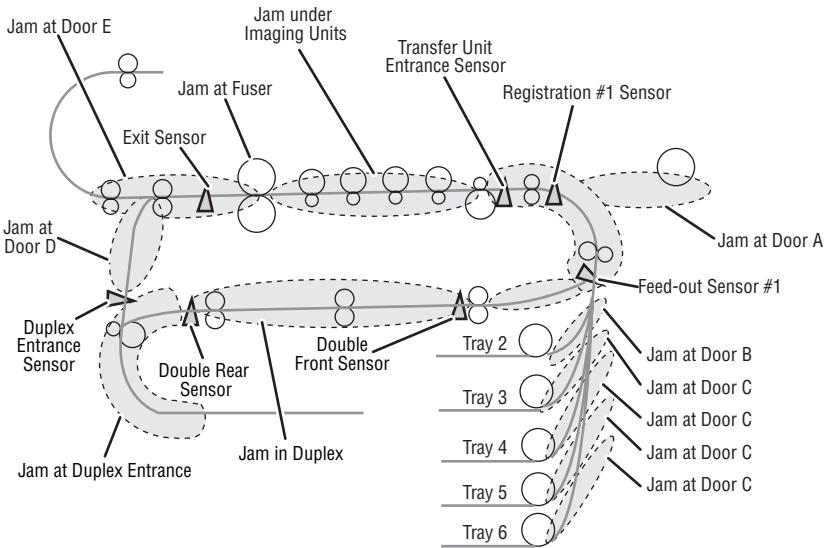

s7400-036

## Interlock Detection

If the Top Cover, Door A is opened, or the Waste Toner Reservoir is removed, an Interlock Switch is opened cutting the +24V source to the HVPS. At the same time, the CPU receives a signal indicating the Interlock Switch state, and displays the appropriate error message.

## Toner Detection

Each Imaging Unit contains an Agitation Gear and Agitation Bar. The Agitation Bar moves toner delivered by the Toner Cartridge to the area above the Developer Roller. Located at one end of the Agitation Bar is the Low Toner Sensor target.

The photo-reflective, Low Toner Sensor mounted on the Imaging Unit Sensor Board detects the target at the end of the Agitation Bar and changes state in relation to light reflected back from the target. As the toner level drops, the period of time the Agitation Bar target remains at its highest point is reduced. This change in Agitation Bar timing signals toner level changes.

OFF Time (Minimum Height)

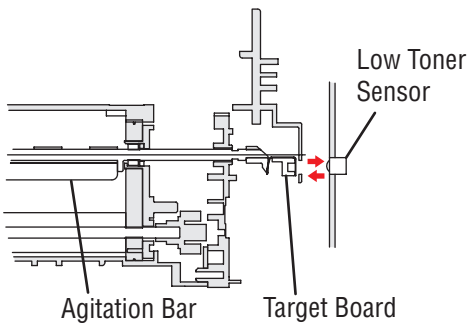

ON Time (Maximum Height)

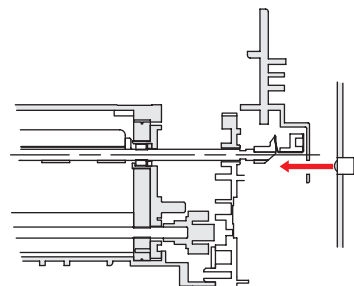

s7400-173

## Toner Full State

When the Imaging Unit is at a toner full state, the Agitation Bar target remains at its maximum height for a period exceeding .85 seconds. Periods in excess of .85 seconds indicate a toner full state. Periods below .85 seconds indicate at toner low state.

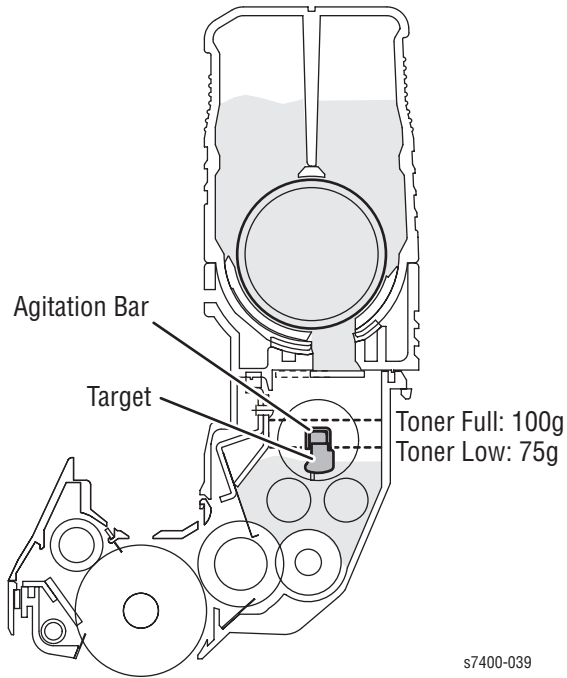

## Toner Low State

As the toner supply is depleted at the Imaging Unit Drum, the period of time the Agitation Bar remains at its lowest position increases reducing the amount of time the target remains in the sensor's range. This period of time (<.85 sec.) is monitored to determine when a toner low condition exists.

### Note

The time used to determine the amount of toner in the Imaging Unit varies with print speed. The value of .85 seconds relates to a print speed of 37 ppm.

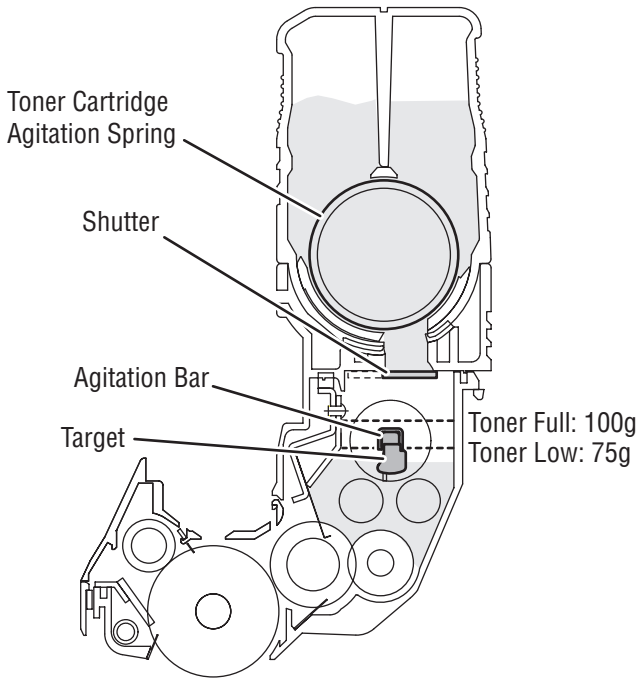

s7400-040

## Toner Supply

If after checking the Low Toner Sensor three times, the state remains low, then the toner supply agitator and toner cartridge agitation spring rotate, supplying additional toner to the Imaging Unit. This continues until one cycle of toner high level is detected. At this point, the toner supply agitator and a toner cartridge agitation spring stop.

When a toner low state is detected 20 consecutive times, it indicates that the Toner Cartridge is low. Once this condition is recognized, the Toner Low warning message for the appropriate color is displayed after the printing of an equivalent of 5% coverage for 200 A sized sheets. At this point, the Toner Cartridge is considered empty.



# Input Paper Path

Paper is transported through the printer along the paper path shown below.

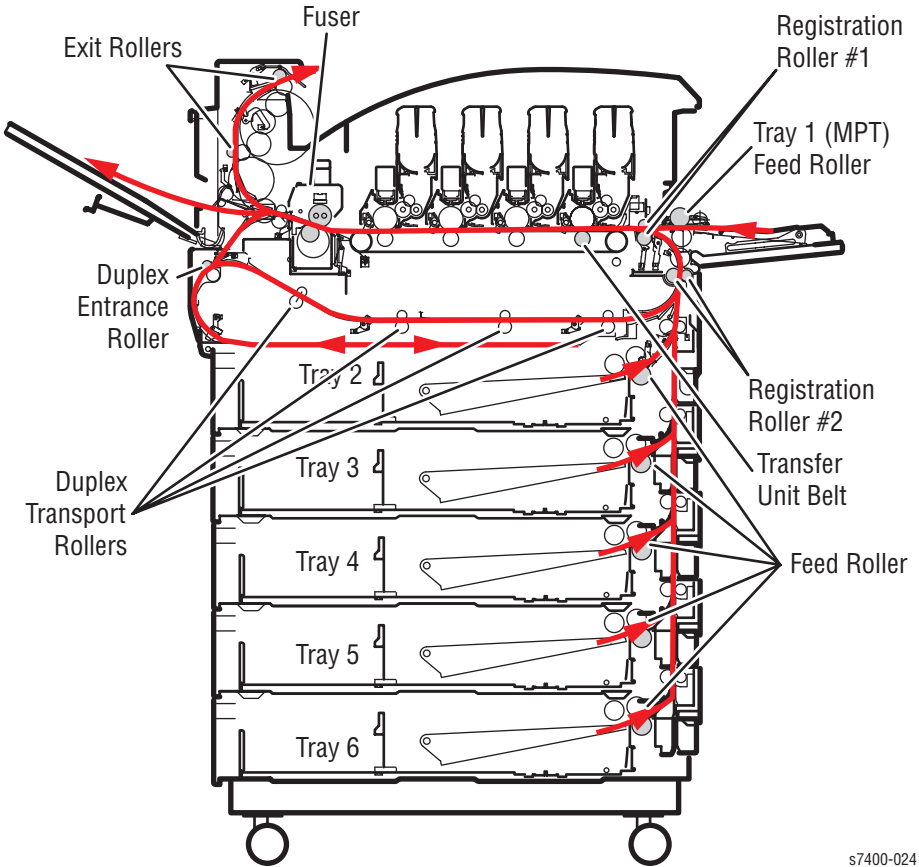

s7400-024

## Paper Fed from Tray 1 (MPT)

1. Paper loaded in the tray is detected by the Tray 1 (MPT) No Paper Sensor.
2. The Registration Motor rotates CCW (b) lifting the sheet to the pre-feed position detected by the Tray 1 (MPT) Level Sensor.
3. The Feed Motor is shared with Tray 2. To feed media from Tray 1 (MPT), the Feed Motor reverses direction (CCW) to drive the Pick and Feed Rollers pulling the sheet into the printer

4. The leading edge of the sheet is detected by the Feed-Out Sensor #1. Depending on the size of the sheet, the Feed Motor continues to drive the sheet until the leading edge reaches the Registration Sensor #1 and a deskew buckle is induced to align the sheet.
5. The Registration Motor rotates CW (a) and the Registration Clutch #1 is engaged moving the media to the Transfer Unit Entrance Sensor. The Feed Motor continues to rotate until the leading edge arrives at the Transfer Unit Entrance Sensor.
6. As each sheet passes the Feed-Out Sensor #1, the Registration Motor lifts the next sheet to pre-feed position.
7. Following the last sheet being fed, the Level Sensor goes low, the Registration Motor rotates in the CCW (b) direction to return the Lift Plate to a home position detected by the Tray 1 (MPT) Home Position Sensor.

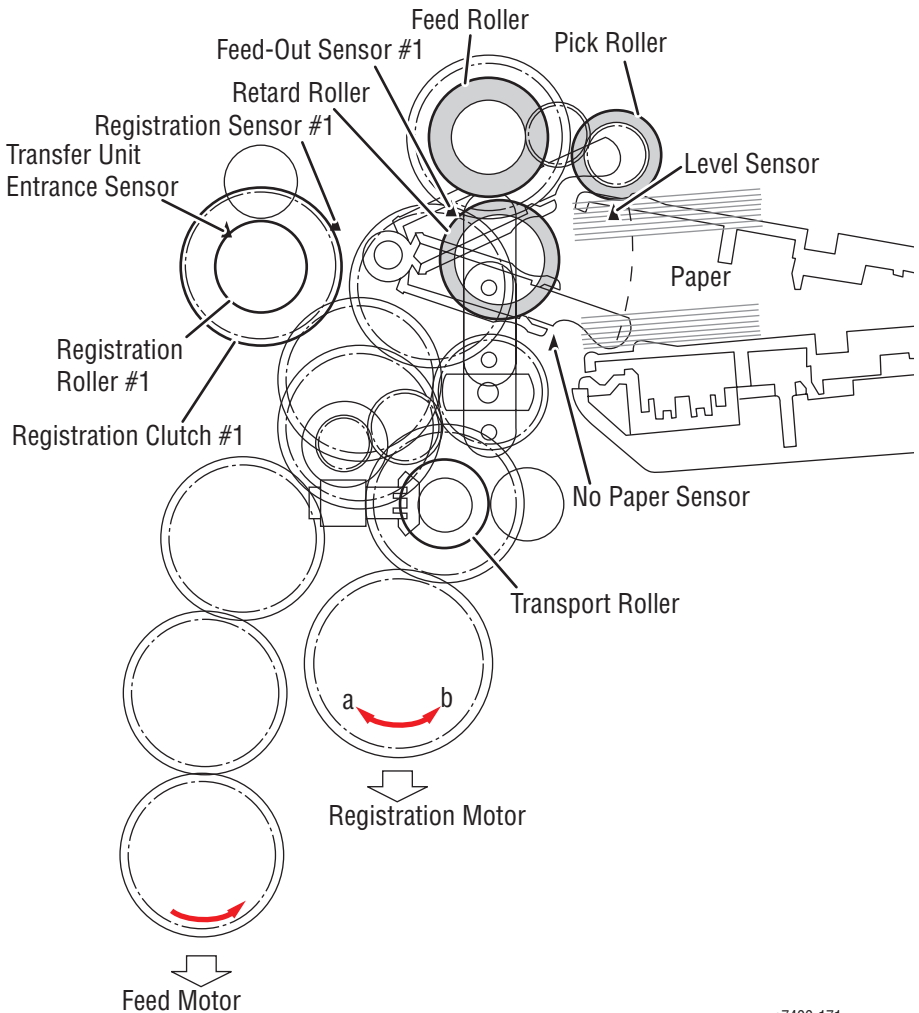

s7400-171

The Tray 1 (MPT) Lift Plate should remain down (home position) when opened. It should only lift when media is sensed. However, the Tray 1 (MPT) Lift Plate is spring loaded. These springs are compressed under the Lift Plate by the Lift Arms driven by the Registration Motor.

When you open Door A, the Lift Arm gear train is disengaged from the Registration Motor and the springs are free to raise the Lift Plate. This becomes important when servicing Tray 1 (MPT) as the Lift Arms can be trapped underneath the Lift Plate.

When the printer's on, closing the Tray 1 (MPT) and then reopening it returns the Lift Plate to home position. When the printer's off, to return the Lift Plate to home position, close the Tray 1 (MPT) and Door A. Next, open Door A with the Tray 1 (MPT) closed. Now, when Tray 1 (MPT) is opened, it should be back to its home position.

Components of Tray 1 (MPT) include:

- No Paper Sensor  
Detects presence or absence of print media in the tray.
- Home Position Sensor  
Detects the position of the lift arm. When the lift arm is down, the lift plate is at Home Position.
- Level Sensor  
Detects the leading edge of the media based on the position of the Actuator.
- Registration Clutch #1  
This clutch transfers Registration Motor drive to the lift arms.
- Feed-Out Sensor #1  
Detects the leading edge as the media leaves the Feed Rollers.
- Registration Roller #1  
This roller assembly aligns the leading edge of the sheet to correct any skew.
- Registration Sensor #1  
These sensors detect the presence of media as it arrives at the Registration Rollers.
- Transfer Unit Entrance Sensor  
Detects the media as it leaves the Registration Roller #1.

## Paper Fed from Tray 2

1. Paper loaded in the tray is detected by the Tray 2 Paper Size Switch.
2. The Tray 2 Lift Motor rotates lifting the sheet to the pre-feed position detected by the Tray 2 Level Sensor.
3. The Feed Motor turns (CCW) driving the Feed and Pick rollers to feed the sheet from Tray 2.
4. The Feed-Out Sensor #2 detects the media as it leaves the Feed Rollers.
5. The Feed Motor continues to rotate until a deskew buckle is induced in the sheet against the Registration Roller #2. Registration Sensor #2 goes High when the sheet reaches the Registration Roller #2.
6. The sheet moves towards the Transfer Unit when the Registration Clutch #2 is engaged driving the Registration Roller #2 and Transport Rollers.
7. As the sheet reaches the Registration Roller #1, it is detected by the Registration Sensor #1.
8. When the Registration Sensor #1 goes High, the Registration Clutch #1 is activated to move the sheet through the Registration Roller #1 to the Transfer Unit.
9. The sheet is detected by the Transfer Unit Entrance Sensor and the Transfer Unit Motor rotates to drive the sheet through the Imaging Units.
10. As the trailing edge of each sheet passes the Feed-Out Sensor, the Lift Motor lifts the next sheet to pre-feed position.

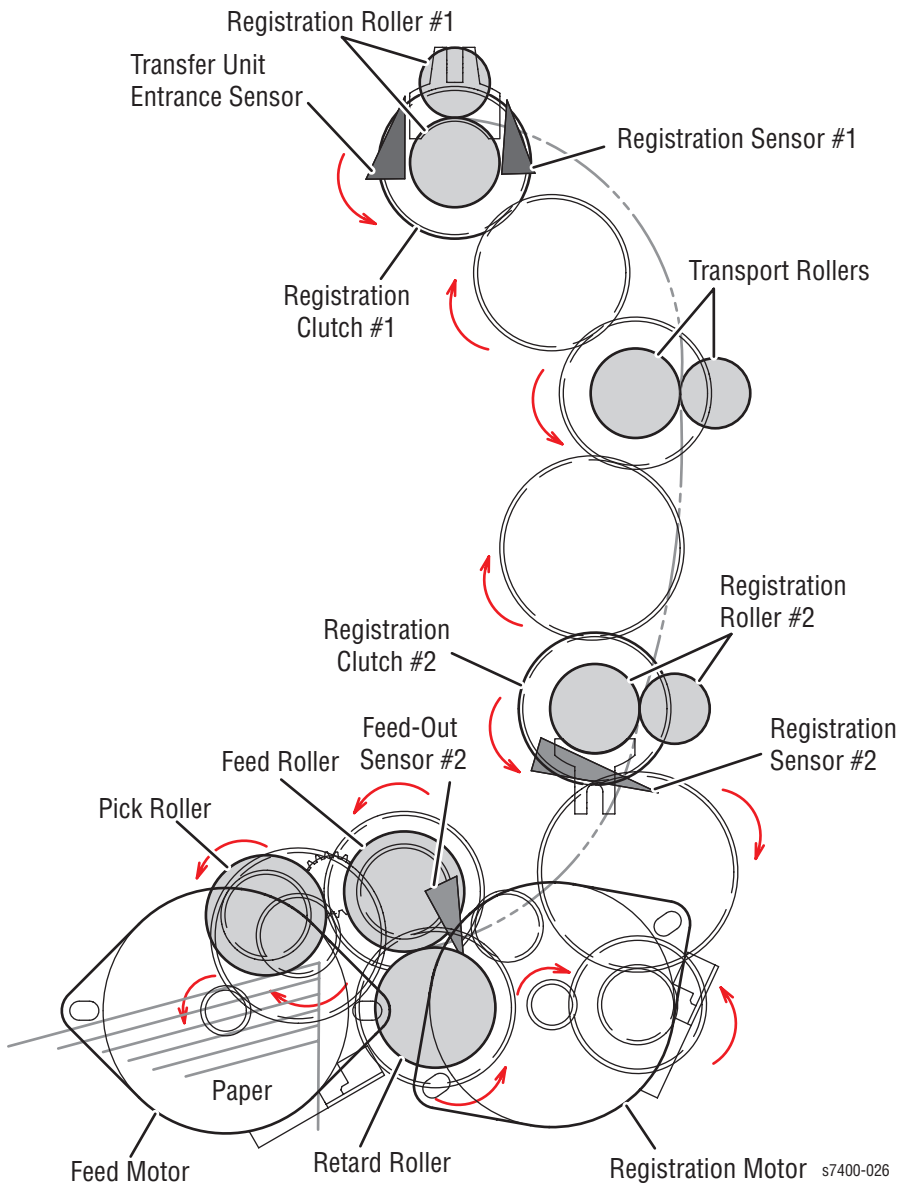

- **No Paper Sensor**  
Detects presence or absence of print media in the tray based on the position of the Actuator.
- **Level Sensor**  
Detects presence of media in the tray based on the position of the Actuator.
- **Paper Size Switches**  
Detects media size using the position of the side and rear guides, and presence of the paper tray.
- **Registration Motor**  
This motor drives the Registration Rollers to pull media from the tray into the paper path.
- **Registration Clutch #2**  
This clutch transfers Tray 2 Registration Motor drive to the Registration Rollers.
- **Registration Roller #2**  
This roller is used to align the leading edge of the sheet to correct any skew.
- **Registration Sensor #2**  
This sensor detects the media as it arrives at the Registration Roller #2.
- **Feed-Out Sensor #2**  
This sensor detects the media as it leaves the Tray 2 Feed Rollers.
- **Feed Motor**  
This motor drives the Feed Rollers to pick paper from the tray and position it at the Registration Roller.
- **Lift Motor**  
This motor lifts the tray's base plate raising the media to the pre-feed position.
- **Low Paper Sensor**  
The actuator lowers as print media is used in the tray. When the actuator lowers to a pre-determined position, it blocks the sensor to trigger a low paper status.

## Paper Fed from Optional Trays

The following describes the paper path as it is fed from the optional Tray 3. Trays 4 through 6 function in the same manner. Media moves along the paper path as follows:

1. Paper loaded in the tray is detected by the Paper Size Switches.
2. The tray's Lift Motor rotates lifting the sheet to the pre-feed position detected by the Level Sensor.
3. The Feed Motor turns (CCW) driving the Feed and Pick rollers to feed the sheet from the tray into the Registration Roller.
4. The Feed-Out Sensor #3 detects the media as it leaves the Feed Rollers.
5. As the trailing edge of each sheet passes the Feed-Out Sensor #3, the Lift Motor lifts the next sheet to pre-feed position.
6. The Feed Motor rotates until the leading edge is against the Registration Roller #3 inducing a deskew buckle. Registration Sensor #3 goes High to indicate the sheet's position.
7. The sheet moves towards the Transfer Unit when the Registration Clutch #3 is engaged driving the Registration Roller #3 and Transport Rollers.
8. As the sheet reaches the Registration Roller #2, it is again aligned and detected by the Registration Sensor #2.
9. When the Registration Sensor #2 goes High, the Registration Clutch #2 is activated to move the sheet through the Registration Roller #2 to the Registration Roller #1.
10. As the sheet reaches the Registration Roller #1, it is detected by the Registration Sensor #1.
11. When the Registration Sensor #1 goes High, the Registration Clutch #1 is activated to move the sheet through the Registration Roller #1 to the Transfer Unit.
12. The sheet is detected by the Transfer Unit Entrance Sensor and the Transfer Unit Motor rotates to drive the sheet under the Imaging Units.

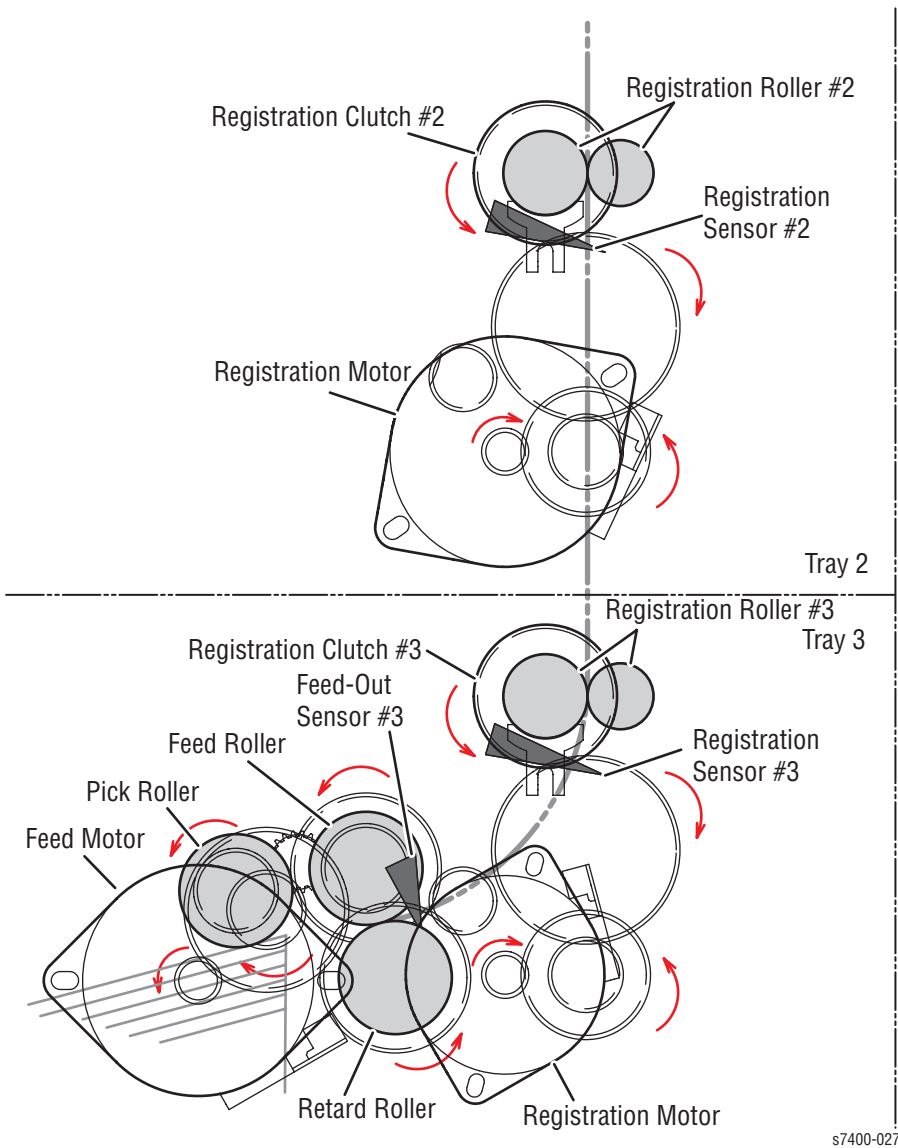

s7400-027

The paper supply and path for the optional trays involve these components:

- **Level Sensor**  
Detects presence of media in the tray based on the position of the Actuator.
- **Paper Size Switches**  
Detects media size using the position of the side and rear guides, and presence of the paper tray.



- **Registration Motor**  
This motor drives the Registration Rollers to pull media from the tray into the paper path.
- **Registration Clutch**  
This clutch transfers Registration Motor drive to the Registration Roller.
- **Registration Roller**  
This roller aligns the leading edge of the sheet to correct any skew.
- **Registration Sensor**  
This sensor detects media as it arrives at the Registration Rollers.
- **Feed-Out Sensor**  
This sensor detects the media as it leaves the Tray 3 Feed Rollers.
- **Transfer Unit Entrance Sensor**  
Detects the media as it leaves the Registration Roller #1.
- **Lift Motor**  
This motor lifts the tray's base plate raising the media to the pre-feed position.
- **Feed Motor**  
This motor drives the Feed Rollers to pick paper from the tray and position it at the Registration Roller.
- **Low Paper Sensor**  
The actuator lowers as print media is used in the tray. When the actuator lowers to a pre-determined position, it blocks the sensor to trigger a low paper status.

## Duplex Unit

The Duplex Unit receives media diverted to the Side Exit by the Exit Gate. The media is detected by the Duplex Entrance Sensor and drawn into the Duplex Unit by the Entrance Roller. The media is inverted and exits the Duplex Unit just above Registration Roller #2. Media moves through the Duplex Unit as follows:

1. After Side 2 is printed, the Exit Gate Solenoid switches the Exit Gate to its side output position. This directs the sheet downwards toward the Duplex Unit.
2. As the sheet reaches the Duplex Entrance Sensor, roller 1 turns, drawing the media into the lower portion of the Duplex Unit
3. After the trailing edge of the media clears the Duplex Entrance Sensor, and with the Duplex Reverse Sensor High, the Entrance Roller is reversed and the Duplex Solenoid is activated to position the Duplex Gate to direct the inverted media into the upper portion of the Duplex Unit.
4. The Duplex Rollers transport the media out of the Duplex Unit and into the printer where Side 1 is printed. This portion of the duplex path is monitored by the Front and Rear Duplex Sensors.

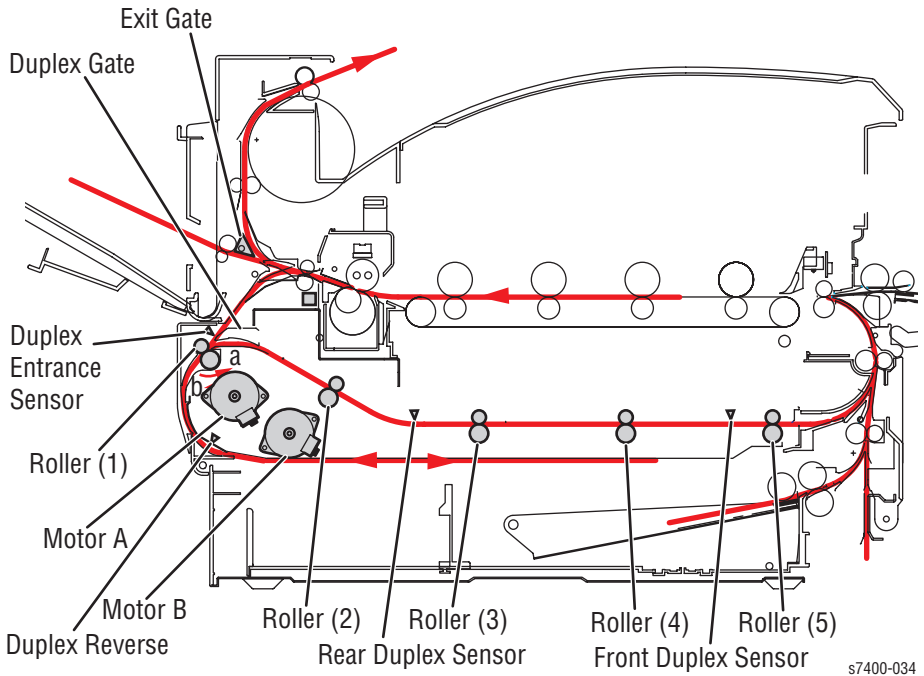

- **Duplex Entrance Sensor**  
Detects the leading edge of the media and signals the Duplex Motor to begin rotation in the forward direction.
- **Duplex Gate Solenoid**  
Activates the Duplex Gate directing media to the Duplex Transport Rollers.
- **Duplex Reverse Sensor**  
Detects media in the lower portion of the Duplex Unit and signals the Duplex Motor to reverse rotation.
- **Duplex Front and Rear Sensors**  
Monitor media transport through the upper portion of the Duplex Unit.
- **Duplex Entrance Roller**  
Drive the media into the Duplex Unit.
- **Duplex Transport Rollers**  
Transport the media through the Duplex Unit and drive the sheet into the primary paper path.
- **Duplex Motors**  
One motor drives the Duplex Entrance Roller, the other drives the Transport Rollers using a series of belts.

# Output Paper Path

The Phaser 7400 paper path for paper exiting the Fuser are:

- Directed by the Exit Gate to the Top Output Tray on the Top Cover (facedown).
- Directed by the Exit Gate to the Side Output Tray or Finisher.
- Directed by the Exit Gate and Duplex Gate into the Duplex Unit.

## Fuser and Exit

The Fuser and Exit Rollers are driven by the Fuser Motor. The Exit Rollers rotate in the direction of the arrows. The discharge path is determined by the position of Exit Gate and Duplex Gate.

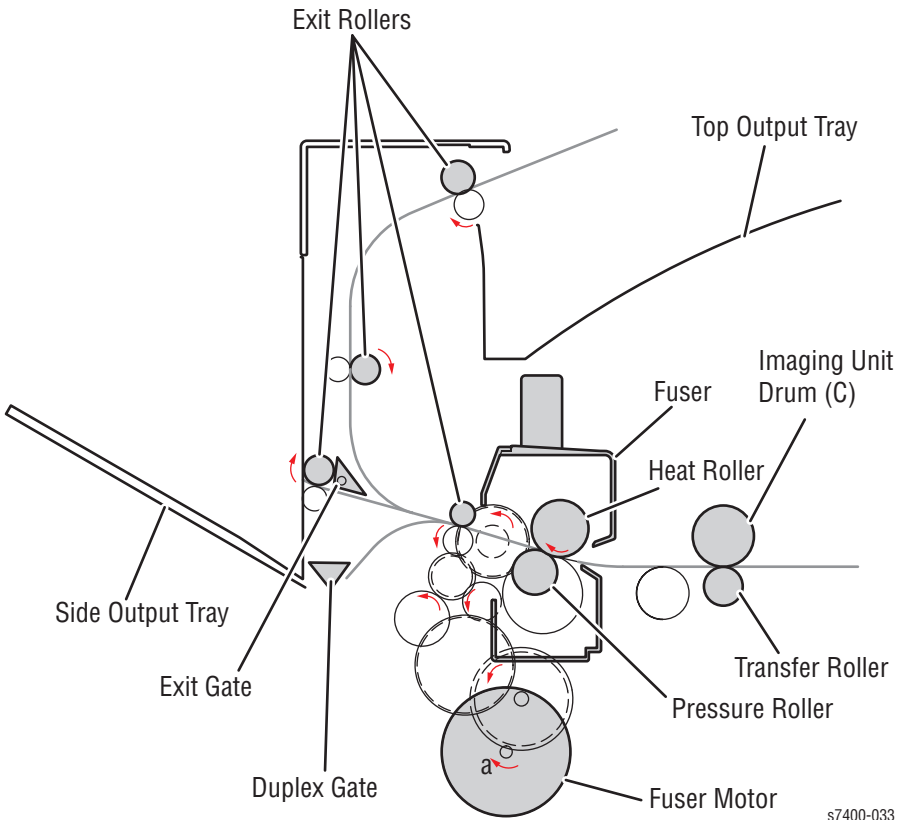

## Top Output Tray

The Top Output Tray is a facedown, 500-sheet tray located on the printer's Top Cover. The tray receives paper from the Exit Assembly which includes a Job Offset Assembly for offset output capability.

## Side Output Tray

The Side Output Tray is a faceup, 250-sheet tray located on the printer's left side. Installation of the Finisher requires that this tray be closed and locked.

## Finisher/Inverter

What follows is a summary of the output path through the Finisher. A detailed description of the Finisher paper path appears in Book 2, Section 2.

Paper fed from the printer's left side exit enters the Finisher and passes through the Finisher Punch. If punching is specified, the Punch sensors align the sheet and punch the prescribed holes. The sheet is then transferred to the Compiler Tray for stacking. If stapling is specified, the stack is drawn into the Stapler and the Staple Head places a staple at the point specified then the Compiler Tray ejects the stapled stack to the Upper Tray. For Saddle stitching, the stack is drawn through the Stapler and stapled at the center point. The stapled stack continues through the Stapler and is folded in the Saddle Unit. The stapled and folded stack is delivered to the Lower Tray.

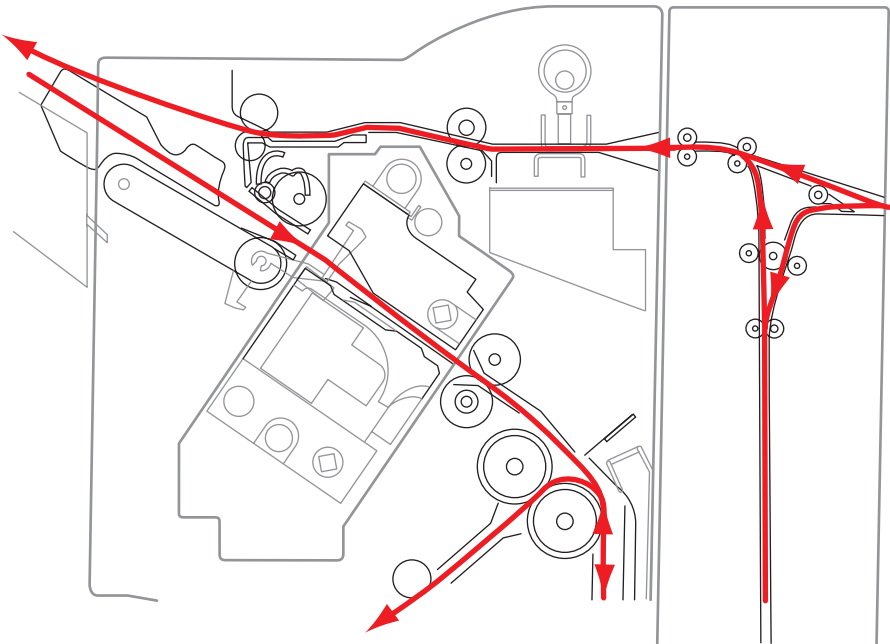

s7400-386

# Drive Assemblies

The following illustration shows the location for all the printer's motors.

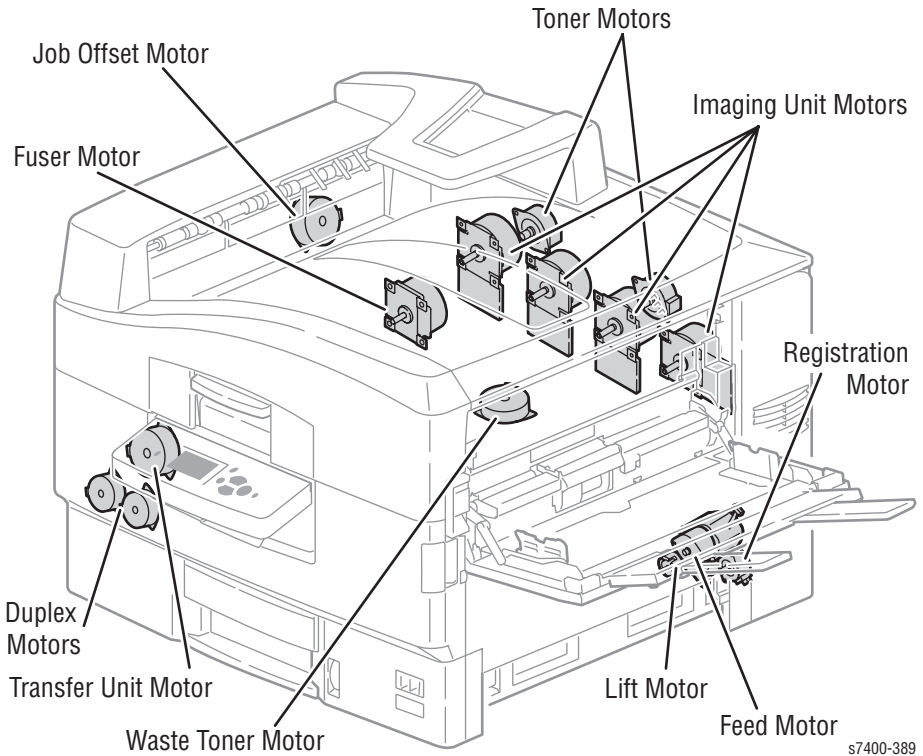

## Imaging Unit Drive Motors

The Imaging Unit Motors drive the Imaging Unit drums, toner Agitation Bars and Agitation Gears. Imaging Unit drive varies depending on the print mode. In addition to the developing components, the Cyan Imaging Unit Motor uses a Lift Uplink mechanism to raise the CMY Imaging Units during monochrome printing. When the Cyan Imaging Unit Motor rotates (CCW), the Lift Uplink slides to the left, and as indicated in the figure below, each Imaging Unit moves down for color printing. When the Cyan Imaging Unit Motor rotates (CW), the Lift Uplink slides to the right, the CMY Imaging Units move up for black and white printing.

### ID Unit Operations During Color Printing

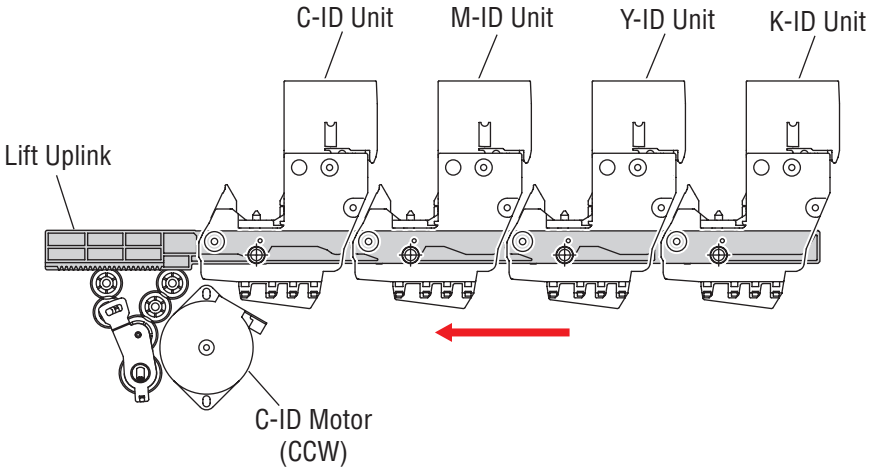

### ID Unit Operations During Monochrome Printing

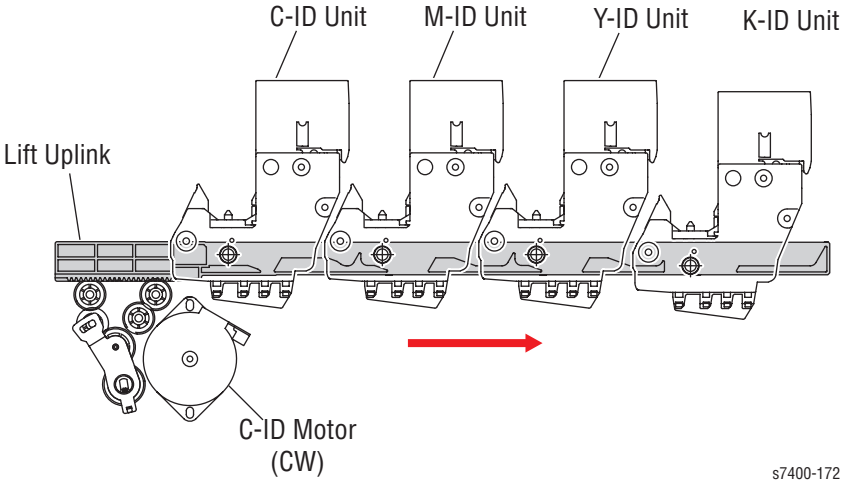

s7400-172

## Imaging Unit Drive

The four Imaging Unit Motors supply the drive to the Imaging Unit drum and Agitation Bar and Gear as shown in the following figure.

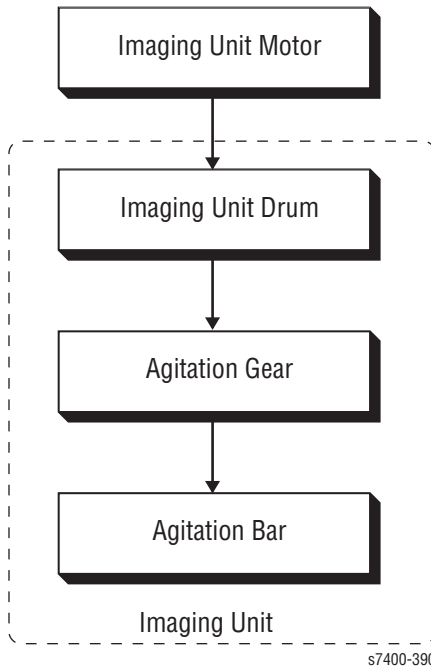

## Transfer Unit Motor

The Transfer Unit motor turns clockwise driving the Transfer Unit belt. Inside the Transfer Unit are four Transfer Rollers located just under each Imaging Unit drum. When the Transfer Unit Motor and Imaging Unit Motors are activated, they carry the paper on the transfer belt to the Fuser. The voltages applied to the Transfer Rollers attract the toner image from the Imaging Unit drum to the media.

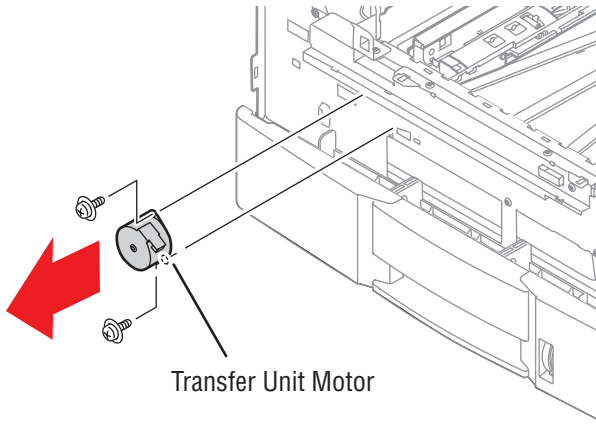

s7400-360

## Transfer Unit Drive

The Transfer Unit Motor supplies the drive to the transfer belt as shown in the following figure.

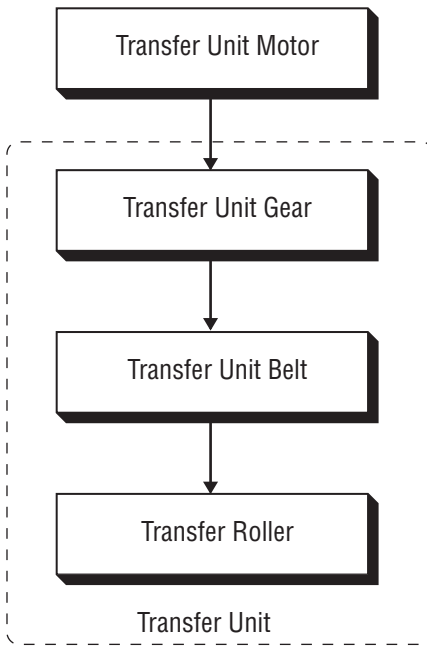

s7400-391



# Fuser Motor

The Fuser Motor drives the Fuser Heat and Pressure Rollers, as well as the Exit Rollers. This is shown in the following figure.

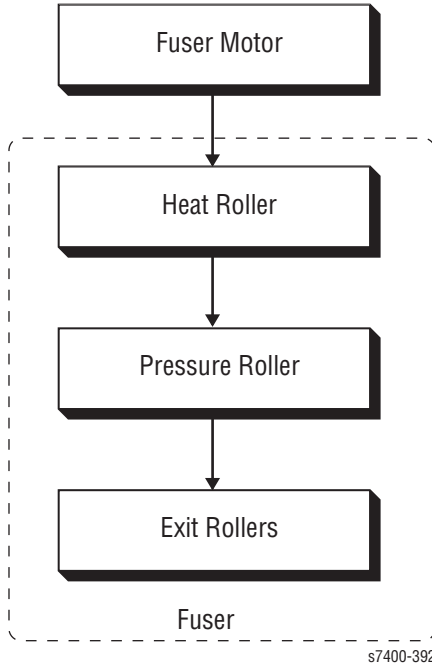

# Toner Dispense Motors

The CM and YK Toner Dispense Motors are mounted above the Imaging Unit Motors and drive the Toner Cartridge Supply Augers and Agitation Springs to deliver toner to the Imaging Units.

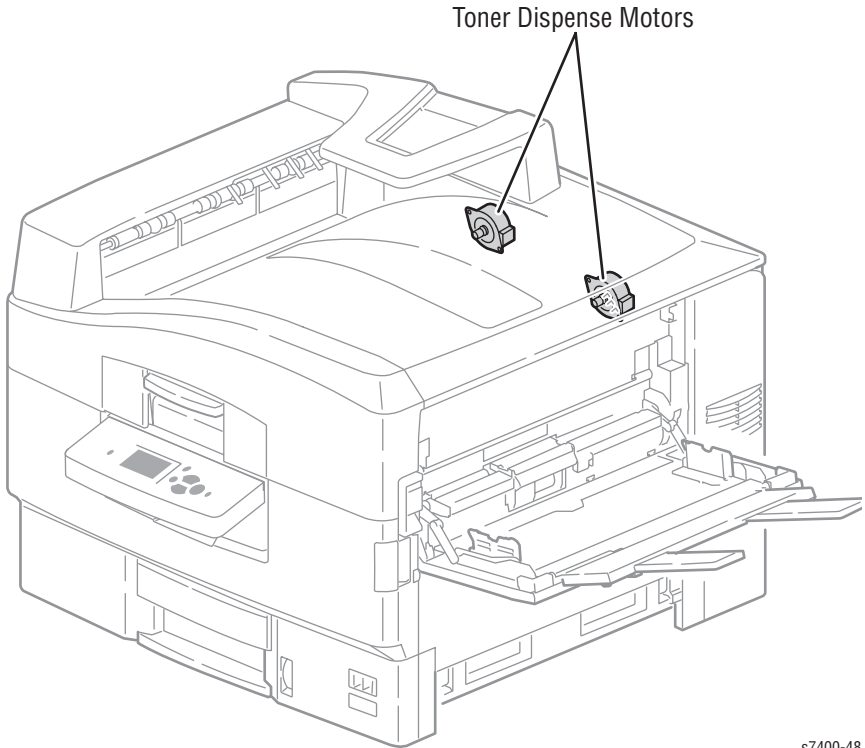

s7400-48

# Duplex Drive Motors

Two motors are used to capture and transport paper in the Duplex Unit. Duplex Motor A drives the Entrance Roller CCW to capture paper, then CW to drive the media into the Transport Rollers. Motor B uses a series of belts to drive the four Transport Rollers that move media to the Registration Assembly.

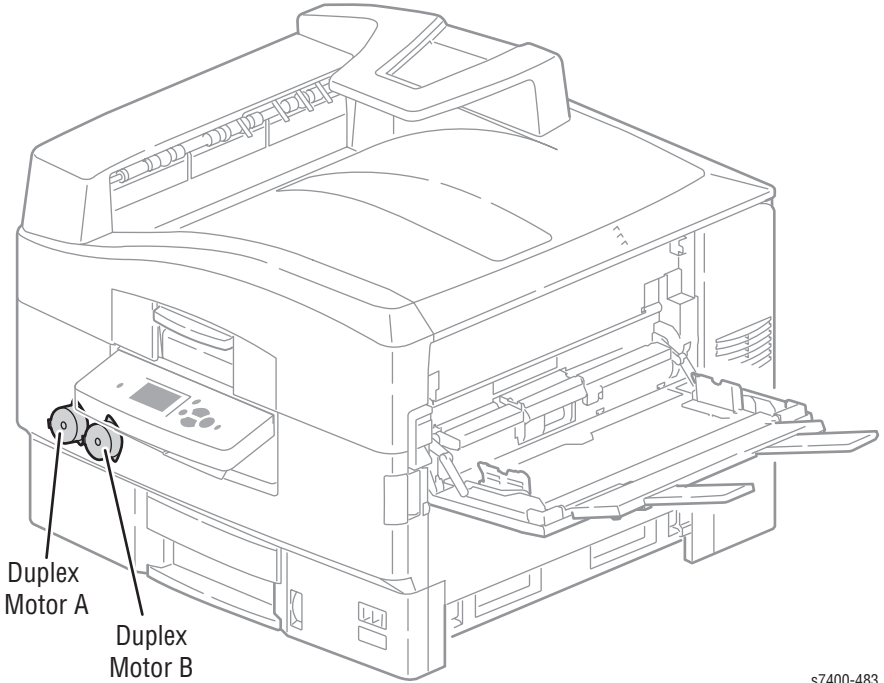

s7400-483

# Chassis Assemblies

## Basket Assembly

The Basket Assembly allows all four Imaging Units to be raised from the Transfer Unit to facilitate jam clearance. A latch at the front of the Basket Assembly releases the locking catch.

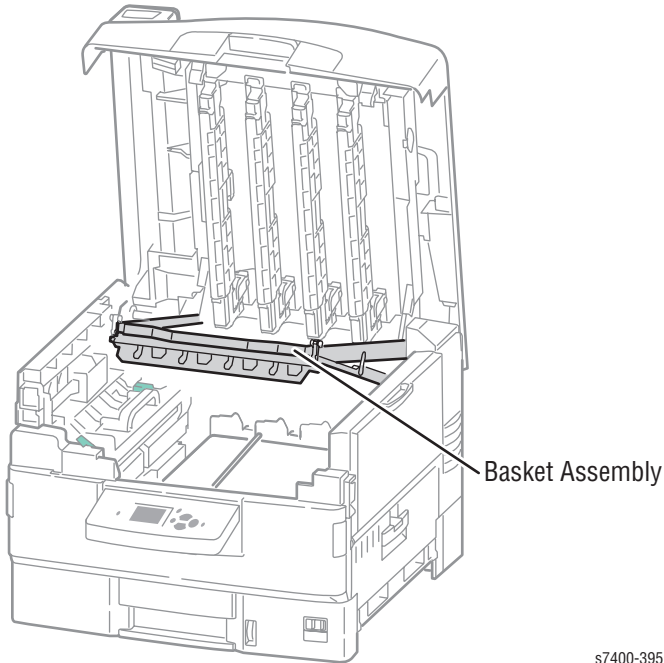

s7400-395

The Basket Assembly is comprised of an upper and lower sub-assembly. The Upper Basket Assembly attaches to the printer frame and supports the Lower Basket Assembly. The Lower Basket Assembly connects to the Upper Basket Assembly and supports the four Imaging Units and the Waste Toner Manifold. The Lower Basket sub-assembly, or the entire Basket Assembly are available as replacement parts.

# Waste Toner Recovery

Waste toner recovery moves the toner collected from the Imaging Unit drums and Transfer Unit belt to the Waste Toner Reservoir located at the front of the printer. Driven by the Waste Toner Motor, separate Augers in the Waste Toner Manifold and Waste Toner Duct pull toner through a tube to the Waste Toner Reservoir. Waste toner is moved within the reservoir by another Auger driven by the Waste Toner Motor.

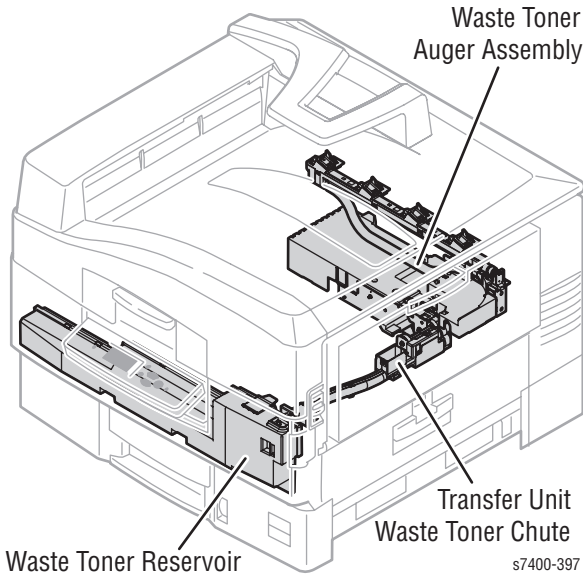

Status of the Waste Toner Reservoir is monitored by the Engine Control Board. The Engine Control Board receives count signals from the Waste Toner Reservoir Auger Rotation Sensor located behind the Right Front Cover. This Hall-Effect sensor is activated each time a small, magnetic disk, embedded in the reservoir auger gear, passes in front of the sensor. The auger revolutions are converted into a life count.

- Waste Toner Reservoir Detect Switch  
Detects the presence of the Waste Toner Reservoir.
- Waste Toner Reservoir Full Sensor  
Detects when the Waste Toner Reservoir is full.
- Waste Toner Reservoir Auger Rotation Sensor  
Detects revolutions of the reservoir auger.
- Waste Toner Auger Rotation Sensor  
Detects revolutions of the manifold auger.
- Waste Toner Motor  
Drives augers in the Waste Toner Manifold, Waste Toner Duct, and Waste Toner Reservoir.

# Registration Assembly

Shown in the following figure are the components associated with the Registration Assembly.

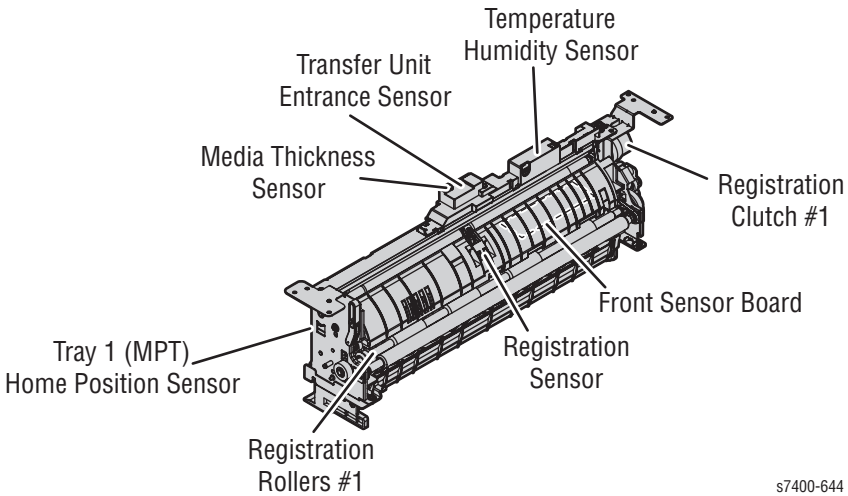

s7400-644

- Tray 1 (MPT) Home Position Sensor  
Detects the position of the Feed drive.
- Registration Sensor #1  
Detects the when the media's leading edge has reached the Registration Rollers.
- Registration Rollers #1  
Driven by the Registration Motor through the Registration Clutch, the Registration Rollers work to correct media skew and transport media to the Transfer Unit belt.
- Registration Clutch #1  
Transfers drive from the Registration Motor to the Registration Rollers.
- Transfer Unit Entrance Sensor  
Detect the arrival of the media at the Transfer Unit.
- Media Thickness Sensor  
Produces a signal that varies dependent on media thickness.
- Temperature/Humidity Sensor  
Monitors environmental conditions surrounding the printer.
- Front Sensor Board  
Communicates the status of Tray 1 (MPT) and Registration Assembly sensors to the Motor Driver Board.

# Exit Assembly

The Exit Assembly uses rollers, solenoids, sensors, and diversion gates to handle media exiting the Fuser.

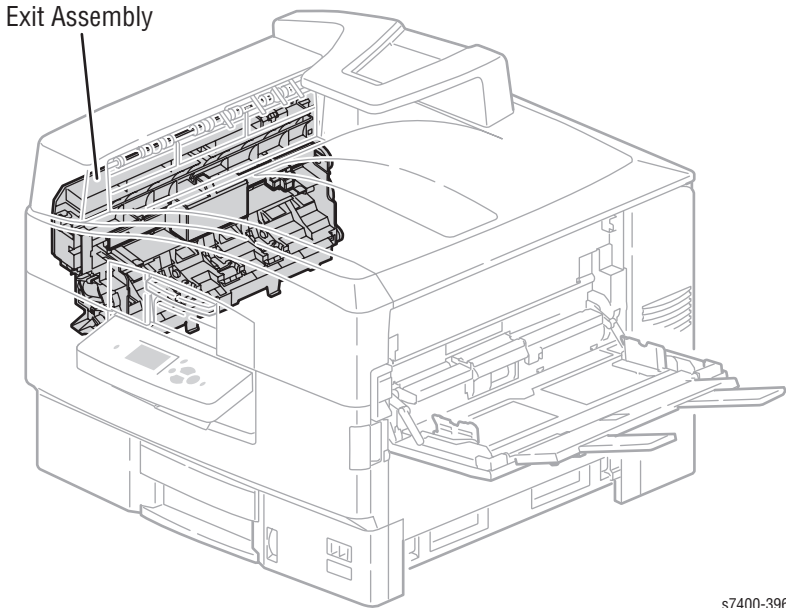

s7400-396

Exit Assembly components include:

- **Exit Gate**  
The Exit Gate switches the paper path. When the Exit Gate is in its resting position, paper is fed to the Top Output Tray. When it is lowered by the Exit Gate Solenoid, paper is fed to the Side Output Tray or Duplex Unit.
- **Exit Gate Solenoid**  
Switches the paper discharge path between the Top and Side Output Trays.
- **Side Output Tray Full Stack Sensors**  
These sensors use an actuator to detect when the Top or Side Output Tray is full.
- **Fuser Exit Sensor**  
The Fuser Exit Sensor detects whether paper remains in the output rollers.
- **Door E Detect Sensor**  
Detects whether Door E is open or closed.
- **Side Output Tray Detect Sensor**  
Detects whether the Side Output Tray is open or closed.

- **Offset Home Position Sensor**  
The Offset Home Position Sensor detects the roller position.
- **Job Offset Trailing Edge Sensor**  
Detects the trailing edge of the media as it leaves the Exit Assembly.
- **Exit Rollers**  
Driven by the Fuser Motor, the Exit Rollers transport media from the Fuser through the Exit Assembly. Exit Roller drive gearing is shown in the following figure.

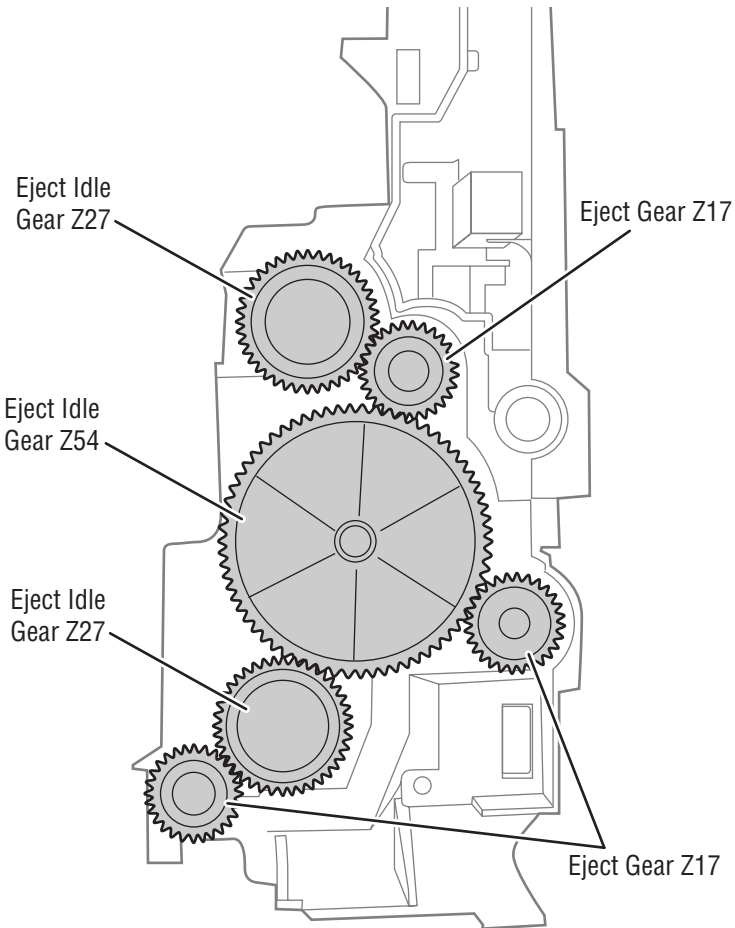

s7400-406

- **Duplex Gate**  
Actuated by the Duplex Gate Solenoid in the Duplex Unit, the Duplex Gate directs media through the upper portion of the Duplex Unit and returns it to the Registration Assembly for printing on side 2. The following figure shows the Duplex Gate linkage between the Duplex Unit and Exit Assembly



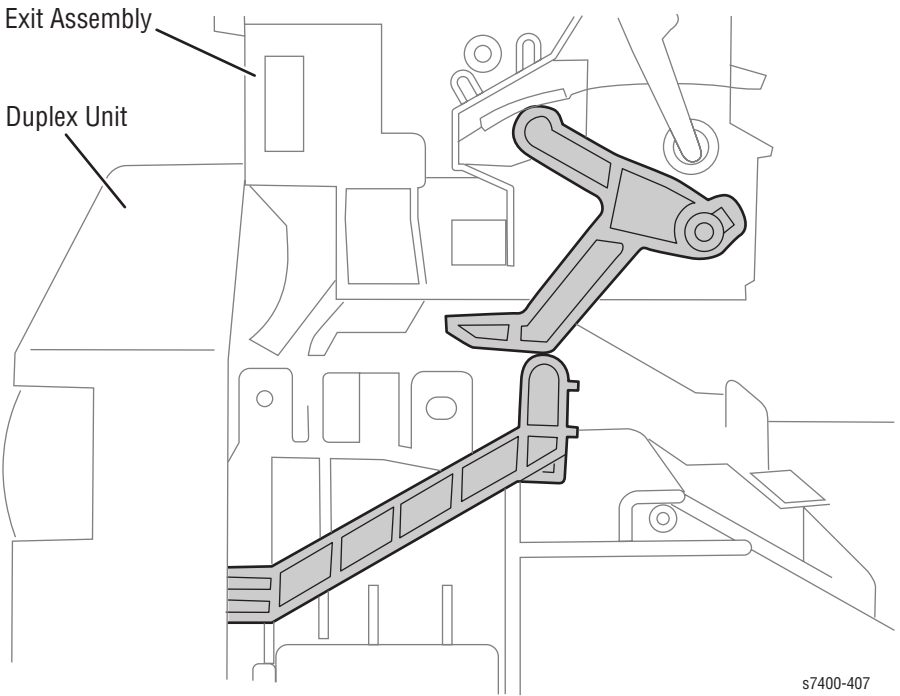

s7400-407

## Job Offset Assembly

- Job Offset Motor

The Offset Motor acting through the Offset Gear shifts the media forward or backward providing offset capability. The flow diagram shows the components involved in the offset process.

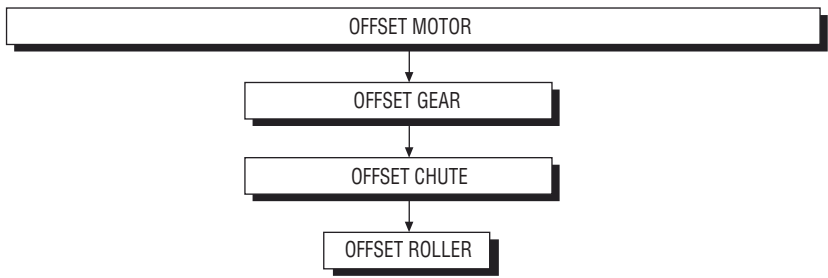

s7400-646

- Top Output Tray Full Stack Actuator

Actuates the Top Output Tray Full Stack Sensor to limit the number of sheets sent to the tray.

# Trays

Standard input trays include the 100-sheet, multi-purpose Tray 1 (MPT) and one 550-sheet universal tray. Standard output trays include a 500-Sheet facedown Top Output Tray with offset capability, and a 250-sheet faceup Side Output Tray.

## Tray 1 (MPT)

The Tray 1 (MPT) feeds standard and custom size media into the printer. The printer's Feed Motor, shared with Tray 2, drives the Tray 1 (MPT) Feed Roller to feed media from the tray. Tray 1 (MPT) components include:

- **Feed Rollers (Feed Retard and Pick)**  
Transport media from Tray 1 (MPT) to the Registration Assembly.
- **Tray 1 (MPT) No Paper Sensor**  
Detects when media is in Tray 1 (MPT).
- **Tray 1 (MPT) Level Sensor**  
Detects the presence of media at the Pick Roller.
- **Tray 1 (MPT) Home Position Sensor**  
Located in the Registration Assembly, it detects the position of the Feed drive.
- **Feed-Out Sensor #1**  
Detects media exiting the Tray 1 (MPT) Feed Rollers
- **OHP Sensor**  
Detects when transparency media is being fed to the Registration Assembly.

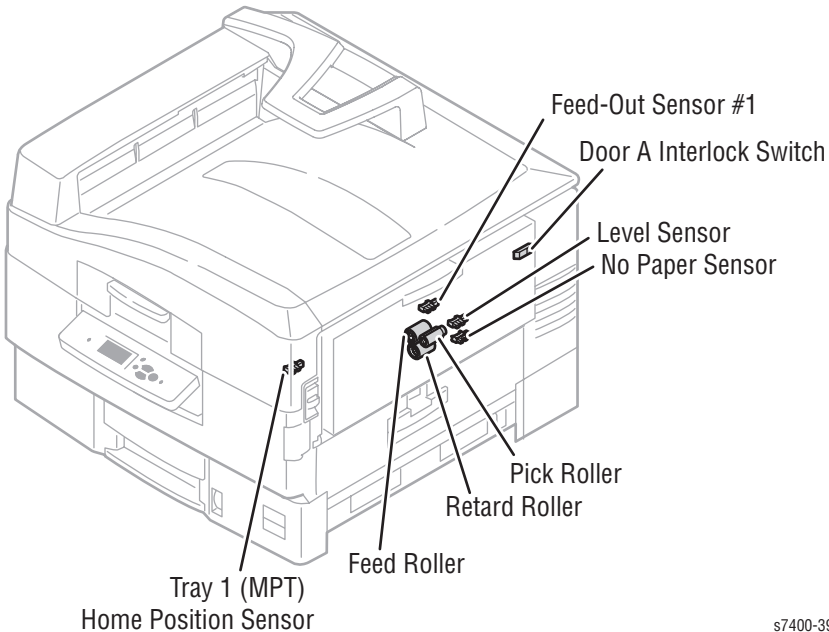

s7400-399

Tray 1 (MPT) incorporates a single set of guides to establish paper width. The time required for the paper to clear the No Paper Sensor identifies the paper's length. When media is placed in Tray 1 (MPT), the leading edge strikes the actuator of the No Paper Sensor indicating the presence of paper. As the last sheet of paper is fed from the tray the actuator drops through an opening indicating No Paper remains in the tray.

## Universal Trays

The universal trays 2 through 6 include end and side guides that manually adjust to the paper loaded in the tray. These guides come into contact with the front and rear edges of the paper and hold it in position. Paper size is determined by the signal created by the guides interacting with the Paper Size Switch actuators.

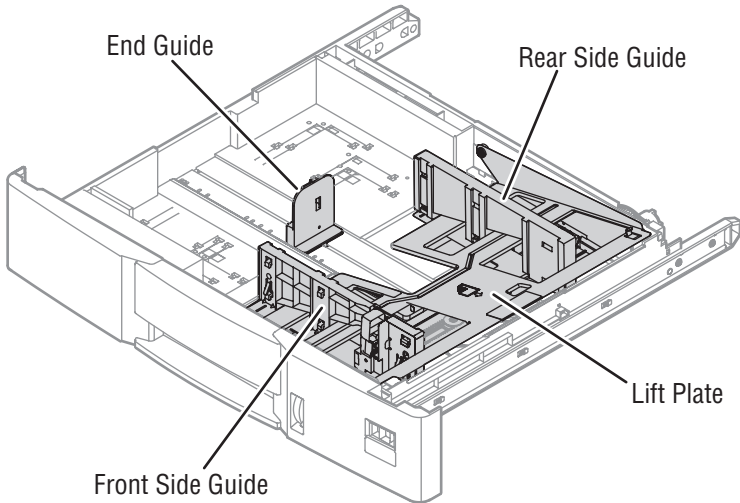

s7400-199

- Side Guides Right and Left  
The side guides move against media to align or register the width of print media in the paper feed direction.
- Rear Guide  
The Rear Guide moves to determine the length of print media in the paper feed direction. The Rear Guide contacts the Paper Size Switch actuators to detect the paper size loaded in the tray.
- Lift Plate  
The Lift Plate is raised by the Lift Motor to position the media for picking.

# Universal Feeder

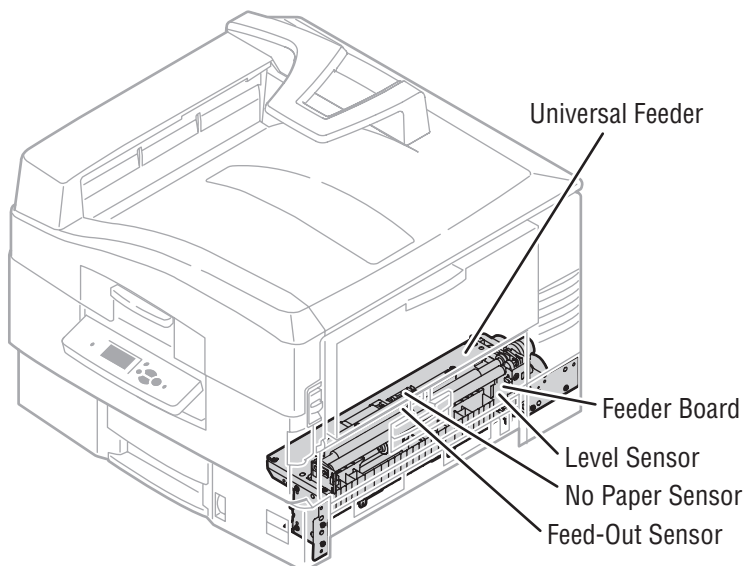

s7400-571

- **Level Sensor**  
The Level Sensor uses an actuator to determine whether paper in the tray is lifted to the optimum feeding position. When the flag of the actuator leaves the sensing area, the sensor detects that the paper has been lifted.
- **Feed-Out Sensor**  
The Feed-Out Sensor detects a paper jam in the tray by the paper position and sensor transition time.
- **No Paper Sensor**  
The No Paper Sensor uses an actuator to determine whether the tray is empty. When the actuator lowers, the No Paper Sensor signal goes High indicating an empty tray.
- **Feeder Board**  
The Feeder Board communicates sensor information to the Motor Driver Board.

## Side Output Tray

The Side Output Tray provides 250-sheets of faceup output capacity. Included is a Paper Support that rotates 180 degrees to support the stack, and a latching door for printers equipped with a Finisher. Stack level is monitored by The Side Output Tray Full Stack Sensor mounted in the Exit Assembly.

# Electrical

The following provides an overview of the major electrical components. Additional detail is located in Section 10, Wiring Diagrams.

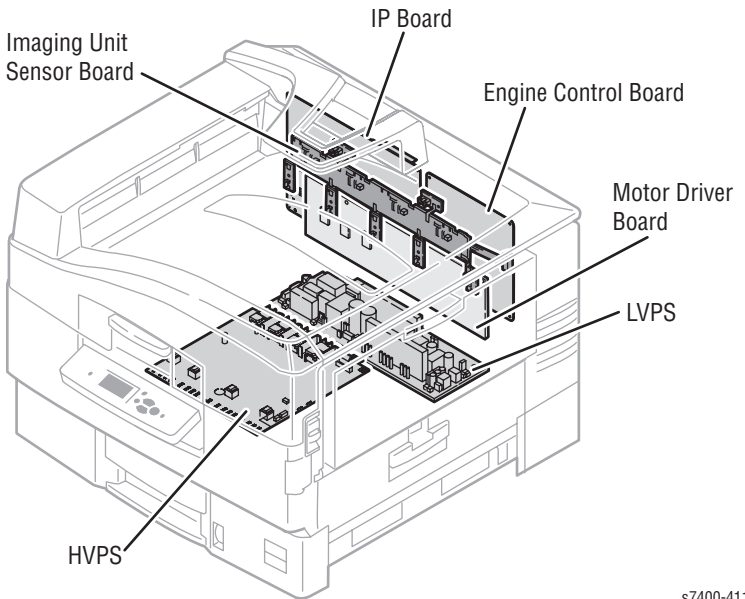
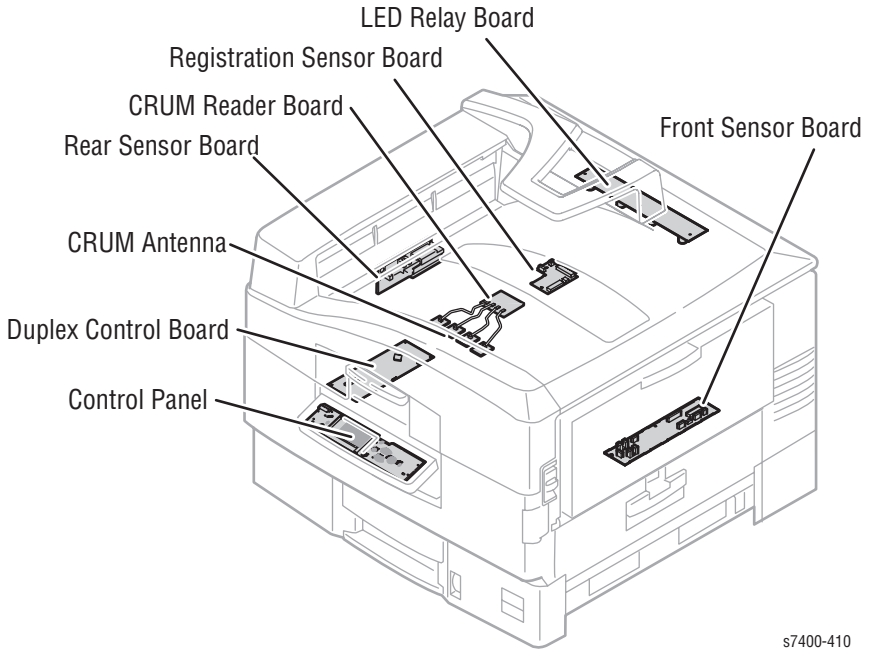

## Control Panel

The Control Panel is the primary interface to the printer's functions and includes the display, keypad, and status LED.

## Image Processor Board

The Image Processor Board receives host data through the USB or Ethernet port. The received data is buffered and stored, and then sent to the print engine in a rasterized format. The Image Processor Board connects to the Engine Control Board directly. The image processor board contains:

- Memory - RAM
- Flash DIMM
- NVRAM - Control Panel and network settings.
- Configuration Chip - determines the printer configuration.
- Optional Hard Drive

## Engine Control Board

The Engine Control Board synchronizes the print process by controlling the LED Heads, motors, fans, sensors, solenoids, clutches and Fuser temperatures. The Engine Control Board also controls the voltages to the Imaging Units and the print speed to compensate for changes in media and environmental conditions.

### Major Functions:

- Communicates with the Image Processor Board
- Receives information from the sensors and/or switches.
- Generates the image based on information from the Image Processor Board.
- Controls high-voltage sent to the Imaging Unit to perform charging, development, primary and secondary transfer.
- Distributes the low-voltage DC power from the Low-Voltage Power Supply.

## Registration Sensor Board

Located in the Registration Sensor Assembly, the Registration Sensor Board includes the two sensors that monitor color registration.

## LED Relay Board

Distributes power from the LVPS to the four LED Heads.

## Imaging Unit Sensor Board

The Imaging Unit Sensor Board communicates with the Engine Control Board and supplies voltage for the two Imaging Unit Fans and Fuser Fan. The board also includes the four Low Toner Sensors that monitor toner levels in the Imaging Units, and the Imaging Unit Position sensor that detects the position of the Lift Uplink.

- Low Toner Sensors [C][M][Y][K]  
Detects level of toner in the Imaging Unit.
- Toner Cartridge In Sensors [C][M][Y][K]  
Detects the presence of the Toner Cartridge in the holder.
- Lift Uplink Position Sensor  
Detects the position of the Lift Uplink.
- Imaging Unit Drum Phase Sensors  
Detects the position of the Imaging Unit Drums.

## Motor Driver Board

Located directly below the Imaging Unit motors, the Motor Driver Board receives +24 V from the LVPS and distributes power and control signals to these devices:

- Imaging Unit Motors
- Toner Motors
- Waste Toner Motor
- Fuser Motor
- Tray 2 Paper Size Switches

## Feeder Board

The Feeder Board communicates with the Motor Diver Board and provides connections for these components:

- Registration Clutch #2
- Registration Sensor #2
- Feed-Out Sensor #2
- Tray 2 No Paper Sensor
- Door B Interlock.

Integrated on the board are the Tray 2 Level Sensor and Tray 2 Low Paper Sensor.

# HVPS

Located under the Transfer Unit and HVPS Cover, the HVPS supplies high-voltage to the Transfer Unit and Imaging Units. The HVPS also provides connections for the Front Door Interlock (CN3) that disables +24V when opened, the Waste Toner Reservoir Full (CN4) and Detect (CN2) Hall-effect sensors.

## HVPS Imaging Outputs

Output	Voltage	Purpose
CH	-0.8 to -1.4kV	Charge Roller voltage
DB	-100 to -450V/250V	Developer Roller voltage
SB	-300 to -700V	Sponge Roller voltage
BB	Drop from SB Output with Zener	Cleaning Blade voltage
TR	0 to 7kV	Transfer Roller voltage (not shown)

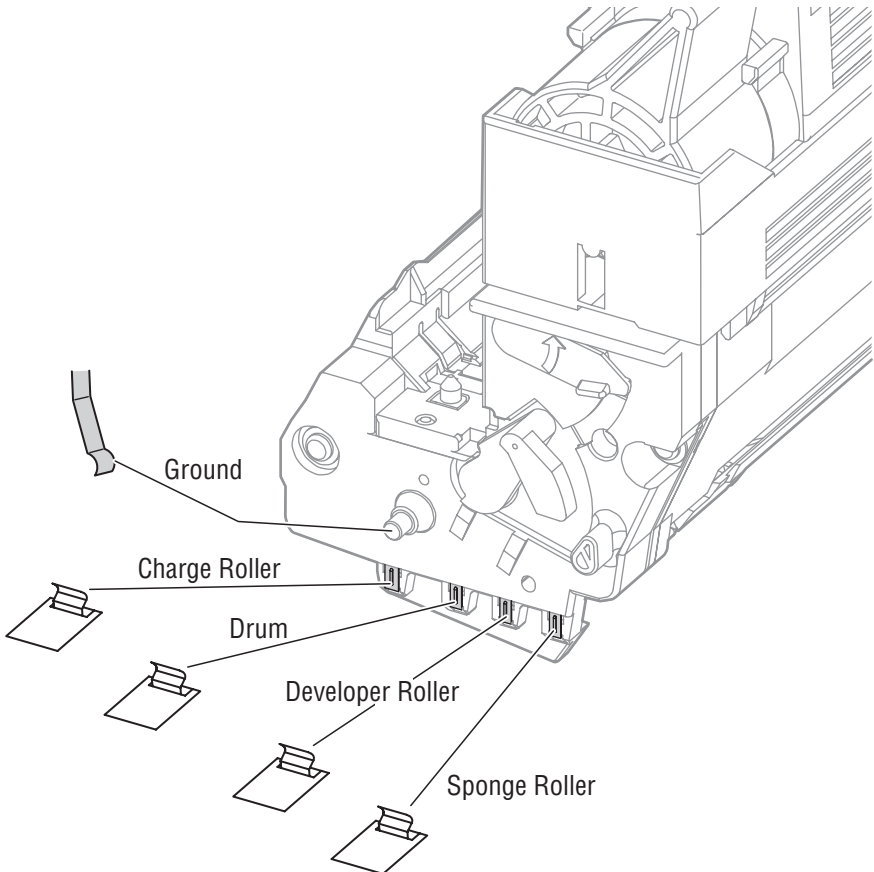

s7400-337



# LVPS

Supplies AC power from the power source to the Fuser heater. Generates and supplies stable low-voltage DC power (+5 VDC, and +24 VDC) to be used for the logic and other circuits within the printer. The LVPS includes the LVPS Board with attached Power Switch, the AC Harness, a Fan, and the box enclosure.

## LVPS Outputs

Output Voltage	Purpose
+5 V (1)	Engine Control Board power
+5 V (2)	LED Head power
+5 V (3)	Image Processor Board power
+24 V	For motor, clutch, and solenoid drive

## Front Sensor Board

Located under the Registration Roller #1, the Front Sensor Board communicates with the Motor Driver Board and connects to these components:

- Media Thickness Sensor
- Registration Clutch #1
- Temperature/Humidity Sensor
- Tray 1 (MPT) Home Position Sensor
- OHP (Transparency) Sensor
- Tray 1 (MPT) Level Sensor
- Tray 1 (MPT) No Paper Sensor

Mounted directly on the board are the Registration Sensor #1 and Transfer Unit Entrance Sensor.

## Rear Sensor Board

Located behind the Rear Sensor Board Cover on the Exit Assembly, the Rear Sensor Board communicates with the Engine Control Board and connects to these components:

- Fuser Exit Sensor
- Full Stack Sensors for Top and Side Output Trays
- Job Offset Position Sensor

- Side Output Tray Detect Sensor
- Door E Detect Sensor
- Exit Gate Solenoid

Mounted directly on the board is the Offset Paper End Sensor.

## Fans

A number of fans are used to circulate air throughout the printer. When servicing a fan, note the orientation of the Fan label before removal.

- Top Cover Fan located above the Cyan LED Head in the Top Cover
- Card Cage Fan located behind the Right Rear Cover
- Fuser Fan located at the upper left rear corner underneath the Top Cover
- Imaging Unit Fan located behind the Control Panel
- Transfer Unit Fan located below the Imaging Unit Motors
- IP Fan located in the Card Cage
- LVPS Fan located in the LVPS
- Duplex Unit Fan inside the Duplex Unit

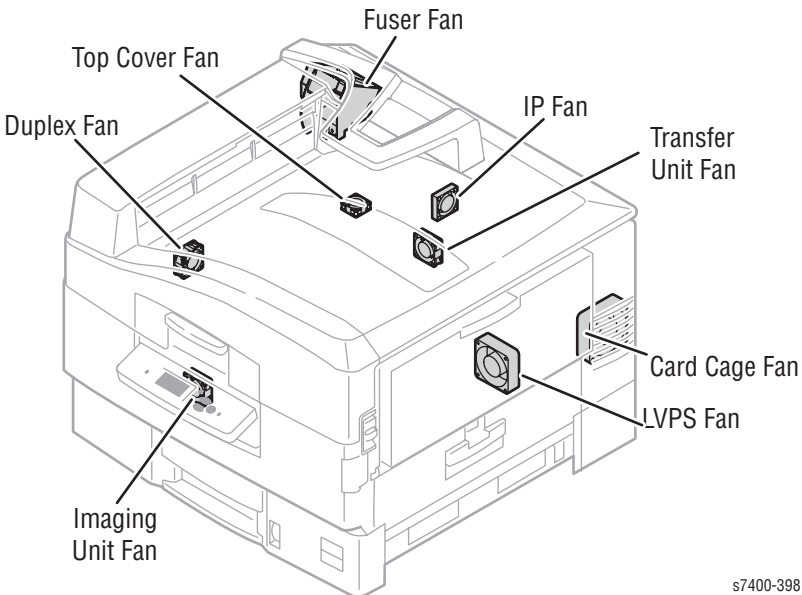

s7400-398

# Solenoids and Clutches

A number of solenoids and clutches are used to actuate various gates and rollers. The figure below shows the position of all the solenoids and clutches in the Print Engine.

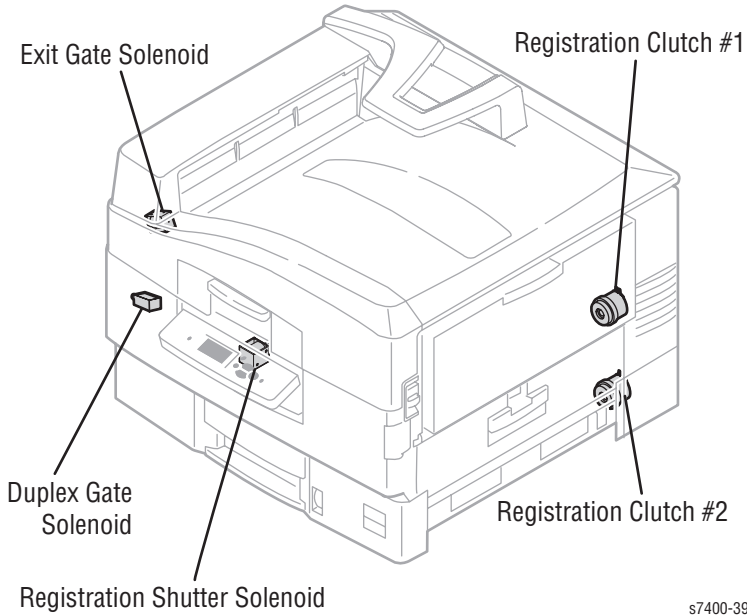

s7400-394



# Error Messages and Codes

## In this chapter...

- Introduction
- Servicing Instructions
- Messages, Codes, and Procedures

Section

3



# Introduction

This section describes error messages and numeric codes displayed on the Control Panel, listed on the Status page, or logged in the Service Usage Profile. These error indications serve as the entry point into the troubleshooting process. Along with the error message itself, help text including the associated code is available by pressing the **Help (?)** button. Printer problems not directly indicated by, or associated with an error message or code are covered in Section 4, "General Troubleshooting." Print-quality problems are covered in Section 5, "Print-Quality Troubleshooting."

The printer tracks and reports errors in a number of ways. The three types of error reporting discussed in this Section include:

- Error messages and help text displayed on the Control Panel.
- Fault Descriptions and Codes listed on the Status page.
- Engine (fatal) and Jam Error logs displayed on the Control Panel or listed in the Service Usage Profile.

Messages indicating the occurrence of either a fatal or jam error appear on the Control Panel and include their related code within the help text. Warning messages also appear, but do not have a corresponding code.

## Accessing Fault History

Listed below are three ways in which you can access fault history records.

1. Print (if possible) the Status page from the **Troubleshooting** menu --> **Service Tools**. The fault history is listed on the second page of the report.
2. View the printer's fault history on the Control Panel. Go to **Troubleshooting** --> **Service Tools** --> **Engine Error History**.

### Note

Definitions of the codes that appear in the fault history are given in "Printer Status Codes" on page A-4.

3. If the printer is connected to a network and has a TCP/IP address, view the printer's web page using a web browser.
  - a. Open a web browser.
  - b. Enter the printer's IP address as the URL.
  - c. Select the **Support** --> **Troubleshooting** --> **Diagnostics Logs** and the fault history displays.

If additional information is required, print the Service Usage Profile from **Troubleshooting** --> **Service Tools**.

# Status Page

The Status page is a two-page report that provides general information about the printer, the consumables, the status of routine maintenance items, registration and color test patterns. The first page includes general information about the printer including firmware versions, page count, feature set, and consumables. Page 1 also provides color registration, calibration, and print target examples.

The second page provides a log of the last 50 errors with date, page count, description, and code. For a complete listing of all possible codes, see "Printer Status Codes" on page A-4.

To print the Status page, go to the **Troubleshooting** menu, and then select **Service Tools**. The Status page appears as an option on the Service Tools menu.

## Service Usage Profile

The Service Usage Profile tracks printer activity, consumable usage and printer status. This data is stored in NVRAM. Service Usage Profile data includes error logs that retain detail on the type, date, location and frequency of both engine and jam errors. While the Service Usage Profile includes data on all aspects of the printer, this section focuses on accessing these two error logs to review printer fault history. Only Engine (fatal) and jam errors are recorded in these two logs. Other errors and warnings are recorded elsewhere in the Service Usage Profile. Print the Status page for a complete history. The Error Message Summary table beginning on (page 3-7) lists all errors, their respective codes, and the page where the troubleshooting procedure begins.

## Interpreting Error Logs

Error logs appear on the Control Panel as a list of semi-colon separated value pairs of the form <code>, <pg\_count>:. The Engine and Jam Error Logs record the last 30 events. Log entries move top to bottom. Note that a value of 0 (zero) or "--" in a log indicates no data and <pg\_count> is the Total Page count when the error occurred.

For example, the following provides a partial example of the Engine Error Log as it might appear on the display:

```
U32,1460;  
0,0;  
0,0;  
0,0;  
0,0;
```

The U32,1460 pair indicates the printer recorded a Fuser Fan failure, represented by the code U32, at total page count 1460. The 0,0 pairs indicate no error activity. A printed log consists of several lines in the Service Usage Profile report (typically 2-5 lines). Each log typically includes an event code, a corresponding date, a corresponding page, and a total event counter. In the case of fatal errors, there are four lines (261-264). In the case of jams, there are five lines (291-295 and 298).

# Servicing Instructions

The service checklist below is an overview of the path a service technician should take when servicing the printer and printer optional equipment.

---

## Step 1 - Identify the Problem

---

1. Verify the reported problem does exist. Verify failure symptoms/behavior/noises with customer/end user.
2. Check for any error codes and write them down.
3. Print normal customer prints and service test prints.
4. Make note of any print quality problems in the test prints.
5. Make note of any mechanical or electrical abnormalities present.
6. Make note of any unusual noise or smell coming from the printer.
7. Print a Status page, if the printer is able to print.
8. View the fault history under the Service Tools Menu.
9. Verify the AC input power supply is within proper specifications.

---

## Step 2 - Inspect and Clean the Printer

---

1. Switch Off printer power.
2. Disconnect the AC power cord from the wall outlet.
3. Verify the power cord is serviceable.
4. Remove the Imaging Unit and protect it from light.
5. Inspect the printer interior and remove any foreign matter, dust or loose toner.
  - Do not use solvents or chemical cleaners to clean the printer interior.
  - Do not use any type of oil or lubricant on printer parts unless directed to do so.
  - Do not use canned air to clean spilled toner or dust from the printer.
  - Use only an approved toner vacuum.
6. Clean all rubber rollers with a lint-free cloth, dampened slightly with cold water.
7. Inspect the interior of the printer for damaged wires, loose connections, toner leakage, and damaged or obviously worn parts.
8. Replace damaged or empty Toner Cartridges with new, customer-supplied ones.

---

## Step 3 - Find the Cause of the Problem

---

1. Read and understand the theory of how the printer operates.
2. Use the troubleshooting procedures to find the cause of the problem.
3. Use Service Diagnostics to check printer and optional components.
4. Use the wiring diagrams and plug/jack locator to locate test points.
5. Take voltage readings at various test points as instructed in the appropriate troubleshooting procedure.
6. Use the " Test Prints" described on page 5-4, to isolate problems to the Engine or the Image Processor Board.

---

## Step 4 - Correct the Problem

---

1. Use the Parts List to locate a part number.
2. Use the Disassembly Procedures to replace the part.

---

## Step 5 - Final Check

---

Test the printer to be sure you have corrected the initial problem and verify there are no additional problems present.

---



# Messages, Codes, and Procedures

This section correlates the output of the printer's diagnostic aids and provides the troubleshooting procedure to locate and correct reported errors.

## Error Message Abbreviations

Due to limited space, some error messages, procedures, or descriptions include abbreviations. The most common abbreviations used are listed here.

<b>Term</b>	<b>Definition</b>	<b>Comment</b>
Reg or REGI	Registration	Used in designators such as Reg SNR.
SNR	Sensor	Often seen as SNR1 or Reg SNR.
CW	Clockwise	Rotational direction
CCW	Counter-clockwise	Rotational direction
DUP	Duplex	Optional for 2-sided printing
I/P Board	Image Processor	Image Processor Board
LTA	Lower Tray Assembly	Optional 550-Sheet Feeder (Tray 3)
HCF	High-Capacity Feeder	Optional 1100-Sheet Feeder
MSI or MPT	Multi-Sheet Input	Used to describe Tray 1 (MPT).
P/J	Plug/Jack	Plug (P) and or Jack (J) designators
SW	Switch	Appears as a designator.
NVM	Non-volatile Memory	Used instead of NVRAM.
CRUM	Customer-Replaceable Unit Monitor	Device used to store usage information on the Imaging Unit and Toner Cartridges.
Comm	Communication	As in Comm Error
TNR	Toner	Used as an abbreviation for Toner.
FDR	Feeder	Used as an abbreviation for Feeder.
FSR	Fuser	Used as an abbreviation for Fuser.
ADC	Automatic Density Control	Designator for the ADC Sensor.
ATS	Automatic Thickness Sensor	Feature using the Media Thickness Sensor to automatically determine media weight.
LVPS	Low-Voltage Power Supply	Primary power supply
LED	Light-emitting Diode	Light source for drum exposure and sensors.
PWB	Printed Wire Board	Used to describe a circuit board.
HVPS	High-Voltage Power Supply	Supplies voltages to the Imaging and Laser units.
IU	Imaging Unit	Used as an abbreviation for Imaging Unit.
I/F	Interface	Used as an abbreviation for an interface.
Sub-CPU	Secondary processor	Device located on the Motor Driver Board.
Comp	Compensation	Used as an abbreviation for Compensation.

# Jam Locator

The following illustrates the Door designators that key the jam location error codes and messages. Refer to this diagram when questions arise regarding the area of the jam.

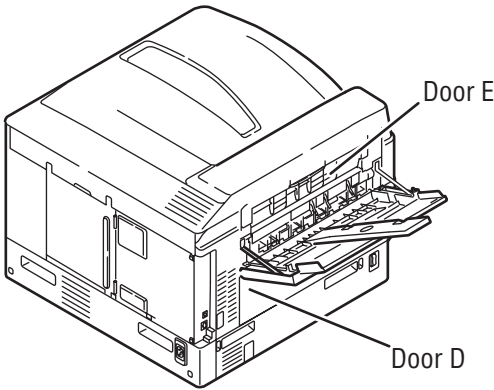
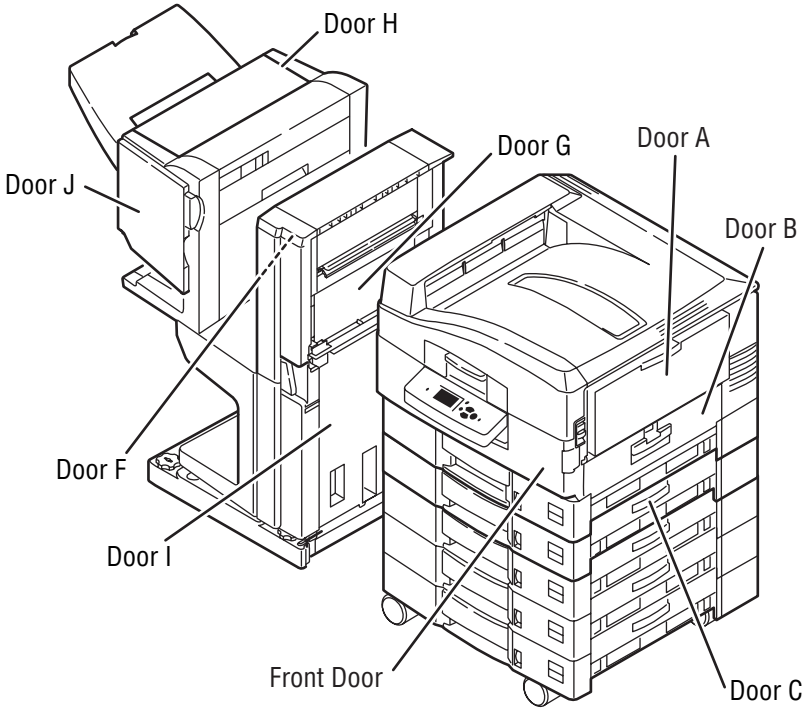

s7400-484

# Error Message Summary

The Error Message Summary table lists possible errors, along with the corresponding code, and page reference for the corrective procedure. The Error column lists the error code for fatal or jam errors that appears in the Help text displayed by pressing the **Help(?)** button, listed on the printer Status page, or logged by the Service Usage Profile. The Control Panel Message column shows the message as it appears on the printer's display when the error occurs during normal operation. The Page column provides the page reference to the corrective procedure. Use this table to identify the proper procedure to clear the reported error.

## Note

When **Printer error - Contact service; report fault [nnn]** is displayed, [nnn] is replaced by a code. These codes, along with a brief description, appear in this table under Fatal Errors. Appendix A includes a complete list of codes arranged in alphanumeric order.

## Error Message Summary

Error	Control Panel Message	Page
<b>Jam Errors</b>		
A1	Jam at Door A Open Door A to Clear	3-17
A2	Jam at Door A Open Door A to Clear	3-19
A3	Jam at Door A Misfeed at Tray 1 (MPT) Open to Clear	3-20
B1	Jam at Door B Misfeed at Tray 2 Open to Clear	3-21
C3~C6	Jam at Door C for Tray [3][4][5][6] Open to Clear	3-23
D1	Jam at Door D Open Door D to Clear	3-25
D2	Jam in Duplex Unit Pull out Duplex Unit to Clear	3-26
E1	Jam at Door E Open Left Side Output Tray and Door E to Clear	3-27
TC1	Jam Under Imaging Units Open Top Cover to Clear	3-29
TC2	Jam in Fuser Open Top Cover to Clear	3-31
TC3	Jam at Duplex Entrance Open Top Cover to Clear	3-33
FN1	Jam at Finisher Punch Unit Open Door H to Clear	3-35
FN2	Jam at Finisher Door H Open Door H to Clear	3-36
FN3	Jam at Finisher Door H Open Door H to Clear	3-37
FN4	Jam at Finisher Upper Output Tray Remove paper from Finisher	3-38
FN5	Jam at Finisher Saddle Stapler Open Door G to Clear	3-39
FN6	Jam at Finisher Upper Output Tray Open Door H to Clear	3-40
FN7	Jam at Finisher Stapler Open Door G to Clear	3-41

## Error Message Summary (Continued)

Error	Control Panel Message	Page
<b>Jam Errors (Continued)</b>		
FN8	Jam at Finisher Door G Open Door G to Clear	3-42
FN9	Jam at Finisher Saddle Stapler Open Door G to Clear	3-43
FN10	Jam at Finisher Upper Output Tray Remove paper from Finisher Output	3-44
IN1~IN4, IN6, IN7	Jam Inside Finisher Open Door F and Door I to Clear	3-45
IN5, IN8	Jam at Finisher Entrance Separate Finisher Base from Printer	3-46
FT	Finisher Output Tray Jammed Remove Obstruction to Clear	3-47
<b>Door and Cover Errors</b>		
_	Close Top Cover	3-49
_	Close Right Door A	3-50
_	Close Right Door B	3-51
_	Open and Close Door B	3-51
_	Close Right Door C for Tray [3][4][5][6]	3-53
_	Close Left Door D	3-54
_	Close Duplex Unit	3-54
_	Close Left Door E	3-55
_	Close Finisher Door F	3-56
_	Close Finisher Door H	3-57
_	Close Finisher Door J	3-58
_	Reposition the Finisher (Finisher away from base)	3-184
_	Reposition the Finisher (Finisher away from printer)	3-185
<b>Consumable/Routine Maintenance Item Errors</b>		
_	Replace [C][M][Y][K] Toner Cartridge	3-59
_	Replace [C][M][Y][K] Imaging Unit	3-60
_	Replace Transfer Unit	3-61
_	Replace Waste Cartridge	3-62
_	Replace Fuser	3-63
_	Install or Reseat [C][M][Y][K] Toner Cartridge	3-64
_	Install or Reseat [C][M][Y][K] Imaging Unit	3-65
_	Install or Reseat Transfer Unit	3-66
_	Install or Reseat Waste Cartridge+	3-67

## Error Message Summary (Continued)

Error	Control Panel Message	Page
<b>Consumable/Routine Maintenance Item Errors (continued)</b>		
_	Install or Reseat Fuser	3-68
_	Metered Toner is not Enabled	3-69
_	Replace Metered [C][M][Y][K] Toner Cartridge	3-70
_	Lock or Replace [C][M][Y][K] Toner Cartridge	3-64
<b>Tray and Media Errors</b>		
_	Clear Tray 1 (MPT) Riser Plate	3-71
_	Clear Tray [2][3][4][5][6] Riser Plate	3-73
_	Out of Paper Load Tray 1 (MPT) with [size] [type]	3-74
_	Out of Paper Load Tray [2][3][4][5][6] with [size] [type]	3-75
_	Manual Feed [size] [type]	3-76
_	Top Output Tray is Full, Unload Paper	3-77
_	Left Side Output Tray is Full, Unload Paper	3-78
_	Finisher Lower Output Tray is Full, Unload Paper	3-79
_	Finisher Upper Output Tray is Full, Unload Paper	3-80
_	Remove Paper from Tray 1 (MPT)	3-71
_	Remove Paper from Tray [2][3][4][5][6]	3-73
_	Open Left Side Output Tray	3-81
<b>Media Mismatch Errors</b>		
_	Wrong Paper Size Load Tray 1 (MPT) with [size] [type]	3-82
_	Wrong Paper Size Load Tray [2] with [size] [type]	3-83
_	Wrong Paper Size Load Tray [3][4][5][6] with [size] [type]	3-84
_	Wrong Paper Type Load Tray [1 (MPT)][2][3][4][5][6] with [size] [type]	3-85
_	Paper Not Available Load Tray 1 (MPT) with [size] [type]	3-86
_	Paper Not Available Load Tray 2 with [size] [type]	3-87
_	Paper Not Available Load Tray [3][4][5][6] with [size] [type]	3-88
<b>Configuration Errors</b>		
_	Invalid Configuration Card	3-89
_	Configuration Card Missing	3-89

## Error Message Summary (Continued)

<b>Error</b>	<b>Control Panel Message</b>	<b>Page</b>
<b>Fatal Errors</b>		
T1	Fuser Upper Failure	3-90
T2	Fuser Lower Failure	3-90
T29	Temp Sensor Failure	3-92
T30	RH Sensor Failure	3-93
T31	RH Wet Sensor Failure	3-93
T32	LED Over Temperature Failure	3-94
T34	Motor Overheating Failure	3-95
U0	Engine ROM Failure	3-96
U1	Engine RAM Failure	3-96
U2	Engine EPROM Failure	3-96
U3	Engine EPROM Missing Failure	3-96
U4	Engine SRAM Failure	3-96
U5	Engine Control Failure	3-96
U6	Power Supply Failure	3-97
U7	Feeder Home Failure	3-98
U8	Controller Fan Failure	3-99
U9	Power Supply Fan Failure	3-100
U10	Top Cover Cooling Fan Failure	3-101
U11	Imaging Unit Fan Failure	3-102
U40	Transfer Unit Fan Failure	3-103
U41	Engine Cavity Fan Failure	3-104
U12	Duplex Interface Failure	3-105
U14	Tray 3 Interface Failure	3-106
U13	Tray 4 Interface Failure	3-106
U16	Tray 5 Interface Failure	3-106
U17	Tray 6 Interface Failure	3-106
U51	Inverter Unit Interface Failure	3-107
U18	Yellow LED Failure	3-108
U19	Magenta LED Failure	3-108
U20	Cyan LED Failure	3-108
U21	Black LED Failure	3-108

## Error Message Summary (Continued)

<b>Error</b>	<b>Control Panel Message</b>	<b>Page</b>
<b>Fatal Errors (Continued)</b>		
U26	Yellow Imaging Unit Failure	3-109
U27	Magenta Imaging Unit Failure	3-109
U28	Cyan Imaging Unit Failure	3-109
U29	Black Imaging Unit Failure	3-109
U30	Flash Hardware Failure	3-111
U31	Flash Software Failure	3-111
U32	Fuser Fan Failure	3-112
U33	Fuser 110v/220v Mismatch Failure	3-113
U34	Unsupported Duplex Unit ROM	3-114
U39	Unsupported Tray 2 ROM	3-115
U35	Unsupported Tray 3 ROM	3-116
U36	Unsupported Tray 4 ROM	3-116
U37	Unsupported Tray 5 ROM	3-116
U38	Unsupported Tray 6 ROM	3-116
U50	Unsupported Inverter Unit ROM	3-117
U55	Unsupported Finisher Unit ROM	3-118
H80	Hard Drive Failure	3-119
W16	Fuse Cut Error In Fuser	3-120
W17	Fuse Cut Error In Transfer Unit	3-121
W18	Fuse Cut Error In Cyan Imaging Unit	3-122
W19	Fuse Cut Error In Magenta Imaging Unit	3-122
W20	Fuse Cut Error In Yellow Imaging Unit	3-122
W21	Fuse Cut Error In Black Imaging Unit	3-122
F130	Controller to Engine Communications Failure	3-123
F131	Finisher Folder Sensor Failure	3-124
F103	Finisher Paddle Failure	3-125
F106	Finisher Stapler Swing Motor Failure	3-126
F111	Finisher Stapler Stack Handling Motor Failure	3-127
F110	Finisher Staple Motor Failure	3-128
F93	Finisher Jog Motor Failure	3-129
F115	Finisher Tray Lift Motor Failure	3-130

## Error Message Summary (Continued)

Error	Control Panel Message	Page
<b>Fatal Errors (Continued)</b>		
F116	Finisher Exit Failure	3-132
F133	Finisher Punch Side Registration Sensor Failure	3-133
F136	Finisher Punch Registration Sensor Failure	3-134
F138	Finisher Punch Backup RAM Failure	3-135
F132	Finisher Punch Communications Failure	3-136
F181	Finisher Punch Transfer Motor Failure	3-137
F134	Finisher Punch Motor Failure	3-138
F137	Finisher Backup RAM Failure	3-139
F139	Finisher Punch Dust Sensor Failure	3-140
<b>Printer error - Contact service; report fault [nnn]</b> Where [nnn] is one of the codes described below.		
F141	Finisher Punch Unit counter at end of life. The Punch count exceeds life limit.	3-141
F142	Finisher Staple Unit counter at end of life. The Staple count exceeds life limit.	3-142
F186	Finisher interface error. Communications lost with Finisher.	3-143
I97	Inverter Power Supply Error.	3-144
T3	Fuser belt thermistor short circuit.	3-145
T4	Fuser belt thermistor open circuit.	3-145
T5	Fuser belt thermistor temperature too high.	3-145
T6	Fuser belt thermistor temperature too low.	3-145
T7	Fuser release error.	3-145
T8	Fuser belt slack error.	3-145
U60	Job Offset Home Position error. Job Offset does not reach home position.	3-146
U61	Control Panel Communications Failure.	3-147
135	No data to the Yellow LED Head	3-148
136	No data to the Magenta LED Head	3-148
137	No data to the Cyan LED Head	3-148
138	No data to the Black LED Head.	3-148
172	Fuser compensation thermistor indicates temperature too high.	3-145
173	Fuser compensation thermistor indicates temperature too low.	3-145
176	Fuser compensation thermistor short error.	3-145
177	Fuser compensation thermistor open error.	3-145



## Error Message Summary (Continued)

Error	Control Panel Message	Page
<b>Printer error - Contact service; report fault [nnn]" (Continued)</b> Where [nnn] is one of the codes described below.		
188	Motor Driver Board Option tray communications error.	3-149
221	Tray 3 Firmware Error. Firmware error in Tray 3 Flash Memory.	3-150
222	Tray 4 Firmware Error. Firmware error in Tray 4 Flash Memory.	3-150
223	Tray 5 Firmware Error. Firmware error in Tray 5 Flash Memory.	3-150
224	Tray 6 Firmware Error. Firmware error in Tray 6 Flash Memory.	3-150
225	Duplex Unit Firmware Error. Firmware error in Duplex Unit Flash Memory.	3-151
226	Motor Driver Board Firmware Error. Software error in Flash Memory.	3-152
227	Finisher Inverter Firmware Error. Firmware error in Inverter Flash Memory.	3-153
230	CRUM Reader Board not installed or failed.	3-154
231	CRUM Reader Interface Failure. A communication error has occurred between the Engine Logic Board and CRUM Reader Board.	3-154
232	CRUM Reader Interface Failure. Error detected in the CRUM Reader Board transmit circuitry.	3-154
233	CRUM Reader Interface Failure. A communications failure has occurred between the CRUM Antenna and the consumable CRUM.	3-154
234	CRUM Reader has detected five or more RFID devices.	3-154
242	Tray 3 Flash Memory Failure. Hardware error in the Tray 3 Flash Memory device.	3-155
243	Tray 4 Flash Memory Failure. Hardware error in the Tray 4 Flash Memory device.	3-155
244	Tray 5 Flash Memory Failure. Hardware error in the Tray 5 Flash Memory device.	3-155
245	Tray 6 Flash Memory Failure. Hardware error in the Tray 6 Flash Memory device.	3-155
246	Duplex Unit Flash Memory Failure. Hardware error in the Flash Memory device.	3-156
247	Motor Driver Board Flash Memory Failure. Flash Memory device error.	3-157
248	Finisher Inverter Flash Memory Error. Inverter Flash Memory device error.	3-158
910	The Tray 2 Lift Motor has failed.	3-159
911	The Tray 3 Lift Motor has failed.	3-160
912	The Tray 4 Lift Motor has failed.	3-160
913	The Tray 5 Lift Motor has failed.	3-160
914	The Tray 6 Lift Motor has failed.	3-160
917	Error in the Transfer Unit Belt. The Belt Rotation Sensor indicates an error.	3-162
918	The Duplex Unit Fan has failed.	3-163
919	+24 V not available to the Duplex Unit.	3-164
920	Failure in the Yellow Imaging Unit Drum or Motor.	3-165

## Error Message Summary (Continued)

Error	Control Panel Message	Page
<b>Printer error - Contact service; report fault [nnn]" (Continued)</b> Where [nnn] is one of the codes described below.		
921	Failure in the Magenta Imaging Unit Drum or Motor.	3-165
922	Failure in the Cyan Imaging Unit Drum or Motor.	3-165
923	Failure in the Black Imaging Unit Drum or Motor.	3-165
924	+24 V not available to Tray 3.	3-167
925	+24 V not available to Tray 4.	3-167
926	+24 V not available to Tray 5.	3-167
927	+24 V not available to Tray 6.	3-167
928	Failure in the Fuser Motor.	3-168
929	Failure in the Waste Toner Motor.	3-169
930	The Motor Driver Board sub-CPU clock frequency is inaccurate.	3-170
931	The Duplex Unit CPU clock frequency is inaccurate.	3-171
932	The Inverter CPU clock frequency is inaccurate.	3-172
933	The Tray 3 Feeder Board clock frequency is inaccurate.	3-173
934	The Tray 4 Feeder Board clock frequency is inaccurate.	3-173
935	The Tray 5 Feeder Board clock frequency is inaccurate.	3-173
936	The Tray 6 Feeder Board clock frequency is inaccurate.	3-173
940	Waste Toner Auger Sensor indicates a toner transfer error.	3-174
941	CM Toner supply failure. Toner Sensor failure with Cyan or Magenta Toner.	3-176
942	YK Toner supply failure. Toner Sensor failure with Black or Yellow Toner.	3-176
<b>Warning Messages</b>		
_	Tray [1 (MPT)][2][3][4][5][6] is too full	3-73
_	Tray 1 (MPT) is not lifted	3-71
_	Tray [2][3][4][5][6] is not lifted	3-73
_	No Paper in Tray 1 (MPT)	3-177
_	No Paper in Tray [2][3][4][5][6]	3-178
_	Left Side Output Tray is Closed	3-179
_	[C][M][Y][K] Toner is Low	3-59
_	[C][M][Y][K] Imaging Unit is Near End of Life	3-60
_	Fuser is Near End of Life	3-63
_	Transfer Unit is Near End of Life	3-61

## Error Message Summary (Continued)

Error	Control Panel Message	Page
<b>Warning Messages (continued)</b>		
–	Waste Cartridge is Almost Full	3-180
–	[C][M][Y][K] Imaging Unit is Past End of Life	3-60
–	Fuser is Past End of Life	3-63
–	Transfer Unit is Past End of Life	3-61
–	[C][M][Y] Toner Cartridge Empty	3-59
–	Transfer Roller is at End of Life	3-61
–	Replace Fuser	3-63
–	Non-Xerox [C][M][Y][K] Toner Cartridge	3-181
–	Staple Cartridge Is Empty	3-182
–	Punch Waste Box is Full or Missing	3-183
–	Finisher Away From Base	3-184
–	Finisher Away From Printer	3-185
–	Duplicate IP Address Detected	3-89

## Using the Troubleshooting Procedures

1. **Applicable Status Code(s)** lists the error message(s) addressed by each troubleshooting procedure.
2. **Applicable Parts** and **Wiring and Plug/Jack References** assist you in locating information available for a particular part or procedure.
3. Follow each **Step** in a troubleshooting procedure sequentially in the order given until the problem is fixed or resolved.
4. The **Actions and Questions** box instructs you to perform a certain action or procedure. Also included are precautions and/or additional procedures you must follow to isolate the problem.
5. When a procedure instructs you to test a component using Service Diagnostics, see "Service Diagnostics" on page 4-7 for the detailed steps and functions for testing parts, assemblies, or subsystems of the printer.
6. Some actions are followed by a question. If your response to the question is **Yes**, then follow the instructions for a **Yes** reply. If your response to the question is **No**, then follow the instructions for a **No** reply.
7. Troubleshooting procedures frequently ask you to take voltage readings or test for continuity or resistance at certain test points. The **Wiring and Plug/Jack References** table provides pointers to the diagrams that provide this information.
8. Troubleshooting procedures often ask you to replace a printer component. When instructed to replace a non-spared component and that component is part of a parent assembly, replace the entire parent assembly.

# Measurement Techniques

1. Unless indicated otherwise, the instruction “switch On printer power” means for you to switch On printer power and let the printer proceed through Power On Self Test (POST) to a ‘Ready’ condition.
2. Conventions used in this manual to represent connectors

**Jack**



**Plug**



s7400-314

3. When instructed to take voltage, continuity or resistance readings on wiring harness, proceed as follows; Check P/J 232–1 to P/J 210–5 by placing the red probe (+) of your meter on pin 1 of P/J 232, and place the black probe (–) of your meter on pin 5 of P/J 210.
4. When you are instructed to take resistance readings between “P/J 232 <=> P/J 210” (without specified pin numbers), check all pins. See “Wiring Diagrams” on page 10-17 for the location of all wiring harnesses and pins.
5. When you are instructed to run a test, run the Service Diagnostics test associated with the component being examined.
6. When you are instructed to take a voltage reading, the black probe (–) is generally connected to a pin that is either RTN (Return) or SG (Signal Ground). You can substitute any RTN pin or test point in the printer, and you can use FG (frame ground) in place of any SG pin or test point.
7. Before measuring voltages make sure the printer is switched On, the Imaging Unit and the paper trays are in place, and the interlock switch is actuated, unless a troubleshooting procedure instructs otherwise.
8. All voltage values given in the troubleshooting procedures are approximate values. The main purpose of voltage readings is to determine whether or not a component is receiving the correct voltage value from the power supply and if gating (a voltage drop) occurs during component actuation. Gating signals may be nothing more than a pulse, resulting in a momentary drop in voltage that may be difficult or impossible to read on the average multi-meter.
9. When a troubleshooting procedure instructs you to replace a non-spared component and that component is part of a parent assembly, you should replace the entire parent assembly.
10. Ensure that you are using a supported media size and type, see “Media and Tray Specifications” on page 1-18.
11. Power and signal grounds are connected to the frame ground. All circuit troubleshooting can be performed using the metal frame (chassis) as the grounding point. To locate connectors or test points, see “Plug/Jack Locator Maps” on page 10-2 or “Wiring Diagrams” on page 10-17 for more information.

Unless otherwise specified, the following voltage tolerances are used:

<b>Stated</b>	<b>Measured</b>
+3.3 VDC	+3.135 to +3.465 VDC
+5.0 VDC	+4.75 to +5.25 VDC
+24.0 VDC	+21.6 to +26.4 VDC
0.0 VDC	Less than +0.5 VDC

## Jam Error Procedures

For jam errors, perform these basic steps before you begin the troubleshooting procedure to rule out factors not related to mechanical function.

1. Ask the customer about the paper types being used. If not on the recommended list, determine if this is contributing to the problem. Recycled, multi-purpose or copier paper tends to contaminate the paper path. Constant use of special papers such as labels or business cards can also contribute to jamming.
2. Ensure the correct tray loading and setup procedures are followed (securing the guides, selecting the correct paper type, fanning the paper, etc.).
3. Make every attempt to establish a jam rate prior to starting any work. If possible print a Status page or Usage Profile report and note the page count between jams.
4. Determine if jamming is occurring in one tray but not another. This helps to identify any dirty or defective parts.
5. Clear the paper path of any jams or paper debris.
6. Clean the Feed and Pick Rollers using a slightly damp (water only) lint free cloth.
7. Cycle printer power and retest.

If after following these steps, the printer continues to jam, go to the troubleshooting procedure indicated by the error.

### Jam at Door A Open Door A to Clear

Media reached Feed-Out Sensor #1, but did not arrive at the Registration Sensor #1 or Transfer Unit Entrance Sensor on time. This error represents a misfeed jam for media fed from Tray 1 (MPT).

## Applicable Status Code:

**Code A1:** Jam at Door A

## Initial Actions:

- Ensure that Tray 1 (MPT) is securely attached to the printer.
- Ensure that the media guides are set correctly.
- Cycle printer power.
- If the problem persists, follow the procedure below.

## Troubleshooting Reference Table

Applicable Parts	Wiring and Plug/Jack References
<ul style="list-style-type: none"><li>■ Tray 1 (MPT) Feed Roller, PL10.1.53</li><li>■ Tray 1 (MPT) Pick Roller, PL10.1.43</li><li>■ Tray 1 (MPT) Retard Roller, PL10.1.16</li><li>■ Registration Clutch #1, PL8.1.85</li><li>■ Tray 2 Registration Motor, PL4.2.36</li><li>■ Tray 2 Feed Motor, PL4.2.35</li><li>■ Front Sensor Board, PL4.2.97</li></ul>	<ul style="list-style-type: none"><li>■ Print Engine Map 5 (page 10-8)</li><li>■ Print Engine Front Sensor Board (1/2) (page 10-26)</li><li>■ Print Engine Front Sensor Board (2/2) (page 10-27)</li><li>■ Print Engine Motor Driver Board (4/6) (page 10-34)</li></ul>

## Troubleshooting Procedure Table

Step	Actions and Questions	Yes	No
1	Check the following for evidence of fault, dirt, debris, or damage: <ul style="list-style-type: none"><li>■ Tray 1 (MPT) Feed Rollers</li><li>■ Registration Rollers</li><li>■ Sensor Actuator</li></ul> Is there any damage or debris?	Clean or replace the appropriate parts.	Go to Step 2.
2	Test the Registration #1 Sensor. Run the Service Diagnostics Registration Entrance Sensor test. Does the sensor operate correctly?	Go to Step 3.	Replace the actuator. If the error persists, replace the Front Sensor Board (page 8-150).
3	Test the Feed Motor, Registration Motor, and Registration Clutch #1. Do the components function correctly?	Replace the Engine Control Board (page 8-112).	Go to Step 4.
4	Check the harness for each motor and clutch. Are the wiring harnesses properly connected and free from defects?	Replace the Engine Control Board (page 8-112).	Replace the wiring harness and/or the problem motor/clutch.

# Jam at Door A Open Door A to Clear

Media reached Duplex Entrance Sensor, but a second sheet was detected in the feed path. This error represents a misfeed jam for the Duplex Unit.

## Applicable Status Code:

**Code A2:** Jam at Door A

## Initial Actions:

- Check the paper path for obstructions or debris.
- Cycle printer power.
- If the problem persists, follow the procedure below.

## Troubleshooting Reference Table

Applicable Parts	Wiring and Plug/Jack References
■ Duplex Unit, PL16.1.0	■ Print Engine Map 5 (page 10-8) ■ Print Engine Motor Driver Board (5/6) (page 10-35)

## Troubleshooting Procedure Table

Step	Actions and Questions	Yes	No
1	Check the following for evidence of fault, dirt, debris, or damage: <ul style="list-style-type: none"><li>■ Door A</li><li>■ Door D</li><li>■ Duplex Unit Rollers</li><li>■ Duplex Unit connector</li><li>■ Duplex Sensors and Actuators</li></ul> Is there any damage or debris?	Clean or replace the appropriate parts.	Go to Step 2.
2	Test the Duplex Unit sensors. Run the Service Diagnostics for each of the four Duplex Unit sensors. Do the sensors and actuators function correctly	Go to Step 3.	Replace the damaged sensor.
3	Test the Duplex Unit motors. Run the Service Diagnostics Duplex Motor tests. Do the motors function correctly	Go to Step 4.	Replace the Duplex Unit
4	Inspect the wiring harness for the Duplex Unit. Is the wiring harness properly connected and free from defects?	Replace the Duplex Unit.	Replace the Engine Control Board (page 8-112).

# Jam at Door A Misfeed at Tray 1 (MPT)

Media reached the Duplex Reverse Sensor, but a second sheet was detected entering the feed path from Tray 1 (MPT). This error represents a misfeed jam for media fed from Tray 1 (MPT).

## Applicable Status Code:

**Code A3:** Jam at Door A, Misfeed at Tray 1 (MPT)

## Initial Actions:

- Cycle printer power.
- If the problem persists, follow the procedure below.

## Troubleshooting Reference Table

Applicable Parts	Wiring and Plug/Jack References
<ul style="list-style-type: none"><li>■ Tray 1 (MPT) Feed Roller, PL10.1.53</li><li>■ Tray 1 (MPT) Pick Roller, PL10.1.43</li><li>■ Tray 2 Registration Motor, PL4.2.36</li><li>■ Tray 2 Feed Motor, PL4.2.35</li><li>■ Front Sensor Board, PL4.2.97</li></ul>	<ul style="list-style-type: none"><li>■ Print Engine Map 5 (page 10-8)</li><li>■ Print Engine Front Sensor Board (1/2) (page 10-26)</li><li>■ Print Engine Front Sensor Board (2/2) (page 10-27)</li><li>■ Print Engine Motor Driver Board (4/6) (page 10-34)</li></ul>

## Troubleshooting Procedure Table

Step	Actions and Questions	Yes	No
1	Check the following for evidence of fault, dirt, debris, or damage: <ul style="list-style-type: none"><li>■ Tray 1 (MPT) Feed Rollers</li><li>■ Registration Rollers</li><li>■ Sensor Actuator</li></ul> Is there any damage or debris?	Clean or replace the appropriate parts.	Go to Step 2.
2	Test the Registration #1 Sensor. Run the Service Diagnostics Registration Entrance Sensor test. Does the sensor operate correctly?	Go to Step 3.	Replace the actuator. If the error persists, replace the Front Sensor Board (page 8-150).
3	Test the Feed Motor, Registration Motor, and Registration Clutch #1. Do the components function correctly?	Replace the Engine Control Board (page 8-112).	Go to Step 4.
4	Check each motor and clutch harness. Are the harnesses properly connected and free from defects?	Replace the Engine Control Board (page 8-112).	Replace the harness and/or problem motor/clutch.



# Jam at Door B Misfeed at Tray 2

Media reached Feed-Out Sensor #2, but did not arrive at the Transfer Unit Entrance Sensor on time. This error represents a misfeed jam for media fed from Tray 2.

## Applicable Status Code:

**Code B1:** Jam at Door B, Misfeed at Tray 2

## Initial Actions:

- Try picking paper from a different tray.
- Ensure that Tray 2 is installed properly and the paper guides are set correctly.
- Remove any obstructions or debris in the paper path.
- Cycle printer power.
- If the problem persists, follow the procedure below.

## Troubleshooting Reference Table

Applicable Parts	Wiring and Plug/Jack References
<ul style="list-style-type: none"><li>■ Feeder Assembly, PL4.2.0</li><li>■ Registration Sensor #2, PL4.2.89</li><li>■ Registration Clutch #2, PL4.2.87</li><li>■ Tray 2 Registration Motor, PL4.2.36</li><li>■ Tray 2 Feed Motor, PL4.2.35</li><li>■ Feeder Board, PL4.2.97</li></ul>	<ul style="list-style-type: none"><li>■ Print Engine Map 11 (page 10-14)</li><li>■ Print Engine Map 5 (page 10-8)</li><li>■ Print Engine Map 12 Feeder Board (page 10-15)</li><li>■ Print Engine Feeder Board (page 10-28)</li><li>■ Print Engine Motor Driver Board (4/6) (page 10-34)</li></ul>

## Troubleshooting Procedure Table

Step	Actions and Questions	Yes	No
1	Check the following for evidence of fault, dirt, debris, or damage: <ul style="list-style-type: none"><li>■ Door B</li><li>■ Tray 2 Feed Rollers</li><li>■ Registration Rollers</li><li>■ Transport Rollers</li><li>■ Sensor Actuators</li></ul> Is there any damage or debris?	Clean or replace the appropriate parts.	Go to Step 2.
2	Test the Tray 2 sensors. Run the Service Diagnostics Tray 2 Switches test. Do the sensors function correctly?	Go to Step 4.	Go to Step 3.

## Troubleshooting Procedure Table (Continued)

Step	Actions and Questions	Yes	No
3	Check the TRYSNS1 harness continuity. Is the harness conductive?	Replace the sensor. If the error persists, replace the Feeder Board (page 8-53).	Replace the harness.
4	Test the Tray 2 Feeder Motors. Run the Service Diagnostics Tray 2 Motor tests for the Feed and Registration Motors. Do the motors function correctly?	Go to step 6.	Go to Step 5.
5	Check the REGHOP harness continuity. Is the harness conductive?	Replace the motor. If the error persists, Go to Step 8.	Replace the harness.
6	Test the Registration Clutch #2 Run the Service Diagnostics Tray 2 Clutch test. Does the clutch function correctly?	Go to step 10.	Go to step 7.
7	Check the CL1 harness continuity. Is the harness conductive?	Replace the clutch (page 8-42). If the error persists, go to Step 8.	Replace the harness.
8	Check for +24 V to the Motor Driver Board. Disconnect POW24. Is there +24 V across POW24-1 and 2?	Replace the Motor Driver Board (page 8-141).	Go to Step 9.
9	Check for 24 V at the LVPS 1. Disconnect CN2 on the LVPS. Is there +24 V across pins 1 and 2?	Replace the POW24 Harness.	Replace the LVPS (page 8-121).
10	Check the Registration Assembly for gaps between the rollers. Is there a gap between the Registration Rollers?	Replace the Registration Assembly (page 8-84).	Go to Step 11.
11	Check the DRV1 harness continuity. Is the harness conductive?	Replace the Motor Driver Board (page 8-141). If the error persists, replace the Engine Control Board (page 8-112)	Replace the harness.

# Jam at Door C for Tray [3][4][5][6]

Media reached the Feed-Out Sensor, but did not arrive at the Transfer Unit Entrance Sensor on time. This error represents a misfeed jam for media fed from an optional tray.

## Applicable Status Codes:

**Code C3:** Jam at Door C for Tray 3

**Code C4:** Jam at Door C for Tray 4

**Code C5:** Jam at Door C for Tray 5

**Code C6:** Jam at Door C for Tray 6

## Initial Actions:

- Try picking paper from a different tray.
- Ensure the tray is installed properly and the paper guides are set correctly.
- Remove any obstructions or debris in the paper path.
- Cycle printer power.
- If the problem persists, follow the procedure below.

## Troubleshooting Reference Table

Applicable Parts	Wiring and Plug/Jack References
<ul style="list-style-type: none"><li>■ Feed Rollers</li><li>■ Feeder Assembly</li><li>■ Option Control Board</li><li>■ Feeder Board</li></ul>	<ul style="list-style-type: none"><li>■ Print Engine Map 3 (page 10-6)</li><li>■ Print Engine Map 5 (page 10-8)</li><li>■ Print Engine Map 11 (page 10-14)</li><li>■ Print Engine Motor Driver Board (6/6) (page 10-36)</li><li>■ Options Map 5, Paper Tray Controller Board</li><li>■ Options Paper Tray Sensors and Interconnect Wiring</li></ul>

## Troubleshooting Procedure Table

Step	Actions and Questions	Yes	No
1	Check the following for evidence of fault, dirt, debris, or damage: <ul style="list-style-type: none"><li>■ Door C</li><li>■ Feed Rollers</li><li>■ Registration Rollers</li><li>■ Transport Rollers</li><li>■ Sensor Actuators</li></ul> Is there any damage or debris?	Clean or replace the appropriate parts.	Go to Step 2.
2	Check the Option connection. Is the Option connection to the Printer damaged or disconnected?	Reconnect or replace the cable.	Go to Step 3.

## Troubleshooting Procedure Table (Continued)

Step	Actions and Questions	Yes	No
3	Check the Option Harness continuity. Disconnect OPTIF from the Engine Control Board and the Option connector. Is the harness conductive?	Go to Step 4.	Replace the Option harness.
4	Test the tray sensors. Run the Service Diagnostics Tray Switches test for the appropriate tray. Do the sensors function correctly?	Go to Step 6.	Go to Step 5.
5	Check the sensor harness continuity. Is the harness conductive?	Replace the sensor. If the error persists, replace the Feeder Board.	Replace the harness.
6	Test the Feeder Motors. Run the Service Diagnostics Motor tests. Do the motors function correctly?	Go to step 8.	Go to Step 7.
7	Check the motor harness continuity. Is the harness conductive?	Replace the motor. If the error persists, Go to Step 10.	Replace the harness.
8	Test the Registration Clutch. Run the Service Diagnostics Clutch test. Does the clutch function correctly?	Go to step 11.	Go to step 9.
9	Check the CL1 harness continuity. Is the harness conductive?	Replace the clutch. If the error persists, go to Step 10.	Replace the harness.
10	Check for +24 V at the Motor Driver Board's OPTRY24 connector. 1. Close the Interlock Switches. 2. Disconnect OPTRY24. Is there +24 V at OPTRY24-1 and -2 <=> ground?	Replace the affected Option Control Board.	Go to Step 11.
11	Check OPTRY24 Harness continuity. Disconnect the OPTRY24 Harness. Is the OPTRY24 Harness conductive?	Go to Step 13.	Replace the OPTRY24 Harness.
12	Check the Registration Assembly. Is there a gap between the rollers?	Replace the Registration Assembly (page 8-84).	Go to Step 13.
13	Check the DRV1 harness continuity. Is the harness conductive?	Replace the Motor Driver Board (page 8-141). If the error persists, replace the Engine Control Board (page 8-112)	Replace the harness.

# Jam at Door D Open Door D to Clear

Media reached Duplex Reverse Sensor, but did not leave the Duplex Unit on time. This error represents a misfeed jam inside the Duplex Unit.

## Applicable Status Code:

**Code D1:** Jam at Door D

## Initial Actions:

- Ensure that the Duplex Unit is free of obstructions and fully seated.
- Cycle printer power.
- If the problem persists, follow the procedure below.

## Troubleshooting Reference Table

Applicable Parts	Wiring and Plug/Jack References
■ Duplex Unit, PL16.1.0	<ul style="list-style-type: none"><li>■ Print Engine Map 5 (page 10-8)</li><li>■ Print Engine Motor Driver Board (5/6) (page 10-35)</li><li>■ Options Map 4, Duplex Unit Controller Board</li><li>■ Options Duplex Unit Sensors and Interconnect Wiring</li></ul>

## Troubleshooting Procedure Table

Step	Actions and Questions	Yes	No
1	Check the following for evidence of fault or damage: <ul style="list-style-type: none"><li>■ Duplex Unit Entrance Roller</li><li>■ Duplex Unit Connector</li><li>■ Duplex Unit</li></ul> Is there any damage or debris?	Replace any damaged parts.	Go to Step 2.
2	Test the Duplex Entrance, Reverse, Front, and Rear actuators and sensors using Service Diagnostics. Do the sensors and actuators function correctly?	Go to Step 3.	Replace the Duplex Unit.
3	Test the Duplex Motors using Service Diagnostics. Do the motors function correctly?	Go to Step 4.	Replace the Duplex Unit.
4	Inspect the DUPLEX harness. If defective, replace the wiring harness. Is the harness properly seated and free from defects?	Replace the Motor Driver Board (page 8-141).	Replace the Duplex Unit.

# Jam in Duplex Unit

Media reached Duplex Reverse Sensor, but did not leave the Duplex Unit on time. This error represents a misfeed jam inside the Duplex Unit.

## Applicable Status Code:

**Code D2:** Jam in Duplex Unit

## Initial Actions:

- Cycle printer power.
- If the problem persists, follow the procedure below.

## Troubleshooting Reference Table

Applicable Parts	Wiring and Plug/Jack References
<ul style="list-style-type: none"><li>■ Duplex Unit, PL16.1.0</li></ul>	<ul style="list-style-type: none"><li>■ Print Engine Motor Driver Board (5/6) (page 10-35)</li><li>■ Options Map 4, Duplex Unit Controller Board</li><li>■ Options Duplex Unit Sensors and Interconnect Wiring</li></ul>

## Troubleshooting Procedure Table

Step	Actions and Questions	Yes	No
1	Ensure the correct weight and type of paper is loaded in the tray. Does the media meet specifications?	Go to Step 2.	Run several test prints. If a jam persists, go to Step 2.
2	Check for and remove any dirt, debris or obstructions in the paper path around the Duplex Unit. Did this correct the problem?	Complete	Go to Step 3.
3	Clean and check the Duplex Unit rollers. Do the rollers move freely and are free of dirt or debris?	Go to Step 4.	Replace the Duplex Unit.
4	Test the Duplex Entrance, Reverse, Front, and Rear actuators and sensors using Service Diagnostics. Do the sensors function correctly?	Go to Step 5.	Replace the Duplex Unit.
5	Test the Duplex Motors. Do the motors function correctly?	Go to Step 6.	Replace the Duplex Unit.
6	Inspect the DUPLEX harness. If defective, replace the wiring harness. Is the harness properly seated and free from defects?	Replace the Motor Driver Board (page 8-141).	Replace the Duplex Unit.

# Jam at Door E

Paper misfeed jam between the Fuser and the Top Output Tray. Media reached the Fuser Exit Sensor, but did not reach the Top Output Tray Stack Full Sensor on time. This error represents a misfeed jam inside the Exit Assembly.

## Applicable Status Code:

**Code E1:** Jam at Door E

## Initial Actions:

- Ensure that the Exit Assembly is free of obstructions.
- Cycle printer power.
- If the problem persists, follow the procedure below.

## Troubleshooting Reference Table

Applicable Parts	Wiring and Plug/Jack References
<ul style="list-style-type: none"><li>■ Exit Assembly, PL11.1.0</li><li>■ Fuser Motor, PL2.1.9</li><li>■ Exit Gate Solenoid, PL11.1.17</li><li>■ Full Stack Sensor, PL11.1.39</li></ul>	<ul style="list-style-type: none"><li>■ Print Engine Map 5 (page 10-8)</li><li>■ Print Engine Map 11 (page 10-14)</li><li>■ Print Engine Rear Sensor Board (page 10-29)</li><li>■ Print Engine Motor Driver Board (2/6) (page 10-32)</li></ul>

## Troubleshooting Procedure Table

Step	Actions and Questions	Yes	No
1	Check the following for evidence of fault or damage: <ul style="list-style-type: none"><li>■ Door E</li><li>■ Fuser</li><li>■ Exit Rollers and drive gears</li><li>■ Stack Full Actuator</li><li>■ Exit Assembly</li></ul> Is there any damage or debris?	Replace any damaged parts.	Go to Step 2.
2	Test the Fuser Exit and Top Output Tray Stack Full Sensors. Do the sensors function correctly?	Go to Step 4.	Replace the sensor. If the error persists, go to Step 3.
3	Check all pins on the SNS Harness for continuity. Is the harness conductive?	Go to Step 4.	Replace the SNS Harness.

## Troubleshooting Procedure Table (Continued)

Step	Actions and Questions	Yes	No
4	Test the Fuser Motor. Run the Service Diagnostics Fuser Motor test. Does the motor function correctly?	Go to Step 6.	Replace the motor. If the error persists, go to Step 5.
5	Check for +24 V to the Fuser Motor. Disconnect DCHEAT on the Motor Driver Board. Is there +24 V across DCHEAT-3 <=> ground?	Go to Step 6.	Replace the Motor Driver Board (page 8-141). If the error persists, go to Step 6.
6	Test the Exit Gate Solenoid. Run the Service Diagnostics Exit Gate Solenoid test. Does the solenoid function correctly.	Go to Step 8.	Replace the solenoid (page 8-70). If the error persists, go to Step 7.
7	Check for +24 V to the solenoid. 1. Actuate the interlock switches. 2. Disconnect SOLENOID from the Rear Sensor Board. Is there +24 V across SOLENOID-1 <=> ground?	Go to Step 8.	Replace the Rear Sensor Board (page 8-151).
8	Check the DRV0 and DRV1 ribbon cables that connect the Motor Driver Board to the Engine Control Board. Are these cables connected and undamaged?	Replace the Engine Control Board (page 8-112).	Replace the harnesses.



# Jam Under Imaging Units

Paper transport jam on Transfer Unit belt. Media reached the Transfer Unit Entrance Sensor, but did not reach the Media Slack Sensor on time.

## Applicable Status Code:

**Code TC1:** Jam Under Imaging Units

## Initial Actions:

- Ensure that the Transfer Unit is free of obstructions and fully seated.
- Cycle printer power.
- If the problem persists, follow the procedure below.

## Troubleshooting Reference Table

Applicable Parts	Wiring and Plug/Jack References
<ul style="list-style-type: none"> <li>■ Transfer Unit Motor, PL2.1.86</li> <li>■ Transfer Unit, PL1.1.20</li> <li>■ Media Slack Sensor, PL9.1.77</li> <li>■ Registration Sensor Board, PL9.1.73</li> <li>■ Imaging Units, PL1.1.23</li> </ul>	<ul style="list-style-type: none"> <li>■ Print Engine Registration (page 10-30).</li> <li>■ Print Engine Motor Driver Board (4/6) (page 10-34)</li> </ul>

## Troubleshooting Procedure Table

Step	Actions and Questions	Yes	No
1	Check the following for evidence of fault or damage: <ul style="list-style-type: none"> <li>■ Transfer Unit</li> <li>■ Media Slack Sensor Actuator</li> <li>■ Transfer Unit Motor</li> </ul> Is there any damage or debris?	Replace any damaged parts.	Go to Step 2.
2	Test the Media Slack Sensor. Run the Service Diagnostics Paper Slack test. Does the sensor function correctly?	Go to Step 7.	Replace the sensor. If the error persists, go to Step 3.
3	Check all pins on the DSNS Harness for continuity. Is the harness conductive?	Go to Step 4.	Replace the DSNS Harness.
4	Check for +5 V to the Media Slack Sensor. Disconnect DSNS from the Registration Sensor Board. Is there +5 V across DSNS-9 <=> ground?	Go to Step 6.	Go to Step 5.

## Troubleshooting Procedure Table (Continued)

<b>Step</b>	<b>Actions and Questions</b>	<b>Yes</b>	<b>No</b>
<b>5</b>	Check for +5 V to the Registration Sensor Board. Disconnect the harness from CSNS on the Engine Control Board. Is there +5 V across CSNS-14 <=> ground?	Go to Step 6.	Replace the Engine Control Board (page 8-112).
<b>6</b>	Check all pins on the CSNS Harness for continuity Is the harness conductive?	Replace the Registration Sensor Board (page 8-148).	Replace the harness.
<b>7</b>	Test the Transfer Unit Motor. Run the Service Diagnostics Transfer Belt Motor test. Does the motor function correctly?	Replace the Transfer Unit.	Replace the motor (page 8-103).

# Jam in Fuser

Media reached the Media Slack Sensor, but did not clear the Fuser Exit Sensor on time. This error represents a jam inside the Fuser.

## Applicable Status Code:

**Code TC2:** Jam in Fuser

## Initial Actions:

- Remove the Fuser and check for any obstructions, media, damage, or debris.
- Cycle printer power.
- If the problem persists, follow the procedure below.

### Warning

To avoid the potential of electric shock, ensure the power to the printer is off and the power cord is disconnected from the wall outlet prior to performing Step 2 of the following troubleshooting procedure.

### Caution

Allow adequate time for the Fuser to cool before servicing the printer.

## Troubleshooting Reference Table

Applicable Parts	Wiring and Plug/Jack References
<ul style="list-style-type: none"><li>■ Fuser, PL1.1.21</li><li>■ Fuser Exit Sensor, PL11.1.13</li><li>■ Rear Sensor Board, PL11.1.33</li><li>■ Fuser Motor, PL2.1.9</li><li>■ Motor Driver Board, PL2.1.10</li></ul>	<ul style="list-style-type: none"><li>■ Print Engine Map 2 (page 10-5)</li><li>■ Print Engine Map 5 (page 10-8)</li><li>■ Print Engine Map 11 (page 10-14)</li><li>■ Print Engine Rear Sensor Board (page 10-29)</li><li>■ Print Engine Motor Driver Board (2/6) (page 10-32)</li></ul>

## Troubleshooting Procedure Table

Step	Actions and Questions	Yes	No
1	Check the following for evidence of fault or damage: <ul style="list-style-type: none"><li>■ Fuser</li><li>■ Fuser Exit Actuator and Sensor</li><li>■ Fuser Motor</li></ul> Is there any damage?	Replace any damaged parts.	Go to Step 2.
2	Remove the Fuser and check for broken or bent connector pins or damaged gears.	Repair or replace damaged parts.	Go to Step 3.
3	Reinstall the Fuser. Does the error persist?	Go to Step 4.	Complete

## Troubleshooting Procedure Table (Continued)

Step	Actions and Questions	Yes	No
4	Test the Fuser Exit Sensor. Run the Service Diagnostics Fuser Exit Sensor Test. Does the sensor function correctly?	Go to Step 7.	Replace the sensor (page 8-71). If the error persists, go to Step 5.
5	Check all pins on the SNS Harness for continuity. 1. Disconnect SNS from the Rear Sensor Board. 2. Check continuity between SNS<=>J140.	Go to Step 6.	Replace the SNS Harness. If the error persists, go to Step 6.
6	Check the HEATR signal to the Engine Control Board. 1. Disconnect RSNS from the Rear Sensor Board. 2. Actuate the Fuser Exit Sensor. Does the voltage across RSNS-6 <=> ground change?	Replace the Engine Control Board (page 8-112).	Replace the Rear Sensor Board (page 8-151).
7	If possible print one sheet of paper. Does the Fuser Motor turn?	Inspect and replace defective gear(s).	Go to Step 8.
8	Test the Fuser Motor. Run the Service Diagnostics Fuser Motor test. Does the Fuser Motor function correctly?	Replace the Fuser.	Go to Step 9.
9	Check for +24 V to the Fuser Motor. Disconnect DCHEAT on the Motor Driver Board. Is there +24 V across DCHEAT-3 <=> ground?	Go to Step 10.	Replace the Motor Driver Board (page 8-141). If the error persists, go to Step 10.
10	Replace the Fuser Motor. Does the Fuser Motor function correctly?	Complete	Go to Step 11.
11	Check the DRV0 and DRV1 ribbon cables that connect the Motor Driver Board to the Engine Control Board. Are these cables connected and undamaged?	Replace the Engine Control Board (page 8-112).	Replace the SVM1 and SVM2 Harnesses.

# Jam at Duplex Entrance

Media reached the Fuser Exit Sensor, but did not reach the Duplex Entrance Sensor on time. This error represents a jam at the Duplex entrance or in the Exit Assembly.

## Applicable Status Code:

**Code TC3:** Jam at Duplex Entrance

## Initial Actions:

- Check for obstructions or debris in the output paper path.
- Reseat the Duplex Unit.
- Cycle printer power.
- If the problem persists, follow the procedure below.

## Troubleshooting Reference Table

Applicable Parts	Wiring and Plug/Jack References
<ul style="list-style-type: none"><li>■ Duplex Unit, PL16.1.0</li><li>■ Duplex Entrance Sensor, PL16.1.4</li><li>■ Exit Assembly, PL11.1.0</li><li>■ Fuser Motor, PL2.1.9</li><li>■ Motor Driver Board, PL2.1.10</li></ul>	<ul style="list-style-type: none"><li>■ Print Engine Map 5 (page 10-8)</li><li>■ Print Engine Map 6 (page 10-9)</li><li>■ Print Engine Map 11 (page 10-14)</li><li>■ Print Engine Rear Sensor Board (page 10-29)</li><li>■ Print Engine Motor Driver Board (5/6) (page 10-35)</li><li>■ Options Map 4, Duplex Unit Controller Board</li><li>■ Options Duplex Unit Sensors and Interconnect Wiring</li></ul>

## Troubleshooting Procedure Table

Step	Actions and Questions	Yes	No
1	Check the following for evidence of fault or damage: <ul style="list-style-type: none"><li>■ Duplex Unit</li><li>■ Exit Gate</li><li>■ Exit Assembly</li><li>■ Duplex Gate</li></ul> Are there any defects?	Replace any damaged parts.	Go to Step 2.
2	Test the Duplex Entrance Sensor. Run the Service Diagnostics Duplex Entrance (IN1) Sensor test. Does the sensor function correctly?	Go to Step 4.	Replace the Duplex Entrance Sensor, if the error persists, go to Step 3.
3	Check DUPLEX Harness continuity. Is the DUPLEX Harness conductive?	Go to Step 4.	Replace the DUPLEX Harness.

## Troubleshooting Procedure Table (Continued)

Step	Actions and Questions	Yes	No
4	Print a test print in Duplex mode Does the sheet reverse in the printer?	Go to Step 6.	Replace the Duplex Unit. If the error persists, go to Step 5.
5	Check for +24 V to the Duplex Motors. Disconnect DUPLEX on the Motor Driver Board. Is there +24 V at DUPLEX-6 <=> ground?	Go to Step 6.	Go to Step 10.
6	Test the Fuser Motor. Run the Service Diagnostics Fuser Motor test. Does the Fuser Motor function correctly?	Go to Step 8.	Go to Step 7.
7	Check for +24 V to the Fuser Motor. Disconnect DCHEAT on the Motor Driver Board. Is there +24 V at DCHEAT-3 <=> ground?	Replace the Fuser Motor (page 8-106).	Go to Step 10.
8	Test the Exit Gate Solenoid. Run the Service Diagnostics Exit Gate Solenoid test. Does the solenoid function correctly.	Replace the Exit Assembly (page 8-68).	Go to Step 9.
9	Check for +24 V to the solenoid. 1. Actuate the interlock switches. 2. Disconnect SOLENOID from the Rear Sensor Board. Is there +24 V across SOLENOID-1 <=> ground?	Replace the solenoid (page 8-70).	Replace the Rear Sensor Board (page 8-151).
10	Check Motor Driver Board POW24 connector for 24 V. 1. Disconnect POW24. Is there +24 V across POW24-1 <=> POW24-2?	Replace the Motor Driver Board (page 8-141).	Go to Step 11.
11	Check for 24 V at the LVPS 1. Disconnect CN2 on the LVPS. Is there +24 V across pins 1 and 2?	Replace the POW24 Harness.	Replace the LVPS (page 8-121).
12	Check the DRV0 and DRV1 ribbon cables that connect the Motor Driver Board to the Engine Control Board. Are these cables connected and undamaged?	Replace the Engine Control Board (page 8-112).	Replace the DRV0 and DRV1 Harnesses.

# Jam at Finisher Punch Unit

Media did not clear the Finisher Entrance Sensor on time. This error represents a jam at the Finisher entrance.

## Applicable Status Code:

**Code FN1:** Jam at Finisher Punch

## Initial Actions:

- Check for obstructions or debris in the paper path.
- Cycle printer power.
- If the problem persists, follow the procedure below.

## Troubleshooting Reference Table

Applicable Parts	Wiring and Plug/Jack References
<ul style="list-style-type: none"><li>■ Punch Unit</li><li>■ Finisher Entrance Sensor</li><li>■ Finisher Transport Rollers</li></ul>	<ul style="list-style-type: none"><li>■ Options Map 2, Punch Unit Controller Board</li><li>■ Options Map 8, Finisher Sensor Locator (2/2)</li><li>■ Options Punch Unit Sensors and Motors</li><li>■ Options Finisher Controller to Sensors (2/3)</li></ul>

## Troubleshooting Procedure Table

Step	Actions and Questions	Yes	No
1	Check the following for evidence of fault or damage: <ul style="list-style-type: none"><li>■ Punch Unit</li><li>■ Transport Rollers</li><li>■ Exit Rollers</li></ul> Are there any defects or misalignment?	Replace any damaged parts.	Go to Step 2.
2	Test the Finisher Entrance Sensor. Run the Service Diagnostics Finisher Entrance Sensor test. Does the sensor function correctly?	Replace the Engine Control Board (page 8-112).	Replace the sensor. If the error persists, go to Step 3.
3	Check the Entrance Sensor signal at the Finisher Control Board. Actuate the Entrance Sensor. Does the voltage across CN16-12 <=> ground change when the sensor is actuated?	Replace the Finisher Control Board.	Replace the harness.

# Jam at Finisher Door H

Media reached the Finisher Entrance Sensor, but did not clear the Inverter on time. This error represents a jam in the Finisher Inverter.

## Applicable Status Code:

**Code FN2:** Jam at Finisher Door H

## Initial Actions:

- Check for obstructions or debris in the paper path.
- Cycle printer power.
- If the problem persists, follow the procedure below.

## Troubleshooting Reference Table

Applicable Parts	Wiring and Plug/Jack References
<ul style="list-style-type: none"><li>■ Inverter</li><li>■ Finisher Entrance Sensor</li><li>■ Finisher Inverter Rollers</li></ul>	<ul style="list-style-type: none"><li>■ Options Map 7, Finisher Sensor Locator (1/2)</li><li>■ Options Map 8, Finisher Sensor Locator (2/2)</li><li>■ Options Map 9, Inverter Sensor Locator</li><li>■ Options Finisher Controller to Sensors (2/3)</li></ul>

## Troubleshooting Procedure Table

Step	Actions and Questions	Yes	No
1	Check the following for evidence of fault or damage: <ul style="list-style-type: none"><li>■ Inverter</li><li>■ Inverter Rollers</li><li>■ Finisher Transport Rollers</li></ul> Are there any defects or misalignment?	Replace any damaged parts.	Go to Step 2.
2	Test the Finisher Entrance Sensor. Run the Service Diagnostics Finisher Entrance Sensor test. Does the sensor function correctly?	Replace the Engine Control Board (page 8-112).	Replace the sensor. If the error persists, go to Step 3.
3	Check the Entrance Sensor signal at the Finisher Control Board. Actuate the Entrance Sensor. Does the voltage across CN16-12 <=> ground change when the sensor is actuated?	Replace the Finisher Control Board.	Replace the harness.



# Jam at Finisher Door H

Media reached the Finisher Entrance Sensor, but did not clear before the arrival of a second sheet. This error represents a multi-sheet jam in the Finisher. Paper remains in the path after another jam in the Finisher has been cleared

## Applicable Status Code:

**Code FN3:** Jam at Finisher Door H

## Initial Actions:

- Check for obstructions or debris in the paper path.
- Cycle printer power.
- If the problem persists, follow the procedure below.

## Troubleshooting Reference Table

Applicable Parts	Wiring and Plug/Jack References
<ul style="list-style-type: none"> <li>■ Punch Unit</li> <li>■ Finisher Entrance Sensor</li> <li>■ Finisher Inverter Rollers</li> </ul>	<ul style="list-style-type: none"> <li>■ Options Map 7, Finisher Sensor Locator (1/2)</li> <li>■ Options Map 8, Finisher Sensor Locator (2/2)</li> <li>■ Options Map 9, Inverter Sensor Locator</li> <li>■ Options Finisher Controller to Sensors (2/3)</li> </ul>

## Troubleshooting Procedure Table

Step	Actions and Questions	Yes	No
<b>1</b>	Check the following for evidence of fault or damage: <ul style="list-style-type: none"> <li>■ Inverter</li> <li>■ Inverter Rollers</li> <li>■ Finisher Transport Rollers</li> </ul> Are there any defects or misalignment?	Replace any damaged parts.	Go to Step 2.
<b>2</b>	Test the Finisher Entrance Sensor. Run the Service Diagnostics Finisher Entrance Sensor test. Does the sensor function correctly?	Replace the Engine Control Board (page 8-112).	Replace the sensor. If the error persists, go to Step 3.
<b>3</b>	Check the Entrance Sensor signal at the Finisher Control Board. Actuate the Entrance Sensor. Does the voltage across CN16-12 <=> ground change when the sensor is actuated?	Replace the Finisher Control Board.	Replace the harness.

# Jam at Finisher Upper Output Tray

Media remains in the upper output path. This error represents a jam in the Finisher.

## Applicable Status Code:

**Code FN4:** Jam at Finisher Upper Output Tray

## Initial Actions:

- Check for obstructions or debris in the paper path.
- Cycle printer power.
- If the problem persists, follow the procedure below.

## Troubleshooting Reference Table

Applicable Parts	Wiring and Plug/Jack References
<ul style="list-style-type: none"><li>■ Compiler Tray</li><li>■ Front and Rear Alignment Guides</li><li>■ Transport Rollers</li></ul>	<ul style="list-style-type: none"><li>■ Options Map 8, Finisher Sensor Locator (2/2)</li><li>■ Options Finisher Controller to Sensors (1/3)</li></ul>

## Troubleshooting Procedure Table

Step	Actions and Questions	Yes	No
1	Check the following for evidence of fault or damage: <ul style="list-style-type: none"><li>■ Compiler Tray</li><li>■ Front and Rear Alignment Guides</li><li>■ Transport Rollers</li></ul> Are there any defects or misalignment?	Replace any damaged parts.	Go to Step 2.
2	Test the Processing Tray Sensor. Run the Service Diagnostics sensor test. Does the sensor function correctly?	Replace the Engine Control Board (page 8-112).	Replace the sensor. If the error persists, go to Step 3.
3	Check the Processing Tray Sensor signal. Actuate the sensor at the Finisher Control Board. Does the voltage across CN5-9 <=> ground change when the sensor is actuated?	Replace the Finisher Control Board.	Replace the harness.

# Jam at Finisher Saddle Stapler

Media remains in the buffer area. This error represents a jam in the Finisher.

## Applicable Status Code:

**Code FN5:** Jam at Finisher Saddle Stapler

## Initial Actions:

- Check for obstructions or debris in the paper path.
- Cycle printer power.
- If the problem persists, follow the procedure below.

## Troubleshooting Reference Table

Applicable Parts	Wiring and Plug/Jack References
<ul style="list-style-type: none"><li>■ Compiler Tray</li><li>■ Front and Rear Alignment Guides</li><li>■ Transport Rollers</li><li>■ Stapler</li></ul>	<ul style="list-style-type: none"><li>■ Options Map 7, Finisher Sensor Locator (1/2)</li><li>■ Options Map 8, Finisher Sensor Locator (2/2)</li><li>■ Options Finisher Controller to Sensors (1/3)</li><li>■ Options Finisher Controller to Sensors (2/3)</li></ul>

## Troubleshooting Procedure Table

Step	Actions and Questions	Yes	No
1	Check the following for evidence of fault or damage: <ul style="list-style-type: none"><li>■ Compiler Tray</li><li>■ Front and Rear Alignment Guides</li><li>■ Transport Rollers</li><li>■ Stapler</li></ul> Are there any defects or misalignment?	Replace any damaged parts.	Go to Step 2.
2	Test the Folding Position Sensor. Run the Service Diagnostics Folding Position Sensor test. Do the sensor function correctly?	Replace the Engine Control Board (page 8-112).	Replace the sensor. If the error persists, go to Step 3.
3	Check the Folding Position Sensor signal at the Finisher Control Board. Actuate the sensor. Does the voltage across CN16-2 <=> ground change when the sensor is actuated?	Replace the Finisher Control Board.	Replace the harness.

# Jam at Finisher Upper Output Tray

Media remains in the Finisher offset rollers. This error represents a jam in the Finisher upper output path.

## Applicable Status Code:

**Code FN6:** Jam at Finisher Upper Output Tray

## Initial Actions:

- Cycle printer power.
- If the problem persists, follow the procedure below.

## Troubleshooting Reference Table

Applicable Parts	Wiring and Plug/Jack References
<ul style="list-style-type: none"><li>■ Compiler Tray</li><li>■ Front and Rear Alignment Guides</li><li>■ Transport Rollers</li><li>■ Stapler</li></ul>	<ul style="list-style-type: none"><li>■ Options Map 7, Finisher Sensor Locator (1/2)</li><li>■ Options Map 8, Finisher Sensor Locator (2/2)</li><li>■ Options Finisher Controller to Sensors (1/3)</li><li>■ Options Finisher Controller to Sensors (2/3)</li></ul>

## Troubleshooting Procedure Table

Step	Actions and Questions	Yes	No
1	Check the following for evidence of fault or damage: <ul style="list-style-type: none"><li>■ Compiler Tray</li><li>■ Front and Rear Alignment Guides</li><li>■ Transport Rollers</li><li>■ Stapler</li></ul> Are there any defects or misalignment?	Replace any damaged parts.	Go to Step 2.
2	Test the Processing Tray Sensor. Run the Service Diagnostics sensor test. Does the sensor function correctly?	Replace the Engine Control Board (page 8-112).	Replace the sensor. If the error persists, go to Step 3.
3	Check the Processing Tray Sensor signal at the Finisher Control Board. Actuate the sensor. Does the voltage across CN5-3 <=> ground change when the sensor is actuated?	Replace the Finisher Control Board.	Replace the harness.

# Jam at Finisher Stapler

Media remains in the Compiler Tray. This error represents a jam in the Finisher staple path.

## Applicable Status Code:

**Code FN7:** Jam at Finisher Stapler

## Initial Actions:

- Cycle printer power.
- If the problem persists, follow the procedure below.

## Troubleshooting Reference Table

Applicable Parts	Wiring and Plug/Jack References
<ul style="list-style-type: none"><li>■ Compiler Tray</li><li>■ Front and Rear Alignment Guides</li><li>■ Transport Rollers</li><li>■ Stapler</li></ul>	<ul style="list-style-type: none"><li>■ Options Map 7, Finisher Sensor Locator (1/2)</li><li>■ Options Map 8, Finisher Sensor Locator (2/2)</li><li>■ Options Finisher Controller to Sensors (1/3)</li><li>■ Options Finisher Controller to Sensors (2/3)</li></ul>

## Troubleshooting Procedure Table

Step	Actions and Questions	Yes	No
1	Check the following for evidence of fault or damage: <ul style="list-style-type: none"><li>■ Compiler Tray</li><li>■ Front and Rear Alignment Guides</li><li>■ Transport Rollers</li><li>■ Stapler</li></ul> Are there any defects or misalignment?	Replace any damaged parts.	Go to Step 2.
2	Test the Bind Tray Sensor. Run the Service Diagnostics sensor test. Does the sensor function correctly?	Replace the Engine Control Board (page 8-112).	Replace the sensor. If the error persists, go to Step 3.
3	Check the Processing Tray Sensor signal at the Finisher Control Board. Actuate the sensor. Does the voltage across CN15-3 <=> ground change when the sensor is actuated?	Replace the Finisher Control Board.	Replace the harness.

# Jam at Finisher Door G

Jam detected in the saddle stitch path.

## Applicable Status Code:

**Code FN8:** Jam at Finisher Door G

## Initial Actions:

- Cycle printer power.
- If the problem persists, follow the procedure below.

## Troubleshooting Reference Table

Applicable Parts	Wiring and Plug/Jack References
<ul style="list-style-type: none"><li>■ Compiler Tray</li><li>■ Front and Rear Alignment Guides</li><li>■ Transport Rollers</li><li>■ Stapler</li></ul>	<ul style="list-style-type: none"><li>■ Options Map 7, Finisher Sensor Locator (1/2)</li><li>■ Options Map 8, Finisher Sensor Locator (2/2)</li><li>■ Options Finisher Controller to Sensors (1/3)</li><li>■ Options Finisher Controller to Sensors (2/3)</li></ul>

## Troubleshooting Procedure Table

Step	Actions and Questions	Yes	No
1	Check the following for evidence of fault or damage: <ul style="list-style-type: none"><li>■ Compiler Tray</li><li>■ Front and Rear Alignment Guides</li><li>■ Transport Rollers</li><li>■ Stapler</li></ul> Are there any defects or misalignment?	Replace any damaged parts.	Go to Step 2.
2	Test the Bind Tray Sensor. Run the Service Diagnostics sensor test. Does the sensor function correctly?	Replace the Engine Control Board (page 8-112).	Replace the sensor. If the error persists, go to Step 3.
3	Check the Processing Tray Sensor signal at the Finisher Control Board. Actuate the sensor. Does the voltage across CN15-3 <=> ground change when the sensor is actuated?	Replace the Finisher Control Board.	Replace the harness.

# Jam at Finisher Saddle Stapler

This error represents a jam in the Finisher staple path.

## Applicable Status Code:

**Code FN9:** Jam at Finisher Saddle Stapler

## Initial Actions:

- Cycle printer power.
- If the problem persists, follow the procedure below.

## Troubleshooting Reference Table

Applicable Parts	Wiring and Plug/Jack References
<ul style="list-style-type: none"><li>■ Compiler Tray</li><li>■ Front and Rear Alignment Guides</li><li>■ Transport Rollers</li><li>■ Stapler</li></ul>	<ul style="list-style-type: none"><li>■ Options Map 7, Finisher Sensor Locator (1/2)</li><li>■ Options Map 8, Finisher Sensor Locator (2/2)</li><li>■ Options Finisher Controller to Sensors (1/3)</li><li>■ Options Finisher Controller to Sensors (2/3)</li></ul>

## Troubleshooting Procedure Table

Step	Actions and Questions	Yes	No
1	Check the following for evidence of fault or damage: <ul style="list-style-type: none"><li>■ Compiler Tray</li><li>■ Front and Rear Alignment Guides</li><li>■ Transport Rollers</li><li>■ Stapler</li></ul> Are there any defects or misalignment?	Replace any damaged parts.	Go to Step 2.
2	Test the Folding Position Sensor. Run the Service Diagnostics sensor test. Does the sensor function correctly?	Replace the Engine Control Board (page 8-112).	Replace the sensor. If the error persists, go to Step 3.
3	Check the Processing Tray Sensor signal at the Finisher Control Board. Actuate the sensor. Does the voltage across CN16-2 <=> ground change when the sensor is actuated?	Replace the Finisher Control Board.	Replace the harness.

# Jam at Finisher Upper Output Tray

Media remains in the Compiler Tray. This error represents a jam in the Finisher eject path.

## Applicable Status Code:

**Code FN10:** Jam at Finisher Upper Output Tray

## Initial Actions:

- Cycle printer power.
- If the problem persists, follow the procedure below.

## Troubleshooting Reference Table

Applicable Parts	Wiring and Plug/Jack References
<ul style="list-style-type: none"><li>■ Compiler Tray</li><li>■ Front and Rear Alignment Guides</li><li>■ Transport Rollers</li></ul>	<ul style="list-style-type: none"><li>■ Options Map 8, Finisher Sensor Locator (2/2)</li><li>■ Options Finisher Controller to Sensors (1/3)</li><li>■ Options Finisher Controller to Sensors (2/3)</li></ul>

## Troubleshooting Procedure Table

Step	Actions and Questions	Yes	No
1	Check the following for evidence of fault or damage: <ul style="list-style-type: none"><li>■ Compiler Tray</li><li>■ Front and Rear Alignment Guides</li><li>■ Transport Rollers</li></ul> Are there any defects or misalignment?	Replace any damaged parts.	Go to Step 2.
2	Test the Tray Paper Sensor. Run the Service Diagnostics sensor test. Does the sensor function correctly?	Replace the Engine Control Board (page 8-112).	Replace the sensor. If the error persists, go to Step 3.
3	Check the Processing Tray Sensor signal at the Finisher Control Board. Actuate the sensor. Does the voltage across CN5-9 <=> ground change when the sensor is actuated?	Replace the Finisher Control Board.	Replace the harness.



# Jam Inside Finisher

Media remains in the Inverter. These errors represent a jam in the Inverter path.

## Applicable Status Codes:

**Code: IN1:** Media remains in the Inverter Lower Sensor.

**Code: IN2:** Media remains in the Inverter Exit Sensor.

**Code: IN3:** Media reached the Inverter Entrance Sensor, but did not reach the Inverter Exit Sensor on time.

**Code: IN4:** Media reached the Inverter Entrance Sensor, but did not clear on time.

**Code: IN6:** Media reached the Inverter Exit Sensor, but did not clear on time.

**Code: IN7:** Media remains in the Inverter Lower Sensor.

## Initial Actions:

- Cycle printer power.
- If the problem persists, follow the procedure below.

## Troubleshooting Reference Table

Applicable Parts	Wiring and Plug/Jack References
<ul style="list-style-type: none"><li>■ Inverter Lower Sensor</li><li>■ Inverter Entrance Sensor</li><li>■ Inverter Exit Sensor</li></ul>	<ul style="list-style-type: none"><li>■ Options Map 3, Inverter Controller Board</li><li>■ Options Map 9, Inverter Sensor Locator</li><li>■ Options Inverter Sensors Diagram</li></ul>

## Troubleshooting Procedure Table

Step	Actions and Questions	Yes	No
1	Check the following for evidence of fault, damage, obstruction, or debris: <ul style="list-style-type: none"><li>■ Sensor Actuator</li><li>■ Paper Guides</li><li>■ Transport Rollers</li></ul> Are there any defects or misalignment?	Replace any damaged parts.	Go to Step 2.
2	Test the affected sensor. Run the Service Diagnostics test for the reporting sensor. Does the sensor function correctly?	Replace the Engine Control Board (page 8-112).	Go to Step 3.
3	Test the sensor signal. Does the signal voltage change on the SNSCNO connector of the Inverter Control Board?	Replace the Inverter Control Board.	Either the sensor or the wiring is defective. Check the resistance of the wires and if no problem is found replace the sensor.

# Jam at Finisher Entrance

Media remains in the Inverter Entrance Sensor. This error represents a jam in the Printer/Finisher interface.

## Applicable Status Codes:

**Code IN5:** Media did not reach the Inverter Entrance Sensor following an Eject command from the printer.

**Code IN8:** Media remains in the Inverter Entrance Sensor.

## Initial Actions:

- Cycle printer power.
- If the problem persists, follow the procedure below.

## Troubleshooting Reference Table

Applicable Parts	Wiring and Plug/Jack References
<ul style="list-style-type: none"><li>■ Inverter Entrance Sensor</li></ul>	<ul style="list-style-type: none"><li>■ Options Map 3, Inverter Controller Board</li><li>■ Options Map 9, Inverter Sensor Locator</li><li>■ Options Inverter Sensors Diagram</li></ul>

## Troubleshooting Procedure Table

Step	Actions and Questions	Yes	No
1	Check the following for evidence of fault, damage, obstruction, or debris: <ul style="list-style-type: none"><li>■ Sensor Actuator</li><li>■ Paper Guides</li><li>■ Transport Rollers</li></ul> Are there any defects or misalignment?	Replace any damaged parts.	Go to Step 2.
2	Test the Inverter Entrance Sensor. Run the Service Diagnostics Inverter Input Sensor test. Does the sensor function correctly?	Replace the Engine Control Board (page 8-112).	Go to Step 3.
3	Test the sensor signal. Does the voltage change on SNSCNO-5 connector of the Inverter Control Board when the sensor is actuated?	Replace the Inverter Control Board.	Either the sensor or the wiring is defective. Check the resistance of the wires and if no problem is found replace the sensor.

# Finisher Output Tray Jammed

This error represents a failure of, or an obstruction in the Finisher Upper Output Tray's up or down motion.

## Applicable Status Code:

**Code FT:** Finisher Output Tray Jammed

## Initial Actions:

- Cycle printer power.
- If the problem persists, follow the procedure below.

## Troubleshooting Reference Table

Applicable Parts	Wiring and Plug/Jack References
<ul style="list-style-type: none"><li>■ Finisher Lift Motor</li><li>■ Lift Motor Clock Sensor</li><li>■ Upper or Lower Limit Sensors</li><li>■ Lift Belts</li></ul>	<ul style="list-style-type: none"><li>■ Options Map 7, Finisher Sensor Locator (1/2)</li><li>■ Options Map 8, Finisher Sensor Locator (2/2)</li><li>■ Options Finisher Controller to Sensors (2/3)</li><li>■ Options Finisher Controller to Switches</li></ul>

## Troubleshooting Procedure Table

Step	Actions and Questions	Yes	No
1	Check the following for evidence of fault, damage, obstruction, or debris: <ul style="list-style-type: none"><li>■ Upper Output Tray</li><li>■ Lift belts and actuators</li><li>■ Limit Sensors</li><li>■ Shift Motor</li></ul> Are there any defects or misalignment?	Replace any damaged parts.	Go to Step 2.
2	Test the Limit Sensors. Run the Service Diagnostics Tray Upper and Lower Limit Sensor tests. Do the sensors function correctly?	Go to Step 4.	Replace the affected sensor. If the error persists, go to Step 3.
3	Test the sensor signals. Does the voltage change on CN15-12 (Upper) and CN-15-9 (Lower) connector of the Finisher Control Board when the sensors are actuated?	Replace the Finisher Control Board.	Replace the harness.
4	Test the Shift Motor. Run the Service Diagnostics Shift Motor test. Does the motor function correctly?	Go to Step 4.	Replace the motor.

## Troubleshooting Procedure Table (Continued)

<b>Step</b>	<b>Actions and Questions</b>	<b>Yes</b>	<b>No</b>
<b>5</b>	Check for +24 V to the Shift Motor. Disconnect CN6 from the Finisher Control Board. Is there +24 V CN6-1 <=> CN6-2?	Replace the Shift Motor.	Replace the Finisher Control Board. If the error persists, go to Step 6.
<b>6</b>	Test the Shift Motor Clock Sensor. Run the Shift Motor Clock Sensor test. Does the sensor function correctly?	Go to Step 8.	Replace the sensor.
<b>7</b>	Test the sensor signal. Does the voltage change on CN15-5 when the sensor is actuated?	Replace the Finisher Control Board.	Replace the wiring. If the error persists, replace the Engine Control Board (page 8-112).

# Door and Cover Errors

## Close Top Cover

The Top Cover Interlock Switch indicates that the Top Cover is open.

### Initial Actions:

- Ensure that the Top Cover Latch is free of obstructions and fully closed.
- Cycle printer power.
- If the problem persists, follow the procedure below.

### Troubleshooting Reference Table

Applicable Parts	Wiring and Plug/Jack References
<ul style="list-style-type: none"><li>■ Top Cover Interlock Switch, PL6.1.18</li><li>■ HVPS, PL2.1.26</li></ul>	<ul style="list-style-type: none"><li>■ Print Engine Map 3 (page 10-6)</li><li>■ Print Engine Xerographics (page 10-38)</li></ul>

### Troubleshooting Procedure Table

Step	Actions and Questions	Yes	No
1	Check the following for evidence of fault or damage: <ul style="list-style-type: none"><li>■ Top Cover latch (right side)</li><li>■ Top Cover Interlock Actuator</li></ul> Is there any damage or misalignment?	Replace any damaged parts.	Go to Step 2.
2	Test the Top Cover Interlock Switch. Run the Service Diagnostics Top Cover Interlock Test. Does the switch function correctly?	Replace the Engine Control Board (page 8-112).	Go to Step 3.
3	Check the Top Cover Interlock Switch. Disconnect the harness at CN3 on the HVPS. When the switch is closed there should be continuity between pins 1 and 2 on the harness. With the switch open there should be not continuity on pins 1 and 2 on the harness. Does the switch function correctly?	Go to Step 5.	Go to Step 4.
4	Replace the Top Cover Interlock Switch. Does the error persist?	Go to Step 5.	Complete
5	Check the switch voltage at CN3 on the HVPS. Is there +24V across CN3?	Replace the Engine Control Board (8-112)	Go to Step 6.
6	Check for +24V at the Engine Control Board. Is there +24V between pin 16 on the HVOLT connector and ground?	Replace the HVPS (8-112)	Go to Step 7.
7	Replace the Engine Control Board. Is the problem resolved?	Complete	Replace the Motor Driver Board.

# Close Right Door A

The Door A Interlock Switch indicates that Door A is open.

## Initial Actions:

- Ensure that Door A is free of obstructions and fully closed.
- Cycle printer power.
- If the problem persists, follow the procedure below.

## Troubleshooting Reference Table

Applicable Parts	Wiring and Plug/Jack References
<ul style="list-style-type: none"><li>■ Door A, PL10.1.1</li><li>■ Door A Interlock Switch, PL5.1.50</li><li>■ Motor Driver Board, PL2.1.10</li></ul>	<ul style="list-style-type: none"><li>■ Print Engine Map 5 (page 10-8)</li><li>■ Print Engine Motor Driver Board (1/6) (page 10-31)</li></ul>

## Troubleshooting Procedure Table

Step	Actions and Questions	Yes	No
1	Check the following for evidence of fault or damage: <ul style="list-style-type: none"><li>■ Door A</li><li>■ Door A Interlock Actuator</li><li>■ Door A Interlock Switch</li></ul> Is there any damage or misalignment?	Replace any damaged parts.	Go to Step 2.
2	Test the Door A Interlock Switch. Run the Service Diagnostics Door A Interlock Test. Does the switch function correctly?	Replace the Engine Control Board (page 8-112).	Go to Step 3.
3	Check the switch connection. Is the switch connected to MPTCOV on the Motor Driver Board?	Go to Step 4.	Reconnect the switch.
4	Check the Interlock Switch voltage. Is there +5 V at MPTCOV-1?	Replace the Door A Interlock Switch (page 8-132).	Replace the Motor Driver Board (page 8-141).

# Close Right Door B

The Door B Detect Sensor, located in the Tray 2 Feeder, indicates that Door B is open.

## Note

In the case of the Open and Close Door B error, the printer requires that a door be opened and closed to reset status and resume printing. Open and close any door to reset the status.

## Initial Actions:

- Ensure that Door B is free of obstructions and fully closed.
- Cycle printer power.
- If the problem persists, follow the procedure below.

## Troubleshooting Reference Table

Applicable Parts	Wiring and Plug/Jack References
<ul style="list-style-type: none"><li>■ Door B, PL2.1.1</li><li>■ Door B Detect Sensor, PL4.2.89</li><li>■ Feeder Board, PL4.2.97</li><li>■ Motor Driver Board, PL2.1.10</li></ul>	<ul style="list-style-type: none"><li>■ Print Engine Map 2 (page 10-5)</li><li>■ Print Engine Map 12 (page 10-15)</li><li>■ Print Engine Feeder Board Wiring (page 10-28)</li></ul>

## Troubleshooting Procedure Table

Step	Actions and Questions	Yes	No
1	Check the following for evidence of fault or damage: <ul style="list-style-type: none"><li>■ Door B Detect Sensor Actuator</li><li>■ Door B Detect Sensor Holder</li><li>■ Door B Detect Sensor</li></ul> Is there any damage or misalignment?	Replace any damaged parts.	Go to Step 2.
2	Test the Door B Detect Sensor. Run the Service Diagnostics Right Door B Test. <b>NOTE:</b> Door sensor tests are located under the Interlock Switches sub-menu. Does the switch function correctly?	Replace the Engine Control Board (page 8-112).	Go to Step 3.
3	Replace the Door B Detect Sensor. Does the error persist?	Go to Step 4.	Complete.
4	Check the TRYSNS2 connection. Is TRYSNS2 connected to the Feeder Board?	Go to Step 5.	Reconnect the harness.

## Troubleshooting Procedure Table (Continued)

<b>Step</b>	<b>Actions and Questions</b>	<b>Yes</b>	<b>No</b>
<b>5</b>	Check the Door B Detect Sensor voltage. Disconnect P/J41. Is there +5 V at J41-1?	Go to Step 6.	Replace the Feeder Board (page 8-53).
<b>6</b>	Check all pins on the TRYSNS2 Harness PL4.2.91 for continuity. 1. Disconnect TRYSNS2 and P/J41. 2. Check continuity between TRYSNS2 <=>J41.	Go to Step 7.	Replace the TRYSNS2 Harness.
<b>7</b>	Check the Door B signal. Does the voltage change at TRYSNS1-8 when the sensor is actuated?	Go to Step 8.	Replace the Feeder Board (page 8-53).
<b>8</b>	Check all pins on the TRYSNS1 Harness PL4.2.98 for continuity. Is the harness conductive?	Replace the Motor Driver Board (page 8-141).	Replace the TRYSNS1 Harness.



# Close Right Door C for Tray [3][4][5][6]

The Door C Detect Sensor for one of the option trays indicates that Door C is open.

## Initial Actions:

- Ensure that the door is free of obstructions and fully closed.
- Verify that the Detect Sensor Actuator molded into the Door is not damaged.
- Cycle printer power.
- If the problem persists, follow the procedure below.

## Troubleshooting Reference Table

Applicable Parts	Wiring and Plug/Jack References
<ul style="list-style-type: none"><li>■ Door C</li><li>■ Door C Detect Sensor</li><li>■ Option Feeder Board</li><li>■ Motor Driver Board, PL2.1.10</li></ul>	<ul style="list-style-type: none"><li>■ Print Engine Map 3 (page 10-6)</li><li>■ Options Map 5, Paper Tray Controller Board</li><li>■ Options Paper Tray Sensors and Interconnect Wiring</li></ul>

## Troubleshooting Procedure Table

Step	Actions and Questions	Yes	No
1	Check the following for evidence of fault or damage: <ul style="list-style-type: none"><li>■ Door C Detect Sensor Actuator</li><li>■ Door C Detect Sensor Holder</li><li>■ Door C Detect Sensor</li></ul> Is there any damage or misalignment?	Replace any damaged parts.	Go to Step 2.
2	Test the Door C Detect Sensor. Run the Service Diagnostics Door C test for the appropriate tray. <b>NOTE:</b> Door sensor tests are located under the Interlock Switches sub-menu. Does the switch function correctly?	Replace the Engine Control Board (page 8-112).	Go to Step 3.
3	Replace the Door C Detect Sensor. Does the error persist?	Go to Step 4.	Complete.
4	Check for +0V on the OPTIF connection. Is there +0 V at OPTIF-7 when the door is closed?	Replace the Engine Control Board (page 8-112).	The Door C sensor is signaling an open condition, go to Step 5.
5	Check for +0V on the FFSNS connector of the Option Control Board. Is there +0 V at FFSNS-8 when the door is closed?	Replace the Option Control Board.	If the wiring from the Option Control Board to the sensor is OK, replace the sensor.

# Close Left Door D

The Door D Detect Sensor on the Duplex Unit indicates that Door D is open.

## Initial Actions:

- Ensure that the door is free of obstructions and fully closed.
- Verify that the Detect Sensor Actuator is not broken.
- Cycle printer power.
- If the problem persists, follow the procedure below.

## Troubleshooting Reference Table

Applicable Parts	Wiring and Plug/Jack References
<ul style="list-style-type: none"><li>■ Door D Detect Sensor, PL16.1.6</li></ul>	<ul style="list-style-type: none"><li>■ Print Engine Map 3 (page 10-6)</li><li>■ Options Map 4, Duplex Unit Controller Board</li><li>■ Options Duplex Unit Sensors and Interconnect Wiring</li></ul>

## Troubleshooting Procedure Table

Step	Actions and Questions	Yes	No
1	Check the following for evidence of fault or damage: <ul style="list-style-type: none"><li>■ Door D Detect Sensor Actuator</li><li>■ Door D Detect Sensor</li><li>■ Door D</li></ul> Is there any damage or misalignment?	Replace any damaged parts.	Go to Step 2.
2	Test the Door D Detect Sensor. Run the Service Diagnostics Door D test for the appropriate tray. <b>NOTE:</b> Door sensor tests are located under the Interlock Switches sub-menu. Does the switch function correctly?	Replace the Engine Control Board (page 8-112).	Go to Step 3.
3	Replace the Door D Detect Sensor. Does the error persist?	Replace the DUPLEX Harness, if the error persists, replace the Duplex Unit.	Complete.

# Close Left Door E

The Door E Detect Sensor located in the Exit Assembly indicates that Door E is open.

## Initial Actions:

- Ensure that the door is free of obstructions and fully closed.
- Verify that the Detect Sensor Actuator is not broken.
- Cycle printer power.
- If the problem persists, follow the procedure below.
- If the problem persists follow the procedure below.

## Troubleshooting Reference Table

Applicable Parts	Wiring and Plug/Jack References
<ul style="list-style-type: none"> <li>■ Door E Detect Sensor, PL11.1.32</li> <li>■ Door E, PL11.1.43</li> <li>■ COVSNS Harness, PL11.1.34</li> </ul>	<ul style="list-style-type: none"> <li>■ Print Engine Map 2 (page 10-5)</li> <li>■ Print Engine Map 3 (page 10-6)</li> <li>■ Print Engine Rear Sensor Board (page 10-29)</li> </ul>

## Troubleshooting Procedure Table

Step	Actions and Questions	Yes	No
1	Check the following for evidence of fault or damage: <ul style="list-style-type: none"> <li>■ Door E Detect Sensor</li> <li>■ Door E</li> </ul>	Replace the parts concerned.	Go to Step 2.
2	Test the Door E Detect Sensor. <b>NOTE:</b> Door sensor tests are located under the Interlock Switches sub-menu. Run the Service Diagnostics Door E test. Does the sensor function correctly?	Replace the Engine Control Board (page 8-112).	Go to Step 3.
3	Check the sensor connection. Is P/J130 connected?	Go to Step 4.	Reconnect the sensor.
4	Replace the Door E Detect Sensor. Does the error persist?	Go to Step 5.	Complete
5	Check all pins on the COVSNS Harness for continuity. Is the harness conductive?	Replace the Engine Control Board (page 8-112).	Replace the COVSNS Harness.

# Close Finisher Door F

The Door F Interlock Switch indicates that Door F is open.

## Initial Actions:

- Ensure that the door is free of obstructions and fully closed.
- Verify that the actuator is not broken.
- Cycle printer power.
- If the problem persists, follow the procedure below.

## Troubleshooting Reference Table

Applicable Parts	Wiring and Plug/Jack References
<ul style="list-style-type: none"><li>■ Door F Interlock Switch and actuator</li></ul>	<ul style="list-style-type: none"><li>■ Options Map 9 Inverter Sensor Locations</li><li>■ Options Inverter Sensors Diagram</li></ul>

## Troubleshooting Procedure Table

Step	Actions and Questions	Yes	No
1	Check the following for evidence of fault or damage: <ul style="list-style-type: none"><li>■ Door F Interlock Switch</li><li>■ Switch actuator</li></ul>	Replace the parts concerned.	Go to Step 2.
2	Test the Door F Interlock Switch. <b>NOTE:</b> Door sensor tests are located under the Interlock Switches sub-menu. Run the Service Diagnostics Front Door Switch test. Does the switch function correctly?	Replace the Engine Control Board (page 8-112).	Go to Step 3.
3	Check the switch connection. Is CN68 connected?	Go to Step 4.	Connect the switch.
4	Check all pins on the harness for continuity. Disconnect the Switch harness from CN8. Is the harness conductive?	Go to Step 5.	Replace the harness.
5	Replace the Door F Interlock Switch. Does the error persist?	Replace the Finisher Control Board.	Complete

# Close Finisher Door H

The Upper Cover (Door H) Sensor indicates that Door H is open.

## Initial Actions:

- Ensure that the door is free of obstructions and fully closed.
- Verify that the actuator is not broken.
- Cycle printer power.
- If the problem persists, follow the procedure below.

## Troubleshooting Reference Table

Applicable Parts	Wiring and Plug/Jack References
■ Upper Cover Sensor	■ Options Map 7, Finisher Sensor Locator (1/2) ■ Options Finisher Controller to Sensors (1/3)

## Troubleshooting Procedure Table

Step	Actions and Questions	Yes	No
1	Check the following for evidence of fault or damage: <ul style="list-style-type: none"><li>■ Door H Actuator</li><li>■ Door H Switch</li></ul>	Replace the parts concerned.	Go to Step 2.
2	Test the Door H Switch. Run the Service Diagnostics Upper Cover test. Does the sensor function correctly?	Replace the Engine Control Board (page 8-112).	Go to Step 3.
3	Check the sensor connection. Is CN4 on the Finisher Control Board connected?	Go to Step 4.	Reconnect the sensor.
4	Check the Door H signal. Does the voltage change on CN4-6 of the Finisher Control Board when the switch is activated?	Replace the Finisher Control Board.	Replace the harness.

# Close Finisher Door J

The Front Cover (Door J) Sensor indicates that Door J is open.

## Initial Actions:

- Ensure that the door is free of obstructions and fully closed.
- Verify that the actuator is not broken.
- Cycle printer power.
- If the problem persists, follow the procedure below.

## Troubleshooting Reference Table

Applicable Parts	Wiring and Plug/Jack References
<ul style="list-style-type: none"><li>■ Door J Actuator</li><li>■ Door J Switch</li></ul>	<ul style="list-style-type: none"><li>■ Options Map 7, Finisher Sensor Locator (1/2)</li><li>■ Options Finisher Controller to Sensors (1/3)</li></ul>

## Troubleshooting Procedure Table

Step	Actions and Questions	Yes	No
1	Check the following for evidence of fault or damage: <ul style="list-style-type: none"><li>■ Door J Actuator</li><li>■ Door J Switch</li></ul>	Replace the parts concerned.	Go to Step 2.
2	Test the Door J Switch. Run the Service Diagnostics Front Cover test. Does the sensor function correctly?	Replace the Engine Control Board (page 8-112).	Go to Step 3.
3	Check the sensor connection. Is CN4 on the Finisher Control Board connected?	Go to Step 4.	Reconnect the sensor.
4	Check the Door J signal. Does the voltage change on CN4-9 of the Finisher Control Board when the switch is activated?	Replace the Finisher Control Board.	Replace the harness.

# Consumable/Routine Maintenance Procedures

## Replace [C][M][Y][K] Toner Cartridge

An empty cartridge, a metered cartridge installed in a non-metered printer, an unsupported cartridge, or a fatal error within the cartridge or printer can cause this error condition. Check for an error code in the help text prior to troubleshooting this error message.

### Note

[C] [M] [Y] [K] Toner Is Low or [C] [M] [Y] Toner is Empty are warning conditions. Replace [C] [M] [Y] [K] Toner Cartridge is an error condition. Use this procedure to correct these types of errors.

### Initial Actions:

- Replace the affected cartridge.
- Cycle printer power.
- If the problem persists, follow the procedure below.

### Troubleshooting Reference Table

Applicable Parts	Wiring and Plug/Jack References
<ul style="list-style-type: none"><li>■ Toner Cartridge, PL1.1.29</li><li>■ CRUM Harness, PL2.1.93</li><li>■ CRUM Reader Board, PL2.1.92</li></ul>	<ul style="list-style-type: none"><li>■ Print Engine Map 1 (page 10-4)</li><li>■ Print Engine Map 3 (page 10-6)</li><li>■ Print Engine Fuser (page 10-40)</li></ul>

### Troubleshooting Procedure Table

Step	Actions and Questions	Yes	No
1	Check Toner Cartridge installation. Are the Toner Cartridges properly installed?	Go to Step 2.	Correct the installation.
2	Replace the affected Toner Cartridge. Does the error persist after a genuine Xerox Toner Cartridge is installed?	Go to Step 3.	Complete
3	Check all pins of the CRUM Harness for continuity. 1. Remove the Top Cover (page 8-24). 2. Disconnect the CRUM cable from RFID on the Engine Control Board and CN1 on the CRUM Reader Board. Is the cable conductive?	Replace the CRUM Reader Board (page 8-146). If the error persists, go to Step 4.	Replace the CRUM Harness. If the error persists, go to Step 4.

## Troubleshooting Procedure Table (Continued)

Step	Actions and Questions	Yes	No
4	Check continuity of the affected Antenna Harness. Disconnect CN2, CN3, CN4, or CN5 from the CRUM Reader Board and CRUM Antennas. Is each harness conductive?	Go to Step 5.	Replace damaged wiring.
5	Check for +5V at RFID-2 on the Engine Control Board. Is there +5 V at RFID-2 <=> ground?	Go to Step 6.	Replace the Engine Control Board (page 8-112).
6	Check for +5V at POWER-2 on the Engine Control Board. Is there +5 V at POWER-2 <=> ground?	Replace the Engine Control Board (page 8-112).	Replace the LVPS (page 8-121).

## Replace [C][M][Y][K] Imaging Unit

The Imaging Unit life counter indicates that the Imaging Unit has reached end of life.

### Initial Actions:

- Print a Supplies Usage page to check Imaging Unit life and install date.
- Replace the affected Imaging Unit and cycle printer power.
- If the problem persists, follow the procedure below.

## Troubleshooting Reference Table

Applicable Parts	Wiring and Plug/Jack References
■ [C][M][Y][K] Imaging Unit, PL1.1.23	■ Print Engine Map 3 (page 10-6)

## Troubleshooting Procedure Table

Step	Actions and Questions	Yes	No
1	Check the count value stored in NVRAM. Run the Service Diagnostics CRU Counter Read utility. Has the counter been reset?	Replace the Engine Control Board (page 8-112).	Go to Step 2.
2	Reset the Imaging Unit count. 1. Run the Service Diagnostics Reset I/U Counts utility. 2. Reset the count for the affected I/U. Did the count value change?	Replace the Engine Control Board (page 8-112).	Replace the Engine Control Board NVRAM.



# Replace Transfer Unit

The end of life counter indicates that the Transfer Unit requires replacement.

## Initial Actions:

- Replace the Transfer Unit.
- Cycle printer power.
- If the problem persists, follow the procedure below.

## Note

The Transfer Unit is at End of Life is a warning. Replace Transfer Unit is a hard stop.

## Troubleshooting Reference Table

Applicable Parts	Wiring and Plug/Jack References
■ Transfer Unit, PL1.1.20	■ Print Engine Map 3 (page 10-6)

## Troubleshooting Procedure Table

Step	Actions and Questions	Yes	No
1	Check the count value stored in NVRAM. Run the Service Diagnostics CRU Counter Read utility. Has the counter for the Transfer Unit been reset?	Replace the Engine Control Board (page 8-112).	Go to Step 2.
2	Reset the Transfer Unit count. 1. Run the Service Diagnostics Reset Transfer Belt Count utility. 2. Reset the Transfer Unit count. Did the count value change?	Replace the Engine Control Board (page 8-112).	Replace the Engine Control Board NVRAM.

# Replace Waste Cartridge

The end of life counter indicates that the Waste Toner Reservoir requires replacement.

## Initial Actions:

- Replace the Waste Toner Reservoir
- Cycle printer power.
- If the problem persists, follow the procedure below.

Applicable Parts		Wiring and Plug/Jack References
Waste Toner Cartridge,	PL 1.1.22	Print Engine Map 1 (page 10-4)
Gear-Coupling-A-Assembly,	PL 8.1.23	Print Engine Map 3 (page 10-6)
OR-HAL (Waste Toner Reservoir Auger Rotation Sensor, PL 6.1.21		Print Engine Map 5 (page 10-8)
OR-S2V (Engine Control Board),	PL 1.1.4	
OR-S2M (Motor Driver Board),	PL 2.1.10	

## Troubleshooting Procedure Table

Step	Actions and Questions	Yes	No
1	Replace the Waste Cartridge. Is the problem resolved?	Complete	Go to Step 2
2	Inspect the Waste Cartridge auger drive coupling assembly in the printer (see Figure 1 and 2). Is the coupling assembly missing or damaged?	Replace the Gear-Coupling-A-Assy (PL 8.1.23)	Go to Step 3
3	Open the Front Cover and remove the Waste Cartridge. Defeat the Waste Cartridge Installed/Front Cover Interlock (see Fig. 3) and watch the Waste Cartridge Auger Coupling in the printer. Does the coupling rotate briefly when the interlock is defeated?	Go to Step 4.	Go to Step 5.
4	Enter Service Diagnostics and test the Waste Toner Box Hole IC sensor (see <a href="#">attachment for testing the sensor</a> ). Does the sensor transition from ON to OFF	Go to Step 7. 	Replace the OR-HAL (Waste Toner Reservoir Auger Rotation Sensor (PL 6.1.21)
5	Open the top cover and remove the Imaging Units and Transfer Unit. Remove the cover from the Waste Toner Drive Assembly. Defeat the Top Cover interlock and observe the Waste Toner Drive Motor. Does the motor rotate briefly when the interlock is defeated?	Go to Step 6.	Replace the OR-S2M (Motor Driver Board) (PL 2.1.10)
6	Inspect the drive components between the Waste Toner Drive Motor and the Waste Cartridge Auger Coupling for damage. Are there any damaged components?	Replace any damaged components.	Replace the Gear-Coupling-A-Assy (PL 8.1.23)
7	Reinstall all consumables and close all covers. Enter Service Diagnostics and run the Engine Status test under the General Status menu. Is the Replace Waste Cartridge message displayed at the bottom of the engine status list?	Replace the OR-S2V (Engine Control Board) (PL 1.1.4)	Exit Diagnostics and test in customer mode.

# Replace Fuser

The Fuser Life counter indicates that the Fuser has reached its end of life. Fuser replacement is necessary to avoid print quality problems.

## Note

There is no hard stop associated with the Replace Fuser message.

## Initial Actions:

- Print the Supplies Usage page to verify remaining life and Fuser install date.
- Replace the Fuser.
- Cycle printer power.
- If the problem persists, follow the procedure below.

## Troubleshooting Reference Table

Applicable Parts	Wiring and Plug/Jack References
■ Fuser, PL1.1.21	■ Print Engine Map 3 (page 10-6)

## Caution

Allow adequate time for the Fuser to cool before servicing the printer.

## Troubleshooting Procedure Table

Step	Actions and Questions	Yes	No
1	Check the count value stored in NVRAM. Run the Service Diagnostics CRU Counter Read utility. Has the counter for the Fuser been reset?	Replace the Engine Control Board (page 8-112).	Go to Step 2.
2	Reset the Fuser count. 1. Run the Service Diagnostics Reset Fuser Count utility. 2. Reset the Fuser count. Did the count value change?	Replace the Engine Control Board (page 8-112).	Replace in the following order: Engine Control Board NVRAM, LVPS and wiring harness.

# Install, Reseat or Lock [C][M][Y][K] Toner Cartridge

The printer does not detect the 'Toner Cartridge', or toner is not being supplied.

## Initial Actions:

- Ensure that the Toner Cartridges are fully seated and locked into position.
- Cycle printer power.
- If the problem persists, follow the procedure below.

## Troubleshooting Reference Table

Applicable Parts	Wiring and Plug/Jack References
<ul style="list-style-type: none"> <li>■ [C][M][Y][K] Toner Cartridge, PL1.1.29</li> <li>■ CRUM Reader Board, PL2.1.92</li> </ul>	<ul style="list-style-type: none"> <li>■ Print Engine Map 1 (page 10-4)</li> <li>■ Print Engine Map 3 (page 10-6)</li> <li>■ Print Engine Fuser (page 10-40)</li> </ul>

## Troubleshooting Procedure Table

Step	Actions and Questions	Yes	No
<b>1</b>	Check for packaging material . Is there packing materials present?	Remove the material.	Go to Step 2.
<b>2</b>	Remove the cartridge and tap it on a hard surface to break up any compacted toner. Reinstall the cartridge. Does the error persist?	Go to Step 3.	Complete.
<b>3</b>	Check the CRUM Harness continuity. 1. Remove the Top Cover (page 8-24). 2. Disconnect the CRUM cable from RFID on the Engine Control Board and CN1 on the CRUM Reader Board. Is the cable conductive?	Replace the CRUM Reader Board (page 8-146). If the error persists, go to Step 4.	Replace the CRUM Harness. If the error persists, go to Step 4.
<b>4</b>	Check the Antenna Harness continuity. Disconnect CN2, CN3, CN4, and CN5 from the CRUM Reader Board and Antennas. Is each harness conductive?	Replace the CRUM Antennas (page 8-147). If the error persists, go to Step 5.	Replace damaged wiring.
<b>5</b>	Check for +5V at RFID-2 on the Engine Control Board. Is there +5 V at RFID-2 <=> ground?	Go to Step 6.	Replace the Engine Control Board (page 8-112).
<b>6</b>	Check for +5V at POWER-2 on the Engine Control Board. Is there +5 V at POWER-2 <=> ground?	Replace the Engine Control Board (page 8-112).	Replace the LVPS (page 8-121).

# Install or Reseat [C][M][Y][K] Imaging Unit

The Imaging Unit CRUM fails to detect the Imaging Unit.

## Initial Actions:

- Remove and reseal the Imaging Unit.
- Cycle printer power.
- If the problem persists, follow the procedure below

## Troubleshooting Reference Table

Applicable Parts	Wiring and Plug/Jack References
■ Imaging Unit, PL1.1.23	■ Print Engine Map 8 (page 10-11)
■ Imaging Unit Sensor Board, PL5.1.21	■ Print Engine I/U Sensor Board (page 10-41)

## Troubleshooting Procedure Table

Step	Actions and Questions	Yes	No
1	Is the Imaging Unit installed and seated properly?	Go to Step 2].	Reseat the Imaging Unit.
2	Visually inspect the Imaging Unit Contact Assembly and springs. Are the contacts free from damage and debris?	Go to Step 3.	Clean or replace the Imaging Drum contacts.
3	Use service diagnostics to test the CMYK IU Sensor. Does the sensor function correctly?	Replace the Engine Controller Board (page 8-112).	Go to Step 4.
4	Verify continuity of the CTG0 harness. Is the harness conductive?	Replace the Imaging Unit Sensor Board (page 8-142).	Replace the harness.

# Install or Reset Transfer Unit

The printer does not detect the Transfer Unit.

## Initial Actions:

- Check the installation of the Transfer Unit.
- Cycle the printer's power.
- If the problem persists follow the procedure below.

## Troubleshooting Reference Table

Applicable Parts	Wiring and Plug/Jack References
<ul style="list-style-type: none"><li>■ Transfer Unit, PL1.1.20</li><li>■ Belt Rotation Sensor, PL2.1.146</li></ul>	<ul style="list-style-type: none"><li>■ Print Engine Map 1 (page 10-4)</li><li>■ Print Engine Map 5 (page 10-8)</li><li>■ Print Engine Motor Driver Board (1/6) (page 10-31)</li><li>■ Print Engine Motor Driver Board (4/6) (page 10-34)</li></ul>

## Troubleshooting Procedure Table

Step	Actions and Questions	Yes	No
1	Test the Belt Rotation Sensor. Run the Service Diagnostics Belt Hole IC test. Does the sensor function correctly?	Go to Step 2.	Replace the sensor (8-91). If the error persists, go to Step 3.
2	Check all pins on the HALL1 Harness for continuity. Disconnect HALL1 and P/J310 Is the harness conductive?	Replace the Motor Driver Board (page 8-141). If the error persists, go to Step 3.	Replace the HALL1 Harness.
3	Check all pins of the DRV0 harness for continuity. Disconnect the DRV0 ribbon cable. Is the cable conductive?	Replace the Engine Control Board (page 8-112).	Replace the DRV0 Harness.

# Install or Reseat Waste Cartridge

The Waste Toner Reservoir Detect Switch indicates the reservoir is missing. Two actuators are used to actuate the switch. One is attached to the Front Door by a single screw, the other is incorporated into the Waste Toner Reservoir.

## Initial Actions:

- Reseat the Waste Toner Reservoir.
- Cycle printer power.
- If the problem persists, follow the procedure below.

## Troubleshooting Reference Table

Applicable Parts	Wiring and Plug/Jack References
<ul style="list-style-type: none"><li>■ Waste Toner Reservoir Detect Switch, PL6.1.8</li><li>■ Waste Toner Reservoir, PL1.1.22</li></ul>	<ul style="list-style-type: none"><li>■ Print Engine Map 5 (page 10-8)</li><li>■ Print Engine Xerographics (page 10-38)</li></ul>

## Troubleshooting Procedure Table

Step	Actions and Questions	Yes	No
1	Check the following for evidence of fault or damage: <ul style="list-style-type: none"><li>■ Front Door actuator</li><li>■ Waste Toner Reservoir</li><li>■ Waste Toner Reservoir Detect Switch</li></ul> Is there any damage?	Replace any damaged parts.	Go to Step 2.
2	Test the Waste Toner Reservoir Detect Switch. Run the Service Diagnostics Waste Bin Missing test. Does the switch function properly?	Replace the Engine Control Board (page 8-112).	Replace the switch (page 8-130). If the error persists, Go to Step 3.
3	Check the HVOLT harness to the HVPS. Is the HVOLT harness conductive?	Replace the HVPS (page 8-119).	Replace the HVOLT Harness.

# Install or Reset Fuser

The Fuser Release Sensor indicates the Fuser is missing.

## Initial Actions:

- Ensure that the Fuser latches are fully latched.
- Cycle printer power.
- If the problem persists, follow the procedure below.

## Troubleshooting Reference Table

Applicable Parts	Wiring and Plug/Jack References
<ul style="list-style-type: none"><li>■ Fuser, PL1.1.21</li><li>■ Fuser Release Sensor, PL2.1.36</li></ul>	<ul style="list-style-type: none"><li>■ Print Engine Map 2 (page 10-5)</li><li>■ Print Engine Registration (page 10-30)</li><li>■ Print Engine Fuser (page 10-40)</li></ul>

### Caution

Allow adequate time for the Fuser to cool before servicing the printer.

## Troubleshooting Procedure Table

Step	Actions and Questions	Yes	No
1	Check the following for evidence of fault or damage: <ul style="list-style-type: none"><li>■ Fuser</li><li>■ Fuser Connector</li><li>■ Fuser Release Sensor</li></ul> Is there any damage?	Replace any damaged parts, and then cycle printer power.	Replace the Fuser. If the error persists, Go to Step 2.
2	Test the Fuser Release Sensor. Run the Service Diagnostics Fuser Installed test, Does the sensor function correctly?	Replace the Engine Control Board (page 8-112).	Replace the sensor (page 8-79). If the error persists, go to Step 3.
3	Check for +5 V to the sensor. Is there +5 V at DSNS-7?	Replace the sensor harness.	Replace the Registration Sensor Board (page 8-148)



# Metered Toner Is not Enabled

A metered Toner Cartridge is installed in a non-metered printer.

## Initial Actions:

- Ensure that the Toner Cartridge installed matches the printer's configuration.
- Cycle the printer's power.
- If the problem persists follow the procedure below.

## Applicable Status Code:

**Code:** Metered Toner Is not Enabled

## Troubleshooting Reference Table

Applicable Parts	Wiring and Plug/Jack References
■ Toner Cartridges, PL1.1.24	

## Troubleshooting Procedure Table

Step	Actions and Questions	Yes	No
1	Check the configuration of the Printer. Is the printer covered under a Metered Toner contract?	Enable the Metered Toner via the Control Panel.	Replace the affected Toner Cartridge with a Non-Metered Toner Cartridge.

# Replace Metered [C][M][Y][K] Toner Cartridge

The printer is set to metered operation. An empty cartridge, a non-metered cartridge installed in a metered printer, an unsupported cartridge, or a fatal error within the cartridge or printer can cause this error condition. Check for an error code in the help text prior to troubleshooting this error message.

## Initial Actions:

- Replace the affected cartridge with a Xerox, metered version.
- Cycle printer power.
- If the problem persists, follow the procedure below.

## Troubleshooting Reference Table

Applicable Parts	Wiring and Plug/Jack References
<ul style="list-style-type: none"><li>■ Metered Toner Cartridge</li><li>■ CRUM Harness, PL2.1.93</li><li>■ CRUM Reader Board, PL2.1.92</li></ul>	<ul style="list-style-type: none"><li>■ Print Engine Map 1 (page 10-4)</li><li>■ Print Engine Map 3 (page 10-6)</li><li>■ Print Engine Fuser (page 10-40)</li></ul>

## Troubleshooting Procedure Table

Step	Actions and Questions	Yes	No
1	Check Toner Cartridge type. Is the cartridge a metered cartridge?	Go to Step 2.	Install a Xerox, metered cartridge.
2	Check all CRUM Harness pins for continuity. 1. Remove the Top Cover (page 8-24). 2. Disconnect the CRUM cable from RFID on the Engine Control Board and CN1 on the CRUM Reader Board. Is the cable conductive?	Replace the CRUM Reader Board (page 8-146). If the error persists, go to Step 3.	Replace the CRUM Harness. If the error persists, go to Step 3.
3	Check continuity of the Antenna Harness. Disconnect CN2, CN3, CN4, or CN5 from the CRUM Reader Board and CRUM Antennas. Is each harness conductive?	Go to Step 4.	Replace damaged wiring.
4	Check for +5V at RFID-2 on the Engine Control Board. Is there +5 V at RFID-2 <=> ground?	Go to Step 5.	Replace the Engine Control Board (page 8-112).
5	Check for +5V at POWER-2 on the Engine Control Board. Is there +5 V at POWER-2 <=> ground?	Replace the Engine Control Board (page 8-112).	Replace the LVPS (page 8-121).

# Tray and Media Errors

When a tray is pulled out that prevents printing during a print job, an error condition exists. When a tray is pulled out while no job is printing or that does not prevent printing during a print job, a warning condition exists.

## Clear Tray 1 (MPT) Riser Plate

The Tray 1 (MPT) Level Sensor indicates that the Registration Motor failed to raise the media to the pre-feed position. For a Remove Paper error, the Level Sensor indicates Pre-Feed position or higher before a lift is executed.

### Initial Actions:

- Inspect the tray to ensure that it is free of obstructions or debris.
- Check that the Lift Levers are above the Lift Plate.
- Cycle printer power.
- If the problem persists, follow the procedure below.

### Troubleshooting Reference Table

Applicable Parts	Wiring and Plug/Jack References
<ul style="list-style-type: none"><li>■ Tray 1 (MPT) Level Sensor, PL10.1.36</li><li>■ Tray 1 (MPT) Assembly</li><li>■ Registration Motor, PL4.2.36</li><li>■ Registration Clutch #1, PL8.1.85</li></ul>	<ul style="list-style-type: none"><li>■ Print Engine Map 5 (page 10-8)</li><li>■ Print Engine Map 9 (page 10-12)</li><li>■ Print Engine Motor Driver Board (1/6) (page 10-31)</li><li>■ Print Engine Motor Driver Board (4/6) (page 10-34)</li></ul>

### Troubleshooting Procedure Table

Step	Actions and Questions	Yes	No
1	Check the following for evidence of fault or damage: <ul style="list-style-type: none"><li>■ Tray 1 (MPT) Assembly</li><li>■ Tray 1 (MPT) Level Sensor Actuator</li><li>■ Lift Plate, Springs and Levers</li><li>■ Registration Motor</li><li>■ Registration Clutch #1</li></ul> Is there any damage?	Replace any damaged parts.	Go to Step 2.
2	Test the Level Sensor. Run the Service Diagnostics Tray 1 Switches Level Sensor test. Does the sensor function correctly?	Go to Step 3.	Replace the Sensor. If the error persists, go to Step 9.

## Troubleshooting Procedure Table (Continued)

Step	Actions and Questions	Yes	No
3	Test the Registration Motor. Run the Service Diagnostics Registration Motor A test. Does the motor function correctly?	Go to Step 7.	Replace the motor (page 8-39). If the error persists, go to Step 4.
4	Check for +24 V to the Registration Motor. Is there +24 V across REGHOP-1 <=> ground?	Replace the REGHOP Harness. If the error persists, go to Step 5.	Replace the Motor Driver Board (page 8-141).
5	Check Motor Driver Board POW24 connector for 24 V. 1. Disconnect POW24. Is there +24 V across POW24-1 <=> POW24-2?	Replace the Motor Driver Board (page 8-141).	Go to Step 6.
6	Check for 24 V at the LVPS 1. Disconnect CN2 on the LVPS. Is there +24 V across pins 1 and 2?	Replace the POW24 Harness.	Replace the LVPS (page 8-121).
7	Test Registration Clutch #1. Run the Service Diagnostics Registration Clutch A test. Does the clutch function correctly?	Go to Step 9.	Go to Step 8.
8	Check for +24 V to Registration Clutch #1. Is there +24 V across CLUTCH-1 <=> ground?	Replace the clutch (page 8-85).	Replace the Front Sensor Board (page 8-150).
9	Test for +5 V to the Tray 1 (MPT) Level Sensor. Disconnect MPTSNS. Is there +5 V at MPTSNS-7 <=> ground?	Replace the MPTSNS Harness.	Replace the Front Sensor Board (page 8-150).
10	Check all pins of the FSNS harness for continuity. Disconnect the FSNS Harness. Is the harness conductive?	Replace the Motor Driver Board (page 8-141). If the error persists, go to Step 11.	Replace the FNSNS Harness.
11	Check all pins of the DRV0 harness for continuity. Disconnect the DRV0 ribbon cable. Is the cable conductive?	Replace the Engine Control Board (page 8-112).	Replace the DRV0 Harness.

# Clear Tray [2][3][4][5][6] Riser Plate

The Lift Motor failed to raise the media to the pre-feed position. For a Remove Paper error, the Level Sensor indicates Pre-Feed position or higher before a lift is executed

## Initial Actions:

- Remove the tray and inspect the tray cavity to ensure that it is free of obstructions or debris.
- Reinstall the tray and cycle printer power.
- If the problem persists, follow the procedure below.

## Troubleshooting Reference Table

Applicable Parts	Wiring and Plug/Jack References
<ul style="list-style-type: none"> <li>■ Level Sensor</li> <li>■ Lift Motor</li> <li>■ Universal Tray, PL1.1.41</li> <li>■ Option Control Board</li> <li>■ Option Feeder Board</li> </ul>	<ul style="list-style-type: none"> <li>■ Print Engine Map 5 (page 10-8)</li> <li>■ Print Engine Map 12 (page 10-15)</li> <li>■ Print Engine Feeder Board (page 10-28)</li> <li>■ Options Map 5 Paper Tray Controller Board</li> <li>■ Options Map 6 Paper Tray Feeder Board</li> <li>■ Options Paper Tray Motors and Clutches</li> </ul>

## Troubleshooting Procedure Table

Step	Actions and Questions	Yes	No
1	Check the following for evidence of fault or damage: <ul style="list-style-type: none"> <li>■ Level Sensor Actuator</li> <li>■ Lift Plate and gearing</li> <li>■ Lift Motor</li> </ul> Is there any damage?	Replace any damaged parts.	Go to Step 2.
2	Test the Level Sensor. Run the Service Diagnostics Level Sensor test for the appropriate tray. Does the sensor function correctly?	Go to Step 3.	Replace the Sensor. If the error persists, go to Step 4.
3	Test the Lift Motor. Run the Service Diagnostics Lift Motor test for the appropriate tray. Does the motor function correctly?	Go to Step 4.	Replace the Lift Motor. If the error persists, go to Step 4.
4	Check for +24 V to the Lift Motor. Is there +24 V across GDDC-1 <=> ground?	Go to Step 5.	Replace the Option Control Board.
5	Test the OPTIF Harness continuity. Is the OPTIF Harness conductive?	Replace the Engine Control Board (page 8-112).	Replace the harness.

# Out of Paper Load Tray 1(MPT) with [size] [type]

The Tray 1 (MPT) No Paper Sensor indicates the tray is empty.

## Initial Actions:

- Inspect the tray to ensure that it is free of obstructions, is loaded with supported media, and the guides are adjusted correctly.
- Cycle printer power.
- If the problem persists, follow the procedure below

## Troubleshooting Reference Table

Applicable Parts	Wiring and Plug/Jack References
<ul style="list-style-type: none"><li>■ No Paper Sensor, PL10.1.32</li><li>■ No Paper Sensor Actuator, PL10.1.79</li><li>■ MPTPAP Harness, PL10.1.33</li></ul>	<ul style="list-style-type: none"><li>■ Print Engine Map 9 (page 10-12)</li><li>■ Print Engine Map 10 (page 10-13)</li><li>■ Print Engine Front Sensor Board (1/2) (page 10-26)</li></ul>

## Troubleshooting Procedure Table

Step	Actions and Questions	Yes	No
1	Check the following for evidence of fault or damage: <ul style="list-style-type: none"><li>■ Tray 1 (MPT) No Paper Sensor, PL5.3.14</li><li>■ Sensor Actuator, PL5.3.15</li></ul> Is there any damage?	Replace any damaged parts.	Go to Step 2.
2	Test the Tray 1 (MPT) No Paper Sensor. Run the Service Diagnostics Tray 1 (MPT) Switches No Paper Sensor test. Does the sensor function correctly?	Replace the Engine Control Board (page 8-112).	Go to Step 3.
3	Check for +5 V to the Tray 1 (MPT) No Paper Sensor. Is there +5 V across MPTPAP-1 <=> ground?	Replace the sensor (page 8-33).	Replace the Front Sensor Board (page 8-150).
4	Check all pins of the FSNS harness for continuity. Disconnect the FSNS Harness. Is the harness conductive?	Replace the Motor Driver Board (page 8-141). If the error persists, go to Step 5.	Replace the FNSNS Harness.
5	Check all pins of the DRV0 harness for continuity. Disconnect the DRV0 ribbon cable. Is the cable conductive?	Replace the Engine Control Board (page 8-112).	Replace the DRV0 Harness.

# Out of Paper Load Tray [2][3][4][5][6] with [size][type]

The tray's No Paper Sensor indicates the tray is empty.

## Initial Actions:

- Inspect the tray to ensure that it is free of obstructions, is loaded with supported media, and the guides are adjusted correctly.
- Cycle printer power.
- If the problem persists, follow the procedure below

## Troubleshooting Reference Table

Applicable Parts	Wiring and Plug/Jack References
<ul style="list-style-type: none"><li>■ No Paper Sensor</li><li>■ No Paper Actuator</li></ul>	<ul style="list-style-type: none"><li>■ Print Engine Map 12 (page 10-15)</li><li>■ Print Engine Feeder Board (page 10-28)</li><li>■ Options Map 5 Paper Tray Controller Board</li><li>■ Options Map 6 Paper Tray Feeder Board</li><li>■ Options Paper Tray Motors and Clutches</li></ul>

## Troubleshooting Procedure Table

Step	Actions and Questions	Yes	No
1	Check the following for evidence of fault or damage: <ul style="list-style-type: none"><li>■ No Paper Sensor</li><li>■ No Paper Actuator</li></ul> Is there any damage?	Replace any damaged parts.	Go to Step 2.
2	Test the No Paper Sensor for the affected tray. Run the Service Diagnostics Tray Switches test. Does the sensor function correctly?	Replace the Engine Control Board (page 8-112).	Replace the sensor. If the error persists, go to Step 3.
3	Check for +5 V to the No Paper Sensor. Is there +5 V across PAPEND-1 <=> ground?	Go to Step 4.	Replace the Feeder Board.
4	Check all pins on the Main Harnesses for continuity. Is the harness conductive?	Replace the Option Control Board.	Replace the Main Harness.
5	Test the OPTIF Harness continuity. Is the OPTIF Harness conductive?	Replace the Engine Control Board (page 8-112).	Replace the harness.

# Manual Feed [size][type]

The print job specifications request the manual feed of media [size][type].

## Initial Actions:

- Inspect the tray to ensure that it is free of obstructions, is reloaded with requested media, and the guides are adjusted correctly.
- Cycle printer power.
- If the problem persists, follow the procedure below

## Troubleshooting Reference Table

Applicable Parts	Wiring and Plug/Jack References
<ul style="list-style-type: none"><li>■ No Paper Sensor, PL5.3.14</li><li>■ No Paper Sensor Actuator, PL5.3.15</li></ul>	<ul style="list-style-type: none"><li>■ Print Engine Map 9 (page 10-12)</li><li>■ Print Engine Front Sensor Board (1/2) (page 10-26)</li></ul>

## Troubleshooting Procedure Table

Step	Actions and Questions	Yes	No
1	Fill Tray 1 (MPT) with paper. Does the error persist?	Go to Step 2.	Complete.
2	Check the following for evidence of fault or damage: <ul style="list-style-type: none"><li>■ Tray 1 (MPT) No Paper Sensor</li><li>■ Sensor Actuator</li></ul> Is there any damage?	Replace any damaged parts.	Go to Step 3.
3	Test the Tray 1 (MPT) No Paper Sensor. Run the Service Diagnostics Tray 1 (MPT) No Paper Sensor test. Does the sensor function correctly?	Replace the Engine Control Board (page 8-112).	Go to Step 4.
4	Check for +5 V to the Tray 1 (MPT) No Paper Sensor. Is there +5 V across MPTPAP-1 <=> ground?	Replace the sensor (page 8-33).	Replace the Front Sensor Board (page 8-150).
5	Check all pins of the FSNS harness for continuity. Disconnect the FSNS Harness. Is the harness conductive?	Replace the Motor Driver Board (page 8-141). If the error persists, go to Step 6.	Replace the FNSNS Harness.
6	Check all pins of the DRV0 harness for continuity. Disconnect the DRV0 ribbon cable. Is the cable conductive?	Replace the Engine Control Board (page 8-112).	Replace the DRV0 Harness.



# Top Output Tray Is Full, Unload Paper

The Full Stack Sensor indicates the output tray is full.

## Initial Actions:

- Ensure that the output tray is empty and the actuator is in the correct position.
- Cycle printer power.
- If the problem persists, follow the procedure below.

## Troubleshooting Reference Table

Applicable Parts	Wiring and Plug/Jack References
<ul style="list-style-type: none"><li>■ Full Stack Sensor, PL11.1.39</li><li>■ Full Stack Sensor Actuator</li><li>■ SNS Harness, PL11.1.35</li></ul>	<ul style="list-style-type: none"><li>■ Print Engine Map 7 (page 10-10)</li><li>■ Print Engine Map 11 (page 10-14)</li><li>■ Print Engine Rear Sensor Board (page 10-29)</li></ul>

## Troubleshooting Procedure Table

Step	Actions and Questions	Yes	No
1	Check the following for evidence of fault or damage: <ul style="list-style-type: none"><li>■ Full Stack Sensor</li><li>■ Full Stack Sensor Actuator</li></ul>	Replace the parts concerned.	Go to Step 2.
2	Test the Top Output Tray Full Stack Sensor. Run the Service Diagnostics Face Down Stack Full Sensor test. Does the sensor function correctly?	Replace the Engine Control Board (page 8-112).	Go to Step 3.
3	Check the Full Stack Sensor connection. Is P/J160 connected?	Go to Step 4.	Reconnect the sensor.
4	Replace the Top Output Tray Full Stack Sensor. Does the error persist?	Go to Step 5.	Complete
5	Check all pins on the SNS Harness PL5.3.28 for continuity. Is the harness conductive?	Replace the Engine Control Board (page 8-112).	Replace the SNS Harness.

# Left Side Output Tray Is Full, Unload Paper

The Full Stack Sensor indicates the Side Output Tray is full.

## Initial Actions:

- Ensure that the output tray is empty and the actuator is in the correct position.
- Cycle printer power.
- If the problem persists, follow the procedure below.

## Troubleshooting Reference Table

Applicable Parts	Wiring and Plug/Jack References
<ul style="list-style-type: none"><li>■ Stack Full Sensor, PL11.1.39</li><li>■ Stack Full Sensor Actuator, PL11.1.38</li><li>■ SNS Harness, PL11.1.35</li></ul>	<ul style="list-style-type: none"><li>■ Print Engine Map 7 (page 10-10)</li><li>■ Print Engine Map 11 (page 10-14)</li><li>■ Print Engine Rear Sensor Board (page 10-29)</li></ul>

## Troubleshooting Procedure Table

Step	Actions and Questions	Yes	No
1	Check the following for evidence of fault or damage: <ul style="list-style-type: none"><li>■ Full Stack Sensor, PL11.1.39</li><li>■ Full Stack Sensor Actuator, PL11.1.38</li></ul>	Replace the parts concerned.	Go to Step 2.
2	Test the Side Output Tray Full Stack Sensor. Run the Service Diagnostics Face Up Stack Full Sensor test. Does the sensor function correctly?	Replace the Engine Control Board (page 8-112).	Go to Step 3.
3	Check the Full Stack Sensor connection. Is P/J170 connected?	Go to Step 4.	Reconnect the sensor.
4	Replace the Side Output Tray Stack Full Sensor (page 8-75). Does the error persist?	Go to Step 5.	Complete
5	Check all pins on the SNS Harness PL5.3.28 for continuity. Is the harness conductive?	Replace the Engine Control Board (page 8-112).	Replace the SNS Harness.

# Finisher Lower Output Tray is Full, Unload Paper

## Initial Actions:

- Ensure that the output tray is empty and the actuator is in the correct position.
- Cycle printer power.
- If the problem persists, follow the procedure below.

## Troubleshooting Reference Table

Applicable Parts	Wiring and Plug/Jack References
<ul style="list-style-type: none"><li>■ Saddle Stitch Bind Tray</li><li>■ Bind Tray Sensor Flag</li><li>■ Stapler</li></ul>	<ul style="list-style-type: none"><li>■ Options Map 7 Finisher Sensor Locator (1/2)</li><li>■ Options Finisher Controller to Sensors (2/3)</li></ul>

## Troubleshooting Procedure Table

Step	Actions and Questions	Yes	No
1	Check the following for evidence of fault, damage, obstruction, or debris: <ul style="list-style-type: none"><li>■ Saddle Stitch Bind tray</li><li>■ Bind Tray Sensor Flag</li><li>■ Stapler</li></ul> Are there any defects or misalignment?	Replace any damaged parts.	Go to Step 2.
2	Test the Binding Sensor. Run the Service Diagnostics Bookbinding Sensor tests. Does the Binding Sensor function correctly?	Replace the Engine Control Board (page 8-112).	Go to Step 3.
3	Test the sensor signal. Does the voltage change on CN15-3 connector of the Finisher Control Board when the sensor is actuated?	Replace the Finisher Control Board.	Either the sensor or the wiring is defective. Check the resistance of the wires and if no problem is found replace the sensor.

# Finisher Upper Output Tray is Full, Unload Paper

## Initial Actions:

- Ensure that the output tray is empty and the actuator is in the correct position.
- Cycle printer power.
- If the problem persists, follow the procedure below.

## Troubleshooting Reference Table

Applicable Parts	Wiring and Plug/Jack References
<ul style="list-style-type: none"><li>■ Stack Full Sensor</li></ul>	<ul style="list-style-type: none"><li>■ Options Map 7 Finisher Sensor Locator (1/2)</li><li>■ Options Finisher Controller to Sensors (3/3)</li></ul>

## Troubleshooting Procedure Table

Step	Actions and Questions	Yes	No
1	Test the Upper Tray Stack Full Sensor. Run the Service Diagnostics Upper Tray Full Sensor test. Does the sensor state change when the sensor is actuated?	Replace the Finisher Control Board.	Go to Step 2.
2	Check the sensor harness connections. Is the sensor connected?	Go to Step 4.	Connect and go to Step 3.
3	Print a test print. Does the error still occur?	Go to Step 4.	Problem solved.
4	Check sensor harness continuity. Is the harness conductive?	Go to Step 5.	Replace the Sensor Harness.
5	Check for +5 V to the Upper Tray Stack Full Sensor. Is there +5 V on the Finisher Control Board?	Go to Step 6.	Replace the Finisher Control Board.
6	Check the Finisher Control Board signal. Does the voltage across on the Finisher Control Board change when the sensor is actuated?	Replace the Finisher Control Board.	Replace the Upper Tray Full Stack Sensor.

# Open Left Side Output Tray

The Side Output Tray Detect Sensor indicates the tray is closed.

## Initial Actions:

- Ensure that the output tray is empty and the actuator is in the correct position.
- Cycle printer power.
- If the problem persists, follow the procedure below.

## Troubleshooting Reference Table

Applicable Parts	Wiring and Plug/Jack References
<ul style="list-style-type: none"> <li>■ Side Output Tray Detect Sensor, PL11.1.32</li> <li>■ Side Output Tray, PL2.1.124</li> <li>■ COVSNS Harness, PL11.1.34</li> </ul>	<ul style="list-style-type: none"> <li>■ Print Engine Map 7 (page 10-10)</li> <li>■ Print Engine Map 11 (page 10-14)</li> <li>■ Print Engine Rear Sensor Board (page 10-29)</li> </ul>

## Troubleshooting Procedure Table

Step	Actions and Questions	Yes	No
1	Check the following for evidence of fault or damage: <ul style="list-style-type: none"> <li>■ Tray Detect Sensor, PL11.1.32</li> <li>■ Side Output Tray, PL2.1.124</li> </ul>	Replace the parts concerned.	Go to Step 2.
2	Test the Side Output Tray Detect Sensor. <b>NOTE:</b> Door sensor tests are located under the Interlock Switches sub-menu. Run the Service Diagnostics Side Output Tray test. Does the sensor function correctly?	Replace the Engine Control Board (page 8-112).	Go to Step 3.
3	Check the sensor connection. Is P/J180 connected?	Go to Step 4.	Reconnect the sensor.
4	Replace the Side Output Tray Detect Sensor. Does the error persist?	Go to Step 5.	Complete
5	Check all pins on the COVSNS Harness for continuity. Is the harness conductive?	Replace the Engine Control Board (page 8-112).	Replace the COVSNS Harness.

# Media Mismatch Errors

## Wrong Paper Size; Load Tray 1 (MPT) with [size][type]

Tray 1 (MPT) paper size mismatch error. The size setting stored in NVRAM differs from the size specified by the print job.

### Initial Actions:

- Check that the size setting in NVRAM, media loaded in the tray, and specification for the job match.
- Cycle printer power.
- If the problem persists, follow the procedure below.

### Troubleshooting Reference Table

Applicable Parts	Wiring and Plug/Jack References
<ul style="list-style-type: none"><li>■ Front Sensor Board, PL8.1.7</li><li>■ Engine Control Board, PL1.1.4</li></ul>	<ul style="list-style-type: none"><li>■ Print Engine Map 9 (page 10-12)</li><li>■ Print Engine Front Sensor Board (2/2) (page 10-27)</li></ul>

### Troubleshooting Procedure Table

Step	Actions and Questions	Yes	No
1	Check the following for evidence of fault, debris, damage, of misalignment: <ul style="list-style-type: none"><li>■ Feed-Out #1 Sensor Actuator</li><li>■ Registration Sensor #1 Actuator</li><li>■ Transfer Unit Entrance Sensor</li><li>■ MPTSNS Harness</li></ul>	Replace the parts concerned.	Go to Step 2.
2	Check the MPTSNS Harness continuity. Is the harness conductive?	Go to Step 3.	Replace the harness.
3	Check for +5 V to the Feed-Out #1 Sensor. Disconnect MPTSNS at the Front Sensor Board. Is there +5 V at MPTSNS-4 <=> ground?	Replace the sensor (page 8-32).	Go to Step 4.
4	Check for +5 V to the Front Sensor Board. Disconnect FSNS at the Motor Driver Board. Is there +5 V at FSNS-10 and -14<=> ground?	Replace the Front Sensor Board (page 8-150).	Go to Step 6.
5	Check the FSNS Harness continuity. Is the harness conductive?	Replace the Motor Driver Board (page 8-141).	Replace the FSNS Harness.

# Wrong Paper Size; Load Tray 2 with [size][type]

Tray 2 paper size mismatch error. The Paper Size Switch indicates that the media loaded in Tray 2 does not match the size specified by the print job.

## Initial Actions:

- Inspect the tray to ensure that it is free of obstructions, is loaded with the expected media, and the guides are adjusted correctly.
- Cycle printer power.
- If the problem persists, follow the procedure below.

## Troubleshooting Reference Table

Applicable Parts	Wiring and Plug/Jack References
<ul style="list-style-type: none"><li>■ Paper Size Switch, PL4.1.19</li><li>■ Paper Tray</li><li>■ PSIZE Harness, PL4.1.20</li></ul>	<ul style="list-style-type: none"><li>■ Print Engine Map 5 (page 10-8)</li><li>■ Print Engine Map 10 (page 10-13)</li><li>■ Print Engine Motor Driver Board (1/6) (</li></ul>

## Troubleshooting Procedure Table

Step	Actions and Questions	Yes	No
1	Check the paper in the affected tray. Is paper loaded in the tray properly?	Go to Step 2.	Reload the paper.
2	Check the tray paper guides. Are the paper guides set correctly?	Go to Step 3.	Reset the guides.
3	Check the Paper Size Switch for the affected tray. Is the switch installed correctly?	Go to Step 4.	Correct the installation.
4	Test the Paper Size Switch. Run the Service Diagnostics Tray 2 Switches test. Does the sensor state change each time the loaded tray is moved in or out?	Go to Step 7.	Go to Step 5.
5	Check the Paper Size Switch connection. Are PSIZE and P/J471 connected?	Go to Step 6.	Connect the Paper Size Switch.
6	Check continuity between the Paper Size Switch and the Motor Driver Board. 1. Disconnect PSIZE and P/J471. 2. Check harness continuity. Is the harness conductive?	Go to Step 7.	Repair the wiring.
7	Check for +5 V at the Paper Size Switch. Is there +5 V across J471-1 (+) <=> ground when PS0 is actuated?	Replace the Paper Size Switch (page 8-139).	Replace the Motor Driver Board (page 8-141).

# Wrong Paper Size; Load Tray [3][4][5][6] with [size][type]

Tray [3] [4] [5] [6] paper size mismatch error. The Paper Size Switch indicates that the media loaded in the source tray does not match the size specified by the print job.

## Initial Actions:

- Inspect the tray to ensure that it is free of obstructions, is loaded with the expected media, and the guides are adjusted correctly.
- Cycle printer power.
- If the problem persists, follow the procedure below.

## Troubleshooting Reference Table

Applicable Parts	Wiring and Plug/Jack References
<ul style="list-style-type: none"><li>■ Paper Size Switch</li><li>■ Paper Tray</li><li>■ SIZE Harness</li></ul>	<ul style="list-style-type: none"><li>■ Paper Size Switch Signal Definitions table (page 2-13)</li></ul>

## Troubleshooting Procedure Table

Step	Actions and Questions	Yes	No
1	Check the paper in the affected tray. Is paper loaded in the tray properly?	Go to Step 2.	Reload the paper.
2	Check the tray paper guides. Are the paper guides set correctly?	Go to Step 3.	Reset the guides.
3	Check the Paper Size Switch for the affected tray. Is the switch installed correctly?	Go to Step 4.	Correct the installation.
4	Test the Paper Size Switch for the affected tray. Run the Service Diagnostics Size Sensor test for the affected tray. Does the sensor state change each time the loaded tray is moved in or out?	Go to Step 7.	Go to Step 5.
5	Check the Paper Size Switch connection. Is the switch connected at either end?	Go to Step 6.	Connect the switch.
6	Check continuity between the affected Paper Size Switch and the Option Control Board. Is the harness conductive?	Go to Step 7.	Repair the wiring.
7	Check for +5 V to the Paper Size Switch. Is there +5 V across each switch <=> ground when the switch is actuated?	Replace the Paper Size Switch for the affected tray.	Replace the Option Control Board.



# Wrong Paper Type Load Tray [1 (MPT)][2][3][4][5][6] with [size][type]

The Media Thickness Sensor has detected a change in the media type (thickness) in the same tray, or reports a thickness value exceeding the reference.

## Initial Actions:

- Ensure the tray is free of obstructions and loaded with the expected media.
- Cycle printer power.
- If the problem persists, follow the procedure below.

## Troubleshooting Reference Table

Applicable Parts	Wiring and Plug/Jack References
<ul style="list-style-type: none"> <li>■ Media Thickness Sensor, PL8.1.74</li> <li>■ Front Sensor Board, PL8.1.7</li> </ul>	<ul style="list-style-type: none"> <li>■ Print Engine Map 9 (page 10-12)</li> <li>■ Print Engine Front Sensor Board (1/2) (page 10-26)</li> </ul>

## Troubleshooting Procedure Table

Step	Actions and Questions	Yes	No
<b>1</b>	Check the following for evidence of fault, debris, damage, of misalignment: <ul style="list-style-type: none"> <li>■ Media Thickness Sensor</li> <li>■ PATHICK Harness</li> </ul>	Replace the parts concerned.	Go to Step 2.
<b>2</b>	Recalibrate the sensor. See (page 6-4). Did the calibration pass?	Complete.	Go to Step 3.
<b>3</b>	Check the PATHICK Harness continuity. Is the harness conductive?	Go to Step 4.	Replace the harness.
<b>4</b>	Check for +5 V to the sensor. Disconnect PATHICK at the Front Sensor Board. Is there +5 V across PATHICK-3 <=> ground?	Replace the sensor (page 8-66). Recalibrate the sensor following replacement.	Go to Step 5.
<b>5</b>	Check for +5 V to the Front Sensor Board. Disconnect FSNS at the Motor Driver Board. Is there +5 V across FSNS-10 and -14<=> ground?	Replace the Front Sensor Board (page 8-150).	Go to Step 6.
<b>6</b>	Check the FSNS Harness continuity. Is the harness conductive?	Replace the Motor Driver Board (page 8-141).	Replace the FSNS Harness.

# Paper Not Available Load Tray 1 (MPT) with [size] [type]

Tray 1 (MPT) Paper Size mismatch error. The size setting stored in NVRAM differs from the size specified by the print job.

## Initial Actions:

- Check that the size setting in NVRAM, media loaded in the tray, and specification for the job match.
- Cycle printer power.
- If the problem persists, follow the procedure below.

## Troubleshooting Reference Table

Applicable Parts	Wiring and Plug/Jack References
<ul style="list-style-type: none"><li>■ Front Sensor Board, PL8.1.7</li><li>■ Engine Control Board, PL1.1.4</li></ul>	<ul style="list-style-type: none"><li>■ Print Engine Map 9 (page 10-12)</li><li>■ Print Engine Front Sensor Board (2/2) (page 10-27)</li></ul>

## Troubleshooting Procedure Table

Step	Actions and Questions	Yes	No
1	Check the following for evidence of fault, debris, damage, or misalignment: <ul style="list-style-type: none"><li>■ Feed-Out #1 Sensor Actuator</li><li>■ Registration Sensor #1 Actuator</li><li>■ MPTSNS Harness</li></ul>	Replace the parts concerned.	Go to Step 2.
2	Check the MPTSNS Harness continuity. Is the harness conductive?	Go to Step 3.	Replace the harness.
3	Check for +5 V to the sensor. Disconnect MPTSNS at the Front Sensor Board. Is there +5 V across MPTSNS-4 <=> ground?	Replace the sensor (page 8-32).	Go to Step 4.
4	Check for +5 V to the Front Sensor Board. Disconnect FSNS at the Motor Driver Board. Is there +5 V across FSNS-10 and -14<=> ground?	Replace the Front Sensor Board (page 8-150).	Go to Step 6.
5	Check the FSNS Harness continuity. Is the harness conductive?	Replace the Motor Driver Board (page 8-141).	Replace the FSNS Harness.

# Paper Not Available; Load Tray 2 with [size][type]

Tray 2 Paper Size mismatch error. The Paper Size Switch indicates that the media loaded in Tray 2 does not match the size specified by the print job

## Initial Actions:

- Inspect the tray to ensure that it is free of obstructions, is loaded with supported media, and the guides are adjusted correctly.
- Cycle printer power.
- If the problem persists, follow the procedure below.

## Troubleshooting Reference Table

Applicable Parts	Wiring and Plug/Jack References
<ul style="list-style-type: none"><li>■ Paper Size Switch</li><li>■ Paper Tray</li><li>■ PSIZE Harness</li></ul>	<ul style="list-style-type: none"><li>■ Print Engine Map 5 (page 10-8)</li><li>■ Print Engine Map 10 (page 10-13)</li><li>■ Print Engine Motor Driver Board (1/6) (</li></ul>

## Troubleshooting Procedure Table

Step	Actions and Questions	Yes	No
1	Check the paper in the affected tray. Is paper loaded in the tray properly?	Go to Step 2.	Reload the paper.
2	Check the tray paper guides. Are the paper guides set correctly?	Go to Step 3.	Reset the guides.
3	Check the Paper Size Switch for the affected tray. Is the switch installed correctly?	Go to Step 4.	Correct the installation.
4	Test the Paper Size Switch. Run the Service Diagnostics Tray 2 Switches test. Does the sensor state change each time the loaded tray is moved in or out?	Go to Step 7.	Go to Step 5.
5	Check the Paper Size Switch connection. Are PSIZE and P/J471 connected?	Go to Step 6.	Connect the Paper Size Switch.
6	Check continuity between the Paper Size Switch and the Motor Driver Board. 1. Disconnect PSIZE and P/J471. 2. Check harness continuity. Is the harness conductive?	Go to Step 7.	Repair the wiring.
7	Check for +5 V at the Paper Size Switch. Is there +5 V across J471-1 (+) <=> ground when PS0 is actuated?	Replace the Paper Size Switch (page 8-139).	Replace the Motor Driver Board (page 8-141).

# Paper Not Available Load Tray [3][4][5][6] with [size][type]

Tray [3] [4] [5] [6] paper type mismatch error. The Paper Size Switch indicates that the media loaded in the source tray does not match the size specified by the print job.

## Initial Actions:

- Inspect the tray to ensure that it is free of obstructions, is loaded with the expected media, and the guides are adjusted correctly.
- Cycle printer power.
- If the problem persists, follow the procedure below.

## Troubleshooting Reference Table

Applicable Parts	Wiring and Plug/Jack References
<ul style="list-style-type: none"><li>■ Paper Size Switch</li><li>■ Paper Tray</li><li>■ SIZE Harness</li></ul>	<ul style="list-style-type: none"><li>■ Paper Size Switch Signal Definitions table (page 2-13)</li></ul>

## Troubleshooting Procedure Table

Step	Actions and Questions	Yes	No
1	Check the paper in the affected tray. Is paper loaded in the tray properly?	Go to Step 2.	Reload the paper.
2	Check the tray paper guides. Are the paper guides set correctly?	Go to Step 3.	Reset the guides.
3	Check the Paper Size Switch for the affected tray. Is the switch installed correctly?	Go to Step 4.	Correct the installation.
4	Test the Paper Size Switch for the affected tray. Run the Service Diagnostics Size Sensor test for the affected tray. Does the sensor state change each time the loaded tray is moved in or out?	Go to Step 7.	Go to Step 5.
5	Check the Paper Size Switch connection. Is the switch connected at either end?	Go to Step 6.	Connect the switch.
6	Check continuity between the affected Paper Size Switch and the Option Control Board. Is the harness conductive?	Go to Step 7.	Repair the wiring.
7	Check for +5 V to the Paper Size Switch. Is there +5 V across each switch <=> ground when the switch is actuated?	Replace the Paper Size Switch for the affected tray.	Replace the Option Control Board.

# Configuration Errors

## Invalid or Missing Configuration Card

The printer's Configuration Card is missing or defective.

### Troubleshooting Reference Table

Applicable Parts	Wiring and Plug/Jack References
<ul style="list-style-type: none"><li>■ Configuration Card, PL9.1.31</li><li>■ Image Processor Board, PL9.1.3</li></ul>	<ul style="list-style-type: none"><li>■ Print Engine Map 4 (page 10-7)</li></ul>

### Troubleshooting Procedure Table

Step	Actions and Questions	Yes	No
1	Check the Configuration Card installation. Remove and reinsert the Configuration Card. Does the error still occur?	Replace the Configuration Card. If the problem persists, replace the I/P Board (page 8-113).	Problem solved.

## Duplicate IP Address Detected

Another device on the network is using the IP address assigned to this printer.

### Troubleshooting Reference Table

Applicable Parts	Wiring and Plug/Jack References
<ul style="list-style-type: none"><li>■ Image Processor Board, PL9.1.3</li></ul>	<ul style="list-style-type: none"><li>■ Print Engine Map 4 (page 10-7)</li></ul>

### Troubleshooting Procedure Table

Step	Actions and Questions	Yes	No
1	Check the TCP/IP Address stored in the printer's NVRAM. Is the address correct for the printer?	Advise the customer of the address conflict.	Enter the correct IP address.

# Fatal Error Procedures

## Fuser Failure

The Fuser temperature regulation has failed.

### Applicable Status Codes:

**Code T1:** Fuser Upper Failure

**Code T2:** Fuser Lower Failure

### Initial Actions:

- Reseat the Fuser.
- Cycle the printer's power.
- If the problem persists follow the procedure below.

### Troubleshooting Reference Table

Applicable Parts	Wiring and Plug/Jack References
<ul style="list-style-type: none"><li>■ Fuser, PL1.1.21</li><li>■ LVPS, PL3.1.4</li><li>■ Engine Control Board, PL1.1.4</li></ul>	<ul style="list-style-type: none"><li>■ Print Engine Map 6 (page 10-9)</li><li>■ Print Engine LVPS (page 10-39)</li></ul>

### Warning

Avoid the potential of electric shock by removing the power cord from the wall outlet prior to performing the following procedure.

### Caution

Allow adequate time for the Fuser to cool before servicing the printer.

### Troubleshooting Procedure Table

Step	Actions and Questions	Yes	No
1	Replace the Fuser. Does the error persist?	Go to Step 2	Complete.
2	Check the Fuser Heat Lamps. Does the Fuser error occur after at least 3 minutes of operation?	Go to Step 3.	Go to Step 4.
3	Did the Fuser warm up?	Replace the Engine Control Board (page 8-112).	Replace the Fuser.
4	Check the LVPS. Is there AC voltage between CN4-1<=>CN4-4?	Replace the Fuser.	Replace the LVPS (page 8-121).

## Fuser Electrical Connections

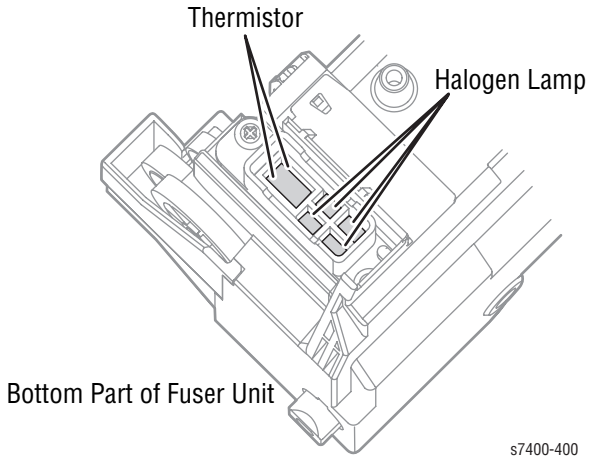

# Temp Sensor Failure

The Temperature Sensor has failed.

## Applicable Status Code:

**Code T29:** Temperature Sensor Failure

## Initial Actions:

- Cycle the printer's power.
- If the problem persists follow the procedure below.

## Troubleshooting Reference Table

Applicable Parts	Wiring and Plug/Jack References
<ul style="list-style-type: none"><li>■ Temp/Humidity Sensor, PL8.1.80</li><li>■ ENV Harness, PL8.1.81</li><li>■ Engine Control Board, PL1.1.4</li></ul>	<ul style="list-style-type: none"><li>■ Print Engine Map 2 (page 10-5)</li><li>■ Print Engine Map 9 (page 10-12)</li><li>■ Print Engine Front Sensor Board (1/2) (page 10-26)</li></ul>

## Troubleshooting Procedure Table

Step	Actions and Questions	Yes	No
1	Test the Temp/Humidity Sensor. 1. Run the Service Diagnostics Ambient Temp/Hum Sensor test. 2. Verify proper operation by blowing on the sensor. Is the sensor operating correctly?	Replace the Engine Control Board (page 8-112).	Go to Step 2.
2	Replace the Temp/Humidity Sensor. Does the error persist?	Go to Step 3.	Complete.
3	Check the ENV harness connection. Is the ENV Harness connected?	Go to Step 4.	Reconnect the harness.
4	Check all pins on the ENV Harness for continuity. 1. Disconnect ENV and P/J420. 2. Check continuity between ENV <=> J420.	Go to Step 5.	Replace the ENV Harness.
5	Check the Temp/Humidity Sensor signal. Is there voltage present at FSNS-17 when the sensor is active?	Go to Step 6.	Replace the Front Sensor Board (page 8-150).
6	Check all pins on the FSNS Harness PL4.2.98 for continuity. 1. Disconnect FSNS. 2. Check continuity on all contacts.	Replace the Motor Driver Board (page 8-141).	Replace the FSNS Harness.



# RH Sensor Failure

## Applicable Status Code:

**Code T30:** Humidity Sensor Failure

**Code T31:** Condensation detected in the printer.

## Initial Actions:

- Cycle the printer's power.
- If the problem persists follow the procedure below.

## Troubleshooting Reference Table

Applicable Parts	Wiring and Plug/Jack References
■ Temp/Humidity Sensor, PL8.1.80	■ Print Engine Map 2 (page 10-5)
■ ENV Harness, PL8.1.81	■ Print Engine Map 9 (page 10-12)
■ Engine Control Board, PL1.1.4	■ Print Engine Front Sensor Board (1/2) (page 10-26)

## Troubleshooting Procedure Table

Step	Actions and Questions	Yes	No
1	Test the Temp/Humidity Sensor. 1. Run the Service Diagnostics Ambient Temp/Hum Sensor test. 2. Verify proper operation by blowing on the sensor. Is the sensor operating correctly?	Replace the Engine Control Board (page 8-112).	Go to Step 2.
2	Replace the Temp/Humidity Sensor. Does the error persist?	Go to Step 3.	Complete.
3	Check the ENV harness connection. Is the ENV Harness connected to the Front Sensor Board?	Go to Step 4.	Reconnect the harness.
4	Check all pins on the ENV Harness PL8.1.81 for continuity. 1. Disconnect ENV and P/J420. 2. Check continuity between ENV <=> J420.	Go to Step 5.	Replace the ENV Harness.
5	Check the Temp/Humidity Sensor signal. Is there voltage present at FSNS-15 when the sensor is active?	Go to Step 6.	Replace the Front Sensor Board (page 8-150).
6	Check all pins on the FSNS Harness PL4.2.98 for continuity. 1. Disconnect FSNS. 2. Check continuity on all contacts.	Replace the Motor Driver Board (page 8-141).	Replace the FSNS Harness.

# LED Over Temperature Failure

## Applicable Status Code:

**Code T32:** LED Head too hot

## Initial Actions:

- Open the Top Cover and allow the printer to cool.
- Cycle the printer's power.
- If the problem persists follow the procedure below.

## Troubleshooting Reference Table

Applicable Parts	Wiring and Plug/Jack References
■ LED Heads, PL1.1.2	■ Print Engine Map 1 (page 10-4) ■ Print Engine LED Heads (page 10-37)

## Troubleshooting Procedure Table

Step	Actions and Questions	Yes	No
1	Check for proper clearances around the printer and ensure proper fan operation. Is the printer properly installed and are the cooling vents clear?	Go to Step 2.	Advise customer on clearance for the printer. Replace an inoperable fan.
2	Check the LED Head installation. Are the LED Heads properly seated in their holders and the wiring correctly routed?	Replace in the following order: LED Head (page 8-125), Engine Control Board (page 8-112).	Reseat the LED Head or replace any damaged wiring.

# Motor Overheating Failure

## Applicable Status Code:

**Code T34:** Imaging Unit Motor Overheating

## Initial Actions:

- Ensure the ambient temperature and installation clearances meet printer specifications.
- Clean all fan ducts.
- Turn the printer off and allow a minimum of 30 minutes for cooling.
- Restart the printer.
- If the problem persists follow the procedure below.

## Troubleshooting Reference Table

Applicable Parts	Wiring and Plug/Jack References
<ul style="list-style-type: none"><li>■ Imaging Unit Motors</li><li>■ Motor Driver Board,</li></ul>	<ul style="list-style-type: none"><li>■ Print Engine Motor Driver Board (2/6) (page 10-32)</li></ul>

## Troubleshooting Procedure Table

Step	Actions and Questions	Yes	No
1	Test the cooling fans for proper operation and adequate airflow. Run the Service Diagnostic Fan tests. Do the fans operate correctly?	Go to Step 2.	Replace the defective fan.
2	Test the Imaging Unit Motors. Run the Service Diagnostics Imaging Unit Motor tests. Do the motors operate correctly?	Replace the Motor Driver Board (page 8-141).	Replace the defective motor (page 8-105).

# Engine Failure

An Engine Control Board error is detected.

## Applicable Status Codes:

**Code U0:** Engine ROM Failure

**Code U1:** Engine RAM Failure

**Code U2:** Engine EEPROM Failure

**Code U3:** Engine EEPROM Missing Failure

**Code U4:** Engine SRAM Failure

**Code U5:** Engine Control Failure

## Initial Actions:

- Cycle the printer's power.
- If the problem persists follow the procedure below.

## Troubleshooting Reference Table

Applicable Parts	Wiring and Plug/Jack References
<ul style="list-style-type: none"><li>■ Engine Control EEPROM</li><li>■ Engine Control Board, PL1.1.4</li></ul>	

## Troubleshooting Procedure Table

Step	Actions and Questions	Yes	No
1	Cycle power to the printer. Does the error still appear?	Go to Step 2.	Complete
2	Perform an NVRAM Reset. Does the error still appear?	Replace the EEPROM for U2 or U3 errors. Otherwise, replace the Engine Control Board.	Complete

# Power Supply Failure

## Applicable Status Code:

**Code U6:** Power Supply voltage irregularly high.

## Initial Actions:

- Cycle the printer's power.
- If the problem persists follow the procedure below.

## Troubleshooting Reference Table

Applicable Parts	Wiring and Plug/Jack References
■ LVPS, PL3.1.4	<ul style="list-style-type: none"><li>■ Print Engine Map 3 (page 10-6)</li><li>■ Print Engine Map 6 (page 10-9)</li><li>■ Print Engine LVPS (page 10-39)</li></ul>

## Troubleshooting Procedure Table

Step	Actions and Questions	Yes	No
1	Visually inspect the LVPS for damage or excessive dust. Is the LVPS damaged or dirty?	Clean the LVPS if dirty. If damaged, replace the LVPS (page 8-121).	Go to Step 2.
2	Check the LVPS output voltages at the POWER connector on the Engine Control Board.	Replace the Engine Controller Board.	Replace the LVPS (page 8-121) or POWER harness.

# Feeder Home Failure

## Applicable Status Code:

**Code U7:** Tray 1 (MPT) does not reach home position.

## Initial Actions:

- Cycle the printer's power.
- If the problem persists follow the procedure below.

## Troubleshooting Reference Table

Applicable Parts	Wiring and Plug/Jack References
<ul style="list-style-type: none"><li>■ Home Position Sensor, PL8.1.8</li><li>■ Registration Motor, PL4.2.36</li><li>■ MPTHOME Harness, PL8.1.9</li></ul>	<ul style="list-style-type: none"><li>■ Print Engine Map 9 (page 10-12)</li><li>■ Print Engine Front Sensor Board (1/2) (page 10-26)</li><li>■ Print Engine Motor Driver Board (4/6) (page 10-34)</li></ul>

## Troubleshooting Procedure Table

Step	Actions and Questions	Yes	No
1	Check the Tray 1 (MPT) Lift Plate by printing a job from Tray 1 (MPT). Does the Lift Plate operate correctly?	Go to Step 3.	Go to Step 2.
2	Test the Registration Motor Run the Service Diagnostics Registration Motor B test. Is the motor operating correctly?	Replace the Tray 1 (MPT) Assembly (page 8-25).	Replace the Registration Motor (page 8-39).
3	Test the Tray 1 (MPT) Home Position Sensor. Run the Service Diagnostics MPT Roller Home test. Does the sensor function correctly?	Replace the Engine Control Board (page 8-112).	Go to Step 4.
4	Check continuity of the MPTHOME harness. Is the wiring harness conductive?	Replace the Engine Control Board (page 8-112).	Replace the MPTHOME harness.

# Controller Fan Failure

The Image Processor Board Fan has failed.

## Applicable Status Code:

**Code U8:** Controller Fan Failure

## Initial Actions:

- Cycle the printer's power.
- If the problem persists follow the procedure below.

## Troubleshooting Reference Table

Applicable Parts	Wiring and Plug/Jack References
■ IP Fan, PL1.1.74	■ Print Engine Map 4 (page 10-7) ■ Print Engine Motor Driver Board (2/6) (page 10-32)

## Troubleshooting Procedure Table

Step	Actions and Questions	Yes	No
1	Check the IP Fan operation and airflow. Does the fan operate correctly?	Replace the Engine Control Board (page 8-112).	Go to Step 2.
2	Check for +5 V to the fan. Disconnect P/J200 from the Image Processor Board. Is there +5 V at J200-1 <=> ground?	Replace the IP Fan (page 8-138).	Replace the Image Processor Board (page 8-113).

# Power Supply Fan Failure

The LVPS Fan has failed.

## Applicable Status Code:

**Code U9:** LVPS Fan Failure

## Initial Actions:

- Clear any obstructions from the LVPS Fan vent.
- Cycle the printer's power.
- If the problem persists follow the procedure below.

## Troubleshooting Reference Table

Applicable Parts	Wiring and Plug/Jack References
<ul style="list-style-type: none"><li>■ LVPS Fan, PL3.1.2</li><li>■ LVPS, PL3.1.4</li><li>■ Engine Control Board, PL1.1.4</li></ul>	<ul style="list-style-type: none"><li>■ Print Engine Map 6 (page 10-9)</li><li>■ Print Engine LVPS (page 10-39)</li></ul>

## Troubleshooting Procedure Table

Step	Actions and Questions	Yes	No
1	Test the LVPS Fan. Run the Service Diagnostics Power Supply Fan test. Does the Fan operate correctly.	Replace the Engine Control Board (page 8-112).	Go to Step 2.
2	Check the LVPS Fan connection. Is FAN1 securely connected?	Go to Step 3.	Reconnect the Fan.
3	Verify +24 volts is available to the Fan. Disconnect FAN1. Is there +24 volts at FAN1?	Replace the LVPS Fan (page 8-124).	Replace the LVPS (page 8-121).



# Top Cover Cooling Fan Failure

## Applicable Status Code:

**Code U10:** Top Cover Fan Failure

## Initial Actions:

- Cycle the printer's power.
- If the problem persists follow the procedure below.

## Troubleshooting Reference Table

Applicable Parts	Wiring and Plug/Jack References
■ Top Cover Fan, PL12.1.4	■ Print Engine Map 7 (page 10-10)
■ IDFAN Harness, PL5.1.31	■ Print Engine Map 8 (page 10-11)
■ GTG0 Harness, PL5.1.32	■ Print Engine Imaging Unit Sensor Board (page 10-41)

## Troubleshooting Procedure Table

Step	Actions and Questions	Yes	No
1	Test the Top Cover Fan. Run the Service Diagnostics Top Cover Fan test. Does the fan operate correctly.	Replace the Engine Control Board (page 8-112).	Go to Step 2.
2	Check the Fan connection. Is P/J492 securely connected?	Go to Step 3.	Connect the Fan.
3	Check continuity of the Top Cover Fan Harness. Is the wiring harness conductive?	Replace the Fan (page 8-135). If the error persists, go to Step 4.	Replace the harness.
4	Verify +24 volts is available to the Fan. Disconnect IDFAN. Is there +24 volts at IDFAN-???	Go to Step 5.	Go to Step 6.
5	Check continuity of the IDFAN Harness. Is the wiring harness conductive?	Go to Step 6.	Replace the harness.
6	Verify +24 volts is available to the Imaging Unit Sensor Board. Disconnect CTG0. Is there +24 volts at CTG0-9?	Replace the Imaging Unit Sensor Board (page 8-142).	Go to Step 7.
7	Check continuity of the CTG0 Harness. Is the wiring harness conductive?	Replace the Engine Control Board (page 8-112)	Replace the harness.

# Imaging Unit Fan Failure

## Applicable Status Code:

**Code U11:** Imaging Unit Fan Failure

## Initial Actions:

- Cycle the printer's power.
- If the problem persists follow the procedure below.

## Troubleshooting Reference Table

Applicable Parts	Wiring and Plug/Jack References
<ul style="list-style-type: none"><li>■ Imaging Unit Fan, PL6.1.23</li><li>■ IDFAN Harness, PL5.1.31</li><li>■ GTG0 Harness, PL5.1.32</li></ul>	<ul style="list-style-type: none"><li>■ Print Engine Map 7 (page 10-10)</li><li>■ Print Engine Map 8 (page 10-11)</li><li>■ Print Engine Imaging Unit Sensor Board (page 10-41)</li></ul>

## Troubleshooting Procedure Table

Step	Actions and Questions	Yes	No
1	Test the Imaging Unit Fan. Run the Service Diagnostics Imaging Unit Fan test. Does the Fan operate correctly.	Replace the Engine Control Board (page 8-112).	Go to Step 2.
2	Check the Fan connection. Is P/J100 securely connected?	Replace the Fan (page 8-133). If the error persists, go to Step 3.	Connect the Fan.
3	Check for +24 V at the Fan. Disconnect P/J100. Is there +24 V between J100-1 <=> ground?	Go to Step 4.	Go to Step 5.
4	Check continuity of the IDFAN Harness. Is the wiring harness conductive?	Go to Step 5.	Replace the harness.
5	Check for +24 V at the Imaging Unit Sensor Board. Disconnect CTG0. Is there +24 V at CTG0-9?	Replace the Imaging Unit Sensor Board (page 8-142).	Go to Step 6.
6	Check continuity of the CTG0 Harness. Is the wiring harness conductive?	Replace the Engine Control Board (page 8-112)	Replace the harness.

# Transfer Unit Fan Failure

## Applicable Status Code:

**Code T40:** Transfer Unit Fan Failure

## Initial Actions:

- Cycle the printer's power.
- If the problem persists follow the procedure below.

## Troubleshooting Reference Table

Applicable Parts	Wiring and Plug/Jack References
<ul style="list-style-type: none"><li>■ Transfer Unit Fan, PL5.1.48</li><li>■ Motor Driver Board, PL2.1.10</li></ul>	<ul style="list-style-type: none"><li>■ Print Engine Map 5 (page 10-8)</li><li>■ Print Engine Map 7 (page 10-10)</li><li>■ Print Engine Motor Driver Board (2/6) (page 10-32)</li></ul>

## Troubleshooting Procedure Table

Step	Actions and Questions	Yes	No
1	Test the Transfer Unit Fan. Run the Service Diagnostics Belt Fan test. Does the Fan operate correctly.	Replace the Engine Control Board (page 8-112).	Go to Step 2.
2	Check the Fan connection. Is BELTFAN on the Motor Driver Board securely connected?	Go to Step 3.	Connect the Fan.
3	Check for +24 V at the Fan connector. Disconnect the Fan from BELTFAN. Is there +24 V between BELTFAN-1 <=> ground?	Replace the Fan (page 8-134).	Go to Step 4.
4	Check for +24 V at the POW24 connector. Disconnect the POW24 Harness from the Motor Driver Board. Is there +24 V between POW24-1 <=> ground?	Replace the Motor Driver Board (page 8-141).	Go to Step 5.
5	Check continuity of the POW24 Harness. Is the wiring harness conductive?	Replace the LVPS (page 8-121)	Replace the harness.

# Engine Cavity Fan Failure

The rotation signal from the Card Cage Fan indicates the fan has stopped rotating.

## Applicable Status Code:

**Code T41:** Fan Failure

## Initial Actions:

- Cycle the printer's power.
- If the problem persists follow the procedure below.

## Troubleshooting Reference Table

Applicable Parts	Wiring and Plug/Jack References
<ul style="list-style-type: none"><li>■ Card Cage Fan, PL2.1.118</li><li>■ Motor Driver Board, PL2.1.10</li></ul>	<ul style="list-style-type: none"><li>■ Print Engine Map 5 (page 10-8)</li><li>■ Print Engine Motor Driver Board (2/6) (page 10-32)</li></ul>

## Troubleshooting Procedure Table

Step	Actions and Questions	Yes	No
1	Test the Card Cage Fan. Run the Service Diagnostics Chassis test. Does the Fan operate correctly.	Replace the Engine Control Board (page 8-112).	Go to Step 2.
2	Check the Fan connection. Is FAN on the Motor Driver Board securely connected?	Go to Step 3.	Connect the Fan.
3	Check for +24 V at the Fan connector. Disconnect the Fan from FAN. Is there +24 V between FAN-1 <=> ground?	Replace the Fan (page 8-115).	Go to Step 4.
4	Check for +24 V at the POW24 connector. Disconnect the POW24 Harness from the Motor Driver Board. Is there +24 V between POW24-1 <=> ground?	Replace the Motor Driver Board (page 8-141).	Go to Step 5.
5	Check continuity of the POW24 Harness. Is the wiring harness conductive?	Replace the LVPS (page 8-121)	Replace the harness.

# Duplex Interface Failure

Error occurs only after the detection of a properly installed and functioning Duplex Unit.

## Applicable Status Code:

**Code U12:** Communication lost with Duplex Unit

## Initial Actions:

- Reseat the Duplex Unit
- Cycle the printer's power.
- If the problem persists follow the procedure below.

## Troubleshooting Reference Table

Applicable Parts	Wiring and Plug/Jack References
<ul style="list-style-type: none"><li>■ Duplex Unit, PL16.1.0</li><li>■ Motor Driver Board, PL2.1.10</li></ul>	<ul style="list-style-type: none"><li>■ Print Engine Map 5 (page 10-8)</li><li>■ Print Engine Motor Driver Board (5/6) (page 10-35)</li><li>■ Options Duplex Unit Sensors and Interconnect</li></ul>

## Troubleshooting Procedure Table

Step	Actions and Questions	Yes	No
1	Check the Duplex Unit connector for damage. Is the connector damaged?	Replace the connector.	Replace the Duplex Unit. If the error persists, go to Step 2.
2	Check all pins on the DUPLEX Harness for continuity. Disconnect the DUPLEX Harness. Is the DUPLEX Harness conductive?	Replace the Motor Driver Board (page 8-141). If the error persists, go to Step 3.	Replace the DUPLEX Harness.
3	Check all pins of the DRV1 harness for continuity. Disconnect the DRV1 ribbon cable. Is the cable conductive?	Replace the Engine Control Board (page 8-112).	Replace the DRV1 Harness.

# Tray [3][4][5][6] Interface Failure

A communications failure has occurred in the option tray interface.

## Applicable Status Codes:

**Code U14:** Tray 3 Interface Failure

**Code U13:** Tray 4 Interface Failure

**Code U16:** Tray 5 Interface Failure

**Code U17:** Tray 6 Interface Failure

## Initial Actions:

- Cycle the printer's power.
- If the problem persists follow the procedure below.

## Troubleshooting Reference Table

Applicable Parts	Wiring and Plug/Jack References
<ul style="list-style-type: none"><li>■ Option Tray Control Board</li><li>■ Engine Control Board, PL1.1.4</li></ul>	<ul style="list-style-type: none"><li>■ Print Engine Map 3 (page 10-6)</li><li>■ Print Engine Motor Driver Board (6/6) (page 10-36)</li><li>■ Options Map 5 Paper Tray Controller Board</li></ul>

## Troubleshooting Procedure Table

Step	Actions and Questions	Yes	No
1	Check the Option Tray connector for damage. Is the connector damaged?	Replace the connector.	Go to Step 2.
2	Check all pins on the OPTIF Harness for continuity. Disconnect OPTIF from the Engine Control Board and Option connector. Is the harness conductive?	Replace the Option Control Board. If the error persists, replace the Engine Control Board (page 8-112).	Replace the OPTIF Harness.

# Inverter Unit Interface Failure

A communication error has occurred in the Finisher Inverter.

## Applicable Status Code:

**Code U51:** Inverter Unit Interface Failure.

## Initial Actions:

- Reseat the Finisher connections.
- Cycle the printer's power.
- If the problem persists follow the procedure below.

## Troubleshooting Reference Table

Applicable Parts	Wiring and Plug/Jack References
<ul style="list-style-type: none"><li>■ Inverter Control Board</li><li>■ Engine Control Board, PL1.1.4</li></ul>	<ul style="list-style-type: none"><li>■ Print Engine Map 3 (page 10-6)</li><li>■ Print Engine Motor Driver Board (6/6) (page 10-36)</li><li>■ Options Map 3 Inverter Controller Board</li></ul>

## Troubleshooting Procedure Table

Step	Actions and Questions	Yes	No
1	Check the following for evidence of fault or damage: <ul style="list-style-type: none"><li>■ Inverter Interface Cable</li><li>■ Inverter connections</li></ul> Is there any damage?	Replace any damaged parts.	Go to Step 2.
2	Check the Inverter connection. Is the Inverter interface cable securely connected at both ends?	Go to Step 3.	Connect the Inverter to the Finisher.
3	Check all pins on the OPTIF Harness for continuity. Disconnect OPTIF from the Engine Control Board and Option connector. Is the harness conductive?	Replace the Inverter Control Board. If the error persists, replace the Engine Control Board (page 8-112).	Replace the OPTIF Harness.

# [C][M][Y][K] LED Failure

## Applicable Status Codes:

**Code U18:** Yellow LED Failure

**Code U19:** Magenta LED Failure

**Code U20:** Cyan LED Failure

**Code U21:** Black LED Failure

## Initial Actions:

- Cycle the printer's power.
- If the problem persists follow the procedure below.

## Troubleshooting Reference Table

Applicable Parts	Wiring and Plug/Jack References
<ul style="list-style-type: none"><li>■ LED Head, PL1.1.2</li><li>■ LEDPWR harness, PL12.1.20</li><li>■ LED Relay Board, PL12.1.34</li><li>■ YK LEDDATA harness, PL12.1.21</li><li>■ CM LEDDATA harness, PL12.1.22</li></ul>	<ul style="list-style-type: none"><li>■ Print Engine Map 1 (page 10-4)</li><li>■ Print Engine Map 3 (page 10-6)</li><li>■ Print Engine Map 13 (page 10-16)</li><li>■ Print Engine LED Heads (page 10-37)</li></ul>

## Troubleshooting Procedure Table

Step	Actions and Questions	Yes	No
1	Check LED Head. Exchange the affected LED Head with another LED Head. Does the error move with the LED Head?	Replace the LED Head.	Go to Step 2.
2	Ensure the LED Head harness is properly connected and not damaged. Is the wiring harness defective?	Reconnect or replace wiring harness.	Go to Step 3.
3	Check harness continuity between the LED Head and the Engine Control Board. Is there continuity?	Go to Step 4.	Replace the data harness.
4	Check harness continuity between the LED Head and the LED Relay Board. Is there continuity?	Go to Step 5.	Replace the power harness.
5	Check for +5 V to the LED Relay Board. Disconnect the POWER connector. Is there +5 V between POWER-1 <=> ground?	Replace the LED Relay Board (page 8-126).	Go to Step 6.
6	Check for +5 V at the LVPS. Disconnect CN1 from the LVPS. Is there +5 V between CN1-1 and CN1-2?	Replace the Engine Control Board (page 8-112).	Replace the LVPS (page 8-121).



# [C][M][Y][K] Imaging Unit Failure

The Drum Phase Sensor for the named Imaging Unit indicates that the drum is out of position.

## Applicable Status Codes:

**Code U26:** Yellow Imaging Unit Failure

**Code U27:** Magenta Imaging Unit Failure

**Code U28:** Cyan Imaging Unit Failure

**Code U29:** Black Imaging Unit Failure

## Initial Actions:

- Reseat the indicated Imaging Unit
- Cycle the printer's power.
- If the problem persists follow the procedure below.

## Troubleshooting Reference Table

Applicable Parts	Wiring and Plug/Jack References
■ [C][M][Y][K] Imaging Unit, PL1.1.23	■ Print Engine Map 5 (page 10-8)
■ [C][M][Y][K] I/U Motor, PL2.1.8	■ Print Engine Map 8 (page 10-11)
■ I/U Sensor Board, PL5.1.21	■ Print Engine Imaging Unit Sensor Board (page 10-41)
■ I/U Lift Uplink, PL6.1.4, PL5.1.11	■ Print Engine Motor Driver Board (3/6) (page 10-33)

## Troubleshooting Procedure Table

Step	Actions and Questions	Yes	No
1	Check the following for evidence of fault or damage: <ul style="list-style-type: none"><li>■ Imaging Unit</li><li>■ Imaging Unit Drive Gears</li><li>■ Imaging Unit Sensor Board</li><li>■ Imaging Unit Lift Uplink</li></ul> Is there any damage?	Replace any damaged parts.	Go to Step 2.
2	Test the Drum Phase Sensor. Run the Service Diagnostics Drum Phase Sensor test for the indicated Imaging Unit. Does the sensor function correctly?	Go to Step 5	Go to Step 3.
3	Check the I/U Phase signal: CIDPHASE at CTG1-18 MIDPHASE at CTG1-20 YIDPHASE at CTG1-22 KIDPHASE at CTG1-24 Does the Drum Phase signal change when the sensor is blocked?	Go to Step 4.	Replace the I/U Sensor Board (page 8-142).

## Troubleshooting Procedure Table (Continued)

Step	Actions and Questions	Yes	No
4	<p>Check the CTG0 harness continuity. Disconnect CTG1 from the Imaging Unit Sensor Board and CTG0 from the Engine Control Board.</p> <p>Is the harness conductive?</p>	<p>Replace the Engine Control Board (page 8-112).</p>	<p>Replace the harness.</p>
5	<p>Test the indicated Imaging Unit Motor.</p> <ol style="list-style-type: none"> <li>1. Remove the affected Imaging Unit.</li> <li>2. Close the Interlock Switches.</li> <li>3. Run the Service Diagnostics Imaging Unit Motor test for the affected motor.</li> </ol> <p>Does the motor function correctly?</p>	<p>Go to Step 6.</p>	<p>Replace the motor (page 8-105). If the error persists, go to Step 6.</p>
6	<p>Check the Lift Uplink and associated gears. See "Imaging Unit Drive Motors" on page 2-39 for a description of Lift Uplink operation.</p> <ol style="list-style-type: none"> <li>1. Access the Cyan Imaging Unit Motor.</li> <li>2. Rotate the Cyan Motor manually in both directions.</li> </ol> <p>Do the gears and links function properly?</p>	<p>Replace the Cyan Imaging Unit Motor (page 8-105). If the error persists, go to Step 7.</p>	<p>Replace the Lift Uplink (page 8-108).</p>
7	<p>Check for +24 V at the Motor Driver Board POW24 connector.</p> <p>Is there +24 V at POW24-1</p>	<p>Replace the Motor Driver Board (page 8-141).</p>	<p>Replace the LVPS (page 8-121) and/or POW24 harness.</p>

# Flash Failure

The Flash Memory device on the Engine Control Board has failed.

## Applicable Status Codes:

**Code U30:** Flash Hardware Failure

**Code U31:** Flash Software Failure

## Initial Actions:

- Cycle the printer's power.
- If the problem persists follow the procedure below.

## Troubleshooting Reference Table

Applicable Parts	Wiring and Plug/Jack References
■ Engine Control Board, PL1.1.4	■ Print Engine Map 3 (page 10-6)

## Troubleshooting Procedure Table

Step	Actions and Questions	Yes	No
1	Cycle power to the printer. Does the error reappear?	Replace the Engine Control Board (page 8-112).	Complete

# Fuser Fan Failure

The Fuser Fan rotation signal indicates that the fan is no longer operational.

## Applicable Status Code:

**Code U32:** Fuser Fan Failure

## Troubleshooting Reference Table

Applicable Parts	Wiring and Plug/Jack References
<ul style="list-style-type: none"><li>■ Fuser Fan, PL2.1.111</li><li>■ IDFAN harness, PL5.1.31</li><li>■ Engine Control Board, PL1.1.4</li></ul>	<ul style="list-style-type: none"><li>■ Print Engine Map 7 (page 10-10)</li><li>■ Print Engine Map 8 (page 10-11)</li><li>■ Print Engine Imaging Unit Sensor Board (page 10-41)</li></ul>

## Troubleshooting Procedure Table

Step	Actions and Questions	Yes	No
1	Check the following for evidence of fault or damage: <ul style="list-style-type: none"><li>■ Fuser Fan</li><li>■ P/J250</li><li>■ FSRFAN Harness</li></ul> Is there any damage?	Replace any damaged parts.	Go to Step 2.
2	Check the Fan connection. Is P/J250 on the printer frame securely connected?	Go to Step 3.	Connect the Fan.
3	Check for +24 V at the Fan connector. Disconnect the P/J250. Is there +24 V between J250-1 <=> ground?	Replace the Fuser Fan (page 8-149).	Go to Step 4.
4	Check for +24 V at the IDFAN connector. Disconnect IDFAN from the Imaging Unit Sensor Board. Is there +24 V between IDFAN-7 <=> ground?	Go to Step 5.	Go to Step 6.
5	Check continuity of the FSRFAN Harness. Disconnect IDFAN and P/J250. Is the wiring harness conductive?	Replace the Fuser Fan (page 8-149).	Replace the harness.
6	Check continuity of the CTG1 Harness. Is the wiring harness conductive?	Replace the Engine Control Board (page 8-112)	Replace the harness.

# Fuser 110v/220v Mismatch Failure

An error was detected in the Fuser.

## Applicable Status Code:

**Code U33:** Fuser Mismatch Failure

## Initial Actions:

- Cycle the printer's power.
- If the problem persists follow the procedure below.

## Troubleshooting Reference Table

Applicable Parts	Wiring and Plug/Jack References
<ul style="list-style-type: none"><li>■ Fuser PL1.1.21</li><li>■ Engine Control Board, PL1.1.4</li></ul>	

## Troubleshooting Procedure Table

Step	Actions and Questions	Yes	No
1	Ensure the proper Fuser (110v vs. 220v) is installed in the printer. Is the correct Fuser installed?	Replace the Engine Control Board (page 8-112).	Replace the Fuser.

# Unsupported Duplex Unit ROM

The installed Duplex Unit does not contain the correct firmware.

## Applicable Status Code:

**Code U34:** Unsupported Duplex Unit ROM

## Initial Actions:

- Reseat the Duplex Unit.
- Cycle the printer's power.
- If the problem persists follow the procedure below.

## Troubleshooting Reference Table

Applicable Parts	Wiring and Plug/Jack References
<ul style="list-style-type: none"><li>■ Duplex Unit, PL16.1.0</li><li>■ Engine Control Board PL1.1.4</li></ul>	<ul style="list-style-type: none"><li>■ Options Map 4 Duplex Unit Controller Board</li></ul>

## Troubleshooting Procedure Table

Step	Actions and Questions	Yes	No
1	Check the following for evidence of fault or damage: <ul style="list-style-type: none"><li>■ Duplex Connector</li></ul> Is there any damage?	Replace any damaged parts.	Go to Step 2.
2	Check that the Duplex Unit is correctly installed and fully seated.	Go to Step 3.	Reseat the Duplex Unit
3	Check the Duplex Unit version using the Service Diagnostics General Status menu. Is the version current?	Replace Engine Control Board (page 8-112), if the error persists, replace the DUPLEX harness.	Replace the Duplex Unit.

# Unsupported Tray 2 ROM

The firmware version of the Tray 2 Feeder Board is unsupported by the Engine Control Board.

## Applicable Status Code:

**Code 39:** Unsupported Tray 2 ROM

## Initial Actions:

- Cycle the printer's power.
- If the problem persists follow the procedure below.

## Troubleshooting Reference Table

Applicable Parts	Wiring and Plug/Jack References
<ul style="list-style-type: none"><li>■ Feeder Board, PL4.2.97</li></ul>	<ul style="list-style-type: none"><li>■ Print Engine Map 12 (page 10-15)</li><li>■ Print Engine Feeder Board (page 10-28)</li></ul>

## Troubleshooting Procedure Table

Step	Actions and Questions	Yes	No
1	Check the Feeder Board version using the Service Diagnostics General Status menu. Is the version current?	Replace the Engine Control Board (page 8-112)	Replace the Feeder Board (page 8-53).

# Unsupported Tray [3][4][5][6] ROM

The printer has detected an incompatible LTA or HCF assembly.

## Applicable Status Codes:

**Code U35:** Unsupported Tray 3 ROM

**Code U36:** Unsupported Tray 4 ROM

**Code U37:** Unsupported Tray 5 ROM

**Code U38:** Unsupported Tray 6 ROM

## Initial Actions:

- Reseat the Option Tray connector.
- Cycle the printer's power.
- If the problem persists follow the procedure below.

## Troubleshooting Reference Table

Applicable Parts	Wiring and Plug/Jack References
■ Option Control Board	■ Options Map 5 Paper Tray Controller Board

## Troubleshooting Procedure Table

Step	Actions and Questions	Yes	No
1	Check the following for evidence of fault or damage: <ul style="list-style-type: none"><li>■ Option Connector</li></ul> Is there any damage?	Replace any damaged parts.	Go to Step 2.
2	Check that the optional tray is correctly installed and fully seated.	Go to Step 3.	Reseat the option tray.
3	Check the Option Control Board version using the Service Diagnostics General Status menu. Is the version current?	Replace the Engine Control Board (page 8-112)	Replace the Option Control Board.



# Unsupported Inverter Unit ROM

The printer has detected an incompatible Inverter assembly.

## Applicable Status Code:

**Code U50:** Unsupported Inverter ROM

## Initial Actions:

- Cycle the printer's power.
- If the problem persists follow the procedure below.

## Troubleshooting Reference Table

Applicable Parts	Wiring and Plug/Jack References
■ Inverter Control Board	■ Options Map 3 Inverter Controller Board

## Troubleshooting Procedure Table

Step	Actions and Questions	Yes	No
1	Check the Inverter firmware version using the Service Diagnostics General Status menu. Is the version current?	Replace the Engine Control Board (page 8-112)	Replace the Inverter Control Board.

# Unsupported Finisher Unit ROM

The printer has detected an incompatible Finisher.

## Applicable Status Code:

**Code U55:** Unsupported Finisher Unit ROM

## Initial Actions:

- Cycle the printer's power.
- If the problem persists follow the procedure below.

## Troubleshooting Reference Table

Applicable Parts	Wiring and Plug/Jack References
■ Finisher Control Board	■ Options Map 1 Finisher Controller Board

## Troubleshooting Procedure Table

Step	Actions and Questions	Yes	No
1	Check the Finisher firmware version using the Service Diagnostics General Status menu. Is the version current?	Replace the Engine Control Board (page 8-112)	Replace the Finisher Control Board.

# Hard Drive Failure

An error was detected in the Hard Drive.

## Applicable Status Code:

**Code H80:** Hard Drive Failure

## Initial Actions:

- Cycle the printer's power.
- If the problem persists follow the procedure below.

## Troubleshooting Reference Table

Applicable Parts	Wiring and Plug/Jack References
<ul style="list-style-type: none"><li>■ Hard Drive, PL1.1.61</li><li>■ Image Processor Board</li></ul>	<ul style="list-style-type: none"><li>■ Print Engine Map 4 (page 10-7)</li></ul>

## Troubleshooting Procedure Table

Step	Actions and Questions	Yes	No
1	Check the Hard Drive installation. Is the Hard Drive properly installed?	Go to Step 2.	Correct the installation.
2	Replace the Hard Drive. Does the error persist?	Replace the Image Processor Board (page 8-113)	Complete

# Fuse Cut Error In Fuser

The in-use fuse for the indicated Fuser remains intact.

## Applicable Status Code:

**Code W16:** Fuse Cut Error in Fuser

## Initial Actions:

- Cycle the printer's power.
- If the problem persists follow the procedure below.

## Troubleshooting Reference Table

Applicable Parts	Wiring and Plug/Jack References
<ul style="list-style-type: none"><li>■ Fuser, PL1.1.21</li></ul>	<ul style="list-style-type: none"><li>■ Print Engine Map 3 (page 10-6)</li><li>■ Print Engine Fuser (page 10-40)</li></ul>

## Troubleshooting Procedure Table

Step	Actions and Questions	Yes	No
1	Test the Fuser fuse. Run the Service Diagnostics Read Fuse test on the Fuser. Is the Fuse Cut?	Replace the Engine Control Board (page 8-112).	Go to Step 2.
2	Replace the Fuser. Cycle the power. Does the error persist?	Go to Step 3.	Complete.
3	Check all pins of the HEATIF harness between the Fuser and Engine Control Board. Is the HEATIF harness conductive?	Replace the Engine Control Board (page 8-112).	Replace the HEATIF Harness.

# Fuse Cut Error In Transfer Unit

The in-use fuse for the indicated Transfer Unit remains intact.

## Applicable Status Code:

**Code W17:** Fuse Cut Error in Transfer Unit

## Initial Actions:

- Cycle the printer's power.
- If the problem persists follow the procedure below.

## Troubleshooting Reference Table

Applicable Parts	Wiring and Plug/Jack References
<ul style="list-style-type: none"><li>■ Transfer Unit, PL1.1.20</li><li>■ HVPS Cover, PL2.1.27</li><li>■ HVPS, PL2.1.26</li></ul>	<ul style="list-style-type: none"><li>■ Print Engine Map 3 (page 10-6)</li><li>■ Print Engine Xerographics (page 10-38)</li></ul>

## Troubleshooting Procedure Table

Step	Actions and Questions	Yes	No
1	Test the condition of the fuse. Run the Service Diagnostics Read Fuse test for the TBelt. Is the Fuse cut?	Replace the Engine Control Board (page 8-112).	Go to Step 2.
2	Check the connections between HVPS, HVPS Cover, and Transfer Unit. Are the contacts clean and intact?	Install a new Transfer Unit and verify the fuse blows.	Clean or align contacts as needed. If the error persists, go to Step 3.
3	Does the error persist?	Replace in the following order: HVPS Cover (page 8-118) HVPS (page 8-119).	Complete

# Fuse Cut Error In [C][M][Y][K] Imaging Unit

The in-use fuse for the indicated Imaging Unit remains intact.

## Applicable Status Codes:

**Code W18:** Fuse Cut Error in Cyan Imaging Unit

**Code W19:** Fuse Cut Error in Magenta Imaging Unit

**Code W20:** Fuse Cut Error in Yellow Imaging Unit

**Code W21:** Fuse Cut Error in Black Imaging Unit

## Initial Actions:

- Reseat the indicated Imaging Unit.
- Cycle the printer's power.
- If the problem persists follow the procedure below.

## Troubleshooting Reference Table

Applicable Parts	Wiring and Plug/Jack References
<ul style="list-style-type: none"><li>■ [C][M][Y][K] Imaging Unit, PL1.1.23</li><li>■ I/U Sensor Board, PL5.1.21</li></ul>	<ul style="list-style-type: none"><li>■ Print Engine Map 8 (page 10-11)</li><li>■ Print Engine Imaging Unit Sensor Board (page 10-41)</li></ul>

## Troubleshooting Procedure Table

Step	Actions and Questions	Yes	No
1	Check the affected Imaging Unit contacts for evidence of fault or damage: Is there any damage, debris or corrosion?	Replace the damaged parts.	Go to Step 2.
2	Test the Imaging Unit fuse. Run the Service Diagnostics Read Fuse test on the affected Imaging Unit. Is the Fuse Cut?	Replace the Engine Control Board (page 8-112).	Go to Step 3.
3	Replace the affected Imaging Unit. Does the error persist?	Go to Step 4.	Complete.
4	Check the CTG0 harness continuity. Disconnect CTG1 from the Imaging Unit Sensor Board and CTG0 from the Engine Control Board. Is the harness conductive?	Replace the I/U Sensor Board (page 8-142).	Replace the harness.

# Controller to Engine Communications Failure

An communications error was detected.

## Applicable Status Code:

**Code F130:** Engine Communications Failure

## Initial Actions:

- Cycle the printer's power.
- If the problem persists follow the procedure below.

## Troubleshooting Reference Table

Applicable Parts	Wiring and Plug/Jack References
■ Engine Control Board, PL1.1.4	■ Print Engine Map 3 (page 10-6) ■ Print Engine Control Panel (page 10-43)

## Troubleshooting Procedure Table

Step	Actions and Questions	Yes	No
1	Cycle power to the printer. Does the error persist?	Go to Step 2.	Complete
2	Reseat the CUIF connector. Does the error persist?	Replace the Engine Control Board (page 8-112). If the error persists, replace the Image Processor Board (page 8-113)	Complete

# Finisher Fold Position Sensor Failure

An error was detected with the Fold Position Sensor.

## Applicable Status Code:

**Code F131:** Fold Position Sensor failure

## Initial Actions:

- Cycle the printer's power.
- If the problem persists follow the procedure below.

## Troubleshooting Reference Table

Applicable Parts	Wiring and Plug/Jack References
<ul style="list-style-type: none"><li>■ Fold Position Sensor</li><li>■ Finisher Control Board</li></ul>	<ul style="list-style-type: none"><li>■ Options Map 1 Finisher Controller Board</li><li>■ Options Map 8 Finisher Sensor Locator</li><li>■ Options Finisher Controller to Sensors (2/3)</li></ul>

## Troubleshooting Procedure Table

Step	Actions and Questions	Yes	No
1	Test the Folding Position Sensor. Run the Service Diagnostics Bookbinding Position Sensor test. Does the sensor function correctly?	Replace the Finisher Control Board.	Go to Step 2.
2	Check the sensor connection. Is CN39 connected?	Go to Step 3.	Reconnect the sensor.
3	Replace the sensor. Does the error persist?	Go to Step 4.	Complete
4	Check all pins on the harness for continuity. Is the harness conductive?	Replace the Finisher Control Board.	Replace the harness.



# Finisher Paddle Failure

An error was detected in the Finisher Paddle Motor.

## Applicable Status Code:

**Code F103:** Paddle Motor failure

## Initial Actions:

- Cycle the printer's power.
- If the problem persists follow the procedure below.

## Troubleshooting Reference Table

Applicable Parts	Wiring and Plug/Jack References
<ul style="list-style-type: none"><li>■ Finisher Paddle Motor</li><li>■ Finisher Control Board</li></ul>	<ul style="list-style-type: none"><li>■ Options Map 1 Finisher Controller Board</li><li>■ Options Finisher Controller to Motors</li></ul>

## Troubleshooting Procedure Table

Step	Actions and Questions	Yes	No
1	Test these sensors. <ul style="list-style-type: none"><li>■ Swing Guide Home Position Sensor</li><li>■ Paddle Home Position Sensor</li></ul> Run the appropriate Service Diagnostics sensor test. Do the sensors operate?	Go to Step 2.	Replace the sensor. If the error persists, go to Step 2.
2	Test the Paddle Motor. <ol style="list-style-type: none"><li>1. Close the Interlock Switches for test.</li><li>2. Run the Service Diagnostics Paddle Motor test.</li></ol> Does the motor operate?	Replace the Finisher Control Board. If the error persists, go to Step 4.	Go to Step 4.
3	Check for +24 V to the Paddle Motor. Disconnect CN57. Is there +24 V across CN57-1 and -2 <=> ground?	Replace the Delivery Motor.	Replace the harness. If the error persists, go to Step 5.
4	Check all pins of the Inverter Interface Cable for continuity. Disconnect CN1 and CN2 from the Finisher Control Board and the opposite end from the Inverter. Is the cable conductive?	Replace the Inverter Power Supply.	Replace the cable.

# Finisher Stapler Swing Motor Failure

The Stapler Swing Home Position Sensor detected a Stapler Swing Motor error.

## Applicable Status Code:

**Code F106:** Swing Motor Failure

## Initial Actions:

- Cycle the printer's power.
- If the problem persists follow the procedure below.

## Troubleshooting Reference Table

Applicable Parts	Wiring and Plug/Jack References
<ul style="list-style-type: none"><li>■ Stapler Swing Motor</li><li>■ Finisher Control Board</li></ul>	<ul style="list-style-type: none"><li>■ Options Map 1 Finisher Controller Board</li><li>■ Options Finisher Controller to Switches</li></ul>

## Troubleshooting Procedure Table

Step	Actions and Questions	Yes	No
1	Test the Stapler Swing Home Position Sensor Run the Service Diagnostics Stapler Slide Home Position Sensor test. Do the sensors operate?	Go to Step 2.	Replace the sensor. If the error persists, go to Step 2.
2	Test the Swing Motor. 1. Close the Interlock Switches for test. 2. Run the Service Diagnostics Sliding Motor test. Does the motor operate?	Replace the Finisher Control Board. If the error persists, go to Step 4.	Go to Step 4.
3	Check for +24 V to the Swing Motor. Disconnect CN72. Is there +24 V across CN72-8 and -9 <=> ground?	Replace the Slide Motor.	Replace the harness. If the error persists, go to Step 5.
4	Check all pins of the Inverter Interface Cable for continuity. Disconnect CN1 and CN2 from the Finisher Control Board and the opposite end from the Inverter. Is the cable conductive?	Replace the Inverter Power Supply.	Replace the cable.

# Finisher Stack Handling Motor Failure

The Delivery Belt Home Position Sensor detected a Stack Handling error.

## Applicable Status Code:

**Code F111:** Stack Handling Motor Failure

## Initial Actions:

- Cycle the printer's power.
- If the problem persists follow the procedure below.

## Troubleshooting Reference Table

Applicable Parts	Wiring and Plug/Jack References
<ul style="list-style-type: none"><li>■ Finisher Stack Handling Motor</li><li>■ Finisher Control Board</li></ul>	<ul style="list-style-type: none"><li>■ Options Map 1 Finisher Controller Board</li><li>■ Options Finisher Controller to Motors</li></ul>

## Troubleshooting Procedure Table

Step	Actions and Questions	Yes	No
1	Check the delivery mechanism. Does the Delivery Belt turn freely when operated manually?	Go to Step 2.	Repair the mechanism.
2	Test the Delivery Belt Home Position Sensor. Run the Service Diagnostics Exit Belt Home Position Sensor test. Does the sensor operate?	Go to Step 3.	Replace the sensor. If the error persists, go to Step 3.
3	Test the Staple Motor. 1. Close the Interlock Switches for test. 2. Run the Service Diagnostics Staple Motor tests. Does the motor operate?	Replace the Finisher Control Board. If the error persists, go to Step 4.	Go to Step 4.
4	Check for +24 V to the Staple Motor. Disconnect CN59. Is there +24 V across CN59-1 and -2 <=> ground?	Replace the Stack Handling Motor.	Replace the harness. If the error persists, go to Step 5.
5	Check all pins of the Inverter Interface Cable for continuity. Disconnect CN1 and CN2 from the Finisher Control Board and the opposite end from the Inverter. Is the cable conductive?	Replace the Inverter Power Supply.	Replace the cable.

# Finisher Staple Motor Failure

An error was detected in the Staple Motor.

## Applicable Status Code:

**Code F110:** Staple Motor

## Initial Actions:

- Cycle the printer's power.
- If the problem persists follow the procedure below.

## Troubleshooting Reference Table

Applicable Parts	Wiring and Plug/Jack References
<ul style="list-style-type: none"><li>■ Finisher Staple Motor</li><li>■ Finisher Control Board</li></ul>	<ul style="list-style-type: none"><li>■ Options Map 1 Finisher Controller Board</li><li>■ Options Finisher Controller to Switches</li></ul>

## Troubleshooting Procedure Table

Step	Actions and Questions	Yes	No
1	Test these sensors. <ul style="list-style-type: none"><li>■ Staple Clock Sensor</li><li>■ Fold Home Position Sensor</li></ul> Run the appropriate Service Diagnostics sensor test. Do the sensors operate?	Go to Step 2.	Replace the sensor. If the error persists, go to Step 2.
2	Test the Staple Motor. 1. Close the Interlock Switches for test. 2. Run the Service Diagnostics Staple Motor tests. Does the motor operate?	Replace the Finisher Control Board. If the error persists, go to Step 4.	Go to Step 3.
3	Check for +24 V to the Staple Motor. Disconnect CN71. Is there +24 V across CN71-1 and -2 <=> ground?	Replace the Staple Motor.	Replace the harness. If the error persists, go to Step 4.
4	Check all pins of the Inverter Interface Cable for continuity. Disconnect CN1 and CN2 from the Finisher Control Board and the opposite end from the Inverter. Is the cable conductive?	Replace the Inverter Power Supply.	Replace the cable.

# Finisher Jog Motor Failure

An error was detected in either the Front or Rear Alignment Motor.

## Applicable Status Code:

**Code F93:** Jog Motor Failure

## Initial Actions:

- Cycle the printer's power.
- If the problem persists follow the procedure below.

## Troubleshooting Reference Table

Applicable Parts	Wiring and Plug/Jack References
<ul style="list-style-type: none"><li>■ Paddle Assembly</li><li>■ Alignment Motors</li></ul>	<ul style="list-style-type: none"><li>■ Options Map 1 Finisher Controller Board</li><li>■ Options Finisher Controller to Motors</li></ul>

## Troubleshooting Procedure Table

Step	Actions and Questions	Yes	No
1	Check the following for evidence of fault or damage: <ul style="list-style-type: none"><li>■ Paddle Assembly</li><li>■ Alignment Motors</li></ul> Is there any damage?	Replace any damaged parts.	Go to Step 2.
2	Test the Alignment Plate Sensors. Run the Service Diagnostics Front and Rear Alignment Plate Sensor tests. Do the sensors function correctly?	Replace the Paddle Assembly,	Replace the sensor.

# Finisher Lift Motor Failure

The Paper Surface, Upper Limit, or Lift Motor Clock Sensor detected a Lift Motor error.

## Applicable Status Code:

**Code F115:** Lift Motor Failure

## Initial Actions:

- Check the Tray lift mechanism for obstructions or damage.
- Cycle the printer's power.
- If the problem persists follow the procedure below.

## Troubleshooting Reference Table

Applicable Parts	Wiring and Plug/Jack References
<ul style="list-style-type: none"><li>■ Upper Tray Lift Motor</li><li>■ Finisher Control Board</li><li>■ Inverter Power Supply</li></ul>	<ul style="list-style-type: none"><li>■ Options Map 1 Finisher Controller Board</li><li>■ Options Finisher Controller to Switches</li></ul>

## Troubleshooting Procedure Table

Step	Actions and Questions	Yes	No
1	Test each of these sensors. <ul style="list-style-type: none"><li>■ Paper Surface Sensor</li><li>■ Tray Upper Limit Sensor</li><li>■ Shift Motor Clock Sensor</li></ul> Run the appropriate Service Diagnostics sensor test. Do all sensors function correctly?	Go to Step 2.	Replace the sensor. If the error persists, go to Step 2.
2	Check the tray lift mechanism. Does the mechanism move freely?	Go to Step 5.	Repair the lift mechanism.
3	Test the Lift Motor. 1. Close the Interlock Switches for test. 2. Run the Service Diagnostics Shift Motor test. Does the motor operate?	Go to Step 8.	Replace the motor. If the error persists, go to Step 6.
4	Check for +24 V to the Lift Motor. Disconnect CN70. Is there +24 V across CN70-1 and -2 <=> ground when the test is executed?	Replace the Lift Motor.	Replace the Finisher Control Board. If the error persists, go to Step 5.

## Troubleshooting Procedure Table (Continued)

<b>Step</b>	<b>Actions and Questions</b>	<b>Yes</b>	<b>No</b>
<b>5</b>	Check all pins of the Inverter Interface Cable for continuity. Disconnect CN1 and CN2 from the Finisher Control Board and the opposite end from the Inverter. Is the cable conductive?	Replace the Inverter Power Supply.	Replace the cable.

# Finisher Exit Failure

The Delivery Belt Home Position Sensor detected a Delivery Motor error.

## Applicable Status Code:

**Code F116:** Delivery Motor Failure

## Initial Actions:

- Cycle the printer's power.
- If the problem persists follow the procedure below.

## Troubleshooting Reference Table

Applicable Parts	Wiring and Plug/Jack References
<ul style="list-style-type: none"><li>■ Finisher Delivery Motor</li><li>■ Finisher Control Board</li></ul>	<ul style="list-style-type: none"><li>■ Options Map 1 Finisher Controller Board</li><li>■ Options Finisher Controller to Motors</li></ul>

## Troubleshooting Procedure Table

Step	Actions and Questions	Yes	No
1	Test the Exit Motor. 1. Close the Interlock Switches for test. 2. Run the Service Diagnostics Finisher Bundle Motor tests. Does the motor operate?	Complete.	Go to Step 2.
2	Check for +24 V to the Exit Motor. Disconnect CN59. Is the +24 V across CN59-1 and -2 <=> ground?	Replace the Exit Motor.	Go to Step 3.
3	Check Finisher Control Board for +24 V. 1. Disconnect CN13 on the Finisher Control Board. Is the +24 V across CN13-1 and -2?	Replace the Exit Motor Harness.	Replace the Finisher Control Board. If the error persists, go to Step 4.
4	Check the Inverter Interface Cable for continuity. Disconnect CN1 and CN2 from the Finisher Control Board and the opposite end from the Inverter. Is the cable conductive?	Replace the Inverter Power Supply.	Replace the cable.



# Finisher Punch Side Registration Sensor Failure

An error was detected in the Punch Side Registration Sensor.

## Applicable Status Code:

**Code F133:** Punch Side Registration Sensor Failure

## Initial Actions:

- Cycle the printer's power.
- If the problem persists follow the procedure below.

## Troubleshooting Reference Table

Applicable Parts	Wiring and Plug/Jack References
<ul style="list-style-type: none"><li>■ Side Registration Emitter Board</li><li>■ Side Registration Receiver Board</li><li>■ Punch Control Board</li><li>■ Finisher Control Board</li></ul>	<ul style="list-style-type: none"><li>■ Options Map 2 Punch Controller Board</li><li>■ Options Punch Controller to Sensor and Motors</li></ul>

## Troubleshooting Procedure Table

Step	Actions and Questions	Yes	No
1	Test the Side Registration Sensor. Run the Service Diagnostics Side Registration Sensor test. Does the sensor function correctly?	Go to Step 6.	Go to Step 2.
2	Check the harness connection. Is P/J1007 connected to the Punch Control Board? Are P/J2010 and P/J2011 connected to the Emitter and Receiver boards?	Go to Step 3.	Connect the harness.
3	Check the harness continuity. Is the harness conductive?	Go to Step 4.	Replace the harness.
4	Check the Side Registration Sensor Emitter Board. Are the LEDs illuminated?	Go to Step 5.	Replace the Emitter Board.
5	Check for +5 V to the sensor. Disconnect P/J1007. Is there +5 V at J1007-9 <=> ground?	Replace the Receiver Board.	Replace the Punch Control Board.
6	Replace the Finisher Control Board. Does the error still occur?	Replace the Engine Control Board (page 8-112).	Complete.

# Finisher Punch Registration Sensor Failure

An error was detected in the Horizontal Registration Home Position Sensor.

## Applicable Status Code:

**Code 136:** Punch Registration Sensor Failure

## Initial Actions:

- Cycle the printer's power.
- If the problem persists follow the procedure below.

## Troubleshooting Reference Table

Applicable Parts	Wiring and Plug/Jack References
<ul style="list-style-type: none"><li>■ Horizontal Registration Home Position Sensor</li><li>■ Punch Control Board</li><li>■ Finisher Control Board</li></ul>	<ul style="list-style-type: none"><li>■ Options Map 2 Punch Controller Board</li><li>■ Options Punch Controller Sensors and Motors</li></ul>

## Troubleshooting Procedure Table

Step	Actions and Questions	Yes	No
1	Test the Punch Registration Sensor. Run the Service Diagnostics Punch Registration Sensor test. Does the sensor function correctly?	Go to Step 6.	Go to Step 2.
2	Check the sensor harness connection. Is P/J1006 connected to the Punch Control Board?	Replace the sensor. If the error persists, go to Step 3.	Connect the harness.
3	Check the harness continuity. Disconnect P/J1006 and P/J2007. Is the harness conductive?	Go to Step 5.	Replace the harness.
4	Check for +5 V to the sensor. Disconnect P/J1006. Is there +5 V at J1006-3 <=> ground?	Go to Step 5.	Replace the Punch Control Board.
5	Replace the Finisher Control Board. Does the error still occur?	Replace the Engine Control Board (page 8-112).	Complete.

# Finisher Punch Backup RAM Failure

An error was detected in the Punch Unit's backup RAM.

## Applicable Status Code:

**Code F138:** Punch Unit's backup RAM failure

## Initial Actions:

- Cycle the printer's power.
- If the problem persists follow the procedure below.

## Troubleshooting Reference Table

Applicable Parts	Wiring and Plug/Jack References
■ Punch Control Board	■ Options Map 2 Punch Controller Board

## Troubleshooting Procedure Table

Step	Actions and Questions	Yes	No
1	Check the Punch Control Board connections. Are P/J2003 and P/J2004 connected?	Go to Step 2.	Reseat or reconnect the harness.
2	Cycle printer power. Does the error persist?	Replace the Punch Control Board.	Complete.

# Finisher Punch Communications Failure

An communications error occurred with the Punch Unit.

## Applicable Status Code:

**Code F132:** Punch Unit communications failure

## Initial Actions:

- Cycle the printer's power.
- If the problem persists follow the procedure below.

## Troubleshooting Reference Table

Applicable Parts	Wiring and Plug/Jack References
<ul style="list-style-type: none"><li>■ Finisher Control Board</li><li>■ Punch Control Board</li></ul>	<ul style="list-style-type: none"><li>■ Print Engine Motor Driver Board (6/6) (page 10-36)</li><li>■ Options Map 2 Punch Controller Board</li></ul>

## Troubleshooting Procedure Table

Step	Actions and Questions	Yes	No
1	Check the connection between the Finisher and Punch Controller Boards. Are CN12 and CN14 on the Finisher Control Board connected? Are P/J2003 and P/J2004 on the Punch Control Board connected?	Go to Step 2.	Connect the harness.
2	Check all the pins of the harness for continuity. Is the cable conductive?	Go to Step 3.	Replace the harness.
3	Check for +24 V at the Finisher Control Board. Is there +24 V at CN14-5 <=> CN14-3?	Replace the Punch Control Board.	Replace the Finisher Control Board.

# Finisher Punch Unit Transfer Motor Failure

An error was detected in the Punch Transfer Motor.

## Applicable Status Code:

**Code F181:** Punch Transfer Motor Failure

## Initial Actions:

- Cycle the printer's power.
- If the problem persists follow the procedure below.

## Troubleshooting Reference Table

Applicable Parts	Wiring and Plug/Jack References
<ul style="list-style-type: none"><li>■ Punch Transfer Motor</li><li>■ Punch Control Board</li><li>■ Inverter Power Supply</li></ul>	<ul style="list-style-type: none"><li>■ Options Map 2 Punch Controller Board</li><li>■ Options Punch Controller to Sensor and Motors</li></ul>

## Troubleshooting Procedure Table

Step	Actions and Questions	Yes	No
1	Test the Punch Transfer Motor. 1. Close the Interlock Switches for test. 2. Run the Service Diagnostics Transfer Motor test. Does the motor operate?	Complete.	Go to Step 2.
2	Check for +24 V to the Punch Transfer Motor. Disconnect P/J2001. Is the +24 V across J2001-1 <=> ground?	Replace the Punch Transfer Motor.	Go to Step 3.
3	Check Punch Control Board for 24 V. 1. Disconnect P/J1001 on the Punch Control Board. Is the +24 V across P1001 pins 1 and 2?	Replace the Punch Transfer Motor Harness.	Replace the Punch Control Board. If the error persists, go to Step 4.
4	Check all pins of the Inverter Interface Cable for continuity. Disconnect CN1 and CN2 from the Finisher Control Board and the opposite end from the Inverter. Is the cable conductive?	Replace the Inverter Power Supply. If the error persists, replace the Finisher Control Board.	Replace the cable.

# Finisher Punch Motor Failure

An error was detected in the Punch Motor.

## Applicable Status Code:

**Code F134:** Punch Motor Failure

## Initial Actions:

- Cycle the printer's power.
- If the problem persists follow the procedure below.

## Troubleshooting Reference Table

Applicable Parts	Wiring and Plug/Jack References
<ul style="list-style-type: none"><li>■ Punch Motor</li><li>■ Punch Control Board</li><li>■ Inverter Power Supply</li></ul>	<ul style="list-style-type: none"><li>■ Options Map 2 Punch Controller Board</li><li>■ Options Punch Controller to Sensor and Motors</li></ul>

## Troubleshooting Procedure Table

Step	Actions and Questions	Yes	No
1	Test the Punch Motor. 1. Close the Interlock Switches for test. 2. Run the Service Diagnostics Punch Motor test. Does the motor operate?	Complete.	Go to Step 2.
2	Check for +24 V to the Punch Motor. Disconnect P/J2002. Is the +24 V across J2002-1 <=> ground?	Replace the Punch Motor.	Go to Step 3.
3	Check Punch Control Board for 24 V. 1. Disconnect P/J1002 on the Punch Control Board. Is the +24 V across P1002 pins 1 and 2?	Replace the Punch Motor Harness.	Replace the Punch Control Board. If the error persists, go to Step 4.
4	Check all pins of the Inverter Interface Cable for continuity. Disconnect CN1 and CN2 from the Finisher Control Board and the opposite end from the Inverter. Is the cable conductive?	Replace the Inverter Power Supply. If the error persists, replace the Finisher Control Board.	Replace the cable.

# Finisher Backup RAM Failure

An error was detected in the Finisher's backup RAM.

## Applicable Status Code:

**Code F137:** Finisher's backup RAM Failure

## Initial Actions:

- Cycle the printer's power.
- If the problem persists follow the procedure below.

## Troubleshooting Reference Table

Applicable Parts	Wiring and Plug/Jack References
<ul style="list-style-type: none"><li>■ Finisher Control Board</li><li>■ Finisher Interconnect Cable</li><li>■ Engine Control Board, PL1.1.4</li></ul>	<ul style="list-style-type: none"><li>■ Print Engine Motor Driver Board (6/6) (page 10-36)</li><li>■ Options Map 1 Finisher Controller Board</li><li>■ Options Finisher Controller to Printer</li></ul>

## Troubleshooting Procedure Table

Step	Actions and Questions	Yes	No
1	Check the following for evidence of fault or damage: <ul style="list-style-type: none"><li>■ Finisher Interconnect Cable</li><li>■ Finisher connections</li></ul> Is there any damage?	Replace any damaged parts.	Go to Step 2.
2	Check all the pins of the Finisher Interconnect Cable for continuity. Is the cable conductive?	Go to Step 3.	Replace the cable.
3	Check all the pins of the OPTIF Harness for continuity. Is the harness conductive?	Go to Step 4.	Replace the OPTIF harness.
4	Replace the Finisher Control Board. Does the error persists?	Replace the Engine Control Board (page 8-112)	Complete.

# Finisher Punch Dust Sensor Failure

An error was detected in the Punch Waste Sensor.

## Applicable Status Code:

**Code F139:** Punch Waste Sensor Failure

## Initial Actions:

- Cycle the printer's power.
- If the problem persists follow the procedure below.

## Troubleshooting Reference Table

Applicable Parts	Wiring and Plug/Jack References
<ul style="list-style-type: none"><li>■ Punch Box Sensor Emitter Board</li><li>■ Punch Box Sensor Receiver Board</li></ul>	<ul style="list-style-type: none"><li>■ Options Map 2 Punch Controller Board</li><li>■ Options Punch Controller to Sensor and Motors</li></ul>

## Troubleshooting Procedure Table

Step	Actions and Questions	Yes	No
1	Test the Punch Box Sensor. Run the Service Diagnostics Punch Box Set Sensor test. Does the sensor state change when the emitter is blocked?	Go to Step 6.	Go to Step 2.
2	Check the Punch Box Sensor Harness connection. Is P/J1005 connected to the Punch Control Board? Are P/J2005 and P/J2006 connected to the Emitter and Receiver boards?	Go to Step 3.	Connect the harness.
3	Check the Punch Box Sensor Harness continuity. Is the harness conductive?	Go to Step 4.	Replace the harness.
4	Check the Punch Box Sensor Emitter Board. Is the LED illuminated?	Go to Step 5.	Replace the Punch Box Emitter Board.
5	Check for +5 V to the Punch Box Sensor. Disconnect P/J2006. Is there +5 V at J2006-1 <=> J2006-2?	Replace the Punch Box Sensor Receiver Board.	Replace the Punch Control Board.
6	Replace the Finisher Control Board. Does the error still occur?	Replace the Engine Control Board (page 8-112).	Complete.



# Printer Error - Contact Service; report fault [n]

The following procedures apply to codes associated with the Printer Error message.

## Finisher Punch Unit Counter at End of Life

The Punch Count indicates that Punch Unit has reached its end of life.

### Applicable Status Code:

**Code F141:** Punch Unit at End of Life

### Initial Actions:

- Cycle the printer's power.
- If the problem persists follow the procedure below.

### Troubleshooting Reference Table

Applicable Parts	Wiring and Plug/Jack References
<ul style="list-style-type: none"><li>■ Punch</li><li>■ Punch Control Board</li></ul>	<ul style="list-style-type: none"><li>■ Options Map 2 Punch Controller Board</li><li>■ Options Punch Controller to Sensor and Motors</li><li>■ Options Map 1 Finisher Controller Board</li><li>■ Options Finisher Controller to Printer</li></ul>

### Troubleshooting Procedure Table

Step	Actions and Questions	Yes	No
1	Replace the Punch. Cycle printer power. Does the error persist?	Replace the Engine Control Board NVRAM. If the error persists, replace the Engine Control Board (page 8-112).	Complete.

# Finisher Staple Unit Counter at End of Life

## Applicable Status Code:

**Code F142:** Staple Unit at End of Life

## Initial Actions:

- Cycle the printer's power.
- If the problem persists follow the procedure below.

## Troubleshooting Reference Table

Applicable Parts	Wiring and Plug/Jack References
■ Stapler	■ Options Map 1 Finisher Controller Board ■ Options Finisher Controller to Printer

## Troubleshooting Procedure Table

Step	Actions and Questions	Yes	No
1	Replace the Stapler. Cycle printer power. Does the error persist?	Replace the Engine Control Board NVRAM. If the error persists, replace the Engine Control Board (page 8-112).	Complete.

# Finisher Interface Error

## Applicable Status Code:

**Code F186:** Finisher serial communications error.

## Initial Actions:

- Cycle the printer's power.
- If the problem persists follow the procedure below.

## Troubleshooting Reference Table

Applicable Parts	Wiring and Plug/Jack References
<ul style="list-style-type: none"><li>■ Finisher Control Board</li><li>■ Finisher Interconnect Cable</li><li>■ Engine Control Board, PL1.1.4</li></ul>	<ul style="list-style-type: none"><li>■ Print Engine Motor Driver Board (6/6) (page 10-36)</li><li>■ Options Map 1 Finisher Controller Board</li><li>■ Options Finisher Controller to Printer</li></ul>

## Troubleshooting Procedure Table

Step	Actions and Questions	Yes	No
1	Check the following for evidence of fault or damage: <ul style="list-style-type: none"><li>■ Finisher Interconnect Cable</li><li>■ Finisher connections</li></ul> Is there any damage?	Replace any damaged parts.	Go to Step 2.
2	Check all the pins of the Finisher Interconnect Cable for continuity. Is the cable conductive?	Go to Step 3.	Replace the cable.
3	Check all the pins of the OPTIF Harness for continuity. Is the harness conductive?	Go to Step 4.	Replace the OPTIF harness.
4	Replace the Finisher Control Board. Does the error persists?	Replace the Engine Control Board (page 8-112)	Complete.

# Inverter Power Supply Failure

## Applicable Status Code:

**Code I97:** Inverter hardware error

## Initial Actions:

- Cycle the printer's power.
- If the problem persists follow the procedure below.

## Troubleshooting Reference Table

Applicable Parts	Wiring and Plug/Jack References
■ Inverter Power Supply	■ Options Map 3 Inverter Controller Board ■ Options Inverter Motors

## Troubleshooting Procedure Table

Step	Actions and Questions	Yes	No
1	Check the following for evidence of fault or damage: <ul style="list-style-type: none"><li>■ Inverter Power Cord</li><li>■ Inverter Power Supply</li></ul> Is there any damage?	Replace any damaged parts.	Go to Step 2.
2	Check AC Power. Is the AC voltage available at the outlet?	Go to Step 3.	Advise customer.
3	Check the Inverter connection. Is the Inverter interface cable securely connected at both ends?	Go to Step 4.	Connect the Inverter to the Finisher.
4	Replace the Inverter Power Supply. Does the error persist?	Replace the Inverter Control Board.	Complete.

# Fuser Thermistor Errors

## Applicable Status Codes:

**Code T3:** Fuser Belt Thermistor Short Circuit

**Code T4:** Fuser Belt Thermistor Open Circuit

**Code T5:** Fuser Belt Thermistor Temperature too High

**Code T6:** Fuser Belt Thermistor Temperature too Low

**Code T7:** Fuser Release Error

**Code T8:** Fuser Belt Slack Error

**Code 172:** Fuser Compensation Thermistor indicates temperature too High

**Code 173:** Fuser Compensation Thermistor indicates temperature too Low

**Code 176:** Fuser Compensation Thermistor Short Error

**Code 177:** Fuser Compensation Thermistor Open Error

## Initial Actions:

- Cycle the printer's power.
- If the problem persists follow the procedure below.

## Troubleshooting Reference Table

Applicable Parts	Wiring and Plug/Jack References
<ul style="list-style-type: none"><li>■ Fuser, PL1.1.21</li><li>■ Engine Control Board, PL1.1.4</li></ul>	<ul style="list-style-type: none"><li>■ Print Engine Map 3 (page 10-6)</li><li>■ Print Engine Fuser (page 10-40)</li></ul>

## Caution

Allow adequate time for the Fuser to cool before servicing the printer.

## Troubleshooting Procedure Table

Step	Actions and Questions	Yes	No
1	Check the Fuser for damage. Is the Fuser connector damaged?	Replace the Fuser.	Go to Step 2.
2	Check all pins on the FSRSNR Harness for continuity. Disconnect the FSRSNR Harness from the Engine Control Board HEATIF connector and Fuser connector. Is the harness conductive?	Go to Step 6.	Replace the FSRSNR Harness.
3	Check all pins on the FSRPWR Harness for continuity. Disconnect CN4 on the LVPS. Is the harness conductive?	Replace the LVPS (page 8-121). If the error persists, replace the Engine Control Board (page 8-112).	Replace the FSRPWR Harness.

# Job Offset Home Position Error

## Applicable Status Code:

**Code U60:** Job Offset Home Position Sensor does not detect home position for the Job Offset Assembly.

## Initial Actions:

- Cycle the printer's power.
- If the problem persists follow the procedure below.

## Troubleshooting Reference Table

Applicable Parts	Wiring and Plug/Jack References
<ul style="list-style-type: none"><li>■ Offset Home Position Sensor, PL11.1.32</li><li>■ Rear Sensor Board, PL11.1.33</li><li>■ Job Offset Assembly, PL13.1.1</li></ul>	<ul style="list-style-type: none"><li>■ Print Engine Map 7 (page 10-10)</li><li>■ Print Engine Map 11 (page 10-14)</li><li>■ Print Engine Rear Sensor Board (page 10-29)</li></ul>

## Troubleshooting Procedure Table

Step	Actions and Questions	Yes	No
1	Check the following for evidence of fault or damage: <ul style="list-style-type: none"><li>■ Home Position Sensor Actuator</li><li>■ Home Position Sensor</li><li>■ SNS Harness</li></ul> Is there any damage or misalignment?	Replace any damaged parts.	Go to Step 2.
2	Test the Job Offset Home Position Sensor. Run the Service Diagnostics Offset Home Position test. Does the sensor function correctly?	Replace the Engine Control Board (page 8-112).	Go to Step 3.
3	Replace the Job Offset Home Position Sensor. Does the error persist?	Go to Step 4.	Complete.
4	Check the SNS connection. Is SNS connected to the Rear Sensor Board?	Go to Step 5.	Reconnect the harness.
5	Check for +5V to the sensor. Disconnect P/J150. Is there +5 V at J150-1?	Go to Step 6.	Replace the Rear Sensor Board (page 8-151).

## Troubleshooting Procedure Table (Continued)

Step	Actions and Questions	Yes	No
6	Check the SNS Harness for continuity. 1. Disconnect SNS and P/J150. 2. Check continuity between SNS <=>J150.	Go to Step 7.	Replace the SNS Harness.
7	Check the Job Offset Home Position signal. Does the voltage change at RSNS-10 when the sensor is actuated?	Go to Step 8.	Replace the Rear Sensor Board (page 8-151).
8	Check all pins on the RSNS Harness for continuity. Is the harness conductive?	Replace the Engine Control Board (page 8-112).	Replace the RSNS Harness.

## Control Panel Communications Failure

### Applicable Status Code:

**Code U61:** A communications error with the Control Panel.

### Initial Actions:

- Cycle the printer's power.
- If the problem persists follow the procedure below.

### Troubleshooting Reference Table

Applicable Parts	Wiring and Plug/Jack References
<ul style="list-style-type: none"> <li>■ Engine Control Board, PL1.1.4</li> <li>■ Control Panel Harness</li> <li>■ Control Panel</li> </ul>	<ul style="list-style-type: none"> <li>■ Print Engine Map 3 (page 10-6)</li> <li>■ Print Engine Control panel (page 10-43)</li> </ul>

### Troubleshooting Procedure Table

Step	Actions and Questions	Yes	No
1	Check the Control Panel connection. Is the Control Panel Harness connected to OPEPANE on the Engine Control Board?	Go to Step 2.	Connect the Control Panel harness,
2	Check all pins on the Control Panel Harness for continuity. Disconnect the harness from the Engine Control Board and Control Panel connectors. Is the harness conductive?	Replace the Engine Control Board (page 8-112). If the error persists, replace the Control Panel (page 8-111).	Replace the harness.

# No Data to the [C][M][Y][K] LED Head

## Applicable Status Codes:

**Code 135:** No data to the Yellow LED Head.

**Code 136:** No data to the Magenta LED Head.

**Code 137:** No data to the Cyan LED Head.

**Code 139:** No data to the Black LED Head.

## Initial Actions:

- Cycle the printer's power.
- If the problem persists follow the procedure below.

## Troubleshooting Reference Table

Applicable Parts	Wiring and Plug/Jack References
<ul style="list-style-type: none"><li>■ YK LEDDATA harness, PL12.1.21</li><li>■ CM LEDDATA harness, PL12.1.22</li><li>■ Engine Control Board, PL1.1.4</li></ul>	<ul style="list-style-type: none"><li>■ Print Engine Map 1 (page 10-4)</li><li>■ Print Engine Map 3 (page 10-6)</li><li>■ Print Engine LED Heads (page 10-37)</li></ul>

## Troubleshooting Procedure Table

Step	Actions and Questions	Yes	No
1	Check LED Head. Exchange the affected LED Head with another LED Head. Does the error move with the LED Head?	Replace the LED Head.	Go to Step 2.
2	Ensure the LED Head harness is properly connected and not damaged. Is the wiring harness defective?	Reconnect or replace wiring harness.	Go to Step 3.
3	Check harness continuity between the LED Head and the Engine Control Board. Is there continuity?	Go to Step 4.	Replace the data harness.
4	Check the CUIF connection. Is CUIF firmly connected?	Replace the Engine Control Board (page 8-112)	Connect the two boards and secure the screws. If the error persists, replace the Image Processor Board (page 8-113).



# Motor Driver Board Communications Error

## Applicable Status Code:

**Code 188:** A Sub-CPU communications error with installed options.

## Initial Actions:

- Cycle the printer's power.
- If the problem persists follow the procedure below.

## Troubleshooting Reference Table

Applicable Parts	Wiring and Plug/Jack References
■ Motor Driver Board, PL2.1.10	■ Print Engine Map 5 (page 10-8) ■ Print Engine Motor Driver Board (5/6) (page 10-35) ■ Print Engine Motor Driver Board (6/6) (page 10-36)

## Troubleshooting Procedure Table

Step	Actions and Questions	Yes	No
1	Check the connections to the Engine Control Board. Are DV0 and DV1 completely connected?	Replace the Motor Driver Board (page 8-141).	Connect the two ribbon cables.

# Tray [3][4][5][6] Firmware Error

## Applicable Status Codes:

**Code 221:** Software error in Tray 3 Flash Memory.

**Code 222:** Software error in Tray 4 Flash Memory.

**Code 223:** Software error in Tray 5 Flash Memory.

**Code 224:** Software error in Tray 6 Flash Memory.

## Initial Actions:

- Cycle the printer's power.
- If the problem persists follow the procedure below.

## Troubleshooting Reference Table

Applicable Parts	Wiring and Plug/Jack References
<ul style="list-style-type: none"><li>■ Option Tray Control Board</li><li>■ Engine Control Board, PL1.1.4</li></ul>	<ul style="list-style-type: none"><li>■ Print Engine Map 5 (page 10-8)</li><li>■ Print Engine Motor Driver Board (6/6) (page 10-36)</li><li>■ Options Map 5 Paper Tray Controller Board</li><li>■ Options Paper Tray Sensors and Interconnect</li></ul>

## Troubleshooting Procedure Table

Step	Actions and Questions	Yes	No
1	Check the Option Tray connector for damage. Is the connector damaged?	Replace the connector.	Go to Step 2.
2	Check all pins on the OPTIF Harness for continuity. Disconnect OPTIF from the Engine Control Board and Option connector. Is the harness conductive?	Replace the Option Control Board. If the error persists, replace the Engine Control Board (page 8-112).	Replace the OPTIF Harness.

# Duplex Unit Firmware Error

## Applicable Status Code:

**Code 225:** A firmware error with the Duplex Unit.

## Initial Actions:

- Reseat the Duplex Unit
- Cycle the printer's power.
- If the problem persists follow the procedure below.

## Troubleshooting Reference Table

Applicable Parts	Wiring and Plug/Jack References
<ul style="list-style-type: none"><li>■ Duplex Unit, PL16.1.0</li><li>■ Motor Driver Board, PL2.1.10</li></ul>	<ul style="list-style-type: none"><li>■ Print Engine Map 5 (page 10-8)</li><li>■ Print Engine Motor Driver Board (5/6) (page 10-35)</li><li>■ Options Duplex Unit Sensors and Interconnect</li></ul>

## Troubleshooting Procedure Table

Step	Actions and Questions	Yes	No
1	Check the Duplex Unit connector for damage. Is the connector damaged?	Replace the connector.	Replace the Duplex Unit. If the error persists, go to Step 2.
2	Check all pins on the DUPLEX Harness for continuity. Disconnect the DUPLEX Harness. Is the DUPLEX Harness conductive?	Replace the Motor Driver Board (page 8-141). If the error persists, go to Step 3.	Replace the DUPLEX Harness.
3	Check all pins of the DRV1 harness for continuity. Disconnect the DRV1 ribbon cable. Is the cable conductive?	Replace the Engine Control Board (page 8-112).	Replace the DRV1 Harness.

# Motor Driver Board Firmware Error

## Applicable Status Code:

**Code 225:** Motor Driver Board Flash Memory software error.

## Initial Actions:

- Cycle the printer's power.
- If the problem persists follow the procedure below.

## Troubleshooting Reference Table

Applicable Parts	Wiring and Plug/Jack References
■ Motor Driver Board, PL2.1.10	■ Print Engine Map 5 (page 10-8)

## Troubleshooting Procedure Table

Step	Actions and Questions	Yes	No
1	Check the connections to the Engine Control Board. Are DV0 and DV1 completely connected?	Replace the Motor Driver Board (page 8-141).	Connect the two ribbon cables.

# Finisher Inverter Firmware Error

## Applicable Status Code:

**Code 227:** A software error with the Inverter's Flash Memory.

## Initial Actions:

- Cycle the printer's power.
- If the problem persists follow the procedure below.

## Troubleshooting Reference Table

Applicable Parts	Wiring and Plug/Jack References
■ Inverter Control Board	<ul style="list-style-type: none"><li>■ Print Engine Map 3 (page 10-6)</li><li>■ Print Engine Motor Driver Board (6/6) (page 10-36)</li><li>■ Options Map 3 Inverter Controller Board</li></ul>

## Troubleshooting Procedure Table

Step	Actions and Questions	Yes	No
1	Check the following for evidence of fault or damage: <ul style="list-style-type: none"><li>■ Inverter Interface Cable</li><li>■ Inverter connections</li></ul> Is there any damage?	Replace any damaged parts.	Go to Step 2.
2	Check the Inverter connection. Is the Inverter interface cable securely connected at both ends?	Go to Step 3.	Connect the Inverter to the Finisher.
3	Check the version of Inverter firmware. Is the latest version installed?	Replace the Inverter Control Board.	Reload the Inverter firmware.

# CRUM Reader Board Failure

An error occurred while attempting to read the status of the Toner Cartridge CRUMs.

## Applicable Status Codes:

**Code 230:** The CRUM Reader Board does not respond.

**Code 231:** A communications error with the CRUM Reader Board.

**Code 232:** A transmit error with the CRUM Reader Board at power on.

**Code 233:** A communications error between the CRUM Antenna and CRUM.

**Code 234:** The CRUM Reader Board detects five or more CRUMs.

## Initial Actions:

- Cycle the printer's power.
- If the problem persists follow the procedure below.

## Troubleshooting Reference Table

Applicable Parts	Wiring and Plug/Jack References
<ul style="list-style-type: none"><li>■ CRUM Antenna</li><li>■ CRUM Reader Board</li></ul>	<ul style="list-style-type: none"><li>■ Print Engine Map 1 (page 10-4)</li><li>■ Print Engine Fuser (page 10-40)</li></ul>

## Troubleshooting Procedure Table

Step	Actions and Questions	Yes	No
1	Check all pins of the CRUM Harness for continuity. 1. Remove the Top Cover (page 8-24). 2. Disconnect the CRUM cable from RFID on the Engine Control Board and CN1 on the CRUM Reader Board. Is the cable conductive?	Replace the CRUM Reader Board (page 8-146). If the error persists, go to Step 2.	Replace the CRUM Harness. If the error persists, go to Step 2.
2	Check continuity of each Antenna Harness. Disconnect CN2, CN3, CN4, and CN5 from the CRUM Reader Board and CRUM Antennas. Is each harness conductive?	Replace the CRUM Antennas (page 8-147). If the error persists, go to Step 3.	Replace damaged wiring.
3	Check for +5V at RFID-2 on the Engine Control Board. Is there +5 V at RFID-2 <=> ground?	Go to Step 4.	Replace the Engine Control Board (page 8-112).
4	Check for +5V at POWER-2 on the Engine Control Board. Is there +5 V at POWER-2 <=> ground?	Replace the Engine Control Board (page 8-112).	Replace the LVPS (page 8-121).

# Tray [3][4][5][6] Flash Memory Failure

## Applicable Status Codes:

**Code 242:** Hardware error in Tray 3 Flash Memory.

**Code 243:** Hardware error in Tray 4 Flash Memory.

**Code 244:** Hardware error in Tray 5 Flash Memory.

**Code 245:** Hardware error in Tray 6 Flash Memory.

## Initial Actions:

- Cycle the printer's power.
- If the problem persists follow the procedure below.

## Troubleshooting Reference Table

Applicable Parts	Wiring and Plug/Jack References
<ul style="list-style-type: none"><li>■ Option Tray Control Board</li><li>■ Engine Control Board, PL1.1.4</li></ul>	<ul style="list-style-type: none"><li>■ Print Engine Map 3 (page 10-6)</li><li>■ Print Engine Motor Driver Board (6/6) (page 10-36)</li><li>■ Options Map 5 Paper Tray Controller Board</li></ul>

## Troubleshooting Procedure Table

Step	Actions and Questions	Yes	No
1	Check the Option Tray connector for damage. Is the connector damaged?	Replace the connector.	Go to Step 2.
2	Check all pins on the OPTIF Harness for continuity. Disconnect OPTIF from the Engine Control Board and Option connector. Is the harness conductive?	Replace the Option Control Board. If the error persists, replace the Engine Control Board (page 8-112).	Replace the OPTIF Harness.

# Duplex Unit Flash Memory Failure

## Applicable Status Code:

**Code 246:** Hardware failure with Duplex Unit Flash Memory.

## Initial Actions:

- Cycle the printer's power.
- If the problem persists follow the procedure below.

## Troubleshooting Reference Table

Applicable Parts	Wiring and Plug/Jack References
<ul style="list-style-type: none"><li>■ Duplex Unit</li><li>■ Motor Driver Board, PL2.1.10</li></ul>	<ul style="list-style-type: none"><li>■ Print Engine Map 5 (page 10-8)</li><li>■ Print Engine Motor Driver Board (5/6) (page 10-35)</li><li>■ Options Map 4 Duplex Unit Controller Board</li></ul>

## Troubleshooting Procedure Table

Step	Actions and Questions	Yes	No
1	Check the Duplex Unit connector for damage. Is the connector damaged?	Replace the connector.	Replace the Duplex Unit. If the error persists, go to Step 2.
2	Check all pins on the DUPLEX Harness for continuity. Disconnect the DUPLEX Harness. Is the DUPLEX Harness conductive?	Replace the Motor Driver Board (page 8-141). If the error persists, go to Step 3.	Replace the DUPLEX Harness.
3	Check all pins of the DRV1 harness for continuity. Disconnect the DRV1 ribbon cable. Is the cable conductive?	Replace the Engine Control Board (page 8-112).	Replace the DRV1 Harness.



# Motor Driver Board Flash Memory Failure

## Applicable Status Code:

**Code 247:** Hardware failure with the Motor Driver Board Flash Memory.

## Initial Actions:

- Cycle the printer's power.
- If the problem persists follow the procedure below.

## Troubleshooting Reference Table

Applicable Parts	Wiring and Plug/Jack References
■ Motor Driver Board, PL2.1.10	■ Print Engine Map 5 (page 10-8) ■ Print Engine Motor Driver Board (5/6) (page 10-35) ■ Print Engine Motor Driver Board (6/6) (page 10-36)

## Troubleshooting Procedure Table

Step	Actions and Questions	Yes	No
1	Check the connections to the Engine Control Board. Are DV0 and DV1 completely connected?	Replace the Motor Driver Board (page 8-141).	Connect the two ribbon cables.

# Finisher Inverter Flash Memory Failure

## Applicable Status Code:

**Code 225:** Hardware failure with Inverter Flash Memory.

## Initial Actions:

- Cycle the printer's power.
- If the problem persists follow the procedure below.

## Troubleshooting Reference Table

Applicable Parts	Wiring and Plug/Jack References
■ Inverter Control Board	■ Options Map 3 Inverter Controller Board

## Troubleshooting Procedure Table

Step	Actions and Questions	Yes	No
1	Check the following for evidence of fault or damage: <ul style="list-style-type: none"><li>■ Inverter Control Board</li><li>■ Inverter Interface Cable</li><li>■ Inverter connections</li></ul> Is there any damage?	Replace any damaged parts.	Go to Step 2.
2	Check the Inverter connection. Is the Inverter interface cable securely connected at both ends?	Go to Step 3.	Connect the Inverter to the Finisher.
3	Check the connections at the Inverter Control Board. Are the connections secure?	Replace the Inverter Control Board.	Reconnect the connectors.

# Tray 2 Lift Motor Failure

## Applicable Status Codes:

**Code 910:** The Tray 2 Lift Motor is not rotating.

## Initial Actions:

- Cycle the printer's power.
- If the problem persists follow the procedure below.

## Troubleshooting Reference Table

Applicable Parts	Wiring and Plug/Jack References
<ul style="list-style-type: none"><li>■ Tray 2 Lift Motor, PL4.1.23</li><li>■ Motor Driver Board, PL2.1.10</li><li>■ LVPS, PL3.1.1</li></ul>	<ul style="list-style-type: none"><li>■ Print Engine Map 5 (page 10-8)</li><li>■ Print Engine Motor Driver Board (4/6) (page 10-34)</li><li>■ Print Engine LVPS (page 10-39)</li></ul>

## Troubleshooting Procedure Table

Step	Actions and Questions	Yes	No
1	Test the Lift Motor. 1. Close the Interlock Switches for test. 2. Run the Service Diagnostics Tray 2 Lift Motor test. Does the motor operate?	Complete.	Replace the motor (page 8-106). If the error persists, go to Step 2.
2	Check for +24 V to the Lift Motor. Is there +24 V across GDDC-1 <=> ground?	Go to Step 5.	Go to Step 3.
3	Check Motor Driver Board POW24 connector for 24 V. 1. Disconnect POW24. Is there +24 V across POW24 pins 1 and 2?	Replace the Motor Driver Board (page 8-141).	Go to Step 4.
4	Check for 24 V at the LVPS 1. Disconnect CN2 on the LVPS. Is there +24 V across pins 1 and 2?	Replace the POW24 Harness.	Replace the LVPS (page 8-121).
5	Check all pins of the DRV1 harness for continuity. Disconnect the DRV1 ribbon cable. Is the cable conductive?	Replace the Engine Control Board (page 8-112).	Replace the DRV1 Harness.

# Tray [3][4][5][6] Lift Motor Failure

## Applicable Status Codes:

**Code 911:** The Tray 3 Lift Motor is not rotating.

**Code 912:** The Tray 4 Lift Motor is not rotating.

**Code 913:** The Tray 5 Lift Motor is not rotating.

**Code 914:** The Tray 6 Lift Motor is not rotating.

## Initial Actions:

- Cycle the printer's power.
- If the problem persists follow the procedure below.

## Troubleshooting Reference Table

Applicable Parts	Wiring and Plug/Jack References
<ul style="list-style-type: none"><li>■ Lift Motor, PL4.1.23</li><li>■ Option Control Board</li><li>■ Engine Control Board, PL1.1.4</li><li>■ LVPS, PL3.1.1</li></ul>	<ul style="list-style-type: none"><li>■ Print Engine Map 3 (page 10-6)</li><li>■ Print Engine Map 5 (page 10-8)</li><li>■ Print Engine Motor Driver Board (6/6) (page 10-36)</li><li>■ Print Engine LVPS (page 10-39)</li><li>■ Options Map 5 Paper Tray Controller Board</li><li>■ Options Paper Tray Motors and Clutches</li></ul>

## Troubleshooting Procedure Table

Step	Actions and Questions	Yes	No
1	Check the Option Tray connector for damage. Is the connector damaged?	Replace the connector.	Go to Step 2.
2	Test the appropriate Lift Motor. 1. Close the Interlock Switches for test. 2. Run the Service Diagnostics Lift Motor test. Does the motor operate?	Go to Step 3.	Replace the motor. If the error persists, go to Step 4.
3	Check all pins on the OPTIF Harness for continuity. Disconnect OPTIF from the Engine Control Board and Option connector. Is the harness conductive?	Replace the Option Control Board. If the error persists, replace the Engine Control Board (page 8-112).	Replace the OPTIF Harness.

## Troubleshooting Procedure Table (Continued)

Step	Actions and Questions	Yes	No
4	Check for +24 V at OPTRY24. 1. Close the Interlock Switches. 2. Disconnect OPTRY24. Is there +24 V at OPTRY24-1 and -2 <=> ground?	Replace the affected Option Control Board.	Go to Step 5.
5	Check all pins on the OPTRY24 Harness for continuity. Disconnect the OPTRY24 Harness. Is the OPTRY24 Harness conductive?	Go to Step 6.	Replace the OPTRY24 Harness.
6	Check for +24 V from the LVPS. Disconnect POW24. Is there +24 V at POW24-1 <=> ground?	Replace the Motor Driver Board (page 8-141)	Go to Step 7.
7	Check the LVPS +24 V output. 1. Close the Interlock Switches. 2. Disconnect CN2. Is there +24 V at CN2-1 and <=> ground?	Replace the Engine Control Board (page 8-112)	Replace the LVPS (page 8-121).

# Error in the Transfer Unit Belt

## Applicable Status Code:

**Code 917:** The Transfer Belt Rotation Sensor indicates a belt error.

## Initial Actions:

- Check the condition of the Transfer Unit drive gear.
- Cycle the printer's power.
- If the problem persists follow the procedure below.

## Troubleshooting Reference Table

Applicable Parts	Wiring and Plug/Jack References
<ul style="list-style-type: none"><li>■ Transfer Unit, PL1.1.20</li><li>■ Transfer Unit Motor, PL2.1.86</li><li>■ Belt Rotation Sensor, PL2.1.146</li></ul>	<ul style="list-style-type: none"><li>■ Print Engine Map 1 (page 10-4)</li><li>■ Print Engine Map 7 (page 10-10)</li><li>■ Print Engine Motor Driver Board (1/6) (page 10-31)</li><li>■ Print Engine Motor Driver Board (4/6) (page 10-34)</li></ul>

## Troubleshooting Procedure Table

Step	Actions and Questions	Yes	No
1	Test the Belt Rotation Sensor. Run the Service Diagnostics Belt Hole IC test. Does the sensor function correctly?	Go to Step 2.	Replace the sensor (8-91). If the error persists, go to Step 3.
2	Test the Transfer Unit Motor. 1. Close the Interlock Switches for test. 2. Run the Service Diagnostics Transfer Belt Motor test. Does the motor operate?	Replace the Transfer Unit. If the error persists, go to Step 3.	Replace the motor (page 8-103). If the error persists, go to Step 3.
3	Check all pins on the HALL1 Harness for continuity. Disconnect HALL1 and P/J310 Is the harness conductive?	Replace the Motor Driver Board (page 8-141). If the error persists, go to Step 4.	Replace the HALL1 Harness.
4	Check all pins of the DRV0 harness for continuity. Disconnect the DRV0 ribbon cable. Is the cable conductive?	Replace the Engine Control Board (page 8-112).	Replace the DRV0 Harness.

# Duplex Unit Fan Failure

The Duplex Fan rotation signal indicates the Duplex Fan has stopped rotating.

## Applicable Status Code:

**Code 918:** The Duplex Fan has failed.

## Initial Actions:

- Cycle the printer's power.
- If the problem persists follow the procedure below.

## Troubleshooting Reference Table

Applicable Parts	Wiring and Plug/Jack References
<ul style="list-style-type: none"><li>■ Duplex Unit Fan</li><li>■ Duplex Unit Control Board</li><li>■ Duplex Unit</li></ul>	<ul style="list-style-type: none"><li>■ Print Engine Map 5 (page 10-8)</li><li>■ Print Engine Motor Driver Board (5/6) (page 10-35)</li><li>■ Options Map 4 Duplex Unit Controller Board</li><li>■ Options Duplex Unit Motors and Solenoid</li></ul>

## Troubleshooting Procedure Table

Step	Actions and Questions	Yes	No
1	Check the Duplex Unit connector for damage. Is the connector damaged?	Replace the connector.	Go to Step 2.
2	Test the Duplex Unit Fan. Run the Service Diagnostics Duplex Fan test. Does the Fan function correctly?	Go to Step 3.	Replace the Duplex Unit. If the error persists, go to Step 3.
3	Check all pins on the DUPLEX Harness for continuity. Disconnect the DUPLEX Harness. Is the DUPLEX Harness conductive?	Replace the Motor Driver Board (page 8-141). If the error persists, go to Step 4.	Replace the DUPLEX Harness.
4	Check all pins of the DRV1 harness for continuity. Disconnect the DRV1 ribbon cable. Is the cable conductive?	Replace the Engine Control Board (page 8-112).	Replace the DRV1 Harness.

# +24V Not Available to the Duplex Unit

Abnormal current indicates that +24 V is not being supplied to the Duplex Unit.

## Applicable Status Code:

**Code 225:** Duplex Unit is not receiving +24 V.

## Initial Actions:

- Reseat the Duplex Unit.
- Cycle the printer's power.
- If the problem persists follow the procedure below.

## Troubleshooting Reference Table

Applicable Parts	Wiring and Plug/Jack References
<ul style="list-style-type: none"><li>■ Motor Driver Board, PL2.1.10</li><li>■ LVPS, PL3.1.1</li><li>■ Duplex Unit, PL16.1.1A</li></ul>	<ul style="list-style-type: none"><li>■ Print Engine Map 5 (page 10-8)</li><li>■ Print Engine Map 6 (page 10-9)</li><li>■ Print Engine Motor Driver Board (1/6) (page 10-31)</li><li>■ Print Engine Motor Driver Board (5/6) (page 10-35)</li><li>■ Print Engine LVPS (page 10-39)</li><li>■ Options Map 4 Duplex Unit Controller Board</li><li>■ Options Duplex Unit Motors and Solenoid</li></ul>

## Troubleshooting Procedure Table

Step	Actions and Questions	Yes	No
1	Check the Duplex Unit connector for damage. Is the connector damaged?	Replace the connector.	Go to Step 2.
2	Check for +24 V at DUPLEX on the Motor Driver Board. 1. Close the Interlock Switches. 2. Disconnect DUPLEX. Is there +24 V at DUPLEX-6 and -13 <=> ground?	Replace the Duplex Control Board.	Go to Step 3.
3	Check all pins on the DUPLEX Harness for continuity. Disconnect the DUPLEX Harness. Is the DUPLEX Harness conductive?	Go to Step 4.	Replace the DUPLEX Harness.
4	Check for +24 V from the LVPS. Disconnect POW24 on the Motor Driver Board. Is there +24 V at POW24-1 <=> ground?	Replace the Motor Driver Board (page 8-141)	Go to Step 5.



## Troubleshooting Procedure Table (Continued)

Step	Actions and Questions	Yes	No
5	Check the LVPS +24 V output. 1. Close the Interlock Switches. 2. Disconnect CN2. Is there +24 V at CN2-1 and <=> ground?	Go to Step 6.	Replace the LVPS (page 8-121).
6	Check all pins of the DRV1 harness for continuity. Disconnect the DRV1 ribbon cable. Is the cable conductive?	Replace the Engine Control Board (page 8-112).	Replace the DRV1 Harness.

## Failure in the [C][M][Y][K] Imaging Unit Drum or Motor

The Drum Phase Sensor integrated on the Imaging Unit Sensor Board indicates an error in one of the Imaging Units.

### Applicable Status Codes:

**Code 920:** The Yellow Imaging Unit drum is not rotating.

**Code 921:** The Magenta Imaging Unit drum is not rotating.

**Code 922:** The Cyan Imaging Unit drum is not rotating.

**Code 923:** The Black Imaging Unit drum is not rotating.

### Initial Actions:

- Reseat the affected Imaging Unit
- Cycle the printer's power.
- If the problem persists follow the procedure below.

### Troubleshooting Reference Table

Applicable Parts	Wiring and Plug/Jack References
<ul style="list-style-type: none"><li>■ Imaging Unit Motors, PL2.1.8</li><li>■ Imaging Unit Sensor Board, PL5.1.20</li><li>■ LVPS, PL3.1.1</li><li>■ Motor Driver Board, PL2.1.10</li></ul>	<ul style="list-style-type: none"><li>■ Print Engine Map 5 (page 10-8)</li><li>■ Print Engine Map 6 (page 10-9)</li><li>■ Print Engine Map 8 (page 10-11)</li><li>■ Print Engine Motor Driver Board (3/6) (page 10-33)</li><li>■ Print Engine Imaging Unit Sensor Board (page 10-41)</li></ul>

## Troubleshooting Procedure Table

Step	Actions and Questions	Yes	No
1	Test the Drum Phase Sensor for the affected color. Run the Service Diagnostics Drum Phase Sensor test. Does the sensor function correctly?	Go to Step 2.	Replace the Imaging Unit Sensor Board (page 8-142). If the error persists, go to Step 2.
2	Test the affected Imaging Unit Motor. 1. Close the Interlock Switches for test. 2. Run the appropriate Service Diagnostics motor test. Does the motor operate?	Replace the affected Imaging Unit. If the error persists, go to Step 3.	Replace the motor (page 8-106). If the error persists, go to Step 3.
3	Check for +24 V to the motor. Is there +24 V across DC(0,1,2,3)- 3 <=> ground?	Go to Step 6.	Go to Step 4.
4	Check Motor Driver Board POW24 connector for 24 V. 1. Disconnect POW24. Is there +24 V across POW24-1 and 2?	Replace the Motor Driver Board (page 8-141).	Go to Step 5.
5	Check for 24 V at the LVPS 1. Disconnect CN2 on the LVPS. Is there +24 V across pins 1 and 2?	Replace the POW24 Harness.	Replace the LVPS (page 8-121).
6	Check all pins of the DRV1 harness for continuity. Disconnect the DRV1 ribbon cable. Is the cable conductive?	Go to Step 7.	Replace the DRV1 Harness.
7	Check the Imaging Unit Sensor Board connection. Is the CTG0 Harness connected?	Go to Step 8.	Connect the Imaging Unit Sensor Board.
8	Check all pins of the CTG0 harness for continuity Disconnect the CTG0 Harness. Is the harness conductive?	Replace the Engine Control Board (page 8-112).	Replace the CTG0 harness.

# +24 V Not Available to Tray [3][4][5][6]

Voltage detection indicates that +24 V is not available to the indicated option tray.

## Applicable Status Codes:

**Code 924:** Tray 3 not receiving +24 V

**Code 925:** Tray 4 not receiving +24 V

**Code 926:** Tray 5 not receiving +24 V

**Code 927:** Tray 6 not receiving +24 V

## Initial Actions:

- Reset the Option connector at the base of the printer.
- Cycle the printer's power.
- If the problem persists follow the procedure below.

## Troubleshooting Reference Table

Applicable Parts	Wiring and Plug/Jack References
<ul style="list-style-type: none"><li>■ Motor Driver Board, PL2.1.10</li><li>■ LVPS, PL3.1.1</li></ul>	<ul style="list-style-type: none"><li>■ Print Engine Motor Driver Board (6/6) (page 10-36)</li><li>■ Options Paper Tray Motors and Interconnect</li></ul>

## Troubleshooting Procedure Table

Step	Actions and Questions	Yes	No
1	Check the Option Tray connector for damage. Is the connector damaged?	Replace the connector.	Go to Step 2.
2	Check for +24 V at OPRY24. 1. Close the Interlock Switches. 2. Disconnect OPRY24. Is there +24 V at OPRY24-1 and -2 <=> ground?	Replace the affected Option Control Board.	Go to Step 3.
3	Check all pins on the OPRY24 Harness for continuity. Disconnect the OPRY24 Harness. Is the OPRY24 Harness conductive?	Go to Step 4.	Replace the OPRY24 Harness.
4	Check for +24 V from the LVPS. Disconnect POW24. Is there +24 V at POW24-1 <=> ground?	Replace the Motor Driver Board (page 8-141)	Go to Step 5.
5	Check the LVPS +24 V output. 1. Close the Interlock Switches. 2. Disconnect CN2. Is there +24 V at CN2-1 and <=> ground?	Replace the Engine Control Board (page 8-112)	Replace the LVPS (page 8-121).

# Failure in the Fuser Motor

The Fuser Motor has stopped rotating.

## Applicable Status Code:

**Code 928:** The Fuser Motor has failed.

## Initial Actions:

- Cycle the printer's power.
- If the problem persists follow the procedure below.

## Troubleshooting Reference Table

Applicable Parts	Wiring and Plug/Jack References
<ul style="list-style-type: none"><li>■ Fuser Motor, PL2.1.9</li><li>■ Motor Driver Board, PL2.1.10</li><li>■ Engine Control Board, PL1.1.4</li></ul>	<ul style="list-style-type: none"><li>■ Print Engine Map 5 (page 10-8)</li><li>■ Print Engine Motor Driver Board (2/6) (page 10-32)</li><li>■ Print Engine Motor Driver Board (6/6) (page 10-36)</li></ul>

## Troubleshooting Procedure Table

Step	Actions and Questions	Yes	No
1	Test the Fuser Motor. 1. Close the Interlock Switches for test. 2. Run the Service Diagnostics Fuser Motor test. Does the motor operate?	Complete.	Replace the motor (page 8-106). If the error persists, go to Step 2.
2	Check for +24 V to the Fuser Motor. Is the +24 V across DCHEAT- 3 <=> ground?	Go to Step 5.	Go to Step 3.
3	Check Motor Driver Board POW24 connector for 24 V. 1. Disconnect POW24. Is the +24 V across POW24 pins 1 and 2?	Replace the Motor Driver Board (page 8-141).	Go to Step 4.
4	Check for 24 V at the LVPS 1. Disconnect CN2 on the LVPS. Is the +24 V across pins 1 and 2?	Replace the POW24 Harness.	Replace the LVPS (page 8-121).
5	Check all pins of the DRV1 harness for continuity. Disconnect the DRV1 ribbon cable. Is the cable conductive?	Replace the Engine Control Board (page 8-112).	Replace the DRV1 Harness.

# Failure in the Waste Toner Motor

The Waste Toner Motor has stopped rotating.

## Applicable Status Code:

**Code 929:** The Waste Toner Motor has failed.

## Initial Actions:

- Cycle the printer's power.
- If the problem persists follow the procedure below.

## Troubleshooting Reference Table

Applicable Parts	Wiring and Plug/Jack References
■ Waste Toner Motor, PL7.1.3	■ Print Engine Map 5 (page 10-8)
■ Motor Driver Board, PL2.1.10	■ Print Engine Motor Driver Board (2/6) (page 10-32)
■ Engine Control Board, PL1.1.4	■ Print Engine Motor Driver Board (6/6) (page 10-36)

## Troubleshooting Procedure Table

Step	Actions and Questions	Yes	No
1	Step deleted. Proceed to Step 2.		
2	Check for +24 V to the Waste Toner Motor. Is the +24 V across WTDC- 3 <=> ground?	Go to Step 5.	Go to Step 3.
3	Check Motor Driver Board POW24 connector for 24 V. 1. Disconnect POW24. Is the +24 V across POW24 pins 1 and 2?	Replace the Motor Driver Board (page 8-141).	Go to Step 4.
4	Check for 24 V at the LVPS 1. Disconnect CN2 on the LVPS. Is the +24 V across pins 1 and 2?	Replace the POW24 Harness.	Replace the LVPS (page 8-121).
5	Check all pins of the DRV1 harness for continuity. Disconnect the DRV1 ribbon cable. Is the cable conductive?	Replace the Engine Control Board (page 8-112).	Replace the DRV1 Harness.

# Motor Driver Board Clock Frequency Error

The Sub-CPU clock frequency on the Motor Driver Board is inaccurate.

## Applicable Status Code:

**Code 930:** The Sub-CPU clock frequency is inaccurate.

## Initial Actions:

- Cycle the printer's power.
- If the problem persists follow the procedure below.

## Troubleshooting Reference Table

Applicable Parts	Wiring and Plug/Jack References
<ul style="list-style-type: none"><li>■ Motor Driver Board, PL2.1.10</li><li>■ Engine Control Board, PL1.1.4</li></ul>	<ul style="list-style-type: none"><li>■ Print Engine Map 3 (page 10-6)</li><li>■ Print Engine Map 5 (page 10-8)</li><li>■ Print Engine Motor Driver Board (5/6) (page 10-35)</li></ul>

## Troubleshooting Procedure Table

Step	Actions and Questions	Yes	No
1	Check the Motor Driver Board connection. Is DRV0 harness damaged or disconnected or?	Replace the harness.	Go to Step 2.
2	Check all pins of the DRV0 harness for continuity. Disconnect the DRV1 ribbon cable. Is the cable conductive?	Replace the Motor Driver Board (page 8-141). If the error persists, replace the Engine Control Board (page 8-112).	Replace the DRV1 Harness.

# Duplex Unit Clock Frequency Error

The clock frequency for the Duplex Unit Control Board CPU is inaccurate.

## Applicable Status Code:

**Code 931:** The Duplex Unit's CPU clock frequency is inaccurate.

## Initial Actions:

- Reseat the Duplex Unit.
- Cycle the printer's power.
- If the problem persists follow the procedure below.

## Troubleshooting Reference Table

Applicable Parts	Wiring and Plug/Jack References
<ul style="list-style-type: none"><li>■ Motor Driver Board, PL2.1.10</li><li>■ Duplex Unit, PL16.1.1A</li></ul>	<ul style="list-style-type: none"><li>■ Print Engine Map 3 (page 10-6)</li><li>■ Print Engine Map 5 (page 10-8)</li><li>■ Print Engine Motor Driver Board (5/6) (page 10-35)</li><li>■ Print Engine Motor Driver Board (6/6) (page 10-36)</li><li>■ Options Map 4 Duplex Unit Controller Board</li></ul>

## Troubleshooting Procedure Table

Step	Actions and Questions	Yes	No
1	Check the Duplex Unit connector for damage. Is the connector damaged?	Replace the connector.	Go to Step 2.
2	Check all pins on the DUPLEX Harness for continuity. Disconnect the DUPLEX Harness. Is the DUPLEX Harness conductive?	Replace the Duplex Unit. If the error persists, go to Step 3.	Replace the DUPLEX Harness.
3	Check all pins of the DRV1 harness for continuity. Disconnect the DRV1 ribbon cable. Is the cable conductive?	Replace the Engine Control Board (page 8-112).	Replace the DRV1 Harness.

# Finisher Inverter Clock Frequency Error

The clock frequency for the Inverter Control Board CPU is inaccurate.

## Applicable Status Code:

**Code 932:** The Inverter's CPU clock frequency is inaccurate.

## Initial Actions:

- Cycle the printer's power.
- If the problem persists follow the procedure below.

## Troubleshooting Reference Table

Applicable Parts	Wiring and Plug/Jack References
<ul style="list-style-type: none"><li>■ Inverter Control Board</li><li>■ Engine Control Board, PL1.1.4</li></ul>	<ul style="list-style-type: none"><li>■ Print Engine Map 3 (page 10-6)</li><li>■ Print Engine Motor Driver Board (6/6) (page 10-36)</li><li>■ Options Map 3 Inverter Controller Board</li></ul>

## Troubleshooting Procedure Table

Step	Actions and Questions	Yes	No
1	Check the Option connection. Is the Option connection from the Inverter to the Printer damaged or disconnected?	Reconnect or replace the cable.	Go to Step 2.
2	Check all pins on the Option Harness for continuity. Disconnect OPTIF from the Engine Control Board and the Option connector. Is the harness conductive?	Go to Step 3.	Replace the Option harness.
3	Check the Inverter Control Board POWER connection. Is POWER disconnected or damaged?	Replace or reconnect the harness.	Replace the Inverter Control Board. If the error persists, replace the Engine Control Board (page 8-112).



# Tray [3][4][5][6] Feeder Board Clock Frequency Error

The clock frequency on the indicated Feeder Board is inaccurate.

## Applicable Status Codes:

**Code 933:** Tray 3 Feeder Board CPU clock frequency is inaccurate.

**Code 934:** Tray 4 Feeder Board CPU clock frequency is inaccurate.

**Code 935:** Tray 5 Feeder Board CPU clock frequency is inaccurate.

**Code 936:** Tray 6 Feeder Board CPU clock frequency is inaccurate.

## Initial Actions:

- Cycle the printer's power.
- If the problem persists follow the procedure below.

## Troubleshooting Reference Table

Applicable Parts	Wiring and Plug/Jack References
<ul style="list-style-type: none"><li>■ Option Feeder Board</li><li>■ Engine Control Board, PL1.1.4</li></ul>	<ul style="list-style-type: none"><li>■ Print Engine Map 3 (page 10-6)</li><li>■ Print Engine Motor Driver Board (6/6) (page 10-36)</li><li>■ Options Map 5 Paper Tray Controller Board</li></ul>

## Troubleshooting Procedure Table

Step	Actions and Questions	Yes	No
1	Check the Option Tray connector for damage. Is the connector damaged?	Replace the connector.	Go to Step 2.
2	Check all pins on the OPTIF Harness for continuity. Disconnect OPTIF from the Engine Control Board and Option connector. Is the harness conductive?	Replace the Option Feeder Board. If the error persists, replace the Engine Control Board (page 8-112).	Replace the OPTIF Harness.

# Waste Toner Transfer Error

The Waste Toner Auger Rotation Sensor indicates that the Waste Toner Auger has stopped rotating.

## Applicable Status Code:

**Code 940:** The Waste Toner Auger has failed.

## Initial Actions:

- Cycle the printer's power.
- If the problem persists follow the procedure below.

## Troubleshooting Reference Table

Applicable Parts	Wiring and Plug/Jack References
<ul style="list-style-type: none"><li>■ Waste Toner Auger Rotation Sensor</li><li>■ Waste Toner Auger Assembly</li><li>■ Waste Toner Motor</li></ul>	<ul style="list-style-type: none"><li>■ Print Engine Map 1 (page 10-4)</li><li>■ Print Engine Map 5 (page 10-8)</li><li>■ Print Engine Map 7 (page 10-10)</li><li>■ Print Engine Motor Driver Board (2/6) (page 10-31)</li></ul>

## Troubleshooting Procedure Table

Step	Actions and Questions	Yes	No
1	Check the following for evidence of fault or damage: <ul style="list-style-type: none"><li>■ Waste Toner Manifold</li><li>■ Waste Toner Auger Rotation Sensor</li><li>■ HALLDCT Harness</li></ul> Is there any damage or debris?	Replace any damaged parts.	Go to Step 2.
2	Test the Waste Toner Auger Rotation Sensor. Run the Service Diagnostics Waste Toner Hole IC test using a magnetic source to actuate the Hall-effect sensor. Does the sensor function correctly?	Go to Step 3.	Replace the sensor (page 8-90). If the error persists, go to Step 6.
3	Check the Waste Toner Manifold Auger drive. With the Basket Assembly closed, rotate the Waste Toner Motor. Does the Auger rotate?	Go to Step 4.	Replace the Waste Toner Gear Assembly PL2.1.41.(

## Troubleshooting Procedure Table (Continued)

<b>Step</b>	<b>Actions and Questions</b>	<b>Yes</b>	<b>No</b>
<b>4</b>	Test the Waste Toner Motor. Run the Service Diagnostics Waste Motor test. Does the motor rotate?	Go to Step 7.	Replace the motor (page 8-107). If the error persists, go to Step 5.
<b>5</b>	Check all pins of the WTDC Harness for continuity. Disconnect WTDC and P/J50. Is the harness conductive?	Replace the Motor Driver Board (page 8-141).	Replace the harness.
<b>6</b>	Check all pins of the HALLDCT Harness for continuity. Disconnect HALLDCT and P/J320. Is the harness conductive?	Replace the Motor Driver Board (page 8-141).	Replace the harness.
<b>7</b>	Check all pins of the DRV0 Harness for continuity. Disconnect DRV0. Is the harness conductive?	Replace the Motor Driver Board (page 8-141). If the error persists, replace the Engine Control Board (page 8-112).	Replace the harness.

# [CM][YK] Toner Supply Failure

The Low Toner Sensor indicates a supply failure at the indicated Imaging Unit.

## Applicable Status Codes:

**Code 941:** Toner supply failure with Cyan or Magenta Toner.

**Code 942:** Toner supply failure with Yellow or Black Toner.

## Initial Actions:

- Cycle the printer's power.
- If the problem persists follow the procedure below.

## Troubleshooting Reference Table

Applicable Parts	Wiring and Plug/Jack References
<ul style="list-style-type: none"><li>■ Toner Cartridges, PL1.1.24</li><li>■ Imaging Unit, PL1.1.23</li><li>■ Toner Motors, PL5.1.22</li><li>■ Imaging Unit Sensor Board, PL5.1.21</li></ul>	<ul style="list-style-type: none"><li>■ Print Engine Map 5 (page 10-8)</li><li>■ Print Engine Map 8 (page 10-11)</li><li>■ Print Engine Motor Driver Board (2/6) (page 10-32)</li><li>■ Print Engine Imaging Unit Sensor Board (page 10-41)</li></ul>

## Troubleshooting Procedure Table

Step	Actions and Questions	Yes	No
1	Check the following for evidence of fault or damage: <ul style="list-style-type: none"><li>■ Toner Cartridge</li><li>■ Imaging Unit Agitator Bar</li><li>■ Low Toner Sensors</li></ul> Is there any damage, debris or blockage?	Replace any damaged parts.	Go to Step 2.
2	Test the affected Toner Motor. <ol style="list-style-type: none"><li>1. Remove the CM or YK Toner Cartridges.</li><li>2. Run the appropriate Service Diagnostics Toner Supply Motor test.</li></ol> Does the motor rotate?	Go to Step 3.	Replace the motor (page 8-104). If the error persists, replace the Motor Driver Board (page 8-141).
3	Does the plunger that engages the Agitation Bar move in and out while the Toner Motor rotates?	Go to Step 4.	Replace the Toner Supply Camshafts (page 8-144).
4	Test the affected Low Toner Sensors. <ol style="list-style-type: none"><li>1. Remove the CM or YK Imaging Units.</li><li>2. Run the appropriate Service Diagnostics Toner Cart Sensor test.</li></ol> Do the sensors function correctly?	Replace the Engine Control Board (page 8-112)	Replace the Imaging Unit Sensor Board (page 8-142).

# Warning Messages

## No Paper in Tray 1 (MPT)

The Tray 1 (MPT) No Paper Sensor indicates the tray is empty.

### Initial Actions:

- Cycle the printer's power.
- If the problem persists follow the procedure below.

### Troubleshooting Reference Table

Applicable Parts	Wiring and Plug/Jack References
<ul style="list-style-type: none"><li>■ No Paper Sensor, PL4.2.89</li><li>■ No Paper Actuator, PL4.2.65</li></ul>	<ul style="list-style-type: none"><li>■ Print Engine Map 9 (page 10-12)</li><li>■ Print Engine Front Sensor Board (1/2) page 10-26</li></ul>

### Troubleshooting Procedure Table

Step	Actions and Questions	Yes	No
1	Fill the tray. Does the error occur even if the tray is full?	Go to Step 2.	Complete
2	Check the following for evidence of fault or damage: <ul style="list-style-type: none"><li>■ No Paper Sensor</li><li>■ No Paper Actuator</li></ul> Is there any damage?	Replace any damaged parts.	Go to Step 3.
3	Test the Tray 1 (MPT) No Paper Sensor. Run the Service Diagnostics No Paper Sensor test. Does the sensor function correctly?	Replace the Engine Control Board (page 8-112).	Go to Step 4.
4	Check the No Paper Sensor signal. Does the voltage level change across MPTPAP-2 when the sensor is actuated?	Go to Step 5.	Replace the No Paper Sensor.
5	Check all pins on the FSNS Harness for continuity. Is the harness conductive?	Replace the Engine Control Board (page 8-112).	Replace the FSNS Harness.

# No Paper in Tray [2][3][4][5][6]

The No Paper Sensor indicates that the named tray is empty.

## Initial Actions:

- Cycle the printer's power.
- If the problem persists follow the procedure below.

## Troubleshooting Reference Table

Applicable Parts	Wiring and Plug/Jack References
<ul style="list-style-type: none"><li>■ No Paper Sensor, PL4.2.89</li><li>■ No Paper Actuator, PL4.2.65</li></ul>	<ul style="list-style-type: none"><li>■ Print Engine Map 12 (page 10-15)</li><li>■ Print Engine Feeder Board (page 10-28)</li><li>■ Options Map 5 Paper Tray Controller Board</li><li>■ Options Map 6 Paper Tray Feeder Board</li><li>■ Options Paper Tray Sensors and Interconnect</li></ul>

## Troubleshooting Procedure Table

Step	Actions and Questions	Yes	No
1	Fill the tray. Does the error occur even if the tray is full?	Go to Step 2.	Complete
2	Check the following for evidence of fault or damage: <ul style="list-style-type: none"><li>■ No Paper Sensor and actuator</li></ul> Is there any damage?	Replace any damaged parts.	Go to Step 3.
3	Test the No Paper Sensor. for the affected tray. Run the Service Diagnostics No Paper Sensor test. Does the sensor function correctly?	Replace the Engine Control Board (page 8-112).	Go to Step 4.
4	Check the No Paper Sensor signal. Does the voltage level change when the sensor is actuated?	Go to Step 5.	Replace the No Paper Sensor.
5	Check all pins on the TRYSNS1 Harness for continuity. Is the harness conductive?	Replace the Engine Control Board (page 8-112).	Replace the TRYSNS1 Harness.

# Left Side Output Tray is Closed

The Side Output Tray Detect Sensor indicates the tray is closed. This warning typically occurs when side output (faceup) is requested and the tray is closed.

## Initial Actions:

- Cycle the printer's power.
- If the problem persists follow the procedure below.

## Troubleshooting Reference Table

Applicable Parts	Wiring and Plug/Jack References
<ul style="list-style-type: none"> <li>■ Side Output Tray Detect Sensor, PL11.1.32</li> <li>■ Side Output Tray, PL2.1.124</li> <li>■ COVSNS Harness, PL11.1.34</li> </ul>	<ul style="list-style-type: none"> <li>■ Print Engine Map 2 (page 10-5)</li> <li>■ Print Engine Map 11 (page 10-14)</li> <li>■ Print Engine Rear Sensor Board (page 10-29)</li> </ul>

## Troubleshooting Procedure Table

Step	Actions and Questions	Yes	No
<b>1</b>	Check the following for evidence of fault or damage: <ul style="list-style-type: none"> <li>■ Tray Detect Sensor, PL11.1.32</li> <li>■ Side Output Tray, PL2.1.124</li> </ul>	Replace the parts concerned.	Go to Step 2.
<b>2</b>	Test the Side Output Tray Detect Sensor. <b>NOTE:</b> Door sensor tests are located under the Interlock Switches sub-menu. Run the Service Diagnostics Side Output Tray test. Does the sensor function correctly?	Replace the Engine Control Board (page 8-112).	Go to Step 3.
<b>3</b>	Check the sensor connection. Is P/J180 connected?	Go to Step 4.	Reconnect the sensor.
<b>4</b>	Replace the Side Output Tray Detect Sensor. Does the error persist?	Go to Step 5.	Complete
<b>5</b>	Check all pins on the COVSNS Harness for continuity. Is the harness conductive?	Replace the Engine Control Board (page 8-112).	Replace the COVSNS Harness.

# Waste Cartridge is Almost Full

The Waste Toner Reservoir Full Sensor signal connects to HVPS connector CN4, and then from the HVPS connector CN1 through a ribbon cable to the Engine Control Board HVOLT connector. The Waste Toner Reservoir Full Sensor is a Hall-Effect sensor. Test this type of sensor by placing a strong magnetic source near the sensor.

## Initial Actions:

- Cycle the printer's power.
- If the problem persists follow the procedure below.

## Troubleshooting Reference Table

Applicable Parts	Wiring and Plug/Jack References
■ Waste Toner Reservoir Full Sensor	■ Print Engine Map 1 (page 10-4) ■ Print Engine HVPS (page 10-38)

## Troubleshooting Procedure Table

Step	Actions and Questions	Yes	No
1	Check the following for evidence of fault, debris, or damage: <ul style="list-style-type: none"><li>■ Waste Toner Reservoir Full Sensor and harness</li><li>■ HVPS</li><li>■ HVOLT Harness</li></ul>	Replace any damaged parts.	Go to Step 2.
2	Check the Waste Toner Reservoir Full Sensor harness for continuity. Is the harness conductive?	Go to Step 3.	Replace the harness.
3	Replace the Waste Toner Reservoir Full Sensor. Does the error persist?	Replace the Engine Control Board (page 8-112).	Complete



# Non-Xerox [C][M][Y][K] Toner Cartridge

A Non-Xerox Toner Cartridge warning message occurs when the printer detects the presence of non-Xerox Toner. The customer can continue to print by selecting use it on the Control Panel when queried whether to use the non-Xerox cartridge. If the customer chooses Do Not Use, the warning message is replaced by the Replace [C] [M] [Y] [K] Toner Cartridge error message.

## Initial Actions:

- Ensure that the Toner Cartridges are fully seated and locked into position.
- Cycle printer power.
- If the problem persists, follow the procedure below.

## Troubleshooting Reference Table

Applicable Parts	Wiring and Plug/Jack References
<ul style="list-style-type: none"><li>■ Toner Cartridge, PL1.1.29</li><li>■ CRUM Reader Board, PL2.1.92</li></ul>	<ul style="list-style-type: none"><li>■ Print Engine Map 1 (page 10-4)</li><li>■ Print Engine Fuser (page 10-40)</li></ul>

## Troubleshooting Procedure Table

Step	Actions and Questions	Yes	No
1	Check Toner Cartridge installation. Are the cartridges properly installed?	Go to Step 2.	Correct the installation.
2	Replace the affected Toner Cartridge. Does the error persist?	Go to Step 3.	Complete
3	Check the CRUM Harness continuity. 1. Remove the Top Cover (page 8-24). 2. Disconnect the CRUM cable from RFID and CN1 on the CRUM Reader Board. Is the cable conductive?	Replace the CRUM Reader Board (page 8-146). If the error persists, go to Step 4.	Replace the CRUM Harness. If the error persists, go to Step 4.
4	Check continuity of the Antenna Harness. Disconnect CN2, CN3, CN4, or CN5 from the CRUM Reader Board and CRUM Antennas. Is each harness conductive?	Go to Step 5.	Replace damaged wiring.
5	Check for +5V at RFID-2 on the Engine Control Board. Is there +5 V at RFID-2 <=> ground?	Go to Step 6.	Replace the Engine Control Board (page 8-112).
6	Check for +5V at POWER-2 on the Engine Control Board. Is there +5 V at POWER-2 <=> ground?	Replace the Engine Control Board (page 8-112).	Replace the LVPS (page 8-121).

# Staple Cartridge Is Empty

The Stapler Self-Prime Sensor in the Staple Cartridge indicates no staples remain.

## Initial Actions:

- Cycle the printer's power.
- If the problem persists follow the procedure below.

## Troubleshooting Reference Table

Applicable Parts	Wiring and Plug/Jack References
<ul style="list-style-type: none"><li>■ Stapler Self-Prime Sensor</li><li>■ Finisher Control Board</li></ul>	<ul style="list-style-type: none"><li>■ Options Map 1 Finisher Controller Board</li></ul>

## Troubleshooting Procedure Table

Step	Actions and Questions	Yes	No
1	Test the Stapler Self-Prime Sensor. Run the Service Diagnostics Stapler Self-Prime Sensor test. Does the sensor state change when the Staple Cartridge is removed or replaced?	Go to Step 9.	Go to Step 2.
2	Check the Staple Cartridge for faulty parts or debris. Are there damaged parts or debris?	Replace faulty parts or clean as needed.	Go to Step 3.
3	Check the Staple Harness connections. Is the Staple Harness connected?	Go to Step 5.	Connect the harness. If the error persists, go to Step 4.
4	Check Staple Harness continuity. Is the Staple Harness conductive?	Go to Step 6.	Replace the Staple Harness.
5	Check for +5 V to the Stapler Self-Prime Sensor. Is there +5 V on the Finisher Control Board?	Go to Step 7.	Replace the Finisher Control Board.
6	Check the Stapler Self-Prime signal. Does the voltage on the Finisher Control Board change when the Staple Cartridge is removed or replaced?	Go to Step 8.	Replace the Finisher Control Board.
7	Replace the Stapler Assembly. Does the error still occur?	Go to Step 9.	Complete.
8	Replace the Finisher Control Board. Does the error still occur?	Replace the Engine Control Board (8-112).	Complete.

# Punch Waste Box is Full or Missing

The Punch Box Sensor indicates the Punch Box is full or not installed in the Finisher.

## Initial Actions:

- Cycle the printer's power.
- If the problem persists follow the procedure below.

## Troubleshooting Reference Table

Applicable Parts	Wiring and Plug/Jack References
<ul style="list-style-type: none"><li>■ Punch Box Sensor Emitter Board</li><li>■ Punch Box Sensor Receiver Board</li><li>■ Punch Box Sensor Harness</li></ul>	<ul style="list-style-type: none"><li>■ Options Map 2 Punch Controller Board</li><li>■ Options Punch Controller to Sensors</li></ul>

## Troubleshooting Procedure Table

Step	Actions and Questions	Yes	No
1	Test the Punch Box Set Sensor. Run the Service Diagnostics Punch Box Set Sensor test. Does the sensor state change when the emitter is blocked?	Go to Step 6.	Go to Step 2.
2	Check the Punch Box Sensor Harness connections. Is P/J1005 connected to the Punch Control Board? Are P/J2005 and P/J2006 connected to the Emitter and Receiver boards?	Go to Step 3.	Connect the harness.
3	Check the Punch Box Sensor Harness continuity. Is the harness conductive?	Go to Step 5.	Replace the harness.
4	Check the Punch Box Sensor Emitter Board. Is the LED illuminated?	Go to Step 5.	Replace the Punch Box Sensor Emitter Board.
5	Check for +5 V to the Punch Box Sensor. Disconnect P/J2006. Is there +5 V across J2006-1 <=> J2006-2?	Replace the Punch Box Sensor Receiver Board.	Replace the Punch Control Board.
6	Replace the Finisher Control Board. Does the error still occur?	Replace the Engine Control Board (page 8-112).	Complete.

# Finisher Away From Base

The Finisher Switch indicates that the Finisher is detached from the Inverter.

## Initial Actions:

- Cycle the printer's power.
- If the problem persists follow the procedure below.

## Troubleshooting Reference Table

Applicable Parts	Wiring and Plug/Jack References
<ul style="list-style-type: none"><li>■ Joint Switch</li><li>■ Finisher Control Board</li></ul>	<ul style="list-style-type: none"><li>■ Options Map 7 Finisher Sensor Locator</li><li>■ Options Finisher Controller to Switches</li></ul>

## Troubleshooting Procedure Table

Step	Actions and Questions	Yes	No
1	Check the following for evidence of fault, damage, obstruction, or debris: <ul style="list-style-type: none"><li>■ Joint Switch and actuator</li><li>■ Finisher Base</li></ul> Are there any defects or misalignment?	Replace any damaged parts.	Go to Step 2.
2	Test the Joint Switch <b>NOTE:</b> Door sensor tests are located under the Covers, Doors, and Interlocks sub-menu. Run the Service Diagnostics Joint Switch test. Does the switch function correctly?	Replace the Engine Control Board (page 8-112).	Go to Step 3.
3	Check the switch signal. Disconnect CN8 from the Finisher Control Board. Is there +24 V at CN8-5 when the switch is activated?	Replace the Finisher Control Board.	Go to Step 4.
4	Check the switch signal. Disconnect CN8 from the Finisher Control Board. Is there +24 V at CN8-6 when the switch is activated?	Replace the Joint Switch. If the error persists, replace the wiring.	Replace the Finisher Control Board.

# Finisher Away From Printer

The Inverter Docking (Joint) Switch indicates that the Finisher is detached from the printer.

## Initial Actions:

- Cycle the printer's power.
- If the problem persists follow the procedure below.

## Troubleshooting Reference Table

Applicable Parts	Wiring and Plug/Jack References
<ul style="list-style-type: none"><li>■ Inverter Docking Sensor</li><li>■ Inverter Control Board</li></ul>	<ul style="list-style-type: none"><li>■ Options Map 9 Inverter Sensor Locator</li><li>■ Options Inverter Sensors diagram</li></ul>

## Troubleshooting Procedure Table

Step	Actions and Questions	Yes	No
1	Check the following for evidence of fault, damage, obstruction, or debris: <ul style="list-style-type: none"><li>■ Inverter Docking Sensor</li><li>■ Finisher Base</li></ul> Are there any defects or misalignment?	Replace any damaged parts.	Go to Step 2.
2	Test the Inverter Joint Sensor Run the Service Diagnostics Inverter Joint Sensor test. Does the switch function correctly?	Replace the Engine Control Board (page 8-112).	Go to Step 3.
3	Check the Inverter Docking Sensor signal. Disconnect SNSCN1 from the Inverter Control Board. Does the voltage change between 0 and 5vdc on connector SNSCN1-2 when the sensor is actuated?	Replace the Inverter Control Board.	Replace the sensor. If the error persists, replace the harness.



# General Troubleshooting

## In this chapter...

- Power On Self Test (POST)
- Service Diagnostics
- Control Panel Troubleshooting
- Inoperable Printer Troubleshooting
- AC Power Supply Troubleshooting
- DC Power Supply Troubleshooting
- Media Jams and the Paper Path
- Operating System and Application Problems
- Network Problems

Section

4

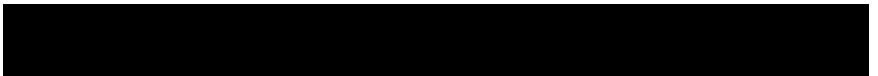

# Introduction

This section covers the start-up, Power On Self Test (POST), Service Diagnostics, and power supply operations of the printer to aid in troubleshooting problems not associated with a reported error. For problems associated with an error message or code, see "Error Messages and Codes" on page 3-1. Troubleshooting tips are available on the Xerox website at: [www.xerox.com/office/7400support](http://www.xerox.com/office/7400support).

Troubleshooting procedures isolate a problem to a specific component or subassembly. If you go through the procedures and are still unable to solve the problem, re-read the "Theory of Operation" section for the problem area to understand how that section of the printer functions.

## System Startup

Listed here is a typical startup routine from a cold start. The printer requires approximately 45 seconds to complete this sequence.

1. When the power switch is turned On, the 'Health' LED on the Image Processor Board turns on immediately.
2. System RAM is tested. If an error is detected, RAM ERROR displays and one or both of the Control Panel and Health LEDs alternately blink at 1/2 second intervals.
3. The Boot Loader then loads and runs POST diagnostics.
4. POST turns off the Health LED.
5. POST checks the Control Panel.
6. POST checks the keypad buffer. If a shortcut has been selected, the printer displays Processing Input and the shortcut executes. If a random button is pushed, or there is an indication of a button press, Processing Input displays and POST continues. If no buttons have been pushed, POST continues execution.
7. The display is reset (addressable area turns "Gray").
8. The Control Panel LED cycles: Green, Yellow, Red, and then Off.
9. The display backlight turns on (high intensity), with nominal contrast display.
10. The display area is turned on, dark Black for 1 second.
11. The display is cleared.
12. The display backlight turns on with nominal intensity.
13. The POST Vn.nn message displays, and tests are quickly executed.
14. For Hard Faults, the display indicates the last test run and "CALL SERVICE".
15. After the POST tests have successfully finished, the Xerox 'splash screen' displays on the Control Panel and PostScript begins initialization.
16. If the printer is able, the display reads Warming up - Please wait.
17. When the final operating state of the printer is determined, the printer displays a message and LED color, Red, Yellow, or Green to indicate its condition.



# Power On Self Test (POST)

POST diagnostics provide a quick means of isolating a defective subsystem associated with the Image Processor Board and SDRAM. There are two kinds of POST faults: soft and hard. A soft fault is any fault that allows the operating system to initialize. Soft faults do not stop printer operation and are reported on the Startup page after the system is running. A hard fault prevents the operating system from initializing stopping further printer operation. Hard faults are indicated with blinking LEDs and the failed test appearing on the display.

The following tests execute when the printer is powered on after the Boot Loader runs, and before the operating system is loaded and initialized. Bypass POST by pressing the **OK** button at power on until the splash screen displays.

## POST Test Descriptions

Test	Fault Code	Fault Type	Description
SDRAM	1	Hard	This test fails if the boot loader finds no or faulty RAM (Run prior to POST). The boot loader displays "RAM ERROR" and blinks the Health and Control Panel LEDs.
Control Panel		Hard	This test checks the Control Panel connection and firmware. A fault is indicated on the Health LED.
EEPROM	10	Hard	This test checks addressing of the EEPROM.
Ethernet	11	Soft	This test checks the ethernet core.
CPU Interrupts	12	Hard	This test checks that each interrupt to the CPU is functioning.
USB	13	Soft	This test checks that the USB core is functioning properly.
Real-Time Clock	14	Soft	The real-time clock is tested.
Min. RAM	16	Hard	Checks that there is at least 128 Mbytes installed. Control Panel displays "Install More RAM" on failure.
Max. RAM	17	Soft	Checks that there is no more than 1 GB installed.
IDE Disk	20	Soft	Checks for a hard drive, then checks the disk controller core.

# POST Soft Fault Messages

When POST detects a soft error, the printer continues the startup process. Before the printer reaches its "Ready" state, the Startup page is printed with soft errors appearing in a red box. The box contains all soft faults encountered, with the upper left corner of the box in the center of the Startup page, and extending to the right margin, similar to the one shown here.



Hardware Failure:  
<device>:  
General Failure

These messages are substituted for <device>:

- Real-Time Clock
- RAM Memory Slot 1 Checksum
- RAM Memory Slot 2 Checksum
- RAM Memory Slot 1 Rejected
- RAM Memory Slot 2 Rejected
- IDE Disk

For Real-Time Clock errors, replace the Image Processor Board. For memory errors, see "RAM Memory Fault Isolation" on page 4-17. For IDE Disk errors, replace the Hard Drive.

# POST Hard Fault Messages

POST indicates a hard fault by displaying a message on the Control Panel and blinking the fault code on the health and Control Panel LEDs. There are long and short blinks. A long blink is worth 5 and a short blink is worth 1. As an example, a blink pattern flashed as long, long, short, short, represents fault code 5+5+1+1=12, indicating a failure in the CPU interrupt test. Along with the blinking LEDs, the failed test also displays as:

**POWER ON SELF TEST ERROR  
12:CPU INTERRUPTS  
CALL SERVICE**

The exception to this reporting scheme is a RAM test error. The Boot Loader executes a RAM test prior to loading POST. If the Boot Loader encounters a RAM error, POST does not load.

## Hard Error LED Blink Patterns and Messages

LED Blink Pattern	Control Panel Message	Action
1	RAM ERROR	No RAM present, or faulty RAM. Alternate 1/2 second interval blink at Control Panel and Health LEDs if the controller has initialized the FPGA. Otherwise, only the Health LED blinks.
1+1		Control Panel disconnected or defective.
5+5	10: EEPROM	<ol style="list-style-type: none"><li>1. Switch Off printer power.</li><li>2. Remove and re-install the NVRAM EEPROM.</li><li>3. Switch On printer power.</li><li>4. If the error message persists, replace NVRAM, and then the Image Processor Board.</li></ol>
5+5+1+1	12: CPU INTERRUPTS	Replace Image Processor Board (page 8-113).
5+5+5+1	16: Min RAM	Add additional RAM memory.

# Fault Isolation

Isolate a fault to the print engine or Image Processor Board by printing a test print.

- If the printer successfully prints, replace the Image Processor Board (page 8-113).
- If the Printer fails to print, troubleshoot the print engine starting with the AC power supply on (page 4-16).

## Entry Level Fault Isolation Procedure

Use this procedure to quickly locate the general area of the problem.

### Entry Level Troubleshooting Procedure

Step	Actions and Questions	Yes	No
1	Cycle printer power. Does READY TO PRINT appear on the Control Panel within 1 minute?	Go to Step 4.	Go to Step 2.
2	Does the printer display an error message?	Go to the procedure for that error.	Go to Step 3.
3	Is the Control Panel display defective, or the buttons inoperable?	Go to Control Panel Troubleshooting (page 4-10).	Go to Step 4.
4	Run test prints from all input trays: In the Main Menu, select <b>Troubleshooting</b> and press <b>OK</b> . Select <b>Print Quality Problems</b> and press <b>OK</b> . Select <b>Test Prints</b> and press <b>OK</b> . Does the printer display an error message or code while printing?	Go to the procedure for that error message or code.	Go to Step 5.
5	Do the test prints print?	Go to Step 6.	Go to Step 7.
6	Evaluate the test prints. Does the print meet specifications?	Go to Step 8.	Go to "Test Prints" on page 4-10.
7	Enter Service Diagnostics and generate test prints from all input trays. Do the test prints print?	Go to "Test Prints" on page 4-10.	Go to "Inoperative Printer" (page 4-11).
8	Request the customer send a print job from their application. Did the job print successfully?	Problem solved.	Go to "Network Diagnostics" (page 4-24).

# Service Diagnostics

Service Diagnostics provides tests for most electro-mechanical components in the printer. Service Diagnostics also contains test prints, printer status and some NVRAM access. If confronted with an error that requires more than a cursory investigation to clear or when directed by a troubleshooting procedure, use Service Diagnostics to exercise selected sub-assemblies of parts in the vicinity of the reported error. Tests are controlled from the Control Panel and are described in detail in the Appendix.

The Service Diagnostics Main menu offers the options listed in the following table.

## Service Diagnostics Main Menu

Menu Item	Test Target
Print Service Menu Map	Prints the Service Diagnostics menu map.
General Status	Query information about the status, versions, and counts.
Test Prints	Isolate problems with Xerographics and paper handling.
Motors/Fan Tests	These tests exercise each motor or fan.
Sensor/Switch Test	Tests sensor status and operation.
Clutch Tests	Tests clutch function.
Solenoid Tests	Tests solenoid function.
Finisher Tests	Tests Finisher components.
Adjustments/Calibrations	Utilities for calibrating ADC and ATS functions.
NVRAM Access	Reset PostScript or all NVRAM.
IP Controller Diagnostics	Tests the Image Processor Board.
Exit	Exits Service Diagnostics and reboots the printer.

## Using Service Diagnostics

Sensors located throughout the printer and attached options monitor paper handling and mechanical activity along the entire paper path. As a sheet travels along the paper path, sensors change state temporarily to indicate the sheet's presence. If the pattern of sensor state changes differs from the expected timing for a particular paper size and path, the sensor where the timing difference occurs identifies the error to report.

However, having the error message information doesn't necessarily pinpoint the problem. Sensor signals locate where, but often cannot identify why. Motors, belts, gears, solenoids, and numerous other parts are involved in paper transport. The Service Diagnostics' suite of tests and utilities are the best tools available to pinpoint the root cause behind the reported error.

Access Service Diagnostics one of two ways:

### Entering Diagnostics Without Rebooting the Printer:

1. On the Control panel, select **Troubleshooting**, and then press the **OK** button.
2. Select **Service Tools**, and then press the **OK** button.
3. Hold down both the **Up Arrow** and **Down Arrow** buttons for about three seconds. When the **Hidden Service** menu displays, scroll to **Run Service Diagnostics**, and then press the **OK** button.

### Entering Diagnostics by Rebooting the Printer:

1. Turn the printer power Off.
2. Press the **Back** and **Help (?)** buttons simultaneously and turn the printer On.
3. Continue to hold the buttons until “Entering Service Diagnostics” is displayed.

Print a Service Diagnostics Menu Map by selecting **Print Service Menu Map**, and then pressing the **OK** button. The printer executes POST and returns to Ready. You will need to re-enter Service Diagnostics. For convenience, the Service Diagnostics Menu Map is reproduced on page A-11.

## Service Diagnostics Controls

Use the Control Panel buttons to interact with Service Diagnostics’ tests and utilities.

Button	Function
<b>Back</b>	Returns to the prior higher level menu structure, if available. If help text is displayed, pressing Back restores the current menu item.
<b>Cancel</b>	Terminates the current test or cancels current Help display.
<b>Help (?)</b>	Provides help information, if available. Pressing <b>Help (?)</b> again restores the current menu item and removes the help text.
<b>Up Arrow</b>	Scrolls up one menu item within a menu list. This control does not ‘wrap’. Used to increment data in tests requiring user input.
<b>Down Arrow</b>	Scrolls down one menu item within a menu list. This control does not ‘wrap’, the end of a menu list is designated by three asterisks. Used to decrement data in tests requiring user input.
<b>OK</b>	Enters the highlighted menu. Executes the current test item. Used to select a data value entered by the user.

## Control Panel Shortcuts

The following are Control Panel button sequences that provide shortcuts to specific commands when pressed while turning On the printer's power.

Mode	Buttons Pressed at Power On
Skip POST Diagnostics	<b>OK</b>
Print Service Diagnostics Menu Map	<b>Help (?)</b>
Reset PostScript NVRAM	<b>Back + OK</b>
Password Bypass	<b>Up Arrow + Down Arrow</b>
Enter Service Diagnostics	<b>Back + Help (?)</b>

### Note

The best method of exiting Service Diagnostics is to cycle printer power. This insures all printer components are reset. Also, an occasional paper jam is normal on the first print if clutch or solenoid tests were run.

## Hidden Service Menu

The Hidden Service menu includes a list of functions providing direct access to Service Diagnostics, counters, and the Enable Metered Toner routine. Access the Hidden Service menu as follows:

1. Highlight **Troubleshooting** --> **Service Tools**.
2. With the cursor at the top of the **Service Tools** menu, press both the **Up Arrow** and **Down Arrow** buttons.

## Service Diagnostics Utilities

Two Service Diagnostics utilities are especially useful for troubleshooting:

- Status
- Test Prints

What follows is an overview that describes the function and proper application of each utility.

### Status

Located in the General Status menu, Status reports on the condition of the printer. Status reports either No Status to Report, or sequentially lists error conditions occurring since power-up. Conditions that prevent printing are listed before warnings. Status listings are not stored. If the printer reaches Ready, the list is cleared.

# Test Prints

Test Prints can isolate printing problems to the Engine Control or Image Processor Board by eliminating image data transfer between the two. Test Prints does not exercise any Image Processor Board circuitry. Test Prints gets its image data from ROM. This allows the examination of Engine Control Board function in isolation.

Some other key features of Test Prints:

- Is the only diagnostic utility to exercise the entire print cycle.
- Isolated from the operating system (PostScript). Runs from firmware.
- Isolates the Image Processor Board from Engine Control Board.
- Helps to isolate events that cause print artifacts or prevents printing.

# Control Panel Troubleshooting

## No Control Panel Display after Power Is Turned On

### Initial Actions:

- Remove and reseat the Image Processor Board (page 8-113).
- Print an engine test print.
- Replace the Image Processor Board (page 8-113) (if Step 2 passes).
- See “DC Power Supply Troubleshooting” on (page 4-17).

### Troubleshooting Procedure Table

Step	Action and Questions	Yes	No
1	Check for +5 V at the OPEPWR connector of the Engine Control Board. Is there +5 V at OPEPWR-5 <=> ground?	Go to Step 2.	Replace the Engine Control Board (page 112).
2	Check the Control Panel connection. Is the Control Panel harness connected?	Replace the Control Panel harness. If the error persists, replace the Control Panel (page 8-111).	Connect the harness.



# Control Panel LED Is On, Control Panel Display Is Blank

1. Remove and reseal the Image Processor Board (page 8-113).
2. Replace the Control Panel (page 8-111).
3. Replace the Image Processor Board (page 8-113).
4. Replace the Control Panel harness.

## Inoperable Printer Troubleshooting

The printer does not appear to operate after the Power Switch is turned On.

### Initial Actions:

- Check the wall outlet for available AC voltage.
- Cycle printer power.
- Check the Image Processor Board Health LED for a fault indication. See "Power On Self Test (POST)" on page 4-3 for information on blink patterns.
- Systematically remove all printer options to isolate a possible problem component.
- If the problem persists, follow the procedure below.

### Troubleshooting Reference Table

Applicable Parts	Wiring and Plug/Jack References
<ul style="list-style-type: none"><li>■ LED Relay Board, PL12.1.34</li><li>■ Image Processor Board</li><li>■ Engine Control Board, PL1.1.4</li><li>■ LVPS, PL3.1.4</li></ul>	<ul style="list-style-type: none"><li>■ Print Engine Map 13 (page 10-16)</li><li>■ Print Engine LED Heads (page 10-37)</li></ul>

### Troubleshooting Procedure Table

Step	Action and Questions	Yes	No
1	Check the Control Panel. Do characters appear on the display?	Go to Step 9.	Go to Step 2.
2	Check for +5 V at the LED Relay Board. Is the voltage to the LED Board correct?	Replace the LED Relay Board (page 8-126).	Go to Step 4.
3	Check the Control Panel connection. Is the Control Panel harness connected?	Replace the Control Panel harness. Go to Step 5.	Connect the harness.

## Troubleshooting Procedure Table

<b>4</b>	Does the error persist?	Replace the Control Panel (page 8-111).	Complete.
<b>5</b>	Check voltages at the Engine Control Board. Disconnect the POWER connector. Is the voltage at each POWER pin correct?	Replace the Engine Control Board (page 8-112).	Go to Step 7.
<b>6</b>	Check the POWER connector. Reconnect the POWER Connector and cycle printer power. Does the error persist?	Replace the LVPS (page 8-121).	Complete.
<b>7</b>	Check voltages at the Image Processor Board. Disconnect the CUIF connector. Is the voltage at each POWER pin correct?	Replace the Image Processor Board (page 8-113).	Go to Step 9.
<b>8</b>	Check voltages at the Engine Control Board. Disconnect the POWER connector. Is the voltage at each POWER pin correct?	Replace the Engine Control Board (page 8-112).	Replace the LVPS (page 8-121).

## Engine Power-Up Sequence (BIST)

The following checks are made by the printer's firmware at each power-up.

- 1.** Engine Control Board logic check
- 2.** Imaging Unit (Missing, NVRAM (CRUM) Error, CRUM ID, Life Over)
- 3.** Fuser (Missing, NVRAM (CRUM) Error, Life Over)
- 4.** Toner Cartridge (Missing, Life Over)
- 5.** Transfer Roller (Missing, Life Over)
- 6.** ADC Sensor (Error)
- 7.** All paper sensor (Jam)
- 8.** Door(s) (Open)
- 9.** Environment Sensor (Error)
- 10.** NVRAM (NVRAM error)
- 11.** Image Processor Board POST Diagnostic check

## Printer Continually Displays Warming Up...

The most likely cause is that the Image Processor Board has not successfully loaded its NVRAM contents (instructions) into RAM. All print engine operation halts, and will only become ready when the Image Processor Board successfully boots.

1. Check for media or debris in the paper path.
2. Power cycle the printer.
3. Verifying Image Processor Board failure:
  - a. Power-off the printer, and remove the Image Processor Board.
  - b. Power-on the printer. Wait at least 5 minutes while the print engine initializes. If there was a problem with the Image Processor Board, it will now not affect the Engine Control Board.
  - c. If characters appear on the Control Panel display, the Engine Control Board is functional and the problem is most likely with the Image Processor Board.
  - d. Turn off the printer and reseat the Image Processor Board and turn on the printer to determine if seating was the problem.
  - e. Perform a PostScript NVRAM reset, see "Postscript NVRAM Reset" on page 6-9.
  - f. Turn off the printer and systematically remove individual optional components from the Image Processor Board to isolate a possible problem component.
  - g. Replace the Image Processor Board.

## Printer Displays Install or Reseat Imaging Unit

1. See "Install or Reseat [C][M][Y][K] Imaging Unit" on page 3-65.

## Printer Displays Reseat Controller Board

1. Turn Off printer power.
2. Remove the Image Processor Board (page 8-113).
3. Check the condition of the CUIF connector.
4. Install the Image Processor Board, and then reboot the printer. If the error persists, turn Off printer power and verify voltages supplied from the LVPS. See "DC Power Supply Troubleshooting" on page 4-17.
5. Reboot the printer. If the error persists, turn Off printer power and replace the Image Processor Board.
6. Reboot the printer. If the error persists, turn Off printer power and replace the Engine Control Board (page 8-112).

### Note

A failure of the NVRAM chip on the Engine Control Board will produce this message. Reseat the NVRAM component in the socket and retest.

# Printer Does Not Come to a Ready State

- See “AC Power Supply Troubleshooting” on (page 4-16).
- See "Fault Isolation" on (page 4-6).

## Paper Size Switch Assembly

The position of a multi-slotted plate, at the rear of the universal paper tray, is set according to the position of the tray’s paper guides. Upon insertion of the tray, the plate’s position actuates the Paper Size Switch.

A Paper Size Mismatch or Tray Missing error are sometimes the result of a damaged or jammed Paper Size Switch. To correct these types of errors, use the following procedure.

### Initial Actions:

- Remove the affected tray and examine the switch actuators for evidence of damage or debris.
- Cycle printer power.
- If the problem persists, follow the procedure below.

### Troubleshooting Reference Table

Applicable Parts	Wiring and Plug/Jack References
<ul style="list-style-type: none"><li>■ Paper Size Switch, PL4.1.19</li><li>■ Motor Driver Board, PL2.1.10</li></ul>	<ul style="list-style-type: none"><li>■ Print Engine Motor Driver Board (1/5) (page 10-31)</li></ul>

### Troubleshooting Procedure Table

Step	Action and Questions	Yes	No
1	Check the tray. Exchange the tray. Does the error follow the tray?	Replace the tray.	Go to Step 2.
2	Check the affected Paper Size Switch for damage or debris. Is there any damage or debris?	Clean or replace as necessary.	Go to Step 3.
3	Check the size of the loaded media. Is the media the correct size?	Go to Step 4.	Load the correct media.
4	Check the adjustment of the paper guides. Are the guides adjusted properly?	Go to Step 5.	Readjust the guides.

## Troubleshooting Procedure Table

<p><b>5</b></p>	<p>Test the affected Paper Size Switch.</p> <ol style="list-style-type: none"> <li>1. Disconnect P/J471.</li> <li>2. Run the Service Diagnostics Paper Size Switch Test.</li> </ol> <p>Does the switches function normally? Use the Paper Size Switch State table to verify proper operation.</p>	<p>Go to Step 6.</p>	<p>Replace the Paper Size Switch (page 8-139).</p>
<p><b>6</b></p>	<p>Check the Paper Size Switch signals.</p> <ol style="list-style-type: none"> <li>1. Disconnect the Motor Driver Board PSIZE connector.</li> <li>2. Check voltages at these pins:  PSIZE-1 = +5 V  PSIZE-2 = +5 V  PSIZE-4 = +5 V  PSIZE-5 = +5 V  Is +5 V available at each PSIZE pin?</li> </ol>	<p>Replace the Paper Size Switch (page 8-139)</p>	<p>Replace the Motor Driver Board (page 8-141).</p>

## Universal Tray Paper Size Switch States

SW1	SW2	SW3	SW4	Media Size
0	0	0	0	No tray installed
1	1	1	1	A/Letter (LEF)
1	0	1	0	A/Letter (SEF)
1	0	0	1	A3
0	0	1	1	A3-Nobi
1	1	1	0	A4 (LEF)
0	0	1	0	A4 (SEF)
0	1	1	0	A5
0	1	1	1	A6
0	0	0	1	B4
1	1	0	0	B5 (LEF)
1	0	0	0	B5 (SEF)
1	0	1	1	B/Tabloid
1	1	0	1	Executive
0	1	0	0	Ledger 13 in.
0	1	0	1	Legal 14 in.

# Power Supply

## LVPS Overcurrent Protection Circuit

This circuit stops all outputs if the 24 VDC, 5 VDC or 3.3 VDC power supply detect a short circuit. The circuit is reset when the short is removed, the power is turned off, and then on again.

## LVPS Overvoltage Protection Circuit

This circuit stops all outputs if the 24 VDC, 5 VDC or 3.3 VDC power supply exceeds the specified voltage. The operating point is 32 VDC or more for 24 VDC, 7 VDC or more for 5 VDC, or 6 VDC or more for 3.3 VDC.

## +24 VDC Output Stopped By Interlock Switch

Opening the Top Cover, Door A or Front Door opens the Interlock Switch. This shuts off the +24 VDC supplied to the motors, clutches, and solenoids.

# AC Power Supply Troubleshooting

## Troubleshooting Reference Table

Applicable Parts	Wiring and Plug/Jack References
■ LVPS, PL3.1.4	■ Print Engine LVPS (page 10-39)

## Troubleshooting Procedure Table

Step	Action and Questions	Yes	No
1	Check the voltage at the AC wall outlet. Is there approximately 110 VAC (or 220 VAC if the printer is a 220 V configuration) at the AC wall outlet?	Go to Step 2.	Notify the customer of improper AC output from the outlet.
2	Check the power cord for defects or a loose connection.	Replace or reseal the power cord.	Replace the LVPS (page 8-121).

# DC Power Supply Troubleshooting

## Troubleshooting Reference Table

Applicable Parts	Wiring and Plug/Jack References
■ LVPS, PL3.1.4	■ Print Engine LVPS (page 10-39)

## Troubleshooting Procedure Table

Step	Action and Questions	Yes	No
1	Perform the AC power supply troubleshooting procedure. Does the problem persist?	Go to Step 2.	Complete.
2	Check for +24 V at CN2. Is there +24 V at CN2-1 <=> ground?	Replace the affected harness..	Replace the LVPS (page 8-121).

## RAM Memory Fault Isolation

Image Processor Board RAM memory has failed or is not installed. A minimum of 256 MB of RAM must be installed for proper printer operation. The Phaser 7400 Color Printer supports DDR PC2700 in 200-pin SODIMM form. The printer accepts modules of 256 or 512 MB in combinations up to the maximum of 1 GB.

### Errors appearing on the Startup page:

Hardware Failure: RAM Memory Slot 1 Checksum  
Hardware Failure: RAM Memory Slot 2 Checksum  
Hardware Failure: RAM Memory Slot 1 Rejected  
Hardware Failure: RAM Memory Slot 2 Rejected

### Errors appearing on the Control Panel:

Power On Self Test Error 15: RAM DIMM  
Power On Self Test Error 16: Minimum RAM Limit  
Power On Self Test Error RAM ERROR

### Initial Actions:

Check that the RAM devices are making positive contact with their connectors.

1. Power off the printer.
2. Remove and re-install the RAM memory after verifying it meets the Xerox specifications. See "Memory Specifications" on page 1-13. If the problem persists, use the following procedure to correct it

## Troubleshooting Reference Table

Applicable Parts	Wiring and Plug/Jack References
<ul style="list-style-type: none"> <li>■ SDRAM Memory</li> <li>■ Image Processor Board</li> </ul>	<ul style="list-style-type: none"> <li>■ Print Engine Map 4 (page 10-7)</li> </ul>

## Troubleshooting Procedure Table

Step	Action and Questions	Yes	No
1	Power on the printer. Is RAM ERROR displayed on the Control Panel?	Go to Step 5.	Go to Step 2.
2	Is 15: RAM DIMM displayed on the Control Panel?	Go to Step 5.	Go to Step 3.
3	Is 16: Min RAM Limit displayed on the Control Panel?	Go to Step 5.	Go to Step 4.
4	Print a Startup Page and review the contents. Does the Startup Page identify a failed memory DIMM?	Replace the DIMM and go to Step 9.	Go to Step 5.
5	Are there two DIMMs installed in the printer?	Go to Step 6.	Go to Step 8.
6	Determine Memory condition. 1. Power off the printer and remove one of the DIMMs. 2. Power on the printer. Is a memory fault message displayed?	Go to Step 8.	Go to Step 7.
7	1. Power off the printer and remove the first DIMM. 2. Install the second DIMM and power on the printer. Is a memory fault message displayed?	Go to Step 8.	Go to Step 9.
8	1. Power off the printer and move the suspected defective DIMM to the other memory socket. 2. Power on the printer. Does the DIMM fail in the new location?	Replace the DIMM and go to Step 9.	Replace the I/P board (page 8-113).
9	Install all of the DIMMs and power on the printer. Is a memory fault message displayed?	Replace the I/P board (page 8-113).	Complete



# Media Jams and the Paper Path

## Media-Based Problems

1. Check that the correct type of media is being used; for the correct media types and weights, see the Recommended Media List on the Xerox website at: [www.xerox.com/office/7400support](http://www.xerox.com/office/7400support). The customer should use a quality printer paper. The printer may have trouble picking glossy or overly smooth paper.
2. Only Phaser 35-Series Premium Transparency Film can be used in this printer.
3. Inspect the paper for bent, torn, or folded corners.
4. Check the paper path for obstructions or debris.
5. Ensure that the correct media type is set in the Control Panel.
6. Ensure that the paper guides are set correctly.
7. Ensure that the media is a supported type for the tray. See the Recommended Media List for the correct media types, sizes and weights for each tray.
8. Load a fresh ream of paper in the tray.

## Multiple-Sheet Pick

1. Ensure that the paper is in good condition and is listed on the Recommended Media List as supported media; quality office printer paper works best.
2. Ensure that the printer is printing within its environmental specifications by printing and reviewing the Status page.
3. Open the tray and remove, fan, and reload the media. Ensure that the guides are securely against the paper and the tray has not been over filled.
4. Try loading paper from a fresh, unopened ream, fan the paper, and then insert into the tray or flip existing paper over.
5. Check the tray's Retard Roller for damage.
6. Clean the Feed Rollers with a clean, dry, lint-free wipe.
7. Replace the Feed Rollers.
8. Replace the paper tray.

## Mis-Pick

1. Check that the correct type of media for the tray is being used and the paper guides are set correctly.
2. Remove, fan, and reload the media. Ensure that the tray has not been over filled.
3. Try loading paper from a fresh ream, fan the paper, and then insert into the tray or flip existing paper over.
4. Clean the Feed Rollers with a clean, dry, lint-free wipe.
5. Troubleshoot the feed assemblies.

## Skewed Image

1. The image area is not parallel “Skewed” with the sides of the page but the printer neither jams nor displays an error code.
2. Remove the tray and ensure the paper guides are set correctly.
3. Check that the correct type of media for the tray is being used.
4. Ensure that the tray has not been over filled. (Skewed images are a common defect when Tray 1 (MPT) is overfilled.)
5. Verify the Feed Rollers are installed correctly.
6. Clean the Feed Rollers with a clean, dry, lint-free wipe.
7. Troubleshoot the feed assemblies.

## Damaged Prints

The printed page exits the printer either wrinkled, creased, or torn. The printer neither jams nor displays an error code.

1. Stop the page at various points in the paper path to determine where the media becomes damaged. See “Input Paper Path ” on page 2-27 for more information.
2. Inspect the paper tray and path for debris or broken components.
3. Try using the next heaviest type of paper. For more information print the Paper Tips Page from the printer’s Information Pages menu.
4. Feed paper through the printer from each of the available trays. Is the paper damaged when fed out of one tray but not when fed out of the others? If so, inspect the tray for damage, ensure that the media guides are set correctly and verify that the proper media is being used.
5. If media shows damage from all trays, check for a problem in Registration Roller Assembly area.

## Fuser Jams

1. Check that the Fuser is properly seated, locked, and operates normally.
2. Ensure that the paper is in good condition and is listed on the Recommended Media List as supported media. Try loading new media from a fresh ream.
3. Ensure that only Phaser 35-Series transparency film is being used.
4. Check that the printer is operating within its environmental specifications by using the Printer Status Page.
5. Ensure that the loaded media matches the Control Panel settings.
6. Are the margins on the page greater than 5 mm?
7. Check the Fuser area for debris.
8. Visually inspect the Fuser baffle for burrs.
9. Test the Fuser Motor using Service Diagnostics.
10. See “Jam at Fuser” on page 3-31 for troubleshooting Fuser Jams.

## Exit Jams

1. Ensure the paper is in good condition and is the correct type for the printer. See “Media and Tray Specifications” on page 1-18 for the correct media types, sizes and weights for each tray.
2. Ensure the printer is within its operating environmental specifications.
3. If media is showing excessive curl when exiting, try turning the media over, loading new media from a fresh ream, or a different type of media.
4. Ensure that the loaded media matches the Control Panel settings.
5. Is the jam caused by a heavy, stiff paper being used for two-sided printing? In such cases, a lighter grade of paper should be used, see the printer’s Paper Tips page.
6. Clean all exit locations in the Fuser and the Exit Assembly, with a clean, dry, lint-free wipe, if debris is visible.
7. Does the Exit Rollers turn? Test the Duplex Motors using Service Diagnostics. For information on Service Diagnostics, see “Service Diagnostics” on page 4-7.
8. See “Jam at Duplex Unit” on page 3-26 for troubleshooting duplex jams if the Duplex Motor tests fails.

## Operating System and Application Problems

Print a Status page to ensure the problem is not printer related. See “Status Page” on page 3-3. Troubleshooting tips and additional information are also available on the Xerox website at: [www.xerox.com/office/7400support](http://www.xerox.com/office/7400support).

## Macintosh Printing Problems

### Image Never Prints

#### Note

The following steps are for diagnosing a networked printer running Mac OS X, version 10.2.6 or later, and assume that CentreWare access is enabled. If you are using Mac OS X, but an earlier version than 10.2.6, upgrade first.

1. Cycle power to the printer Off and On, and then try printing again.
2. Determine the printer’s IP address from the Control Panel or Startup page. Return the Control Panel to the initial menu, and then check to make sure it indicates Ready to Print. If it does not indicate Ready to Print, correct that first.

3. Make sure you can connect to the printer via network from the host: Open a Safari or Internet Explorer window to the printer IP address. Once you have established basic network connectivity, proceed to Step 4.
  - a. If you can not see the CentreWare IS page from the printer CentreWare IS web server, the printer may be Off, on a different network, or the host is not networked correctly. Try Steps b through f to correct the problem. If you make any changes to the network, try printing the job again.
  - b. Open **System Preferences**, select **Network**, and select the **TCP/IP** tab. Make sure you have a valid IP address. Correct the settings and retry if needed.
  - c. If you are on a network with a proxy server, ensure the local connections are excluded from the proxy. Check **System Preferences, Proxies** tab – in the Bypass proxy settings for these Hosts and Domains, to ensure the local network devices are excluded from proxy redirection.

For example: If you open Safari to the printer IP and get an error message similar to Error – the request item could not be loaded by the proxy, you are probably accessing the proxy server for a local address. This is incorrect.

- d. Open the Terminal tool located at **Applications --> Utilities** at the root of the Mac OS X boot disk, and select New Window. Once you have a prompt, try network connectivity using the Ping command.

For example: **ping 13.62.70.112** will check for echo replies from the printer with that IP address.

- e. In the Terminal tool, try using Traceroute to determine if you are on the same subnet as your printer.

For example: **tracert 13.62.70.112** should produce exactly one hop before completing the trace. Correct as needed, and retry your print job.

- f. If you still cannot connect to the printer via network, try another computer.

4. In Mac OS X, open Printer Setup Utility, located at **Applications --> Utilities** at the root of the Mac OS X boot disk. Check to make sure the printer status does not indicate Stopped. If it does, check your network and insure the host system is on the same subnet as the printer. Correct if needed. Delete all jobs in the queue for the printer by double-clicking the printer name, selecting each job, and clicking **Delete**. Restart the print queue by clicking **Start Jobs**. Try your print job again.
5. In the Printer Setup Utility, select your printer. In the **Printers** menu, select **Show Info**. From the pull-down menu in Printer Info, make sure the configuration shown for the printer is correct. If the configuration is wrong, click the configuration in the pull-down menu, and re-install. Check the Installable Options and make sure they match the printer's configuration. If any changes are made, retry your print job.
6. If there is still no output, try printing from a simple application. Open TextEdit located at the Applications folder, select **New File**, and create a small test document. Select **Print** from the **File** menu.
7. If an error message displays or there is no output, try turning on the PostScript error status from CentreWare IS or the printer's Control Panel. PostScript will now output an error page if an error occurred during the print job, assuming the printer received it.

8. Try printing again using the TextEdit tool located at the Applications folder. Once you have opened a document or created a new document, select **Print** from the **File** menu. Click on the **Printer** pull-down menu, and then select **Edit Printer List**. Click the **add** button, or pick **Add Printer** from the **Printers** menu (The add button is configurable, so it may not be there). Select **IP Printing** from the pull-down menu. Put the IP address your printer in the Printer's Address text area. Click on the **Printer Configuration** pull-down menu, and then select **XEROX**. A scrolling list should display. Pick the correct Xerox Phaser 7400 configuration. You can check the exact configuration on the printer's Startup page in the upper right corner. The newly added printer displays in bold on the printer list, indicating it is the default printer. When you are done adding the new printer, close the Printer List dialog. Now select your printer from the **Printer** pull-down menu, and then click **Print** in the dialog box.
9. If you can print from the TextEdit tool, but cannot print from your application, the problem is likely in your application. Check for upgrade availability or contact the application vendor for further diagnosis.

## Windows Printing Problems

### Image never prints

1. Try printing a test page from the printer driver's Properties dialog box.
2. Try printing from another application.
3. Try printing to another network/PostScript printer.
4. Try printing from another computer.
5. If the error returns, turn On the PostScript error handler through the Control Panel PostScript Error Info in the Support menu, or CentreWare IS and print the document again. Take note of the information on the error page that just printed.

# Network Problems

The Phaser 7400 printers include diagnostic tools to help resolve networking problems that prevent printing. Located in the Troubleshooting menu is the Network Problems menu. The Network Problems menu lists the Network Diagnostics test and the Network Log Pages. Use these tools to verify network connectivity.

## Initial Actions:

- Check that the driver software is properly installed on the host.
- Make sure the network cable is connected at both ends and is serviceable.
- Print a Configuration page to verify the correct IP address, network mask, and gateway are entered into the printer's NVRAM.
- Reboot the printer to clear the network logs.
- If the problem persists, follow the procedure below.

## Network Diagnostics

Selecting Network Diagnostics runs a test on the TCP/IP connection (Ethernet Port) and displays the results. If no errors are detected, the message Network diagnostics completed, No problem detected displays, along with options for Help or printing either the Connection Setup or Configuration page. The Connection Setup and Configuration pages list current network parameters stored in the printer's NVRAM. If Network Diagnostics detects an error, the error message displays with menu options to assist in correcting the error. Pressing **Help (?)** provides help text listing steps to help diagnose and clear the error.

In situations where Network Diagnostics completes without an error, but printing continues to fail, test the printer's Ethernet Port directly using a cross-over cable and a second, known good, Ethernet Port. A successful test using this procedure eliminates the printer's networking hardware as the root cause.

### Note

The Ethernet Port verification procedures were developed for Windows XP or Mac OS X. If a different operating system is in use, adapt the steps as necessary.

## Windows Ethernet Port Verification

1. Connect a crossover cable between the printer and computer's Ethernet Ports.
2. Verify that the printer is Ready To Print.
3. Click **Start**, and then **Run** at the computer to access the **Run** dialog.
4. Type in **cmd** and click **OK** on the **Run** dialog to launch the MS-DOS command window.
5. Type in **ipconfig** at the MS\_DOS command prompt and press **Enter** to display the computer's IP address, subnet mask, and gateway.
6. Print the Configuration page to verify that TCP/IP is enabled and obtain the current TCP/IP values stored in the printer's NVRAM.

### Note

Configure the printer's TCP/IP network parameters to enable direct communication with the computer.

7. Disable DHCP/BOOTP and AutoIP on the printer.
8. Select an IP address for the printer that matches the computer, except for the last field, which must be unique.
9. Edit the printer's gateway and subnet mask to match the computer.
10. Type **ping** followed by a space and the printer's IP address at the MS\_DOS command prompt, and then press **Enter**. If the number of packets sent and received match, the Ethernet Port is functional. If the request times out and fails to reply, either the cable or the port is defective.

## Mac OS X Ethernet Port Verification

1. Turn the printer on and wait until it is Ready to Print.
2. To check the computer's TCP/IP settings, use the Apple menu to select System Preferences.
3. Select **Network**.
4. Select **Show Built-in Ethernet**.
5. Click the **TCP/IP** tab and record the computer's IP address, subnet mask, and gateway.
6. Print the Configuration page and verify that TCP/IP is enabled on the printer.
7. Select an IP address for the printer that matches the computer, except for the last field, which must be unique.
8. Edit the printer's gateway and subnet mask to exactly match the computer's.
9. Connect a crossover cable between the Ethernet ports on the printer and the Mac.
10. Test the application using Network Utility by double-clicking the hard drive icon.
11. Select **Applications --> Utilities --> Network Utility**.
12. Click the **PING** tab.

13. Enter the printer's IP address.
14. Configure the utility to PING the printer four times. The test will end after four attempts.
15. Click the **PING** button to complete the test.
16. If the number of packets sent and received match, the test was successful and the Ethernet port is functioning. If the request times out and fails, the cable or the port are malfunctioning.

## Network Logging

Four logs are stored in the printer that detail network functions. The logs contain TCP/IP and AppleTalk initialization and runtime events. The logs can also be accessed remotely via CentreWare IS. The logs list events chronologically. The log is limited in length; when the log is full the printer stops recording data to the log. The logs are cleared each time the printer's power is cycled.

To print the network logs:

1. On the Control Panel, select **Troubleshooting**, and then press the **OK** button.
2. Select the **Network Problems** menu, and then press the **OK** button.
3. Select the **Network Log Pages** menu, and then press the **OK** button..
4. Select the desired log, and then press the **OK** button.



# USB Port Testing

## Initial Actions:

- Check that the driver software is properly installed on the host.
- Make sure the USB cable is connected at both ends and is serviceable.
- Print a Configuration page and verify that USB 2.0 is enabled in the printer's NVRAM.
- Reboot the printer.
- If the problem persists, follow the procedure below.

## Note

The testing procedure was developed for Windows XP. If a different operating system is in use, adapt the steps as necessary.

In situations where USB communications fail, test the printer's USB Port directly using a USB cable and a second, known good, USB Port. A successful test using this procedure eliminates the printer's USB Port as the root cause.

1. Verify that the printer is Ready To Print.
2. Insert the Phaser 7400 Software and Documentation CD-ROM into the computer.
3. If the installer autoruns, exit the installer window.
4. Connect a USB cable between the printer and computer's USB Ports. The computer automatically detects the new hardware and creates a driver.

## Note

If the driver is not installed on the computer, locate the driver files on the CD-ROM. Once the files are located, the computer installs the driver and automatically configures it to match the printer's feature set.

5. Open the **Printers and Faxes** window on the computer by clicking **Start**, **Settings**, and then **Printers and Faxes**.
6. Locate the correct entry for the printer being tested and display its properties from the **File** menu pull-down.
7. Open the **General** tab and click the **Print Test Page** button to generate the test print. If the test page prints, the USB port is functioning normally.



# Print-Quality Troubleshooting

## In this chapter...

- Print-Quality Problems Overview
- Control Panel Test Prints
- Service Test Prints
- Print Engine Test Print
- Print-Quality Troubleshooting

Section

5

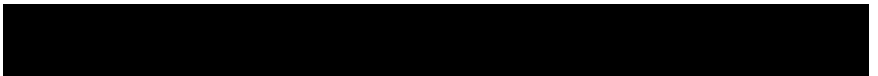

# Print-Quality Problems Overview

Print-quality defects can be attributed to printer components, consumables, media, internal software, external software applications, and environmental conditions. To successfully troubleshoot print-quality problems, eliminate as many variables as possible. The first step is to generate prints using printable pages embedded in the printer on paper from the Supported Media List. Use paper from an fresh, unopened ream that is acclimated to room temperature and humidity.

See "Media and Tray Specifications" on page 1-18 or the Paper Tips page for media that has been tested and approved for use in Phaser 7400 printers. If the print-quality defect is still present when printing on approved media, then investigate software applications and environmental conditions.

Print the Status or Configuration page to determine the temperature and humidity under which the printer is operating. Compare this to the "Environmental Specifications" on page 1-17. Temperature and humidity extremes can adversely effect the xerographic and fusing characteristics of the printer.

Phaser 7400 printers use separate Imaging Units to develop a latent image for each color where the colors are combined on the Transfer Unit to form the final image. In most cases, print-quality defects are the result of one particular component in the print engine. See the Repeating Defects chart or print the Repeating Defects page from the Control Panel. When a single component of the Imaging Unit is causing a print-quality defect, replace the Imaging Unit.

When analyzing a print-quality defect, first determine if the defect occurs in all colors or only one color and if it is repeating or random. Continuous defects in the process direction, such as voids and lines, are the most difficult to diagnose. Inspect the visible surfaces of all rollers for obvious defects. If no defects are observed, replace the Imaging Units, Transfer Unit, and Fuser one at a time until the defect is eliminated.

# Defects Associated with Specific Printer Components

Some print-quality problems can be associated with specific assemblies, the most common problems and the associated assemblies are listed below. Also, refer to the printer's Troubleshooting Print-Quality Problems pages or a specific print-quality troubleshooting procedure for more information.

## Imaging Unit

- Streaks in Process Direction (in the direction of feed, parallel with paper travel)
- Banding in Scan Direction (across the page, perpendicular to paper travel)
- Uneven Density
- Voids
- Repeating Defects
- Mis-registration

### Note

See "Cleaning the Imaging Unit Contacts" on page 7-3 for instructions on how to clean the contacts.

## Transfer Unit

- Toner on the back side of the printed page (simplex mode)
- Light Prints
- Repeating Defects
- Mis-registration - only when there is obvious damage to the belt.

## Fuser

- Hot or Cold Offsetting
- Repeating Defects
- Dark Streaks in Process Direction

## LED Head

- Streaks in the Process Direction
- Uneven Density in the Scan Direction

# Test Prints

A variety of test prints are available to aid in determining the quality of output from the printer and to assist in troubleshooting. This section shows how to select and analyze test prints.

On the Control Panel, select **Troubleshooting**, select **Print Quality Problems**, and then **Color Test Pages**.

## Analyzing the 100% Solid Fill Pages

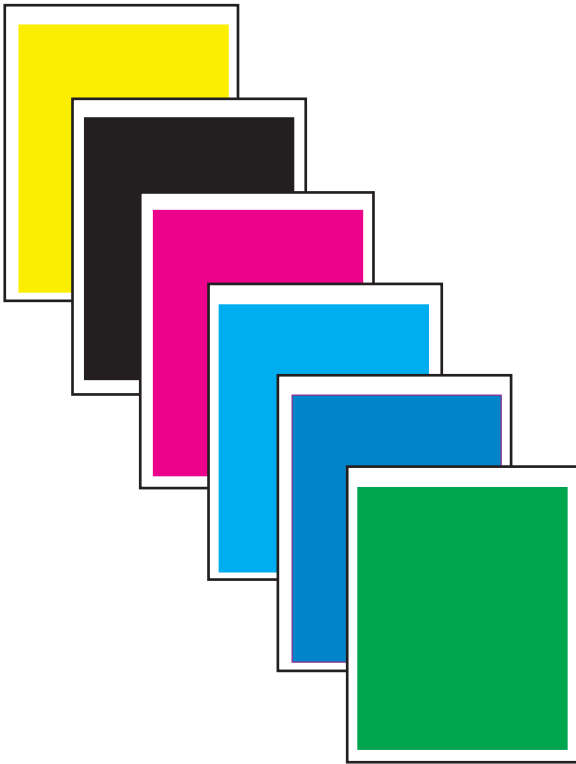

s7400-315

This print consists of 6 pages, 100% solid fill in CMYK, Blue and Green. Things to look for on the 100% Solid Fill:

- Wrinkling
- Creases
- Roller marks
- Scratches

- Repeating defects or banding
- Missing Color(s)
- Streaks
- Voids

## Analyzing the Color Test Pages

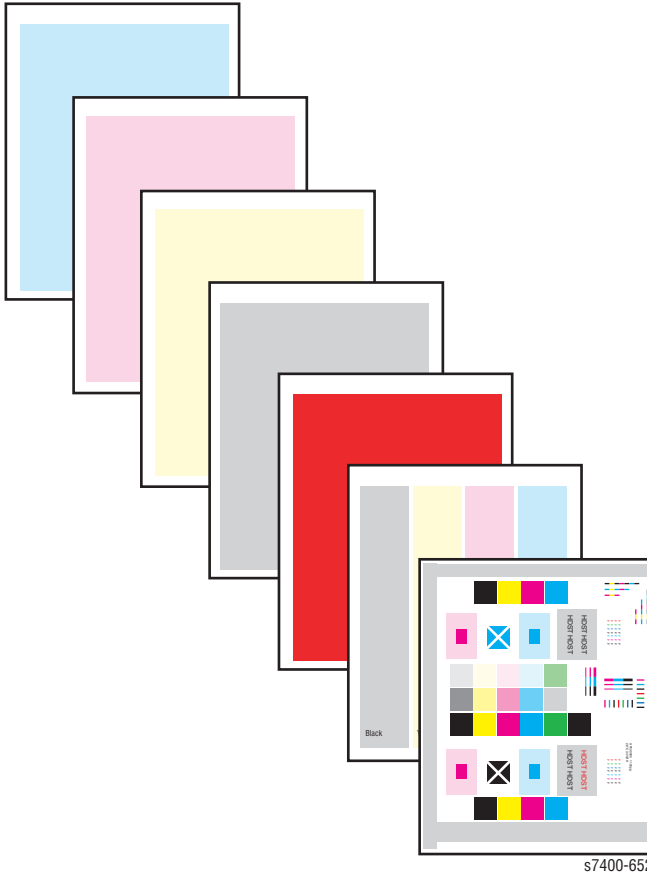

This print consists of 7 pages, 25% fill in CMYK, 100% solid fill red, and the PS Pattern page.

Things to look for:

- Repeating defects or banding
- Missing Color(s)
- Streaks
- Voids

1. Consistent fills in each primary color. Each color should be consistent across the width of the page with no voids.
2. No separation or misconvergence where each bar meets its neighbor. Each bar is separated by a thin black line.
3. Look for thin white lines that would indicate a dirty LED lens or a scratched Imaging Unit.
4. Look for dark lines that would indicate a dirty or damaged Imaging Unit.
5. Look for complete fusing. Cold or hot offset fusing could indicate the incorrect paper weight has been selected.

## Analyzing the PS Pattern

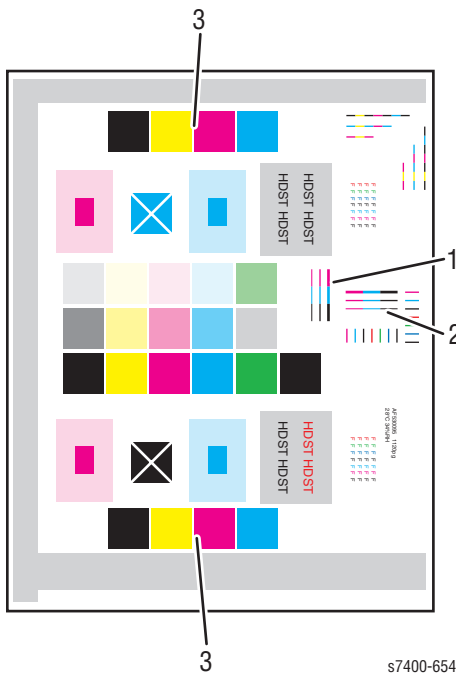

This print is found in the Hidden Service menu. Things to look for include:

1. Color Registration (Horizontal): The colored lines should match up. Perform the color registration procedure. Clean the Color Registration Sensor and cycle power to the printer.
2. Color Registration (Vertical): The colored lines should match up.
3. Uniform RGB: The secondary color squares should be uniformly colored with no mottling.
4. Density: The color bars should have even density from top to bottom.



5. Margins: Margins should be 8 mm from the edge of the paper to the line.
6. Image Size: The image height should be 261 mm between the top and bottom lines. The image width should be 192 mm between the left and right lines.

## Analyzing the Color Step Pages

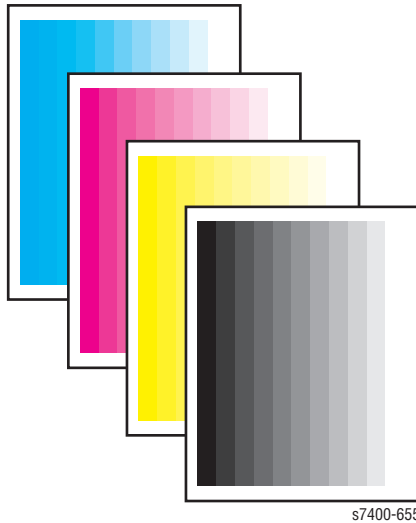

This print consists of 4 pages, CMYK in graduated fills of decreasing density.

Things to look for:

- Repeating defects or banding
  - Inconsistent variations in density
  - Streaks
  - Voids
1. Graduated fills in each color. Each color should be consistent across the width of the page with no voids.
  2. No separation or misconvergence where each bar meets its neighbor. Each bar is separated by a thin black line.
  3. Look for thin white lines that would indicate a dirty LED lens or a scratched Imaging Unit.
  4. Look for dark lines that would indicate a dirty or damaged Imaging Unit.
  5. Look for complete fusing. Cold or hot offset fusing could indicate the incorrect paper weight has been selected.

# Print-Quality Troubleshooting

## Light Prints in All Colors

The overall image density is too light in all colors. If the image is light in only one color, see "Light Print in Only One Color" on page 5-10.

### Initial Actions

- Verify the media used is supported by this printer.
- Verify the media settings are correct at the Control Panel.
- Print the Color Calibration page to rule out an application problem.
- Run the color calibration routine prior to using this troubleshooting procedure.

### Troubleshooting Reference Table

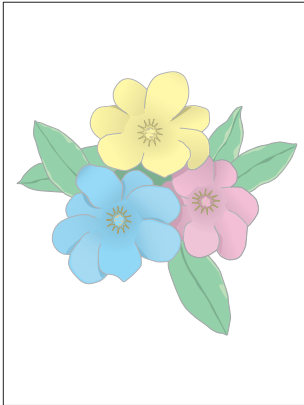
Applicable Parts	Example Print
<ul style="list-style-type: none"><li>■ Imaging Unit</li><li>■ LED Head</li><li>■ Transfer Unit</li><li>■ HVPS</li><li>■ Engine Control Board</li></ul>	 <p>s7400-319</p>

### Troubleshooting Procedure Table

Step	Actions and Questions	Yes	No
1	Verify all packaging material has been removed from the toner cartridges.	Go to Step 2.	Remove the packing material.
2	Verify the correct color correction setting is selected in the printer driver? <b>NOTE:</b> TekColor correction set to Automatic provides the best results for most documents.	Go to Step 3.	Set the color correction to automatic and reprint the job.

## Troubleshooting Procedure Table (Continued)

<b>Step</b>	<b>Actions and Questions</b>	<b>Yes</b>	<b>No</b>
<b>3</b>	Perform the Light and Darkness Color Balance Procedure. Did this correct the problem?	Complete.	Go to Step 4.
<b>4</b>	Remove the Imaging Units and Transfer Unit and check for toner contamination on the high voltage contacts.	Clean the contacts.	Go to Step 5.
<b>5</b>	Are the LED Heads dirty? Clean the heads with a clean, lint-free cloth. Did this correct the problem?	Complete.	Go to Step 6.
<b>6</b>	Are the harnesses on the LED Heads undamaged, properly routed and seated?	Go to Step 7.	Replace or reseal the wiring harness.
<b>7</b>	Is +5 V supplied to each LED Head?	Go to Step 9.	Go to Step 8.
<b>8</b>	Is +5 V supplied to the POWER connector on the Imaging Unit Sensor Board?	Replace the Imaging Unit Sensor Board (page 8-142).	Replace the LVPS (page 8-121).
<b>9</b>	Is +24 V supplied to the POWER connector on the Engine Control Board?	Go to Step 10.	Replace the LVPS or wiring harness.
<b>10</b>	Is +24 V supplied to the HVOLT connector on the Engine Control Board.	Go to Step 11.	Replace the Engine Control Board (page 8-112).
<b>11</b>	Inspect the high-voltage wiring harness.	Replace defective wiring harness.	Replace the Transfer Unit. If the error persists, replace the HVPS (page 8-119).

# Light Print in Only One Color

Only one color; yellow, magenta, cyan, or black, is too light on the printed image. In the example below, cyan is printing too light causing the blue flower to look too light and effecting the true green of the leaves.

## Initial Actions

- Verify that color calibration has been performed prior to using this troubleshooting procedure.
- Check that the Toner Cartridge pull strip is completely removed from the affected color.

## Troubleshooting Reference Table

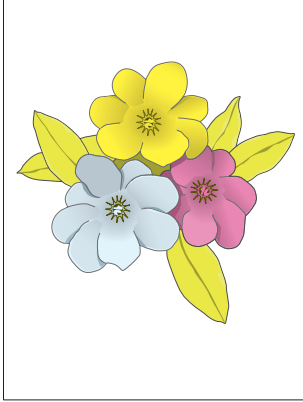
Applicable Parts	Example Print
<ul style="list-style-type: none"><li>■ Imaging Unit</li><li>■ LED Head</li><li>■ Engine Control Board</li><li>■ Toner Supply</li><li>■ Housing Bias Assembly</li></ul>	 <p>s7400-320</p>

## Troubleshooting Procedure Table

Step	Actions and Questions	Yes	No
1	Verify all packaging material has been removed from the toner cartridges.	Go to Step 2.	Remove the packing material.
2	Verify the correct color correction setting is selected in the printer driver? <b>NOTE:</b> TekColor correction set to Automatic provides the best results for most documents.	Go to Step 3.	Set the color correction to automatic and reprint the job.
3	Print the 100% Solid Fill test print. Can the problem be isolated to one primary color?	Go to Step 4.	"Light Print in Only One Color" on page 5-10.

## Troubleshooting Procedure Table (Continued)

Step	Actions and Questions	Yes	No
4	Remove the Toner Cartridge and check for toner starvation in the Imaging Unit. Is there evidence of toner starvation?	Replace the Toner Cartridge.	Go to Step 5.
5	Remove the Imaging Units and the Transfer Unit and check for toner contamination on the high voltage contacts. Are the contacts contaminated?	Clean the contacts.	Go to Step 6.
6	Are the LED Heads dirty? Clean the heads with a clean, lint-free cloth. Did this correct the problem?	Complete.	Go to Step 7.
7	Swap the LED Head of the problem color with any other LED Head. Print a Solid Fill Test Pattern. Has the problem moved with the LED Head?	Replace the LED Head.	Go to Step 8.
8	Are the wiring harnesses on the LED Heads undamaged, properly routed and seated?	Go to Step 9.	Replace or reseal the wiring harness.
9	Is +5 V supplied to the problem LED Head?	Replace the Imaging Unit.	Go to Step 10.
10	Is +5 V supplied to the POWER connector on the Imaging Unit Sensor Board?	Replace the Imaging Unit Sensor Board (page 8-142).	Replace in the following order: Transfer Unit LVPS (page 8-121).

# Blank Prints

## Initial Actions

- Run a test print to help isolate the problem between the Image Processor Board and the Engine Control Board.

## Troubleshooting Reference Table

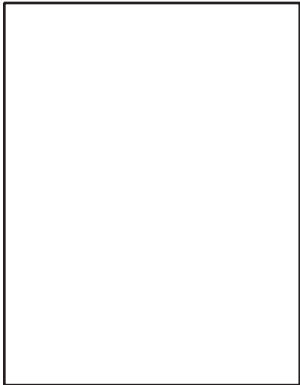
Applicable Parts	Example Print
<ul style="list-style-type: none"><li>■ Imaging Unit</li><li>■ LED Head</li><li>■ Engine Control Board</li></ul>	 <p>s7400-321</p>

## Troubleshooting Procedure Table

Step	Actions and Questions	Yes	No
1	Print a 100% Solid Fill Test Print from the printer's Control Panel. Is the entire test print blank?	Go to Step 2.	Have the customer check their application and printer settings.
2	Verify all packaging material has been removed from the Toner Cartridges.	Go to Step 3.	Remove the packaging material.
3	Remove the Toner Cartridge and check for toner starvation inside the Imaging Unit. Is there evidence of toner starvation?	Replace the Toner Cartridge.	Go to Step 4.
4	Are the wiring harnesses on the LED Heads undamaged, properly routed and seated?	Go to Step 5.	Replace or reseal the wiring harness.
5	Is +5 V supplied to each LED Head?	Go to Step 7.	Go to Step 6.
6	Is +5 V supplied to the POWER connector on the Imaging Unit Sensor Board?	Replace the Imaging Unit Sensor Board (page 8-142).	Replace the LVPS (page 8-121).

## Troubleshooting Procedure Table (Continued)

<b>Step</b>	<b>Actions and Questions</b>	<b>Yes</b>	<b>No</b>
<b>7</b>	Is +24 V supplied to the POWER connector on the Engine Control Board?	Go to Step 8.	Replace the LVPS or wiring harness.
<b>8</b>	Is +24 V supplied to the HVOLT connector on the Engine Control Board.	Go to Step 9.	Replace the Engine Control Board (page 8-112).
<b>9</b>	Inspect the high-voltage wiring harness.	Replace defective wiring harness.	Replace the Transfer Unit. If the error persists, replace the HVPS (page 8-119).

# Mottled or Splotchy Prints

The print image has a mottled appearance.

## Note

This defect is known to occur when manually duplexing, at low humidity, and when printing on heavy weight media.

## Troubleshooting Reference Table

Applicable Parts	Example Print
<ul style="list-style-type: none"><li>■ Imaging Unit</li><li>■ LED Head</li><li>■ HVPS</li><li>■ Engine Control Board</li></ul>	 <p style="text-align: right; font-size: small;">s7400-322</p>

## Troubleshooting Procedure Table

Step	Actions and Questions	Yes	No
1	Ensure the media is approved and the Control Panel and driver settings match the loaded media.	Go to Step 2.	Have the customer load approved media or correct the settings.
2	Print the Status page to verify the operating environment. <b>NOTE:</b> Low humidity, less than 20% relative humidity can cause mottling on prints.	Go to Step 3.	Advise customer regarding the printer's environmental specifications.



## Troubleshooting Procedure Table (Continued)

Step	Actions and Questions	Yes	No
3	<p>Set the Color Correction to a setting other than “Automatic” in the printer driver and try a different print mode.</p> <p><b>NOTE:</b> Mottling usually occurs in large areas of most any dark secondary color. Dark Blues, Purples, Dark Greens, Maroons, Some Browns, composite Blacks, etc.</p> <p>Have the customer reduce the percent of fill in those areas to see if mottling diminishes. Did this correct the problem?</p>	Complete.	Go to Step 4.
4	<p>Check for toner contamination on the high voltage contacts. Remove the Imaging Units and Transfer Unit. Is there contamination?</p>	Clean the contacts.	Go to Step 5.
5	<p>Is +24 V supplied to the POWER connector on the Engine Control Board?</p>	Go to Step 6.	Replace the LVPS or wiring harness.
6	<p>Is +24 V supplied to the HVOLT connector on the Engine Control Board.</p>	Go to Step 7.	Replace the Engine Control Board (page 8-112).
7	<p>Inspect the high-voltage wiring harness.</p>	Replace defective wiring harness.	Replace the Transfer Unit. If the error persists, replace the HVPS (page 8-119).

# Unexpected Colors

The colors produced by the printer are dramatically different from the color expected.

## Troubleshooting Reference Table

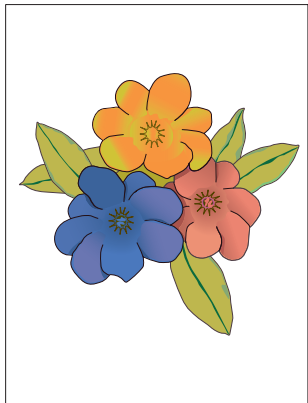
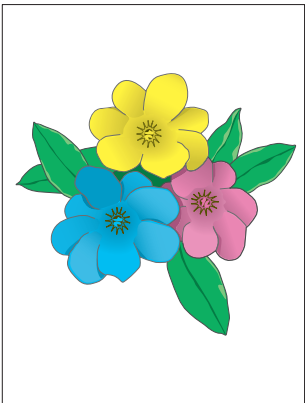
Applicable Parts	Example Print	
<ul style="list-style-type: none"> <li>■ Imaging Unit</li> <li>■ HVPS</li> <li>■ Engine Control Board</li> </ul>		

s7400-323

## Troubleshooting Procedure Table

Step	Actions and Questions	Yes	No
1	Print the Color Reference Page and evaluate the colors. Are the colors on the Color Reference Page representative of what the customer expects?	Complete, the problem is with the customer application.	Go to Step 2.
2	Perform the Light and Dark Color Balance procedure. Did this fix the problem?	Complete.	Go to Step 3.
3	Print a Supplies page to check the Imaging Unit life remaining. If the Imaging Unit is reaching it's maximum image count, the printer will not hard stop due to pixel count, but this can reduce print-quality.	Have the customer replace the Imaging Unit.	Go to Step 4.
4	Print the 100% Solid Fill Test pattern and check for any missing colors. Is the problem with a single color?	Go to Step 5.	Go to Step 7.
5	Is there debris or contamination on the LED Head?	Clean them with a dry, lint free cloth.	Go to Step 6.

## Troubleshooting Procedure Table (Continued)

Step	Actions and Questions	Yes	No
6	Swap the LED Head of the problem color with any other LED Head. Print a Solid Fill Test Pattern. Has the problem moved with the LED Head?	Replace the defective LED Head (page 8-125).	Go to Step 7.
7	Swap the Imaging Unit of the problem color with any other Imaging Unit. <b>NOTE:</b> Remove the keys before swapping. Print a Solid Fill Test Pattern to check for defects. Has the problem color moved with the Imaging Unit?	Replace the Imaging Unit (page 8-8).	Go to Step 8.
8	Check for toner contamination on the high voltage contacts. Remove the Imaging Units and the Transfer Unit and Is there contamination on the contacts?	Clean the contacts.	Go to Step 9.
9	Are the wiring harnesses on the LED heads undamaged, properly routed and seated?	Go to Step 10.	Replace or reseal the wiring harness.
10	Is +5 V supplied each LED Head?	Go to Step 12.	Go to Step 11].
11	Is +5 V supplied to the POWER connector on the Imaging Unit Sensor Board?	Replace the Imaging Unit Sensor Board (page 8-142).	Replace the LVPS (page 8-121).
12	Is +24 V supplied to the POWER connector on the Engine Control Board?	Go to Step 13.	Replace the LVPS or wiring harness.
13	Is +24 V supplied to the HVOLT connector on the Engine Control Board.	Go to Step 14.	Replace the Engine Control Board (page 8-112).
14	Inspect the high-voltage wiring harness.	Replace defective wiring harness.	Replace the Transfer Unit. If the error persists, replace the HVPS (page 8-119).

# Repeating Bands, Lines, Marks, or Spots

This is usually caused by a damaged roller. In some instances, the spots may be dark instead of white and are repeated.

## Initial Actions

- Print the Color Test pages to identify the color causing the defect.
- Print the Repeating Defects page, and then measure the defect and compare it to the Repeating Defects table to identify the problem component.

## Troubleshooting Reference Table

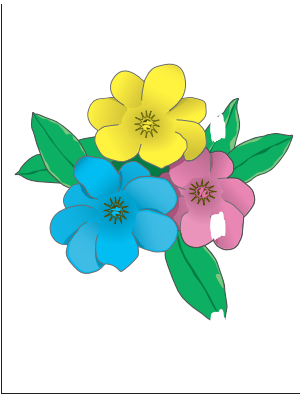
Applicable Parts	Example Print
<ul style="list-style-type: none"><li>■ Imaging Unit</li><li>■ Fuser</li><li>■ Transfer Unit</li></ul>	 <p>s7400-326</p>

## Repeating Defects Spacing

Component	Defect Spacing	Replace
Imaging Drum	94 mm (in.)	Imaging Unit
Developer Roller	49 mm (in.)	Imaging Unit
Charge Roller	37.4 mm (in.)	Imaging Unit
Supply Roller	102 mm (in.)	Imaging Unit
Fuser Belt	124 mm	Fuser
Heat Roller	87.3 mm (in.)	Fuser
Transfer Unit Belt	706 mm	Transfer Unit

# Random Bands, Lines, Marks, or Missing Spots

There are areas of the image extremely light or are missing entirely and do not appear to be a repeating defect or in a single color.

## Caution

Leaving an Imaging Unit exposed to light for periods in excess of a 10 minutes can quickly degrade its performance and result in early failure.

## Initial Actions

- Using a flashlight, carefully examine the area around the Imaging Units and the openings between the Imaging Units and LED Heads. Small obstructions, such as hair or fibers, can create streaks
- When troubleshooting, print a test print on at least letter size paper for diagnosing this problem. The problem may be a repeating defect that is not noticeable on smaller media.
- Random missing spots can also be associated with “Cold Offset”, which lifts toner off the page in certain areas. Usually this will occur in high-coverage areas where the fuser temperature is not high enough to fuse the toner on the media. This causes toner to be redeposited further down the page.

## Troubleshooting Reference Table

Applicable Parts	Example Print
<ul style="list-style-type: none"><li>■ Imaging Unit</li><li>■ Fuser</li><li>■ Transfer Unit</li><li>■ Engine Control Board</li></ul>	 <p data-bbox="838 1219 908 1235">s7400-327</p>

## Troubleshooting Procedure Table

Step	Actions and Questions	Yes	No
1	Check for obstructions between the LED Heads and the Imaging Units. Remove the Imaging Unit and inspect each Drum and corresponding area. Remove any debris.	Remove the obstruction or debris.	Go to Step 2.
2	Replace the Imaging Unit (page 8-8). Does the image quality improve?	Complete.	Go to Step 3.
3	Replace the Transfer Unit (page 8-10). Does the imaging quality improve?	Complete.	Go to Step 4.
4	Replace the Fuser (page 8-11). Does the image quality improve?	Complete.	Go to Step 5.
5	<b>CAUTION:</b> Do not clean the Imaging Unit rollers with a cloth. Carefully remove debris from the rollers using tweezers or similar tool. Does the image quality improve?	Complete.	Go to Step 6.
6	Replace the LED Head (page 8-125). Does the image quality improve?	Complete.	Replace the Engine Control Board (page 8-112).

# Random Spots

There are spots of toner randomly scattered across the page. Toner melting off the Fuser thermistors can also place random spots onto prints.

## Initial Actions

- Verify the Imaging Unit, Fuser, and Transfer Unit are not at or near end of life. Waste toner, especially from the Transfer Unit, can cause random spots to appear on the page.

### Note

Depending on the type of paper and environmental conditions, some light amount of random background spotting is normal. The whiter and glossier the paper, the more noticeable it will be.

## Troubleshooting Reference Table

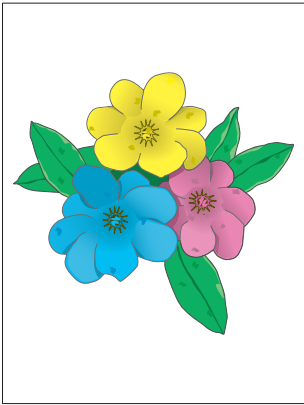
Applicable Parts	Example Print
<ul style="list-style-type: none"><li>■ Imaging Unit</li><li>■ Fuser</li><li>■ Transfer Roller</li></ul>	 <p>s7400-328</p>

## Troubleshooting Procedure Table

Step	Actions and Questions	Yes	No
1	Is there toner spilled inside the printer?	Vacuum inside the printer and remove all visible toner.	Go to Step 2.
2	Check the media for spots or contamination that exists prior to printing. Try printing on a different media, not a glossy media.	Replace with fresh paper.	Go to Step 3.

## Troubleshooting Procedure Table (Continued)

<b>Step</b>	<b>Actions and Questions</b>	<b>Yes</b>	<b>No</b>
<b>3</b>	Print the Color Test Pages to determine which primary color(s) are spotting or missing. Is the problem with one color?	Replace the Imaging Unit (page 8-8).	Go to Step 4.
<b>4</b>	Run the Remove Print Smears from the printer's Control Panel. Did this fix the problem?	Complete.	Go to Step 5.
<b>5</b>	Inspect the Fuser. Is there dirt, debris, or contamination on the Fuser housing or rollers?	Clean the Fuser	Replace the Fuser.



# Background Contamination

There is a very light covering of toner across the entire page. Background contamination can appear in one of the primary colors or gray. The printer displays no error code.

## Note

Depending on the type of paper and environmental conditions, some light amount of random background spotting is normal. The whiter and glossier the paper, the more noticeable it will be.

## Initial Actions:

- Ensure the TekColor correction is not set to **None** in the printer's dialog box.
- Ask the customer about their typical printing habits. A high daily duty cycle can temporarily fatigue the OPC drums within the Imaging Unit and contribute to unwanted background toner.

## Troubleshooting Reference Table

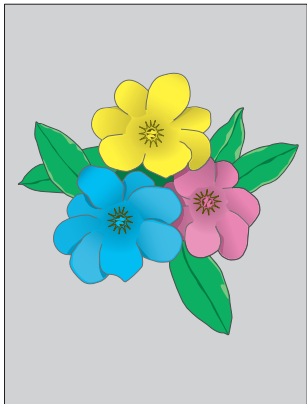
Applicable Parts	Example Print
<ul style="list-style-type: none"><li>■ Imaging Unit</li><li>■ Fuser</li><li>■ Transfer Unit</li><li>■ HVPS</li><li>■ Engine Control Board</li></ul>	 <p>s7400-324</p>

## Troubleshooting Procedure Table

Step	Actions and Questions	Yes	No
1	Is the printer in direct sun light?	Move the printer.	Go to Step 2.
2	Does the background appear to be in only one of the primary colors?	Go to Step 3.	Go to Step 4.

## Troubleshooting Procedure Table (Continued)

Step	Actions and Questions	Yes	No
3	Check the Imaging Unit drum for toner contamination. Remove the Imaging Unit of the problem color. Is there a film of toner across the surface of the drum?	Replace the Imaging Unit.	Go to Step 4.
4	Verify the printer is operating within it's environmental specifications. Low humidity increases the degree of background toner.	Go to Step 5.	Advise the customer of the environmental specifications.
5	Check the Transfer Unit belt. Is the background contamination a mixture of colors and excessive? Is the Transfer Unit belt contaminated with toner.	Replace the Transfer Unit.	Go to Step 6.
6	Is the customer printing on high-gloss media?	Advise the customer of the limitation of this printer.	Go to Step 7.
7	Check minimum clearances around the printer especially sides and back as it can cause heat buildup. Are clearances within specifications?	Go to Step 8.	Advise customer.
8	Test the Fans. Heat build-up under the Imaging Units can cause toner to stain the background. Are the fans operating correctly?	Go to Step 9.	Replace the defective fan.
9	Check that the Imaging Unit contacts are in working condition and clean.	Clean the or replace the drum contacts.	Go to Step 10.
10	Remove the Imaging Units and the Transfer Unit and check for toner contamination on the high voltage contacts.	Clean the contacts.	Replace in the following order: Transfer Unit HVPS (page 8-119).

# Residual Image, Ghosting or Hot Offset

There are faint, ghostly images appearing on the page. The images may be either from a previous page or from the current page. This type of artifact can be related to the percent coverage called out in the file being printed. If the colors are offset by less than 10 mm, this represents mis-registration, not ghosting.

**Ghosting:** This can be the Imaging Unit (green roller) where a residual image is left on the green film, which is then deposited further down the page. This is most noticeable on images that have a dark background with light text. The text is ghosted down the page at 94 mm intervals. This is caused by a defective Imaging Unit. Ghosting every 49 mm is caused by the developer roller and is a limitation of the design; therefore, technicians should not replace Imaging Units for this type of ghosting.

**Hot Offset:** This can be characterized by a repeating image every 87.3 mm or 124 mm. The Fuser temperature is set too high for the given media and the toner adheres to the Fuser rollers causing the image to be deposited further down the page or on the following pages.

**Hot Offsetting and Fuser temperature.** Offsetting occurs on media if the fuser's temperature setting does not match the media type loaded in the tray.

## Initial Actions:

- Verify the correct media type is set at the Control Panel
- Print an internal page to see if ghosting appears there as well.
- Make sure the customer is using TekColor correction (limiting color to max 240%). Other graphic applications can exceed 240%.
- Try printing with fresh media from a recently opened ream.

## Troubleshooting Reference Table

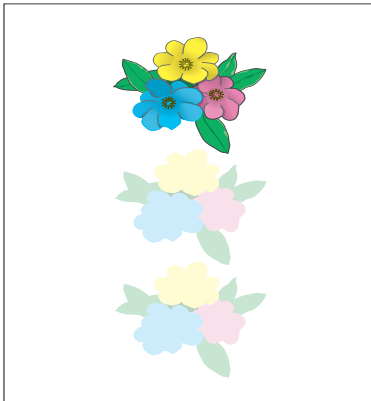
Applicable Parts	Example Print
<ul style="list-style-type: none"> <li>■ Imaging Unit</li> <li>■ Fuser</li> <li>■ Transfer Unit</li> <li>■ LVPS</li> <li>■ Temp/Humidity Sensor</li> <li>■ Engine Control Board</li> </ul>	 <p style="text-align: right; margin-top: 5px;">s7400-329</p>

## Troubleshooting Procedure Table

Step	Actions and Questions	Yes	No
1	Print the Repeating Defects page and compare to the customer's print to determine if the defect is Fuser or Imaging Unit related. Is the defect repeating at 94 mm?	Replace the Imaging Unit.	Go to Step 2.
2	Perform the Remove Print Smears from the printer's Control Panel to clean the fuser. Reprint. Did this correct the problem?	Complete.	Go to Step 3.
3	Check the media settings. Is the setting correct for the media loaded in the tray?	Go to Step 4.	Advise the customer of the correct media settings.
4	Try setting the Control Panel media type to the <b>next lightest</b> type of paper than that loaded in the tray. Did this correct the problem?	Advise customer of the appropriate media type selection.	Go to Step 5.
5	Remove the Fuser covers and inspect the thermistor for debris between it and the rollers. Is there any debris build-up?	Replace the Fuser.	Go to Step 6.
6	Print a test print and monitor the Fuser temperature with Service Diagnostics. Is the temperature within its optimal range?	Replace the Fuser.	Replace the Engine Control Board (page 8-112).

# Incomplete Fusing or Cold Offset

The Fuser temperature is set too low for the media loaded in the tray causing improper fusing resulting in the toner rubbing off easily.

## Initial Actions:

- Verify the correct media type is set at the printer's Control Panel.

## Troubleshooting Reference Table

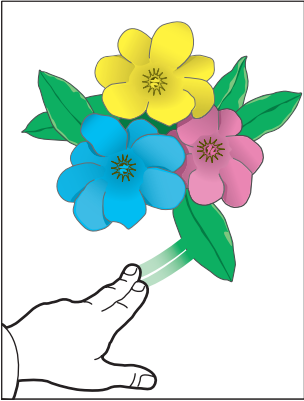
Applicable Parts	Example Prints
<ul style="list-style-type: none"> <li>■ Fuser</li> <li>■ Media Thickness Sensor</li> </ul>	

s7400-330

## Troubleshooting Procedure Table

Step	Actions and Questions	Yes	No
1	Remove the Fuser covers and inspect for debris between the rollers. Is there dirt or debris wrapped around or on the Fuser rollers?	Replace the Fuser.	Go to Step 2.
2	Set the media type to the <b>next heaviest setting</b> than the type loaded. Did this correct the problem?	Advise customer on appropriate media type selection.	Go to Step 3.
3	Run the ATS 4-Sheet Calibration procedure. Did the calibration procedure pass?	Go to Step 4.	Perform the ATS calibration on (page 6-4).
4	Print a test print and monitor the Fuser temperature with Service Diagnostics. Is the temperature within it's optimal range?.	Replace the Fuser.	Replace in this order: Engine Control Board (page 8-112), then LVPS (page 8-121).

# Mis-Registration, Color Layers Not Correctly Registered

The image appears blurred and the primary colors are not aligning correctly into one image. For a page oriented Long-Edge Feed, as the one shown here, the following applies:

- If the colors are shifted from left to right, this is mis-registration in the **process direction**.
- If the colors are shifted from top to bottom, this is mis-registration in the **scan direction**.

## Initial Actions:

- If the mis-registration is in the horizontal direction, perform the color registration adjustment, see (page 6-5).
- If the mis-registration is in the vertical direction, clean the ADC Sensor, and then print the Color Registration page.

## Troubleshooting Reference Table

Applicable Parts	Example Print
<ul style="list-style-type: none"><li>■ Imaging Unit</li><li>■ LED Heads</li><li>■ Color Registration Sensors</li><li>■ Transfer Unit</li><li>■ HVPS</li><li>■ Image Processor Board</li><li>■ Engine Control Board</li></ul>	 <p>s7400-331</p>

## Troubleshooting Procedure Table

Step	Actions and Questions	Yes	No
1	Cycle power to the printer. Did this correct the problem?	Complete	Go to Step 2.

## Troubleshooting Procedure Table (Continued)

Step	Actions and Questions	Yes	No
2	Load media long-edge feed in Tray 1 (MPT). Print the Supplies page and hold the print out in a portrait orientation to evaluate: Are the colors shifted left to right?	Go to Step 3.	Go to Step 9.
3	<b>Process Direction:</b> Remove the Imaging Units and Transfer Unit. Inspect the Color Registration Sensors for dirt, debris or toner build-up. Are the sensors clean?	Go to Step 4.	Clean the sensors.
4	Check the Color Registration Shutter. Run the Service Diagnostics Registration Shutter test. Is the shutter functioning correctly?	Go to Step 5.	Replace the solenoid and wiring harness.
5	Inspect the Transfer Unit for tears or damage on the edges of the belt. Is the belt damaged?	Replace Transfer Unit.	Go to Step 6.
6	Check the Imaging Unit drive gears for missing or worn gear teeth. Run the Service Diagnostics Imaging Unit Motors tests to visually inspect the gears. Are the gears working correctly?	Go to Step 7.	Replace the Imaging Unit Drive Gear.
7	Replace the Registration Sensor Board (page 8-148). Did this fix the problem?	Complete.	Go to Step 9.
8	Replace the Engine Control Board EEPROM. Did this fix the problem?	Complete.	Replace the Engine Control Board (page 8-112).
9	<b>Scan Direction:</b> Use the Supplies page to identify the problem color. Remove the Imaging Unit of the suspect color. Inspect the grounding shaft. Has the shaft shifted?	Replace the Imaging Unit.	Go to Step 10.
10	Check the Imaging Unit guides for debris or damage. Are the guides damaged or obstructed?	Clean the guides on the chassis or Replace the damaged assembly.	Go to Step 11.
11	Check the Color Registration Sensors for dirt or debris. Be sure to check in and around the registration shutter.	Clean the sensor.	Go to Step 12.

## Troubleshooting Procedure Table (Continued)

<b>Step</b>	<b>Actions and Questions</b>	<b>Yes</b>	<b>No</b>
<b>12</b>	Check the Color Registration Shutter. Run the Service Diagnostics Registration Shutter test. Is the shutter functioning correctly?	Go to Step 13.	Replace the solenoid and wiring harness.
<b>13</b>	Are the LED Head ribbon cables undamaged, properly routed and seated?	Go to Step 14.	Reseat, correctly route or replace the wiring harness.
<b>14</b>	Swap the LED Head of the problem color with any other LED Head. Print a Supplies page. Has the problem moved with the LED Head?	Replace the defective LED Head (page 8-125).	Go to Step15.
<b>15</b>	Replace the Registration Sensor Board (page 8-148). Did this fix the problem?	Complete	Go to Step 16.
<b>16</b>	Replace the Engine Control Board EEPROM. Did this fix the problem?	Complete.	Replace the Engine Control Board (page 8-112).



# Toner on Back of Print

There is toner on the back of the printed sheet of paper.

## Troubleshooting Reference Table

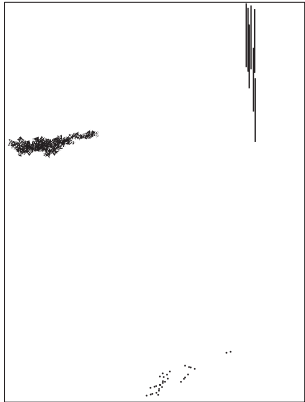
Applicable Parts	Example Print
<ul style="list-style-type: none"><li>■ Imaging Unit</li><li>■ Transfer Unit</li></ul>	 <p style="text-align: right; font-size: small;">s7400-325</p>

## Troubleshooting Procedure Table

Step	Actions and Questions	Yes	No
1	Check and clean the Exit Rollers and paper path for toner or debris. Does this correct the problem?	Complete.	Go to Step 2.
2	Verify the printer is operating within it's environmental specifications.	Go to Step 3.	Advise customer on the specifications.
3	Inspect the Transfer Unit. Has the cleaning blade flipped or failing to clean the Transfer Unit?	Replace the Transfer Unit.	Go to Step 4.
4	Run the Remove Print Smears routine. Did this correct the problem?	Complete.	Go to Step 5.
5	Select the "Special" media setting and experiment with alternate settings, such as the next heaviest or lightest paper type. Does this correct the problem?	Complete.	Go to Step 6.
6	Test the Fuser. Print a test print and monitor the Fuser temperatures. Are temperatures within specifications.	Replace Engine Control Board (page 8-112).	Replace the Fuser.

# Image Not Centered or Positioned Correctly

The image is not centered on the page correctly..

## Troubleshooting Reference Table

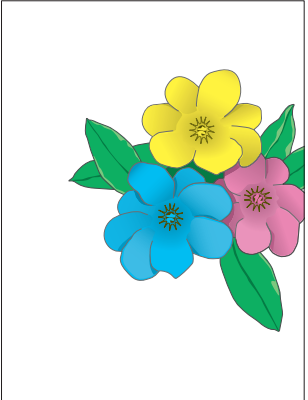
Applicable Parts	Example Print
<ul style="list-style-type: none"><li>■ Imaging Unit</li><li>■ Transfer Unit belt</li></ul>	 <p>s7400-332</p>

## Troubleshooting Procedure Table

Step	Actions and Questions	Yes	No
<b>1</b>	Check the user's application and driver settings to ensure the problem is with the printer and not with the settings. 1. Print an internal page to verify the printer is functioning properly. 2. Check the tray setup settings and ensure Custom is set to Off. 3. Print from a different tray. 4. Clean the Pick and Feed Rollers. Is the problem with the printer?	Go to Step 2.	Advise the customer of the problem with the application.
<b>2</b>	Are the paper guides set snugly against the paper ?	Go to Step 3.	Adjust the guides.
<b>3</b>	Run the Margin Calibration procedure. Does this fix the problem?	Complete.	Go to Step 4.
<b>4</b>	Verify the size of media reported by the printer is the actual size.	Go to Step 8.	Go to Step 5.

## Troubleshooting Procedure Table (Continued)

Step	Actions and Questions	Yes	No
5	Test the Paper Size Switches. Run the Service Diagnostics Paper Size Switch tests. Are the switches functioning correctly.	Go to Step 6.	Go to Step 7.
6	Check the backside of the paper tray for proper movement of the paper size plate while adjusting the tray guides. Did the plate move with the guides?	Go to Step 8.	Replace the tray.
7	Check the wiring harness to the Paper Size Switch for damage or defects. Is the wiring harness defective?	Replace the wiring harness.	Replace in this order: Paper Size Switch (page 8-139), Engine Control Board (page 8-112), or Option Control Board.
8	Inspect the tray pick and feed rollers for dirt, debris or excessive wear.	Clean or replace the roller.	Go to Step 9.
9	Print a test print. Did the test pattern print correctly?	Replace the Image Processor Board (page 8-113).	Replace Engine Control Board (page 8-112).

# Process Direction Bands, Voids, or Streaks

There are areas of the image that are extremely light or missing entirely. These missing areas form wide bands that run along the page parallel to the leading edge of the paper.

## Troubleshooting Reference Table

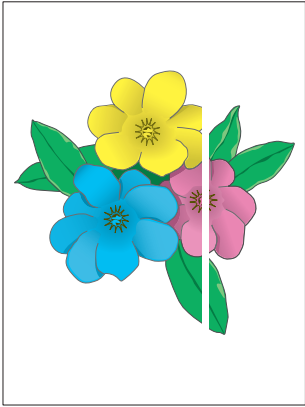
Applicable Parts	Example Print
<ul style="list-style-type: none"> <li>■ Imaging Unit</li> <li>■ Transfer Unit belt</li> </ul>	

## Troubleshooting Procedure Table

Step	Actions and Questions	Yes	No
1	Print the 100% Solid Fill Test print. Is the problem with one primary color?	Replace the defective Imaging Unit.	Go to Step 2.
2	Is the paper wrinkled or dimpled. Indicating a high moisture content? Load a fresh ream of paper. Did this correct the problem?	Complete.	Go to Step 3.
3	Print the Repeating Defects page. Do the defects correspond to a customer Replaceable Consumable?	See "Repeating Bands, Lines, Marks, or Spots" on page 5-18.	Go to Step 4.
4	Inspect the Fuser housing for warping or damage.	Replace the Fuser.	Replace the Engine Control Board (page 8-112).

# Scan Direction Bands, Voids, or Streaks

There are areas of the image that are extremely light or are missing entirely. The missing areas form bands that run along the page from the leading edge to the trailing edge in the direction of paper travel.

## Troubleshooting Reference Table

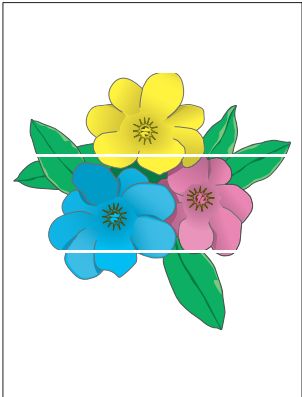
Applicable Parts	Example Print
<ul style="list-style-type: none"> <li>■ Imaging Unit</li> <li>■ Transfer Unit belt</li> <li>■ LED Heads</li> </ul>	

## Troubleshooting Procedure Table

Step	Actions and Questions	Yes	No
1	Print the 100% Solid Fill test print. Are the missing bands in the process direction?	Go to Step 2.	See "Process Direction Bands, Voids, or Streaks" on page 5-34
2	Are there any obstructions, dirt or debris in the printer's paper path?	Clean or remove obstructions.	Go to Step 3.
3	Clean the LED Heads with a dry, lint-free cloth. Did this fix the problem?	Complete.	Go to Step 4.
4	Remove the each Toner Cartridge and check for toner starvation within the Imaging Unit(s).	Replace the Toner Cartridge.	Go to Step 5.
5	Swap the LED Head of the problem color with any other LED Head. Print a Solid Fill Test Pattern. Has the problem moved with the LED Head?	Replace the defective LED Head (page 8-125).	Go to Step 6.

## Troubleshooting Procedure Table (Continued)

<b>Step</b>	<b>Actions and Questions</b>	<b>Yes</b>	<b>No</b>
<b>6</b>	Swap the Imaging Unit of the problem color with any other Imaging Unit. <b>NOTE:</b> Remove the keys before swapping. Print a Solid Fill Test Pattern to check for defects. Has the problem color moved with the Imaging Unit?	Replace the defective Imaging Unit.	Go to Step 7.
<b>7</b>	Check the Fuser for damage.	Replace the Fuser.	Go to Step 8.
<b>8</b>	Verify the ribbon cables and wiring harnesses on the LED Heads are seated, connected and routed properly.	Replace the Engine Control Board (page 8-112).	Reseat, reconnect or replace damaged wiring harnesses.

# Scan Direction Dark Streaks

There are dark lines running parallel with the leading edge of the print.

## Troubleshooting Reference Table

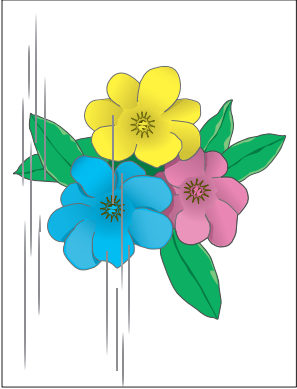
Applicable Parts	Example Print
<ul style="list-style-type: none"> <li>■ Imaging Unit</li> <li>■ Transfer Roller</li> </ul>	 <p style="text-align: right; margin-top: 5px;">s7400-335</p>

## Troubleshooting Procedure Table

Step	Actions and Questions	Yes	No
1	Print the Color Test Pages. Does the problem occur in one primary color?	Replace the Imaging Unit of the defective color.	Go to Step 2.
2	Perform the Remove Print Smears routine from the printer's Control Panel. Did this fix the problem?	Complete.	Go to Step 3.
3	Inspect the Fuser rollers for contamination. Is the Fuser contaminated?	Replace the Fuser.	Go to Step 4.
4	Print a test print Did the test pattern print correctly?	Replace the Image Processor Board (page 8-113).	Replace Engine Control Board (page 8-112).

# Process Direction Bands, Voids, or Streaks

There are dark lines running along the page in the direction of paper travel from the leading edge to the trailing edge. This is generally due to Fuser, paper path roller and/or exit guides contaminated with toner debris.

## Troubleshooting Reference Table

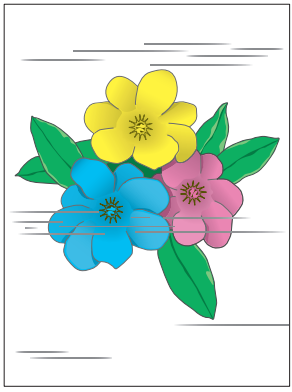
Applicable Parts	Example Print
<ul style="list-style-type: none"> <li>■ Imaging Unit</li> <li>■ Transfer Roller</li> </ul>	

## Troubleshooting Procedure Table

Step	Actions and Questions	Yes	No
1	Run the Remove Print Smears routine from the printer's Control Panel. Did this fix the problem?	Complete	Go to Step 2.
2	Are there any obstructions, dirt or debris in the printer's paper path. Check for toner spills.	Clean and remove obstructions.	Go to Step 3.
3	Visual inspect the Imaging Units and rollers for damage.	Replace the Imaging Unit.	Go to Step 4.
4	Clean the Fuser where paper enters. Did this fix the problem?	Complete	Go to Step 5.
5	Verify the ribbon cables and wiring harnesses on the LED Heads are seated, connected and routed properly.	Go to Step 6.	Reseat, reroute or replace any damaged wiring harnesses.
6	Print a test print. Did the test pattern print correctly?	Replace the Image Processor Board (page 8-113).	Replace Engine Control Board (page 8-112).



# Adjustments and Calibrations

## In this chapter...

- Calibrations
- Adjustments
- Resetting NVRAM
- Service Diagnostics NVRAM Utilities

Section

6



# Calibrations

## Color Calibration

Color calibration procedures adjust the printer for optimal color output. Color settings may need adjustment:

- On initial printer setup.
- When Toner Cartridges and Imaging Units are replaced.
- When the printer environment changes.
- If the printer has been stored for some time.
- If the printer has not received significant use.

There are two procedures: lighten/darken colors and balance colors.

If the overall image appears either too light or dark, use the lighten/darken colors procedure. If a finer adjustment of the primary colors, cyan, magenta and yellow, is needed, continue with the balance colors procedure.

Print the Calibrate Colors Tutorial page from the printer's Control Panel

**Troubleshooting** --> **Print Quality Problems** menu and follow the instructions detailed on the page.

## Margin Calibration

The Calibrate Margins menu allows you to adjust the printer's imaging area relative to the edges of the paper. The imaging area is shown as a dashed rectangle on the front side of the print, the printer will not print outside this rectangle. The dashed rectangle should line up with the two solid lines printed on the back side of the page. Hold up to strong light for verification.

Print the Calibrate Margins page from the **Troubleshooting** --> **Print Quality Problems** menu and follow the instructions detailed on the page.

## Automatic Density Control (ADC) Calibration

To insure optimal print quality, each color image must be predictable and repeatable. Therefore, the print engine must know how much toner to use to create the proper color density. The ADC sensor is built into the middle of the color registration sensor assembly.

The printer performs a density adjustment when:

- A new Imaging Unit or Toner Cartridge is installed
- At 100, 300 and 500 Imaging Unit images, then every 500 images
- At power-on

Service technicians must initiate an ADC calibration upon replacement of the following parts:

- Color Registration Sensor
- Color Registration Shutter (contains Color Chip)
- Engine EEPROM
- Engine Control Board

### Caution

Clean the color chip with IPA to remove any oil that may have been left by your fingers from handling the color chip. It is critical the color chip is clean.

## Entering the New Tag Number

The color chip has a reference value (tag number) that adjusts the ADC sensor to the color chip. The last two digits of the tag number must be input using service diagnostics. The tag number is located on the bottom of the registration shutter next to the color chip.

1. Scroll to **Adjustments/Calibrations**, then press **OK**.
2. Scroll to **Auto Density Control**, then press **OK**.
3. Select **Edit Density Data** and press **OK**. After a short delay, the display indicates the Current Tag Number and prompts for Change Tag Number.

### Note

“h” is a hexadecimal reference.

4. Select **Yes** and press **OK**.
5. When the display prompts to Enter Tag Number, use the Up/Down buttons to enter the tag number on the Registration Shutter Color Chip. When the new number is entered, press **OK**.
6. After a short delay, the display will indicate the new Tag Number. Press the Back key to return to the Automatic Density Control menu.

## Calibration

1. Scroll to **Execute Density Calibration** and press **OK**.
2. The printer will perform the calibration, then report whether the Density Control Calibration has Passed or Failed.
3. If the procedure fails, repeat the calibration routine.
4. If the procedure passes, no further calibration is required.

# Automatic Thickness (ATS) Calibration

The thickness of media being printed on can affect print-quality. The Phaser 7400 measures the thickness of print media and adjusts the Fuser temperature and print speed accordingly. Perform ATS calibration if the NVRAM, Media Thickness Sensor, or Registration Assembly are changed.

## Warning

In order to properly calibrate the Media Thickness Sensor, you **MUST** use Phaser 35-Series Premium Transparencies. Using any other transparency can cause significant damage to the Fuser and fail the adjustment.

## ATS 4-Sheet Calibration

1. Enter Service Diagnostics.
2. Scroll to **Adjustments/Calibrations**, and press **OK**.
3. Select **ATS 4-Sheet Calibration**, and press **OK**.
4. Select **Edit Thickness Data**, and press **OK**.
5. Select **Microns**, and press **OK**.
6. The printer enters the Edit Thickness Data menu.
7. Change the thickness value to 140, using the **Up Arrow / Down Arrow** buttons to change the first number to 1. Press the **Help (?)** key to move the cursor to the second digit, then the third digit. Once the value is set to 140, press **OK**.

## Note

The value set in Step g, 140 microns, is the average thickness of Phaser 35-Series Premium Transparencies. Using another type of transparency produces inaccurate results.

8. On the Control Panel, select Execute Thickness Calibration, and then press the **OK** button.
9. When prompted open Tray 1 (MPT) and load 5 sheets of Phaser 35-Series Premium Transparency.
10. The printer indicates that it is ready to run the calibration and picks 3 consecutive sheets of media from Tray 1 (MPT), using them to calculate a reference thickness.
11. After the reference is set, the printer picks and measures the fourth sheet to test the calibration. If the fourth sheet falls within the expected thickness range, the printer displays Thickness Calibration Passed.
12. If the fourth sheet does not measure as expected, the calibration displays Thickness Calibration Failed. Perform the ATS 4-Sheet Calibration again. Perform the calibration procedures until they pass.

## Note

If a failure occurs, you may need to power cycle the printer to recover.

# Adjustments

## Vertical and Horizontal Color Registration

The Vertical and Horizontal Registration Adjustments do not apply to the 7400.

Color-to-Color Registration is done automatically:

- At power up
- When the top cover is closed
- Every 400 pages at the end of a print job

# Resetting NVRAM

Printer configuration settings are maintained in the Engine Control Board, the Image Processor Board, and the Configuration Card.

## Restore Factory Color Settings

To reset settings for density and color balance to the factory-default values:

1. On the Control Panel, select **Troubleshooting**, and press **OK**.
2. Select **Print Quality Problems** menu, and press **OK**.
3. Select **Calibrate Colors** menu, and press **OK**.
4. Select **Restore Factory Settings**, and press **OK**.
5. Select **Restore Factory Settings NOW**, and press **OK** to reset the color settings to factory defaults.

## Restore Previous Color Settings

To restore the color settings to the ones that existed before you saved the last color balance adjustments.

1. On the Control Panel, select **Troubleshooting**, and press **OK**.
2. Select **Print Quality Problems** menu, and press **OK**.
3. Select **Calibrate Colors** menu, and press **OK**.
4. Select **Restore Previous Settings**, and press **OK**.
5. Select **Restore Previous Settings NOW**, and press **OK** to reset the color settings to the previously set values.

## Restore Factory Margins Settings

You can reset margin settings to the factory-default values.

### Caution

Use caution when resetting your margins to the factory-default settings. Changing these settings back to factory defaults may not be the last-saved settings if you have previously calibrated your margins.

1. On the Control Panel, select **Troubleshooting**, and press **OK**.
2. Select **Print Quality Problems** menu, and press **OK**.
3. Select **Calibrate Margins** menu, and press **OK**.
4. Select **Restore Factory Settings**, and press **OK** to reset the margin settings.

# Resetting Connection Setup Defaults

Resetting the Connection Setup values sets TCP/IP address, TCP/IP address menu settings (gateway, broadcast, etc.), CentreWare IS, EtherTalk, Netware, set IPX frame type, IPP, Ethernet speed, Wait Timeout, Page Description Language, and USB Port selection to their default values.

## Caution

Make note of the current network settings or print a Configuration page to provide a record of the customer's current network settings before resetting the connection setup to the factory default values.

1. On the Control Panel, select **Printer Setup**, and press **OK**.
2. Select **Connection Setup**, and press **OK**.
3. Select **Reset Connection Setup**, and press **OK** to reset connection defaults.

# Resetting PostScript Setup Defaults

Resetting the PostScript setup values resets PostScript Error Information, Print-Quality Mode, TekColor Correction, and Image Smoothing, to their default values.

1. On the Control Panel, select **Printer Setup**, and press **OK**.
2. Select **PostScript Setup**, and press **OK**.
3. Select **Reset PostScript Setup**, and press **OK**.
4. Select **Reset PostScript Setup NOW**, and press **OK** to reset the defaults.

# Resetting PCL Setup Values to Default

Resetting the PCL setup values resets the default font, pitch, size, symbol set, orientation, form length, and line termination settings to their default values.

1. On the Control Panel, select **Printer Setup**, and press **OK**.
2. Select **PCL Setup**, and press **OK**.
3. Select **Reset PCL Setup**, and press **OK**.
4. Select **Reset PCL Setup NOW**, and press **OK** to reset the defaults.

## Resetting Control Panel Setup Values to Default

Resetting the Control Panel Setup values resets the Control Panel language, brightness, contrast and accessibility controls to their default values.

1. On the Control Panel, select **Printer Setup**, and press **OK**.
2. Select **Control Panel Setup**, and press **OK**.
3. Select **Reset Control Panel Setup**, and press **OK**.
4. Select **Reset Control Panel Setup NOW**, and press **OK** to reset the defaults.

## Resetting Printer Controls Values to Default

Resetting the Printer Controls values resets the startup page, power saver timeout, low toner warning level, date and time, intelligent ready, metric defaults, and power saver to their default values.

1. On the Control Panel, select **Printer Setup**, and press **OK**.
2. Select **Printer Controls**, and press **OK**.
3. Select **Reset Printer Controls**, and press **OK**.
4. Select **Reset Printer Controls NOW**, and press **OK** to reset the defaults.

## Resetting All Printer Defaults (PostScript NVRAM)

Resetting NVRAM returns all the Image Processor Board NVRAM-stored parameters to their factory default values. The print counts and the Adobe firmware serial number are not affected by this reset.

1. On the Control Panel, select **Troubleshooting**, and press **OK**.
2. Select **Service Tools**, and press **OK**.
3. Select **Reset NVRAM**, and press **OK**.
4. Select **Reset NVRAM and Reset Printer NOW**, and press **OK** to reset all the settings to their factory default values.



# Service Diagnostics NVRAM Utilities

## Postscript NVRAM Reset

Resetting the NVRAM restores all printer values stored in the Image Processor Board NVRAM including network, printer setup, job defaults, color, margin, and calibrations to their factory default values. The print counts and the Adobe firmware serial number are not affected by this reset.

1. Enter Service Diagnostics.
2. Select **NVRAM Access**, and press **OK**.
3. Select **PostScript NVRAM Reset**, and press **OK**.
4. **Resetting NVRAM! Are you sure?** is displayed. Select **Yes**, and press **OK**.

The printer exits Service Diagnostics and reboots. While booting, NVRAM is reset.

## CRU Counter Read

Displays current life count of the Toner Cartridges, Fuser, Imaging Unit, and Transfer Unit. CRU Life Read also provides the option to display the current Total Page Count.

## CRU Counter Reset

Sets the life count of the following components to Zero. The display updates to reflect the revised status of the life count.

- Reset CMYK Toner Cartridge Counts
- Reset CMYK Imaging Unit Counts
- Reset Fuser Count
- Transfer Belt Count



# Cleaning and Maintenance

## In this chapter...

- Recommended Tools
- Cleaning Procedures
- Routine Maintenance Procedures

Section

7



# Service Maintenance Procedures

Perform the following procedures whenever you check, service, or repair a printer. Cleaning the printer, as outlined in the following steps, assures proper operation of the printer and reduces the probability of having to service the printer in the future.

The frequency of use, Average Monthly Print Volume (AMPV), type of media printed on, and operating environment are factors in determining the frequency of cleaning necessary. Record the number of sheets printed.

## Recommended Tools

- Toner vacuum cleaner
- Clean water
- Clean, dry, lint-free cloth
- Black, light protective bag

## Cleaning

Perform the following general cleaning steps as indicated by the printer's operating environment.

### Caution

Never apply alcohol or other chemicals to any parts in the printer. Never use a damp cloth to clean up toner. If you remove the Imaging Units, place them in a light protective bag or similar means to protect the drums as exposure to light can quickly degrade performance and result in early failure.

1. Record number of sheets printed.
2. Print several sheets of paper to check for problems or defects.
3. Turn off the printer.
4. Clean all fans to remove excess dust.
5. Ensure that all cover vents are clean and free of obstructions.
6. Remove any debris or foreign objects from the Transfer Unit, Fuser, and Imaging Units.
7. Vacuum loose toner from the printer interior using a Type II toner vacuum only.
8. Remove and clean the paper trays.
9. Clean all rubber rollers with a lint-free cloth slightly dampened with cold water.

# Cleaning the Imaging Unit Contacts

1. Open the Top Cover.
2. Remove the Imaging Units and place it on a stable surface.
3. Working quickly to reduce light exposure, clean the four contact at the front of the Imaging Unit.

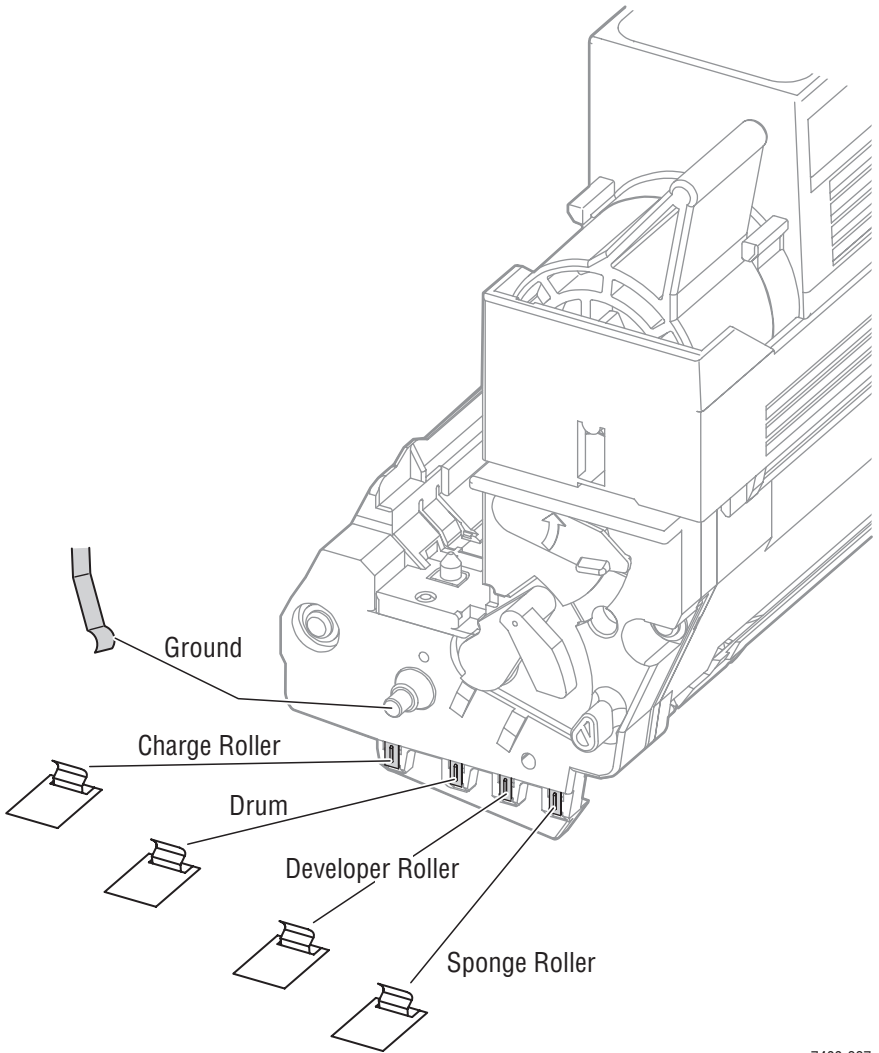

s7400-337

4. Clean the 3 contacts at the rear of the Imaging Unit.

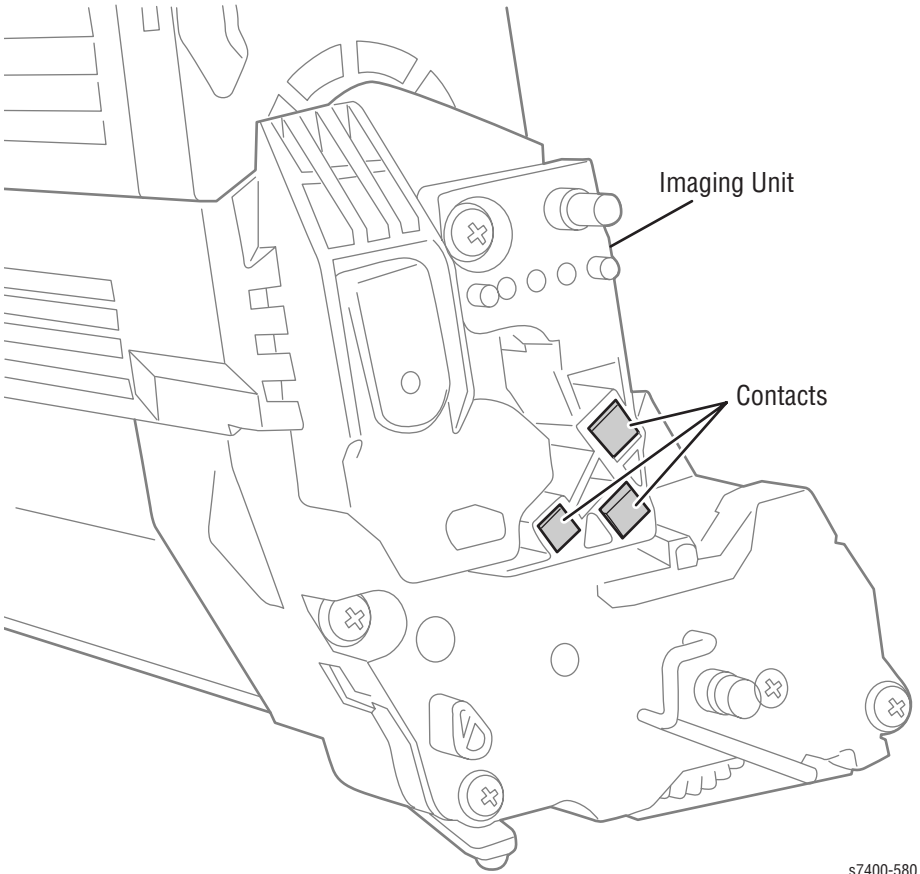

s7400-580

# Cleaning the LED Heads

Clean the LED Head if a vertical White band or White stripe appears on the print.

## Caution

Always use a soft, dry, lint-free cloth to clean the LED Heads. Never use IPA, thinner, or other solvents to clean the lens.

1. Partially open the Top Cover.
2. Clean each LED Head with the pad supplied with the replacement toner, or a clean, lint-free cloth.

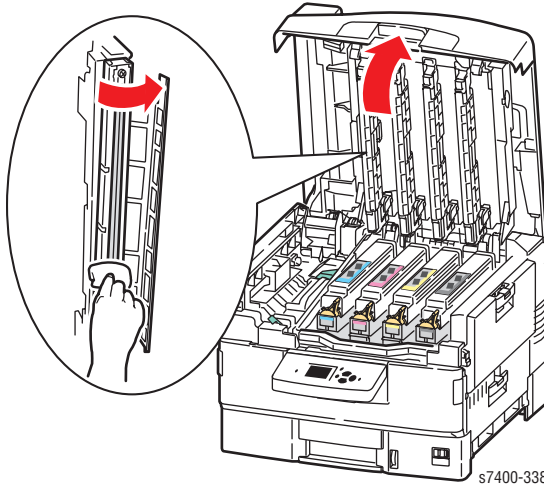

# Cleaning the Feed Rollers

Clean the accumulated dust from the Feed Rollers.

## Caution

Use care not to scratch or otherwise abrade the roller surface while cleaning. Gently rub the roller surface using a soft, lint-free cloth moistened with water.

1. Access the rollers by removing Tray 2 or opening Tray 1 (MPT).
2. Clean each roller with soft, lint-free cloth moistened with water.

# Maintenance

## RIP (Repair, Inspect, and Prevent) Procedures

Perform these routine maintenance procedures during the course of servicing the printer.

- Clean the feed rollers, exit rollers, and guides; replace if necessary.
- Remove and clean all paper trays.
- Clean the Color Registration and ADC Sensors.
- Print a Status page, diagnose, and repair any problems as indicated.
- Check the print engine and image processor firmware version. Update if necessary.
- Check cleanliness of interior and exterior, including fans; if necessary clean (dust or vacuum) these areas.
- Review proper printer operation using a customer file, if possible. Check with the customer regarding any special applications they may be running.
- Review with the customer all work that was performed; also discuss proper printer care.



# Service Parts Disassembly

## In this chapter...

■ Overview	8-5
■ General Notes on Disassembly	8-6
■ Maintenance Items and Consumables	
Imaging Unit Removal	8-8
Toner Cartridge Removal	8-9
Transfer Unit Removal	8-10
Fuser Removal	8-11
■ Covers	
Rear Cover	8-13
Lower Rear Cover	8-14
Right Rear Cover	8-15
Right Side Cover	8-16
Left Side Cover	8-17

Section

8



Front Door	8-18
Door B	8-19
Left Rear Cover	8-20
Left Front Cover	8-21
Upper Front Cover	8-22
Right Front Cover	8-23
Top Cover	8-24
■ Trays	
Tray 1 (MPT)	8-25
Tray 1 (MPT) Level Sensor	8-28
Tray 1 (MPT) Home Position Sensor	8-30
OHP Sensor	8-31
Feed-Out Sensor #1	8-32
Tray 1 (MPT) No Paper Sensor	8-33
Tray 1 (MPT) Feed Rollers	8-34
Tray 2 Feeder	8-38
Registration Motor	8-39
Feed Motor	8-40
Lift Motor	8-41
Registration Clutch #2	8-42
Door B Detect Sensor	8-43
Tray 2 No Paper Sensor	8-45
Registration Sensor #2	8-47
Feed-Out Sensor #2	8-50
Feeder Board	8-53
Tray 2 Feed Rollers	8-54
Side Output Tray	8-55
■ Chassis	
Job Offset Assembly	8-56
Job Offset Motor	8-59
Job Offset Home Position Sensor	8-61
Top Output Chute	8-63
Door A Latch Assembly	8-64
Media Thickness Sensor	8-66

Temperature/Humidity Sensor	8-67
Exit Assembly	8-68
Exit Gate Solenoid	8-70
Fuser Exit Sensor and Actuator	8-71
Top Output Tray Stack Full Sensor	8-72
Side Output Tray Detect Sensor	8-73
Side Output Tray Stack Full Sensor	8-75
Door E Detect Sensor	8-77
Fuser Release Sensor	8-79
Registration Sensor Assembly	8-80
Registration Shutter Solenoid	8-81
ADC Sensor	8-82
Media Slack Sensor and Actuator	8-83
Registration Assembly	8-84
Registration Clutch #1	8-85
Waste Toner Auger Assembly	8-86
Waste Toner Reservoir Full Sensor	8-88
Waste Toner Reservoir Auger Rotation Sensor	8-89
Waste Toner Auger Rotation Sensor	8-90
Transfer Unit Belt Rotation Sensor	8-91
Lower Basket Assembly	8-92
Basket Assembly	8-93
LED Assembly	8-100
■ Drive	
Transfer Unit Motor	8-103
Toner Motors	8-104
Imaging Unit Motors	8-105
Fuser Motor	8-106
Waste Toner Motor	8-107
Imaging Unit Lift Uplink	8-108

■ Electrical	
Control Panel	8-111
Engine Control Board	8-112
Image Processor Board	8-113
Card Cage Fan Duct	8-114
Card Cage Fan	8-115
Card Cage	8-117
HVPS Cover	8-118
High Voltage Power Supply	8-119
Housing Bias Assembly	8-120
Low Voltage Power Supply	8-121
LVPS Fan	8-124
LED Head	8-125
LED Relay Board	8-126
Top Cover Interlock Switch	8-127
Waste Toner Reservoir Detect Switch	8-130
Door A Interlock Switch	8-132
Imaging Unit Fan	8-133
Transfer Unit Fan	8-134
Top Cover Fan	8-135
IP Fan	8-138
Paper Size Switch	8-139
Motor Driver Board	8-141
Imaging Unit Sensor Board	8-142
Toner Supply Camshaft	8-144
Imaging Unit Motor Mounting Plate	8-145
CRUM Reader Board	8-146
CRUM Antenna	8-147
Registration Sensor Board	8-148
Fuser Fan	8-149
Front Sensor Board	8-150
Rear Sensor Board	8-151

# Overview

This section contains the removal and replacement procedures for selected parts of the printer according to the Field Replaceable Units (FRUs) Parts List. Not all replacement procedures are included in this Service Manual. In most cases, to reinstall a part, simply reverse the removal procedure shown. In some instances, replacement notes are included providing special steps. For specific assemblies and parts, refer to the Parts List in Section 9.

## Standard Orientation of the Printer

When needed the orientation of the printer is called out in the procedure for locating printer parts, refer to the printer orientation graphic for locating the right, left, front and back sides of the printer.

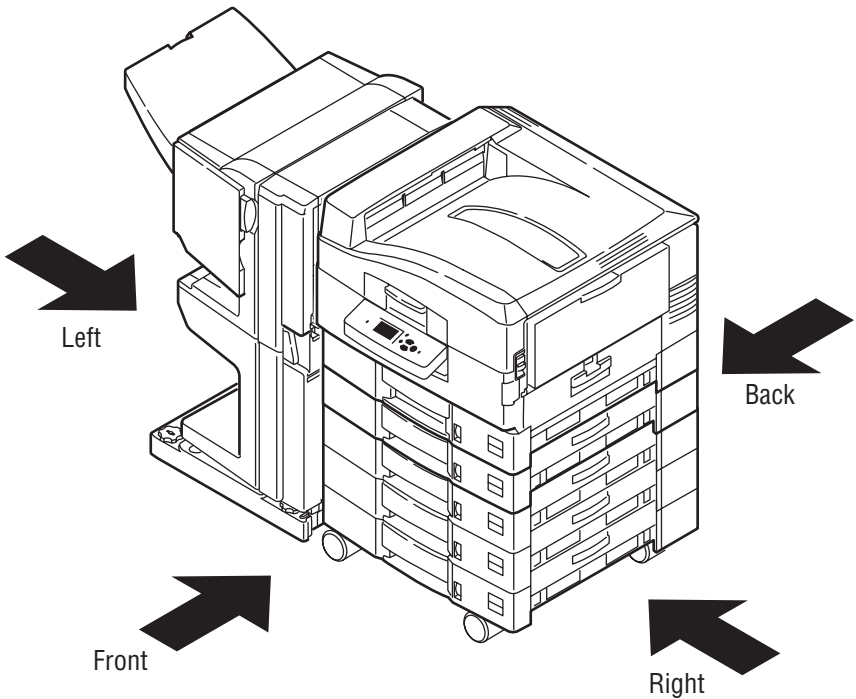

s7400-339

# General Notes on Disassembly

## Preparation

Before you begin any Removal and Replacement Procedure:

1. Switch Off the printer power and disconnect the power cord from the wall outlet.
2. Remove the Imaging Units and cover them with a light proof bag or by placing them in a light-tight container to protect them from exposure to light. Disconnect all computer interface cables from the printer.
3. Wear an electrostatic discharge wrist strap to help prevent damage to the sensitive electronics of the printer circuit boards.
4. Remove the Fuser or wait at least 10 minutes after you have switched Off printer power for the Fuser to cool before you work on or around the Fuser.

### Note

Names of parts that appear in the removal and replacement procedures may not match the names that appear in the Parts List. For example, a part called the Registration Chute Assembly in a removal procedure may appear on the Parts List as Assembly, Chute REGI. When working on a removal procedure, ignore any prerequisite procedure for parts already removed.

### Caution

Many parts are secured by plastic tabs DO NOT over Flex or force these parts. Do not over torque the screws threaded into plastic parts.

Always use the correct type and size screw. Using the wrong screw can damage tapped holes. Do not use excessive force to remove or install either a screw or a printer part.

### Warning

Unplug the AC power cord from the wall outlet before removing any printer part.

## Notations in the Disassembly Text

- The notation “(item X)” points to a numbered callout in the illustration corresponding to the you disassembly procedure being performed.
- The notation “PLX.X.X” indicates that this component is listed in the FRU Parts List.
- Bold arrows in an illustration show direction of movement when removing or replacing a component.





### Replacement Note

Provides information specific to the replacement of parts or assemblies.

# Fastener Types

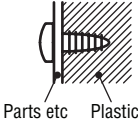
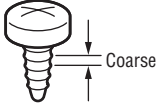
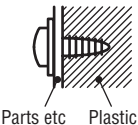
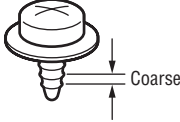
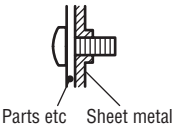
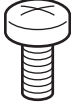
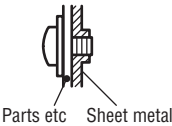
The following table lists the primary types of Posi-Drive screws used to assemble the printer. The procedures provide dimensional specifications for screws being removed.

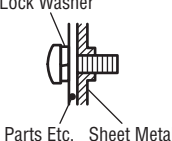
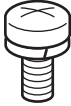
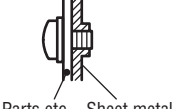
## Posi-Drive Screw Types used in the Printer

Type	Application	Shape	Characteristics
Self-tapping, plastic			<ol style="list-style-type: none"> <li>1. Black colored.</li> <li>2. Screw thread is coarse compared to metal screw.</li> <li>3. Screw tip is thin.</li> </ol>
Self-tapping, plastic with flange			<ol style="list-style-type: none"> <li>1. Black colored.</li> <li>2. It has a flange.</li> <li>3. Screw thread is coarse compared to metal screw.</li> <li>4. Screw tip is thin.</li> </ol>
Sheet Metal, silver			<ol style="list-style-type: none"> <li>1. Silver colored.</li> <li>2. Diameter is uniform.</li> </ol>
Sheet Metal, with flange			<ol style="list-style-type: none"> <li>1. Silver colored.</li> <li>2. It has a flange.</li> <li>3. Diameter is uniform.</li> <li>4. Typically 6 mm or 10 mm in length.</li> </ol>
Sheet Metal, silver with lock washer			<ol style="list-style-type: none"> <li>1. Silver colored.</li> <li>2. Diameter is uniform.</li> <li>3. Typically 6 mm in length.</li> </ol>
Sheet Metal, silver with toothed washer			<ol style="list-style-type: none"> <li>1. Silver colored.</li> <li>2. Includes a toothed washer.</li> <li>3. Diameter is uniform.</li> <li>4. Used for grounding terminals.</li> </ol>

### Caution

Use care when installing self-tapping screws in plastic. To properly start the screw in plastic, turn the screw counter-clockwise in the hole until you feel the screw engage the threads, then tighten as usual. Failure to properly align or over tighten the screw can result in damage to previously tapped threads.

# Maintenance Items and Consumables

Maintenance items include the Transfer Unit and Fuser. The Feed Rollers are also routine maintenance items, but individual procedures for their removal and replacement are provided on page 8-34 and page 8-54. Consumables consist of the Toner Cartridges, Imaging Units, the Waste Toner Reservoir, and if present, the Staple Cartridge.

## Imaging Unit Removal

In this section, Imaging Unit often refers to the combination of the Toner Cartridges and Imaging Units. When asked to remove the Imaging Unit, use this procedure:

1. Power down the printer.
2. Lift the Top Cover.
3. Grasp the top of the Toner Cartridge, and then lift the Imaging Unit out of the printer.
4. Place the Imaging Unit in a light proof bag or other light proof container.

### Caution

Leaving an Imaging Unit exposed to light for periods in excess of a 10 minutes can quickly degrade its performance and result in early failure.

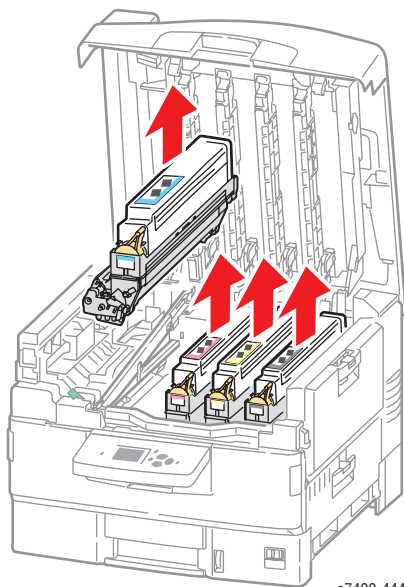

s7400-444



# Toner Cartridge Removal

## Caution

Clean up any toner spills using a Type II Toner Vacuum only. Never use a damp cloth to clean up spilled toner.

If you are removing a Toner Cartridge to facilitate removal of other components, replace the Toner Cartridge as soon as those components have been removed. Keeping the Toner Cartridges locked into place prevents contamination of the toner system and spillage.

1. Power down the printer.
2. Lift the Top Cover.
3. Rotate the locking lever on the end of the cartridge (or cartridges) being removed to the unlocked (closed) position and lift the cartridge out of the printer.

## Note

Some toner adheres to the bottom of the cartridge, so do not set the cartridge on any surface that can be damaged by the toner.

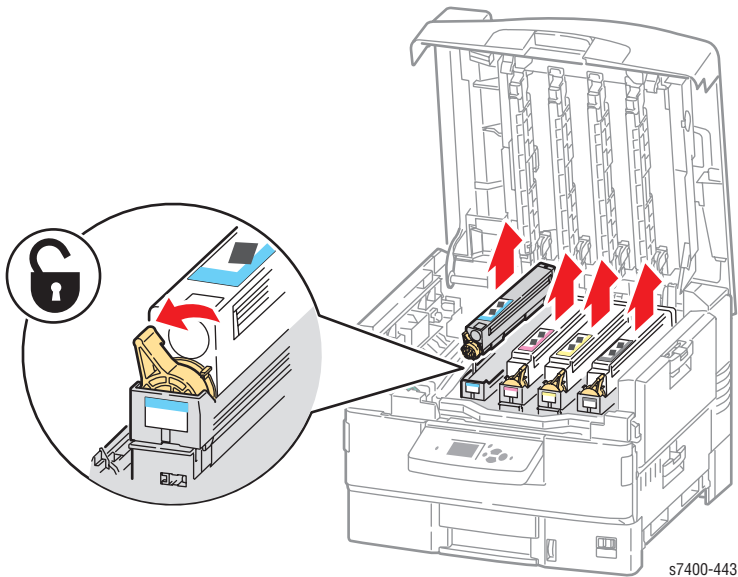

s7400-443

# Transfer Unit Removal

## Caution

Opening the Top Cover exposes the Imaging Units to light. Exposure to light for periods in excess of a 10 minutes can quickly degrade Imaging Unit performance and result in early failure.

1. Open the Top Cover.
2. Remove the 4 Imaging Units with the Toner Cartridges locked in place.
3. Release the Transfer Unit Front and Rear locking latches.
4. Lift the Transfer Unit out of the printer using the handles provided.

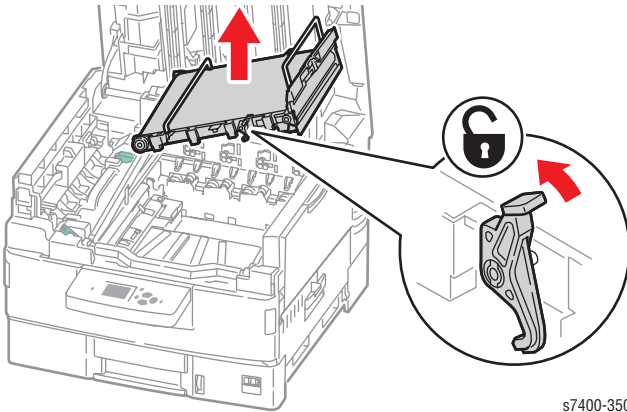

s7400-350

# Fuser Removal

## Warning

Allow adequate time for the Fuser to cool before servicing the printer.

## Caution

Opening the Top Cover exposes the Imaging Units to light. Exposure to light for periods in excess of a 10 minutes can quickly degrade Imaging Unit performance and result in early failure.

1. Power down the printer.
2. Lift the Top Cover.
3. Lift the Lock Lever on the Fuser, and then grasp the handles and lift the Fuser straight up off the mounting studs.

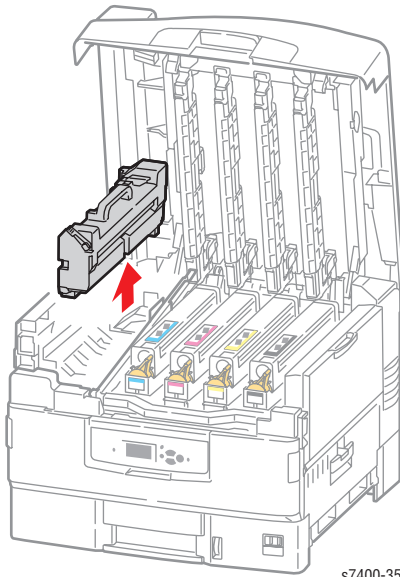

s7400-351

# Print Engine Disassembly

Print Engine disassembly procedures are organized in the following categories:

- Covers
- Trays
- Chassis
- Drive
- Electrical

For convenience, it is recommended that you remove the Imaging Units with the Toner Cartridges locked in place and place them in a light-proof bag. Also remove the Fuser, Transfer Unit, and trays. The procedures presented in this section assume that these components are removed. Place these parts where they do not interfere with the repair. (Note that servicing is possible with these parts in place depending on the location of the procedure being performed.)

## Caution

Do not expose the Imaging Units to light for more than 10 minutes. After removal, cover the Imaging Units to minimize the amount of light striking the rollers. Prolonged exposure to light significantly reduces Imaging Unit performance.

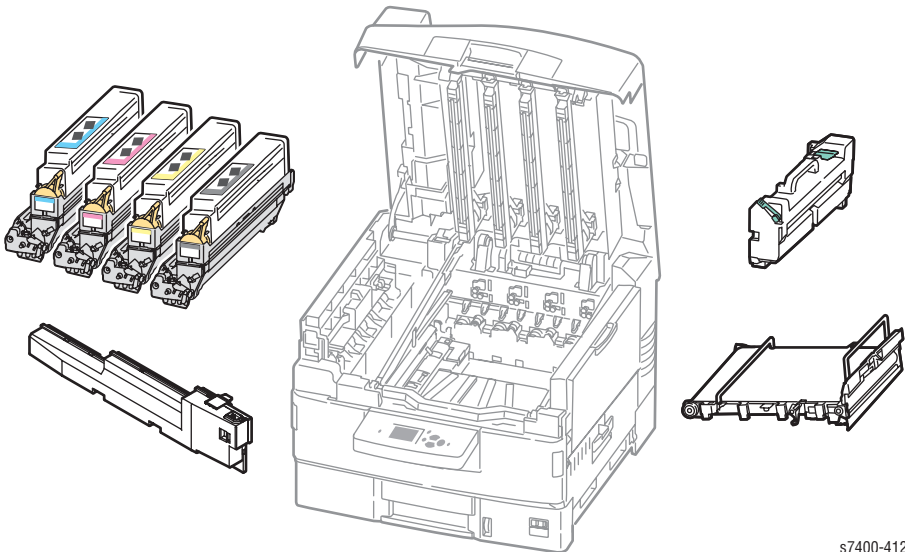

s7400-412

# Covers

## Rear Cover

1. Loosen the 2 captive thumbscrews.
2. Remove the 2 (metal, 6 mm) screws that secure the Rear Cover to the frame.

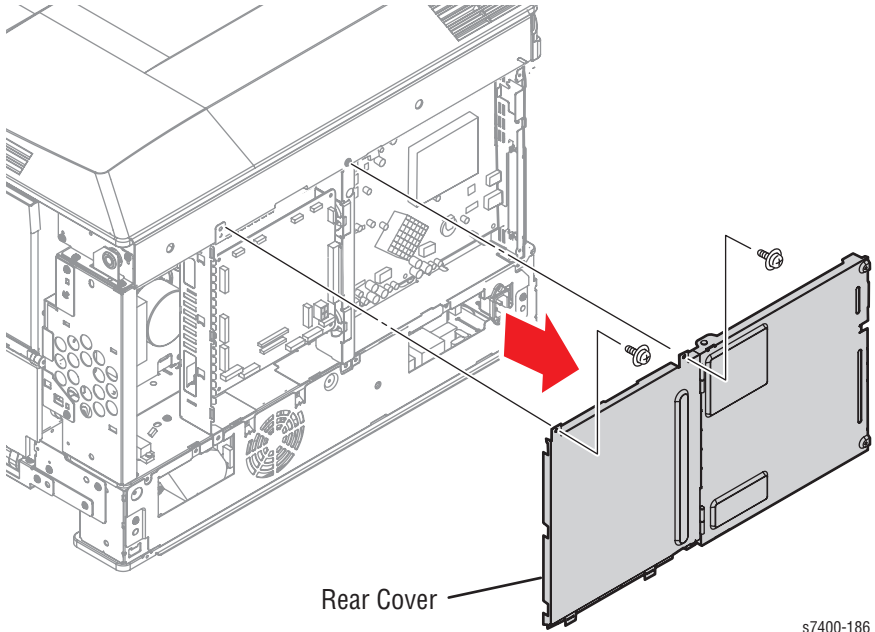

s7400-186

# Lower Rear Cover

1. Remove 5 (metal, 10 mm) screws from the Lower Rear Cover.
2. Using a screwdriver, release the 2 tabs located near the bottom of the Lower Rear Cover.
3. Remove the Lower Rear Cover.

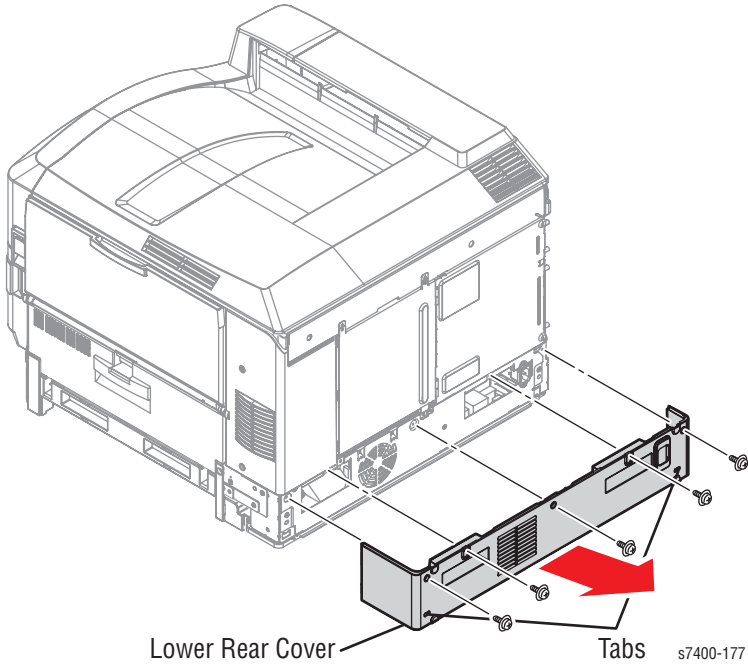

# Right Rear Cover

1. Open the Top Cover.
2. Open Door B.
3. Remove 2 (metal, 6 mm) screws from the Right Rear Cover.
4. Release the 3 guides and remove the cover.

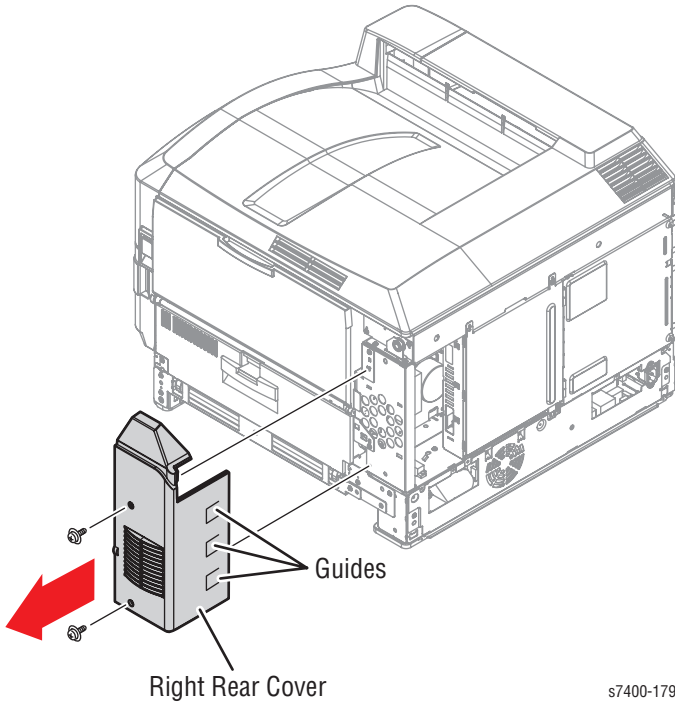

s7400-179

# Right Side Cover

Removal of the Right Side Cover from printers with optional trays installed requires the right hand side of the print engine to be lifted approximately three inches to clear the lower tray. Use a ream of paper, or similar object, to hold the printer above the LTA while removing the cover.

## Caution

Use care not to over stress the plastic while prying the cover to release the hooks.

1. Remove the Lower Rear Cover (page 8-14).
2. Pull out Tray 2 to access 1 (metal, 10 mm) screw on the left side of the Right Side Cover.
3. Remove 1 (metal, 10 mm) screw from the right side of the Right Side Cover.
4. Using a small screwdriver release the 2 hooks at the top and bottom of each hand hold.
5. Release the hook at the right.
6. Lift printer up slightly and remove the Right Side Cover.

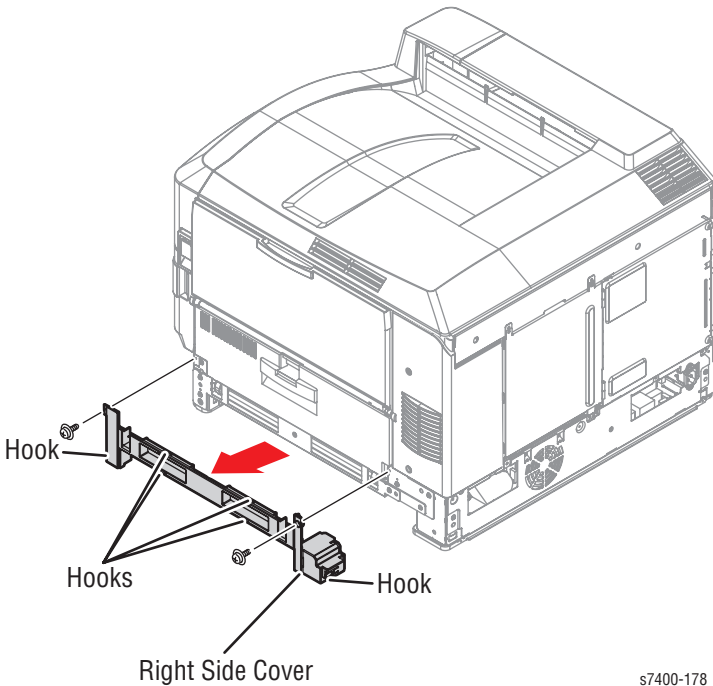

s7400-178



# Left Side Cover

1. Open the Top Cover.
2. Remove the Duplex Unit, if present.
3. Remove 4 (metal, 10 mm) screws securing the Left Side Cover.
4. Using a screw driver, release the center tab on the bottom of the Left Side Cover.
5. Flex the Left Side Cover slightly and pull down on the cover to release it from the printer.

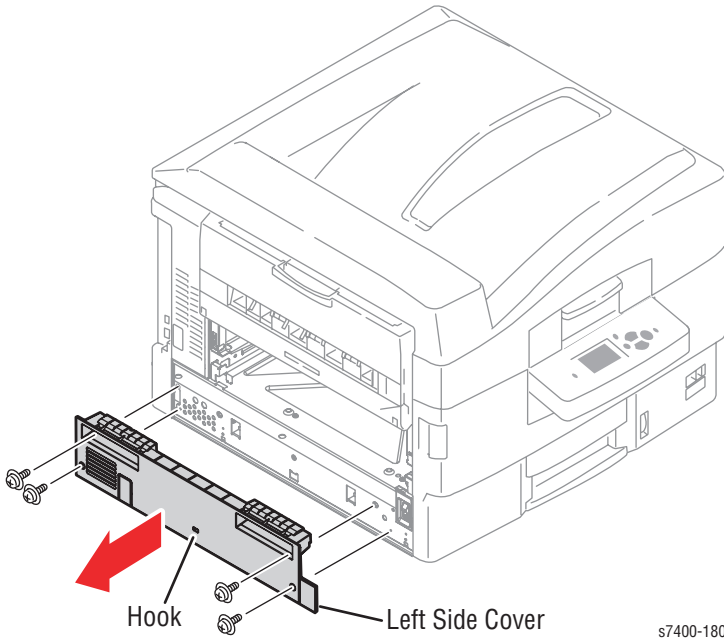

s7400-180

# Front Door

1. Remove 2 (metal, 6 mm) screws securing the Front Door Stopper Straps to the printer.
2. With the Front Door perpendicular to the front of the printer, slide the Front Door to the right to disengage the pivot pins and remove the Front Door.

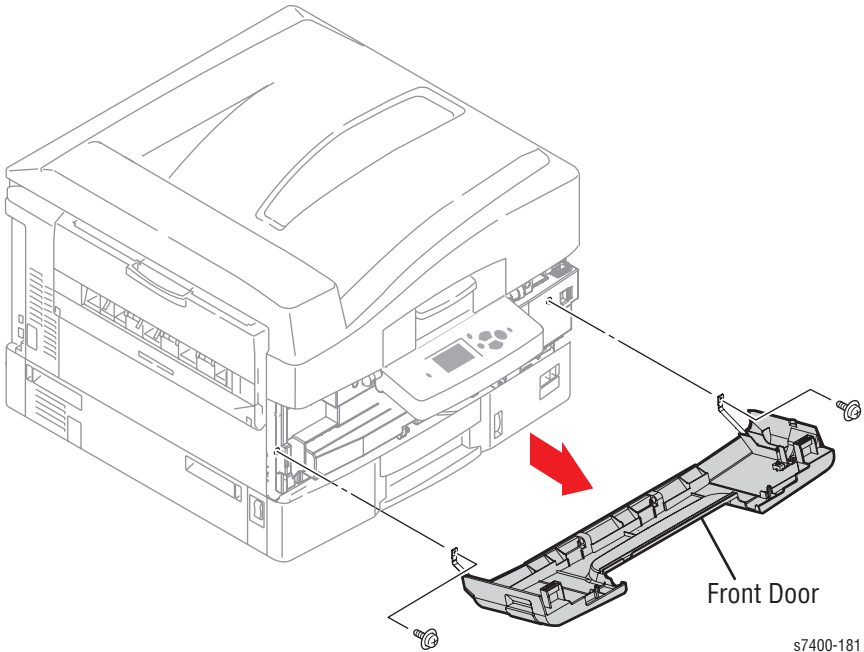

## Door B

1. Remove the Right Side Cover (page 8-16).
2. Open Door B.
3. Remove the Door B Chute by sliding the chute to the left and gently prying the left hinge point from the Door B pivot.
4. Slide Door B to the left to release the bosses from the holes in the frame.

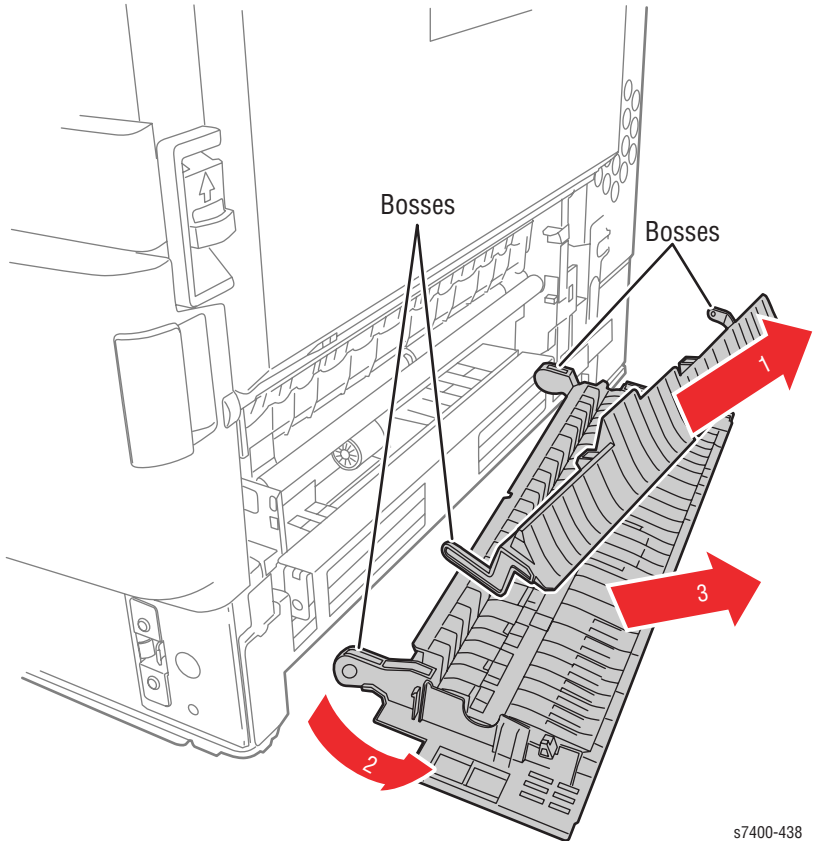

s7400-438

# Left Rear Cover

1. Open the Top Cover.
2. Remove 1 (metal, 6 mm) screw from the Left Rear Cover.

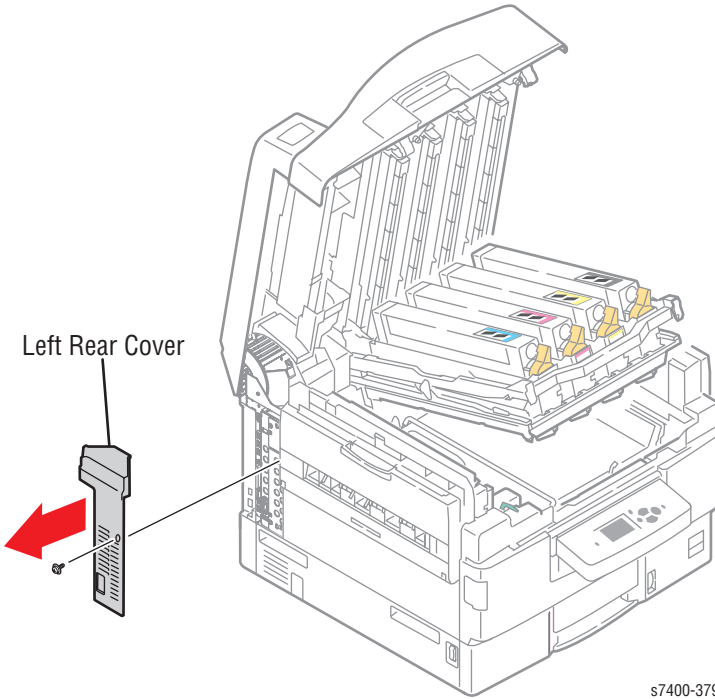

# Left Front Cover

1. Open the Top Cover and lift the Basket Assembly.
2. Open the Front Door.
3. Remove the Waste Toner Reservoir, if present, and then insert the Waste Toner Plug as shown on the reservoir label.
4. Remove 1 (metal, 6 mm) screw that secures the left side Stopper Strap on the Front Door.
5. Remove 2 (metal, 10 mm) screws securing the Left Front Cover.
6. Release the 3 tabs at the left using a flat-blade screwdriver. Insert the screwdriver in the opening provided and carefully lift the cover from the frame. Press the fourth tab, located on the cover's lower edge, upwards to release it from the frame.

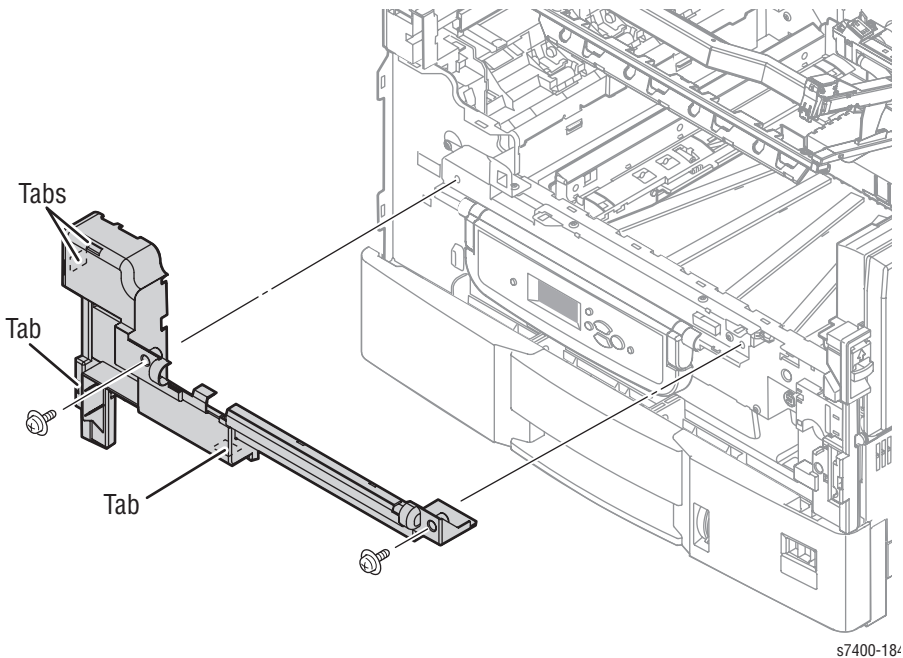

# Upper Front Cover

1. Open the Top Cover.
2. Raise the Basket Assembly.
3. Open the Front Door and lower the Control Panel completely.
4. Remove 2 (metal, 10 mm) screws securing the Left Front Cover.
5. Remove 3 (metal, 6 mm) screws securing the Upper Front Cover.
6. Unlock the Fuser, if installed, and remove the Upper Front Cover from the printer.

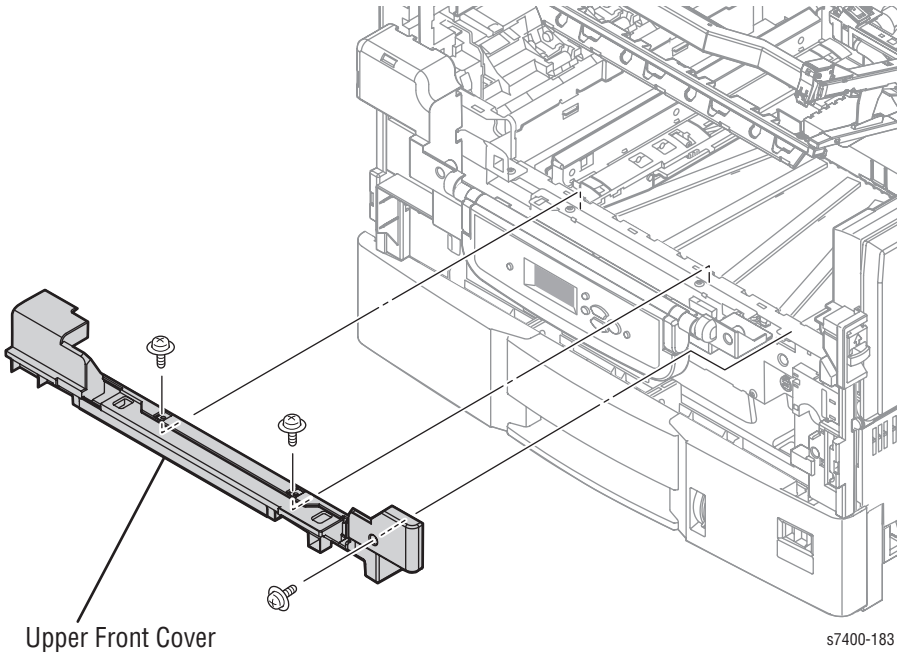

## Replacement Note

Replace the Upper Front Cover starting at the right hand side. Work the lower edge of the cover behind the Control Panel to align the screw holes with those in the frame.

# Right Front Cover

## Caution

The Waste Toner Reservoir Auger Rotation Sensor is mounted in the Right Front Cover. Use care not to damage the sensor wiring during the removal process.

1. Open Door A.
2. Remove the Waste Toner Reservoir if installed.
3. Remove the Front Door (page 8-18).
4. Remove 1 (metal, 6 mm) screw securing the Right Front Cover to the printer.
5. Release 1 tab on the right securing the Right Front Cover, and then remove it from the printer.
6. Release the sensor harness and remove the sensor from the cover.

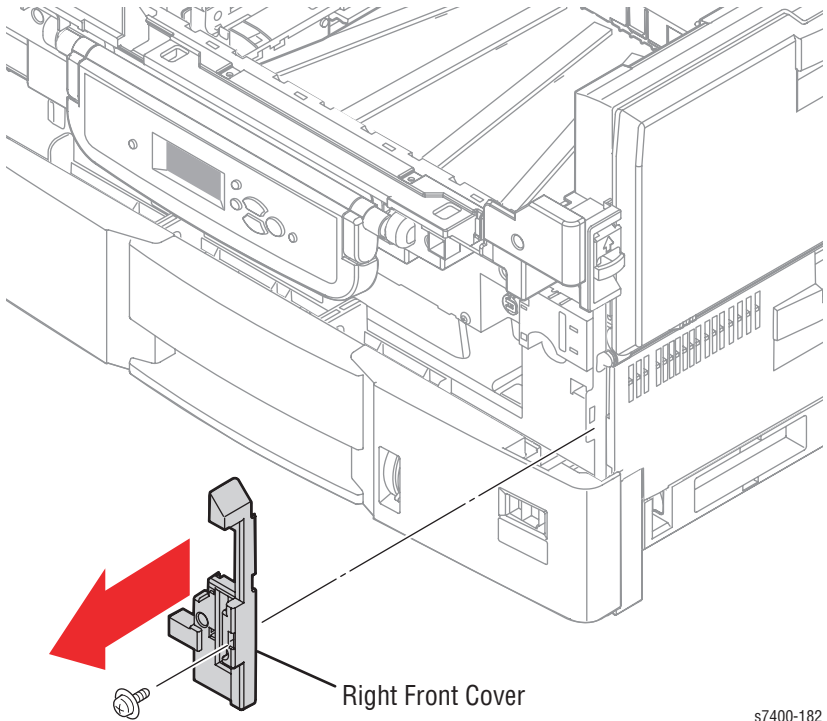

s7400-182

## Replacement Note

After installation, check that the sensor wiring is clear of the Waste Toner Reservoir Auger drive.

# Top Cover

1. Open the Top Cover completely.
2. Remove 1 (metal, 6 mm) screw from the Fuser Fan duct and remove the duct and Fan.
3. Disconnect the Fuser Fan connector (P/J250).
4. Remove 3 (black, plastic 6 mm) screws from the left side support arm.
5. Remove 6 (black, plastic 6 mm) screws securing the Top Cover.
6. Release the 3 hooks along the Exit.
7. Remove the Top Cover.

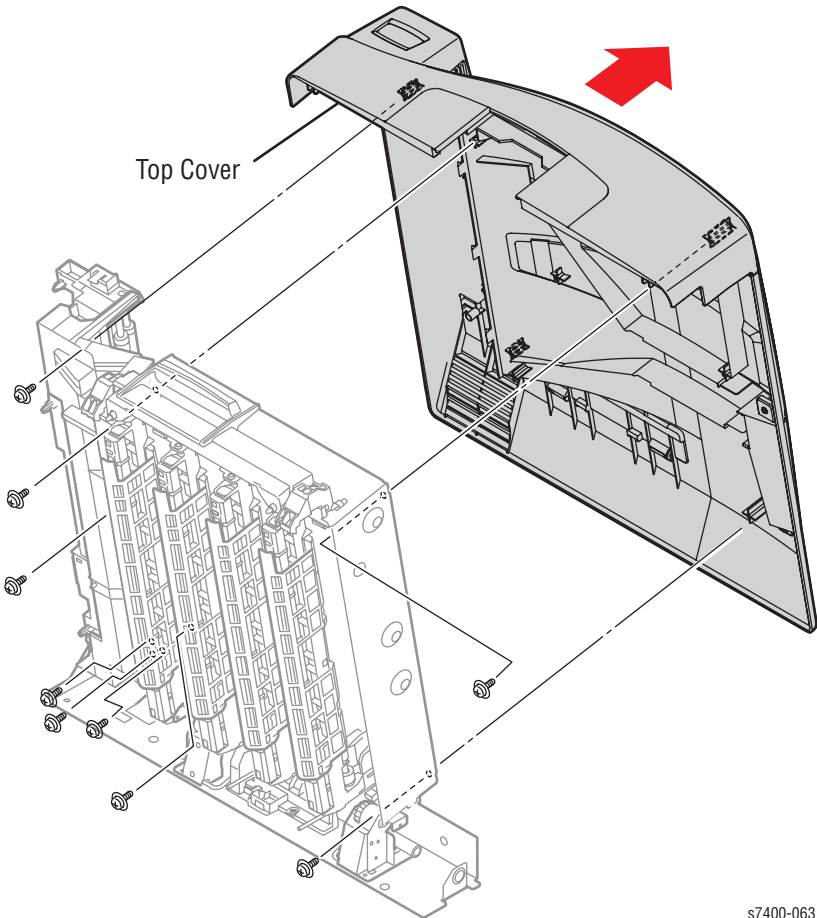

s7400-063

## Replacement Note

When replacing the Top Cover, start by aligning the left side of the cover. There are 2 posts that must slide into springs on the Job Offset Assembly, then the cover will line up correctly.



# Trays

## Tray 1 (MPT)

1. Open the Top Cover.
2. Remove the Front Sensor Board Cover.
3. Disconnect 2 connectors (MPTPAP and MPTSNS) on the Front Sensor Board.

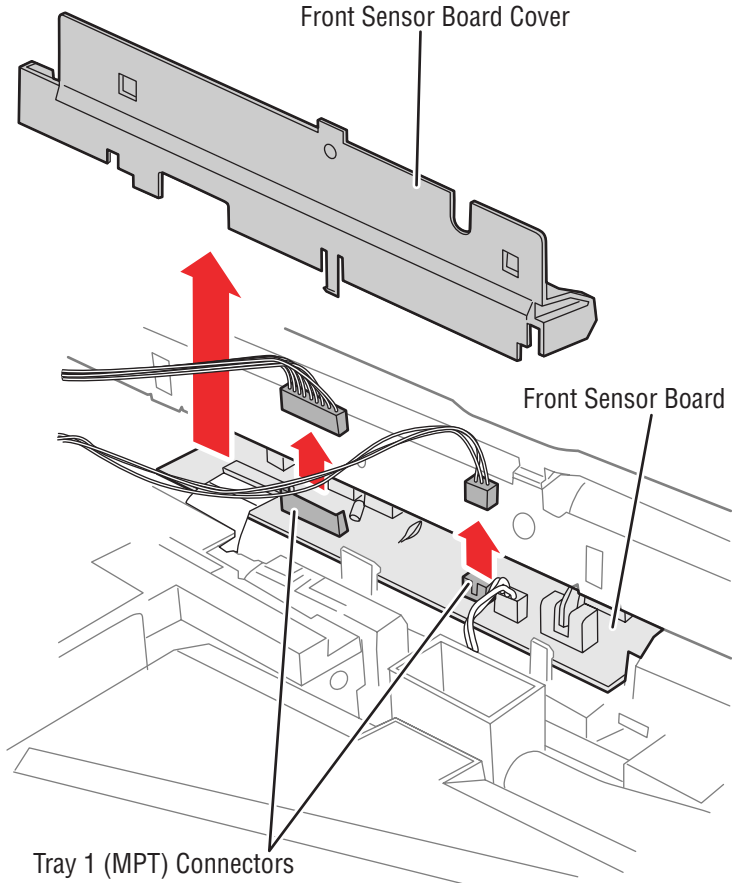

s7400-423

### Caution

The hinges are not captive to the tray. In the following steps, use care not to drop the hinges into the printer when removing the screws.

4. Open Door A.

5. Remove 2 (metal, 6 mm) screws, one at each hinge, that secure either side of Tray 1 (MPT).

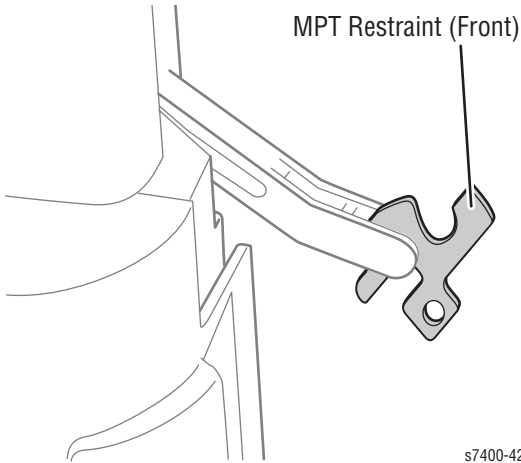

s7400-425

6. Shift Door A towards the front of the printer and lift off the posts to remove the assembly.

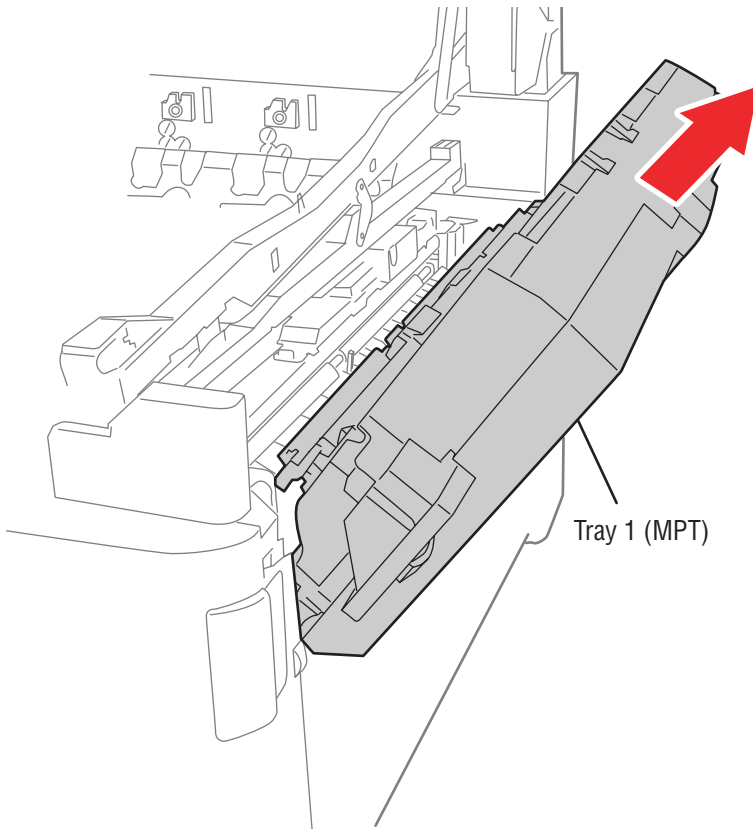

s7400-431

7. Release the wiring from the opening in the Registration Assembly. If the connector hangs inside the Registration Assembly, tape the connector parallel to the wiring to facilitate removal.

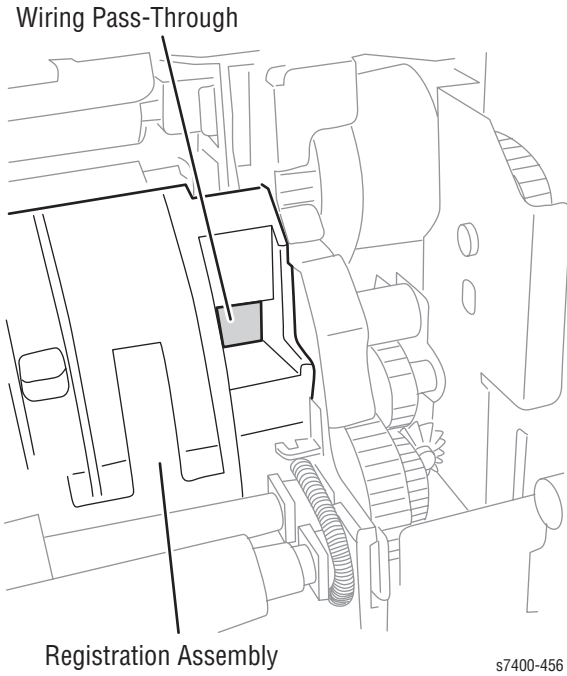

**Replacement Note**

When replacing the Tray 1 (MPT) hinges, replace the rear hinge first.

# Tray 1 (MPT) Level Sensor

Two non-captive springs are installed under the Feed Roller Assembly cover. The smaller of the two springs puts tension on the Pick Roller. The larger spring sets on a boss at the rear of the assembly.

1. Open Tray 1 (MPT).
2. Remove 2 (black, plastic 6 mm) screws that secure the cover on the Feed Roller Assembly.

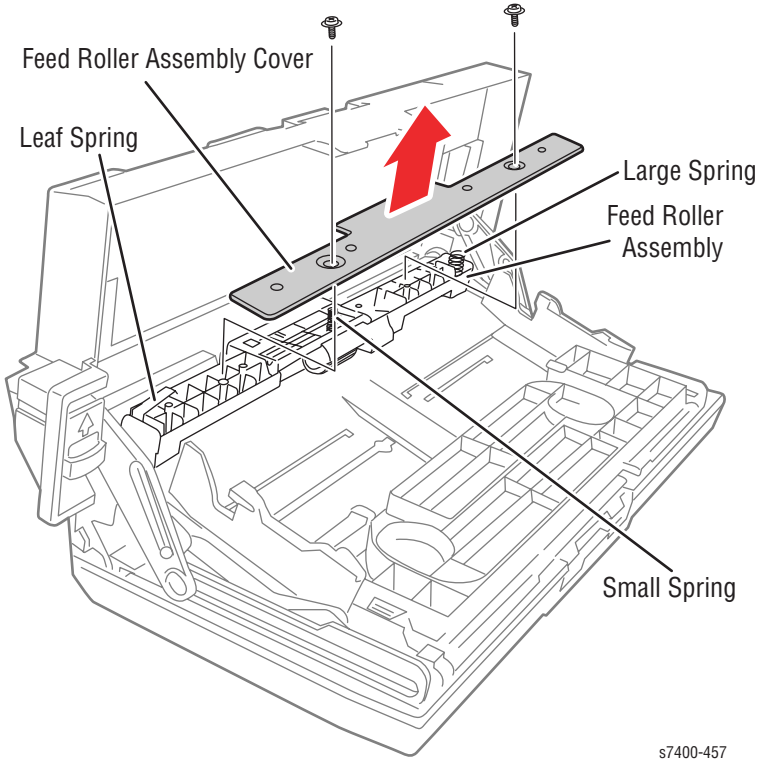

s7400-457

3. Release the hooks that secure the Tray 1 (MPT) Level Sensor to the Feed Roller Assembly.

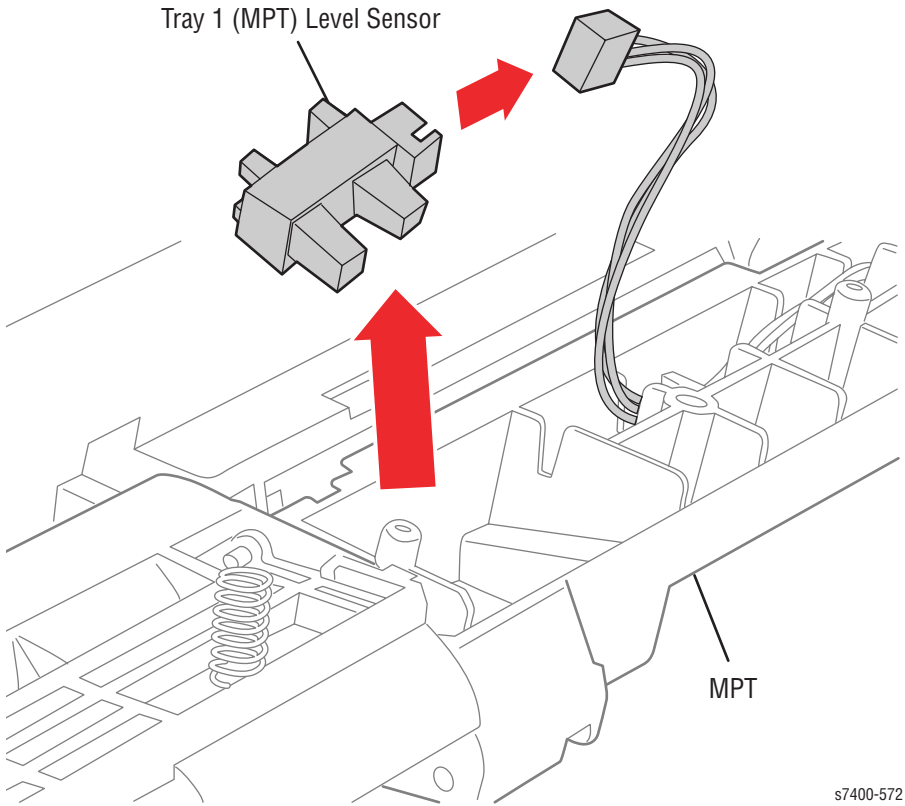

s7400-572

4. Disconnect the sensor (P/J440) from the harness.

## Tray 1 (MPT) Home Position Sensor

1. Remove the Registration Assembly (page 8-84).
2. Release 2 hooks that secure the gear cover to the back of the Registration Assembly.

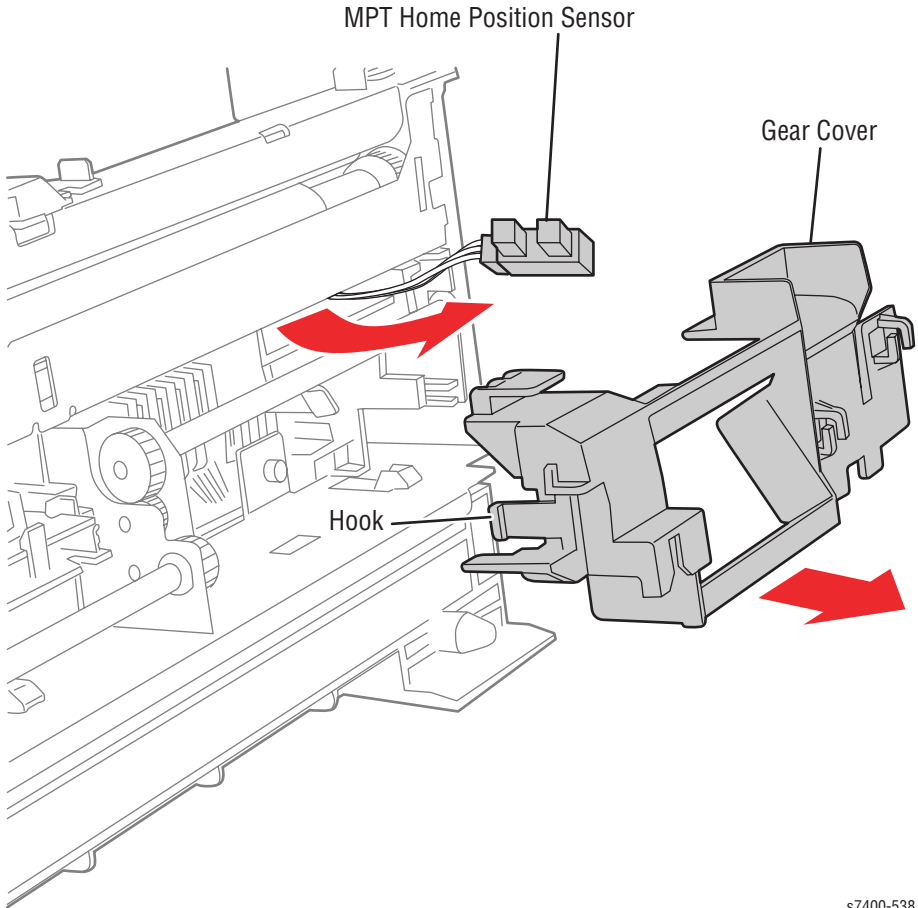

s7400-538

3. Release the 3 hooks that secure the sensor to the Registration Assembly, and then push the sensor through the opening to the back of the assembly.
4. Disconnect the sensor from the harness (P/J430).

# OHP Sensor

1. Open Door A.
2. Remove the Sensor Cover from the back of Tray 1 (MPT).

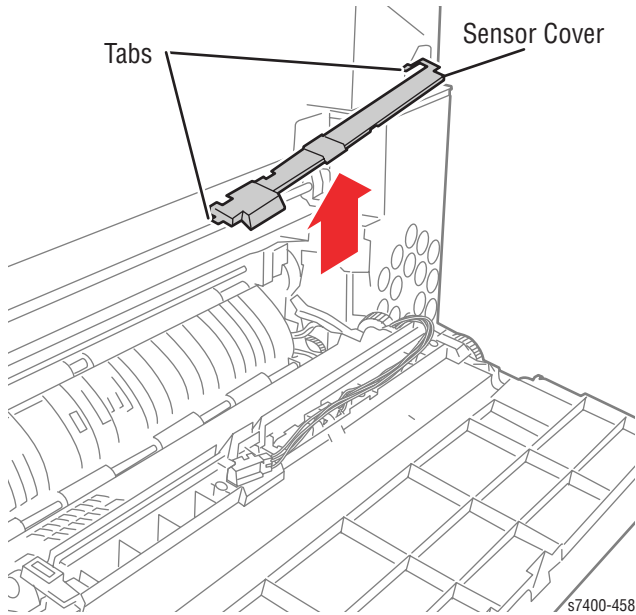

3. Disconnect the sensor from the harness (P/J450).
4. Release the hooks that secures the sensor to Tray 1 (MPT).

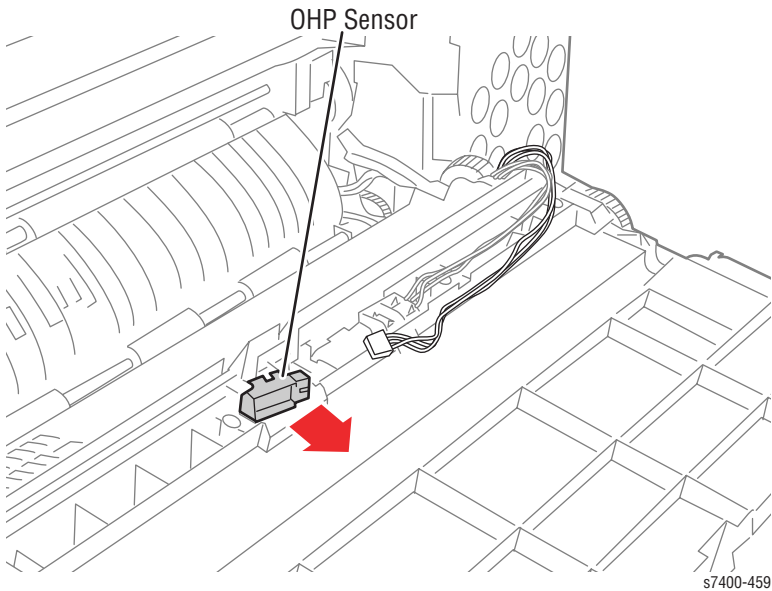

# Feed-Out Sensor #1

1. Open Door A.
2. Remove the Sensor Cover from the back of Tray 1 (MPT).

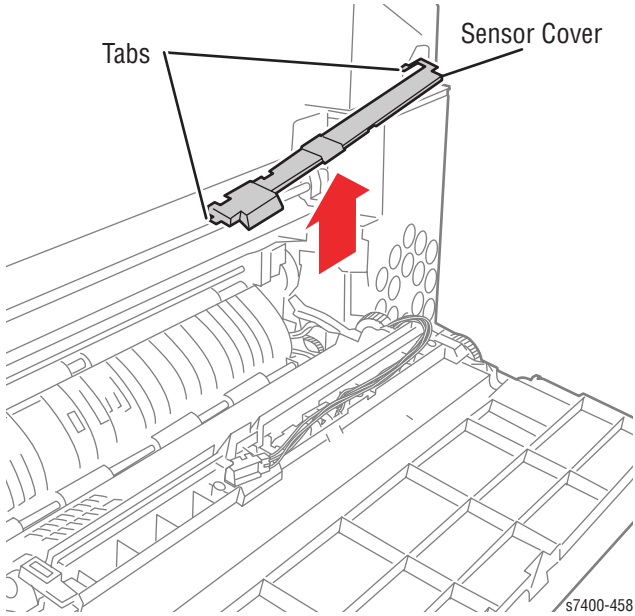

3. Disconnect the sensor from the harness (P/J450).
4. Release the hooks that secure the sensor to Tray 1 (MPT).

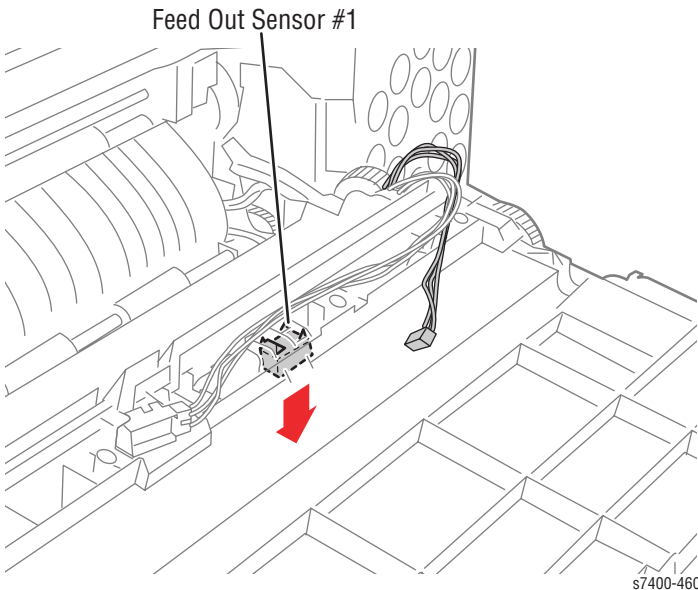



# Tray 1 (MPT) No Paper Sensor

## Note

A non-captive spring is installed in the Rear Chute to tension the Retard Roller.

1. Remove Tray 1 (MPT)
2. Open the tray assembly and depress the lift plate to remove 1 (black, 10 mm) screw at the center.
3. Remove 2 (black, plastic 10 mm) screws that secure the Rear Chute to the Tray 1 (MPT).

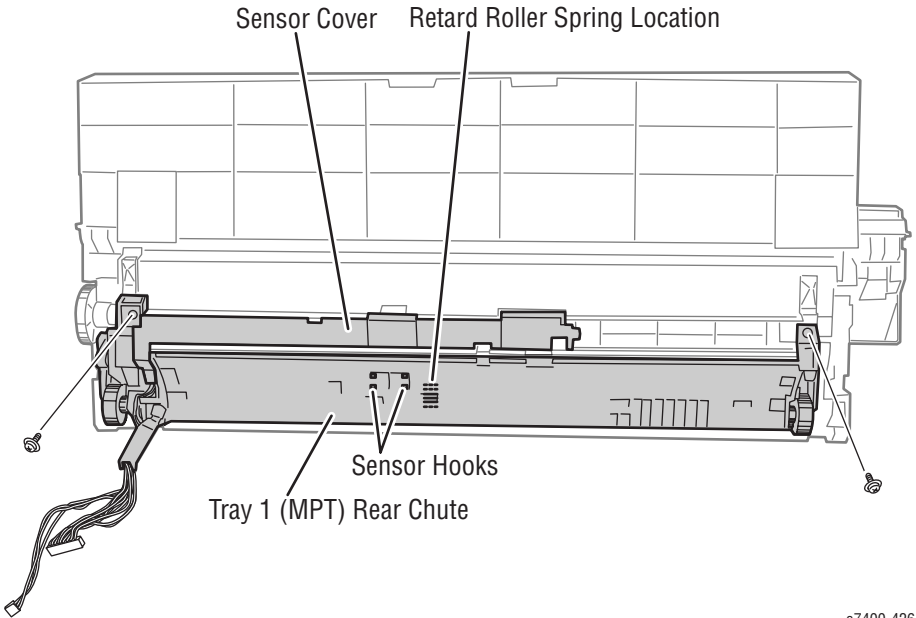

s7400-426

4. Separate the Rear Chute from the assembly.
5. Release the hooks that secure the sensor to the Rear Chute.
6. Disconnect the sensor connector (P/J460).

## Replacement Note

Insert the spring underneath the Retard Roller before installing the Rear Chute. Make sure the lift levers are above the Lift Plate.

# Tray 1 (MPT) Feed Rollers

1. Partially open Tray 1 (MPT).
2. Rotate the 2 levers 90 degrees to unlock the Feed Roller Assembly linkage from the Tray 1 (MPT) Links.

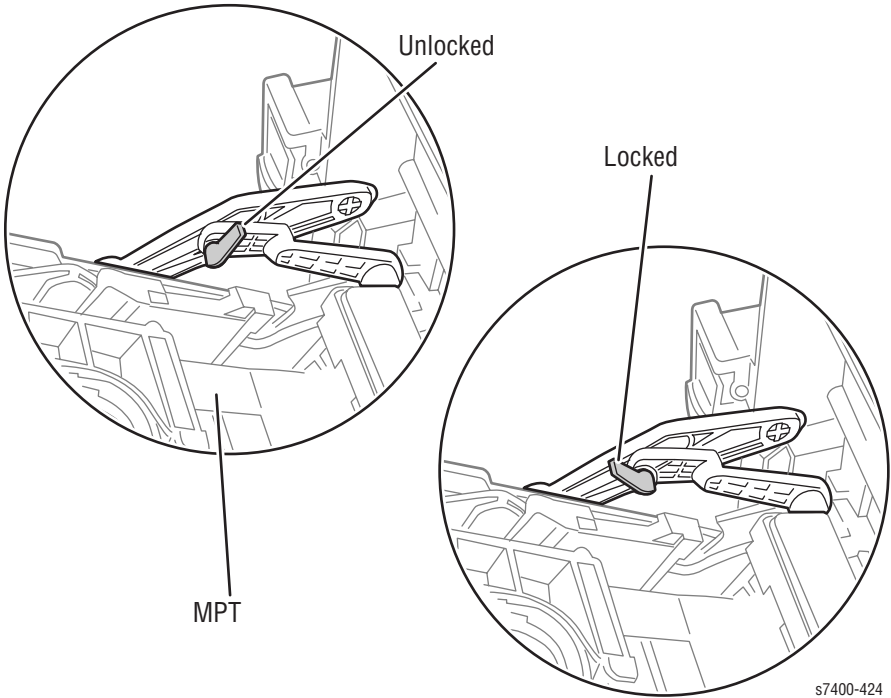

3. Raise the Feed Roller assembly to access the Pick and Feed Rollers.

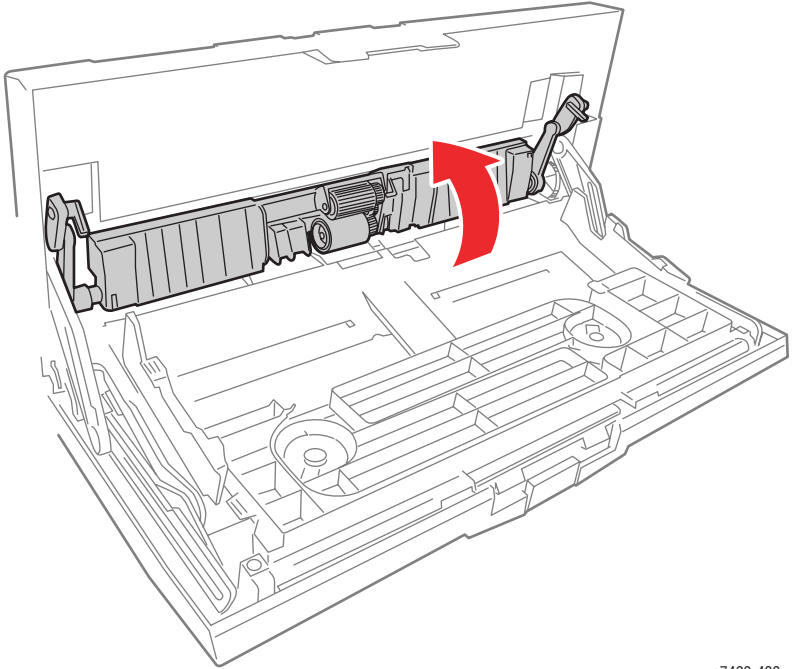

s7400-430

4. Open the Retard Roller Access Door.

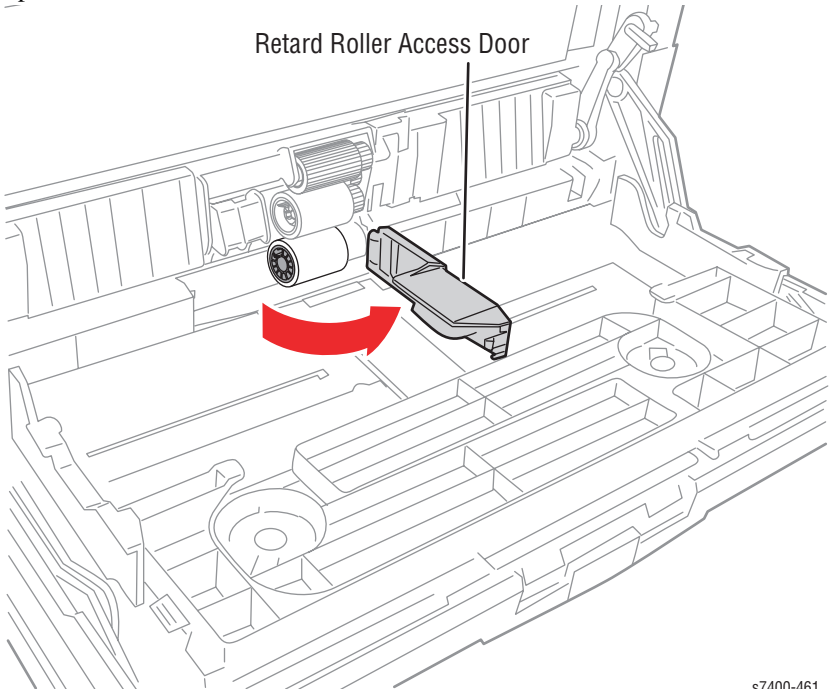

s7400-461

5. Remove the Pick Roller by gently prying the left end away from the housing.

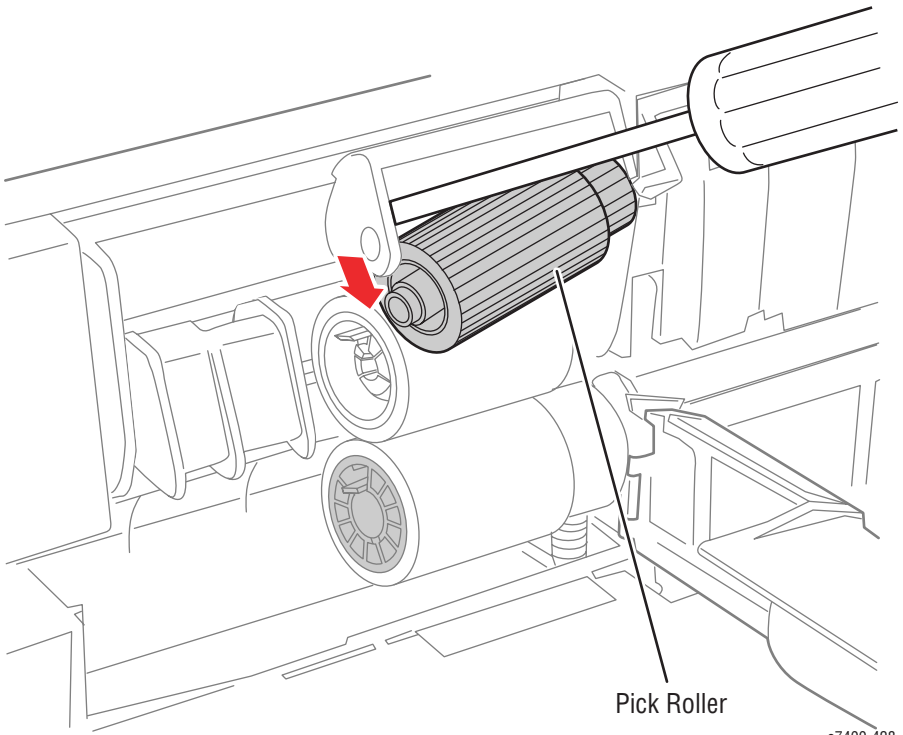

Pick Roller

s7400-428

6. Remove the Feed Roller Paper Guide to provide space to remove the rollers.

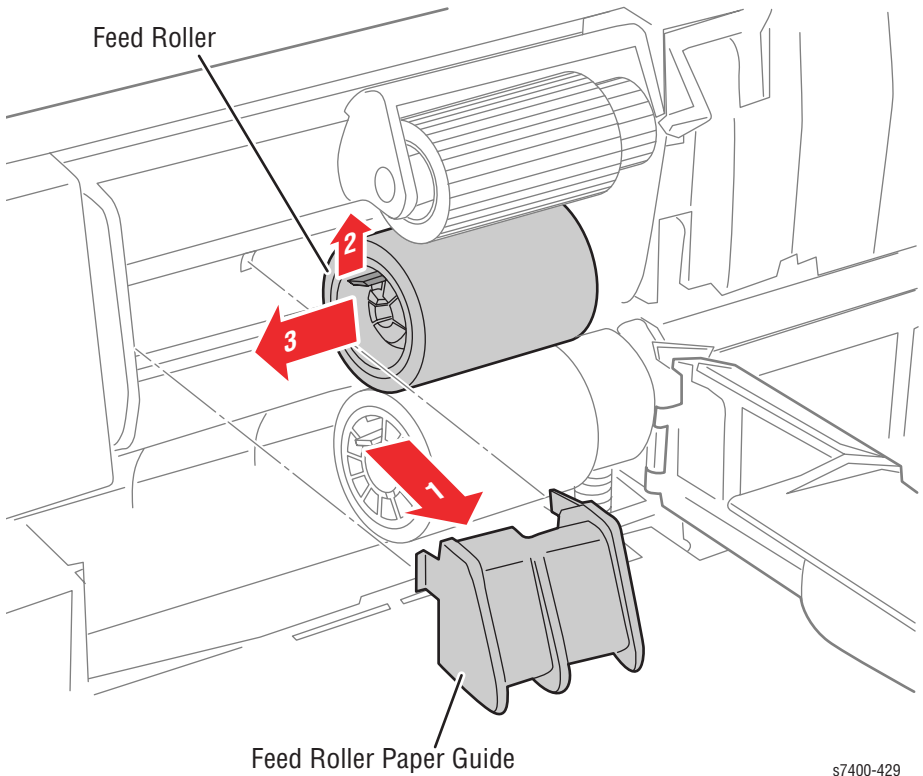

s7400-429

7. Remove the Feed and Retard Rollers by releasing the hook and sliding the roller off the shaft.

### Replacement Note

Match each replacement roller to the one being removed. All three rollers are unique.

# Tray 2 Feeder

## Note

If optional trays are installed, either remove the printer from the optional tray(s), or place a ream of paper, or similar object, to hold the printer above the LTA to provide sufficient clearance to remove 4 screws and pull the Tray 2 Feeder from the frame.

1. Remove Tray 2.
2. Remove the Right Side Cover (page 8-16).
3. Remove the Right Rear Cover (page 8-15).
4. Remove the Rear Cover (page 8-13).
5. Remove Tray 1 (MPT) (page 8-25).
6. Remove Door B (page 8-19).
7. Remove the Card Cage Fan Duct (page 8-114).
8. Unplug connectors CL1, REGHOP, and TRYSNS on the Motor Driver Board.
9. Remove 12 (metal, 10 and 6 mm) screws to remove the Tray 2 Feeder.

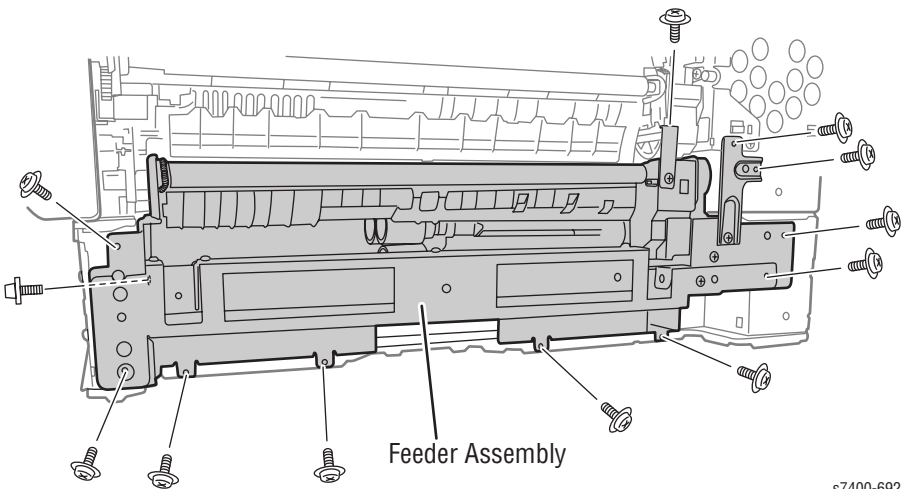

s7400-692

# Registration Motor

1. Remove the Tray 2 Feeder (page 8-38).
2. Release the motor harness from the clamp.
3. Disconnect the Registration Motor connector (P/J40) from the harness.
4. Remove 2 (metal, 6 mm) screws that secure the Registration Motor to the Feeder.

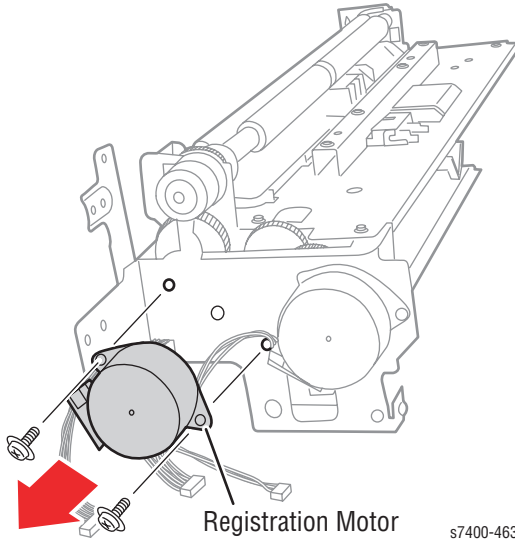

# Feed Motor

1. Remove the Tray 2 Feeder (page 8-38).
2. Release the motor harness from the clamp.
3. Disconnect the Feed Motor connector (P/J30) from the harness.
4. Remove 2 (metal, 6 mm) screws that secure the Feed Motor to the Feeder.

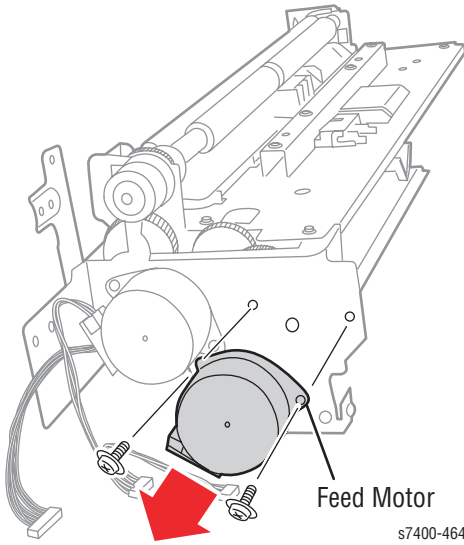



# Lift Motor

1. Remove Tray 2.
2. Open the Top Cover.
3. Remove the Right Rear Cover (page 8-15).
4. Remove the Card Cage Fan Duct (page 8-114).
5. Remove the LVPS (page 8-121).
6. Disconnect the Lift Motor connector GDDC from the Motor Driver Board.
7. Remove the 2 (metal, 6 mm) screws that secure the Lift Motor to the frame.

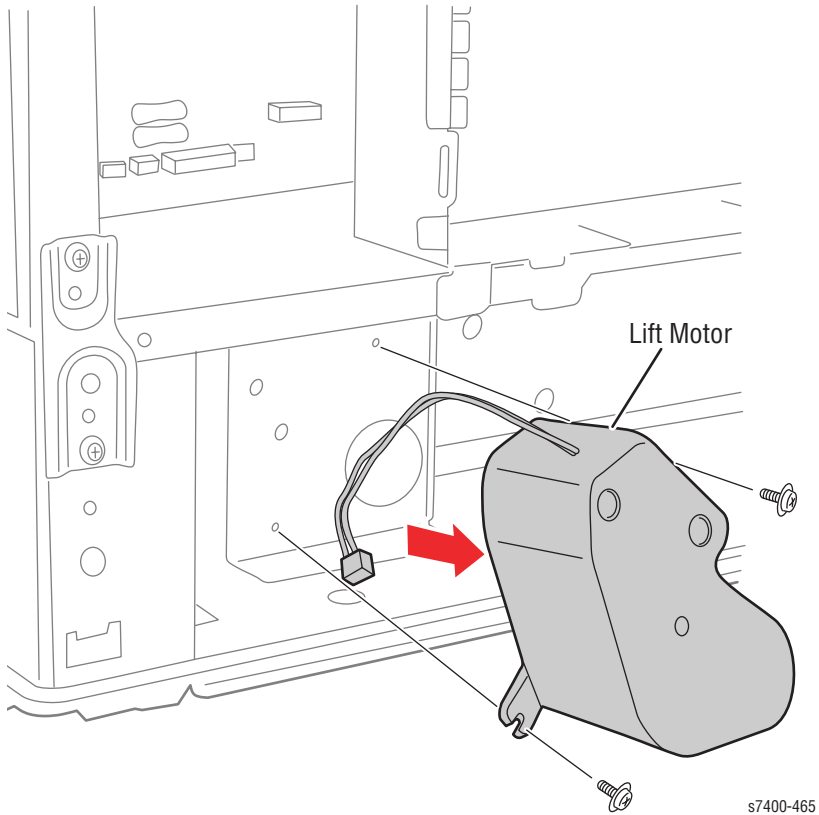

## Registration Clutch #2

1. Remove the Tray 2 Feeder (page 8-38).
2. Remove the E-clip that secures the clutch to the Registration Roller.

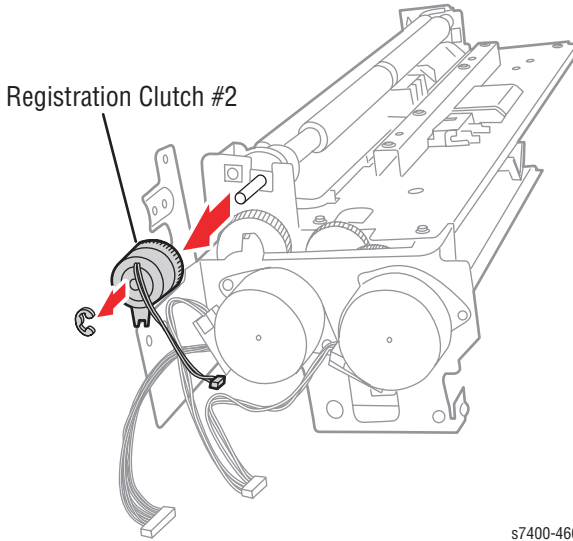

s7400-466

3. While holding the anti-rattle spring, remove the clutch from the roller shaft.

# Door B Detect Sensor

The Door B Detect Sensor is mounted on a carrier located beneath the Registration Rollers near the clutch.

## Caution

Use care when removing the roller shaft bearings. The bearings use a small clip to lock into a notch near the end of each roller shaft. Use a small, flat-bladed screwdriver to release the clip from the shaft before attempting to remove the bearing.

1. Remove the Tray 2 Feeder (page 8-38).
2. Remove the Registration Clutch #2 (page 8-42).
3. Remove the 2 springs that tension the Registration Rollers.
4. Remove the bearings at each end of the rubber roller, and then remove the roller.

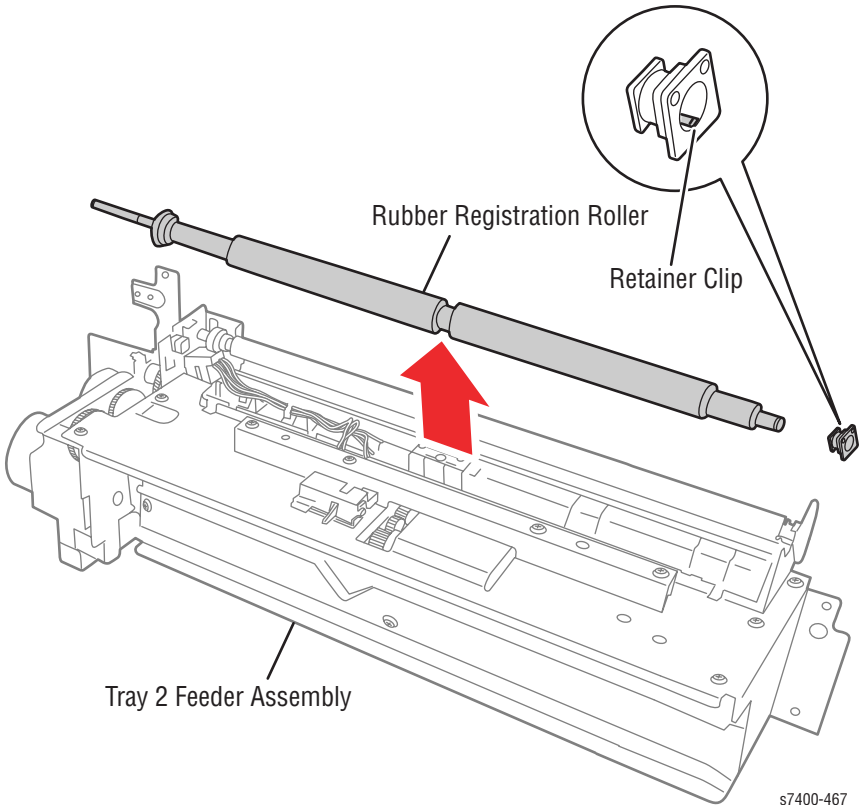

5. Release the hook that secures the sensor carrier to the feeder.

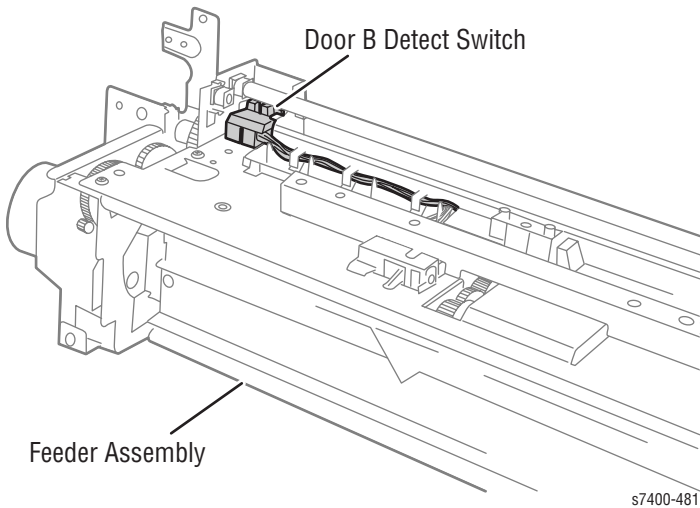

6. Turn the sensor carrier over, and then release the hooks that secure the sensor to the carrier.
7. Disconnect the sensor connector (P/J41).

## Tray 2 No Paper Sensor

1. Remove the Tray 2 Feeder (page 8-38).
2. Remove 4 (metal, 23 mm) screws that secure the brace.

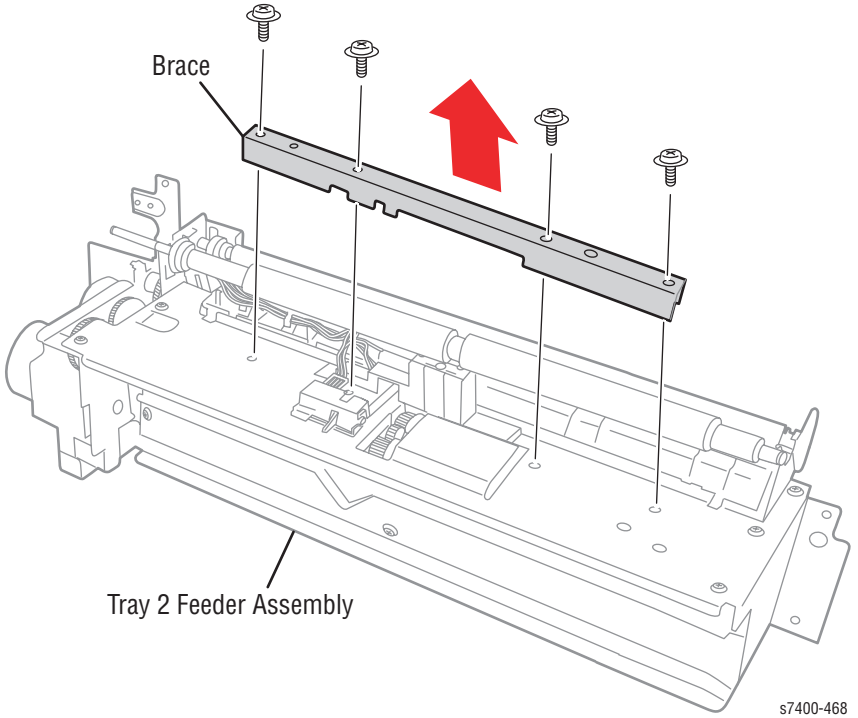

3. Release the hook that secures the No Paper Sensor housing to the feeder.

4. Turn the housing over, and then release the hooks that secure the sensor to the housing.

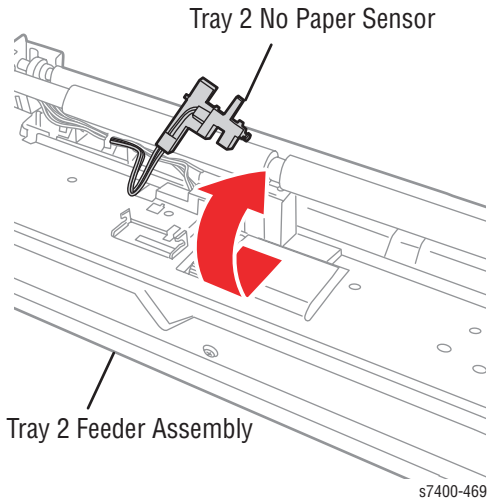

5. Disconnect the sensor connector (P/J43).

## Registration Sensor #2

1. Remove the Tray 2 Feeder (page 8-38).
2. Remove the Registration Clutch #2 (page 8-42).
3. Remove the Feeder Board Cover.
4. Remove 4 (metal, 6 mm) screws that secure the feeder top.

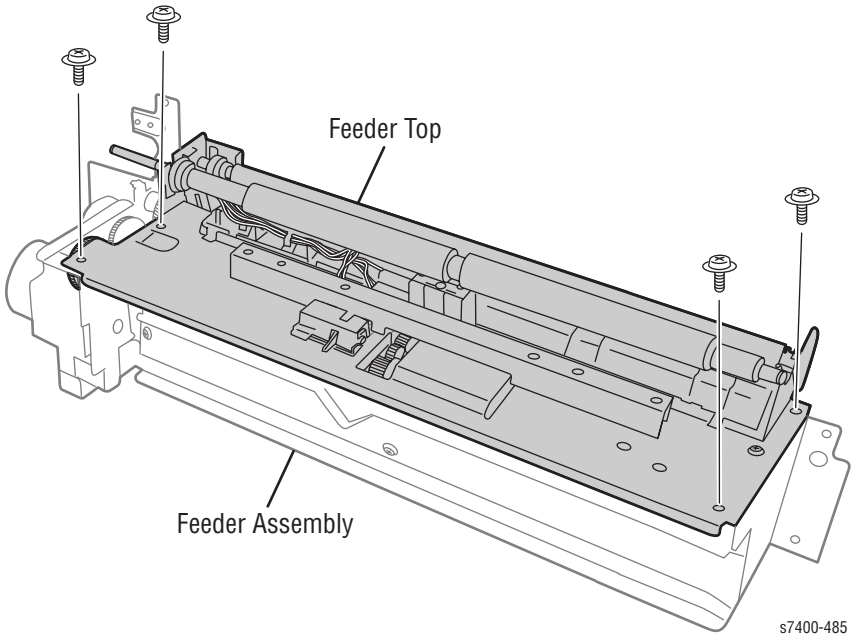

5. Separate the feeder top and then turn the top over.

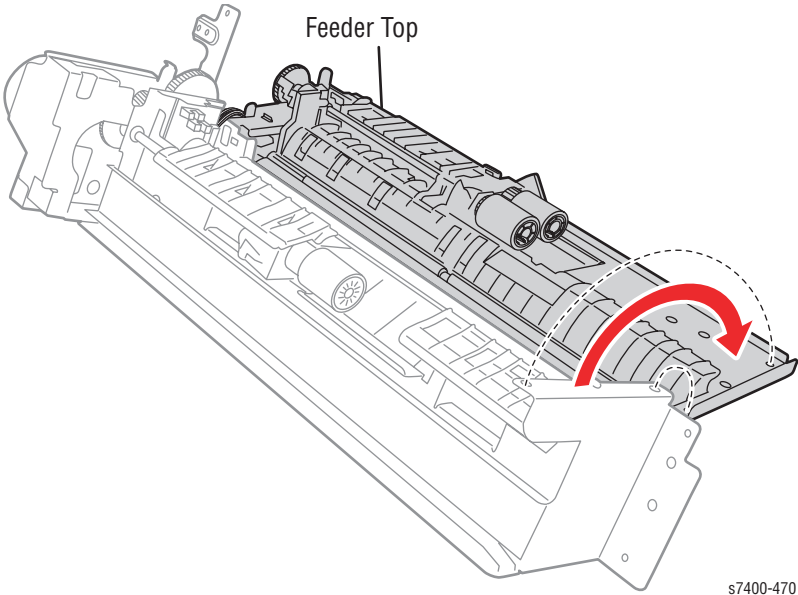

s7400-470

6. Remove 2 (black, plastic 10 mm) screws that secure the sensor housing.

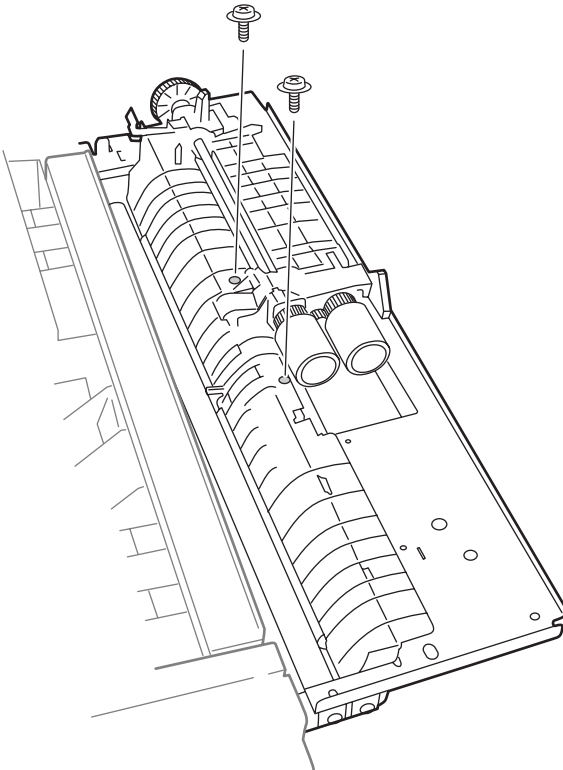



7. Turn the feeder top upright, and then release the 2 hooks that secure the sensor housing to the top of the feeder.

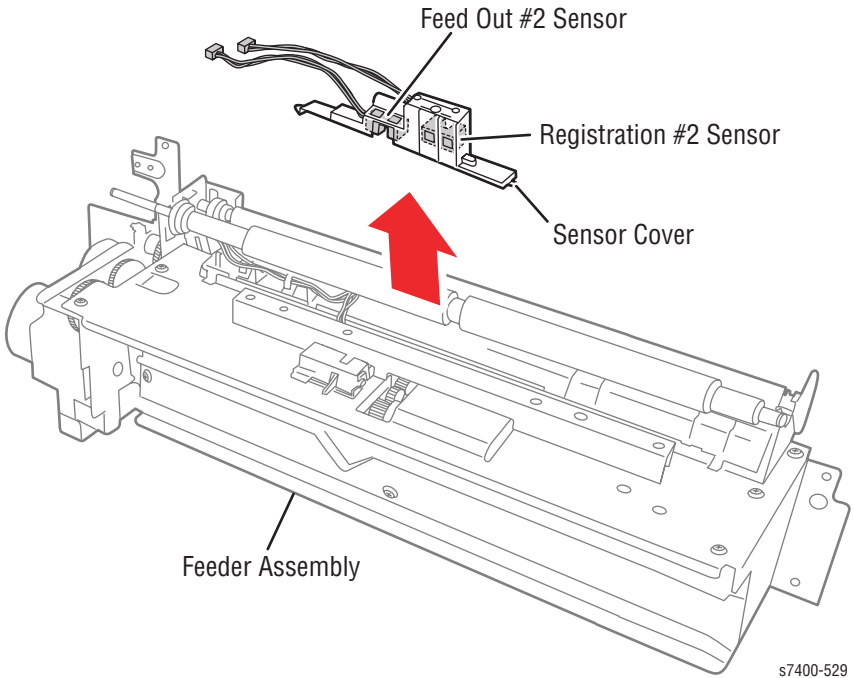

8. Release the hooks that secure the sensor in the housing.
9. Disconnect the sensor connector (P/J42), and then remove the sensor.

### **Replacement Note**

Use care when replacing the feeder top. Make sure the Level, and Low Paper Sensor flags operate properly before tightening the screws.

## Feed-Out Sensor #2

1. Remove the Tray 2 Feeder (page 8-38).
2. Remove the Registration Clutch #2 (page 8-42).
3. Remove the Feeder Board Cover.
4. Remove 4 (metal, 6 mm) screws that secure the feeder top.

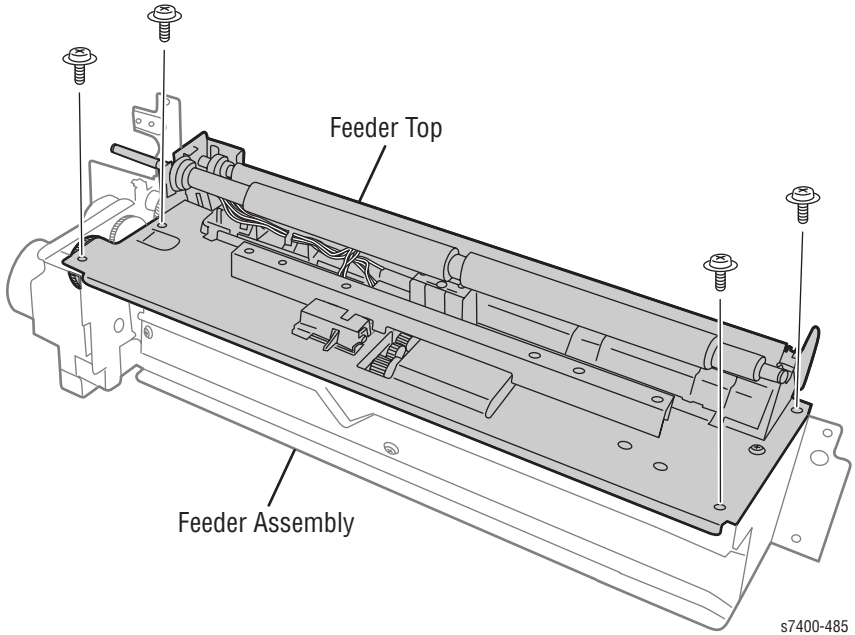

5. Separate the feeder top and then turn the top over.

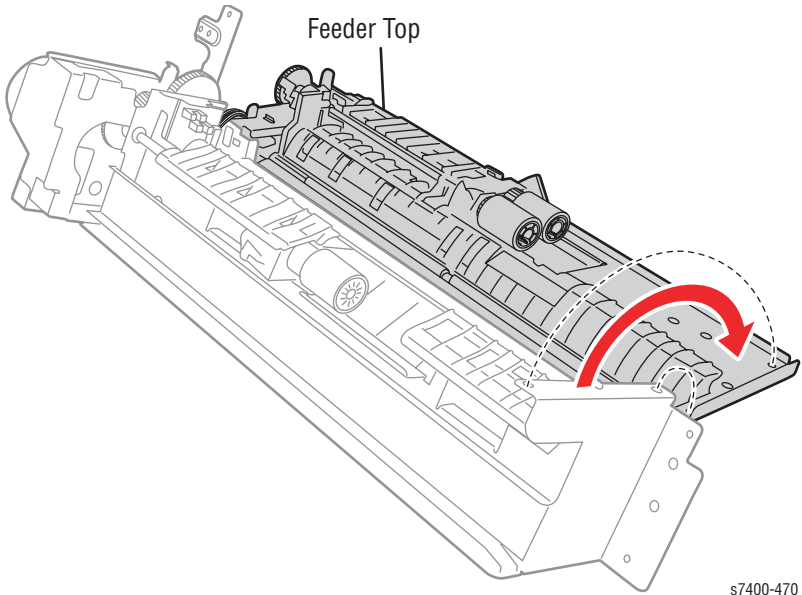

s7400-470

6. Remove 2 (black, plastic 10 mm) screws that secure the sensor housing.

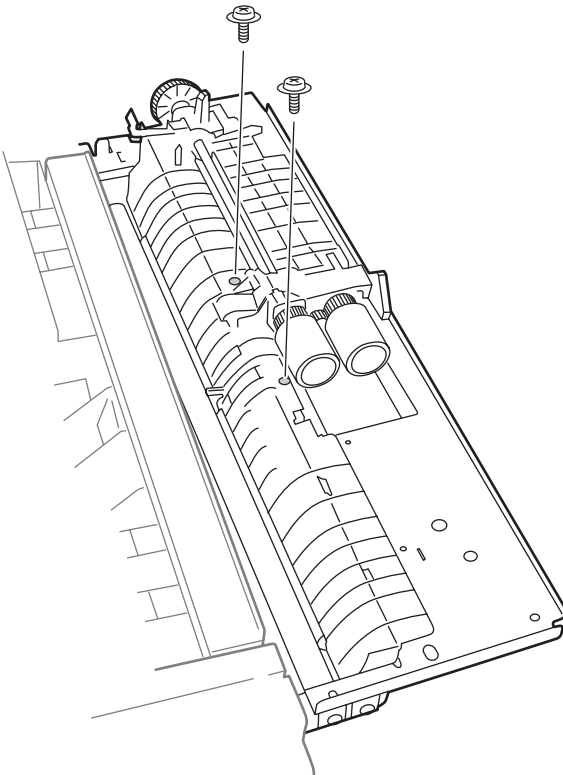

7. Turn the feeder top upright, and release the 2 hooks that secure the sensor housing to the top of the feeder.

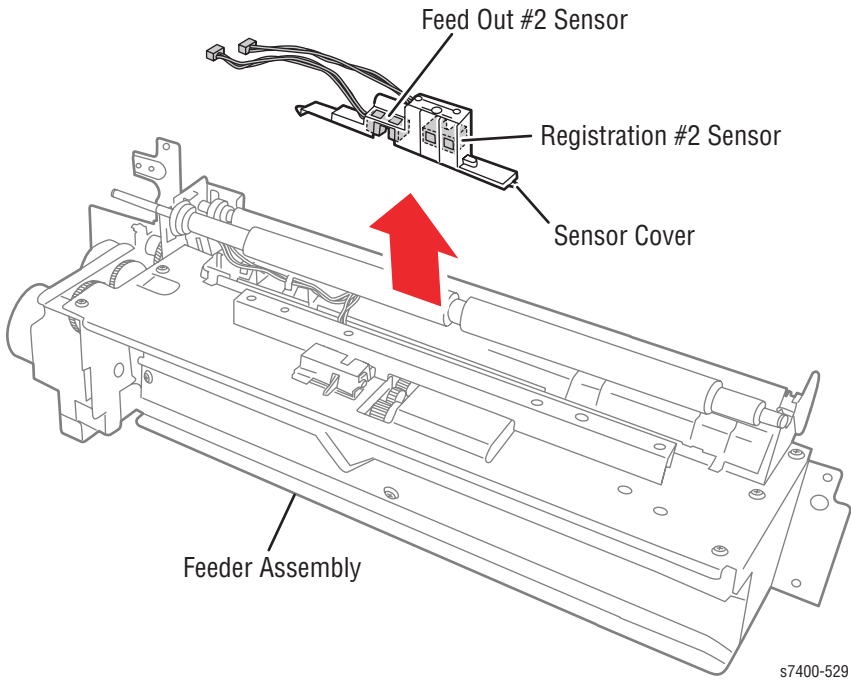

8. Release the hooks that secure the sensor in the housing.
9. Disconnect the sensor connector (P/J43), and then remove the sensor.

### Replacement Note

Use care when replacing the feeder top. Make sure the Level, and Low Paper Sensor flags operate properly before tightening the screws.

# Feeder Board

1. Remove the Tray 2 Feeder (page 8-38).
2. Remove 3 (metal, 10 mm) screws that secure the hand holds to the feeder.

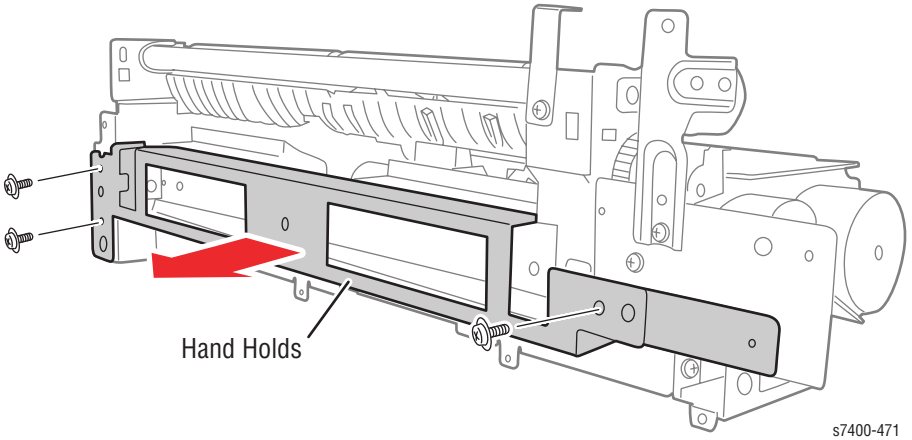

3. Remove 1 (metal, 6 mm) screw that secures the Feeder Board Cover.
4. Remove 1 (metal, 6 mm) screw that secures the Feeder Board to the Feeder.

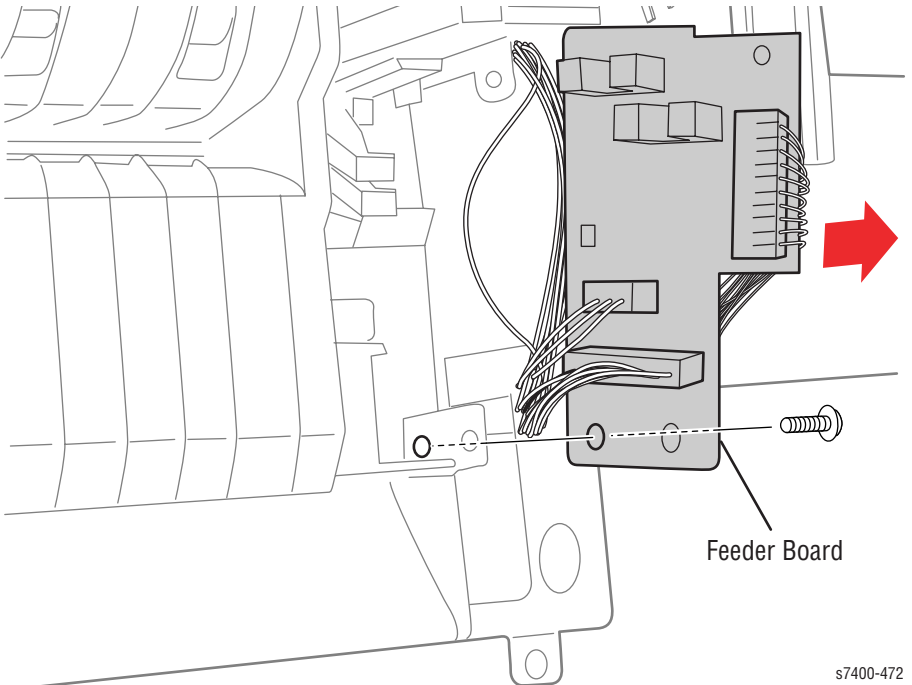

5. Disconnect the connectors (TRYSNS1, TRYSNS2, and PAPEND), and then remove the board.

# Tray 2 Feed Rollers

## Note

Feed Roller (Pick, Feed, Retard) removal is identical for all Universal Trays. However, each roller is unique. Match each replacement roller to the roller being removed.

1. Remove Tray 2.
2. Open Door C.
3. Release the hook that secures each roller to the shaft.

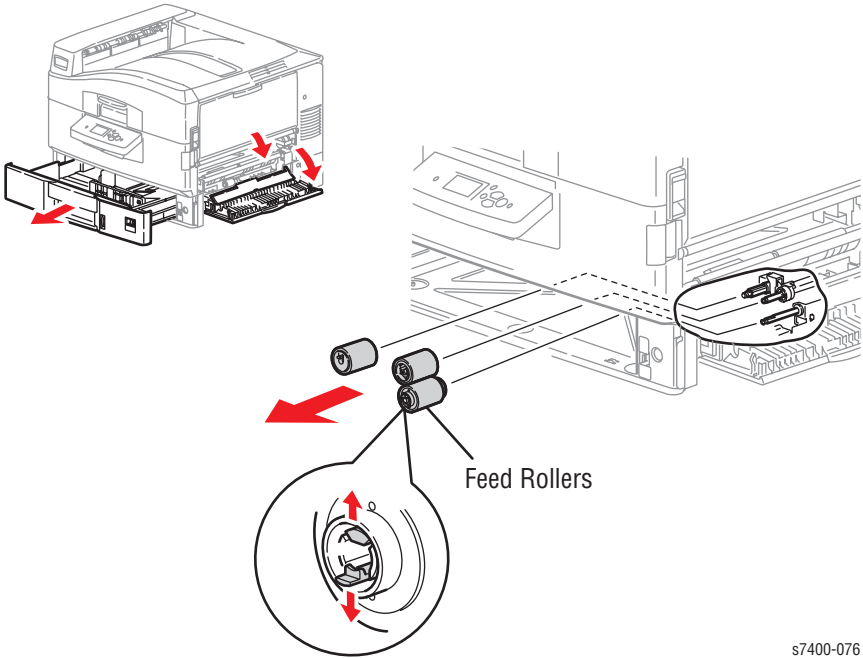

s7400-076

# Side Output Tray

1. Open the Top Cover.
2. Remove the Left Front Cover (page 8-21).
3. Release the Stopper Links from the printer frame.
4. Release the tray from the 2 posts by flexing the tray right to clear the left post and slide left to remove.

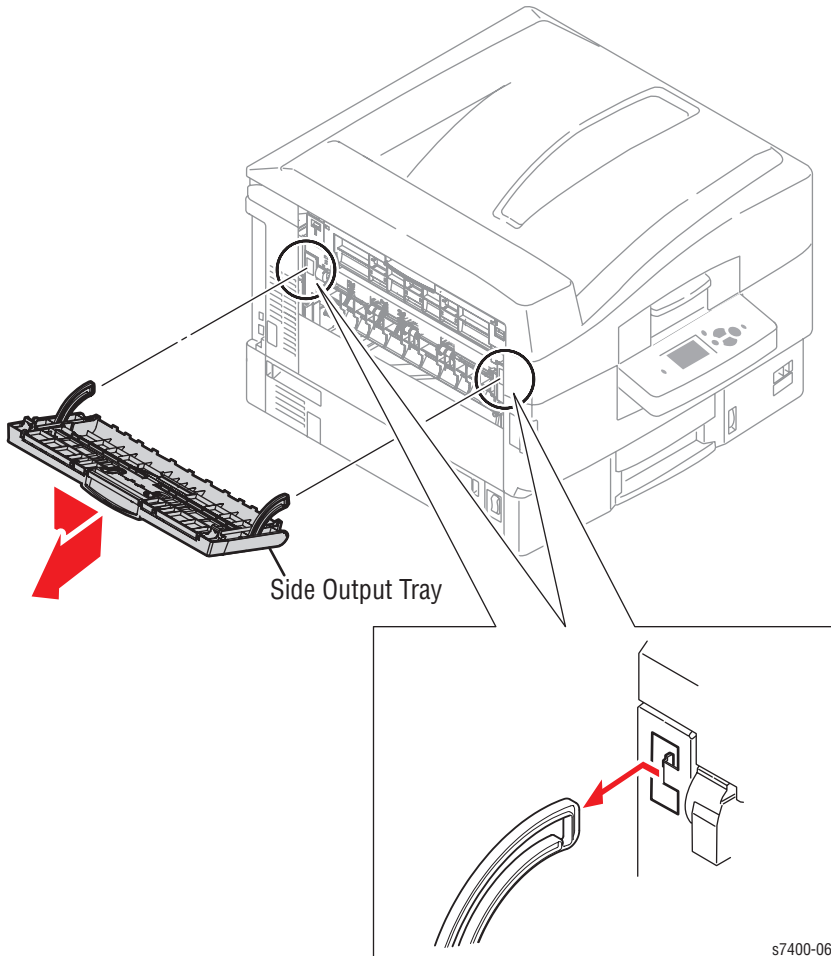

# Chassis

## Job Offset Assembly

### Note

There are two springs on top of the Job Offset Assembly that are not captured. Use care not to loose these springs.

1. Remove the Top Cover (page 8-24).
2. Release the Job Offset Motor harness from the guides at the rear of the LED Assembly (4 red wires).

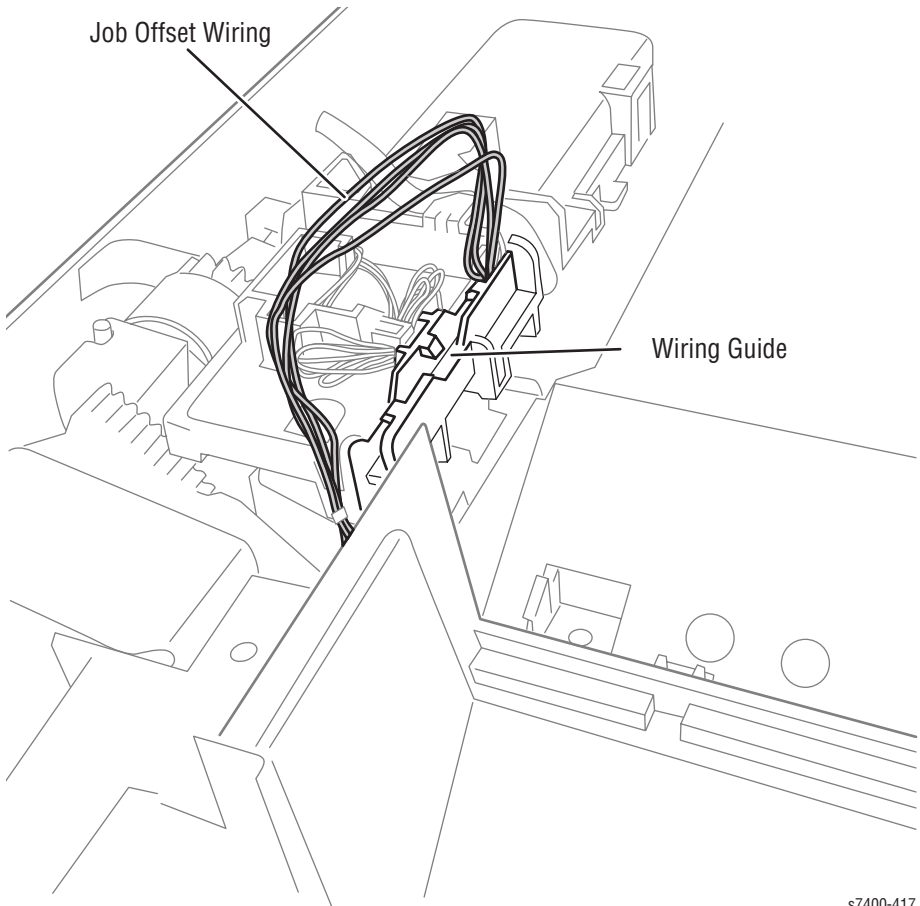

s7400-417



3. Release 2 hooks securing the Job Offset Assembly to the Top Output Chute.

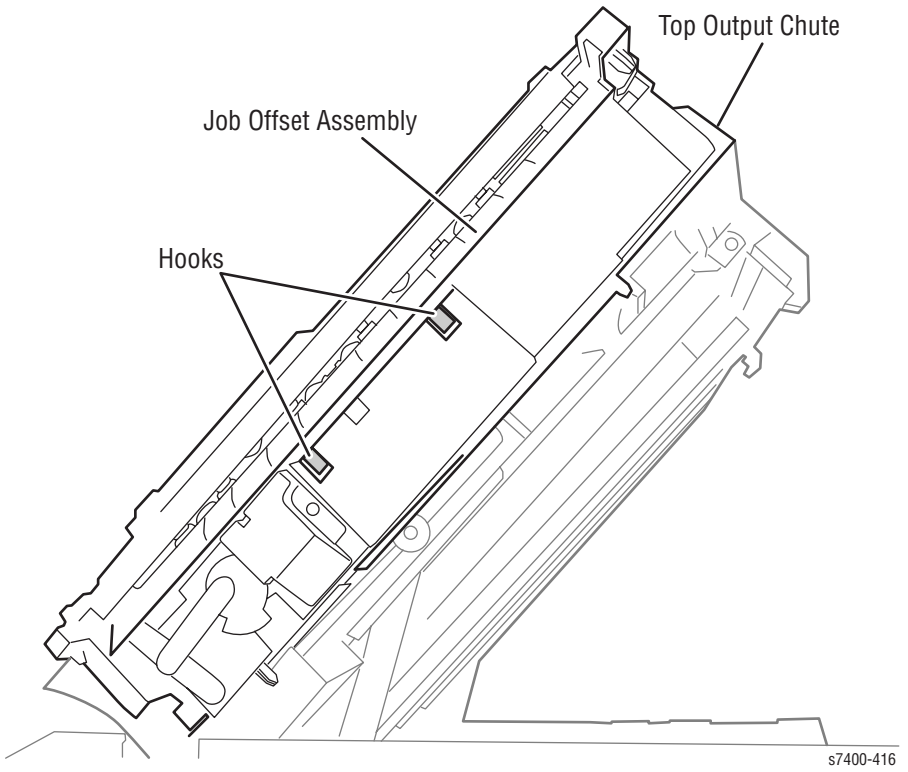

4. Lift the assembly, and then move the front to the left to reveal the Job Offset Motor and connector at the back of the assembly.

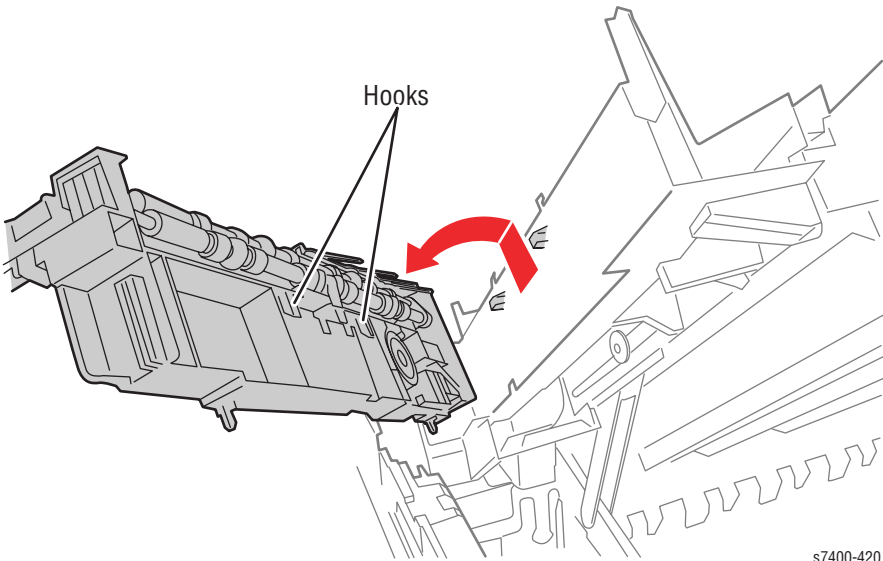

s7400-420

5. Disconnect the Offset Motor from the harness (P/J90).
6. Remove the Job Offset Assembly.

# Job Offset Motor

1. Remove the Job Offset Assembly (page 8-56).
2. Remove the 1 (black, plastic, 10 mm) that secures the Job Offset Gear Cover.
3. Release the 4 hooks that secure the Job Offset Motor mounting plate to the Job Offset Assembly.

Job Offset Gear Cover

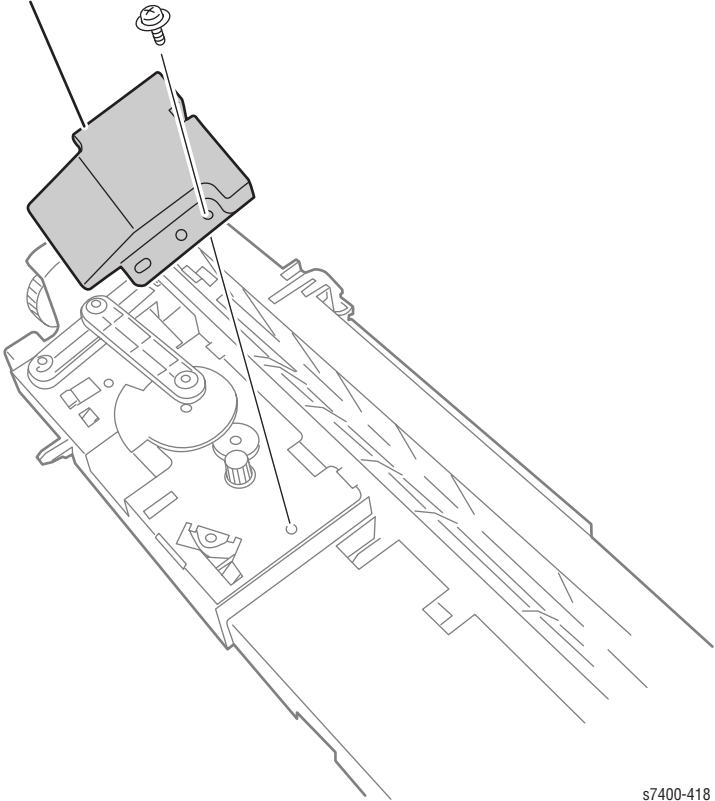

s7400-418

4. Remove the 1 (metal, 6 mm) screw that secures the Job Offset Motor to the mounting plate to remove the motor.

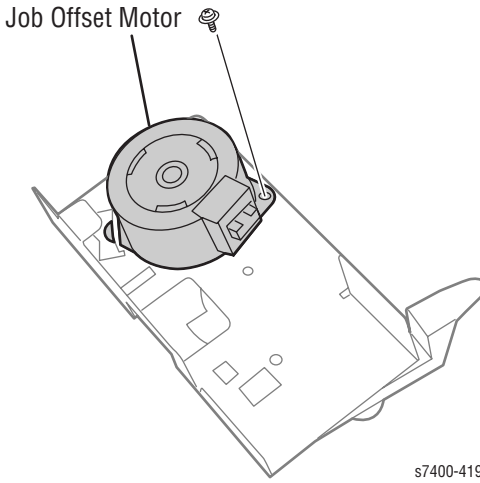

s7400-419

# Job Offset Home Position Sensor

1. Remove the 6 hooks that secure the Rear Sensor Board Cover to the Exit Assembly.

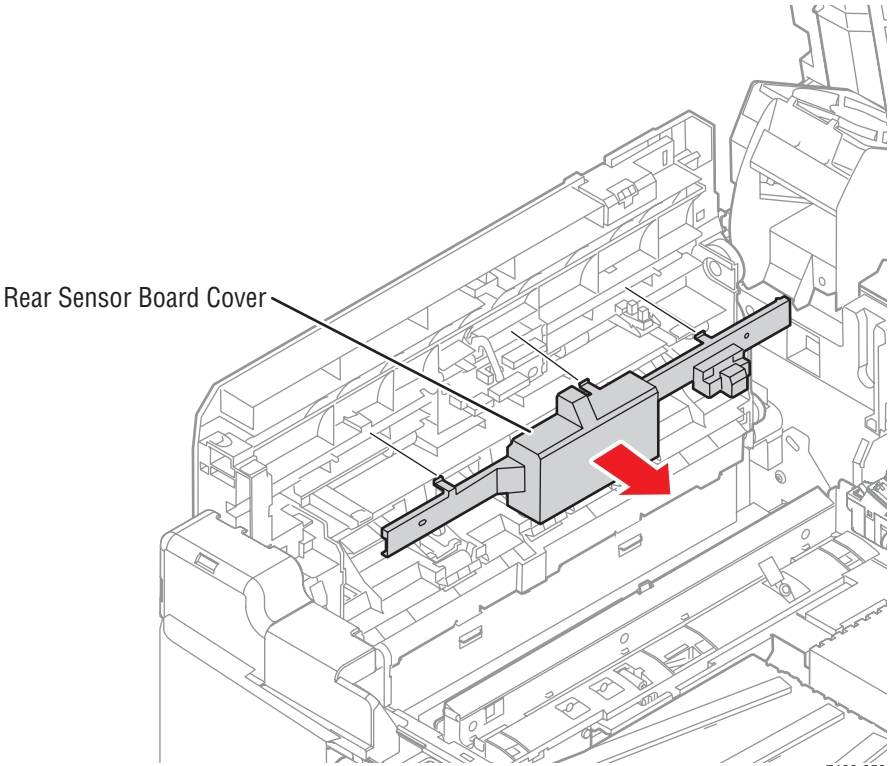

s7400-353

2. Release the hooks that secure the Job Offset Home Position Sensor to the Exit Assembly.

**3.** Release the sensor connector (P/J150) to remove the sensor.

Job Offset Home Position Sensor

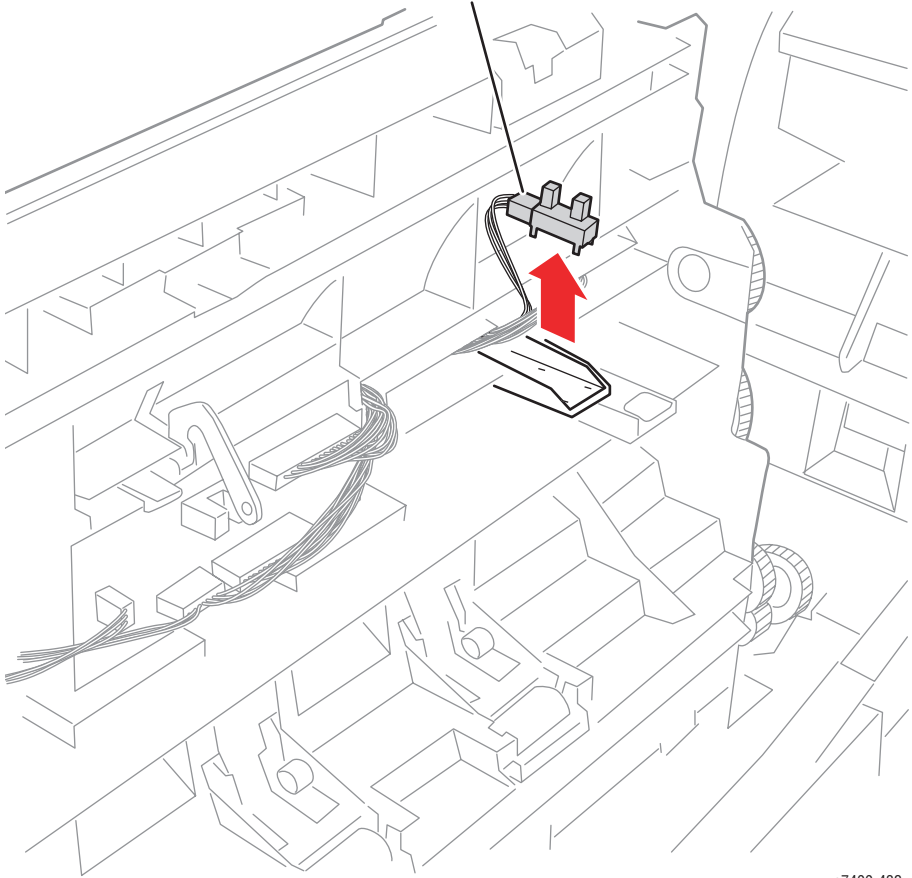

s7400-432

# Top Output Chute

1. Remove the Job Offset Assembly (page 8-56).
2. Release the 2 hooks that secure the Top Output Chute to the LED Assembly.

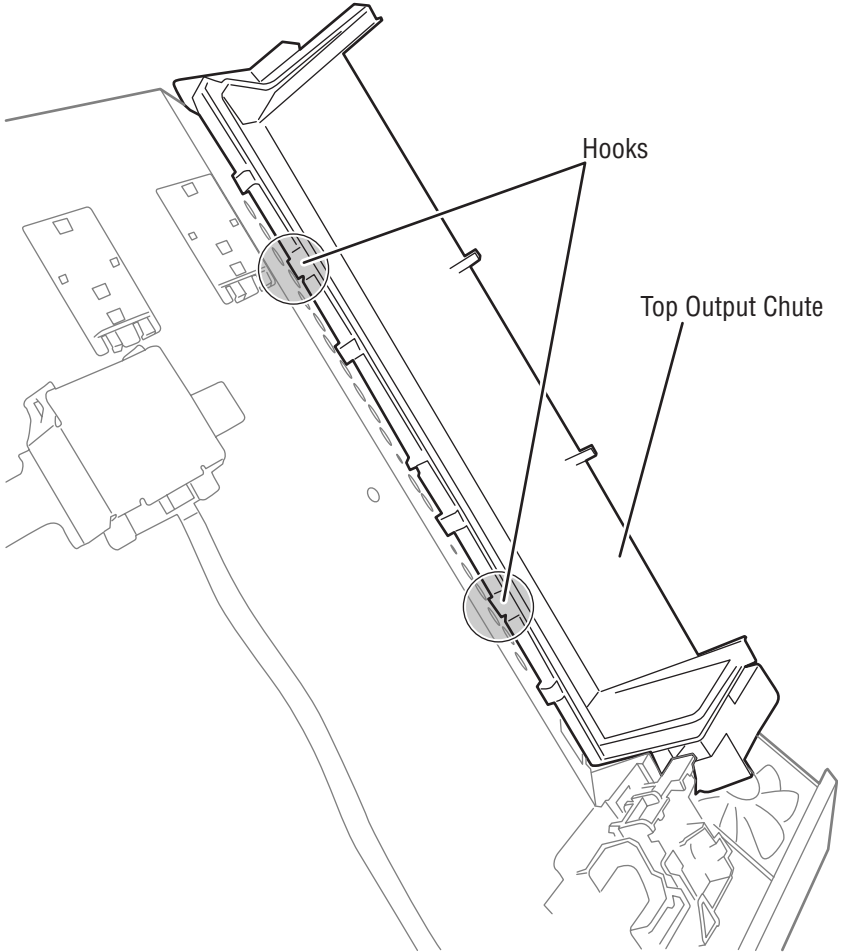

s7400-570

# Door A Latch Assembly

1. Open the Top Cover.
2. Open the Basket Assembly.
3. Open Door A.
4. Release the 3 hooks that secure the Door A Interlock Actuator.

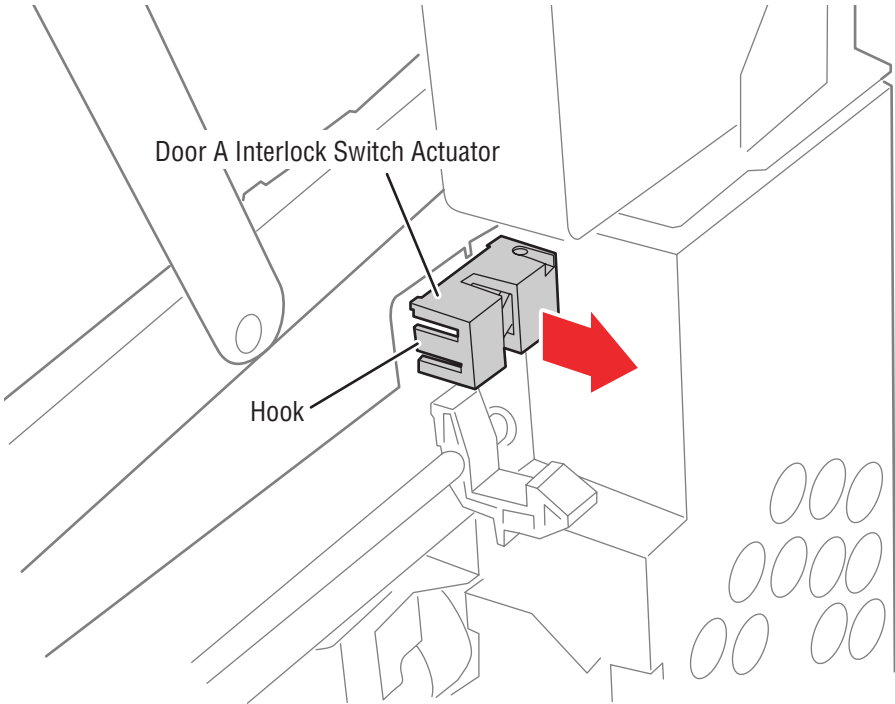

s7400-409



5. Remove the 5 (metal, 6 and 10 mm) screws that secure the latch to the frame.

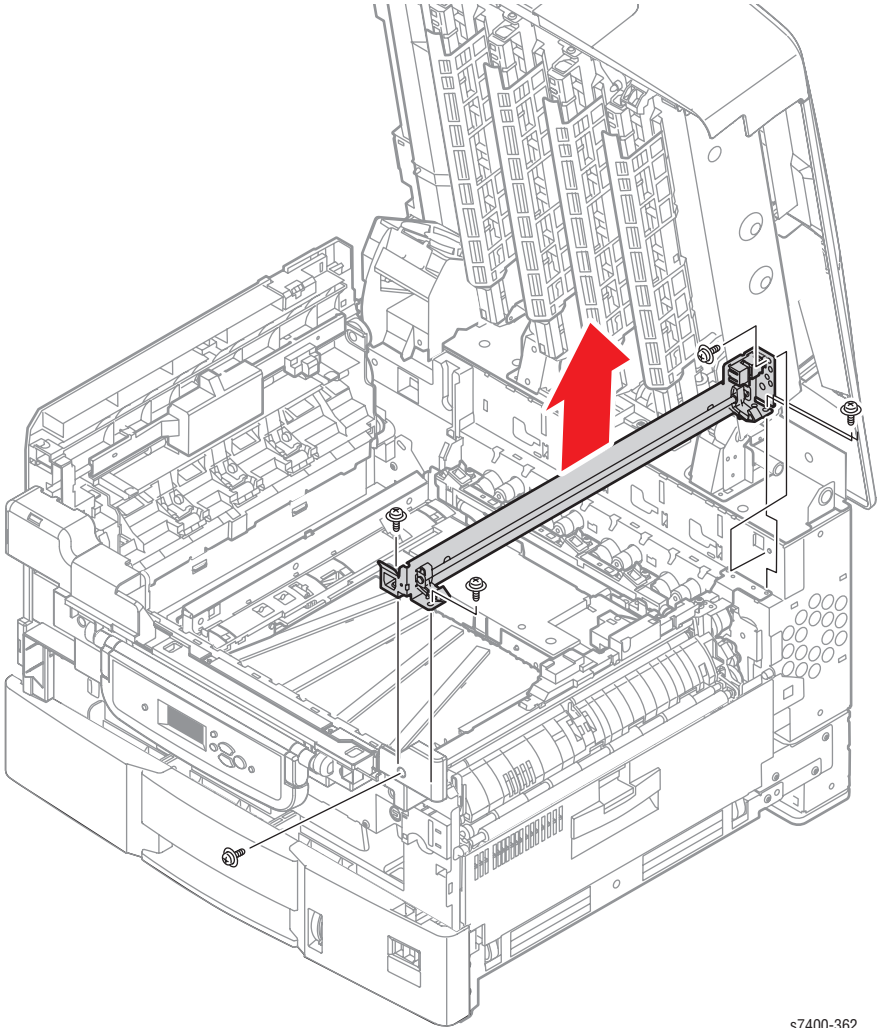

s7400-362

6. Gently pull the Upper Front Cover forward to release the latch assembly from the frame.

# Media Thickness Sensor

1. Open the Top Cover.
2. Open the Basket Assembly.
3. Remove the sensor cover by lifting the front tab slightly and pushing the cover to the rear.
4. Disconnect the sensor connector (P/J410).
5. Remove the 2 (metal, 6 mm) screws that secure the sensor and holder to the frame.

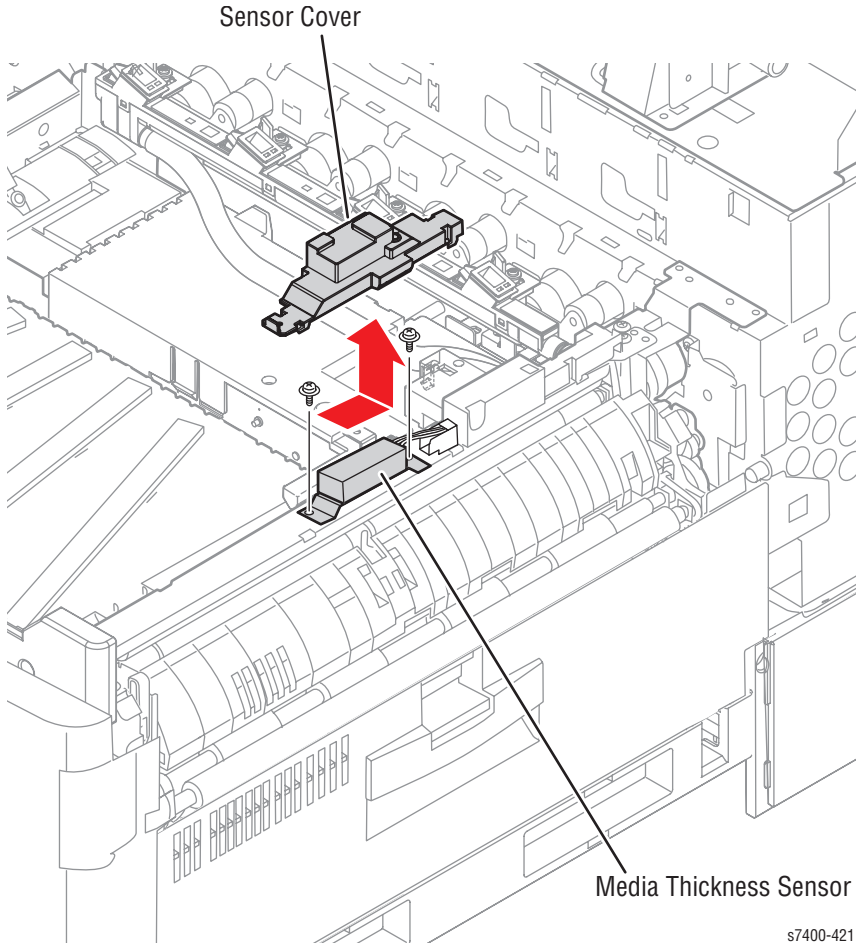

s7400-421

## Replacement Note

Make sure the sensor's gears are engaged and the holder is aligned to the bosses on the frame before tightening the screws.

Also, run the Service Diagnostics calibration utility for ATS to calibrate the replacement sensor.

# Temperature/Humidity Sensor

1. Open the Top Cover.
2. Open the Basket Assembly.
3. Remove the Media Thickness Sensor cover by lifting the front tab slightly and pushing the cover to the rear.
4. Disconnect the Media Thickness Sensor connector (P/J410).
5. Pull the Temp/Humidity Sensor cover towards the front to release the two hooks.

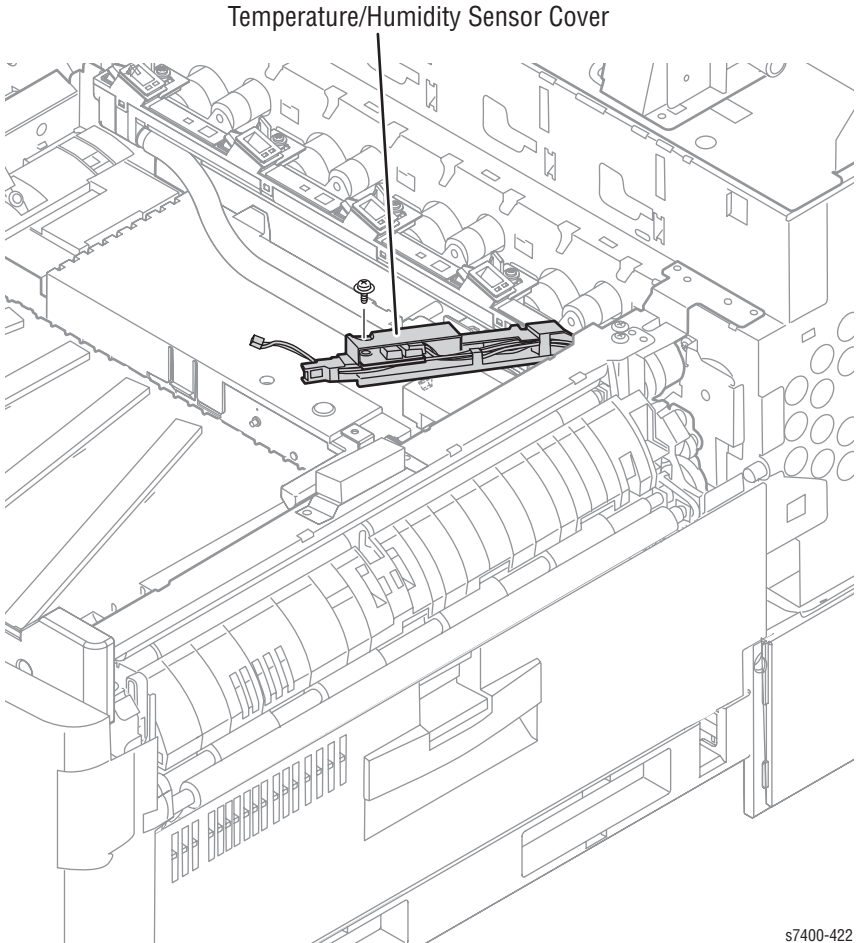

s7400-422

6. Remove 1 (black, plastic 10 mm) screw that secures the sensor to the cover.
7. Disconnect the Temperature/Humidity Sensor connector (P/J420).

# Exit Assembly

1. Open the Top Cover.
2. Remove the Duplex Unit.
3. Remove the Fuser (page 8-11).
4. Remove the Side Output Tray (page 8-55).
5. Release the 6 hooks and 3 tabs that secure the Rear Sensor Board Cover.

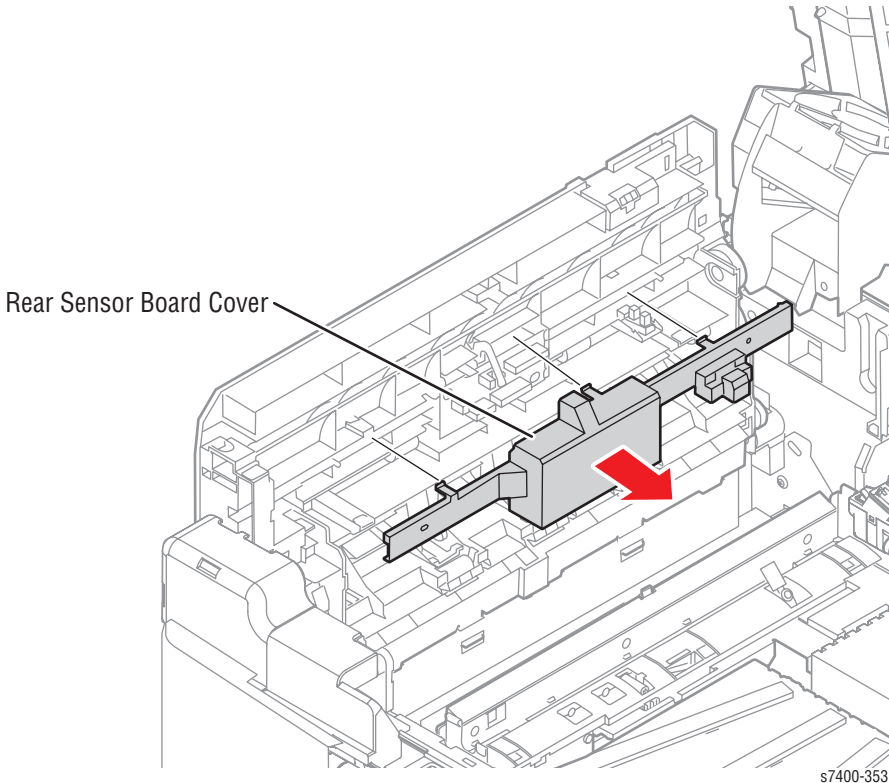

6. Disconnect connector RSNS from the Rear Sensor Board.
7. Carefully remove the RSNS harness from the Exit Assembly. This requires that the RSNS connector be fed through a hole provided at the rear of the Exit Assembly.

8. Remove 2 (metal, 6 mm) screws securing the Exit Assembly to the printer.

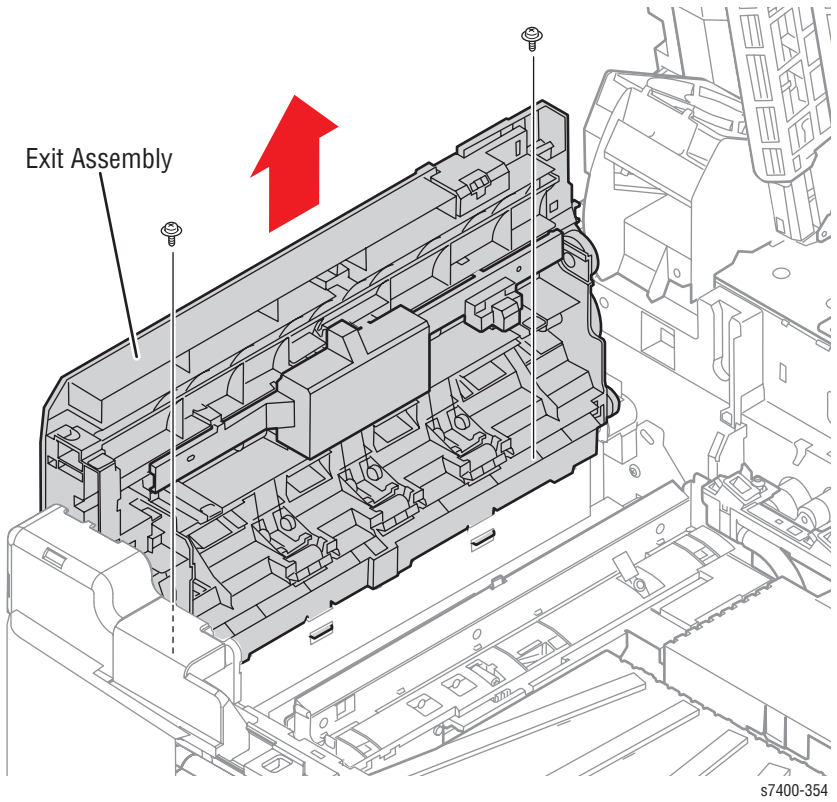

9. Release the 3 hooks at the base of the Exit Assembly and move the assembly slightly to the rear while lifting to release the boss from the frame. Access two hooks from the Fuser well, and the third from the Duplex Unit cavity.

## Exit Gate Solenoid

1. Remove the Exit Assembly (page 8-68).
2. Disconnect the SOLENOID connector from the Rear Sensor Board.
3. Feed the solenoid harness out the opening at the front of the Exit Assembly.
4. Release the hook that secures the Exit Gate Solenoid to the Exit Assembly.

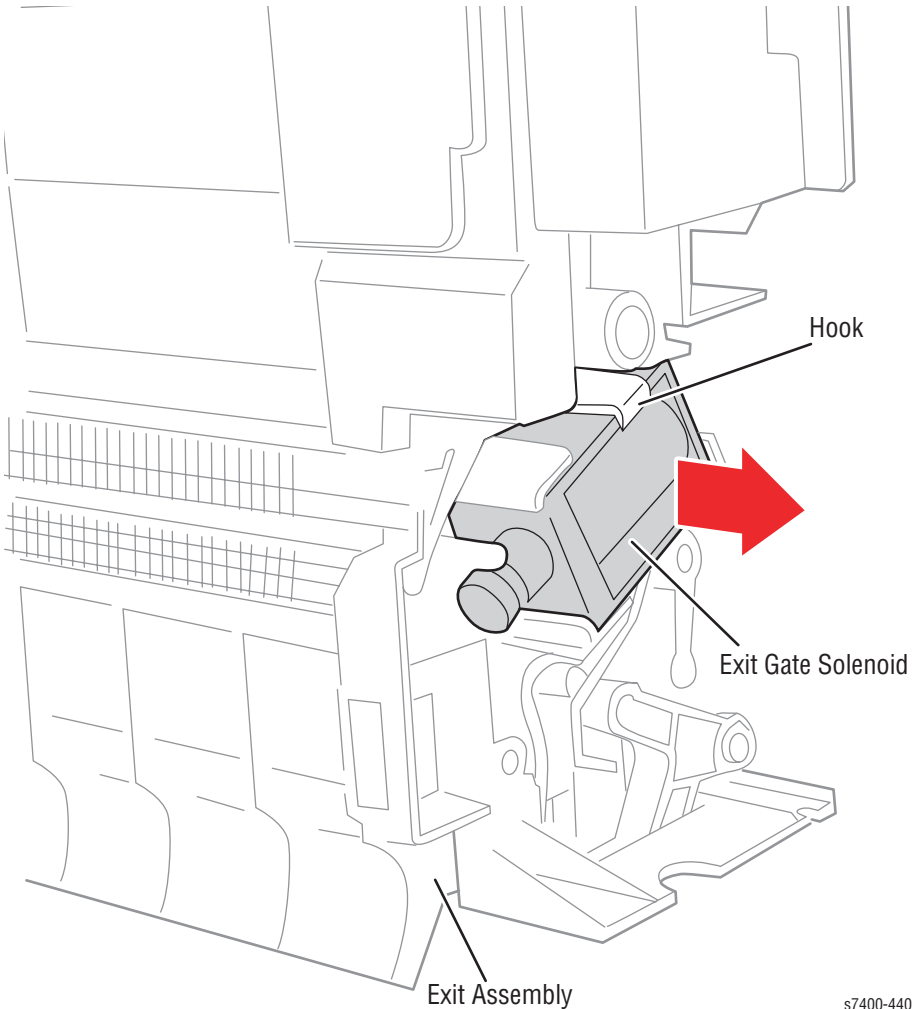

s7400-440

# Fuser Exit Sensor and Actuator

1. Remove the Exit Assembly (page 8-68).
2. Flip the Exit Assembly over and disconnect P/J140 from the Fuser Exit Sensor.
3. Release the 2 tabs that secure the Exit Sensor and Actuator to the Exit Assembly.

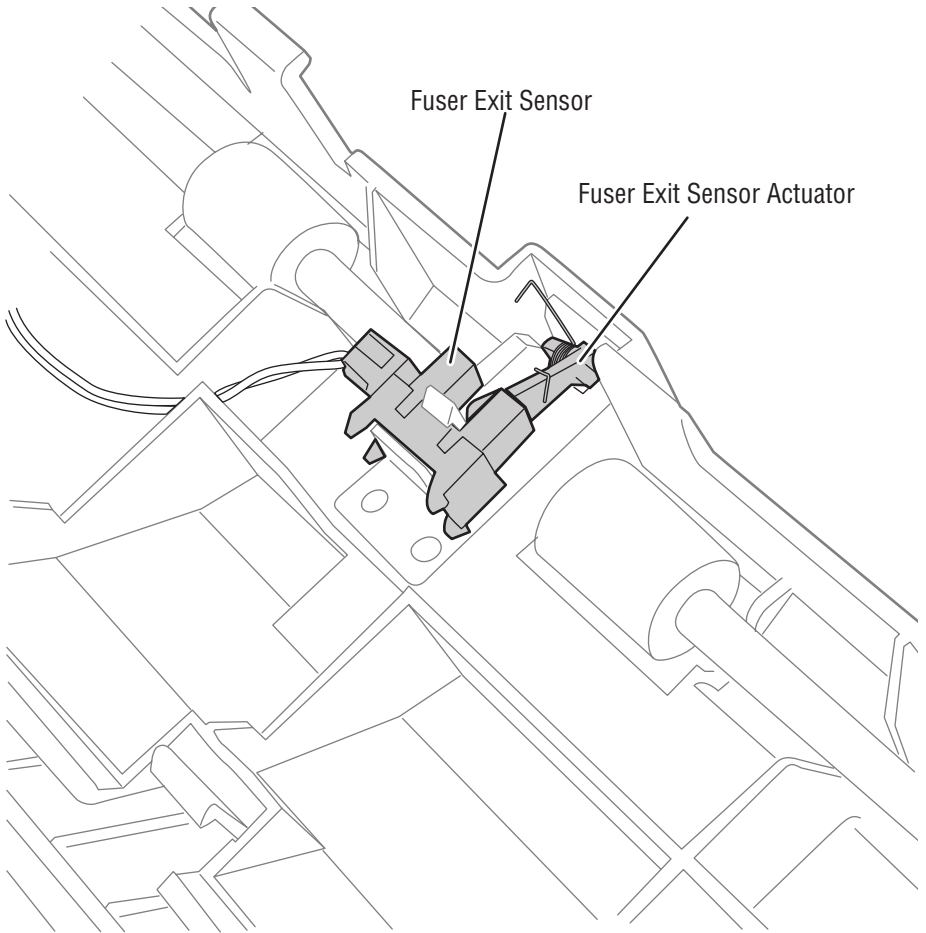

s7400-441

# Top Output Tray Stack Full Sensor

1. Release the 2 hooks that secure the Top Output Tray Stack Full Sensor cover to the Exit Assembly.
2. Disconnect the Top Output Tray Stack Full Sensor (P/J160).
3. Release the wire that surrounds the sensor.
4. Release the hooks that secure the sensor to the Inner Chute to remove the sensor.

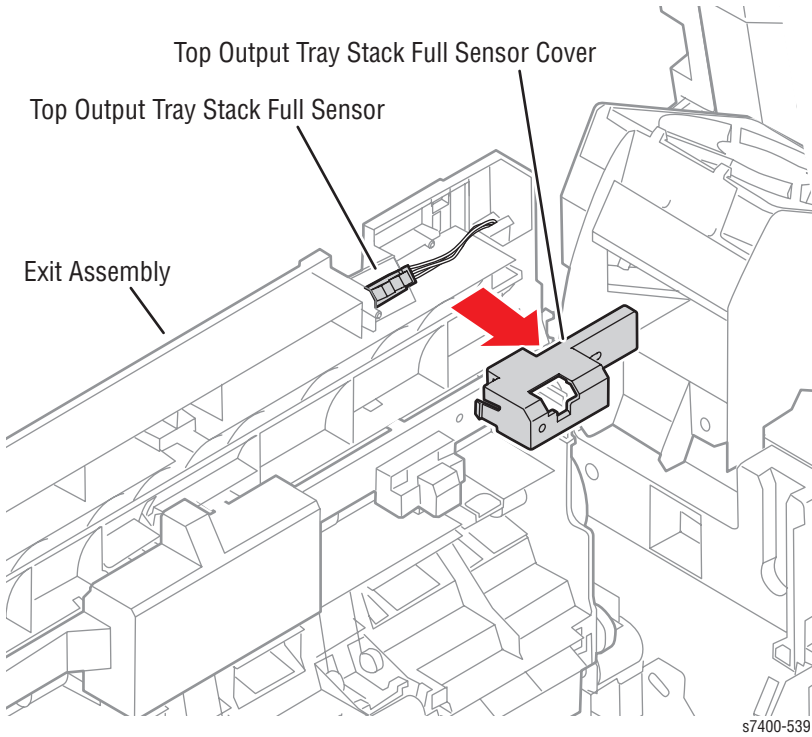



# Side Output Tray Detect Sensor

1. Remove the Exit Assembly (page 8-68).
2. Release the 2 hooks that secure the Top Output Tray Stack Full Sensor cover.
3. Disconnect the Top Output Tray Stack Full Sensor (P/J160).
4. Release the wire that surrounds the sensor.
5. Release the 2 upper hooks of the Outer Exit Chute.
6. Separate the outer and inner chutes enough to disconnect the Side Output Tray Stack Full Sensor (P/J170).
7. Release the 2 lower Outer Exit Chute tabs by gently prying the two chutes apart.

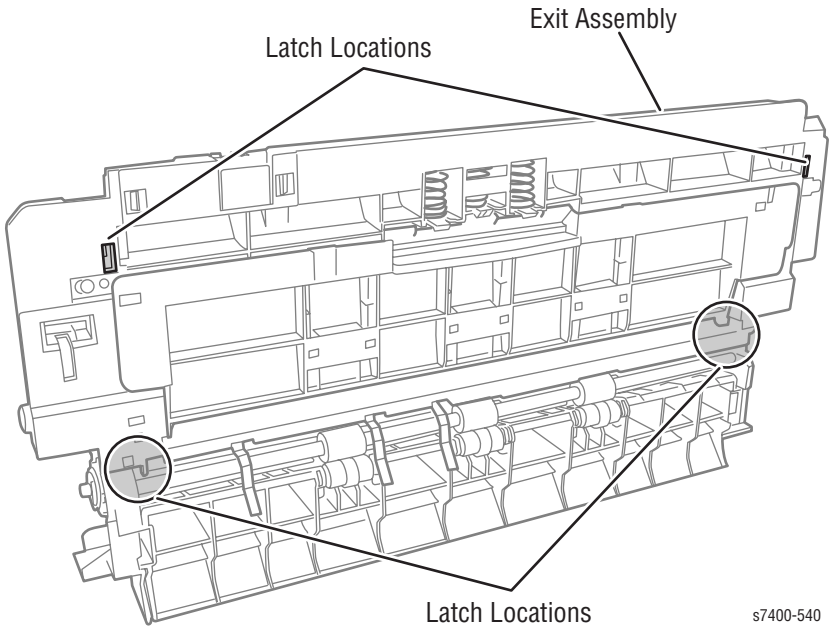

s7400-540

8. Release the hooks that secure the sensor to the Inner Chute.

Side Output Tray Detect Sensor

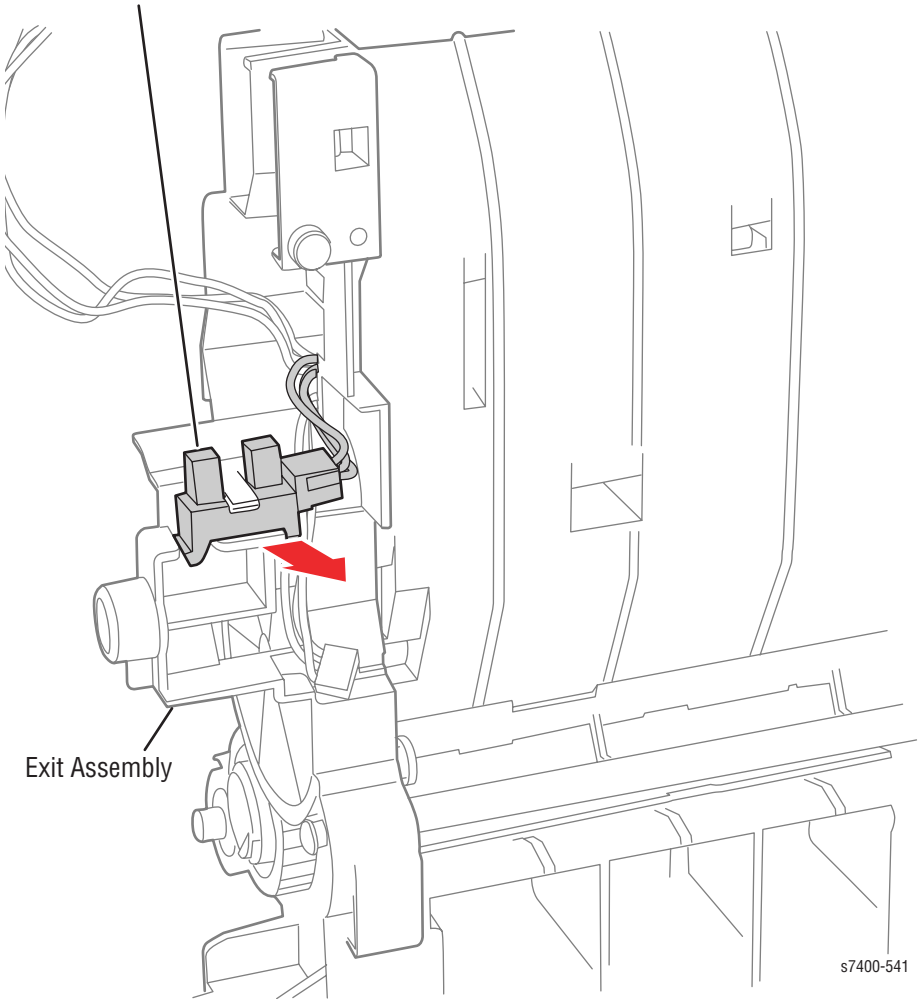

s7400-541

9. Disconnect the sensor connector (P/J180) to remove the sensor.

# Side Output Tray Stack Full Sensor

1. Remove the Exit Assembly (page 8-68).
2. Release the 2 hooks that secure the Top Output Tray Stack Full Sensor cover.
3. Disconnect the Top Output Tray Stack Full Sensor (P/J160).
4. Release the wire that surrounds the sensor.
5. Release the 2 upper hooks of the Outer Exit Chute.
6. Separate the outer and inner chutes enough to disconnect the Side Output Tray Stack Full Sensor (P/J170).
7. Release the 2 lower Outer Exit Chute tabs by gently prying the two chutes apart.

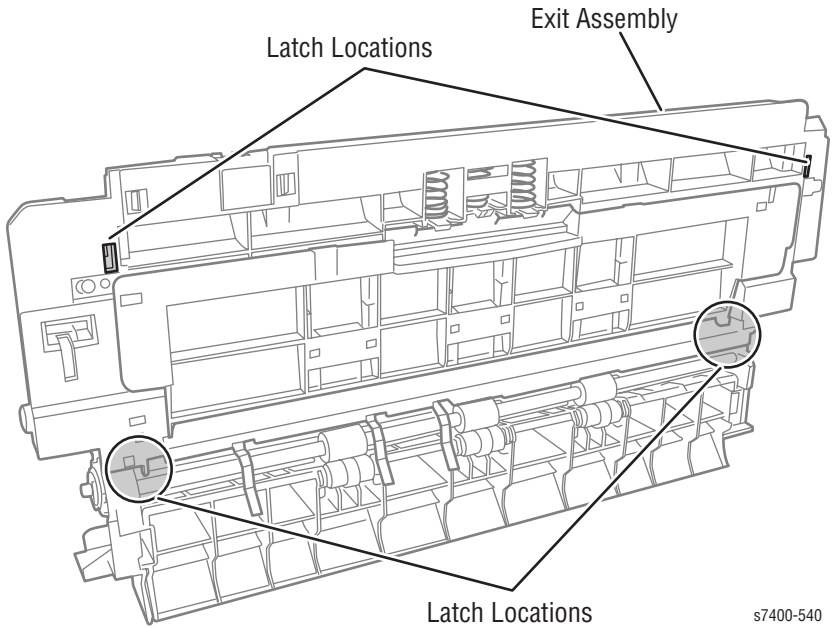

s7400-540

8. Release the hooks that secure the sensor to the Inner Chute to remove the sensor.

Side Output Tray Stack Full Sensor

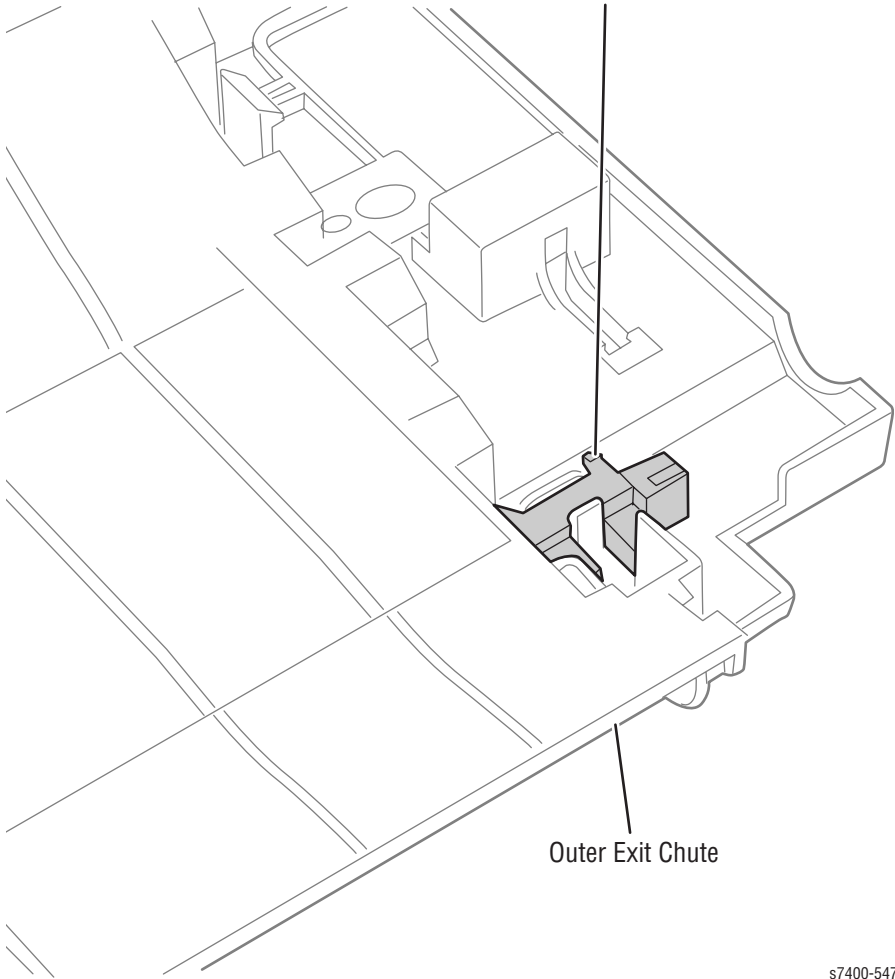

s7400-547

# Door E Detect Sensor

1. Remove the Exit Assembly (page 8-68).
2. Release the 2 hooks that secure the Top Output Tray Stack Full Sensor cover.
3. Disconnect the Top Output Tray Stack Full Sensor (P/J160).
4. Release the wire that surrounds the sensor.
5. Release the 2 upper hooks of the Outer Exit Chute.
6. Separate the outer and inner chutes enough to disconnect the Side Output Tray Stack Full Sensor (P/J170).
7. Release the 2 lower Outer Exit Chute tabs by gently prying the two chutes apart.

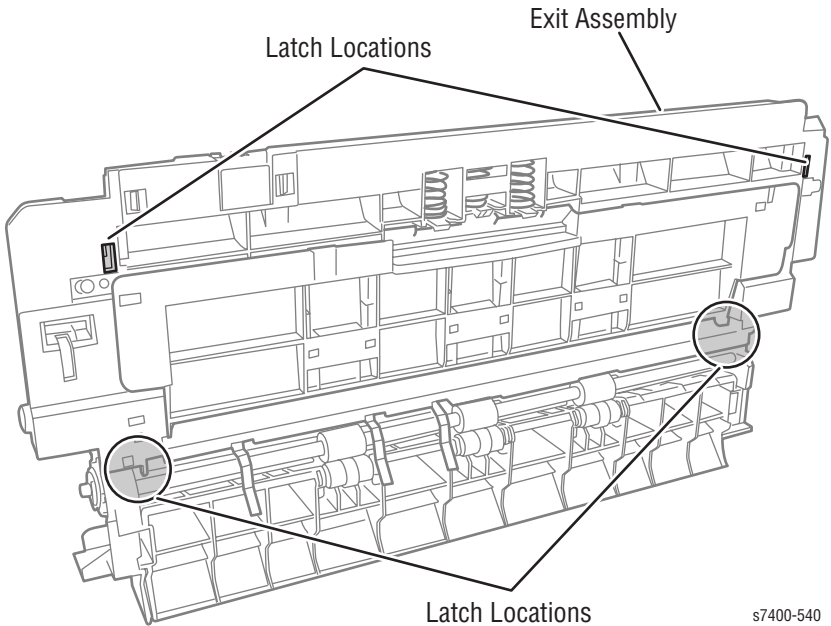

s7400-540

8. Release the hooks that secure the sensor to the Inner Chute.

9. Disconnect the sensor connector (P/J130) to remove the sensor.

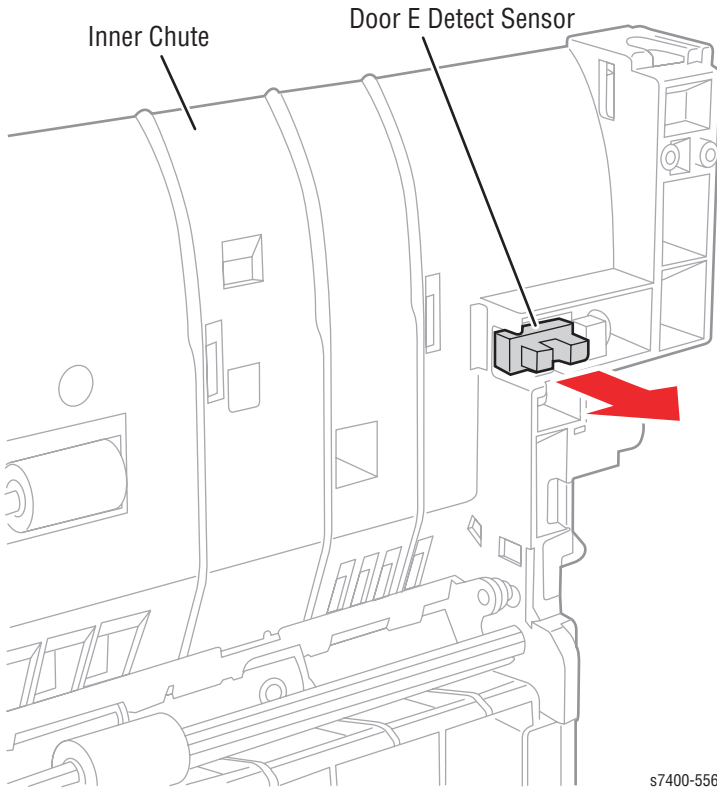

# Fuser Release Sensor

1. Remove the Duplex Unit.
2. Release the 3 hooks that secure the sensor to the frame.
3. Disconnect the Fuser Release Sensor connector (P/J190).

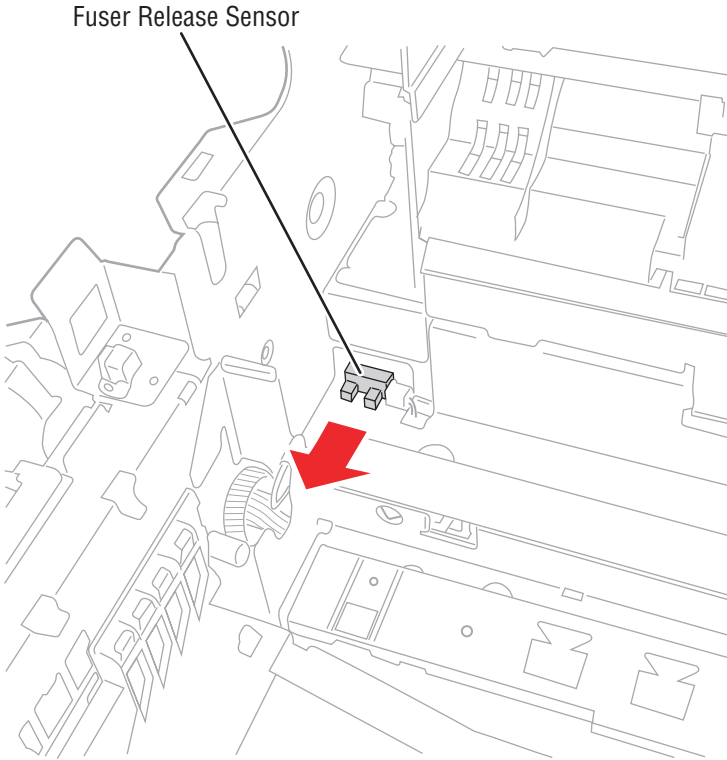

s7400-557

# Registration Sensor Assembly

1. Remove the Front Door (page 8-18).
2. Remove the Waste Toner Reservoir, if installed.
3. Remove the Left Front Cover (page 8-21).
4. Remove the HVPS Cover (page 8-118).
5. Open the Basket Assembly.
6. Remove the Registration Sensor Board Cover.
7. Remove the CSNS connector from the Registration Sensor Board.
8. Remove 6 (metal, 6 mm) screws securing the Registration Sensor Assembly.

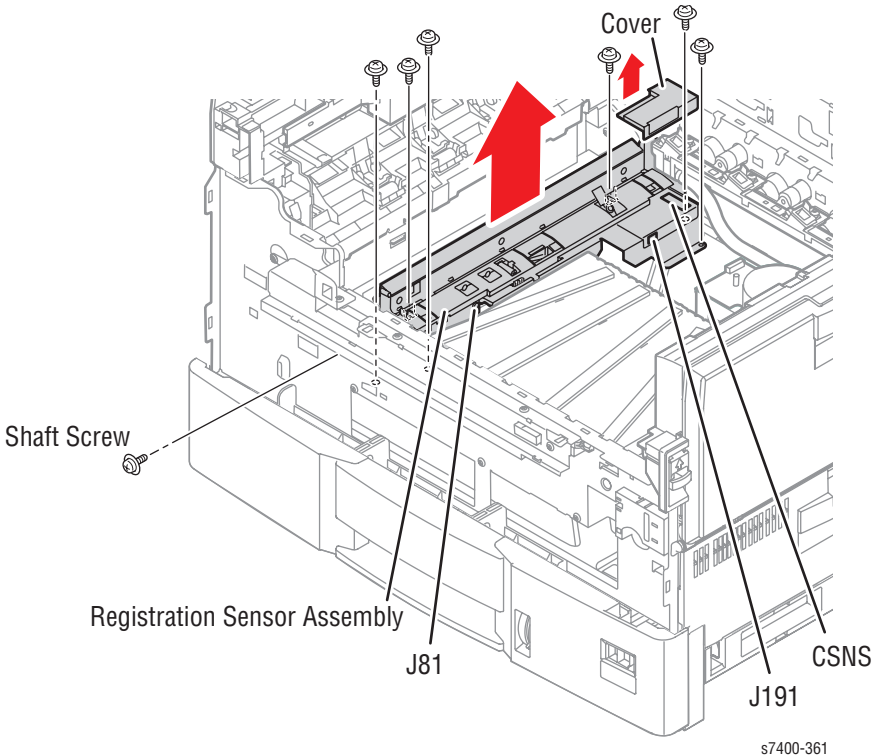

9. Remove the Transfer Unit Motor (page 8-103).
10. Remove 1 (metal, 6 mm) shaft screw located behind the Transfer Unit Motor.
11. Release 2 hooks that secure the Registration Sensor Board Cover.
12. Disconnect 2 wiring harnesses (P/J191, 3-wire Purple, and P/J81, 2-wire Red) and lift the assembly to clear the hook at the rear.

## Replacement Note

Make sure the hook at the rear of the frame engages the assembly.



# Registration Shutter Solenoid

1. Remove the Registration Sensor Assembly (page 8-80).
2. Remove the E-clip that secures the Registration Shutter linkage to the assembly.
3. Disconnect the Registration Shutter Solenoid connector (P/J80).
4. Remove 1 (metal, 6 mm) screw, with washer, securing the Registration Shutter Solenoid to the assembly.

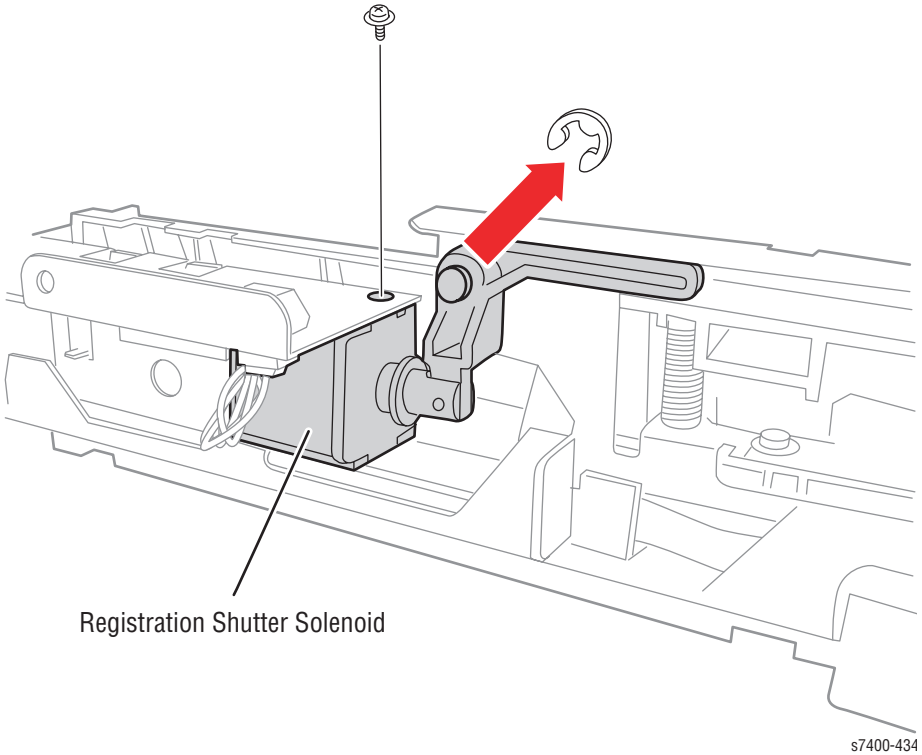

s7400-434

# ADC Sensor

## Note

The Registration Shutter return spring is not captive to the shutter. Note the position of the spring before disassembly.

1. Remove the Registration Sensor Assembly (page 8-80).
2. Turn the assembly over and release the 3 bosses that retain the Registration Shutter in the assembly.
3. Remove the 1 (metal, 6 mm) screw that secures the ADC Sensor to the assembly.
4. Slide the sensor to the left to release the sensor from the assembly.
5. Disconnect the ADC Sensor connector (P/J192), and then remove the ADC Sensor.

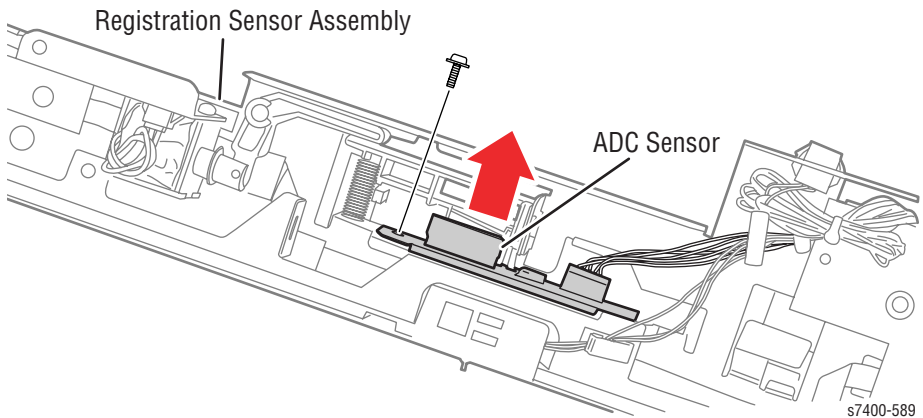

# Media Slack Sensor and Actuator

1. Remove the Registration Sensor Assembly (page 8-80).
2. Remove the 3 (metal, 6 mm) screws that secure the sensor and actuator to the Registration Sensor Assembly.

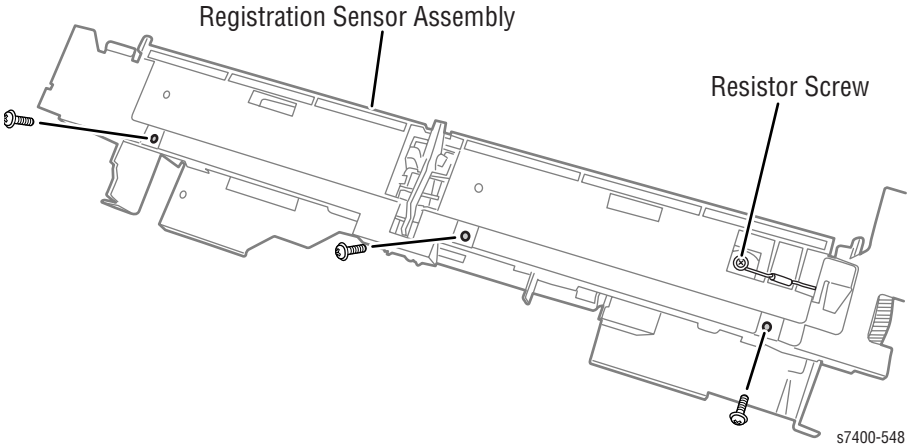

3. Remove the 1 (metal, 6 mm) screw that grounds the resistor to the assembly.
4. Disconnect the sensor connector (P/J193).
5. Release the hooks to remove the Media Slack Sensor.

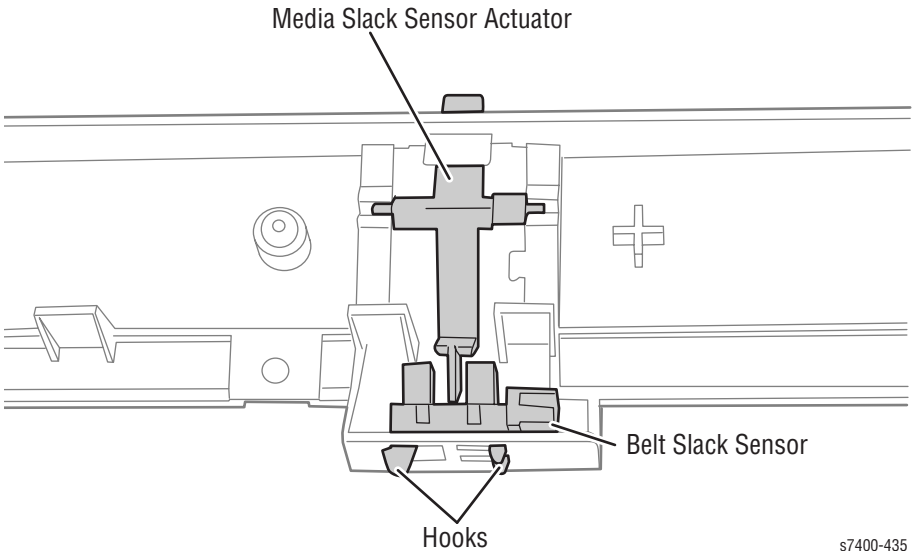

## Replacement Note

Make sure the 3 upper tabs latch to the frame and that the ribbon cable is captured by the 4 lower tabs.

# Registration Assembly

1. Open the Top Cover.
2. Open the Front Door.
3. Open Door C.
4. Open the Basket Assembly.
5. Remove the Duplex Unit.
6. Remove Tray 1 (MPT) (page 8-25).
7. Remove the Door A Latch Assembly (page 8-64).
8. Remove 1 (metal, 10 mm) screw that secures the Registration Assembly.

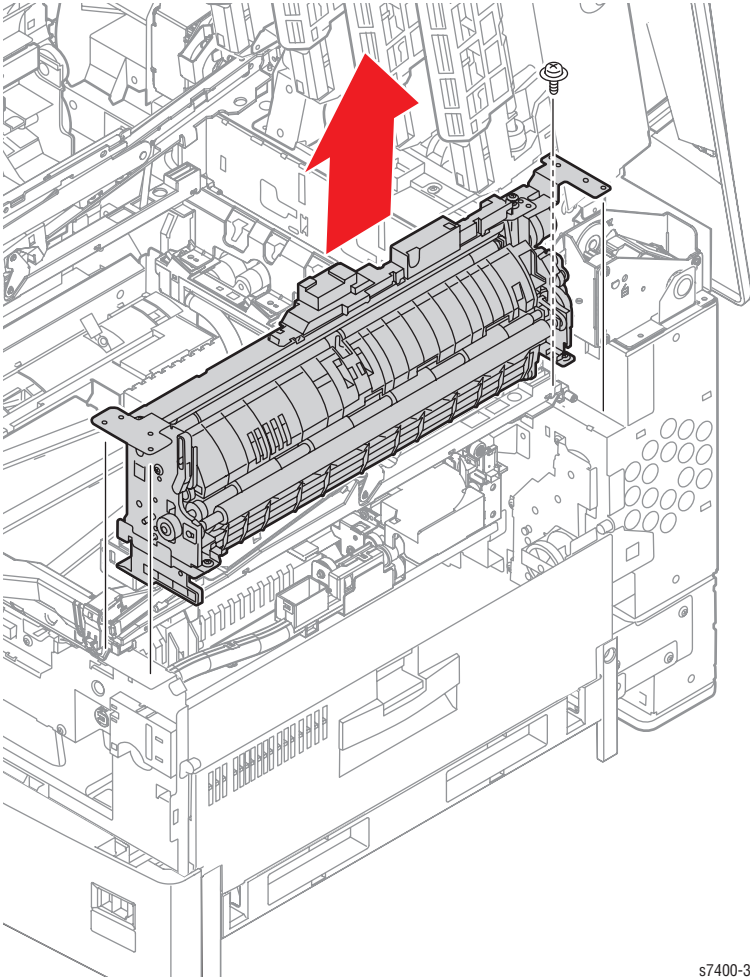

s7400-363

9. Release the wiring from the guides in the Registration Assembly.

10. Disconnect the ribbon cable from the FSNS connector on the Front Sensor Board.
11. Press the Waste Toner Reservoir Auger drive in to clear the frame, and then lift the Registration Assembly up to remove it.

## Registration Clutch #1

1. Remove the Registration Assembly (page 8-84).
2. Disconnect the CLUTCH connector from the Front Sensor Board.
3. Remove the clutch wiring from the opening to free it from the Registration Assembly.
4. Remove the E-clip that secures the Registration Clutch #1 to the lower Registration Roller.
5. Pull the clutch from the shaft while holding the anti-rattle spring.

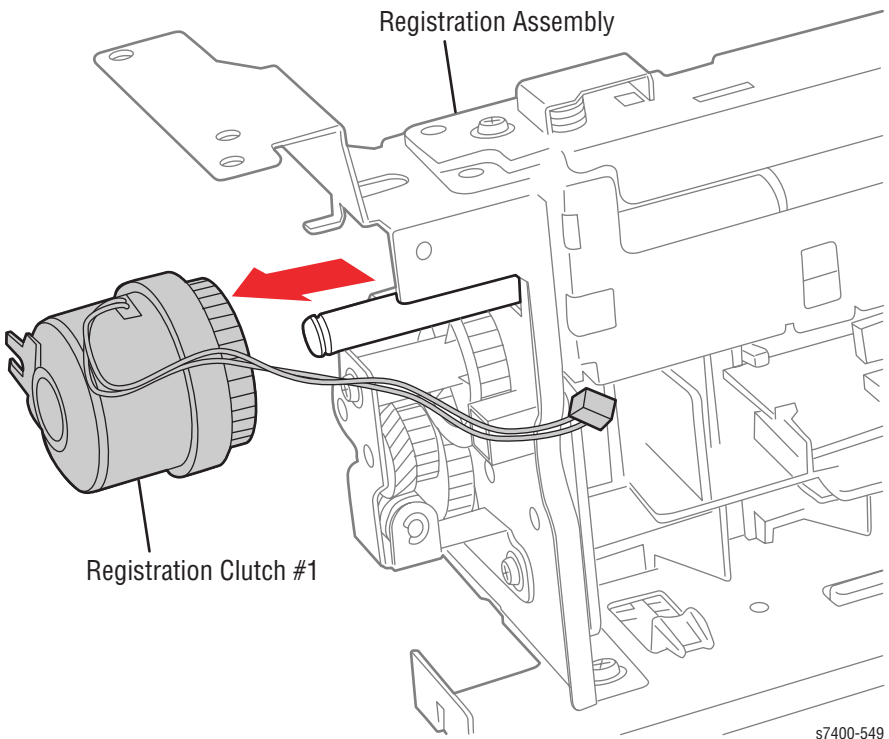

# Waste Toner Auger Assembly

1. Remove the Waste Toner Reservoir and Imaging Units if installed.
2. Remove the Duplex Unit.
3. Release 4 hooks that secure the Waste Toner Motor Cover.
4. Release 1 hook and slide the Auger Tube Guide to the left to release the 1 tab on the right.

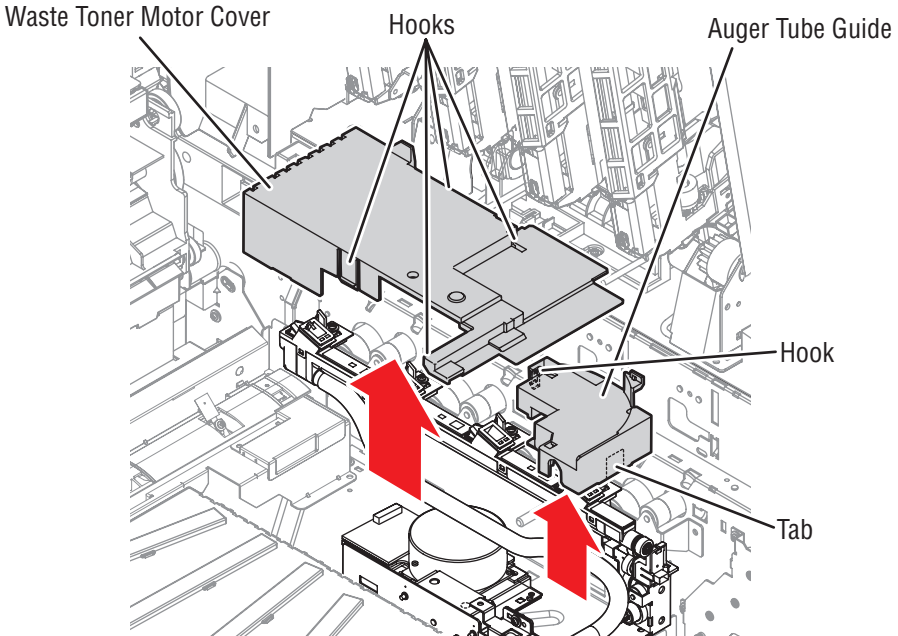

5. Remove 4 (black, plastic 6 mm) screws connecting the Waste Toner Manifold to the Basket Assembly.

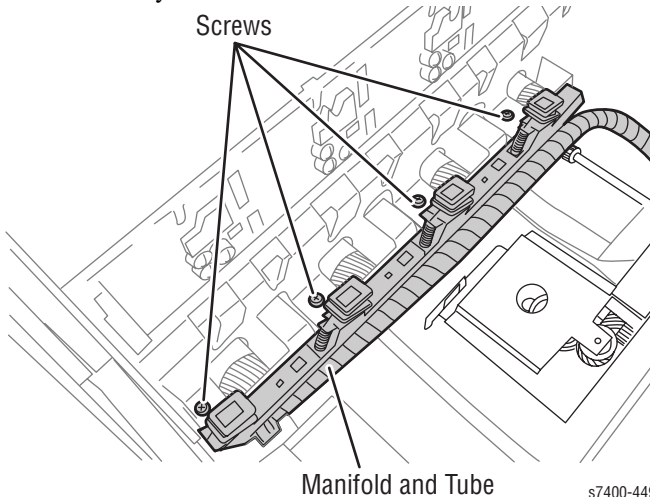

s7400-449

6. Open the Basket Assembly to release the manifold from the basket.
7. Release the Waste Toner Motor harness from the clamp.
8. Remove 7 (metal, 6 mm) screws to remove the Waste Toner Auger Assembly.

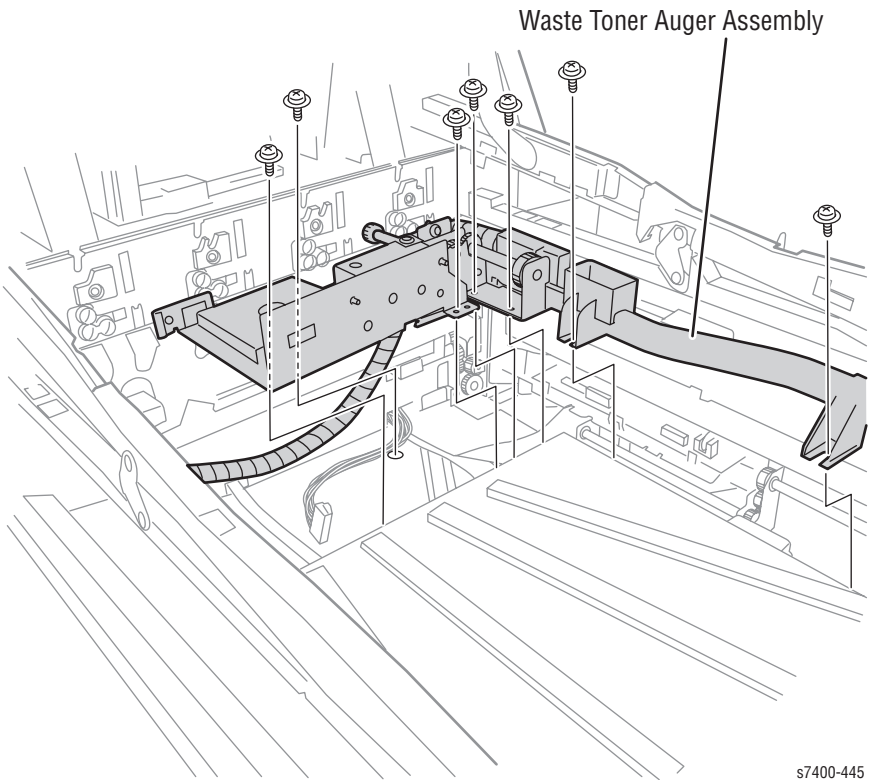

s7400-445

### **Replacement Note**

Clear any debris from the Duplex Unit cavity before installing the Duplex Unit.

# Waste Toner Reservoir Full Sensor

The Waste Toner Reservoir Full Sensor is located in the sensor housing attached directly above the Waste Toner Reservoir Auger drive.

1. Open the Top Cover.
2. Remove the HVPS Cover (page 8-118).
3. Disconnect CN4 from the HVPS
4. Open the Front Door.
5. Remove the Waste Toner Reservoir if installed.
6. Release 1 tab at the top of the sensor housing to release the housing.
7. Disconnect the sensor (P/J220) from the harness.
8. Slide the sensor from the holder.

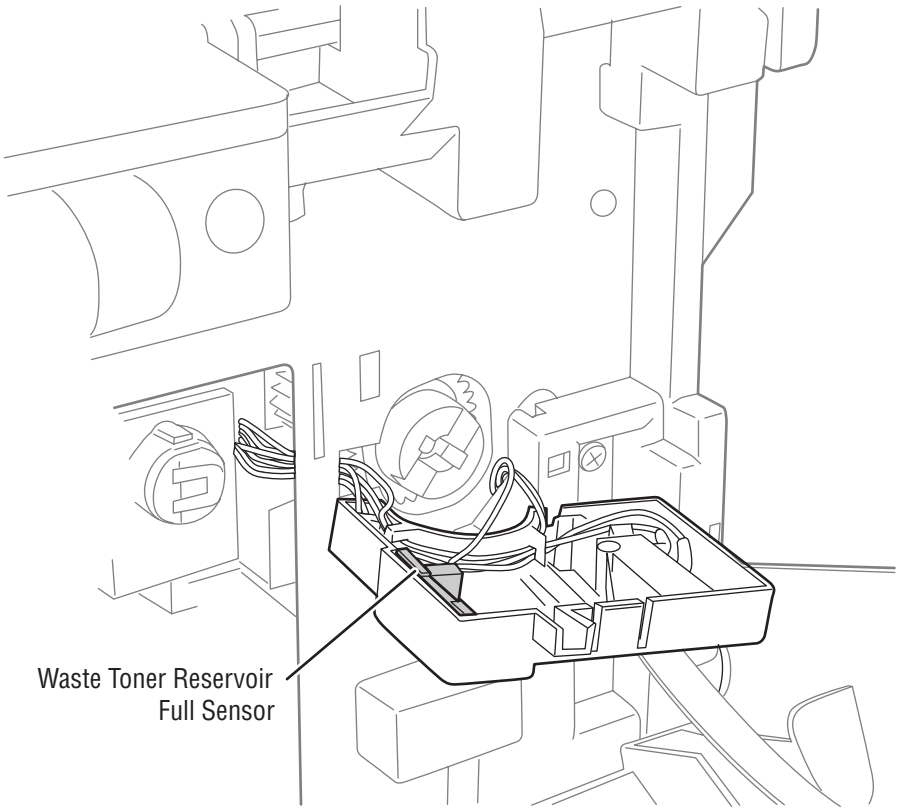

s7400-436



# Waste Toner Reservoir Auger Rotation Sensor

The Waste Toner Reservoir Auger Rotation Sensor is mounted inside the Right Front Cover.

1. Open Door A.
2. Remove the Front Door (page 8-18).
3. Remove the Waste Toner Reservoir if installed.
4. Remove the Right Front Cover (page 8-23).
5. Disconnect the connector (P/J310) from the sensor.
6. Remove the sensor from the Right Front Cover.

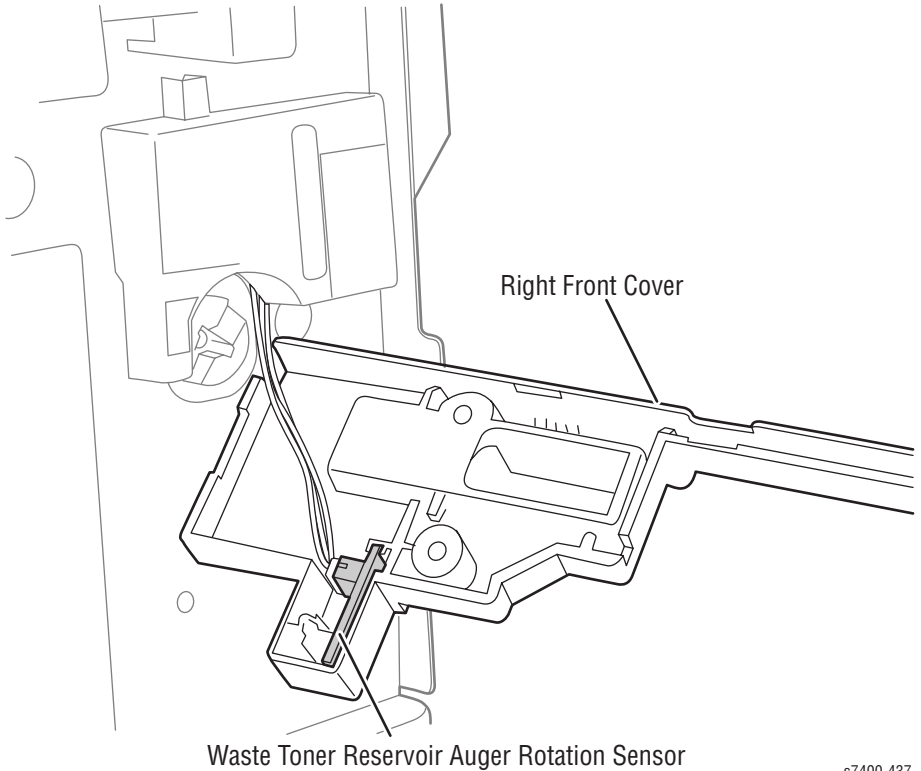

s7400-437

## Replacement Note

Use care when routing the harness near the Auger Drive and through the notch provided in the cover. Check wire routing following installation of the cover.

# Waste Toner Auger Rotation Sensor

The Waste Toner Auger Rotation Sensor is located at the right end of the Waste Toner Manifold. The sensor is connected to the Motor Driver Board.

1. Open the Top Cover.
2. Open the Basket Assembly.
3. Remove 1 (metal, 6 mm) screw that secures the sensor holder.
4. Disconnect the sensor (P/J320) from the harness.
5. Release 1 hook that secures the sensor in the holder.

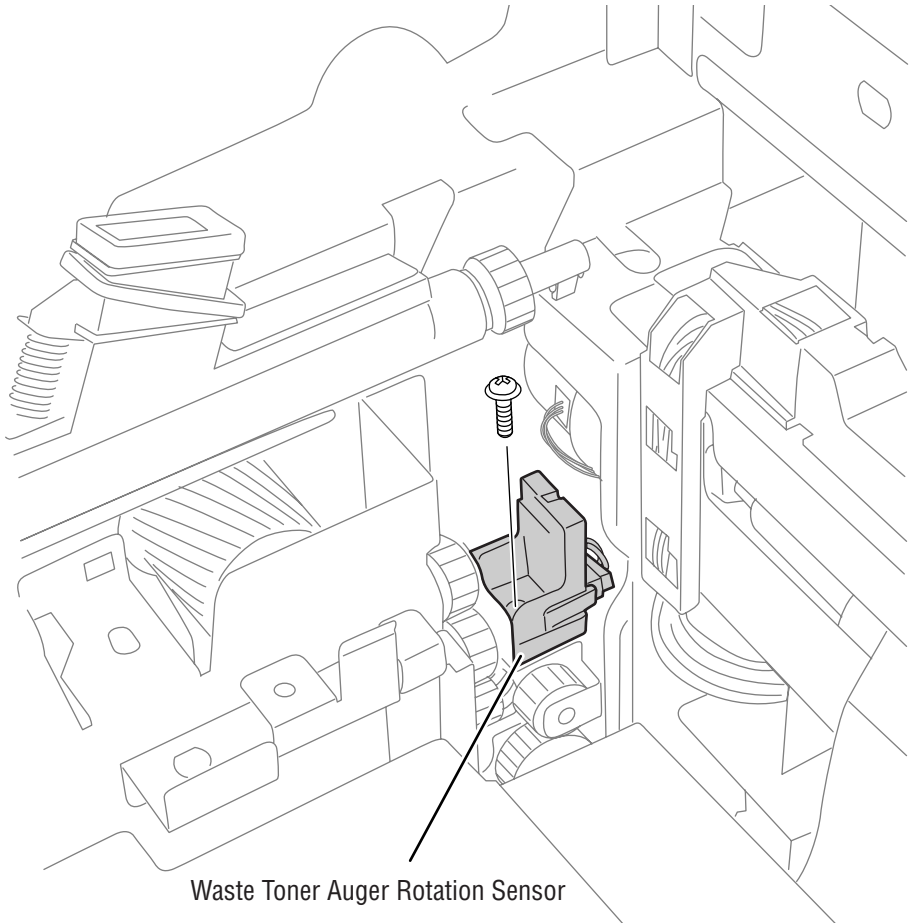

s7400-473

## Replacement Note

Seat the sensor completely in the holder before securing the screw.

# Transfer Unit Belt Rotation Sensor

The Transfer Unit Belt Rotation Sensor is mounted inside the Housing Bias Assembly.

1. Remove the Housing Bias Assembly.
2. Release 2 hooks that secure the sensor to the assembly.
3. Disconnect the sensor (P/J330) from the harness.

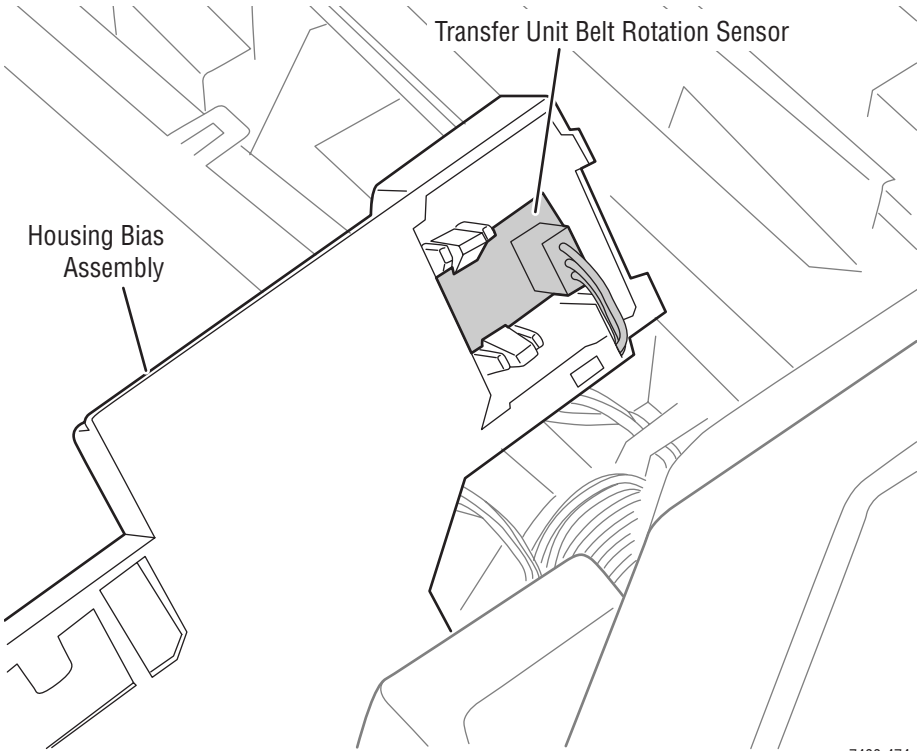

s7400-474

# Lower Basket Assembly

1. Remove 4 (Black, plastic 6 mm) screws that secure the Waste Toner Manifold to the Lower Basket Assembly.

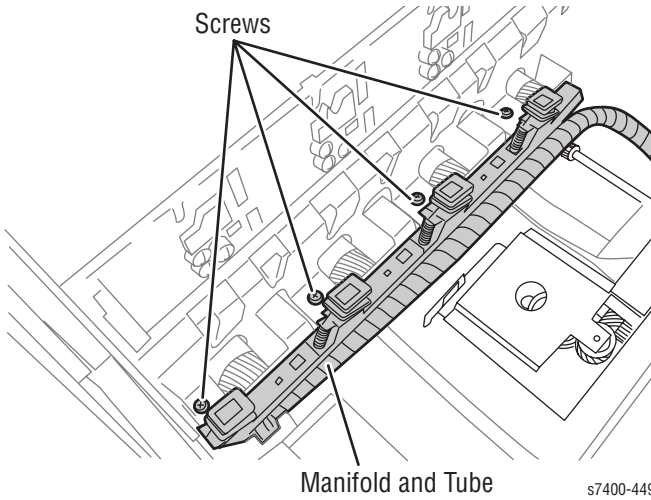

2. Remove 2 E-rings that secure the hinges on either side of the Lower Basket Assembly.

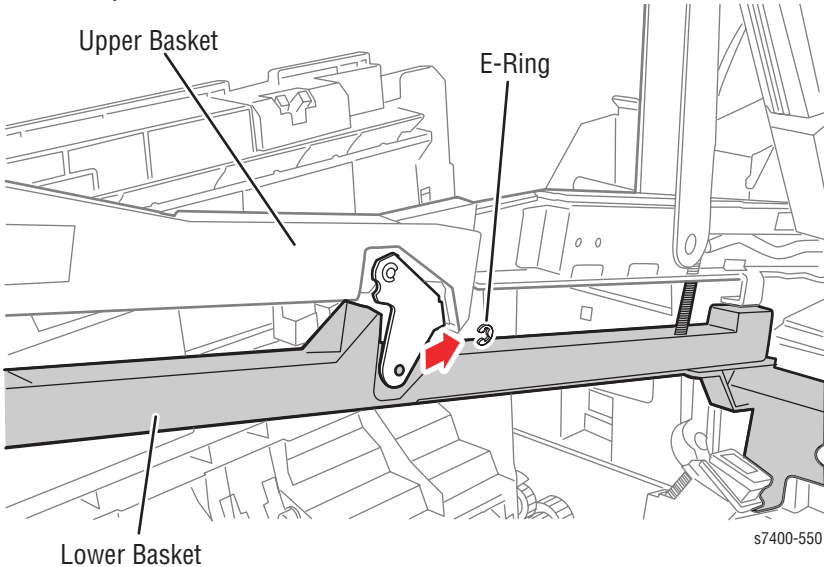

3. Release the Spring from the Upper Basket Assembly at the left, rear of the arm.
4. Remove the Hinge Pins to remove the Lower Basket Assembly.

## Replacement Note

Align the Lower Basket rear guides into frame before installing hinge pins.

# Basket Assembly

## Note

Take note of the Torsion Spring position before removing the Inner Shaft.

1. Remove the Top Cover.
2. Remove the Right Rear Cover (page 8-15).
3. Remove the Left Rear Cover (page 8-20).
4. Remove the Fuser Fan and Fan duct (page 8-149).
5. Remove the Job Offset Assembly (page 8-56).
6. Remove the Top Output Chute (page 8-63).
7. Remove 4 (Black, plastic 6 mm) screws that secure the Waste Toner manifold to the Lower Basket Assembly.

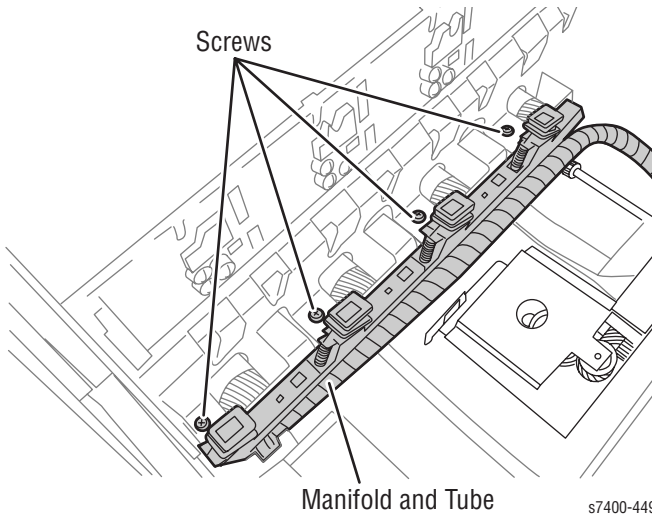

s7400-449

8. Remove 3 (metal, 6 mm) screws that secure the left side Basket Assembly Support Rail to the LED Assembly.

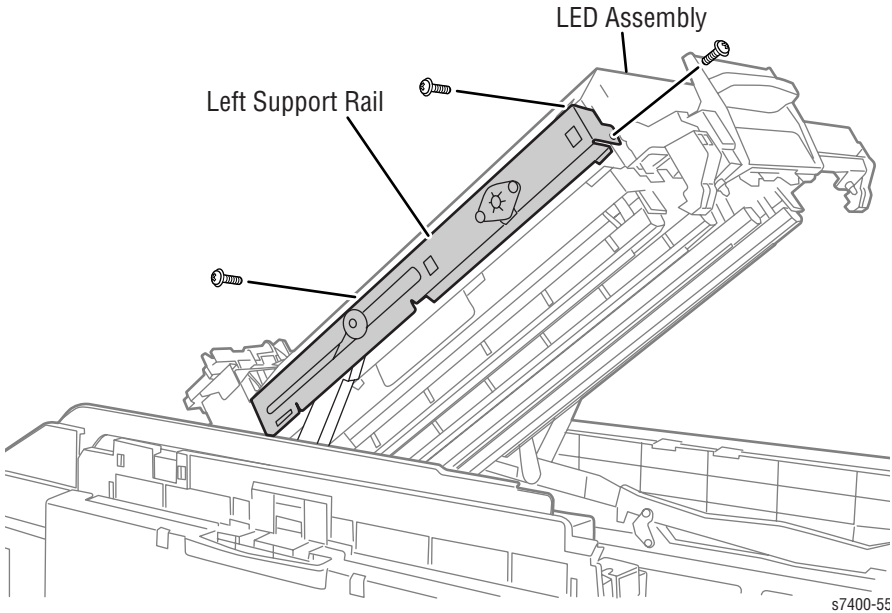

9. Remove 2 (metal, 6 mm) screws, and release two hooks that secure the cover to the right side Basket Assembly Support Rail.

10. Remove 3 (metal, 6 mm) screws that secure the left side Basket Assembly Support Rail to the LED Assembly.

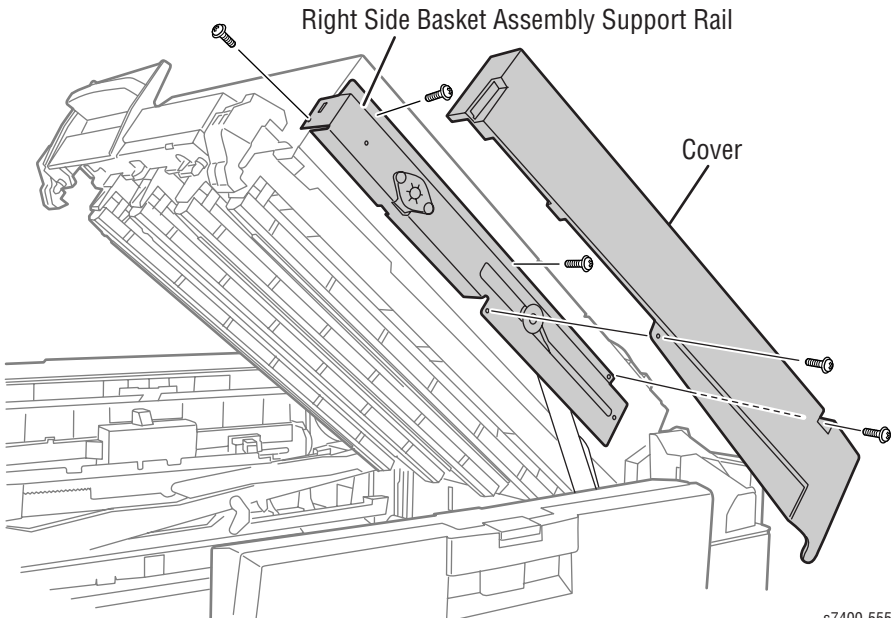

- 11.** Raise the LED Assembly completely, and then, using a small, flat-bladed screwdriver, remove the 2 pins that serve as stops at the rear of the LED Assembly.

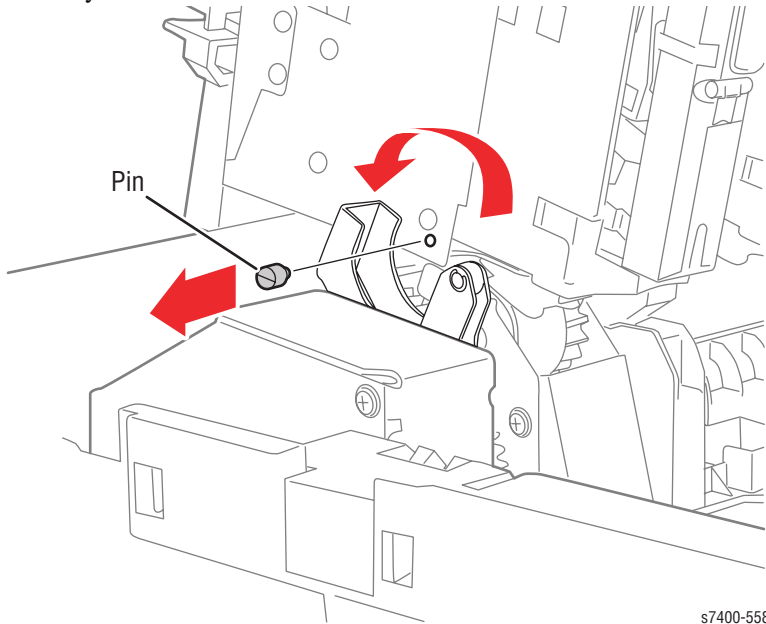

s7400-558

- 12.** Lower the LED Assembly to remove 2 (metal, 10 mm) screws that secures each sector gear located at either side of the LED Assembly.

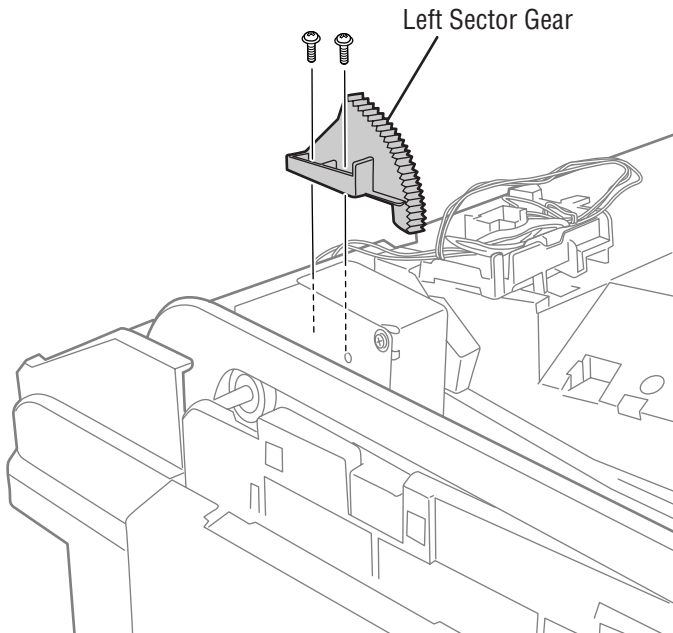

s7400-559

13. Release the Torsion Springs that supply tension to the Lower Basket Assembly. Use a second screwdriver as a stop to prevent the spring from snapping upwards and striking the LED Heads.
14. Remove the E-ring located on the left end of the Inner Shaft.
15. Remove 4 (metal, 10 mm) screws that lock the Inner Shaft to the Dampers. Access two of these screws through holes provided at the back near the LED Assembly hinge point.

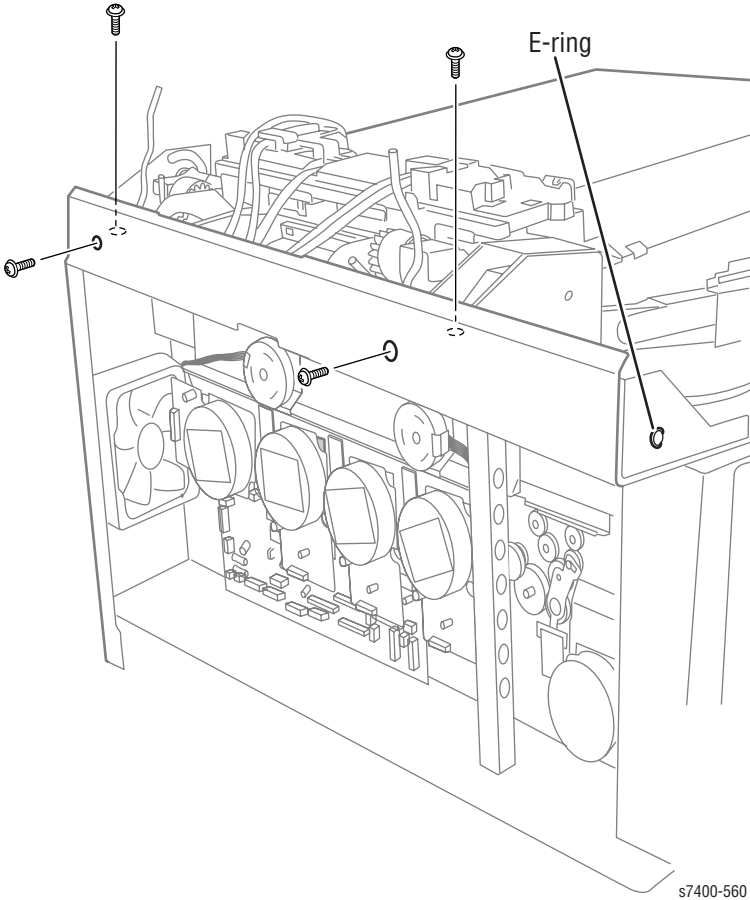



**16.** Remove the Inner Shaft in the direction of the arrow (towards the MPT).

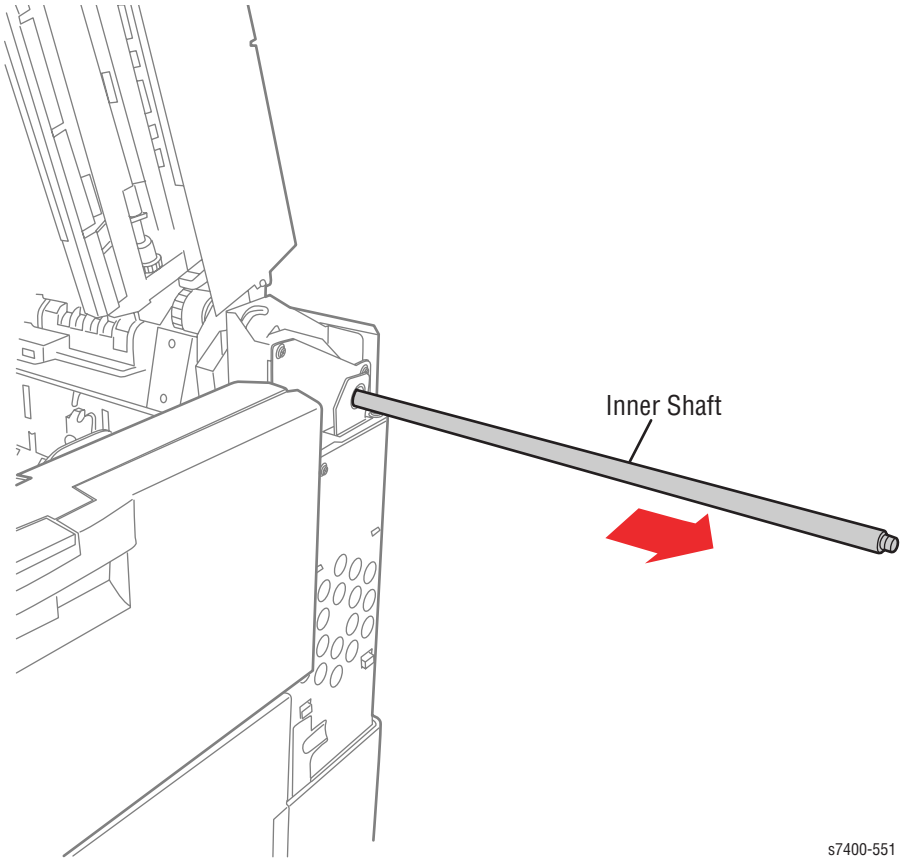

s7400-551

17. Remove 3 (metal, 10 mm) screws that secure each Outer Damper to the frame.

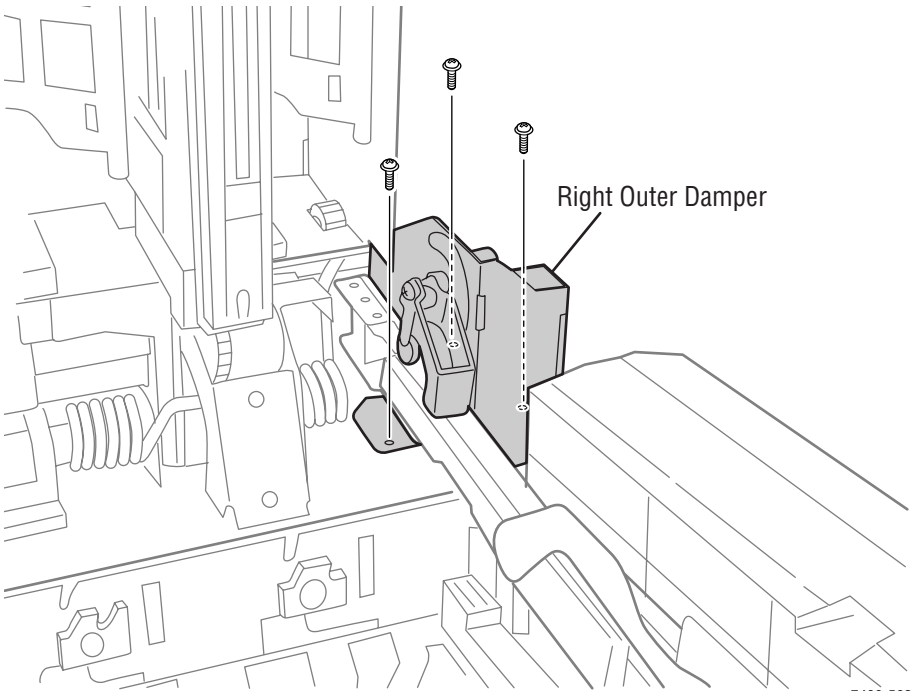
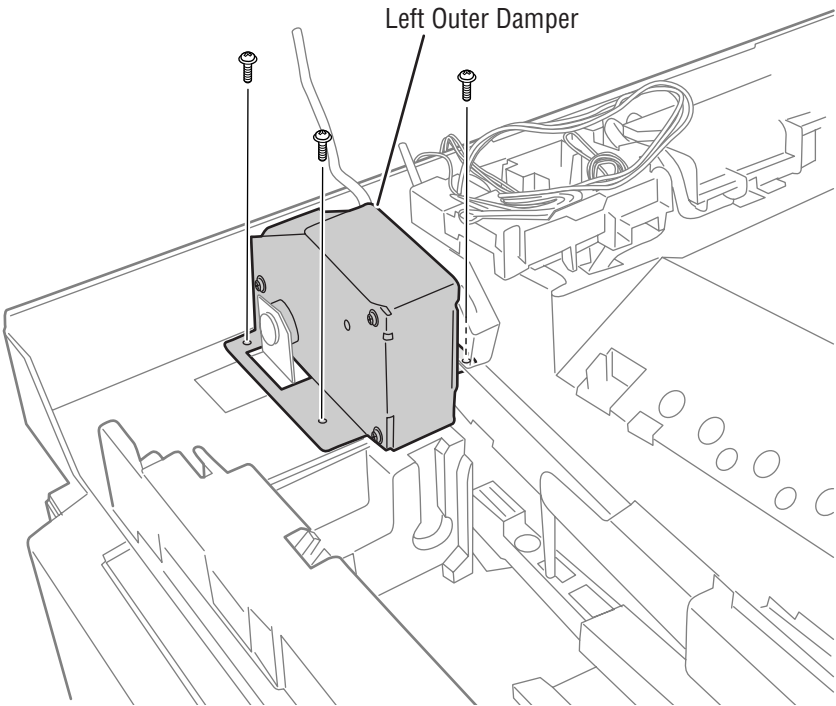

s7400-562

- 18.** Release the bushings from the flange on the frame to remove the Basket Assembly.

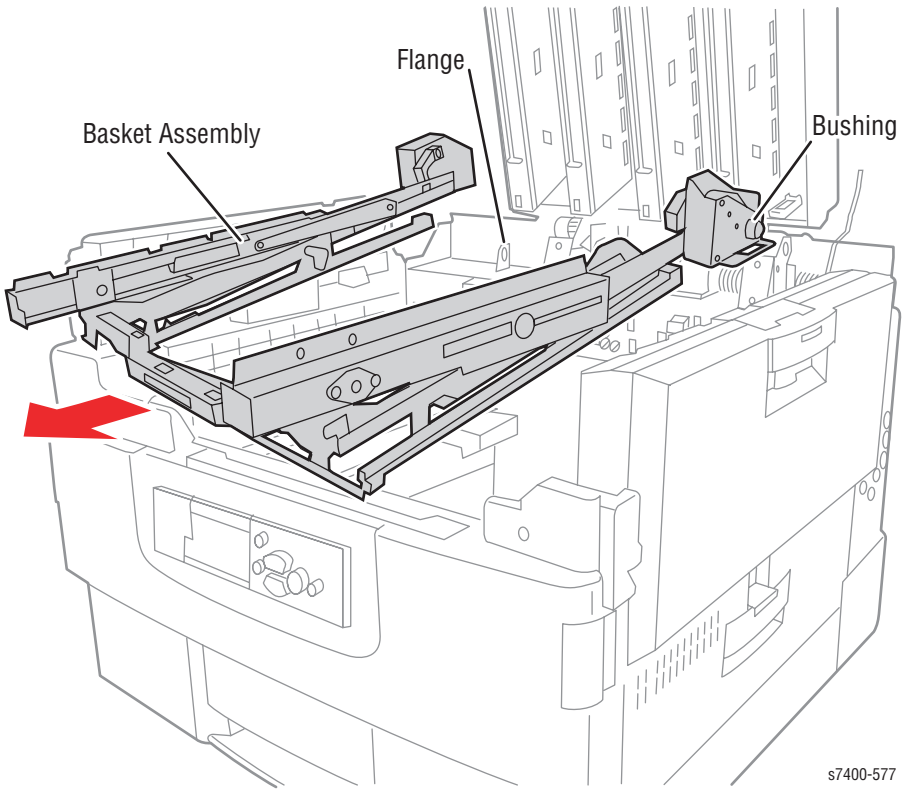

s7400-577

### **Replacement Note**

Observe these notes as you reassemble the Basket Assembly.

- 1.** Replace the screws that secure the Inner Shaft to the Dampers before replacing the E-ring at the end.
- 2.** Align the Guide Rollers at the end of each Lower Basket Assembly arm in the tracks before securing the Dampers.
- 3.** Move the outer stops to the rear before installing the Pins.

# LED Assembly

1. Remove the Basket Assembly (page 8-93).
2. Disconnect the 4 CRUM Antennas from the CRUM Reader Board, and then remove the antennas (page 8-147) from the LED Assembly.
3. Remove the CRUM Reader Board (page 8-146).
4. Remove the LED Relay Board (page 8-126).
5. Disconnect the LED Heads from the Engine Control Board.
6. Release the LED Head cables from the Card Cage clamp.
7. Remove 2 (metal, 10 mm) screws securing the 2 Sector Gears to the shaft.

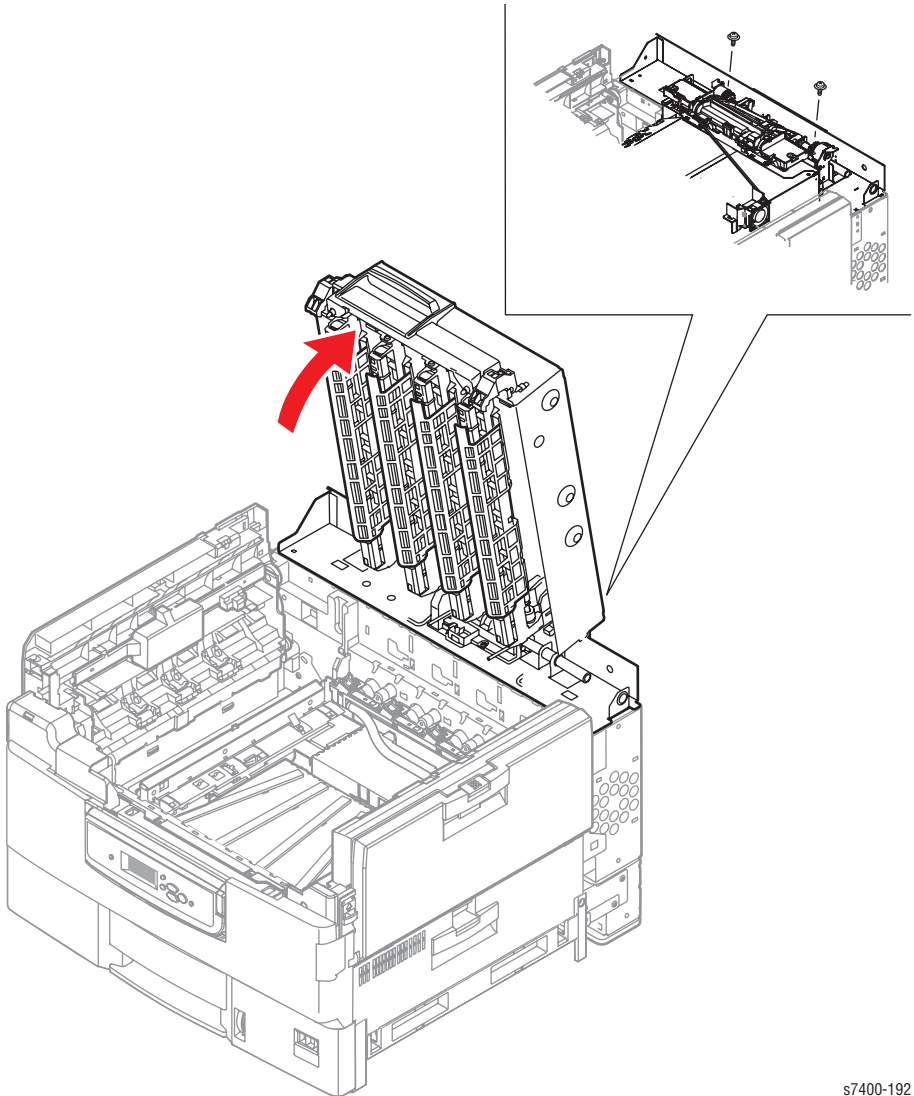

s7400-192

8. Remove 6 (metal, 10 mm) and 2 (metal, 6 mm) screws that secure the 2 Dampers. The 2 (metal, 6 mm) screws are located on the back of the printer.

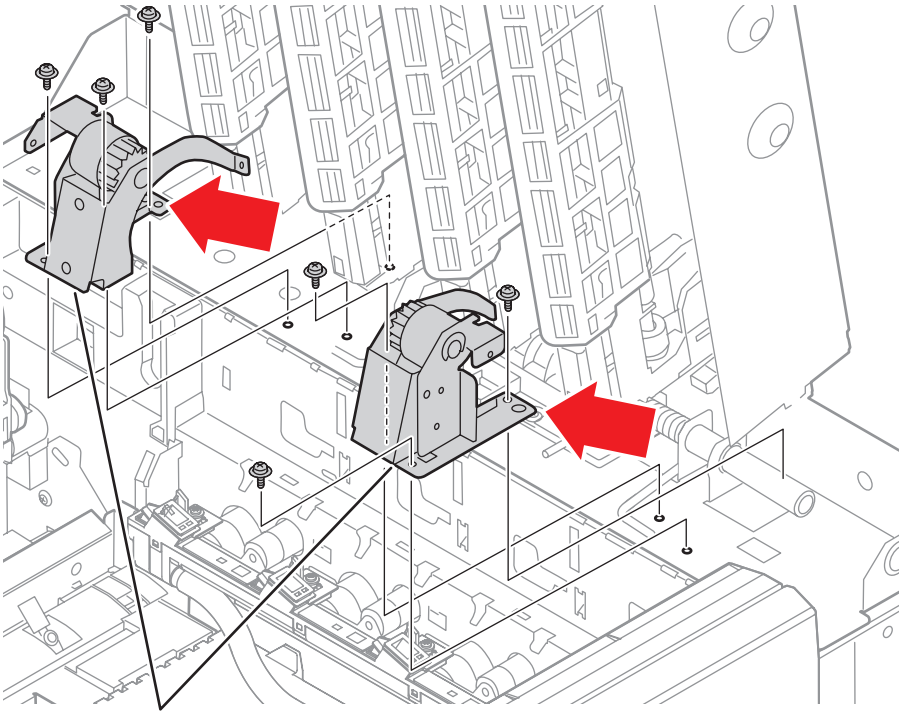

Inner Damper Assemblies

s7400-193

9. Make note of the Torsion Spring position, and then remove the Outer Shaft by pushing in the direction of the arrow.

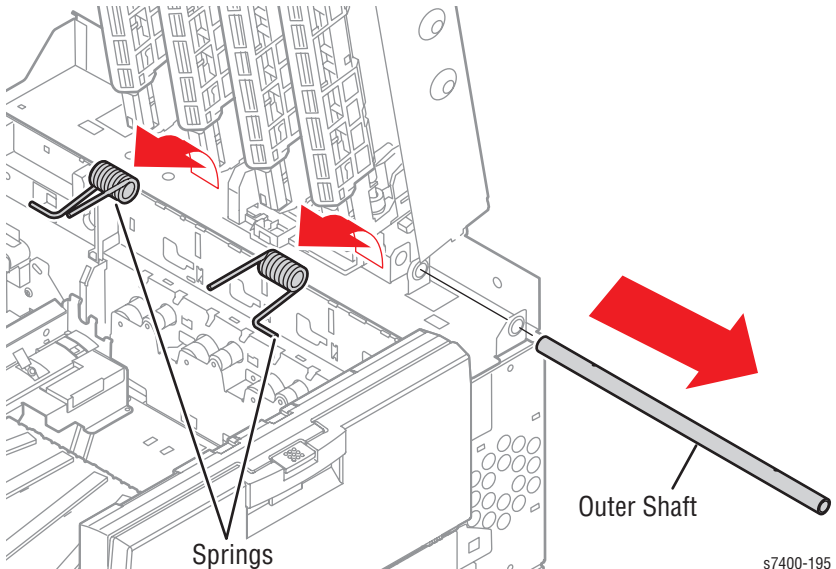

s7400-195

## 10. Remove LED Assembly.

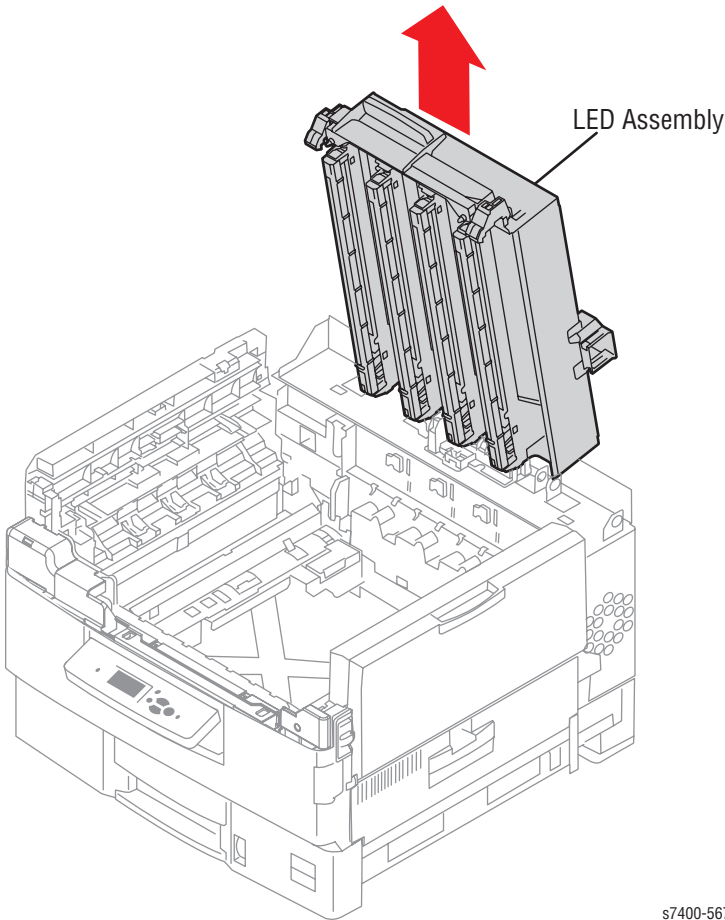

s7400-567

### Replacement Note

Transfer all the LED and CRUM components to the replacement assembly. Make sure the contacts under the outer shaft and springs are properly placed in their notches.

## LED Shutter Gear Replacement



## LED Holder Replacement



# Drive

## Transfer Unit Motor

1. Open the Top Cover.
2. Remove the Front Door (page 8-18).
3. Remove the Waste Toner Reservoir, if installed.
4. Remove the Left Front Cover (page 8-21).
5. Position the Control Panel parallel to the floor.
6. Disconnect the motor connector (P/J120).
7. Remove the 2 (metal, 6 mm) screws securing the motor.

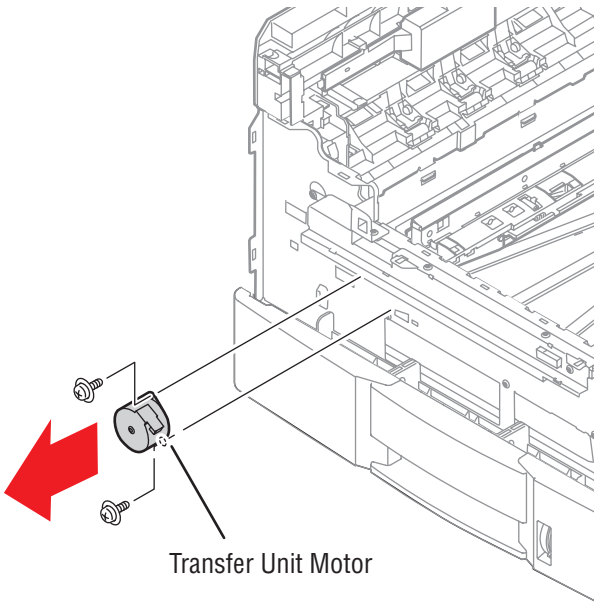

s7400-360

# Toner Motors

The Toner Motor supporting the YK Imaging Units is at the left. The Toner Motor supplying the CM Imaging Units is on the right. While these motors are identical, notice that they are positioned differently on the mounting plate.

## Note

A non-captive spring is located behind each Toner Motor to provide tension against the lower tab.

1. Remove the Card Cage (page 8-117).
2. Release the tab at the bottom of each mounting plate.
3. Lift the motor perpendicular to the printer to release the top tab from the frame.

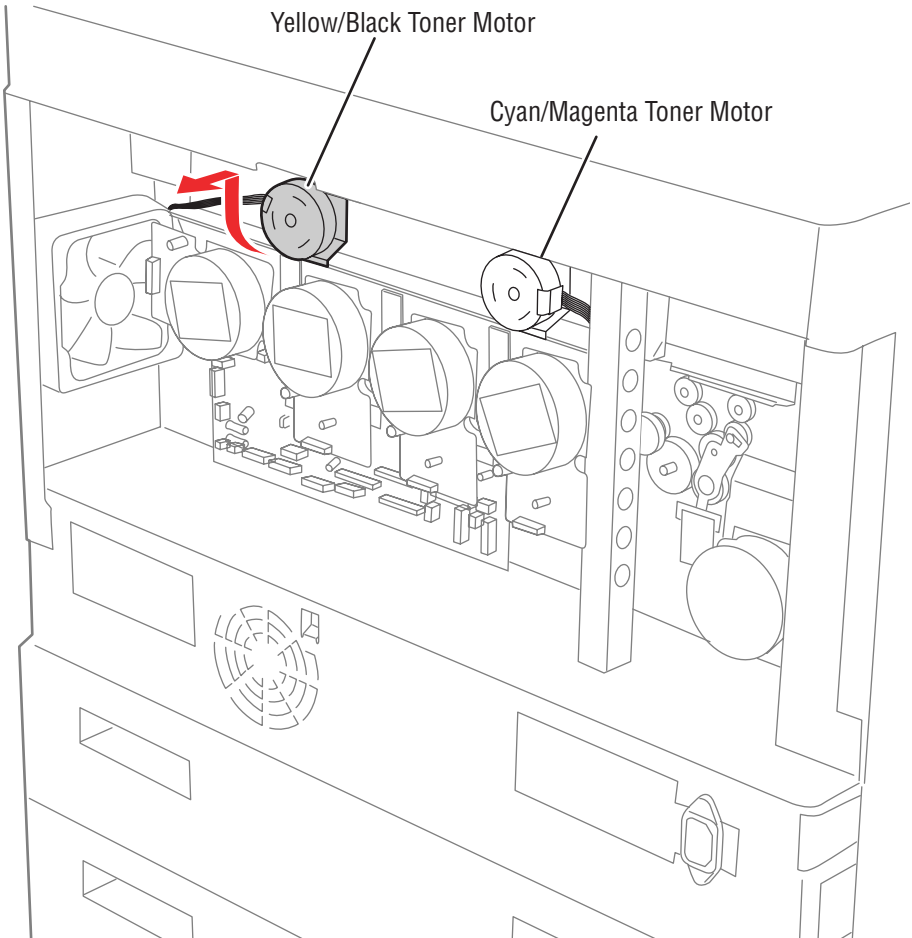

4. In the case of the CM Toner Motor, release the ribbon cable from the clamp.
5. Disconnect the Toner Motor connector from the Motor Diver Board.



# Imaging Unit Motors

The Imaging Unit Motors (CMYK) are all mounted to single mounting plate by 2 (metal, 6 mm) screws. In addition to the screws, each motor has a corresponding connection to the Motor Driver Board. Use the following procedure to remove one or all four Imaging Unit Motors.

## Note

The Black Imaging Unit Motor is oriented differently than the other colors.

1. Remove the Card Cage (page 8-117).
2. Remove 2 (metal, 6 mm) screws that secure the motor.
3. Disconnect the motor's connector on the Motor Driver Board.

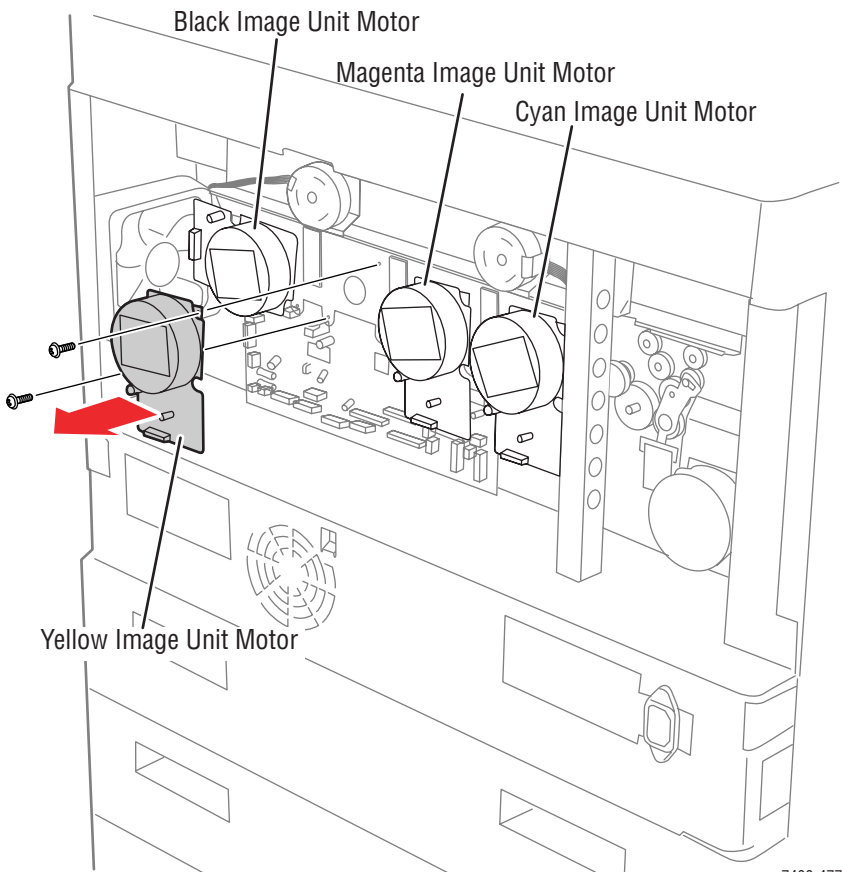

s7400-477

# Fuser Motor

The Fuser Motor is mounted to the frame with 2 (metal, 6 mm) screws, and connects to the Motor Driver Board.

1. Remove the Card Cage (page 8-117).
2. Remove 2 (metal, 6 mm) screws that secure the motor.
3. Release the Fuser Motor wiring from the 3 clamps.
4. Disconnect the motor's connector on the Motor Driver Board.

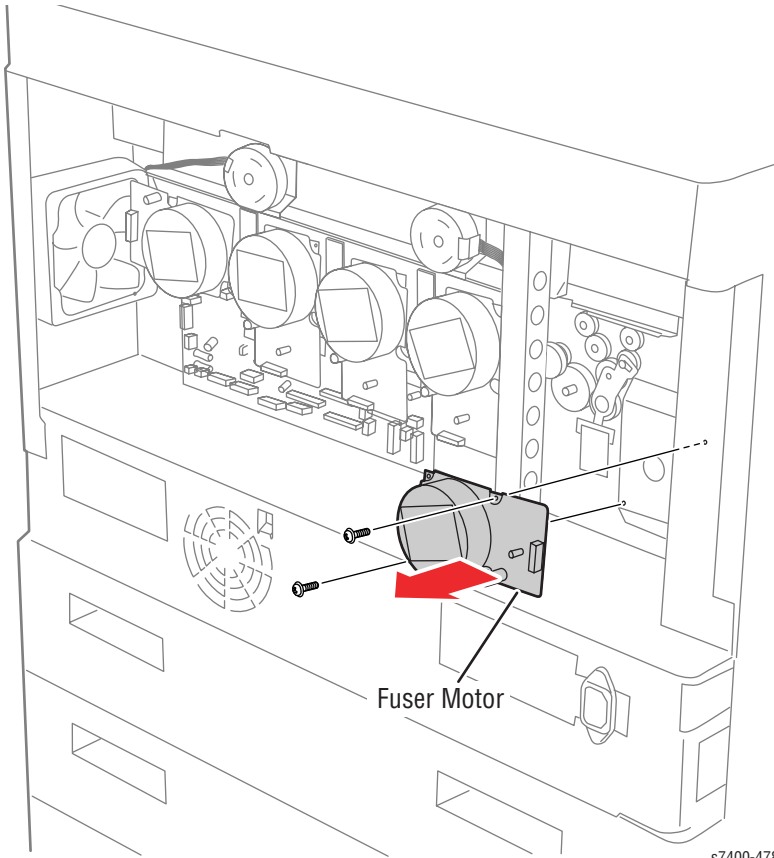

# Waste Toner Motor

1. Release the 4 hooks that secure the Waste Toner Motor Cover.

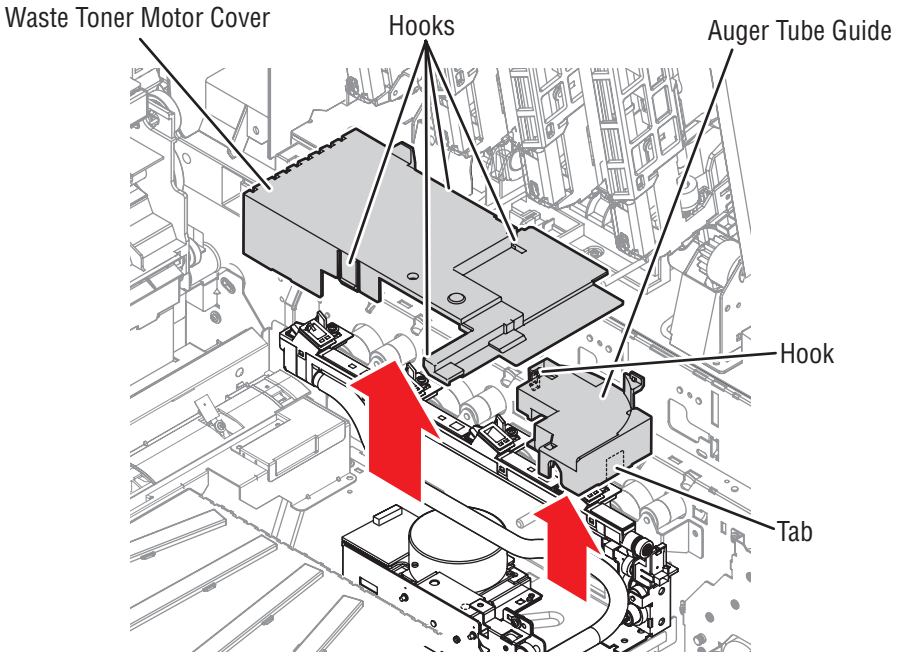

2. Disconnect the Waste Toner Motor connector (P/J50) from the Waste Toner Motor harness.
3. Remove 2 (metal, 6 mm) screws that secure the motor to the frame.

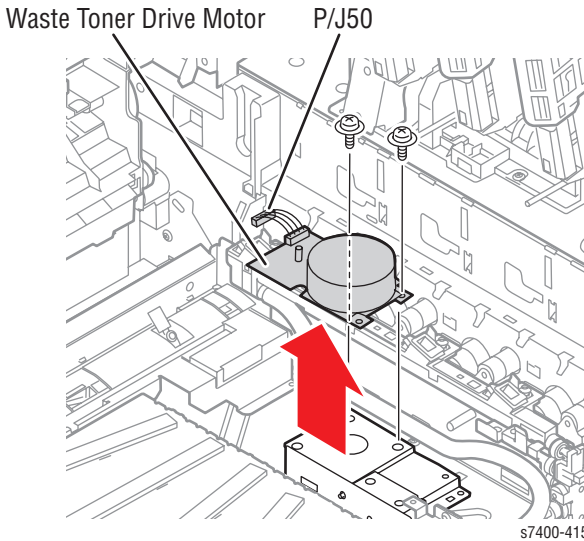

s7400-415

# Imaging Unit Lift Uplink

The Imaging Unit lift mechanism uses two Lift Uplinks, front and back, to lift the color Imaging Units away from the Transfer Unit belt during monochrome printing.

## Rear Lift Uplink

1. Remove the Imaging Unit Sensor Board (page 142).
2. Remove the Registration Assembly (page 84).
3. Release the hook and 4 tabs that secure the Lift Uplink Cover to the frame, and then remove the cover.

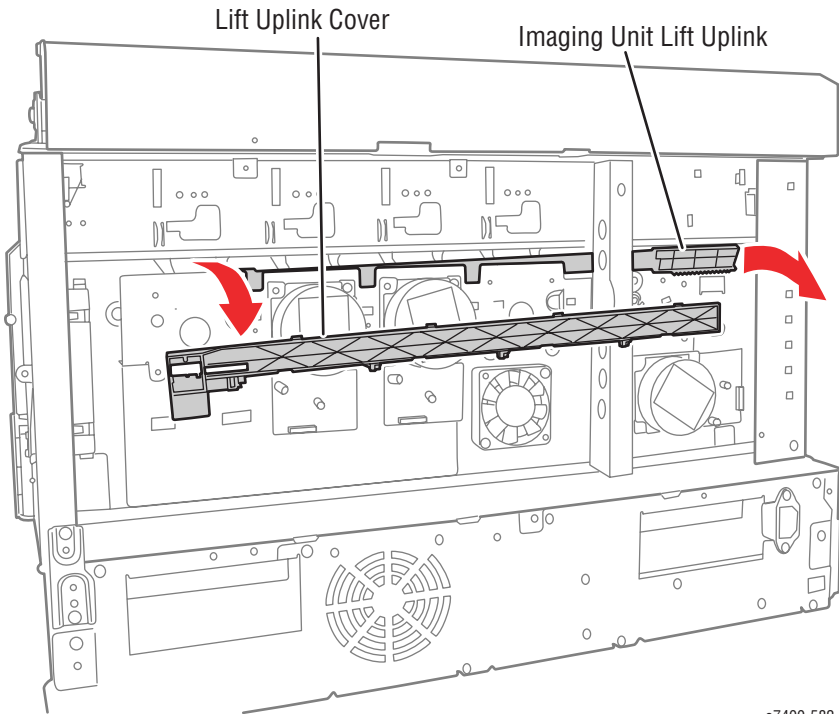

s7400-582

4. Move the Lift Uplink to the right to clear the gear set, and then remove the Lift Uplink.

## Front Lift Uplink

### Note

Two copper contacts are positioned between the frame and the Control Panel bracket. Replace these contacts before securing the bracket to the frame.

1. Raise the Basket Assembly.
2. Remove the Waste Toner Reservoir, if installed.
3. Remove the Front Door (page 18).
4. Remove the Left Front Cover (page 21).
5. Remove the Upper Front Cover (page 22).
6. Remove 4 (metal, 6 mm) screws that secure the Control Panel bracket to the frame.

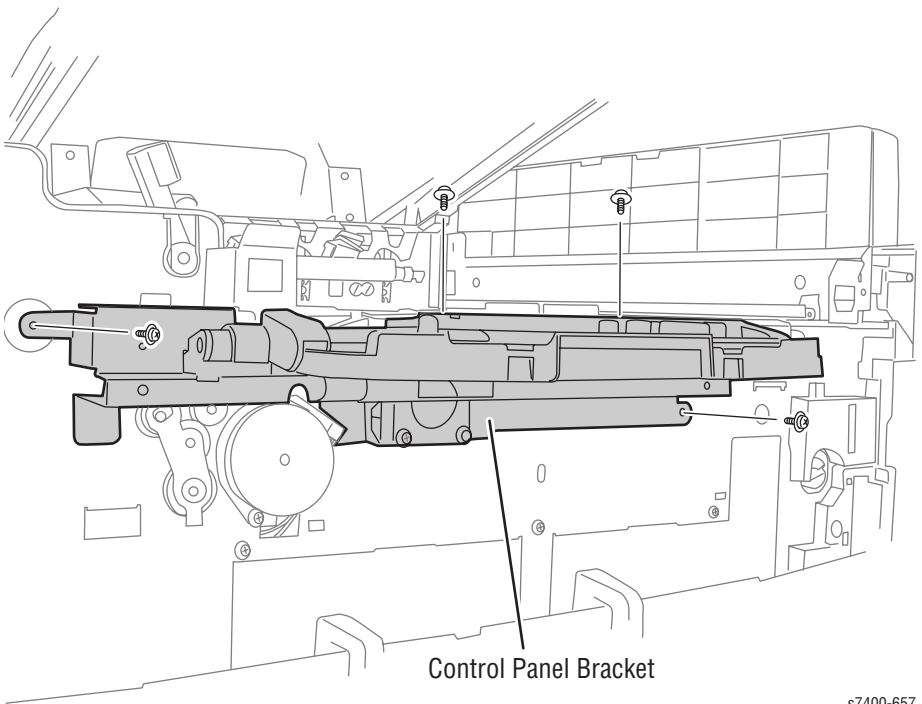

s7400-657

7. Lower the bracket to access the Lift Uplink Cover.

8. Release the hook and 4 tabs that secure the Lift Uplink Cover to the frame, and then remove the cover.

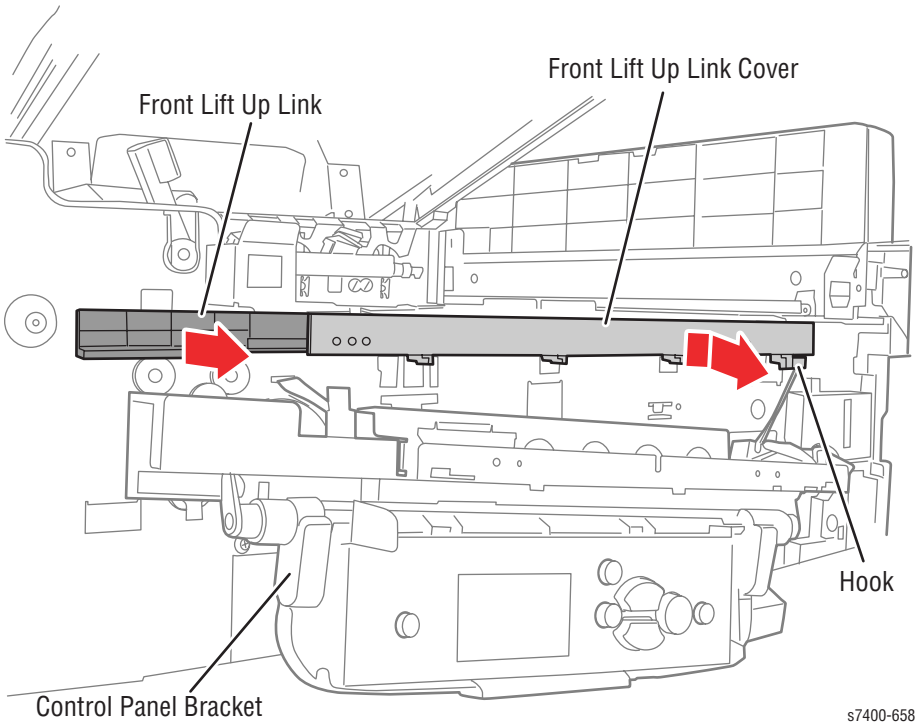

s7400-658

9. Move the Lift Uplink to the right to clear the gear set, and then remove the Lift Uplink.

# Electrical

## Control Panel

1. Release the 2 hooks closest to the printer from underneath the Control Panel.
2. Lift up on the part of the panel closest to the printer to remove the Control Panel faceplate.
3. Remove 1 (metal, 6 mm) screw that secures the ribbon cable.
4. Disconnect the ribbon cable from the Control Panel Board.
5. Remove 4 (Black, plastic, 10 mm) screws to remove the Control Panel Hinges.
6. Remove the Control Panel and Rear Cover.
7. Release the mounting bracket by sliding it slightly downwards.

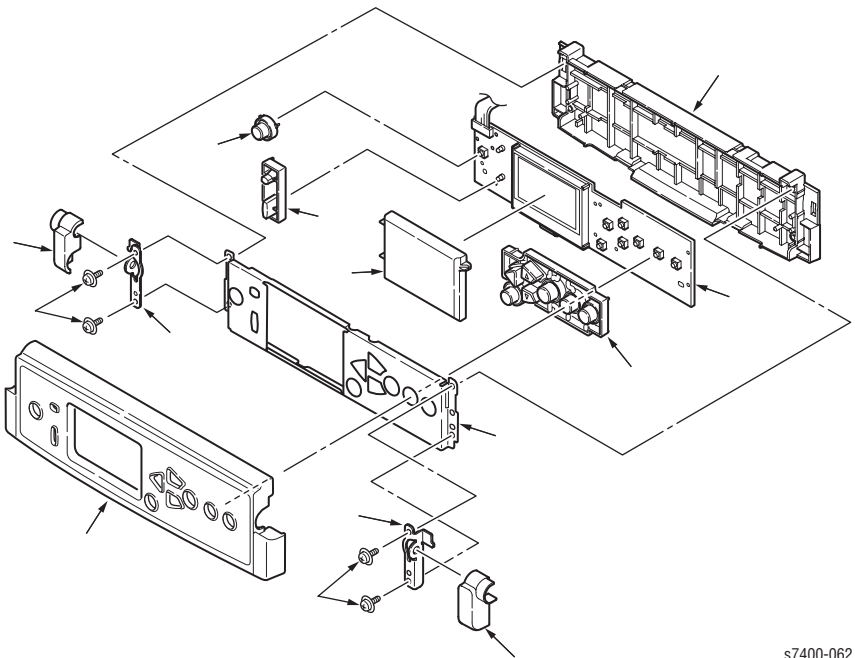

s7400-062

### Replacement Note

Insure the Control Panel, metal mounting bracket, front, and rear covers are assembled correctly before installing any screws.

# Engine Control Board

1. Remove the Rear Cover (page 8-13).
2. Remove the Card Cage Fan Duct (page 8-114).
3. Disconnect 17 connectors from the Engine Control Board.
4. Remove 4 (metal, 6 mm) screws.
5. Shift the board to the left to release the connection to the Image Processor Board.
6. Remove the Engine Control Board. **Note:** When replacing the Engine Control Board, move the NVRAM/EEPROM chip from the old board to the new board.

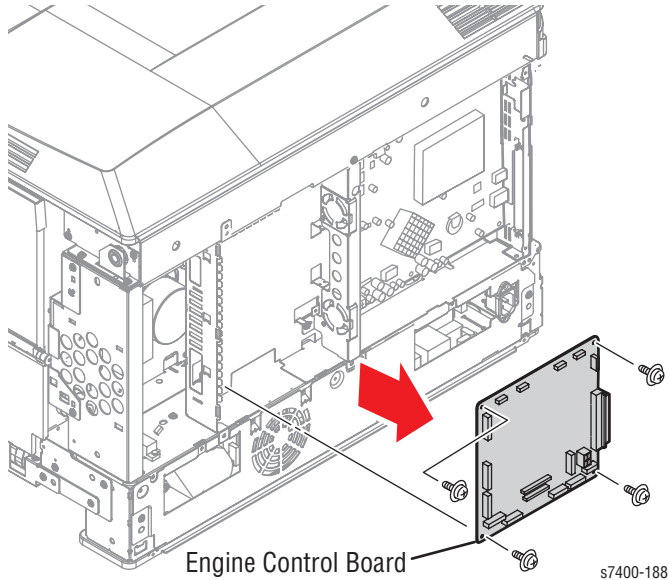



# Image Processor Board

1. Remove the Rear Cover (page 8-13).
2. Disconnect the Fan connector (P/J200).
3. Remove 6 (metal, 6 mm) screws securing the Image Processor Board.
4. Remove the Image Processor Board and Rear Panel. **NOTE:** When replacing the IP Board, move all components from the old board to the new board. (NVRAM, Memory, Config Card, and/or Hard Drive)

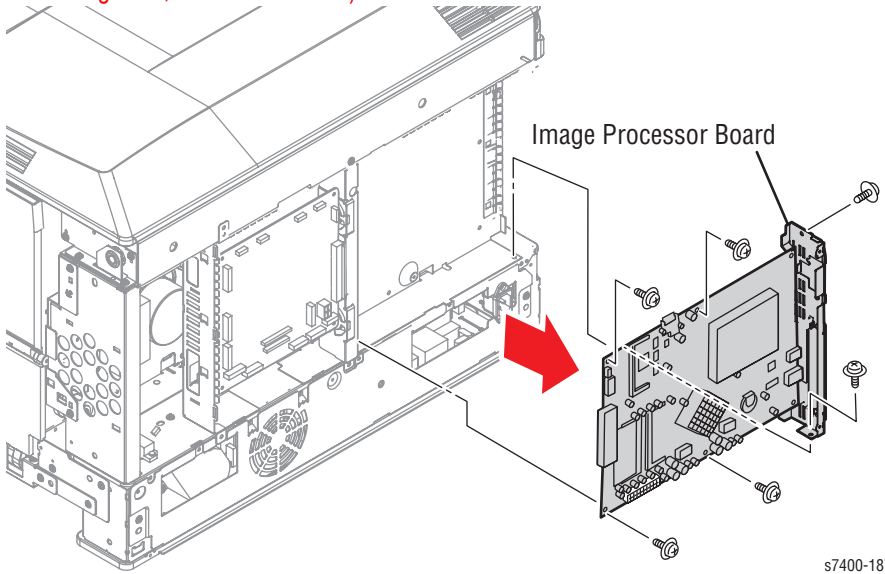

s7400-187

# Card Cage Fan Duct

1. Open the Top Cover.
2. Open Door B.
3. Remove the Right Rear Cover (page 8-15).
4. Release the 2 hooks, top and bottom, that secure the Fan Duct to the Fan Housing.
5. Remove the left side of the Card Cage Fan Duct from the printer to release the 2 tabs from the Card Cage.

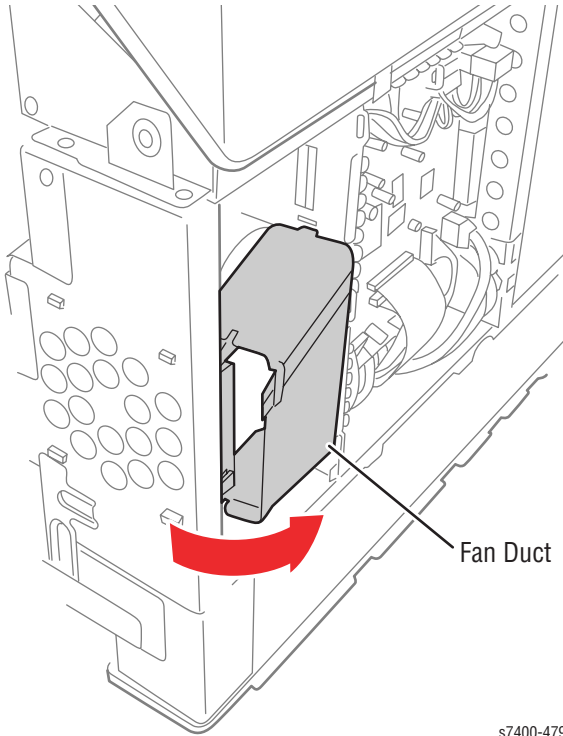

s7400-479

## Replacement Note

Insert the right side of the Card Cage Fan Duct into the printer first to engage the 2 tabs. next, snap the duct onto the card Cage Fan Housing.

# Card Cage Fan

1. Open the Top Cover.
2. Remove the Right Rear Cover (page 8-15).
3. Remove the Card Cage Fan Duct (page 8-114).
4. Release the 4 hooks that secure the Fan Housing to the frame.
5. Disconnect the fan from the Motor Driver Board FAN connector.
6. Move the leading edge of the Fan Housing to the right, and then carefully remove the fan from the frame.

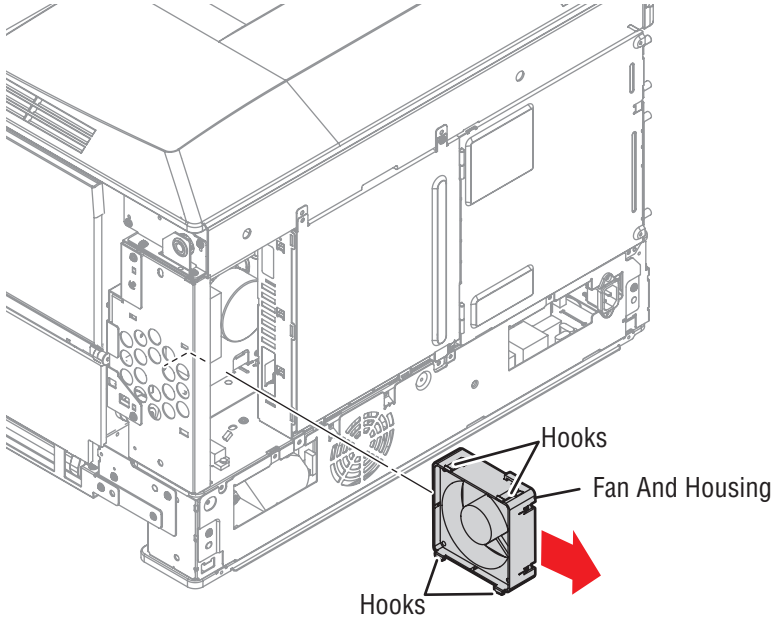

s7400-185

7. Remove the 3 hooks that secure the fan to the Fan Housing.
8. Disconnect the fan harness and remove the fan.

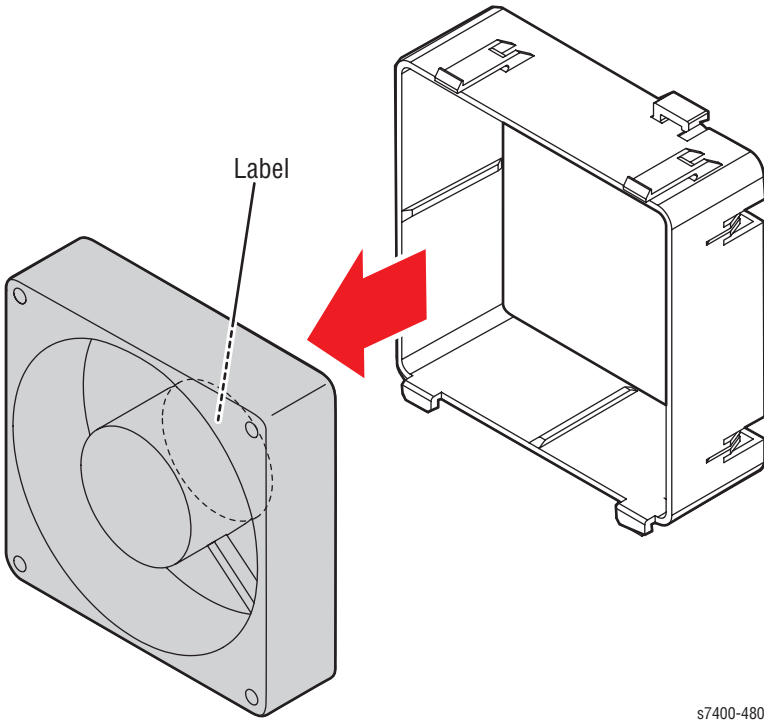

s7400-480

# Card Cage

1. Remove the Rear Cover (page 8-13).
2. Remove the Lower Rear Cover (page 8-14).
3. Remove the Right Rear Cover (page 8-15).
4. Remove the Card Cage Fan Duct (page 8-114).
5. Remove the Engine Control Board (page 8-112).
6. Remove the Image Processor Board (page 8-113).
7. Remove 11 (metal, 6 mm) screws securing the card cage to the printer.
8. Remove 1 (metal, 6mm) screw that secures the LED Head cable clamp and guide block.
9. Release the wiring harnesses from the card cage.
10. Slide the card cage out from the bottom first to protect the wiring.

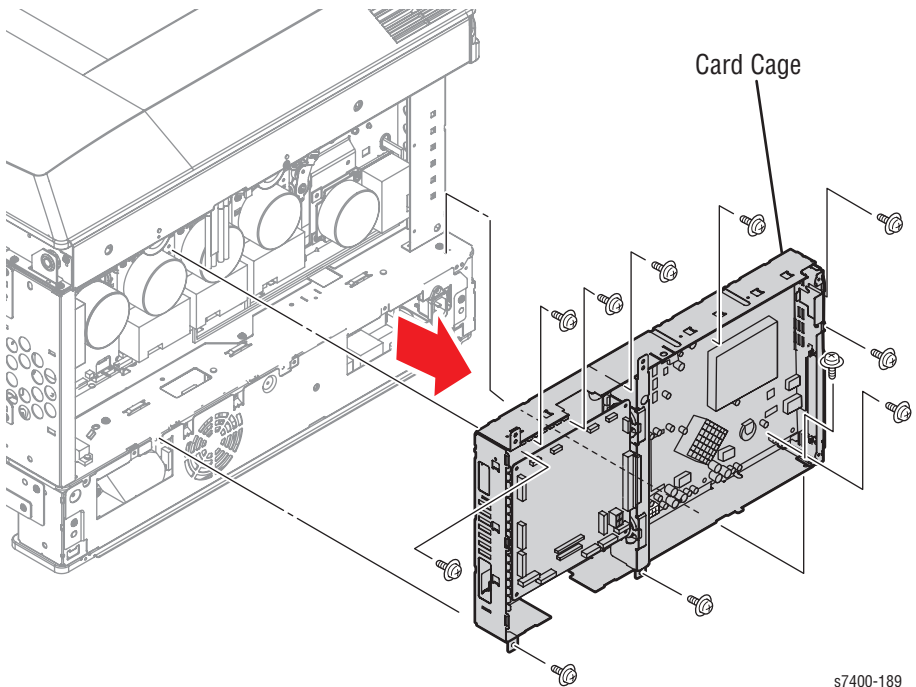

s7400-189

# HVPS Cover

## Caution

Use care when removing the HVPS Cover. The four ribs across the top of the cover are covers for the Transfer Roller conductors. These covers are secured by 2 hooks at their center and are easily broken by flexing the HVPS Cover during removal.

1. Open the Top Cover.
2. Remove the Transfer Unit (page 8-10), if installed.
3. Remove 2 (metal, 6 and 10 mm) screws securing the HVPS Cover and remove.
4. Release 3 tabs at the back of the cover, and then lift the cover while sliding it towards the rear to remove.

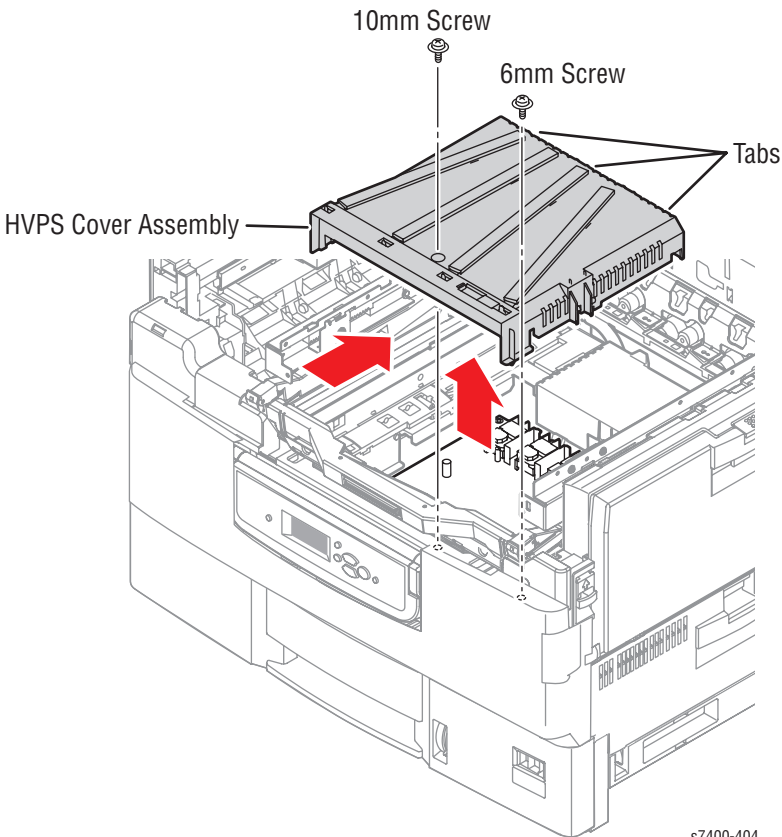

s7400-404

## Replacement Note

Use care not to pinch wiring underneath the 6 mm screw when replacing the cover.

# High Voltage Power Supply

1. Remove the HVPS Cover (page 8-118).
2. Disconnect 4 connectors (CN1, CN3, CN2, CN4) from the HVPS.
3. Remove 2 (metal, 6 mm) screws and carefully slide the board to the rear to clear the Housing Bias Assembly.

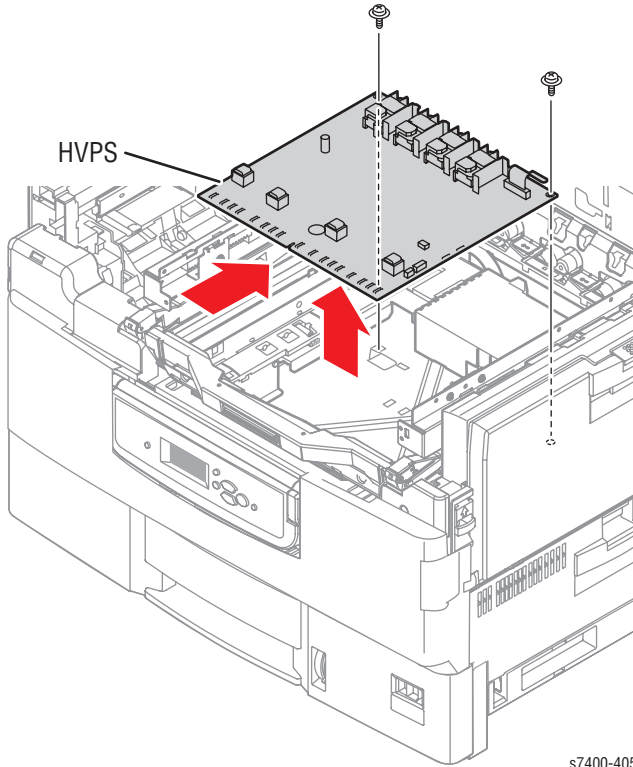

s7400-405

# Housing Bias Assembly

## Caution

The Transfer Unit Belt Rotation Sensor is mounted in the Housing Bias Assembly. Use care not to damage the sensor wiring during the removal process.

1. Remove the HVPS Cover (page 8-118).
2. Open the Front Door.
3. Open the Basket Assembly.
4. Remove the 2 (metal, 6 mm) screws that secure the HVPS.
5. Slide the HVPS to the rear to disconnect it from the Housing Bias Assembly.
6. Release the 2 hooks that secure the Housing Bias Assembly to the frame.
7. Lift the assembly slightly to release the 2 tabs.
8. Remove the sensor by releasing the 2 hooks that secure the sensor board.
9. Remove the sensor wiring from the guides in the Housing Bias Assembly.

Housing Bias Assembly

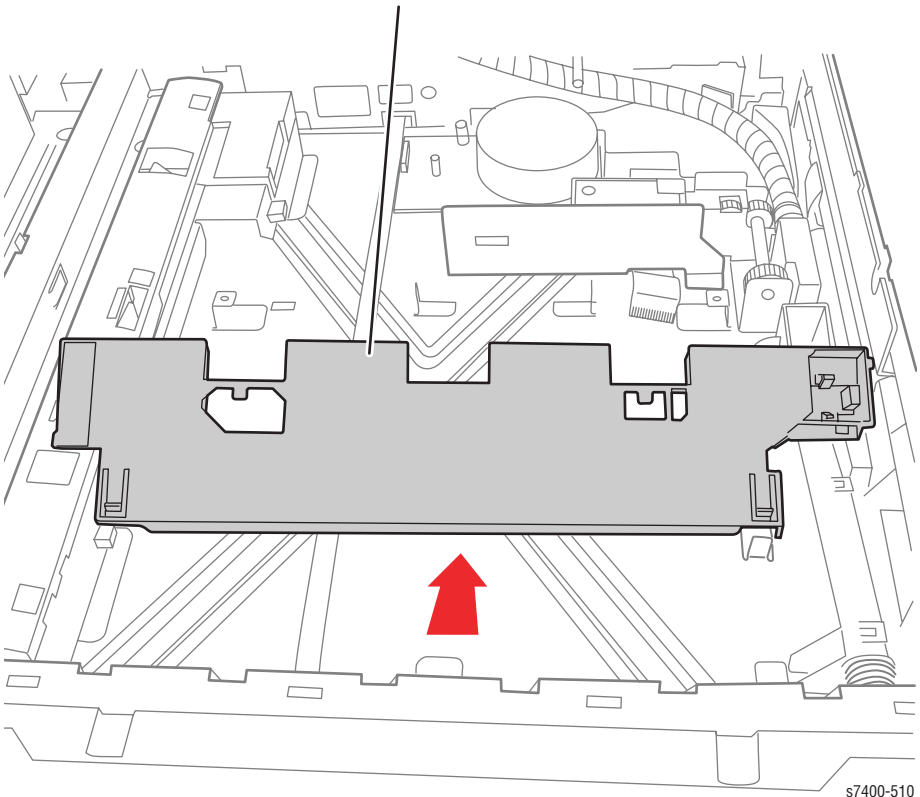

s7400-510



# Low Voltage Power Supply

1. Remove 14 (metal, 6 mm) screws securing the power supply enclosure.
2. Lift the Power Switch Link from the Power Switch on the LVPS.
3. Disconnect 4 connections to the LVPS and remove the LVPS enclosure.

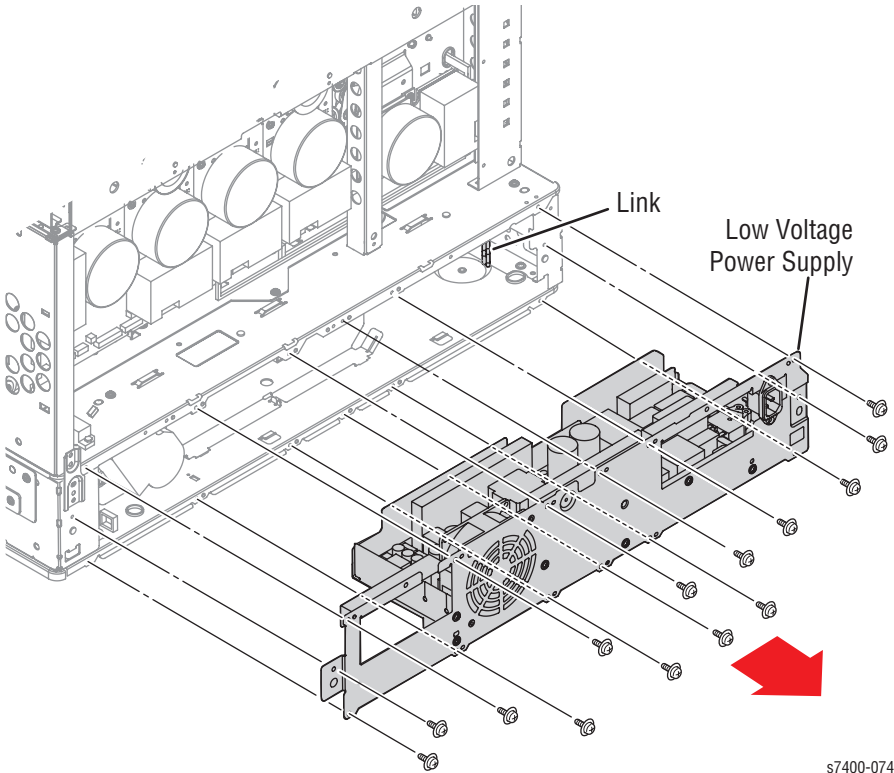

s7400-074

4. Remove the LVPS Fan (page 8-124).
5. Remove the 2 (metal, 10 mm) screws that secure the AC Inlet to the LVPS enclosure.

6. Remove the 1 (metal, 6mm) screw that secures the ground wire to the LVPS enclosure.

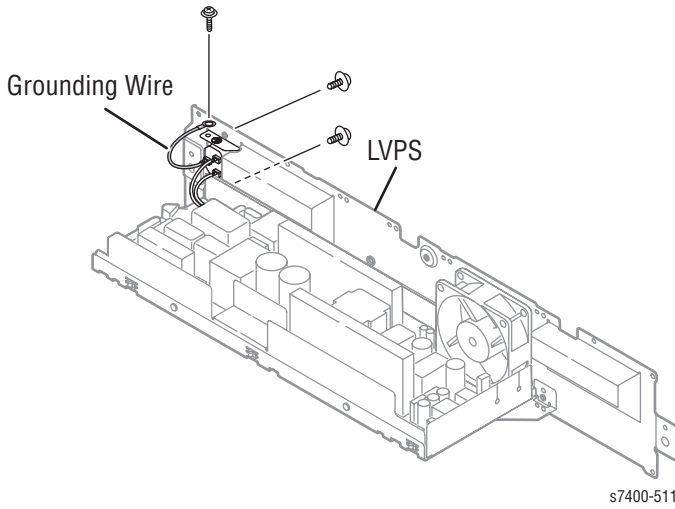

7. Remove 3 (metal, 6 mm) screws that secure the LVPS to the enclosure.

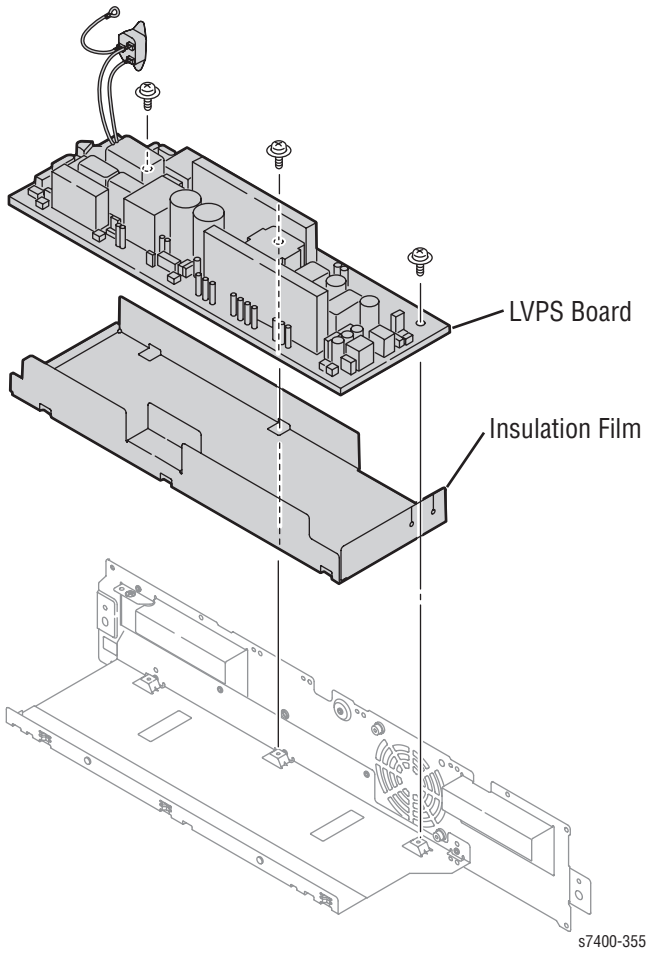

# LVPS Fan

1. Remove the LVPS enclosure (page 8-121).
2. Disconnect the Fan connector (FAN1).
3. Release the Fan harness from the insulation film.
4. Remove 2 (metal, 30 mm) screws securing the fan to the enclosure to remove it.

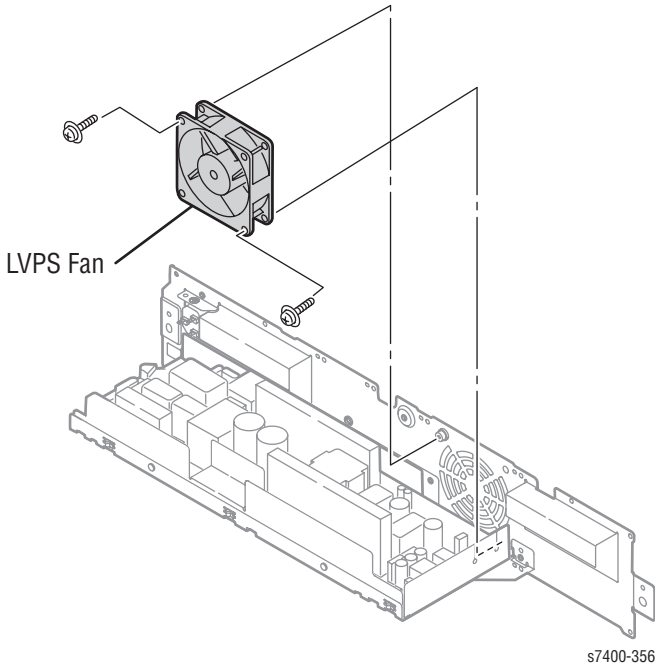

# LED Head

1. Open the Top Cover.
2. Release the front tab of the LED Head from the holder by gently pushing the LED Head towards the rear while pulling the holder forward.
3. Release the rear tab of the LED Head by pulling the LED Head towards the front of the printer.
4. Disconnect 2 connectors to remove the LED Head from the holder.

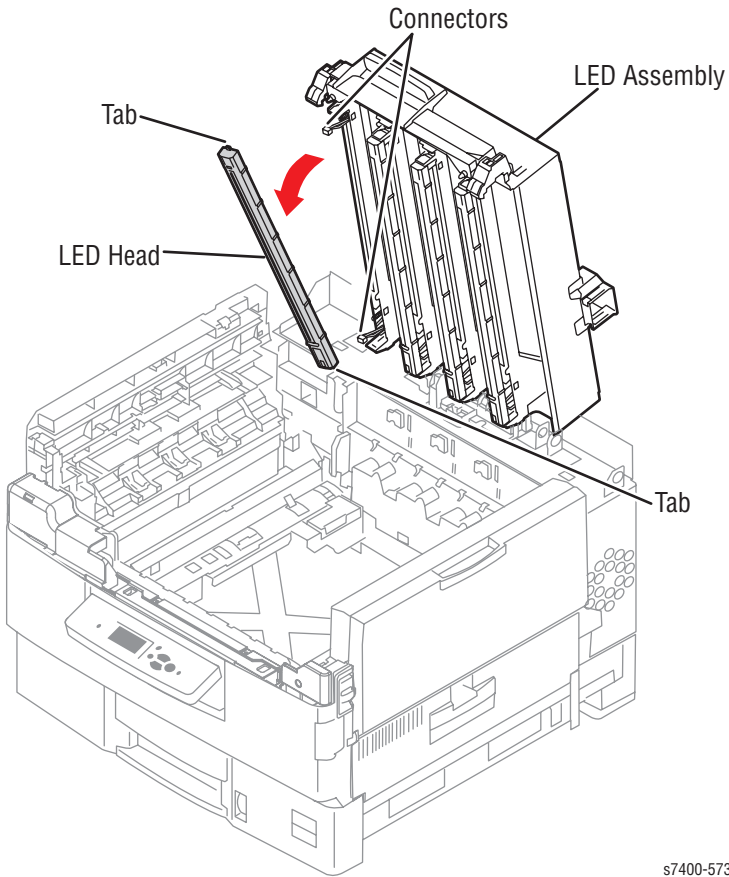

s7400-573

# LED Relay Board

1. Remove the Top Cover.
2. Remove the Rear Cover.
3. Disconnect the 4 LED Heads from the Engine Control Board CC, YY, MM, and KK connectors.
4. Disconnect the CRUM Reader Board ribbon cable from the Engine Control Board RFID connector.
5. Remove 1 (metal, 6 mm) screw that secures the cable clamp holding the LED Head and CRUM Reader Board wiring.
6. Release the Offset Motor and Transfer Unit Fan wiring from the guides in the LED Head Relay Board Cover.
7. Cut 1 cable tie, and then remove the LED Head cables from the guides in the Imaging Unit Relay Board Cover.
8. Release 2 hooks that secure P492 to the LED Head Relay Board Cover.
9. Disconnect the POWER connector from the relay board.
10. Remove 3 (metal, 10 mm) screws that secure the cover to the LED Assembly.

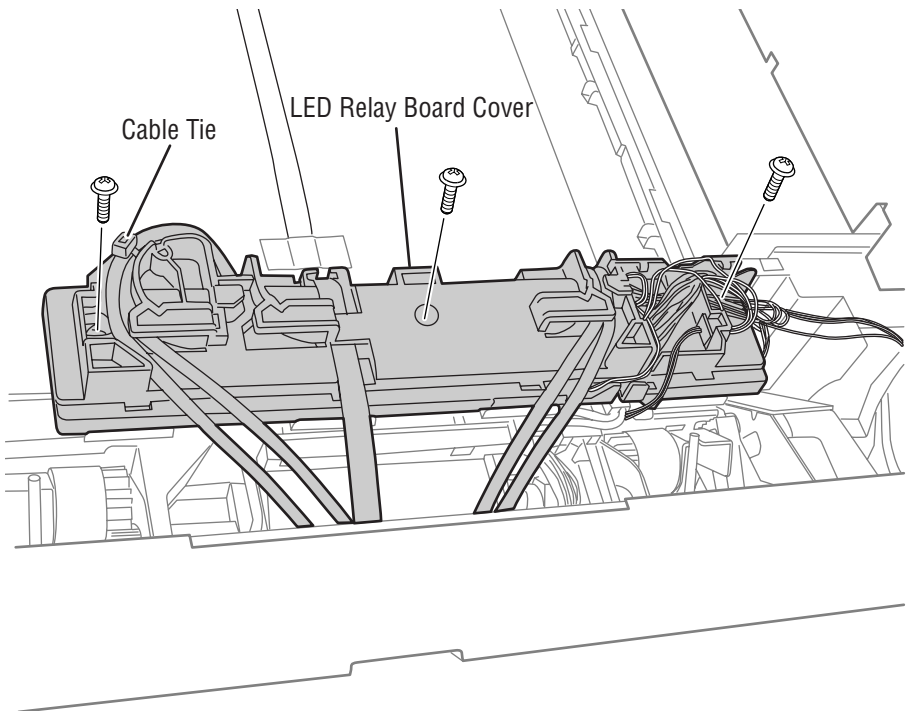

s7400-512

11. Release 1 hook at the front of the cover to remove the cover from the board.
12. Disconnect the KPOW, YPOW, MPOW, and CPOW connectors, and then remove the board.

# Top Cover Interlock Switch

The Top Cover's right hand latching mechanism closes the interlock when latched.

1. Open the Top Cover (page 8-24).
2. Open the Basket Assembly.
3. Remove the HVPS Cover (page 8-118).
4. Disconnect CN3 from the HVPS.

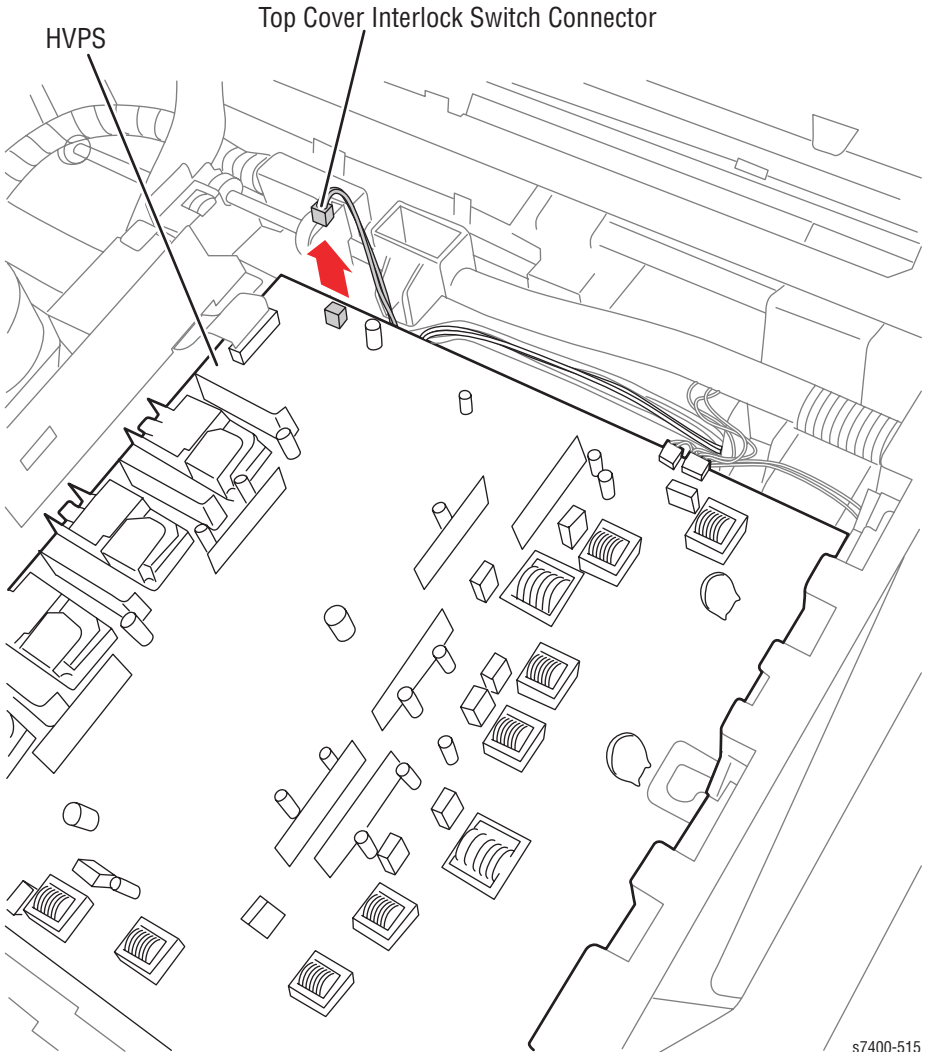

s7400-515

5. Remove the switch wiring from the guides on the Registration Assembly.
6. Remove the Left Front Cover (page 8-21).
7. Remove the Upper Front Cover (page 8-22).

8. Remove 1 (metal, 6 mm) screw that secures the right side Control Panel hinge.
9. Remove 1 (black, 8 mm) screw that secures the switch holder.
10. Remove 2 (metal, 6 mm) screws that secure the Control Panel mounting.
11. Remove the switch by pulling the Control Panel mount away from the frame, and then shift the switch holder first to the right, then down.

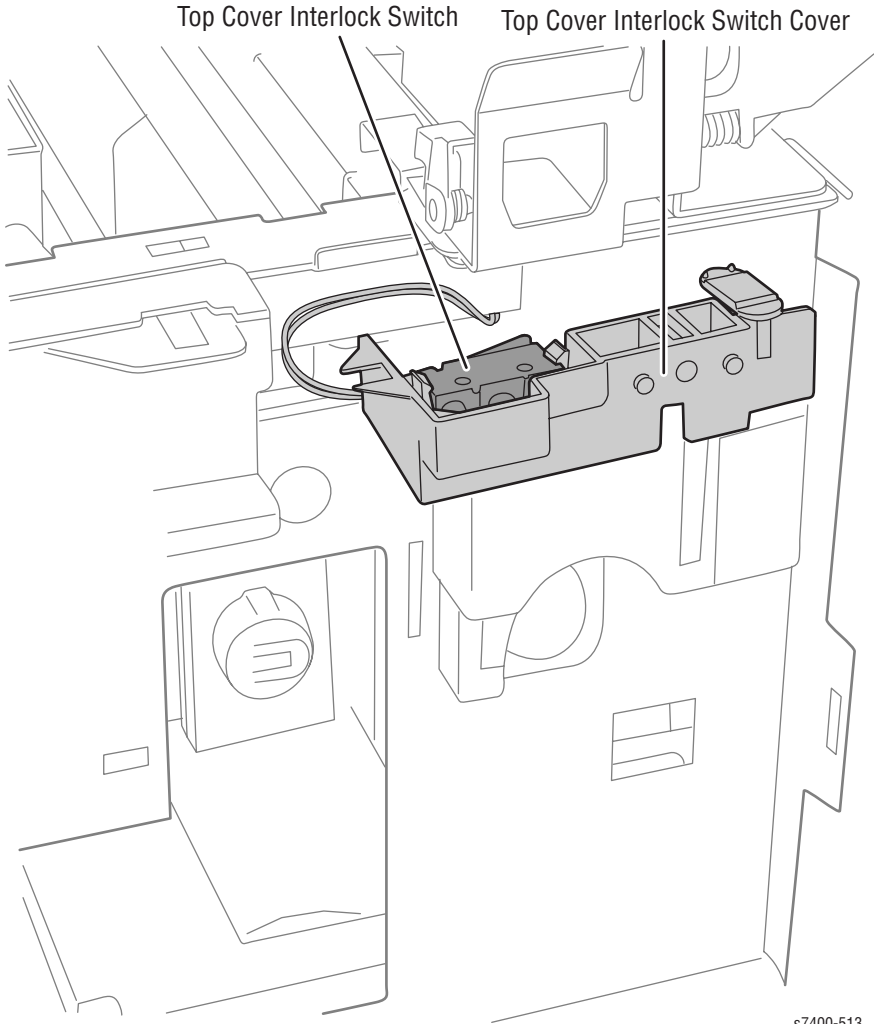

s7400-513

12. Feed the wiring through to the front to remove the switch.



13. Spread the 2 hooks that secure the switch to the holder.
14. Release the harness and remove the switch from the cover.

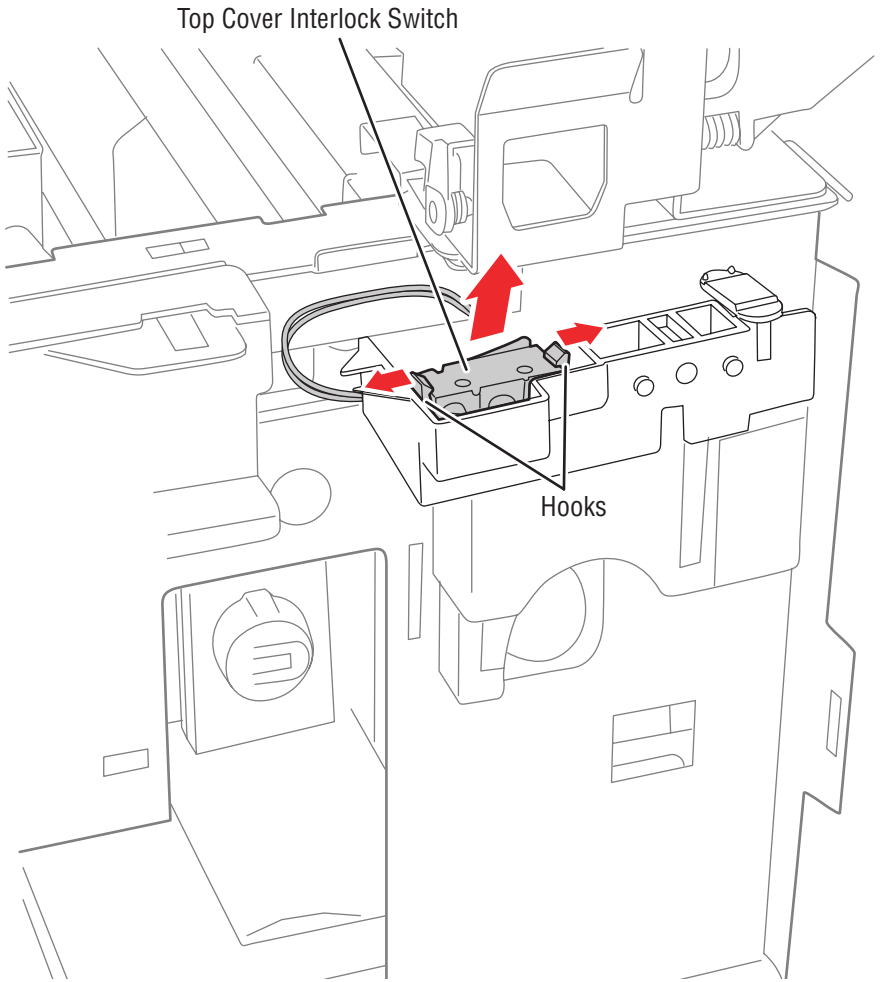

**Replacement Note**

Route the sensor wiring through the guides provided in the sensor housing. Make certain no wiring contacts the Waste Toner Reservoir auger drive.

# Waste Toner Reservoir Detect Switch

An actuator on the back of the Front Door penetrates the Waste Toner Reservoir to activate a switch mounted in a sensor housing attached to the frame.

1. Open the Top Cover.
2. Remove the HVPS Cover (page 8-118).

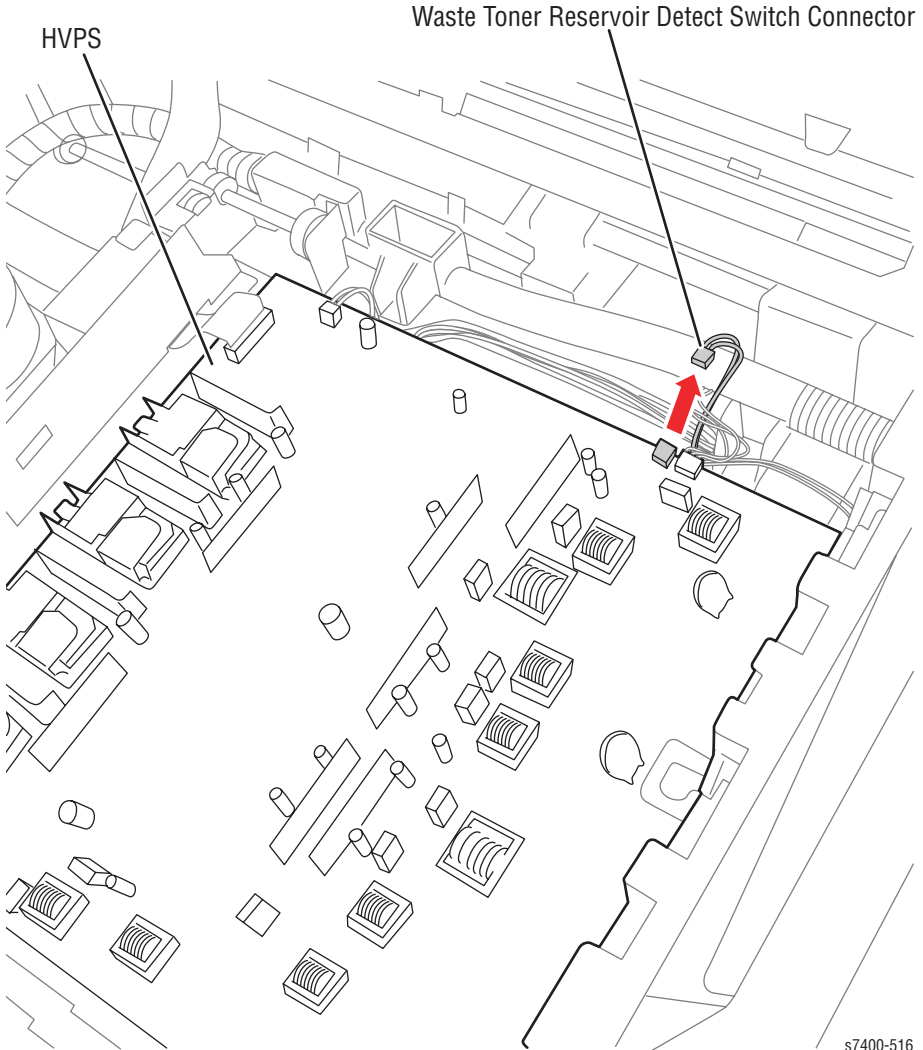

s7400-516

3. Disconnect CN2 from the HVPS
4. Open the Front Door.
5. Remove the Waste Toner Reservoir if installed.

6. Release 1 tab at the top of the sensor housing to release the housing from the frame.

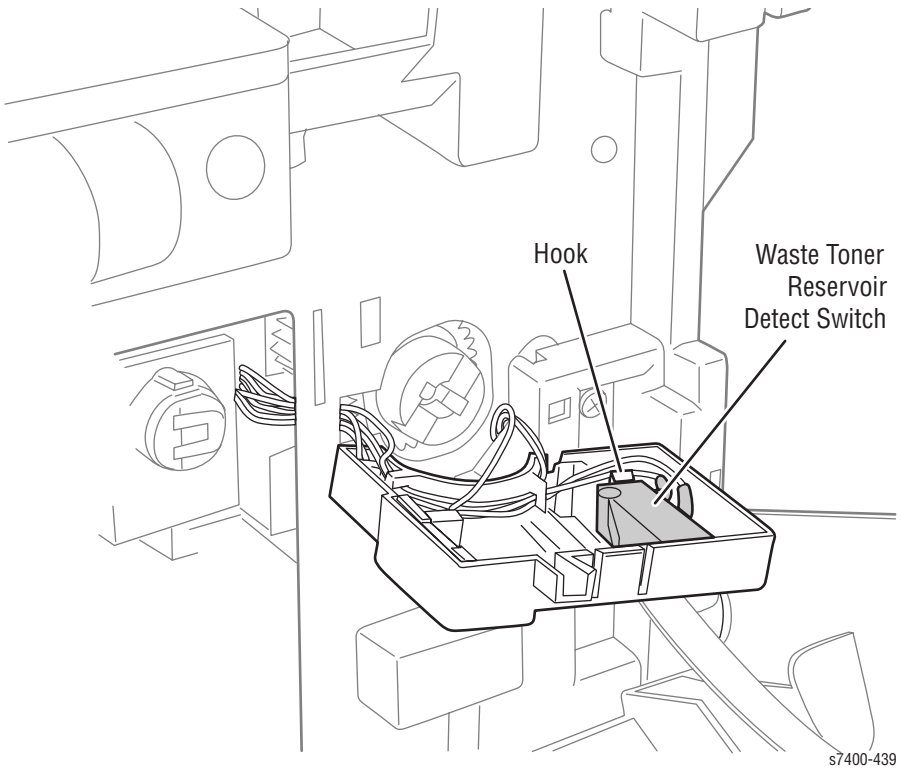

7. Spread the 2 hooks that secure the Waste Toner Reservoir Detect Switch to the sensor housing. Use care not to damage the spring.
8. Release the harness and remove the switch from the cover.

### **Replacement Note**

Route the switch wiring through the guides provided in the sensor housing. Make certain no wiring contacts the Waste Toner Reservoir Auger drive.

## Door A Interlock Switch

An actuator mounted on the Door A Latch Assembly penetrates the frame to activate a microswitch mounted above the Card Cage Fan.

1. Remove the Card Cage Fan Duct (page 8-114).
2. Disconnect the MPTCOV connector from the Motor Driver Board.

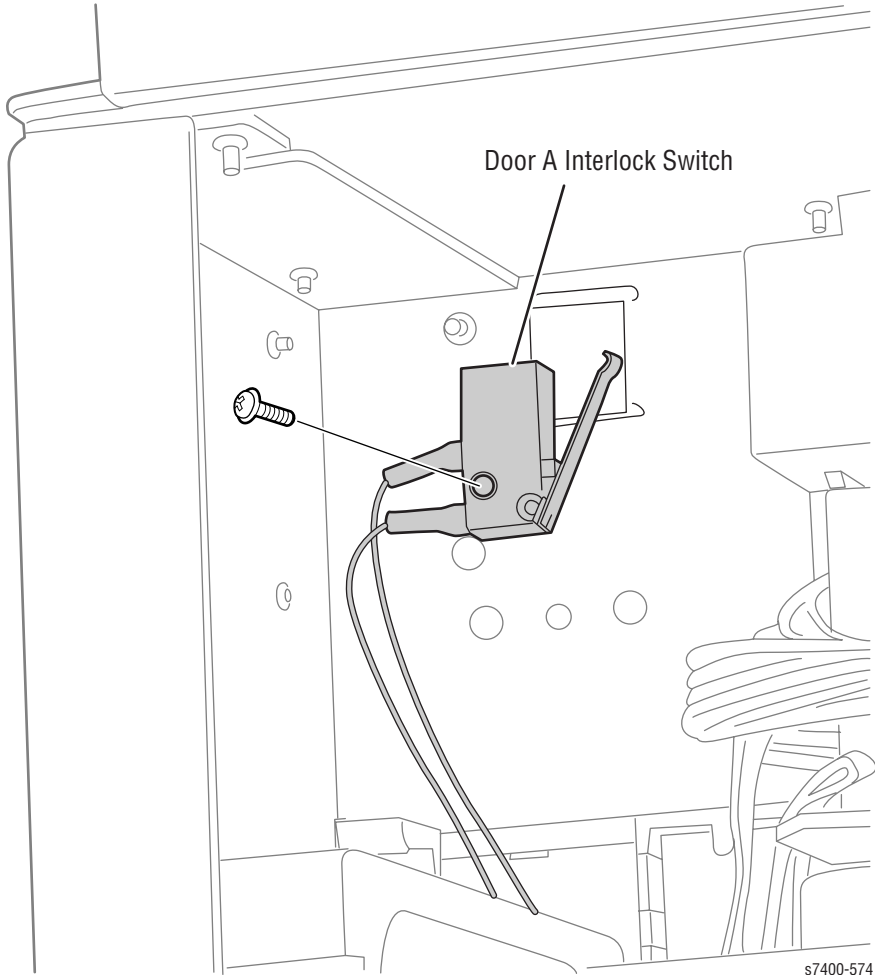

3. Remove 1 screw that secures the microswitch to the frame.

### Replacement Note

Verify that the actuator properly closes the switch when Door A is closed.

# Imaging Unit Fan

1. Open the Top Cover.
2. Open the Front Door.
3. Remove the Left Front Cover (page 8-21).
4. Remove the 2 (metal, 20 mm) screws that secure the fan to the frame.
5. Gently pull the fan downward to remove it from the frame.
6. Disconnect the fan from the harness (P/J100).

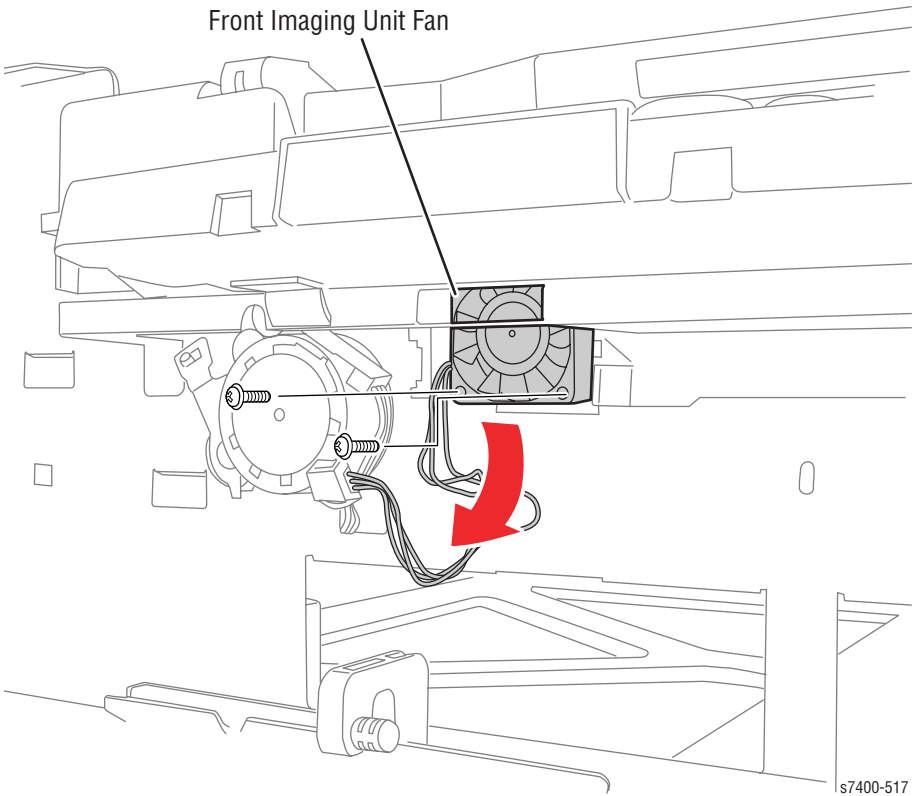

## Transfer Unit Fan

The Transfer Unit Fan is located directly behind the Cyan Imaging Unit Motor.

1. Remove the Rear Cover (page 8-13).
2. Remove the Right Rear Cover (page 8-15).
3. Remove the Card Cage Fan Duct (page 8-114).
4. Remove the Card Cage (page 8-117).
5. Remove 2 (metal, 6 mm) screws that secure the Cyan Imaging Unit Motor.

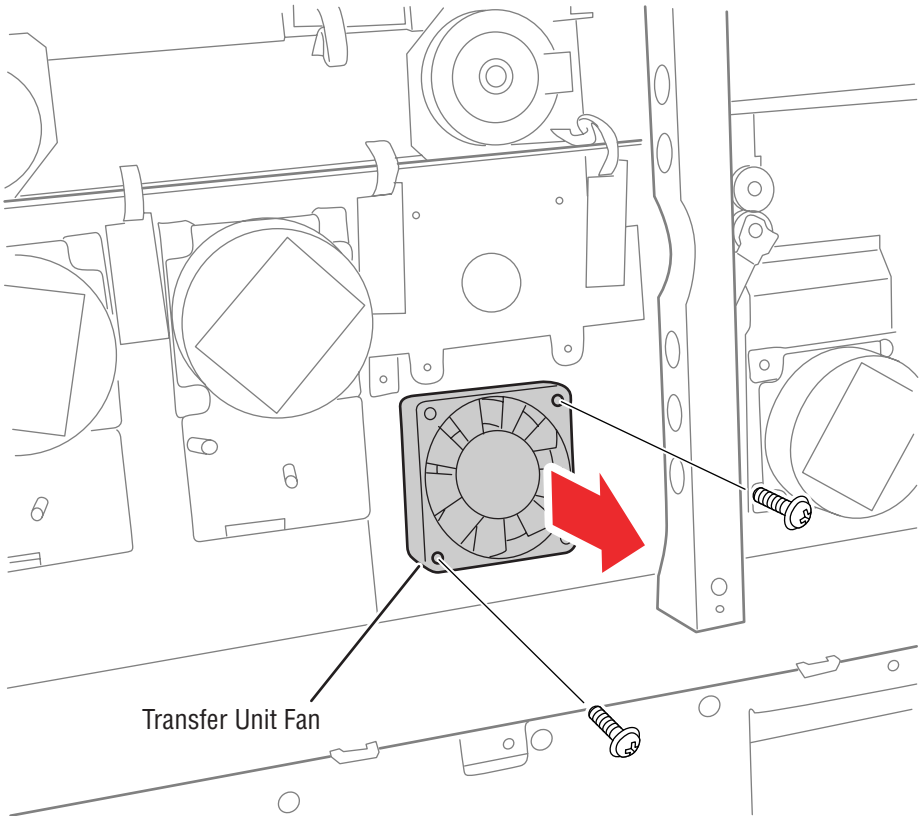

s7400-585

6. Remove 2 (metal, 23 mm) screws with washers that secure the Transfer Unit Fan to the frame.
7. Release the fan wiring from the clamp.
8. Disconnect the fan from the Motor Driver Board.

# Top Cover Fan

The Top Cover Fan is mounted in a duct located underneath the Cyan LED Head.

1. Remove the Job Offset Assembly (page 8-56).
2. Remove the JOFMOT harness from the Upper Fuser Fan Duct and Top Output Chute.

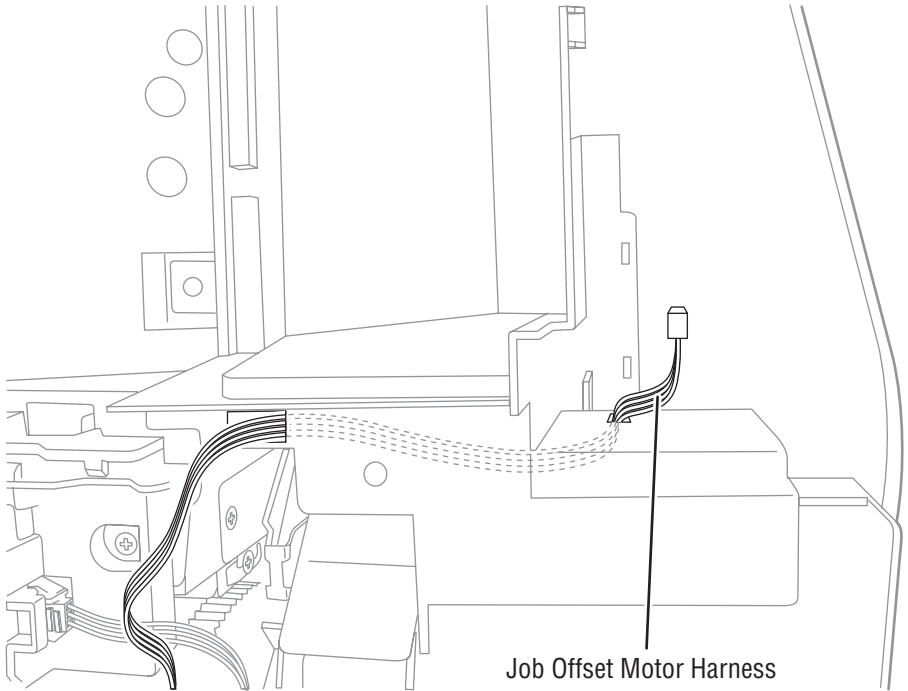

s7400-584

3. Release the 4 hooks that secure the Top Output Chute to remove it from the LED Assembly.
4. Release the Top Cover Fan wiring (Red, Black and White) from the guides in the LED Relay Board cover.
5. Release the 1 hook at the back, and 2 tabs at the front that secure the Top Cover Fan Duct to the LED Assembly.

6. Rotate the Top Cover Latch upward, and then remove the 1 (black, plastic 6 mm) screw that secures the front of the Cyan LED Holder.

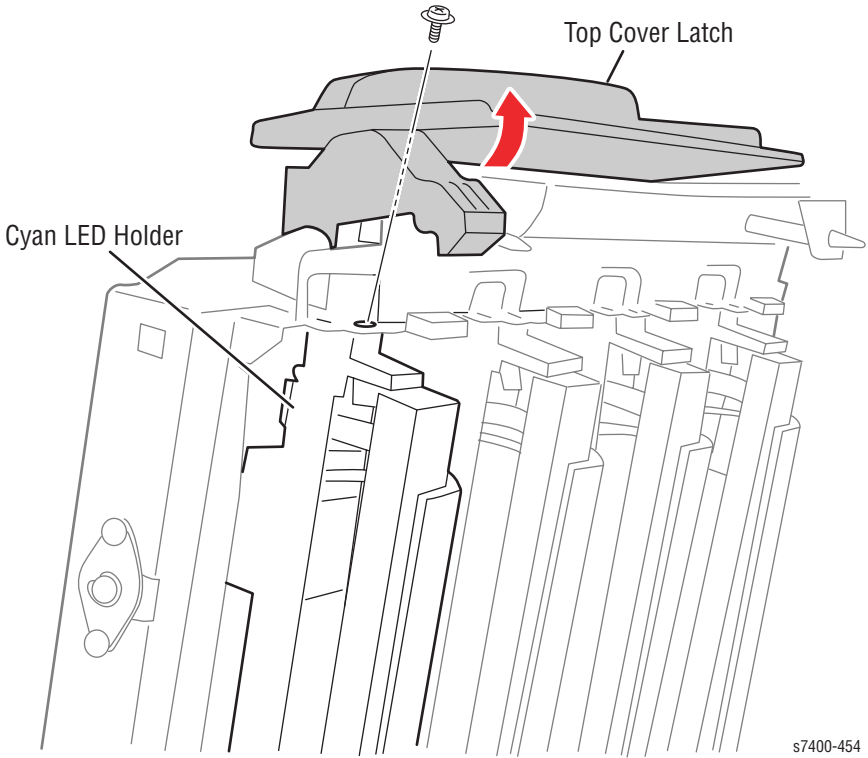

s7400-454



7. Move the Cyan LED Holder to the right to allow sufficient clearance to remove the duct from the LED Assembly.

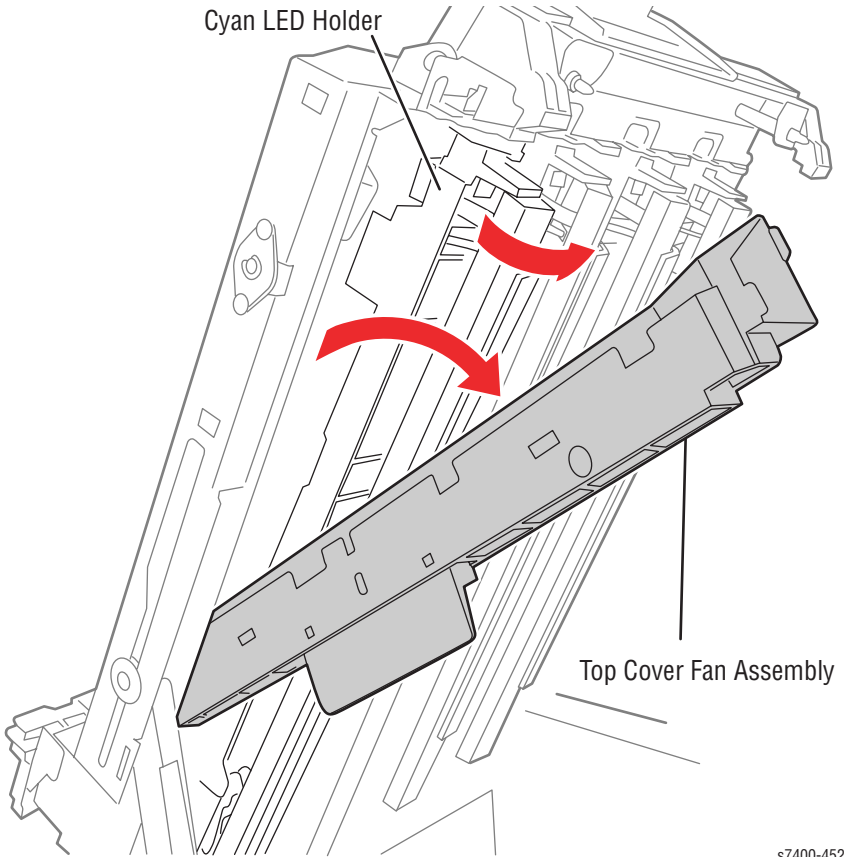

s7400-452

8. Release 2 hooks that secure the diffuser to the duct.

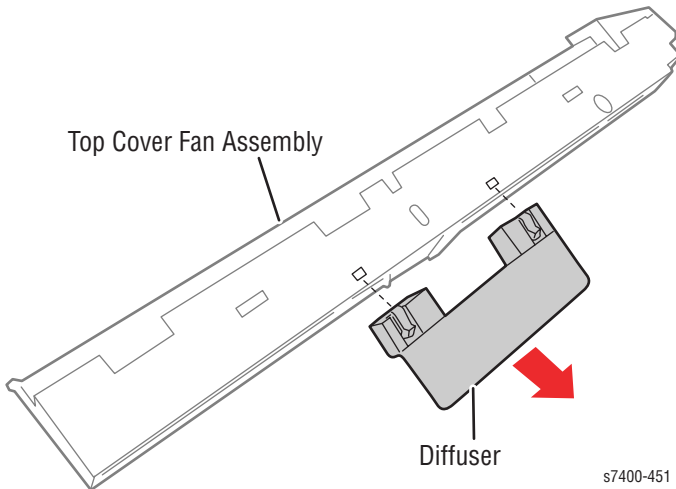

s7400-451

9. Release the fan wiring from the guides in the duct.
10. Release 1 tab that secures the Top Cover Fan to the duct.

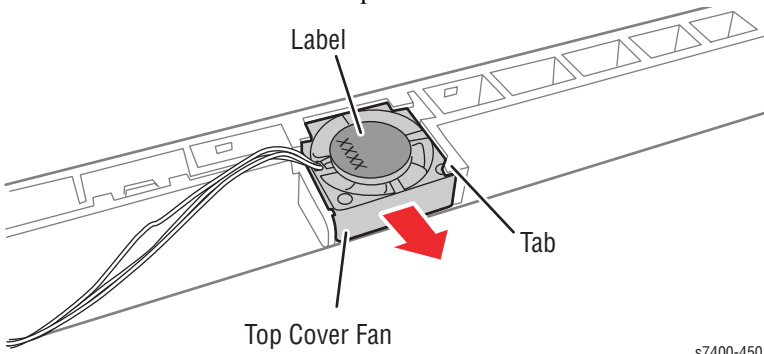

s7400-450

11. Disconnect the Top Cover Fan connector (P/J482) on the LED Relay Board cover.

### Replacement Note

Route the fan wiring through the opening in the Cyan LED Holder and lace the wiring back into the guides provided in the duct. Also, install the fan with the label facing towards the Transfer Unit.

## IP Fan

1. Open the Rear Cover.
2. Remove the Image Processor Board (page 8-113).
3. Remove 1 (metal, 18 mm) screw that secures the IP Fan to the Card Cage.

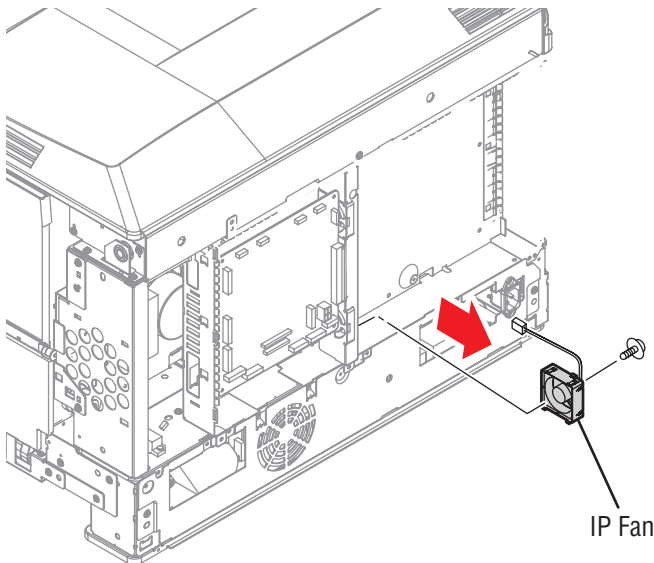

s7400-721

# Paper Size Switch

1. Remove the Tray.
2. Open the Top Cover.
3. Remove the Right Rear Cover (page 8-15).
4. Remove the Card Cage Fan Duct (page 8-114).
5. Remove the LVPS enclosure (page 8-121).
6. Release the 2 hooks that secure the Paper Size Switch Holder to the frame. The four springs are attached to the holder.

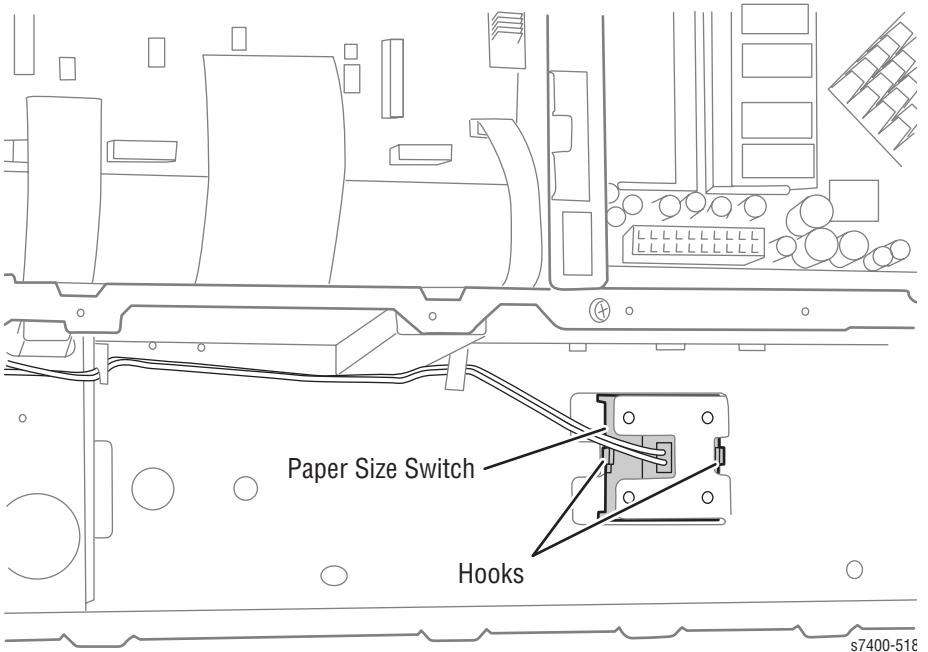

7. Disconnect the Paper Size Switch from the Motor Driver Board PSIZE connector.
8. Release the size switch harness from the 2 cable clamps, and then carefully draw the harness into the tray cavity.
9. Remove the Paper Size Switch and holder from the front of the tray cavity.

10. Release the 2 hooks that secure the Paper Size Switch to the holder.

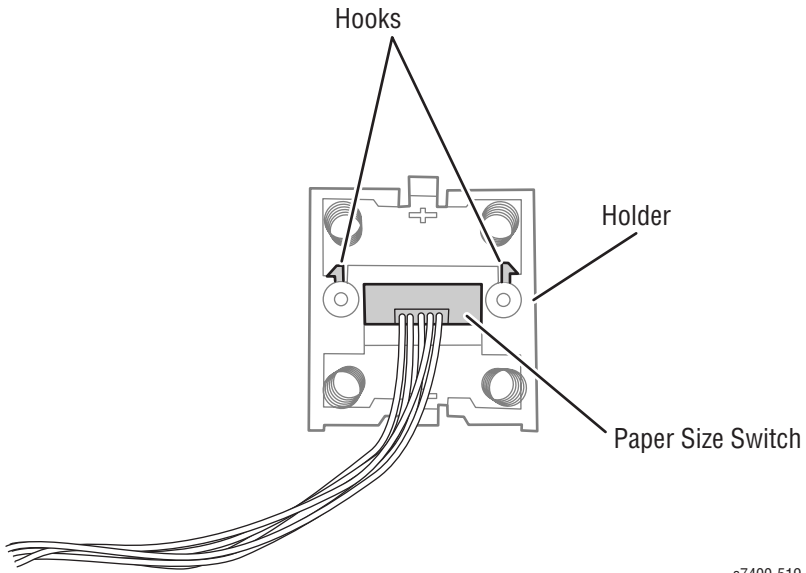

s7400-519

### Replacement Note

After replacement, check that the switch is aligned as shown.

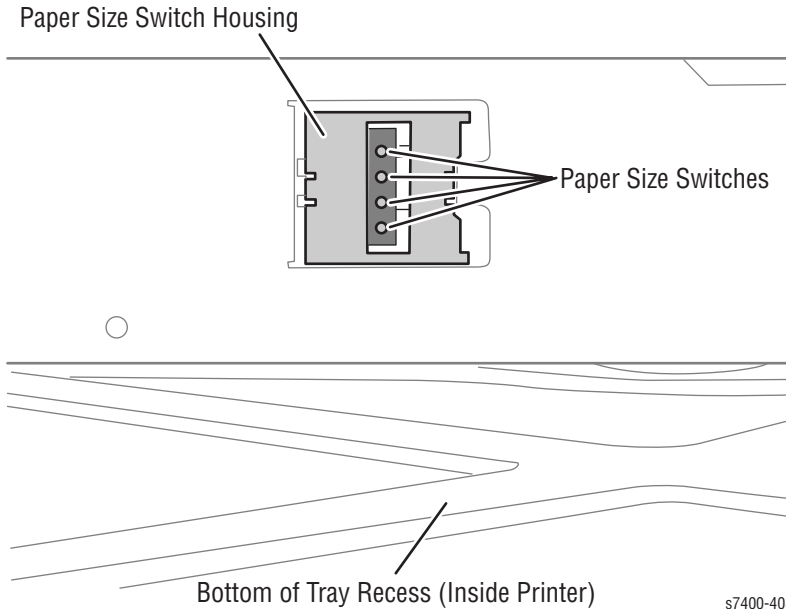

s7400-408

# Motor Driver Board

1. Remove the Rear Cover (page 8-13).
2. Remove the Right Rear Cover (page 8-15).
3. Remove the Card Cage Fan Duct (page 8-114).
4. Remove the Card Cage (page 8-117).
5. Remove 2 (metal, 6 mm) screws that secures the Magenta Imaging Unit Motor.
6. Remove 2 (metal, 6 mm) screws that secures the Yellow Imaging Unit Motor.
7. Remove the DC1 (Yellow) and DC2 (Magenta) connections from the Motor Driver Board.
8. Remove the remaining connections from the Motor Driver Board.

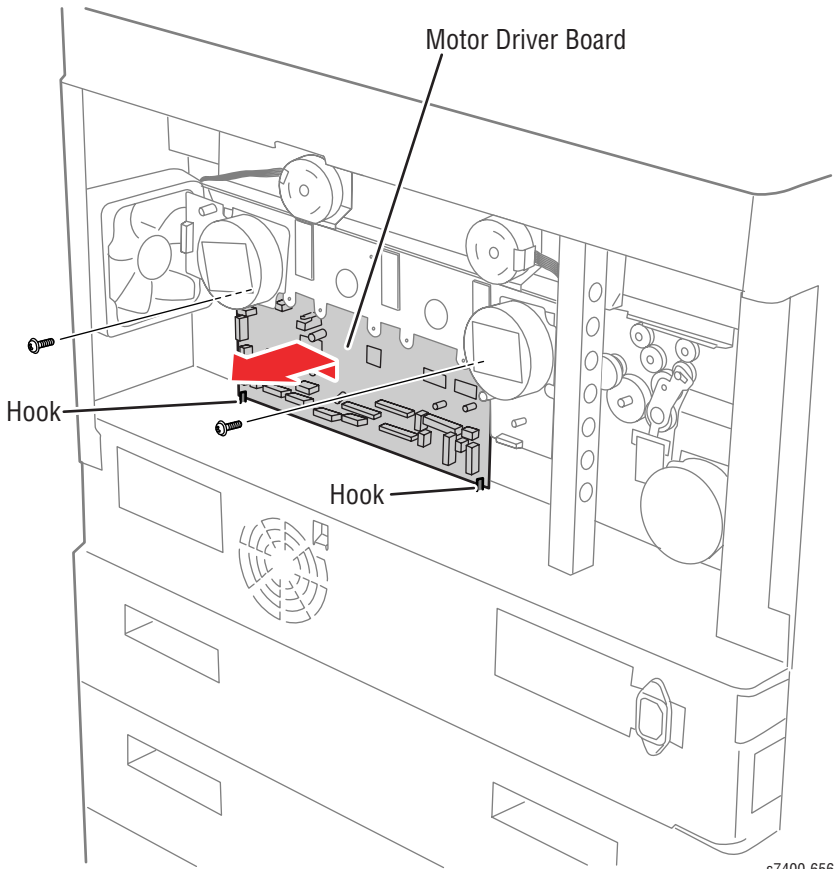

s7400-656

9. Remove 2 (metal, 6 mm) screws at the top of the Motor Driver Board.
10. Lift the board slightly to release it from the hooks along the lower edge.
11. Remove the Motor Driver Board.

# Imaging Unit Sensor Board

The Imaging Unit Sensor Board is held in the Toner Supply Housing. Remove the housing to facilitate replacement of the board.

## Note

A non-captive spring is installed in the Toner Supply Housing just below the Cyan contacts. Removal of the Toner Supply Housing allows this spring to fall from its hole.

1. Remove the Rear Cover (page 8-13).
2. Remove the Right Rear Cover (page 8-15).
3. Remove the Card Cage Fan Duct (page 8-114).
4. Remove the Card Cage (page 8-117).
5. Remove the Black Imaging Unit Motor (page 8-105).
6. Release the 2 Toner Motors (page 8-104) from their mounts.
7. Release the Lift Uplink Sensor from the holder next to the Card Cage Fan.
8. Remove 1 (metal, 6 mm) screw on each of the 4 Imaging Unit Drum Phase Sensors and release the sensors from their retainers.

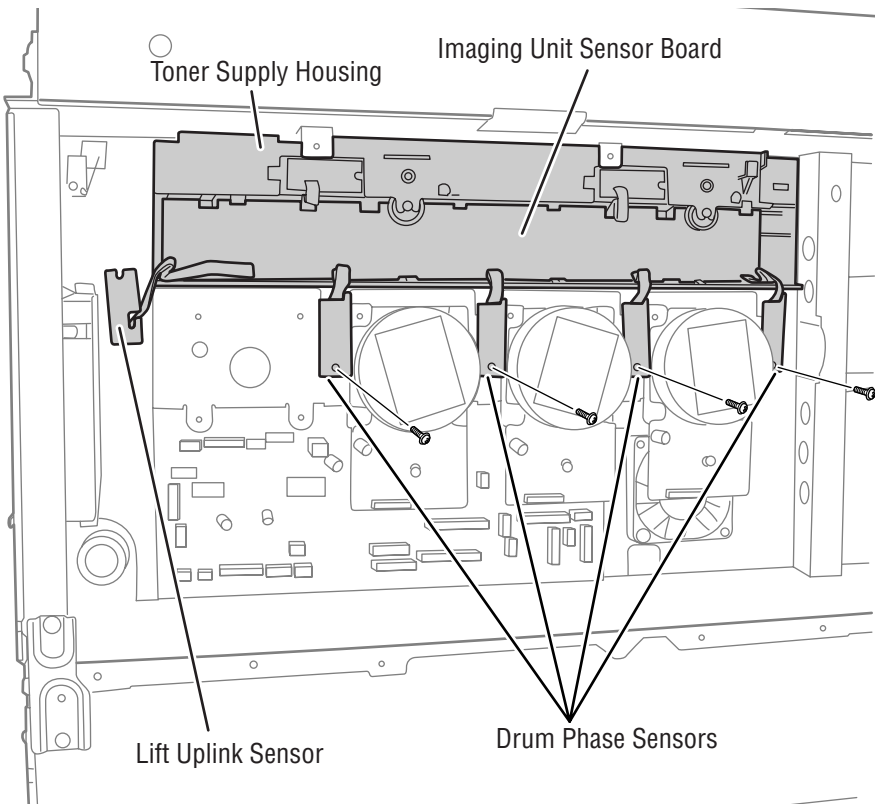

9. Release the wiring from the guide above the Cyan Imaging Motor.
10. Disconnect the Fan connector from the right side of the board.
11. Position the Toner Supply Cams so they are flush with the openings in the frame.
12. Shift the Toner Supply Housing to the left, when viewed from the front, to release the 4 hooks located next to the grounding contacts.
13. Release the 4 hooks located along the top edge of the housing, and then remove the housing.

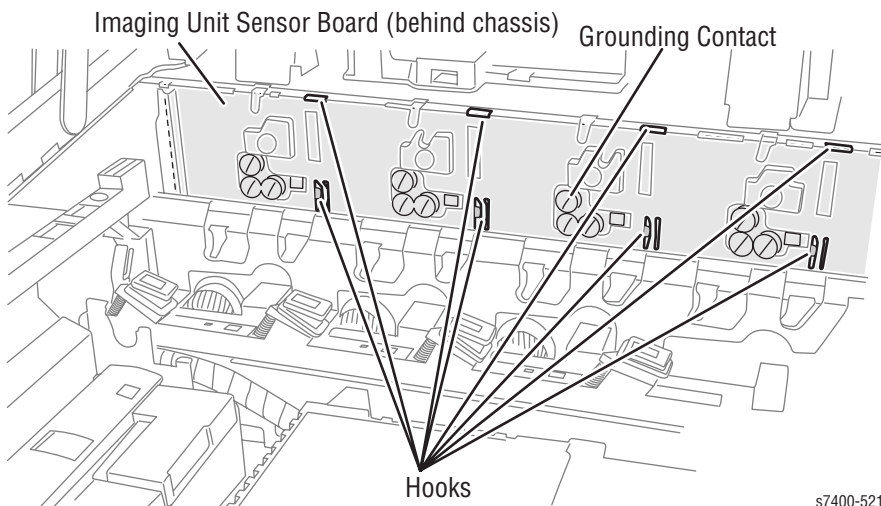

s7400-521

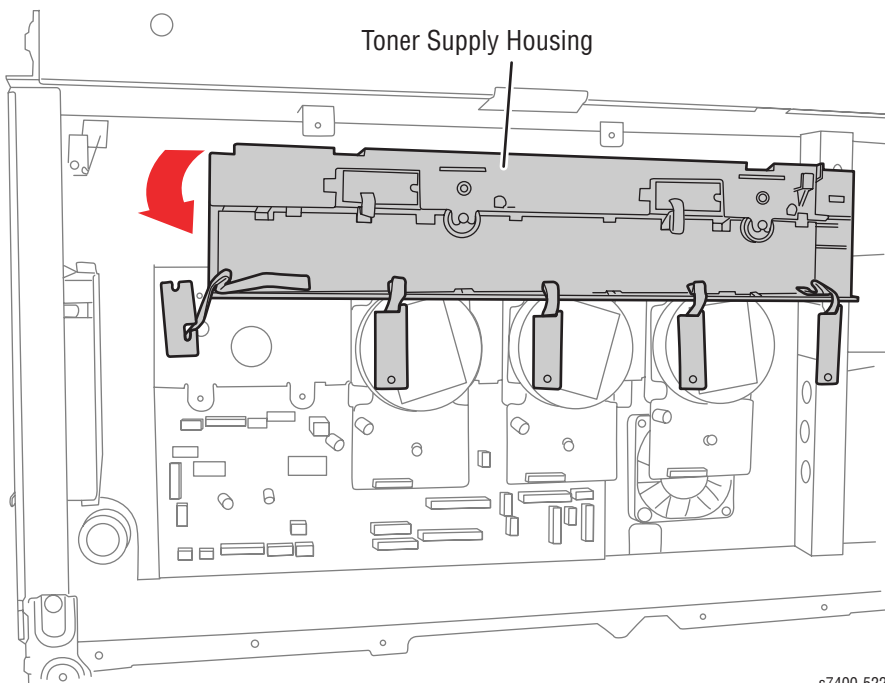

s7400-522

14. Release the 4 tabs along the bottom edge of the board.
15. Lift the lower edge out, and then slide the upper edge from underneath the tabs to remove the Imaging Unit Sensor Board from the housing.

### Replacement Note

Three springs provide contact between the Imaging Unit Sensor Board and each Imaging Unit (12 total). These springs are captured in the housing by the board. When installing the board into the housing, make sure these contact springs are positioned correctly.

## Toner Supply Camshaft

The Toner Supply Camshafts are mounted in the Toner Supply Housing.

1. Follow the Imaging Unit Sensor Board removal procedures (page 8-142) through Step 13 to remove the Toner Supply Housing from the printer.
2. Remove the camshaft by releasing it from the Toner Supply Housing.

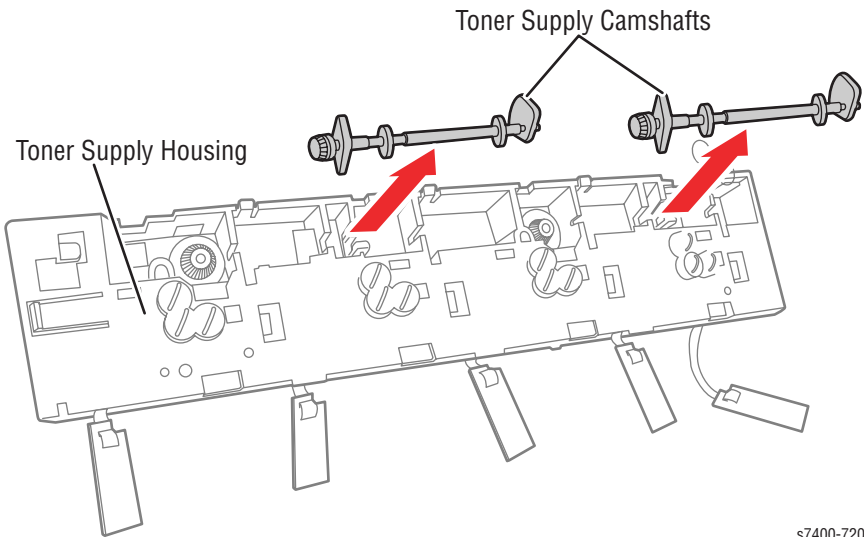



# Imaging Unit Motor Mounting Plate

1. Remove the Motor Driver Board (page 8-141).
2. Remove the YK and CM Toner Motors (page 8-104).
3. Remove the Imaging Unit Sensor Board (page 8-142).
4. Remove the 4 screws that secure the 4 Imaging Unit Drive Gears.
5. Remove the 2 screws that secure the plate to the frame.

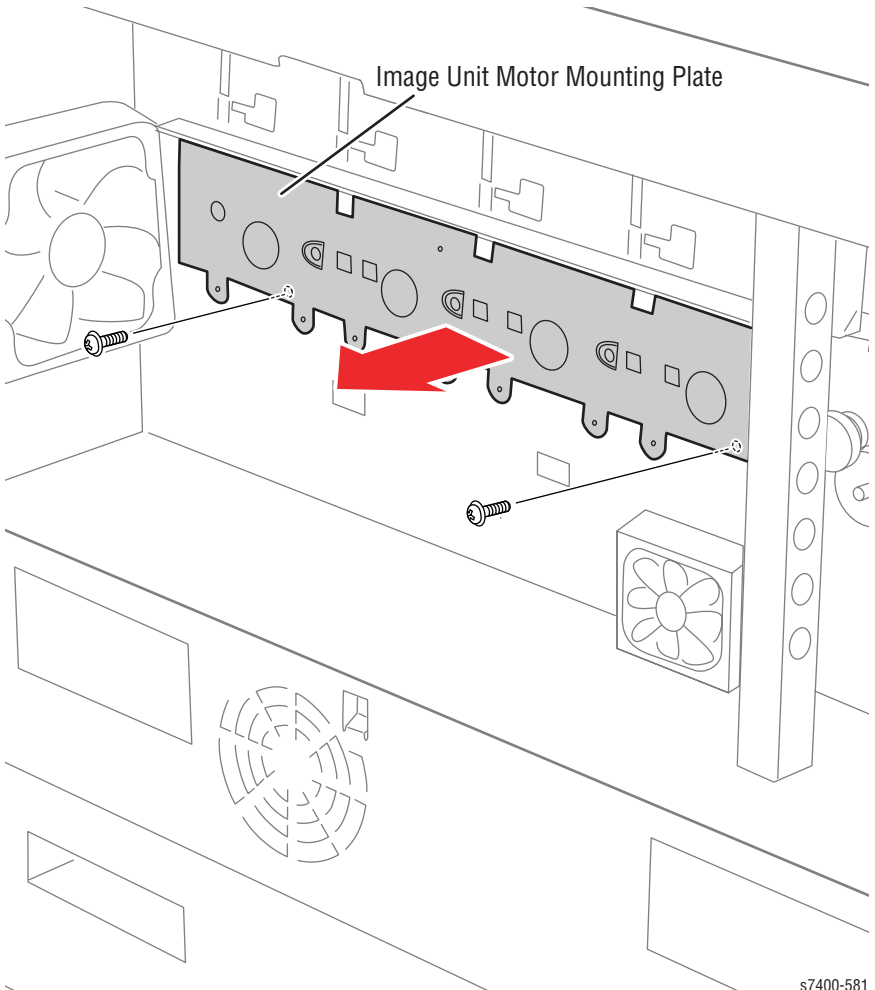

s7400-581

# CRUM Reader Board

1. Remove the Top Cover (page 8-24).
2. Disconnect the ribbon cable CN1 from the CRUM Reader Board.
3. Disconnect the 4 CRUM Antenna connectors CN2, CN3, CN4, and CN5 from the CRUM Reader Board.
4. Remove the 2 (metal, 6 mm) screws that secure the CRUM Reader Board Cover to the top of the LED Assembly.
5. Flip the cover over, and then remove the 2 (metal, 6 mm) screws that secure the CRUM Reader Board to the cover.

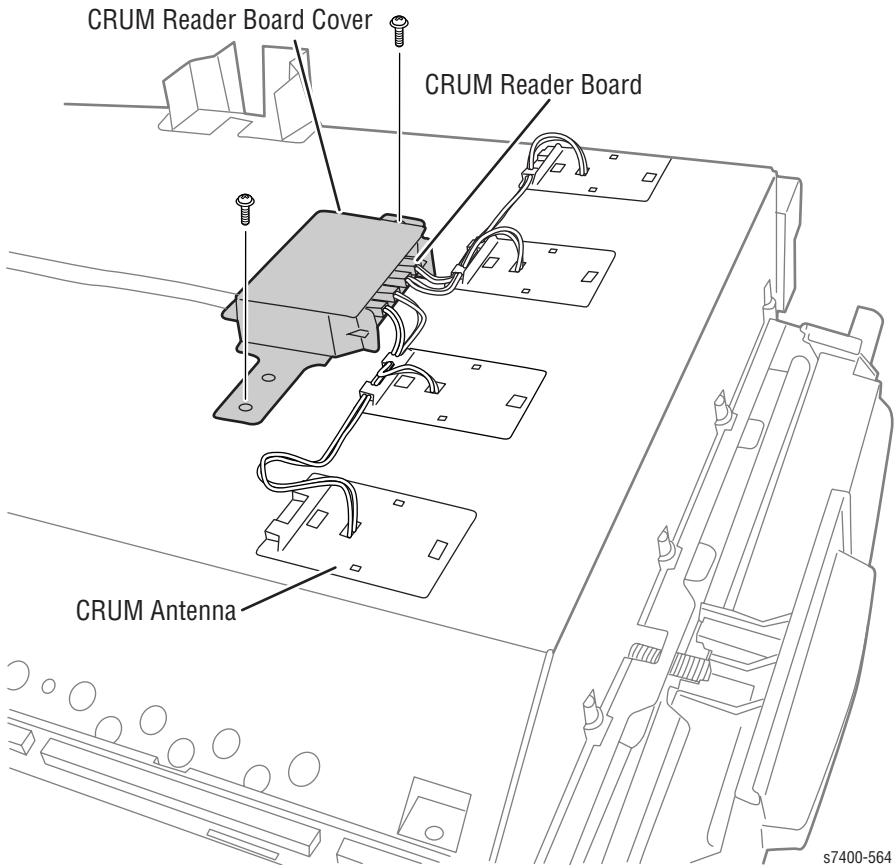

# CRUM Antenna

1. Remove the Top Cover (page 8-24).
2. Disconnect the affected CRUM Antenna connector CN2 [K], CN3 [Y], CN4 [M], and CN5 [C] from the CRUM Reader Board.
3. Release the 2 hooks that secure the antenna to the LED Assembly by reaching between the LED Heads and squeezing the antenna hooks.

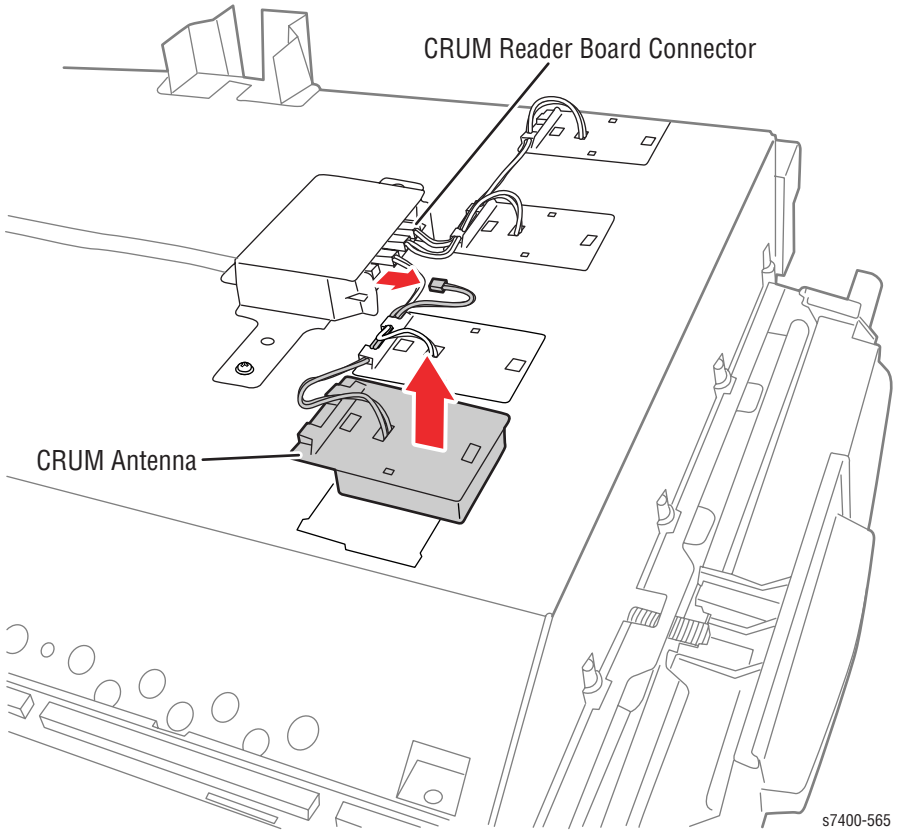

# Registration Sensor Board

The Registration Sensor Board includes the Front Color Registration Sensor attached by a ribbon cable, the Rear Color Registration Sensor integrated onto the board, the interface for the ADC Sensor, and the Transfer Unit Belt Slack Sensor. Replacement of either Color Registration Sensor requires replacement of the board.

## Note

The Color Registration Sensors are protected from the Transfer Unit belt by small, transparent covers. These covers are held in place by a hook and the presence of the sensor. Use care not to loose these sensor covers.

1. Remove the Registration Sensor Assembly (page 8-80).
2. Turn the assembly over and remove the 2 (metal, 6 mm) screws that secure both parts of the board.
3. Remove the Registration Shutter Solenoid (page 8-81).
4. Disconnect the connectors on the Registration Sensor Board.
5. Slide the ribbon cable connected to the Front Color Registration Sensor out from under the retainers and remove the board.

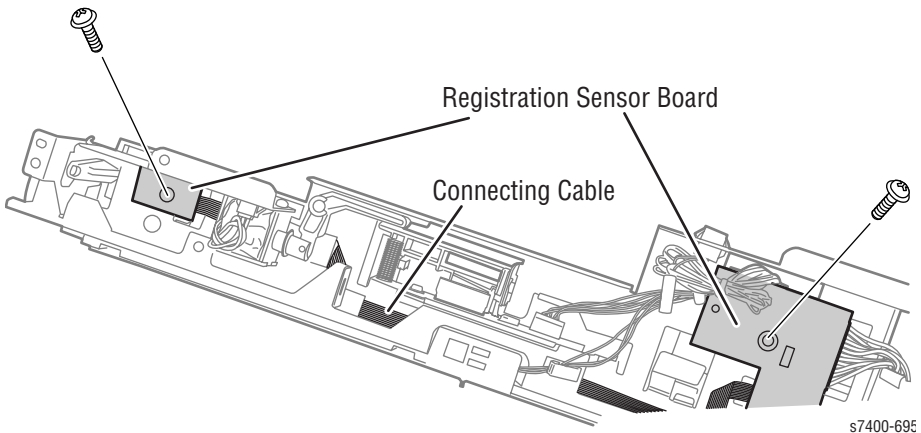

# Fuser Fan

1. Open the Top Cover.
2. Remove the 1 (black, 10 mm) screw that secures the Upper Fuser Fan Duct to the Top Output Chute.
3. Remove the 1 (metal, 6 mm) screw that secures the Lower Fuser Fan Duct to the frame.
4. Disconnect the connector (P/J250) at the top of the frame and remove the Fan and Duct from the printer.

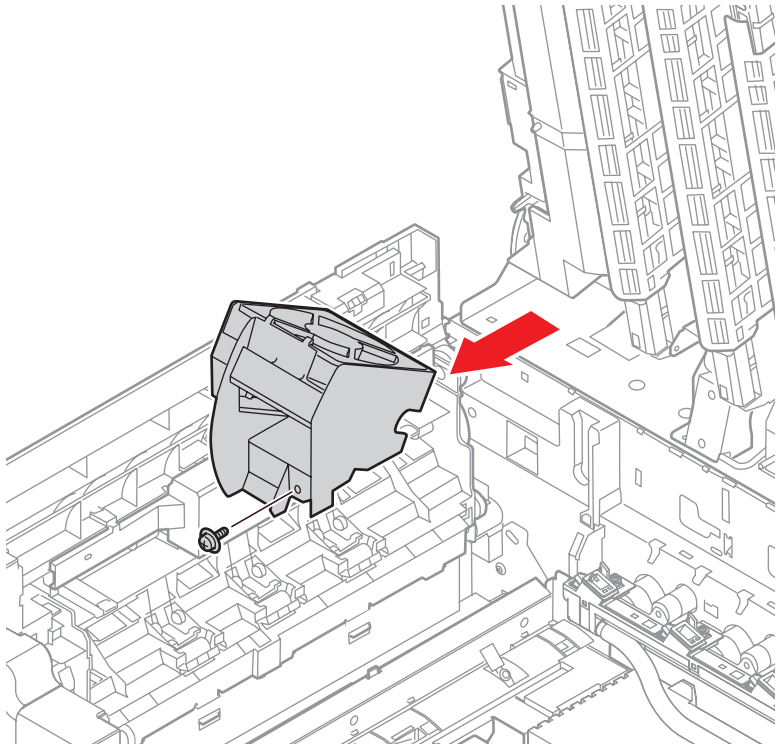

s7400-190

5. Release the 4 hooks that secure the fan to the duct.

# Front Sensor Board

The Front Sensor Board is located behind the Front Sensor Board Cover inside the Registration Assembly.

## Note

A spring is used to maintain tension against the retention hooks. This spring is not captive to either the board or Registration Assembly. Use care not to loose this spring when removing the board.

1. Remove the Registration Assembly (page 8-84).
2. Disconnect 3 (ENV, PATHICK, and MPTHOME) connectors from the board.
3. Move the Registration Sensor #1 and Transfer Unit Entrance Sensor Actuators to allow clearance, and then release the 3 hooks that secure the board to the assembly.

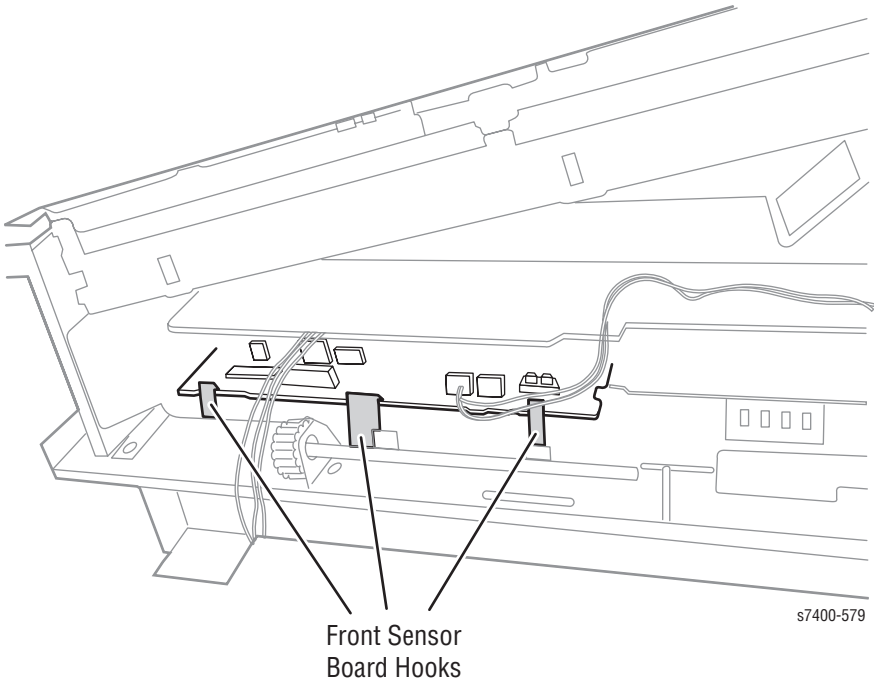

## Replacement Note

Use a piece of non-conductive tape to retain the spring while replacing the board. Remove the tape just prior to snapping the board into the hooks.

Make sure the Transfer Unit Entrance Sensor Actuator rests on the correct side of the lower Registration Roller.

# Rear Sensor Board

The Rear Sensor Board is located underneath the Rear Sensor Board Cover on the Exit Assembly.

1. Open the Top Cover.
2. Release the 6 hooks and 3 tabs that secure the Rear Sensor Board Cover.

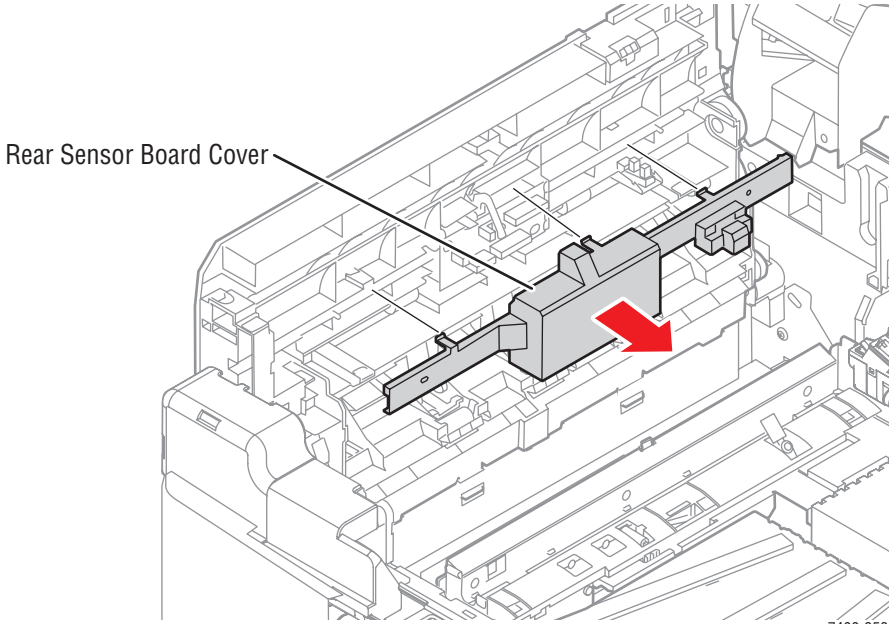

- 3.** Disconnect the 4 connectors on the board.

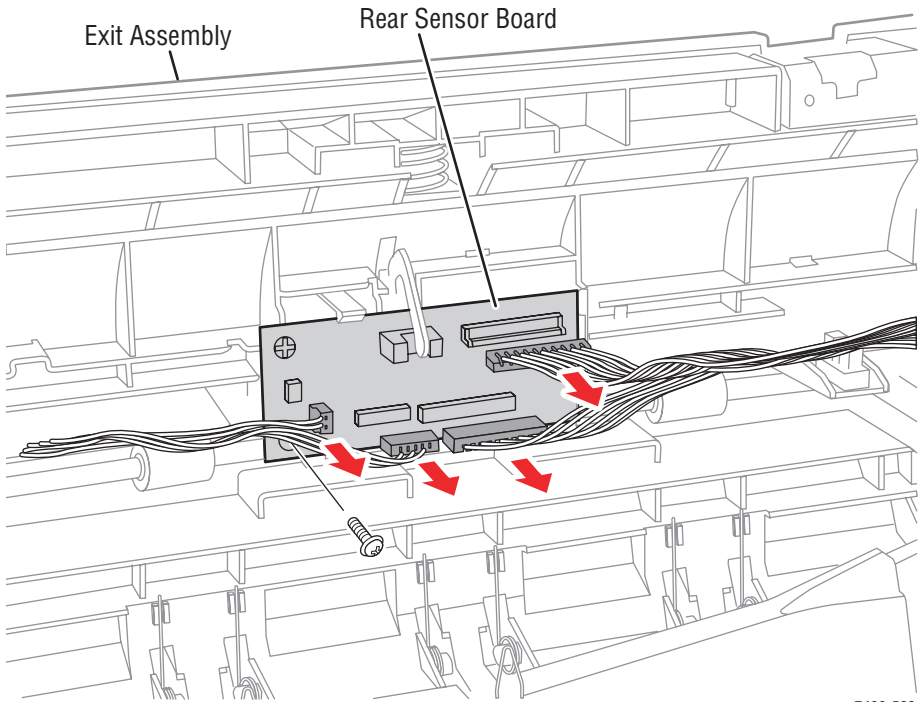

s7400-583

- 4.** Remove 1 (black, plastic 6 mm) screw that secures the board to the Exit Assembly.



# Parts List

## In this chapter...

Parts List 1.1 Main Assembly.....	534
Parts List 2.1 Printer.....	538
Parts List 3.1 LVPS.....	544
Parts List 4.1 Base Assembly.....	546
Parts List 4.2 Feeder Assembly.....	548
Parts List 5.1 Xerographics Drive.....	552
Parts List 6.1 Front Assemblies.....	556
Parts List 7.1 Waste Toner Drive Assembly.....	558
Parts List 8.1 Registration Assembly.....	560
Parts List 9.1 Registration Sensor Assembly.....	564
Parts List 10.1 Tray 1 (MPT) Assembly.....	566
Parts List 11.1 Exit Assembly.....	570
Parts List 12.1 LED Assembly.....	574
Parts List 13.1 Job Offset Assembly.....	577
Parts List 14.1 Basket Assembly.....	579
Parts List 15.1 Duplex Unit.....	583
Xerox Supplies and Accessories.....	587

## Section

# 9



# Serial Number Format

Changes to Xerox products are made to accommodate improved components as they become available. As improvements are made, part numbers may change from those appearing in this section. To get the latest part, provide the following information when ordering:

- Component's part number
- Product type or configuration number
- Serial number of the printer

## The serial number is coded as follows:

- The text “S/N” followed by the serial number in the barcode.
- The barcode **does not** include a field identifier.
- The nine digit serial number format **PPPRSSSSS** where:

**PPP** - Is the alphanumeric Product Code

Product	Configuration	Voltage	Product Code
7400	N, DN, DT, DX, DXF	110 V	WMY
7400V	N, DN, DT, DX, DXF	220 V	WNC

**R** - Is the numeric revision digit. Changes at major product updates or when the serial number is reset to a starting value of 30001, 60001, or 95001 for 7400, and 30001, or 50001 for 7400V.

**SSSSS** - Is the five digit numeric serial number.

## For example:

**S/N WMY453072**

**WMY** = Product code for the 7400, 110 V Printer

**4** = Revision level

**53072** = Serial number for 7400 N

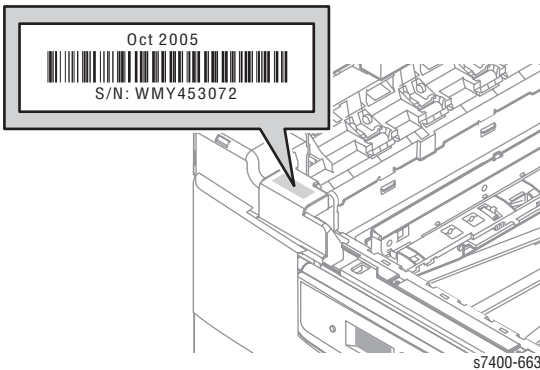

# Using the Parts List

Only those parts listed with part numbers are available for order. Parts listed without part numbers are only available as part of a parent assembly or Service Kit.

1. **No.:** The callout number from the exploded part diagram.
2. **Part Number:** The material part number used to order specific parts.
3. **Name/Description:** Name of the part and number supplied per order.
4. Parts throughout this manual are referenced **PL#.#.#**; For example, PL3.1.10 means the part is item 10 of Parts List 3.1.
5. A black triangle preceding a number followed by a parenthetical statement indicates the item is a parent assembly, made up of the parts listed in parentheses and enclosed by a dashed line.
6. The notation “**(with X~Y)**” following a part name indicates an assembly includes components X through Y. For example, “1 (with 2~4)” means part 1 consists of parts 2, 3, and 4.
7. The notation “**J1<>J2 and P2**” is attached to a wire harness. It indicates that connector Jack 1 is attached to one end of the wire harness and connector J2 is attached to the other end that is plugged into P2.

# Print Engine Parts

## Parts List 1.1 Main Assembly

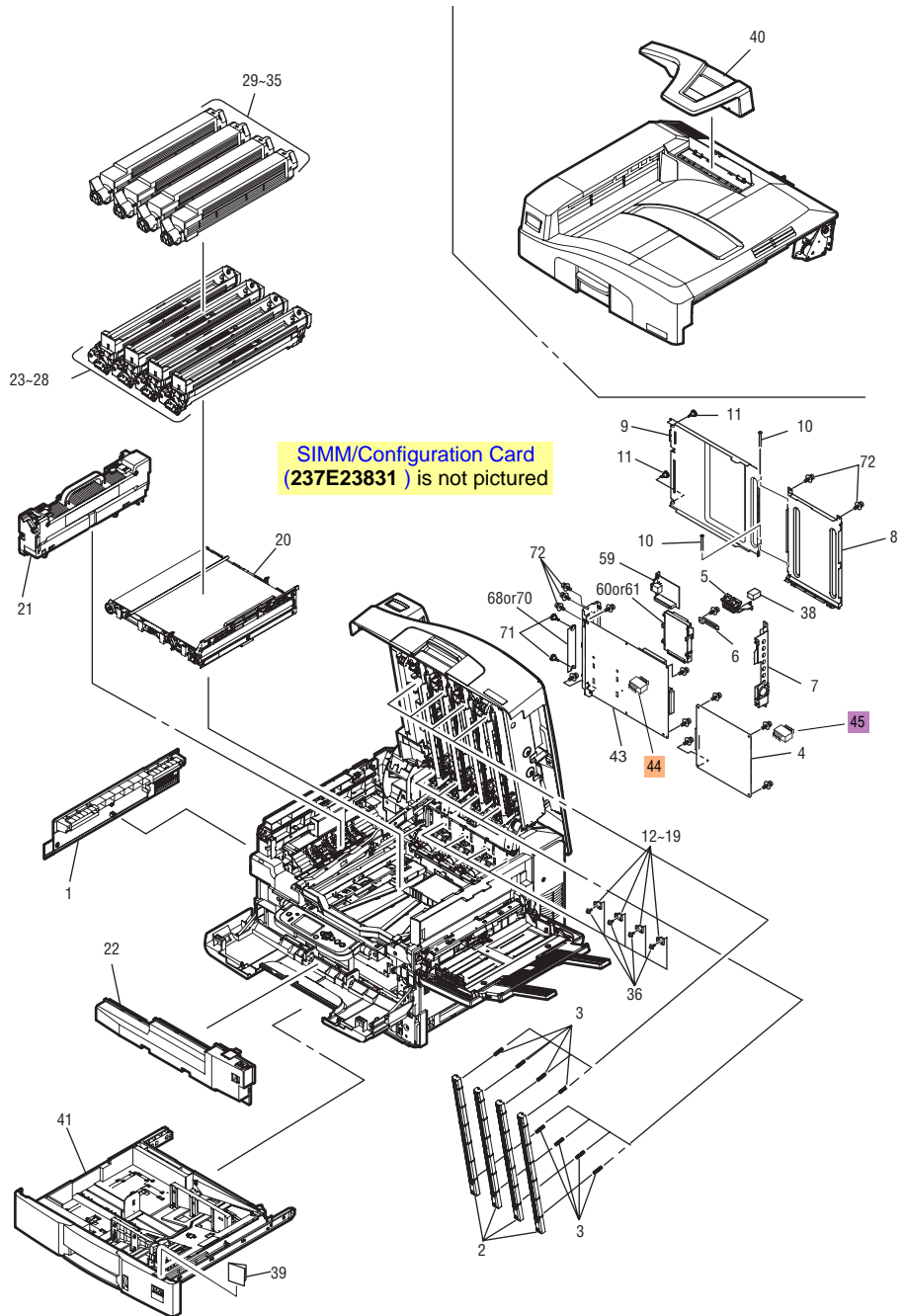

## Parts List 1.1 Main Assembly- Service Parts List

No.	Part Number	Name/Description
1.	802E99390	Cover-Blank (Dup)
2.	107K02330	LED Head-Unit-53MXF
3.	809E77450	Spring-Head
4.	960K27532	OR-S2V (Engine Control Board)
5.	114K01930	Code-Clump (Cable Clamp, Card Cage)
6.		Plate-Clump-HCB (Cable Clamp Retainer)
7.	815E34450	Plate-Beam
8.	815E33950	Plate-Shield
9.	815E33960	Plate-Cover
10.		Shaft-Shield
11.	003E77740	Screw-Knob
12.	032E29850	Block-Lockout-723
13.	032E29860	Block-Lockout-723-2
14.		Block-Lockout-723-3
15.		Block-Lockout-723-4
16.		Block-Lockout-723-5
17.		Block-Lockout-723-6
18.	014E61250	Block-Lockout-723-9
19.	032E29870	Block-Lockout-723-10
20.		Transfer Unit {See Supplies and Accesories (page 9-58)}
21.		Fuser 110 V {See Supplies and Accesories (page 9-58)} Fuser 220 V
22.		Waste Toner Reservoir {See Supplies and Accesories (page 9-58)}
23.		Imaging Unit Type C7 C {See Supplies and Accesories (page 9-58)}
24.		Imaging Unit Type C7 M {See Supplies and Accesories (page 9-58)}
25.		Imaging Unit Type C7 Y {See Supplies and Accesories (page 9-58)}
26.		Imaging Unit Type C7 K {See Supplies and Accesories (page 9-58)}
29.		Toner-Cart Type C7 Y{See Supplies and Accesories (page 9-58)}
30.		Toner-Cart Type C7 M{See Supplies and Accesories (page 9-58)}
31.		Toner-Cart Type C7 C{See Supplies and Accesories (page 9-58)}
32.		Toner-Cart Type C7 K{See Supplies and Accesories (page 9-58)}
36.		Cup_Screw (S Tight M3)

## Parts List 1.1 Main Assembly- Service Parts List

No.	Part Number	Name/Description
37.		Cup_Screw A
38.	835E10830	Gasket-HCB
39.		Indicator-Paper-Size(OKI)
40.	003E77960	Stopper-Paper
41.	802K93850	Case-Cassette-Assy. (Universal Tray)
42.	237E23831	SIMM/Configuration Card (not pictured)
43.	671537283	IP Board (without Memory or Configuration Card)
44.	237E23660	EEPROM(CU) (Image Processor Board EEPROM)
45.	537E66620	EEPROM(CU), (Engine Control Board EEPROM)
46.		BIOSROM
47.		BT100
48.		Board-OWF
49.		Board-OWF
50.		Board-HMY
51.		Board-HMY
52.		Board-HMY
53.		Board-Memory 128MB
54.	856000300	Board-Memory 256MB
55.	856000400	Board-Memory 512MB
61.	121K44690	HDD Assy 20GB (Hard Drive)
62.		Compact Flash
63.		Nylon Stud
64.		Plate-Interface Caulking
65.		Plate-Interface Caulking
66.		Guide-Rail
67.		Plate-Support-PCI
68.		Plate-Blank
69.		Plate-Blank-N
70.		Plate-Blank-W
71.	003E77740	Screw-Knob
72.		Cup_Screw (S Tight M3)
73.		Screw

## Parts List 1.1 Main Assembly- Service Parts List

No.	Part Number	Name/Description
74.	127E15360	Motor-Fan(CU) (IP Fan)
75.		Motor-Fan(CU)
76.		Motor-Fan(CU)
77.		Bracket-Fan-CU1
78.		Bracket-Fan-CU2
79.		Screw-PSW3
80.		Gasket-Interface-A
81.		Gasket-Interface-B
82.		Connector Cover
83.		EEPROM(CU)
84.		Board-BYN
85.		0494 001NR
86.		TFC-20/TFT-102010N (Core of LAN cable)





## Parts List 2.1 Printer - Service Parts List

No.	Part Number	Name/Description
1.	032K04400	Cover-Guide-1st-Assy (Door B)
2.		Guide-Paper
3.		Plate-Stay-A
4.		Plate-Stay-B
5.		Plate-Support-A
6.		Plate-Support-B-Assy
7.		Plate-Support-C
8.	127E15200	Motor-DC (Imaging Unit Motor [CMYK])
9.	127E15190	Motor-DC (Fuser Motor)
10.	960K34910	OR-S2M (Motor Driver Board)
11.		CONN Cord-HIROSE6P-H2P,H4P
12.		CONN Cord-JST2P-JST2P
13.		CONN Cord-AMP11P-AMP11P
14.		CONN Cord-AMP4P-AMP4P
15.		CONN Cord-JST5P-JST4P
16.		TW-VF-16-0.1X0.8-420 CONN PAR- -
17.		SMCD-40-160BD(1.0) CONN PAR- -
18.		SMCD-30-160BD(1.0) CONN PAR- -
19.		Film-Guide FFC
20.		Shaft-LiftUp
21.		Bush
22.	115K02510	Planet Assy.-F
23.		Frame-Holder
24.		Plate-HV-Base
25.	068K46570	Bracket-HV-Assy (Housing Bias Assembly)
26.	105K29311	PWR unit-(HIGH VOLTAGE) (HVPS)
27.	802K93920	Cover-HV- Assy (with 28-32) (HVPS Cover)
28.		Cover-HV
29.		Contact-TR
30.		Cover-Contact-TR
31.		Spring-Fuse-Belt

## Parts List 2.1 Printer - Service Parts List

No.	Part Number	Name/Description
32.		TappingScrew-B2 L=8
33.		Plate-Heat
34.		Clamp-Cable
35.		Stad-Shoulder
36.	<a href="#">See Sensor Kit</a>	Photo-Interrupter (Fuser Release Sensor)
37.		Cover-Cable-Heat A
38.	605K54480	Fuser Power Harness (not pictured)
39.		CONN Cord-JST12P-JST6P,JST7P (FSRSNR Harness)
40.		Plate-Guide-ID
41.	054K37700	Gear-Duct-ID- Assy (with 42~50)
42.		Bracket-D-Caulking
43.		Gear-Bevel
44.		Gear-Idle-D
45.		Bracket-B-Caulking
46.		Gear-Idle
47.		Holder-Hall-Duct (Waste Toner Auger Rotation Sensor Holder)
48.		Ring
49.		Ring
50.		Cup_Screw (S Tight M3)
51.		Guide-Tube-L (Auger Tube Guide)
52.	007K14061	Duct-Gear-Assy (with 53 -60) (Waste Toner Auger Assembly)
53.		Duct- Assy.-Toner
54.		Plate-BKT-Duct A Caulking
55.		Plate-BKT-Duct B
56.		Gear-Reduction-Tube
57.		Gear-Idle-BBD
58.		Gear-Idle-D
59.		Gear-WT-Z20-Z21
60.		Cup_Screw (S Tight M3)
61.	015K77480	Plate Assy.-MPT Lock (Door A Latch Assy)
86.	023E30870	Motor-Pulse-Belt (Transfer Unit Motor)
87.		Gear-Idle-Belt

## Parts List 2.1 Printer - Service Parts List

No.	Part Number	Name/Description
88.		Holder-ANT
89.		Spring-ANT
90.		Bracket-ANT
91.		Cover-ANT
92.		RFID read witer system (CRUM Reader Board)
93.		SMCD-9-560BD(1.0) CONN PAR (RFID harness)
94.		Plate-Shield-RFID (CRUM Reader Board Cover)
95.	802K93870	Cover Assy.-Top(Sub) (Top Output Chute)
96.		Cover-Duct(L)
97.		Plate-Shaft-Base
98.		Code-Guide
99.		Plate-Damper-TCL-Caulking
100.		Damper-L
101.		Plate-Damper-TCL-SUB
102.		Plate-Damper-TCR-Caulking
103.		Damper-R
104.		Plate-Damper-TCR-SUB
105.		Spring-Torsion-Top-L
106.		Spring-Torsion-Top-R
107.		Shaft-Top
108.		Plate-Support(Top)
109.		Collar
110.		Frame-Duct (Fuser Fan Duct)
111.	127E15170	Motor-Fan (Fuser Fan)
112.		Gear-BKL2 (included in Gear Kit)
113.		Gear-BKR2 (included in Gear Kit)
114.		Spring-Torsion-BAS-L
115.		Spring-Torsion-BAS-R
116.	055K36690	Plate-Shield-Box- Assy. (Card Cage)
117.		Holder-Duct-FAN-PCB
118.	127E15170	Motor-Fan (Card Cage Fan)
119.		DUCT-FAN-PCB (Card Cage Fan Duct)

## Parts List 2.1 Printer - Service Parts List

No.	Part Number	Name/Description
120.	802K95170	Cover Assy.-Top
121.		Spring-Comp(Joboff)
122.		Cover-Duct (R)
123.	802K93890	Cover Assy.-Front (Front Door)
124.	802K93900	Cover Assy.-FU (Side Output Tray)
125.		Cover-Guard (L) (Left Front Cover)
126.		Cover-Guard(Front) (Upper Front Cover)
127.		Cover-Side(L) (Left Side Cover)
128.		Cover-Side(L)Rear (Left Rear Cover)
129.		Cover-Side(R) (Right Side Cover)
130.		Cover-Side(R)Rear (Right Rear Cover)
131.		Cover-Rear (Lower Rear Cover)
132.	848K06331	Cover Assy.-OP Panel
133.		Film-FG
134.		TW-VF-6-0.1X0.8-930 CONN PAR- -
135.		Guard-R (Basket Assembly Right Support Rail Cover)
136.		Cup_Screw (S Tight M3)
137.		Cup_Screw A
138.		TappingScrew-B2 L=8
139.		Stay-Rear-MPT (Rear Door A Hinge)
140.		Ring
141.		Ring
142.		SMCD-20-370-AD-P1.0 CONN PAR- -
143.		CONN Cord-AMP10P-AMP9P
144.		292254-9 Connector-Plug-
145.		CONN Cord-JST3P-JST3P
146.		Not pictured
147.	056E05420	Control Panel Bezel
148.		Limiter-Screw
149.		Cover-Cable-Heat B
150.		Guide-Cable_CU
151.		Clamp-Cable

## Parts List 2.1 Printer - Service Parts List

No.	Part Number	Name/Description
152.		Clamp-Cable
153.		Cover-Middle (Waste Toner Motor Cover)
154.		Shaft-Cover
155.		Cover-Sensor(S2S) (Front Sensor Board Cover)
156.		Plate-Support (Feeder Brace)
157.		Cup_Screw A
158.		Limiter-Screw
159.		Code-Guide-Receive
160.		Plate-FG-Rear
161.		Spring-Torsion-FG
162.		Plate-Holder-Detent-L
163.		Plate-Holder-Detent-R
164.		Lever-Detent
165.		Spring-Detent
166.		Post-Detent
167.		Plate-FG-T-Shaft

# Parts List 3.1 LVPS

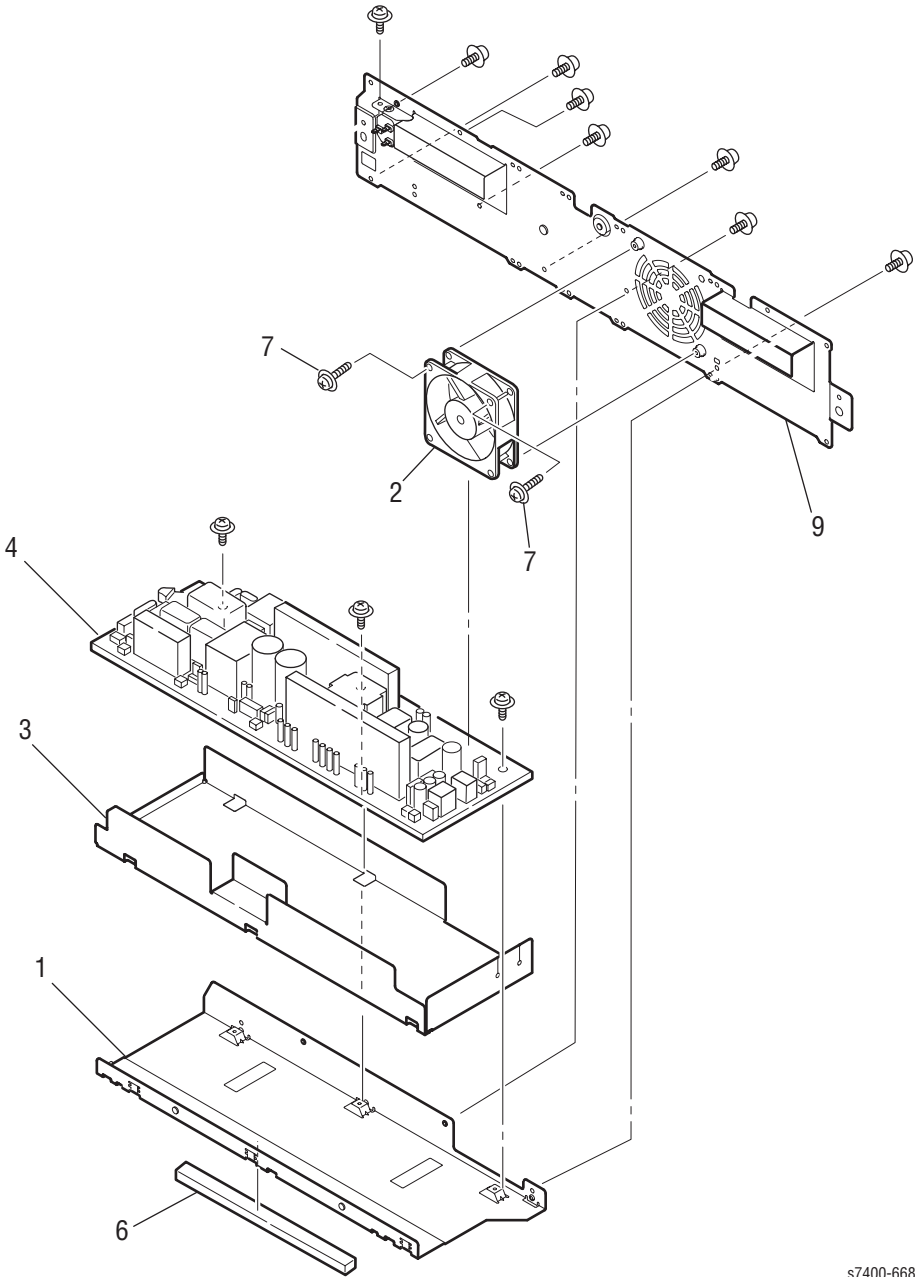

s7400-668

### Parts List 3.1 LVPS - Service Parts List

<b>ID No.</b>	<b>Part Number</b>	<b>Name/Description</b>
0.	015K77470	Plate-Power Assembly
2.	127E15130	Motor-Fan (LVPS Fan)
3.		Film-Insulation
4.		PWR unit-ACDC Switch
5.		Cup_Screw (S Tight M3)
6.		Gasket
7.		Screw (SW+2W)
8.		Screw (SW+2W)
9.		Plate-Rear-Base-Caulking
10.		Cup_Screw A

# Parts List 4.1 Base Assembly

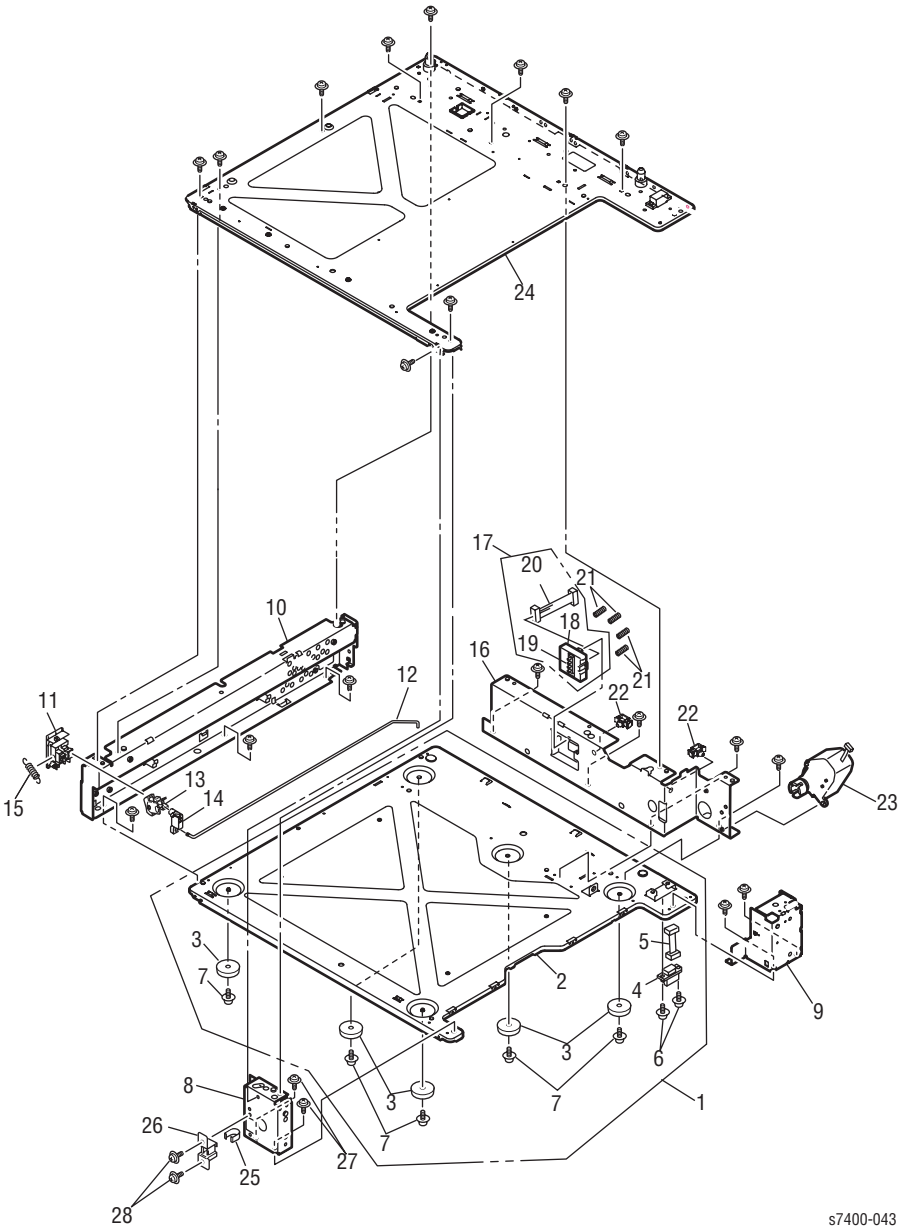

s7400-043



## Parts List 4.1 Base Assembly - Service Parts List

No.	Part Number	Name/Description
0.	801K27780	Base Assembly
1.		Plate Assy.-Bottom (with 2~7)
2.		Plate-Bottom
3.		Rubber-Foot
4.	See note	IMSA-9714N-14Z02 Connector-SQR (Optional Tray Connector)
5.		CONN Cord-JST10P,AMP4P-AMP7PX2 (OPTION Harness)
6.		Cup_Screw A
7.		Cup-Screw-E L=6
8.		Pillar-F
9.		Pillar-R
10.		Plate-Stay-Caulking
11.		Cover-switch
12.		Shaft-Switch (Power Switch Linkage)
13.		Switch-AC (Power Switch Actuator)
14.		Link-Switch (Power Switch Link)
15.		Spring-Switch
16.		Plate-Rear
17.	130K74220	Sensor Assy.-(with 18~20) (Paper Size Switch Assy)
18.		Holder-PS-Switch
19.		HS12-0001 Switch-Push (Paper Size Switch)
20.		CONN Cord-AMP5-AMP5P (PSIZE Harness)
21.		Spring-PS
22.		Clamp-Cable
23.		Geard-Motor(1st) (Lift Motor)
24.		Plate-Top-Welding
25.		Plate-Rock
26.		Lock-Cassette
27.		Cup_Screw (S Tight M3)
28.		Cup_Screw A

## Parts List 4.2 Feeder Assembly and Tray 2 Registration

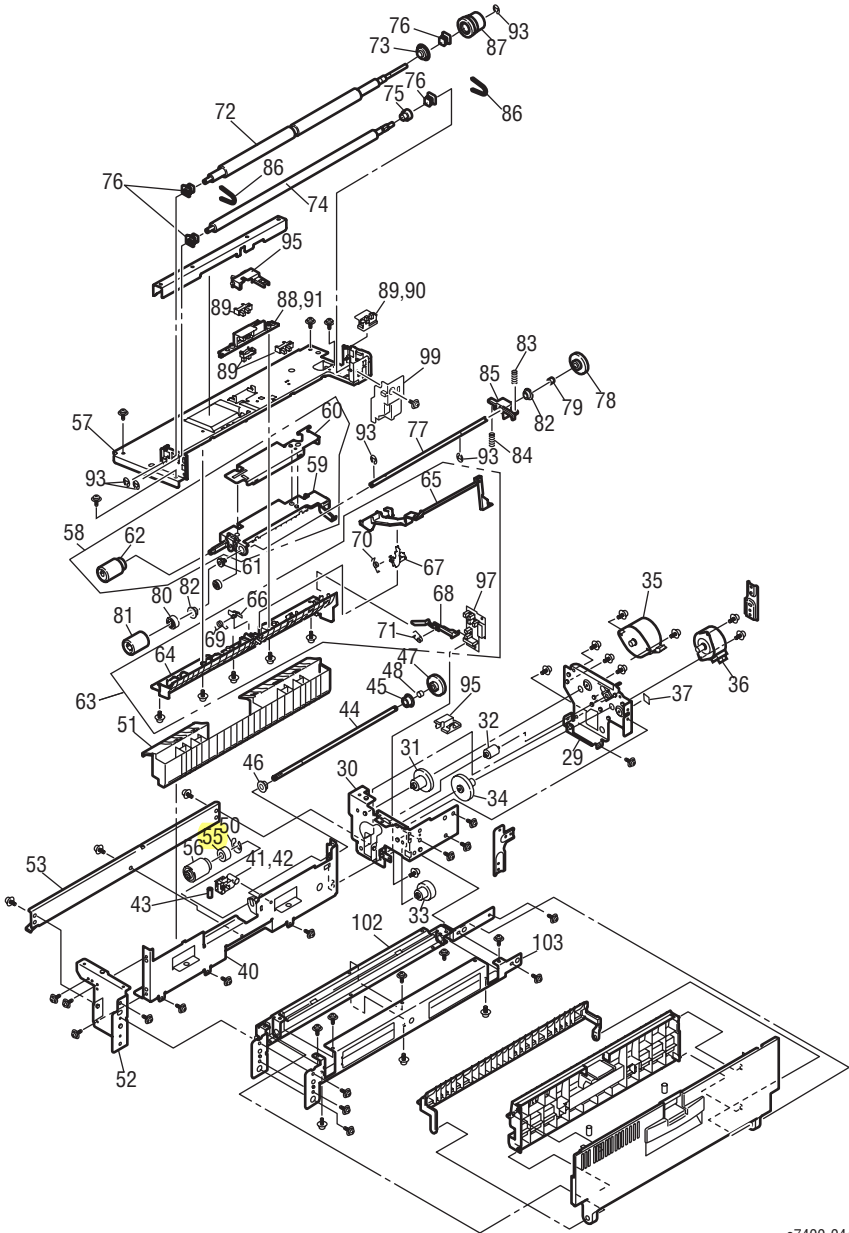

s7400-044

## Parts List 4.2 Feeder Assembly and Tray 2 Registration - Service Parts List

ID No.	Part Number	Name/Description
0.	050K61890	Tray 2 Feeder Assembly
29.		Plate-Motor-A
30.		Plate-Motor-B
31.		Gear-Hopping-Z68-19
32.		Gear-Idle-Retard
33.		Gear-Feed-Z53-18
34.		Gear-Idle-Z48
35.	127E15660	Motor-Pulse (Feed Motor)
36.	127E15670	Motor-Pulse-Regist (Registration Motor)
37.		Clamp-Cable
38.		CONN Cord-AMP8P-JST4P,AMP4P (REGHOP Harness)
39.		Cup_Screw (S Tight M3)
40.		Plate-Retard-Caulking
41.		Lever-Retard
42.		Holder-Spring
43.		Spring-Retard
44.		Shaft-Retard
45.		Bearing-Metal
46.		Bearing-Metal
47.		Gear-Z38(one-way) (included in Gear Kit)
48.		Collar
49.		Pin-Spring
50.		Ring
51.		Guide-Paper-Lower
52.		Plate-Retard-F
53.		Plate-Rail-R
54.		Cup_Screw (S Tight M3)
55.	127E15370	Torque-Limiter-OTLV
56.		Roller-Feed
57.		Plate-Feed
58.		Roller Assy.-Pick-Up (with 59~62)

## Parts List 4.2 Feeder Assembly and Tray 2 Registration - Service Parts List

ID No.	Part Number	Name/Description
59.		Frame-PickUp
60.		Plate-PickUp
61.		Gear-Idle-Z20
62.		Roller-Pick-Up
63.		Frame Assy.-Feed (with 63~71)
64.		Frame-Feed
65.		Lever-End
66.		Lever-Regist
67.		Lever-Hopping
68.		Lever-Near-End
69.		Spring-Lever-Regist
70.		Spring-Lever-Hopping
71.		Spring-Near-End
72.		Roller-Regist1
73.		Gear-Regist
74.		Roller-Pressure1
75.		Gear-PRB
76.		Bearing-Regist
77.		Shaft-Feed
78.		Gear-Z38(oneway)
79.		Collar
80.		Gear-Feed
81.		Roller-Feed-NOW
82.		Bearing-Metal
83.		Spring-PickUp
84.		Spring-Release
85.		Lever-Release
86.		Spring-Regist
87.		Gear-Assy-Clutch
88.		Holder-Photo-Sensor
89.	<a href="#">See Sensor Kit</a>	Photo-Interrupter (No Paper, Low Paper, Door B Detect Sensor)
90.		Holder-Co-Sensor (Door B Detect Sensor Holder)

**Parts List 4.2 Feeder Assembly and Tray 2 Registration - Service Parts List**

<b>ID No.</b>	<b>Part Number</b>	<b>Name/Description</b>
91.		CONN Cord-AMP9P-AMP3PX3 (TRYSNS2 Harness)
92.		TappingScrew-B2 L=8
93.		Ring
94.		Spring-FG-CL1
95.		Holder-PESNS
96.		AMP3P-AMP3P CONN Cord-Wire (PAPEND Harness)
97.		OR-S2C (Feeder Board)
98.		CONN Cord-AMP10P-AMP10P (TRYSNS1 Harness)
99.		Cover-SNS
100.		Cup_Screw (S Tight M3)
101.		BU03P-TR-PC-H(LF) Connector-Plug-
102.		Plate-Grip
103.		Plate-Grip-Sub
104.		Cup_Screw (S Tight M3)
105.		Cup_Screw A
106.		Cup_Screw (S Tight M 3)
107.		Roller-set-723
108.		Roller-set-723
109.		Roller-set-723
110.		Roller-set-723

# Parts List 5.1 Xerographics Drive

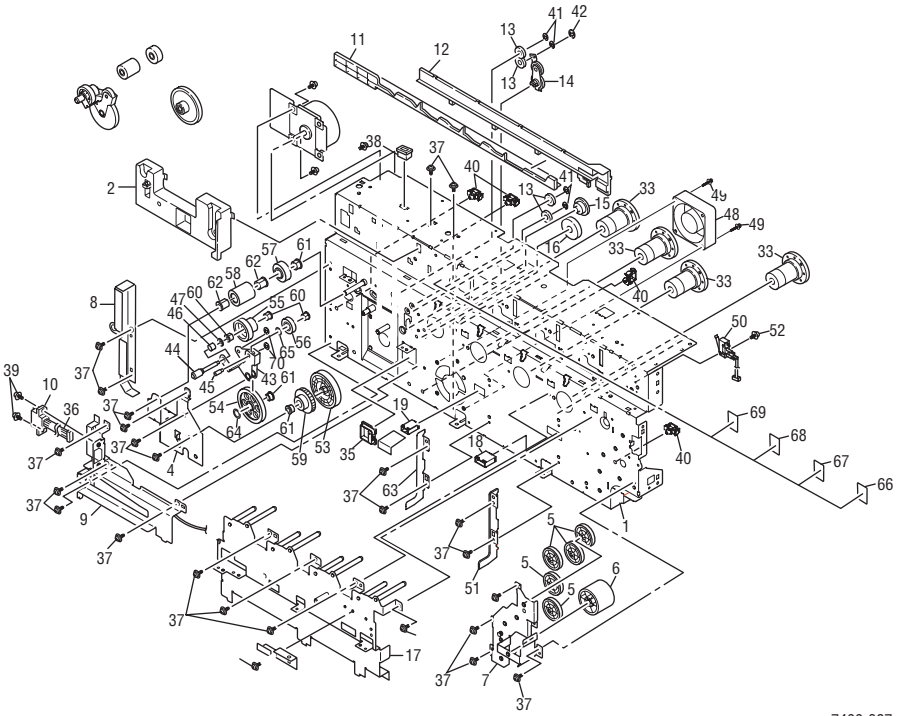

s7400-387

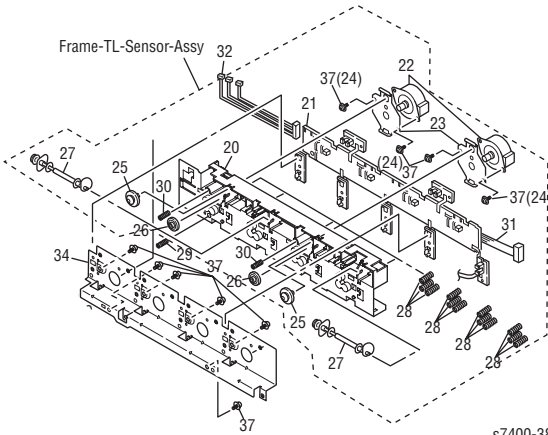

s7400-388

## Parts List 5.1 Xerographics Drive - Service Parts List

No.	Part Number	Name/Description
0.	007K14170	Side-R-Assy
1.		Plate-Side-R-Caulking
2.		Guide-Bracket-FU
3.		Gear-Z17-FU (included in Gear Kit)
4.		Plate-BKT-Fuser
5.		Gear-idle(Z39) (included in Gear Kit)
6.		Gear-Idle(Z44) (included in Gear Kit)
7.		Plate-Side(RER)Caulking
8.		Plate-Stacker-Rear
9.		Plate-Rail-Rear
10.		IMSA-9714N-14Z02 Connector-SQR (Duplex Unit Connector)
11.	010E06290	Slider-Liftup-R (Lift Uplink)
12.		Holder-Slider-R
13.		Gear-Idle-Link (included in Gear Kit)
14.		Planet Assy.-R
15.		Gear-Idle-Liftup-Z20-30 (included in Gear Kit)
16.		Gear-Idle-Lift-UP-Z37 (included in Gear Kit)
17.		Bracket-Inner-Caulking
18.		Guide-Cable-A
19.		Guide-Cable-B
20.		Guide-Rear (Toner Supply Housing)
21.	960K33020	OR-SGG (Imaging Unit Sensor Board)
22.	127E15180	Motor-Pulse (Toner Motors)
23.		Plate-Motor
24.		Cup_Screw (S Tight M3)
25.		Gear-Z14-42 (included in Gear Kit)
26.		Gear-Z14-35 (included in Gear Kit)
27.	008E08270	Camshat (Toner Supply Camshaft)
28.	809E71630	Spring-ID-Fuse (Imaging Unit Contact Springs)
29.	809E71640	Spring-FG
30.	809E71810	Spring-Press-FG

## Parts List 5.1 Xerographics Drive - Service Parts List

No.	Part Number	Name/Description
31.		CONN Cord-JST9P-AMP3P,JST3PX2 (IDFAN Harness)
32.		CONN Cord-JST24P-JST24P (CTG0 Harness)
33.		Gear-Idle-Drum (included in Gear Kit)
34.		Plate-Bracket-Outer
35.		Guide-Cable-FU
36.		CONN Cord-AMP13P-AMP7P,AMP7P (DUPLEX Harness)
37.		Cup_Screw (S Tight M3)
38.		292254-3 Connector-Plug-
39.		Cup_Screw A
40.		Clamp-Cable
41.		Ring
42.		Ring
43.		Plate-Planet
44.		Post-Planet-A
45.		Post-Planet-B
46.		Spring-Planet
47.		Washer
48.	127E15140	Motor-Fan (Transfer Unit Fan)
49.		Screw (SW+2W)
50.		CONN Cord-JST5P-SW (Door A Interlock Switch)
51.		Plate-Support-D
52.		Screw-PSW2W2-10C
53.		Gear-Z77-FU (included in Gear Kit)
54.		Gear-Z47-FU
55.		Gear-Z14-Z24-FU
56.		Gear-Planet-Z16-FU (included in Gear Kit)
57.		Gear-Z20-FU (included in Gear Kit)
58.		Gear-Z17-FU (included in Gear Kit)
59.		Gear-Z16-FU (included in Gear Kit)
60.		Bush-4
61.		Bush-6
62.		Bush-6



## Parts List 5.1 Xerographics Drive - Service Parts List

<b>No.</b>	<b>Part Number</b>	<b>Name/Description</b>
63.		Plate-Support-D2
64.		Spacer-Coupling(STW8.0-0.13)
65.		Spacer-Coupling
66.		Label-ID-Position
67.		Label-ID-Position-Y
68.		Label-ID-Position-M
69.		Label-ID-Position-C

# Parts List 6.1 Front Assemblies

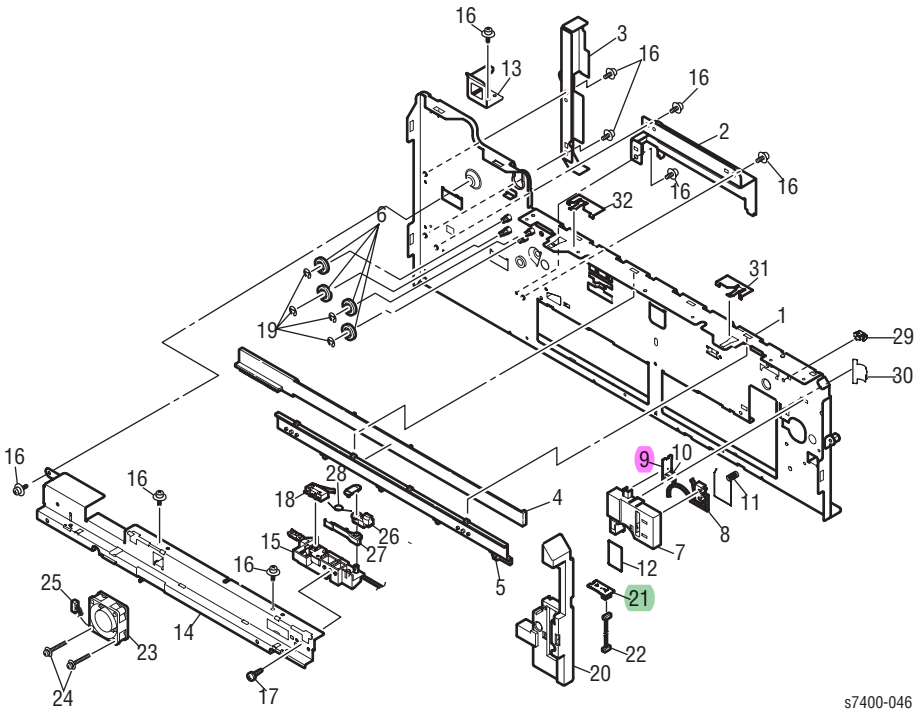

s7400-046

## Parts List 6.1 Front Assemblies - Service Parts List

No.	Part Number	Name/Description
0.	674K01380	Side-F-Assy
1.		Plate-Side-F-Caulking
2.		Plate-Rail-Front
3.		Plate-Stracker-Front
4.	010E06300	Slider-LiftUP-F
5.		Holder-Slider-F
6.		Gear-Idle-Link
7.		Bracket-Sensor- (Sensor Housing)
8.		CONN Cord-AMP2P-SW (Waste Toner Reservoir Detect Switch)
9.	960K34040	OR-HAL (Waste Toner Reservoir Full Sensor)
10.		CONN Cord-AMP3P-JST3P (CN4 Harness)
11.		Spring-FG-SW-F
12.		Label-Cover-OPT
13.		Plate-Guide(L)
14.		Plate-Base(OP)
15.		Holder-Cover-Open-SW (Top Cover Interlock Switch Holder)
16.		Cup_Screw (S Tight M3)
17.		TappingScrew-B2 L=8
18.		CONN Cord-JST2P-SW (Top Cover Interlock Switch)
19.		Ring
20.		Cover-Guard(R) (Right Front Cover)
21.	960K34040	OR-HAL (Waste Toner Reservoir Auger Rotation Sensor)
22.		CONN Cord-JST6P-JST3PX2 (HALL1 harness)
23.	127E15160	Motor-Fan (Imaging Unit Fan)
24.		Screw (SW+2W)
25.		BU03P-TR-PC-H(LF) Connector-Plug-
26.		Lever-CO-A
27.		Lever-CO-B
28.		Spring-Torsion-CO
29.		Clamp-Cable
30.		Clamp-Cable-Film
31.		Plate-FG-Top-F-A
32.		Plate-FG-Top-F-B

# Parts List 7.1 Waste Toner Drive Assembly

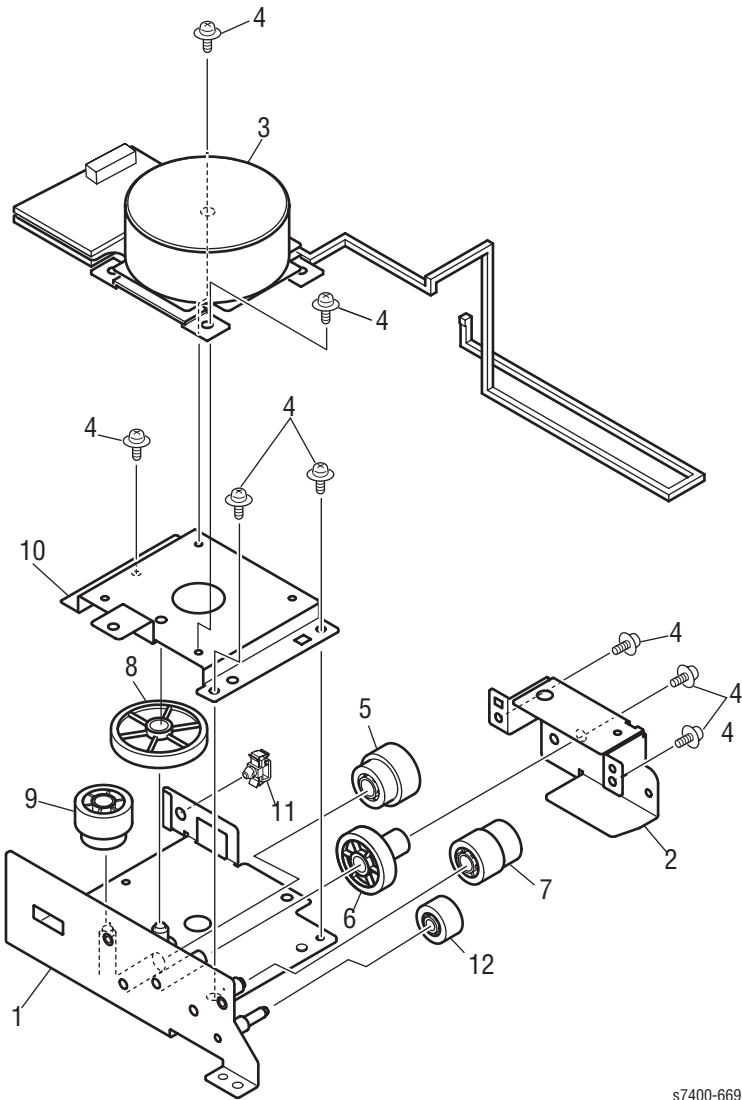

s7400-669

## Parts List 7.1 Waste Toner Drive Assembly - Service Parts List

No.	Part Number	Name/Description
0.	007K14020	Duct Drive Assy
1.		Plate-Bracket-Motor Caulking
2.		Plate-Motor-Sub
3.		Motor-DC(DISTONER) (Watsse Toner Motor)
4.		Cup_Screw (S Tight M3)
5.		Gear-WT-Z18-Z20
6.		Gear-WT-Z30
7.		Gear-WT-Z15-Z21
8.		Gear-WT-Z56
9.		Gear-WT-Z18-Z25
10.		Plate-Motor-DC
11.		Clamp-Cable
12.		Gear-WT-Z14

# Parts List 8.1 Registration Assembly

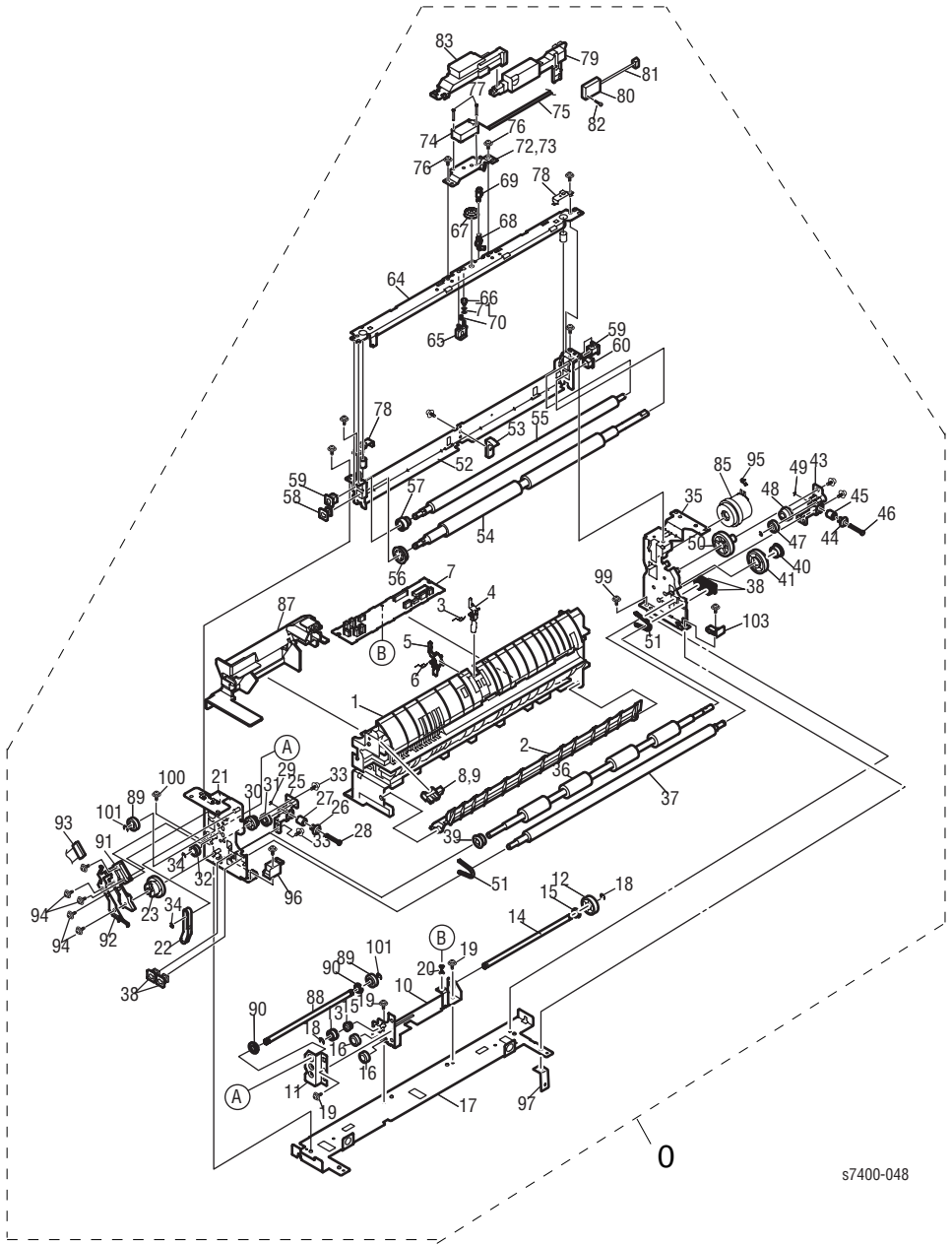

s7400-048

## Parts List 8.1 Registration Assembly - Service Parts List

No.	Part Number	Name/Description
0.	050K61740	Feeder Unit Registration
1.		Frame-Regist
2.		Guide-Regist
3.		Spring-Torsion(IN2) (Registration Sensor #1 Actuator Spring)
4.		Lever-Sensor(IN2) (Registration Sensor #1 Actuator)
5.		Lever-Sensor(WR) (Transfer Unit Entrance Sensor Actuator)
6.		Spring-Torsion(WR) (Transfer Unit Entrance Sensor Actuator Spring)
7.	960K33030	OR-S2S (Front Sensor Board)
8.	<a href="#">See Sensor Kit</a>	Photo-Interrupter 9= (Tray 1 (MPT) Home Position Sensor)
9.		CONN Cord-AMP3P-AMP3P (MPTHOME Harness)
10.		Plate-BKT-Connect A Caulk
11.		Plate-BKT-Connect B
12.		Gear-Connection-Z21
13.		Gear-Connection-Z14
14.		Shaft-Connection A
15.		Bush
16.		Gear-Idle-D
17.		Plate-Base
18.		Ring
19.		Cup_Screw (S Tight M3)
20.		Spring-Earth(S2S)
21.		Plate-Front(Regist)Caulking
22.		Stay-MPT
23.	604K47890	Gear-Coupling-A-Assy
24.		Plate Assy.-Link (Front) (with 25~29)
25.		Plate-Link(Front)-Caulking
26.		Gear-Bevel(Z14)
27.		Gear-Worm(P2)-Front
28.		Shaft-Warm
29.		Ring
30.		Gear-Wheel(Z30)-Front
31.		Gear-Idle(Z16)
32.		Gear-Idle-D
33.		Cup_Screw (S Tight M 3)
34.		Ring

## Parts List 8.1 Registration Assembly - Service Parts List

No.	Part Number	Name/Description
35.		Plate-Rear(Regist)Caulking
36.		Roller-Feed(M)
37.		Roller-Pressure(M)
38.		Bearing-Regist
39.		Gear-OnewayBevel(Z20) (included in Gear Kit)
40.		Gear-OnewayBevel(Z20) (included in Gear Kit)
41.		Gear-Feed-Z36
42.		Plate Assy.-Link (Rear) (with 43~49)
43.		Plate-Link(Rear)Caulking
44.		Gear-Bevel(Z14)
45.		Gear-Worm(P2)-Rear
46.		Shaft-Warm
47.		Gear-Idle(Z16)
48.		Gear-Wheel(Z30)-Rear
49.		Ring
50.		Gear-Idle(Z37)
51.		Spring-Pressure
52.		Plate-Holder(Regist)
53.		Stage-Pickup 723
54.		Roller-Regist(2)
55.		Roller-Pressure(2)
56.		Gear-Regist
57.		Gear-PRB
58.		Bearing-Regist
59.		Bearing-Regist2
60.		Bearing-Regist(CL2)
61.		
62.		Cup_Screw (S Tight M3)
63.		Ring
64.		Plate-Top(Regist)Caulking
65.		Lever-Pickup 723
66.		Gear-SH1
67.	130K75180	Gear-SH2
68.		Gear-SH3
69.		Cap-SH
70.		Spring-SH1



## Parts List 8.1 Registration Assembly - Service Parts List

No.	Part Number	Name/Description
71.		Spring-SH2
72.		Spring-Detent-Re
73.		Plate-Thickness
74.	121E20540	D6E-K SENSOR-Magnet (Media Thickness Sensor)
75.		CONN Cord-AMP4P-JST3P (PTHICK Harness)
76.		Cup_Screw (S Tight M3)
77.		Screw
78.		Plate-Pressure
79.		Cover-Thickness
80.		HSU-06A1T1 Temperature/Humidity Sensor
81.		CONN Cord-JST4P-JST4P (ENV Harness)
82.		TappingScrew-B2 L=8
83.		Cover-Thickness(Front)
84.		Cup_Screw (S Tight M 3)
85.	007K14070	Gear Assy.-CL(Reg2) (Registration Clutch #1) (included in Gear Kit)
86.		Pin
87.		Duct-Fan
88.		Shaft-Connection A
89.		Gear-Connection-Z18
90.		Bush
91.		Bracket-Contact
92.		Plate-FG-REG
93.		MRH9355/HV-38-100MKRES-MET solid -
94.		TappingScrew-B2 L=8
95.		Spring-FG(CL)
96.		Spacer-Lock-F
97.		Plate-Support
98.		Cup_Screw (S Tight M3)
99.		Cup_Screw A
100.		TappingScrew-B2 L=8
101.		Ring
102.		Ring

# Parts List 9.1 Registration Sensor Assembly

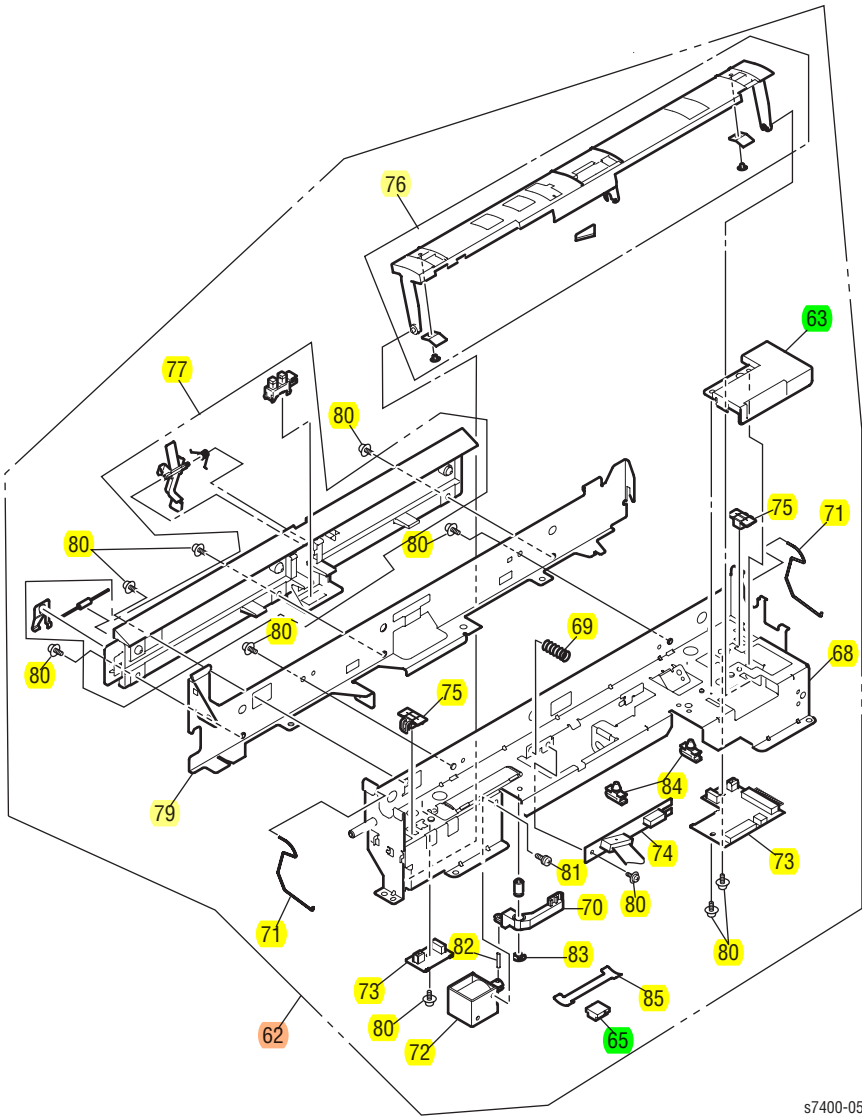

s7400-050

## Parts List 9.1 Registration Sensor Assembly - Service Parts List

No	Part Number	Name/Description
62.	130K74230	Sensor-Regist- Assy (with 63, 64, and 68-85)
63.		Cover-Connector (Registration Sensor Board Cover)
64.		CONN Cord-AMP2P-AMP2P
65.		292254-2 Connector-Plug-
66.		CONN Cord-AMP14P-AMP14P (CSNS Harness)
67.	130K75180	Sensor-Regist-Sub-Assy (with 68~85) also part of <i>Sensor Kit</i>
68.		Plate-Po-Caulking
69.		Spring-Shutter
70.		Lever-Solenoid
71.		Spring-Belt-Fix
72.		DC-Solenoid (Registration Shutter Solenoid)
73.		OR-S2Z (Registration Sensor Board)
74.		GP2TC2 SENSOR-Density - (ADC Sensor)
75.		Plate-Guard-Sensor (Registration Sensor Covers)
76.		Shutter- Assy (Registration Shutter)
77.		TARUMI-Sensor Assy (Media Slack Sensor Assy)
78.		CONN Cord-AMP12P-MOLEX5P,AMP3P,AMP3P (DSNS Harness)
79.		Plate-Beam
80.		Cup_Screw (S Tight M3)
81.		Screw (SW+2W)
82.		Pin
83.		Ring
84.		Clamp-Cable

# Parts List 10.1 Tray 1 (MPT) Assembly

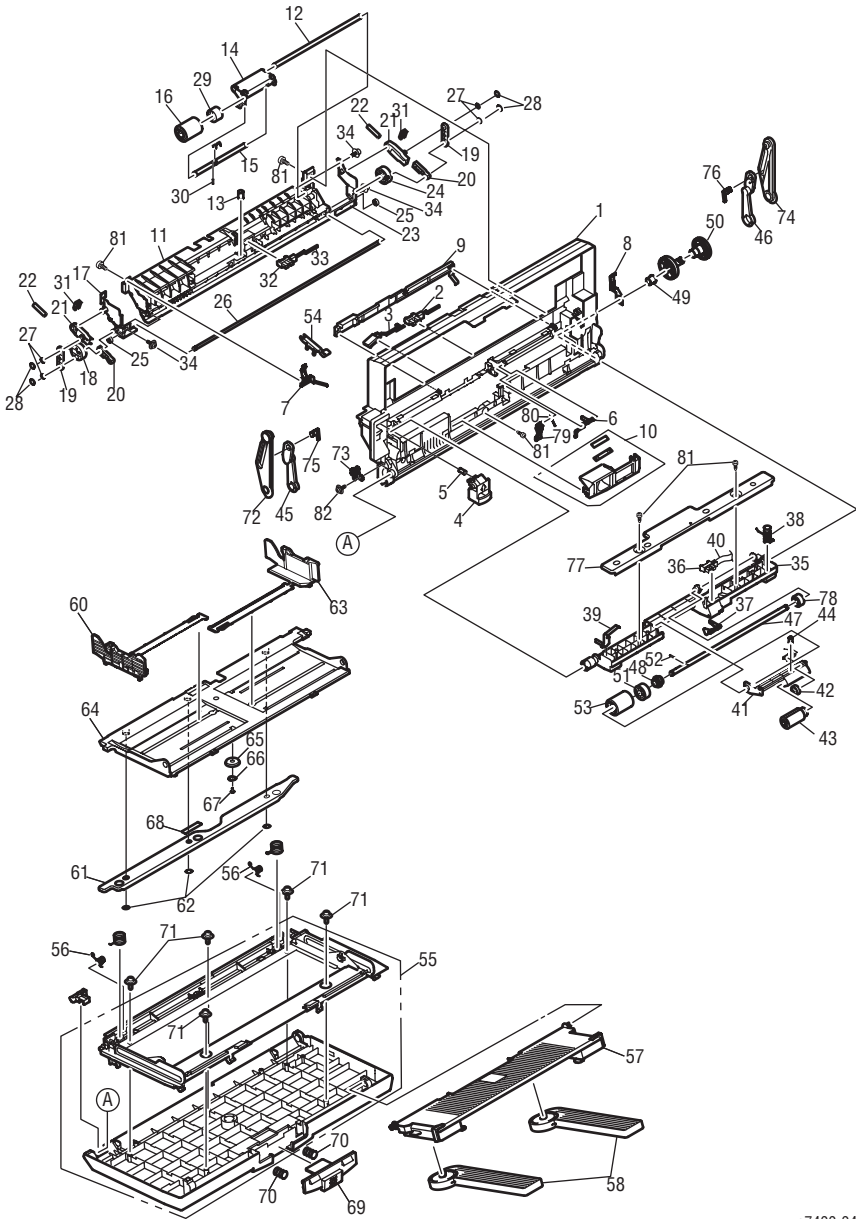

s7400-049

## Parts List 10.1 Tray 1 (MPT) Assembly - Service Parts List

No	Part Number	Name/Description
0.	050K61490	Fdr-Unit-MPT
1.		Frame-MPT
2.	<a href="#">See Sensor Kit</a>	Photo-Interrupter (Feed -Out Sensor #1)
3.	<a href="#">See Sensor Kit</a>	Photointerrupter(REWORK) (OHP Sensor)
4.		Lever-Handle-MPT
5.		Spring-Handle
6.		Lever-Hopping (Feed -Out Sensor #1 Actuator)
7.		Plate-Earth(MPT)Front
8.		Plate-Earth(MPT)Rear
9.		Cover-Sensor(MPT) (Sensor Cover)
10.	032K04470	Guide Assy.-Friction
11.		Guide-Sheet(MPT)
12.		Shaft-Retard(Drive)
13.		Spring-Reatrd
14.		Plate-Retard
15.		Shaft-Retard(Driven)
16.		Roller-Retard
17.		Plate-Arm(Front)Caulking
18.		Gear-Link(Z27)Front
19.		Lever-Link
20.		Lever-Arm
21.		Holder-Arm
22.		Spring-Arm
23.		Plate-Arm(Rear)Caulking
24.		Gear-Link(Z27)Rear
25.		Gear-Link-Z12
26.		Shaft-Link
27.		Spacer-Coupling
28.		CS-RING (CS3-SUS)
29.	127E15370	Torque-Limiter-OTLV
30.		Pin-Spring

## Parts List 10.1 Tray 1 (MPT) Assembly - Service Parts List

No	Part Number	Name/Description
31.		Plate-Support(Arm)
32.	<a href="#">See Sensor Kit</a>	Photo-Interrupter (No Paper Sensor)
33.		CONN Cord-JST3P-AMP3P (MPTPAP Harness)
34.		TappingScrew-B2 L=8
35.		Frame-Feeder
36.	<a href="#">See Sensor Kit</a>	Photo-Interrupter (Level Sensor)
37.		Lever-PaperEnd(MPT) (Level Sensor Actuator)
38.		Spring-Earth(Feeder)
39.		Plate-Earth(Feeder)
40.		CONN Cord-AMP10P-AMP3PX2,JST3P (MPTSNS Harness)
41.		Holder-Pickup
42.		Gear-Planet(Z20)-HP
43.	059K51070	Roller Assy.-Pickup (Pick Roller)
44.		Spring-Pickup
45.		Stay-Hopper(Front)
46.		Stay-Hopper(Rear)
47.		Shaft-Feed
48.		Bearing-Feeder
49.		Bearing-Metal
50.		Gear-Oneway(Z38/Z53)
51.		Gear-Feed(Z25)
52.		Pin
53.		Roller-Feed(OW) (Feed Roller)
54.		Guide-Cable
55.		Hopper Assy.-MPT (with 56~59, 69~71)
56.		Spring-FG
57.		Tray-SubHopper
58.		Supporter-Sheet
59.		Sheet-Recieve-Assy.
60.		Frame-Hopper-MPT
61.		Plate-Beam-Hopper
62.		CS-2

## Parts List 10.1 Tray 1 (MPT) Assembly - Service Parts List

No	Part Number	Name/Description
63.		Guide-Paper(MPT)-R (with 60~68)
64.		Guide-Paper(MPT)-F
65.		PINION GEAR B
66.		WAVE WASHER B
67.		Screw-T2D3-5
68.		Plate-Friction
69.		Lever-Lock(MPT)
70.		Spring-Lever(MPT)
71.		TappingScrew-B2 L=8
72.		Link-F(MPT)
73.		Plate-Hook-Front
74.		Link-R(MPT)
75.		Post-Stay_Front
76.		Post-Stay_Rear
77.		Plate-Cover(Feeder) (Feed Roller Assy Cover)
78.		Bush
79.		Lever-Paper(MPT) (No Paper Sensor Actuator)
80.		Spring-Paper(MPT)
81.		TappingScrew-B2 L=8
82.		Cup_Screw (S Tight M3)
83.		Roller-set-MPT-723

# Parts List 11.1 Exit Assembly

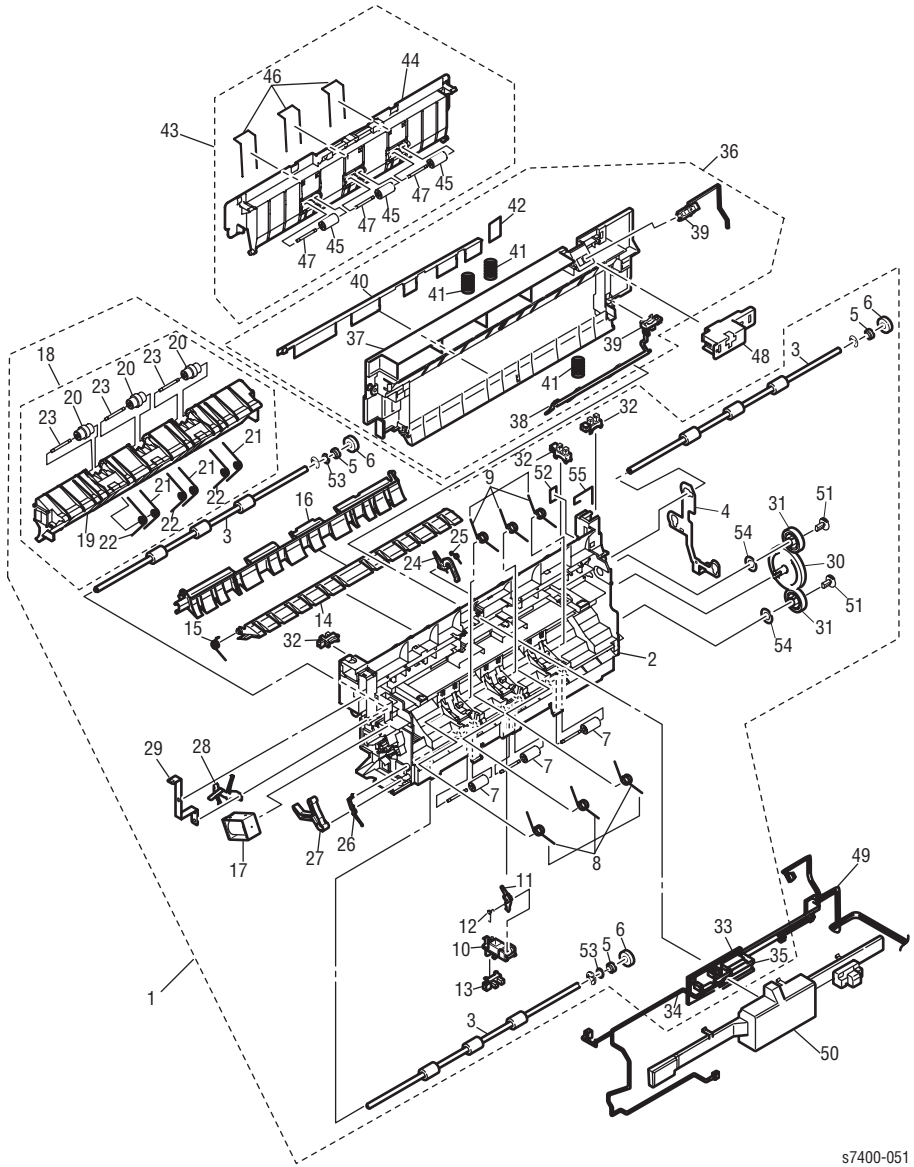

s7400-051



## Parts List 11.1 Exit Assembly - Service Parts List

No.	Part Number	Name/Description
0.	054K37720	Eject Assy
1.		Guide-Eject-Assy
2.		Guide-Eject
3.		Roller-Eject
4.		Plate-FG_Eject-R
5.		Bush
6.		Gear-Eject_Z17
7.		Roller-Pinch-Eject
8.		Spring-Torsion-Eject
9.		Spring-Torsion-Eject
10.		Holder-Lever
11.		Lever-Exit Sensor (Fuser Exit Sensor Actuator)
12.		Spring-SNS(F/R) (Fuser Exit Sensor Actuator Spring)
13.	<a href="#">See Sensor Kit</a>	Photo-Interrupter (Fuser Exit Sensor)
14.		Lever-Separator_DUP (Duplex Gate)
15.		Spring-Separator_DUP (Duplex Gate Spring)
16.		Lever-Separator_Sheet (Exit Gate)
17.		DC-Solenoid-10SL-144 (Exit Gate Solenoid)
18.		Guide-Sheet-FU-Assy (with 19~23)
19.		Guide-Sheet-FU
20.		Roller Assy.-FU
21.		Spring-Torsion-FU
22.		Spring-Torsion-FU
23.		Shaft-Pinch
24.		Lever-Paper-END (Job Offset Trailing Edge Sensor Actuator)
25.		Spring-Paper-End(joboff)
26.		Plate-FG-Eject-L3
27.		Lever-Link-DUP (Duplex Gate Actuator)
28.		Plate-FG-Eject-L1
29.		Plate-FG-Eject-L2
30.		Gear-Idle-Eject-Z54

## Parts List 11.1 Exit Assembly - Service Parts List

No.	Part Number	Name/Description
31.		GEAR-IDLE-Eject_Z27
32.	<a href="#">See Sensor Kit</a>	Photo-Interrupter (Side Output Tray Detect Sensor)
33.		OR-S2R (Rear Sensor Board)
34.		CONN Cord-AMP6P-AMP3PX2 (COVSNS Harness)
35.		CONN Cord-AMP12P-AMP3PX4 (SNS Harness)
36.		Guide-Eject-Outer- Assy (with 37~42)
37.		Guide-Eject-Outer
38.		Lever-Stacker-Full-FU (Side Output Tray Stack Full Sensor Acuator)
39.	<a href="#">See Sensor Kit</a>	Photo-Interrupter (Top Output Tray Stack Full / Door E Detect Sensor)
40.		Sheet-Discharge(FU)
41.		Spring-Lock(Outer)
42.		Label-Cover-OPT
43.		Cover-Eject-Outer-Assy (with 44~47) (Door E)
44.		Cover-Eject-Outer
45.		Roller-Pinch-Eject
46.		Spring-Torsion-FD
47.		Shaft-Pinch
48.		Cover-SNS-FD (Top Output Tray Stack Full Sensor Cover)
49.		CONN Cord-AMP13P-AMP13P (RSNS Harness)
50.		Cover-Board (Rear Sensor Board Cover)



# Parts List 12.1 Top Plate Assembly

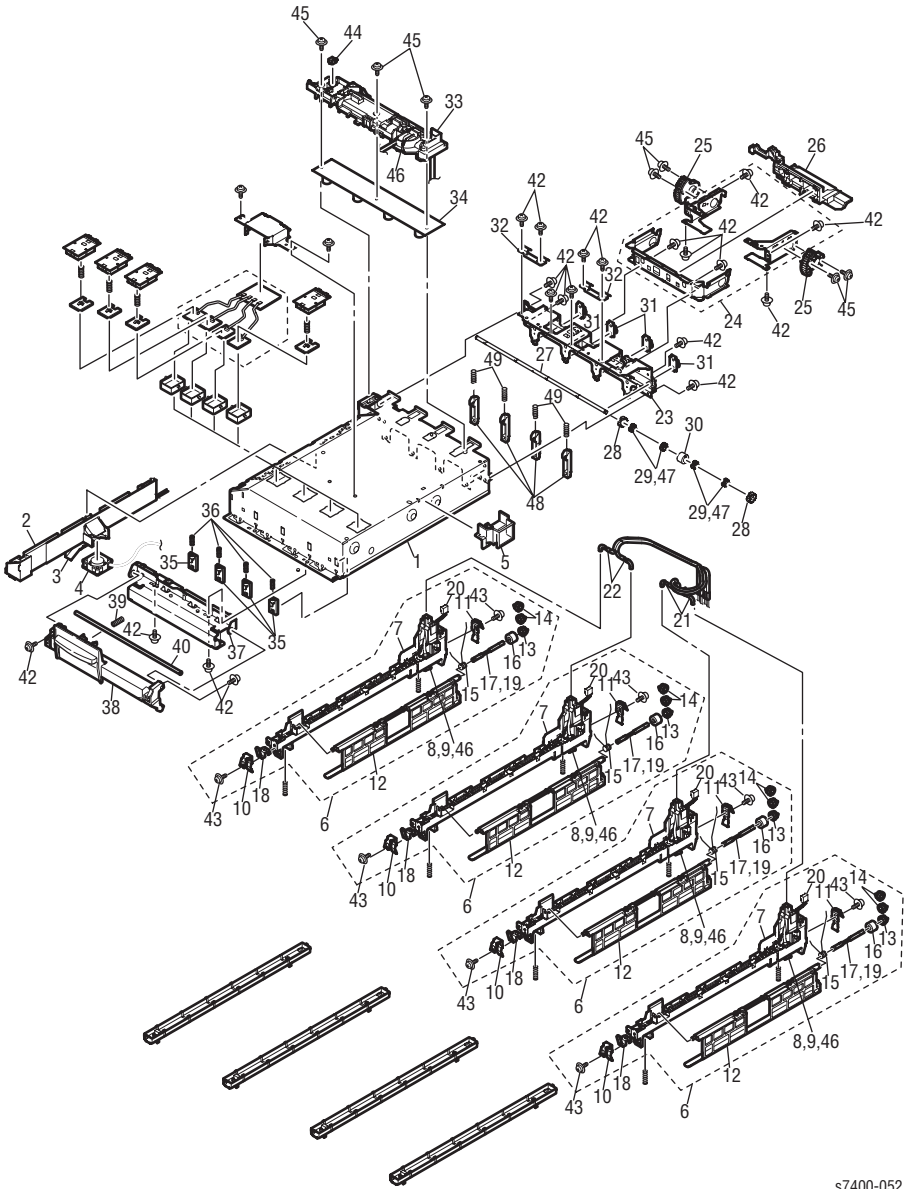

s7400-052

## Parts List 12.1 Top Plate Assembly - Service Parts List

No.	Part Number	Name/Description
0.	815K12570	Plate-Top-Assy (with 2-49; LED assemblies are not included)
1.		Plate-Top-Welding
2.		Chamber-Duct-Top (Top Cover Fan Duct)
3.		Spoiler-FAN (Top Cover Fan Diffuser)
4.	127E15150	Motor-Fan (Top Cover Fan)
5.		Holder-FAN-Intake
6.	019K13060	Holder-Head- Assy (with 7~19) (LED Head Holder Assy)
7.		Holder-Head
8.		Clump-Cable-Head
9.		Spring-Torsion-100
10.		Plate-Contact-Head-F
11.		Plate-Contact-Head-R
12.		Plate-Shutter-LED1
13.		Gear-LED1
14.		Gear-LED4
15.		Spring-Torsion1
16.		Limiter-torque
17.		Post-shutter
18.		Plate-FG-Head-FS
19.		Pin
20.		CONN Cord-JST4P-JST4P (LEDPWR Harness)
21.		CONN Cord-JST10P-JST10P (LEDDATA Harness [YK])
22.		CONN Cord-JST10P-JST10P (LEDDATA Harness [CM])
23.		Plate-Top-Support
24.		Plate-Pivot-Welding
25.		Gear-Damper-TOP
26.		Code-Cover-Top
27.		Shaft-LED-Shutter
28.		Gear-LED2
29.		Gear-LED3
30.		Limiter-torque

## Parts List 12.1 Top Plate Assembly - Service Parts List

No.	Part Number	Name/Description
31.		Plate-FG-Top-R
32.		Plate-Clump-HCT
33.		Code-Guide-Top (LED Relay Board Cover)
34.		OR-S2H (LED Relay Board)
35.		Holder-Spring-ID
36.		Spring-Tension
37.		Plate-Lock-Caulking
38.		Lever-Top
39.		Spring-Lock
40.		Shaft-Support-Lock
41.		Cup_Screw A
42.		Cup_Screw (S Tight M 3)
43.		TappingScrew-B2 L=8
44.		BU03P-TR-PC-H(LF)Connector-Plug-
45.		Cup_Screw A
46.		TYING CORD
47.		Pin
48.		Cap-Press-ID
49.		Spring-Press-ID



# Parts List 13.1 Job Offset Assembly

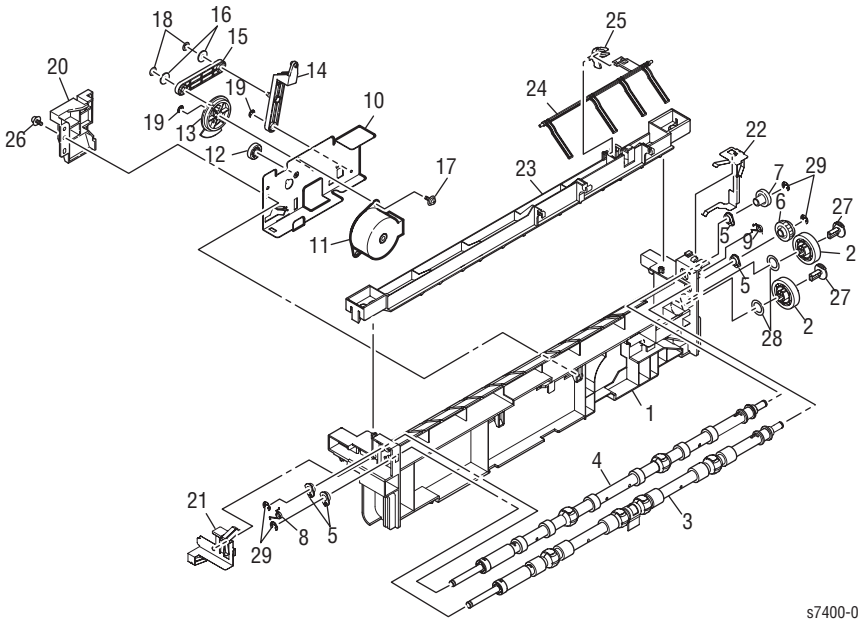

s7400-053



## Parts List 13.1 Job Offset Assembly - Service Parts List

No.	Part Number	Name/Description
0.	054K37730	Job-Offset-Assy
1.		Holder-Joboff-Lower
2.		GEAR-IDLE-Eject_Z27
3.		Pipe-Assy-Drive_723
4.		Pipe-Assy-Driven_723
5.		Bush-Shaft
6.		Gear-Drive
7.		Gear-Driven
8.		Spring-Bush-L
9.		Spring-Bush-R
10.		Bracket-Motor(Caulking)
11.		Motor-Resist (Job Offset Motor)
12.		Gear-Idle-Z28
13.		Gear-Link-Z60
14.		Lever-Link-B
15.		Lever-Link-A
16.		Washer - 2W3
17.		Cup_Screw (S Tight M 3)
18.		CS-RING (CS3-SUS)
19.		Ring
20.		Cover-Motor_Joboff (Gear Cover)
21.		Contact-Joboff-L
22.		Contact-Joboff-R
23.		Holder-Joboff-Upper
24.		Lever-Stacker-Full-F (Top Output Tray Stack Full Feelers)
25.		Lever-Stacker-Full-Sub (Top Output Tray Stack Full Sensor Actuator)
26.		TappingScrew-B2 L=8
27.		Limiter-Pin
28.		Spacer-Coupling
29.		Ring

# Parts List 14.1 Basket Assembly

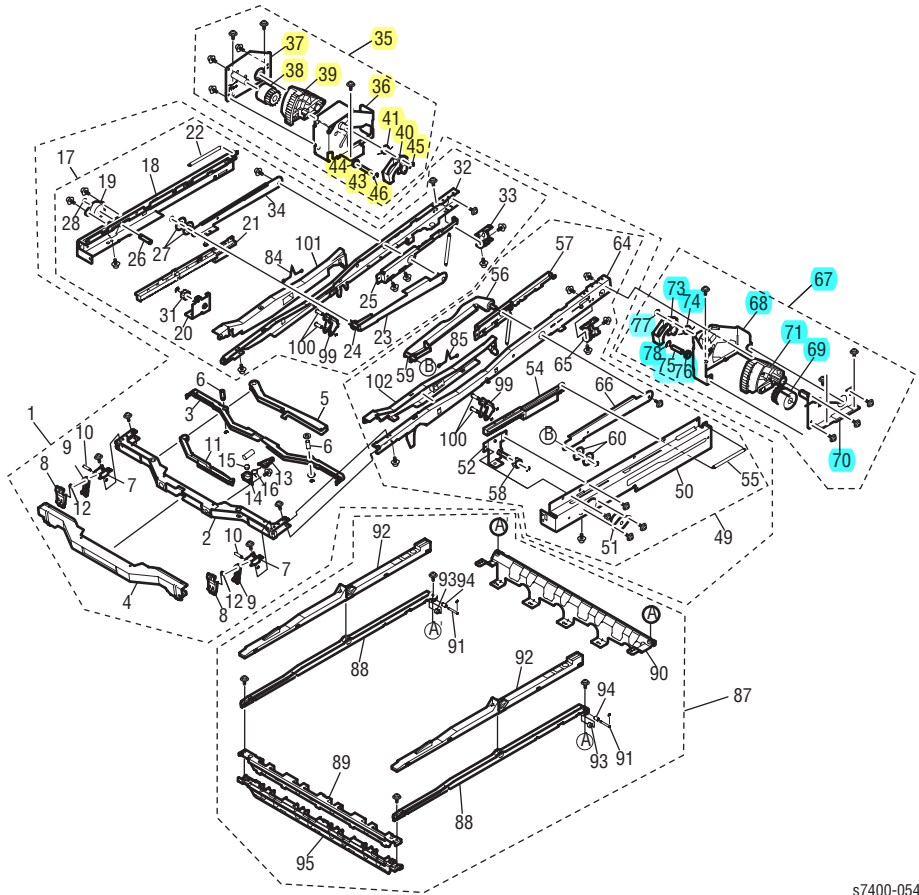

s7400-054

## Parts List 14.1 Basket Assembly - Service Parts List

No.	Part Number	Name/Description
0.	674K01390	Basket Assy (Upper and Lower Assy)
1.		Basket-Main-Assy (with 2~17, 49, 81~86) (Upper Basket Assy)
2.		Plate-Bar
3.		Plate-Lever-01
4.		Lever-Basket-01
5.		Lever-Basket-02
6.		Post-Lever-01
7.		Plate-Lock-01
8.		Cover-Lock-Lever
9.		Plate-Lock-02
10.		Post-Lock-Lever
11.		Lever-Basket-03
12.		Spring-Lock-L
13.		Lever-Stopper
14.		Plate-Stopper
15.		Post-Stopper
16.		Spring-Stopper
17.		Link-Unit-L (with 18~35, 47~48) (Left Support Rail Assy)
18.		Guide-Link-L
19.		One-Way-Hinge-L
20.		Plate-Damper-L
21.		Rack-Damper-L
22.		Spring-Lack-Damper-0.4
23.		Link-Caulking-L
24.		Post-Link-6
25.		Bracket-Link-L
26.		Post-One-Way
27.		Washer-6-22
28.		Ring
29.		Cup_Screw (S Tight M 3)
30.		Cup_Screw A
31.		Gear-Damper
32.		Plate-BKL
33.		Plate-Support-BK
34.		Plate-Link-L
35.	007K14030	Gear Assy.-L (with 36~46) (Left Damper Assy)

## Parts List 14.1 Basket Assembly - Service Parts List

No.	Part Number	Name/Description
36.		Plate-damper-L-Caulking
37.		Plate-Dumper-L2-Caulking
38.		Damper-R
39.		Gear-BKL
40.		Plate-Limiter
41.		Spring-Limiter L
42.		Cup_Screw (S Tight M 3)
43.		Post-Limiter-Roller
44.		Roller-Limiter
45.		Ring
46.		Ring
47.		Tap_Thigt_Screw
48.		Bearing-6-10-2.7T
49.		Link-Unit-R (with 50~67, 79, 80) (Right Support Rail Assy)
50.		Guide-Link-R
51.		One-Way-Hinge-R
52.		Plate-Damper-R
53.		Post-One-Way
54.		Rack-Damper-R
55.		Spring-Lack-Damper-0.4
56.		Link-Caulking-R
57.		Bracket-Link-R
58.		Gear-Damper
59.		Post-Link-6
60.		Washer-6-22
61.		Ring
62.		Cup_Screw (S Tight M 3)
63.		Cup_Screw A
64.		Plate-BKR
65.		Plate-Support-BK
66.		Plate-Link-R
67.	007K14040	Gear Assy.-R (with 68~78) (Right Damper Assy)
68.		Plate-Damper-R-Caulking
69.		Damper-L
70.		Plate-Dumper-R2-Caulking
71.		Gear-BKR
72.		Cup_Screw (S Tight M 3)

## Parts List 14.1 Basket Assembly - Service Parts List

No.	Part Number	Name/Description
73.		Plate-Limiter
74.		Spring-Limiter R
75.		Post-Limiter-Roller
76.		Roller-Limiter
77.		Ring
78.		Ring
79.		Tap_Thigt_Screw
80.		Bearing-6-10-2.7T
81.		Cup_Screw (S Tight M 3)
82.		Ring
83.		Screw-PSW3
84.		Spring-FG-L
85.		Spring-FG-R
86.		Gasket
87.	674K01410	Basket-Inner- Assy (with 88~97) (Lower Basket Assembly)
88.		Plate-Beam
89.		Plate-BKF
90.		Plate-BK-Rear
91.		Post-Guide-Roller
92.		Cover-Beam
93.		Roller-Guide-BK
94.		Roller-Guide BK2
95.		Frame-BKF
96.		Ring
97.		Cup_Screw (S Tight M 3)
98.		Spring-BK
99.		Plate-Link
100.		Post-Basket-01
101.		Cover-BKL
102.		Cover-BKR
103.		Label-ID-Position-Bas
104.		Ring

# Parts List 15.1 Duplex Unit

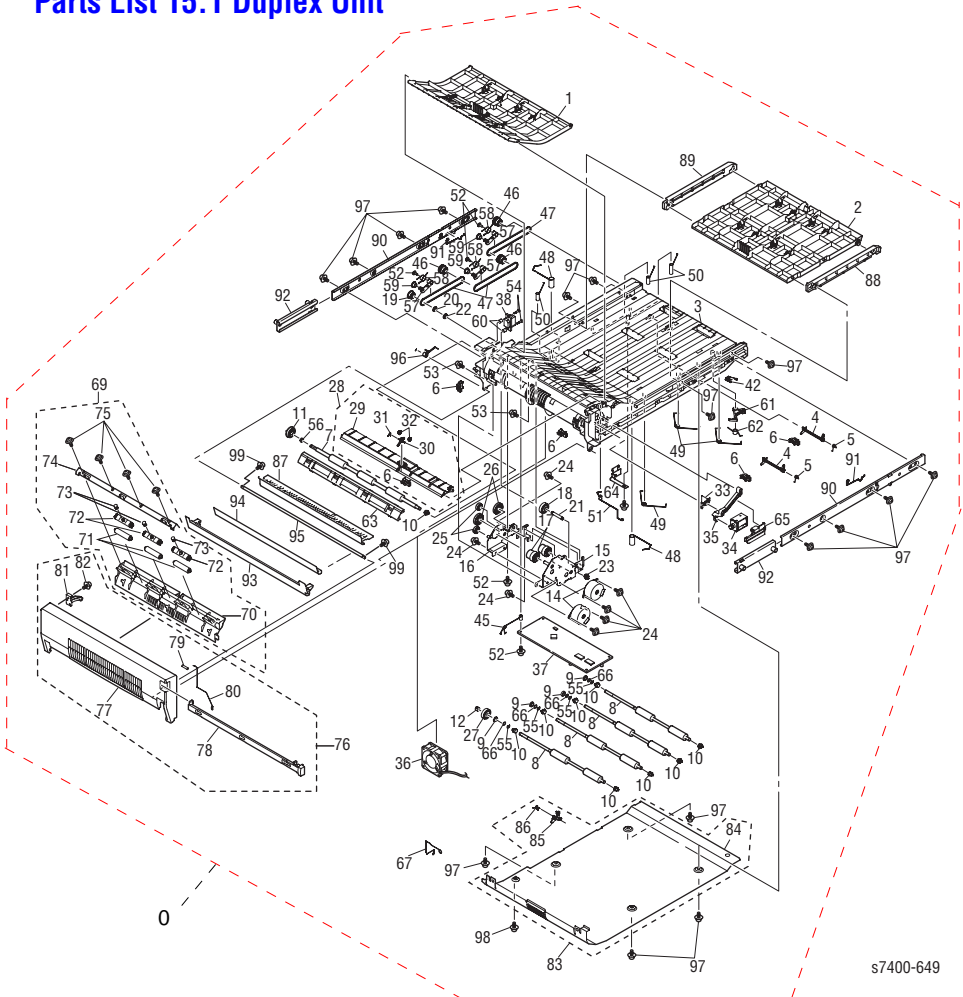

s7400-649

## Parts List 16.1 Duplex Unit - Service Parts List

No.	Part Number	Name/Description
0.	084K36080	Duplex Unit
1.		Frame Assy Uppper Left
2.		Frame Assy Upper Right
3.		Frame Lower
4.		Lever-Sensor(F/R)
5.		Spring-Sensor(F/R)
6.		Photo-Interrupter
7.		Roller-SwB
8.		Roller-Feed-Dup
9.		Bush
10.		Bearing-Feed
11.		Gear-Z40
12.		Stopper-Gear
13.		Motor-Assy-Dup Assy (Include:No.14~26)
14.		Motor-Resist
15.		Bracket-Motor-A-Caulking
16.		Bracket-Motor-B-Caulking
17.		Gear-Z46/32
18.		Gear-RE3
19.		Pulley-MXL(25)
20.		Collar
21.		Shaft-Pulley
22.		Bush
23.		Bearing-Feed
24.		Cup_Screw (S Tight M3)
25.		Gear-Z26
26.		Gear-Z44
27.		Gear-RE3
28.		Guide-Assy-Reverse Assy (Include:No.29~32)
29.		Guide-Reverse
30.		Lever-Sns-Reverse
31.		Spring-Sns-Reverse
32.		Stopper-Sns-RV

## Parts List 16.1 Duplex Unit - Service Parts List

No.	Part Number	Name/Description
33.		Plate-FG-Solenoid
34.		Solenoid
35.		Lever-Solenoid-Dup
36.		Motor-Fan (Duplex Fan)
37.		OR-Board Assy.-V72-2
38.		IMSA-9714N-14Z03 Connector-SQR
39.		CONN Cord-AMP14P-AMP7Px2
40.		CONN Cord-AMP10P-AMP3Px3
41.		CONN Cord-AMP6P-AMP3Px2
42.		CONN Cord-JST3P-SW
43.		CONN Cord-JST5P-JST4P
44.		CONN Cord-JST4P-JST4P
45.		Spring-FG-Board
46.		Pulley-MXL25(W)
47.		Belt-Mini Pitch(B151)
48.		Spring-FG-Base
49.		Spring-FG-Roller-Feed-F
50.		Spring-FG-Roller-Feed-R
51.		Spring-FG-Roller-Feed-F2
52.		TappingScrew-B2 L=8
53.		Cup_Screw A
54.		Screw-Shoulder
55.		Ring
56.		Bush
57.		Holder-Tensioner
58.		Spring-Tensioner
59.		Pulley-Idle
60.		Spring-JIC
61.		Link-Inter-Lock
62.		Spring-Inter-Lock
63.		Guide-SwB
64.		Plate-FG-Base-R
65.		Cover-Solenoid
66.		Spacer-Coupling



## Parts List 16.1 Duplex Unit - Service Parts List

No.	Part Number	Name/Description
67.		Spring-FG-Sns
68.		Cover-Reverse- Assy (with 69,76)
69.		Frame-Reverse-Assy (with 70~75
70.		Frame-Reverse
71.		Roller-Pinch
72.		Holder-Roller-Pinch
73.		Spring-Pressure-Pinch
74.		Plate-Bracket-Spring
75.		TappingScrew-B2 L=8
76.		Cover-Outer-Assy (with 77~82)
77.		Cover-Reverse
78.		Lever-Lock-Reverse
79.		Spring-Lock-Reverse
80.		Spring-FG-Reverse
81.		Stopper-CR
82.		TappingScrew-B2 L=8
83.		Plate-Assy-Lower (with 84~86)
84.		Plate-Base-Lower
85.		Lever-Sns-Dup2
86.		Spring-SNS-Dup2
87.		Guide-Paper-Reverse
88.		Guide-Slide-F
89.		Guide-Slide-R
90.		Plate-Rail
91.		Spring-Rail-Lock
92.		Bracket-Guide-Slide-Caulking
93.		Lever-Lock-CR
94.		Plate-Lever-Lock
95.		Shaft-Lock
96.		Spring-Lock
97.		TappingScrew-B2 L=8
98.		Cup_Screw (S Tight M3)
99.		Screw (SW+2W)

# Xerox Supplies and Accessories

**Service Kits** (also see [Service Kits](#) for detailed content)

Description	Part Number
Kit, Hardware (screws, E-rings)	604K35560
Kit, MPT Roller	604K35570
Kit, Gear	604K35550
Kit, Sensor	604K35590
Kit, Actuator	604K35580
Kit, Cable	604K40950

## Phaser 7400 Maintenance Items

Description	Part Number
Cyan Imaging Unit	108R00647
Magenta Imaging Unit	108R00648
Yellow Imaging Unit	108R00649
Black Imaging Unit	108R00650
<b>Fuser, Phaser 7400</b>	
110 V	115R00037
220 V	115R00038
Transfer Unit	101R00421
<b>Paper Feed Roller Kit</b> (this is a Maintenance item & a Service item)	604K41690
Waste Toner Reservoir	106R0108

## Power Cords

Description	Part Number
Cable PWR, 115 V, 98, 0L	161-0312-00
Cable PWR EURO 220V , 99L	161-0066-09
Cable PWR U.K. 240 V, 96L	161-0066-10
Cable PWR AUST 240 V, 96L	161-0066-11
Cable Assy SWISS 220/240 V, 50 Hz	161-0154-00
Cable Assy PWR. DANISH, 250 V	161-0240-00
Cable Assy PWR, PRC	161-0304-00
Power, 240 V, ARGENTINA	161-0307-00

## Upgrade Kits and Options

Description	Part Number
Internal Hard Drive	121K44692
Memory: 256 MB, 16M x 64, PC133; Memory DIMM	856000300
512 MB, 32M x 64, PC133; Memory DIMM	856000400
Duplex Unit	084K35440
1650-Sheet Feeder w/ Trays	097S03368
550-Sheet Feeder w/ Tray	097S03361

## Toner Cartridge Consumables

Description (capacity)	Part Number
Yellow Toner Cartridge, Standard-Capacity (7.5K)	106R01152
Yellow Toner Cartridge, High-Capacity (15K)	106R01079
Yellow Toner Cartridge, Metered (15K)	106R01155
Magenta Toner Cartridge, Standard Capacity (7.5K)	106R01151
Magenta Toner Cartridge, High-Capacity (15K)	106R01078
Magenta Toner Cartridge, Metered (15K)	106R01154
Cyan Toner Cartridge, Standard-Capacity (7.5K)	106R01150
Cyan Toner Cartridge, High-Capacity (15K)	106R01077
Cyan Toner Cartridge, Metered (15K)	106R01153
Black Toner Cartridge, High-Capacity (15K)	106R01080
Black Toner Cartridge, Metered (15K)	106R01156

## Service Kits

Service kits are developed to provide an easy means to obtain spare parts normally associated with larger assemblies. A number of Service Kits have been developed for the Phaser 7400. The following tables list each kit's contents.

### Feed Roller Kit

The Feed Roller Kit provides replacement rollers for the Feeder Assemblies.

#### Feed Roller Kit Contents - 604K41690

Name/Description	Quantity
Feed Roller	1
Torque Limiter	1
Roller, Feed Now	1
Pick Roller	1
MPT Roller Kit	1

# Sensor Kit

The Sensor Kit provides replacement sensor actuators.

## Sensor Kit Contents - 604K35590

Sensor Kit Contains 6 sensors that are used for in the following locations:

PL 2.1.36	Fuser Release Sensor
PL 4.2.89	No Paper-Low Paper-Door B Detect Sensor
PL 8.1.8	Tray 1 (MPT) Home Position Sensor
PL 9.1.67	1-Sensor-Regist-Sub-Assy
PL 10.1.2	Feed Out Sensor #1
PL 10.1.3	OHP Sensor 1-Photo-Interrupter
PL 10.1.32	No Paper Sensor
PL 10.1.36	Level Sensor
PL 11.1.13	Fuser Exit Sensor
PL 11.1.32	Side Output Tray Detect Sensor
PL 11.1.39	Top Output Tray Stack Full/Door E Detect Sensor

# Actuator Kit

The Actuator Kit provides replacement sensor actuators.

## Actuator Kit Contents - 604K35580

Name/Description	Quantity
Spring-Torsion (IN2)	1
Lever-Sensor (IN2)	1
Lever-Sensor( WR)	1
Spring-Torsion (WR)	1
Lever-Exit_Sensor	1
Spring-SNS (F/R)	1
Lever-Stacker-Full-F	1
Lever-Stacker-Full-Sub	1
Lever-Paper-END	1
Spring-Paper-End (joboff)	1
Lever-Stacker-Full-FU	1
Lever-Hopping	1
Lever-Paper End (MPT)	1
Lever-Paper (MPT)	1
Spring-Paper (MPT)	1
Link-Inter-Lock	1
Spring-Inter-Lock	1
Lever-Sns-Dup2	1
Spring-SNS-Dup2	1



# Gear Kit

## Gear Kit Contents - 604K35550

<b>Name/Description</b>	<b>Quantity</b>
Gear-BKL2	1
Gear-BKR2	1
Gear-Z38(one-way)	1
Gear-idle(Z39)	1
Gear-Idle(Z44)	2
Gear-Idle-Link	1
Gear-Idle-Liftup-Z20-30	1
Gear-Idle-Lift-UP-Z37	1
Gear-Z14-42	1
Gear-Z14-35	2
Gear-Idle-Drum	1
Gear-Z77-FU	1
Gear-Ground-Z16-FU	1
Gear-Z20-FU	1
Gear-Z17-FU	1
Gear-Z16-FU	1
Gear-OnewayBevel(Z20)	1
Gear-OnewayBevel(Z20)	1
Gear Assy.-CL(Reg2) (Registration Clutch #1)	1





# Wiring Diagrams

## In this chapter...

- Plug/Jack Designators
- Plug/Jack Locators
- Wiring Diagrams

## Section 10

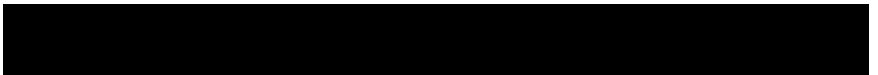

# Plug/Jack Locator Diagrams

The P/J Locator diagrams show the location of primary connections within the printer and optional sheet feeders. Use these illustrations to locate connections called out in the troubleshooting procedures presented in Sections 3, 4, and 5.

To find the location of a Plug or Jack:

1. Locate the P/J connector designator in the first column of the table.
2. With this information, go to the map listed in the second column.
3. Use the coordinates to quickly locate the connection indicated on the map with its P/J designation number.

## Print Engine Plug/Jack Designators

### Print Engine Plug/Jack Designators

P/J	Map	Coordinates	Remarks
30	7	I-839	Connects the Feed Motor to the REGHOP harness.
40	7	I-839	Connects the Registration Motor to the REGHOP harness.
41	2	I-839	Connects the Door B Detect Sensor to the TRYSNS2 harness.
42	7	G-841	Connects the Registration #2 Sensor to the TRYSNS2 harness.
43	7	G-841	Connects the Feed-Out #2 Sensor to the TRYSNS2 harness.
44	7	G-841	Connects the No Paper Sensor to the PAPEND harness.
50	7	G-838	Connect the Waste Toner Motor the WTDC harness.
80	1	D-838	Connect the Registration Shutter Solenoid to the SHUT harness.
81	1	E-837	Connects the SHUT harness to the Motor Driver Board.
90	7	C-837	Connects the Offset Motor to the JOFMOT harness.
100	7	B-839	Connects the Imaging Unit Fan to the IDFAN harness.
120	7	B-839	Connects the Transfer Unit Motor to the Transfer Motor harness.
130	2	B-837	Connects the Door E Detect Sensor to the Exit SNR harness.
140	2	D-837	Connects the Fuser Exit Sensor to the Exit SNR harness.
150	7	E-837	Connects the Offset Position Sensor to the Exit SNR harness.
160	7	E-836	Connects the Top Output Tray Stack Full Sensor to the Exit SNR harness.
170	7	D-836	Connects the Side Output Tray Stack Full Sensor to the Exit SNR harness.
180	2	E-836	Connects the Side Output Tray Detect Sensor to the Exit SNR harness.

## Print Engine Plug/Jack Designators (Continued)

<b>P/J</b>	<b>Map</b>	<b>Coordinates</b>	<b>Remarks</b>
190	2	B-838	Connects the Fuser Release Sensor to the Fuser Release harness.
191	1	F-836	Connects the Fuser Release harness to the Registration SNR harness.
192	1	E-837	Connects the ADC Sensor to the Registration SNR harness.
193	2	E-837	Connects the Media Slack Sensor to the Registration SNR harness.
200	4	A-835	Connects the Image Processor Board and IP Fan.
220	1	E-840	Connects the Waste Toner Reservoir Full Sensor and CN4 harness.
250	7	E-836	Connects the Fuser Fan to the FSRFAN Harness.
260	7	G-837	Connects the FSRFAN Harness to the IDFAN Harness.
310	1	E-840	Connects the Waste Toner Reservoir Auger Rotation Sensor to the HALL1 harness.
320	1	H-838	Connects the Waste Toner Auger Rotation Sensor and HALLDCT harness.
330	1	D-839	Connects the Transfer Unit Belt Rotation Sensor and HALL1 harness.
350	1	D-837	Connects the Cyan LED Head to CPOW2 on the LED Relay Board.
351	1	D-838	Connects the Magenta LED Head MPOW2 on to the LED Relay Board.
352	1	E-838	Connects the Yellow LED Head to YPOW2 on the LED Relay Board.
353	1	F-838	Connects the Black LED Head to KPOW2 on the LED Relay Board.
360	1	F-836	Connects the Cyan LED Head to CC on the Engine Control Board.
361	1	F-836	Connects the Magenta LED Head MM on to the Engine Control Board.
362	1	G-836	Connects the Yellow LED Head to YY on the Engine Control Board.
363	1	H-837	Connects the Black LED Head to KK on the Engine Control Board.
410	2	H-839	Connects the Media Thickness Sensor to the PTHICK harness.
420	2	H-839	Connects the Temperature/Humidity Sensor to the ENV harness.
430	2	F-840	Connects the Tray 1 (MPT) Home Position Sensor and MPTHOME harness.
433	10	F-837	Connects the OHP Sensor to the MPTSNS harness.
440	10	G-837	Connects the Tray 1 (MPT) No Paper Sensor and MPTSNS harness.
450	10	H-836	Connects Feed-Out Sensor #1 to the MPTSNS harness.
460	10	G-836	Connects the Tray 1 (MPT) Level Sensor and MPTPAP harness.
471	10	G-835	Connects the Tray 2 Paper Size Switch to the PSIZE harness.
491	2	F-837	Connects the LVPS to the Fuser.
492	7	H-837	Connects the Top Cover Fan to the IDFAN harness.

# Print Engine Plug/Jack Locators

The following maps indicate the location of key connections within the printer. Connections are referenced by their P/J designation.

## Map 1 - Xerographics

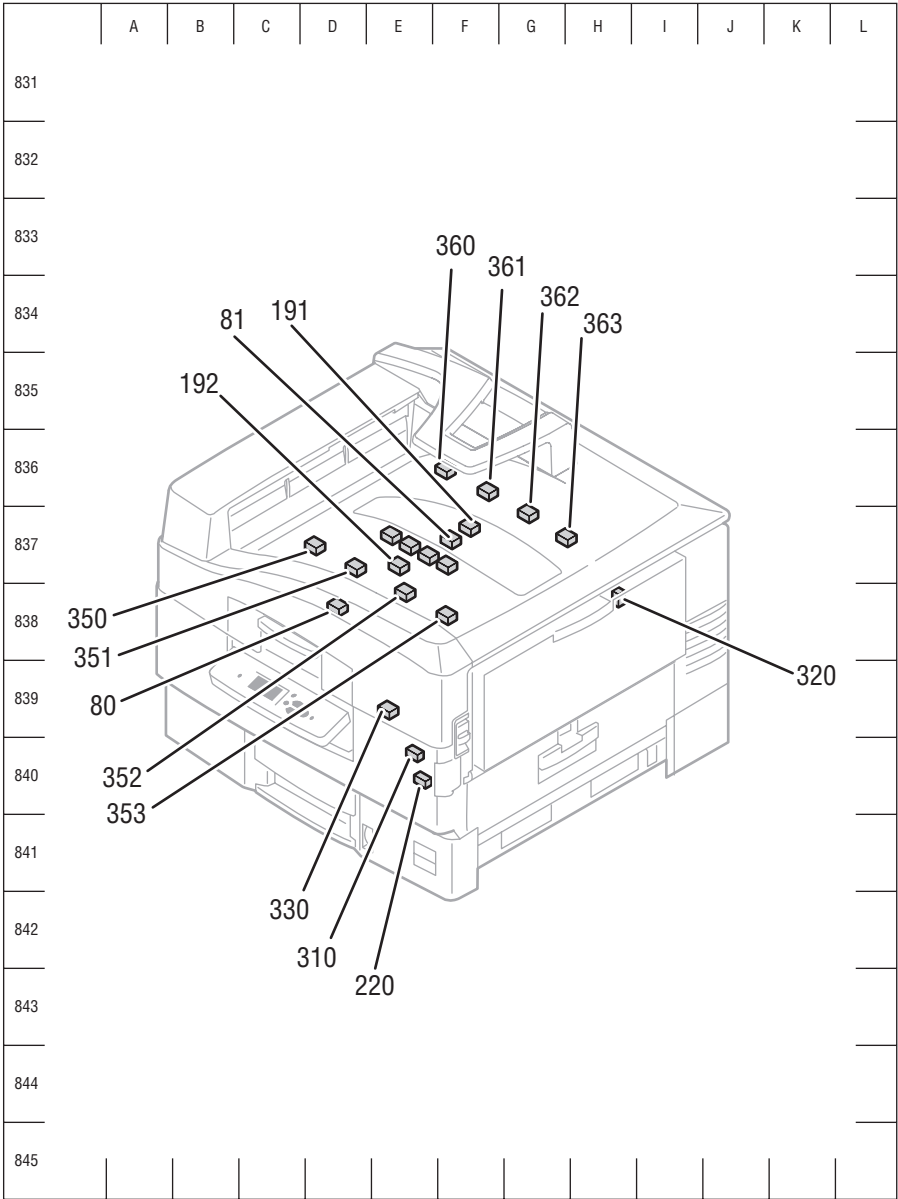

s7400-590

## Map 2 - LVPS and Drive

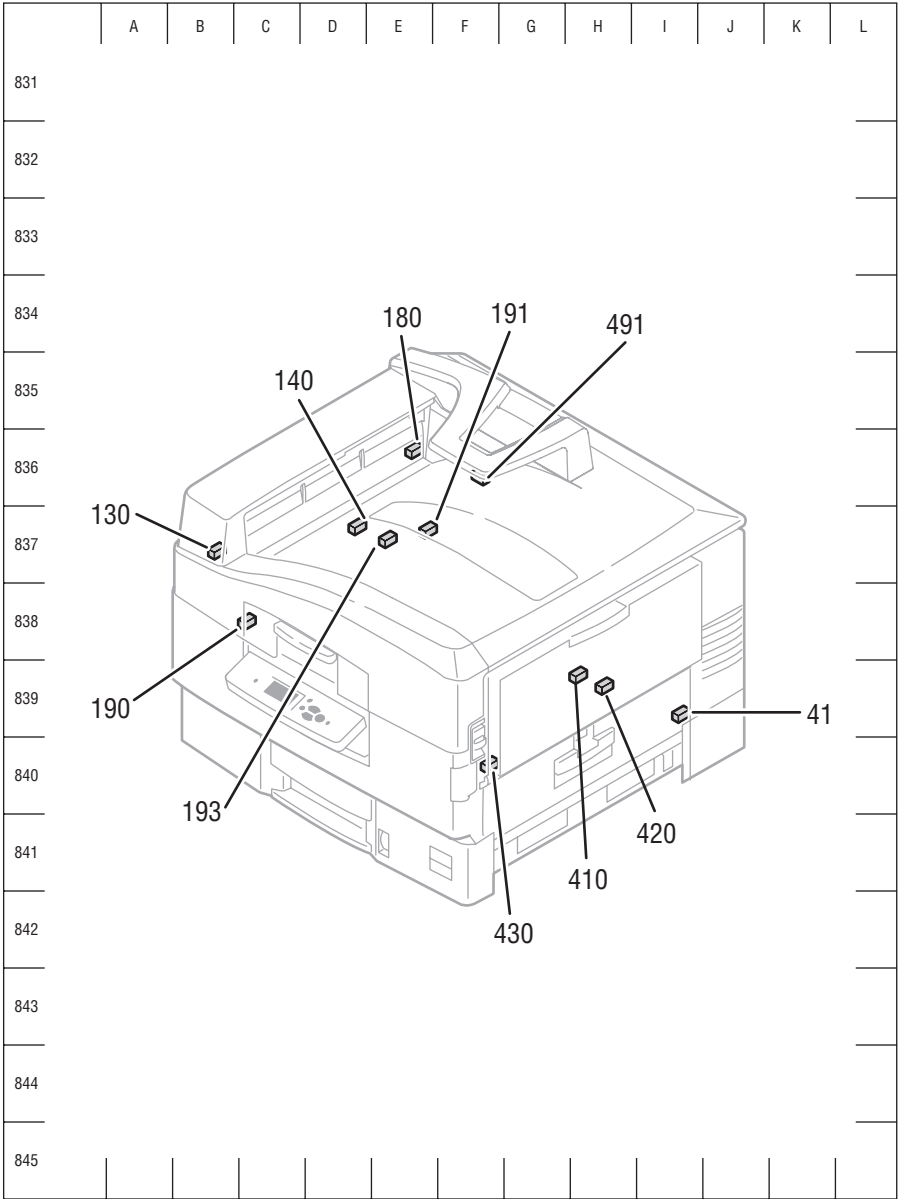

s7400-591

# Map 3 - Engine Control Board

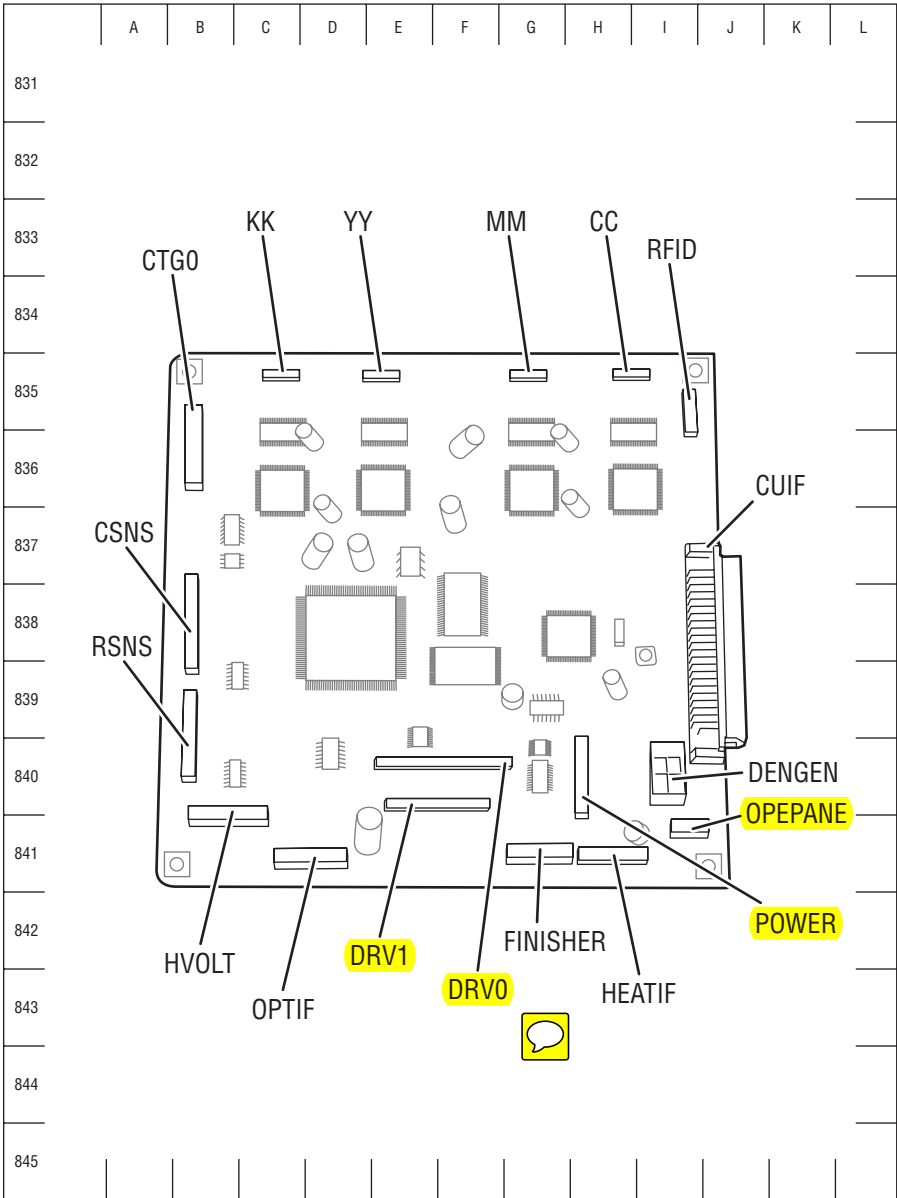

s7400-566

# Map 4 - Image Processor Board

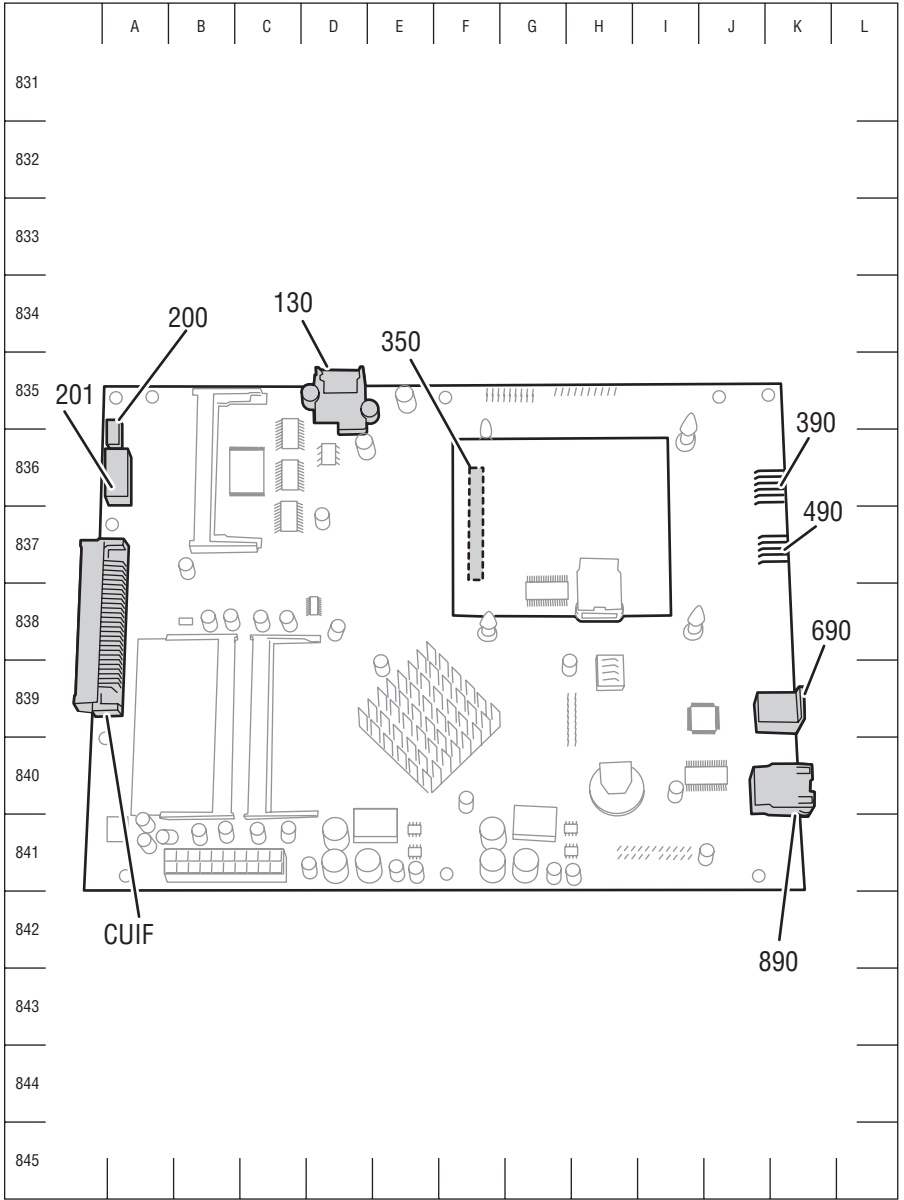

s7400-606

# Map 5 - Motor Driver Board

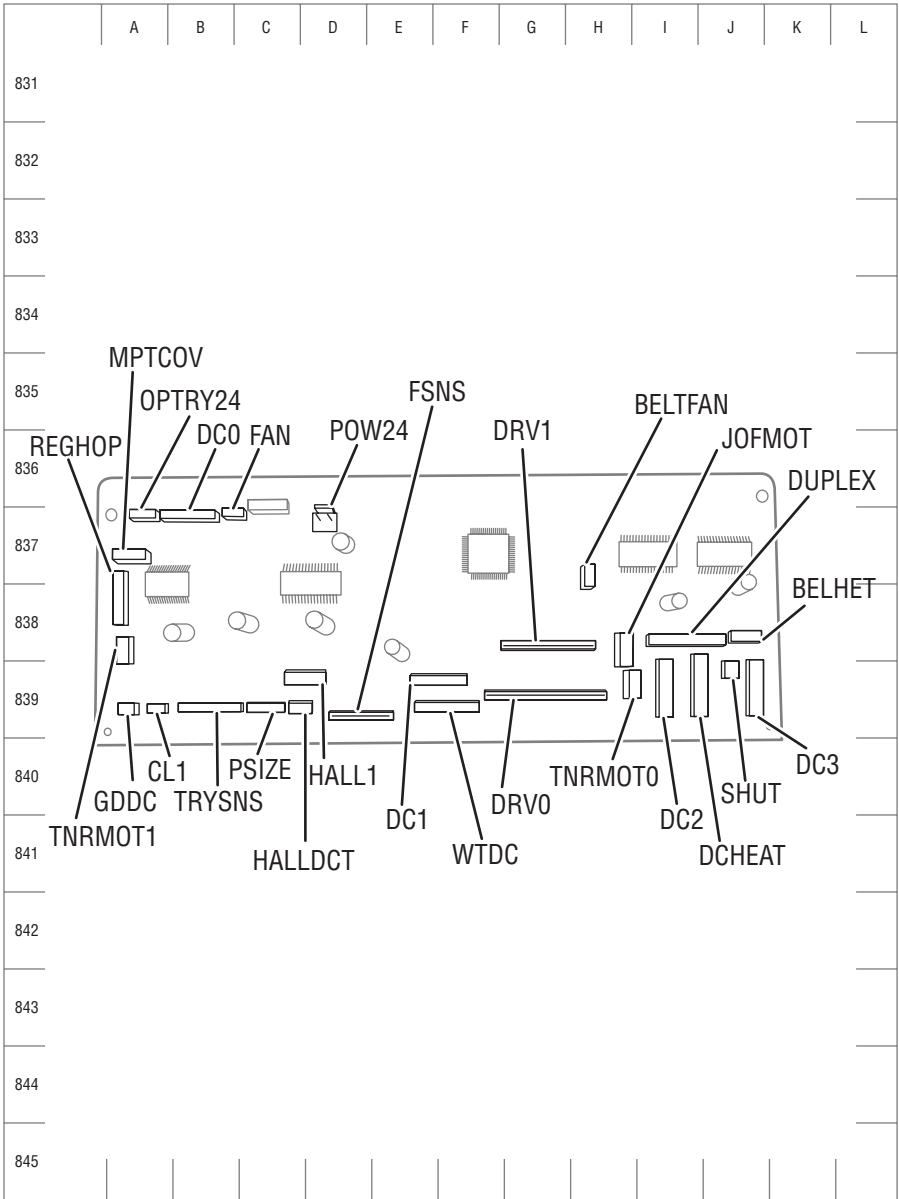

s7400-530



# Map 6 - LVPS

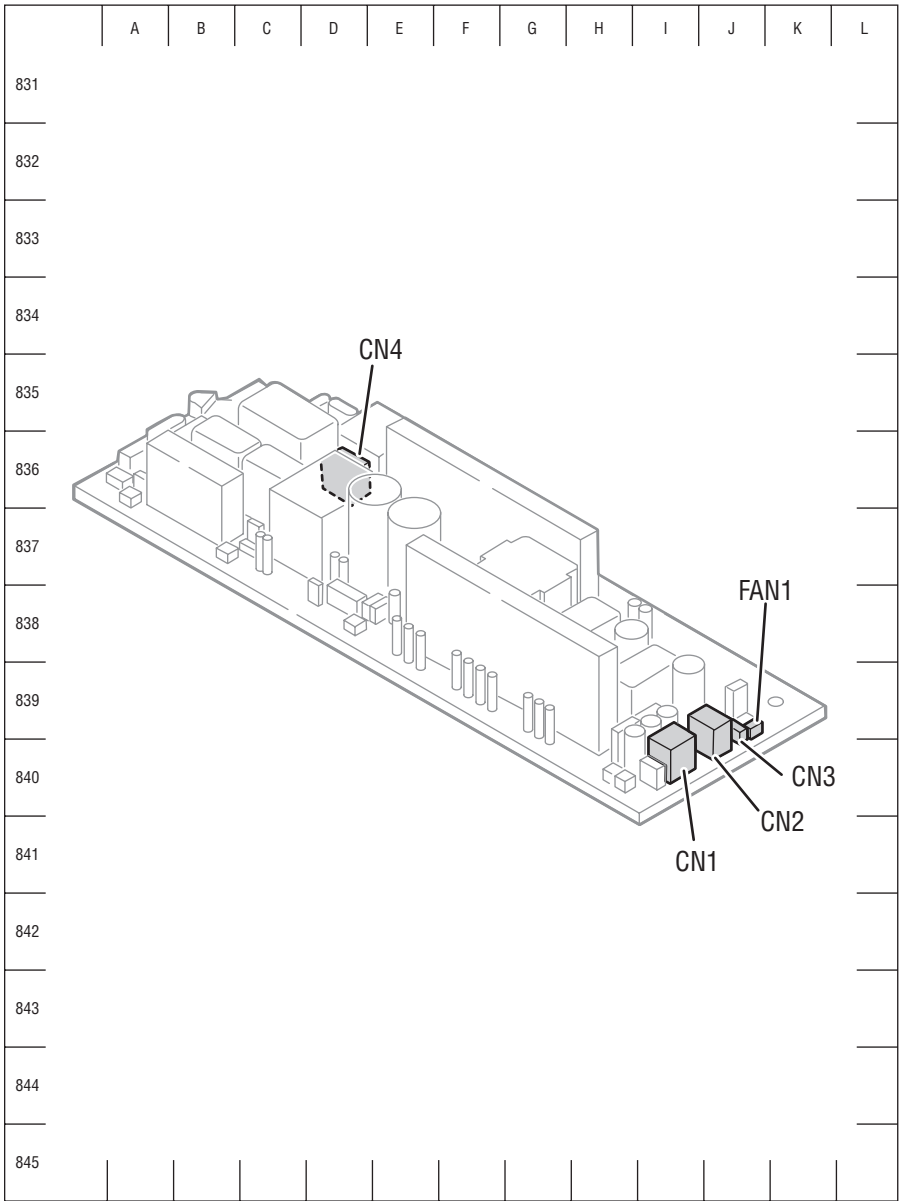

s7400-622

# Map 7 - Universal Feeder

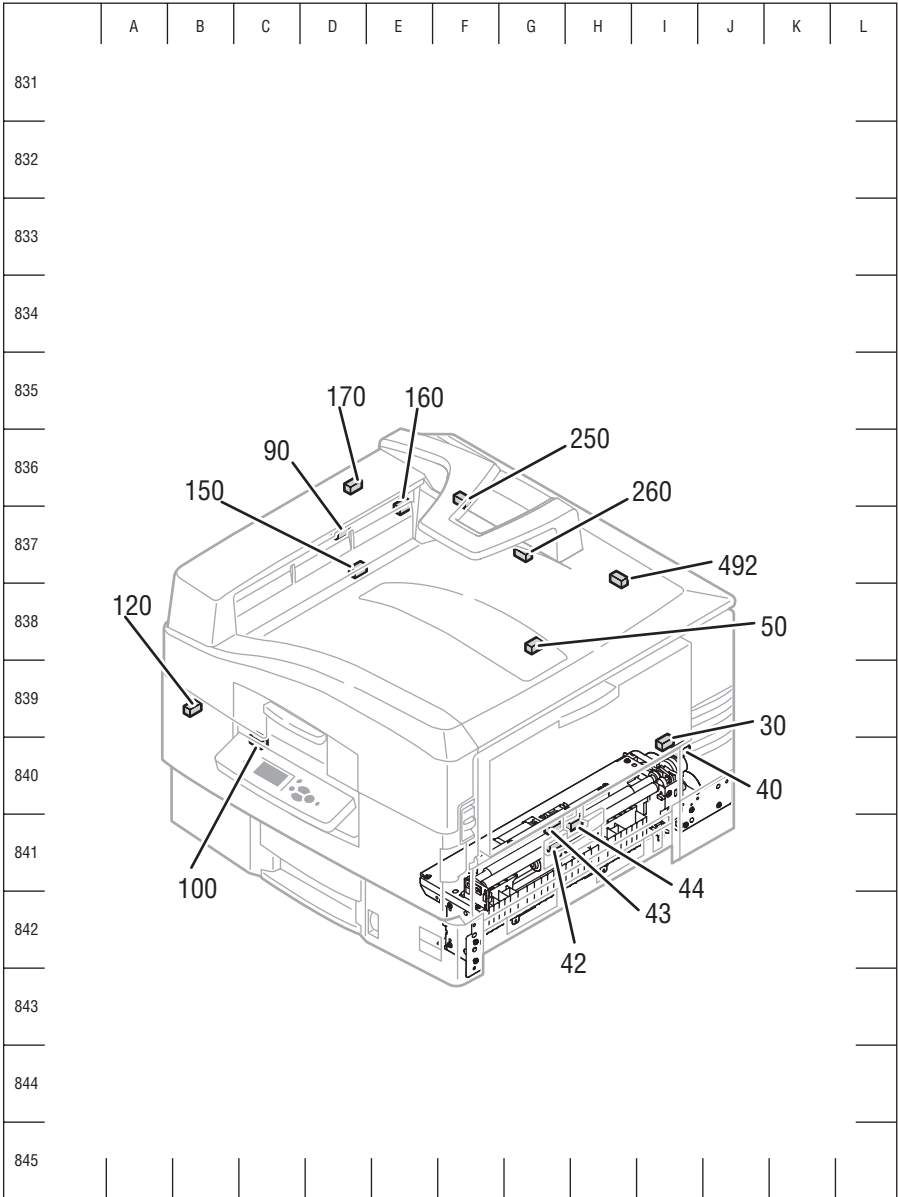

s7400-609

# Map 8 - Imaging Unit Sensor Board

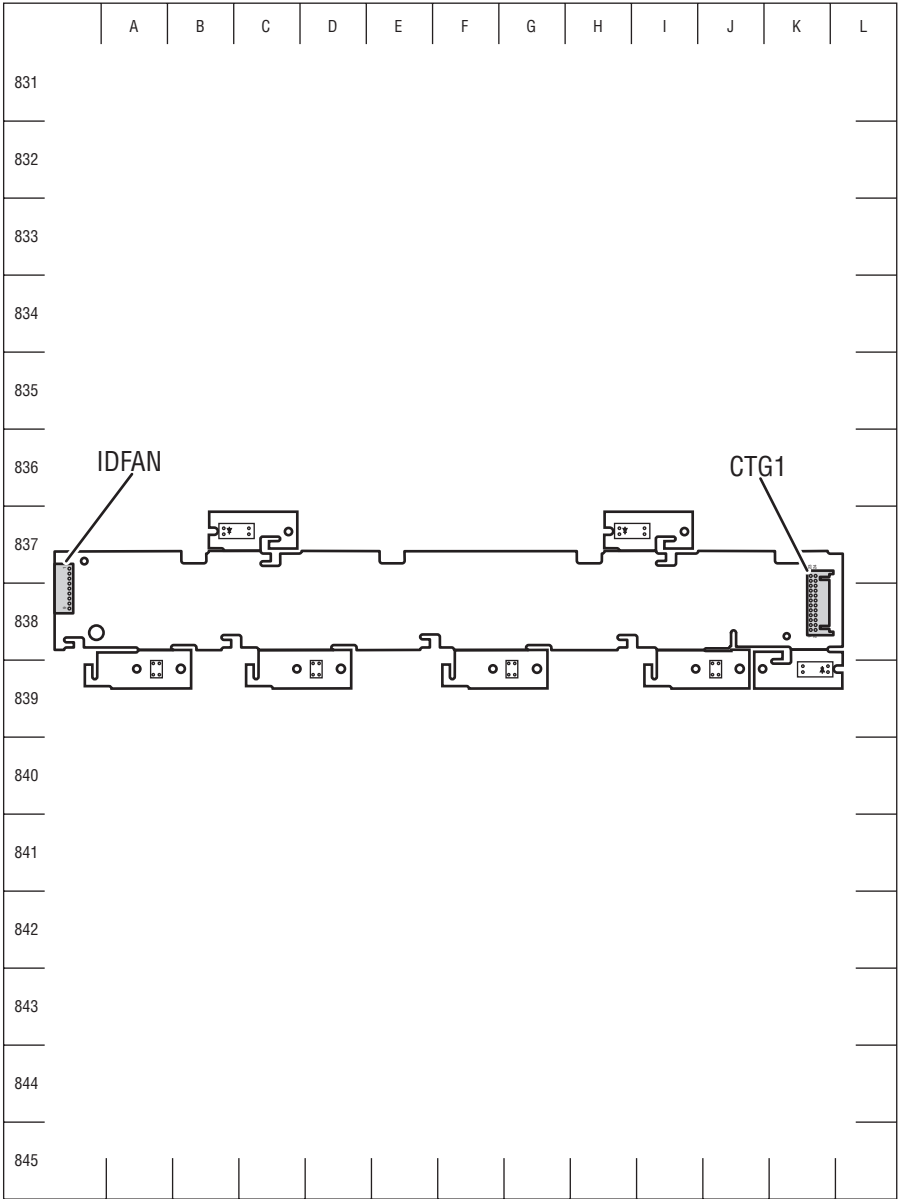

s7400-604

# Map 9 - Front Sensor Board

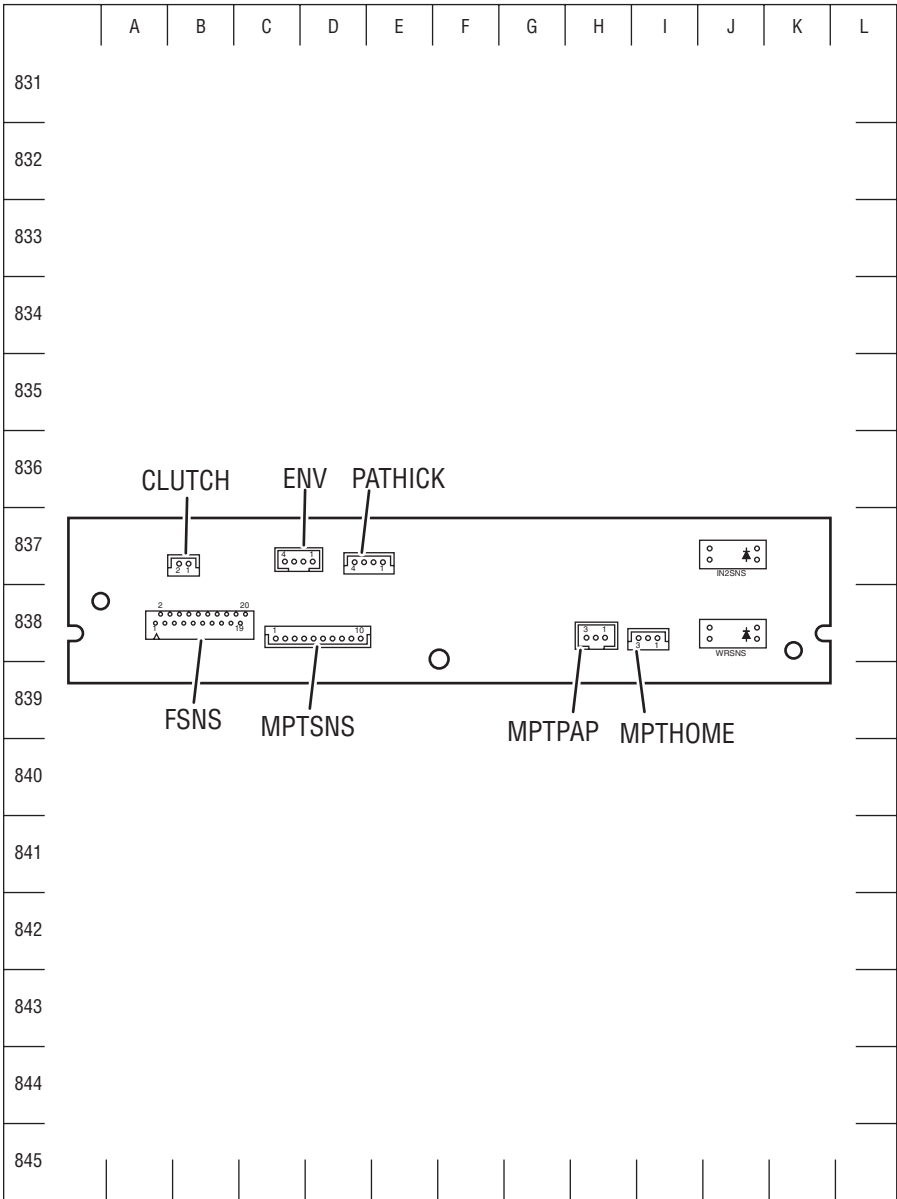

s7400-602

# Map 10 - Tray 1 (MPT) Feeder

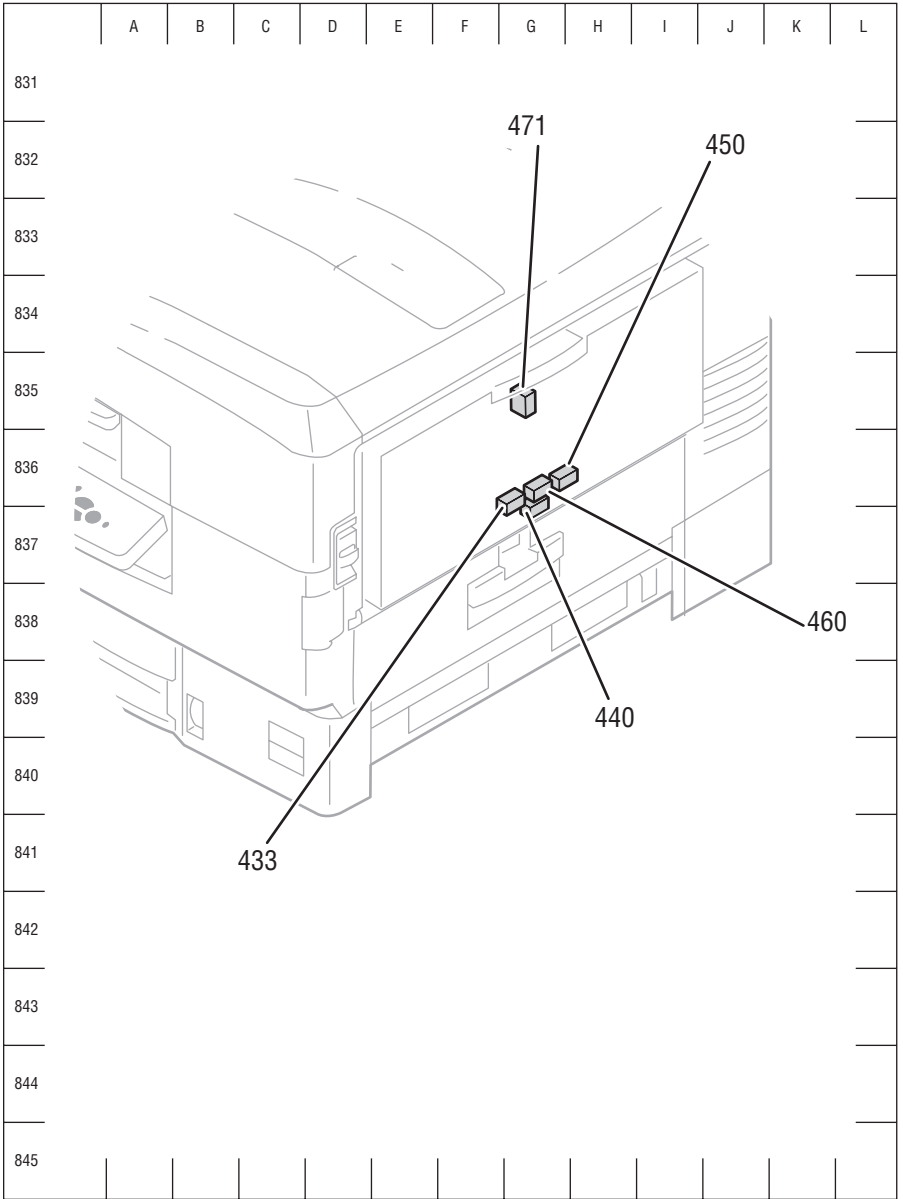

57400-693

# Map 11 - Rear Sensor Board

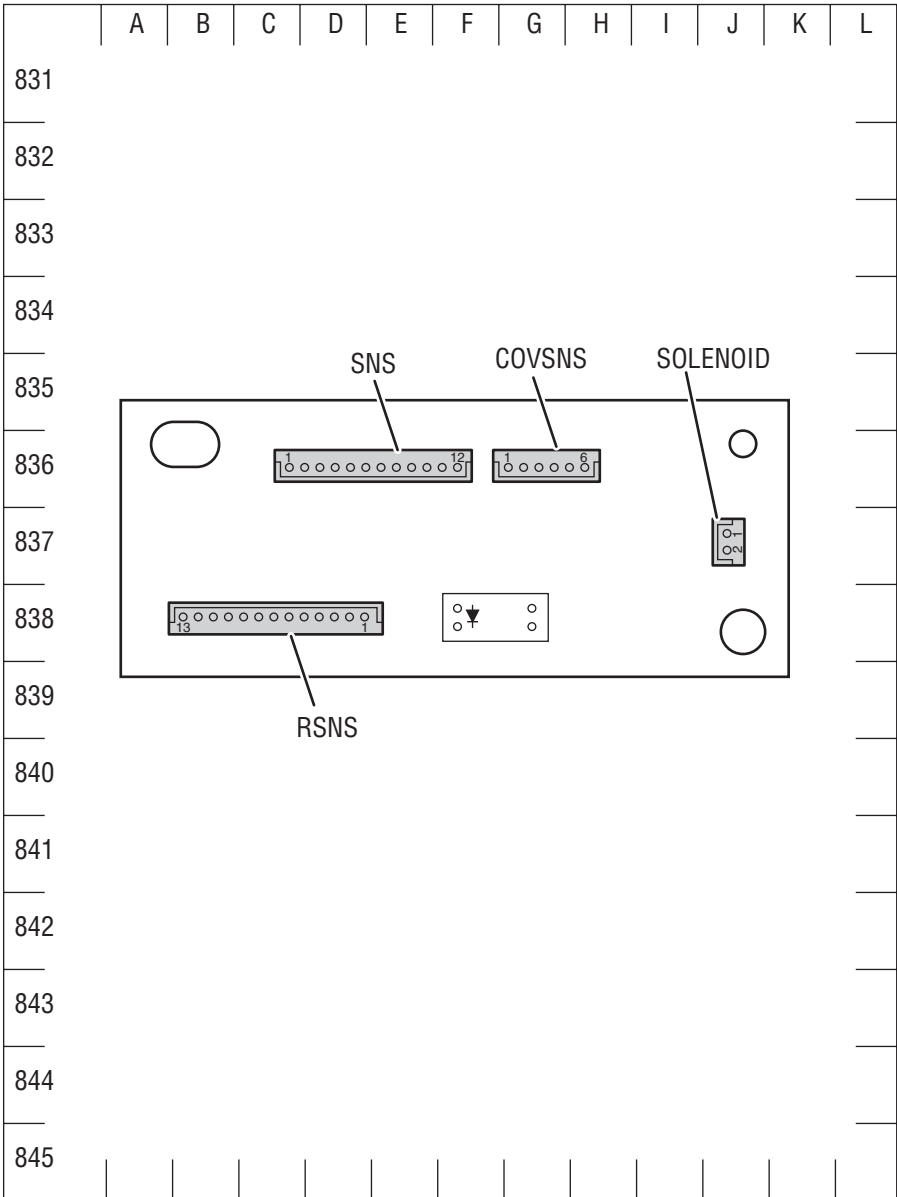

s7400-601

# Map 12 - Feeder Board

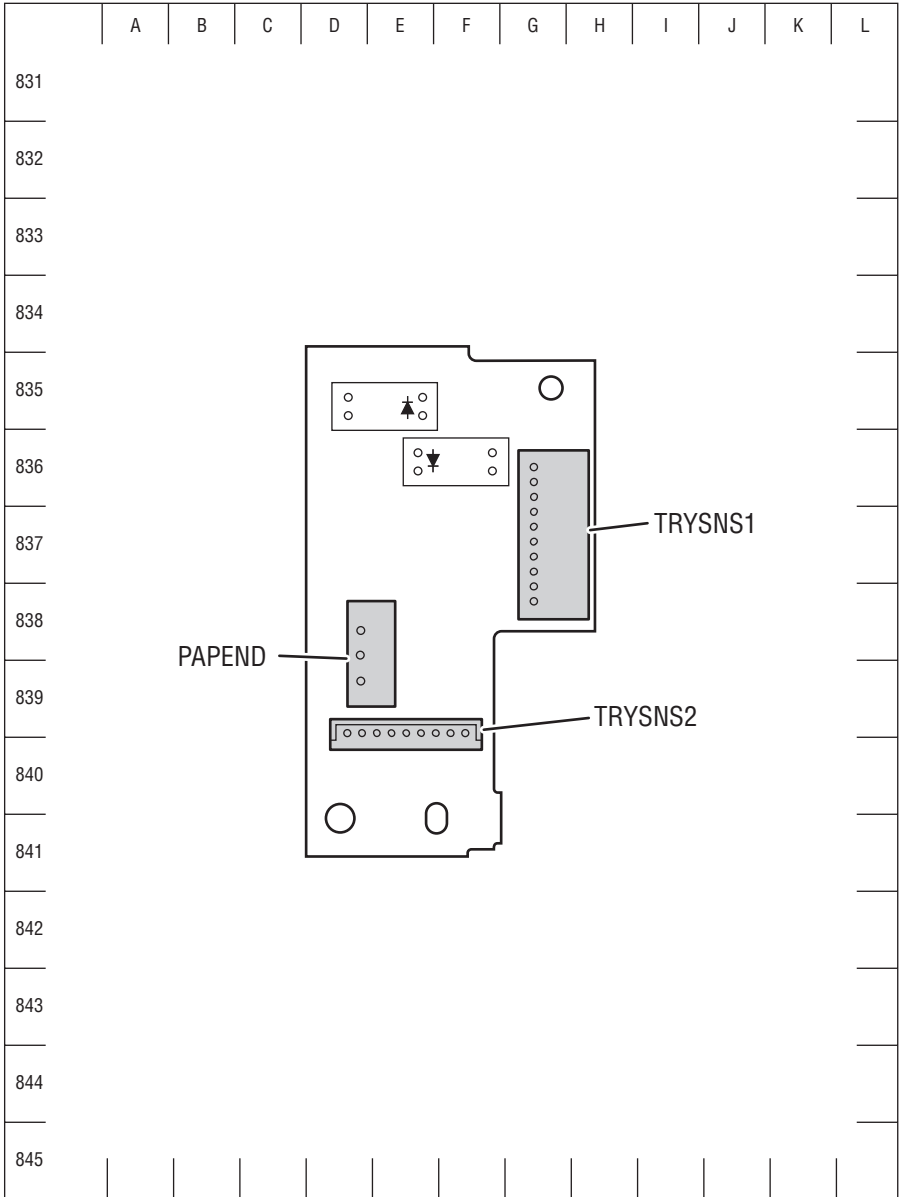

# Map 13 - LED Relay Board

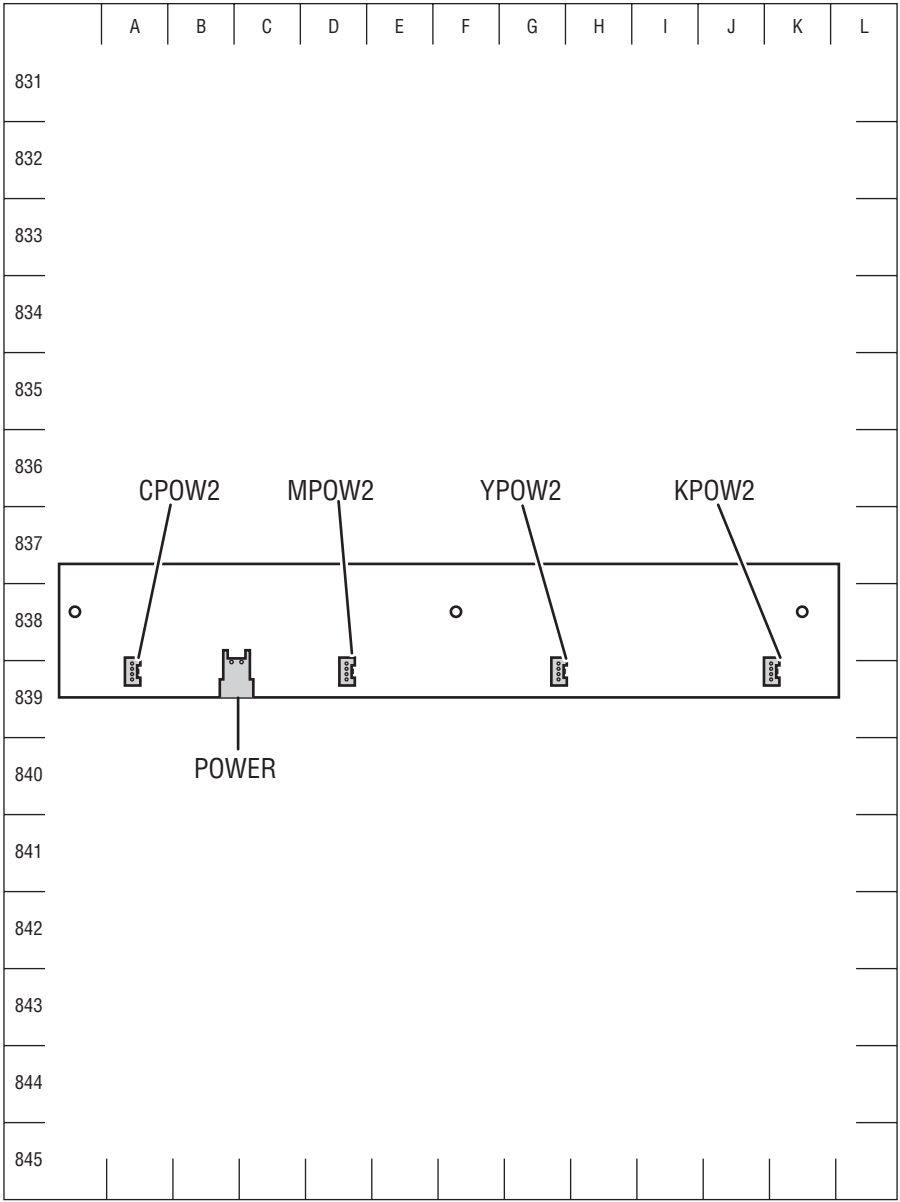





s7400-605





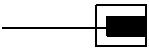
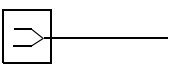
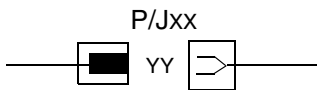

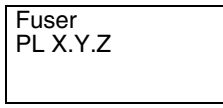
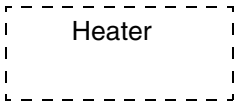
# Wiring Diagrams

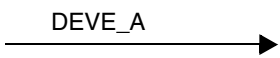
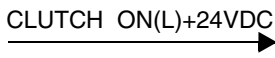
## Notations Used in Wiring Diagrams

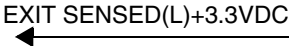
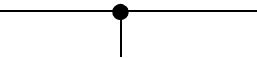
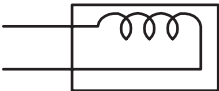
The following describes the legend used in the wiring diagrams shown on the following pages.

Symbol	Description
	Denotes a plug.
	Denotes a jack.
	Denotes Pin yy and Jack yy of the connector Pxx and Jxx.
	Denotes a Jumper Connection(JCxxx/xxx). Each end of the Jumper connection has a numeric designation.
	Denotes the parts. PL X.Y.Z implies the item "Z" of plate (PL) "X.Y" in Parts List.
	Denotes functional parts attached with functional parts name.
	Denotes the control and its outline in PWB.
	Denotes a connection between parts with harnesses or wires, attached with signal name/contents.
	Denotes the function, and logic value of the signal to operate the function (Low: L, High: H). The given voltage is for signal in high status. The arrow indicates the direction of signal.

Symbol	Description
	<p>Denotes the function, and logic value of the signal when the function operated (Low: L, High: H). The given voltage is for signal in high status. The arrow indicates the direction of signal.</p>
	<p>Denotes a connection between wires.</p>
	<p>Denotes a Clutch or Solenoid.</p>
	<p>Denotes a Motor.</p>
	<p>Denotes a photo-receptive sensor.</p>
	<p>Denotes a photo-reflective sensor.</p>
	<p>Denotes a fuse.</p>
<p>I/L +24VDC</p>	<p>Denotes DC voltage when the interlock switch in Engine Control Board turns on.</p>
<p>+5VDC +3.3VDC</p>	<p>Denotes DC voltage.</p>
<p>SG</p>	<p>Denotes signal ground.</p>

# Print Engine Wiring Diagrams

## Print Engine General Wiring (1/7)

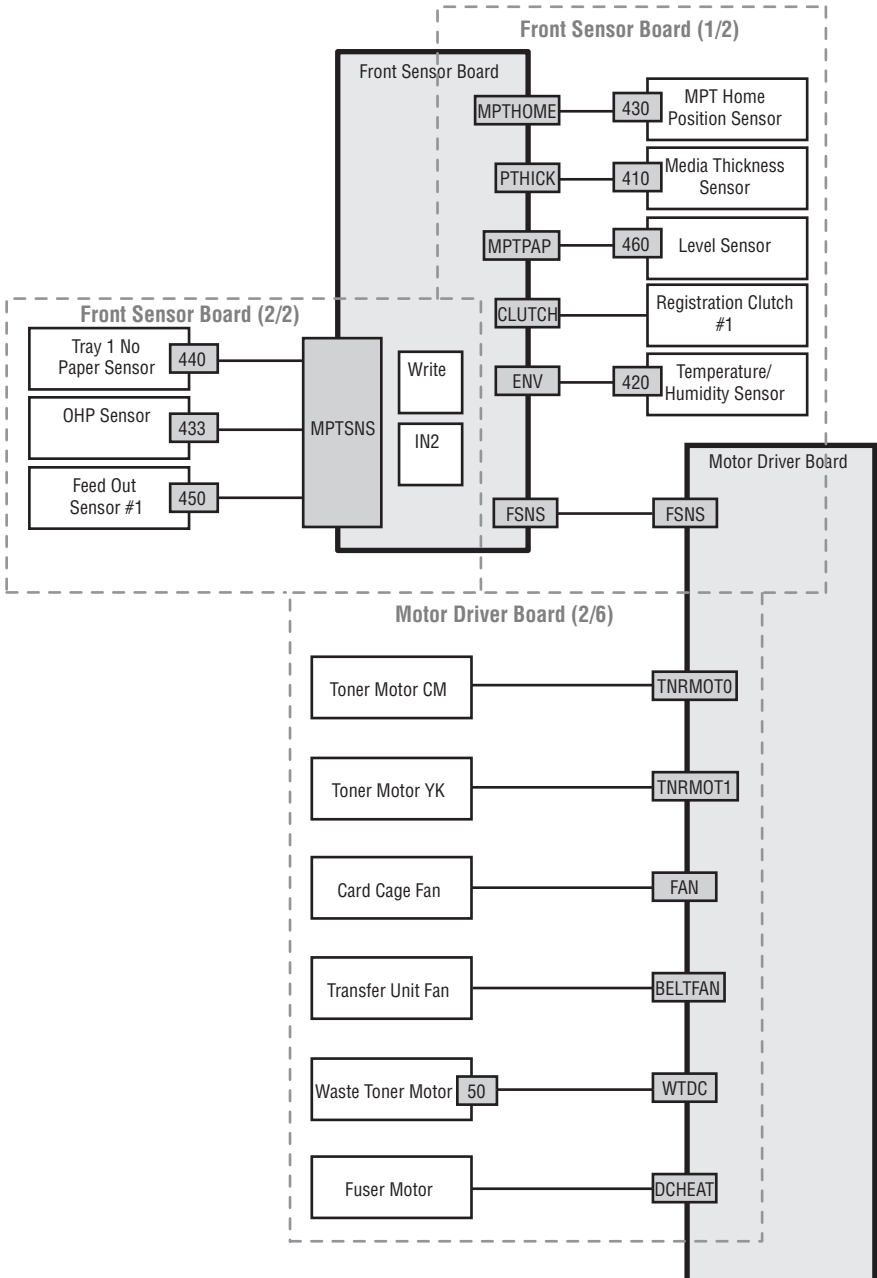

s7400-593

# Print Engine General Wiring (2/7)

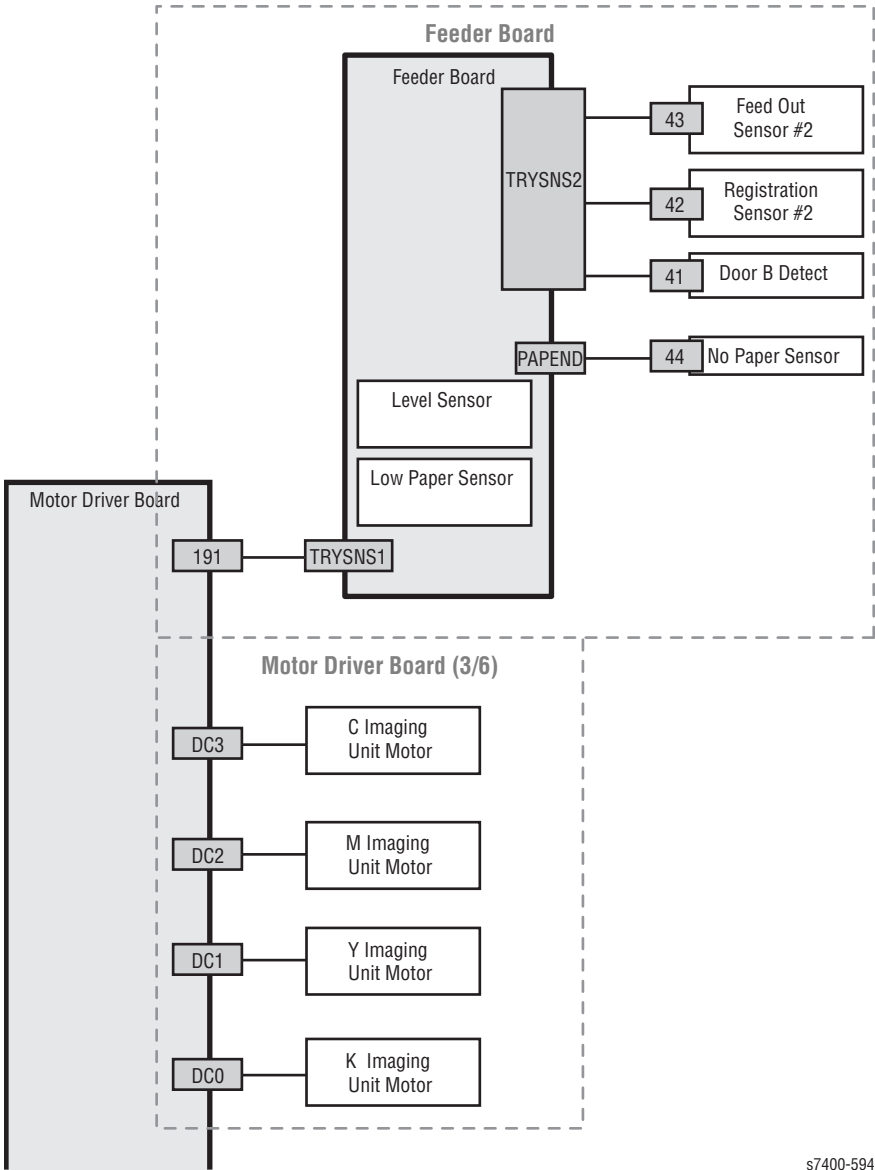

s7400-594

# Print Engine General Wiring (3/7)

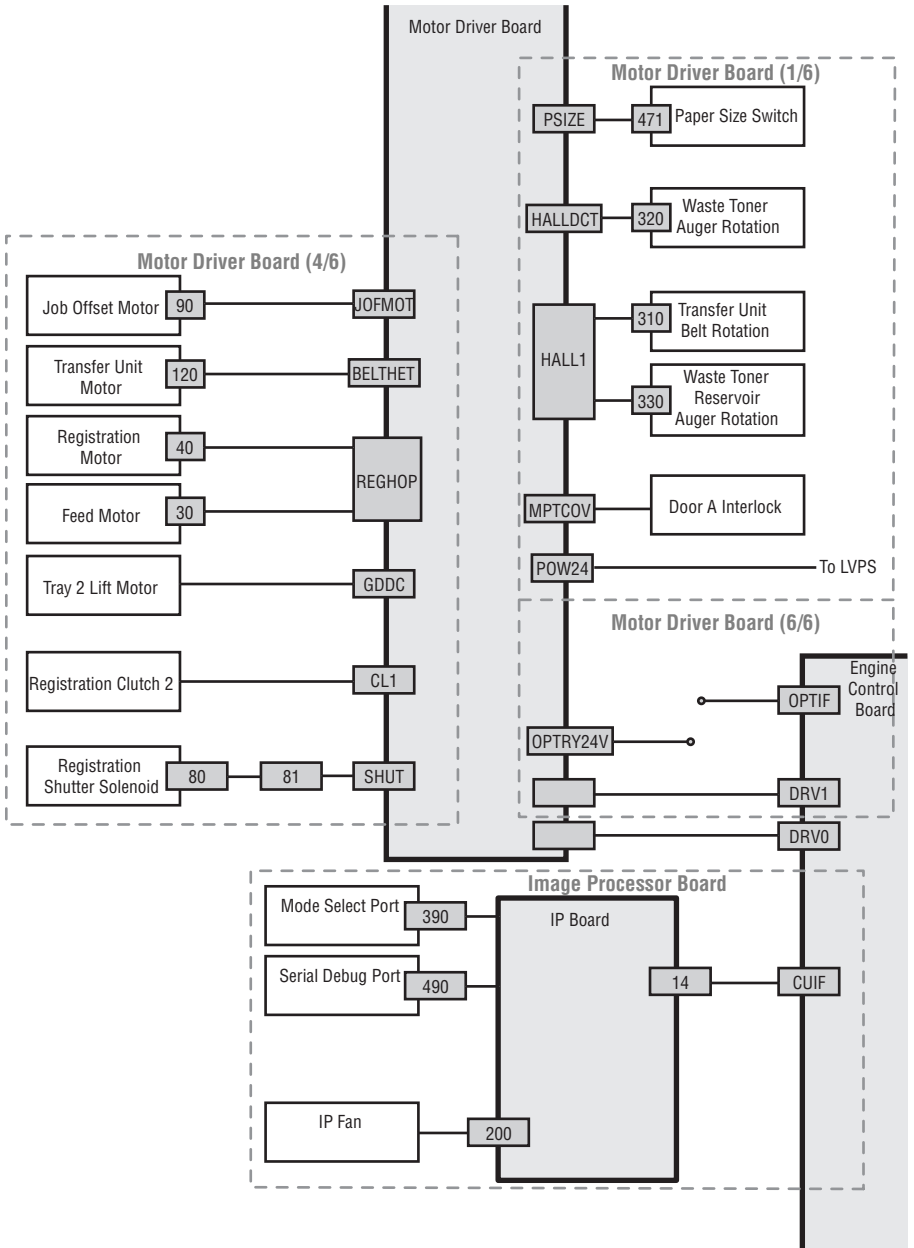

s7400-595

# Print Engine General Wiring (4/7)

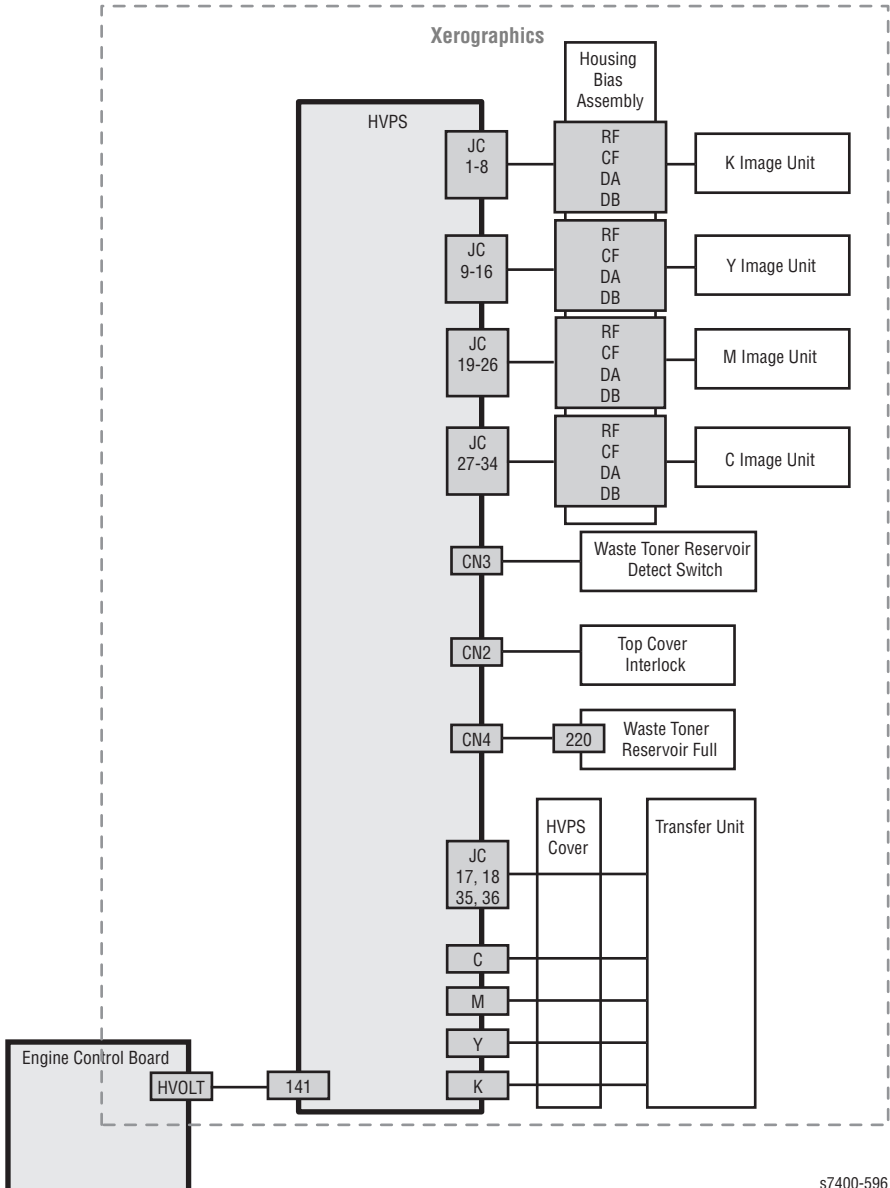

s7400-596

# Print Engine General Wiring (5/7)

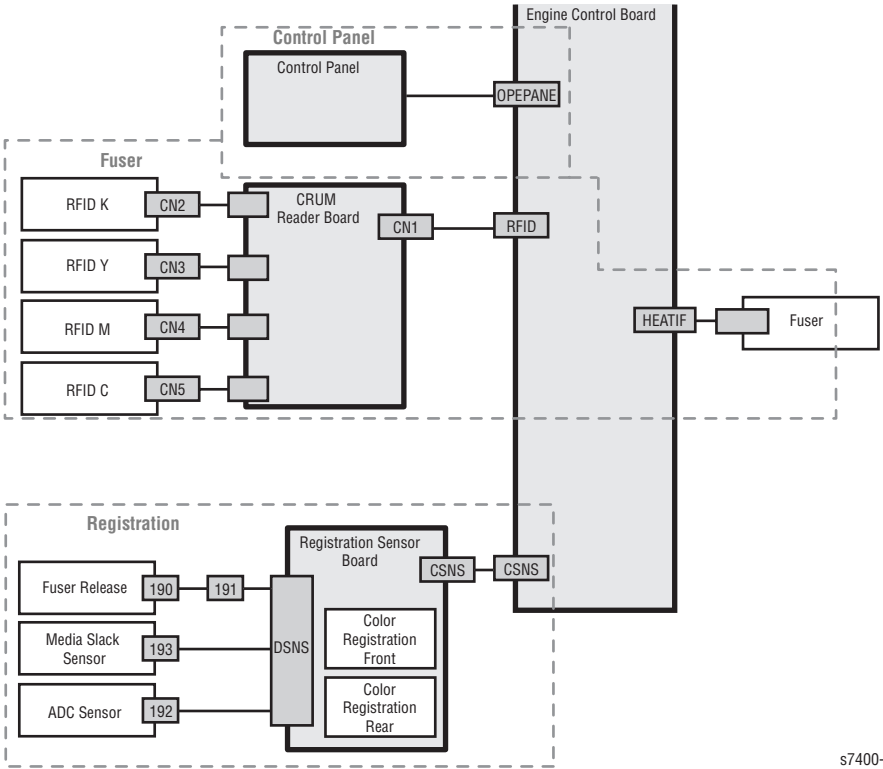

s7400-597

# Print Engine General Wiring (6/7)

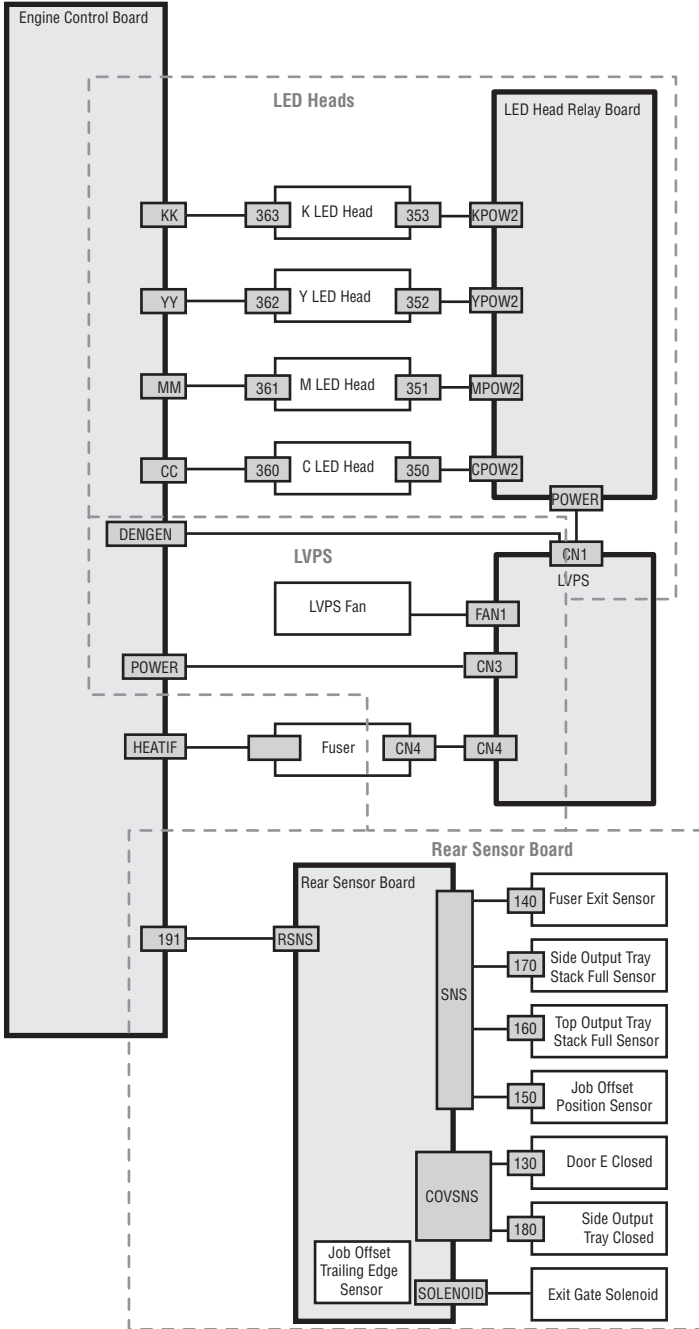

s7400-598



# Print Engine General Wiring (7/7)

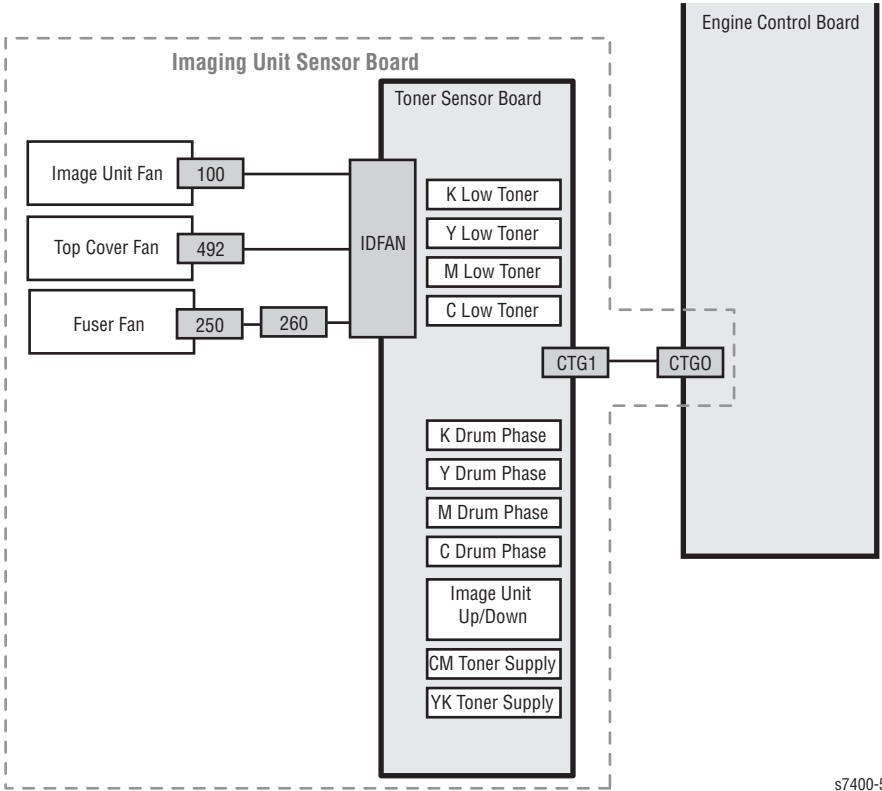

s7400-599

# Front Sensor Board (1/2)

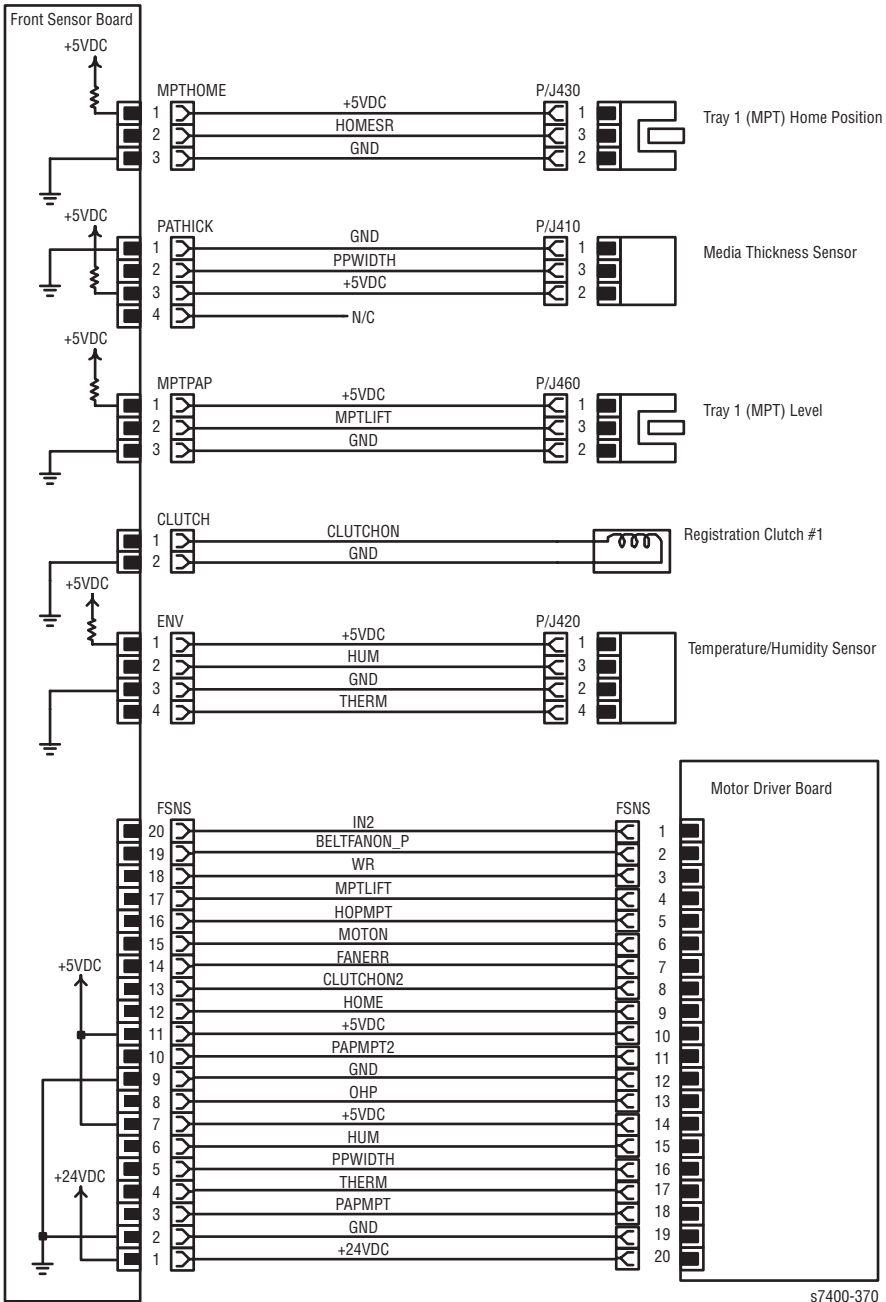

s7400-370

# Front Sensor Board (2/2)

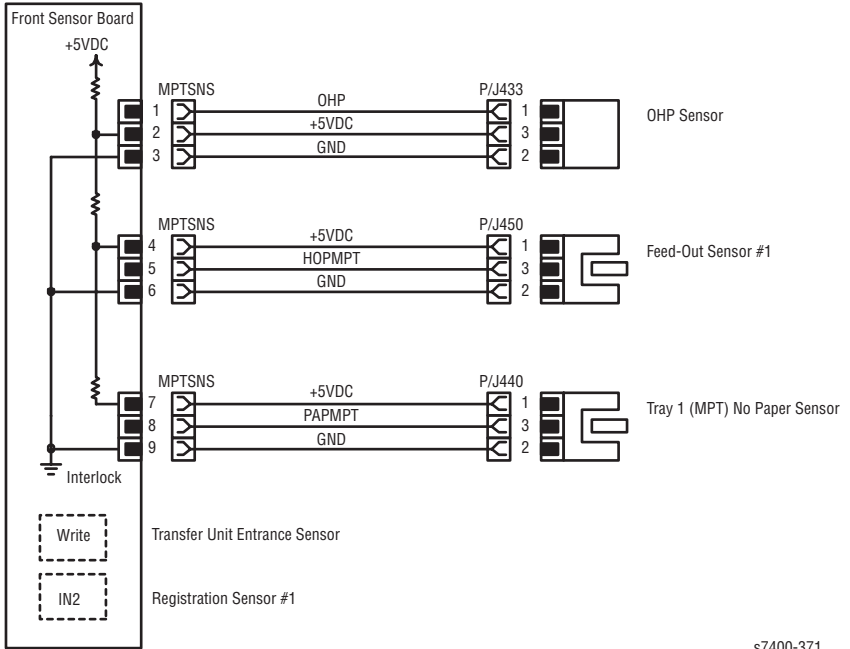

s7400-371

# Feeder Board

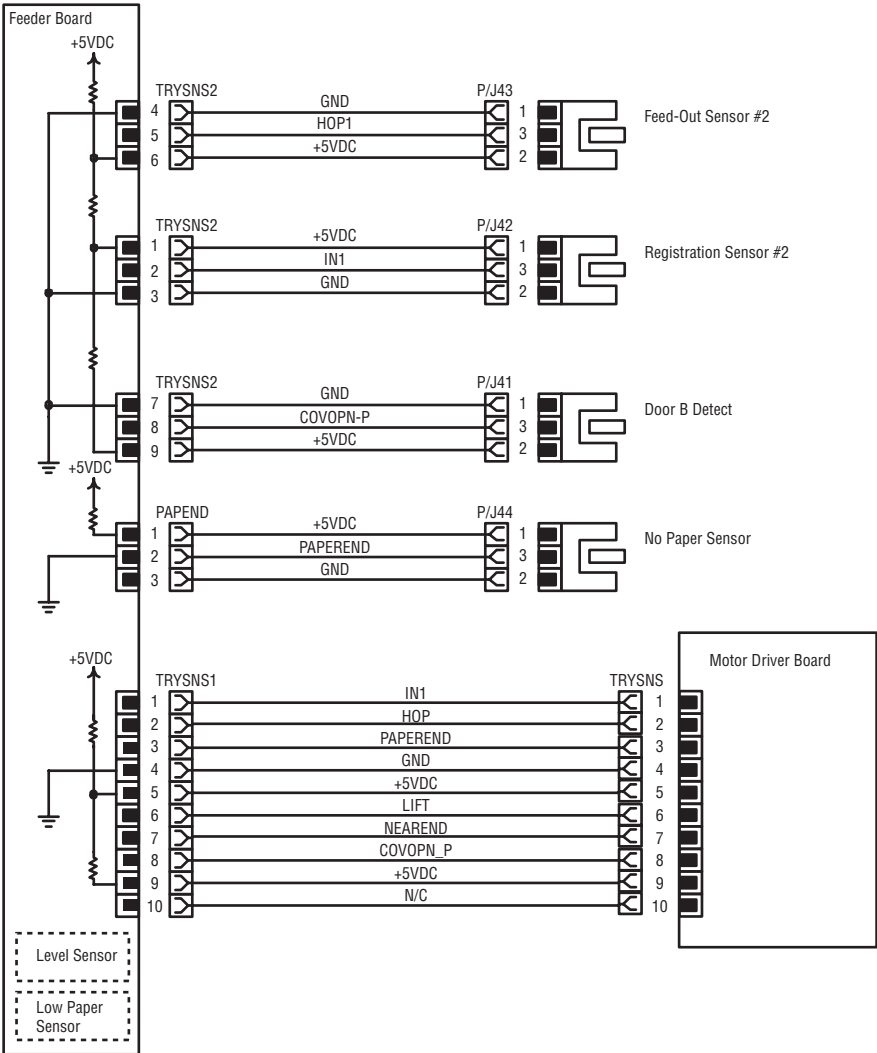

s7400-372

# Rear Sensor Board

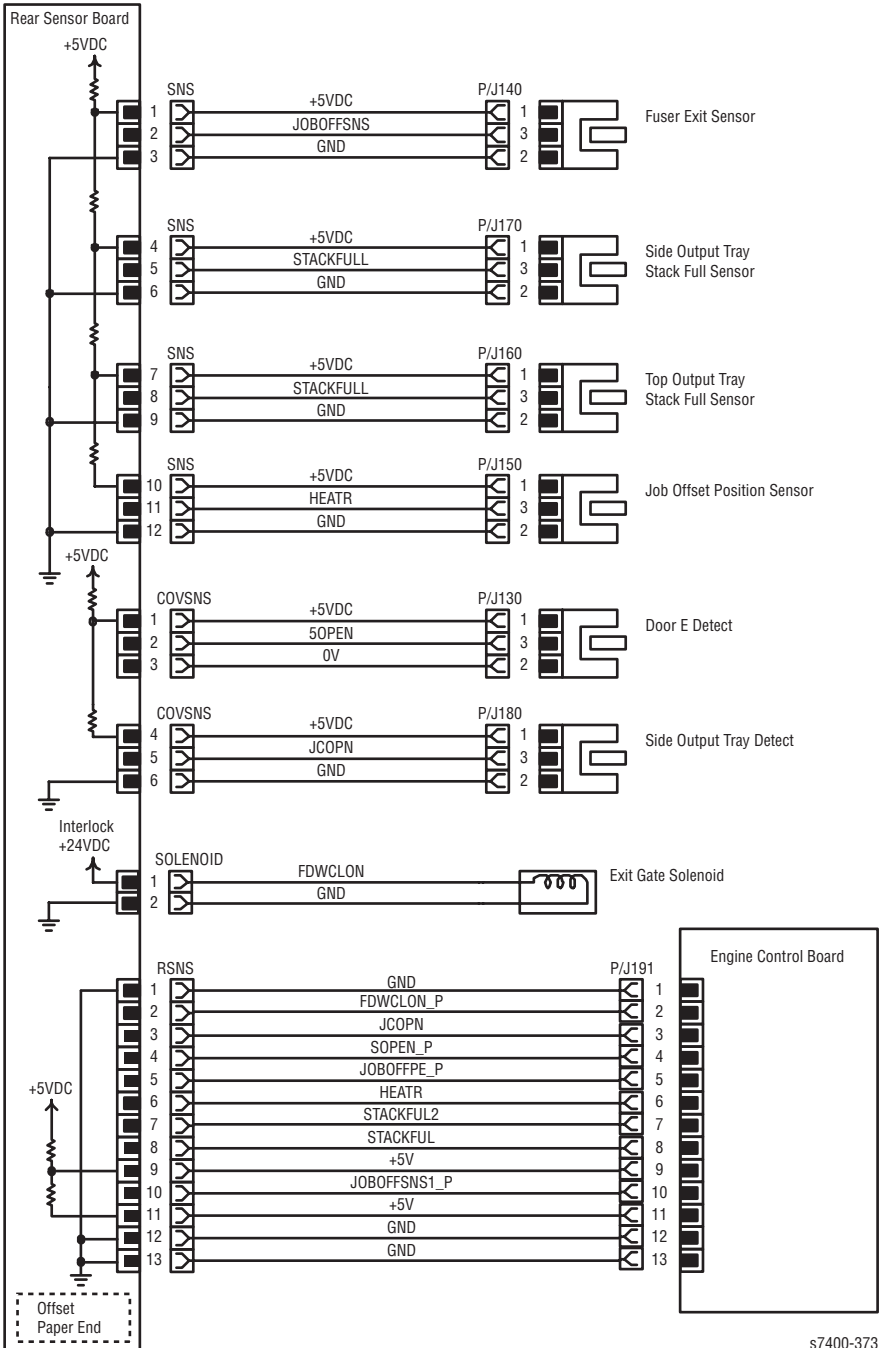

s7400-373

# Registration

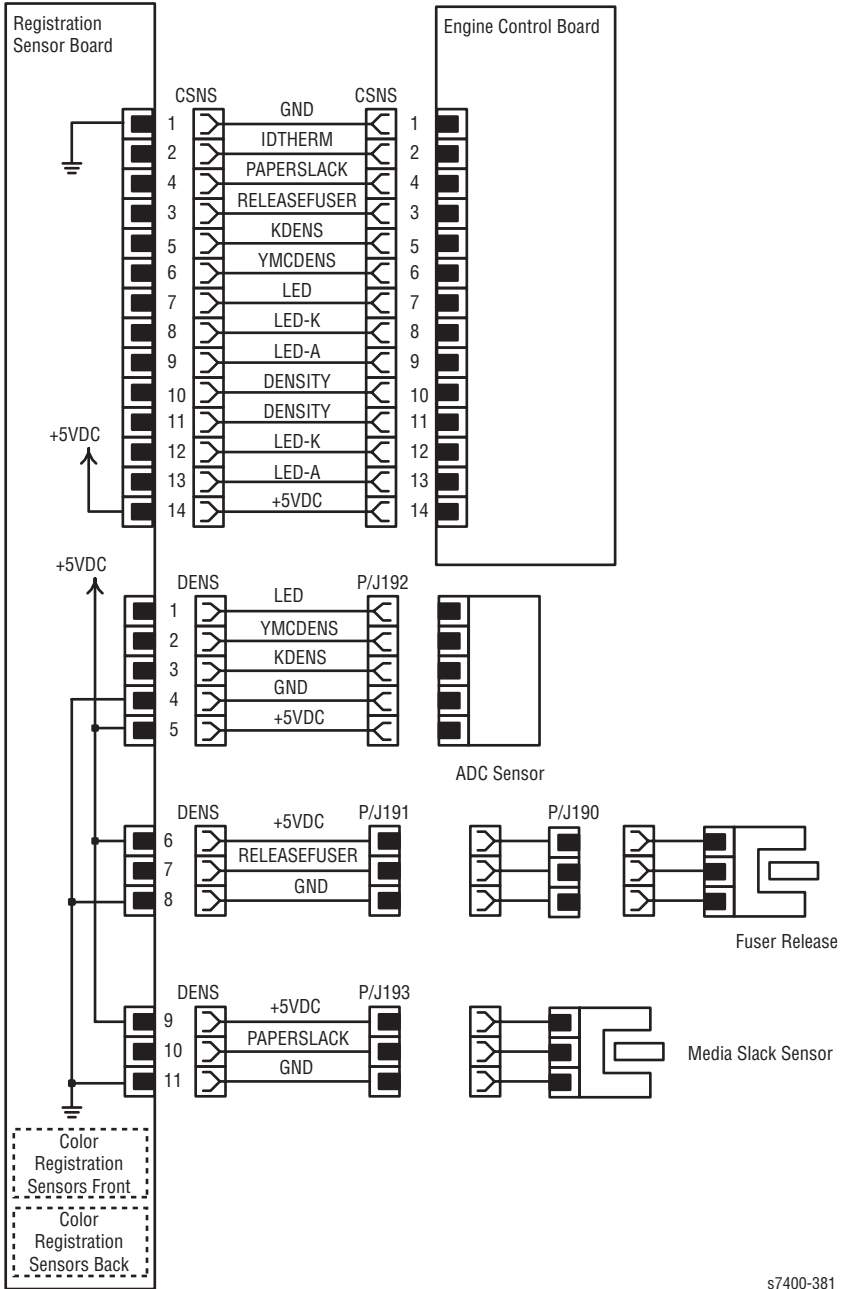

s7400-381

# Motor Driver Board (1/6)

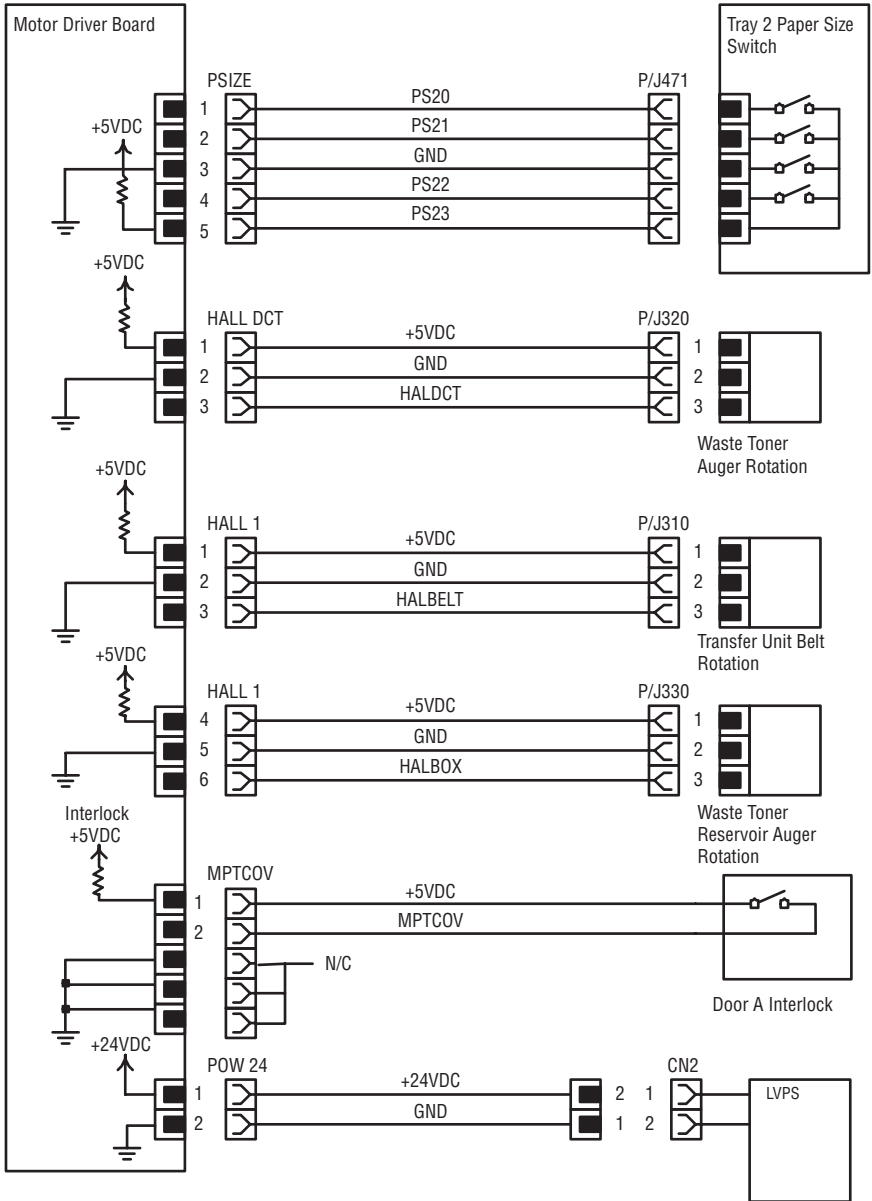

s7400-365

# Motor Driver Board (2/6)

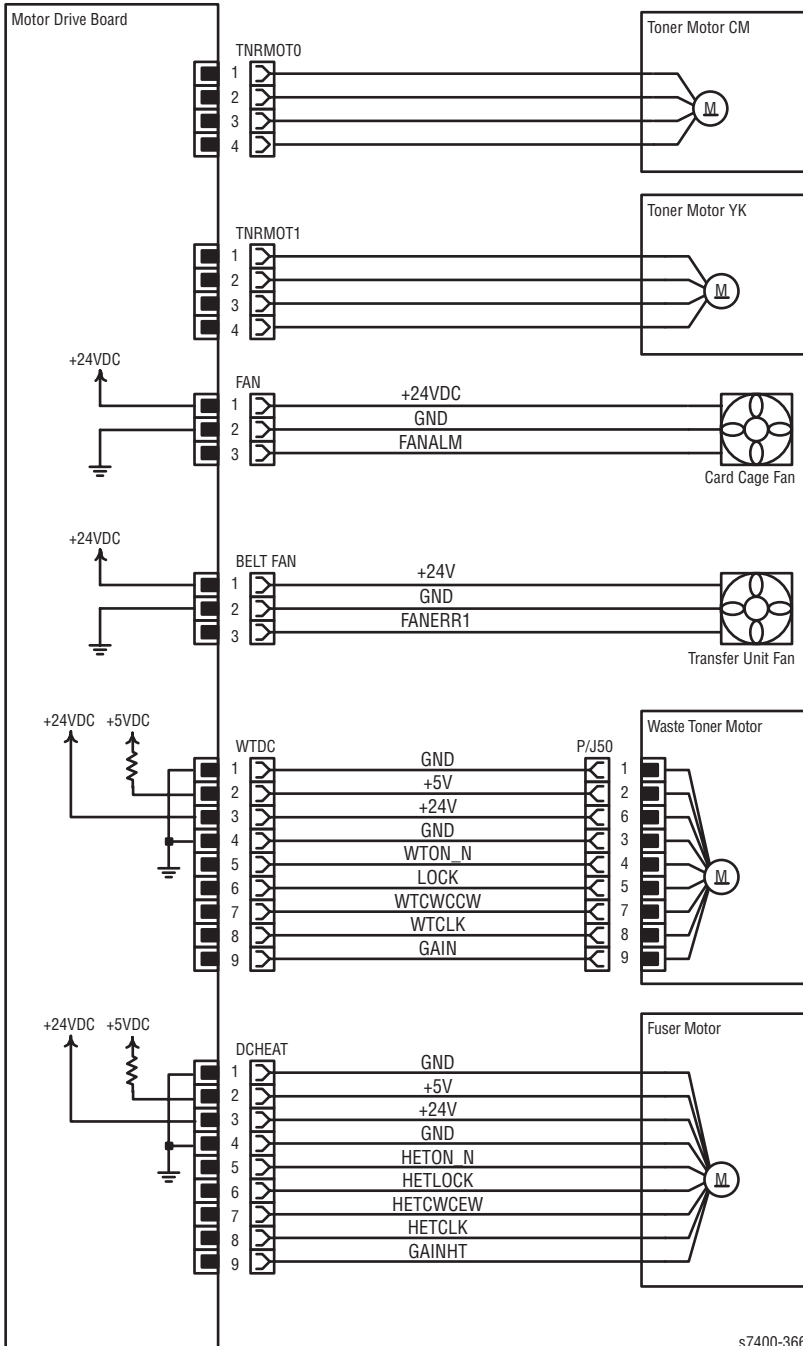

s7400-366



# Motor Driver Board (3/6)

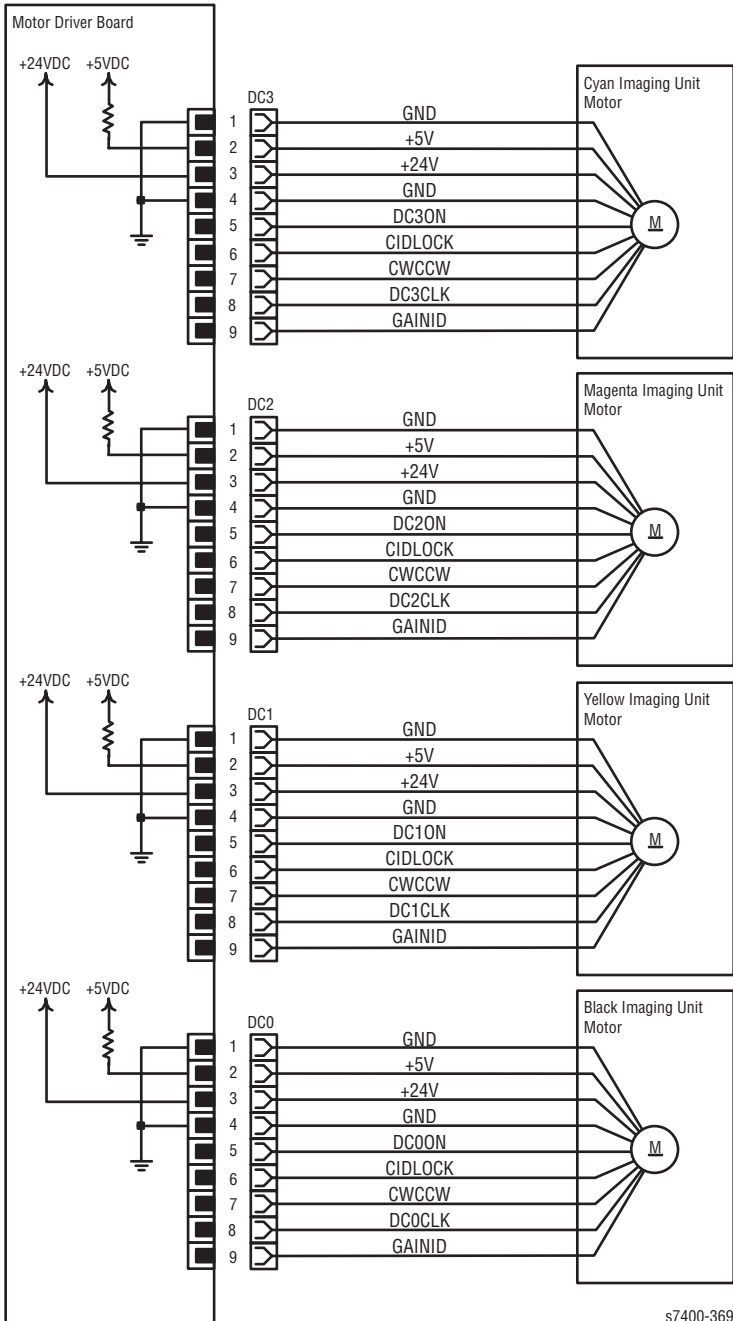

s7400-369

# Motor Driver Board (4/6)

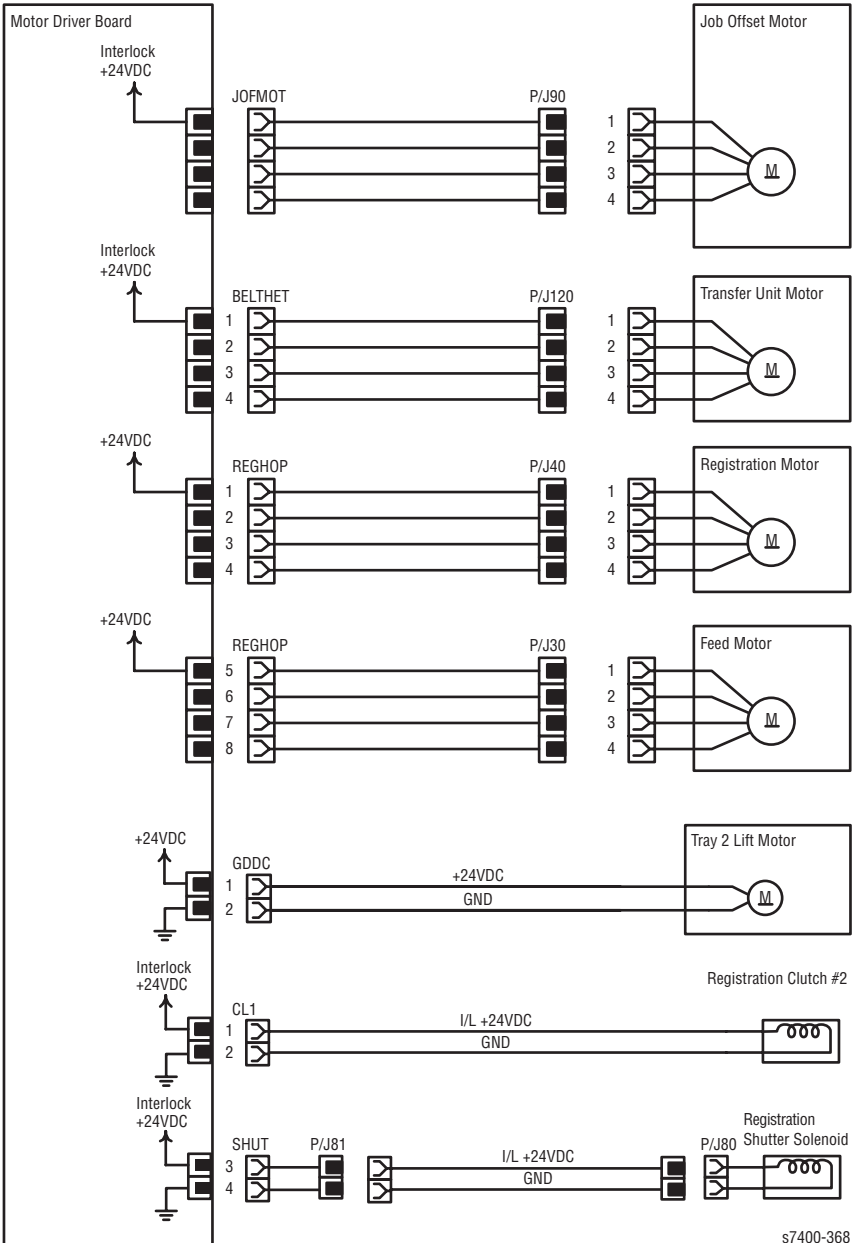

s7400-368

# Motor Driver Board (5/6)

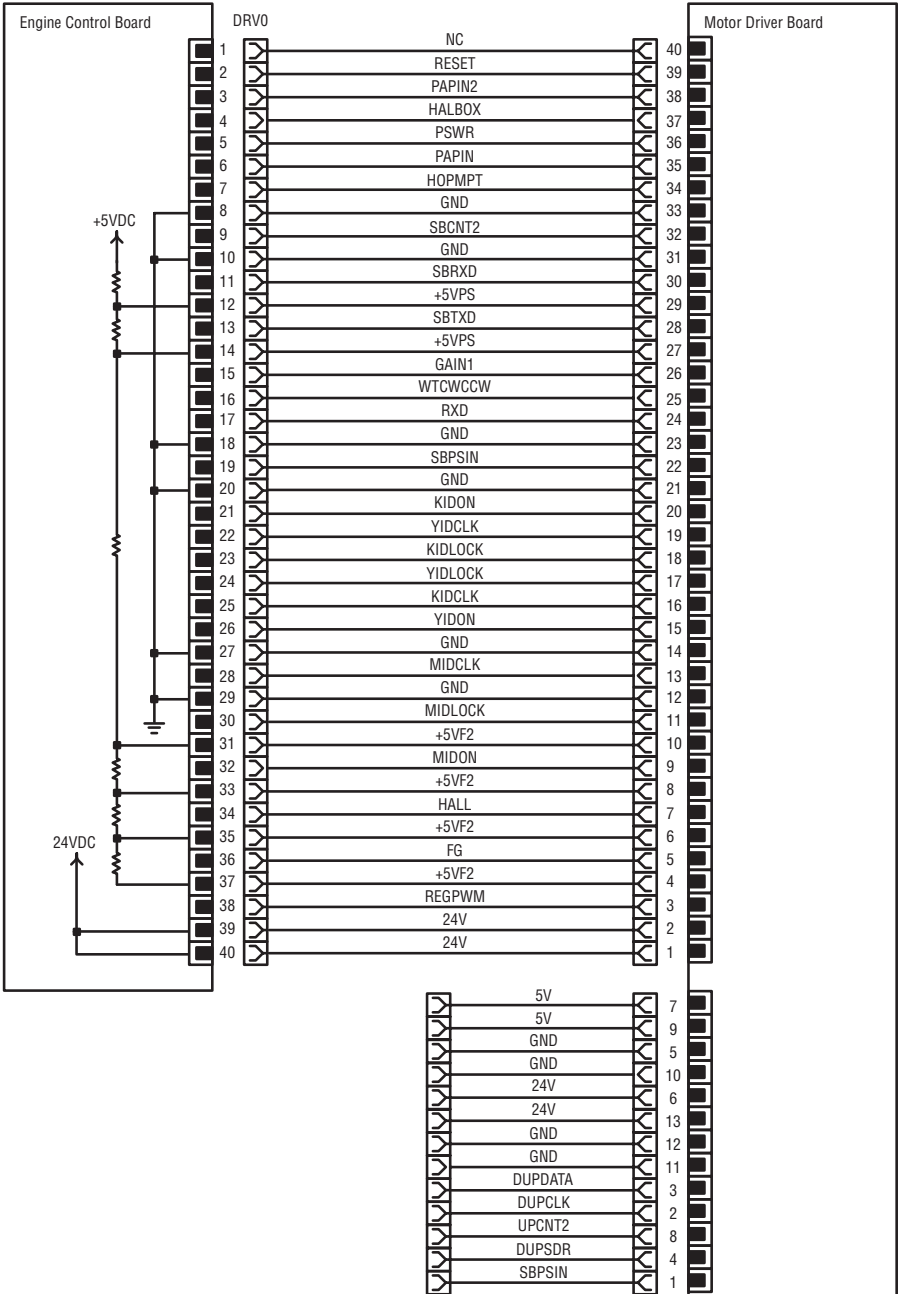

s7400-568

# Motor Driver Board (6/6)

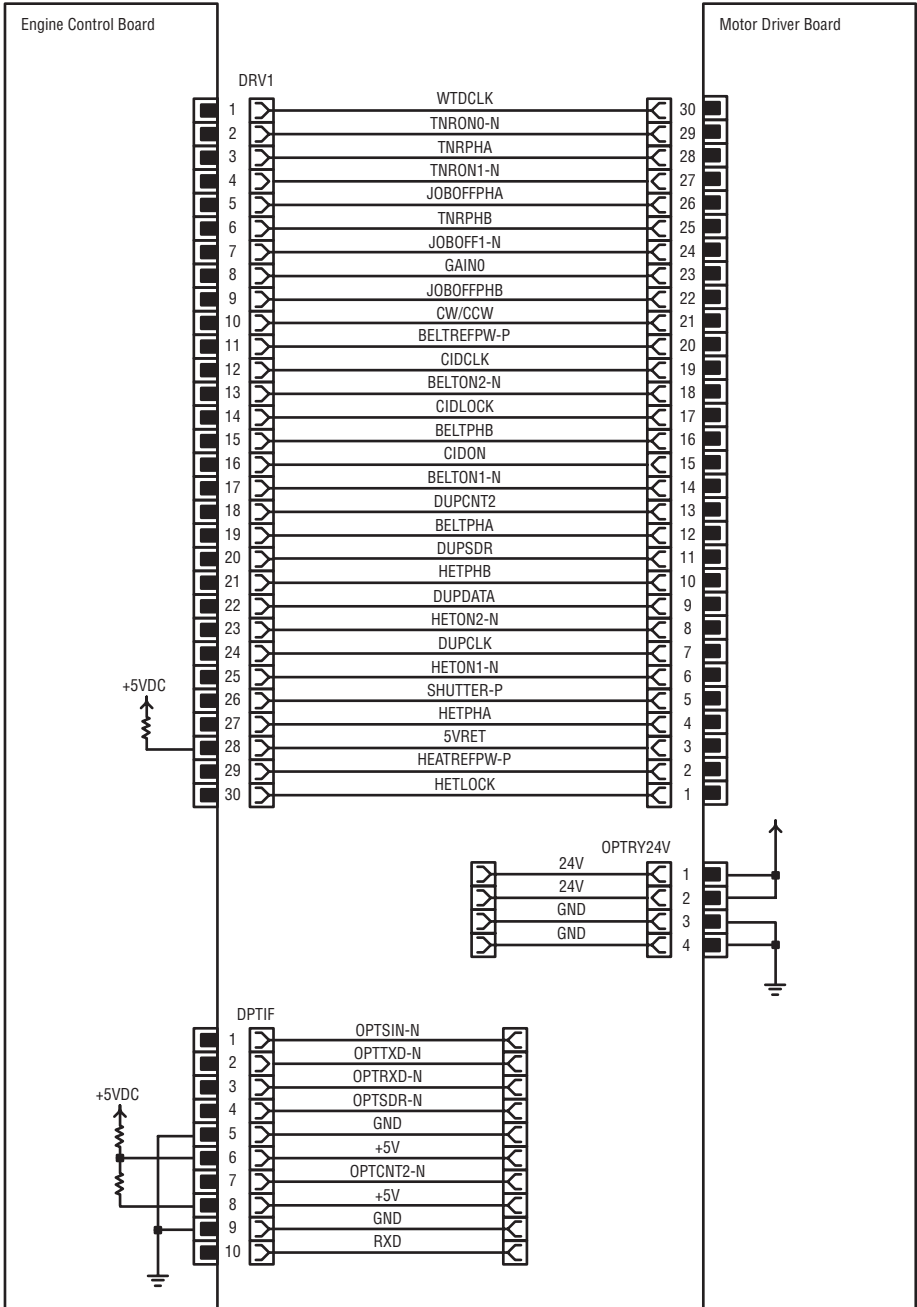

s7400-569

# LED Heads

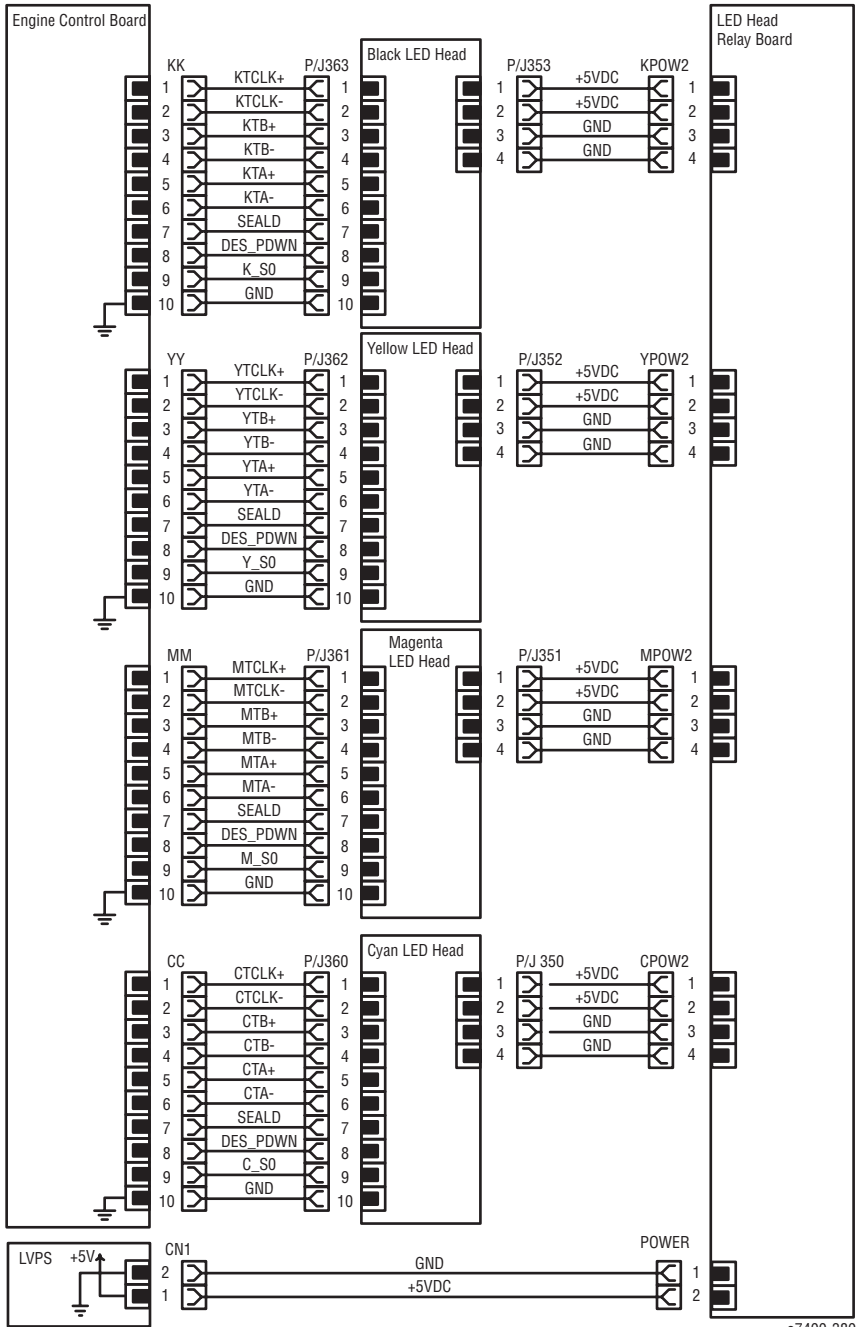

s7400-380

# Xerographics

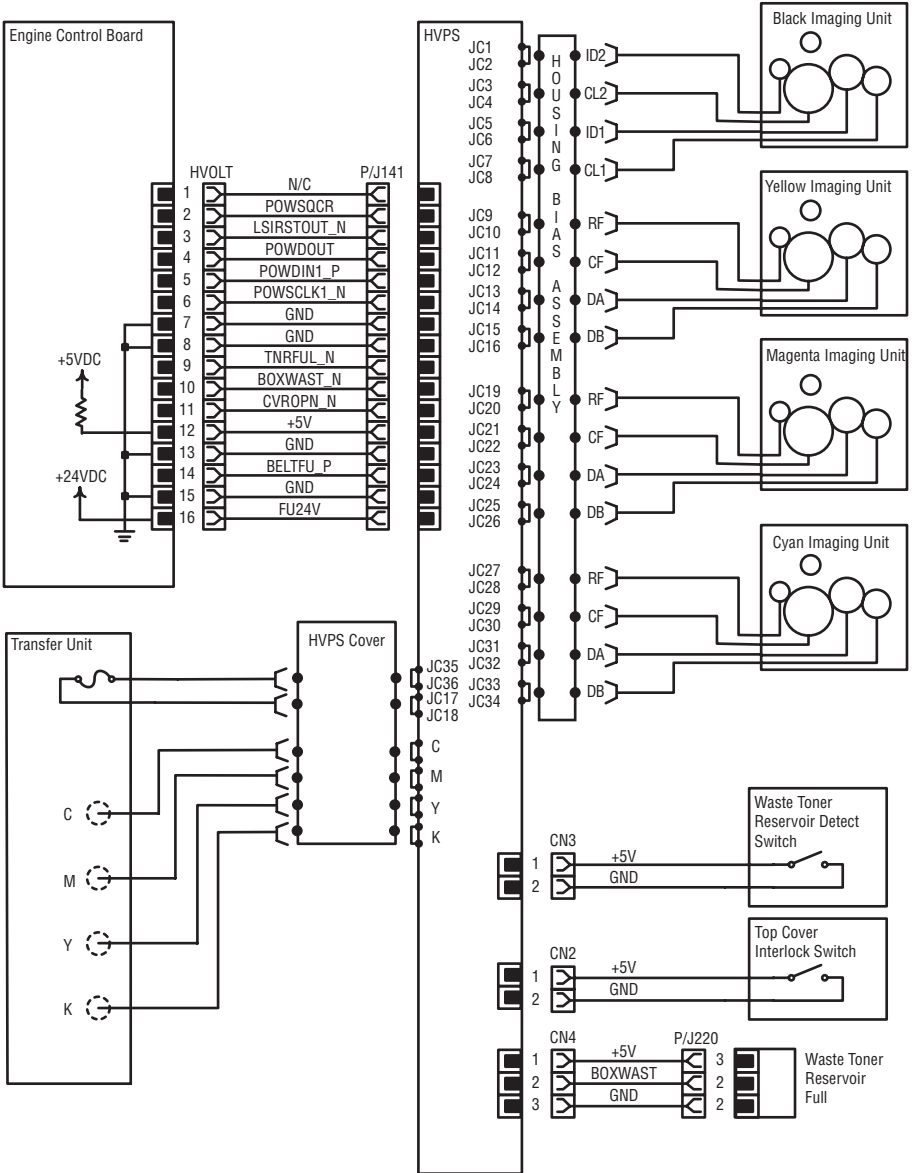

s7400-376

# LVPS

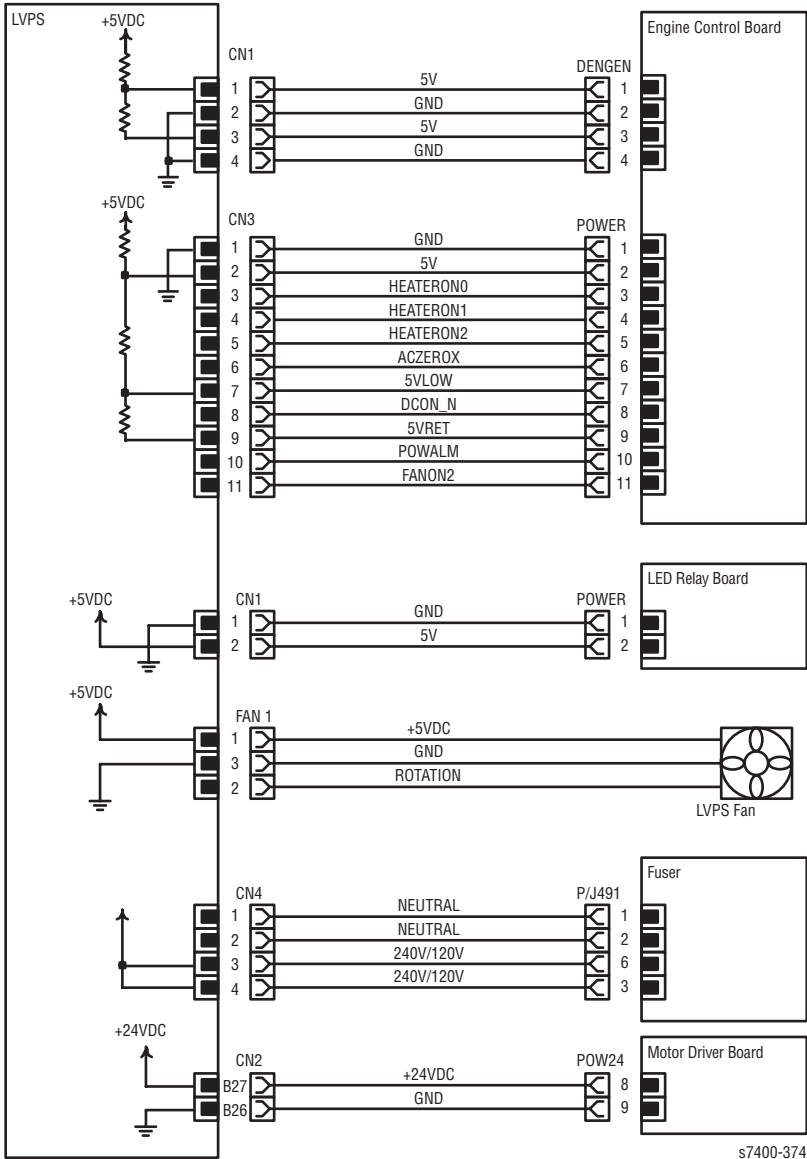

# Fuser

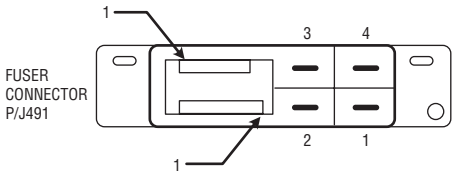
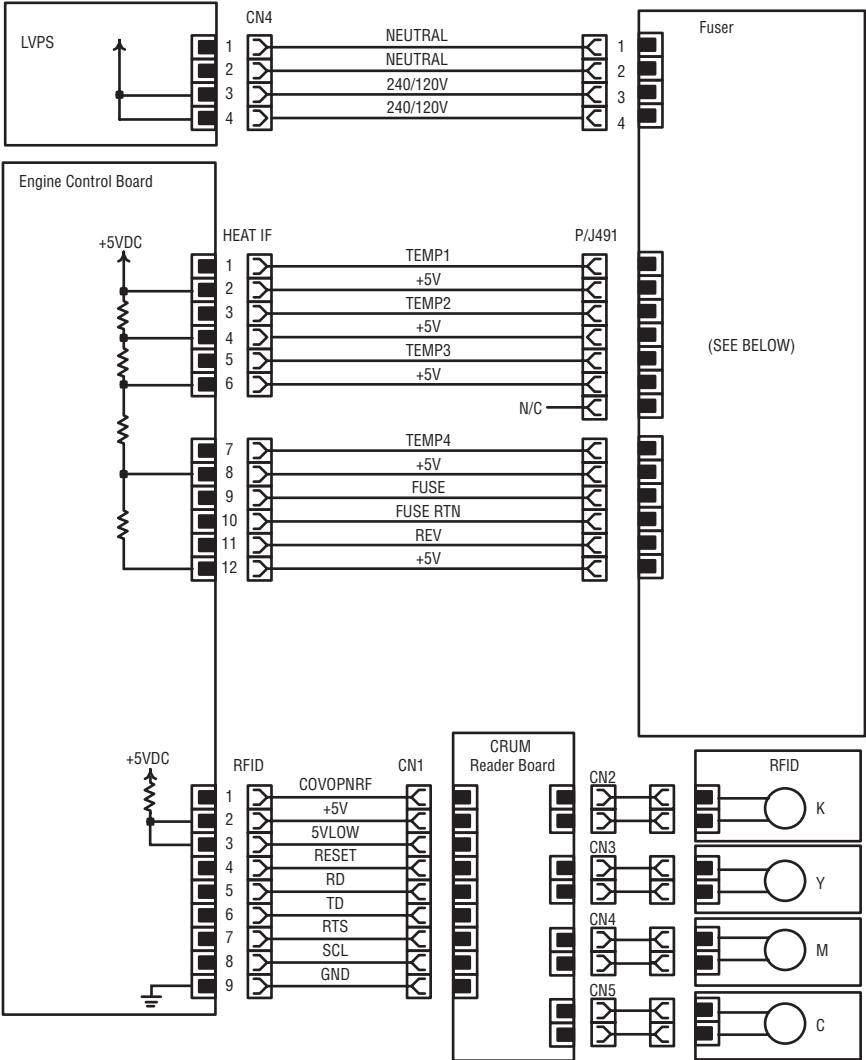

s7400-382



# Imaging Unit Sensor Board

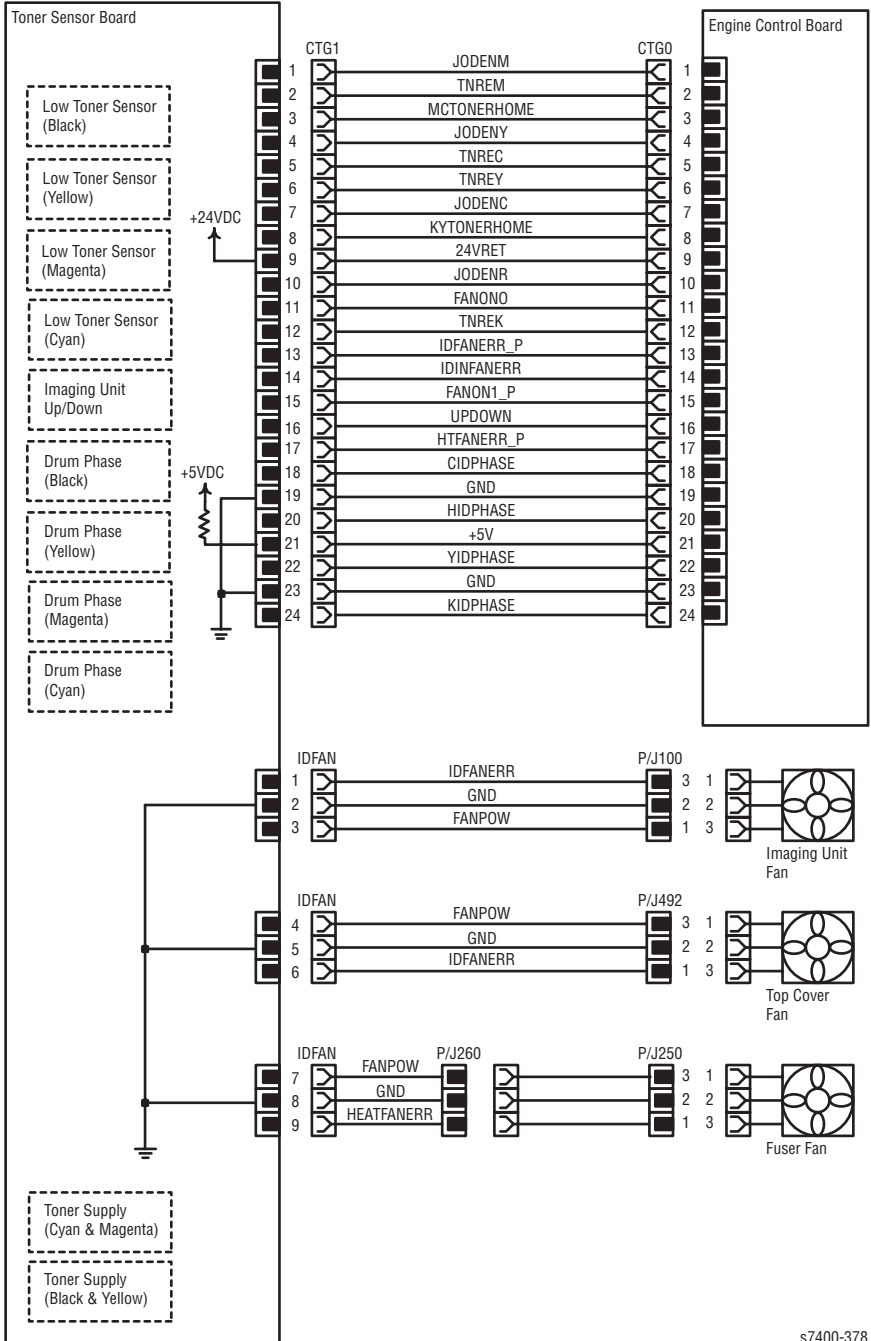

s7400-378

# Image Processor Board

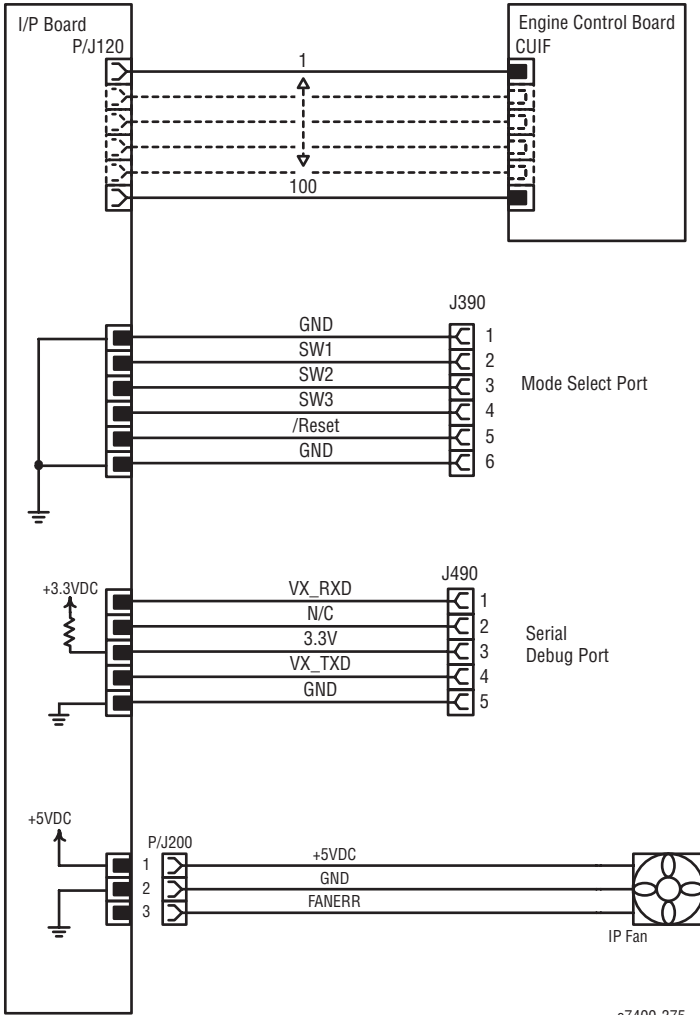

# Control Panel

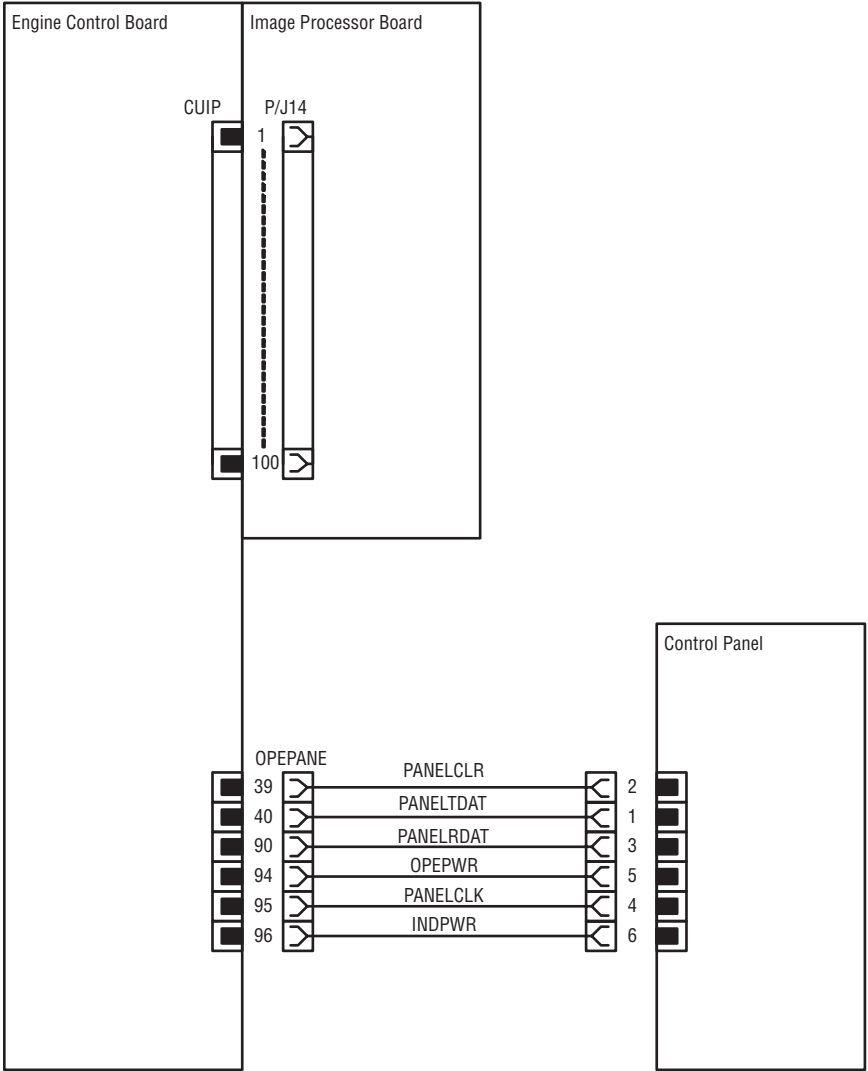

s7400-377



# Reference

## Contents...

- Phaser 7400 Menu Map
- Printer Status Codes
- Service Diagnostics Menu Map
- Service Diagnostic Test Descriptions
- Preparing the Printer for Shipment

Appendix

A



# Phaser 7400 Menu Map

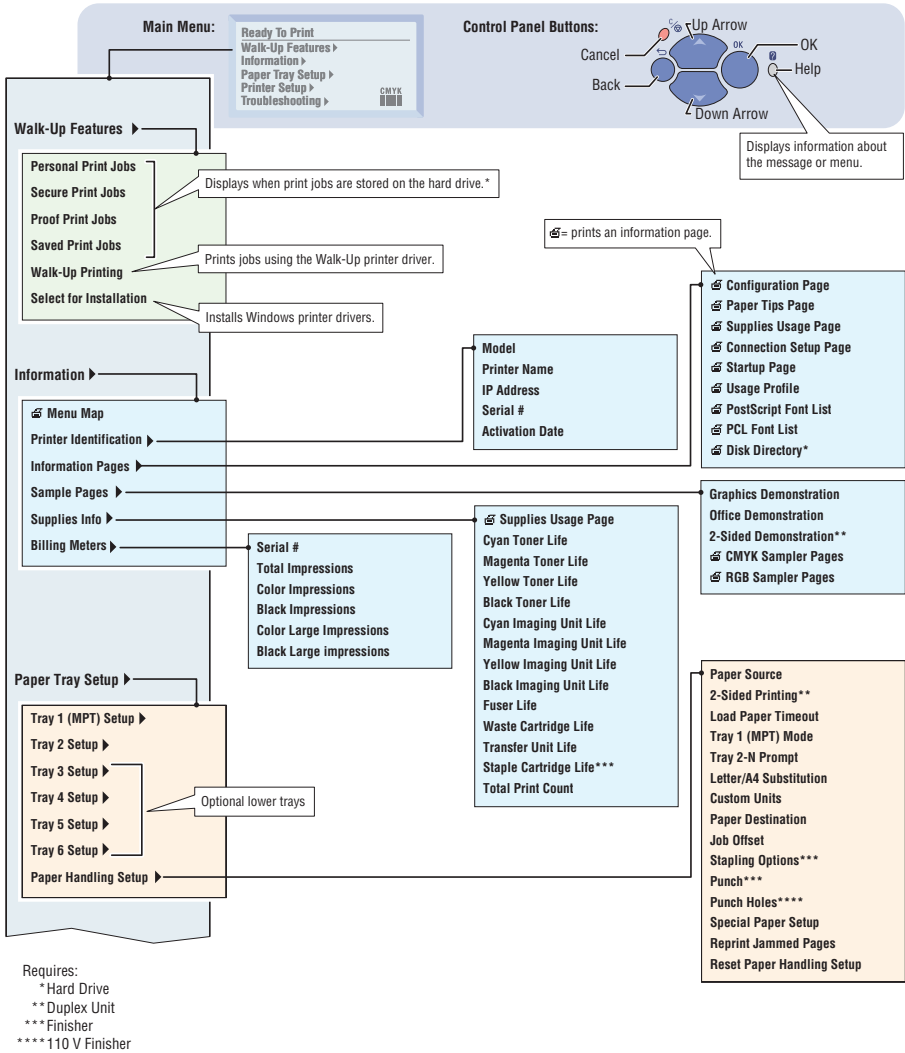

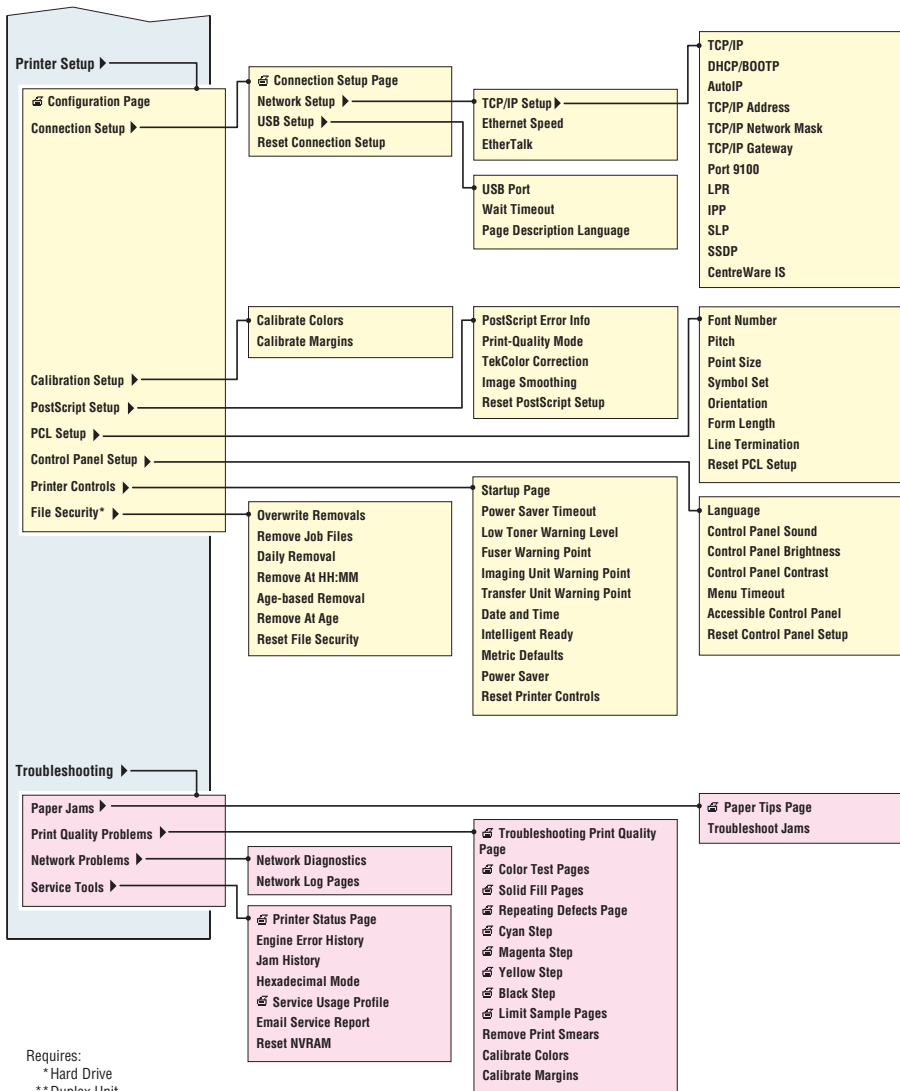

Requires:  
 \* Hard Drive  
 \*\* Duplex Unit  
 \*\*\* Finisher  
 \*\*\*\* 110 V Finisher

# Printer Status Codes

Printer status codes that appear in the Service Usage Profile at line 237, on the printer Status page, and output by the Fault History utility are defined in the following table. Refer to the "Messages, Codes, and Procedures" on page 3-5 for additional information.

## Printer Status Codes

Code	Description
A1	Jam at A1. Misfeed while feeding paper from Tray 1 (MPT).
A2	Jam at A2. Jam at the Duplex Unit entrance.
A3	Jam at A3. Jam while feeding paper from Tray 1 (MPT).
B1	Jam at B1. Jam while feeding paper from Tray 2.
C3	Jam at C3. Jam while feeding paper from Tray 3.
C4	Jam at C4. Jam while feeding paper from Tray 4.
C5	Jam at C5. Jam while feeding paper from Tray 5.
C6	Jam at C6. Jam while feeding paper from Tray 6.
D1	Jam at D1. Paper reversal jam in Duplex Unit.
D2	Jam at D2. Misfeed inside the Duplex Unit.
E1	Jam at E1. Finisher Stacker jam.
TC1	Jam at TC1. Jam at the Transfer Unit belt.
TC2	Jam at TC2. Jam in the Fuser.
TC3	Jam at TC3. Jam at the Duplex Unit entrance.
E12	Top Output Tray Stack Full Sensor detects a full stack in the tray.
E13	Side Output Tray Stack Full Sensor detects a full stack in the tray.
E14	Finisher Lower Tray Stack Full Sensor detects a full stack in the tray.
E15	Finisher Upper Tray (Stacker) Stack Full Sensor detects a full stack in the tray.
F1	Jam at FN1. Jam at the Finisher Punch.
F2	Jam at Finisher FN2. Jam at the Finisher Inverter entrance.
F3	Jam at Finisher FN3. Additional sheet detected in the input path.
F4	Jam at FN4. Jam in the Finisher upper paper path.
F5	Jam at FN5. Jam at the Finisher Saddle Stitch.
F6	Jam at FN6. Jam at the Finisher offset.
F7	Jam at FN7. Jam in the Finisher Compiler Tray.
F8	Jam at FN8. Paper arrived late or not at all to the saddle transport path.



## Printer Status Codes (Continued)

<b>Code</b>	<b>Description</b>
F9	Jam at FN9. Paper remains in the saddle transport path
F10	Jam at FN10. Finisher stack eject jam.
H80	Hard Disk Failure.
I1	Jam at IN1. When a sheet remains in the Inverter Lower Sensor when the power is on and the cover is closed.
I2	Jam at IN2. The Inverter Out Sensor goes High to indicate the sheet's leading edge is detected, but the trailing edge is not detected within a specified amount of time. This indicates a sheet remains in the Inverter Out Sensor when the power is turned on or the cover is closed.
I3	Jam at IN3. The Inverter Out Sensor didn't go High within a specified time following the Inverter IN Sensor detecting the trailing edge of the sheet.
I4	Jam at IN4. The Inverter IN Sensor goes High as the leading edge is detected, but the trailing edge is not detected within a specified amount of time. This indicates a sheet remains in the Inverter IN Sensor when the power is turned on or the cover is closed.
I5	Jam at IN5. The Inverter Out Sensor didn't go High within a specified time following the receipt of an eject command from the printer.
I6	Jam at IN6. The Inverter Out Sensor remains High.
I7	Jam at IN7. The Inverter IN Sensor goes Low indicating the trailing edge, and the Inverter Out sensor remains Low. This indicates a sheet remains in the Inverter Lower Sensor.
I8	Jam at IN8. The Inverter In Sensor remains High.
T1	Upper Fuser Failure. Failure in the Heat Roller thermistor.
T2	Lower Fuser Failure. Failure in the Pressure Roller thermistor.
T29	Temperature Sensor Failure. Out of range or erroneous temperature reading.
T30	Humidity Sensor Failure. Out of range or erroneous humidity reading.
T31	Wet Humidity Sensor Failure. Condensation detected in the printer.
T32	LED Head too hot. The LED Head circuitry is too hot.
T34	Imaging Unit Motor circuitry too hot. The Imaging Unit Motor circuitry is too hot.
U0	Engine ROM Failure. Engine Control Board ROM checksum error.
U1	Engine RAM Failure. Engine Control Board RAM read/write error.
U2	Engine EPROM Failure. Engine Control Board EPROM checksum error.
U3	Engine EPROM Missing. Engine Control Board EPROM not detected.
U4	Engine SRAM Failure. Engine Control Board SRAM read/write error.
U5	Engine Controller Failure. Engine Control Board control logic error.
U6	Power Supply Failure. Power Supply output voltage too high.
U7	Feeder Home Position Failure. The Tray 1 (MPT) Home Position Sensor indicates the feed rollers are out of position.

## Printer Status Codes (Continued)

Code	Description
U8	Controller Fan Failure. The Rotation signal from the I/P Board Fan indicates a failure.
U9	Power Supply Fan Failure. The Rotation signal from the LVPS Fan indicates a failure.
U10	Top Cover Fan Failure. The Rotation signal from the Top Cover Fan indicates a failure.
U11	Imaging Unit Front Fan Failure. The Rotation signal from the Imaging Unit Front Fan indicates a failure.
U12	Duplex Interface Failure. Communication error between the Engine Control Board and Duplex Unit.
U13	Tray 4 Interface Failure. Communication error between the Engine Control Board and HCF.
U14	Tray 3 Interface Failure. Communication error between the Engine Control Board and LTA.
U16	Tray 5 Interface Failure.
U17	Tray 6 Interface Failure.
U18	Yellow LED Failure.
U19	Magenta LED Failure.
U20	Cyan LED Failure.
U21	Black LED Failure.
U26	Yellow Imaging Unit Failure. Yellow drum out of position (Up/Down).
U27	Magenta Imaging Unit Failure. Magenta drum out of position (Up/Down).
U28	Cyan Imaging Unit Failure. Cyan drum out of position (Up/Down).
U29	Black Imaging Unit Failure. Black drum out of position (Up/Down).
U30	Flash Hardware Failure. Flash Memory failure on the Engine Control Board.
U31	Flash Software Failure. Firmware error in Engine Control Board Flash Memory.
U32	Fuser Fan Failure. The Rotation signal from the Fuser Fan indicates a failure.
U33	Fuser Voltage mismatch Failure. The Fuser voltage rating does not match the supply.
U34	Flash memory failure in the Duplex Unit.
U35	Unsupported Tray 3 ROM. The Tray 3 firmware is unsupported.
U36	Unsupported Tray 4 ROM. The Tray 4 firmware is unsupported.
U37	Unsupported Tray 5 ROM. The Tray 5 firmware is unsupported.
U38	Unsupported Tray 6 ROM. The Tray 6 firmware is unsupported.
U39	Unsupported Tray 2 ROM. The Tray 2 firmware is unsupported.
U40	Imaging Unit Rear Fan Failure.
U41	Engine Cavity Fan Failure. The Card Cage Fan has failed.
U50	Unsupported Inverter Unit. The Inverter firmware is unsupported.

## Printer Status Codes (Continued)

<b>Code</b>	<b>Description</b>
U51	Inverter Unit Interface Failure.
U55	Unsupported Finisher Unit. The Finisher firmware is unsupported.
W16	Fuser Fuse Cut Error. The printer checks the consumables at power on and when a cover is closed. If a consumable fuse is detected, the printer will cut it and clear the consumable counter. If the fuse does not blow, this error persists.
W17	Transfer Unit Fuse Cut Error. The printer checks the consumables at power on and when a cover is closed. If a consumable fuse is detected, the printer will cut it and clear the consumable counter. If the fuse does not blow, this error persists.
W18	Cyan Imaging Unit Fuse Cut Error. The printer checks the consumables at power on and when a cover is closed. If a consumable fuse is detected, the printer will cut it and clear the consumable counter. If the fuse does not blow, this error persists.
W19	Magenta Imaging Unit Fuse Cut Error. The printer checks the consumables at power on and when a cover is closed. If a consumable fuse is detected, the printer will cut it and clear the consumable counter. If the fuse does not blow, this error persists.
W20	Yellow Imaging Unit Fuse Cut Error. The printer checks the consumables at power on and when a cover is closed. If a consumable fuse is detected, the printer will cut it and clear the consumable counter. If the fuse does not blow, this error persists.
W21	Black Imaging Unit Fuse Cut Error. The printer checks the consumables at power on and when a cover is closed. If a consumable fuse is detected, the printer will cut it and clear the consumable counter. If the fuse does not blow, this error persists.
F93	Finisher Jog Motor Failure.
F103	Finisher Paddle Motor Failure.
F106	Finisher Stapler Swing Motor Failure.
F110	Finisher Staple Motor Failure.
F111	Finisher Stapler Stack Handling Motor Failure.
F115	Finisher Tray Lift Motor Failure.
F116	Finisher Exit Motor Failure.
F130	Engine Communications Failure.
F131	Finisher Folder Sensor Failure.
F132	Finisher Punch Communications Failure.
F133	Finisher Punch Side Registration Motor Failure.
F134	Finisher Punch Motor Failure.
F136	Finisher Punch Registration Motor Failure.
F137	Finisher Backup RAM Failure.
F138	Finisher Punch Backup RAM Failure.
F139	Finisher Punch Waste Sensor Failure.
F140	Finisher Punch Motor Failure.

## Printer Status Codes (Continued)

Code	Description
F181	Finisher Punch Unit Transfer Motor Failure.
<b>Printer error - Contact service; report fault [nnn]<sup>†</sup></b> Where [nnn] is one of the codes described below.	
F141	Finisher Punch Unit counter at end of life. The Punch count exceeds life limit.
F142	Finisher Staple Unit counter at end of life. The Staple count exceeds life limit.
F186	Finisher interface error. Communications lost with Finisher.
I97	Inverter Power Supply Error. +24V is not available to the Inverter.
T3	Fuser belt thermistor short circuit.
T4	Fuser belt thermistor open circuit.
T5	Fuser belt thermistor temperature too high.
T6	Fuser belt thermistor temperature too low.
T7	Fuser Exit Sensor error.
T8	Fuser belt slack error.
U60	Job Offset Home Position error. Job Offset Assembly does not reach home position.
U61	Control Panel communications failure. Engine Control Board can not communicate with the Control Panel.
135	No data to the Yellow LED Head.
136	No data to the Magenta LED Head.
137	No data to the Cyan LED Head.
138	No data to the Black LED Head.
188	Motor Driver Board Option tray communications error.
221	Tray 3 Firmware Error. Firmware error in Tray 3 Flash Memory.
222	Tray 4 Firmware Error. Firmware error in Tray 4 Flash Memory.
223	Tray 5 Firmware Error. Firmware error in Tray 5 Flash Memory.
224	Tray 6 Firmware Error. Firmware error in Tray 6 Flash Memory.
225	Duplex Unit Firmware Error. Firmware error in Duplex Unit Flash Memory.
226	Motor Driver Board Firmware Error. Firmware error in Inverter Flash Memory.
227	Finisher Inverter Firmware Error. Firmware error in Inverter Flash Memory.
231	CRUM Reader interface Failure. A communication error has occurred between the Engine Logic Board and CRUM Reader Board.
232	CRUM Reader interface Failure. An error has occurred in the CRUM Reader Board transmit circuitry.

## Printer Status Codes (Continued)

Code	Description
<b>Printer error - Contact service; report fault [nnn]" (Continued)</b> Where [nnn] is one of the codes described below.	
233	CRUM Reader interface Failure. A communications failure has occurred between the CRUM Antenna and the consumable CRUM.
234	CRUM Reader has detected five or more RFID devices.
242	Tray 3 Flash Memory Failure. Hardware error in the Tray 3 Flash Memory device.
243	Tray 4 Flash Memory Failure. Hardware error in the Tray 4 Flash Memory device.
244	Tray 5 Flash Memory Failure. Hardware error in the Tray 5 Flash Memory device.
245	Tray 6 Flash Memory Failure. Hardware error in the Tray 6 Flash Memory device.
246	Duplex Unit Flash Memory Failure. Hardware error in the Flash Memory device.
247	Motor Driver Board Flash Memory Failure. Hardware error in the Motor Driver Board Flash Memory device.
248	Finisher Inverter Flash Memory Error. Hardware error in the Inverter Flash Memory device.
910	The Tray 2 Lift Motor has failed.
911	The Tray 3 Lift Motor has failed.
912	The Tray 4 Lift Motor has failed.
913	The Tray 5 Lift Motor has failed.
914	The Tray 6 Lift Motor has failed.
917	Error in the Transfer Unit Belt. Transfer Unit Belt Rotation Sensor indicates an error.
918	The Duplex Unit Fan has failed.
919	+24 V not available to the Duplex Unit.
920	Failure in the Yellow Imaging Unit Drum or Motor.
921	Failure in the Magenta Imaging Unit Drum or Motor.
922	Failure in the Cyan Imaging Unit Drum or Motor.
923	Failure in the Black Imaging Unit Drum or Motor.
924	+24 V not available to Tray 3.
925	+24 V not available to Tray 4.
926	+24 V not available to Tray 5.
927	+24 V not available to Tray 6.
929	Failure in the Waste Toner Motor.
930	The Motor Driver Board sub-CPU clock frequency is inaccurate.
931	The Duplex Unit CPU clock frequency is inaccurate.
932	The Inverter CPU clock frequency is inaccurate.

## Printer Status Codes (Continued)

Code	Description
<b>Printer error - Contact service; report fault [nnn]" (Continued)</b> Where [nnn] is one of the codes described below.	
933	The Tray 3 Feeder Board clock frequency is inaccurate.
934	The Tray 4 Feeder Board clock frequency is inaccurate.
935	The Tray 5 Feeder Board clock frequency is inaccurate.
936	The Tray 6 Feeder Board clock frequency is inaccurate.
940	Waste Toner Auger Rotation Sensor indicates a toner transfer error.
941	CM Toner supply failure. Toner Sensor failure with Cyan or Magenta Toner.
942	YK Toner supply failure. Toner Sensor failure with Black or Yellow Toner.

# Service Diagnostics Menu Map (1/2)

**Print Service Menu Map:** Exits service diagnostics and runs PostScript to print this menu map.

**General Status:** Provides current print engine status.

- Engine Status
- Jam Status
- Engine ROM Version
- Printer Configuration
- Ambient Temperature/Humidity
- Fuser Temperature
- Consumable Status
- Front Panel Control
  - Contrast
  - Intensity

**Test Print:** Generates print engine test prints.

- Print Execute
- Select Page Count
- Select Test Pattern
- Select Media Source
- Select Color/Monochrome
- Select Duplex/Simplex
- Select Job Offset
- Select Output Path
- Finisher
  - Finisher Output Enabled
  - Finisher Offset Enabled
  - Finisher Inverter Enabled
  - Finisher Inverter Disabled
  - Finisher Punch Enabled
  - Finisher Punch Disabled
  - Rear Stapling Enabled
  - Front Stapling Enabled
  - Center Stapling Enabled
  - Saddle Stapling Enabled
  - Finisher Stapling Disabled

**Motor/Fan Tests:** Tests the functionality of motors and fans one component at a time.

- Tray Motors
- Tray Feed Motors
- Tray 1 Lift Motor
- Tray 2 Lift Motor
- Tray 3 Lift Motor
- Tray 4 Lift Motor
- Tray 5 Lift Motor
- Tray 6 Lift Motor
- Registration Motor
- Imaging Unit Motors
  - Black IU Motor
  - Yellow IU Motor
  - Magenta IU Motor
  - Cyan IU Motor
- Imaging Unit Up/Down Test
- Transfer Belt Motor

**Fuser Unit Motors**

- Fuser Motor Forward
- Fuser Motor Release
- Fuser Forward/Release

**Duplex Unit Motor**

**Job Offset Motor**

**Duplex Fan**

**Power Supply Fan**

**Chassis Fan**

**Top Cover Cooling Fan**

**Belt Fan**

**Fuser Fan**

**Toner Supply Motors**

**Sensor/Switch Tests:** Tests the functionality of sensors and switches while service personnel manually change the state of each device.

**Interlock Switches**

- Top Cover Interlock
- Right Door Interlocks
- Left Door Switches

**Tray 2 Switches**

**Tray 3 Switches**

**Tray 4 Switches**

**Tray 5 Switches**

**Tray 6 Switches**

**Tray 1 / MPT Tray Switches**

**Registration Entrance Sensor**

**Tray 1 Entrance Sensor**

**Transfer Belt Entrance Sensor**

**Fuser Exit Sensor**

**Face Down Stack Full Sensor**

**Face Up Stack Full Sensor**

**Offset Home Pos Sensor**

**Duplex Unit Sensors**

**Color Registration Sensors**

**Fuser Temperature Sensors**

**Ambient Temperature/Humidity**

**CMYK IU Sensors**

**CMYK Toner Cart Sensors**

**Read Fuses**

**YMCK Drum Phase Sensors**

**Paper Slack Sensor**

**IU Up/Down Sensor**

**Fuser Release Sensor**

**Waste Bin Missing Sensor**

**Belt Hole IC**

**Waste Toner Box Hole IC**

**Waste Toner Hole IC**

# Service Diagnostics Menu Map (2/2)

**Clutch Tests:** Test the functionality of clutches, one component at a time.

- Tray 3 Feed Clutch
- Tray 4 Feed Clutch
- Tray 5 Feed Clutch
- Tray 6 Feed Clutch
- Registration Roller A Clutch

**Solenoid Tests:** Test the functionality of solenoids, one component at a time.

- Reg Shutter Solenoid
- Exit Gate Solenoid
- Face-Up Gate

## Finisher Tests:

### Finisher Motors

- Feed Motor
- Saddle Roller
- Bundle Motor Forward
- Bundle Motor Reverse
- Paddle Motor
- Bundle Roller
- Shift Motor
- Order Motor
- Staple Motor
- Saddle-stitching Motor
- Saddle Transfer Motor
- Sliding Motor
- Punch Motor
- Punch Registration Motor
- Inverter Motor A
- Inverter Motor B

### Finisher Sensor/Switches

- Entrance Sensor
- Tray Paper Detection Sensor
- Tray Paper Level Sensor
- Tray Upper-limit Sensor
- Tray Lower-limit Sensor
- Tray Middle Position Sensor
- Stapler Home Position Sensor
- Stapler Slide Home Position Sensor
- Stapler Connected Signal
- Stapler Safety Switch
- Stapler Self-Prime Sensor
- Covers/Doors/Interlocks
- Bookbinding Position Sensor
- Alignment Tray Sensor
- Punch Timing Sensor
- Bookbinding Sensors
- Front Alignment Plate Sensor
- Rear Alignment Plate Sensor
- Exit Belt Home Pos Sensor
- Bundle Roller Home Pos Sensor
- Paddle Home Position Sensor
- Bookbinding Clock Sensor
- Tray Lift Motor Clock
- Punch Connected Signal
- Inverter Input Sensor
- Inverter Output Sensor
- Inverter Exit Sensor
- Inverter Cover Switch

- Inverter Joint Sensor
- Inverter CNT2 Signal

### Finisher Solenoids

- Inverter Separator Solenoid
- Inverter Pressure Solenoid

### Finisher Clutches

- Saddle-stitching Clutch
- Inverter Registration Clutch

**Adjustments/Calibrations** Perform adjustments, calibrations or operations essential to the performance of the system.

### Auto Density Control

- Edit Density Data
- Execute Density Calibration
- Density Calibration Results

### ATS 4-Sheet Calibration

- Edit Thickness Data
- Execute Thickness Calibration
- Thickness Calibration Results

**NVRAM Access:** This menu lets you read and reset selected NVRAM address locations.

### NVRAM Reset

### CRU Counter Read

### CRU Counter Resets

### Reset Toner Counts

- Reset IU Counts
- Reset Fuser Count
- Reset Transfer Belt Count

### Save Engine NVRAM

### Restore Engine NVRAM

**IP Controller Diagnostics:** Tests the basic functionality of the Controller Board.

### RAM Read/Write Test

**Exit:** Reboots printer out of diagnostics.

**For Authorized Service Personnel Use Only.** Service Menu functions are to be used by Xerox service personnel and authorized service providers. The printer can be damaged by improper use of the built-in service tests.



# Service Diagnostics Tests

## Service Diagnostics Tests and Utilities

Menu Item	Front Panel Display Results	Functional Definition
<b>Print Service Menu Map</b> - Prints the service diagnostics menu map, exits diagnostics, runs POST and returns printer to Ready.		
<b>General Status</b> - Displays user-selected engine information.		
Engine Status	<p>&lt;No Status to Report&gt; &lt;Error Message&gt;</p> <p><b>NOTE:</b> Generally, staus does not update while in test printing mode. Do not assume that it does.</p>	<p><b>No Status to Report</b> = The printer is online and ready to print.</p> <p><b>Error Message</b> = Displays an error message that prevents printing. Status is displayed sequentially, one line at a time.</p>
Jam Status	<p>&lt;No Jams &gt; &lt;Jam @ &gt; &lt;Jam2 @ &gt;</p>	<p>Status is scrollable using the <b>Up Arrow</b> or <b>Down Arrow</b> buttons. <b>Jam @</b> indicates the first jam location. <b>Jam2 @</b> secondary jam location(s). Clear all jams.</p>
Engine Board ROM Version	<p>Engine Version is n.n.n Duplex Version is n.n.n Tray 3 Version is n.n.n Tray 4 Version is n.n.n Tray 5 Version is n.n.n Tray 6 Version is n.n.n Sub-CPU Version is n.n.n Tray 2 Version is n.n.n Finisher Version is n.n.n Inverster Version is n.n.n Loader Version is n.n.n</p>	<p>Displays the firmware version of the engine and installed optionals. Otherwise a "_" is displayed to indicate an incorrect version.</p> <p>&lt;press <b>Back</b> or <b>Cancel</b> to abort&gt;</p>
Printer Configuration	<p>Installed Memory is: nnnMB Hard Drive is Present/Absent Duplex is Present/Absent Tray 1-n Installed</p>	<p>Displays installed memory. Detects the Hard Drive. Detects the Duplex Unit. Detects the installed Trays.</p> <p>&lt;press <b>Back</b> or <b>Cancel</b> to abort&gt;</p>
Ambient Temp/ Humidity	<p>Amb. Temp. is nnn deg.C (Celsius) Amb. Hum. is nnn % (relative percent)</p>	<p>Displays the current Temperature and Humidity for the printer.</p> <p>&lt;press <b>Back</b> or <b>Cancel</b> to abort&gt;</p>
Fuser Temperature	<p>Fuser Temp Upper is nnn deg.C Fuser Temp Lower is nnn deg.C Removed</p>	<p>Displays reported fuser temperatures in degrees Celsius.</p> <p>&lt;press <b>Back</b> or <b>Cancel</b> to abort&gt;</p>

## Service Diagnostics Tests and Utilities (Continued)

Menu Item	Front Panel Display Results	Functional Definition
Consumable Status	<ul style="list-style-type: none"> <li>■ Total Pages = nnnn</li> <li>■ Fuser Pages = nnnn (total sheets)</li> <li>■ Trans Belt Images = nnnn</li> <li>■ Y = nnn images (Imaging Unit)</li> <li>■ M = nnn images</li> <li>■ C = nnn images</li> <li>■ K = nnn images</li> <li>■ Y = nnn % used (Toner Cartridge)</li> <li>■ M = nnn % used</li> <li>■ C = nnn % used</li> <li>■ K = nnn % used</li> </ul>	<p>Displays current life counts.</p> <p>&lt;press <b>Down Arrow</b> for more data&gt;</p>
Front Panel Control	<p>Contrast: Current Contrast: n</p> <p>Intensity: Current Intensity: n</p>	<p>Contrast range n is 1 - 10. Intensity range n is 0 - 10.</p> <p>&lt;press <b>Up/Down</b> to change value&gt;</p>
<p><b>Test Prints</b> - Prints test prints stored on the Engine Controller Board. The prints are used by service personnel to identify, repair and validate the operability of the printer. Used to isolate print problems to the engine or Image Processor by eliminating the normal image data transfer process from the Image Processor Board to the Engine Controller Board.</p>		
Print Execute	<p>&lt;Engine Status&gt; &lt;Engine Temperature&gt; P=nnn T=nnn U=nnn[nnn] H=n% L=nnn[nnn]</p> <p>&lt;Engine Transfer Voltages&gt; TR K=n.nn KV Y=n.nn KV M=n.nn KV C=n.nn KV</p> <p>&lt;Engine Transfer Resistances&gt; KR=n.nn uA YR=n.nn uA MR=n.nn uA CR=n.nn uA</p> <p>&lt;Engine Media Thickness&gt; Thick=nn um Temp=nn degC Regist=nnnh Exit=nnnh</p> <p>Test print Cancelled &lt;if cancelled&gt; Please wait... Engine Delivering Pages Please wait...</p>	<p>2-line status message <b>P</b>=Sheets, <b>T</b>=Ambient Temp. <b>U</b>=Upper Fuser Temp[Setpoint] <b>H</b>=Ambient Hum. % <b>L</b>=Lower Fuser Temp[Setpoint] Transfer voltage set values (KV) for each color.</p> <p>Transfer roller resistance values (micro Amps) for each color.</p> <p>Thick=Media thickness (microns) Temp=Fuser Temp(deg.C) Regist=Regist Motor speed Exit=Exit Motor Speed</p> <p>&lt;press <b>Up/Down</b> - more reports&gt; &lt;press <b>Cancel</b> to abort&gt;</p>
Select Page Count	<p>Enter Page Count: nnnn</p> <p>Please wait...</p> <p>Page Count set to n</p>	<p>0000 means continuous printing. &lt;press <b>Cancel</b> to stop printing&gt; &lt;Press <b>Info</b> to shift digits&gt; &lt;Press <b>OK</b> to accept value&gt; &lt;Press <b>Back</b> or <b>Cancel</b> to abort&gt;</p> <p><b>NOTE:</b> If Duplex mode is on and the user enters an odd number of pages, the next higher even number is used.</p>

## Service Diagnostics Tests and Utilities (Continued)

Menu Item	Front Panel Display Results	Functional Definition
Select Test Patterns	Blank Pattern 2by2 4by4 Horizontal Slant Vertical Vertical Line Full Please wait... Set pattern to <one of above>	These generated test prints bypass the Image Processor Board.
Select Media Source	Source Tray: n -or- MPT Please wait... Set to Tray n -or- MPT	Sets paper source tray. <Press <b>Up/Down</b> to change> <Press <b>OK</b> to accept value> <Press <b>Back</b> or <b>Cancel</b> to abort>
Select Color /Monochrome	Select: Color / Monochrome Please wait... Color Mode set to Color/Monochrome	Sets print color. <Press <b>Info</b> to change> <Press <b>OK</b> to accept value> <Press <b>Back</b> or <b>Cancel</b> to abort>
Select Duplex / Simplex	Select Duplexing: On/Off Please wait... Duplex is set to On/Off	Sets Duplex printing. <Press <b>Info</b> to change> <Press <b>OK</b> to accept value> <Press <b>Back</b> or <b>Cancel</b> to abort>
Select Job Offset	Select Offset: On/Off Please wait... Offset set to On/Off	Sets stacking in the top tray. <Press <b>Info</b> to change> <Press <b>OK</b> to accept value> <Press <b>Back</b> or <b>Cancel</b> to abort>
Select Output Path	Select: Face Down/Face Up Please wait... Output set to Face Down/Face Up	Sets print job output. <Press <b>Info</b> to change> <Press <b>OK</b> to accept value> <Press <b>Back</b> or <b>Cancel</b> to abort>
Finisher	Finisher Output Enabled Finisher Offset Enabled Finisher Offset Disabled Finisher Inverter Enabled Finisher Inverter Disabled Finisher Punch Enabled Finisher Punch Disabled Rear Stapling Enabled Front Stapling Enabled Center Stpling Enabled Saddle Stapling Enabled Finisher Stapling Disabled	Enables various features related to test printing to the finisher, if the finisher is installed. Unless otherwise specified, messages for each item include: "Finisher is not installed", "Feature Enabled/Disabled", or "Please wait". <Press <b>Back</b> or <b>Cancel</b> to abort>

## Service Diagnostics Tests and Utilities (Continued)

Menu Item	Front Panel Display Results	Functional Definition
<b>Motors/Fans Tests</b> - Tests the functionality of motors or fans.		
Tray Motors	Tray 1 Motor Tray 2 Motor <if installed> Tray 3 Motor Tray 4 Motor Tray 5 Motor Tray 6 Motor Tray Motor On/Off	<b>NOTE:</b> Remove media prior to test. <b>CAUTION:</b> Remove the universal tray before testing. <Press <b>OK</b> to continue> <Press <b>Back</b> or <b>Cancel</b> to abort> <Auto abort in 10 seconds>
Tray Feed Motors	Tray 3 Feed Motor Tray 4 Feed Motor Tray 5 Feed Motor Tray 6 Feed Motor Tray Feed Motor On/Off	<Press <b>OK</b> to continue> <Press <b>Back</b> or <b>Cancel</b> to abort> <Auto abort in 10 seconds>
Tray 1 (MPT) Lift Motor	<Please Wait....> <Motor is on>	<Press <b>OK</b> to continue> <Press <b>Back</b> or <b>Cancel</b> to abort> <Auto abort in 10 seconds>
Tray 2 Lift Motor	<Please Wait....> <Motor is on>	<Press <b>OK</b> to continue> <Press <b>Back</b> or <b>Cancel</b> to abort> <Auto abort in 10 seconds>
Tray 3 Lift Motor	<Please Wait....> <Motor is on>	<Press <b>OK</b> to continue> <Press <b>Back</b> or <b>Cancel</b> to abort> <Auto abort in 10 seconds>
Tray 4 Lift Motor	<Please Wait....> <Motor is on>	<Press <b>OK</b> to continue> <Press <b>Back</b> or <b>Cancel</b> to abort> <Auto abort in 10 seconds>
Tray 5 Lift Motor	<Please Wait....> <Motor is on>	<Press <b>OK</b> to continue> <Press <b>Back</b> or <b>Cancel</b> to abort> <Auto abort in 10 seconds>
Tray 6 Lift Motor	<Please Wait....> <Motor is on>	<Press <b>OK</b> to continue> <Press <b>Back</b> or <b>Cancel</b> to abort> <Auto abort in 10 seconds>
Registration Motor	<Motor is on>	<Press <b>OK</b> to continue> <Press <b>Back</b> or <b>Cancel</b> to abort> <Auto abort in 10 seconds>
Imaging Unit Motors (CMYK)	Black IU Motor Yellow IU Motor Magenta IU Motor Cyan IU Motor  [Black] [Yellow] [Magenta] [Cyan] IU Motor is On/Off	<b>CAUTION:</b> Remove the appropriate Imaging Unit and defeat the interlock switch before testing. <Press <b>OK</b> to start motor> <Press <b>Back</b> or <b>Cancel</b> to abort> <Auto abort in 10 seconds>
Imaging Unit Up/Down	Motor is On/Off	<Press <b>OK</b> to start motor> <Press <b>Back</b> or <b>Cancel</b> to abort> <Auto abort in 10 seconds>

## Service Diagnostics Tests and Utilities (Continued)

Menu Item	Front Panel Display Results	Functional Definition
Transfer Belt Motor	Transfer Motor is On/Off	<b>CAUTION:</b> Remove all Imaging Units and defeat the Top Cover Interlock Switch before testing.  <Press <b>OK</b> to start motor> <Press <b>Back</b> or <b>Cancel</b> to abort> <Auto abort in 10 seconds>
Fuser Unit Motor	Fuser Motor Forward Fuser Motor Release Fuser Motor Forward/Release Fuser Motor is On/Off	<Press <b>OK</b> to start motor> <Press <b>Back</b> or <b>Cancel</b> to abort> <Auto abort in 10 seconds>
Duplex Unit Motor	Motor is On/Off	<Press <b>OK</b> to start motor> <Press <b>Back</b> or <b>Cancel</b> to abort> <Auto abort in 10 seconds>
Job Offset Motor	Motor is On/Off	<Press <b>OK</b> to start motor> <Press <b>Back</b> or <b>Cancel</b> to abort> <Auto abort in 10 seconds>
Duplex Fan	Fan is On/Off	<Press <b>OK</b> to start motor> <Press <b>Back</b> or <b>Cancel</b> to abort> <Auto abort in 10 seconds>
Power Supply (LVPS) Fan	Fan is On/Off	<Press <b>OK</b> to start motor> <Press <b>Back</b> or <b>Cancel</b> to abort> <Auto abort in 10 seconds>
Chassis (Card Cage) Fan	Fan is On/Off	<Press <b>OK</b> to start motor> <Press <b>Back</b> or <b>Cancel</b> to abort> <Auto abort in 10 seconds>
Top Cover Fan	Fan is On/Off	<Press <b>OK</b> to start motor> <Press <b>Back</b> or <b>Cancel</b> to abort> <Auto abort in 10 seconds>
Belt (Transfer Unit) Fan	Fan is On/Off	<Press <b>OK</b> to start motor> <Press <b>Back</b> or <b>Cancel</b> to abort> <Auto abort in 10 seconds>
Fuser Fan	Fan is On/Off	<Press <b>OK</b> to start motor> <Press <b>Back</b> or <b>Cancel</b> to abort> <Auto abort in 10 seconds>
Toner Supply Motors	Black Toner Yellow Toner Black/Yellow Toner Magenta Toner Cyan Toner Magenta/Cyan Toner	<b>CAUTION:</b> Remove Toner Cartridges before test.  <Press <b>OK</b> to start motor> <Press <b>Back</b> or <b>Cancel</b> to abort> <Auto abort in 10 seconds>

## Service Diagnostics Tests and Utilities (Continued)

Menu Item	Front Panel Display Results	Functional Definition
<b>Sensor/Switch Tests</b> - Tests the functionality of the sensors and switches by giving service personnel the ability to input state changes and observe proper function.		
Interlock Switches	Top Cover Switch Top Cover is Open/Closed Right Door Switches Door A is Open/Closed Door B is Open/Closed Door C, Tray 3 is Open/Closed Door C, Tray 4 is Open/Closed Door C, Tray 5 is Open/Closed Door C, Tray 6 is Open/Closed Left Door Switches Side Output Tray is Open/Closed Door D is Open/Closed Door E is Open/Closed	<If Tray 3 is installed> <If Tray 4 is installed> <If Tray 5 is installed> <If Tray 6 is installed>
Tray 2 Switches Tray 3, 4, 5, 6 Switches (Optional)	Tray is Empty / Not Empty, Low / Not Low Lift is H/L, Hop is H/L, Feed H/L Size: SW 1=H/L 2=H/L 3=H/L 4=H/L <media name>	<b>NOTE:</b> Any of the sensor values may appear as N/A meaning 'not applicable'.  Media name is one of: Letter-SEF, A6-SEF, Tabloid-SEF, Tabloid Extra-SEF, Executive-SEF, Legal14-SEF, A3-SEF, B4-SEF, A4-SEF, A5-SEF, Letter-LEF, A4-LEF, B5-SEF, Legal13-SEF, B5-LEF, or Tray Missing See "Paper Size Sensing" on page 236. for more information.
MPT Tray Switches	Feeder is Up/Down Media is Present/Not Present Door A switch is Open/Closed	Tray 1 (MPT) Level Sensor Tray 1 (MPT) No Paper Sensor Door A Interlock Switch Actuate to change state.
Registration Entrance Sensor	Media Present / Not Present	Registration Sensor #1 Actuate to change state.
Tray 1 Entrance Sensor	Media is Present / Not Present	Actuate to change state.
Transfer Unit Entrance	Transfer Belt Paper 1 is Present / Not Present Transfer Belt Paper 2 is Present / Not Present	Actuate to change state.
Fuser Exit	Fuser Exit Paper is Present / Not Present	Fuser Exit Sensor. Actuate the switch to change state.
Face Down Stack Full	Stack Full is Full / Not Full	Top Output Tray Full Stack Sensor. Actuate to change state.
Face Up Stack Full	Stack Full is Full / Not Full	Side Output Tray Full Stack Sensor. Actuate to change state.

## Service Diagnostics Tests and Utilities (Continued)

Menu Item	Front Panel Display Results	Functional Definition
Offset Home Position	Offset Home is On/Off	Job Offset Home Position Sensor. Actuate to change state.
Duplex Unit	IN1 Sensor Signal is High/Low Rear Sensor is High/Low Front Sensor is High/Low	Duplex Entrance Sensor Duplex Reverse Sensor Duplex Rear Sensor Duplex Front Sensor Actuate the switch to change state.
Color Registration	Color Reg. Front is nnnh Color Reg. Rear is nnnh	Front Color Registration Sensor Rear Color Registration Sensor
Fuser Temp Sensors	Fuser Temp Upper is nnn deg.C Fuser Temp Lower is nnn deg.C	
Ambient Temp/ Hum Sensor	Amb. Temp. is nnn deg.C Amb. Hum. is nnn %	
CMYK IU Sensor	Cyan is Present / Missing Magenta is Present / Missing Yellow is Present / Missing Black is Present / Missing	Remove the Imaging Unit and defeat the Top Cover Interlock Switch and depress the 3-pins to change state.
CMYK Toner Cart Sensor	Black Toner is Low/Not Low Cyan Toner is Low/Not Low Magenta Toner is Low/Not Low Yellow Toner is Low/Not Low	Block the sensor to change state.
Read Fuses	Fuser is Cut / Not Cut TBelt is Cut / Not Cut CIU is Cut / Not Cut MIU is Cut / Not Cut YIU is Cut / Not Cut KIU is Cut / Not Cut	
CMYK Drum Phase Sensors	Black Phase is In Phase/Out of Phase Yellow Phase is In Phase/Out of Phase Magenta Phase is In Phase/Out of Phase Cyan Phase is In Phase/Out of Phase	CYMK Drum Phase Sensors
Paper Slack	Media is Present/Not Present	Belt Slack Sensor Actuate to change state.
IU Up/Down	IU is Up/Down	Lift Uplink Position Sensor Actuate to change state.
Fuser Release Sensor	Sensor is Detecting/Not Detecting	Fuser Release Sensor
Waste Bin Missing Sensor	Waste Container Missing/Present	Waste Toner Reservoir Detect Switch

## Service Diagnostics Tests and Utilities (Continued)

Menu Item	Front Panel Display Results	Functional Definition
Belt Hole IC	Belt Hole is On/Off	Transfer Belt Rotation Sensor. Actuate the Hall-effect sensors by placing a magnetic source near the sensor.
Waste Toner Box Hole IC	Waste Toner Box Hole IC is On/Off	Waste Toner Reservoir Auger Rotation Sensor. Actuate the Hall-effect sensors by placing a magnetic source near the sensor.
Waste Toner Hole IC	Waste Toner Hole IC is On/Off	Waste Toner Auger Rotation Sensor. Actuate the Hall-effect sensors by placing a magnetic source near the sensor.
<b>Clutch Tests</b> - Tests the functionality of the clutches by activating one component at a time. Test runs for 10 seconds or until the test is aborted.		
Tray 3 Feed	Clutch is On/Off	Listen for the clutch to engage. <Press <b>Back</b> or <b>Cancel</b> to abort> <Auto abort in 10 seconds>
Tray 4 Feed	Clutch is On/Off	
Tray 5 Feed	Clutch is On/Off	
Tray 6 Feed	Clutch is On/Off	
Reg Roller A	Clutch is On/Off	
<b>Solenoid Tests</b> - Tests the functionality of the solenoids by activating one component at a time. Test runs for 10 seconds or until the test is aborted.		
Registration Shutter	Shutter is Open/Closed	Listen for the click. <Press <b>Back</b> or <b>Cancel</b> to abort> <Auto abort in 10 seconds>
Exit Gate	Solenoid is On/Off	
Face-Up Gate	Solenoid is On/Off	



## Service Diagnostics Tests and Utilities (Continued)

Menu Item	Front Panel Display Results	Functional Definition
<b>Finsher Tests</b> - Tests the functionality of Finisher components.		
<b>Finisher Motor Tests</b> - Tests the functionality of the motors by activating one motor at a time. Test runs for 10 seconds or until the test is aborted.		
Feed Motor	Motor is On/Off	<Press <b>OK</b> to start motor> <Press <b>Back</b> or <b>Cancel</b> to abort> <Auto abort in 10 seconds>
Saddle Roller	Motor is On/Off	
Bundle Motor Forward	Motor is On/Off	
Bundle Motor Reverse	Motor is On/Off	
Paddle Motor	Motor is On/Off	
Bundle Roller	Motor is On/Off	
Shift Motor	Motor is On/Off	
Order Motor	Motor is On/Off	
Staple Motor	Motor is On/Off	
Saddle Sticking Motor	Motor is On/Off	
Saddle Transfer Motor	Motor is On/Off	
Saddle Transfer Motor	Motor is On/Off	
Sliding Motor	Motor is On/Off	
Punch Motor	Motor is On/Off	
Punch Registration Motor	Motor is On/Off	
Inverter Motor A	Motor is On/Off	
Inverter Motor B	Motor is On/Off	
<b>Finisher Sensor/Switch Tests</b> - Tests display the status each sensor or switch.		
Entrance Sensor	Entrance paper is Present / Not Present	
Tray Paper Detection Sensor	Media Present/Not Present	
Tray Paper Level Sensor	Media Present/Not Present	

## Service Diagnostics Tests and Utilities (Continued)

Menu Item	Front Panel Display Results	Functional Definition
Tray Upper Limit Sensor	Limit is Detected/Not Detected	
Tray Lower Limit Sensor	Limit is Detected/Not Detected	
Tray Middle Position Sensor	Tray Middle Position Limit is Detected/Not Detected	
Stapler Home Position Sensor	Stapler is Home/Not Home	
Stapler Slide Home Position Sensor	Stapler Slide is Home/Not Home	
Stapler Connected Signal	Stapler is Connected/Not Connected	
Stapler Safety Switch	Guide is Open/Closed	
Stapler Self-prime Sensor	Stapler is Empty/Not Empty	
Covers, Doors, and Interlocks	Upper Cover is Open/Closed Front Door Switch is Open/Closed Front Door is Open/Closed Joint Switch is Connected/Not Connected	
Bookbinding Position Sensor	Media is Present/Not Present	
Alignment Tray Sensor	Media is Present/Not Present	
Punch Timing Sensor	Media is Present/Not Present	
Bookbinding Sensors	Binding Sensor: Media is Present/Not Present Binding Home Pos: Home/Not Home Binding Roller Pos: Home/Not Home	
Front Alignment Plate Sensor	Alignment Plate is Home/Not Home	
Rear Alignment Plate Sensor	Alignment Plate is Home/Not Home	
Exit Belt Home Position Sensor	Exit belt home sensor is Home/Not Home	
Bundle Roller Home Position Sensor	Oscillation guide is Home/Not Home	

## Service Diagnostics Tests and Utilities (Continued)

Menu Item	Front Panel Display Results	Functional Definition
Paddle Home Position Sensor	Paddle is Home/Not Home	
Bookbinding Clock Sensor	Clock is High/Low	
Tray Lift Motor Clock	Clock is High/Low	
Punch Connected Signal	Punch is Connected/Not Connected	
Inverter Input Sensor	Input Sensor On/Off	
Inverter Output Sensor	Output Sensor On/Off	
Inverter Exit Sensor	Exit Sensor signal On/Off	
Inverter Cover Switch	Cover Switch Open/Closed	
Inverter Lower Sensor	Lower Inverter Sensor is On/Off	
Inverter Joint Sensor	Inverter Joint Sensor is On/Off	
Inverter CNT2 Signal	CNT2 Signal is On/Off	<b>NOTE:</b> At the time of publication, this test was not functional.
<b>Finisher Solenoid Tests</b> - Tests display the status of each solenoid.		
Inverter Separator Solenoid	Solenoid is On	Listen for the click. <Press <b>Back</b> or <b>Cancel</b> to abort> <Auto abort in 10 seconds>
Inverter Pressure Solenoid	Solenoid is On	Listen for the click. <Press <b>Back</b> or <b>Cancel</b> to abort> <Auto abort in 10 seconds>
<b>Finisher Clutch Tests</b> - Tests display the status of each clutch.		
Saddle Sticking Clutch	Clutch is On	Listen for the clutch to engage. <Press <b>Back</b> or <b>Cancel</b> to abort> <Auto abort in 10 seconds>
Inverter Registration Clutch	Clutch is On	Listen for the clutch to engage. <Press <b>Back</b> or <b>Cancel</b> to abort> <Auto abort in 10 seconds>

## Service Diagnostics Tests and Utilities (Continued)

Menu Item	Front Panel Display Results	Functional Definition
<p><b>Adjustments/Calibrations</b> - Performs adjustments, calibrations or operations essential to the performance of the printer. For complete walk-through procedures, see "Calibrations" on page 6-2.</p>		
<p>(ADC) Auto Density Control - Density Calibration: Verifies ADC operation, replacement ADC tag number is entered, then the operation is tested. The following functions are all part of the Auto Density Control.</p>		
Edit Density Data	Current Tag Number: nnn Change Tag Number? Yes No	Find the tag number on the bottom of the Registration Shutter. Enter the last two digits (hh) <Press <b>OK</b> to select> <Press <b>Back</b> or <b>Cancel</b> to abort>
	Enter Tag Number: nnnnnnnhh	<Press <b>Up/Down</b> to change> <Press <b>OK</b> to select value> <Press <b>Back</b> or <b>Cancel</b> to abort>
	Tag Number set to nnnh	<Press <b>Back</b> or <b>Cancel</b> to abort>
Execute Density Calibration	Density Adj. Test Passed / Failed	Engine is prepared for calibration run, and ADC operation is verified. <Press <b>Back</b> or <b>Cancel</b> to abort>
Density Calibration Results	Passed / Calibration Error / Density Sensor Error / Density Shutter Error / Density ID Error / Unknown Error YMC: V=nnn DAC=nnH K: V=nnn DAC=nnH	Example: YMC: V=120 D: V=130  <Press <b>Help(?)</b> to toggle display> <Press <b>Back</b> or <b>Cancel</b> to exit>
<p><b>(ATS) Auto Thickness Sensor</b>  <b>ATS 4-Sheet Calibration</b> - Verifies ATS operation. Test requires 4 sheets of premeasured media. A fifth sheet of paper, the bottom sheet, is recommended to prevent 'tray empty' issues. Media is picked from Tray 1 (MPT). "Automatic Thickness (ATS) Calibration" on page 6-4 for the detailed procedure. The following tests are all part of the ATS Thickness Sensor.</p>		
<p><b>Edit Thickness Data</b> - Thickness Calibration: Premeasured media thickness can be entered here in units of mils or microns, the calibration procedures use <b>Microns</b>. Input is constrained, when necessary, to system-dependent limits independent of actual user input values. Limits are 70 - 200 um.</p>		
	Select Thickness Units Mils Microns	<Press <b>OK</b> to select> <Press <b>Back</b> or <b>Cancel</b> to abort> <b>Microns</b> are used in test examples.
	Enter Thickness: n.nn Mils -or- xxx Microns	<b>Default</b> thickness is <b>140</b> microns. <Press <b>Up/Down</b> to modify> <Press <b>Help(?)</b> to change digit> <Press <b>OK</b> to select value> <Press <b>Back</b> or <b>Cancel</b> to abort>

## Service Diagnostics Tests and Utilities (Continued)

Menu Item	Front Panel Display Results	Functional Definition
<p><b>Execute Thickness Calibration</b> - Thickness Calibration: Engine is prepared for calibration run, then media is picked from the MPT. Cycle power to the printer if repeated failures are encountered.</p>		
	<p>Test Fault Cycle Printer Power Now</p> <p>Media Feed Sheet n Thickness Calibration Passed / Failed</p> <p>Adjusting page 1-4 to nnn um Current Value = nnn</p>	<p>Unexpected result requires reboot.</p> <p>&lt;Press <b>Back</b> or <b>Cancel</b> to abort&gt;</p> <p>This indicates that setting the page thickness is proceeding, showing current value relative to target value. Value is set to the same target value for each of the four pages. After adjustment completes, feeding of media and automatic measurement begins.</p>
<p><b>Thickness Calibration Results</b> - Thickness Calibration: Results from calibration run during this power on session. If result indicates failure, reboot, re-enter diagnostics and try again.</p>		
	<p>Curr Tray1 Thick = nnn um No extended data to display - or - Cal. Result: Passed / Non-Paper ADC Error / Thickness Error / Slant Error / Sensor ADC Error / Sensor Failure / Unknown</p>	<p>&lt;only when test failed&gt;</p> <p>&lt;Press <b>Down</b> for more data&gt; &lt;Press <b>Help(?)</b> for help&gt; &lt;Press <b>Back</b> or <b>Cancel</b> to exit&gt;</p>
<p><b>NOTE:</b> The next data screens are information screens. While viewing the data, press <b>Help(?)</b>. Press <b>Help(?)</b> again to see data. &lt;Press <b>Back</b> or <b>Cancel</b> to exit&gt;. The value of Curr Tray 1 (MPT) Thick will be zero until re-entry into this test.</p>		
	<p>Paper Thickness: 1=nnn um 2=nnn um 3=nnn um CHK=nnn um &lt;Press <b>Down</b> for more data&gt;</p>	<p>Measured Paper Thickness in microns. &lt;Press <b>Help(?)</b> for help&gt; &lt;Press <b>Back</b> or <b>Cancel</b> to exit&gt;</p>
	<p>Calc. Values: (mV/um) 1=n.n 2=n.n 3=n.n AVE=n.n &lt;Press <b>Down</b> for more data&gt;</p>	<p>Calculated sensor values, where 1.40mV/micron is the standard sensitivity value. &lt;Press <b>Help(?)</b> for help&gt; &lt;Press <b>Back</b> or <b>Cancel</b> to exit&gt;</p>
	<p>No Paper Samples: 1=nnV, 2=nnV, 3=nnV, CHK=nnV Paper Samples: 1=nnV, 2=nnV, 3=nnV, CHK=nnV, &lt;Press <b>Down</b> for more data&gt;</p>	<p>Measured samples without and with media present in sensor. No-Paper Samples = 3.33V. &lt;Press <b>Help(?)</b> to toggle display&gt; &lt;Press <b>Back</b> or <b>Cancel</b> to exit&gt;</p>

## Service Diagnostics Tests and Utilities (Continued)

Menu Item	Front Panel Display Results	Functional Definition
	No Paper Average: 1=nnV, 2=nnV, 3=nnV, CHK=nnV Paper Average: 1=nnV, 2=nnV, 3=nnH, CHK=nnV <Press <b>Down</b> for more data>	Measured averages without and with media present in sensor. No- Paper Average = 3.33V <Press <b>Help(?)</b> to toggle display> <Press <b>Back</b> or <b>Cancel</b> to exit>
	Corr. Sens. = n.n mV/um <Press <b>Back</b> or <b>Cancel</b> to exit>	The corrected sensitivity after calibration (in mVolts/microns).
<b>NVRAM Access</b> - This menu lets you read, set or reset selected NVRAM address locations.		
NVRAM Reset	Resetting NVRAM Are you sure? Yes No Exiting Service Diagnostics	Restores the printers setup values to their factory defaults. For more information on resetting NVRAM, see "Postscript NVRAM Reset" on page 6-9.
CRU Counter Read	Total Pages = nnn Fuser pages = nnn Trans.Belt Images = nnn	<Press <b>Down</b> for more data>
	IUs: Y = nnn images M = nnn images C = nnn images K = nnn images	<Press <b>Down</b> for more data>
	Toner: Y = nnn % used M = nnn % used C = nnn % used K = nnn % used	<Press <b>Down</b> to repeat data>
<b>CRU Counter Resets:</b> Resets the selected Customer Replaceable Consumable count on the engine. This resets the image count only, not the pixel count.		
Reset Toner Counts	Reset Black Toner Count Resetting Toner Count	
	Reset Yellow Toner Count Resetting Toner Count	
	Reset Magenta Toner Count Resetting Toner Count	
	Reset Cyan Toner Count Resetting Toner Count	
	No Reset	

## Service Diagnostics Tests and Utilities (Continued)

Menu Item	Front Panel Display Results	Functional Definition
Reset IU Counts	Reset Black IU Count Resetting IU Count	<Press <b>OK</b> to select value> <Press <b>Back</b> or <b>Cancel</b> to abort>
	Reset Yellow IU Count Resetting IU Count	<Press <b>OK</b> to select value> <Press <b>Back</b> or <b>Cancel</b> to abort>
	Reset Magenta IU Count Resetting IU Count	<Press <b>OK</b> to select value> <Press <b>Back</b> or <b>Cancel</b> to abort>
	Reset Cyan IU Count Resetting IU Count	<Press <b>OK</b> to select value> <Press <b>Back</b> or <b>Cancel</b> to abort>
	No Reset	
Reset Fuser Count	Reset Fuser Count? Y / N Resetting Fuser Count	<Press <b>Help(?)</b> to toggle choice> <Press <b>OK</b> to execute reset> <Press <b>Back</b> or <b>Cancel</b> to abort>
Reset Transfer Belt Count	Reset Transfer Belt Count? Y / N Resetting Transfer Belt Count	<Press <b>Help(?)</b> to toggle choice> <Press <b>OK</b> to execute reset> <Press <b>Back</b> or <b>Cancel</b> to abort>
Save Engine NVRAM		Saves Imaging unit life counts, transfer belt, stapler, punch, finisher output, electricity needle, staple needle life counts to controller NVRAM. Use this function before replacing the Engine Control Board.
Restore Engine NVRAM		Restores previously saved data to the replacement Engine Control Board.
<b>IP Controller Diagnostics</b> - Tests the basic functionality of the Image Processor Board Memory.		
RAM Read/Write Test	Executing..... <approx. 6 seconds per 256MB> Passed / Failed	Performs an extended memory test on the Image Processor Board. <b>NOTE:</b> Cycle power to the printer after executing this test.
<b>Exit</b> - Exits service diagnostics to PostScript without running power on self test.		

# Mode Select Port

The Mode Select Port (J390), accessible from the Rear Panel, is a 6-pin port used to place the printer in one of two operational modes or to reset the Image Processor Board. To access these modes, turn off the power and connect a jumper between the pin or pins indicated in the following table and either pin1 or 6. When power is restored, the printer boots in the selected mode. The Mode Select Port pins are arranged in numeric order with Pin 1 nearest the power cord connection. Pins 1 and 6 are tied to a common ground with the Rear Panel.

## Caution

To reset the Image Processor Board, momentarily ground pin 5, and then immediately re-open the connection. Grounding pin 5 for more than a few seconds could damage the processor.

## Mode Select Port Settings

Mode	1	2	3	4	5	6
Printer Reset	GND				GND	GND
Customer	GND					GND
Service	GND		GND	GND		GND

- Reset is a hardware reset of the Image Processor Board.
- Customer Mode is the normal mode for printing. The Serial Debug Port is receiving PostScript back channel information.
- Service Mode inhibits printing of the Startup page and causes POST to treat all errors as Hard Faults. See "Power On Self Test (POST)" on page 4-3. Service Mode also switches the Serial Debug Port from PostScript back channel information to the printer's operating system console.



# Obtaining Serial Back Channel Traces

In rare cases the printer may exhibit unusual behavior that is difficult to troubleshoot. In such cases, if feasible, it can be useful to obtain a back channel trace from the printer's Serial Debug Port. The back channel trace, lists step-by-step what the printer is doing up to the point that an error occurs. The trace may offer clues to help troubleshoot the problem. Alternately, you can email the trace to your RSS for his interpretation. You will need the following:

- Computer with a serial port
- Serial Cable, part number 012-1535-00
- Level Adaptor, part number 012-1543-00

To obtain a trace:

1. Connect the Serial Cable and Level Adaptor, then connect the Serial Cable to your PC. Serial port settings are COM1, 19.2 kbaud, 8 bits, no parity, 1 stop bit, and hardware control.
2. Turn off the printer.
3. Connect the Level Adaptor with adapter's THIS SIDE UP label facing upwards to the Serial Debug Port located on the printer's Rear Panel.
4. Start up a terminal program such as in Window's HyperTerminal (usually located in **Programs -- > Accessories --> Communications --> HyperTerminal**). Verify the serial port settings are correct, usually COM1:.
5. Set the printer to Service Mode by grounding the appropriate Mode Select Port pins (3 and 4).

## Note

Service Mode inhibits automatic Startup page printing. Also, the Mode Select Port jumpers must remain in place to display the printer's operating system console.

6. Turn on the printer.

The trace should appear in the terminal window. Examine the trace to troubleshoot the problem. Save the trace as a file, if necessary.

# Preparing the Printer for Shipment

Use either the original packing materials or the Repackaging Kit (065-0637-00) to ship the printer. The Repackaging Kit includes detailed instructions to prepare and package the printer for shipment. If the original packaging is available, follow these instructions:

## Caution

Do not remove the Toner Cartridges from the printer. Make sure each cartridge is securely locked in the Imaging Unit before sealing the box. Failure to secure the Toner Cartridges in the Imaging Units for transport can result in irreversible damage to the printer.

1. Remove the Transfer Unit and place in sealed bag.
2. Remove the Imaging Units and place in sealed, light-restrictive bag.
3. Secure the printer in the box using the original foam and cardboard inserts.
4. Securely seal and properly label the printer for shipment.

# Index

## Numerics

- 1650-Sheet Feeder, 1-10
  - dimensions, 1-14
  - feed operation, 2-33
  - height, 1-14
  - part number, 9-59
  - tray designations, 2-13
  - weight, 1-14
- 550-Sheet Feeder, 1-10
  - dimensions, 1-14
  - feed operation, 2-33
  - height, 1-14
  - part number, 9-59
  - tray designation, 2-13
  - weight, 1-14

## A

- abbreviations, 3-5
- AC power, 2-59
  - consumption, 1-14
  - input specifications, 1-14
  - troubleshooting, 4-16
- Actuator Kit
  - contents, 9-61
  - part number, 9-58
- ADC Sensor
  - location, 2-17
  - removal, 8-82
  - wiring, 10-30
- addressability, 1-16
- adjustments, 6-5
  - color balance, 6-2
  - color intensity, 6-2
  - color registration, 6-5
  - image area, 6-2
  - margins, 6-2
- automatic mode, 2-10

## B

- back channel trace, A-29
- background contamination, 5-23
- Basket Assembly, 2-46
  - Lower
    - removal, 8-92
    - part number, 9-51
    - removal, 8-93
- blank prints, 5-12
- boot
  - boot sequence, 4-2
  - command shortcuts, 1-7
- Boot Loader, 4-5
- button functions, 1-7

## C

- calibration
  - calibrate colors page, 6-2
  - color, 6-2
  - margins, 6-2
- Card Cage
  - fan wiring, 10-32
  - removal, 8-117
- Card Cage Fan
  - fan failure error, 3-104
  - location, 2-60
- Cavity Fan, see Card Cage Fan
- cleaning procedures, 7-2
  - Feed Roller, 7-5
  - Imaging Unit, 7-3
  - LED Head, 7-5
- clearances, minimum, 1-14
- Clutch, 2-61
- codes
  - error, 3-7
  - status, A-4
- cold offset, 5-27

- color
    - balance, 6-2
    - calibration, 6-2
    - intensity, 6-2
    - restore default settings, 6-6
  - color registration, 2-12
  - Color Registration Sensor
    - location, 2-17
  - Configuration Card, 1-10
    - configuration card missing, 3-9
    - failure, 3-89
    - invalid configuration card, 3-9
    - upgrades, 9-59
  - Configuration page
    - Hard Drive usage, 1-9
    - memory statistics, 1-9
    - metered operation, 1-4
  - connector
    - designators, 10-2
    - representation, 3-16
  - consumable, 1-12
    - errors, 3-8, 3-9
    - life counts, 1-13, 2-14
  - Control Panel, 1-7
    - blank display, 4-11
    - buttons, 1-7
    - command shortcuts, 1-7, 4-9
    - communications failure error, 3-147
    - error log format, 3-3
    - error messages, 3-7
    - LED, 1-7
    - POST testing, 4-3
    - removal, 8-111
    - reset defaults, 6-8
    - troubleshooting, 4-10
    - wiring, 10-43
  - Controller Fan, see IP Fan
  - counters
    - Fuser life, 6-9
    - life counts, 1-13
    - reset, 6-9
    - status page, 3-3
    - storage, 1-10
    - Toner Cartridge life, 6-9
  - CPU interrupts error, 4-5
  - crossover cable, 4-25
  - CRUM, 3-5
  - CRUM Antenna, 2-16
    - removal, 8-147
  - CRUM Reader Board
    - failure error, 3-154
    - location, 2-55
    - removal, 8-146
  - customer mode, A-28
- D**
- DC power, 2-59
  - Door A
    - Interlock Switch
      - location, 2-17
      - removal, 8-132
      - wiring, 10-31
    - jam error, 3-18
    - Latch Assembly removal, 8-64
    - location, 1-5
    - open error, 3-50
  - Door B
    - Detect Sensor
      - location, 2-17
      - removal, 8-43
      - wiring, 10-28
    - jam error, 3-21
    - location, 1-5
    - open error, 3-51
    - removal, 8-19
  - Door C
    - jam error, 3-23
    - location, 8-12
    - open error, 3-53
  - Door D
    - jam error, 3-25
    - location, 1-6
    - open error, 3-54
  - Door designations, 3-6
  - Door E
    - Detect Sensor
      - location, 2-17
      - removal, 8-77
      - wiring, 10-29
    - jam error, 3-27
    - location, 1-6
    - open error, 3-55

- Door F
    - location, 3-6
    - open error, 3-56
  - Door G
    - jam error, 3-42
    - location, 3-6
  - Door H
    - jam error, 3-36
    - location, 3-6
    - open error, 3-57
  - Door I
    - location, 3-6
  - Door J
    - location, 3-6
    - open error, 3-58
  - Duplex Fan
    - fan failure error, 3-163
    - location, 2-60
  - Duplex Gate, 2-50
    - linkage, 2-51
    - location, 2-37
    - solenoid, 2-36
  - Duplex Unit, 1-11
    - +24 V not available error, 3-164
    - clock frequency error, 3-171
    - close Door D error, 3-54
    - Duplex Gate linkage, 2-51
    - entrance jam error, 3-33
    - fan failure error, 3-163
    - fan location, 2-60
    - firmware error, 3-151
    - flash memory failure error, 3-156
    - interface failure error, 3-105
    - jam error, 3-25
    - motor location, 2-45
    - operation, 2-35
    - part number, 9-55
    - sensors, 2-36
    - unsupported ROM error, 3-114
  - duplicate IP address, 3-89
- E**
- EEPROM error, 4-5
  - Eject Assembly, see Exit Assembly
  - Engine Control Board, 2-56
    - connector locations, 10-6
    - fault isolation, 4-6
    - flash failure error, 3-111
    - location, 2-55
    - operation, 2-56
    - option interface wiring, 10-36
    - part number, 9-5
    - removal, 8-112
  - engine error history, 3-3
  - engine error log, 3-3
    - display, 3-3
    - format, 3-3
  - enhanced mode, 2-10
  - envelopes
    - supported sizes, 1-18
  - error message summary, 3-7
  - error messages
    - abbreviations used, 3-5
    - Control Panel, 3-7
    - jam errors, 3-7, 3-8
    - list of errors, 3-7
    - POST, 4-3
    - printer status, A-4
    - Status page, 3-3
    - warnings, 3-14, 3-15
  - Ethernet Port, 1-2
    - configuration, 6-7
    - location, 1-6
    - operational testing, 4-24, 4-27
    - POST testing, 4-3
    - testing, 4-25
  - Exit Assembly, 2-49
    - gears, 2-50
    - operation, 2-49
    - part number, 9-41
    - removal, 8-68
    - sensors, 2-49
    - troubleshooting, 4-21
  - Exit Gate, 2-49
    - location, 2-37
    - solenoid
      - removal, 8-70
      - wiring, 10-29

## F

- Fan
  - controller fan error, 3-99
  - duplex fan error, 3-163
  - fuser fan error, 3-112
  - imaging unit fan error, 3-102
  - locations, 2-60
  - LVPS removal, 8-124
  - power supply fan error, 3-100
  - top cover failure error, 3-101
  - transfer unit error, 3-103
- fasteners
  - Hardware Kit, 9-62
  - precautions, 8-6
  
  - screws, 8-7
- Feed Roller
  - cleaning, 7-5
  - life specification, 1-13
  - removal, 8-54
- Feed Roller Kit
  - contents, 9-60
  - part number, 9-58
- Feeder
  - clock frequency error, 3-173
  - removal, 8-38
  - sensors, 2-34
- Feeder Board, 2-57
  - connector locations, 10-15
  - removal, 8-53
  - wiring, 10-28
- Finisher, 1-11, 2-38
  - entrance jam error, 3-46
  - height, 1-14
  - inverter jam error, 3-45
  - jam at punch error, 3-35
  - lower tray full error, 3-79
  - operation, 2-38
  - paper path, 2-38
  - punch box full warning, 3-183
  - punch box missing, 3-183
  - stacker jam, 3-47
  - staple empty warning, 3-182
  - unsupported ROM error, 3-118
  - upper tray full error, 3-80
  - weight, 1-14
- fonts
  - reset defaults, 6-7
  - supplied fonts, 1-2
- Front Door
  - location, 1-5
  - removal, 8-18
- Front Sensor Board, 2-59
  - connector locations, 10-12
  - location, 2-55
  - removal, 8-150
  - wiring, 10-26
- Fuser, 2-4
  - components, 2-4
  - Exit Sensor, 2-5
    - location, 2-17
    - removal, 8-71
    - wiring, 10-29
  - fan failure error, 3-112
  - fan removal, 8-149
  - fuse, 2-14
  - fuse cut error, 3-120
  - Heat Roller, 2-4
  - install or reseal error, 3-68
  - jam error, 3-31
  - life count reset, 6-9
  - life expectancy, 2-5
  - life specification, 1-13
  - motor
    - drive train, 2-43
    - location, 2-39
  - motor failure error, 3-168
  - motor wiring, 10-32
  - operational description, 2-4
  - part number, 9-58
  - Pressure Roller, 2-4
  - Release Sensor removal, 8-79
  - removal, 8-11
  - replace error, 3-63
  - temperature
    - regulation, 2-14
    - sensing, 2-16
  - thermistor error, 3-145
  - troubleshooting, 4-20
  - voltage mismatch error, 3-113
  - wiring, 10-40

## Fuser Fan

- location, 2-60
- removal, 8-149
- wiring, 10-41

## Fuser Motor

- location, 2-39
- removal, 8-106

## G

### Gate

- duplex, 2-37
- exit, 2-37

### Gear Kit

- contents, 9-63
- part number, 9-58

### ghosting, 5-25

### guides, 2-53

## H

### Hall-Effect Sensor, 2-16

### Hard Drive, 1-9

- failure error, 3-119
- IDE disk error, 4-4
- part number, 9-59
- POST testing, 4-3

### Hardware Kit

- contents, 9-62
- part number, 9-58

### Harness Kit

- contents, 9-64

### HCF, see 1650-Sheet Feeder

### Health LED, 4-2

### Heat Roller, 2-4

### help text, 3-2

### hidden service menu, 4-9

### horizontal color registration, 6-5

### hot offset, 5-25

### Housing Bias Assembly

- removal, 8-120
- wiring, 10-38

### HVPS, 2-58

- location, 2-55
- operation, 2-58
- part number, 9-9
- removal, 8-119
- wiring, 10-38

## I

### IDE disk error, 4-4

### image intensity, 6-2

### Image Processor Board, 2-56

- connector locations, 10-7
- CPU interrupts error, 4-5
- exchange parts, 1-8
- fault isolation, 4-6
- location, 2-55
- NVRAM (EEPROM) error, 4-5
- operation, 2-56
- removal, 8-113
- reset, A-28
- wiring, 10-42
- wiring diagram, 10-42

### Imaging Unit, 2-3

- agitation bar, 2-24
- cleaning, 7-3
- components, 2-3
- drum error, 3-165
- failure error, 3-109
- fan failure error, 3-102
- fan removal, 8-133
- fuse, 2-14
- fuse cut error, 3-122
- install, reseal, or lock error, 3-65
- jam error, 3-29
- life count reset, 6-9
- life specification, 1-13
- Lift Uplink operation, 2-39
- motor
  - connections, 10-8
  - drive train, 2-41
  - location, 2-39
  - plate removal, 8-145
  - removal, 8-105
  - wiring, 10-33
- part number, 9-58
- precautions, 8-12
- print defect spacing, 5-18
- removal, 8-8
- replace error, 3-60
- toner detection, 2-25
- waste toner recovery, 2-47
- wiring, 10-38

- Imaging Unit Fan
  - fan failure error, 3-102
  - location, 2-60
- Imaging Unit Motor
  - removal, 8-105
- Imaging Unit Sensor Board, 2-57
  - connector locations, 10-11
  - location, 2-55
  - operation, 2-57
  - removal, 8-142
  - wiring, 10-41
- Interlock, 2-24
- Interlock Switch, 4-16
- Inverter
  - clock frequency error, 3-172
  - firmware error, 3-153
  - flash memory failure error, 3-158
  - interface failure error, 3-107
  - unsupported ROM error, 3-117
- IP Fan
  - controller fan failure error, 3-99
  - location, 2-60

## J

- Jam
  - detection, 2-23
  - door locator map, 3-6
  - error procedures, 3-17
  - locations, 2-23
- jam error log, 3-3
  - format, 3-3
- jam errors, 3-7, 3-8
- jam history, 3-3
- job collation, 1-2
- Job Offset Assembly, 2-51
  - home position error, 3-146
- Home Position Sensor
  - removal, 8-61
  - wiring, 10-29
- motor
  - drive train, 2-51
  - location, 2-39
  - removal, 8-59
  - part number, 9-49
  - removal, 8-56
  - sensors, 2-50

## L

- LED
  - blink patterns, 4-5
  - color definitions, 1-7
  - Health LED, 4-2
- LED Assembly
  - part number, 9-45
  - removal, 8-100
- LED Head, 2-4
  - cleaning, 7-5
  - connector locations, 10-4
  - LED failure error, 3-108
  - no data error, 3-148
  - part number, 9-5
  - removal, 8-125
  - wiring, 10-37
- LED Relay Board, 2-56
  - connector locations, 10-16
  - location, 2-55
  - removal, 8-126
  - wiring, 10-37
- life counts, 2-14
- Lift Uplink, 2-39
  - operation, 2-39
  - removal, 8-108
- Low Paper Sensor, 2-35
- Low Toner Sensor, 2-24
- LTA, see 550-Sheet Feeder
- LVPS, 2-59
  - connector locations, 10-9
  - fan failure error, 3-100
  - fan removal, 8-124
  - location, 2-55
  - overcurrent protection, 4-16
  - overvoltage protection, 4-16
  - power supply failure error, 3-97
  - removal, 8-121
  - troubleshooting, 4-16
  - wiring, 10-39
- LVPS Fan
  - location, 2-60
  - power supply fan error, 3-100
  - removal, 8-124



## M

- Macintosh printing problems, 4-21
- maintenance
  - life counts, 1-13
- margins
  - adjustment, 6-2
  - restore defaults, 6-6
- measurement techniques, 3-16
- media errors, 3-9
- Media Slack Sensor
  - connector location, 10-5
  - removal, 8-83
  - wiring, 10-30
- Media Thickness Sensor, 2-21
  - connector location, 10-5
  - removal, 8-66
  - wiring, 10-26
- Memory, 1-13
  - errors, 4-3
  - maximum, 1-13
  - maximum error, 4-3
  - minimum, 1-13
  - minimum error, 4-3
  - options, 1-9
  - POST testing, 4-3
  - supported types, 1-13
  - troubleshooting, 4-17
  - upgrades, 9-59
- metered printing, 1-4
  - enable, 4-9
- Microswitch, 2-16
- Mode Select Port, A-28
  - location, 1-6
  - operation, A-28
  - wiring, 10-42
- modes
  - customer mode, A-28
  - print quality, 2-10
  - service mode, A-28
- Motor
  - locations, 2-39
- Motor Driver Board, 2-57
  - clock frequency error, 3-170
  - communications error, 3-149
  - connector locations, 10-8
  - firmware error, 3-152

- flash memory failure error, 3-157
- location, 2-55
- removal, 8-141
- wiring, 10-31

## N

- network
  - Apple troubleshooting, 4-21
  - log format, 4-26
  - logging, 4-26
  - remote access, 4-26
  - restore defaults, 6-7
  - troubleshooting, 4-24
- Network Diagnostics, 4-24
- NVRAM
  - POST testing, 4-3
  - reset postscript, 6-9
  - supported types, 1-13

## O

- OHP Sensor, 2-21
  - connector location, 10-13
  - removal, 8-31
  - wiring, 10-27
- options, 1-9

## P

- PagePack, 1-4
- paper guides, 2-53
- paper path
  - input, 2-27
  - output, 2-37
  - sensing, 2-17
- paper size detection, 2-13
- Paper Size Switch, 2-16
  - connector location, 10-13
  - removal, 8-139
  - state table, 2-22
  - wiring, 10-31
- Paper Tips
  - printing, 1-19
- personal print, 1-2
- photo mode, 2-10

- postscript NVRAM, 6-9
- Power On Self Test (POST)
  - bypass testing, 4-3
  - description, 4-3
  - error indications, 4-3
  - fault types, 4-3
  - hard faults, 4-5
    - error display, 4-5
    - LED blink patterns, 4-5
    - types, 4-5
  - Health LED, 4-2
  - indicators, 4-2
  - memory error correction, 4-17
  - soft faults, 4-4
    - corrective actions, 4-4
    - Startup page format, 4-4
    - types, 4-4
  - version, 4-2
- power requirements, 1-14
- power saver mode, 1-16
- Power Supply
  - failure error, 3-97
  - fan failure error, 3-100
  - fan removal, 8-124
  - troubleshooting, 4-16
- Pressure Roller, 2-4
- preventative maintenance, 7-6
- print quality
  - background contamination, 5-23
  - blank prints, 5-12
  - cold offset, 5-27
  - color mis-registration, 5-28
  - color step test print, 5-7
  - color test print, 5-5
  - defect analysis, 5-2
  - ghosting, 5-25
  - improper image position, 5-32
  - mottled prints, 5-14
  - paper tips page, 5-2
  - ps test print, 5-6
  - random defects, 5-19
  - repeating defects, 5-2, 5-18
  - solid fill test print, 5-4
  - streaks, 5-38
  - unusual colors, 5-16
- Printer, 1-2
  - boot sequence, 4-2
  - circuit board location, 2-55
  - cleaning, 7-2
  - configurations, 1-3
  - dimensions, 1-14
  - door designations, 3-6
  - error reporting, 3-2
  - fans, 2-60
  - height, 1-14
  - image area, 1-17
  - lift motor failure, 3-159
  - manual feed error, 3-76
  - memory configurations, 1-9
  - menu map, A-2
  - metered operation, 1-4
  - metered toner not enabled error, 3-69
  - operational characteristics, 1-16
  - operational modes
    - customer mode, A-28
    - service mode, A-28
  - options, 1-9
  - paper outputs, 2-37
  - paper transport, 2-27
  - power consumption, 1-14
  - power requirements, 1-14
  - print process, 2-6
  - required minimum clearances, 1-14
  - sensor types, 2-15
  - serial number, 9-2
  - status codes, A-4
  - unsupported tray 2 ROM, 3-115
  - weight, 1-14
- print-quality modes, 2-10
- proof print, 1-2
- Punch
  - waste box missing, 3-183

## R

- random print defects, 5-19
- Rear Sensor Board, 2-59
  - connector locations, 10-14
  - location, 2-55
  - removal, 8-151
  - wiring, 10-29

- Registration Assembly, 2-48
  - part number, 9-31
  - removal, 8-84
- Registration Roller
  - components, 2-48
- Registration Sensor Assembly
  - removal, 8-80
  - wiring, 10-30
- Registration Sensor Board, 2-56
  - location, 2-55
  - removal, 8-148
  - wiring, 10-30
- Registration Shutter Solenoid
  - removal, 8-81
  - wiring, 10-34
- repeating print defects, 5-18
- resolution, 1-16
- routine maintenance
  - errors, 3-8, 3-9
  - items, 1-12

## S

- screw types, 8-7
- secure print, 1-2
- Sensor, 2-15
  - Actuator Kit, 9-61
  - Automatic Density Sensor, 2-13
  - Color Registration, 2-16
  - Color Registration Sensor, 2-10
  - CRUM, 2-16
  - Duplex Unit, 2-36
  - Exit Assembly, 2-49
  - feed sensors, 2-34
  - Feed-Out, 2-16
  - functions, 2-19
  - Fuser Exit, 2-16
  - Hall-Effect, 2-16
  - Imaging Unit Sensor Board, 2-57
  - interlocks, 2-24
  - Job Offset, 2-16, 2-50
  - level sensing, 2-21
  - Level Sensor, 2-16
  - locations, 2-17

- Low Paper Sensor, 2-35
- Low Toner, 2-16
  - operation, 2-24
- Media Thickness Sensor, 2-21
- microswitch, 2-16
- No Paper Sensor, 2-16
- OHP Sensor, 2-21
- paper detection, 2-21
- paper size detection, 2-22
- photo-receptive, 2-15
- photo-reflective, 2-15
- Registration Sensor, 2-16, 2-48
- replacement kit, 9-61
- Stack Full Sensor, 2-16
- Temperature Sensor, 2-16
- Temperature/Humidity, 2-16
- thermistor, 2-16
- Tray 1 (MPT) sensors, 2-52
- types, 2-15
- waste toner recovery, 2-47
- Waste Toner Sensors, 2-16

- Sensor Kit
  - contents, 9-61
  - part number, 9-58
- Serial Debug Port
  - back channel trace, A-29
  - location, 1-6
  - operation, A-28
  - wiring, 10-42
- serial number, 9-2
- location, 9-2
- Service Diagnostics, 4-7
  - button functions, 4-8
  - exiting, 4-9
  - main menu, 4-7
  - menu map, A-11
  - print menu map, 4-8
  - starting, 4-8
  - status reporting, 4-9
  - test print generation, 4-10
- Service Kits, 9-60
  - Actuator Kit
    - contents, 9-61
    - part number, 9-58

- Feed Roller Kit
  - contents, 9-60
  - part number, 9-58
- Gear Kit
  - contents, 9-63
  - part number, 9-58
- Hardware Kit
  - contents, 9-62
  - part number, 9-58
- Harness Kit
  - contents, 9-64
  
- Sensor Kit
  - contents, 9-61
  - part number, 9-58
- service mode, A-28
- Service Usage Profile, 3-3
  - description, 3-3
  - engine error log, 3-3
    - display format, 3-3
  - error logging, 3-3
- Side Output Tray, 2-38, 2-54
- Detect Sensor
  - removal, 8-73
  - wiring, 10-29
- location, 1-6
- open tray error, 3-81
- removal, 8-55
- Stack Full Sensor
  - removal, 8-75
  - wiring, 10-29
- tray closed warning, 3-179, 3-180
- tray full error, 3-78
- Solenoid, 2-61
- Specifications, 1-13
  - consumable life counts, 1-13
  - electrical, 1-14
  - environmental, 1-17
  - functional, 1-16
  - image, 1-17
  - media, 1-18
  - memory, 1-13
- standard mode, 2-10

- Stapler
  - staple empty warning, 3-182
  - stapler is empty, 3-182
- Startup page
  - network parameters, 4-21
  - POST error reports, 4-4
- startup process, 4-2
- status codes, A-4
- Status page, 3-3
  - printing, 3-3
- streaks, 5-38

## T

- Temperature/Humidity Sensor
  - connector location, 10-5
  - failure error, 3-92
  - removal, 8-67
  - wiring, 10-26
- test print, 5-4
  - color step, 5-7
  - color test, 5-5
  - ps pattern, 5-6
  - solid fill, 5-4
- Thermistor, 2-16
- Toner
  - camshaft removal, 8-144
  - life count, 1-13
  - metered, 1-4
- Toner Camshaft, 8-144
- Toner Cartridge
  - install, reseal or lock error, 3-64
  - life count reset, 6-9
  - metered cartridges, 1-4
  - metered error, 3-69
  - non-xerox warning, 3-181
  - part number, 9-60
  - removal, 8-9
  - replace error, 3-59
  - replace metered error, 3-70
  - view life count, 6-9
- Toner Motor
  - connector locations, 10-8
  - location, 2-44
  - removal, 8-104
  - toner supply failure, 3-176
  - wiring, 10-32

- Top Cover Fan
  - fan failure error, 3-101
  - location, 2-60
  - removal, 8-135
  - wiring, 10-41
- Top Cover Interlock Switch
  - location, 2-17
  - open error, 3-49
  - removal, 8-127
  - wiring, 10-38
- Top Output Tray, 2-38
  - Stack Full Sensor
    - removal, 8-72
    - wiring, 10-29
  - tray full error, 3-77
- Transfer Roller
  - life count reset, 6-9
- Transfer Unit, 2-5
  - belt error, 3-162
  - Belt Rotation Sensor removal, 8-91
  - components, 2-5
  - fan failure error, 3-103
  - fan removal, 8-134
  - fan wiring, 10-32
  - fuse, 2-14
  - fuse cut error, 3-121
  - install, reseal, or lock error, 3-66
  - life specification, 1-13
  - motor
    - drive train, 2-42
    - location, 2-42
    - operation, 2-41
  - part number, 9-58
  - removal, 8-10
  - replace error, 3-61
  - waste toner recovery, 2-47
- Transfer Unit Fan
  - fan failure error, 3-103
  - location, 2-60
  - wiring, 10-41
- Transfer Unit Motor
  - removal, 8-103
- Tray
  - +24 V not available error, 3-167
  - capacity, 1-18
  - clear tray riser plate error, 3-73
  - clock frequency error, 3-173
  - feed operation, 2-30
  - Feed Roller
    - replacement kit, 9-60
  - Feed Roller removal, 8-54
  - firmware error, 3-150
  - flash memory failure error, 3-155
  - guides, 2-53
  - interface failure error, 3-106
  - Label Kit, 9-59
  - lift motor failure error, 3-160
  - Lift Plate, 2-53
  - No Paper Sensor
    - removal, 8-45
  - no paper warning, 3-178
  - numbering, 2-13
  - optional trays, 1-10
  - out of paper error, 3-75
  - paper guides, 2-53
  - paper level detection, 2-21
  - paper size detection, 2-22
  - sensors, 2-32
  - Side Output, 2-38
  - Top Output, 2-38
  - universal trays, 2-53
  - unsupported ROM error, 3-116
  - wrong paper size error, 3-83
- Tray 1 (MPT)
  - clear riser plate error, 3-71
  - components, 2-52
  - connector locations, 10-13
  - feed operation, 2-27
  - Feed Roller removal, 8-34
  - home position error, 3-98
  - Home Position Sensor, 2-29
    - connector location, 10-5
    - removal, 8-30
    - wiring, 10-26
  - Level Sensor, 2-29
    - connector location, 10-13
    - removal, 8-28
    - wiring, 10-26
  - manual feed error, 3-76
  - No Paper Sensor, 2-29
    - connector location, 10-13
    - removal, 8-33

- wiring, 10-27
- no paper warning, 3-177
- out of paper error, 3-74
- part number, 9-37
- removal, 8-25
- sensors, 2-29
- troubleshooting
  - back channel trace, A-29
  - boot errors, 4-3
  - color calibration, 6-2
  - damaged prints, 4-20
  - diagnostic testing, 4-7
  - error messages, 3-7
  - Fuser jams, 4-20
  - Image Processor Board, 4-6
  - margins, 6-2
  - measurement techniques, 3-16
  - media-based problems, 4-19
  - mis-picks, 4-19
  - multiple-sheet picks, 4-19
  - network connection, 4-24
  - power supply problems, 4-16
  - printing defects, 5-3
  - procedural instructions, 3-15
  - repeating print defects, 5-2
  - skewed images, 4-20

## U

- Universal tray, 2-53
- unusual colors, 5-16
- USB Port
  - configuration, 6-7
  - location, 1-6
  - operational testing, 4-27
  - POST testing, 4-3

## V

- vertical color registration, 6-5
- voltage
  - frequency ranges, 1-14
  - input requirements, 1-14
  - measured tolerances, 3-17

## W

- warm-up time, 1-16
- warning messages, 3-14, 3-15
- Waste Toner Auger Assembly, 2-47
  - removal, 8-86
  - toner transfer error, 3-174
- Waste Toner Auger Rotation Sensor
  - location, 2-17
  - removal, 8-90
  - wiring, 10-31
- Waste Toner Cartridge, see Waste Toner Reservoir
- Waste Toner Manifold, 2-47
- Waste Toner Motor
  - location, 2-39
  - motor failure error, 3-169
  - part number, 9-29
  - removal, 8-107
- Waste Toner Reservoir, 2-47
  - Auger Rotation Sensor
    - location, 2-17
    - removal, 8-89
    - wiring, 10-31
  - Detect Switch
    - location, 2-17
    - removal, 8-130
    - wiring, 10-38
  - install or reseal error, 3-67
  - life specification, 1-13
  - part number, 9-58
  - replace error, 3-62
- Waste Toner Reservoir Full Sensor
  - location, 2-17
  - removal, 8-88
  - wiring, 10-38
- web browsing, 3-2
- web support, 4-2
- Windows printing problems, 4-23

## X

- xerographics
  - Fuser, 2-4
  - wiring, 10-38
- Xerox Supplies and Accessories, 9-58







Phaser® 7400

XEROX®



color printer

# Service Manual



Book 2: Options



# Phaser<sup>®</sup> 7400 Color Printer

## Service Manual Book 2: Options

### **Warning**

The following servicing instructions are for use by qualified service personnel only. To avoid personal injury, do not perform any servicing other than that contained in the operating instructions, unless you are qualified to do so.

First Printing: August 2005

071-0876-00



Copyright © 2005 Xerox Corporation. All Rights Reserved. Unpublished rights reserved under the copyright laws of the United States. Contents of this publication may not be reproduced in any form without permission of Xerox Corporation.

Copyright protection claimed includes all forms of matters of copyrightable materials and information now allowed by statutory or judicial law or hereinafter granted, including without limitation, material generated from the software programs which are displayed on the screen such as styles, templates, icons, screen displays, looks, etc.

XEROX<sup>®</sup>, The Document Company<sup>®</sup>, the digital X<sup>®</sup>, CentreWare<sup>®</sup>, infoSMART<sup>®</sup>, Made For Each Other<sup>®</sup>, PagePack<sup>™</sup>, Phaser<sup>®</sup>, PhaserSMART<sup>®</sup>, and Walk-Up<sup>™</sup> are trademarks of Xerox Corporation in the United States and/or other countries.

Acrobat<sup>®</sup>, Adobe<sup>®</sup> Reader<sup>®</sup>, Adobe Type Manager<sup>®</sup>, ATM<sup>™</sup>, Illustrator<sup>®</sup>, PageMaker<sup>®</sup>, Photoshop<sup>®</sup>, PostScript<sup>®</sup>, Adobe Brilliant<sup>®</sup> Screens, Adobe Garamond<sup>®</sup>, Adobe Jenson<sup>™</sup>, Birch<sup>®</sup>, Carta<sup>®</sup>, IntelliSelect<sup>®</sup>, Mythos<sup>®</sup>, Quake<sup>®</sup>, and Tekton<sup>®</sup> are trademarks of Adobe Systems Incorporated in the United States and/or other countries.

Apple<sup>®</sup>, AppleTalk<sup>®</sup>, EtherTalk<sup>®</sup>, LaserWriter<sup>®</sup>, LocalTalk<sup>®</sup>, Macintosh<sup>®</sup>, Mac OS<sup>®</sup>, TrueType<sup>®</sup>, Apple Chancery<sup>®</sup>, Chicago<sup>®</sup>, Geneva<sup>®</sup>, Monaco<sup>®</sup>, New York<sup>®</sup>, and QuickDraw<sup>®</sup> are trademarks of Apple Computer, Inc. in the United States and/or other countries.

HP-GL<sup>®</sup>, HP-UX<sup>®</sup>, and PCL<sup>®</sup> are trademarks of Hewlett-Packard Corporation in the United States and/or other countries.

IBM<sup>®</sup> and AIX<sup>®</sup> are trademarks of International Business Machines Corporation in the United States and/or other countries.

Windows<sup>®</sup>, Windows NT<sup>®</sup>, Windows Server<sup>™</sup>, and Wingdings<sup>®</sup> are trademarks of Microsoft Corporation in the United States and/or other countries.

Novell<sup>®</sup>, NetWare<sup>®</sup>, NDPS<sup>®</sup>, NDS<sup>®</sup>, Novell Directory Services<sup>®</sup>, IPX<sup>™</sup>, and Novell Distributed Print Services<sup>™</sup> are trademarks of Novell, Incorporated in the United States and/or other countries.

Sun<sup>SM</sup>, Sun Microsystems<sup>™</sup>, and Solaris<sup>®</sup> are trademarks of Sun Microsystems, Incorporated in the United States and/or other countries.

SWOP<sup>®</sup> is a trademark of SWOP, Inc.

UNIX<sup>®</sup> is a trademark in the United States and other countries, licensed exclusively through X/Open Company Limited.

As an ENERGY STAR<sup>®</sup> partner, Xerox Corporation has determined that this product meets the ENERGY STAR guidelines for energy efficiency. The ENERGY STAR name and logo are registered U.S. marks.



PANTONE<sup>®</sup> Colors generated may not match PANTONE-identified standards. Consult current PANTONE Publications for accurate color. PANTONE<sup>®</sup> and other Pantone, Inc. trademarks are the property of Pantone, Inc. © Pantone, Inc., 2000.

# Service Terms

## Manual Terms

Various terms are used throughout this manual to either provide additional information on a specific topic or to warn of possible danger present during a procedure or action. Be aware of all symbols and terms when they are used, and always read NOTE, CAUTION, and WARNING statements.

### Common Acronyms:

The following list defines the acronyms that may be found in this manual.

<b>ADC:</b> Automatic Density Control	<b>MCU:</b> Engine Control Board
<b>BTR:</b> Bias Transfer Roller	<b>NCS:</b> Non-Contact Sensor
<b>CRUM:</b> Customer Replaceable Unit Monitor	<b>PHD:</b> Imaging Unit
<b>CTD:</b> Toner Density Control	<b>PL:</b> Corresponds to the FRU Parts List.
<b>ESD:</b> Electrostatic Discharge	<b>ROS:</b> Laser Scanning Unit
<b>IDT:</b> Intermediate Transfer Unit	<b>RTC:</b> Charge Roller

### Note

A note indicates an operating or maintenance procedure, practice or condition that is necessary to efficiently accomplish a task.  
A note can provide additional information related to a specific subject or add a comment on the results achieved through a previous action.

### Caution

A caution indicates an operating or maintenance procedure, practice or condition that, if not strictly observed, results in damage to, or destruction of, equipment.

### Warning

A warning indicates an operating or maintenance procedure, practice or condition that, if not strictly observed, results in injury or loss of life.

## Product Terms

**Caution:** A personal injury hazard exists that may not be apparent. For example, a panel may cover the hazardous area.

**Danger:** A personal injury hazard exists in the area where you see the sign.

# Symbols Marked on the Product

DANGER high voltage.



Protective ground (earth) symbol.



Hot surface on or in the printer. Use caution to avoid personal injury.



The surface is hot while the printer is running. After turning off the power, wait 30 minutes.



Avoid pinching fingers in the printer. Use caution to avoid personal injury.



Use caution (or draws attention to a particular component). Refer to the manual(s) for information.



# Power Safety Precautions

## Power Source

For 115 VAC printers, do not apply more than 135 volts RMS between the supply conductors or between either supply conductor and ground. For 230 VAC printers, do not apply more than 254 volts RMS between the supply conductors or between either supply conductor and ground. Use only the specified power cord and connector. This manual assumes that the reader is a qualified service technician.

Plug the three-wire power cord (with grounding prong) into a grounded AC outlet only. If necessary, contact a licensed electrician to install a properly grounded outlet. If the product loses its ground connection, contact with conductive parts may cause an electrical shock. A protective ground connection by way of the grounding conductor in the power cord is essential for safe operation.

## Disconnecting Power

### Warning

Turning the power off using the power switch does not completely de-energize the printer. You must also disconnect the power cord from the printer's AC inlet. Disconnect the power cord by pulling the plug, not the cord.

Disconnect the power cord in the following cases:

- if the power cord or plug is frayed or otherwise damaged,
- if any liquid or foreign material is spilled into the product,
- if the printer is exposed to any excess moisture,
- if the printer is dropped or damaged,
- if you suspect that the product needs servicing or repair,
- whenever you clean the product.

# Electrostatic Discharge (ESD) Precautions

Some semiconductor components, and the respective sub-assemblies that contain them, are vulnerable to damage by Electrostatic discharge (ESD). These components include Integrated Circuits (ICs), Large-Scale Integrated circuits (LSIs), field-effect transistors and other semiconductor chip components. The following techniques will reduce the occurrence of component damage caused by static electricity.

Be sure the power is off to the chassis or circuit board, and observe all other safety precautions.

- Immediately before handling any semiconductor components assemblies, drain the electrostatic charge from your body. This can be accomplished by touching an earth ground source or by wearing a wrist strap device connected to an earth ground source. Wearing a wrist strap will also prevent accumulation of additional bodily static charges. Be sure to remove the wrist strap before applying power to the unit under test to avoid potential shock.
- After removing a static sensitive assembly from its anti-static bag, place it on a grounded conductive surface. If the anti-static bag is conductive, you may ground the bag and use it as a conductive surface.
- Do not use freon-propelled chemicals. These can generate electrical charges sufficient to damage some devices.
- Do not remove a replacement component or electrical sub-assembly from its protective package until you are ready to install it.
- Immediately before removing the protective material from the leads of a replacement device, touch the protective material to the chassis or circuit assembly into which the device will be installed.
- Minimize body motions when handling unpacked replacement devices. Motion such as your clothes brushing together, or lifting a foot from a carpeted floor can generate enough static electricity to damage an electro-statically sensitive device
- Handle IC's and EPROM's carefully to avoid bending pins.
- Pay attention to the direction of parts when mounting or inserting them on Printed Circuit Boards.



# Service Safety Summary

## General Guidelines

**For qualified service personnel only:** Refer also to the preceding Power Safety Precautions.

**Avoid servicing alone:** Do not perform internal service or adjustment of this product unless another person capable of rendering first aid or resuscitation is present.

**Use care when servicing with power:** Dangerous voltages may exist at several points in this product. To avoid personal injury, do not touch exposed connections and components while power is on. Disconnect power before removing the power supply shield or replacing components.

**Do not wear jewelry:** Remove jewelry prior to servicing. Rings, necklaces and other metallic objects could come into contact with dangerous voltages and currents.

## Warning Labels

Read and obey all posted warning labels. Throughout the printer, warning labels are displayed on potentially dangerous components. As you service the printer, check to make certain that all warning labels remain in place.

## Safety Interlocks

Make sure all covers are in place and all interlock switches are functioning correctly after you have completed a printer service call. If you bypass an interlock switch during a service call, use extreme caution when working on or around the printer.

## Servicing Electrical Components

Before starting any service procedure, switch off the printer power and unplug the power cord from the wall outlet. If you must service the printer with power applied, be aware of the potential for electrical shock.

### Warning

Do not touch any electrical component unless you are instructed to do so by a service procedure.

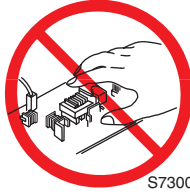

## Servicing Mechanical Components

When servicing mechanical components within the printer, manually rotate drive assemblies, rollers, and gears.

### Warning

Do not try to manually rotate or manually stop the drive assemblies while any printer motor is running.



# Regulatory Specifications

Xerox has tested this product to electromagnetic emission and immunity standards. These standards are designed to mitigate interference caused or received by this product in a typical office environment.

## United States (FCC Regulations)

This equipment has been tested and found to comply with the limits for a Class A digital device, pursuant to Part 15 of the FCC Rules. These limits are designed to provide reasonable protection against harmful interference when the equipment is operated in a commercial environment. This equipment generates, uses, and can radiate radio frequency energy. If it is not installed and used in accordance with these instructions, it may cause harmful interference to radio communications. Operation of this equipment in a residential area is likely to cause harmful interference in which case the user will be required to correct the interference at his/her own expense.

If this equipment does cause harmful interference to radio or television reception, which can be determined by turning the equipment off and on, the user is encouraged to try to correct the interference by one or more of the following measures:

- Reorient or relocate the receiver.
- Increase the separation between the equipment and receiver.
- Connect the equipment into an outlet on a circuit different from that to which the receiver is connected.
- Consult the dealer or an experienced radio/television technician for help.

Any changes or modifications not expressly approved by Xerox could void the user's authority to operate the equipment. To ensure compliance with Part 15 of the FCC rules, use shielded interface cables.

## Canada (Regulations)

This Class A digital apparatus complies with Canadian ICES-003.

Cet appareil numérique de la classe A est conforme à la norme NMB-003 du Canada.

# European Union

## Warning

This is a class A product. In a domestic environment this product may cause radio interference in which case the user may be required to take adequate measures.

Xerox Corporation declares, under our sole responsibility, that the product to which this declaration relates is in conformity with the following standards and other normative documents:

### Low Voltage Directive 73/23/EEC as amended

---

EN 60950:2000

---

EN 60825-1:1994+A1:2001+A2:2002

---

### Electromagnetic Compatibility Directive 89/336/EEC as amended

---

EN 55022:1998 +A1:2000 +A2:2003

---

EN 55024:1998 +A1:2000 +A2:2003

---

EN 61000-3-2:2000

---

EN 61000-3-3:1995 +A1:2001

---

### Radio & Telecommunications Terminal Equipment Directive 1999/5/EC as amended

---

EN 300 330-2 V1.1.1

---

EN 300 440-2 V1.1.1

---

EN 300 489-3 V1.3.1

---

This product, if used properly in accordance with the user's instructions, is neither dangerous for the consumer nor for the environment.

A signed copy of the Declaration of Conformity for this product can be obtained from Xerox.

# Manual Organization

The *Xerox Phaser 7400 Color Printer Service Manual* is the primary document used for repairing, maintaining, and troubleshooting the printer. The manual is organized into two books. This volume, Book 2, Phaser 7400 Options includes an overview of option theory, option FRU replacement procedures, parts lists, and wiring diagrams. Use this volume after you've isolated a problem internal to a specific option or when a problem arises at the engine/option interface. Use Book 1 for diagnostic and troubleshooting procedures for the printer and all its options.

Use Book 2 as a reference when servicing printer options. Book 2 includes information important for the repair or replacement of option components. Use the troubleshooting procedures in Book 1 to diagnose and isolated the problem.

Book 2 contains these sections:

**Introductory, Safety, and Regulatory Information:** This section contains important safety information, regulatory requirements, and information about this manual.

**Section 1 - General Information:** This section contains an overview of the options available, configuration, specifications, and consumables.

**Section 2 - Theory of Operation:** This section contains functional information on each option.

**Section 3 - General Troubleshooting:** This section provides troubleshooting methods for situations where no error indicator is available.

**Section 4 - Adjustments and Calibrations:** This section provides procedures for the adjustment of print engine components.

**Section 5 - Service Parts Disassembly:** This section contains removal procedures for parts listed in the option's Field Replaceable Units (FRUs) Parts List. A replacement procedure is included when necessary.

**Section 6 - Parts Lists:** This section contains exploded views of the option FRUs as well as FRU part numbers.

**Section 7 - Wiring Diagrams:** This section contains option plug/jack locations and wiring diagrams.

# Book 1 - Print Engine

Use Book 1 as your primary resource for understanding the operational characteristics of the print engine. Book 1 describes printer specifications, theory and includes information important to the diagnosis and repair of problems occurring in the print engine and attached options. Book 1 also provides detailed print engine replacement procedures, parts lists, and wiring diagrams.

Book 1 contains these sections:

**Introductory, Safety and Regulatory Information:** This section contains important safety information, regulatory requirements, and information about this manual.

**Section 1 - General Information:** This section contains an overview of the printer's operation, configuration, specifications, and consumables.

**Section 2 - Theory of Operation:** This section contains detailed functional information on print engine components.

**Section 3 - Error Codes and Messages:** This section describes the resident diagnostics available to assist the troubleshooting process. These diagnostics include error codes and messages and Service Usage Profile data stored in the printer. This section provides complete troubleshooting information for the print engine and all options.

**Section 4 - General Troubleshooting:** Troubleshooting discussions cover the operation of Power On Self Test (POST), Service Diagnostics, In addition, this section includes troubleshooting methods for situations where no error indicator is available.

**Section 5 - Print-Quality Troubleshooting:** This section focuses on techniques to correct image quality problems associated with printer output.

**Section 6 - Adjustments and Calibrations:** This section provides procedures for the adjustment of print engine components.

**Section 7 - Cleaning and Maintenance:** This section provides periodic cleaning procedures for the printer.

**Section 8 - FRU Disassembly:** This section contains removal procedures for parts listed in the print engine's Field Replaceable Units (FRUs) Parts List. A replacement procedure is included when necessary.

**Section 9 - Parts Lists:** This section contains exploded views of the print engine FRUs as well as part numbers for items available as FRUs. Part numbers for printer options and accessories are also included.

**Section 10 - Wiring Diagrams:** This section contains the plug/jack locations and the wiring diagrams for the print engine.

**Appendix A - Menu Maps:** This section provides an illustration of the front-panel menu as well as a listing of the Service Diagnostics tests available.

# Contents

Service Terms .....	iii
Symbols Marked on the Product .....	iv
Power Safety Precautions .....	v
Electrostatic Discharge (ESD) Precautions .....	vi
Service Safety Summary .....	vii
Regulatory Specifications .....	ix
Manual Organization .....	xi

## 1 General Information

Printer Introduction and Overview .....	1-2
Printer Configurations .....	1-3
Parts of the Finisher and Paper Trays .....	1-4
Printer Options .....	1-5
Finisher .....	1-5
Duplex Unit .....	1-6
550-Sheet Feeder .....	1-6
1650-Sheet Feeder .....	1-7
Specifications .....	1-7
Consumable Life Specifications .....	1-7
Finisher Electrical Specifications .....	1-7
Physical Dimensions and Clearances .....	1-8
Finisher Functional Specifications .....	1-8
Finisher Environmental Specifications .....	1-10

## 2 Theory of Operation

Options Operational Overview .....	2-2
Finisher Overview .....	2-3
Punch Unit .....	2-4
Staple Unit .....	2-6
Saddle Unit .....	2-8
Inverter Unit .....	2-10
Printer Options .....	2-11
Duplex Unit .....	2-11
550-Sheet Feeder .....	2-11
1650-Sheet Feeder .....	2-12
Finishing Process Summary .....	2-13
Inverting .....	2-14
Punching .....	2-14
Folding .....	2-18
Stacking .....	2-19
Stapling .....	2-23
Delivery .....	2-24

Sensors . . . . .	2-25
Finisher Paper Path Sensors . . . . .	2-27
Inverter Sensors . . . . .	2-30
Duplex Sensors . . . . .	2-31
Optional Tray Sensors . . . . .	2-32
Motors, Rollers, Solenoids, and Clutches . . . . .	2-33
Finisher Motors . . . . .	2-33
Inverter Solenoids and Motors. . . . .	2-35
Duplex Solenoids, Rollers, and Motors . . . . .	2-36
Optional Tray Motors, Rollers, and Clutches . . . . .	2-37
Detecting Jams . . . . .	2-40
Finisher/Punch Power Supply . . . . .	2-41
Finisher Power Supply Protection . . . . .	2-42
Punch Unit Power Supply Protection. . . . .	2-42

### 3 General Troubleshooting

Introduction. . . . .	3-2
Using Service Diagnostics . . . . .	3-2
Servicing Instructions . . . . .	3-3
Jam Locator . . . . .	3-4
Jam Detection Chart . . . . .	3-5
Error Message Summary . . . . .	3-6
Using the Troubleshooting Procedures . . . . .	3-11
Measurement Techniques . . . . .	3-12
Troubleshooting the Finisher. . . . .	3-13
Jam at Door C for Tray [3][4][5][6]. . . . .	3-13
Jam at Door D Open Door D to Clear. . . . .	3-16
Jam in Duplex Unit. . . . .	3-17
Jam at Duplex Entrance . . . . .	3-18
Jam at Finisher Punch Unit . . . . .	3-20
Jam at Finisher Door H . . . . .	3-21
Jam at Finisher Upper Output Tray . . . . .	3-22
Jam at Finisher Saddle Stapler. . . . .	3-23
Jam at Finisher Upper Output Tray . . . . .	3-24
Jam at Finisher Stapler . . . . .	3-25
Jam at Finisher Door G . . . . .	3-26
Jam at Finisher Saddle Stapler. . . . .	3-27
Jam at Finisher Upper Output Tray . . . . .	3-28
Jam Inside Finisher . . . . .	3-29
Jam at Finisher Entrance . . . . .	3-30
Finisher Output Tray Jammed . . . . .	3-31
Close Right Door C for Tray [3][4][5][6] . . . . .	3-33
Close Left Door D. . . . .	3-34
Close Finisher Door F. . . . .	3-35
Close Finisher Door H . . . . .	3-36
Close Finisher Door J. . . . .	3-37



Clear Tray [2][3][4][5][6] Riser Plate . . . . .	3-38
Out of Paper Load Tray [2][3][4][5][6] with [size][type] . . . . .	3-39
Finisher Lower Output Tray is Full, Unload Paper . . . . .	3-40
Finisher Upper Output Tray is Full, Unload Paper . . . . .	3-41
Wrong Paper Size; Load Tray [3][4][5][6] with [size][type] . . . . .	3-42
Wrong Paper Type Load Tray [3][4][5][6] with [size][type] . . . . .	3-43
Paper Not Available Load Tray [3][4][5][6] with [size][type] . . . . .	3-44
Duplex Interface Failure . . . . .	3-45
Tray [3][4][5][6] Interface Failure. . . . .	3-46
Inverter Unit Interface Failure . . . . .	3-47
Unsupported Duplex Unit ROM. . . . .	3-48
Unsupported Tray [3][4][5][6] ROM . . . . .	3-49
Unsupported Inverter Unit ROM. . . . .	3-50
Unsupported Finisher Unit ROM. . . . .	3-51
Finisher Fold Position Sensor Failure . . . . .	3-52
Finisher Paddle Failure . . . . .	3-53
Finisher Stapler Swing Motor Failure . . . . .	3-54
Finisher Stack Handling Motor Failure . . . . .	3-55
Finisher Staple Motor Failure . . . . .	3-56
Finisher Jog Motor Failure . . . . .	3-57
Finisher Lift Motor Failure. . . . .	3-58
Finisher Exit Failure. . . . .	3-60
Finisher Punch Backup RAM Failure. . . . .	3-61
Finisher Punch Communications Failure. . . . .	3-62
Finisher Punch Unit Transfer Motor Failure . . . . .	3-63
Finisher Punch Motor Failure . . . . .	3-64
Finisher Backup RAM Failure . . . . .	3-65
Finisher Punch Dust Sensor Failure . . . . .	3-66
Printer Error - Contact Service; report fault [n] . . . . .	3-68
Finisher Punch Unit Counter at End of Life . . . . .	3-68
Finisher Staple Unit Counter at End of Life . . . . .	3-69
Finisher Interface Error . . . . .	3-70
Inverter Power Supply Failure. . . . .	3-71
Tray [3][4][5][6] Firmware Error . . . . .	3-72
Duplex Unit Firmware Error . . . . .	3-73
Finisher Inverter Firmware Error. . . . .	3-74
Tray [3][4][5][6] Flash Memory Failure . . . . .	3-75
Duplex Unit Flash Memory Failure . . . . .	3-76
Finisher Inverter Flash Memory Failure. . . . .	3-77
Tray [3][4][5][6] Lift Motor Failure. . . . .	3-78
Duplex Unit Fan Failure. . . . .	3-80
+24V Not Available to the Duplex Unit . . . . .	3-81
+24 V Not Available to Tray [3][4][5][6]. . . . .	3-83
Duplex Unit Clock Frequency Error. . . . .	3-84
Finisher Inverter Clock Frequency Error . . . . .	3-85
Tray [3][4][5][6] Feeder Board Clock Frequency Error. . . . .	3-86

No Paper in Tray [2][3][4][5][6] . . . . .	3-87
Staple Cartridge Is Empty . . . . .	3-88
Punch Waste Box is Full or Missing . . . . .	3-89
Finisher Away From Base . . . . .	3-90
Finisher Away From Printer . . . . .	3-91

## 4 Adjustments and Calibrations

Punch Unit Adjustments . . . . .	4-2
Registering Punch Holes . . . . .	4-2
Adjusting Sensor Output After Sensor Replacement . . . . .	4-4
Adjusting Sensor Output After EE-PROM Replacement . . . . .	4-5
Stapler Unit Adjustments . . . . .	4-6
Adjusting the Saddle Stitch Double Stapling Position . . . . .	4-6
Adjusting the Stapler Phase . . . . .	4-7
Saddle Unit Adjustments . . . . .	4-17
Adjusting the Folding Position . . . . .	4-17
Adjusting the Phase of the Saddle Unit Gear . . . . .	4-18

## 5 Service Parts Disassembly

Overview . . . . .	5-2
General Notes on Disassembly . . . . .	5-2
Preparation . . . . .	5-2
Notations in the disassembly text . . . . .	5-3
Fastener Types . . . . .	5-3
Standard Orientation . . . . .	5-4
Finisher Disassembly . . . . .	5-5
Removing Inverter Base Unit from Finisher . . . . .	5-5
Undocking Inverter from Printer . . . . .	5-6
Trays and Covers . . . . .	5-7
Paper Exit Tray . . . . .	5-7
Front Door (Door J) . . . . .	5-8
Right Side Door (Door G) . . . . .	5-10
Rear Cover . . . . .	5-11
Upper Cover (Door H) . . . . .	5-13
Processing Tray Upper Cover . . . . .	5-15
Inverter Front Covers . . . . .	5-17
Inverter Rear Covers . . . . .	5-19
Inverter Left Side Door (Door F) . . . . .	5-21
Inverter Right Side Door (Door I) . . . . .	5-22
Inverter Top Cover . . . . .	5-23
Units . . . . .	5-24
Punch Unit . . . . .	5-24
Staple Unit . . . . .	5-29
Staple/Fold Drive Unit . . . . .	5-30
Saddle Unit . . . . .	5-34
Assemblies . . . . .	5-37

Upper Right Cover Assembly . . . . .	5-37
Processing Tray Assembly . . . . .	5-38
Paddle Assembly . . . . .	5-43
Boards . . . . .	5-46
Finisher Controller Board . . . . .	5-46
Home Position Board . . . . .	5-47
Punch Control Board . . . . .	5-50
Photo Sensor Board . . . . .	5-51
Punch LED Board . . . . .	5-53
Waste Full LED Board . . . . .	5-54
Inverter Controller Board . . . . .	5-55
Inverter Power Supply Board . . . . .	5-56
Motors, Clutches, and Solenoids . . . . .	5-57
Punch Motor . . . . .	5-57
Finisher Punch Transfer Motor . . . . .	5-58
Lift Motor . . . . .	5-59
Staple/Fold Motor . . . . .	5-60
Slide Motor . . . . .	5-61
Feed Motor . . . . .	5-62
Paddle Motor . . . . .	5-63
Delivery Motor . . . . .	5-64
Alignment (Front and Rear) Motors . . . . .	5-65
Binding Clutch . . . . .	5-66
Inverter Upper Roller Motor . . . . .	5-67
Inverter Lower Roller Motor . . . . .	5-68
Inverter Feeder Clutch . . . . .	5-69
Inverter Upper Roller Solenoid . . . . .	5-70
Inverter Lower Roller Solenoid . . . . .	5-71
Finisher Sensors and Switches . . . . .	5-72
Joint Switch . . . . .	5-73
Front Door Switch and Sensor . . . . .	5-74
Inlet Sensor . . . . .	5-75
Tray Paper Sensor . . . . .	5-76
Paper Surface Sensor . . . . .	5-77
Upper Cover Sensor . . . . .	5-78
Shift Limit Sensors . . . . .	5-79
Lift Motor Clock Sensor . . . . .	5-80
Stack Full Sensor . . . . .	5-81
Processing Tray Sensor . . . . .	5-82
Aligning Plate Home Position Sensors . . . . .	5-83
Stack Feed Roller Home Position Sensor . . . . .	5-85
Waste Full Sensor . . . . .	5-87
Swing Guide Home Position Sensor . . . . .	5-89
Delivery Belt Home Position Sensor . . . . .	5-90
Paddle Home Position Sensor . . . . .	5-91
Stapler Safety Interlock Switch . . . . .	5-92

Staple/Fold Clock Sensor . . . . .	5-93
Folding Home Position Sensor . . . . .	5-94
Folding Position Sensor . . . . .	5-96
Bind Tray Sensor . . . . .	5-98
Inverter Sensors and Switches . . . . .	5-99
Inverter Docking Sensor . . . . .	5-100
Inverter Door (Door F) Open Interlock Switch . . . . .	5-101
Inverter Upper Paper-Present Sensor . . . . .	5-102
Inverter Lower Paper-Present Sensor . . . . .	5-104
Inverter Paper-in Sensor . . . . .	5-106
Guides and Rollers . . . . .	5-107
Side Guide . . . . .	5-107
Feed Roller . . . . .	5-109
Upper Stack Delivery Roller . . . . .	5-112
Paddle . . . . .	5-115
Lower Stack Delivery Roller Belt . . . . .	5-117
Duplex Unit Disassembly . . . . .	5-122
Front Cover Assembly . . . . .	5-122
Bottom Cover Plate . . . . .	5-124
Side Rails . . . . .	5-126
Paper Guides . . . . .	5-127
Duplex Motor Assembly . . . . .	5-128
Diverter Solenoid . . . . .	5-129
Duplex Unit Sensors and Switches . . . . .	5-130
Duplex Fan . . . . .	5-131
Interconnect Connector . . . . .	5-132
Paper Tray Disassembly . . . . .	5-133
Options Connector . . . . .	5-133
Tray Covers and Tray Door (Door C) . . . . .	5-134
Tray Feeder . . . . .	5-136
Registration Motor . . . . .	5-137
Feed Motor . . . . .	5-138
Lift Motor . . . . .	5-139
Registration Clutch . . . . .	5-140
Door C Detect Sensor . . . . .	5-141
No Paper Sensor . . . . .	5-142
Registration Sensor #2 . . . . .	5-143
Feed-Out Sensor #2 . . . . .	5-146
Feeder Board . . . . .	5-148
Tray Feed Rollers . . . . .	5-150

## 6 Parts List

Using the Parts List . . . . .	6-2
Finisher Parts . . . . .	6-3
Finisher Unit Assembly Diagram . . . . .	6-4
Parts List 1.1 Finisher Unit Assembly Parts List . . . . .	6-5
Finisher External Parts Diagram . . . . .	6-6
Parts List 1.2 Finisher External Parts List . . . . .	6-7
Finisher Internal Parts Diagram (1 of 2) . . . . .	6-9
Finisher Internal Parts Diagram (2 of 2) . . . . .	6-10
Parts List 1.3 Finisher Internal Parts List . . . . .	6-11
Stack (Lift) Motor Drive Assembly Parts Diagram . . . . .	6-12
Parts List 1.4 Stack (Lift) Motor Drive Assembly Parts List . . . . .	6-13
(Staple/Fold) Drive Assembly Parts Diagram . . . . .	6-14
Parts List 1.5 (Staple/Fold) Drive Assembly Parts List . . . . .	6-15
Bundle Support Cover Assembly Parts Diagram . . . . .	6-16
Parts List 1.6 Bundle Support Cover Parts List . . . . .	6-17
Dispose Assembly (Processing Tray) Parts Diagram . . . . .	6-18
Parts List 1.7 Dispose Assembly (Processing Tray) Parts List . . . . .	6-19
Paper Feeder (Paddle) Assembly Parts Diagram . . . . .	6-20
Parts List 1.8 Paper Feeder (Paddle) Assembly Parts List . . . . .	6-21
Puncher Assembly Parts Diagram . . . . .	6-22
Parts List 1.9 Puncher Assembly Parts List . . . . .	6-23
Punch Total Assembly Diagram . . . . .	6-24
Parts List 1.10 Punch Total Assembly Parts List . . . . .	6-25
Staple Unit Diagram (1 of 2) . . . . .	6-27
Staple Unit Diagram (2 of 2) . . . . .	6-28
Parts List 1.11 Staple Unit Parts List . . . . .	6-29
Fold Unit Diagram (1 of 3) . . . . .	6-30
Fold Unit Diagram (2 of 3) . . . . .	6-31
Fold Unit Diagram (3 of 3) . . . . .	6-32
Parts List 1.12 Fold Unit Parts List . . . . .	6-33
Inverter Parts Diagram (1 of 3) . . . . .	6-34
Inverter Parts Diagram (2 of 3) . . . . .	6-35
Inverter Parts Diagram (3 of 3) . . . . .	6-36
Parts List 1.13 Inverter Parts List . . . . .	6-37
Duplex Unit Parts . . . . .	6-38
Duplex Unit Parts Diagram . . . . .	6-38
Parts List 1.14 Duplex Unit Parts List . . . . .	6-39
Optional Paper Tray Parts . . . . .	6-40
Optional Tray Parts Diagram (1 of 2) . . . . .	6-41
Optional Tray Parts Diagram (2 of 2) . . . . .	6-42
Parts List 1.15 Optional Tray Parts List . . . . .	6-43

## 7 Wiring Diagrams

Plug/Jack Locator Diagrams . . . . .	7-2
Print Options Plug/Jack Designators . . . . .	7-2
Finisher Wiring Diagrams . . . . .	7-16
Finisher/Punch Power Supply Wiring Diagram . . . . .	7-16
Finisher Controller to Printer Wiring . . . . .	7-17
Finisher Controller to Sensors (1 of 3) . . . . .	7-18
Finisher Controller to Sensors (2 of 3) . . . . .	7-19
Finisher Controller to Sensors (3 of 3) . . . . .	7-20
Finisher Controller to Motors . . . . .	7-21
Finisher Controller to Switches . . . . .	7-22
Finisher Controller to Stapler Sensors and Motors . . . . .	7-23
Finisher Controller to Punch Controller . . . . .	7-24
Punch Controller to Sensors and Motors . . . . .	7-25
Inverter Sensors Wiring Diagram . . . . .	7-26
Inverter Motors, Solenoids, and Clutch Wiring Diagram . . . . .	7-27
Duplex Unit Wiring Diagrams . . . . .	7-28
Duplex Unit Sensors and Interconnect Wiring . . . . .	7-28
Duplex Unit Motors and Solenoids . . . . .	7-29
Optional Tray Wiring Diagrams . . . . .	7-30
Paper Tray Sensors and Interconnect Wiring . . . . .	7-30
Paper Tray Motors, Clutches, and Interconnect Wiring . . . . .	7-31

## Index

# General Information

## In this chapter...

- Printer Introduction and Overview
- Printer Configurations
- Printer Options
- Specifications

Section

1

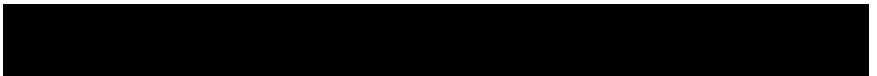

# Printer Introduction and Overview

The *Xerox Phaser 7400 Color Printer Service Manual* is the primary document used to repair, maintain, and troubleshoot this printer. For manual updates, Service Bulletins, knowledge base, etc., see [www.xerox.com/office/7400support](http://www.xerox.com/office/7400support). For further technical support, contact your assigned Xerox Technical Support for this product.

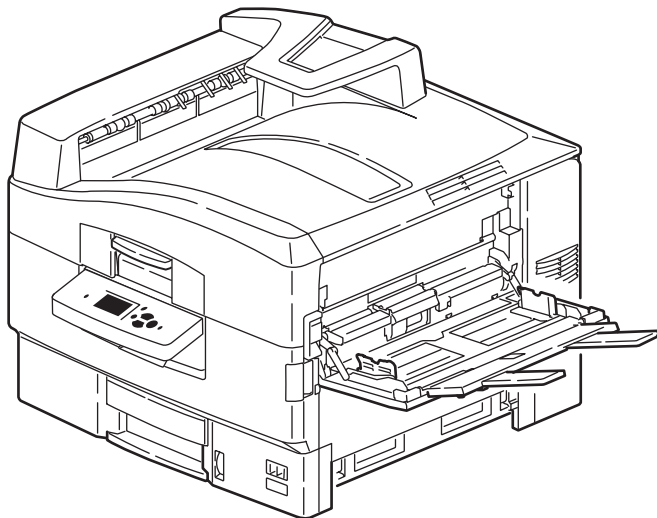

s7400-301

The Xerox Phaser 7400 Color Printer is a single pass, electrophotographic design, using light emitting diodes (LED) for image exposure. The Phaser 7400 supports PostScript 3 and PCL5c page description languages. Print performance for A4 paper is 40 pages per minute (ppm) monochrome, 36 ppm for full color in 1-sided or 2-sided modes. Resolutions of up to 600 x 1200 dots per inch (dpi), 32-level grayscale print is applicable at 600x600 dpi. The base configuration (Phaser 7400N) features USB 2.0 and 10/100baseT Ethernet Ports, 256 MB of memory, a 250-sheet multi-purpose Tray 1 (MPT), a 550-sheet input tray (Tray 2), a 500-sheet face-down Top Output Tray, and a 250-sheet face-up Side Output Tray.

Phaser 7400 printer options add memory, paper capacity and functionality. For configurations not originally equipped, an internal Hard Drive is available for font storage, storing print files, job collation, proof, personal, and secure print support. A selection of RAM memory upgrades are available to raise the installed quantity to the 1 GB maximum. A 1650-Sheet High-Capacity Feeder (HCF) is available with three, 550-sheet universal trays. A 550-Sheet Feeder (Tray 3) Lower Tray Assembly (LTA) is also available. On the output side, a 1000-Sheet Finisher provides punching, stapling, saddle stitching, and offset stacking, which raises the output total to 1750 sheets. A Duplex Unit is available to add automatic, 2-sided printing for supported paper sizes from all trays.



# Printer Configurations

The Phaser 7400 Color Printer is available in five configurations. The main differences are standard memory, optional high-capacity feeders, duplexing (2-sided printing) capabilities, networking, Finisher capabilities, and internal Hard Drive. The following table lists the available configurations.

Features	Printer Configuration				
	7400N	7400DN	7400DT	7400DX	7400DXF
Max Print Speed (ppm) color / monochrome	36/40	36/40	36/40	36/40	36/40
Hard Drive for Secure, Proof, Personal, and Saved Print Jobs	Optional	Optional	Yes	Yes	Yes
Standard Memory*	256 MB	256 MB	512 MB	512 MB	512 MB
USB Port	Yes	Yes	Yes	Yes	Yes
10/100 Ethernet Port	Yes	Yes	Yes	Yes	Yes
RAM Collation	Yes	Yes	Yes	Yes	Yes
Duplex Unit	Optional	Yes	Yes	Yes	Yes
PostScript / PCL Fonts	Yes	Yes	Yes	Yes	Yes
Resolutions (dpi):					
Standard	600x600x1	600x600x1	600x600x1	600x600x1	600x600x1
Enhanced	1200x600x1	200x600x1	1200x600x1	1200x600x1	1200x600x1
Photo	600x600x5	600x600x5	600x600x5	600x600x5	600x600x5
Tray 1 (MPT)**	Yes	Yes	Yes	Yes	Yes
Optional Trays **	Optional	Optional	1 x 550	3 x 550	4 x 550
550-Sheet Feeder**	Optional	Optional	Yes	Optional	Yes
1650-Sheet Feeder**	Optional	Optional	Optional	Yes	Yes
1000-Sheet Finisher***	Optional	Optional	Optional	Optional	Yes

\* All configurations have two memory slots supporting 256 MB and 512 MB cards, up to a maximum of 1 GB.

\*\* Trays 1 and 2 are standard on all configurations. All configurations support additional paper trays in the following combinations:

One 550-Sheet Feeder (Tray 3)

One 1650-Sheet Feeder (Trays 3, 4, and 5 or 4, 5, and 6)

One 550-Sheet Feeder (Tray 3) and one 1650-Sheet Feeder (Trays 4, 5, and 6)

\*\*\* Requires a total of 4 optional trays for fitment.

# Parts of the Finisher and Paper Trays

## Front View

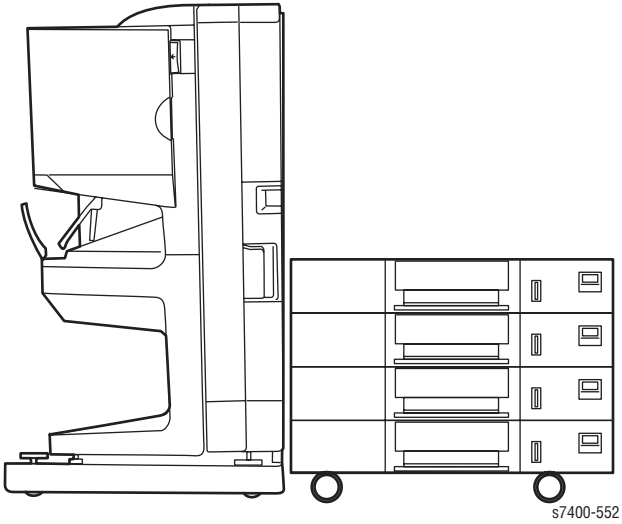

## Rear View

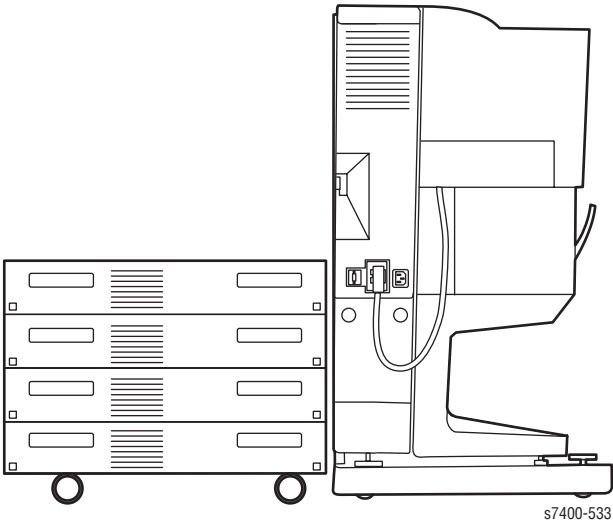

# Printer Options

Phaser 7400 Color Printer options include:

- 1,000-Sheet Finisher (with hole punch, staple, saddle-stitch, and inverter)
- 550-Sheet Feeder (LTA)
- 1650-Sheet Feeder (HCF)
- Duplex Unit

## Finisher

The Finisher increases the output capacity of the printer by 1,000 sheets. Printer output is directed to the Finisher by way of the side exit. Depending on the job specifications, as paper enters the Finisher it is punched, stapled, offset and stacked. The Finisher has two cables; one to hook up to the printer, and another to connect to the Inverter. The Finisher also includes its own power supply.

The Finisher includes a separate Inverter unit to position paper from the printer before the paper reaches the finisher unit for final stacking.

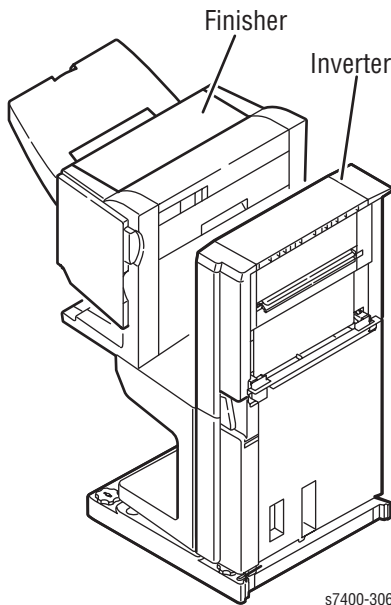

## Duplex Unit

The Duplex Unit adds two-sided printing. The Duplex Unit attaches into the left side above Tray 2 using two latches.

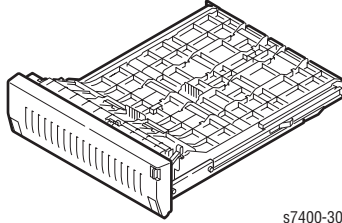

s7400-305

## 550-Sheet Feeder

The 550-Sheet Feeder increases the input capacity of the printer. The feeder attaches below Tray 2 with four screws. When used in combination with the 1650-Sheet Feeder, the 550-Sheet Feeder is installed between the printer and 1650-Sheet Feeder. Up to four optional 550-Sheet Feeders per printer, totaling six universal trays (Trays 2~6), is allowed. However, when the 1650-Sheet Feeder (HCF) is installed, only one additional 550-Sheet Feeder is allowed between the HCF and the printer. Electrical connection to the printer is made by a single interface connector.

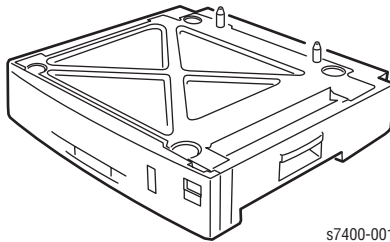

s7400-001

# 1650-Sheet Feeder

The 1650-Sheet Feeder adds three, 550-sheet trays. Control signals reach the sheet feeder by a single connection. The sheet feeder is secured both to the print engine and the 550-Sheet Feeder.

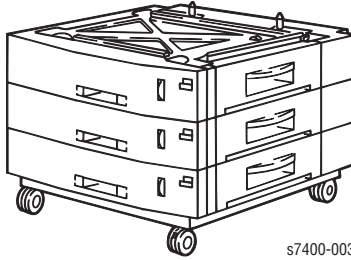

## Specifications

### Consumable Life Specifications

Maintenance Items	Size	Product name
Staple Cartridge <sup>1</sup>	5000 staples x3	AR-SC2

### Finisher Electrical Specifications

Characteristic	Specification	
Primary line voltages	110-127 V Printer - 12 amp circuit 220-240 V Printer - 6 amp circuit	
Primary line voltage frequency range	100-120 V Printer - 50/60 Hz $\pm$ 2 Hz 220-240 V Printer - 50/60 Hz $\pm$ 2 Hz	
Power consumption	<b>60 watts</b> (finishing)	<b>12 Watts</b> (standby)

# Physical Dimensions and Clearances

<b>Finisher (including stand)</b>	<b>Value</b>
Height:	1016 mm (40.0 in.)
Width:	813 mm (32 in.)
Depth:	595 mm (23.6 in.)
Weight:	Approximately 55 kg (122 lb.) Finisher only
<b>1650-Sheet Feeder</b>	<b>Value</b>
Height:	401 mm (15.8 in.) Optional Paper Tray Assembly
Width:	597 mm (23.5 in.)
Depth:	599 mm (23.6 in.)
Weight:	Approximately 53.6 kg (117 lb.)
<b>550-Sheet Feeder</b>	<b>Value</b>
Height:	109 mm (4.3 in.) Optional Paper Tray Assembly
Width:	597 mm (23.5 in.)
Depth:	599 mm (23.6 in.)
Weight:	16 kg (36 lb.)
<b>Surface</b>	<b>Value</b>
Tilt tolerance:	Within 50 mm side to side.

## Finisher Functional Specifications

### Functional Specifications

<b>Characteristic</b>	<b>Specification</b>	
Transport Speed	34 - 45 PPM	
Transport Reference	Center Reference	
Tray Type (number of trays)	Upper Tray	Lift-up/down offset tray
	Lower tray	Book tray for saddle stitch
Capacity of paper exit and load	Non-staple	1,000 sheets (Small size) 500 sheets (Large size)
	Staple sort	30 sheets
	Max	1,000 sheets (Small size) 500 sheets: (Large size)
	Large size Small size	A3, B4, 11" x 17", 8.5" x 11" A4R, B5, B5R, A5R, 8.5 x 11 R and Executive

## Functional Specifications (Continued)

Characteristic	Specification	
Quantity of paper to be stapled	50 sheets	Small size, 128 g/m <sup>2</sup> x 48
		Large size, 128 g/m <sup>2</sup> x 25
	25 sheets	Large size, 128 g/m <sup>2</sup> x 25
Stapling	Two positions	A3, B4, 11" x 17", 8.5" x 14", 8.5 x 13, A4, 8.5 x 11 R and Executive
	One at the back	A3, B4, A4, A4R, B5
	One in the front	11 x 17, 8.5 x 14, 8.5 x 13, 8.5 x 11, 8.5 x 11R, Executive
Paper exit direction	Face down	
Paper Exit Paper size	A3, B4, A4, A4R, B5, B5R, A5R, 11" x 17", 8.5" x 14", 8.5" x 13", 8.5" x 11", 8.5" x 11"R, 5.5" x 8.5"R Executive	
Offset function	Provided (output paper size (except for A5R, 5.5 x 8.5	
Recommended paper and weight	Normal paper	60 - 12g/m <sup>2</sup> (16 - 34 lbs)
	Index paper	176 g/m <sup>2</sup> (47 lbs)
	Cover paper	200 - 205 g/m <sup>2</sup> (54-55 lb.)
Staple supply	Staple cartridge replacement	
Staple detection	Staple empty detection	provided
	Cartridge empty detection	provided
	Staple jam detection	provided
Stapling type	Center stapling (center fold)	
Stapling position	1200 mm pitch from the paper center	
Paper size (for saddle stitch)	A3, A4R, B4, 11 x 17, 8.5 x 11R	
Weight of paper (for saddle stitch)	64 - 80 g/m <sup>2</sup> (Cover: 64 - 128 g/m <sup>2</sup> )	
Book tray stacking type	Fixed	
Quantity of paper to be stapled	10 sets (6 - 10 pages)	
	20 sets (1 - 5 pages)	

# Finisher Environmental Specifications

<b>Characteristic</b>	<b>Specification</b>
<b>Temperature</b>	
Operating	10 to 32° C (50 to 89.6° F)
Storage	0 to 4 °C (32 to 109.4° F)
Transport	-10 to 43° C (-14 to 109.4° F)
<b>Humidity (RH)</b>	
	Relative Humidity (50 - 70% to assure the best print-quality)
Operating	20 - 80%
Storage	10 - 95%
Transport	10 - 95%
<b>Altitude</b>	
Operating	0 to 2500 meters (8,000 ft.) at 25° C
Non-operating	0 to 6000 meters (20,000 ft.)



# Theory of Operation

## In this chapter...

- Operational Overview
- Finisher Overview
- Printer Options
- Finishing Process Summary
- Sensors
- Motors, Rollers, Solenoids, and Clutches
- Detecting Jams
- Power Supplies

Section

2



# Options Operational Overview

The Phaser 7400 Color Printer Options package consists of:

## Finisher:

- **Punch Unit** - Provides various punch hole (2, 3, and 4 hole) options.
- **Staple Unit** - Staples stacked paper for various media type and size.
- **Saddle Unit** - Delivers and folds stacked paper.
- **Inverter** - Physically inverts the paper for stacking or folding.

## Print Options:

- **550-Sheet Feeder** - Represents one physical tray with 550-sheet output.
- **1650-Sheet Feeder** - Represents a 3-tray combined output of 1650 sheets.
- **Duplex Unit**- Provides printing for both sides of selected media.

# Finisher Overview

The Finisher increases the output capacity of the printer by 1,000 sheets. Printer output is directed to the Finisher by way of the side exit. Depending on the job specifications, as paper enters the Finisher it can be inverted, punched, stapled, offset and stacked. Power is supplied from the printer's AC Accessory Panel.

The Finisher consists of the following major assemblies:

- **Punch Unit** - Provides various punch hole (2, 3, and 4 hole) options.
- **Staple Unit** - Staples stacked paper for various media type and size.
- **Saddle Unit** - Delivers and folds stacked paper.
- **Inverter** - Physically inverts the paper for stacking or folding.

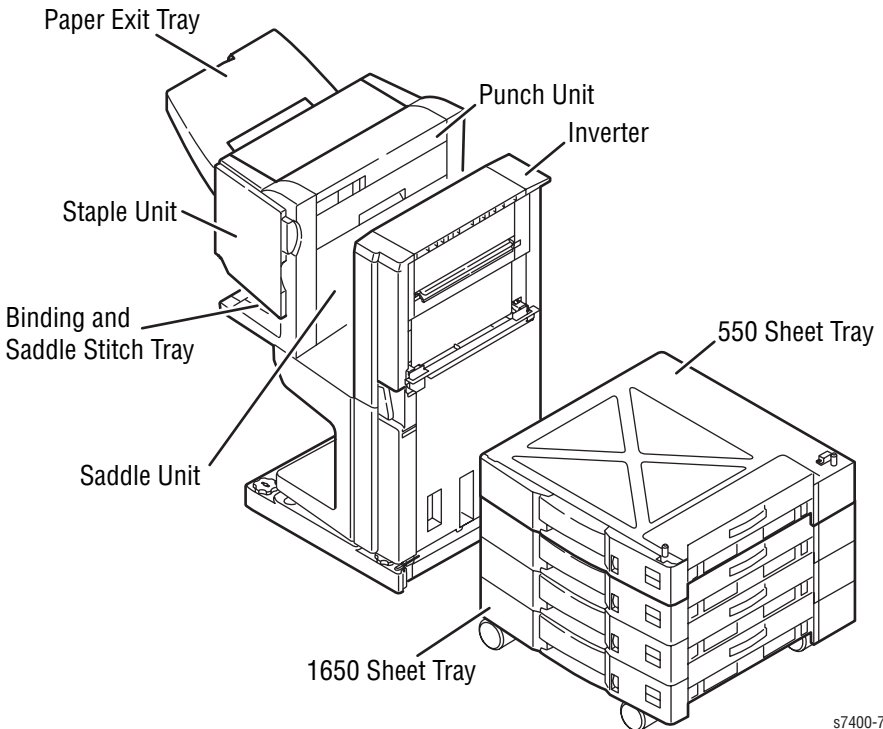

s7400-709

# Punch Unit

The Punch Unit punches holes in sheets coming from the printer. It provides for 2-hole, 3-hole, and 4-hole punching. The unit installs into the pickup assembly of the finisher. Since the punch unit is not equipped with a paper feeding mechanism, the sheets from the printer move through the punch unit and feed system of the finisher. If the punch feature has been selected, when the trailing edge of a sheet from the printer reaches the punch unit, the sheet stops while the punch shaft rotates to punch a hole along the trailing edge. This operation is controlled through various commands from the Finisher Controller Board and the Punch Controller Board.

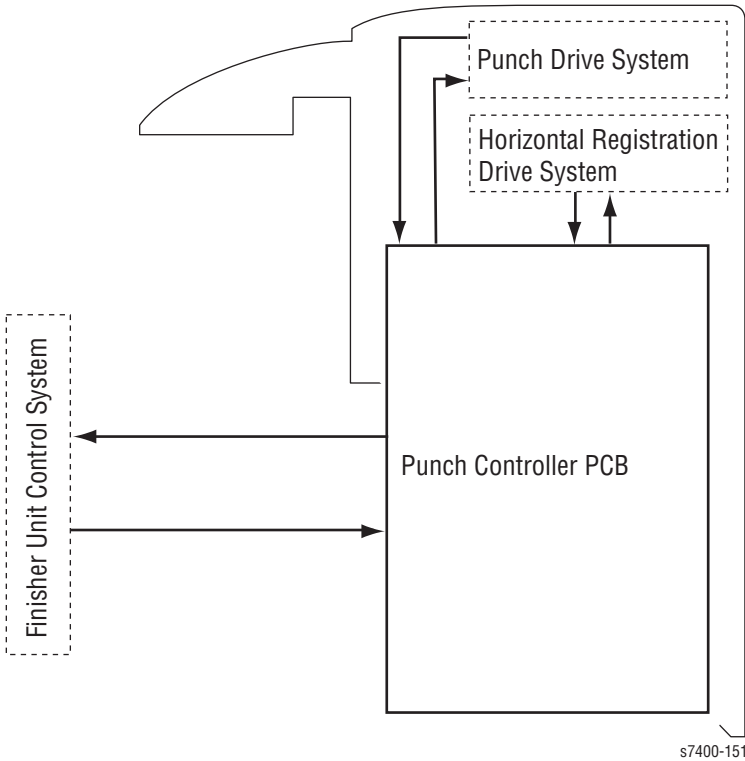

The Punch Unit consists of a die and hole punch (punch blade), which is driven by a DC motor. The unit attaches to the eccentric cam of the punch shaft. A punch home position sensor detects the home position of the punch shaft to ensure that the punch motor stops exactly at its home position, the punch motor stops in relation to the count of clock pulses from the Punch Motor Clock Sensor. When the punch shaft rotates 180 degrees from its home position, it initiates a single punch operation.

## Punch Unit Components

<b>Component</b>	<b>Function</b>
Punch mechanism	When sensor detects proper paper position, the punch blade punches holes in with paper stack following 180 degree rotation of the punch shaft.
Punch Controller Board	Receives instructions from the printer and converts them to control all punch unit operations.
Horizontal Registration System	Detects the home position of the punch slide unit to move it to the appropriate position of the selected paper size.
Photo sensors	Five LED's mount over the inlet paper path to detect the leading and trailing edges of the paper.

# Staple Unit

The Staple Unit receives instructions from the printer through the Finisher Controller Board to initiate staple operation and deliver up to 50 sheets of paper (depending on the paper size) to the finisher staple subassembly. The unit mounts in the Finisher and, depending on the media selection, provides front stapling, rear stapling, dual stapling, and saddle stitching (center stapling with fold).

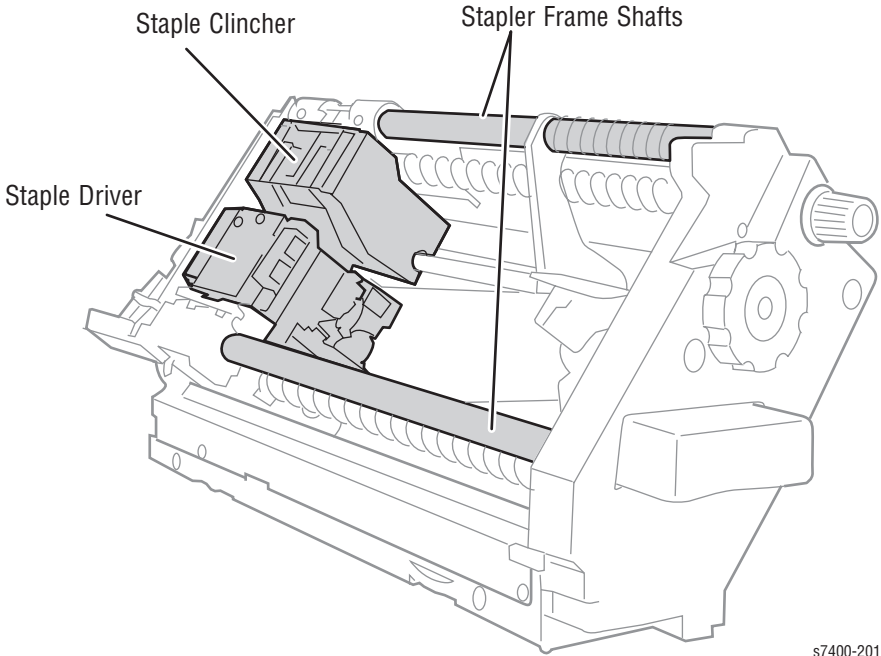

s7400-201

The stapling position depends on the staple mode and paper size. After power-on, the Finisher Controller Board drives the Finisher Slide Motor to place the Staple Unit in the home position. The stapler starts moving toward the front of the stapler frame and stops when the Slide Home Position Sensor detects the home position.

The slide motor is then driven a specified number of pulses until the stapler reaches the rear standby position at the back of the machine. At this point, the unit enters the standby state.

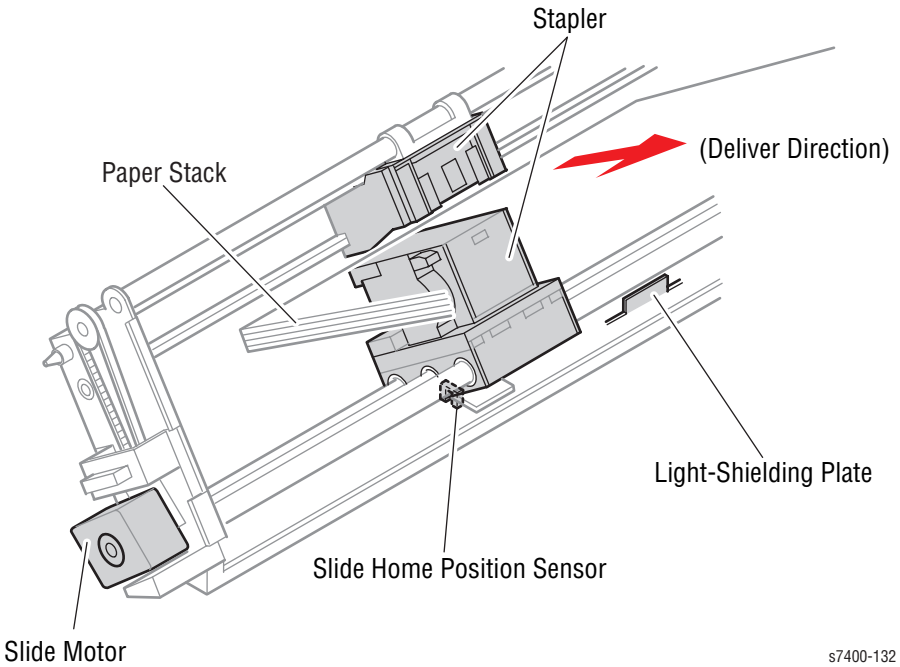

s7400-132

## Staple Unit Components

Component	Function
Staple/Fold Motor	Rotates the cam in the appropriate direction for the stapling process.
Stapler sensors	Detects the absence of and/or the position of the stapling mechanism and motors.
Finisher Slide Motor	Moves the Stapler Unit to the appropriate location on the paper stack for stapling.

# Saddle Unit

The Saddle Unit stitches (center staples) up to 50 sheets (middle 2-point), then folds the stack in two in the Finisher. The Finisher Controller Board receives commands from the printer to control the following operations:

- a. **Paper feed in** - After alignment on the processing tray, the feed drive system inserts a stack of sheets between the stack delivery rollers. As the stack delivery rollers rotate, the stack is fed toward the saddle unit.
- b. **Stitching** - When the center of the paper stack (stitching position) reaches the stapler's staple position, the unit staples the paper stack. When only one sheet is fed from the printer, the next step (stack feed) occurs without performing the stitching operation.
- c. **Stack Feed** - The stack feed rollers feed the paper stack to the stack folding and delivery position where the center of the stack (stitched position) is level with the paper-pushing plate and paper-folding roller.
- d. **Folding/Delivery** - The paper pushing plate pushes the center of the paper stack inward to feed it toward the paper fold rollers. The paper fold rollers and bind delivery rollers then deliver the paper stack to the bind tray (e).

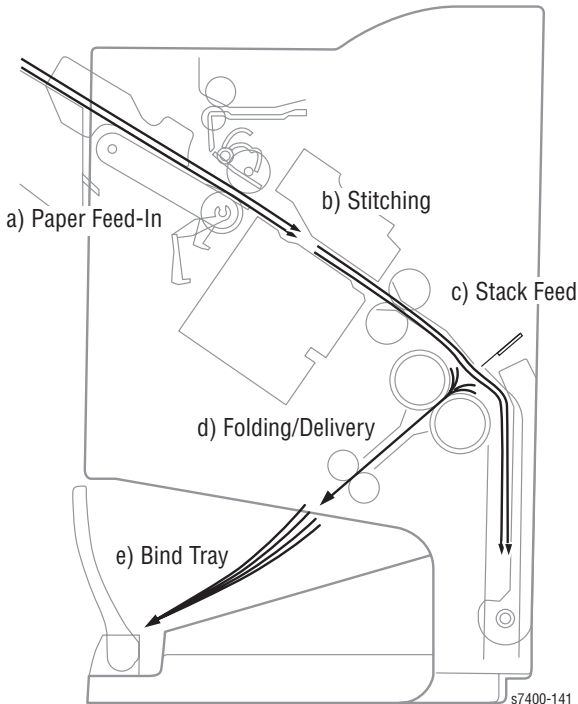



## Paper Fold System

The paper fold mechanism consists of a guide plate, paper fold rollers, and a paper pushing plate. The Staple/Fold Motor drives the guide plate, paper-fold rollers, and paper-pushing plate. A combination of gears and cams transfer the drive force while the Staple/Fold Motor Sensor monitors the operation.

Until the paper stack reaches the folding position, the guide plate covers the paper fold rollers to act as a paper path through which the paper stack feeds into the Saddle Unit, preventing the paper stack from touching the rollers. A Folding Home Position Sensor detects the positions of the paper-fold rollers and paper-pushing plate.

The bind delivery rollers deliver and folds the paper stack with the paper fold rollers. The Staple/Fold Motor drives the bind delivery rollers. A Bind Tray Sensor on the bind tray can then detect the presence of the paper stack.

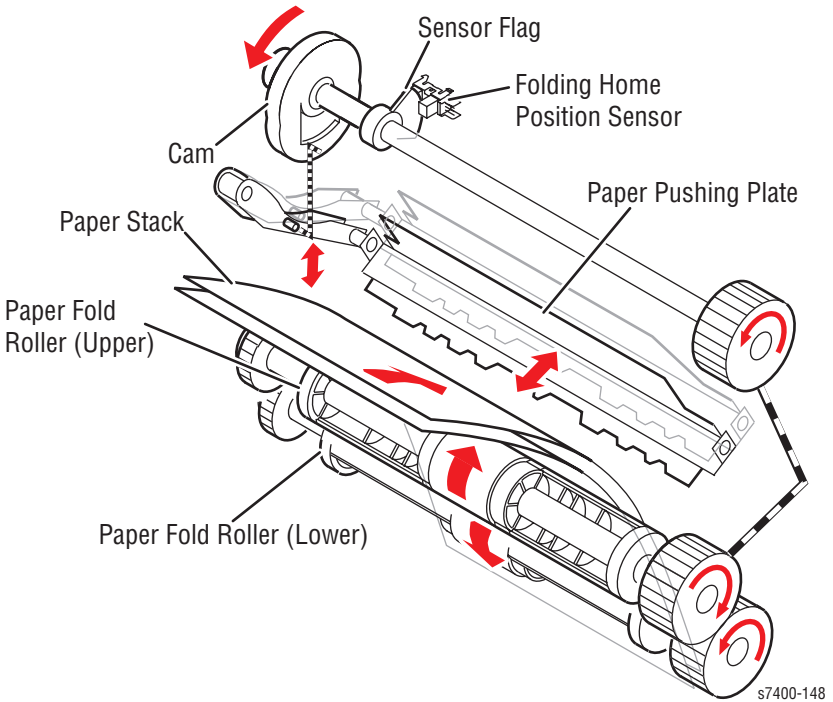

## Saddle Unit Components

Component	Function
Stack feed rollers	Rotates to feed the stacking mechanism.
Paper pushing plate	Pushes the center of the paper stack toward the feed rollers.
Stapling mechanism	Performs stitching (term for center punching).
Swing guide	Places the paper stack between the delivery rollers.

# Inverter Unit

The Inverter Unit receives paper from the printer and physically inverts the paper for stacking or folding. The Inverter is a self-enclosed unit which connects on a common base with the Finisher itself. The entire Finisher/Inverter can then physically connect to the printer and tray units with a sliding mount.

The Inverter receives instructions from the printer and/or Finisher Controller Board. Through various sensors, switches, solenoids, and motors, it moves the selected media through the paper path to invert and position the paper for stacking or folding.

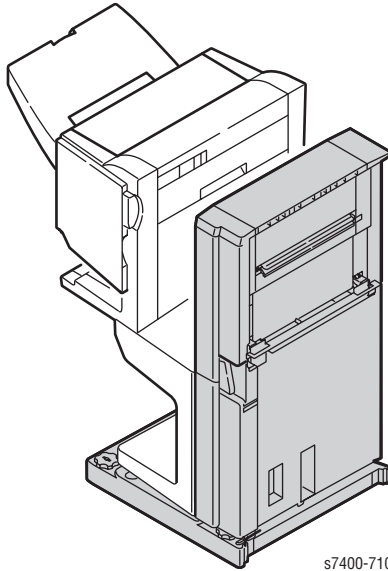

s7400-710

## Inverter Unit Components

Component	Function
Inverter controller board	Receives commands from the printer and controls all elements of Inverter operation.
Sensors and switches	Detects the position of the paper through all phases of the inversion process.
Solenoids and clutch	Receives commands from the Inverter controller board to determine the paper path (invert or not).
Delivery motors	Physically moves the media through the designated paper path.

# Printer Options

## Duplex Unit

The Duplex Unit adds two-sided printing. The Duplex Unit attaches to the left side above Tray 1 using two twist locks. Installation of the Duplex Unit requires that the Exit 2 Module also be added to provide reverse drive. Electrical connection to the printer is made by an interface cable.

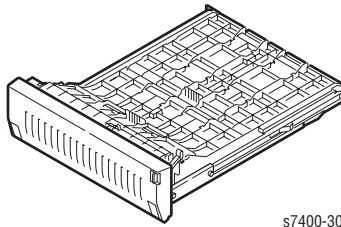

s7400-305

## 550-Sheet Feeder

The 550-Sheet Feeder increases the input capacity of the printer. The feeder attaches below Tray 2 with four screws. When used in combination with the 1650-Sheet Feeder, the 550-Sheet Feeder is installed between the printer and 1650-Sheet Feeder. Up to four optional 550-Sheet Feeders per printer can be installed, totaling six universal trays (Trays 2~6). However, when the 1650-Sheet Feeder (HCF) is installed, only one additional 550-Sheet Feeder is allowed between the HCF and the printer. Electrical connection to the printer is made by a single interface connector.

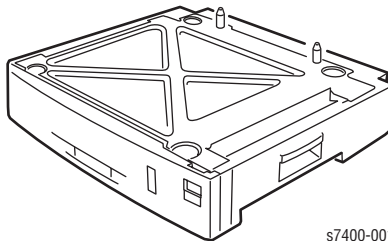

s7400-001

# 1650-Sheet Feeder

The 1650-Sheet Feeder combines three, 550-sheet trays. Control signals reach the 1650-sheet feeder through a single connection. The sheet feeder is secured to the print engine or 550-Sheet Feeder with four screws located under the front and rear edges of the tray.

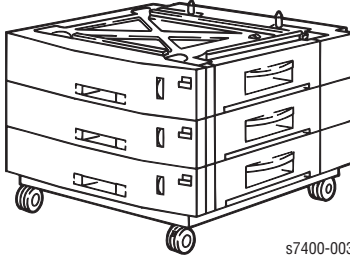

# Finishing Process Summary

The following illustration shows the various printing processes and process decisions that the finishing components handle on command from the printer.

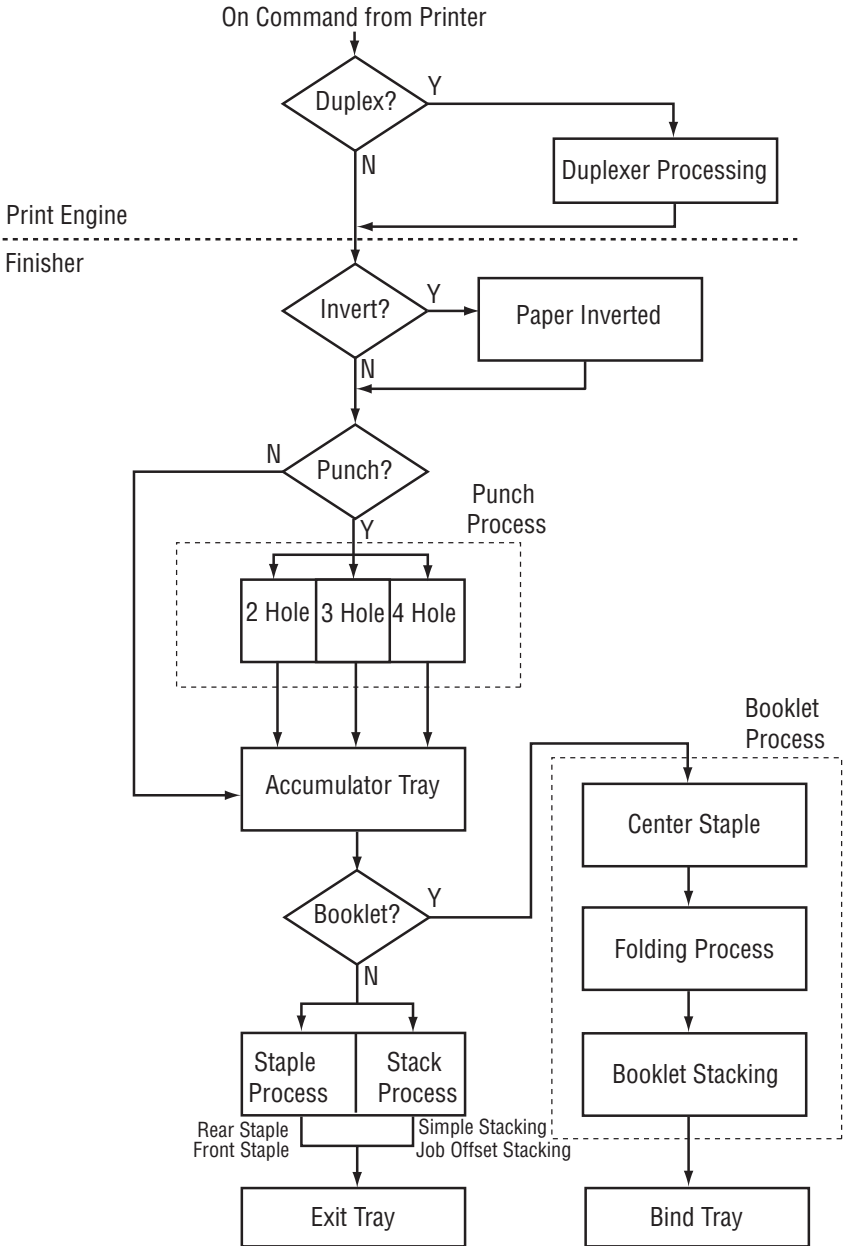

s7400-546

The finishing processes include six major functions:

1. Inverting
2. Folding
3. Punching
4. Stacking
5. Stapling
6. Delivery

## Inverting

The sole purpose of the inverter function is to position the paper for stacking or folding. On command from the printer, The Inverter receives paper from a printer or a Duplex Unit for inversion, if needed, and sent on to the Finisher.

The Inverter receives commands from the printer to receive and position entering media. A Paper-in sensor detects the presence of paper. If the paper is not to be inverted, it merely transfers to the Finisher. If the paper is to be inverted or prepared for stacking or folding, a solenoid is energized to divert the paper into the inversion path. Sensors in the upper and lower paper paths detect the leading and trailing edges of the selected media. At the end of the paper path, the paper is then sent on to the Finisher.

## Punching

The Punch Unit is located in the pickup assembly of the Finisher. It is designed to punch 2-holes, 3-holes, or 4-holes in sheets sent from the printer. When the trailing edge of a sheet reaches the Punch Unit, the inlet roller of the Finisher assembly stops the sheet long enough to punch a hole along the trailing edge of the sheet. The Punch Unit is available in two unit types to accommodate the country of installation: 2- and 3-hole (punch Unit-K1), or 4-hole (Unit-G1 or H1).

The Punch Motor stops in relation to the count of the clock pulses from the Punch Motor Clock Sensor. When the punch shaft rotates 180 degrees from its home position, it initiates a single punching operation.

The 2-hole and 4-hole types punch a hole when the punch shaft rotates 180 degrees from the home position, causing the punch to make a single rotation. The 2 and 3-hole type punches a hole, but the circumference of the punch shaft is divided into two (one-half for the 2-hole punch and one-half for the 3-hole punch).

The Punch Motor, Punch Unit, and sensors comprise the Punch Slide Unit, which moves to the front/rear to accommodate the selected paper size. The Finisher Punch Transfer Motor is a stepping motor that drives the movement to the front or rear.

- 4-Hole Type** - The punching operation for the first sheet ends when the punch shaft rotates 180 degrees and the Punch Home Position Sensor activates. The punching operation for the second sheet ends when the punch shaft rotates 180 degrees in reverse and the Punch Home Position Sensor activates.

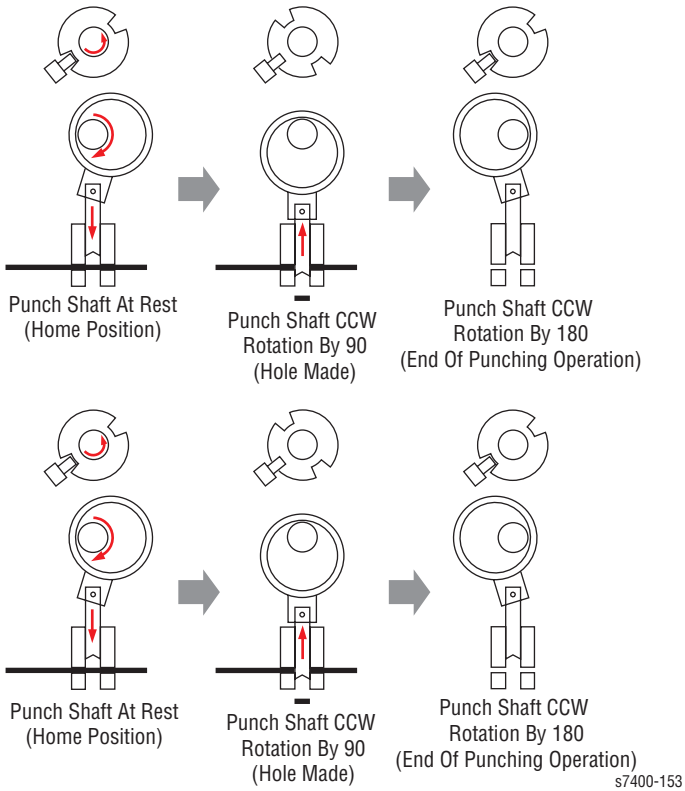

- 2-Hole, 3-Hole Type** - To make two holes, the punching operation for the first sheet ends when the punch shaft rotates 180 degrees (half-circumference) and the Punch Home Position Sensor activates. At this time, the 3-hole punch rotates once on a half-circumference of the punch shaft. The punching operation for the second sheet ends when the punch shaft rotates 180 degrees counterclockwise and the Punch Home Position Sensor activates (half-circumference). At this time, the 3-hole punch then releases itself from the punch process on the other half circumference of the punch shaft.

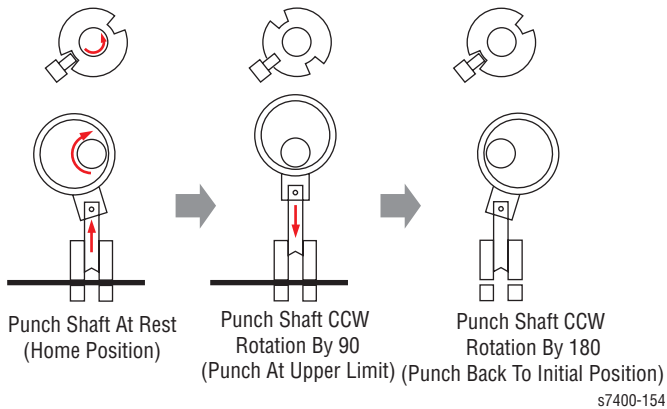

## Finisher Punch Transfer Operation

The Finisher Punch Transfer Motor provides horizontal registration for the punch slide unit. The Finisher Punch Transfer Home Position Sensor detects the home position of the punch slide unit. The punch slide unit detects the trailing edge of sheets with the trailing edge sensor (LED5, PT5) and the horizontal registration sensors (LED1 through 4, SREG1 through 4). This action moves the unit to the desired position matching the trailing edge of each sheet (in relation to the size of the sheet).

The horizontal registration operation takes place as follows:

- When the trailing edge sensor (LED5, PT5) detects the leading edge of a sheet from the printer, the Finisher Punch Transfer Motor begins to move the punch slide unit toward the front.
- When the horizontal registration sensor (LED1 through 4 for the appropriate the paper size from the printer) detects the leading edge of the sheet, the Finisher Punch Transfer Motor moves to the specified position then stops the slide unit.
- When the trailing edge sensor (LED5, PT5) detects the trailing edge of the sheet, the drive of the Feed Motor stops, also stopping the sheet. Then, the Finisher Punch Motor energizes to punch holes in the sheet.



4. When the punching operation ends, the Feed Motor moves the paper through the rest of the paper path. The Finisher Punch Transfer Motor then rotates in reverse to return the slide unit to home.
5. For each sheet that arrives in succession, the Punch Slide Unit returns to its home position and repeat steps 1 through 4 (the following illustration shows the top view of the Punch Slide Unit in the Finisher).

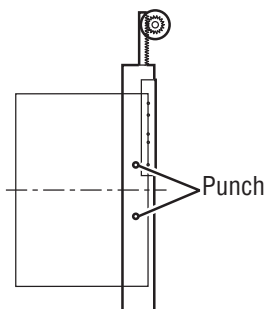
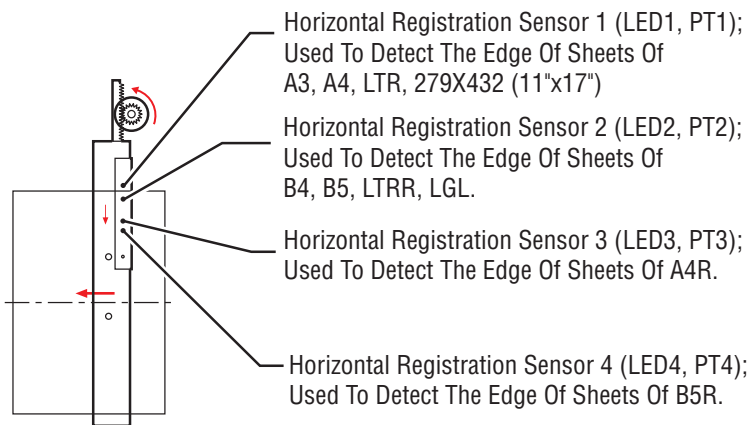
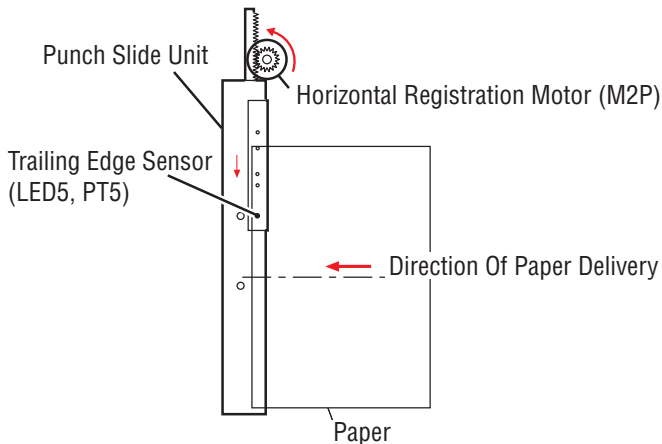

# Folding

Finisher paper fold rollers and a paper pushing plate are the main assemblies for the paper folding process when creating a booklet. Concurrent with the start of the stack feed roller rotation, the paper pushing plate pushes the middle of the paper stack into the gap between the paper fold rollers. When the paper stack is fed about 10 mm into the rotating paper fold rollers, the paper pushing plate returns to the home position. The paper stack is then delivered to the Bind Tray using the paper fold rollers and bind delivery rollers.

Because of the large area size of the rollers, the paper stack is fed without paper creases. The large size of the area also allows the paper stack to fold while being fed.

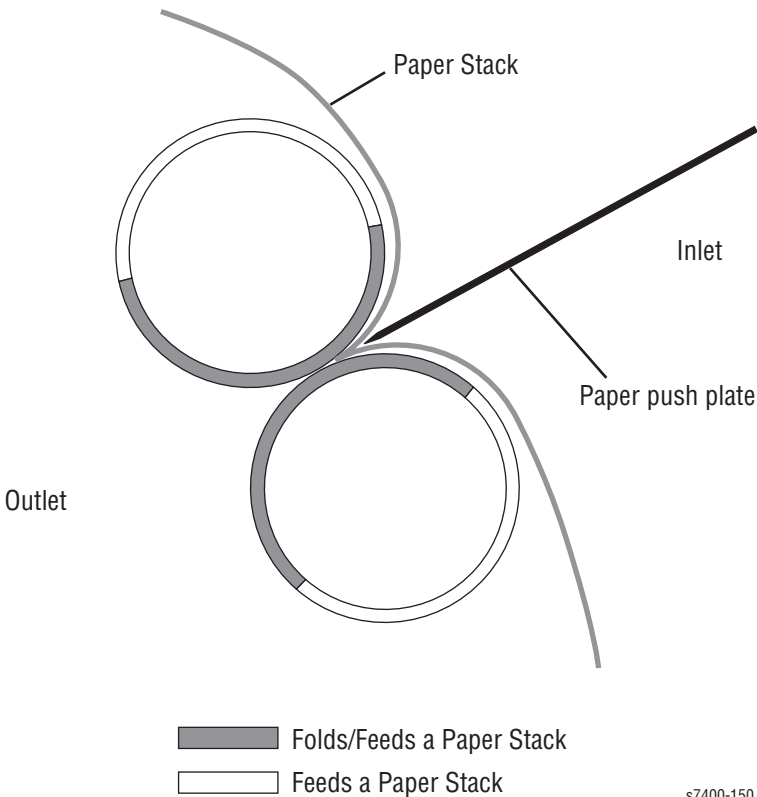

s7400-150

# Stacking

There are two types of stacking presented to the delivery tray:

- **Simple Stacking** - The unit pulls in the sheet to the processing tray and then delivers it to the delivery tray.

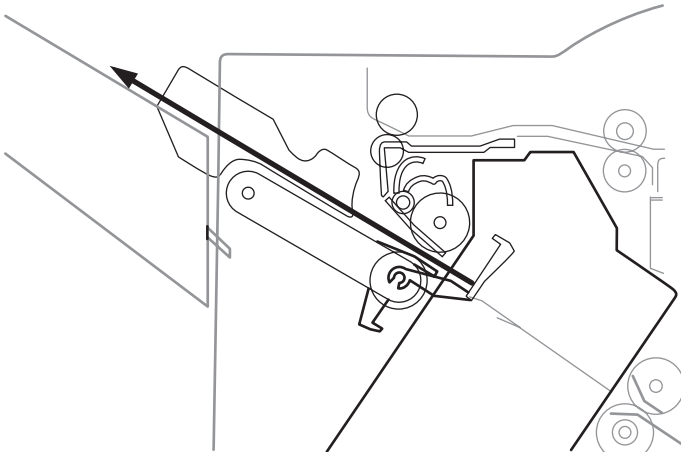
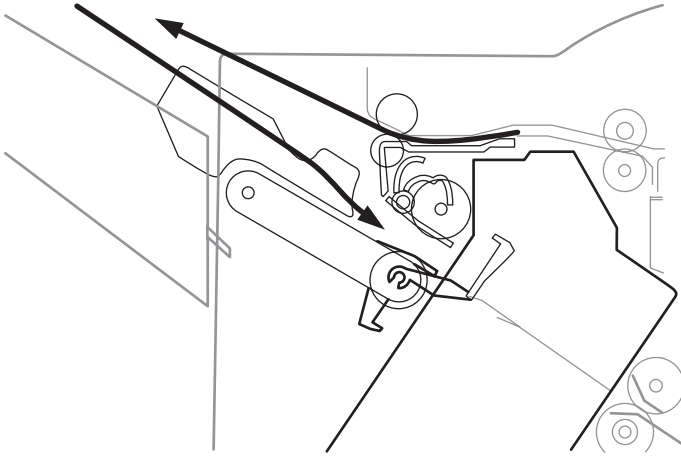

s7400-122

- **Job offset** - The machine places the sheet into the processing tray. It then moves the sheet to the front or the rear using the aligning plate. When it has deposited a specific number of sheets, it delivers them as a stacked set.)

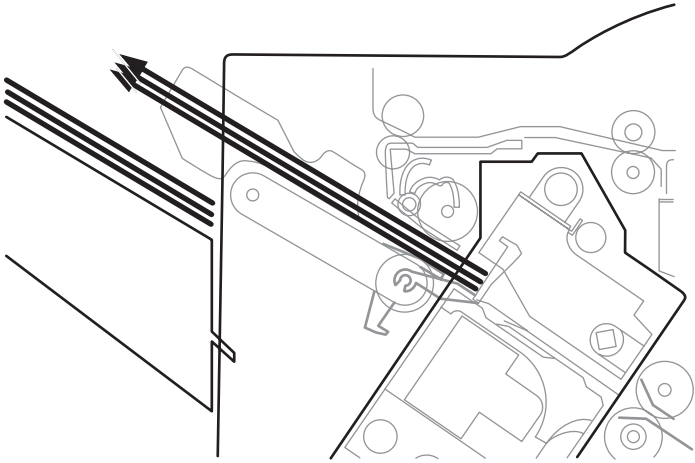
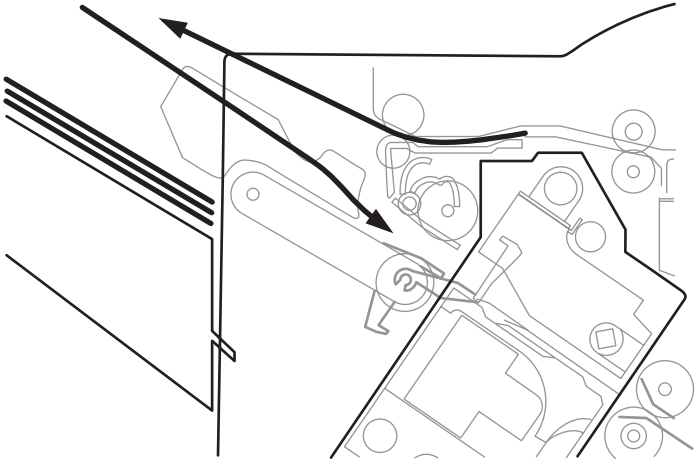

Results Of Offset Delivery (4 Jobs)

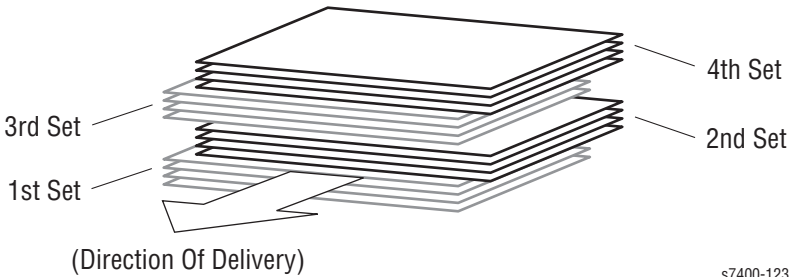

s7400-123

When the number of sheets stacked on the processing tray reaches a specified value, the sheets are delivered in stack form. Even if the unit never reaches a specified value, stacked sheets are temporarily delivered when 25 sheets of large-size paper (300 mm or longer) or 50 sheets of small-size paper (299 mm or shorter) have been stacked.

The finisher also uses a Tray Paper Sensor to detect the presence or absence of paper in the stack tray. It also includes a Full Stack Sensor to detect overstacking.

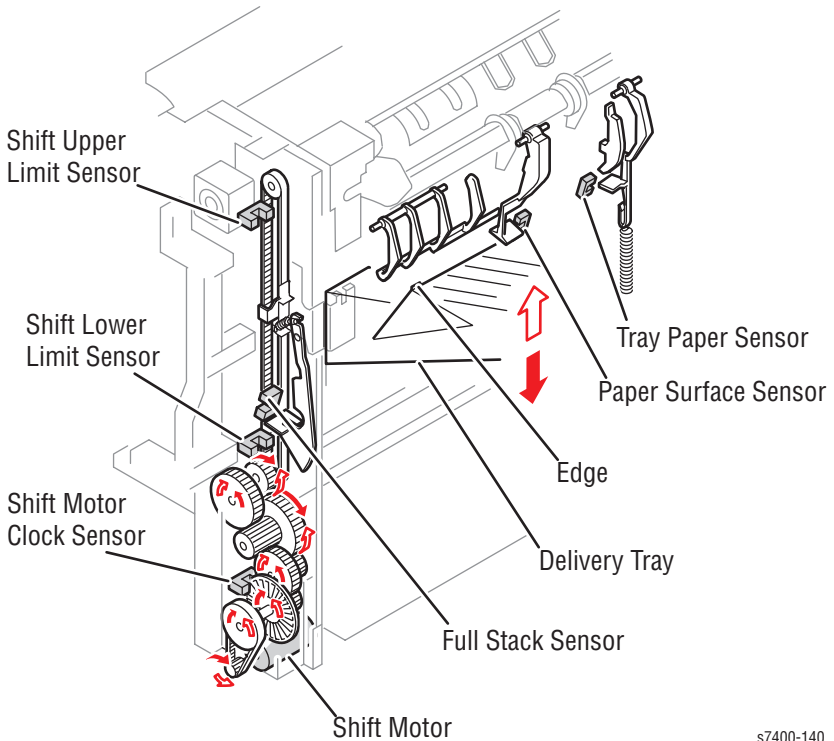

s7400-140

## Stacking in Booklet Mode

In the Booklet stitching format, the stack feed system feeds up to 50 sheets of stitched paper stack to the folding position. When stitching is complete, the Feed Motor rotates until the upper stack feed roller begins to descend. After the paper stack is inserted between the stack feed rollers, the Bind Clutch activates and rotates the Feed Motor in the forward direction, feeding the paper stack to the middle position for folding. The feed amount is equivalent to the number of pulses necessary to drive the Feed Motor until the paper stack is ready for folding.

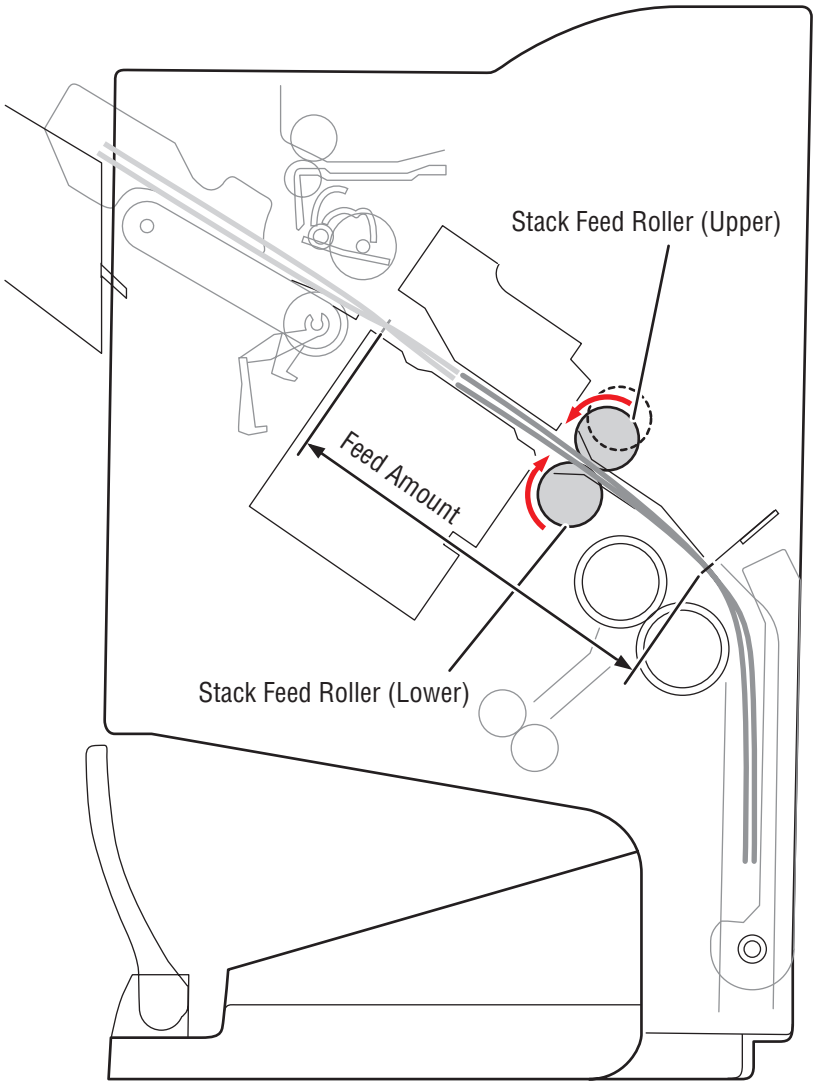

s7400-147

# Stapling

After stacking and alignment of paper on the processing tray is complete, the finisher controller board moves the stapler for stapling according to the specified stapling position. When the controller specifies rear 1-point stapling, the stapler does not move; it staples while in the standby position. If a different stapling option is selected, the stapler moves forward and the processing tray stopper leans to the forward position.

The Finisher Slide Motor moves the stapler unit. The Slide Home Position Sensor detects when the unit reaches its home position. The stapler waits at the back end of the stack irrespective of the staple mode and paper size.

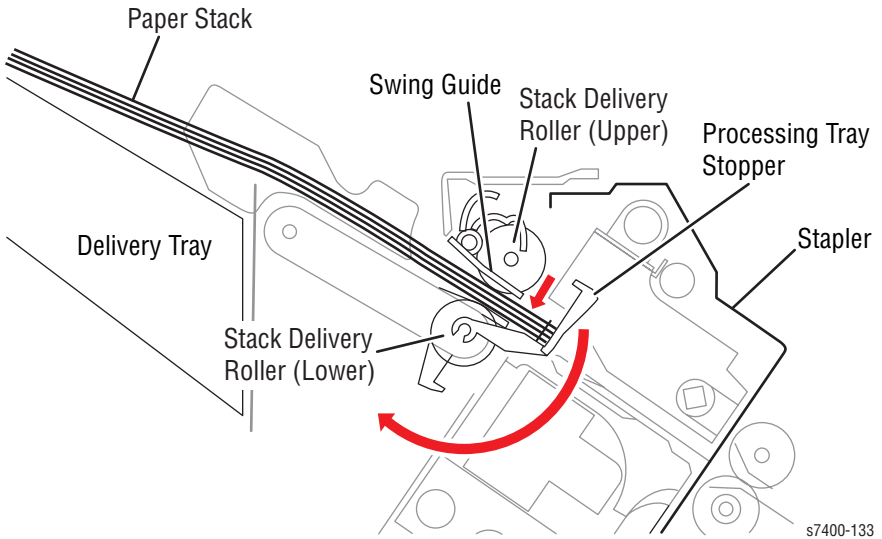

The position of the stapler depends on the staple mode:

- **Front 1-point stapling** - The stapler moves to the front stapling position of the paper for stapling and then returns to the standby position.
- **Rear 1-point stapling** - The stapler moves to the opposite end (rear) of its travel length for stapling and then returns to the standby position.
- **Middle 2-point stapling** - The stapler moves to the rear stapling position first, then to the front stapling position, and then returns to the standby position.

The Staple Empty Sensor detects the presence of a staple cartridge in the machine as well as the presence of staples in the cartridge. A Staple Top Position Sensor determines when to push staples up to the top of the staple cartridge.

# Delivery

The Finisher Unit includes a Delivery Tray, and the Saddle Unit includes a Bind Tray. The Bind Tray is a fixed unit where all folded paper stacks are delivered. The Bind Tray includes a Bind Tray Sensor to detect the presence of paper. The delivery tray in the finisher unit moves up and down using a Lift Motor.

The Paper Surface Sensor detects the home position of the delivery tray. If paper is already stacked on the delivery tray, the home position is sensed on the top surface of the stacked paper. When the paper coming from the processing tray stacks on the Delivery Tray, the Lift Motor receives a specified number of pulses, which causes the Delivery Tray to lower to the home position. The Lift Motor Clock Sensor detects when the tray reaches the home (lowest) position.

The Shift Upper Limit Sensor detects the upper limit of the Delivery Tray. In an upper limit condition, the Finisher Controller Board stops sending commands that lift the Lift Motor. Conversely, the Shift Lower Limit Sensor detects the lower limit of the Delivery Tray. In a lower limit condition, the controller board stops the Lift Motor.

## Delivery after Stapling

When stapling completes, the Finisher Controller Board drives the Delivery Motor in the forward direction to feed the paper stack. When the Delivery Belt Home Position Sensor reaches the OFF position, the delivery stack is full.

The Slide Motor is then driven to return the Stapler Unit back to the standby position, which initiates the Delivery Motor drive. Then, the paper stack is delivered to the tray.

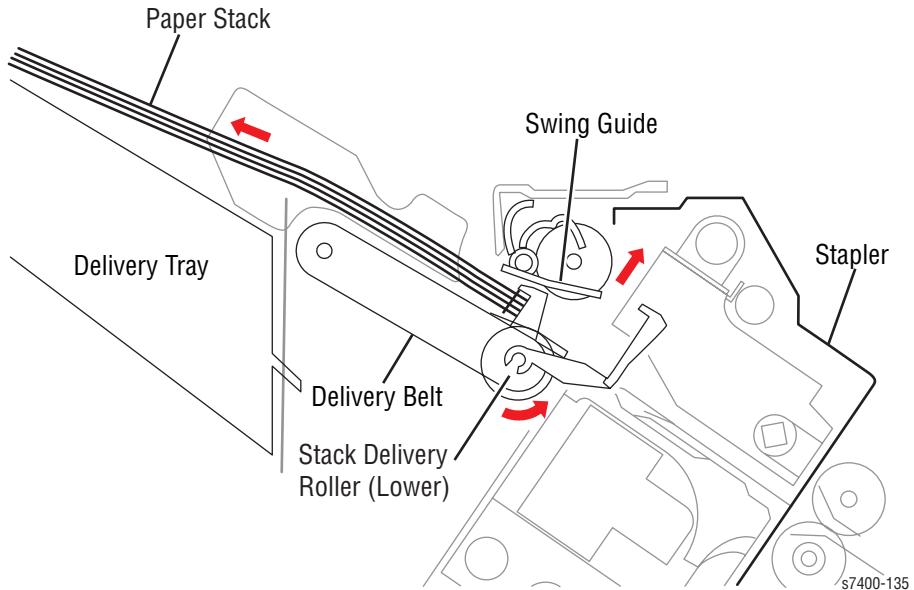



# Sensors

The Finisher/Inverter, Duplex Unit, and paper trays contain sensors of various types that perform a variety of functions. One group of sensors track the progress of the paper along the paper path and detects if a paper jam occurs. Other sensors stop printer activity if a door is open (interlock), detect the presence and size of media in the trays, and monitor the fusing temperature.

## Photo Sensors

Two types of photo sensors are used, photo-reflective and photo-receptive. Photo-reflective sensors use light reflected back from an object to detect its presence. Photo-receptive sensors use an actuator or the object itself to block the light path to detect an object or condition.

Photo-reflective sensors have the light emitter and light receiver aligned on a single surface. Output of the photo-receptor is High ( $> +4.5\text{ V}$ ) when light is being reflected back and Low ( $< +3\text{ V}$ ) when it isn't. Photo-receptive sensors consist of a LED in one arm of a U-shaped holder, and a photo-transistor in the other arm. When the sensing area is vacant, nothing is between the arms of the sensor, light falls on the photo-receptor sending the signal High. If the light is interrupted, the photo-transistor goes Low.

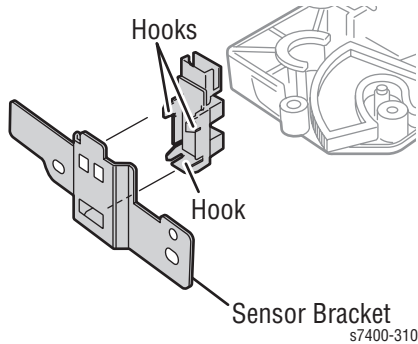

## Microswitches

Microswitches are used primarily as paper size sensors and cover interlocks. They are in a normally open state, and close when actuated. A bank of microswitches detect paper size in the universal trays. Microswitches also employ hooks or catches for retention in the bracket or frame.

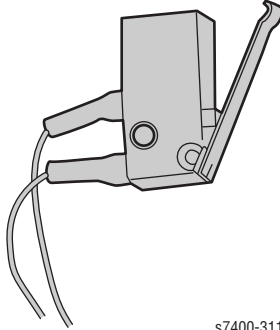

s7400-311

# Finisher Paper Path Sensors

The following illustration identifies the various sensors located in the Finisher. Error reporting is dependent on these sensors as the paper moves through the paper path.

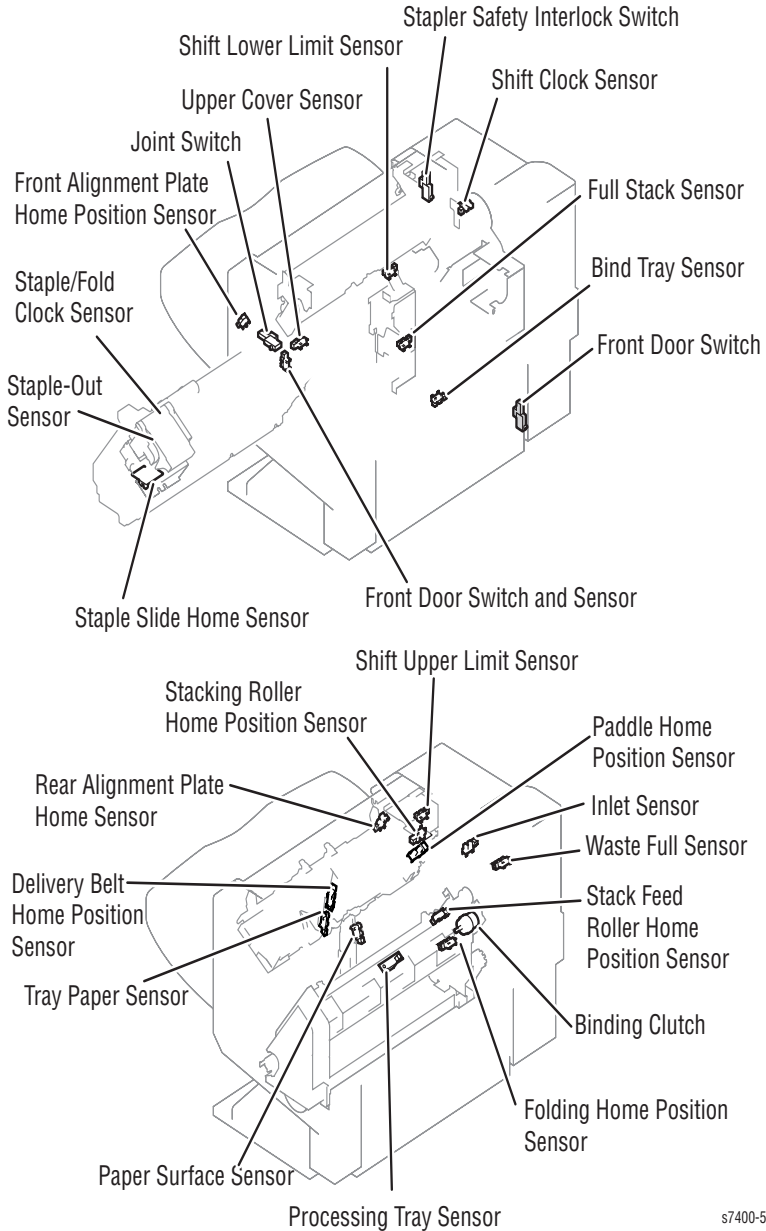

s7400-542

## Sensor Function

Sensor	Function
Joint Switch	Prevents the power supply from placing hazardous voltages in accessible areas when the Finisher is undocks from the Printer.
Front Door Switch	Prevents the power supply from placing hazardous voltages in accessible areas when the Front Door (Door J) is removed.
Front Door Sensor	Detects when the Front Door is open or removed.
Inlet Sensor	Detects the presence of media in the finisher paper path.
Tray Paper Sensor	Detects when the paper tray is removed from the Finisher.
Paper Surface Sensor	Detects media in the home position of the delivery tray.
Upper Cover (Door H) Sensor	Detects when the Upper Cover (Door H) is open or removed
Shift (Upper) Limit Sensor	Detects the upper limit of the delivery tray stack.
Shift (Lower) Limit Sensor	Detects the lower limit of the delivery tray stack.
Lift Motor Clock Sensor	Detects clock pulses for the stacking operation.
Full Stack Sensor	Detects overstacking of media in the delivery tray.
Processing Tray Sensor	Detects the processing stack within the delivery path.
Aligning Plate (Front) Home Position Sensor	Aligns one side of the selected paper with the entrance into the paper path.
Aligning Plate (Rear) Home Position Sensor	Aligns one side of the selected paper with the entrance into the paper path.
Stack Feed Roller Home Position Sensor	Detects the initial home position of the stack feed rollers.
Waster Full Sensor	Detects the full condition of the punch waste unit.
Swing Guide Home Position Sensor	Detects the home position for the Swing Guide.
Delivery Belt Home Position Sensor	Detects the end location of the delivery rollers.
Paddle Home Position Sensor	Detects when it is necessary to drive the paddle and feed the next sheet of paper.
Stapler Safety Interlock Switch	Protects current overloads in case of a staple jam.
Staple/Fold Cock Sensor	Counts timing pulses during staple and fold operations.

## Sensor Function (Continued)

Sensor	Function
Folding Home Position Sensor	Detects the positions of the paper fold rollers and the paper pushing plate.
Bind Tray Sensor	Detects when paper is present in the Saddle Unit's bind tray.
Folding Position Sensor	Detects the leading edge of the paper stack.

### Note

The punch assembly includes up to five light-receiving transistors (photosensor board) mounted over the inlet paper path of the Punch Unit. The same number of LEDs are mounted under the path, as well. The front-most sensor (LED5, PT5) detects the trailing edge of each sheet. The remaining four LEDs (LED1 through LED4, PT1 through PT4) are horizontal registration sensors which detect the rear position of sheets when punching holes.

# Inverter Sensors

The following illustration shows the general location of the Inverter sensors. The topics in this section describe the disassembly for each sensor..

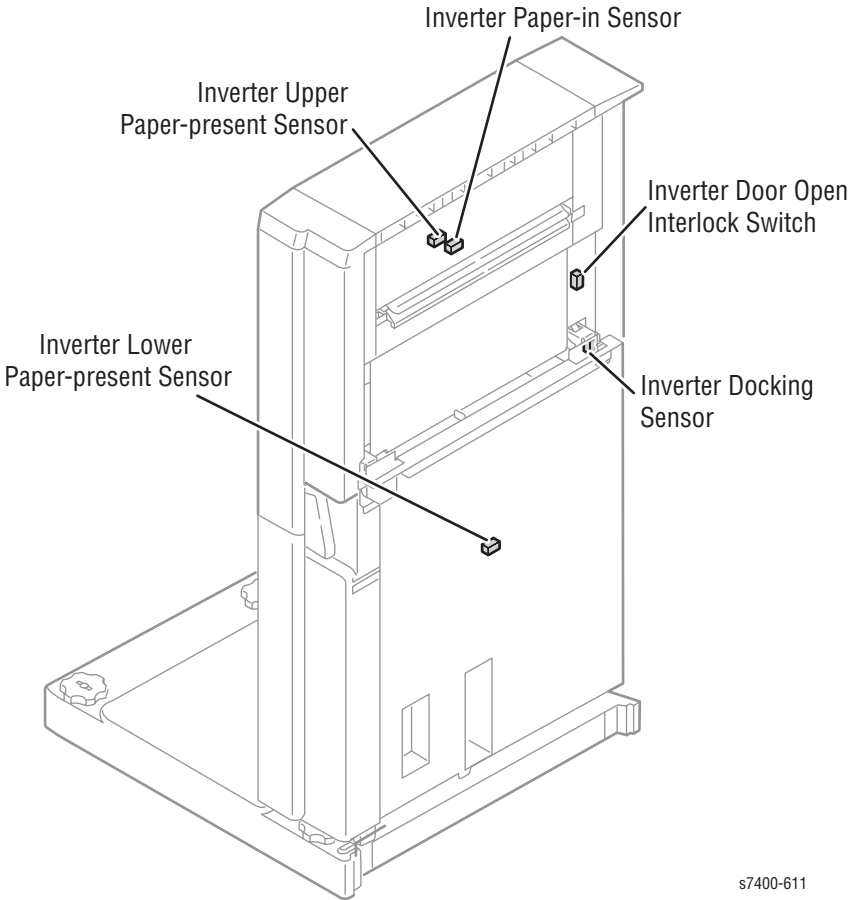

s7400-611

## Sensor Function

Sensor	Function
Inverter Docking Sensor	Detects when the Inverter interconnects with the Printer.
Inverter Door Open Interlock Switch	Detects when the Inverter Door (F) is open.

## Sensor Function (Continued)

Sensor	Function
Inverter Upper Paper-Present Sensor	Detects the leading edge of the selected paper size.
Inverter Lower Paper-Present Sensor	Detects the trailing edge of the selected paper size.
Inverter Paper-in Sensor	Detects the presence of media in the Inverter.

## Duplex Sensors

The Duplex Unit receives media diverted to the Side Exit by the Exit Gate. The media is detected by the Duplex Entrance Sensor and drawn into the Duplex Unit. The media is inverted and exits the Duplex Unit just above Registration Roller #2. Media moves through the Duplex Unit as follows:

1. After Side 2 is printed, the Exit Gate Solenoid switches the Exit Gate to its side output position. This directs the sheet downwards toward the Duplex Unit.
2. As the sheet reaches the Duplex Entrance Sensor, roller 1 turns, drawing the media into the lower portion of the Duplex Unit
3. After the trailing edge of the media clears the Duplex Entrance Sensor, and with the Duplex Reverse Sensor High, the Entrance Roller is reversed and the Duplex Solenoid is activated to position the Duplex Gate to direct the inverted media into the upper portion of the Duplex Unit.
4. The Duplex Rollers transport the media out of the Duplex Unit and into the printer where Side 1 is printed. This portion of the duplex path is monitored by the Front and Rear Duplex Sensors.

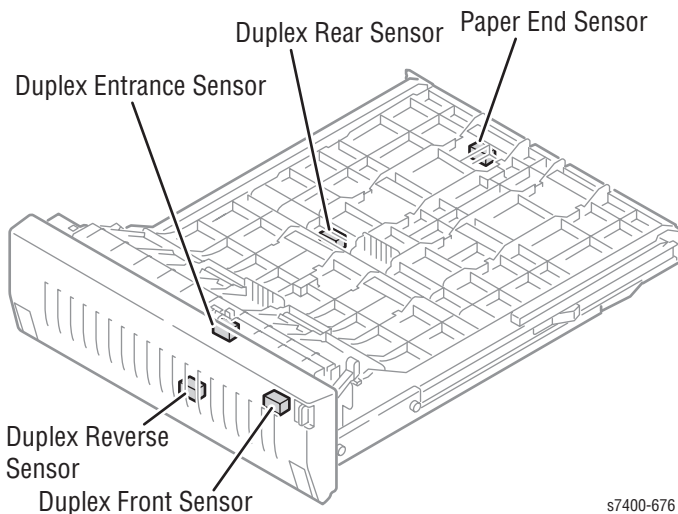

s7400-676

Duplex sensors include:

- **Duplex Entrance Sensor**  
Detects the leading edge of the media and signals the Duplex Motor to begin rotation in the forward direction.
- **Duplex Reverse Sensor**  
Detects media in the lower portion of the Duplex Unit and signals the Duplex Motor to reverse rotation.
- **Duplex Front and Rear Sensors**  
Monitor media transport through the upper portion of the Duplex Unit.

## Optional Tray Sensors

The paper supply and path for the optional trays involve these sensors (see page 5-133 for detailed illustrations and sensor location):

- **Door C Detect Sensor**  
Detects presence of media in the tray based on the position of the Actuator.
- **Registration Sensor**  
This sensor detects media as it arrives at the Registration Rollers.
- **Feed-Out Sensor**  
This sensor detects the media as it leaves the Tray 3 Feed Rollers.
- **No Paper Sensor**  
The actuator lowers as print media is used in the tray. When the actuator lowers to a pre-determined position, it blocks the sensor to trigger a low paper status.



# Motors, Rollers, Solenoids, and Clutches

## Finisher Motors

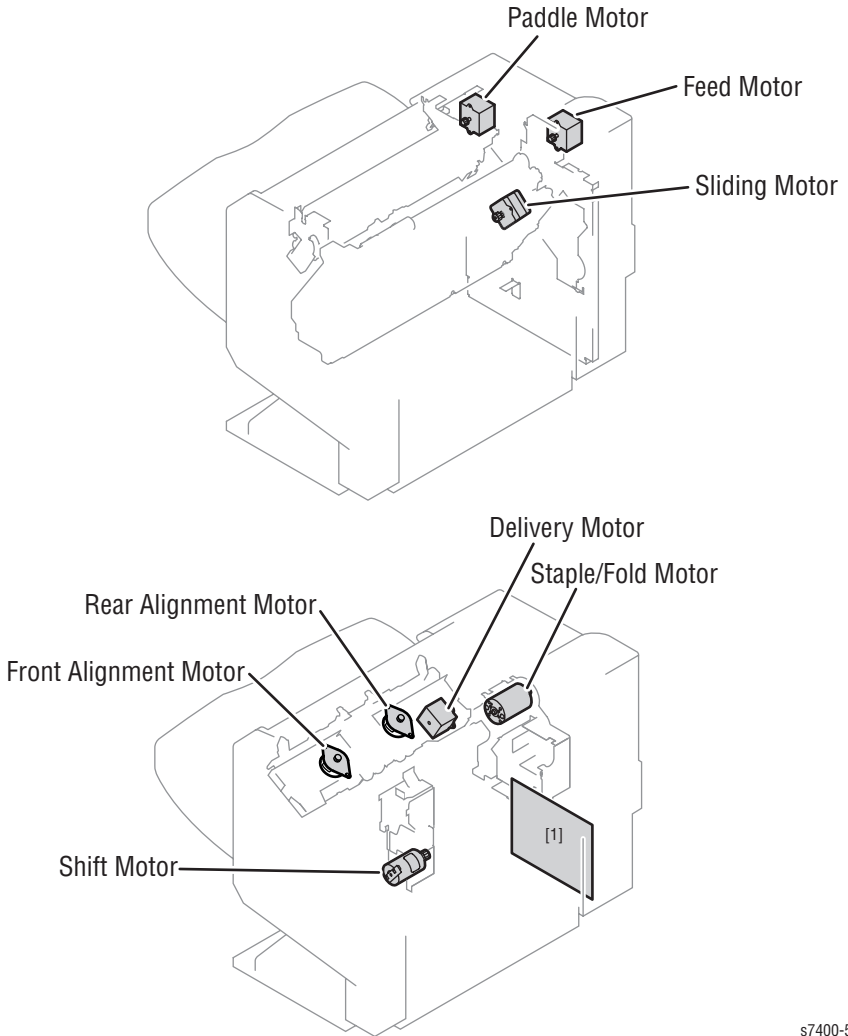

s7400-543

# Punch Unit Solenoids and Motors

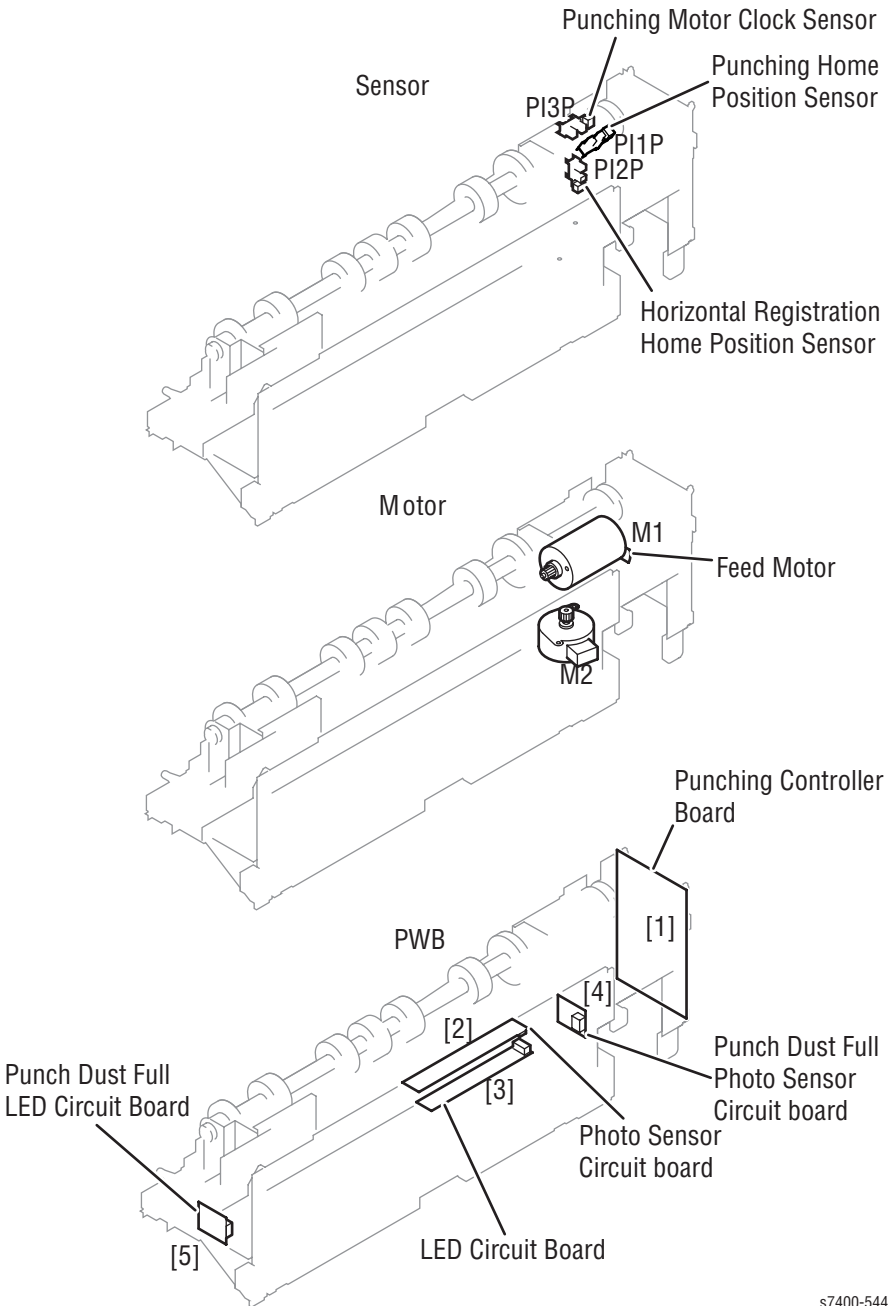

s7400-544

# Inverter Solenoids and Motors

The Inverter motors move the rollers to move the media throughout the paper path. The Feeder Clutch, on command from the printer, engages the motors. The Inverter Solenoids, also on command from the printer, energize the upper and lower paper rollers.

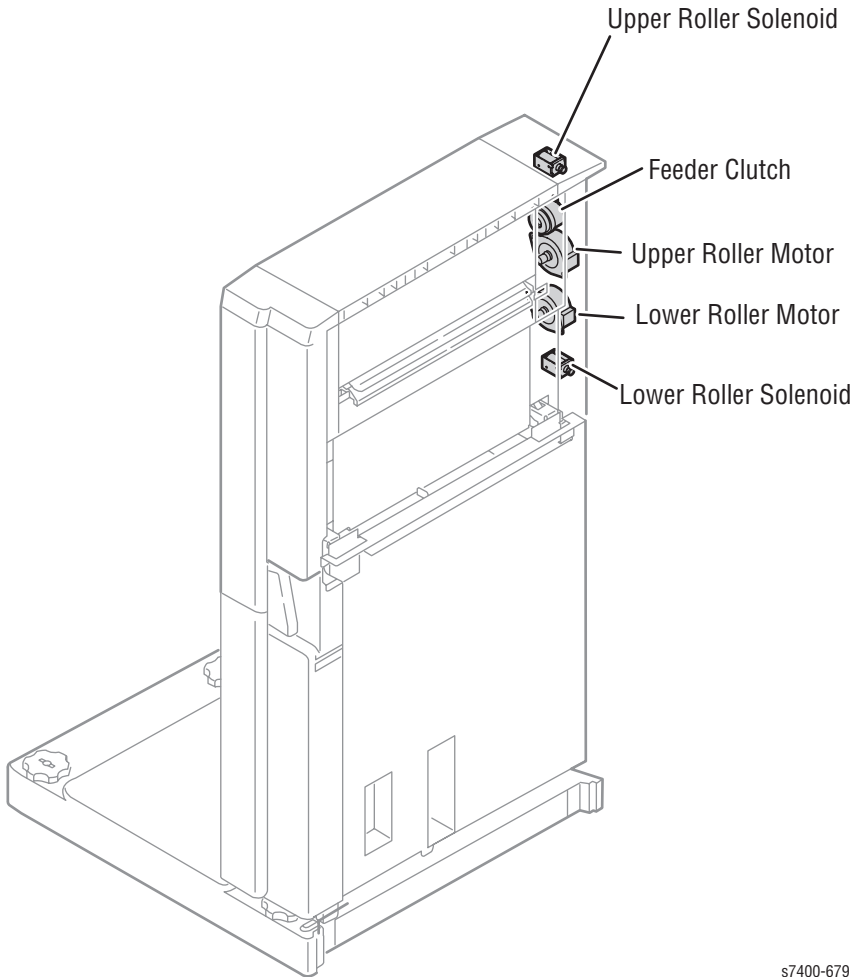

s7400-679

# Duplex Solenoids, Rollers, and Motors

The Duplex Unit receives media diverted to the Side Exit by the Exit Gate. The media is detected by the Duplex Entrance Sensor and drawn into the Duplex Unit. The media is inverted and exits the Duplex Unit just above Registration Roller #2. Media moves through the Duplex Unit using the following solenoids, rollers, and motors:

- Duplex Solenoid - Activates the Duplex Gate directing media to the Duplex Transport Rollers.
- Duplex Entrance Roller - Drive the media into the Duplex Unit.
- Duplex Transport Rollers - Transport the media through the Duplex Unit and drive the sheet into the primary paper path.
- Duplex Motors - One motor drives the Duplex Entrance Roller, the other drives the Transport Rollers using a series of belts.

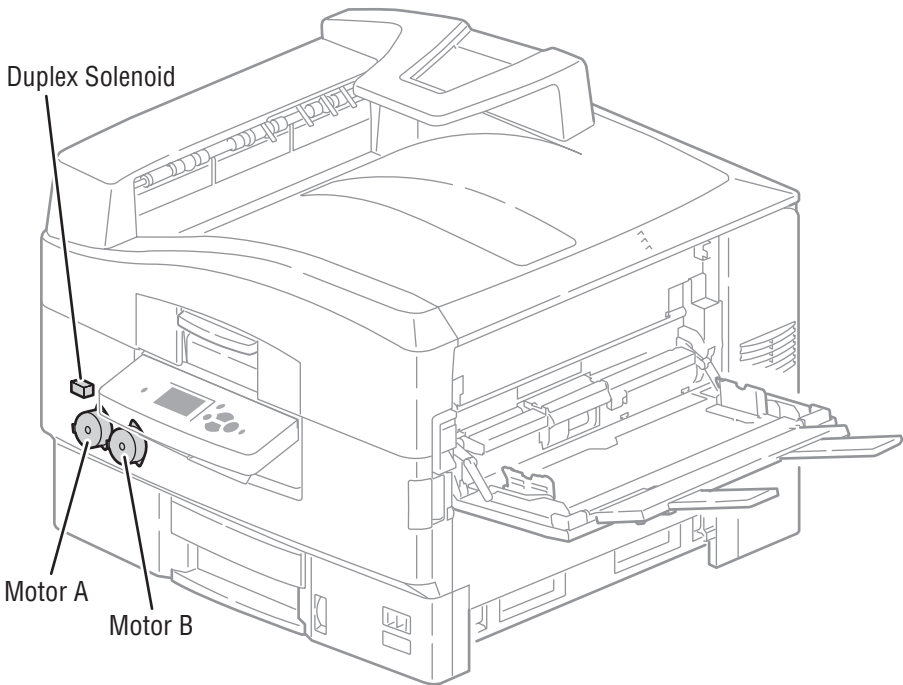

s7400-678

## Optional Tray Motors, Rollers, and Clutches

The following describes the paper path as it is fed from the optional Tray 3. Trays 4 through 6 function in the same manner. Media moves along the paper path as follows:

1. Paper loaded in the tray is detected by the Paper Size Switches.
2. The tray's Lift Motor rotates lifting the sheet to the pre-feed position detected by the Level Sensor.
3. The Feed Motor turns (CCW) driving the Feed and Pick rollers to feed the sheet from the tray into the Registration Roller.
4. The Feed-Out Sensor #3 detects the media as it leaves the Feed Rollers.
5. As the trailing edge of each sheet passes the Feed-Out Sensor #3, the Lift Motor lifts the next sheet to pre-feed position.
6. The Feed Motor rotates until the leading edge is against the Registration Roller #3 inducing a deskew buckle. Registration Sensor #3 goes High to indicate the sheet's position.
7. The sheet moves towards the Transfer Unit when the Registration Clutch #3 is engaged driving the Registration Roller #3 and Transport Rollers.
8. As the sheet reaches the Registration Roller #2, it is again aligned and detected by the Registration Sensor #2.
9. When the Registration Sensor #2 goes High, the Registration Clutch #2 is activated to move the sheet through the Registration Roller #2 to the Registration Roller #1.
10. As the sheet reaches the Registration Roller #1, it is detected by the Registration Sensor #1.
11. When the Registration Sensor #1 goes High, the Registration Clutch #1 is activated to move the sheet through the Registration Roller #1 to the Transfer Unit.
12. The sheet is detected by the Transfer Unit Entrance Sensor and the Transfer Unit Motor rotates to drive the sheet under the Imaging Units.

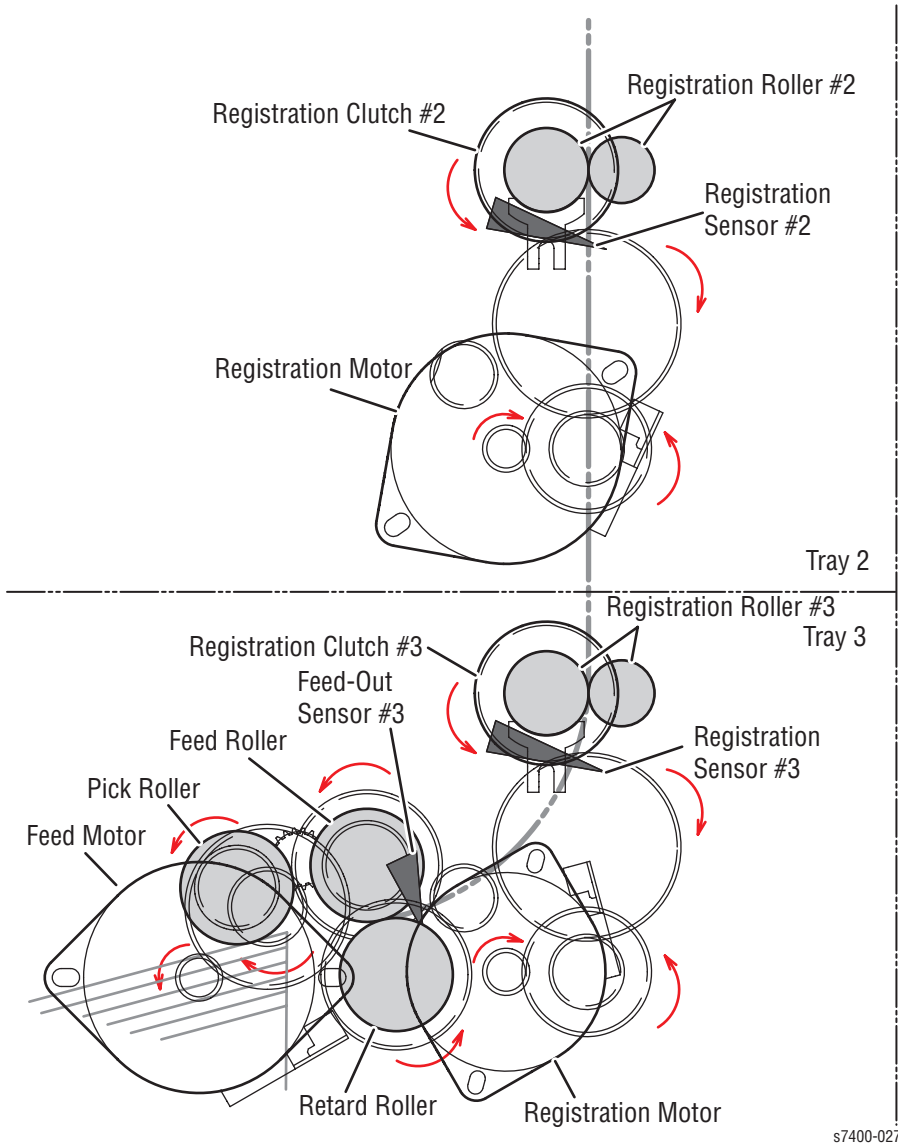

The paper supply and path for the optional trays involve these motors, rollers, and clutches:

- Registration Motor  
This motor drives the Registration Rollers to pull media from the tray into the paper path.
- Registration Clutch  
This clutch transfers Registration Motor drive to the Registration Roller.
- Registration Roller  
This roller aligns the leading edge of the sheet to correct any skew.
- Lift Motor  
This motor lifts the tray's base plate raising the media to the pre-feed position.
- Feed Motor  
This motor drives the Feed Rollers to pick paper from the tray and position it at the Registration Roller.

# Detecting Jams

The microprocessor (CPU) on the Finisher Controller Board checks for jams in the Finisher and other optional units. The CPU identifies a jam in reference to the presence or absence of paper at a specific sensor. In general, the Jam will be generated because of sensors from one or more of the following door locations (see illustration below).

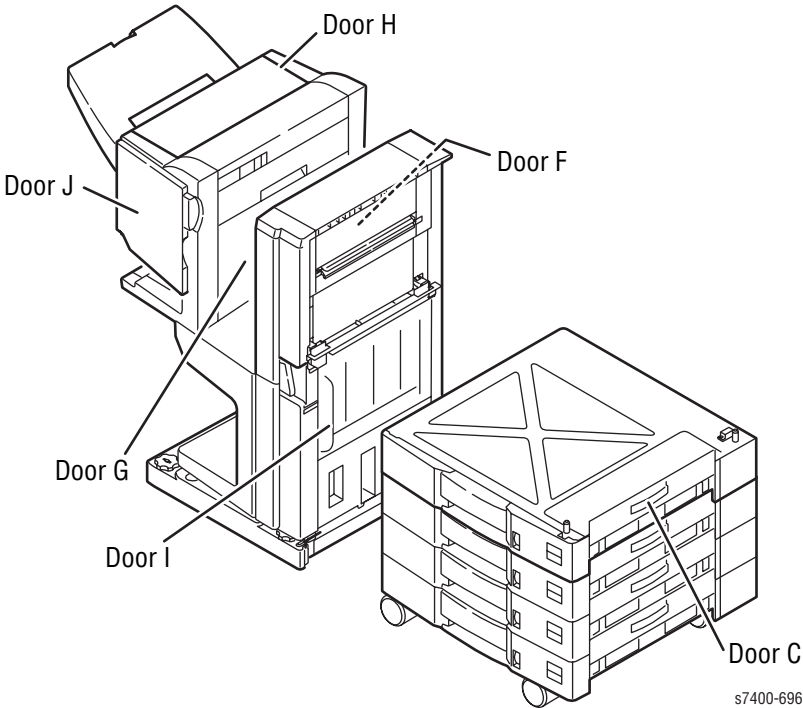

When a jam is detected, the Finisher Controller Board communicates the nature of the jam to the printer in the form of a jam code from one or more specific locations. The jam code descriptions are found when viewing the service mode of the Phaser 7400 printer. Refer to Section 3 for troubleshooting information.



# Finisher/Punch Power Supply

When the printer is powered ON and connected to the finisher, it supplies the Finisher Controller Board with two channels of 24 VDC: one for the motors and clutches, and the other for conversion into 5 VDC in the regulator IC (IC1) of the Finisher Controller Board. The 5 VDC supplies power to sensors and ICs on the printed circuit boards. If the system configuration includes a punch unit (option), power is also supplied to the Punch Controller Board.

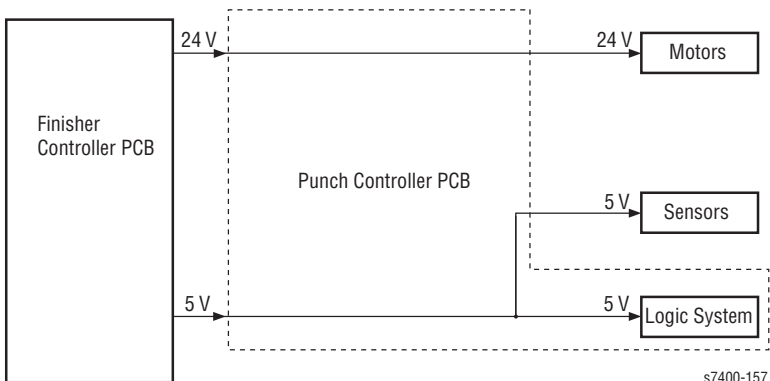
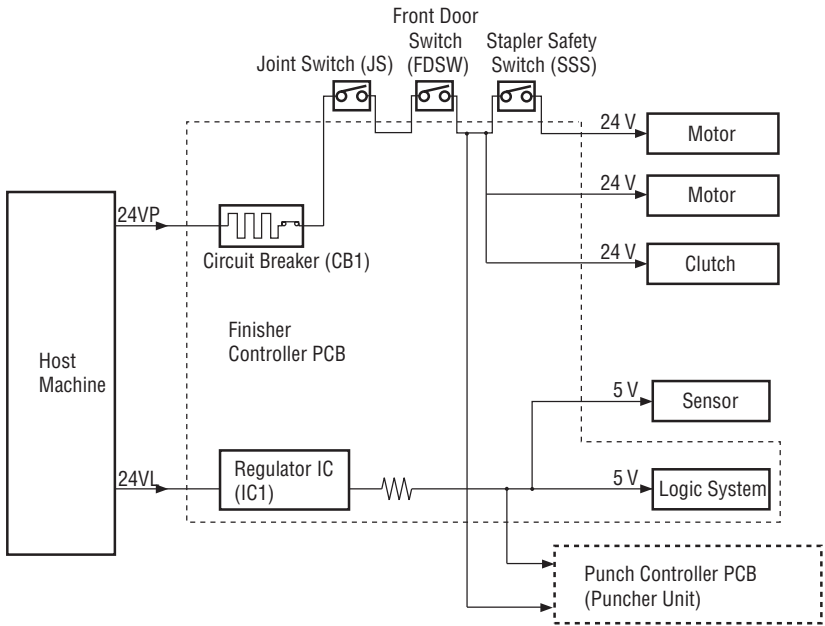

s7400-157

## Finisher Power Supply Protection

A circuit breaker (CB1) is available to protect the 24 VDC system that drives the motors against overcurrent conditions. The 24 VDC system drives the feed motor, paddle motor, and delivery motor.

## Punch Unit Power Supply Protection

After the printer is powered ON, the Finisher Controller Board supplies the punch unit with 24 VDC and 5 VDC power. The 24 VDC power drives the motors, while the 5 VDC power supplies the associated sensors and ICs on the Punch Controller Board. The 24VDC power to the motors is removed if the joint switch (MS2) or the Front Door (Door J) switch (MS1) of the Finisher is open.

# General Troubleshooting

## In this chapter...

- Power On Self Test (POST)
- Service Diagnostics
- Error Message Table
- Troubleshooting the Options

Section

3



# Introduction

This section covers the startup, Service Diagnostics, and power supply operations of the Finisher, Inverter, Duplex Unit, and Paper Tray options to aid in troubleshooting problems.

Troubleshooting procedures isolate a problem to a specific component or subassembly. If you go through the procedures and are still unable to solve the problem, re-read the “Theory of Operation” section for the problem area to understand how that section of the option functions.

## Using Service Diagnostics

Service Diagnostics provides tests for most electro-mechanical components. Service Diagnostics also contains test procedures. If confronted with an error that requires more than a cursory investigation to clear or when directed by a troubleshooting procedure, use Service Diagnostics to exercise selected sub-assemblies of parts in the vicinity of the reported error.

The system monitors sensors located throughout all attached options. Sensor signals are used to monitor paper handling and mechanical activity along the entire paper path. As a sheet travels along the paper path, sensors change state temporarily to indicate the sheet’s presence. If the pattern of sensor state changes differs from the expected timing for a particular paper size and path, the sensor where the timing difference occurs identifies the error to report.

However, having the error message information doesn’t necessarily pinpoint the problem. Sensor signals locate where, but often cannot identify why. Motors, belts, gears, solenoids, and numerous other parts are involved in paper transport. The Service Diagnostics’ suite of tests and utilities are the best tools available to pinpoint the root cause behind the reported error.

# Servicing Instructions

The service checklist below is an overview of the path a service technician should take when servicing the printer and printer optional equipment.

---

## Step 1 - Identify the Problem

---

1. Verify the reported problem does exist. Verify failure symptoms/behavior/noises with customer/end user.
2. Check for any error codes and write them down.
3. Print normal customer prints and service test prints.
4. Make note of any print quality problems in the test prints.
5. Make note of any mechanical or electrical abnormalities present.
6. Make note of any unusual noise or smell coming from the printer.
7. Print a Status page, if the printer is able to print.
8. View the fault history under the Service Tools Menu.
9. Verify the AC input power supply is within proper specifications.

---

## Step 2 - Inspect and Clean the Printer

---

1. Switch Off printer power.
2. Disconnect the AC power cord from the wall outlet.
3. Verify the power cord is serviceable.
4. Remove the Imaging Unit and protect it from light.
5. Inspect the printer interior and remove any foreign matter, dust or loose toner.
  - Do not use solvents or chemical cleaners to clean the printer interior.
  - Do not use any type of oil or lubricant on printer parts unless directed to do so.
  - Do not use canned air to clean spilled toner or dust from the printer.
  - Use only an approved toner vacuum.
6. Clean all rubber rollers with a lint-free cloth, dampened slightly with cold water.
7. Inspect the interior of the printer for damaged wires, loose connections, toner leakage, and damaged or obviously worn parts.
8. Replace damaged or empty Toner Cartridges with new, customer-supplied ones.

---

## Step 3 - Find the Cause of the Problem

---

1. Read and understand the theory of how the printer operates.
2. Use the troubleshooting procedures to find the cause of the problem.
3. Use Service Diagnostics to check printer and optional components.
4. Use the wiring diagrams and plug/jack locator to locate test points.
5. Take voltage readings at various test points as instructed in the appropriate troubleshooting procedure.
6. Use the "Test Prints" described on page 5-4, to isolate problems to the Engine or the Image Processor Board.

---

## Step 4 - Correct the Problem

---

1. Use the Parts List to locate a part number.
2. Use the Disassembly Procedures to replace the part.

---

## Step 5 - Final Check

---

Test the printer to be sure you have corrected the initial problem and verify there are no additional problems present.

---

# Jam Locator

The following illustrates the Door designators that key the jam location error codes and messages. Refer to this diagram when questions arise regarding the area of the jam.

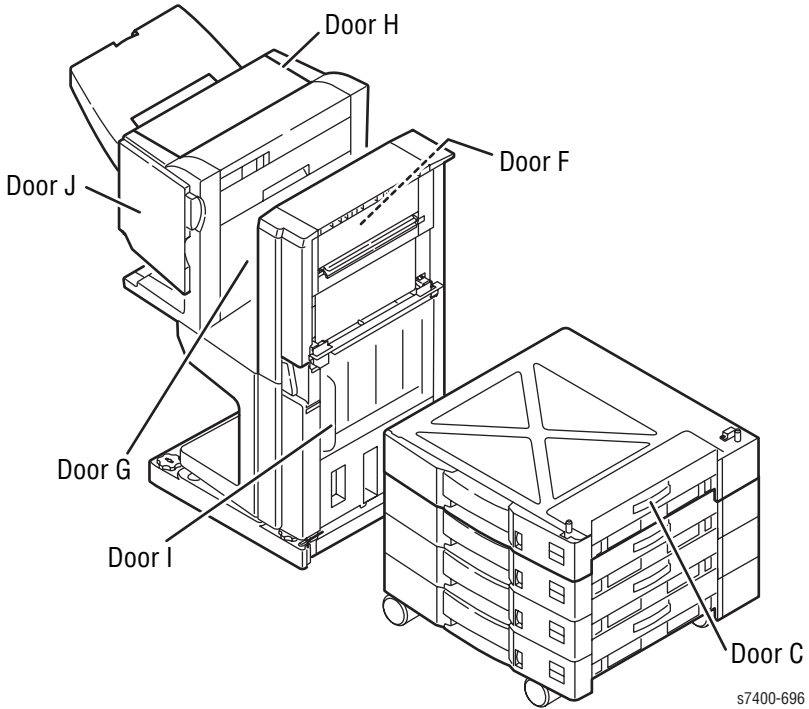

# Jam Detection Chart

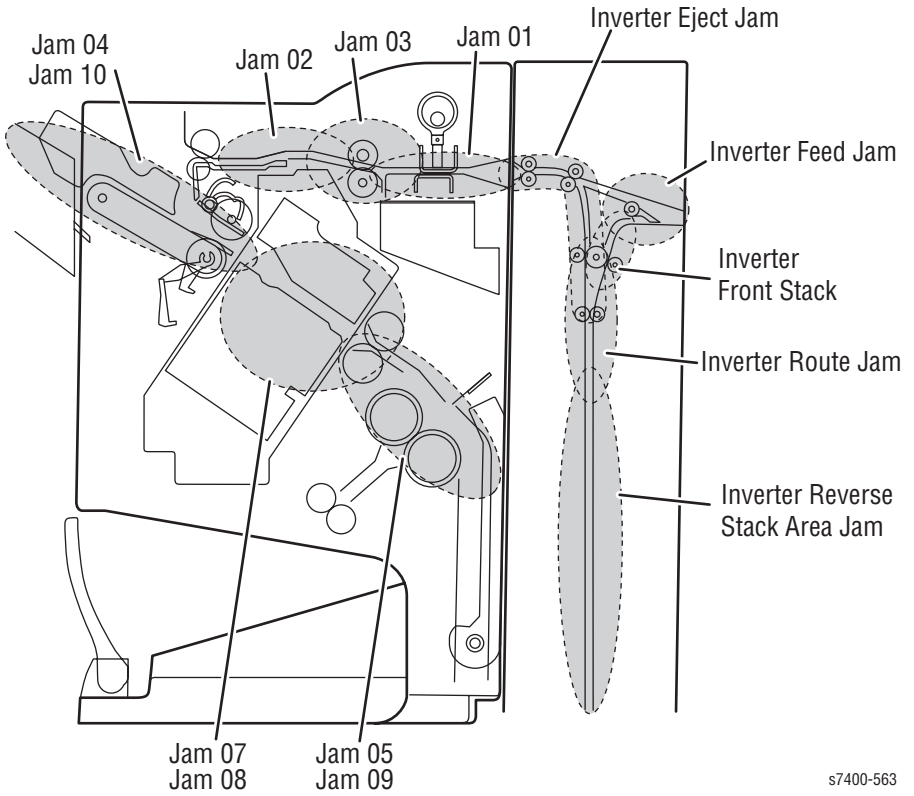

# Error Message Summary

The Error Message Summary table below lists possible errors, along with the corresponding code, and page reference for the corrective procedure for the finisher, Duplex Unit, and paper trays. The Error column lists the error code for fatal or jam errors that appears in the Help text displayed by pressing the **Help(?)** button, listed on the printer's Status page, or logged by the Service Usage Profile. The Control Panel Message column shows the message as it appears on the printer's display when the error occurs during normal operation. The Page column provides the page reference to the corrective procedure. Use this table to identify the proper procedure to clear the reported error.

## Note

When **Printer error - Contact service; report fault [nnn]** is displayed, [nnn] is replaced by a code. These codes, along with a brief description, appear in this table under Fatal Errors. Appendix A includes a complete list of codes arranged in alphanumeric order.

Error	Control Panel Message	Page
<b>Jam Errors</b>		
D1	Jam at Door D Open Door D to Clear	3-16
D2	Jam in Duplex Unit Pull out Duplex Unit to Clear	3-17
TC3	Jam at Duplex Entrance Open Top Cover to Clear	3-18
FN1	Jam at Finisher Punch Unit Open Door H to Clear	3-20
FN2	Jam at Finisher Door H Open Door H to Clear	3-21
FN4	Jam at Finisher Upper Output Tray Remove paper from Finisher	3-22
FN5	Jam at Finisher Saddle Stapler Open Door G to Clear	3-23
FN6	Jam at Finisher Upper Output Tray Open Door H to Clear	3-24
FN7	Jam at Finisher Stapler Open Door G to Clear	3-25
FN8	Jam at Finisher Door G Open Door G to Clear	3-26
FN9	Jam at Finisher Saddle Stapler Open Door G to Clear	3-27
FN10	Jam at Finisher Upper Output Tray Remove paper from Finisher Output	3-28
IN1~IN4, IN6, IN7	Jam Inside Finisher Open Door F and Door I to Clear	3-29
IN5, IN8	Jam at Finisher Entrance Separate Finisher Base from Printer	3-30
FT	Finisher Output Tray Jammed Remove Obstruction to Clear	3-31
<b>Door and Cover Errors</b>		
_	Close Right Door C for Tray [3][4][5][6]	3-33



<b>Error</b>	<b>Control Panel Message</b>	<b>Page</b>
–	Close Door D	3-34
–	Close Finisher Door F	3-35
–	Close Finisher Door H	3-36
–	Close Finisher Door J	3-37
<b>Tray and Media Errors</b>		
–	Clear Tray [3][4][5][6] Riser Plate	3-38
–	Out of Paper Load Tray [3][4][5][6] with [size] [type]	3-39
–	Finisher Lower Output Tray is Full, Unload Paper	3-41
–	Finisher Upper Output Tray is Full, Unload Paper	3-41
–	Remove Paper from Tray [2][3][4][5][6]	3-41
<b>Media Mismatch Errors</b>		
–	Wrong Paper Size Load Tray [3][4][5][6] with [size] [type]	3-42
–	Paper Not Available Load Tray [3][4][5][6] with [size] [type]	3-44

<b>Error</b>	<b>Control Panel Message</b>	<b>Page</b>
<b>Fatal Errors</b>		
U12	Duplex Interface Failure	3-45
U14	Tray 3 Interface Failure	3-46
U13	Tray 4 Interface Failure	3-46
U16	Tray 5 Interface Failure	3-46
U17	Tray 6 Interface Failure	3-46
U51	Inverter Unit Interface Failure	3-47
U34	Unsupported Duplex Unit ROM	3-48
U35	Unsupported Tray 3 ROM	3-49
U36	Unsupported Tray 4 ROM	3-49
U37	Unsupported Tray 5 ROM	3-49
U38	Unsupported Tray 6 ROM	3-49
U50	Unsupported Inverter Unit ROM	3-50
U55	Unsupported Finisher Unit ROM	3-51
F131	Finisher Folder Sensor Failure	3-52
F103	Finisher Paddle Failure	3-53
F106	Finisher Stapler Swing Motor Failure	3-54
F111	Finisher Stapler Stack Handling Motor Failure	3-55
F110	Finisher Staple Motor Failure	3-54
F93	Finisher Jog Motor Failure	3-56
F115	Finisher Tray Lift Motor Failure	3-58
F116	Finisher Exit Failure	3-60
F138	Finisher Punch Backup RAM Failure	3-61
F132	Finisher Punch Communications Failure	3-62
F181	Finisher Punch Transfer Motor Failure	3-63
F134	Finisher Punch Motor Failure	3-64
F137	Finisher Backup RAM Failure	3-65
F139	Finisher Punch Dust Sensor Failure	3-66
<b>Printer error - Contact service; report fault [nnn]</b> Where [nnn] is one of the codes described below.		
F141	Finisher Punch Unit counter at end of life. The Punch count exceeds life limit.	3-68
F142	Finisher Staple Unit counter at end of life. The Staple count exceeds life limit.	3-69
F186	Finisher interface error. Communications lost with Finisher.	3-70

<b>Error</b>	<b>Control Panel Message</b>	<b>Page</b>
I97	Inverter Power Supply Error.	3-71
221	Tray 3 Firmware Error. Firmware error in Tray 3 Flash Memory.	3-72
222	Tray 4 Firmware Error. Firmware error in Tray 4 Flash Memory.	3-72
223	Tray 5 Firmware Error. Firmware error in Tray 5 Flash Memory.	3-72
224	Tray 6 Firmware Error. Firmware error in Tray 6 Flash Memory.	3-72
225	Duplex Unit Firmware Error. Firmware error in Duplex Unit Flash Memory.	3-73
227	Finisher Inverter Firmware Error. Firmware error in Inverter Flash Memory.	3-74
242	Tray 3 Flash Memory Failure. Hardware error in the Tray 3 Flash Memory device.	3-75
243	Tray 4 Flash Memory Failure. Hardware error in the Tray 4 Flash Memory device.	3-75
244	Tray 5 Flash Memory Failure. Hardware error in the Tray 5 Flash Memory device.	3-75
245	Tray 6 Flash Memory Failure. Hardware error in the Tray 6 Flash Memory device.	3-75
246	Duplex Unit Flash Memory Failure. Hardware error in the Flash Memory device.	3-76
248	Finisher Inverter Flash Memory Error. Inverter Flash Memory device error.	3-77
911	The Tray 3 Lift Motor has failed.	3-78
912	The Tray 4 Lift Motor has failed.	3-78
913	The Tray 5 Lift Motor has failed.	3-78
914	The Tray 6 Lift Motor has failed.	3-78
918	The Duplex Unit Fan has failed.	3-80
919	+24 V not available to the Duplex Unit.	3-81
<b>Printer error - Contact service; report fault [nnn]<sup>†</sup> (Continued)</b> Where [nnn] is one of the codes described below.		
924	+24 V not available to Tray 3.	3-83
925	+24 V not available to Tray 4.	3-83+
926	+24 V not available to Tray 5.	3-83
927	+24 V not available to Tray 6.	3-83
931	The Duplex Unit CPU clock frequency is inaccurate.	3-84
932	The Inverter CPU clock frequency is inaccurate.	3-85
933	The Tray 3 Feeder Board clock frequency is inaccurate.	3-86
934	The Tray 4 Feeder Board clock frequency is inaccurate.	3-86
935	The Tray 5 Feeder Board clock frequency is inaccurate.	3-86
936	The Tray 6 Feeder Board clock frequency is inaccurate.	3-86
<b>Warning Messages</b>		
–	No Paper in Tray [3][4][5][6]	3-87

<b>Error</b>	<b>Control Panel Message</b>	<b>Page</b>
–	Staple Cartridge Is Empty	3-88
–	Punch Waste Box is Full or Missing	3-89
–	Finisher Away From Base	3-90
–	Finisher Away From Printer	3-91

# Using the Troubleshooting Procedures

1. **Applicable Status Code(s)** lists the error message(s) addressed by each troubleshooting procedure.
2. **Applicable Parts** and **Wiring and Plug/Jack References** assist you in locating information available for a particular part or procedure.
3. Follow each **Step** in a troubleshooting procedure sequentially in the order given until the problem is fixed or resolved.
4. The **Actions and Questions** box instructs you to perform a certain action or procedure. Also included are precautions and/or additional procedures you must follow to isolate the problem.
5. When a procedure instructs you to test a component using Service Diagnostics, see "Fault Isolation" on page 4-6 for the detailed steps and functions for testing parts, assemblies, or subsystems of the printer.
6. Some actions are followed by a question. If your response to the question is **Yes**, then follow the instructions for a **Yes** reply. If your response to the question is **No**, then follow the instructions for a **No** reply.
7. Note that two types of photo sensors are used: photo-reflective and photo-receptive. Photo-reflective sensors use light reflected back from an object to detect its presence or absence. Photo-receptive sensors use an actuator or the object itself to block the light path to detect an object or condition.
8. Troubleshooting procedures frequently ask you to take voltage readings or test for continuity or resistance at certain test points. The **Wiring and Plug/Jack References** table provides pointers to the diagrams that provide this information.
9. Troubleshooting procedures often ask you to replace a printer component. When instructed to replace a non-spared component and that component is part of a parent assembly, replace the entire parent assembly.

# Measurement Techniques

1. Unless indicated otherwise, the instruction “switch On printer power” means for you to switch On printer power and let the printer proceed through Power On Self Test (POST) to a ‘Ready’ condition.

2. Conventions used in this manual to represent connectors

**Jack**



**Plug**



s7400-314

3. When instructed to take voltage, continuity or resistance readings on wiring harness, proceed as follows; Check P/J 232–1 to P/J 210–5 by placing the red probe (+) of your meter on pin 1 of P/J 232, and place the black probe (–) of your meter on pin 5 of P/J 210.
4. When you are instructed to take resistance readings between “P/J 232 <=> P/J 210” (without specified pin numbers), check all pins. When you are instructed to run a test, run the Service Diagnostics test associated with the component being examined.
5. When you are instructed to take a voltage reading, the black probe (–) is generally connected to a pin that is either RTN (Return) or SG (Signal Ground). You can substitute any RTN pin or test point in the printer, and you can use FG (frame ground) in place of any SG pin or test point.
6. Before measuring voltages make sure the printer is switched On, the Imaging Unit and the paper trays are in place, and the interlock switch is actuated, unless a troubleshooting procedure instructs otherwise.
7. All voltage values given in the troubleshooting procedures are approximate values. The main purpose of voltage readings is to determine whether or not a component is receiving the correct voltage value from the power supply and if gating (a voltage drop) occurs during component actuation. Gating signals may be nothing more than a pulse, resulting in a momentary drop in voltage that may be difficult or impossible to read on the average multi-meter.
8. When a troubleshooting procedure instructs you to replace a non-spared component and that component is part of a parent assembly, you should replace the entire parent assembly.
9. Ensure that you are using a supported media size and type.
10. Power and signal grounds are connected to the frame ground. All circuit troubleshooting can be performed using the metal frame (chassis) as the grounding point.

# Troubleshooting the Finisher

## Jam at Door C for Tray [3][4][5][6]

Media reached the Feed-Out Sensor, but did not arrive at the Transfer Unit Entrance Sensor on time. This error represents a misfeed jam for media fed from an optional tray.

### Applicable Status Codes:

**Code C3:** Jam at Door C for Tray 3

**Code C4:** Jam at Door C for Tray 4

**Code C5:** Jam at Door C for Tray 5

**Code C6:** Jam at Door C for Tray 6

### Initial Actions:

- Try picking paper from a different tray.
- Ensure the tray is installed properly and the paper guides are set correctly.
- Remove any obstructions or debris in the paper path.
- Cycle printer power.
- If the problem persists, follow the procedure below.

### Troubleshooting Reference Table

Applicable Parts	Wiring and Plug/Jack References
<ul style="list-style-type: none"><li>■ Feed Rollers</li><li>■ Feeder Assembly</li><li>■ Option Control Board</li><li>■ Feeder Board</li></ul>	<ul style="list-style-type: none"><li>■ Print Engine Map 3 (page 10-6)</li><li>■ Print Engine Map 5 (page 10-8)</li><li>■ Print Engine Map 11 (page 10-14)</li><li>■ Print Engine Motor Driver Board (6/6) (page 10-36)</li><li>■ Options Map 5, Paper Tray Controller Board</li><li>■ Options Paper Tray Sensors and Interconnect Wiring</li></ul>

## Troubleshooting Procedure Table

Step	Actions and Questions	Yes	No
1	<p>Check the following for evidence of fault, dirt, debris, or damage:</p> <ul style="list-style-type: none"> <li>■ Door C</li> <li>■ Feed Rollers</li> <li>■ Registration Rollers</li> <li>■ Transport Rollers</li> <li>■ Sensor Actuators</li> </ul> <p>Is there any damage or debris?</p>	Clean or replace the appropriate parts.	Go to Step 2.
2	<p>Check the Option connection. Is the Option connection to the Printer damaged or disconnected?</p>	Reconnect or replace the cable.	Go to Step 3.
3	<p>Check the Option Harness continuity. Disconnect OPTIF from the Engine Control Board and the Option connector. Is the harness conductive?</p>	Go to Step 4.	Replace the Option harness.
4	<p>Test the tray sensors. Run the Service Diagnostics Tray Switches test for the appropriate tray. Do the sensors function correctly?</p>	Go to Step 6.	Go to Step 5.
5	<p>Check the sensor harness continuity. Is the harness conductive?</p>	Replace the sensor. If the error persists, replace the Feeder Board.	Replace the harness.
6	<p>Test the Feeder Motors. Run the Service Diagnostics Motor tests. Do the motors function correctly?</p>	Go to step 8.	Go to Step 7.
7	<p>Check the motor harness continuity. Is the harness conductive?</p>	Replace the motor. If the error persists, Go to Step 10.	Replace the harness.
8	<p>Test the Registration Clutch. Run the Service Diagnostics Clutch test. Does the clutch function correctly?</p>	Go to step 11.	Go to step 9.
9	<p>Check the CL1 harness continuity. Is the harness conductive?</p>	Replace the clutch. If the error persists, go to Step 10.	Replace the harness.
10	<p>Check for +24 V at the Motor Driver Board's OPTRY24 connector.</p> <ol style="list-style-type: none"> <li>1. Close the Interlock Switches.</li> <li>2. Disconnect OPTRY24.</li> </ol> <p>Is there +24 V at OPTRY24-1 and -2 &lt;=&gt; ground?</p>	Replace the affected Option Control Board.	Go to Step 11.



## Troubleshooting Procedure Table (Continued)

<b>Step</b>	<b>Actions and Questions</b>	<b>Yes</b>	<b>No</b>
<b>11</b>	Check OPRY24 Harness continuity. Disconnect the OPRY24 Harness. Is the OPRY24 Harness conductive?	Go to Step 13.	Replace the OPRY24 Harness.
<b>12</b>	Check the Registration Assembly. Is there a gap between the rollers?	Replace the Registration Assembly (page 8-84).	Go to Step 13.
<b>13</b>	Check the DRV1 harness continuity. Is the harness conductive?	Replace the Motor Driver Board (page 8-141). If the error persists, replace the Engine Control Board (page 8-112)	Replace the harness.

# Jam at Door D Open Door D to Clear

Media reached Duplex Reverse Sensor, but did not leave the Duplex Unit on time. This error represents a misfeed jam inside the Duplex Unit.

## Applicable Status Code:

**Code D1:** Jam at Door D

## Initial Actions:

- Ensure that the Duplex Unit is free of obstructions and fully seated.
- Cycle printer power.
- If the problem persists, follow the procedure below.

## Troubleshooting Reference Table

Applicable Parts	Wiring and Plug/Jack References
■ Duplex Unit	■ Options Map 4, Duplex Unit Controller Board ■ Options Duplex Unit Sensors and Interconnect Wiring

## Troubleshooting Procedure Table

Step	Actions and Questions	Yes	No
1	Check the following for evidence of fault or damage: <ul style="list-style-type: none"><li>■ Duplex Unit Entrance Roller</li><li>■ Duplex Unit Connector</li><li>■ Duplex Unit</li></ul> Is there any damage or debris?	Replace any damaged parts.	Go to Step 2.
2	Test the Duplex Entrance, Reverse, Front, and Rear actuators and sensors using Service Diagnostics. Do the sensors and actuators function correctly?	Go to Step 3.	Replace the Duplex Unit (page 5-122).
3	Test the Duplex Motors using Service Diagnostics. Do the motors function correctly?	Go to Step 4.	Replace the Duplex Unit (page 5-122).
4	Inspect the DUPLEX harness. If defective, replace the wiring harness. Is the harness properly seated and free from defects?	Replace the Motor Driver Board (see Book 1).	Replace the Duplex Unit (page 5-122).

# Jam in Duplex Unit

Media reached Duplex Reverse Sensor, but did not leave the Duplex Unit on time. This error represents a misfeed jam inside the Duplex Unit.

## Applicable Status Code:

**Code D2:** Jam in Duplex Unit

## Initial Actions:

- Cycle printer power.
- If the problem persists, follow the procedure below.

## Troubleshooting Reference Table

Applicable Parts	Wiring and Plug/Jack References
■ Duplex Unit	■ Options Map 4, Duplex Unit Controller Board ■ Options Duplex Unit Sensors and Interconnect Wiring

## Troubleshooting Procedure Table

Step	Actions and Questions	Yes	No
1	Ensure the correct weight and type of paper is loaded in the tray. Does the media meet specifications?	Go to Step 2.	Run several test prints. If a jam persists, go to Step 2.
2	Check for and remove any dirt, debris or obstructions in the paper path around the Duplex Unit. Did this correct the problem?	Complete	Go to Step 3.
3	Clean and check the Duplex Unit rollers. Do the rollers move freely and are free of dirt or debris?	Go to Step 4.	Replace the Duplex Unit (page 5-122).
4	Test the Duplex Entrance, Reverse, Front, and Rear actuators and sensors using Service Diagnostics. Do the sensors function correctly?	Go to Step 5.	Replace the Duplex Unit (page 5-122).
5	Test the Duplex Motors. Do the motors function correctly?	Go to Step 6.	Replace the Duplex Unit (page 5-122).
6	Inspect the DUPLEX harness. If defective, replace the wiring harness. Is the harness properly seated and free from defects?	Replace the Motor Driver Board (see Book 1).	Replace the Duplex Unit (page 5-122).

# Jam at Duplex Entrance

Media reached the Fuser Exit Sensor, but did not reach the Duplex Entrance Sensor on time. This error represents a jam at the Duplex entrance or in the Exit Assembly.

## Applicable Status Code:

**Code TC3:** Jam at Duplex Entrance

## Initial Actions:

- Check for obstructions or debris in the output paper path.
- Reseat the Duplex Unit.
- Cycle printer power.
- If the problem persists, follow the procedure below.

## Troubleshooting Reference Table

Applicable Parts	Wiring and Plug/Jack References
<ul style="list-style-type: none"><li>■ Duplex Unit</li><li>■ Duplex Entrance Sensor</li><li>■ Exit Assembly (see Book 1)</li><li>■ Fuser Motor, (see Book 1)</li><li>■ Motor Driver (see Book 1)</li></ul>	<ul style="list-style-type: none"><li>■ Print Engine Map 5 (see Book 1)</li><li>■ Options Map 4, Duplex Unit Controller Board.</li><li>■ Options Duplex Unit Sensors and Interconnect Wiring</li></ul>

## Troubleshooting Procedure Table

Step	Actions and Questions	Yes	No
1	Check the following for evidence of fault or damage: <ul style="list-style-type: none"><li>■ Duplex Unit</li><li>■ Exit Gate</li><li>■ Exit Assembly</li><li>■ Duplex Gate</li></ul> Are there any defects?	Replace any damaged parts.	Go to Step 2.
2	Test the Duplex Entrance Sensor. Run the Service Diagnostics Duplex Entrance (IN1) Sensor test. Does the sensor function correctly?	Go to Step 4.	Replace the Duplex Entrance Sensor, if the error persists, go to Step 3.
3	Check DUPLEX Harness continuity. Is the DUPLEX Harness conductive?	Go to Step 4.	Replace the DUPLEX Harness.
4	Print a test print in Duplex mode Does the sheet reverse in the printer?	Go to Step 6.	Replace the Duplex Unit. If the error persists, go to Step 5.

## Troubleshooting Procedure Table (Continued)

Step	Actions and Questions	Yes	No
5	<p>Check for +24 V to the Duplex Motors. Disconnect DUPLEX on the Motor Driver Board. Is there +24 V at DUPLEX-6 &lt;=&gt; ground?</p>	Go to Step 6.	Go to Step 10.
6	<p>Test the Fuser Motor. Run the Service Diagnostics Fuser Motor test. Does the Fuser Motor function correctly?</p>	Go to Step 8.	Go to Step 7.
7	<p>Check for +24 V to the Fuser Motor. Disconnect DCHEAT on the Motor Driver Board. Is there +24 V at DCHEAT-3 &lt;=&gt; ground?</p>	Replace the Fuser Motor (see Book 1).	Go to Step 10.
8	<p>Test the Exit Gate Solenoid. Run the Service Diagnostics Exit Gate Solenoid test. Does the solenoid function correctly.</p>	Replace the Exit Assembly (see Book 1).	Go to Step 9.
9	<p>Check for +24 V to the solenoid. 1. Actuate the interlock switches. 2. Disconnect SOLENOID from the Rear Sensor Board. Is there +24 V across SOLENOID-1 &lt;=&gt; ground?</p>	Replace the solenoid (page 5-129).	Replace the Rear Sensor Board (See Book 1).
10	<p>Check Motor Driver Board POW24 connector for 24 V. 1. Disconnect POW24. Is there +24 V across POW24-1 &lt;=&gt; POW24-2?</p>	Replace the Motor Driver Board (see Book 1).	Go to Step 11.
11	<p>Check for 24 V at the LVPS 1. Disconnect CN2 on the LVPS. Is there +24 V across pins 1 and 2?</p>	Replace the POW24 Harness.	Replace the LVPS (See Book 1).
12	<p>Check the DRV0 and DRV1 ribbon cables that connect the Motor Driver Board to the Engine Control Board. Are these cables connected and undamaged?</p>	Replace the Engine Control Board (See Book 1).	Replace the DRV0 and DRV1 Harnesses.

# Jam at Finisher Punch Unit

Media did not clear the Finisher Entrance Sensor on time. This error represents a jam at the Finisher entrance.

## Applicable Status Code:

**Code FN1:** Jam at Finisher Punch

## Initial Actions:

- Check for obstructions or debris in the paper path.
- Cycle printer power.
- If the problem persists, follow the procedure below.

## Troubleshooting Reference Table

Applicable Parts	Wiring and Plug/Jack References
<ul style="list-style-type: none"><li>■ Punch Unit</li><li>■ Finisher Entrance Sensor</li><li>■ Finisher Transport Rollers</li></ul>	<ul style="list-style-type: none"><li>■ Options Map 2, Punch Unit Controller Board</li><li>■ Options Map 8, Finisher Sensor Locator (2/2)</li><li>■ Options Punch Unit Sensors and Motors</li><li>■ Options Finisher Controller to Sensors (2/3)</li></ul>

## Troubleshooting Procedure Table

Step	Actions and Questions	Yes	No
1	Check the following for evidence of fault or damage: <ul style="list-style-type: none"><li>■ Punch Unit</li><li>■ Transport Rollers</li><li>■ Exit Rollers</li></ul> Are there any defects or misalignment?	Replace any damaged parts.	Go to Step 2.
2	Test the Finisher Entrance Sensor. Run the Service Diagnostics Finisher Entrance Sensor test. Does the sensor function correctly?	Replace the Engine Control Board (see Book 1).	Replace the sensor. If the error persists, go to Step 3.
3	Check the Entrance Sensor signal at the Finisher Control Board. Actuate the Entrance Sensor. Does the voltage across CN16-12 <=> ground change when the sensor is actuated?	Replace the Finisher Control Board (page 5-46).	Replace the harness.

# Jam at Finisher Door H

Media reached the Finisher Entrance Sensor, but did not clear the Inverter on time. This error represents a jam in the Finisher Inverter.

## Applicable Status Code:

**Code FN2:** Jam at Finisher Door H

## Initial Actions:

- Check for obstructions or debris in the paper path.
- Cycle printer power.
- If the problem persists, follow the procedure below.

## Troubleshooting Reference Table

Applicable Parts	Wiring and Plug/Jack References
<ul style="list-style-type: none"><li>■ Inverter</li><li>■ Finisher Entrance Sensor</li><li>■ Finisher Inverter Rollers</li></ul>	<ul style="list-style-type: none"><li>■ Options Map 7, Finisher Sensor Locator (1/2)</li><li>■ Options Map 8, Finisher Sensor Locator (2/2)</li><li>■ Options Map 9, Inverter Sensor Locator</li><li>■ Options Finisher Controller to Sensors (2/3)</li></ul>

## Troubleshooting Procedure Table

Step	Actions and Questions	Yes	No
1	Check the following for evidence of fault or damage: <ul style="list-style-type: none"><li>■ Inverter</li><li>■ Inverter Rollers</li><li>■ Finisher Transport Rollers</li></ul> Are there any defects or misalignment?	Replace any damaged parts.	Go to Step 2.
2	Test the Finisher Entrance Sensor. Run the Service Diagnostics Finisher Entrance Sensor test. Does the sensor function correctly?	Replace the Engine Control Board (see Book 1).	Replace the sensor. If the error persists, go to Step 3.
3	Check the Entrance Sensor signal at the Finisher Control Board. Actuate the Entrance Sensor. Does the voltage across CN16-12 <=> ground change when the sensor is actuated?	Replace the Finisher Control Board ( page 5-46).	Replace the harness.

# Jam at Finisher Upper Output Tray

Media remains in the upper output path. This error represents a jam in the Finisher.

## Applicable Status Code:

**Code FN4:** Jam at Finisher Upper Output Tray

## Initial Actions:

- Check for obstructions or debris in the paper path.
- Cycle printer power.
- If the problem persists, follow the procedure below.

## Troubleshooting Reference Table

Applicable Parts	Wiring and Plug/Jack References
<ul style="list-style-type: none"><li>■ Compiler Tray</li><li>■ Front and Rear Alignment Guides</li><li>■ Transport Rollers</li></ul>	<ul style="list-style-type: none"><li>■ Options Map 8, Finisher Sensor Locator (2/2)</li><li>■ Options Finisher Controller to Sensors (1/3)</li></ul>

## Troubleshooting Procedure Table

Step	Actions and Questions	Yes	No
1	Check the following for evidence of fault or damage: <ul style="list-style-type: none"><li>■ Compiler Tray</li><li>■ Front and Rear Alignment Guides</li><li>■ Transport Rollers</li></ul> Are there any defects or misalignment?	Replace any damaged parts.	Go to Step 2.
2	Test the Processing Tray Sensor. Run the Service Diagnostics sensor test. Does the sensor function correctly?	Replace the Engine Control Board (see Book 1).	Replace the sensor. If the error persists, go to Step 3.
3	Check the Processing Tray Sensor signal. Actuate the sensor at the Finisher Control Board. Does the voltage across CN5-9 <=> ground change when the sensor is actuated?	Replace the Finisher Control Board (page 5-46).	Replace the harness.



# Jam at Finisher Saddle Stapler

Media remains in the buffer area. This error represents a jam in the Finisher.

## Applicable Status Code:

**Code FN5:** Jam at Finisher Saddle Stapler

## Initial Actions:

- Check for obstructions or debris in the paper path.
- Cycle printer power.
- If the problem persists, follow the procedure below.

## Troubleshooting Reference Table

Applicable Parts	Wiring and Plug/Jack References
<ul style="list-style-type: none"><li>■ Compiler Tray</li><li>■ Front and Rear Alignment Guides</li><li>■ Transport Rollers</li><li>■ Stapler</li></ul>	<ul style="list-style-type: none"><li>■ Options Map 7, Finisher Sensor Locator (1/2)</li><li>■ Options Map 8, Finisher Sensor Locator (2/2)</li><li>■ Options Finisher Controller to Sensors (1/3)</li><li>■ Options Finisher Controller to Sensors (2/3)</li></ul>

## Troubleshooting Procedure Table

Step	Actions and Questions	Yes	No
1	Check the following for evidence of fault or damage: <ul style="list-style-type: none"><li>■ Compiler Tray</li><li>■ Front and Rear Alignment Guides</li><li>■ Transport Rollers</li><li>■ Stapler</li></ul> Are there any defects or misalignment?	Replace any damaged parts.	Go to Step 2.
2	Test the Folding Position Sensor. Run the Service Diagnostics Folding Position Sensor test. Do the sensor function correctly?	Replace the Engine Control Board (see Book 1).	Replace the sensor. If the error persists, go to Step 3.
3	Check the Folding Position Sensor signal at the Finisher Control Board. Actuate the sensor. Does the voltage across CN16-2 <=> ground change when the sensor is actuated?	Replace the Finisher Control Board (page 5-46).	Replace the harness.

# Jam at Finisher Upper Output Tray

Media remains in the Finisher offset rollers. This error represents a jam in the Finisher upper output path.

## Applicable Status Code:

**Code FN6:** Jam at Finisher Upper Output Tray

## Initial Actions:

- Cycle printer power.
- If the problem persists, follow the procedure below.

## Troubleshooting Reference Table

Applicable Parts	Wiring and Plug/Jack References
<ul style="list-style-type: none"><li>■ Compiler Tray</li><li>■ Front and Rear Alignment Guides</li><li>■ Transport Rollers</li><li>■ Stapler</li></ul>	<ul style="list-style-type: none"><li>■ Options Map 7, Finisher Sensor Locator (1/2)</li><li>■ Options Map 8, Finisher Sensor Locator (2/2)</li><li>■ Options Finisher Controller to Sensors (1/3)</li><li>■ Options Finisher Controller to Sensors (2/3)</li></ul>

## Troubleshooting Procedure Table

Step	Actions and Questions	Yes	No
1	Check the following for evidence of fault or damage: <ul style="list-style-type: none"><li>■ Compiler Tray</li><li>■ Front and Rear Alignment Guides</li><li>■ Transport Rollers</li><li>■ Stapler</li></ul> Are there any defects or misalignment?	Replace any damaged parts.	Go to Step 2.
2	Test the Processing Tray Sensor. Run the Service Diagnostics sensor test. Does the sensor function correctly?	Replace the Engine Control Board (see Book 1).	Replace the sensor. If the error persists, go to Step 3.
3	Check the Processing Tray Sensor signal at the Finisher Control Board. Actuate the sensor. Does the voltage across CN5-3 <=> ground change when the sensor is actuated?	Replace the Finisher Control Board(page 5-46).	Replace the harness.

# Jam at Finisher Stapler

Media remains in the Compiler Tray. This error represents a jam in the Finisher staple path.

## Applicable Status Code:

**Code FN7:** Jam at Finisher Stapler

## Initial Actions:

- Cycle printer power.
- If the problem persists, follow the procedure below.

## Troubleshooting Reference Table

Applicable Parts	Wiring and Plug/Jack References
<ul style="list-style-type: none"><li>■ Compiler Tray</li><li>■ Front and Rear Alignment Guides</li><li>■ Transport Rollers</li><li>■ Stapler</li></ul>	<ul style="list-style-type: none"><li>■ Options Map 7, Finisher Sensor Locator (1/2)</li><li>■ Options Map 8, Finisher Sensor Locator (2/2)</li><li>■ Options Finisher Controller to Sensors (1/3)</li><li>■ Options Finisher Controller to Sensors (2/3)</li></ul>

## Troubleshooting Procedure Table

Step	Actions and Questions	Yes	No
1	Check the following for evidence of fault or damage: <ul style="list-style-type: none"><li>■ Compiler Tray</li><li>■ Front and Rear Alignment Guides</li><li>■ Transport Rollers</li><li>■ Stapler</li></ul> Are there any defects or misalignment?	Replace any damaged parts.	Go to Step 2.
2	Test the Bind Tray Sensor. Run the Service Diagnostics sensor test. Does the sensor function correctly?	Replace the Engine Control Board (see Book 1).	Replace the sensor. If the error persists, go to Step 3.
3	Check the Processing Tray Sensor signal at the Finisher Control Board. Actuate the sensor. Does the voltage across CN15-3 <=> ground change when the sensor is actuated?	Replace the Finisher Control Board (page 5-46).	Replace the harness.

# Jam at Finisher Door G

Jam detected in the saddle stitch path.

## Applicable Status Code:

**Code FN8:** Jam at Finisher Door G

## Initial Actions:

- Cycle printer power.
- If the problem persists, follow the procedure below.

## Troubleshooting Reference Table

Applicable Parts	Wiring and Plug/Jack References
<ul style="list-style-type: none"><li>■ Compiler Tray</li><li>■ Front and Rear Alignment Guides</li><li>■ Transport Rollers</li><li>■ Stapler</li></ul>	<ul style="list-style-type: none"><li>■ Options Map 7, Finisher Sensor Locator (1/2)</li><li>■ Options Map 8, Finisher Sensor Locator (2/2)</li><li>■ Options Finisher Controller to Sensors (1/3)</li><li>■ Options Finisher Controller to Sensors (2/3)</li></ul>

## Troubleshooting Procedure Table

Step	Actions and Questions	Yes	No
1	Check the following for evidence of fault or damage: <ul style="list-style-type: none"><li>■ Compiler Tray</li><li>■ Front and Rear Alignment Guides</li><li>■ Transport Rollers</li><li>■ Stapler</li></ul> Are there any defects or misalignment?	Replace any damaged parts.	Go to Step 2.
2	Test the Bind Tray Sensor. Run the Service Diagnostics sensor test. Does the sensor function correctly?	Replace the Engine Control Board (see Book 1).	Replace the sensor. If the error persists, go to Step 3.
3	Check the Processing Tray Sensor signal at the Finisher Control Board. Actuate the sensor. Does the voltage across CN15-3 <=> ground change when the sensor is actuated?	Replace the Finisher Control Board (page 5-46).	Replace the harness.

# Jam at Finisher Saddle Stapler

This error represents a jam in the Finisher staple path.

## Applicable Status Code:

**Code FN9:** Jam at Finisher Saddle Stapler

## Initial Actions:

- Cycle printer power.
- If the problem persists, follow the procedure below.

## Troubleshooting Reference Table

Applicable Parts	Wiring and Plug/Jack References
<ul style="list-style-type: none"><li>■ Compiler Tray</li><li>■ Front and Rear Alignment Guides</li><li>■ Transport Rollers</li><li>■ Stapler</li></ul>	<ul style="list-style-type: none"><li>■ Options Map 7, Finisher Sensor Locator (1/2)</li><li>■ Options Map 8, Finisher Sensor Locator (2/2)</li><li>■ Options Finisher Controller to Sensors (1/3)</li><li>■ Options Finisher Controller to Sensors (2/3)</li></ul>

## Troubleshooting Procedure Table

Step	Actions and Questions	Yes	No
1	Check the following for evidence of fault or damage: <ul style="list-style-type: none"><li>■ Compiler Tray</li><li>■ Front and Rear Alignment Guides</li><li>■ Transport Rollers</li><li>■ Stapler</li></ul> Are there any defects or misalignment?	Replace any damaged parts.	Go to Step 2.
2	Test the Folding Position Sensor. Run the Service Diagnostics sensor test. Does the sensor function correctly?	Replace the Engine Control Board (see Book 1).	Replace the sensor. If the error persists, go to Step 3.
3	Check the Processing Tray Sensor signal at the Finisher Control Board. Actuate the sensor. Does the voltage across CN16-2 <=> ground change when the sensor is actuated?	Replace the Finisher Control Board (page 5-46).	Replace the harness.

# Jam at Finisher Upper Output Tray

Media remains in the Compiler Tray. This error represents a jam in the Finisher eject path.

## Applicable Status Code:

**Code FN10:** Jam at Finisher Upper Output Tray

## Initial Actions:

- Cycle printer power.
- If the problem persists, follow the procedure below.

## Troubleshooting Reference Table

Applicable Parts	Wiring and Plug/Jack References
<ul style="list-style-type: none"><li>■ Compiler Tray</li><li>■ Front and Rear Alignment Guides</li><li>■ Transport Rollers</li></ul>	<ul style="list-style-type: none"><li>■ Options Map 8, Finisher Sensor Locator (2/2)</li><li>■ Options Finisher Controller to Sensors (1/3)</li><li>■ Options Finisher Controller to Sensors (2/3)</li></ul>

## Troubleshooting Procedure Table

Step	Actions and Questions	Yes	No
1	Check the following for evidence of fault or damage: <ul style="list-style-type: none"><li>■ Compiler Tray</li><li>■ Front and Rear Alignment Guides</li><li>■ Transport Rollers</li></ul> Are there any defects or misalignment?	Replace any damaged parts.	Go to Step 2.
2	Test the Tray Paper Sensor. Run the Service Diagnostics sensor test. Does the sensor function correctly?	Replace the Engine Control Board (see Book 1).	Replace the sensor. If the error persists, go to Step 3.
3	Check the Processing Tray Sensor signal at the Finisher Control Board. Actuate the sensor. Does the voltage across CN5-9 <=> ground change when the sensor is actuated?	Replace the Finisher Control Board (page 5-46).	Replace the harness.

# Jam Inside Finisher

Media remains in the Inverter. These errors represent a jam in the Inverter path.

## Applicable Status Codes:

**Code: IN1:** Media remains in the Inverter Lower Sensor.

**Code: IN2:** Media remains in the Inverter Exit Sensor.

**Code: IN3:** Media reached the Inverter Entrance Sensor, but did not reach the Inverter Exit Sensor on time.

**Code: IN4:** Media reached the Inverter Entrance Sensor, but did not clear on time.

**Code: IN6:** Media reached the Inverter Exit Sensor, but did not clear on time.

**Code: IN7:** Media remains in the Inverter Lower Sensor.

## Initial Actions:

- Cycle printer power.
- If the problem persists, follow the procedure below.

## Troubleshooting Reference Table

Applicable Parts	Wiring and Plug/Jack References
<ul style="list-style-type: none"><li>■ Inverter Lower Sensor</li><li>■ Inverter Entrance Sensor</li><li>■ Inverter Exit Sensor</li></ul>	<ul style="list-style-type: none"><li>■ Options Map 3, Inverter Controller Board</li><li>■ Options Map 9, Inverter Sensor Locator</li><li>■ Options Inverter Sensors Diagram</li></ul>

## Troubleshooting Procedure Table

Step	Actions and Questions	Yes	No
1	Check the following for evidence of fault, damage, obstruction, or debris: <ul style="list-style-type: none"><li>■ Sensor Actuator</li><li>■ Paper Guides</li><li>■ Transport Rollers</li></ul> Are there any defects or misalignment?	Replace any damaged parts.	Go to Step 2.
2	Test the affected sensor. Run the Service Diagnostics test for the reporting sensor. Does the sensor function correctly?	Replace the Engine Control Board (see Book 1).	Go to Step 3.
3	Test the sensor signal. Does the signal voltage change on the SNSCNO connector of the Inverter Control Board?	Replace the Inverter Control Board (page 5-46).	Either the sensor or the wiring is defective. Check the resistance of the wires and if no problem is found replace the sensor.

# Jam at Finisher Entrance

Media remains in the Inverter Entrance Sensor. This error represents a jam in the Printer/Finisher interface.

## Applicable Status Codes:

**Code IN5:** Media did not reach the Inverter Entrance Sensor following an Eject command from the printer.

**Code IN8:** Media remains in the Inverter Entrance Sensor.

## Initial Actions:

- Cycle printer power.
- If the problem persists, follow the procedure below.

## Troubleshooting Reference Table

Applicable Parts	Wiring and Plug/Jack References
<ul style="list-style-type: none"><li>■ Inverter Entrance Sensor</li></ul>	<ul style="list-style-type: none"><li>■ Options Map 3, Inverter Controller Board</li><li>■ Options Map 9, Inverter Sensor Locator</li><li>■ Options Inverter Sensors Diagram</li></ul>

## Troubleshooting Procedure Table

Step	Actions and Questions	Yes	No
1	Check the following for evidence of fault, damage, obstruction, or debris: <ul style="list-style-type: none"><li>■ Sensor Actuator</li><li>■ Paper Guides</li><li>■ Transport Rollers</li></ul> Are there any defects or misalignment?	Replace any damaged parts.	Go to Step 2.
2	Test the Inverter Entrance Sensor. Run the Service Diagnostics Inverter Input Sensor test. Does the sensor function correctly?	Replace the Engine Control Board (see Book 1).	Go to Step 3.
3	Test the sensor signal. Does the voltage change on SNSCNO-5 connector of the Inverter Control Board when the sensor is actuated?	Replace the Inverter Control Board (page 5-55).	Either the sensor or the wiring is defective. Check the resistance of the wires and if no problem is found replace the sensor.



# Finisher Output Tray Jammed

This error represents a failure of, or an obstruction in the Finisher Upper Output Tray's up or down motion.

## Applicable Status Code:

**Code FT:** Finisher Output Tray Jammed

## Initial Actions:

- Cycle printer power.
- If the problem persists, follow the procedure below.

## Troubleshooting Reference Table

Applicable Parts	Wiring and Plug/Jack References
<ul style="list-style-type: none"><li>■ Finisher Lift Motor</li><li>■ Lift Motor Clock Sensor</li><li>■ Upper or Lower Limit Sensors</li><li>■ Lift Belts</li></ul>	<ul style="list-style-type: none"><li>■ Options Map 7, Finisher Sensor Locator (1/2)</li><li>■ Options Map 8, Finisher Sensor Locator (2/2)</li><li>■ Options Finisher Controller to Sensors (2/3)</li><li>■ Options Finisher Controller to Switches</li></ul>

## Troubleshooting Procedure Table

Step	Actions and Questions	Yes	No
1	Check the following for evidence of fault, damage, obstruction, or debris: <ul style="list-style-type: none"><li>■ Upper Output Tray</li><li>■ Lift belts and actuators</li><li>■ Limit Sensors</li><li>■ Shift Motor</li></ul> Are there any defects or misalignment?	Replace any damaged parts.	Go to Step 2.
2	Test the Limit Sensors. Run the Service Diagnostics Tray Upper and Lower Limit Sensor tests. Do the sensors function correctly?	Go to Step 4.	Replace the affected sensor. If the error persists, go to Step 3.
3	Test the sensor signals. Does the voltage change on CN15-12 (Upper) and CN-15-9 (Lower) connector of the Finisher Control Board when the sensors are actuated?	Replace the Finisher Control Board (page 5-46).	Replace the harness.
4	Test the Shift Motor. Run the Service Diagnostics Shift Motor test. Does the motor function correctly?	Go to Step 4.	Replace the motor.

## Troubleshooting Procedure Table (Continued)

<b>Step</b>	<b>Actions and Questions</b>	<b>Yes</b>	<b>No</b>
<b>5</b>	Check for +24 V to the Shift Motor. Disconnect CN6 from the Finisher Control Board. Is there +24 V CN6-1 <=> CN6-2?	Replace the Shift Motor (page 5-59).	Replace the Finisher Control Board. If the error persists, go to Step 6.
<b>6</b>	Test the Shift Motor Clock Sensor. Run the Shift Motor Clock Sensor test. Does the sensor function correctly?	Go to Step 8.	Replace the sensor.
<b>7</b>	Test the sensor signal. Does the voltage change on CN15-5 when the sensor is actuated?	Replace the Finisher Control Board (page 5-46).	Replace the wiring. If the error persists, replace the Engine Control Board (page 8-112).

# Close Right Door C for Tray [3][4][5][6]

The Door C Detect Sensor for one of the option trays indicates that Door C is open.

## Initial Actions:

- Ensure that the door is free of obstructions and fully closed.
- Verify that the Detect Sensor Actuator molded into the Door is not damaged.
- Cycle printer power.
- If the problem persists, follow the procedure below.

## Troubleshooting Reference Table

Applicable Parts	Wiring and Plug/Jack References
<ul style="list-style-type: none"> <li>■ Door C</li> <li>■ Door C Detect Sensor</li> <li>■ Option Feeder Board</li> <li>■ Motor Driver Board</li> </ul>	<ul style="list-style-type: none"> <li>■ Print Engine Map 3 (page 10-6)</li> <li>■ Options Map 5, Paper Tray Controller Board</li> <li>■ Options Paper Tray Sensors and Interconnect Wiring</li> </ul>

## Troubleshooting Procedure Table

Step	Actions and Questions	Yes	No
<b>1</b>	Check the following for evidence of fault or damage: <ul style="list-style-type: none"> <li>■ Door C Detect Sensor Actuator</li> <li>■ Door C Detect Sensor Holder</li> <li>■ Door C Detect Sensor</li> </ul> Is there any damage or misalignment?	Replace any damaged parts.	Go to Step 2.
<b>2</b>	Test the Door C Detect Sensor. Run the Service Diagnostics Door C test for the appropriate tray.  <b>NOTE:</b> Door sensor tests are located under the Interlock Switches sub-menu.  Does the switch function correctly?	Replace the Engine Control Board (page 8-112).	Go to Step 3.
<b>3</b>	Replace the Door C Detect Sensor. Does the error persist?	Go to Step 4.	Complete.
<b>4</b>	Check for +0V on the OPTIF connection. Is there +0 V at OPTIF-7 when the door is closed?	Replace the Engine Control Board (see Book 1).	The Door C sensor is signaling an open condition, go to Step 5.
<b>5</b>	Check for +0V on the FFSNS connector of the Option Control Board. Is there +0 V at FFSNS-8 when the door is closed?	Replace the Option Control Board.	If the wiring from the Option Control Board to the sensor is OK, replace the sensor.

# Close Left Door D

The Door D Detect Sensor on the Duplex Unit indicates that Door D is open.

## Initial Actions:

- Ensure that the door is free of obstructions and fully closed.
- Verify that the Detect Sensor Actuator is not broken.
- Cycle printer power.
- If the problem persists, follow the procedure below.

## Troubleshooting Reference Table

Applicable Parts	Wiring and Plug/Jack References
<ul style="list-style-type: none"><li>■ Door D Detect Sensor</li></ul>	<ul style="list-style-type: none"><li>■ Print Engine Map 3 (see Book 1)</li><li>■ Options Map 4, Duplex Unit Controller Board</li><li>■ Options Duplex Unit Sensors and Interconnect Wiring</li></ul>

## Troubleshooting Procedure Table

Step	Actions and Questions	Yes	No
1	Check the following for evidence of fault or damage: <ul style="list-style-type: none"><li>■ Door D Detect Sensor Actuator</li><li>■ Door D Detect Sensor</li><li>■ Door D</li></ul> Is there any damage or misalignment?	Replace any damaged parts.	Go to Step 2.
2	Test the Door D Detect Sensor. Run the Service Diagnostics Door D test for the appropriate tray. <b>NOTE:</b> Door sensor tests are located under the Interlock Switches sub-menu. Does the switch function correctly?	Replace the Engine Control Board (see Book 1).	Go to Step 3.
3	Replace the Door D Detect Sensor. Does the error persist?	Replace the DUPLEX Harness, if the error persists, replace the Duplex Unit.	Complete.

# Close Finisher Door F

The Door F Interlock Switch indicates that Door F is open.

## Initial Actions:

- Ensure that the door is free of obstructions and fully closed.
- Verify that the actuator is not broken.
- Cycle printer power.
- If the problem persists, follow the procedure below.

## Troubleshooting Reference Table

Applicable Parts	Wiring and Plug/Jack References
<ul style="list-style-type: none"> <li>■ Door F Interlock Switch and actuator</li> </ul>	<ul style="list-style-type: none"> <li>■ Options Map 9 Inverter Sensor Locations</li> <li>■ Options Inverter Sensors Diagram</li> </ul>

## Troubleshooting Procedure Table

Step	Actions and Questions	Yes	No
<b>1</b>	Check the following for evidence of fault or damage: <ul style="list-style-type: none"> <li>■ Door F Interlock Switch</li> <li>■ Switch actuator</li> </ul>	Replace the parts concerned.	Go to Step 2.
<b>2</b>	Test the Door F Interlock Switch. <b>NOTE:</b> Door sensor tests are located under the Interlock Switches sub-menu. Run the Service Diagnostics Front Door Switch test. Does the switch function correctly?	Replace the Engine Control Board (see Book 1).	Go to Step 3.
<b>3</b>	Check the switch connection. Is CN68 connected?	Go to Step 4.	Connect the switch.
<b>4</b>	Check all pins on the harness for continuity. Disconnect the Switch harness from CN8. Is the harness conductive?	Go to Step 5.	Replace the harness.
<b>5</b>	Replace the Door F Interlock Switch. Does the error persist?	Replace the Finisher Control Board (page 5-46).	Complete

# Close Finisher Door H

The Upper Cover (Door H) Sensor indicates that Door H is open.

## Initial Actions:

- Ensure that the door is free of obstructions and fully closed.
- Verify that the actuator is not broken.
- Cycle printer power.
- If the problem persists, follow the procedure below.

## Troubleshooting Reference Table

Applicable Parts	Wiring and Plug/Jack References
■ Upper Cover Sensor	■ Options Map 7, Finisher Sensor Locator (1/2) ■ Options Finisher Controller to Sensors (1/3)

## Troubleshooting Procedure Table

Step	Actions and Questions	Yes	No
1	Check the following for evidence of fault or damage: <ul style="list-style-type: none"><li>■ Door H Actuator</li><li>■ Door H Switch</li></ul>	Replace the parts concerned.	Go to Step 2.
2	Test the Door H Switch. Run the Service Diagnostics Upper Cover test. Does the sensor function correctly?	Replace the Engine Control Board (see Book 1).	Go to Step 3.
3	Check the sensor connection. Is CN4 on the Finisher Control Board connected?	Go to Step 4.	Reconnect the sensor.
4	Check the Door H signal. Does the voltage change on CN4-6 of the Finisher Control Board when the switch is activated?	Replace the Finisher Control Board (page 5-46).	Replace the harness.

# Close Finisher Door J

The Front Cover (Door J) Sensor indicates that Door J is open.

## Initial Actions:

- Ensure that the door is free of obstructions and fully closed.
- Verify that the actuator is not broken.
- Cycle printer power.
- If the problem persists, follow the procedure below.

## Troubleshooting Reference Table

Applicable Parts	Wiring and Plug/Jack References
<ul style="list-style-type: none"><li>■ Door J Actuator</li><li>■ Door J Switch</li></ul>	<ul style="list-style-type: none"><li>■ Options Map 7, Finisher Sensor Locator (1/2)</li><li>■ Options Finisher Controller to Sensors (1/3)</li></ul>

## Troubleshooting Procedure Table

Step	Actions and Questions	Yes	No
1	Check the following for evidence of fault or damage: <ul style="list-style-type: none"><li>■ Door J Actuator</li><li>■ Door J Switch</li></ul>	Replace the parts concerned.	Go to Step 2.
2	Test the Door J Switch. Run the Service Diagnostics Front Cover test. Does the sensor function correctly?	Replace the Engine Control Board (see Book 1).	Go to Step 3.
3	Check the sensor connection. Is CN4 on the Finisher Control Board connected?	Go to Step 4.	Reconnect the sensor.
4	Check the Door J signal. Does the voltage change on CN4-9 of the Finisher Control Board when the switch is activated?	Replace the Finisher Control Board (page 5-46).	Replace the harness.

# Clear Tray [2][3][4][5][6] Riser Plate

The Lift Motor failed to raise the media to the pre-feed position. For a Remove Paper error, the Level Sensor indicates Pre-Feed position or higher before a lift is executed

## Initial Actions:

- Remove the tray and inspect the tray cavity to ensure that it is free of obstructions or debris.
- Reinstall the tray and cycle printer power.
- If the problem persists, follow the procedure below.

## Troubleshooting Reference Table

Applicable Parts	Wiring and Plug/Jack References
<ul style="list-style-type: none"><li>■ Level Sensor</li><li>■ Lift Motor</li><li>■ Universal Tray</li><li>■ Option Control Board</li><li>■ Option Feeder Board</li></ul>	<ul style="list-style-type: none"><li>■ Print Engine Map 5 (see Book 1)</li><li>■ Print Engine Map 12 (see Book 1)</li><li>■ Print Engine Feeder Board (see Book 1)</li><li>■ Options Map 5 Paper Tray Controller Board</li><li>■ Options Map 6 Paper Tray Feeder Board</li><li>■ Options Paper Tray Motors and Clutches</li></ul>

## Troubleshooting Procedure Table

Step	Actions and Questions	Yes	No
1	Check the following for evidence of fault or damage: <ul style="list-style-type: none"><li>■ Level Sensor Actuator</li><li>■ Lift Plate and gearing</li><li>■ Lift Motor</li></ul> Is there any damage?	Replace any damaged parts.	Go to Step 2.
2	Test the Level Sensor. Run the Service Diagnostics Level Sensor test for the appropriate tray. Does the sensor function correctly?	Go to Step 3.	Replace the Sensor. If the error persists, go to Step 4.
3	Test the Lift Motor. Run the Service Diagnostics Lift Motor test for the appropriate tray. Does the motor function correctly?	Go to Step 4.	Replace the Lift Motor. If the error persists, go to Step 4.
4	Check for +24 V to the Lift Motor. Is there +24 V across GDDC-1 <=> ground?	Go to Step 5.	Replace the Option Control Board.
5	Test the OPTIF Harness continuity. Is the OPTIF Harness conductive?	Replace the Engine Control Board (see Book 1).	Replace the harness.



# Out of Paper Load Tray [2][3][4][5][6] with [size][type]

The tray's No Paper Sensor indicates the tray is empty.

## Initial Actions:

- Inspect the tray to ensure that it is free of obstructions, is loaded with supported media, and the guides are adjusted correctly.
- Cycle printer power.
- If the problem persists, follow the procedure below

## Troubleshooting Reference Table

Applicable Parts	Wiring and Plug/Jack References
<ul style="list-style-type: none"><li>■ No Paper Sensor</li><li>■ No Paper Actuator</li></ul>	<ul style="list-style-type: none"><li>■ Print Engine Map 12 (see Book 1)</li><li>■ Print Engine Feeder Board (see Book 1)</li><li>■ Options Map 5 Paper Tray Controller Board</li><li>■ Options Map 6 Paper Tray Feeder Board</li><li>■ Options Paper Tray Motors and Clutches</li></ul>

## Troubleshooting Procedure Table

Step	Actions and Questions	Yes	No
1	Check the following for evidence of fault or damage: <ul style="list-style-type: none"><li>■ No Paper Sensor</li><li>■ No Paper Actuator</li></ul> Is there any damage?	Replace any damaged parts.	Go to Step 2.
2	Test the No Paper Sensor for the affected tray. Run the Service Diagnostics Tray Switches test. Does the sensor function correctly?	Replace the Engine Control Board (see Book 1).	Replace the sensor. If the error persists, go to Step 3.
3	Check for +5 V to the No Paper Sensor. Is there +5 V across PAPEND-1 <=> ground?	Go to Step 4.	Replace the Feeder Board.
4	Check all pins on the Main Harnesses for continuity. Is the harness conductive?	Replace the Option Control Board.	Replace the Main Harness.
5	Test the OPTIF Harness continuity. Is the OPTIF Harness conductive?	Replace the Engine Control Board (see Book 1).	Replace the harness.

# Finisher Lower Output Tray is Full, Unload Paper

## Initial Actions:

- Ensure that the output tray is empty and the actuator is in the correct position.
- Cycle printer power.
- If the problem persists, follow the procedure below.

## Troubleshooting Reference Table

Applicable Parts	Wiring and Plug/Jack References
<ul style="list-style-type: none"><li>■ Saddle Stitch Bind Tray</li><li>■ Bind Tray Sensor Flag</li><li>■ Stapler</li></ul>	<ul style="list-style-type: none"><li>■ Options Map 7 Finisher Sensor Locator (1/2)</li><li>■ Options Finisher Controller to Sensors (2/3)</li></ul>

## Troubleshooting Procedure Table

Step	Actions and Questions	Yes	No
1	Check the following for evidence of fault, damage, obstruction, or debris: <ul style="list-style-type: none"><li>■ Saddle Stitch Bind tray</li><li>■ Bind Tray Sensor Flag</li><li>■ Stapler</li></ul> Are there any defects or misalignment?	Replace any damaged parts.	Go to Step 2.
2	Test the Binding Sensor. Run the Service Diagnostics Bookbinding Sensor tests. Does the Binding Sensor function correctly?	Replace the Engine Control Board (see Book 1).	Go to Step 3.
3	Test the sensor signal. Does the voltage change on CN15-3 connector of the Finisher Control Board when the sensor is actuated?	Replace the Finisher Control Board (page 5-46).	Either the sensor or the wiring is defective. Check the resistance of the wires and if no problem is found replace the sensor.

# Finisher Upper Output Tray is Full, Unload Paper

## Initial Actions:

- Ensure that the output tray is empty and the actuator is in the correct position.
- Cycle printer power.
- If the problem persists, follow the procedure below.

## Troubleshooting Reference Table

Applicable Parts	Wiring and Plug/Jack References
■ Stack Full Sensor	■ Options Map 7 Finisher Sensor Locator (1/2) ■ Options Finisher Controller to Sensors (3/3)

## Troubleshooting Procedure Table

Step	Actions and Questions	Yes	No
1	Test the Upper Tray Stack Full Sensor. Run the Service Diagnostics Upper Tray Full Sensor test. Does the sensor state change when the sensor is actuated?	Replace the Finisher Control Board.	Go to Step 2.
2	Check the sensor harness connections. Is the sensor connected?	Go to Step 4.	Connect and go to Step 3.
3	Print a test print. Does the error still occur?	Go to Step 4.	Problem solved.
4	Check sensor harness continuity. Is the harness conductive?	Go to Step 5.	Replace the Sensor Harness.
5	Check for +5 V to the Upper Tray Stack Full Sensor. Is there +5 V on the Finisher Control Board?	Go to Step 6.	Replace the Finisher Control Board.
6	Check the Finisher Control Board signal. Does the voltage across on the Finisher Control Board change when the sensor is actuated?	Replace the Finisher Control Board (page 5-46).	Replace the Upper Tray Full Stack Sensor.

# Wrong Paper Size; Load Tray [3][4][5][6] with [size][type]

Tray [3] [4] [5] [6] paper size mismatch error. The Paper Size Switch indicates that the media loaded in the source tray does not match the size specified by the print job.

## Initial Actions:

- Inspect the tray to ensure that it is free of obstructions, is loaded with the expected media, and the guides are adjusted correctly.
- Cycle printer power.
- If the problem persists, follow the procedure below.

## Troubleshooting Reference Table

Applicable Parts	Wiring and Plug/Jack References
<ul style="list-style-type: none"><li>■ Paper Size Switch</li><li>■ Paper Tray</li><li>■ SIZE Harness</li></ul>	<ul style="list-style-type: none"><li>■ Paper Size Switch Signal Definitions table (see Book 1)</li></ul>

## Troubleshooting Procedure Table

Step	Actions and Questions	Yes	No
1	Check the paper in the affected tray. Is paper loaded in the tray properly?	Go to Step 2.	Reload the paper.
2	Check the tray paper guides. Are the paper guides set correctly?	Go to Step 3.	Reset the guides.
3	Check the Paper Size Switch for the affected tray. Is the switch installed correctly?	Go to Step 4.	Correct the installation.
4	Test the Paper Size Switch for the affected tray. Run the Service Diagnostics Size Sensor test for the affected tray. Does the sensor state change each time the loaded tray is moved in or out?	Go to Step 7.	Go to Step 5.
5	Check the Paper Size Switch connection. Is the switch connected at either end?	Go to Step 6.	Connect the switch.
6	Check continuity between the affected Paper Size Switch and the Option Control Board. Is the harness conductive?	Go to Step 7.	Repair the wiring.
7	Check for +5 V to the Paper Size Switch. Is there +5 V across each switch <=> ground when the switch is actuated?	Replace the Paper Size Switch for the affected tray (page 7-30).	Replace the Option Control Board.

# Wrong Paper Type Load Tray [3][4][5][6] with [size][type]

The Media Thickness Sensor has detected a change in the media type (thickness) in the same tray, or reports a thickness value exceeding the reference.

## Initial Actions:

- Ensure the tray is free of obstructions and loaded with the expected media.
- Cycle printer power.
- If the problem persists, follow the procedure below.

## Troubleshooting Reference Table

Applicable Parts	Wiring and Plug/Jack References
<ul style="list-style-type: none"> <li>■ Media Thickness Sensor</li> <li>■ Front Sensor Board</li> </ul>	<ul style="list-style-type: none"> <li>■ Print Engine Map 9 (see Book 1)</li> <li>■ Print Engine Front Sensor Board (1/2) (see Book 1)</li> </ul>

## Troubleshooting Procedure Table

Step	Actions and Questions	Yes	No
1	Check the following for evidence of fault, debris, damage, of misalignment: <ul style="list-style-type: none"> <li>■ Media Thickness Sensor</li> <li>■ PATHICK Harness</li> </ul>	Replace the parts concerned.	Go to Step 2.
2	Recalibrate the sensor. See (page 6-4). Did the calibration pass?	Complete.	Go to Step 3.
3	Check the PATHICK Harness continuity. Is the harness conductive?	Go to Step 4.	Replace the harness.
4	Check for +5 V to the sensor. Disconnect PATHICK at the Front Sensor Board. Is there +5 V across PATHICK-3 <=> ground?	Replace the sensor. Recalibrate the sensor following replacement.	Go to Step 5.
5	Check for +5 V to the Front Sensor Board. Disconnect FSNS at the Motor Driver Board. Is there +5 V across FSNS-10 and -14<=> ground?	Replace the Front Sensor Board (see Book 1).	Go to Step 6.
6	Check the FSNS Harness continuity. Is the harness conductive?	Replace the Motor Driver Board (see Book 1).	Replace the FSNS Harness.

# Paper Not Available Load Tray [3][4][5][6] with [size][type]

Tray [3] [4] [5] [6] paper type mismatch error. The Paper Size Switch indicates that the media loaded in the source tray does not match the size specified by the print job.

## Initial Actions:

- Inspect the tray to ensure that it is free of obstructions, is loaded with the expected media, and the guides are adjusted correctly.
- Cycle printer power.
- If the problem persists, follow the procedure below.

## Troubleshooting Reference Table

Applicable Parts	Wiring and Plug/Jack References
<ul style="list-style-type: none"><li>■ Paper Size Switch</li><li>■ Paper Tray</li><li>■ SIZE Harness</li></ul>	<ul style="list-style-type: none"><li>■ Paper Size Switch Signal Definitions table (see Book 1)</li></ul>

## Troubleshooting Procedure Table

Step	Actions and Questions	Yes	No
1	Check the paper in the affected tray. Is paper loaded in the tray properly?	Go to Step 2.	Reload the paper.
2	Check the tray paper guides. Are the paper guides set correctly?	Go to Step 3.	Reset the guides.
3	Check the Paper Size Switch for the affected tray. Is the switch installed correctly?	Go to Step 4.	Correct the installation.
4	Test the Paper Size Switch for the affected tray. Run the Service Diagnostics Size Sensor test for the affected tray. Does the sensor state change each time the loaded tray is moved in or out?	Go to Step 7.	Go to Step 5.
5	Check the Paper Size Switch connection. Is the switch connected at either end?	Go to Step 6.	Connect the switch.
6	Check continuity between the affected Paper Size Switch and the Option Control Board. Is the harness conductive?	Go to Step 7.	Repair the wiring.
7	Check for +5 V to the Paper Size Switch. Is there +5 V across each switch <=> ground when the switch is actuated?	Replace the Paper Size Switch for the affected tray (page 7-30).	Replace the Option Control Board.

# Duplex Interface Failure

Error occurs only after the detection of a properly installed and functioning Duplex Unit.

## Applicable Status Code:

**Code U12:** Communication lost with Duplex Unit

## Initial Actions:

- Reseat the Duplex Unit
- Cycle the printer's power.
- If the problem persists follow the procedure below.

## Troubleshooting Reference Table

Applicable Parts	Wiring and Plug/Jack References
<ul style="list-style-type: none"><li>■ Duplex Unit</li><li>■ Motor Driver Board</li></ul>	<ul style="list-style-type: none"><li>■ Print Engine Map 5 (see Book 1)</li><li>■ Print Engine Motor Driver Board (5/6) (see Book 1)</li><li>■ Options Duplex Unit Sensors and Interconnect</li></ul>

## Troubleshooting Procedure Table

Step	Actions and Questions	Yes	No
1	Check the Duplex Unit connector for damage. Is the connector damaged?	Replace the connector.	Replace the Duplex Unit (page 5-122). If the error persists, go to Step 2.
2	Check all pins on the DUPLEX Harness for continuity. Disconnect the DUPLEX Harness. Is the DUPLEX Harness conductive?	Replace the Motor Driver Board (see Book 1). If the error persists, go to Step 3.	Replace the DUPLEX Harness.
3	Check all pins of the DRV1 harness for continuity. Disconnect the DRV1 ribbon cable. Is the cable conductive?	Replace the Engine Control Board (see Book 1).	Replace the DRV1 Harness.

# Tray [3][4][5][6] Interface Failure

A communications failure has occurred in the option tray interface.

## Applicable Status Codes:

**Code U14:** Tray 3 Interface Failure

**Code U13:** Tray 4 Interface Failure

**Code U16:** Tray 5 Interface Failure

**Code U17:** Tray 6 Interface Failure

## Initial Actions:

- Cycle the printer's power.
- If the problem persists follow the procedure below.

## Troubleshooting Reference Table

Applicable Parts	Wiring and Plug/Jack References
<ul style="list-style-type: none"><li>■ Option Tray Control Board</li><li>■ Engine Control Board</li></ul>	<ul style="list-style-type: none"><li>■ Print Engine Map 3 (see Book 1)</li><li>■ Print Engine Motor Driver Board (6/6) (see Book 1)</li><li>■ Options Map 5 Paper Tray Controller Board</li></ul>

## Troubleshooting Procedure Table

Step	Actions and Questions	Yes	No
1	Check the Option Tray connector for damage. Is the connector damaged?	Replace the connector.	Go to Step 2.
2	Check all pins on the OPTIF Harness for continuity. Disconnect OPTIF from the Engine Control Board and Option connector. Is the harness conductive?	Replace the Option Control Board. If the error persists, replace the Engine Control Board (see Book 1).	Replace the OPTIF Harness.



# Inverter Unit Interface Failure

A communication error has occurred in the Finisher Inverter.

## Applicable Status Code:

**Code U51:** Inverter Unit Interface Failure.

## Initial Actions:

- Reseat the Finisher connections.
- Cycle the printer's power.
- If the problem persists follow the procedure below.

## Troubleshooting Reference Table

Applicable Parts	Wiring and Plug/Jack References
<ul style="list-style-type: none"><li>■ Inverter Control Board</li><li>■ Engine Control Board</li></ul>	<ul style="list-style-type: none"><li>■ Print Engine Map 3 (see Book 1)</li><li>■ Print Engine Motor Driver Board (6/6) (see Book 1)</li><li>■ Options Map 3 Inverter Controller Board</li></ul>

## Troubleshooting Procedure Table

Step	Actions and Questions	Yes	No
1	Check the following for evidence of fault or damage: <ul style="list-style-type: none"><li>■ Inverter Interface Cable</li><li>■ Inverter connections</li></ul> Is there any damage?	Replace any damaged parts.	Go to Step 2.
2	Check the Inverter connection. Is the Inverter interface cable securely connected at both ends?	Go to Step 3.	Connect the Inverter to the Finisher.
3	Check all pins on the OPTIF Harness for continuity. Disconnect OPTIF from the Engine Control Board and Option connector. Is the harness conductive?	Replace the Inverter Control Board. If the error persists, replace the Engine Control Board (see Book 1).	Replace the OPTIF Harness.

# Unsupported Duplex Unit ROM

The installed Duplex Unit does not contain the correct firmware.

## Applicable Status Code:

**Code U34:** Unsupported Duplex Unit ROM

## Initial Actions:

- Reseat the Duplex Unit.
- Cycle the printer's power.
- If the problem persists follow the procedure below.

## Troubleshooting Reference Table

Applicable Parts	Wiring and Plug/Jack References
<ul style="list-style-type: none"><li>■ Duplex Unit</li><li>■ Engine Control Board</li></ul>	<ul style="list-style-type: none"><li>■ Options Map 4 Duplex Unit Controller Board</li></ul>

## Troubleshooting Procedure Table

Step	Actions and Questions	Yes	No
1	Check the following for evidence of fault or damage: <ul style="list-style-type: none"><li>■ Duplex Connector</li></ul> Is there any damage?	Replace any damaged parts.	Go to Step 2.
2	Check that the Duplex Unit is correctly installed and fully seated.	Go to Step 3.	Reseat the Duplex Unit (page 5-122).
3	Check the Duplex Unit version using the Service Diagnostics General Status menu. Is the version current?	Replace Engine Control Board (see Book 1), if the error persists, replace the DUPLEX harness.	Replace the Duplex Unit (page 5-122).

# Unsupported Tray [3][4][5][6] ROM

The printer has detected an incompatible LTA or HCF assembly.

## Applicable Status Codes:

**Code U35:** Unsupported Tray 3 ROM

**Code U36:** Unsupported Tray 4 ROM

**Code U37:** Unsupported Tray 5 ROM

**Code U38:** Unsupported Tray 6 ROM

## Initial Actions:

- Reseat the Option Tray connector.
- Cycle the printer's power.
- If the problem persists follow the procedure below.

## Troubleshooting Reference Table

Applicable Parts	Wiring and Plug/Jack References
■ Option Control Board	■ Options Map 5 Paper Tray Controller Board

## Troubleshooting Procedure Table

Step	Actions and Questions	Yes	No
1	Check the following for evidence of fault or damage: <ul style="list-style-type: none"><li>■ Option Connector</li></ul> Is there any damage?	Replace any damaged parts.	Go to Step 2.
2	Check that the optional tray is correctly installed and fully seated.	Go to Step 3.	Reseat the option tray.
3	Check the Option Control Board version using the Service Diagnostics General Status menu. Is the version current?	Replace the Engine Control Board (see Book 1)	Replace the Option Control Board.

# Unsupported Inverter Unit ROM

The printer has detected an incompatible Inverter assembly.

## Applicable Status Code:

**Code U50:** Unsupported Inverter ROM

## Initial Actions:

- Cycle the printer's power.
- If the problem persists follow the procedure below.

## Troubleshooting Reference Table

Applicable Parts	Wiring and Plug/Jack References
■ Inverter Control Board	■ Options Map 3 Inverter Controller Board

## Troubleshooting Procedure Table

Step	Actions and Questions	Yes	No
1	Check the Inverter firmware version using the Service Diagnostics General Status menu. Is the version current?	Replace the Engine Control Board (see Book 1)	Replace the Inverter Control Board (page 5-55).

# Unsupported Finisher Unit ROM

The printer has detected an incompatible Finisher.

## Applicable Status Code:

**Code U55:** Unsupported Finisher Unit ROM

## Initial Actions:

- Cycle the printer's power.
- If the problem persists follow the procedure below.

## Troubleshooting Reference Table

Applicable Parts	Wiring and Plug/Jack References
■ Finisher Control Board	■ Options Map 1 Finisher Controller Board

## Troubleshooting Procedure Table

Step	Actions and Questions	Yes	No
1	Check the Finisher firmware version using the Service Diagnostics General Status menu.	Replace the Engine Control Board (see Book 1)	Replace the Finisher Control Board (page 5-46).

# Finisher Fold Position Sensor Failure

An error was detected with the Fold Position Sensor.

## Applicable Status Code:

**Code F131:** Fold Position Sensor failure

## Initial Actions:

- Cycle the printer's power.
- If the problem persists follow the procedure below.

## Troubleshooting Reference Table

Applicable Parts	Wiring and Plug/Jack References
<ul style="list-style-type: none"><li>■ Fold Position Sensor</li><li>■ Finisher Control Board</li></ul>	<ul style="list-style-type: none"><li>■ Options Map 1 Finisher Controller Board</li><li>■ Options Map 8 Finisher Sensor Locator</li><li>■ Options Finisher Controller to Sensors (2/3)</li></ul>

## Troubleshooting Procedure Table

Step	Actions and Questions	Yes	No
1	Test the Folding Position Sensor. Run the Service Diagnostics Bookbinding Position Sensor test. Does the sensor function correctly?	Replace the Finisher Control Board.	Go to Step 2.
2	Check the sensor connection. Is CN39 connected?	Go to Step 3.	Reconnect the sensor.
3	Replace the sensor. Does the error persist?	Go to Step 4.	Complete
4	Check all pins on the harness for continuity. Is the harness conductive?	Replace the Finisher Control Board (page 5-46).	Replace the harness.

# Finisher Paddle Failure

An error was detected in the Finisher Paddle Motor.

## Applicable Status Code:

**Code F103:** Paddle Motor failure

## Initial Actions:

- Cycle the printer's power.
- If the problem persists follow the procedure below.

## Troubleshooting Reference Table

Applicable Parts	Wiring and Plug/Jack References
<ul style="list-style-type: none"><li>■ Finisher Paddle Motor</li><li>■ Finisher Control Board</li></ul>	<ul style="list-style-type: none"><li>■ Options Map 1 Finisher Controller Board</li><li>■ Options Finisher Controller to Motors</li></ul>

## Troubleshooting Procedure Table

Step	Actions and Questions	Yes	No
1	Test these sensors. <ul style="list-style-type: none"><li>■ Swing Guide Home Position Sensor</li><li>■ Paddle Home Position Sensor</li></ul> Run the appropriate Service Diagnostics sensor test. Do the sensors operate?	Go to Step 2.	Replace the sensor. If the error persists, go to Step 2.
2	Test the Paddle Motor. <ol style="list-style-type: none"><li>1. Close the Interlock Switches for test.</li><li>2. Run the Service Diagnostics Paddle Motor test.</li></ol> Does the motor operate?	Replace the Finisher Control Board (page 5-46). If the error persists, go to Step 4.	Go to Step 4.
3	Check for +24 V to the Paddle Motor. Disconnect CN57. Is there +24 V across CN57-1 and -2 <=> ground?	Replace the Delivery Motor (page 5-64).	Replace the harness. If the error persists, go to Step 5.
4	Check all pins of the Inverter Interface Cable for continuity. Disconnect CN1 and CN2 from the Finisher Control Board and the opposite end from the Inverter. Is the cable conductive?	Replace the Inverter Power Supply (page 5-56).	Replace the cable.

# Finisher Stapler Swing Motor Failure

The Stapler Swing Home Position Sensor detected a Stapler Swing Motor error.

## Applicable Status Code:

**Code F106:** Swing Motor Failure

## Initial Actions:

- Cycle the printer's power.
- If the problem persists follow the procedure below.

## Troubleshooting Reference Table

Applicable Parts	Wiring and Plug/Jack References
<ul style="list-style-type: none"><li>■ Stapler Swing Motor</li><li>■ Finisher Control Board</li></ul>	<ul style="list-style-type: none"><li>■ Options Map 1 Finisher Controller Board</li><li>■ Options Finisher Controller to Switches</li></ul>

## Troubleshooting Procedure Table

Step	Actions and Questions	Yes	No
1	Test the Stapler Swing Home Position Sensor Run the Service Diagnostics Stapler Slide Home Position Sensor test. Do the sensors operate?	Go to Step 2.	Replace the sensor. If the error persists, go to Step 2.
2	Test the Swing Motor. 1. Close the Interlock Switches for test. 2. Run the Service Diagnostics Sliding Motor test. Does the motor operate?	Replace the Finisher Control Board (page 5-46). If the error persists, go to Step 4.	Go to Step 4.
3	Check for +24 V to the Swing Motor. Disconnect CN72. Is there +24 V across CN72-8 and -9 <=> ground?	Replace the Slide Motor (page 5-61).	Replace the harness. If the error persists, go to Step 5.
4	Check all pins of the Inverter Interface Cable for continuity. Disconnect CN1 and CN2 from the Finisher Control Board and the opposite end from the Inverter. Is the cable conductive?	Replace the Inverter Power Supply (page 5-56).	Replace the cable.



# Finisher Stack Handling Motor Failure

The Delivery Belt Home Position Sensor detected a Stack Handling error.

## Applicable Status Code:

**Code F111:** Stack Handling Motor Failure

## Initial Actions:

- Cycle the printer's power.
- If the problem persists follow the procedure below.

## Troubleshooting Reference Table

Applicable Parts	Wiring and Plug/Jack References
<ul style="list-style-type: none"><li>■ Finisher Stack Handling Motor</li><li>■ Finisher Control Board</li></ul>	<ul style="list-style-type: none"><li>■ Options Map 1 Finisher Controller Board</li><li>■ Options Finisher Controller to Motors</li></ul>

## Troubleshooting Procedure Table

Step	Actions and Questions	Yes	No
1	Check the delivery mechanism. Does the Delivery Belt turn freely when operated manually?	Go to Step 2.	Repair the mechanism.
2	Test the Delivery Belt Home Position Sensor. Run the Service Diagnostics Exit Belt Home Position Sensor test. Does the sensor operate?	Go to Step 3.	Replace the sensor. If the error persists, go to Step 3.
3	Test the Staple Motor. 1. Close the Interlock Switches for test. 2. Run the Service Diagnostics Staple Motor tests. Does the motor operate?	Replace the Finisher Control Board (page 5-46). If the error persists, go to Step 4.	Go to Step 4.
4	Check for +24 V to the Staple Motor. Disconnect CN59. Is there +24 V across CN59-1 and -2 <=> ground?	Replace the Stack Handling Motor (page 5-60).	Replace the harness. If the error persists, go to Step 5.
5	Check all pins of the Inverter Interface Cable for continuity. Disconnect CN1 and CN2 from the Finisher Control Board and the opposite end from the Inverter. Is the cable conductive?	Replace the Inverter Power Supply (page 5-56).	Replace the cable.

# Finisher Staple Motor Failure

An error was detected in the Staple Motor.

## Applicable Status Code:

**Code F110:** Staple Motor

## Initial Actions:

- Cycle the printer's power.
- If the problem persists follow the procedure below.

## Troubleshooting Reference Table

Applicable Parts	Wiring and Plug/Jack References
<ul style="list-style-type: none"><li>■ Finisher Staple Motor</li><li>■ Finisher Control Board</li></ul>	<ul style="list-style-type: none"><li>■ Options Map 1 Finisher Controller Board</li><li>■ Options Finisher Controller to Switches</li></ul>

## Troubleshooting Procedure Table

Step	Actions and Questions	Yes	No
1	Test these sensors. <ul style="list-style-type: none"><li>■ Staple Clock Sensor</li><li>■ Fold Home Position Sensor</li></ul> Run the appropriate Service Diagnostics sensor test. Do the sensors operate?	Go to Step 2.	Replace the sensor. If the error persists, go to Step 2.
2	Test the Staple Motor. 1. Close the Interlock Switches for test. 2. Run the Service Diagnostics Staple Motor tests. Does the motor operate?	Replace the Finisher Control Board (page 5-46). If the error persists, go to Step 4.	Go to Step 3.
3	Check for +24 V to the Staple Motor. Disconnect CN71. Is there +24 V across CN71-1 and -2 <=> ground?	Replace the Staple Motor (page 5-60).	Replace the harness. If the error persists, go to Step 4.
4	Check all pins of the Inverter Interface Cable for continuity. Disconnect CN1 and CN2 from the Finisher Control Board and the opposite end from the Inverter. Is the cable conductive?	Replace the Inverter Power Supply (page 5-56).	Replace the cable.

# Finisher Jog Motor Failure

An error was detected in either the Front or Rear Alignment Motor.

## Applicable Status Code:

**Code F93:** Jog Motor Failure

## Initial Actions:

- Cycle the printer's power.
- If the problem persists follow the procedure below.

## Troubleshooting Reference Table

Applicable Parts	Wiring and Plug/Jack References
<ul style="list-style-type: none"><li>■ Paddle Assembly</li><li>■ Alignment Motors</li></ul>	<ul style="list-style-type: none"><li>■ Options Map 1 Finisher Controller Board</li><li>■ Options Finisher Controller to Motors</li></ul>

## Troubleshooting Procedure Table

Step	Actions and Questions	Yes	No
1	Check the following for evidence of fault or damage: <ul style="list-style-type: none"><li>■ Paddle Assembly</li><li>■ Alignment Motors</li></ul> Is there any damage?	Replace any damaged parts.	Go to Step 2.
2	Test the Alignment Plate Sensors. Run the Service Diagnostics Front and Rear Alignment Plate Sensor tests. Do the sensors function correctly?	Replace the Paddle Assembly (page 5-43),	Replace the sensor.

# Finisher Lift Motor Failure

The Paper Surface, Upper Limit, or Lift Motor Clock Sensor detected a Lift Motor error.

## Applicable Status Code:

**Code F115:** Lift Motor Failure

## Initial Actions:

- Check the Tray lift mechanism for obstructions or damage.
- Cycle the printer's power.
- If the problem persists follow the procedure below.

## Troubleshooting Reference Table

Applicable Parts	Wiring and Plug/Jack References
<ul style="list-style-type: none"><li>■ Upper Tray Lift Motor</li><li>■ Finisher Control Board</li><li>■ Inverter Power Supply</li></ul>	<ul style="list-style-type: none"><li>■ Options Map 1 Finisher Controller Board</li><li>■ Options Finisher Controller to Switches</li></ul>

## Troubleshooting Procedure Table

Step	Actions and Questions	Yes	No
1	Test each of these sensors. <ul style="list-style-type: none"><li>■ Paper Surface Sensor</li><li>■ Tray Upper Limit Sensor</li><li>■ Shift Motor Clock Sensor</li></ul> Run the appropriate Service Diagnostics sensor test. Do all sensors function correctly?	Go to Step 2.	Replace the sensor. If the error persists, go to Step 2.
2	Check the tray lift mechanism. Does the mechanism move freely?	Go to Step 5.	Repair the lift mechanism.
3	Test the Lift Motor. 1. Close the Interlock Switches for test. 2. Run the Service Diagnostics Shift Motor test. Does the motor operate?	Go to Step 8.	Replace the motor. If the error persists, go to Step 6.
4	Check for +24 V to the Lift Motor. Disconnect CN70. Is there +24 V across CN70-1 and -2 <=> ground when the test is executed?	Replace the Lift Motor (page 5-59).	Replace the Finisher Control Board (page 5-46). If the error persists, go to Step 5.

## Troubleshooting Procedure Table (Continued)

<b>Step</b>	<b>Actions and Questions</b>	<b>Yes</b>	<b>No</b>
<b>5</b>	Check all pins of the Inverter Interface Cable for continuity. Disconnect CN1 and CN2 from the Finisher Control Board and the opposite end from the Inverter. Is the cable conductive?	Replace the Inverter Power Supply (page 5-56).	Replace the cable.

# Finisher Exit Failure

The Delivery Belt Home Position Sensor detected a Delivery Motor error.

## Applicable Status Code:

**Code F116:** Delivery Motor Failure

## Initial Actions:

- Cycle the printer's power.
- If the problem persists follow the procedure below.

## Troubleshooting Reference Table

Applicable Parts	Wiring and Plug/Jack References
<ul style="list-style-type: none"><li>■ Finisher Delivery Motor</li><li>■ Finisher Control Board</li></ul>	<ul style="list-style-type: none"><li>■ Options Map 1 Finisher Controller Board</li><li>■ Options Finisher Controller to Motors</li></ul>

## Troubleshooting Procedure Table

Step	Actions and Questions	Yes	No
1	Test the Exit Motor. 1. Close the Interlock Switches for test. 2. Run the Service Diagnostics Finisher Bundle Motor tests. Does the motor operate?	Complete.	Go to Step 2.
2	Check for +24 V to the Exit Motor. Disconnect CN59. Is the +24 V across CN59-1 and -2 <=> ground?	Replace the Exit Motor (page 5-64).	Go to Step 3.
3	Check Finisher Control Board for +24 V. 1. Disconnect CN13 on the Finisher Control Board. Is the +24 V across CN13-1 and -2?	Replace the Exit Motor Harness.	Replace the Finisher Control Board (page 5-46). If the error persists, go to Step 4.
4	Check the Inverter Interface Cable for continuity. Disconnect CN1 and CN2 from the Finisher Control Board and the opposite end from the Inverter. Is the cable conductive?	Replace the Inverter Power Supply (page 5-56).	Replace the cable.

# Finisher Punch Backup RAM Failure

An error was detected in the Punch Unit's backup RAM.

## Applicable Status Code:

**Code F138:** Punch Unit's backup RAM failure

## Initial Actions:

- Cycle the printer's power.
- If the problem persists follow the procedure below.

## Troubleshooting Reference Table

Applicable Parts	Wiring and Plug/Jack References
■ Punch Control Board	■ Options Map 2 Punch Controller Board

## Troubleshooting Procedure Table

Step	Actions and Questions	Yes	No
1	Check the Punch Control Board connections. Are P/J2003 and P/J2004 connected?	Go to Step 2.	Reseat or reconnect the harness.
2	Cycle printer power. Does the error persist?	Replace the Punch Control Board (page 5-50).	Complete.

# Finisher Punch Communications Failure

An communications error occurred with the Punch Unit.

## Applicable Status Code:

**Code F132:** Punch Unit communications failure

## Initial Actions:

- Cycle the printer's power.
- If the problem persists follow the procedure below.

## Troubleshooting Reference Table

Applicable Parts	Wiring and Plug/Jack References
<ul style="list-style-type: none"><li>■ Finisher Control Board</li><li>■ Punch Control Board</li></ul>	<ul style="list-style-type: none"><li>■ Print Engine Motor Driver Board (6/6) (see Book 1)</li><li>■ Options Map 2 Punch Controller Board</li></ul>

## Troubleshooting Procedure Table

Step	Actions and Questions	Yes	No
1	Check the connection between the Finisher and Punch Controller Boards. Are CN12 and CN14 on the Finisher Control Board connected? Are P/J2003 and P/J2004 on the Punch Control Board connected?	Go to Step 2.	Connect the harness.
2	Check all the pins of the harness for continuity. Is the cable conductive?	Go to Step 3.	Replace the harness.
3	Check for +24 V at the Finisher Control Board. Is there +24 V at CN14-5 <=> CN14-3?	Replace the Punch Control Board (page 5-50).	Replace the Finisher Control Board (page 5-46).



# Finisher Punch Unit Transfer Motor Failure

An error was detected in the Punch Transfer Motor.

## Applicable Status Code:

**Code F181:** Punch Transfer Motor Failure

## Initial Actions:

- Cycle the printer's power.
- If the problem persists follow the procedure below.

## Troubleshooting Reference Table

Applicable Parts	Wiring and Plug/Jack References
<ul style="list-style-type: none"><li>■ Punch Transfer Motor</li><li>■ Punch Control Board</li><li>■ Inverter Power Supply</li></ul>	<ul style="list-style-type: none"><li>■ Options Map 2 Punch Controller Board</li><li>■ Options Punch Controller to Sensor and Motors</li></ul>

## Troubleshooting Procedure Table

Step	Actions and Questions	Yes	No
1	Test the Punch Transfer Motor. 1. Close the Interlock Switches for test. 2. Run the Service Diagnostics Transfer Motor test. Does the motor operate?	Complete.	Go to Step 2.
2	Check for +24 V to the Punch Transfer Motor. Disconnect P/J2001. Is the +24 V across J2001-1 <=> ground?	Replace the Punch Transfer Motor.	Go to Step 3.
3	Check Punch Control Board for 24 V. 1. Disconnect P/J1001 on the Punch Control Board. Is the +24 V across P1001 pins 1 and 2?	Replace the Punch Transfer Motor Harness.	Replace the Punch Control Board (page 5-50). If the error persists, go to Step 4.
4	Check all pins of the Inverter Interface Cable for continuity. Disconnect CN1 and CN2 from the Finisher Control Board and the opposite end from the Inverter. Is the cable conductive?	Replace the Inverter Power Supply (page 5-56). If the error persists, replace the Finisher Control Board (page 5-46).	Replace the cable.

# Finisher Punch Motor Failure

An error was detected in the Punch Motor.

## Applicable Status Code:

**Code F134:** Punch Motor Failure

## Initial Actions:

- Cycle the printer's power.
- If the problem persists follow the procedure below.

## Troubleshooting Reference Table

Applicable Parts	Wiring and Plug/Jack References
<ul style="list-style-type: none"><li>■ Punch Motor</li><li>■ Punch Control Board</li><li>■ Inverter Power Supply</li></ul>	<ul style="list-style-type: none"><li>■ Options Map 2 Punch Controller Board</li><li>■ Options Punch Controller to Sensor and Motors</li></ul>

## Troubleshooting Procedure Table

Step	Actions and Questions	Yes	No
1	Test the Punch Motor. 1. Close the Interlock Switches for test. 2. Run the Service Diagnostics Punch Motor test. Does the motor operate?	Complete.	Go to Step 2.
2	Check for +24 V to the Punch Motor. Disconnect P/J2002. Is the +24 V across J2002-1 <=> ground?	Replace the Punch Motor (page 5-50).	Go to Step 3.
3	Check Punch Control Board for 24 V. 1. Disconnect P/J1002 on the Punch Control Board. Is the +24 V across P1002 pins 1 and 2?	Replace the Punch Motor Harness.	Replace the Punch Control Board (page 5-50). If the error persists, go to Step 4.
4	Check all pins of the Inverter Interface Cable for continuity. Disconnect CN1 and CN2 from the Finisher Control Board and the opposite end from the Inverter. Is the cable conductive?	Replace the Inverter Power Supply (page 5-56). If the error persists, replace the Finisher Control Board (page 5-46).	Replace the cable.

# Finisher Backup RAM Failure

An error was detected in the Finisher's backup RAM.

## Applicable Status Code:

**Code F137:** Finisher's backup RAM Failure

## Initial Actions:

- Cycle the printer's power.
- If the problem persists follow the procedure below.

## Troubleshooting Reference Table

Applicable Parts	Wiring and Plug/Jack References
<ul style="list-style-type: none"><li>■ Finisher Control Board</li><li>■ Finisher Interconnect Cable</li><li>■ Engine Control Board</li></ul>	<ul style="list-style-type: none"><li>■ Print Engine Motor Driver Board (6/6) (see Book 1)</li><li>■ Options Map 1 Finisher Controller Board</li><li>■ Options Finisher Controller to Printer</li></ul>

## Troubleshooting Procedure Table

Step	Actions and Questions	Yes	No
1	Check the following for evidence of fault or damage: <ul style="list-style-type: none"><li>■ Finisher Interconnect Cable</li><li>■ Finisher connections</li></ul> Is there any damage?	Replace any damaged parts.	Go to Step 2.
2	Check all the pins of the Finisher Interconnect Cable for continuity. Is the cable conductive?	Go to Step 3.	Replace the cable.
3	Check all the pins of the OPTIF Harness for continuity. Is the harness conductive?	Go to Step 4.	Replace the OPTIF harness.
4	Replace the Finisher Control Board. Does the error persists?	Replace the Engine Control Board (see Book 1)	Complete.

# Finisher Punch Dust Sensor Failure

An error was detected in the Punch Waste Sensor.

## Applicable Status Code:

**Code F139:** Punch Waste Sensor Failure

## Initial Actions:

- Cycle the printer's power.
- If the problem persists follow the procedure below.

## Troubleshooting Reference Table

Applicable Parts	Wiring and Plug/Jack References
<ul style="list-style-type: none"><li>■ Punch Box Sensor Emitter Board</li><li>■ Punch Box Sensor Receiver Board</li></ul>	<ul style="list-style-type: none"><li>■ Options Map 2 Punch Controller Board</li><li>■ Options Punch Controller to Sensor and Motors</li></ul>

## Troubleshooting Procedure Table

Step	Actions and Questions	Yes	No
1	Test the Punch Box Sensor. Run the Service Diagnostics Punch Box Set Sensor test. Does the sensor state change when the emitter is blocked?	Go to Step 6.	Go to Step 2.
2	Check the Punch Box Sensor Harness connection. Is P/J1005 connected to the Punch Control Board? Are P/J2005 and P/J2006 connected to the Emitter and Receiver boards?	Go to Step 3.	Connect the harness.
3	Check the Punch Box Sensor Harness continuity. Is the harness conductive?	Go to Step 4.	Replace the harness.
4	Check the Punch Box Sensor Emitter Board. Is the LED illuminated?	Go to Step 5.	Replace the Punch Box Emitter Board.
5	Check for +5 V to the Punch Box Sensor. Disconnect P/J2006. Is there +5 V at J2006-1 <=> J2006-2?	Replace the Punch Box Sensor Receiver Board (see Book 1).	Replace the Punch Control Board (page 5-50).

## Troubleshooting Procedure Table (Continued)

<b>Step</b>	<b>Actions and Questions</b>	<b>Yes</b>	<b>No</b>
<b>6</b>	Replace the Finisher Control Board (page 5-46). Does the error still occur?	Replace the Engine Control Board (see Book 1).	Complete.

# Printer Error - Contact Service; report fault [n]

The following procedures apply to codes associated with the Printer Error message.

## Finisher Punch Unit Counter at End of Life

The Punch Count indicates that Punch Unit has reached its end of life.

### Applicable Status Code:

**Code F141:** Punch Unit at End of Life

### Initial Actions:

- Cycle the printer's power.
- If the problem persists follow the procedure below.

### Troubleshooting Reference Table

Applicable Parts	Wiring and Plug/Jack References
<ul style="list-style-type: none"><li>■ Punch</li><li>■ Punch Control Board</li></ul>	<ul style="list-style-type: none"><li>■ Options Map 2 Punch Controller Board</li><li>■ Options Punch Controller to Sensor and Motors</li><li>■ Options Map 1 Finisher Controller Board</li><li>■ Options Finisher Controller to Printer</li></ul>

### Troubleshooting Procedure Table

Step	Actions and Questions	Yes	No
1	Replace the Punch (page 5-24). Cycle printer power. Does the error persist?	Replace the Engine Control Board NVRAM. If the error persists, replace the Engine Control Board (see Book 1).	Complete.

# Finisher Staple Unit Counter at End of Life

## Applicable Status Code:

**Code F142:** Staple Unit at End of Life

## Initial Actions:

- Cycle the printer's power.
- If the problem persists follow the procedure below.

## Troubleshooting Reference Table

Applicable Parts	Wiring and Plug/Jack References
■ Stapler	■ Options Map 1 Finisher Controller Board ■ Options Finisher Controller to Printer

## Troubleshooting Procedure Table

Step	Actions and Questions	Yes	No
1	Replace the Stapler (page 5-29). Cycle printer power. Does the error persist?	Replace the Engine Control Board NVRAM. If the error persists, replace the Engine Control Board (see Book 1).	Complete.

# Finisher Interface Error

## Applicable Status Code:

**Code F186:** Finisher serial communications error.

## Initial Actions:

- Cycle the printer's power.
- If the problem persists follow the procedure below.

## Troubleshooting Reference Table

Applicable Parts	Wiring and Plug/Jack References
<ul style="list-style-type: none"><li>■ Finisher Control Board</li><li>■ Finisher Interconnect Cable</li><li>■ Engine Control Board</li></ul>	<ul style="list-style-type: none"><li>■ Print Engine Motor Driver Board (6/6) (see Book 1)</li><li>■ Options Map 1 Finisher Controller Board</li><li>■ Options Finisher Controller to Printer</li></ul>

## Troubleshooting Procedure Table

Step	Actions and Questions	Yes	No
1	Check the following for evidence of fault or damage: <ul style="list-style-type: none"><li>■ Finisher Interconnect Cable</li><li>■ Finisher connections</li></ul> Is there any damage?	Replace any damaged parts.	Go to Step 2.
2	Check all the pins of the Finisher Interconnect Cable for continuity. Is the cable conductive?	Go to Step 3.	Replace the cable.
3	Check all the pins of the OPTIF Harness for continuity. Is the harness conductive?	Go to Step 4.	Replace the OPTIF harness.
4	Replace the Finisher Control Board (page 5-46). Does the error persists?	Replace the Engine Control Board (see Book 1)	Complete.



# Inverter Power Supply Failure

## Applicable Status Code:

**Code I97:** Inverter hardware error

## Initial Actions:

- Cycle the printer's power.
- If the problem persists follow the procedure below.

## Troubleshooting Reference Table

Applicable Parts	Wiring and Plug/Jack References
■ Inverter Power Supply	■ Options Map 3 Inverter Controller Board ■ Options Inverter Motors

## Troubleshooting Procedure Table

Step	Actions and Questions	Yes	No
1	Check the following for evidence of fault or damage: <ul style="list-style-type: none"><li>■ Inverter Power Cord</li><li>■ Inverter Power Supply</li></ul> Is there any damage?	Replace any damaged parts.	Go to Step 2.
2	Check AC Power. Is the AC voltage available at the outlet?	Go to Step 3.	Advise customer.
3	Check the Inverter connection. Is the Inverter interface cable securely connected at both ends?	Go to Step 4.	Connect the Inverter to the Finisher.
4	Replace the Inverter Power Supply (page 5-56). Does the error persist?	Replace the Inverter Control Board (page 5-46).	Complete.

# Tray [3][4][5][6] Firmware Error

## Applicable Status Codes:

**Code 221:** Software error in Tray 3 Flash Memory.

**Code 222:** Software error in Tray 4 Flash Memory.

**Code 223:** Software error in Tray 5 Flash Memory.

**Code 224:** Software error in Tray 6 Flash Memory.

## Initial Actions:

- Cycle the printer's power.
- If the problem persists follow the procedure below.

## Troubleshooting Reference Table

Applicable Parts	Wiring and Plug/Jack References
<ul style="list-style-type: none"><li>■ Option Tray Control Board</li><li>■ Engine Control Board</li></ul>	<ul style="list-style-type: none"><li>■ Print Engine Map 5 (see Book 1)</li><li>■ Print Engine Motor Driver Board (6/6) (see Book 1)</li><li>■ Options Map 5 Paper Tray Controller Board</li><li>■ Options Paper Tray Sensors and Interconnect</li></ul>

## Troubleshooting Procedure Table

Step	Actions and Questions	Yes	No
1	Check the Option Tray connector for damage. Is the connector damaged?	Replace the connector.	Go to Step 2.
2	Check all pins on the OPTIF Harness for continuity. Disconnect OPTIF from the Engine Control Board and Option connector. Is the harness conductive?	Replace the Option Control Board. If the error persists, replace the Engine Control Board (see Book 1).	Replace the OPTIF Harness.

# Duplex Unit Firmware Error

## Applicable Status Code:

**Code 225:** A firmware error with the Duplex Unit.

## Initial Actions:

- Reseat the Duplex Unit
- Cycle the printer's power.
- If the problem persists follow the procedure below.

## Troubleshooting Reference Table

Applicable Parts	Wiring and Plug/Jack References
<ul style="list-style-type: none"><li>■ Duplex Unit</li><li>■ Motor Driver Board</li></ul>	<ul style="list-style-type: none"><li>■ Print Engine Map 5 (see Book 1)</li><li>■ Print Engine Motor Driver Board (5/6) (see Book 1)</li><li>■ Options Duplex Unit Sensors and Interconnect</li></ul>

## Troubleshooting Procedure Table

Step	Actions and Questions	Yes	No
1	Check the Duplex Unit connector for damage. Is the connector damaged?	Replace the connector.	Replace the Duplex Unit (page 5-122). If the error persists, go to Step 2.
2	Check all pins on the DUPLEX Harness for continuity. Disconnect the DUPLEX Harness. Is the DUPLEX Harness conductive?	Replace the Motor Driver Board (see Book 1). If the error persists, go to Step 3.	Replace the DUPLEX Harness.
3	Check all pins of the DRV1 harness for continuity. Disconnect the DRV1 ribbon cable. Is the cable conductive?	Replace the Engine Control Board (see Book 1).	Replace the DRV1 Harness.

# Finisher Inverter Firmware Error

## Applicable Status Code:

**Code 227:** A software error with the Inverter's Flash Memory.

## Initial Actions:

- Cycle the printer's power.
- If the problem persists follow the procedure below.

## Troubleshooting Reference Table

Applicable Parts	Wiring and Plug/Jack References
<ul style="list-style-type: none"><li>■ Inverter Control Board</li></ul>	<ul style="list-style-type: none"><li>■ Print Engine Map 3 (see Book 1)</li><li>■ Print Engine Motor Driver Board (6/6) (see Book 1)</li><li>■ Options Map 3 Inverter Controller Board</li></ul>

## Troubleshooting Procedure Table

Step	Actions and Questions	Yes	No
1	Check the following for evidence of fault or damage: <ul style="list-style-type: none"><li>■ Inverter Interface Cable</li><li>■ Inverter connections</li></ul> Is there any damage?	Replace any damaged parts.	Go to Step 2.
2	Check the Inverter connection. Is the Inverter interface cable securely connected at both ends?	Go to Step 3.	Connect the Inverter to the Finisher.
3	Check the version of Inverter firmware. Is the latest version installed?	Replace the Inverter Control Board (page 5-55).	Reload the Inverter firmware.

# Tray [3][4][5][6] Flash Memory Failure

## Applicable Status Codes:

**Code 242:** Hardware error in Tray 3 Flash Memory.

**Code 243:** Hardware error in Tray 4 Flash Memory.

**Code 244:** Hardware error in Tray 5 Flash Memory.

**Code 245:** Hardware error in Tray 6 Flash Memory.

## Initial Actions:

- Cycle the printer's power.
- If the problem persists follow the procedure below.

## Troubleshooting Reference Table

Applicable Parts	Wiring and Plug/Jack References
<ul style="list-style-type: none"><li>■ Option Tray Control Board</li><li>■ Engine Control Board</li></ul>	<ul style="list-style-type: none"><li>■ Print Engine Map 3 (see Book 1)</li><li>■ Print Engine Motor Driver Board (6/6) (see Book 1)</li><li>■ Options Map 5 Paper Tray Controller Board</li></ul>

## Troubleshooting Procedure Table

Step	Actions and Questions	Yes	No
1	Check the Option Tray connector for damage. Is the connector damaged?	Replace the connector.	Go to Step 2.
2	Check all pins on the OPTIF Harness for continuity. Disconnect OPTIF from the Engine Control Board and Option connector. Is the harness conductive?	Replace the Option Control Board. If the error persists, replace the Engine Control Board (see Book 1).	Replace the OPTIF Harness.

# Duplex Unit Flash Memory Failure

## Applicable Status Code:

**Code 246:** Hardware failure with Duplex Unit Flash Memory.

## Initial Actions:

- Cycle the printer's power.
- If the problem persists follow the procedure below.

## Troubleshooting Reference Table

Applicable Parts	Wiring and Plug/Jack References
<ul style="list-style-type: none"><li>■ Duplex Unit</li><li>■ Motor Driver Board</li></ul>	<ul style="list-style-type: none"><li>■ Print Engine Map 5 (see Book 1)</li><li>■ Print Engine Motor Driver Board (5/6) (see Book 1)</li><li>■ Options Map 4 Duplex Unit Controller Board</li></ul>

## Troubleshooting Procedure Table

Step	Actions and Questions	Yes	No
1	Check the Duplex Unit connector for damage. Is the connector damaged?	Replace the connector.	Replace the Duplex Unit (page 5-122). If the error persists, go to Step 2.
2	Check all pins on the DUPLEX Harness for continuity. Disconnect the DUPLEX Harness. Is the DUPLEX Harness conductive?	Replace the Motor Driver Board (see Book 1). If the error persists, go to Step 3.	Replace the DUPLEX Harness.
3	Check all pins of the DRV1 harness for continuity. Disconnect the DRV1 ribbon cable. Is the cable conductive?	Replace the Engine Control Board (see Book 1).	Replace the DRV1 Harness.

# Finisher Inverter Flash Memory Failure

## Applicable Status Code:

**Code 225:** Hardware failure with Inverter Flash Memory.

## Initial Actions:

- Cycle the printer's power.
- If the problem persists follow the procedure below.

## Troubleshooting Reference Table

Applicable Parts	Wiring and Plug/Jack References
■ Inverter Control Board	■ Options Map 3 Inverter Controller Board

## Troubleshooting Procedure Table

Step	Actions and Questions	Yes	No
1	Check the following for evidence of fault or damage: <ul style="list-style-type: none"><li>■ Inverter Control Board</li><li>■ Inverter Interface Cable</li><li>■ Inverter connections</li></ul> Is there any damage?	Replace any damaged parts.	Go to Step 2.
2	Check the Inverter connection. Is the Inverter interface cable securely connected at both ends?	Go to Step 3.	Connect the Inverter to the Finisher.
3	Check the connections at the Inverter Control Board. Are the connections secure?	Replace the Inverter Control Board (page 5-55).	Reconnect the connectors.

# Tray [3][4][5][6] Lift Motor Failure

## Applicable Status Codes:

**Code 911:** The Tray 3 Lift Motor is not rotating.

**Code 912:** The Tray 4 Lift Motor is not rotating.

**Code 913:** The Tray 5 Lift Motor is not rotating.

**Code 914:** The Tray 6 Lift Motor is not rotating.

## Initial Actions:

- Cycle the printer's power.
- If the problem persists follow the procedure below.

## Troubleshooting Reference Table

Applicable Parts	Wiring and Plug/Jack References
<ul style="list-style-type: none"><li>■ Lift Motor</li><li>■ Option Control Board</li><li>■ Engine Control Board</li><li>■ LVPS</li></ul>	<ul style="list-style-type: none"><li>■ Print Engine Map 3 (see Book 1)</li><li>■ Print Engine Map 5 (see Book 1)</li><li>■ Print Engine Motor Driver Board (6/6) (see Book 1)</li><li>■ Print Engine LVPS (see Book 1)</li><li>■ Options Map 5 Paper Tray Controller Board</li><li>■ Options Paper Tray Motors and Clutches</li></ul>

## Troubleshooting Procedure Table

Step	Actions and Questions	Yes	No
1	Check the Option Tray connector for damage. Is the connector damaged?	Replace the connector.	Go to Step 2.
2	Test the appropriate Lift Motor (page 5-139). 1. Close the Interlock Switches for test. 2. Run the Service Diagnostics Lift Motor test. Does the motor operate?	Go to Step 3.	Replace the motor. If the error persists, go to Step 4.
3	Check all pins on the OPTIF Harness for continuity. Disconnect OPTIF from the Engine Control Board and Option connector. Is the harness conductive?	Replace the Option Control Board. If the error persists, replace the Engine Control Board (see Book 1).	Replace the OPTIF Harness.



## Troubleshooting Procedure Table (Continued)

Step	Actions and Questions	Yes	No
4	Check for +24 V at OPRY24. 1. Close the Interlock Switches. 2. Disconnect OPRY24. Is there +24 V at OPRY24-1 and -2 <=> ground?	Replace the affected Option Control Board.	Go to Step 5.
5	Check all pins on the OPRY24 Harness for continuity. Disconnect the OPRY24 Harness. Is the OPRY24 Harness conductive?	Go to Step 6.	Replace the OPRY24 Harness.
6	Check for +24 V from the LVPS. Disconnect POW24. Is there +24 V at POW24-1 <=> ground?	Replace the Motor Driver Board (see Book 1)	Go to Step 7.
7	Check the LVPS +24 V output. 1. Close the Interlock Switches. 2. Disconnect CN2. Is there +24 V at CN2-1 and <=> ground?	Replace the Engine Control Board (see Book 1)	Replace the LVPS (see Book 1).

# Duplex Unit Fan Failure

The Duplex Fan rotation signal indicates the Duplex Fan has stopped rotating.

## Applicable Status Code:

**Code 918:** The Duplex Fan has failed.

## Initial Actions:

- Cycle the printer's power.
- If the problem persists follow the procedure below.

## Troubleshooting Reference Table

Applicable Parts	Wiring and Plug/Jack References
<ul style="list-style-type: none"><li>■ Duplex Unit Fan</li><li>■ Duplex Unit Control Board</li><li>■ Duplex Unit</li></ul>	<ul style="list-style-type: none"><li>■ Print Engine Map 5 (see Book 1)</li><li>■ Print Engine Motor Driver Board (5/6) (see Book 1)</li><li>■ Options Map 4 Duplex Unit Controller Board</li><li>■ Options Duplex Unit Motors and Solenoid</li></ul>

## Troubleshooting Procedure Table

Step	Actions and Questions	Yes	No
1	Check the Duplex Unit connector for damage. Is the connector damaged?	Replace the connector.	Go to Step 2.
2	Test the Duplex Unit Fan. Run the Service Diagnostics Duplex Fan test. Does the Fan function correctly?	Go to Step 3.	Replace the Duplex Unit (page 5-122). If the error persists, go to Step 3.
3	Check all pins on the DUPLEX Harness for continuity. Disconnect the DUPLEX Harness. Is the DUPLEX Harness conductive?	Replace the Motor Driver Board (see Book 1). If the error persists, go to Step 4.	Replace the DUPLEX Harness.
4	Check all pins of the DRV1 harness for continuity. Disconnect the DRV1 ribbon cable. Is the cable conductive?	Replace the Engine Control Board (see Book 1).	Replace the DRV1 Harness.

# +24V Not Available to the Duplex Unit

Abnormal current indicates that +24 V is not being supplied to the Duplex Unit.

## Applicable Status Code:

**Code 225:** Duplex Unit is not receiving +24 V.

## Initial Actions:

- Reseat the Duplex Unit.
- Cycle the printer's power.
- If the problem persists follow the procedure below.

## Troubleshooting Reference Table

Applicable Parts	Wiring and Plug/Jack References
<ul style="list-style-type: none"><li>■ Motor Driver Board</li><li>■ LVPS</li><li>■ Duplex Unit</li></ul>	<ul style="list-style-type: none"><li>■ Print Engine Map 5 (see Book 1)</li><li>■ Print Engine Map 6 (see Book 1)</li><li>■ Print Engine Motor Driver Board (1/6) (see Book 1)</li><li>■ Print Engine Motor Driver Board (5/6) (see Book 1)</li><li>■ Print Engine LVPS (see Book 1)</li><li>■ Options Map 4 Duplex Unit Controller Board</li><li>■ Options Duplex Unit Motors and Solenoid</li></ul>

## Troubleshooting Procedure Table

Step	Actions and Questions	Yes	No
1	Check the Duplex Unit connector for damage. Is the connector damaged?	Replace the connector.	Go to Step 2.
2	Check for +24 V at DUPLEX on the Motor Driver Board. 1. Close the Interlock Switches. 2. Disconnect DUPLEX. Is there +24 V at DUPLEX-6 and -13 <=> ground?	Replace the Duplex Control Board (page 5-139).	Go to Step 3.
3	Check all pins on the DUPLEX Harness for continuity. Disconnect the DUPLEX Harness. Is the DUPLEX Harness conductive?	Go to Step 4.	Replace the DUPLEX Harness.
4	Check for +24 V from the LVPS. Disconnect POW24 on the Motor Driver Board. Is there +24 V at POW24-1 <=> ground?	Replace the Motor Driver Board (see Book 1)	Go to Step 5.

## Troubleshooting Procedure Table (Continued)

<b>Step</b>	<b>Actions and Questions</b>	<b>Yes</b>	<b>No</b>
<b>5</b>	Check the LVPS +24 V output. 1. Close the Interlock Switches. 2. Disconnect CN2. Is there +24 V at CN2-1 and <=> ground?	Go to Step 6.	Replace the LVPS (see book 1).
<b>6</b>	Check all pins of the DRV1 harness for continuity. Disconnect the DRV1 ribbon cable. Is the cable conductive?	Replace the Engine Control Board (see Book 1).	Replace the DRV1 Harness.

# +24 V Not Available to Tray [3][4][5][6]

Voltage detection indicates that +24 V is not available to the indicated option tray.

## Applicable Status Codes:

**Code 924:** Tray 3 not receiving +24 V

**Code 925:** Tray 4 not receiving +24 V

**Code 926:** Tray 5 not receiving +24 V

**Code 927:** Tray 6 not receiving +24 V

## Initial Actions:

- Reset the Option connector at the base of the printer.
- Cycle the printer's power.
- If the problem persists follow the procedure below.

## Troubleshooting Reference Table

Applicable Parts	Wiring and Plug/Jack References
<ul style="list-style-type: none"><li>■ Motor Driver Board</li><li>■ LVPS</li></ul>	<ul style="list-style-type: none"><li>■ Print Engine Motor Driver Board (6/6) (see Book 1)</li><li>■ Options Paper Tray Motors and Interconnect</li></ul>

## Troubleshooting Procedure Table

Step	Actions and Questions	Yes	No
1	Check the Option Tray connector for damage. Is the connector damaged?	Replace the connector.	Go to Step 2.
2	Check for +24 V at OPRY24. 1. Close the Interlock Switches. 2. Disconnect OPRY24. Is there +24 V at OPRY24-1 and -2 <=> ground?	Replace the affected Option Control Board.	Go to Step 3.
3	Check all pins on the OPRY24 Harness for continuity. Disconnect the OPRY24 Harness. Is the OPRY24 Harness conductive?	Go to Step 4.	Replace the OPRY24 Harness.
4	Check for +24 V from the LVPS. Disconnect POW24. Is there +24 V at POW24-1 <=> ground?	Replace the Motor Driver Board (see Book 1)	Go to Step 5.
5	Check the LVPS +24 V output. 1. Close the Interlock Switches. 2. Disconnect CN2. Is there +24 V at CN2-1 and <=> ground?	Replace the Engine Control Board (see Book 1)	Replace the LVPS (see Book 1).

# Duplex Unit Clock Frequency Error

The clock frequency for the Duplex Unit Control Board CPU is inaccurate.

## Applicable Status Code:

**Code 931:** The Duplex Unit's CPU clock frequency is inaccurate.

## Initial Actions:

- Reseat the Duplex Unit.
- Cycle the printer's power.
- If the problem persists follow the procedure below.

## Troubleshooting Reference Table

Applicable Parts	Wiring and Plug/Jack References
<ul style="list-style-type: none"><li>■ Motor Driver Board</li><li>■ Duplex Unit</li></ul>	<ul style="list-style-type: none"><li>■ Print Engine Map 3 (see Book 1)</li><li>■ Print Engine Map 5 (see Book 1)</li><li>■ Print Engine Motor Driver Board (5/6) (see Book 1)</li><li>■ Print Engine Motor Driver Board (6/6) (see Book 1)</li><li>■ Options Map 4 Duplex Unit Controller Board</li></ul>

## Troubleshooting Procedure Table

Step	Actions and Questions	Yes	No
1	Check the Duplex Unit connector for damage. Is the connector damaged?	Replace the connector.	Go to Step 2.
2	Check all pins on the DUPLEX Harness for continuity. Disconnect the DUPLEX Harness. Is the DUPLEX Harness conductive?	Replace the Duplex Unit (page 5-122). If the error persists, go to Step 3.	Replace the DUPLEX Harness.
3	Check all pins of the DRV1 harness for continuity. Disconnect the DRV1 ribbon cable. Is the cable conductive?	Replace the Engine Control Board (see Book 1).	Replace the DRV1 Harness.

# Finisher Inverter Clock Frequency Error

The clock frequency for the Inverter Control Board CPU is inaccurate.

## Applicable Status Code:

**Code 932:** The Inverter's CPU clock frequency is inaccurate.

## Initial Actions:

- Cycle the printer's power.
- If the problem persists follow the procedure below.

## Troubleshooting Reference Table

Applicable Parts	Wiring and Plug/Jack References
<ul style="list-style-type: none"><li>■ Inverter Control Board</li><li>■ Engine Control Board</li></ul>	<ul style="list-style-type: none"><li>■ Print Engine Map 3 (see Book 1)</li><li>■ Print Engine Motor Driver Board (6/6) (see Book 1)</li><li>■ Options Map 3 Inverter Controller Board</li></ul>

## Troubleshooting Procedure Table

Step	Actions and Questions	Yes	No
1	Check the Option connection. Is the Option connection from the Inverter to the Printer damaged or disconnected?	Reconnect or replace the cable.	Go to Step 2.
2	Check all pins on the Option Harness for continuity. Disconnect OPTIF from the Engine Control Board and the Option connector. Is the harness conductive?	Go to Step 3.	Replace the Option harness.
3	Check the Inverter Control Board POWER connection. Is POWER disconnected or damaged?	Replace or reconnect the harness.	Replace the Inverter Control Board (page 5-55). If the error persists, replace the Engine Control Board (see Book 1).

# Tray [3][4][5][6] Feeder Board Clock Frequency Error

The clock frequency on the indicated Feeder Board is inaccurate.

## Applicable Status Codes:

**Code 933:** Tray 3 Feeder Board CPU clock frequency is inaccurate.

**Code 934:** Tray 4 Feeder Board CPU clock frequency is inaccurate.

**Code 935:** Tray 5 Feeder Board CPU clock frequency is inaccurate.

**Code 936:** Tray 6 Feeder Board CPU clock frequency is inaccurate.

## Initial Actions:

- Cycle the printer's power.
- If the problem persists follow the procedure below.

## Troubleshooting Reference Table

Applicable Parts	Wiring and Plug/Jack References
<ul style="list-style-type: none"><li>■ Option Feeder Board</li><li>■ Engine Control Board, PL1.1.4</li></ul>	<ul style="list-style-type: none"><li>■ Print Engine Map 3 (see Book 1)</li><li>■ Print Engine Motor Driver Board (6/6) (see Book 1)</li><li>■ Options Map 5 Paper Tray Controller Board</li></ul>

## Troubleshooting Procedure Table

Step	Actions and Questions	Yes	No
1	Check the Option Tray connector for damage. Is the connector damaged?	Replace the connector.	Go to Step 2.
2	Check all pins on the OPTIF Harness for continuity. Disconnect OPTIF from the Engine Control Board and Option connector. Is the harness conductive?	Replace the Option Feeder Board. If the error persists, replace the Engine Control Board (see Book 1).	Replace the OPTIF Harness.



# No Paper in Tray [2][3][4][5][6]

The No Paper Sensor indicates that the named tray is empty.

## Initial Actions:

- Cycle the printer's power.
- If the problem persists follow the procedure below.

## Troubleshooting Reference Table

Applicable Parts	Wiring and Plug/Jack References
<ul style="list-style-type: none"><li>■ No Paper Sensor</li><li>■ No Paper Actuator</li></ul>	<ul style="list-style-type: none"><li>■ Print Engine Map 12 (see Book 1)</li><li>■ Print Engine Feeder Board (see Book 1)</li><li>■ Options Map 5 Paper Tray Controller Board</li><li>■ Options Map 6 Paper Tray Feeder Board</li><li>■ Options Paper Tray Sensors and Interconnect</li></ul>

## Troubleshooting Procedure Table

Step	Actions and Questions	Yes	No
1	Fill the tray. Does the error occur even if the tray is full?	Go to Step 2.	Complete
2	Check the following for evidence of fault or damage: <ul style="list-style-type: none"><li>■ No Paper Sensor and actuator</li></ul> Is there any damage?	Replace any damaged parts.	Go to Step 3.
3	Test the No Paper Sensor. for the affected tray. Run the Service Diagnostics No Paper Sensor test. Does the sensor function correctly?	Replace the Engine Control Board (see Book 1).	Go to Step 4.
4	Check the No Paper Sensor signal. Does the voltage level change when the sensor is actuated?	Go to Step 5.	Replace the No Paper Sensor (page 5-142).
5	Check all pins on the TRYSNS1 Harness for continuity. Is the harness conductive?	Replace the Engine Control Board (see Book 1).	Replace the TRYSNS1 Harness.

# Staple Cartridge Is Empty

The Stapler Self-Prime Sensor in the Staple Cartridge indicates no staples remain.

## Initial Actions:

- Cycle the printer's power.
- If the problem persists follow the procedure below.

## Troubleshooting Reference Table

Applicable Parts	Wiring and Plug/Jack References
<ul style="list-style-type: none"><li>■ Stapler Self-Prime Sensor</li><li>■ Finisher Control Board</li></ul>	<ul style="list-style-type: none"><li>■ Options Map 1 Finisher Controller Board</li></ul>

## Troubleshooting Procedure Table

Step	Actions and Questions	Yes	No
1	Test the Stapler Self-Prime Sensor. Run the Service Diagnostics Stapler Self-Prime Sensor test. Does the sensor state change when the Staple Cartridge is removed or replaced?	Go to Step 9.	Go to Step 2.
2	Check the Staple Cartridge for faulty parts or debris. Are there damaged parts or debris?	Replace faulty parts or clean as needed.	Go to Step 3.
3	Check the Staple Harness connections. Is the Staple Harness connected?	Go to Step 5.	Connect the harness. If the error persists, go to Step 4.
4	Check Staple Harness continuity. Is the Staple Harness conductive?	Go to Step 6.	Replace the Staple Harness.
5	Check for +5 V to the Stapler Self-Prime Sensor. Is there +5 V on the Finisher Control Board?	Go to Step 7.	Replace the Finisher Control Board (page 5-46).
6	Check the Stapler Self-Prime signal. Does the voltage on the Finisher Control Board change when the Staple Cartridge is removed or replaced?	Go to Step 8.	Replace the Finisher Control Board (page 5-46).
7	Replace the Stapler Assembly (page 5-29). Does the error still occur?	Go to Step 9.	Complete.
8	Replace the Finisher Control Board (page 5-46). Does the error still occur?	Replace Engine Control Board (see Book 1).	Complete.

# Punch Waste Box is Full or Missing

The Punch Box Sensor indicates the Punch Box is full or not installed in the Finisher.

## Initial Actions:

- Cycle the printer's power.
- If the problem persists follow the procedure below.

## Troubleshooting Reference Table

Applicable Parts	Wiring and Plug/Jack References
<ul style="list-style-type: none"> <li>■ Punch Box Sensor Emitter Board</li> <li>■ Punch Box Sensor Receiver Board</li> <li>■ Punch Box Sensor Harness</li> </ul>	<ul style="list-style-type: none"> <li>■ Options Map 2 Punch Controller Board</li> <li>■ Options Punch Controller to Sensors</li> </ul>

## Troubleshooting Procedure Table

Step	Actions and Questions	Yes	No
1	Test the Punch Box Set Sensor. Run the Service Diagnostics Punch Box Set Sensor test. Does the sensor state change when the emitter is blocked?	Go to Step 6.	Go to Step 2.
2	Check the Punch Box Sensor Harness connections. Is P/J1005 connected to the Punch Control Board? Are P/J2005 and P/J2006 connected to the Emitter and Receiver boards?	Go to Step 3.	Connect the harness.
3	Check the Punch Box Sensor Harness continuity. Is the harness conductive?	Go to Step 5.	Replace the harness.
4	Check the Punch Box Sensor Emitter Board. Is the LED illuminated?	Go to Step 5.	Replace the Punch Box Sensor Emitter Board.
5	Check for +5 V to the Punch Box Sensor. Disconnect P/J2006. Is there +5 V across J2006-1 <=> J2006-2?	Replace the Punch Box Sensor Receiver Board.	Replace the Punch Control Board (page 5-50).
6	Replace the Finisher Control Board (page 5-46). Does the error still occur?	Replace Engine Control Board (see Book 1).	Complete.

# Finisher Away From Base

The Finisher Switch indicates that the Finisher is detached from the Inverter.

## Initial Actions:

- Cycle the printer's power.
- If the problem persists follow the procedure below.

## Troubleshooting Reference Table

Applicable Parts	Wiring and Plug/Jack References
<ul style="list-style-type: none"><li>■ Joint Switch</li><li>■ Finisher Control Board</li></ul>	<ul style="list-style-type: none"><li>■ Options Map 7 Finisher Sensor Locator</li><li>■ Options Finisher Controller to Switches</li></ul>

## Troubleshooting Procedure Table

Step	Actions and Questions	Yes	No
1	Check the following for evidence of fault, damage, obstruction, or debris: <ul style="list-style-type: none"><li>■ Joint Switch and actuator</li><li>■ Finisher Base</li></ul> Are there any defects or misalignment?	Replace any damaged parts.	Go to Step 2.
2	Test the Joint Switch <b>NOTE:</b> Door sensor tests are located under the Covers, Doors, and Interlocks sub-menu. Run the Service Diagnostics Joint Switch test. Does the switch function correctly?	Replace the Engine Control Board (see Book 1).	Go to Step 3.
3	Check the switch signal. Disconnect CN8 from the Finisher Control Board. Is there +24 V at CN8-5 when the switch is activated?	Replace the Finisher Control Board (page 5-46).	Go to Step 4.
4	Check the switch signal. Disconnect CN8 from the Finisher Control Board. Is there +24 V at CN8-6 when the switch is activated?	Replace the Joint Switch (page 5-73). If the error persists, replace the wiring.	Replace the Finisher Control Board (page 5-46).

# Finisher Away From Printer

The Inverter Docking (Joint) Switch indicates that the Finisher is detached from the printer.

## Initial Actions:

- Cycle the printer's power.
- If the problem persists follow the procedure below.

## Troubleshooting Reference Table

Applicable Parts	Wiring and Plug/Jack References
<ul style="list-style-type: none"><li>■ Inverter Docking Sensor</li><li>■ Inverter Control Board</li></ul>	<ul style="list-style-type: none"><li>■ Options Map 9 Inverter Sensor Locator</li><li>■ Options Inverter Sensors diagram</li></ul>

## Troubleshooting Procedure Table

Step	Actions and Questions	Yes	No
1	Check the following for evidence of fault, damage, obstruction, or debris: <ul style="list-style-type: none"><li>■ Inverter Docking Sensor</li><li>■ Finisher Base</li></ul> Are there any defects or misalignment?	Replace any damaged parts.	Go to Step 2.
2	Test the Inverter Joint Sensor Run the Service Diagnostics Inverter Joint Sensor test. Does the switch function correctly?	Replace the Engine Control Board (see Book 1).	Go to Step 3.
3	Check the Inverter Docking Sensor signal. Disconnect SNSCN1 from the Inverter Control Board. Does the voltage change between 0 and 5vdc on connector SNSCN1-2 when the sensor is actuated?	Replace the Inverter Control Board (page 5-55).	Replace the sensor (page 5-100). If the error persists, replace the harness.



# Adjustments and Calibrations

## In this chapter...

- Punch Unit Adjustments
- Staple Unit Adjustments
- Saddle Unit Adjustments

Section

4

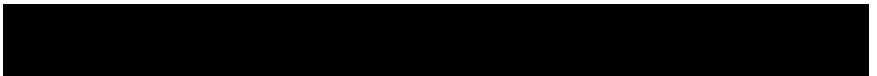

# Punch Unit Adjustments

## Registering Punch Holes

Perform the following steps to identify the type of punch unit and associated number of punch holes. The Punch Controller Board uses this switching information to identify and register the finisher type whenever you replace the board. To register the punch holes:

1. Locate DIP switches SW1001, SW1002, and SW1003 and LEDs LED1001, LED1002, and LED1003 on the Punch Controller Board.

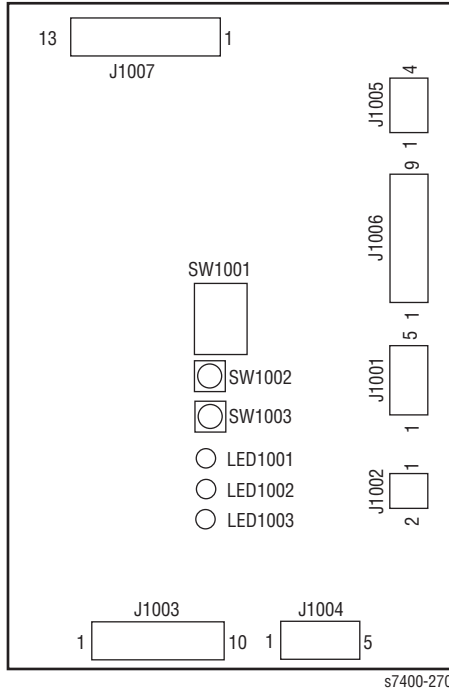

2. Set bits 1 through 4 on the switch SW1001 on the Punch Controller Board as follows:

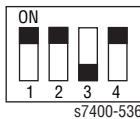



3. Press Switch SW1002 on the Punch Controller Board to select the appropriate number of punch holes. Each press on SW1002 moves the selection through the following (repeatedly from top to bottom).

<b>Number of punch holes</b>	<b>LED1001</b>	<b>LED1002</b>	<b>LED1003</b>
2 holes (punch Unit-J1)	ON	OFF	OFF
2/3 holes (punch Unit-K1)	ON	ON	OFF
4 holes (punch Unit-G1)	OFF	OFF	OFF
4 holes (punch Unit-H1)	OFF	OFF	ON

4. Press switch SW1003 on the Punch Controller Board twice. The presses will store the selected number of punch holes on the Punch Controller Board.
  - A single press on SW1003 will cause the LED indication to flash
  - Another press on SW1003 will cause the indication to remain ON to indicate the end of registration.
5. Shift all bits of DIPSW1001 to OFF (this action ensures that the LEDs will remain unaffected and the switch setting will have no further effect).

# Adjusting Sensor Output After Sensor Replacement

Perform the following steps whenever you replace the Punch Controller Board, horizontal registration sensor (photosensor board/LED board), or waste full sensor (waste full photosensor board/waste full LED board):

1. Locate DIP switches SW1001, SW1002, and SW1003 and LEDs LED1001, LED1002, and LED1003 on the Punch Controller Board.

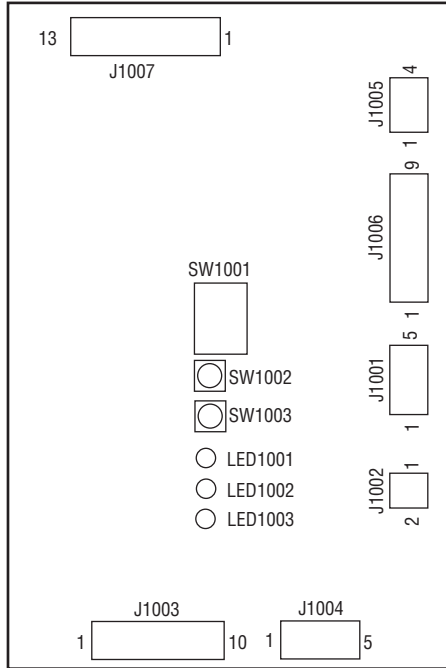

s7400-270

2. For DIP switch SW1001 on the Punch Controller Board, press shift bits 1 through 4 as follows:

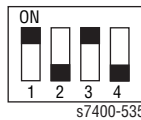

s7400-535

3. Press switches SW1002 or SW1003 on the Punch Controller Board:
  - Pressing either switch will adjust the sensor output.
  - The adjustment is complete when all LEDs on the Punch Controller Board are ON for LEDs LED1001, LED1002, LED1003.
4. Shift all bits of DIPSW1001 to OFF (this action ensures that the LEDs will remain unaffected and the switch setting will have no further effect).

# Adjusting Sensor Output After EE-PROM Replacement

To adjust the sensor output after replacing the EE-PROM, use the following steps:

1. Turn off the Phaser 7400 Color Printer.
2. Locate DIP switches SW1001, SW1002, and SW1003 and LEDs LED1001, LED1002, and LED1003 on the Punch Controller Board.

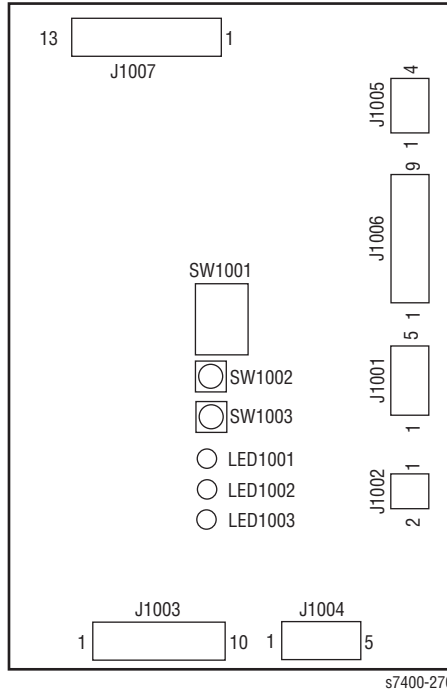

3. For DIP switch SW1001 on the Punch Controller Board, press shift bits 1 through 4 as follows:

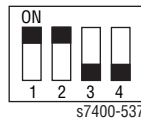

- Press switches SW1002 and SW1003 on the Punch Controller Board simultaneously.
  - The presses will initialize the EEP-ROM. At the end, all LEDs(LED1001, LED1002, LED1003) will go ON.
4. Adjust the sensor output (page 4-4) and register the number of punch holes (page 4-2).

# Stapler Unit Adjustments

## Adjusting the Saddle Stitch Double Stapling Position

To adjust the stapling position for middle 2-point stapling, you must match it with the folding position. If you have replaced the Finisher Controller Board, you must transfer the existing settings to the new board.

### Note

Both the folding and stapling positions may vary for some types of paper. In these cases, change the middle stapling position in the user mode of the printer.

Use the following steps:

1. Locate DIP switch SW1 on the Finisher Controller Board.

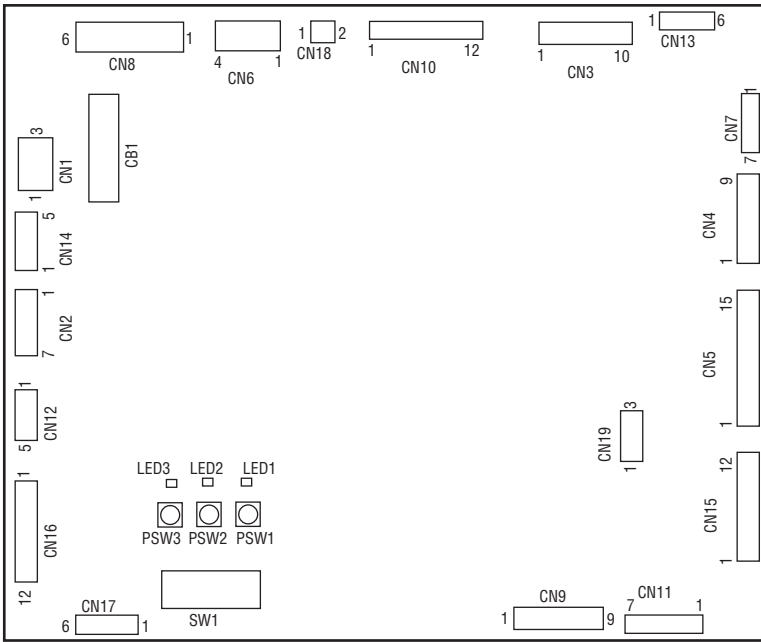

2. Set switch SW1 on the Finisher Controller Board as follows.

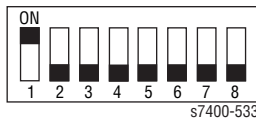

3. Press switches PSW1 or PSW2 on the Finisher Controller Board as necessary to move the stapling position to the proper location (pressing the switch once moves the stapling position about 0.14 mm):
  - To move the stapling position in the "-" direction, press switch PSW1.
  - To move the stapling position in the "+" direction, press switch PSW2.
  - Pressing the PSW1 and PSW2 at the same time clears the adjustment value.
4. After adjusting the stapling position, set all bits of switch SW1 on the Finisher Controller Board to OFF (this action ensures that the LEDs will remain unaffected and the switch setting will have no further effect).
5. Enter the **booklet mode** of the printer and check whether the stapling position is adjusted properly. If necessary, adjust repeat the above steps to adjust the stapling position again.

## Adjusting the Stapler Phase

When you remove or replace the gears or timing belt at the front of the stapler, the staple insertion timing of the staple unit may be faulty. Use the following steps to adjust the timing for the Finisher stapler phase.

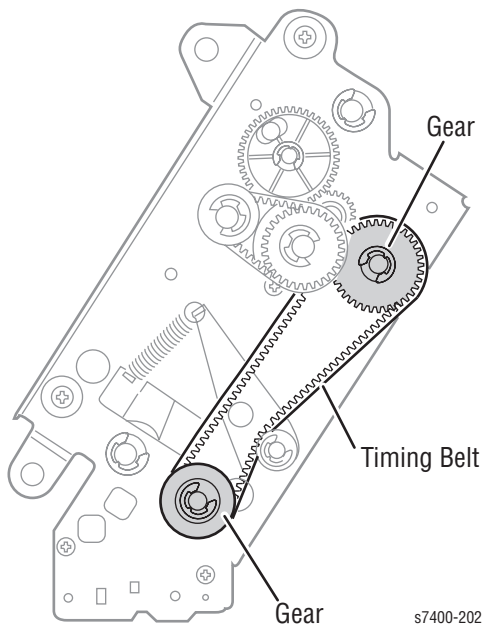

1. Remove the two knobs from the front of the Staple Unit.
2. Remove 3 screws and remove the Staple Unit Cover.
3. Detach the gear cover from the staple driver.

4. Remove the E-ring to detach the side cover of the staple clincher.

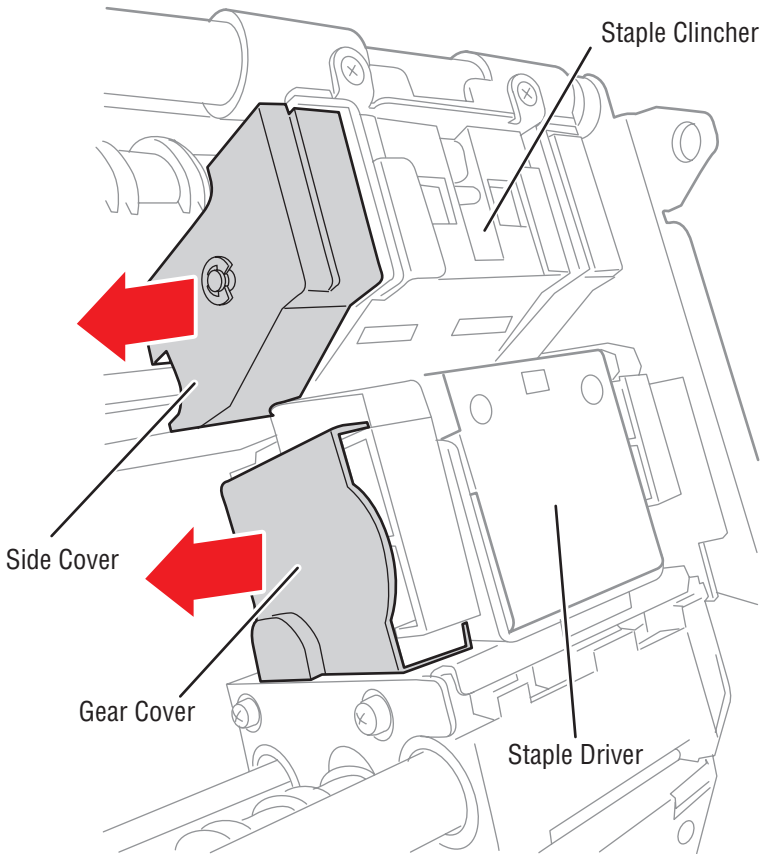

s7400-203

5. Remove the two E-rings to remove the staple jam releasing gear, timing belt, and relay gear 1. Remove the spacer and spring at the back of the staple jam releasing gear.

6. Remove the screw to remove the belt tensioner from its mounting post (also remove the spring).

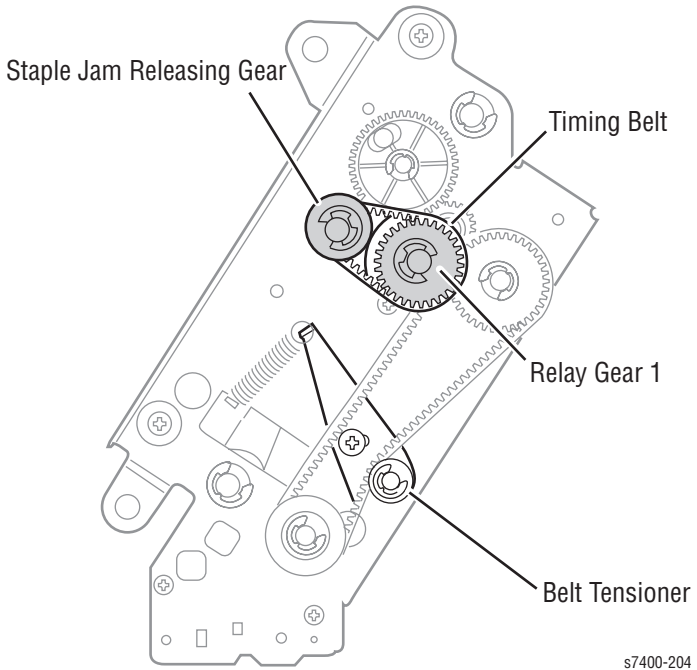

7. Remove the timing belt.

8. Remove the E-ring to remove the staple position check gear.

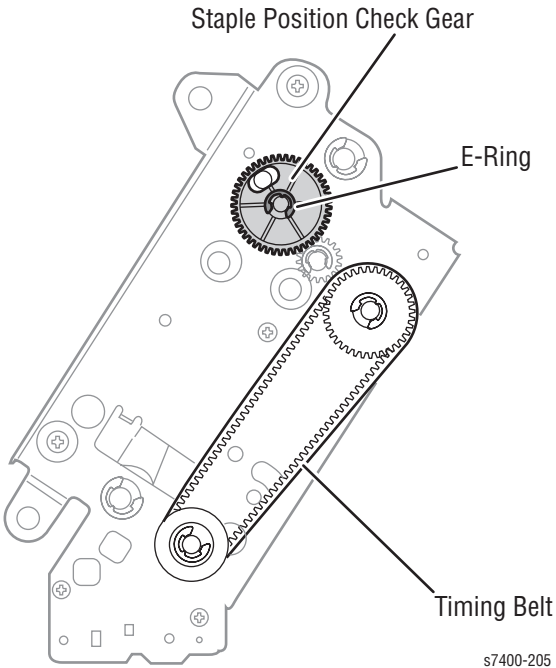



9. Turn the gear to align the round hole in the staple driver gear with the round hole at the back.

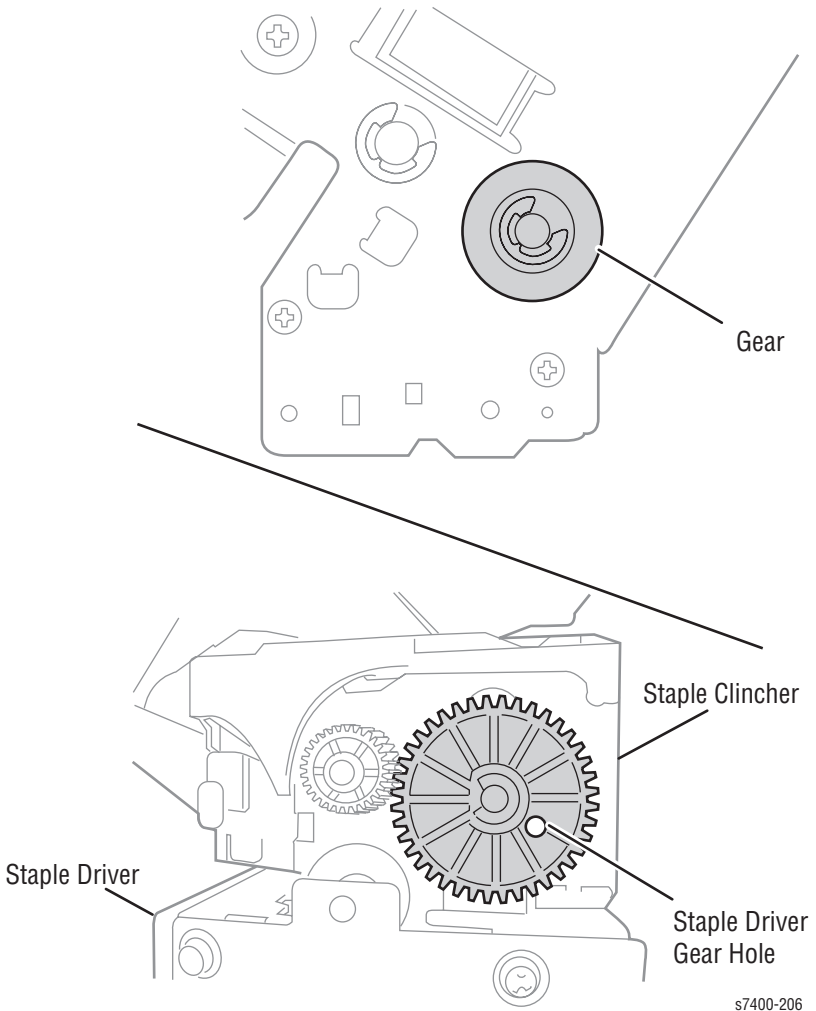

s7400-206

10. Insert a pin with a diameter of approximately 2 mm (use recommended diameter size) in the round hole to secure the gear.

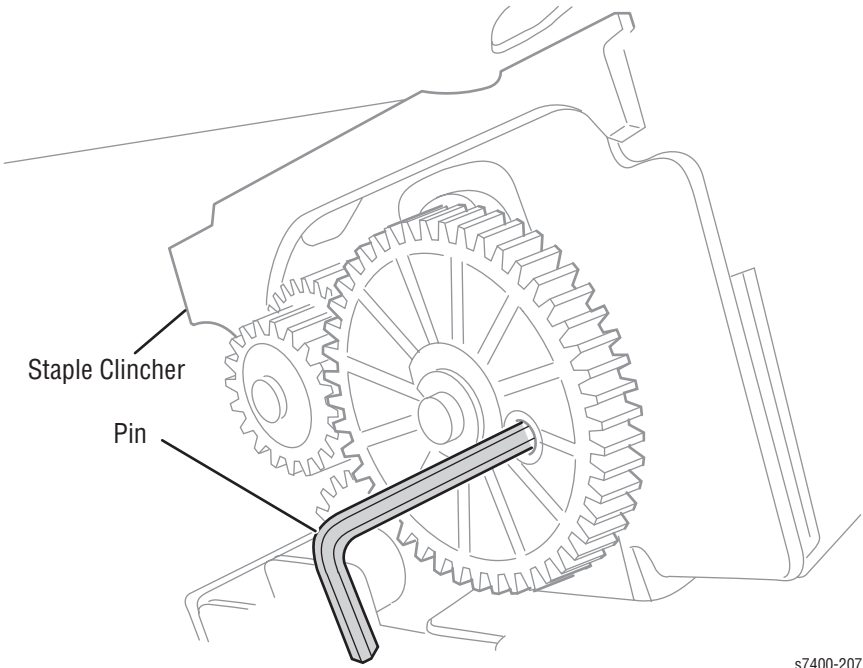

s7400-207

11. Turn the gear to align the round hole in the staple clincher cam with the round hole at the back.

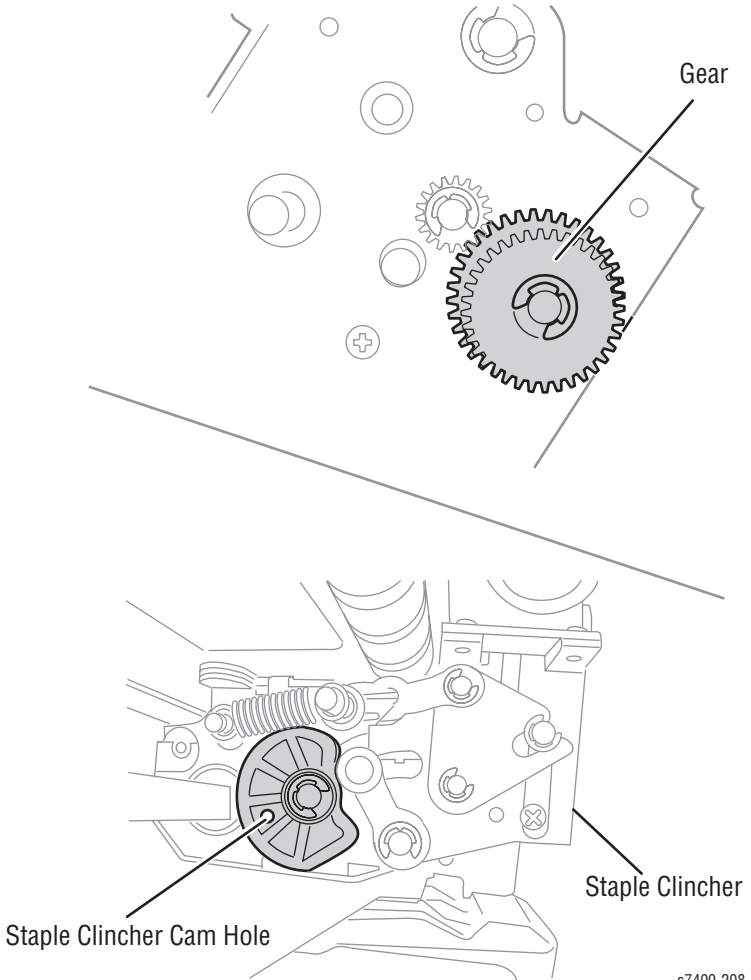

s7400-208

- 12.** Insert a pin with a diameter of approximately 2 mm (use of a 2 mm Allen wrench as recommended) in the round hole to secure the gear.

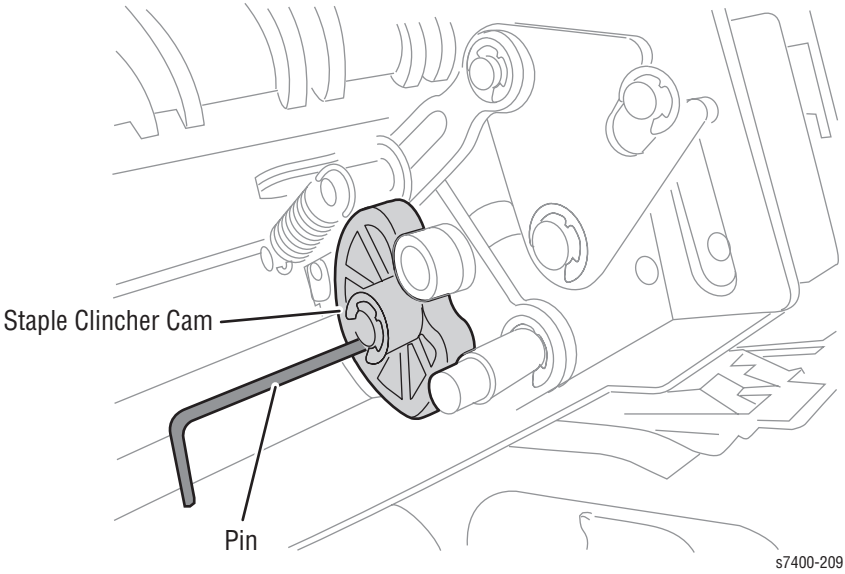

- 13.** With the gears and cam fixed, install the timing belt on the gears.

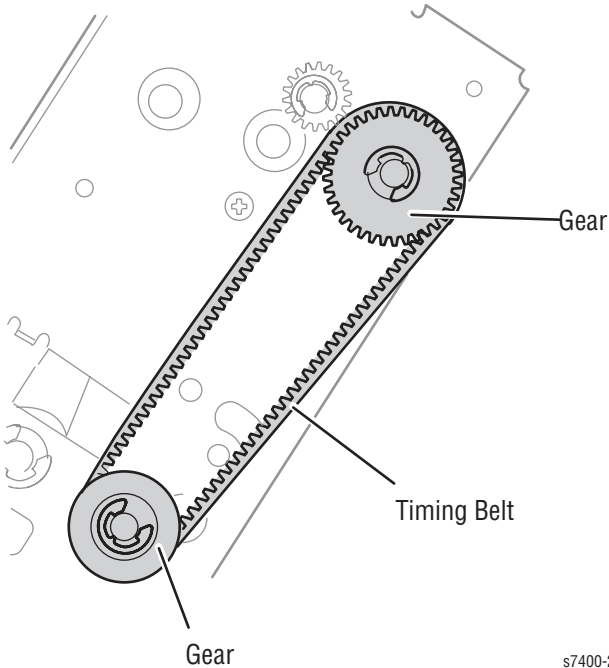

14. Mount the staple position check gear so that the blue mark on the staple position check gear is aligned with the round hole in the frame. Reinstall the E-ring on the gear.

### Caution

It is necessary to mount the gear at the correct position. The position where the blue mark aligns with the round hole is the home position for stapling. If you move the staple jam cancel dial, the home position deviates, making it impossible to remove the stapler cartridge. If this happens, you can return the gear to the home position by checking the blue mark position with the cover installed.

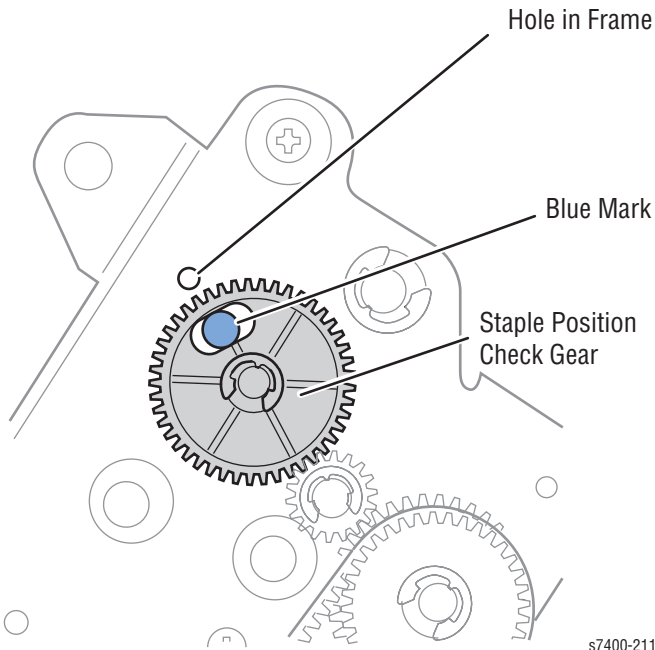

15. Remove the pins securing the gear and the cam.

16. Assemble the spring, spacer, staple jam releasing gear, timing belt, and relay gear. Secure them with the E-ring.

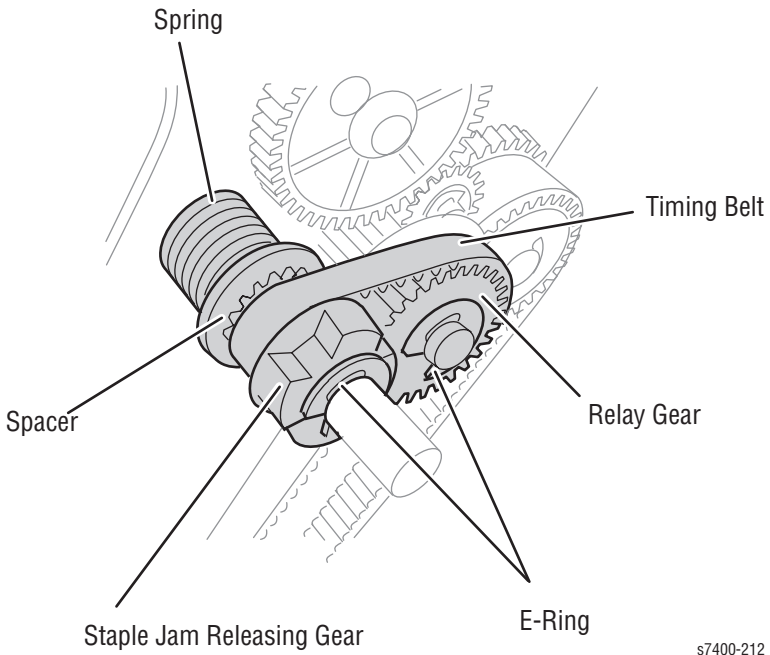

s7400-212

17. Replace the front cover and two knobs and reinstall the Stapler Unit.

# Saddle Unit Adjustments

## Adjusting the Folding Position

If you replace the Finisher Controller Board, you must match the folding position to the stapling position. Perform the following steps:

1. Locate DIP switch SW1 on the Finisher Controller Board.

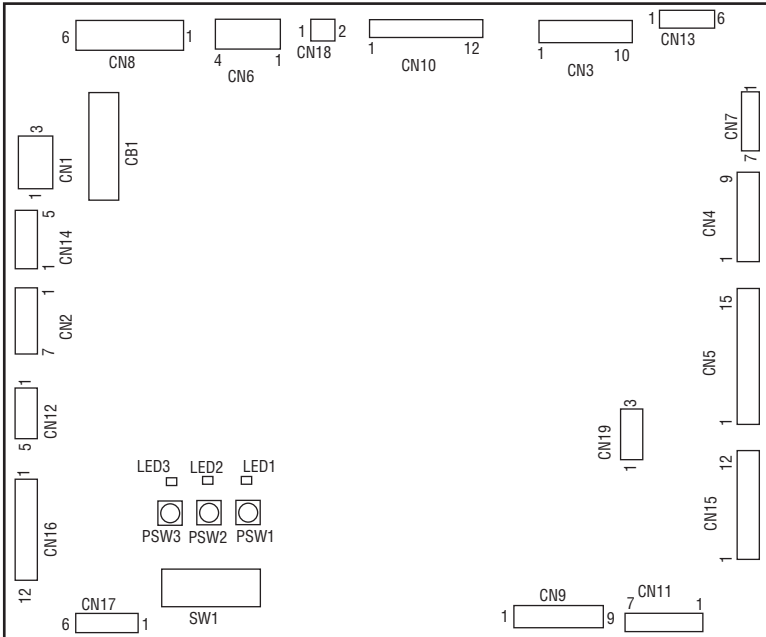

2. Set SW1 on the Finisher Controller Board as follows:

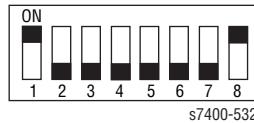

3. To adjust the folding position, press the PSW1 or PSW2 switches on the Finisher Controller Board as necessary to move the folding position to the correct location.

Pressing the switch once moves the folding position about 0.16 mm.

- To move the folding position in the "-" direction, press PSW1.
- To move the folding position in the "+" direction, press PSW2.
- Pressing the PSW1 and PSW2 at the same time clears the adjustment value.

4. After adjusting the folding position, set all bits of SW1 on the Finisher Controller Board to OFF (this action will ensure that the switch will no longer affect the settings).
5. Enter the **booklet mode** of the printer and check whether the folding position is adjusted properly. If necessary, repeat the procedure.

## Adjusting the Phase of the Saddle Unit Gear

If you replace or remove the gears at the front of the saddle unit or the paper fold rollers in the saddle unit, adjust the gear phase using the following procedure:

1. Position the paper fold rollers and saddle cam as shown below.

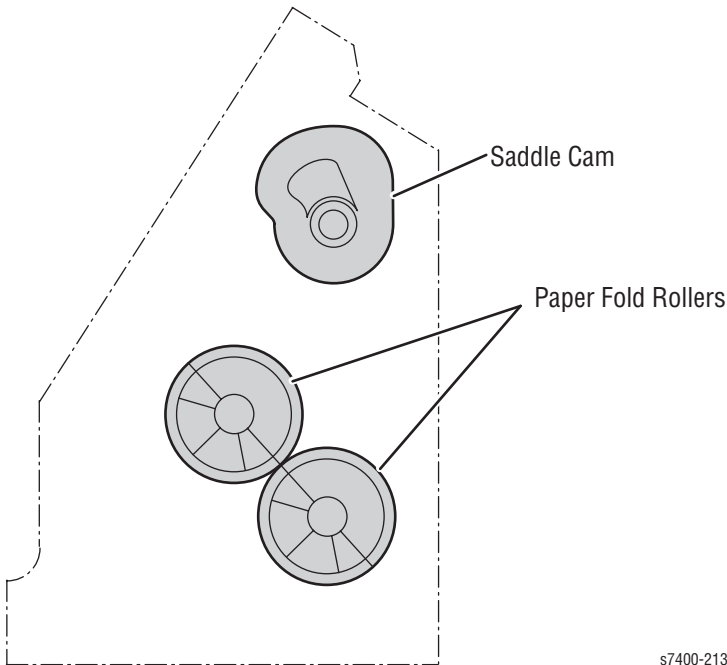

s7400-213



2. With the paper fold rollers and saddle cam positioned as shown in the preceding figure, mount gears as shown in the following figure. Align the mark (either one of the two marks) on the saddle cam drive gear with the mark on the relay gear. The relay gear is located on the half of the periphery where gears with a smaller face width are arranged).

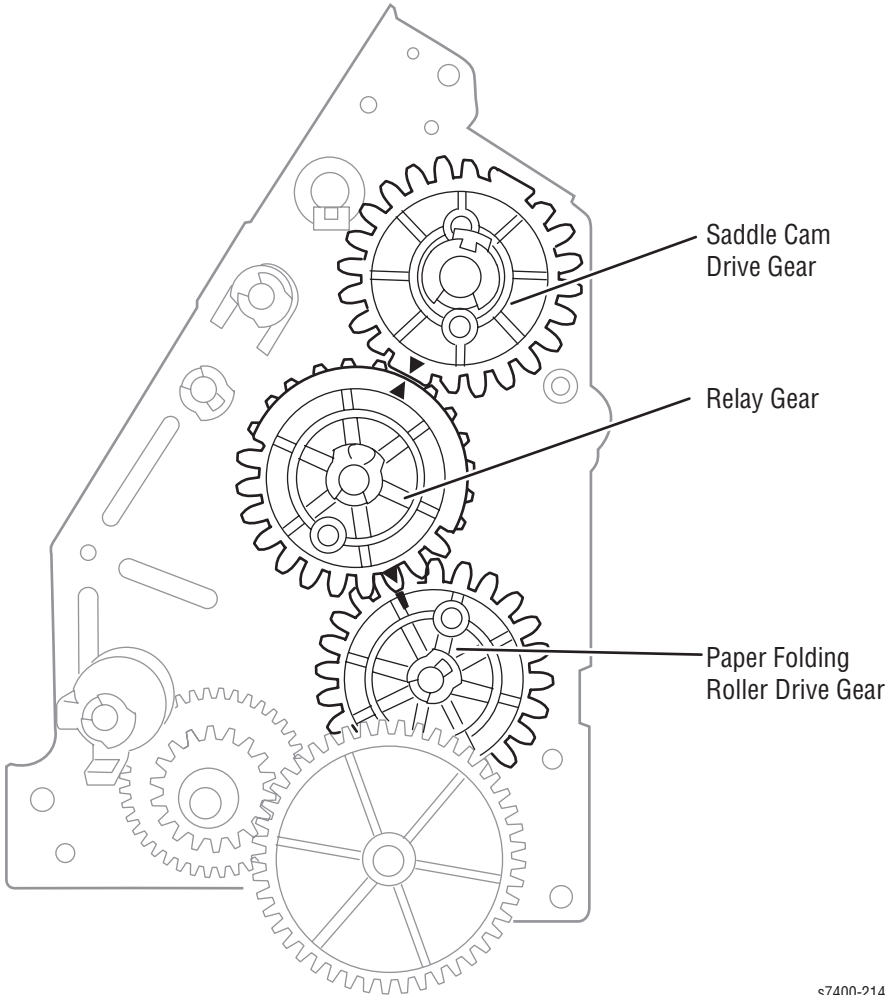

s7400-214

3. With the mark on the saddle cam drive gear aligned with the mark on the relay gear, align the other mark on the relay gear with the rib of the paper folding roller drive gear.



# Service Parts Disassembly

## In this chapter...

- General Notes on Disassembly
- Overview
- Finisher Disassembly
- Inverter Disassembly
- Duplex Unit Disassembly
- Optional Paper Tray Disassembly

Section

5

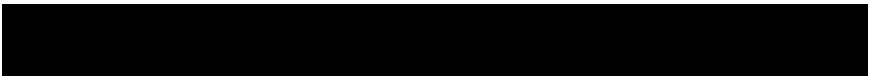

# Overview

This section contains the removal and replacement procedures for selected parts of the printer options package according to the Field Replaceable Units (FRUs) Parts List. Not all replacement procedures are included in this Service Manual. In most cases, to reinstall a part, simply reverse the removal procedure shown. In some instances, replacement notes are included providing special steps. For specific assemblies and parts, see the "Parts List" on page 6-1.

## General Notes on Disassembly

### Preparation

Before you begin any Removal and Replacement Procedure:

1. Switch Off the printer power, as well as power to the Finisher and options.
2. Wear an electrostatic discharge wrist strap to help prevent damage to the sensitive electronics of the printer circuit boards.

#### Note

Names of parts that appear in the removal and replacement procedures may not match the names that appear in the Parts List. For example, a part called the Registration Chute Assembly in a removal procedure may appear on the Parts List as Assembly, Chute REGI. When working on a removal procedure, ignore any prerequisite procedure for parts already removed.

#### Caution

Many parts are secured by plastic tabs DO NOT over Flex or force these parts. Do not over torque the screws threaded into plastic parts.

Always use the correct type and size screw. Using the wrong screw can damage tapped holes. Do not use excessive force to remove or install either a screw or a printer part.

#### Warning

Unplug the AC power cord from the wall outlet before removing any printer part.

# Notations in the disassembly text

- The notation “(item X)” points to a numbered callout in the illustration corresponding to the you disassembly procedure being performed.
- The notation “PLX.X.X” indicates that this component is listed in the FRU Parts List.
- Bold arrows in an illustration show direction of movement when removing or replacing a component.



## Replacement Note

Underneath the lower output tray are three spare k-clips of various sizes. These clips are small and easy to lose. Keep them in a location near your work area in case you need them.

# Fastener Types

The following table lists the primary types of Posi-Drive screws used to assemble the printer. The procedures provide dimensional specifications for screws being removed.

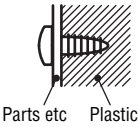
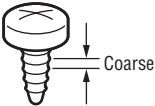
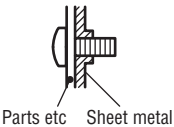
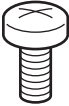
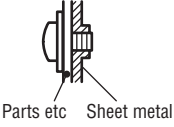
## Posi-Drive Screw Types used in the Printer

Type	Application	Shape	Characteristics
Self-tapping, plastic			<ol style="list-style-type: none"><li>1. Black colored</li><li>2. Screw thread is coarse compared to metal screw.</li><li>3. Screw tip is thin.</li></ol>
Sheet Metal, silver			<ol style="list-style-type: none"><li>1. Silver colored</li><li>2. Diameter is uniform.</li><li>3. Typically 6 mm in length</li></ol>
Sheet Metal, with flange			<ol style="list-style-type: none"><li>1. Silver colored</li><li>2. It has a flange.</li><li>3. Diameter is uniform.</li></ol>

## Caution

Use care when installing self-tapping screws in plastic. To properly start the screw in plastic, turn the screw counter-clockwise in the hole until you feel the screw engage the threads, and then tighten as usual. Failure to properly align or over tighten the screw can result in damage to previously tapped threads.

## Standard Orientation

When needed the orientation of the option is called out in the procedure for locating parts, refer to the orientation graphic for locating the right, left, front and back sides of the printer.

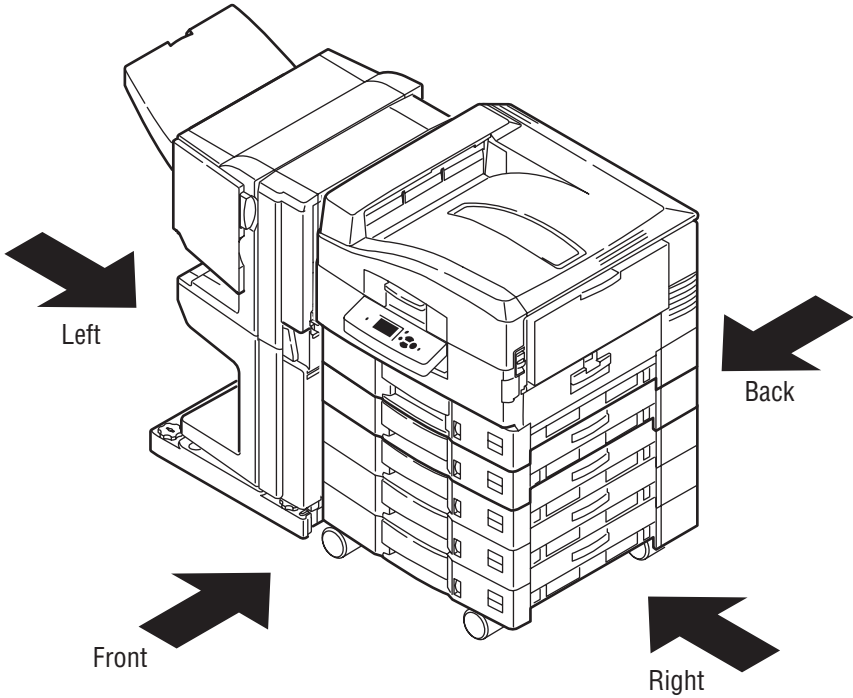

s7400-339

# Finisher Disassembly

The Finisher disassembly is presented in the following categories:

- Base Unit and Inverter
- Tray and Covers
- Subassemblies
- Field Replaceable Units

## Removing Inverter Base Unit from Finisher

1. Release the hook attaching the Finisher to the Base Unit.
2. Remove the two screws (metal, 6 mm) securing the Base Unit to the Finisher.
3. Lift the Finisher from the four slots on the Base Unit.

### Caution

Use two people to lift the Finisher from the Base Unit.

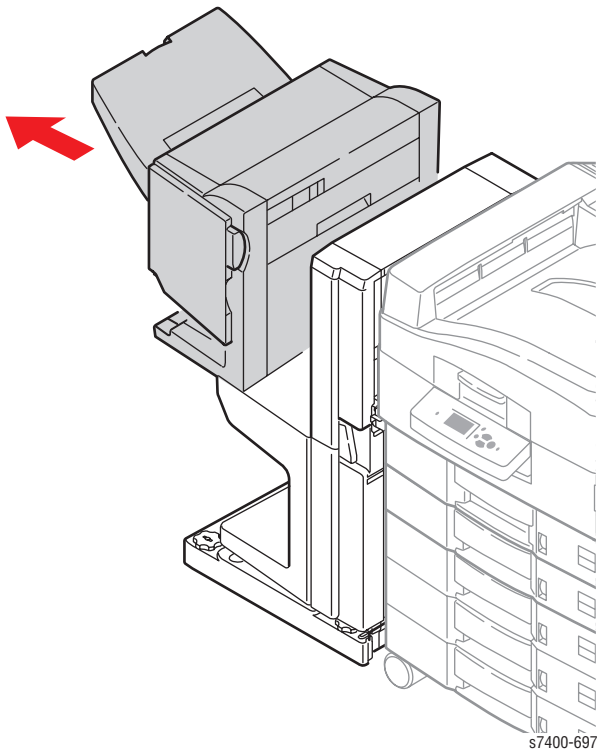

# Undocking Inverter from Printer

1. Slide out the bar on the bottom of the Finisher Base Unit.
2. Remove two screws (metal, 6 mm) holding the Inverter to the printer.
3. Remove guide pins.
4. Slide Inverter away from the printer.

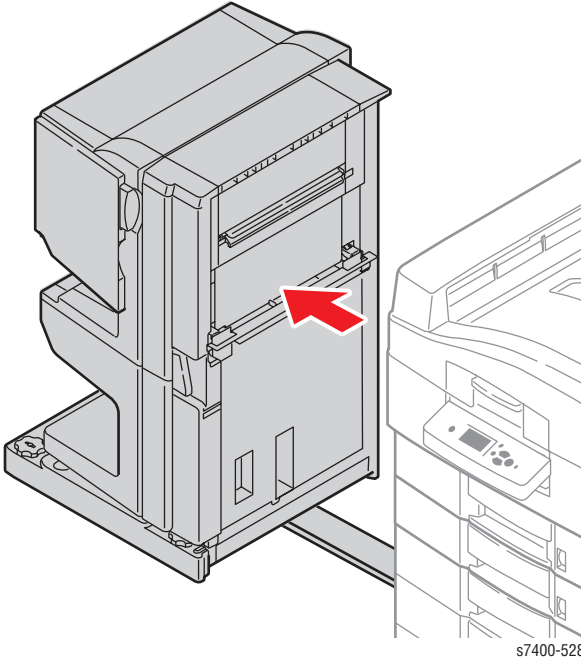

s7400-528



# Trays and Covers

## Paper Exit Tray

1. Remove four screws (metal, 6 mm) and detach the Paper Exit Tray.

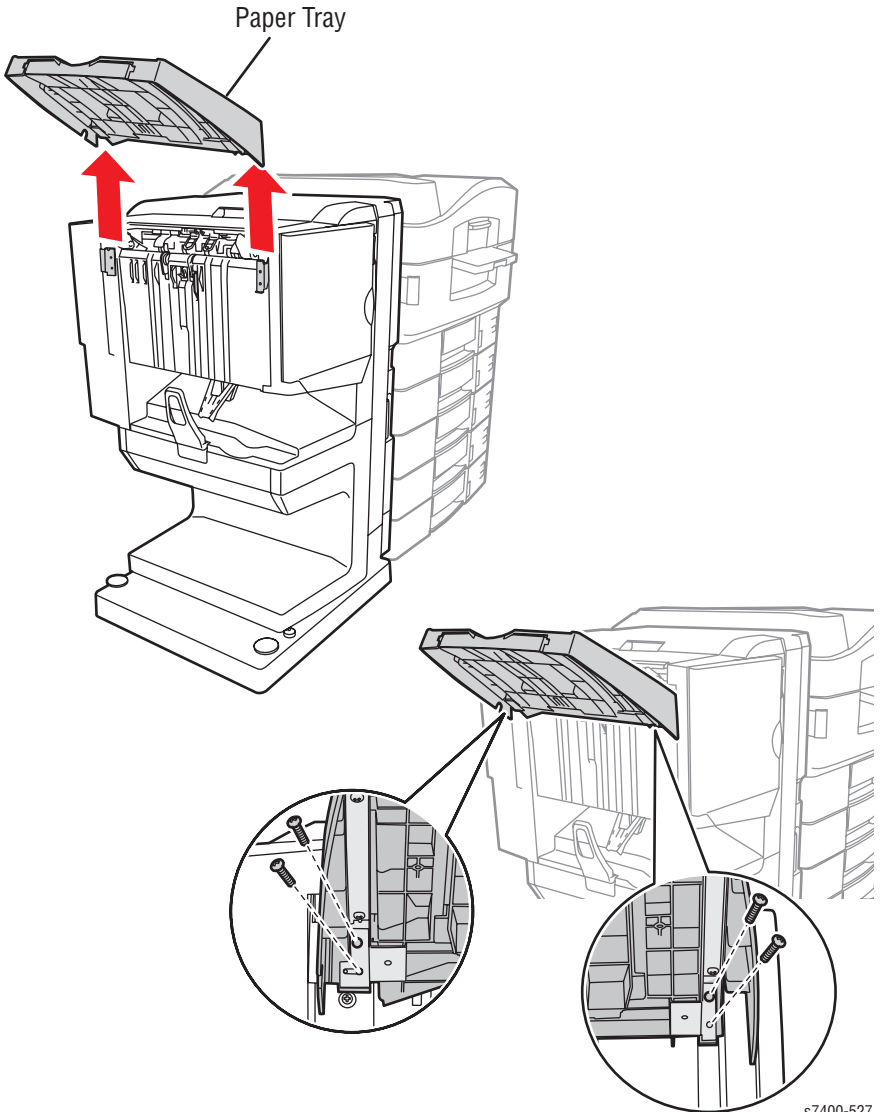

s7400-527

## Front Door (Door J)

1. Open the Front Door.
2. Remove two screws (metal, 6 mm).
3. While squeezing the plastic hooks, remove the fold jam release knob.

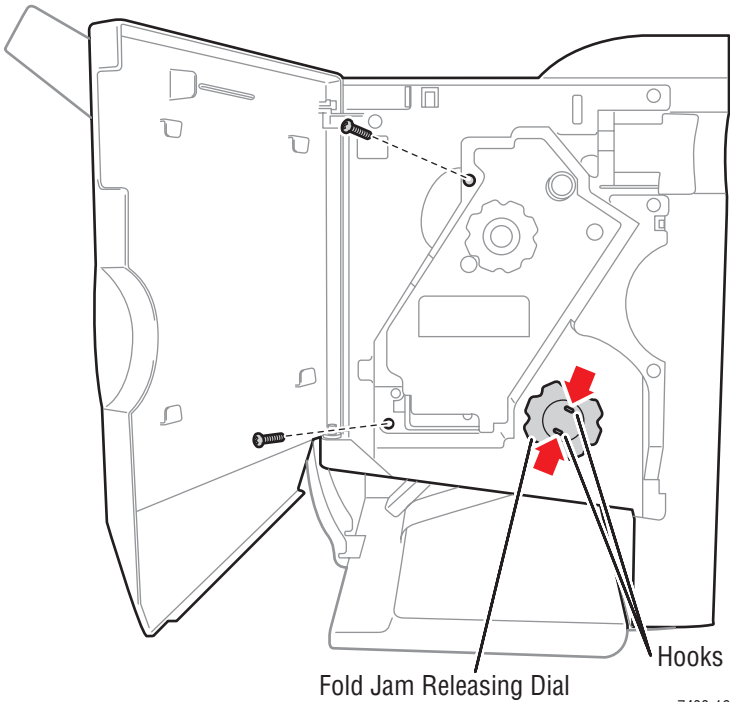

4. Press the release latch and slide the finisher away from the Finisher Base Unit.

5. To detach the Front Door, remove four screws (metal, 6 mm), pull the right side of the cover away from the Finisher, and then slide the cover to the left (moving the guide tab out of the slot on the cover).

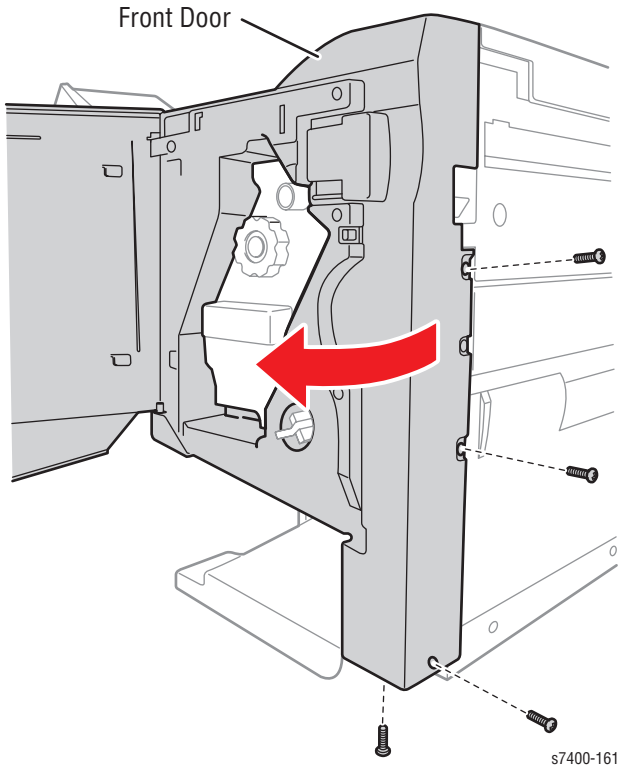

## Right Side Door (Door G)

For diagnostic purposes, you may be instructed to open or close the Right Side Door on the Finisher. The illustration below identifies the location of the Right Side Door (Door G).

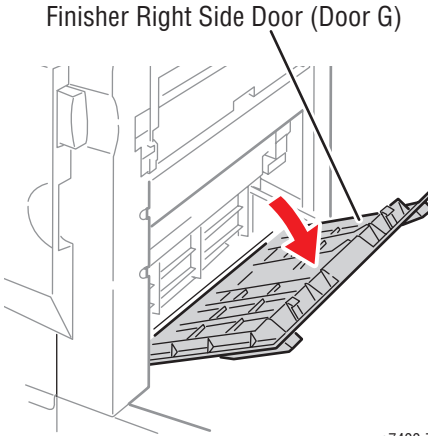

s7400-719

## Rear Cover

1. Remove the Paper Exit Tray (page 5-7).
2. Press the release latch and slide the Finisher away from the base.
3. Detach the cable from the Finisher to the Inverter (at the rear of the Finisher).

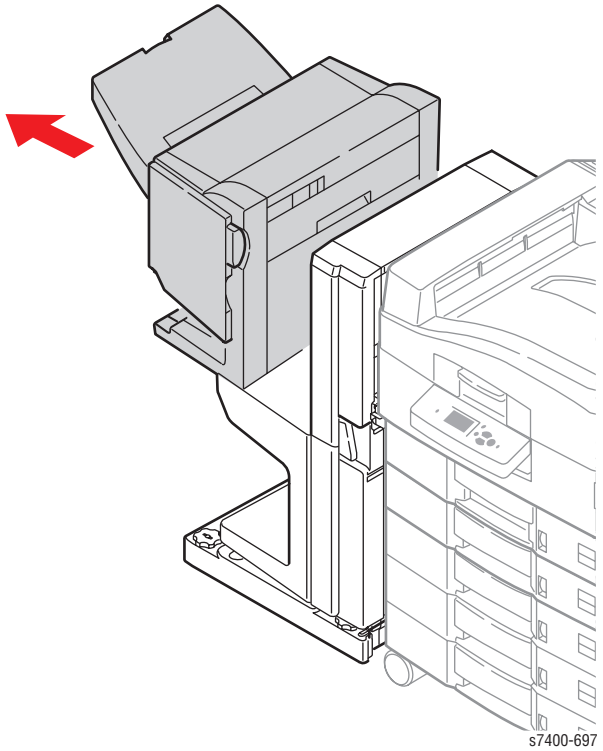

s7400-697

4. Remove two screws (metal, 6 mm) on the left side of the rear cover.

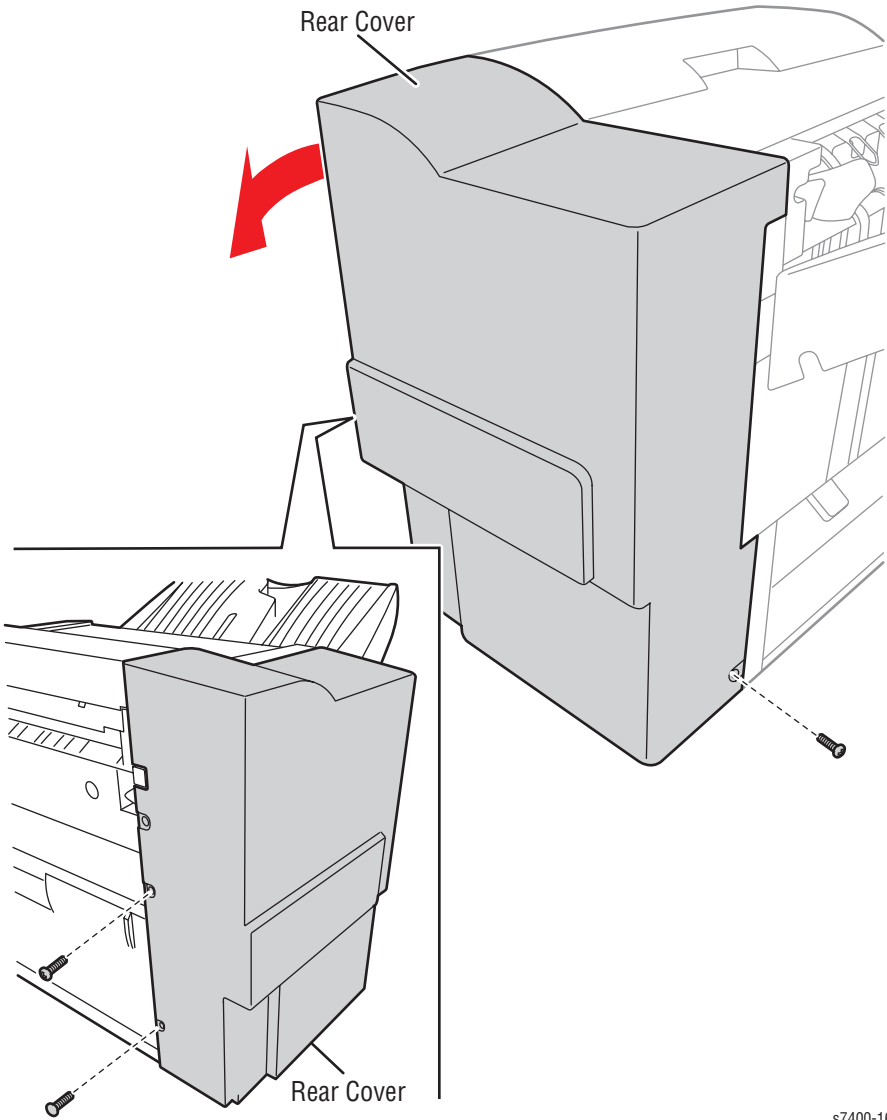

s7400-162

5. Remove one screw (metal, 6 mm) on the right side of the rear cover.

6. Slide the Rear Cover towards the right side of the Finisher and remove.

## Upper Cover (Door H)

1. Remove the Paper Exit Tray (page 5-7).
2. Remove the Rear Cover (page 5-11).
3. Open the Upper Cover and turn the stopper strap retainer clip counter-clockwise, then remove the strap from the cover.

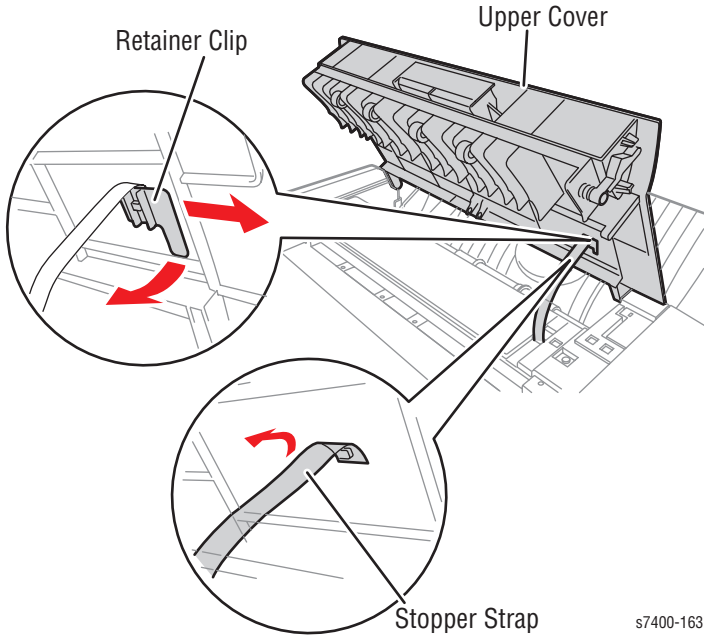

4. Remove the screw (metal, 6 mm) and detach the Processing Tray Rear Cover.

5. Detach the Upper Cover.

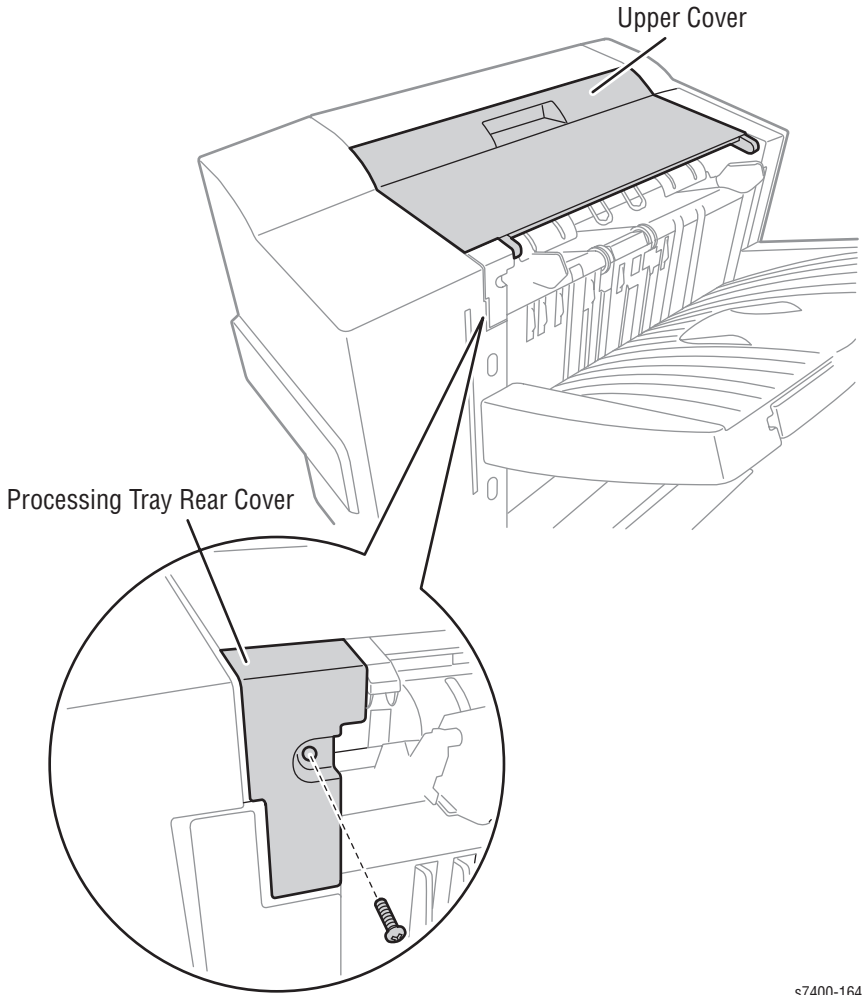

s7400-164



# Processing Tray Upper Cover

1. Remove the Paper Exit Tray (page 5-7).
2. Remove the Rear Cover (page 5-11).
3. Remove the Upper Cover. (page 5-13).
4. Disconnect the top end of the cable from the connector and free the cable from the harness.
5. Remove the single screw (metal, 6 mm) holding the tray to the chassis.

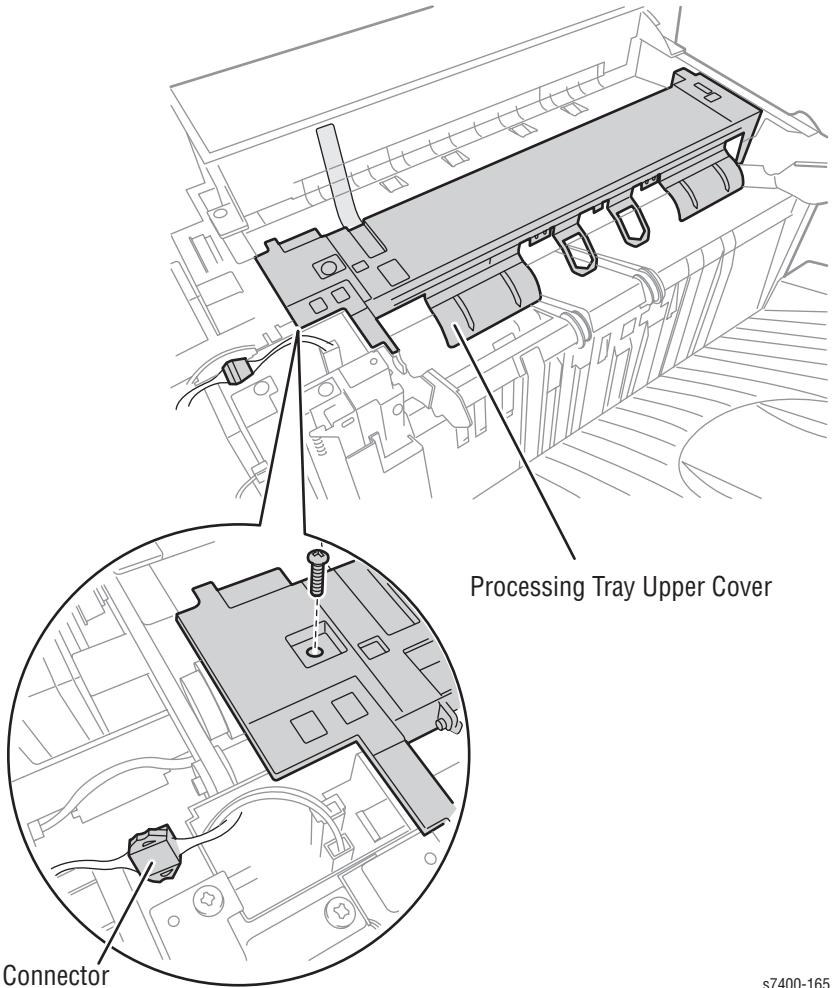

s7400-165

6. While lifting the Processing Tray Upper Cover, disconnect the other end of the cable from the connector underneath the tray.

### Replacement Note

When replacing or reconnecting the connector, be sure the connection is firm and secure. Otherwise, you will receive a Paddle Motor error.

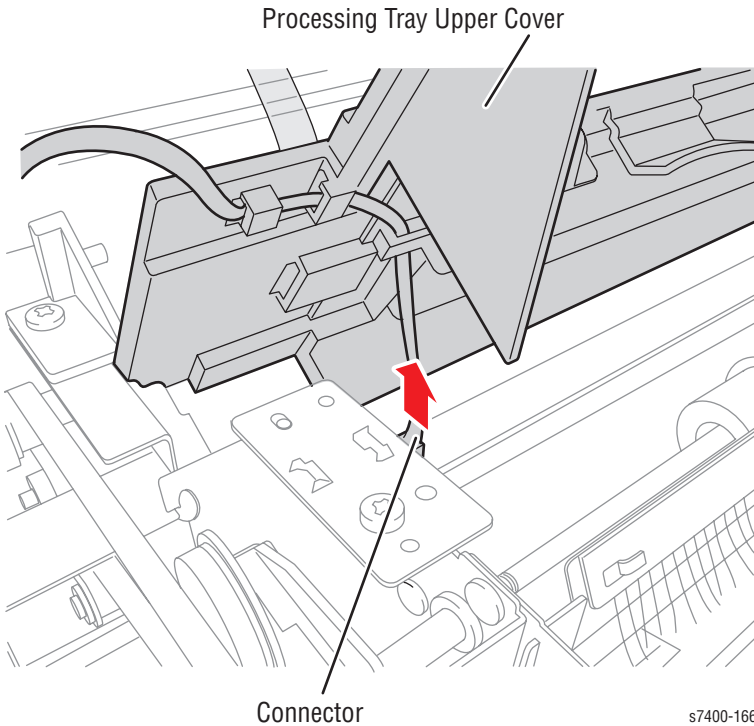

# Inverter Front Covers

1. Remove the Inverter and base unit from the Finisher (page 5-5).
2. Press the release latch and slide the Finisher away from the printer.
3. Remove two screws (metal flange, 10 mm) holding the Lower Front Cover to the chassis.
4. Remove the Lower Front Cover.

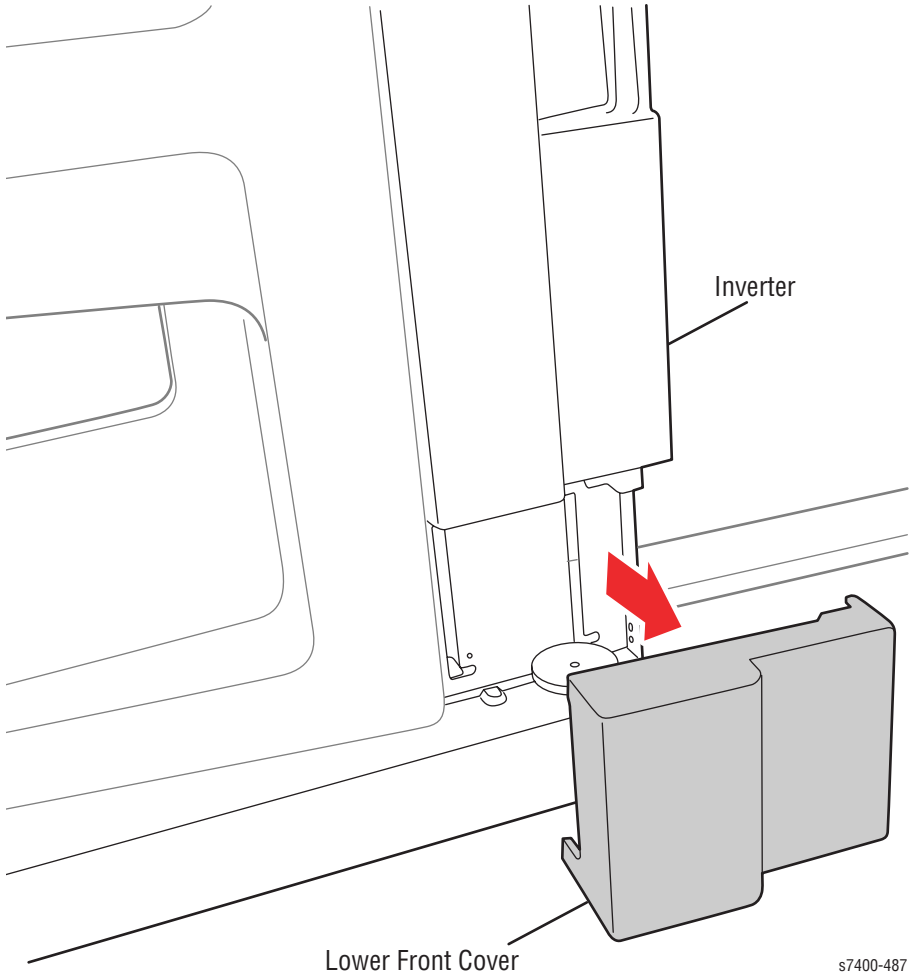

s7400-487

5. Remove two screws (metal flange, 10 mm) from the left side and two screws from the right side of the Upper Front Cover.
6. Remove one screw (metal flange, 10 mm) from the bottom of the Upper Front Cover.
7. Carefully move the Finisher release latch out of the slot and remove the Upper Front Cover.

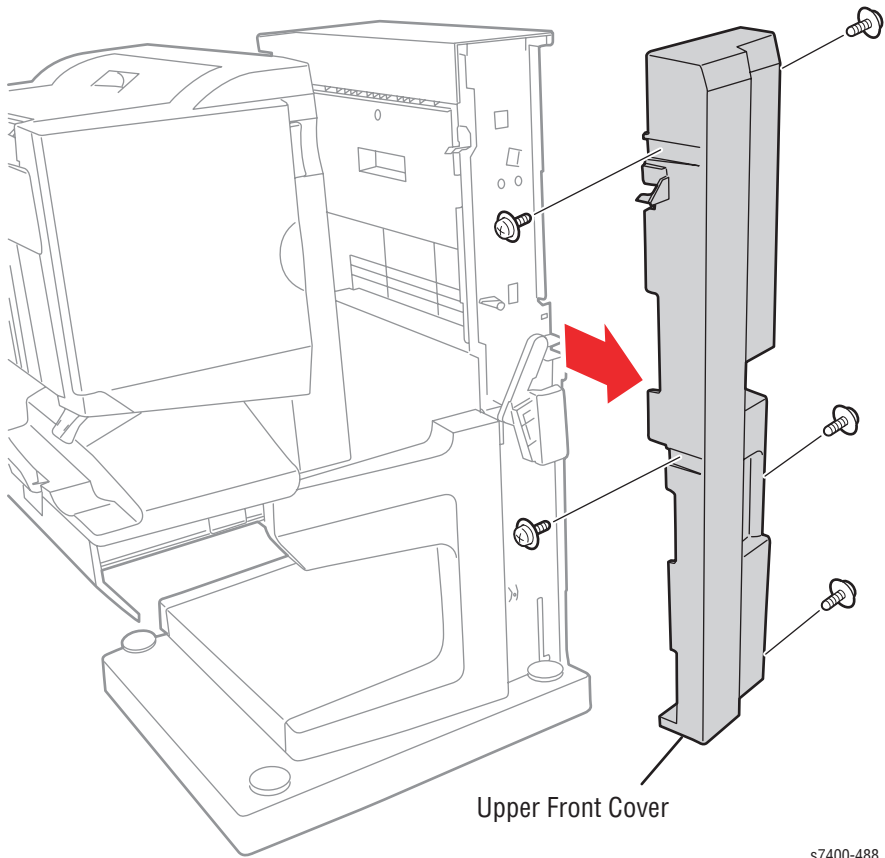

## Inverter Rear Covers

1. Remove the Inverter and base unit from the Finisher (page 5-5).
2. Press the release latch and slide the Finisher away from the printer.
3. Remove two screws (metal flange, 10 mm) holding the Lower Rear Cover to the chassis.
4. Remove the Lower Rear Cover.

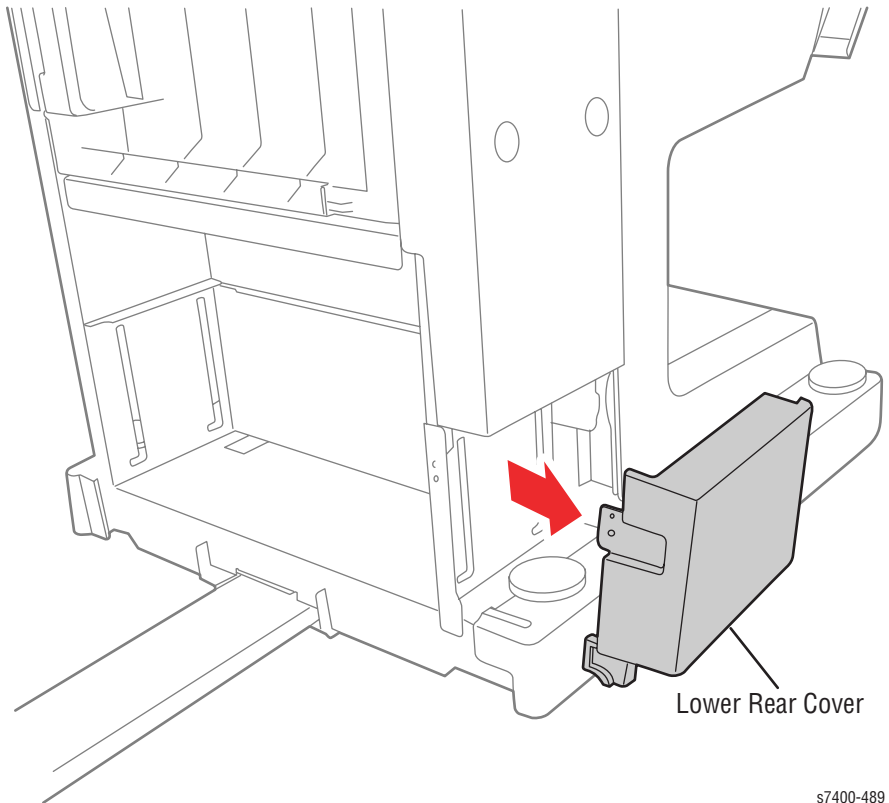

s7400-489

5. Remove one screw (metal flange, 10 mm) from the left side and one screw from the right side of the Upper Rear Cover.
6. Remove two inset screws (metal flange, 10 mm) near the bottom of the Upper Rear Cover.
7. Remove one screw (metal flange, 10 mm) from the bottom of the Upper Rear Cover.

8. Release the cover from the four tabs holding the cover to the frame.
9. Pull the cover away from the frame. This will expose the boards, motors, and clutch units.

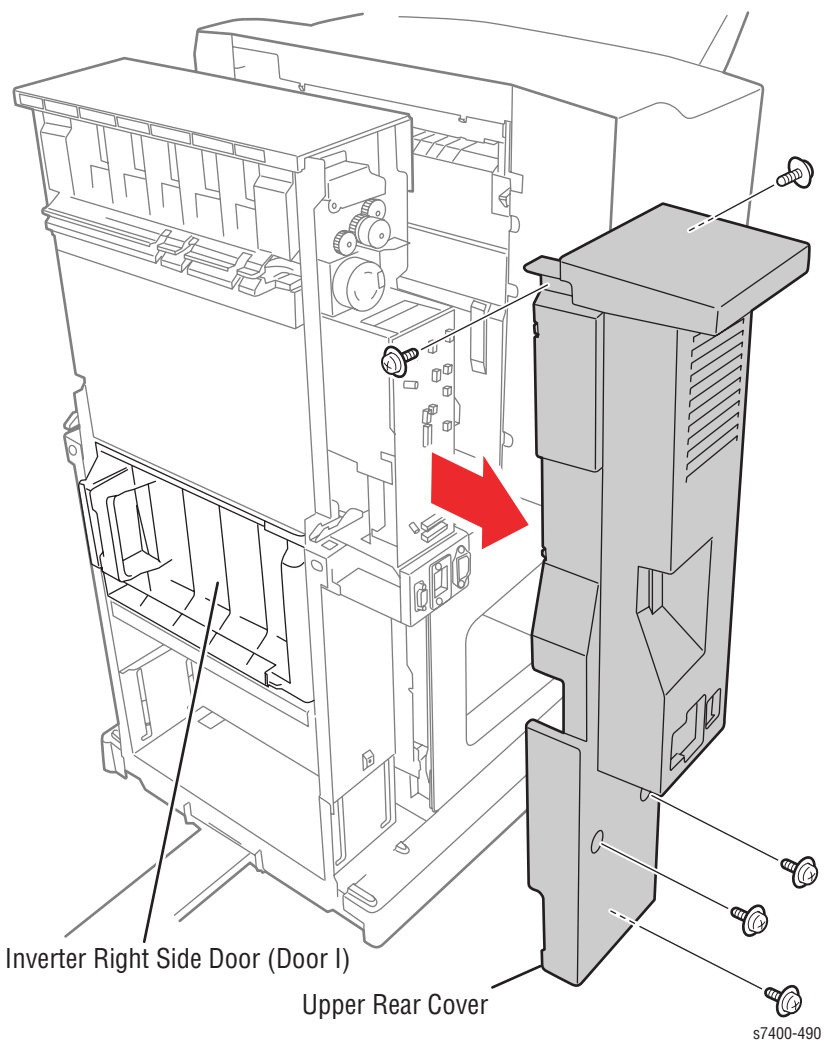

# Inverter Left Side Door (Door F)

For diagnostic purposes, you may be instructed to open or close the Left Side Door on the Inverter. The illustration below identifies the location of the Inverter Left Side Door (Door F).

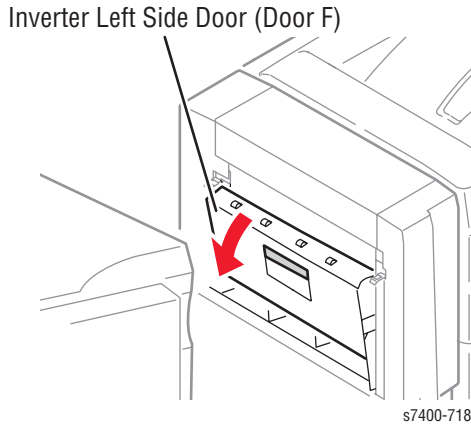

# Inverter Right Side Door (Door I)

For diagnostic purposes, you may be instructed to open or close the Right Side Door on the Inverter. The illustration below identifies the location of the Right Side Door (Door I).

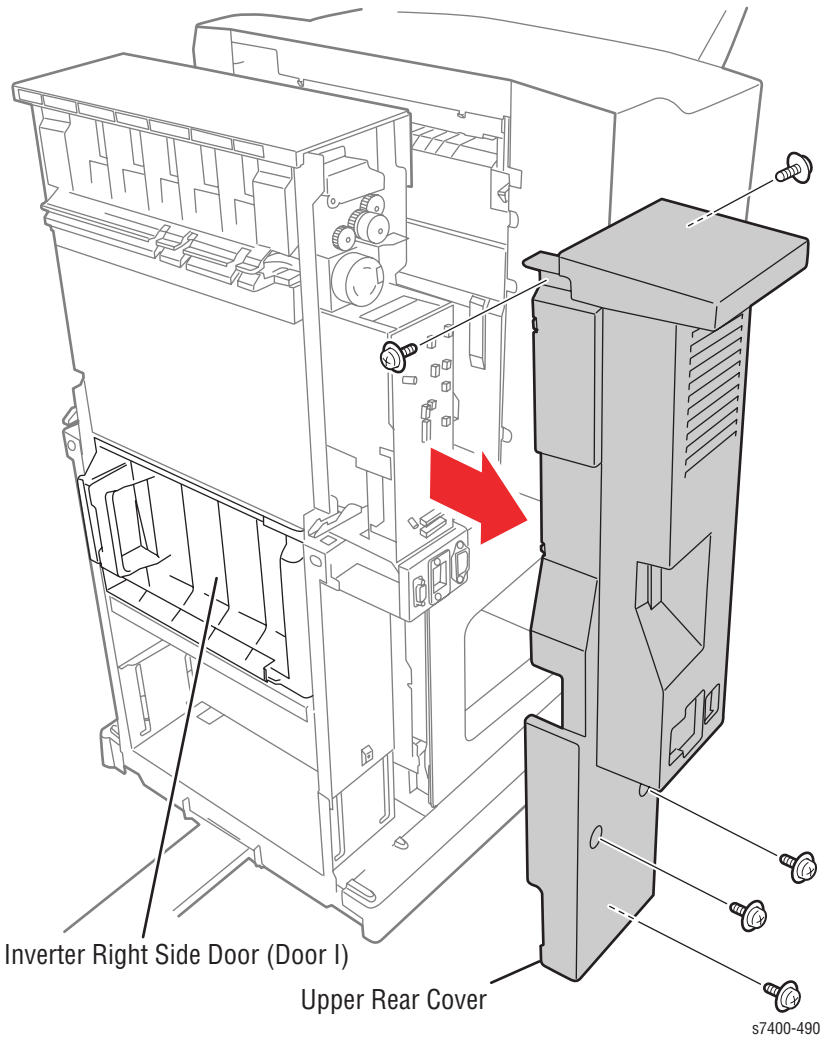



# Inverter Top Cover

1. Remove the Inverter and base unit from the Finisher (page 5-5).
2. Remove the Inverter Front Covers (page 5-17).
3. Remove the Inverter Rear Covers (page 5-19).
4. Remove two black screws (self-tapping, 6 mm) on each side of the cover.
5. Lift the cover up and away from the chassis.

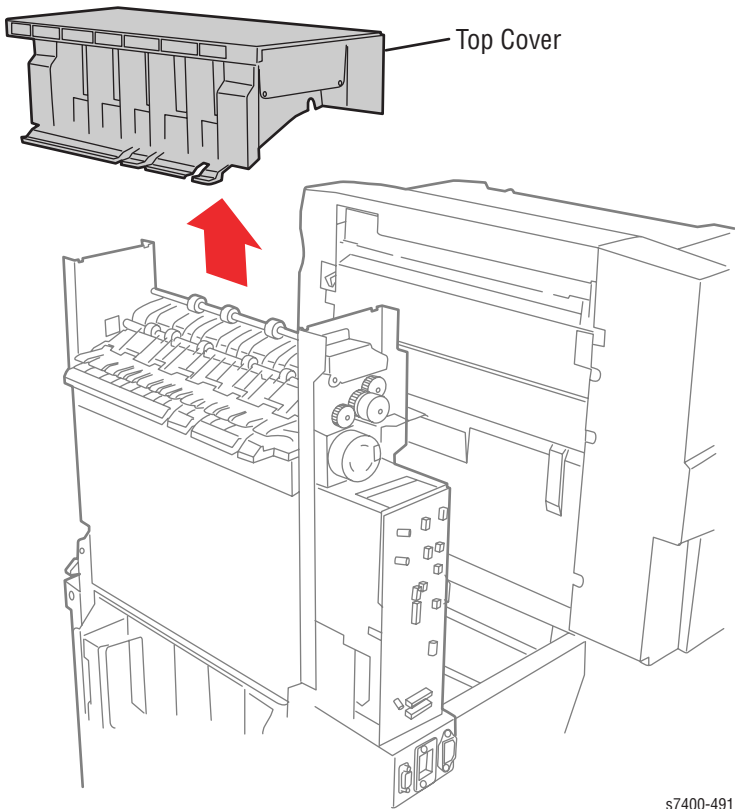

s7400-491

# Units

## Punch Unit

The steps in this procedure show you how to remove the Punch Unit.

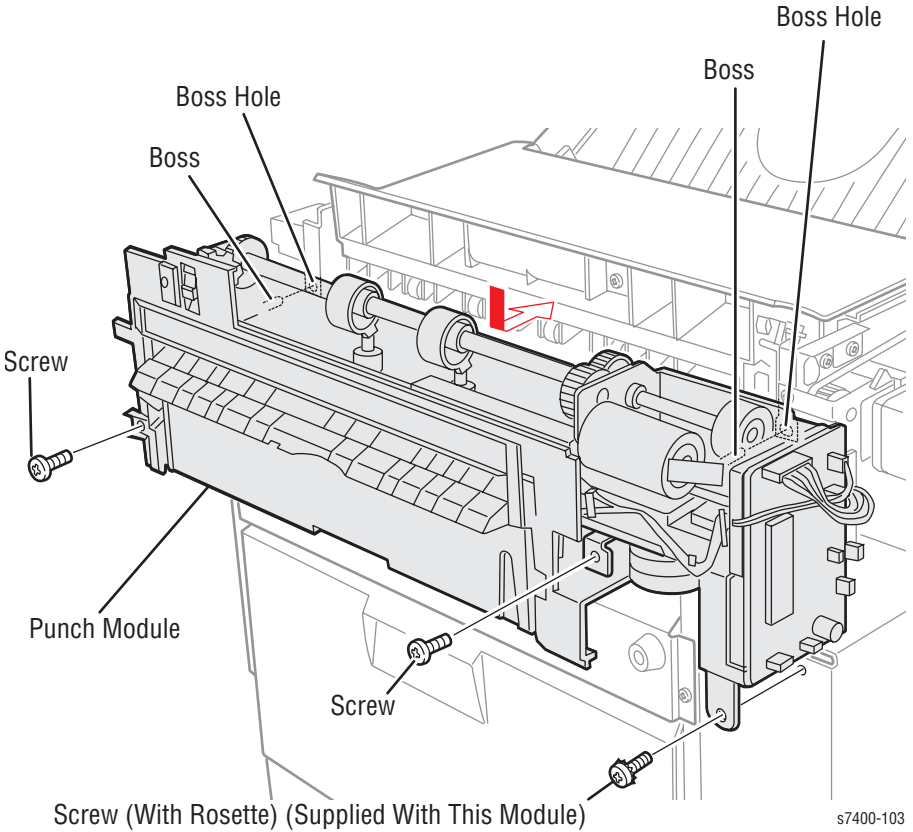

s7400-103

1. Remove the Paper Exit Tray (page 5-7).
2. Remove the Front Door (page 5-8).
3. Remove the Rear Cover (page 5-11).
4. Remove the Waste Case Box.
5. Remove the two screws (metal, 6 mm) securing the top cover of the punch unit.

6. Remove the screw (self-tapping, plastic 10 mm) to detach the Jam Processing Cover.

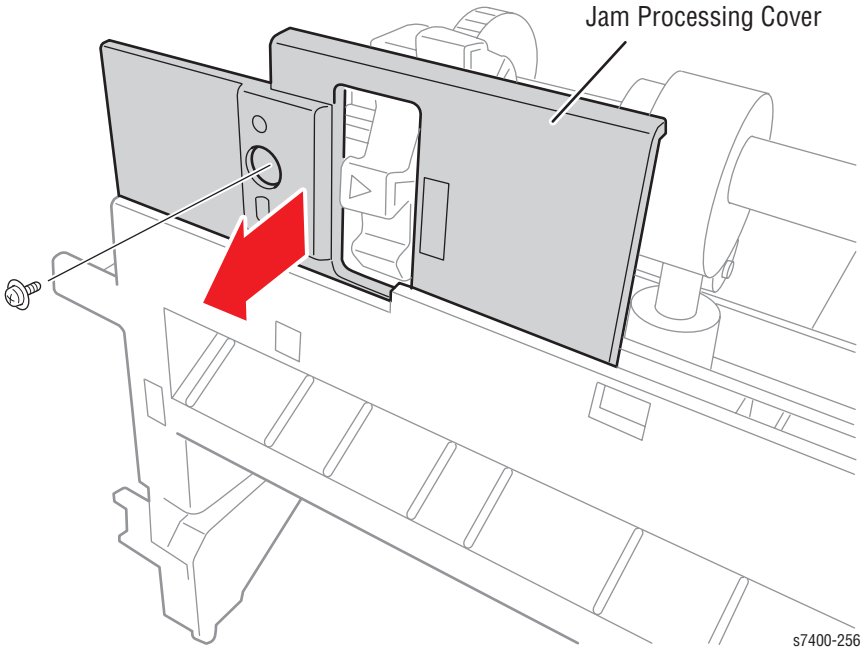

7. Disconnect the connector, and remove the harness from the harness guide.

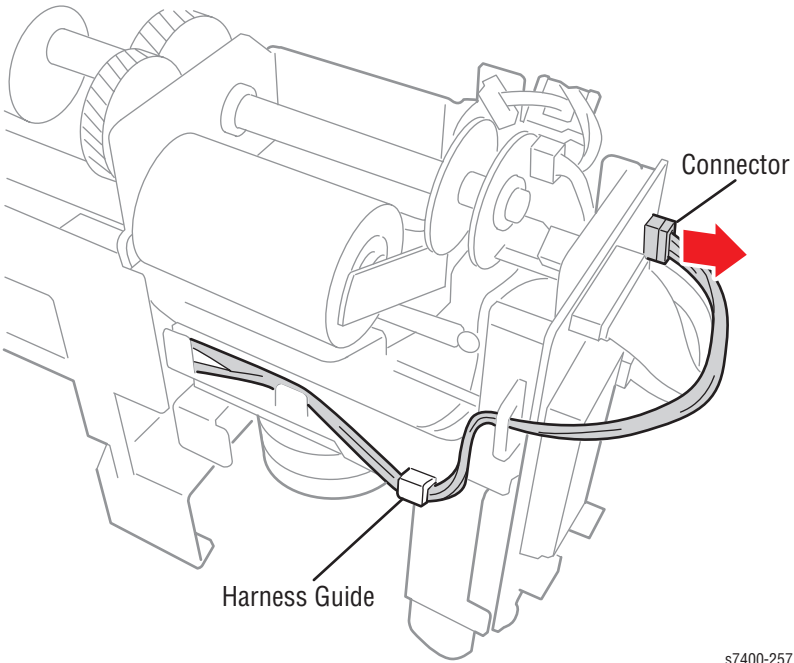

s7400-257

8. Remove the screw (metal flange, 6 mm) and Sensor Support Plate.

9. From the left side view, disconnect the sensor connector.

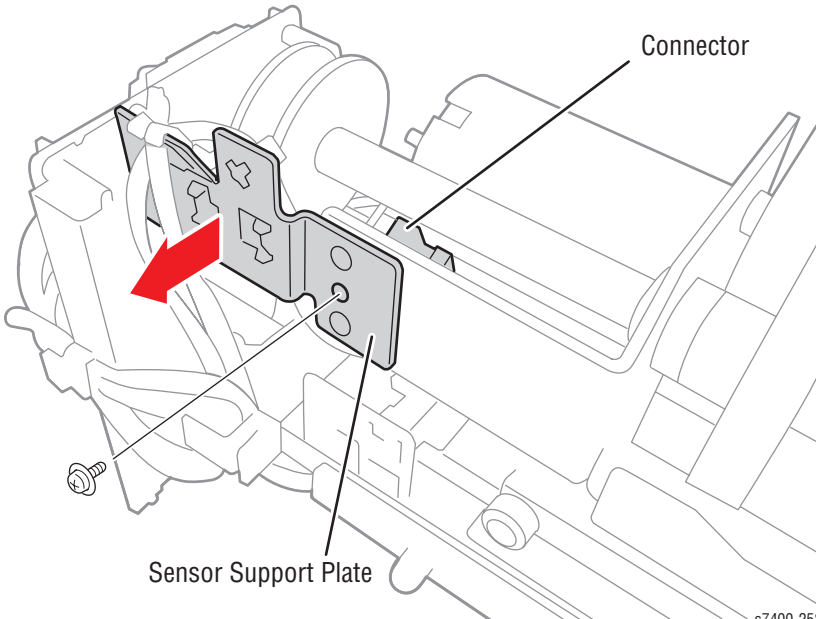

s7400-258

10. Remove one screw (metal flange, 6 mm) and washer.
11. Disconnect the connector (from the underside of the unit) and then the assembly. Remove the two screws (self-tapping, plastic 10 mm) to detach the base cover.

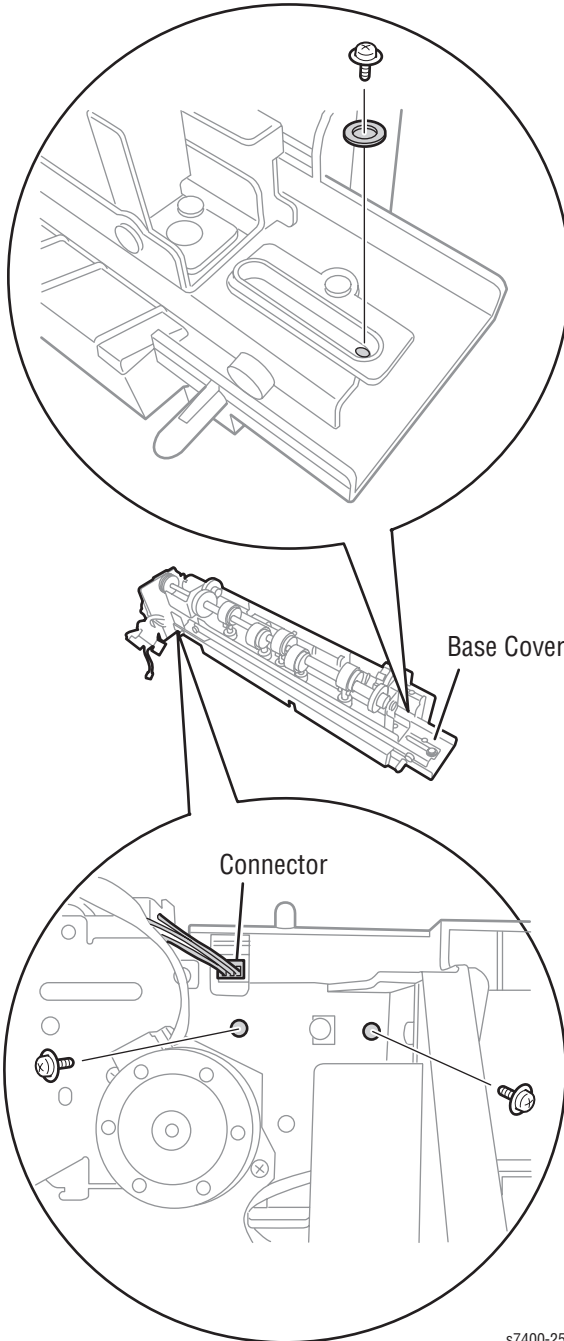

s7400-259

- 12.** Remove the three screws (metal flange, 6 mm) to remove the Upper Transmission Sensor Unit and the Lower Transmission Sensor.

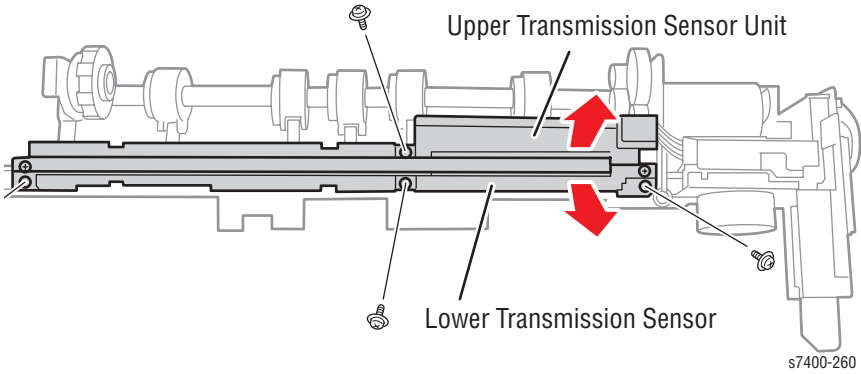

- 13.** Remove the Punch Unit from the Finisher Punch Transfer Motor assembly.

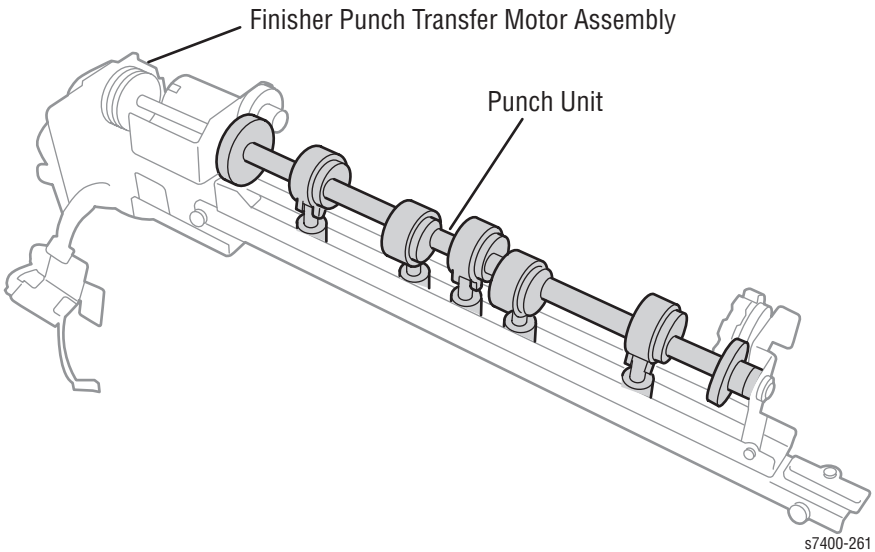

# Staple Unit

1. Open the Front Door to gain access to the Staple Unit.
2. Slide out the Staple Unit while pressing the stopper.

## Note

Do not remove the Stapler Frame Shaft. If removed, the position where the staple driver (lower unit of the stapler) inserts the staple through the paper will shift from the position where the staple clincher (upper unit of the stapler) clinches staples.

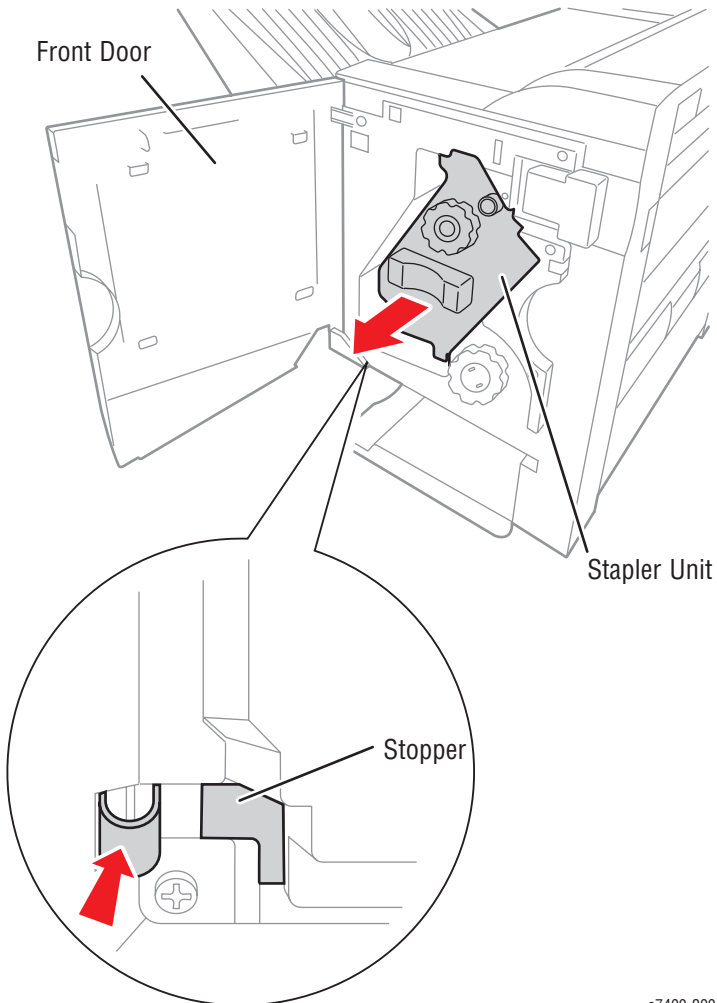

s7400-200

# Staple/Fold Drive Unit

## Note

The references indicate the connector on the Finisher Controller Board.

1. Remove the Front Door (page 5-8) and slide out the Stapler Unit to the front.
2. Remove the Rear Cover (page 5-11).
3. Remove the screw (metal flange, 6 mm) and detach the Interface Retainer.
4. Free the seven harness retainers, and disconnect the cable to connector CN18.
5. Free the harness from the harness retainer and the Edge Saddle, disconnect the two remaining cables to connector CN11 and CN7 and unroute from the harness.

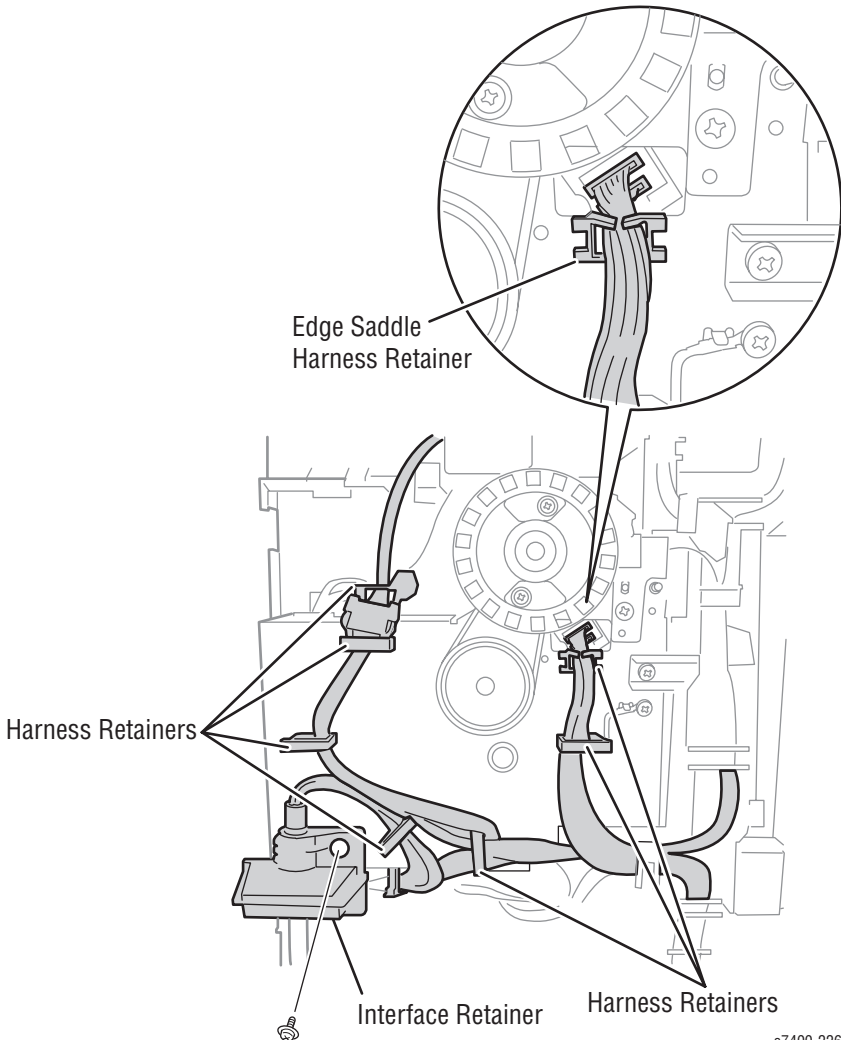

s7400-226



6. Disconnect the cable connector (to CN10) behind the Punch Unit.
7. Slide the Finisher away from the Inverter and then free the harness.
8. Free the harness from the Edge Saddle and disconnect the two connectors (to CN18).

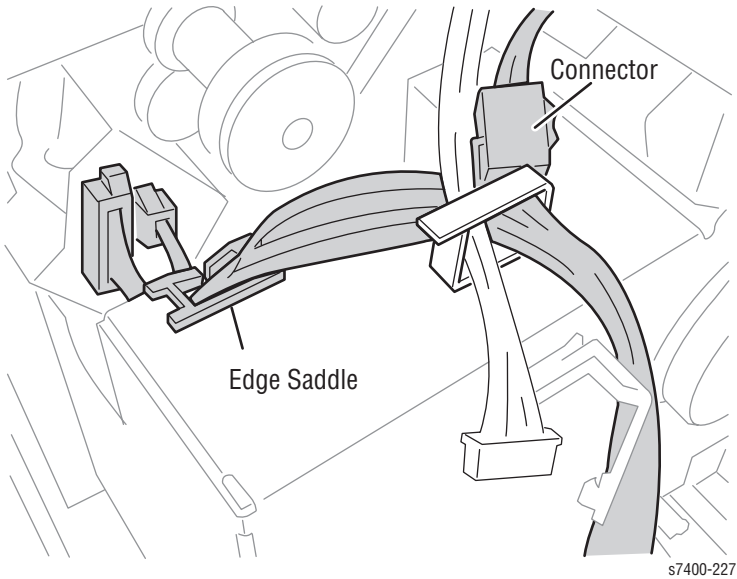

9. Remove the two screws (metal flange, 6 mm), free the tab of the harness guide, and remove all connectors to clear the harness guide.

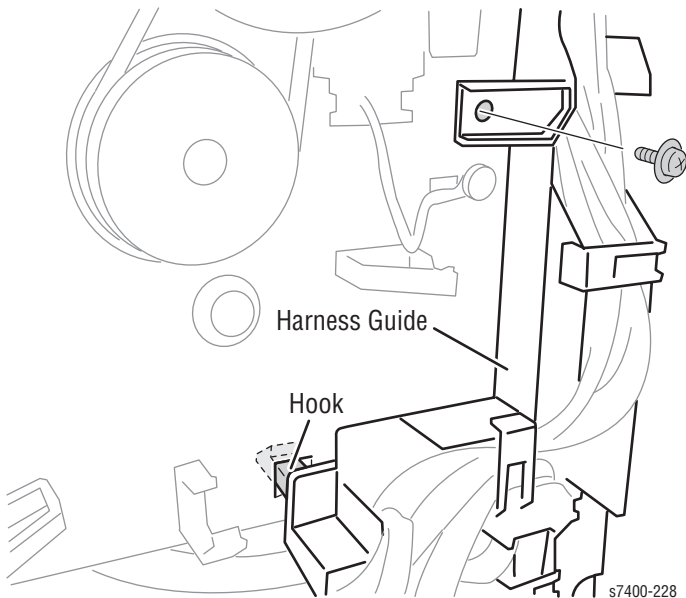

10. Disconnect the connector to CN8 and the connector to CN6, and free the harness from the Edge Saddle.

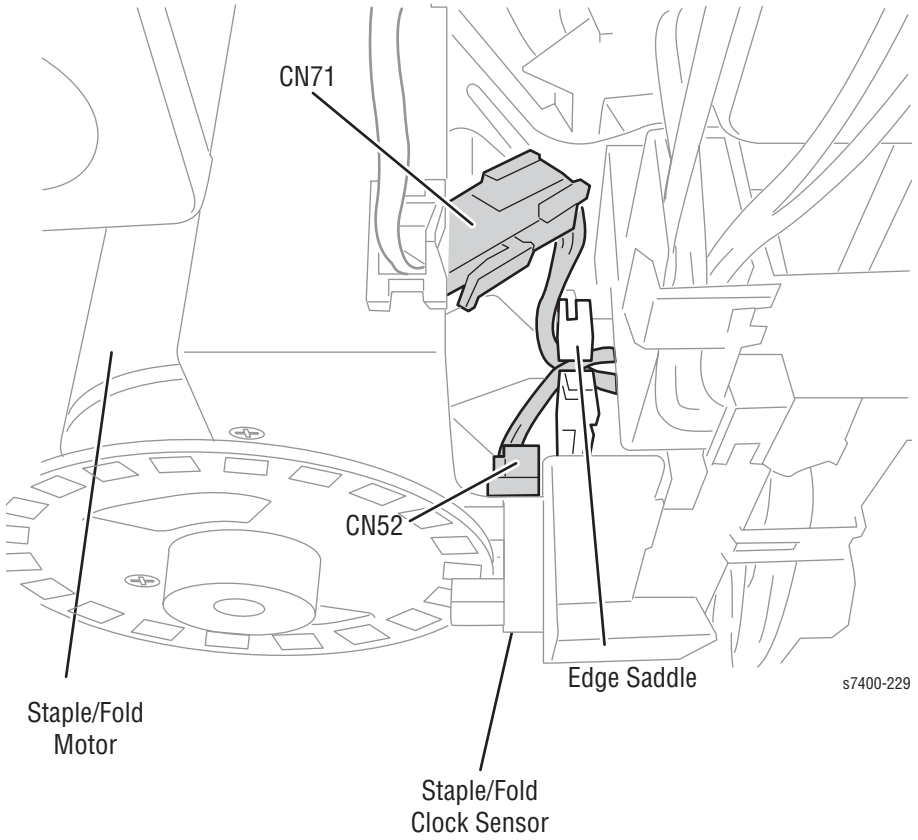

s7400-229

- 11.** Remove the five screws (metal, 10 mm), lift to free two hooks (one on each side, and remove the unit.

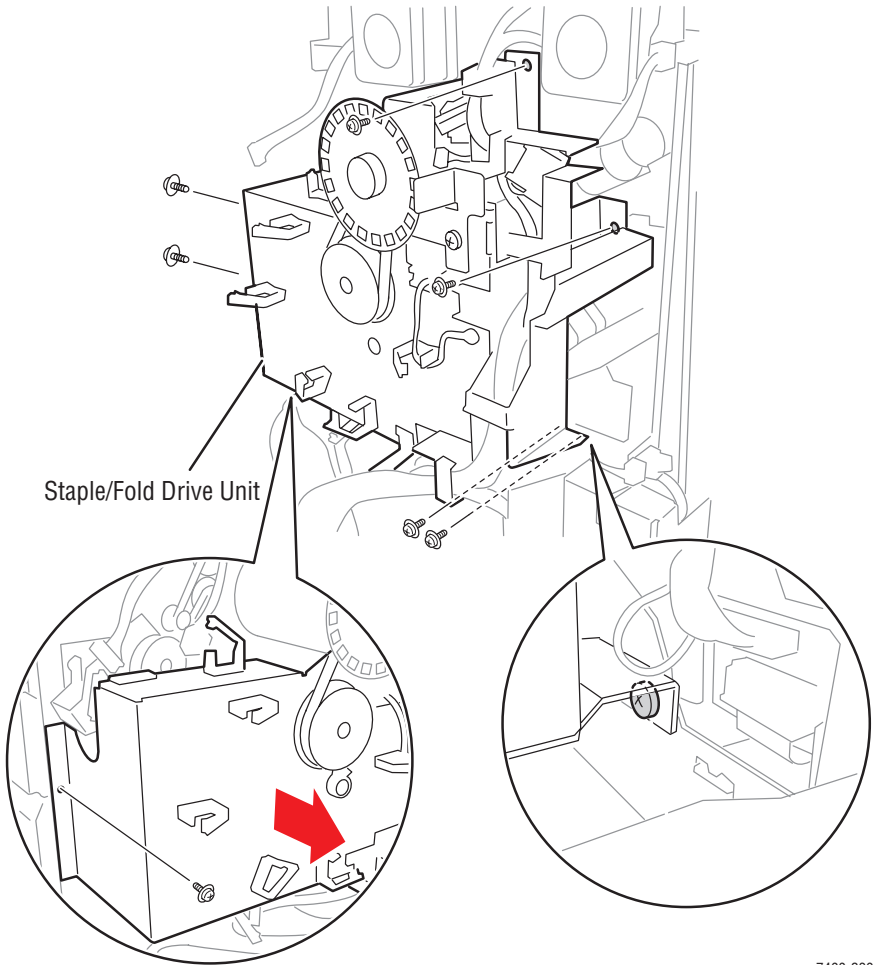

s7400-230

# Saddle Unit

1. Remove the Paper Exit Tray (page 5-7).
2. Remove the Front Door (page 5-8).
3. Remove the Rear Cover (page 5-11).
4. Open the Jam Removal Cover (Door I) and remove two screws (metal, 10mm) and the right stay.
5. Turn the Fold Jam Releasing Dial Assembly to move the Paper Retaining Plate Assembly to the inside.

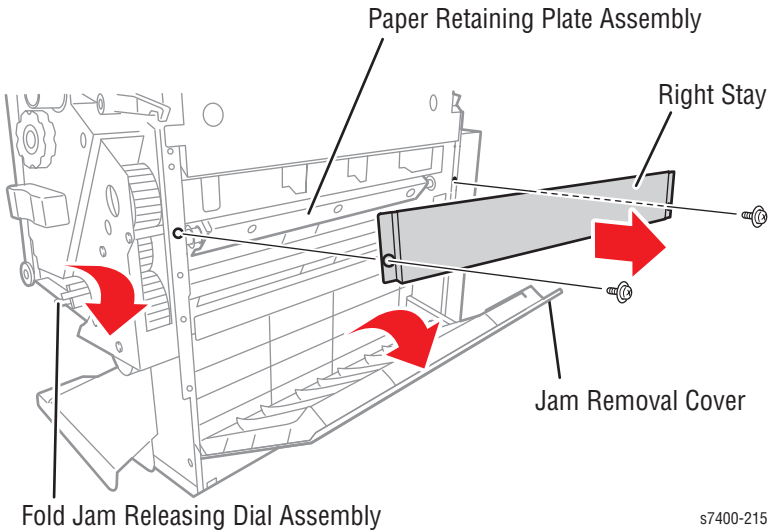

6. Remove the Punch Unit Assembly (page 5-24).

**7.** Remove the Stop Ring and detach the Timing Belt.

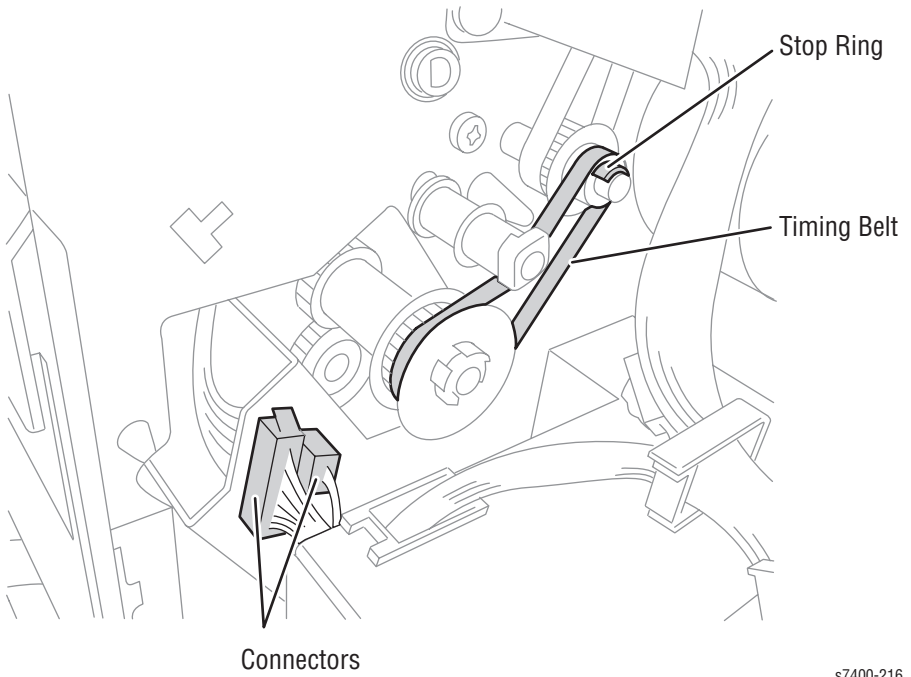

s7400-216

**8.** Disconnect the two connectors.

9. Remove the three screws (metal, 10mm) and slide out the Stapler Unit slightly to the front and remove the Saddle Unit.

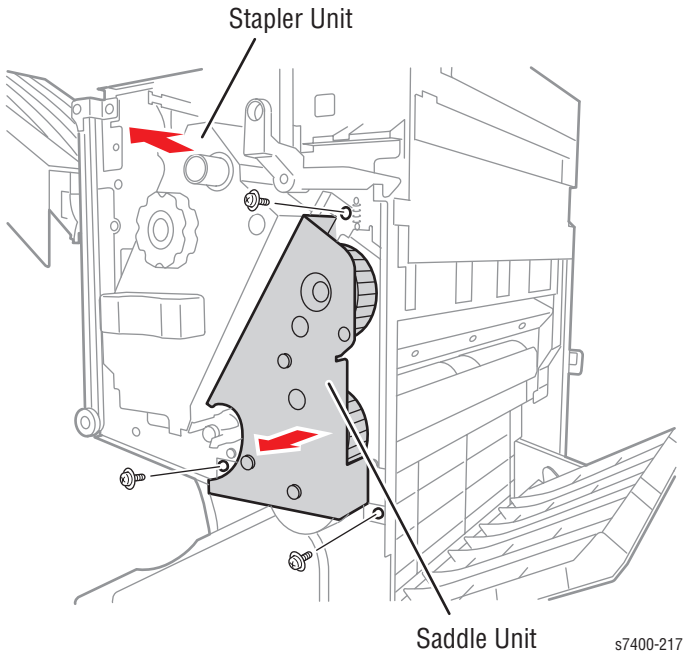

# Assemblies

## Upper Right Cover Assembly

1. Remove the Front Door (page 5-8).
2. Remove the Rear Cover (page 5-11).
3. Remove two screws (metal, 6 mm) at the front and two screws at the rear of the assembly.
4. Detach the assembly and lift up to remove.

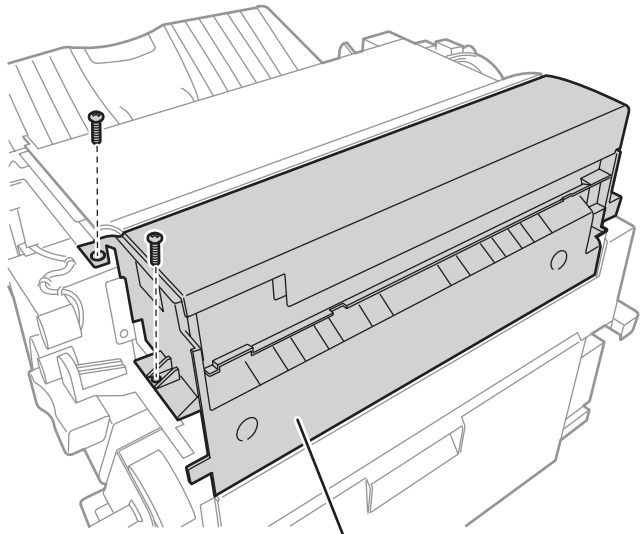

Upper Right Cover Assembly

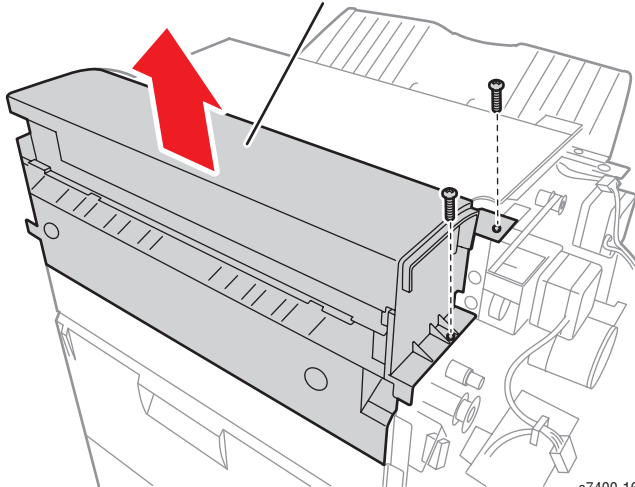

s7400-167

# Processing Tray Assembly

1. Remove the Processing Tray Upper Cover (page 5-15).
2. Remove the Upper Right Cover Assembly (page 5-37).
3. Remove the Side Guide (page 5-107).
4. Remove the two screws (metal, 10 mm) and disconnect the following four connectors:
  - CN36 to Clutch
  - CN85 to Rear Alignment Motor
  - CN63 to Front Alignment Motor
  - CN57 to Delivery Motor

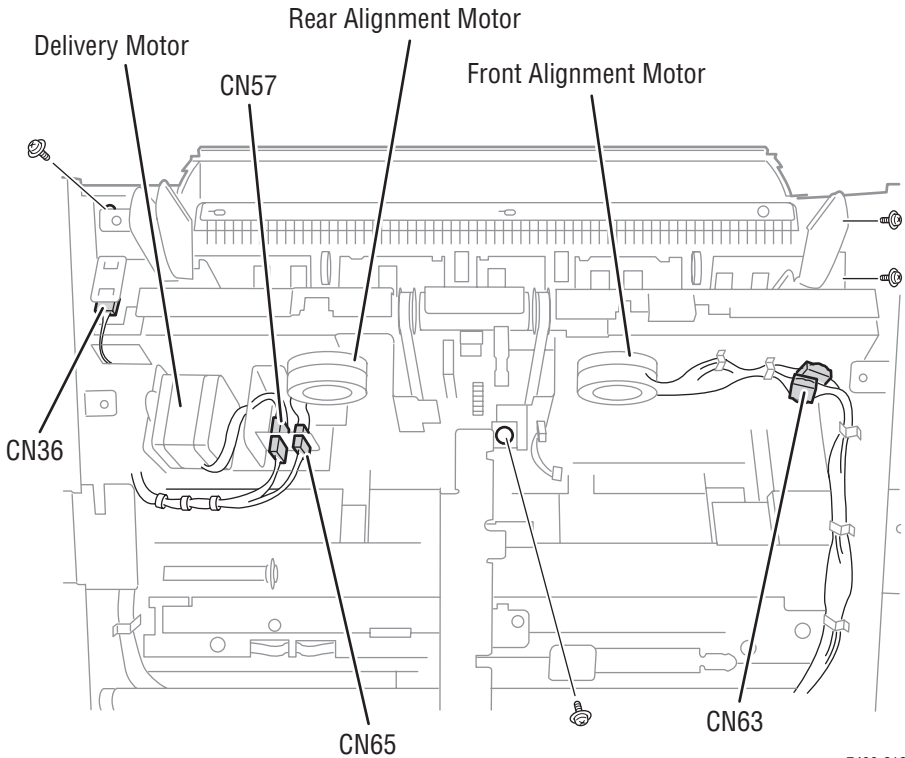

s7400-218



5. Pull the Processing Stopper Base to the front and free the hooks at the front and rear of the Processing Stopper.

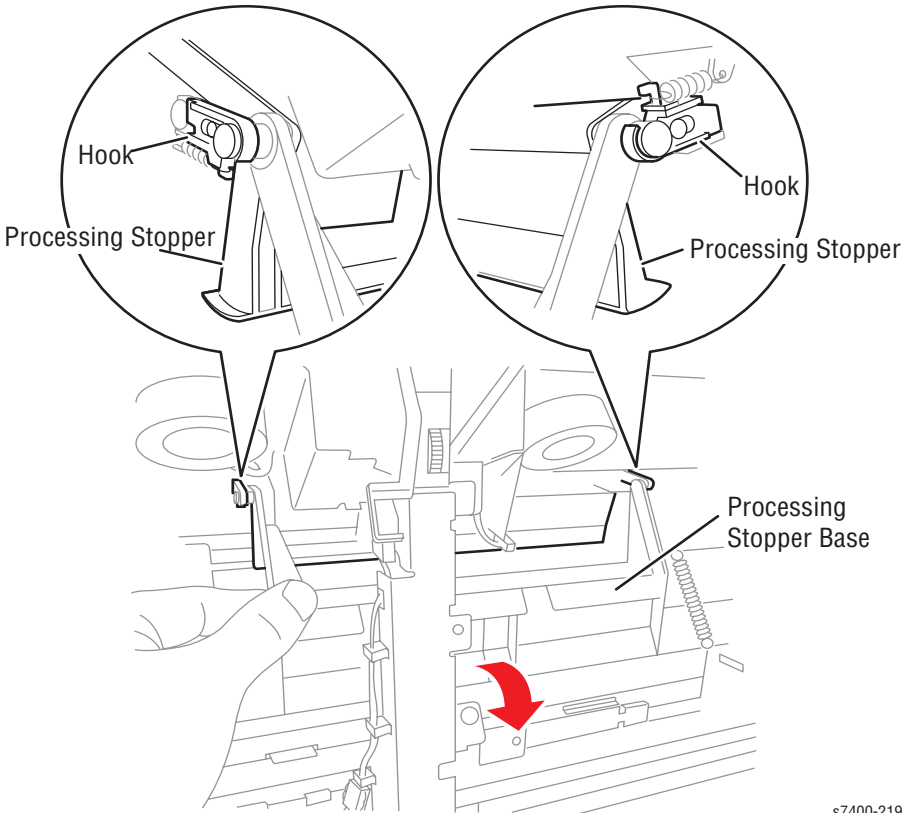

s7400-219

6. Release the two hooks of the harness retainer, remove three connectors and detach the motor harness.

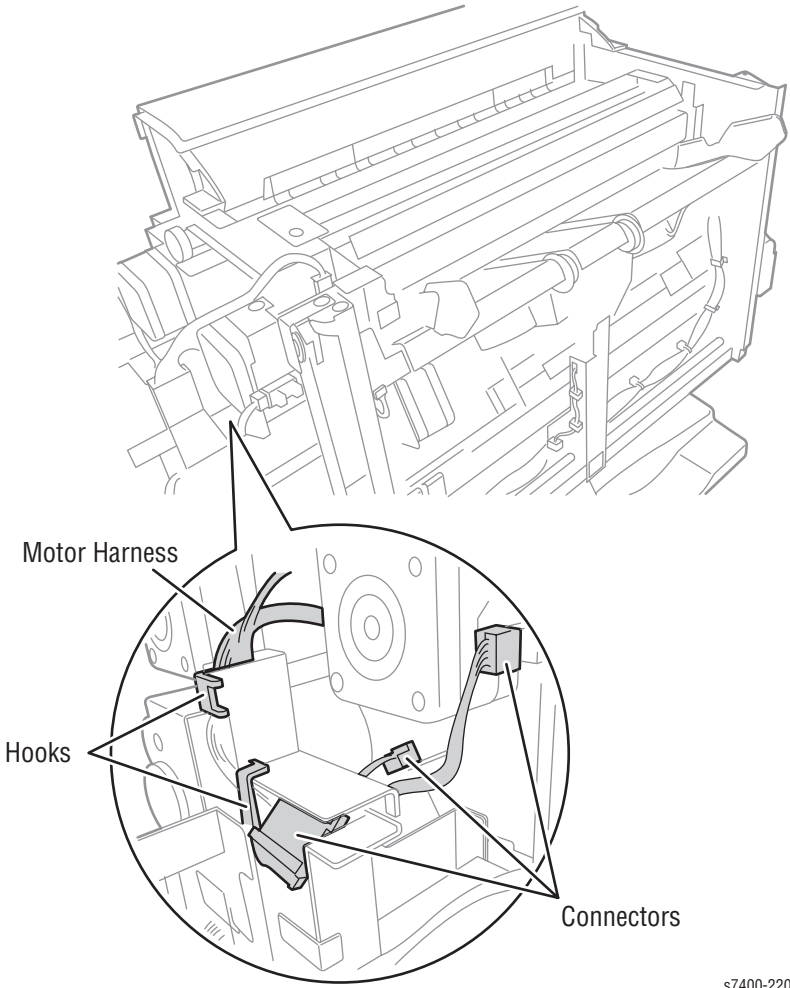

s7400-220

7. Remove the Stop Ring and detach the Timing Belt.

**Caution**

A free-floating pin is inserted in the gear shaft that can easily fall into the chassis. Be careful when loosening or removing the belt from the gear.

8. Disconnect the connector and free the harness from the Edge Saddle.

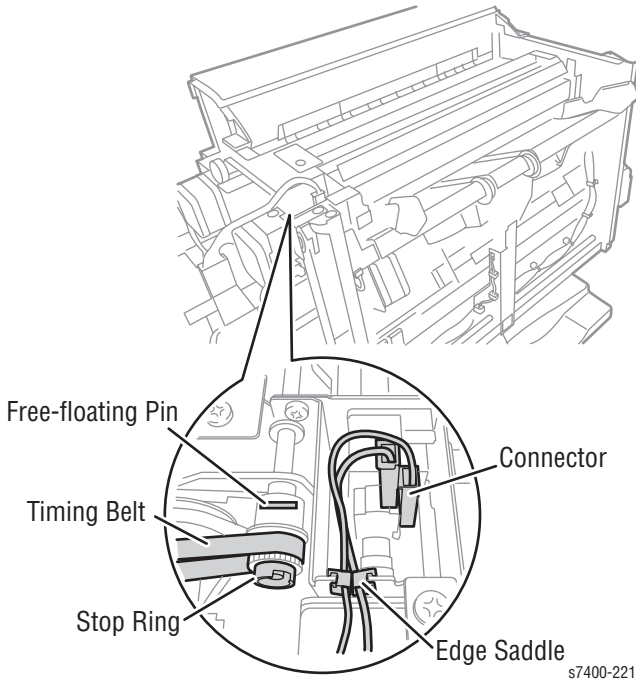

s7400-221

9. Remove the two screws (metal flange, 6 mm), slide the Processing Tray Assembly to the rear, then lift it to detach.

**Caution**

Note the inset in the illustration below to find two screws on the chassis side holding the tray to the unit. You must remove these screws before you can free the unit.

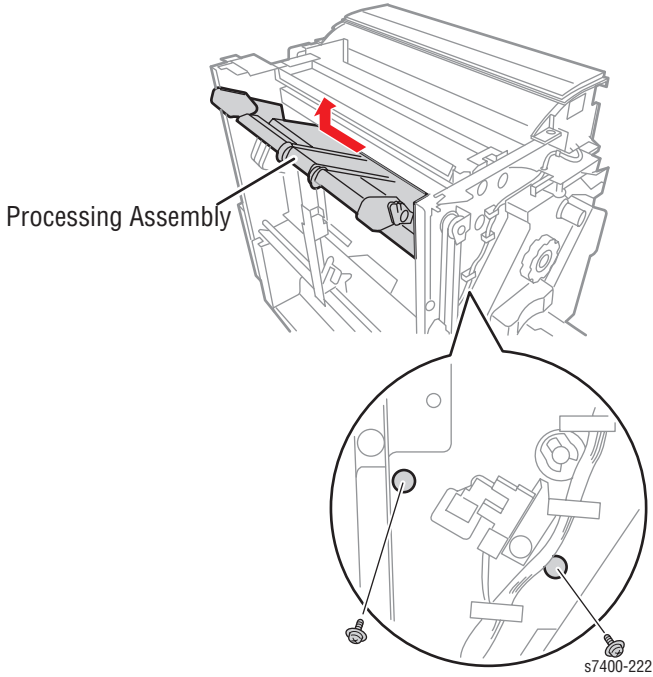

# Paddle Assembly

1. Remove the Processing Tray Assembly (page 5-38).
2. Place the assembly as shown.

## Caution

Be sure to take care not to damage the aligning plates.

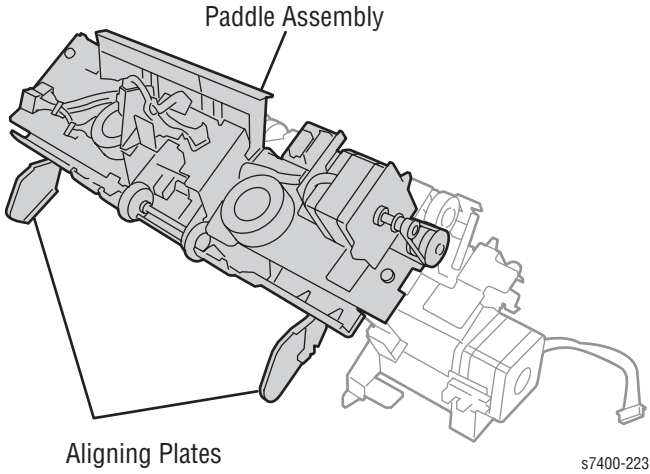

**3.** Detach the Timing Belt and remove the two screws (metal flange, 6 mm).

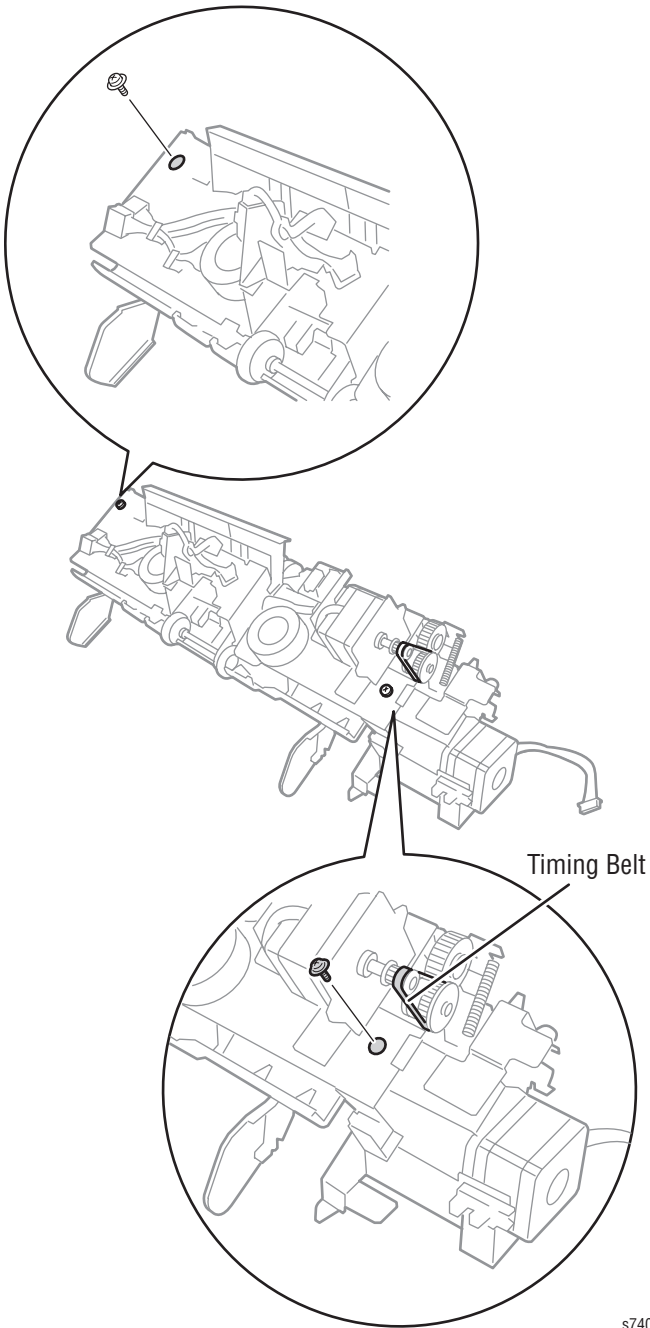

s7400-224

4. Separate the Processing Tray Assembly and the Paddle Assembly as shown.

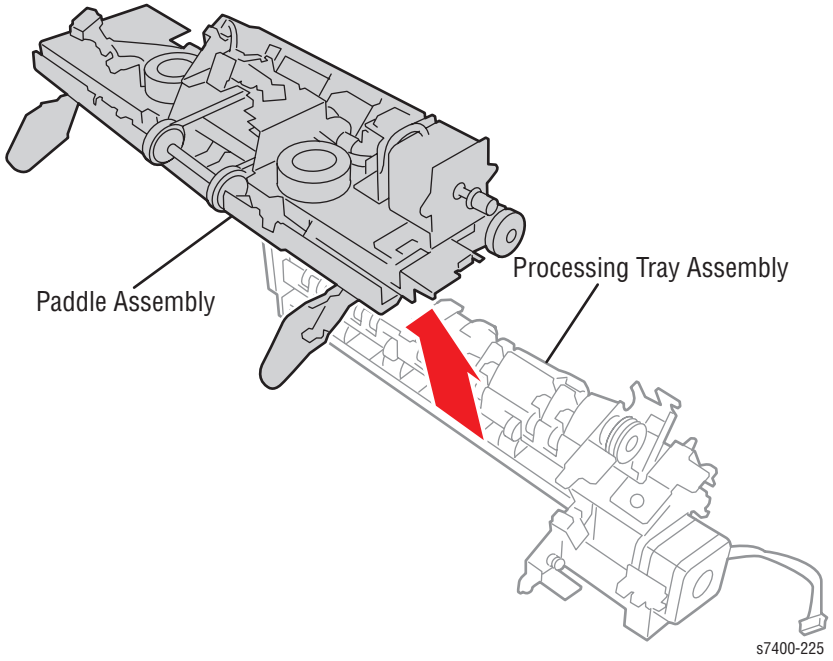

# Boards

## Finisher Controller Board

1. Remove the Rear Cover (page 5-11).
2. Disconnect the 17 connectors and remove the screw (metal flange, 6 mm).
3. Free the board retainer and detach the Finisher Controller Board.

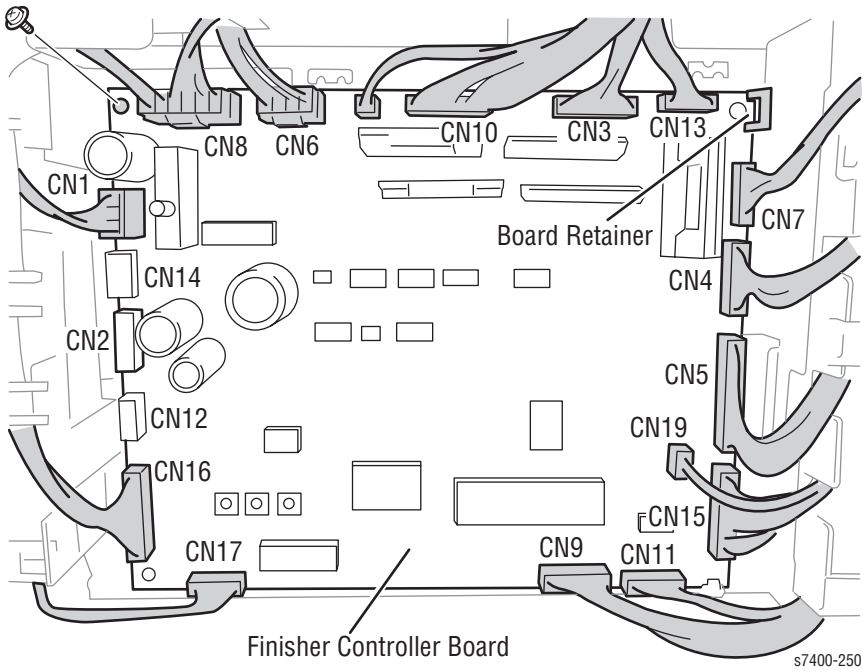



# Home Position Board

1. Remove the Rear Cover (page 5-11).
2. Remove the Front Door (page 5-8).
3. Remove the Upper Cover (page 5-13).
4. Open the Front Door and turn the knob on the stapler slide in the direction of the arrow to slide the stapler to the front-most position.
5. Remove the Stapler Unit (page 5-108).
6. Place the Stapler Unit as shown below.
7. Remove the two screws (metal flange, 6 mm) and detach the metal guide.

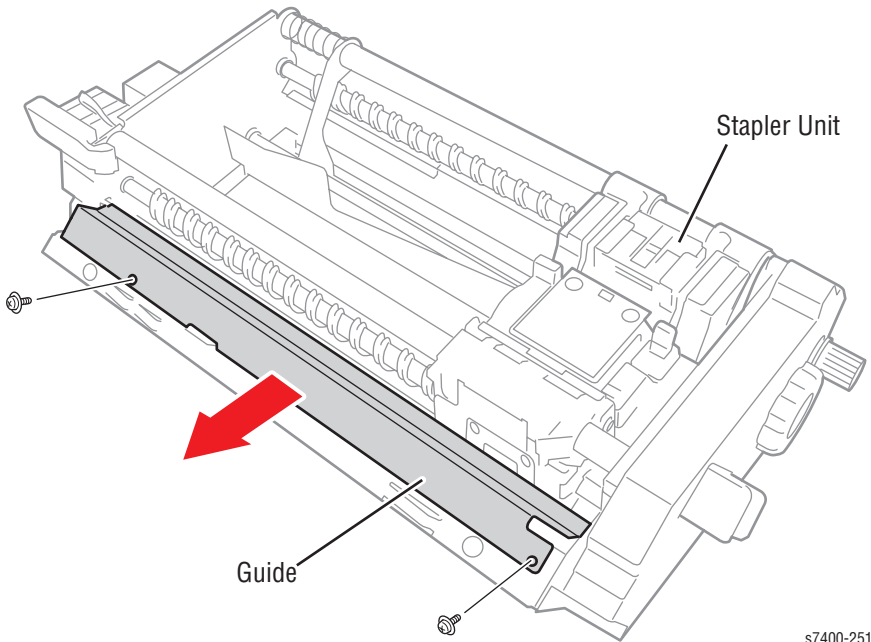

s7400-251

8. Turn the knob on the stapler side in the direction of the arrow so that the fixing screw (metal, 10 mm) of the Slide Home Position Board is in view through the round hole.

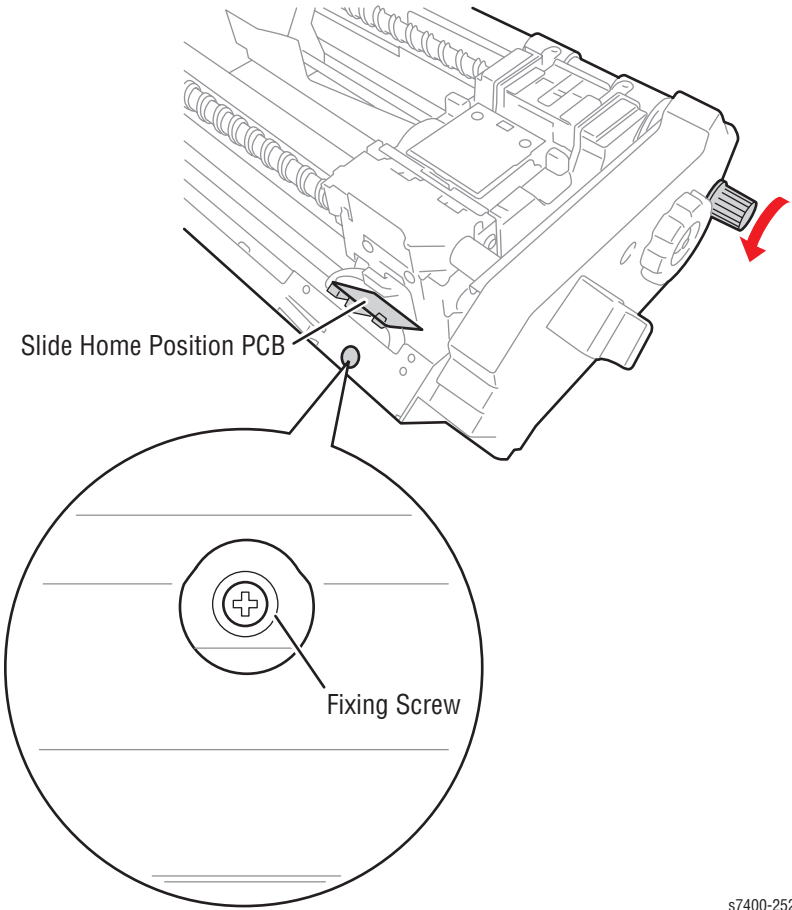

s7400-252

9. Remove the fixing screw (metal, 10mm).

10. Disconnect the connector.
11. Remove the flexible cable retainer.
12. Free the lock of the connector in the direction of the arrow, and then detach the flexible cable.

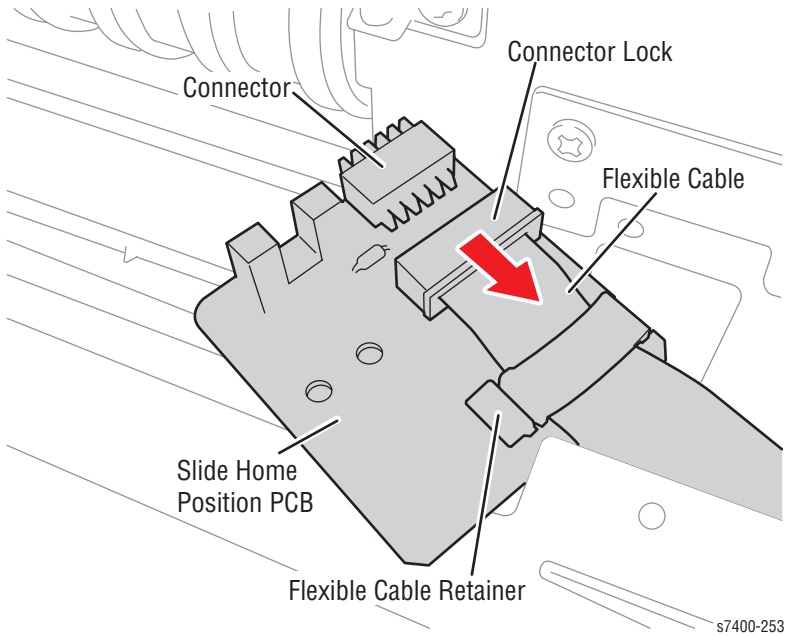

13. Detach the board.

# Punch Control Board

1. Remove the Rear Cover (page 5-11).
2. Remove the Front Door (page 5-8).
3. Remove the Upper Cover (page 5-13).
4. Remove the two screws (metal flange, 6 mm).
5. Disconnect the five connectors to remove the Punch Control Board.

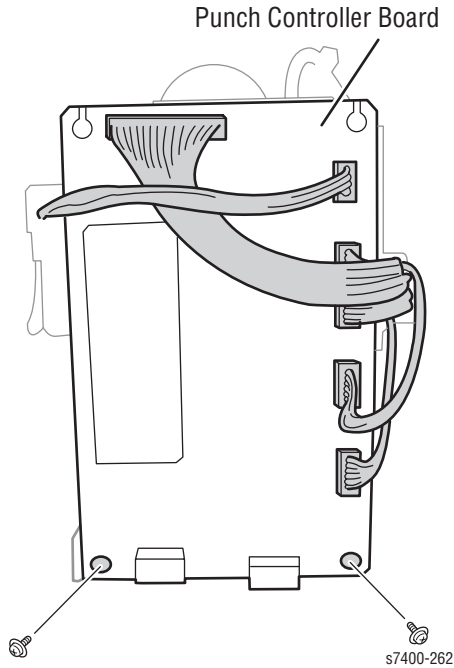

# Photo Sensor Board

1. Remove the Rear Cover (page 5-11).
2. Remove the Front Door (page 5-8).
3. Remove the Upper Cover (page 5-13).
4. Remove the Punch Motor Assembly (page 5-46).
5. Remove the screw (metal flange, 6 mm).
6. Remove the harness from the harness guide on the board, and then detach the cover.

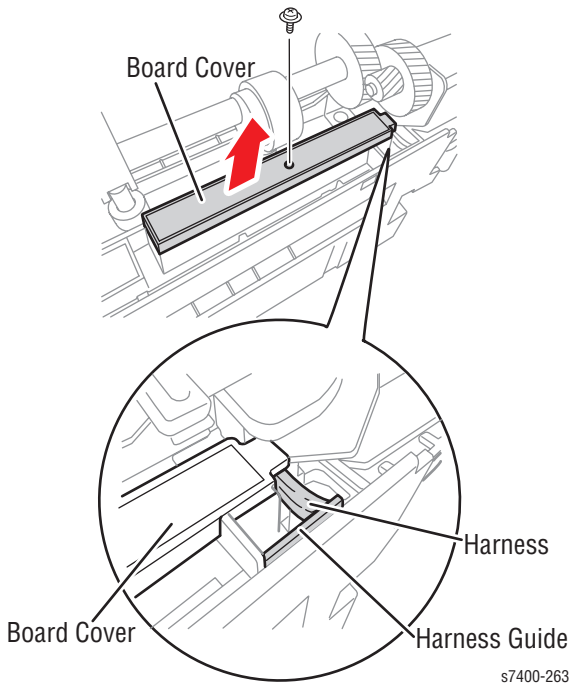

**7.** Disconnect the connector to remove the Photosensor Board.

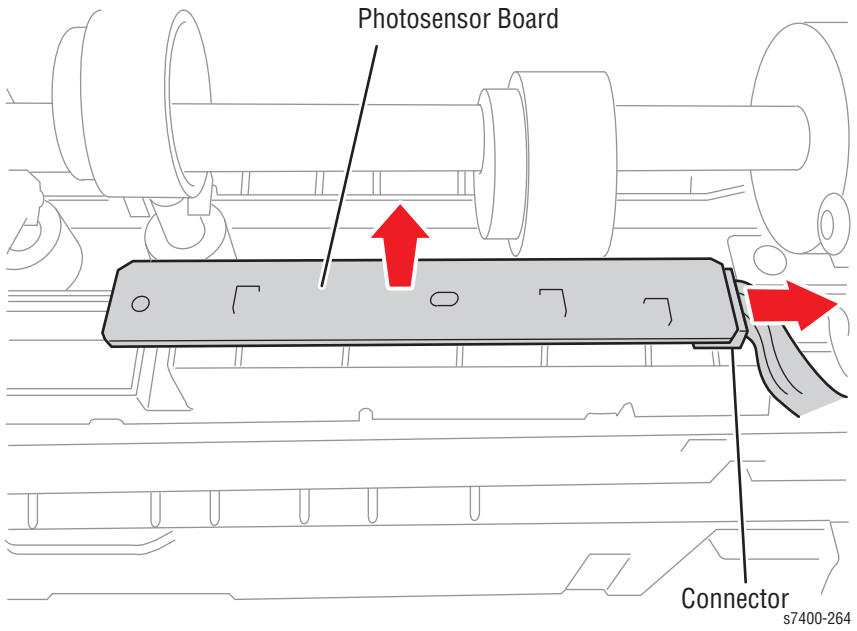

## Punch LED Board

1. Remove the Rear Cover (page 5-11).
2. Remove the Front Door (page 5-8).
3. Remove the Upper Cover (page 5-13).
4. Remove the Waste Case Box.
5. Disconnect the connector.
6. Remove the harness from the harness guide.
7. Remove the metal screw (metal flange, 6 mm).
8. Remove the screw (metal flange, 6 mm) to detach the base cover.
9. Disconnect the connector to remove the Punch LED Board.

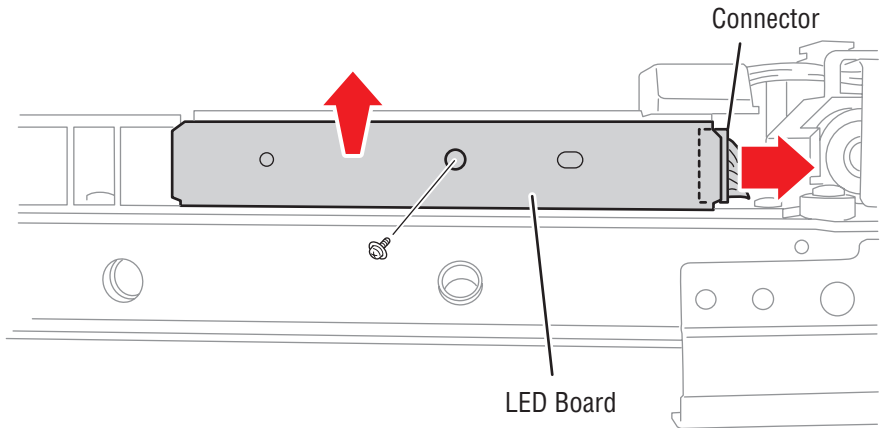

s7400-265

## Waste Full LED Board

1. Remove the Rear Cover (page 5-11).
2. Remove the Front Door (page 5-8).
3. Remove the Upper Cover (page 5-13).
4. Remove the screw (metal flange, 6 mm).
5. Disconnect the connector to remove the board.

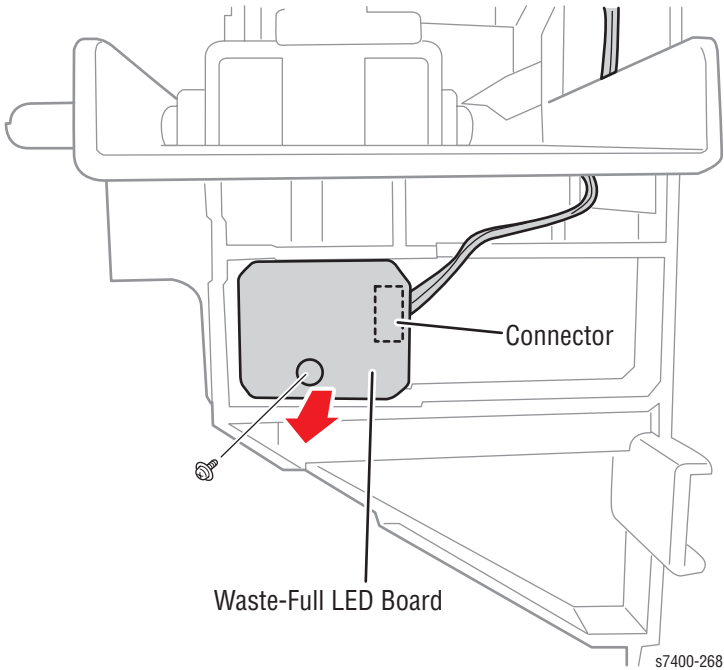



# Inverter Controller Board

1. Remove the Inverter and base unit from the Finisher (page 5-5).
2. Remove the Inverter Rear Covers (page 5-19).
3. Disconnect all cables.

## Replacement Note

It is a good idea to label all connectors to make sure that you replace each one in its proper plug during reassembly.

4. Remove the two top screws (metal flange, 6 mm) securing the board to the chassis. It is not necessary to remove the lower left screw.
5. Lift the board up to free it from the slots before you pull it out of the chassis.

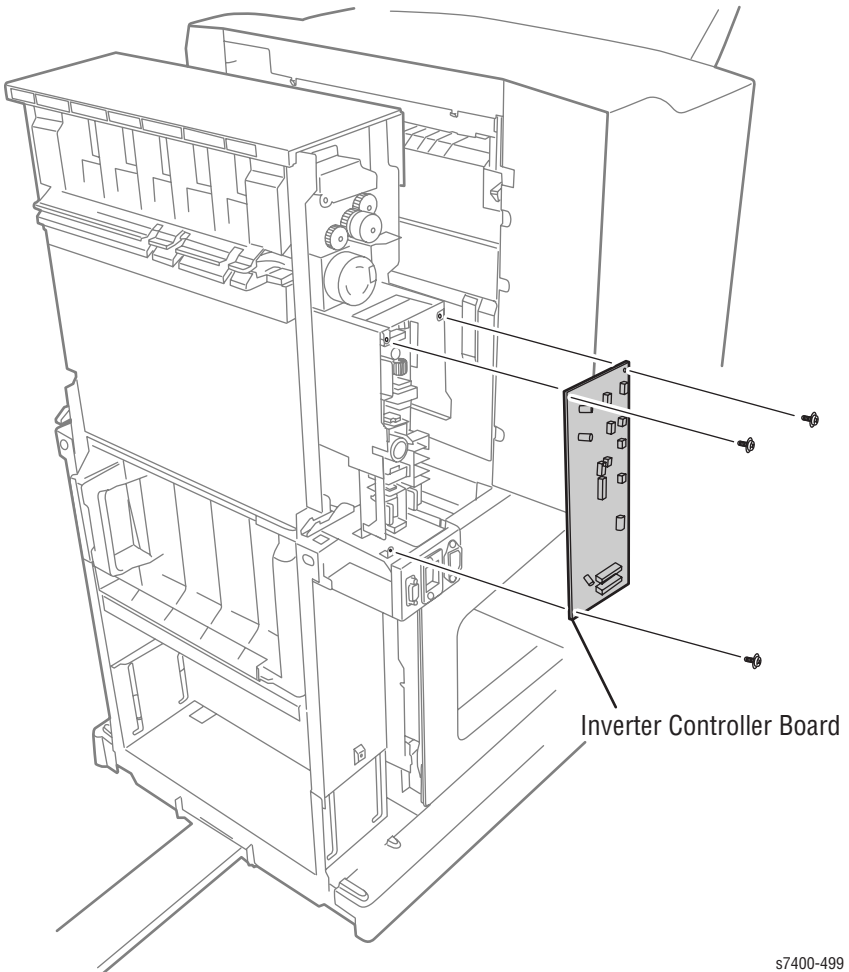

s7400-499

# Inverter Power Supply Board

1. Remove the Inverter and base unit from the Finisher (page 5-5).
2. Remove the Inverter Rear Covers (page 5-19).
3. Remove the Inverter Controller Board (page 5-55).
4. Disconnect all cables.

## Replacement Note

It is a good idea to label all connectors to make sure that you replace each one in its proper plug during reassembly.

5. Remove three screws (metal flange, 6 mm) securing the board to the chassis.
6. Pull the board out of the chassis slots to remove the board.

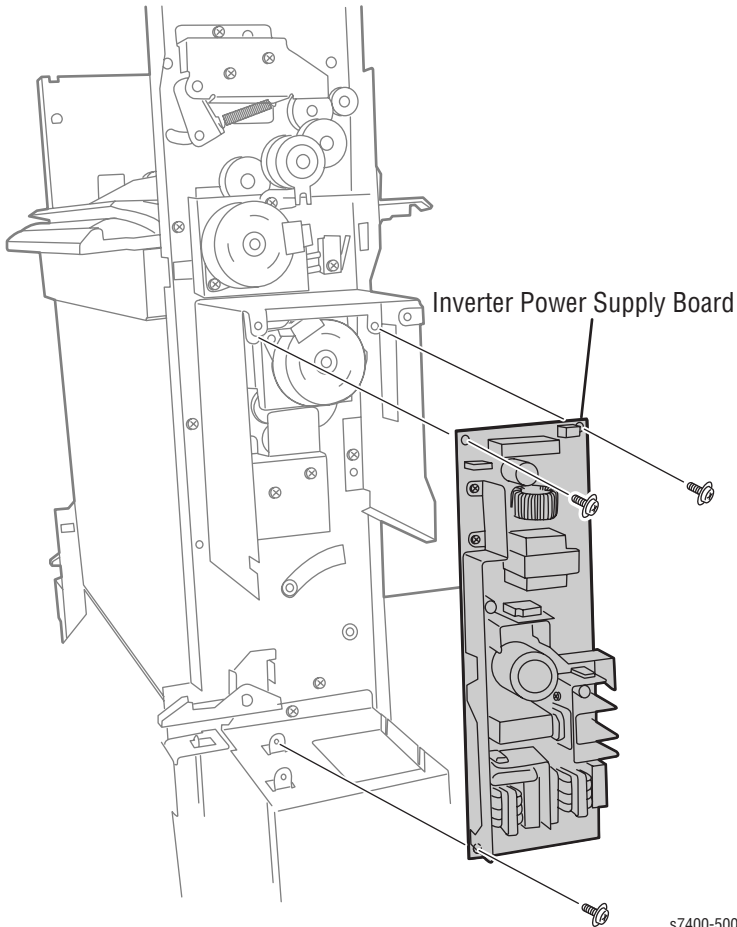

s7400-500

# Motors, Clutches, and Solenoids

## Punch Motor

1. Remove the Rear Cover (page 5-11).
2. Remove the Front Door (page 5-8).
3. Remove the Upper Cover (page 5-13).
4. Disconnect the connector J002 on the Punch Motor.
5. Remove the two metal screws (metal flange, 6 mm) securing the motor to the chassis.
6. Lift out and remove the Punch Motor Unit.

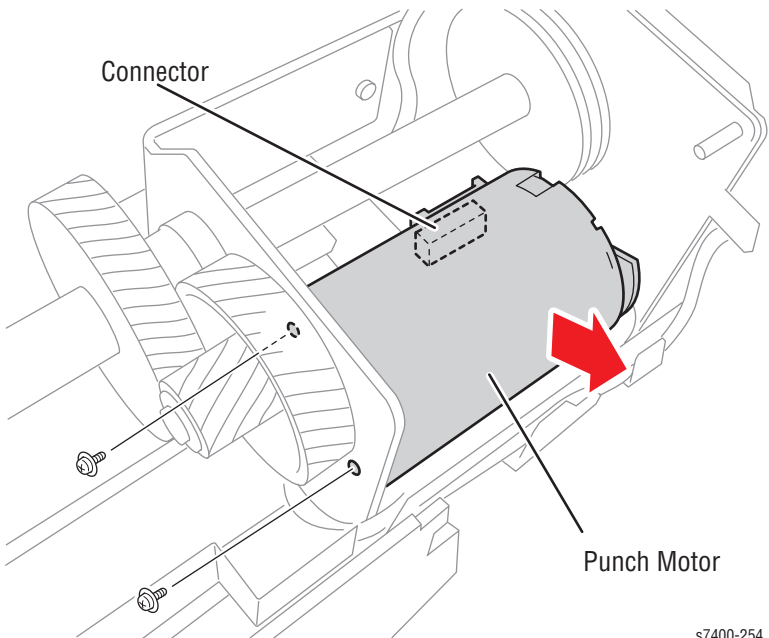

s7400-254

# Finisher Punch Transfer Motor

1. Remove the Rear Cover (page 5-11).
2. Remove the Front Door (page 5-8).
3. Remove the Upper Cover (page 5-13).
4. Disconnect connector to the motor.
5. Remove the harness from the harness guide.
6. To remove the Finisher Punch Transfer Motor from the Punch Unit, remove the two metal screws (metal flange, 6 mm) securing the motor to the chassis and lift out.

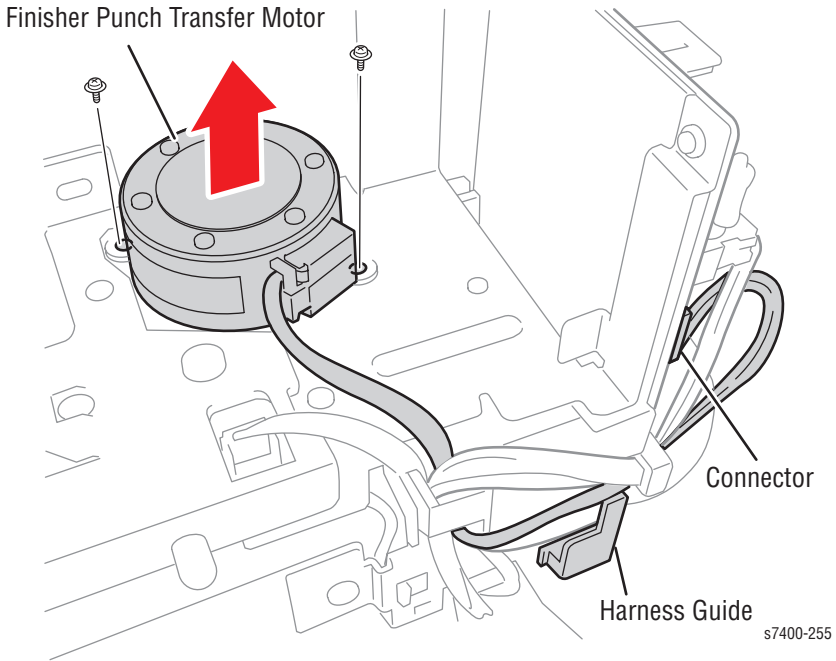

## Lift Motor

1. Remove the Paper Exit Tray (page 5-7).
2. Remove the Rear Cover (page 5-11).
3. Remove the Upper Cover (page 5-13).
4. Remove the Side Guide (page 5-107).
5. Remove three screws (metal, 6 mm) from the Lift Motor cover box.
6. Disconnect connector CN 70 from the cover box and motor, then lift the cover box (which includes motor and gear assembly) free from the chassis.
7. Slide the belt off of the motor.

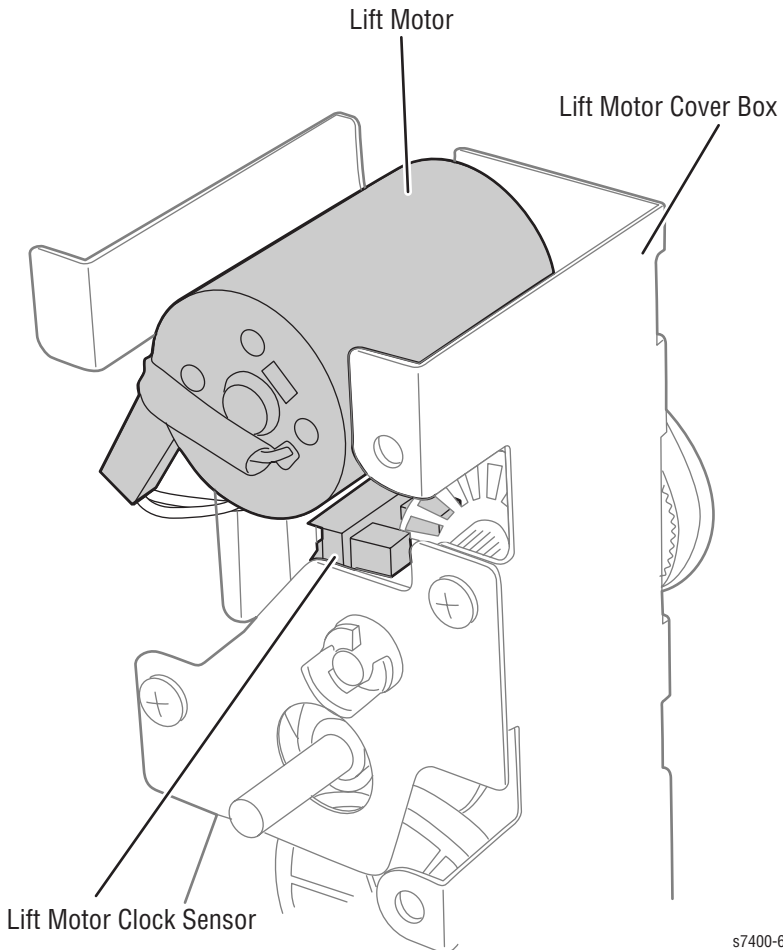

s7400-667

8. To remove the motor, remove the two small screws (metal, 4 mm) holding the motor to the cover box.

# Staple/Fold Motor

1. Remove the Paper Exit Tray (page 5-7).
2. Remove the Rear Cover (page 5-11).
3. Remove the Staple/Fold Drive Unit (page 5-30).
4. Disconnect connector CN71 from the motor.
5. Face the drive unit toward you and remove two screws (metal, 6 mm) holding the motor to the Staple/Fold Drive Unit.

## Note

You will need to rotate the sensor wheel to access the screws.

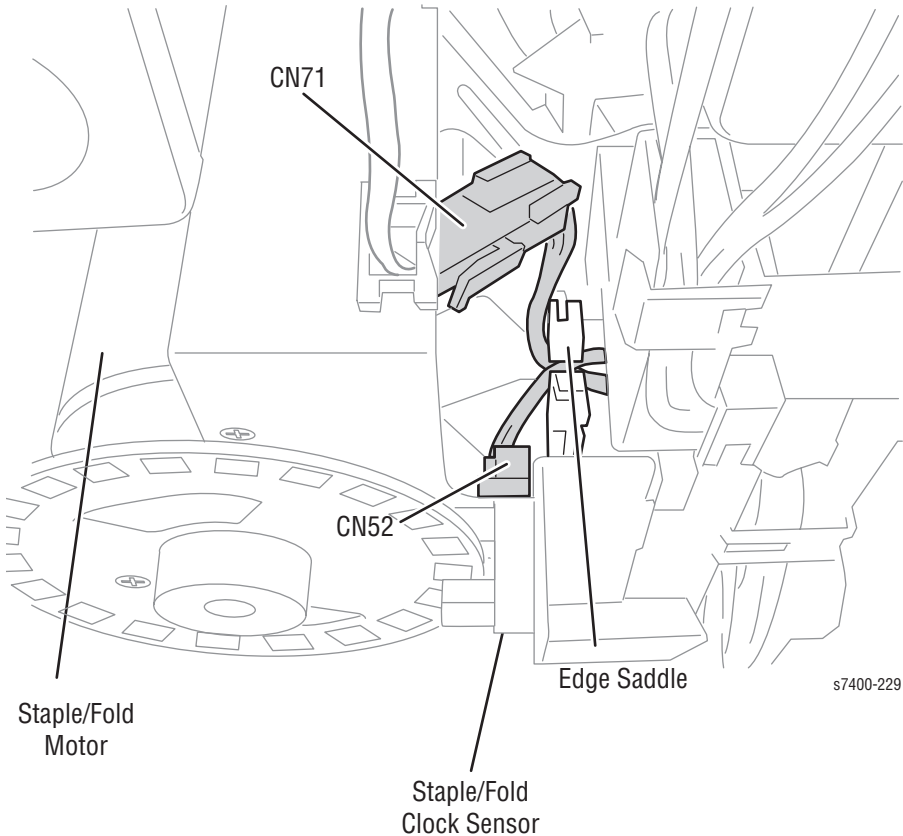

s7400-229

# Slide Motor

1. Remove the Paper Exit Tray (page 5-7).
2. Remove the Rear Cover (page 5-11).
3. Remove the Staple Unit (page 5-29).
4. With the Staple Unit facing you, disconnect connector CN72 from the motor.
5. Slide the belt off of the motor gear.
6. Remove two screws (metal, 4 mm) holding the motor to the Staple Unit.

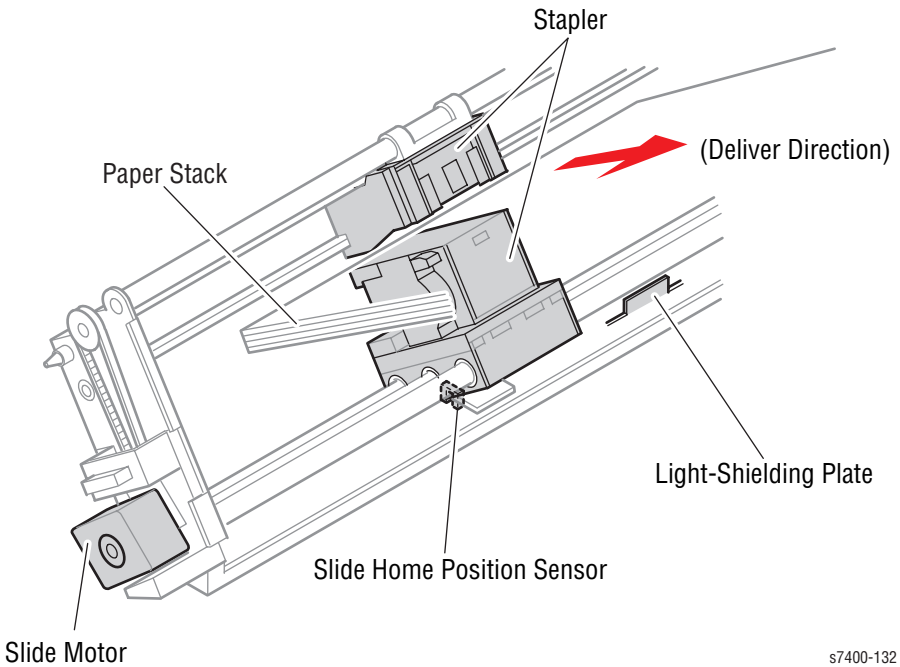

s7400-132

# Feed Motor

1. Remove the Front Door (page 5-8).
2. Remove the Rear Cover (page 5-11).
3. Remove the Punch Unit (page 5-50).
4. Open the harness retainer and disconnect the cable from connector CN56.
5. Remove two small screws (metal flange, 6 mm) and detach the Feed Motor Unit.

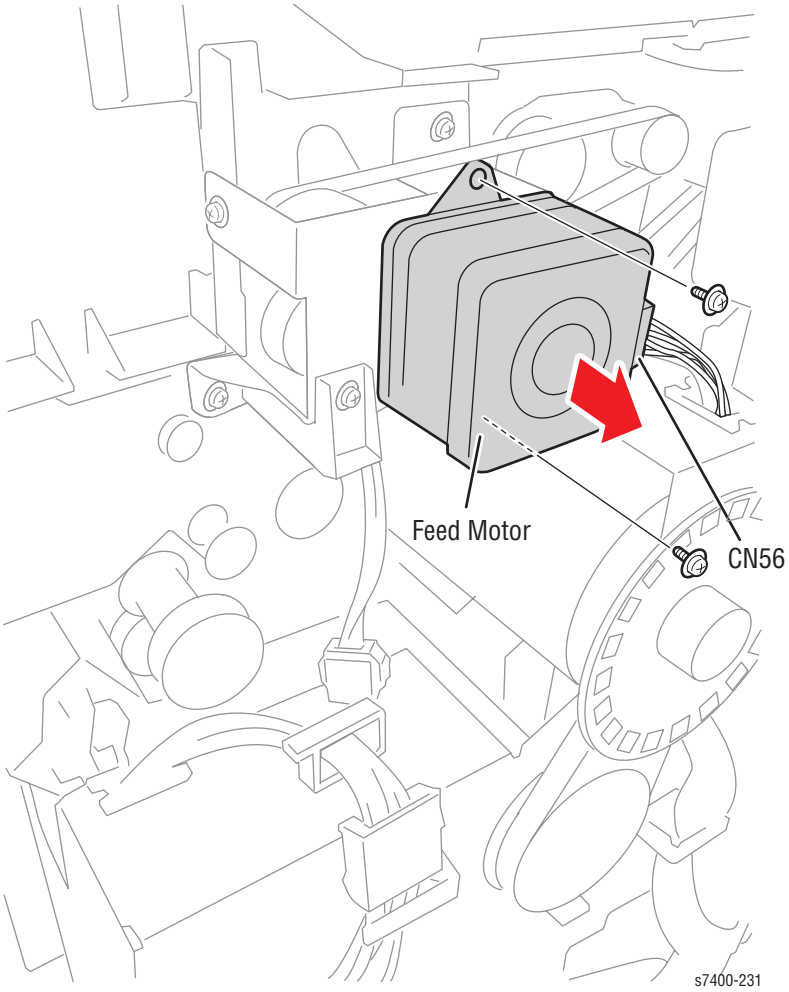



# Paddle Motor

1. Remove the Paper Exit Tray (page 5-7).
2. Remove the Rear Cover (page 5-11).
3. Remove the Upper Cover (page 5-13).
4. Disconnect connector CN57 from motor wiring.

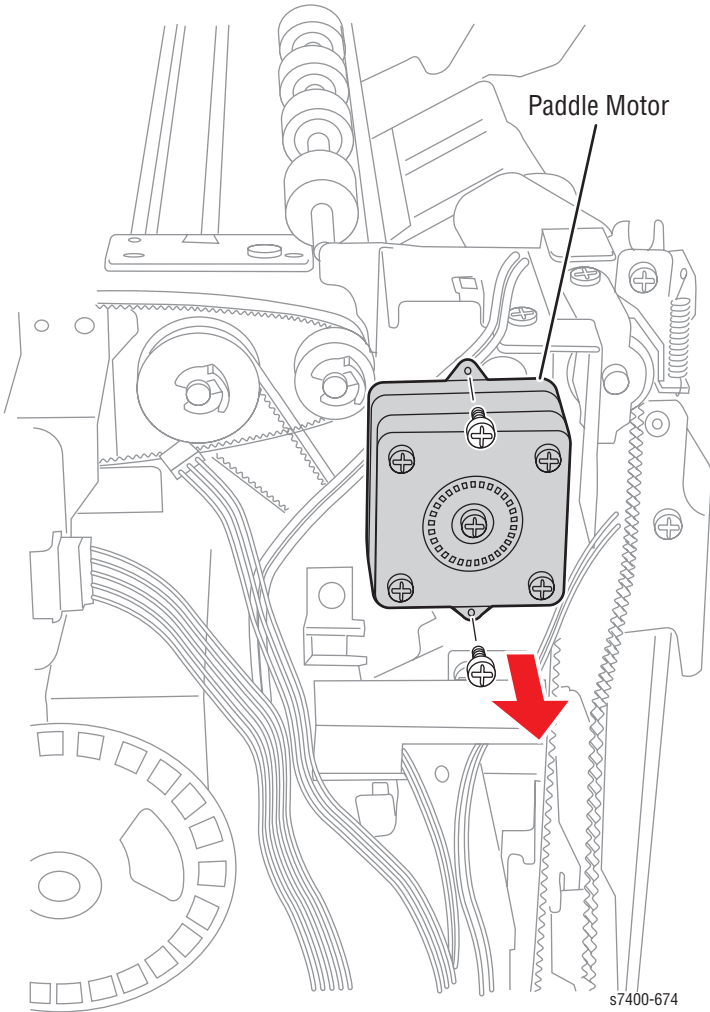

5. To remove the motor, remove two screws (metal, 6 mm), and lift the unit free from the chassis.

# Delivery Motor

1. Remove the Paper Exit Tray (page 5-7).
2. Remove the Rear Cover (page 5-11).
3. Remove the Side Guide (page 5-107).
4. Refer to the illustration below to locate the Delivery Motor.

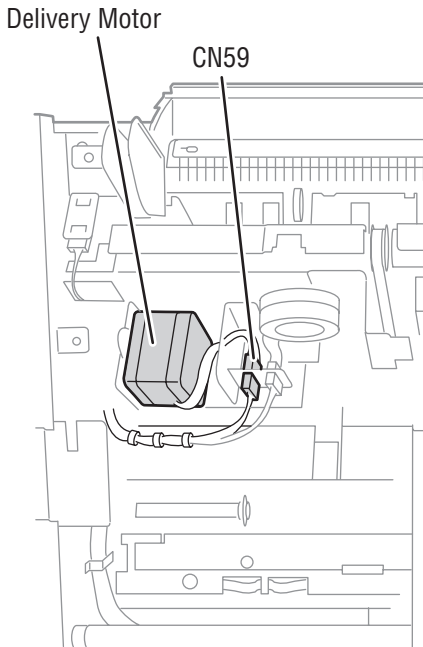

s7400-698

5. Slide the belt off of the motor gear.
6. To remove the motor, first remove the 6-wire connector CN59 from the motor, and then remove two small screws (metal, 4 mm) holding the motor to the chassis.

# Alignment (Front and Rear) Motors

1. Remove the Paper Exit Tray (page 5-7).
2. Remove the Front Door (page 5-8).
3. Remove the Rear Cover (page 5-11).
4. Remove the Upper Cover (page 5-13).
5. Remove the Side Guide (page 5-107).
6. Refer to the illustration below to locate both Alignment Motors.

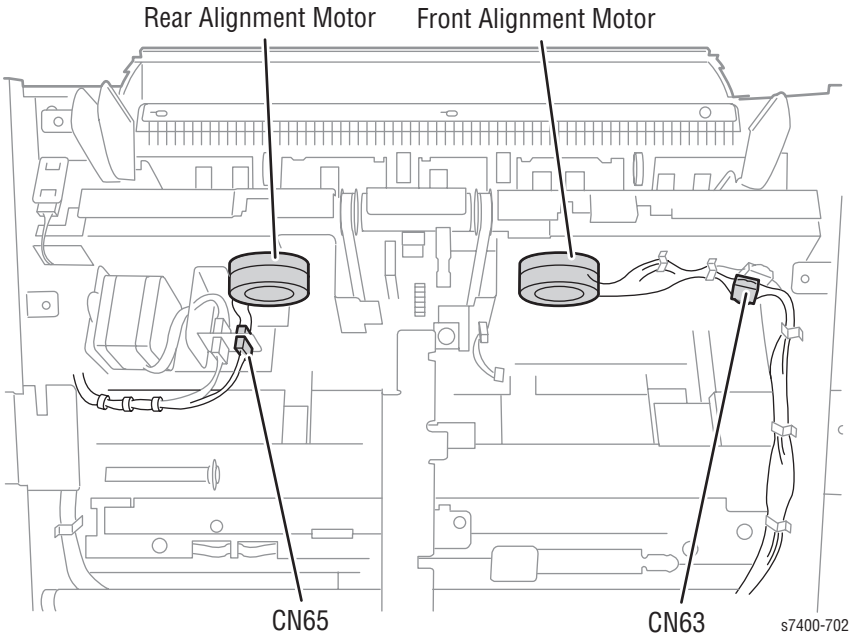

7. To remove either motor, first remove the 5-wire connector (CN63 Front, and CN65 Rear) from the motor, and then remove two screws (metal, 6 mm) and a washer holding the motor to the paper guide.

# Binding Clutch

1. Remove the Paper Exit Tray (page 5-7).
2. Remove the Rear Cover (page 5-11).
3. Remove the Staple/Fold Drive Unit (page 5-30).
4. With Staple/Fold unit out of the way, you can now disconnect connector CN72 from the clutch.
5. Remove the k-clips from the gear assembly of the clutch.
6. Slide the belt off of the clutch gear.
7. Remove three screws (metal, 6 mm) holding the clutch to the chassis.

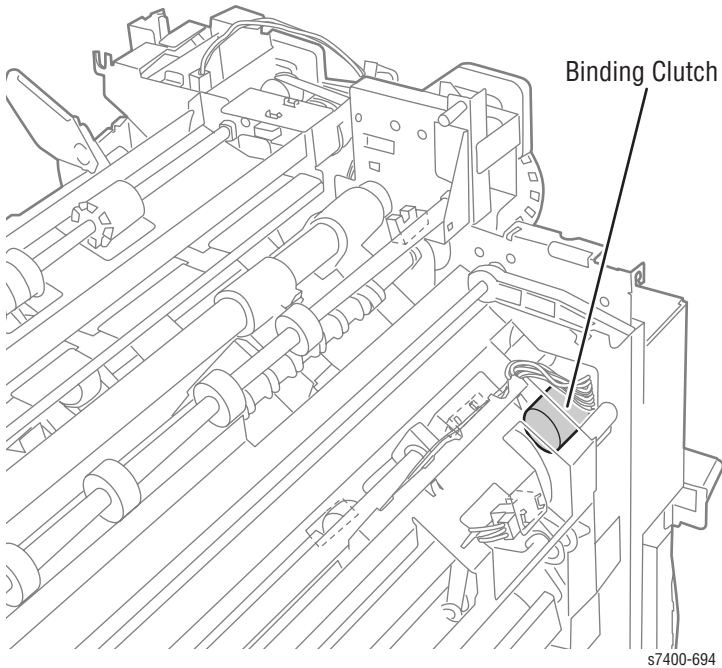

# Inverter Upper Roller Motor

1. Remove the Inverter and base unit from the Finisher (page 5-5).
2. Remove the Inverter Rear Covers (page 5-19).
3. Disconnect the 4-wire cable from the Inverter Controller Board connector labeled Motor\_B. Be sure to lift the cable harness out of the cable guides.
4. Remove one screw (metal flange, 6 mm) from the upper right (and its anti-vibration spring) and one screw from the lower left of the motor.
5. Pull the motor and its associated gear free from the gear assembly.

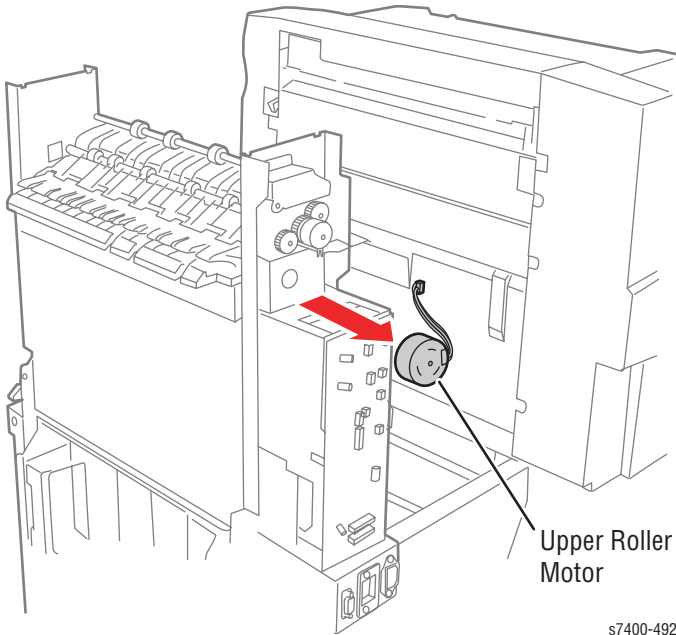

s7400-492

# Inverter Lower Roller Motor

1. Remove the Inverter and base unit from the Finisher (page 5-5).
2. Remove the Inverter Rear Covers (page 5-19).
3. Disconnect the 4-wire cable from the inverter controller board connector labeled Motor\_A. Be sure to lift the cable harness out of the cable guides.
4. Remove the Inverter Controller Board (page 5-55).
5. Remove the Power Supply Board (page 5-56).
6. Remove the two screws (metal flange, 6 mm) and the anti-vibration spring from the motor.
7. Pull the motor and its associated gear free from the gear assembly.

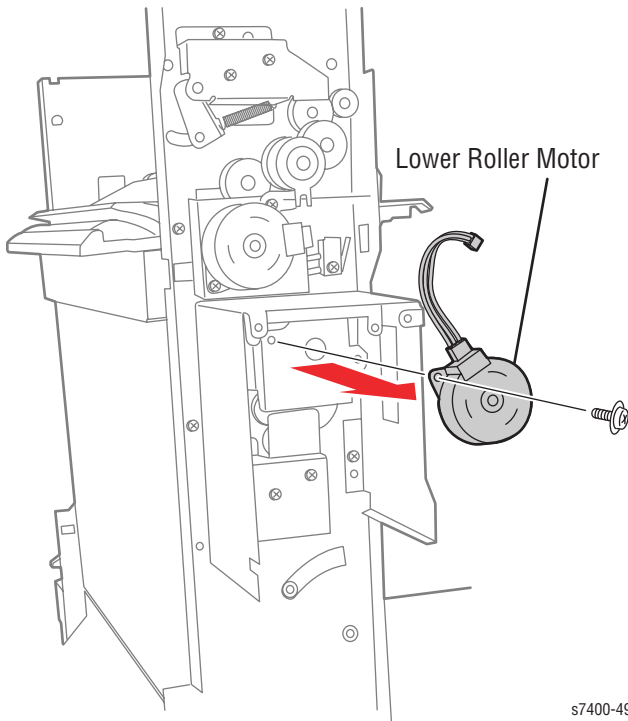

s7400-494

# Inverter Feeder Clutch

1. Remove the Inverter and base unit from the Finisher (page 5-5).
2. Remove the Inverter Rear Covers (page 5-19).
3. Remove the Inverter Top Cover (page 5-23).
4. Disconnect the two-wire connector from connector plug (FAN) on the Inverter Controller Board. Make sure you also pull the wires free from the cable guides.
5. Remove the screw (metal flange, 6 mm) and anti-vibration spring from the lower left side of the clutch.
6. Remove the e-clip from the end of the clutch.
7. With the anti-vibration spring and e-clip removed, you can pull the clutch and its gear free from the roller gear assembly.

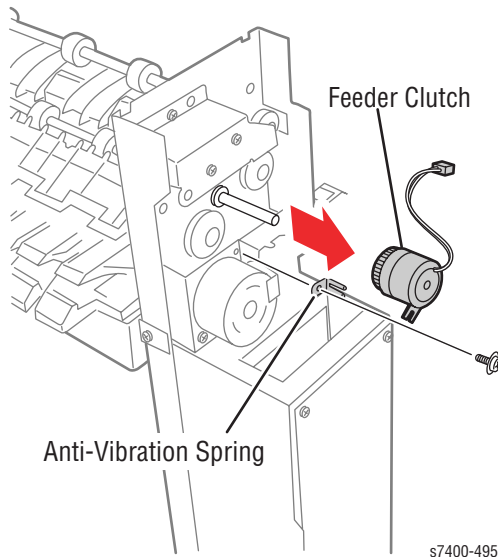

# Inverter Upper Roller Solenoid

1. Remove the Inverter and base unit from the Finisher (page 5-5).
2. Remove the Inverter Rear Covers (page 5-19).
3. Remove the Top Cover (page 5-23).
4. Disconnect the cable from the connector (CL2) on the Inverter Controller Board. Be sure you also free the cable harness from the cable guide.
5. Carefully remove the tension spring from the solenoid and swing plate.
6. From the chassis side, carefully free the paper guide from the swing plate.
7. Remove two screws (metal flange, 6 mm) from the solenoid casing.
8. To remove the solenoid unit, remove two small brass screws (metal, 4 mm) from the solenoid casing and lift the relay from the casing.

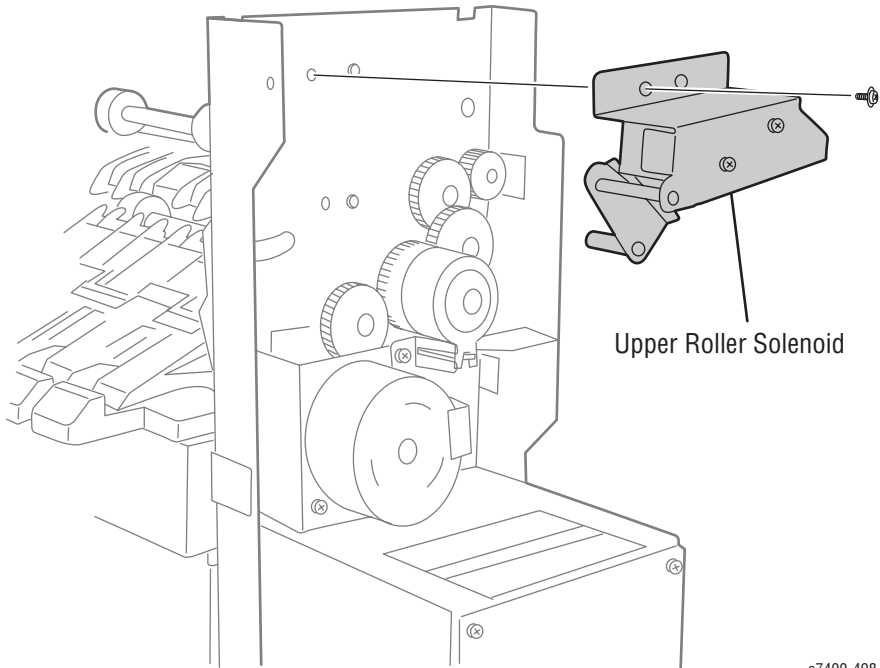

s7400-498



# Inverter Lower Roller Solenoid

1. Remove the Inverter and base unit from the Finisher (page 5-5).
2. Remove the Inverter Rear Covers (page 5-19).
3. Remove the Top Cover (page 5-23).
4. Disconnect the cable from the Inverter Controller Board. Be sure you free the cable harness from the cable guide.
5. Remove the Inverter Controller Board (page 5-55).
6. Remove the Power Supply Board (page 5-56).
7. Remove the tension spring from the solenoid and swing plate.
8. From the chassis side, carefully free the paper guide from the swing plate.
9. Remove two screws (metal flange, 6 mm) from the solenoid casing.
10. To remove the solenoid unit, remove two small brass screws (metal, 4 mm) from the solenoid casing and lift the relay from the casing.

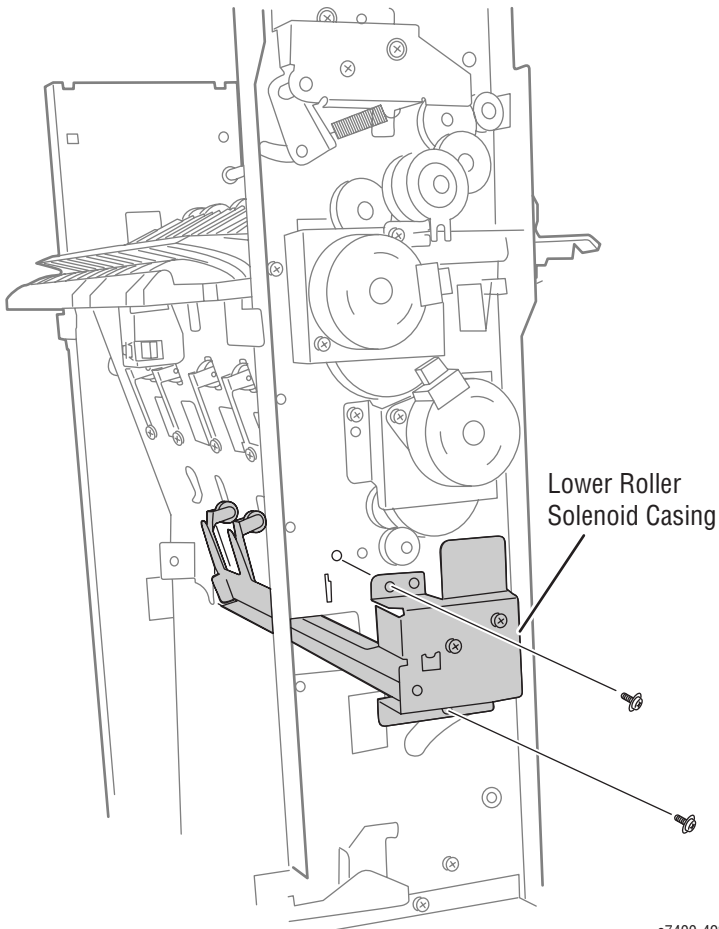

s7400-493

# Finisher Sensors and Switches

The topics in this section describe the disassembly for each sensor in the Finisher. See page 5-99 for details of the Inverter sensors within the Finisher.

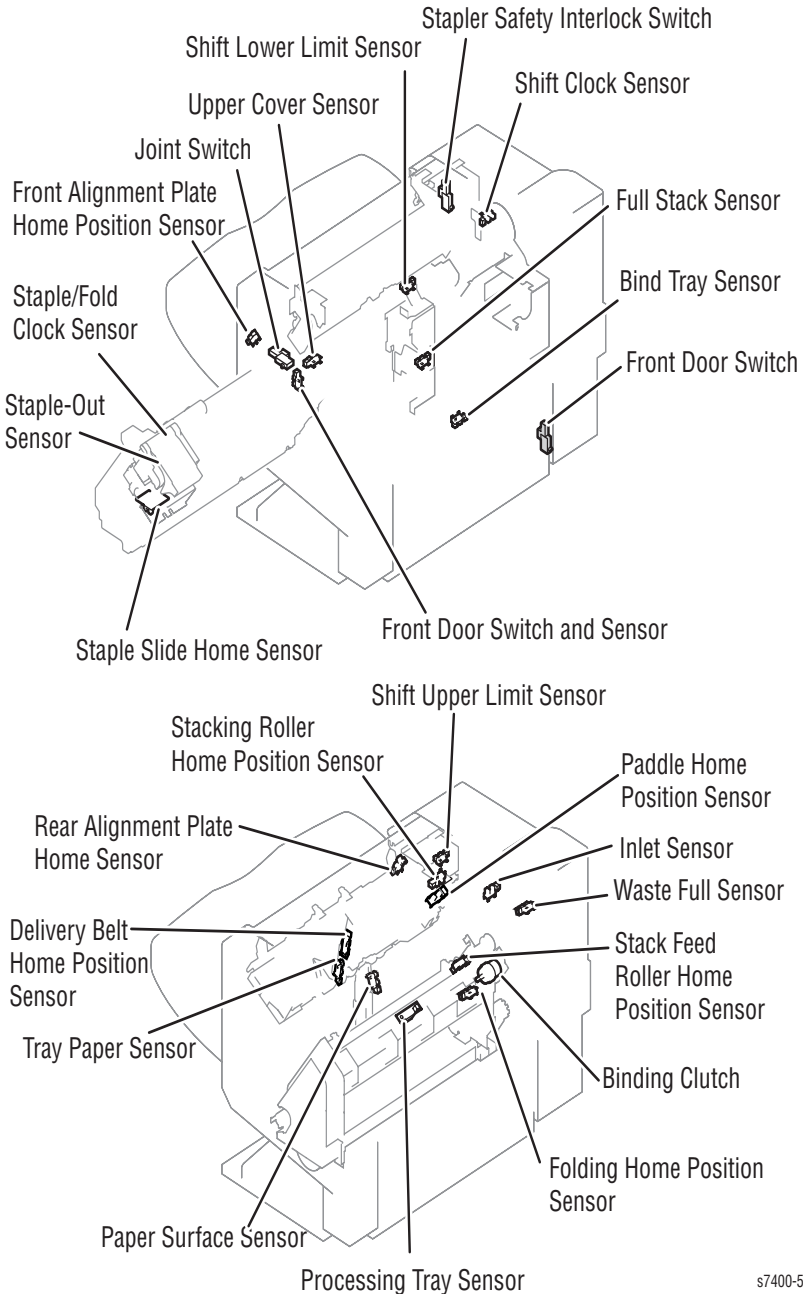

s7400-542

# Joint Switch

The Joint Switch is activated when the Finisher Unit connects to the printer. This switch opens to prevent the power supply from placing hazardous voltages in accessible areas when the Finisher is undocked from the printer. To replace:

1. Remove the Paper Exit Tray (page 5-7).
2. Remove the Front Door (page 5-8).
3. Remove the Rear Cover (page 5-11).
4. Remove the Upper Cover (page 5-13).
5. Locate the Joint Switch and plastic harness protector (see illustration).

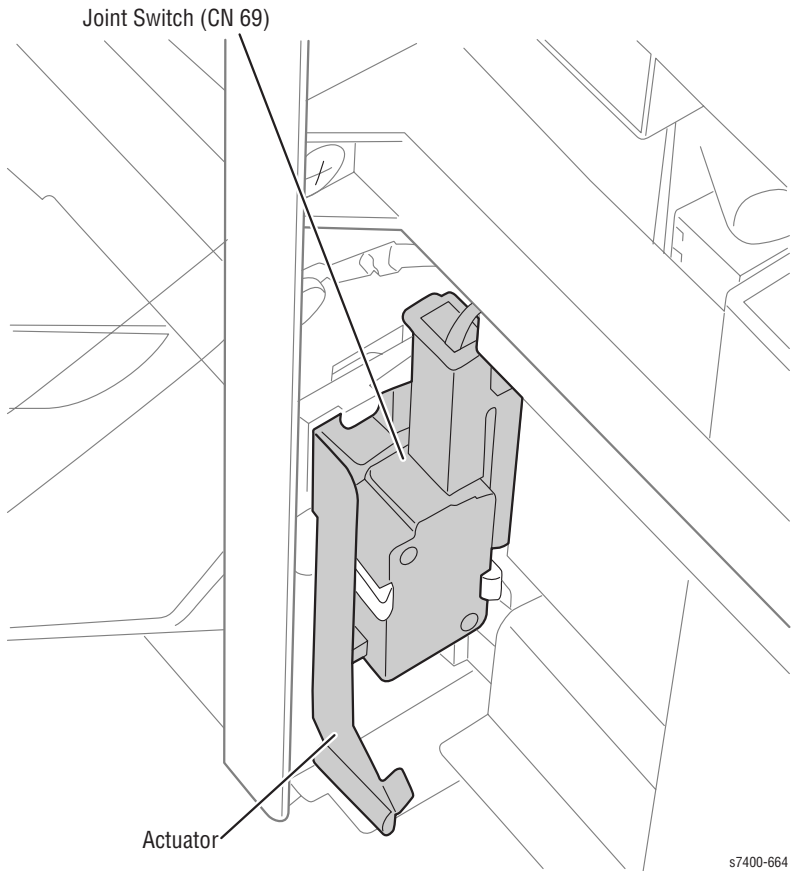

s7400-664

6. Lift connector CN69 off of the two connector pins. You may need to free the two wires from the cable harness.
7. Carefully holding the large plastic harness protector to one side, remove the single screw (metal, 6 mm) holding the switch to the chassis.
8. Release the three plastic hooks securing the switch to the plastic and remove.

# Front Door Switch and Sensor

The Front Door Sensor detects when the Front Door (Door J) is open or removed. The Front Door Interlock Switch will open to prevent the power supply from placing hazardous voltages in accessible areas when the Front Door is removed. To remove and replace the switch and/or the Sensor:

1. Remove the Paper Exit Tray (page 5-7).
2. Remove the Front Door (page 5-8).
3. Remove the Rear Cover (page 5-11).
4. Remove the Upper Cover (page 5-13).
5. Locate the plastic mounting unit that houses the Front Door Switch and the Front Door Sensor (see illustration).

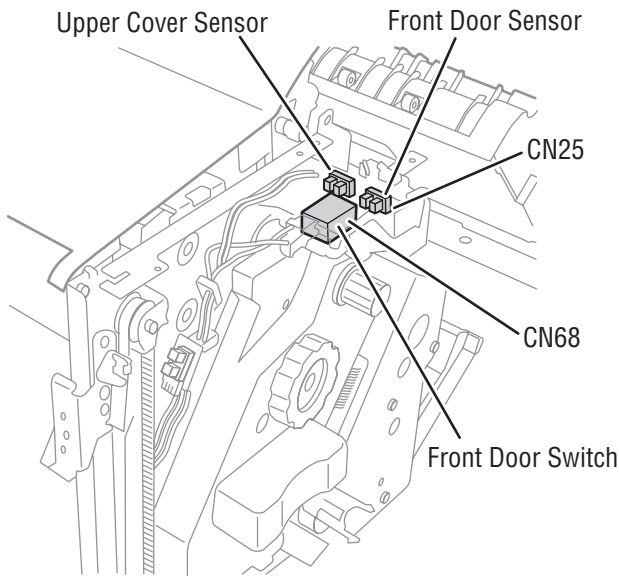

s7400-699

6. Remove the single screw (metal, 6 mm) holding the plastic mounting holder to the chassis.
7. To remove the Front Door Switch, first lift connector CN68 off of the two connector pins, and then release the two hooks securing the switch to the chassis.
8. To remove the Front Door Sensor, first remove the 4-wire connector CN25 from the sensor, and then pinch the plastic tabs to pull the sensor free.

# Inlet Sensor

1. Remove the Upper Cover (page 5-13).
2. Remove the Upper Right Cover Assembly (page 5-37).
3. Remove the Feed Motor Unit (page 5-62).
4. Remove the Feed Roller (page 5-109).
5. Remove the screw (metal flange, 6 mm) and detach the Inlet Sensor.

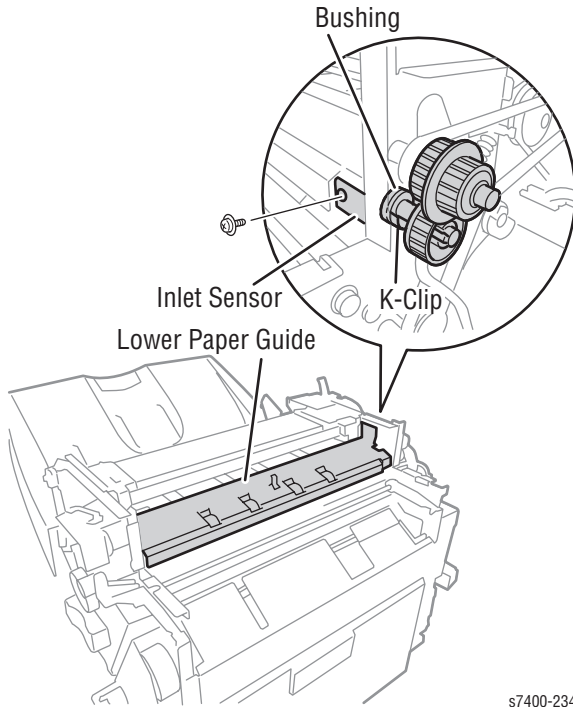

s7400-234

# Tray Paper Sensor

The Tray Paper Sensor detects when the paper tray is removed from the Finisher. To remove and replace the Tray Paper Sensor:

1. Remove the Paper Exit Tray (page 5-7).
2. Remove the Front Door (page 5-8).
3. Remove the Rear Cover (page 5-11).
4. Remove the Upper Cover (page 5-13).
5. Remove the Side Guide (page 5-107).
6. To locate the sensor, look through the top of the side area (where you removed the Side Guide) and press the paper tray activator a few times (see illustration). You will see the activator as it enters the sensor below.

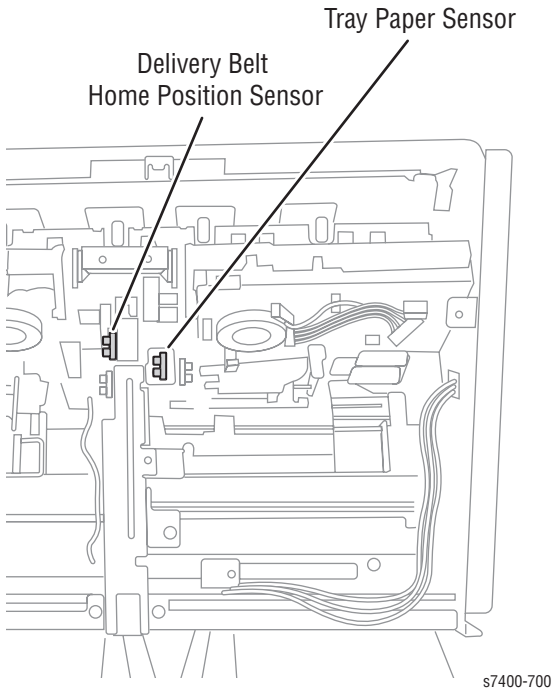

7. To remove the sensor, first remove the 4-wire connector CN32 from the sensor, and then, using small needle nose pliers, pinch the plastic tabs to pull one side of the sensor free.

# Paper Surface Sensor

The Paper Surface Sensor detects media in the home position of the delivery tray. To remove and replace the Paper Surface Sensor:

1. Remove the Paper Exit Tray (page 5-7).
2. Remove the Front Door (page 5-8).
3. Remove the Rear Cover (page 5-11).
4. Remove the Upper Cover (page 5-13).
5. Remove the Side Guide (page 5-107).
6. To locate the sensor, look through the top of the side area (where you removed the Side Guide) and press the paper surface activator a few times (see illustration). You will see the activator as it enters the sensor below.

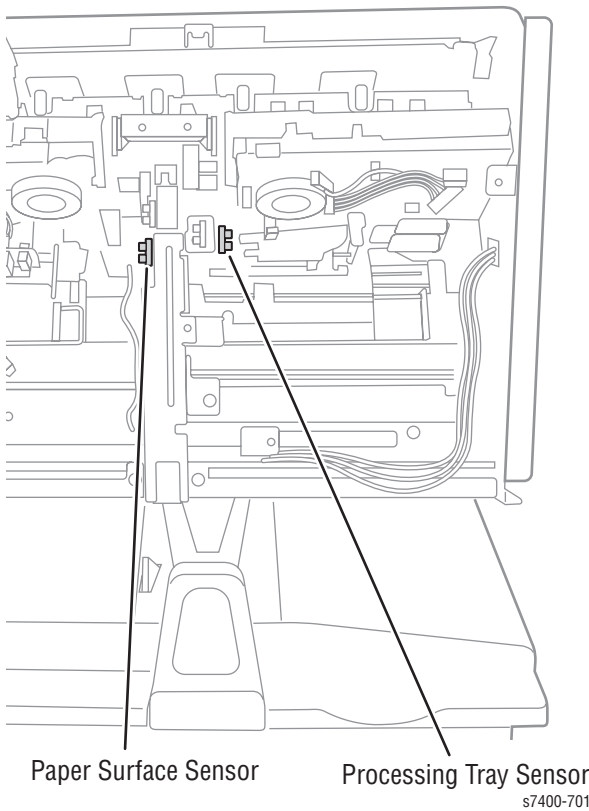

7. To remove the sensor, first remove the 4-wire connector CN35 from the sensor, and then, using small neediness pliers, pinch the plastic tabs to pull one side of the sensor free.

# Upper Cover Sensor

The Upper Cover Sensor detects when the Upper Cover (Door I) is open or removed. To remove and replace the Sensor:

1. Remove the Paper Exit Tray (page 5-7).
2. Remove the Front Door (page 5-8).
3. Remove the Rear Cover (page 5-11).
4. Remove the Upper Cover (page 5-13).
5. Locate the Upper Cover Sensor (see illustration).

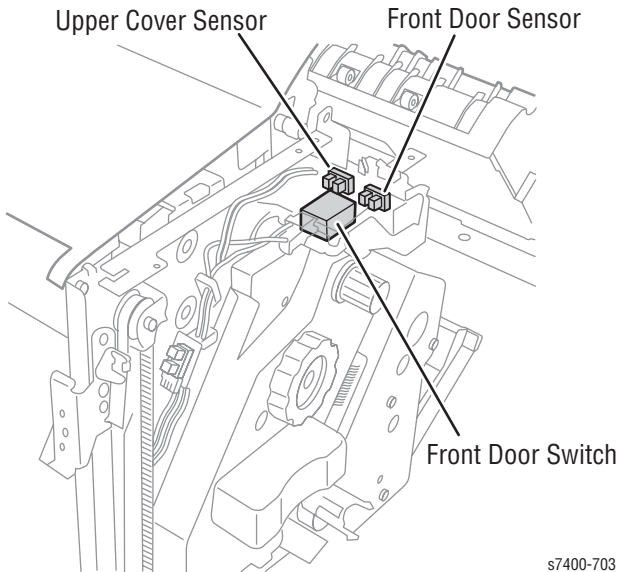

s7400-703

6. To remove the Upper Cover Sensor, first remove the 4-wire connector CN24 from the sensor, and then pinch the plastic hooks to pull the sensor free.



# Shift Limit Sensors

The Shift (Upper and Lower) Limit Sensors detect the upper and lower limits of the delivery tray stack. To remove and replace either of the sensors:

1. Remove the Paper Exit Tray (page 5-7).
2. Remove the Rear Cover (page 5-11).
3. Remove the Upper Cover (page 5-13).
4. Remove the Side Guide (page 5-107).
5. Refer to the illustration below to locate either sensor.

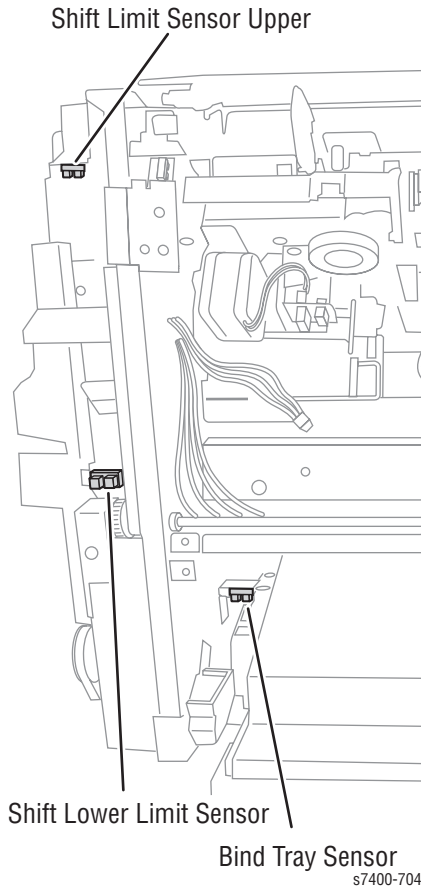

6. To remove either sensor, first remove the 4-wire connector (CN49 Lower, and CN50 Upper) from the sensor. Pinch the plastic tabs to pull the sensor free.

# Lift Motor Clock Sensor

The Lift Motor Clock Sensor detects clock pulses for the stacking operation. To remove and replace the sensor:

1. Remove the Paper Exit Tray (page 5-7).
2. Remove the Rear Cover (page 5-11).
3. Remove the Upper Cover (page 5-13).
4. Remove the Side Guide (page 5-107).
5. Remove 4 screws (metal flange, 6 mm) holding the metal cover box to the chassis, and one screw (metal flange, 6 mm) attaching the large harness to the metal cover box.
6. Turn the box so that you can view the sensor.

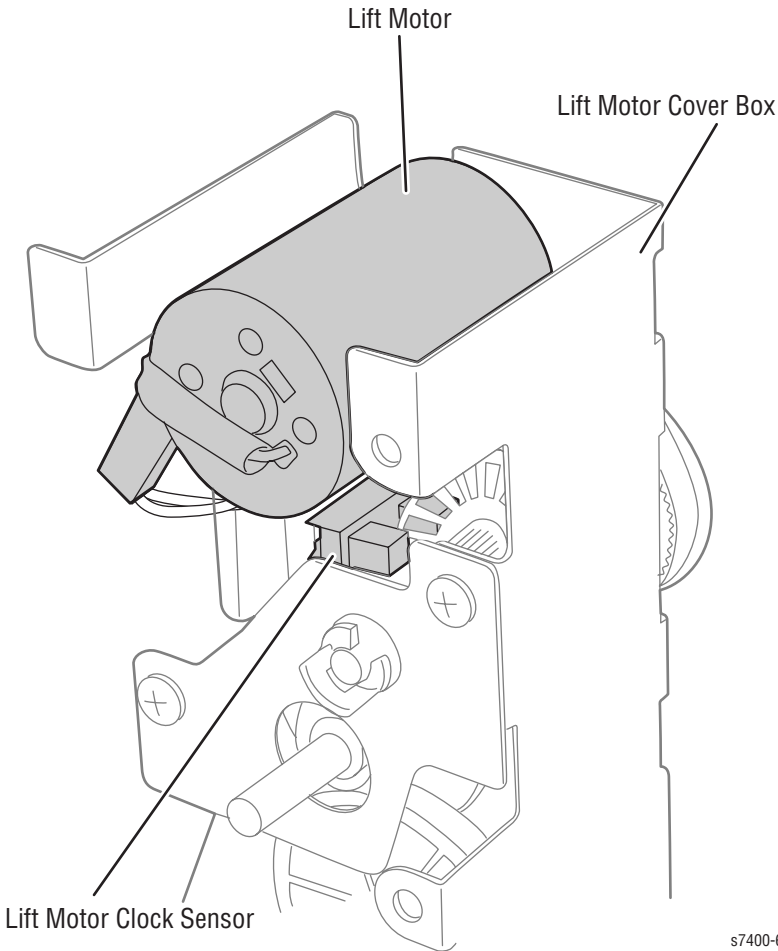

s7400-667

7. To remove the sensor, first remove the 4-wire connector (CN48) from the sensor. Using small needle nose pliers, pinch the plastic tabs to pull the sensor free.

# Stack Full Sensor

The Stack Full Sensor detects over-stacking of media in the delivery tray. To remove and replace the sensor:

1. Remove the Paper Exit Tray (page 5-7).
2. Remove the Rear Cover (page 5-11).
3. Remove the Upper Cover (page 5-13).
4. Remove the Side Guide (page 5-107).

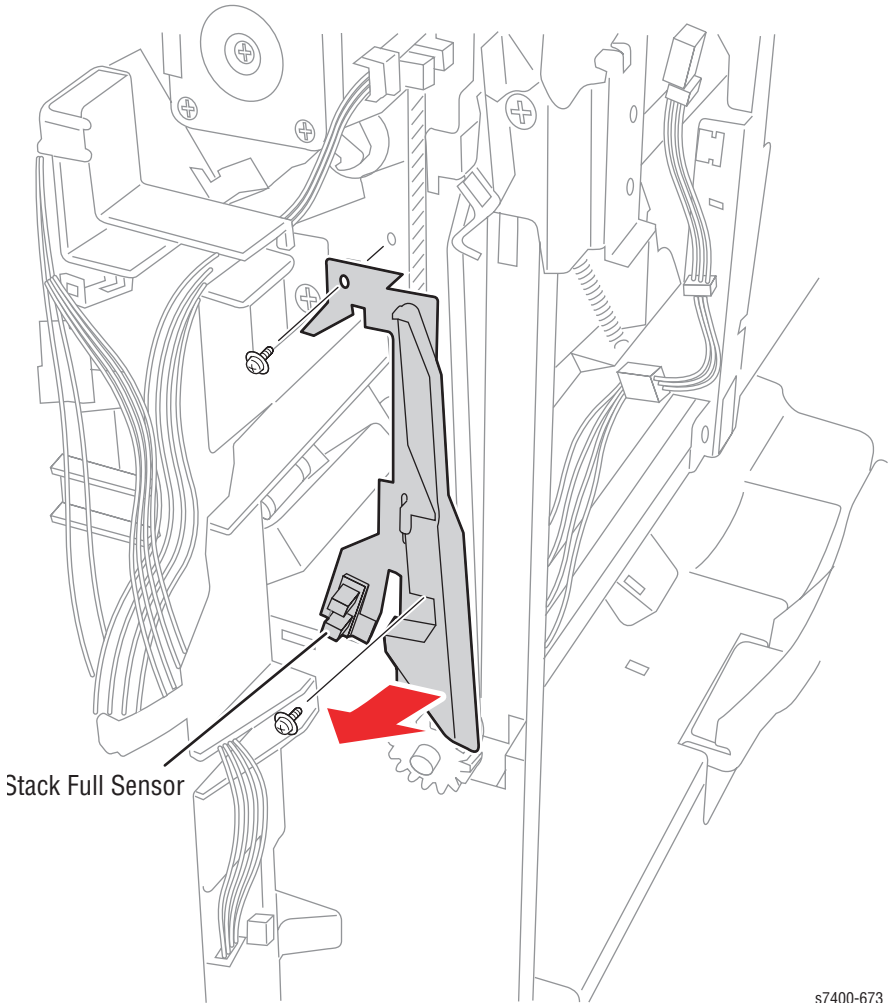

s7400-673

5. Remove two screws (metal flange, 6 mm) holding the sensor to the sensor bracket and activator. Hold the belt to one side to free the bracket and sensor
6. To remove the sensor, first remove the 3-wire connector (CN44) from the sensor. Using small needle nose pliers, pinch the plastic tabs to pull the sensor free.

# Processing Tray Sensor

The Processing Tray Sensor detects the processing stack within the delivery path. To remove and replace the Processing Tray Sensor:

1. Remove the Paper Exit Tray (page 5-7).
2. Remove the Front Door (page 5-8).
3. Remove the Rear Cover (page 5-11).
4. Remove the Upper Cover (page 5-13).
5. Remove the Side Guide (page 5-107).
6. Refer to the illustration to locate the sensor.

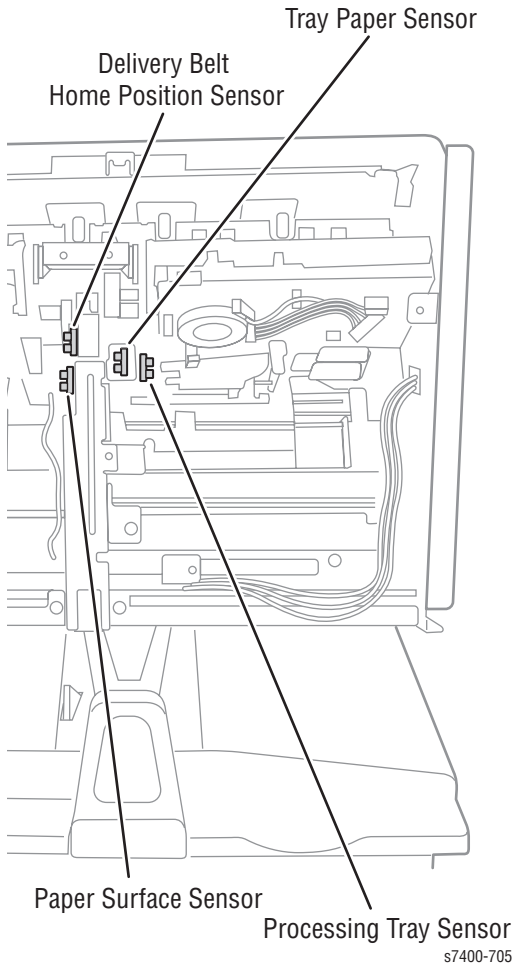

7. To remove the sensor, first remove the 4-wire connector CN29 from the sensor. Pinch the plastic tabs to pull one side of the sensor free.

# Aligning Plate Home Position Sensors

The Aligning Plate Home Position Sensors (front and back) ensure that the size of the selected paper aligns properly with the entrance into the paper path. To remove and replace either Sensor:

1. Remove the Paper Exit Tray (page 5-7).
2. Remove the Front Door (page 5-8).
3. Remove the Rear Cover (page 5-11).
4. Remove the Upper Cover (page 5-13).
5. Locate the sliding position activators (see illustration).
6. Locate the front sensor.

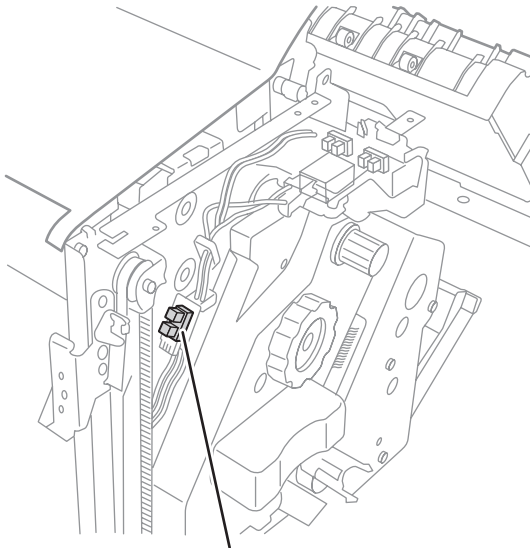

Front Aligning Plate  
Home Position Sensor

s7400-706

7. Locate the rear sensor.

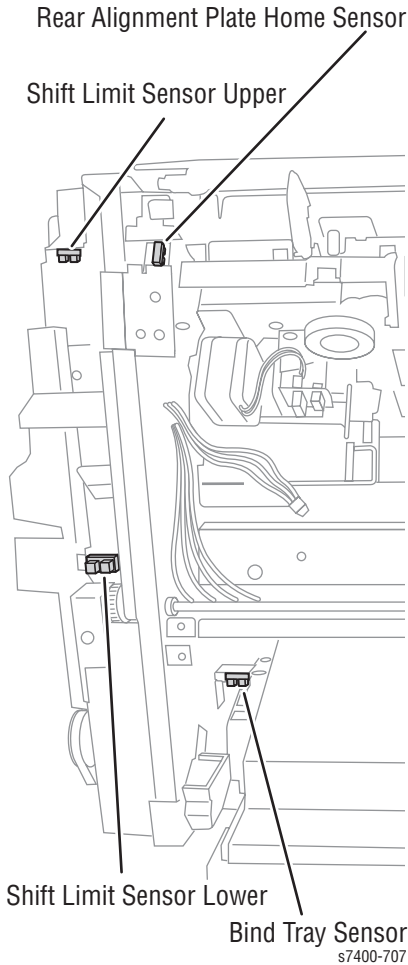

8. To remove the Front or Rear Aligning Plate Home Position Sensor, first remove the 4-wire connector (CN23 for the front or CN36 for the rear), and then pinch the plastic tabs to pull the sensor free.

# Stack Feed Roller Home Position Sensor

The Stack Feed Roller Home Position Sensor detects the initial home position of the stack feed. To remove and replace the sensor:

1. Remove the Paper Exit Tray (page 5-7).
2. Remove the Front Door (page 5-8).
3. Remove the Rear Cover (page 5-11).
4. Remove the Upper Cover (page 5-13).
5. Remove the metal cover plate to expose the sensor and connector CN41.

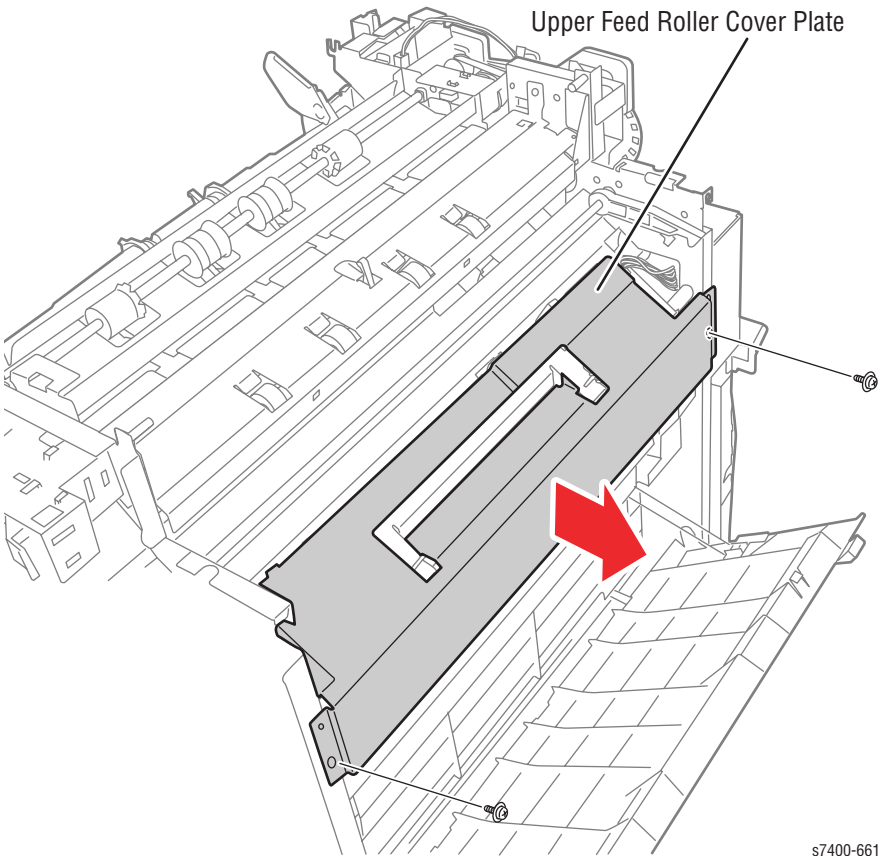

s7400-661

6. To remove the sensor, disconnect CN41 from the sensor, remove one screw (metal, 4 mm), and then pull the sensor free.

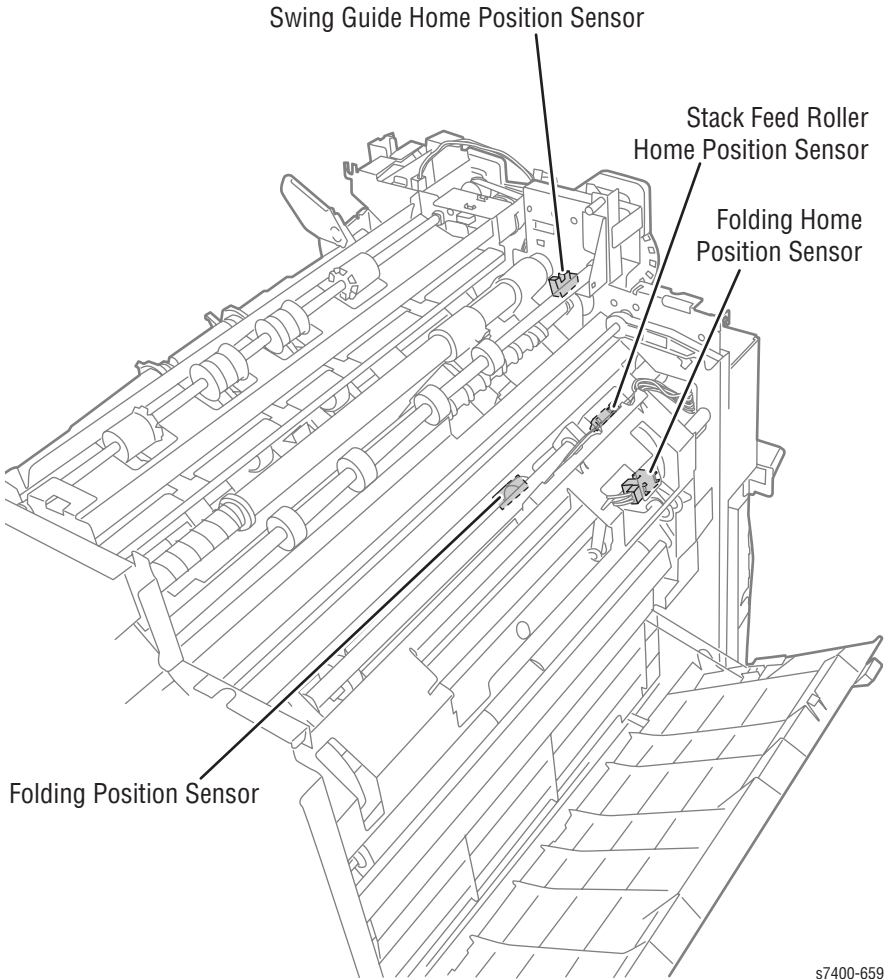

7. To remove the sensor, disconnect CN41 from the sensor, remove one screw (metal, 4 mm), and then pull the sensor free.



# Waste Full Sensor

1. Remove the Rear Cover (page 5-11).
2. Remove the Front Door (page 5-8).
3. Remove the Upper Cover (page 5-13).
4. Remove the Punch Control Board (page 5-50).
5. Remove the two screws (metal flange, 6 mm) to remove the controller board film.

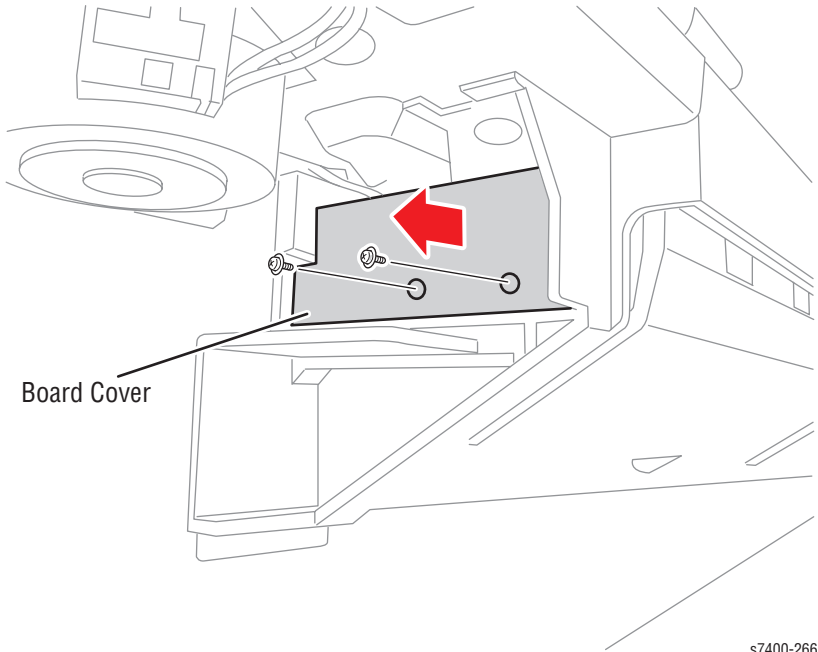

s7400-266

6. Disconnect the connector to remove the Waste-full Sensor Board.

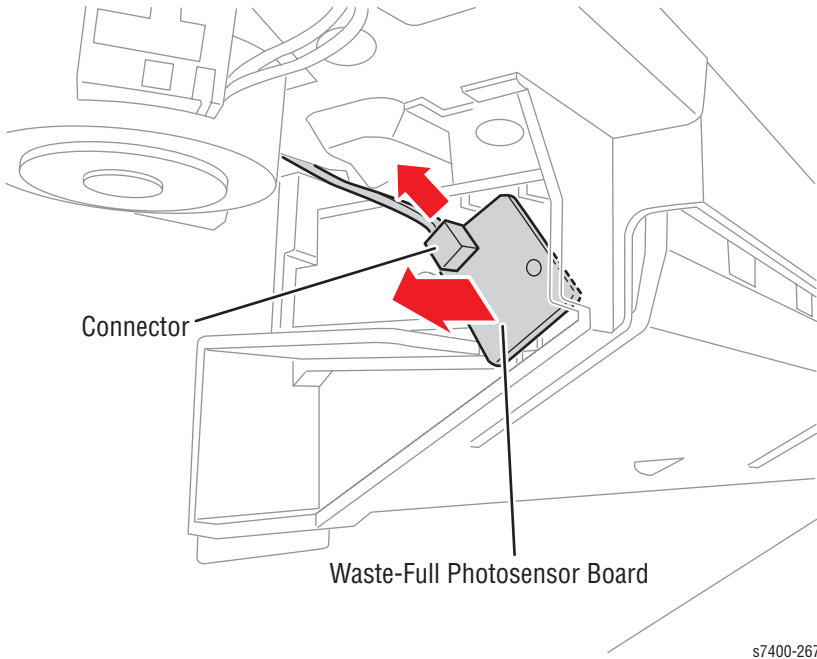

s7400-267

# Swing Guide Home Position Sensor

The Swing Guide Home Position Sensor detects the home position for the Swing Guide. To remove the sensor.

1. Remove the Paper Exit Tray (page 5-7).
2. Remove the Rear Cover (page 5-11).
3. Remove the Upper Cover (page 5-13).
4. Remove two screws (metal, 6 mm) and remove the swing guide cover.
5. Locate the sensor (see illustration) and disconnect connector CN41.

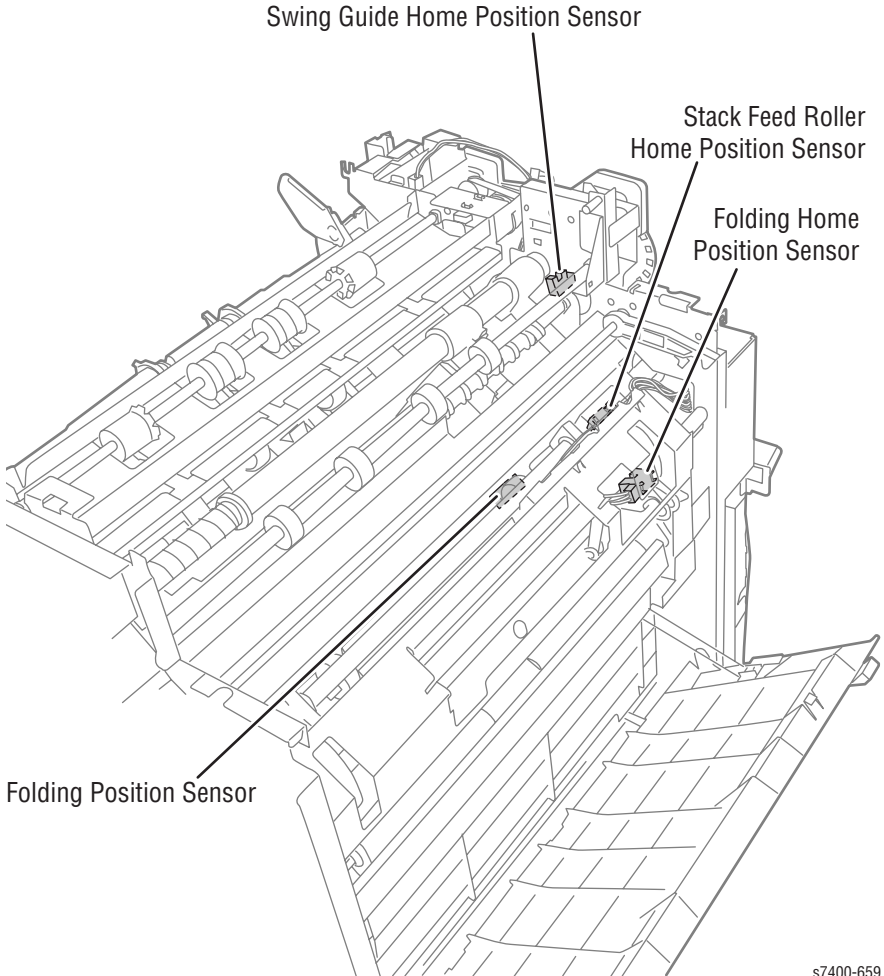

s7400-659

6. To remove the sensor, pinch the plastic tabs with needle nose pliers, and then pull the sensor free.

## Delivery Belt Home Position Sensor

The Delivery Belt Home Position Sensor detects the end location of the delivery rollers (sensor is off). To remove and replace the Delivery Belt Home Position Sensor:

1. Remove the Paper Exit Tray (page 5-7).
2. Remove the Front Door (page 5-8).
3. Remove the Rear Cover (page 5-11).
4. Remove the Upper Cover (page 5-13).
5. Remove the Side Guide (page 5-107).
6. To locate the sensor, manually rotate the delivery roller belts. You will see the activator (which is attached to the belt) trip the sensor.

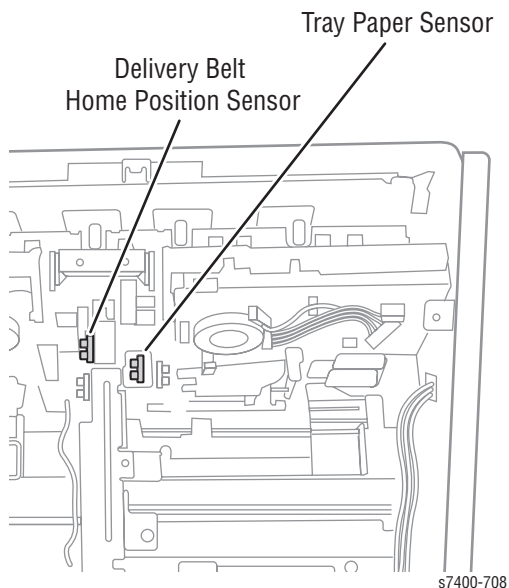

7. To remove the sensor, first remove the 4-wire connector CN31 from the sensor. Using small needle nose pliers, pinch the plastic tabs to pull one side of the sensor free.

# Paddle Home Position Sensor

The Paddle Home Position Sensor detects when it is necessary to drive the paddle and feed the next sheet of paper. To remove the sensor.

1. Remove the Paper Exit Tray (page 5-7).
2. Remove the Rear Cover (page 5-11).
3. Locate the sensor (see illustration) and disconnect connector CN39.

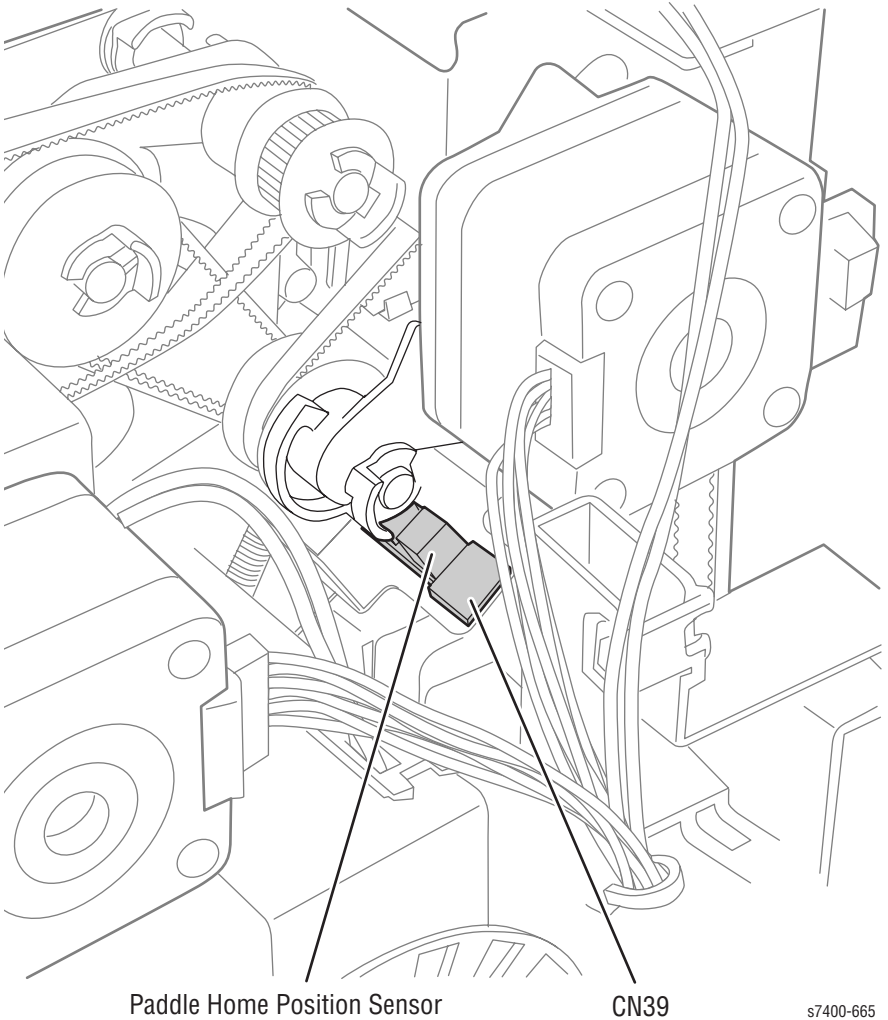

4. To remove the sensor, pinch the plastic tabs with needle nose pliers, and then pull the sensor free.

# Stapler Safety Interlock Switch

The Stapler Safety Interlock Switch protects current overloads in case of a staple jam. This switch will open to remove voltage from the stapler unit. To remove and replace the switch:

1. Remove the Paper Exit Tray (page 5-7).
2. Remove the Front Door (page 5-8).
3. Remove the Rear Cover (page 5-11).
4. Remove the Upper Cover (page 5-13).
5. Locate the Paddle Motor and Staple Safety Switch (see illustration).

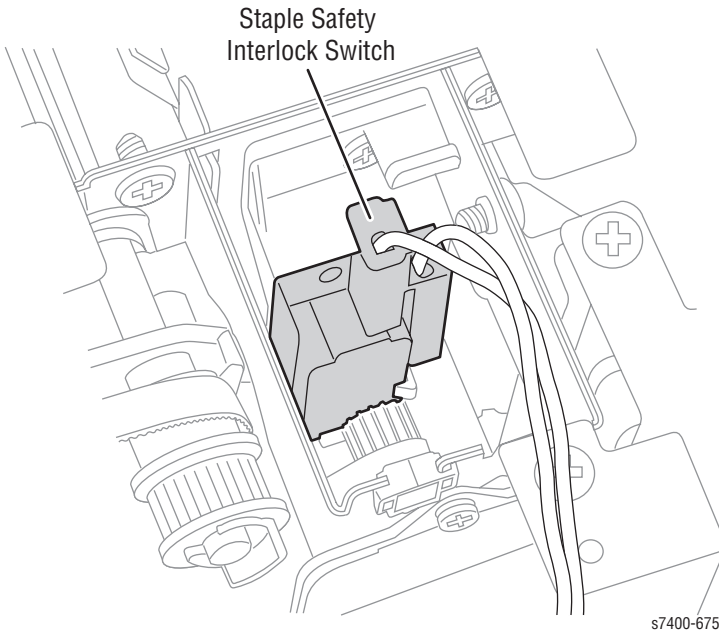

6. Slide the small belt from the Paddle Motor.
7. Remove two screws (metal, 6 mm) and washers from the motor casing and pull the motor away from the chassis so that you have access to the switch.
8. Lift connector CN66 off of the two connector pins. You may need to free the two wires from the cable harness.
9. Remove the single screw (metal, 6 mm) holding the switch to the chassis.
10. To remove the switch, release the three plastic hooks securing the switch to the plastic.

# Staple/Fold Clock Sensor

The Staple/Fold Clock Sensor counts timing pulses during staple and fold operations. To remove the sensor:

1. Remove the Paper Exit Tray (page 5-7).
2. Remove the Rear Cover (page 5-11).
3. Locate the sensor (see illustration) and disconnect connector CN52.

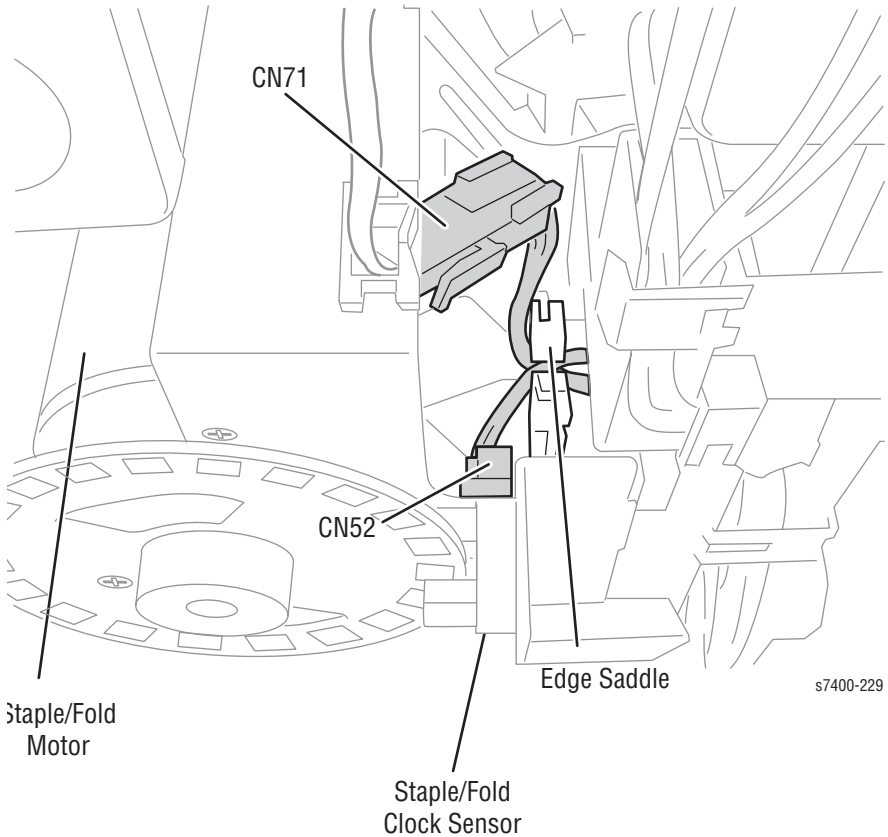

s7400-229

4. To remove the sensor, pinch the plastic tabs with needle nose pliers, and then pull the sensor free.

# Folding Home Position Sensor

The Folding Home Position Sensor detects the positions of the paper fold rollers and the paper pushing plate. To remove and replace the sensor:

1. Remove the Paper Exit Tray (page 5-7).
2. Remove the Front Door (page 5-8).
3. Remove the Rear Cover (page 5-11).
4. Remove the Upper Cover (page 5-13).
5. Remove the Side Guide (page 5-107).
6. Remove the metal cover plate to expose the sensor.

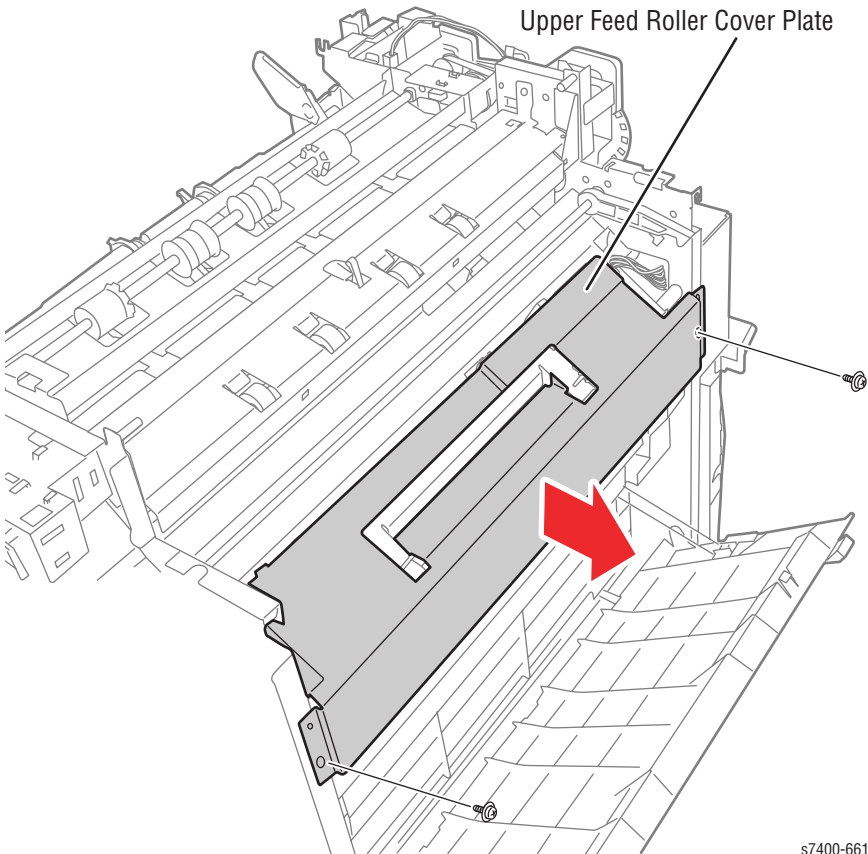

s7400-661



**7.** Locate the sensor (see illustration).

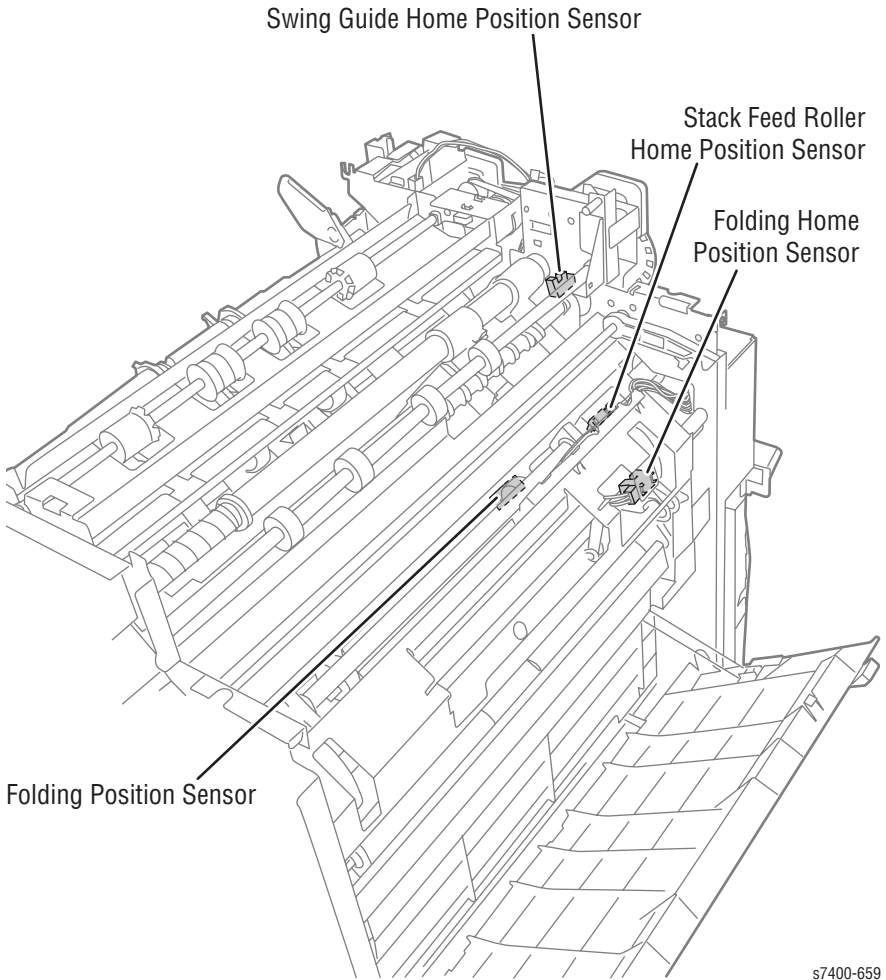

s7400-659

**8.** To remove the sensor, disconnect CN40 from the sensor, remove one screw (metal, 4 mm), and then pull the sensor free.

# Folding Position Sensor

The Folding Position Sensor detects the leading edge of the paper stack. To remove and replace the sensor:

1. Remove the Paper Exit Tray (page 5-7).
2. Remove the Front Door (page 5-8).
3. Remove the Rear Cover (page 5-11).
4. Remove the Upper Cover (page 5-13).
5. Remove the metal cover plate to expose the sensor.

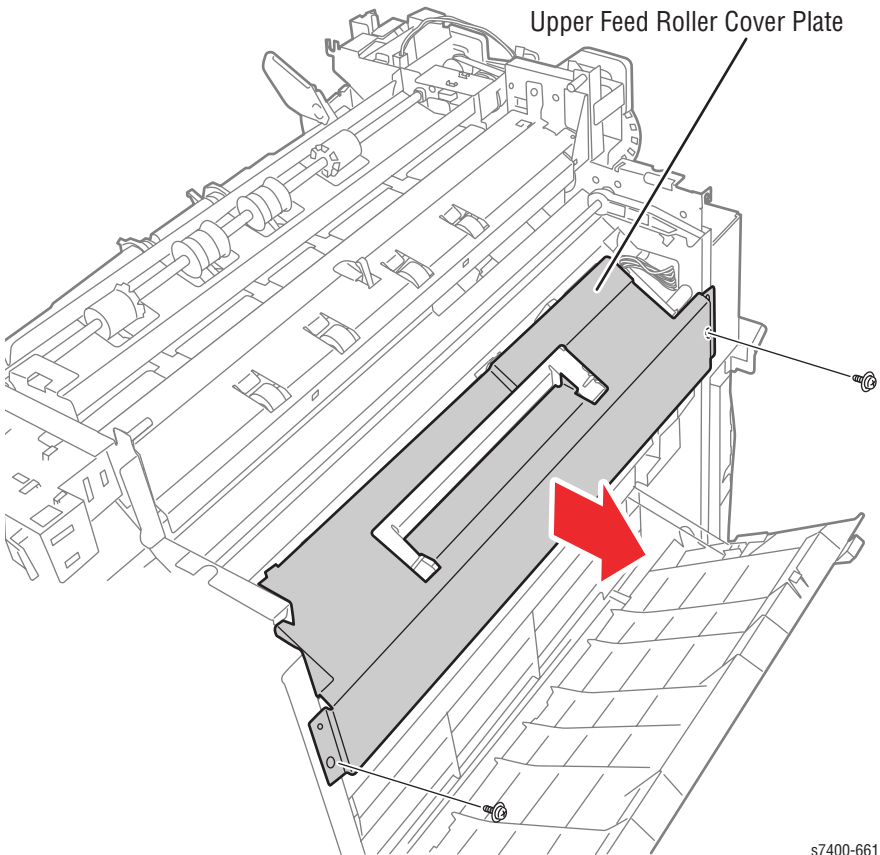

s7400-661

**6.** Locate the sensor (see illustration).

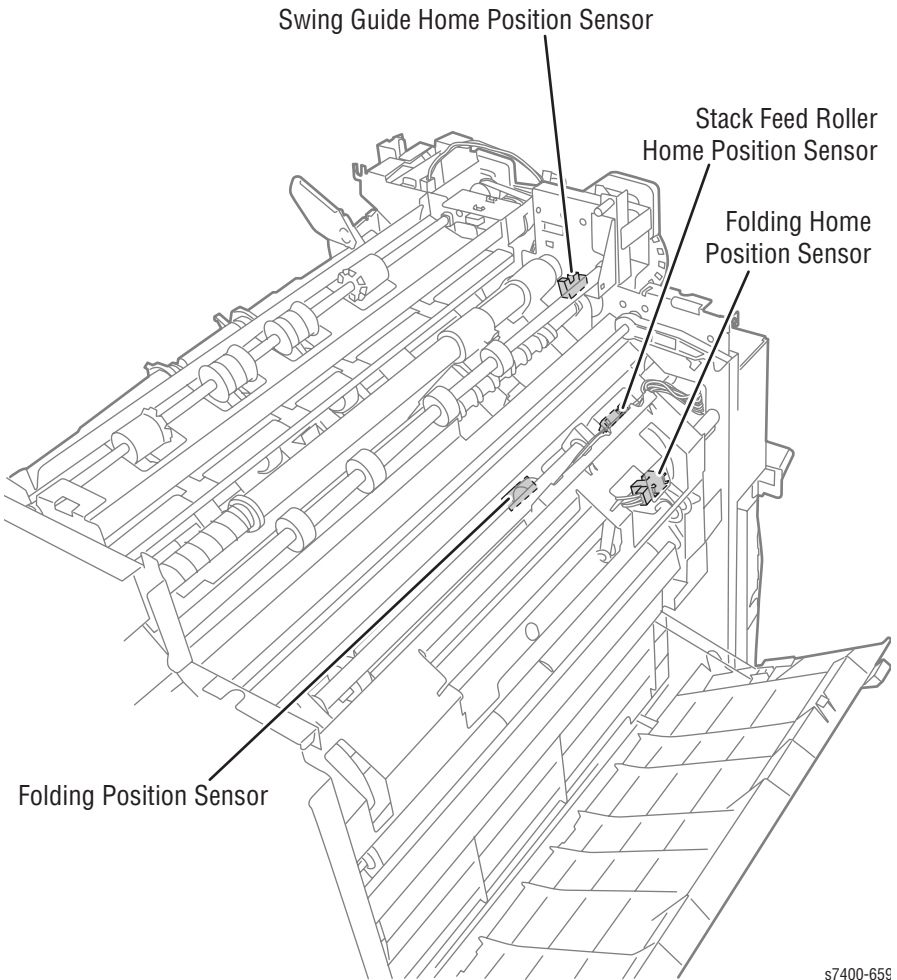

**7.** To remove the sensor, disconnect CN40 from the sensor, remove one screw (metal, 4 mm), and then pull the sensor free.

# Bind Tray Sensor

The Bind Tray Sensor detects when paper is present in the Saddle Unit's bind tray. To remove and replace the sensor:

1. Remove the Paper Exit Tray (page 5-7).
2. Remove the Front Door (page 5-8).
3. Remove the Rear Cover (page 5-11).
4. Remove the Upper Cover (page 5-13).
5. Remove the Side Guide (page 5-107).
6. Remove the Bind Tray Sensor Cover (see illustration).

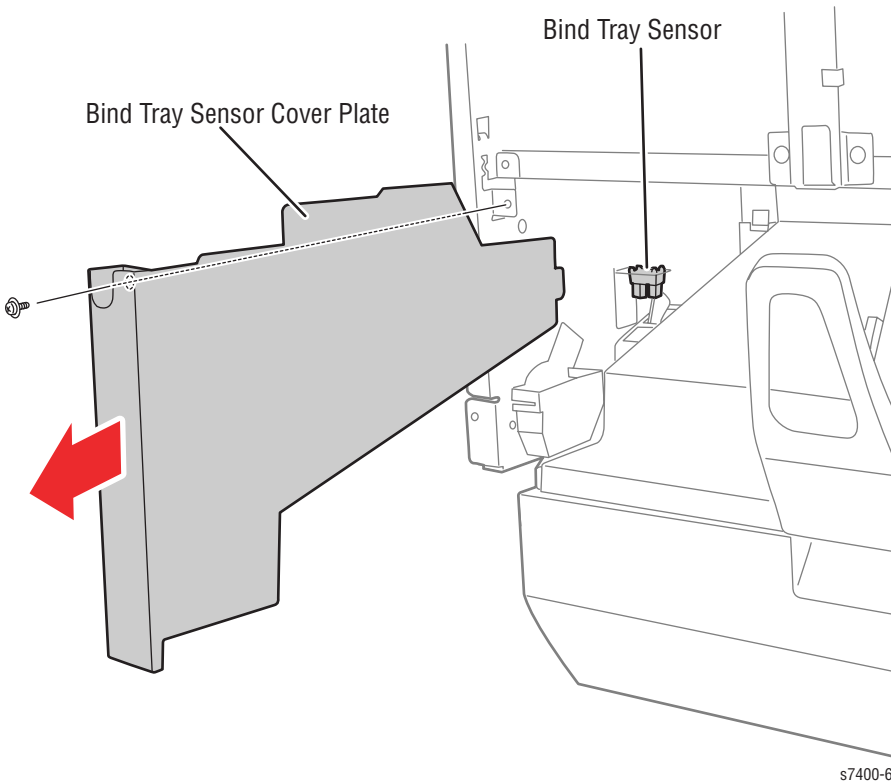

s7400-6

7. To remove the Bind Tray Sensor, first remove the 4-wire connector CN47 from the sensor, and then pinch the plastic tabs to pull the sensor free.

# Inverter Sensors and Switches

The following illustration shows the general location of the Inverter sensors. The topics in this section describe the disassembly for each sensor.

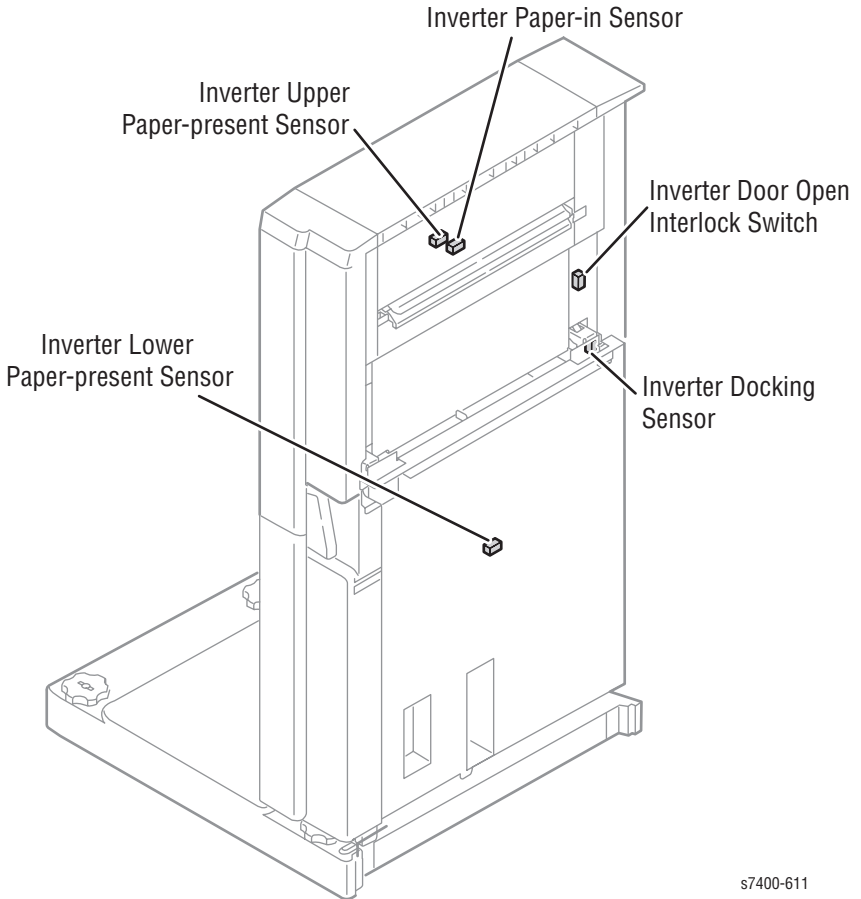

s7400-611

# Inverter Docking Sensor

The Inverter Docking Sensor detects when the Inverter interconnects with the Printer. To remove the sensor:

1. Remove the Inverter and base unit from the Finisher (page 5-5).
2. Remove the Inverter Rear Covers (page 5-19).
3. Disconnect the 3-wire cable from the connector (SNSCN1) at the Inverter Controller Board.
4. Free the cable from the cable harness.
5. Remove single screw (self-tapping, plastic 10 mm) and open Door I to expose the sensor.
6. Pinch the plastic hooks on the interlock switch to remove the switch from the chassis.

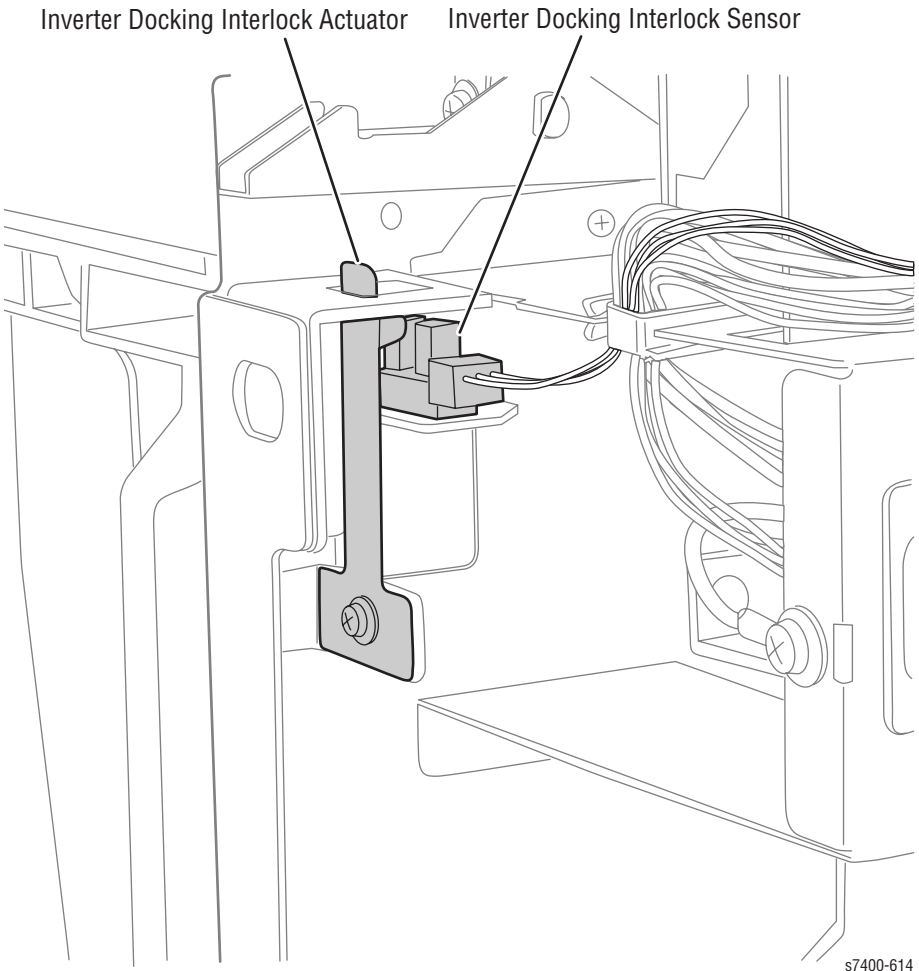

s7400-614

# Inverter Door (Door F) Open Interlock Switch

The Inverter Door Open Interlock Switch detects when the Inverter Door (F) is open. To remove the switch:

1. Remove the Inverter and base unit from the Finisher (page 5-5).
2. Remove the Inverter Rear Covers (page 5-19).
3. Remove the Top Cover (page 5-23).
4. Disconnect the 2-wire cable from the connector (SNSCN2) at the Inverter Controller Board.
5. Free the cable from the cable harness.
6. Remove a single small metal screw (metal, 4 mm) and remove the switch.

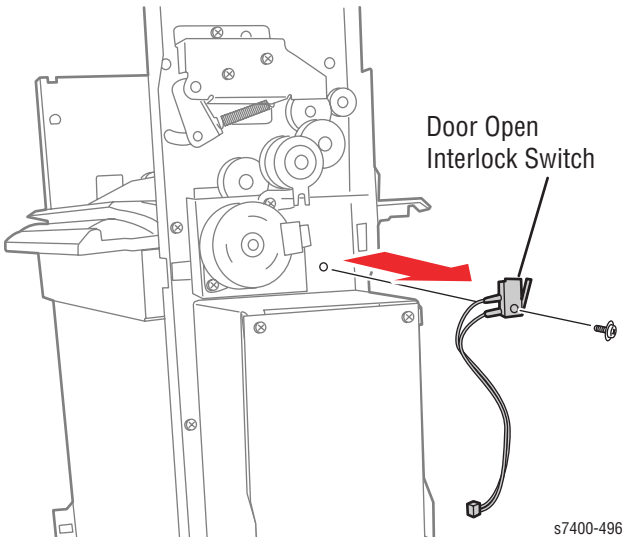

# Inverter Upper Paper-Present Sensor

The Inverter Upper Paper-Present Sensor detects the leading edge of the selected paper size. To remove the sensor:

1. Remove the Inverter and base unit from the Finisher (page 5-5).
2. Remove the Inverter Front Covers (page 5-17).
3. Remove the Inverter Rear Covers (page 5-19).
4. Remove the Top Cover (page 5-23).
5. Open Door F to expose the screws (metal flange, 6 mm) to the top paper guide and the Upper Paper-Present Actuator.
6. Disconnect the 3-wire cable from the actuator.

## Note

The other end of this cable connects to connector (SNSCN0) on the Inverter Controller Board.

7. Free the cable from the cable harness near the paper guide.
8. Remove two screws (metal flange, 6 mm) holding the top paper guide to the lower paper guide, and then remove the top paper guide.
9. To remove the actuator from the top paper guide, pinch the plastic release tab to free the actuator.
10. To remove the Upper Paper-Present Sensor, pull the connector off the sensor, pinch the plastic hooks together, and push the sensor free from the chassis.

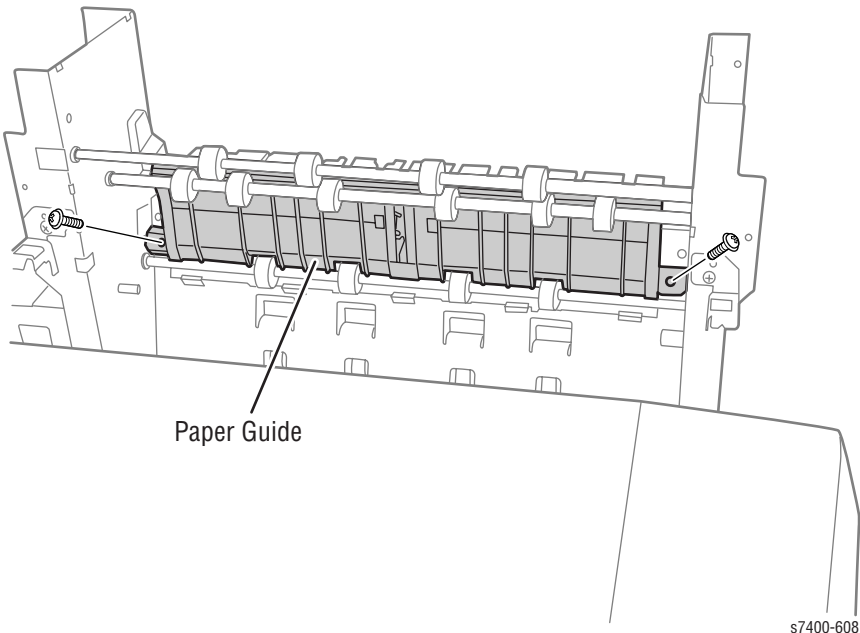

s7400-608



11. To remove the Upper Paper-Present Sensor, pull the connector off the sensor, pinch the plastic hooks together, and push the sensor free from the chassis.

Inverter Upper Paper Present Sensor

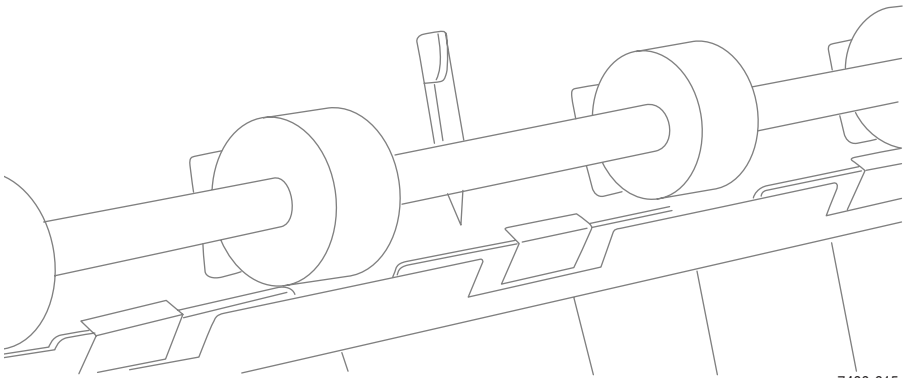
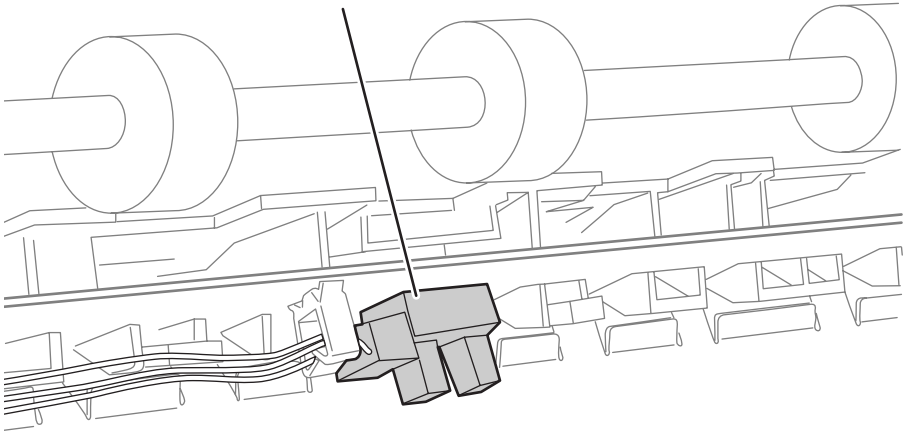

s7400-615

# Inverter Lower Paper-Present Sensor

The Inverter Lower Paper-Present Sensor detects the trailing edge of the selected paper size. To remove the sensor:

1. Remove the Inverter and base unit from the Finisher (page 5-5).
2. Remove the Inverter Front Covers (page 5-17).
3. Remove the Inverter Rear Covers (page 5-19).
4. Remove the Top Cover (page 5-23).
5. Remove the Inverter Controller Board (page 5-55).
6. Remove the Inverter Power Supply Board (page 5-56).

## Note

Both Inverter boards must be removed in order to access one of the side screws in the metal plate.

7. Remove seven screws (metal flange, 6 mm) from the front metal cover plate; one from each side near the top, and five from the front of the plate.
8. Slide the front metal plate away from the chassis to expose the Lower Paper-Present Actuator.
9. Disconnect the 3-wire cable from the actuator.

## Note

The other end of this cable connects to connector (SNSCN0) on the Inverter Controller Board.

10. To remove the actuator from the top paper guide, pinch the plastic release tab to free the actuator.

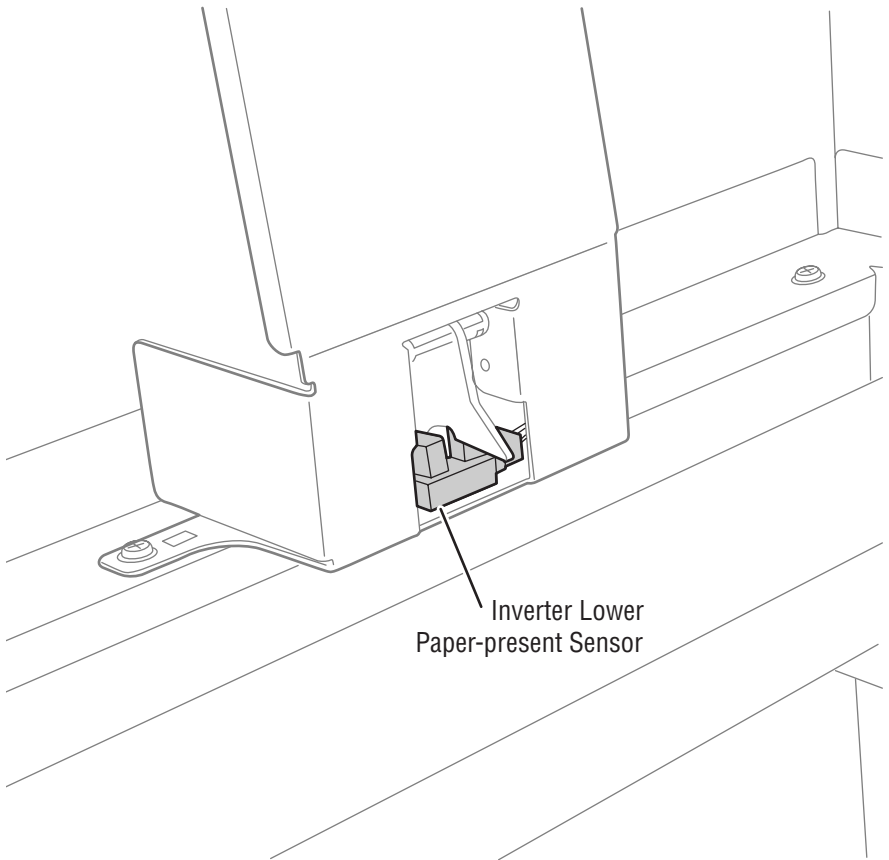

s7400-607

# Inverter Paper-in Sensor

The Inverter Paper-in Sensor detects the presence of media in the Inverter. To remove the sensor:

1. Remove the Inverter and base unit from the Finisher (page 5-5).
2. Remove the Inverter Front Covers (page 5-17).
3. Remove the Inverter Rear Covers (page 5-19).
4. Remove the Top Cover (page 5-23).
5. Remove six screws (metal flange, 6 mm) from the actuator cover metal plate.
6. Disconnect the 3-wire connector at the actuator location.

## Note

The other end of this cable connects to connector (SNSCN0) on the Inverter Controller Board.

7. Pinch the plastic hooks together to free the actuator from the metal support case, then pinch the plastic tab to pull the actuator free from the chassis.

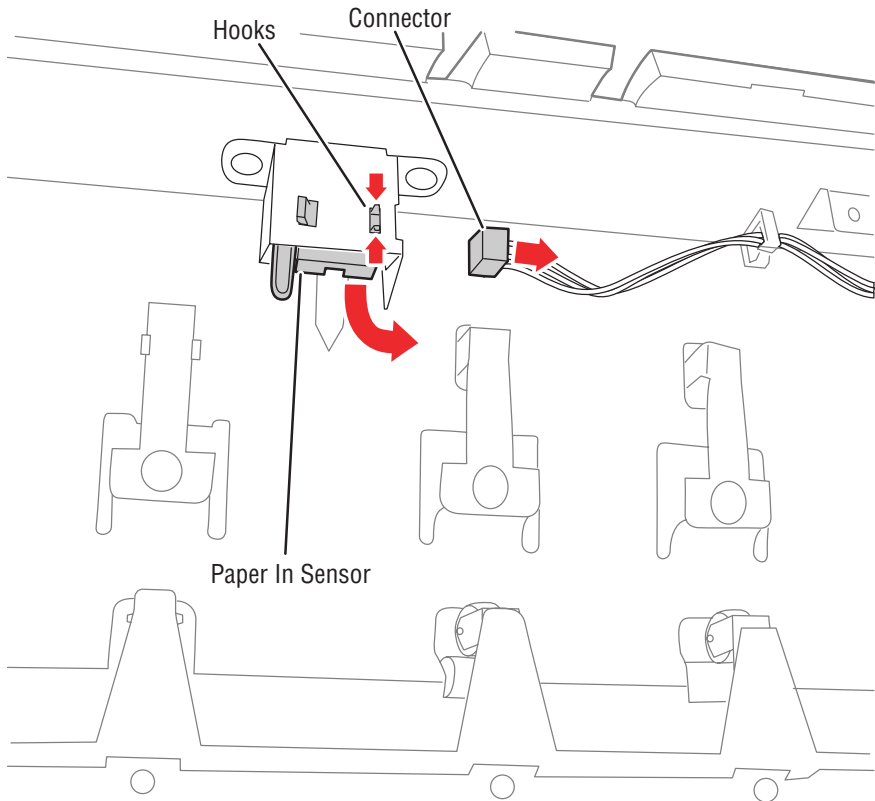

# Guides and Rollers

## Side Guide

1. Remove the Paper Exit Tray (page 5-7).
2. Remove the Front Door (page 5-8).
3. Remove the Rear Cover (page 5-11).
4. While gently holding the Rear Delivery Tray Support Plate (and track) to the side, remove three screws (metal, 10 mm) and one specialty screw (metal, 16 mm), from the Side Guide.
5. Pull the Side Guide slightly away from the Finisher.

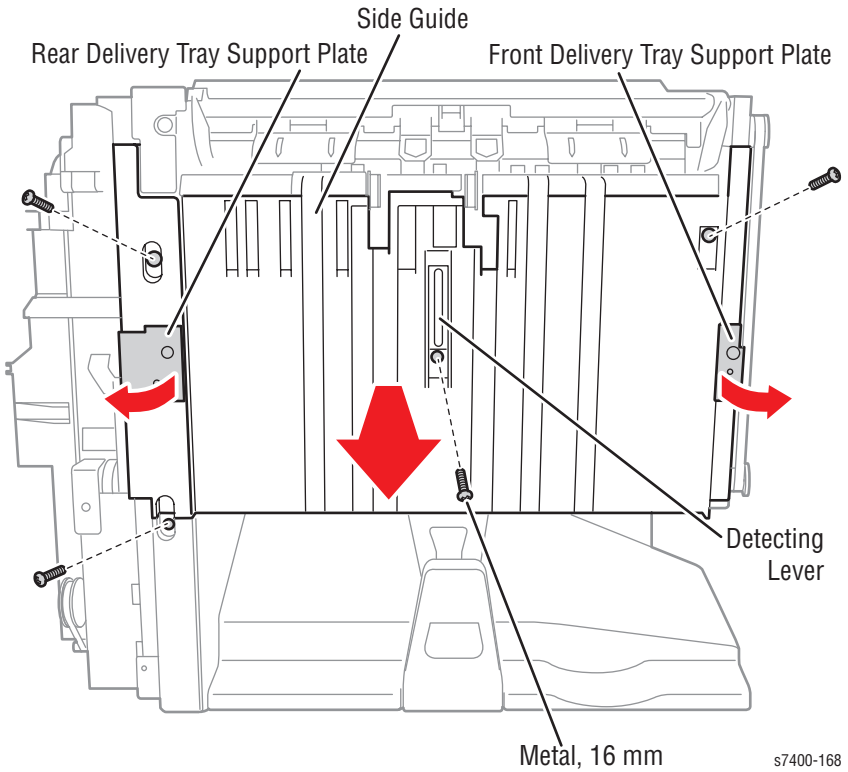

6. Twist the guide slightly clockwise, free the engagement of the paper surface detecting lever (rear), and then remove the guide.

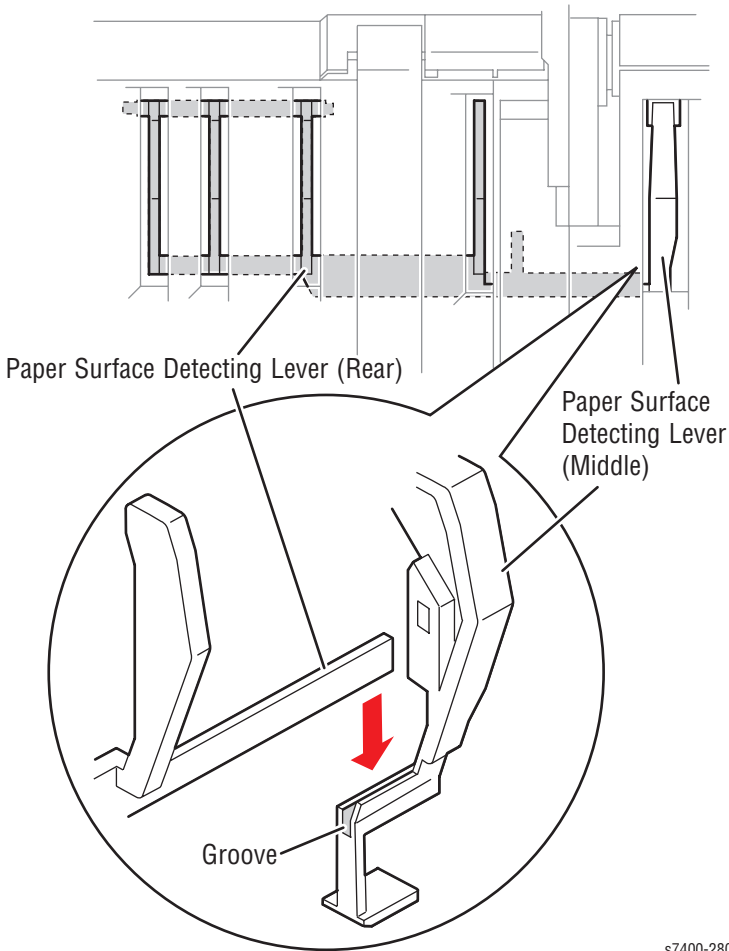

### Replacement Note

Be sure to insert the paper detecting lever in the groove of the paper surface. After completion of mounting, activate the paper detecting lever several times to make sure that side guide is mounted securely.

# Feed Roller

1. Remove the Upper Cover (page 5-13).
2. Remove the Upper Right Cover Assembly (page 5-37).
3. Remove the Feed Motor Unit (page 5-62).
4. Remove the screw (metal flange, 6 mm).
5. Remove the stop ring, and detach the bushing.

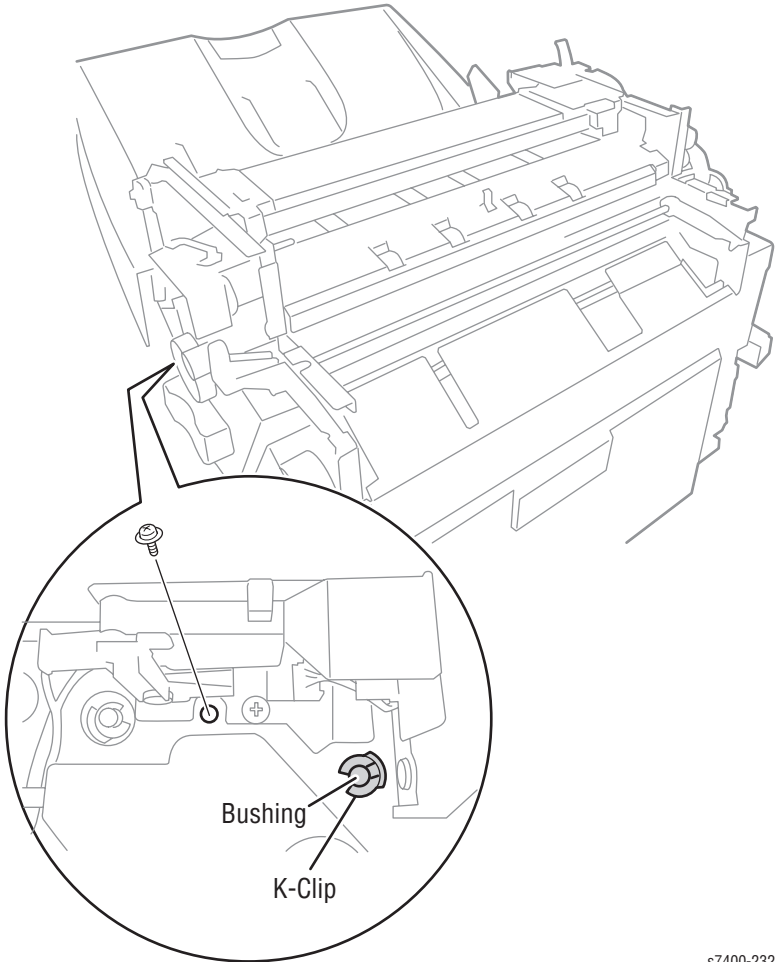

s7400-232

6. Remove the two screws (metal flange, 6 mm).
7. Remove the gear and detach the gear while releasing the latch.
8. Remove the stop ring and detach the bushing.

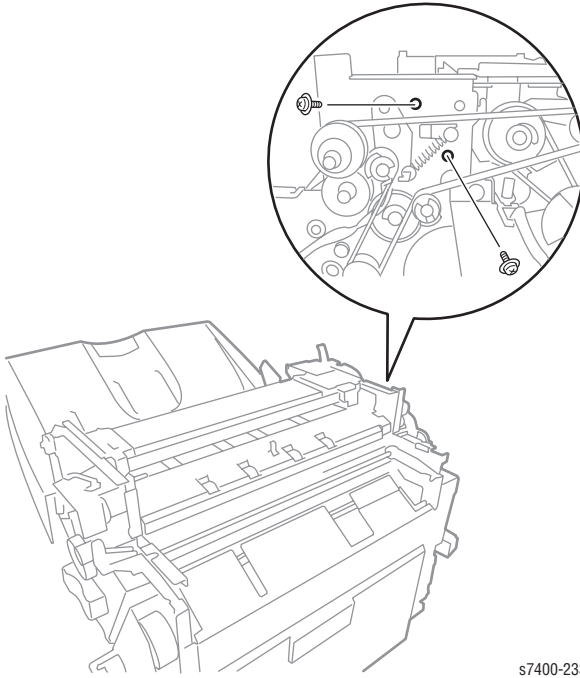

s7400-233



**9.** Remove the Lower Paper Guide.

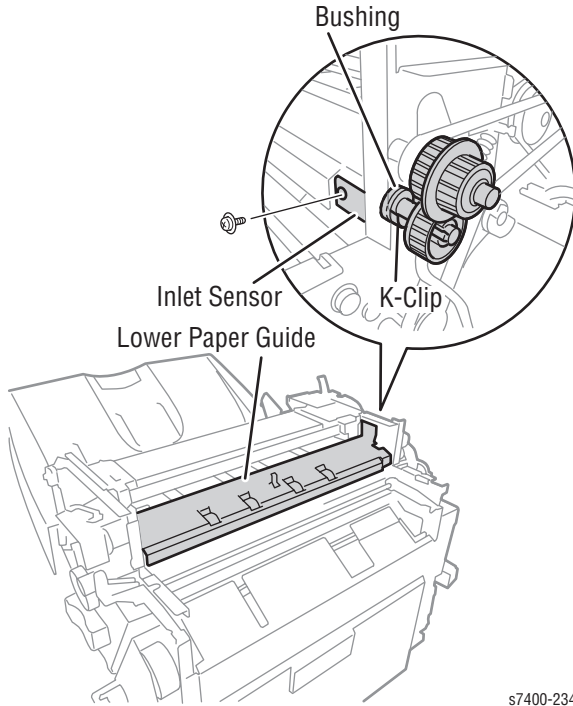

**10.** Remove the Feed Roller.

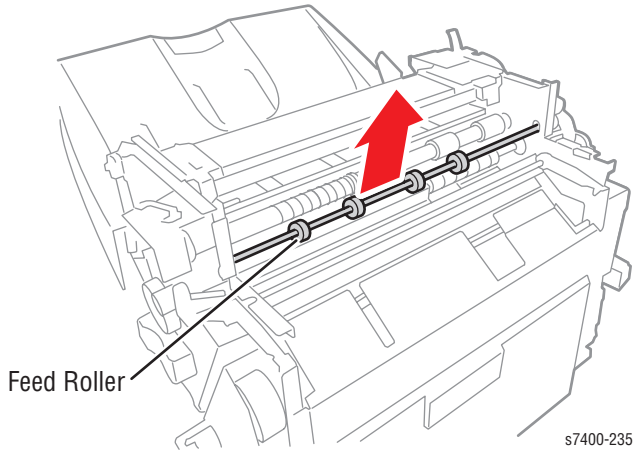

# Upper Stack Delivery Roller

1. Remove the Paddle Assembly (page 5-46).
2. Place the assembly as shown.
3. Push up the Upper Stack Delivery Roller from below to free it from the shaft.

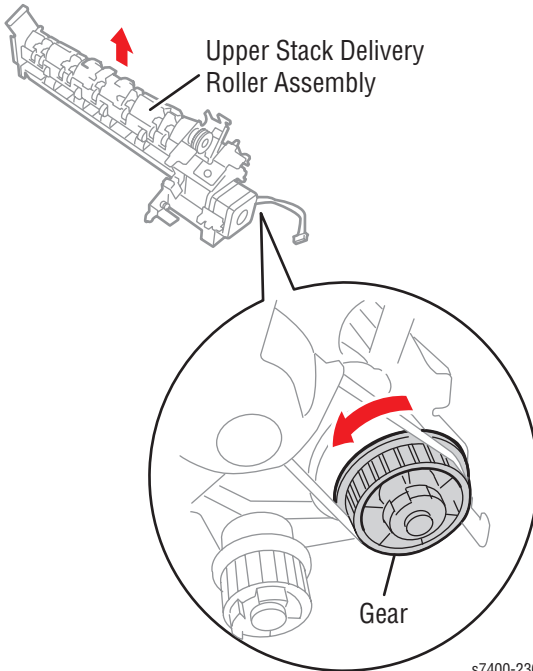

s7400-236

4. Shift the roller upwards and then push down to detach.

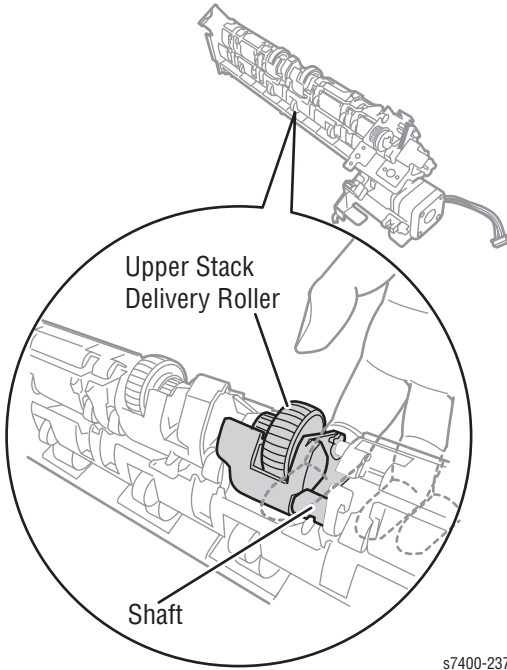

s7400-237

5. In a similar manner, remove the Upper Stack Delivery Roller at the front.

**Note**

Be careful not to lose the gear pin in the roller.

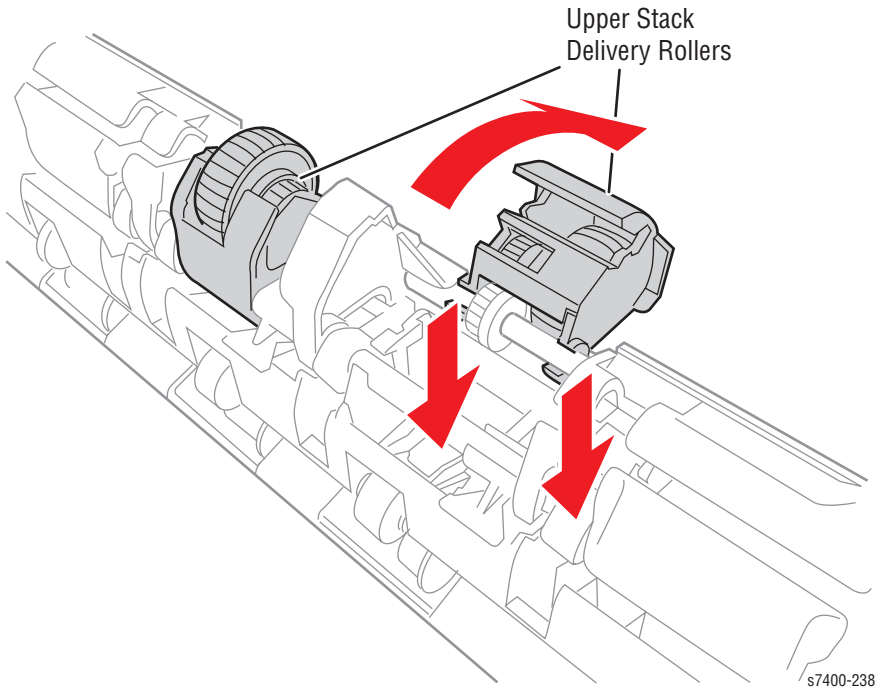

# Paddle

1. Remove the Paddle Assembly (page 5-46).
2. Place the assembly as shown.
3. Turn the gear in the direction of the arrow to move the upper stack delivery roller assembly upwards.
4. Push up the safety guide from below to free one side of the safety guide from the shaft.

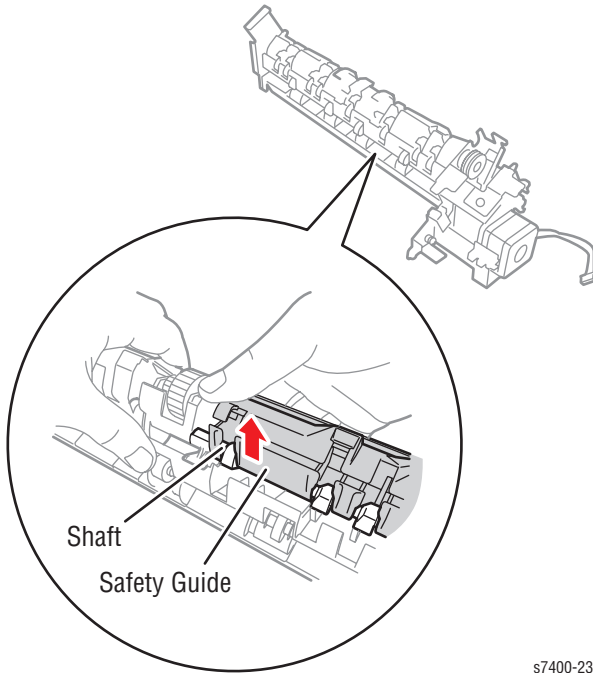

s7400-239

5. Push up the Safety Guide from below to free it from the shaft.

6. Remove the Paddle in the direction of the arrow (see the following illustrations).

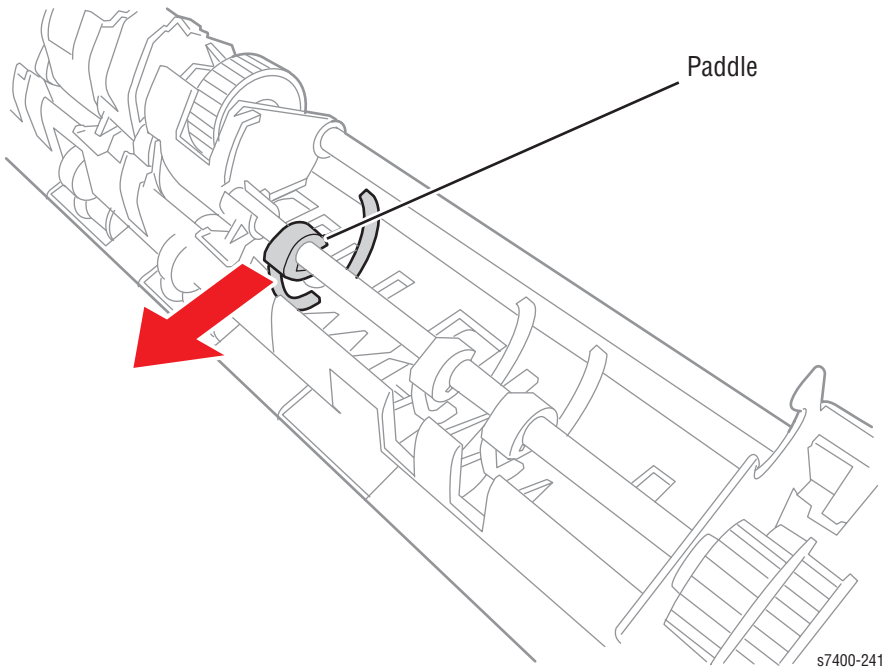
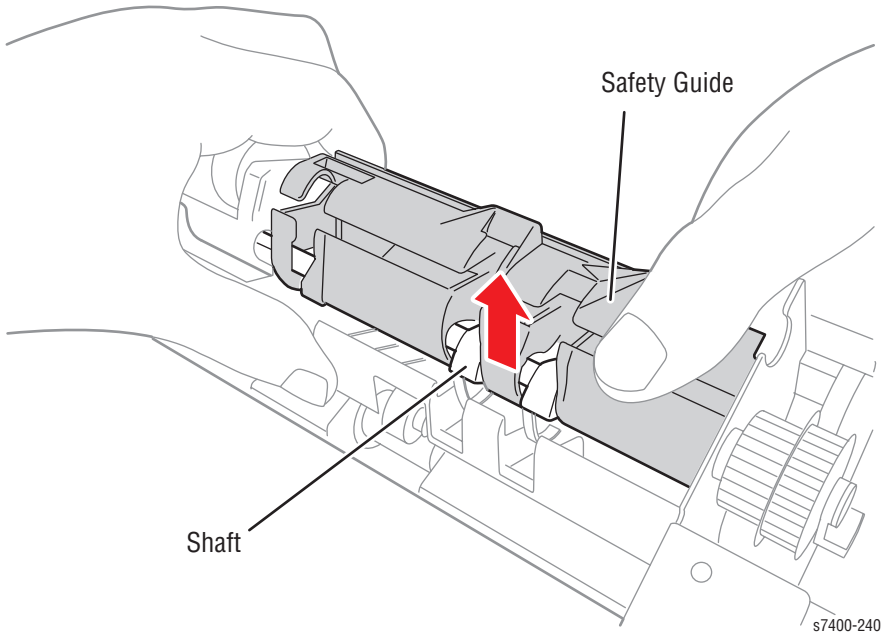

# Lower Stack Delivery Roller Belt

1. Remove the Paddle Assembly (page 5-46) and separate it from the Processing Tray Assembly.
2. Slide the front and rear tamper plate of the processing tray to the outside.
3. Remove the processing tray stopper.

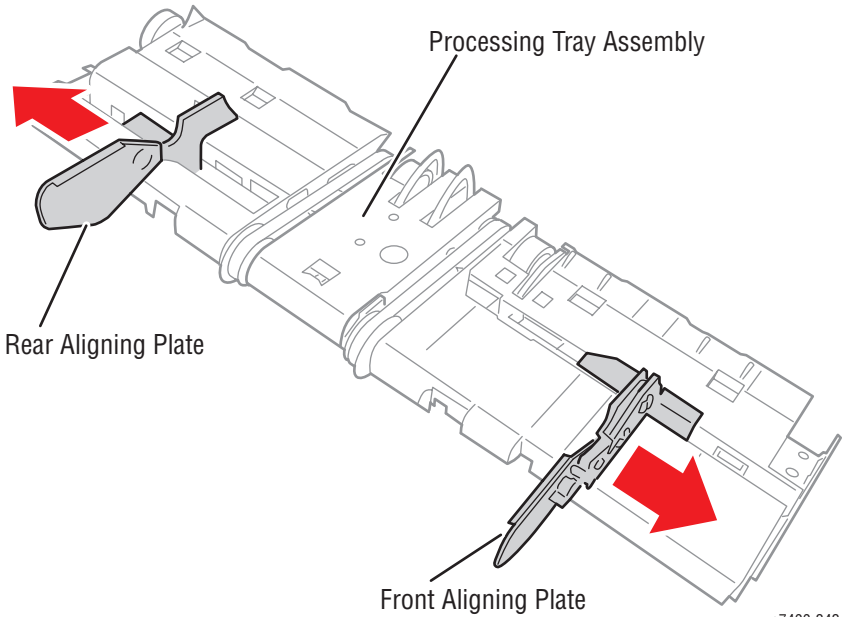

s7400-242

4. Remove the screw (metal flange, 6 mm) and detach the Front Paper Guide while freeing the two tabs.

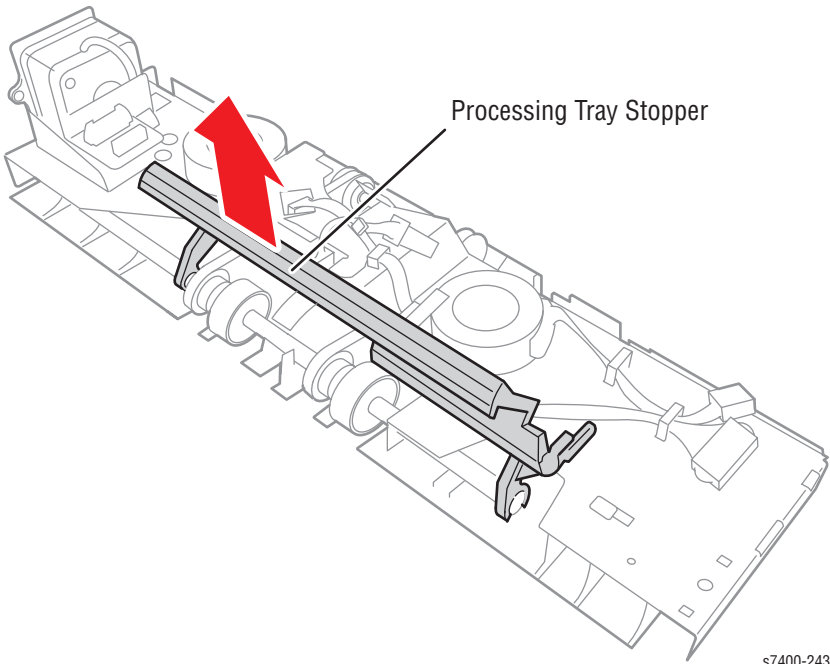

s7400-243



5. Remove the screw, (metal flange, 6 mm) and while freeing the tab, remove the Rear Paper Guide.

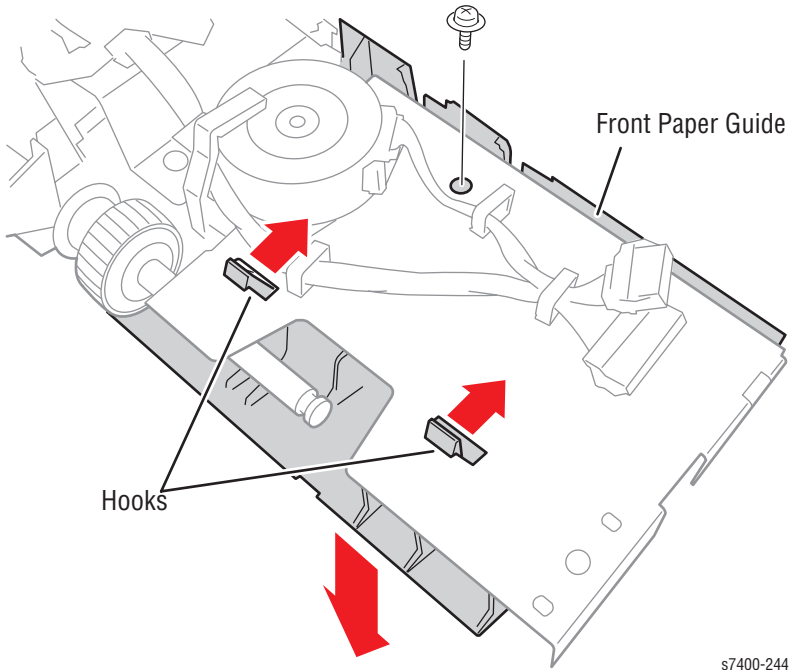

s7400-244

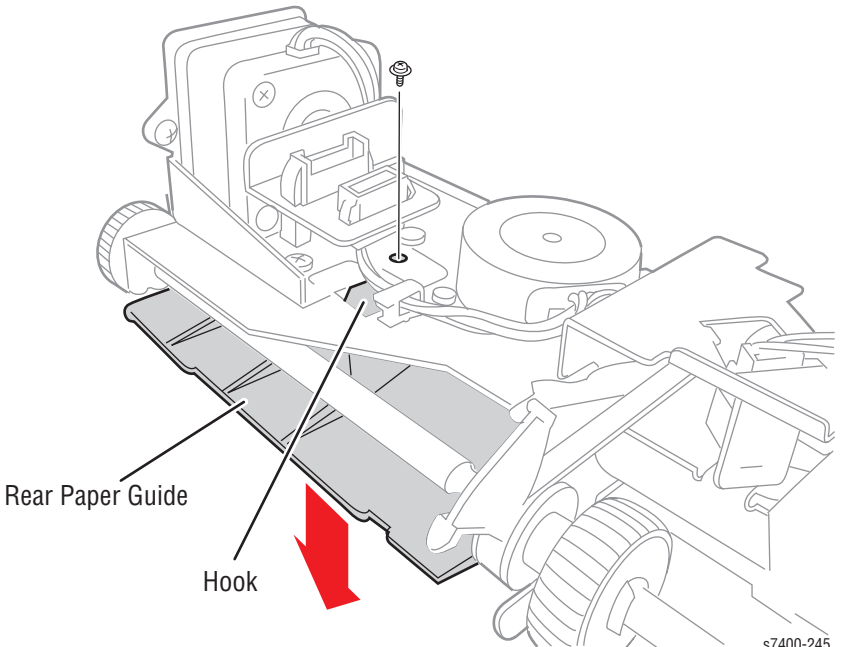

s7400-245

6. Repeat Step 5 for the Front Guide.

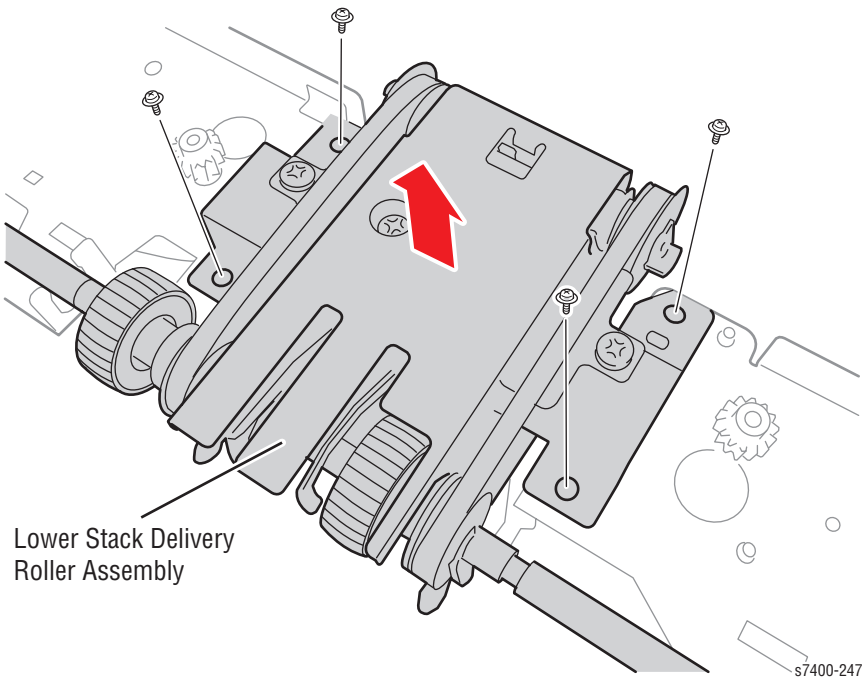
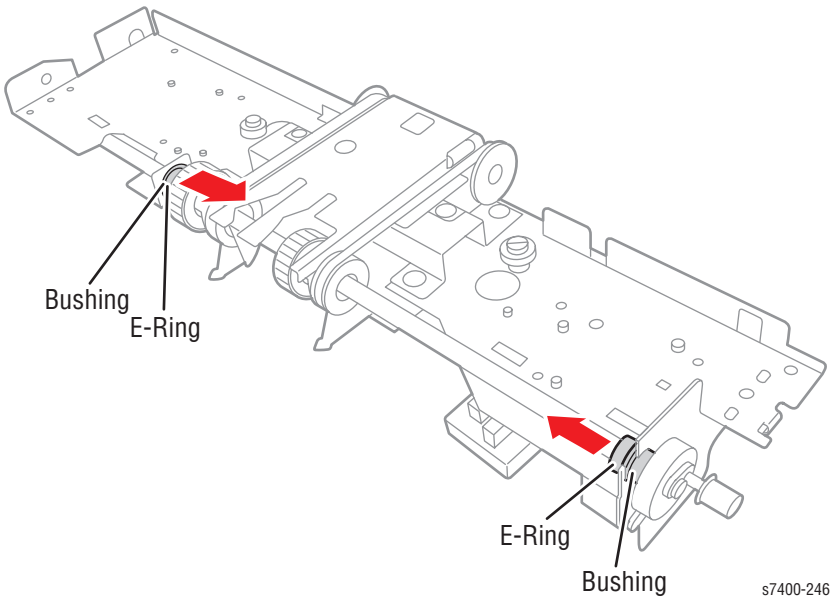

7. Remove the two stop rings and move the two bushings to the inside.

8. Remove the four screws (metal flange, 6 mm) then lift the Lower Stack Delivery Roller Assembly to detach.

9. Remove the two delivery belts.

**Note**

Be sure to mount the belts so that the edges of the claws of the belts are flush.

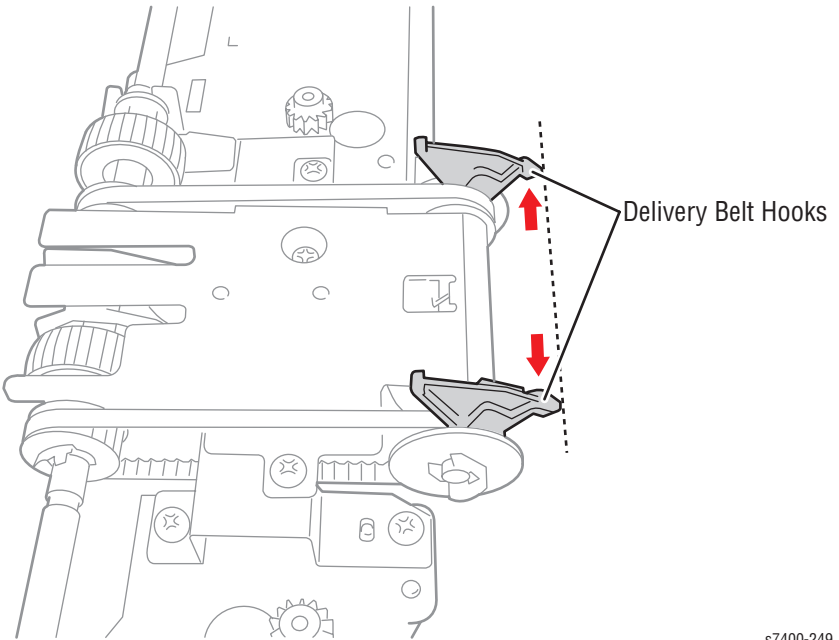
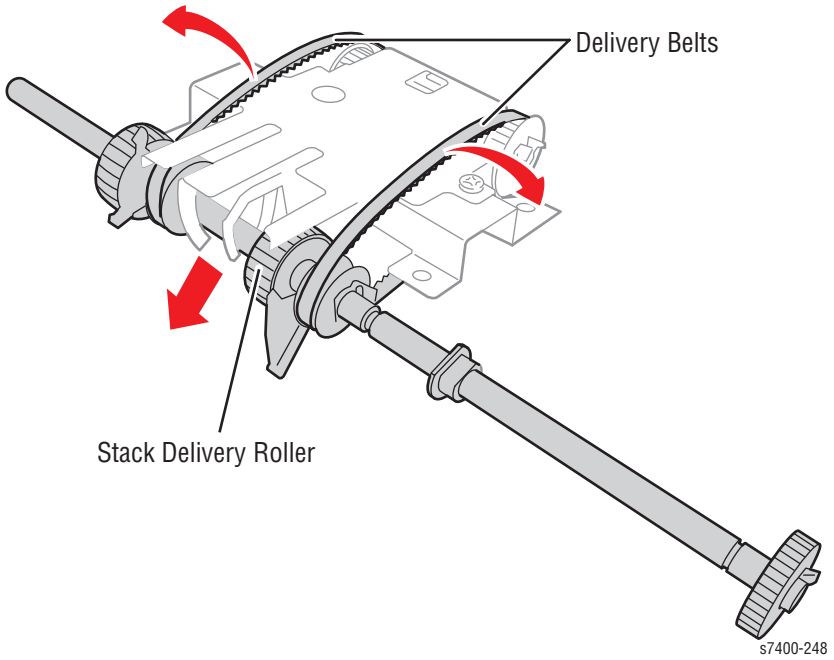

# Duplex Unit Disassembly

To view sensors, motors, solenoids, gears, belts, and boards in the Duplex Unit, you must first remove the following:

- Front Cover Assembly
- Bottom Plate
- Side Rails

## Note

If you need to remove the Duplex Unit Controller Board for any of the following procedures, disconnect all connectors and remove one screw (self tapping, 6 mm) securing the board to the frame, and then pull free from the mounting post.

## Front Cover Assembly

From the front assembly, you can see three sensors and the connector to the Duplex Unit Controller board. To remove the Front Cover assembly:

1. Remove two screws (metal flange, 6 mm) from the front cover.

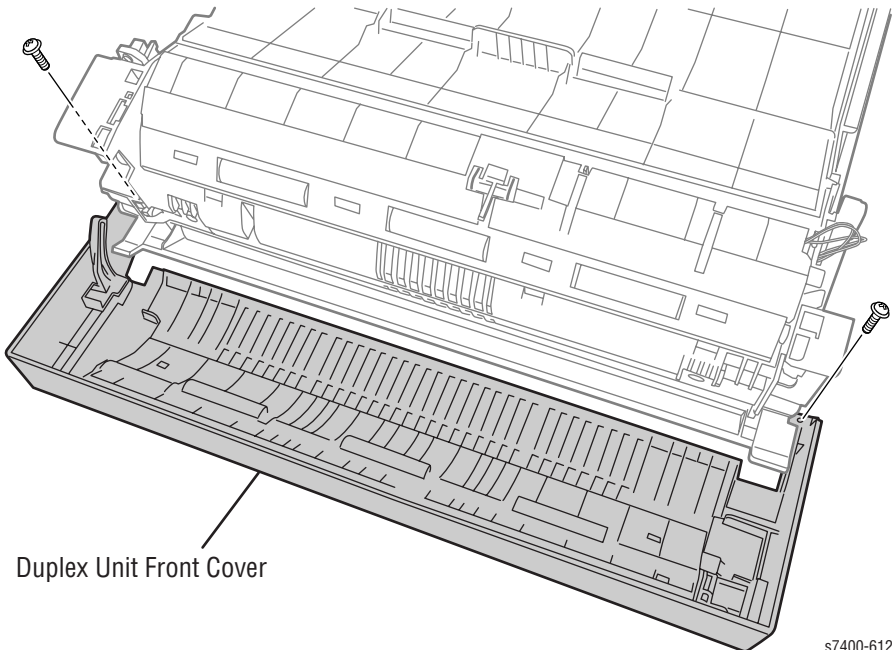

s7400-612

2. Slide the front assembly mounting rod out of the slot.

**Caution**

Be careful not to lose the retaining springs when you remove the assembly mounting rod.

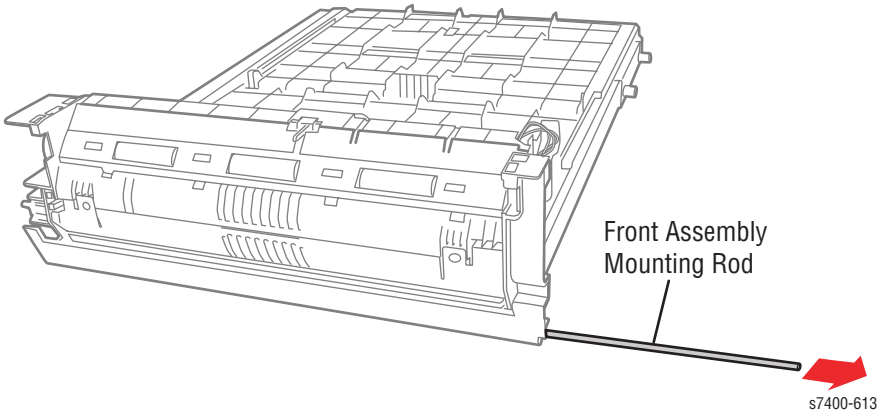

3. From the remaining plastic piece, carefully loosen the plastic from the metal support bar. This exposes two support screws (metal flange, 6 mm) from the lower metal cover plate.

## Bottom Cover Plate

Removing the Bottom Cover Plate will expose the Duplex Controller Board, the fan, the two motors, five sensor switches, three belts, and the door solenoid.

To remove the Bottom Cover Plate:

1. Remove the Front Cover Assembly (page 5-122).
2. Turn the Duplex unit over so that the bottom plate is facing up.
3. Remove four black screws (self-tapping, 10 mm) and one silver screw (metal, 10 mm) fastening the plate to the chassis.
4. From the front end of the assembly, remove two black screws (self-tapping, 10 mm) from the folded end of the bottom plate.

5. Lift the bottom plate free from the chassis.

**Caution**

Be careful to keep the unit upside down so that you do not lose any of the retaining springs from the unit

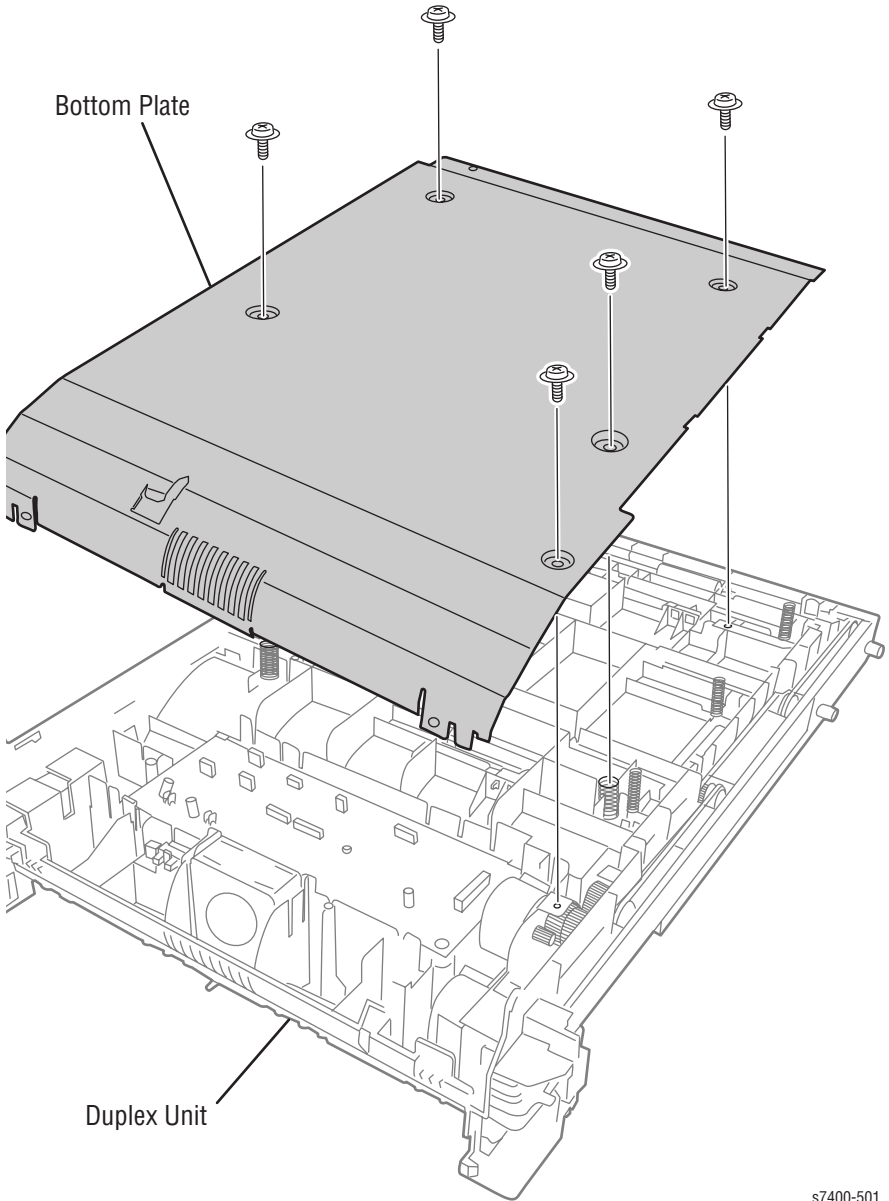

s7400-501

## Side Rails

Removing the Side Rails exposes gears, belts, and the door solenoid. To remove the belts, remove only the left side rail using the following steps:

1. Remove the Front Cover assembly (page 5-122).
2. Slide the mounting slides to the rear of the side rail.
3. Remove three screws (metal flange, 6 mm) fastening the side rail to the chassis and lift the rail free from the chassis.

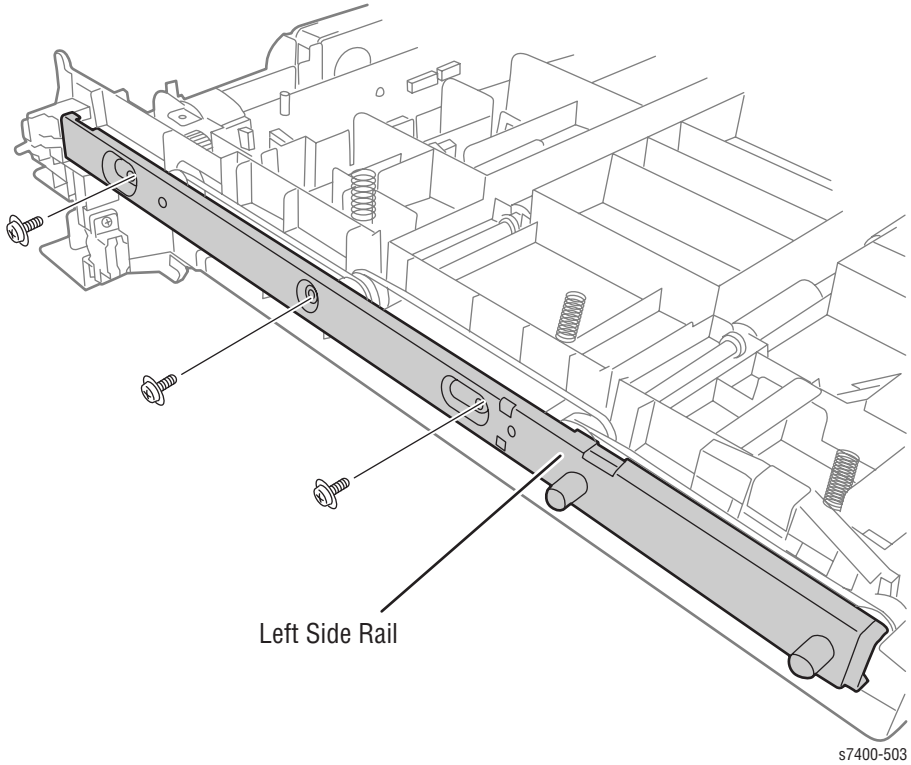



# Paper Guides

1. Remove Front Door and Cover assembly (page 5-122).
2. To remove either the Top Paper Guide or the Lower Paper Guide, lift the paper guide to the open position, loosen one end of the plastic insert, and lift away from the chassis.

## Caution

Removing any of the guides will expose paper sensors.

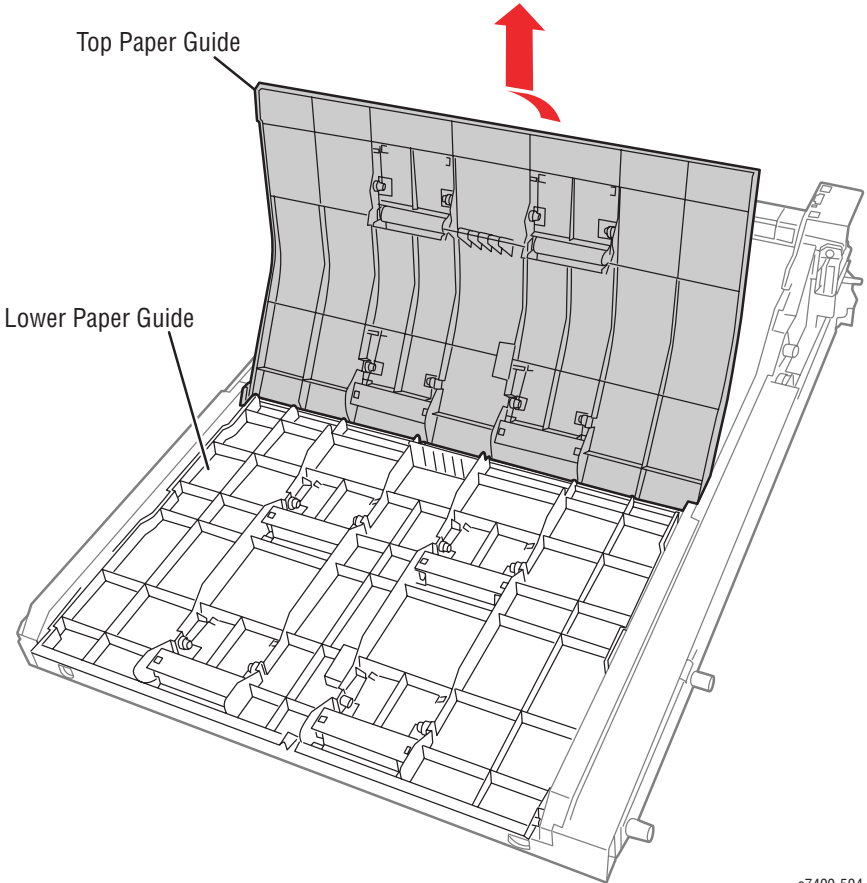

s7400-504

# Duplex Motor Assembly

Motor A and Motor B are assembled in one unit. Use the following steps to remove and replace the motor assembly:

1. Remove the Front Door and Front Cover Assembly (page 5-122).
2. Remove the right side rail (page 5-126).
3. Lift the rubber belt free from the motor gears.
4. Disconnect Motor A and Motor B connectors (Motor\_A and Motor\_B) from the Duplex Unit Controller board.
5. Remove two screws (metal flange, 6 mm) from the motor assembly (see illustration).
6. Lift the motor assembly (two motors and associated gears) from the chassis.

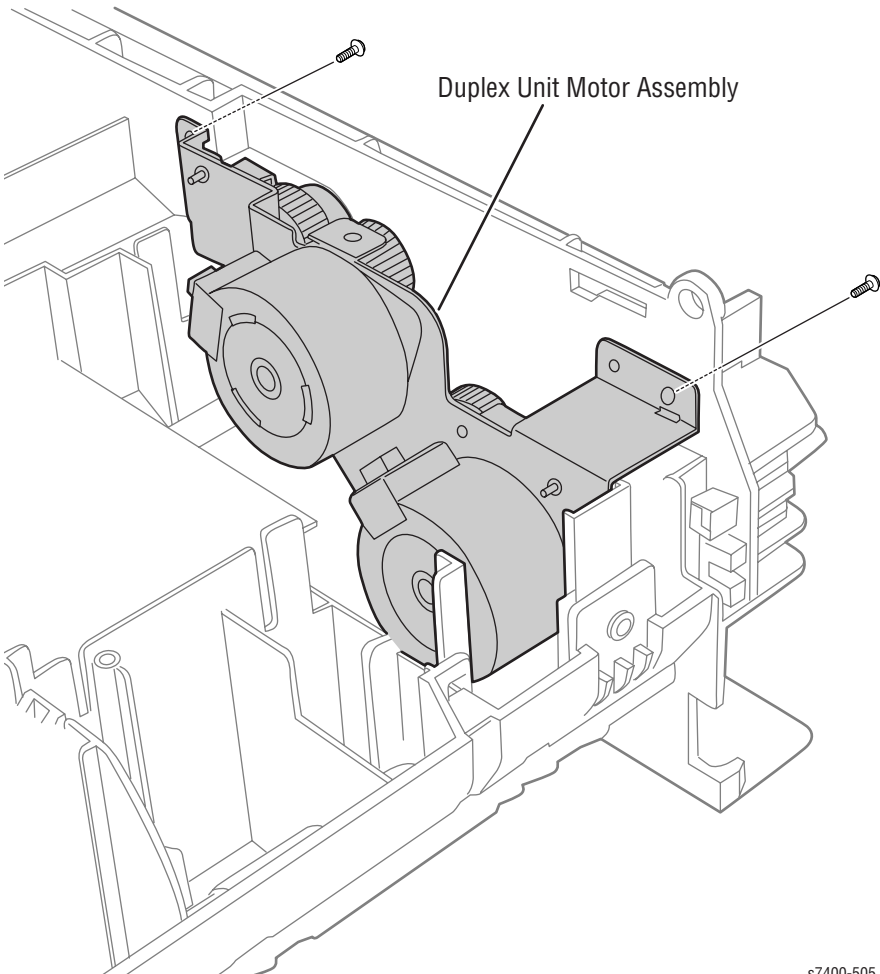

s7400-505

# Diverter Solenoid

The Diverter Solenoid re-routes the paper in the opposite direction on its paper path during duplex operation. To remove the solenoid:

1. Remove the Front Door and Front Cover Assembly (page 5-122).
2. Remove the Left Side Rail (page 5-126).
3. Disconnect the solenoid connector (CL1) from the Duplex Controller Board.
4. Remove the solenoid plastic cover.
5. Remove the single (metal flange, 6 mm) screw from the solenoid and lift the solenoid free from the chassis.

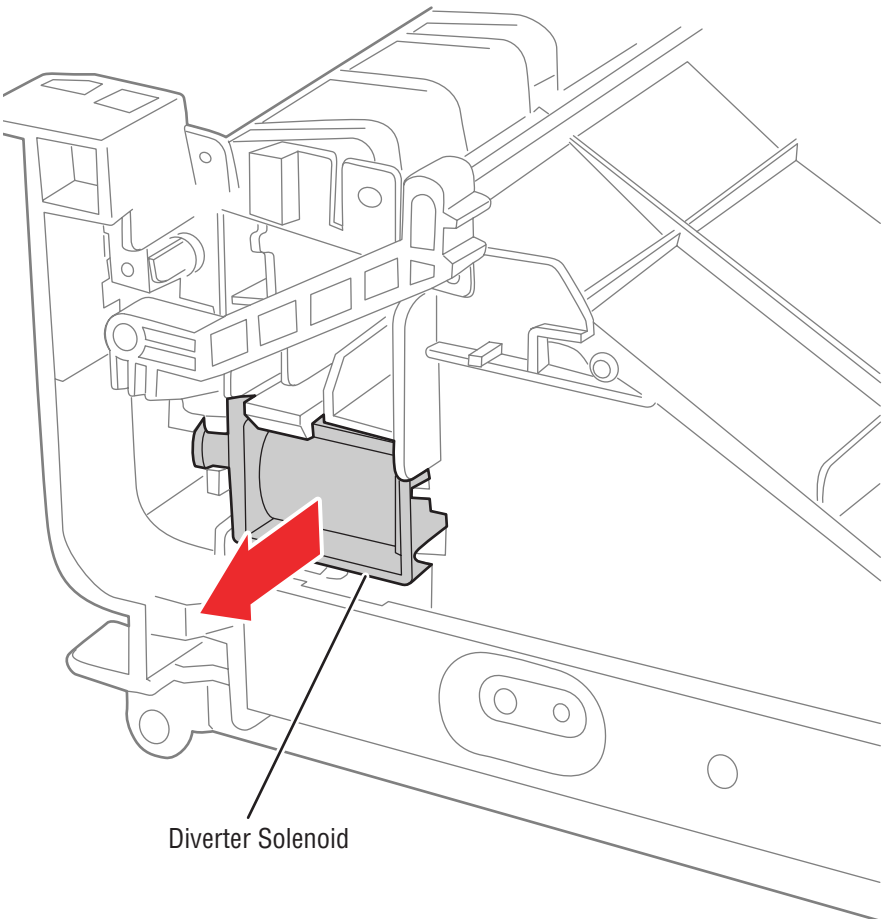

s7400-506

# Duplex Unit Sensors and Switches

There are a total of five sensors for the various duplex interlocks and paper paths. Refer to the sensor locator illustration to locate the appropriate sensor. To remove any of the sensors:

1. Remove the Front Cover Assembly (page 5-122).
2. Disconnect the sensor connector (either SNSCN0 or SNSCN1) from the Duplex Unit Controller Board.
3. Pinch the plastic insert pins on the connector together and lift free from the chassis.

## Caution

Be careful not to lose any of the retainer springs.

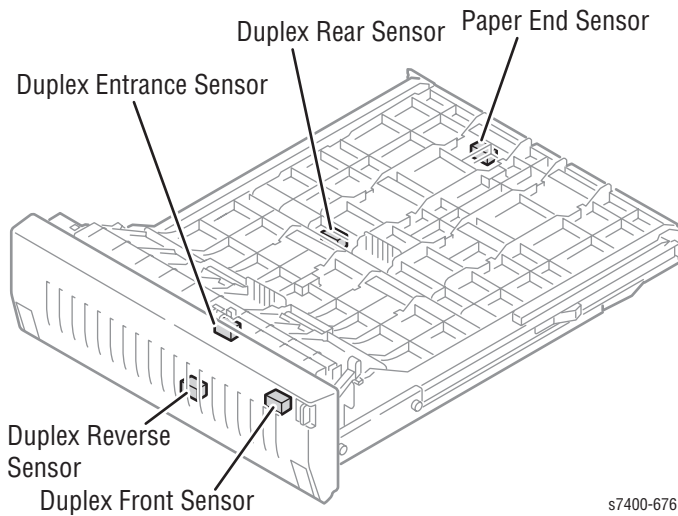

s7400-676

# Duplex Fan

To remove the Duplex Fan:

1. Remove the Front Cover Assembly (page 5-122).
2. Disconnect the fan connector (FAN) from the Duplex Unit Controller Board.
3. Lift the fan free from the plastic molding.

## Caution

Be careful not to lose any of the retainer springs.

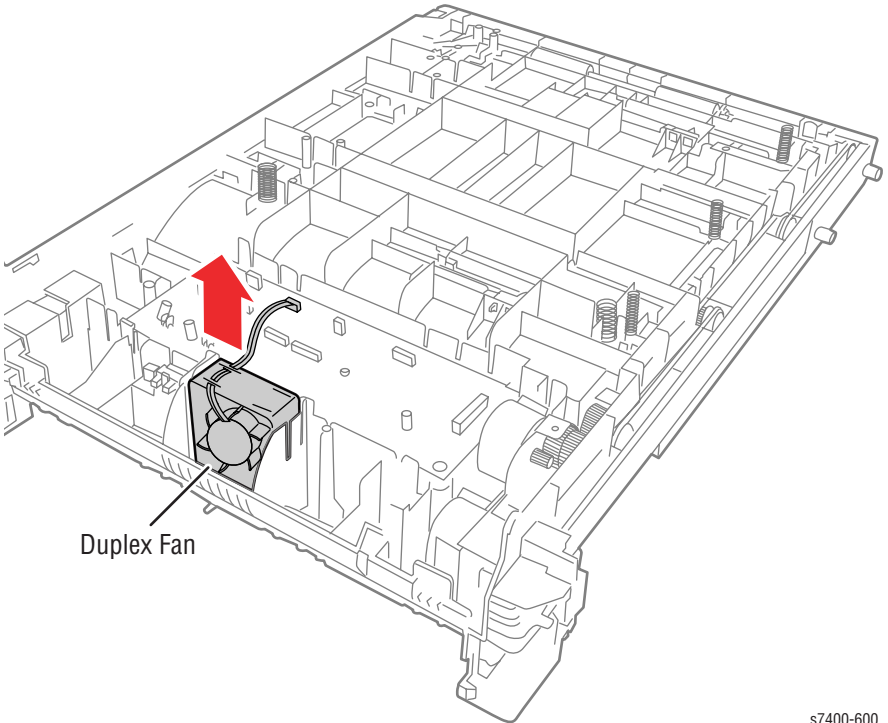

s7400-600

# Interconnect Connector

The Duplex Unit Connector transfers signals between the printer and the Duplex Controller Board. To remove the connector.

1. Remove the Front Door and Front Cover Assembly (page 5-122).
2. Disconnect the Duplex Connector plug from the controller (MAIN1).
3. Free the cable harness from the chassis.
4. Remove two screws (metal, 4 mm) from the connector and lift the connector and cable from the chassis.

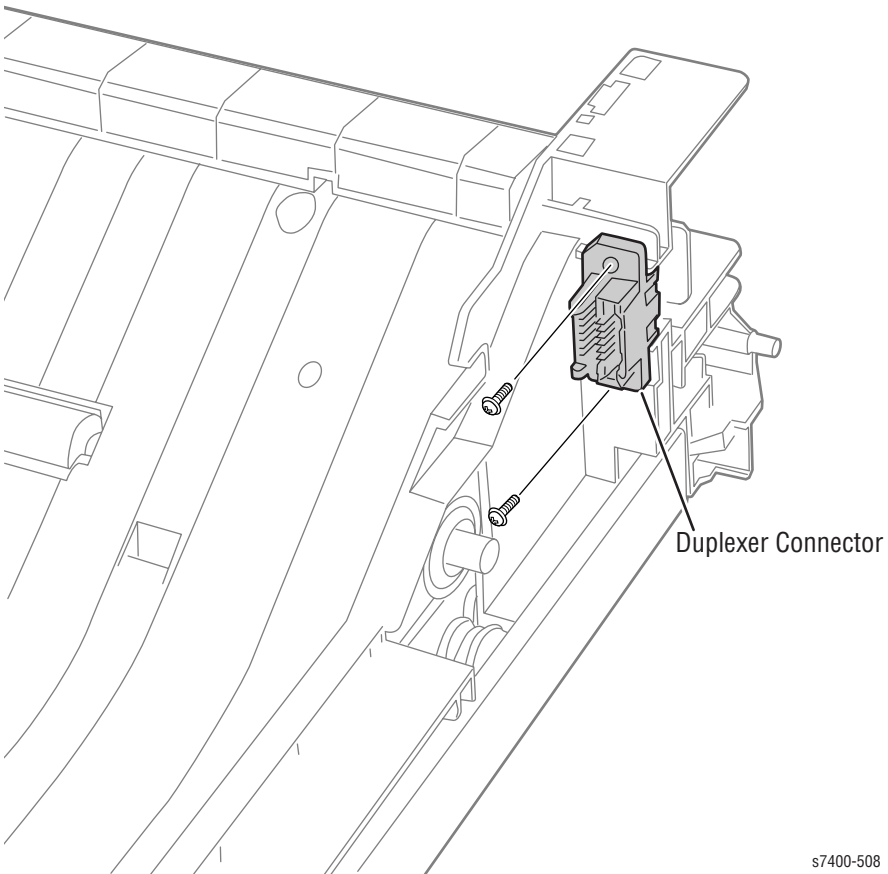

s7400-508

# Paper Tray Disassembly

The printer includes one 550-sheet tray. Below the single tray on the printer, the options tray includes one single tray (550-sheets) and 3 additional stacked trays (1650-sheets). Each tray is basically identical, except for some interconnecting hardware.

The following subsections describe how to remove elements of an optional 550-sheet tray.

## Options Connector

On top of each optional tray is an options connector for cascading each of the trays as they rest on top of each other. To replace:

1. Remove the two screws (metal flange, 6 mm) that fasten the connector to the top of the tray.
2. Lift the connector up to reveal the two connector plugs on the underside of the connector.
3. Disconnect the two plugs and replace the connector.

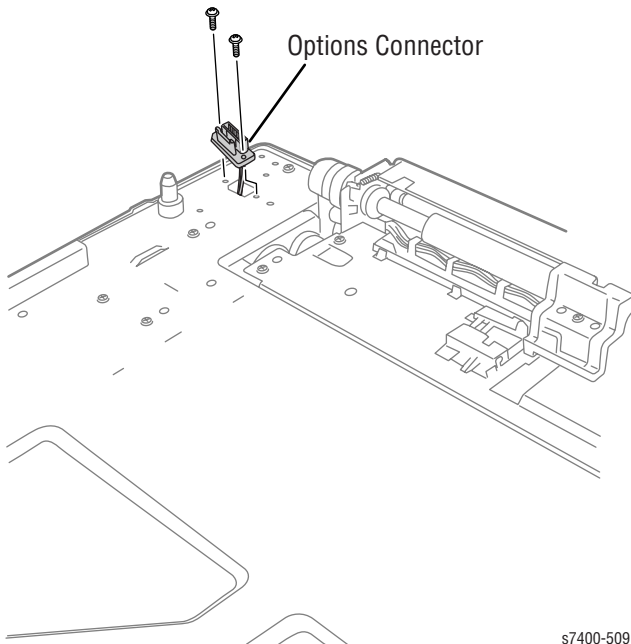

s7400-509

# Tray Covers and Tray Door (Door C)

## Note

If optional trays are installed, either remove the printer from the optional tray(s), or lift the right hand side of the printer to provide sufficient clearance to remove 4 screws and pull the Tray Feeder from the frame.

To remove or replace any of the clutches, motors, or sensors, you must first remove either or both the Rear Cover and the Right Side Cover (and in some cases, you will need to remove the tray itself on the front of the unit or open the Tray door, Door C).

To replace the Rear Cover or the Right Side Cover:

1. Remove five screws (metal flange, 6 mm) fastening each plastic cover to the chassis frame.
2. With a screwdriver, press down inside of the tab slots to pop the plastic cover away from the frame.

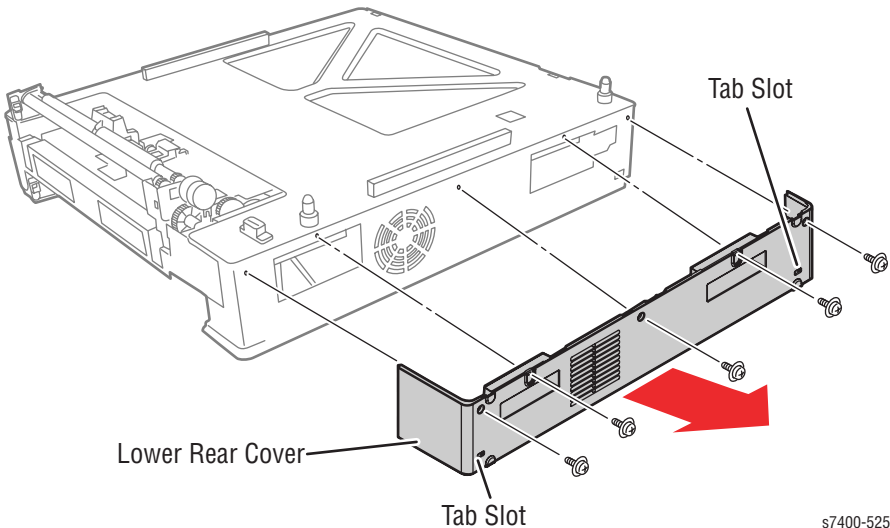

s7400-525

3. On some disassembly of sensors or diagnostic testing, you may need to open the Tray Door (Door C).



4. To locate and open Door C, see the following illustration.

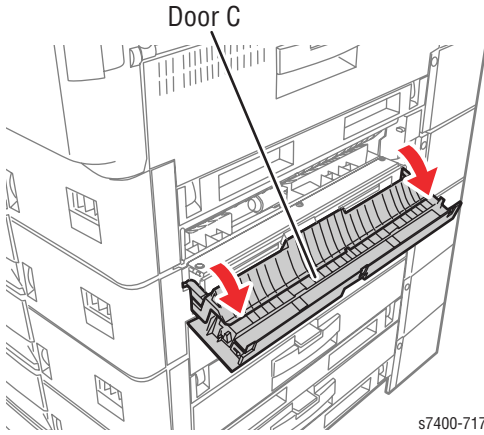

# Tray Feeder

1. Remove Tray 2.
2. Remove the Right Side Cover and Rear Cover (page 5-134).
3. Remove the paper tray.
4. Remove 12 (metal, 10 and 6 mm) screws to remove the Tray 2 Feeder.

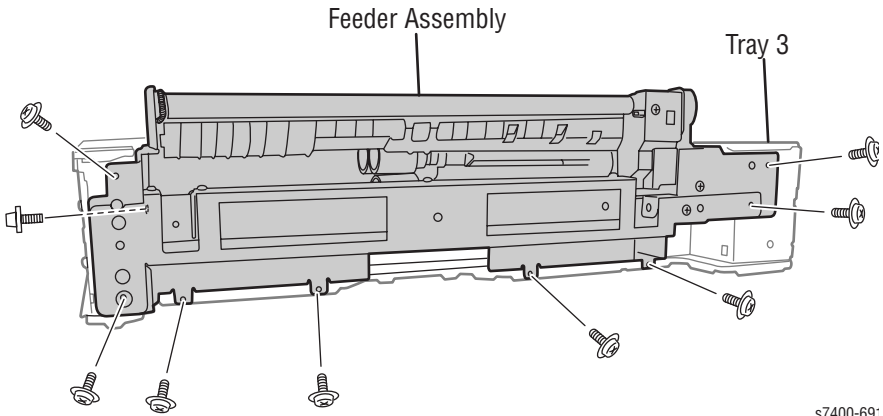

s7400-69'

# Registration Motor

1. Remove the Tray Feeder (page 5-136).
2. Release the motor harness from the clamp.
3. Disconnect the Registration Motor connector (P/J40) from the harness.
4. Remove two (metal, 6 mm) screws that secure the Registration Motor to the Feeder.

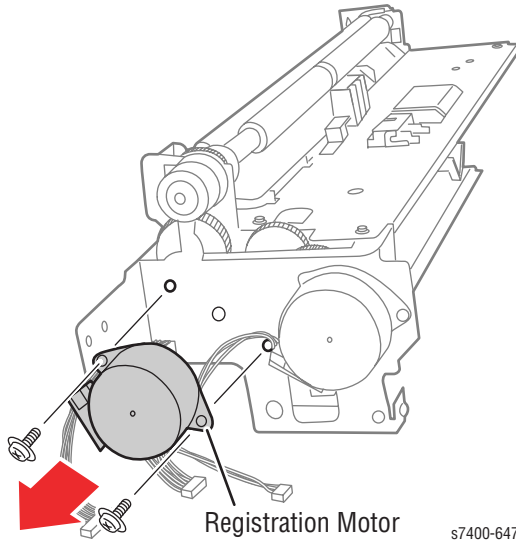

# Feed Motor

1. Remove the Tray 2 Feeder (page 5-136).
2. Release the motor harness from the clamp.
3. Disconnect the Feed Motor connector (P/J30) from the harness.
4. Remove two (metal, 6 mm) screws that secure the Feed Motor to the Feeder.

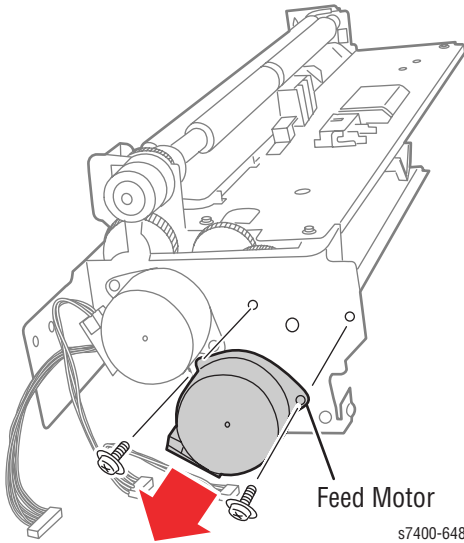

# Lift Motor

1. Remove the tray.
2. Remove the Right Rear Cover (page 5-134).
3. Disconnect the Lift Motor connector GDDC from the Motor Driver Board.
4. Remove the two (metal, 6 mm) screws that secure the Lift Motor to the frame.

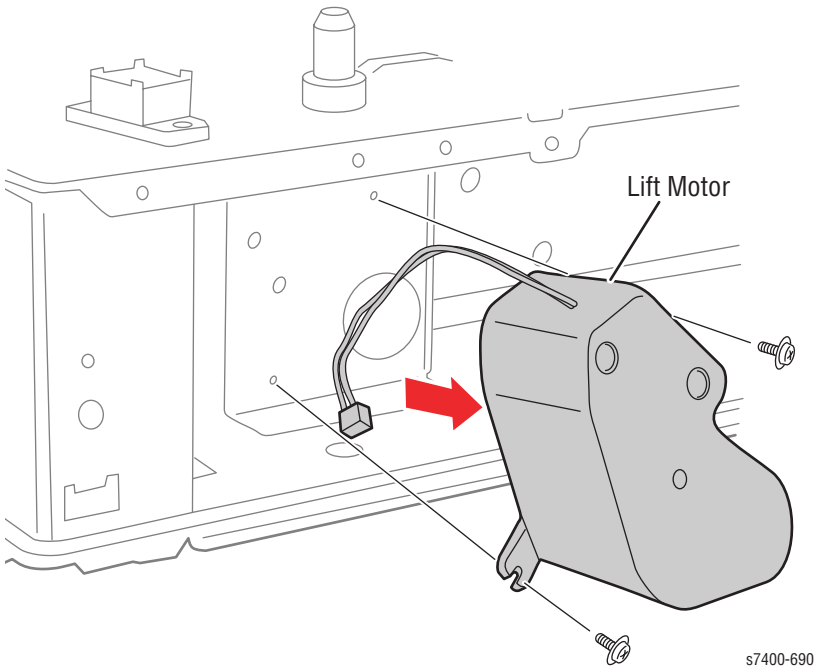

# Registration Clutch

1. Remove the Tray Feeder (page 5-136).
2. Remove the E-clip that secures the clutch to the Registration Roller.

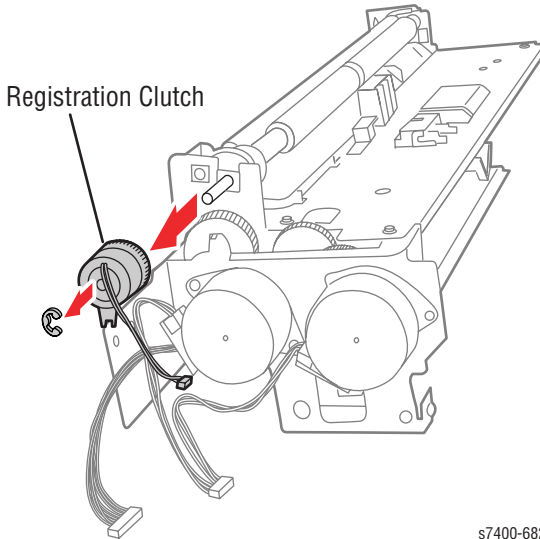

s7400-682

3. While holding the anti-rattle spring, remove the clutch from the roller shaft.

# Door C Detect Sensor

The Door C Detect Sensor is mounted on a carrier located beneath the Registration Rollers near the clutch.

## Caution

Use care when removing the roller shaft bearings. The bearings use a small clip to lock into a notch near the end of each roller shaft. Use a small, flat-bladed screwdriver to release the clip from the shaft before attempting to remove the bearing.

1. Remove the Tray 2 Feeder (page 5-136).
2. Remove the Registration Clutch #2 (page 5-140).
3. Remove the 2 springs that tension the Registration Rollers.
4. Remove the bearings at each end of the rubber roller, and then remove the roller.

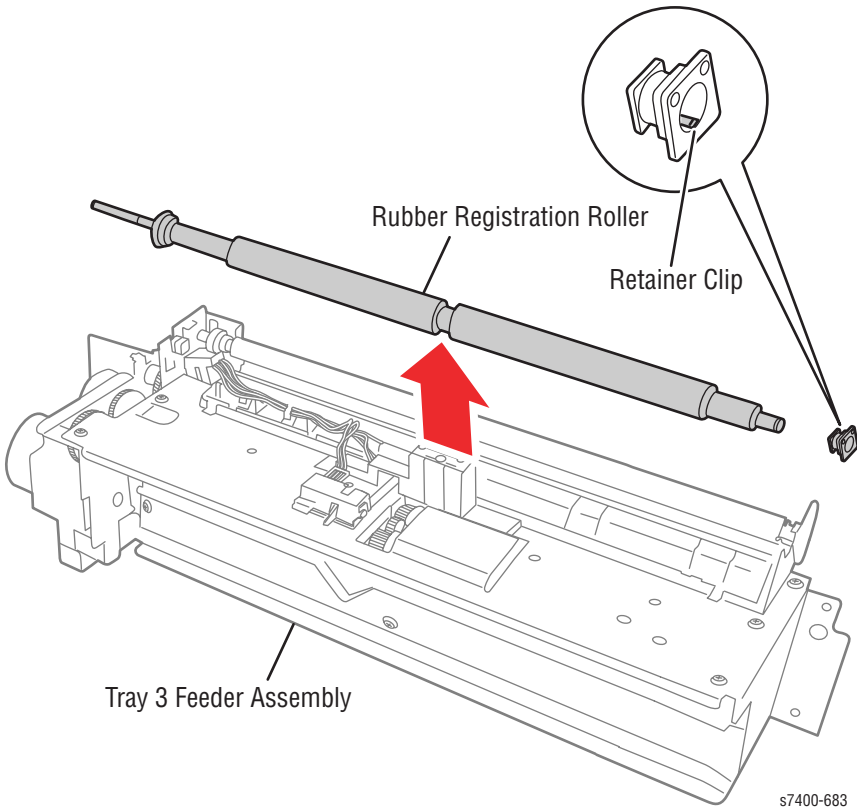

5. Release the hook that secures the sensor carrier to the feeder.
6. Turn the sensor carrier over, and then release the hooks that secure the sensor to the carrier.
7. Disconnect the sensor connector (P/J41).

# No Paper Sensor

1. Remove the Tray Feeder (page 5-136).
2. Remove 4 (metal, 23 mm) screws that secure the brace. Release the hook that secures the No Paper Sensor housing to the feeder.
3. Turn the housing over, and then release the hooks that secure the sensor to the housing.

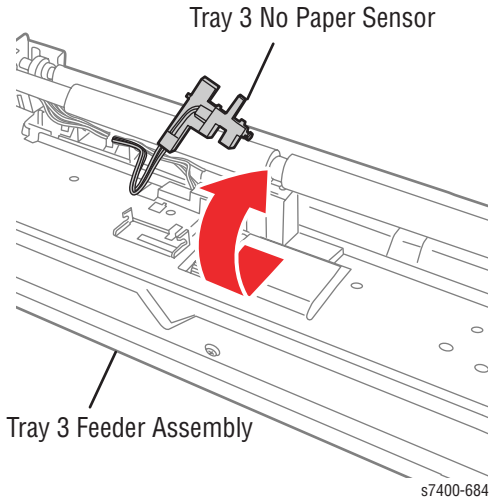

4. Disconnect the sensor connector (P/J43).



## Registration Sensor #2

1. Remove the Tray Feeder (page 5-136).
2. Remove the Registration Clutch #2 (page 5-140)
3. Remove the Feeder Board Cover.
4. Remove 4 (metal, 6 mm) screws that secure the feeder top.

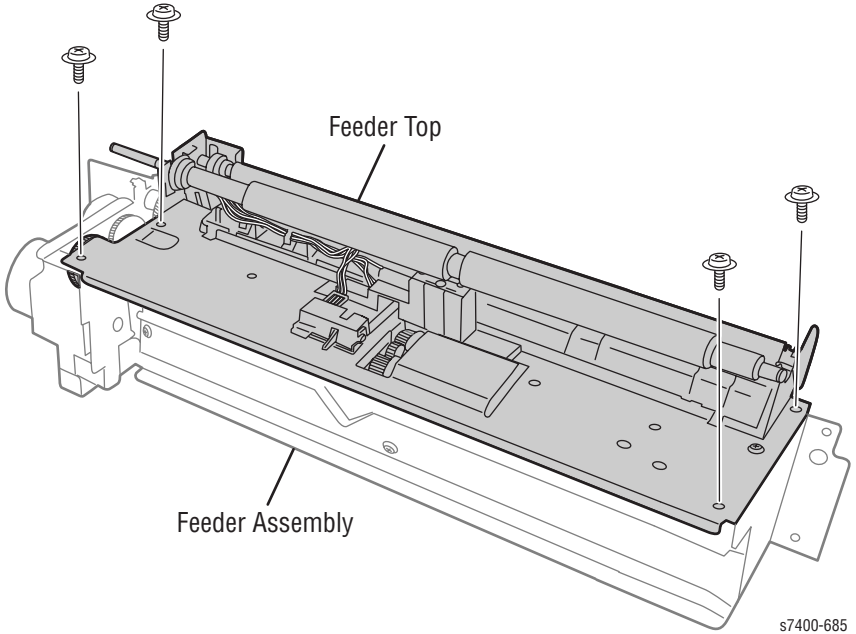

5. Separate the feeder top, and then turn the top over to remove 2 (black, plastic 10 mm) screws that secure the sensor housing to the feeder.

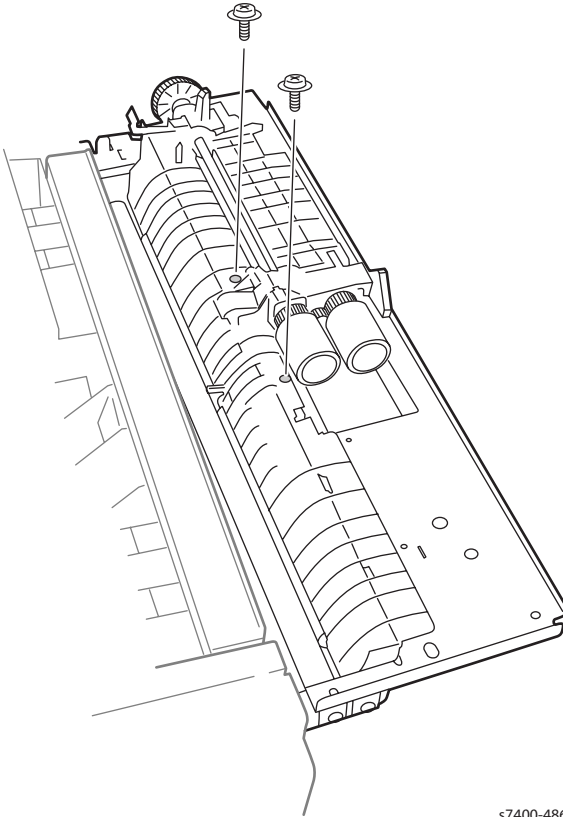

s7400-486

6. Turn the feeder top upright, and release the 2 hooks that secure the sensor housing to the top of the feeder.

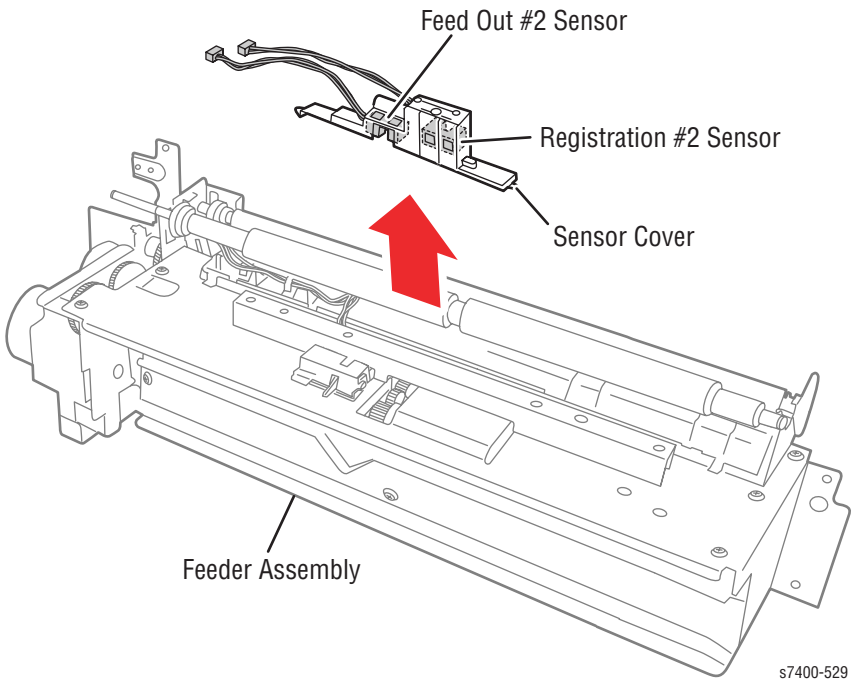

7. Release the hooks that secure the sensor in the housing.
8. Disconnect the sensor connector (P/J42), and then remove the sensor.

### Replacement Note

Use care when replacing the feeder top. Make sure the Level, and Low Paper Sensor flags operate properly before tightening the screws.

## Feed-Out Sensor #2

1. Remove the Tray Feeder (page 5-136).
2. Remove the Registration Clutch #2 (page 5-140).
3. Remove the Feeder Board Cover.
4. Remove 4 (metal, 6 mm) screws that secure the feeder top.

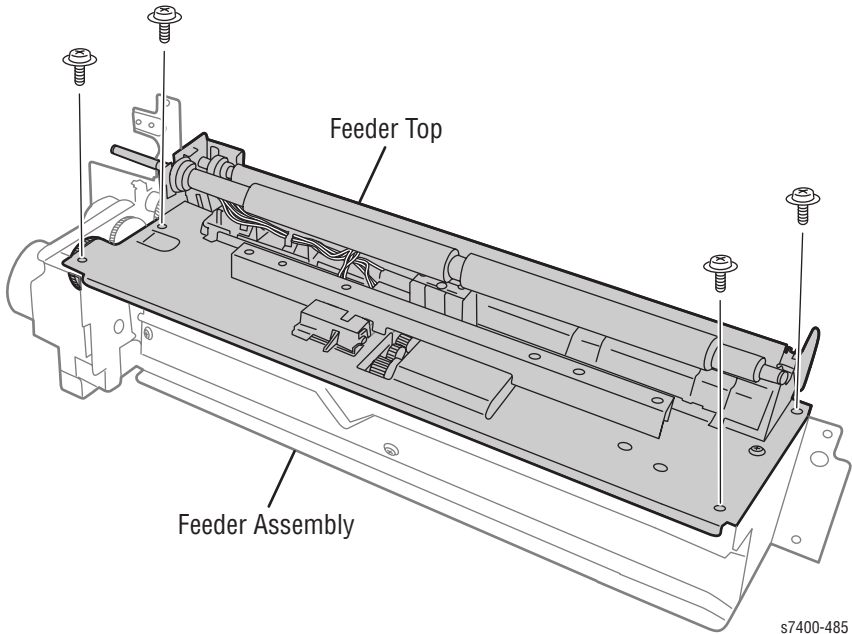

5. Separate the feeder top, and then turn the top over to remove 2 (black, plastic 10 mm) screws that secure the sensor housing to the feeder.

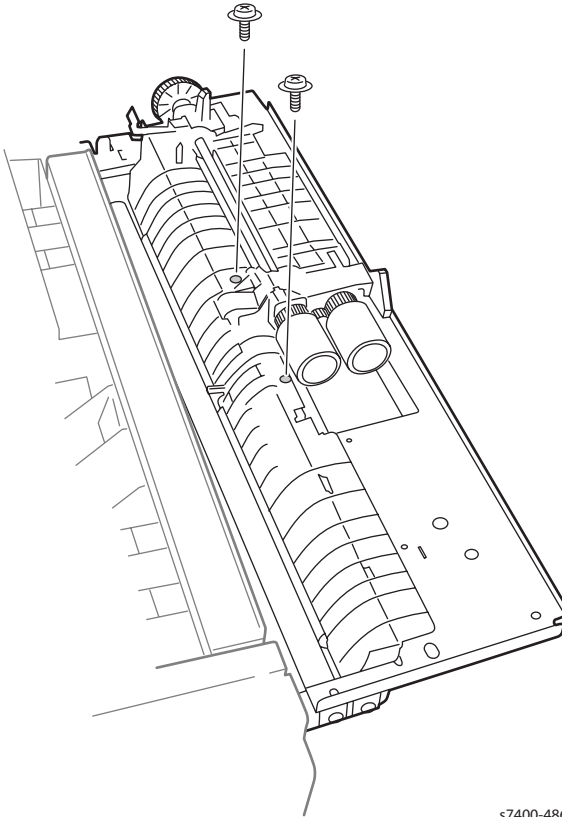

s7400-486

6. Turn the feeder top upright, and release the 2 hooks that secure the sensor housing to the top of the feeder.
7. Release the hooks that secure the sensor in the housing.
8. Disconnect the sensor connector (P/J43), and then remove the sensor.

### Replacement Note

Use care when replacing the feeder top. Make sure the Level, and Low Paper Sensor flags operate properly before tightening the screws.

# Feeder Board

1. Remove the Tray Feeder (page 5-136).
2. Remove 3 (metal, 10 mm) screws that secure the hand holds to the feeder.

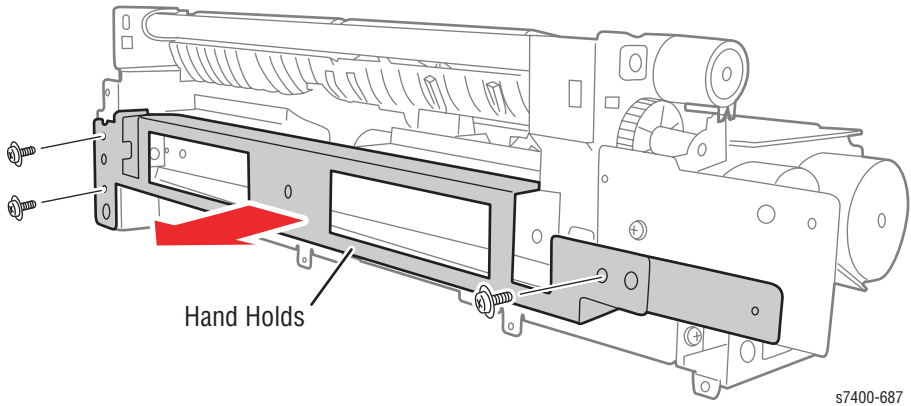

3. Remove 1 (metal, 6 mm) screw that secures the Feeder Board Cover.

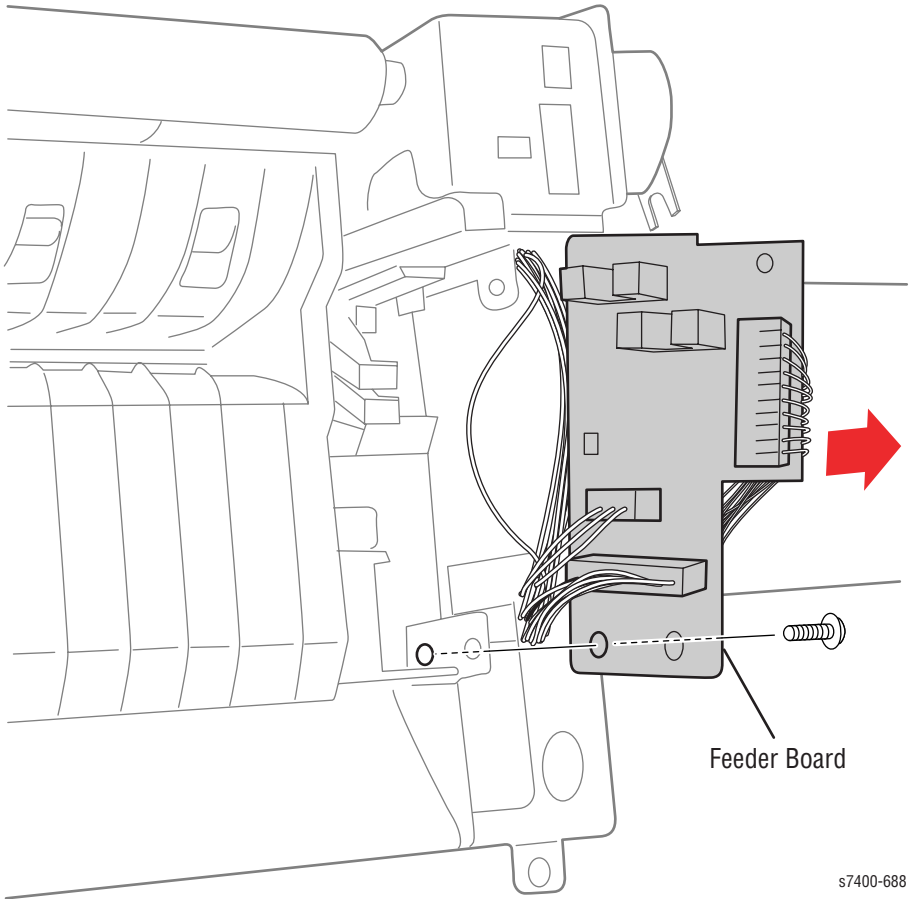

s7400-688

4. Remove 1 (metal, 6 mm) screw that secures the Feeder Board to the Feeder. Disconnect the connectors (TRYSNS1, TRYNS2, and PAPEND) to remove the board.

# Tray Feed Rollers

## Note

Feed Roller (Pick, Feed, Retard) removal is identical for all Universal Trays. Since each roller is unique, match each replacement roller to the roller being removed.

1. Remove Tray 2.
2. Open Door B.
3. Release the hook that secures each roller to the shaft.

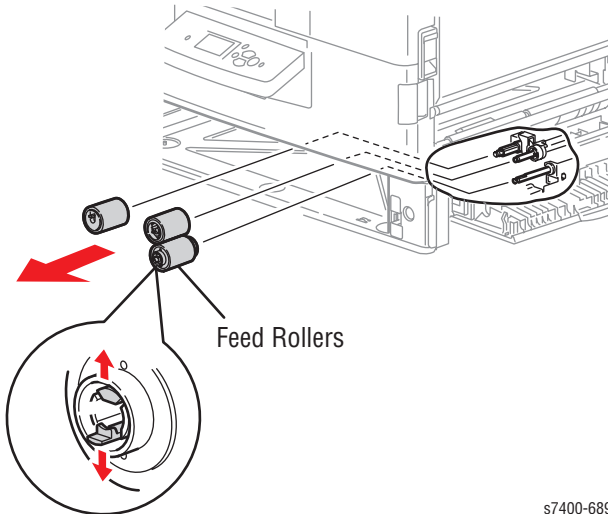

s7400-689



# Parts List

## In this chapter...

- Using the Parts List
- Finisher Parts
- Duplex Unit Parts
- Tray Parts

Section

6



# Using the Parts List

Only those parts listed with part numbers are available for order. Parts listed without part numbers are only available as part of a parent assembly or Service Kit.

1. **No.:** The callout number from the exploded part diagram.
2. **Part Number:** The material part number used to order specific parts.
3. **Name/Description:** Name of the part and number supplied per order.

## Note

In some cases, the Name/Description will be followed with a different name in parentheses. This indicates the same part but with a different name in the disassembly section.

4. Parts throughout this manual are referenced **PL#.#.#**; For example, PL3.1.10 means the part is item 10 of Parts List 3.1.
5. A black triangle preceding a number followed by a parenthetical statement indicates the item is a parent assembly, made up of the parts listed in parentheses and enclosed by a dashed line.
6. The notation “**(with X~Y)**” following a part name indicates an assembly includes components X through Y. For example, “1 (with 2~4)” means part 1 consists of parts 2, 3, and 4.
7. The notation “**J1<>J2 and P2**” is attached to a wire harness. It indicates that connector Jack 1 is attached to one end of the wire harness and connector J2 is attached to the other end that is plugged into P2.

# Finisher Parts

The following pages show a parts locator diagram and parts list table for each unit of the Finisher.

# Finisher Unit Assembly Diagram

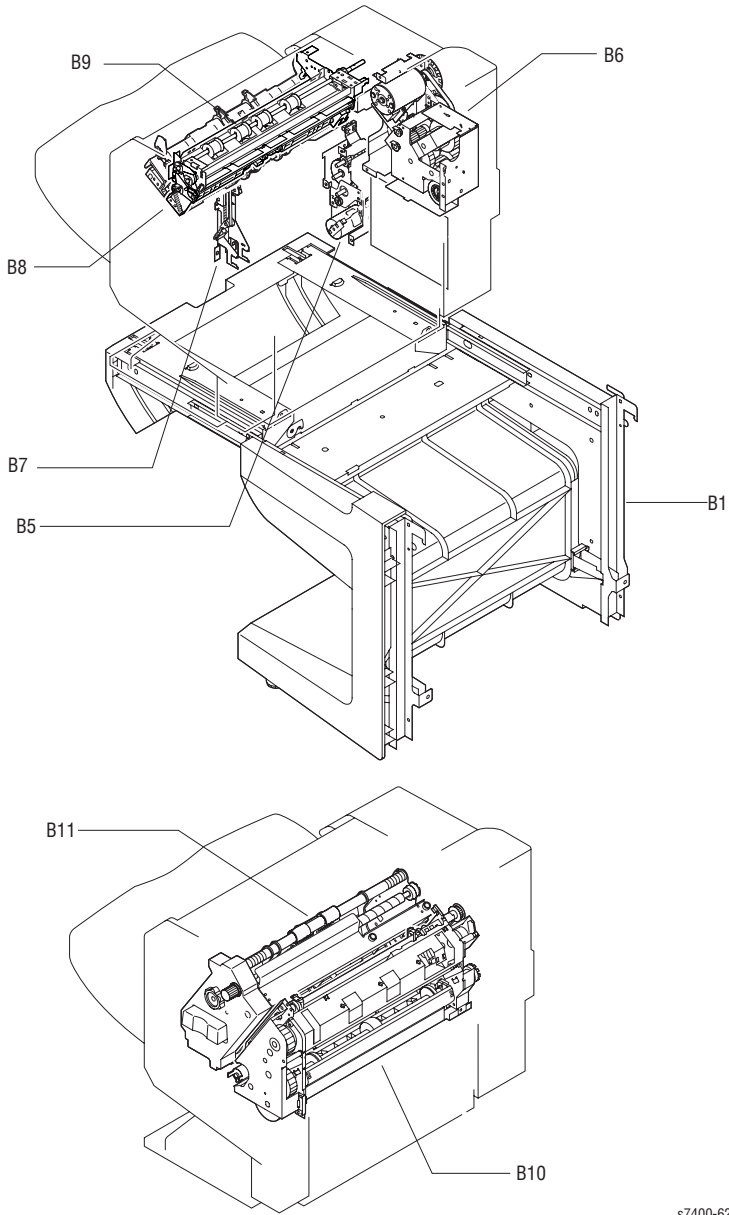

s7400-628

# Parts List 1.1 Finisher Unit Assembly Parts List

## Finisher Unit Parts List

ID #	Part Number	Name/Description
0	██████████ ██████████	██████████ ██████████
B-1	050E23450	Base Unit
B-5	005K12430	Stack Motor Drive Assembly (Lift Motor and sensors)
B-6	005K12440	Drive Assembly (Delivery Motor Assembly)
B-7	848K00040	Bundle Support Cover (Paper Detector)
B-8	054K37780	Dispose assembly (ProcessingTray)
B-9	059K52480	Paper Feeder Assembly (Paddle Assembly)
B-10	054K37790	Fold Assembly
B-11	029K04400	Staple Assembly (Staple Unit)

# Finisher External Parts Diagram

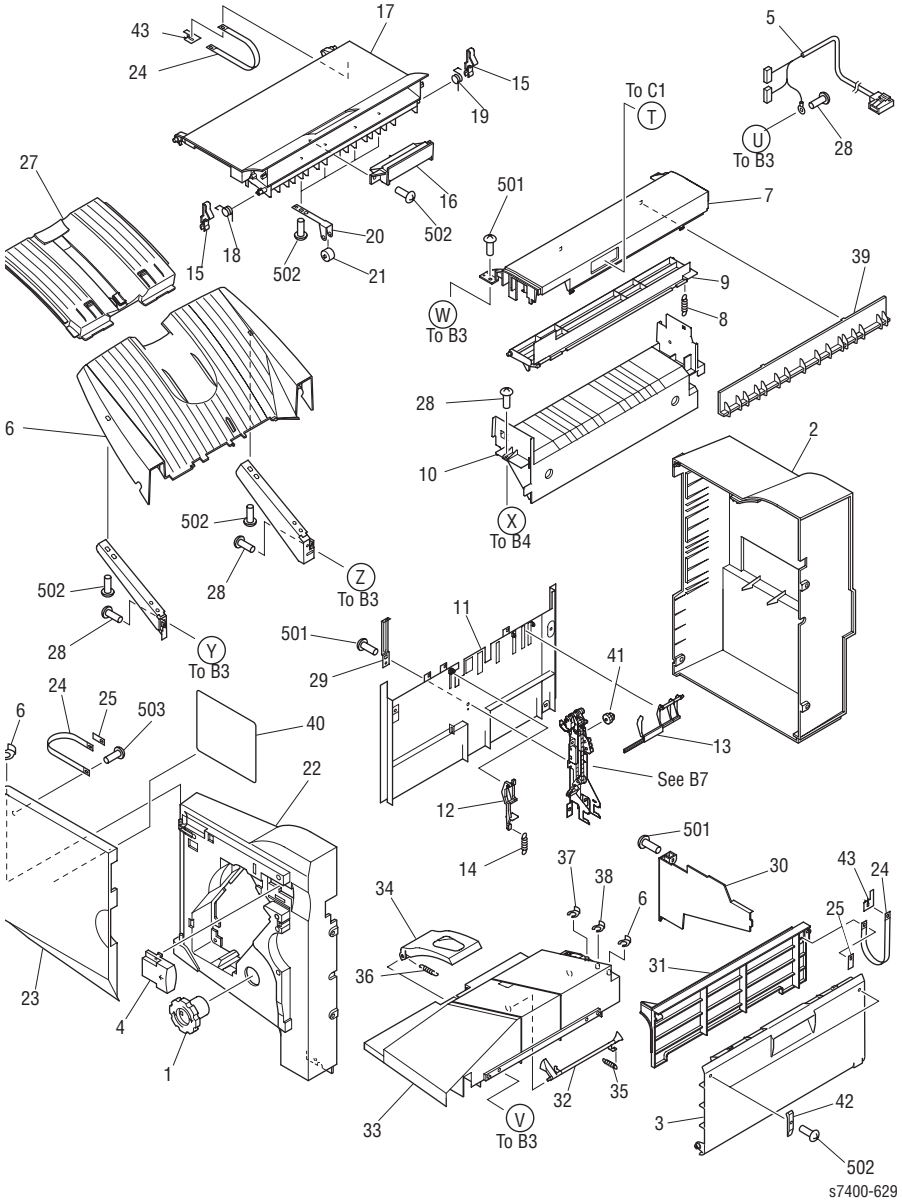

# Parts List 1.2 Finisher External Parts List

## Finisher External Parts List

ID #	Part Number	Name/Description
●	●	●





# Finisher Internal Parts Diagram (1 of 2)

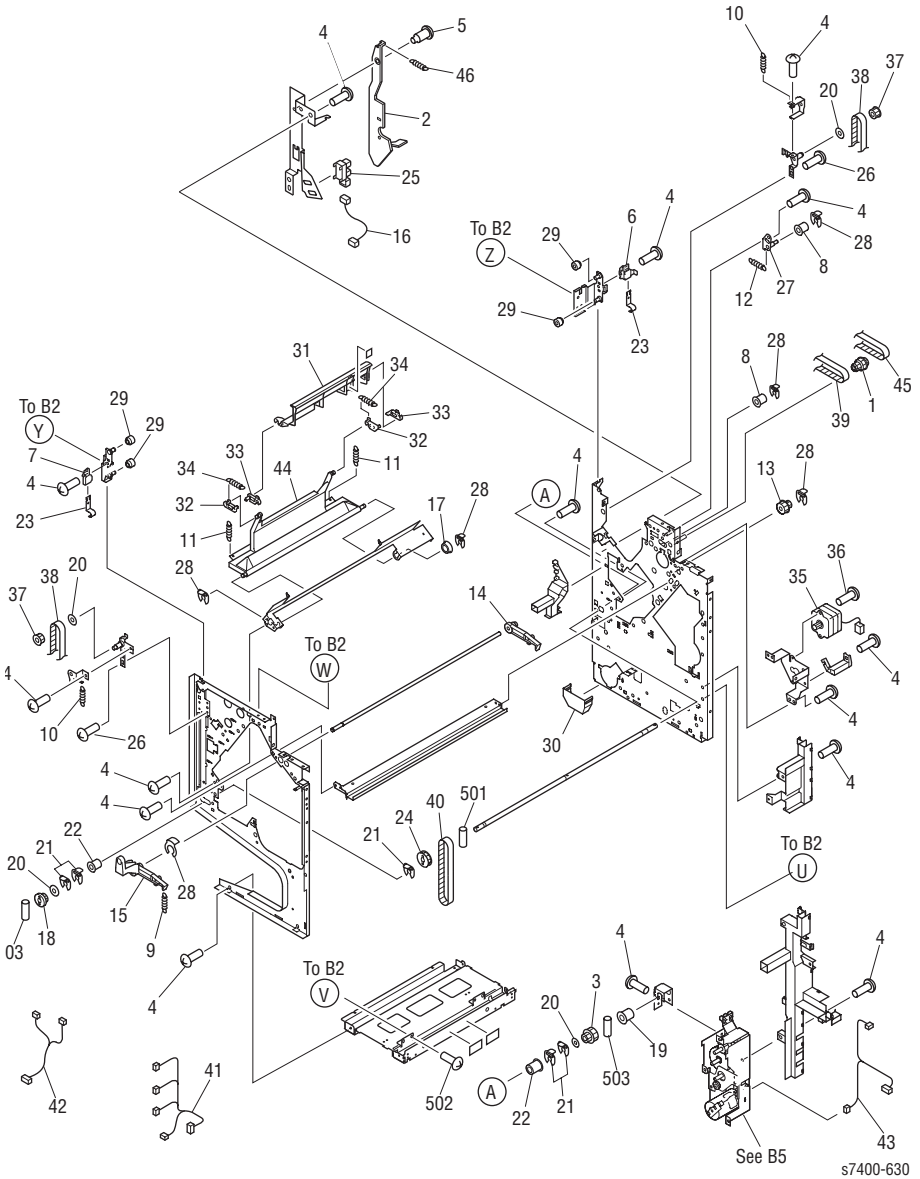

# Finisher Internal Parts Diagram (2 of 2)

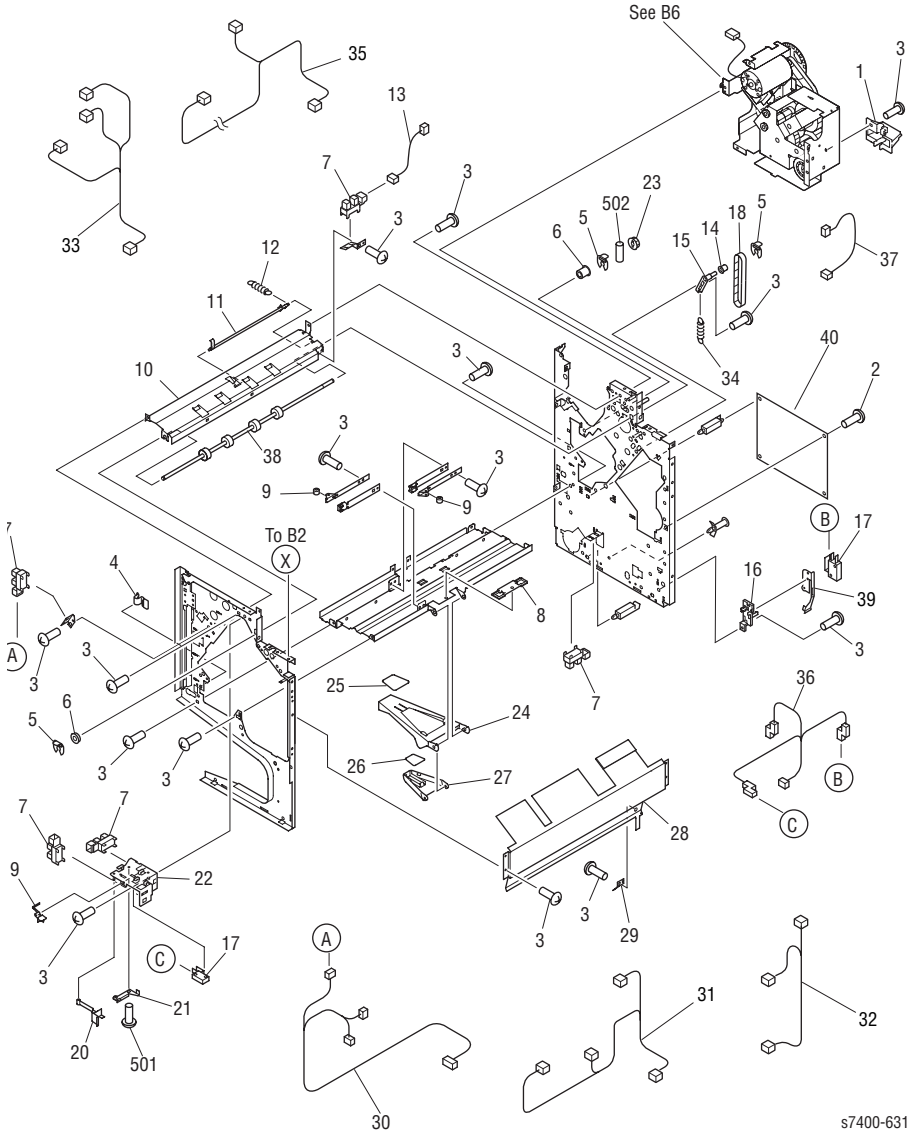

s7400-631

# Parts List 1.3 Finisher Internal Parts List

## Finisher Internal Parts List

ID #	Part Number	Name/Description
7	137E16140	IC TLP1241 Photo Interrupter

# Stack (Lift) Motor Drive Assembly Parts Diagram

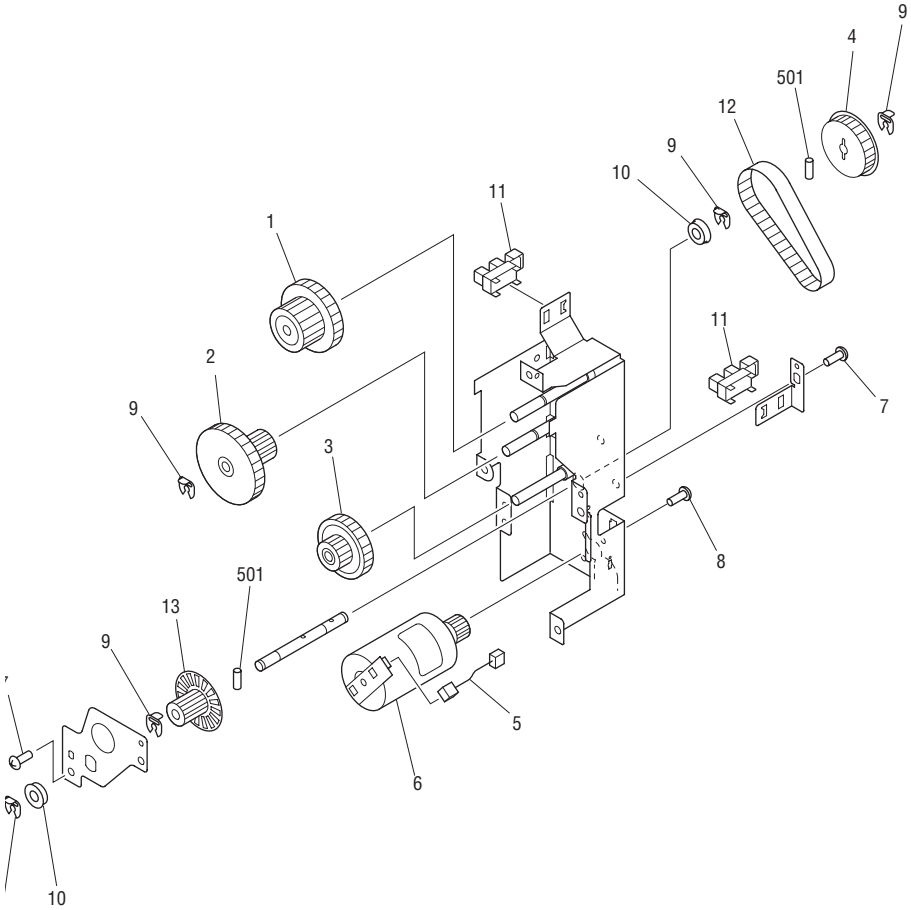

s7400-632

# Parts List 1.4 Stack (Lift) Motor Drive Assembly Parts List

## Stack (Lift) Motor Drive Assembly Parts List

ID #	Part Number	Name/Description
0	005K12430	Stack Motor Drive Assembly (Lift Motor)

# (Staple/Fold) Drive Assembly Parts Diagram

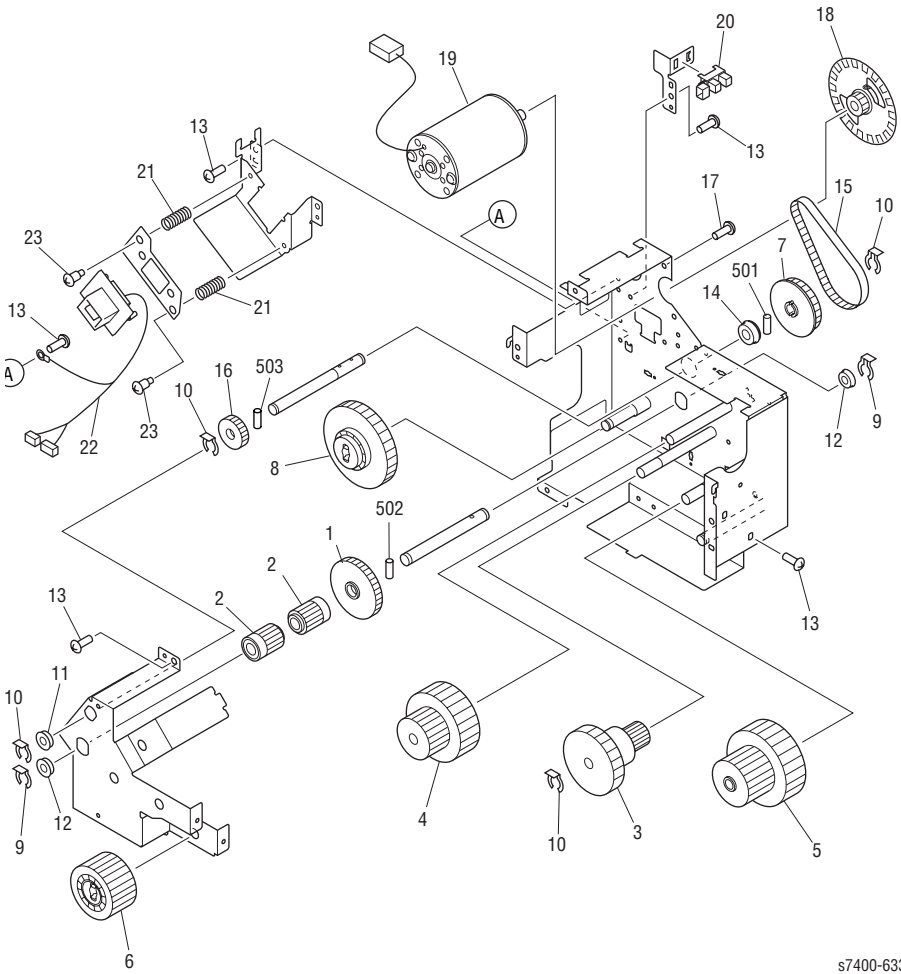

s7400-633

# Parts List 1.5 (Staple/Fold) Drive Assembly Parts List

## Staple/Fold Drive Assembly Parts List

ID #	Part Number	Name/Description
0	005K12440	Drive Assembly (Staple/Fold)

# Bundle Support Cover Assembly Parts Diagram

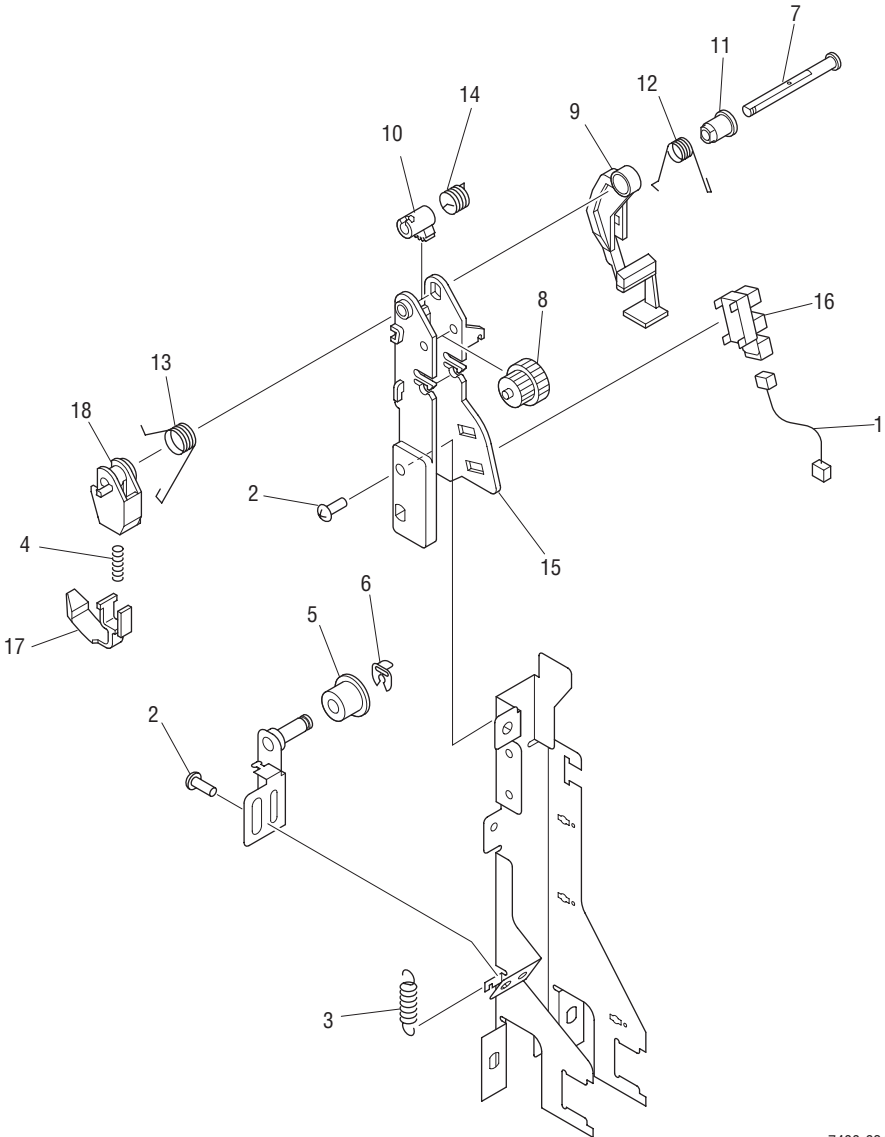

s7400-634



# Parts List 1.6 Bundle Support Cover Parts List

## Bundle Support Cover Assembly (Paper Detection) Parts List

ID #	Part Number	Name/Description
0	848K00040	Bundle Support Cover (Paper Detection)

# Dispose Assembly (Processing Tray) Parts Diagram

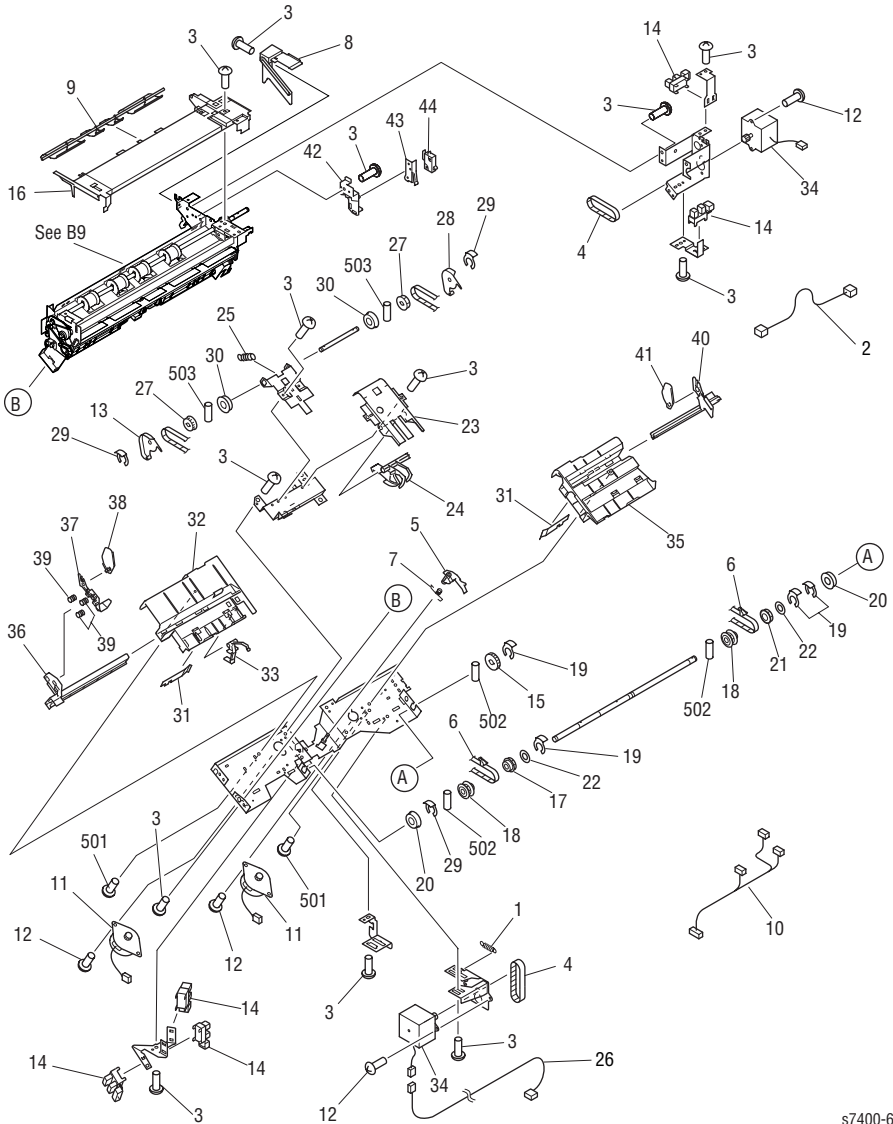

s7400-6c

# Parts List 1.7 Dispose Assembly (Processing Tray) Parts List

## Dispose Assembly (Processing Tray) Parts List

ID #	Part Number	Name/Description
0	054K37780	Dispose Assembly (Processing Tray)

# Paper Feeder (Paddle) Assembly Parts Diagram

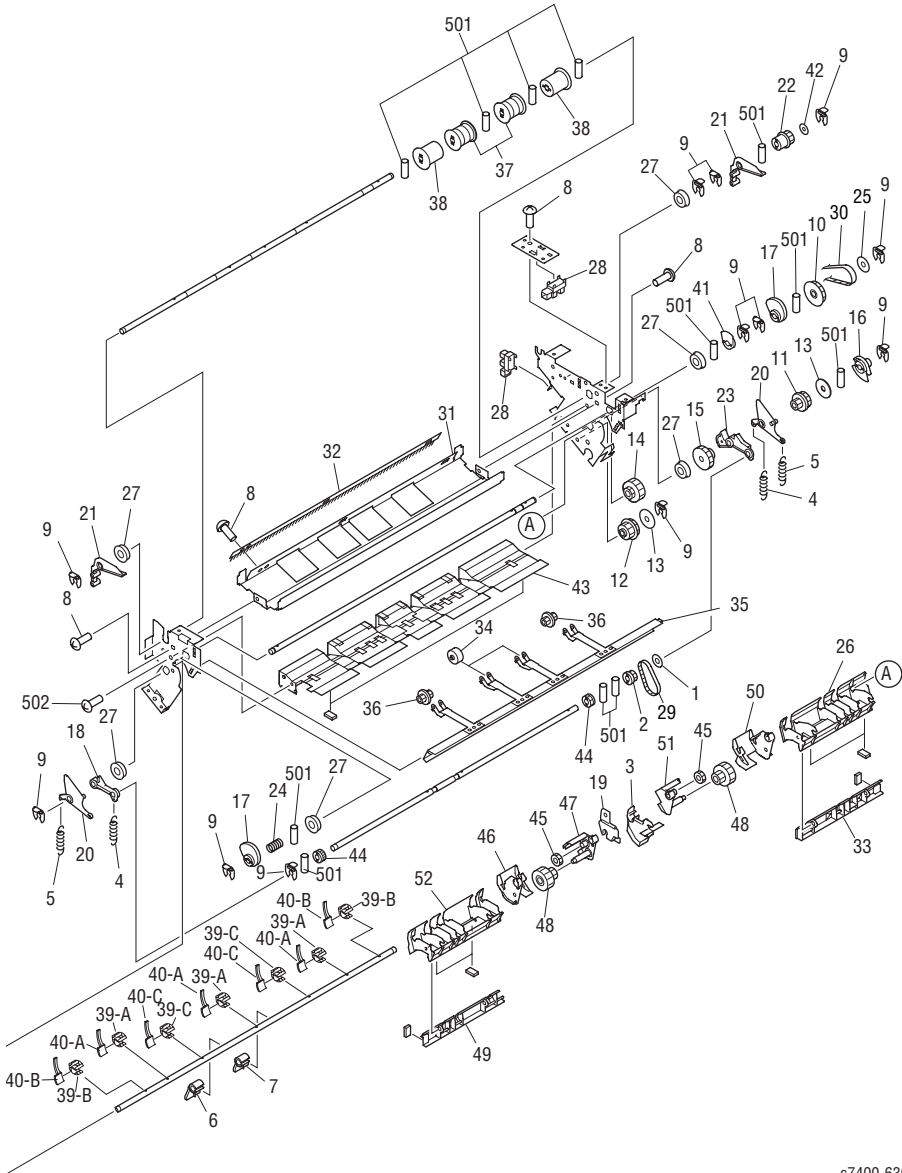

s7400-636

# Parts List 1.8 Paper Feeder (Paddle) Assembly Parts List

## Paper Feeder (Paddle) Assembly Parts List

ID #	Part Number	Name/Description
0	059K52480	Paper Feeder (Paddle) Assembly

# Puncher Assembly Parts Diagram

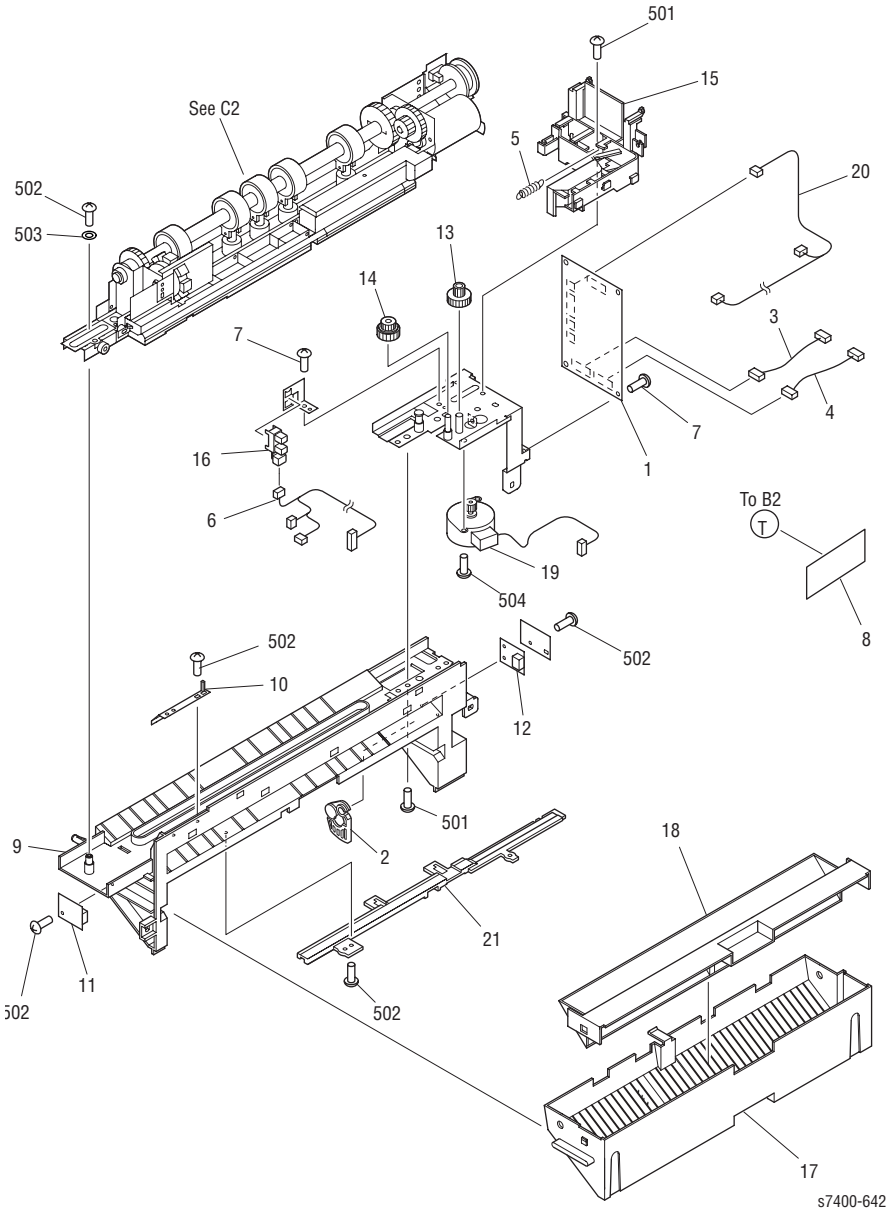

# Parts List 1.9 Puncher Assembly Parts List

## Puncher Assembly Parts List

<b>ID</b>	<b>Part Number</b>	<b>Name/Description</b>
1	109K02020	Puncher Controller Board Assy
11	848E05300	Dust-LED Board Unit
12	848E05310	Dust-PTR Board Unit
16	137E16140	IC TLP1241 Photo-Interrupter
17	848E05320	Panel - Dust Box
18	848E05330	Cover - Dust Box
19	127E15510	Motor - Stepping

# Punch Total Assembly Diagram

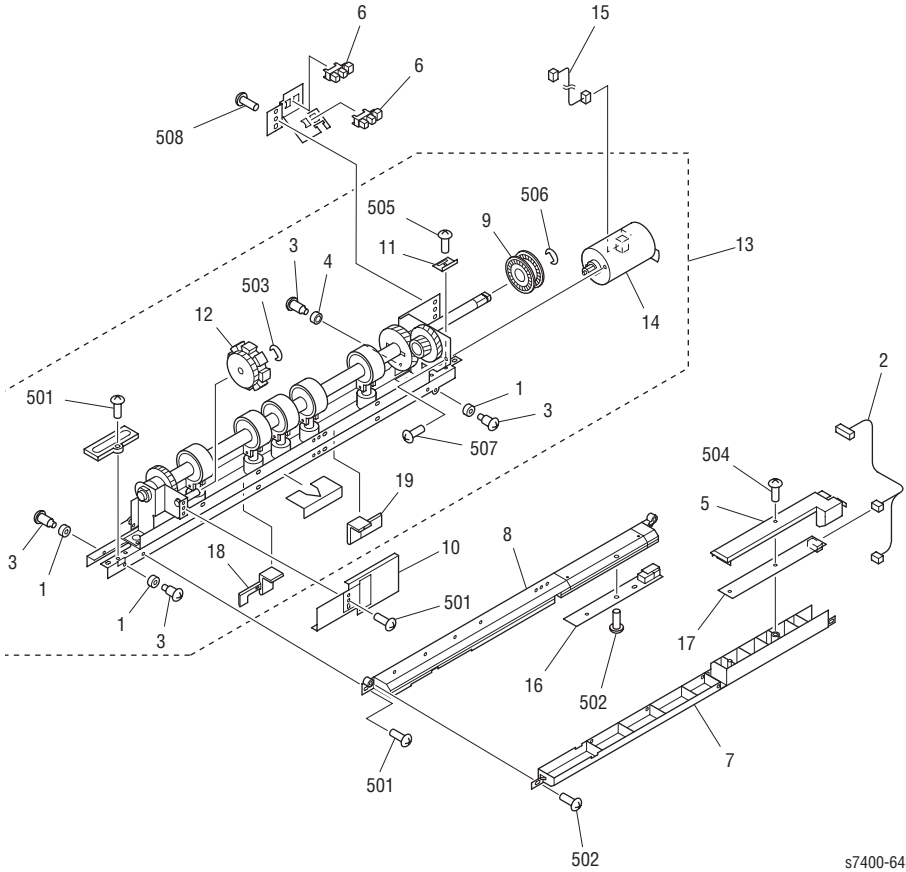

s7400-643



# Parts List 1.10 Punch Total Assembly Parts List

## Punch Total Assembly Parts List

<b>ID</b>	<b>Part Number</b>	<b>Name/Description</b>
0	084K35580 084K35590	Puncher 2/3 holes XC Punch Unit 4 hole-F XC
6	137E16140	IC TLP1241 Photo Interrupter
13	180K00230 108K00240	Punch Unit 2/3H XC Punch Unit 4H-F XC
14	127K55160	Motor - DC
16	960K32910	PCB- Unit1
17	960K32920	PCB- Unit2





# Staple Unit Diagram (2 of 2)

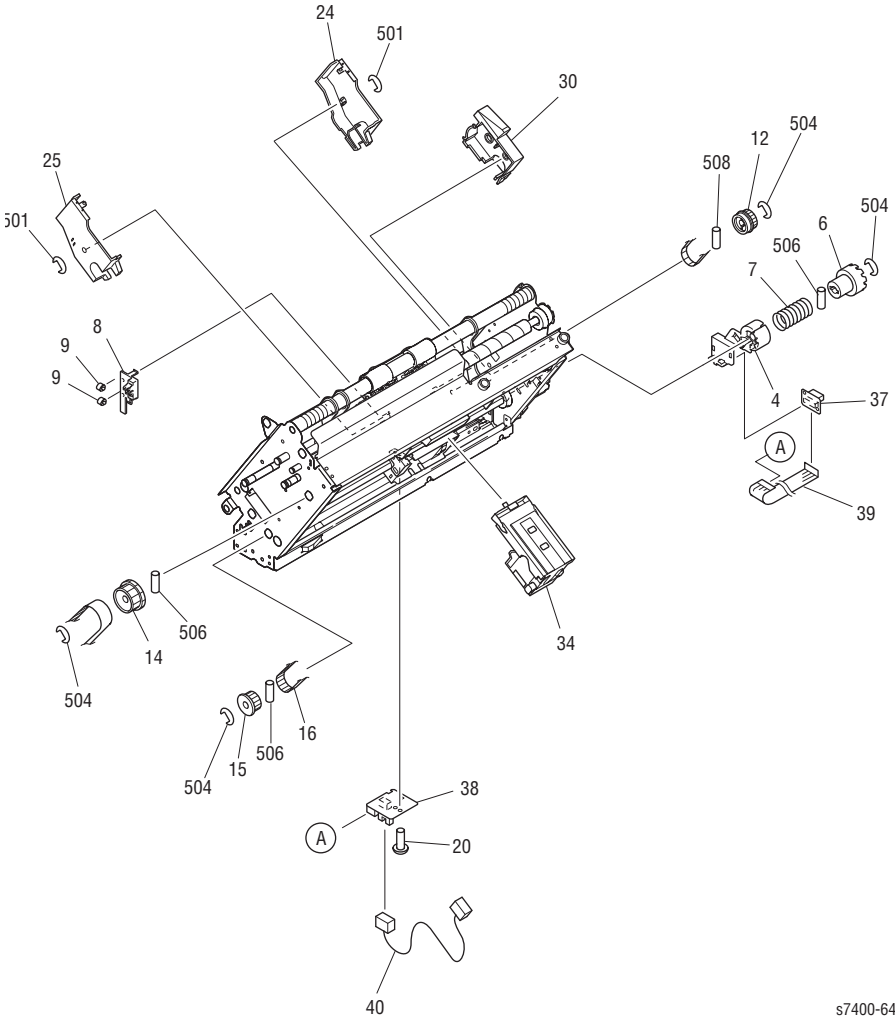

s7400-641

# Parts List 1.11 Staple Unit Parts List

## Staple Unit Parts List

ID #	Part Number	Name/Description
0	029K04400	Staple Assembly

# Fold Unit Diagram (1 of 3)

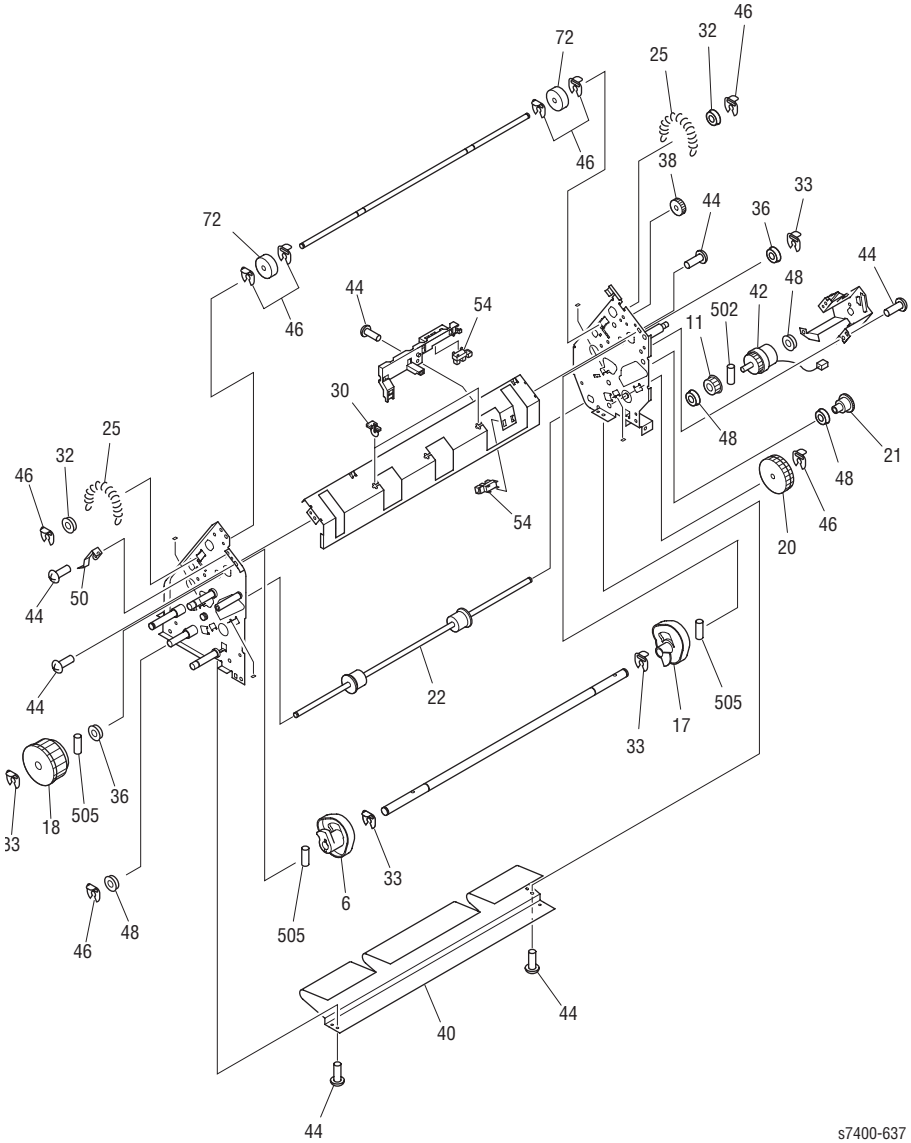

s7400-637

# Fold Unit Diagram (2 of 3)

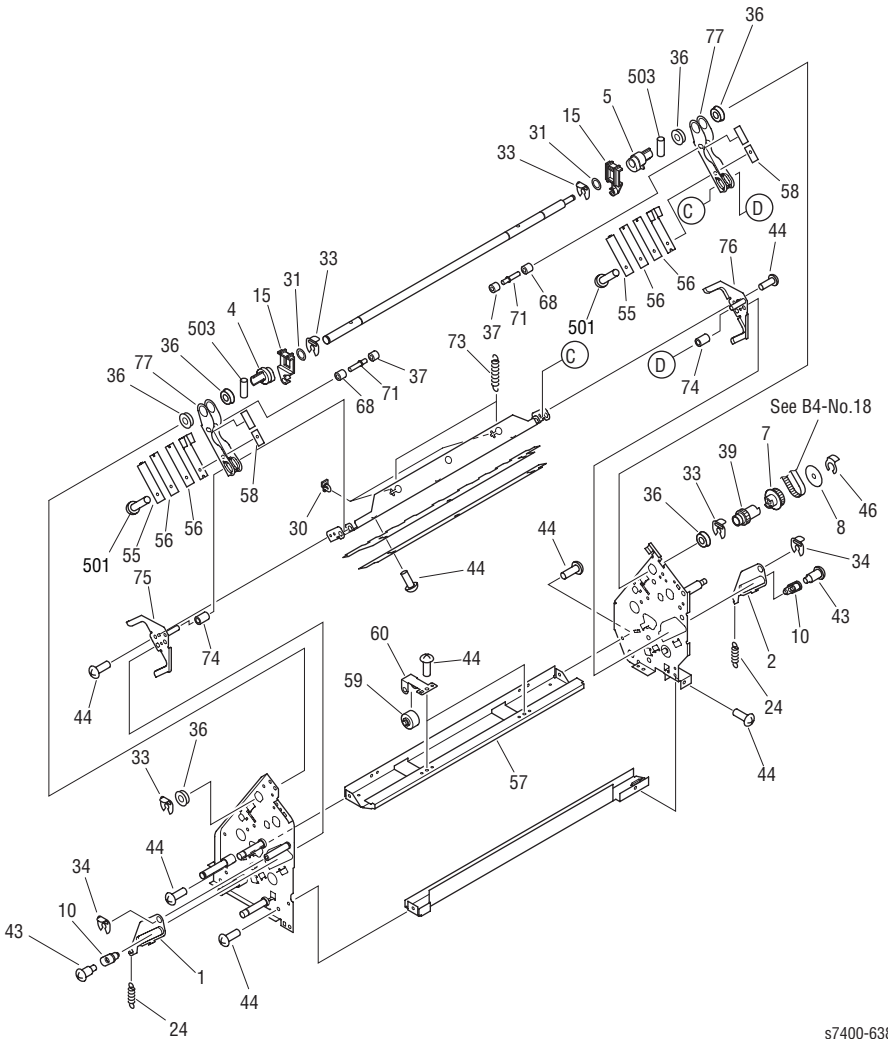

s7400-638

# Fold Unit Diagram (3 of 3)

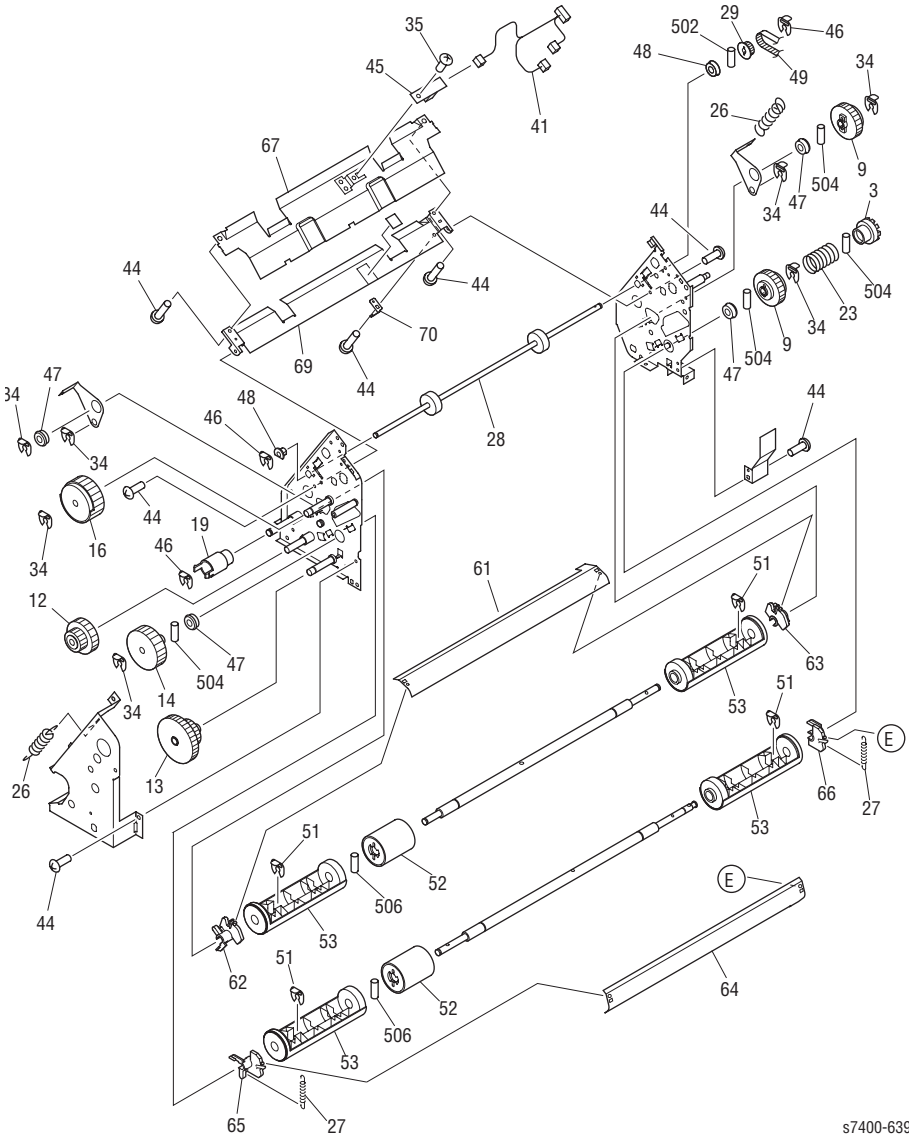

s7400-639



# Parts List 1.12 Fold Unit Parts List

## Fold Unit Parts List

ID #	Part Number	Name/Description
0	054K37790	Fold Assembly

# Inverter Parts Diagram (1 of 3)

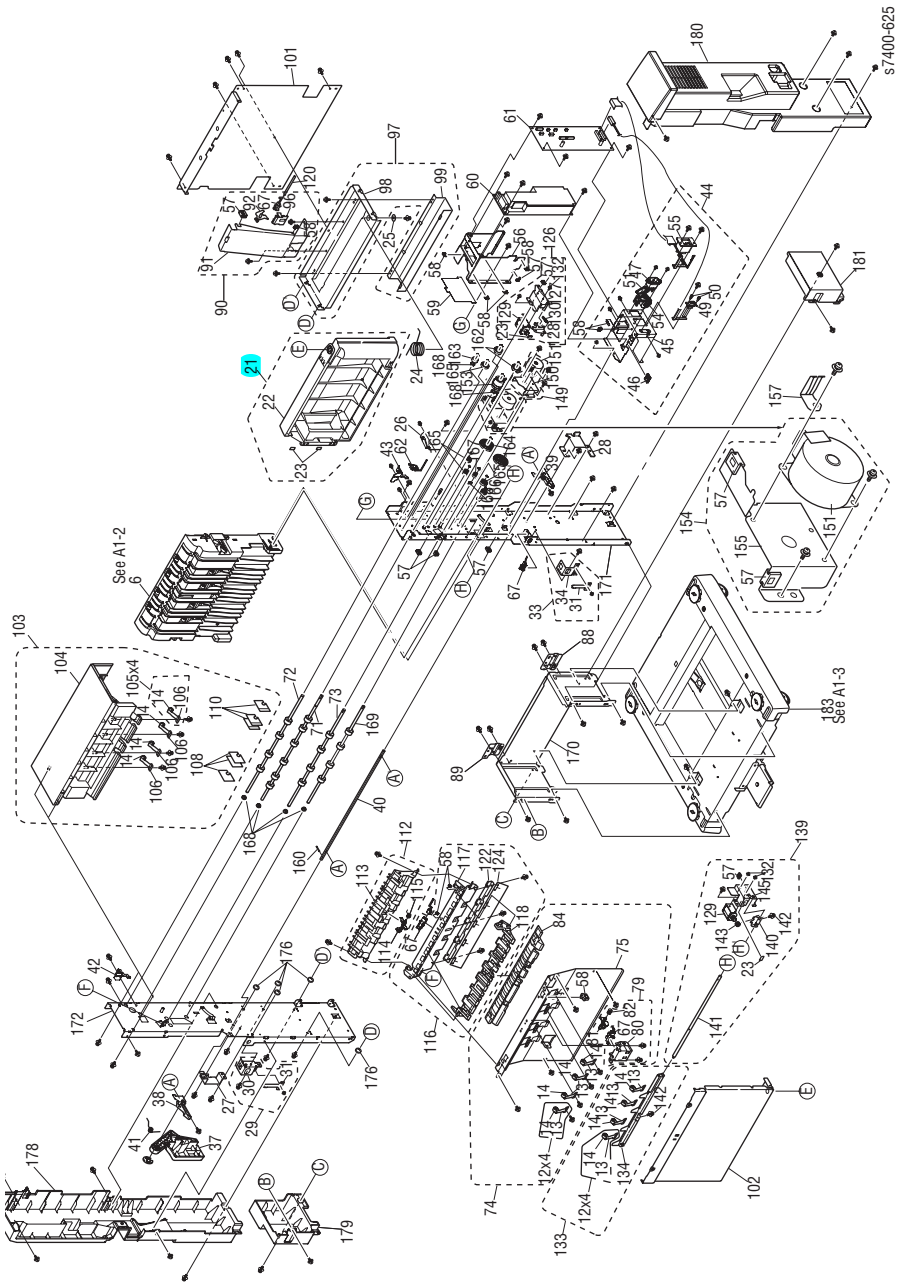

# Inverter Parts Diagram (2 of 3)

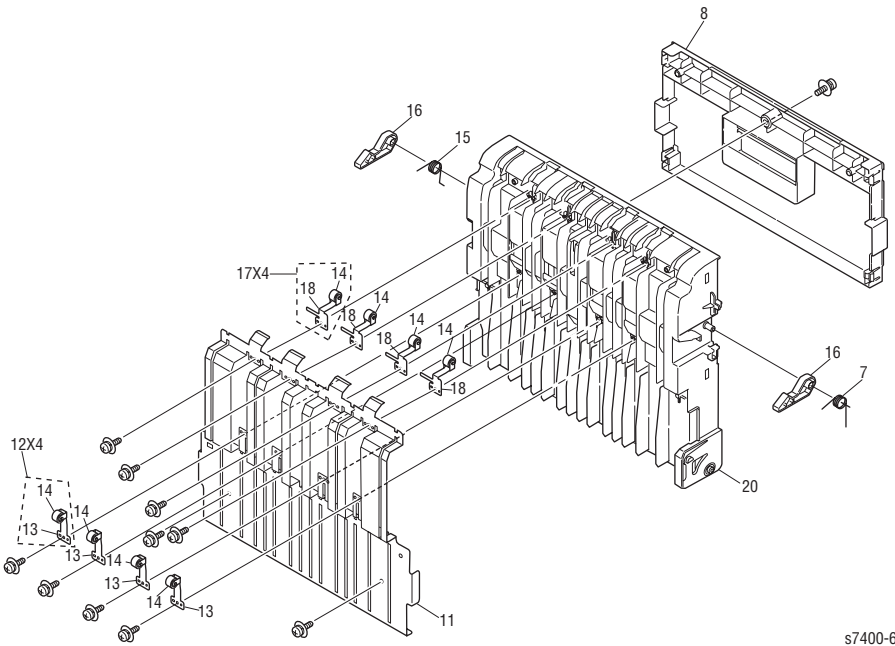

s7400-62

# Inverter Parts Diagram (3 of 3)

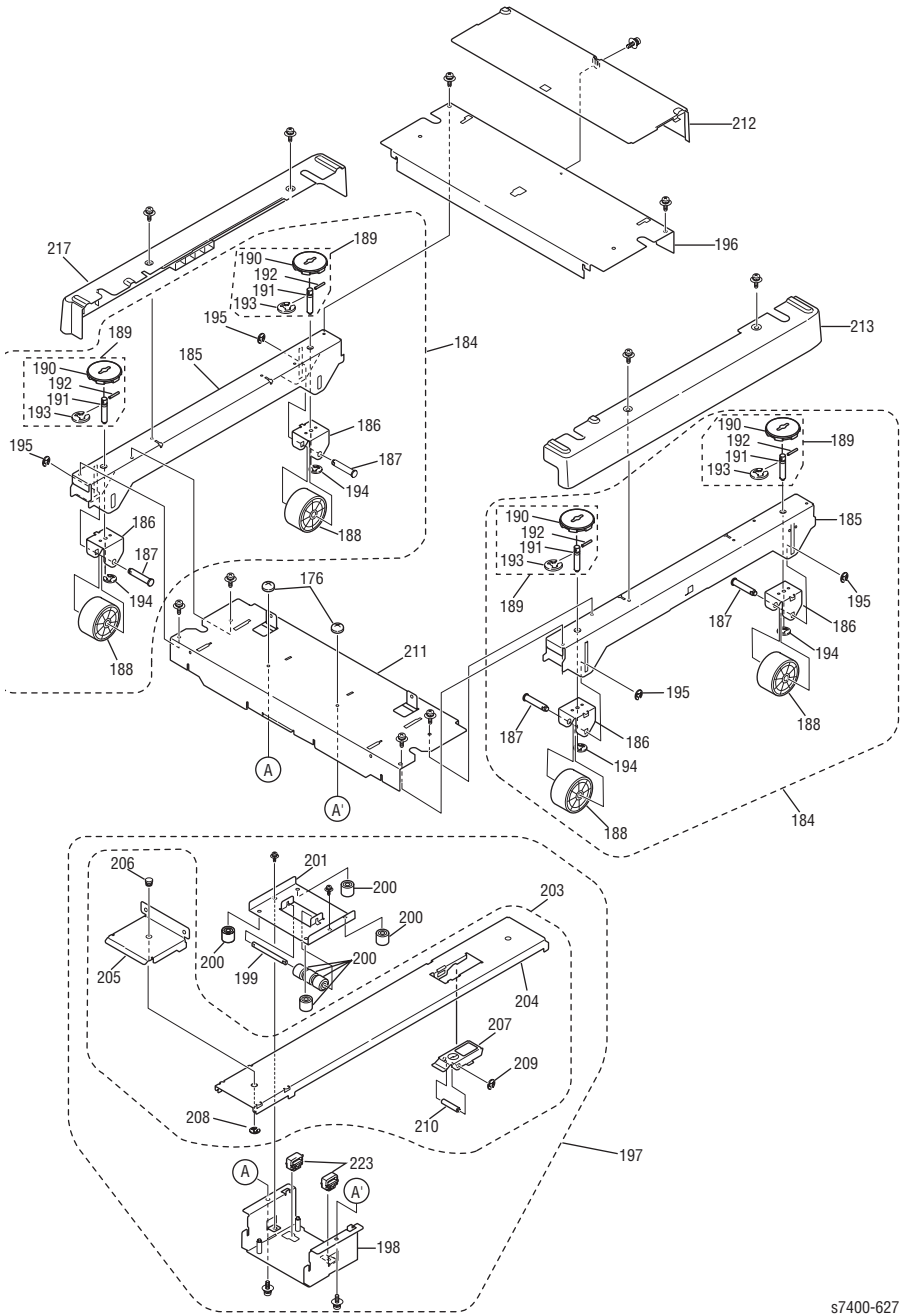

s7400-627

# Parts List 1.13 Inverter Parts List

## Inverter Parts List

<b>ID</b>	<b>Part Number</b>	<b>Name/Description</b>
0	112K00720	Inverter and Base
6	031E11260	Guide-Sheet-L-Assy XOBG
60	110E20010	PWR unit-ACDC Switch
61	960K32850	On-Board Assy.-V72-3
62	117E29240	CONN Cord-Wire AMP3P-SW
67	106E00920	Photo-Interrupter
71	059E05480	Roller-Register
72	059E05490	Roller-Exit
73	059E05500	Roller-Main
116	055K37080	Plate-Guide-C-Assy
129	121E20450	Solenoid
151	127E15500	Motor-Inverter
169	059E05510	Roller-Invert

# Duplex Unit Parts

## Duplex Unit Parts Diagram

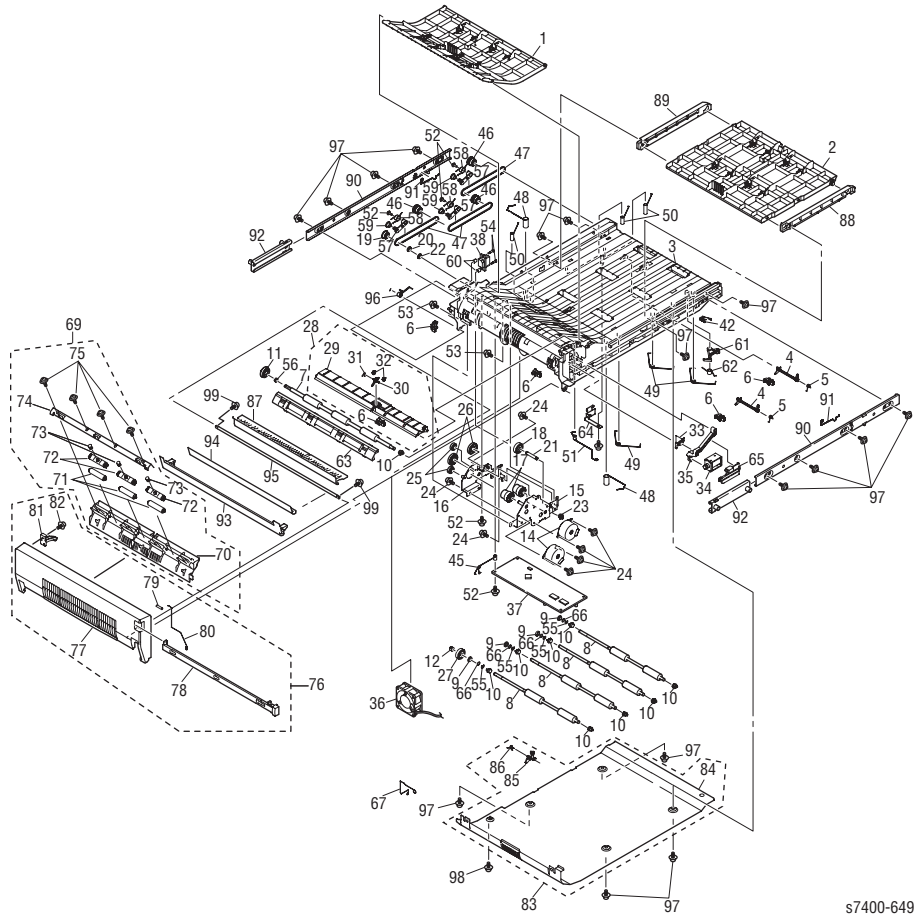

# Parts List 1.14 Duplex Unit Parts List

## Duplex Unit Parts List

<b>ID</b>	<b>Part Number</b>	<b>Name/Description</b>
0	084K35440	Duplex Unit

# Optional Paper Tray Parts



# Optional Tray Parts Diagram (1 of 2)

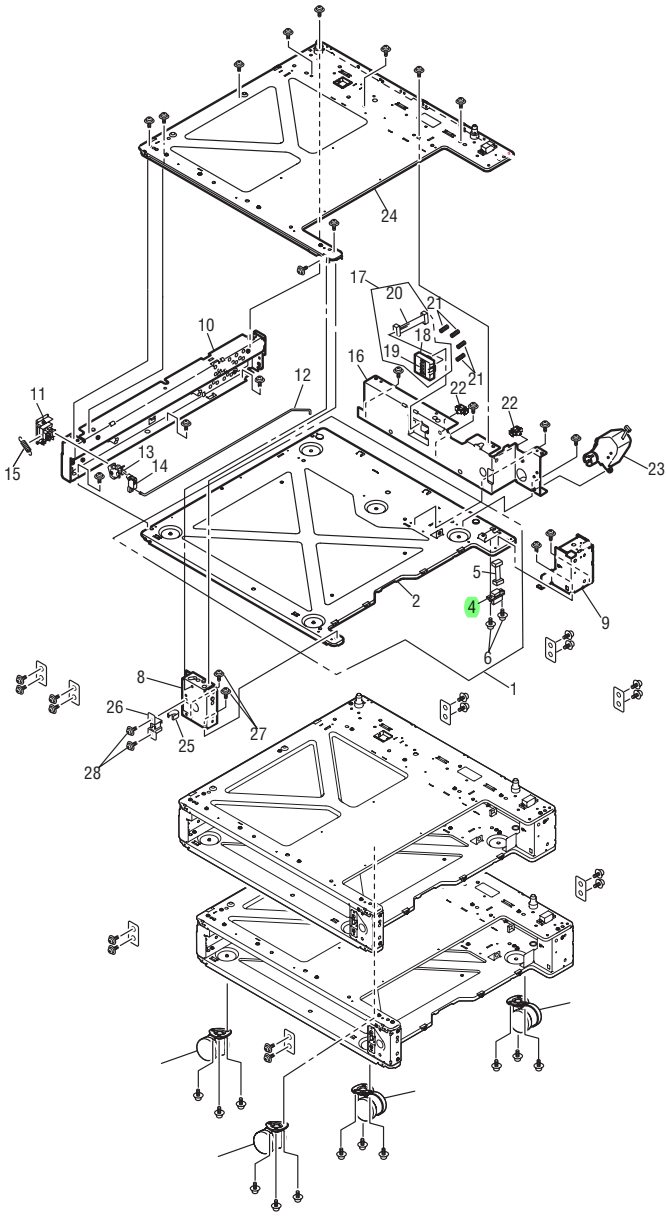

s7400-610

# Optional Tray Parts Diagram (2 of 2)

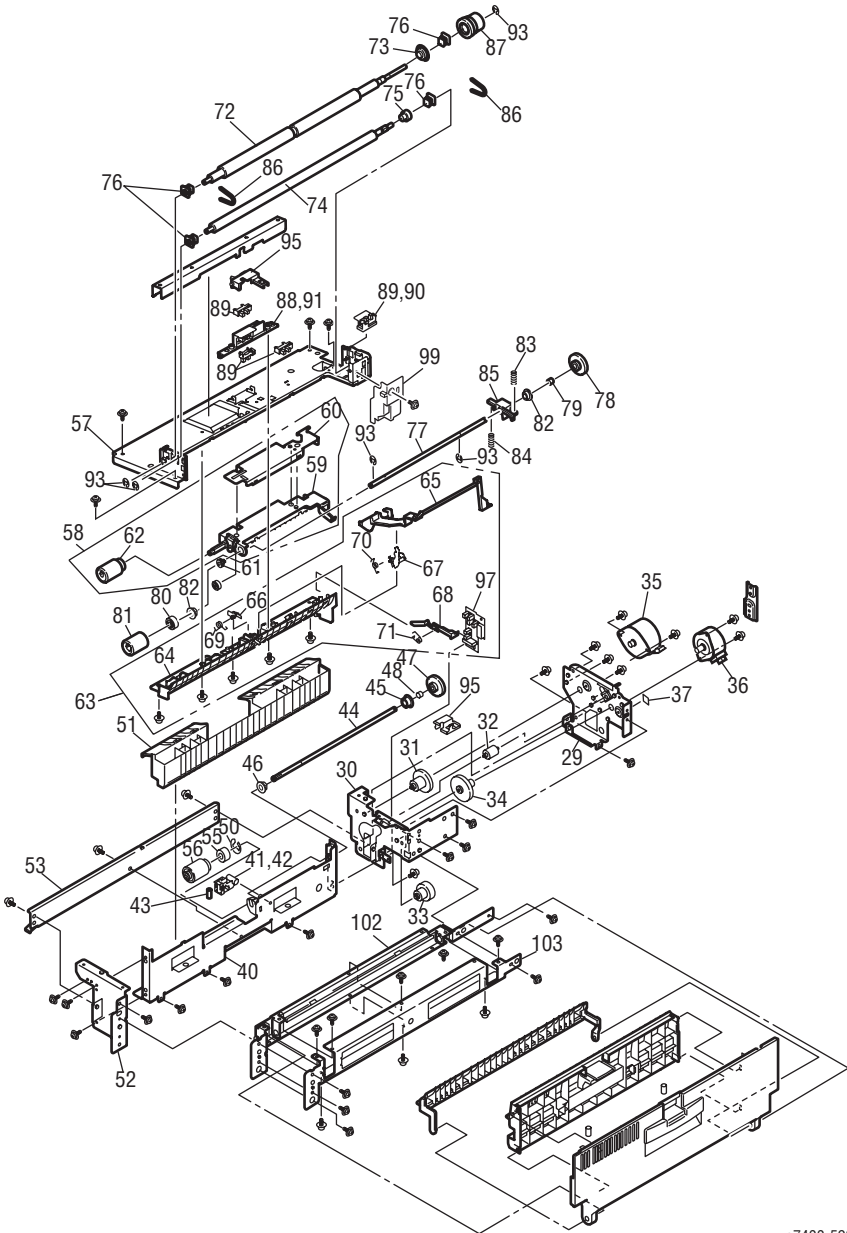

s7400-592

# Parts List 1.15 Optional Tray Parts List

## Optional Tray Parts List

ID #	Part Number	Name/Description
0	059K51750	Optional Tray Assembly (Single Tray)
*	059K52510	LTD Assembly (High-capacity feeder)
*	050K61900	Optional feeder

### Note

The LTD assembly and optional feeders are not referenced in the preceding diagram.



# Wiring Diagrams

## In this chapter...

- Plug/Jack Designators
- Plug/Jack Locators
- Wiring Diagrams

## Section 7

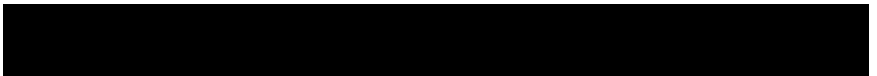

# Plug/Jack Locator Diagrams

The P/J Locator diagrams show the location of primary connections within the option devices. Use these illustrations to locate connections called out in the troubleshooting procedures presented in Section 3.

To find the location of a Plug or Jack:

1. Locate the P/J connector designator in the first column of the table.
2. With this information, go to the map listed in the second column.
3. Use the coordinates to quickly locate the connection indicated on the map with its P/J designation number.

## Print Options Plug/Jack Designators

### Finisher/Plug/Jack Designators

P/J	Map	Coord	Remarks
CN1	1	A-835	Receives 24-volt from the printer.
CN2	1	A-837	Monitors transmit and receive voltage levels from the printer.
CN3	1	I-834	Connects to the front and rear alignment motor signals.
CN4	1	K-836	Connects to front door (Door J), upper cover (Door H), and home position sensors.
CN5	1	K-838	Connects to rear home position, tray paper, delivery belt position, and processing tray sensors.
CN6	1	D-834	Connects to the Lift Motor and the staple/fold motor.
CN7	1	K-835	Supplies required voltages for the Stapler unit.
CN8	1	B-834	Connects to the Stapler Safety, Front Door (Door J), and Joint switches.
CN9	1	H-841	Connects to swing guide home position, staple fold clock, and paddle home position sensors.
CN10	1	F-834	Connects to the paddle motor and feed motor signals.
CN11	1	J-841	Receives detect signals from the Stapler unit.
CN12	1	A-838	Supplies required signals for 1/2 of the punch unit (optional).
CN13	1	J-834	Connects to the delivery motor signals.
CN14	1	A-836	Supplies required signals for 1/2 of the punch unit (optional).
CN15	1	K-838	Connects to shift limit, Lift Motor clock, and bind tray sensors.
CN16	1	A-840	Connects to Inlet, stack feed roller, folding home position, and folding position sensors.

## Finisher/Plug/Jack Designators (Continued)

<b>P/J</b>	<b>Map</b>	<b>Coord</b>	<b>Remarks</b>
CN17	1	A-841	Connects to signal ground, transmit and receive data, DSR and DTR signals, and reset.
CN18	1	E-834	Supplies 24 volts to the Slide motor.
CN19	1	I-839	Connects to the full stack sensor.
SW1	1	C-841	Folding position adjustment, middle 2-point stapling.
PSW3	1	B-840	Factory mode
PSW2	1	C-840	Folding position adjustment, middle 2-point stapling.
PSW1	1	D-840	Folding position adjustment, middle 2-point stapling.
LED3	1	B-839	LED for PSW1.
LED2	1	C-839	LED for PSW2.
LED1	1	D-839	LED for PSW3.
CB1	1	B-835	Circuit breaker between Joint Switch and 24 volts from the printer.

## Punch Controller Board Plug/Jack Designator

<b>P/J</b>	<b>Map</b>	<b>Coord</b>	<b>Remarks</b>
J1001	2	H-838	Connects to Finisher Punch Transfer Motor.
J1002	2	H-840	Connects to Punch Motor.
J1003	2	D-842	Connects to CN12 of Finisher Unit.
J1004	2	G-842	Connects to CN14 of Finisher Unit.
J1005	2	H-835	Connects to waste-full photosensor board and the Waste-full LED board.
J1006	2	H-836	Connects to punch motor clock, punch home, and punch home position sensors.
J1007	2	D-834	Connects to the photosensor and LED boards.
SW1001	2	E-837	Punch hole count registration/sensor output adjustment, etc.
SW1002	2	E-838	Punch hole count registration/sensor output adjustment, etc.
SW1003	2	E-839	Punch hole count registration/sensor output adjustment, etc.
LED100 1	2	E-839	Determines number of punch holes (see page 4-2).
LED100 2	2	E-840	Determines number of punch holes (see page 4-2).
LED100 3	2	E840	Determines number of punch holes (see page 4-2).

## Inverter Controller Board Plug/Jack Designator

P/J	Map	Coord	Remarks
SNSCN0	3	F-837	Connects to paper sensors.
SNSCN1	3	E-837	Connects to Inverter Docking Sensor.
SNSCN2	3	E-837	Connects to Door Open Interlock Switch (Door F).
CL1	3	F-836	Connects to Lower Roller Solenoid.
CL2	3	C-836	Connects to Paper Diverter Solenoid.
FAN	3	D-836	Connects to diverter clutch.
MOTOR-A	3	C-837	Connects to the Upper Feed Motor.
MOTOR-B	3	A-837	Connects to the Lower Feed Motor.
MAIN1	3	J-837	Connects to connector supplying Finisher Controller Board signals.
MAIN2	3	E-839	Connects to power supply from the Finisher.
FLASH	3	H-836	Connect to external equipment for FLASH memory.
POWER	3	A-836	Connects to the Power Supply Board.

## Duplex Unit Controller Board Plug/Jack Designator

P/J	Map	Coord	Remarks
SNSCN0	4	F-837	Connects to the Front and Rear Paper Sensor.
SNSCN1	4	E-837	Connects to the Entrance Sensor and the Reverse Sensor.
SNSCN2	4	E-837	No connection.
CL1	4	F-836	Connects to the Paper Diverter Solenoid.
CL2	4	C-836	No connection.
FAN	4	D-836	Connects to the fan.
MOTOR-A	4	C-837	Connects to the Roller Motor.
MOTOR-B	4	A-837	Connects to the Reverse Roller Motor.
MAIN1	4	J-837	Connects to connector supplying signals from the Finisher, including power.
MAIN2	4	E-839	No connection.
FLASH	4	H-836	Connect to external equipment for FLASH memory.
POWER	4	A-836	No connection.



## Paper Tray Controller Board Plug/Jack Designator

P/J	Map	Coord	Remarks
FFSNS	5	F-837	Connects to TRYSNS1 and TRYSNS2 signals from the feeder board.
CL1	5	F-836	Connects to the registration clutch.
CL2	5	C-836	No connection.
GDDC	5	D-836	Connects to the Lift Motor.
MOTOR-A	5	C-837	Connects to the Feed Motor.
MOTOR-B	5	A-837	Connects to the Registration Motor.
MAIN1	5	J-837	Connects to connector supplying Feeder Board signals.
MAIN2	5	E-839	Connects to power supply from the Finisher.
FLASH	5	H-836	Connect to external equipment for FLASH memory.
POWER	5	A-836	No connection.

## Paper Tray Feeder Board Plug/Jack Designator

P/J	Map	Coord	Remarks
TRYSNS1	6	G-836	Connects signals from the Paper Tray Controller Board.
TRYSNS2	6	E-839	Connects to the Door C detect Sensor, the Feed-Out Sensor, and the Registration Sensor.
PAPEND	6	D-838	Connects to the No Paper Sensor.

## Finisher Sensor Designators

P/J	Map	Coord	Remarks
MS2	7	D-839	Connects to the Joint Switch
MS1	7	H-839	Connects to the Front Door Switch
CN25	7	D-839	Connects to the Front Door Sensor
CN44	8	G-836	Connects to the Inlet Sensor
CN32	8	D-837	Connects to the Tray Paper Sensor
CN35	8	E-837	Connects to the Paper Surface Sensor
CN24	7	D-838	Connects to the Upper Cover (Door H) Sensor
CN50	8	F-836	Connects to the Shift (Upper) Limit Sensor
CN49	7	F-837	Connects to the Shift (Lower) Limit Sensor
CN48	7	B-839	Connects to the Shift Clock Sensor

## Finisher Sensor Designators (Continued)

<b>P/J</b>	<b>Map</b>	<b>Coord</b>	<b>Remarks</b>
CN73	7	F-838	Connects to the Full Stack Sensor
CN30	8	E-838	Connects to the Processing Tray Sensor
CN23	7	C-838	Connects to the Aligning Plate (Front) Home Position Sensor
CN36	8	E-836	Connects to the Aligning Plate (Rear) Home Position Sensor
CN41	8	F-837	Connects to the Stack Feed Roller Home Position Sensor
J2006	8	G-836	Connects to the Waste Full Sensor
CN31	8	E-837	Connects to the Delivery Belt Home Position Sensor
CN51	8	F-836	Connects to the Paddle Home Position Sensor
SSS	7	F-836	Connects to the Stapler Safety Interlock Switch
CN52	7	B-839	Connects to the Staple/Fold Cock Sensor
CN40	8	C-838	Connects to the Folding Home Position Sensor
CN47	7	F-839	Connects to the Bind Tray Sensor
CN39	8	G-838	Connects to the Folding Position Sensor

## Inverter Sensor Designator

<b>P/J</b>	<b>Map</b>	<b>Coord</b>	<b>Remarks</b>
P/J13	9	H-837	Connects to the Inverter Docking Sensor
SNSCN2	9	H-836	Connects to the Inverter Door Open Interlock Switch
P/J10	9	F-835	Connects to the Inverter Upper Paper-Present Sensor
P/J12	9	G-839	Connects to the Inverter Lower Paper-Present Sensor
P/J11	9	F-835	Connects to the Inverter Paper-in Sensor

# Map 1: Finisher Controller Board Locator Diagram

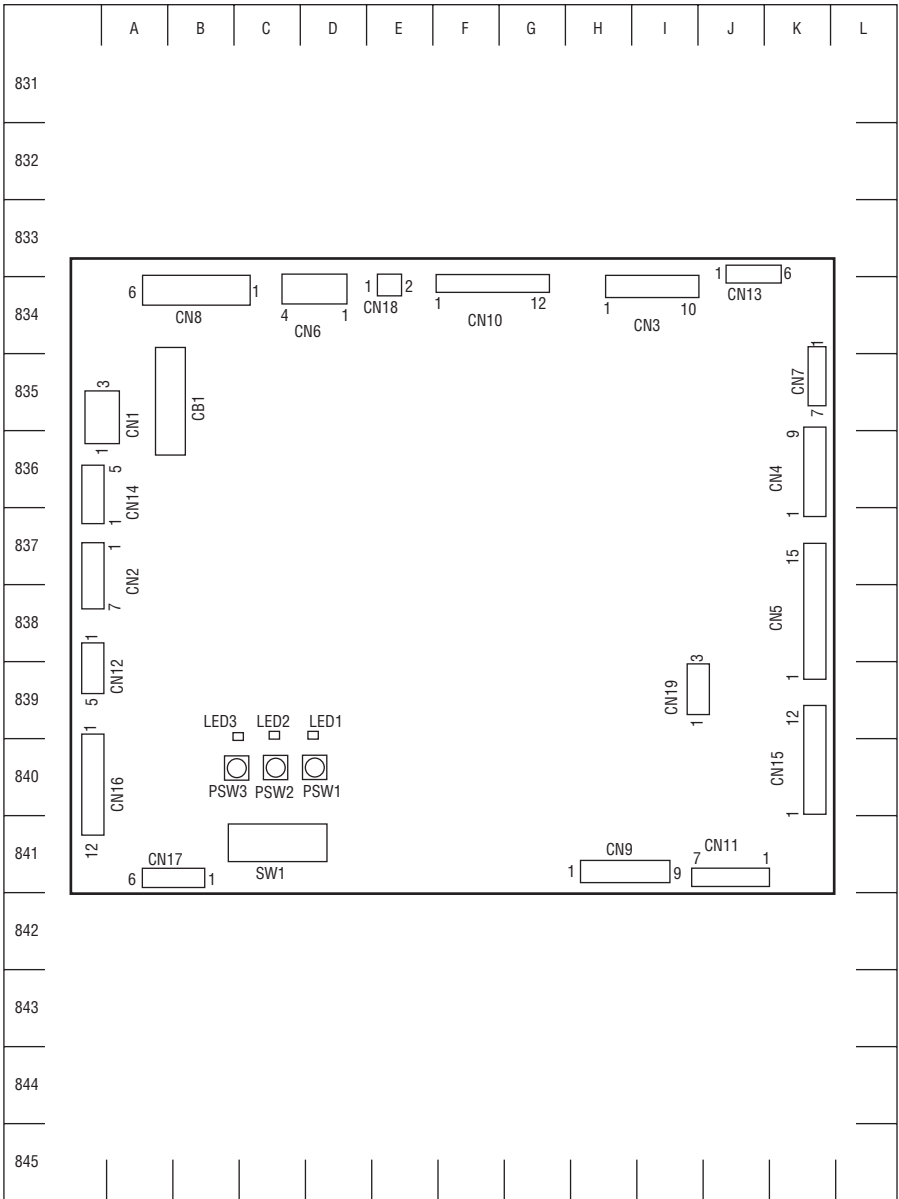

s7400-269

## Map 2: Punch Controller Board Locator Diagram

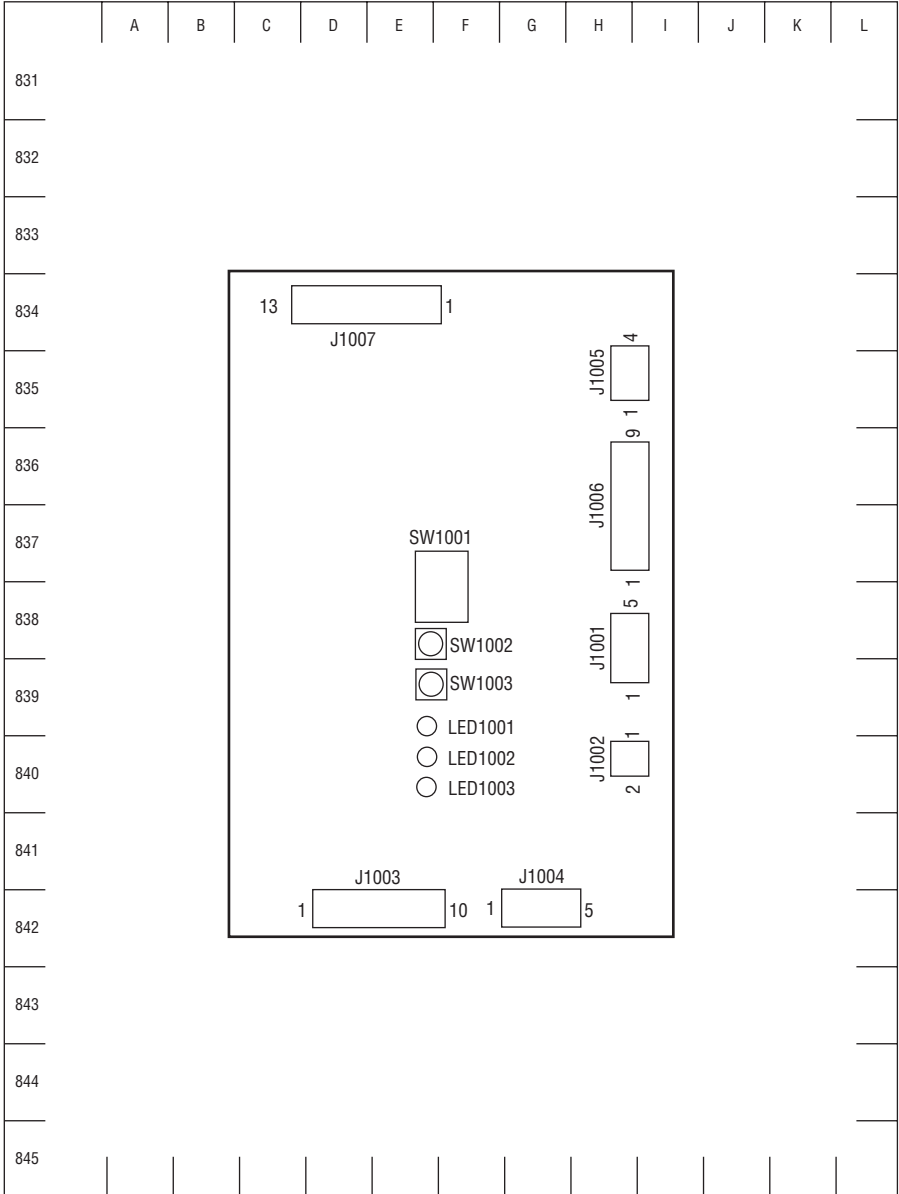

s7400-716

# Map 3: Inverter Controller Board Locator Diagram

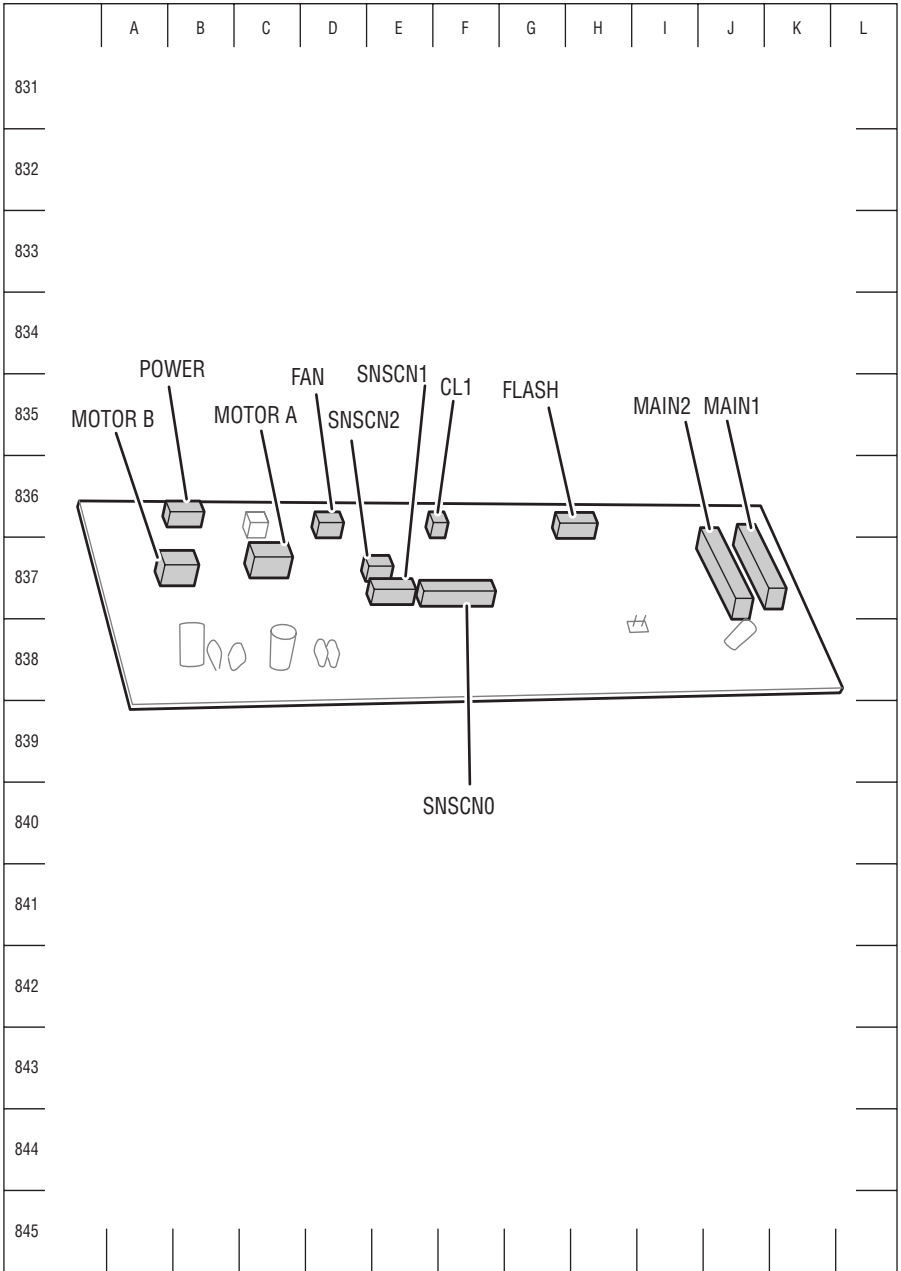

s7400-711

# Map 4: Duplex Unit Controller Board Locator Diagram

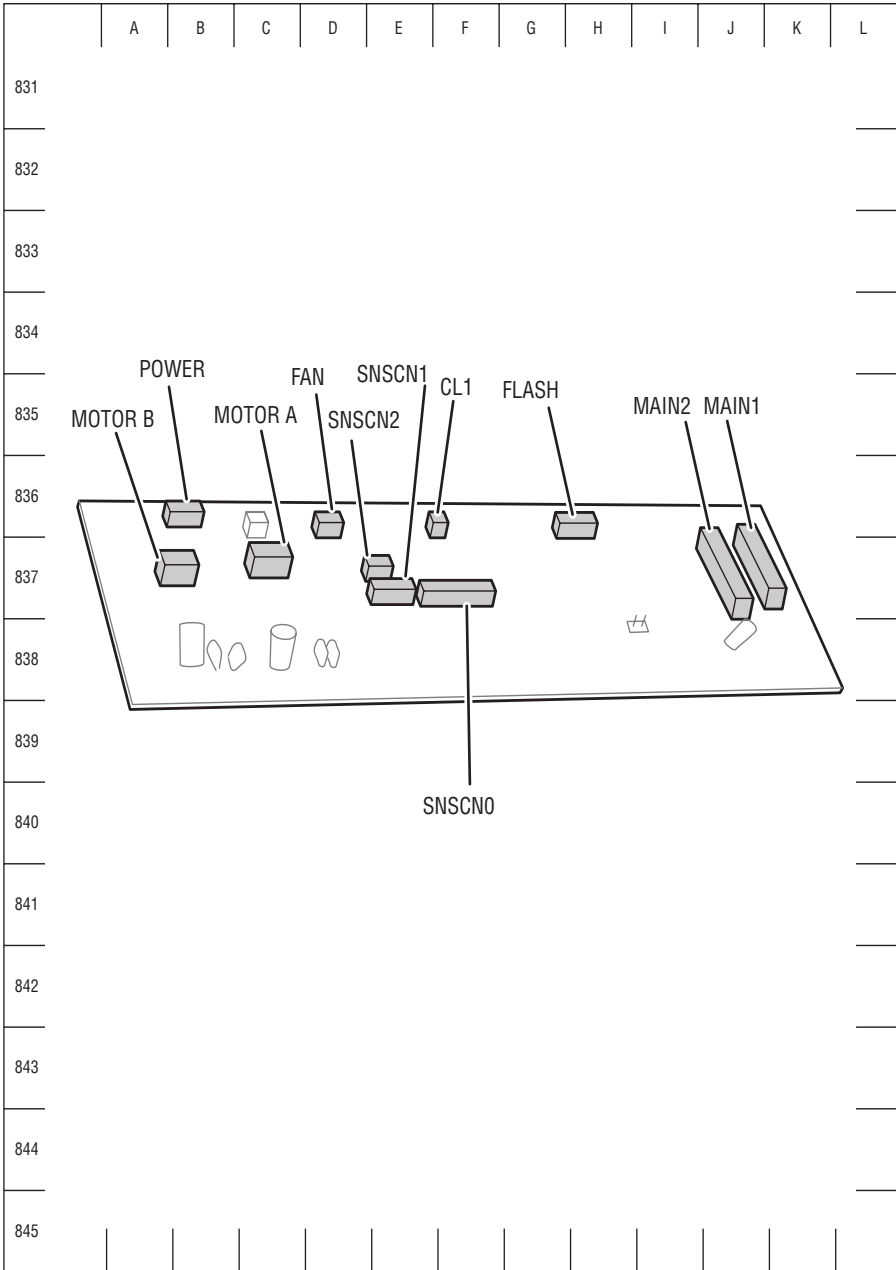

s7400-711

# Map 5: Paper Tray Controller Board Locator Diagram

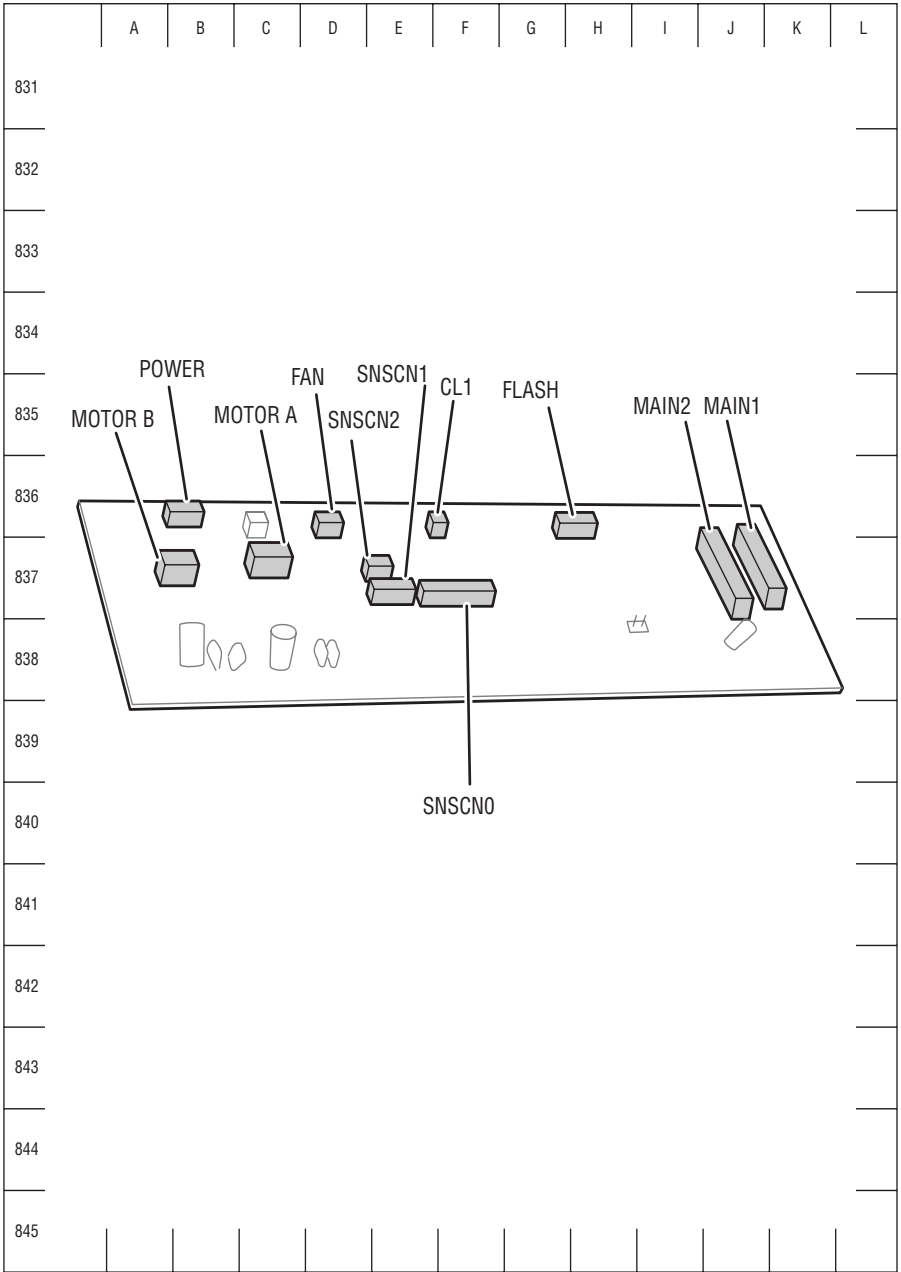

s7400-711

# Map 6: Paper Tray Feeder Board Locator Diagram

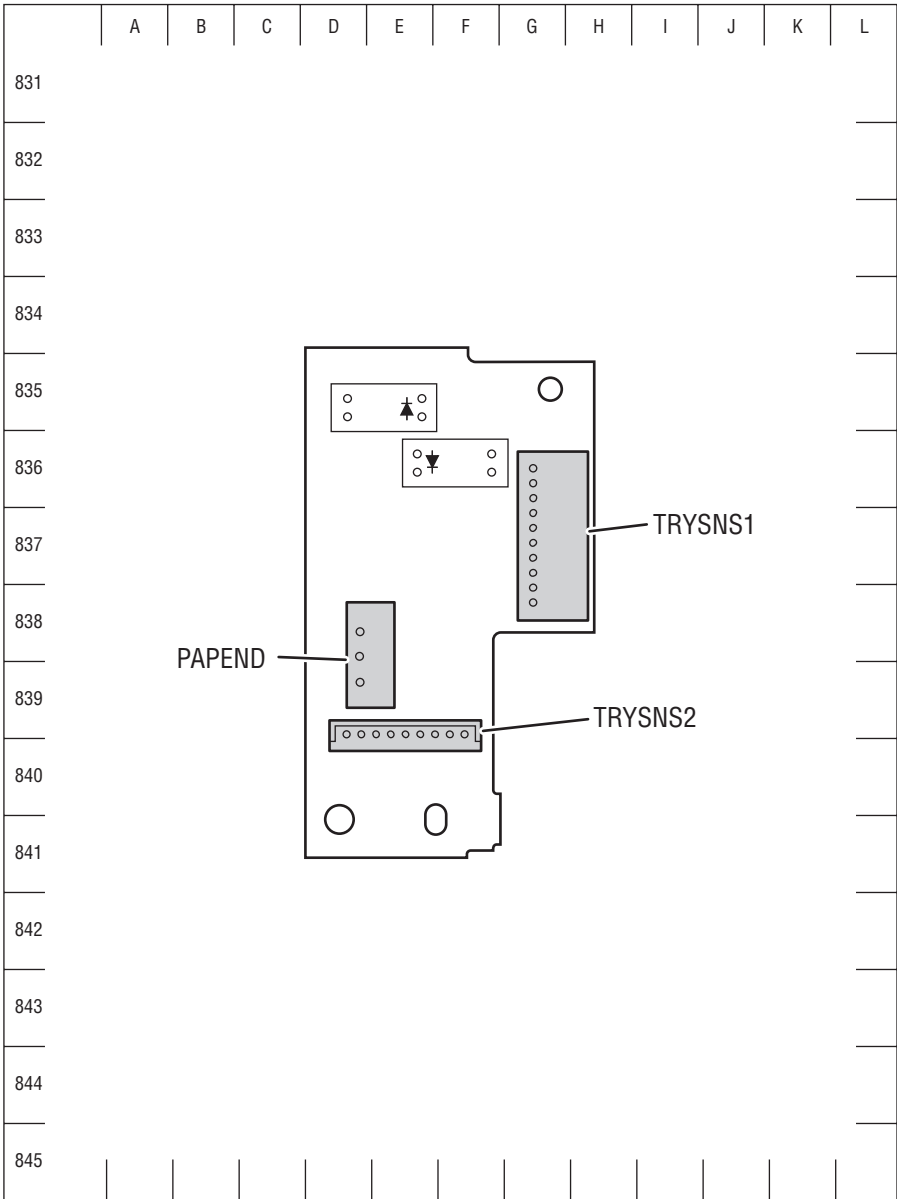

s7400-603



# Map 7: Finisher Sensor Locator Diagram (1 of 2)

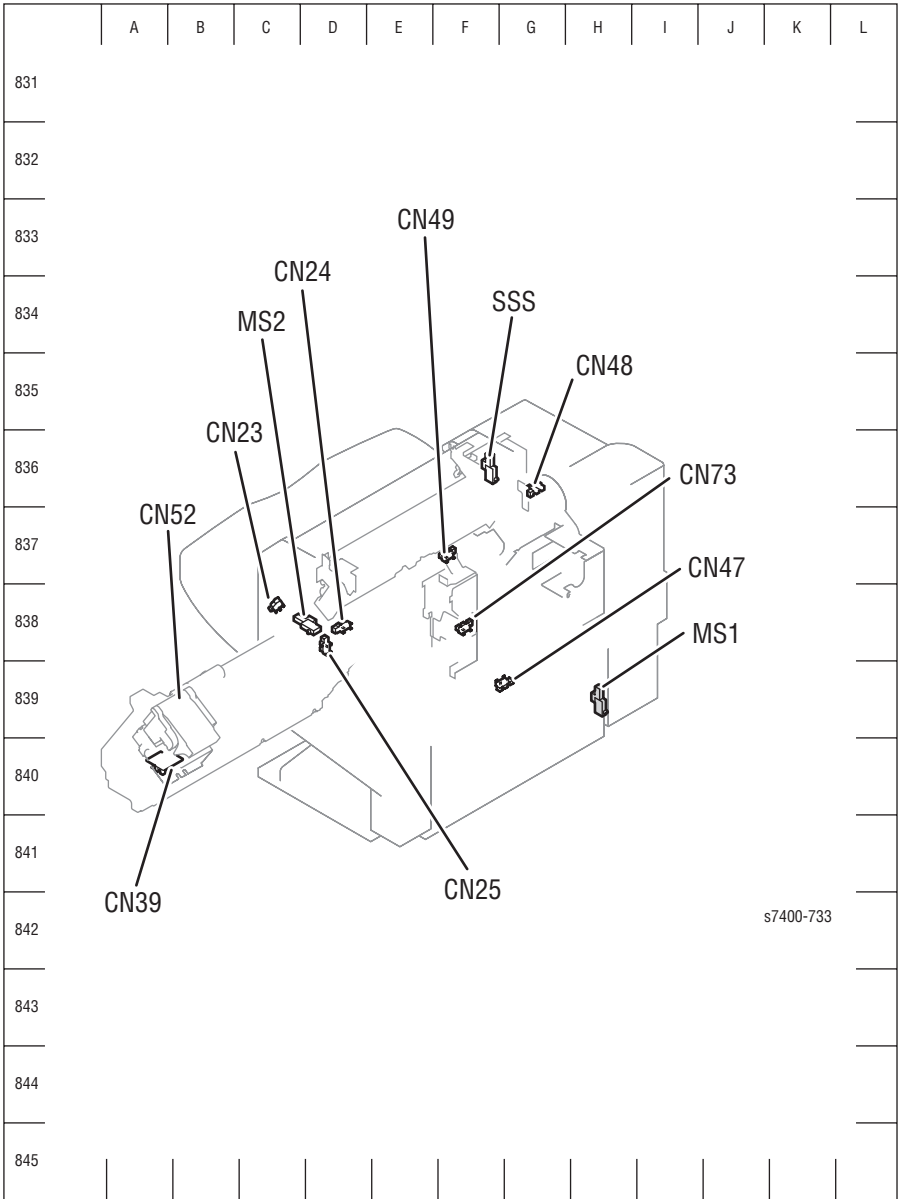

## Map 8: Finisher Sensor Locator Diagram (2 of 2)

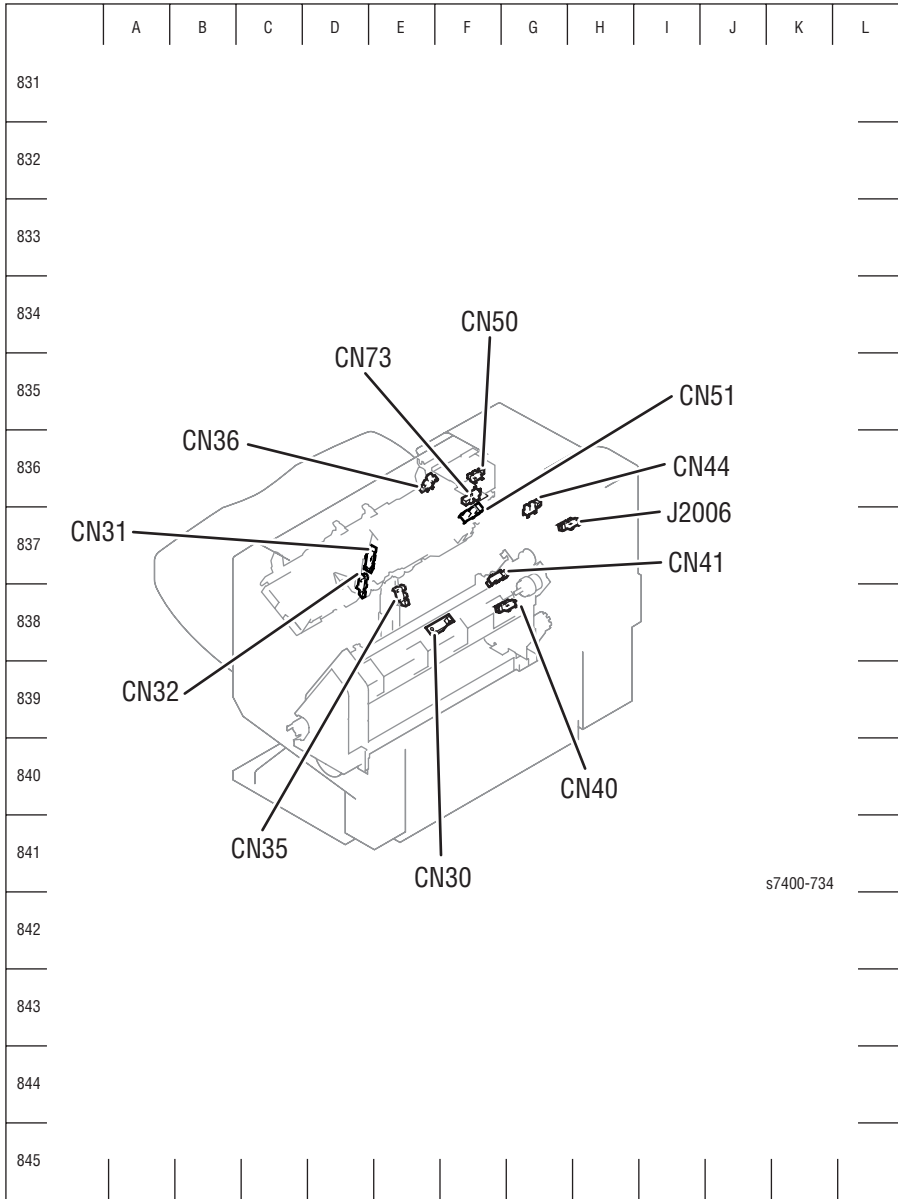

# Map 9: Inverter Sensor Locator Diagram

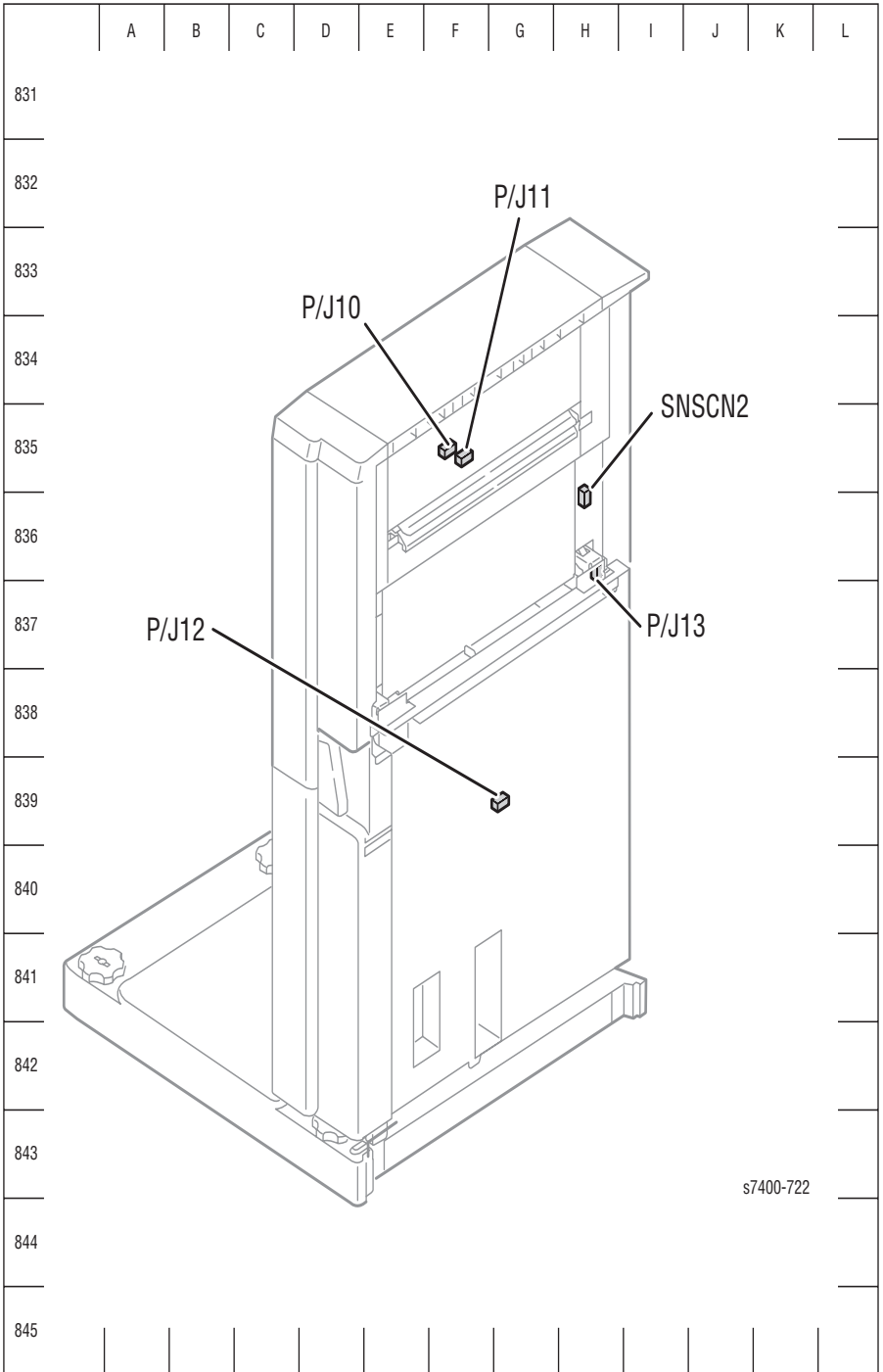

# Finisher Wiring Diagrams

## Finisher/Punch Power Supply Wiring Diagram

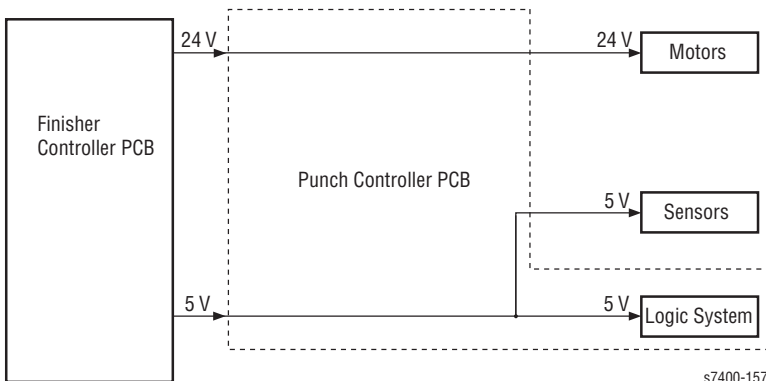
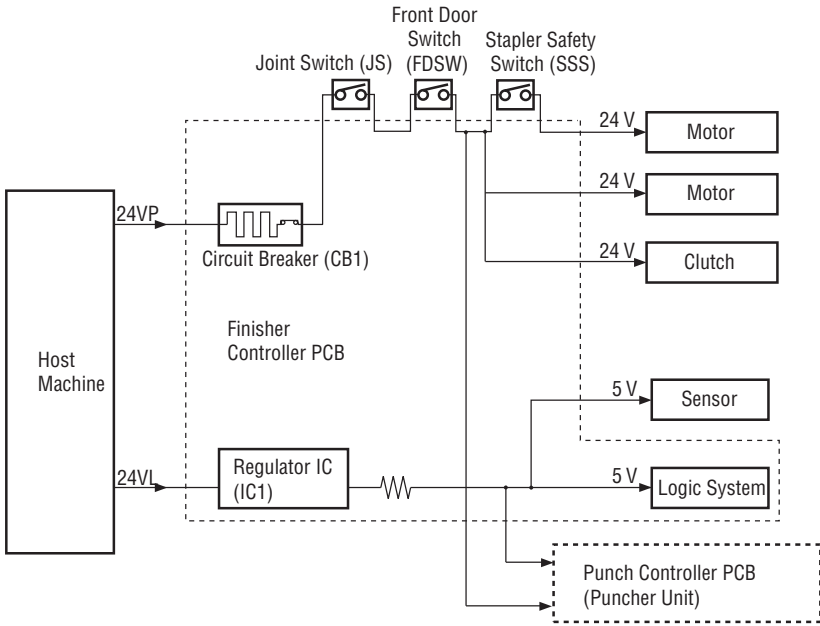

s7400-157

# Finisher Controller to Printer Wiring

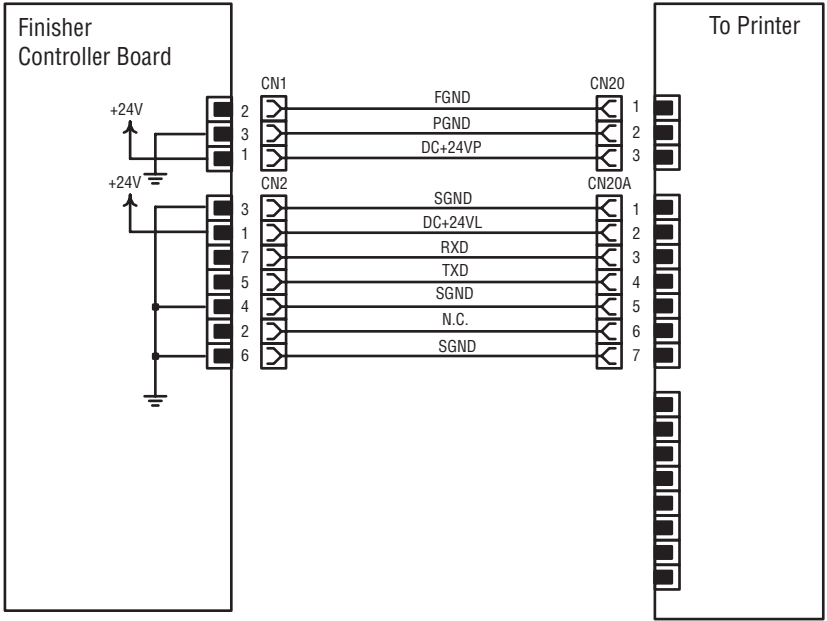

s7400-271

# Finisher Controller to Sensors (1 of 3)

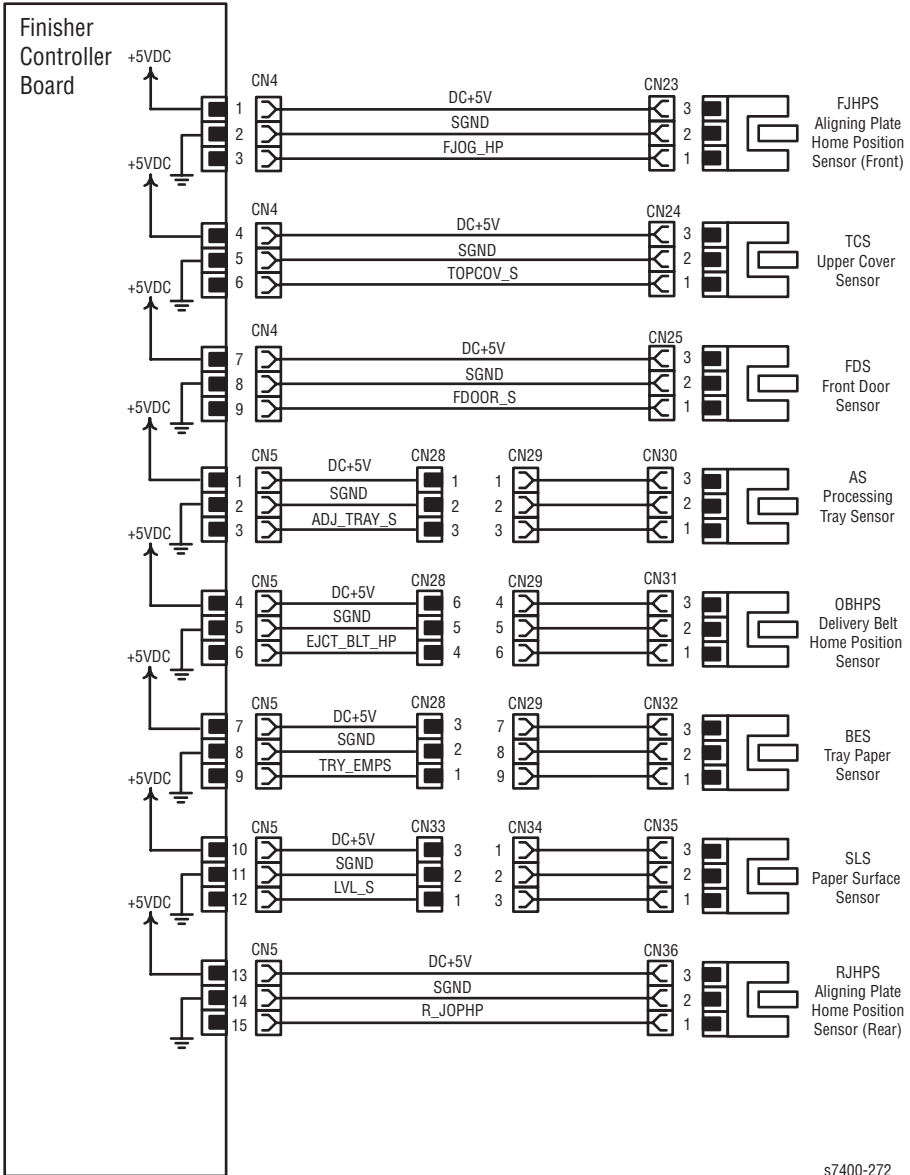

s7400-272

# Finisher Controller to Sensors (2 of 3)

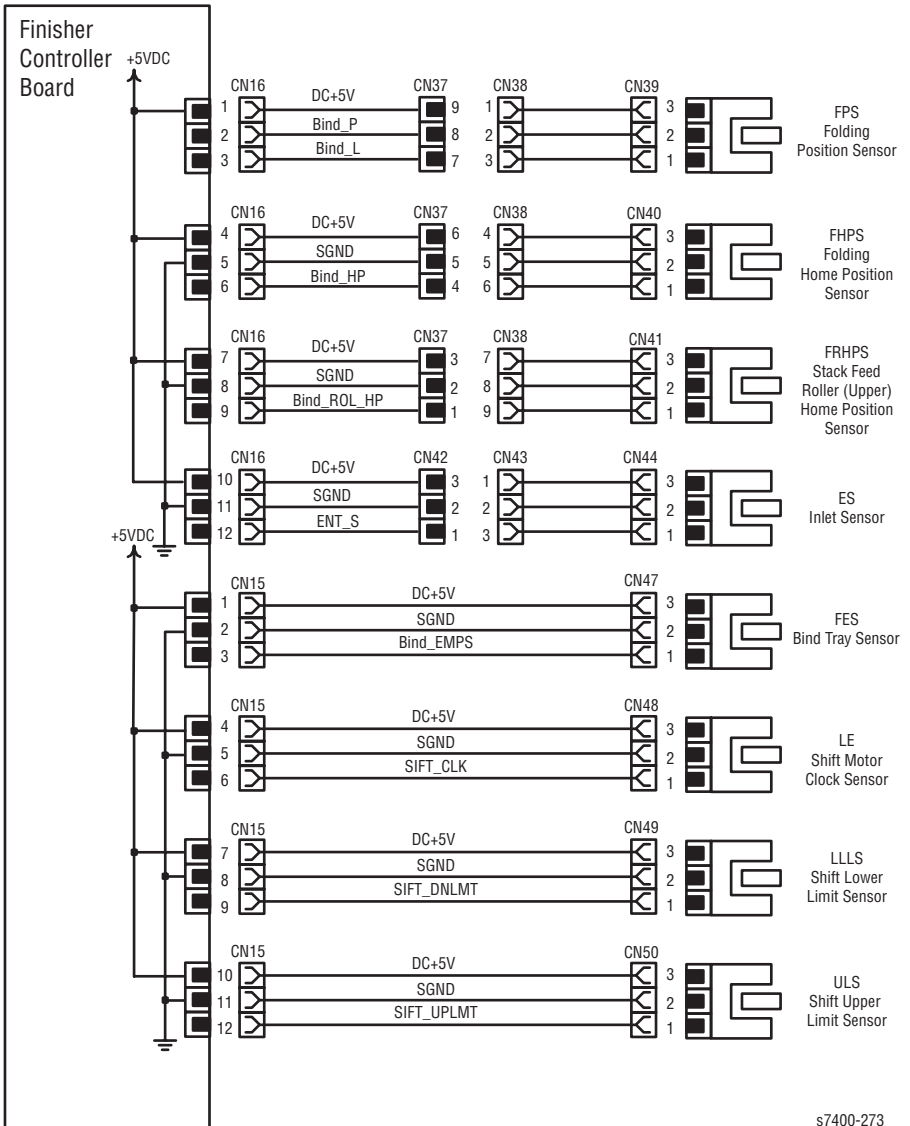

s7400-273

# Finisher Controller to Sensors (3 of 3)

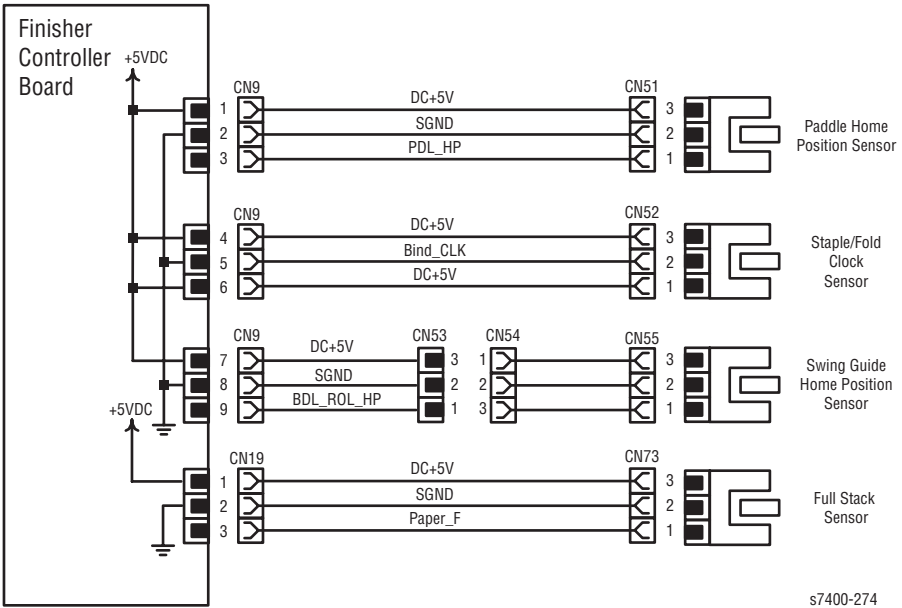



# Finisher Controller to Motors

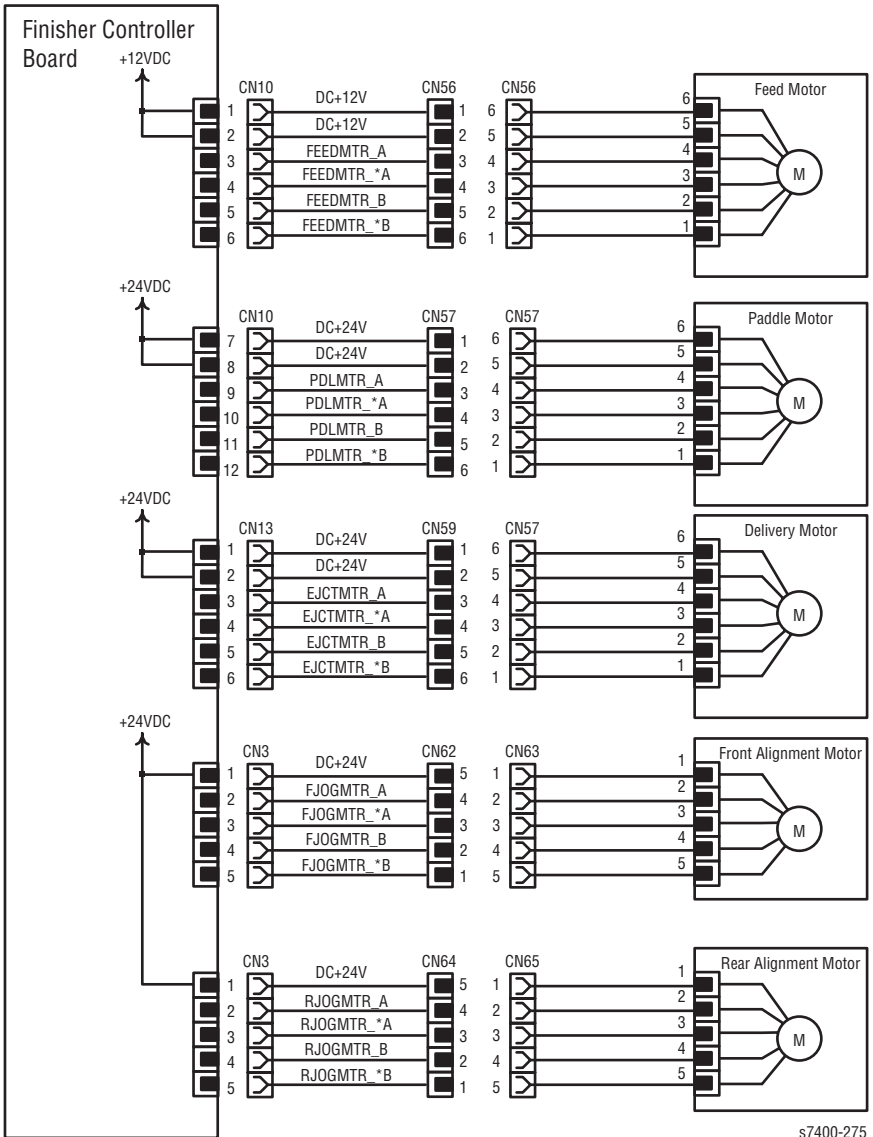

s7400-275

# Finisher Controller to Switches

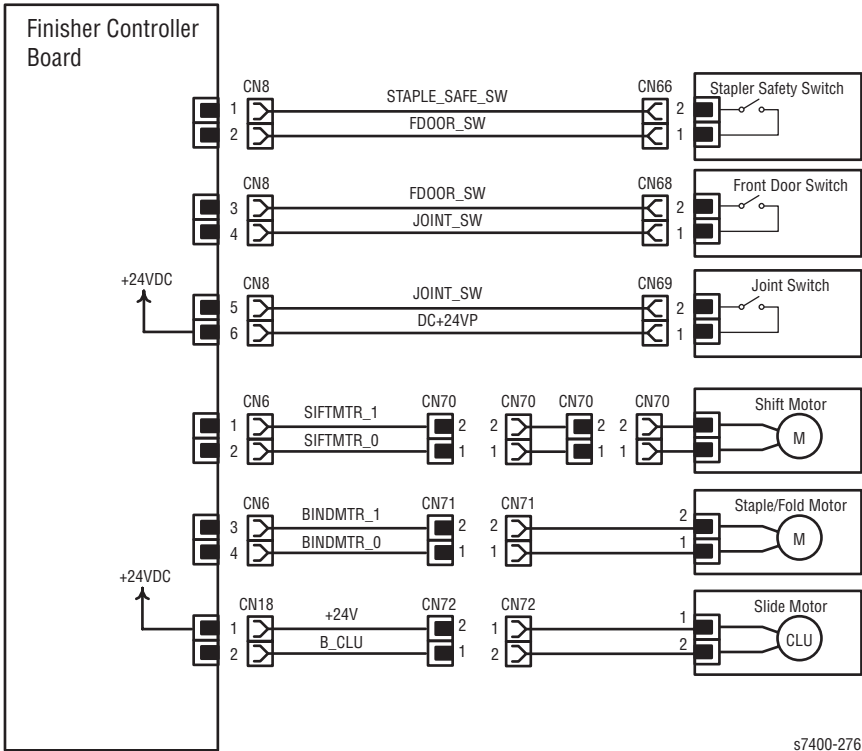

s7400-276

# Finisher Controller to Stapler Sensors and Motors

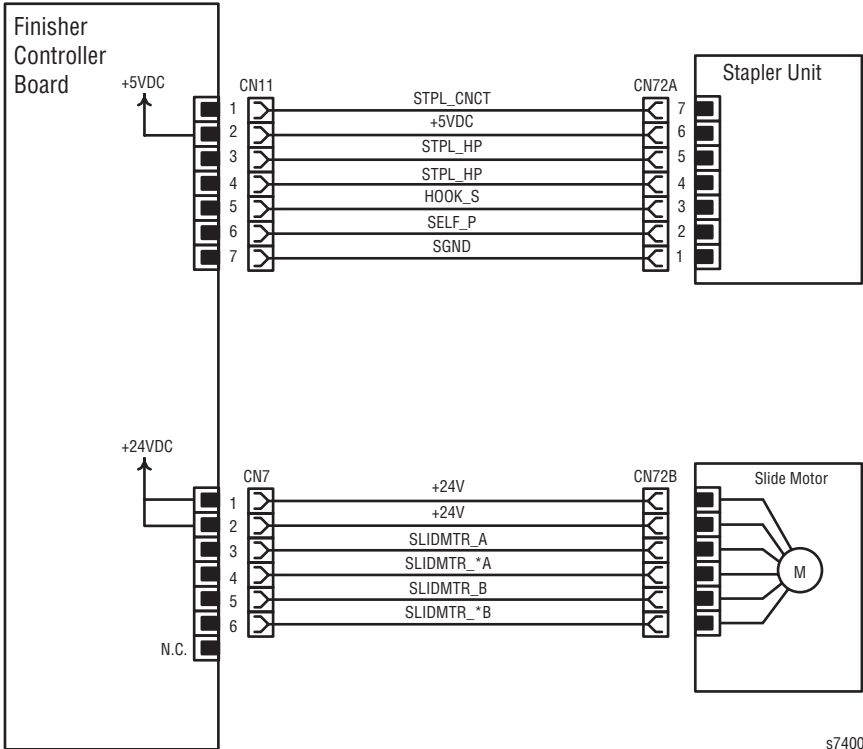

s7400-277

# Finisher Controller to Punch Controller

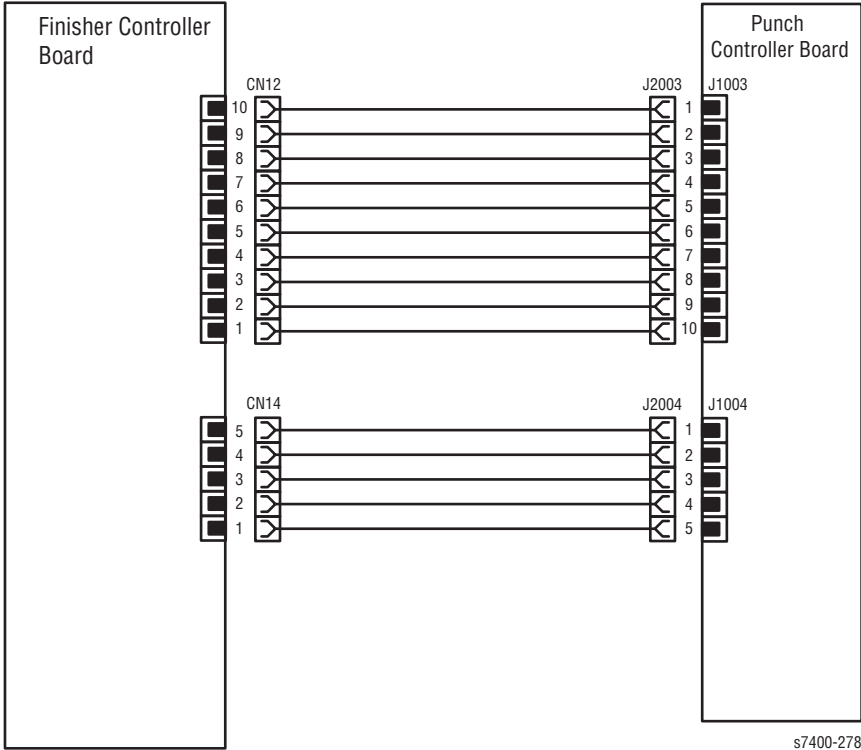

# Punch Controller to Sensors and Motors

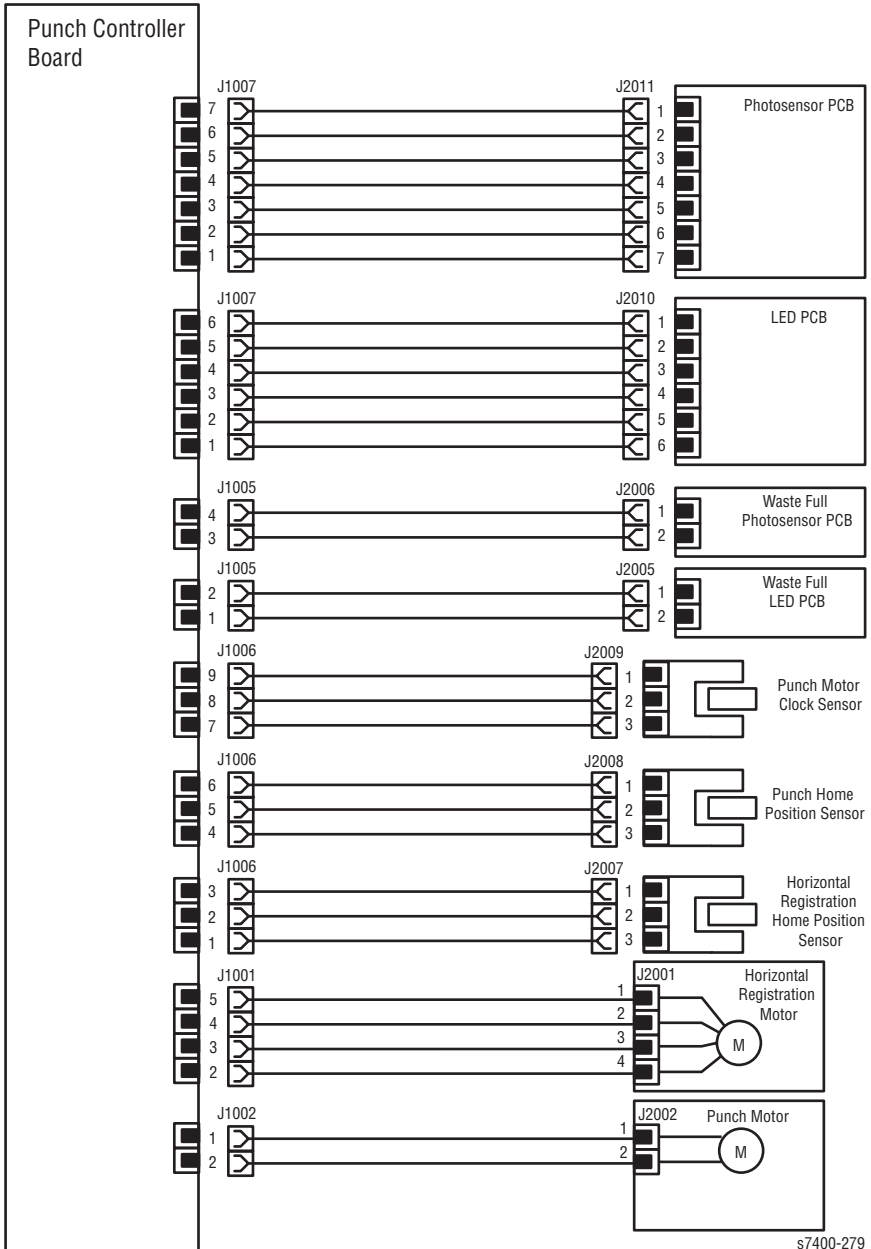

# Inverter Sensors Wiring Diagram

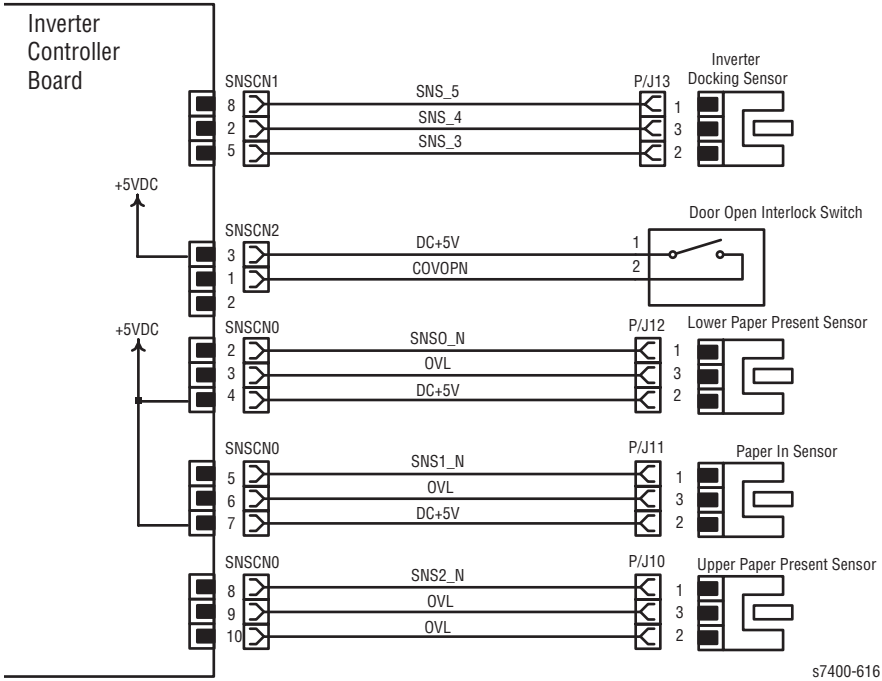

# Inverter Motors, Solenoids, and Clutch Wiring Diagram

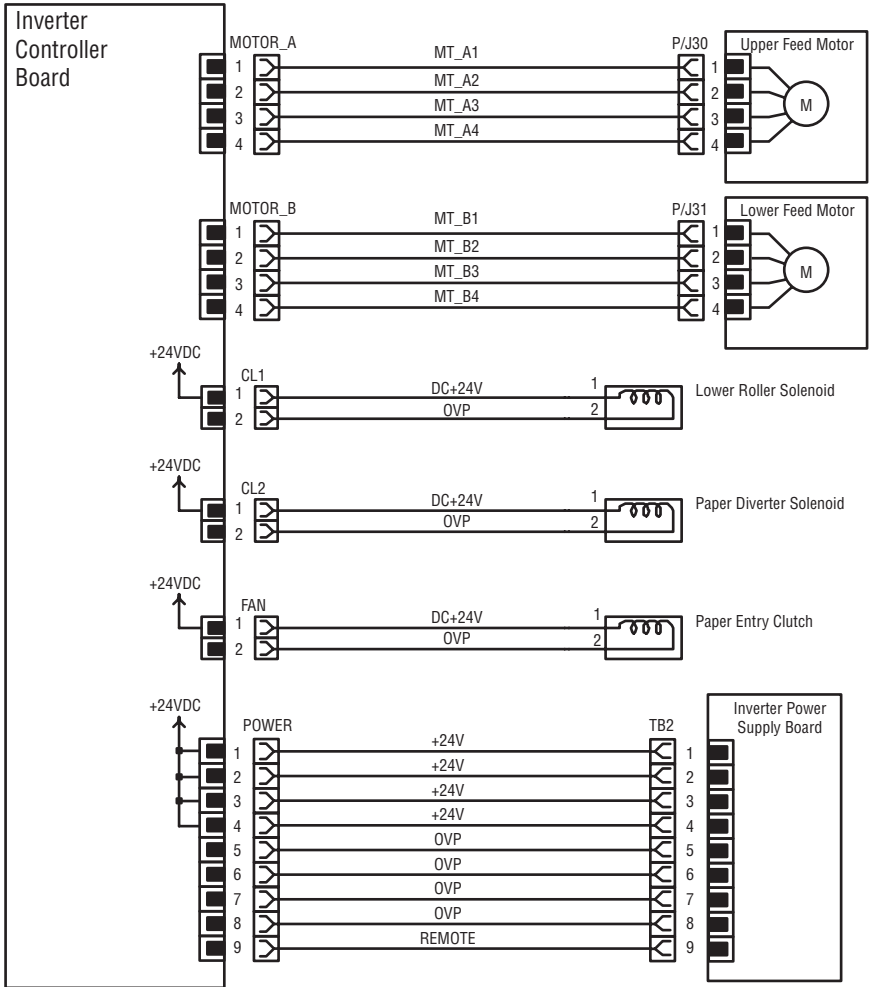

s7400-617

# Duplex Unit Wiring Diagrams

## Duplex Unit Sensors and Interconnect Wiring

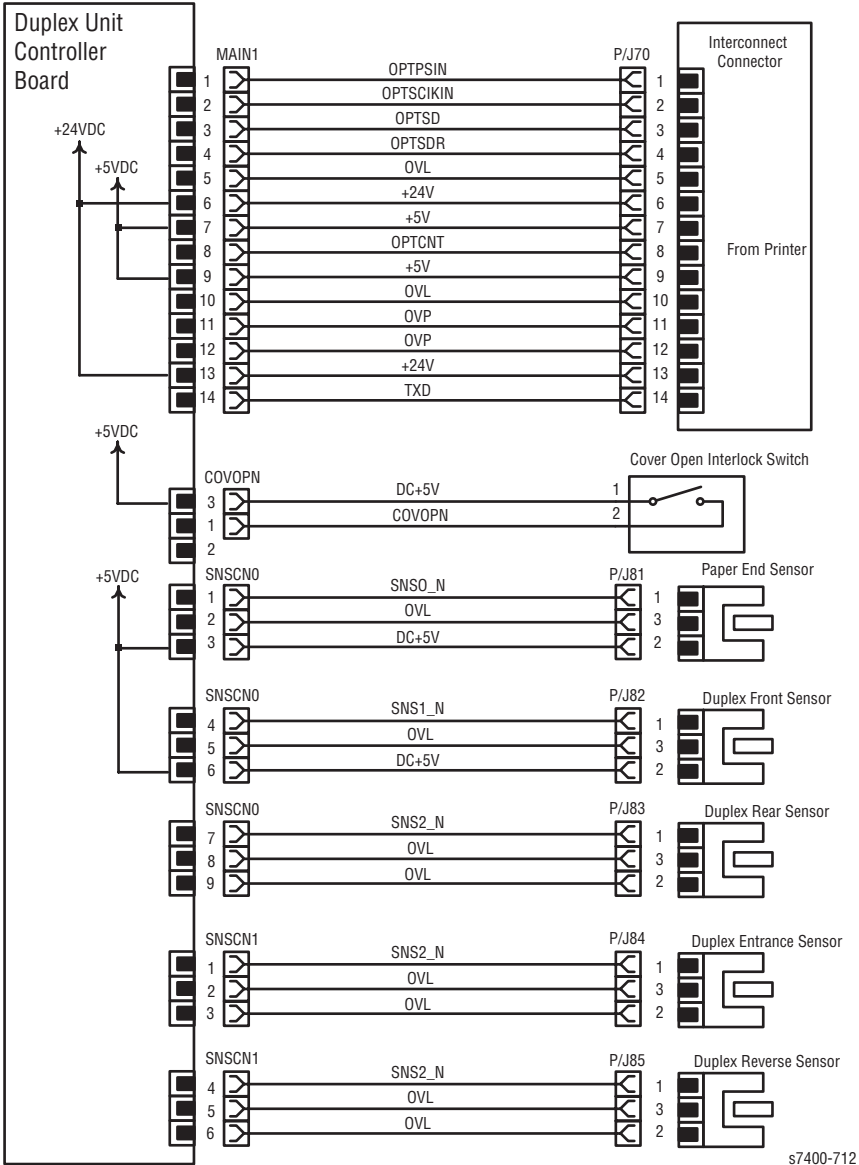



# Duplex Unit Motors and Solenoids

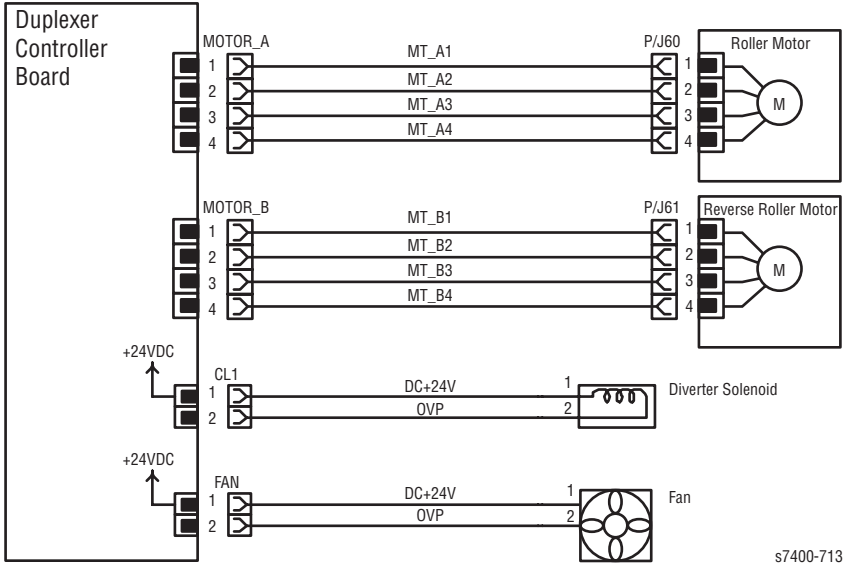

# Optional Tray Wiring Diagrams

## Paper Tray Sensors and Interconnect Wiring

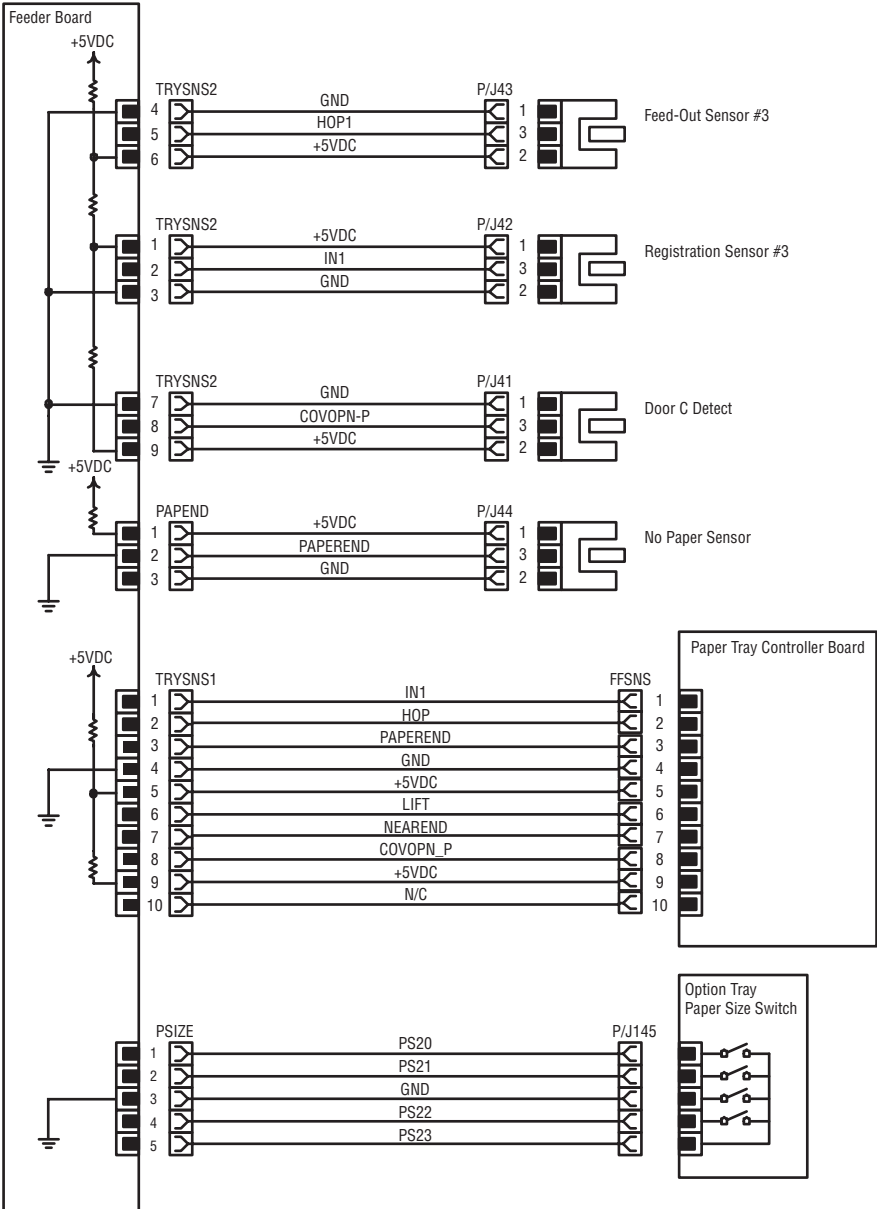

s7400-714

# Paper Tray Motors, Clutches, and Interconnect Wiring

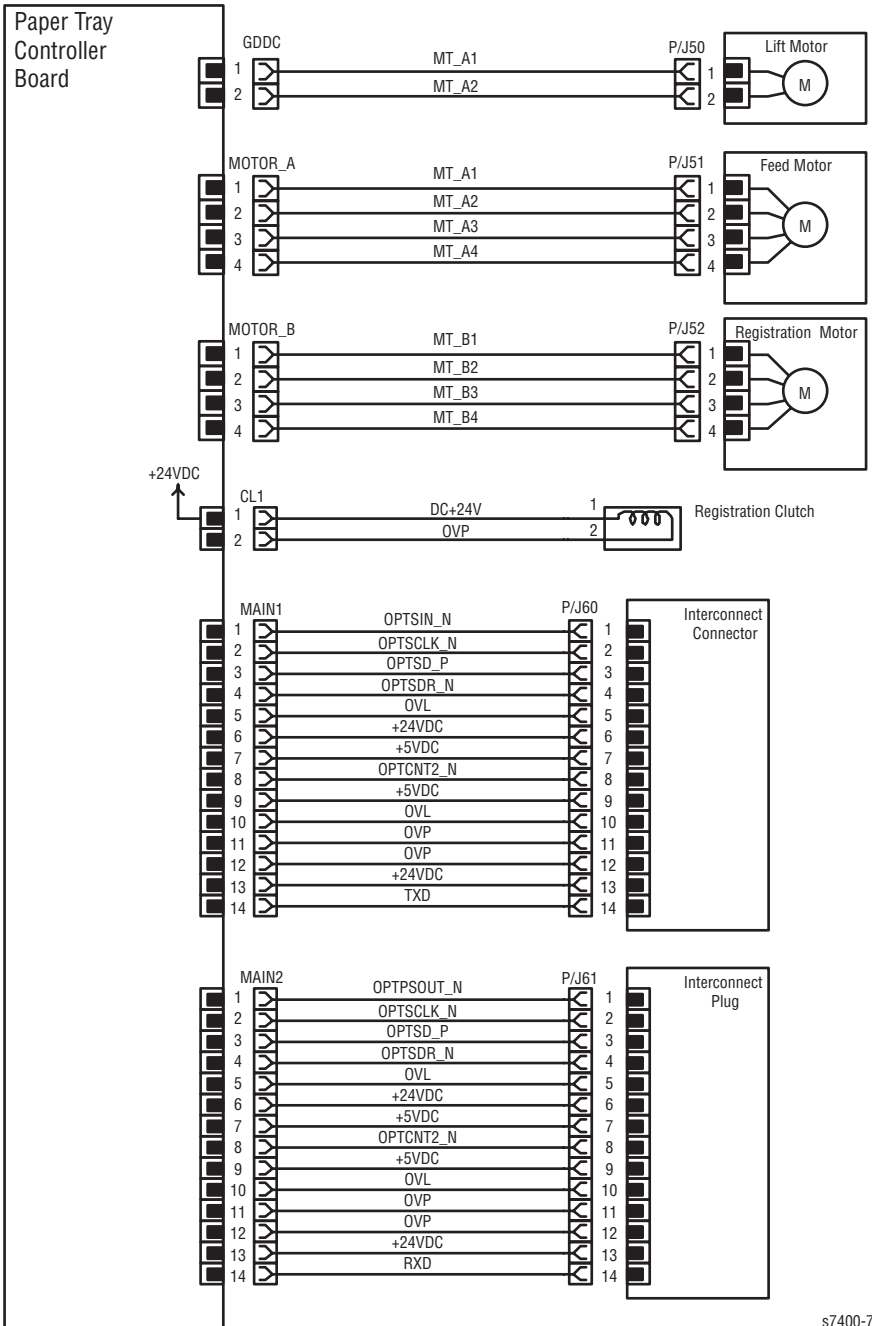

s7400-715



# Index

## Numerics

- 1650-Sheet Feeder
  - dimensions, 1-8
  - overview, 1-7
- 5 VDC Power Supply, 2-41
- 550-Sheet Feeder
  - dimensions, 1-8
  - overview, 1-6

## A

- AC power
  - consumption, 1-7
  - input specifications, 1-7
- addressability, 1-8
- adjustments, 4-2
  - gear phase, 4-18
  - registering punch holes, 4-2
  - sensor output, 4-4
  - stapler phase, 4-7
  - stapling position, 4-6
- aligning plates, 5-43
- assembly removal
  - Duplex Motor Assembly, 5-128
  - Front Cover Assembly, 5-122
  - Paddle Assembly, 5-43
  - Processing Tray Assembly, 5-38
  - Upper Right Cover Assembly, 5-37

## B

- Bind Clutch, 2-21
- Bind Tray, 2-24
- Bind Tray Sensor, 2-24
- Binding Clutch removal, 5-66
- board removal
  - Duplex Unit Controller Board, 5-122
  - Finisher Controller Board, 5-46
  - Home Position Board, 5-48

- Inverter Controller Board, 5-55
- Inverter Power Supply Board, 5-56
- Paper Tray Feeder Board, 5-149
- Photosensor Board, 5-52
- Punch LED Board, 5-53
- Waste Full LED Board, 5-54
- booklet, 2-21
- booklet mode, 4-7

## C

- circuit breaker, 2-42
- clearances, minimum, 1-8
- Clock
  - Lift Motor Clock Sensor, 2-24, 2-28, 7-5
  - Punch Motor Clock Sensor, 2-5
- connector
  - designators, 7-2
  - representation, 3-12
- Control Panel
  - error messages, 3-6
- cover removal
  - Finisher Rear Cover, 5-12
  - Finisher Upper Cover, 5-13
  - Inverter Front Cover, 5-17
  - Inverter Rear Cover, 5-19
  - Inverter Top Cover, 5-23
  - Paper Tray Covers, 5-134
  - Processing Tray Upper Cover, 5-15

## D

- delivery
  - Delivery Belt Home Position Sensor, 2-24
  - Delivery Motor, 2-24
  - delivery process, 2-24
  - Tray, 2-24

disconnecting base unit, 5-5

Door C

- jam error, 3-13
- open error, 3-33

Door D

- jam error, 3-16
- open error, 3-34

door designators, 3-4

Door C, Detect Door C Sensor, 5-141

Door C, Paper Tray (3 thru 6) Detect Sensor, 2-32

Door F, Inverter Door Open Interlock Switch, 5-101

Door F, Inverter Left Side Door, 5-21

Door F, Inverter Open Interlock Switch, 2-30, 7-6

Door G, Finisher Right Side Door, 5-10

Door H, Upper Cover Sensor, 2-28, 7-5

Door I, Inverter Right Side Door, 5-22

Door J, Finisher Front Door, 5-8

Door J, Front Door Switch, 2-28, 7-5

Door J, Front Door Switch and Sensor, 5-74

Door F

- open error, 3-35

Door G

- jam error, 3-26

Door H

- jam error, 3-21
- open error, 3-36

Door J

- open error, 3-37

Duplex Fan

- fan failure error, 3-80
- removal, 5-131

Duplex Unit, 1-6

- +24 V not available error, 3-81
- clock frequency error, 3-84
- close Door D error, 3-34
- Connector removal, 5-132
- Cover Plate removal, 5-124
- Duplex Entrance Roller, 2-36
- Duplex Solenoid, 2-36

entrance jam error, 3-18

Entrance Sensor, 2-31

fan failure error, 3-80

Fan removal, 5-131

firmware error, 3-73

flash memory failure error, 3-76

front and rear duplex sensors, 2-31

interface failure error, 3-45

jam error, 3-16

motor and solenoid wiring, 7-29

Motor Assembly, 5-128

Motors, 2-36

parts diagram, 6-38

parts list, 6-39

Reverse Sensor, 2-31

sensor and interconnect wiring, 7-28

sensor locator, 2-31, 5-130

Side Rails, 5-126

Transport Rollers, 2-36

unsupported ROM error, 3-48

Duplex Unit Controller Board

plug/jack locator diagram, 7-10

wiring to motors and solenoids, 7-29

wiring to solenoids and interconnect connector, 7-28

## E

edge saddle, 5-30

error messages

Control Panel, 3-6

jam errors, 3-6

list of errors, 3-6

warnings, 3-9

Ethernet Port, 1-2

Exit Gate Solenoid, 2-31

## F

fasteners

precautions, 5-2

screws, 5-3

Feed Motor, function, 2-21

Feed Motor, Paper Tray, 2-37

Feeder Board

clock frequency error, 3-86

- Feeder Board cover removal, 5-143
  - Feeder Board removal, 5-148
  - Paper Tray Feeder Board parts, 7-5
  - Paper Tray Feeder diagram, 7-12
  - Feeder Clutch, Inverter, 2-35
  - Feed-Out Sensor, Paper Tray, 2-32, 2-37
  - Field Replaceable Units, 5-2
  - Finisher
    - assembly diagram, 6-4
    - cover parts list, 6-7
    - entrance jam error, 3-30
    - Feed Motor, 2-16
    - internal parts diagram, 6-9
    - internal parts list, 6-11
    - inverter jam error, 3-29
    - jam at punch error, 3-20
    - locator diagram, 7-2
    - lower tray full error, 3-40
    - Power supply wiring, 7-16
    - punch box full warning, 3-89
    - Slide Motor
      - , 2-6
    - stacker jam, 3-31
    - staple empty warning, 3-88
    - theory, 1-5
    - unsupported ROM error, 3-51
    - upper tray full error, 3-41
  - Finisher Controller Board
    - adjusting stapling position, 4-6
    - plug/jack locator diagram, 7-7
    - removal, 5-46
    - wiring to motors, 7-21
    - wiring to printer, 7-17
    - wiring to Punch Controller Board, 7-24
    - wiring to stapler sensors and motors, 7-23
    - wiring to switches, 7-22
  - fold jam release knob, 5-8, 5-10, 5-21, 5-22
  - fold jam releasing dial, 5-34
  - Fold Unit parts diagram, 6-30
  - Fold Unit parts list, 6-33
  - folding position, 4-17
  - folding process, 2-18
  - fonts, 1-2
  - Front Door Interlock Switch removal, 5-74
  - Full Stack Sensor, 2-21
- G**
- guide removal
    - Paddle Guide, 5-116
    - Paper Guide, 5-127
    - Side Guide, 5-107
- H**
- Home Position Board removal, 5-47
- I**
- Inverter
    - clock frequency error, 3-85
    - Door Open Interlock Switch removal, 5-101
    - Feeder Clutch removal, 5-69
    - firmware error, 3-74
    - flash memory failure error, 3-77
    - interface failure error, 3-47
    - sensor locator, 5-99
    - theory, 2-14
    - unsupported ROM error, 3-50
  - Inverter Controller Board
    - plug/jack locator diagram, 7-9
    - wiring to sensors and switches, 7-26
    - wiring to solenoids and clutch, 7-27
  - Inverter Controller Board removal, 5-55
  - Inverter parts diagram, 6-34
  - Inverter parts list, 6-37
  - Inverter Power Supply Board removal, 5-56
- J**
- jam detection
    - jam code, 2-40
    - jam location map, 3-4
  - jam errors, 3-6
  - job collation, 1-2
  - Joint Switch removal, 5-73

## L

### Lift Motor

- Clock Sensor, 2-24
- Drive Assembly parts diagram, 6-12
- Drive Assembly parts list, 6-13
- Paper Tray theory, 2-37
- theory, 2-24

### LVPS

- troubleshooting, 3-4

## M

- measurement techniques, 3-12
- media errors, 3-7
- motor disassembly
  - Alignment Motors, 5-65
  - Delivery Motor, 5-64
  - Feed Motor, 5-62
  - Finisher Punch Transfer Motor, 5-58
  - Inverter Lower Roller Motor, 5-68
  - Inverter Upper Roller Motor, 5-67
  - Lift Motor, 5-59
  - Paddle Motor, 5-63
  - Paper Tray Feed Motor, 5-138
  - Paper Tray Lift Motor, 5-139
  - Paper Tray Registration Motor, 5-137
  - Punch Motor, 5-57
  - Slide Motor, 5-61
  - Staple/Fold Motor, 5-60

## O

### Optional Trays

- parts diagram, 6-41, 6-42
- parts list, 6-43
- options, 1-5

## P

- Paddle Assembly, 5-45
- Paper Feeder Assembly parts diagram, 6-20
- Paper Feeder Assembly parts list, 6-21
- paper path
  - paper detecting lever, 5-108

- paper fold rollers, 4-19
- paper folding drive gear, 4-19
- paper pushing plate, 2-18
- paper retaining plate, 5-34
- sensing, 2-27

### Paper Tray

- Feeder removal, 5-136
- Options Connector removal, 5-133
- Registration Clutch, 2-39
- Registration Motor, 2-39
- Registration Roller, 2-39

### Paper Tray Controller Board

- plug/jack locator diagram, 7-11
- wiring to motors and clutches, 7-31
- wiring to sensors and interconnect connector, 7-30

### Paper Tray Feeder Board

- plug/jack locator diagram, 7-12
- parts list, using, 6-2
- personal print, 1-2
- Photosensor Board removal, 5-52
- power requirements, 1-7
- power saver mode, 1-9
- power supplies, 2-42

### Printer, 1-2

- configurations, 1-3
- dimensions, 1-8
- operational characteristics, 1-8
- options, 1-5
- power consumption, 1-7
- power requirements, 1-7
- required minimum clearances, 1-8

### printing process, 2-13

### processing stopper base, 5-39

### Processing Tray

- Assembly, 5-45
- Upper Cover, 5-38

### Processing Tray parts diagram, 6-18

### Processing Tray parts list, 6-19

### proof print, 1-2

### Punch Controller Board

- function, 2-5
- plug/jack locator diagram, 7-8
- registering punch holes, 4-2
- removal, 5-50
- wiring to sensors and motors, 7-25



- Punch LED Board removal, 5-53
- Punch Unit
  - parts list, 6-23, 6-25
  - punch assembly photosensors, 2-29
  - punch blade, 2-5
  - Punch Home Position Sensor, 2-15
  - Punch Motor Clock Sensor, 2-5
  - Punch Motor function, 2-14
  - punch process, 2-14
  - Punch Slide Unit, 2-14
  - Punch Transfer Motor, 2-14
  - Punch Transfer Motor function, 2-16
  - theory, 2-4
  - waste box missing error, 3-89

## R

- Registering, 4-2
- registering punch holes, 4-2
- Registration Clutch removal, 5-140
- Registration Roller, 2-31
- Registration Sensor, 2-32
- relay gear, 4-19
- release latch, 5-8
- resolution, 1-8
- roller disassembly
  - Finisher Feed Roller, 5-109
  - Lower Stack Delivery Roller, 5-120
  - Paper Tray Feed Roller, 5-150
  - Upper Stack Delivery Roller, 5-112

## S

- saddle cam, 4-19
- screw types, 5-3
- secure print, 1-2
- self-tapping screws, 5-3
- sensor locator
  - Duplex Unit, 2-31
  - Finisher, 2-27
  - Inverter, 2-30
  - Paper Trays, 2-32
- sensor removal
  - Aligning Plate Home Position Sensors, 5-83
  - Bind Tray Sensor, 5-98

- Delivery Belt Home Position Sensor, 5-90
- Door C Detect Sensor, 5-141
- Finisher Front Door Sensor, 5-74
- Finisher Upper Cover Sensor, 5-78
- Folding Home Position Sensor, 5-94
- Folding Position Sensor, 5-96
- Inlet Sensor, 5-75
- Inverter Docking Sensor, 5-100
- Inverter Lower Paper-Present Sensor, 5-104
- Inverter Paper-in Sensor, 5-106
- Inverter Upper Paper-Present Sensor, 5-102
- Lift Motor Clock Sensor, 5-80
- Paddle Home Position Sensor, 5-91
- Paper Registration Sensor #2, 5-143
- Paper Surface Sensor, 5-77
- Paper Tray Feed-Out Sensor, 5-146
- Paper Tray No Paper Sensor, 5-142
- Processing Tray Sensor, 5-82
- Shift Limit Sensors, 5-79
- Stack Feed Roller Home Position Sensor, 5-85
- Stack Full Sensor, 5-81
- Staple/Fold Clock Sensor, 5-93
- Swing Guide Home Position Sensor, 5-89
- Tray Paper Sensor, 5-76
- Waste-full Sensor, 5-88
- sensor type, 2-25
  - microswitch, 2-26
  - photo-receptive, 2-25
  - photo-reflective, 2-25
- service bulletins, 1-2
- Service Diagnostics, 3-2
- Shift Lower Limit Sensor, 2-24
- Shift Upper Limit Sensor, 2-24
- Side Cover/Paper Detection (Bundle)
  - parts diagram, 6-16
- Side Cover/Paper Detection (Bundle)
  - parts list, 6-17
- Slide Motor theory, 2-23
- solenoid removal
  - Diverter Solenoid, 5-129
  - Inverter Lower Roller Solenoid, 5-71

- Inverter Upper Roller Solenoid, 5-69, 5-70
- Specifications, 1-7
  - electrical, 1-7
  - environmental, 1-10
  - functional, 1-8
- stacking process, 2-19
- standard orientation, 5-4
- Staple Empty Sensor, 2-23
- Staple Top Position Sensor, 2-23
- Staple Unit
  - clincher cam, 4-13
  - driver gear, 4-11
  - process, 2-23
- Safety Interlock Switch removal, 5-92
- staple position check gear, 4-10, 4-15
- theory, 2-6
- Staple Unit parts diagram, 6-27
- Staple Unit parts list, 6-29
- Staple/Fold Drive Assembly parts diagram, 6-14
- Staple/Fold Drive Assembly parts list, 6-15
- Stapler
  - staple empty warning, 3-88
  - stapler is empty, 3-88
- stapling
  - front 1-point, 2-23
  - middle 2-point, 2-23
- stapling position, 4-17
- stapling process, 2-23
- stop ring, 5-35

## T

- timing belt, 4-14, 5-35
- Transfer Unit Entrance Sensor, 2-37
- Transfer Unit Motor, 2-37
- Transmission Sensor Units, 5-28
- Tray
  - +24 V not available error, 3-83
  - clear tray riser plate error, 3-38
  - clock frequency error, 3-86
  - firmware error, 3-72

- flash memory failure error, 3-75
- interface failure error, 3-46
- lift motor failure error, 3-78
- no paper warning, 3-87
- optional trays, 1-6, 2-11
- out of paper error, 3-39
- Paper Exit Tray, 5-7
- unsupported ROM error, 3-49
- Tray Paper Sensor, 2-21
- troubleshooting
  - diagnostic testing, 3-2
  - error messages, 3-6
  - measurement techniques, 3-12
  - procedural instructions, 3-11

## U

- undocking, 5-6
- unit disassembly
  - Punch Unit, 5-24
  - Saddle Unit, 5-36
  - Staple/Fold Drive Unit, 5-30
  - Stapler Unit, 5-29

## V

- voltage
  - frequency ranges, 1-7
  - input requirements, 1-7

## W

- warning messages, 3-9
- Waste Full LED Board removal, 5-54
- wrist strap, 5-2



