

5 Parts Lists

PL 1 - Standby Power		
PL 1.10 HVPS	5-3	
PL 1.15 Fuser Drive Board Assembly	5-4	
PL 2 - User Interface		
PL 2.10 Control Panel	5-5	
PL 3 - Machine Run Control		
PL 3.10 Main PWB's	5-6	
PL 4 - Main Drives		
PL 4.10 Main Drives	5-7	
PL 6 - Imaging		
PL 6.10 Laser Unit	5-8	
PL 7 - Paper Supply		
PL 7.10 Paper Tray (Tray 2 & Optional Feeder)	5-9	
PL 7.15 Optional Feeder Main Covers	5-10	
PL 7.20 HCF Covers	5-11	
PL 7.25 HCF Assembly	5-12	
PL 8 - Paper Transport		
PL 8.10 Tray 1 Feeder Assembly	5-13	
PL 8.15 Tray 2 Pick-up Assembly	5-14	
PL 8.20 Optional Feeder Pick-up Assembly	5-15	
PL 8.25 HCF Pick-up Assembly	5-16	
PL 8.30 Optional Feeder Main Drives	5-17	
PL 8.35 Optional Feeder Lift Assembly	5-18	
PL 8.40 Optional Feeder Feed Assembly	5-19	
PL 8.45 Registration Roller Assembly	5-20	
PL 8.50 Middle Frame Assembly	5-21	
PL 8.55 Upper Frame Assembly	5-22	
PL 9 - Xerographics		
PL 9.10 Drum Cartridge	5-23	
PL 9.15 Waste Toner	5-24	
PL 10 - Copy Transportation and Fusing		
PL 10.10 Fuser Assembly (1 of 2)	5-25	
PL 10.11 Fuser Assembly (2 of 2)	5-26	
PL 10.15 Upper Fuser Bracket Assembly	5-27	
PL 10.20 Lower Fuser Exit Guide Assembly	5-28	
PL 10.25 Duplex Unit Assembly	5-29	
PL 10.30 Exit Assembly	5-30	
PL 11 - Sorting		
PL 11.10 Mailbox Covers	5-31	
PL 11.15 Mailbox Control Board	5-32	
PL 11.20 Mailbox Drive Belts	5-33	
PL 11.25 Mailbox Diverter Assembly	5-34	
PL 11.30 Mailbox Top Stacker Assembly	5-35	
PL 11.35 Mailbox Actuator Shield Assembly	5-36	
PL 11.40 Mailbox Base Assembly	5-37	
PL 12 - Finisher		
PL 12.10 Finisher Covers	5-38	
PL 12.15 Finisher Control Board	5-39	
PL 12.20 Finisher Stacker Shield Assembly	5-40	
PL 12.25 Finisher Stacker Drive Assembly	5-41	
PL 12.30 Finisher Compile Tray Eject Assembly	5-42	
PL 12.35 Finisher Compile Tray Assembly	5-43	
PL 12.40 Finisher Transport Drive Assembly	5-44	
PL 12.45 Finisher Stapler Assembly	5-45	
PL 28 - Covers		
PL 28.10 Main Covers	5-46	
PL 28.15 Top Cover Assembly	5-47	
PL 28.20 Front Cover Assembly	5-48	
PL 28.25 Rear Door Assembly	5-49	
Supplies, Options and Accessories		
Option and Accessories Part Numbers	5-50	

Serial Number Prefixes

XLTnnnnnn - Phaser 4600 (110 VAC)
XLTnnnnnn - Phaser 4600 (110 VAC)

XLVnnnnnn - Phaser 4620 (220 VAC)
XLWnnnnnn - Phaser 4620 (220 VAC)

Table 1 Option and Accessory Part Numbers

Item	Service Part Number	Sales Part Number
520-Sheet Feeder	050K74180	097N01874
2000-Sheet Feeder	059K77920	097N01875
Finisher (500-Sheet)	059K77910	097N01876
Mailbox (400-Sheet)	050K74190	097N01877
Duplex Unit	022N02484	097N01923
Memory Upgrade	128K01770	097N01878
160MB Hard Disk	007N01651	097N01879
Wireless Network Adaptor	120K03640	097N01880
Stand	078K00870	097N01916

PL 1.10 HVPS

Item	Part	Description
1	105N02193	HVPS (REP 1.4)
2	105N02157	SMPS (110V) (REP 1.5)
-	105N02158	SMPS (220V) (REP 1.5)
3	-	HVPS shield (P/O PL 1.10 Item 6)
4	-	HVPS insulation sheet (P/O PL 1.10 Item 6)
5	-	Fuser connector (P/O PL 1.10 Item 6)
6	-	HVPS assembly (Not Spared)
7	-	Bottom fuser bracket (Not Spared)

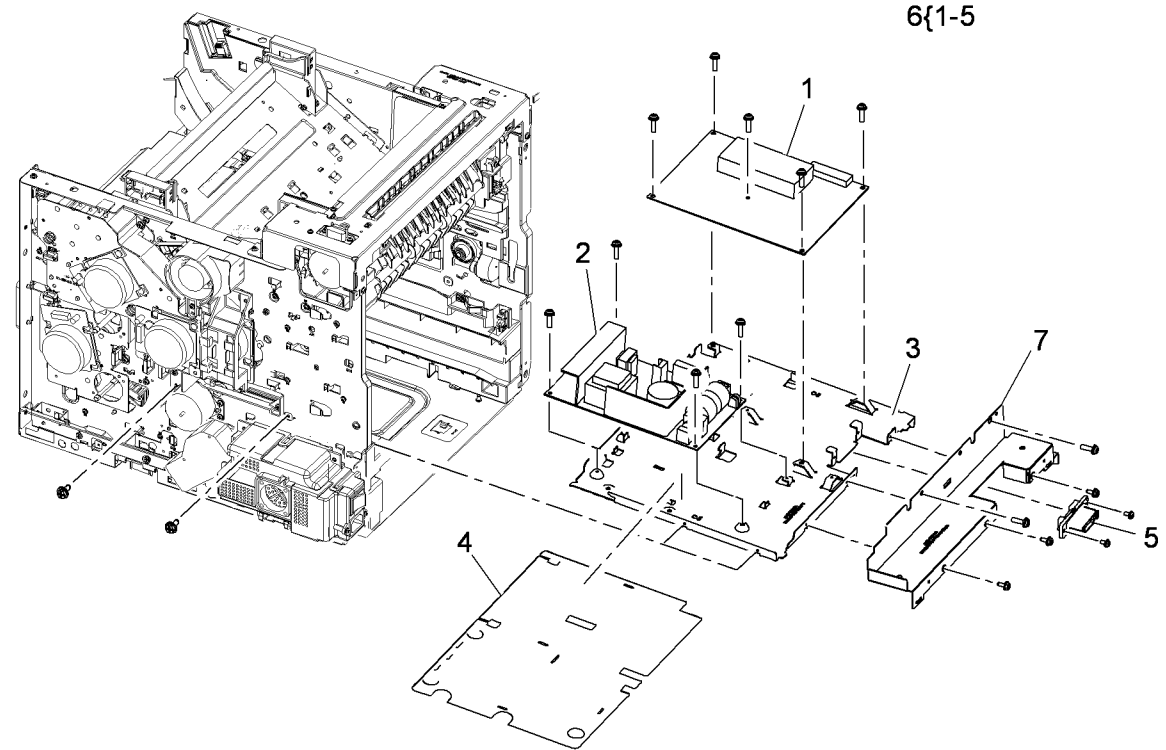

s4620-101

PL 1.15 Fuser Drive Board Assembly

Item	Part	Description
1	—	Fuser drive cover (P/O PL 1.15 Item 8)
2	140N63472	Fuser drive board (110V) (REP 1.2)
—	140N63473	Fuser drive board (220V) (REP 1.2)
3	—	Back cover (P/O PL 1.15 Item 8)
4	—	Main power switch (P/O PL 1.15 Item 8)
5	—	Main power socket (P/O PL 1.15 Item 8)
6	127N07668	SMPS fan (MOT09-500) (REP 1.7)
7	—	Fan duct (Not Spared)
8	001N00525	Fuser drive board assembly (110V) (REP 1.3)
—	140N63538	Fuser drive board assembly (220V) (REP 1.3)
9	127N07584	Fan-DC

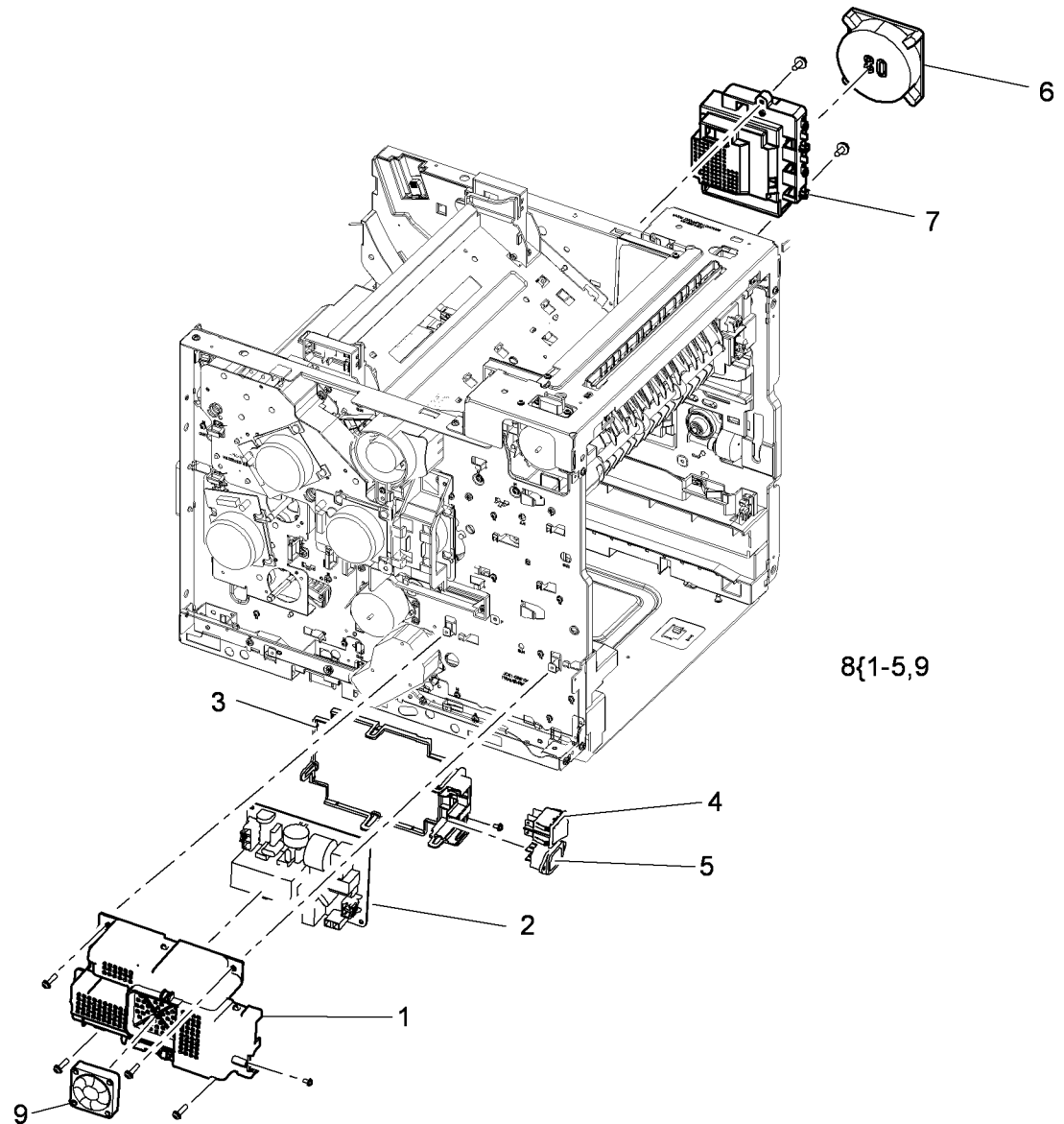

s4620-102

PL 2.10 Control Panel

Item	Part	Description
1	002N02990	Control panel assembly (4600) (REP 2.1)
-	002N02989	Control panel assembly (4620) (REP 2.1)
2	-	Decoration cover (P/O PL 2.10 Item 1)
3	-	Top cover housing (P/O PL 2.10 Item 1)
4	-	UI top cover (P/O PL 2.10 Item 1)
5	-	Help key (P/O PL 2.10 Item 1)
6	-	Power key (P/O PL 2.10 Item 1)
7	-	Stop key (P/O PL 2.10 Item 1)
8	140N63466	Main board (REP 2.2)
9	-	Lower cover (P/O PL 2.10 Item 1)
10	-	LCD screen housing (P/O PL 2.10 Item 1)
11	-	LCD ground (P/O PL 2.10 Item 1)
12	-	LCD screen (P/O PL 2.10 Item 1)
13	-	Rubber stop (P/O PL 2.10 Item 1)
14	-	Number keys (P/O PL 2.10 Item 1)

1{2-14

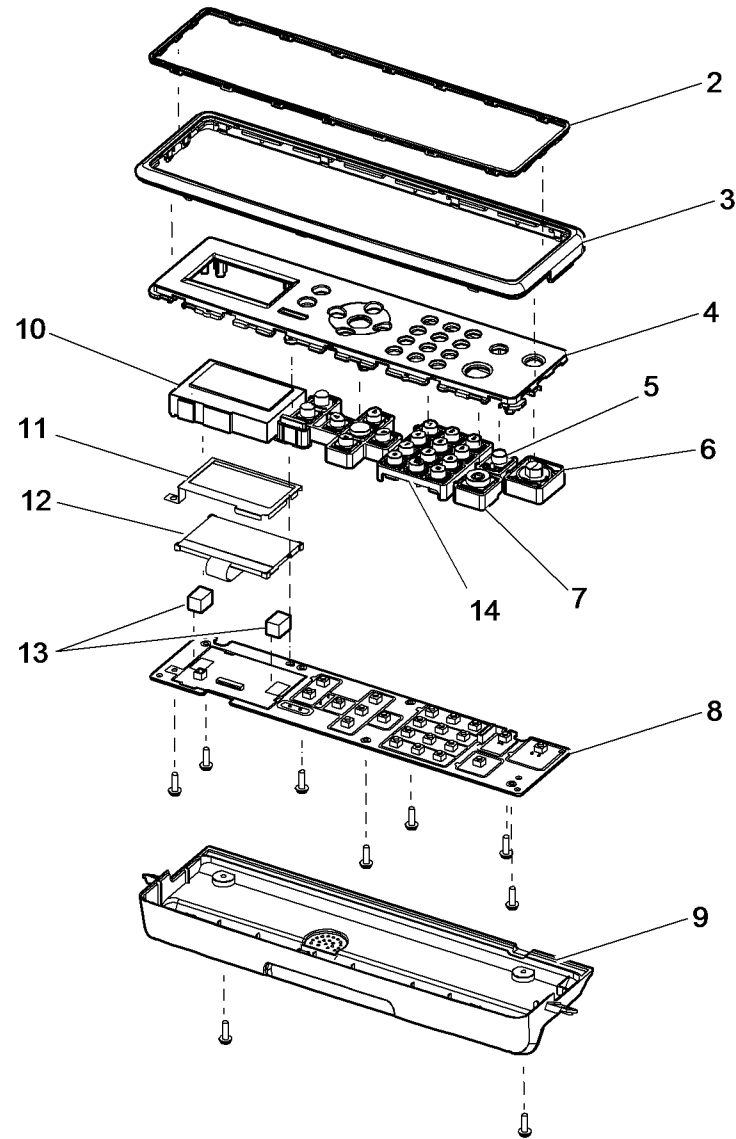

s4620-103

PL 3.10 Main PWB's

Item	Part	Description
1	—	IP board cage (Not Spared) (REP 3.5)
2	109N00709	IP board (4600) (REP 3.6)
—	109N00710	IP board (4620) (REP 3.6)
3	140N63467	MCU board (REP 3.4)
4	—	MCU board bracket (Not Spared) (REP 3.4)
5	—	Lower option connector (Not Spared) (REP 10.5)
6	—	Configuration card (Not Spared)
7	113N01312	Configuration card holder
8	128K01770	Memory card (512 Mb)
9	007N01651	160Gb Hard disk
10	see note	Tray 2 size switch (Not Spared)
11	117N01902	Ribbon cable
-	120K03640	Wireless I/F option (not shown)

NOTE: Tray 2 size switch is not spared but available as part of the 520-Sheet Feeder (050K74180).

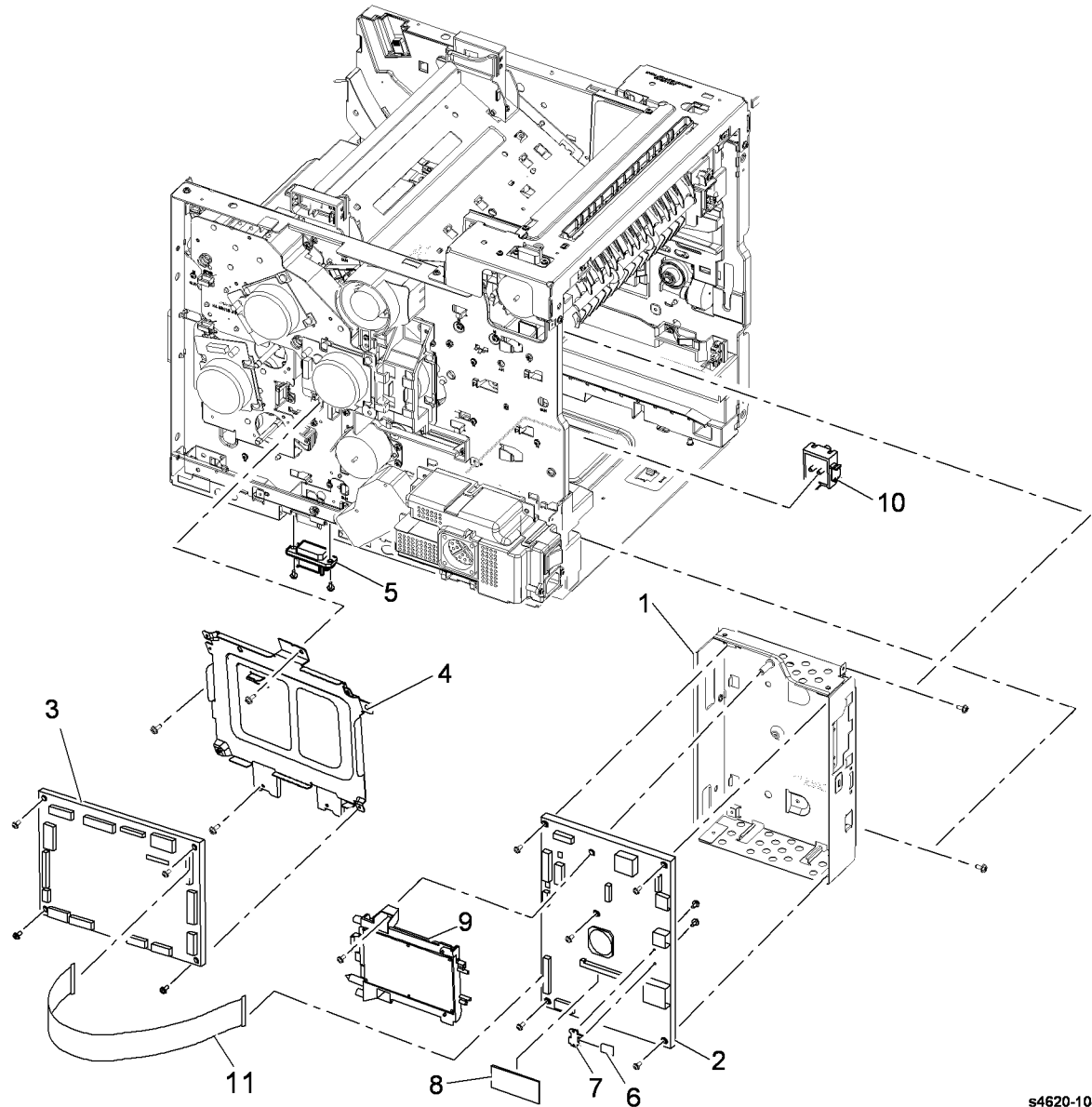

s4620-104

PL 4.10 Main Drives

Item	Part	Description
1	007N01663	Main drive assembly (REP 4.1)
2	127N07590	Right side chassis fan (MOT06-300) (REP 4.5)
3	007N01664	Fuser release drive assembly (REP 10.17)
4	007N01659	Fuser drive assembly (REP 10.8)
5	007N01661	Duplex drive assembly (REP 10.9)
6	007N01662	Feed drive assembly (REP 4.4)
7	005N01128	Registration clutch (CL08-850)(REP 4.3)/Tray 2 feed clutch (CL08-820)(REP 4.2) (Not Spared)
8	-	Registration clutch bracket (Not Spared)
9	-	Not Used
10	-	Feed clutch bracket (Not Spared)
11	127N07488	Tray 2 lift motor (REP 7.7)
12	007N01665	Tray 2 lift gear (REP 7.8)
13	-	Lift motor housing (Not Spared)
14	-	Spring (Not Spared)
15	007N01658	Pick-up drive

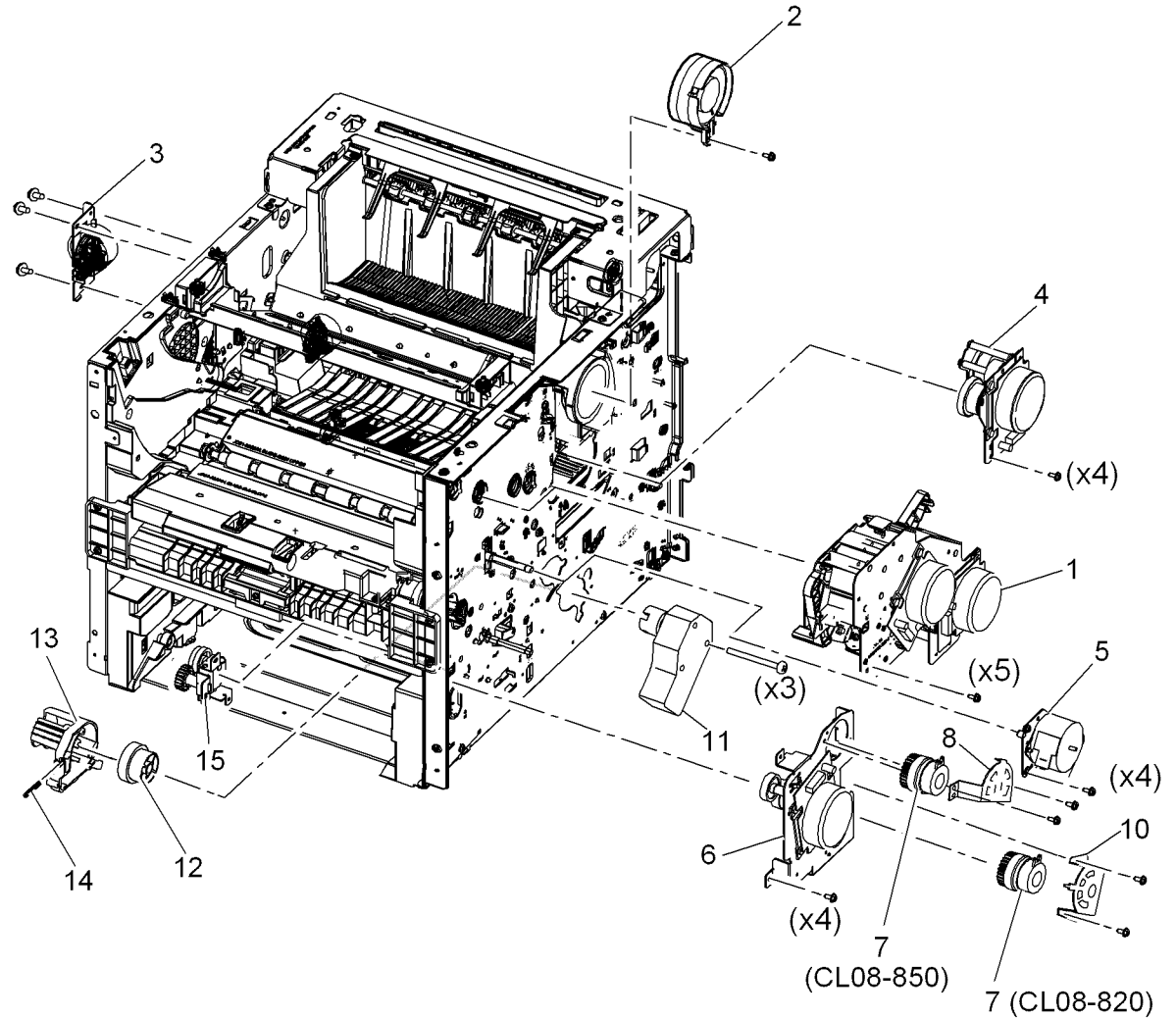

s4620-105

PL 6.10 Laser Unit

Item	Part	Description
1	122N00292	Laser unit (4600) (REP 6.1)
-	122N00293	Laser unit (4620) (REP 6.1)

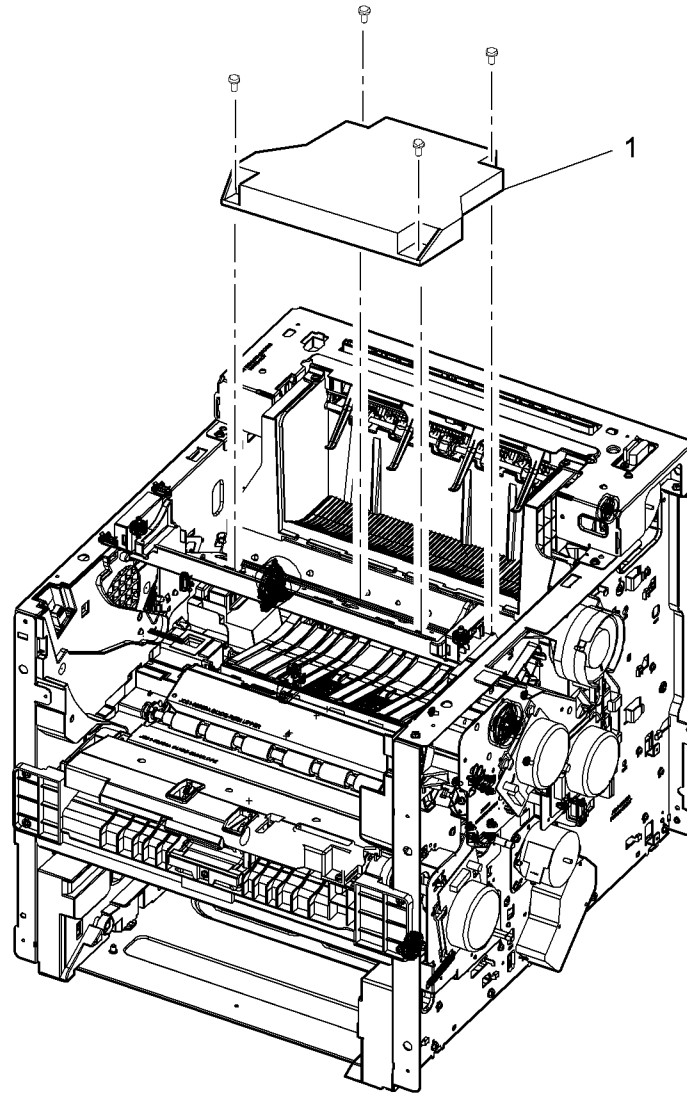

s4620-106

PL 7.10 Paper Tray (Tray 2 & Optional Feeder)

Item	Part	Description
1	-	Front cover (P/O PL 7.10 Item 23) (REP 7.22)
2	-	Tray frame (P/O PL 7.10 Item 23)
3	-	Tray lift plate (P/O PL 7.10 Item 23)
4	-	Left width paper guide (P/O PL 7.10 Item 23)
5	-	Right width paper guide (P/O PL 7.10 Item 23)
6	-	Seperator roller (P/O PL 7.10 Item 23) (REP 7.20)
7	-	Seperator clutch (P/O PL 7.10 Item 23) (REP 7.21)
8	-	Roller (P/O PL 7.10 Item 23)
9	-	Shaft (P/O PL 7.10 Item 23)
10	-	Bearing (P/O PL 7.10 Item 23)
11	-	Idle shaft (P/O PL 7.10 Item 23)
12	-	Lift plate shaft (P/O PL 7.10 Item 23)
13	-	Lift shaft plate (P/O PL 7.10 Item 23)
14	-	Pad (P/O PL 7.10 Item 23)
15	-	Pick-up mounting bracket (P/O PL 7.10 Item 23)
16	-	Rack guide (P/O PL 7.10 Item 23)
17	-	Rack drive gear (P/O PL 7.10 Item 23)
18	-	Sector gear (P/O PL 7.10 Item 23)
19	-	Pick-up gear (P/O PL 7.10 Item 23)
20	-	Pick-up idle gear (P/O PL 7.10 Item 23)
21	-	Tray guide roller (P/O PL 7.10 Item 23)
22	-	Media level indicator (P/O PL 7.10 Item 23) (REP 7.23)
23	050N00562	Tray assembly

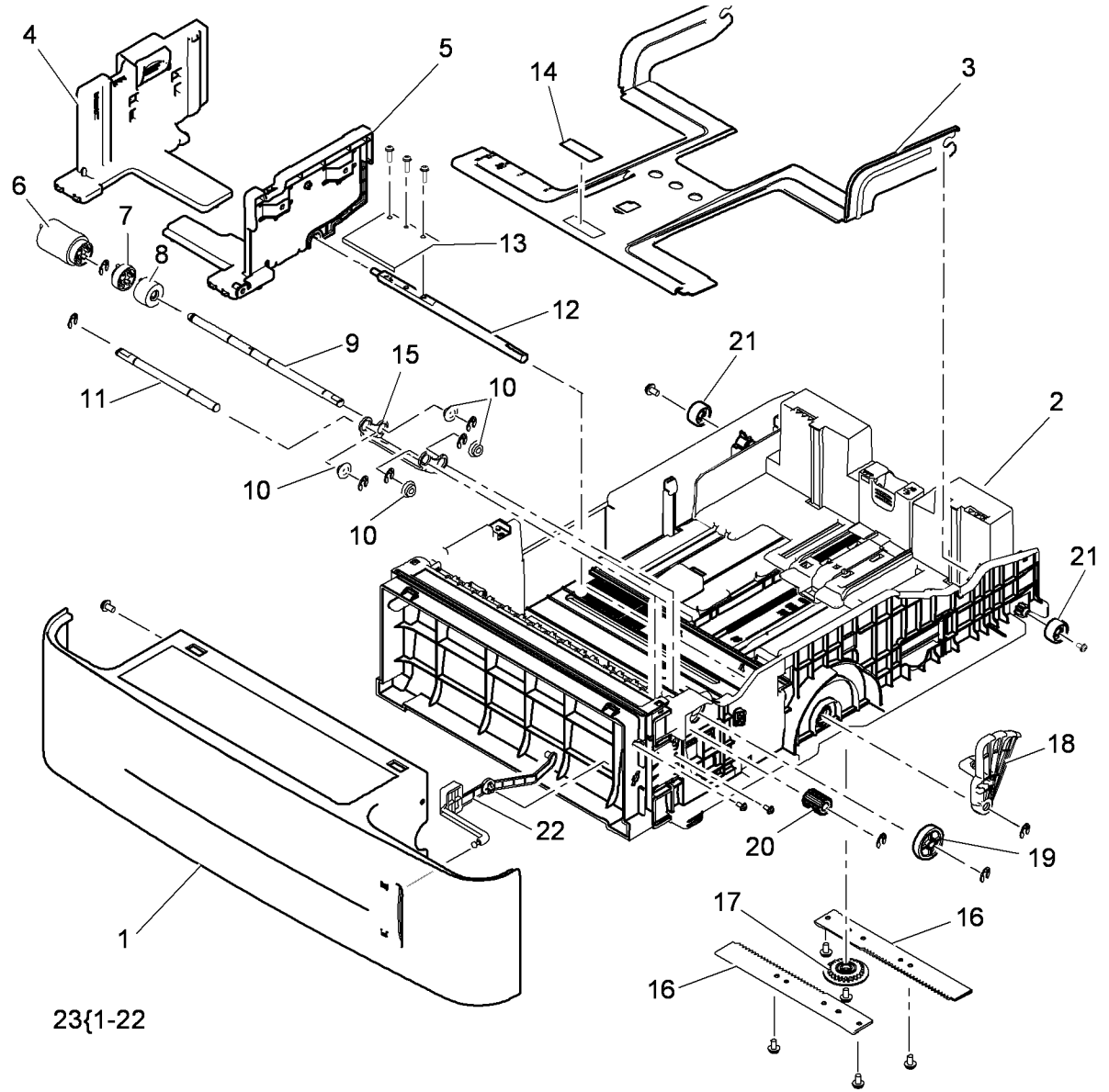

PL 7.15 Optional Feeder Main Covers

Item	Part	Description
1	—	Left cover (Not Spared) (REP 7.26)
2	—	Left side frame (Not Spared) (REP 7.33)
3	—	Front cover (Not Spared) (REP 7.24)
4	—	Rear tray cover (Not Spared)
5	—	Rear cover (Not Spared) (REP 7.27)
6	—	Right side frame (Not Spared) (REP 7.34)
7	—	Right cover (Not Spared) (REP 7.25)
8	—	Clutch cover (Not Spared)

NOTE: Order the entire 520-Sheet Feeder using Service part number 050K74180 or Sales part number 097N01874.

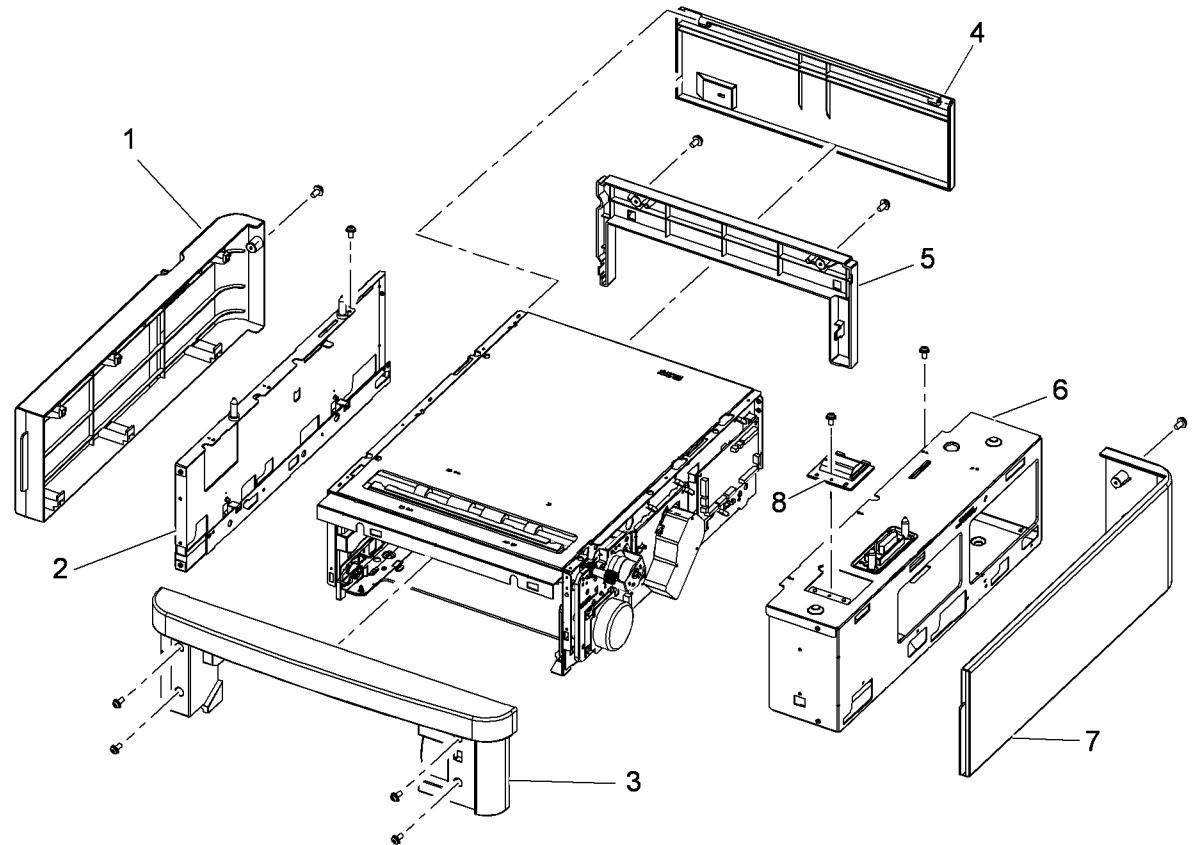

s4620-108

PL 7.20 HCF Covers

Item	Part	Description
1	-	Paper feed assembly (Not Spared)
2	-	Rear cover (Not Spared) (REP 7.38)
3	-	Right cover (Not Spared) (REP 7.39)
4	-	Front cover assembly (Not Spared)
5	-	Left cover (Not Spared) (REP 7.40)
6	002N02988	Front cover dummy
7	-	Retard cover (Not Spared)

NOTE: Order the entire 2000-Sheet Feeder using Service part number 059K77920 or Sales part number 097N01875.

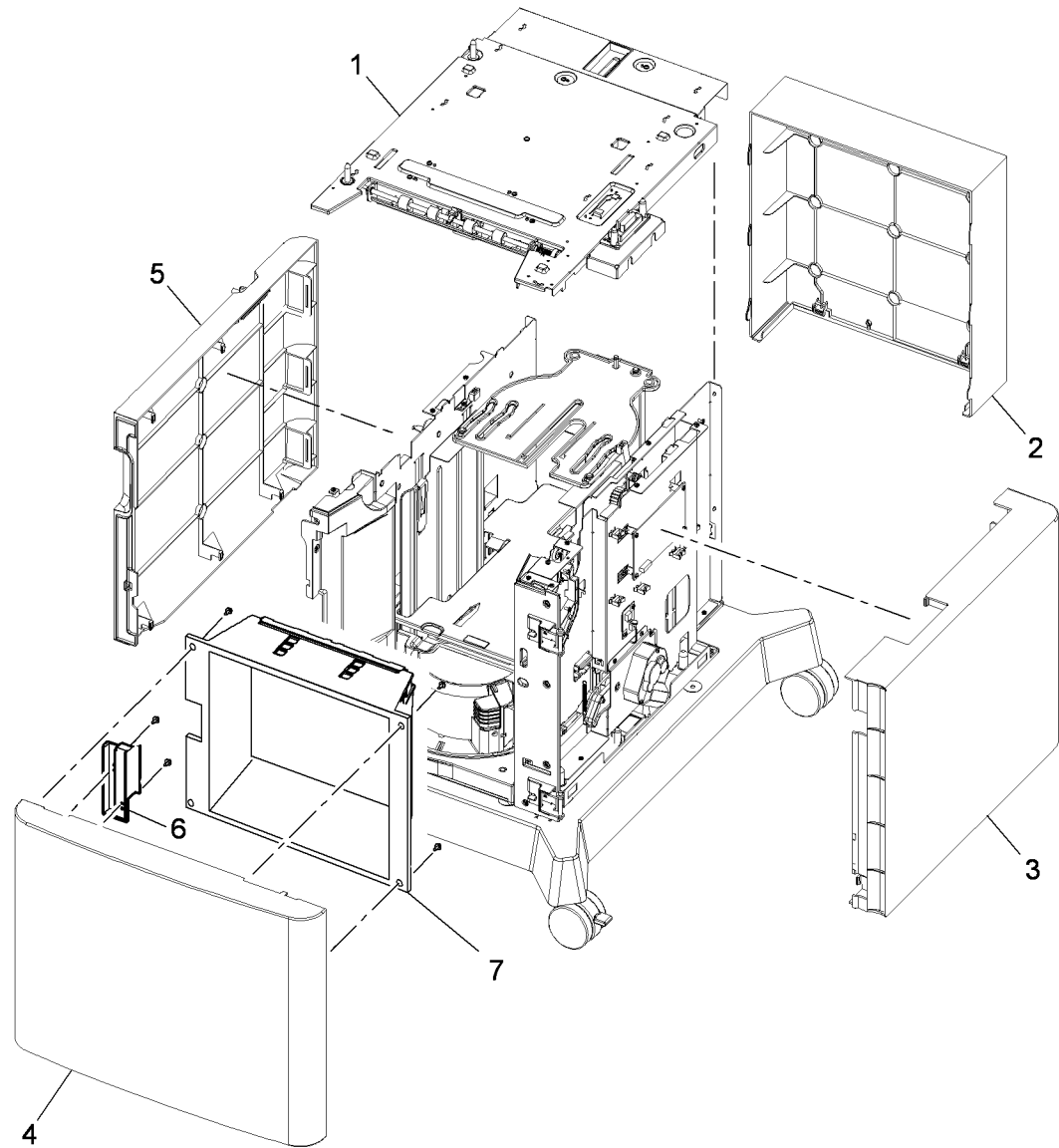

s4620-109

PL 7.25 HCF Assembly

Item	Part	Description
1	–	Base unit (P/O PL 7.25 Item 26)
2	017N00295	Caster (REP 7.41)
3	017N00294	Locking caster
4	–	Sensor bracket (P/O PL 7.25 Item 26)
5	110K14300	Size 1 sensor / Size 2 sensor / Size 3 sensor (see NOTE)
6	–	Safety cover (P/O PL 7.25 Item 26)
7	007N01669	Reduction gear assembly (REP 7.42)
8	–	Lift plate housing (P/O PL 7.25 Item 26)
9	–	Left side plate (P/O PL 7.25 Item 26)
10	022N02481	Paper feeder
11	–	Lift plate (lower) (P/O PL 7.25 Item 26)
12	–	Lift plate (upper) (P/O PL 7.25 Item 26)
13	–	Top plate (P/O PL 7.25 Item 26) (REP 7.49)
14	–	Harness mount (P/O PL 7.25 Item 26)
15	–	Harness (P/O PL 7.25 Item 26)
16	–	Rear plate (P/O PL 7.25 Item 26)
17	–	Right side plate (P/O PL 7.25 Item 26)
18	140N63469	HCF control board (REP 7.44)
19	127N07669	Lift motor (REP 7.45) (see NOTE)
20	127N07588	Feed motor (REP 7.48) (see NOTE)
21	–	Feed motor gear bracket (P/O PL 7.25 Item 28)
22	–	Clutch bracket assembly (P/O PL 7.25 Item 27)
23	–	Bearing (P/O PL 7.25 Item 27)
24	121N01206	Feed clutch (REP 7.46) (see NOTE)
25	–	Clutch shaft (P/O PL 7.25 Item 27)
26	059K77920	HCF assembly
27	121N01205	Clutch assembly
28	007N01667	Feed drive assembly (REP 7.47)
29	110N01452	Front door interlock switch (REP 7.43) (see NOTE)
30	140N63395	Jumper board
31	–	Feed sensor (P/O) (see NOTE)

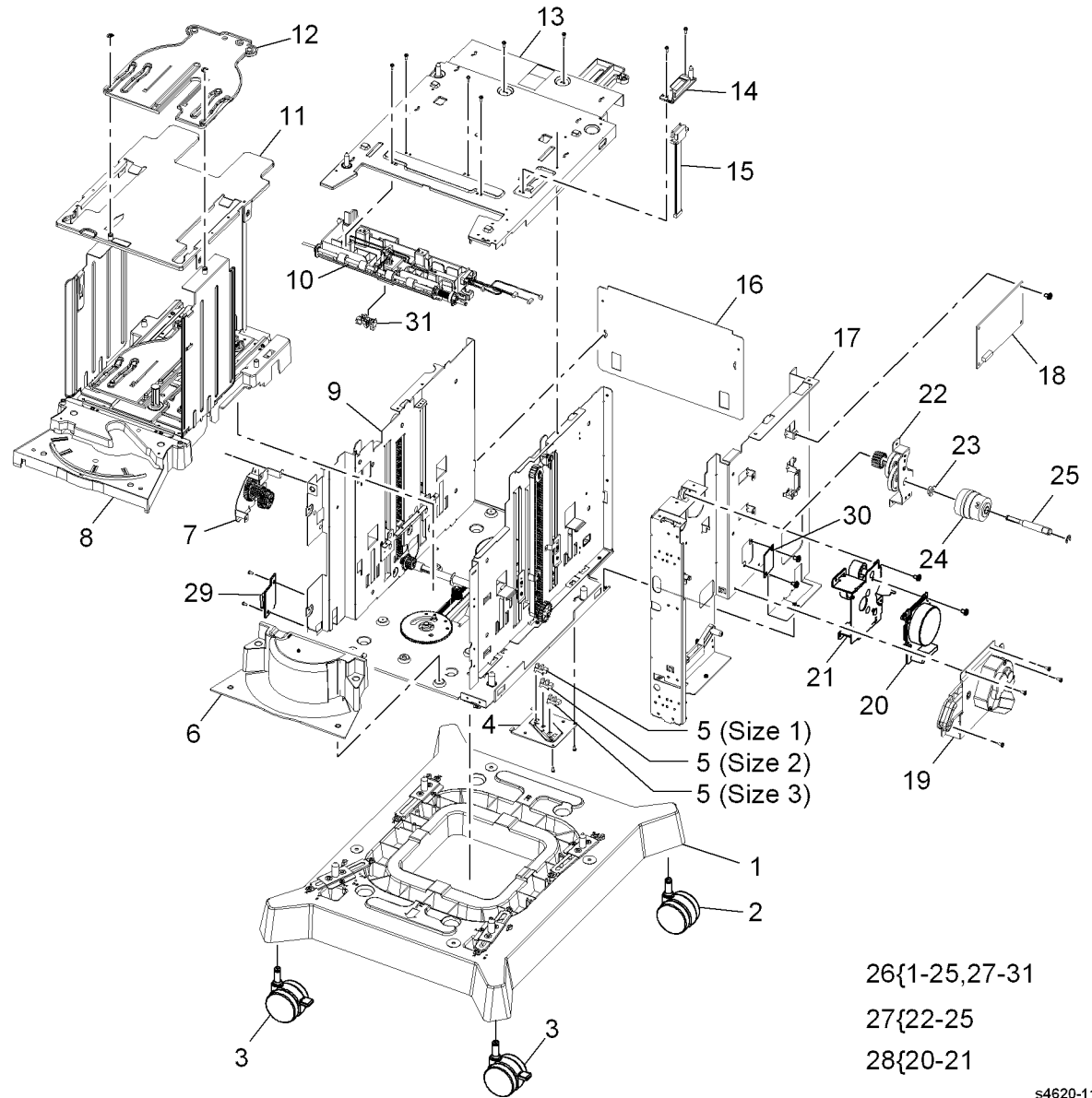

NOTE: The component control codes are dependent on the machine configuration.

PL 8.10 Tray 1 Feeder Assembly

Item	Part	Description
1	—	Bottom frame (P/O PL 8.10 Item 14)
2	—	Top frame (P/O PL 8.10 Item 14)
3	022N02480	Pick assembly (REP 7.3)
4	022N02479	Seperator roller assembly (REP 7.5)
5	—	Envelope guide (P/O PL 8.10 Item 14)
6	—	Release guide (P/O PL 8.10 Item 14)
7	—	Top ground (P/O PL 8.10 Item 14)
8	—	Ground (P/O PL 8.10 Item 14)
9	—	Release ground (P/O PL 8.10 Item 14)
10	130N01628	No paper sensor (Q07-110) (REP 7.15)
11	—	Feed clutch (CL08-810) (P/O PL 8.10 Item 14) (REP 7.16)
12	—	Bearing (P/O PL 8.10 Item 14)
13	—	Actuator arm (P/O PL 8.10 Item 14)
14	038N00539	Tray 1 feeder assembly (REP 7.0)

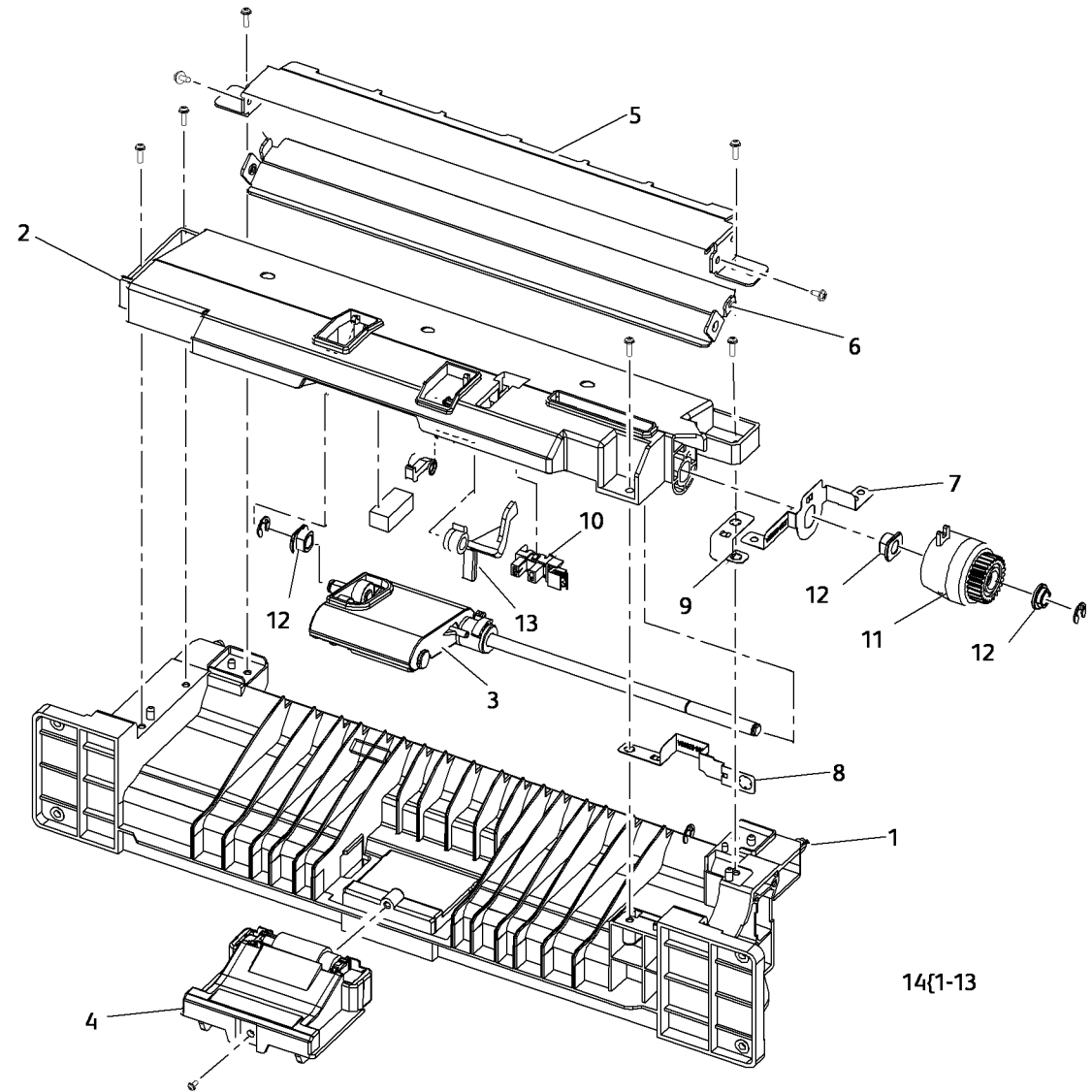

s4620-112

PL 8.15 Tray 2 Pick-up Assembly

Item	Part	Description
1	-	Baseplate (P/O PL 8.15 Item 21)
2	-	Holder (P/O PL 8.15 Item 21)
3	-	Housing (P/O PL 8.15 Item 21)
4	-	No paper sensor actuator (P/O PL 8.15 Item 21)
5	-	Duplex feed sensor actuator (P/O PL 8.15 Item 21)
6	-	Drive gear (P/O PL 8.15 Item 21)
7	-	Paper guide (P/O PL 8.15 Item 21)
8	-	Shaft (P/O PL 8.15 Item 21)
9	-	Static eliminator (P/O PL 8.15 Item 21)
10	022N02232	Feed roller
11	-	Idle forward roller (P/O PL 8.15 Item 21)
12	-	One way gear (P/O PL 8.15 Item 21)
13	-	Feed idle gear (P/O PL 8.15 Item 21)
14	-	Feed joint gear (P/O PL 8.15 Item 21)
15	-	Spring (P/O PL 8.15 Item 21)
16	-	Bearing (P/O PL 8.15 Item 21)
17	-	Bearing (P/O PL 8.15 Item 21)
18	-	Tray up limit switch (P/O PL 8.15 Item 21)
19	130N01628	Duplex feed sensor (Q08-700)/ Registration sensor (Q07-250)/ No paper sensor (Q07-210)
20	-	Not Used
21	001N00527	Feed assembly

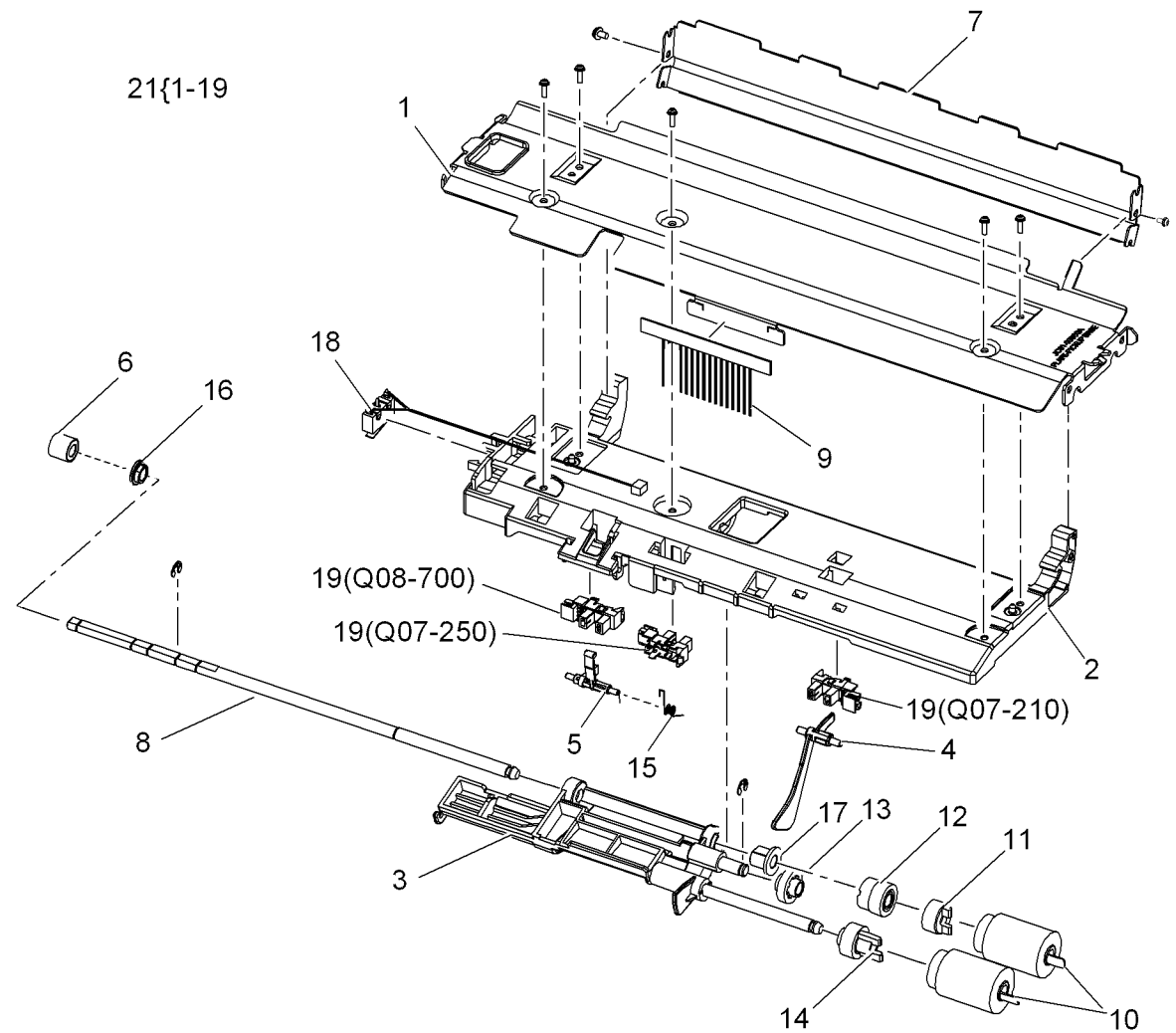

s4620-113

PL 8.20 Optional Feeder Pick-up Assembly

Item	Part	Description
1	—	Feed roll frame (P/O PL 8.20 Item 17)
2	130N01628	Tray 3 no paper sensor (Q07-310), Tray 4 no paper sensor (Q07-410), Tray 5 no paper sensor (Q07-501), Tray 6 (Q07-610) (REP 7.35)/Tray 3 level sensor (Q07-350), Tray 4 level sensor (Q07-450), Tray 5 level sensor (Q07-550), Tray 6 Level sensor (Q07-650) (REP 7.37) (see NOTE)
3	—	No paper sensor actuator (P/O PL 8.20 Item 17) (REP 7.36)
4	022N02232	Feed roller (1 each)
5	—	Idle gear (P/O PL 8.20 Item 17)
6	—	One way gear (P/O PL 8.20 Item 17)
7	—	Bearing (P/O PL 8.20 Item 17)
8	—	Feed roll shaft (P/O PL 8.20 Item 17)
9	—	Static eliminator (P/O PL 8.20 Item 17)
10	—	Ground strip (P/O PL 8.20 Item 17)
11	—	Feed joint gear (P/O PL 8.20 Item 17)
12	—	Idle gear (P/O PL 8.20 Item 17)
13	—	Not used
14	—	Housing (P/O PL 8.20 Item 17)
15	—	Tray up limit switch (P/O PL 8.20 Item 17) (see NOTE)
16	—	Bearing (P/O PL 8.20 Item 17)
17	—	Feed assembly

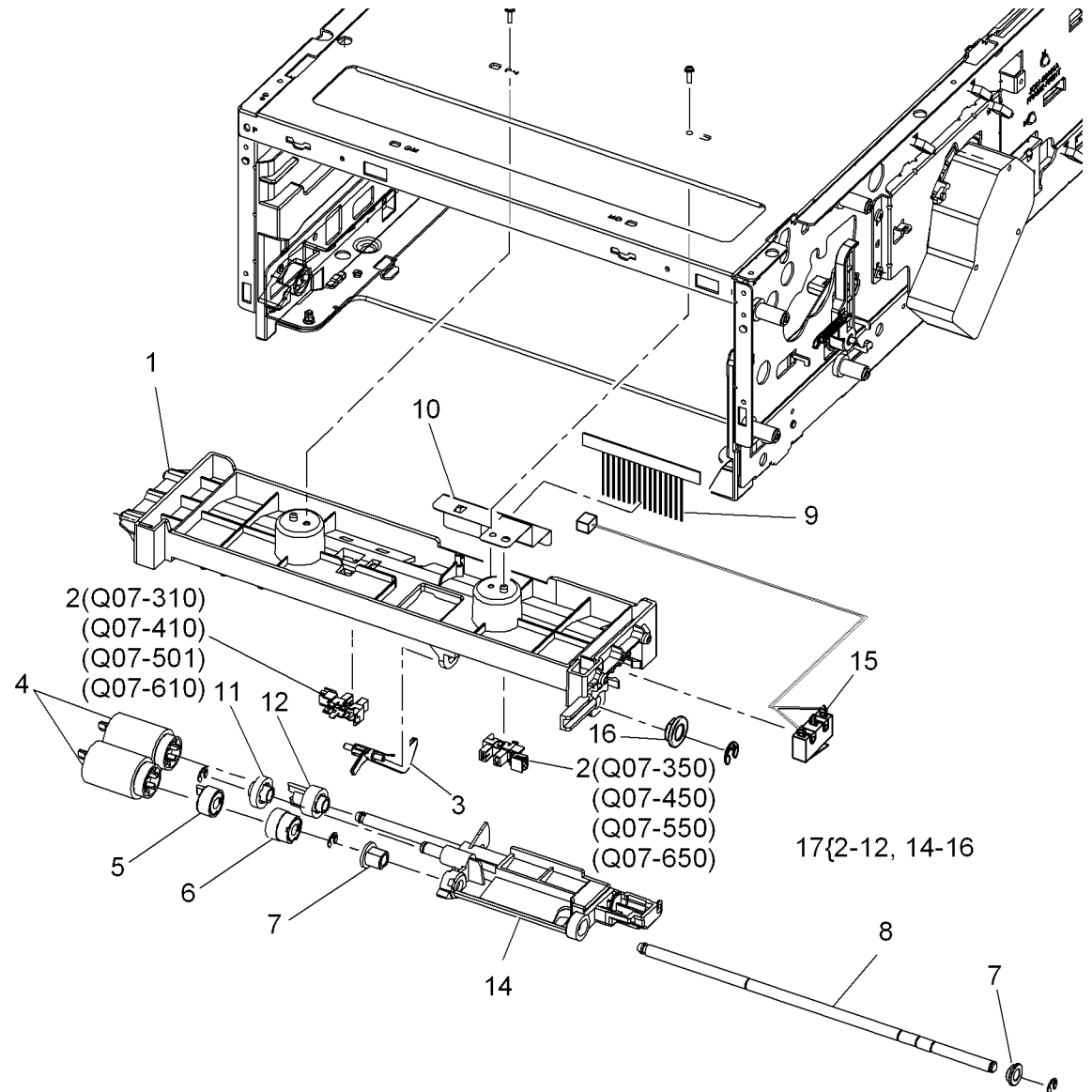

NOTE: Order the entire 520-Sheet Feeder using Service part number 050K74180 or Sales part number 097N01874

NOTE: The component control codes are dependent on the machine configuration.

s4620-114

PL 8.25 HCF Pick-up Assembly

Item	Part	Description
1	—	Feed roll frame (P/O PL 8.25 Item 16)
2	130N01628	No paper sensor (A)(REP 8.50)/ Feed sensor (B)(REP 8.51) (see NOTE)
3	—	No paper sensor actuator (P/O PL 8.25 Item 16) (REP 7.36)
4	022N02232	Feed roller
5	—	Idle gear (P/O PL 8.25 Item 16)
6	—	One way gear (P/O PL 8.25 Item 16)
7	—	Bearing (P/O PL 8.25 Item 16)
8	—	Feed roll shaft (P/O PL 8.25 Item 16)
9	—	Static eliminator (P/O PL 8.25 Item 16)
10	—	Ground strip (P/O PL 8.25 Item 16)
11	—	Feed joint gear (P/O PL 8.25 Item 16)
12	—	Idle gear (P/O PL 8.25 Item 16)
13	—	Housing (P/O PL 8.25 Item 16)
14	—	Tray up limit switch (P/O PL 8.25 Item 16) (see NOTE)
15	—	Bearing (P/O PL 8.25 Item 16)
16	—	Feed assembly (REP 8.47)

NOTE: The component control codes are dependent on the machine configuration.

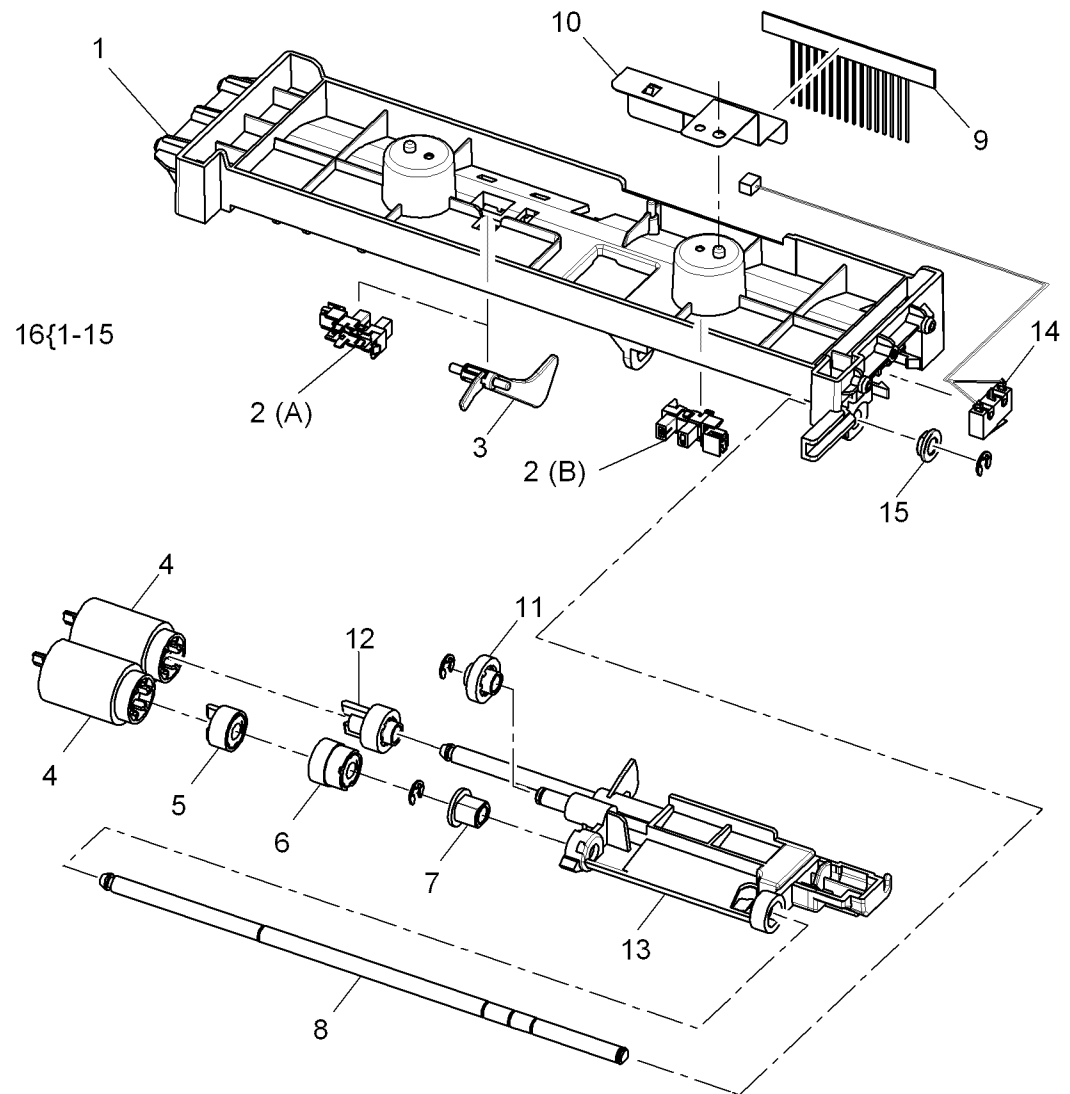

s4620-111

PL 8.30 Optional Feeder Main Drives

Item	Part	Description
1	007N01666	Feed drive assembly (REP 8.42)
2	005N01116	Tray 3 feed clutch (CL08-830), Tray 4 feed clutch (CL08-840), Tray 5 feed clutch (CL08-855), Tray 6 feed clutch (CL08-856) (REP 8.41) (see NOTE)
3	—	Bracket (Not Spared)
4	—	Bearing (Not Spared)
5	005N01085	Take away clutch (REP 8.40) (see NOTE)
6	—	Bracket (Not Spared)
7	140N63468	Feeder board (REP 7.28)
8	—	Take away roller (Not Spared) (REP 8.45)
9	—	Size switch (Not Spared) (REP 7.30) (see NOTE)
10	—	Upper option harness (Not Spared) (REP 7.31)
11	—	Lower option harness (Not Spared) (REP 7.32)

NOTE: The component control codes are dependent on the machine configuration.

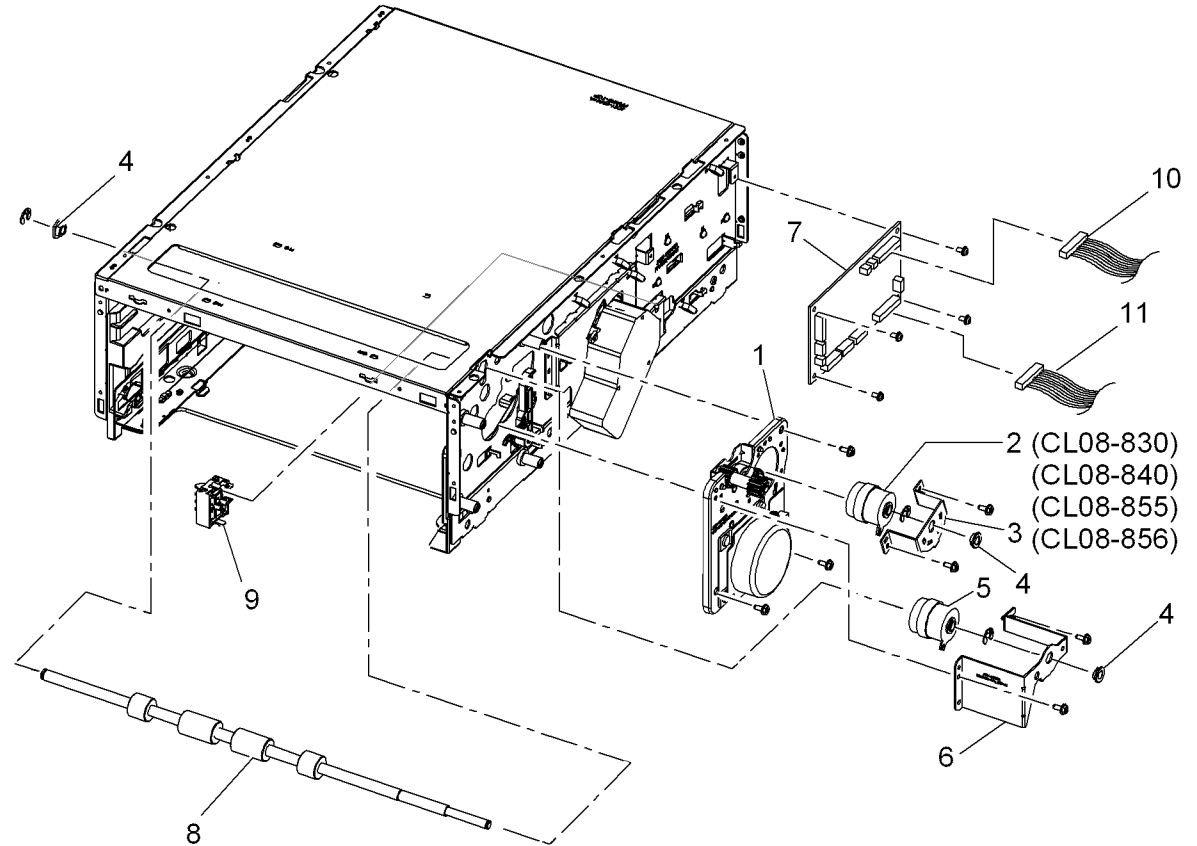

s4620-115

PL 8.35 Optional Feeder Lift Assembly

Item	Part	Description
1	120N00537	Lift motor (REP 7.29) (see NOTE)
2	—	Lift motor bracket (Not Spared)
3	—	Swing housing (Not Spared)
4	—	Lift gear (Not Spared)

NOTE: The component control codes are dependent on the machine configuration.

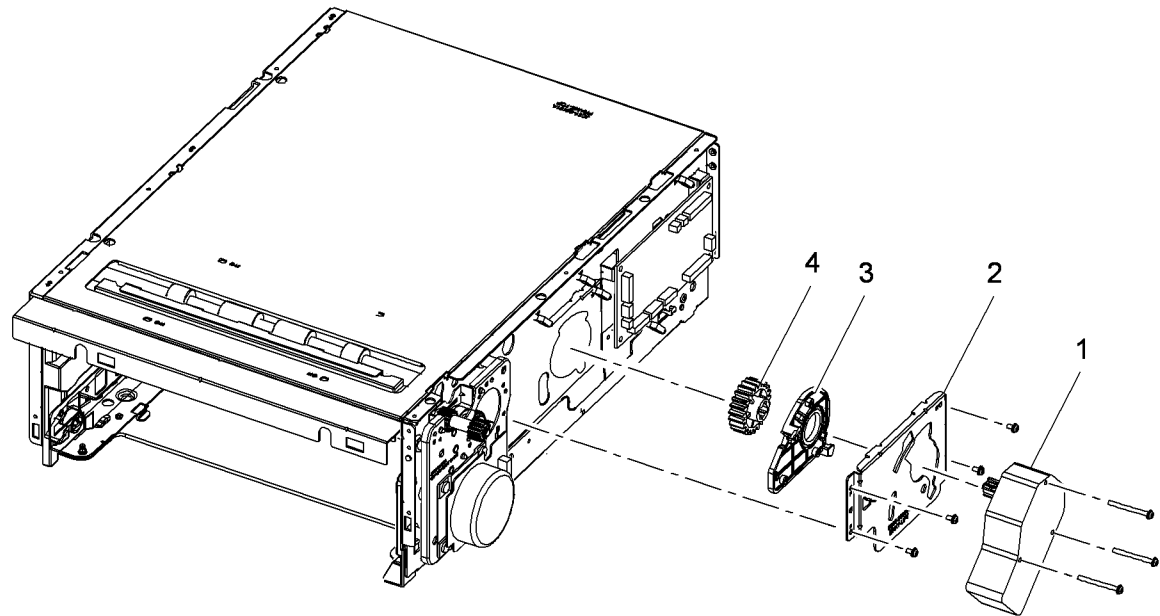

s4620-116

PL 8.40 Optional Feeder Feed Assembly

Item	Part	Description
1	—	Feed guide frame (P/O PL 8.40 Item 10)
2	—	Idle roller assembly (P/O PL 8.40 Item 10)
3	—	Feed guide plate (P/O PL 8.40 Item 10)
4	—	Paper guide plate (P/O PL 8.40 Item 10)
5	—	Mylar guide (P/O PL 8.40 Item 10)
6	—	Ground strip (P/O PL 8.40 Item 10)
7	130N01628	Tray 3 take away sensor (Q08-300), Tray 4 take away sensor (Q08-400), Tray 5 take away sensor (Q08-550), Tray 6 take away sensor (REP 8.44) (see NOTE)
8	—	Spring (P/O PL 8.40 Item 10)
9	—	Take away sensor actuator (P/O PL 8.40 Item 10) (REP 8.43)
10	—	Feed assembly (Not Spared) (REP 8.46)

NOTE: The component control codes are dependent on the machine configuration. The code for tray 6 was not known at time of publication.

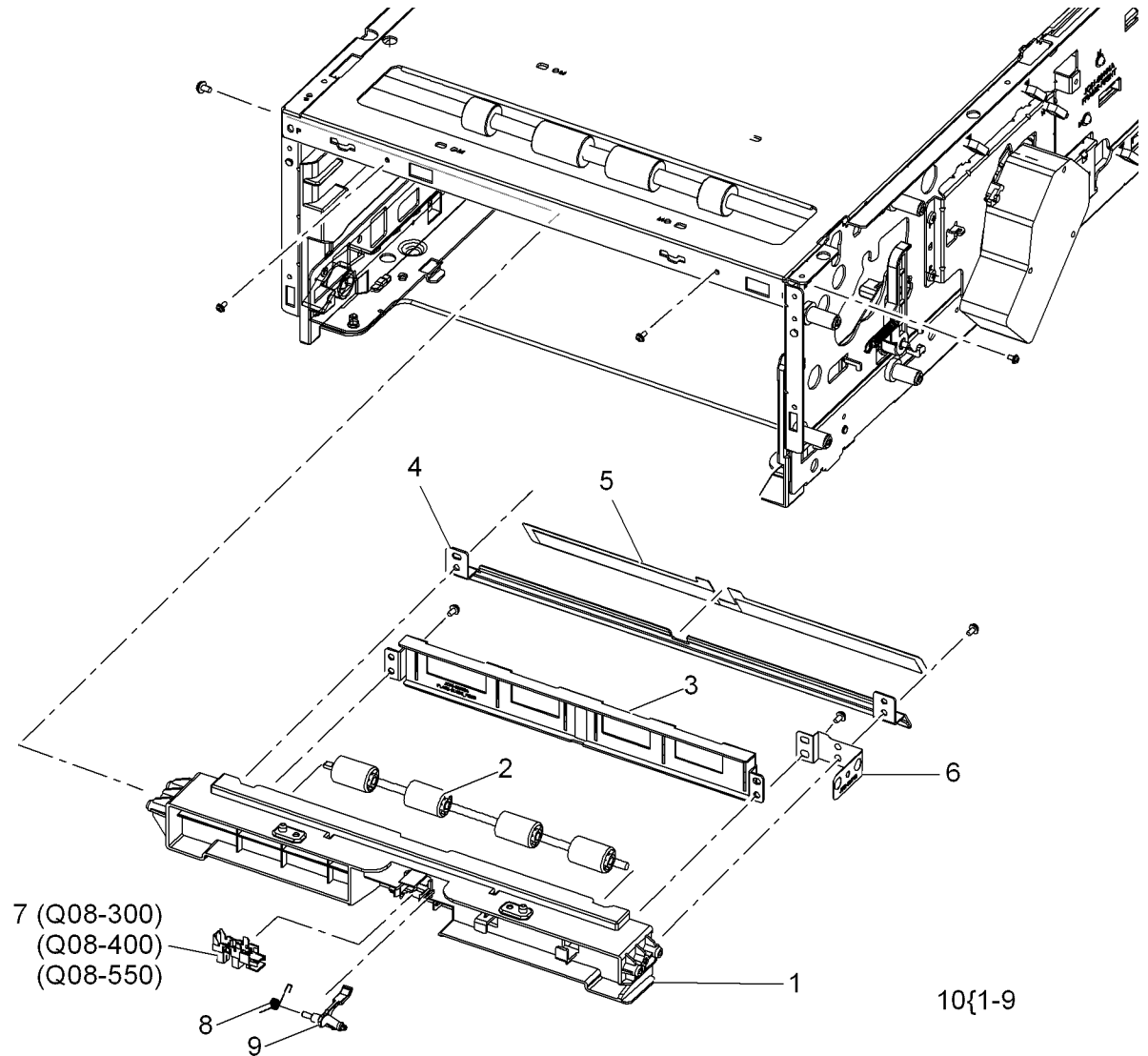

s4620-117

PL 8.45 Registration Roller Assembly

Item	Part	Description
1	-	Registration drive roller (P/O PL 8.45 Item 12)
2	-	Registration idle roller (P/O PL 8.45 Item 12)
3	-	Not Used
4	-	Right registration bracket (P/O PL 8.45 Item 12)
5	-	Left registration bracket (P/O PL 8.45 Item 12)
6	-	Spring (P/O PL 8.45 Item 12)
7	-	Not Used
8	-	Not Used
9	-	Spring (P/O PL 8.45 Item 12)
10	-	Bearing (P/O PL 8.45 Item 12)
11	-	Bearing (bronze) (P/O PL 8.45 Item 12)
12	105N02192	Registration roller assembly (REP 8.27)

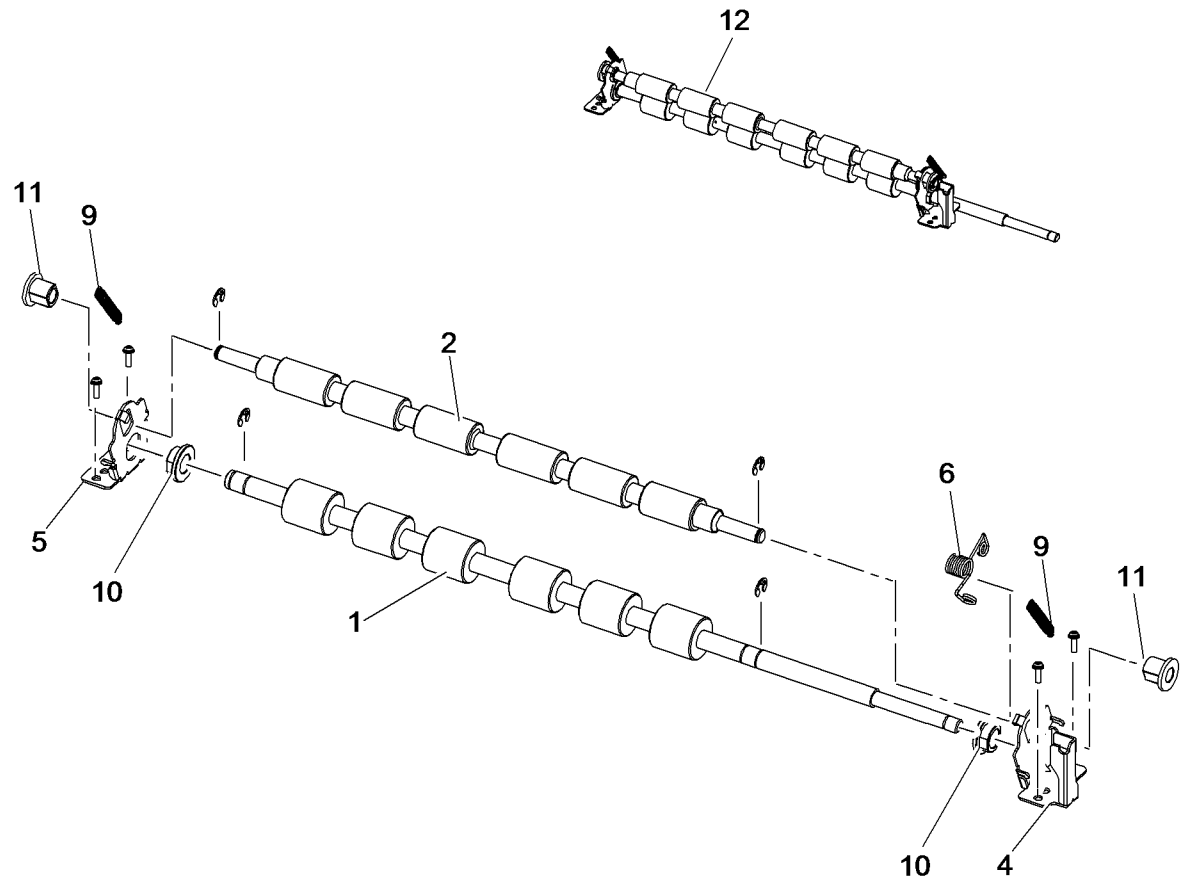

s4620-118

PL 8.50 Middle Frame Assembly

Item	Part	Description
1	-	Base frame (P/O PL 8.50 Item 28)
2	-	Actuator frame (P/O PL 8.50 Item 28)
3	-	Connector board (P/O PL 8.50 Item 28)
4	-	Rear transfer ground (P/O PL 8.50 Item 28)
5	-	Saw side ground (P/O PL 8.50 Item 28)
6	-	Earth ground (P/O PL 8.50 Item 28)
7	-	Spring (P/O PL 8.50 Item 28)
8	-	Ground (P/O PL 8.50 Item 28)
9	-	ADC sensor holder (P/O PL 8.50 Item 28)
10	-	Guide plate (P/O PL 8.50 Item 28)
11	-	Shaft (P/O PL 8.50 Item 28)
12	-	PMO Bearing (P/O PL 8.50 Item 28)
13	-	Exit gear (P/O PL 8.50 Item 28)
14	-	Rear transfer guide (P/O PL 8.50 Item 28)
15	001N00526	Shaft frame assembly (REP 8.16)
16	-	Feed sheet (P/O PL 8.50 Item 28)
17	-	Registration ground (P/O PL 8.50 Item 28)
18	-	Take away roller (P/O PL 8.50 Item 28)
19	-	Bearing (P/O PL 8.50 Item 28)
20	-	Feed frame assembly (P/O PL 8.50 Item 28)
21	-	Feed gear (P/O PL 8.50 Item 28)
22	-	Drum cartridge CRUM connector (P/O PL 8.50 Item 28) (REP 8.24)
23	-	Actuator cover (P/O PL 8.50 Item 28)
24	-	Harness connector (P/O PL 8.50 Item 28)
25	130N01628	Registration sensor (Q08-500)(REP 8.11)/Feed sensor (Q08-100)(REP 8.12)
26	-	Feed sensor actuator (P/O PL 8.50 Item 28) (REP 8.31)
27	-	Registration sensor actuator (P/O PL 8.50 Item 28) (REP 8.32)
28	-	Middle frame assembly (Not Spared)
29	-	ADC sensor (REP 9.2) (Not Spared)

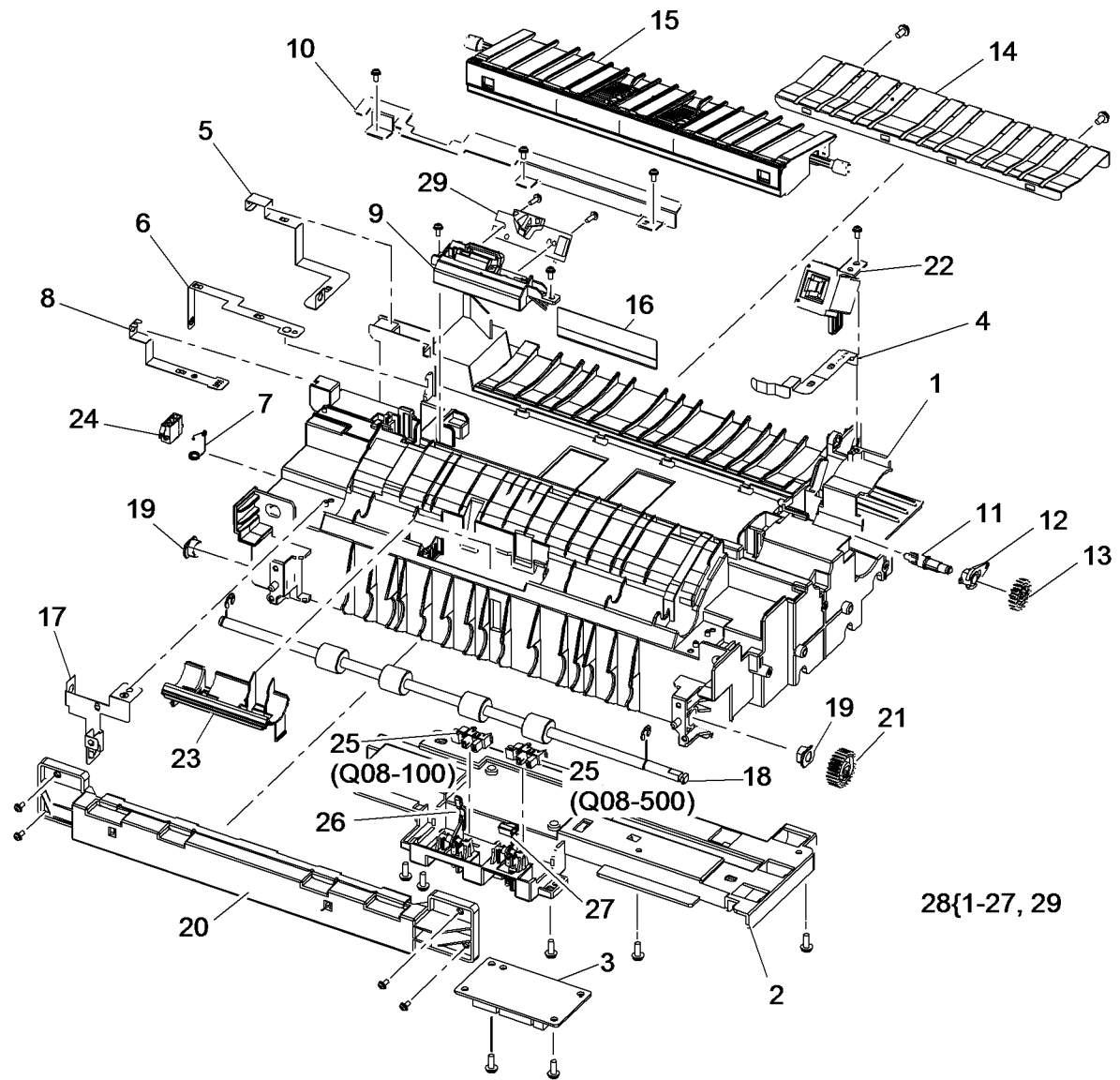

28{1-27, 29

s4620-119

PL 8.55 Upper Frame Assembly

Item	Part	Description
1	-	Lower LSU frame
2	-	Upper fuser frame (P/O PL 8.55 Item 9)
3	-	Left registration bracket (P/O PL 8.55 Item 9)
4	-	Right registration bracket (P/O PL 8.55 Item 9)
5	-	LED holder (P/O PL 8.55 Item 9)
6	-	Eraser board (P/O PL 8.55 Item 9)
7	-	Slide B roller (P/O PL 8.55 Item 9)
8	-	Spring (P/O PL 8.55 Item 9)
9	-	Upper frame assembly (Not Spared)

9{1-8

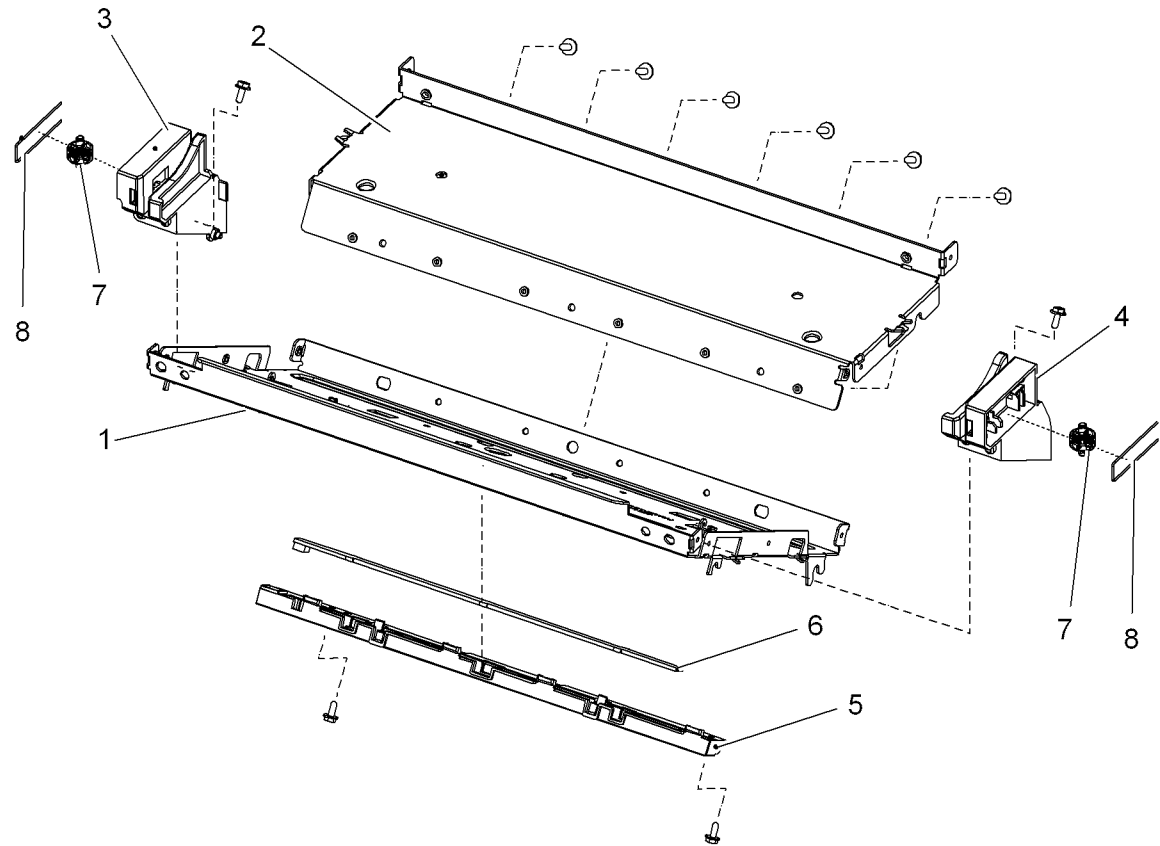

s4620-120

PL 9.10 Drum Cartridge

Item	Part	Description
1	113R00762	Drum cartridge
2	022N02478	Transfer roller (REP 9.1)
3	—	Holder (Not Spared)
4	—	Spring (Not Spared)
5	—	Retaining clip (Not Spared)
6	106R01533	NA/XE std toner cartridge (13K)
—	106R01534	DMO std toner cartridge (13K)
—	106R01535	NA/XE Hi-Cap toner cartridge (30K)
—	106R01536	DMO Hi-Cap toner cartridge (30K)
—	106R01532	Metered/PagePack Hi-Cap toner cartridge

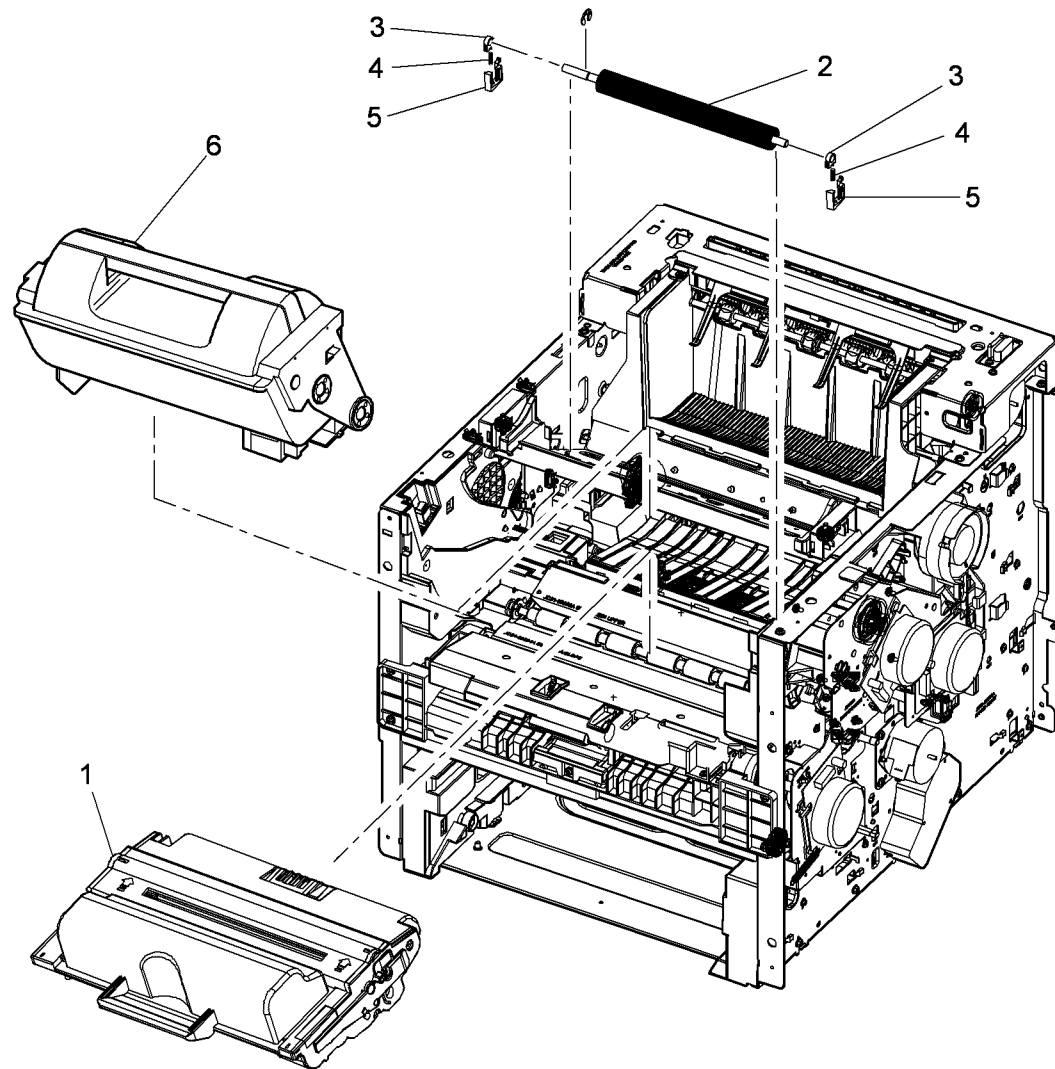

s4620-121

PL 9.15 Waste Toner

Item	Part	Description
1	-	Bias contact cover (Not Spared)
2	001N00528	Pipe assembly (REP 9.7)
3	127N07668	Left side chassis fan (MOT04-120) (REP 9.4)
4	093N01732	Waste toner cartridge
5	-	Waste toner full sensor (Not Spared) (REP 9.6)
6	130N01628	Waste toner cartridge detect sensor (REP 9.3)
7	140N63465	Joint board (REP 9.8)
8	-	Environmental sensor (Not Spared) (REP 9.5)
9	-	Sensor holder (Not Spared)

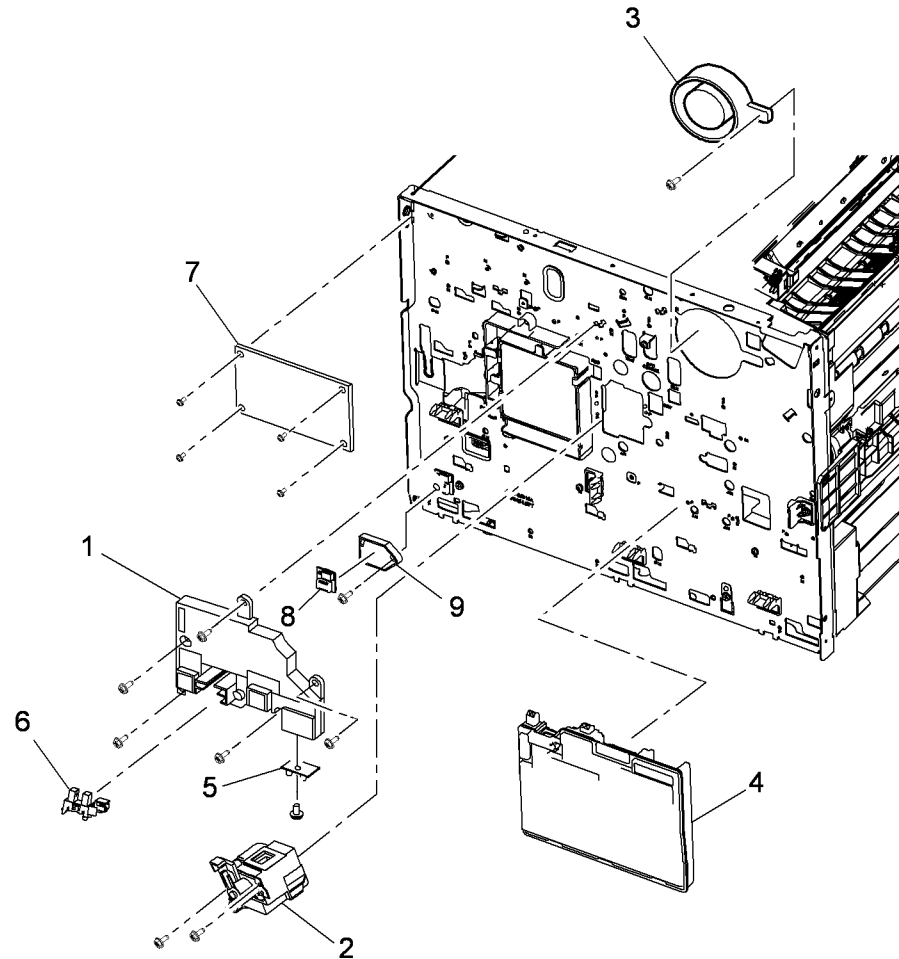

s4620-122

PL 10.10 Fuser Assembly (1 of 2)

Item	Part	Description
1	126N00339	Fuser assembly (110V) (REP 10.10)
-	126N00340	Fuser assembly (220V) (REP 10.10)
2	-	Thumbscrew (Not Spared)

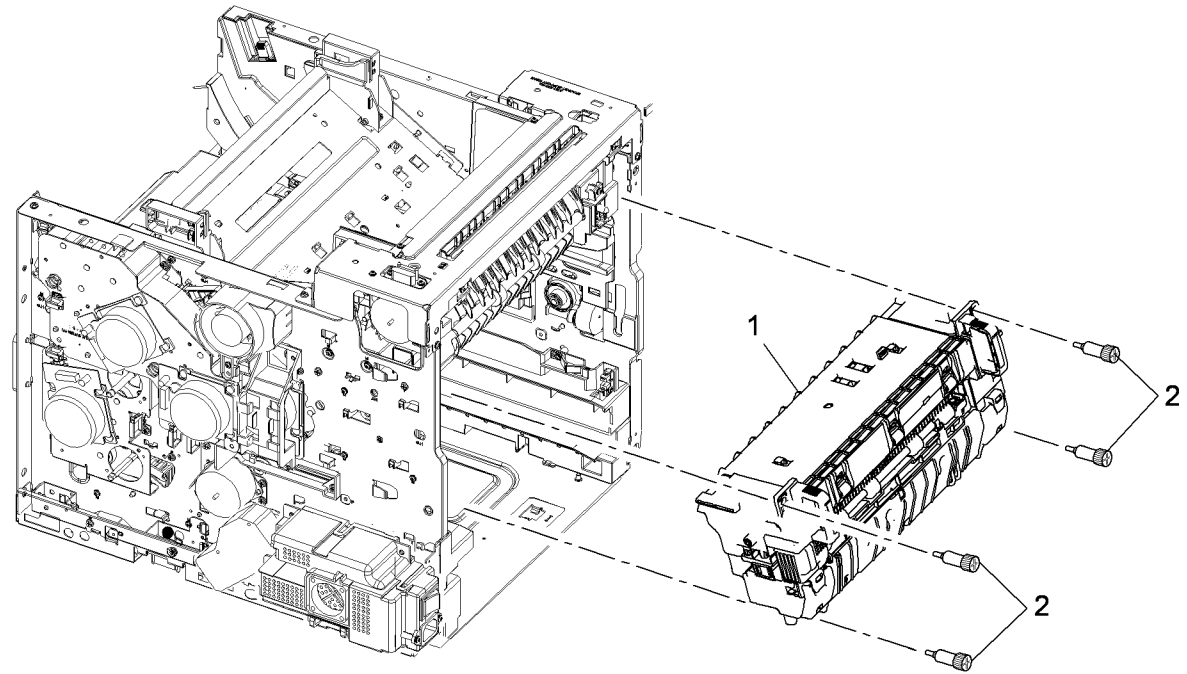

s4620-123

PL 10.11 Fuser Assembly (2 of 2)

Item	Part	Description
1	—	Lower bracket (P/O PL 10.10 Item 1)
2	—	Cleaning roller assembly (P/O PL 10.10 Item 1)
3	022N02476	Pressure roller (REP 10.16)
4	013N13847	Roller bearing
5	—	Right bracket (P/O PL 10.10 Item 1)
6	—	Left bracket (P/O PL 10.10 Item 1)
7	—	Cam shaft assembly (P/O PL 10.10 Item 1)
8	—	Bush (P/O PL 10.10 Item 1)
9	—	Release cam (P/O PL 10.10 Item 1)
10	—	Shaft holder (P/O PL 10.10 Item 1)
11	—	Spring (P/O PL 10.10 Item 1)
12	022N02477	Heat roller (REP 10.15)
13	013N13929	Heat roller bearing (REP 10.15)
14	007N01657	Fuser gear (REP 10.14)
15	—	Spring clamp (P/O PL 10.10 Item 1)
16	—	Upper fuser bracket assembly (REF: PL 10.15)
17	122N00290	Heat lamp (110V) (REP 10.13)
—	122N00291	Heat lamp (220V)
18	—	Lamp bracket (P/O PL 10.10 Item 1)
19	—	Gear bracket (P/O PL 10.10 Item 1)
20	—	Upper exit guide (P/O PL 10.10 Item 1)
21	—	AC harness holder (P/O PL 10.10 Item 1)
22	—	Sub AC harness holder (P/O PL 10.10 Item 1)
23	—	Right cover (P/O PL 10.10 Item 1)
24	—	Left cover (P/O PL 10.10 Item 1)
25	—	Duplex cover (P/O PL 10.10 Item 1)
26	—	Upper cover (P/O PL 10.10 Item 1)
27	—	Input guide (P/O PL 10.10 Item 1)
28	—	Lower fuser exit guide assembly (REF: PL 10.20)
29	—	Connector (P/O PL 10.10 Item 1)
30	130N01628	Fuser exit sensor (Q08-600)/ Fuser home sensor (Q10-910)

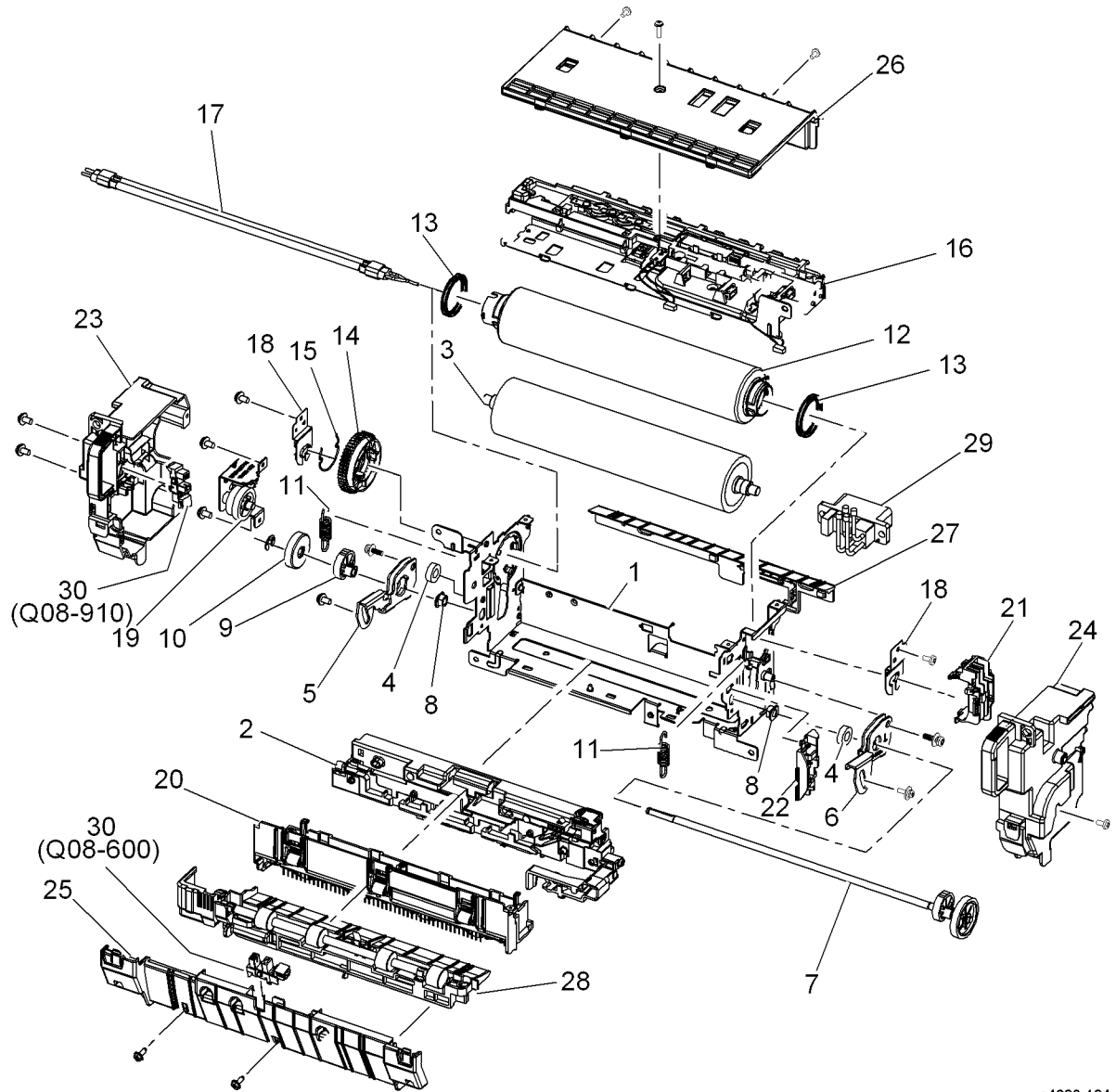

s4620-124

PL 10.15 Upper Fuser Bracket Assembly

Item	Part	Description
1	–	Upper bracket (Not Spared)
2	–	Thermostat holder (Not Spared)
3	130N01531	Thermistor NTC (REP 10.11)
4	–	Thermostat (Not Spared) (REP 10.12)
5	130N01615	Thermistor NTC (side)
6	130N01614	Thermistor NTC (center)

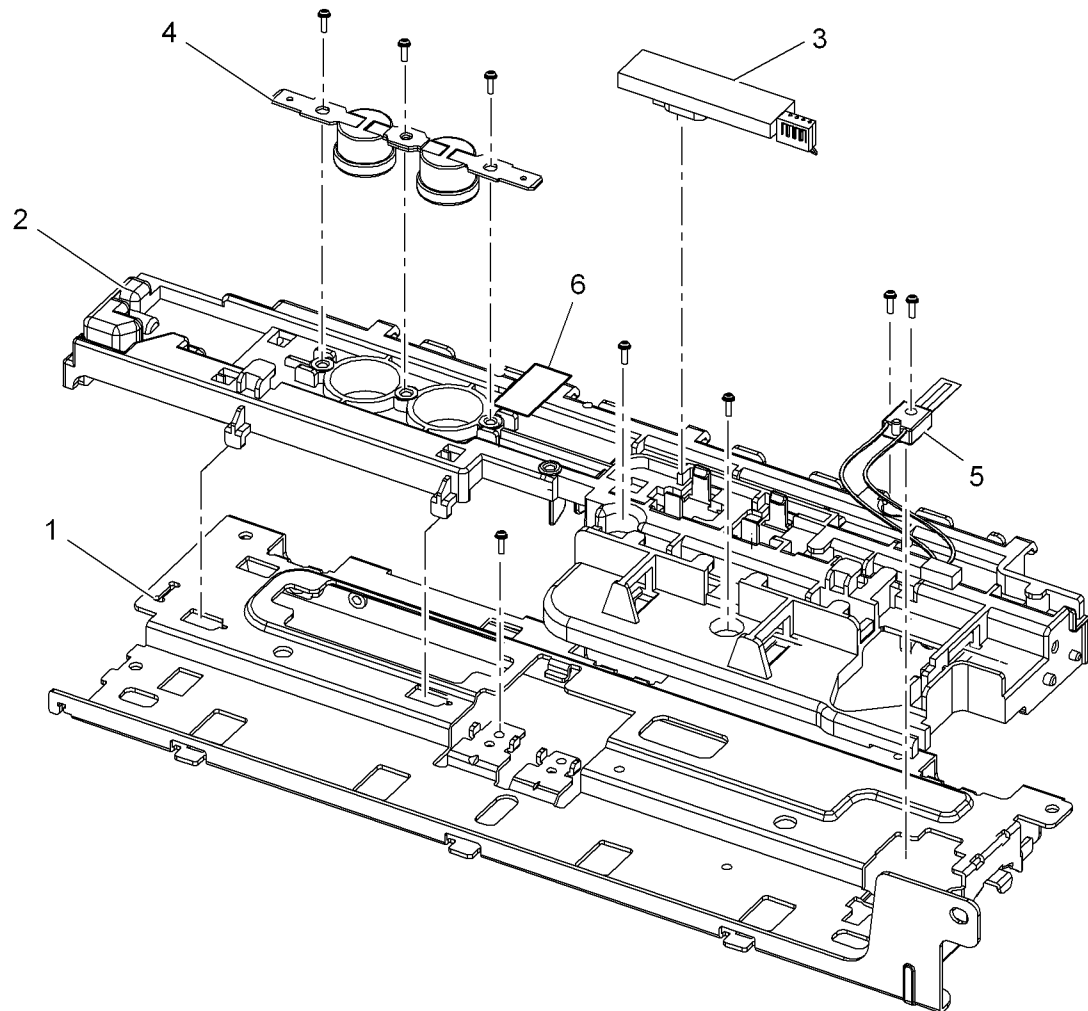

s4620-125

PL 10.20 Lower Fuser Exit Guide Assembly

Item	Part	Description
1	-	Lower exit guide (Not Spared)
2	-	Clip (Not Spared)
3	-	Spring (Not Spared)
4	-	Rear lever (Not Spared)
5	-	Actuator holder (Not Spared)
6	-	Fuser exit sensor actuator (Not Spared)
7	-	Actuator spring (Not Spared)
8	-	Upper fuser exit roller (Not Spared)
9	-	Duplex exit gear (Not Spared)

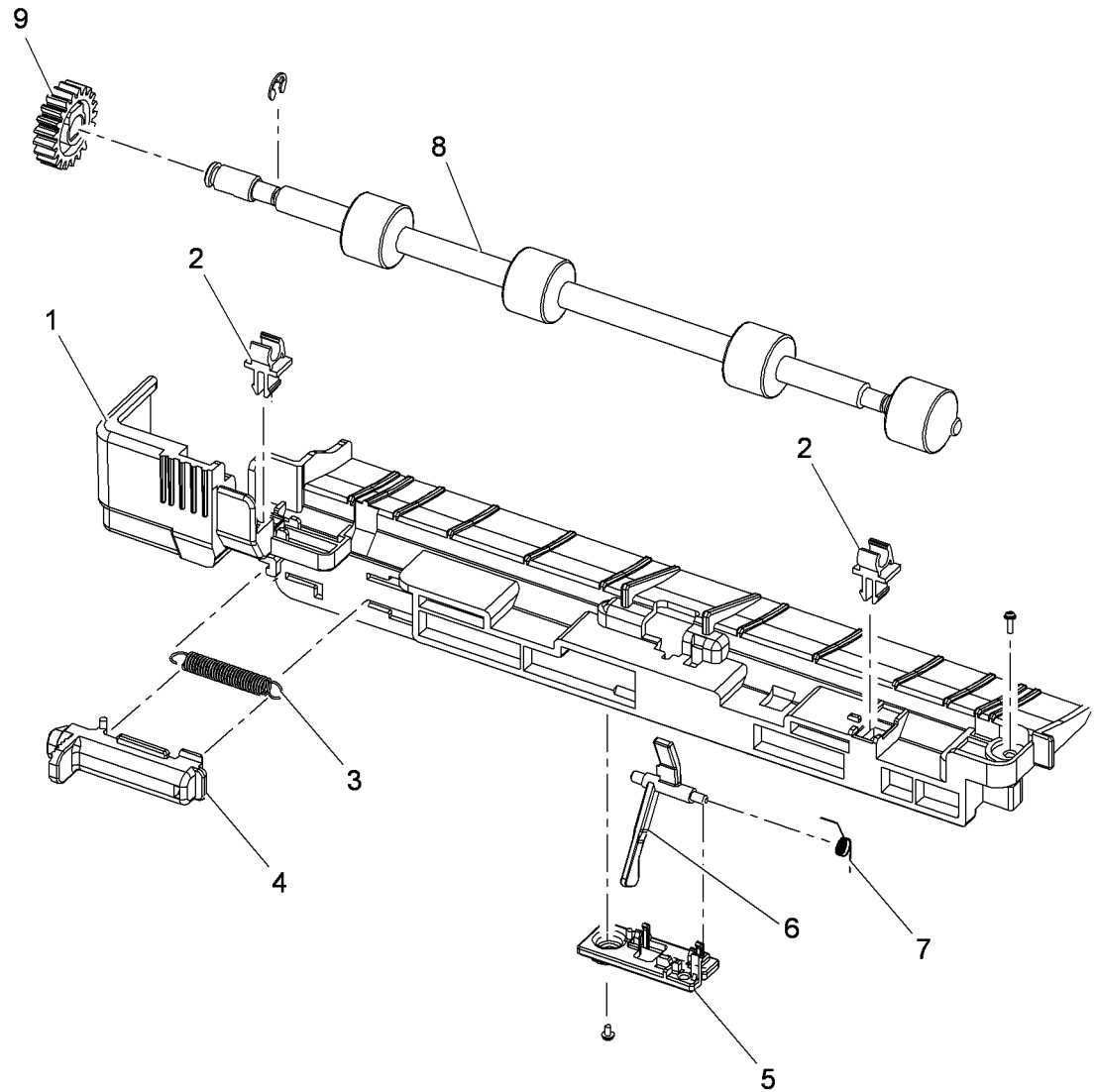

s4620-126

PL 10.25 Duplex Unit Assembly

Item	Part	Description
1	-	Duplex lower frame (P/O PL 10.25 Item 26)
2	-	Duplex upper frame (P/O PL 10.25 Item 26)
3	-	Duplex align guide (P/O PL 10.25 Item 26)
4	-	Bottom duplex ground (P/O PL 10.25 Item 26)
5	-	Duplex feed brush ground (P/O PL 10.25 Item 26)
6	-	Duplex gasket ground (P/O PL 10.25 Item 26)
7	-	PTT label (P/O PL 10.25 Item 26)
8	-	Information label (P/O PL 10.25 Item 26)
9	-	Cassette cover (P/O PL 10.25 Item 26)
10	-	Tension spring (P/O PL 10.25 Item 18)
11	023N01051	Timing belt (REP 10.19)
12	-	M-feed bush (P/O PL 10.25 Item 26)
13	-	Conductive gasket (P/O PL 10.25 Item 26)
14	-	P terminal ground (P/O PL 10.25 Item 26)
15	-	Exit F gear (P/O PL 10.25 Item 26)
16	-	Idle roll shaft (P/O PL 10.25 Item 26)
17	-	Pulley-18 (P/O PL 10.25 Item 26)
18	-	Pulley-M-18-dummy (P/O PL 10.25 Item 26)
19	-	Idle roller (P/O PL 10.25 Item 26)
20	-	Static eliminator (P/O PL 10.25 Item 26)
21	-	Paper guide stud (P/O PL 10.25 Item 26)
22	-	Sponge cover (P/O PL 10.25 Item 26)
23	-	ELA unit roller 1 (P/O PL 10.25 Item 26)
24	-	ELA unit roller 2 (P/O PL 10.25 Item 26)
25	130N01628	Duplex unit detect sensor (REP 10.18)
26	022N02484	Duplex unit assembly (REP 10.1)

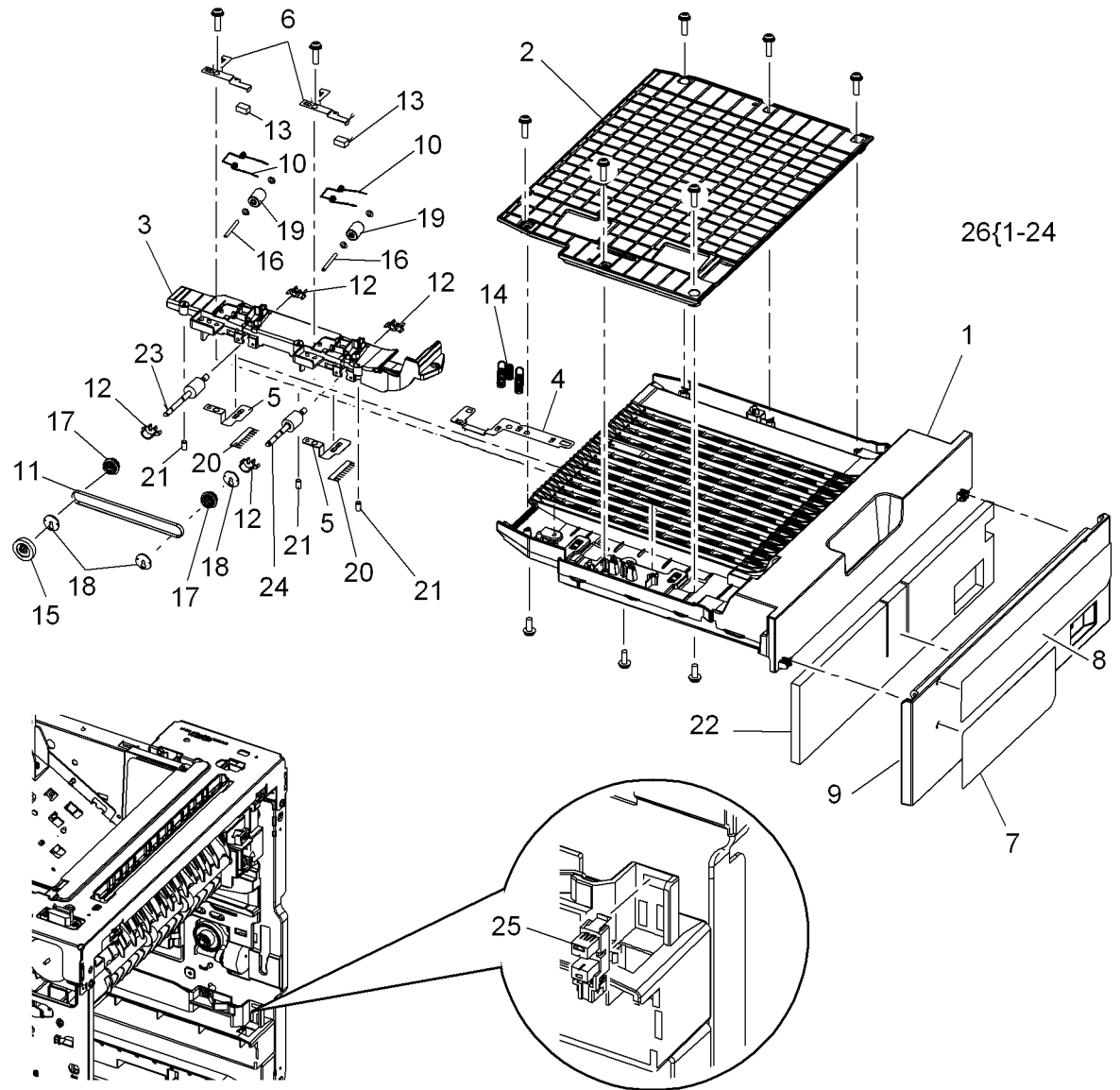

s4620-127

PL 10.30 Exit Assembly

Item	Part	Description
1	-	Exit frame (P/O PL 10.30 Item 25)
2	-	Exit chute (P/O PL 10.30 Item 25)
3	-	Stacking lever (P/O PL 10.30 Item 25)
4	-	Deflector guide (P/O PL 10.30 Item 25)
5	-	Exit roller ground (P/O PL 10.30 Item 25)
6	-	Exit ground (P/O PL 10.30 Item 25)
7	-	Upper exit roller (P/O PL 10.30 Item 25)
8	-	Lower exit roller (P/O PL 10.30 Item 25)
9	130N01628	Stack full sensor (Q08-720) (REP 10.7)
10	-	Spring (P/O PL 10.30 Item 25)
11	-	Bearing (P/O PL 10.30 Item 25)
12	-	Bearing (P/O PL 10.30 Item 25)
13	-	Bearing (P/O PL 10.30 Item 25)
14	-	Rear bracket (P/O PL 10.30 Item 25)
15	-	Damper pad (P/O PL 10.30 Item 25)
16	-	Duplex exit gear (P/O PL 10.30 Item 25)
17	-	Upper exit gear (P/O PL 10.30 Item 25)
18	-	Lower exit gear (P/O PL 10.30 Item 25)
19	-	Static eliminator (P/O PL 10.30 Item 25)
20	-	Stacking lever sponge (P/O PL 10.30 Item 25)
21	-	Exit roller cap (P/O PL 10.30 Item 25)
22	-	Duplex roller (P/O PL 10.30 Item 25)
23	007N01660	Exit drive assembly (REP 10.32)
24	-	Upper option connector (Not Spared) (REP 10.4)
25	022N02483	Exit assembly (REP 10.6)

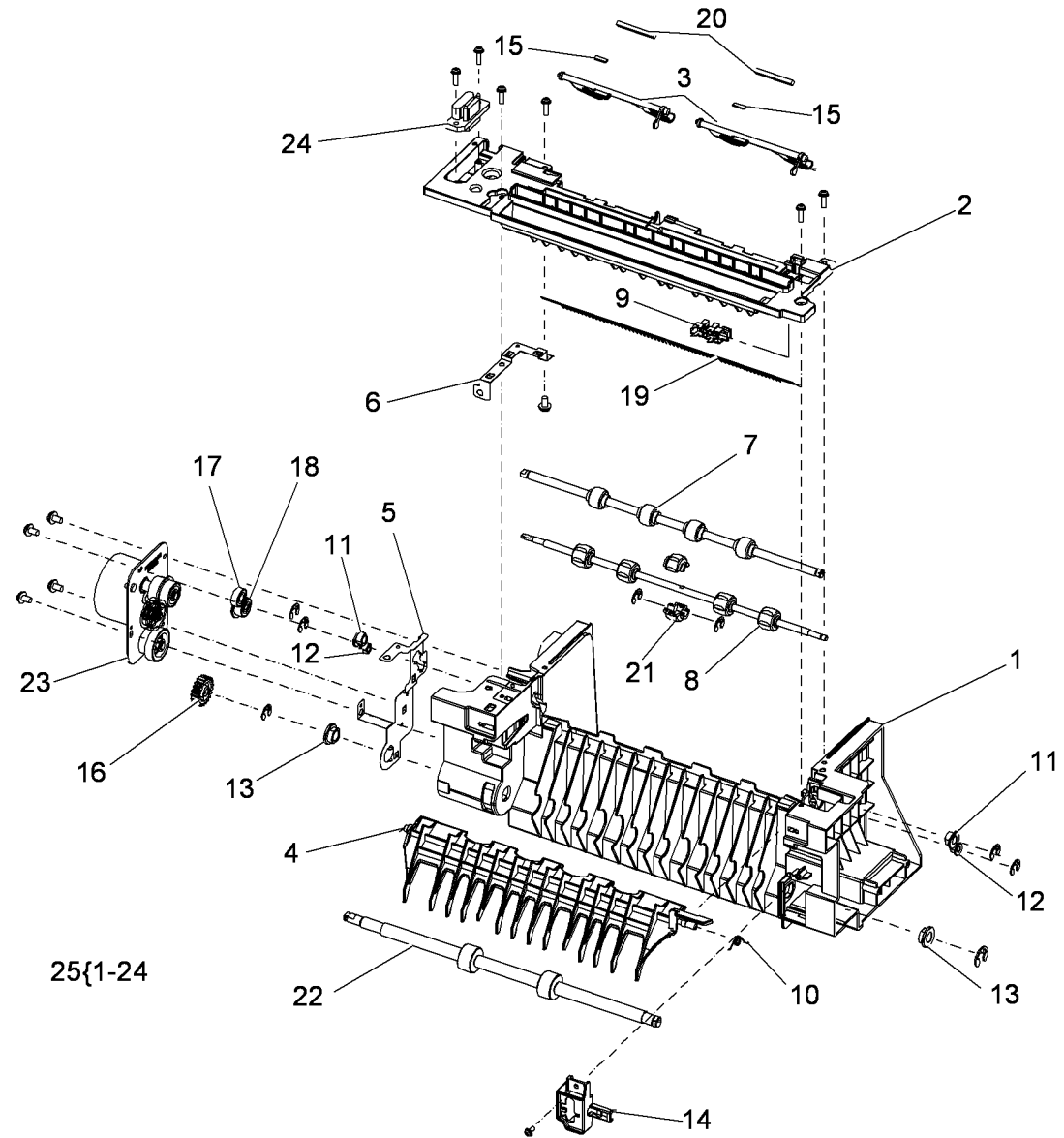

s4620-128

PL 11.10 Mailbox Covers

Item	Part	Description
1	-	Left cover (Not Spared) (REP 11.2)
2	-	Right cover (Not Spared) (REP 11.3)
3	-	Top cover (Not Spared)
4	-	Output tray assembly (Not Spared) (REP 11.1)
5	-	Rear door (Not Spared) (REP 11.4)
6	-	Connector cover (Not Spared)
7	-	Base plate (Not Spared)

NOTE: Order the entire Mailbox using Service part number 050K74190 or Sales part number 097N01877.

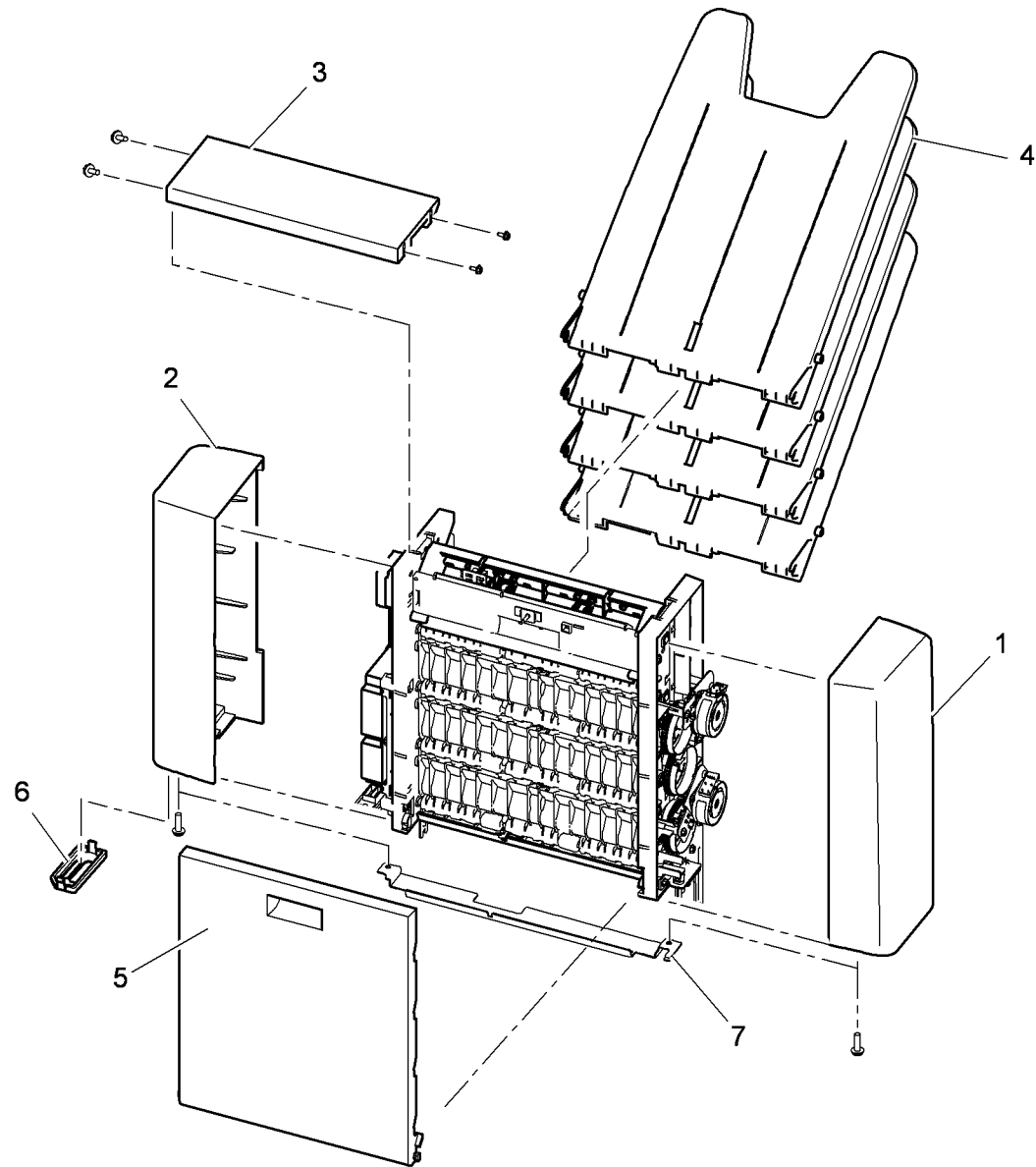

s4620-137

PL 11.15 Mailbox Control Board

Item	Part	Description
1	140N63470	Control board (REP 11.5)
2	-	Control board bracket (Not Spared)
3	-	Mounting bracket (Not Spared)
4	-	Mailbox option harness (Not Spared) (REP 11.11)

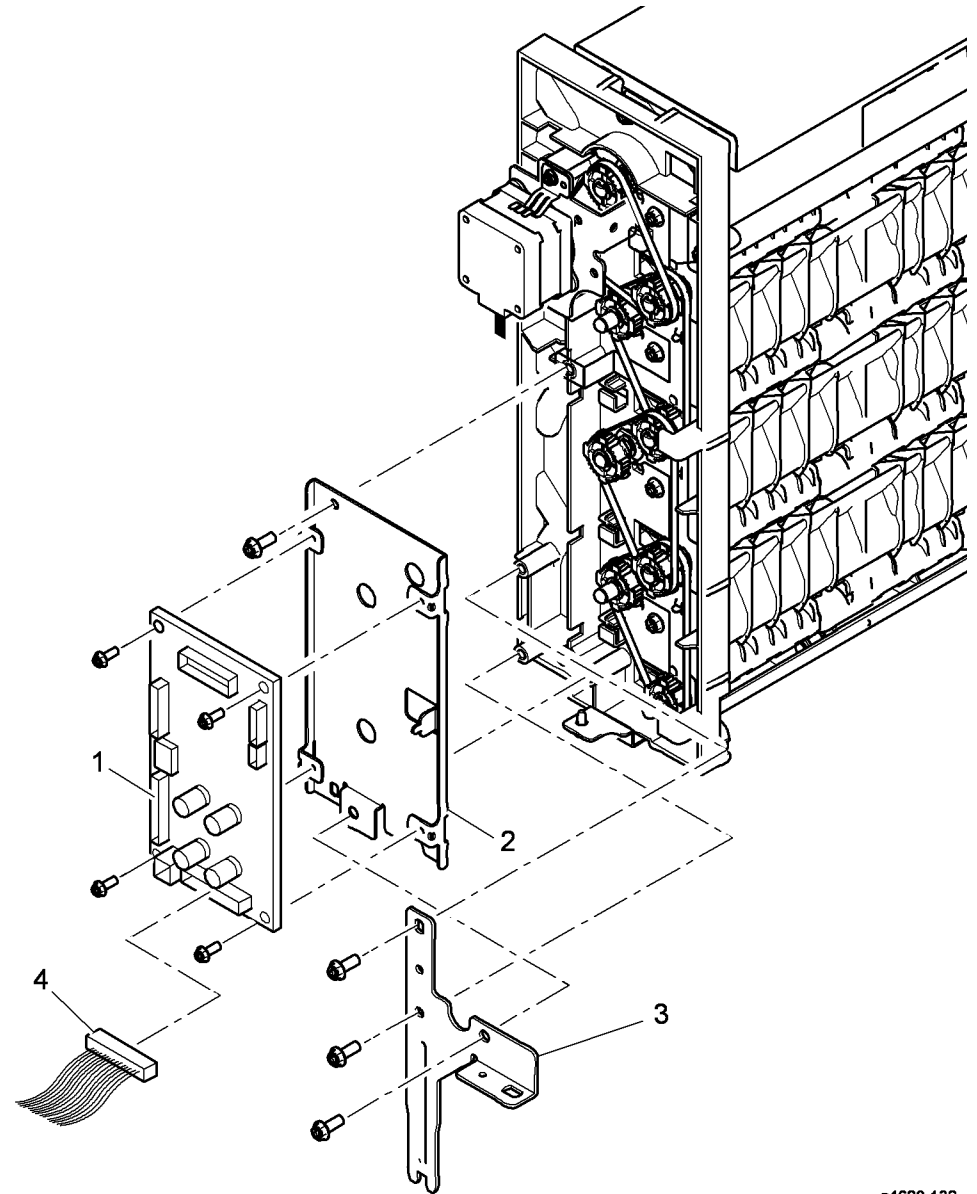

s4620-138

PL 11.20 Mailbox Drive Belts

Item	Part	Description
1	127N07670	Transport motor (MOT12-120) (REP 11.14)
2	—	Grounding strip (Not Spared)
3	—	Motor bracket (Not Spared)
4	023N01282	Primary drive belt (REP 11.6)
5	023N01281	Drive belt (REP 11.6)

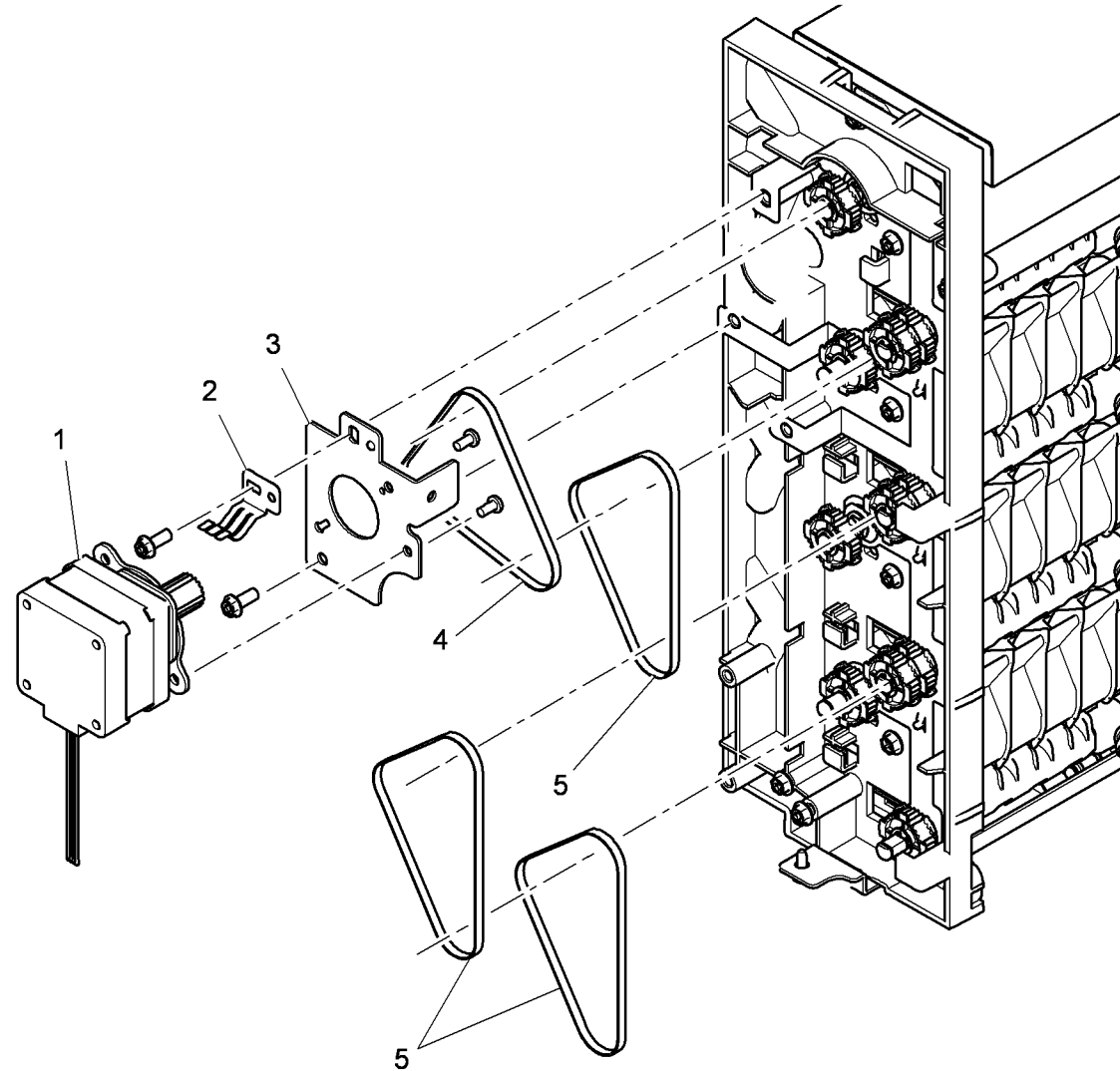

s4620-139

PL 11.25 Mailbox Diverter Assembly

Item	Part	Description
1	127N07671	Upper diverter drive assembly (MOT12-935) / Lower diverter drive assembly (MOT12-955) (REP 11.7)
2	-	Upper diverter home position sensor (Q12-925)/ Lower diverter home position sensor (Q12-945) (Not Spared) (REP 11.8)
3	-	Not used
4	-	Cam gear (Not Spared)
5	-	Exit gate cam follower (Not Spared) (REP 11.10)
6	-	Exit gate actuator (Not Spared) (REP 11.9)
7	-	Mounting bracket (Not Spared)
8	-	Bearing (Not Spared)
9	-	Cam follower spring (Not Spared)

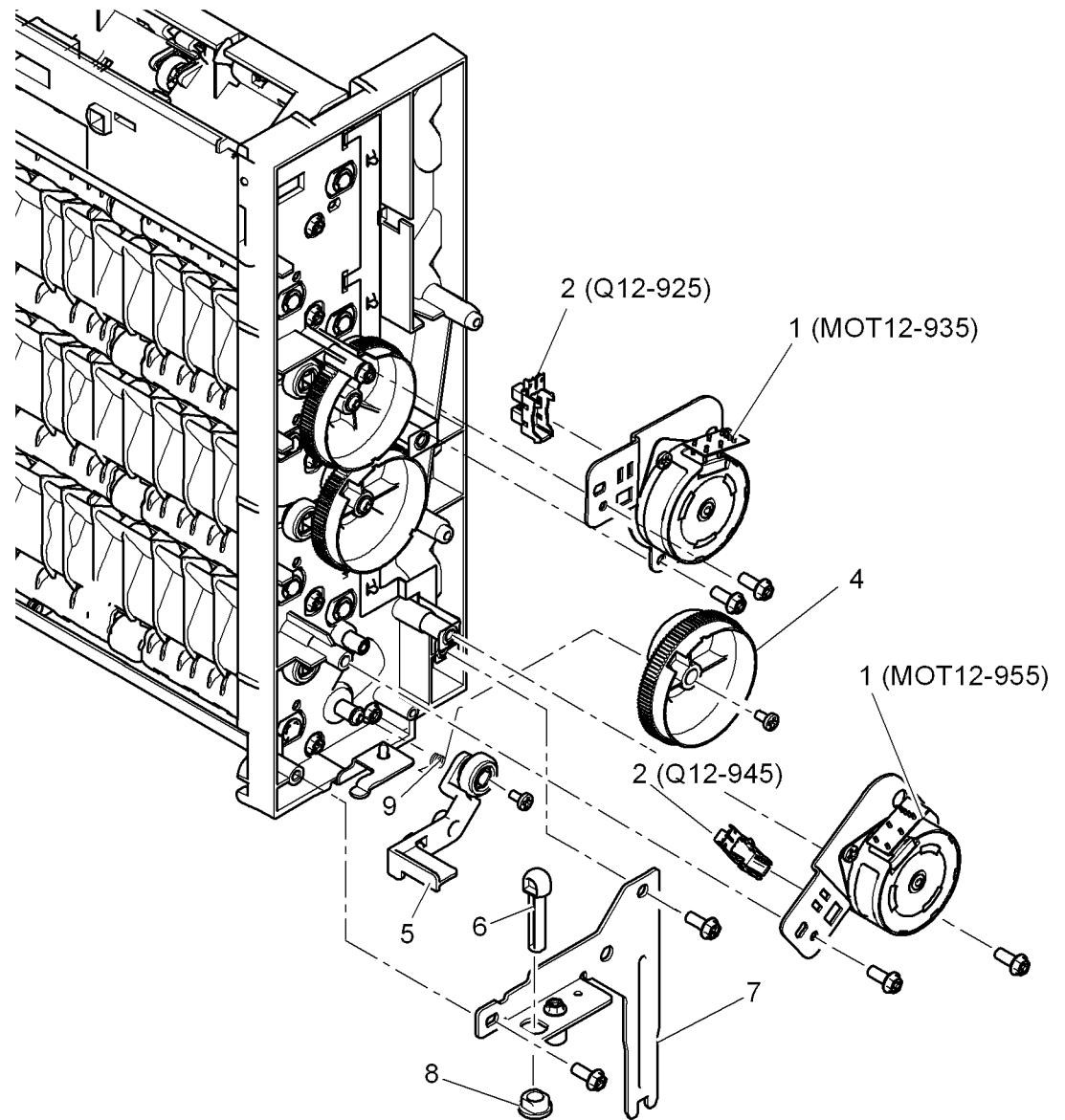

s4620-140

PL 11.30 Mailbox Top Stacker Assembly

Item	Part	Description
1	—	Harness cover assembly (Not Spared)
2	—	Harness cover (Not Spared)
3	—	Magnet (Not Spared)
4	—	Rear door interlock switch (S12-915) (Not Spared) (REP 11.13)
5	—	Top stacker shield (Not Spared)
6	—	Static eliminator (Not Spared)
7	—	Stacker full actuator (Not Spared)
8	—	Idle feed roll assembly (Not Spared)
9	—	Idle feed roll (Not Spared)
10	—	Pin (Not Spared)
11	—	Spring (Not Spared)
12	—	Stack full sensor assembly (Not Spared)
13	—	Output tray 1 stack full sensor (Q12-910) (Not Spared) (REP 11.12)
14	—	Sensor bracket (Not Spared)

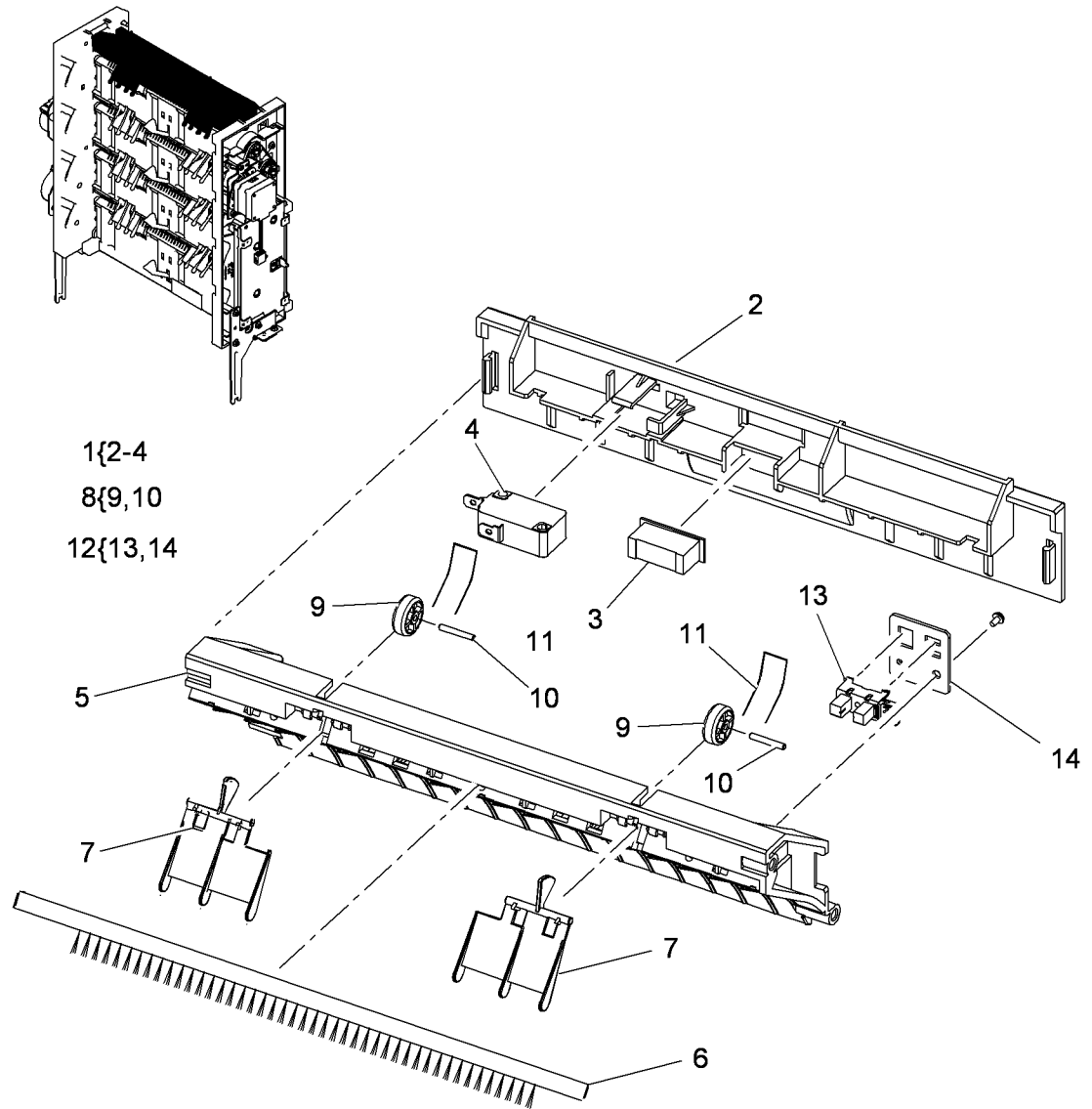

s4620-142

PL 11.35 Mailbox Actuator Shield Assembly

Item	Part	Description
1	-	Stacker shield (Not Spared)
2	-	Tray 1 stacker empty sensor (Q12-911), Tray 2 stacker empty sensor (Q12-921), Tray 3 stacker empty sensor (Q12-931), Tray 4 stacker empty sensor (Q12-941)/Tray 2 stacker full sensor (Q12-920), Tray 3 stacker full sensor (Q12-930), Tray 4 stacker full sensor (Q12-940) (Not Spared)
3	-	Actuator shaft (Not Spared)
4	-	Spring (Not Spared)
5	-	Stacker empty actuator (Not Spared)
6	-	Exit feed actuator (Not Spared)
7	-	Spring (Not Spared)
8	-	Stacker sensor bracket (Not Spared)
9	-	Idle feed roll assembly (Not Spared)
10	-	Idle feed shaft (Not Spared)
11	-	Idle feed roll (Not Spared)
12	-	Spring guide (Not Spared)
13	-	Feed guide (Not Spared)
14	-	Static eliminator (Not Spared)
15	-	Stacker full actuator (Not Spared)
16	-	Harness (Not Spared)

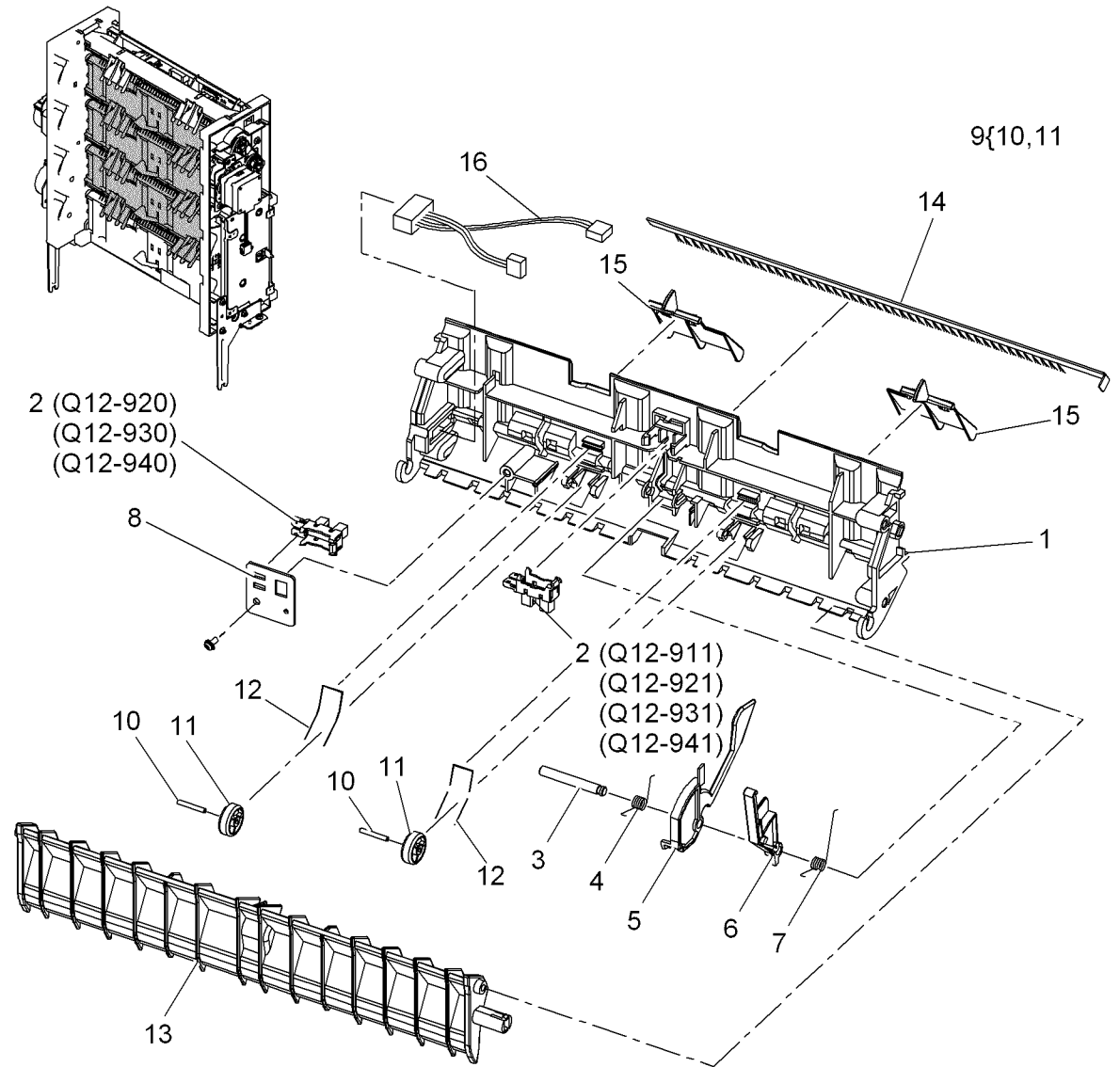

s4620-143

PL 11.40 Mailbox Base Assembly

Item	Part	Description
1	—	Bottom shield (Not Spared)
2	—	Entrance feed sensor (Q12-905)/ Stacker empty sensor (Q12-910) (Not Spared)
3	—	Entrance actuator assembly (Not Spared)
4	—	Shaft (Not Spared)
5	—	Entrance feed actuator (Not Spared)
6	—	Spring (Not Spared)
7	—	Stacker actuator shaft (Not Spared)
8	—	Spring (tray empty) (Not Spared)
9	—	Stacker empty actuator (Not Spared)
10	—	Exit feed actuator (Not Spared)
11	—	Spring (paper path) (Not Spared)
12	—	Harness (Not Spared)

NOTE: Order the entire Mailbox using Service part number 050K74190 or Sales part number 097N01877.

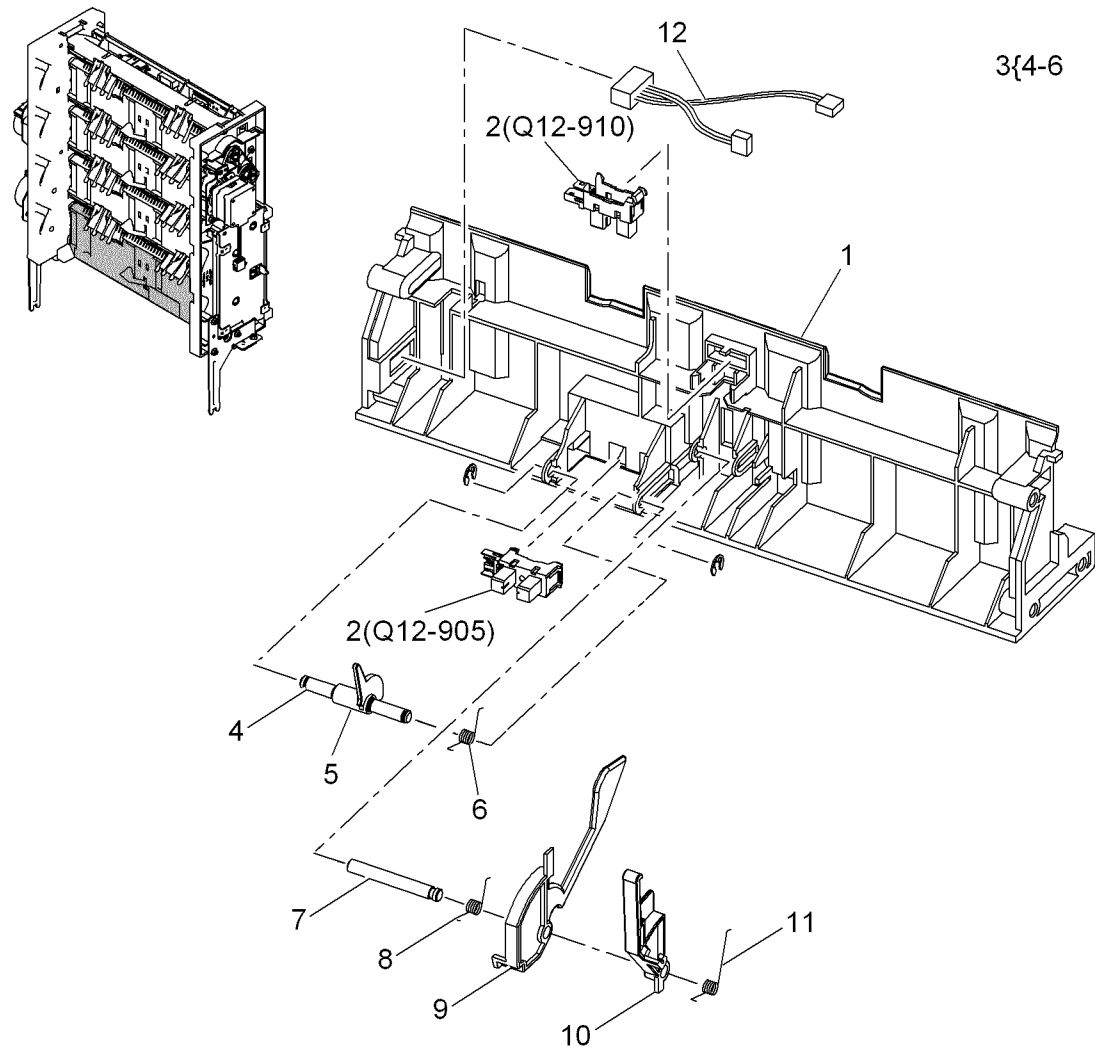

s4620-144

PL 12.10 Finisher Covers

Item	Part	Description
1	–	Left cover (Not Spared) (REP 12.1)
2	–	Right cover (Not Spared) (REP 12.11)
3	–	Option connector cover (Not Spared)
4	–	Rear door (Not Spared) (REP 12.17)
5	–	Bearing (Not Spared)
6	–	Top cover (Not Spared) (REP 12.18)

NOTE: Order the entire Finisher using Service part number 059K77910 or Sales part number 097N01876.

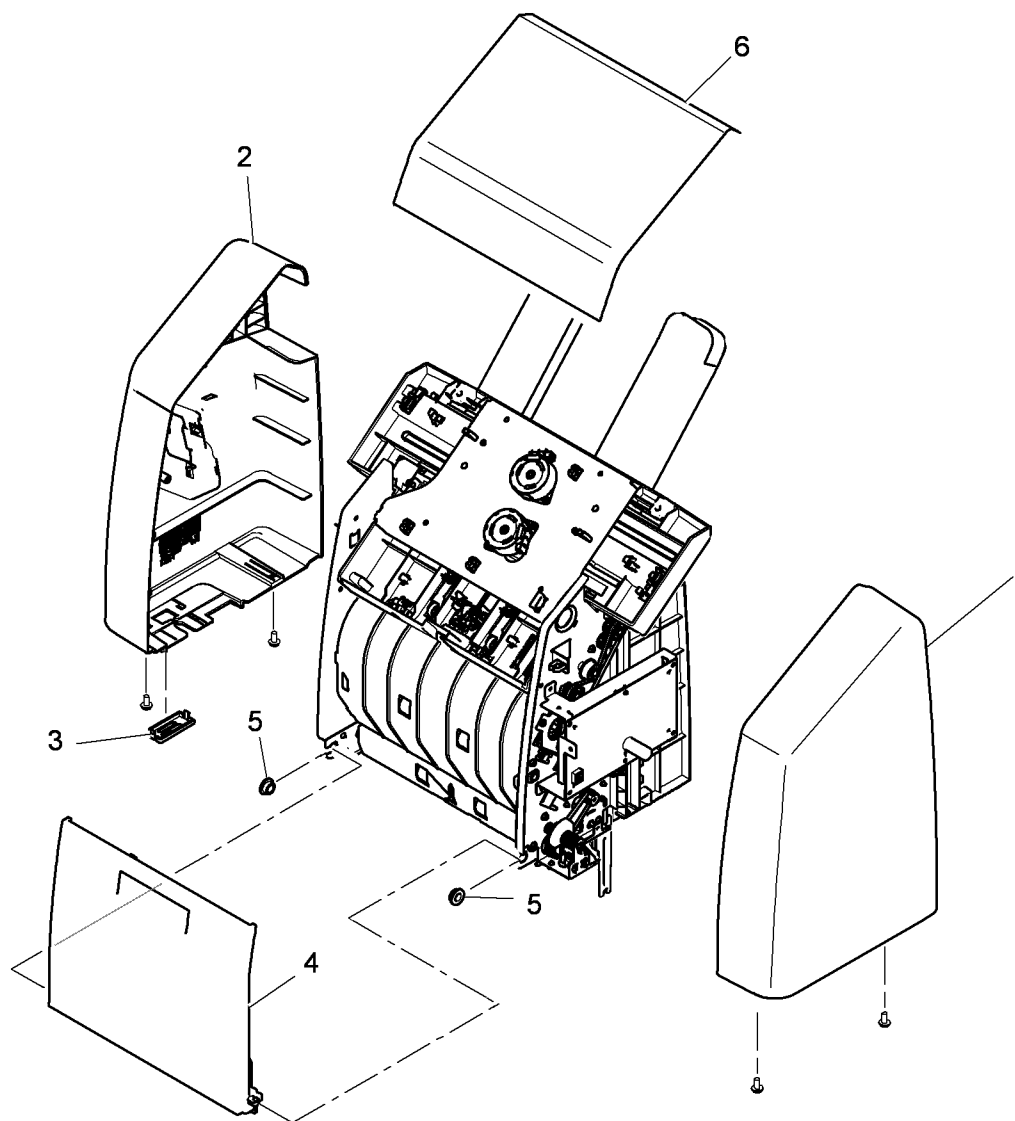

s4620-129

PL 12.15 Finisher Control Board

Item	Part	Description
1	-	Control board bracket (Not Spared) (REP 12.3)
2	140N63471	Control board (REP 12.2)
3	-	Stacker full sensor (Q12-845) (Not Spared) (REP 12.3)

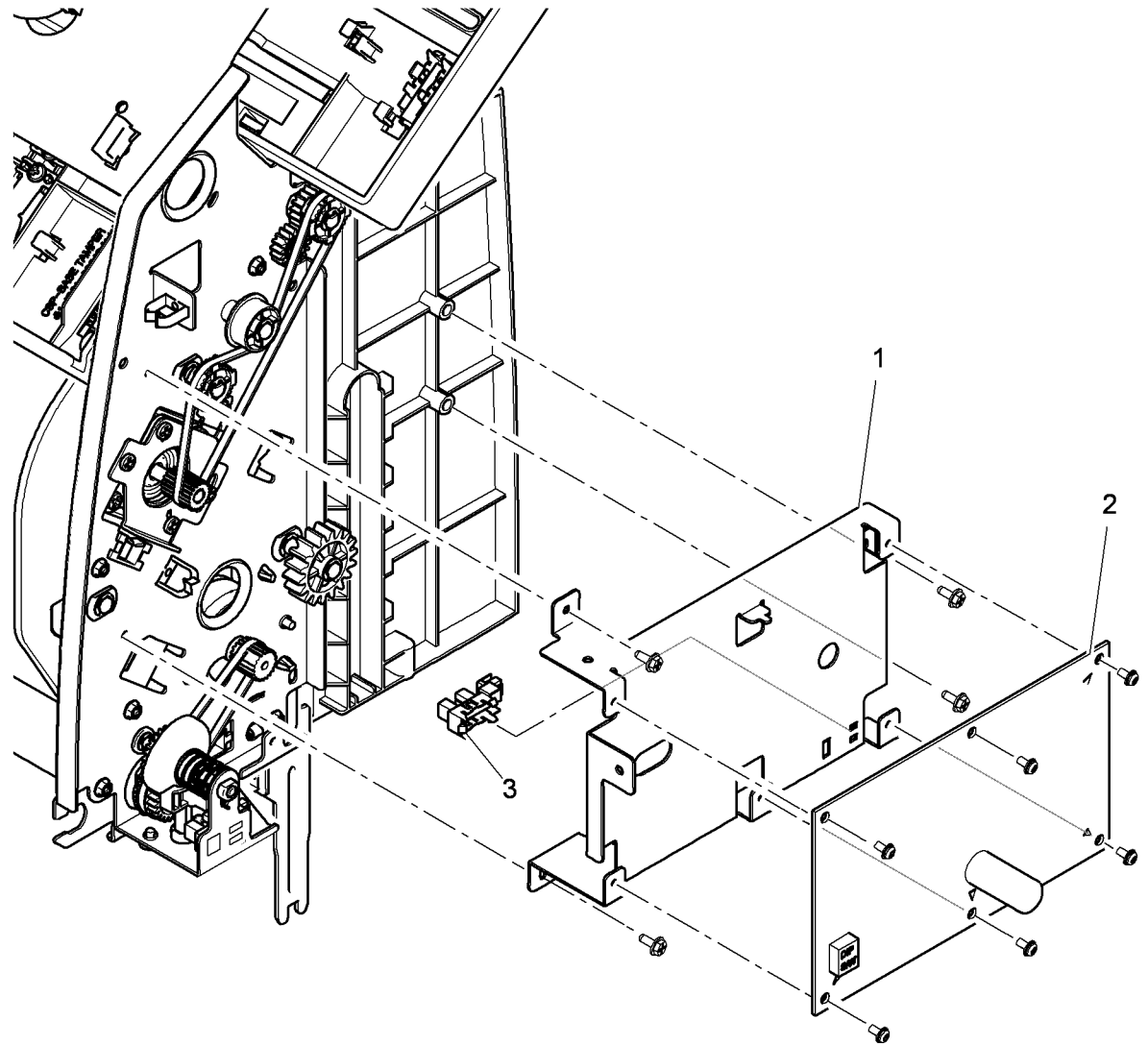

s4620-130

PL 12.20 Finisher Stacker Shield Assembly

Item	Part	Description
1	050N00559	Stacker shield assembly (REP 12.24)
2	—	Stacker tray (P/O PL 12.20 Item 1)
3	—	Left guide (P/O PL 12.20 Item 1)
4	—	Right guide (P/O PL 12.20 Item 1)
5	—	Bearing (P/O PL 12.20 Item 1)
6	—	Gear (P/O PL 12.20 Item 1)
7	—	Shaft (P/O PL 12.20 Item 1)
8	—	Guide roll (P/O PL 12.20 Item 1)

NOTE: Order the entire Finisher using Service part number 059K77910 or Sales part number 097N01876.

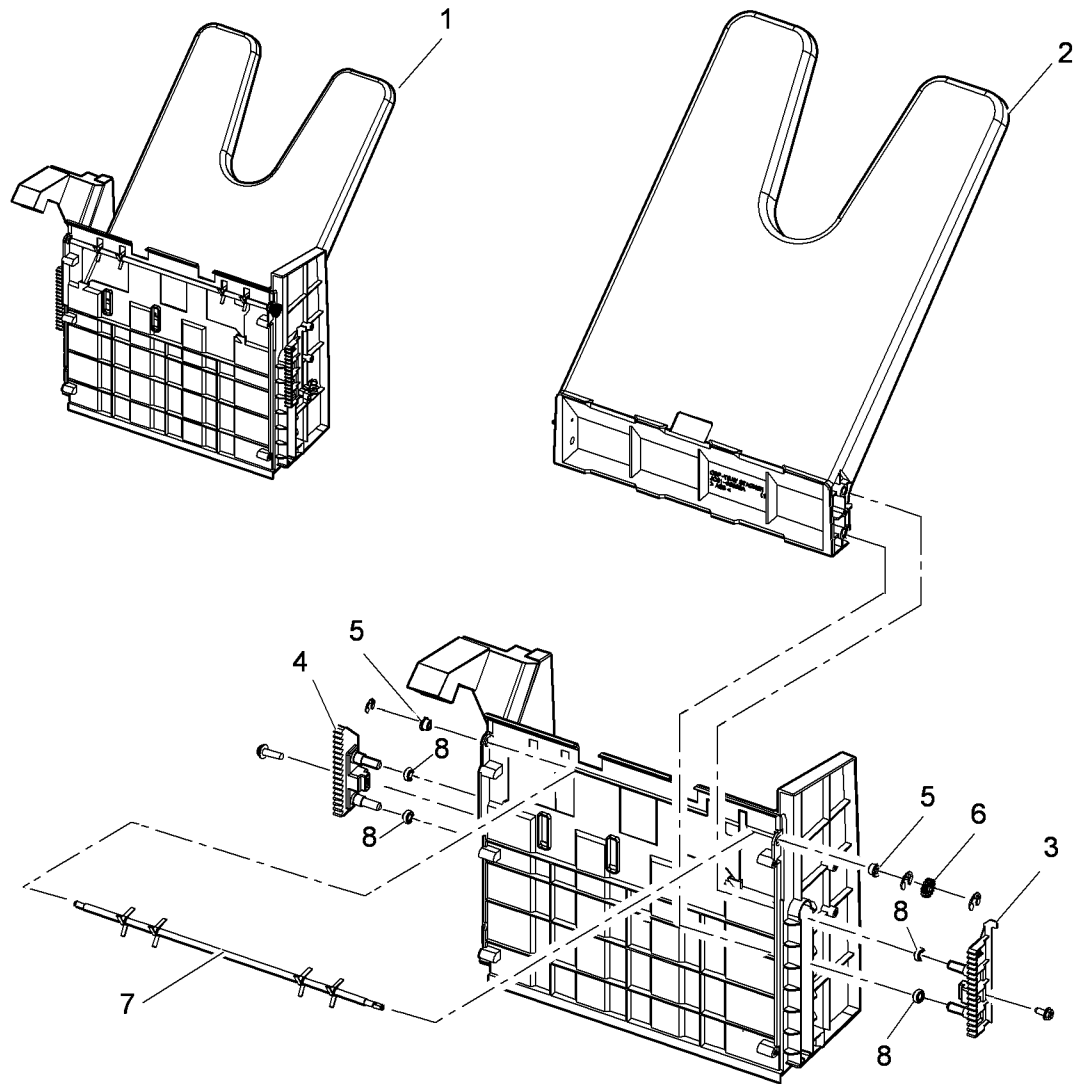

s4620-131

PL 12.25 Finisher Stacker Drive Assembly

Item	Part	Description
1	007N01668	Stacker drive assembly (REP 12.15)
2	—	Bearing (P/O PL 12.25 Item 1)
3	—	Collar (P/O PL 12.25 Item 1)
4	—	Shaft (P/O PL 12.25 Item 1)
5	—	Mounting bracket (P/O PL 12.25 Item 1)
6	—	Idle shaft (P/O PL 12.25 Item 1)
7	—	Idle gear (P/O PL 12.25 Item 1)
8	—	Transport motor (P/O PL 12.25 Item 1)
9	—	Drive gear (P/O PL 12.25 Item 1)
10	—	Drive belt (P/O PL 12.25 Item 1)
11	—	Securing bracket (P/O PL 12.25 Item 1)

NOTE: Order the entire Finisher using Service part number 059K77910 or Sales part number 097N01876.

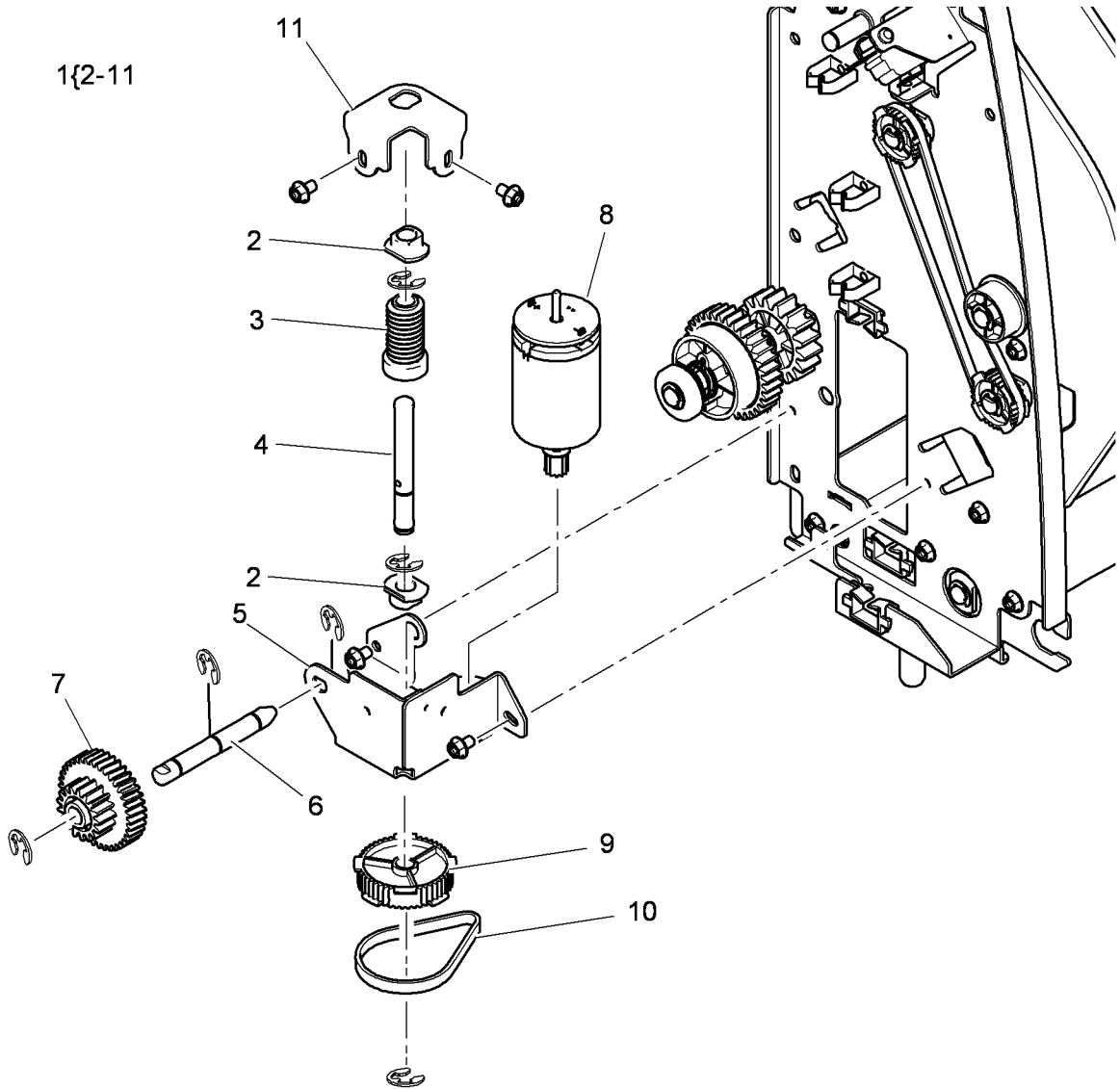

1{2-11

s4620-132

PL 12.30 Finisher Compile Tray Eject Assembly

Item	Part	Description
1	–	Extension tray assembly (Not Spared)
2	–	Clip (P/O PL 12.30 Item 1)
3	–	Tray (P/O PL 12.30 Item 1)
4	–	Right bracket (P/O PL 12.30 Item 1)
5	–	Roller (P/O PL 12.30 Item 1)
6	–	Link arm (P/O PL 12.30 Item 1)
7	–	Idle gear (P/O PL 12.30 Item 1)
8	–	Drive belt (P/O PL 12.30 Item 1)
9	–	Drive gear (P/O PL 12.30 Item 1)
10	–	Actuator (P/O PL 12.30 Item 1)
11	–	Mounting plate (P/O PL 12.30 Item 1)
12	–	Drive motor (MOT12-400) (P/O PL 12.30 Item 1)
13	–	Left bracket (P/O PL 12.30 Item 1)
14	–	Support finger home sensor (Q12-825)/Stacker top sensor (Q12-840) (P/O PL 12.30 Item 1)

NOTE: Order the entire Finisher using Service part number 059K77910 or Sales part number 097N01876.

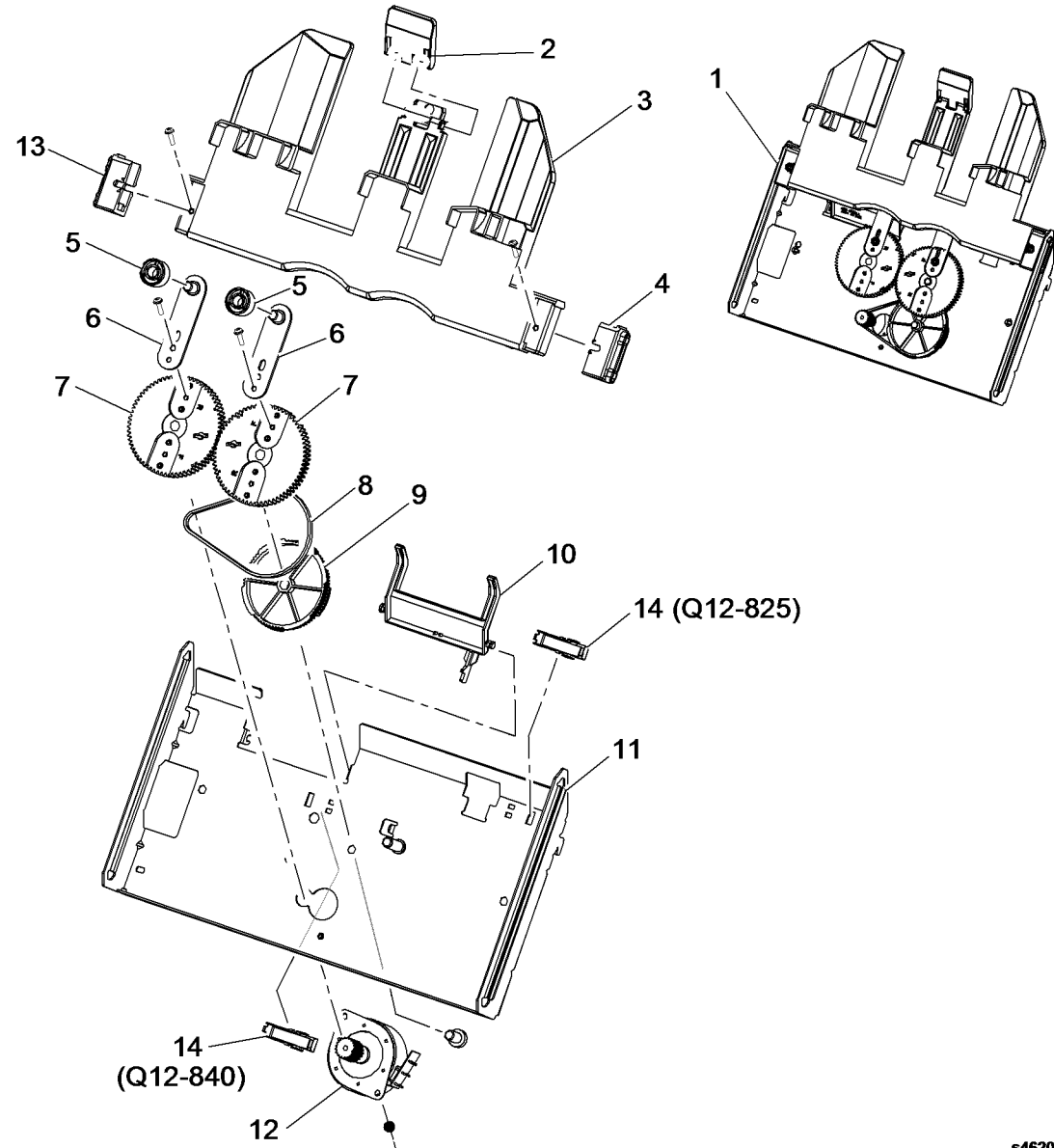

s4620-133

PL 12.35 Finisher Compile Tray Assembly

Item	Part	Description
1	022N02482	Compile tray assembly (REP 12.23)
2	-	Left guide (P/O PL 12.35 Item 1)
3	-	Right guide (P/O PL 12.35 Item 1)
4	-	Mylar guide (P/O PL 12.35 Item 1)
5	-	Left rack (P/O PL 12.35 Item 1)
6	-	Right rack (P/O PL 12.35 Item 1)
7	-	Static eliminator (P/O PL 12.35 Item 1)
8	-	Compile tray (P/O PL 12.35 Item 1)
9	-	Idle roll (P/O PL 12.35 Item 1)
10	-	Left tamper home position sensor (Q12-820)(REP 12.10)/Rear door open sensor (Q12-895)(REP 12.20)/Right tamper home position sensor (Q12-815)(REP 12.12)/Exit sensor (Q12-805)(REP 12.21)
11	-	Exit sensor actuator (P/O PL 12.35 Item 1) (REP 12.22)
12	-	Spring (P/O PL 12.35 Item 1)
13	-	Drive gear (P/O PL 12.35 Item 1)
14	-	Not used
15	-	Tamper link arm (P/O PL 12.35 Item 1)
16	-	Shaft (P/O PL 12.35 Item 1)
17	-	Not used
18	-	Mounting bracket (P/O PL 12.35 Item 1)
19	-	Right tamper motor (MOT12-300)/Left tamper motor (MOT12-320) (P/O PL 12.35 Item 1) (REP 12.19)

NOTE: Order the entire Finisher using Service part number 059K77910 or Sales part number 097N01876.

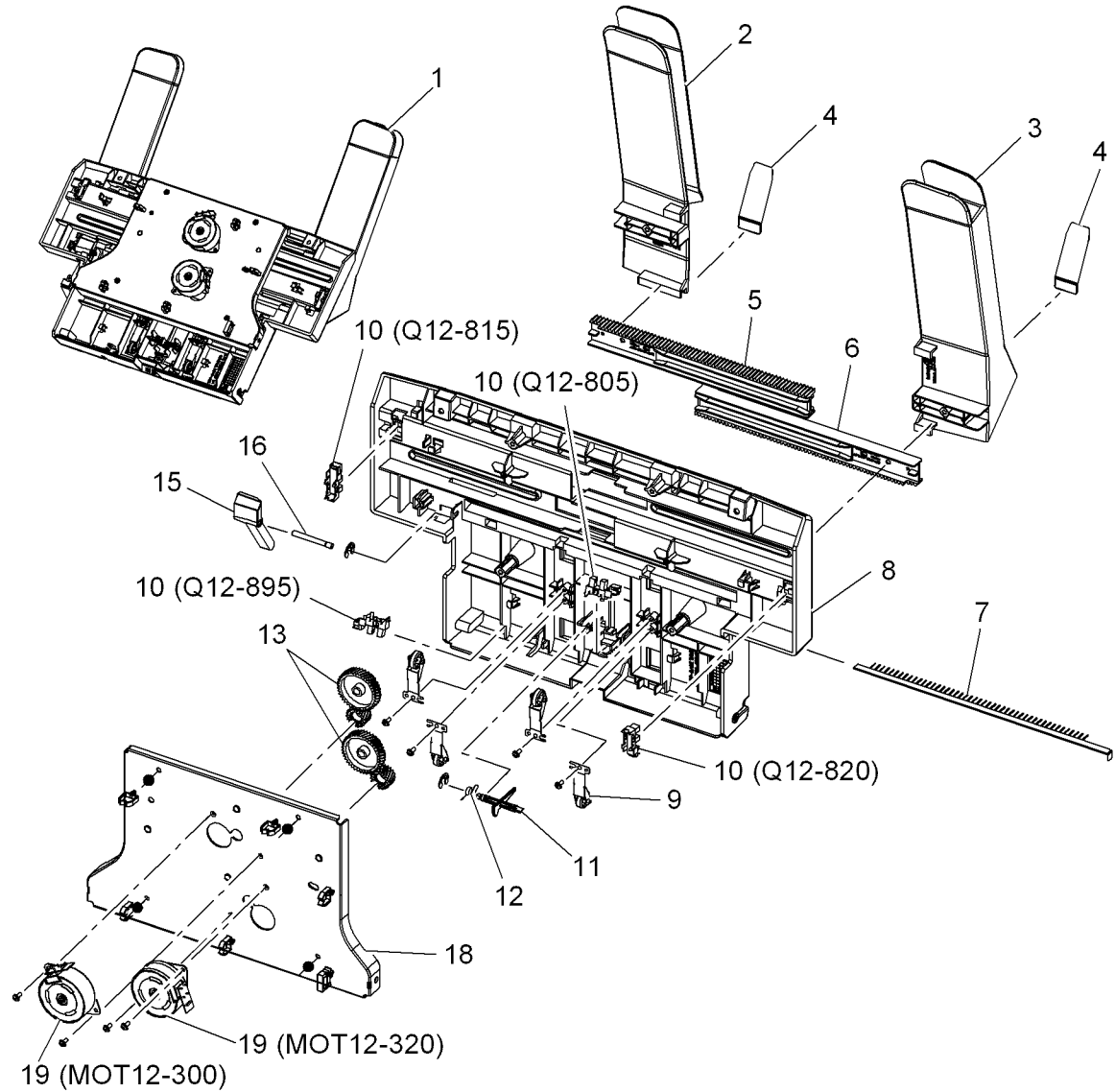

s4620-134

PL 12.40 Finisher Transport Drive Assembly

Item	Part	Description
1	-	Transport drive assembly (Not Spared) (REP 12.5)
2	-	Front frame (P/O PL 12.40 Item 1)
3	-	Rear frame (P/O PL 12.40 Item 1)
4	-	Feed roll 1 (P/O PL 12.40 Item 1)
5	-	Feed roll 2 (P/O PL 12.40 Item 1)
6	-	Feed roll 3 (P/O PL 12.40 Item 1)
7	-	Feed roll 4 (P/O PL 12.40 Item 1)
8	-	Transport motor (MOT12-110) (P/O PL 12.40 Item 1) (REP 12.5)
9	-	Bracket (P/O PL 12.40 Item 1)
10	-	Entrance motor (MOT12-100) (P/O PL 12.40 Item 1)
11	-	Bearing (P/O PL 12.40 Item 1)
12	-	Drive gear (P/O PL 12.40 Item 1)
13	-	Idle pulley (P/O PL 12.40 Item 1)
14	-	Idle gear (P/O PL 12.40 Item 1)
15	-	Motor bracket (P/O PL 12.40 Item 1)
16	023N01283	Entrance drive belt (REP 12.8)
17	-	Transport drive belt (P/O PL 12.40 Item 1) (REP 12.5)
18	-	Exit gate sensor (Q12-900)(/ Finisher entrance sensor (Q12-800)(REP 12.21) (Not Spared)
19	-	Exit gate sensor actuator (P/O PL 12.40 Item 1) (REP 12.7)
20	-	Actuator bearing (P/O PL 12.40 Item 1)
21	-	Plastic washer (P/O PL 12.40 Item 1)
22	-	Lower drive gear (P/O PL 12.40 Item 1)
23	-	Bearing (P/O PL 12.40 Item 1)
24	-	Lower idle gear (P/O PL 12.40 Item 1)
25	-	Exit gate cam shaft (P/O PL 12.40 Item 1) (REP 12.9)
26	-	Cam (P/O PL 12.40 Item 1)
27	-	Spring (P/O PL 12.40 Item 1)
28	-	Lower frame (P/O PL 12.40 Item 1)
29	-	Entrance sensor actuator (P/O PL 12.40 Item 1) (REP 12.22)
30	-	Inner rear cover (P/O PL 12.40 Item 1)
31	023N01284	Rear drive belt
32	-	Ground strip (P/O PL 12.40 Item 1)

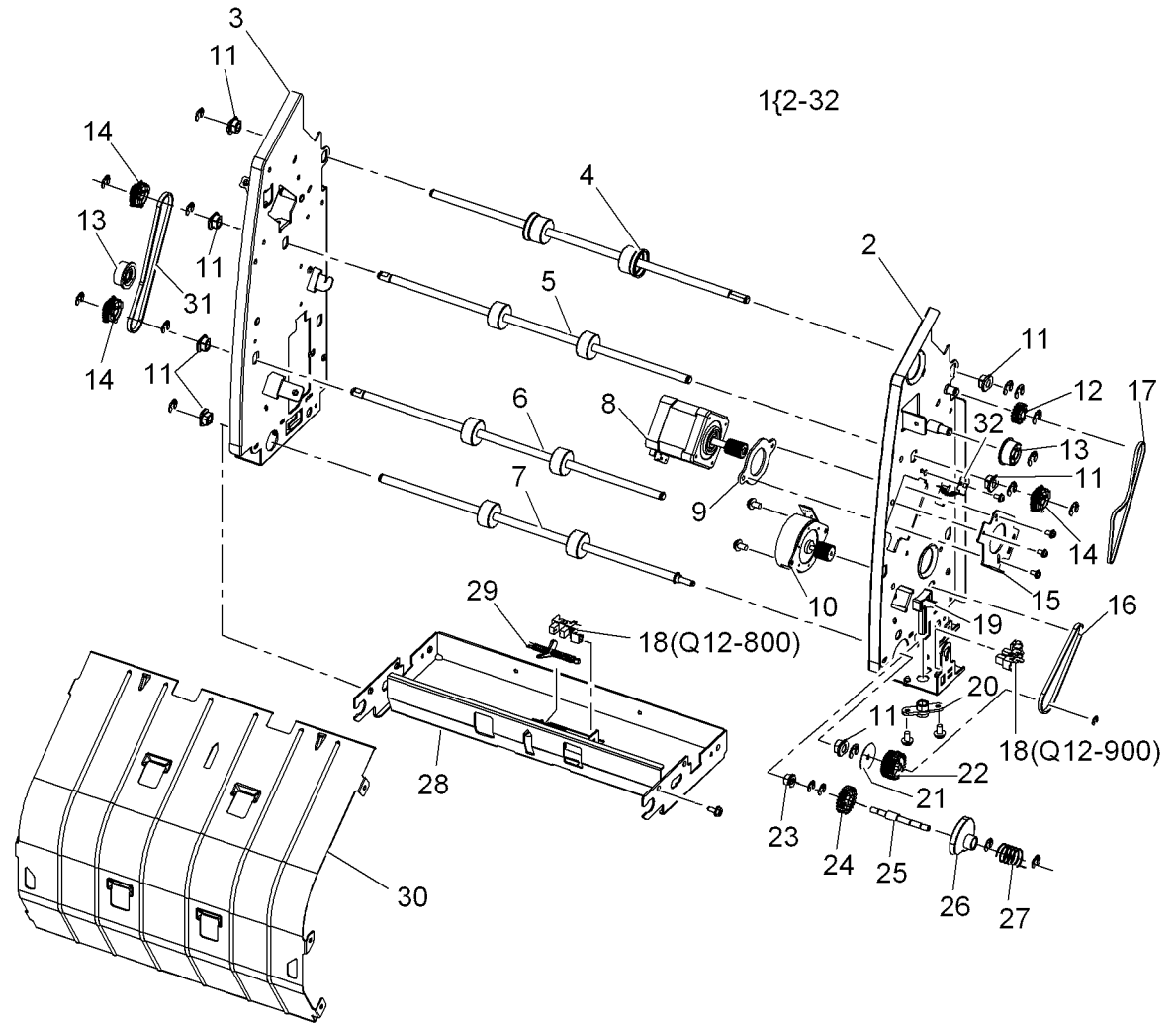

s4620-135

PL 12.45 Finisher Stapler Assembly

Item	Part	Description
1	029N00417	Stapler assembly (REP 12.14)
2	—	Stapler bracket (P/O PL 12.45 Item 1)
3	—	Stapler (P/O PL 12.45 Item 1)
4	—	Staple cartridge door interlock switch (S12-870) (Not Spared) (REP 12.13)
5	—	Staple interlock switch (S12-890) (Not Spared) (REP 12.16)

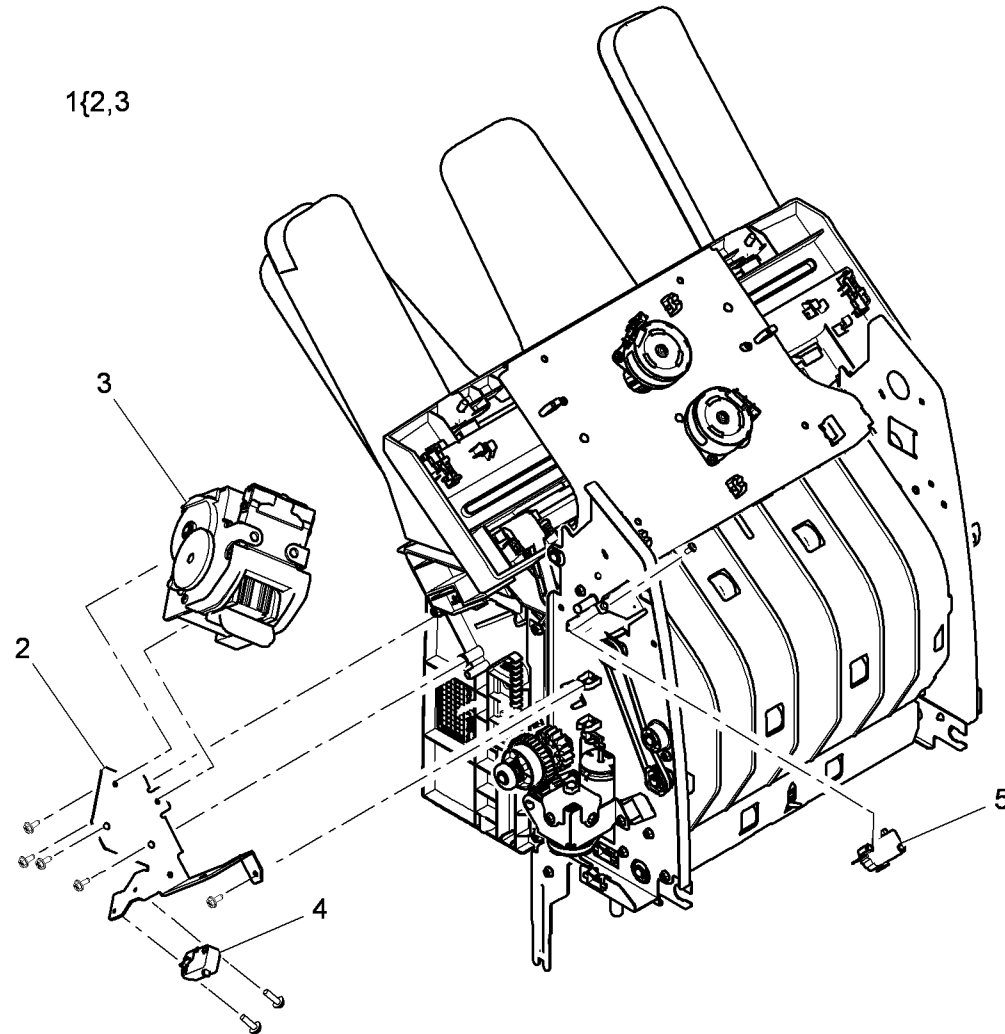

s4620-136

PL 28.10 Main Covers

Item	Part	Description
1	002N02984	Left cover (REP 28.3)
2	002N03024	Waste toner box cover
3	002N02996	Rear door assembly (REP 28.1)
4	002N02986	Right cover (REP 28.2)
5	002N02995	Front cover assembly (REF: PL 28.20 Item 2) (REP 28.4)
6	002N02985	IP board cover (REP 28.1)
7	—	Top cover (REF: PL 28.15 Item 9) (REP 28.5)
8	—	Right fan cover (Not Spared)
9	—	Option cover (Not Spared)
10	035N00428	Right seal filter
11	—	Rear support bracket (Not Spared)

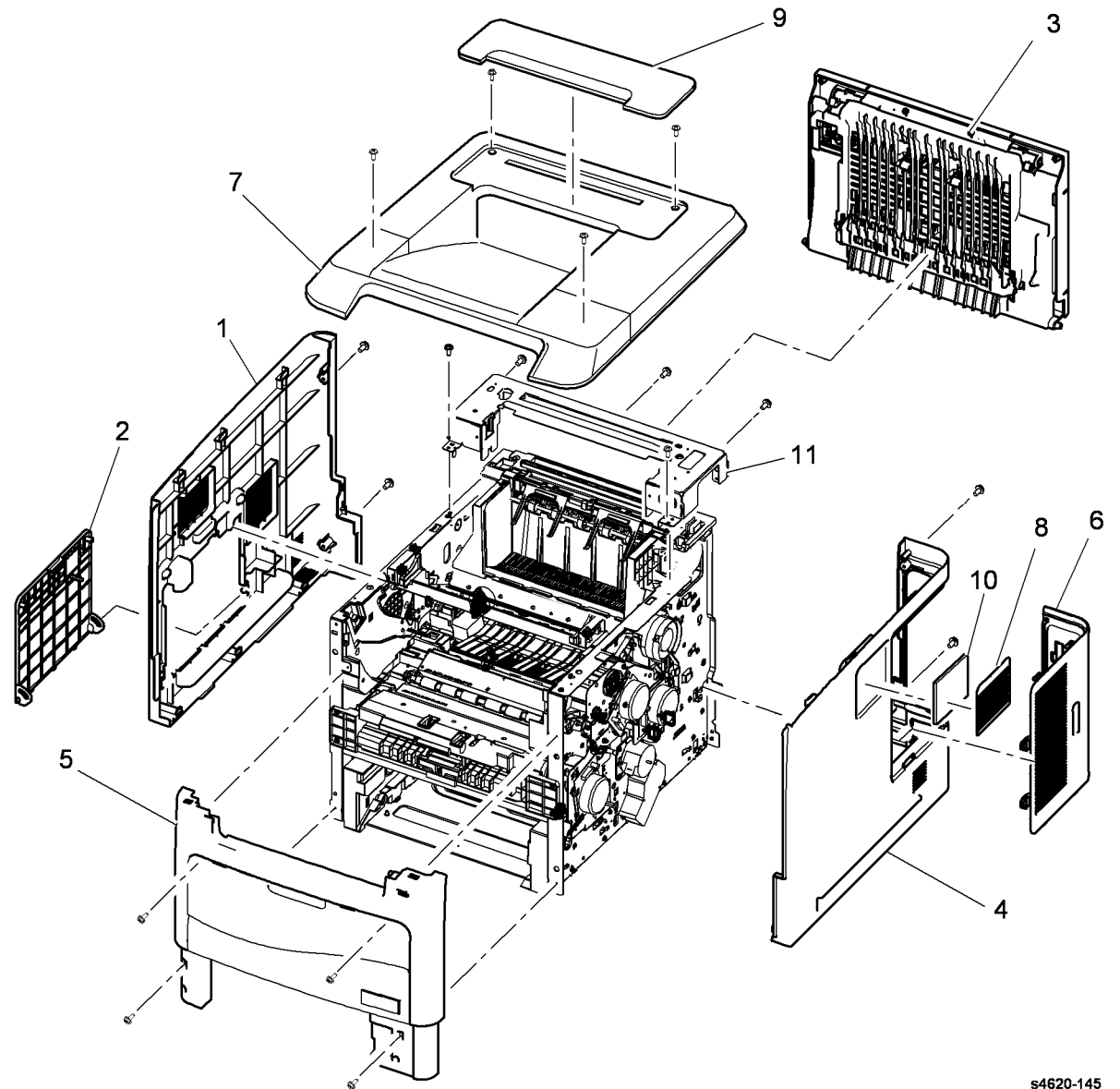

s4620-145

PL 28.15 Top Cover Assembly

Item	Part	Description
1	002N02981	Top cover
2	130N01399	Top door interlock switch (Q01-100) (REP 1.6)
3	—	Hinge stopper (P/O PL 28.15 Item 9)
4	—	Harness cover (P/O PL 28.15 Item 9)
5	—	Control panel assembly (REF: PL 2.10 Item 1)
6	—	Top door (P/O PL 28.15 Item 9)
7	—	Exit gate actuator (P/O PL 28.15 Item 9)
8	—	Stacker guide (P/O PL 28.15 Item 9)
9	002N02982	Top cover assembly

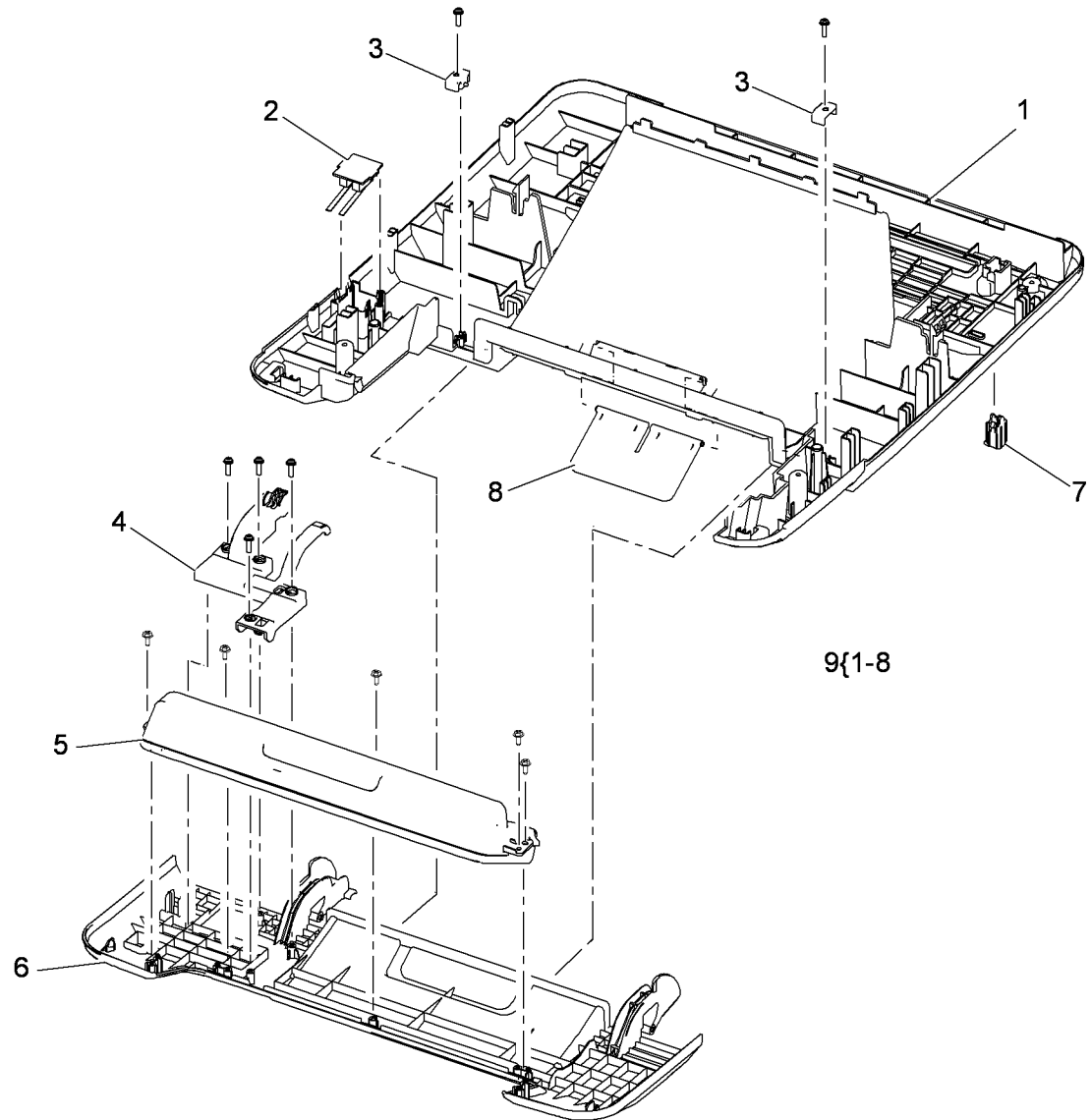

s4620-146

PL 28.20 Front Cover Assembly

Item	Part	Description
1	—	Front cover assembly (REF:) (REP 28.4)
2	—	Front cover (P/O)
3	—	Tray 1 cover (P/O PL 28.20 Item 1)
4	—	Tray 1 paper guide assembly (P/O PL 28.20 Item 1)
5	002N02991	Tray 1 stacker
6	—	Tray 1 extension tray (P/O PL 28.20 Item 1)
7	—	USB host holder (P/O PL 28.20 Item 1)
8	140N63464	USB host board (REP 28.9)

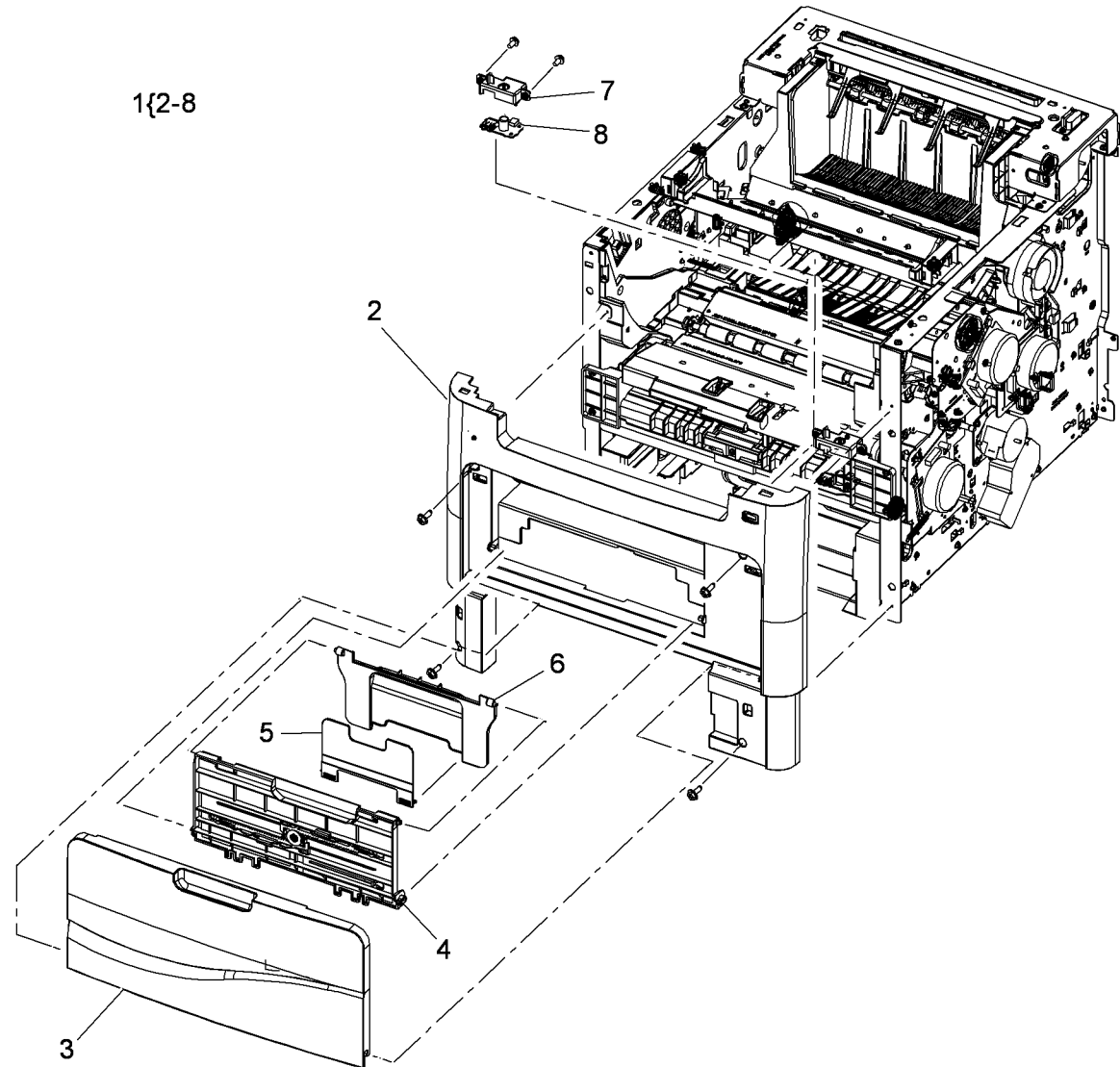

s4620-147

PL 28.25 Rear Door Assembly

Item	Part	Description
1	002N02996	Rear door assembly (REP 28.5)
2	-	Rear cover (P/O)
3	-	Rear guide (P/O PL 28.15 Item 1)
4	-	Exit guide (P/O PL 28.15 Item 1)
5	-	Rear left locker (P/O PL 28.15 Item 1)
6	-	Rear right locker (P/O PL 28.15 Item 1)
7	-	Spring (P/O PL 28.15 Item 1)
8	-	Handle bracket (P/O PL 28.15 Item 1)
9	-	Rear cover handle (P/O PL 28.15 Item 1)
10	-	Handle sponge (P/O PL 28.15 Item 1)
11	-	Locker handle (P/O PL 28.15 Item 1)
12	-	Not used
13	127N07668	Rear door fan (MOT10-500) (REP 28.7)
14	-	Tension spring (P/O PL 28.15 Item 1)
15	-	Roller (P/O PL 28.15 Item 1)
16	-	Idle shaft (P/O PL 28.15 Item 1)
17	-	Damper pad (P/O PL 28.15 Item 1)
18	-	Female bracket (P/O PL 28.15 Item 1)
19	-	Rear door switch (Q01-300) (P/O PL 28.15 Item 1)

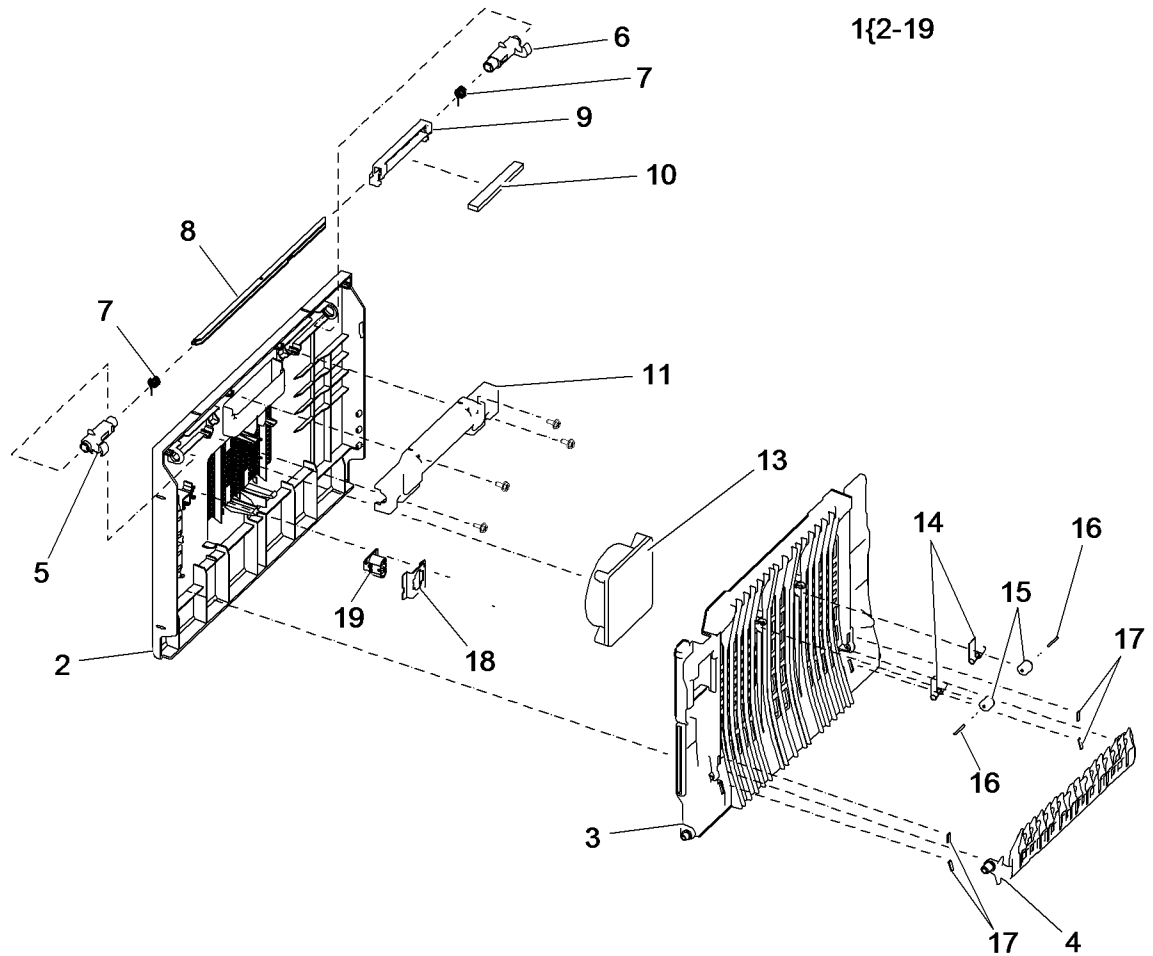

s4620-148

Supplies, Options and Accessories

Listed below are 4600/4620 supplies, options and accessories.

- Maintenance Kit (Fuser, Transfer Roller, Feed Rollers)
 - 115R00063 110V
 - 115R00070 220V
- Staple Cartridge 008R12941

Table 1 Options and Accessories

Item	Service Part Number	Sales Part Number
520-Sheet Feeder	050K74180	097N01874
2000-Sheet Feeder	059K77920	097N01875
Finisher (500-Sheet)	059K77910	097N01876
Mailbox (400-Sheet)	050K74190	097N01877
Duplex Unit	022N02484	097N01923
Memory Upgrade	128K01770	097N01878
160MB Hard Disk	007N01651	097N01879
Wireless Network Adaptor	120K03640	097N01880
Stand	078K00870	097N01916