

Phaser® 3610, WorkCentre® 3615
Service Manual



**Fault Code Sample:
093-925**

Phaser® 3610, WorkCentre® 3615 Service Manual **Updated 8/27/15 DAW**

August 2015



Prepared By:
Xerox Corporation
Content Development and Language Services - North America
800 Phillips Road
Webster, NY
14580

© 2013 by Xerox Corporation. All rights reserved. Unpublished rights reserved under the copyright laws of the United States. Contents of this publication may not be reproduced in any form without permission of Xerox Corporation.

Copyright protection claimed includes all forms and matters of copyrightable materials and information now allowed by statutory or judicial law or hereinafter granted, including without limitation, material generated from the software programs which are displayed on the screen such as styles, templates, icons, screen displays, looks, etc.

Xerox technical training materials and service manuals are intended for use by authorized Xerox service technicians and service partners only and are not for resale. These materials may not be distributed, copied, or otherwise reproduced without prior written consent from Xerox Corporation.

Xerox®, the sphere of connectivity design, ColorQube®, Phaser®, CentreWare®, Printing Scout®, Walk-Up®, Global Print Driver, and Mobile Express Driver are trademarks of Xerox Corporation in the United States and/or other countries.

Adobe® Reader®, Adobe Type Manager®, ATM™, Flash®, Macromedia®, Photoshop®, and PostScript® are trademarks of Adobe Systems Incorporated in the United States and/or other countries.

Apple®, AppleTalk®, Bonjour®, EtherTalk®, Macintosh®, Mac OS®, and TrueType® are trademarks of Apple Computer, Inc. in the United States and/or other countries.

HP-GL®, HP-UJ®, and PCL® are trademarks of Hewlett-Packard Corporation in the United States and/or other countries.

IBM® and AIX® are trademarks of International Business Machines Corporation in the United States and/or other countries.

Microsoft® Windows Vista®, Windows®, and Windows Server™ are trademarks of Microsoft Corporation in the United States and/or other countries.

Novell®, NetWare®, NDPS®, NDS®, Novell Directory Services®, IPX™, and Novell Distributed Print Services™ are trademarks of Novell, Incorporated in the United States and/or other countries.

SGI® IRIX® is a trademark of Silicon Graphics, Inc.

SunSM, Sun Microsystems™, and Solaris™ are trademarks of Sun Microsystems, Incorporated in the United States and/or other countries.

UNIX® is a registered trademark in the US and other countries, licensed exclusively through X/Open Company Limited.

PANTONE® and other Pantone, Inc. trademarks are the property of Pantone, Inc. © Pantone, Inc.

PANTONE® Colors generated may not match PANTONE-identified standards. Consult current PANTONE Publications for accurate color. PANTONE® and other Pantone, Inc. trademarks are the property of Pantone, Inc. © Pantone, Inc., 2000.

Table of Contents

1. PRODUCT OVERVIEW	
About this Service Manual	1-2
Service Manual Revision	1-2
Technical Support Information	1-2
Manual Terms	1-2
Manual Organization	1-3
Safety	1-4
Power Safety Precautions	1-4
Power Source	1-4
Disconnecting Power	1-4
Electrostatic Discharge (ESD) Precautions	1-5
Service Safety Summary	1-6
General Guidelines	1-6
Warning Labels	1-6
Safety Interlocks	1-6
Servicing Mechanical Components	1-7
Servicing Fuser Components	1-7
Printer Location	1-8
Operational Guidelines	1-8
Printer Supplies	1-8
Maintenance Safety	1-9
Printer Symbols	1-9
Introduction	1-11
Phaser 3610 Configurations	1-12
WorkCentre 3615 Configurations	1-13
Printer Options	1-14
Additional Memory	1-14
Optional 550-Sheet Feeder (Trays 2, 3, and 4)	1-14
External Wireless Network Adapter	1-14
Control Panel (3610)	1-15
Control Panel Layout (3615)	1-16
Operational Modes	1-17
Running Mode	1-17
Ready Mode	1-17
Low Power Mode	1-17
Sleep Mode	1-17
Media Path	1-18
Media Path Components	1-21

Major Component Locations	1-25
Illustration 1 (3610 / 3615)	1-26
Illustration 2 (3610 / 3615)	1-27
Illustration 3 (3610 / 3615)	1-28
Illustration 4 (3610 / 3615)	1-29
Illustration 5 (3610 / 3615)	1-30
Illustration 6 (3610 / 3615)	1-31
Illustration 7 (3610 / 3615)	1-32
Illustration 8 (3615 only).....	1-33
Illustration 9 (3615 only).....	1-34
Illustration 10 (3615 only)	1-35
Illustration 11 (Tray 1).....	1-36
Illustration 12 (Tray 1).....	1-37
Information Pages	1-38
2. TROUBLESHOOTING	
Introduction	2-2
Flow of Troubleshooting	2-2
Servicing Instructions.....	2-3
Check Installation Status.....	2-4
Initial Actions	2-4
Display Problems	2-4
Printing Problems.....	2-5
Copy/Scan Problems.....	2-5
DADF Problems.....	2-6
Fax Problems.....	2-6
Media-Based Problems.....	2-6
Multiple-Sheet Pick or MisPick	2-7
Skewed Image	2-7
Damaged Prints	2-7
Wrinkled Envelopes	2-8
Fuser Jams	2-8
Exit Jams	2-8
Service Diagnostics.....	2-9
How To Enter Service Mode	2-9
Phaser 3610	2-9
WorkCentre 3615	2-9
Service Mode Menu Map.....	2-10
Engine Diagnostic Testing	2-14
Sensor Test (Digital Output).....	2-14
Motor Test (Digital Output)	2-15
Administration Mode Menu Map	2-17
Status Code List (3610).....	2-19
Status Code List (3615).....	2-44

Error Code Fault Isolation Procedures (FIP).....	2-125
FIP 1. 01 / 004-310 IOT Option Feeder I/F Failure	2-125
FIP 1. 02 / 005-110 PICKUP JAM	2-126
FIP 1. 03 / 005-301 DADF Cover Open	2-127
FIP 1. 04 / 010-397 FUSING ASSEMBLY Failure	2-128
FIP 1. 08 / 016-338 Wireless Option Error	2-129
FIP 1. 09 / 016-359 MRAM Fail	2-130
FIP 1. 10 / 016-369 UI Panel - ESS Communication Fail	2-130
FIP 1. 11 / 016-404 Certificate DB Error.....	2-131
FIP 1. 12 / 016-405 Certificate DB Error	2-131
FIP 1. 13 / 016-500 Download Delete Error.....	2-132
FIP 1. 14 / 016-501 Download Write Error	2-132
FIP 1. 15 / 016-502 Download Verify Error	2-132
FIP 1. 16 / 016-503 SMTP Server Address Resolution Fail for Maillib.....	2-133
FIP 1. 17 / 016-504 POP Server Address Resolution Fail for Maillib	2-133
FIP 1. 18 / 016-505 POP Authentication Fail for Maillib	2-134
FIP 1. 19 / 016-506 Required user entry item is empty	2-134
FIP 1. 20 / 016-507 SMTP Authentication Fail for Maillib	2-135
FIP 1. 21 / 016-520 Isec Certificate Error.....	2-135
FIP 1. 22 / 016-521 Isec Certificate Error.....	2-135
FIP 1. 23 / 016-522 LDAP Certificate Error	2-136
FIP 1. 24 / 016-523 LDAP Certificate Error	2-136
FIP 1. 25 / 016-524 LDAP Certificate Error	2-136
FIP 1. 26 / 016-527 LDAP Certificate Error	2-137
FIP 1. 27 / 016-530 LDAP Address Book- Access Error	2-137
FIP 1. 28 / 016-541 Wireless Certificate Error	2-137
FIP 1. 29 / 016-542 Wireless Certificate Error.....	2-138
FIP 1. 30 / 016-543 Wireless Certificate Error	2-138
FIP 1. 31 / 016-570 Job Ticket Out Of Memory	2-138
FIP 1. 32 / 016-571 Job ticket wrong	2-139
FIP 1. 33 / 016-572 Job ticket media error	2-139
FIP 1. 34 / 016-573 Job ticket parse error	2-139
FIP 1. 35 / 016-602 System NVM Initialize	2-139
FIP 1. 36 / 016-603 ESS-NVM Parameter The machine will recover	2-140
FIP 1. 37 / 016-604 ESS-NVM Parameter Copy	2-140
FIP 1. 38 / 016-605 ESS-NVM Parameter Copy	2-140
FIP 1. 39 / 016-606 Clear Job History	2-140
FIP 1. 40 / 016-610 Panel Destination Mismatch	2-141
FIP 1. 41 / 016-612 Invalid MAC Address	2-141
FIP 1. 42 / 016- 718 Memory Over flow	2-141
FIP 1. 43 / 016- 720 PDL Error	2-142
FIP 1. 44 / 016-734 Download Signature Error.....	2-142
FIP 1. 45 / 016-737 Download Format Error	2-143
FIP 1. 46 / 016-741 Download Protect Error	2-143
FIP 1. 47 / 016-742 Download ID Error	2-144
FIP 1. 48 / 016- 743 Download Range Error	2-144
FIP 1. 49 / 016-744 Download Check Sum Error	2-145
FIP 1. 50 / 016-745 Download header Error	2-145
FIP 1. 51 / 016-746 Prohibit Error	2-146

FIP 1. 52 / 016-750 Job Ticket Error	2-146
FIP 1. 53 / 016-753 Wrong Password	2-146
FIP 1. 54 / 016-755 PDF Print Disabled	2-147
FIP 1. 55 / 016-758 Auditron - Disabled Function	2-147
FIP 1. 57 / 016-759 Auditron - Reached Limit	2-148
FIP 1. 58 / 016-764 SMTP Server Connection Error	2-148
FIP 1. 59 / 016-765 SMTP Server HD Full	2-149
FIP 1. 60 / 016-766 SMTP Server File System Error	2-149
FIP 1. 61 / 016-767 Invalid Recipient Email Address	2-150
FIP 1. 62 / 016-768 Invalid Sender Address (Login Error)	2-150
FIP 1. 63 / 016-786 Data Send/Receive Timeout Error	2-151
FIP 1. 64 / 016-790 F2N Module Starting-up	2-151
FIP 1. 65 / 016-791 USB Memory Removal Error (During Read)	2-152
FIP 1. 66 / 016-799 Job Environment Violation	2-152
FIP 1. 67 / 016-923 Wireless Password Error	2-153
FIP 1. 68 / 016-924 Wireless Setting Error	2-153
FIP 1. 69 / 016-930 USB Host Error	2-153
FIP 1. 70 / 016-931 USB Hub Error	2-154
FIP 1. 71 / 016-982 Disk Full	2-154
FIP 1. 72 / 016-985 Mail Size Error	2-155
FIP 1. 73 / 016-986 File Size Error	2-155
FIP 1. 74 / 017-321 SD CARD Type Invalid Error	2-156
FIP 1. 75 / 017-600 Address Info Sum Check Fail	2-156
FIP 1. 76 / 017-970 FAX Memory Full	2-157
FIP 1. 77 / 017-971 FAX Controller Error	2-157
FIP 1. 78 / 017-972 FAX Controller Error	2-158
FIP 1. 79 / 017-973 FAX Controller Error	2-158
FIP 1. 80 / 017-974 FAX Controller Error	2-159
FIP 1. 81 / 017-975 FAX Controller Error	2-159
FIP 1. 82 / 017-976 FAX Controller Error	2-160
FIP 1. 83 / 017-977 FAX Controller Error	2-160
FIP 1. 84 / 017-978 FAX Controller Error	2-161
FIP 1. 85 / 017-979 FAX Controller Error	2-161
FIP 1. 86 / 017-980 Report File Open/Close Error	2-162
FIP 1. 87 / 017-983 EEPROM R/W Error	2-162
FIP 1. 88 / 017-986 FAX Controller Error	2-162
FIP 1. 89 / 017-987 FAX Controller Error	2-163
FIP 1. 90 / 017-988 Scan Time Out	2-163
FIP 1. 91 / 017-989 FAX Controller Error	2-164
FIP 1. 92 / 017-990 IIT Auto Registration Adjustment Fail	2-164
FIP 1. 93 / 017-991 IIT Level Adjustment Fail	2-165
FIP 1. 94 / 018-722 Google Cloud Print Network Error	2-165
FIP 1. 95 / 018-723 Google Cloud Print Certificate Error	2-166
FIP 1. 96 / 018-724 Google Cloud Print SSL Error	2-166
FIP 1. 97 / 018-729 Google Cloud Print Timeout Error	2-167
FIP 1. 98 / 018-730 Google Cloud Print Network Other Error	2-167
FIP 1. 99 / 018-737 Google Cloud Print Other Error	2-168
FIP 1. 100 / 018-738 Google Cloud Print XMPP Network Error	2-168
FIP 1. 101 / 018-739 Google Cloud Print XMPP Network Other Error	2-169
FIP 1. 102 / 018-740 Google Cloud Print XMPP Certificate Error	2-169

FIP 1. 103 / 018-741 Google Cloud Print XMPP Other Error	2-170
FIP 1. 104 / 018-743 Google Cloud Print Proxy Error	2-170
FIP 1. 105 / 018-744 Google Cloud Print DNS Resolve Error	2-171
FIP 1. 106 / 018-745 Google Cloud Print XMPP Proxy Error	2-171
FIP 1. 107 / 018-746 Google Cloud Print XMPP DNS Resolve Error	2-172
FIP 1. 108 / 024-340 Engine Controller Error	2-172
FIP 1. 109 / 024-360 Engine Code DownLoad Error	2-173
FIP 1. 110 / 024-362 Print Engine Start Error	2-173
FIP 1. 111 / 024-371 Engine Communication Error	2-173
FIP 1. 112 / 024-910 Tray 1 Paper Size Mismatch.....	2-174
FIP 1. 113 / 024-913 Tray 4 Paper Size Mismatch.....	2-175
FIP 1. 114 / 024-920 IOT Standard Stacker Full.....	2-175
FIP 1.115 / 024-958 MSI Paper Size Mismatch	2-176
FIP 1. 116 / 024-963 MSI No Suitable Paper	2-177
FIP 1. 117 / 026-720 USB Memory Full.....	2-177
FIP 1. 118 / 026-721 USB Memory Write Error.....	2-178
FIP 1. 119 / 027-446 IPv6 Duplicate	2-178
FIP 1. 120 / 027-452 IPv4 duplicate	2-178
FIP 1. 121 / 031-521 SMB Error	2-179
FIP 1. 122 / 031-522 SMB user authentication fail or SMB Scanner login fail	2-179
FIP 1. 123 / 031-523 Problem with share name in SMB scan server	2-180
FIP 1. 124 / 031-524 SMB Scan User Over limit	2-180
FIP 1. 125 / 031-525 SMB Error	2-181
FIP 1. 126 / 031-526 SMB Scan Host Name Resolution Fail.....	2-181
FIP 1. 127 / 031-527 SMB Scan DNS Server Not Set	2-182
FIP 1. 128 / 031-528 In SMB scan, server connection error	2-182
FIP 1. 129 / 031-529 Problem with SMB scan login name or password	2-183
FIP 1. 130 / 031-530 Problem with location of scanned image in SMB scan server	2-183
FIP 1. 131 / 031-531 Couldn't get file/folder name of SMB scan server	2-184
FIP 1. 132 / 031-532 Suffix of SMB scan file name/folder name is over limit.....	2-184
FIP 1. 133 / 031-533 SMB Scan File Creation Fail	2-185
FIP 1. 134 / 031-534 SMB Scan Folder Creation Fail	2-185
FIP 1. 135 / 031-535 SMB Scan File Deletion Fail	2-186
FIP 1. 136 / 031-536 SMB Scan Folder Deletion Fail	2-186
FIP 1. 137 / 031-537 No free space in storage location on SMB scan data server	2-187
FIP 1. 138 / 031-539 Invalid SMB server (Net BIOS) name is specified	2-187
FIP 1. 139 / 031-540 SMB protocol error(4-007)Invalid scan domain name	2-188
FIP 1. 140 / 031-541 SMB protocol error (4-008) Invalid scan user name.....	2-188
FIP 1. 141 / 031-542 SMB(TCP/IP) is not active	2-189
FIP 1. 142 / 031-543 SMB protocol error(4-045)Scan login prohibited time	2-189
FIP 1. 143 / 031-544 SMB protocol error(4-046) Password expired	2-190
FIP 1. 144 / 031-545 SMB protocol error(4-047) Password change is required	2-190
FIP 1. 145 / 031-546 SMB protocol error(4-048)User is invalid	2-191
FIP 1. 146 / 031-547 SMB protocol error(4-049)Lock-out	2-191
FIP 1. 147 / 031-548 SMB protocol error (4-050) User is expired	2-192
FIP 1. 148 / 031-549 SMB protocol error (4-051) User is restricted	2-192
FIP 1. 149 / 031-550 SMB Scan Append Command Fail	2-193
FIP 1. 150 / 031-551 SMB Scan Rename Command Fail	2-193
FIP 1. 151 / 031-552 SMB scan	2-194
FIP 1. 152 / 031-574 FTP Scan Host Name Resolution Fail	2-194

FIP 1. 153 / 031-575 FTP Scan DNS Server Not Set	2-195
FIP 1. 154 / 031-576 Server Connection Error in FTP Scan	2-195
FIP 1. 155 / 031-578 FTP Scan Login Name or Password Error	2-196
FIP 1. 156 / 031-579 Problem with Location FTP-scanned Image is Saved in	2-197
FIP 1. 157 / 031-580 Fail to get file name/folder name of FTP scan server.....	2-197
FIP 1. 158 / 031-581 Suffix of FTP scan file name/folder name is over limit	2-198
FIP 1. 159 / 031-582 FTP Scan File Creation Fail.....	2-198
FIP 1. 160 / 031-584 FTP Scan Folder Creation Fail	2-199
FIP 1. 161 / 031-585 FTP Scan File Deletion Fail	2-199
FIP 1. 162 / 031-587 FTP Scan Folder Deletion Fail	2-200
FIP 1. 163 / 031-588 FTP Scan Server Data Write Fail	2-200
FIP 1. 164 / 031-590 FTP Error	2-201
FIP 1. 165 / 031-594 FTP Scan TYPE Command Fail (Network Error)	2-201
FIP 1. 166 / 031-595 FTP Scan PORT Command Fail (Network Error).....	2-202
FIP 1. 167 / 031-598 FTP Scan Append Command Fail	2-202
FIP 1. 168 / 031-599 FTP Scan Rename Command Fail	2-203
FIP 1. 169 / 033-501 Fax Codec Error	2-203
FIP 1. 170 / 033-502 File Open Error	2-204
FIP 1. 171 / 033-503 Memory Full	2-204
FIP 1. 172 / 033-510 Fax Codec Error	2-205
FIP 1. 173 / 033-511 Fax Code Error	2-205
FIP 1. 174 / 033-512 Fax Communication Error	2-206
FIP 1. 175 / 033-513 Fax Communication Error.....	2-206
FIP 1. 176 / 033-515 JBIG NF Error	2-207
FIP 1. 177 / 033-517 DFAX Password Error	2-207
FIP 1. 178 / 033-518 DFAX Fax Country is not set correctly	2-208
FIP 1. 179 / 033-519 DFAX Fax Function is not available	2-208
FIP 1. 180 / 033-520 JBF_ERROR_CALLBACK	2-209
FIP 1. 181 / 033-521 JBF_ERROR_MARKER_ABORT.....	2-209
FIP 1. 182 / 033-522 JBF_ERROR_MARKER_UNKNOWN	2-210
FIP 1. 183 / 033-523 JBF_ERROR_MARKER_NOT_FOUND	2-210
FIP 1. 184 / 033-524 JBF_ERROR_MARKER_BAD_ATMOVE	2-211
FIP 1. 185 / 033-525 JBF_ERROR_MARKER_BAD_NEWLEN	2-211
FIP 1. 186 / 033-526 JBF_ERROR_BIH	2-212
FIP 1. 187 / 033-573 E-mail Sending Error.....	2-212
FIP 1. 188 / 033-751 Over Run	2-213
FIP 1. 189 / 033-752 During Call Busy Tone	2-213
FIP 1. 190 / 033-753 CJ Not Detection.....	2-214
FIP 1. 191 / 033-754 V8 Error	2-214
FIP 1. 192 / 033-755 Phase2 Error	2-215
FIP 1. 193 / 033-756 Phase3 Error	2-215
FIP 1. 194 / 033-757 Primary Channel Synchronization Error	2-216
FIP 1. 195 / 033-758 Control Channel Synchronization Error	2-216
FIP 1. 196 / 033-759 Control Channel Retrain Error	2-217
FIP 1. 197 / 033-760 Control Channel OFF Time Out.....	2-217
FIP 1. 198 / 033-761 Primary Channel OFF Time Out	2-218
FIP 1. 199 / 033-762 DM Prevention Function Receive Refuse	2-218
FIP 1. 200 / 033-763 Manual Transmission Read Manuscript Not Do.....	2-219
FIP 1. 201 / 033-764 Draw Data Create Not Do	2-219
FIP 1. 202 / 033-765 File Pointer Error	2-220

FIP 1. 203 / 033-766 Target File Opening	2-220
FIP 1. 204 / 033-767 MMR MN86064 Decode Error	2-221
FIP 1. 205 / 033-768 AT Move Counter Over	2-221
FIP 1. 206 / 033-769 JBIG NEWLEN Marker Error	2-222
FIP 1. 207 / 033-770 YD Error	2-222
FIP 1. 208 / 033-771 Abort Marker Error	2-223
FIP 1. 209 / 033-772 Undefined Marker Error	2-223
FIP 1. 210 / 033-773 BIH Error	2-224
FIP 1. 211 / 033-774 FAX TX Encode Output Buffer Over	2-224
FIP 1. 212 / 033-775 FAX RX Encode Output Buffer Over	2-225
FIP 1. 213 / 033-776 SCAN Encode Output Buffer Over	2-225
FIP 1. 214 / 033-777 FAX RX Decode Input Buffer Over	2-226
FIP 1. 215 / 033-779 Log File Create Fail	2-226
FIP 1. 216 / 033-782 NSS/DCS Function disagreement	2-227
FIP 1. 217 / 033-784 Fax Codec Error	2-227
FIP 1. 218 / 033-786 Fax Codec Error	2-228
FIP 1. 219 / 033-787 Fax Memory Error	2-228
FIP 1. 220 / 033-788 Fax Memory Full	2-229
FIP 1. 221 / 033-789/ 033-790/033-791 Fax Job Canceled	2-229
FIP 1. 222 / 033-795 FAX Send Count Limit	2-230
FIP 1. 223 / 033-799 Fax Codec Error	2-230
FIP 1. 224 / 034-508 Command Refuse Signal Send	2-231
FIP 1. 225 / 034-515 DIS DCS Illegal Command Receive	2-231
FIP 1. 226 / 034-791 Check Line Connection	2-232
FIP 1. 227 / 034-799 No Dial Data	2-232
FIP 1. 228 / 035-701 Send T1 Time Out	2-233
FIP 1. 229 / 035-702 Receive DCN	2-233
FIP 1. 230 / 035-704 Not Send Ability	2-234
FIP 1. 231 / 035-705 DCS/NSS Resend Over	2-234
FIP 1. 232 / 035-706 Fall Back Error	2-235
FIP 1. 233 / 035-708 Post Message Resend Over	2-235
FIP 1. 234 / 035-709 G3 Send RTN/PIN Receive	2-236
FIP 1. 235 / 035-710 Receive PIN	2-236
FIP 1. 236 / 035-716 T2 Time Out	2-237
FIP 1. 237 / 035-717 G3 Receive RTN Send	2-237
FIP 1. 238 / 035-718 Receive T1 Time Out	2-238
FIP 1. 239 / 035-720 Not Receive Ability	2-238
FIP 1. 240 / 035-728 G3 EOL Not Receive	2-239
FIP 1. 241 / 035-729 Career Cut	2-239
FIP 1. 242 / 035-730 RS Request CS NOT ON	2-240
FIP 1. 243 / 035-737 CTC/EOR Resend Over	2-240
FIP 1. 244 / 035-739 T5 Time Out	2-241
FIP 1. 245 / 035-740 ECM Send EOR-Q Send	2-241
FIP 1. 246 / 035-742 ECM Receive EOR-Q Receive	2-242
FIP 1. 247 / 035-746 Before Dial Tone	2-242
FIP 1. 248 / 035-779 FAX FWD document change error	2-243
FIP 1. 249 / 035-781 Target Fax Busy	2-243
FIP 1. 250 / 035-792 JM Not Detection	2-244
FIP 1. 251 / 035-793 Digital Line Detection	2-244
FIP 1. 252 / 041-340 IOT NVRAM Error	2-245

FIP 1. 253 / 041-347 IOT I/F Failure	2-245
FIP 1. 254 / 042-313 LVPS Fan Motor Failure.....	2-246
FIP 1. 255 / 042-330 Rear Fan Failure	2-247
FIP 1. 256 / 092-661 IOT Environment Sensor Error	2-248
FIP 1. 257 / 050-130 IOT Remain Zone Fusing Jam.....	2-249
FIP 1. 258 / 077-107 Duplex Regi On Jam	2-250
FIP 1. 259 / 050-132 IOT Remain Zone Regi + MSI + T1 + T2 Jam	2-251
FIP 1. 260 / 050-134 IOT Zone MSI + T1 Jam	2-251
FIP 1. 261 / 050-135 IOT Zone T2 + T3 + T4 + TR2 + TR3 Jam.....	2-252
FIP 1. 262 / 050-136 IOT Zone T3 + T4 + TR3 Jam.....	2-252
FIP 1. 263 / 050-137 IOT Zone T2 + T3 + TR2 + TR3 Jam	2-253
FIP 1. 264 / 050-138 IOT Zone T3 + TR2 + TR3 Jam	2-253
FIP 1. 265 / 050-139 IOT Zone T2 + TR2 Jam	2-254
FIP 1. 266 / 050-140 IOT Zone T3 + TR2 Jam	2-254
FIP 1. 267 / 050-141 IOT Zone T4 + TR3 Jam	2-255
FIP 1. 268 / 050-142 IOT Remain Zone Regi + MSI + T1 Jam.....	2-255
FIP 1. 269 / 061-370 IOT ROS Failure	2-256
FIP 1. 270 / 371/062-393 Scanner Error.....	2-257
FIP 1. 271 / 062-316 DADF Motor Fail	2-258
FIP 1. 272 / 062-790 Copy Limit.....	2-258
FIP 1. 273 / 071-100 IOT Tray1 Misfeed Jam.....	2-259
FIP 1. 274 / 071-920 Waiting to Print Side 2 Load Printed Pages	2-260
FIP 1. 275 / 071-921 Manual Duplex Print	2-260
FIP 1. 276 / 074-100 IOT Tray4 Misfeed Jam	2-260
FIP 1. 277 / 073-101 IOT Path 3 SNS On Jam	2-262
FIP 1. 278 / 072-102 IOT Option Regi On Jam	2-263
FIP 1. 279 / 072-211 Feeder 2 Error	2-265
FIP 1. 280 / 074-211 Feeder 4 Error	2-266
FIP 1. 281 / 075-100 MSI Misfeed Jam	2-267
FIP 1. 282 / 077-101 VSYNC ON Jam	2-268
FIP 1. 283 / 077-104 Regi. Off Jam	2-268
FIP 1. 284 / 077-109 Exit Off Jam	2-269
FIP 1. 285 / 077-217 Duplex Miss Configuration	2-271
FIP 1. 286 / 077-300 IOT Cover Front Open	2-271
FIP 1. 287 / 077-304 IOT Cover Rear Open	2-272
FIP 1. 288 / 077-312 Tray Configure Error.....	2-274
FIP 1. 290 / 091-963 IOT Drum CRUM ID Error	2-275
FIP 1. 291 / 091-953 Drum Tape Staying	2-277
FIP 1. 292 / 092-315 ATC Fail	2-277
FIP 1. 293 / 093-426 Toner Near Life	2-278
FIP 1. 294 / 093-922 Toner Low Density	2-278
FIP 1. 295 / 093-973 Toner Detached	2-279
FIP 1. 296 / 093-933 Toner Life Over.....	2-280
FIP 1. 297 / 116-210 USB Host Error	2-280
FIP 1. 298 / 116-313 Encryption Setting Error	2-281
FIP 1. 299 / 116-314 MAC Address Error	2-281
FIP 1. 300 / 116-315 ESS On Board RAM W/R Check Fail	2-282
FIP 1. 301 / 116-317 ESS ROM Check (Main) Fail	2-282
FIP 1. 302 / 116-317 ESS ROM Check (Main) Fail	2-282
FIP 1. 303 / 116-324 ESS Illegal Exception	2-283

FIP 1. 304 / 116-326 ESS NVRAM2 W/R Check Fail	2-283
FIP 1. 305 / 116-327 ESS Instruction Cache Error	2-283
FIP 1. 306 / 116-328 ESS Data Cache Error	2-284
FIP 1. 307 / 116-343 ASIC Fail	2-284
FIP 1. 308 / 116-350 On Board Network Communication Fail	2-284
FIP 1. 309 / 116-351/116-352/116-355 Network Error	2-285
FIP 1. 310 / 116-356 SD CARD Overwrite Error	2-285
FIP 1. 311 / 116-361 PCI Bus #0 Error Detected	2-286
FIP 1. 312 / 116-362 PCI Bus #0 Host Bridge Controller Error	2-286
FIP 1. 313 / 116-363 PCI Bus #1 Host Bridge Controller Error	2-286
FIP 1. 314 / 116-364 Timer Fail	2-287
FIP 1. 315 / 116-366 PCI Bus #1 Error Detected	2-287
FIP 1. 316 / 116-368 PCI Error Messages received from Bus #0 - Device #1	2-287
FIP 1. 317 / 116-369 PCI Error Messages received from Bus #0 - Device #0	2-288
FIP 1. 318 / 116-390 ESS NVRAM1 SIZE And ID Check Fail.....	2-288
FIP 1. 319 / 116-396 Fatal Error Related to Maillib Other Errors	2-288
FIP 1. 320 / 116-719 XPIF Parameter Cancelled	2-289
FIP 1. 321 / 116-721 Collate Full.....	2-289
FIP 1. 322 / 116-722 WSD (Web Services on Device) Scan destination error	2-290
FIP 1. 323 / 116-987 Fatal Error Related to Format Library	2-290
FIP 1. 324 / 117-315 EEPROM Driver Error	2-291
FIP 1. 327 / 117-321 Device Memory Error	2-291
FIP 1. 326 / 117-331 IPS Error	2-292
FIP 1. 327 / 117-338 Enable Device Memory Error	2-292
FIP 1. 328 / 117-340 Controller Error.....	2-293
FIP 1. 329 / 117-344 FAX Error	2-293
FIP 1. 330 / 117-350 Controller Error	2-293
FIP 1. 331 / 117-361 IIT Parameter Verify NG	2-294
FIP 1. 332 / 117-362 EEPROM Sum Check Error.....	2-294
FIP 1. 333 / 117-363 NVM Sum Check Error	2-294
FIP 1. 334 / 117-365 Low Voltage	2-295
FIP 1. 335 / 117-367 FXIF error	2-295
FIP 1. 336 / 118-311 Google Cloud Print Software Error.....	2-296
FIP 1. 337 / 123-314 Panel Power On Error	2-296
FIP 1. 338 / 123-333 Panel FW transmission error	2-297
FIP 1. 339 / 123-399 Panel Device Reboot Error	2-297
FIP 1. 340 / 131-397 File2Net Fatal Error	2-297
FIP 1. 341 / 131-398 SMB client Fatal Error	2-298
FIP 1. 342 / 131-399 FTP client Fatal Error	2-298
FIP 1. 343 / 133-231 T_FAXCOM Data Receive I/F Error	2-298
FIP 1. 344 / 133-234 JBIG Parameter Error	2-299
FIP 1. 345 / 133-235 MHR Parameter Error	2-299
FIP 1. 346 / 133-236 MHR Encode Error.....	2-299
FIP 1. 347 / 133-237 MHR Input Buffer Error	2-300
FIP 1. 348 / 133-238 MHR Output Buffer Error.....	2-300
FIP 1. 349 / 133-239 FAX ECM Buffer Address Error	2-300
FIP 1. 350 / 133-240 Resolution Change Error	2-301
FIP 1. 351 / 133-241 Memory Pool Get Error	2-301
FIP 1. 352 / 133-242 Memory Pool Release Error	2-301
FIP 1. 353 / 133-243 Message Send Error	2-302

FIP 1. 354 / 133-244 Message Receive Error	2-302
FIP 1. 357 / 133-246 Memory Pool Get Error	2-302
FIP 1. 356 / 133-247 Message Send Error	2-303
FIP 1. 357 / 133-248 Memory Pool Release Error	2-303
FIP 1. 358 / 133-249 Message Receive Error	2-303
FIP 1. 359 / 133-251 File Open Error	2-304
FIP 1. 360 / 133-252 File Close Error	2-304
FIP 1. 361 / 133-253 File Erase Error	2-304
FIP 1. 362 / 133-254 Memory Full	2-305
FIP 1. 363 / 133-259 OS Call Error	2-305
FIP 1. 364 / 133-260 File Open Error	2-305
FIP 1. 365 / 133-261/133-269 File Close Error	2-306
FIP 1. 366 / 133-271 Memory Pool Get Error	2-306
FIP 1. 367 / 133-272 Message Send Error	2-306
FIP 1. 368 / 133-273 Memory Pool Release Error	2-307
FIP 1. 369 / 133-274 Message Receive Error	2-307
FIP 1. 370 / 133-275 OS Call Error	2-307
FIP 1. 371 / 133-276 File Open Error	2-308
FIP 1. 372 / 133-277 File Close Error	2-308
FIP 1. 373 / 133-278 File Erase Error	2-308
FIP 1. 374 / 133-279 FAX CODEC I/F Error	2-309
FIP 1. 375 / 133-280 ERR_FAX_TIME	2-309
FIP 1. 376 / 133-281 Power Off Report Create Fail	2-310
FIP 1. 377 / 133-282 Memory Pool Get Error	2-310
FIP 1. 378 / 133-283 Message Send Error	2-310
FIP 1. 379 / 133-286 OS Call Error	2-311
FIP 1. 380 / 133-287 File Open Error	2-311
FIP 1. 381 / 133-288 File Close Error	2-311
FIP 1. 382 / 133-289 File Erase Error	2-312
FIP 1. 383 / 133-290 Print Decode Error	2-312
FIP 1. 384 / 134-211 Fax Card Modem Error	2-313
FIP 1. 385 / 142-700 IOT Over Heat Forced Half Speed	2-313
FIP 1. 386 / 193-700 Custom Toner Mode	2-313
Level 2 FIPs	2-314
FIP 2.01 / Exit Sensor	2-314
FIP 2.02 / IOT Standard Stacker Full	2-315
FIP 2.03 / Registration Sensor	2-316
FIP 2.04 / CST No Paper Sensor	2-317
FIP 2.05 / MSI No Paper Sensor	2-318
FIP 2.06 / No Paper Sensor	2-319
FIP 2.07 / Path Sensor	2-320
FIP 2.08 / Exit Clutch Assembly	2-321
FIP 2.09 / Invert Clutch Assembly	2-322
FIP 2.10 / Registration Clutch Assembly	2-323
FIP 2.11 / Feed Clutch	2-324
FIP 2.12 / Optional Feeder Clutch Assembly	2-325
FIP 2.13 / Registration Clutch Assembly	2-326
FIP 2.14 / MSI Feed Solenoid	2-327
FIP 2.15 / Main Drive Assembly	2-328

FIP 2.16 / Dispanse Motor	2-329
FIP 2.17 / Optional Tray Motor Assembly	2-330
FIP 2.18 / Abnormal Noise: When power is turned on	2-331
FIP 2.19 / Abnormal Noise:During Printing	2-333
FIP 2.20 / AC Power FIP	2-334
FIP 2.21 / DC Power FIP	2-335
Network System Fault Check	2-336
Interface (Physical/Logical)	2-336
Not connected to network or Unable to find the device from the PC	2-337
Printing can be performed but abnormally	2-338
Network-related Details Check Flow	2-339
Check Flow at SMB Failure	2-339
Check Flow at Net Ware Failure	2-343
Check Flow at TCP/IP (LPD) Failure	2-348
Check Flow at CentreWare Internet Services Failure	2-351
3. IMAGE QUALITY	
Image Quality Overview	3-2
Repeating Defect Measurement	3-2
Image Quality Specifications	3-3
Environmental Condition	3-3
Quality Paper	3-3
Paper Condition	3-3
Printer Condition	3-3
Specifications	3-3
Skew	3-4
Checklist Before Troubleshooting Image Quality	3-6
Check Printer Condition	3-6
Toner and Drum Cartridge Status	3-6
Cleaning	3-6
Operating Environment	3-6
Media Condition	3-6
Image Quality Troubleshooting	3-7
Image Quality Defects	3-7
IQ-1 Light Prints	3-8
IQ-2 Unfused Image	3-11
IQ-3 Random Spots	3-12
IQ-4 Blank Print	3-14
IQ-5 Streaks	3-17
IQ-6 Black Print	3-19
IQ-7 Pitched Black Dots	3-21
IQ-8 Vertical Bands, Voids, or Streaks (In Paper Feed Direction)	3-23
IQ-9 Ghosting	3-25
IQ-10 Light Induced Fatigue	3-27
IQ-11 Background	3-28
IQ-12 Bead Carry-out	3-30
IQ-13 Jagged Characters	3-31
IQ-14 Banding	3-33

IQ-15 Auger Marks	3-35
IQ-16 Wrinkled / Stained Paper	3-37
IQ-17 Damage to the Lead Edge of the Print	3-39
IQ-18 Incorrect Margins	3-41
IQ-19 Skewed Image	3-43
Printing Test Patterns	3-45
Service Diagnostic Mode Test Patterns	3-45
Administration Mode Test Patterns	3-45
Diagnostics Test Pattern #1 - Pattern IOT	3-46
Diagnostics Test Pattern #2 - Gradation ESS	3-47
Diagnostics Test Pattern #3 - Ghost Chart ESS	3-48
Admin Mode Test Pattern #1 - Pitch Chart	3-49
Admin Mode Test Pattern #2 - Alignment Chart	3-51
Admin Mode Test Pattern #3 - Full Page Solid	3-52
4. DISSASSEMBLY	
Overview	4-2
Standard Orientation of the Printer	4-2
Precautions	4-3
Notations in the Disassembly Text	4-4
Fastener Types	4-5
Covers	4-6
REP 1.1 Control Panel (3610)	4-6
REP 1.2 Front Cover Assembly (3610 / 3615)	4-7
REP 1.3 Top Front Cover (3610)	4-10
REP 1.4 Top Cover Assembly (3610)	4-12
REP 1.5 Rear Cover Assembly	4-13
REP 1.6 Right Side Cover (3610)	4-15
REP 1.7 Left Side Cover (3610)	4-16
REP 1.8 Lower Rear Cover (3610)	4-17
REP 1.9 IIT Left Side Cover	4-18
REP 1.10 IIT Front Top Cover	4-19
REP 1.11 IIT Front Bottom Cover	4-20
REP 1.12 Control Panel (3615)	4-21
REP 1.13 Right Side Cover (3615)	4-23
REP 1.14 Right Inner Cover (3615)	4-25
REP 1.15 Top Cover Assembly (3615)	4-26
REP 1.16 Upper Left Side Cover (3615)	4-27
REP 1.17 Lower Left Side Cover (3615)	4-28
REP 1.18 Lower Rear Cover (3615)	4-29
Chassis Repairs	4-30
REP 2.1 Duplex Chute Assembly	4-30
REP 2.2 Transport Assembly	4-32
REP 2.3 Feeder Assembly	4-43
REP 2.4 Tray 1 Feed Rollers	4-46
REP 2.5 Feed Clutch	4-47
REP 2.6 Registration Clutch	4-48
REP 2.7 Rubber Registration Roller	4-49

REP 2.8 Registration Sensor Shutter.....	4-51
REP 2.9 Tray 1 Stopper.....	4-52
REP 2.10 Rear Interlock Switch Assembly.....	4-55
REP 2.11 Exit Chute Assembly.....	4-58
REP 2.12 Left / Right Pinch Roller.....	4-60
REP 2.13 Full Stack Sensor.....	4-61
REP 2.14 MSI Feed Solenoid.....	4-62
REP 2.15 Pick-up Holder Assembly.....	4-64
REP 2.16 Top Frame Assembly.....	4-65
REP 2.17 Bypass Tray Retard Roller.....	4-66
Xerographic Repairs.....	4-67
REP 3.1 ROS Assembly.....	4-67
REP 3.2 Toner Dispense CRUM Assembly.....	4-71
REP 3.3 Xerographic Connector Assembly.....	4-74
REP 3.4 Transfer Roller Assembly.....	4-76
REP 3.5 Fusing Assembly.....	4-77
Drive Repairs.....	4-78
REP 4.1 Main Drive Assembly.....	4-78
REP 4.2 Exit Output Drive Assembly.....	4-80
REP 4.3 Exit Invert Drive Assembly.....	4-85
REP 4.4 Duplex Drive Gear and Holder.....	4-90
REP 4.5 Front Links.....	4-91
REP 4.6 Dispense Drive Assembly.....	4-92
REP 4.7 Toner Dispense Motor.....	4-94
Electrical Repairs.....	4-98
REP 5.1 ESS PWB.....	4-98
REP 5.2 ESS PWB Housing.....	4-101
REP 5.3 LVPS.....	4-104
REP 5.4 Fax PWB.....	4-105
REP 5.5 Front USB PWB.....	4-106
REP 5.6 MCU PWB.....	4-107
REP 5.7 HVPS (3610).....	4-108
REP 5.8 HVPS (3615).....	4-110
REP 5.9 AC Inlet Harness.....	4-112
IIT / DADF Repairs.....	4-113
REP 6.1 IIT Assembly.....	4-113
REP 6.2 DADF.....	4-115
REP 6.3 DADF Hinges.....	4-116
REP 6.4 Pick-up Module Kit.....	4-117
REP 6.5 DADF Tray Assembly.....	4-119
550-Sheet Feeder Repairs.....	4-120
REP 7.1 550-Sheet Feeder.....	4-120
REP 7.2 Left Side Cover.....	4-121
REP 7.3 Right Side Cover.....	4-122
REP 7.4 Rear Cover.....	4-123
REP 7.5 Optional Tray PWB Assembly.....	4-124
REP 7.6 Drive Assembly.....	4-125
REP 7.7 Feed Clutch Assembly.....	4-127
REP 7.8 Feeder Assembly.....	4-128
REP 7.9 No Paper Sensor.....	4-130

REP 7.10 Registration Clutch Assembly.....	4-131
REP 7.11 Feed Roller Assembly	4-132
REP 7.12 Retard Roller Assembly.....	4-133
REP 7.13 Pre-Registration Sensor	4-134
REP 7.14 Take Away Roller Assembly.....	4-135

5. PARTS LIST

Serial Number Format	5-2
110V Engine Format.....	5-2
Examples	5-3
110V Printer	5-3
220V Printer	5-3
Using the Parts List.....	5-5
Parts Lists.....	5-6
PL 1.1 Covers (3610).....	5-6
PL 1.2 Covers (3615).....	5-8
PL 1.3 Rear Cover Assembly	5-10
PL 1.4 Control Panel (3610)	5-12
PL 1.5 Control Panel (3615)	5-14
PL 2.1 Registration.....	5-16
PL 2.2 Transport Assembly	5-18
PL 2.3 Feed Assembly	5-20
PL 2.4 Duplex Chute	5-22
PL 2.5 Exit Chute	5-24
PL 2.6 MSI	5-26
PL 2.7 Bypass Tray.....	5-28
PL 3.1 Xerographics.....	5-30
PL 3.2 ROS Assembly.....	5-32
PL 3.3 Toner Dispense	5-34
PL 3.4 Transfer Roller	5-36
PL 3.5 Fusing Assembly	5-38
PL 4.1 Drive	5-40
PL 4.2 NOHAD.....	5-42
PL 5.1 Electrical (ESS PWB / LVPS) (3610)	5-44
PL 5.2 Electrical (ESS PWB / LVPS) (3615)	5-46
PL 5.3 Electrical (MCU PWB / HVPS).....	5-48
PL 5.4 Electrical Connections	5-50
PL 6.1 IIT Scanner / DADF.....	5-52
PL 7.1 Tray 1/Optional Tray 550-Sheet Feeder (1/4)	5-54
PL 7.2 Tray 1/Optional Tray 550-Sheet Feeder (2/4)	5-56
PL 7.3 Tray 1/Optional Tray 550-Sheet Feeder (3/4)	5-58
PL 7.4 Tray 1/Optional Tray 550-Sheet Feeder (4/4)	5-60
Quick Reference Spares List for the 3610 and 3615.....	5-62
Xerox Supplies	5-66

6. MAINTENANCE	
Service Maintenance Procedure	6-2
Maintenance Safety	6-2
Recommended Materials	6-2
Repair, Inspect, and Prevent (RIP) Procedure	6-2
Cleaning	6-3
General Precautions	6-3
General Cleaning	6-4
Cleaning the Scanner (3615)	6-4
Moving the Printers	6-5
After moving the printer	6-5
Resetting Counters	6-6
Resetting the Transfer Unit / Fuser Counters (3610)	6-6
Resetting the Transfer Roller / Fuser Assembly Counter (3615)	6-6
Adjustments	6-7
ADJ 1 Adjusting Paper Type	6-7
ADJ 2 Adjusting the Transfer Unit	6-8
ADJ 3 Adjusting the Fuser	6-9
ADJ 4 Adjusting the Density	6-10
ADJ 5 Adjusting Altitude	6-11
Firmware Update	6-12
Upgrade Procedure	6-14
For Network Connections	6-15
For USB Connection	6-17
Tag Matrix	6-18
7. WIRING	
Plug/Jack Locations	7-2
Plug/Jack Locations for the 3610	7-2
Plug/Jack Locations for the 3615	7-4
Plug/Jack Locations for Tray 1 and the Optional Feeders	7-6
Illustration 01	7-7
Illustration 02	7-8
Illustration 03	7-9
Illustration 04	7-10
Illustration 05	7-11
Illustration 06	7-12
Illustration 07	7-13
Illustration 08	7-14
Illustration 09	7-15
Illustration 10	7-16
Illustration 11	7-17
Illustration 12	7-18
Illustration 13	7-19
Wire Harnessing for the Printer	7-20
MCU PWB to HVPS / Dispense Motor Assembly	7-20
MCU PWB to Xerographic Connector Assembly	7-21
MCU PWB to Main Motor Assembly / LVPS	7-22
MCU PWB to Optional Feeder Connector	7-23

MCU PWB to the ROS Assembly	7-24
ROS Assembly to the ESS PWB	7-25
MCU PWB to the Full Stack Sensor / Exit Sensor	7-26
MCU PWB to the LVPS (1 of 2)	7-27
MCU PWB to the LVPS (2 of 2)	7-28
MCU PWB to ESS	7-29
MCU PWB to the Fusing Assembly	7-30
MCU PWB to the Rear Fan Connector	7-31
ESS PWB to the LVPS / UI (3610)	7-32
ESS PWB to the LVPS / UI (3615)	7-33
IIT/DADF Assembly to the ESS PWBA (3615)	7-34
ESS PWB to the Front USB (3615)	7-35
Wire Harnessing for Option Trays	7-36
No Paper Sensor	7-36
Optional Tray Pre-Registration Sensor	7-37
Optional Tray PWB Assembly (1 of 3)	7-38
Optional Tray PWB Assembly (2 of 3)	7-39
Optional Tray PWB Assembly (3 of 3)	7-40
Notations Used in the Wiring Diagrams	7-41
Wiring Diagrams	7-44
General Wiring Diagram for 3610	7-44
General Wiring Diagram for 3615	7-45
1. Power	7-46
2. Drive	7-47
3. ROS	7-48
4. Xerographics / HVPS	7-49
5. Fusing	7-50
6. Controller (3610)	7-51
6. Controller (3615)	7-52
7. Scanner	7-53
8. Optional Feeder	7-54
8. SPECIFICATIONS	
Configuration of Printer	8-2
System Configuration for the 3610	8-2
Functional Configuration	8-3
System Configuration for the 3615	8-3
Functional Configuration	8-4
Electrical Properties	8-5
Mechanical Properties	8-6
Space Requirements for the 3610	8-7
Space Requirements for the 3615	8-8
Consumables	8-9
Machine Functions	8-10
Resolution	8-10
Operation Mode	8-10
Sleep Mode	8-11
Deep Sleep Mode	8-11
Machine Status for the 3610	8-12
Machine Status for the 3615	8-12

Warm-up Time	8-13
FPOT (First Print Output Time)	8-13
Operating Environment	8-15
Safety / Environment Conditions	8-16
Print Image Quality	8-17
Print Image Quality Guarantee Conditions	8-17
Printer Options	8-19
ESS Specification	8-19
ESS-Supporting OS	8-19
Interface Port	8-20
Network Protocol	8-22
Decomposer	8-24
Job Control	8-25
Logging	8-26
ID Print	8-27
Non-Genuine Mode	8-27
Cable Characteristics	8-27
Communication Load Characteristics	8-27
Incoming Call Level	8-27
IIT (Image Input Terminal) Specifications (3615)	8-28
Scanner	8-28
Platen	8-28
DADF	8-30
FAX Specifications (3615)	8-32
FAX Communication	8-32
Media Guidelines	8-34
Paper Characteristics	8-34
Weight	8-34
Curl	8-34
Smoothness	8-34
Moisture Content	8-34
Grain Direction	8-35
Fiber Content	8-35
Recommended Paper	8-35
Unacceptable Paper	8-35

Overview

1

This chapter includes:

- [About this Service Manual](#)
- [Manual Organization](#)
- [Safety](#)
- [Introduction](#)
- [Phaser 3610 Configurations](#)
- [WorkCentre 3615 Configurations](#)
- [Operational Modes](#)
- [Media Path](#)
- [Media Path Components](#)
- [Major Component Locations](#)
- [Information Pages](#)

About this Service Manual

The Phaser 3610, WorkCentre 3615 Service Manual is the primary document used for diagnosing, repairing, maintaining, and troubleshooting the printer. Use this manual as your primary resource for understanding the operational characteristics of the printer and all available options. This manual describes specifications and the diagnosis and repair of problems occurring in the printer and attached options. Also included are detailed replacement procedures, parts lists, and wiring diagrams.

Throughout the manual you may see references to SFP and MFP. The Phaser 3610 is referred to as the SFP (Single Function Printer), while the WorkCentre 3615 is referred to as the MFP (Multi-function Printer).

Service Manual Revision

Updates may be issued as the printer changes or as corrections are identified.

Technical Support Information

For manual updates, Service Bulletins, knowledge base, and technical support, go to:

- Xerox Global Service Net - <https://www.xrxgsn.com/secure/main.pl>

For further technical support, contact your assigned Xerox Technical Support for this product.

Manual Terms

Various terms are used throughout this manual to either provide additional information on a specific topic or to warn of possible danger present during a procedure or action. Be aware of all symbols and terms when they are used, and always read Note, Caution, and Warning statements.

 **CAUTION:** A caution indicates an operating or maintenance procedure, practice or condition that, if not strictly observed, results in damage to, or destruction of, equipment.

 **WARNING:** A warning indicates an operating or maintenance procedure, practice or condition that, if not strictly observed, results in injury or loss of life.

Note: A note indicates an operating or maintenance procedure, practice or condition that is necessary to efficiently accomplish a task. A note can provide additional information related to a specific subject or add a comment on the results achieved through a previous action.

Manual Organization

The Phaser 3610 and the WorkCentre 3615 Service Manuals contains the following chapters:

Chapter 1 - Operational Overview

This chapter contains important safety information, printer operations modes, configuration, component locations and information pages.

Chapter 2 - Troubleshooting

This chapter contains detailed troubleshooting procedures for error messages and codes generated by resident diagnostics. In addition, this chapter includes Service Diagnostics procedures and troubleshooting methods for situations where an error indicator is not available.

Chapter 3 - Image Quality

This chapter contains the diagnostic aids for troubleshooting image quality problems, as well as image quality specifications and image defect samples associated with the printer output.

Chapter 4 - Service Parts Disassembly

This chapter contains removal procedures for spare parts listed in the Parts List. A replacement procedure is included when necessary.

Chapter 5 - Parts List

This chapter contains exploded views of the print engine and optional Field Replaceable Units (FRUs), as well as part numbers for orderable parts.

Chapter 6 - Maintenance

This chapter contains procedures for how to maintain the print engine components and periodic cleaning procedures.

Chapter 7 - Wiring Diagrams

This chapter contains, lists of the plug/jack locations, wiring harness illustrations, and wiring diagrams.

Chapter 8 - Specifications

This chapter provides a comprehensive look at most of the machine specs.

Safety

The following are hazards to your safety:

- A power cord that is damaged or frayed.
- Liquid that are spilled onto or into the printer.
- A printer that is exposed to water.

If any of these conditions occur, do the following:

1. Turn Off the printer immediately.
2. Disconnect the power cord from the electrical outlet.

Power Safety Precautions

Power Source

For 120 VAC printers (110-127v), do not apply more than 127 volts RMS between the supply conductors or between either supply conductor and ground. For 230 VAC printers (220-240v), do not apply more than 240 volts RMS between the supply conductors or between either supply conductor and ground. Use only the specified power cord and connector.

Power Source information is listed on the data plate on the back of every machine.

Plug the three-wire power cord (with grounding prong) into a grounded AC outlet only. If the product loses its ground connection, contact with conductive parts may cause an electrical shock. A protective ground connection by way of the grounding conductor in the power cord is essential for safe operation.

Disconnecting Power



WARNING: Turning the power Off using the power switch does not completely de-energize the printer. You must also disconnect the power cord from the printer's Alternating Current (AC) inlet. Disconnect the power cord by pulling the plug, not the cord.

Disconnect the power cord in the following cases:

- if the power cord or plug is frayed or otherwise damaged,
- if any liquid or foreign material is spilled onto or into the printer,
- if the printer is exposed to any excess moisture,
- if the printer is dropped or damaged,
- whenever you clean or service the product.

Power Cord

- Use the power cord supplied with the printer.
- Plug the power cord directly into a properly grounded electrical outlet. Make sure each end of the cord is securely connected.
- Do not use a ground adapter plug to connect the printer to an electrical outlet that does not have a ground connection terminal.

 **WARNING:** Avoid the potential of electrical shock by ensuring that the printer is properly grounded. Electrical printers may be hazardous if misused.

- Do not use an extension cord, power strip, or surge protector.
- Verify the printer is plugged into an outlet capable of providing the correct voltage and power.
- Do not place the printer in an area where people might step on the power cord.
- Do not place objects on the power cord.

The power cord is attached to the printer as a plug-in device on the back of the printer. If it is necessary to disconnect all electrical power from the printer, disconnect the power cord from the electrical outlet.

Electrostatic Discharge (ESD) Precautions

Some semiconductor components, and the respective sub-assemblies that contain them, are vulnerable to damage by Electrostatic Discharge (ESD). These components include Integrated Circuits (ICs), Large-Scale Integrated circuits (LSIs), field-effect transistors, and other semiconductor chip components. These techniques reduce component damage caused by static electricity.

Be sure the power is Off to the chassis or circuit board, and observe all other safety precautions.

- Immediately before handling any semiconductor components, drain the electrostatic charge from your body by touching an earth ground source or wearing a grounded wrist strap device. Wearing a wrist strap also prevents accumulation of bodily static charges. Remove the wrist strap before applying power to the unit under test to avoid potential shock.
- After removing a static sensitive assembly from its anti-static bag, place it on a grounded conductive surface. If the anti-static bag is conductive, you may ground the bag and use it as a conductive surface.
- Do not use freon-propelled chemicals. These can generate electrical charges sufficient to damage some devices.
- Do not remove replacement parts from the protective package until you are ready to install it.
- Immediately before removing the protective material from the replacement device, touch the protective material to the chassis or circuit assembly into which the device will be installed.
- Minimize body motions when handling unpacked replacement devices. Motion such as your clothes brushing together, or lifting a foot from a carpeted floor can generate enough static electricity to damage an electro-statically sensitive device.
- Handle IC's and EPROM's carefully to avoid bending connector pins.
- Pay attention to the direction of parts when mounting or inserting them on the Printed Wiring Boards (PWB's).

Service Safety Summary

General Guidelines

Use care when servicing with power:

Dangerous voltages may exist at several points in the printer. To avoid personal injury, do not touch exposed connections and components while power is On. Disconnect power before removing the power supply shield or replacing components.

Do not wear jewelry:

Remove jewelry prior to servicing. Rings, necklaces and other metallic objects could come into contact with dangerous voltages and currents.

Warning Labels

Read and obey all posted warning labels. Throughout the printer, warning labels are displayed on potentially dangerous components. As you service the printer, check to make certain that all warning labels remain in place.

Safety Interlocks

Make sure all covers are in place and all Interlock Switches are functioning correctly after you have completed a printer service call. If you bypass an Interlock Switch during a service call, use extreme caution when working on or around the printer.

Servicing Electrical Components

Before starting any service procedure, switch the printer power Off and unplug the power cord from the wall outlet. If you must service the printer with power applied, be aware of the potential for electrical shock.

 **WARNING:** Do not touch any electrical component unless you are instructed to do so by a service procedure.



Servicing Mechanical Components

When servicing mechanical components within the printer, manually rotate the Drive Assemblies, Rollers, and Gears.

 **WARNING:** Do not try to manually rotate or manually stop the drive assemblies while any printer motor is running.

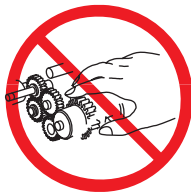

Servicing Fuser Components

 **WARNING:** This printer uses heat to fuse the toner image to paper. The Fuser is VERY HOT. Turn the printer power Off and wait at least 5 minutes for the Fuser to cool before attempting to service the Fuser or adjacent components.

Operational Safety

Your printer and supplies were designed and tested to meet strict safety requirements. These include safety agency examination, approval, and compliance with established environmental standards.

Your attention to the following safety guidelines helps to ensure the continued, safe operation of your printer.

Printer Location

- Do not block or cover the slots or openings on the printer. These openings are provided for ventilation and to prevent overheating of the printer.
- Place the printer in an area where there is adequate space for operation and servicing.
- Place the printer in a dust-free area.
- Do not store or operate the printer in an extremely hot, cold, or humid environment.
- Place the printer on a level, solid non-vibrating surface with adequate strength to hold the weight of the printer.
- Do not place the printer near a heat source.
- Do not place the printer in direct sunlight to avoid exposure to light-sensitive components.
- Do not place the printer where it is directly exposed to the cold air flow from an air conditioning unit.

Operational Guidelines

- Do not open any media tray during operation. The media from the lower trays passes through the upper trays and opening one could cause a jam.
- Do not open the doors when the printer is printing.
- Do not move the printer when it is printing.
- Keep hands, hair, neckties, etc., away from the Exit and Feed Roller.

Printer Supplies

- Use the supplies specifically designed for your printer. The use of unsuitable materials may cause poor performance and a possible safety hazard.
- Follow all warnings and instructions marked on, or supplied with, the printer, options, and supplies.









CAUTION: Use of non-Xerox supplies is not recommended. The Xerox Warranty, Service Agreements, and Total Satisfaction Guarantee do not cover damage, malfunction, or degradation of performance caused by use of non-Xerox supplies, or the use of Xerox supplies not specified for this printer. The Total Satisfaction Guarantee is available in the United States and Canada. Coverage may vary outside these areas; please contact your local representative for details.





Maintenance Safety

- Do not attempt any maintenance procedure that is not specifically described in the documentation supplied with your printer.
- Do not use aerosol cleaners. Clean the printer with a dry lint-free cloth only.

Do not burn any consumables or long life maintenance items. For information on Xerox supplies recycling programs, go to www.xerox.com/gwa.

Printer Symbols

Symbol	Description
	Warning or Caution Ignoring this warning could cause serious injury or even death. Ignoring this caution could cause injury or damage to the property.
	Hot surface on or in the printer. Use caution to avoid personal injury.
	Danger invisible laser radiation when open. Avoid direct exposure to beam.
	Do not touch components as personal injury could result.
	Do not burn the Drum Cartridge / Waste Toner Box.
	Do not burn the Toner Cartridge.
	Do not burn the item.

Symbol	Description
	Do not expose the Drum Cartridge to light.
 	It may take 40 minutes for the Fuser to cool down.
	Recycle the item.
	Protective Ground symbol.

Introduction

The Phaser 3610, WorkCentre 3615 laser printers have a single-pass laser-design architecture based on the electrophotographic recording principle, which offers mono print speed at 30/30 ppm, and resolutions up to 1200 x 1200 dots-per-inch (dpi). The printers supports Adobe PostScript 3 and PCL6, USB 2.0, and 10/100 Base-TX Ethernet. The Phaser 3610, WorkCentre 3615 printers provides a standard 150-Sheet Bypass Tray and a standard 250-Sheet Tray 1. The Bypass Tray supports specialty media, card stock, and envelopes. The standard paper input is 400 sheets and the maximum input with optional Trays 2, 3, and 4 is 2,050 sheets. The Output Tray holds 300 sheets facedown.

The printer options add memory, paper capacity, and functionality. Memory upgrades are available to increase the standard RAM from 1 GB up to 2 GB maximum. A 40 GB Hard Disk Drive and a 550-Sheet Feeder are available as an option. Auto-duplexing is available and no tools are required to install the Duplex Unit.



Phaser 3610 Configurations

The Phaser 3610 is available in three configurations.

Features	Configurations		
	3610 N	3610 DN	3610 YDN
Processor and Clock Speed	667 MHz	667 MHz	
Memory Configuration*	256 MB	256 MB	256 MB
Print Speed (ppm)	47	47	47
Adobe PostScript 3 Fonts	Standard	Standard	Standard
PCL6 Fonts	Standard	Standard	Standard
Resident Fonts	PS: 136 PCL: 82	PS: 136 PCL: 82	
USB 2.0 Hi-Speed Support	Standard	Standard	Standard
Ethernet Interface	10/100/1000 Base-TX	10/100/1000 Base-TX	10/100/1000 Base-TX
Bypass Tray (150 Sheets)	Standard	Standard	Standard
Tray 1 (550 Sheets)	Standard	Standard	Standard
Tray 2/3/4 550-Sheet Feeder	Optional	Optional	
Duplex Unit	Optional	Standard	Standard
SD Card (4 GB)	Optional	Optional	Optional
External Wireless LAN	Optional	Optional	Optional
Printer Resolutions (dpi)			
<ul style="list-style-type: none"> Standard Enhanced Photo 	<ul style="list-style-type: none"> 600 x 600 x 1 1200 x 1200 x 1 600 x 600 x 8 	<ul style="list-style-type: none"> 600 x 600 x 1 1200 x 1200 x 1 600 x 600 x 8 	
* All configurations have one memory slot supporting a 512 MB DDR3 DIMM, to a maximum of 712 MB.			

WorkCentre 3615 Configurations

The WorkCentre 3615 is available in two configurations.

Features	Configurations	
	3615 N	3615 DN
Processor and Clock Speed	667 MHz	667 MHz
Memory Configuration*	256 MB	256 MB
Print Speed (ppm)	47	47
Adobe PostScript 3 Fonts	Standard	Standard
PCL6 Fonts	Standard	Standard
Resident Fonts	PS: 136 PCL: 82	PS: 136 PCL: 82
USB 2.0 Hi-Speed Support	Standard	Standard
Ethernet Interface	10/100/1000 Base-TX	10/100/1000 Base-TX
Bypass Tray (150 Sheets)	Standard	Standard
Tray 1 (550 Sheets)	Standard	Standard
Tray 2/3/4 550-Sheet Feeder	Optional	Optional
Duplex Unit	Optional	Standard
SD Card (4 GB)	Optional	Optional
External Wireless LAN	Optional	Optional
Printer Resolutions (dpi)		
<ul style="list-style-type: none"> • Standard • Enhanced • Photo 	<ul style="list-style-type: none"> • 600 x 600 x 1 • 1200 x 1200 x 1 • 600 x 600 x 8 	<ul style="list-style-type: none"> • 600 x 600 x 1 • 1200 x 1200 x 1 • 600 x 600 x 8
* All configurations have one memory slot supporting a 512 MB DDR3 DIMM, to a maximum of 712 MB.		

Printer Options

The Phaser 3610, WorkCentre 3615 printer options include:

- Additional RAM (512 MB - 3610 only)
- Productivity Kit (Device Memory 4G)
- Duplex Unit
- Optional 550-Sheet Feeder (Trays 2, 3, and 4)
- Printer Stand
- External Wireless Network Adaptor

Additional Memory

The Phaser 3610, WorkCentre 3615 features 1 slot that accepts a 512 MB of DDR2 DIMM. Memory module must meet the following characteristics:

- PC2-5300 (667MHz memory bus speed)
- 200 Pin DDR2 DIMM (8 chip type)
- Unbuffered, Non-parity

The printer's configuration page lists the amount of RAM installed in the printer.

Optional 550-Sheet Feeder (Trays 2, 3, and 4)

The Optional 550-Sheet Feeder increases the input capacity of the printer and can be attached to the printer underneath Tray 1. Up to three Optional 550-Sheet Feeders can be installed on the printer. The Optional 550-Sheet Feeder is customer installable.

External Wireless Network Adapter

The External Wireless Network Adapter enables the printer to connect to a wireless network.

Control Panel (3610)

The Control Panel consists of a display, indicator lights, and buttons to control available functions.

The Control Panel:

- Displays the current operating status of the printer.
- Provides access to print features, reference materials, and admin and maintenance menus.
- Prompts you to load paper, replace supplies, and clear jams.
- Displays errors and warnings.

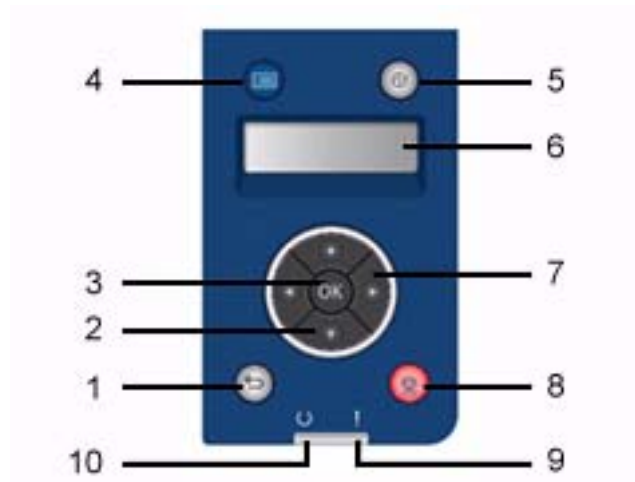

- | | | |
|----|----------------------------------|--|
| 1 | Back/Return: | Moves up one level in the menu. |
| 2 | Up and Down arrows: | Navigates to the next menu, item, or option. |
| 3 | OK: | Displays the selected menu or selects the current menu option. |
| 4 | Menu: | Displays the Information Pages, Billing Meters, Admin, Tray Settings, and Panel Language menus. |
| 5 | Power Saver: | Enters and exits low-power mode. |
| 6 | The Control Panel Display | provides information about settings, statuses, and error messages. An asterisk (*) next to a menu option indicates the current default setting. |
| 7 | Left and Right arrows: | Moves forward and backward through submenus or number fields. To display the Walk-up Features menu and to list Secure Jobs and Saved Jobs, press the Left arrow button. |
| 8 | Cancel: | Ends the active print job |
| 9 | Error Indicator | <ul style="list-style-type: none"> – Lights red to indicate an error condition or warning that requires your attention. – Blinks red when an error occurs that requires technical support. |
| 10 | Ready Indicator | <ul style="list-style-type: none"> – Lights green when the printer is ready to receive data. – Blinks green when the printer is busy receiving data. |

Control Panel Layout (3615)

The Control Panel:

- Displays the current operating status of the printer.
- Provides access to print features, information pages, and setup menus.
- Displays prompt to load paper, replace supplies, and clear jams.
- Displays errors and warnings.

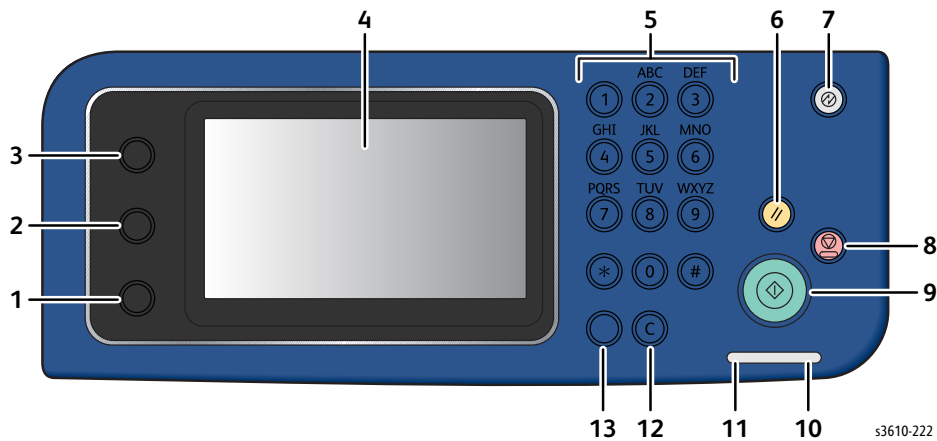

1. **Machine Status** button switches the display to the System menus.
2. **Job Status** displays the active jobs, Secure Print Jobs, and Secure Fax Jobs available in Job Status on the touch screen.
3. **Services Home** button invokes the Services home menu for access to printer features, such as copy, scan, and fax.
4. **Touch Screen** displays information and provides access to printer functions.
5. **Alphanumeric Keypad** enters alphanumeric information.
6. **Clear All** clears previous and changed settings for the current selection.
7. **Power Saver** enters and exits low-power mode.
8. **Stop** cancels the current job.
9. **Start** starts the selected copy, scan, fax, or Print From job, such as Print from USB.
10. **Error Indicator**
 - Lights red to indicate an error condition or warning that requires your attention.
 - Blinks red when an error occurs that requires technical support.
11. **Data Indicator**
 - Blinks green when the printer is sending or receiving a fax.
 - Lights green when there is at least one saved job, secure print job, or secure fax job on the device.
12. **Clear** clears a number field or clears the last number of a numeric entry.
13. **Redial / Pause** recalls the last fax number used or inserts pauses in fax numbers.

Operational Modes

The following 4 modes are available in the Phaser 3610, WorkCentre 3615 printers:

- Running Mode
- Ready Mode
- Low Power Mode
- Sleep Mode

Running Mode

Running Mode contains operating states such as data receive/ image creation, or recording (print).

Ready Mode

The printers are ready to print at Ready state. It is possible to enter this mode within the Warm Up Time after power Off and On or from the Energy Saver Mode.

Low Power Mode

To reduce energy consumption, the printers will enter Low Power Mode when it has not received any print data within a certain time after it has entered Ready Mode. The waiting time before switching to this mode is set at 1 minute by default. It can be set in increments of 1 minute in the range between 1 and 60 minutes from the Control Panel. Furthermore, it can also change when the Energy Saver button is pressed. The printers can be set to prohibit the transition to Low Power Mode or Sleep Mode. Furthermore, the printers will enter or exit the Low Power Mode when the Energy Saver button is pressed.

When the printers receive a Print Job or when the Energy Saver button on the Control Panel is pressed, Low Power Mode will be canceled.

Sleep Mode

To reduce energy consumption, the printers will enter the Sleep Mode when it has not received any print data within a certain time after it has entered the Ready Mode or the Low Power Mode. (When an error, such as Out of Toner, has occurred, the printers will not transition to Sleep Mode unless the transition condition has been fulfilled). The waiting time before switching to this mode is set as 1 minute by default. It can be set in increments of 1 minute in the range between 1 and 60 minutes from the Control Panel. Furthermore, it can also transition when the Energy Saver button is pressed. The printers can be set to prohibit the transition to Low Power Mode or Sleep Mode.

When the printers receives a Print Job or when the Energy Saver button on the Control Panel is pressed, Sleep Mode will be canceled.

Media Path

IOT Configuration w/ Optional Trays

-----▶ : Paper flow

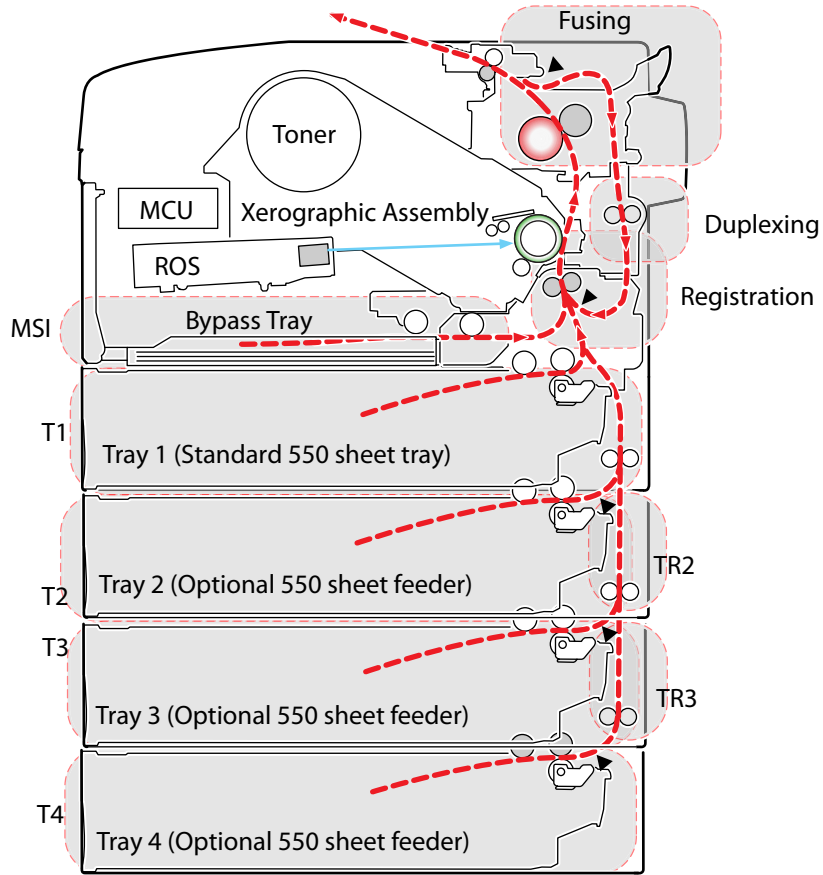

s3610-264a

Standard IOT Configuration

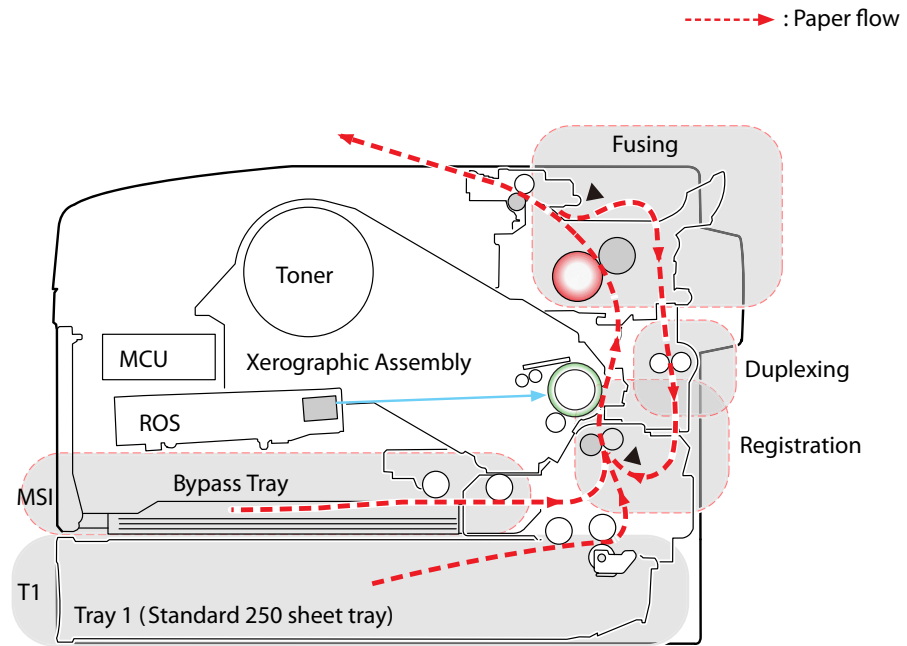

s3610-263a

DADF (3615)

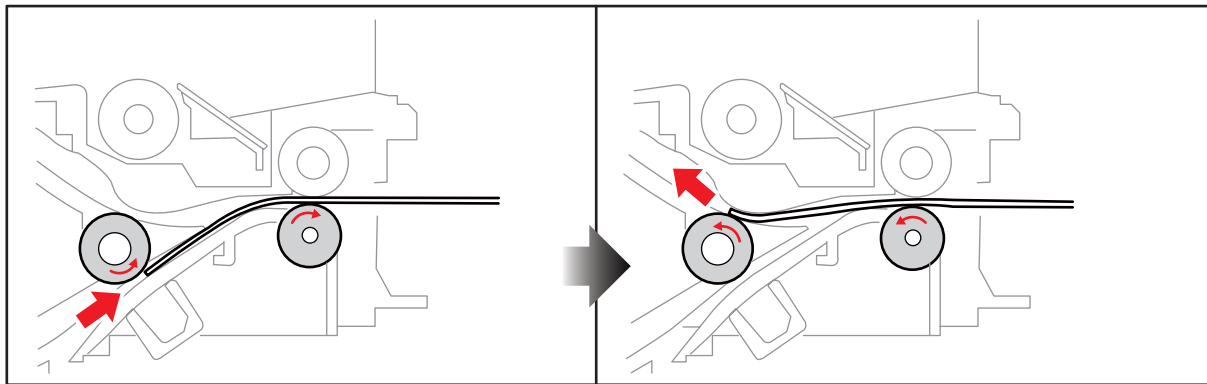
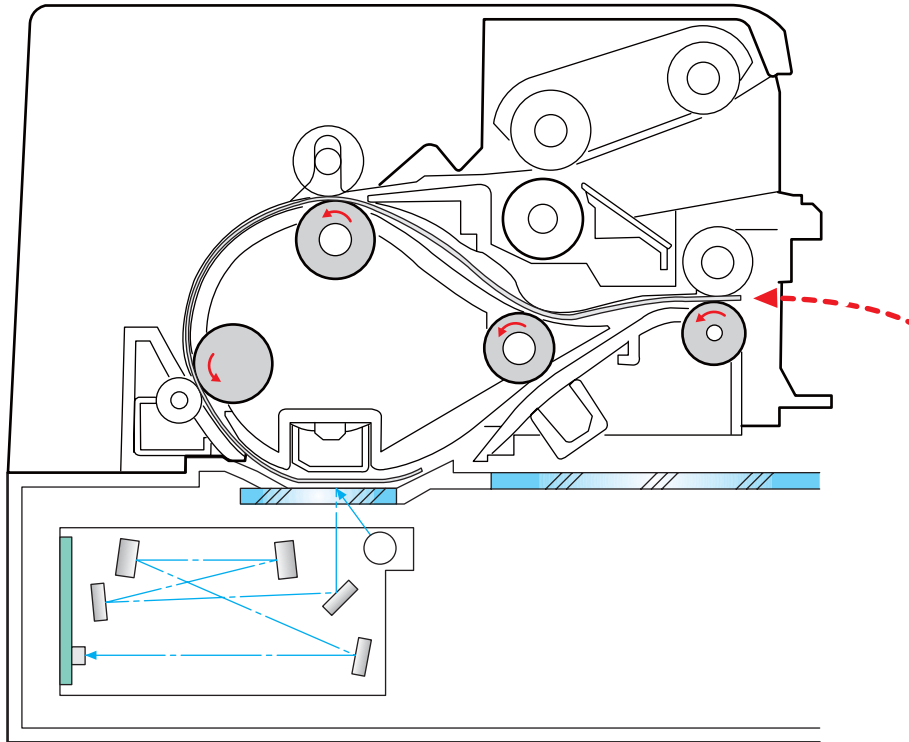

s3610-337

Media Path Components

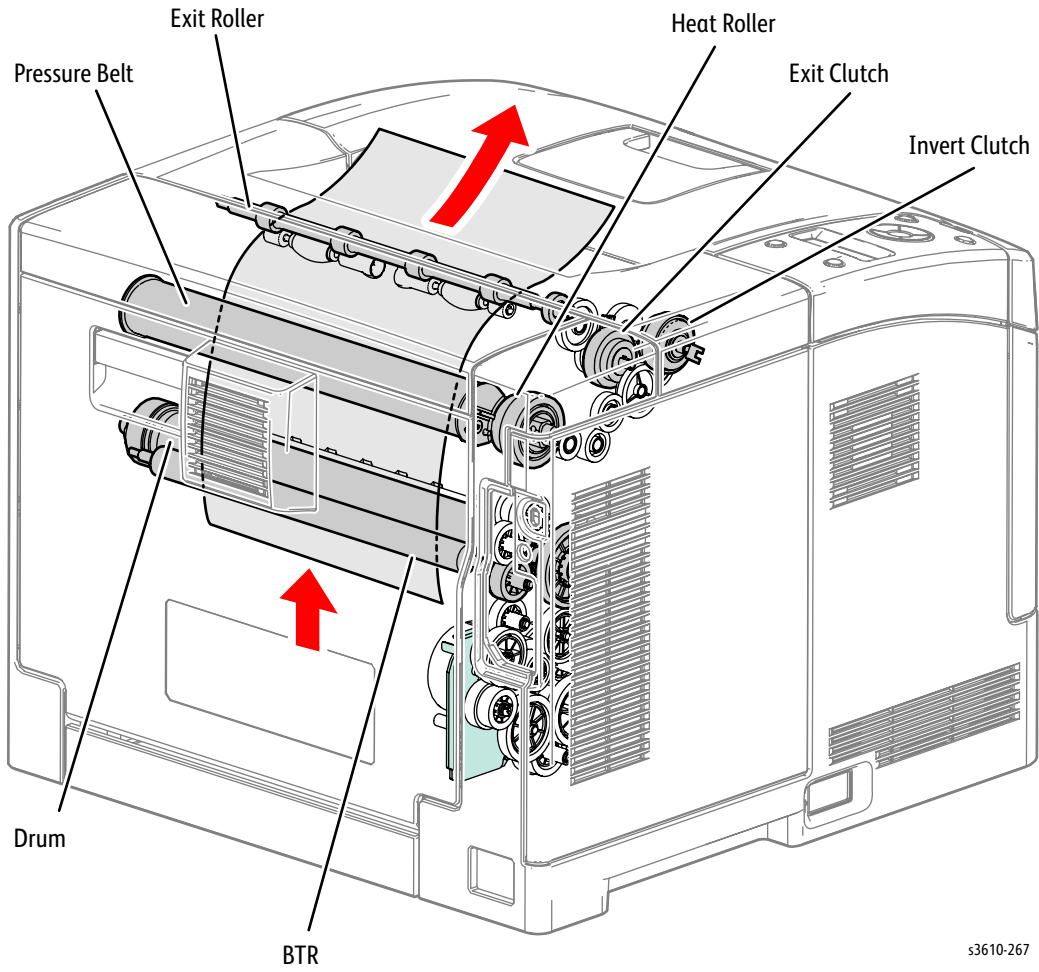

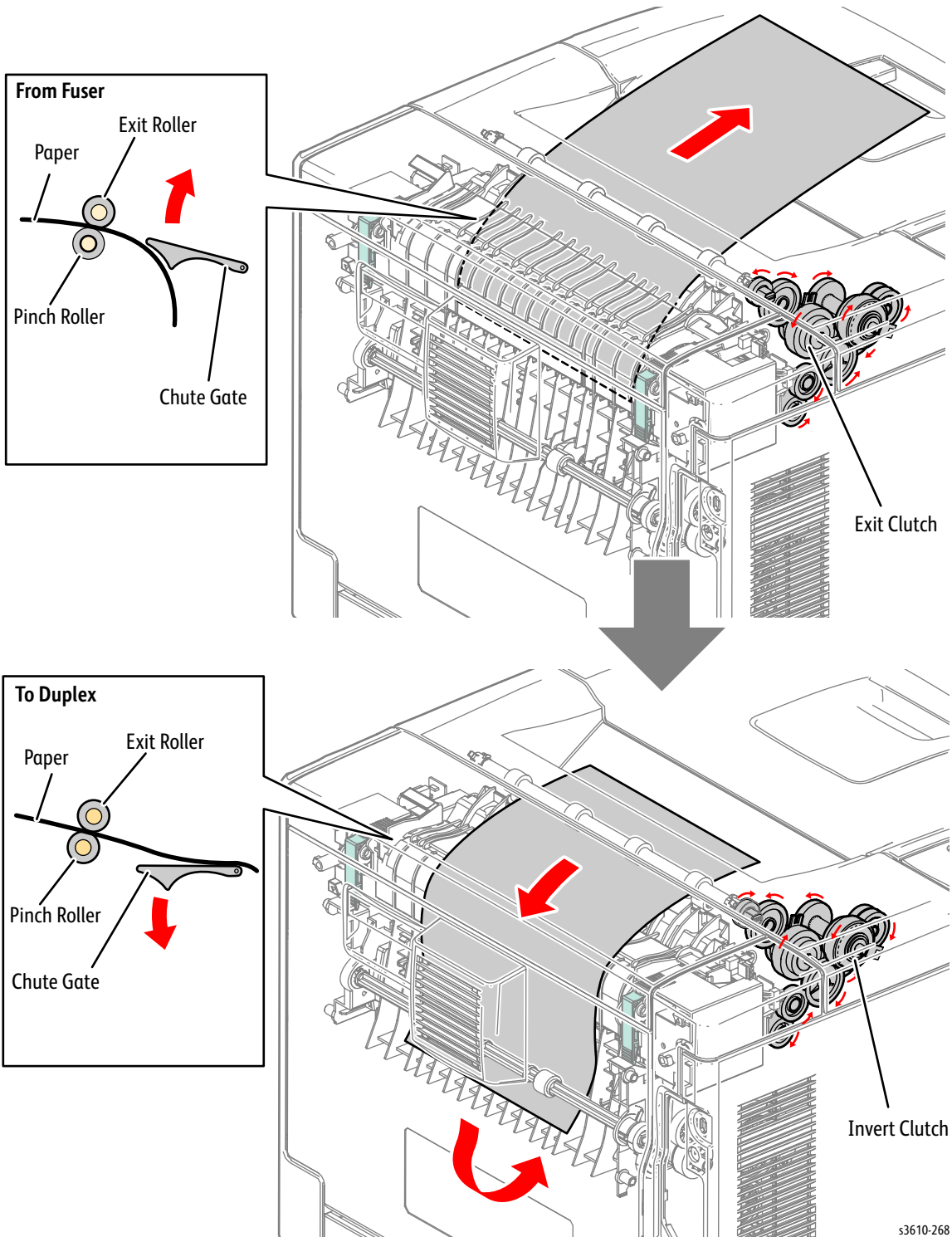

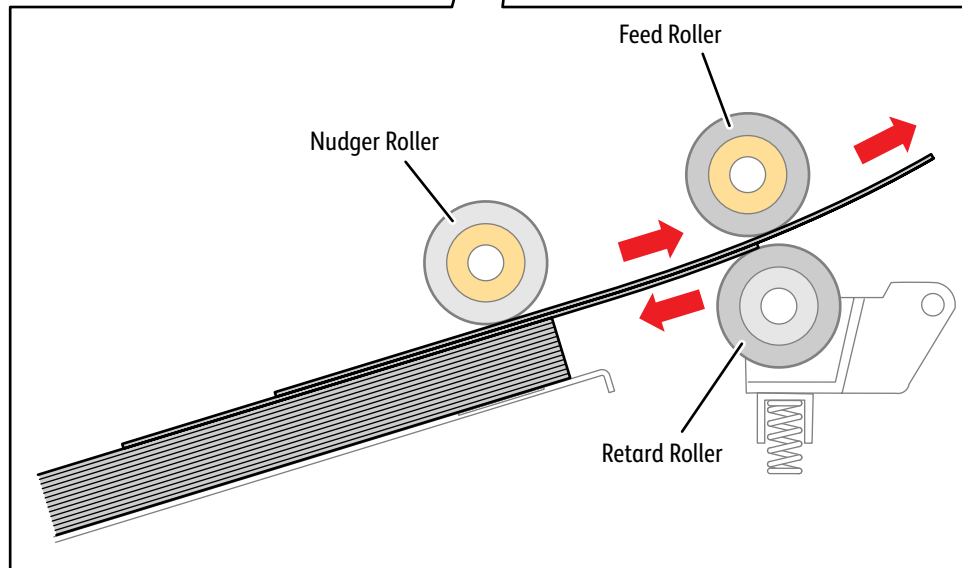
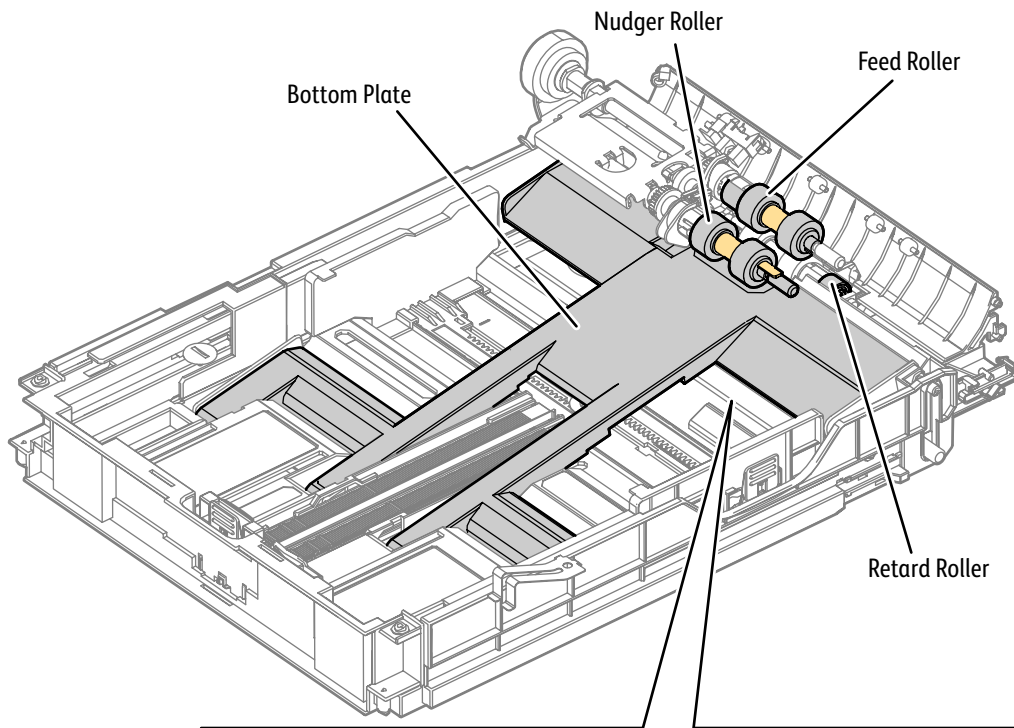

s3610-242

Overview

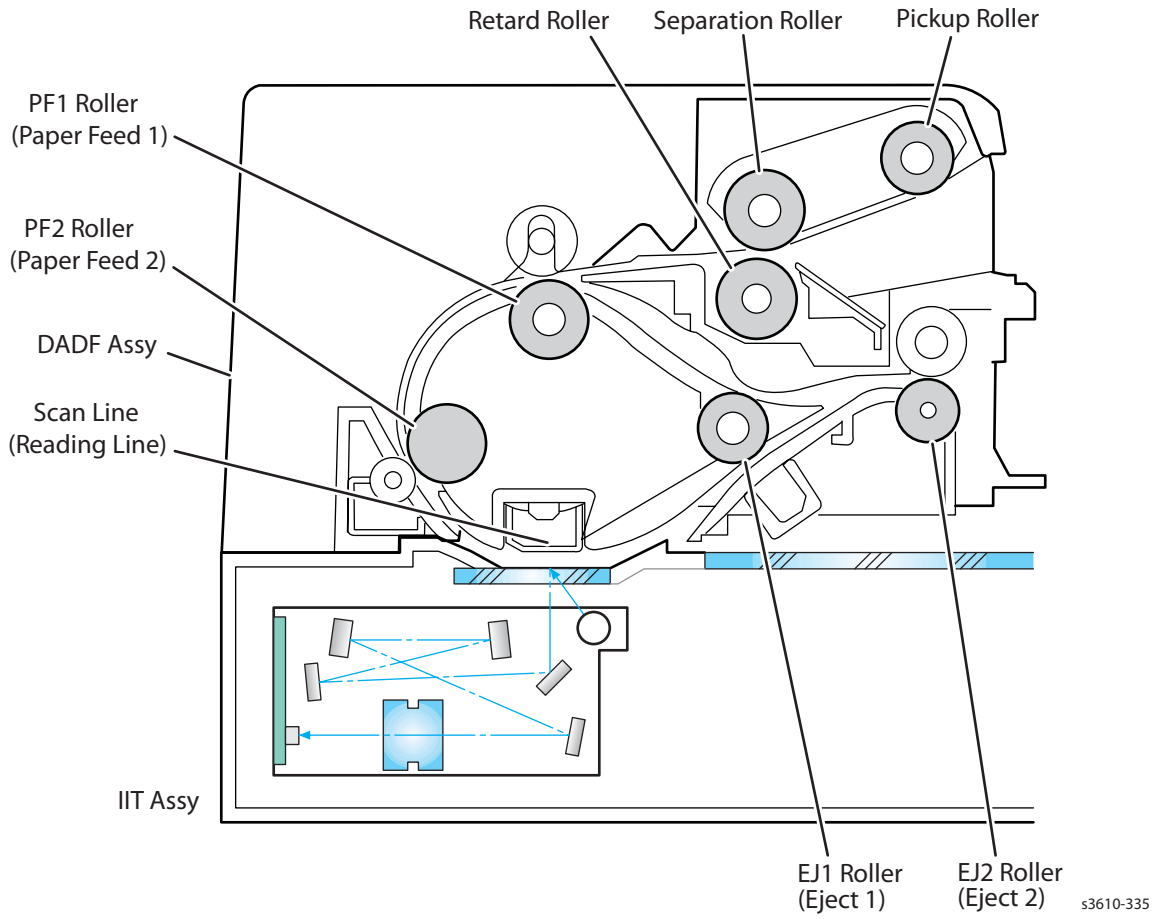

Major Component Locations

3610 / 3615

ATC Sensor ([page 1-28](#))

Auger ([page 1-28](#))

Bias Charge Roll ([page 1-30](#))

(Bias Transfer Roll ([page 1-27](#)))

MSI Feed Solenoid ([page 1-32](#))

MSI No Paper Sensor
([page 1-32](#))

Cleaning Blade ([page 1-30](#))

3610 Control Panel ([page 1-26](#))

Dispense Motor ([page 1-28](#))

Drum ([page 1-27](#))

ESS PWB ([page 1-26](#))

Exit Clutch ([page 1-29](#))

Exit Sensor ([page 1-29](#))

Front Interlock Switch
([page 1-26](#))

Full Stack Sensor ([page 1-29](#))

Fusing Assembly ([page 1-29](#))

Heat Lamp 1 ([page 1-29](#))

Heat Lamp 2 ([page 1-29](#))

Heat Roll ([page 1-29](#))

HVPS ([page 1-26](#))

Invert Clutch ([page 1-29](#))

LDD PWB ([page 1-31](#))

LVPS ([page 1-26](#))

LVPS Fan ([page 1-26](#))

MCU PWB ([page 1-26](#))

Magnetic Roll ([page 1-28](#))

Main Drive ([page 1-27](#))

Main Switch ([page 1-26](#))

Polygon Motor ([page 1-31](#))

Pressure Belt ([page 1-29](#))

ROS Assembly ([page 1-31](#))

Rear Fan ([page 1-26](#))

Rear Interlock Switch ([page 1-26](#))

Registration Clutch ([page 1-32](#))

Registration Sensor ([page 1-32](#))

SOS PWB ([page 1-31](#))

Temperature Sensor (Main)
([page 1-29](#))

Temperature Sensor (Side)
([page 1-29](#))

Thermostat ([page 1-29](#))

Toner Cartridge ([page 1-28](#))

Toner Crum Connector ([page 1-28](#))

Trimmer Rod ([page 1-28](#))

Xerographic Assembly ([page 1-30](#))

Xero Crum Connector ([page 1-28](#))

3615 (only)

Carriage Motor ([page 1-34](#))

Control Panel ([page 1-33](#))

CCD PWB ([page 1-34](#))

DADF Cover Sensor ([page 1-35](#))

DADF Document LED ([page 1-35](#))

DADF Motor ([page 1-35](#))

DADF Stage Sensor ([page 1-35](#))

FAX PWB ([page 1-33](#))

Feed Sensor ([page 1-35](#))

Front USB Port ([page 1-33](#))

Home Position Sensor
([page 1-34](#))

Legal Paper Sensor ([page 1-35](#))

Pick-up Motor ([page 1-35](#))

Speaker ([page 1-33](#))

Tray 1

Actuator ([page 1-37](#))

End Guide ([page 1-37](#))

Feeder PWB ([page 1-36](#))

Feed Clutch ([page 1-36](#))

Feed Motor ([page 1-36](#))

No Paper Sensor ([page 1-36](#))

Illustration 1 (3610 / 3615)

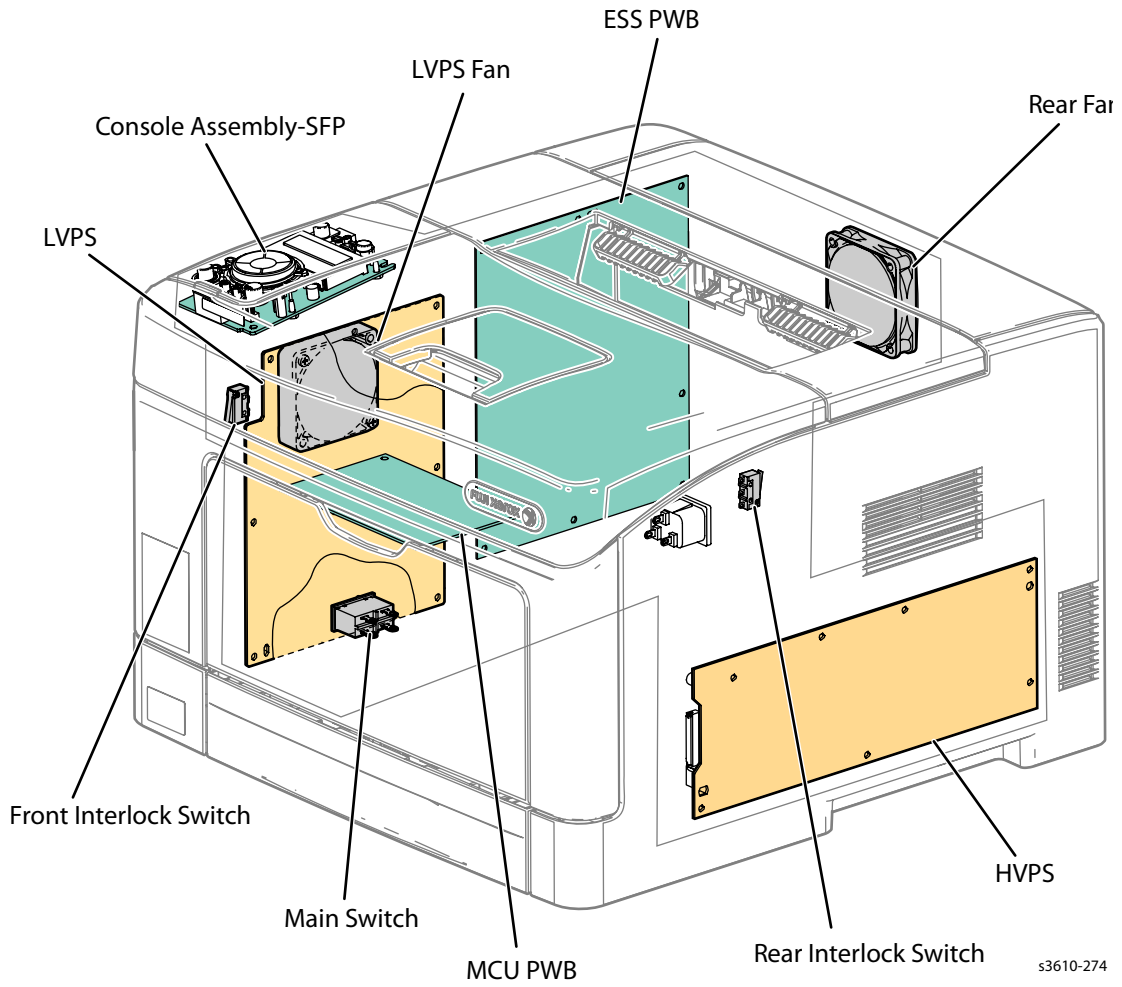
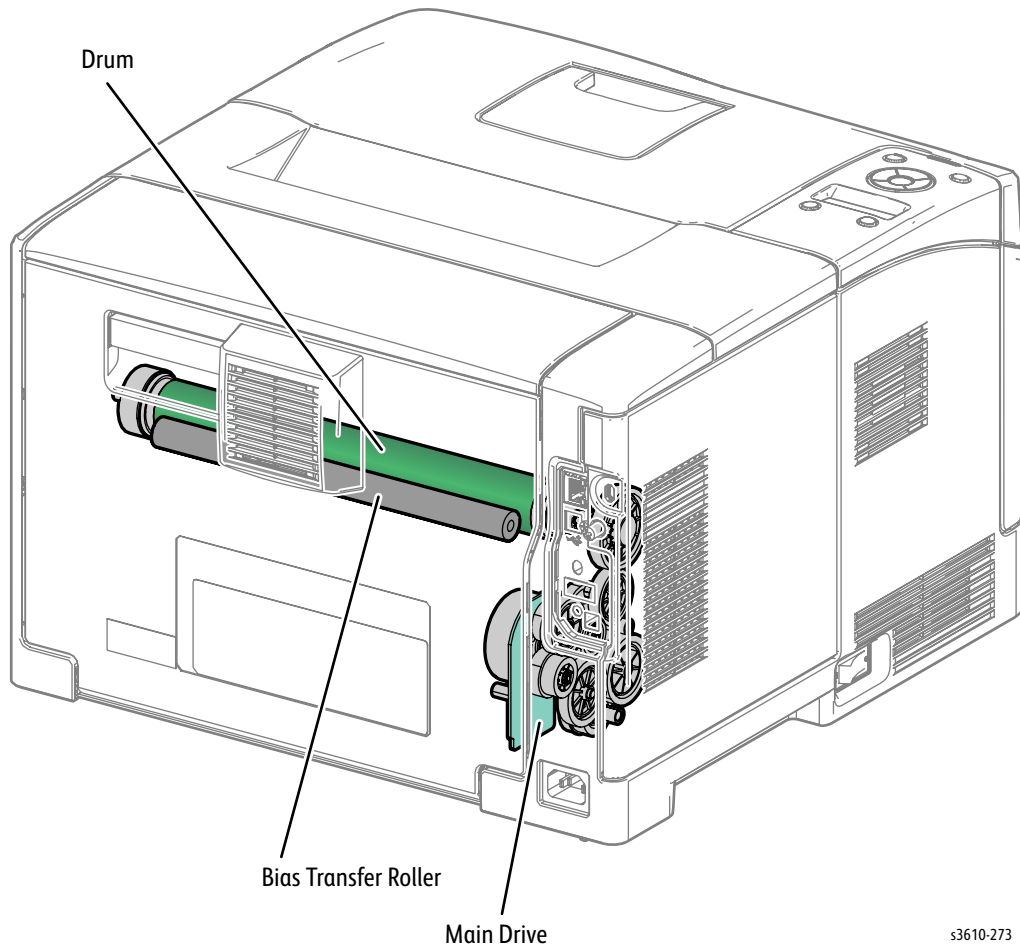
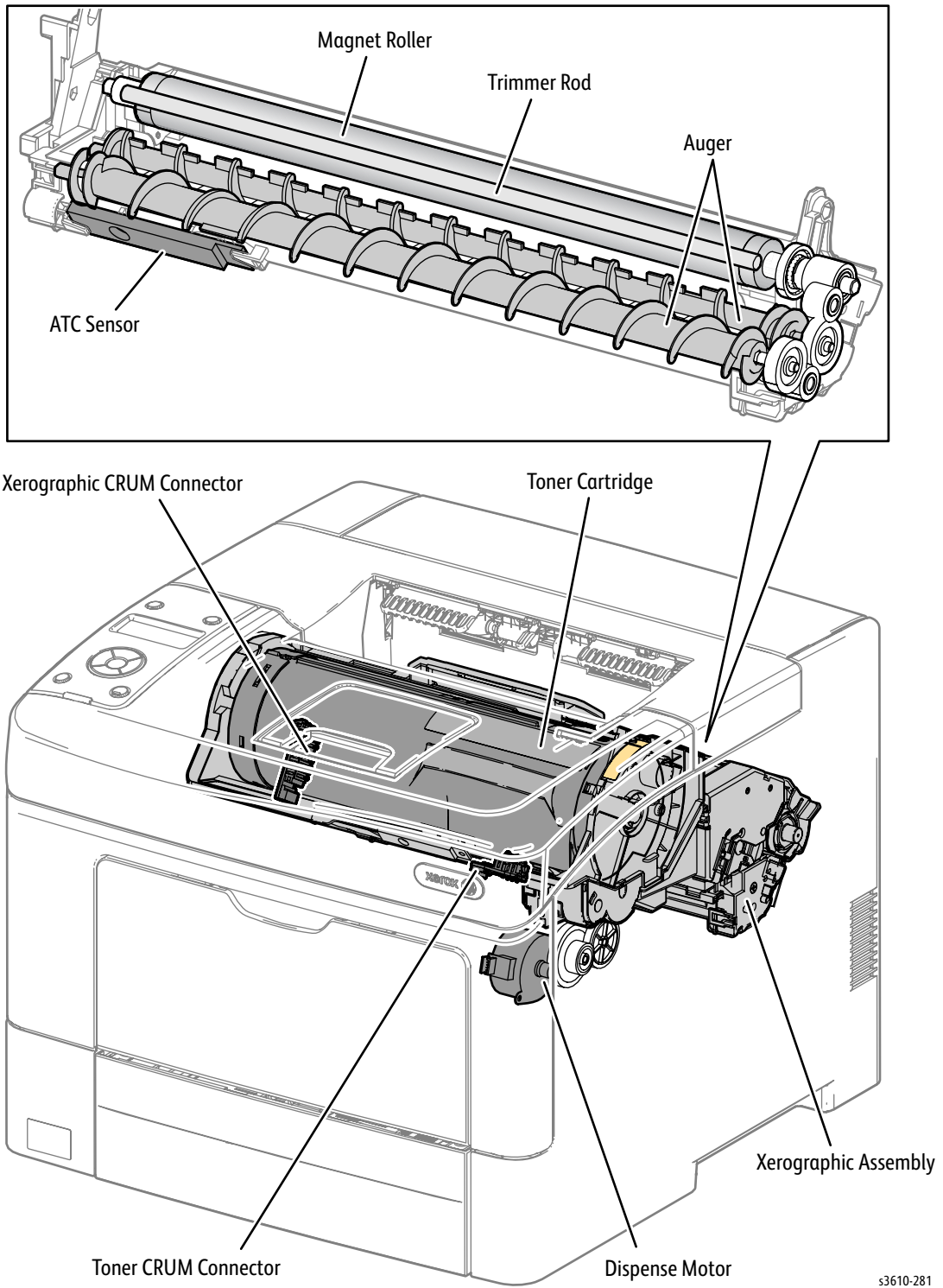

Illustration 2 (3610 / 3615)



s3610-273

Illustration 3 (3610 / 3615)



s3610-281

Illustration 4 (3610 / 3615)

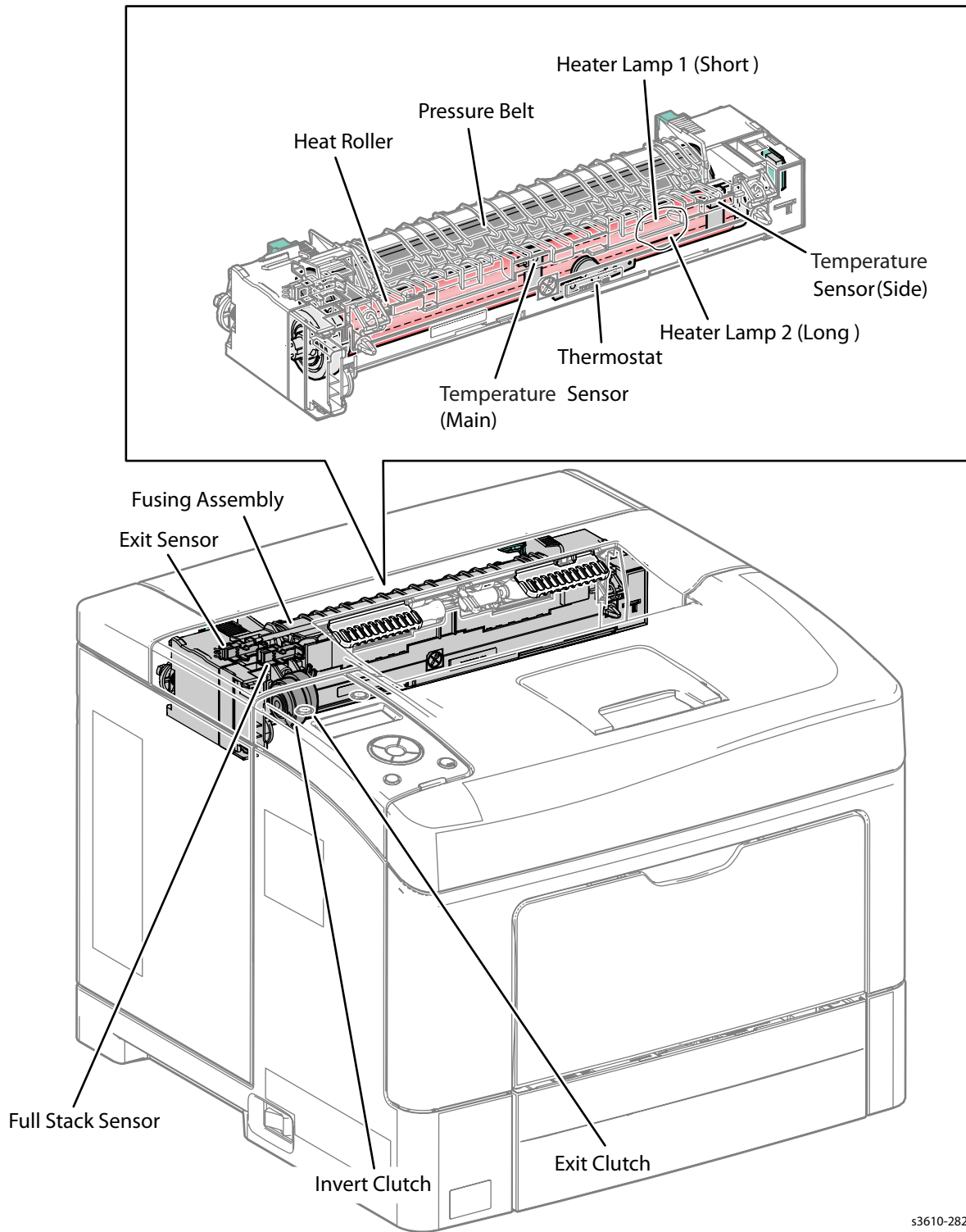

s3610-282

Illustration 5 (3610 / 3615)

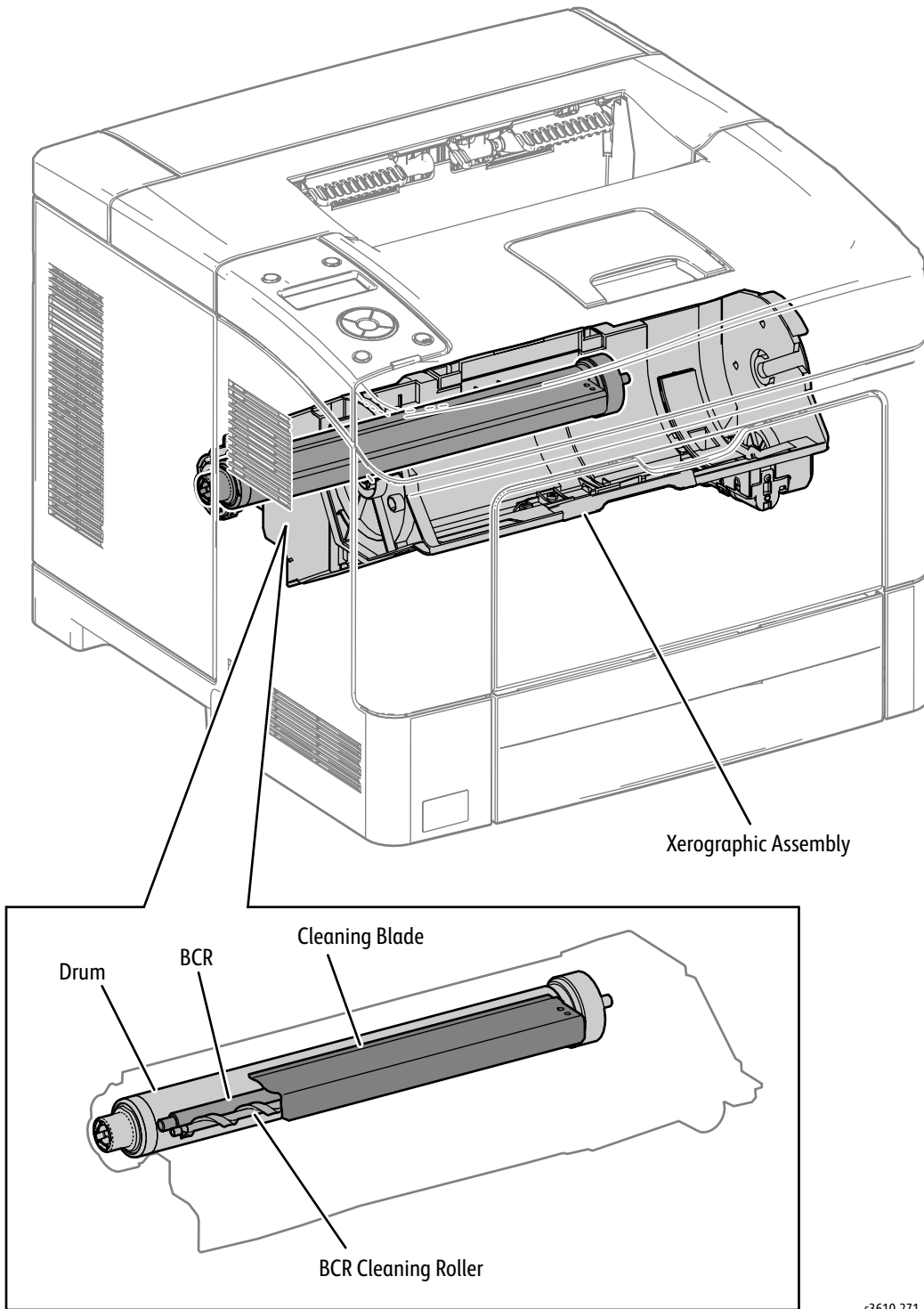

s3610-271

Illustration 6 (3610 / 3615)

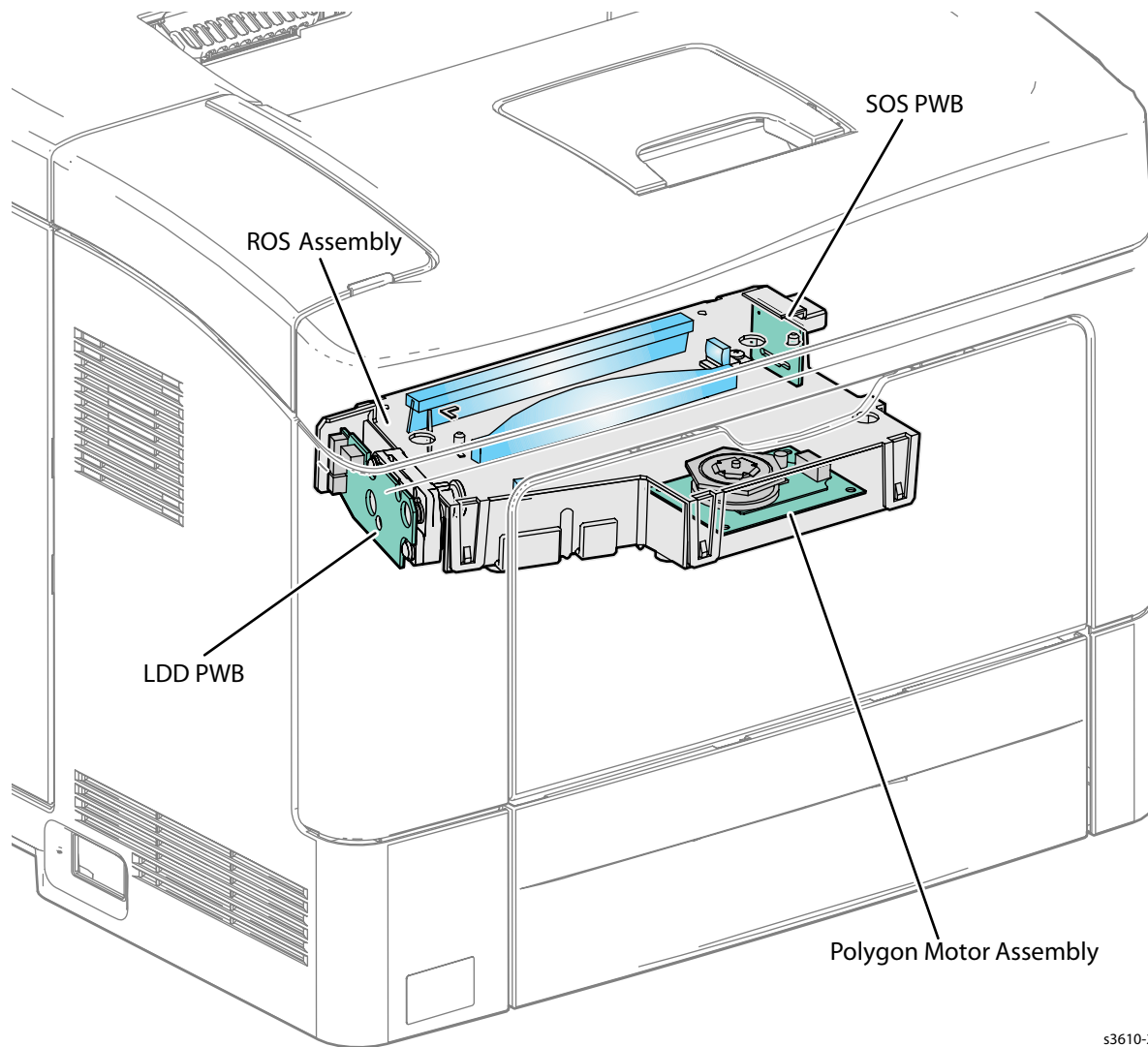

s3610-255

Illustration 7 (3610 / 3615)

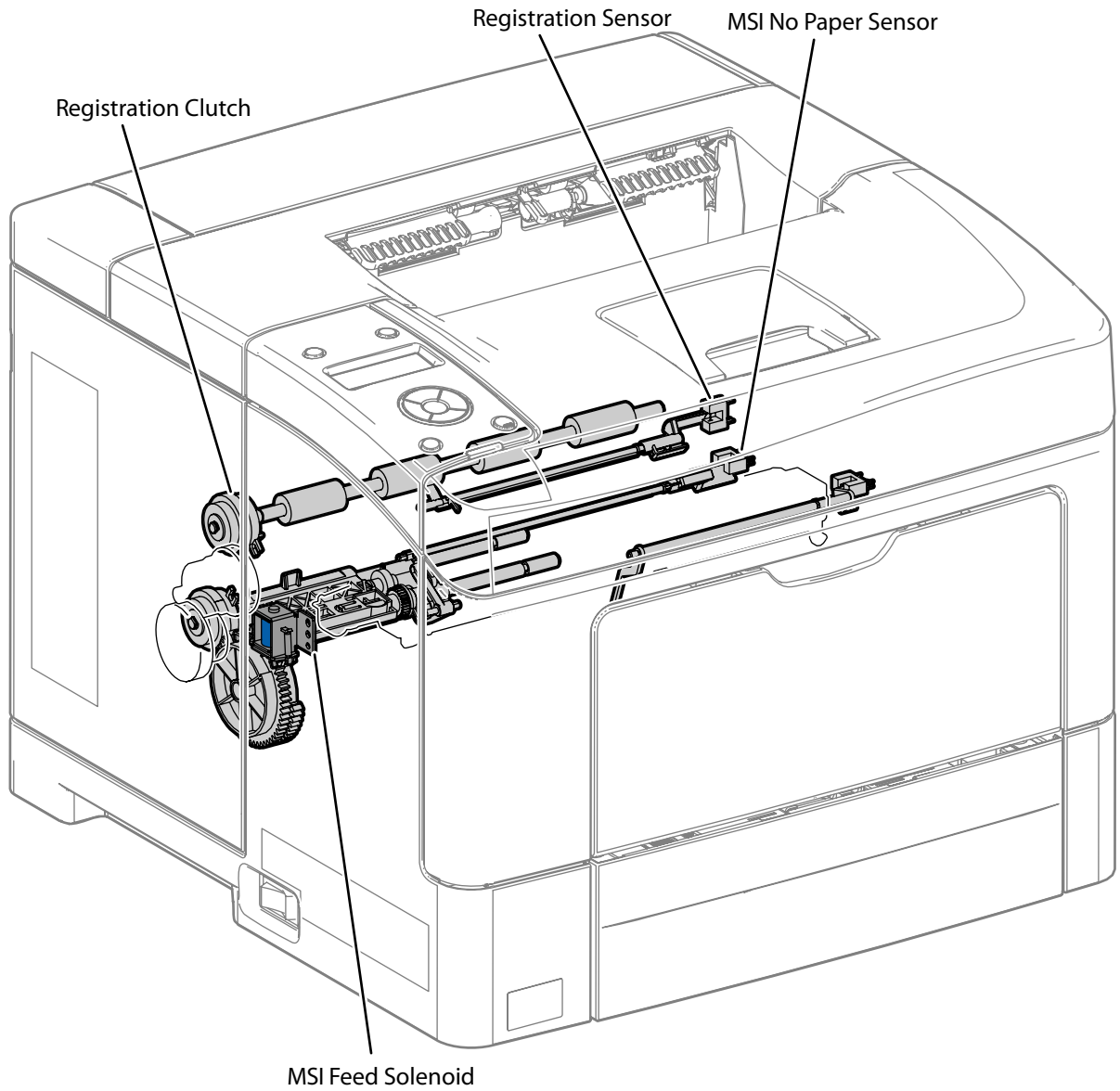

s3610-280

Illustration 8 (3615 only)

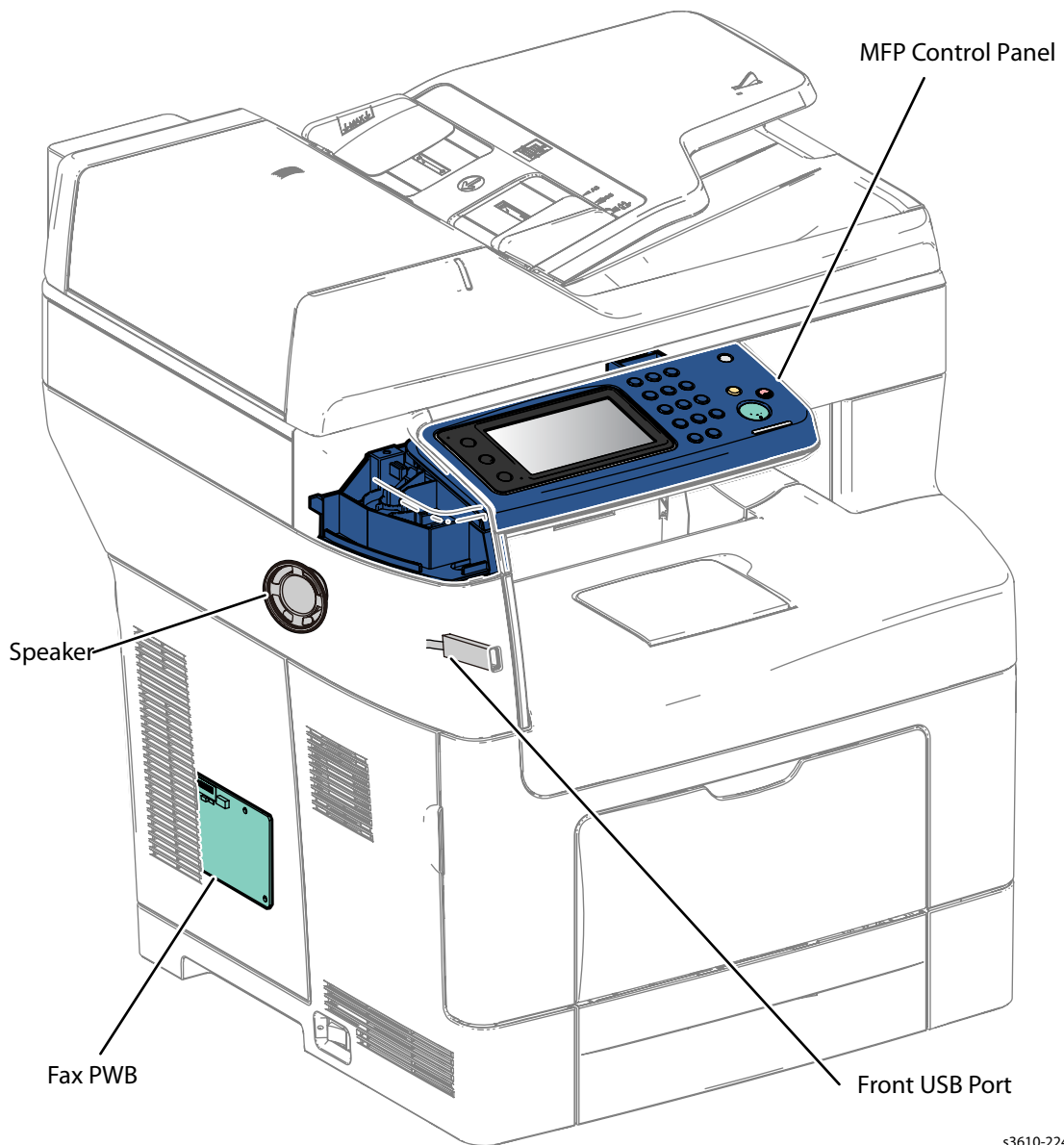

s3610-224

Illustration 9 (3615 only)

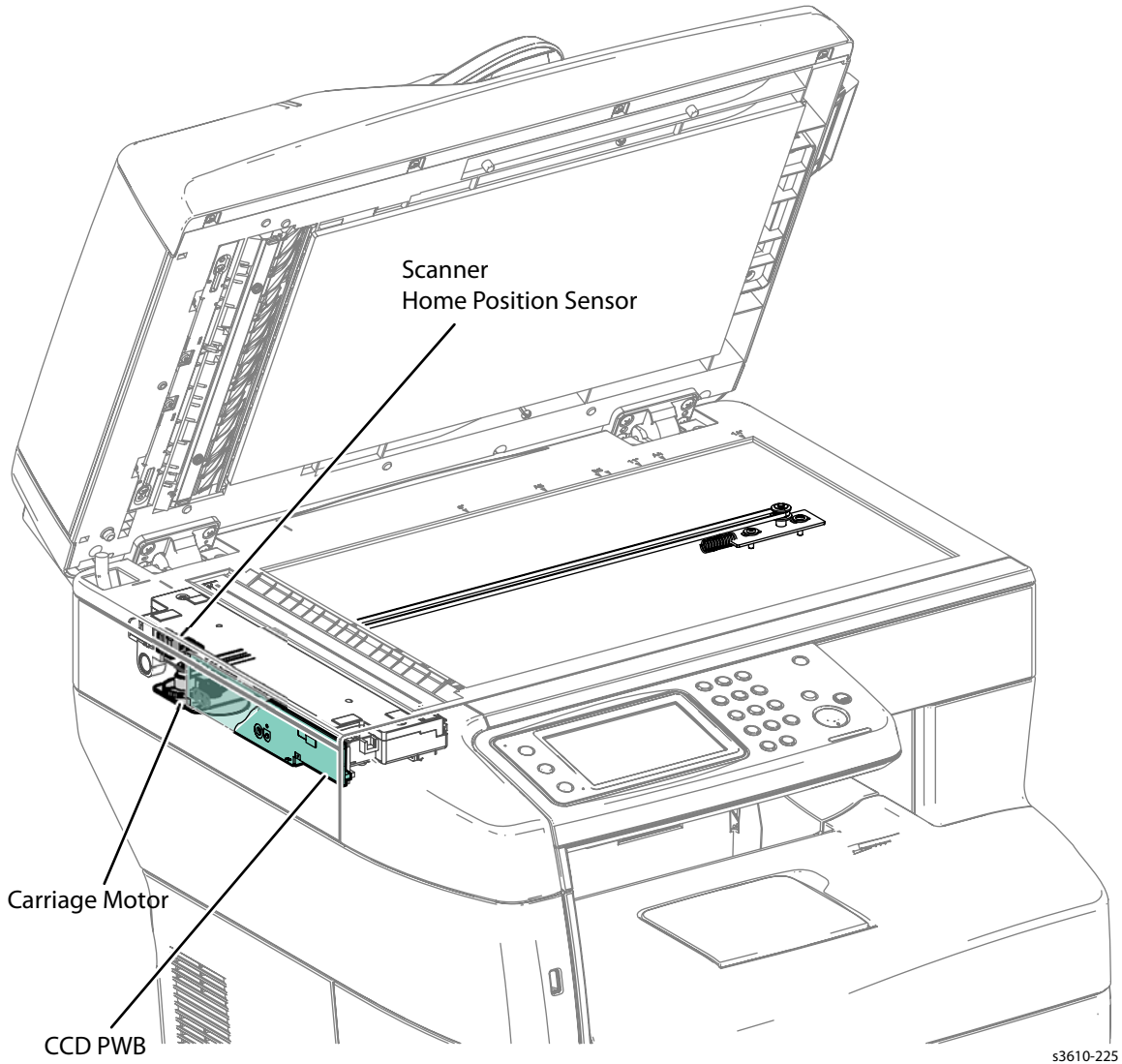

Illustration 10 (3615 only)

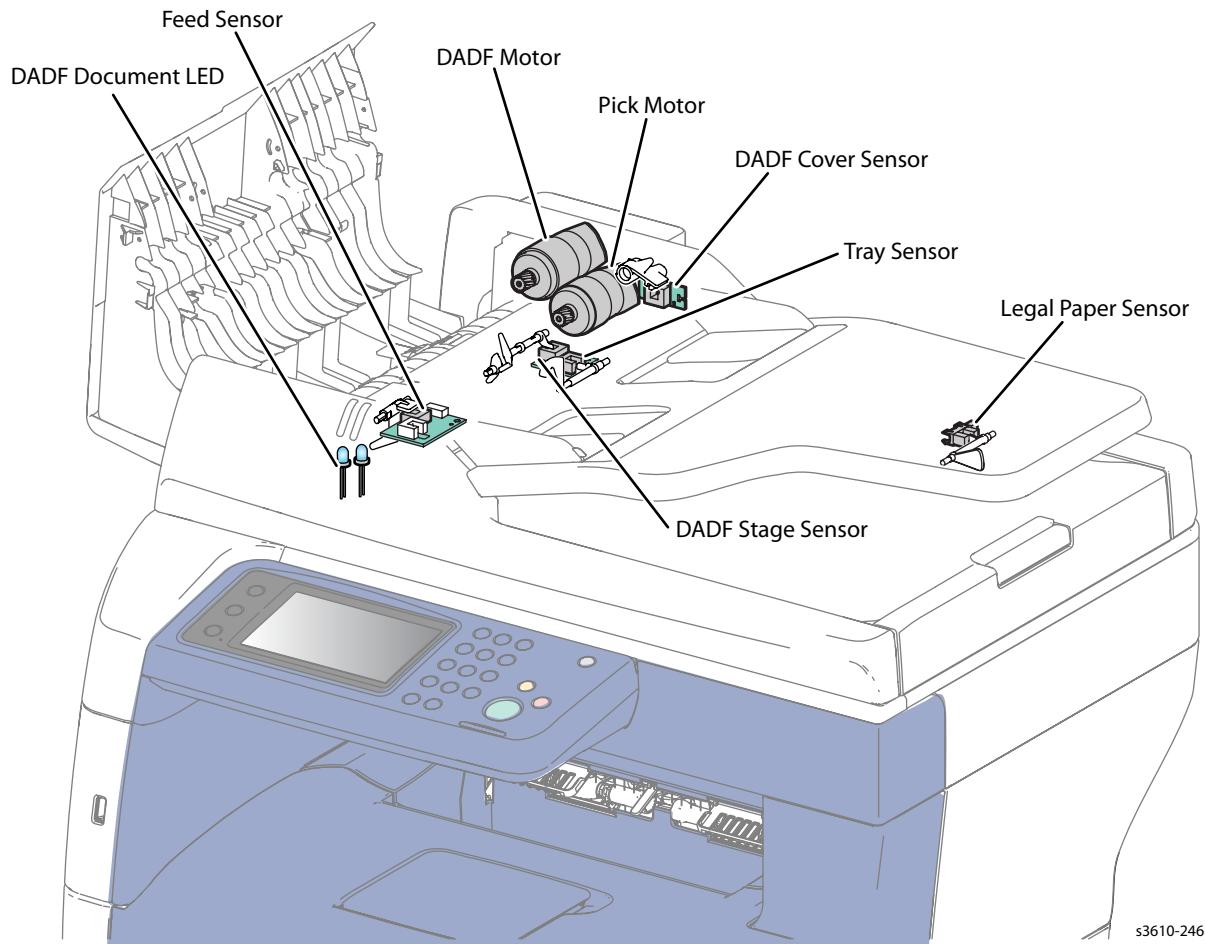

Illustration 11 (Tray 1)

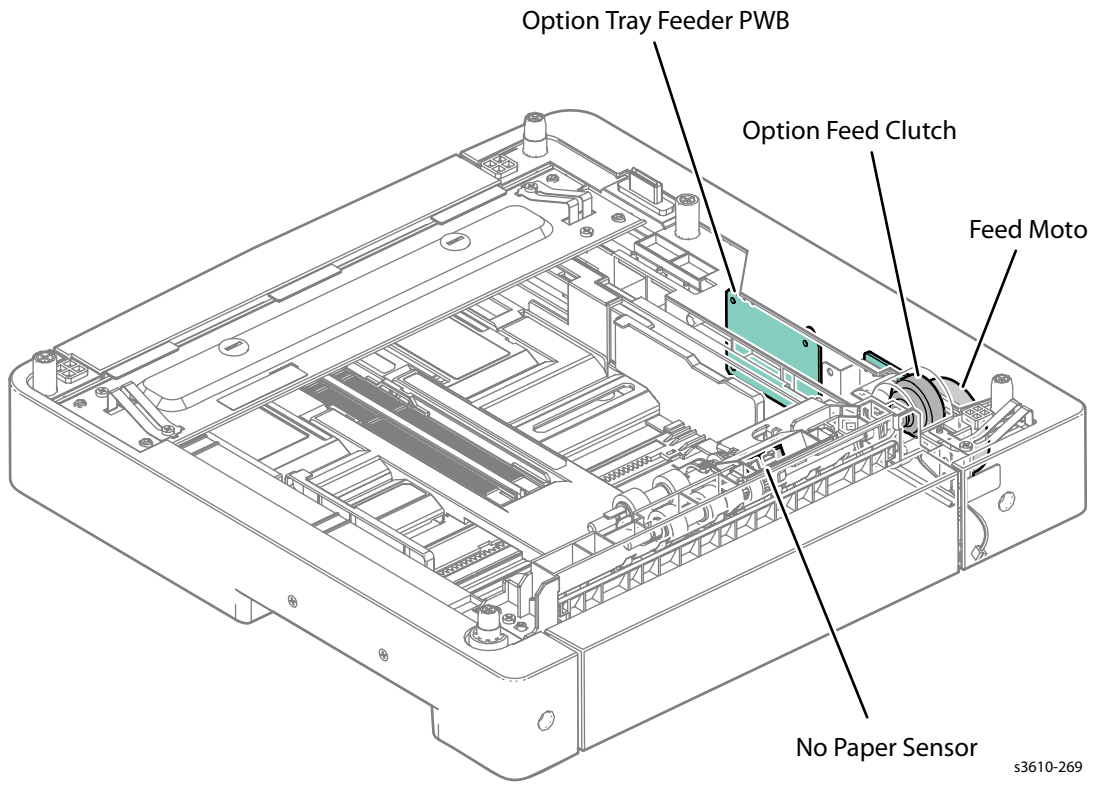
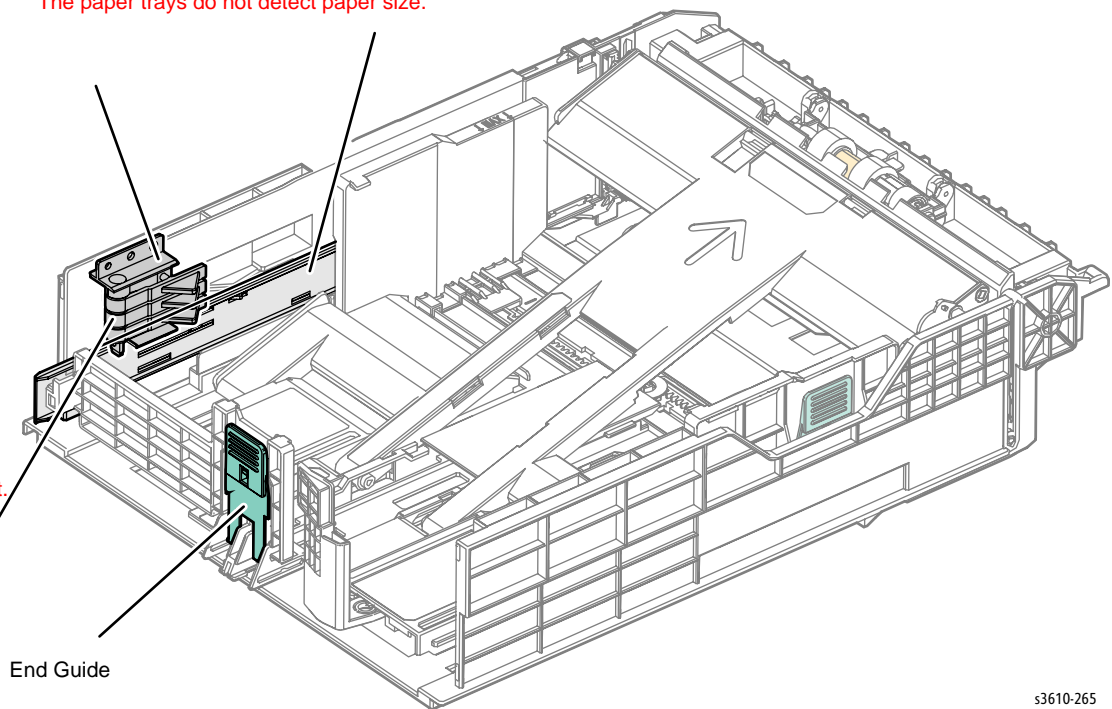

Illustration 12 (Tray 1)

These parts do not exist.
The paper trays do not detect paper size.

This parts does not exist.
The paper trays do not detect paper size.



s3610-265

Information Pages

The following Embedded Pages and Reports are available in the 3610 and 3615 printers. The pages can be accessed through the Machine Status / Information Pages...

Selection		Page	Selection
(3610)			(3615)
Menu Map		Page 1	Configuration
Configuration			PCL Font List
PCL Font List			PS Macros List
PS Macros List			PS Font List
PS Font List		Page 2	PDF Fonts
PDF Fonts			Job History
Job History			Error History
Error History			Meter/ Auditron
Print Meter		Page 3	Demo Page
Stored Documents			Protocol Monitor
			Fax Address Book
			Email Address Book
		Page 4	Server Address
			Fax Activity
			Fax Pending
			Stored Documents

Troubleshooting

2

In this chapter...

- [Introduction](#)
- [Servicing Instructions](#)
- [Service Diagnostics](#)
- [Engine Diagnostic Testing](#)
- [Administration Mode Menu Map](#)
- [Status Code List \(3610\)](#)
- [Status Code List \(3615\)](#)
- [Error Code Fault Isolation Procedures \(FIP\)](#)
- [Level 2 FIPs](#)
- [Network System Fault Check](#)
- [Network-related Details Check Flow](#)

Introduction

This chapter describes error messages displayed on the Control Panel or listed on the Error History page, Service Diagnostics used to test system operation and troubleshooting procedures to correct problems.

Flow of Troubleshooting

The fault repair operation proceeds in the following flow:

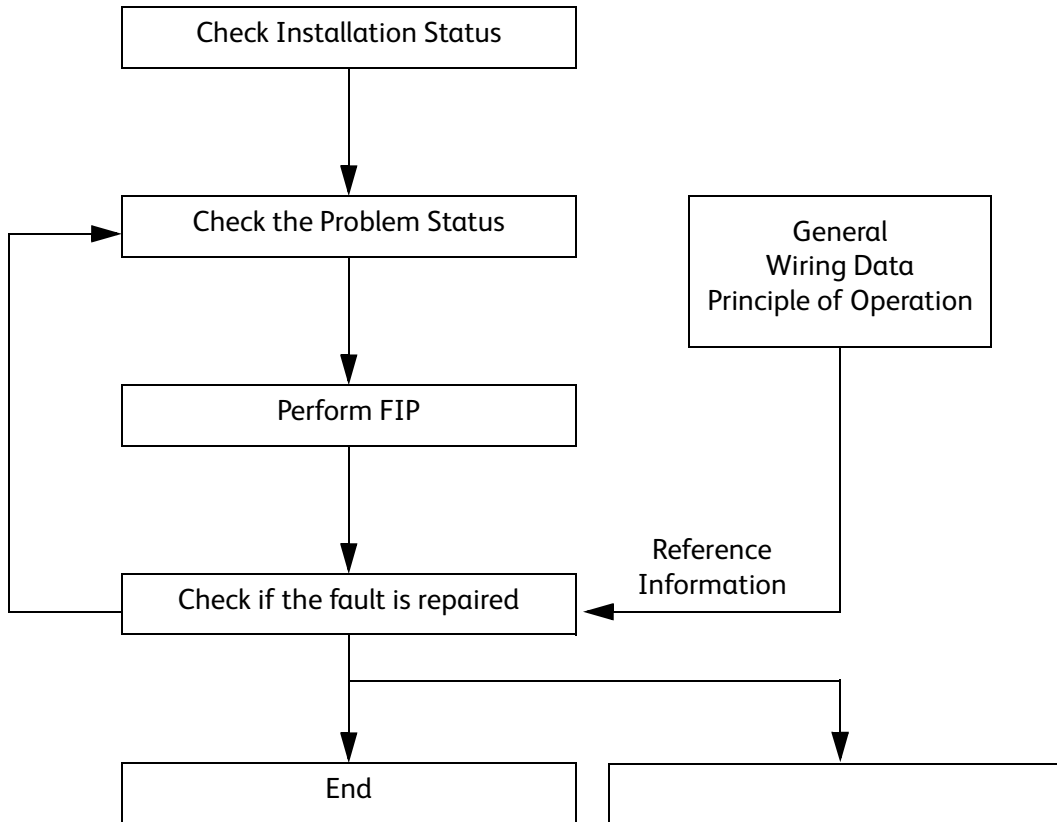

Servicing Instructions

This checklist outlines the path a service technician should take when servicing the printer.

Step 1: Identify the Problem

1. Verify the reported problem does exist.
2. Check for any error codes and write them down.
3. Print normal customer prints and service test prints.
4. Make note of any print-quality problems in the test prints.
5. Make note of any mechanical or electrical abnormalities present.
6. Make note of any unusual noise or smell coming from the printer.
7. View the System Fail History and Paper Jam History on the Error History Report.
8. Verify the AC supply is within proper specifications by measuring the voltage at the electric outlet while the printer is running.

Step 2: Inspect and Clean the Printer

1. Turn the printer power Off.
2. Disconnect the AC power cord from the wall outlet.
3. Verify the power cord is free from damage or short circuit and is connected properly.
4. Remove the Toner and Drum Cartridges.
5. Inspect the printer interior and remove any foreign matter such as paper clips, staples, pieces of paper, dust, or loose toner.
6. Do not use solvents or chemical cleaners to clean the printer interior.
7. Do not use any type of oil or lubricant on printer parts.
8. Use only an approved toner vacuum.
9. Clean all rubber rollers with a lint-free cloth, dampened slightly with cold water and mild detergent.
10. Inspect the printer interior for damaged wires, loose connections, toner leakage or obviously worn parts.
11. If the Toner or Drum Cartridge is damaged, replace with a new one.

Step 3: Find the Cause: of the Problem

1. Use the Troubleshooting procedures to find the cause of the problem.
2. Use Service Diagnostics to check the printer and optional components.
3. Use the Wiring Diagrams and Plug/Jack Locator to locate test points.
4. Take voltage readings as instructed in the appropriate troubleshooting procedure.

Step 4: Correct the Problem

1. Use the Parts List to locate a part number.
2. Use the Disassembly procedures to replace the part.

Step 5: Final Checkout

Test the printer to be sure you have corrected the initial problem and there are no additional problems present.

Check Installation Status

Before starting to troubleshoot, always check the following items.

1. The voltage of the Power Supply is within the specification. (Measure the voltage at the electrical outlet.)
2. Check the power cord for damage, short circuit, open circuit, bare wire, and improper connection.
3. The machine for proper grounding.
4. The machine is not installed in a place with high temperature, high humidity, low temperature, low humidity, or a place with drastic changes in temperature.
5. The machine is not installed near a water outlet, humidifier, heater or fire, dusty areas, or under the direct draft of an air-conditioner.
6. The machine is not installed in a place where volatile or flammable gas is generated.
7. The machine is not installed in a place exposed to direct sunlight.
8. The machine is installed in a well-ventilated place.
9. The machine is installed on a stable level surface.
10. The paper is within the specification. (Standard paper is recommended.)
11. The machine for any improper handling.

Initial Actions

Some problems are easy to resolve. Use these Steps in an attempt to quickly isolate the problem.

1. Turn Off the printer, wait 10 seconds, then turn On the printer. This often solves problems related to power transients, ESD, and software errors.
2. If a message appears on the Control Panel, see “Error Messages” for specific procedures related to error messages.
3. Check the power cord. Is the power cord plugged into the printer and a properly grounded electrical outlet? Is the power cord damaged?
4. Check the electrical outlet. Is the outlet turned off by a switch or breaker?
5. Does other electrical equipment plugged into the outlet operate?

Display Problems

If the Control Panel is blank:

1. Turn the printer Off, wait 10 seconds, then turn the printer On.
2. When tests complete, **Ready** should appear on the display.
3. If the problem persists:
4. Check the connections to the Control Panel.
 - Phaser 3610: Check the Control Panel connection, and P/J331 on the ESS PWB.
 - WorkCentre 3615: Check P/J01 and P/J02 on the USB Board, and P/J413 on the ESS PWB.
5. Check +3.3 and +5 VDC from the LVPS.
6. Replace the Control Panel.
7. Replace the ESS PWB.

Printing Problems

If menu settings entered from the Control Panel have no effect, change or disable print settings from the print driver, the print utilities, or the application.

Note: Settings made in the application, print driver, or print utilities override settings made from the Control Panel.

If a job did not print correctly or incorrect characters were printed, check the following:

1. Check that the printer is in a “Ready to Print” state before sending a print job.
2. Check the loaded media.
3. Check the print driver.
4. Check the printer connections to Ethernet or USB.
5. Verify that the correct print media size is selected.
6. If using a print spooler, verify that the spooler has not stalled.
7. Check the printer’s interface configuration. Determine the host interface you are using. Print a Configuration Report to verify that the current settings are correct.

Copy/Scan Problems

If the scanner does not work or operates slowly, check the following:

1. Ensure that you place the document to be scanned face down from the document feeder glass, or face up in the DADF.
2. There may not be enough available memory to hold the document you want to scan. Try the Prescan function to see if that works. Try lowering the scan resolution rate.
3. Check that the USB cable is connected properly.
4. Ensure that the USB cable is not defective. Switch the cable with a known good cable. If necessary, replace the cable.
5. Check that the scanner is configured correctly. Check the application you want to use to make certain that the scanner job is being sent to the correct port.
6. Graphics are scanned more slowly than text when using the Scan to E-mail or Scan to Network feature.
7. Communication speed becomes slow in scan mode because of the large amount of memory required to analyze and reproduce the scanned image.
8. Scanning images at a high resolution takes more time than scanning at a low resolution.

DADF Problems

If document misfeeds or multiple feeds occur in the Duplexing Automatic Document Feeder (DADF), check and try the following actions.

1. Check whether the DADF roller assembly is installed properly.
2. Ensure the document's paper type meets the specifications for the printer.
3. Check whether the document is properly loaded in the DADF.
4. Ensure that the document guides are adjusted properly.
5. Ensure that the number of document sheets do not exceed the maximum capacity of the DADF.
6. Ensure that the document is not curled.

Fax Problems

If printer does not properly send or receive faxes, check the following:

1. Check your scan glass for marks and clean it.
2. The other fax machine may be turned off, out of paper, or cannot answer incoming calls. Speak with the other machine operator and ask her/him to sort out the problem.
3. The FAX mode should be selected.
4. Ensure that there is paper in the paper tray.
5. Check to see if the display shows Memory Full.
6. Ensure that the document is loaded in the DADF or on the document glass.
7. Sending should show up on the display.
8. A noisy phone line can cause line errors.
9. Check your printer by making a copy.
10. The toner cartridge may be empty. Replace the toner cartridge.
11. The fax machine sending you the fax may be faulty.

Media-Based Problems

Check that the correct type of media is being used; for the correct media types and weights, refer to the "Supplies" page on the Xerox web site. The customer should be using a quality laser printer paper. The printer may have trouble picking glossy or overly smooth paper.

1. Inspect the paper for bent, torn, or folded corners.
2. Check the media path for obstructions or debris.
3. Ensure that the correct media type is set at the Control Panel.
4. Ensure that the media guides are set correctly.
5. Ensure that the media is a supported type for the tray.
6. Load a fresh ream of paper in the tray.

Multiple-Sheet Pick or MisPick

1. Check the media. Is the media in good condition and listed as supported media? Quality office laser printer paper works best.
2. Check that the printer is printing within its environmental specifications by printing and review the environmental information on the Information page.
3. Remove, fan, and then reload the media. Ensure that the guides are securely against the media and the tray has not been over filled.
4. Try loading paper from a fresh ream, fan the paper, and then insert into the tray or flip existing paper over.
5. Check the tray's Separator Roller for damage.
6. Clean the Feed Rollers with a clean, dry, lint-free wipe.
7. Replace the Feed Rollers.

Skewed Image

The image area is not parallel, skewed, with the sides of the page but the printer neither jams nor displays an error code.

1. Remove the tray and ensure the paper guides are set correctly.
2. Check that the correct type of media for the tray is being used.
3. Ensure that the tray has not been over filled. (Skewed images are a common defect when the tray is overfilled.)
4. Verify the Feed Rollers are installed correctly.
5. Clean the Feed and Separator Rollers with a clean, dry, lint-free wipe.

Damaged Prints

The printed page exits the printer either wrinkled, creased, or torn. The printer neither jams nor displays an error code.

1. Stop the sheet at various points in the media path to determine where the media is damaged.
2. Try using the next heaviest type of paper.
3. Feed paper through the printer from each of the available trays. Is the paper damaged when fed out of one tray but not when fed out of the others? If so, inspect the tray for damage, ensure that the media guides are set correctly and verify that the proper media is being used.
4. If media shows damage from all trays, check the registration rollers.
5. Inspect the tray and media path for debris or broken components.

Wrinkled Envelopes (Ensure that an Envelope Fuser is installed. See PL 3.5.1)

Envelope wrinkling of varying severity can sometimes occur. In general, envelope wrinkling is considered a technology limitation due to the fusing process which relies on heat and pressure to bond toner to the media. The #10 Commercial envelopes are particularly susceptible to wrinkling.

1. Check the media path for obstructions or debris.
2. Check that the media guides are set correctly.
3. Test envelopes from other manufacturers to find the best result.

Fuser Jams

1. Check that the Fuser is properly seated, locked, and operates normally.
2. Ensure that the paper is in good condition and is listed as supported media. Try loading new media from a fresh ream.
3. Ensure that only supported transparency film is being used.
4. Check that the printer is operating within its environmental specifications by printing the Information page.
5. Ensure that the loaded media matches the Control Panel settings.
6. Are the margins on the page greater than 4.1 mm?
7. Check the Fuser area for debris.
8. Visually inspect the Fuser for burrs.

Exit Jams

1. Check that the correct type of media is being used; refer to “Supplies” on the Xerox web site.
2. Ensure the printer is within its operating environmental specifications.
3. If media is showing excessive curl, turn the media over, load new media from a fresh ream, or a different type of media.
4. Ensure that the loaded media matches the Control Panel settings.
5. Is heavy, stiff paper being used for two-sided printing? In such cases, use a lighter grade of paper.
6. If debris is visible, clean the printer with a clean, dry, lint-free wipe.
7. Turn the printer off and then back on. The exit roller in the Fuser should turn for a few seconds.

Service Diagnostics

Service Diagnostics provides service engineers with diagnostic routines for testing electro-mechanical components, displaying status, and accessing NVRAM. Additionally, the WorkCentre 3615 has diagnostic tests for the Fax and Scanner subsystems. Service Diagnostics are available when the printer is placed in Service Mode. Use the tests to help diagnose problems and isolate which component or sub assembly part needs replacement.

How To Enter Service Mode

Phaser 3610

1. Hold down the Up and Down arrow buttons and turn “On” the power of the printer.
2. Hold buttons until the display changes from Diagnosing to the Service Mode menu.

After Service Mode is started, use the buttons on the control panel and messages displayed in the LCD to operate Service Mode. Use the **Stop Button** to return to the previous menu.

WorkCentre 3615

1. Start Service Mode by holding down the 2 and 8 buttons on the Control Panel while turning “On” the printer.
2. Hold buttons until the display changes from Please Wait to the Service Mode menu.

After entering Service Diagnostics, use the touchscreen buttons and messages displayed in the LCD to operate the Service Mode. Use the **Back Arrow** on the UI to return to the previous menu.

Service Mode Menu Map

The Menu Map details all the Console Panel selections for the 3610 and the 3615. Whenever these are selected, the follow-up screen will produce information or prompt the running of the program or test. The ESS Printer Diag is resident on both machines, with noted exceptions, while the 3615 also includes the Fax / Scanner and Panel Diag.

Printer Diag (3610 / 3615)	Fax / Scanner Diag (3615)	Panel Diag (3615)
<p>1. ESS Diag</p> <ul style="list-style-type: none"> • All Test • FlashROM Test • EEPROM Test • DRAM Test • MAC + PHY Test • Panel Test (3610) • ASIC Test • Engine Test • RTC Test 	<p>1. Board Test</p> <ul style="list-style-type: none"> • All Test • Fax Memory Test <ul style="list-style-type: none"> – Fax Flash W/R Test – MRAM W/R Test • I/F Test <ul style="list-style-type: none"> – Fax Card I/F Test – AFE Serial Test – IIT I/F Test • ASIC Test <ul style="list-style-type: none"> – ADIC IJAC Test – ASIC JBIG Test • Relay / Signal Test <ul style="list-style-type: none"> – Relay Test – Hook Test – Single Tone Send – DTMF Send – Dial Pulse Send – Ring Bank Send – Data Send – Line Voltage – Line Current 	<p>1. Memory Test...</p> <ul style="list-style-type: none"> • Flash Memory • SDRAM Test • NVM Test
<p>2. Engine Diag</p> <ul style="list-style-type: none"> • Sensor Test • Motor Test • NVM Setting • ROS Exposure • Dew Prevention • ATC Mode 	<p>2. Information</p> <ul style="list-style-type: none"> • Scan Counter 	<p>2. Hardware Key Test...</p>

Printer Diag (3610 / 3615)	Fax / Scanner Diag (3615)	Panel Diag (3615)
<p>3. Print Info</p> <ul style="list-style-type: none"> • Info Page • Print Settings 	<p>3. Scanner Maintenance</p> <ul style="list-style-type: none"> • White Balance <ul style="list-style-type: none"> – Auto Adjust (FB) – Auto Adjust (DADF) • Shading Parameter <ul style="list-style-type: none"> – Coeff FB RED – Coeff FB Green – Coeff FB Blue – Coeff FB Grey – Coeff DADF RED – Coeff DADF Green – Coeff DADF Blue – Coeff DADF Grey – Target RED – Target Green – Target Blue – Target Grey • Registration Parameter <ul style="list-style-type: none"> – Regi FB Lead – Regi FB Side – RegiDADFLead (Front) – RegiDADFSide (Front) – RegiDADFLead (Back) – RegiDADFSide(Back) – RegiDADFLead (FrontDUP) • Auto Registration • Sensor Parameter <ul style="list-style-type: none"> – Feed Sensor • Vertical Scan Mag <ul style="list-style-type: none"> – Mag FB Color – Mag FB Grey – Mag DADF Color – Mag DADF Grey • Test Pattern <ul style="list-style-type: none"> – Pattern No. 	<p>3. Adjust Touch-screen...</p>

Printer Diag (3610 / 3615)	Fax / Scanner Diag (3615)	Panel Diag (3615)
	<p>3. Scanner Maintenance (cont.)</p> <ul style="list-style-type: none"> • IIT I/O Check <ul style="list-style-type: none"> – Home POS Sensor – Tray Sensor – Feed Sensor – DADF Cover Sensor – DADF Stage Sensor – FB Cover Sensor – Legal Paper Sensor – Lamp – FB Motor – DADF Motor – Pick Motor • Scan Counter Clear <ul style="list-style-type: none"> – Counter Clear (FB) – Counter Clear (DADF) • Carriage drive_100 	
<p>4. Installation</p> <ul style="list-style-type: none"> • Serial Number • Page Pack • Hex Dump • Toner Correction • Pixel Counter • Configuration • XCPT Mode • Print Counter • CopyCounter MtoB • Clear All NVM • Clear Job History • Clear Auditron PV • Clear Device Data 	<p>4. Parameter</p>	<p>4. Touchscreen...</p>

Printer Diag (3610 / 3615)	Fax / Scanner Diag (3615)	Panel Diag (3615)
5. Test Print <ul style="list-style-type: none"> • Pattern IOT • Gradation ESS • Ghost Chart ESS 	5. Back Up Data <ul style="list-style-type: none"> • All Clear • User Clear • System Clear • User & System Clear • System Data • Document Clear 	5. LED Test <ul style="list-style-type: none"> • Services • job Status • System • Energy Saver • Data • Error
6. Parameter <ul style="list-style-type: none"> • Regi <ul style="list-style-type: none"> – SlowScan KtoP – FastScan SmpBTray – FastScan SmpBTray1 – FastScan SmpBTray2 (3610) – FastScan DupBTray – FastScan DupTray1 – FastScan DupTray2 (3610) • Life <ul style="list-style-type: none"> – Fuser PV – Fuser Heattime – Trans Unit PV – IU PV – IU Thickness – Waste Full Count – Toner Disp Time – Toner Pixel – Toner Gas Gauge • Print <ul style="list-style-type: none"> – Print Parameter 	6. Complete <ul style="list-style-type: none"> • Complete? 	6. Brightness Test...
7. RTC Set		7. Display Test...
8. Exit Mode <ul style="list-style-type: none"> • Complete Exit <ul style="list-style-type: none"> – Exit 		8. Adjust Sense of Touch...
		9. Buzzer Test...

Engine Diagnostic Testing

Sensor Test (Digital Output)

Checks whether the DI (digital input) components such as sensors and switches on the IOT are functioning properly.

Displays “0” when Sensor Test is started. This value is increased when the DI components are switched from OFF to ON, which is used for confirming that the component functions normally. Sensor Test targets all DI components.

Sensor Test Parameter Table

Chain	Link	Component
010	200	Fusing Relay Enable
010	201	Fusing Fuse Open (invalid code)
041	300	Inter Lock Front Cover
041	301	Inter Lock Rear Cover
042	200	Rear Fan Alarm
042	201	LVPS Fan Alarm
071	100	MSI No Paper Sensor
071	101	Tray 1 No Paper Sensor [CST No Paper Sensor]
071	102	Regi Sensor
071	103	Exit Sensor
071	116	Option Feeder 1 No Paper Sensor [Tray 2 No Paper Sensor]
071	117	Option Feeder 2 No Paper Sensor [Tray 3 No Paper Sensor]
071	118	Option Feeder 3 No Paper Sensor [Tray 4 No Paper Sensor]
071	119	Option Feeder 1 Path Sensor [Tray 2 Path Sensor]
071	120	Option Feeder 2 Path Sensor [Tray 3 Path Sensor]
071	121	Option Feeder 3 Path Sensor [Tray 4 Path Sensor]
071	122	Full Stack Sensor
071	200	Option Feeder 1 Motor Alarm [(Tray 2)MOTOR ASSY OPTION]
071	201	Option Feeder 2 Motor Alarm [(Tray 3)MOTOR ASSY OPTION]
071	202	Option Feeder 3 Motor Alarm [(Tray 4)MOTOR ASSY OPTION]

Motor Test (Digital Output)

Checks whether the DO (digital output) components such as motors and clutches are functioning properly. You can enable the test for each DO component and check the operation from the outside, which helps you judge which component functions normally.

The Motor Test allows you to operate all components at one time.

If the interlock is opened during a motor test, the operation of each component is stopped.

Note: Except for 010-001, and 042-003, set LVPS 24V (041-001) to ON (EXEC). Otherwise, the component does not operate.

Motor Test Parameter Table

Chain	Link	Component
010	001	Fusing Relay
041	001	Low Voltage Power Supply 24V
042	001	Rear Fan (Normal)
042	002	Rear Fan (Half)
042	003	LVPS Fan
061	001	ROS Motor [Motor Polygon ASSY]
071	001	Main Motor [DRIVE ASSY MAIN] (Normal)
071	002	Main Motor [DRIVE ASSY MAIN] (Half)
071	003	Main Motor [DRIVE ASSY MAIN] (Low)
071	004	MSI Feed Solenoid [SOLENOID FEED MSI] (Auto OFF)
071	005	Tray 1 Feed Clutch [CST FEED CLUTCH]
071	006	Regi Clutch
071	007	Exit Clutch [CLUTCH ASSY EXIT]
071	008	Exit Invert Clutch [CLUTCH ASSY INVERT]
071	009	Option Feeder 1 Motor [(Tray 2)MOTOR ASSY OPTION] (Normal)
071	010	Option Feeder 1 Motor [(Tray 2)MOTOR ASSY OPTION] (Half)
071	011	Option Feeder 1 Motor [(Tray 2)MOTOR ASSY OPTION] (Low)
071	012	Option Feeder 2 Motor [(Tray 3)MOTOR ASSY OPTION] (Normal)
071	013	Option Feeder 2 Motor [(Tray 3)MOTOR ASSY OPTION] (Half)
071	014	Option Feeder 2 Motor [(Tray 3)MOTOR ASSY OPTION] (Low)
071	015	Option Feeder 3 Motor [(Tray 4)MOTOR ASSY OPTION] (Normal)

Motor Test Parameter Table

Chain	Link	Component
071	016	Option Feeder 3 Motor [(Tray 4)MOTOR ASSY OPTION] (Half)
071	017	Option Feeder 3 Motor [(Tray 4)MOTOR ASSY OPTION] (Low)
071	018	Option Feeder 1 Feed Clutch [(Tray 2)CLUTCH ASSY OPT FEED] (Auto OFF)
071	019	Option Feeder 2 Feed Clutch [(Tray 3)CLUTCH ASSY OPT FEED] (Auto OFF)
071	020	Option Feeder 3 Feed Clutch [(Tray 4)CLUTCH ASSY OPT FEED] (Auto OFF)
071	021	Option Feeder 1 Take Away Clutch [(Tray 2)CLUTCH ASSY REGI]
071	022	Option Feeder 2 Take Away Clutch [(Tray 3)CLUTCH ASSY REGI]
071	023	Option Feeder 3 Take Away Clutch [(Tray 4)CLUTCH ASSY REGI]
093	001	Toner Dispense Motor [MOTOR DISP] (Normal)
093	002	Toner Dispense Motor [MOTOR DISP] (Half)

Administration Mode Menu Map

(3610) Select the **Menu Button** on the Control Panel and scroll to **Admin Settings** and select **OK**. Select **Service Tools** to access the following:

(3615) Select **Machine Status** on the Control Panel and the **Tools** tab on the UI. Select **Admin Settings...** and using the keypad, enter **1111** and **OK on the UI**. Select the **Service Tools** option to access the following:

3610	3615
F/W Version	Page 1
Adjust Paper type <ul style="list-style-type: none"> – Plain <ul style="list-style-type: none"> • Lightweight • Heavyweight – Heavyweight <ul style="list-style-type: none"> • Lightweight • Heavyweight 	Adjust Paper type <ul style="list-style-type: none"> – Plain <ul style="list-style-type: none"> • Lightweight • Heavyweight – Heavyweight <ul style="list-style-type: none"> • Lightweight • Heavyweight
Adjust Transfer Unit <ul style="list-style-type: none"> – Plain – Plain Thick – Lightweight Card Stock – Heavyweight Card Stock 	Adjust Transfer Unit <ul style="list-style-type: none"> – Plain – Plain Thick – Lightweight Card Stock – Heavyweight Card Stock
Adjust Fuser <ul style="list-style-type: none"> – Plain – Plain Thick – Lightweight Card Stock – Heavyweight Card Stock 	Adjust Fuser <ul style="list-style-type: none"> – Plain – Plain Thick – Lightweight Card Stock – Heavyweight Card Stock
Adjust Density	Adjust Density
	Page 2
Chart <ul style="list-style-type: none"> – Pitch Chart – Full Page Solid – Alignment 	Chart <ul style="list-style-type: none"> – Pitch Chart – Full Page Solid – Alignment
Clean Developer	Clean Developer
Clean Transfer Unit	Clean Transfer Unit
Toner Refresh	Toner Refresh

3610	3615
	Page 3
Reset Defaults	Initialize NVM <ul style="list-style-type: none"> - Fax Setting - Scan Setting - System Setting
Initialize Print Meter	Initialize Print Meter
Reset Trans Unit	Reset Trans Unit
Reset Fuser	Reset Fuser
	Page 4
Clean Storage <ul style="list-style-type: none"> - All - Secure Jobs - Saved Jobs 	Clean Storage <ul style="list-style-type: none"> - All - Secure Jobs - Saved Jobs
Adjust Altitude <ul style="list-style-type: none"> - 0m - 1000m - 2000m - 3000m 	Adjust Altitude <ul style="list-style-type: none"> - 0m - 1000m - 2000m - 3000m
Static Memory CTR	Decrease Electrostatic Memory
Ghost Control	Decrease Ghosting
	Page 5
Clear job History	Clear job History
Adjust Touchscreen	Adjust Touchscreen

Status Code List (3610)

Note: Be aware that the error code that shows up on the UI for some errors does not have the same chain link code that will be displayed in the Error History report.

Note: When the LCD Message column displays '-', 'xxxxxxx', the LCD doesn't display any messages (it displays only the Status code), the error is dealt with internally. When the LCD Message column displays 'xxxxxxx Duplicate IPv6 Add....', the LCD doesn't display any messages (displays only the Status code).

Status Code (3610)	LCD Message	Name/Description of Error	FIP
004-310	Reseat Feeder Power Off/On Error 004-310 Power Off/On	<IOT Option Feeder I/F Failure> Cause: The Option Feeder communication failure is detected.	FIP 1. 01
010-317	Insert Fuser 010-317 Insert Fuser Power Off/On	<FUSING ASSEMBLY Detached> Cause: FUSING ASSEMBLY detached is detected.	FIP 1. 04
010-397	Fuser Error Power Off/On Error 010-397 Power Off/On	<FUSING ASSEMBLY Failure> Cause: The operation error of FUSING ASSEMBLY (Temperature anomaly error etc.) is detected.	FIP 1. 04
016-338	Reseat Wi-Fi Contact Admin. Error 016-338 Power Off/On	<Wireless Option Error> Cause: Wireless Driver starting error.	FIP 1. 08
016-359	MRAM Error Power Off/On Error 016-359 Power Off/On	<MRAM Fail> Cause: MRAM Device Error.	FIP 1. 09
016-369	Error 016-369 Power Off/On	<UI Panel - ESS Communication Fail> Cause: Communication Fail with a UI Panel and ESS F/W.	FIP 1. 10

Status Code (3610)	LCD Message	Name/Description of Error	FIP
016-404	Certificate Fail Init Certificate Error 016-404	<Certificate DB Error> Cause: Certificate DB access error.	FIP 1.11
016-405	Certificate Fail Init Certificate Error 016-405	<Certificate DB Error> Cause: Invalid security setting error.	FIP 1.12
016-500	Flash Erase Err Power Off/On Error 016-500 Power Off/On	<Download Delete Error> Cause: Flash delete error in download.	FIP 1.13
016-501	Flash Write Err Power Off/On Error 016-501 Power Off/On	<Download Write Error> Cause: Flash write error in download.	FIP 1.14
016-502	Flash ROM Err Power Off/On Error 016-502 Power Off/On	<Download Verify Error> Cause: Flash verify error in download.	FIP 1.15
016-520	Certificate Fail Contact Admin. Error 016-520 Power Off/On	<Ipssec Certificate Error> Cause: Self device certificate error.	FIP 1.21
016-521	Certificate Fail Contact Admin. Error 016-521 Power Off/On	<Ipssec Certificate Error> Cause: Remote device certification verification error.	FIP 1.22
016-522	Certificate Fail Contact Admin. Error 016-522 Power Off/On	<LDAP Certificate Error> Cause: No client certificate exists.	FIP 1.23

Status Code (3610)	LCD Message	Name/Description of Error	FIP
016-523	Certificate Fail Contact Admin. Error 016-523 Power Off/On	<LDAP Certificate Error> Cause: Server certificate verification error.	FIP 1.24
016-524	Certificate Fail Contact Admin. Error 016-524 Power Off/On	<LDAP Certificate Error> Cause: No server certificate exists.	FIP 1.25
016-527	Certificate Fail Contact Admin. Error 016-527 Power Off/On	<LDAP Certificate Error> Cause: SSL authentication internal error.	FIP 1.26
016-541	Certificate Fail Contact Admin. Error 016-541 Power Off/On	<Wireless Certificate Error> Cause: No certificate exists.	FIP 1.28
016-542	Certificate Fail Contact Admin. Error 016-542 Power Off/On	<Wireless Certificate Error> Cause: Server certificate error.	FIP 1.29
016-543	Certificate Fail Contact Admin. Error 016-543 Power Off/On	<Wireless Certificate Error> Cause: Certificate corruption error.	FIP 1.30
016-570	Print Job Error Press Ok Button Error 016-570 Press Ok Button	<Job Ticket Out Of Memory> Cause: XPIF parser detects insufficient memory in the processing of XCPT (XPIF) interpretation.	FIP 1.31
016-571	Print Job Error Press Ok Button Error 016-571 Press Ok Button	<Job ticket wrong> Cause: Print instruction contents that the device cannot execute are detected.	FIP 1.32

Status Code (3610)	LCD Message	Name/Description of Error	FIP
016-572	Print Job Error Press Ok Button Error 016-572 Press Ok Button	<Job ticket media error> Cause: The paper attribute specified by XCPT (XPIF) cannot solve paper selection.	FIP 1.33
016-573	Print Job Error Press Ok Button Error 016-573 Press Ok Button	<Job ticket parse error> Cause: XPIF parser detects error other than those listed above.	FIP 1.34
016-602	Initialize NVM Initializing...	<System NVM Initialize> Cause: At POWON start-up, execute NVM clear.	FIP 1.35
016-603	-	<ESS-NVM Parameter Recover> Cause: Executed ESS-NVM Parameter Recovery.	FIP 1.36
016-604	-	<ESS-NVM Parameter Copy> Cause: Executed ESS-NVM Parameter Copy.	FIP 1.37
016-606	-	<Clear Job History> Cause: Clear Job History.	FIP 1.39
016-610	Error 016-610 Power Off/On	<Panel Destination Mismatch> Cause: Only for Production Line. Tried to apply JP setting to non-JP panel, or tried to apply non-JP setting to JP panel.	FIP 1.40
016-612	Error 016-612 Power Off/On	<Invalid MAC Address> Cause: Only for Production Line. MAC address is invalid.	FIP 1.41
016-718	Out of Memory Press Ok Button Error 016-718 Press Ok Button	<Memory Over flow> Cause: The current printing job process cannot be continued because the memory capacity is exceeded.	FIP 1.42
016-720	Print Job Error Press Ok Button Error 016-720 Press Ok Button	<PDL Error> Cause: The print data cannot be processed by PDL.	FIP 1.43

Status Code (3610)	LCD Message	Name/Description of Error	FIP
016-734	Signature Error Press Ok Button Error 016-734 Press Ok Button	<Download Signature Error> Cause: Download file signature data is invalid.	FIP 1.44
016-737	Format Error Press Ok Button Error 016-737 Press Ok Button	<Download Format Error> Cause: Download file format is invalid.	FIP 1.45
016-741	Protection Error Press Ok Button Error 016-741 Press Ok Button	<Download Protect Error> Cause: Performed FW download although FW update is prohibited by panel settings.	FIP 1.46
016-742	Invalid ID Press Ok Button Error 016-742 Press Ok Button	<Download ID Error> Cause: Download file ID is invalid.	FIP 1.47
016-743	Range Chk Error Press Ok Button Error 016-743 Press Ok Button	<Download Range Error> Cause: At download, write-in destination address is invalid. Range check error.	FIP 1.48
016-744	Check Sum Error Press Ok Button Error 016-744 Press Ok Button	<Download Check Sum Error> Cause: Download file checksum is invalid.	FIP 1.49
016-745	Header Error Press Ok Button Error 016-745 Press Ok Button	<Download header Error> Cause: Download file header is invalid.	FIP 1.50
016-746	Prohibition Error Press Ok Button Error 016-746 Press Ok Button	<Prohibit Error> Cause: Download Prohibit Error.	FIP 1.51

Status Code (3610)	LCD Message	Name/Description of Error	FIP
016-750	PDF Job Error Press Ok Button Error 016-750 Press Ok Button	<Job Ticket Error> Cause: PDF print job ticket description error.	FIP 1.52
016-753	Wrong Password Press Ok Button Error 016-753 Press Ok Button	<Wrong Password> Cause: PDF password error.	FIP 1.53
016-755	PDF Print Disabled Error 016-755 Press Ok Button	<PDF Print Disabled> Cause: PDF print is not allowed.	FIP 1.54
016-757	Invalid User Press Ok Button Error 016-757 Press Ok Button	<Auditron - Invalid User> Cause: Account is not registered.	FIP 1.55
016-758	Acct. Restricted Press Ok Button Error 016-758 Press Ok Button	<Auditron - Disabled Function> Cause: Detect invalid account.	FIP 1.56
016-759	Limit Exceeded Press Ok Button Error 016-759 Press Ok Button	<Auditron - Reached Limit> Cause: Reached the limit of the number of registered users.	FIP 1.57
016-799	Invalid Job Press Ok Button Error 016-799 Press Ok Button	<Job Environment Violation> Cause: Print condition conflicts with other condition.	FIP 1.66
016-920	Wi-Fi Timeout Press Ok Button Error 016-920 Press Ok Button	<Wireless Setting Error> Cause: Timeout Error.	FIP 1.08

Status Code (3610)	LCD Message	Name/Description of Error	FIP
016-921	Wi-Fi DL Error Press Ok Button Error 016-921 Press Ok Button	<Wireless Setting Error> Cause: Download Error.	FIP 1.08
016-922	Wi-Fi Session Err Press Ok Button Error 016-922 Press Ok Button	<Wireless Setting Error> Cause: Session Overlap Error.	FIP 1.08
016-923	Wi-Fi Password Error Error 016-923 Press Ok Button	<Wireless Password Error> Cause: Wireless Password is wrong.	FIP 1.67
016-924	Wi-Fi WEP AP Connected Error Error 016-924 Press Ok Button	<Wireless Setting Error> Cause: WEP AP Connected Error.	FIP 1.68
016-930	USB Memory Error Unsupported Error 016-930 Unsupported	<USB Host Error> Cause: Warning when unsupported device is installed to USB host. <ul style="list-style-type: none"> • Detect installation of device of which class driver cannot be found. • Detect installation of device that class driver judges not to support. • Detect installation of Low-Speed device. 	FIP 1.69
016-931	USB Memory Error Unsupported Error 016-931 Unsupported	<USB Hub Error> Cause: Warning to installation of hub that cannot be used to USB host. Detect installation of hubs in more than supported number of stacks.	FIP 1.70
016-982	RAM Disk Full Press Ok Button Error 016-982 Press Ok Button	<Disk Full> Cause: The current printing job process cannot be continued because the RAM disk is full.	FIP 1.71

Status Code (3610)	LCD Message	Name/Description of Error	FIP
017-321	Invalid Memory	<SD CARD Type Invalid Error> Cause: SD CARD Type Invalid Error was detected.	FIP 1.74
018-722	Google Cloud Print Network Error Error 018-722 Check Network	<Google Cloud Print Network Error > Cause: A network-related error has occurred.	FIP 1.94
018-723	Google Cloud Print Cert Error Error 018-723 Check Settings	<Google Cloud Print Certificate Error > Cause: A certificate connection error has occurred.	FIP 1.95
018-724	Google Cloud Print SSL Error Error 018-724 Check Network	<Google Cloud Print SSL Error> Cause: An SSL connection error has occurred.	FIP 1.96
018-729	Google Cloud Print Timeout Error Error 018-729 Check Network	<Google Cloud Print Timeout Error> Cause: A timeout has led to an error.	FIP 1.97
018-730	Google Cloud Print Net Other Error Error 018-730 Check Network	<Google Cloud Print Network Other Error> Cause: A network-related internal error has occurred.	FIP 1.98
018-737	Google Cloud Print Other Error Error 018-737 Check Network	<Google Cloud Print Other Error> Cause: Another internal error has occurred.	FIP 1.99
018-738	Google Cloud Print XMPP Net Error Error 018-738 Check Network	<Google Cloud Print XMPP Network Error> Cause: A XMPP protocol network-related internal error has occurred.	FIP 1.100

Status Code (3610)	LCD Message	Name/Description of Error	FIP
018-739	Google Cloud Print XMPP Net Error Error 018-739 Check Network	<Google Cloud Print XMPP Network Other Error> Cause: A XMPP protocol network-related internal error has occurred.	FIP 1. 101
018-740	Google Cloud Print XMPP Cert Error Error 018-740 Check Settings	<Google Cloud Print XMPP Certificate Error> Cause: A XMPP protocol network-related certificate connection error has occurred.	FIP 1. 102
018-741	Google Cloud Print XMPP Other Error Error 018-741 Check Network	<Google Cloud Print XMPP Other Error> Cause: Another XMPP protocol error has occurred. Check the settings, and try again.	FIP 1. 103
018-743	Google Cloud Print Proxy Error Error 018-743 Check Settings	<Google Cloud Print Proxy Error> Cause: A network-related (proxy connection) error has occurred.	FIP 1. 104
018-744	Google Cloud Print DNS Error Error 018-744 Check Settings	<Google Cloud Print DNS Resolve Error> Cause: A network-related (DNS Name Resolution) error has occurred.	FIP 1. 105
018-745	Google Cloud Print XMPP Proxy Error Error 018-745 Check Settings	<Google Cloud Print XMPP Proxy Error> Cause: A XMPP protocol network-related (proxy connection) error has occurred.	FIP 1. 106
018-746	Google Cloud Print XMPP DNS Error Error 018-746 Check Settings	<Google Cloud Print XMPP DNS Resolve Error> Cause: A XMPP protocol network-related (DNS Name Resolution) error has occurred.	FIP 1. 107
024-340	MCU Firmware Err Power Off/On Error 024-340 Power Off/On	<Engine Controller Error > Cause: Engine firmware error occurs.	FIP 1. 108

Status Code (3610)	LCD Message	Name/Description of Error	FIP
024-360	Download Error Send FW Data Error 024-360 Send FW Data	<Engine Code DownLoad Error> Cause: Download failure of MCU firmware.	FIP 1. 109
024-362	IOT Start Error Power Off/On Error 024-362 Power Off/On	<Print Engine Start Error> Cause: "Start Image Making" has not been issued within the time allowed.	FIP 1. 110
024-371	MCU Comm. Error Power Off/On Error 024-371 Power Off/On	<Engine Communication Error> Cause: Communication fail between MCU and ESS.	FIP 1. 111
024-910	Load Tray 1 XXX Load Tray 1 YYY (XXX:Paper Size YYY:Paper Type)	<Tray 1 Paper Size Mismatch> Cause: The size of paper in the Tray 1 does not match the specified print size.	FIP 1. 112
024-911	Load Tray 2 XXX Load Tray 2 YYY (XXX:Paper Size YYY:Paper Type)	<Tray 2 Paper Size Mismatch> Cause: The size of paper in the Tray 2 does not match the specified print size.	FIP 1. 113
024-912	Load Tray 3 XXX Load Tray 3 YYY (XXX:Paper Size YYY:Paper Type)	<Tray 3 Paper Size Mismatch> Cause: The size of paper in the Tray 3 does not match the specified print size.	FIP 1. 113

Status Code (3610)	LCD Message	Name/Description of Error	FIP
024-913	Load Tray 4 XXX Load Tray 4 YYY (XXX:Paper Size YYY:Paper Type)	<Tray 4 Paper Size Mismatch> Cause: The size of paper in the Tray 4 does not match the specified print size.	FIP 1. 113
024-920	Output Tray Full Remove Paper	<IOT Standard Stacker Full> Cause: Output Tray Full is Detected.	FIP 1. 114
024-958	Load NNN XXX Load NNN YYY (NNN:Manual Feed XXX:Paper Size YYY:Paper Type)	<MSI Paper Size Mismatch> Cause: The size of paper in the MSI does not match the specified print size.	FIP 1.115
024-959	Load Tray 1 XXX Load Tray 1 YYY (XXX:Paper Size YYY:Paper Type)	<Tray 1 No Suitable Paper> Cause: <ul style="list-style-type: none"> • Displayed when any of the following errors occurs and tray setting needs to be changed after paper is loaded. • When paper source auto selection is selected, paper sizes of all existing trays do not match. (All Tray Size Mismatch) • When a tray is specified, no paper is loaded in the specified tray. (Specified Tray Empty) • When a tray is specified, paper size loaded in the specified tray does not match. (Specified Tray Size Mismatch) • When Substitute Tray is Off and a paper type is specified, there is no tray loading the specified paper type. (Specified Tray Media Mismatch) 	FIP 1. 116

Status Code (3610)	LCD Message	Name/Description of Error	FIP
024-960	Load Tray 2 XXX Load Tray 2 YYY (XXX:Paper Size YYY:Paper Type)	<Tray 2 No Suitable Paper> Cause: <ul style="list-style-type: none"> • Displayed when any of the following errors occurs and tray setting needs to be changed after paper is loaded. • When paper source auto selection is selected, paper sizes of all existing trays do not match. (All Tray Size Mismatch) • When a tray is specified, no paper is loaded in the specified tray. (Specified Tray Empty) • When a tray is specified, paper size loaded in the specified tray does not match. (Specified Tray Size Mismatch) • When Substitute Tray is Off and a paper type is specified, there is no tray loading the specified paper type. (Specified Tray Media Mismatch) 	FIP 1. 116
024-961	Load Tray 3 XXX Load Tray 3 YYY (XXX:Paper Size YYY:Paper Type)	<Tray 3 No Suitable Paper> Cause: <ul style="list-style-type: none"> • Displayed when any of the following errors occurs and tray setting needs to be changed after paper is loaded. • When paper source auto selection is selected, paper sizes of all existing trays do not match. (All Tray Size Mismatch) • When a tray is specified, no paper is loaded in the specified tray. (Specified Tray Empty) • When a tray is specified, paper size loaded in the specified tray does not match. (Specified Tray Size Mismatch) • When Substitute Tray is Off and a paper type is specified, there is no tray loading the specified paper type. (Specified Tray Media Mismatch) 	FIP 1. 116

Status Code (3610)	LCD Message	Name/Description of Error	FIP
024-962	Load Tray 4 XXX Load Tray 4 YYY (XXX:Paper Size YYY:Paper Type)	<Tray 4 No Suitable Paper> Cause: <ul style="list-style-type: none"> • Displayed when any of the following errors occurs and tray setting needs to be changed after paper is loaded. • When paper source auto selection is selected, paper sizes of all existing trays do not match. (All Tray Size Mismatch) • When a tray is specified, no paper is loaded in the specified tray. (Specified Tray Empty) • When a tray is specified, paper size loaded in the specified tray does not match. (Specified Tray Size Mismatch) • When Substitute Tray is Off and a paper type is specified, there is no tray loading the specified paper type. (Specified Tray Media Mismatch) 	FIP 1. 116
024-963	Load NNN XXX Load NNN YYY (NNN:Manual Feed XXX:Paper Size YYY:Paper Type)	<MSI No Suitable Paper> Cause: <ul style="list-style-type: none"> • Displayed when any of the following errors occurs and tray setting needs to be changed after paper is loaded. • When paper source auto selection is selected, paper sizes of all existing trays do not match. (All Tray Size Mismatch) • When a tray is specified, no paper is loaded in the specified tray. (Specified Tray Empty) • When a tray is specified, paper size loaded in the specified tray does not match. (Specified Tray Size Mismatch) • When Substitute Tray is Off and a paper type is specified, there is no tray loading the specified paper type. (Specified Tray Media Mismatch) 	FIP 1. 116
027-446	IPv6 Duplicate	<IPv6 duplicate> Cause: At start-up, detect duplicate IPv6 address on network.	FIP 1. 119
027-452	IPv4 Duplicate	<IPv4 duplicate> Cause: At start-up, detect duplicate IPv4 address on network.	FIP 1. 120

Status Code (3610)	LCD Message	Name/Description of Error	FIP
041-340	MCU NVRAM Error Power Off/On Error 041-340 Power Off/On	<IOT NVRAM Error> Cause: The operation error of NVM (read/write check error etc.) is detected.	FIP 1. 252
041-347	MCU Int. Error Power Off/On Error 041-347 Power Off/On	<IOT I/F Failure> Cause: MCU Internal Error (I/F part).	FIP 1. 253
042-313	Fan Motor Error Power Off/On Error 042-313 Power Off/On	<LVPS Fan Motor Failure> Cause: MCU detects an error upon receiving error signal from the LVPS Fan.	FIP 1. 254
042-330	IOT Start Error Power Off/On Error 042-330 Power Off/On	<Rear Fan Failure> Cause: MCU detects an error upon receiving error signal from the Rear Fan.	FIP 1. 255
042-700	Printer Error Power Off/On Error 042-700 Power Off/On	<IOT Over Heat Stop> Cause: The temp. Sensor sensed high temperature.	FIP 1. 256
050-130	Paper Jam Open Rear Door and remove jammed paper	<IOT Remain Zone Fusing Jam> Cause: When Dynamic Jam (cause) was detected: <ul style="list-style-type: none"> • 077-104 Regi Off Jam • 077-106 Exit On Jam • 077-108 Exit Off Early Jam • 077-109 Exit Off Jam When Static Jam (collateral) was detected: <ul style="list-style-type: none"> • Exit Sensor On 	FIP 1. 257
050-131	Paper Jam Open Rear Door and remove jammed paper	<IOT Remain Zone Duplex Jam> Cause: When Dynamic Jam (cause) was detected: <ul style="list-style-type: none"> • 077-107 Duplex Regi On Jam 	FIP 1. 258

Status Code (3610)	LCD Message	Name/Description of Error	FIP
050-132	Paper Jam Open Bypass Tray, Tray1, Tray2, Rear Door and remove paper	<IOT Remain Zone Regi + MSI + T1 + T2 Jam> Cause: When Dynamic Jam (cause) was detected: <ul style="list-style-type: none"> • 077-106 Exit On Jam When Static Jam (collateral) was detected: <ul style="list-style-type: none"> • Regi Sensor On 	FIP 1. 259
050-134	Paper Jam Open Bypass Tray, Tray1, and remove paper Press OK to start	<IOT Zone MSI+T1 Jam> Cause: When Dynamic Jam (cause) was detected: <ul style="list-style-type: none"> • 071-100 IOT Tray1 Misfeed Jam • 075-100 MSI Misfeed Jam 	FIP 1. 260
050-135	Paper Jam Pull Out Tray4 Clear Jam. Or Clear Jam From Back of Tray. Press OK to start	<IOT Zone T2 + T3 + T4 + TR2 + TR3 Jam> Cause: When Dynamic Jam (cause) was detected: <ul style="list-style-type: none"> • 073-101 IOT Path3 SNS On Jam When Static Jam (collateral) was detected: <ul style="list-style-type: none"> • Tray2 Path Sensor On, Tray3 Path Sensor On, and Tray4 Path Sensor On 	FIP 1. 261
050-136	Paper Jam Pull Out Tray3,4, Clear Jam. Or Clear Jam From Back of Tray3. Press OK to start	<IOT Zone T3 + T4 + TR3 Jam> Cause: When Dynamic Jam (cause) was detected: <ul style="list-style-type: none"> • 072-101 IOT Path2 SNS On Jam When Static Jam (collateral) was detected: <ul style="list-style-type: none"> • Tray3 Path Sensor On 	FIP 1. 262
050-137	Paper Jam Pull Out Tray3 Clear Jam. Or Clear Jam From Back of Tray. Press OK to start	<IOT Zone T2 + T3 + TR2 + TR3 Jam> Cause: When Dynamic Jam (cause) was detected: <ul style="list-style-type: none"> • 072-102 IOT Option Regi On Jam When Static Jam (collateral) was detected: <ul style="list-style-type: none"> • Tray2 Path Sensor On and Tray3 Path Sensor On 	FIP 1. 263

Status Code (3610)	LCD Message	Name/Description of Error	FIP
050-138	Paper Jam Pull Out Tray3 Clear Jam. Or Clear Jam From Back of Tray. Press OK to start	<IOT Zone T3 + TR2 + TR3 Jam> Cause: When Dynamic Jam (cause) was detected: <ul style="list-style-type: none"> • 072-102 IOT Option Regi On Jam When Static Jam (collateral) was detected: <ul style="list-style-type: none"> • Tray3 Path Sensor On 	FIP 1. 264
050-139	Paper Jam Pull Out Tray2 Clear Jam. Or Clear Jam From Back of Tray2. Press OK to start	<IOT Zone T2 + TR2 Jam> Cause: When Dynamic Jam (cause) was detected: <ul style="list-style-type: none"> • 072-100 IOT Tray2 Misfeed Jam When Static Jam (collateral) was detected: <ul style="list-style-type: none"> • Tray2 Path Sensor On 	FIP 1. 265
050-140	Paper Jam Pull Out Tray3 Clear Jam. Or Clear Jam From Back of Tray2. Press OK to start	<IOT Zone T3 + TR2 Jam> Cause: When Dynamic Jam (cause) was detected: <ul style="list-style-type: none"> • 073-100 IOT Tray3 Misfeed Jam 	FIP 1. 266
050-141	Paper Jam Pull Out Tray4 Clear Jam. Or Clear Jam From Back of Tray3. Press OK to start	<IOT Zone T4 + TR3 Jam> Cause: When Dynamic Jam (cause) was detected: <ul style="list-style-type: none"> • 074-100 IOT Tray4 Misfeed Jam When Static Jam (collateral) was detected: <ul style="list-style-type: none"> • Tray4 Path Sensor On 	FIP 1. 267
050-142	Paper Jam Open Bypass Tray, Tray1, Rear Door and remove paper	<IOT Remain Zone Regi + MSI + T1 Jam> Cause: When Dynamic Jam (cause) was detected: <ul style="list-style-type: none"> • 077-106 Exit On Jam When Static Jam (collateral) was detected: <ul style="list-style-type: none"> • Regi. Sensor On 	FIP 1. 268

Status Code (3610)	LCD Message	Name/Description of Error	FIP
061-370	Laser Error Power Off/On Error 061-370 Power Off/On	<IOT ROS Failure> Cause: The operation error of ROS (rotational error etc.) is detected.	FIP 1. 269
071-100	-	<IOT Tray1 Misfeed Jam> Cause: After the Tray 1 Feed Clutch turned ON, the Regi. Sensor did not turn ON within the specified time.	FIP 1. 273
071-920	Insert Output to NNN	<Waiting to Print Side 2 Load Printed Pages into the NNN> Cause: Waiting for side 2 to be set for manual duplex print (Tray).	FIP 1. 274
071-921	Press Ok Button to continue	<Manual Duplex Print> Cause: Waiting for Set key to be pressed after setting side 2 for manual duplex print (Tray).	FIP 1. 275
072-100	-	<IOT Tray2 Misfeed Jam> Cause: After the Tray 2 Feed Clutch turned ON, the Tray 2 Path Sensor did not turn ON within the specified time.	FIP 1. 265
072-101	-	<IOT Path 2 SNS On Jam> Cause: The Tray 2 Path Sensor did not turn ON within the specified time after the Tray 3 Path Sensor turned ON.	FIP 1. 277
072-102	-	<IOT Option Regi On Jam> Cause: After the Tray 2 Path Sensor turned ON, the Regi. Sensor did not turn ON within the specified time.	FIP 1. 278
072-211	Tray2 Error Power Off/On Error 072-211 Power Off/On	<Feeder 2 Error> Cause: IOT Option Feeder2 Failure.	FIP 1. 279

Status Code (3610)	LCD Message	Name/Description of Error	FIP
073-100	-	<IOT Tray 3 Misfeed Jam> Cause: After the Tray 3 Feed Clutch turned ON, the Tray 3 Path Sensor did not turn ON within the specified time.	FIP 1. 265
073-101	-	<IOT Path 3 SNS On Jam> Cause: The Tray 3 Path Sensor did not turn ON within the specified time after the Tray 4 Path Sensor turned ON.	FIP 1. 277
073-211	Tray3 Error Power Off/On Error 073-211 Power Off/On	<Feeder 3 Error> Cause: IOT Option Feeder3 Failure.	FIP 1. 280
074-100	-	<IOT Tray 4 Misfeed Jam> Cause: After the Tray 4 Feed Clutch turned ON, the Tray 4 Path Sensor did not turn ON within the specified time.	FIP 1. 265
074-211	Tray4 Error Power Off/On Error 074-211 Power Off/On	<Feeder 4 Error> Cause: IOT Option Feeder4 Failure.	FIP 1. 280
075-100	-	<MSI Misfeed Jam> Cause: After the MSI Feed Solenoid turned ON, the Regi. Sensor did not turn ON within the specified time.	FIP 1. 281
077-101	-	<VSYNC ON Jam> Cause: Detect VSYNC ON Jam.	FIP 1. 282
077-104	-	<Regi. Off Jam> Cause: The Regi Sensor does not turn OFF within the specified time after the Regi Clutch turned On.	FIP 1. 283
077-106	-	<Exit On Jam> Cause: The Exit Sensor does not turn ON within the specified time after the Regi Clutch turned On.	FIP 1. 257

Status Code (3610)	LCD Message	Name/Description of Error	FIP
077-107	-	<Duplex Regi On Jam> Cause: After the Invert Clutch turned ON, the Regi. Sensor did not turn ON within the specified time.	FIP 1. 258
077-108	-	<Exit Off early Jam> Cause: After the Exit Sensor turned ON, the Exit Sensor turned OFF before the specified time.	FIP 1. 257
077-109	-	<Exit Off Jam> Cause: After the Regi. Sensor turned OFF, the Exit Sensor did not turn OFF within the specified time.	FIP 1. 257
077-215	Duplexer Error Power Off/On Error 077-215 Power Off/On	<IOT Duplexer Error> Cause: Duplex Unit Configuration error is detected.	FIP 1. 285
077-217	Duplexer Error Power Off/On Error 077-217 Power Off/On	<Duplex Miss Configuration> Cause: Duplex Unit Configuration error is detected.	FIP 1. 285
077-300	Front Cover Open Close Front Cover	<IOT Cover Front Open> Cause: Beep sounds after Front Cover remains open for 3 minutes.	FIP 1. 286
077-304	Rear Door Open Close Rear Door	<IOT Cover Rear Open> Cause: The Rear Cover is open.	FIP 1. 287
077-312	Tray Config Err. Power Off/On Error 077-312 Power Off/On	<Tray Configure Error> Cause: Tray configuration error was detected. (including all of the wrong configurations)	FIP 1. 288
091-914	Drum Error Reseat Drum Error 091-914 Reseat Drum	<IOT Drum Communication Fail> Cause: Communication failure with Drum CRUM was detected.	FIP 1. 290

Status Code (3610)	LCD Message	Name/Description of Error	FIP
091-915	Drum Error Reseat Drum Error 091-915 Reseat Drum	<Drum CRUM Data Broken Fail> Cause: Malfunction of Drum CRUM was detected.	FIP 1. 290
091-921	Insert Drum Cartridge	<IOT Drum Detached> Cause: It was detected that the Drum CRUM is not at the specified position. (Loose CRUM)	FIP 1. 290
091-953	Seal Tape Error Drum Cartridge	<Drum Tape Staying> Cause: The remaining Tape of the Drum Cartridge was detected.	FIP 1. 291
091-963	Invalid Drum Cartridge	<IOT Drum CRUM ID Error> Cause: The Drum CRUM ID error was detected.	FIP 1. 290
092-315	ATC Sensor Err Reseat Cartridge Error 092-315 Power Off/On	<ATC Fail> Cause: The ATC Sensor error was detected.	FIP 1. 292
092-661	Env Sensor Error Power Off/On Error 092-661 Power Off/On	<IOT Environment Sensor Error> Cause: The Temp. Sensor or the Humidity Sensor error was detected.	FIP 1. 256
093-426	Toner Low Replace Soon	<Toner Near Life> Cause: It was detected that the Toner Cartridge needed to be replaced soon.	FIP 1. 293
093-922	Low Toner Density Remove Toner, Shake Cartridge and Reinstall	<Toner Low Density> Cause: Low concentration of the Toner was detected.	FIP 1. 294
093-925	CRUM Error Reseat Cartridge Error 093-925 Reseat Cartridge	<Toner CRUM Error> Cause: The Toner CRUM error was detected.	FIP 1. 295

Status Code (3610)	LCD Message	Name/Description of Error	FIP
093-926	Invalid Toner Cartridge	<Toner CRUM ID Error> Cause: The Toner CRUM ID error was detected.	FIP 1. 295
093-928	Toner Type Error Reseat Cartridge Error 093-928 Reseat Cartridge	<Toner Type Error> Cause: The Toner Type Error was detected.	FIP 1. 295
093-933	Replace Toner Cartridge	<Toner Life Over> Cause: It was detected that the Toner Cartridge needed to be replaced soon.	FIP 1. 296
093-973	Insert Toner Cartridge	<Toner Detached> Cause: It was detected that the Toner CRUM is not at the specified position. (Loose CRUM)	FIP 1. 295
116-210	USB Host Error Power Off/On Error 116-210 Power Off/On	<USB Host Error> Cause: Fatal error of USB Host driver.	FIP 1. 297
116-312	Memory Error Power Off/On Error 116-312 Power Off/On	<Encryption Key Error> Cause: Encryption key mismatch.	FIP 1. 298
116-313	Memory Error Power Off/On Error 116-313 Power Off/On	<Encryption Setting Error> Cause: Encryption setting mismatch.	FIP 1. 298
116-314	MAC Addr. Error Power Off/On Error 116-314 Power Off/On	<MAC Address Error> Cause: On Board Network MAC Address Checksum Error.	FIP 1. 299
116-315	RAM Error Power Off/On Error 116-315 Power Off/On	<ESS On Board RAM W/R Check Fail> Cause: Detected by On Board RAM W/R Check at the time of initialization.	FIP 1. 300

Status Code (3610)	LCD Message	Name/Description of Error	FIP
116-316	DIMM RAM Error Reseat Memory Error 116-316 Power Off/On	<ESS DIMM Slot RAM W/R Check Fail> Cause: Detected by DIMM Slot RAM W/R Check at the time of initialization.	FIP 1.301
116-317	Controller Error Power Off/On Error 116-317 Power Off/On	<ESS ROM Check (Main) Fail> Cause: Main Program ROM checksum error.	FIP 1.302
116-320	DIMM Error Reseat Memory Error 116-320 Power Off/On	<ESS DIMM Slot RAM Error> Cause: Occurs when unusable DIMM is inserted in DIMM slot in initialization processing at power-on.	FIP 1.301
116-323	NVRAM Error Power Off/On Error 116-323 Power Off/On	<ESS NVRAM1 W/R Check Fail> Cause: Detected by master NVRAM W/R check.	FIP 1.303
116-324	Controller Error Power Off/On Error 116-324 Power Off/On	<ESS Illegal Exception> Cause: CPU illegal exception.	FIP 1.303
116-325	NVRAM Error Power Off/On Error 116-325 Power Off/On	<ESS NVRAM3 W/R Check Fail> Cause: It detects with the W/R check of a Slave NVRAM at the time of initialization.	FIP 1.304
116-326	NVRAM Error Power Off/On Error 116-326 Power Off/On	ESS NVRAM2 W/R Check Fail Cause: Detected by master NVRAM W/R check.	FIP 1.304
116-327	Controller Error Power Off/On Error 116-327 Power Off/On	<ESS Instruction Cache Error> Cause: CPU instruction cache error.	FIP 1.305

Status Code (3610)	LCD Message	Name/Description of Error	FIP
116-328	Controller Error Power Off/On Error 116-328 Power Off/On	<ESS Data Cache Error> Cause: CPU data cache error.	FIP 1. 306
116-343	ASIC Error Power Off/On Error 116-343 Power Off/On	<ASIC Fail> Cause: ASIC-related Fatal Error.	FIP 1. 307
116-350	Network Error Power Off/On Error 116-350 Power Off/On	<On Board Network Communication Fail> Cause: Communication fail between 1 CPU network and ESS F/W.	FIP 1. 308
116-351	Network Error Power Off/On Error 116-351 Power Off/On	<Network Error> Cause: On Board Network Ethernet BIST parity/RAM R/W Error.	FIP 1. 309
116-352	Network Error Power Off/On Error 116-352 Power Off/On	<Network Error> Cause: On Board Network Internal Loop back Error.	FIP 1. 309
116-353	Memory Error Power Off/On Error 116-353 Power Off/On	<ESS SD CARD Fail> Cause: Detect SD CARD Error.	FIP 1. 310
116-355	Network Error Power Off/On Error 116-355 Power Off/On	<Network Error> Cause: On Board Network Fatal Error.	FIP 1. 309
116-356	Memory Error Power Off/On Error 116-356 Power Off/On	<SD CARD Overwrite Error> Cause: Error has occurred during SD CARD overwrite.	FIP 1. 310

Status Code (3610)	LCD Message	Name/Description of Error	FIP
116-361	PCI Error Power Off/On Error 116-361 Power Off/On	<PCI Bus #0 Error Detected> Cause: PCI Bus #0 Uncorrectable Error Detected. (Connected with Remora EX(x4 port))	FIP 1.311
116-362	PCI Error Power Off/On Error 116-362 Power Off/On	<PCI Bus #0 Host Bridge Controller Error> Cause: PCI Bus #0 Host Bridge Controller Error. (Connected with Remora EX port)	FIP 1.312
116-363	PCI Error Power Off/On Error 116-363 Power Off/On	<PCI Bus #1 Host Bridge Controller Error> Cause: PCI Bus #1 Host Bridge Controller Error. (Connected with Remora EX port.)	FIP 1.313
116-364	Clock Error Power Off/On Error 116-364 Power Off/On	<Timer Fail> Cause: Timer error is detected.	FIP 1.314
116-366	PCI Error Power Off/On Error 116-366 Power Off/On	<PCI Bus #1 Error Detected> Cause: PCI Bus #1 Uncorrectable Error Detected. (Connected with RemoraEX(x1 port))	FIP 1.315
116-368	PCI Error Power Off/On Error 116-368 Power Off/On	<PCI Error Messages received from Bus #0 - Device #1> Cause: Remora EX PCI x1 port Error. (Device ID 0x65 (x1))	FIP 1.316
116-369	PCI Error Power Off/On Error 116-369 Power Off/On	<PCI Error Messages received from Bus #0 - Device #0> Cause: Remora EX PCI x4 port Error. (Device ID 0x64 (x4))	FIP 1.317
116-390	NVRAM Error Power Off/On Error 116-390 Power Off/On	<ESS NVRAM1 SIZE And ID Check Fail> Cause: Detected by consistency check between NVRAM size requested by the system and actual size and consistency check of ID recorded at the first power-on.	FIP 1.318

Status Code (3610)	LCD Message	Name/Description of Error	FIP
116-719		<XPIF Parameter Cancelled> Cause: Due to conflict among multiple print instructions, print instructions are ignored.	FIP 1.320
116-721	Memory Full Press Ok Button Error 116-721 Press Ok Button	<Collate Full> Cause: Unable to collate due to insufficient memory.	FIP 1.321
117-321	Controller Error Power Off/On Error 117-321 Power Off/On	<Device Memory Error > Cause: SD CARD Type Invalid.	FIP 1.327
117-338	Memory Detected Power Off/On	<Enable Device Memory Error > Cause: Invalid, although SD CARD was detected.	FIP 1.327
118-311	Google Cloud Print Software Error Error 118-311 Power Off/On	<Google Cloud Print Software Error> Cause: A critical internal error has occurred.	FIP 1.336
142-700	Over Heating Run Half-speed	<IOT Over Heat Forced Half Speed> Cause: Half-speed operation was forced due to abnormally high temperature inside the IOT.	FIP 1.385
193-700	Non-Xerox Toner	<Custom Toner Mode> Cause: The printer is in custom toner mode.	FIP 1.386

Status Code List (3615)

Note: Be aware that the error code that shows up on the UI for some errors does not have the same chain link code that will be displayed in the Error History report.

Note: When the LCD Message column displays ‘-’, ‘xxxxxxx’, the LCD doesn’t display any messages (it displays only the Status code), the error is dealt with internally. When the LCD Message column displays ‘xxxxxxx Duplicate IPv6 Add...’, the LCD doesn’t display any messages (displays only the Status code).

Status Code (3615)	LCD Display	Name/Description of Error	FIP
004-310	Optional Feeder Error 004-310 Reseat Optional Feeder. Power Off/On the Printer. If this failure occurs again, please contact customer support.	<IOT Option Feeder I/F Failure> Cause: The Option Feeder communication failure is detected.	FIP 1.01
005-110	Paper Jam 005-110 Open the Document Feeder Cover and remove paper. (After jam recovery) Reload the original that was removed from the Document Feeder and press the Start button. N Scanned	<PICK UP JAM> Cause: Detect PICK UP JAM.	FIP 1.02
005-112	Paper Jam 005-112 Open the Document Feeder Cover and remove paper. (After jam recovery) Reload the original that was removed from the Document Feeder and press the Start button. N Scanned.	<REVERSE JAM> Cause: Detect REVERSE JAM.	FIP 1.02

Status Code (3615)	LCD Display	Name/Description of Error	FIP
005-121	<p>Paper Jam 005-121 Open the Document Feeder Cover and remove paper.</p> <p>(After jam recovery) Reload the original that was removed from the Document Feeder and press the Start button. N Scanned</p>	<p><DADF JAM> Cause: Detect DADF JAM.</p>	<p>FIP 1.02</p>
005-124	<p>Document Feeder Jam 005-124 Job Canceled. Open Document Feeder Cover and Remove Jammed Paper.</p>	<p><Virtual JAM> Cause: Detect Virtual JAM.</p>	<p>FIP 1.02</p>
005-301	<p>Document Feeder Cover Open 005-301 Close Document Feeder Cover.</p>	<p><DADF Cover Open> Cause: Detect DADF Cover Open.</p>	<p>FIP 1.03</p>
005-900	<p>Paper Jam 005-900 Open the Document Feeder Cover and remove paper.</p> <p>(After jam recovery) Reload the original that was removed from the Document Feeder and press the Start button. N Scanned.</p>	<p><DADF STATIC JAM> Cause: Detect DADF STATIC JAM.</p>	<p>FIP 1.02</p>
010-317	<p>Fuser Connection Error 010-317 Turn off the printer and reseal the Fuser.</p>	<p><FUSING ASSEMBLY Detached> Cause: FUSING ASSEMBLY detached is detected.</p>	<p>FIP 1.04</p>
010-397	<p>Fuser Error 010-397 Power Off/On the Printer. If this failure occurs again, please contact customer support. Code:xxxxxxxh</p>	<p><FUSING ASSEMBLY Failure> Cause: The operation error of FUSING ASSEMBLY (Temperature anomaly error etc.) is detected.</p>	<p>FIP 1.04</p>

Status Code (3615)	LCD Display	Name/Description of Error	FIP
016-338	Reset Wi-Fi Option 016-338 Power Off/On the Printer and contact the administrator if problem persists after reboot.	<Wireless Option Error> Cause: Wireless Driver starting error.	FIP 1.08
016-359	MRAM Error 016-359 Power Off/On the Printer. If this failure occurs again, please contact customer support.	<MRAM Fail> Cause: MRAM Device Error.	FIP 1.09
016-369	Control Panel Error 016-369 Power Off/On the Printer. If this failure occurs again, please contact customer support.	<UI Panel - ESS Communication Fail> Cause: Communication Fail with a UI Panel and ESS F/W.	FIP 1.10
016-404	Certificate Failure 016-404 Contact the administrator. Initialization required. Press OK to start certificate initialization. After initialization, reboot the printer. *Fault screen with OK button	<Certificate DB Error> Cause: Certificate DB access error.	FIP 1.11
016-405	Certificate Failure 016-405 Contact the administrator. Initialization required. Press OK to start certificate initialization. After initialization, reboot the printer. *Fault screen with OK button	<Certificate DB Error> Cause: Invalid security setting error.	FIP 1.12
016-500	Flash ROM Erase Error 016-500 Job canceled. Power Off/On the Printer.	<Download Delete Error> Cause: Flash delete error in download.	FIP 1.13
016-501	Flash ROM Write Error 016-501 Job canceled. Power Off/On the Printer.	<Download Write Error> Cause: Flash write error in download.	FIP 1.14

Status Code (3615)	LCD Display	Name/Description of Error	FIP
016-502	Flash ROM Verification Error 016-502 Job canceled. Power Off/On the Printer.	<Download Verify Error> Cause: Flash verify error in download.	FIP 1.15
016-503	Network Error 016-503 Unable to resolve Email SMTP Server host name. Please check the SMTP and DNS Server settings, or contact your System Administrator. Job canceled. *Caution screen with Close button	<SMTP Server Address Resolution Fail for Maillib> Cause: SMTP server name resolution for email send failed.	FIP 1.16
016-504	Network Error 016-504 Unable to resolve Email POP3 Server host name. Please check the POP3 and DNS Server settings, or contact your System Administrator. Job canceled. *Caution screen with Close button	<POP Server Address Resolution Fail for Maillib> Cause: POP3 server name resolution for email send failed.	FIP 1.17
016-505	Network Error 016-505 Email POP3 Server Login Error. Please check the POP3 Server settings and confirm the login details, or contact your System Administrator. Job canceled. *Caution screen with Close button	<POP Authentication Fail for Maillib> Cause: Cannot login to POP3 server to send email.	FIP 1.18

Status Code (3615)	LCD Display	Name/Description of Error	FIP
016-506	<p>Network Error 016-506 SMTP Server not configured. Please configure the Email SMTP Server Settings on the printer's Web Interface. Job canceled.</p> <p>*Caution screen with Close button</p>	<p><Required user entry item is empty> Cause: Some item is not set.</p>	<p>FIP 1.19</p>
016-507	<p>Network Error 016-507 Email SMTP Server Login Error. Please check the SMTP Server settings and confirm the login details, or contact your System Administrator. Job canceled.</p> <p>*Caution screen with Close button</p>	<p><SMTP Authentication Fail for Maillib> Cause: Cannot login to SMTP server to send email.</p>	<p>FIP 1.20</p>
016-520	<p>Certificate Failure 016-520 Power Off/On the Printer and contact the administrator if problem persists after reboot.</p>	<p><Ipsec Certificate Error> Cause: Self device certificate error.</p>	<p>FIP 1.21</p>
016-521	<p>Certificate Failure 016-521 Power Off/On the Printer and contact the administrator if problem persists after reboot.</p>	<p><Ipsec Certificate Error> Cause: Remote device certification verification error.</p>	<p>FIP 1.22</p>
016-522	<p>LDAPS Error@016-522 Unable to obtain SSL client certificate. Please consult your system administrator.</p>	<p><LDAP Certificate Error> Cause: No client certificate exists.</p>	<p>FIP 1.23</p>
016-523	<p>LDAPS Error@016-523 SSL certificate data is incorrect. Please consult your system administrator.</p>	<p><LDAP Certificate Error> Cause: Server certificate verification error.</p>	<p>FIP 1.24</p>

Status Code (3615)	LCD Display	Name/Description of Error	FIP
016-524	LDAPS Error 016-524 Expiry date of SSL certificate is invalid. Please consult your system administrator.	<LDAP Certificate Error> Cause: No server certificate exists.	FIP 1.25
016-527	LDAPS SSL Authentication - Internal Error 016-527 Please consult your system administrator. Contact customer support if this error is repeated.	<LDAP Certificate Error> Cause: SSL authentication internal error.	FIP 1.26
016-530	Certificate Error 016-530 Job canceled. Power Off/On the Printer.	<LDAP Address Book- Access Error> Cause: LDAP Address Book Other Access Errors.	FIP 1.27
016-541	Certificate Failure 016-541 Power Off/On the Printer and contact the administrator if problem persists after reboot.	<Wireless Certificate Error> Cause: No certificate exists.	FIP 1.28
016-542	Certificate Failure 016-542 Power Off/On the Printer and contact the administrator if problem persists after reboot.	<Wireless Certificate Error> Cause: Server certificate error.	FIP 1.29
016-543	Certificate Failure 016-543 Power Off/On the Printer and contact the administrator if problem persists after reboot.	<Wireless Certificate Error> Cause: Certificate corruption error.	FIP 1.30
016-570	Print Job Processing Error 016-570 Insufficient Memory for Job Ticket Processing Job canceled. *Caution screen with Close button	<Job Ticket Out Of Memory> Cause: XPIF parser detects insufficient memory in the processing of XCPT (XPIF) interpretation.	FIP 1.31

Status Code (3615)	LCD Display	Name/Description of Error	FIP
016-571	Print Job Processing Error 016-571 Invalid Job Ticket Command Job canceled. *Caution screen with Close button	<Job ticket wrong> Cause: Print instruction contents that the device cannot execute are detected.	FIP 1.32
016-572	Print Job Processing Error 016-572 Invalid Job Ticket Parameter Job canceled. *Caution screen with Close button	<Job ticket media error> Cause: The paper attribute specified by XCPT (XPIF) cannot solve paper selection.	FIP 1.33
016-573	Print Job Processing Error 016-573 Job Ticket Error Job canceled. *Caution screen with Close button	<Job ticket parse error> Cause: XPIF parser detects error other than those listed above.	FIP 1.34
016-602	Initialize NVM Initializing...	<System NVM Initialize> Cause: At POWON start-up, execute NVM clear.	FIP 1.35
016-603	-	<ESS-NVM Parameter Recover> Cause: Executed ESS-NVM Parameter Recovery.	FIP 1.36
016-604	-	<ESS-NVM Parameter Copy> Cause: Executed ESS-NVM Parameter Copy.	FIP 1.37
016-605	-	<ESS-NVM Parameter Copy> Cause: Executed ESS-NVM Parameter Copy.	FIP 1.38
016-606	-	<Clear Job History> Cause: Clear Job History.	FIP 1.39

Status Code (3615)	LCD Display	Name/Description of Error	FIP
016-610	Control Panel Error 016-610 Power Off/On the Printer. If this failure occurs again, please contact customer support.	<Panel Destination Mismatch> Cause: Only for Production Line. Tried to apply JP setting to non-JP panel, or tried to apply non-JP setting to JP panel.	FIP 1.40
016-612	Invalid MAC Address 016-612 Power Off/On the Printer. If this failure occurs again, please contact customer support.	<Invalid MAC Address> Cause: Only for Production Line. MAC address is invalid.	FIP 1.41
016-718	Job exceeded memory capacity. 016-718 Job canceled. *Caution screen with Close button	<Memory Over flow> Cause: The current printing job process cannot be continued because the memory capacity is exceeded.	FIP 1.42
016-720	Print Job Processing Error 016-720 Job canceled. *Caution screen with Close button	<PDL Error> Cause: The print data cannot be processed by PDL.	FIP 1.43
016-734	Signature Error 016-734 Job canceled. *Caution screen with Close button	<Download Signature Error> Cause: Download file signature data is invalid.	FIP 1.44
016-737	File Format Error 016-737 Job canceled. *Caution screen with Close button	<Download Format Error> Cause: Download file format is invalid.	FIP 1.45
016-741	File Protection Error 016-741 Job canceled. *Caution screen with Close button	<Download Protect Error> Cause: Performed FW download although FW update is prohibited by panel settings.	FIP 1.46

Status Code (3615)	LCD Display	Name/Description of Error	FIP
016-742	Invalid File ID 016-742 Job canceled. *Caution screen with Close button	<Download ID Error> Cause: Download file ID is invalid.	FIP 1.47
016-743	Range Check Error 016-743 Job canceled. *Caution screen with Close button	<Download Range Error> Cause: At download, write-in destination address is invalid. Range check error.	FIP 1.48
016-744	Check Sum Error 016-744 Job canceled. *Caution screen with Close button	<Download Check Sum Error> Cause: Download file checksum is invalid.	FIP 1.49
016-745	File Header Error 016-745 Job canceled. *Caution screen with Close button	<Download header Error> Cause: Download file header is invalid.	FIP 1.50
016-746	Prohibition Error 016-746 Job canceled. *Caution screen with Close button	<Prohibit Error> Cause: Download Prohibit Error.	FIP 1.51
016-750	PDF Job Processing Error 016-750 Invalid Job Ticket PDF Description. Job canceled. *Caution screen with Close button	<Job Ticket Error> Cause: PDF print job ticket description error.	FIP 1.52
016-753	Wrong PDF Password 016-753 Job canceled. *Caution screen with Close button	<Wrong Password> Cause: PDF password error.	FIP 1.53

Status Code (3615)	LCD Display	Name/Description of Error	FIP
016-755	Direct PDF Print Disabled 016-755 Job canceled. *Caution screen with Close button	<PDF Print Disabled> Cause: PDF print is not allowed.	FIP 1.54
016-757	Authentication Error@016-757 The user name or password does not match.	<Auditron - Invalid User> Cause: Account is not registered.	FIP 1.55
016-758	User Account Restriction 016-758 Job canceled. *Caution screen with Close button	<Auditron - Disabled Function> Cause: Detect invalid account.	FIP 1.56
016-759	User Account Limit Exceeded 016-759 Job canceled. *Caution screen with Close button	<Auditron - Reached Limit> Cause: Reached the limit of the number of registered users.	FIP 1.57
016-764	Network Error 016-764 Unable to connect to Email SMTP Server. Please check the SMTP Server settings or contact your System Administrator. Job canceled. *Caution screen with Close button	<SMTP Server Connection Error> Cause: Error occurs when connecting to SMTP server.	FIP 1.58
016-765	Network Error 016-765 Email SMTP Server Capacity Exceeded. Contact System Administrator. Job canceled. *Caution screen with Close button	<SMTP Server HD Full> Cause: Capacity of SMTP server is not enough.	FIP 1.59

Status Code (3615)	LCD Display	Name/Description of Error	FIP
016-766	<p>Network Error 016-766 Email exceeds SMTP Server size restriction. Contact SMTP Server Administrator. Job canceled.</p> <p>*Caution screen with Close button</p>	<p><SMTP Server File System Error> Cause: Error in SMTP server.</p>	<p>FIP 1.60</p>
016-767	<p>Network Error 016-767 Invalid Recipient Email Address. Please check the recipient Email Address and try again. Job canceled.</p> <p>*Caution screen with Close button</p>	<p><Invalid Recipient Email Address> Cause: Recipient email address is incorrect.</p>	<p>FIP 1.61</p>
016-768	<p>Network Error 016-768 Invalid Sender Email Address. Please check the sender Email Address and try again. Job canceled.</p> <p>*Caution screen with Close button</p>	<p><Invalid Sender Address (Login Error)> Cause: Sender email address is incorrect.</p>	<p>FIP 1.62</p>
016-786	<p>Network Timeout Error 016-786 Job canceled.</p> <p>*Caution screen with Close button</p>	<p><Data Send/Receive Timeout Error> Cause: Timeout error occurs in scan data send/receive.</p>	<p>FIP 1.63</p>
016-790	<p>Network Connection Error 016-790 Check network cable connection and the network status. If problem persists, contact network administrator.</p> <p>*Caution screen with Close button</p>	<p><F2N Module Starting-up> Cause: F2N module task is starting up, or IP address is not determined.</p>	<p>FIP 1.64</p>

Status Code (3615)	LCD Display	Name/Description of Error	FIP
016-791	USB Memory Read Error 016-791 Job canceled. Please insert USB memory and restart job. *Caution screen with Close button	<USB Memory Removal Error (During Read)> Cause: USB memory is removed while memory reading job is being executed.	FIP 1.65
016-799	Invalid Job 016-799 Job canceled. *Caution screen with Close button	<Job Environment Violation> Cause: Print condition conflicts with other condition.	FIP 1.66
016-920	Wi-Fi Timeout Error 016-920 Try again. *Caution screen with Close button	<Wireless Setting Error> Cause: Timeout Error.	FIP 1.08
016-921	Wi-Fi Download Error 016-921 Try again. *Caution screen with Close button	<Wireless Setting Error> Cause: Download Error.	FIP 1.08
016-922	Wi-Fi Session Overlap Error 016-922 Try again. *Caution screen with Close button	<Wireless Setting Error> Cause: Session Overlap Error.	FIP 1.08
016-923	Wi-Fi Password Error 016-923 Try again. *Caution screen with Close button	<Wireless Password Error> Cause: Wireless Password is wrong.	FIP 1.67

Status Code (3615)	LCD Display	Name/Description of Error	FIP
016-924	Wi-Fi Error 016-924 Wi-Fi WEP Access Point Connected Error. Try again. *Caution screen with Close button	<Wireless Setting Error> Cause: WEP AP Connected Error.	FIP 1. 68
016-930	USB Error 016-930 Unsupported USB Memory Device. Remove Device.	<USB Host Error> Cause: Warning when unsupported device is installed to USB host. <ul style="list-style-type: none"> • Detect installation of device of which class driver cannot be found. • Detect installation of device that class driver judges not to support. • Detect installation of Low-Speed device. 	FIP 1. 69
016-931	USB Error 016-931 USB Hub is not supported. Remove Device.	<USB Hub Error> Cause: Warning to installation of hub that cannot be used to USB host. Detect installation of hubs in more than supported number of stacks.	FIP 1. 70
016-982	RAM Disk Full 016-982 Job canceled. *Caution screen with Close button	<Disk Full> Cause: The current printing job process cannot be continued because the RAM disk is full.	FIP 1. 71
016-985	Email Size Limit Exceeded 016-985 Job canceled. *Caution screen with Close button	<Mail Size Error> Cause: Exceed the max mail size specified on the menu.	FIP 1. 72

Status Code (3615)	LCD Display	Name/Description of Error	FIP
016-986	File Size Limit Exceeded 016-986 Job canceled. *Caution screen with Close button	<File Size Error> Cause: As a result of conversion to the specified format, exceed the max file size specified for each format.	FIP 1.73
017-321	XXXXXXXXXXXXXXXXXXXX Unsupported Device Memory has been detected.	<SD CARD Type Invalid Error> Cause: SD CARD Type Invalid Error was detected.	FIP 1.74
017-600	Initialize User Data Initializing...	<Address Info Sum Check Fail> Cause: At POWON start-up, Check phone book and address book data and initializing incorrect data automatically.	FIP 1.75
017-970	Fax Memory Error 017-970 Fax Memory Full. Check Job Status for pending fax jobs. Job canceled. Please try again later. *Caution screen with Close button	<FAX Memory Full> Cause: AIOC memory run out.	FIP 1.76
017-971	Fax Controller Error 017-971 Write Error in Flash ROM Image Data Storage Job canceled. Please try again. *Caution screen with Close button	<FAX Controller Error> Cause: Write error of image data storage Flash ROM.	FIP 1.77
017-972	Fax Controller Error 017-972 Erase Error in Flash ROM Image Data Storage Job canceled. Please try again. *Caution screen with Close button	<FAX Controller Error> Cause: Erase error of image data storage Flash ROM.	FIP 1.78

Status Code (3615)	LCD Display	Name/Description of Error	FIP
017-973	Fax Controller Error 017-973 Suspend Error in Flash ROM Image Data Storage. Job canceled. Please try again. *Caution screen with Close button	<FAX Controller Error> Cause: Suspend error of image data storage Flash ROM.	FIP 1.79
017-974	Fax Controller Error 017-974 Resume Error in Flash ROM Image Data Storage Job canceled. Please try again. *Caution screen with Close button	<FAX Controller Error> Cause: Resume error of image data storage Flash ROM.	FIP 1.80
017-975	Fax Controller Error 017-975 Maximum number of file handles exceeded. Job canceled. Please restart device and try again. *Caution screen with Close button	<FAX Controller Error> Cause: Exceed the maximum number of file handles.	FIP 1.81
017-976	Fax Controller Error 017-976 Maximum number of controlled files exceeded. Job canceled. Please try again later. *Caution screen with Close button	<FAX Controller Error> Cause: Exceed the maximum number of controlled files.	FIP 1.82
017-977	Fax Controller Error 017-977 Maximum number of controlled documents exceeded. Job canceled. Please try again later. *Caution screen with Close button	<FAX Controller Error> Cause: Exceed the maximum number of controlled documents.	FIP 1.83

Status Code (3615)	LCD Display	Name/Description of Error	FIP
017-978	Fax Controller Error 017-978 Maximum number of pages exceeded. Job canceled. Please re-load document and try again. *Caution screen with Close button	<FAX Controller Error> Cause: Exceed the maximum number of pages in document.	FIP 1.84
017-979	Fax Controller Error 017-979 Multiple Files Open Job canceled. Please restart device and try again. *Caution screen with Close button	<FAX Controller Error> Cause: File multi-open.	FIP 1.85
017-980	Fax Report Error 017-980 Failed to Open/Close Report File Job canceled. *Caution screen with Close button	<Report File Open/Close Error> Cause: Report job fails to open/close report file.	FIP 1.86
017-983	Initialize NVM Initializing...	<EEPROM R/W Error> Cause: At system boot, EEPROM Read/Write check error (sum check error).	FIP 1.87
017-986	Fax Controller Error 017-986 Empty File created Job canceled. Please restart device and try again. *Caution screen with Close button	<FAX Controller Error> Cause: Create empty file (0Byte).	FIP 1.88
017-987	Fax Controller Error 017-987 File exceeds destination buffer size Job canceled. Please try again later. *Caution screen with Close button	<FAX Controller Error> Cause: Cannot read file because it is bigger than read destination buffer.	FIP 1.89

Status Code (3615)	LCD Display	Name/Description of Error	FIP
017-988	<p>Scan Job Timeout Error 017-988 Job canceled. Restart Scan Job.</p> <p>*Caution screen with Close button</p>	<p><Scan Time Out> Cause: Timeout at start of Scan To Application.</p>	<p>FIP 1.90</p>
017-989	<p>Fax Controller Error 017-989 File to be written exceeds destination buffer size Job canceled. Please try again later.</p> <p>*Caution screen with Close button</p>	<p><FAX Controller Error> Cause: Stop writing because size of file to be written is bigger than read destination buffer (even if file writing is continued, it is impossible to read the file).</p>	<p>FIP 1.91</p>
017-990	-	<p><IIT Auto Registration Adjustment Fail> Cause: Fail to adjust IIT registration automatically at start-up. Set to default value and continue processing.</p>	<p>FIP 1.92</p>
017-991	-	<p><IIT Level Adjustment Fail> Cause: At the start of IIT read job, fail to adjust IIT level. Set to default value and continue processing.</p>	<p>FIP 1.93</p>
018-722	<p>Google Cloud Print Network Error 018-722 A network-related error has occurred. Check the network connection status and the network settings. *Caution screen with Close button</p>	<p><Google Cloud Print Network Error > Cause: A network-related error has occurred.</p>	<p>FIP 1.94</p>

Status Code (3615)	LCD Display	Name/Description of Error	FIP
018-723	<p>Google Cloud Print Certificate Error 018-723</p> <p>A certificate connection error has occurred.</p> <p>Check whether the Root CA Certificate(s) is correct, or if the certificate validation settings are correct.</p> <p>*Caution screen with Close button</p>	<p><Google Cloud Print Certificate Error ></p> <p>Cause:</p> <p>A certificate connection error has occurred.</p>	<p>FIP 1.95</p>
018-724	<p>Google Cloud Print SSL Error 018-724</p> <p>An SSL connection error has occurred.</p> <p>Check the SSL connection status and settings.</p> <p>*Caution screen with Close button</p>	<p><Google Cloud Print SSL Error></p> <p>Cause:</p> <p>An SSL connection error has occurred.</p>	<p>FIP 1.96</p>
018-729	<p>Google Cloud Print Timeout Error 018-729</p> <p>A timeout has led to an error.</p> <p>Check the network connection status and the network settings. The network may be congested.</p> <p>*Caution screen with Close button</p>	<p><Google Cloud Print Timeout Error></p> <p>Cause:</p> <p>A timeout has led to an error.</p>	<p>FIP 1.97</p>
018-730	<p>Google Cloud Print Network Other Error 018-730</p> <p>A network-related internal error has occurred.</p> <p>Check the network connection status and the network settings. Contact customer support if the issue reoccurs.</p> <p>*Caution screen with Close button</p>	<p><Google Cloud Print Network Other Error></p> <p>Cause:</p> <p>A network-related internal error has occurred.</p>	<p>FIP 1.98</p>

Status Code (3615)	LCD Display	Name/Description of Error	FIP
018-737	<p>Google Cloud Print Other Error 018-737 Another internal error has occurred. Check the settings, and try again. Contact customer support if the issue reoccurs. *Caution screen with Close button</p>	<p><Google Cloud Print Other Error> Cause: Another internal error has occurred.</p>	<p>FIP 1. 99</p>
018-738	<p>Google Cloud Print XMPP Network Error 018-738 A XMPP protocol network-related internal error has occurred. Check the network connection status and the network settings. *Caution screen with Close button</p>	<p><Google Cloud Print XMPP Network Error> Cause: A XMPP protocol network-related internal error has occurred.</p>	<p>FIP 1. 100</p>
018-739	<p>Google Cloud Print XMPP Network Other Error 018-739 A XMPP protocol network-related internal error has occurred. Check the network connection status and the network settings. Contact customer support if the issue reoccurs. *Caution screen with Close button</p>	<p><Google Cloud Print XMPP Network Other Error> Cause: A XMPP protocol network-related internal error has occurred.</p>	<p>FIP 1. 101</p>
018-740	<p>Google Cloud Print XMPP Certificate Error 018-740 A XMPP protocol network-related certificate connection error has occurred. Check whether the Root CA Certificate(s) is correct, or if the certificate validation settings are correct. *Caution screen with Close button</p>	<p><Google Cloud Print XMPP Certificate Error> Cause: A XMPP protocol network-related certificate connection error has occurred.</p>	<p>FIP 1. 102</p>

Status Code (3615)	LCD Display	Name/Description of Error	FIP
018-741	<p>Google Cloud Print XMPP Other Error 018-741</p> <p>Another XMPP protocol error has occurred.</p> <p>Check the settings, and try again.</p> <p>Contact customer support if the issue reoccurs.</p> <p>*Caution screen with Close button</p>	<p><Google Cloud Print XMPP Other Error></p> <p>Cause:</p> <p>Another XMPP protocol error has occurred.</p> <p>Check the settings, and try again.</p>	<p>FIP 1.103</p>
018-743	<p>Google Cloud Print Proxy Error 018-743</p> <p>A network-related (proxy connection) error has occurred.</p> <p>Check the network connection status, especially the proxy settings.</p> <p>*Caution screen with Close button</p>	<p><Google Cloud Print Proxy Error></p> <p>Cause:</p> <p>A network-related (proxy connection) error has occurred.</p>	<p>FIP 1.104</p>
018-744	<p>Google Cloud Print DNS Resolve Error 018-744</p> <p>A network-related (DNS Name Resolution) error has occurred.</p> <p>Check the network connection status, especially the DNS settings.</p> <p>*Caution screen with Close button</p>	<p><Google Cloud Print DNS Resolve Error></p> <p>Cause:</p> <p>A network-related (DNS Name Resolution) error has occurred.</p>	<p>FIP 1.105</p>
018-745	<p>Google Cloud Print XMPP Proxy Error 018-745</p> <p>A XMPP protocol network-related (proxy connection) error has occurred.</p> <p>Check the network connection status, especially the proxy settings.</p> <p>*Caution screen with Close button</p>	<p><Google Cloud Print XMPP Proxy Error></p> <p>Cause:</p> <p>A XMPP protocol network-related (proxy connection) error has occurred.</p>	<p>FIP 1.106</p>

Status Code (3615)	LCD Display	Name/Description of Error	FIP
018-746	<p>Google Cloud Print XMPP DNS Resolve Error 018-746</p> <p>A XMPP protocol network-related (DNS Name Resolution) error has occurred.</p> <p>Check the network connection status, especially the DNS settings.</p> <p>*Caution screen with Close button</p>	<p><Google Cloud Print XMPP DNS Resolve Error></p> <p>Cause: A XMPP protocol network-related (DNS Name Resolution) error has occurred.</p>	<p>FIP 1. 107</p>
024-340	<p>Engine Controller Error 024-340</p> <p>Power Off/On the Printer.</p> <p>If this failure occurs again, please contact customer support.</p> <p>Code:xxxxxxxxh</p>	<p><Engine Controller Error ></p> <p>Cause: Engine firmware error occurs.</p>	<p>FIP 1. 108</p>
024-360	<p>Engine Code DownLoad Error 024-360</p> <p>Power Off/On Printer and Send Firmware Data again.</p>	<p><Engine Code DownLoad Error></p> <p>Cause: Download failure of MCU firmware.</p>	<p>FIP 1. 109</p>
024-362	<p>Print Engine Start Error 024-362</p> <p>Power Off/On the Printer.</p> <p>If this failure occurs again, please contact customer support.</p>	<p><Print Engine Start Error></p> <p>Cause: "Start Image Making" has not been issued within the time allowed.</p>	<p>FIP 1. 110</p>
024-371	<p>Engine Communication Error 024-371</p> <p>Power Off/On the Printer.</p> <p>If this failure occurs again, please contact customer support.</p>	<p><Engine Communication Error></p> <p>Cause: Communication fail between MCU and ESS.</p>	<p>FIP 1. 111</p>
024-910	<p>Paper Size Mismatch 024-910</p> <p>Load paper in Tray 1.</p> <p>XXX</p> <p>YYY</p> <p>(XXX: Paper Size YYY: Paper Type)</p>	<p><Tray 1 Paper Size Mismatch></p> <p>Cause: The size of paper in the Tray 1 does not match the specified print size.</p>	<p>FIP 1. 112</p>

Status Code (3615)	LCD Display	Name/Description of Error	FIP
024-911	Paper Size Mismatch 024-911 Load paper in Tray 2. XXX YYY (XXX: Paper Size YYY: Paper Type)	<Tray 2 Paper Size Mismatch> Cause: The size of paper in the Tray 2 does not match the specified print size.	FIP 1.113
024-912	Paper Size Mismatch 024-912 Load paper in Tray 3. XXX YYY (XXX: Paper Size YYY: Paper Type)	<Tray 3 Paper Size Mismatch> Cause: The size of paper in the Tray 3 does not match the specified print size.	FIP 1.113
024-913	Paper Size Mismatch 024-913 Load paper in Tray 4. XXX YYY (XXX: Paper Size YYY: Paper Type)	<Tray 4 Paper Size Mismatch> Cause: The size of paper in the Tray 4 does not match the specified print size.	FIP 1.113
024-920	Output Tray Full Remove Paper from Output Tray.	<IOT Standard Stacker Full> Cause: Output Tray Full is Detected.	FIP 1.114
024-958	Paper Size Mismatch 024-958 Load paper in NNN. XXX YYY (NNN: Manual Feed XXX: Paper Size YYY: Paper Type)	<MSI Paper Size Mismatch> Cause: The size of paper in the MSI does not match the specified print size.	FIP 1.115

Status Code (3615)	LCD Display	Name/Description of Error	FIP
024-959	Paper not available 024-959 Load paper XXX / YYY in Tray 1. (XXX: Paper Size YYY: Paper Type)	<Tray 1 No Suitable Paper> Cause: <ul style="list-style-type: none"> • Displayed when any of the following errors occurs and tray setting needs to be changed after paper is loaded. • When paper source auto selection is selected, paper sizes of all existing trays do not match. (All Tray Size Mismatch) • When a tray is specified, no paper is loaded in the specified tray. (Specified Tray Empty) • When a tray is specified, paper size loaded in the specified tray does not match. (Specified Tray Size Mismatch) • When Substitute Tray is Off and a paper type is specified, there is no tray loading the specified paper type. (Specified Tray Media Mismatch) 	FIP 1.116

Status Code (3615)	LCD Display	Name/Description of Error	FIP
024-960	<p>Paper not available 024-960 Load paper XXX / YYY in Tray 2.</p> <p>(XXX: Paper Size YYY: Paper Type)</p>	<p><Tray 2 No Suitable Paper> Cause:</p> <ul style="list-style-type: none"> • Displayed when any of the following errors occurs and tray setting needs to be changed after paper is loaded. • When paper source auto selection is selected, paper sizes of all existing trays do not match. (All Tray Size Mismatch) • When a tray is specified, no paper is loaded in the specified tray. (Specified Tray Empty) • When a tray is specified, paper size loaded in the specified tray does not match. (Specified Tray Size Mismatch) • When Substitute Tray is Off and a paper type is specified, there is no tray loading the specified paper type. (Specified Tray Media Mismatch) 	<p>FIP 1.116</p>

Status Code (3615)	LCD Display	Name/Description of Error	FIP
024-961	Paper not available 024-961 Load paper XXX / YYY in Tray 3. (XXX: Paper Size YYY: Paper Type)	<Tray 3 No Suitable Paper> Cause: <ul style="list-style-type: none"> • Displayed when any of the following errors occurs and tray setting needs to be changed after paper is loaded. • When paper source auto selection is selected, paper sizes of all existing trays do not match. (All Tray Size Mismatch) • When a tray is specified, no paper is loaded in the specified tray. (Specified Tray Empty) • When a tray is specified, paper size loaded in the specified tray does not match. (Specified Tray Size Mismatch) • When Substitute Tray is Off and a paper type is specified, there is no tray loading the specified paper type. (Specified Tray Media Mismatch) 	FIP 1.116

Status Code (3615)	LCD Display	Name/Description of Error	FIP
024-962	<p>Paper not available 024-962 Load paper XXX / YYY in Tray 4. (XXX: Paper Size YYY: Paper Type)</p>	<p><Tray 4 No Suitable Paper> Cause:</p> <ul style="list-style-type: none"> • Displayed when any of the following errors occurs and tray setting needs to be changed after paper is loaded. • When paper source auto selection is selected, paper sizes of all existing trays do not match. (All Tray Size Mismatch) • When a tray is specified, no paper is loaded in the specified tray. (Specified Tray Empty) • When a tray is specified, paper size loaded in the specified tray does not match. (Specified Tray Size Mismatch) • When Substitute Tray is Off and a paper type is specified, there is no tray loading the specified paper type. (Specified Tray Media Mismatch) 	FIP 1.116

Status Code (3615)	LCD Display	Name/Description of Error	FIP
024-963	<p>Paper not available 024-963 Load paper XXX / YYY in NNN.</p> <p>(NNN: Manual Feed XXX: Paper Size YYY: Paper Type)</p>	<p><MSI No Suitable Paper> Cause:</p> <ul style="list-style-type: none"> • Displayed when any of the following errors occurs and tray setting needs to be changed after paper is loaded. • When paper source auto selection is selected, paper sizes of all existing trays do not match. (All Tray Size Mismatch) • When a tray is specified, no paper is loaded in the specified tray. (Specified Tray Empty) • When a tray is specified, paper size loaded in the specified tray does not match. (Specified Tray Size Mismatch) • When Substitute Tray is Off and a paper type is specified, there is no tray loading the specified paper type. (Specified Tray Media Mismatch) 	FIP 1.116
026-720	<p>USB Memory Full 026-720 Job canceled.</p> <p>*Caution screen with Close button</p>	<p><USB Memory Full> Cause: Writing to USB memory failed.</p>	FIP 1.117
026-721	<p>USB Memory Write Error 026-721 Job canceled.</p> <p>*Caution screen with Close button</p>	<p><USB Memory Write Error> Cause: Writing to USB memory failed.</p>	FIP 1.118
027-446	<p>XXXXXXXXXXXXXXXXXX Duplicate IPv6 Add, Reconfigure</p>	<p><IPv6 duplicate> Cause: At start-up, detect duplicate IPv6 address on network.</p>	FIP 1.119

Status Code (3615)	LCD Display	Name/Description of Error	FIP
027-452	XXXXXXXXXXXXXXXXXX Duplicate IPv4 Add, Reconfigure	<IPv4 duplicate> Cause: At start-up, detect duplicate IPv4 address on network.	FIP 1. 120
031-521	SMB Error 031-521 SMB Server Login Error. Please check the SMB Server settings and confirm the login details, or contact your System Administrator. Job canceled. *Caution screen with Close button	<SMB Error> Cause: In SMB scan, login-able workstation is restricted.	FIP 1. 121
031-522	SMB Error 031-522 SMB Server Login Error. Please check the SMB Server settings and confirm the login details, or contact your System Administrator. Job canceled. *Caution screen with Close button	<SMB user authentication fail or SMB Scanner login fail> Cause: In SMB scan, login access is rejected. Request is not allowed.	FIP 1. 122
031-523	SMB Error 031-523 Invalid SMB Share name specified. Please check the SMB Server settings and confirm the Share name, or contact your System Administrator. Job canceled. *Caution screen with Close button	<Problem with share name in SMB scan server> Cause: Problem with share name in SMB scan server.	FIP 1. 123

Status Code (3615)	LCD Display	Name/Description of Error	FIP
031-524	<p>SMB Error 031-524 SMB Server user account limit exceeded. Contact your System Administrator. Job canceled.</p> <p>*Caution screen with Close button</p>	<p><SMB Scan User Over limit> Cause: Exceed the upper limit of the number of SMB scan users.</p>	<p>FIP 1.124</p>
031-525	<p>SMB Error 031-525 SMB destination client permission error. Please check the SMB Server settings and confirm the login details, or contact your System Administrator. Job canceled.</p> <p>*Caution screen with Close button</p>	<p><SMB Error> Cause: SMB scan client has no access right (Win9x).</p>	<p>FIP 1.125</p>
031-526	<p>SMB Error 031-526 Unable to resolve SMB Server host name. Please check the SMB and DNS Server settings, or contact your System Administrator.</p> <p>*Caution screen with Close button</p>	<p><SMB Scan Host Name Resolution Fail> Cause: SMB server name resolution failed.</p>	<p>FIP 1.126</p>
031-527	<p>SMB Error 031-527 Unable to resolve SMB Server host name. Please check the DNS Server settings or contact your System Administrator. Job canceled.</p> <p>*Caution screen with Close button</p>	<p><SMB Scan DNS Server Not Set> Cause: DNS server is not set.</p>	<p>FIP 1.127</p>

Status Code (3615)	LCD Display	Name/Description of Error	FIP
031-528	<p>SMB Error 031-528 Unable to connect to SMB Server. Please check the SMB Server settings and confirm the SMB Server, or contact your System Administrator. Job canceled.</p> <p>*Caution screen with Close button</p>	<p><In SMB scan, server connection error> Cause: Cannot find SMB server.</p>	<p>FIP 1. 128</p>
031-529	<p>SMB Error 031-529 SMB Server login error, invalid password. Please check the SMB Server settings and confirm the login password, or contact your System Administrator. Job canceled.</p> <p>*Caution screen with Close button</p>	<p><Problem with SMB scan login name or password> Cause: Invalid password (Win9x).</p>	<p>FIP 1. 129</p>
031-530	<p>SMB Error 031-530 SMB Share folder was not found on the specified SMB server. Please check the SMB Server settings and confirm the SMB Server and Share name, or contact your System Administrator.</p> <p>*Caution screen with Close button</p>	<p><Problem with storage location of scanned image in SMB scan server> Cause: Problem with storage location.</p>	<p>FIP 1. 130</p>
031-531	<p>SMB Error 031-531 Unable to get file/folder name on SMB Server. Please check the SMB Server settings and confirm the SMB Server and Share name, or contact your System Administrator. Job canceled.</p> <p>*Caution screen with Close button</p>	<p><Couldn't get file/folder name of SMB scan server> Cause: Couldn't get file/folder name of server.</p>	<p>FIP 1. 131</p>

Status Code (3615)	LCD Display	Name/Description of Error	FIP
031-532	<p>SMB Error 031-532 SMB scan file/folder name limit exceeded. Reduce the SMB file/folder name length, or contact your System Administrator. Job canceled.</p> <p>*Caution screen with Close button</p>	<p><Suffix of SMB scan file name/folder name is over limit> Cause: Suffix of file name/folder name is over limit.</p>	<p>FIP 1.132</p>
031-533	<p>SMB Error 031-533 Unable write file in SMB Server. Please check the SMB Server settings or contact your System Administrator. Job canceled.</p> <p>*Caution screen with Close button</p>	<p><SMB Scan File Creation Fail> Cause: Fail to create file.</p>	<p>FIP 1.133</p>
031-534	<p>SMB Error 031-534 Unable to create folder on SMB Server. Please check the SMB Server settings or contact your System Administrator. Job canceled.</p> <p>*Caution screen with Close button</p>	<p><SMB Scan Folder Creation Fail> Cause: Fail to create folder.</p>	<p>FIP 1.134</p>
031-535	<p>SMB Error 031-535 Unable to delete file on SMB Server. Please check if the file is currently in use and try again. Job canceled.</p> <p>*Caution screen with Close button</p>	<p><SMB Scan File Deletion Fail> Cause: Fail to delete file.</p>	<p>FIP 1.135</p>

Status Code (3615)	LCD Display	Name/Description of Error	FIP
031-536	<p>SMB Error 031-536 Unable to delete folder on SMB Server. Please check if the folder is currently in use and try again. Job canceled.</p> <p>*Caution screen with Close button</p>	<p><SMB Scan Folder Deletion Fail> Cause: Fail to delete folder.</p>	<p>FIP 1.136</p>
031-537	<p>SMB Error 031-537 SMB Server Capacity Exceeded. Contact your System Administrator. Job canceled.</p> <p>*Caution screen with Close button</p>	<p><No free space in storage location on SMB scan data server> Cause: Storage location has no free space.</p>	<p>FIP 1.137</p>
031-539	<p>SMB Error 031-539 Invalid SMB server specified. Please check SMB Server settings and confirm the Server name, or contact your System Administrator. Job canceled.</p> <p>*Caution screen with Close button</p>	<p><Invalid SMB server (Net BIOS) name is specified> Cause: Invalid SMB server (Net BIOS) name is specified.</p>	<p>FIP 1.138</p>
031-540	<p>SMB Error 031-540 Invalid domain name specified. Please check the SMB Server settings or contact your System Administrator. Job canceled.</p> <p>*Caution screen with Close button</p>	<p><SMB protocol error(4-007)Invalid scan domain name is specified> Cause: Invalid domain name is specified. (User name is specified in domain user form)</p>	<p>FIP 1.139</p>

Status Code (3615)	LCD Display	Name/Description of Error	FIP
031-541	<p>SMB Error 031-541 Invalid user name specified for SMB Server. Please check the SMB Server settings and confirm the login user, or contact your System Administrator. Job canceled.</p> <p>*Caution screen with Close button</p>	<p><SMB protocol error (4-008) Invalid scan user name is specified> Cause: Invalid scan user name is specified.</p>	<p>FIP 1. 140</p>
031-542	<p>SMB Error 031-542 TCP/IP not initialized. Job canceled. Please try again later.</p> <p>*Caution screen with Close button</p>	<p><SMB(TCP/IP) is not active> Cause: SMB(TCP/IP) is not active.</p>	<p>FIP 1. 141</p>
031-543	<p>SMB Error 031-543 SMB Server Login Error. Please check the SMB Server settings and confirm the login details, or contact your System Administrator. Job canceled.</p> <p>*Caution screen with Close button</p>	<p><SMB protocol error(4-045)Scan login prohibited time> Cause: Login prohibited time.</p>	<p>FIP 1. 142</p>
031-544	<p>SMB Error 031-544 SMB Server Login Error, password has expired. Please check the SMB Server settings and confirm the login password, or contact your System Administrator. Job canceled.</p> <p>*Caution screen with Close button</p>	<p><SMB protocol error(4-046) Password expired> Cause: Password expired.</p>	<p>FIP 1. 143</p>

Status Code (3615)	LCD Display	Name/Description of Error	FIP
031-545	<p>SMB Error 031-545 SMB Server Login Error, a password change is required. Please check the SMB Server settings and update the login password, or contact your System Administrator. Job canceled.</p> <p>*Caution screen with Close button</p>	<p><SMB protocol error(4-047) Password change is required> Cause: Password change is required.</p>	<p>FIP 1. 144</p>
031-546	<p>SMB Error 031-546 SMB Server Login Error, invalid User specified. Please check the SMB Server settings and confirm the login user, or contact your System Administrator. Job canceled.</p> <p>*Caution screen with Close button</p>	<p><SMB protocol error(4-048)User is invalid> Cause: User is invalid.</p>	<p>FIP 1. 145</p>
031-547	<p>SMB Error 031-547 SMB Server Login Error, user specified is restricted. Please check the SMB Server settings and confirm the login user, or contact your System Administrator. Job canceled.</p> <p>*Caution screen with Close button</p>	<p><SMB protocol error(4-049)Lock-out> Cause: User is locked out.</p>	<p>FIP 1. 146</p>

Status Code (3615)	LCD Display	Name/Description of Error	FIP
031-548	<p>SMB Error 031-548 SMB Server Login Error, user specified has expired. Please check the SMB Server settings and confirm the login user, or contact your System Administrator. Job canceled.</p> <p>*Caution screen with Close button</p>	<p><SMB protocol error(4-050)User is expired> Cause: User is expired.</p>	<p>FIP 1. 147</p>
031-549	<p>SMB Error 031-549 SMB Server Login Error. User specified is restricted, null password is prohibited. Please check the SMB Server settings and confirm the login details, or contact your System Administrator. Job canceled.</p> <p>*Caution screen with Close button</p>	<p><SMB protocol error(4-051)User is restricted. Null password is prohibited> Cause: User is restricted. Null password is prohibited.</p>	<p>FIP 1. 148</p>
031-550	<p>SMB Error 031-550 Append command not supported by SMB Server. Contact your System Administrator. Job canceled.</p> <p>*Caution screen with Close button</p>	<p><SMB Scan Append Command Fail> Cause: Have no append access right to the file. Server does not support SMB append command.</p>	<p>FIP 1. 149</p>
031-551	<p>SMB Error 031-551 Rename command not supported by SMB Server. Contact your System Administrator. Job canceled.</p> <p>*Caution screen with Close button</p>	<p><SMB Scan Rename Command Fail> Cause: Have no rename access right to the file. Server does not support SMB rename command.</p>	<p>FIP 1. 150</p>

Status Code (3615)	LCD Display	Name/Description of Error	FIP
031-552	<p>SMB Error 031-552 Job canceled.</p> <p>*Caution screen with Close button</p>	<p><In SMB scan, Cancel is selected for processing in the case of file name duplication, and job is cancelled because of file name duplication> Cause: Cancel is selected for processing in the case of file name duplication, and job is cancelled because of file name duplication.</p>	<p>FIP 1. 151</p>
031-574	<p>FTP Error 031-574 Unable to resolve FTP Server host name. Please check the FTP and DNS Server settings, or contact your System Administrator. Job canceled.</p> <p>*Caution screen with Close button</p>	<p><FTP Scan Host Name Resolution Fail> Cause: DNS library call error.</p>	<p>FIP 1. 152</p>
031-575	<p>FTP Error 031-575 Unable to resolve FTP Server host name. Please check the DNS Server settings, or contact System Administrator. Job canceled.</p> <p>*Caution screen with Close button</p>	<p><FTP Scan DNS Server Not Set> Cause: DNS library call error.</p>	<p>FIP 1. 153</p>
031-576	<p>FTP Error 031-576 Unable to connect to FTP Server. Please check FTP Server settings or contact your System Administrator. Job canceled.</p> <p>*Caution screen with Close button</p>	<p><Server Connection Error in FTP Scan> Cause: Network connection failed.</p>	<p>FIP 1. 154</p>

Status Code (3615)	LCD Display	Name/Description of Error	FIP
031-578	<p>FTP Error 031-578 FTP Server Login Error. Please check the FTP Server settings and confirm the login details, or contact your System Administrator. Job canceled.</p> <p>*Caution screen with Close button</p>	<p><FTP Scan Login Name or Password Error> Cause: USER/PASS command failed.</p>	<p>FIP 1. 155</p>
031-579	<p>FTP Error 031-579 Invalid FTP Subdirectory Path. Please check the FTP Server settings and confirm the Subdirectory Path, or contact your System Administrator. Job canceled.</p> <p>*Caution screen with Close button</p>	<p><Problem with Location FTP-scanned Image is Saved in> Cause: Fail to move data to Repository Path.</p>	<p>FIP 1. 156</p>
031-580	<p>FTP Error 031-580 Failed to obtain file/folder Name of FTP Server. NLST command failure. Contact System Administrator. Job canceled.</p> <p>*Caution screen with Close button</p>	<p><Fail to get file name/folder name of FTP scan server> Cause: NLST command failed.</p>	<p>FIP 1. 157</p>
031-581	<p>FTP Error 031-581 FTP scan file/folder name limit exceeded. Reduce the file/folder name length, or contact your System Administrator. Job canceled.</p> <p>*Caution screen with Close button</p>	<p><Suffix of FTP scan file name/folder name is over limit> Cause: Same as left.</p>	<p>FIP 1. 158</p>

Status Code (3615)	LCD Display	Name/Description of Error	FIP
031-582	<p>FTP Error 031-582 Unable to write scan file to FTP Server location. STOR command failure. Contact your System Administrator. Job canceled.</p> <p>*Caution screen with Close button</p>	<p><FTP Scan File Creation Fail> Cause: STOR command failed.</p>	<p>FIP 1. 159</p>
031-584	<p>FTP Error 031-584 Unable to create scan folder on FTP Server. MKD command failure. Contact your System Administrator. Job canceled.</p> <p>*Caution screen with Close button</p>	<p><FTP Scan Folder Creation Fail> Cause: MKD command failed.</p>	<p>FIP 1. 160</p>
031-585	<p>FTP Error 031-585 Unable to delete file on FTP Server. DEL command failure. Contact your System Administrator. Job canceled.</p> <p>*Caution screen with Close button</p>	<p><FTP Scan File Deletion Fail> Cause: DEL command failed.</p>	<p>FIP 1. 161</p>
031-587	<p>FTP Error 031-587 Unable to delete folder on FTP Server. RMD command failure. Contact your System Administrator. Job canceled.</p> <p>*Caution screen with Close button</p>	<p><FTP Scan Folder Deletion Fail> Cause: RMD command failed.</p>	<p>FIP 1. 162</p>

Status Code (3615)	LCD Display	Name/Description of Error	FIP
031-588	<p>FTP Error 031-588 Unable to write file in FTP Server location. Contact your System Administrator. Job canceled.</p> <p>*Caution screen with Close button</p>	<p><FTP Scan Server Data Write Fail> Cause: Data writing to FTP scan server has failed.</p>	<p>FIP 1.163</p>
031-590	<p>FTP Error 031-590 Job canceled.</p> <p>*Caution screen with Close button</p>	<p><FTP Error> Cause: Cancel is selected for processing in the case of file name duplication, and job is cancelled because of file name duplication.</p>	<p>FIP 1.164</p>
031-594	<p>FTP Error 031-594 FTP transfer TYPE command failure. Contact your System Administrator. Job canceled.</p> <p>*Caution screen with Close button</p>	<p><FTP Scan TYPE Command Fail (Network Error)> Cause: TYPE command failed.</p>	<p>FIP 1.165</p>
031-595	<p>FTP Error 031-595 FTP data PORT command failure. Contact your System Administrator. Job canceled.</p> <p>*Caution screen with Close button</p>	<p><FTP Scan PORT Command Fail (Network Error)> Cause: PORT command failed.</p>	<p>FIP 1.166</p>
031-598	<p>FTP Error 031-598 FTP append data APPE command failure. Contact your System Administrator. Job canceled.</p> <p>*Caution screen with Close button</p>	<p><FTP Scan Append Command Fail> Cause: APPE command failed.</p>	<p>FIP 1.167</p>

Status Code (3615)	LCD Display	Name/Description of Error	FIP
031-599	<p>FTP Error 031-599 FTP rename file RNFR command failure. Contact your System Administrator. Job canceled.</p> <p>*Caution screen with Close button</p>	<p><FTP Scan Rename Command Fail> Cause: RNFR command or RNT0 command failed.</p>	<p>FIP 1.168</p>
033-501	<p>Fax Codec Error 033-501 Codec processing canceled during manual send. Job canceled. Please try again.</p> <p>*Caution screen with Close button</p>	<p><Fax Codec Error> Cause: Cancel Codec processing due to error of read part during manual send.</p>	<p>FIP 1.169</p>
033-502	<p>Fax Error 033-502 Unable to open File Job canceled.</p> <p>*Caution screen with Close button</p>	<p><File Open Error> Cause: File open error.</p>	<p>FIP 1.170</p>
033-503	<p>Device Memory Full 033-503 Job canceled. Remote device will try again.</p> <p>*Caution screen with Close button</p>	<p><Memory Full> Cause: In receive, memory full.</p>	<p>FIP 1.171</p>
033-510	<p>Fax Codec Error 033-510 JBIG Compression error. Error in the number of decode lines. Job canceled. Please try again.</p> <p>*Caution screen with Close button</p>	<p><Fax Codec Error> Cause: In JBIG data decode, error in the number of decode line in one stripe.</p>	<p>FIP 1.172</p>

Status Code (3615)	LCD Display	Name/Description of Error	FIP
033-511	Fax Codec Error 033-511 No lines received for decode Job canceled. Remote device will try again. *Caution screen with Close button	<Fax Code Error > Cause: Result of MH,HR,MMR receive decode is 0Line.	FIP 1. 173
033-512	Fax Communication Error 033-512 Modem parameter error Job canceled. *Caution screen with Close button	<Fax Communication Error> Cause: Modem Parameter Exchange Error.	FIP 1. 174
033-513	Fax Communication Error 033-513 Communication stopped due to memory full Job canceled. Please try again later. *Caution screen with Close button	<Fax Communication Error> Cause: Communication shutdown due to memory full.	FIP 1. 175
033-515	Fax Codec Error 033-515 JPEG receive did not get proper multi- level data Job canceled. Remote device will try again. *Caution screen with Close button	<JBIG NF Error> Cause: In JPEG receive, cannot get color/monochrome multi-level data.	FIP 1. 176
033-517	Incorrect Password 033-517 Please confirm password Job canceled. *Caution screen with Close button	<DFAX Password Error> Cause: Mismatch between DFAX Password and Fax/Scan Lock Password.	FIP 1. 177

Status Code (3615)	LCD Display	Name/Description of Error	FIP
033-518	Fax Country is not Set 033-518 Please set Country code to correct region Job canceled. *Caution screen with Close button	<DFAX Fax Country is not set correctly> Cause: When DFAX job is executed, Fax Country code is Unknown.	FIP 1. 178
033-519	Fax Function is Disabled 033-519 Please confirm Fax is Enabled Job canceled. *Caution screen with Close button	<DFAX Fax Function is not available> Cause: When DFAX job is executed, Fax function is not Enabled. *When this error occurs at the same time as 033-518, 033-519 is displayed preferentially.	FIP 1. 179
033-520	Fax Codec Error 033-520 Callback returned error Job canceled. Please try again. *Caution screen with Close button	<JBF_ERROR_CALLBACK> Cause: Callback function returns error.	FIP 1. 180
033-521	Fax Codec Error 033-521 Detected Terminate Marker Job canceled. *Caution screen with Close button	<JBF_ERROR_MARKER_ABORT> Cause: Detect ABORT marker.	FIP 1. 181
033-522	Fax Codec Error 033-522 Invalid Marker detected Job canceled. *Caution screen with Close button	<JBF_ERROR_MARKER_UNKNOWN> Cause: Detect invalid marker.	FIP 1. 182
033-523	Fax Codec Error 033-523 Marker can not be found Job canceled. *Caution screen with Close button	<JBF_ERROR_MARKER_NOT_FOUND> Cause: Predetermined marker cannot be found.	FIP 1. 183

Status Code (3615)	LCD Display	Name/Description of Error	FIP
033-524	Fax Codec Error 033-524 Adaptive template incorrect Job canceled. *Caution screen with Close button	<JBF_ERROR_MARKER_BAD_ATMOVE > Cause: Adaptive template is moved incorrectly.	FIP 1.184
033-525	Fax Codec Error 033-525 Image height is incorrect Job canceled. *Caution screen with Close button	<JBF_ERROR_MARKER_BAD_NEWLEN > Cause: Image height is changed incorrectly.	FIP 1.185
033-526	Fax Codec Error 033-526 Data Error Job canceled. *Caution screen with Close button	<JBF_ERROR_BIH> Cause: BIH data error.	FIP 1.186
033-573	E-mail Sending Error 033-573 You do not have access to the destination domain. The transfer job has been canceled.	<E-mail Sending Error> Cause: Domain regulation check error. The domain which is not permitted was specified and address directions were performed.	FIP 1.187
033-751	Fax Communication Error 033-751 Fax Modem receive data overrun. Sender will retransmit as required. Job canceled. *Caution screen with Close button	<Over Run> Cause: Modem receive data overrun.	FIP 1.188

Status Code (3615)	LCD Display	Name/Description of Error	FIP
033-752	Fax Communication Error 033-752 Fax Recipient Line is Busy. Job canceled. Please try again. *Caution screen with Close button	<During Call Busy Tone> Cause: In Tel/Fax mode, detect busy tone while calling external phone.	FIP 1. 189
033-753	Fax Communication Error 033-753 CJ undetected to terminate the call menu. Job canceled. Please try again. *Caution screen with Close button	<CJ Not Detection> Cause: CJ undetected.	FIP 1. 190
033-754	Fax Communication Error 033-754 Fax V8 Communication Error Job canceled. Please try again. *Caution screen with Close button	<V8 Error> Cause: V8 error.	FIP 1. 191
033-755	Fax Communication Error 033-755 Phase 2 Communication Line Error. Job canceled. Please try again, if error persists check Fax line quality. *Caution screen with Close button	<Phase2 Error> Cause: Phase2(Line Probing) error.	FIP 1. 192
033-756	Fax Communication Error 033-756 Phase 3 Training Error Job canceled. Please try again. *Caution screen with Close button	<Phase3 Error> Cause: Phase3(Primary Channel Equalizer Training) error.	FIP 1. 193

Status Code (3615)	LCD Display	Name/Description of Error	FIP
033-757	Fax Communication Error 033-757 Primary Channel Synchronization Error Job canceled. Please try again. *Caution screen with Close button	<Primary Channel Synchronization Error> Cause: The Primary Channel Synchronization Error occurred.	FIP 1. 194
033-758	Fax Communication Error 033-758 Control Channel Synchronization Error Job canceled. Please try again. *Caution screen with Close button	<Control Channel Synchronization Error> Cause: The Control Channel Synchronization Error occurred.	FIP 1. 195
033-759	Fax Communication Error 033-759 Control Channel Retrain Error Job canceled. Please try again. *Caution screen with Close button	<Control Channel Retrain Error> Cause: Control channel retrain error.	FIP 1. 196
033-760	Fax Communication Error 033-760 Control Channel OFF Timeout Job canceled. Please try again. *Caution screen with Close button	<Control Channel OFF Time Out> Cause: The Control Channel OFF Time Out occurred.	FIP 1. 197
033-761	Fax Communication Error 033-761 Primary Channel OFF Timeout Job canceled. Please try again. *Caution screen with Close button	<Primary Channel OFF Time Out> Cause: The Primary Channel OFF Time Out occurred.	FIP 1. 198

Status Code (3615)	LCD Display	Name/Description of Error	FIP
033-762	Fax Communication Error 033-762 Invalid Fax command received Job canceled. *Caution screen with Close button	<DM Prevention Function Receive Refuse> Cause: DM prevention function rejects to receive data.	FIP 1.199
033-763	Fax Communication Error 033-763 Manual Fax transmission error Job canceled. Please re-load document and try again. *Caution screen with Close button	<Manual Transmission Read Manuscript Not Do> Cause: In manual send, cannot make document read on time.	FIP 1.200
033-764	Fax Communication Error 033-764 Fax Data error Job canceled. Please try again. *Caution screen with Close button	<Draw Data Create Not Do> Cause: When sending, cannot make image data creation on time.	FIP 1.201
033-765	Fax Codec Error 033-765 File Pointer Error Job canceled. Please restart device and try again. *Caution screen with Close button	<File Pointer Error> Cause: In encode/decode, Read/Write file pointer error.	FIP 1.202
033-766	Fax Codec Error 033-766 Target File Opening Job canceled. Please restart device and try again. *Caution screen with Close button	<Target File Opening> In decode, encoding target file open.	FIP 1.203

Status Code (3615)	LCD Display	Name/Description of Error	FIP
033-767	Fax Codec Error 033-767 MMR MN86064 Decode Error Job canceled. Please restart device and try again. *Caution screen with Close button	<MMR MN86064 Decode Error> Cause: In MMR decode, MN86064 decode error.	FIP 1. 204
033-768	Fax Codec Error 033-768 AT Move Counter Over Job canceled. Please restart device and try again. *Caution screen with Close button	<AT Move Counter Over> Cause: The number of AT Move is 5 or more in one stripe.	FIP 1. 205
033-769	Fax Codec Error 033-769 JBIG Compression error. NEWLEN marker not detected. Job canceled. Please try again. *Caution screen with Close button	<JBIG NEWLEN Marker Error> Cause: NEWLEN marker undetected.	FIP 1. 206
033-770	Fax Codec Error 033-770 JBIG Compression error. YD error detected in JBIG data decode. Job canceled. Please try again. *Caution screen with Close button	<YD Error> Cause: Detect YD error in JBIG data decode.	FIP 1. 207
033-771	Fax Codec Error 033-771 JBIG Compression error. Terminate marker error detected in JBIG data decode. Job canceled. Please try again. *Caution screen with Close button	<Abort Marker Error> Cause: Detect abort marker error in JBIG data decode.	FIP 1. 208

Status Code (3615)	LCD Display	Name/Description of Error	FIP
033-772	Fax Codec Error 033-772 JBIG Compression error. Undefined marker detected. Job canceled. Please try again. *Caution screen with Close button	<Undefined Marker Error> Cause: Detect undefined marker.	FIP 1. 209
033-773	Fax Codec Error 033-773 JBIG Compression error. BIH Error in JBIG data decode. Job canceled. Please try again. *Caution screen with Close button	<BIH Error> Cause: BIH error in JBIG data decode.	FIP 1. 210
033-774	Fax Codec Error 033-774 JBIG Compression error. FAX TX Encode Output Buffer exceeded. Job canceled. Please try again. *Caution screen with Close button	<FAX TX Encode Output Buffer Over> Cause: In FAX send, JBIG encode output buffer overflow.	FIP 1. 211
033-775	Fax Codec Error 033-775 JBIG Compression error. FAX RX Encode Output Buffer exceeded. Job canceled. *Caution screen with Close button	<FAX RX Encode Output Buffer Over> Cause: In FAX receive, JBIG encode output buffer overflow.	FIP 1. 212
033-776	Fax Codec Error 033-776 JBIG Compression error. SCAN Encode Output Buffer exceeded. Job canceled. Please try again. *Caution screen with Close button	<SCAN Encode Output Buffer Over> Cause: In FAX scan and D-FAX scan, JBIG encode output buffer overflow.	FIP 1. 213

Status Code (3615)	LCD Display	Name/Description of Error	FIP
033-777	Fax Codec Error 033-777 JBIG Compression error. FAX RX Decode Input Buffer exceeded. Job canceled. Please try again. *Caution screen with Close button	<FAX RX Decode Input Buffer Over> Cause: In FAX receive, when copying from ECM buffer to JBIG decode input buffer, input buffer overflow.	FIP 1.214
033-779	Fax Report Error 033-779 Log file creation error Job canceled. Please restart device and try again. *Caution screen with Close button	<Log File Create Fail> Cause: Cannot create log file of communication result.	FIP 1.215
033-782	Fax Communication Error 033-782 Incompatible NSS/DCS function received Job canceled. Please try again. *Caution screen with Close button	<NSS/DCS Function disagreement> Cause: Received NSS/DCS function disagrees with capability of own terminal.	FIP 1.216
033-784	Fax Codec Error 033-784 JBIG Compression error. JBIG decode output buffer exceeded. Job canceled. Please try again. *Caution screen with Close button	<Fax Codec Error> Cause: In FAX receive, JBIG decode output buffer overflow.	FIP 1.217
033-786	Fax Codec Error 033-786 JBIG Compression error. The number of decode lines do not match the number of BIH lines. Job canceled. Please try again. *Caution screen with Close button	<Fax Codec Error> Cause: In JBIG data decode, discrepancy between the number of decode line and the number of BIH line.	FIP 1.218

Status Code (3615)	LCD Display	Name/Description of Error	FIP
033-787	Fax Memory Error 033-787 Maximum number of pending fax jobs has been exceeded. Job canceled. *Caution screen with Close button	<Fax Memory Error> Cause: Calling table full.	FIP 1.219
033-788	Fax Memory Full 033-788 Job canceled. *Caution screen with Close button	<Fax Memory Full> Cause: Flash full. (for DFAX)	FIP 1.220
033-789	Fax Job Canceled 033-789 *Caution screen with Close button	<Fax Job Canceled> Cause: Cancel.	FIP 1.221
033-790	Fax Job Canceled 033-790 *Caution screen with Close button	<Fax Job Canceled> Cause: Cancel.	FIP 1.221
033-791	Fax Job Canceled 033-791 *Caution screen with Close button	<Fax Job Canceled> Cause: Cancel.	FIP 1.221
033-795	Fax Send Error 033-795 Maximum number of send pages has been exceeded. Job canceled. Please wait then try again. *Caution screen with Close button	<FAX Send Count Limit> Cause: Reach the upper limit of Fax send accumulation pages.	FIP 1.222

Status Code (3615)	LCD Display	Name/Description of Error	FIP
033-799	Fax Codec Error 033-799 Maximum number of received lines for one page exceeded. Job canceled. Remote device will try again. *Caution screen with Close button	<Fax Codec Error> Cause: In MH,HR,MMR receive, exceed the maximum number of received lines for 1 page.	FIP 1. 223
034-508	Fax Communication Error 034-508 Refused command signal sent Job canceled. Please try again. *Caution screen with Close button	<Command Refuse Signal Send> Cause: Send command refuse signal to stop communication. The sender discontinued the communication.	FIP 1. 224
034-515	Fax Communication Error 034-515 Digital identification signal or Digital command signal had illegal command. Job canceled. Remote device will try again. *Caution screen with Close button	<DIS DCS Illegal Command Receive> Cause: Receive illegal command such as DIS, DCS receive from calling terminal in spite of having no ability to receive.	FIP 1. 225
034-791	No Answer 034-791 Check Line Connection. Please disconnect and reconnect fax line to insure proper connection. Job canceled. *Caution screen with Close button	<Check Line Connection> Cause: The Telephone Line Connection Error.	FIP 1. 226
034-799	Fax Number Error 034-799 No dial Data, please confirm and enter fax number or try again. Job canceled. *Caution screen with Close button	<No Dial Data> Cause: Auto dial is activated but no dial data exist.	FIP 1. 227

Status Code (3615)	LCD Display	Name/Description of Error	FIP
035-701	<p>Target Fax is Not Answering 035-701 T1 time out, no response detected from remote device. Job canceled. Confirm fax number and contact receiving party if issue persists.</p> <p>*Caution screen with Close button</p>	<p><Send T1 Time Out> Cause: In send, T1 timeout.</p>	<p>FIP 1. 228</p>
035-702	<p>Fax Communication Error 035-702 Disconnect signal received from remote device. Job canceled. Remote device will try again.</p> <p>*Caution screen with Close button</p>	<p><Receive DCN> Cause: DCN receive.</p>	<p>FIP 1. 229</p>
035-704	<p>Fax Communication Error 035-704 Please check remote device if error persists. Job canceled.</p> <p>*Caution screen with Close button</p>	<p><Not Send Ability> Cause: Remote device has no ability to send.</p>	<p>FIP 1. 230</p>
035-705	<p>Fax Communication Error 035-705 Digital Command Signal/Non-standard Setup error. Job canceled. Please try again.</p> <p>*Caution screen with Close button</p>	<p><DCS/NSS Resend Over> Cause: DCS/NSS resend over.</p>	<p>FIP 1. 231</p>

Status Code (3615)	LCD Display	Name/Description of Error	FIP
035-706	Fax Communication Error 035-706 Failure to negotiate fall back. Job canceled. Please try again. *Caution screen with Close button	<Fall Back Error> Cause: Fall back error.	FIP 1. 232
035-708	Fax Communication Error 035-708 Post message response Error. Job canceled. Please try again. *Caution screen with Close button	<Post Message Resend Over> Cause: Post message resend over.	FIP 1. 233
035-709	Fax Communication Error 035-709 Retrain error received Job canceled. Please try again. *Caution screen with Close button	<G3 Send RTN/PIN Receive> Cause: In G3 send, receive RTN/PIN.	FIP 1. 234
035-710	Fax Communication Error 035-710 Procedural interrupt negative received Job canceled. Please try again. *Caution screen with Close button	<Receive PIN> Cause: PIN receive (excl. EOR).	FIP 1. 235
035-716	Fax Communication Error 035-716 T2 time out - Timing between commands exceeded 6 seconds Job canceled. Please try again. *Caution screen with Close button	<T2 Time Out> Cause: T2 timeout.	FIP 1. 236

Status Code (3615)	LCD Display	Name/Description of Error	FIP
035-717	Fax Communication Error 035-717 Retrain signal sent Job canceled. Sender will try again. *Caution screen with Close button	<G3 Receive RTN Send> Cause: In G3 receive, send RTN.	FIP 1. 237
035-718	Target Fax is Not Answering 035-718 T1 timeout, no response from sender received. Job canceled. Remote device will try again. *Caution screen with Close button	<Receive T1 Time Out> Cause: In receive, T1 timeout.	FIP 1. 238
035-720	Fax Communication Error 035-720 Remote device unable to receive. Job canceled. Please try again later. Remote device may be full. *Caution screen with Close button	<Not Receive Ability> Cause: Remote device has no ability to receive.	FIP 1. 239
035-728	Fax Communication Error 035-728 No end of line signal received within 13 seconds. Job canceled. Sender will try again. *Caution screen with Close button	<G3 EOL Not Receive> Cause: In G3 image data receive, cannot receive EOL for 13 sec (default).	FIP 1. 240

Status Code (3615)	LCD Display	Name/Description of Error	FIP
035-729	Fax Communication Error 035-729 Job canceled. *Caution screen with Close button	<Career Cut> Cause: Career cut.	FIP 1. 241
035-730	Fax Communication Error 035-730 High speed training error. Job canceled. Please try again. *Caution screen with Close button	<RS Request CS NOT ON> Cause: In high-speed training, modem CS does not become ON against RS request.	FIP 1. 242
035-737	Fax Communication Error 035-737 Continue to correct / End of transmission resend over. Job canceled. Please try again. *Caution screen with Close button	<CTC/EOR Resend Over> Cause: CTC/EOR resend over.	FIP 1. 243
035-739	Fax Communication Error 035-739 T5 Time out for Error Correction Mode exceeded. Job canceled. Please try again. *Caution screen with Close button	<T5 Time Out> Cause: T5 timeout.	FIP 1. 244
035-740	Fax Communication Error 035-740 End of retransmission ECM error Job canceled. Please try again. *Caution screen with Close button	<ECM Send EOR-Q Send> Cause: IN ECM send, send EOR-Q.	FIP 1. 245

Status Code (3615)	LCD Display	Name/Description of Error	FIP
035-742	Fax Communication Error 035-742 Received ECM error Job canceled. Remote device will try again. *Caution screen with Close button	<ECM Receive EOR-Q Receive> Cause: IN ECM receive, receive EOR-Q.	FIP 1. 246
035-746	No Dial Tone 035-746 Please check that fax line is connected and working Job canceled. *Caution screen with Close button	<Before Dial Tone> Cause: Cannot detect dial tone before dialing.	FIP 1. 247
035-779	Fax Communication Error 035-779 Fax forward document error Job canceled. *Caution screen with Close button	<FAX FWD document change error> Cause: FAX forward document change error.	FIP 1. 248
035-781	Target Fax Busy 035-781 Busy tone detected Job canceled. *Caution screen with Close button	<Target Fax Busy> Cause: Detect busy tone after dialing.	FIP 1. 249
035-792	Fax Communication Error 035-792 Joint Menu signal not Detected Job canceled. Please try again. *Caution screen with Close button	<JM Not Detection> Cause: JM undetected.	FIP 1. 250

Status Code (3615)	LCD Display	Name/Description of Error	FIP
035-793	Fax Communication Error 035-793 Digital line detected, an analog line is required Job canceled. Please confirm fax line is Analog and not Digital. If error persists, contact phone provider. *Caution screen with Close button	<Digital Line Detection> Cause: Connected to digital line and cannot connect. (Detect when connecting to line.)	FIP 1. 251
041-340	Engine NVRAM Error 041-340 Power Off/On the Printer. If this failure occurs again, please contact customer support. Code:xxxxxxxxh	<IOT NVRAM Error> Cause: The operation error of NVM (read/write check error etc.) is detected.	FIP 1. 252
041-347	Engine Controller Error 041-347 Power Off/On the Printer. If this failure occurs again, please contact customer support.	<IOT I/F Failure> Cause: MCU Internal Error (I/F part).	FIP 1. 253
042-313	Fan Motor Error 042-313 Power Off/On the Printer. If this failure occurs again, please contact customer support.	<LVPS Fan Motor Failure> Cause: MCU detects an error upon receiving error signal from the LVPS Fan.	FIP 1. 254
042-330	IOT Start Error 042-330 Power Off/On the Printer. Contact customer support if this failure is repeated.	<Rear Fan Failure> Cause: MCU detects an error upon receiving error signal from the Rear Fan.	FIP 1. 255
042-700	Printer Error 042-700 Power Off/On the Printer. If this failure occurs again, please contact customer support.	<IOT Over Heat Stop> Cause: The temp. Sensor sensed high temperature.	FIP 1. 256

Status Code (3615)	LCD Display	Name/Description of Error	FIP
050-130	<p>Paper Jam 050-130</p> <p>Open the Rear Door and remove any jammed paper.</p>	<p><IOT Remain Zone Fusing Jam></p> <p>Cause:</p> <p>When Dynamic Jam (cause) was detected:</p> <ul style="list-style-type: none"> • 077-104 Regi Off Jam • 077-106 Exit On Jam • 077-108 Exit Off Early Jam • 077-109 Exit Off Jam <p>When Static Jam (collateral) was detected:</p> <ul style="list-style-type: none"> • Exit Sensor On 	<p>FIP 1. 257</p>
050-131	<p>Paper Jam 050-131</p> <p>Open the Rear Door and remove any jammed paper.</p>	<p><IOT Remain Zone Duplex Jam></p> <p>Cause:</p> <p>When Dynamic Jam (cause) was detected:</p> <ul style="list-style-type: none"> • 077-107 Duplex Regi On Jam 	<p>FIP 1. 258</p>
050-132	<p>Paper Jam 050-132</p> <p>1. Pull out Bypass Tray, Tray1 and Tray2, and remove any jammed paper.</p> <p>2. If the jammed paper cannot be removed, open the Rear Door to remove it.</p>	<p><IOT Remain Zone Regi + MSI + T1 + T2 Jam></p> <p>Cause:</p> <p>When Dynamic Jam (cause) was detected:</p> <ul style="list-style-type: none"> • 077-106 Exit On Jam <p>When Static Jam (collateral) was detected:</p> <ul style="list-style-type: none"> • Regi Sensor On 	<p>FIP 1. 259</p>
050-134	<p>Paper Jam 050-134</p> <p>1. Pull out Bypass Tray and Tray1, and remove any jammed paper.</p> <p>2. Insert Bypass Tray and Tray1, and press Start.</p>	<p><IOT Zone MSI+T1 Jam></p> <p>Cause:</p> <p>When Dynamic Jam (cause) was detected:</p> <ul style="list-style-type: none"> • 071-100 IOT Tray1 Misfeed Jam • 075-100 MSI Misfeed Jam 	<p>FIP 1. 260</p>

Status Code (3615)	LCD Display	Name/Description of Error	FIP
050-135	<p>Paper Jam 050-135</p> <ol style="list-style-type: none"> 1. Pull out Tray4, and remove any jammed paper. 2. If the jammed paper cannot be removed, open the Back of Tray to remove it. 3. Insert Tray4 and press Start. 	<p><IOT Zone T2 + T3 + T4 + TR2 + TR3 Jam></p> <p>Cause:</p> <p>When Dynamic Jam (cause) was detected:</p> <ul style="list-style-type: none"> • 073-101 IOT Path3 SNS On Jam <p>When Static Jam (collateral) was detected:</p> <ul style="list-style-type: none"> • Tray2 Path Sensor On, Tray3 Path Sensor On, and Tray4 Path Sensor On 	<p>FIP 1. 261</p>
050-136	<p>Paper Jam 050-136</p> <ol style="list-style-type: none"> 1. Pull out Tray3 and Tray4, and remove any jammed paper. 2. If the jammed paper cannot be removed, open the Back of Tray3 to remove it. 3. Insert Tray3 and Tray4, and press Start. 	<p><IOT Zone T3 + T4 + TR3 Jam></p> <p>Cause:</p> <p>When Dynamic Jam (cause) was detected:</p> <ul style="list-style-type: none"> • 072-101 IOT Path2 SNS On Jam <p>When Static Jam (collateral) was detected:</p> <ul style="list-style-type: none"> • Tray3 Path Sensor On 	<p>FIP 1. 262</p>
050-137	<p>Paper Jam 050-137</p> <ol style="list-style-type: none"> 1. Pull out Tray3, and remove any jammed paper. 2. If the jammed paper cannot be removed, open the Back of Tray to remove it. 3. Insert Tray3 and press Start. 	<p><IOT Zone T2 + T3 + TR2 + TR3 Jam></p> <p>Cause:</p> <p>When Dynamic Jam (cause) was detected:</p> <ul style="list-style-type: none"> • 072-102 IOT Option Regi On Jam <p>When Static Jam (collateral) was detected:</p> <ul style="list-style-type: none"> • Tray2 Path Sensor On and Tray3 Path Sensor On 	<p>FIP 1. 263</p>
050-138	<p>Paper Jam 050-138</p> <ol style="list-style-type: none"> 1. Pull out Tray3, and remove any jammed paper. 2. If the jammed paper cannot be removed, open the Back of Tray to remove it. 3. Insert Tray3 and press Start. 	<p><IOT Zone T3 + TR2 + TR3 Jam></p> <p>Cause:</p> <p>When Dynamic Jam (cause) was detected:</p> <ul style="list-style-type: none"> • 072-102 IOT Option Regi On Jam <p>When Static Jam (collateral) was detected:</p> <ul style="list-style-type: none"> • Tray3 Path Sensor On 	<p>FIP 1. 264</p>

Status Code (3615)	LCD Display	Name/Description of Error	FIP
050-139	<p>Paper Jam 050-139</p> <ol style="list-style-type: none"> 1. Pull out Tray2, and remove any jammed paper. 2. If the jammed paper cannot be removed, open the Back of Tray2 to remove it. 3. Insert Tray2 and press Start. 	<p><IOT Zone T2 + TR2 Jam> Cause: When Dynamic Jam (cause) was detected:</p> <ul style="list-style-type: none"> • 072-100 IOT Tray2 Misfeed Jam <p>When Static Jam (collateral) was detected:</p> <ul style="list-style-type: none"> • Tray2 Path Sensor On 	<p>FIP 1.265</p>
050-140	<p>Paper Jam 050-140</p> <ol style="list-style-type: none"> 1. Pull out Tray3, and remove any jammed paper. 2. If the jammed paper cannot be removed, open the Back of Tray2 to remove it. 3. Insert Tray3 and press Start. 	<p><IOT Zone T3 + TR2 Jam> Cause: When Dynamic Jam (cause) was detected:</p> <ul style="list-style-type: none"> • 073-100 IOT Tray3 Misfeed Jam 	<p>FIP 1.266</p>
050-141	<p>Paper Jam 050-141</p> <ol style="list-style-type: none"> 1. Pull out Tray4, and remove any jammed paper. 2. If the jammed paper cannot be removed, open the Back of Tray3 to remove it. 3. Insert Tray4 and press Start. 	<p><IOT Zone T4 + TR3 Jam> Cause: When Dynamic Jam (cause) was detected:</p> <ul style="list-style-type: none"> • 074-100 IOT Tray4 Misfeed Jam <p>When Static Jam (collateral) was detected:</p> <ul style="list-style-type: none"> • Tray4 Path Sensor On 	<p>FIP 1.267</p>
050-142	<p>Paper Jam 050-142</p> <p>Pull out Bypass Tray and Tray1. Open Rear Door and remove any jammed paper.</p>	<p><IOT Remain Zone Regi + MSI + T1 Jam> Cause: When Dynamic Jam (cause) was detected:</p> <ul style="list-style-type: none"> • 077-106 Exit On Jam <p>When Static Jam (collateral) was detected:</p> <ul style="list-style-type: none"> • Regi. Sensor On 	<p>FIP 1.268</p>
061-370	<p>ROS Assembly Error 061-370</p> <p>Power Off/On the Printer.</p> <p>If this failure occurs again, please contact customer support.</p> <p>Code:xxxxxxxxh</p>	<p><IOT ROS Failure> Cause: The operation error of ROS (rotational error etc.) is detected.</p>	<p>FIP 1.269</p>

Status Code (3615)	LCD Display	Name/Description of Error	FIP
062-277	Scanner Error 062-277 Power Off/On the Printer. If this failure occurs again, please contact customer support.	<Scanner Error> Cause: IIT internal communication error.	FIP 1.270
062-311	Scanner Error 062-311 Power Off/On the Printer. If this failure occurs again, please contact customer support.	<Scanner Error> Cause: IIT failure initialization error.	FIP 1.270
062-316	Scanner Error 062-316 Power Off/On the Printer. If this failure occurs again, please contact customer support.	<DADF Motor Fail> Cause: Detect DADF Motor Fail.	FIP 1.271
062-317	Scanner Error 062-317 Power Off/On the Printer. If this failure occurs again, please contact customer support.	<IIT Video overrun> Cause: Interference buffer full was detected at the time of DADF scan.	FIP 1.270
062-318	Scanner Error 062-318 Power Off/On the Printer. If this failure occurs again, please contact customer support.	<IIT scan timing error> Cause: A Scan setup did not meet the deadline into Page Gap.	FIP 1.270
062-319	Scanner Error 062-319 Power Off/On the Printer. If this failure occurs again, please contact customer support.	<PLL lock timeout error> Cause: A PLL lock was not carried out before 1stScan start, but the lock has separated during continuation.	FIP 1.270
062-320	Scanner Error 062-320 Power Off/On the Printer. If this failure occurs again, please contact customer support.	<Scanner Error> Cause: Scanning error.	FIP 1.270

Status Code (3615)	LCD Display	Name/Description of Error	FIP
062-321	Scanner Error 062-321 Power Off/On the Printer. If this failure occurs again, please contact customer support.	<Scanner Error> Cause: Unexecutable error. (carriage is at the locked position, etc.)	FIP 1. 270
062-322	Scanner Error 062-322 Power Off/On the Printer. If this failure occurs again, please contact customer support.	<Scanner Error> Cause: Parameter error.	FIP 1. 270
062-360	Scanner Home Position Sensor Error 062-360 Power Off/On the Printer. If this failure occurs again, please contact customer support.	<HP Sensor Error> Cause: Carriage home position error.	FIP 1. 270
062-371	Scanner Lamp Error 062-371 Power Off/On the Printer. If this failure occurs again, please contact customer support.	<Scanner Lamp Error> Cause: IIT failure Lamp error.	FIP 1. 270
062-393	Scanner Error 062-393 Power Off/On the Printer. If this failure occurs again, please contact customer support.	<CCD ASIC Error> Cause: CCD ASIC communication error.	FIP 1. 270
062-790	Copy Limit Error 062-790 Last sheet not copied. *Caution screen with Close button	<Copy Limit> Cause: Copy limit.	FIP 1. 272
071-100	-	<IOT Tray1 Misfeed Jam> Cause: After the Tray 1 Feed Clutch turned ON, the Regi. Sensor did not turn ON within the specified time.	FIP 1. 273

Status Code (3615)	LCD Display	Name/Description of Error	FIP
071-920	-	<Waiting to Print Side 2 Load Printed Pages into the NNN> Cause: Waiting for side 2 to be set for manual duplex print (Tray).	FIP 1. 274
071-921	-	<Manual Duplex Print> Cause: Waiting for Set key to be pressed after setting side 2 for manual duplex print (Tray).	FIP 1. 275
072-100	-	<IOT Tray2 Misfeed Jam> Cause: After the Tray 2 Feed Clutch turned ON, the Tray 2 Path Sensor did not turn ON within the specified time.	FIP 1. 276
072-101	-	<IOT Path 2 SNS On Jam> Cause: The Tray 2 Path Sensor did not turn ON within the specified time after the Tray 3 Path Sensor turned ON.	FIP 1. 277
072-102	-	<IOT Option Regi On Jam> Cause: After the Tray 2 Path Sensor turned ON, the Regi. Sensor did not turn ON within the specified time.	FIP 1. 278
072-211	Tray 2 Error 072-211 Power Off/On the Printer. If this failure occurs again, please contact customer support. Code:xxxxxxxxh	<Feeder 2 Error> Cause: IOT Option Feeder2 Failure.	FIP 1. 279
073-100	-	<IOT Tray 3 Misfeed Jam> Cause: After the Tray 3 Feed Clutch turned ON, the Tray 3 Path Sensor did not turn ON within the specified time.	FIP 1. 276

Status Code (3615)	LCD Display	Name/Description of Error	FIP
073-101	-	<p><IOT Path 3 SNS On Jam> Cause: The Tray 3 Path Sensor did not turn ON within the specified time after the Tray 4 Path Sensor turned ON.</p>	<p>FIP 1. 277</p>
073-211	<p>Tray3 Error 073-211 Power Off/On the Printer. If this failure occurs again, please contact customer support. Code:xxxxxxxxh</p>	<p><Feeder 3 Error> Cause: IOT Option Feeder3 Failure.</p>	<p>FIP 1. 280</p>
074-100	-	<p><IOT Tray 4 Misfeed Jam> Cause: After the Tray 4 Feed Clutch turned ON, the Tray 4 Path Sensor did not turn ON within the specified time.</p>	<p>FIP 1. 276</p>
074-211	<p>Tray4 Error 074-211 Power Off/On the Printer. Contact customer support if this failure is repeated.</p>	<p><Feeder 4 Error> Cause: IOT Option Feeder4 Failure.</p>	<p>FIP 1. 280</p>
075-100	-	<p><MSI Misfeed Jam> Cause: After the MSI Feed Solenoid turned ON, the Regi. Sensor did not turn ON within the specified time.</p>	<p>FIP 1. 281</p>
077-101	-	<p><VSYNC ON Jam> Cause: Detect VSYNC ON Jam.</p>	<p>FIP 1. 282</p>
077-104	-	<p><Regi. Off Jam> Cause: The Regi Sensor does not turn OFF within the specified time after the Regi Clutch turned On.</p>	<p>FIP 1. 283</p>
077-106	-	<p><Exit On Jam> Cause: The Exit Sensor does not turn ON within the specified time after the Regi Clutch turned On.</p>	<p>FIP 1. 284</p>

Status Code (3615)	LCD Display	Name/Description of Error	FIP
077-107	-	<Duplex Regi On Jam> Cause: After the Invert Clutch turned ON, the Regi. Sensor did not turn ON within the specified time.	FIP 1. 284
077-108	-	<Exit Off early Jam> Cause: After the Exit Sensor turned ON, the Exit Sensor turned OFF before the specified time.	FIP 1. 284
077-109	-	<Exit Off Jam> Cause: After the Regi. Sensor turned OFF, the Exit Sensor did not turn OFF within the specified time.	FIP 1. 284
077-215	Duplex Unit Error Reseat Duplex Unit and Power Off/On the Printer. If this failure occurs again, please contact customer support.	<IOT Duplexer Error> Cause: Duplex Unit Configuration error is detected.	FIP 1. 285
077-217	Duplexer Error Power Off/On the Printer. If this failure occurs again, please contact customer support.	<Duplex Miss Configuration> Cause: Duplex Unit Configuration error is detected.	FIP 1. 285
077-300	Front Cover Open Close Front Cover.	<IOT Cover Front Open> Cause: Beep sounds after Front Cover remains open for 3 minutes.	FIP 1. 286
077-304	Rear Door Open Close Rear Door.	<IOT Cover Rear Open> Cause: The Rear Cover is open.	FIP 1. 287
077-312	Tray Configuration Error Power Off/On the Printer. If this failure occurs again, please contact customer support. Code:xxxxxxxh	<Tray Configure Error> Cause: Tray configuration error was detected. (including all of the wrong configurations)	FIP 1. 288

Status Code (3615)	LCD Display	Name/Description of Error	FIP
091-914	Drum Cartridge Error 091-914 Open the Front Cover. Then reseal Drum Cartridge or replace the Drum Cartridge.	<IOT Drum Communication Fail> Cause: Communication failure with Drum CRUM was detected.	FIP 1. 290
091-915	Drum Cartridge Error 091-915 Open the Front Cover. Then reseal the Drum Cartridge or replace the Drum Cartridge.	<Drum CRUM Data Broken Fail> Cause: Malfunction of Drum CRUM was detected.	FIP 1. 290
091-921	Drum Cartridge Missing 091-921 Open the Front Cover. Then insert the Drum Cartridge.	<IOT Drum Detached> Cause: It was detected that the Drum CRUM is not at the specified position. (Loose CRUM)	FIP 1. 290
091-953	Drum Cartridge Seal Tape Error 091-953 Remove Seal Tape from the Drum Cartridge.	<Drum Tape Staying> Cause: The remaining Tape of the Drum Cartridge was detected.	FIP 1. 291
091-963	Invalid Drum Cartridge 091-963 Open the Front Cover. Then reseal/replace the Drum Cartridge.	<IOT Drum CRUM ID Error> Cause: The Drum CRUM ID error was detected.	FIP 1. 290
092-315	ATC Sensor Error 092-315 Power Off/On the Printer. Contact customer support if this failure is repeated. Code:xxxxxxxh	<ATC Fail> Cause: The ATC Sensor error was detected.	FIP 1. 292
092-661	Temperature/Humidity Sensor Error 092-661 Power Off/On the Printer. If this failure occurs again, please contact customer support.	<IOT Environment Sensor Error> Cause: The Temp. Sensor or the Humidity Sensor error was detected.	FIP 1. 256
093-426	XXXXXXXXXXXXXXXXXX Toner Low	<Toner Near Life> Cause: It was detected that the Toner Cartridge needed to be replaced soon.	FIP 1. 293

Status Code (3615)	LCD Display	Name/Description of Error	FIP
093-922	Low Toner Density 093-922 Remove Toner, Shake Cartridge and Reinstall.	<Toner Low Density> Cause: Low concentration of the Toner was detected.	FIP 1. 294
093-925	Toner Chip Error 093-925 Open the Front Cover. Then reseal/replace the Cartridge.	<Toner CRUM Error> Cause: The Toner CRUM error was detected.	FIP 1. 295
093-926	Invalid Toner Cartridge 093-926 Open the Front Cover. Then reseal/replace the Toner Cartridge.	<Toner CRUM ID Error> Cause: The Toner CRUM ID error was detected.	FIP 1. 295
093-928	Toner Type Error 093-928 Open the Front Cover. Then reseal/replace the Cartridge.	<Toner Type Error> Cause: The Toner Type Error was detected.	FIP 1. 295
093-933	Toner Empty 093-933 Open the Front Cover. Then replace the Toner Cartridge.	<Toner Life Over> Cause: It was detected that the Toner Cartridge needed to be replaced soon.	FIP 1. 296
093-973	Toner Cartridge Missing 093-973 Open the Front Cover. Then insert the Toner Cartridge.	<Toner Detached> Cause: It was detected that the Toner CRUM is not at the specified position. (Loose CRUM)	FIP 1. 295
116-210	USB Host Error 116-210 Power Off/On the Printer. If this failure occurs again, please contact customer support.	<USB Host Error> Cause: Fatal error of USB Host driver.	FIP 1. 297
116-312	Device Memory Error 116-312 Power Off/On the Printer. If this failure occurs again, please contact customer support.	<Encryption Key Error> Cause: Encryption key mismatch.	FIP 1. 298

Status Code (3615)	LCD Display	Name/Description of Error	FIP
116-313	Device Memory Error 116-313 Power Off/On the Printer. If this failure occurs again, please contact customer support.	<Encryption Setting Error> Cause: Encryption setting mismatch.	FIP 1. 298
116-314	MAC Address Error Power Off/On the Printer. If this failure occurs again, please contact customer support.	<MAC Address Error> Cause: On Board Network MAC Address Checksum Error.	FIP 1. 299
116-315	Controller Memory RAM Error Power Off/On the Printer. If this failure occurs again, please contact customer support.	<ESS On Board RAM W/R Check Fail> Cause: Detected by On Board RAM W/R Check at the time of initialization.	FIP 1. 300
116-317	Controller ROM Error Power Off/On the Printer. If this failure occurs again, please contact customer support.	<ESS ROM Check (Main) Fail> Cause: Main Program ROM checksum error.	FIP 1. 302
116-323	Controller NVRAM Error Power Off/On the Printer. If this failure occurs again, please contact customer support.	<ESS NVRAM1 W/R Check Fail> Cause: Detected by master NVRAM W/R check.	FIP 1. 303
116-324	Controller Error Power Off/On the Printer. If this failure occurs again, please contact customer support.	<ESS Illegal Exception> Cause: CPU illegal exception.	FIP 1. 303
116-326	Controller NVRAM Error Power Off/On the Printer. If this failure occurs again, please contact customer support.	ESS NVRAM2 W/R Check Fail Cause: Detected by master NVRAM W/R check.	FIP 1. 304

Status Code (3615)	LCD Display	Name/Description of Error	FIP
116-327	Controller Error Power Off/On the Printer. If this failure occurs again, please contact customer support.	<ESS Instruction Cache Error> Cause: CPU instruction cache error.	FIP 1. 305
116-328	Controller Error Power Off/On the Printer. If this failure occurs again, please contact customer support.	<ESS Data Cache Error> Cause: CPU data cache error.	FIP 1. 306
116-343	Controller ASIC Error 116-343 Power Off/On the Printer. If this failure occurs again, please contact customer support.	<ASIC Fail> Cause: ASIC-related Fatal Error.	FIP 1. 307
116-350	Network Error 116-350 Power Off/On the Printer. If this failure occurs again, please contact customer support.	<On Board Network Communication Fail> Cause: Communication fail between 1 CPU network and ESS F/W.	FIP 1. 308
116-351	Network Error 116-351 Power Off/On the Printer. If this failure occurs again, please contact customer support.	<Network Error> Cause: On Board Network Ethernet BIST parity/RAM R/W Error.	FIP 1. 309
116-352	Network Error 116-352 Power Off/On the Printer. If this failure occurs again, please contact customer support.	<Network Error> Cause: On Board Network Internal Loop back Error.	FIP 1. 309
116-353	Device Memory Error 116-353 Power Off/On the Printer. If this failure occurs again, please contact customer support.	<ESS SD CARD Fail> Cause: Detect SD CARD Error.	FIP 1. 310

Status Code (3615)	LCD Display	Name/Description of Error	FIP
116-355	Network Error 116-355 Power Off/On the Printer. If this failure occurs again, please contact customer support.	<Network Error> Cause: On Board Network Fatal Error.	FIP 1. 309
116-356	Device Memory Error 116-356 Power Off/On the Printer. If this failure occurs again, please contact customer support.	<SD CARD Overwrite Error> Cause: Error has occurred during SD CARD overwrite.	FIP 1. 310
116-361	Controller PCI Error 116-361 Power Off/On the Printer. If this failure occurs again, please contact customer support.	<PCI Bus #0 Error Detected> Cause: PCI Bus #0 Uncorrectable Error Detected. (Connected with Remora EX(x4 port))	FIP 1. 311
116-362	Controller PCI Error 116-362 Power Off/On the Printer. If this failure occurs again, please contact customer support.	<PCI Bus #0 Host Bridge Controller Error> Cause: PCI Bus #0 Host Bridge Controller Error. (Connected with Remora EX port)	FIP 1. 312
116-363	Controller PCI Error 116-363 Power Off/On the Printer. If this failure occurs again, please contact customer support.	<PCI Bus #1 Host Bridge Controller Error> Cause: PCI Bus #1 Host Bridge Controller Error. (Connected with Remora EX port.)	FIP 1. 313
116-364	Controller Clock Error 116-364 Power Off/On the Printer. If this failure occurs again, please contact customer support.	<Timer Fail> Cause: Timer error is detected.	FIP 1. 314
116-366	Controller PCI Error 116-366 Power Off/On the Printer. If this failure occurs again, please contact customer support.	<PCI Bus #1 Error Detected> Cause: PCI Bus #1 Uncorrectable Error Detected. (Connected with RemoraEX(x1 port))	FIP 1. 315

Status Code (3615)	LCD Display	Name/Description of Error	FIP
116-368	Controller PCI Error 116-368 Power Off/On the Printer. If this failure occurs again, please contact customer support.	<PCI Error Messages received from Bus #0 - Device #1> Cause: Remora EX PCI x1 port Error. (Device ID 0x65 (x1))	FIP 1. 316
116-369	Controller PCI Error 116-369 Power Off/On the Printer. If this failure occurs again, please contact customer support.	<PCI Error Messages received from Bus #0 - Device #0> Cause: Remora EX PCI x4 port Error. (Device ID 0x64 (x4))	FIP 1. 317
116-390	Controller NVRAM Error 116-390 Power Off/On the Printer. If this failure occurs again, please contact customer support.	<ESS NVRAM1 SIZE And ID Check Fail> Cause: Detected by consistency check between NVRAM size requested by the system and actual size and consistency check of ID recorded at the first power-on.	FIP 1. 318
116-396	Network Error 116-396 Power Off/On the Printer. If this failure occurs again, please contact customer support.	<Fatal Error Related to Maillib Other Errors (of File 2 Net Library)> Cause: S/W bug.	FIP 1. 319
116-719	-	<XPIF Parameter Cancelled> Cause: Due to conflict among multiple print instructions, print instructions are ignored.	FIP 1. 320
116-721	Memory Full 116-721 Job too large to Collate. Job canceled. *Caution screen with Close button	<Collate Full> Cause: Unable to collate due to insufficient memory.	FIP 1. 321

Status Code (3615)	LCD Display	Name/Description of Error	FIP
116-722	WSD Scan Destination Error 116-722 Job canceled. Check Destination PC and Restart Scan Job. *Caution screen with Close button	<WSD (Web Services on Device) Scan destination error> Cause: The scan job cannot be executed on the device-driven Web Services on Device Scan, because the destination PC has been stopped.	FIP 1.322
116-987	Scanner Error 116-987 Power Off/On the Printer. If this failure occurs again, please contact customer support.	<Fatal Error Related to Format Library> Cause: S/W bug.	FIP 1.323
117-315	Fax EEPROM Error 117-315 Power Off/On the Printer. If this failure occurs again, please contact customer support.	<EEPROM Driver Error> Cause: EEPROM Driver program error.	FIP 1.324
117-321	Device Memory Error 117-321 A faulty Device Memory has been detected. Power Off/On the Printer.	<Device Memory Error > Cause: SD CARD Type Invalid.	FIP 1.327
117-331	Controller Error 117-331 Restart the printer. Contact customer support if this failure is repeated.	<IPS Error> Cause: In relation to IPS, the following internal error has occurred. <ul style="list-style-type: none"> • -OS function return value error • -DSP program load fail 	FIP 1.326
117-338	XXXXXXXXXXXXXXXXXXXX To enable Device Memory, power off/on the printer.	<Enable Device Memory Error > Cause: Invalid, although SD CARD was detected.	FIP 1.327
117-340	Fax Controller Error 117-340 Power Off/On the Printer. If this failure occurs again, please contact customer support.	<Controller Error> Cause: HOOK task error.	FIP 1.328

Status Code (3615)	LCD Display	Name/Description of Error	FIP
117-344	Fax Error 117-344 Power Off/On the Printer. If this failure occurs again, please contact customer support.	<Fax Error> Cause: FLASHFILE task error.	FIP 1. 329
117-350	Fax Controller Error 117-350 Power Off/On the Printer. If this failure occurs again, please contact customer support.	<Controller Error> Cause: Task initialization (start) error.	FIP 1. 330
117-361	Scanner Parameter Error 117-361 Power Off/On the Printer. If this failure occurs again, please contact customer support.	<IIT Parameter Verify NG> Cause: IIT registration adjustment value verification NG. (Checked only at production process)	FIP 1. 331
117-362	Fax EEPROM Error 117-362 Power Off/On the Printer. If this failure occurs again, please contact customer support.	<EEPROM Sum Check Error> Cause: EEPROM sum check value error.	FIP 1. 332
117-363	Fax NVRAM Error 117-363 Power Off/On the Printer. If this failure occurs again, please contact customer support.	<NVM Sum Check Error> Cause: NVM sum check value error.	FIP 1. 333
117-365	Controller Clock Voltage Low Error 117-365 Power Off/On the Printer. If this failure occurs again, please contact customer support.	<Low Voltage> Cause: RTC detected Low Voltage. RTC clock setting and content of SRAM are invalid. Initialize them.	FIP 1. 334
117-367	Scanner Controller Error 117-367 Power Off/On the Printer. If this failure occurs again, please contact customer support.	<FXIF error> Cause: An error occurred on FXIF (such as the Video Underrun error).	FIP 1. 335

Status Code (3615)	LCD Display	Name/Description of Error	FIP
118-311	<p>Google Cloud Print Software Error 118-311 A critical internal error has occurred. Power Off/On the Printer. Contact customer support if the issue reoccurs.</p>	<p><Google Cloud Print Software Error> Cause: A critical internal error has occurred.</p>	<p>FIP 1. 336</p>
123-314	<p>Control Panel Error 123-314 Power Off/On the Printer. If this failure occurs again, please contact customer support.</p>	<p><Panel Power On Error> Cause: Communication error at panel power on. Startup sequence does not start from AIOC within 1 minute after panel power on.</p>	<p>FIP 1. 337</p>
123-333	<p>Control Panel Error 123-333 Power Off/On the Printer. If this failure occurs again, please contact customer support.</p>	<p><Panel FW transmission error> Cause: An error which occurred when the Panel Main FW transmission was performed from ESS.</p>	<p>FIP 1. 338</p>
123-399	<p>Control Panel Error 123-399 Power Off/On the Printer. If this failure occurs again, please contact customer support.</p>	<p><Panel Device Reboot Error> Cause: An error which was caused by an unexpected reboot, such as reboot due to static electricity.</p>	<p>FIP 1. 339</p>
131-397	<p>Network Error 131-397 Power Off/On the Printer. If this failure occurs again, please contact customer support.</p>	<p><File2Net Fatal Error> Cause: File2Net fatal error. S/W bug.</p>	<p>FIP 1. 340</p>
131-398	<p>Network Error 131-398 Power Off/On the Printer. If this failure occurs again, please contact customer support.</p>	<p><SMB client Fatal Error> Cause: SMB Client fatal error.</p>	<p>FIP 1. 341</p>
131-399	<p>Network Error 131-399 Power Off/On the Printer. If this failure occurs again, please contact customer support.</p>	<p><FTP client Fatal Error> Cause: FTP Client fatal error.</p>	<p>FIP 1. 342</p>

Status Code (3615)	LCD Display	Name/Description of Error	FIP
133-231	Fax Communication Error 133-231 Power Off/On the Printer. If this failure occurs again, please contact customer support.	<T_FAXCOM Data Receive I/F Error> Cause: T_FAXCOM<->Data processing I/F error.	FIP 1. 343
133-234	Fax Error 133-234 Power Off/On the Printer. If this failure occurs again, please contact customer support.	<JBIG Parameter Error> Cause: JBIG parameter error.	FIP 1. 344
133-235	Fax Error 133-235 Power Off/On the Printer. If this failure occurs again, please contact customer support.	<MHR Parameter Error> Cause: MHR parameter error.	FIP 1. 345
133-236	Fax Error 133-236 Power Off/On the Printer. If this failure occurs again, please contact customer support.	<MHR Encode Error> Cause: MHR encode error.	FIP 1. 346
133-237	Fax Codec Error 133-237 Power Off/On the Printer. If this failure occurs again, please contact customer support.	<MHR Input Buffer Error> Cause: Data error of MHR input buffer.	FIP 1. 347
133-238	Fax Codec Error 133-238 Power Off/On the Printer. If this failure occurs again, please contact customer support.	<MHR Output Buffer Error> Cause: Data error of MHR output buffer.	FIP 1. 348
133-239	Fax Error 133-239 Power Off/On the Printer. If this failure occurs again, please contact customer support.	<FAX ECM Buffer Address Error> Cause: At FAX send/receive, address to get from and write in ECM buffer is wrong.	FIP 1. 349

Status Code (3615)	LCD Display	Name/Description of Error	FIP
133-240	Fax Error 133-240 Power Off/On the Printer. If this failure occurs again, please contact customer support.	<Resolution Change Error> Cause: Resolution error in FAX send resolution conversion.	FIP 1. 350
133-241	Fax Error 133-241 Power Off/On the Printer. If this failure occurs again, please contact customer support.	<Memory Pool Get Error> Cause: Memory pool get error. (OS error)	FIP 1. 351
133-242	Fax Error 133-242 Power Off/On the Printer. If this failure occurs again, please contact customer support.	<Memory Pool Release Error> Cause: Memory pool release error. (OS error)	FIP 1. 352
133-243	Fax Error 133-243 Power Off/On the Printer. If this failure occurs again, please contact customer support.	<Message Send Error> Cause: Message send error. (OS error)	FIP 1. 353
133-244	Fax Error 133-244 Power Off/On the Printer. If this failure occurs again, please contact customer support.	<Message Receive Error> Cause: Message receive error. (OS error)	FIP 1. 354
133-246	Fax Error 133-246 Power Off/On the Printer. If this failure occurs again, please contact customer support.	<Memory Pool Get Error> Cause: Memory pool get error. (OS error)	FIP 1. 357
133-247	Fax Error 133-247 Power Off/On the Printer. If this failure occurs again, please contact customer support.	<Message Send Error> Cause: Message send error. (OS error)	FIP 1. 356

Status Code (3615)	LCD Display	Name/Description of Error	FIP
133-248	Fax Error 133-248 Power Off/On the Printer. If this failure occurs again, please contact customer support.	<Memory Pool Release Error> Cause: Memory pool release error. (OS error)	FIP 1. 357
133-249	Fax Error 133-249 Power Off/On the Printer. If this failure occurs again, please contact customer support.	<Message Receive Error> Cause: Message receive error. (OS error)	FIP 1. 358
133-251	Fax Error 133-251 Power Off/On the Printer. If this failure occurs again, please contact customer support.	<File Open Error> Cause: File open error.	FIP 1. 359
133-252	Fax Error 133-252 Power Off/On the Printer. If this failure occurs again, please contact customer support.	<File Close Error> Cause: File close error.	FIP 1. 360
133-253	Fax Error 133-253 Power Off/On the Printer. If this failure occurs again, please contact customer support.	<File Erase Error> Cause: File erase error.	FIP 1. 361
133-254	Fax Error 133-254 Power Off/On the Printer. If this failure occurs again, please contact customer support.	<Memory Full> Cause: Cannot secure memory necessary to print.	FIP 1. 362
133-259	Fax Error 133-259 Power Off/On the Printer. If this failure occurs again, please contact customer support.	<OS Call Error> Cause: OS Call error.	FIP 1. 363

Status Code (3615)	LCD Display	Name/Description of Error	FIP
133-260	Fax Error 133-260 Power Off/On the Printer. If this failure occurs again, please contact customer support.	<File Open Error> Cause: File open error.	FIP 1. 364
133-261	Fax Error 133-261 Power Off/On the Printer. If this failure occurs again, please contact customer support.	<File Close Error> Cause: File close error.	FIP 1. 365
133-269	Fax Error 133-269 Power Off/On the Printer. If this failure occurs again, please contact customer support.	<File Close Error> Cause: File close error.	FIP 1. 365
133-271	Fax Error 133-271 Power Off/On the Printer. If this failure occurs again, please contact customer support.	<Memory Pool Get Error> Cause: Memory pool get error. (OS error)	FIP 1. 366
133-272	Fax Error 133-272 Power Off/On the Printer. If this failure occurs again, please contact customer support.	<Message Send Error> Cause: Message send error. (OS error)	FIP 1. 367
133-273	Fax Error 133-273 Power Off/On the Printer. If this failure occurs again, please contact customer support.	<Memory Pool Release Error> Cause: Memory pool release error. (OS error)	FIP 1. 368
133-274	Fax Error 133-274 Power Off/On the Printer. If this failure occurs again, please contact customer support.	<Message Receive Error> Cause: Message receive error. (OS error)	FIP 1. 369

Status Code (3615)	LCD Display	Name/Description of Error	FIP
133-275	Fax Error 133-275 Power Off/On the Printer. If this failure occurs again, please contact customer support.	<OS Call Error> Cause: OS Call error.	FIP 1.370
133-276	Fax Error 133-276 Power Off/On the Printer. If this failure occurs again, please contact customer support.	<File Open Error> Cause: File open error.	FIP 1.371
133-277	Fax Error 133-277 Power Off/On the Printer. If this failure occurs again, please contact customer support.	<File Close Error> Cause: File close error.	FIP 1.372
133-278	Fax Error 133-278 Power Off/On the Printer. If this failure occurs again, please contact customer support.	<File Erase Error> Cause: File erase error.	FIP 1.373
133-279	Fax Error 133-279 Power Off/On the Printer. If this failure occurs again, please contact customer support.	<FAX CODEC I/F Error> Cause: FAX CODEC I/F error.	FIP 1.374
133-280	Fax Error 133-280 Power Off/On the Printer. If this failure occurs again, please contact customer support.	<ERR_FAX_TIME> Cause: FAX timer error.	FIP 1.375
133-281	Fax Report Error 133-281 Power Off/On the Printer. If this failure occurs again, please contact customer support.	<Power Off Report Create Fail> Cause: Failed in creating power-off report.	FIP 1.376

Status Code (3615)	LCD Display	Name/Description of Error	FIP
133-282	Fax Error 133-282 Power Off/On the Printer. If this failure occurs again, please contact customer support.	<Memory Pool Get Error> Cause: Memory pool get error. (OS error)	FIP 1. 377
133-283	Fax Error 133-283 Power Off/On the Printer. If this failure occurs again, please contact customer support.	<Message Send Error> Cause: Message send error. (OS error)	FIP 1. 378
133-286	Fax Error 133-286 Power Off/On the Printer. If this failure occurs again, please contact customer support.	<OS Call Error> Cause: OS Call error.	FIP 1. 379
133-287	Fax Error 133-287 Power Off/On the Printer. If this failure occurs again, please contact customer support.	<File Open Error> Cause: File open error.	FIP 1. 380
133-288	Fax Error 133-288 Power Off/On the Printer. If this failure occurs again, please contact customer support.	<File Close Error> Cause: File close error.	FIP 1. 381
133-289	Fax Error 133-289 Power Off/On the Printer. If this failure occurs again, please contact customer support.	<File Erase Error> Cause: File erase error.	FIP 1. 382
133-290	Fax Error 133-290 Power Off/On the Printer. If this failure occurs again, please contact customer support.	<Print Decode Error> Cause: At JBIG data print decode, decode error occurred three successive times.	FIP 1. 383

Status Code (3615)	LCD Display	Name/Description of Error	FIP
134-211	Fax Error 134-211 Power Off/On the Printer. If this failure occurs again, please contact customer support.	<Fax Card Modem Error> Cause: Fax Card parts error. (MODEM error)	FIP 1.384
142-700	XXXXXXXXXXXXXXXXXX Over Heating. Running Half-speed mode.	<IOT Over Heat Forced Half Speed> Cause: Half-speed operation was forced due to abnormally high temperature inside the IOT.	FIP 1.385
193-700	XXXXXXXXXXXXXXXXXX Non-Xerox Toner Cartridge Installed	<Custom Toner Mode> Cause: The printer is in custom toner mode.	FIP 1.386

Error Code Fault Isolation Procedures (FIP)

FIP 1. 01

004-310 IOT Option Feeder I/F Failure

Cause:

The Option Feeder communication failure is detected.

Solution:

Turn the power **Off** and **On** to check that the error recurs, then proceed to the FIP.

Step	Check and Action	Yes	No
1	<ul style="list-style-type: none"> Check the connections between the OPTIONAL TRAY PWB ASSEMBLY and the MCU PWB, as well as between the OPTIONAL TRAY PWB ASSEMBLY and the LVPS PWB. Are the OPTIONAL FEEDER HARNESS ASSEMBLY and the FEEDER HARNESS ASSEMBLY DRAWER 1 connected securely? 	Go to Step 2.	Securely connect the OPTIONAL FEEDER HARNESS ASSEMBLY and the FEEDER HARNESS ASSEMBLY DRAWER 1
2	<ul style="list-style-type: none"> Replace the OPTIONAL FEEDER HARNESS ASSEMBLY. Does an error occur? 	Go to Step 3.	Troubleshooting complete.
3	<ul style="list-style-type: none"> Replace the FEEDER HARNESS ASSEMBLY DRAWER 1. Does an error occur? 	Go to Step 4.	Troubleshooting complete.
4	<ul style="list-style-type: none"> Replace (REP 7.5 Optional Tray PWB Assembly). Does an error occur? 	Replace (REP 5.6 MCU PWB)	Troubleshooting complete.

FIP 1. 02

005-110 PICKUP JAM

005-112 REVERSE JAM

005-121 DADF JAM

005-124 Virtual JAM

005-900 DADF STATIC JAM

Cause:

005-110: Detect PICK UP JAM.

005-112: Detect REVERSE JAM.

005-121: Detect DADF JAM.

005-124: Detect Virtual JAM.

005-900: Detect DADF STATIC JAM.

Solution:

If there is no jammed document, or the error still occurs after having removed the jammed document, turn the power **Off** and **On** to check that the error recurs, then proceed to the FIP.

Step	Check and Action	Yes	No
1	<ul style="list-style-type: none"> Does the original document match the device specification? 	Go to Step 2.	Use the correct original document
2	<ul style="list-style-type: none"> Is the DADF ASSEMBLY properly closed against the Platen Glass? 	Go to Step 3.	Close the DADF ASSEMBLY properly
3	Check the connection between the DADF ASSEMBLY and the ESS PWB. <ul style="list-style-type: none"> Is the P/J453 connected securely? 	Go to Step 4.	Connect P/J453 securely
4	<ul style="list-style-type: none"> Open the DADF cover, and check the original document transport path. Is there any foreign substances or bits of paper found on the original document transport path? 	Remove the foreign substances and bits of paper, etc.	Go to Step 5.
5	<ul style="list-style-type: none"> Is the DADF PICK UP MODULE installed properly? 	Go to Step 6.	Reinstall the DADF PICK UP MODULE
6	<ul style="list-style-type: none"> Is the DADF PICK UP MODULE deformed or worn out? 	Replace (REP 6.4 Pick-up Module Kit)	Go to Step 7.
7	<ul style="list-style-type: none"> Replace (REP 6.2 DADF). Does an error occur? 	Replace (REP 5.1 ESS PWB).	Troubleshooting complete.

FIP 1. 03

005-301 DADF Cover Open

Cause:

Detect DADF Cover Open.

Solution:

- Close the ADF Cover.
- If the error persists, ensure that the error is replicated after the printer is powered **Off** and then **On**, and then proceed to the FIP.

Step	Check and Action	Yes	No
1	<ul style="list-style-type: none"> • Is the DADF Cover closed properly? 	Go to Step 2.	Close the DADF Cover properly
2	Check the connection between the DADF ASSEMBLY and the ESS PWB. <ul style="list-style-type: none"> • Is the P/J453 connected securely? 	Go to Step 3.	Connect P/J453 securely
3	<ul style="list-style-type: none"> • Replace (REP 6.2 DADF). • Does an error occur? 	Replace (REP 5.1 ESS PWB).	Troubleshooting complete.

FIP 1. 04

010-317 FUSING ASSEMBLY Detached

010-397 FUSING ASSEMBLY Failure

Cause:

010-317: FUSING ASSEMBLY detached is detected.

010-397: The operation error of FUSING ASSEMBLY (Temperature anomaly error etc.) is detected.

Solution:

Turn the power **Off** and **On** to check that the error recurs, then proceed to the FIP.

Step	Check and Action	Yes	No
1	Check the installation of the FUSING ASSEMBLY. <ul style="list-style-type: none"> Is the Drawer Connector between the FUSING ASSEMBLY and the Main unit free of broken/bent pins, foreign substances, burns, and etc., and is the unit installed properly? Make sure that the FUSING ASSEMBLY has cooled down before performing the operation. 	Go to Step 2.	Reinstall the FUSING ASSEMBLY
2	Check the connection between the FUSING ASSEMBLY and the MCU PWB, FUSING ASSEMBLY and the LVPS, as well as between the LVPS PWB - MCU PWB. <ul style="list-style-type: none"> Are the FUSER HARNESS ASSEMBLY and the LVPS HARNESS ASSEMBLY connected securely? 	Go to Step 3.	Securely connect the Fuser HARNESS ASSEMBLY and the LVPS HARNESS ASSEMBLY
3	<ul style="list-style-type: none"> Replace the FUSER HARNESS ASSEMBLY. Does an error occur? 	Go to Step 4.	Troubleshooting complete.
4	<ul style="list-style-type: none"> Replace the LVPS HARNESS ASSEMBLY. Does an error occur? 	Go to Step 5.	Troubleshooting complete.
5	<ul style="list-style-type: none"> Replace (REP 3.5 Fusing Assembly). Does an error occur? 	Go to Step 6.	Troubleshooting complete.
6	<ul style="list-style-type: none"> Replace (REP 5.3 LVPS.) Does an error occur? 	Replace (REP 5.6 MCU PWB)	Troubleshooting complete.

FIP 1. 08

016-338 Wireless Option Error

016-920/016-921/016-922 Wireless Setting Error

Cause:

016-338:Wireless Driver starting error.

016-920:Timeout Error.

016-921:Download Error.

016-922:Session Overlap Error.

Solution:

016-338:

Turn the power **Off** and **On** to check that the error recurs. Then proceed to the FIP.

016-920:

The machine will recover after the **OK** or **Close** button is pressed or message is displayed for specified time.

- A time-out error occurred. Contact the system administrator.
- The WPS procedure between the wireless LAN access point (Registrar) timed out. Try connecting again.

If the error persists, ensure that the error is replicated after the printer is powered **Off** and then **On**, and then proceed to the FIP.

016-921:

The machine will recover after the **OK** or **Close** button is pressed or message is displayed for specified time.

- An error occurred while connecting. Contact the system administrator.
- An error occurred while connecting to the wireless LAN access point (Registrar) in WPS mode. Try connecting again.

If the error persists, ensure that the error is replicated after the printer is powered **Off** and then **On**, and then proceed to the FIP.

016-922:

The machine will recover after the **OK** or **Close** button is pressed or message is displayed for specified time.

- Two or more wireless LAN access points (Registrars) have been found to operate in the WPS-PBC mode.
- Set only one wireless access point (Registrar) to operate in the WPS-PBC mode, and execute the process again according to the procedure.

If the error persists, ensure that the error is replicated after the printer is powered **Off** and then **On**, and then proceed to the FIP.

Step	Check and Action	Yes	No
1	<ul style="list-style-type: none"> Check the installation of the WIRELESS ADAPTER Is the Connector between the WIRELESS ADAPTER and the ESS PWB free of broken/bent pins, foreign substances, burns, and etc., and is the unit installed properly? 	Go to Step 2.	Reinstall the WIRELESS ADAPTER
2	<ul style="list-style-type: none"> Replace the WIRELESS ADAPTER. Does an error occur? 	Replace (REP 5.1 ESS PWB)	Troubleshooting complete.

FIP 1.09

016-359 MRAM Fail

Cause:

MRAM Device Error

Solution:

1. Turn the power **Off** and **On** to check that the error recurs.
2. Update to the latest F/W.
3. If the problem cannot be solved, replace (REP 5.1 ESS PWB).

FIP 1.10

016-369 UI Panel - ESS Communication Fail

Cause:

Communication Fail with a UI Panel and ESS F/W.

Solution:

Turn the power **Off** and **On** to check that the error recurs, then proceed to the FIP.

Step	Check and Action	Yes	No
1	<p>Check the connection between the CONTROL PANEL and the ESS PWB.</p> <ul style="list-style-type: none"> Is the UI HARNESS ASSEMBLY connected securely? 	Go to Step 2.	Securely connect the UI HARNESS ASSEMBLY
2	<ul style="list-style-type: none"> Replace the UI HARNESS ASSEMBLY. Does an error occur? 	Go to Step 3.	Troubleshooting complete.
3	<ul style="list-style-type: none"> Replace the CONTROL PANEL. (REP 1.1 Control Panel (3610) / REP 1.12 Control Panel (3615)) Does an error occur? 	Replace (REP 5.1 ESS PWB)	Troubleshooting complete.

FIP 1. 11

016-404 Certificate DB Error

Cause:

Certificate DB access error.

Solution:

The Certificate DB is invalid. Initialize the Certificate DB and security setting and then restart the printer.

FIP 1. 12

016-405 Certificate DB Error

Cause:

Invalid security setting error.

Solution:

Initialize the Certificate DB and security setting and then restart the printer. Contact the administrator for security resetting.

FIP 1. 13

016-500 Download Delete Error

Cause:

Flash delete error in download.

Solution:

1. Turn the power **Off** and **On** to check that the error recurs.
2. Update to the latest F/W.
3. If the problem cannot be solved, replace ([REP 5.1 ESS PWB](#)).

FIP 1. 14

016-501 Download Write Error

Cause:

Flash write error in download.

Solution:

1. Turn the power **Off** and **On** to check that the error recurs.
2. Update to the latest F/W.
3. If the problem cannot be solved, replace ([REP 5.1 ESS PWB](#)).

FIP 1. 15

016-502 Download Verify Error

Cause:

Flash verify error in download.

Solution:

1. Turn the power **Off** and **On** to check that the error recurs.
2. Update to the latest F/W.
3. If the problem cannot be solved, replace ([REP 5.1 ESS PWB](#)).

FIP 1. 16

016-503 SMTP Server Address Resolution Fail for Maillib

Cause:

SMTP server name resolution for email send failed.

Solution:

The machine will recover after the **OK** or **Close** button is pressed or message is displayed for specified time.

If the error persists:

1. On the CWIS, check SMTP server is set correctly. In addition, check if DNS server is set correctly.
2. Ensure that the error is replicated after the printer is powered **Off** and then **On**, and then replace ([REP 5.1 ESS PWB](#)).

FIP 1. 17

016-504 POP Server Address Resolution Fail for Maillib

Cause:

POP3 server name resolution for email send failed.

Solution:

The machine will recover after the **OK** or **Close** button is pressed or message is displayed for specified time.

If the error persists:

1. On the CWIS, check POP3 server is set correctly. In addition, check if DNS server is set correctly.
2. Ensure that the error is replicated after the printer is powered **Off** and then **On**, and then replace ([REP 5.1 ESS PWB](#)).

FIP 1. 18

016-505 POP Authentication Fail for Maillib

Cause:

Cannot login to POP3 server to send email.

Solution:

The machine will recover after the **OK** or **Close** button is pressed or message is displayed for specified time.

If the error persists:

1. On CWIS, check if user name and password used for POP3 server are set correctly. In addition, check if DNS server is set correctly.
2. Ensure that the error is replicated after the printer is powered **Off** and then **On**, and then replace ([REP 5.1 ESS PWB](#)).

FIP 1. 19

016-506 Required user entry item is empty

Cause:

Some item is not set.

Solution:

The machine will recover after the **OK** or **Close** button is pressed or message is displayed for specified time.

If the error persists:

1. On CWIS, check if SMTP server or POP3 server is set.
2. Ensure that the error is replicated after the printer is powered **Off** and then **On**, and then replace ([REP 5.1 ESS PWB](#)).

FIP 1. 20

016-507 SMTP Authentication Fail for Maillib

Cause:

Cannot login to SMTP server to send email.

Solution:

The machine will recover after the **OK** or **Close** button is pressed or message is displayed for specified time.

If the error persists:

1. On CWIS, check if user name and password used for SMTP server are set correctly.
2. Ensure that the error is replicated after the printer is powered **Off** and then **On**, and then replace ([REP 5.1 ESS PWB](#)).

FIP 1. 21

016-520 Ipsec Certificate Error

Cause:

Self device certificate error.

Solution:

1. Certificate of self device is invalid. Contact administrator.
 - Reset the certificate from other connectable client with EWS.
2. If no device can be connected, disconnect cable, turn off IPsec, and then reset certificate with EWS.

FIP 1. 22

016-521 Ipsec Certificate Error

Cause:

Remote device certification verification error.

Solution:

1. Contact administrator. Certificate of destination client is invalid.
2. Confirm certificate of destination client and reset.

FIP 1. 23

016-522 LDAP Certificate Error

Cause:

No client certificate exists.

Solution:

1. Contact administrator. The SSL client certificate is requested by LDAP server. Set the SSL client certificate to the device.
2. Set the LDAP correctly.

FIP 1. 24

016-523 LDAP Certificate Error

Cause:

Server certificate verification error.

Solution:

1. The SSL certificate of LDAP server is not trusted by the device. Register the root certificate of the LDAP server's SSL certificate with the device.
2. Set the LDAP correctly.

FIP 1. 25

016-524 LDAP Certificate Error

Cause:

No server certificate exists.

Solution:

1. Change the SSL certificate of the LDAP server to the valid one.
2. Set the LDAP correctly.

FIP 1. 26

016-527 LDAP Certificate Error

Cause:

SSL authentication internal error.

Solution:

1. Contact administrator. The error has occurred inside the program.
2. Set the LDAP correctly.

FIP 1. 27

016-530 LDAP Address Book- Access Error

Cause:

LDAP Address Book Other Access Errors.

Solution:

1. Turn the power **Off** and **On** to check that the error recurs.
2. Check the LDAP setting.
3. Update to the latest F/W.
4. If the error persists replace ([REP 5.1 ESS PWB](#)).

FIP 1. 28

016-541 Wireless Certificate Error

Cause:

No certificate exists.

Solution:

Initialize Wireless setting.

FIP 1. 29

016-542 Wireless Certificate Error

Cause:

Server certificate error.

Solution:

Check server certificate.

FIP 1. 30

016-543 Wireless Certificate Error

Cause:

Certificate corruption error.

Solution:

Initialize Wireless setting.

FIP 1. 31

016-570 Job Ticket Out Of Memory

Cause:

XPIF parser detects insufficient memory in the processing of XCPT (XPIF) interpretation.

Solution:

The machine will recover after the **OK** button is pressed or message is displayed for specified time.

If the error persists, an upgrade of the memory as required.

FIP 1. 32

016-571 Job ticket wrong

Cause:

Print instruction contents that the device cannot execute are detected.

Solution:

The machine will recover after the **OK** button is pressed or message is displayed for specified time.

FIP 1. 33

016-572 Job ticket media error

Cause:

The paper attribute specified by XCPT (XPIF) cannot solve paper selection.

Solution:

The machine will recover after the **OK** button is pressed or message is displayed for specified time.

FIP 1. 34

016-573 Job ticket parse error

Cause:

XPIF parser detects error other than those listed above.

Solution:

The machine will recover after the **OK** button is pressed or message is displayed for specified time.

FIP 1. 35

016-602 System NVM Initialize

Cause:

At Power ON start-up, execute NVM clear.

Solution:

The machine will recover after message is displayed for 3 seconds. No action is required.

FIP 1. 36

016-603 ESS-NVM Parameter The machine will recover

Cause:

Executed ESS-NVM Parameter Recovery

Solution:

No action is required.

FIP 1. 37

016-604 ESS-NVM Parameter Copy

Cause:

Executed ESS-NVM Parameter Copy.

Solution:

No action is required.

FIP 1. 38

016-605 ESS-NVM Parameter Copy

Cause:

Executed ESS-NVM Parameter Copy.

Solution:

No action is required.

FIP 1. 39

016-606 Clear Job History

Cause:

Clear Job History

Solution:

No action is required.

FIP 1. 40

016-610 Panel Destination Mismatch

Cause:

Only for Production Line.

An attempt was made to apply JP setting to non-JP panel,

Solution:

No action is required.

FIP 1. 41

016-612 Invalid MAC Address

Cause:

MAC address is invalid.

Solution:

1. Rewrite Mac address.
2. Update to the latest F/W.
3. If the error persists, ensure that the error is replicated after the printer is powered **Off** and then **On**, and then replace ([REP 5.1 ESS PWB](#)).

FIP 1. 42

016- 718 Memory Over flow

Cause:

The current printing job process cannot be continued because the memory capacity is exceeded.

Solution:

The machine will recover after the **OK** button is pressed or message is displayed for specified time.

If the error persists:

1. Deleting the data by executing Clear Storage.
2. Execute "Clear Storage" under "Maintenance" in the Control Panel.
3. Ensure that the error is replicated after the printer is powered **Off** and then **On**, and then upgrade the memory as required.

FIP 1. 43

016- 720 PDL Error

Cause:

The print data cannot be processed by PDL.

Solution:

The machine will recover after the **OK** button is pressed or message is displayed for specified time.

If the error persists:

1. Check the cable between the Printer and PC (or Printer and Hub).
 - For local printer: USB cable.
 - For network printer: Ethernet cable.
2. Take corrective actions at the host side.

FIP 1. 44

016-734 Download Signature Error

Cause:

Download file signature data is invalid.

Solution:

1. Turn the power **Off** and **On** to check that the error recurs.
2. Re-download the correct file.
3. Check the cable between the Printer and PC (or Printer and Hub).
 - For local printer: USB cable.
 - For network printer: Ethernet cable.
4. Take corrective actions at the host side.

FIP 1. 45

016-737 Download Format Error

Cause:

Download file format is invalid.

Solution:

1. Turn the power **Off** and **On** to check that the error recurs.
2. Re-download the correct file.
3. Check the cable between the Printer and PC (or Printer and Hub).
 - For local printer: USB cable.
 - For network printer: Ethernet cable.
4. Take corrective actions at the host side.

FIP 1. 46

016-741 Download Protect Error

Cause:

Performed FW download although FW update is prohibited by panel settings.

Solution:

1. Turn the power **Off** and **On** to check that the error recurs.
2. Re-download the correct file.
3. Check the cable between the Printer and PC (or Printer and Hub).
 - For local printer: USB cable.
 - For network printer: Ethernet cable.
4. Take corrective actions at the host side.

FIP 1. 47

016-742 Download ID Error

Cause:

Download file ID is invalid.

Solution:

1. Turn the power **Off** and **On** to check that the error recurs.
2. Re-download the correct file.
3. Check the cable between the Printer and PC (or Printer and Hub).
 - For local printer: USB cable.
 - For network printer: Ethernet cable.
4. Take corrective actions at the host side.

FIP 1. 48

016- 743 Download Range Error

Cause:

At download, write-in destination address is invalid. Range check error.

Solution:

1. Turn the power **Off** and **On** to check that the error recurs.
2. Re-download the correct file.
3. Check the cable between the Printer and PC (or Printer and Hub).
 - For local printer: USB cable.
 - For network printer: Ethernet cable.
4. Take corrective actions at the host side.

FIP 1. 49

016-744 Download Check Sum Error

Cause:

Download file checksum is invalid.

Solution:

1. Turn the power **Off** and **On** to check that the error recurs.
2. Re-download the correct file.
3. Check the cable between the Printer and PC (or Printer and Hub).
 - For local printer: USB cable.
 - For network printer: Ethernet cable.
4. Take corrective actions at the host side.

FIP 1. 50

016-745 Download header Error

Cause:

Download file header is invalid.

Solution:

1. Turn the power **Off** and **On** to check that the error recurs.
2. Re-download the correct file.
3. Check the cable between the Printer and PC (or Printer and Hub).
 - For local printer: USB cable.
 - For network printer: Ethernet cable.
4. Take corrective actions at the host side.

FIP 1. 51

016-746 Prohibit Error

Cause:

Download Prohibit Error.

Solution:

1. Turn the power **Off** and **On** to check that the error recurs.
2. Re-download the correct file.
3. Check the cable between the Printer and PC (or Printer and Hub).
 - For local printer: USB cable.
 - For network printer: Ethernet cable.
4. Take corrective actions at the host side.

FIP 1. 52

016-750 Job Ticket Error

Cause:

PDF print job ticket description error.

Solution:

The machine will recover after the **OK** button is pressed or message is displayed for specified time.

If the error persists, check the PDF data and then take corrective actions at the host side.

FIP 1. 53

016-753 Wrong Password

Cause:

PDF password error.

Solution:

The machine will recover after the **OK** button is pressed or message is displayed for specified time.

If the error persists, enter the correct PDF document password again, and then take corrective actions at the host side.

FIP 1. 54

016-755 PDF Print Disabled

Cause:

PDF print is not allowed.

Solution:

The machine will recover after the **OK** button is pressed or message is displayed for specified time.

If the error persists, enter the correct PDF document password again, and then take corrective actions at the host side.

FIP 1. 55

016-757 Auditron - Invalid User

Cause:

Account is not registered.

Solution:

The machine will recover after the **OK** button is pressed or message is displayed for specified time.

If the error persists, set the correct user's account (user name and password), and then take corrective actions at the host side.

FIP 1. 56

016-758 Auditron - Disabled Function

Cause:

Detect invalid account.

Solution:

The machine will recover after the **OK** button is pressed or message is displayed for specified time.

If the error persists:

1. Set the new function that is allowed for that account and try again.
2. Request the Account Administrator to add the rights, and then update to the latest F/W.
3. Take corrective actions at the host side.

FIP 1. 57

016-759 Auditron - Reached Limit

Cause:

Reached the limit of the number of registered users.

Solution:

The machine will recover after the **OK** button is pressed or message is displayed for specified time.

If the error persists:

1. Set the correct value of "User Registration" exceed the limitation.
2. Update to the latest F/W.
3. Take corrective actions at the host side.

FIP 1. 58

016-764 SMTP Server Connection Error

Cause:

Error occurs when connecting to SMTP server.

Solution:

The machine will recover after the **OK** button is pressed or message is displayed for specified time.

If the error persists:

1. Contact the SMTP Server Administrator.
 - Check the network connection using the ping command.
 - Check the network setting.(E-Mail Server Settings / DNS settings)
2. Take corrective actions at the host side.

FIP 1. 59

016-765 SMTP Server HD Full

Cause:

Capacity of SMTP server is not enough.

Solution:

The machine will recover after the **OK** button is pressed or message is displayed for specified time.

If the error persists:

1. Contact the SMTP Server Administrator.
2. Retrieve E-mails in the SMTP Server HD and check the server capacity.
3. Take corrective actions at the host side.

FIP 1. 60

016-766 SMTP Server File System Error

Cause:

Error in SMTP server.

Solution:

The machine will recover after the **OK** button is pressed or message is displayed for specified time.

If the error persists:

1. Contact the SMTP Server Administrator.
2. Check the SMTP Server Error.
3. Take corrective actions at the host side.

FIP 1. 61

016-767 Invalid Recipient Email Address

Cause:

Recipient email address is incorrect.

Solution:

The machine will recover after the **OK** button is pressed or message is displayed for specified time.

If the error persists:

1. Check the email address and try scanning again.
2. Take corrective actions at the host side.

FIP 1. 62

016-768 Invalid Sender Address (Login Error)

Cause:

Sender email address is incorrect.

Solution:

The machine will recover after the **OK** button is pressed or message is displayed for specified time.

If the error persists:

1. Check the email address and try scanning again.
2. Take corrective actions at the host side.

FIP 1. 63

016-786 Data Send/Receive Timeout Error

Cause:

Timeout error occurs in scan data send/receive.

Solution:

The machine will recover after the **OK** button is pressed or message is displayed for specified time.

If the error persists:

1. Check if the network cable is disconnected or connected properly. When there is no problem with network cable, contact Server Administrator.
2. Perform the following in sequence.
 - " Network System Fault Check"
 - " Network-related Details Check Flow"
3. Take corrective actions at the host side.

FIP 1. 64

016-790 F2N Module Starting-up

Cause:

F2N module task is starting up, or IP address is not determined.

Solution:

The machine will recover after the **OK** button is pressed or message is displayed for specified time.

If the error persists:

1. Check if the network cable is disconnected or connected properly. When there is no problem with network cable, contact Server Administrator.
2. Take corrective actions at the host side.

FIP 1. 65

016-791 USB Memory Removal Error (During Read)

Cause:

USB memory is removed while memory reading job is being executed.

Solution:

The machine will recover after the **OK** button is pressed or message is displayed for specified time.

If the error persists:

1. Check the USB Memory.
2. Ensure that the error is replicated after the printer is powered **Off** and then **On**, and then change the USB.
3. Take corrective actions at the host side.

FIP 1. 66

016-799 Job Environment Violation

Cause:

Print condition conflicts with other condition.

Solution:

The machine will recover after the **OK** button is pressed or message is displayed for specified time.

If the error persists:

1. Ensure that the printer configuration on the printer driver conforms to the printer you are using.
2. Take corrective actions at the host side.

FIP 1. 67

016-923 Wireless Password Error

Cause:

Wireless Password is wrong.

Solution:

The machine will recover after the **OK** button is pressed or message is displayed for specified time.

If the error persists:

1. Modify the setting WEP Key or WPA Pass phrase.
2. Change the password.

FIP 1. 68

016-924 Wireless Setting Error

Cause:

WEP AP Connected Error.

Solution:

1. Press set and try again.
2. Reinstall the WIRELESS ADAPTER.
3. If the problem cannot be solved, configure the wireless settings again.

FIP 1. 69

016-930 USB Host Error

Cause:

Warning when unsupported device is installed to USB host.

- Detect installation of device of which class driver cannot be found.
- Detect installation of device that class driver judges not to support.
- Detect installation of Low-Speed device.

Solution:

1. Devices not available are connected to the USB port.
 - Remove the devices from the USB port.
2. If the error persists, ensure that the error is replicated after the printer is powered **Off** and then **On**, and then replace ([REP 5.1 ESS PWB](#)).

FIP 1. 70

016-931 USB Hub Error

Cause:

- Warning to installation of hub that cannot be used to USB host.
- Detect installation of hubs in more than supported number of stacks.

Solution:

1. The number of hub stages exceeds the specified value.
 - Reduce the number of the hub stages.
2. If the error persists, ensure that the error is replicated after the printer is powered **Off** and then **On**, and then replace ([REP 5.1 ESS PWB](#)).

FIP 1. 71

016-982 Disk Full

Cause:

The current printing job process cannot be continued because the RAM disk is full.

Solution:

The machine will recover after the **OK** button is pressed or message is displayed for specified time.

If the error persists:

1. It is necessary to delete unnecessary data or System Settings increase the RAM Disk capacity in System Settings.
2. After increasing the RAM Disk capacity, turn the printer Off and then On.
3. Ensure that the error is replicated after the printer is powered **Off** and then **On**, and then divide the print job into several blocks, then execute printing on a block by block basis.
 - Upgrade memory as required.
 - Upgrade SD CARD as required.

FIP 1. 72

016-985 Mail Size Error

Cause:

Exceed the max mail size specified on the menu.

Solution:

The machine will recover after the **OK** button is pressed or message is displayed for specified time.

If the error persists:

1. Degrade image quality. (Change scan resolution, etc.)
2. Change file format.
3. Divide the document into blocks and retry scanning block by block.
4. Ensure that the error is replicated after the printer is powered **Off** and then **On**, and then replace ([REP 5.1 ESS PWB](#)).

FIP 1. 73

016-986 File Size Error

Cause:

As a result of conversion to the specified format, exceed the max file size specified for each format.

Solution:

The machine will recover after the **OK** button is pressed or message is displayed for specified time.

If the error persists:

1. Degrade image quality. (Change scan resolution, etc.)
2. Change file format.
3. Divide the document into blocks and retry scanning block by block.
4. Ensure that the error is replicated after the printer is powered **Off** and then **On**, and then replace ([REP 5.1 ESS PWB](#)).

FIP 1. 74

017-321 SD CARD Type Invalid Error

Cause:

SD CARD Type Invalid Error was detected.

Solution:

1. Install the SD CARD properly.
2. If the error persists, ensure that the error is replicated after the printer is powered **Off** and then **On**, and then replace the following parts in sequence.
 - SD CARD
 - ([REP 5.1 ESS PWB](#))

FIP 1. 75

017-600 Address Info Sum Check Fail

Cause:

At Power ON start-up, Check phone book and address book data and initializing incorrect data automatically.

Solution:

The machine will recover after message is displayed for 3 seconds. (When initialization is not completed, continue displaying message)

If the error persists, ensure that the error is replicated after the printer is powered **Off** and then **On**, and then replace the following parts in sequence.

- ([REP 5.4 Fax PWB](#))
- ([REP 5.1 ESS PWB](#))

FIP 1. 76

017-970 FAX Memory Full

Cause:

AIOC memory run out.

Solution:

The machine will recover after the **OK** button is pressed or message is displayed for specified time.

If the error persists:

1. Wait until the Pending FAX Jobs will be sent, or delete the Pending FAX data.
2. Try dividing the FAX data into smaller blocks or converting the data to a smaller format.
3. Update to the latest F/W.
4. Ensure that the error is replicated after the printer is powered **Off** and then **On**, and then replace the following parts in sequence.
 - ([REP 5.4 Fax PWB](#))
 - ([REP 5.1 ESS PWB](#))

FIP 1. 77

017-971 FAX Controller Error

Cause:

Write error of image data storage Flash ROM.

Solution:

The machine will recover after the **OK** button is pressed or message is displayed for specified time.

If the error persists:

1. Turn the power **Off** and **On** to check that the error recurs.
2. Update to the latest F/W.
3. If the problem cannot be solved, replace the following parts in sequence.
 - ([REP 5.4 Fax PWB](#))
 - ([REP 5.1 ESS PWB](#))

FIP 1. 78

017-972 FAX Controller Error

Cause:

Erase error of image data storage Flash ROM.

Solution:

The machine will recover after the **OK** button is pressed or message is displayed for specified time.

If the error persists:

1. Turn the power **Off** and **On** to check that the error recurs.
2. Update to the latest F/W.
3. If the problem cannot be solved, replace the following parts in sequence.
 - [\(REP 5.4 Fax PWB\)](#)
 - [\(REP 5.1 ESS PWB\)](#)

FIP 1. 79

017-973 FAX Controller Error

Cause:

Suspend error of image data storage Flash ROM.

Solution:

The machine will recover after the **OK** button is pressed or message is displayed for specified time.

If the error persists:

1. Turn the power **Off** and **On** to check that the error recurs.
2. Update to the latest F/W.
3. If the problem cannot be solved, replace the following parts in sequence.
 - [\(REP 5.4 Fax PWB\)](#)
 - [\(REP 5.1 ESS PWB\)](#)

FIP 1. 80

017-974 FAX Controller Error

Cause:

Resume error of image data storage Flash ROM.

Solution:

The machine will recover after the **OK** button is pressed or message is displayed for specified time.

If the error persists:

1. Turn the power **Off** and **On** to check that the error recurs.
2. Update to the latest F/W.
3. If the problem cannot be solved, replace the following parts in sequence.
 - (REP 5.4 Fax PWB)
 - (REP 5.1 ESS PWB)

FIP 1. 81

017-975 FAX Controller Error

Cause:

Exceed the maximum number of file handles.

Solution:

The machine will recover after the **OK** button is pressed or message is displayed for specified time.

If the error persists:

1. Wait until the Pending FAX Jobs will be sent, or delete the Pending FAX data.
2. Divide the FAX data into smaller blocks or convert the data to a smaller format.
3. Update to the latest F/W.
4. Ensure that the error is replicated after the printer is powered **Off** and then **On**, and then replace the following parts in sequence.
 - (REP 5.4 Fax PWB)
 - (REP 5.1 ESS PWB)

FIP 1. 82

017-976 FAX Controller Error

Cause:

Exceed the maximum number of controlled files.

Solution:

The machine will recover after the **OK** button is pressed or message is displayed for specified time.

If the error persists:

1. Wait until the Pending FAX Jobs will be sent, or delete the Pending FAX data.
2. Divide the FAX data into smaller blocks or convert the data to a smaller format.
3. Update to the latest F/W.
4. Ensure that the error is replicated after the printer is powered **Off** and then **On**, and then replace the following parts in sequence.
 - [\(REP 5.4 Fax PWB\)](#)
 - [\(REP 5.1 ESS PWB\)](#)

FIP 1. 83

017-977 FAX Controller Error

Cause:

Exceed the maximum number of controlled documents.

Solution:

The machine will recover after the **OK** button is pressed or message is displayed for specified time.

If the error persists:

1. Wait until the Pending FAX Jobs will be sent, or delete the Pending FAX data.
2. Divide the FAX data into smaller blocks or convert the data to a smaller format.
3. Update to the latest F/W.
4. Ensure that the error is replicated after the printer is powered **Off** and then **On**, and then replace the following parts in sequence.
 - [\(REP 5.4 Fax PWB\)](#)
 - [\(REP 5.1 ESS PWB\)](#)

FIP 1. 84

017-978 FAX Controller Error

Cause:

Exceed the maximum number of pages in document.

Solution:

The machine will recover after the **OK** button is pressed or message is displayed for specified time.

If the error persists:

1. Wait until the Pending FAX Jobs will be sent, or delete the Pending FAX data.
2. Divide the FAX data into smaller blocks or convert the data to a smaller format.
3. Update to the latest F/W.
4. Ensure that the error is replicated after the printer is powered **Off** and then **On**, and then replace the following parts in sequence.
 - ([REP 5.4 Fax PWB](#))
 - ([REP 5.1 ESS PWB](#))

FIP 1. 85

017-979 FAX Controller Error

Cause:

File multi-open.

Solution:

The machine will recover after the **OK** button is pressed or message is displayed for specified time.

If the error persists:

1. Turn the power **Off** and **On** to check that the error recurs.
2. Update to the latest F/W.
3. If the problem cannot be solved, replace ([REP 5.1 ESS PWB](#)).

FIP 1. 86

017-980 Report File Open/Close Error

Cause:

Report job fails to open/close report file.

Solution:

The machine will recover after the **OK** button is pressed or message is displayed for specified time.

If the error persists:

1. Turn the power **Off** and **On** to check that the error recurs.
2. Update to the latest F/W.
3. If the problem cannot be solved, replace ([REP 5.1 ESS PWB](#)).

FIP 1. 87

017-983 EEPROM R/W Error

Cause:

At system boot, EEPROM Read/Write check error (sum check error).

Solution:

1. Delete message after start-up processing is completed.
2. Turn the power **Off** and **On** to check that the error recurs and then replace ([REP 5.1 ESS PWB](#)).

FIP 1. 88

017-986 FAX Controller Error

Cause:

Create empty file (0Byte).

Solution:

The machine will recover after the **OK** button is pressed or message is displayed for specified time.

If the error persists:

1. Turn the power **Off** and **On** to check that the error recurs, then update to the latest F/W.
2. If the problem cannot be solved, replace ([REP 5.1 ESS PWB](#)).

FIP 1. 89

017-987 FAX Controller Error

Cause:

Cannot read file because it is bigger than read destination buffer.

Solution:

The machine will recover after the **OK** button is pressed or message is displayed for specified time.

If the error persists:

1. Wait until the Pending FAX Jobs will be sent, or delete the Pending FAX data.
2. Divide the FAX data into smaller blocks or convert the data to a smaller format.
3. Update to the latest F/W.
4. Power the printer Off and On. If there is still an issue, replace the following parts in sequence.
 - ([REP 5.4 Fax PWB](#))
 - ([REP 5.1 ESS PWB](#))

FIP 1. 90

017-988 Scan Time Out

Cause:

Timeout at start of Scan To Application.

Solution:

The machine will recover after the **OK** button is pressed or message is displayed for specified time.

If the error persists:

1. Check the USB connection.
2. Reconnect the PC and the printer.
3. Set these items correctly. (Scan Form/Image Type/Resolution/Paper size/Output Destination)
4. Ensure that the error is replicated after the printer is powered **Off** and then **On**, and then Install the correct Driver Software.

FIP 1. 91

017-989 FAX Controller Error

Cause:

Stop writing because size of file to be written is bigger than read destination buffer (even if file writing is continued, it is impossible to read the file).

Solution:

The machine will recover after the **OK** button is pressed or message is displayed for specified time.

If the error persists:

1. Wait until the Pending FAX Jobs will be sent, or delete the Pending FAX data.
2. Try dividing the FAX data into smaller blocks or converting the data to a smaller format.
3. Update to the latest F/W.
4. Ensure that the error is replicated after the printer is powered **Off** and then **On**, and then replace the following parts in sequence.
 - (REP 5.4 Fax PWB)
 - (REP 5.1 ESS PWB)

FIP 1. 92

017-990 IIT Auto Registration Adjustment Fail

Cause:

Fail to adjust IIT registration automatically at start-up. Set to default value and continue processing.

Solution:

The machine will recover after the **OK** button is pressed or message is displayed for specified time.

If the error persists:

1. Wait until the Pending FAX Jobs will be sent, or delete the Pending FAX data.
2. Try dividing the FAX data into smaller blocks or converting the data to a smaller format.
3. Update to the latest F/W.
4. Ensure that the error is replicated after the printer is powered **Off** and then **On**, and then replace the following parts in sequence.
 - (REP 5.4 Fax PWB)
 - (REP 5.1 ESS PWB)

FIP 1. 93

017-991 IIT Level Adjustment Fail

Cause:

At the start of IIT read job, fail to adjust IIT level.
Set to default value and continue processing.

Solution:

The machine will recover automatically.

If the error persists:

1. Turn the power **Off** and **On** to check that the error recurs.
2. Replace ([REP 6.1 IIT Assembly](#))

FIP 1. 94

018-722 Google Cloud Print Network Error

Cause:

A network-related error has occurred.

Solution:

The machine will recover after the **OK** button is pressed or message is displayed for specified time.

If the error persists:

1. Check the network connection status and the network settings.
2. Perform the following in sequence.
 - " Network System Fault Check"
 - " Network-related Details Check Flow"
3. Update to the latest F/W.
4. Ensure that the error is replicated after the printer is powered **Off** and then **On**, and then replace ([REP 5.1 ESS PWB](#)).

FIP 1. 95

018-723 Google Cloud Print Certificate Error

Cause:

A certificate connection error has occurred.

Solution:

The machine will recover after the **OK** button is pressed or message is displayed for specified time.

If the error persists:

1. Check whether the Root CA Certificate(s) is correct, or if the certificate validation settings are correct.
2. Perform the following in sequence.
 - " Network System Fault Check"
 - " Network-related Details Check Flow"
3. Update to the latest F/W.
4. Ensure that the error is replicated after the printer is powered **Off** and then **On**, and then replace ([REP 5.1 ESS PWB](#)).

FIP 1. 96

018-724 Google Cloud Print SSL Error

Cause:

An SSL connection error has occurred.

Solution:

The machine will recover after the **OK** button is pressed or message is displayed for specified time.

If the error persists:

1. Check the SSL connection status and settings.
2. Perform the following in sequence.
 - " Network System Fault Check"
 - " Network-related Details Check Flow"
3. Update to the latest F/W.
4. Ensure that the error is replicated after the printer is powered **Off** and then **On**, and then replace ([REP 5.1 ESS PWB](#)).

FIP 1. 97

018-729 Google Cloud Print Timeout Error

Cause:

A timeout has led to an error.

Solution:

The machine will recover after the **OK** button is pressed or message is displayed for specified time.

If the error persists:

1. Check the network connection status and the network settings.
2. The network may be congested.
3. Perform the following in sequence.
 - " Network System Fault Check"
 - " Network-related Details Check Flow"
4. Update to the latest F/W.
5. Ensure that the error is replicated after the printer is powered **Off** and then **On**, and then replace ([REP 5.1 ESS PWB](#)).

FIP 1. 98

018-730 Google Cloud Print Network Other Error

Cause:

A network-related internal error has occurred.

Solution:

The machine will recover after the **OK** button is pressed or message is displayed for specified time.

If the error persists:

1. Check the network connection status and settings. Contact customer support if the issue recurs. Perform the following in sequence.
 - " Network System Fault Check"
 - " Network-related Details Check Flow"
2. Update to the latest F/W.
3. Ensure that the error is replicated after the printer is powered **Off** and then **On**, and then replace ([REP 5.1 ESS PWB](#)).

FIP 1. 99

018-737 Google Cloud Print Other Error

Cause:

Another internal error has occurred.

Solution:

The machine will recover after the **OK** button is pressed or message is displayed for specified time.

If the error persists:

1. Check the settings, and try again.
2. Contact customer support if the issue reoccurs.
3. Perform the following in sequence.
 - " Network System Fault Check"
 - " Network-related Details Check Flow"
4. Update to the latest F/W.
5. Ensure that the error is replicated after the printer is powered **Off** and then **On**, and then replace ([REP 5.1 ESS PWB](#)).

FIP 1. 100

018-738 Google Cloud Print XMPP Network Error

Cause:

A XMPP protocol network-related internal error has occurred.

Solution:

The machine will recover after the **OK** button is pressed or message is displayed for specified time.

If the error persists:

1. Check the network connection status and the network settings.
2. Perform the following in sequence.
 - " Network System Fault Check"
 - " Network-related Details Check Flow"
3. Update to the latest F/W.
4. Ensure that the error is replicated after the printer is powered **Off** and then **On**, and then replace ([REP 5.1 ESS PWB](#)).

FIP 1. 101

018-739 Google Cloud Print XMPP Network Other Error

Cause:

A XMPP protocol network-related internal error has occurred.

Solution:

The machine will recover after the **OK** button is pressed or message is displayed for specified time.

If the error persists:

1. Check the network connection status and the network settings.
2. Perform the following in sequence.
 - " Network System Fault Check"
 - " Network-related Details Check Flow"
3. Update to the latest F/W.
4. Ensure that the error is replicated after the printer is powered **Off** and then **On**, and then replace ([REP 5.1 ESS PWB](#)).

FIP 1. 102

018-740 Google Cloud Print XMPP Certificate Error

Cause:

A XMPP protocol network-related certificate connection error has occurred.

Solution:

The machine will recover after the **OK** button is pressed or message is displayed for specified time.

If the error persists:

1. Check whether the Root CA Certificate(s) and settings are is correct.
2. Perform the following in sequence.
 - " Network System Fault Check"
 - " Network-related Details Check Flow"
3. Update to the latest F/W.
Ensure that the error is replicated after the printer is powered **Off** and then **On**, and then replace ([REP 5.1 ESS PWB](#)).

FIP 1. 103

018-741 Google Cloud Print XMPP Other Error

Cause:

Another XMPP protocol error has occurred.
Check the settings, and try again.

Solution:

The machine will recover after the **OK** button is pressed or message is displayed for specified time.

If the error persists:

1. Check the settings, and try again. Contact customer support if the issue reoccurs.
2. Perform the following in sequence.
 - " Network System Fault Check"
 - " Network-related Details Check Flow"
3. Update to the latest F/W.
4. Ensure that the error is replicated after the printer is powered **Off** and then **On**, and then replace ([REP 5.1 ESS PWB](#)).

FIP 1. 104

018-743 Google Cloud Print Proxy Error

Cause:

A network-related (proxy connection) error has occurred.

Solution:

The machine will recover after the **OK** button is pressed or message is displayed for specified time.

If the error persists:

1. Check the network connection status, especially the proxy settings.
2. Perform the following in sequence.
 - " Network System Fault Check"
 - " Network-related Details Check Flow"
3. Update to the latest F/W.
4. Ensure that the error is replicated after the printer is powered **Off** and then **On**, and then replace ([REP 5.1 ESS PWB](#)).

FIP 1. 105

018-744 Google Cloud Print DNS Resolve Error

Cause:

A network-related (DNS Name Resolution) error has occurred.

Solution:

The machine will recover after the **OK** button is pressed or message is displayed for specified time.

If the error persists:

1. Check the network connection status, especially the DNS settings.
2. Perform the following in sequence.
 - " Network System Fault Check"
 - " Network-related Details Check Flow"
3. Update to the latest F/W.
4. Ensure that the error is replicated after the printer is powered **Off** and then **On**, and then replace ([REP 5.1 ESS PWB](#)).

FIP 1. 106

018-745 Google Cloud Print XMPP Proxy Error

Cause:

A XMPP protocol network-related (proxy connection) error has occurred.

Solution:

The machine will recover after the **OK** button is pressed or message is displayed for specified time.

If the error persists:

1. Check the network connection status, especially the proxy settings.
2. Perform the following in sequence.
 - " Network System Fault Check"
 - " Network-related Details Check Flow"
3. Update to the latest F/W.
4. Ensure that the error is replicated after the printer is powered **Off** and then **On**, and then replace ([REP 5.1 ESS PWB](#)).

FIP 1. 107

018-746 Google Cloud Print XMPP DNS Resolve Error

Cause:

A XMPP protocol network-related (DNS Name Resolution) error has occurred.

Solution:

The machine will recover after the **OK** button is pressed or message is displayed for specified time.

If the error persists:

1. Check the network connection status, especially the DNS settings.
2. Perform the following in sequence.
 - " Network System Fault Check"
 - " Network-related Details Check Flow"
3. Update to the latest F/W.
4. Ensure that the error is replicated after the printer is powered **Off** and then **On**, and then replace ([REP 5.1 ESS PWB](#)).

FIP 1. 108

024-340 Engine Controller Error

Cause:

Engine firmware error occurs.

Solution:

1. Turn the power **Off** and **On** to check that the error recurs.
2. Update to the latest F/W.
3. If the problem cannot be solved, replace ([REP 5.6 MCU PWB](#)).

FIP 1. 109

024-360 Engine Code Download Error

Cause:

Download failure of MCU firmware.

Solution:

1. Turn the power **Off** and **On** to check that the error recurs.
2. Update to the latest F/W.
3. If the problem cannot be solved, replace ([REP 5.6 MCU PWB](#)).

FIP 1. 110

024-362 Print Engine Start Error

Cause:

"Start Image Making" has not been issued within the time allowed.

Solution:

1. Turn the power **Off** and **On** to check that the error recurs.
2. Update to the latest F/W.
3. If the problem cannot be solved, replace the following parts in sequence.
 - ([REP 5.6 MCU PWB](#))
 - ([REP 5.1 ESS PWB](#))

FIP 1. 111

024-371 Engine Communication Error

Cause:

Communication fail between MCU and ESS.

Solution:

Turn the power **Off** and **On** to check that the error recurs, then proceed to the FIP.

Step	Check and Action	Yes	No
1	Check the connection between the MCU PWB and the ESS PWB. <ul style="list-style-type: none"> Is the ESS HARNESS ASSEMBLY connected securely? 	Go to Step 2.	Securely connect the ESS HARNESS ASSEMBLY
2	<ul style="list-style-type: none"> Replace the ESS HARNESS ASSEMBLY. Does an error occur? 	Go to Step 3.	Troubleshooting complete.
3	<ul style="list-style-type: none"> Replace (REP 5.6 MCU PWB). Does an error occur? 	Replace (REP 5.1 ESS PWB)	Troubleshooting complete.

FIP 1. 112

024-910 Tray 1 Paper Size Mismatch

Cause:

The size of paper in the Tray 1 does not match the specified print size.

Solution:

1. Open/close Tray, or reset paper on the manual feed tray.
2. Use the paper that meets the specifications.
3. Make sure that you are using the correct printer driver.
4. Check the Paper Size and Paper Type of the Tray Setting menu on the printer operator panel and the printer driver.
5. If the problem cannot be solved, replace the corresponding paper feed rolls.
 - TRAY 1 FEED ROLL / NUDGER ROLL ([PL 2.3 Feed Assembly](#))
 - TRAY 1 RETARD ROLL ([PL 7.3 Tray 1/Optional Tray 550-Sheet Feeder \(3/4\)](#))
 - RUBBER ROLL ASSEMBLY ([PL 2.2 Transport Assembly](#))
 - REGI PINCHROLL ASSEMBLY ([PL 2.2 Transport Assembly](#))
 - REGI PINCH ROLL ([PL 2.2 Transport Assembly](#))

FIP 1. 113

024-911 Tray 2 Paper Size Mismatch

024-912 Tray 3 Paper Size Mismatch

024-913 Tray 4 Paper Size Mismatch

Cause:

024-911: The size of paper in the Tray 2 does not match the specified print size.

024-912: The size of paper in the Tray 3 does not match the specified print size.

024-913: The size of paper in the Tray 4 does not match the specified print size.

Solution:

1. Open/close Tray, or reseal paper on manual feed tray.
2. Use the paper that meets the specifications.
3. Make sure that you are using the correct printer driver.
4. Check the Paper Size and Paper Type of the Tray Setting menu on the printer operator panel and the printer driver.
5. If the problem cannot be solved, replace the corresponding paper feed rolls.
 - FEED ROLL / NUDGER ROLL (PL 7.2 Tray 1/Optional Tray 550-Sheet Feeder (2/4))
 - RETARD ROLL (PL 7.3 Tray 1/Optional Tray 550-Sheet Feeder (3/4))
 - TAKE AWAYROLL ASSEMBLY (PL 7.2 Tray 1/Optional Tray 550-Sheet Feeder (2/4))
 - TAKE AWAYROLL PINCH (PL 7.4 Tray 1/Optional Tray 550-Sheet Feeder (4/4))
 - RUBBER ROLL ASSEMBLY (PL 2.2 Transport Assembly)
 - REGI PINCHROLL ASSEMBLY (PL 2.2 Transport Assembly)
 - REGI PINCH ROLL (PL 2.2 Transport Assembly)

FIP 1. 114

024-920 IOT Standard Stacker Full

Cause:

Output Tray Full is Detected.

Solution:

1. Remove the paper from the Output Tray.
2. If the error persists, ensure that the error is replicated after the printer is powered **Off** and then **On**, and then proceed to the FIP.

Step	Check and Action	Yes	No
1	<ul style="list-style-type: none"> Check the shapes of the ACTUATOR FULL STACK Do the ACTUATOR FULL STACK move smoothly? Do they have any damage? 	Replace the ACTUATOR FULL STACK.	Go to Step 2.
2	<ul style="list-style-type: none"> Execute the Diag Digital Input 071-122 to check the operation of the FULL STACK SENSOR. Is the FULL STACK SENSOR operating normally? 	Replace (REP 5.6 MCU PWB)	Go to FIP 2.02

FIP 1.115

024-958 MSI Paper Size Mismatch

Cause:

The size of paper in the MSI does not match the specified print size.

Solution:

1. Open/close Tray, or reseal paper on manual feed tray.
2. Use the paper that meets the specifications.
3. Make sure that you are using the correct printer driver.
4. Check the Paper Size and Paper Type of the Tray Setting menu on the printer operator panel and the printer driver.
5. If the problem cannot be solved, replace the corresponding paper feed rolls.
 - MSI FEED ROLL / NUDGER ROLL (PL 2.6 MSI)
 - MSI RETARD ROLL (PL 2.7 Bypass Tray)
 - RUBBER ROLL ASSEMBLY (PL 2.2 Transport Assembly)
 - REGI PINCHROLL ASSEMBLY (PL 2.2 Transport Assembly)
 - REGI PINCH ROLL (PL 2.2 Transport Assembly)

FIP 1. 116

024-959 Tray 1 No Suitable Paper

024-960 Tray 2 No Suitable Paper

024-961 Tray 3 No Suitable Paper

024-962 Tray 4 No Suitable Paper

024-963 MSI No Suitable Paper

Cause:

- Displayed when any of the following errors occur and tray setting needs to be changed after paper is loaded.
- When paper source auto selection is selected, paper sizes of all existing trays do not match. (All Tray Size Mismatch)
- When a tray is specified, no paper is loaded in the specified tray. (Specified Tray Emptied)
- When a tray is specified, paper size loaded in the specified tray does not match. (Specified Tray Size Mismatch)
- When Substitute Tray is Off and a paper type is specified, there is no tray loading the specified paper type. (Specified Tray Media Mismatch)

Solution:

1. Change tray setting, or cancel the job.
2. Use the paper that meets the specifications.
3. Check the Paper Size of the Tray Setting menu on the printer operator panel and the printer driver.

FIP 1. 117

026-720 USB Memory Full

Cause:

Writing to USB memory failed.

Solution:

The machine will recover after the **OK** or **Close** button is pressed or message is displayed for specified time.

If the error persists:

1. Delete unnecessary data. Change the USB Memory that satisfies the specification.
2. Ensure that the error is replicated after the printer is powered **Off** and then **On**, and then replace the following parts in sequence.
 - (REP 5.5 Front USB PWB)
 - (REP 5.1 ESS PWB)

FIP 1. 118

026-721 USB Memory Write Error

Cause:

Writing to USB memory failed.

Solution:

The machine will recover after the **OK** or **Close** button is pressed or message is displayed for specified time.

If the error persists:

1. Change the USB Memory that satisfies the specification.
2. Ensure that the error is replicated after the printer is powered **Off** and then **On**, and then replace the following parts in sequence.
 - (REP 5.5 Front USB PWB)
 - (REP 5.1 ESS PWB)

FIP 1. 119

027-446 IPv6 Duplicate

Cause:

At start-up, detect duplicate IPv6 address on network.

Solution:

1. Duplicate IPv6 addresses have been detected. Contact the system administrator.
2. Remove duplicates and then power off the printer and then on. Take corrective actions at the host side.

FIP 1. 120

027-452 IPv4 duplicate

Cause:

At start-up, detect duplicate IPv4 address on network.

Solution:

1. Duplicate IPv4 addresses have been detected. Contact the system administrator.
2. Remove duplicates and then power off the printer and then on. Take corrective actions at the host side.

FIP 1. 121

031-521 SMB Error

Cause:

In SMB scan, login-able workstation is restricted.

Solution:

The machine will recover after the **OK** or **Close** button is pressed or message is displayed for specified time.

If the error persists:

1. About user settings, confirm the following with the system administrator. Restriction on login-able workstation.
2. Perform the following in sequence.
 - " Network System Fault Check"
 - " Network-related Details Check Flow"
3. Ensure that the error is replicated after the printer is powered **Off** and then **On**, and then replace ([REP 5.1 ESS PWB](#)).

FIP 1. 122

031-522 SMB user authentication fail or SMB Scanner login fail

Cause:

In SMB scan, login access is rejected. Request is not allowed.

Solution:

The machine will recover after the **OK** or **Close** button is pressed or message is displayed for specified time.

If the error persists:

1. About user settings, confirm the following with the system administrator. Restriction on login-able workstation.
2. Perform the following in sequence.
 - " Network System Fault Check"
 - " Network-related Details Check Flow"
3. Ensure that the error is replicated after the printer is powered **Off** and then **On**, and then replace ([REP 5.1 ESS PWB](#)).

FIP 1. 123

031-523 Problem with share name in SMB scan server

Cause:

Problem with share name in SMB scan server.

Solution:

The machine will recover after the **OK** or **Close** button is pressed or message is displayed for specified time.

If the error persists:

1. Check SMB Server connection, or check share name you specified.
2. Perform the following in sequence.
 - " Network System Fault Check"
 - " Network-related Details Check Flow"
3. Ensure that the error is replicated after the printer is powered **Off** and then **On**, and then replace ([REP 5.1 ESS PWB](#)).

FIP 1. 124

031-524 SMB Scan User Over limit

Cause:

Exceed the upper limit of the number of SMB scan users.

Solution:

The machine will recover after the **OK** or **Close** button is pressed or message is displayed for specified time.

If the error persists:

1. Check the number of users who use the server at the same time is not exceeding the upper limit.
2. Perform the following in sequence.
 - " Network System Fault Check"
 - " Network-related Details Check Flow"
3. Ensure that the error is replicated after the printer is powered **Off** and then **On**, and then replace ([REP 5.1 ESS PWB](#)).

FIP 1. 125

031-525 SMB Error

Cause:

SMB scan client has no access right (Win9x).

Solution:

The machine will recover after the **OK** or **Close** button is pressed or message is displayed for specified time.

If the error persists:

1. Check if the specified user can read and write file at the storage location.
2. Perform the following in sequence.
 - " Network System Fault Check"
 - " Network-related Details Check Flow"
3. Ensure that the error is replicated after the printer is powered **Off** and then **On**, and then replace ([REP 5.1 ESS PWB](#)).

FIP 1. 126

031-526 SMB Scan Host Name Resolution Fail

Cause:

SMB server name resolution failed.

Solution:

The machine will recover after the **OK** or **Close** button is pressed or message is displayed for specified time.

If the error persists:

1. Check DNS connection, or check if name of forwarding destination server is registered with DNS.
2. Perform the following in sequence.
 - " Network System Fault Check"
 - " Network-related Details Check Flow"
3. Ensure that the error is replicated after the printer is powered **Off** and then **On**, and then replace ([REP 5.1 ESS PWB](#)).

FIP 1. 127

031-527 SMB Scan DNS Server Not Set

Cause:

DNS server is not set.

Solution:

The machine will recover after the **OK** or **Close** button is pressed or message is displayed for specified time.

If the error persists:

1. Set DNS address, or set forwarding destination server address as IP address.
2. Perform the following in sequence.
 - " Network System Fault Check"
 - " Network-related Details Check Flow"
3. Take corrective actions at the host side.

FIP 1. 128

031-528 In SMB scan, server connection error

Cause:

Cannot find SMB server.

Solution:

The machine will recover after the **OK** or **Close** button is pressed or message is displayed for specified time.

If the error persists:

1. Check if this device can communicate by network with the forwarding destination SMB server.
 - Check connection of network cable, then check the TCP/IP setting.
 - Check communication with Port 137(UDP), 138(UDP), and 139(TCP).
2. Check setting of WINS server and if server name can be resolved correctly.
3. Perform the following in sequence.
 - " Network System Fault Check"
 - " Network-related Details Check Flow"
4. Ensure that the error is replicated after the printer is powered **Off** and then **On**, and then replace ([REP 5.1 ESS PWB](#)).

FIP 1. 129

031-529 Problem with SMB scan login name or password

Cause:

Invalid password (Win9x).

Solution:

The machine will recover after the **OK** or **Close** button is pressed or message is displayed for specified time.

If the error persists:

1. Check if password is correct.
2. Perform the following in sequence.
 - " Network System Fault Check"
 - " Network-related Details Check Flow"
3. Ensure that the error is replicated after the printer is powered **Off** and then **On**, and then replace ([REP 5.1 ESS PWB](#)).

FIP 1. 130

031-530 Problem with storage location of scanned image in SMB scan server

Cause:

Problem with storage location.

Solution:

The machine will recover after the **OK** or **Close** button is pressed or message is displayed for specified time.

If the error persists:

1. Check if the storage location is correct.
2. Storage location you specified is DFS setting and check if it is linked to other server.
3. Specify the linked server, share name, and storage location.
4. Perform the following in sequence.
 - " Network System Fault Check"
 - " Network-related Details Check Flow"
5. Ensure that the error is replicated after the printer is powered **Off** and then **On**, and then replace ([REP 5.1 ESS PWB](#)).

FIP 1. 131

031-531 Couldn't get file/folder name of SMB scan server

Cause:

Couldn't get file/folder name of server.

Solution:

The machine will recover after the **OK** or **Close** button is pressed or message is displayed for specified time.

If the error persists:

1. Check access right of the folder you specified.
2. Perform the following in sequence.
 - " Network System Fault Check"
 - " Network-related Details Check Flow"
3. Ensure that the error is replicated after the printer is powered **Off** and then **On**, and then replace ([REP 5.1 ESS PWB](#)).

FIP 1. 132

031-532 Suffix of SMB scan file name/folder name is over limit

Cause:

Suffix of file name/folder name is over limit.

Solution:

The machine will recover after the **OK** or **Close** button is pressed or message is displayed for specified time.

If the error persists:

1. Change file name/forwarding destination folder, or move or delete file in forwarding destination folder.
2. Perform the following in sequence.
 - " Network System Fault Check"
 - " Network-related Details Check Flow"
3. Take corrective actions at the host side.

FIP 1. 133

031-533 SMB Scan File Creation Fail

Cause:

Fail to create file.

Solution:

The machine will recover after the **OK** or **Close** button is pressed or message is displayed for specified time.

If the error persists:

1. Check if the file name you specified can be created in storage location.
2. Check if the file name you specified is not used by other user.
3. Check if file or folder whose name is the same as the one you specified already exists.
4. Perform the following in sequence.
 - " Network System Fault Check"
 - " Network-related Details Check Flow"
5. Take corrective actions at the host side.

FIP 1. 134

031-534 SMB Scan Folder Creation Fail

Cause:

Fail to create folder.

Solution:

The machine will recover after the **OK** or **Close** button is pressed or message is displayed for specified time.

If the error persists:

1. Check if the file name you specified can be created in storage location.
2. Check if file or folder whose name is the same as the one you specified already exists.
3. Perform the following in sequence.
 - " Network System Fault Check"
 - " Network-related Details Check Flow"
4. Take corrective actions at the host side.

FIP 1. 135

031-535 SMB Scan File Deletion Fail

Cause:

Fail to delete file.

Solution:

The machine will recover after the **OK** or **Close** button is pressed or message is displayed for specified time.

If the error persists:

1. Check if other user is not operating file in storage location you specified.
2. Perform the following in sequence.
 - " Network System Fault Check"
 - " Network-related Details Check Flow"
3. Take corrective actions at the host side.

FIP 1. 136

031-536 SMB Scan Folder Deletion Fail

Cause:

Fail to delete folder.

Solution:

The machine will recover after the **OK** or **Close** button is pressed or message is displayed for specified time.

If the error persists:

1. Check if other user is not operating file in storage location you specified.
2. Perform the following in sequence.
 - " Network System Fault Check"
 - " Network-related Details Check Flow"
3. Take corrective actions at the host side.

FIP 1. 137

031-537 No free space in storage location on SMB scan data server

Cause:

Storage location has no free space.

Solution:

The machine will recover after the **OK** or **Close** button is pressed or message is displayed for specified time.

If the error persists:

1. Check storage location has free space.
2. Perform the following in sequence.
 - " Network System Fault Check"
 - " Network-related Details Check Flow"
3. Take corrective actions at the host side.

FIP 1. 138

031-539 Invalid SMB server (Net BIOS) name is specified

Cause:

Invalid SMB server (Net BIOS) name is specified

Solution:

The machine will recover after the **OK** or **Close** button is pressed or message is displayed for specified time.

If the error persists:

1. Check if server name is correct.
2. Perform the following in sequence.
 - " Network System Fault Check"
 - " Network-related Details Check Flow"
3. Take corrective actions at the host side.

FIP 1. 139

031-540 SMB protocol error(4-007)Invalid scan domain name is specified

Cause:

Invalid domain name is specified.
(User name is specified in domain user form)

Solution:

The machine will recover after the **OK** or **Close** button is pressed or message is displayed for specified time.

If the error persists:

1. Check if domain name is correct.
2. Perform the following in sequence.
 - " Network System Fault Check"
 - " Network-related Details Check Flow"
3. Take corrective actions at the host side.

FIP 1. 140

031-541 SMB protocol error (4-008) Invalid scan user name is specified

Cause:

Invalid scan user name is specified.

Solution:

The machine will recover after the **OK** or **Close** button is pressed or message is displayed for specified time.

If the error persists:

1. Check if login name (user name) is correct.
2. Perform the following in sequence.
 - " Network System Fault Check"
 - " Network-related Details Check Flow"
3. Ensure that the error is replicated after the printer is powered **Off** and then **On**, and then replace ([REP 5.1 ESS PWB](#)).

FIP 1. 141

031-542 SMB(TCP/IP) is not active

Cause:

SMB(TCP/IP) is not active.

Solution:

The machine will recover after the **OK** or **Close** button is pressed or message is displayed for specified time.

If the error persists:

1. Wait for a short period of time and try the same operation again.
2. Perform the following in sequence.
 - " Network System Fault Check"
 - " Network-related Details Check Flow"
3. Take corrective actions at the host side.

FIP 1. 142

031-543 SMB protocol error(4-045)Scan login prohibited time

Cause:

Login prohibited time.

Solution:

The machine will recover after the **OK** or **Close** button is pressed or message is displayed for specified time.

If the error persists:

1. On user settings, check the Login permitted time with system administrator.
2. Perform the following in sequence.
 - " Network System Fault Check"
 - " Network-related Details Check Flow"
3. Take corrective actions at the host side.

FIP 1. 143

031-544 SMB protocol error(4-046) Password expired

Cause:

Password expired.

Solution:

The machine will recover after the **OK** or **Close** button is pressed or message is displayed for specified time.

If the error persists:

1. On user settings, check the password valid period with system administrator.
2. Perform the following in sequence.
 - " Network System Fault Check"
 - " Network-related Details Check Flow"
3. Take corrective actions at the host side.

FIP 1. 144

031-545 SMB protocol error(4-047) Password change is required

Cause:

Password change is required.

Solution:

The machine will recover after the **OK** or **Close** button is pressed or message is displayed for specified time.

If the error persists:

1. On user settings, check the necessity of password change with system administrator.
2. Perform the following in sequence.
 - " Network System Fault Check"
 - " Network-related Details Check Flow"
3. Take corrective actions at the host side.

FIP 1. 145

031-546 SMB protocol error(4-048)User is invalid

Cause:

User is invalid.

Solution:

The machine will recover after the **OK** or **Close** button is pressed or message is displayed for specified time.

If the error persists:

1. On user settings, check the user invalid setting with system administrator.
2. Perform the following in sequence.
 - " Network System Fault Check"
 - " Network-related Details Check Flow"
3. Ensure that the error is replicated after the printer is powered **Off** and then **On**, and then replace ([REP 5.1 ESS PWB](#)).

FIP 1. 146

031-547 SMB protocol error(4-049)Lock-out

Cause:

User is locked out.

Solution:

The machine will recover after the **OK** or **Close** button is pressed or message is displayed for specified time.

If the error persists:

1. On user settings, check the user lock-out status with system administrator.
2. Perform the following in sequence.
 - " Network System Fault Check"
 - " Network-related Details Check Flow"
3. Ensure that the error is replicated after the printer is powered **Off** and then **On**, and then replace ([REP 5.1 ESS PWB](#)).

FIP 1. 147

031-548 SMB protocol error (4-050) User is expired

Cause:

User is expired.

Solution:

The machine will recover after the **OK** or **Close** button is pressed or message is displayed for specified time.

If the error persists:

1. On user settings, check the user valid period with system administrator.
2. Perform the following in sequence.
 - " Network System Fault Check"
 - " Network-related Details Check Flow"
3. Take corrective actions at the host side.

FIP 1. 148

031-549 SMB protocol error (4-051) User is restricted. Null password is prohibited

Cause:

User is restricted. Null password is prohibited.

Solution:

The machine will recover after the **OK** or **Close** button is pressed or message is displayed for specified time.

If the error persists:

1. On server security settings, check the access permission of a password user.
2. Perform the following in sequence.
 - " Network System Fault Check"
 - " Network-related Details Check Flow"
3. Take corrective actions at the host side.

FIP 1. 149

031-550 SMB Scan Append Command Fail

Cause:

Have no append access right to the file.
Server does not support SMB append command.

Solution:

The machine will recover after the **OK** or **Close** button is pressed or message is displayed for specified time.

If the error persists:

1. Check append access right to the file. Check server supports SMB append command.
2. Perform the following in sequence.
 - " Network System Fault Check"
 - " Network-related Details Check Flow"
3. Take corrective actions at the host side.

FIP 1. 150

031-551 SMB Scan Rename Command Fail

Cause:

Have no rename access right to the file.
Server does not support SMB rename command.

Solution:

The machine will recover after the **OK** or **Close** button is pressed or message is displayed for specified time.

If the error persists:

1. Check rename access right to the file. Check server supports SMB rename command.
2. Perform the following in sequence.
 - " Network System Fault Check"
 - " Network-related Details Check Flow"
3. Take corrective actions at the host side.

FIP 1. 151

031-552 SMB scan

Cause:

Cancel is selected for processing in the case of file name duplication, and job is cancelled because of file name duplication.

Solution:

The machine will recover after the **OK** or **Close** button is pressed or message is displayed for specified time.

If the error persists:

1. Set other than "Cancel" for processing in the case of file name duplication, or change/delete the file name the same as the one specified in sending a destination folder.
2. Perform the following in sequence.
 - " Network System Fault Check"
 - " Network-related Details Check Flow"
3. Take corrective actions at the host side.

FIP 1. 152

031-574 FTP Scan Host Name Resolution Fail

Cause:

DNS library call error.

Solution:

The machine will recover after the **OK** or **Close** button is pressed or message is displayed for specified time.

If the error persists:

1. Check DNS connection, or check if name of forwarding destination server is registered with DNS.
2. Take corrective actions at the host side.

FIP 1. 153

031-575 FTP Scan DNS Server Not Set

Cause:

DNS library call error.

Solution:

The machine will recover after the **OK** or **Close** button is pressed or message is displayed for specified time.

If the error persists:

1. Set DNS address, or set forwarding destination server address as IP address.
2. Take corrective actions at the host side.

FIP 1. 154

031-576 Server Connection Error in FTP Scan

Cause:

Network connection failed.

Solution:

The machine will recover after the **OK** or **Close** button is pressed or message is displayed for specified time.

If the error persists:

1. Check if this device can communicate with forwarding destination FTP server.
 - Check if server's IP address is correct.
 - Check connection of network cable.
2. Take corrective actions at the host side.

FIP 1. 155

031-578 FTP Scan Login Name or Password Error

Cause:

USER/PASS command failed.

Solution:

The machine will recover after the **OK** or **Close** button is pressed or message is displayed for specified time.

If the error persists:

1. Check if the login name (user name) and password are correct.
2. Take corrective actions at the host side.

FIP 1. 156

031-579 Problem with Location FTP-scanned Image is Saved in

Cause:

Fail to move data to Repository Path.

Solution:

The machine will recover after the **OK** or **Close** button is pressed or message is displayed for specified time.

If the error persists:

1. Check if storage location is correct.
2. Take corrective actions at the host side.

FIP 1. 157

031-580 Fail to get file name/folder name of FTP scan server

Cause:

NLST command failed.

Solution:

The machine will recover after the **OK** or **Close** button is pressed or message is displayed for specified time.

If the error persists:

1. Check server access right.
2. Take corrective actions at the host side.

FIP 1. 158

031-581 Suffix of FTP scan file name/folder name is over limit

Cause:

Same as left.

Solution:

The machine will recover after the **OK** or **Close** button is pressed or message is displayed for specified time.

If the error persists:

1. Change file name / forwarding destination folder, or move or delete file in forwarding destination folder.
2. Take corrective actions at the host side.

FIP 1. 159

031-582 FTP Scan File Creation Fail

Cause:

STOR command failed.

Solution:

The machine will recover after the **OK** or **Close** button is pressed or message is displayed for specified time.

If the error persists:

1. Check if the file name you specified can be created in storage location.
2. Check if there is free space in the storage location.
3. Take corrective actions at the host side.

FIP 1. 160

031-584 FTP Scan Folder Creation Fail

Cause:

MKD command failed.

Solution:

The machine will recover after the **OK** or **Close** button is pressed or message is displayed for specified time.

If the error persists:

1. Check if the folder name you specified can be created in storage location.
2. Check if the folder whose name is the same as the one you specified already exists.
3. Take corrective actions at the host side.

FIP 1. 161

031-585 FTP Scan File Deletion Fail

Cause:

DEL command failed.

Solution:

The machine will recover after the **OK** or **Close** button is pressed or message is displayed for specified time.

If the error persists:

1. Check server access right.
2. Take corrective actions at the host side.

FIP 1. 162

031-587 FTP Scan Folder Deletion Fail

Cause:

RMD command failed.

Solution:

The machine will recover after the **OK** or **Close** button is pressed or message is displayed for specified time.

If the error persists:

1. Check server access right.
2. Take corrective actions at the host side.

FIP 1. 163

031-588 FTP Scan Server Data Write Fail

Cause:

Data writing to FTP scan server has failed.

Solution:

The machine will recover after the **OK** or **Close** button is pressed or message is displayed for specified time.

If the error persists:

1. Check if there is free space in storage location.
2. Take corrective actions at the host side.

FIP 1. 164

031-590 FTP Error

Cause:

Cancel is selected for processing in the case of file name duplication, and job is cancelled because of file name duplication.

Solution:

The machine will recover after the **OK** or **Close** button is pressed or message is displayed for specified time.

If the error persists:

1. Set other than "Cancel" for processing in the case of file name duplication, or change/delete file name the same as the one specified in sending destination folder.
2. Take corrective actions at the host side.

FIP 1. 165

031-594 FTP Scan TYPE Command Fail (Network Error)

Cause:

TYPE command failed.

Solution:

The machine will recover after the **OK** or **Close** button is pressed or message is displayed for specified time.

If the error persists:

1. Do the same operation again.
2. If still not improved, contact the system administrator.
3. Check whether you have the access permission for appending files, or whether the server supports the append command of FTP.
4. Take corrective actions at the host side.

FIP 1. 166

031-595 FTP Scan PORT Command Fail (Network Error)

Cause:

PORT command failed.

Solution:

The machine will recover after the **OK** or **Close** button is pressed or message is displayed for specified time.

If the error persists:

1. Do the same operation again.
2. If still not improved, contact the system administrator. Check whether you have the access permission for renaming files, or whether the server supports the rename command of FTP.
3. Take corrective actions at the host side.

FIP 1. 167

031-598 FTP Scan Append Command Fail

Cause:

APPE command failed.

Solution:

The machine will recover after the **OK** or **Close** button is pressed or message is displayed for specified time.

If the error persists:

1. Check append access right to the file. Check server supports FTP append command.
2. Take corrective actions at the host side.

FIP 1. 168

031-599 FTP Scan Rename Command Fail

Cause:

RNFR command or RNTD command failed.

Solution:

The machine will recover after the **OK** or **Close** button is pressed or message is displayed for specified time.

If the error persists:

1. Check rename access right to the file. Check that the server supports FTP rename command.
2. Take corrective actions at the host side.

FIP 1. 169

033-501 Fax Codec Error

Cause:

Cancel Codec processing due to error of read part during manual send.

Solution:

The machine will recover after the **OK** or **Close** button is pressed or message is displayed for specified time.

If the error persists:

1. Turn the power **Off** and **On** to check that the error recurs.
2. Update to the latest F/W.
3. If the problem cannot be solved, replace the following parts in sequence.
 - (REP 5.1 ESS PWB)
 - (REP 6.1 IIT Assembly)

FIP 1. 170

033-502 File Open Error

Cause:

File open error.

Solution:

The machine will recover after the **OK** or **Close** button is pressed or message is displayed for specified time.

If the error persists:

1. Turn the power **Off** and **On** to check that the error recurs.
2. Update to the latest F/W.
3. If the problem cannot be solved, replace ([REP 5.1 ESS PWB](#)).

FIP 1. 171

033-503 Memory Full

Cause:

In receive, memory full.

Solution:

The machine will recover after the **OK** or **Close** button is pressed or message is displayed for specified time.

If the error persists:

1. Wait until the Pending FAX Jobs will be sent.Or delete the Pending FAX data.
2. Try dividing the FAX data into smaller blocks or converting the data to a smaller format.
3. Update to the latest F/W.
4. Ensure that the error is replicated after the printer is powered **Off** and then **On**, and then replace the following parts in sequence.
 - ([REP 5.4 Fax PWB](#))
 - ([REP 5.1 ESS PWB](#))

FIP 1. 172

033-510 Fax Codec Error

Cause:

In JBIG data decode, error in the number of decode line in one stripe.

Solution:

The machine will recover after the **OK** or **Close** button is pressed or message is displayed for specified time.

If the error persists:

1. Turn the power **Off** and **On** to check that the error recurs.
2. Update to the latest F/W.
3. If the problem cannot be solved, replace the following parts in sequence.
 - (REP 5.4 Fax PWB)
 - (REP 5.1 ESS PWB)

FIP 1. 173

033-511 Fax Code Error

Cause:

Result of MH, HR, MMR receive decode is 0Line.

Solution:

The machine will recover after the **OK** or **Close** button is pressed or message is displayed for specified time.

If the error persists:

1. Check the telephone line connection. Reconnect the telephone line connector.
2. Check the receiving side fax. Send the fax data to a good fax machine.
3. Update to the latest F/W.
4. Ensure that the error is replicated after the printer is powered **Off** and then **On**, and then replace the following parts in sequence.
 - (REP 5.4 Fax PWB)
 - (REP 5.1 ESS PWB)

FIP 1. 174

033-512 Fax Communication Error

Cause:

Modem Parameter Exchange Error.

Solution:

The machine will recover after the **OK** or **Close** button is pressed or message is displayed for specified time.

If the error persists:

1. Check the telephone line connection. Reconnect the telephone line connector.
2. Check the sending side fax. Receive the fax data from a good fax machine.
3. Update to the latest F/W.
4. Ensure that the error is replicated after the printer is powered **Off** and then **On**, and then replace the following parts in sequence.
 - [\(REP 5.4 Fax PWB\)](#)
 - [\(REP 5.1 ESS PWB\)](#)

FIP 1. 175

033-513 Fax Communication Error

Cause:

Communication shutdown due to memory full.

Solution:

The machine will recover after the **OK** or **Close** button is pressed or message is displayed for specified time.

If the error persists:

1. Wait until the Pending FAX Jobs will be sent. Or delete the Pending FAX data.
2. Try dividing the FAX data into smaller blocks or converting the data to a smaller format.
3. Update to the latest F/W.
4. Ensure that the error is replicated after the printer is powered **Off** and then **On**, and then replace the following parts in sequence.
 - [\(REP 5.4 Fax PWB\)](#)
 - [\(REP 5.1 ESS PWB\)](#)

FIP 1. 176

033-515 JBIG NF Error

Cause:

In JPEG receive, cannot get color/monochrome multi-level data.

Solution:

The machine will recover after the **OK** or **Close** button is pressed or message is displayed for specified time.

If the error persists:

1. Turn the power **Off** and **On** to check that the error recurs.
2. Update to the latest F/W.
3. If the problem cannot be solved, replace ([REP 5.1 ESS PWB](#)).

FIP 1. 177

033-517 DFAX Password Error

Cause:

Mismatch between DFAX Password and Fax/Scan Lock Password.

Solution:

The machine will recover after the **OK** or **Close** button is pressed or message is displayed for specified time.

If the error persists:

1. The password is incorrect. Enter the correct password. If you have forgotten your password, contact the system administrator.
2. Take corrective actions at the host side.

FIP 1. 178

033-518 DFAX Fax Country is not set correctly

Cause:

When DFAX job is executed, Fax Country code is Unknown.

Solution:

The machine will recover after the **OK** or **Close** button is pressed or message is displayed for specified time.

If the error persists:

1. Set the Country code correctly.
2. Take corrective actions at the host side.

FIP 1. 179

033-519 DFAX Fax Function is not available

Cause:

When DFAX job is executed, Fax function is not Enabled.

*When this error occurs at the same time as 033-518, 033-519 is displayed preferentially.

Solution:

The machine will recover after the **OK** or **Close** button is pressed or message is displayed for specified time.

If the error persists:

1. Set the Fax function Enable.
2. Take corrective actions at the host side.

FIP 1. 180

033-520 JBF_ERROR_CALLBACK

Cause:

Callback function returns error.

Solution:

The machine will recover after the **OK** or **Close** button is pressed or message is displayed for specified time.

If the error persists:

1. Turn the power **Off** and **On** to check that the error recurs.
2. Update to the latest F/W.
3. If the problem cannot be solved, replace ([REP 5.1 ESS PWB](#)).

FIP 1. 181

033-521 JBF_ERROR_MARKER_ABORT

Cause:

Detect ABORT marker.

Solution:

The machine will recover after the **OK** or **Close** button is pressed or message is displayed for specified time.

If the error persists:

1. Turn the power **Off** and **On** to check that the error recurs.
2. Update to the latest F/W.
3. If the problem cannot be solved, replace ([REP 5.1 ESS PWB](#)).

FIP 1. 182

033-522 JBF_ERROR_MARKER_UNKNOWN

Cause:

Detect invalid marker.

Solution:

The machine will recover after the **OK** or **Close** button is pressed or message is displayed for specified time.

If the error persists:

1. Turn the power **Off** and **On** to check that the error recurs.
2. Update to the latest F/W.
3. If the problem cannot be solved, replace ([REP 5.1 ESS PWB](#)).

FIP 1. 183

033-523 JBF_ERROR_MARKER_NOT_FOUND

Cause:

Predetermined marker cannot be found.

Solution:

The machine will recover after the **OK** or **Close** button is pressed or message is displayed for specified time.

If the error persists:

1. Turn the power **Off** and **On** to check that the error recurs.
2. Update to the latest F/W.
3. If the problem cannot be solved, replace ([REP 5.1 ESS PWB](#)).

FIP 1. 184

033-524 JBF_ERROR_MARKER_BAD_ATMOVE

Cause:

Adaptive template is moved incorrectly.

Solution:

The machine will recover after the **OK** or **Close** button is pressed or message is displayed for specified time.

If the error persists:

1. Turn the power **Off** and **On** to check that the error recurs.
2. Update to the latest F/W.
3. If the problem cannot be solved, replace ([REP 5.1 ESS PWB](#)).

FIP 1. 185

033-525 JBF_ERROR_MARKER_BAD_NEWLEN

Cause:

Image height is changed incorrectly.

Solution:

The machine will recover after the **OK** or **Close** button is pressed or message is displayed for specified time.

If the error persists:

1. Turn the power **Off** and **On** to check that the error recurs.
2. Update to the latest F/W.
3. If the problem cannot be solved, replace ([REP 5.1 ESS PWB](#)).

FIP 1. 186

033-526 JBF_ERROR_BIH

Cause:

BIH data error.

Solution:

The machine will recover after the **OK** or **Close** button is pressed or message is displayed for specified time.

If the error persists:

1. Turn the power **Off** and **On** to check that the error recurs.
2. Update to the latest F/W.
3. If the problem cannot be solved, replace ([REP 5.1 ESS PWB](#)).

FIP 1. 187

033-573 E-mail Sending Error

Cause:

Domain regulation check error.

The domain which is not permitted was specified and address directions were performed.

Solution:

The machine will recover after the **OK** or **Close** button is pressed or message is displayed for specified time.

If the error persists:

1. Check email address and try scanning again.
2. Take corrective actions at the host side.

FIP 1. 188

033-751 Over Run

Cause:

Modem receive data overrun.

Solution:

The machine will recover after the **OK** or **Close** button is pressed or message is displayed for specified time.

If the error persists:

1. Turn the power **Off** and **On** to check that the error recurs.
2. Update to the latest F/W.
3. If the problem cannot be solved, replace the following parts in sequence.
 - ([REP 5.4 Fax PWB](#))
 - ([REP 5.1 ESS PWB](#))

FIP 1. 189

033-752 During Call Busy Tone

Cause:

In Tel/Fax mode, detect busy tone while calling external phone.

Solution:

The machine will recover after the **OK** or **Close** button is pressed or message is displayed for specified time.

If the error persists:

1. Check the sending side fax. Receive the fax data from a good fax machine.
2. Set the Country code correctly.
3. Update to the latest F/W.
4. Ensure that the error is replicated after the printer is powered **Off** and then **On**, and then replace the following parts in sequence.
 - ([REP 5.4 Fax PWB](#))
 - ([REP 5.1 ESS PWB](#))

FIP 1. 190

033-753 CJ Not Detection

Cause:

CJ undetected.

Solution:

The machine will recover after the **OK** or **Close** button is pressed or message is displayed for specified time.

If the error persists:

1. Turn the power **Off** and **On** to check that the error recurs.
2. Update to the latest F/W.
3. If the problem cannot be solved, replace the following parts in sequence.
 - ([REP 5.4 Fax PWB](#))
 - ([REP 5.1 ESS PWB](#))

FIP 1. 191

033-754 V8 Error

Cause:

V8 error.

Solution:

The machine will recover after the **OK** or **Close** button is pressed or message is displayed for specified time.

If the error persists:

1. Turn the power **Off** and **On** to check that the error recurs.
2. Update to the latest F/W.
3. If the problem cannot be solved, replace the following parts in sequence.
 - ([REP 5.4 Fax PWB](#))
 - ([REP 5.1 ESS PWB](#))

FIP 1. 192

033-755 Phase2 Error

Cause:

Phase2 (Line Probing) error.

Solution:

The machine will recover after the **OK** or **Close** button is pressed or message is displayed for specified time.

If the error persists:

1. Turn the power **Off** and **On** to check that the error recurs.
2. Update to the latest F/W.
3. If the problem cannot be solved, replace the following parts in sequence.
 - ([REP 5.4 Fax PWB](#))
 - ([REP 5.1 ESS PWB](#))

FIP 1. 193

033-756 Phase3 Error

Cause:

Phase3(Primary Channel Equalizer Training) error.

Solution:

The machine will recover after the **OK** or **Close** button is pressed or message is displayed for specified time.

If the error persists:

1. Turn the power **Off** and **On** to check that the error recurs.
2. Update to the latest F/W.
3. If the problem cannot be solved, replace the following parts in sequence.
 - ([REP 5.4 Fax PWB](#))
 - ([REP 5.1 ESS PWB](#))

FIP 1. 194

033-757 Primary Channel Synchronization Error

Cause:

The Primary Channel Synchronization Error occurred.

Solution:

The machine will recover after the **OK** or **Close** button is pressed or message is displayed for specified time.

If the error persists:

1. Turn the power **Off** and **On** to check that the error recurs.
2. Update to the latest F/W.
3. If the problem cannot be solved, replace the following parts in sequence.
 - ([REP 5.4 Fax PWB](#))
 - ([REP 5.1 ESS PWB](#))

FIP 1. 195

033-758 Control Channel Synchronization Error

Cause:

The Control Channel Synchronization Error occurred.

Solution:

The machine will recover after the **OK** or **Close** button is pressed or message is displayed for specified time.

If the error persists:

1. Turn the power **Off** and **On** to check that the error recurs.
2. Update to the latest F/W.
3. If the problem cannot be solved, replace the following parts in sequence.
 - ([REP 5.4 Fax PWB](#))
 - ([REP 5.1 ESS PWB](#))

FIP 1. 196

033-759 Control Channel Retrain Error

Cause:

Control channel retrain error.

Solution:

The machine will recover after the **OK** or **Close** button is pressed or message is displayed for specified time.

If the error persists:

1. Turn the power **Off** and **On** to check that the error recurs.
2. Update to the latest F/W.
3. If the problem cannot be solved, replace the following parts in sequence.
 - ([REP 5.4 Fax PWB](#))
 - ([REP 5.1 ESS PWB](#))

FIP 1. 197

033-760 Control Channel OFF Time Out

Cause:

The Control Channel OFF Time Out occurred.

Solution:

The machine will recover after the **OK** or **Close** button is pressed or message is displayed for specified time.

If the error persists:

1. Turn the power **Off** and **On** to check that the error recurs.
2. Update to the latest F/W.
3. If the problem cannot be solved, replace the following parts in sequence.
 - ([REP 5.4 Fax PWB](#))
 - ([REP 5.1 ESS PWB](#))

FIP 1. 198

033-761 Primary Channel OFF Time Out

Cause:

The Primary Channel OFF Time Out occurred.

Solution:

The machine will recover after the **OK** or **Close** button is pressed or message is displayed for specified time.

If the error persists:

1. Turn the power **Off** and **On** to check that the error recurs.
2. Update to the latest F/W.
3. If the problem cannot be solved, replace the following parts in sequence.
 - ([REP 5.4 Fax PWB](#))
 - ([REP 5.1 ESS PWB](#))

FIP 1. 199

033-762 DM Prevention Function Receive Refuse

Cause:

DM prevention function rejects to receive data.

Solution:

The machine will recover after the **OK** or **Close** button is pressed or message is displayed for specified time.

If the error persists:

1. Set the receiving side fax. Set the Speed Dial.
2. Update to the latest F/W.
3. Ensure that the error is replicated after the printer is powered **Off** and then **On**, and then replace the following parts in sequence.
 - ([REP 5.4 Fax PWB](#))
 - ([REP 5.1 ESS PWB](#))

FIP 1. 200

033-763 Manual Transmission Read Manuscript Not Do

Cause:

In manual send, cannot make document read on time.

Solution:

The machine will recover after the **OK** or **Close** button is pressed or message is displayed for specified time.

If the error persists:

1. Turn the power **Off** and **On** to check that the error recurs.
2. Update to the latest F/W.
3. If the problem cannot be solved, replace the following parts in sequence.
 - ([REP 5.4 Fax PWB](#))
 - ([REP 5.1 ESS PWB](#))

FIP 1. 201

033-764 Draw Data Create Not Do

Cause:

When sending, cannot make image data creation on time.

Solution:

The machine will recover after the **OK** or **Close** button is pressed or message is displayed for specified time.

If the error persists:

1. Turn the power **Off** and **On** to check that the error recurs.
2. Update to the latest F/W.
3. If the problem cannot be solved, replace the following parts in sequence.
 - ([REP 5.4 Fax PWB](#))
 - ([REP 5.1 ESS PWB](#))

FIP 1. 202

033-765 File Pointer Error

Cause:

In encode/decode, Read/Write file pointer error.

Solution:

The machine will recover after the **OK** or **Close** button is pressed or message is displayed for specified time.

If the error persists:

1. Turn the power **Off** and **On** to check that the error recurs.
2. Update to the latest F/W.
3. If the problem cannot be solved, replace the following parts in sequence.
 - ([REP 5.4 Fax PWB](#))
 - ([REP 5.1 ESS PWB](#))

FIP 1. 203

033-766 Target File Opening

Cause:

In decode, encoding target file open.

Solution:

The machine will recover after the **OK** or **Close** button is pressed or message is displayed for specified time.

If the error persists:

1. Turn the power **Off** and **On** to check that the error recurs.
2. Update to the latest F/W.
3. If the problem cannot be solved, replace the following parts in sequence.
 - ([REP 5.4 Fax PWB](#))
 - ([REP 5.1 ESS PWB](#))

FIP 1. 204

033-767 MMR MN86064 Decode Error

Cause:

In MMR decode, MN86064 decode error.

Solution:

The machine will recover after the **OK** or **Close** button is pressed or message is displayed for specified time.

If the error persists:

1. Turn the power **Off** and **On** to check that the error recurs.
2. Update to the latest F/W.
3. If the problem cannot be solved, replace the following parts in sequence.
 - ([REP 5.4 Fax PWB](#))
 - ([REP 5.1 ESS PWB](#))

FIP 1. 205

033-768 AT Move Counter Over

Cause:

The number of AT Move is 5 or more in one stripe.

Solution:

The machine will recover after the **OK** or **Close** button is pressed or message is displayed for specified time.

If the error persists:

1. Turn the power **Off** and **On** to check that the error recurs.
2. Update to the latest F/W.
3. If the problem cannot be solved, replace the following parts in sequence.
 - ([REP 5.4 Fax PWB](#))
 - ([REP 5.1 ESS PWB](#))

FIP 1. 206

033-769 JBIG NEWLEN Marker Error

Cause:

NEWLEN marker undetected.

Solution:

The machine will recover after the **OK** or **Close** button is pressed or message is displayed for specified time.

If the error persists:

1. Turn the power **Off** and **On** to check that the error recurs.
2. Update to the latest F/W.
3. If the problem cannot be solved, replace the following parts in sequence.
 - ([REP 5.4 Fax PWB](#))
 - ([REP 5.1 ESS PWB](#))

FIP 1. 207

033-770 YD Error

Cause:

Detect YD error in JBIG data decode.

Solution:

The machine will recover after the **OK** or **Close** button is pressed or message is displayed for specified time.

If the error persists:

1. Turn the power **Off** and **On** to check that the error recurs.
2. Update to the latest F/W.
3. If the problem cannot be solved, replace the following parts in sequence.
 - ([REP 5.4 Fax PWB](#))
 - ([REP 5.1 ESS PWB](#))

FIP 1. 208

033-771 Abort Marker Error

Cause:

Detect abort marker error in JBIG data decode.

Solution:

The machine will recover after the **OK** or **Close** button is pressed or message is displayed for specified time.

If the error persists:

1. Turn the power **Off** and **On** to check that the error recurs.
2. Update to the latest F/W.
3. If the problem cannot be solved, replace the following parts in sequence.
 - ([REP 5.4 Fax PWB](#))
 - ([REP 5.1 ESS PWB](#))

FIP 1. 209

033-772 Undefined Marker Error

Cause:

Detect undefined marker.

Solution:

The machine will recover after the **OK** or **Close** button is pressed or message is displayed for specified time.

If the error persists:

1. Turn the power **Off** and **On** to check that the error recurs.
2. Update to the latest F/W.
3. If the problem cannot be solved, replace the following parts in sequence.
 - ([REP 5.4 Fax PWB](#))
 - ([REP 5.1 ESS PWB](#))

FIP 1. 210

033-773 BIH Error

Cause:

BIH error in JBIG data decode.

Solution:

The machine will recover after the **OK** or **Close** button is pressed or message is displayed for specified time.

If the error persists:

1. Turn the power **Off** and **On** to check that the error recurs.
2. Update to the latest F/W.
3. If the problem cannot be solved, replace the following parts in sequence.
 - ([REP 5.4 Fax PWB](#))
 - ([REP 5.1 ESS PWB](#))

FIP 1. 211

033-774 FAX TX Encode Output Buffer Over

Cause:

In FAX send, JBIG encode output buffer overflow.

Solution:

The machine will recover after the **OK** or **Close** button is pressed or message is displayed for specified time.

If the error persists:

1. Check the resolution setting.
2. Retry sending by lowering the resolution setting.
3. Update to the latest F/W.
4. Ensure that the error is replicated after the printer is powered **Off** and then **On**, and then replace the following parts in sequence.
 - ([REP 5.4 Fax PWB](#))
 - ([REP 5.1 ESS PWB](#))

FIP 1. 212

033-775 FAX RX Encode Output Buffer Over

Cause:

In FAX receive, JBIG encode output buffer overflow.

Solution:

The machine will recover after the **OK** or **Close** button is pressed or message is displayed for specified time.

If the error persists:

1. Check the sending side fax machine or retry sending by lowering the resolution setting.
2. Update to the latest F/W.
3. Ensure that the error is replicated after the printer is powered **Off** and then **On**, and then replace the following parts in sequence.
 - (REP 5.4 Fax PWB)
 - (REP 5.1 ESS PWB)

FIP 1. 213

033-776 SCAN Encode Output Buffer Over

Cause:

In FAX scan and D-FAX scan, JBIG encode output buffer overflow.

Solution:

The machine will recover after the **OK** or **Close** button is pressed or message is displayed for specified time.

If the error persists:

1. Check the resolution setting.
2. Retry sending by lowering the resolution setting.
3. Update to the latest F/W.
4. Ensure that the error is replicated after the printer is powered **Off** and then **On**, and then replace the following parts in sequence.
 - (REP 5.4 Fax PWB)
 - (REP 5.1 ESS PWB)

FIP 1. 214

033-777 FAX RX Decode Input Buffer Over

Cause:

In FAX receive, when copying from ECM buffer to JBIG decode input buffer, input buffer overflow.

Solution:

The machine will recover after the **OK** or **Close** button is pressed or message is displayed for specified time.

If the error persists:

1. Check the sending side fax machine or retry sending by lowering the resolution setting.
2. Update to the latest F/W.
3. Ensure that the error is replicated after the printer is powered **Off** and then **On**, and then replace the following parts in sequence.
 - [\(REP 5.4 Fax PWB\)](#)
 - [\(REP 5.1 ESS PWB\)](#)

FIP 1. 215

033-779 Log File Create Fail

Cause:

Cannot create log file of communication result.

Solution:

The machine will recover after the **OK** or **Close** button is pressed or message is displayed for specified time.

If the error persists:

1. Check the telephone line connection. Reconnect the telephone line connector.
2. Check the sending side fax. Receive the fax data from a good fax machine.
3. Update to the latest F/W.
4. Ensure that the error is replicated after the printer is powered **Off** and then **On**, and then replace the following parts in sequence.
 - [\(REP 5.4 Fax PWB\)](#)
 - [\(REP 5.1 ESS PWB\)](#)

FIP 1. 216

033-782 NSS/DCS Function disagreement

Cause:

Received NSS/DCS function disagrees with capability of own terminal.

Solution:

The machine will recover after the **OK** or **Close** button is pressed or message is displayed for specified time.

If the error persists:

1. Set the Modem Speed correctly.
2. Update to the latest F/W.
3. Ensure that the error is replicated after the printer is powered **Off** and then **On**, and then replace the following parts in sequence.
 - ([REP 5.4 Fax PWB](#))
 - ([REP 5.1 ESS PWB](#))

FIP 1. 217

033-784 Fax Codec Error

Cause:

In FAX receive, JBIG decode output buffer overflow.

Solution:

The machine will recover after the **OK** or **Close** button is pressed or message is displayed for specified time.

If the error persists:

1. Check the sending side fax machine or retry sending by lowering the resolution setting.
2. Update to the latest F/W.
3. Ensure that the error is replicated after the printer is powered **Off** and then **On**, and then replace the following parts in sequence.
 - ([REP 5.4 Fax PWB](#))
 - ([REP 5.1 ESS PWB](#))

FIP 1. 218

033-786 Fax Codec Error

Cause:

In JBIG data decode, discrepancy between the number of decode line and the number of BIH line.

Solution:

The machine will recover after the **OK** or **Close** button is pressed or message is displayed for specified time.

If the error persists:

1. Turn the power **Off** and **On** to check that the error recurs.
2. Update to the latest F/W.
3. If the problem cannot be solved, replace the following parts in sequence.
 - (REP 5.4 Fax PWB)
 - (REP 5.1 ESS PWB)

FIP 1. 219

033-787 Fax Memory Error

Cause:

Calling table full.

Solution:

The machine will recover after the **OK** or **Close** button is pressed or message is displayed for specified time.

If the error persists:

1. Turn the power **Off** and **On** to check that the error recurs.
2. Update to the latest F/W.
3. If the problem cannot be solved, replace the following parts in sequence.
 - (REP 5.4 Fax PWB)
 - (REP 5.1 ESS PWB)

FIP 1. 220

033-788 Fax Memory Full

Cause:

Flash full. (for DFAX)

Solution:

The machine will recover after the **OK** or **Close** button is pressed or message is displayed for specified time.

If the error persists:

1. Wait until the Pending FAX Jobs will be sent.Or delete the Pending FAX data.
2. Try dividing the FAX data into smaller blocks or converting the data to a smaller format.
3. Update to the latest F/W.
4. Ensure that the error is replicated after the printer is powered **Off** and then **On**, and then replace the following parts in sequence.
 - [\(REP 5.4 Fax PWB\)](#)
 - [\(REP 5.1 ESS PWB\)](#)

FIP 1. 221

033-789/ 033-790/033-791 Fax Job Canceled

Cause:

Fax job was canceled.

Solution:

The machine will recover after the **OK** or **Close** button is pressed or message is displayed for specified time. No action is required.

FIP 1. 222

033-795 FAX Send Count Limit

Cause:

Reach the upper limit of Fax send accumulation pages.

Solution:

The machine will recover after the **OK** or **Close** button is pressed or message is displayed for specified time.

If the error persists:

1. Divide the documents in blocks.
2. Explain the maximum number of Fax scan pages to the operator.

FIP 1. 223

033-799 Fax Codec Error

Cause:

In MH,HR,MMR receive, exceed the maximum number of received lines for 1 page.

Solution:

The machine will recover after the **OK** or **Close** button is pressed or message is displayed for specified time.

If the error persists:

1. Check the sending side fax machine or sending data.
2. Update to the latest F/W.
3. Ensure that the error is replicated after the printer is powered **Off** and then **On**, and then replace the following parts in sequence.
 - (REP 5.4 Fax PWB)
 - (REP 5.1 ESS PWB)

FIP 1. 224

034-508 Command Refuse Signal Send

Cause:

Send command refuse signal to stop communication.
The sender discontinued the communication.

Solution:

The machine will recover after the **OK** or **Close** button is pressed or message is displayed for specified time. No action is required.

FIP 1. 225

034-515 DIS DCS Illegal Command Receive

Cause:

Receive illegal command such as DIS, DCS receive from calling terminal in spite of having no ability to receive.

Solution:

The machine will recover after the **OK** or **Close** button is pressed or message is displayed for specified time.

If the error persists:

1. Check the telephone line connection. Reconnect the telephone line connector.
2. Check the sending side fax. Receive the fax data from a good fax machine.
3. Update to the latest F/W.
4. Ensure that the error is replicated after the printer is powered **Off** and then **On**, and then replace the following parts in sequence.
 - ([REP 5.4 Fax PWB](#))
 - ([REP 5.1 ESS PWB](#))

FIP 1. 226

034-791 Check Line Connection

Cause:

The Telephone Line Connection Error.

Solution:

The machine will recover after the **OK** or **Close** button is pressed or message is displayed for specified time.

Line connection error (unconnected or mis connected) might have occurred. Check the line connection.

FIP 1. 227

034-799 No Dial Data

Cause:

Auto dial is activated but no dial data exist.

Solution:

The machine will recover after the **OK** or **Close** button is pressed or message is displayed for specified time.

If the error persists:

1. Check the telephone line connection. Reconnect the telephone line connector.
2. Check the sending side fax. Receive the fax data from a good fax machine.
3. Update to the latest F/W.
4. Ensure that the error is replicated after the printer is powered **Off** and then **On**, and then replace the following parts in sequence.
 - ([REP 5.4 Fax PWB](#))
 - ([REP 5.1 ESS PWB](#))

FIP 1. 228

035-701 Send T1 Time Out

Cause:

In send, T1 timeout.

Solution:

The machine will recover after the **OK** or **Close** button is pressed or message is displayed for specified time.

If the error persists:

1. Check the telephone line connection. Reconnect the telephone line connector.
2. Check the sending side fax. Receive the fax data from a good fax machine.
3. Update to the latest F/W.
4. Ensure that the error is replicated after the printer is powered **Off** and then **On**, and then replace the following parts in sequence.
 - [\(REP 5.4 Fax PWB\)](#)
 - [\(REP 5.1 ESS PWB\)](#)

FIP 1. 229

035-702 Receive DCN

Cause:

DCN receive.

Solution:

The machine will recover after the **OK** or **Close** button is pressed or message is displayed for specified time.

If the error persists:

1. Check the telephone line connection. Reconnect the telephone line connector.
2. Check the sending side fax. Receive the fax data from a good fax machine.
3. Update to the latest F/W.
4. Ensure that the error is replicated after the printer is powered **Off** and then **On**, and then replace the following parts in sequence.
 - [\(REP 5.4 Fax PWB\)](#)
 - [\(REP 5.1 ESS PWB\)](#)

FIP 1. 230

035-704 Not Send Ability

Cause:

Remote device has no ability to send.

Solution:

The machine will recover after the **OK** or **Close** button is pressed or message is displayed for specified time.

If the error persists:

1. Check the telephone line connection. Reconnect the telephone line connector.
2. Check the sending side fax. Receive the fax data from a good fax machine.
3. Update to the latest F/W.
4. Ensure that the error is replicated after the printer is powered **Off** and then **On**, and then replace the following parts in sequence.
 - [\(REP 5.4 Fax PWB\)](#)
 - [\(REP 5.1 ESS PWB\)](#)

FIP 1. 231

035-705 DCS/NSS Resend Over

Cause:

DCS/NSS resend over.

Solution:

The machine will recover after the **OK** or **Close** button is pressed or message is displayed for specified time.

If the error persists:

1. Check the telephone line connection. Reconnect the telephone line connector.
2. Check the sending side fax. Receive the fax data from a good fax machine.
3. Update to the latest F/W.
4. Ensure that the error is replicated after the printer is powered **Off** and then **On**, and then replace the following parts in sequence.
 - [\(REP 5.4 Fax PWB\)](#)
 - [\(REP 5.1 ESS PWB\)](#)

FIP 1. 232

035-706 Fall Back Error

Cause:

Fall back error.

Solution:

The machine will recover after the **OK** or **Close** button is pressed or message is displayed for specified time.

If the error persists:

1. Check the telephone line connection. Reconnect the telephone line connector.
2. Check the sending side fax. Receive the fax data from a good fax machine.
3. Update to the latest F/W.
4. Ensure that the error is replicated after the printer is powered **Off** and then **On**, and then replace the following parts in sequence.
 - [\(REP 5.4 Fax PWB\)](#)
 - [\(REP 5.1 ESS PWB\)](#)

FIP 1. 233

035-708 Post Message Resend Over

Cause:

Post message resend over.

Solution:

The machine will recover after the **OK** or **Close** button is pressed or message is displayed for specified time.

If the error persists:

1. Check the telephone line connection. Reconnect the telephone line connector.
2. Check the sending side fax. Receive the fax data from a good fax machine.
3. Update to the latest F/W.
4. Ensure that the error is replicated after the printer is powered **Off** and then **On**, and then replace the following parts in sequence.
 - [\(REP 5.4 Fax PWB\)](#)
 - [\(REP 5.1 ESS PWB\)](#)

FIP 1. 234

035-709 G3 Send RTN/PIN Receive

Cause:

In G3 send, receive RTN/PIN.

Solution:

The machine will recover after the **OK** or **Close** button is pressed or message is displayed for specified time.

If the error persists:

1. Check the telephone line connection. Reconnect the telephone line connector.
2. Check the sending side fax. Receive the fax data from a good fax machine.
3. Update to the latest F/W.
4. Ensure that the error is replicated after the printer is powered **Off** and then **On**, and then replace the following parts in sequence.
 - ([REP 5.4 Fax PWB](#))
 - ([REP 5.1 ESS PWB](#))

FIP 1. 235

035-710 Receive PIN

Cause:

PIN receive (excl. EOR).

Solution:

The machine will recover after the **OK** or **Close** button is pressed or message is displayed for specified time.

If the error persists:

1. Check the telephone line connection. Reconnect the telephone line connector.
2. Check the sending side fax. Receive the fax data from a good fax machine.
3. Update to the latest F/W.
4. Ensure that the error is replicated after the printer is powered **Off** and then **On**, and then replace the following parts in sequence.
 - ([REP 5.4 Fax PWB](#))
 - ([REP 5.1 ESS PWB](#))

FIP 1. 236

035-716 T2 Time Out

Cause:

T2 timeout.

Solution:

The machine will recover after the **OK** or **Close** button is pressed or message is displayed for specified time.

If the error persists:

1. Check the telephone line connection. Reconnect the telephone line connector.
2. Check the sending side fax. Receive the fax data from a good fax machine.
3. Update to the latest F/W.
4. Ensure that the error is replicated after the printer is powered **Off** and then **On**, and then replace the following parts in sequence.
 - [\(REP 5.4 Fax PWB\)](#)
 - [\(REP 5.1 ESS PWB\)](#)

FIP 1. 237

035-717 G3 Receive RTN Send

Cause:

In G3 receive, send RTN.

Solution:

The machine will recover after the **OK** or **Close** button is pressed or message is displayed for specified time.

If the error persists:

1. Check the telephone line connection. Reconnect the telephone line connector.
2. Check the sending side fax. Receive the fax data from a good fax machine.
3. Update to the latest F/W.
4. Ensure that the error is replicated after the printer is powered **Off** and then **On**, and then replace the following parts in sequence.
 - [\(REP 5.4 Fax PWB\)](#)
 - [\(REP 5.1 ESS PWB\)](#)

FIP 1. 238

035-718 Receive T1 Time Out

Cause:

In receive, T1 timeout.

Solution:

The machine will recover after the **OK** or **Close** button is pressed or message is displayed for specified time.

If the error persists:

1. Check the telephone line connection. Reconnect the telephone line connector.
2. Check the sending side fax. Receive the fax data from a good fax machine.
3. Update to the latest F/W.
4. Ensure that the error is replicated after the printer is powered **Off** and then **On**, and then replace the following parts in sequence.
 - [\(REP 5.4 Fax PWB\)](#)
 - [\(REP 5.1 ESS PWB\)](#)

FIP 1. 239

035-720 Not Receive Ability

Cause:

Remote device has no ability to receive.

Solution:

The machine will recover after the **OK** or **Close** button is pressed or message is displayed for specified time.

If the error persists:

1. Check the telephone line connection. Reconnect the telephone line connector.
2. Check the sending side fax. Receive the fax data from a good fax machine.
3. Update to the latest F/W.
4. Ensure that the error is replicated after the printer is powered **Off** and then **On**, and then replace the following parts in sequence.
 - [\(REP 5.4 Fax PWB\)](#)
 - [\(REP 5.1 ESS PWB\)](#)

FIP 1. 240

035-728 G3 EOL Not Receive

Cause:

In G3 image data receive, cannot receive EOL for 13 sec (default).

Solution:

The machine will recover after the **OK** or **Close** button is pressed or message is displayed for specified time.

If the error persists:

1. Check the telephone line connection. Reconnect the telephone line connector.
2. Check the sending side fax. Receive the fax data from a good fax machine.
3. Update to the latest F/W.
4. Ensure that the error is replicated after the printer is powered **Off** and then **On**, and then replace the following parts in sequence.
 - [\(REP 5.4 Fax PWB\)](#)
 - [\(REP 5.1 ESS PWB\)](#)

FIP 1. 241

035-729 Career Cut

Cause:

Career Cut

Solution:

The machine will recover after the **OK** or **Close** button is pressed or message is displayed for specified time.

If the error persists:

1. Check the telephone line connection. Reconnect the telephone line connector.
2. Check the sending side fax. Receive the fax data from a good fax machine.
3. Update to the latest F/W.
4. Ensure that the error is replicated after the printer is powered **Off** and then **On**, and then replace the following parts in sequence.
 - [\(REP 5.4 Fax PWB\)](#)
 - [\(REP 5.1 ESS PWB\)](#)

FIP 1. 242

035-730 RS Request CS NOT ON

Cause:

In high-speed training, modem CS does not become ON against RS request.

Solution:

The machine will recover after the **OK** or **Close** button is pressed or message is displayed for specified time.

If the error persists:

1. Check the telephone line connection. Reconnect the telephone line connector.
2. Check the sending side fax. Receive the fax data from a good fax machine.
3. Update to the latest F/W.
4. Ensure that the error is replicated after the printer is powered **Off** and then **On**, and then replace the following parts in sequence.
 - [\(REP 5.4 Fax PWB\)](#)
 - [\(REP 5.1 ESS PWB\)](#)

FIP 1. 243

035-737 CTC/EOR Resend Over

Cause:

CTC/EOR resend over.

Solution:

The machine will recover after the **OK** or **Close** button is pressed or message is displayed for specified time.

If the error persists:

1. Check the telephone line connection. Reconnect the telephone line connector.
2. Check the sending side fax. Receive the fax data from a good fax machine.
3. Update to the latest F/W.
4. Ensure that the error is replicated after the printer is powered **Off** and then **On**, and then replace the following parts in sequence.
 - [\(REP 5.4 Fax PWB\)](#)
 - [\(REP 5.1 ESS PWB\)](#)

FIP 1. 244

035-739 T5 Time Out

Cause:

T5 Time Out.

Solution:

The machine will recover after the **OK** or **Close** button is pressed or message is displayed for specified time.

If the error persists:

1. Check the telephone line connection. Reconnect the telephone line connector.
2. Check the sending side fax. Receive the fax data from a good fax machine.
3. Update to the latest F/W.
4. Ensure that the error is replicated after the printer is powered **Off** and then **On**, and then replace the following parts in sequence.
 - [\(REP 5.4 Fax PWB\)](#)
 - [\(REP 5.1 ESS PWB\)](#)

FIP 1. 245

035-740 ECM Send EOR-Q Send

Cause:

IN ECM send, send EOR-Q.

Solution:

The machine will recover after the **OK** or **Close** button is pressed or message is displayed for specified time.

If the error persists:

1. Check the telephone line connection. Reconnect the telephone line connector.
2. Check the sending side fax. Receive the fax data from a good fax machine.
3. Update to the latest F/W.
4. Ensure that the error is replicated after the printer is powered **Off** and then **On**, and then replace the following parts in sequence.
 - [\(REP 5.4 Fax PWB\)](#)
 - [\(REP 5.1 ESS PWB\)](#)

FIP 1. 246

035-742 ECM Receive EOR-Q Receive

Cause:

IN ECM receive, receive EOR-Q.

Solution:

The machine will recover after the **OK** or **Close** button is pressed or message is displayed for specified time.

If the error persists:

1. Check the telephone line connection. Reconnect the telephone line connector.
2. Check the sending side fax. Receive the fax data from a good fax machine.
3. Update to the latest F/W.
4. Ensure that the error is replicated after the printer is powered **Off** and then **On**, and then replace the following parts in sequence.
 - [\(REP 5.4 Fax PWB\)](#)
 - [\(REP 5.1 ESS PWB\)](#)

FIP 1. 247

035-746 Before Dial Tone

Cause:

Cannot detect dial tone before dialing.

Solution:

The machine will recover after the **OK** or **Close** button is pressed or message is displayed for specified time.

If the error persists:

1. Check that the telephone line is not busy. Set the a good fax number manually.
2. Update to the latest F/W.
3. Ensure that the error is replicated after the printer is powered **Off** and then **On**, and then replace the following parts in sequence.
 - [\(REP 5.4 Fax PWB\)](#)
 - [\(REP 5.1 ESS PWB\)](#)

FIP 1. 248

035-779 FAX FWD document change error

Cause:

FAX forward document change error.

Solution:

The machine will recover after the **OK** or **Close** button is pressed or message is displayed for specified time.

1. If the error persists:
2. Turn the power **Off** and **On** to check that the error recurs.
3. Update to the latest F/W.
4. If the problem cannot be solved, replace the following parts in sequence.
 - (REP 5.4 Fax PWB)
 - (REP 5.1 ESS PWB)

FIP 1. 249

035-781 Target Fax Busy

Cause:

Detect busy tone after dialing.

Solution:

The machine will recover after the **OK** or **Close** button is pressed or message is displayed for specified time.

If the error persists:

1. Check the receiving side fax. Send the fax data to a good fax machine.
2. Check the printer setting. (Line type, Country code)
3. Update to the latest F/W.
4. Ensure that the error is replicated after the printer is powered **Off** and then **On**, and then replace the following parts in sequence.
 - (REP 5.4 Fax PWB)
 - (REP 5.1 ESS PWB)

FIP 1. 250

035-792 JM Not Detection

Cause:

JM undetected.

Solution:

The machine will recover after the **OK** or **Close** button is pressed or message is displayed for specified time.

If the error persists:

1. Turn the power **Off** and **On** to check that the error recurs.
2. Update to the latest F/W.
3. If the problem cannot be solved, replace the following parts in sequence.
 - [\(REP 5.4 Fax PWB\)](#)
 - [\(REP 5.1 ESS PWB\)](#)

FIP 1. 251

035-793 Digital Line Detection

Cause:

Connected to digital line and cannot connect.
(Detect when connecting to line.)

Solution:

The machine will recover after the **OK** or **Close** button is pressed or message is displayed for specified time.

If the error persists:

1. Check the Line type. (PSTN / PBX)
2. Update to the latest F/W.
3. Ensure that the error is replicated after the printer is powered **Off** and then **On**, and then replace the following parts in sequence.
 - [\(REP 5.4 Fax PWB\)](#)
 - [\(REP 5.1 ESS PWB\)](#)

FIP 1. 252

041-340 IOT NVRAM Error

Cause:

The operation error of NVM (read/write check error etc.) is detected.

Solution:

1. Turn the power **Off** and **On** to check that the error recurs.
2. Update to the latest F/W.
3. If the problem cannot be solved, replace ([REP 5.6 MCU PWB](#)).

FIP 1. 253

041-347 IOT I/F Failure

Cause:

MCU Internal Error (I/F part).

Solution:

1. Turn the power **Off** and **On** to check that the error recurs
2. Update to the latest F/W.
3. If the problem cannot be solved, replace the following parts in sequence.
 - ([REP 5.6 MCU PWB](#))
 - ([REP 5.1 ESS PWB](#))

FIP 1. 254

042-313 LVPS Fan Motor Failure

Cause:

MCU detects an error upon receiving error signal from the LVPS Fan.

Solution:

Turn the power **Off** and **On** to check that the error recurs, then proceed to the FIP.

Step	Check and Action	Yes	No
1	<ul style="list-style-type: none"> Execute the Diag Digital Output [042-003] to check the rotation of the LVPS FAN. Is it working properly? 	Replace (REP 5.6 MCU PWB)	Go to Step 2.
2	<ul style="list-style-type: none"> Check the installation of the LVPS FAN. Manually rotate the LVPS FAN. Is there any resistance? 	Reinstall the LVPS FAN properly	Go to Step 3.
3	<ul style="list-style-type: none"> Check the connection between the LVPS FAN and LVPS, as well as between the LVPS PWB and MCU PWB. Are the LVPS FAN and the LVPS HARNESS ASSEMBLY connected securely? 	Go to Step 4.	Securely connect the LVPS FAN and the LVPS HARNESS ASSEMBLY
4	<ul style="list-style-type: none"> Replace the LVPS FAN. PL Does an error occur? 	Go to Step 5.	Troubleshooting complete.
5	<ul style="list-style-type: none"> Replace the LVPS HARNESS ASSEMBLY. Does an error occur? 	Go to Step 6.	Troubleshooting complete.
6	<ul style="list-style-type: none"> Replace (REP 5.3 LVPS). Does an error occur? 	Replace (REP 5.6 MCU PWB)	Troubleshooting complete.

FIP 1. 255

042-330 Rear Fan Failure

Cause:

MCU detects an error upon receiving error signal from the Rear Fan.

Solution:

Turn the power **Off** and **On** to check that the error recurs, then proceed to the FIP.

Step	Check and Action	Yes	No
1	<ul style="list-style-type: none"> Execute the Diag Digital Output [042-001] to check the rotation of the Rear Fan. Is it working properly? 	Replace (REP 5.6 MCU PWB)	Go to Step 2.
2	<ul style="list-style-type: none"> Check the installation of the Rear Fan. Manually rotate the Rear Fan. Is there any resistance? 	Reinstall the Rear Fan properly	Go to Step 3.
3	<ul style="list-style-type: none"> Check the connection between the Rear Fan and the LVPS, as well as between the LVPS PWB and the MCU PWB. Are the REAR FAN HARNESS ASSEMBLY and the LVPS HARNESS ASSEMBLY connected securely? 	Go to Step 4.	Securely connect the REAR FAN HARNESS ASSEMBLY and the LVPS HARNESS ASSEMBLY
4	<ul style="list-style-type: none"> Replace the Rear Fan. PL Does an error occur? 	Go to Step 5.	Troubleshooting complete.
5	<ul style="list-style-type: none"> Replace the REAR FAN HARNESS ASSEMBLY. Does an error occur? 	Go to Step 6.	Troubleshooting complete.
6	<ul style="list-style-type: none"> Replace the LVPS HARNESS ASSEMBLY. Does an error occur? 	Go to Step 7.	Troubleshooting complete.
7	<ul style="list-style-type: none"> Replace (REP 5.3 LVPS). Does an error occur? 	Replace (REP 5.6 MCU PWB)	Troubleshooting complete.

FIP 1. 256

042-700 IOT Over Heat Stop 092-661 IOT Environment Sensor Error

Cause:

042-700: The Temp. Sensor sensed high temperature.

092-661: The Temp. Sensor or the Humidity Sensor error was detected.

Solution:

042-700:

- Printing has been suspended because inside of the printer is extraordinarily hot.
- Start the operation after the Printer has cooled down.
- Turn the power **Off** and **On** to check that the error recurs. Then proceed to the FIP.

092-661:

Turn the power **Off** and **On** to check that the error recurs. Then proceed to the FIP.

Step	Check and Action	Yes	No
1	Is there a heat source near the device?	Remove the heat source	Go to Step 2.
2	Are there any foreign substances in the Temp. Sensor /Humidity Sensor HVPS Detector?	Remove the foreign substances	Go to Step 3.
3	<ul style="list-style-type: none"> • Check the connection between the HVPS and the MCU PWB. • Is the HVPS HARNESS ASSEMBLY connected securely? 	Go to Step 4.	Securely connect the HVPS HARNESS ASSEMBLY
4	<ul style="list-style-type: none"> • Replace the HVPS HARNESS ASSEMBLY. • Does an error occur? 	Go to Step 5.	Troubleshooting complete.
5	<ul style="list-style-type: none"> • Replace (REP 5.7 HVPS (3610)) (REP 5.8 HVPS (3615)). • Does an error occur? 	Replace (REP 5.6 MCU PWB)	Troubleshooting complete.

FIP 1. 257

050-130 IOT Remain Zone Fusing Jam

051-130 is displayed in the UI.

Either of the following error codes is registered in the Error Log.

- **077-104** Regi Off Jam
- **077-106** Exit On Jam
- **077-108** Exit Off Early Jam
- **077-109** Exit Off Jam

Cause:

When Dynamic Jam (cause) was detected:

- **077-104** Regi Off Jam
- **077-106** Exit On Jam
- **077-108** Exit Off Early Jam
- **077-109** Exit Off Jam

When Static Jam (collateral) was detected:

- Exit Sensor On

Solution:

Paper jam has occurred. Remove the jammed paper.

If there is no jammed paper, or the error still occurs after having removed the jammed paper, turn the power **Off** and **On** to check that the error recurs, then proceed to the appropriate FIP.

- For **077-104** Regi Off Jam, go to [FIP 1. 283](#)
- For **077-106** Exit On Jam, **077-108** Exit Off Early Jam, and **077-109** Exit Off Jam, go to [FIP 1. 284](#)

FIP 1. 258

050-131 IOT Remain Zone Duplex Jam

077-107 Duplex Regi On Jam

050-131 is displayed in the UI. 077-107 is registered in the Error Log.

Cause:

050-131: When Dynamic Jam (cause) was detected: - **077-107** Duplex Regi On Jam

077-107: After the Invert Clutch turned ON, the Regi. Sensor did not turn ON within the specified time.

Solution:

1. Paper jam has occurred. Remove the jammed paper.
2. If there is no jammed paper, or the error still occurs after having removed the jammed paper, turn the power **Off** and **On** to check that the error recurs, then proceed to the FIP.

Step	Check and Action	Yes	No
1	Is there any foreign substances or bits of paper found on the paper transport path?	Remove the foreign substances and bits of paper, etc.	Go to Step 2.
2	Are the paper feed rolls installed properly?	Go to Step 3.	Reinstall the paper feed rolls
3	Are the paper feed rolls deformed or worn out?	Replace the corresponding paper feed rolls	Go to Step 4.
4	<ul style="list-style-type: none"> • Execute the Diag Digital Input [071-102] to check the operation of the Regi. Sensor HVPS. • Is the Regi. Sensor HVPS operating normally? 	Go to Step 5.	Go to FIP 2.03
5	<ul style="list-style-type: none"> • Execute the Diag Digital Output [071-008] to check the operation of the CLUTCH ASSEMBLY INVERT. • Is the CLUTCH ASSEMBLY INVERT operating normally? 	Step 6	Go to FIP 2.09
6	<ul style="list-style-type: none"> • Execute the Diag Digital Output [071-001] to check the rotation of the MAIN DRIVE ASSEMBLY. • Is it working properly? 	Replace (REP 5.6 MCU PWB)	Go to FIP 2.15

FIP 1. 259

050-132 IOT Remain Zone Regi + MSI + T1 + T2 Jam

050-132 is displayed in the UI. 077-106 is registered in the Error Log.

Cause:

When Dynamic Jam (cause) was detected:

- 077-106 Exit On Jam

When Static Jam (collateral) was detected:

- Regi Sensor On

Solution:

1. Paper jam has occurred. Remove the jammed paper.
2. If there is no jammed paper, or the error still occurs after having removed the jammed paper, turn the power **Off** and **On** to check that the error recurs, then proceed to the [FIP 1. 284](#).

FIP 1. 260

050-134 IOT Zone MSI + T1 Jam

051-134 is displayed in the UI. Either of the following error codes is registered in the Error Log.

- 071-100 IOT Tray1 Misfeed Jam
- 075-100 MSI Misfeed Jam

Cause:

When Dynamic Jam (cause) was detected:

- 071-100 IOT Tray1 Misfeed Jam
- 075-100 MSI Misfeed Jam

Solution:

1. Paper jam has occurred. Remove the jammed paper.
2. If there is no jammed paper, or the error still occurs after having removed the jammed paper, turn the power **Off** and **On** to check that the error recurs, then proceed to the FIP.
 - 071-100 IOT Tray1 Misfeed Jam, go to [FIP 1. 273](#).
 - 075-100 MSI Misfeed Jam, go to [FIP 1. 281](#).

FIP 1. 261

050-135 IOT Zone T2 + T3 + T4 + TR2 + TR3 Jam

050-135 is displayed in the UI. 073-101 is registered in the Error Log.

Cause:

When Dynamic Jam (cause) was detected:

- 073-101 IOT Path3 SNS On Jam

When Static Jam (collateral) was detected:

- Tray2 Path Sensor On, Tray3 Path Sensor On, and Tray4 Path Sensor On

Solution:

1. Paper jam has occurred. Remove the jammed paper.
2. If there is no jammed paper, or the error still occurs after having removed the jammed paper, turn the power **Off** and **On** to check that the error recurs, then proceed to [FIP 1. 277](#).

FIP 1. 262

050-136 IOT Zone T3 + T4 + TR3 Jam

050-136 is displayed in the UI. 072-101 is registered in the Error Log.

Cause:

When Dynamic Jam (cause) was detected:

- 072-101 IOT Path2 SNS On Jam

When Static Jam (collateral) was detected:

- Tray3 Path Sensor On

Solution:

1. Paper jam has occurred. Remove the jammed paper.
2. If there is no jammed paper, or the error still occurs after having removed the jammed paper, turn the power **Off** and **On** to check that the error recurs, then proceed to [FIP 1. 277](#).

FIP 1. 263

050-137 IOT Zone T2 + T3 + TR2 + TR3 Jam

050-137 is displayed in the UI. 072-102 is registered in the Error Log.

Cause:

When Dynamic Jam (cause) was detected:

- 072-102 IOT Option Regi On Jam

When Static Jam (collateral) was detected:

- Tray2 Path Sensor On and Tray3 Path Sensor On

Solution:

1. Paper jam has occurred. Remove the jammed paper.
2. If there is no jammed paper, or the error still occurs after having removed the jammed paper, turn the power **Off** and **On** to check that the error recurs, then proceed to [FIP 1. 278](#).

FIP 1. 264

050-138 IOT Zone T3 + TR2 + TR3 Jam

050-138 is displayed in the UI. 072-102 is registered in the Error Log.

Cause:

When Dynamic Jam (cause) was detected:

- 072-102 IOT Option Regi On Jam

When Static Jam (collateral) was detected:

- Tray3 Path Sensor On

Solution:

1. Paper jam has occurred. Remove the jammed paper.
2. If there is no jammed paper, or the error still occurs after having removed the jammed paper, turn the power **Off** and **On** to check that the error recurs, then proceed to the [FIP 1. 278](#).

FIP 1. 265

050-139 IOT Zone T2 + TR2 Jam

050-139 is displayed in the UI. 072-100 is registered in the Error Log.

Cause:

When Dynamic Jam (cause) was detected:

- 072-100 IOT Tray2 Misfeed Jam

When Static Jam (collateral) was detected:

- Tray2 Path Sensor On

Solution:

1. Paper jam has occurred. Remove the jammed paper.
2. If there is no jammed paper, or the error still occurs after having removed the jammed paper, turn the power **Off** and **On** to check that the error recurs, then proceed to the [FIP 1. 276](#).

FIP 1. 266

050-140 IOT Zone T3 + TR2 Jam

050-140 is displayed in the UI. 073-100 is registered in the Error Log.

Cause:

When Dynamic Jam (cause) was detected:

- 073-100 IOT Tray3 Misfeed Jam

Solution:

1. Paper jam has occurred. Remove the jammed paper.
2. If there is no jammed paper, or the error still occurs after having removed the jammed paper, turn the power **Off** and **On** to check that the error recurs, then proceed to the [FIP 1. 276](#).

FIP 1. 267

050-141 IOT Zone T4 + TR3 Jam

050-141 is displayed in the UI. 074-100 is registered in the Error Log.

Cause:

When Dynamic Jam (cause) was detected:

- 074-100 IOT Tray4 Misfeed Jam

When Static Jam (collateral) was detected:

- Tray4 Path Sensor On

Solution:

1. Paper jam has occurred. Remove the jammed paper.
2. If there is no jammed paper, or the error still occurs after having removed the jammed paper, turn the power **Off** and **On** to check that the error recurs, then proceed to the [FIP 1. 276](#).

FIP 1. 268

050-142 IOT Remain Zone Regi + MSI + T1 Jam

050-142 is displayed in the UI. 077-106 is registered in the Error Log.

Cause:

When Dynamic Jam (cause) was detected:

- 077-106 Exit On Jam

When Static Jam (collateral) was detected:

- Regi Sensor On

Solution:

1. Paper jam has occurred. Remove the jammed paper.
2. If there is no jammed paper, or the error still occurs after having removed the jammed paper, turn the power **Off** and **On** to check that the error recurs, then proceed to the [FIP 1. 284](#).

FIP 1. 269

061-370 IOT ROS Failure

Cause:

The operation error of ROS (rotational error etc.) is detected.

Solution:

Turn the power **Off** and **On** to check that the error recurs, then proceed to the FIP.

Step	Check and Action	Yes	No
1	Check the connections between the ROS ASSEMBLY and the MCU PWB, as well as between the ROS ASSEMBLY and the ESS PWB. <ul style="list-style-type: none"> Are the ROS-MCU HARNESS (P/J501-P/J19), ROS ASSEMBLY (P/J18), and the VIDEO HARNESS (P/J502 - P/J322) connected securely? 	Go to Step 2.	Securely connect the ROS-MCU HARNESS, ROS ASSEMBLY and the VIDEO HARNESS
2	<ul style="list-style-type: none"> Replace (REP 3.1 ROS Assembly). Does an error occur? 	Go to Step 3.	Troubleshooting complete.
3	<ul style="list-style-type: none"> Replace (REP 5.6 MCU PWB). Does an error occur? 	Replace (REP 5.1 ESS PWB)	Troubleshooting complete.

FIP 1. 270

062-277/062-311/062-317/062-318/062-319/062-320/062-321/062-322/062-360/062-371/062-393 Scanner Error

Cause:

- 062-277:** IIT internal communication error.
- 062-311:** IIT failure initialization error.
- 062-317:** Interference buffer full was detected at the time of DADF scan.
- 062-318:** A Scan setup did not meet the deadline into Page Gap.
- 062-319:** A PLL lock was not carried out before 1stScan start, but the lock has separated during continuation.
- 062-320:** Scanning error.
- 062-321:** Unexecutable error. (carriage is at the locked position, etc.)
- 062-322:** Parameter error.
- 062-360:** Carriage home position error.
- 062-371:** IIT failure Lamp error.
- 062-393:** CCD ASIC communication error.

Solution:

062-277/062-311/062-317/062-318/062-319/062-321/062-322/062-360/062-371/062-393:

- Turn the power **Off** and **On** to check that the error recurs. Then proceed to the FIP.

062-320:

1. Check the file data in the printer. Print or clear the stored files and data at the printer memory.
2. Perform a black and white scan.
3. If the error occurs again, proceed to the FIP.

Step	Check and Action	Yes	No
1	Check the connection between the IIT ASSEMBLY and the ESS PWB. <ul style="list-style-type: none"> • Are the P/J451 and the P/J452 connected securely? 	Go to Step 2.	Connect that P/J451 and P/J452 are secure
2	<ul style="list-style-type: none"> • Replace (REP 6.1 IIT Assembly). • Does an error occur? 	Replace (REP 5.1 ESS PWB)	Troubleshooting complete.

FIP 1. 271

062-316 DADF Motor Fail

Cause:

Detect DADF Motor Fail.

Solution:

Turn the power **Off** and **On** to check that the error recurs, then proceed to the FIP.

Step	Check and Action	Yes	No
1	Are there any foreign substances in the DADF Motor Drive Section?	Remove the foreign substances.	Go to Step 2.
2	Check the connection between the DADF ASSEMBLY and the ESS PWB. <ul style="list-style-type: none"> Is the P/J453 connected securely? 	Go to Step 3.	Connect P/J453 securely
3	<ul style="list-style-type: none"> Replace (REP 6.2 DADF). Does an error occur? 	Replace (REP 5.1 ESS PWB).	Troubleshooting complete.

FIP 1. 272

062-790 Copy Limit

Cause:

Copy Limit.

Solution:

The machine will recover after the Enter Key is pressed or message is displayed for 60 seconds.

If the error persists:

1. Change your original.
2. Ensure that the error is replicated after the printer is powered **Off** and then **On**, and then replace (REP 5.1 ESS PWB).

FIP 1. 273

071-100 IOT Tray1 Misfeed Jam

050-134 is displayed in the UI.

Cause:

After the Tray 1 Feed Clutch turned ON, the Regi. Sensor did not turn ON within the specified time.

Solution:

1. Paper jam has occurred. Remove the jammed paper.
2. If there is no jammed paper, or the error still occurs after having removed the jammed paper, turn the power **Off** and **On** to check that the error recurs, then proceed to the FIP.

Step	Check and Action	Yes	No
1	Is there any foreign substances or bits of paper found on the paper transport path?	Remove the foreign substances and bits of paper, etc.	Go to Step 2.
2	Are the paper feed rolls installed properly?	Go to Step 3.	Reinstall the corresponding paper feed rolls
3	Are the paper feed rolls deformed or worn out?	Replace the corresponding paper feed rolls	Go to Step 4.
4	<ul style="list-style-type: none"> • Execute the Diag Digital Input [071-102] to check the operation of the Regi. Sensor HVPS. • Is the Regi. Sensor HVPS operating normally? 	Go to Step 5.	Go to FIP 2.03
5	<ul style="list-style-type: none"> • Execute the Diag Digital Output [071-005] to check the operation of the CST FEED CLUTCH. • Is the CST FEED CLUTCH operating properly? 	Go to Step 6.	Go to FIP 2.11
6	<ul style="list-style-type: none"> • Execute the Diag Digital Output [071-001] to check the rotation of the MAIN DRIVE ASSEMBLY. • Is it working properly? 	Replace (REP 5.6 MCU PWB)	Go to FIP 2.15

FIP 1. 274

071-920 Waiting to Print Side 2 Load Printed Pages into the NNN

Cause:

Waiting for side 2 to be set for manual duplex print (Tray).

Solution:

Set the Paper correctly. Press **OK** button within the specified time.

FIP 1. 275

071-921 Manual Duplex Print

Cause:

Waiting for Set key to be pressed after setting side 2 for manual duplex print (Tray).

Solution:

Set the Paper correctly. Press **OK** button within the specified time.

FIP 1. 276

072-100 IOT Tray2 Misfeed Jam

073-100 IOT Tray3 Misfeed Jam

074-100 IOT Tray4 Misfeed Jam

Cause:

072-100:

050-139 is displayed in the UI.

After the Tray 2 Feed Clutch turned ON, the Tray 2 Path Sensor did not turn ON within the specified time.

073-100:

050-140 is displayed in the UI.

After the Tray 3 Feed Clutch turned ON, the Tray 3 Path Sensor did not turn ON within the specified time.

074-100:

050-141 is displayed in the UI.

After the Tray 4 Feed Clutch turned ON, the Tray 4 Path Sensor did not turn ON within the specified time.

Solution:

1. Paper jam has occurred. Remove the jammed paper.
2. If there is no jammed paper, or the error still occurs after having removed the jammed paper, turn the power **Off** and **On** to check that the error recurs, then proceed to the FIP.

Step	Check and Action	Yes	No
1	Is there any foreign substances or bits of paper found on the paper transport path?	Remove the foreign substances and bits of paper, etc.	Go to Step 2.
2	Are the paper feed rolls installed properly?	Go to Step 3.	Reinstall the corresponding paper feed rolls
3	Are the paper feed rolls deformed or worn out?	Replace the corresponding paper feed rolls	Go to Step 4.
4	<ul style="list-style-type: none"> • Execute the Diag Digital Input Tray 2: 071-119 / Tray 3:071-120 / Tray 4:071-121 to check the operation of the Path Sensor. • Is the Path Sensor operating normally? 	Go to Step 5.	Go to FIP 2.07
5	<ul style="list-style-type: none"> • Execute the Diag Digital Output Tray 2: 071-018 / Tray 3:071-019 / Tray 4:071-020 to check the operation of the OPTIONAL FEEDER CLUTCH ASSEMBLY. • Is the OPTIONAL FEEDER CLUTCH ASSEMBLY operating normally? 	Go to Step 6.	Go to FIP 2.12
6	<ul style="list-style-type: none"> • Execute the Diag Digital Output Tray 2: 071-009 / Tray 3:071-012 / Tray 4:071-015 to check the rotation of the MOTOR-ASSEMBLY OPTION. • Is it working properly? 	Go to Step 7.	Go to FIP 2.17
7	<ul style="list-style-type: none"> • Replace (REP 7.8 Feeder Assembly). • Does an error occur? 	Replace (REP 5.6 MCU PWB)	Troubleshooting complete.

FIP 1. 277

072-101 IOT Path 2 SNS On Jam

073-101 IOT Path 3 SNS On Jam

Cause:

072-101:

050-136 is displayed in the UI.

The Tray 2 Path Sensor did not turn ON within the specified time after the Tray 3 Path Sensor turned ON.

073-101:

050-135 is displayed in the UI.

The Tray 3 Path Sensor did not turn ON within the specified time after the Tray 4 Path Sensor turned ON.

Solution:

1. Paper jam has occurred. Remove the jammed paper.
2. If there is no jammed paper, or the error still occurs after having removed the jammed paper, turn the power **Off** and **On** to check that the error recurs, then proceed to the FIP.

Step	Check and Action	Yes	No
1	Is there any foreign substances or bits of paper found on the paper transport path?	Remove the foreign substances and bits of paper, etc.	Go to Step 2.
2	Are the paper feed rolls installed properly?	Go to Step 3.	Reinstall the corresponding paper feed rolls
3	Are the paper feed rolls deformed or worn out?	Replace the corresponding paper feed rolls	Go to Step 4.
4	<ul style="list-style-type: none"> • Execute the Diag Digital Input Tray 2: 071-119 / Tray 3:071-120 / Tray 4:071-121 to check the operation of the Path Sensor. • Is the Path Sensor operating normally? 	Go to Step 5.	Go to FIP 2.07
5	<ul style="list-style-type: none"> • Execute the Diag Digital Output Tray 2: 071-018 / Tray 3:071-019 / Tray 4:071-020 to check the operation of the OPTIONAL FEEDER CLUTCH ASSEMBLY. • Is the OPTIONAL FEEDER CLUTCH ASSEMBLY operating normally? 	Go to Step 6.	Go to FIP 2.13

Step	Check and Action	Yes	No
6	<ul style="list-style-type: none"> Execute the Diag Digital Output Tray 2: 071-009 / Tray 3:071-012 / Tray 4:071-015 to check the rotation of the OPTIONAL TRAY MOTOR-ASSEMBLY. Is it working properly? 	Go to Step 7.	Go to FIP 2.17
7	<ul style="list-style-type: none"> Replace (REP 7.8 Feeder Assembly). Does an error occur? 	Replace (REP 5.6 MCU PWB)	Troubleshooting complete.

FIP 1. 278

072-102 IOT Option Regi On Jam

Either of the following error codes is displayed in the UI.

- 050-137
- 050-138

Cause:

After the Tray 2 Path Sensor turned ON, the Regi. Sensor did not turn ON within the specified time.

Solution:

1. Paper jam has occurred. Remove the jammed paper.
2. If there is no jammed paper, or the error still occurs after having removed the jammed paper, turn the power **Off** and **On** to check that the error recurs, then proceed to the FIP.

Step	Check and Action	Yes	No
1	Is there any foreign substances or bits of paper found on the paper transport path?	Remove the foreign substances and bits of paper, etc.	Go to Step 2.
2	Are the paper feed rolls installed properly?	Go to Step 3.	Reinstall the corresponding paper feed rolls
3	Are the paper feed rolls deformed or worn out?	Replace the corresponding paper feed rolls	Go to Step 4.

Step	Check and Action	Yes	No
4	<ul style="list-style-type: none"> Execute the Diag Digital Input 071-102 to check the operation of the REGI-SENSOR HVPS. Is the REGI-SENSOR HVPS operating normally? 	Go to Step 5.	Go to FIP 2.03
5	<ul style="list-style-type: none"> Execute the Diag Digital Input [071-119] to check the operation of the Tray 2 Path Sensor. Is the Tray 2 Path Sensor operating normally? 	Go to Step 6.	Go to FIP 2.07
6	<ul style="list-style-type: none"> Execute the Diag Digital Output 071-021 to check the operation of the Tray 2 TAKE AWAY CLUTCH. Is the Tray 2 TAKE AWAY CLUTCH operating normally? 	Go to Step 7.	Go to FIP 2.13
7	<ul style="list-style-type: none"> Check the operation of the OPTIONAL TRAY MOTOR-ASSEMBLY Execute the Diag Digital Output Tray 2: [071-009] to check the rotation of the OPTIONAL TRAY MOTOR-ASSEMBLY. Is it working properly? 	Go to Step 8.	Go to FIP 2.17
8	<ul style="list-style-type: none"> Replace (REP 7.8 Feeder Assembly). Does an error occur? 	Replace (REP 5.6 MCU PWB)	Troubleshooting complete.

FIP 1. 279

072-211 Feeder 2 Error

Cause:

IOT Option Feeder2 Failure.

Solution:

Turn the power **Off** and **On** to check that the error recurs, then proceed to the FIP.

Step	Check and Action	Yes	No
1	<p>Check the operation of the OPTIONAL TRAY MOTOR ASSEMBLY (when the Optional Sheet Feeder is installed)</p> <ul style="list-style-type: none"> Execute the Diag Digital Output [071-009] to check the rotation of the OPTIONAL TRAY MOTOR ASSEMBLY. Is it working properly? 	Go to Step 2.	Go to FIP 2.17
2	<p>Check the connections between the OPTIONAL TRAY PWB ASSEMBLY and the MCU PWB, as well as between the OPTIONAL TRAY PWB ASSEMBLY and the LVPS PWB.</p> <ul style="list-style-type: none"> Are the OPTIONAL TRAY HARNESS ASSEMBLY (P/J213P/J243, P/J24P/J243) and the HARNESS ASSEMBLY FEEDER DRAWER 1 (P/J243P/J419) connected securely? 	Go to Step 3.	Securely connect the OPTIONAL FEEDER HARNESS ASSEMBLY FEEDER and the DRAWER 1 HARNESS ASSEMBLY
3	<ul style="list-style-type: none"> Replace the OPTIONAL FEEDER HARNESS ASSEMBLY. Does an error occur? 	Go to Step 4.	Troubleshooting complete.
4	<ul style="list-style-type: none"> Replace the DRAWER 1 FEEDER HARNESS ASSEMBLY . Does an error occur? 	Go to Step 5.	Troubleshooting complete.
5	<ul style="list-style-type: none"> Replace (REP 7.5 Optional Tray PWB Assembly) Does an error occur? 	Go to Step 6.	Troubleshooting complete.
6	<ul style="list-style-type: none"> Replace (REP 7.8 Feeder Assembly). Does an error occur? 	Replace (REP 5.6 MCU PWB)	Troubleshooting complete.

FIP 1. 280

073-211 Feeder 3 Error

074-211 Feeder 4 Error

Cause:

073-211: IOT Option Feeder3 Failure.

074-211: IOT Option Feeder4 Failure.

Solution:

Turn the power **Off** and **On** to check that the error recurs, then proceed to the FIP.

Step	Check and Action	Yes	No
1	Check the operation of the OPTIONAL TRAY MOTOR ASSEMBLY <ul style="list-style-type: none"> Execute the Diag Digital Output Tray 3:071-012 / Tray 4:071-015 to check the rotation of the OPTIONAL TRAY MOTOR ASSEMBLY. Is it working properly? 	Go to Step 2.	Go to FIP 2.17
2	Check the connection between the OPTIONAL TRAY PWB ASSEMBLY (Upper) and the OPTIONAL TRAY PWB ASSEMBLY (Lower). <ul style="list-style-type: none"> Are the FEEDER HARNESS ASSEMBLY DRAWER 2 (P/J423P/J4231) and the FEEDER HARNESS ASSEMBLY DRAWER 1 (P/J4231P/J419) connected securely? 	Go to Step 3.	Securely connect the FEEDER HARNESS ASSEMBLY DRAWER 2 and the FEEDER HARNESS ASSEMBLY DRAWER 1
3	<ul style="list-style-type: none"> Replace the FEEDER HARNESS ASSEMBLY DRAWER 2. Does an error occur? 	Go to Step 4.	Troubleshooting complete.
4	<ul style="list-style-type: none"> Replace the FEEDER HARNESS ASSEMBLY DRAWER 1. Does an error occur? 	Go to Step 5.	Troubleshooting complete.
5	<ul style="list-style-type: none"> Replace(REP 7.5 Optional Tray PWB Assembly) Does an error occur? 	Go to Step 6.	Troubleshooting complete.
6	<ul style="list-style-type: none"> Replace (REP 7.8 Feeder Assembly). Does an error occur? 	Replace (REP 5.6 MCU PWB)	Troubleshooting complete.

FIP 1. 281

075-100 MSI Misfeed Jam

050-134 is displayed in the UI.

Cause:

After the MSI Feed Solenoid turned ON, the Regi. Sensor did not turn ON within the specified time.

Solution:

1. Paper jam has occurred. Remove the jammed paper.
2. If there is no jammed paper, or the error still occurs after having removed the jammed paper, turn the power **Off** and **On** to check that the error recurs, then proceed to the FIP.

Step	Check and Action	Yes	No
1	Is there any foreign substances or bits of paper found on the paper transport path?	Remove the foreign substances and bits of paper, etc.	Go to Step 2.
2	Are the paper feed rolls installed properly?	Go to Step 3.	Reinstall the corresponding paper feed rolls
3	Are the paper feed rolls deformed or worn out?	Replace the corresponding paper feed rolls	Go to Step 4.
4	<ul style="list-style-type: none"> • Execute the Diag Digital Input [071-102] to check the operation of the REGI-SENSOR HVPS. • Is the REGI-SENSOR HVPS operating normally? 	Go to Step 5.	Go to FIP 2.03
5	<ul style="list-style-type: none"> • Execute the Diag Digital Output [071-004] to check the operation of the SOLENOID FEED MSI. • Is the SOLENOID FEED MSI operating normally? 	Go to Step 6.	Go to FIP 2.14
6	<ul style="list-style-type: none"> • Execute the Diag Digital Output [071-001] to check the rotation of the MAIN DRIVE ASSEMBLY. • Is it working properly? 	Replace (REP 5.6 MCU PWB)	Go to FIP 2.15

FIP 1. 282

077-101 VSYNC ON Jam

Cause:

Detect VSYNC ON Jam.

Solution:

1. Turn the power **Off** and **On** to check that the error recurs.
2. Update to the latest F/W.
3. If the problem cannot be solved, replace ([REP 5.6 MCU PWB](#)).

FIP 1. 283

077-104 Regi. Off Jam

050-130 is displayed in the UI.

Cause:

The Regi Sensor does not turn OFF within the specified time after the Regi Clutch turned On.

Solution:

1. Paper jam has occurred. Remove the jammed paper.
2. If there is no jammed paper, or the error still occurs after having removed the jammed paper, turn the power **Off** and **On** to check that the error recurs, then proceed to the FIP.

Step	Check and Action	Yes	No
1	Is there any foreign substances or bits of paper found on the paper transport path?	Remove the foreign substances and bits of paper, etc.	Go to Step 2.
2	Are the paper feed rolls installed properly?	Go to Step 3.	Reinstall the corresponding paper feed rolls
3	Are the paper feed rolls deformed or worn out?	Replace the corresponding paper feed rolls	Go to Step 4.
4	<ul style="list-style-type: none"> • Execute the Diag Digital Input [071-102] to check the operation of the REGI-SENSOR HVPS. • Is the REGI-SENSOR HVPS operating normally? 	Go to Step 5.	Go to FIP 2.03

Step	Check and Action	Yes	No
5	<ul style="list-style-type: none"> Execute the Diag Digital Output [071-006] to check the operation of the REGI. CLUTCH. Is the REGI. CLUTCH operating normally? 	Go to Step 6.	Go to FIP 2.10
6	<ul style="list-style-type: none"> Execute the Diag Digital Output [071-001] to check the rotation of the MAIN DRIVE ASSEMBLY. Is it working properly? 	Replace (REP 5.6 MCU PWB)	Go to FIP 2.15

FIP 1. 284

077-106 Exit On Jam

077-108 Exit Off early Jam

077-109 Exit Off Jam

Cause:

077-106:

Either of the following error codes is displayed in the UI.

050-130 - 050-132 - 050-142

The Exit Sensor does not turn ON within the specified time after the Regi Clutch turned On.

077-108:

050-130 is displayed in the UI.

After the Exit Sensor turned ON, the Exit Sensor turned OFF before the specified time.

077-109:

050-130 is displayed in the UI.

After the Regi. Sensor turned OFF, the Exit Sensor did not turn OFF within the specified time.

Solution:

1. Paper jam has occurred. Remove the jammed paper.
2. If there is no jammed paper, or the error still occurs after having removed the jammed paper, turn the power **Off** and **On** to check that the error recurs, then proceed to the FIP.

Step	Check and Action	Yes	No
1	<ul style="list-style-type: none"> Is there any foreign substances or bits of paper found on the paper transport path? <p>Note: Make sure that the FUSING ASSEMBLY has cooled down before performing the operation.</p>	Remove the foreign substances and bits of paper, etc.	Go to Step 2.
2	Are the paper feed rolls installed properly?	Go to Step 3.	Reinstall the corresponding paper feed rolls
3	Are the paper feed rolls deformed or worn out?	Replace the corresponding paper feed rolls	Go to Step 4.
4	<ul style="list-style-type: none"> Execute the Diag Digital Input [071-103] to check the operation of the EXIT SENSOR. Is the EXIT SENSOR operating normally? 	Go to Step 5.	Go to FIP 2.01
5	<ul style="list-style-type: none"> Execute the Diag Digital Input [071-102] to check the operation of the REGI-SENSOR HVPS. Is the REGI-SENSOR HVPS operating normally? 	Go to Step 6.	Go to FIP 2.03
6	<ul style="list-style-type: none"> Execute the Diag Digital Output [071-007] to check the operation of the EXIT CLUTCH ASSEMBLY. Is the EXIT CLUTCH ASSEMBLY operating normally? 	Go to Step 7.	Go to FIP 2.08
7	<ul style="list-style-type: none"> Execute the Diag Digital Output [071-006] to check the operation of the REGI. CLUTCH. Is the REGI. CLUTCH operating normally? 	Go to Step 8.	Go to FIP 2.10
8	<ul style="list-style-type: none"> Execute the Diag Digital Output [071-001] to check the rotation of the MAIN DRIVE ASSEMBLY. Is it working properly? 	Replace (REP 5.6 MCU PWB)	Go to FIP 2.15

FIP 1. 285

077-215 IOT Duplex Error 077-217 Duplex Miss Configuration

Cause:

Duplex Unit Configuration error is detected.

Solution:

Turn the power **Off** and **On** to check that the error recurs, then replace the Duplex Unit.

FIP 1. 286

077-300 IOT Cover Front Open

Cause:

Beep sounds after Front Cover remains open for 3 minutes.

Solution:

1. Close the Front Cover.
2. Inspect the mechanical link that blocks the Interlock Switch (PL 4.2) when the Drum Cartridge is removed, to see if it is retracting properly when the Drum is inserted.
3. If the error persists, ensure that the error is replicated after the printer is powered **Off** and then **On**, and then proceed to the FIP.

Step	Check and Action	Yes	No
1	<ul style="list-style-type: none"> • Is the protruding portion of the FRONT COVER ASSEMBLY damaged? 	Replace (REP 1.2 Front Cover Assembly (3610 / 3615))	Go to Step 2.
2	<ul style="list-style-type: none"> • Execute the Diag Digital Output [041-300] to check the operation of the Front Interlock Switch. • Is it working properly? 	Replace (REP 5.6 MCU PWB)	Go to Step 3.
3	<ul style="list-style-type: none"> • Check the connection between the LVPS PWB and the MCU PWB. Is the LVPS HARNESS ASSEMBLY (P/J220P/J22) connected securely? 	Go to Step 4.	Securely connect the LVPS HARNESS ASSEMBLY
4	<ul style="list-style-type: none"> • Replace the LVPS HARNESS ASSEMBLY. • Does an error occur? 	Go to Step 5.	Troubleshooting complete.

Step	Check and Action	Yes	No
5	<ul style="list-style-type: none"> Replace the Front Interlock Switch. Does an error occur? 	Replace (REP 5.6 MCU PWB)	Troubleshooting complete.

FIP 1. 287

077-304 IOT Cover Rear Open

Cause:

The Rear Cover is open.

Solution:

1. Close the Rear Cover.
2. If the error persists, ensure that the error is replicated after the printer is powered **Off** and then **On**, and then proceed to the FIP.

Step	Check and Action	Yes	No
1	<ul style="list-style-type: none"> Is the protruding portion of the REAR COVER ASSEMBLY damaged? 	Replace (REP 1.5 Rear Cover Assembly)	Go to Step 2.
2	<ul style="list-style-type: none"> Execute the Diag Digital Output 041-301 to check the operation of the Rear Interlock Switch. Is it working properly? 	Replace (REP 5.6 MCU PWB)	Go to Step 3.
3	<ul style="list-style-type: none"> Check the connection between the Rear Interlock Switch and the LVPS, as well as between the LVPS PWB and the MCU PWB. Are the Rear Interlock Switch (P/J230) and the LVPS HARNESS ASSEMBLY (P/J220P/J22) connected securely? 	Go to Step 4.	Securely connect the Rear Interlock Switch and the LVPS HARNESS ASSEMBLY
4	<ul style="list-style-type: none"> Replace the (REP 2.10 Rear Interlock Switch Assembly). Does an error occur? 	Go to Step 5.	Troubleshooting complete.
5	<ul style="list-style-type: none"> Replace the LVPS HARNESS ASSEMBLY. Does an error occur? 	Go to Step 6.	Troubleshooting complete.

Step	Check and Action	Yes	No
6	<ul style="list-style-type: none">• Replace (REP 5.3 LVPS).• Does an error occur?	Replace (REP 5.6 MCU PWB)	Troubleshooting complete.

FIP 1. 288

077-312 Tray Configure Error

Cause:

Tray configuration error was detected. (including all of the wrong configurations)

Solution:

Turn the power **Off** and **On** to check that the error recurs, then proceed to the FIP.

Step	Check and Action	Yes	No
1	<ul style="list-style-type: none"> Does the Tray configuration suit the specification? 	Go to Step 2.	Change the Tray configuration related to the specification
2	<ul style="list-style-type: none"> Check the connections between the OPTIONAL TRAY PWB ASSEMBLY and the MCU PWB, as well as between the OPTIONAL TRAY PWB ASSEMBLY and the LVPS PWB. Are the OPTIONAL FEEDER HARNESS ASSEMBLY (P/J213P/J243, P/J24P/J243) and the FEEDER HARNESS ASSEMBLY DRAWER 1 (P/J243P/J419) connected securely? 	Go to Step 3.	Securely connect the OPTIONAL FEEDER HARNESS ASSEMBLY and the FEEDER HARNESS ASSEMBLY DRAWER 1
3	<ul style="list-style-type: none"> Replace the OPTIONAL FEEDER HARNESS ASSEMBLY. Does an error occur? 	Go to Step 4.	Troubleshooting complete.
4	<ul style="list-style-type: none"> Replace the FEEDER HARNESS ASSEMBLY DRAWER 1. Does an error occur? 	Go to Step 5.	Troubleshooting complete.
5	<ul style="list-style-type: none"> Check the connection between the OPTIONAL TRAY PWB ASSEMBLY (Upper) and the OPTIONAL TRAY PWB ASSEMBLY (Lower). Are the FEEDER HARNESS ASSEMBLY DRAWER 2 (P/J423 - P/J4231) and the FEEDER HARNESS ASSEMBLY DRAWER 1 (P/J4231 - P/J419) connected securely? 	Go to Step 6.	Securely connect the FEEDER HARNESS ASSEMBLY DRAWER 2 and the FEEDER HARNESS ASSEMBLY DRAWER 1
6	<ul style="list-style-type: none"> Replace the FEEDER HARNESS ASSEMBLY DRAWER 2. Does an error occur? 	Go to Step 7.	Troubleshooting complete.
7	<ul style="list-style-type: none"> Replace the FEEDER HARNESS ASSEMBLY DRAWER 1. Does an error occur? 	Go to Step 8.	Troubleshooting complete.

Step	Check and Action	Yes	No
8	<ul style="list-style-type: none"> Replace (REP 7.5 Optional Tray PWB Assembly) Does an error occur? 	Go to Step 9.	Troubleshooting complete.
9	<ul style="list-style-type: none"> Replace (REP 7.8 Feeder Assembly). Does an error occur? 	Replace (REP 5.6 MCU PWB)	Troubleshooting complete.

FIP 1. 290

091-914 IOT Drum Communication Fail

091-915 Drum CRUM Data Broken Fail

091-921 IOT Drum Detached

091-963 IOT Drum CRUM ID Error

Cause:

091-914: Communication failure with Drum CRUM was detected.

091-915: Malfunction of Drum CRUM was detected.

091-921: It was detected that the Drum CRUM is not at the specified position.(Loose CRUM)

091-963: The Drum CRUM ID error was detected.

Solution:

1. Install the Drum Cartridge properly.
2. If the error persists, ensure that the error is replicated after the printer is powered **Off** and then **On**, and then proceed to the FIP.

Step	Check and Action	Yes	No
1	Is the DRUM CARTRIDGE installed properly, with no foreign substances at the contact point between the CRUM in the DRUM CARTRIDGE and the XEROGRAPHIC CONNECTOR ASSEMBLY?	Go to Step 2.	Reinstall the DRUM CARTRIDGE
2	Is the DRUM CARTRIDGE, which is installed in the device, a genuine product?	Go to Step 3.	Replace the DRUM CARTRIDGE with a genuine product
3	Is the connection terminal of the CRUM part in the DRUM CARTRIDGE damaged?	Replace the DRUM CARTRIDGE	Go to Step 4.
4	Is the connection terminal of the XEROGRAPHIC CONNECTOR ASSEMBLY damaged?	Replace (REP 3.3 Xerographic Connector Assembly)	Go to Step 5.
5	<ul style="list-style-type: none"> • Check the connection between the XEROGRAPHIC CONNECTOR ASSEMBLY and the MCU PWB. • Is the XEROGRAPHIC CRUM HARNESS ASSEMBLY (P/J254 - P/J25) connected securely? 	Go to Step 6.	Securely connect the XEROGRAPHIC CRUM HARNESS ASSEMBLY
6	<ul style="list-style-type: none"> • Replace the DRUM CARTRIDGE. • Does an error occur? 	Go to Step 7.	Troubleshooting complete.
7	<ul style="list-style-type: none"> • Replace (REP 3.3 Xerographic Connector Assembly) • Does an error occur? 	Go to Step 8.	Troubleshooting complete.
8	<ul style="list-style-type: none"> • Replace the XEROGRAPHIC CRUM HARNESS ASSEMBLY. • Does an error occur? 	Replace (REP 5.6 MCU PWB)	Troubleshooting complete.

FIP 1. 291

091-953 Drum Tape Staying

Cause:

The remaining Tape of the Drum Cartridge was detected.

Solution:

Remove the Drum Cartridge Tape.

FIP 1. 292

092-315 ATC Fail

Cause:

The ATC Sensor error was detected.

Solution:

Turn the power **Off** and **On** to check that the error recurs, then proceed to the FIP.

Step	Check and Action	Yes	No
1	Is the DRUM CARTRIDGE installed properly, with no foreign substances at the contact point between the ATC Sensor in the DRUM CARTRIDGE and the XEROGRAPHIC CONNECTOR ASSEMBLY?	Go to Step 2.	Reinstall the DRUM CARTRIDGE
2	Is the connection terminal of the ATC SENSOR part in the DRUM CARTRIDGE damaged?	Replace the DRUM CARTRIDGE	Go to Step 3.
3	Is the connection terminal of the XEROGRAPHIC CONNECTOR ASSEMBLY damaged?	Replace (REP 3.3 Xerographic Connector Assembly)	Go to Step 4.
4	<ul style="list-style-type: none"> Check the connection between the XEROGRAPHIC CONNECTOR ASSEMBLY and the MCU PWB. Is the XEROGRAPHIC CRUM HARNESS ASSEMBLY(P/J254 - P/J25) connected securely? 	Go to Step 5.	Securely connect the XEROGRAPHIC CRUM HARNESS ASSEMBLY
5	<ul style="list-style-type: none"> Replace the DRUM CARTRIDGE. Does an error occur? 	Go to Step 6.	Troubleshooting complete.

Step	Check and Action	Yes	No
6	<ul style="list-style-type: none"> Replace (REP 3.3 Xerographic Connector Assembly). Does an error occur? 	Go to Step 7.	Troubleshooting complete.
7	<ul style="list-style-type: none"> Replace the XEROGRAPHIC CRUM HARNESS ASSEMBLY. Does an error occur? 	Replace (REP 5.6 MCU PWB)	Troubleshooting complete.

FIP 1. 293

093-426 Toner Near Life

Cause:

It was detected that the Toner Cartridge needed to be replaced soon.

Solution:

The Toner Cartridge is approaching the replacement time. Prepare a new Toner Cartridge.

FIP 1. 294

093-922 Toner Low Density

Cause:

Low concentration of the Toner was detected.

Solution:

1. Remove the Toner Cartridge, shake it a few times, and then reinstall it.
2. If the error persists, ensure that the error is replicated after the printer is powered **Off** and then **On**, and then proceed to the FIP.

Step	Check and Action	Yes	No
1	<ul style="list-style-type: none"> Remove the TONER CARTRIDGE, shake it a few times, and then reinstall it. Does an error occur? 	Go to Step 2.	Troubleshooting complete.
2	<ul style="list-style-type: none"> Remove the DRUM CARTRIDGE. Is the contact points of the DRUM CARTRIDGE clean, and correctly installed? 	Go to Step 3.	Clean the contact points and reinstall the DRUM CARTRIDGE

Step	Check and Action	Yes	No
3	<ul style="list-style-type: none"> Replace the TONER CARTRIDGE. Does an error occur? 	Go to Step 4.	Troubleshooting complete.
4	<ul style="list-style-type: none"> Replace the DRUM CARTRIDGE. Does an error occur? 	Replace (REP 5.6 MCU PWB)	Troubleshooting complete.

FIP 1. 295

093-925 Toner CRUM Error

093-926 Toner CRUM ID Error

093-928 Toner Type Error

093-973 Toner Detached

Cause:

093-925: The Toner CRUM error was detected.

093-926: The Toner CRUM ID error was detected.

093-928: The Toner Type Error was detected.

093-973: Toner Detached

Solution:

1. Install the Toner Cartridge properly.
2. If the error persists, ensure that the error is replicated after the printer is powered **Off** and then **On**, and then proceed to the FIP.

Step	Check and Action	Yes	No
1	Is the DRUM CARTRIDGE installed properly, with no foreign substances at the contact point between the CRUM in the TONER CARTRIDGE and the TONER DISPENSE CRUM ASSEMBLY?	Go to Step 2.	Reinstall the TONER CARTRIDGE
2	Is the TONER CARTRIDGE, which is installed in the device, a genuine product?	Go to Step 3.	Replace the TONER CARTRIDGE with a genuine product
3	Is the connection terminal of the CRUM part in the TONER CARTRIDGE damaged?	Replace the TONER CARTRIDGE	Go to Step 4.
4	Is the connection terminal of the TONER DISPENSE CRUM ASSEMBLY damaged?	Replace (REP 3.2 Toner Dispense CRUM Assembly)	Go to Step 5.

Step	Check and Action	Yes	No
5	<ul style="list-style-type: none"> Check the connection between the CONNECTOR ASSEMBLY, the CRUM TONER, and the MCU PWB. Is the XEROGRAPHIC CRUM HARNESS ASSEMBLY(P/J253 - P/J25) connected securely? 	Go to Step 6.	Securely connect the XEROGRAPHIC CRUM HARNESS ASSEMBLY
6	<ul style="list-style-type: none"> Replace the TONER CARTRIDGE. Does an error occur? 	Go to Step 7.	Troubleshooting complete.
7	<ul style="list-style-type: none"> Replace (REP 5.6 MCU PWB) Does an error occur? 	Go to Step 8.	Troubleshooting complete.
8	<ul style="list-style-type: none"> Replace the XEROGRAPHIC CRUM HARNESS ASSEMBLY Does an error occur? 	Replace (REP 5.6 MCU PWB)	Troubleshooting complete.

FIP 1. 296

093-933 Toner Life Over

Cause:

It was detected that the Toner Cartridge needed to be replaced soon.

Solution:

The Toner Cartridge is approaching the replacement time. Prepare a new Toner Cartridge.

FIP 1. 297

116-210 USB Host Error

Cause:

Fatal error of USB Host driver.

Solution:

1. Turn the power **Off** and **On** to check that the error recurs.
2. Update to the latest F/W.
3. If the problem cannot be solved, replace ([REP 5.1 ESS PWB](#)).

FIP 1. 298

116-312 Encryption Key Error

116-313 Encryption Setting Error

Cause:

116-312: Encryption key mismatch.

116-313: Encryption setting mismatch.

Solution:

Turn the power **Off** and **On** to check that the error recurs, then proceed to the FIP.

Step	Check and Action	Yes	No
1	Is the Connector (P/J221) between the SD CARD and the ESS PWB free of broken/bent pins, foreign substances, burns, and etc., and is the unit installed properly?	Go to Step 2.	Reinstall the SD CARD
2	<ul style="list-style-type: none"> Re-set up the security of the SD CARD. Does an error occur? 	Go to Step 3.	Troubleshooting complete.
3	<ul style="list-style-type: none"> Replace the SD CARD. Does an error occur? 	Replace (REP 5.1 ESS PWB)	Troubleshooting complete.

FIP 1. 299

116-314 MAC Address Error

Cause:

On Board Network MAC Address Checksum Error.

Solution:

1. Turn the power **Off** and **On** to check that the error recurs, then replace ([REP 5.1 ESS PWB](#)).

FIP 1. 300

116-315 ESS On Board RAM W/R Check Fail

Cause:

Detected by On Board RAM W/R Check at the time of initialization.

Solution:

1. Turn the power **Off** and **On** to check that the error recurs.
2. Update to the latest F/W.
3. If the problem cannot be solved, replace ([REP 5.1 ESS PWB](#)).

FIP 1. 301

116-317 ESS ROM Check (Main) Fail

Cause:

Main Program ROM checksum error.

Solution:

1. Turn the power **Off** and **On** to check that the error recurs.
2. Update to the latest F/W.
3. If the problem cannot be solved, replace ([REP 5.1 ESS PWB](#)).

FIP 1. 302

116-317 ESS ROM Check (Main) Fail

Cause:

Detected by master NVRAM W/R check.

Solution:

1. Turn the power **Off** and **On** to check that the error recurs.
2. Replace ([REP 5.1 ESS PWB](#)).

FIP 1. 303

116-324 ESS Illegal Exception

Cause:

CPU illegal exception.

Solution:

1. Turn the power **Off** and **On** to check that the error recurs.
2. Update to the latest F/W.
3. If the problem cannot be solved, replace ([REP 5.1 ESS PWB](#)).

FIP 1. 304

116-326 ESS NVRAM2 W/R Check Fail

Cause:

Detected by master NVRAM W/R check.

Solution:

1. Turn the power **Off** and **On** to check that the error recurs, then replace ([REP 5.1 ESS PWB](#)).

FIP 1. 305

116-327 ESS Instruction Cache Error

Cause:

CPU instruction cache error.

Solution:

1. Turn the power **Off** and **On** to check that the error recurs.
2. Update to the latest F/W.
3. If the problem cannot be solved, replace ([REP 5.1 ESS PWB](#)).

FIP 1. 306

116-328 ESS Data Cache Error

Cause:

Communication fail between 1 CPU network and ESS F/W.

Solution:

1. Turn the power **Off** and **On** to check that the error recurs.
2. Update to the latest F/W.
3. If the problem cannot be solved, replace ([REP 5.1 ESS PWB](#)).

FIP 1. 307

116-343 ASIC Fail

Cause:

ASIC-related Fatal Error.

Solution:

1. Turn the power **Off** and **On** to check that the error recurs.
2. Update to the latest F/W.
3. If the problem cannot be solved, replace ([REP 5.1 ESS PWB](#)).

FIP 1. 308

116-350 On Board Network Communication Fail

Cause:

Communication fail between 1 CPU network and ESS F/W.

Solution:

1. Turn the power **Off** and **On** to check that the error recurs.
2. Perform the following in sequence
 - " Network System Fault Check"
 - " Network-related Details Check Flow"
3. Update to the latest F/W.
4. If the error persists, ensure that the error is replicated after the printer is powered **Off** and then **On**, and then replace ([REP 5.1 ESS PWB](#)).

FIP 1. 309

116-351/116-352/116-355 Network Error

Cause:

116-351: On Board Network Ethernet BIST parity/RAM R/W Error.

116-352: On Board Network Internal Loop back Error.

116-355: On Board Network Fatal Error.

Solution:

1. Turn the power **Off** and **On** to check that the error recurs.
2. Perform the following in sequence
 - " Network System Fault Check"
 - " Network-related Details Check Flow"
3. Update to the latest F/W.
4. If the error persists, ensure that the error is replicated after the printer is powered **Off** and then **On**, and then replace ([REP 5.1 ESS PWB](#)).

FIP 1. 310

116-353 ESS SD CARD Fail 116-356 SD CARD Overwrite Error

Cause:

116-353: Detect SD CARD Error.

116-356: Error has occurred during SD CARD overwrite.

Solution:

Turn the power **Off** and **On** to check that the error recurs, then proceed to the FIP.

Step	Check and Action	Yes	No
1	Is the Connector (P/J221) between the SD CARD and the ESS PWB free of broken/bent pins, foreign substances, burns, and etc., and is the unit installed properly?	Go to Step 2.	Reinstall the SD CARD
2	<ul style="list-style-type: none"> • Replace the SD CARD. • Does an error occur? 	Replace (REP 5.1 ESS PWB)	Troubleshooting complete.

FIP 1. 311

116-361 PCI Bus #0 Error Detected

Cause:

PCI Bus #0 Uncorrectable Error Detected.
(Connected with Remora EX(x4 port))

Solution:

1. Turn the power **Off** and **On** to check that the error recurs.
2. Update to the latest F/W.
3. If the problem cannot be solved, replace ([REP 5.1 ESS PWB](#)).

FIP 1. 312

116-362 PCI Bus #0 Host Bridge Controller Error

Cause:

PCI Bus #0 Host Bridge Controller Error. (Connected with Remora EX port)

Solution:

1. Turn the power **Off** and **On** to check that the error recurs.
2. Update to the latest F/W.
3. If the problem cannot be solved, replace ([REP 5.1 ESS PWB](#)).

FIP 1. 313

116-363 PCI Bus #1 Host Bridge Controller Error

Cause:

PCI Bus #1 Host Bridge Controller Error. (Connected with Remora EX port.)

Solution:

1. Turn the power **Off** and **On** to check that the error recurs.
2. Update to the latest F/W.
3. If the problem cannot be solved, replace ([REP 5.1 ESS PWB](#)).

FIP 1. 314

116-364 Timer Fail

Cause:

Timer error is detected.

Solution:

1. Turn the power **Off** and **On** to check that the error recurs.
2. Update to the latest F/W.
3. If the problem cannot be solved, set the RTC correctly.

FIP 1. 315

116-366 PCI Bus #1 Error Detected>

Cause:

PCI Bus #1 Uncorrectable Error Detected.
(Connected with RemoraEX(x1 port))

Solution:

1. Turn the power **Off** and **On** to check that the error recurs.
2. Update to the latest F/W.
3. If the problem cannot be solved, replace ([REP 5.1 ESS PWB](#)).

FIP 1. 316

116-368 PCI Error Messages received from Bus #0 - Device #1

Cause:

Remora EX PCI x1 port Error. (Device ID 0x65 (x1))

Solution:

1. Turn the power **Off** and **On** to check that the error recurs.
2. Update to the latest F/W.
3. If the problem cannot be solved, replace ([REP 5.1 ESS PWB](#)).

FIP 1. 317

116-369 PCI Error Messages received from Bus #0 - Device #0

Cause:

Remove EX PCI x4 port Error. (Device ID 0x64 (x4))

Solution:

1. Turn the power **Off** and **On** to check that the error recurs.
2. Update to the latest F/W.
3. If the problem cannot be solved, replace ([REP 5.1 ESS PWB](#)).

FIP 1. 318

116-390 ESS NVRAM1 SIZE And ID Check Fail

Cause:

Detected by consistency check between NVRAM size requested by the system and actual size and consistency check of ID recorded at the first power-on.

Solution:

1. Turn the power **Off** and **On** to check that the error recurs.
2. Update to the latest F/W.
3. If the problem cannot be solved, replace ([REP 5.1 ESS PWB](#)).

FIP 1. 319

116-396 Fatal Error Related to Maillib Other Errors (of File 2 Net Library)

Cause:

S/W bug.

Solution:

1. Turn the power **Off** and **On** to check that the error recurs.
2. Perform the following in sequence
 - " Network System Fault Check"
 - " Network-related Details Check Flow"
3. Update to the latest F/W.
4. If the error persists, ensure that the error is replicated after the printer is powered **Off** and then **On**, and then replace ([REP 5.1 ESS PWB](#)).

FIP 1. 320

116-719 XPIF Parameter Cancelled

Cause:

Due to conflict among multiple print instructions, print instructions are ignored.

Solution:

Make sure that you are using the correct printer driver.

FIP 1. 321

116-721 Collate Full

Cause:

Unable to collate due to insufficient memory.

Solution:

The machine will recover after the **OK** button is pressed or message is displayed for specified time.

If the error persists:

1. Split the document into blocks to decrease the number of pages to be collated.
2. Upgrade SD CARD as required.
3. Take corrective actions at the host side.

FIP 1. 322

116-722 WSD (Web Services on Device) Scan destination error

Cause:

The scan job cannot be executed on the device-driven Web Services on Device Scan, because the destination PC has been stopped.

Solution:

The machine will recover after the **OK** button is pressed or message is displayed for specified time.

If the error persists:

1. Check the destination PC.
2. Perform the following in sequence.
 - " Network System Fault Check"
 - " Network-related Details Check Flow"
3. Take corrective actions at the host side.

FIP 1. 323

116-987 Fatal Error Related to Format Library

Cause:

S/W bug.

Solution:

1. Turn the power **Off** and **On** to check that the error recurs.
2. Perform the following in sequence
 - " Network System Fault Check"
 - " Network-related Details Check Flow"
3. Update to the latest F/W.
4. If the error persists, ensure that the error is replicated after the printer is powered **Off** and then **On**, and then replace ([REP 5.1 ESS PWB](#)).

FIP 1.324

117-315 EEPROM Driver Error

Cause:

EEPROM Driver program error.

Solution:

1. Turn the power **Off** and **On** to check that the error recurs.
2. Update to the latest F/W.

FIP 1. 327

117-321 Device Memory Error

Cause:

SD CARD Type Invalid.

Solution:

Turn the power **Off** and **On** to check that the error recurs, then proceed to the FIP.

Step	Check and Action	Yes	No
1	Is the regular SD CARD used?	Go to Step 2.	Use the regular SD CARD
2	Is the Connector (P/J221) between the SD CARD and the ESS PWB free of broken/bent pins, foreign substances, burns, and etc., and is the unit installed properly?	Go to Step 3.	Reinstall the SD CARD
3	<ul style="list-style-type: none"> • Replace the SD CARD. • Does an error occur? 	Replace (REP 5.1 ESS PWB)	Troubleshooting complete.

FIP 1. 326

117-331 IPS Error

Cause:

In relation to IPS, the following internal error has occurred.

- OS function return value error
- DSP program load fail

Solution:

1. Turn the power **Off** and **On** to check that the error recurs.
2. Update to the latest F/W.
3. If the problem cannot be solved, replace ([REP 5.1 ESS PWB](#)).

FIP 1. 327

117-338 Enable Device Memory Error

Cause:

Invalid, although SD CARD was detected.

This error will be outputted if SD CARD is removed where the power is on.

Solution:

Turn the power **Off** and **On** to check that the error recurs, then proceed to the FIP.

Step	Check and Action	Yes	No
1	Is the Connector (P/J221) between the SD CARD and the ESS PWB free of broken/bent pins, foreign substances, burns, and etc., and is the unit installed properly?	Replace the SD CARD.	Reinstall the SD CARD

FIP 1. 328

117-340 Controller Error

Cause:

HOOK task error.

Solution:

1. Turn the power **Off** and **On** to check that the error recurs, then update to the latest F/W.
2. If the problem cannot be solved, replace the following parts in sequence.
 - (REP 5.4 Fax PWB)
 - (REP 5.1 ESS PWB)

FIP 1. 329

117-344 FAX Error

Cause:

FLASHFILE task error.

Solution:

1. Turn the power **Off** and **On** to check that the error recurs, then update to the latest F/W.
2. If the problem cannot be solved, replace the following parts in sequence.
 - (REP 5.4 Fax PWB)
 - (REP 5.1 ESS PWB)

FIP 1. 330

117-350 Controller Error

Cause:

Task initialization (start) error.

Solution:

1. Turn the power **Off** and **On** to check that the error recurs.
2. Update to the latest F/W.
3. If the problem cannot be solved, replace (REP 5.1 ESS PWB).

FIP 1. 331

117-361 IIT Parameter Verify NG

Cause:

IIT registration adjustment value verification NG.
(Checked only at production process)

Solution:

1. Turn the power **Off** and **On** to check that the error recurs.
2. Update to the latest F/W.

FIP 1. 332

117-362 EEPROM Sum Check Error

Cause:

EEPROM sum check value error.

Solution:

1. Turn the power **Off** and **On** to check that the error recurs.
2. Update to the latest F/W.

FIP 1. 333

117-363 NVM Sum Check Error

Cause:

NVM sum check value error.

Solution:

1. Turn the power **Off** and **On** to check that the error recurs.
2. Update to the latest F/W.

FIP 1. 334

117-365 Low Voltage

Cause:

RTC detected Low Voltage. RTC clock setting and content of SRAM are invalid. Initialize them.

Solution:

1. Turn the power **Off** and **On** to check that the error recurs.
2. Update to the latest F/W.
3. If the problem cannot be solved, replace ([REP 5.1 ESS PWB](#)).

FIP 1. 335

117-367 FXIF error

Cause:

An error occurred on FXIF (such as the Video Underrun error).

Solution:

1. Turn the power **Off** and **On** to check that the error recurs.
2. Then update to the latest F/W.
3. If the problem cannot be solved, replace the following parts in sequence.
 - ([REP 5.1 ESS PWB](#))
 - ([REP 6.1 IIT Assembly](#))

FIP 1. 336

118-311 Google Cloud Print Software Error

Cause:

A critical internal error has occurred.

Solution:

1. Check the settings, and try again.
2. Contact customer support if the issue reoccurs.
3. Perform the following in sequence.
 - " Network System Fault Check"
 - " Network-related Details Check Flow"
4. Update to the latest F/W.
5. If the error persists, ensure that the error is replicated after the printer is powered **Off** and then **On**, and then replace ([REP 5.1 ESS PWB](#)).

FIP 1. 337

123-314 Panel Power On Error

Cause:

Communication error at panel power on.

Startup sequence does not start from AIOC within 1 minute after panel power on.

Solution:

1. Turn the power **Off** and **On** to check that the error recurs.
2. Update to the latest F/W.
3. If the problem cannot be solved, replace ([REP 5.1 ESS PWB](#)).

FIP 1. 338

123-333 Panel FW transmission error

Cause:

An error which occurred when the Panel Main FW transmission was performed from ESS.

Solution:

1. Turn the power **Off** and **On** to check that the error recurs.
2. Update to the latest F/W.
3. If the error persists, ensure that the error is replicated after the printer is powered **Off** and then **On**, and then replace the following parts in sequence.
 - (REP 5.4 Fax PWB)
 - (REP 5.1 ESS PWB)

FIP 1. 339

123-399 Panel Device Reboot Error

Cause:

An error which was caused by an unexpected reboot, such as reboot due to static electricity.

Solution:

1. Turn the power **Off** and **On** to check that the error recurs, then update to the latest F/W.
2. If the problem cannot be solved, replace (REP 1.1 Control Panel (3610)) (REP 1.12 Control Panel (3615))

FIP 1. 340

131-397 File2Net Fatal Error

Cause:

File2Net fatal error. S/W bug.

Solution:

1. Turn the power **Off** and **On** to check that the error recurs.
2. Perform the following in sequence
 - " Network System Fault Check"
 - " Network-related Details Check Flow"
3. Update to the latest F/W.
4. If the error persists, ensure that the error is replicated after the printer is powered **Off** and then **On**, and then replace (REP 5.1 ESS PWB).

FIP 1. 341

131-398 SMB client Fatal Error

Cause:

SMB Client fatal error.

Solution:

1. Turn the power **Off** and **On**, perform the same operation and check whether the problem is reoccurring.
2. If the problem still persists, perform the following in sequence.
 - " Network System Fault Check"
 - " Network-related Details Check Flow"
3. Take corrective actions at the host side.

FIP 1. 342

131-399 FTP client Fatal Error

Cause:

FTP Client fatal error.

Solution:

1. Turn the power **Off** and **On**, perform the same operation and check whether the problem is reoccurring.
2. If the problem still persists, perform the following in sequence.
 - " Network System Fault Check"
 - " Network-related Details Check Flow"
3. Take corrective actions at the host side.

FIP 1. 343

133-231 T_FAXCOM Data Receive I/F Error

Cause:

T_FAXCOM<->Data processing I/F error.

Solution:

1. Turn the power **Off** and **On** to check that the error recurs, then update to the latest F/W.
2. If the problem cannot be solved, replace the following parts in sequence.
 - ([REP 5.4 Fax PWB](#))
 - ([REP 5.1 ESS PWB](#))

FIP 1. 344

133-234 JBIG Parameter Error

Cause:

JBIG parameter error.

Solution:

1. Turn the power **Off** and **On** to check that the error recurs.
2. Update to the latest F/W.
3. If the problem cannot be solved, replace the following parts in sequence.
 - (REP 5.4 Fax PWB)
 - (REP 5.1 ESS PWB)

FIP 1. 345

133-235 MHR Parameter Error

Cause:

MHR parameter error.

Solution:

1. Turn the power **Off** and **On** to check that the error recurs.
2. Update to the latest F/W.
3. If the problem cannot be solved, replace the following parts in sequence.
 - (REP 5.4 Fax PWB)
 - (REP 5.1 ESS PWB)

FIP 1. 346

133-236 MHR Encode Error

Cause:

MHR encode error.

Solution:

1. Turn the power **Off** and **On** to check that the error recurs.
2. Update to the latest F/W.
3. If the problem cannot be solved, replace the following parts in sequence.
 - (REP 5.4 Fax PWB)
 - (REP 5.1 ESS PWB)

FIP 1. 347

133-237 MHR Input Buffer Error

Cause:

Data error of MHR input buffer.

Solution:

1. Turn the power **Off** and **On** to check that the error recurs.
2. Update to the latest F/W.
3. If the problem cannot be solved, replace the following parts in sequence.
 - (REP 5.4 Fax PWB)
 - (REP 5.1 ESS PWB)

FIP 1. 348

133-238 MHR Output Buffer Error

Cause:

Data error of MHR output buffer.

Solution:

1. Turn the power **Off** and **On** to check that the error recurs.
2. Update to the latest F/W.
3. If the problem cannot be solved, replace the following parts in sequence.
 - (REP 5.4 Fax PWB)
 - (REP 5.1 ESS PWB)

FIP 1. 349

133-239 FAX ECM Buffer Address Error

Cause:

At FAX send/receive, address to get from and write in ECM buffer is wrong.

Solution:

1. Turn the power **Off** and **On** to check that the error recurs.
2. Update to the latest F/W.
3. If the problem cannot be solved, replace the following parts in sequence.
 - (REP 5.4 Fax PWB)
 - (REP 5.1 ESS PWB)

FIP 1. 350

133-240 Resolution Change Error

Cause:

Resolution error in FAX send resolution conversion.

Solution:

1. Turn the power **Off** and **On** to check that the error recurs.
2. Update to the latest F/W.
3. If the problem cannot be solved, replace the following parts in sequence.
 - [\(REP 5.4 Fax PWB\)](#)
 - [\(REP 5.1 ESS PWB\)](#)

FIP 1. 351

133-241 Memory Pool Get Error

Cause:

Memory pool get error. (OS error)

Solution:

1. Turn the power **Off** and **On** to check that the error recurs.
2. Update to the latest F/W.
3. If the problem cannot be solved, replace the following parts in sequence.
 - [\(REP 5.4 Fax PWB\)](#)
 - [\(REP 5.1 ESS PWB\)](#)

FIP 1. 352

133-242 Memory Pool Release Error

Cause:

Memory pool release error. (OS error)

Solution:

1. Turn the power **Off** and **On** to check that the error recurs.
2. Update to the latest F/W.
3. If the problem cannot be solved, replace the following parts in sequence.
 - [\(REP 5.4 Fax PWB\)](#)
 - [\(REP 5.1 ESS PWB\)](#)

FIP 1. 353

133-243 Message Send Error

Cause:

Message send error. (OS error)

Solution:

1. Turn the power **Off** and **On** to check that the error recurs.
2. Update to the latest F/W.
3. If the problem cannot be solved, replace the following parts in sequence.
 - [\(REP 5.4 Fax PWB\)](#)
 - [\(REP 5.1 ESS PWB\)](#)

FIP 1. 354

133-244 Message Receive Error

Cause:

Message receive error. (OS error)

Solution:

1. Turn the power **Off** and **On** to check that the error recurs.
2. Update to the latest F/W.
3. If the problem cannot be solved, replace the following parts in sequence.
 - [\(REP 5.4 Fax PWB\)](#)
 - [\(REP 5.1 ESS PWB\)](#)

FIP 1. 357

133-246 Memory Pool Get Error

Cause:

Memory pool get error. (OS error)

Solution:

1. Turn the power **Off** and **On** to check that the error recurs.
2. Update to the latest F/W.
3. If the problem cannot be solved, replace the following parts in sequence.
 - [\(REP 5.4 Fax PWB\)](#)
 - [\(REP 5.1 ESS PWB\)](#)

FIP 1. 356

133-247 Message Send Error

Cause:

Message send error. (OS error)

Solution:

1. Turn the power **Off** and **On** to check that the error recurs.
2. Update to the latest F/W.
3. If the problem cannot be solved, replace the following parts in sequence.
 - ([REP 5.4 Fax PWB](#))
 - ([REP 5.1 ESS PWB](#))

FIP 1. 357

133-248 Memory Pool Release Error

Cause:

Memory pool release error. (OS error)

Solution:

1. Turn the power **Off** and **On** to check that the error recurs.
2. Update to the latest F/W.
3. If the problem cannot be solved, replace the following parts in sequence.
 - ([REP 5.4 Fax PWB](#))
 - ([REP 5.1 ESS PWB](#))

FIP 1. 358

133-249 Message Receive Error

Cause:

Message receive error. (OS error)

Solution:

1. Turn the power **Off** and **On** to check that the error recurs.
2. Update to the latest F/W.
3. If the problem cannot be solved, replace the following parts in sequence.
 - ([REP 5.4 Fax PWB](#))
 - ([REP 5.1 ESS PWB](#))

FIP 1. 359

133-251 File Open Error

Cause:

File open error.

Solution:

1. Turn the power **Off** and **On** to check that the error recurs.
2. Update to the latest F/W.
3. If the problem cannot be solved, replace the following parts in sequence.
 - (REP 5.4 Fax PWB)
 - (REP 5.1 ESS PWB)

FIP 1. 360

133-252 File Close Error

Cause:

File close error.

Solution:

1. Turn the power **Off** and **On** to check that the error recurs.
2. Update to the latest F/W.
3. If the problem cannot be solved, replace the following parts in sequence.
 - (REP 5.4 Fax PWB)
 - (REP 5.1 ESS PWB)

FIP 1. 361

133-253 File Erase Error

Cause:

File erase error.

Solution:

1. Turn the power **Off** and **On** to check that the error recurs.
2. Update to the latest F/W.
3. If the problem cannot be solved, replace the following parts in sequence.
 - (REP 5.4 Fax PWB)
 - (REP 5.1 ESS PWB)

FIP 1. 362

133-254 Memory Full

Cause:

Cannot secure memory necessary to print.

Solution:

1. Turn the power **Off** and **On** to check that the error recurs.
2. Update to the latest F/W.
3. If the problem cannot be solved, replace the following parts in sequence.
 - ([REP 5.4 Fax PWB](#))
 - ([REP 5.1 ESS PWB](#))

FIP 1. 363

133-259 OS Call Error

Cause:

OS Call error.

Solution:

1. Turn the power **Off** and **On** to check that the error recurs.
2. Update to the latest F/W.
3. If the problem cannot be solved, replace ([REP 5.1 ESS PWB](#)).

FIP 1. 364

133-260 File Open Error

Cause:

File open error.

Solution:

1. Turn the power **Off** and **On** to check that the error recurs.
2. Update to the latest F/W.
3. If the problem cannot be solved, replace ([REP 5.1 ESS PWB](#)).

FIP 1. 365

133-261/133-269 File Close Error

Cause:

File close error.

Solution:

1. Turn the power **Off** and **On** to check that the error recurs.
2. If the problem cannot be solved, replace the following parts in sequence.
 - (REP 5.4 Fax PWB)
 - (REP 5.1 ESS PWB)

FIP 1. 366

133-271 Memory Pool Get Error

Cause:

Memory pool get error. (OS error)

Solution:

1. Turn the power **Off** and **On** to check that the error recurs.
2. Update to the latest F/W.
3. If the problem cannot be solved, replace (REP 5.1 ESS PWB).

FIP 1. 367

133-272 Message Send Error

Cause:

Message send error. (OS error)

Solution:

1. Turn the power **Off** and **On** to check that the error recurs.
2. Update to the latest F/W.
3. If the problem cannot be solved, replace (REP 5.1 ESS PWB).

FIP 1. 368

133-273 Memory Pool Release Error

Cause:

Memory pool release error. (OS error)

Solution:

1. Turn the power **Off** and **On** to check that the error recurs.
2. Update to the latest F/W.
3. If the problem cannot be solved, replace ([REP 5.1 ESS PWB](#)).

FIP 1. 369

133-274 Message Receive Error

Cause:

Message receive error. (OS error)

Solution:

1. Turn the power **Off** and **On** to check that the error recurs.
2. Update to the latest F/W.
3. If the problem cannot be solved, replace ([REP 5.1 ESS PWB](#)).

FIP 1. 370

133-275 OS Call Error

Cause:

OS Call error.

Solution:

1. Turn the power **Off** and **On** to check that the error recurs.
2. Update to the latest F/W.
3. If the problem cannot be solved, replace ([REP 5.1 ESS PWB](#)).

FIP 1. 371

133-276 File Open Error

Cause:

File open error.

Solution:

1. Turn the power **Off** and **On** to check that the error recurs.
2. Update to the latest F/W.
3. If the problem cannot be solved, replace ([REP 5.1 ESS PWB](#)).

FIP 1. 372

133-277 File Close Error

Cause:

File close error.

Solution:

1. Turn the power **Off** and **On** to check that the error recurs.
2. Update to the latest F/W.
3. If the problem cannot be solved, replace ([REP 5.1 ESS PWB](#)).

FIP 1. 373

133-278 File Erase Error

Cause:

File erase error.

Solution:

1. Turn the power **Off** and **On** to check that the error recurs.
2. Update to the latest F/W.
3. If the problem cannot be solved, replace the following parts in sequence.
 - ([REP 5.4 Fax PWB](#))
 - ([REP 5.1 ESS PWB](#))

FIP 1. 374

133-279 FAX CODEC I/F Error

Cause:

FAX CODEC I/F error.

Solution:

1. Turn the power **Off** and **On** to check that the error recurs.
2. Check the telephone line connection. Reconnect the telephone line connector.
3. Check the sending side fax. Receive the fax data from a good fax machine.
4. Update to the latest F/W.
5. If the error persists, ensure that the error is replicated after the printer is powered **Off** and then **On**, and then replace the following parts in sequence.
 - [\(REP 5.4 Fax PWB\)](#)
 - [\(REP 5.1 ESS PWB\)](#)

FIP 1. 375

133-280 ERR_FAX_TIME

Cause:

FAX timer error.

Solution:

1. Turn the power **Off** and **On** to check that the error recurs.
2. Update to the latest F/W.
3. If the problem cannot be solved, replace the following parts in sequence.
 - [\(REP 5.4 Fax PWB\)](#)
 - [\(REP 5.1 ESS PWB\)](#)

FIP 1. 376

133-281 Power Off Report Create Fail

Cause:

Failed in creating power-off report.

Solution:

1. Turn the power **Off** and **On** to check that the error recurs.
2. Update to the latest F/W.
3. If the problem cannot be solved, replace ([REP 5.1 ESS PWB](#)).

FIP 1. 377

133-282 Memory Pool Get Error

Cause:

Memory pool get error. (OS error)

Solution:

1. Turn the power **Off** and **On** to check that the error recurs.
2. Update to the latest F/W.
3. If the problem cannot be solved, replace ([REP 5.1 ESS PWB](#)).

FIP 1. 378

133-283 Message Send Error

Cause:

Message send error. (OS error)

Solution:

1. Turn the power **Off** and **On** to check that the error recurs.
2. Update to the latest F/W.
3. If the problem cannot be solved, replace ([REP 5.1 ESS PWB](#)).

FIP 1. 379

133-286 OS Call Error

Cause:

OS Call error.

Solution:

1. Turn the power **Off** and **On** to check that the error recurs.
2. Update to the latest F/W.
3. If the problem cannot be solved, replace ([REP 5.1 ESS PWB](#)).

FIP 1. 380

133-287 File Open Error

Cause:

File open error.

Solution:

1. Turn the power **Off** and **On** to check that the error recurs.
2. Update to the latest F/W.
3. If the problem cannot be solved, replace ([REP 5.1 ESS PWB](#)).

FIP 1. 381

133-288 File Close Error

Cause:

File close error.

Solution:

1. Turn the power **Off** and **On** to check that the error recurs.
2. Update to the latest F/W.
3. If the problem cannot be solved, replace ([REP 5.1 ESS PWB](#)).

FIP 1. 382

133-289 File Erase Error

Cause:

File erase error.

Solution:

1. Turn the power **Off** and **On** to check that the error recurs.
2. Update to the latest F/W.
3. If the problem cannot be solved, replace ([REP 5.1 ESS PWB](#)).

FIP 1. 383

133-290 Print Decode Error

Cause:

At JBIG data print decode, decode error occurred three successive times.

Solution:

1. Turn the power **Off** and **On** to check that the error recurs.
2. Check the telephone line connection. Reconnect the telephone line connector.
3. Check the sending side fax. Receive the fax data from a good fax machine.
4. Update to the latest F/W.
5. If the error persists, ensure that the error is replicated after the printer is powered **Off** and then **On**, and then replace the following parts in sequence.
 - ([REP 5.4 Fax PWB](#))
 - ([REP 5.1 ESS PWB](#))

FIP 1. 384

134-211 Fax Card Modem Error

Cause:

Fax Card parts error. (MODEM error)

Solution:

1. Turn the power **Off** and **On** to check that the error recurs.
2. Check the telephone line connection. Reconnect the telephone line connector.
3. Check the sending side fax. Receive the fax data from a good fax machine.
4. Update to the latest F/W.
5. If the error persists, ensure that the error is replicated after the printer is powered **Off** and then **On**, and then replace the following parts in sequence.
 - [\(REP 5.4 Fax PWB\)](#)
 - [\(REP 5.1 ESS PWB\)](#)

FIP 1. 385

142-700 IOT Over Heat Forced Half Speed

Cause:

Half-speed operation was forced due to abnormally high temperature inside the IOT.

Solution:

1. No action is required.
2. Start the operation after the Printer has cooled down.

FIP 1. 386

193-700 Custom Toner Mode

Cause:

The printer is in custom toner mode.

Solution:

No action is required.

Level 2 FIPs

FIP 2.01

Exit Sensor

Cause:

Parts to be considered:

- EXIT CHUTE ASSEMBLY (PL 2.5 Exit Chute)
- EXIT SENSOR (PL 2.5 Exit Chute)
- EXIT SENSOR HARNESS ASSEMBLY (PL 5.4 Electrical Connections)
- MCU PWB (PL 5.3 Electrical (MCU PWB / HVPS))

Solution:

Step	Check and Action	Yes	No
1	Are there any foreign substances in the EXIT SENSOR Detector?	Remove the foreign substances	Go to Step 2.
2	Is the EXIT CHUTE ASSEMBLY damaged?	Replace (REP 2.11 Exit Chute Assembly)	Go to Step 3.
3	Check the connection between the EXIT SENSOR and the MCU PWB. <ul style="list-style-type: none"> • Is the EXIT SENSOR HARNESS ASSEMBLY (P/J271-P/J27) connected securely? 	Go to Step 4.	Securely connect the EXIT SENSOR HARNESS ASSEMBLY
4	<ul style="list-style-type: none"> • Replace the EXIT SENSOR. Does an error occur? 	Go to Step 5.	Troubleshooting complete.
5	<ul style="list-style-type: none"> • Does an error occur? 	Replace (REP 5.6 MCU PWB)	Troubleshooting complete.

FIP 2.02

IOT Standard Stacker Full

Cause:

Parts to be considered:

- FULL STACK SENSOR ([PL 2.5 Exit Chute](#))
- EXIT SENSOR HARNESS ASSEMBLY ([PL 5.4 Electrical Connections](#))
- MCU PWB ([PL 5.3 Electrical \(MCU PWB / HVPS\)](#))

Solution:

Step	Check and Action	Yes	No
1	<ul style="list-style-type: none"> • Check the connection between the FULL STACK SENSOR and the MCU PWB. • Is the EXIT SENSOR HARNESS ASSEMBLY (P/J272 - P/J27) connected securely? 	Go to Step 2.	Securely connect the EXIT SENSOR HARNESS ASSEMBLY
2	<ul style="list-style-type: none"> • Replace the EXIT SENSOR HARNESS ASSEMBLY. • Does an error occur? 	Go to Step 3.	Troubleshooting complete.
3	<ul style="list-style-type: none"> • Replace (REP 2.13 Full Stack Sensor). • Does an error occur? 	Replace (REP 5.6 MCU PWB)	Troubleshooting complete.

FIP 2.03

Registration Sensor

Cause:

Parts to be considered:

- REGI-ACTUATOR ([PL 2.2 Transport Assembly](#))
- REGI-SENSOR ([PL 5.3 Electrical \(MCU PWB / HVPS\)](#))
- HVPS HARNESS ASSEMBLY ([PL 5.4 Electrical Connections](#))
- MCU PWB ([PL 5.3 Electrical \(MCU PWB / HVPS\)](#))

Solution:

Step	Check and Action	Yes	No
1	Are there any foreign substances in the REGI-SENSOR HVPS DETECTOR?	Remove the foreign substances	Go to Step 2.
2	Is the REGI-ACTUATOR damaged?	Replace the REGI-ACTUATOR	Go to Step 3.
3	Check the connection between the HVPS and the MCU PWB. <ul style="list-style-type: none"> • Is the HVPS HARNESS ASSEMBLY (P/J261 - P/J26) connected securely? 	Go to Step 4.	Securely connect the HVPS HARNESS ASSEMBLY
4	<ul style="list-style-type: none"> • Replace the HVPS HARNESS ASSEMBLY. • Does an error occur? 	Go to Step 5.	Troubleshooting complete.
5	<ul style="list-style-type: none"> • Replace (REP 5.7 HVPS (3610)) (REP 5.8 HVPS (3615)) • Does an error occur? 	Replace (REP 5.6 MCU PWB)	Troubleshooting complete.

FIP 2.04

CST No Paper Sensor

Cause:

Parts to be considered:

- NO PAPER TRAY ACTUATOR (PL 2.2 Transport Assembly)
- CST NO PAPER TRAY SENSOR (PL 5.3 Electrical (MCU PWB / HVPS))
- HVPS HARNESS ASSEMBLY (PL 5.4 Electrical Connections)
- MCU PWB (PL 5.3 Electrical (MCU PWB / HVPS))

Solution:

Step	Check and Action	Yes	No
1	Are there any foreign substances in the CST NO PAPER TRAY SENSOR HVPS DETECTOR?	Remove the foreign substances	Go to Step 2.
2	Is the NO PAPER TRAY ACTUATOR damaged?	Replace the NO PAPER TRAY ACTUATOR	Go to Step 3.
3	Check the connection between the HVPS and the MCU PWB. <ul style="list-style-type: none"> • Is the HVPS HARNESS ASSEMBLY(P/J261 - P/J26) connected securely? 	Go to Step 4.	Securely connect the HVPS HARNESS ASSEMBLY
4	<ul style="list-style-type: none"> • Replace the HVPS HARNESS ASSEMBLY. • Does an error occur? 	Go to Step 5.	Troubleshooting complete.
5	<ul style="list-style-type: none"> • Replace (REP 5.7 HVPS (3610)) (REP 5.8 HVPS (3615)) • Does an error occur? 	Replace (REP 5.6 MCU PWB)	Troubleshooting complete.

FIP 2.05

MSI No Paper Sensor

Cause:

Parts to be considered:

- MSI NO PAPER ACTUATOR ([PL 2.6 MSI](#))
- MSI NO PAPER SENSOR ([PL 5.3 Electrical \(MCU PWB / HVPS\)](#))
- HVPS HARNESS ASSEMBLY ([PL 5.4 Electrical Connections](#))
- MCU PWB ([PL 5.3 Electrical \(MCU PWB / HVPS\)](#))

Solution:

Step	Check and Action	Yes	No
1	Are there any foreign substances in the MSI NO PAPER SENSOR HVPS DETECTOR?	Remove the foreign substances	Go to Step 2.
2	Is the MSI NO PAPER ACTUATOR damaged?	Replace the MSI NO PAPER ACTUATOR	Go to Step 3.
3	Check the connection between the HVPS and the MCU PWB. <ul style="list-style-type: none"> • Is the HVPS HARNESS ASSEMBLY(P/J261 - P/J26) connected securely? 	Go to Step 4.	Securely connect the HVPS HARNESS ASSEMBLY
4	<ul style="list-style-type: none"> • Replace the HVPS HARNESS ASSEMBLY. • Does an error occur? 	Go to Step 5.	Troubleshooting complete.
5	<ul style="list-style-type: none"> • Replace (REP 5.7 HVPS (3610)) (REP 5.8 HVPS (3615)) • Does an error occur? 	Replace (REP 5.6 MCU PWB)	Troubleshooting complete.

FIP 2.06

No Paper Sensor

Cause:

Parts to be considered:

- NO PAPER ACTUATOR (PL 7.2 Tray 1/Optional Tray 550-Sheet Feeder (2/4))
- NO PAPER SENSOR (PL 7.2 Tray 1/Optional Tray 550-Sheet Feeder (2/4))
- NO PAPER SENSOR HARNESS ASSEMBLY (PL 7.2 Tray 1/Optional Tray 550-Sheet Feeder (2/4))
- C2 TURN HARNESS ASSEMBLY (PL 7.1 Tray 1/Optional Tray 550-Sheet Feeder (1/4))
- OPTIONAL TRAY PWB ASSEMBLY (PL 7.1 Tray 1/Optional Tray 550-Sheet Feeder (1/4))

Solution:

Step	Check and Action	Yes	No
1	Are there any foreign substances in the NO PAPER SENSOR DETECTOR?	Remove the foreign substances	Go to Step 2.
2	Is the NO PAPER ACTUATOR damaged?	Replace the NO PAPER ACTUATOR	Go to Step 3.
3	Check the connection between the No Paper Sensor and the OPTIONAL TRAY PWB ASSEMBLY. <ul style="list-style-type: none"> • Are the NO PAPER SENSOR HARNESS ASSEMBLY (P/J4203 - P/J4202) and the C2 TURN HARNESS ASSEMBLY (P/J4202 - P/J420) connected securely? 	Go to Step 4.	Securely connect the NO PAPER SENSOR HARNESS ASSEMBLY and the C2 TURN HARNESS ASSEMBLY
4	<ul style="list-style-type: none"> • Replace (REP 7.5 Optional Tray PWB Assembly). Does an error occur?	Go to Step 5.	Troubleshooting complete.
5	<ul style="list-style-type: none"> • Replace the NO PAPER SENSOR Does an error occur?	Go to Step 6.	Troubleshooting complete.
6	<ul style="list-style-type: none"> • Replace the C2 TURN HARNESS ASSEMBLY • Does an error occur? 	Replace (REP 5.6 MCU PWB)	Troubleshooting complete.

FIP 2.07

Path Sensor

Cause:

Parts to be considered:

- PRE REGI-ACTUATOR (PL 7.4 Tray 1/Optional Tray 550-Sheet Feeder (4/4))
- PATH SENSOR (PL 7.4 Tray 1/Optional Tray 550-Sheet Feeder (4/4))
- OPTIONAL REGI HARNESS ASSEMBLY (PL 7.4 Tray 1/Optional Tray 550-Sheet Feeder (4/4))

- OPTIONAL TRAY PWB ASSEMBLY (PL 7.1 Tray 1/Optional Tray 550-Sheet Feeder (1/4))

Solution:

Step	Check and Action	Yes	No
1	Are there any foreign substances in the PATH SENSOR DETECTOR?	Remove the foreign substances	Go to Step 2.
2	Is the PRE REGI-ACTUATOR damaged?	Replace the PRE REGI-ACTUATOR	Go to Step 3.
3	Check the connection between the Path Sensor & the OPTIONAL TRAY PWB ASSY. <ul style="list-style-type: none"> • Is the OPTIONAL REGI HARNESS ASSEMBLY (P/J4212 - P/J4214) connected securely? 	Go to Step 4.	Securely connect the Optional Regi Harness Assembly
4	<ul style="list-style-type: none"> • Replace the Path Sensor. Does an error occur? 	Go to Step 5.	Troubleshooting complete.
5	<ul style="list-style-type: none"> • Replace the OPTIONAL REGI HARNESS ASSEMBLY. Does an error occur? 	Replace the MCU	Troubleshooting complete.

FIP 2.08

Exit Clutch Assembly

Cause:

Parts to be considered:

- DRIVE EXIT OUT HOLDER ASSEMBLY (PL 4.1 Drive)
- DRIVE EXIT IN HOLDER ASSEMBLY (PL 4.1 Drive)
- EXIT CLUTCH ASSEMBLY (PL 4.1 Drive)
- MCU PWB (PL 5.3 Electrical (MCU PWB / HVPS))

Solution:

Step	Check and Action	Yes	No
1	Are there any foreign substances in the EXIT CLUTCH ASSEMBLY Drive Section?	Remove the foreign substances	Go to Step 2.
2	Is the DRIVE EXIT OUT HOLDER ASSEMBLY or the DRIVE EXIT IN HOLDER ASSEMBLY damaged?	Replace the DRIVE EXIT OUT HOLDER ASSEMBLY and the DRIVE EXIT IN HOLDER ASSEMBLY	Go to Step 3.
3	Check the connection between the CLUTCH ASSEMBLY EXIT and the MCU PWB. <ul style="list-style-type: none"> • Is the EXIT CLUTCH ASSEMBLY (P/J16) connected securely? 	Go to Step 4.	Securely connect the CLUTCH ASSEMBLY EXIT
4	<ul style="list-style-type: none"> • Replace the EXIT CLUTCH ASSEMBLY. Does an error occur? 	Replace (REP 5.6 MCU PWB)	Troubleshooting complete.

FIP 2.09

Invert Clutch Assembly

Cause:

Parts to be considered:

- DRIVE EXIT OUT HOLDER ASSEMBLY ([PL 4.1 Drive](#))
- DRIVE EXIT IN HOLDER ASSEMBLY ([PL 4.1 Drive](#))
- INVERT CLUTCH ASSEMBLY ([PL 4.1 Drive](#))
- MCU PWB ([PL 5.3 Electrical \(MCU PWB / HVPS\)](#))

Solution:

Step	Check and Action	Yes	No
1	Are there any foreign substances in the INVERT CLUTCH ASSEMBLY Drive Section?	Remove the foreign substances	Go to Step 2.
2	Is the DRIVE EXIT OUT HOLDER ASSEMBLY or the DRIVE EXIT IN HOLDER ASSEMBLY damaged?	Replace the DRIVE EXIT OUT HOLDER ASSEMBLY and the DRIVE EXIT IN HOLDER ASSEMBLY	Go to Step 3.
3	Check the connection between the INVERT CLUTCH ASSEMBLY and the MCU PWB. <ul style="list-style-type: none"> • Is the INVERT CLUTCH ASSEMBLY (P/J17) connected securely? 	Go to Step 4.	Securely connect the INVERT-CLUTCH ASSEMBLY
4	<ul style="list-style-type: none"> • Replace the INVERT CLUTCH ASSEMBLY. • Does an error occur? 	Replace (REP 5.6 MCU PWB)	Troubleshooting complete.

FIP 2.10

Registration Clutch Assembly

Cause:

Parts to be considered:

- MAIN DRIVE ASSEMBLY ([PL 4.1 Drive](#))
- REGISTRATION CLUTCH ([REP 5.6 MCU PWB](#))
- MCU PWB ([PL 5.3 Electrical \(MCU PWB / HVPS\)](#))

Solution:

Step	Check and Action	Yes	No
1	Are there any foreign substances in the REGI. CLUTCH Drive Section?	Remove the foreign substances	Go to Step 2.
2	Is the MAIN DRIVE ASSEMBLY damaged?	Replace (REP 4.1 Main Drive Assembly)	Go to Step 3.
3	Check the connection between the REGI. CLUTCH and the MCU PWB. <ul style="list-style-type: none"> • Is the REGI. CLUTCH (P/J12) connected securely? 	Go to Step 4.	Securely connect the REGI. CLUTCH
4	<ul style="list-style-type: none"> • Replace (REP 2.6 Registration Clutch) Does an error occur?	Replace (REP 5.6 MCU PWB)	Troubleshooting complete.

FIP 2.11

Feed Clutch

Cause:

Parts to be considered:

- MAIN DRIVE ASSEMBLY ([PL 4.1 Drive](#))
- CST FEED CLUTCH ([PL 2.3 Feed Assembly](#))
- MCU PWB ([PL 5.3 Electrical \(MCU PWB / HVPS\)](#))

Solution:

Step	Check and Action	Yes	No
1	Are there any foreign substances in the FEED CLUTCH Drive Section?	Remove the foreign substances	Go to Step 2.
2	Is the MAIN DRIVE ASSEMBLY damaged?	Replace (REP 4.1 Main Drive Assembly)	Go to Step 3.
3	Check the connection between the FEED CLUTCH and the MCU PWB. <ul style="list-style-type: none"> • Is the FEED CLUTCH (P/J14) connected securely? 	Go to Step 4.	Securely connect the CST FEED CLUTCH
4	Replace (REP 7.7 Feed Clutch Assembly). Does an error occur?	Replace (REP 5.6 MCU PWB)	Troubleshooting complete.

FIP 2.12

Optional Feeder Clutch Assembly

Cause:

Parts to be considered:

- OPTIONAL FEEDER GEAR 550 (PL 7.2 Tray 1/Optional Tray 550-Sheet Feeder (2/4))
- FEED CLUTCH ASSEMBLY (PL 7.1 Tray 1/Optional Tray 550-Sheet Feeder (1/4))
- C2 TURN HARNESS ASSEMBLY (PL 7.1 Tray 1/Optional Tray 550-Sheet Feeder (1/4))
- OPTIONAL TRAY PWB ASSEMBLY (PL 7.1 Tray 1/Optional Tray 550-Sheet Feeder (1/4))

Solution:

Step	Check and Action	Yes	No
1	Are there any foreign substances in the FEED CLUTCH ASSEMBLY Drive Section?	Remove the foreign substances	Go to Step 2.
2	Is the OPTIONAL FEEDER GEAR 550 damaged?	Replace the OPTIONAL FEEDER GEAR 550	Go to Step 3.
3	Check the connection between the FEED CLUTCH ASSEMBLY and the OPTIONAL TRAY PWB ASSEMBLY. <ul style="list-style-type: none"> • Is the C2 TURN HARNESS ASSEMBLY (P/J4201P/J420) connected securely? 	Go to Step 4.	Securely connect the C2 TURN HARNESS ASSEMBLY
4	<ul style="list-style-type: none"> • Replace (REP 7.7 Feed Clutch Assembly). Does an error occur? 	Go to Step 5.	Troubleshooting complete.
5	<ul style="list-style-type: none"> • Replace the C2 TURN HARNESS ASSEMBLY • Does an error occur? 	Replace (REP 5.6 MCU PWB)	Troubleshooting complete.

FIP 2.13

Registration Clutch Assembly

Cause:

Parts to be considered:

- TAKE AWAY ROLL ASSEMBLY (PL 7.2 Tray 1/Optional Tray 550-Sheet Feeder (2/4))
- REGISTRATION CLUTCH ASSEMBLY (PL 7.2 Tray 1/Optional Tray 550-Sheet Feeder (2/4))
- OPTIONAL TRAY PWB ASSEMBLY (PL 7.1 Tray 1/Optional Tray 550-Sheet Feeder (1/4))

Solution:

Step	Check and Action	Yes	No
1	Are there any foreign substances in the REGISTRATION CLUTCH ASSEMBLY Section?	Remove the foreign substances	Go to Step 2.
2	Is the TAKE AWAY ROLL ASSEMBLY damaged?	Replace the TAKE AWAY ROLL ASSEMBLY	Go to Step 3.
3	Check the connection between the Registration Clutch Assembly and the MCU. <ul style="list-style-type: none"> • Is the harness connected securely? 	Go to Step 4.	Securely connect the harness.
4	<ul style="list-style-type: none"> • Replace the REGISTRATION CLUTCH ASSEMBLY. Does an error occur? 	Replace MCU.	Troubleshooting complete.

FIP 2.14

MSI Feed Solenoid

Cause:

Parts to be considered:

- MSI GEAR SEGMENT 1 ([PL 2.6 MSI](#))
- MSI GEAR SEGMENT 2 ([PL 2.6 MSI](#))
- MSI FEED SOLENOID ([PL 2.6 MSI](#))
- MCU PWB ([PL 5.3 Electrical \(MCU PWB / HVPS\)](#))

Solution:

Step	Check and Action	Yes	No
1	Are there any foreign substances in the MSI FEED SOLENOID Drive Section?	Remove the foreign substances	Go to Step 2.
2	Are the MSI GEAR SEGMENT MSI 1 and the MSI GEAR SEGMENT 2 damaged?	Replace the GEAR SEGMENT 1 and the GEAR SEGMENT 2	Go to Step 3.
3	Check the connection between the MSI FEED SOLENOID and the MCU PWB. <ul style="list-style-type: none"> • Is the MSI FEED SOLENOID (P/J15) connected securely? 	Go to Step 4.	Securely connect the MSI FEED SOLENOID
4	<ul style="list-style-type: none"> • Replace (REP 2.14 MSI Feed Solenoid) Does an error occur?	Replace (REP 5.6 MCU PWB)	Troubleshooting complete.

FIP 2.15

Main Drive Assembly

Cause:

Parts to be considered:

- MAIN DRIVE ASSEMBLY ([PL 4.1 Drive](#))
- MAIN MOTOR HARNESS ASSEMBLY ([PL 5.4 Electrical Connections](#))
- LVPS ([PL 5.1 Electrical \(ESS PWB / LVPS\) \(3610\)](#) / [PL 5.2 Electrical \(ESS PWB / LVPS\) \(3615\)](#))
- MCU PWB ([PL 5.3 Electrical \(MCU PWB / HVPS\)](#))

Solution:

Step	Check and Action	Yes	No
1	Are there any foreign substances in the MAIN DRIVE ASSEMBLY Drive Section?	Remove the foreign substances	Go to Step 2.
2	Is the MAIN DRIVE ASSEMBLY damaged?	Replace (REP 4.1 Main Drive Assembly)	Go to Step 3.
3	Check the connections between the MAIN DRIVE ASSEMBLY and the MCU PWB, as well as between the MAIN DRIVE ASSEMBLY and the LVPS PWB. <ul style="list-style-type: none"> • Is the MAIN MOTOR HARNESS ASSEMBLY (P/J101 - P/J10 - P/J101 - P/J212) connected securely? 	Go to Step 4.	Securely connect the MAIN MOTOR HARNESS ASSEMBLY
4	<ul style="list-style-type: none"> • Replace (REP 4.1 Main Drive Assembly) Does an error occur?	Go to Step 5.	Troubleshooting complete.
5	<ul style="list-style-type: none"> • Replace the MAIN MOTOR HARNESS ASSEMBLY. • Does an error occur? 	Go to Step 6.	Troubleshooting complete.
6	<ul style="list-style-type: none"> • Replace (REP 5.3 LVPS). • Does an error occur? 	Replace (REP 5.6 MCU PWB)	Troubleshooting complete.

FIP 2.16

Dispense Motor

Cause:

Parts to be considered:

- DISPENSE DRIVE ASSEMBLY ([PL 3.1 Xerographics](#))
- DISPENSE MOTOR ([PL 3.1 Xerographics](#))
- DISPENSE MOTOR HARNESS ASSEMBLY([PL 5.4 Electrical Connections](#))
- MCU PWB ([PL 5.3 Electrical \(MCU PWB / HVPS\)](#))

Solution:

Step	Check and Action	Yes	No
1	Are there any foreign substances in the DISPENSE MOTOR Drive Section?	Remove the foreign substances	Go to Step 2.
2	Is the DRIVE ASSEMBLY DISP damaged?	Replace (REP 4.6 Dispense Drive Assembly)	Go to Step 3.
3	Check the connection between the MOTOR DISP and the MCU PWB. <ul style="list-style-type: none"> • Is the DISPENSE MOTOR HARNESS ASSEMBLY (P/J111 - P/J11) connected securely? 	Go to Step 4.	Securely connect the DISPENSE MOTOR HARNESS ASSEMBLY
4	<ul style="list-style-type: none"> • Replace (REP 4.7 Toner Dispense Motor) Does an error occur?	Go to Step 5.	Troubleshooting complete.
5	<ul style="list-style-type: none"> • Replace the DISPENSE MOTOR HARNESS ASSEMBLY. • Does an error occur? 	Replace (REP 5.6 MCU PWB)	Troubleshooting complete.

FIP 2.17

Optional Tray Motor Assembly

Cause:

Parts to be considered:

- GEAR (PL 7.1 Tray 1/Optional Tray 550-Sheet Feeder (1/4))
- OPTIONAL FEED GEAR 550 (PL 7.2 Tray 1/Optional Tray 550-Sheet Feeder (2/4))
- MOTOR-ASSEMBLY (PL 7.1 Tray 1/Optional Tray 550-Sheet Feeder (1/4))
- TRAY MOTOR HARNESS ASSEMBLY(PL 7.1 Tray 1/Optional Tray 550-Sheet Feeder (1/4))
- OPTIONAL TRAY PWB ASSEMBLY (PL 7.1 Tray 1/Optional Tray 550-Sheet Feeder (1/4))

Solution:

Step	Check and Action	Yes	No
1	Are there any foreign substances in the MOTOR ASSEMBLY Drive Section?	Remove the foreign substances	Go to Step 2.
2	Is the GEAR OPT and the OPTIONAL FEED GEAR 550 damaged?	Replace the GEAR and the OPTIONAL FEED GEAR 550	Go to Step 3.
3	Check the connection between the MOTOR-ASSEMBLY OPTION and the PWB ASSEMBLY OPT TRAY. <ul style="list-style-type: none"> • Is the TRAY MOTOR HARNESS ASSEMBLY (P/J4221 - P/J422) connected securely? 	Go to Step 4.	Securely connect the TRAY MOTOR HARNESS ASSEMBLY
4	<ul style="list-style-type: none"> • Replace (REP 7.6 Drive Assembly) Does an error occur?	Go to Step 5.	Troubleshooting complete.
5	<ul style="list-style-type: none"> • Replace the TRAY MOTOR HARNESS ASSEMBLY • Does an error occur? 	Replace (REP 5.6 MCU PWB)	Troubleshooting complete.

FIP 2.18

Abnormal Noise: When power is turned on

Cause:

Parts to be considered:

- TONER CARTRIDGE (PL 3.1 Xerographics)
- DISPENSE MOTOR (PL 3.3 Toner Dispense)
- MAIN DRIVE ASSEMBLY (PL 4.1 Drive)
- DRUM CARTRIDGE (PL 3.1 Xerographics)
- FUSING ASSEMBLY (PL 3.5 Fusing Assembly)
- DRIVE EXIT OUT HOLDER ASSEMBLY (PL 4.1 Drive)
- DRIVE EXIT IN HOLDER ASSEMBLY (PL 4.1 Drive)

Solution:

Step	Check and Action	Yes	No
1	<ul style="list-style-type: none"> • Execute the Diag Digital Output[093-001] to check the rotation of the DISPENSE MOTOR. • Is there any abnormal noise from the device? Stop the motor operation within three seconds. If the motor operation is continued for three seconds or longer, the device will be damaged. 	Go to Step 2.	Go to Step 3.
2	<ul style="list-style-type: none"> • Reinstall the TONER CARTRIDGE. • Turn the power Off and On. • Does an abnormal noise occur? 	Replace the TONER CARTRIDGE	Troubleshooting complete.
3	<ul style="list-style-type: none"> • Execute the Diag Digital Output [071-001] to check the rotation of the MAIN DRIVE ASSEMBLY. • Is there any abnormal noise from the device? Stop the motor operation within three seconds. If the motor operation is continued for three seconds or longer, the device will be damaged. 	Go to Step 4.	Troubleshooting complete.
4	<ul style="list-style-type: none"> • Replace the DRUM CARTRIDGE. • Turn the power Off and On. Does an abnormal noise occur? 	Go to Step 5.	Troubleshooting complete.

Step	Check and Action	Yes	No
5	<ul style="list-style-type: none"> Replace (REP 3.5 Fusing Assembly). Note: Make sure that the FUSING ASSEMBLY has cooled down before performing the operation. Turn the power Off and On. Does an abnormal noise occur? 	Go to Step 6.	Troubleshooting complete.
6	<ul style="list-style-type: none"> Replace (REP 4.1 Main Drive Assembly). Turn the power Off and On. Does an abnormal noise occur? 	Replace (REP 5.6 MCU PWB)	Troubleshooting complete.

FIP 2.19

Abnormal Noise:During Printing

Cause:

Parts to be considered:

- REAR FAN (PL 1.3 Rear Cover Assembly)
- LVPS FAN (PL 4.2 NOHAD)
- MSI FEED SOLENOID (PL 2.6 MSI)
- CST FEED CLUTCH (REP 5.6 MCU PWB)
- REGISTRATION CLUTCH (REP 5.6 MCU PWB)

Solution:

Step	Check and Action	Yes	No
1	<ul style="list-style-type: none"> • Execute the Diag Digital Output [042-001] to check the rotation of the REAR FAN. • Is there any abnormal noise from the device? Stop the motor operation within three seconds.If the motor operation is continued for three seconds or longer, the device will be damaged. 	Go to Step 2.	Go to Step 3.
2	<ul style="list-style-type: none"> • Clear any foreign substances in the rotating section of the REAR FAN. • Does an abnormal noise occur while printing? 	Replace the Rear Fan.	Troubleshooting complete.
3	<ul style="list-style-type: none"> • Execute the Diag Digital Output [042-003] to check the rotation of the LVPS FAN. • Is there any abnormal noise from the device? Stop the motor operation within three seconds.If the motor operation is continued for three seconds or longer, the device will be damaged. 	Go to Step 4.	Go to Step 5.
4	<ul style="list-style-type: none"> • Clear any foreign substances in the rotating section of the LVPS FAN. • Does an abnormal noise occur while printing? 	Replace the LVPS Fan	Troubleshooting complete.
5	<ul style="list-style-type: none"> • Replace (REP 5.6 MCU PWB). • Does an abnormal noise occur while feeding paper from the MSI? 	Go to Step 6.	Troubleshooting complete.
6	<ul style="list-style-type: none"> • Replace (REP 5.6 MCU PWB). • Does an abnormal noise occur while feeding paper from the Tray 1? 	Replace (REP 5.6 MCU PWB).	Troubleshooting complete.

FIP 2.20

AC Power FIP

Cause:

Parts to be considered:

- LVPS (PL 5.1 Electrical (ESS PWB / LVPS) (3610) / PL 5.2 Electrical (ESS PWB / LVPS) (3615))
- INLET HARNESS ASSEMBLY (PL 5.4 Electrical Connections)

Solution:

Step	Check and Action	Yes	No
1	<ul style="list-style-type: none"> • Check the printer • Is there any sound from the Motor when the Power Supply is turned ON? 	Go to FIP 2.21	Go to Step 2.
2	<ul style="list-style-type: none"> • Check the Power Outlet • Connect the Power Cord to another Power Outlet. • Does the device operate? 	Troubleshooting complete.	Go to Step 3.
3	<ul style="list-style-type: none"> • Check the connection of the Power Cord • Reconnect the Power Cord. • Does the device operate? 	Troubleshooting complete.	Go to Step 4.
4	<ul style="list-style-type: none"> • Check the connection of the LVPS PWB connectors • Remove the Power Cord and wait for one minute. • Reinstall all of the connectors on the LVPS PWB. • Does the device operate? 	Troubleshooting complete.	Go to Step 5.
5	<ul style="list-style-type: none"> • Replace the INLET HARNESS ASSEMBLY. • Does an error occur? 	Replace (REP 5.3 LVPS)	Troubleshooting complete.

FIP 2.21

DC Power FIP

Cause:

Parts to be considered:

- CONTROL PANEL ([PL 1.4 Control Panel \(3610\)](#) / [PL 1.5 Control Panel \(3615\)](#))
- ESS PWB ([PL 5.1 Electrical \(ESS PWB / LVPS\) \(3610\)](#) / [PL 5.2 Electrical \(ESS PWB / LVPS\) \(3615\)](#))
- LVPS ([PL 5.1 Electrical \(ESS PWB / LVPS\) \(3610\)](#) / [PL 5.2 Electrical \(ESS PWB / LVPS\) \(3615\)](#))
- MCU PWB ([PL 5.3 Electrical \(MCU PWB / HVPS\)](#))

Solution:

Step	Check and Action	Yes	No
1	<ul style="list-style-type: none"> • Check the connection of the LVPS PWB connectors • Remove the Power Cord and wait for one minute. • Reinstall all of the connectors on the LVPS PWB. • Does the device operate? 	Troubleshooting complete.	Go to Step 2.
2	<ul style="list-style-type: none"> • Reinstall the CONTROL PANEL connectors. (REP 1.1 Control Panel (3610)) (REP 1.12 Control Panel (3615)) • Does the device operate? 	Troubleshooting complete.	Go to Step 3.
3	<ul style="list-style-type: none"> • Reinstall (REP 5.1 ESS PWB). • Does the device operate? 	Troubleshooting complete.	Go to Step 4.
4	<ul style="list-style-type: none"> • Reinstall (REP 5.6 MCU PWB). • Does the device operate? 	Troubleshooting complete.	Replace (REP 5.3 LVPS)

Network System Fault Check

Interface (Physical/Logical)

1. Physical Interface Description

The following physical interfaces are supported.

(1) IEEE1284

- Only supported in the Mid range and earlier products.

(2) USB

(3) Ethernet (10BaseT, 100BaseTX)

- Has the features to automatically detect and switch the transmission speed (10Mbps, 100Mbps).

Also, the transmission speed can be fixed by settings.

2. Logical Interface Description

It is possible to set whether to activate the system for each of the following logical interfaces.

Default Activation:IEEE1284, SMB (DLC), SNMP (IPX)

Supported for receiving print jobs

(1) IEEE1284 (when 1.1IEEE1284 is supported)

(2) USB

(3) Lpd

(4) Net Ware

(5) Apple Talk (Ether Talk)

(6) SMB

(7) IPP

(8) Internet Fax Print

(9) Port9100

(10) CWIS File Upload Print

Supported for management interface

(1) SNMP

(2) CWIS

Supported for other services

FTP Server

Not connected to network or Unable to find the device from the PC

Note: When collecting information, use Information Pages, Diagnostics, the Printer Interface or Network Interface.

Get the NET Connection Diagram and take actions by following the instructions in " Network-related Details Check Flow" of this document, and then collect the following information:

- Configuration Report
- Check the client settings (Output Port)
- Check the physical connection
- Check the logical interface
- Other connection environment checks
 - Printer switching machine
 - Availability of printer buffer, etc.
 - The HUB (Switch, Hub) being used, etc.

No output is available, no data is printed
 Check whether the Firmware and the Print Driver are of the latest version.
 If it is not the latest, download the latest Firmware.

After checking the above items, check whether the Indicator is blinking and take the corrective actions accordingly.

(1) When the Indicator (Panel Send/Receive Lamp) is blinking

It is highly possible that print data cannot be decomposed in the Printer.

Perform the corrective actions according to " Network-related Details Check Flow" in this document, and then collect the following information:

- Configuration Report
- Check the panel message (error message, etc.)
- Error History Report
- Job History Report
- Print Driver name and version
- Check the Print Driver settings in Details
- Create Print files on the PC and collect them on CD-R

How to Create a Print file

(Method 1)

1. Select **Print** from File menu in the target document.
2. In the "Print" screen, select the **Output to File** check box and click **OK**.
 If there is no **Output to File** check box displayed in the Print screen, use method 2 to create the file.
3. Enter a descriptive file name in **File Name** using a customer name and date, and click **OK** to create a Print file in the specified destination.

(Method 2)

1. Open the **Print Driver Properties** and select the **Ports** tab.
2. In the **Ports** list, select **FILE:** and click **OK** to close the Properties screen.
Take note of the port setting before it was changed in **FILE:** in order to restore the port to original setting after creating the Print file.
3. Select **Print** from File menu in the target document.
4. The **Output to File** screen appears. Specify a storage destination and file name, and click **OK** to create a Print file in the specified destination.
5. Restore the port to the original setting by using Steps 1 and 2 shown above.

(2) When the Indicator (Panel Send/Receive Lamp) is not blinking

It is highly possible that connection is not established and hence print data has not reached the Printer.

Collect information equivalent to the items in: " Not connected to network or Unable to find the device from the PC".

Printing can be performed but abnormally

1. Check the version of the Firmware and the Print Driver.
If it is not the latest, download the latest Firmware.
2. Ask the customer about the status of unavailable printing and based on it, collect the following information:
 - Configuration Report
 - Check the PDL name (PS, PCL)
 - Print Driver name and version
 - Check the Print Driver settings in Details
 - Print the Printer settings of every mode
 - Print samples of improper printing
 - Print samples of normal printing (including samples from other machines)
 - Create Print files on the PC and collect them on CD-R

Network-related Details Check Flow

Check Flow at SMB Failure

The following describes the possible causes, check procedures, and corrective actions when a failure occurs when SMB is used.

1. Check at Printer Not Found

Cause:	Check Method	Action
The operation protocols of the computer and the machine are different.	Though the printer can be found when search is performed using Search Other Computer (Start > Search > Other Computers), it cannot be found in Network Computers.	Match the SMB transport protocols (Net BEUI, TCP/IP) of the machine and each computer.
Networks (sub nets) are different.	Though the printer can be found when search is performed using Search Other Computer (Start > Search > Other Computers), it cannot be found in Network Computers.	When the machine and the computer are in different networks, check with the System Administrator.
The host name set in the machine already exists.	Print the "Configuration Report". Check that "Duplicate Host Name" is described in the SMB Status.	Use Centre Ware Internet Services to change the host name to an unduplicated name or return the machine settings to default.

2. Check at Print Not Available

Cause:	Check Method	Action
The machine is processing a print request from another computer. (When No Spooling is set for Receiving Buffer)	Check that the printing is in progress in the machine. (A write error dialog appears indicating that there is no area to store the files in queue.)	After print process has been completed in the machine, issue a print request or switch the machine setting to Spool to Memory.
The number of connections in the machine has exceeded the maximum value.	<p>The port connection is also being hold when the printer is paused due to no paper because it is hold "since a job request has been issued to Net until printing is complete".</p> <p>Check the maximum number of sessions of SMB from the EWS Protocol menu to check whether Jobs reaching or exceeding the Maximum Number of Sessions were requested simultaneously at the site.</p>	Wait for a while and issue the same print request again. Or, check the number of users that can use the machine at the same time and set the maximum number of sessions to an appropriate value from the EWS Protocol menu.

3. Check at Documents Cannot be Deleted from Printers Window

Cause:	Check Method	Action
Trying to delete all the print data displayed in Printers window. (This can only be done by the administrator of this machine.)	From the Printers menu, check whether the system is trying to delete the print data. (Clear Print Jobs menu)	Select the print data to be deleted and delete the print data from Documents menu in the Printers window. (Cancel Job menu)
There are different print data owners.	Check that the name displayed in Owner of the selected print data matches the login name that is logged in to Windows.	Log in to Windows using the name displayed in Owner of the print data to delete the data.
Service Pack 4.0 or later is not installed. (For Windows NT 4.0)	Check the version of Service Pack, which is displayed at start up of WindowsNT 4.0.	Install Service Pack version 4.0 or later.

4. Check Machine Settings

1. IP Addresses are addresses that are managed in the whole system. Consult with the Network Administrator thoroughly before perform setting.
2. Depending on the network environment, set the sub net mask and gateway settings only if necessary. Consult with the Network Administrator to set necessary settings.
3. If a memory becomes insufficient when Enabled is set for the port status, the port status may be automatically reset to Disabled. In this case, set Disabled for unused ports or change the memory allocated capacity.
4. Depending on the usage environment, set the receiving buffer capacity SMB (Spool) size. When the receiving buffer capacity SMB (Spool) size is smaller than the sent data, it may not be able to be received.

5. Check Computer Settings

1. IP Addresses are addresses that are managed in the whole system. Consult with the Network Administrator thoroughly before perform setting.
2. To perform network settings (such as IP Address), etc. on the host used under NIS (Network Information Service) management, consult with the NIS Administrator.

6. Check at Power OFF

Before turning the machine OFF, take note of the following:

1. **When Memory is set for SMB (Spool)**
All the print data including the data being printed that have been spooled in the machine memory will be deleted.
When the power is turned ON again, no print data remains. However, if the power is turned OFF immediately after the print instruction, the print data may be stored on the computer.
In this case, even if a new print instruction is issued after the power is turned ON, the stored print data will be printed first.
2. **When Hard Disk is set for SMB (Spool)**
All the print data including the data being printed that have been spooled in the machine hard disk will be saved.
When the power is turned ON again and a new print instruction is issued, the stored print data will be printed first.
3. **When No Spooling is set for SMB (Spool)**
All the print data including the data being printed that have been spooled in the machine receiving buffer will be deleted. When the power is turned ON again, no print data remains. However, if the power is turned OFF immediately after the print instruction, the print data may be stored on the computer.
In this case, even if a new print instruction is issued after the power is turned ON, the stored print data will be printed first.

7. Check At Printing

1. **When Hard Disk or Memory is set for SMB (Spool)**

When the machine starts receiving print data and the print data size is larger than the hard disk or remaining memory capacity, the print data will not be received.

If the print data exceeds the receiving capacity, some computers will resend data immediately. In this case, the computer may look like it has hanged. To correct this, cancel the sending of print data at the computer.

2. **When No Spooling is set for SMB (Spool)**

When a print request is received from a computer, the print requests from other computers cannot be received.

3. **When the IP Address or the name of the computer has been changed**

When the IP Address or the name of the computer has been changed, the inquiry and cancellation of processes from the machine cannot be performed properly. With no print data stored in the machine receiving buffer, turn the machine OFF and ON.

The print cancellation/forced output processes of the print data stored in the machine receiving buffer can be done from the machine Operation Panel. Refer to "11 Job Check" in "User Guide" for more information on how to do this.

4. **When the machine is in the offline state**

When the machine is in offline state and a print instruction is issued from a computer, the data will not be received in the machine, and an error dialog box appears on the computer indicating that write error has occurred. However, for SMB, the print data can be received from the computer even when the machine is offline.

5. **Deleting Jobs**

For WindowNT 4.0, jobs can be deleted when Service Pack 4 or later is installed. When a job is deleted while data is being received, write error appears. In this case, the Retry button on the error dialog box is disabled.

Check Flow at Net Ware Failure

The following describes the possible causes, check procedures, and corrective actions when a failure occurs during Net Ware usage.

1. Check at Printing Not Performed

Cause:	Check Method	Action
The network configuration devices (HUB etc.) do not match the automatic settings of the frame type.	Check that the data link lamp of the network configuration device port that is connected to the machine is lit on. Check that the same frame types are used in the file servers that exist on a network.	Set the frame type that has been set for the file server to be connected from the machine.
A failure has occurred on the network from a workstation to a printer.	Use NWADMIN from the workstation to check that the target printer objects can be viewed.	Replace the non-communicating network cable that exists between the workstation and the printer.
The user name of a job sender or the group name to which the job sender belongs is not registered in the Users for Print queue.	Use NWADMIN from the workstation to view the target queue objects and check that the user name of the job sender or the group name to which the job sender belongs is registered in the Users information.	<p>1. Resend print data to the print queue in which the user name of the job sender or the group name to which the job sender belongs has been registered in Users of Print Queue Information.</p> <p>2. Use NWADMIN from the workstation to register the user name of the job sender or the group name to which the job sender belongs in the Users of Print Queue Information.</p>
Sending jobs to the print queue is prohibited.	Use PCONSOLE to check that Yes is set for User can register data to queue in the Current Queue Status of Print Queue Information.	Set it to Yes using PCONSOLE.
Same as above	Use NWADMIN from the workstation to check that the operator flag is checked in Identification for the target print queue.	Use NWADMIN from the workstation to check that the each item for the operator flag is checked in Identification for the target print queue.

Cause:	Check Method	Action
<p>The user name of a job sender or the group name to which the job sender belongs is not defined for the print server users of a print server.</p>	<p>Use NWADMIN from the workstation to check that the user name of the job sender or the group name to which the job sender belongs is registered in Users of the target print server.</p>	<ol style="list-style-type: none"> 1. Resend print data to the print queue in which the user name of the job sender or the group name to which the job sender belongs has been registered in Users of Print Server Information. 2. Use NWADMIN from the workstation to register the user name of the job sender or the group name to which the job sender belongs in the Users information of the target print server.
<p>The print queue that has sent print data is not allocated to the printer.</p>	<p>Use NWADMIN from the workstation to check that the target printer is allocated in the list of the printers in service in Allocation of the target print queue.</p>	<ol style="list-style-type: none"> 1. Resend print data to the print queue that has been allocated to the printer. 2. Use NWADMIN from the workstation to add a target queue using Allocation of the target printer.
<p>The data type of the print data does not match the print environment settings of the workstation.</p>	<p>-</p>	<p>When the workstation uses Windows, make settings so that it does not output Ctrl-D.</p>
<p>The number of print queues that exceeds the maximum number of supported queues has been set.</p>	<p>Use NWADMIN from the workstation to check that the desired print queue is allocated in the list of the printers in Allocation of the target printer.</p>	<p>Resend print data to the print queue that has been allocated to the printer.</p>
<p>No slave file servers have been set (bindery service mode).</p>	<p>Use PCONSOLE from the workstation to check that a slave file server is registered in Service Net Ware Server of the appropriate print server in Print Server Information.</p>	<p>Use PCONSOLE from the workstation to register a slave file server and then reflect the setting parameters.</p>
<p>Printer types are different.</p>	<p>Use PCONSOLE from the workstation to check that Port:LPT1 and Position: Auto Mode (Local) are set in Print Server Information > Printers > Environment Settings for Printer xxx.</p>	<p>Use PCONSOLE from the workstation to set Port:LPT1 and Position: Auto Mode (Local), and reflect the setting parameters.</p>

Cause:	Check Method	Action
The slave file server settings are different (bindery service mode).	Use PCONSOLE from the workstation to check that Defined by Other Settings is displayed for the printer type in Print Server Information > Printers > Environment Settings for Printer xxx.	If it is not set to Defined by Other Settings, change it to Defined by Other Settings and then reflect the setting parameters.
The sheet number of the print data is different from the sheet number that has been set in the printer.	Use NWADMIN from the workstation to select a target printer and then check that the start sheet number in the environment settings is the same as the number of the print data.	Use NWADMIN from the workstation to match the number for Start Sheet with the number of the print data in the environment settings for the target printer.
IPX checksum level settings are different.	Use the set command in the file server console screen to check the IPX checksum is not set to Level 2.	Enter the following command in the file sever console screen to set the IPX checksum to Level 0 or Level 1. set Enable IPX Checksum = x (x:0 or 1)
NCP packet signature level settings are different.	Use the set command in the file server console screen to check the NCP packet signature is not set to Level 3.	Enter the following command in the file sever console screen to set the NCP packet signature to Level 0, 1, or 2 and then restart the file server. set NCP Packet Signature Option = x (x:0, 1, or 2)
The default device name setting is wrong.	Print "Configuration Report" to check the lower 6-digit (3 bytes) of the Ethernet address.	1. Use a correct Ethernet address to set the device name. 2. Set the device name to other than the default value.
No directory tree name is set.	Print the "Configuration Report" to check if a tree name is set.	Set a tree name.
Context is not set in place.	Print the "Configuration Report" to check if a Context is set.	Set the Context.
Another printer object has been connected.	Use NWADMIN from the workstation to check that a correct object has been allocated in the Layout Information of the desired print server.	1. Use the Centre Ware Utilities CD-ROM from the workstation to set the file server name/tree/context/operation mode correctly. 2. Use the Centre Ware Internet Services from the workstation to set the file server name/tree/context/operation mode correctly.

Cause:	Check Method	Action
The Net Ware port is not enabled.	Print the "Configuration Report" to check if the Net Ware port is enabled.	Enable the Net Ware port.
The file server is down.		Search for a target file server from Network Computers.
A printer with the same device name exists on a network.	Turn OFF the machine and use NWADMIN from the workstation to check that the appropriate printer object status is set to job standby.	Use the Centre Ware Utilities CD-ROM from the workstation to set a different device name.
The Net Ware port is not enabled.	Print the "Configuration Report" to check if the network number remains 0000000 (Net Ware server down) when the IPX/SPX is being used. Also check if the IP Address remains 0.0.0.0 (Fixed IP Address not set, or address providing server (DHCP) is down) when TCP/IP is used.	For IPX/SPX, activate the Net Ware server. For TCP/IP, set a fixed IP Address or activate the address providing server (DHCP).

2. Check at Printing not performed as desired

Cause:	Check Method	Action
Different printer languages are set in the print data and the machine.	Check the printer language in the machine.	Match the printer languages set in the print data and the machine.

3. Check at Printer failure not notified

Cause:	Check Method	Action
The notifier is not registered in the notifier list of the print server.	Use PCONSOLE from the workstation to check that the user name of a job sender or the group name to which the job sender belongs is registered in Print Server Information > Printers > Environment Settings for Printer xxx > Notification.	Register the user name of a job sender or the group name to which the job sender belongs in Notification.

4. Check at Job completion not notified

Cause:	Check Method	Action
The NOTIFY option was not set for sending print data from a workstation.	Check that the NOTIFY option is set for sending print data.	Set the NOTIFY option for sending print data from a workstation.
Net Ware CASTOFF was executed on the user workstation.		Execute Net Ware CASTON on the user workstation.

Check Flow at TCP/IP (LPD) Failure

The following describes the possible causes and actions when a failure occurs when TCP/IP (LPD) is used.

1. For Windows 95, Windows 98 and Windows Me

Cause:	Status Display	Check Method	Action
The machine is connected to a network that is different from the computer.	Unable to print (Network Error)	Check with the network System Administrator that a router or gateway exists between the network in which the computer is connected and the network in which the machine is connected.	Connect the machine directly to the network in which the computer is connected.
Connection cannot be established due to the failure on the network from a computer to the printer.	Unable to print (Network Error)	Not required	Request the network System Administrator to check for any network failures.
The machine was turned OFF after print instruction had been issued from a computer. Or, a print instruction was issued from a computer when the machine is turned OFF.	Unable to print (Network Error)	Check that the machine is turned ON.	Turn ON the machine.
Print instructions are issued from multiple computers to the machine at the same time.	Unable to print (Network Error)	Not required	None (printing will be automatically resumed).
Print files cannot be spooled due to insufficient computer disk capacity.	Unable to print (Spool Error)	Open My Computer and right-click the disk in which the system is installed (e.g. Drive C). Select Properties from the displayed menu to check the free disk space.	Delete unnecessary files to secure the disk free space. Then select Pause from the Document menu of the Printers window to clear the pause status (resumes printing).

2. For Windows NT 4.0, Windows 2000, Windows XP, and Windows Server 2003

When no printing is available or desired printing is not performed, follow the check procedures described below to take the corrective actions.

Cause:	Check Method	Action
Incorrect IP Address is set.	Ask the Network Administrator to check if the IP Address set in this machine is correct.	Set a correct IP Address in the machine.
When the LPD spool is set for a memory spool, the print data size in a single print instruction sent from a computer exceeds the upper limit of receivable capacity.	Check the LPD spool memory capacity and compare it with the print data capacity that is tried to send in a single print instruction.	<ol style="list-style-type: none"> 1. If the print data capacity of a single file exceeds the memory capacity upper limit, split the file into smaller sizes than the memory capacity upper limit and then send the print instruction. 2. If the print data capacity of multiple files exceed the memory capacity upper limit, reduce the number of files being sent simultaneously for printing.
A failure that cannot be repaired has occurred during printing.	Check if an error is displayed on the Operation Panel display.	Turn the power Off and On . Wait for the display to light off and turn ON the power again.
The transport protocol that matches the computer is not selected.	Check the selected transport protocol.	Select the transport protocol that matches the computer.
The data type of the print data the machine tries to process is different from the data type of the print data sent from a computer.	-	Make settings so that Ctrl-D will not be output.
The specified printer language is different from the printer language of the print data.	Check the specified printer language and the printer language of the print data.	Specify the printer language that matches the printer language in the print data.
The Print Driver that was provided with this machine is not used (a Print Driver from other manufacturers is used).	Check if the Print Driver that was provided with this machine has been selected.	Select the Print Driver that was provided with this machine. If it is not found in the selection items, install and select the Print Driver that was provided with this machine.

Precautions and Limitations

The following describes the precautions and limitations for TCP/IP (LPD).

Machine Settings

- IP Addresses are managed in a whole system. Consult with the Network Administrator thoroughly before perform setting.
- Depending on the network environment, perform the sub net mask and gateway settings if necessary. Consult with the Network Administrator to set necessary settings.
- If a memory becomes insufficient when Enabled is set for the port status, the port status may be automatically reset to Disabled. In this case, set Disabled for unused ports or change the memory allocated capacity.
- Depending on the usage environment, set the receiving buffer capacity lpd (Spool) size. When the receiving buffer capacity lpd (Spool) size is smaller than the sent data, it may not be able to be received.

Computer Settings

- IP Addresses are managed in a whole system. Consult with the Network Administrator thoroughly before perform setting.
- To perform network settings (such as IP Address), etc. on the host used under NIS (Network Information Service) management, consult with the NIS Administrator.

At Power OFF

Before turning the machine OFF, take note of the following:

- When Memory is set for lpd (Spool)
All the print data including the data being printed that have been spooled in the machine memory will be deleted. When the power is turned ON again, no print data remains.
However, if the power is turned OFF immediately after the print instruction, the print data may be stored on the computer. In this case, even if a new print instruction is issued after the power is turned ON, the stored print data will be printed first.
- When Hard Disk is set for lpd (Spool)
All the print data including the data being printed that have been spooled in the machine hard disk will be saved. When the power is turned ON again and a new print instruction is issued, the stored print data will be printed first.
- When No Spooling is set for lpd (Spool)
All the print data including the data being printed that have been spooled in the machine receiving buffer will be deleted. When the power is turned ON again, no print data remains.
However, if the power is turned OFF immediately after the print instruction, the print data may be stored on the computer. In this case, even if a new print instruction is issued after the power is turned ON, the stored print data will be printed first.

At Printing

When Hard Disk or Memory is set for lpd (Spool)

- When the machine starts receiving print data and the print data size is larger than the HDD spool area or remaining memory capacity, the print data will not be received.

If the print data exceeds the receiving capacity, some computers will resend data immediately. In this case, the computer may look like it has hanged. To correct this, cancel the sending of print data at the computer.

When No Spooling is set for lpd (Spool)

- When a print request is received from a computer, the print requests from other computers cannot be received.

When a computer IP Address or name has been changed

- When the IP Address or the name of the computer has been changed, the inquiry and cancellation of processes from the machine cannot be performed properly. With no print data stored in the machine receiving buffer, turn the machine OFF and ON.

The print cancellation/forced output processes of the print data stored in the machine receiving buffer can be done from the machine Operation Panel. Refer to "11 Job Check" in "User Guide" for more information on how to operate.

Check Flow at CentreWare Internet Services Failure

The following describes the situations and corrective actions when a failure occurs when "CentreWare Internet Services" is used.

Symptoms	Action
Unable to connect to Centre Ware Internet Services.	Check that the machine is operating properly. Check that the machine is turned ON.
Same as above	Check that "Internet Services" is activated. Print the "Configuration Report".
Same as above	Check that the Internet address has been entered properly. Check the Internet address again. When unable to connect, enter the IP Address and connect again.
Same as above	Check to see if a proxy server is used. Connection might not be possible depending on the Proxy Server. When proxy server is not used, set the Web browser to "Do not use proxy server" or set the used address to "Do not use proxy server".

Symptoms	Action
The message "Wait for a while" is displayed and nothing else happens.	Wait for a while without doing anything. If the situation does not change, select the Refresh button. If the situation does not change even after selecting the Refresh button, check if the machine is operating properly.
The Refresh button is not functioning. Or, even if a menu in the left frame is selected, the right frame cannot be refreshed.	Check that the specified Web browser is used. Refer to "Communication (Port/Protocol) Setting Items in Centre Ware Internet Services" in User Guide to check whether the Web browser being used is supported.
The screen display collapses.	Change the window size of the Web Browser.
The latest information is not displayed	Select the Refresh button.
Selecting the Apply button does not reflect settings.	Check that the entered values are correct. If invalid values have been entered, they are automatically changed to values within the limit range.
Same as above	Check that the machine is operating or has completed operation using the machine Operation Panel. If Auto Reset function is set, the settings in Centre Ware Internet Services will not be applied until the specified time has passed. Wait for a while.
Selecting the Apply button displays a message such as "Invalid or unrecognizable response was returned from the server" or "No data found" on the Web browser.	<ol style="list-style-type: none"> 1. Check if the password is correct. The password confirmation entry does not match. Enter a correct password. 2. Restart the machine.
Jobs cannot be deleted.	Wait for a while and then select the Refresh button.
Cannot enter Japanese characters.	Use Shift-JIS code. And do not use single-byte Katakana characters.
Cannot enter Kanji characters.	Kanji characters cannot be entered for the items displayed with "*".

Image Quality

3

This chapter includes:

- [Image Quality Overview](#)
- [Image Quality Specifications](#)
- [Checklist Before Troubleshooting Image Quality](#)
- [Image Quality Troubleshooting](#)
- [Printing Test Patterns](#)

Image Quality Overview

Image-quality defects can be attributed to printer components, consumables, media, internal software, external software applications, and environmental conditions. To successfully troubleshoot print-quality problems, eliminate as many variables as possible. The first step is to generate prints using information pages embedded in the printer on laser paper from the approved media list. Refer to “Media and Tray Specifications” for supported and specialty media that have been tested and approved for use in this printer. Use paper from a fresh ream that is acclimated to room temperature and humidity.

If the image defect remains after printing on approved media from an unopened ream of paper, then investigate applications and environmental conditions. Determine the temperature and humidity under which the printer is operating. Compare this to the “Environmental Specifications”. Extreme temperature and humidity can adversely affect image quality.

When analyzing a defect, first determine if the defect is repeating or a random occurrence. Continuous defects in the process direction, such as voids and lines, are the most difficult to diagnose. Inspect the visible surfaces of all rollers for obvious defects.

Repeating Defect Measurement

When horizontal streaks or spots appear in a constant cycle, the problem might be due to damaged Fuser, Drum Cartridge, Registration Rollers, or Transfer Rollers. Measure the interval between defects and use the following table to identify the affected Roller.

Component Name		Defect Distance (in / mm)
Fuser	Pinch Roller	1.73 / 44.0
	Exit Roller	1.73 / 44.0
	Heat Roller	3.25 / 82.6
	Pressure Belt	3.72 / 94.5
Transfer Roller	2nd BTR	2.62 / 67.5
Drum Cartridge	Drum	3.70 / 94.2
	BCR	1.48 / 37.7
	Cleaning Roller	1.23 / 31.4
Registration Roller	Registration Roller	1.73 / 44.0

Wrinkling Envelopes

If envelopes are wrinkling, ensure that an "Envelope Fuser" is installed (see [PL3.5.1](#)). If wrinkling continues, see [Wrinkled Envelope Troubleshooting](#).

Image Quality Specifications

The Image Quality specifications are provided as follows.

Environmental Condition

- Temperature: 10° C - 32° C
- Humidity: 15 % RH - 85 % RH (85 % RH at 28° C)

Quality Paper

The print-quality is best when quality paper is fed from the tray. The image quality is evaluated on the maximum size of each standard paper.

- Color Print-Quality: Xerox-brand X-Pression paper
- Black and White Quality: Xerox-brand 4200 paper

Paper Condition

Paper should be fresh and stored in the operating environment for 12 hours before use for printing.

Printer Condition

The specified print-quality is guaranteed with the printer in specified normal environmental condition.

Specifications

The following charts provide specifications for Skew, Perpendicularity, Linearity, Parallelism, Registration, and Magnification.

Image Quality Specifications

Characteristic	Specification
Skew	All Trays
Perpendicularity	7.78 in. \pm 0.05 (200 mm \pm 1.3 mm)
Linearity	<ul style="list-style-type: none"> • Vertical: 15.74 in \pm 0.04 (400 mm \pm 1.0 mm) • Horizontal: 9.45in \pm 0.03 (240 mm \pm 0.7 mm) • Diagonal: 11.1 in \pm 0.03 (282 mm \pm 0.8 mm)
Parallelism	15.74 in \pm 0.08 (400 mm \pm 2.0 mm)
Lead Registration	All Trays
Side Registration	All Trays

Image Quality Specifications (Continued)

Characteristic	Specification
Magnification Deviation (Reduce/ Enlarge Error)	<ul style="list-style-type: none"> Vertical: 15.74 in \pm 0.02 % (400 mm \pm 0.5 %) Horizontal: 9.45 in \pm 0.02 % (240 mm \pm 0.5 %)

Skew

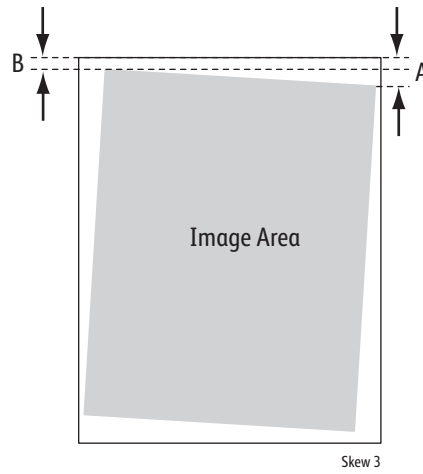
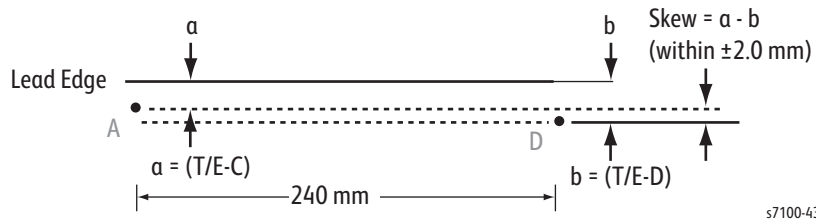

Maximum Print Area

Note: The printer has 4 mm margins on all sides.

Maximum Paper Size

The print engine can feed the following paper size:

- Maximum Paper Size: 8.5 in. x 14 in. (215.9 mm x 355.6 mm)

Maximum and Guaranteed Printable Area

- Maximum Printable Area: 8.3 in. x 13.66 in. (210.9 mm x 351.6 mm)
- Maximum Guaranteed Printable Area: 8.18 in. x 13.66 (207.9 mm x 347 mm)

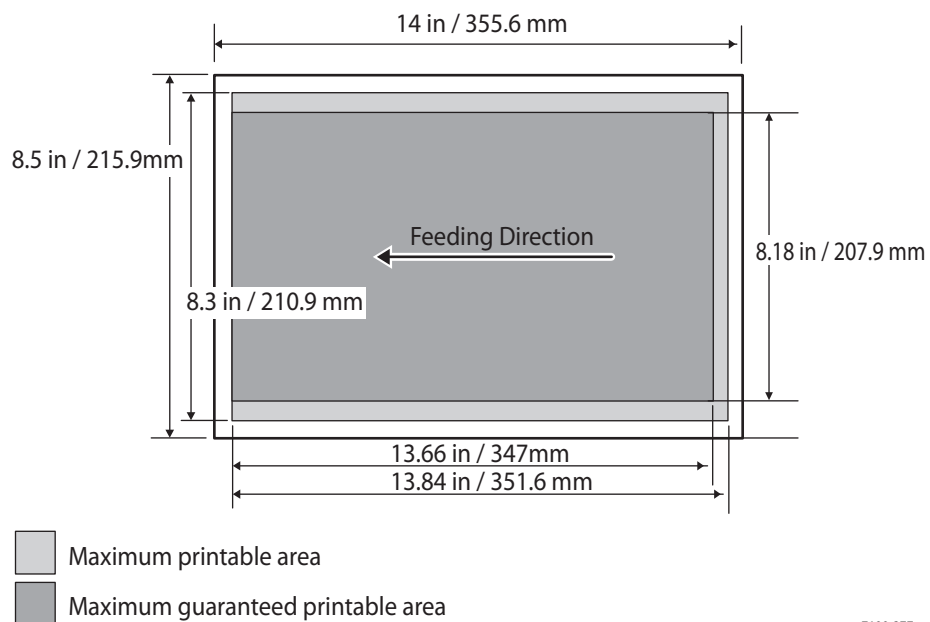

s7100-377a

Checklist Before Troubleshooting Image Quality

Check Printer Condition

Toner and Drum Cartridge Status

Low toner can cause quality problems, such as fading, streaking, White lines, or dropouts. Print a small document from different software applications to replicate the problem and check the amount of toner available. If the toner is low, replace the cartridge. Toner that is not genuine Xerox toner can also cause print-quality problems. If the toner is not Xerox toner, replace the Toner Cartridge and recheck the print-quality issue.

A Drum Cartridge approaching end of life may produce high frequency banding and effect the printer's ability to maintain toner density increasing calibration cycles.

Cleaning

Paper, toner and dust particles accumulate inside the printer and cause image quality problems such as smearing. Clean the inside of the printer to prevent these problems.

Operating Environment

Check the temperature, humidity, clearances, and supporting surface meet specifications. Refer to [Operating Environment](#).

Media Condition

Paper should be fresh and stored in the operating environment for 12 hours before use in the printer. The quality is best when quality paper is fed from the tray. The image quality is evaluated on the maximum size of each centerline media. Check the condition and type of media loaded. Refer to [The Media Guidelines](#) for details on determining proper media condition.

Image Quality Troubleshooting

Image Quality Defects

The following table lists the print-quality defect corrective procedure, their definition, and the page where each procedure is provided.

IQ #	Defect	Description	Page
1	Light Print	Image density is too light for the entire image area.	3-8
2	Unfused Image	Toner has not been fused properly to the paper.	3-11
3	Random Spots	Spots are randomly scattered throughout the page.	3-12
4	Blank Prints	The entire image area is blank.	3-14
5	Streaks	Random streaks appear on the page.	3-17
6	Black Prints	All or part of the image is black.	3-19
7	Pitched Black Dots	Evenly spaced black dots appear vertically in a line.	3-21
8	Vertical Bands, Voids, or Streaks	Faded or completely non printed lines that appear in the process direction.	3-23
9	Ghosting	There is a faint ghost image appearing on the page from the current or previous image.	3-25
10	Light Induced Fatigue	Drum Cartridge has been exposed to too much light and causing density variation.	3-27
11	Background	The overall image or text on the page is blurred.	3-28
12	Bead Carry-out	Spot deletions that has a center weighted bead of toner in it.	3-30
13	Jagged Characters	Text appears blurry due to jagged edges	3-31
14	Banding	A horizontal smear that appears slightly darker than the original.	3-33
15	Auger marks	Uneven density appears in a slanted stripped pattern at approx. a 20 mm pitch	3-35
16	Wrinkles / Stained Paper	The overall output page is wrinkled or stained.	3-37
17	Damage to the Lead Edge of the Paper	Just the Lead edge of the output is wrinkled, folded or worn-out.	3-39
18	Incorrect Margins	The image area is parallel to the edges of the paper but has shifted position	3-41
19	Skewed Image	The image is not parallel to both sides of the paper.	3-43

IQ 1 Light Prints

Troubleshooting Reference

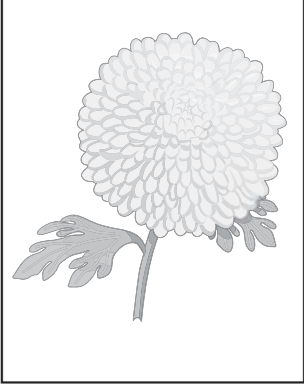
Applicable Parts	Example Print
<ul style="list-style-type: none"> • Toner Cartridge, PL 3.1 • Drum Cartridge, PL 3.1 • Transfer Roller Assembly, PL 3.4 • Dispense Motor, PL 3.3 • ROS Assembly, PL 3.2 • Xerographic Connector Assembly, PL 3.3 • MCU PWB, PL 5.3 • HVPS, PL 5.3 • ESS PWB (3610), PL 5.1 • ESS PWB (3615), PL 5.2 	<div style="text-align: center;">  <p data-bbox="1129 800 1289 821">Light or Undertone Print</p> </div>

Note: for the Phaser 3610, begin the procedure at step 4.

Troubleshooting Procedure

Step	Actions and Questions	Yes	No
1	Does the error occur only during copying?	Go to step 2.	Go to step 4.
2	Is the original density low?	Change the original.	Go to step 3.
3	Is the Lighten/Darken setting set at Lighter 2 or 3.	Set to Normal or Darker 1 to 3 , then go to step 4.	Go to step 4.
4	Is the Adjust Density in Admin Settings / Service Tools set to Lighter 2 or 3?	Set to Normal or Darker 1 to 3 , then go to step 5.	Go to step 5.
5	Is the image printed correctly?	Troubleshooting complete	Go to step 6.
6	On the Image Options tab, ensure that Off is selected in the Toner Saver drop-down menu. Is the image printed correctly?	Troubleshooting complete.	Go to step 7.
7	Is the installed paper new and dry? Does the paper meet specifications?	Go to step 8.	Replace with paper that meets specifications, then go to step 8.

Troubleshooting Procedure (Continued)

Step	Actions and Questions	Yes	No
8	The Toner Cartridge may be low or need to be replaced. Confirm the amount of toner left in each Toner Cartridge. <ul style="list-style-type: none"> Check the toner level in the Status Monitor window. Replace the Toner Cartridge as necessary. Is the image printed correctly?	Troubleshooting complete.	Go to step 9.
9	Check the Toner Type. Is the XEROX Toner seated?	Go to step 10.	Replace the toner with XEROX toner.
10	Remove (REP 3.4 Transfer Roller Assembly). Are the Plate Spring BTR on the HVPS dirty or deformed?	Clean up the Plate Spring BTR or replace (REP 5.7 HVPS (3610) / REP 5.8 HVPS (3615)), then go to step 11.	Go to step 11.
11	Reseat (REP 3.4 Transfer Roller Assembly). Is the image printed correctly?	Troubleshooting complete.	Go to step 12.
12	Replace (REP 3.4 Transfer Roller Assembly). Is the image printed correctly?	Troubleshooting complete.	Go to step 12.
13	Remove the Drum Cartridge. Are the Spring BCR and Spring DB on HVPS dirty or deformed?	Clean up the Spring BCR and Spring DB or replace (REP 5.7 HVPS (3610) / REP 5.8 HVPS (3615)), then go to step 14.	Go to step 14.
14	Reseat the Drum Cartridge. Is the image printed correctly?	Troubleshooting complete.	Go to step 15.
15	Are there any foreign substance between the ROS Assembly and Drum Cartridge?	Remove the foreign substances, then go to step 16.	Go to step 16.
16	Execute the Diag Digital Output [093-001] to check the rotation of the Dispense Motor. Is it working properly?	Go to step 17.	Replace (REP 5.6 MCU PWB).
17	Is the Drum Cartridge installed properly, with no foreign substances at the contact point between the ATC Sensor in the Drum Cartridge and the Xerographic Connector Assembly?	Go to Step 18.	Remove the foreign substances.Reinstall the Drum Cartridge, then go to step 18.
18	Is the connection terminal of the ATC Sensor part in the Drum Cartridge damaged?	Replace the Drum Cartridge, then go to step 19.	Go to Step 19.

Troubleshooting Procedure (Continued)

Step	Actions and Questions	Yes	No
19	Is the connection terminal of the Xerographic Connector Assembly damaged?	Replace (REP 3.3 Xerographic Connector Assembly), then go to step 20.	Go to Step 20.
20	Is the image printed correctly?	Troubleshooting complete.	Go to step 21.
21	Reseat the MCU PWB. Is the image printed correctly?	Troubleshooting complete.	Go to step 22.
22	Reseat the ESS PWB. Is the image printed correctly?	Troubleshooting complete.	Go to step 23.
23	Reseat (REP 3.4 Transfer Roller Assembly). Is the image printed correctly?	Troubleshooting complete.	Go to step 24.
24	Replace (REP 3.4 Transfer Roller Assembly). Is the image printed correctly?	Troubleshooting complete.	Go to step 25.
25	Replace the Drum Cartridge. Is the image printed correctly?	Troubleshooting complete.	Go to step 26.
26	Reseat the HVPS. Is the image printed correctly?	Troubleshooting complete.	Go to step 27.
27	Replace (REP 3.1 ROS Assembly). Is the image printed correctly?	Troubleshooting complete.	Replace (REP 5.7 HVPS (3610) / REP 5.8 HVPS (3615)).

IQ-2 Unfused Image

Troubleshooting Reference

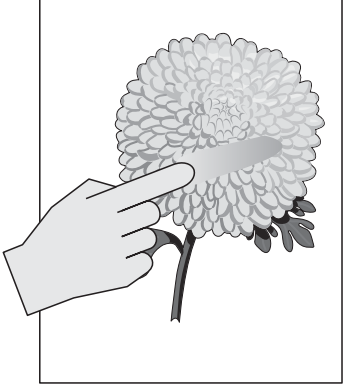
Applicable Parts	Example Print
<ul style="list-style-type: none"> Fusing Assembly, PL 3.5 Drum Cartridge, PL 3.1 Transfer Roller Assembly, PL 3.4 	 <p style="text-align: right; font-size: small;">Unfused Image</p>

! **WARNING:** The Fuser may be hot. Turn the printer power Off and allow at least 30 minutes for the Fuser to cool before removing the Fuser.

Troubleshooting Procedure

Step	Actions and Questions	Yes	No
1	Check that the printer is in a room where air conditioner is operating. If the air conditioner is not operating, turn it on or move the printer to a room with an air conditioner. Are there still toner smears?	Go to step 2.	Troubleshooting complete.
2	Is the installed paper new and dry? Does the paper meet specifications?	Go to step 3.	Replace with paper that meets specifications, then go to step 3.
3	The print media surface may be uneven. Try changing the Paper Type setting in the printer driver. On the Paper/Output tab, change the Paper Type setting. Is the image printed correctly?	Troubleshooting complete.	Go to step 4.
4	Reseat (REP 3.4 Transfer Roller Assembly). Is the image printed correctly?	Troubleshooting complete.	Go to step 5.
5	Replace (REP 3.4 Transfer Roller Assembly). Is the image printed correctly?	Troubleshooting complete.	Go to step 6.
6	Replace (REP 3.5 Fusing Assembly). Is the image printed correctly?	Troubleshooting complete.	Replace the Drum Cartridge.

IQ-3 Random Spots

Troubleshooting Reference

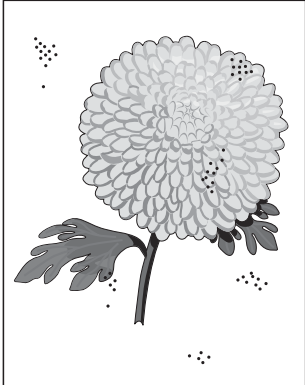
Applicable Parts	Example Print
<ul style="list-style-type: none"> - IIT Assembly, PL 6.1 - DADF Assembly, PL 6.1 - Transfer Roller Assembly, PL 3.4 - Drum Cartridge, PL 3.1 - Fusing Assembly, PL 3.5 - HVPS, PL 5.3 	 <p style="text-align: right; font-size: small;">Random Spots</p>

Note: for the Phaser 3610, begin the procedure at step 4.

Troubleshooting Procedure

Step	Actions and Questions	Yes	No
1	Does the error occur only during copying?	Go to step 2.	Go to step 4.
2	Is the original clean?	Go to step 3.	Change the original.
3	Are there any damages or foreign substances to the Platen Glass and DADF Feed Rollers?	Remove the foreign substances or clean up the IIT/DADF. If the Platen Glass has been damaged, replace (REP 6.1 IIT Assembly), then go to step 5.	Go to step 5.
4	Print the Test Print Gradation ESS in diagnosis. (Service-Mode / Printer Diag / Test Print) Is the image printed correctly?	Troubleshooting complete.	Go to step 5.
5	Clean the inside the Printer. Is the image printed correctly?	Troubleshooting complete.	Go to step 6.
6	Ensure that the Toner Cartridge are installed correctly. Is the image printed correctly?	Troubleshooting complete.	Go to step 7.
7	Ensure that the Drum Cartridge are installed correctly. Is the image printed correctly?	Troubleshooting complete.	Go to step 8.

Troubleshooting Procedure (Continued)

Step	Actions and Questions	Yes	No
8	Is the Adjust Density setting darker 2 or 3? (Machine Status / Tools / Admin Settings / Service Tools)	Change the setting to Normal , then go to step 9.	Go to step 9.
9	Remove (REP 3.4 Transfer Roller Assembly). Are the Plate Spring BTR on the HVPS dirty or deformed?	Clean up the Plate Spring BTR or replace (REP 5.7 HVPS (3610) / REP 5.8 HVPS (3615)), then go to step 10.	Go to step 10.
10	Reseat (REP 3.4 Transfer Roller Assembly). Is the image printed correctly?	Troubleshooting complete.	Go to step 11.
11	Replace (REP 3.4 Transfer Roller Assembly). Is the image printed correctly?	Troubleshooting complete.	Go to step 12.
12	Remove the Drum Cartridge. Are the Spring BCR and Spring DB on the HVPS dirty or deformed?	Clean up the Spring BCR and Spring DB or replace (REP 5.7 HVPS (3610) / REP 5.8 HVPS (3615)), then go to step 13.	Go to step 13.
13	Reseat the Drum Cartridge. Is the image printed correctly?	Troubleshooting complete.	Go to step 14.
14	Replace the Drum Cartridge. Is the image printed correctly?	Troubleshooting complete.	Go to step 15.
15	Replace (REP 3.5 Fusing Assembly). Is the image printed correctly?	Troubleshooting complete.	Replace (REP 5.7 HVPS (3610) / REP 5.8 HVPS (3615)).

IQ-4 Blank Print

Troubleshooting Reference

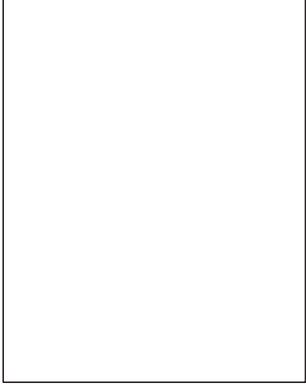
Applicable Parts	Example Print
<ul style="list-style-type: none"> Drum Cartridge, PL 3.1 Transfer Roller Assembly, PL 3.4 ROS Assembly, PL 3.2 HVPS, PL 5.3 Toner Cartridge, PL 3.1 Xerographic Connector Assembly, PL 3.1 Dispense Motor, PL 3.3 MCU PWB, PL 5.3 (3610) ESS PWB, PL 5.1 (3615) ESS PWB, PL 5.2 	 <p style="text-align: right; font-size: small;">Blank Print</p>

Note: for the Phaser 3610, begin the procedure at step 3.

Troubleshooting Procedure

Step	Actions and Questions	Yes	No
1	Does the error occur only during copying?	Go to step 2.	Go to step 3.
2	Is the original placed correctly?	Go to step 4.	Set the original correctly.
3	Print the Windows test page. Is the image printed correctly?	Printing data form is not suitable for the printer, then check the printing data which the problem generated.	Go to step 4.
4	On the Image Options tab, ensure that Off is selected in the Toner Saver drop-down menu. Is the image printed correctly?	Troubleshooting complete.	Go to step 5.
5	Is the installed paper new and dry? Does the paper meet specifications?	Go to step 6.	Replace with paper that meets specifications, then go to step 6.

Troubleshooting Procedure (Continued)

Step	Actions and Questions	Yes	No
6	The Toner Cartridge may be low or need to be replaced. Confirm the amount of toner left in each Toner Cartridge. <ul style="list-style-type: none"> Check the toner level in the Status Monitor window. Replace the Toner Cartridge as necessary. Is the image printed correctly?	Troubleshooting complete.	Go to step 7.
7	Check the Toner Type. Is the XEROX Toner seated?	Go to step 8.	Replace the toner with XEROX toner.
8	Remove (REP 3.4 Transfer Roller Assembly). Are the Plate Spring BTR on the HVPS dirty or deformed?	Clean up the Plate Spring BTR or replace (REP 5.7 HVPS (3610) / REP 5.8 HVPS (3615)), then go to step 9.	Go to step 9.
9	Reseat (REP 3.4 Transfer Roller Assembly). Is the image printed correctly?	Troubleshooting complete.	Go to step 10.
10	Replace (REP 3.4 Transfer Roller Assembly). Is the image printed correctly?	Troubleshooting complete.	Go to step 11.
11	Remove the Drum Cartridge. Are the Spring BCR and Spring DB on the HVPS dirty or deformed?	Clean up the Spring BCR and Spring DB or replace (REP 5.7 HVPS (3610) / REP 5.8 HVPS (3615)), then go to step 12.	Go to step 12.
12	Reseat the Drum Cartridge. Is the image printed correctly?	Troubleshooting complete.	Go to step 13.
13	Are there any foreign substance between the ROS Assembly and Drum Cartridge?	Remove the foreign substances, then go to step 14.	Go to step 14.
14	Execute the Diag Digital Output [093-001] to check the rotation of the Dispense Motor. Is it working properly?	Go to step 15.	Replace (REP 5.6 MCU PWB), then go to step 15.
15	Is the image printed correctly?	Troubleshooting complete.	Go to step 16.
16	Is the Drum Cartridge installed properly, with no foreign substances at the contact point between the ATC Sensor in the Drum Cartridge and the Xerographic Connector Assembly?	Go to Step 17.	Reinstall the Drum Cartridge, then go to step 17.
17	Is the connection terminal of the ATC Sensor part in the Drum Cartridge damaged?	Replace the Drum Cartridge, then go to step 18.	Go to Step 18.

Troubleshooting Procedure (Continued)

Step	Actions and Questions	Yes	No
18	Is the connection terminal of the Xerographic Connector Assembly damaged?	Replace (REP 3.3 Xerographic Connector Assembly), then go to step 19.	Go to Step 19.
19	Is the image printed correctly?	Troubleshooting complete.	Go to step 20.
20	Reseat the MCU PWB. Is the image printed correctly?	Troubleshooting complete.	Go to step 21.
21	Reseat the ESS PWB. Is the image printed correctly?	Troubleshooting complete.	Go to step 22.
22	Reseat (REP 3.4 Transfer Roller Assembly). Is the image printed correctly?	Troubleshooting complete.	Go to step 23.
23	Replace (REP 3.4 Transfer Roller Assembly). Is the image printed correctly?	Troubleshooting complete.	Go to step 24.
24	Replace the Drum Cartridge. Is the image printed correctly?	Troubleshooting complete.	Go to step 25.
25	Reseat the HVPS. Is the image printed correctly?	Troubleshooting complete.	Go to step 26.
26	Replace (REP 3.1 ROS Assembly). Is the image printed correctly?	Troubleshooting complete.	Replace (REP 5.7 HVPS (3610) / REP 5.8 HVPS (3615)).

IQ-5 Streaks

Troubleshooting Reference

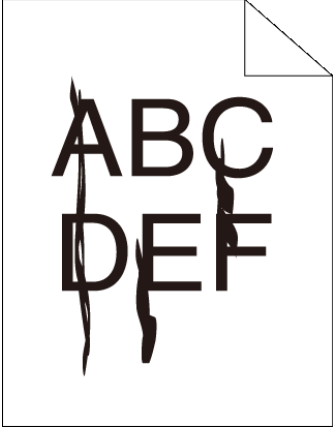
Applicable Parts	Example Print
<ul style="list-style-type: none"> IIT Assembly, PL 6.1 DADF Assembly, PL 6.1 Toner Cartridge, PL 3.1 Drum Cartridge, PL 3.1 Transfer Roller Assembly, PL 3.4 Fusing Assembly, PL 3.5 	

Note: for the Phaser 3610, begin the procedure at step 4.

Troubleshooting Procedure

Step	Actions and Questions	Yes	No
1	Does the error occur only during copying?	Go to step 2.	Go to step 4.
2	Is the original clean?	Go to step 3.	Change the original.
3	Are there any damages or foreign substances to the Platen Glass and DADF Feed Rollers?	Remove the foreign substances or clean up the IIT/DADF. If the Platen Glass has been damaged, replace (REP 6.1 IIT Assembly), then go to step 5.	Go to step 5.
4	Print the Test Print Gradation ESS in diagnosis. (Service-Mode / Printer Diag / Test Print) Is the image printed correctly?	Troubleshooting complete.	Go to step 5.
5	Clean the inside of the Printer. Is the image printed correctly?	Troubleshooting complete.	Go to step 6.

Troubleshooting Procedure (Continued)

Step	Actions and Questions	Yes	No
6	The Toner Cartridge may be low or need to be replaced. Confirm the amount of toner left in each Toner Cartridge. <ul style="list-style-type: none"> Check the toner level in the Status Monitor window. Replace the Toner Cartridge as necessary. Is the image printed correctly?	Troubleshooting complete.	Go to step 7.
7	Check the Toner Type. Is the XEROX Toner seated?	Go to step 8.	Replace the toner with XEROX toner.
8	Remove (REP 3.4 Transfer Roller Assembly). Are the Plate Spring BTR on the HVPS dirty or deformed?	Clean up the Plate Spring BTR or replace (REP 5.7 HVPS (3610) / REP 5.8 HVPS (3615)), then go to step 6.	Go to step 9.
9	Reseat (REP 3.4 Transfer Roller Assembly). Is the image printed correctly?	Troubleshooting complete.	Go to step 10.
10	Replace (REP 3.4 Transfer Roller Assembly). Is the image printed correctly?	Troubleshooting complete.	Go to step 11.
11	Execute the Clean Developer routine. (Machine Status / Tools / Admin Settings / Service Tools.) Is the image printed correctly?	Troubleshooting complete.	Go to step 12.
12	Remove the Drum Cartridge. Are the Spring BCR and Spring DB on the HVPS dirty or deformed?	Clean up the Spring BCR and Spring DB or replace (REP 5.7 HVPS (3610) / REP 5.8 HVPS (3615)), then go to step 13.	Go to step 13.
13	Replace the Drum Cartridge. Is the image printed correctly?	Troubleshooting complete.	Replace (REP 3.5 Fusing Assembly)

IQ-6 Black Print

Troubleshooting Reference

Applicable Parts	Example Print
<ul style="list-style-type: none"> IIT Assembly, PL 6.1 DADF Assembly, PL 6.1 Toner Cartridge, PL 3.1 Drum Cartridge, PL 3.1 ROS Assembly, PL 3.2 HVPS, PL 5.3 	 <p style="text-align: right; font-size: small;">Black Print</p>

Note: for the Phaser 3610, begin the procedure at step 4.

Troubleshooting Procedure

Step	Actions and Questions	Yes	No
1	Does the error occur only during copying?	Go to step 2.	Go to step 4.
2	Is the original clean?	Go to step 3.	Change the original.
3	Are there any damages or foreign substances to the Platen Glass and DADF Feed Rollers?	Remove the foreign substances or clean up the IIT/DADF. If the Platen Glass has been damaged, replace (REP 6.1 IIT Assembly), then go to step 5.	Go to step 5.
4	Print the Test Print Gradation ESS in diagnosis. (Service-Mode / Printer Diag / Test Print) Is the image printed correctly?	Troubleshooting complete.	Go to step 5.
5	Check the Toner Type. Is the XEROX Toner seated?	Go to step 6.	Replace the toner with XEROX toner.
6	Reseat the Drum Cartridge. Is the image printed correctly?	Troubleshooting complete.	Go to step 7.
7	Replace the Drum Cartridge. Is the image printed correctly?	Troubleshooting complete.	Go to step 8.

Troubleshooting Procedure (Continued)

Step	Actions and Questions	Yes	No
8	Check the drum charge status. Cover the ROS Assembly window with a sheet of paper and perform a test print. Is the test print result black? (If the drum is charged correctly, the test print result is white.)	Replace (REP 5.7 HVPS (3610) / REP 5.8 HVPS (3615)).	Go to step 9.
9	Check the ROS Assembly. Cover the half of the ROS Assembly window with a sheet of paper and perform a test print. Is the half page of the test print result white and the other half page is black? (If the ROS is normal, the other half page is not black but test patterned.)	Replace (REP 3.1 ROS Assembly).	

IQ-7 Pitched Black Dots

Troubleshooting Reference

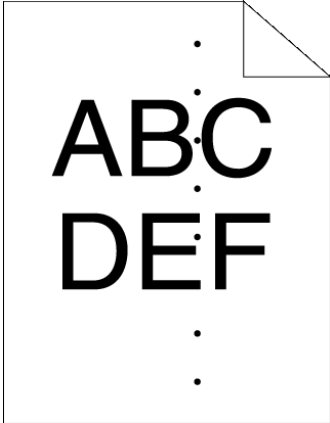
Applicable Parts	Example Print
<ul style="list-style-type: none"> IIT Assembly, PL 6.1 DADF Assembly, PL 6.1 Drum Cartridge, PL 3.1 Transfer Roller Assembly, PL 3.4 Fusing Assembly, PL 3.5 HVPS, PL 5.3 	

Note: for the Phaser 3610, begin the procedure at step 4.

Troubleshooting Procedure

Step	Actions and Questions	Yes	No
1	Does the error occur only during copying?	Go to step 2.	Go to step 4.
2	Is the original clean?	Go to step 3.	Change the original.
3	Is there any damages or foreign substances on the Platen Glass and DADF Feed Roller?	Remove the foreign substances or Clean up the IIT/DADF. If platen glass has been damaged, replace (REP 6.1 IIT Assembly), then go to step 5.	Go to step 5.
4	Print the Pitch Chart. (Machine Status / Tools / Admin Settings / Service Tools / Chart. When a repeating defect / deletion is observed, use the Pitch Chart to determine the defective part. Are there any defects / deletions matching the chart?	Replace the corresponding parts, then go to step 5.	Go to step 5.
5	Clean the inside of the printer. Is the image printed correctly?	Troubleshooting complete.	Go to step 6.

Troubleshooting Procedure (Continued)

Step	Actions and Questions	Yes	No
6	Remove (REP 3.4 Transfer Roller Assembly). Are the Plate Spring BTR on the HVPS dirty or deformed?	Clean up the Plate Spring BTR or replace (REP 5.7 HVPS (3610) / REP 5.8 HVPS (3615)), then go to step 7.	Go to step 7.
7	Reseat (REP 3.4 Transfer Roller Assembly). Is the image printed correctly?	Troubleshooting complete.	Go to step 8.
8	Replace (REP 3.4 Transfer Roller Assembly). Is the image printed correctly?	Troubleshooting complete.	Go to step 9.
9	Remove the Drum Cartridge. Are the Spring BCR and Spring DB on the HVPS dirty or deformed?	Clean up the Spring BCR and Spring DB or replace (REP 5.7 HVPS (3610) / REP 5.8 HVPS (3615)), then go to step 10.	Go to step 10.
10	Reseat the Drum Cartridge. Is the image printed correctly?	Troubleshooting complete.	Go to step 11.
11	Replace the Drum Cartridge. Is the image printed correctly?	Troubleshooting complete.	Go to step 12.
12	Replace (REP 3.5 Fusing Assembly) Is the image printed correctly?	Troubleshooting complete.	Replace (REP 5.7 HVPS (3610) / REP 5.8 HVPS (3615)).

IQ-8 Vertical Bands, Voids, or Streaks (In Paper Feed Direction)

Troubleshooting Reference

Applicable Parts	Example Print
<ul style="list-style-type: none"> Transfer Roller Assembly, 3.4 Drum Cartridge, PL 3.1 ROS Assembly, PL 3.2 Fusing Assembly, PL 3.5 	 <p style="text-align: center; font-size: small;">Vertical Blank Lines</p>

Note: for the Phaser 3610, begin the procedure at step 4.

Troubleshooting Procedure

Step	Actions and Questions	Yes	No
1	Does the error occur only during copying?	Go to step 2.	Go to step 4.
2	Is the original clean?	Go to step 3.	Change the original.
3	Is there any damages or foreign substances on the Platen Glass and DADF Feed Roller?	Remove the foreign substances or clean up the IIT/DADF. If the Platen Glass has been damaged, replace (REP 6.1 IIT Assembly), then go to step 5.	Go to step 4.
4	Print the Pitch Chart. (Machine Status / Tools / Admin Settings / Service Tools / Chart). When a repeating defect / deletion is observed, use the Pitch Chart to determine the defective part. Are there any defects / deletions matching the chart?	Replace the corresponding parts. Go to step 5.	Go to step 5.
5	Is the installed paper new and dry? Does the paper meet specifications?	Go to step 6.	Replace with paper that meets specifications, then go to step 6.

Troubleshooting Procedure (Continued)

Step	Actions and Questions	Yes	No
6	Clean inside the printer by using the cleaning rod. After the cleaning is completed, print the Pitch Chart. (Machine Status / Tools / Admin Settings / Service Tools / Chart) Is the image printed correctly?	Troubleshooting complete.	Go to step 7.
7	Ensure the light path is not covered. <ul style="list-style-type: none"> Remove the Drum Cartridge, and check the light path, and then remove the shielding. Re-install the Drum Cartridge. Print the Pitch Chart. (Machine Status / Tools / Admin Settings / Service Tools / Chart) Is the image printed correctly?	Troubleshooting complete.	Go to step 8.
8	Remove any foreign objects in the paper transfer path between the Transfer Roller Assembly, and the Fusing Assembly. Is the image printed correctly?	Troubleshooting complete.	Go to step 9.
9	Replace (REP 3.4 Transfer Roller Assembly). Is the image printed correctly?	Troubleshooting complete.	Go to step 10.
10	Replace the Drum Cartridge. Is the image printed correctly?	Troubleshooting complete.	Go to step 11.
11	Replace (REP 3.5 Fusing Assembly). Is the image printed correctly?	Troubleshooting complete.	Replace (REP 3.1 ROS Assembly).

IQ-9 Ghosting.

Troubleshooting Reference

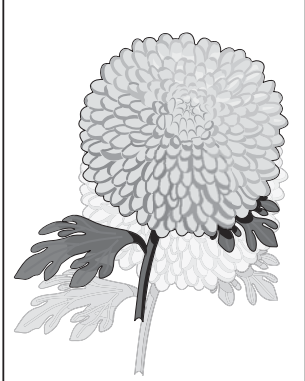
Applicable Parts	Example Print
<ul style="list-style-type: none"> • Drum Assembly, PL 3.1 • Transfer Roller Assembly, PL 3.4 	 <p style="text-align: center; font-size: small;">Residual Image/Ghosting</p>

Note: for the Phaser 3610, begin the procedure at step 3.

Troubleshooting Procedure

Step	Actions and Questions	Yes	No
1	Does the error occur only during copying?	Go to step 2.	Go to step 3.
2	Is the original clean?	Go to step 3.	Change the original.
3	Does the paper meet specifications?	Go to step 4.	Change the paper to meet specifications. Then go to step 4.
4	Print the Test Print Ghost Chart ESS in diagnosis. (Service-Mode / Printer Diag / Test Print) Is the image printed correctly? Is the type of the problem identified?	Proceed to the step corresponding to the type of ghosting. Positive ghost - Go to step 5 Negative ghost - Go to step 6	Troubleshooting complete.
5	Replace the Drum Cartridge. Is the image printed correctly?	Troubleshooting complete.	Go to step 7.
6	In Machine Status / Tools / Admin Tools / Service Tools , set the Ghost Control to "ON". Is the image printed correctly?	Troubleshooting complete.	Go to step 7.

Troubleshooting Procedure (Continued)

Step	Actions and Questions	Yes	No
7	Adjust the voltage value of the Transfer Roller Assembly by performing the Adjust Transfer Unit (ADJ 2 Adjusting the Transfer Unit) Is the image printed correctly?	Troubleshooting complete.	Go to step 8.
8	Reseat the Drum Cartridge. Is the image printed correctly?	Troubleshooting complete.	Go to step 9.
9	Remove (REP 3.4 Transfer Roller Assembly). Are the Plate Spring BTR on the HVPS dirty or deformed?	Clean up the Plate Spring BTR or replace (REP 5.7 HVPS (3610) / REP 5.8 HVPS (3615)), then go to step 10.	Go to step 10.
10	Reseat (REP 3.4 Transfer Roller Assembly). Is the image printed correctly?	Troubleshooting complete.	Replace (REP 3.4 Transfer Roller Assembly).

IQ-10 Light Induced Fatigue

Troubleshooting Reference

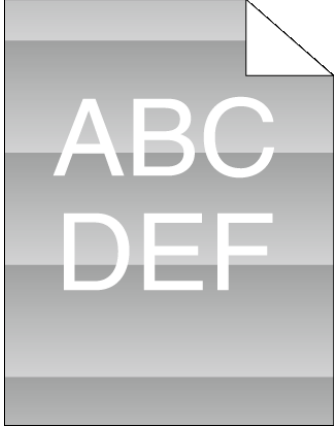
Applicable Parts	Example Print
<ul style="list-style-type: none"> Drum Cartridge, PL 3.1 	

Troubleshooting Procedure

Step	Actions and Questions	Yes	No
1	Print the Pitch Chart. (Machine Status / Tools / Admin Settings / Service Tools / Chart) Does the pattern on the output match with that on the Pitch Configuration Chart?	Replace the Drum Cartridge.	Troubleshooting complete.

IQ-11 Background

Troubleshooting Reference

Applicable Parts	Example Print
<ul style="list-style-type: none"> Xerographic Connector Assembly, PL 3.1 Toner Cartridge, PL 3.1 Drum Cartridge, PL 3.1 HVPS, PL 5.3 	 <p style="text-align: center; font-size: small;">Background Contamination</p>

Note: for the Phaser 3610, begin the procedure at step 4.

Troubleshooting Procedure

Step	Actions and Questions	Yes	No
1	Does the error occur only during copying?	Go to step 2.	Go to step 4.
2	Is the original clean?	Go to step 3.	Change the original.
3	Is the Lighten/Darken set to Darker 2 or 3?	Change the setting to Normal, then go to step 4.	Go to step 4.
4	Is the Adjust Density setting darker 2 or 3? (Machine Status / Tools / Admin Settings / Service Tools)	Change the setting to Normal , then go to step 5.	Go to step 5.
5	Print the Test Print Gradation ESS in diagnosis. (Service-Mode / Printer Diag / Test Print) Is the image printed correctly?	Troubleshooting complete	Go to step 6.
6	Is the installed paper new and dry? Does the paper meet specifications?	Go to step 7.	Replace with paper that meets specifications, then go to step 7.
7	Check the Toner Type. Is the XEROX Toner seated?	Go to step 8.	Replace the toner with XEROX toner.
8	Execute the Clean Developer routine. (Machine Status / Tools / Admin Settings / Service Tools) Is the image printed correctly?	Troubleshooting complete.	Go to step 9.

Troubleshooting Procedure (Continued)

Step	Actions and Questions	Yes	No
9	Is the Drum Cartridge installed properly, with no foreign substances at the contact point between the ATC Sensor in the Drum Cartridge and the Xerographic Connector Assembly?	Go to Step 10.	Reinstall the Drum Cartridge, then go to step 10.
10	Is the connection terminal of the ATC Sensor part in the Drum Cartridge damaged?	Replace the Drum Cartridge, then go to step 11.	Go to Step 11.
11	Is the connection terminal of the Xerographic Connector Assembly damaged?	Replace (REP 3.3 Xerographic Connector Assembly) then go to step 12.	Go to Step 12.
12	Is the image printed correctly?	Troubleshooting complete.	Go to step 13.
13	Reseat the HVPS. Is the image printed correctly?	Troubleshooting complete.	Go to step 14.
14	Replace the Drum Cartridge. Is the image printed correctly?	Troubleshooting complete.	Replace (REP 5.7 HVPS (3610) / REP 5.8 HVPS (3615)).

IQ-12 Bead Carry-out

Troubleshooting Reference

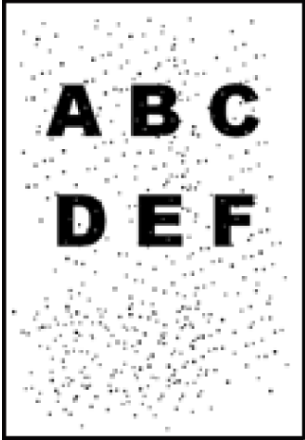
Applicable Parts	Example Print
<ul style="list-style-type: none"> Drum Cartridge, PL 3.1 HVPS, PL 5.3 	

Troubleshooting Procedure

Step	Actions and Questions	Yes	No
1	Set the Altitude. (Machine Status / Tools / Admin Settings / Service Tools / Adjust Altitude) Is the image printed correctly?	Troubleshooting complete.	Go to step 2.
2	Reseat the Drum Cartridge. Is the image printed correctly?	Troubleshooting complete.	Go to step 3.
3	Reseat the HVPS. Is the image printed correctly?	Troubleshooting complete.	Go to step 4.
4	Replace the Drum Cartridge. Is the image printed correctly?	Troubleshooting complete.	Replace (REP 5.7 HVPS (3610) / REP 5.8 HVPS (3615)).

IQ-13 Jagged Characters

Troubleshooting Reference

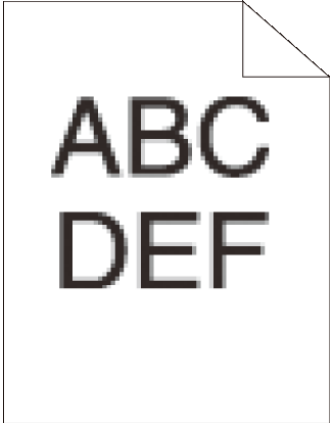
Applicable Parts	Example Print
<ul style="list-style-type: none"> Toner Cartridge, PL 3.1 ROS Assembly, PL 3.2 	

Troubleshooting Procedure

Step	Actions and Questions	Yes	No
1	Is the installed paper new and dry? Does the paper meet specifications?	Go to step 2.	Replace with paper that meets specifications, then go to step 2.
2	Change the Screen setting to "Fineness" via the printer driver. - To change the Screen settings, use [Screen] on the Image Options tab of the printer driver. Note: If using a downloaded font, ensure that the font is recommended for printer, operating system, and the application being used. Is the image printed correctly?	Troubleshooting complete.	Go to step 3.
3	Change the Image Quality setting to "High Resolution" via the printer driver. - To change the Image Quality settings, use [Image Quality] on the Image Options tab of the printer driver. Is the image printed correctly?	Troubleshooting complete.	Go to step 4.

Troubleshooting Procedure (Continued)

Step	Actions and Questions	Yes	No
4	Change the Bitmap Smoothing setting to On via printer driver. - To change the Bitmap Smoothing setting, use (Bitmap Smoothing) on the Advanced tab of the printer driver. Is the image printed correctly?	Troubleshooting complete.	Go to step 5.
5	Check the Toner Type. Is the XEROX Toner seated?	Go to step 6.	Replace the toner with XEROX toner.
6	Reseat the ROS Assembly. Is the image printed correctly?	Troubleshooting complete.	Replace (REP 3.1 ROS Assembly).

IQ-14 Banding

Troubleshooting Reference

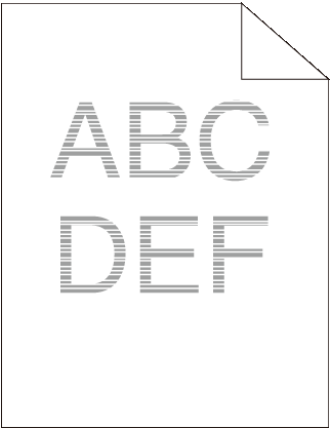
Applicable Parts	Example Print
<ul style="list-style-type: none"> Transfer Roller Assembly, PL 3.4 Drum Cartridge, PL 3.1 Fusing Assembly, PL 3.5 ROS Assembly, PL 3.2 HVPS PWB, PL 5.3 	

Note: for the Phaser 3610, begin the procedure at step 3.

Troubleshooting Procedure

Step	Actions and Questions	Yes	No
1	Does the error occur only during copying?	Go to step 2.	Go to step 3.
2	Is the original clean?	Go to step 4.	Change the original.
3	Print the Test Print Gradation ESS in diagnosis. (Service-Mode / Printer Diag / Test Print) Is the image printed correctly?	Troubleshooting complete.	Go to step 4.
4	Is the installed paper new and dry? Does the paper meet specifications?	Go to step 5.	Replace with paper that meets specifications, then go to step 5.
5	Remove any foreign objects in the paper transfer path between the Transfer Roller Assembly and the Fusing Assembly. Does the printout have a Banding or Horizontal band?	Go to step 6.	Troubleshooting complete.
6	Remove (REP 3.4 Transfer Roller Assembly). Are the Plate Spring BTR on the HVPS dirty or deformed?	Clean up the Plate Spring BTR or replace (REP 5.7 HVPS (3610) / REP 5.8 HVPS (3615)), then go to step 7.	Go to step 7.
7	Reseat (REP 3.4 Transfer Roller Assembly). Is the image printed correctly?	Troubleshooting complete.	Go to step 8.

Troubleshooting Procedure (Continued)

Step	Actions and Questions	Yes	No
8	Remove the Drum Cartridge. Are the Spring BCR and Spring DB on the HVPS dirty or deformed?	Clean up the Spring BCR and Spring DB or replace (REP 5.7 HVPS (3610) / REP 5.8 HVPS (3615)), then go to step 9.	Go to step 9.
9	Reseat the Drum Cartridge. Is the image printed correctly?	Troubleshooting complete.	Go to step 10.
10	Replace (REP 3.4 Transfer Roller Assembly). Is the image printed correctly?	Troubleshooting complete.	Go to step 11.
11	Replace the Drum Cartridge. Is the image printed correctly?	Troubleshooting complete.	Go to step 12.
12	Replace (REP 3.5 Fusing Assembly). Is the image printed correctly?	Troubleshooting complete.	Go to step 13.
13	Replace (REP 3.1 ROS Assembly). Is the image printed correctly?	Troubleshooting complete.	Replace (REP 5.7 HVPS (3610) / REP 5.8 HVPS (3615)).

IQ-15 Auger Marks

Troubleshooting Reference

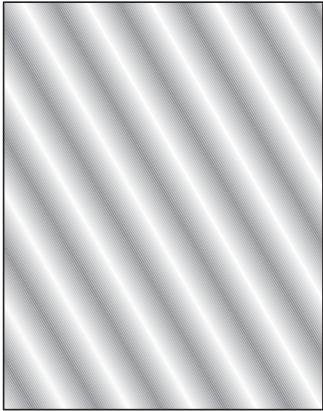
Applicable Parts	Example Print
<ul style="list-style-type: none"> Xerographic Connector Assembly, PL 3.1 Drum Cartridge, PL 3.1 Toner Cartridge, PL 3.1 	 <p style="text-align: right; font-size: small;">AugerMark</p>

Troubleshooting Procedure

Step	Actions and Questions	Yes	No
1	The Toner Cartridge may be low or need to be replaced. Confirm the amount of toner left in each Toner Cartridge. <ul style="list-style-type: none"> Check the toner level in the Status Monitor window. Replace the Toner Cartridge as necessary. Is the image printed correctly?	Troubleshooting complete.	Go to step 2.
2	Check the Toner Type. Is the XEROX Toner seated?	Go to step 3.	Replace the toner with XEROX toner.
3	Execute the Clean Developer. (Machine Status / Tools / Admin Settings / Service Tools / Clean Developer) Is the image printed correctly?	Troubleshooting complete.	Go to step 4.
4	Remove the Drum Cartridge. Are the Spring BCR and Spring DB on the HVPS dirty or deformed?	Clean up the Spring BCR and Spring DB or replace (REP 5.7 HVPS (3610) / REP 5.8 HVPS (3615)), then go to step 5.	Go to step 5.
5	Reseat the Drum Cartridge. Is the image printed correctly?	Troubleshooting complete.	Go to step 6.

Troubleshooting Procedure (Continued)

Step	Actions and Questions	Yes	No
6	Is the Drum Cartridge installed properly, with no foreign substances at the contact point between the ATC Sensor in the Drum Cartridge and the Xerographic Connector Assembly?	Go to Step 7.	Reinstall the Drum Cartridge, then go to step 7.
7	Is the connection terminal of the ATC Sensor part in the Drum Cartridge damaged?	Replace the Drum Cartridge, then go to step 8.	Go to Step 8.
8	Is the connection terminal of the Xerographic Connector Assembly damaged?	Replace (REP 3.3 Xerographic Connector Assembly), then go to step 9.	Go to Step 9.
9	Is the image printed correctly?	Troubleshooting complete.	Replace the Drum Cartridge.

IQ-16 Wrinkled / Stained Paper

Troubleshooting Reference

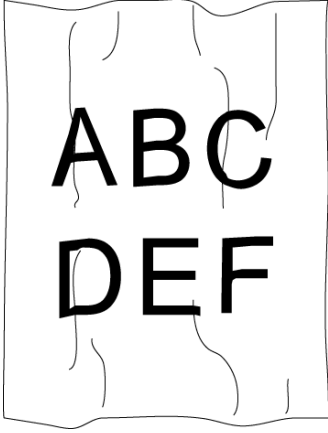
Applicable Parts	Example Print
<ul style="list-style-type: none"> • Rubber Roll Assembly, PL 2.2 • Regi Pinch Roll Assembly, PL 2.2 • Regi Pinch Roll, PL 2.2 • MSI Feed Roll / Nudger Roll, PL 2.6 • MSI Retard Roll Assembly, PL 2.7 • Tray 1 Feed Roll / Nudger Roll, PL 2.3 • Tray 1 Retard Roll, PL 7.3 • Transfer Roller Assembly, PL 3.4 • Drum Cartridge, PL 3.1 • Feed Roll / Nudger Roll, PL 7.2 • Retard Roll, PL 7.3 • Takeaway Pinch Roll Assembly, PL 7.1 • Takeaway Pinch Roll, PL 7.4 • Exit Roll Assembly, PL 2.7 • Left Pinch Roll Assembly, PL 2.5 • Right Pinch Roll Assembly, PL 2.5 • Fusing Assembly, PL 3.5 	

Troubleshooting Procedure

Step	Actions and Questions	Yes	No
1	Is the skewed paper fed from the MSI?	Go to step 2.	Go to step 4.
2	Reset the MSI side guides. Is the image printed correctly?	Troubleshooting complete.	Go to step 3.
3	Is the wrinkle within 30 mm of the four edges of the envelope?	This type of wrinkle is considered normal. Your printer is not at fault.	Go to step 4.
4	Are there any foreign substance on the paper path?	Remove the foreign substances, then go to step 5.	Go to step 6.
5	Is the image printed correctly?	Troubleshooting complete.	Go to step 6.

Troubleshooting Procedure (Continued)

Step	Actions and Questions	Yes	No
6	Are the paper feed rolls (the rolls that are listed among the parts considered to be the cause) installed properly?	Go to Step 8.	Reinstall the corresponding paper feed rolls, then go to step 7.
7	Is the image printed correctly?	Troubleshooting complete.	Go to step 8.
8	Are the paper feed rolls (the rolls that are listed among the parts considered to be the cause in sequence) deformed or worn out?	Replace the corresponding paper feed rolls, then go to step 9.	Go to Step 10.
9	Is the image printed correctly?	Troubleshooting complete.	Go to step 10.
10	Reseat the Paper Cassette. Is the image printed correctly?	Troubleshooting complete.	Go to step 11.
11	Load the unopened (or sealed and stored under humidity control) and recommended paper, and then perform a test print. Is the image printed correctly?	Troubleshooting complete.	Go to step 12.
12	Reset the Paper Cassette side guide. Is the image printed correctly?	Troubleshooting complete.	Go to step 13.
13	Reseat (REP 3.4 Transfer Roller Assembly). Is the image printed correctly?	Troubleshooting complete.	Go to step 14.
14	Reseat the Fusing Assembly. Is the image printed correctly?	Troubleshooting complete.	Replace (REP 3.5 Fusing Assembly).

IQ-17 Damage to the Lead Edge of the Print

Troubleshooting Reference

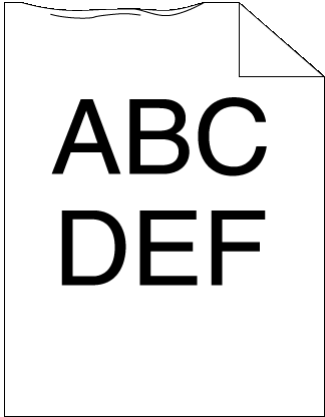
Applicable Parts	Example Print
<ul style="list-style-type: none"> • Rubber Roll Assembly, PL 2.2 • Regi Pinch Roll Assembly, PL 2.2 • Regi Pinch Roll, PL 2.2 • MSI Feed Roll / Nudger Roll, PL 2.6 • MSI Retard Roll Assembly, PL 2.7 • Tray 1 Feed Roll / Nudger Roll, PL 2.3 • Tray 1 Retard Roll, PL 7.3 • Transfer Roller Assembly, PL 3.4 • Drum Cartridge, PL 3.1 • Feed Roll / Nudger Roll, PL 7.2 • Retard Roll, PL 7.3 • Takeaway Pinch Roll Assembly, PL 7.1 • Takeaway Pinch Roll, PL 7.4 • Exit Roll Assembly, PL 2.7 • Left Pinch Roll Assembly, PL 2.5 • Right Pinch Roll Assembly, PL 2.5 • Fusing Assembly, PL 3.5 	

Troubleshooting Procedure

Step	Actions and Questions	Yes	No
1	Is the skewed paper fed from the MSI?	Go to step 2.	Go to step 4.
2	Reset the MSI side guides. Is the image printed correctly?	Troubleshooting complete.	Go to step 3.
3	Is the wrinkle within 30 mm of the four edges of the envelope?	This type of wrinkle is considered normal. Your printer is not at fault.	Go to step 4.
4	Are there any foreign substance on the paper path?	Remove the foreign substances, then go to step 5.	Go to step 6.
5	Is the image printed correctly?	Troubleshooting complete.	Go to step 6.

Troubleshooting Procedure (Continued)

Step	Actions and Questions	Yes	No
6	Are the paper feed rolls (the rolls that are listed among the parts considered to be the cause) installed properly?	Go to Step 8.	Reinstall the corresponding paper feed rolls, then go to step 7.
7	Is the image printed correctly?	Troubleshooting complete.	Go to step 8.
8	Are the paper feed rolls (the rolls that are listed among the parts considered to be the cause in sequence) deformed or worn out?	Replace the corresponding paper feed rolls, then go to step 9.	Go to Step 10.
9	Is the image printed correctly?	Troubleshooting complete.	Go to step 10.
10	Reseat the Paper Cassette. Is the image printed correctly?	Troubleshooting complete.	Go to step 11.
11	Load the unopened (or sealed and stored under humidity control) and recommended paper, and then perform a test print. Is the image printed correctly?	Troubleshooting complete.	Go to step 12.
12	Reset the Paper Cassette side guide. Is the image printed correctly?	Troubleshooting complete.	Go to step 13.
13	Reseat (REP 3.4 Transfer Roller Assembly). Is the image printed correctly?	Troubleshooting complete.	Go to step 14.
14	Reseat the Fusing Assembly. Is the image printed correctly?	Troubleshooting complete.	Replace (REP 3.5 Fusing Assembly).

IQ-18 Incorrect Margins

Troubleshooting Reference

Applicable Parts	Example Print
<ul style="list-style-type: none"> IIT Assembly, PL 6.1 DADF Assembly, PL 6.1 DADF Pick Up Module, PL 6.1 Drum Cartridge, PL 3.1 Transfer Roller Assembly, PL 3.4 ROS Assembly, PL 3.2 	 <p style="text-align: center; font-size: small;">Image Not Centered</p>

Note: for the Phaser 3610, begin the procedure at step 7.

Troubleshooting Procedure

Step	Actions and Questions	Yes	No
1	Does the error occur only during copying?	Go to step 2.	Go to step 7.
2	Does the error occur when feeding the original at the DADF?	Go to step 4.	Go to step 3.
3	Is the original positioned on the Platen Glass correctly?	Replace (REP 6.1 IIT Assembly).	Reseat the original.
4	Does the original meet DADF specs?	Go to step 5.	Use the platen mode or change the paper type.
5	Reseat the DADF Guides. Does the error still occur when copying?	Go to step 6.	Troubleshooting complete.
6	Are there any damages or foreign substances on the DADF Pick Up Module?	Remove the foreign substances or replace (REP 5.6 MCU PWB).	Replace (REP 6.2 DADF).
7	Print the Test Print Gradation ESS in diagnosis. (Service-Mode / Printer Diag / Test Print) Is the image printed correctly?	Check the printing data which generated the problem.	Go to step 8.
8	Replace the Drum Cartridge. Is the image printed correctly?	Troubleshooting complete.	Go to step 9.

Troubleshooting Procedure (Continued)

Step	Actions and Questions	Yes	No
9	Replace (REP 3.4 Transfer Roller Assembly). Is the image printed correctly?	Troubleshooting complete.	Replace (REP 3.1 ROS Assembly).

IQ-19 Skewed Image

Troubleshooting Reference

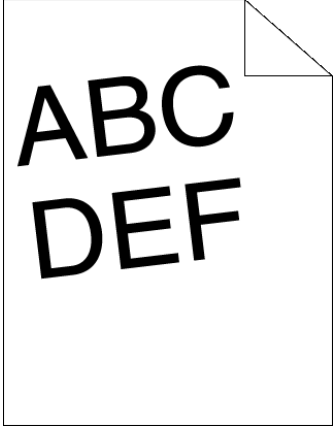
Applicable Parts	Example Print
<ul style="list-style-type: none"> IIT Assembly, PL 6.1 DADF Assembly, PL 6.1 DADF Pick Up Module, PL 6.1 Rubber Roll Assembly, PL 2.2 Regi Pinch Roll Assembly, PL 2.2 Regi Pinch Roll, PL 2.2 Transfer Roller Assembly, PL 3.4 Fusing Assembly, PL 3.5 	

Note: for the Phaser 3610, begin the procedure at step 7.

Troubleshooting Procedure

Step	Actions and Questions	Yes	No
1	Does the error occur only during copying?	Go to step 2.	Go to step 7.
2	Does the error occur when feeding the original at the DADF?	Go to step 4.	Go to step 3.
3	Is the original positioned on the Platen Glass correctly?	Replace (REP 6.1 IIT Assembly).	Reseat the original.
4	Does the original meet the DADF spec?	Go to step 5.	Use the platen mode or change the paper type.
5	Reseat the DADF Guides. Does the error still occur when copying?	Go to step 6.	Troubleshooting complete.
6	Are there any damages or foreign substances on the DADF Pick Up Module?	Remove the foreign substances or replace (REP 5.6 MCU PWB).	Replace (REP 6.2 DADF).
7	Is the skewed paper fed from the MSI?	Go to step 8.	Go to step 9.
8	Reset the MSI side guides. Is the image printed correctly?	Troubleshooting complete.	Go to step 9.
9	Are there any foreign substances on the paper path?	Remove the foreign substances, then go to step 10.	Go to step 11.

Troubleshooting Procedure (Continued)

Step	Actions and Questions	Yes	No
10	Is the image printed correctly?	Troubleshooting complete.	Go to step 11.
11	Are the paper feed rolls (the rolls that are listed among the parts considered to be the cause) installed properly?	Go to Step 13.	Reinstall the corresponding paper feed rolls, then go to step 12.
12	Is the image printed correctly?	Troubleshooting complete.	Go to step 13.
13	Are the paper feed rolls (the rolls that are listed among the parts considered to be the cause in sequence) deformed or worn out?	Replace the corresponding paper feed rolls, then go to step 14.	Go to Step 15.
14	Is the image printed correctly?	Troubleshooting complete.	Go to step 15.
15	Reseat the Paper Cassette. Is the image printed correctly?	Troubleshooting complete.	Go to step 16.
16	Reset the Paper Cassette side guide. Is the image printed correctly?	Troubleshooting complete.	Go to step 17.
17	Reseat (REP 3.4 Transfer Roller Assembly). Is the image printed correctly?	Troubleshooting complete.	Go to step 18.
18	Reseat the Fusing Assembly. Is the image printed correctly?	Troubleshooting complete.	Replace (REP 3.5 Fusing Assembly).

Printing Test Patterns

A variety of test prints are available from the customer menu and service diagnostics to aid in determining the quality of output from the printer to assist in troubleshooting problems.

Print Test patterns routine outputs test patterns stored in the engine firmware or ESS PWB controller PS software. The patterns will be used by the service personnel to identify, repair and validate the operability of printer xerographic and paper handling from all paper sources, options and output sources.

Service Diagnostic Mode Test Patterns

Enter Service Diagnostics / Printer Diag / Test Print

Available Test Patterns are as follows:

- Pattern IOT
- Gradation ESS
- Ghost Chart ESS

Administration Mode Test Patterns

(3610) Select the **Menu Button** on the Control Panel and scroll to **Admin Settings** and select **OK**. Select **Service Tools**

(3615) Select **Machine Status** on the Control Panel and the **Tools** tab on the UI. Select **Admin Settings...** and using the keypad, enter **1111** and **OK on the UI**. Select the **Service Tools**

Available Test Patterns are as follows:

- Pitch Chart
- Alignment Chart
- Full Page Solid

Diagnostics Test Pattern #2 - Gradation ESS

Different Density Patches from 0% to 100%

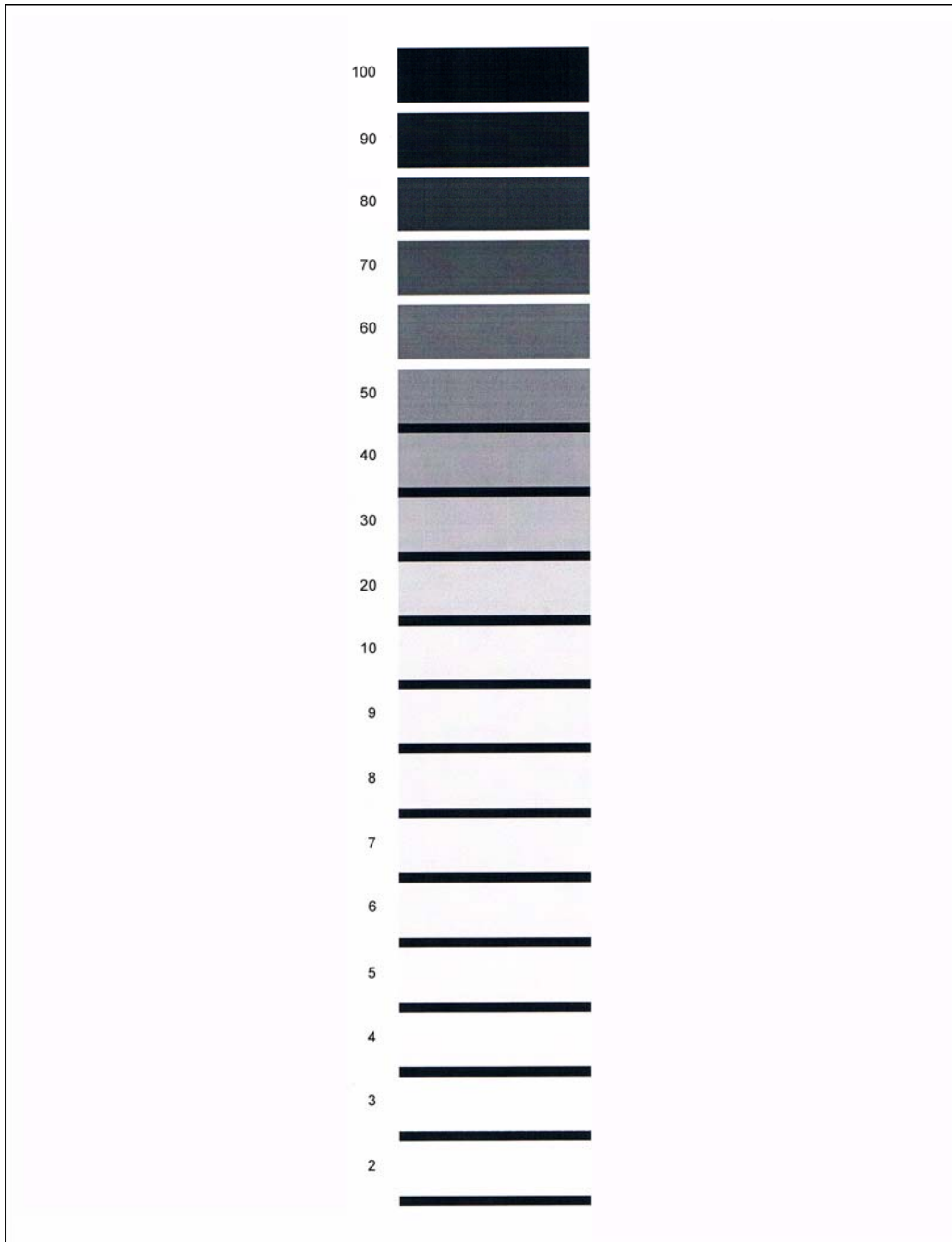

Diagnostics Test Pattern #3 - Ghost Chart ESS

Pattern used to check for ghosting in the image area.

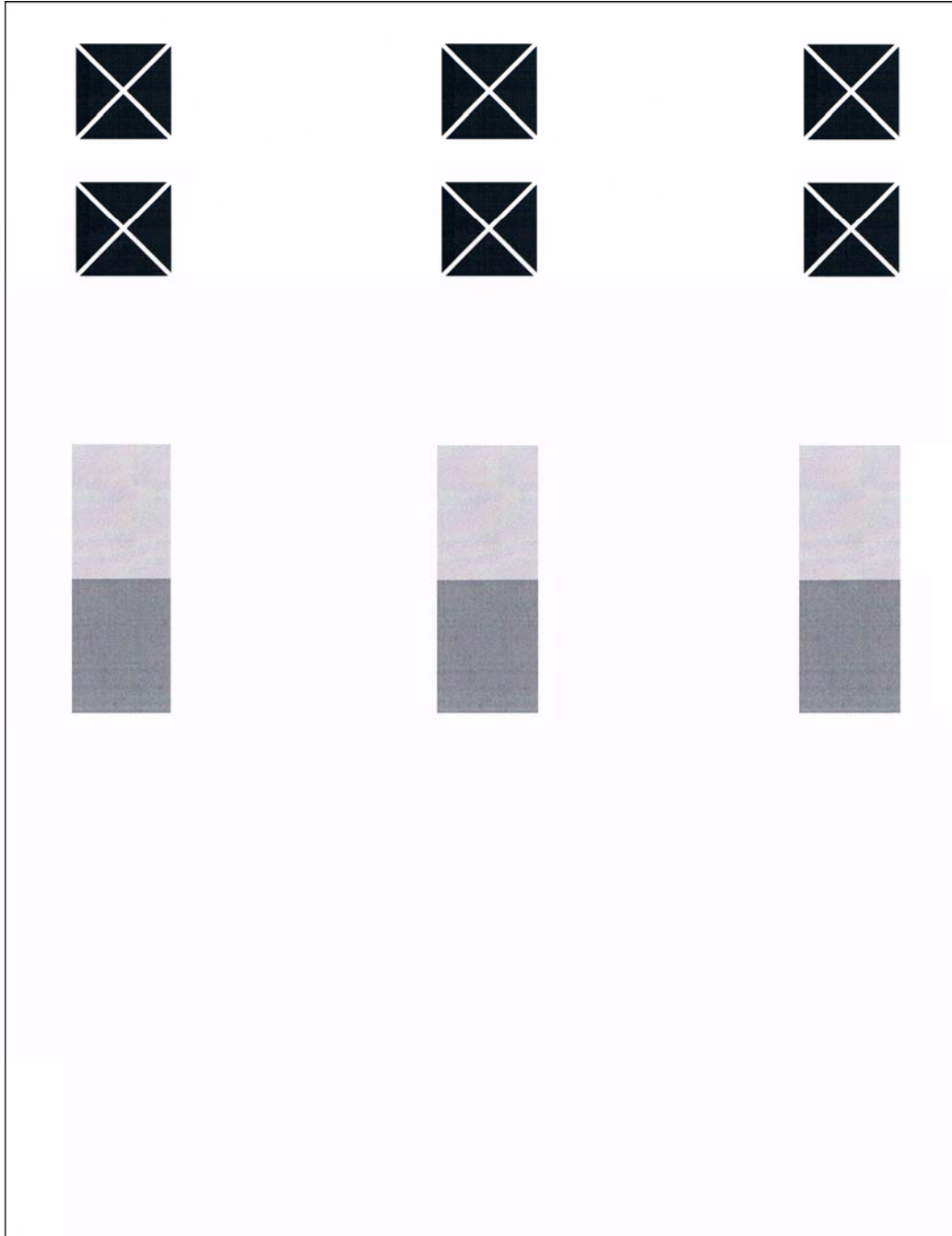

Admin Mode Test Pattern #1 - Pitch Chart

Pitch Chart (Page 1)

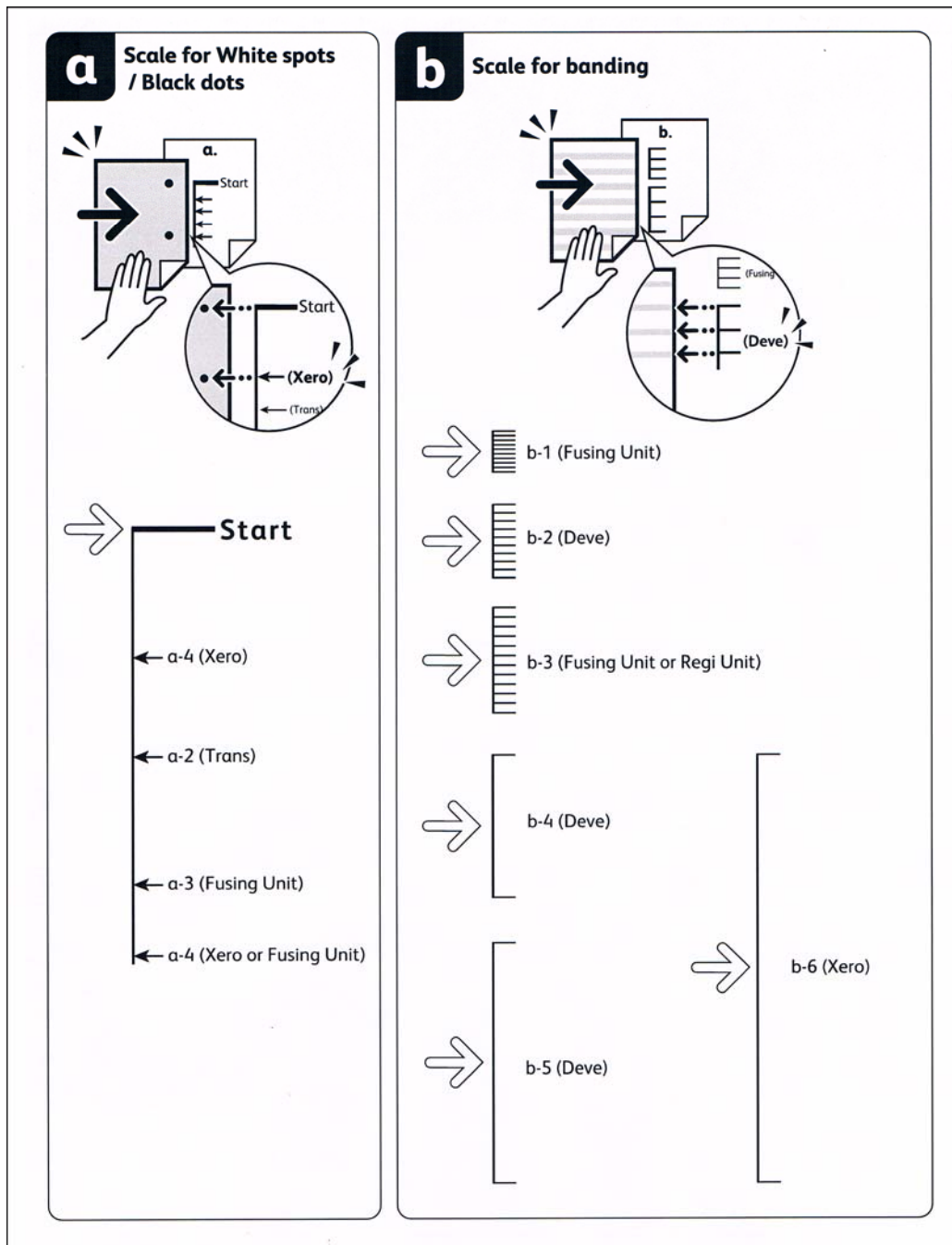

Admin Mode Test Pattern #1 - Pitch Chart

Pitch Chart (Page 2)

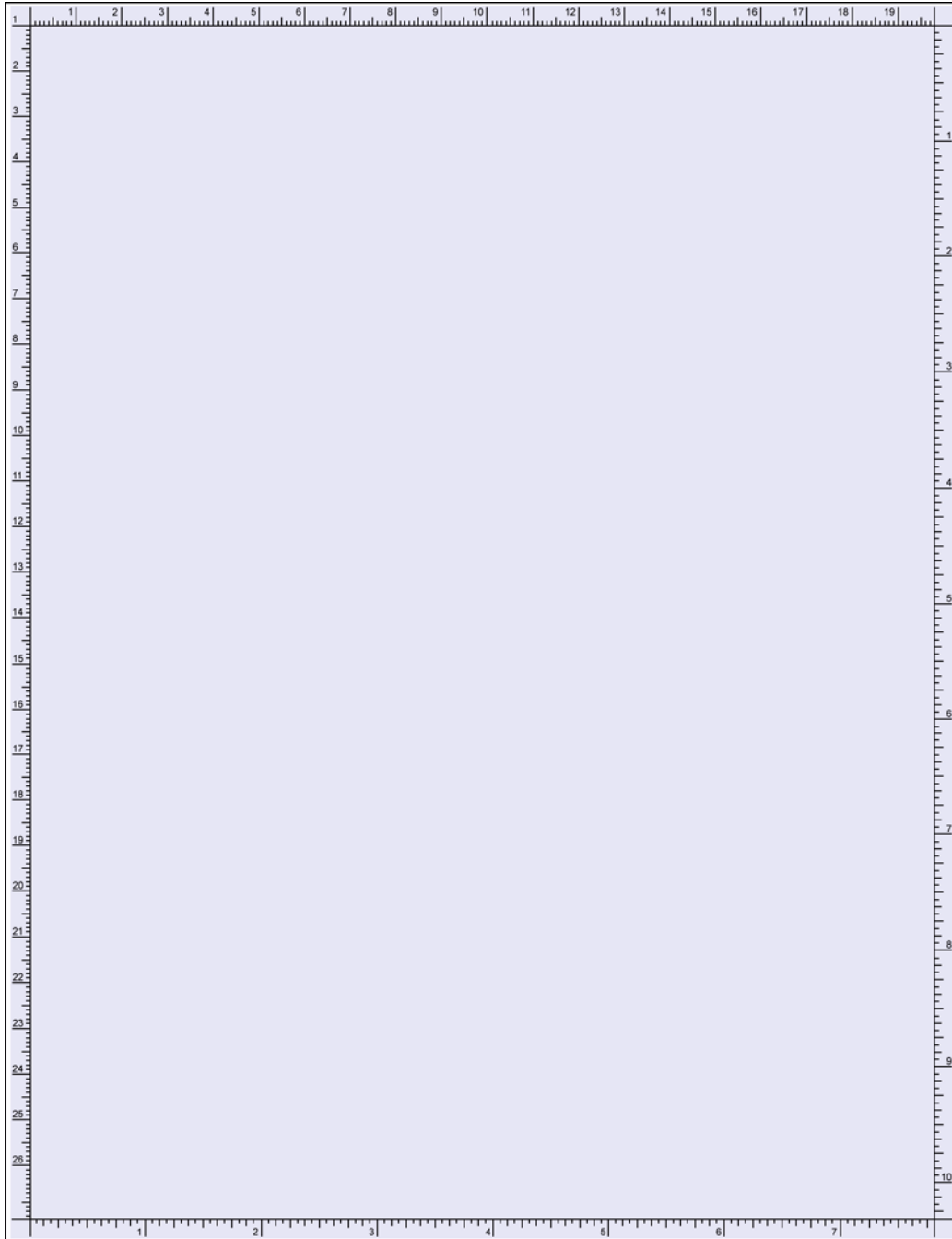

Admin Mode Test Pattern #2 - Alignment Chart

Alignment Chart

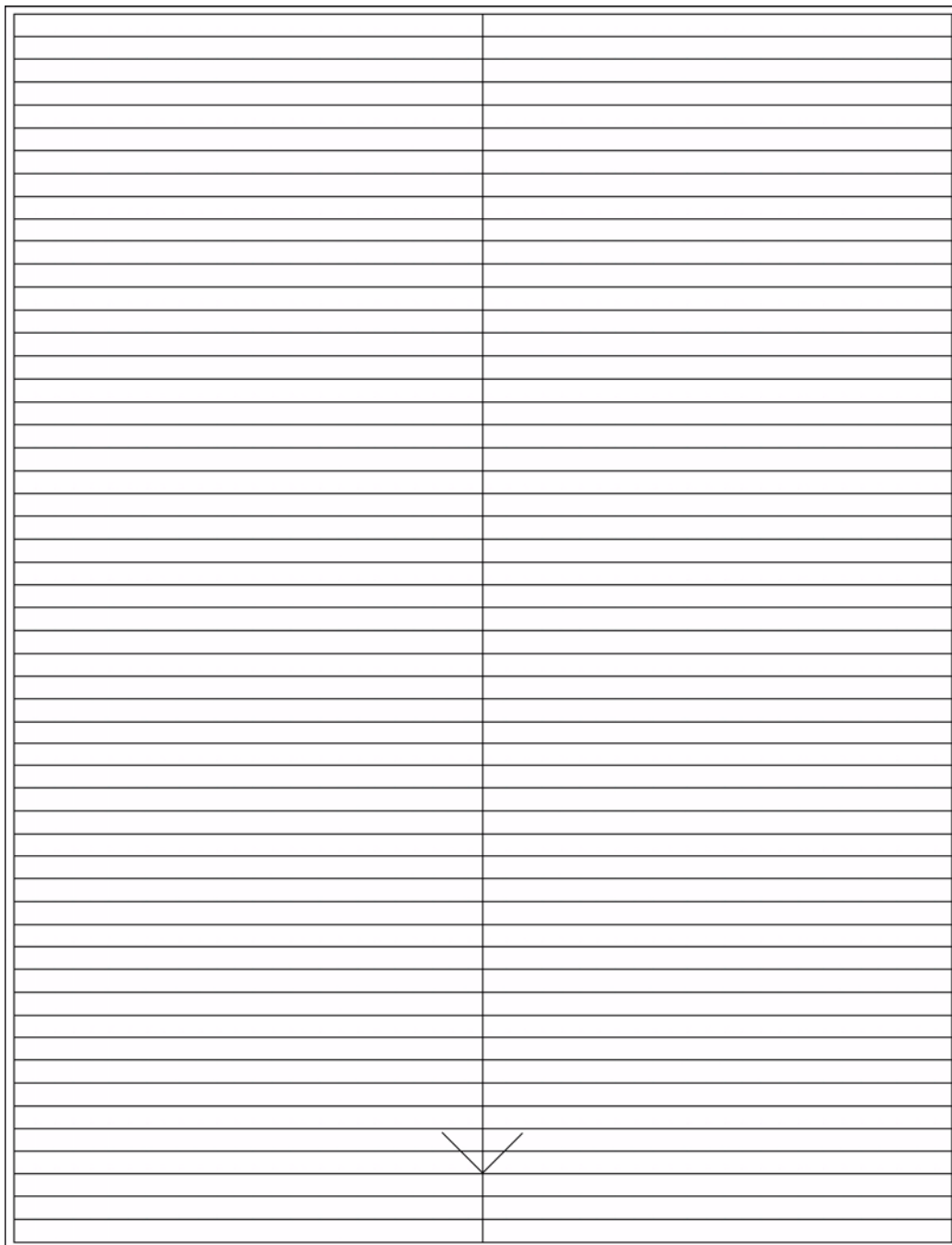
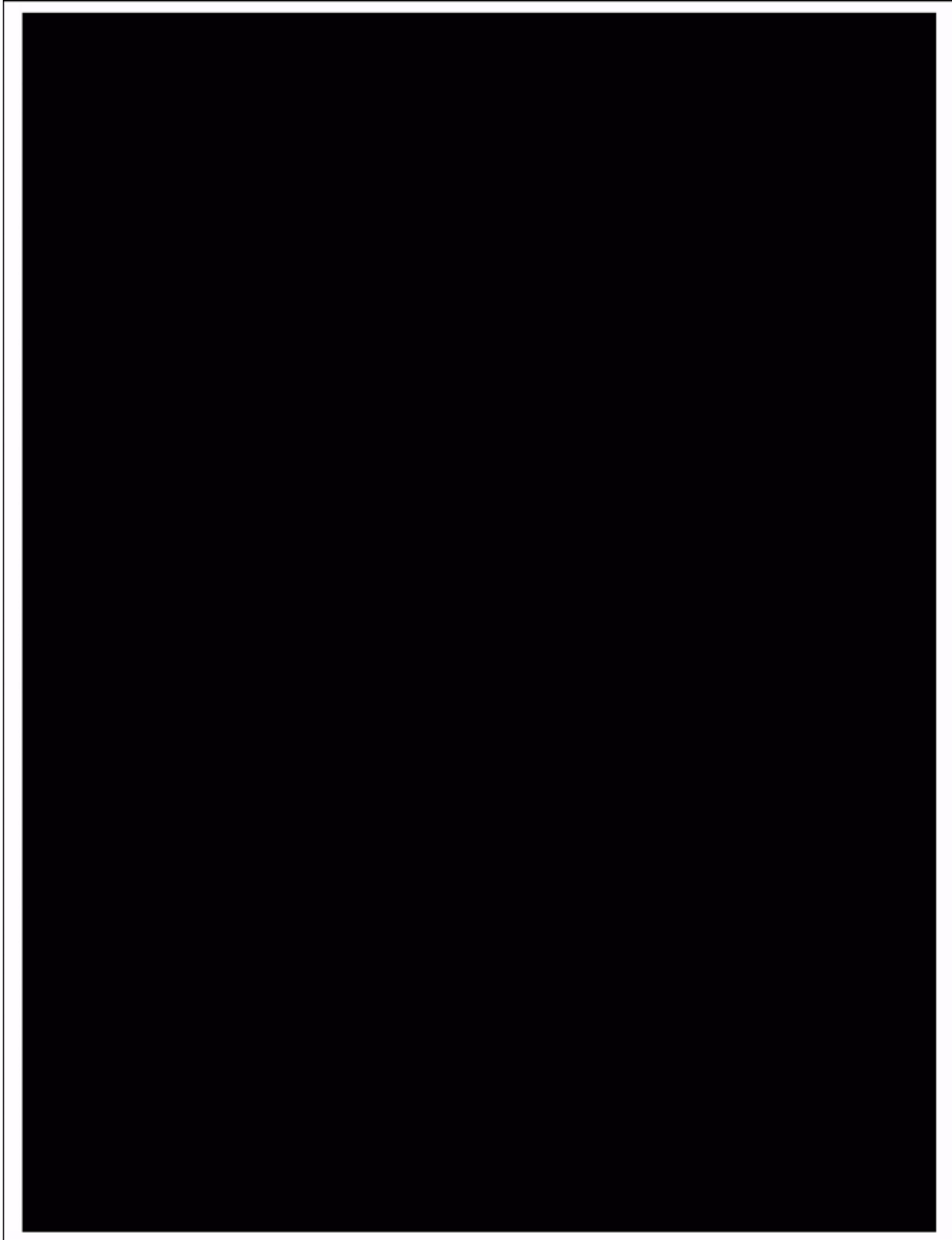

Image Quality

Admin Mode Test Pattern #3 - Full Page Solid

Full Page Solid



Service Parts Disassembly

This chapter includes:

- [Overview](#)
- [Standard Orientation of the Printer](#)
- [Precautions](#)
- [Notations in the Disassembly Text](#)
- [Fastener Types](#)
- [Covers](#)
- [Chassis Repairs](#)
- [Xerographic Repairs](#)
- [Drive Repairs](#)
- [Electrical Repairs](#)
- [IIT / DADF Repairs](#)
- [550-Sheet Feeder Repairs](#)

Overview

This chapter contains the removal procedures for field-replaceable parts listed in Chapter 5, Parts List. In most cases, the replacement procedure is simply the reverse of the removal procedure. If necessary, additional replacement information is provided.

Standard Orientation of the Printer

When needed, printer orientation is called out in the procedure as an aid to locating parts. Illustrated below are the right, left, front, and rear sides of the printer.

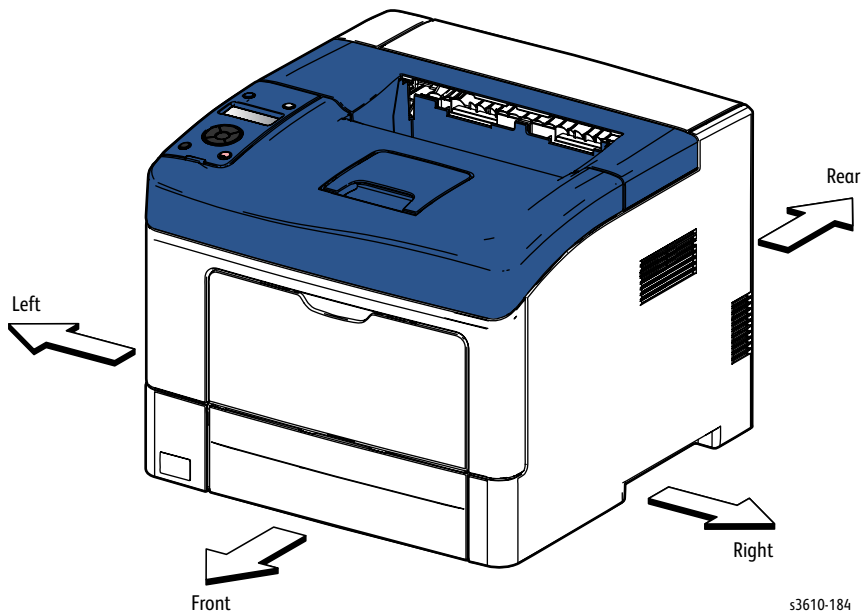

s3610-184

Precautions

- Only replace parts that are provided by the parts unit. Do not remove and replace any parts other than those provided parts. Never break down the provided parts or replace the parts that have been removed. Replacing any parts other than the provided parts will not guaranteed quality or safety, and is strictly forbidden.
- When a harness wiring is removed for service work, make sure that the harness wiring goes through the same route as before. Check that the harness is set into the harness guides properly before proceeding with the procedure. Check that the harness is not trapped when an assembly is replaced, or a cover is closed. There is no unnecessary slack found in any harness so proper re-routing of a harness is crucial.

Before starting service work note the following:

- Start the procedure after turning off the power and removing the power cord from the outlet.
- Wear an anti-static wrist band when performing the removal of any PWBs or electrical circuits.
- When performing the service operation around the Fusing Assembly, ensure that the Fusing Assembly and its surrounding area have cooled down sufficiently.
- Pay sufficient attention to the parts removed during a procedure because they may be broken or may cease to function properly if unreasonable force is applied.
- Put the removed parts, such as Toner Cartridge in a dark place where it will not affect the service procedures. (Note that the service procedures can be performed with those parts in place depending on the target section of removal/replacement.)
- Since various types of screws are used, ensure that the right screws are used in their right positions. Use special caution not to confuse the screws for plastic and the ones for sheet metal, because using the wrong type of screws may result in damage to the screw threads or other troubles.
- When releasing tabs or bosses, it may be best to use a small flat-head screwdriver to assist in the disassembly, by gently prying the intended areas apart.

Warnings and Cautions

Warnings are listed in the manual to indicate areas of the machine or a procedure that may cause personal injury, while cautions are listed to indicate parts of the machine that are at risk for damage during a repair procedure.

 **WARNING:** Unplug the power cord from the wall outlet before servicing the printer.

 **WARNING:** Allow the Fusing Assembly to cool before performing any procedure where contact with the Fusing Assembly is possible.

 **CAUTION:** When replacing the MCU PWB, use a new MCU PWB. Never use an MCU PWB which was installed in another device.

 **CAUTION:** Do not replace the MCU and ESS PWBs at the same time. Replacement of both PWBs simultaneously can cause an error. Replace or check the ESS PWB first, then replace the MCU PWB.

 **CAUTION:** If installing an ESS PWB previously used in another device, never perform NVM loading (Load NVM from ESS). This corrupts MCU PWB NVM causing an error. First save MCU PWB NVM to the ESS PWB (Save NVM to ESS), then load MCU PWB NVM.



 **CAUTION:** Many parts are secured by plastic tabs. Do not over flex or force these parts. Do not over torque screws threaded into plastic.

Notations in the Disassembly Text

- Most of the procedures found in this section are written to assume that any optional trays have been removed, and repairs are performed on the base models.
- Disassembly procedures are listed in sequential order, supported by sub-menus and illustrations. Replacement sequences are also provided. The sequence of operations may reference other procedures or parts and links are provided as (REPx.x) or (PLx.x)
- The notation “PLx.x.” indicates that this component is listed in the Parts List.
- Arrows in an illustration show direction of movement when removing or replacing a component.
- The notation “(tap, plastic, 10 mm)” or “(metal, 6 mm)” refer to the type of screw being removed.

Fastener Types

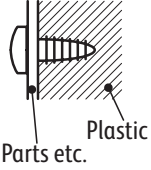
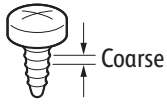
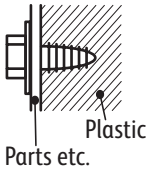
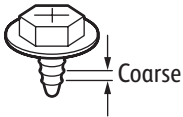
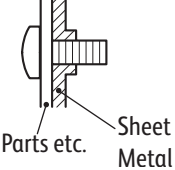
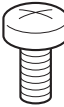
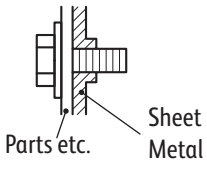
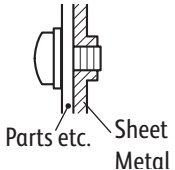
The following table lists the types of screws used to assemble the printer. The procedures provide dimensions for screws being removed.

Type	Application	Shape	Characteristics
Self-tapping, plastic			<ol style="list-style-type: none"> 1. Silver colored. 2. Screw thread is coarse compared to metal screw. 3. Screw tip is thin.
Self-tapping, plastic, with flange			<ol style="list-style-type: none"> 1. Black colored. 2. Screw thread is coarse compared to metal screw. 3. Screw has a flange. 4. Screw tip is thin.
Sheet Metal, silver			<ol style="list-style-type: none"> 1. Silver colored. 2. Diameter is uniform.
Self-tapping, hex-head, with flange			<ol style="list-style-type: none"> 1. Silver colored. 2. Screw has a flange. 3. Diameter is uniform.
Sheet Metal, silver with lock washer			<ol style="list-style-type: none"> 1. Silver colored. 2. Includes a toothed washer. 3. Diameter is uniform. 4. Used for grounding terminals.



CAUTION: Use care when installing self-tapping screws in plastic. To properly start the screw in plastic, turn the screw counter-clockwise until you feel the screw engage the threads, then tighten as usual. Improperly aligning or over tightening the screw can result in damage to previously tapped threads. Always use the correct type and size screw. Using the wrong screw can damage tapped holes. Do not use excessive force to remove or install either a screw or a printer part.

Covers

REP 1.1 Control Panel (3610)

PL 1.1 Covers (3610)

Removal

1. Open the Front Cover.
2. Remove the Control Panel (Control Panel). (Figure 1)
 - a. Release 3 clips.

Note: the use of a small flat-head screwdriver may be necessary to release the 2 tabs on the right of the assembly.

- b. Lift the Control Panel to access the connector and disconnect P/J220.

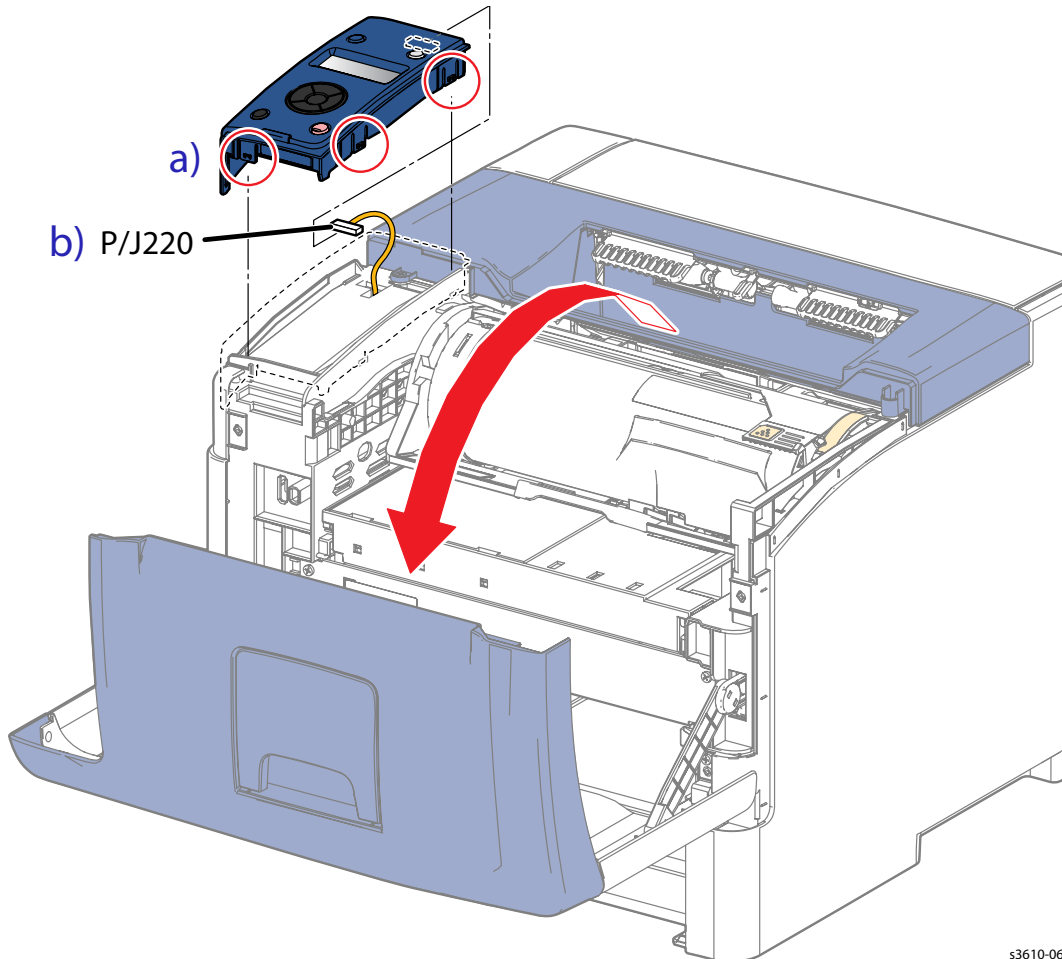

s3610-062

Figure 1

Replacement

1. Replace in reverse order.

REP 1.2 Front Cover Assembly (3610 / 3615)

PL 1.1 Covers (3610)

Removal

1. Remove the Bypass Tray. (Figure 1)

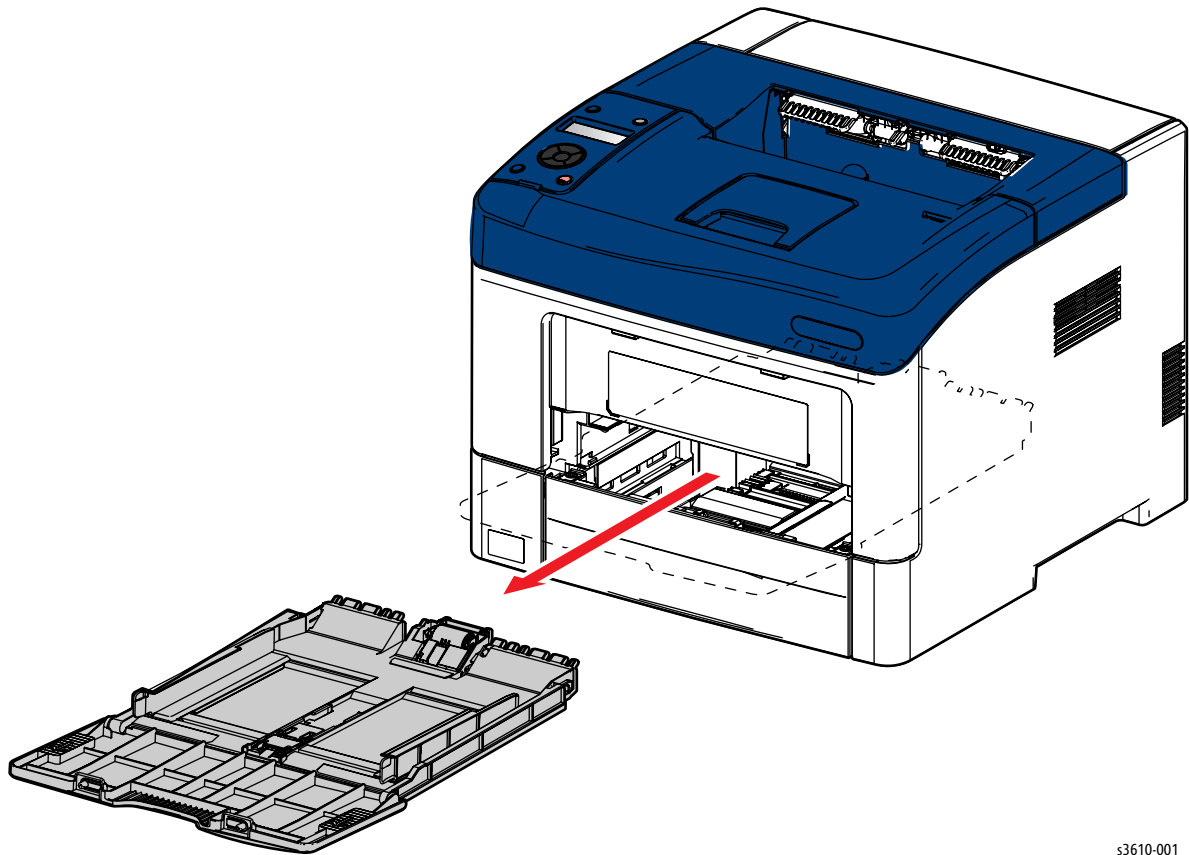

s3610-001

Figure 1

2. Remove the Front Cover Assembly. (Figure 2)
 - a. Open the Front Cover Assembly.
 - b. Release 2 clips from the cover links.
 - c. Release 2 bosses to remove the cover. Release the right side first and move the cover to the right.

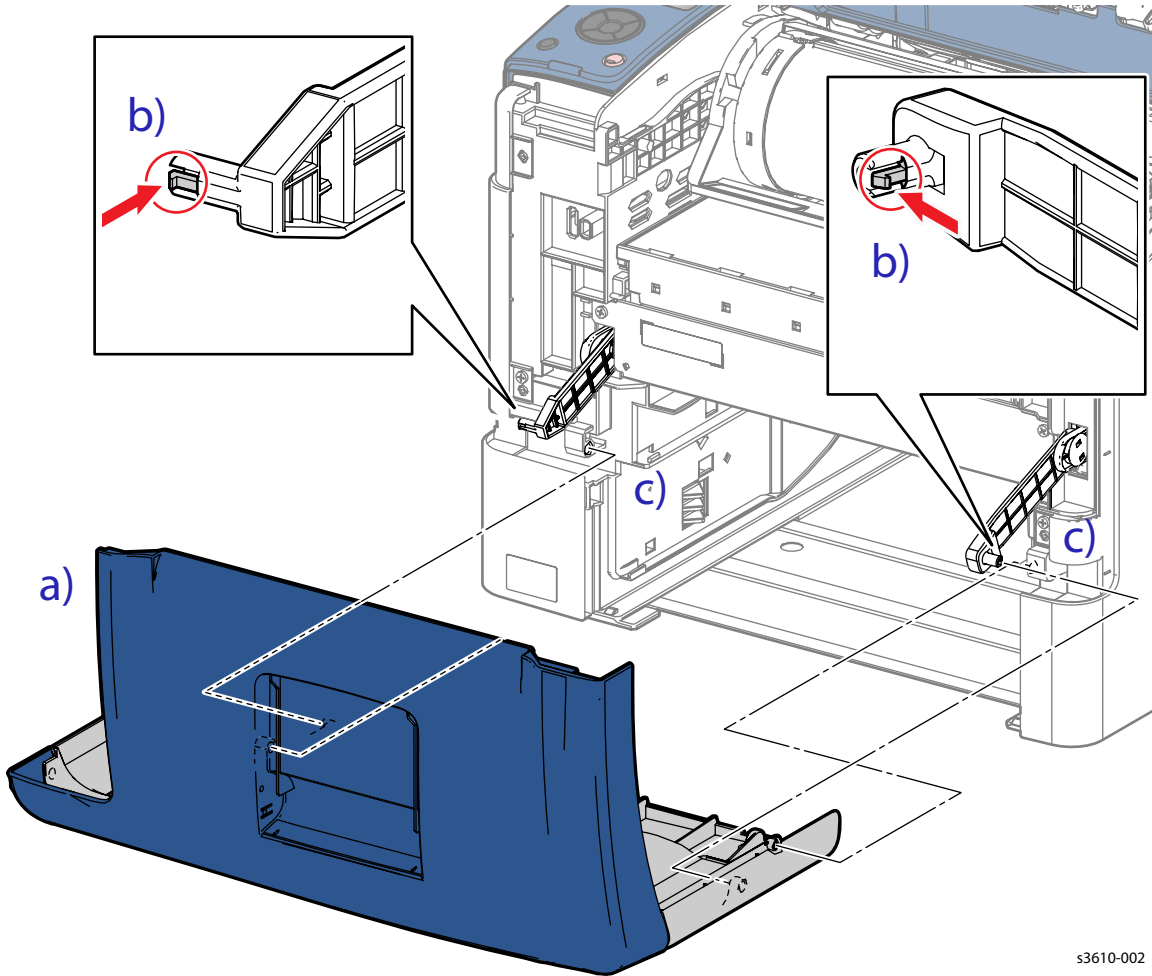

s3610-002

Figure 2

3. If necessary, separate the Front Cover Assembly components; (Figure 3)
 - a. Remove 2 screws (silver, tapping, 8mm).
 - b. Release 2 bosses.

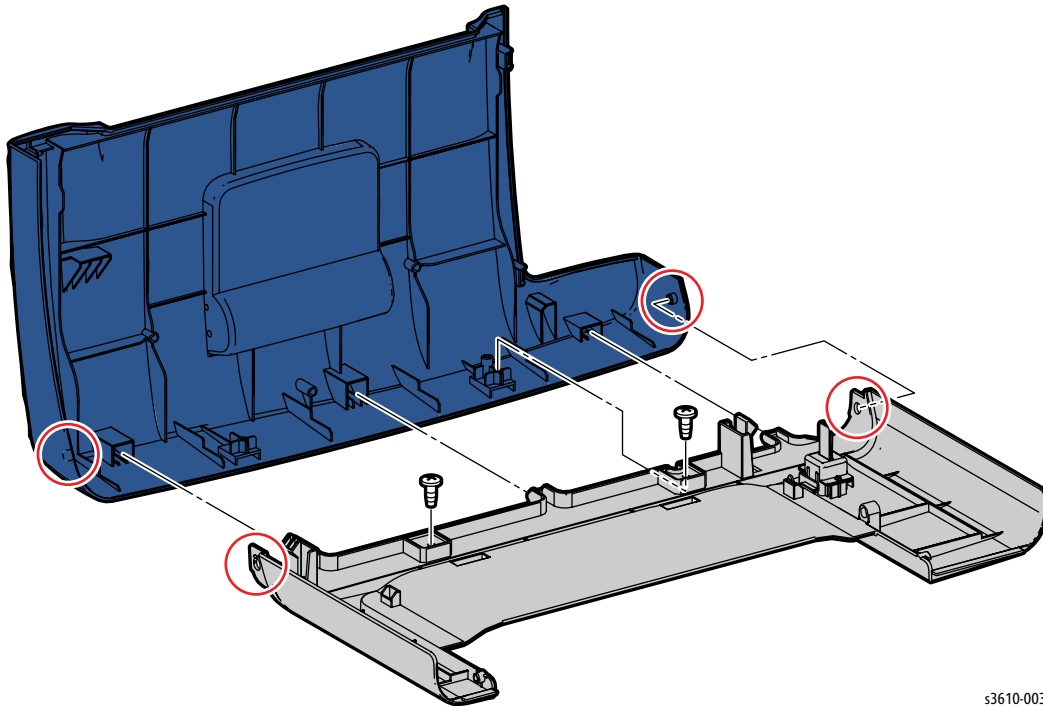

s3610-003

Figure 3

Replacement

1. Replace in reverse order.

REP 1.3 Top Front Cover (3610)

PL 1.1 Covers (3610)

Removal

1. Remove the Bypass Tray.
2. Remove the Cover Extension by flexing the extension to release the bosses. (Figure 1)

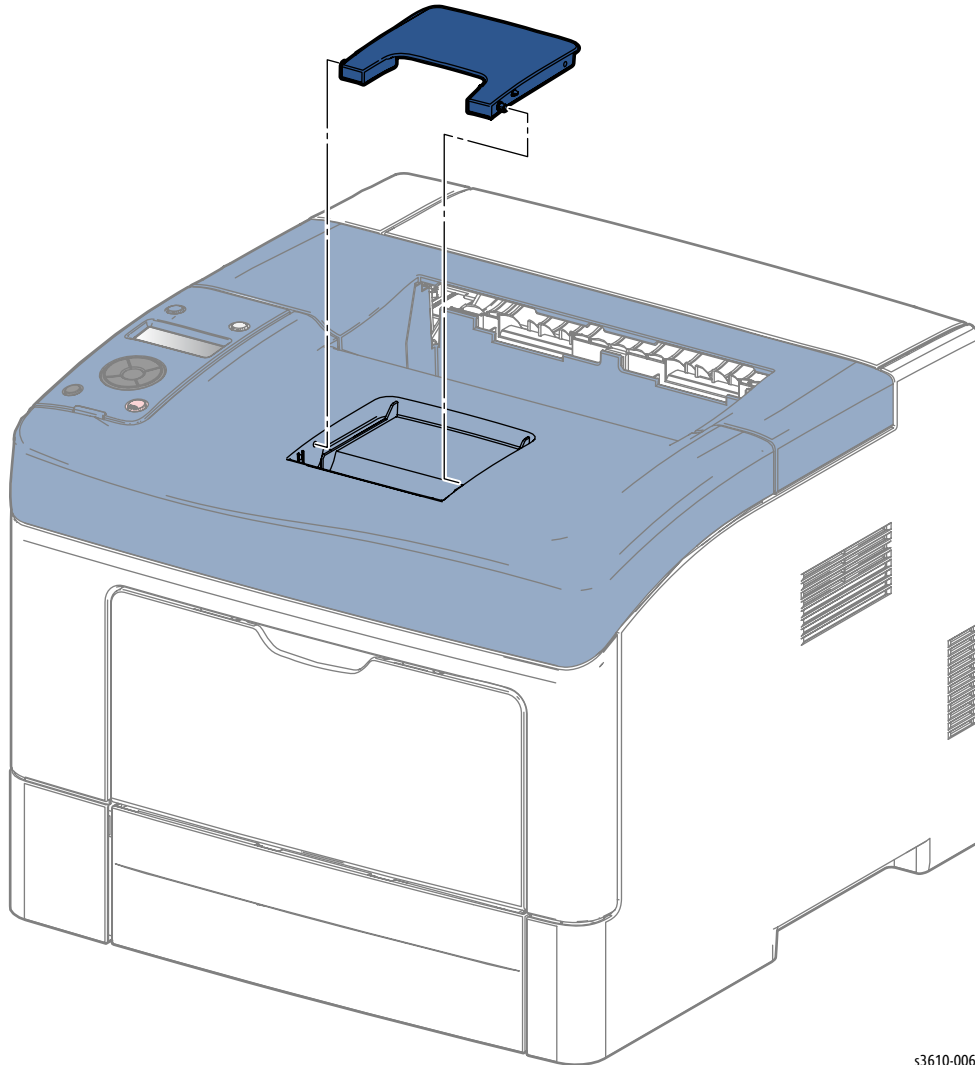
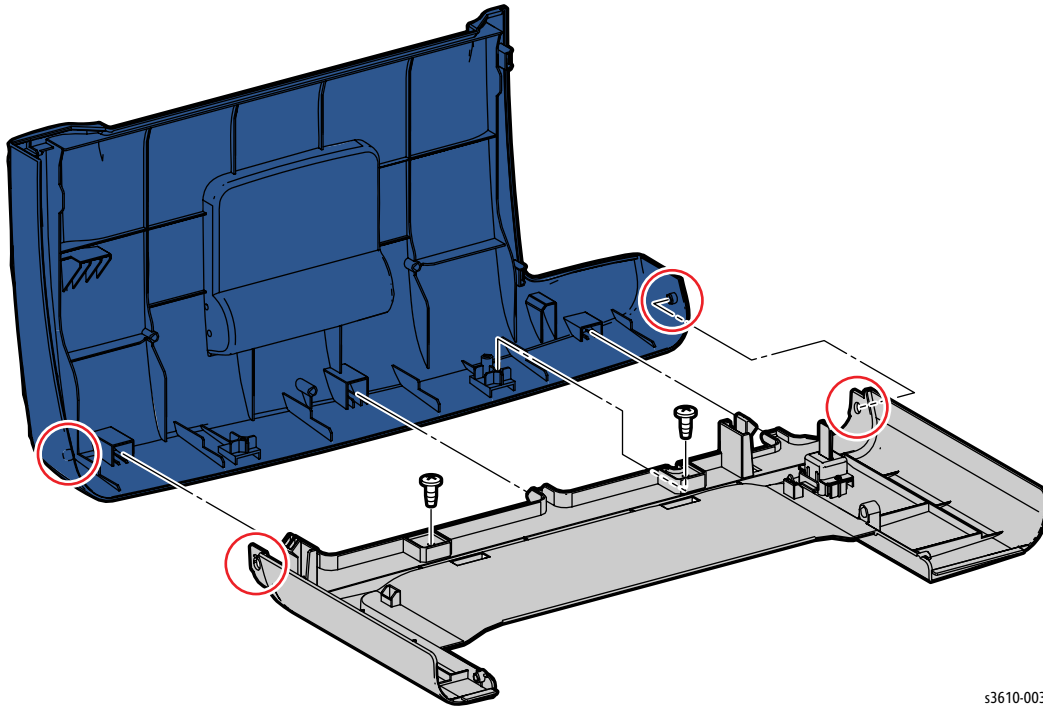

Figure 1

s3610-006

3. Remove (REP 1.2 Front Cover Assembly (3610 / 3615)).
4. To separate the Front Cover Assembly components; (Figure 2)
 - a. Remove 2 screws (silver, tapping, 8mm).
 - b. Release 2 bosses.



s3610-003

Figure 2

Replacement

1. Replace in reverse order.
2. Install the Cover Extension on the replacement Top Front Cover.

REP 1.4 Top Cover Assembly (3610)

Removal

! **WARNING:** Allow the Fusing Assembly to cool before servicing the product.

1. Open the Front Cover.
2. Open the Rear Cover.
3. Remove (REP 1.1 Control Panel (3610))
4. Remove the Top Cover Assembly. (Figure 1)
 - a. Remove 2 screws (silver, tapping, 8mm).
 - b. Slide the cover to the front of the unit as you lift the cover, making sure not to damage the actuator, which is located on the under side of the assembly.

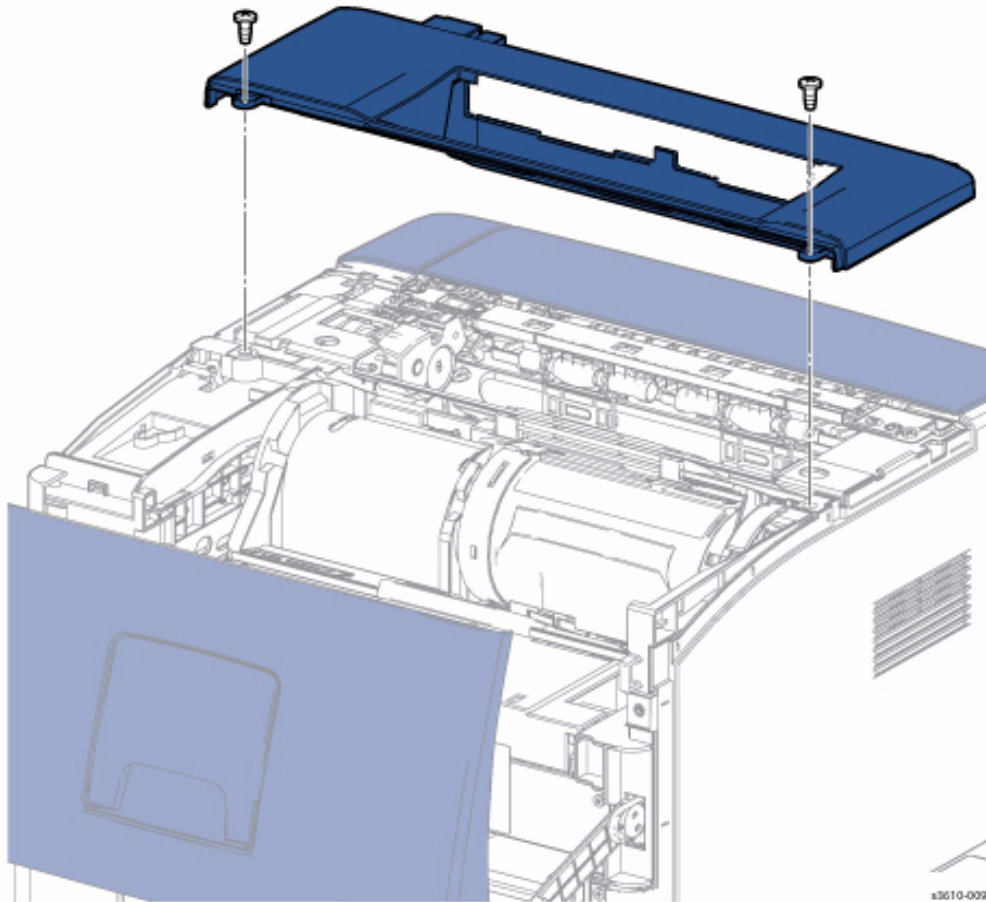

Figure 1

Replacement

1. Hold the actuator so it will fit through the slot as you position the cover for replacement.
2. Replace in reverse order.

REP 1.5 Rear Cover Assembly

Removal

! **WARNING:** Allow the Fusing Assembly to cool before servicing the product.

1. Open the Rear Cover.
2. Remove the Rear Cover Assembly. (Figure 1)
 - a. Release 1 clip to remove the connector cover.
 - b. Disconnect P/J2401.
 - c. Release the Stopper Strap from the chassis.
 - d. Lift up to release 1 hinge hook.
 - e. Release the boss on the left side to remove the cover. The ground spring should release from the chassis hook as you remove the cover.

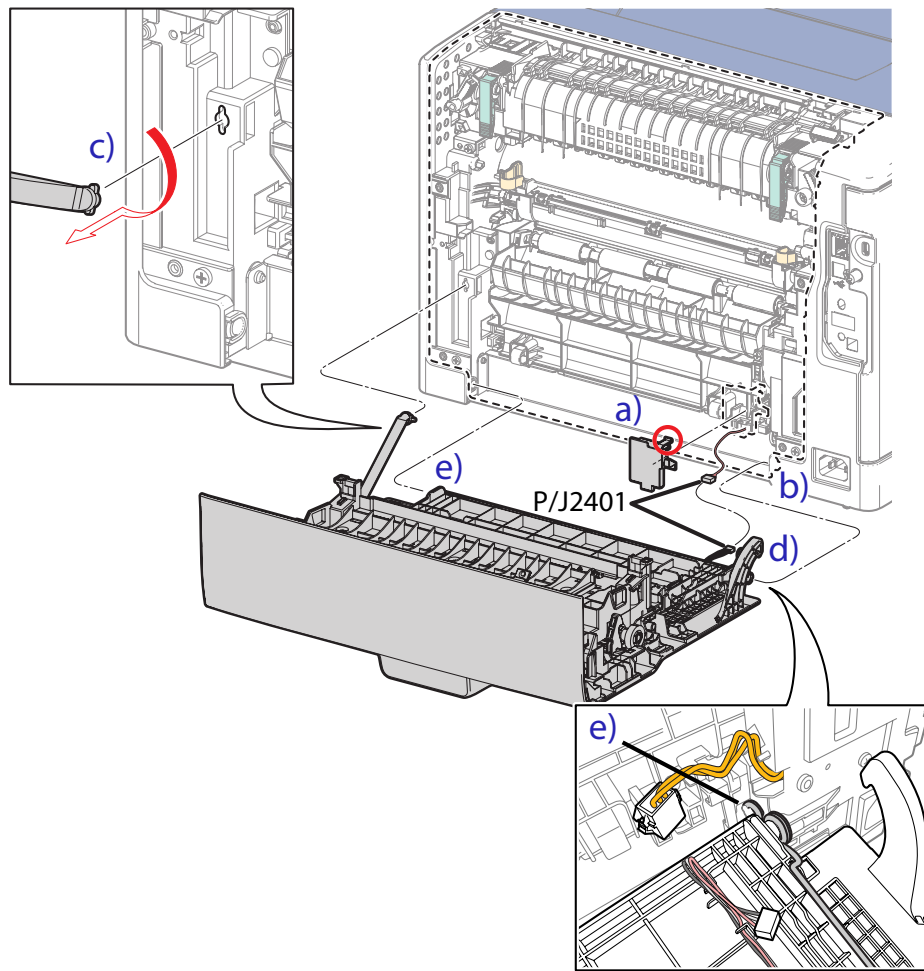

s3610-011

Figure 1

3. If installing a new Rear Cover Assembly, transfer the Transfer Roller Assembly from the old Assembly.

Replacement

1. Re-install the cover assembly. (Figure 2)
 - a. Connect P/J 2401
 - b. Install the boss on the right side of the cover, and make sure the ground spring engages the hook on the chassis.

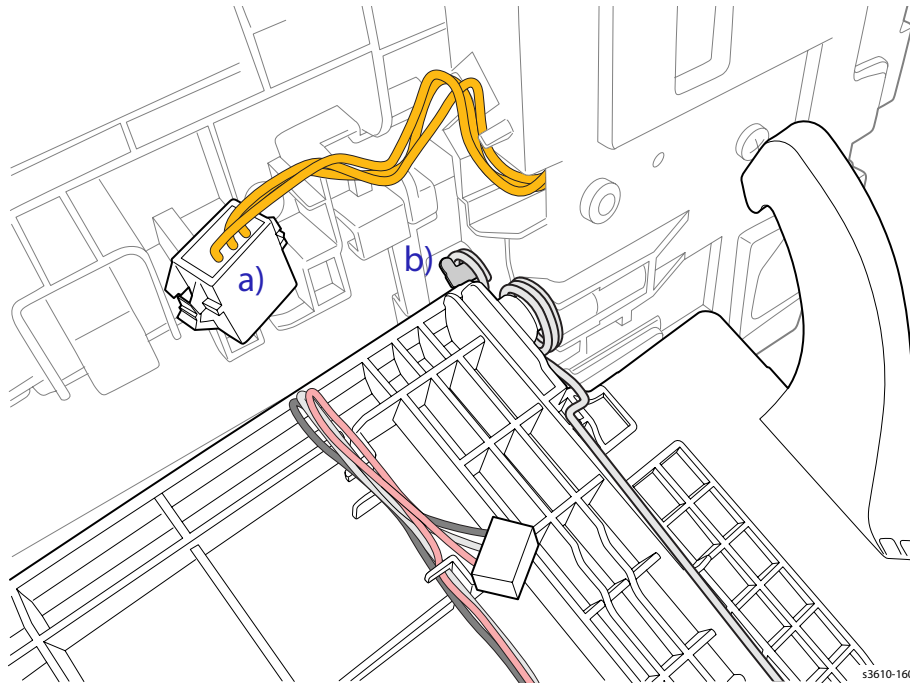

Figure 2

2. Re-engage the left side boss.
3. Replace in reverse order.

REP 1.6 Right Side Cover (3610)

Removal

! **WARNING:** Allow the Fusing Assembly to cool before servicing the product.

1. Remove (REP 1.4 Top Cover Assembly (3610)).
2. Remove the Right Side Cover.
 - a. Remove 2 screws (silver, tapping, 8mm).
 - b. Release 5 bosses.
 - c. Release 3 clips that secure the Right Side Cover to the chassis.

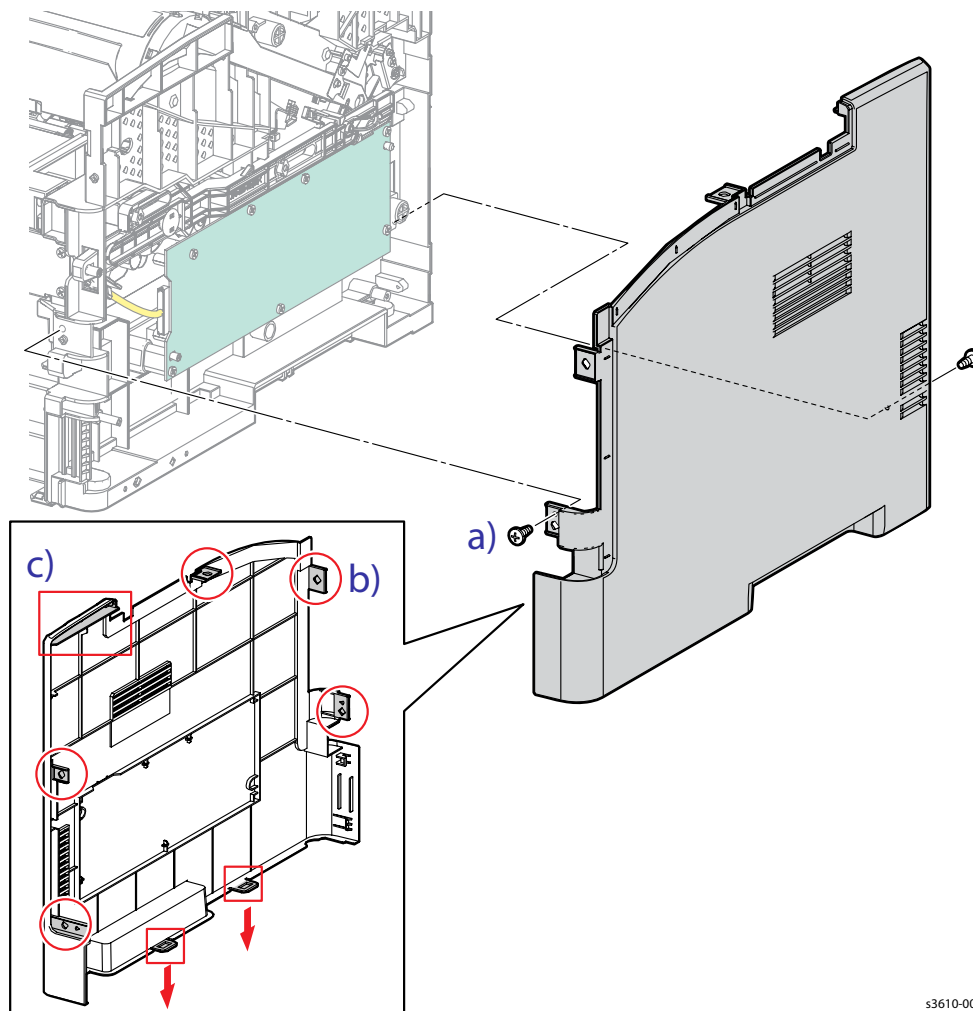

Figure 1

s3610-008

Replacement

1. Secure the clips on the bottom of the cover first, before engaging the remaining clips and bosses.
2. Replace in reverse order.

REP 1.7 Left Side Cover (3610)

PL 1.1 Covers (3610)

Removal

! **WARNING:** Allow the Fusing Assembly to cool before servicing the product.

1. Remove (REP 1.4 Top Cover Assembly (3610)).
2. Release the thumb screw to remove the ESS PWB Cover from the left side of the machine.
3. Remove the Left Side Cover. (Figure 1)
 - a. Remove 1 screw (silver, tapping, 8mm).
 - b. Release 4 bosses.
 - c. Release 3 clips that secure the cover to the chassis.
 - d. Release the fan cable tie, disconnect P/J241 from the LVPS.
 - e. Remove the cover.

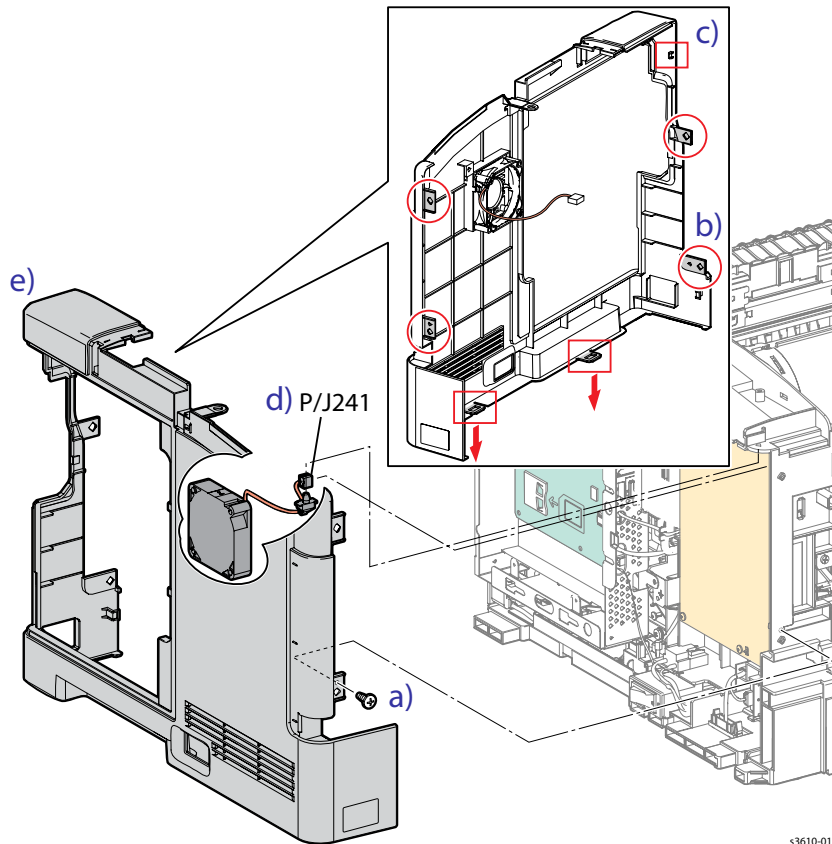

Figure 1

s3610-010

Replacement

1. Connect P/J 241 and re-install the cable tie.
2. Secure the clips on the bottom of the cover first, before engaging the remaining clips and bosses.
3. Replace in reverse order.

REP 1.8 Lower Rear Cover (3610)

PL 1.1 Covers (3610)

Removal

1. Remove (REP 1.7 Left Side Cover (3610)).
2. Remove (REP 1.6 Right Side Cover (3610)).
3. Close the Rear Cover.
4. Remove the Lower Rear Cover. (Figure 1)
 - a. Release the boss at each end of the cover.
 - b. Slide the cover to the left to release 3 clips that secure the cover to the chassis.
 - c. Remove the cover.

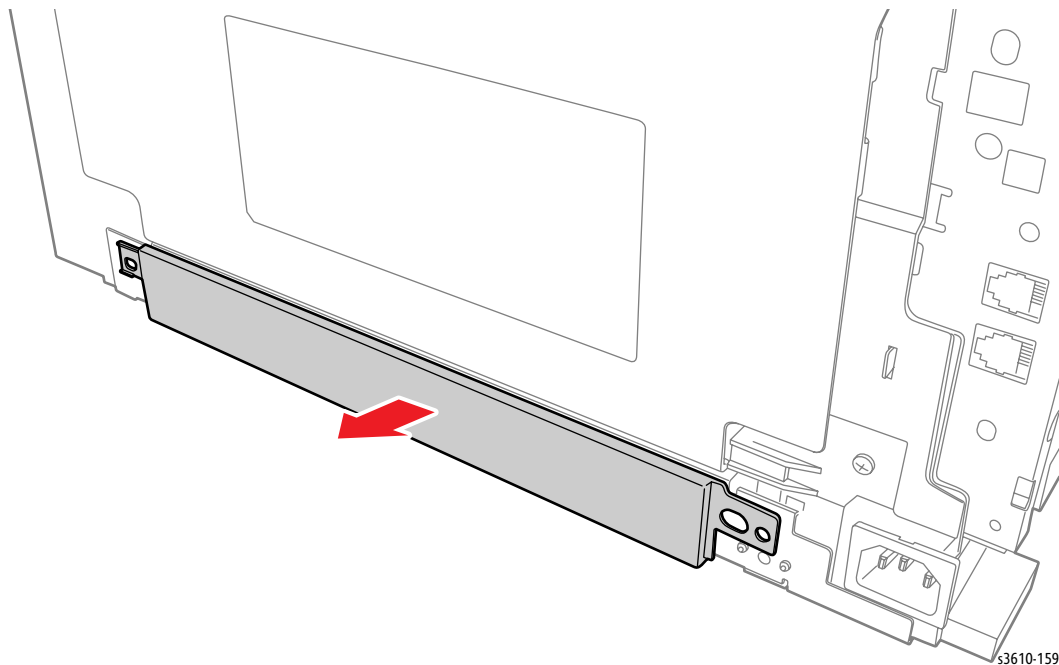

Figure 1

Replacement

1. Replace in reverse order.

REP 1.9 IIT Left Side Cover

PL 1.5 Control Panel (3615)

Removal

1. Remove the Lower rear Cover. (Figure 1)
 - a. Open the IIT Assembly.
 - b. Pry the IIT Left Side Cover from the right and pull straight up to remove.

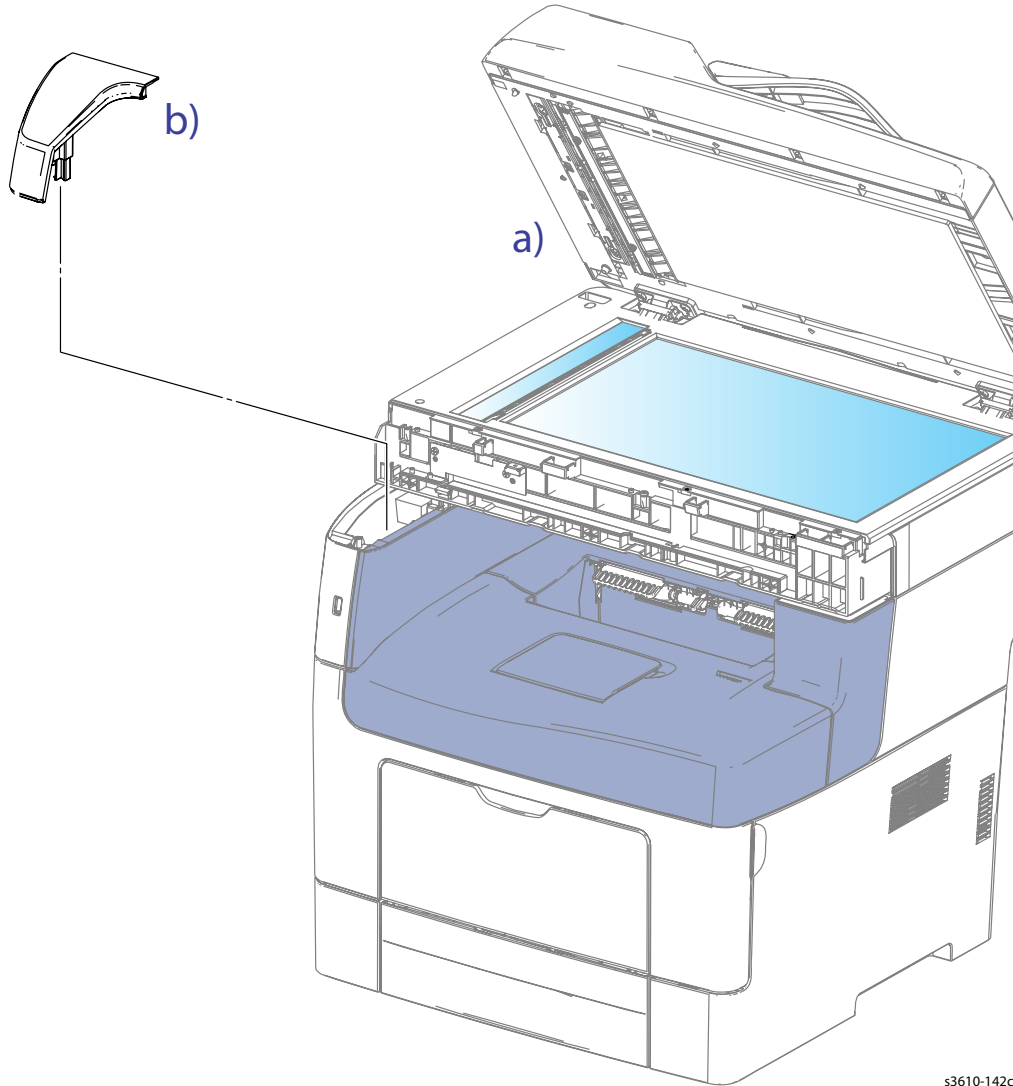

s3610-142c

Figure 1

Replacement

1. Replace in reverse order.

REP 1.10 IIT Front Top Cover

PL 1.5 Control Panel (3615)

Removal

1. Remove (REP 1.9 IIT Left Side Cover).
2. Remove the IIT Front Cover. (Figure 1)
 - a. Release the tab on the left side of the cover.
 - b. Slide the cover to the left and remove.

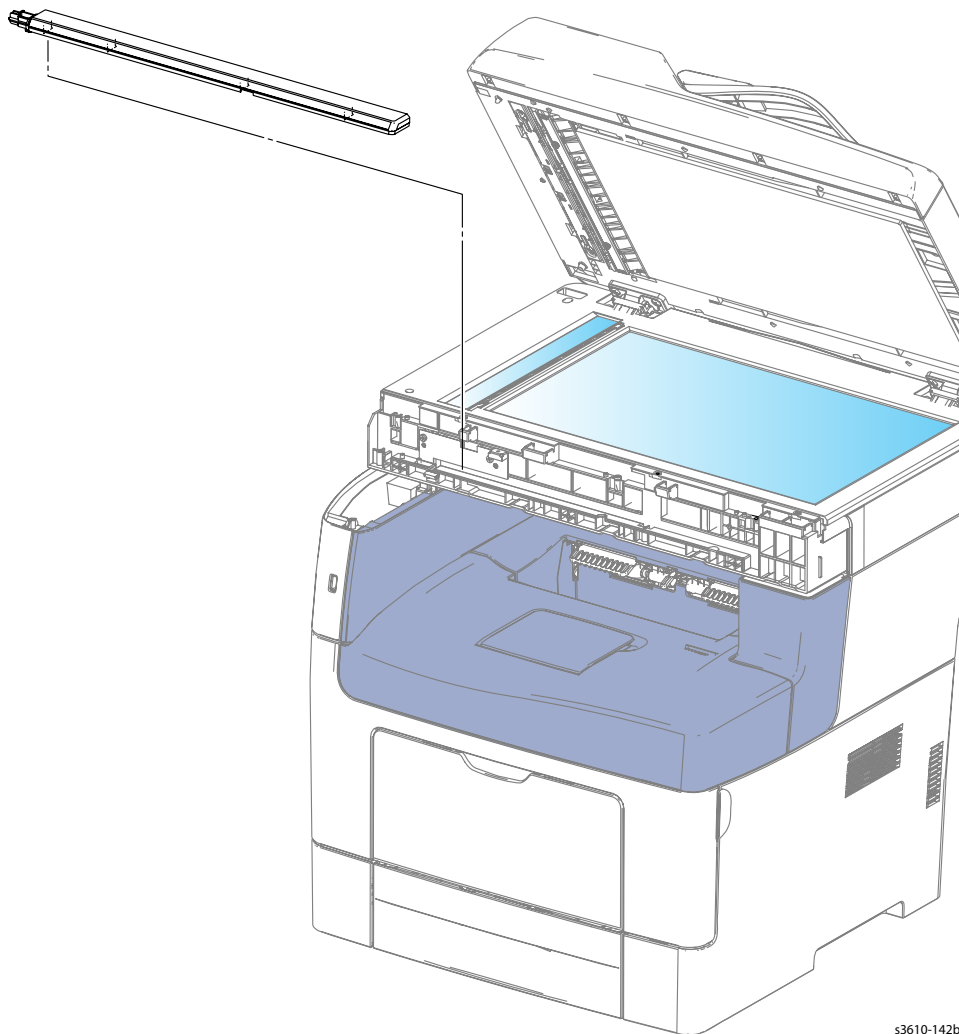

s3610-142b

Figure 1

Replacement

1. Replace in reverse order.

REP 1.11 IIT Front Bottom Cover

PL 1.5 Control Panel (3615)

Removal

1. Remove (REP 6.1 IIT Assembly).
2. Remove the IIT Front Bottom Cover. (Figure 1)
 - a. Remove 1 screw (silver, tapping, 8mm).
 - b. Release the boss on the top of the cover.
 - c. Turn the IIT Assembly over and pry off the 3 clips that hold the cover to the chassis.

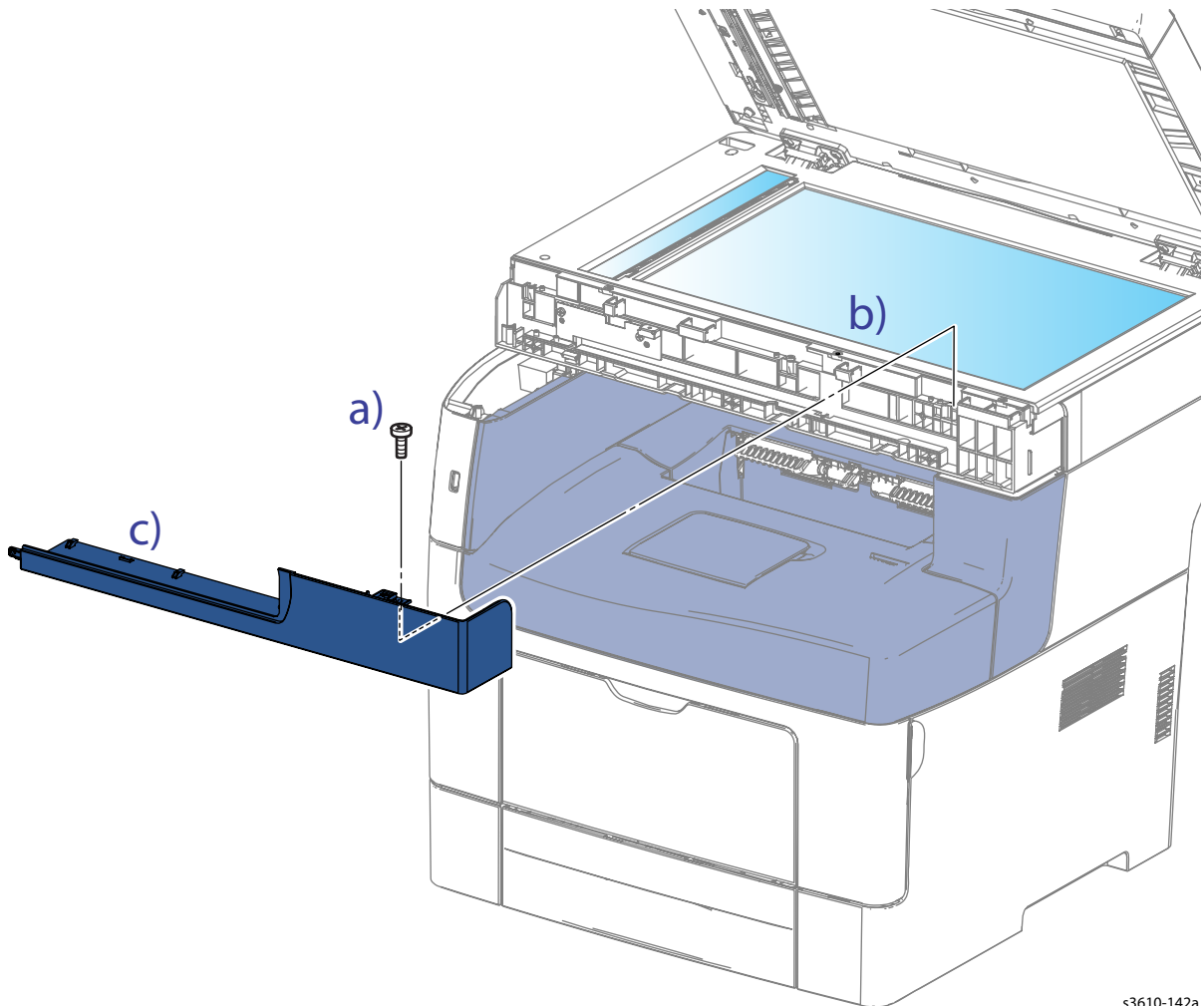

s3610-142a

Figure 1

Replacement

1. Replace in reverse order.

REP 1.12 Control Panel (3615)

PL 1.5 Control Panel (3615)

Removal

1. Remove (REP 1.16 Upper Left Side Cover (3615)).
2. Release the tab on the left side of the Front Scanner Cover, move the cover to the left and lift to remove.
3. Disconnect P/J830 from the Front USB PWB. (Figure 1)
 - a. Disconnect P/J 830
 - b. Release the wire harness from the clips and gently pull the harness up through the access hole in the chassis.

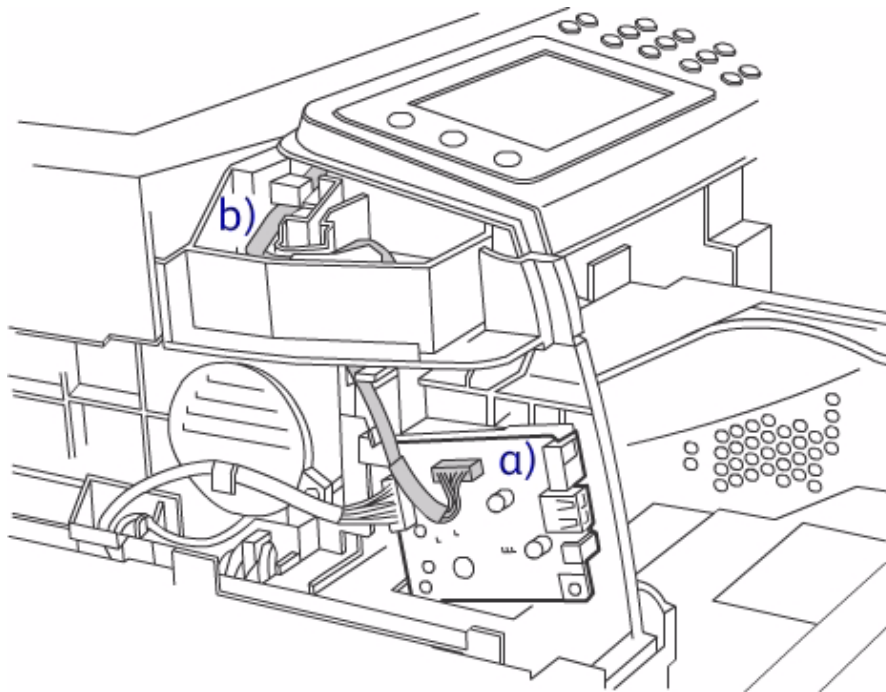

Figure 1

4. Remove the Control Panel (Control Panel). (Figure 2)
 - a. Remove 4 screws (silver, tapping, 8mm).
 - b. Remove 1 screw (silver, M6) screws.
 - c. Lift up on the Control Panel to remove.

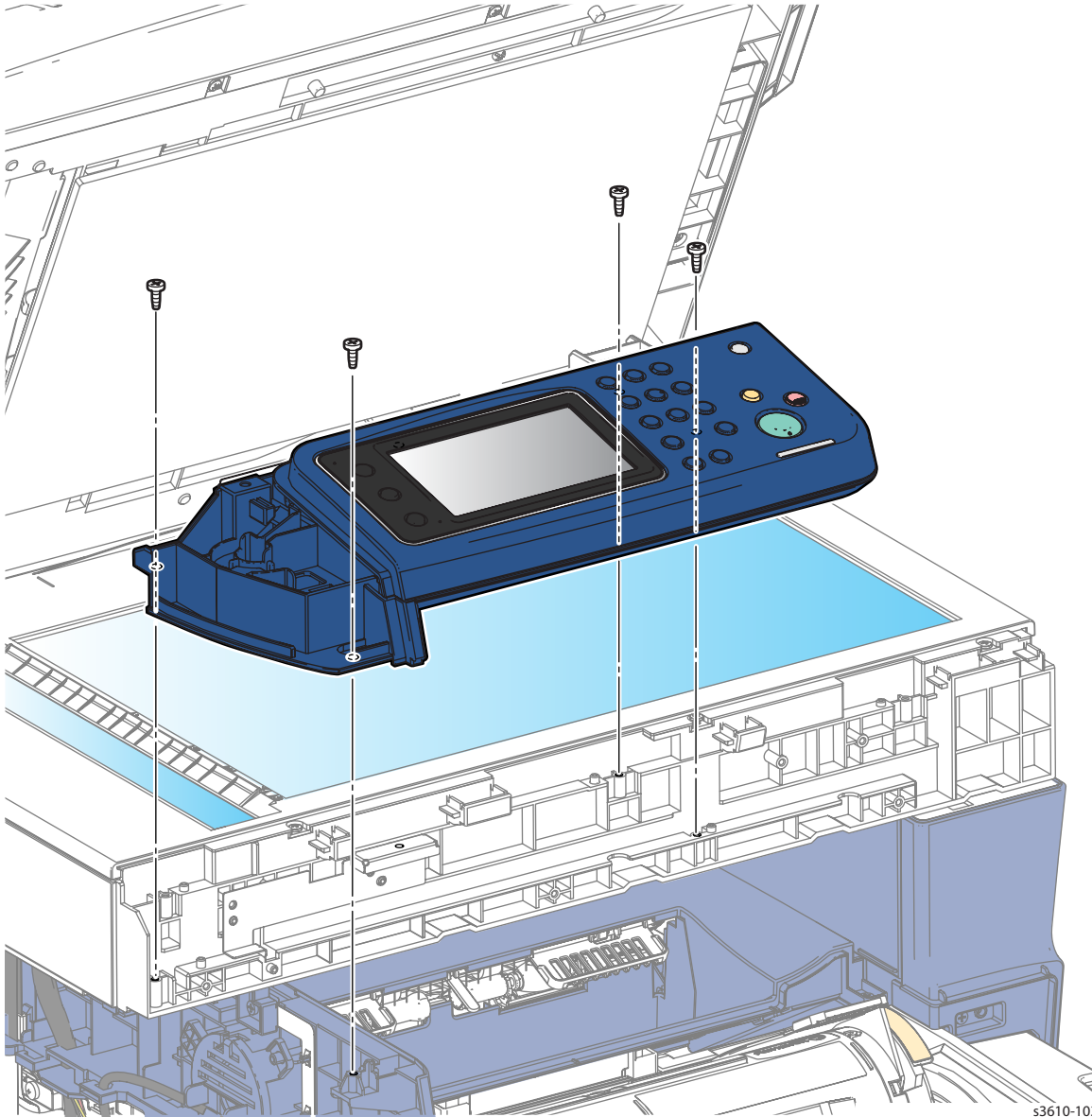

Figure 2

s3610-103

Replacement

1. Replace in reverse order.

REP 1.13 Right Side Cover (3615)

PL 1.2 Covers (3615)

Removal



WARNING: Allow the Fusing Assembly to cool before servicing the product.

1. Remove the Bypass Tray.
2. Remove Tray 1.
3. Remove ([REP 1.2 Front Cover Assembly \(3610 / 3615\)](#)).
4. Open the Rear Cover, release the stopper strap and hinge clip from the chassis and rest the Rear Cover Assembly on the work surface.
5. Remove the IIT Lower Right Cover. (Figure 1)
 - a. Remove 1 screw (silver, tapping, 8mm).
 - b. Release 1 clip from the top of the cover.

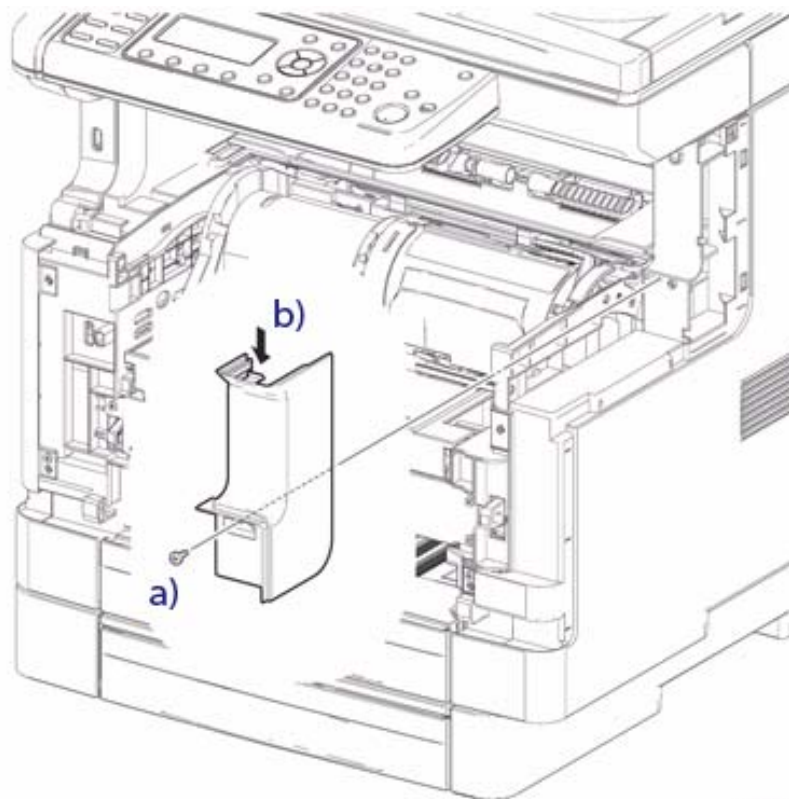

41906A

Figure 1

6. Remove the Right Side Cover. (Figure 2)
 - a. Remove 3 screws (silver, tapping, 8mm).
 - b. Release 4 bosses.
 - c. Release 3 clips.

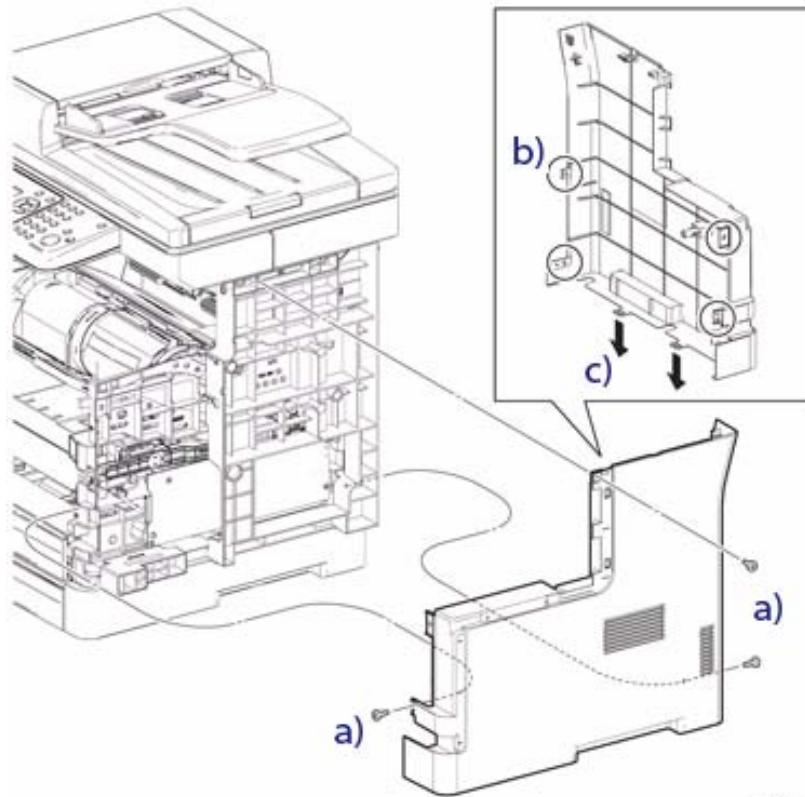

Figure 2

Replacement

1. Secure the clips on the bottom of the cover first, before engaging the bosses.
2. Replace in reverse order.

REP 1.14 Right Inner Cover (3615)

PL 1.2 Covers (3615)

Removal

! **WARNING:** Allow the Fusing Assembly to cool before servicing the product.

1. Remove (REP 1.13 Right Side Cover (3615)).
2. Release the clip to remove the Right Inner Cover. (Figure 1)

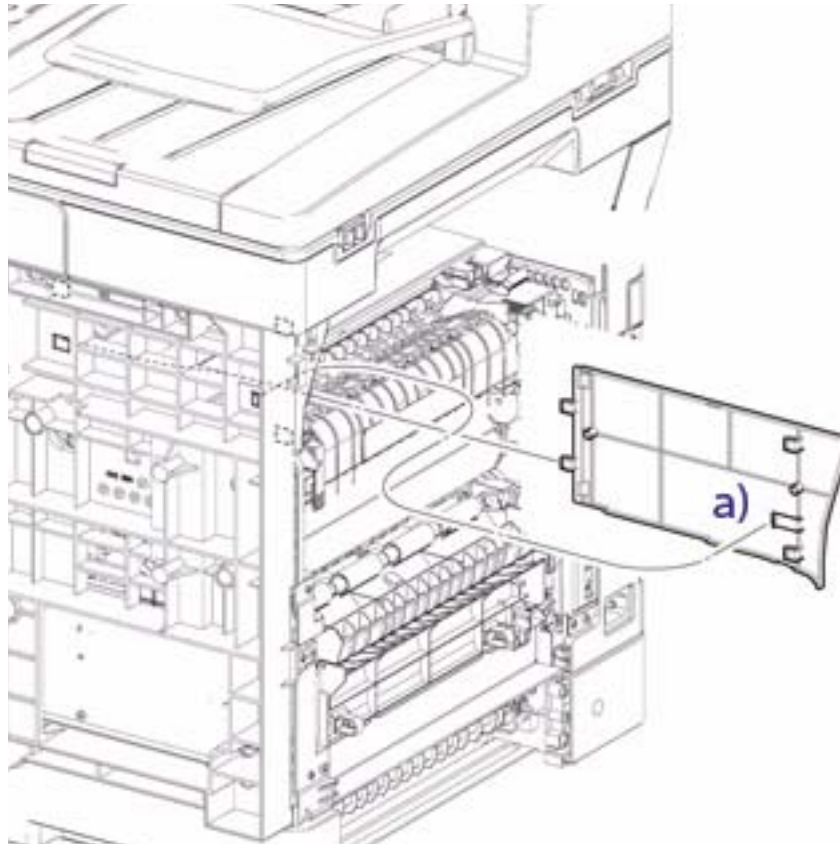

Figure 1

Replacement

1. Replace in reverse order.

REP 1.15 Top Cover Assembly (3615)

PL 1.2 Covers (3615)

Removal

! **WARNING:** Allow the Fusing Assembly to cool before servicing the product.

1. Remove (REP 1.14 Right Inner Cover (3615)).
2. Remove 2 screws (silver, tapping, 8mm) to remove the Top Cover Assembly. (Figure 1)

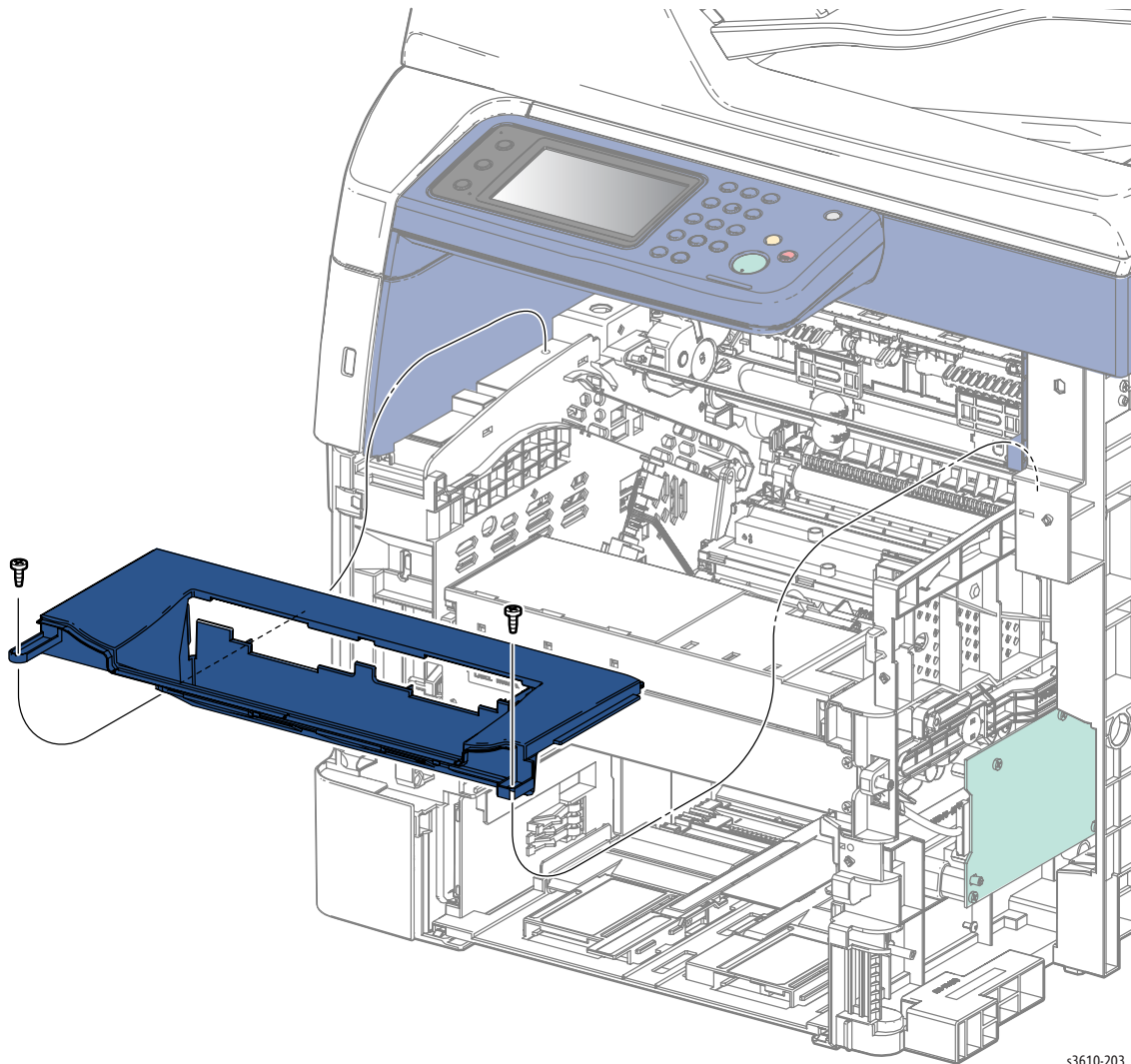

Figure 1

Replacement

1. Hold the actuator so it will fit through the slot as you position the cover for replacement.
2. Replace in reverse order.

REP 1.16 Upper Left Side Cover (3615)

PL 1.2 Covers (3615)

Removal

1. Remove (REP 1.9 IIT Left Side Cover).
2. Remove the Upper Left Side Cover. (Figure 1)
 - a. Starting at the front side of the cover, pry the cover off from the top 3 tabs
 - b. Gently flex the cover and lift to remove.

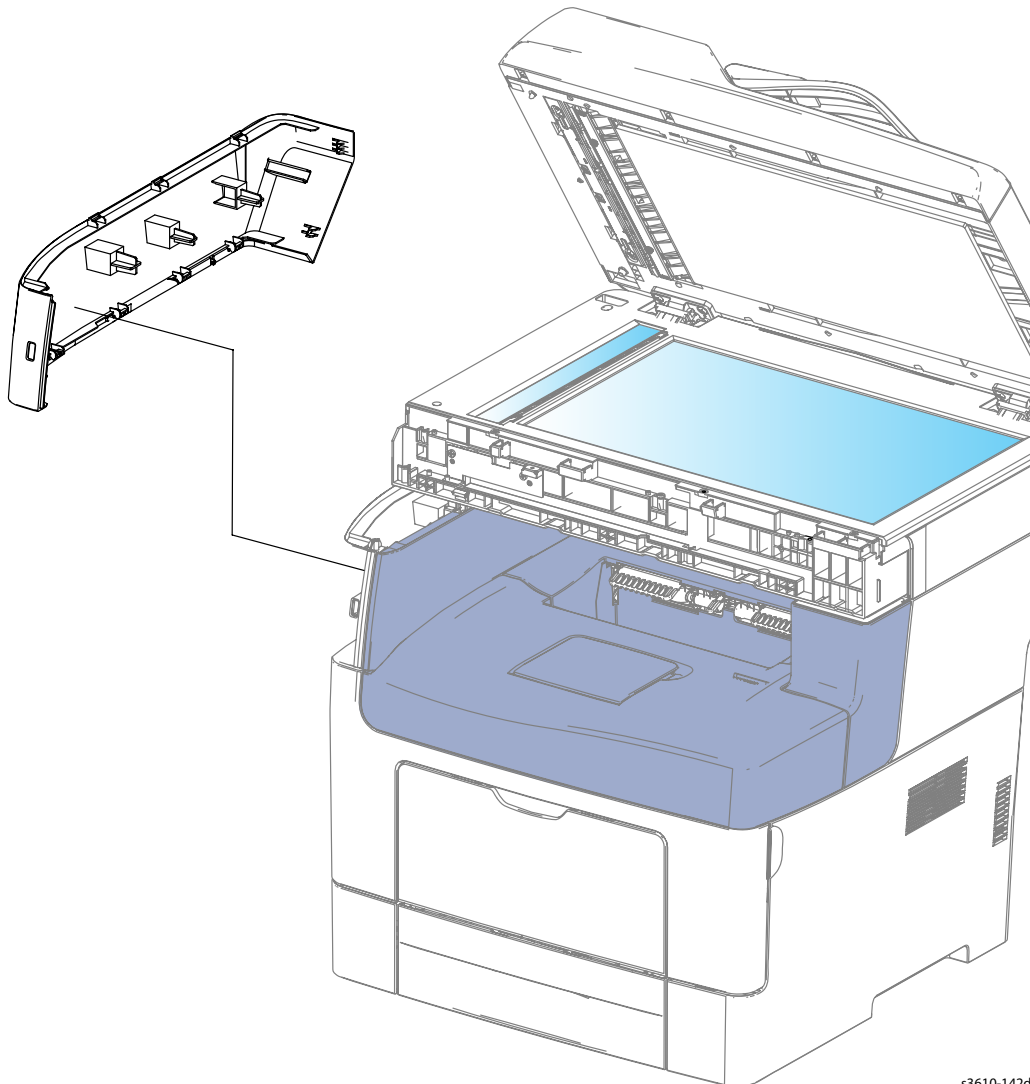

s3610-142d

Figure 1

Replacement

1. Replace in reverse order.

REP 1.17 Lower Left Side Cover (3615)

PL 1.2 Covers (3615)

Removal

! **WARNING:** Allow the Fusing Assembly to cool before servicing the product.

1. Remove (REP 1.16 Upper Left Side Cover (3615)).
2. Remove the ESS Cover.
3. Remove the Lower Left Side Cover. (Figure 1)
 - a. Remove 4 screws (silver, tapping, 8mm).
 - b. Release 4 bosses and 2 clips.
 - c. Disconnect P/J241.
 - d. Release the cable tie.
 - e. Remove the cover.

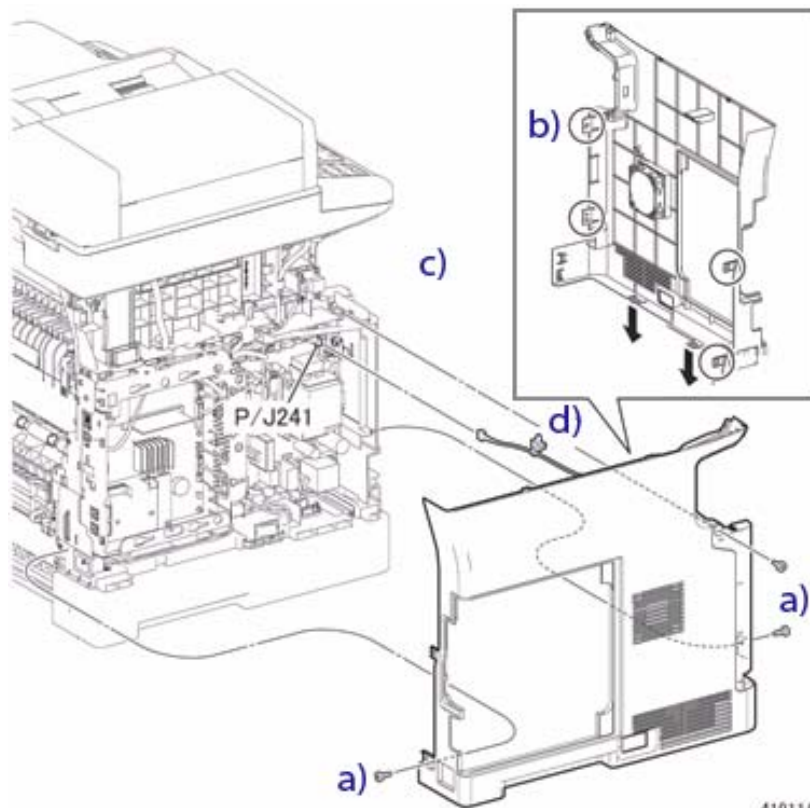

Figure 1

Replacement

1. Secure the clips on the bottom of the cover first, before engaging the bosses.
2. Replace in reverse order.

REP 1.18 Lower Rear Cover (3615)

PL 1.2 Covers (3615)

Removal

1. Remove (REP 1.17 Lower Left Side Cover (3615)).
2. Remove (REP 1.13 Right Side Cover (3615)).
3. Close the Rear Cover.
4. Remove the Lower rear Cover. (Figure 1)
 - a. Release the boss at each end of the cover.
 - b. Slide the cover to the left to release 3 clips that secure the cover to the chassis.
 - c. Remove the cover.

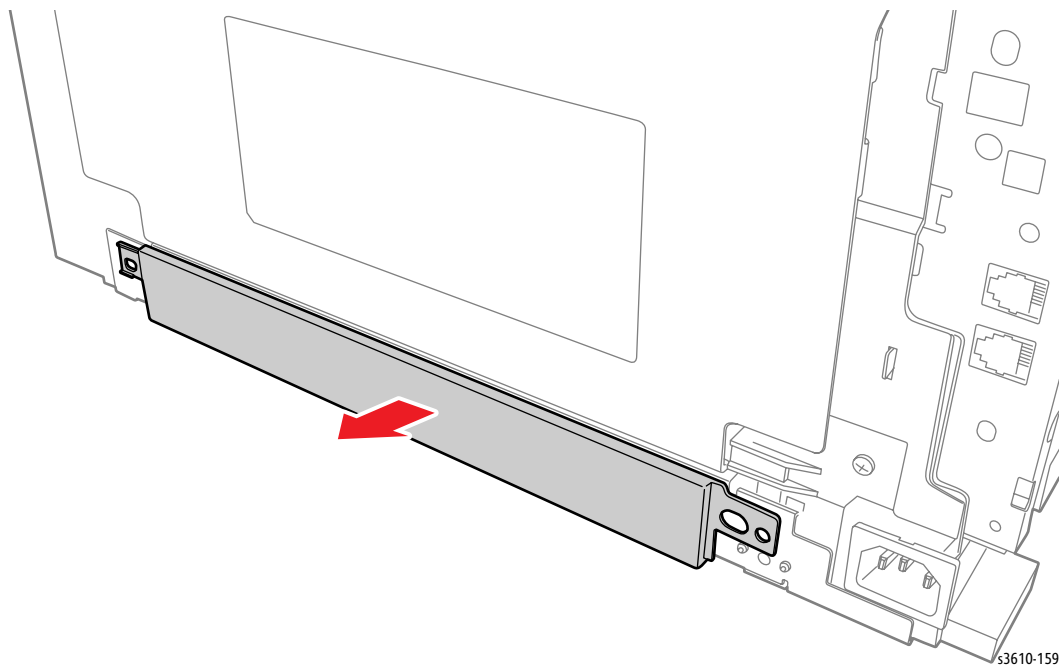

Figure 1

Replacement

1. Replace in reverse order.

Chassis Repairs

REP 2.1 Duplex Chute Assembly

PL 2.1 Registration

Removal

! **WARNING:** Allow the Fusing Assembly to cool before servicing the product.

1. Open the Rear Cover.
2. Remove ([REP 3.4 Transfer Roller Assembly](#)).
3. Remove the Duplex Chute Assembly. (Figure 1)
 - a. Remove 1 screw (silver, tapping, 4mm) that secures the grounding springs to the Rear Cover.
 - b. Release 2 clips that secure the Duplex Chute Assembly to the Rear Cover.
 - c. Rotate and slide the Duplex Chute Assembly to the left until the 4 bosses release.
 - d. Lift to remove the chute.

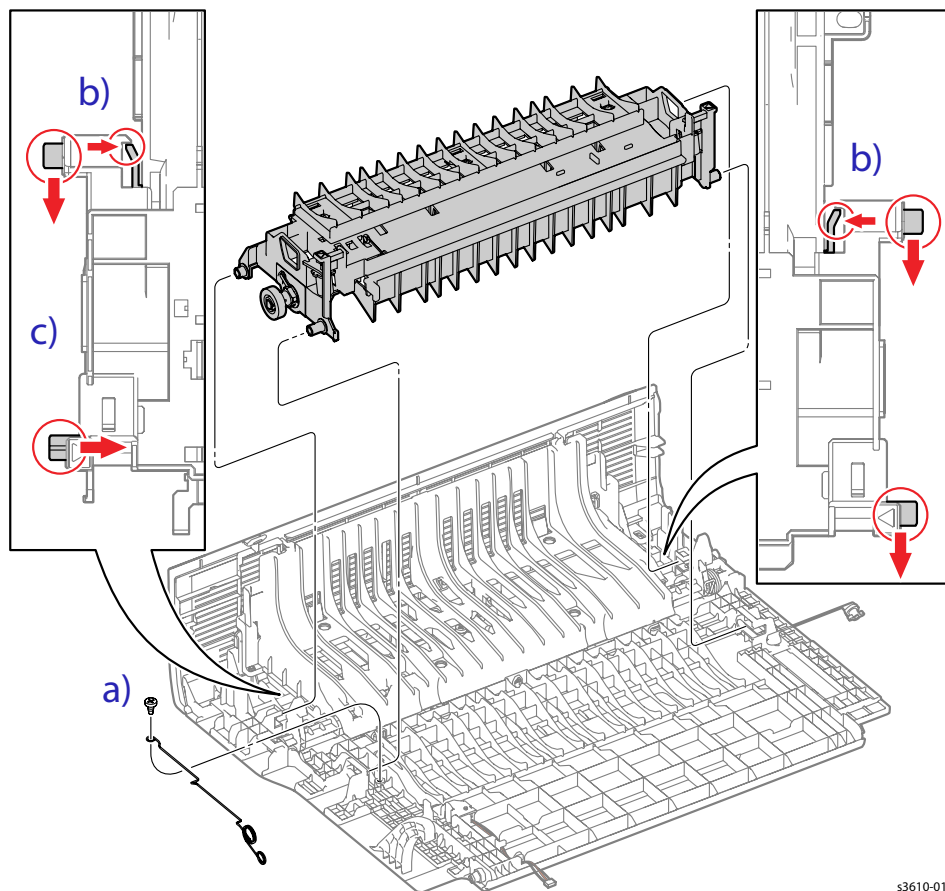
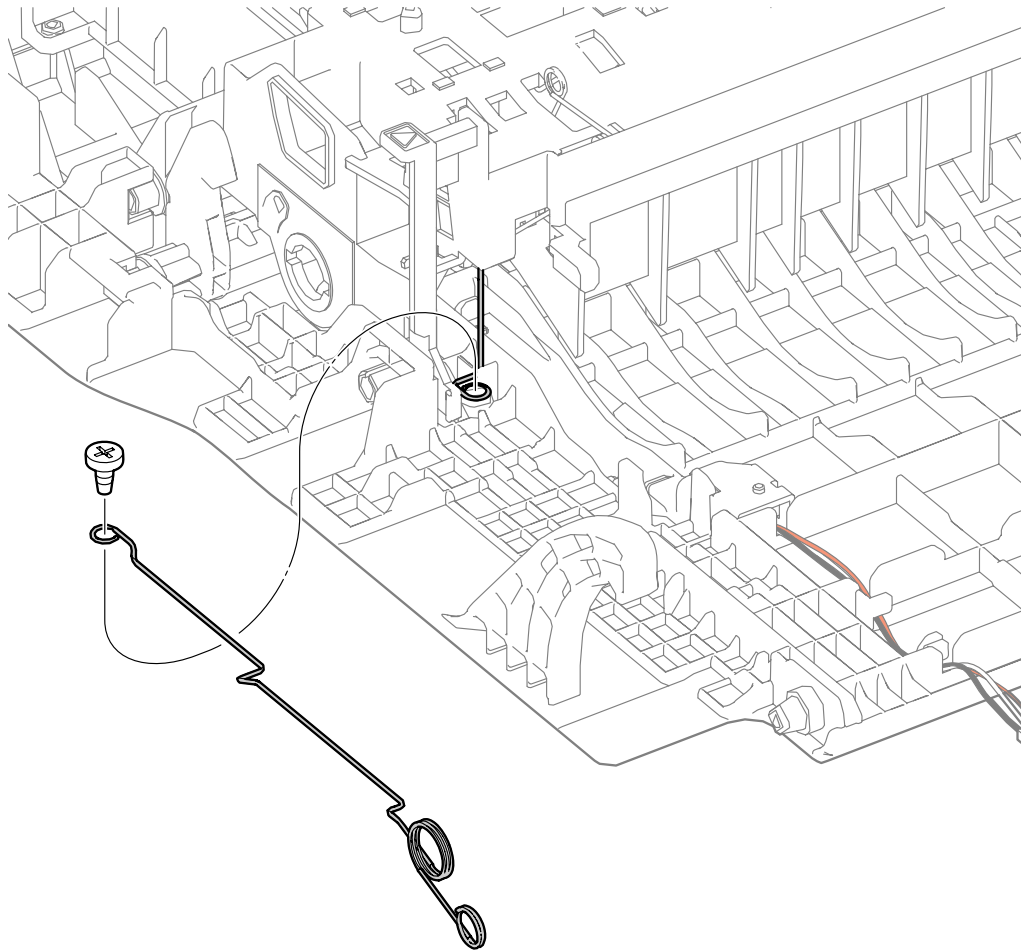

Figure 1

s3610-012

Replacement

1. Install the Duplex Chute Assembly onto the rear Cover Assembly.
2. Secure both grounding springs with the screw. (Figure 2)



s3610-013

Figure 2

3. Replace in reverse order.

REP 2.2 Transport Assembly

PL 2.4 Duplex Chute

Removal

! **WARNING:** Allow the Fusing Assembly to cool before servicing the product.

1. Remove all Trays.
2. Remove the Drum Cartridge.
3. Remove (REP 1.7 Left Side Cover (3610)) (REP 1.17 Lower Left Side Cover (3615)).
4. Remove (REP 1.6 Right Side Cover (3610)) (REP 1.14 Right Inner Cover (3615)).
5. Remove (REP 5.1 ESS PWB).
6. Remove (REP 3.5 Fusing Assembly).
7. Remove (REP 4.1 Main Drive Assembly).
8. Remove (REP 5.7 HVPS (3610)) (REP 5.8 HVPS (3615)).
9. Remove the Interlock Switch Assembly. (Figure 1)
 - a. Remove 1 screw.
 - b. Release 2 tabs on the bottom of the assembly, move to the left to remove, but do not disconnect the assembly.

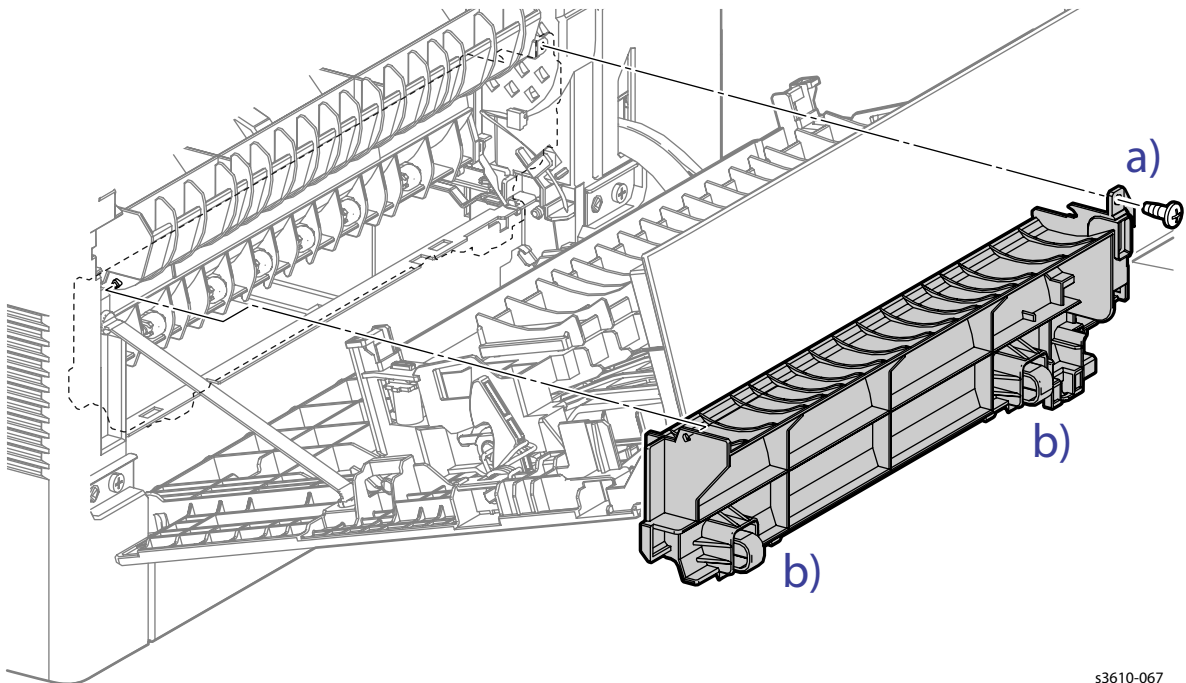

s3610-067

Figure 1

10. Prepare the MCU PWB. (Figure 2)

- a. Release 4 clips that secure the Top Frame Assembly to remove it from the chassis.
- b. Release 3 clips that secure the MCU PWB cover to remove it from the chassis.
- c. Disconnect P/J12 and P/J14 from the MCU PWB, then release the harness from the harness guide.

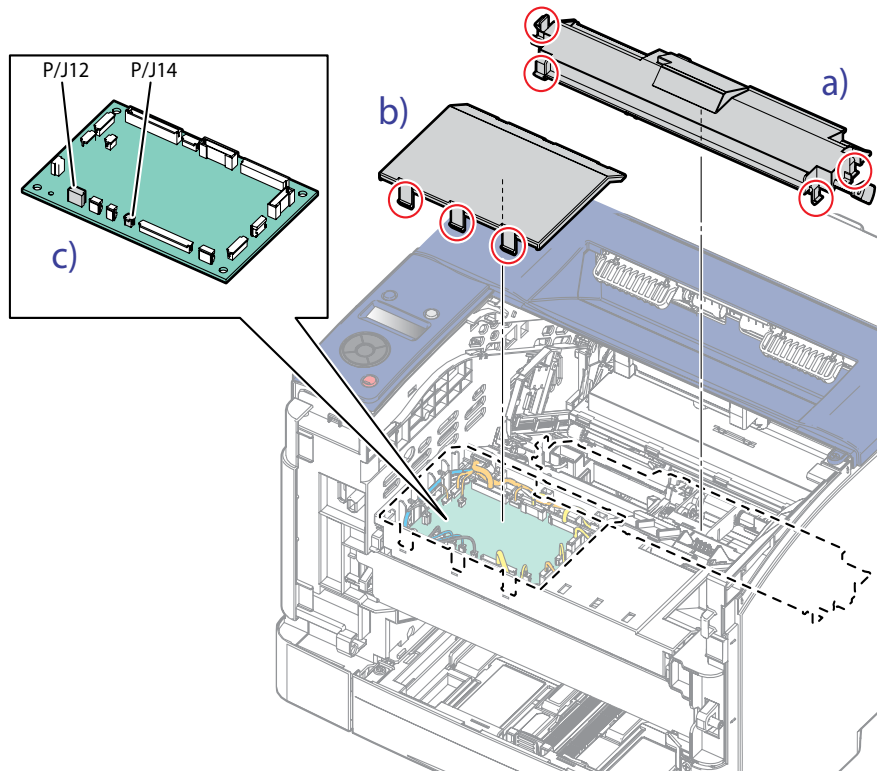

Figure 2

11. From the left side of the machine, remove the Feed Gear Segments. (Figure 3)
 - a. Remove 1 screw (silver, tapping, 8mm) that secures the Feed Solenoid, then move the solenoid away from the Feed Gear.
 - b. Remove the Feed Gear Segments MSI 1 and MSI 2.

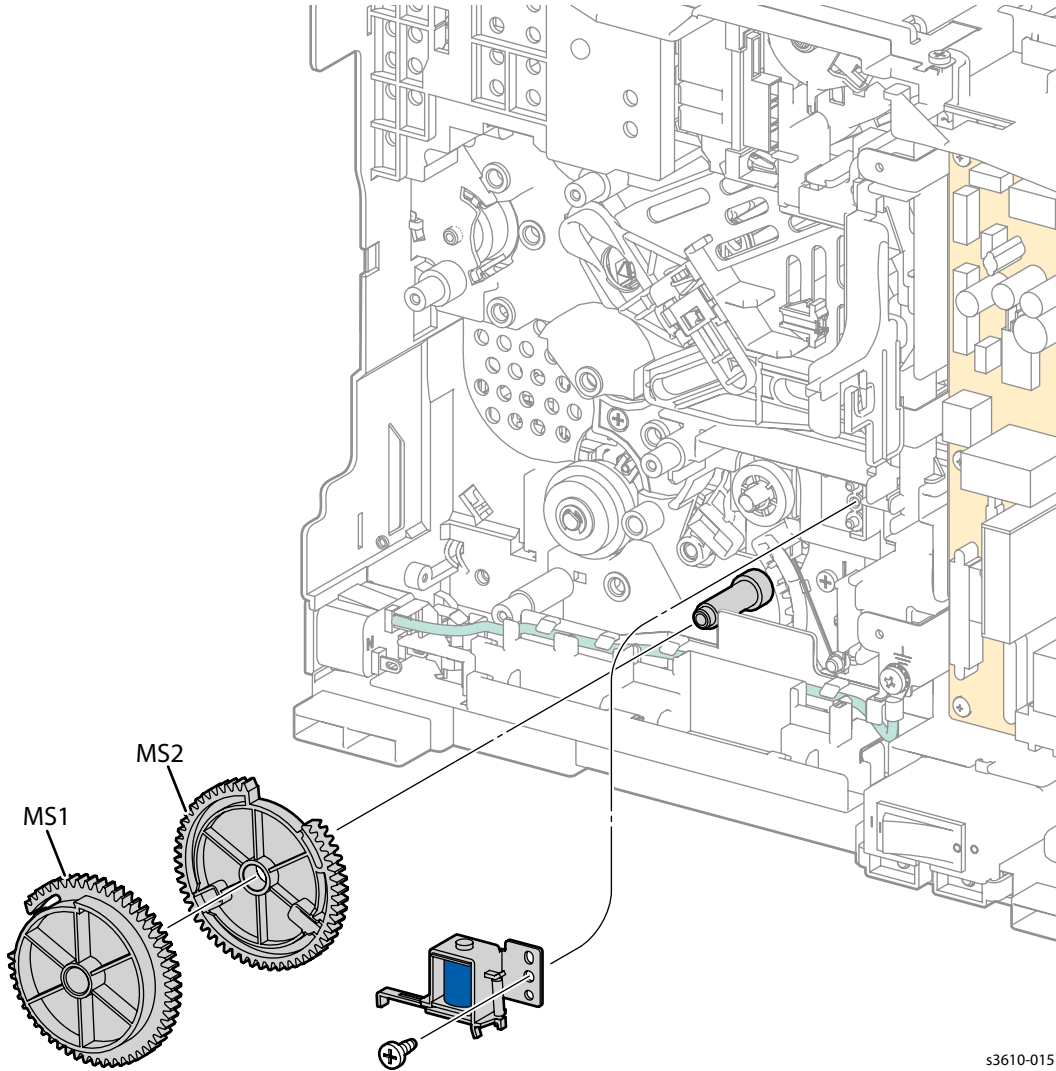
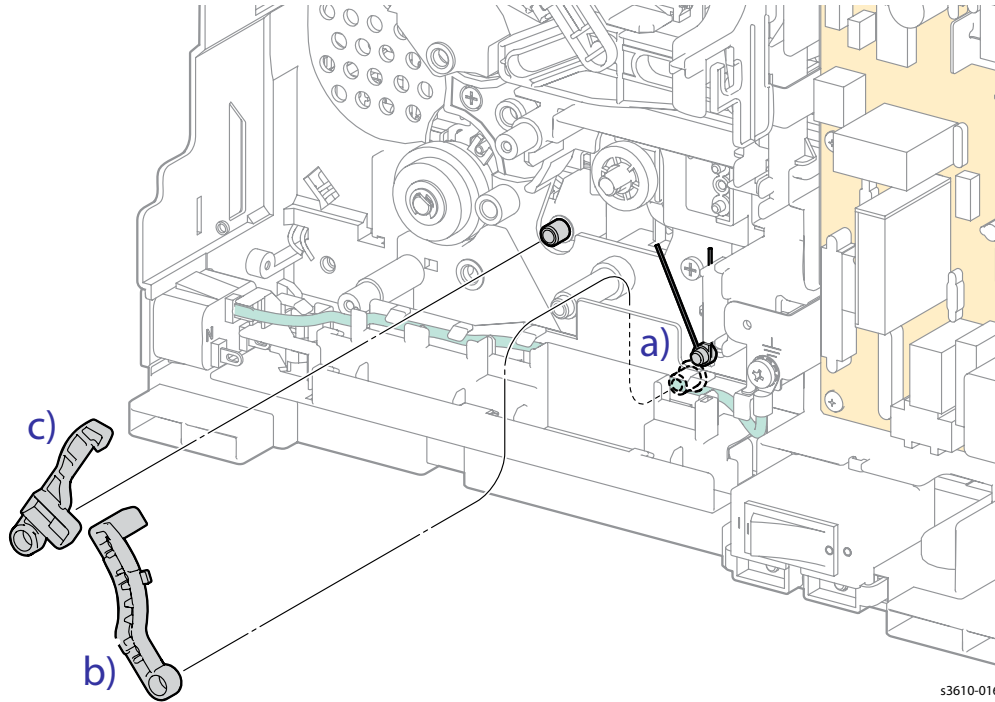

Figure 3

s3610-015

12. Remove the Lifter Components. (Figure 4)
 - a. Release the Feed Spring from the Lifter Arm.
 - b. Remove the Lifter Arm.
 - c. Remove the Lifter Lever.



s3610-016

Figure 4

13. From the right side of the machine, release the clip that secures both of the registration sensor shutters, and remove. (Figure 5)

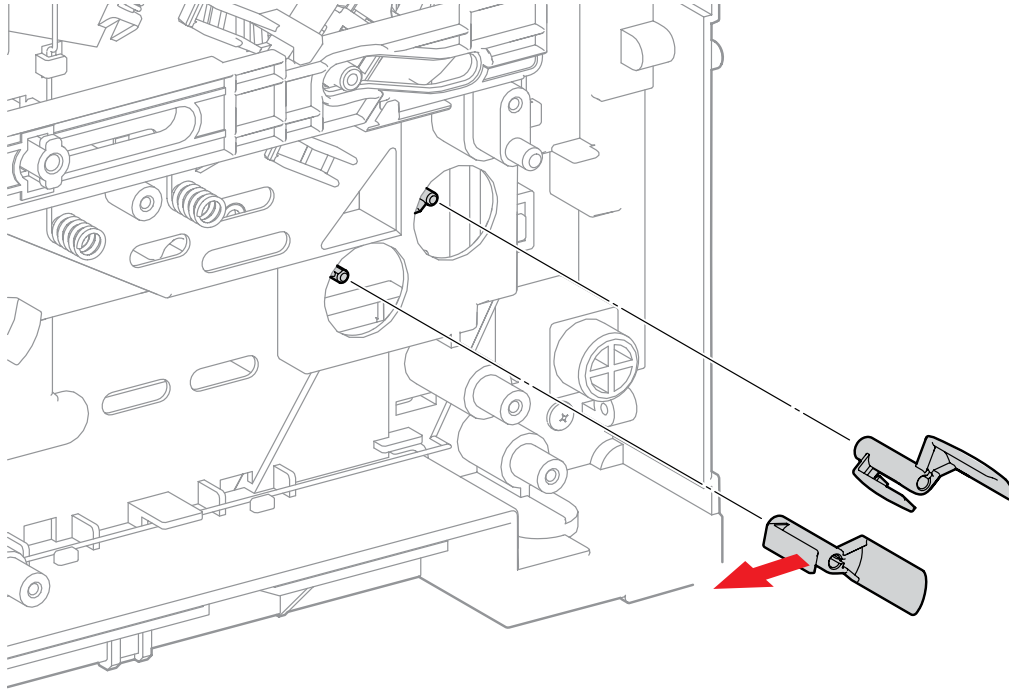

s3610-017

Figure 5

14. From the rear of the machine, release 1 screw (silver, tapping, 8mm) to remove the silver ground plate. (Figure 6)

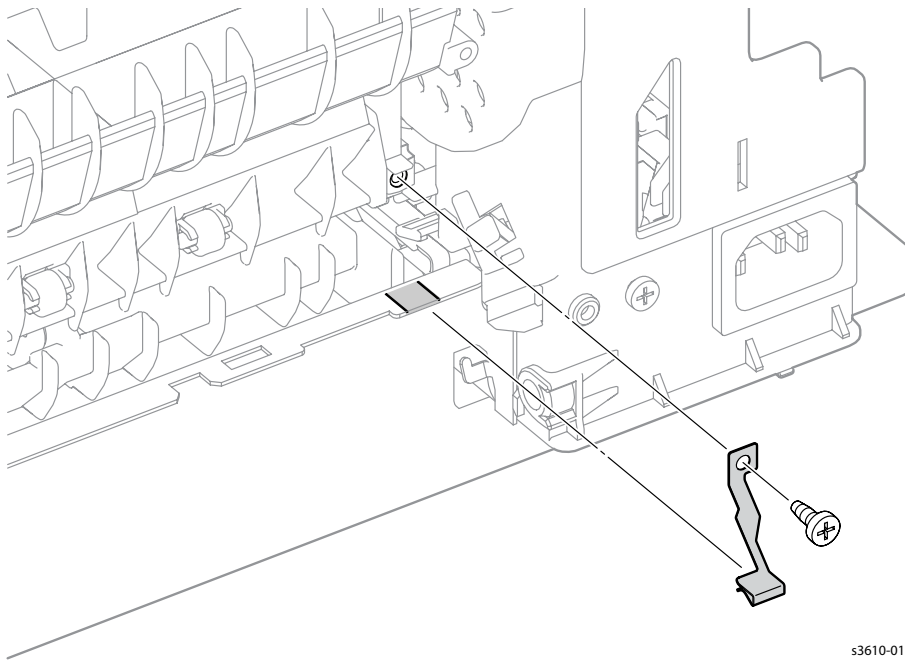

s3610-018

Figure 6

15. Remove the Transport Assembly. (Figure 7)
 - a. Remove 3 screws (silver, tapping, 8mm),
 - b. Rotate the Transport Assembly from the left CW into the cavity of the machine to clear the gears on the right side of the assembly.
 - c. Lift the Transport Assembly towards the front of the machine and remove.

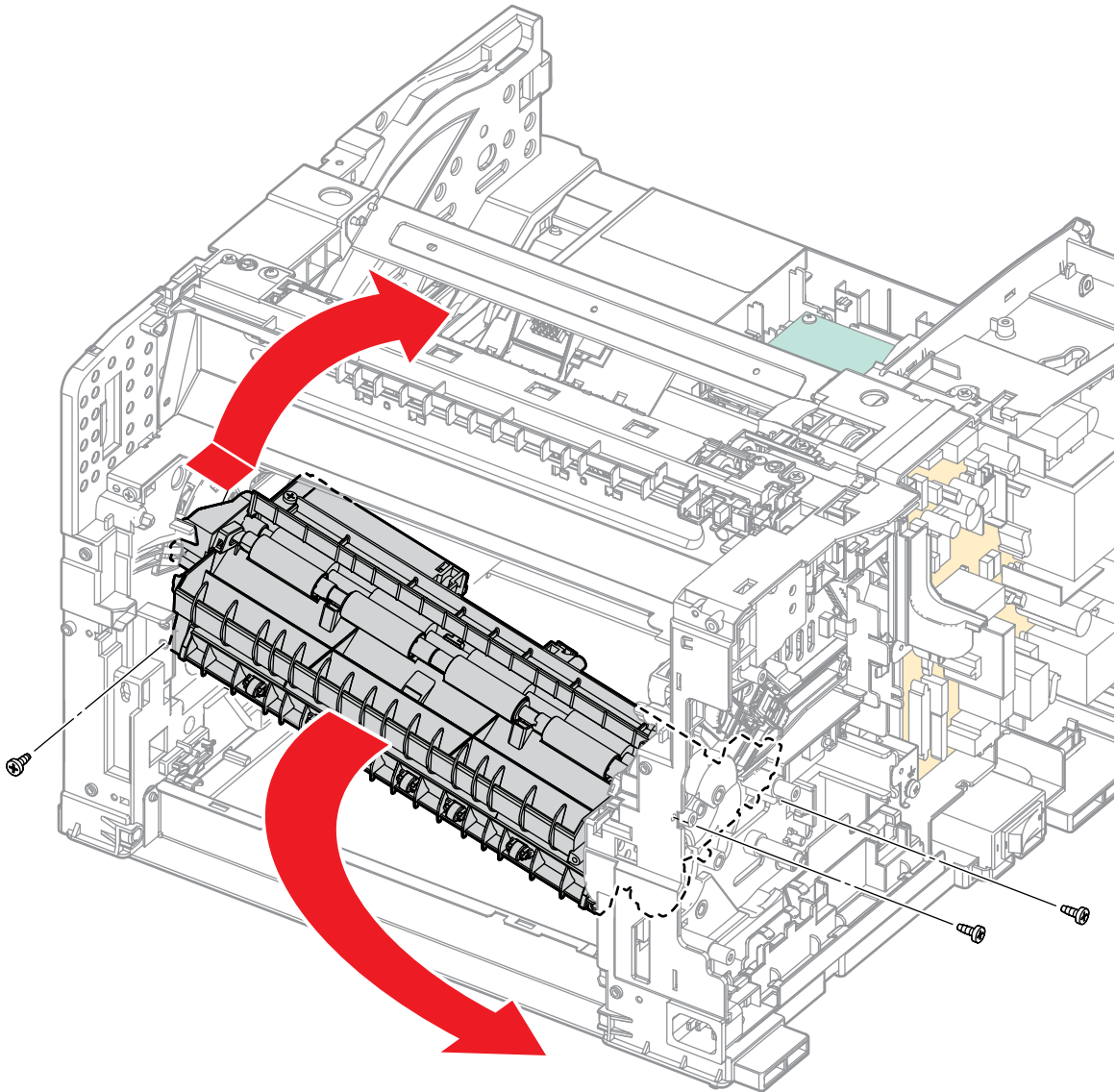

s6310-165

Figure 7

Replacement

1. Check the position of the Registration Sensor Shutter when re-installing the Transport Assembly. (Figure 8)

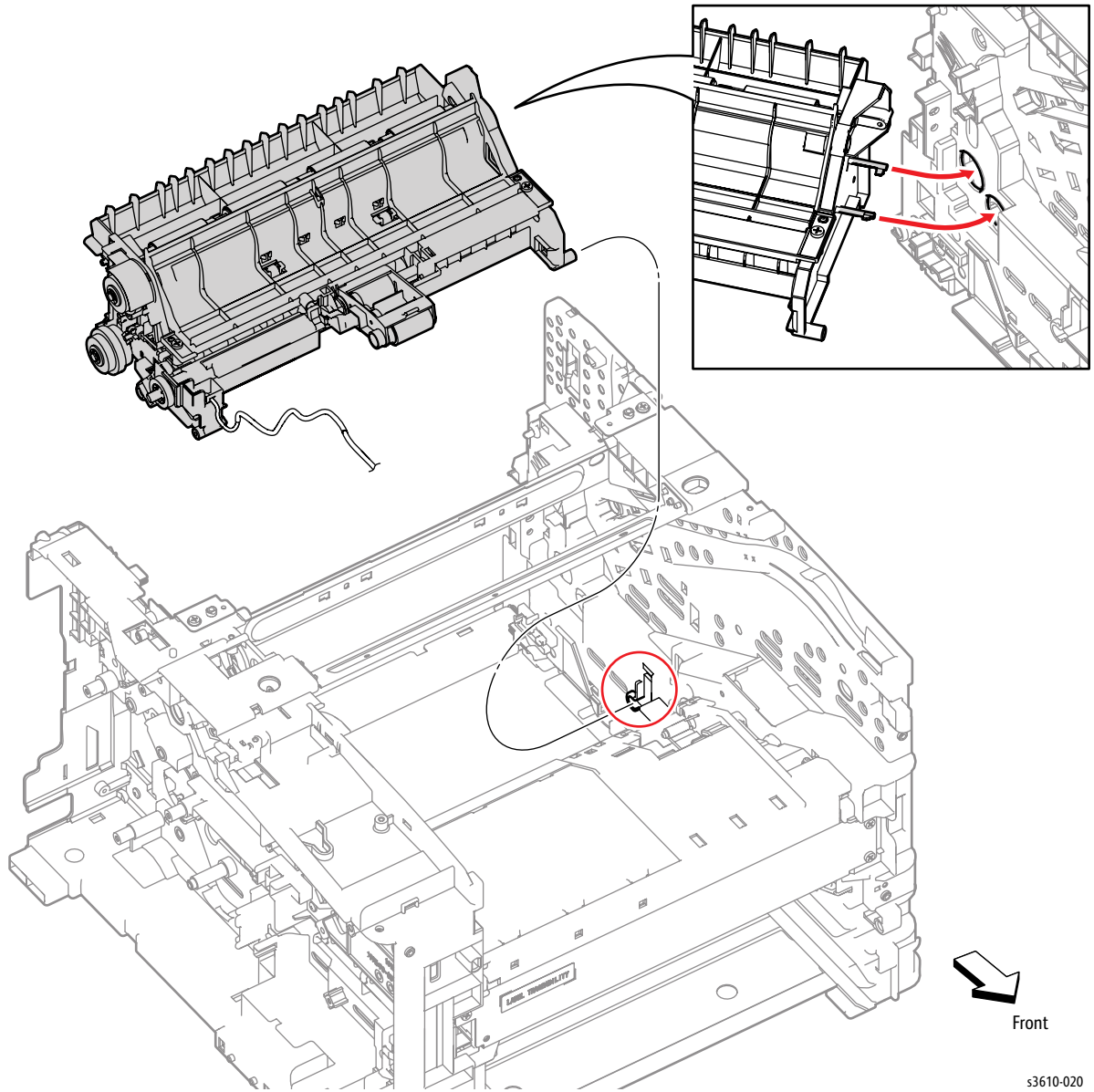

Figure 8

s3610-020

2. When installing the Lifter Stopper, position the Pick up Holder as shown. (Figure 9)

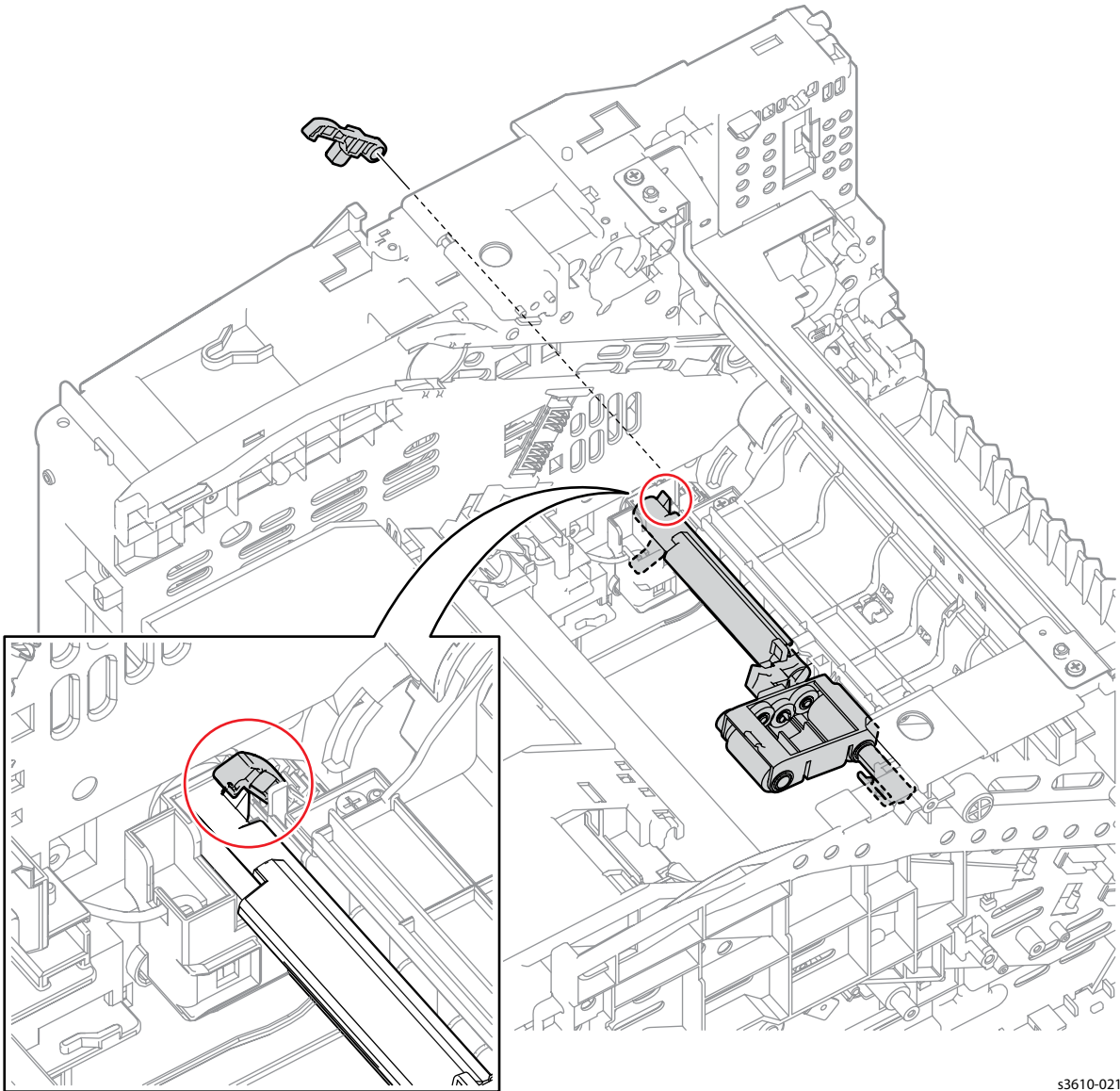
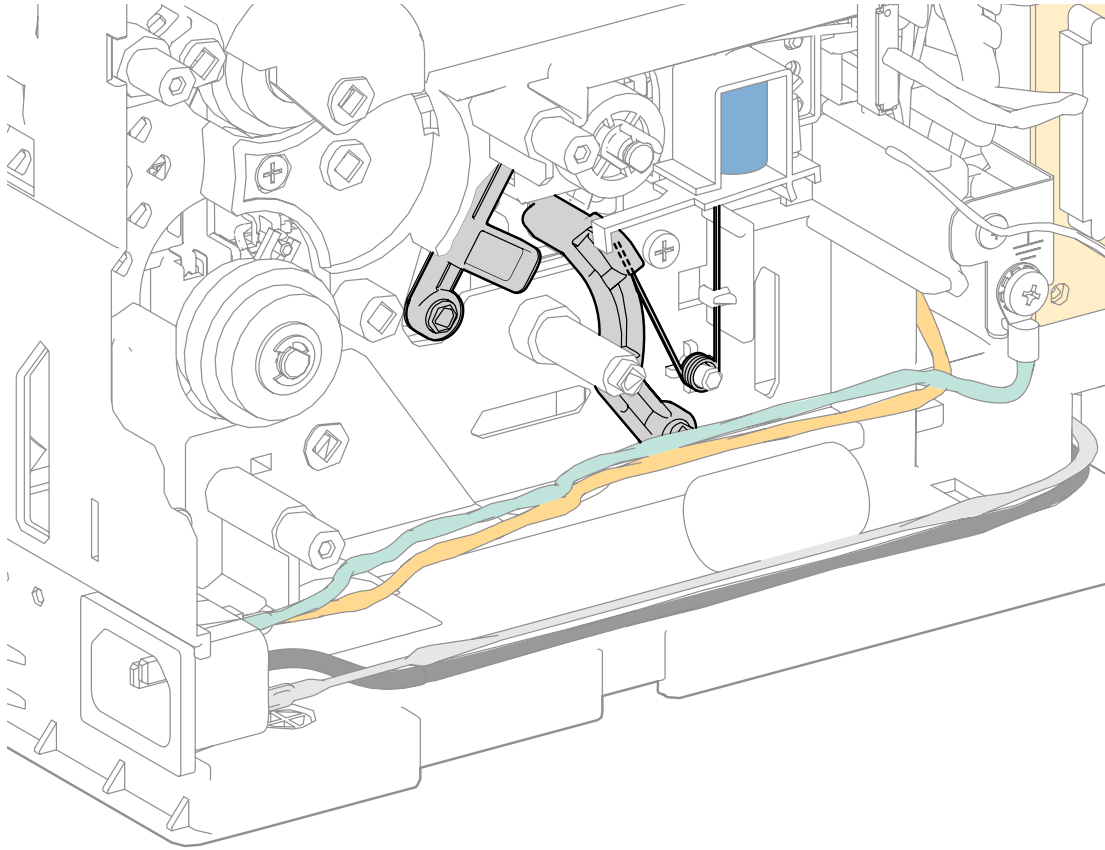

Figure 9

s3610-021

3. When installing the Lifter Arm, check the Feed Spring position. (Figure 10)



s3610-022

Figure 10

4. Assemble the Feed Gear Segments, fit the bosses on MSI 1 into the holes on MSI 2. (Figure 11)

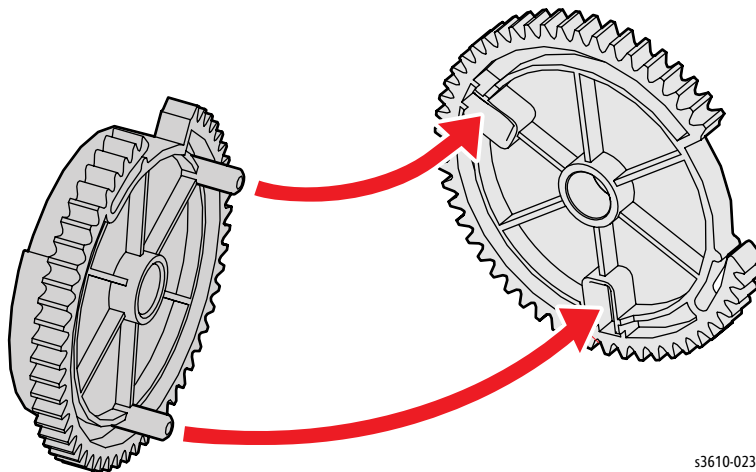

s3610-023

Figure 11

5. When installing the Feed Gear, ensure the actuator engage the Feed Gear. (Figure 12)

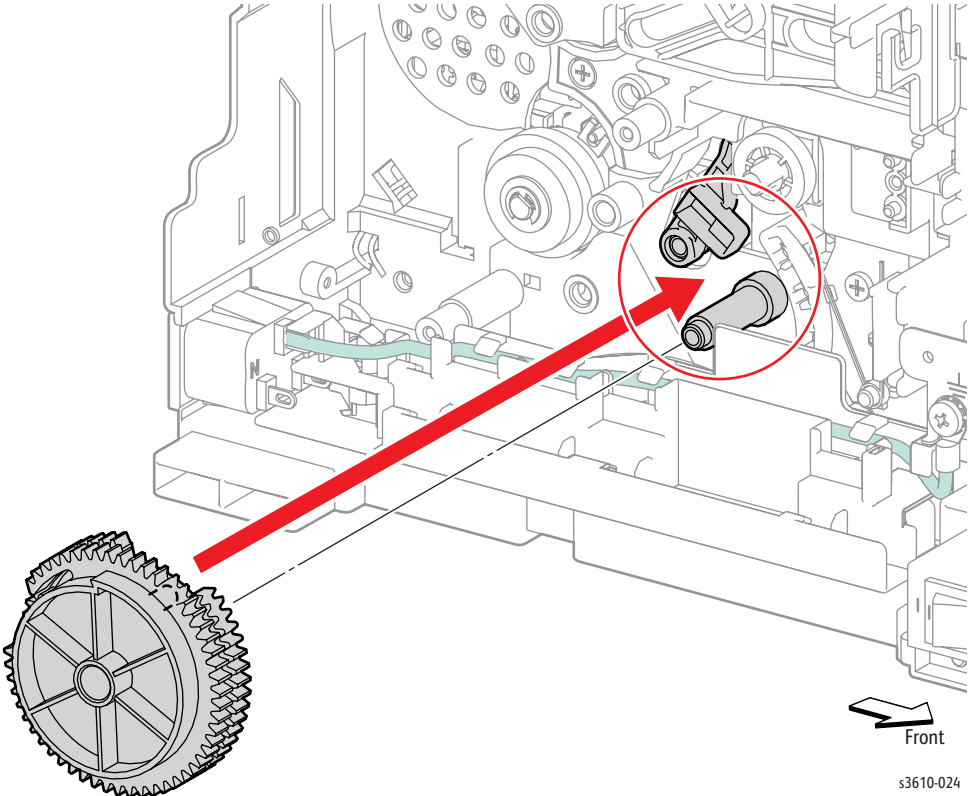

Figure 12

s3610-024

- When replacing the Top Frame Assembly, ensure that the No Paper Sensor Actuator passes through the hole in the chassis. (Figure 13)

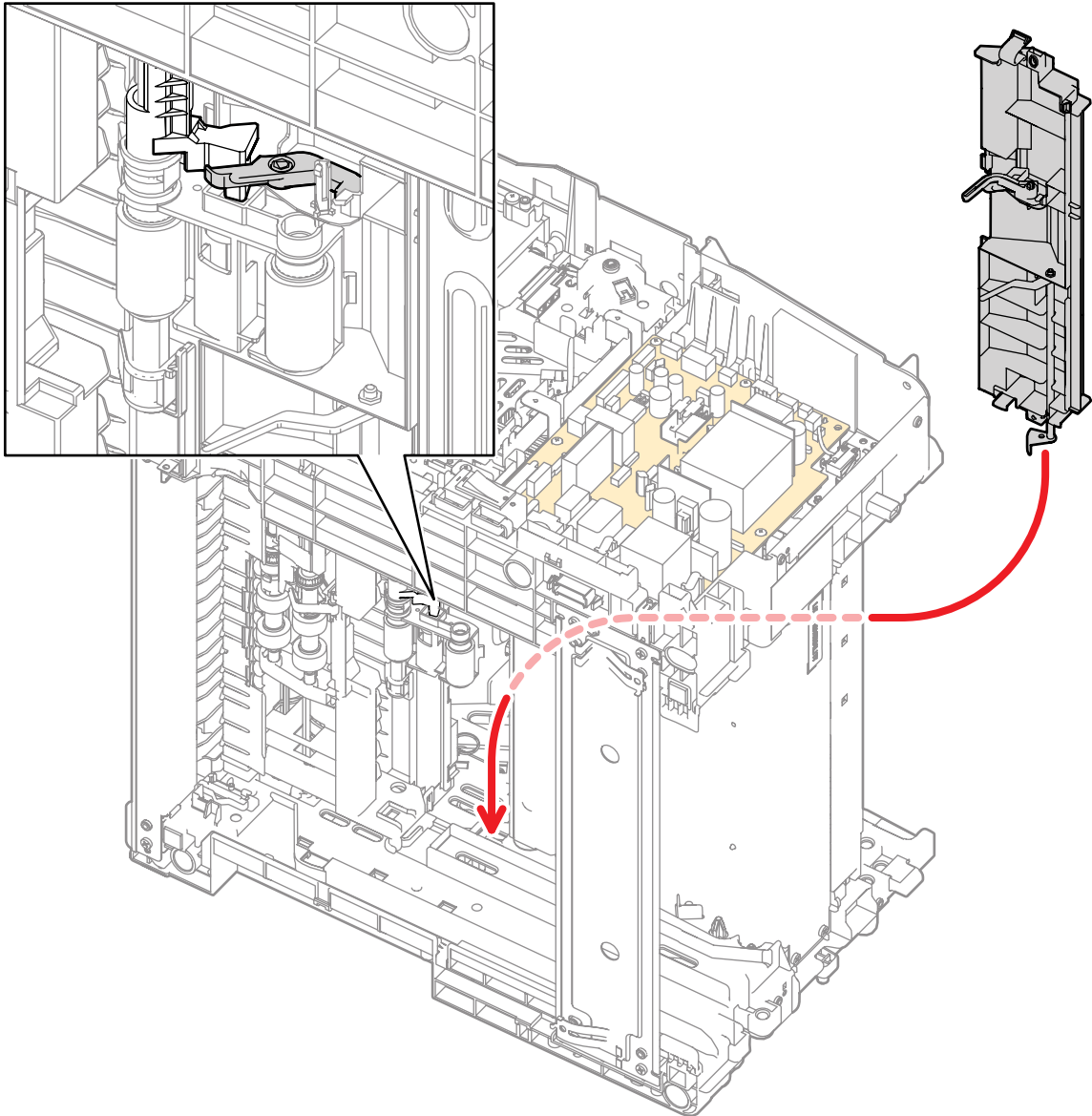

Figure 13

s3610-025

- Replace in reverse order.

REP 2.3 Feeder Assembly

PL 2.3 Feed Assembly

Removal

! **WARNING:** Allow the Fusing Assembly to cool before servicing the product.

1. Remove the (REP 2.2 Transport Assembly).
2. Remove the Feed and Nudger Rollers. (Figure 1)

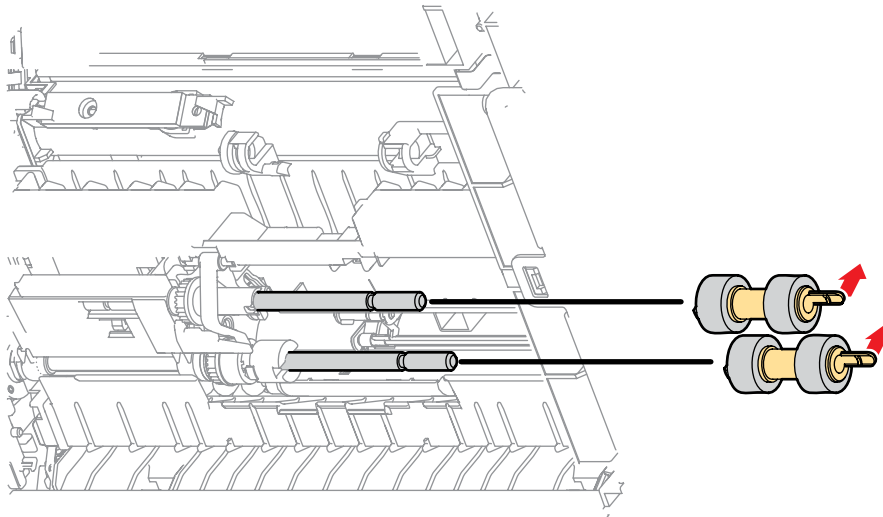

Figure 1

3. Remove the Feeder Assembly. (Figure 2)
 - a. Remove the E-ring that secures the Feed Clutch to the Transport Assembly,
 - b. Remove, but do not disconnect the clutch, and remove the bearing.
 - c. Remove the One-Way Clutch.
 - d. Remove the the Feed Shaft with the Feed Gear.
 - e. Remove the Nudger Bearing that secures the Feeder Assembly to the Transport.
 - f. Remove the Feeder Assembly.

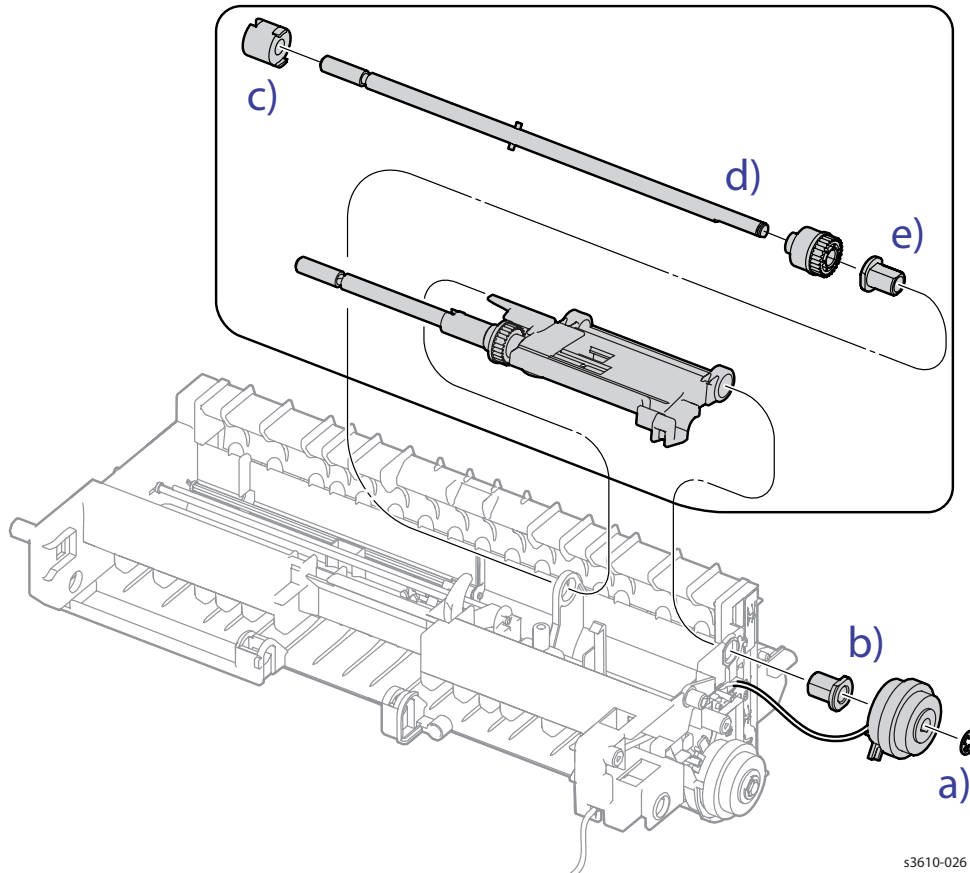

Figure 2

s3610-026

Replacement

1. Installing the Feeder Assembly. (Figure 3)
 - a. position the Feeder Assembly under the actuator
 - b. Make sure the spring is seated correctly in the chassis cavity.

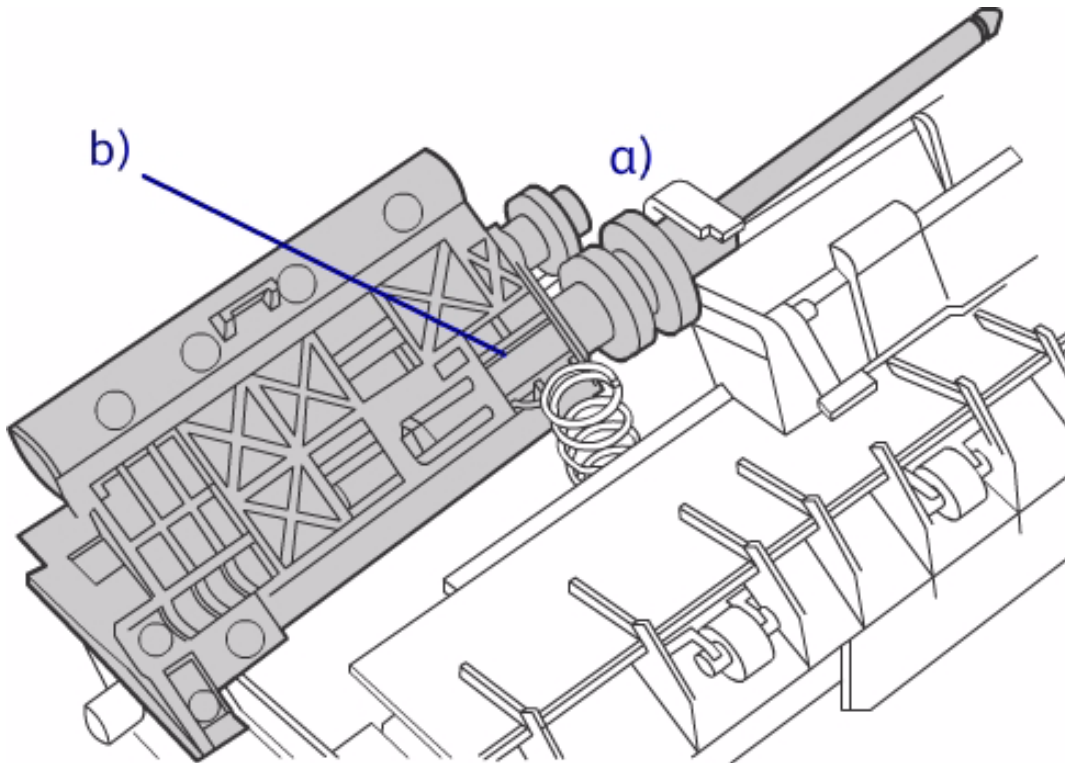

Figure 3

2. Insert the Nudger Bearing to secure the Feeder Assembly to the transport.
3. Replace the shaft with the Feed Gear on it, and then the One Way Clutch.
4. Position the notch on the Feed Clutch onto the tab on the frame, and secure the clutch onto the shaft using the e-ring.
5. Check the assembly for the correct spring tension.
6. Replace in reverse order.

REP 2.4 Tray 1 Feed Rollers

PL 2.2 Transport Assembly

Removal

! **WARNING:** Allow the Fusing Assembly to cool before servicing the product.

1. Remove Tray 1.
2. Reach into the tray cavity and release the clips that secure the Feed and Nudger Rollers to the shafts. (Figure 1)

Note: The illustration shows the unit rotated for clarity.

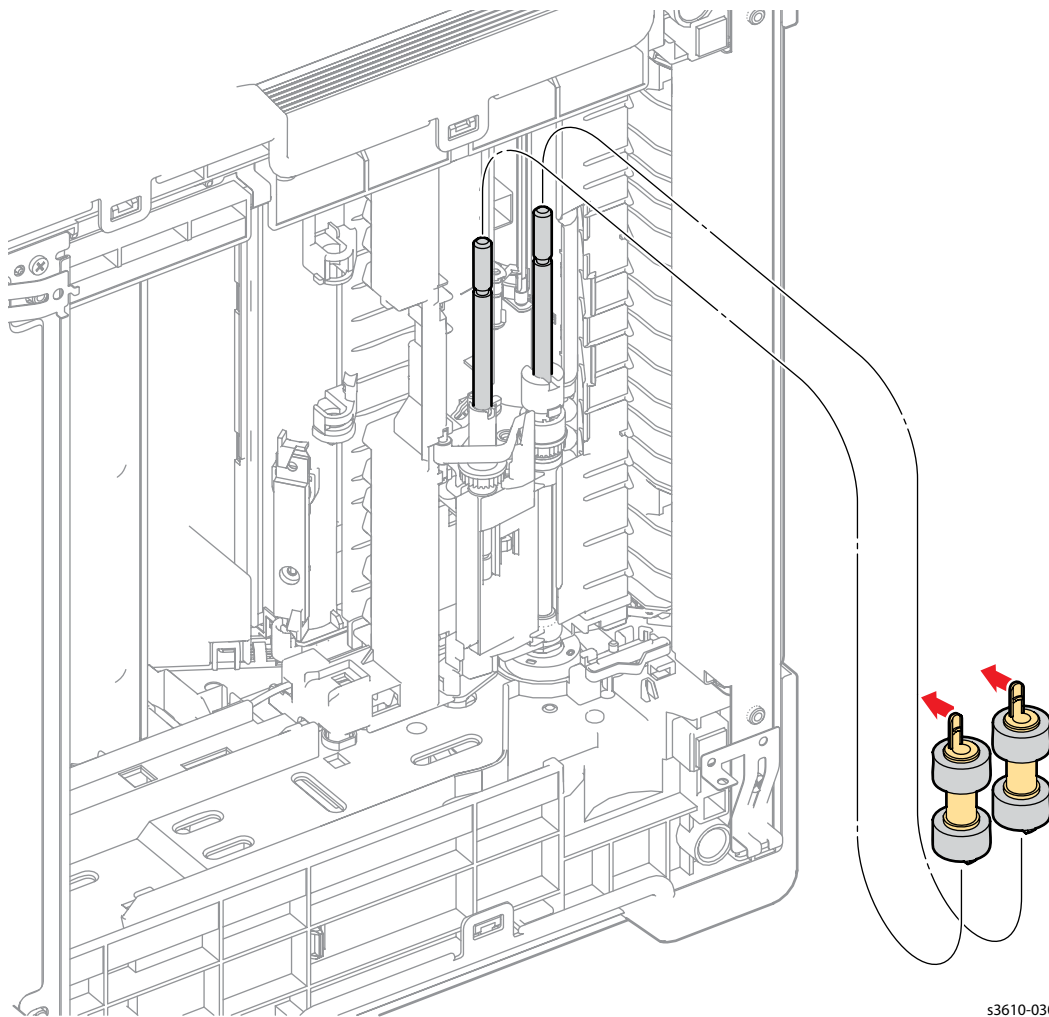

Figure 1

Replacement

1. Make sure the tabs on the bottom of the rollers line up with the notches on the drive assembly and the rollers are firmly locked into place.
2. Replace in reverse order.

REP 2.5 Feed Clutch

PL 2.2 Transport Assembly

Removal



WARNING: Allow the Fusing Assembly to cool before servicing the product.

1. Remove (REP 2.2 Transport Assembly).
2. Remove The Feed Clutch. (Figure 1)
 - a. Remove the E-ring that secures the Feed Clutch to the shaft.
 - b. Release the Feed Clutch harness from the Transport Assembly harness guide to remove the clutch.

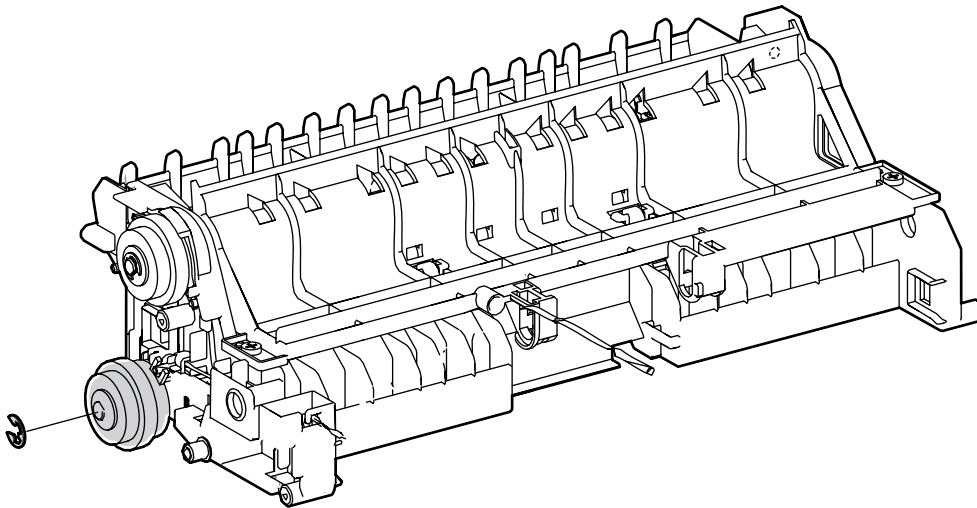

Figure 1

Replacement

1. Replace in reverse order.

REP 2.6 Registration Clutch

PL 2.2 Transport Assembly

Removal

! **WARNING:** Allow the Fusing Assembly to cool before servicing the product.

1. Remove (REP 2.2 Transport Assembly).
2. Remove The Registration Clutch. (Figure 1)
 - a. Remove the E-ring that secures the Registration Clutch to the shaft.
 - b. Release the Registration Clutch harness from the Transport Assembly harness guide to remove the clutch.

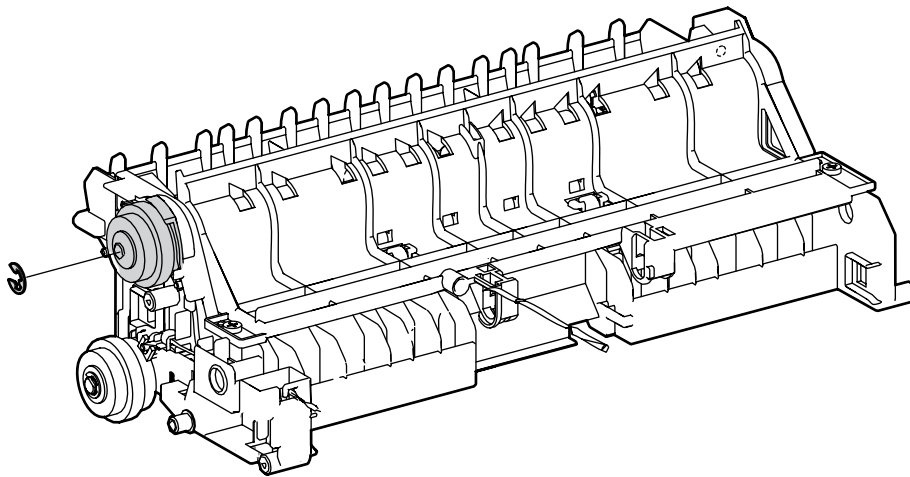

Figure 1

Replacement

1. Replace in reverse order.

REP 2.7 Rubber Registration Roller

PL 2.2 Transport Assembly

Removal



WARNING: Allow the Fusing Assembly to cool before servicing the product.

1. Remove (REP 2.2 Transport Assembly).
2. Remove the Rubber Registration Roller shaft. (Figure 1)
 - a. Remove the E-ring that secures the Registration Clutch to the shaft, then remove, but do not disconnect the clutch.
 - b. Lift the tabs and rotate the registration shaft bearings to release the bearing and remove.
 - c. Release the tension springs from the plastic registration roller shaft.
 - d. Remove the E-ring on the Rubber Registration Roller shaft
 - e. Slide the shaft to the left to release the shaft from the Transport Assembly.

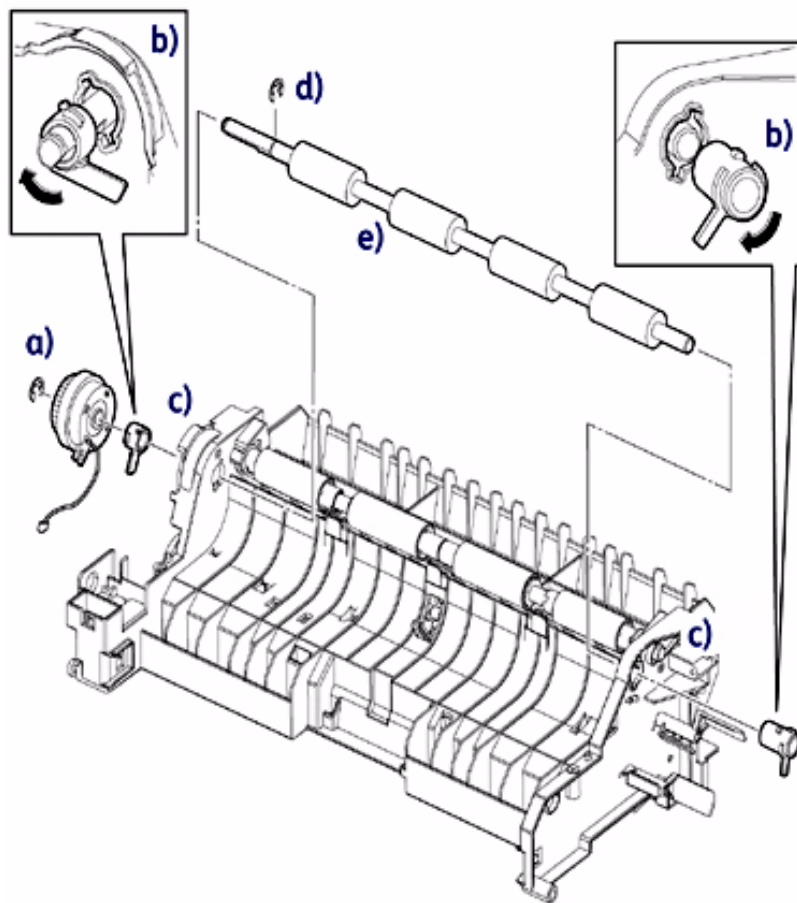

41528A

Figure 1

Replacement

1. Install the plastic registration roller tension springs with the extra coil facing the shaft. (Figure 2)

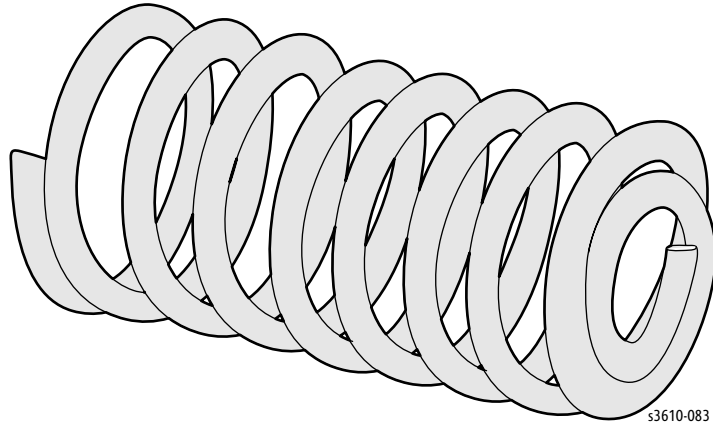

Figure 2

2. Replace in reverse order.

REP 2.8 Registration Sensor Shutter

PL 2.2 Transport Assembly

Removal

! **WARNING:** Allow the Fusing Assembly to cool before servicing the product.

1. Remove (REP 5.7 HVPS (3610)) (REP 5.8 HVPS (3615)).
2. Release the clip that secures the Registration Sensor Shutter to the Actuator Shaft. (Figure 1)

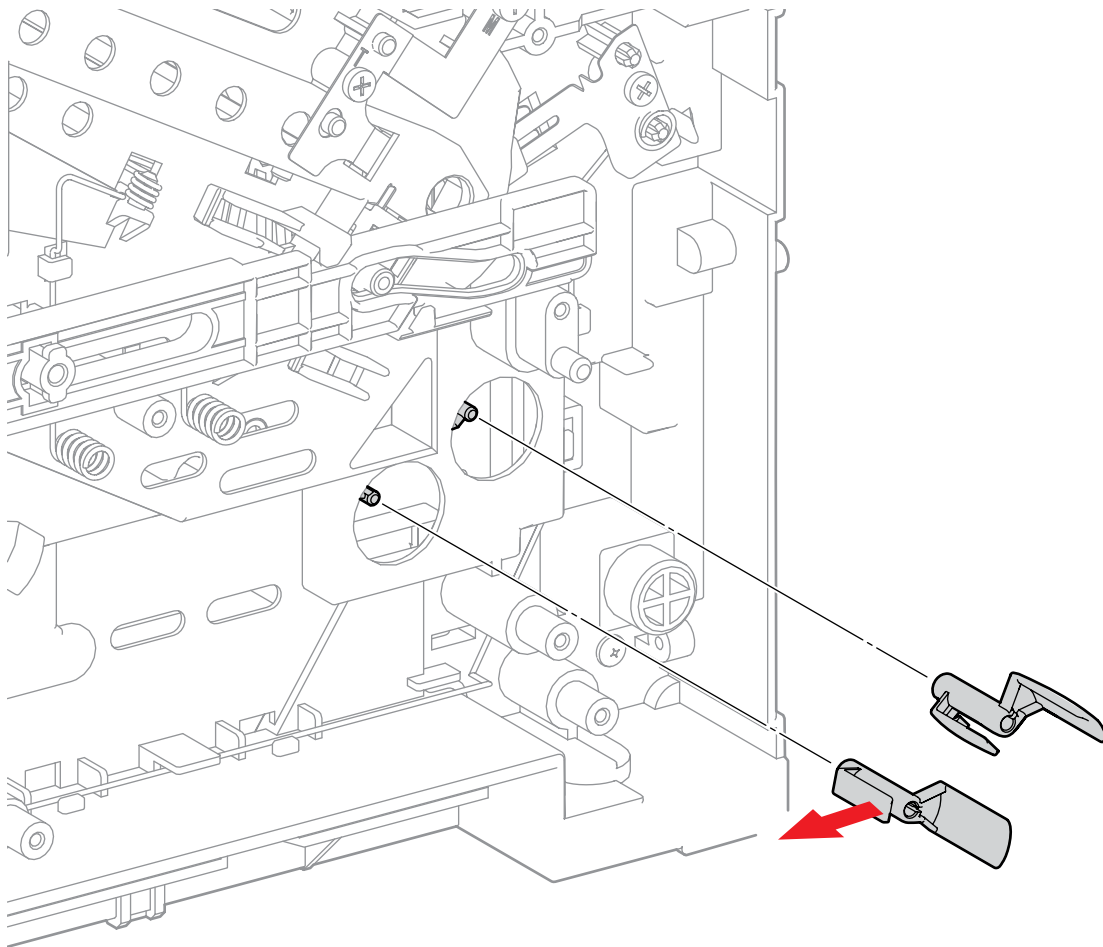

Figure 1

s3610-017

Replacement

1. Replace in Reverse order.

REP 2.9 Tray 1 Stopper

PL 2.4 Duplex Chute

Removal

! **WARNING:** Allow the Fusing Assembly to cool before servicing the product.

1. Remove Tray 1.
2. Open the Rear Cover, release the stopper strap and hinge clip from the chassis and rest the Rear Cover Assembly on the work surface.
3. Remove the Interlock Switch Assembly. (Figure 1)
 - a. Remove 1 screw.
 - b. Release 2 tabs on the bottom of the assembly, move to the left to remove, but do not disconnect the assembly.

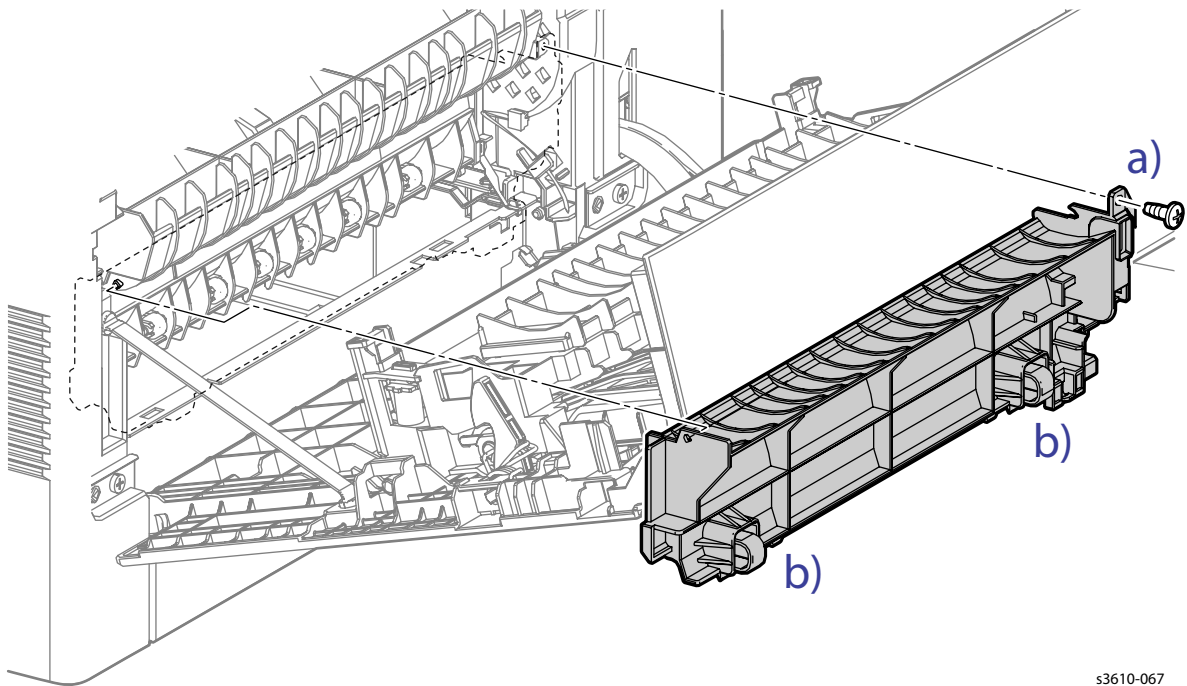

s3610-067

Figure 1

4. Release 1 screw (silver, tapping, 8mm) to remove the silver ground plate. (Figure 2)

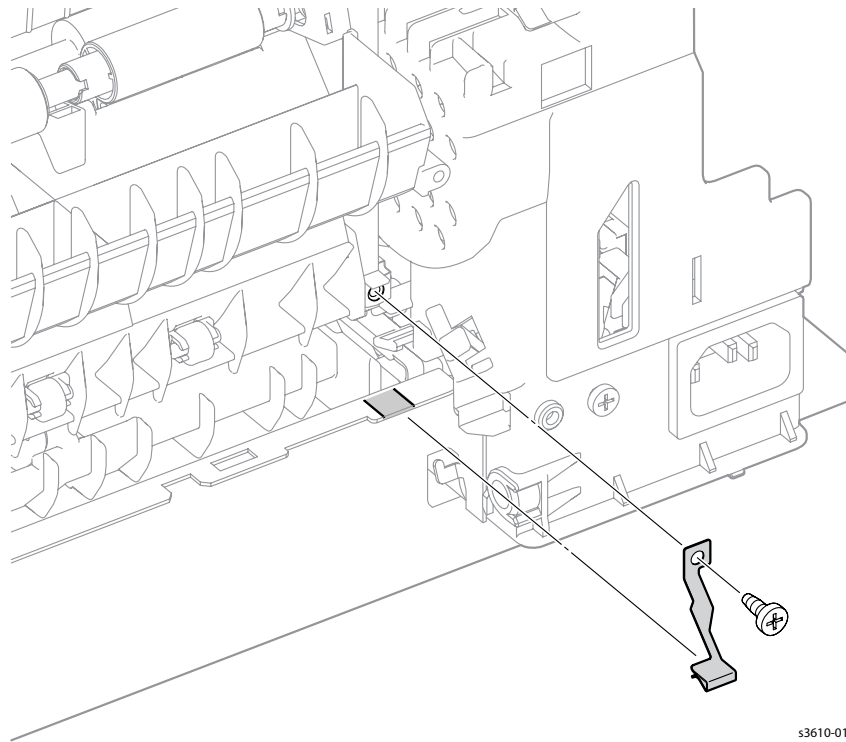
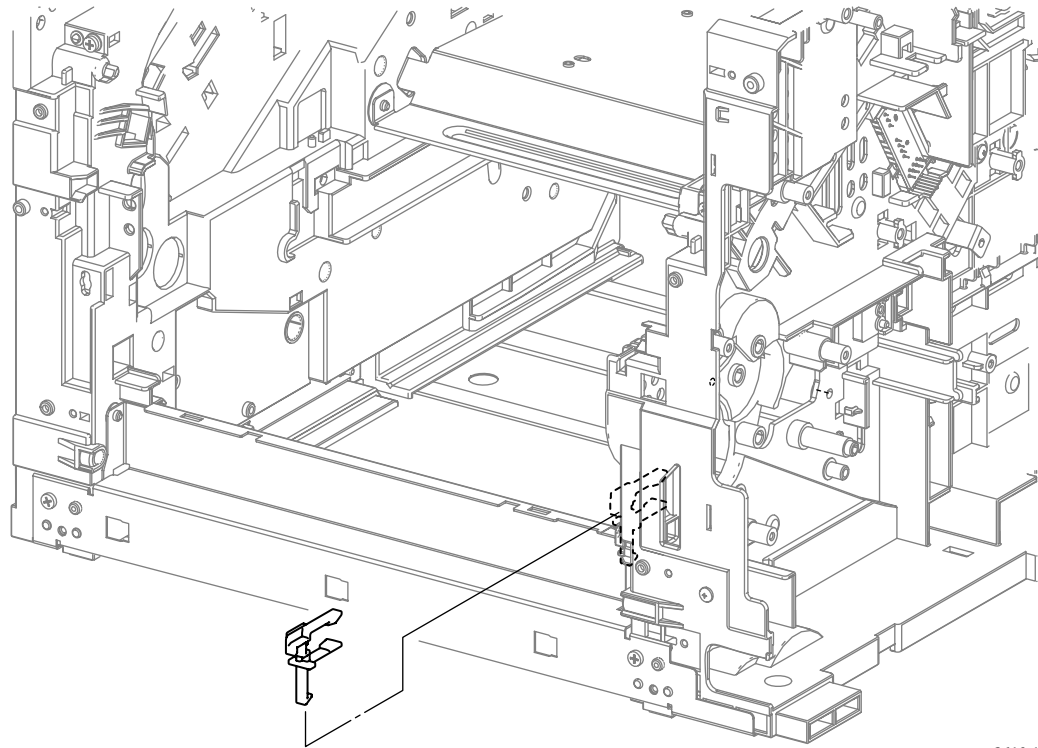

Figure 2

s3610-018

5. Release the clip at the bottom and rotate the Tray 1 Stopper inward to remove. (Figure 3)



s3610-135a

Figure 3

Replacement

1. Replace in reverse order.

REP 2.10 Rear Interlock Switch Assembly

PL 2.4 Duplex Chute

! **WARNING:** Allow the Fusing Assembly to cool before servicing the product.

1. Remove (REP 1.6 Right Side Cover (3610)) (REP 1.13 Right Side Cover (3615)).
2. Remove (REP 5.2 ESS PWB Housing).
3. Disconnect P/J201 from the LVPS, and move the harness guide. (Figure 1)

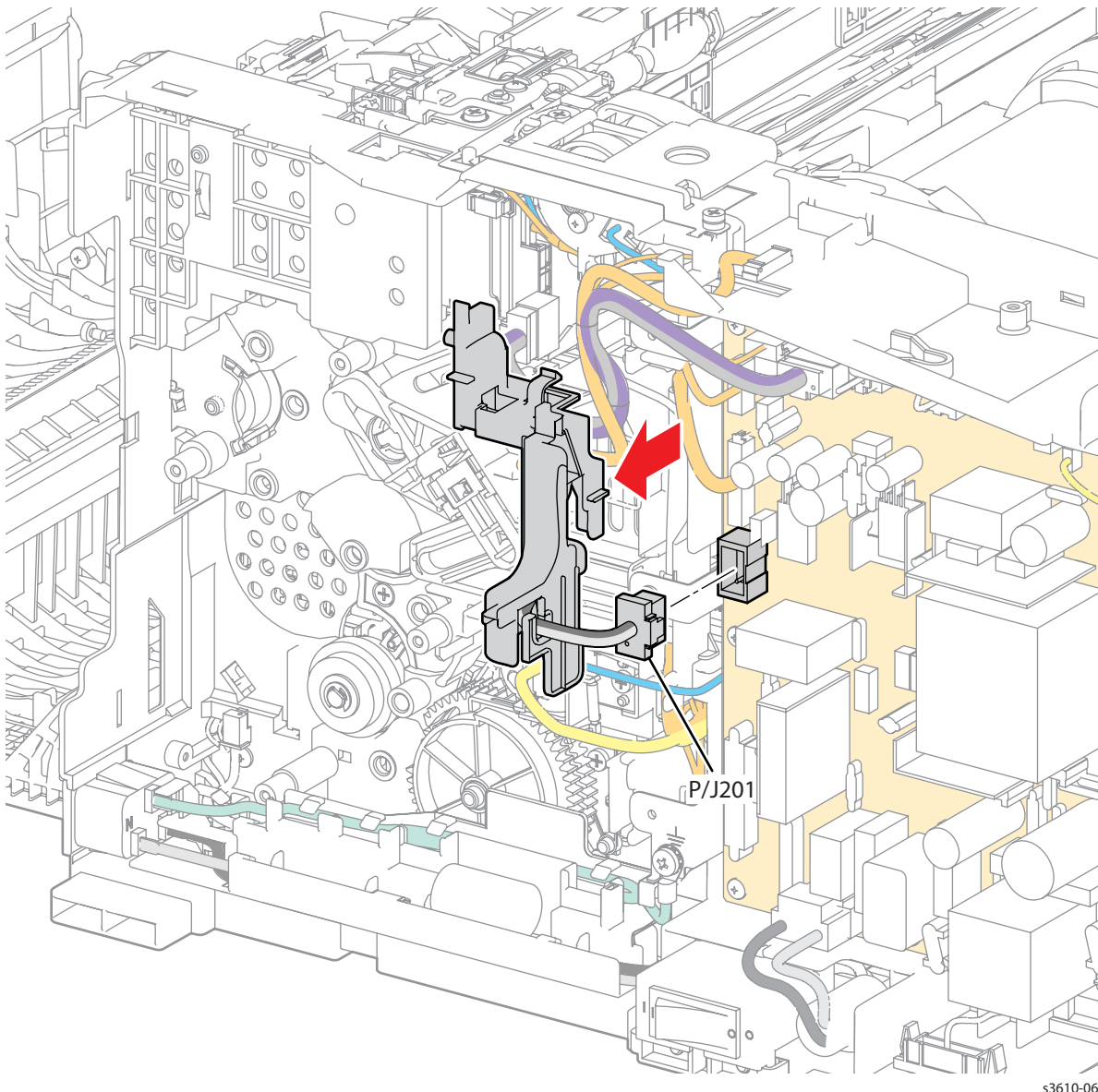

Figure 1

4. From the rear of the machine, remove the Rear Interlock Switch Assembly. (Figure 2)
 - a. Disconnect P/J230 from the LVPS, and release the Rear Interlock Switch harness from the harness guide.
 - b. Remove 1 screw (silver, tapping, 8mm),
 - c. Release 2 clips at the bottom to remove the Interlock Switch Assembly by rotating it upward and to the left to release the assembly off the pin on the upper assembly.

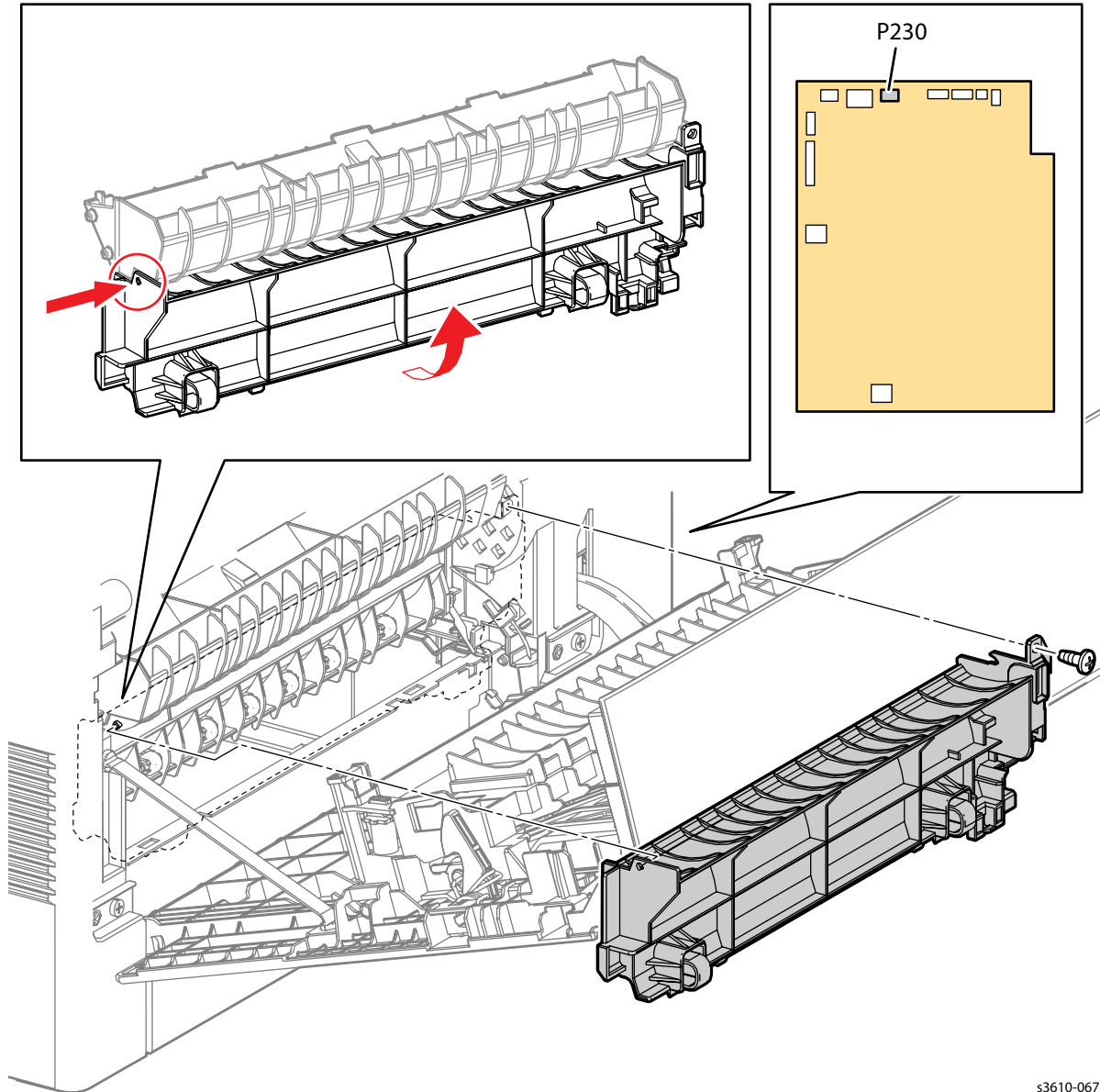

Figure 2

s3610-067

5. Remove the Rear Interlock Switch from the Interlock Switch Assembly. (Figure 3)

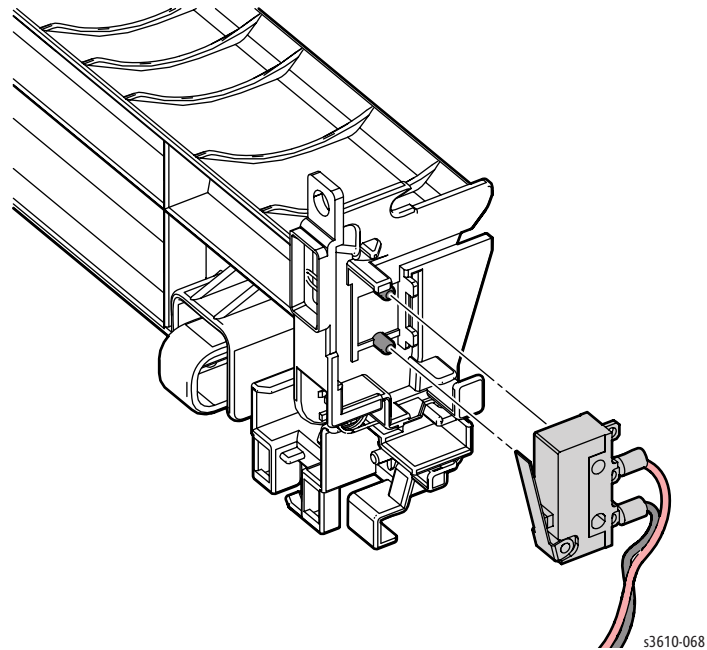

Figure 3

Replacement

1. When installing the Rear Interlock Switch, insert the switch into the holder, then press the switch to engage the clips. (Figure 4)

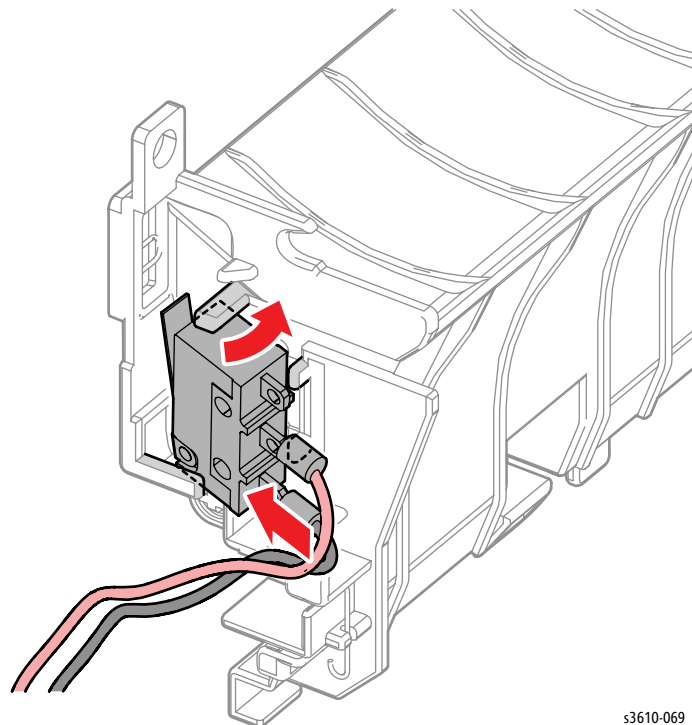

Figure 4

2. Replace in reverse order.

REP 2.11 Exit Chute Assembly

PL 2.5 Exit Chute

Removal

1. Open the Front Cover.
2. Open the Rear Cover.

Note: For the 3615, depending on your tool set, you may need to remove the ([REP 6.1 IIT Assembly](#))

3. Remove ([REP 1.1 Control Panel \(3610\)](#)).
4. Remove ([REP 1.4 Top Cover Assembly \(3610\)](#))
5. Remove the Exit Chute Assembly. (Figure 1)
 - a. Remove 2 screws (silver, M3, 6mm) that secure Exit Chute Assembly to the chassis.
 - b. Lift the chute in the direction of the arrow to disconnect P/J271 and 272.
 - c. Flex the Left Side Cover to release 2 bosses.

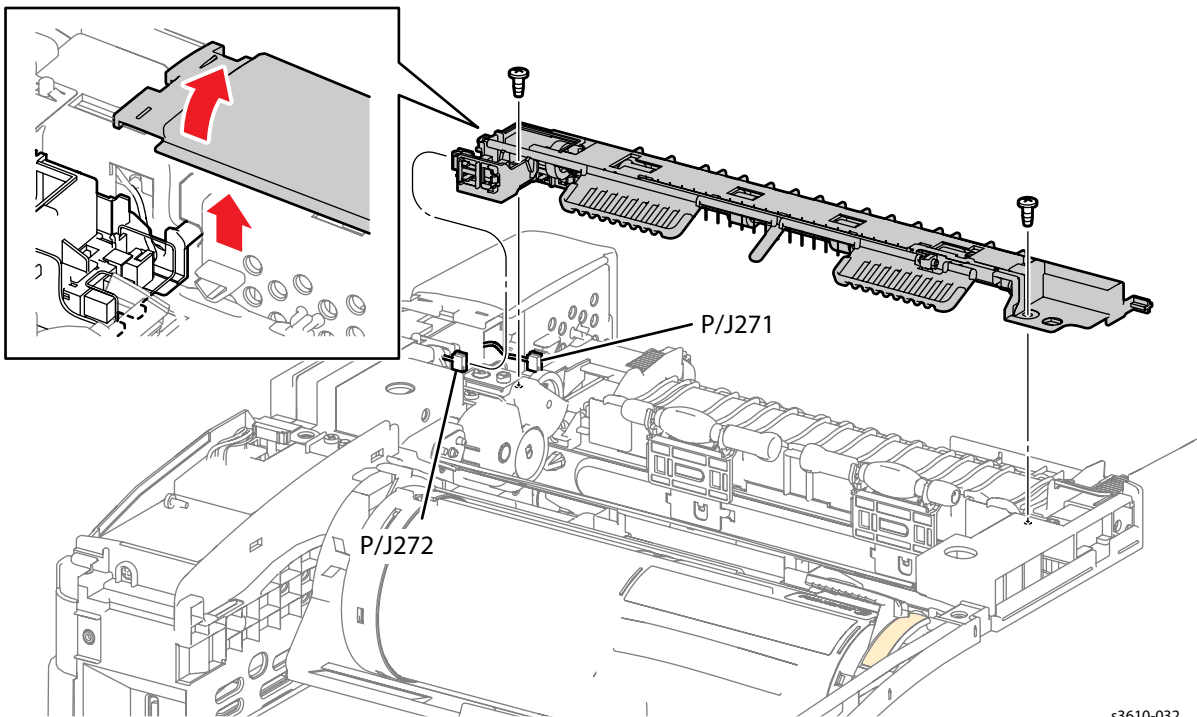

s3610-032

Figure 1

Replacement

1. When installing the Exit Chute Assembly, the Sensor Ground Spring must contact the chassis ground plate. (Figure 2)

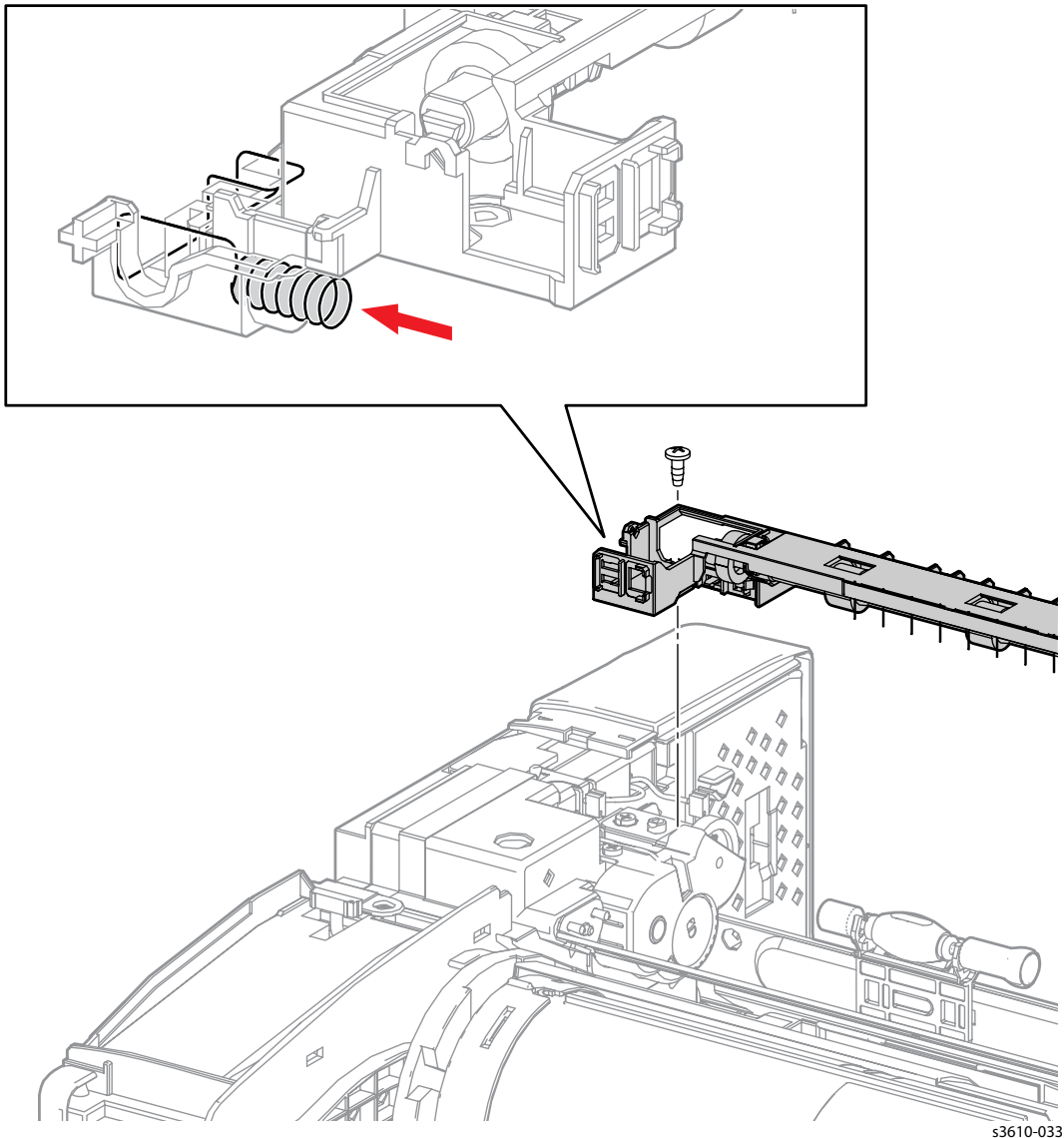

Figure 2

2. Make sure the tabs on the 2 bosses line up with the slots in the frame to ensure the assembly is locked into place.
3. Replace in reverse order.

REP 2.12 Left / Right Pinch Roller

PL 2.5 Exit Chute

Removal

1. Remove (REP 2.11 Exit Chute Assembly).
2. Remove the pinch rollers by carefully releasing the clips and moving them in the direction indicated. (Figure 1)

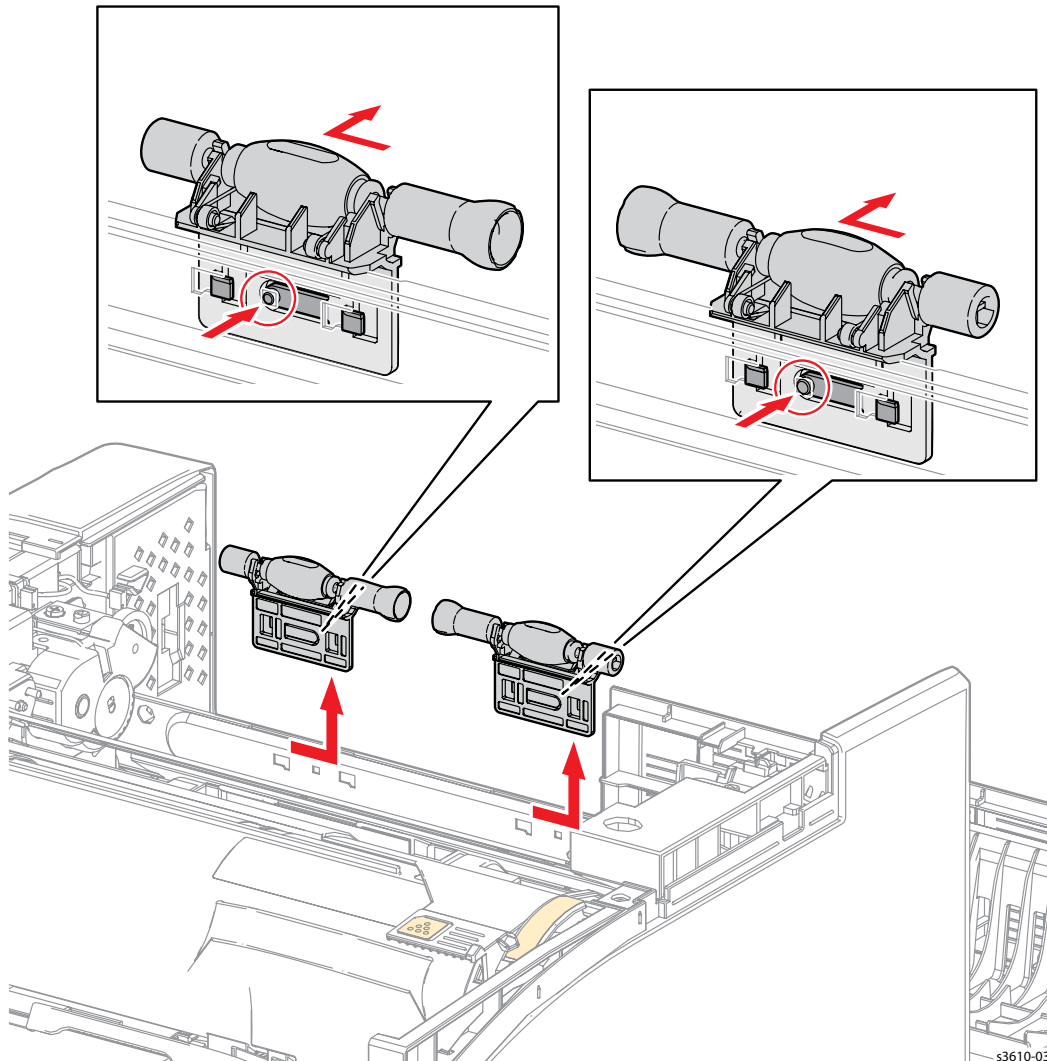

Figure 1

Replacement

1. Replace in reverse order.

REP 2.13 Full Stack Sensor

PL 2.5 Exit Chute

Removal

1. Remove (REP 2.11 Exit Chute Assembly).
2. Release the 4 clips and remove the Full Stack Sensor. (Figure 1)

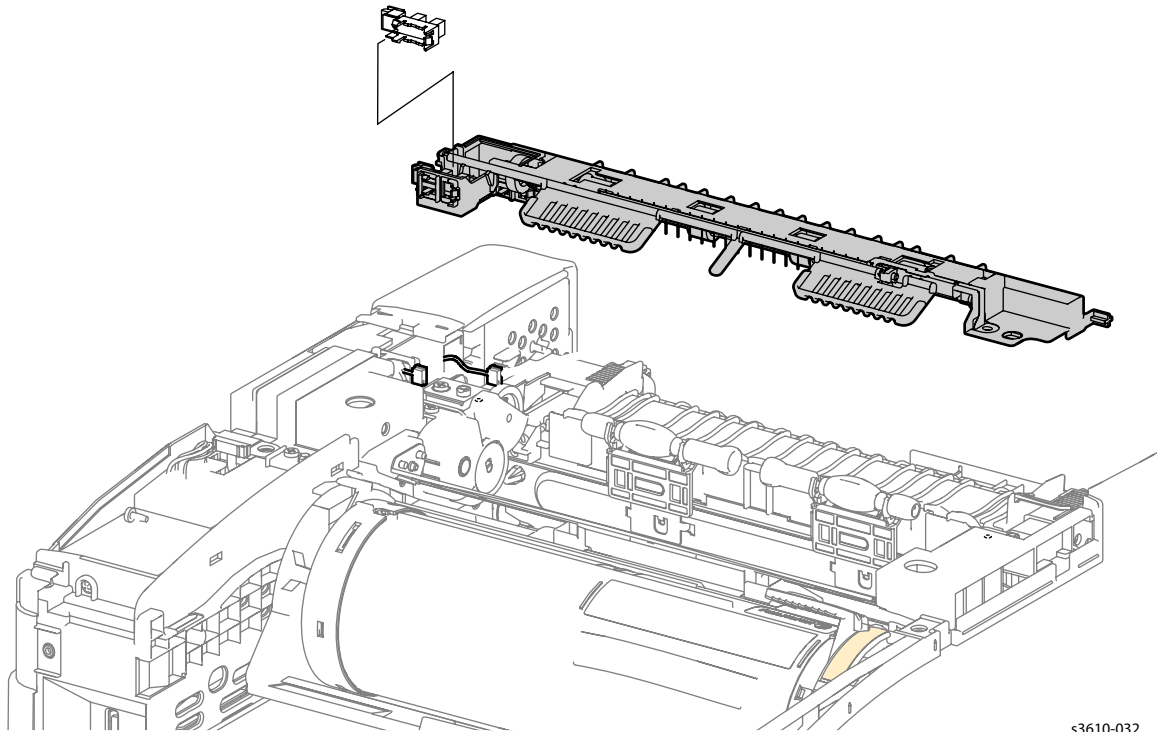

s3610-032

Figure 1

Replacement

1. Replace in reverse order.

REP 2.14 MSI Feed Solenoid

PL 2.6 MSI

Removal

1. Remove the Drum Cartridge ().
2. Remove (REP 1.2 Front Cover Assembly (3610 / 3615)).
3. Disconnect P/J 15. (Figure 1)
 - a. Release 3 clips to remove the MCU PWB Cover.
 - b. Disconnect P/J 15, and release the harness from all the chassis clips.

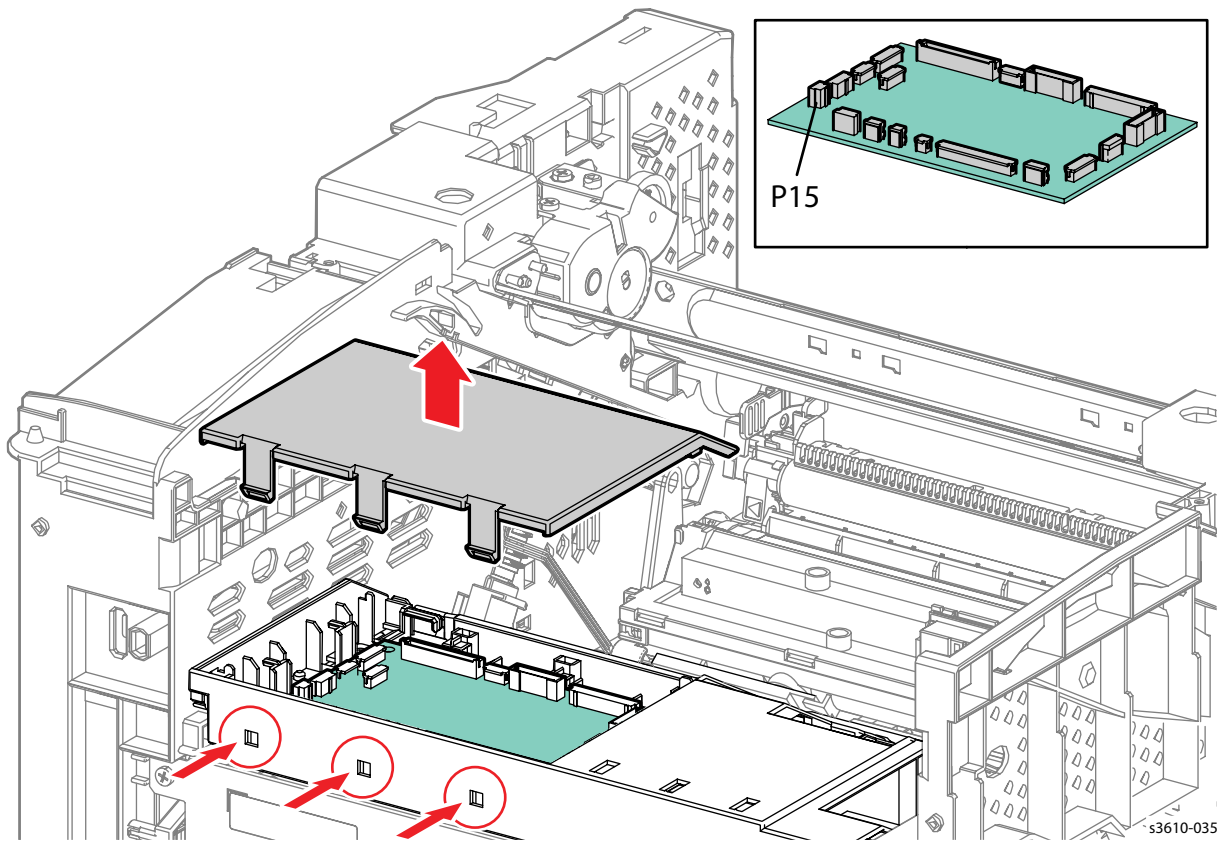
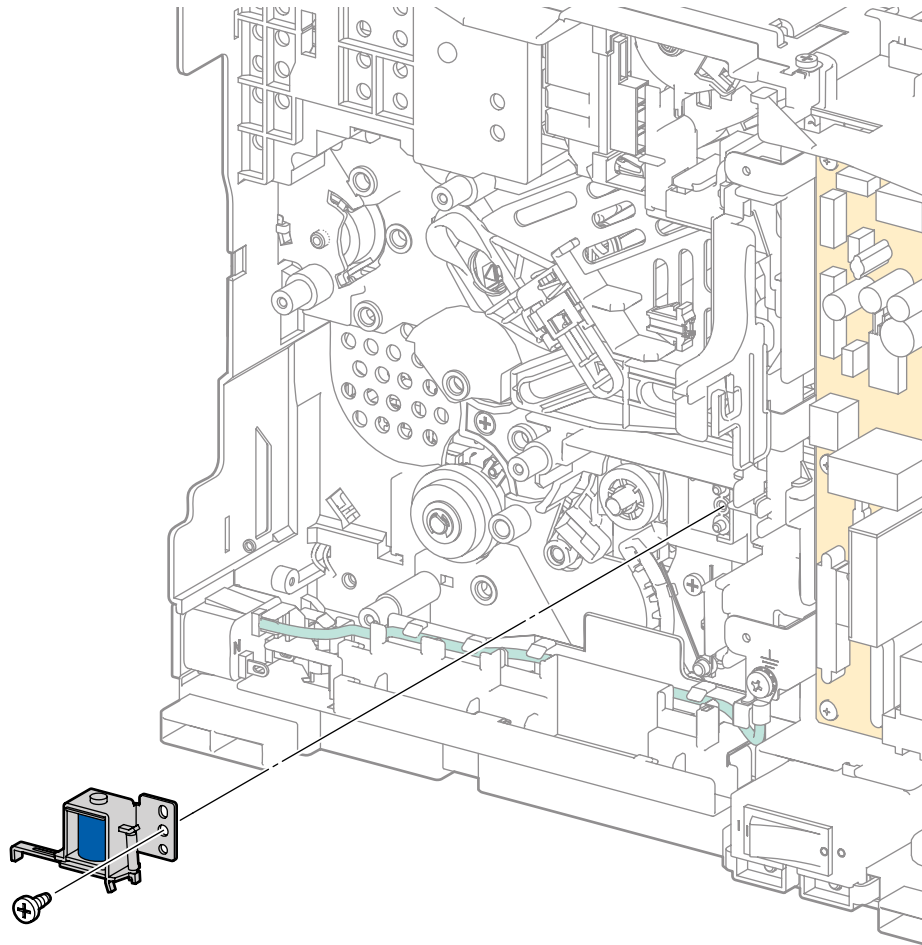

Figure 1

s3610-035

4. Remove (REP 5.2 ESS PWB Housing).
5. Remove the MSI Feed Solenoid. Gently pull the wire harness out through the frame. (Figure 2)



s3610-015a

Figure 2

Replacement

1. Replace in reverse order.

REP 2.15 Pick-up Holder Assembly

PL 2.6 MSI

Removal

1. Remove all the trays.
2. Tip the unit onto the left side.
3. Release the clip that secures the Pick-up Flange and remove the assembly. (Figure 1)

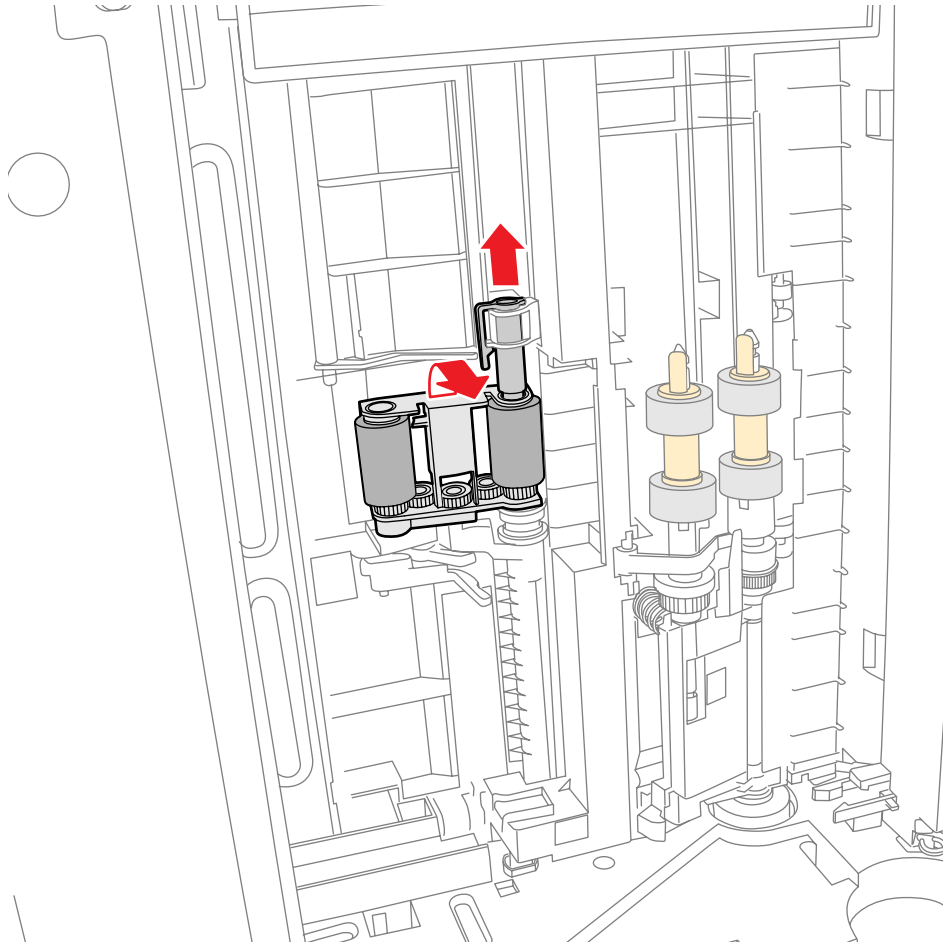

Figure 1

Replacement

1. Make sure the Roller Assembly engages the Lift Lever upon replacement.
2. Replace in reverse order.

REP 2.16 Top Frame Assembly

PL 2.6 MSI

Removal

! **WARNING:** Allow the Fusing Assembly to cool before servicing the product.

1. Remove the Bypass Tray.
2. Remove (REP 1.2 Front Cover Assembly (3610 / 3615)).
3. Remove (REP 1.4 Top Cover Assembly (3610)).
4. Release 4 clips that secure the Top Frame Assembly to remove it from the chassis. (Figure 1)

CAUTION: make sure not to damage the No Paper Actuator when removing the cover.

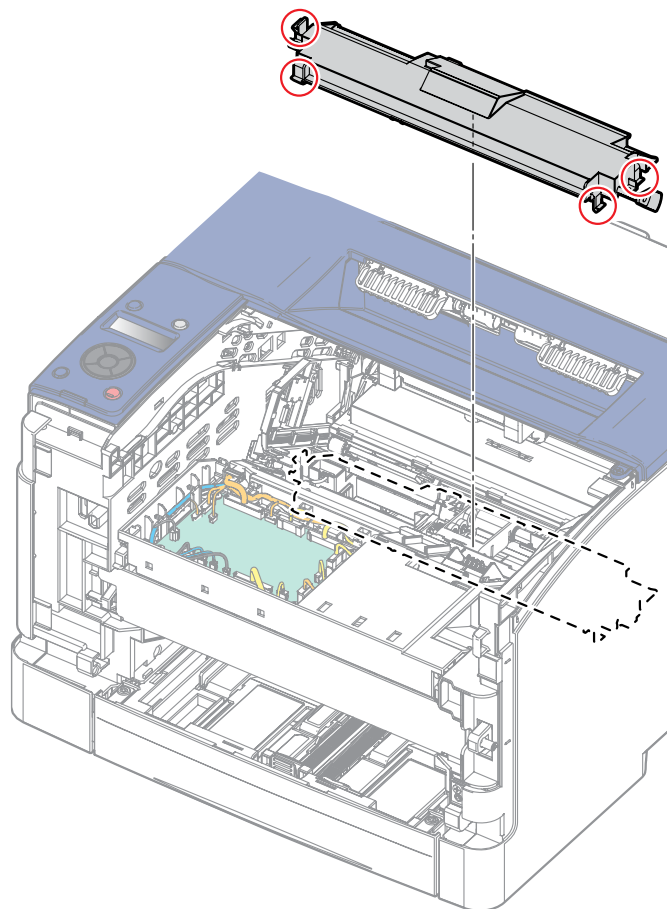

s3610-014a

Figure 1

Replacement

1. Make sure the No Paper Actuator is positioned through the frame chassis correctly.
2. Replace in reverse order.

REP 2.17 Bypass Tray Retard Roller

PL 2.7 Bypass Tray

Removal

1. Remove the Bypass Tray.
2. Release the clip that secures the Retard Roller Assembly to the Bypass Tray, then remove the assembly by rotating it in the direction of the arrow. (Figure 1)

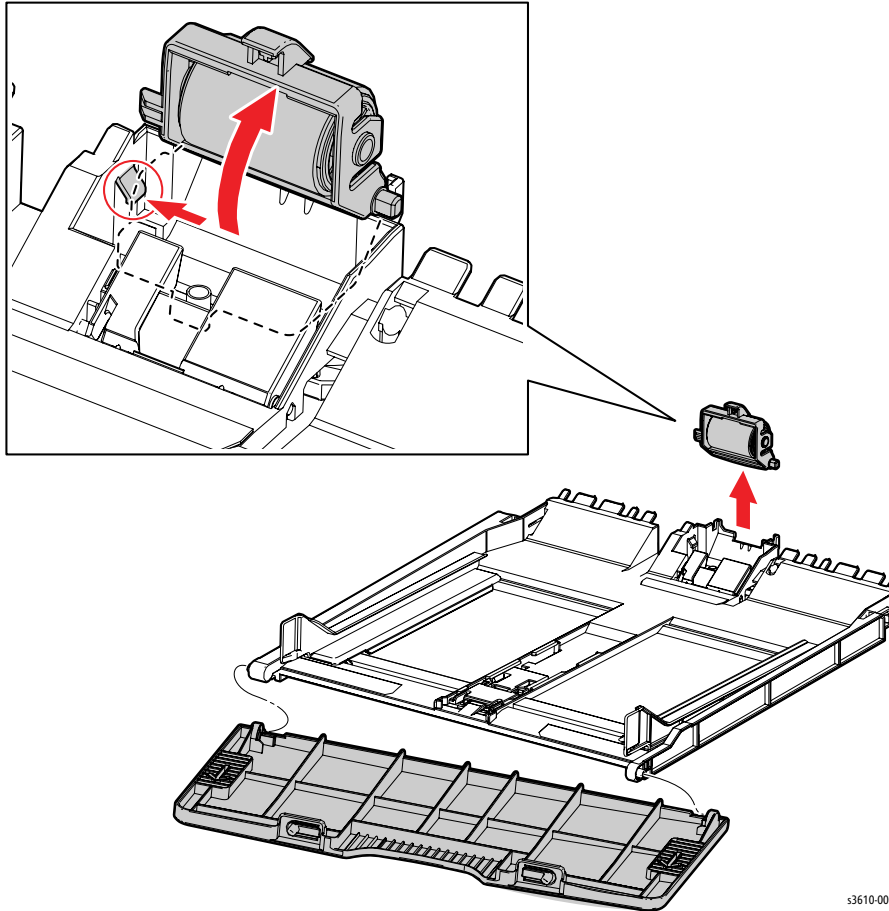

Figure 1

s3610-004

Replacement

1. Make sure the spring is positioned correctly before lowering the Retard Roller Assembly.
2. Test the assembly once you have it secured.
3. Replace in reverse order.

Xerographic Repairs

REP 3.1 ROS Assembly

PL 3.2 ROS Assembly

Removal

1. Remove the Drum Cartridge ().
2. Remove (REP 1.2 Front Cover Assembly (3610 / 3615)).
3. Prepare the MCU PWB. (Figure 1)
 - a. Release 3 clips to remove the MCU PWB Cover.
 - b. Disconnect all MCU PWB connections except P/J11, 18 and 26.

Note: Do not remove the MCU PWB.

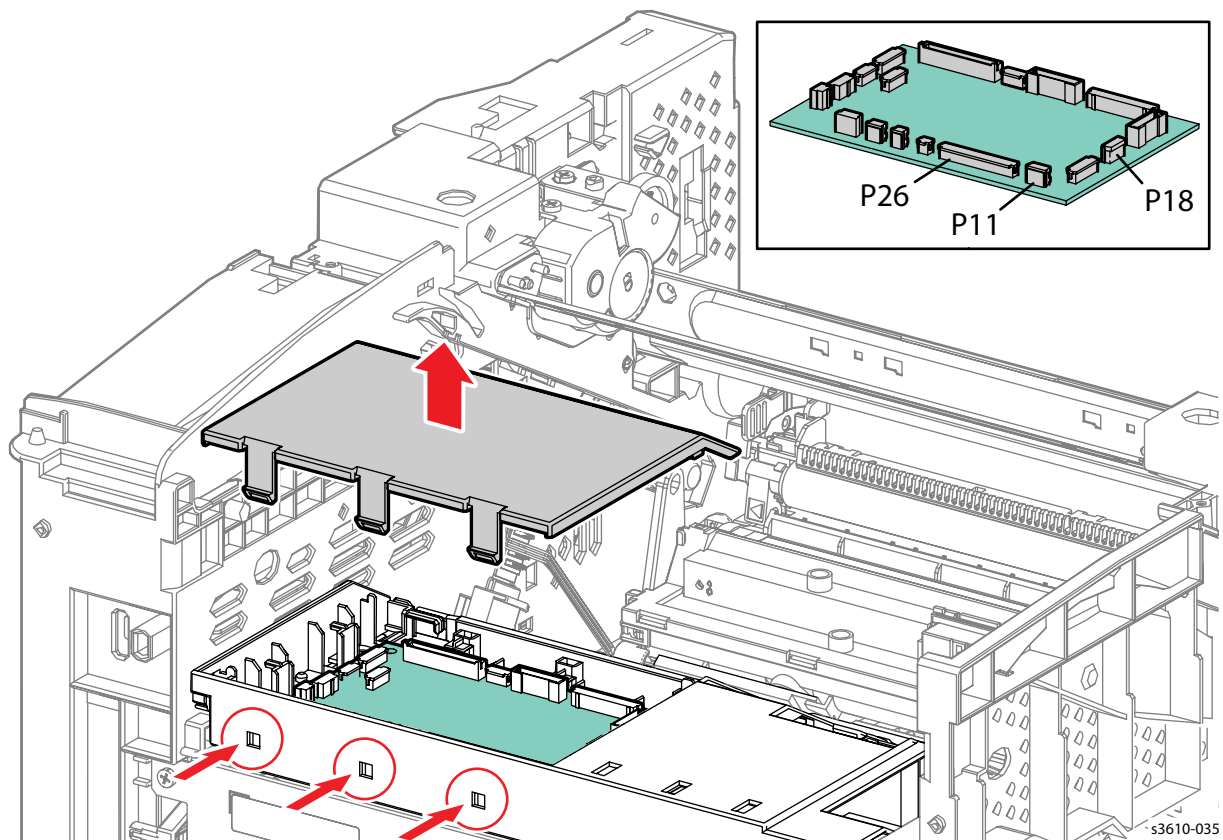

Figure 1

s3610-035

4. Remove 2 screws (silver, M3, 6mm) that secure the MCU Housing to the chassis. (Figure 2)

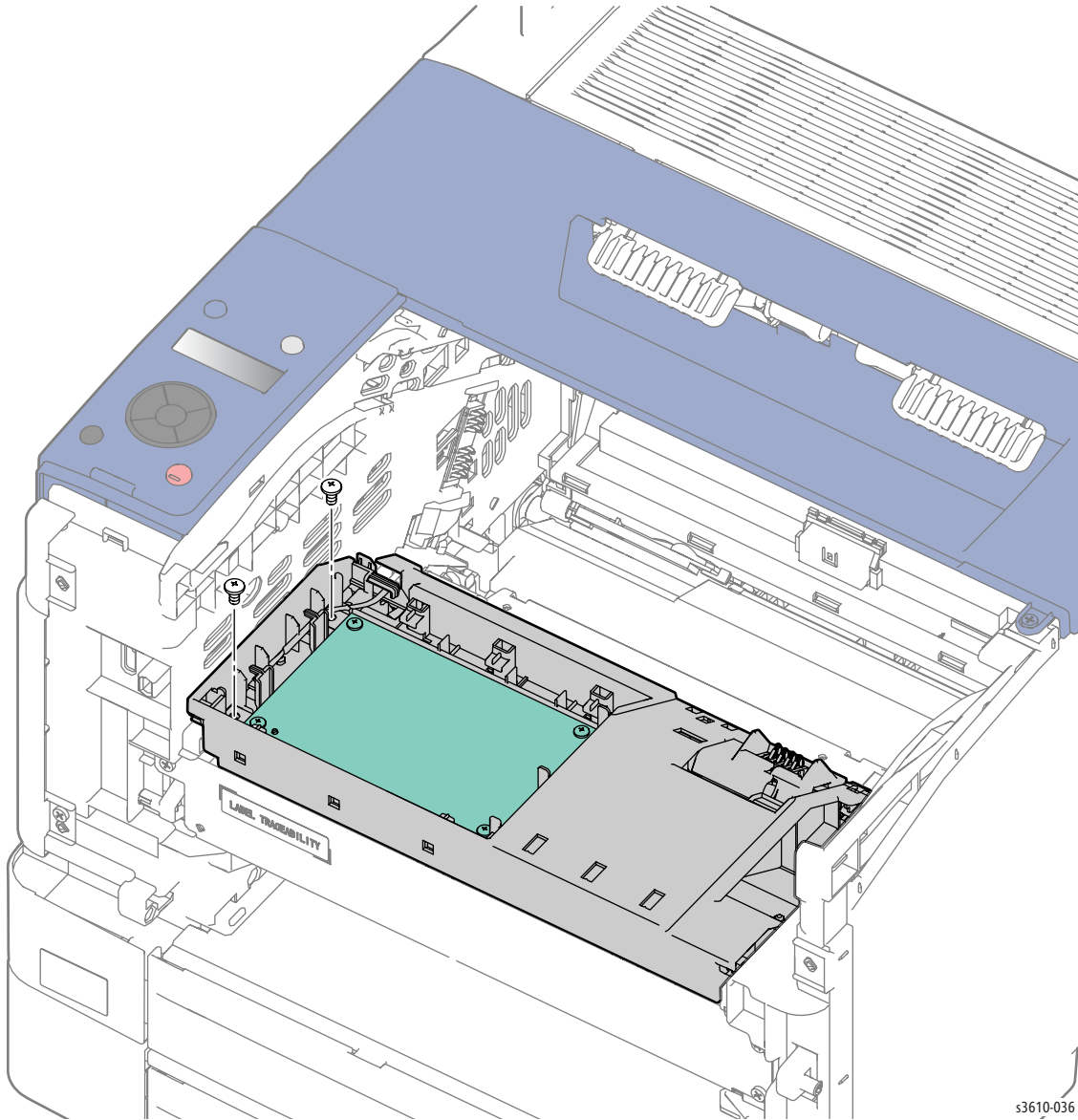

Figure 2

s3610-036

5. Remove the harnesses from the MCU PWB Housing harness guides to provide enough slack to move the MCU Housing to the front of the printer.
6. Release the MCU Housing. (Figure 3)
 - a. Release the clip.
 - b. Rotate the MCU PWB Housing toward the front of the machine,
 - c. Lift the MCU PWB Housing up off of the pins and rest the housing at the front of the printer.

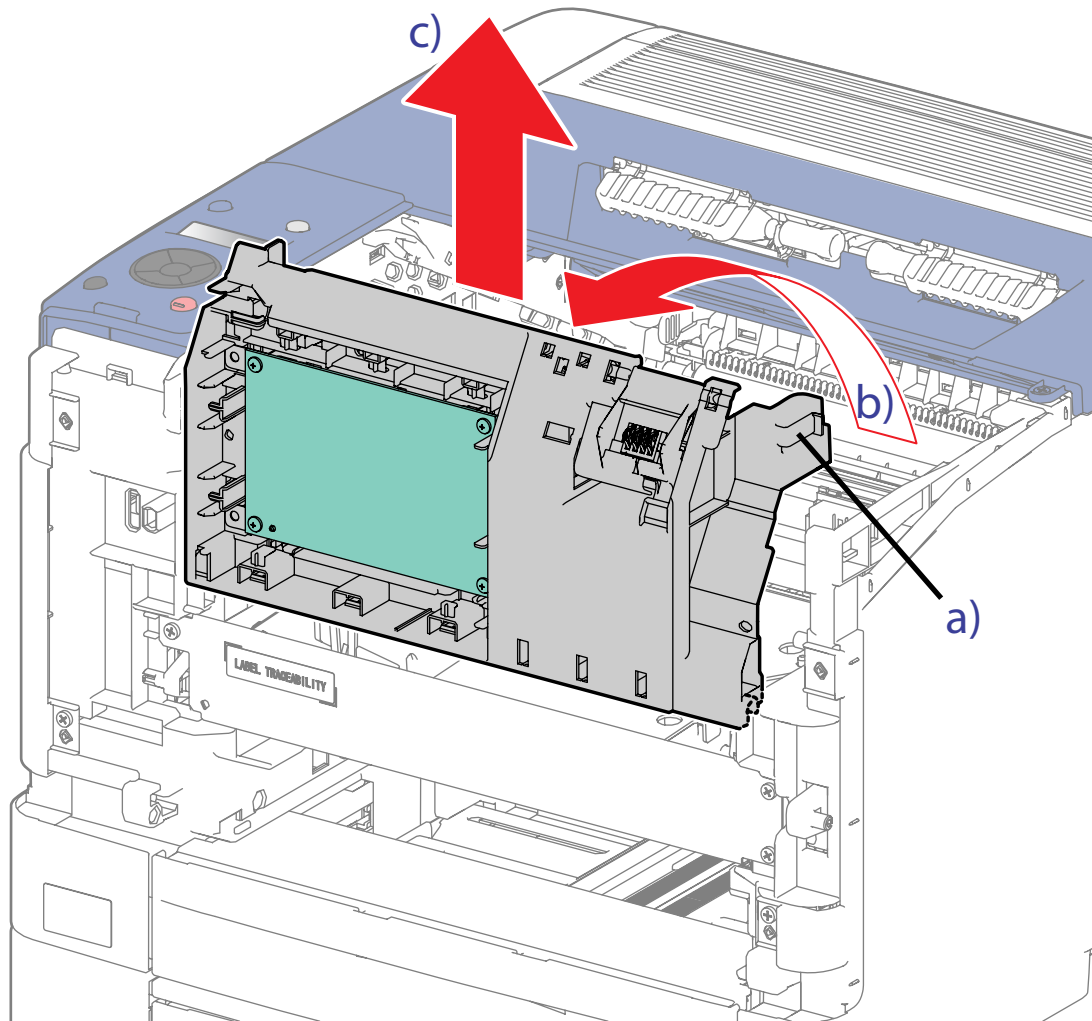

Figure 3

s3610-037

7. Remove the ROS Assembly. (Figure 4)
 - a. 4 screws (silver, flanged, tapping, 10mm),
 - b. Disconnect P/J502.
 - c. Lift to remove the ROS Assembly.

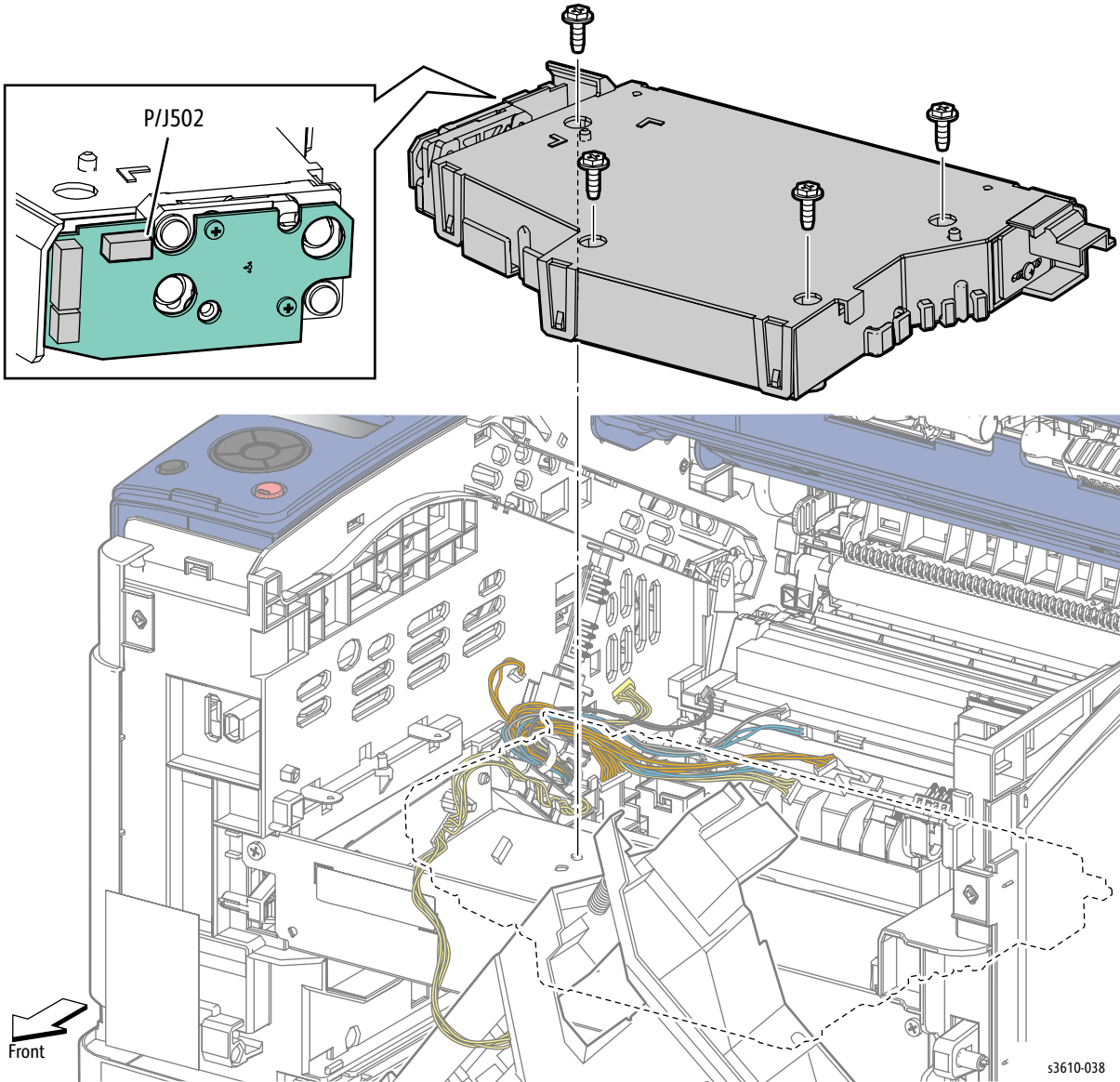

Figure 4

Replacement

1. Make sure the MCU PWB Housing is seated correctly on the pins so it can be rotated back into the proper position.
2. Replace in reverse order.

REP 3.2 Toner Dispense CRUM Assembly

PL 3.3 Toner Dispense

Removal

1. Open the Front Cover.
2. Remove the Drum Cartridge.
3. Access the CRUM. (Figure 1)
 - a. Release 1 clip to open the CRUM Housing from the MCU PWB Housing.
 - b. Disconnect P/J 253.

CAUTION: The wire to the connector may be short, so use caution when removing the connector.

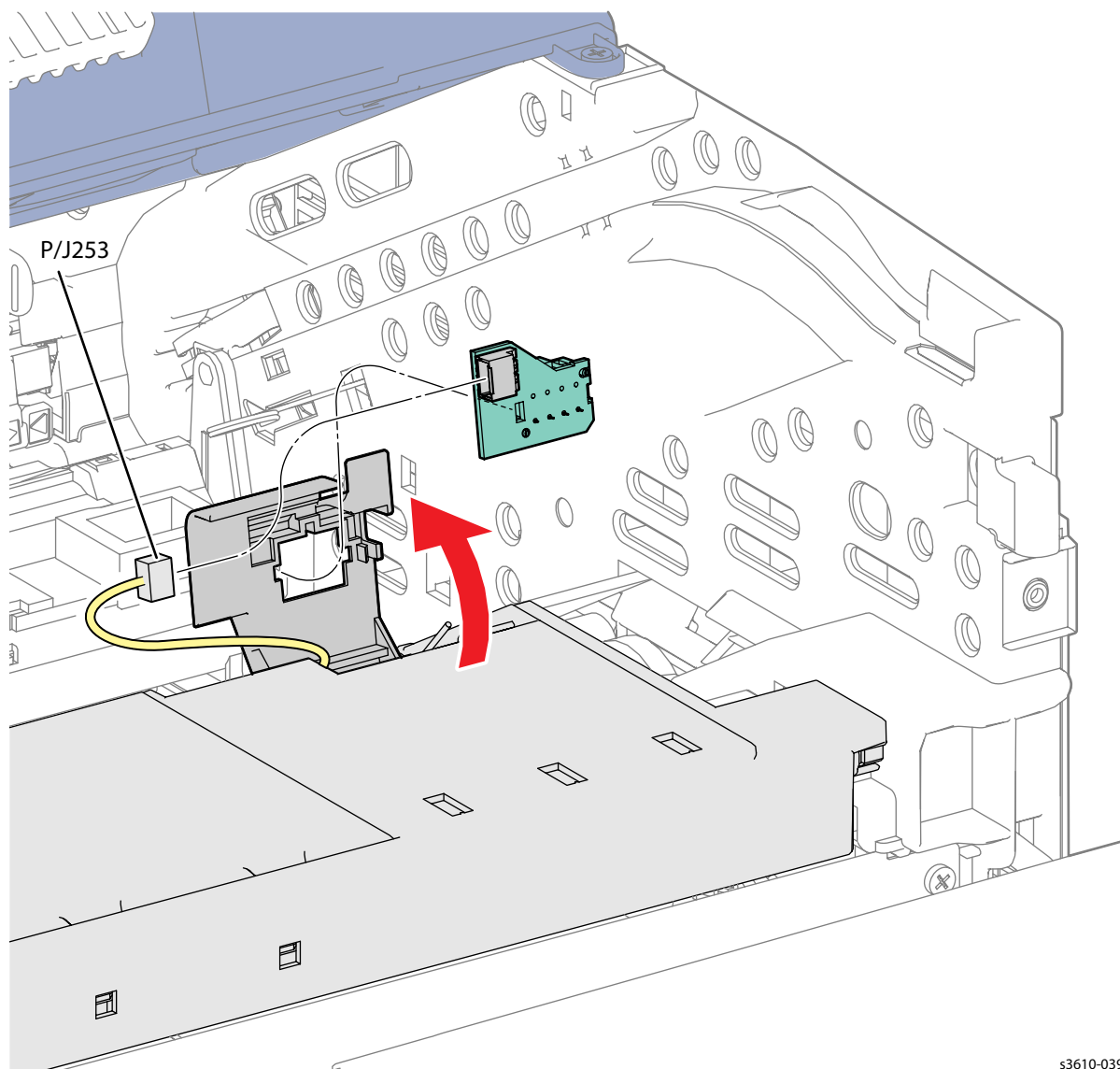

Figure 1

s3610-039

4. Release 1 of the 2 clips on the CRUM Housing, and then slide to remove the housing. (Figure 2)

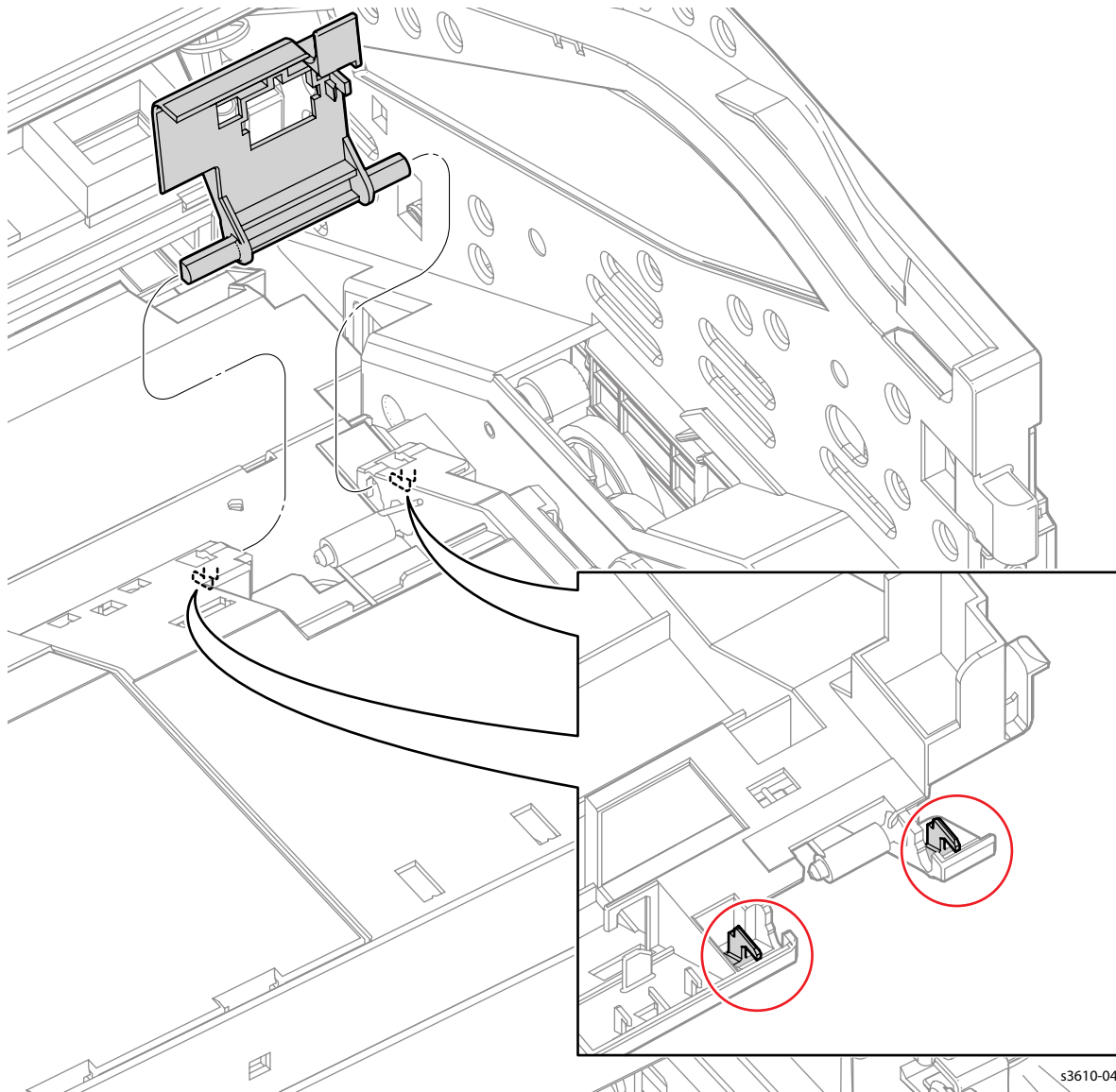

Figure 2

s3610-04c

Replacement

1. You may need to release the wire harness in the housing to connect P/J 253
2. When closing the CRUM Housing, install the CRUM spring correctly. (Figure 3)

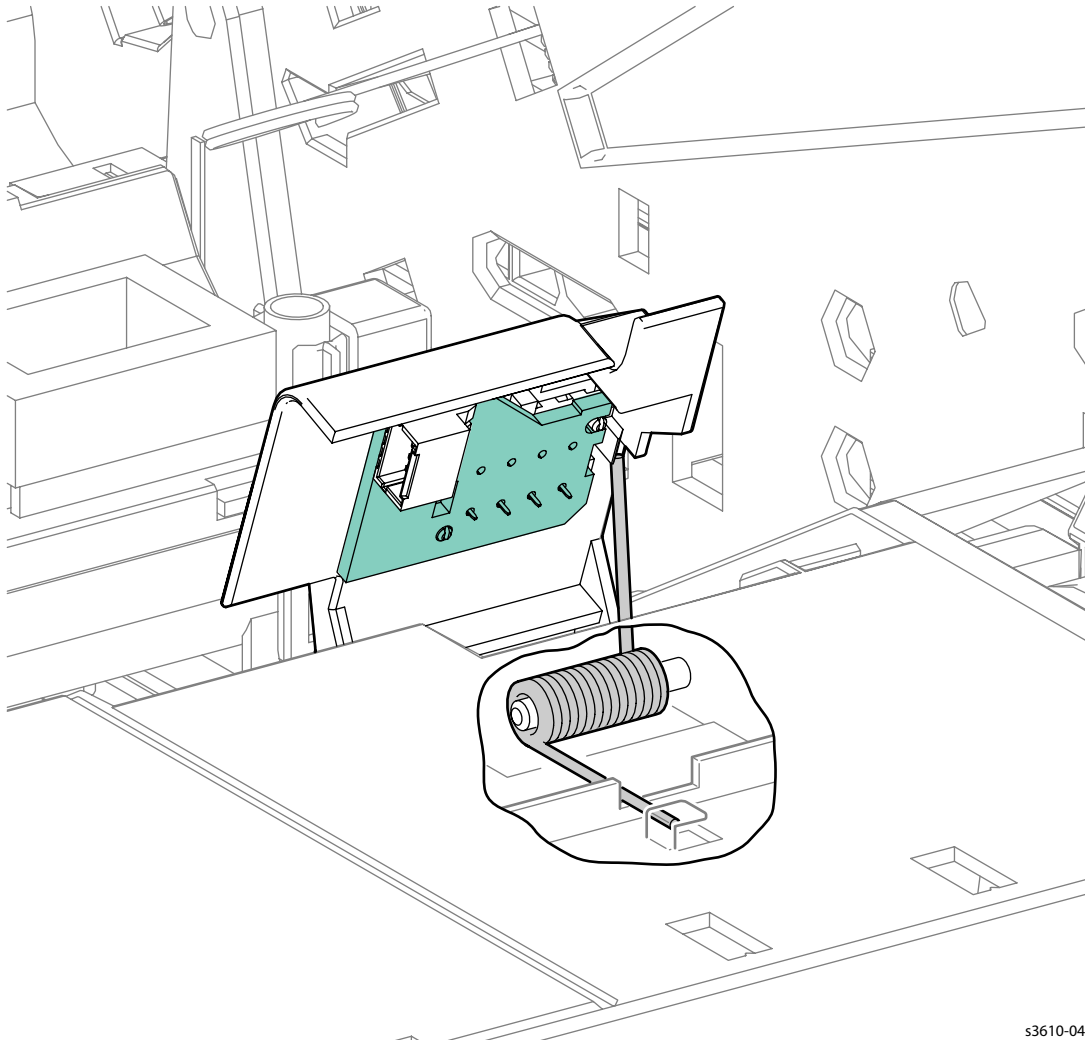

Figure 3

s3610-041

3. Test the spring tension after you close the housing.
4. Replace in reverse order.

REP 3.3 Xerographic Connector Assembly

PL 3.3 Toner Dispense

Removal

1. Remove the Bypass Tray.
2. Remove (REP 1.2 Front Cover Assembly (3610 / 3615)).
3. Prepare the MCU PWB. (Figure 1)
 - a. Release 3 clips to remove the MCU PWB Cover.
 - b. Disconnect all MCU PWB connections except P/J11, 18 and 26.

Note: Do not remove the MCU PWB.

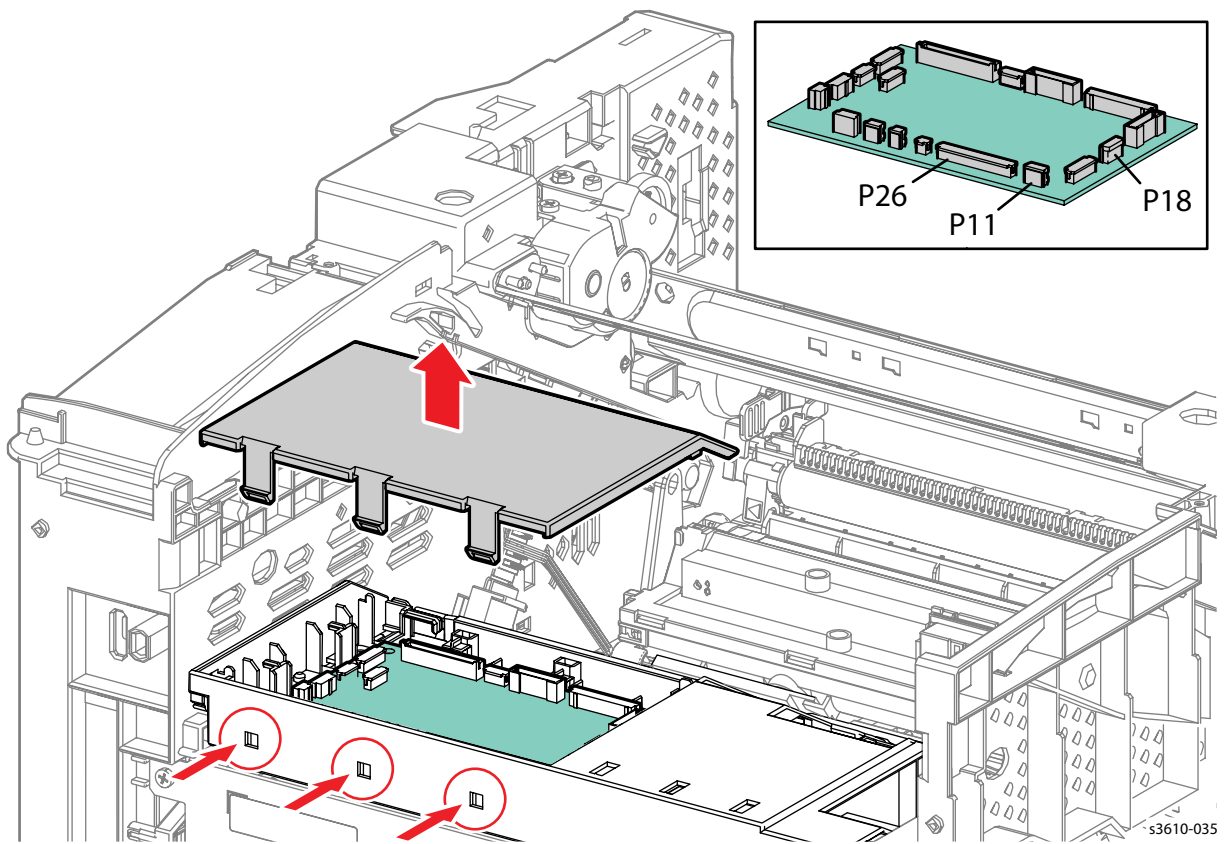

4. Release all the harnesses from the harness guides around the MCU PWB.
5. Remove the Xerographic Connector Assembly. (Figure 2)
 - a. Release the clip at the top of the connector.
 - b. Release the Connector harness from the chassis and gently pull enough slack to remove the connector and disconnect P/J254.

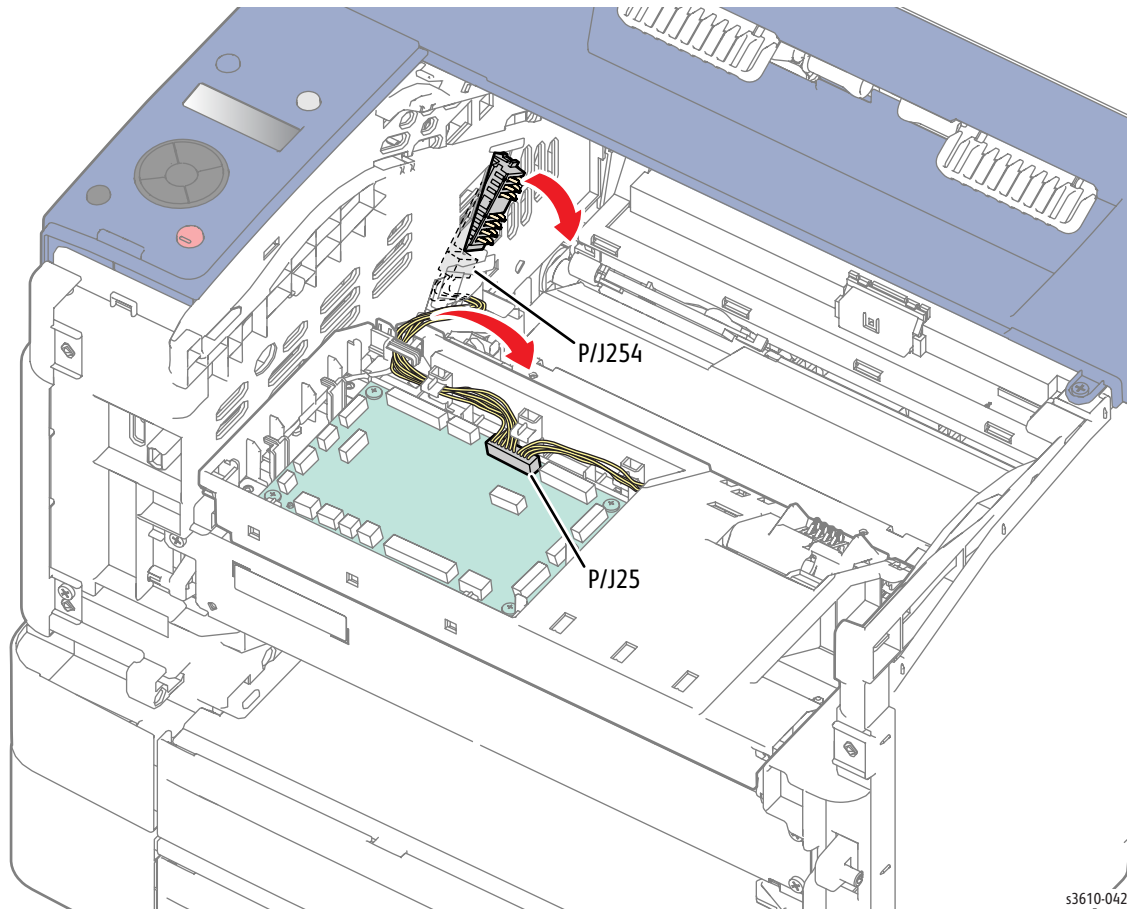

Replacement

1. Replace in reverse order.

REP 3.4 Transfer Roller Assembly

PL 3.4 Transfer Roller

Removal

! **WARNING:** Allow the Fusing Assembly to cool before servicing the product.

1. Open the Rear Cover.
2. Press 2 clips on the left and right sides and rotate the Transfer Roller Assembly upward to remove it. (Figure 1)

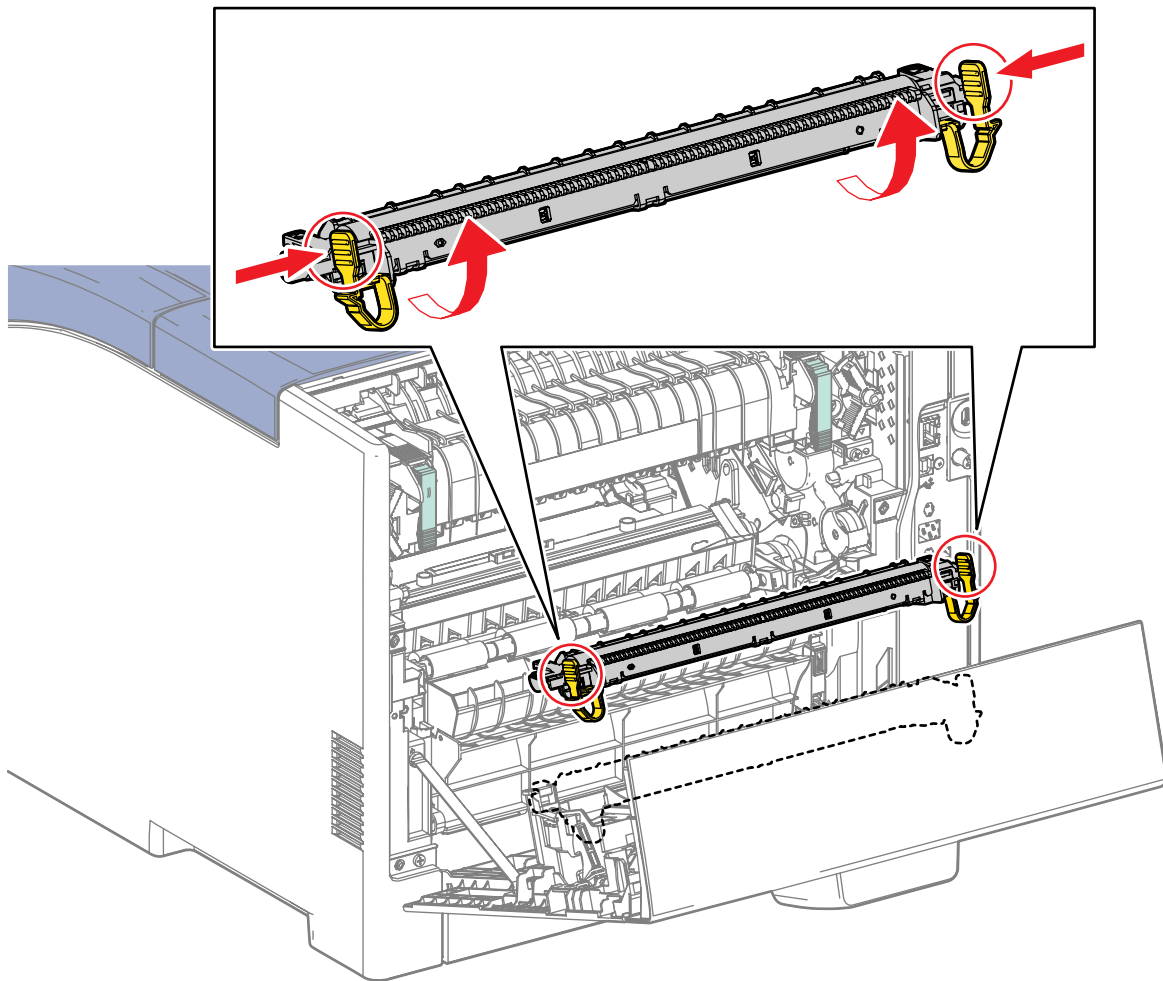

Figure 1

s3610-043

Replacement

1. Replace in reverse order.
2. Reset the Transfer Roller Assembly Counter. ([Resetting Counters](#))

REP 3.5 Fusing Assembly

PL 3.5 Fusing Assembly

Removal

! **WARNING:** Allow the Fusing Assembly to cool before servicing the product.

1. Open the Rear Cover.
2. Rotate the Fusing Assembly locking levers in the direction indicated by the arrows, then pull the Fusing Assembly out of the printer. (Figure 1)

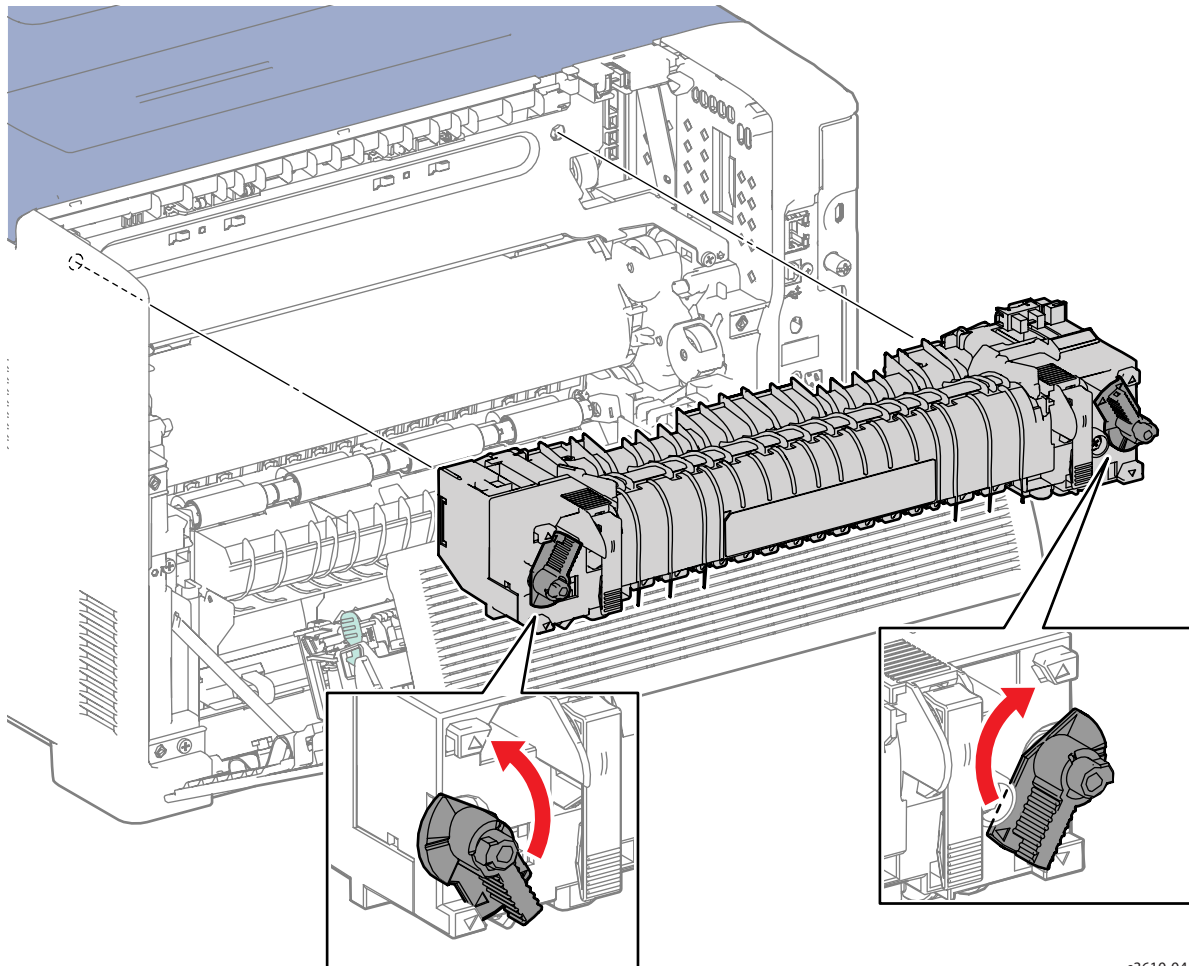

Figure 1

s3610-044

Replacement

1. Replace in reverse order.
2. Reset the Fusing Assembly Counter. ([Resetting Counters](#))

Drive Repairs

REP 4.1 Main Drive Assembly

PL 4.1 Drive

Removal



WARNING: Allow the Fusing Assembly to cool before servicing the product.

1. Remove ([REP 3.5 Fusing Assembly](#)).
2. Remove ([REP 5.2 ESS PWB Housing](#)).

3. Remove the Main Drive Assembly. (Figure 2)
 - a. Push the Front Link all the way into the chassis.
 - b. Remove 4 screws (silver, tapping, 8mm) that secure the Main Drive Assembly.
 - c. Remove the wire from the clip.
 - d. Disconnect P101 to remove the drive.

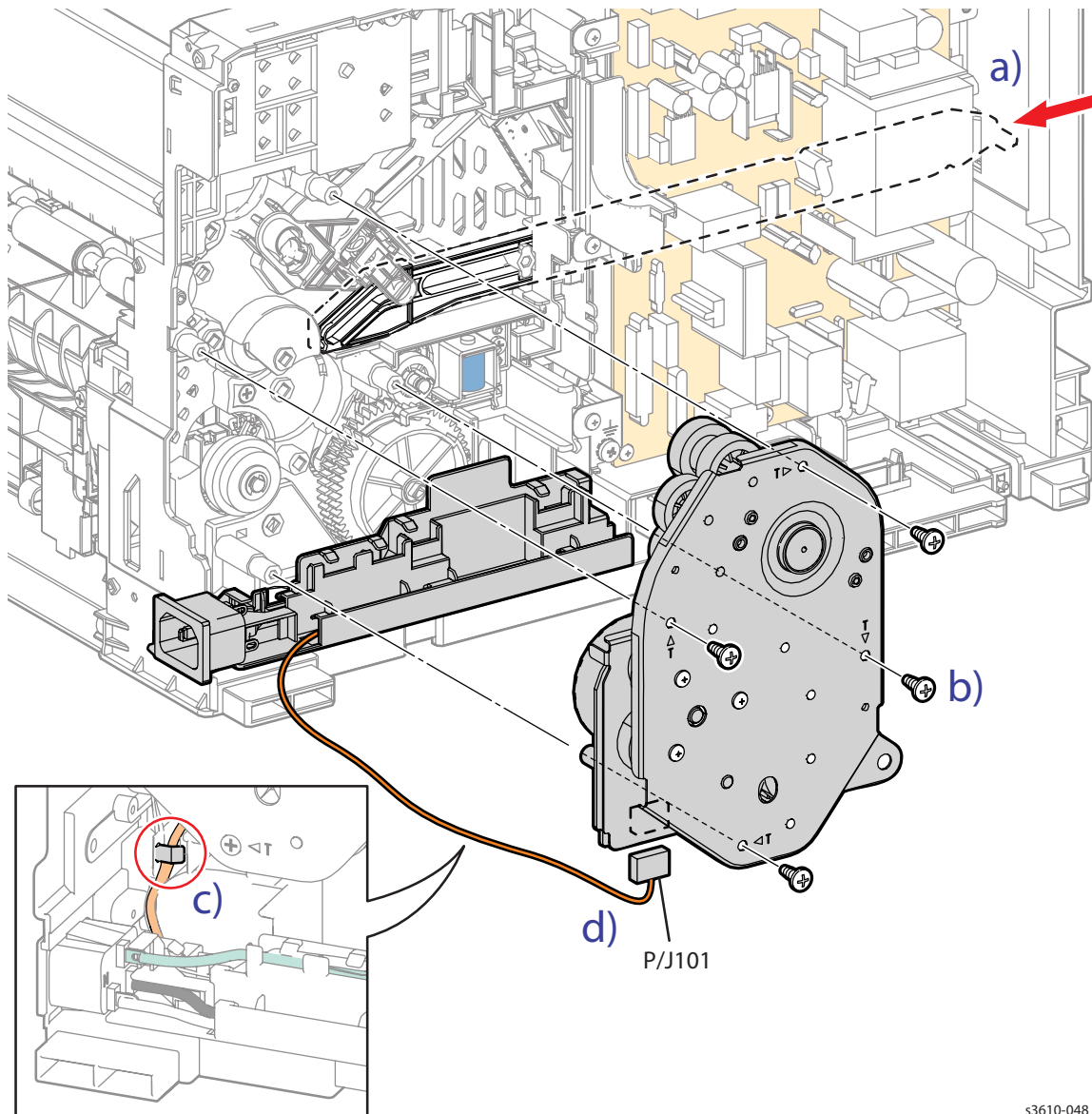

s3610-048

Figure 2

Replacement

1. Replace in reverse order.

REP 4.2 Exit Output Drive Assembly

PL 4.1 Drive

Removal

⚠ WARNING: Allow the Fusing Assembly to cool before servicing the product.

1. Remove (REP 5.2 ESS PWB Housing).
2. Remove the Fusing Assembly Harness. (Figure 1)
 - a. Release 2 clips that secure the Fusing Assembly harness,
 - b. Disconnect P/J233 from the Fusing Assembly harness

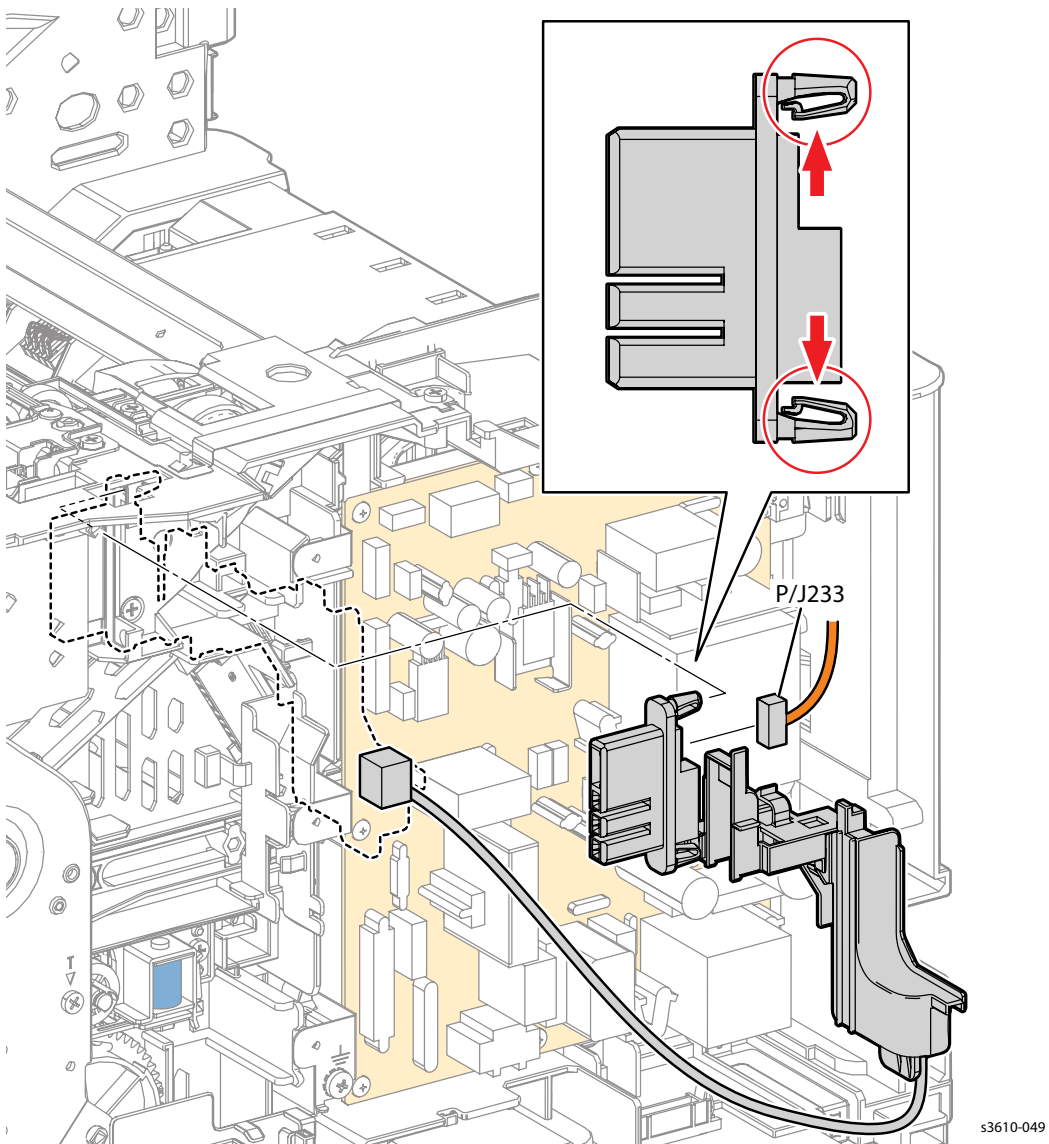

Figure 1

3. Prepare the MCU PWB for removal. (Figure 1)
 - a. Release 4 clips that secure the Top Frame Assembly to remove it from the chassis.
 - b. Release 3 clips that secure the MCU PWB cover to remove it from the chassis.
 - c. Disconnect P/J17 from the MCU PWB and release the exit clutch harness from the guide.

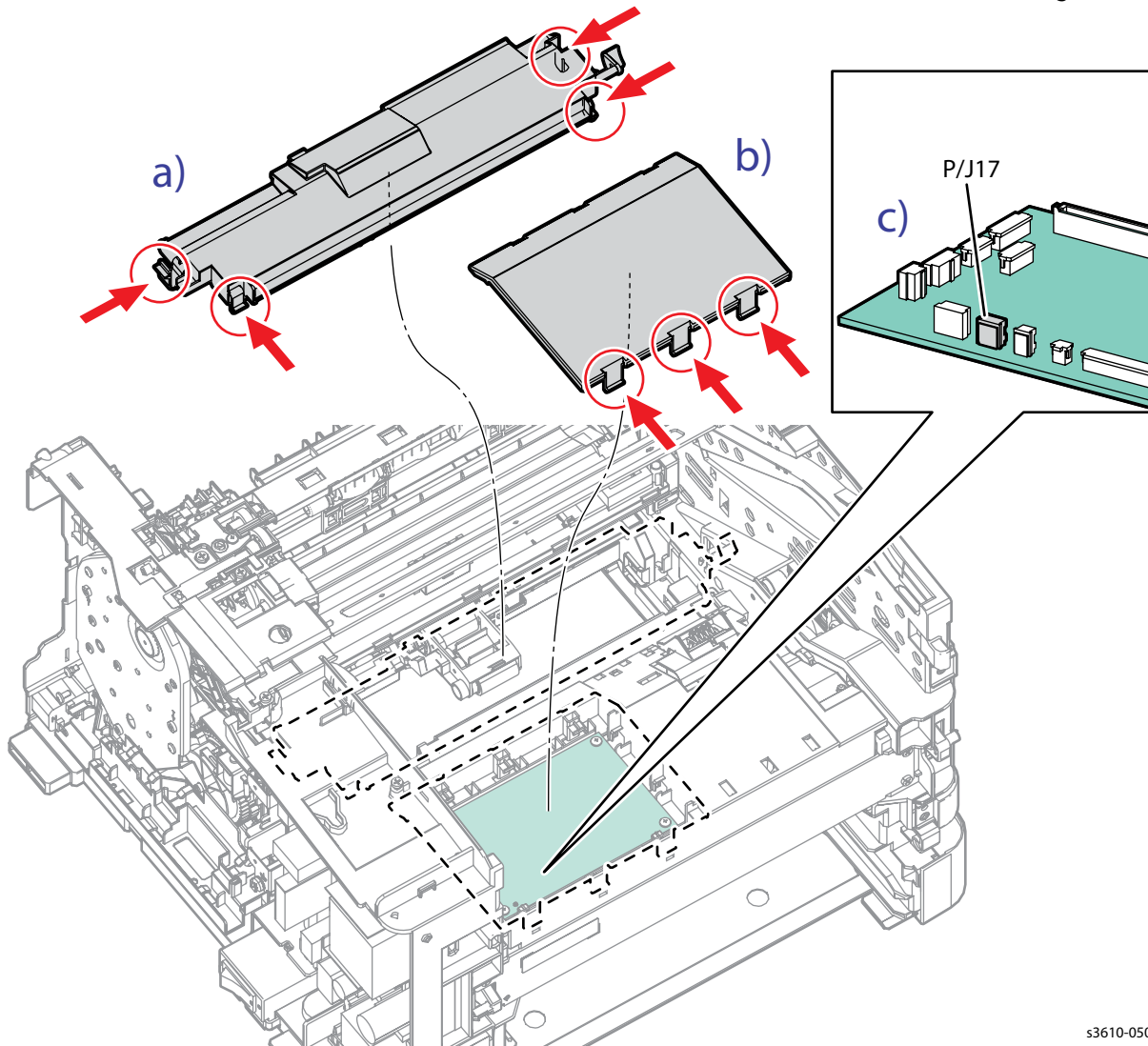

Figure 1

s3610-050

4. Remove the Exit Output Drive Assembly. (Figure 2)
 - a. 1 screw (silver, M3, 6mm) that secures the left upper corner of the LVPS, and lift the ground strap.
 - b. Remove 2 screws (silver, tapping, 6mm) and release 1 clip that secures the Exit Output Drive Assembly.
 - c. Disconnect P/J16 and remove the Exit Output Drive Assembly.

Note: Gears are not captive in the assembly.

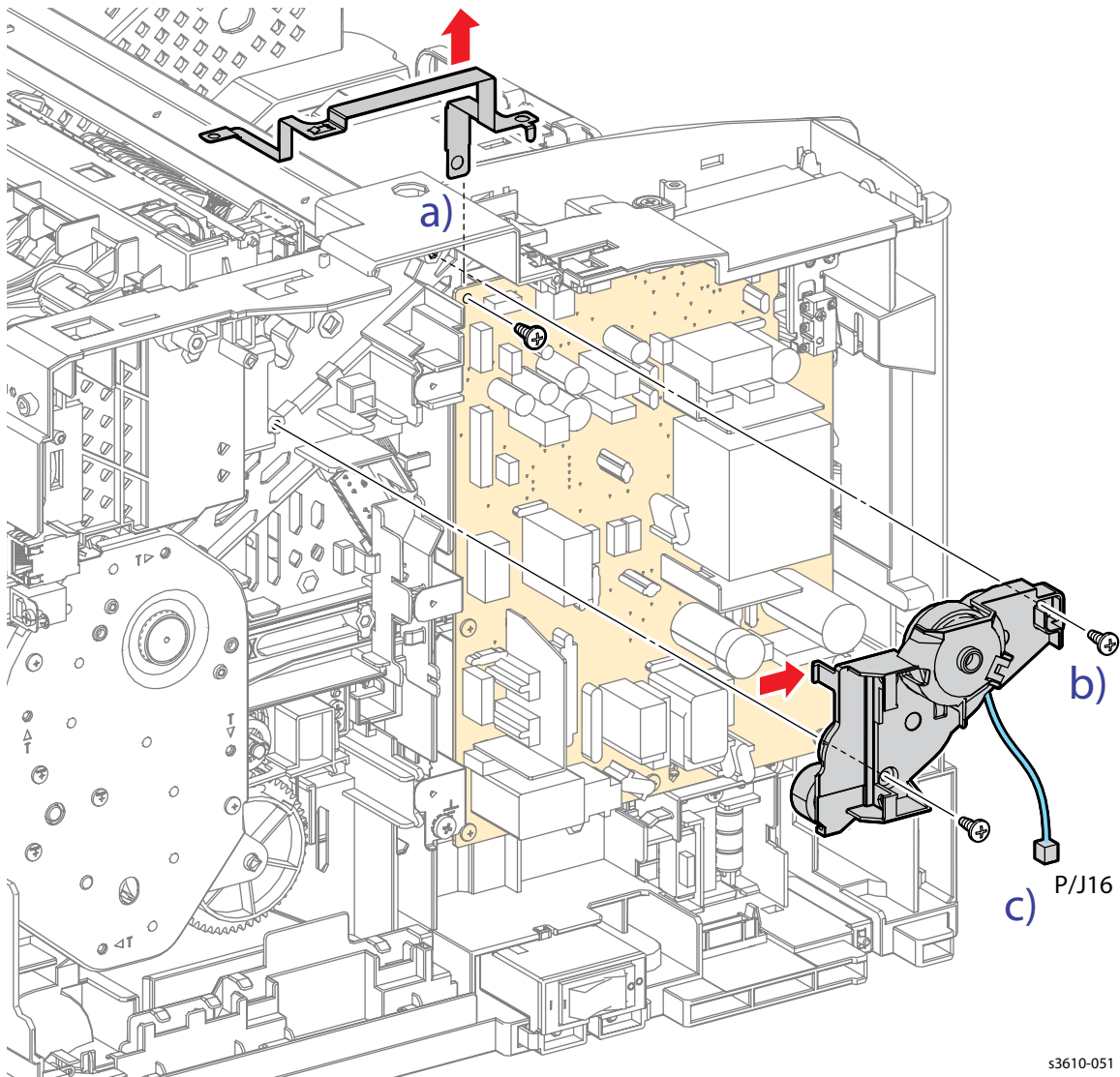

Figure 2

Replacement

1. Component placement in the Exit Output Drive Assembly is shown below. (Figure 1)

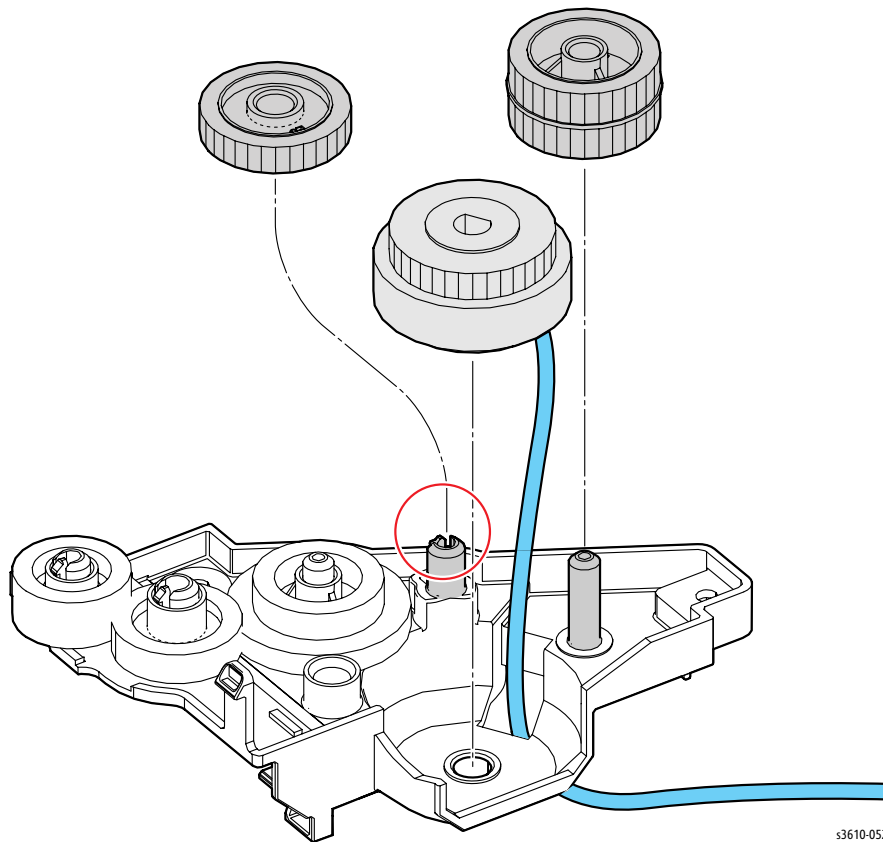

Figure 1

2. Insert the ground strap between the LVPS and frame. Also, when installing the Exit Output Drive Assembly, fit the D-shaped shaft of the Exit Invert Drive Assembly into the D-shaped hole of the exit clutch. (Figure 1)

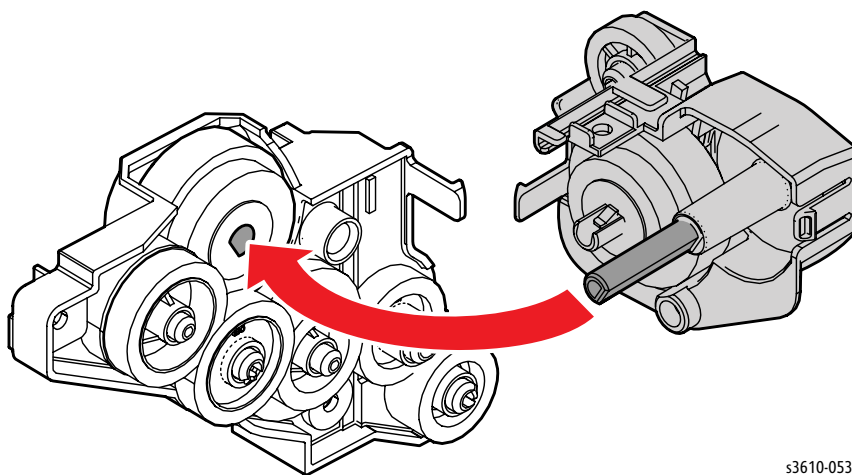
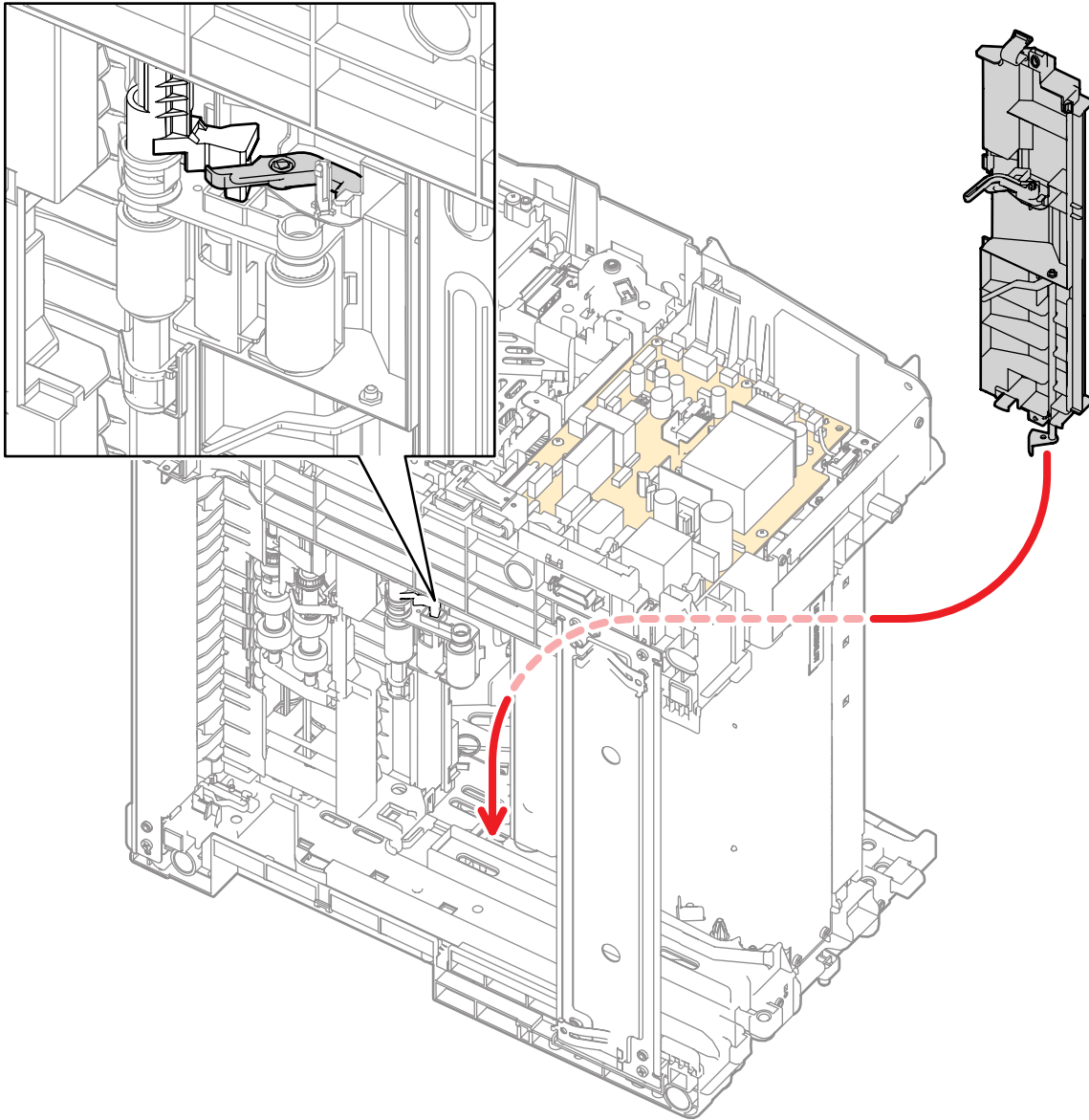

Figure 2

3. When installing the Top Frame Assembly, rest the printer on its right side. Align the Bypass Tray No Paper Sensor Actuator coupled with the Top Frame Assembly so it fits into the hole on the printer and the Lock MSI In connects with the Pick Up Holder Assembly. (Figure 3)



s3610-025

Figure 3

4. Replace in reverse order.

REP 4.3 Exit Invert Drive Assembly

PL 4.1 Drive

! **WARNING:** Allow the Fusing Assembly to cool before servicing the product.

1. Remove (REP 5.2 ESS PWB Housing).
2. Access the MCU PWB. (Figure 1)
 - a. Release 4 clips that secure the Top Frame Assembly to remove it from the chassis.
 - b. Release 3 clips that secure the MCU PWB cover to remove it from the chassis.
 - c. Disconnect P/J16 from the MCU PWB and release the invert clutch harness from the guide.

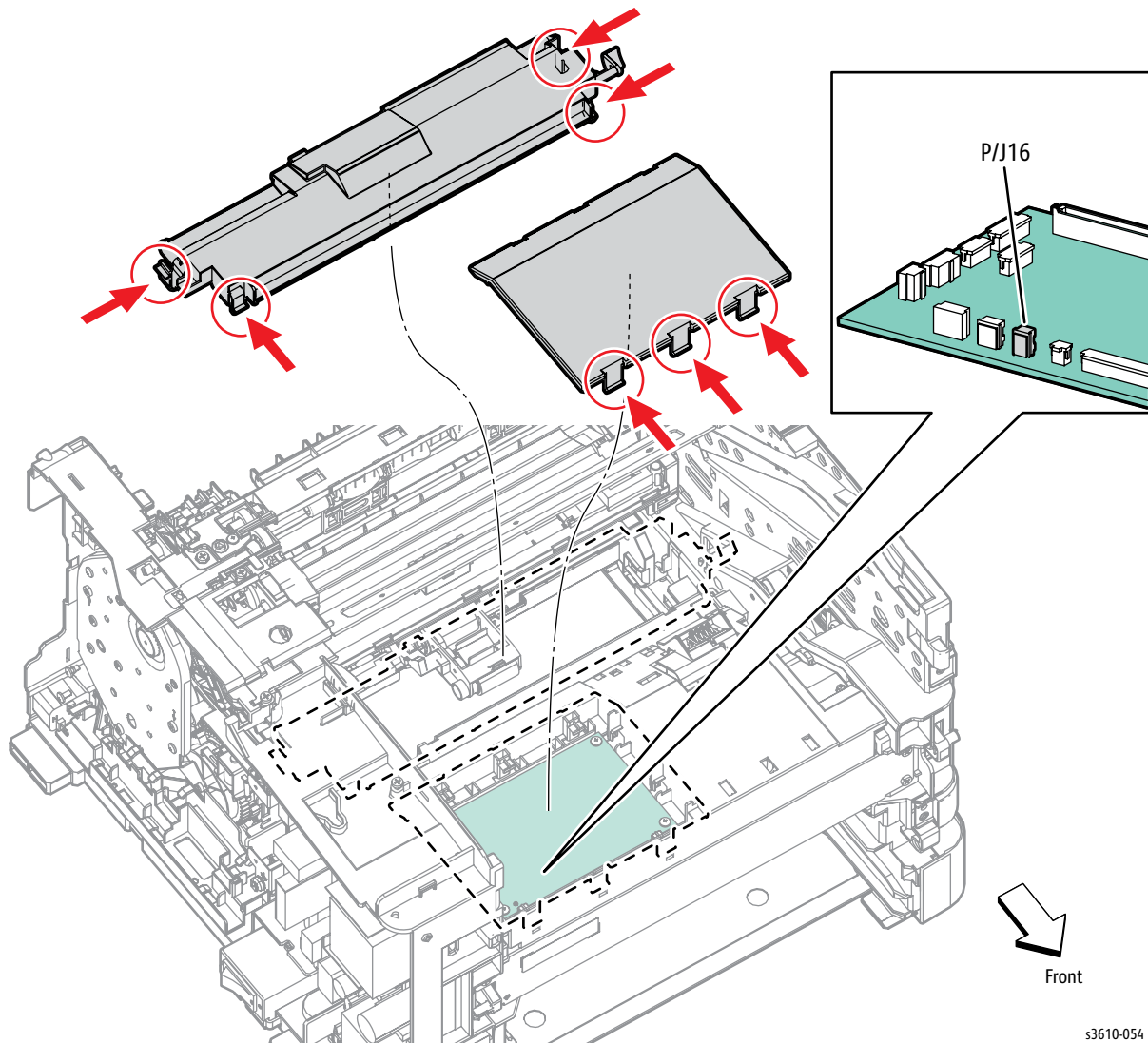
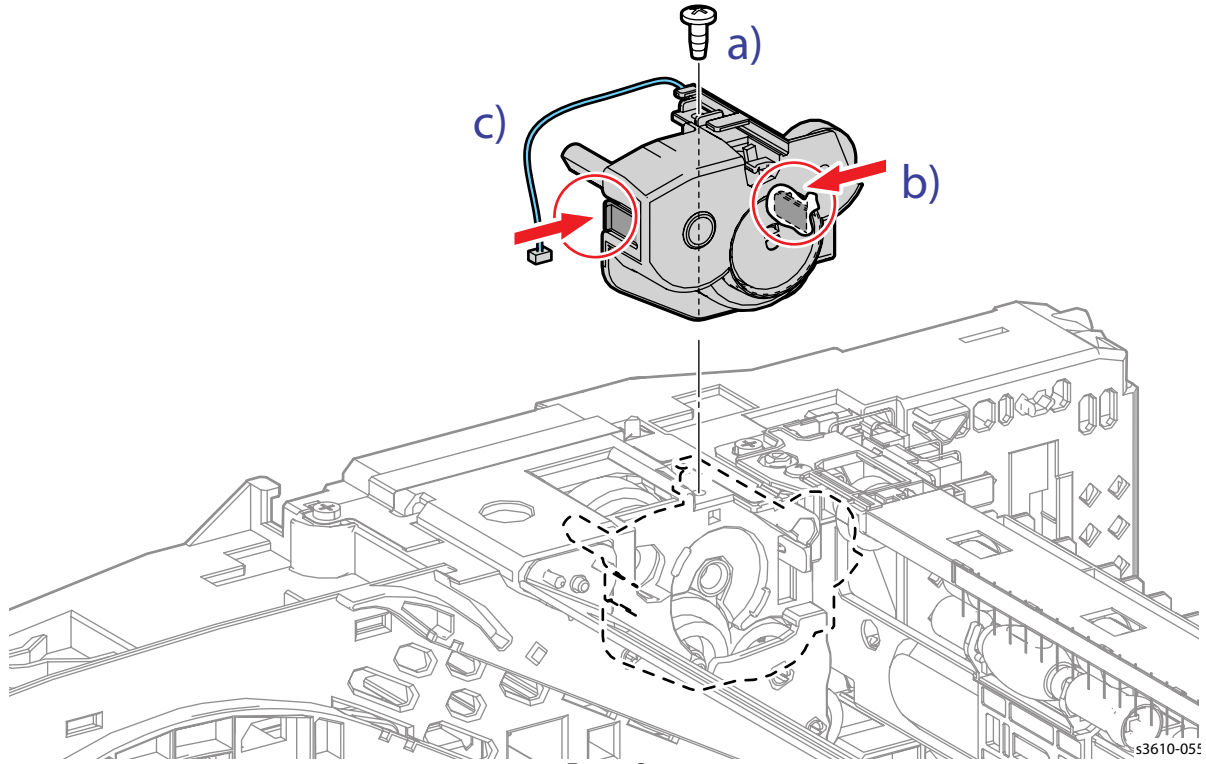

Figure 1

s3610-054

3. Remove the Drive Assembly. (Figure 2)
 - a. Remove 1 screw (silver, tapping, 6mm) that secures the Exit Invert Drive Assembly.
 - b. Release 2 clips.
 - c. Release the harness of the invert clutch, then remove the assembly.



4. Release the harness of the invert clutch from the Exit Invert Drive Assembly.
5. Remove the invert clutch by releasing 1 clip on gear E5. (Figure 3)

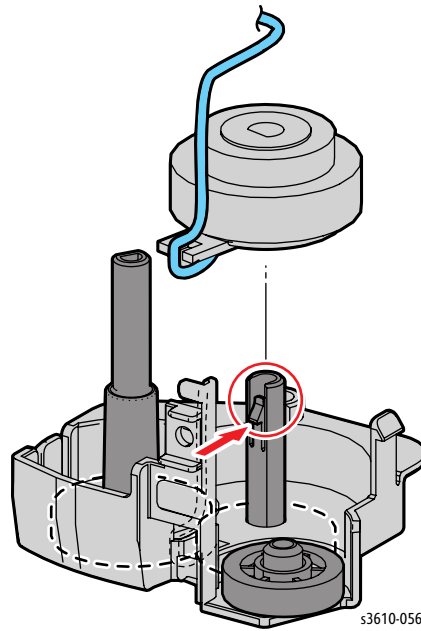

Figure 3

Replacement

1. When installing the invert clutch, align the tab with the Exit Invert Drive Assembly stopper. (Figure 4)

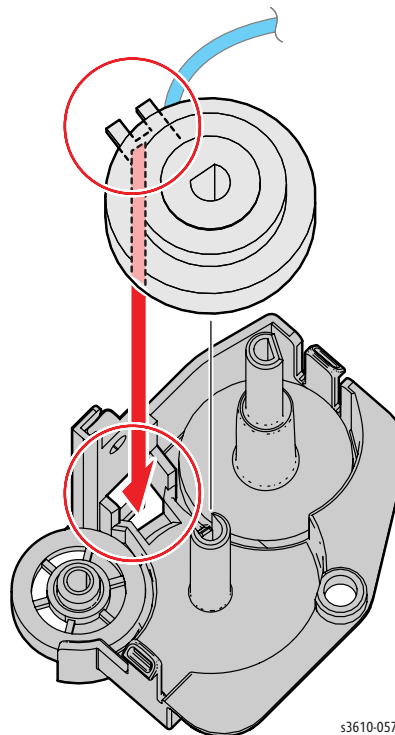

Figure 4

2. When installing the Exit Invert Drive Assembly, fit the D-shaped shaft of the invert clutch into the D-shaped hole of the exit clutch. (Figure 5)

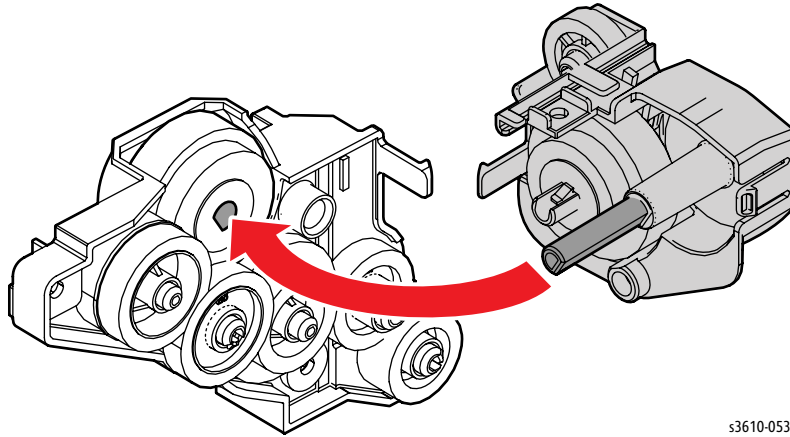
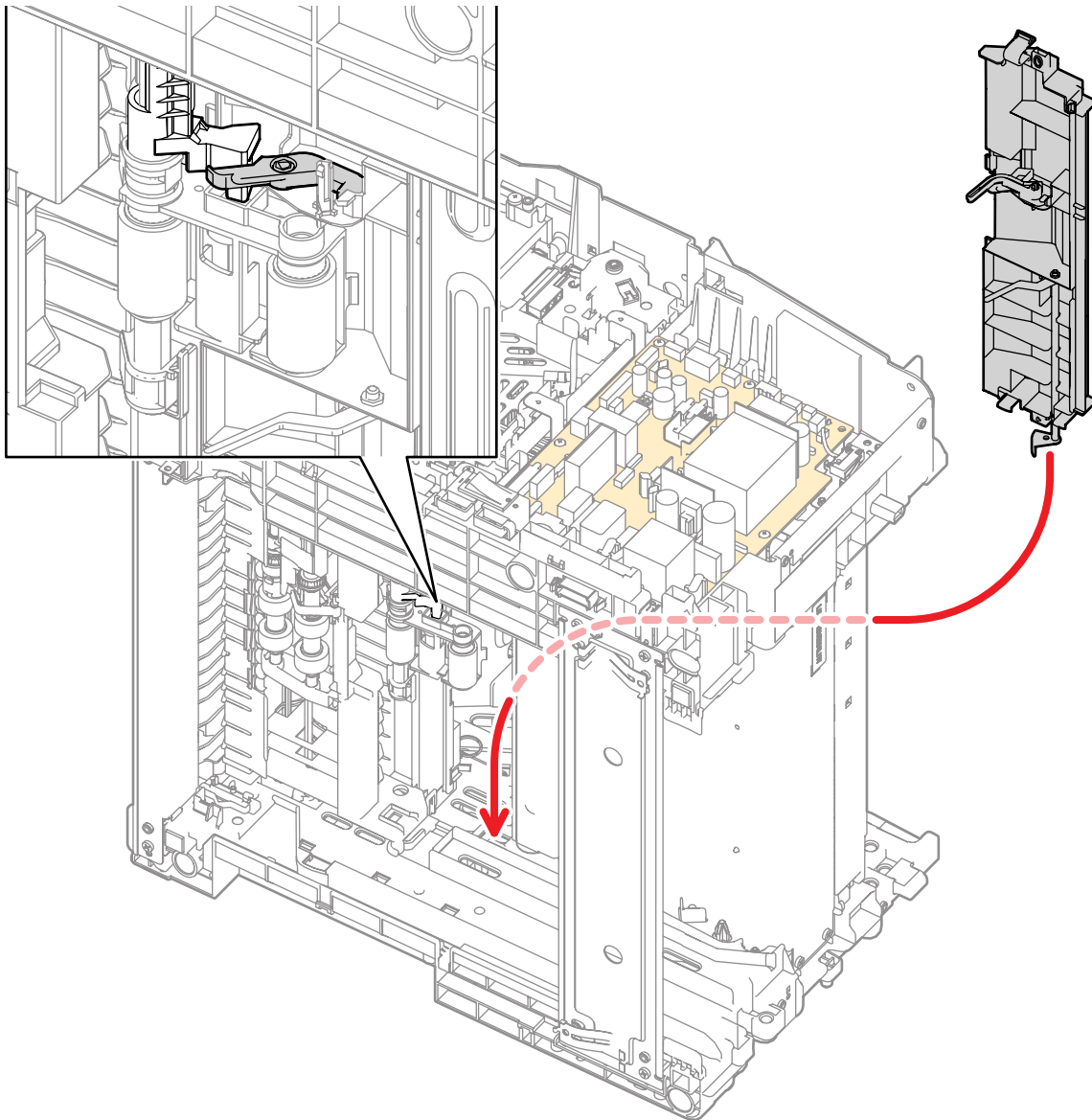

Figure 5

- When installing the Top Frame Assembly, rest the printer on its right side. Align the Bypass Tray No Paper Sensor Actuator coupled with the Top Frame Assembly so it fits into the hole on the printer and the Lock MSI In connects with the Pick Up Holder Assembly. (Figure 6)



s3610-025

Figure 6

- Replace in reverse order.

REP 4.4 Duplex Drive Gear and Holder

PL 4.1 Drive

! **WARNING:** Allow the Fusing Assembly to cool before servicing the product.

1. Open the Rear Cover.
2. Rotate the Gear Holder clockwise while pulling the tab to remove the holder and gear. (Figure 1)

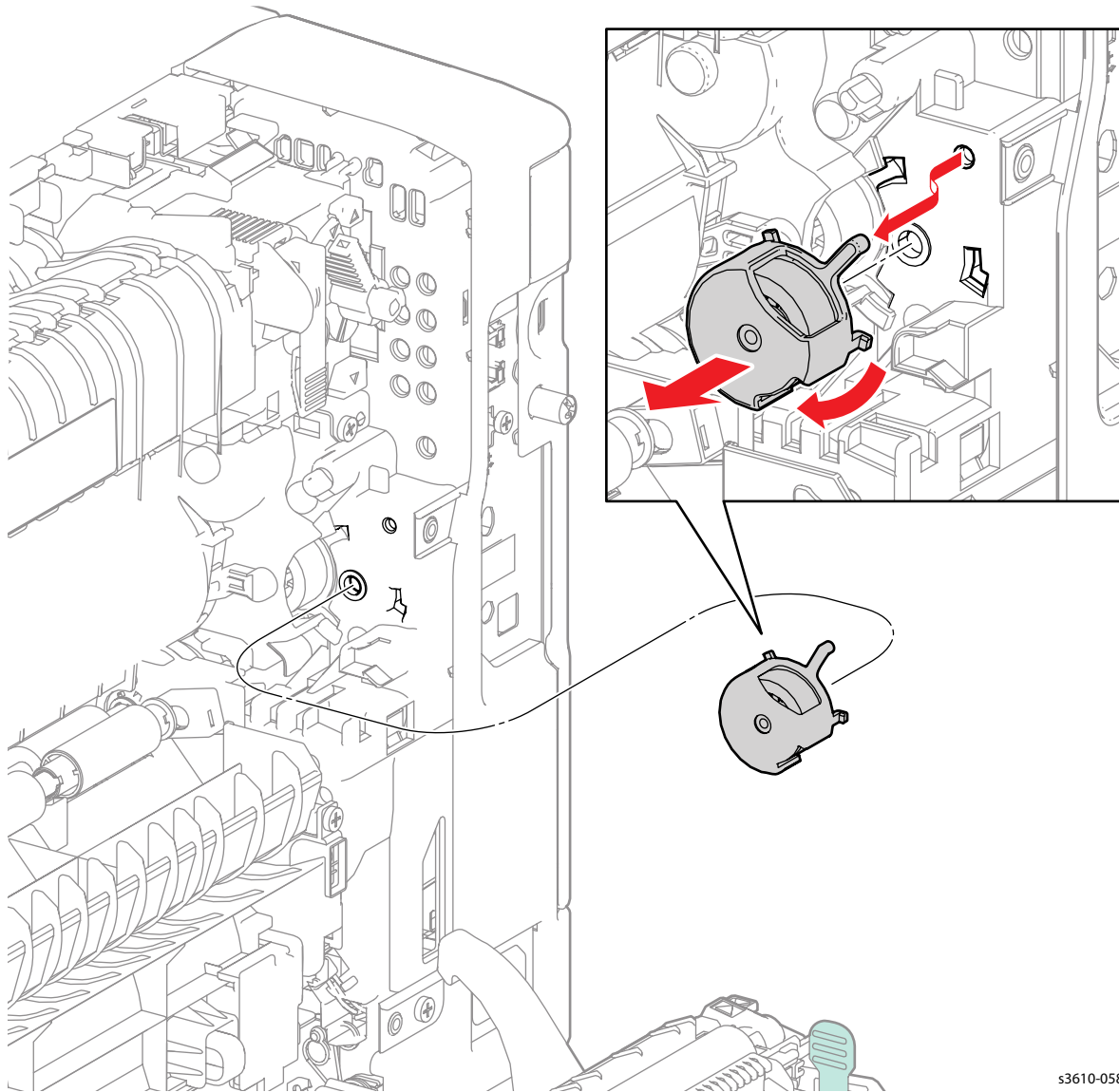

Figure 1

s3610-058

Replacement

1. Replace in reverse order.

REP 4.5 Front Links

PL 4.2 NOHAD

Removal

! **WARNING:** Allow the Fusing Assembly to cool before servicing the product.

1. Open the Front Cover.
2. Release the right or left Front Link from the Front Cover Assembly.
3. Release the Link Connector clips from the link shaft to remove the Front Link. (Figure 1)

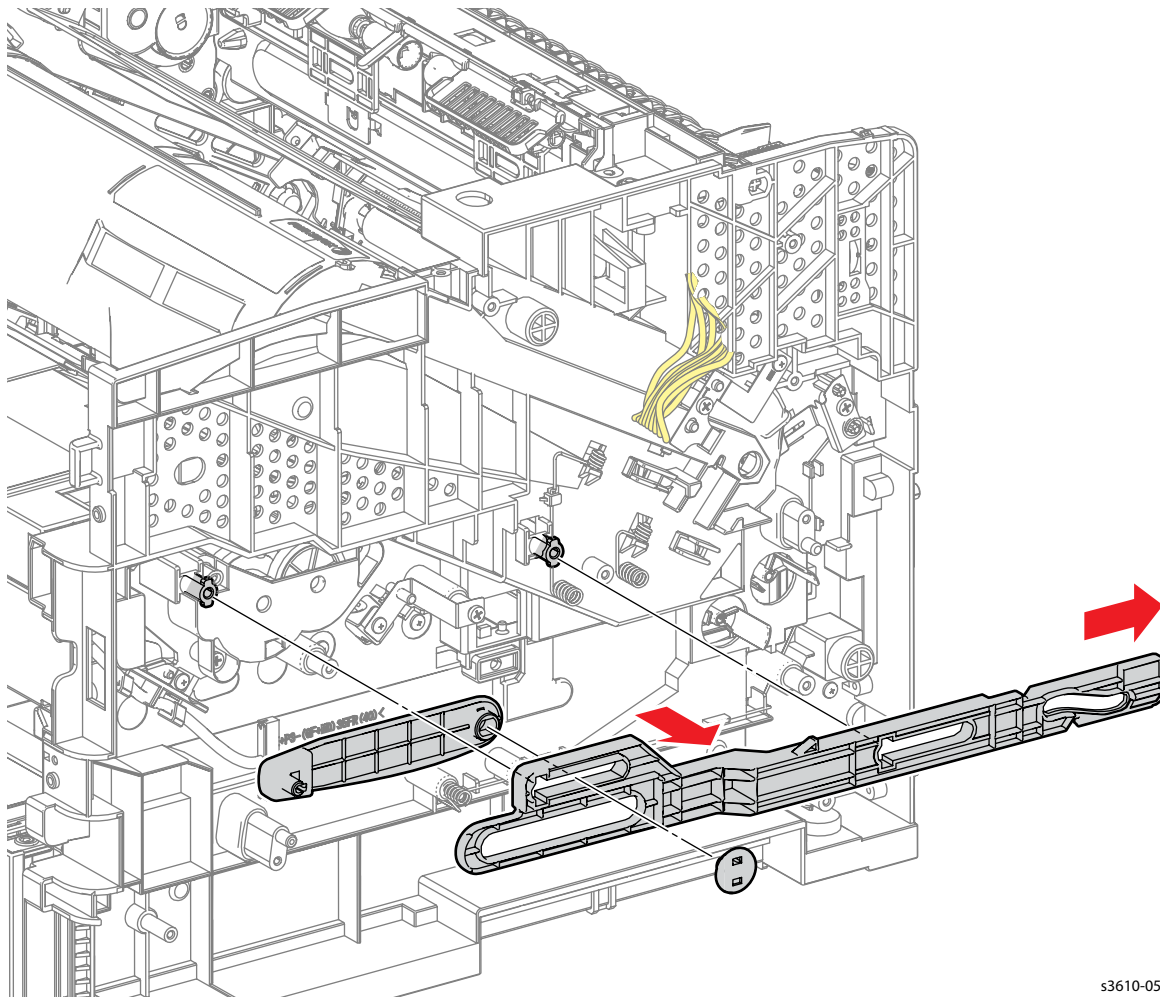

Figure 1

s3610-059

Replacement

1. Replace in reverse order.

REP 4.6 Dispense Drive Assembly

PL 3.3 Toner Dispense

Removal

! **WARNING:** Allow the Fusing Assembly to cool before servicing the product.

1. Open the Bypass Tray.
2. Open the Rear Cover, release the stopper strap and hinge clip from the chassis and rest the Rear Cover Assembly on the work surface.
3. Remove (REP 1.6 Right Side Cover (3610)) (REP 1.13 Right Side Cover (3615)).
4. Remove (REP 5.7 HVPS (3610)) (REP 5.8 HVPS (3615)).
5. Remove the Right Link Shaft. (Figure 1)
 - a. Release the clip on the Right Front Link.
 - b. Pry off the Link Connector
 - c. Pry off the Right Front Link from the Right Link Shaft.
 - d. Remove the Right Link Shaft by gently flexing it away from the chassis.

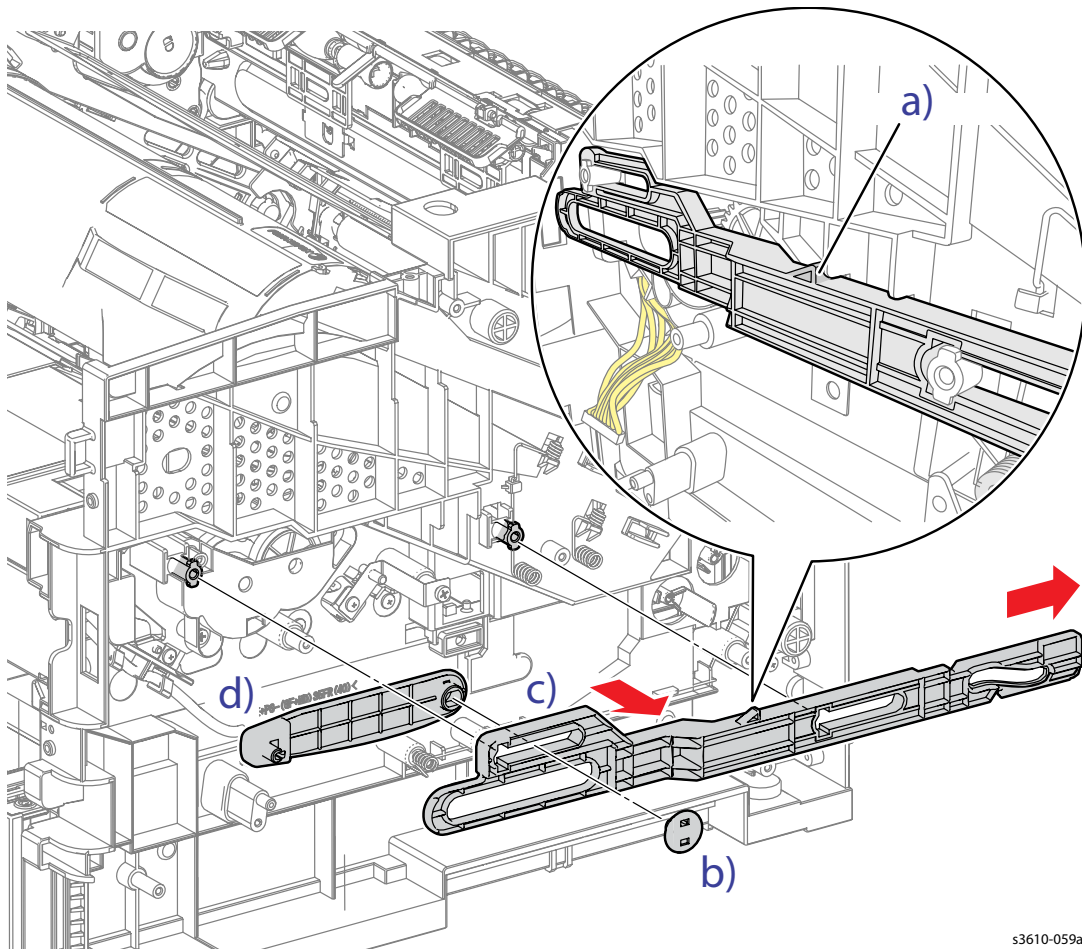

Figure 1

s3610-059a

6. Remove 2 screws (silver, tapping, 8mm) that secure the Dispense Drive Assembly to the chassis. (Figure 2)

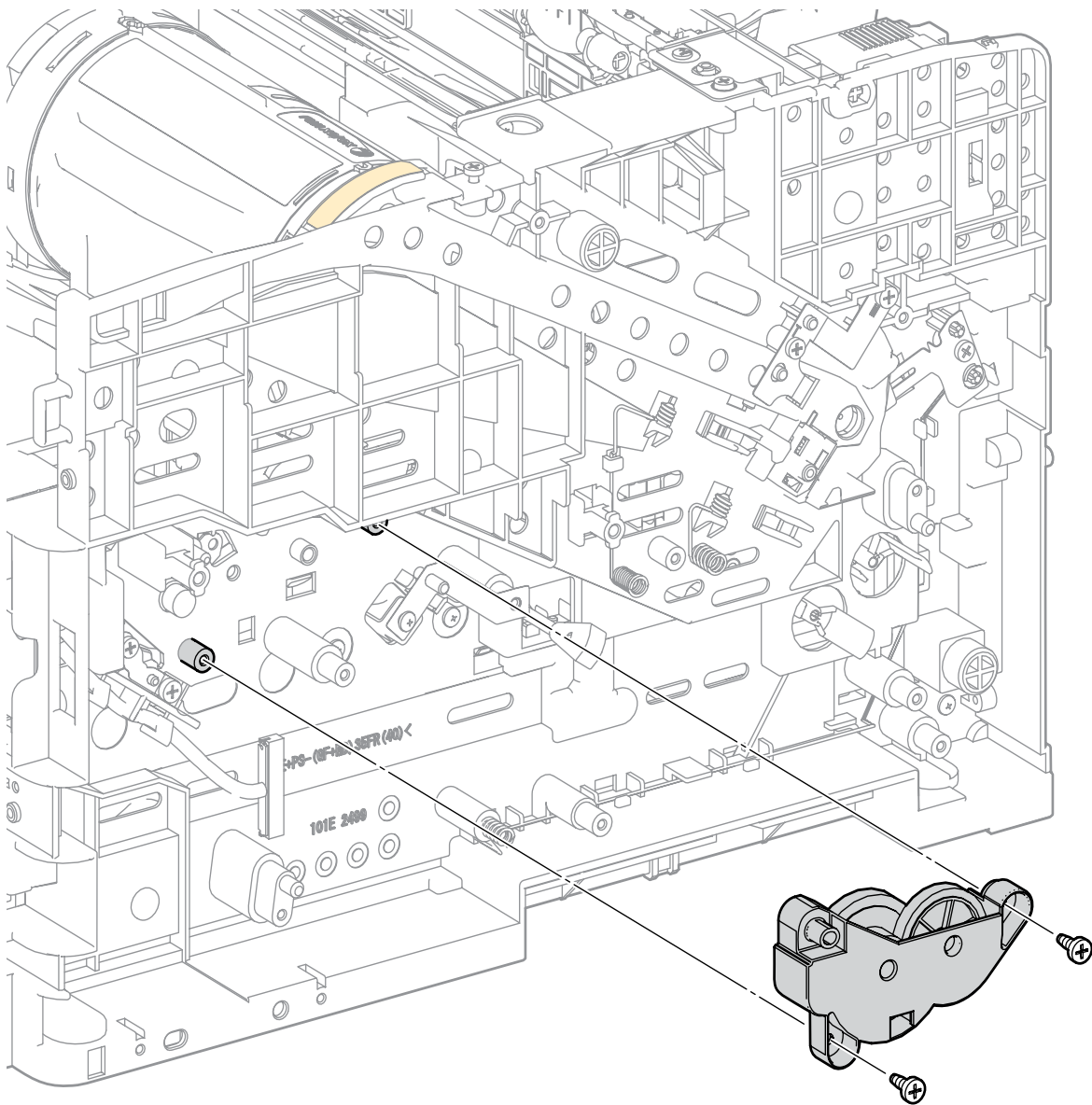

Figure 2

s3610-060

Replacement

1. Replace in reverse order.

REP 4.7 Toner Dispense Motor

PL 3.3 Toner Dispense

! **WARNING:** Allow the Fusing Assembly to cool before servicing the product.

1. Remove the Bypass Tray.
2. Remove the Drum Cartridge.
3. Open the Rear Cover, release the stopper strap and hinge clip from the chassis and rest the Rear Cover Assembly on the work surface.
4. Remove (REP 1.1 Control Panel (3610)).
5. Remove (REP 1.4 Top Cover Assembly (3610)).
6. Remove (REP 1.6 Right Side Cover (3610)).
7. Prepare the MCU PWB. (Figure 1)
 - a. Release 3 clips to remove the MCU PWB Cover.
 - b. Disconnect all MCU PWB connections except P/J11, 18 and 26.

Note: Do not remove the MCU PWB.

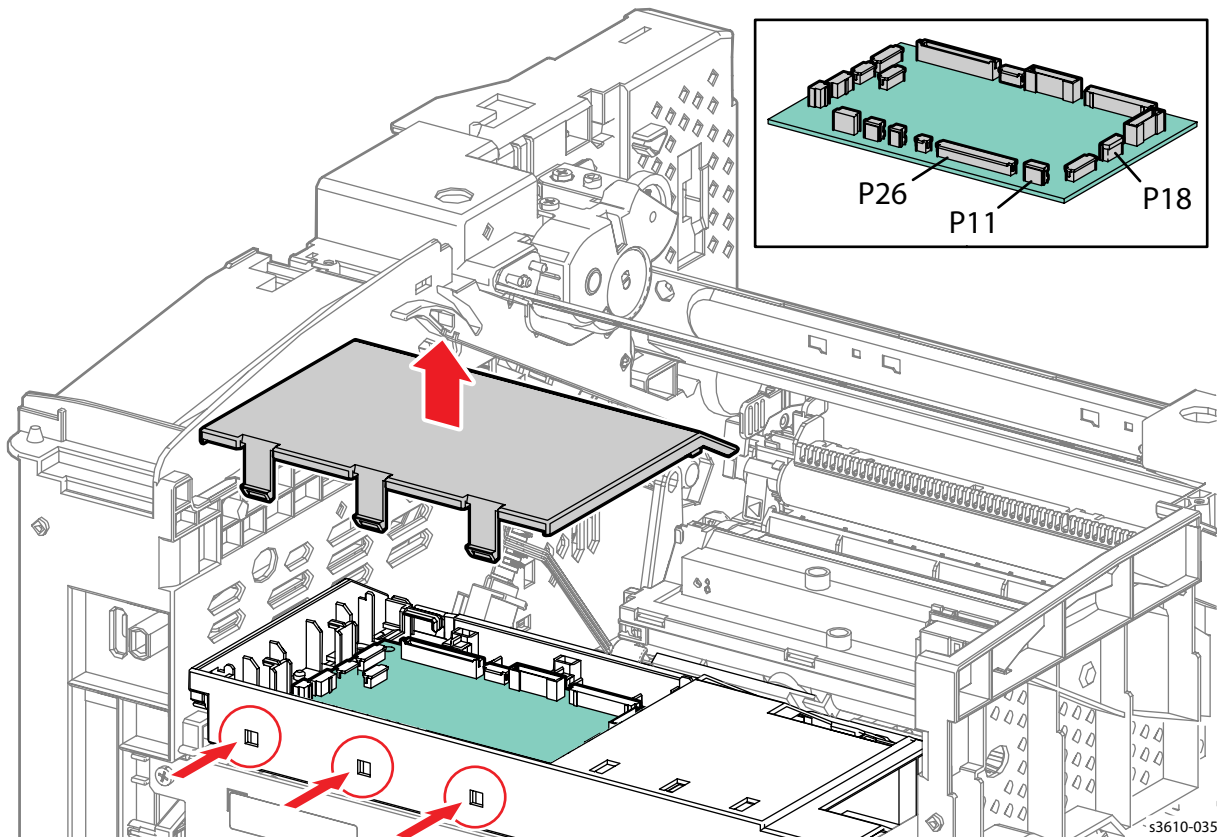

8. Remove 2 screws (silver, M3, 6mm) that secure the MCU Housing to the chassis. (Figure 2)

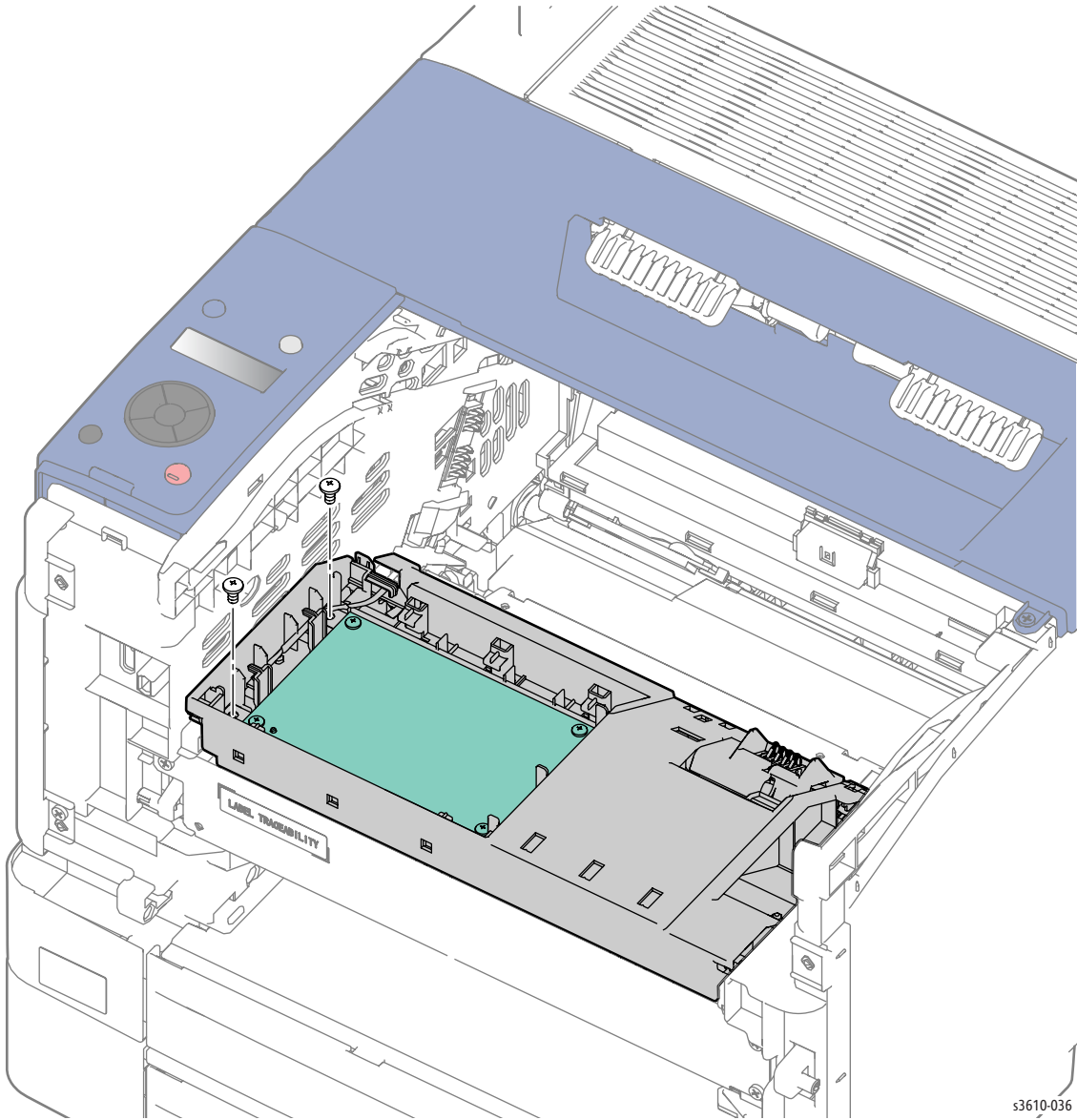

Figure 2

s3610-036

9. Release the harnesses from the MCU PWB Housing harness guides to provide enough slack to move the MCU Housing to the front of the printer.
10. Release the MCU Housing. (Figure 3)
 - a. Release the clip.
 - b. Rotate the MCU PWB Housing toward the front of the machine,
 - c. Lift the MCU PWB Housing up off of the pins and rest the housing at the front of the printer.

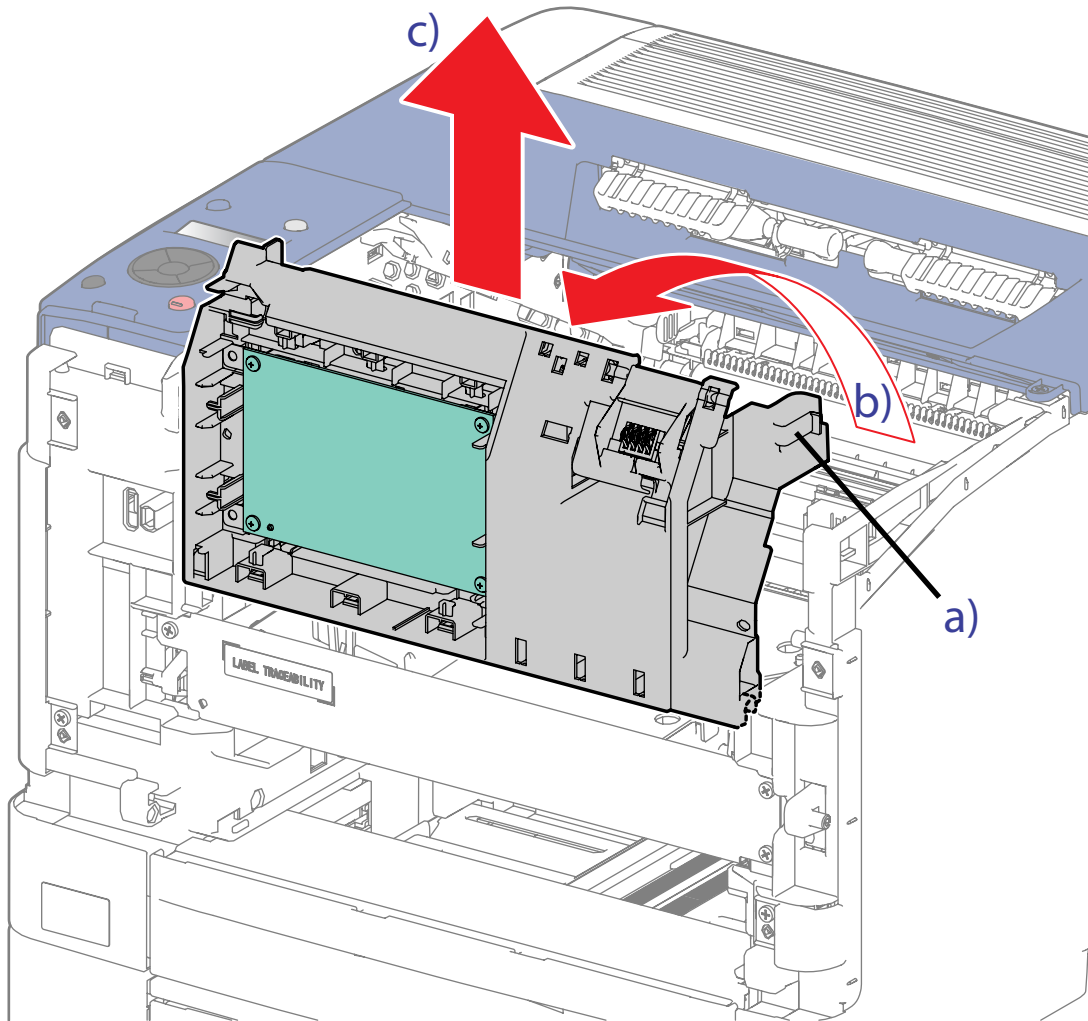

Figure 3

s3610-037

11. Remove the Toner Dispense Motor. (Figure 4)
 - a. Remove 1 screw (silver, tapping, 8mm).
 - b. Disconnect P/J111.
 - c. Rotate to remove the motor from the chassis.

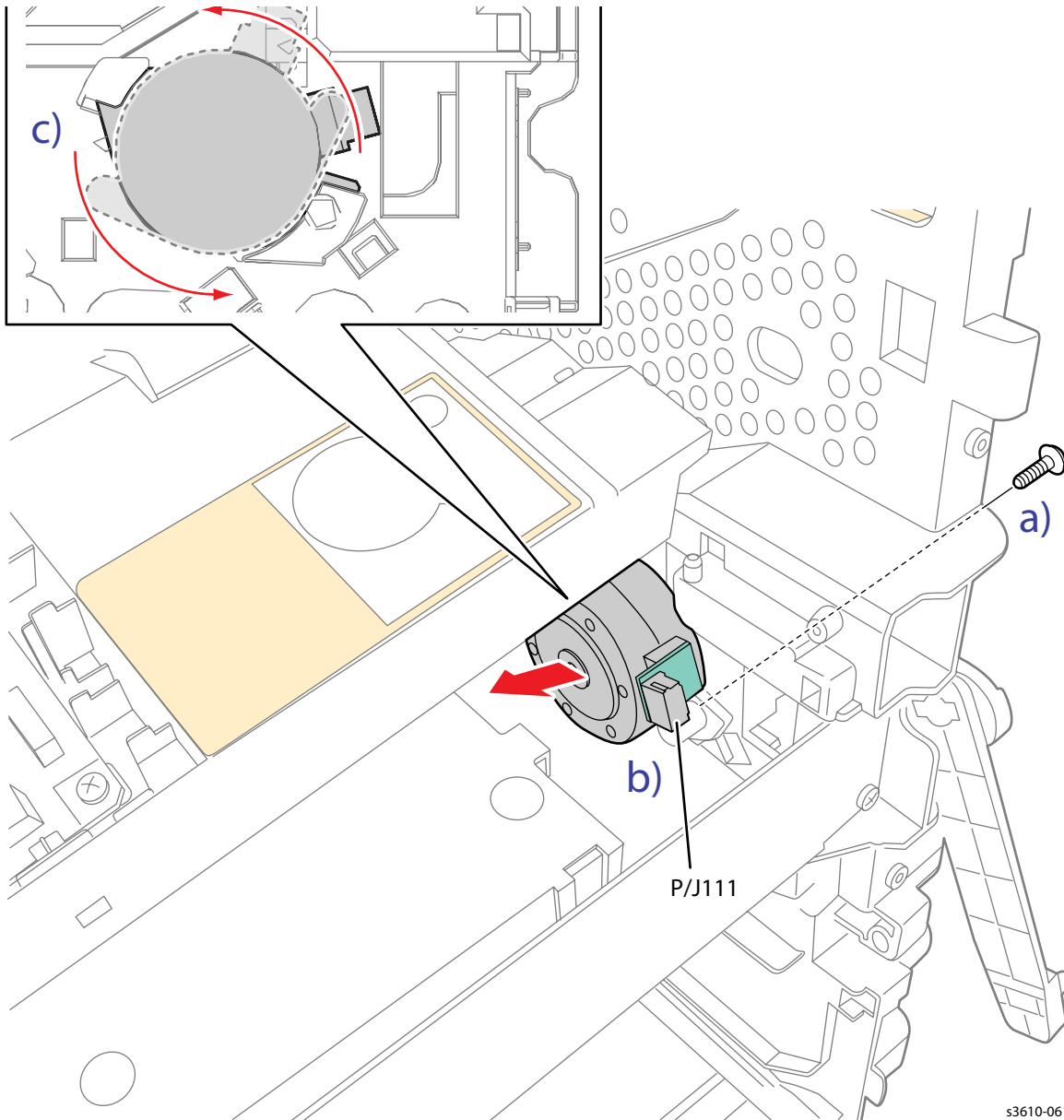

Figure 4

s3610-061

Replacement

1. Make sure the MCU PWB Housing is seated correctly on the pins so it can be rotated back into the proper position.
2. Replace in reverse order.

Electrical Repairs

REP 5.1 ESS PWB

PL 5.1 Electrical (ESS PWB / LVPS) (3610)

PL 5.2 Electrical (ESS PWB / LVPS) (3615)

Removal

! **CAUTION:** Do not replace the MCU and ESS PWBs at the same time. Replace or check the ESS PWB first, then cycle system power before replacing the MCU PWB.

CAUTION: Do not remove the ESS PWB from the protective bag until ready for installation. Always wear a grounded wrist band while handling circuit boards.

1. Ask the customer to export their address book. Customer can find instructions for exporting their address book in their UG or on the Xerox.com Support page.
2. Remove (REP 1.7 Left Side Cover (3610)) (REP 1.17 Lower Left Side Cover (3615)).
3. Disconnect all connections to the ESS PWB.
4. For the 3610, remove 4 screws and the top plate, and remove 8 screws (silver, M3, 6mm) and 1 screw (silver, M3, 4mm) that secure the ESS PWB to the chassis. (Figure 1).

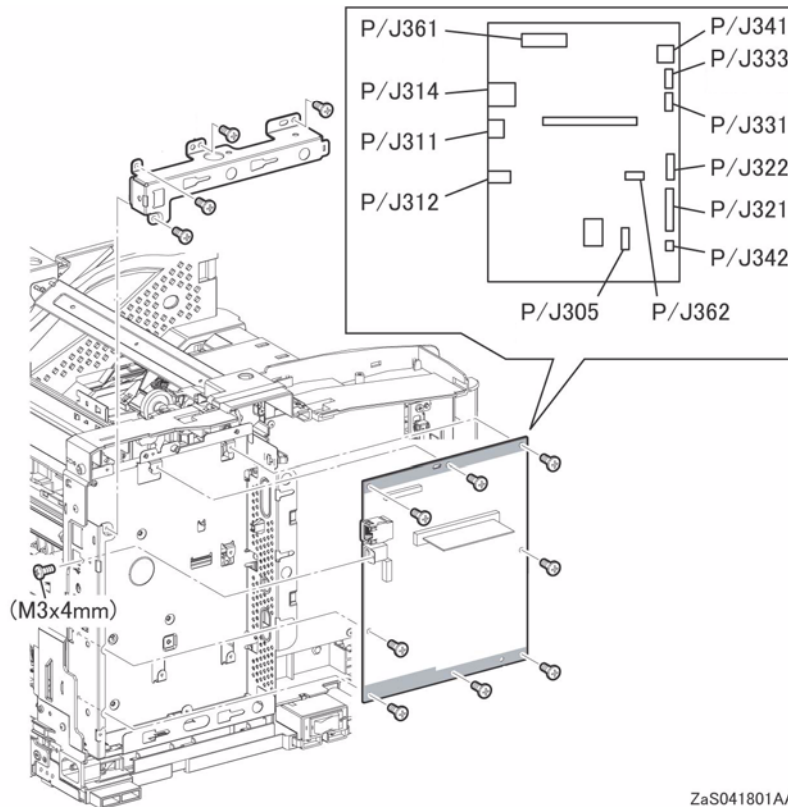
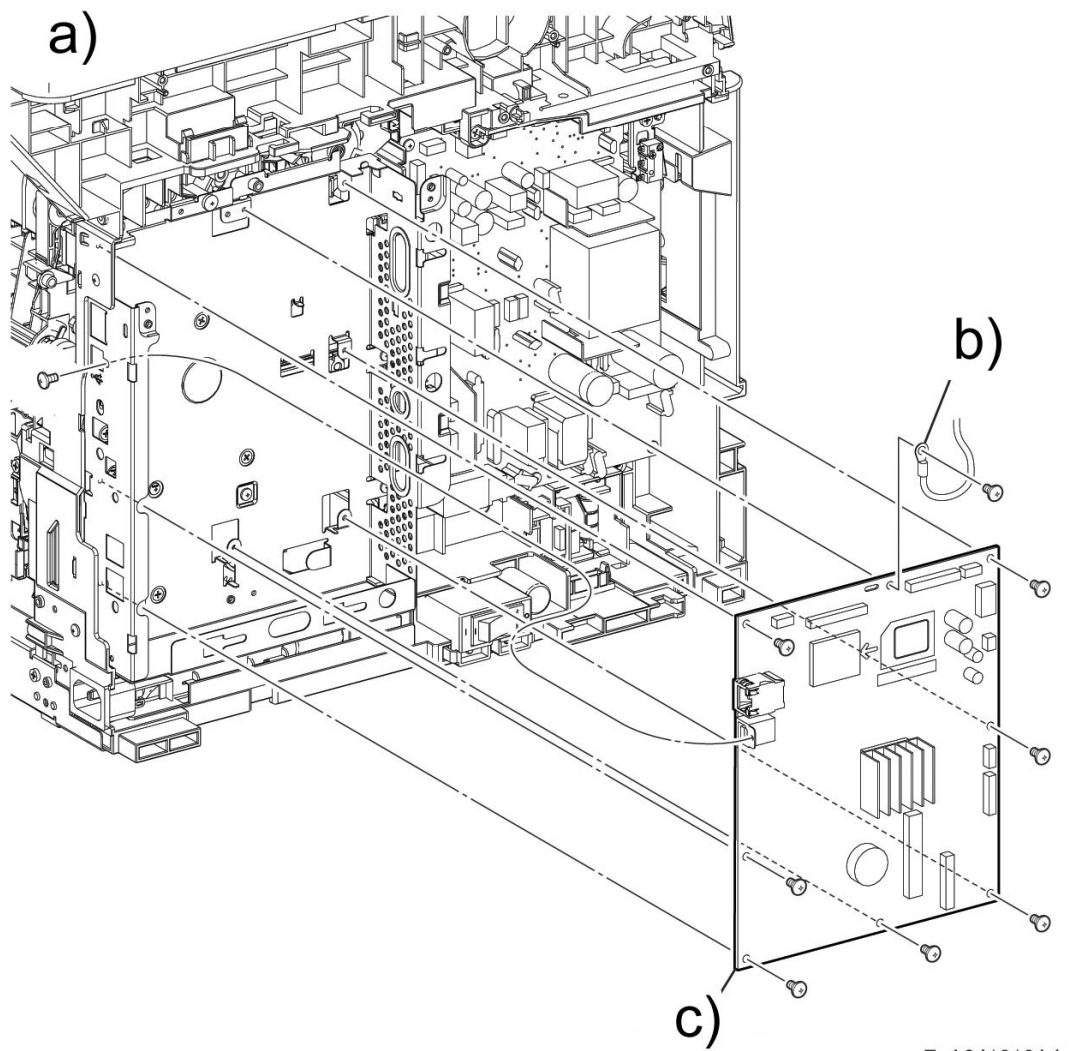

Figure 1

ZaS041801AA

5. For the 3615, Remove the Fax PWB ([REP 5.4 Fax PWB](#))
6. Remove the ESS PWB. (Figure 2)
 - a. Remove 4 screws and the ESS Top Plate.
 - b. Remove the Earth Wire.
 - c. Remove 8 screws (silver, M3, 6mm) and 1 screw (silver, M3, 4mm) that secure the ESS PWB to the chassis.



ZaA041813AA

Figure 2

Replacement

1. Print a configuration page and give to the customer. Due to the replacement of the ESS PWB, tell the customer that they will:
 - lost their fax log.
 - have to set up their network settings after the ESS is replaced.
 - have to import their address book after the ESS is replaced.
2. Before installing a replacement ESS PWB, transfer these components: (Figure 3)
 - a. Remove (U22) / (U1329 / U1330) from the ESS PWB and install on the replacement PWB.
 - b. Remove the Memory / SD Card from the ESS PWB and install on the replacement PWB.

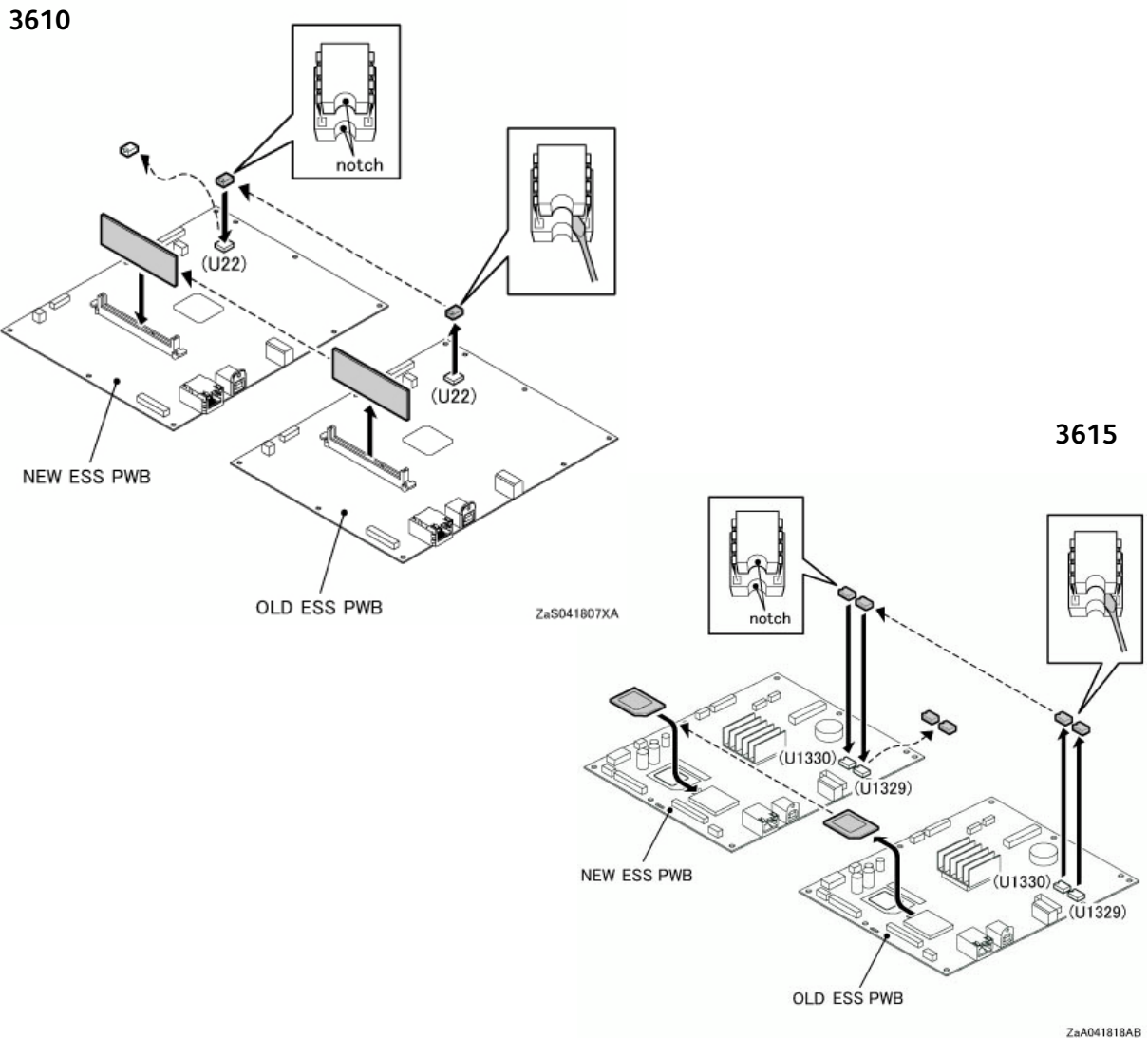

Figure 3

3. Replace in reverse order.

REP 5.2 ESS PWB Housing

PL 5.1 Electrical (ESS PWB / LVPS) (3610)

PL 5.2 Electrical (ESS PWB / LVPS) (3615)

! **WARNING:** Allow the Fusing Assembly to cool before servicing the product.

1. Remove (REP 5.1 ESS PWB).
2. Release the harness clamps from all harnesses routed through the ESS Housing, then disengage the relay connector on the ESS Housing. (Figure 1)

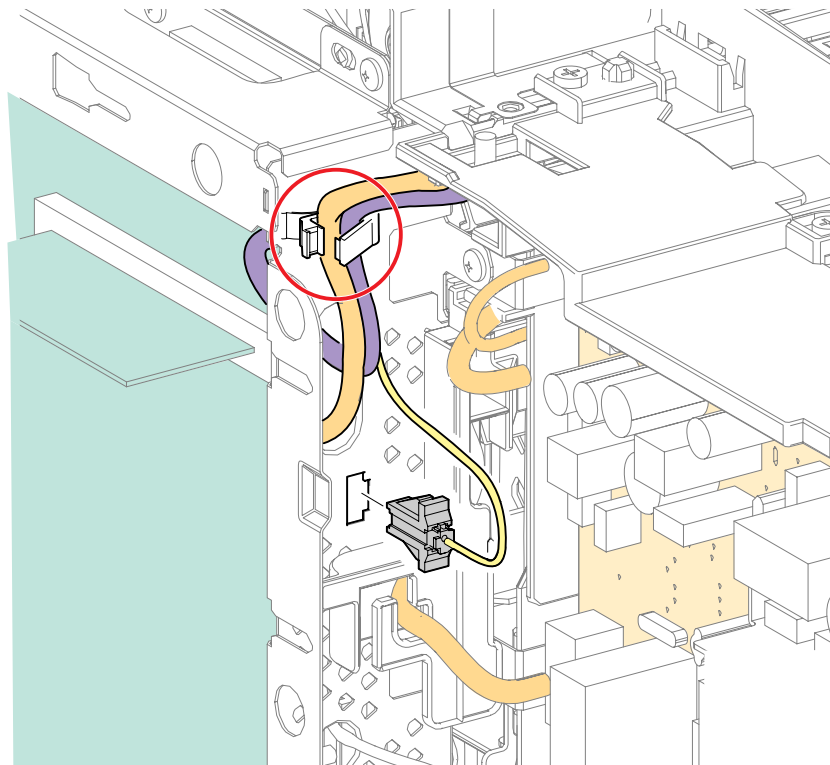

s3610-046

Figure 1

3. (3610) Remove the ESS Housing. (Figure 2)
 - a. Remove 6 screws (silver, M3, 6mm) that secure the ESS Housing,
 - b. Release 2 tabs from the frame.
 - c. Remove the ESS Housing.

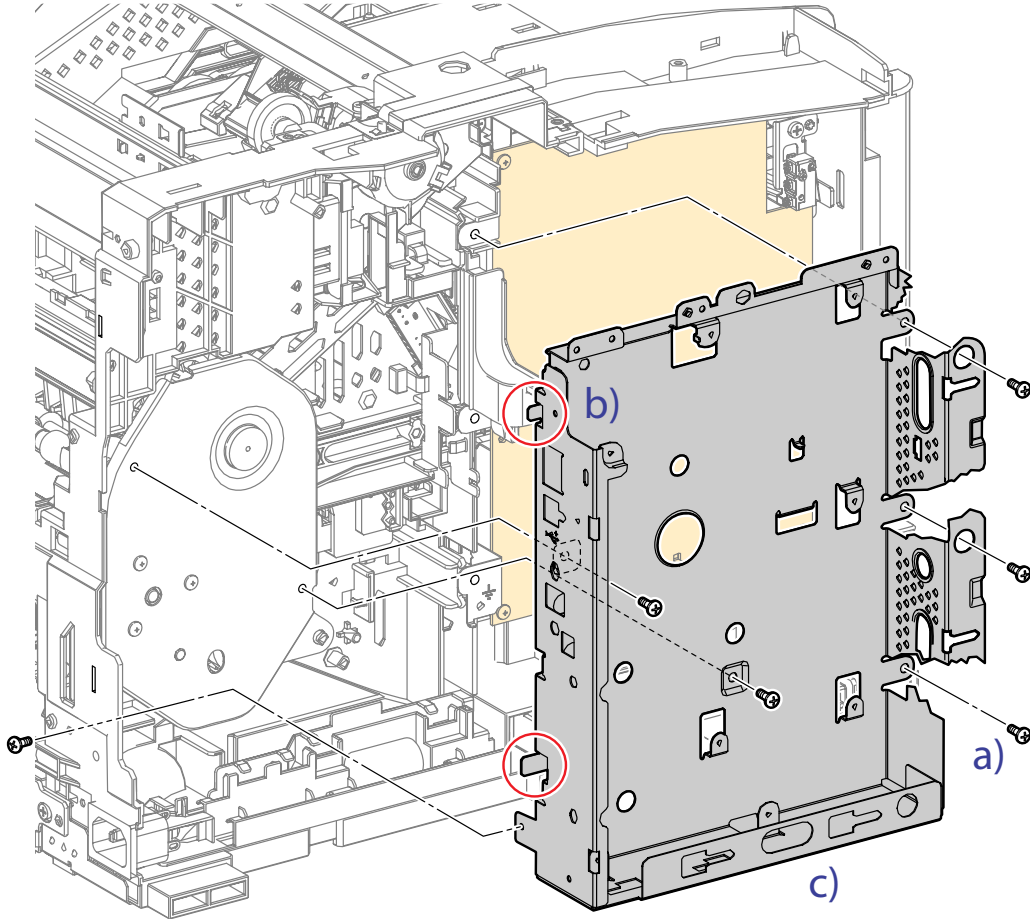

s3610-047

Figure 2

4. (3615) Remove the ESS Housing. (Figure 2)
 - a. Remove 6 screws (silver, M3, 6mm) that secure the ESS Housing,
 - b. Release 2 tabs from the frame.
 - c. Remove the ESS Housing.

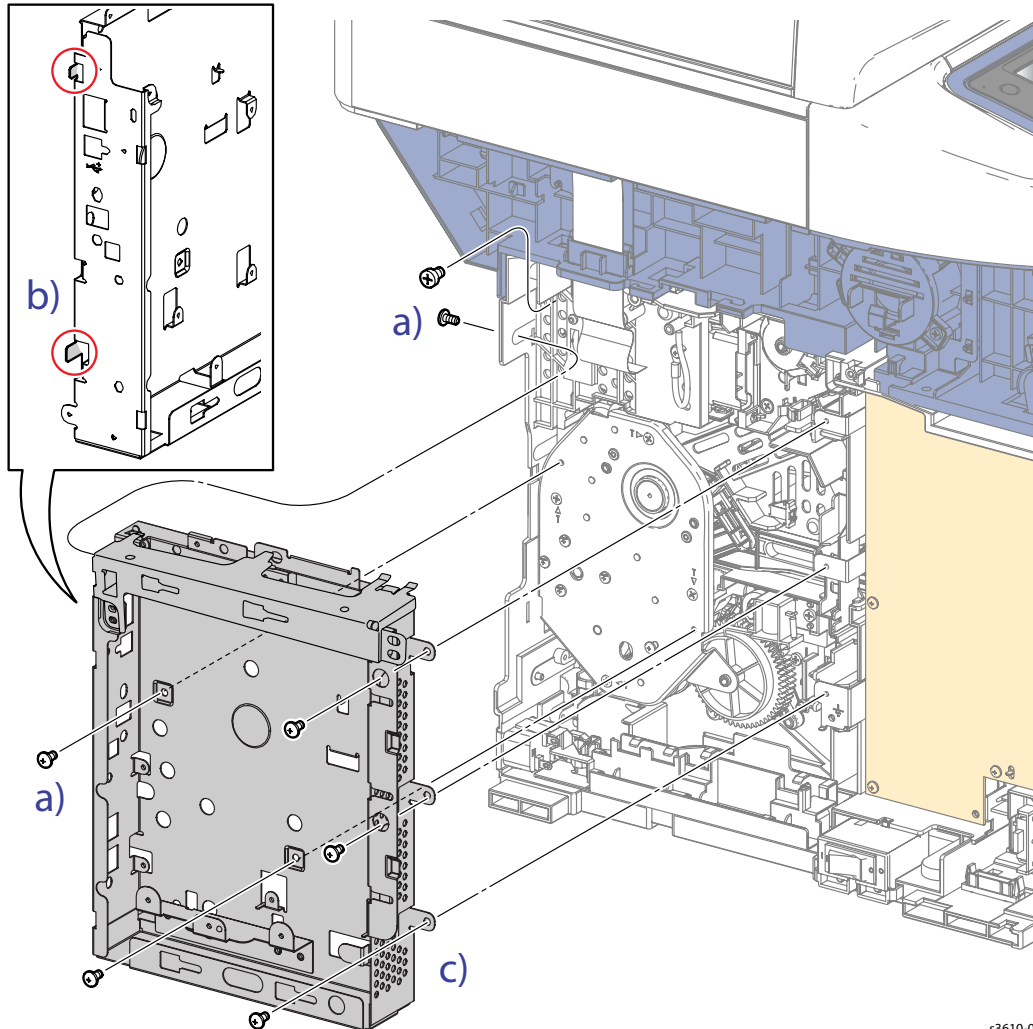

s3610-076

Figure 3

Replacement

1. Replace in reverse order.

REP 5.3 LVPS

PL 5.1 Electrical (ESS PWB / LVPS) (3610)

Removal

! WARNING: Allow the Fusing Assembly to cool before servicing the product.

! CAUTION: Do not remove the LVPS from the protective bag until ready for installation. Always wear a grounded wrist band while handling circuit boards.

1. Remove (REP 1.7 Left Side Cover (3610)) (REP 1.17 Lower Left Side Cover (3615)).
2. Remove the PWB LVPS. (Figure 1)
 - a. Disconnect all the connections to the LVPS.
 - b. Remove the wire harnesses from the clamps.
 - c. Remove 8 screws (silver, M3, 6mm) and 2 screws (silver, tapping, 8mm) that secure the interlock switch bracket to remove the PWB LVPS.

CAUTION: The Interlock Switch is hard wired to the LVPS. Do not try to unplug it.

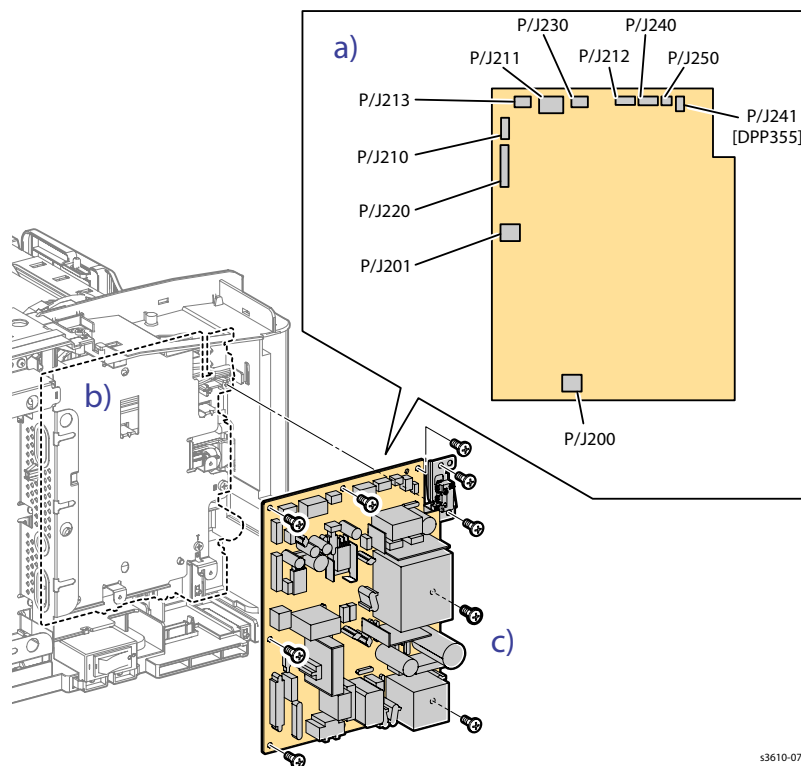

Figure 1

Replacement

1. Make sure the interlock switch is seated correctly on the pins before connecting to the LVPS.
2. Replace in reverse order.

REP 5.4 Fax PWB

PL 5.2 Electrical (ESS PWB / LVPS) (3615)

1. Remove the ESS PWB Cover ([REP 5.6 MCU PWB](#)).
2. Remove the Fax PWB. (Figure 1)
 - a. Remove 1 screw (silver, M3, 6mm) and remove the Fax PWB cover.
 - b. Remove 2 screws (silver, M3, 6mm) and
 - c. Gently pull the FAX PWB to disconnect P/J802 from the ESSPWB.

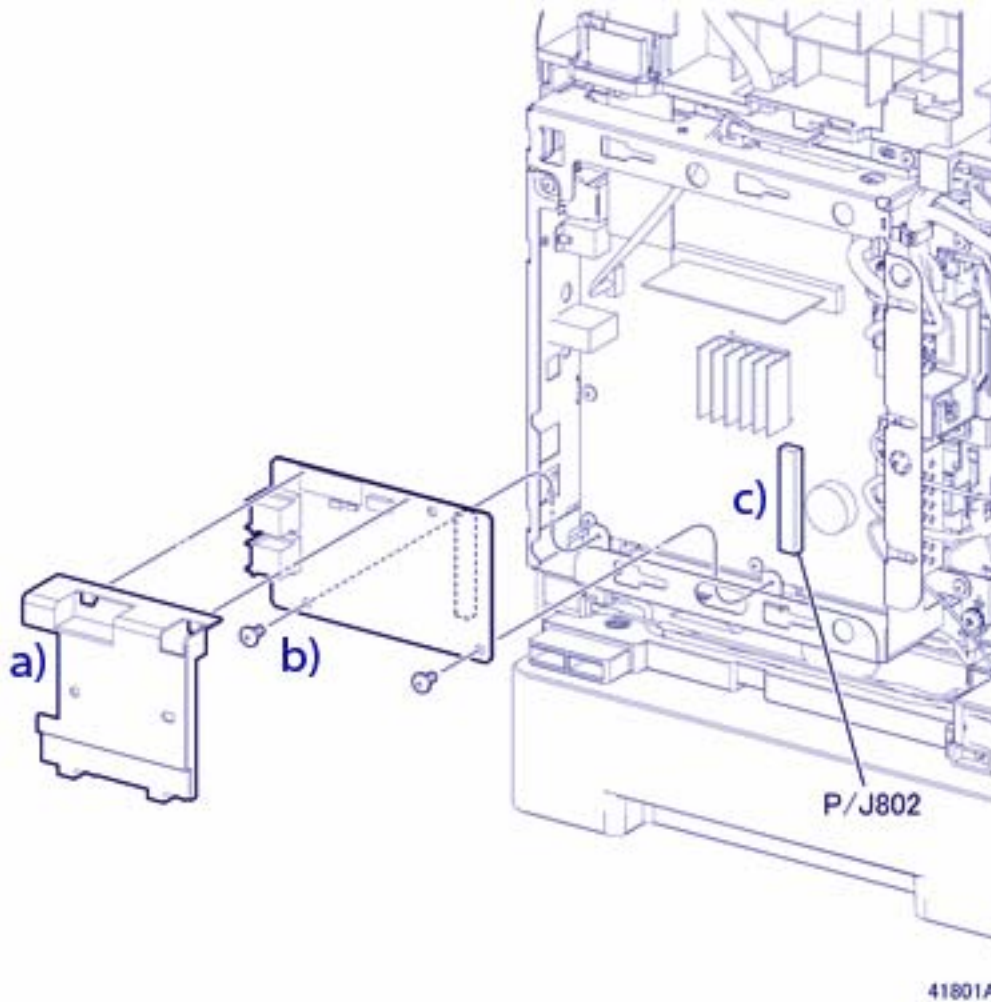

Figure 1

Replacement

1. Replace in reverse order.

REP 5.5 Front USB PWB

PL 5.2 Electrical (ESS PWB / LVPS) (3615)

Removal

! **WARNING:** Allow the Fusing Assembly to cool before servicing the product.

1. Remove the Bypass Tray.
2. Remove (REP 1.2 Front Cover Assembly (3610 / 3615)).
3. Remove (REP 1.5 Rear Cover Assembly).
4. Remove (REP 1.17 Lower Left Side Cover (3615)).
5. Remove the PWB. (Figure 1)
 - a. Disconnect P/J2 from the Front USB PWB.
 - b. Remove 2 screws (silver, tapping, 8mm) to remove the PWB.

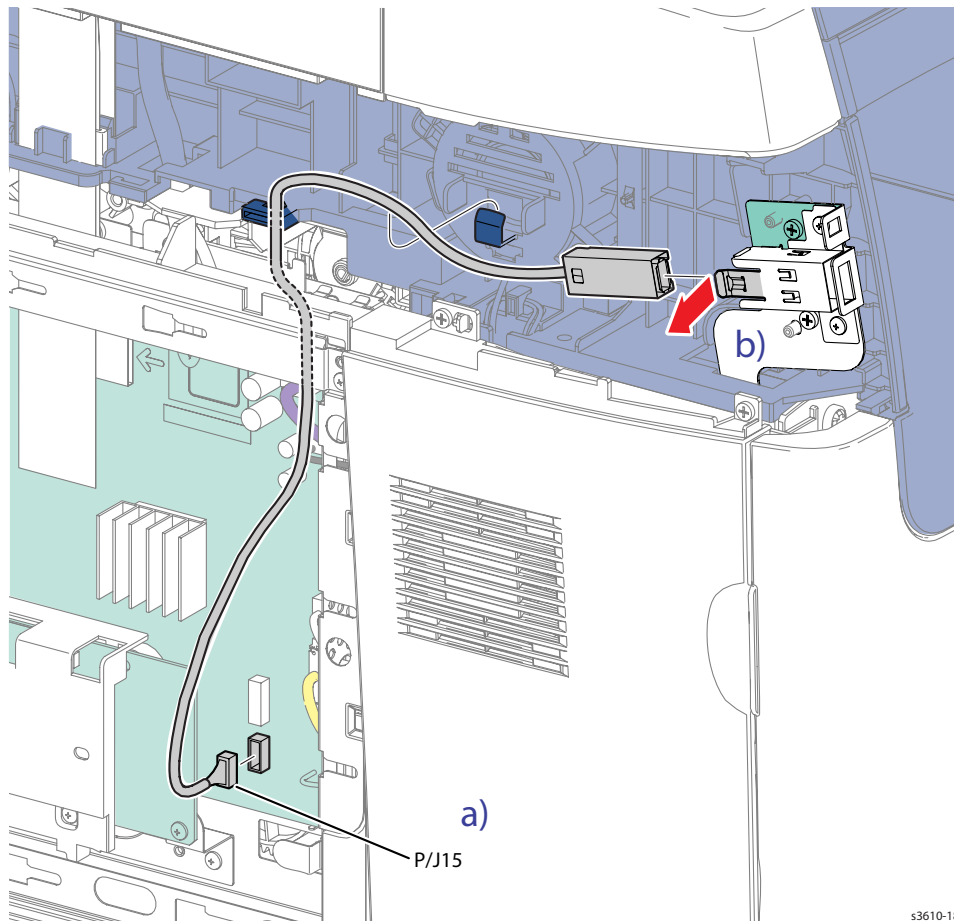

Figure 1

s3610-183

Replacement

1. When installing the Front USB PWB, capture the ground wire with the top screw.
2. Replace in reverse order.

REP 5.6 MCU PWB

PL 5.3 Electrical (MCU PWB / HVPS)

Removal

! **CAUTION:** Do not replace the MCU and ESS PWBs at the same time. Replace or check the ESS PWB first, then cycle system power before replacing the MCU PWB.

CAUTION: Do not remove the MCU PWB from the protective bag until ready for installation. Always wear a grounded wrist band while handling circuit PWBs.

Note: If possible, before replacing the MCU PWB, save NVM to the ESS PWB (Save NVM to ESS) before removal to save configuration data.

1. Open the Front Cover.
2. Remove the Drum Cartridge.
3. Remove the MCU PWB. (Figure 1)
 - a. Release 3 clips that secure the MCU PWB cover and remove.
 - b. Disconnect all the connections to the MCU PWB.
 - c. Remove 4 screws (silver, M3, 6mm) to remove the MCU PWB from the chassis.

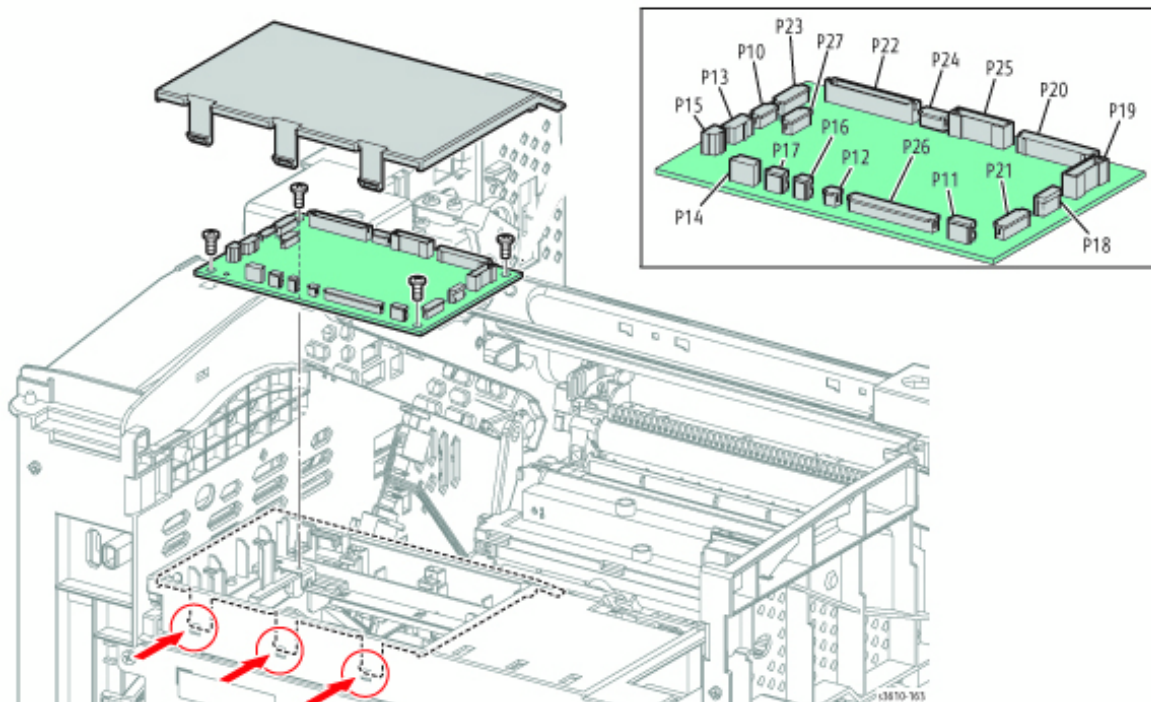

Figure 1

Replacement

1. P15 is Black. P12 is White. Install a new MCU PWB and use **Load NVM** from ESS to restore configuration data from the ESS PWB.
2. Replace in reverse order.

REP 5.7 HVPS (3610)

PL 5.3 Electrical (MCU PWB / HVPS)

Removal

! WARNING: Allow the Fusing Assembly to cool before servicing the product.

! CAUTION: Do not remove the HVPS from the protective bag until ready for installation. Always wear a grounded wrist band while handling circuit boards.

1. Remove the Bypass Tray.
2. Remove (REP 1.2 Front Cover Assembly (3610 / 3615)).
3. Open the Rear Cover, release the stopper strap and hinge clip from the chassis and rest the Rear Cover Assembly on the work surface.
4. Remove (REP 1.4 Top Cover Assembly (3610)).
5. Remove (REP 1.6 Right Side Cover (3610)).
6. Remove the HVPS. (Figure 1)
 - a. Remove 7 screws (silver, tapping, 8mm) to remove the HVPS from the chassis.
 - b. Disconnect P/J261 from the inboard side of the HVPS.

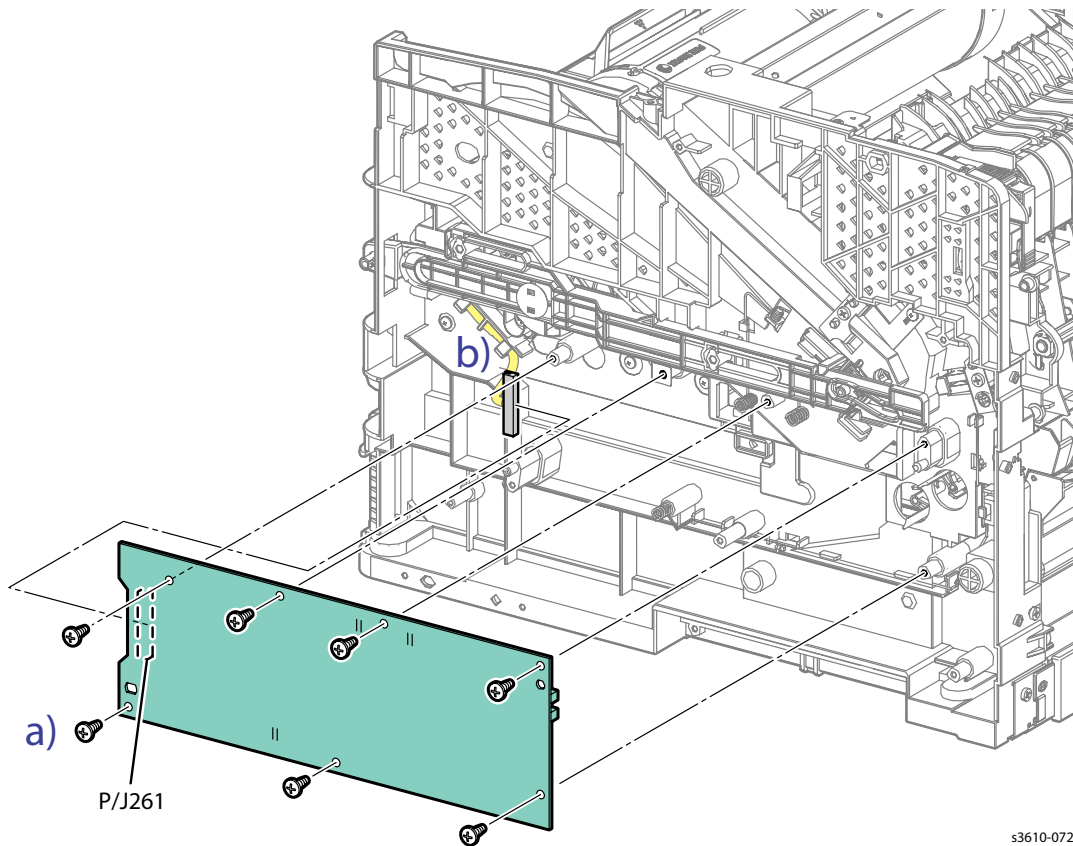

Figure 1

s3610-072

Replacement

1. When installing the HVPS, confirm: (Figure 2)
 - a. the 2 Registration Sensor Shutters are correctly positioned.
 - b. the ends of the 3 conductive springs on the chassis are in contact with the terminals on the PWB.
 - c. the PWB is secured on the bosses.

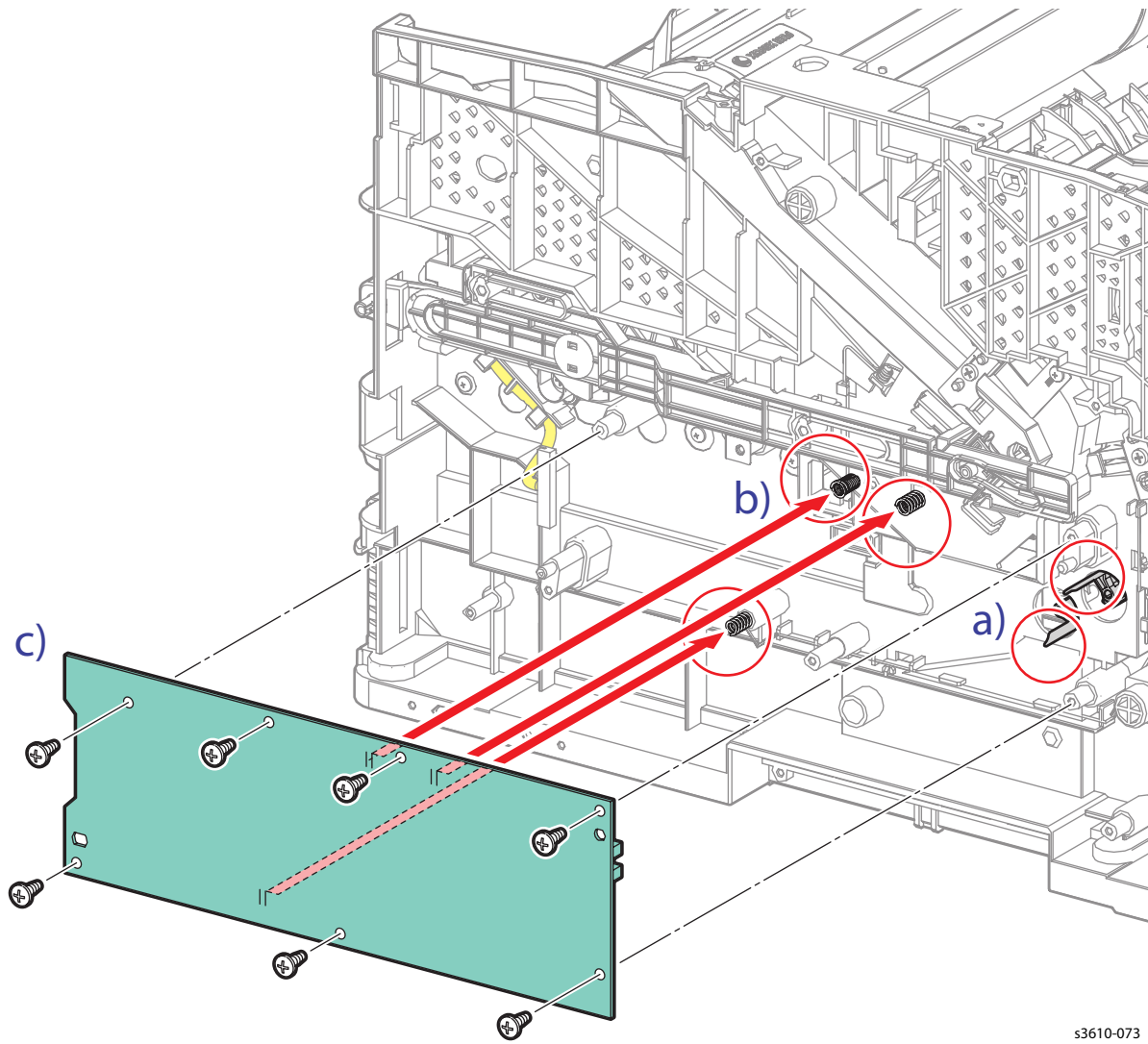

Figure 2

s3610-073

2. Replace in reverse order.

REP 5.8 HVPS (3615)

PL 5.3 Electrical (MCU PWB / HVPS)

Removal

! **WARNING:** Allow the Fusing Assembly to cool before servicing the product.

1. Remove the Bypass Tray.
2. Remove (REP 1.2 Front Cover Assembly (3610 / 3615)).
3. Remove (REP 1.5 Rear Cover Assembly).
4. Remove (REP 1.13 Right Side Cover (3615)).
5. Remove the HVPS. (Figure 1)
 - a. Remove 7 screws (silver, tapping, 8mm),
 - b. Disconnect P/J261 from the HVPS.
 - c. Release 2 bosses to remove the PWB.

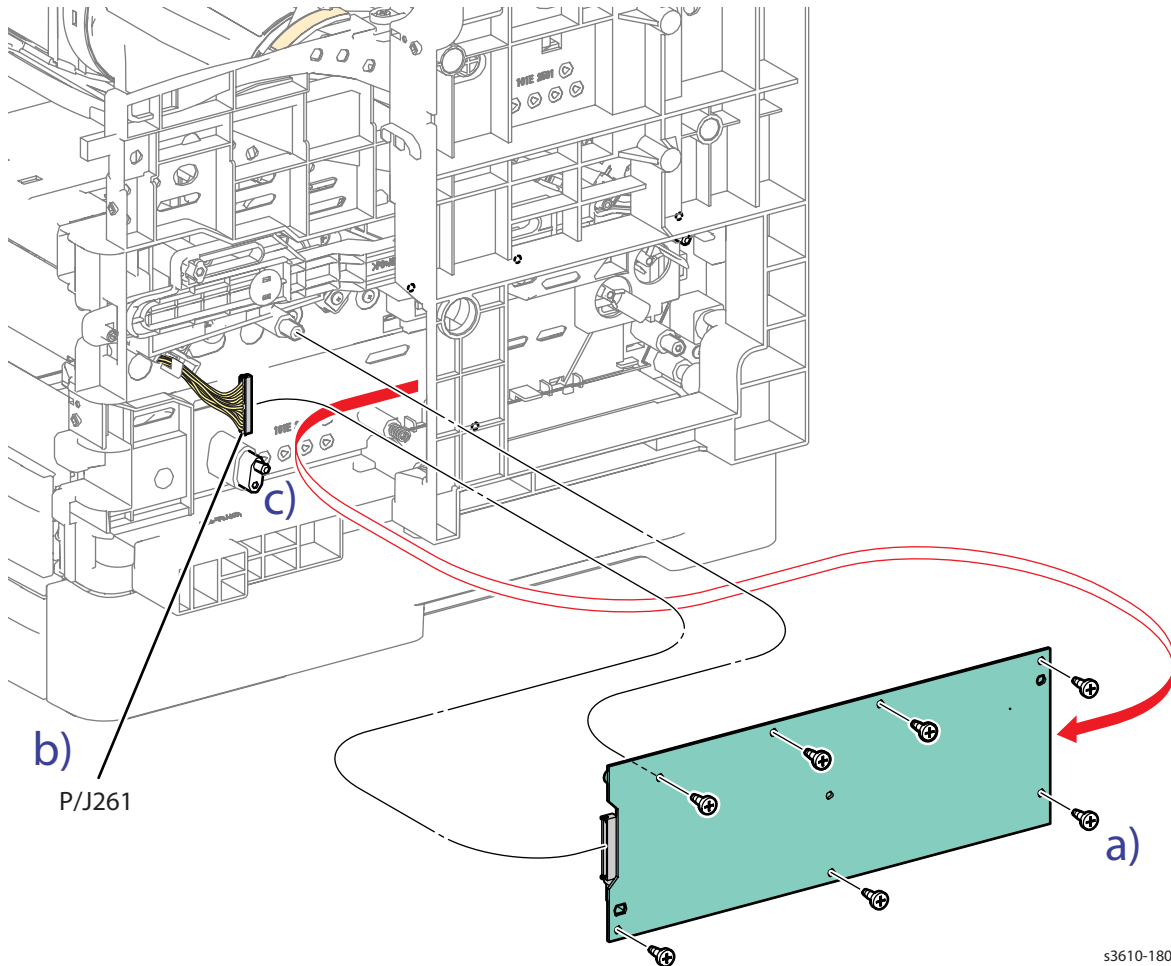

Figure 1

s3610-180

Replacement

1. When installing the HVPS, confirm: (Figure 2)
 - a. the 2 Registration Sensor Shutters are correctly positioned.
 - b. P/J 261 is connected.
 - c. the ends of the 3 conductive springs 3 on the chassis are in contact with the terminals on the PWB.
 - d. the PWB is seated properly on the bosses.

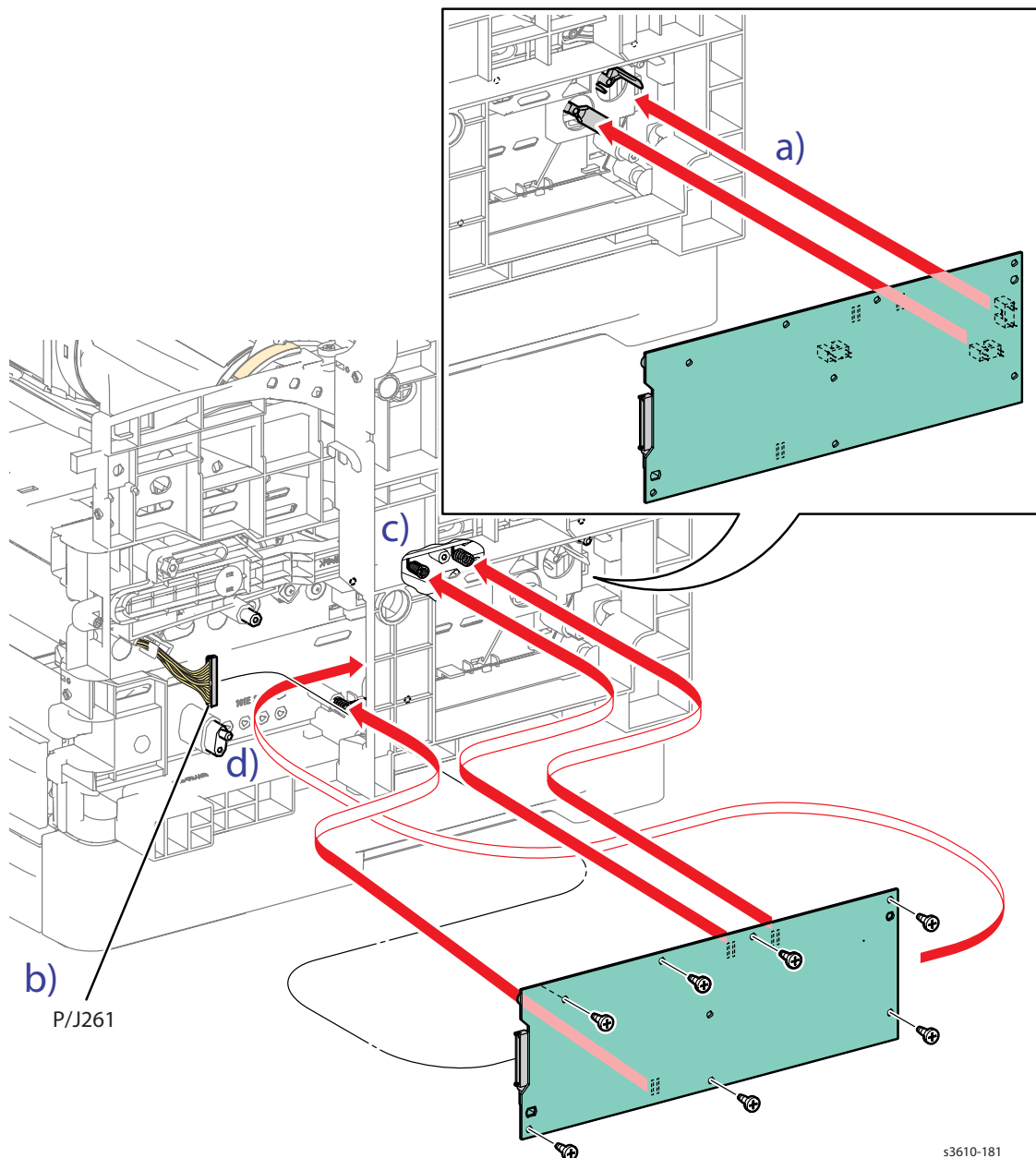

Figure 2

s3610-181

2. Replace in reverse order.

REP 5.9 AC Inlet Harness

PL 5.4 Electrical Connections

Removal

! **WARNING:** Allow the Fusing Assembly to cool before servicing the product.

1. Remove (REP 5.2 ESS PWB Housing).
2. Remove the AC Inlet Harness. (Figure 1)
 - a. Remove 1 screw (silver, M6 with lock washer) that secures the AC ground wire and release the ground wire from the harness clamps.
 - b. Disconnect P/J200 from the LVPS.
 - c. Release 2 clips that secure the power switch to the chassis and release the harness from the harness guide.
 - d. Slide out the AC Socket to remove the AC Inlet Harness from the chassis.

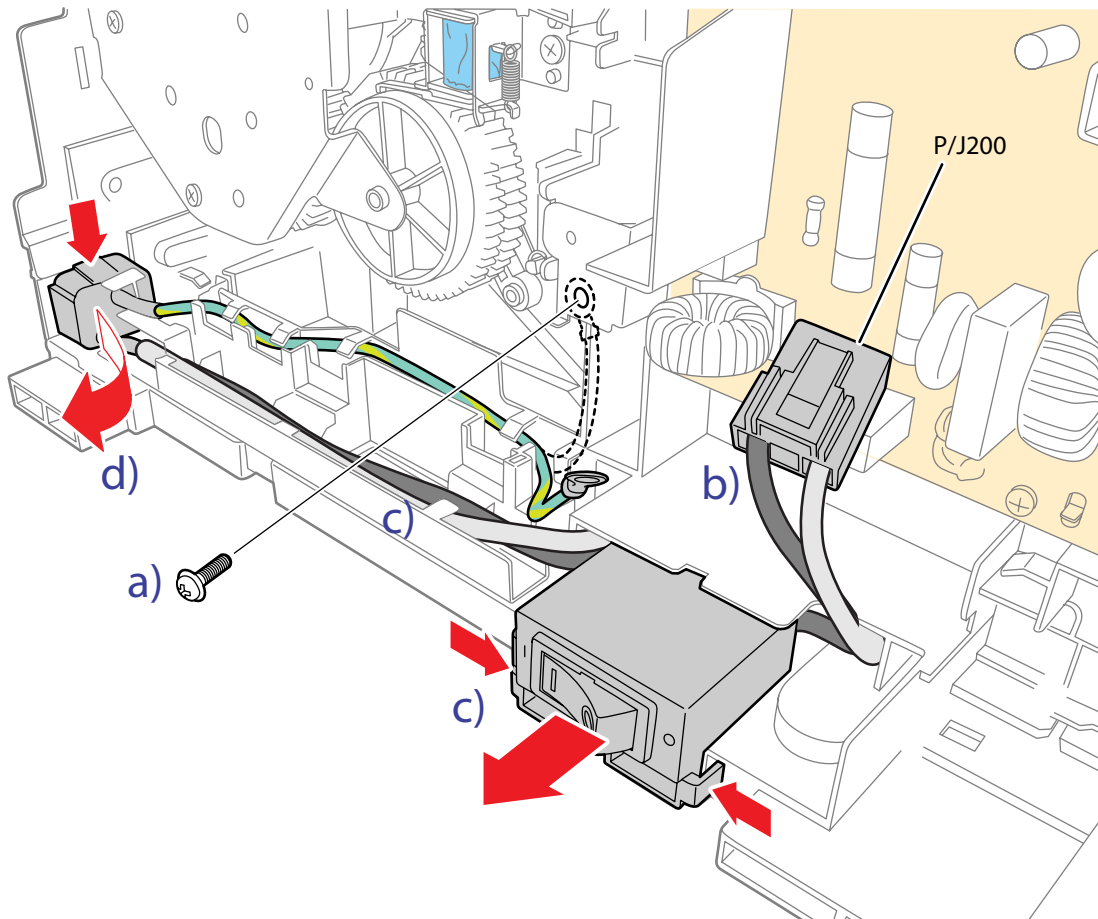

s3610-169

Figure 1

Replacement

1. Replace in reverse order.

IIT / DADF Repairs

REP 6.1 IIT Assembly

PL 6.1 IIT Scanner / DADF

Removal

! **WARNING:** Allow the Fusing Assembly to cool before servicing the product.

1. Remove (REP 1.14 Right Inner Cover (3615)).
2. Remove (REP 1.12 Control Panel (3615)).
3. Disconnect the HVPS. (Figure1)
 - a. Remove 2 screws (silver, M3, 6mm) and the ESS PWB Housing Top Plate.
 - b. Disconnect P/J454, and P/J452 from the ESS PWB,
 - c. Gently pull the flat cable (P/J 451) from the PWB,
 - d. Release the flat cable holder from the chassis, and lift the cable up through the chassis.
 - e. Remove 1 screw (silver, M3, 6mm) to remove the ground wire and disconnect P/J 453.
 - f. Route the wire harnesses to the IIT Assembly up through the chassis to release them.

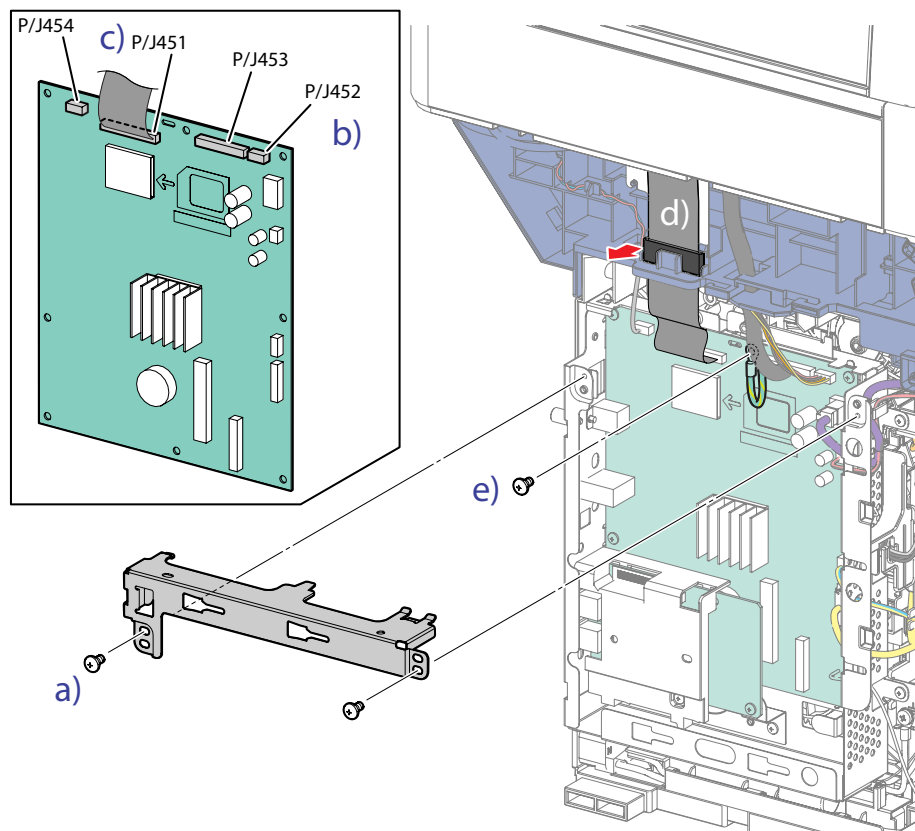
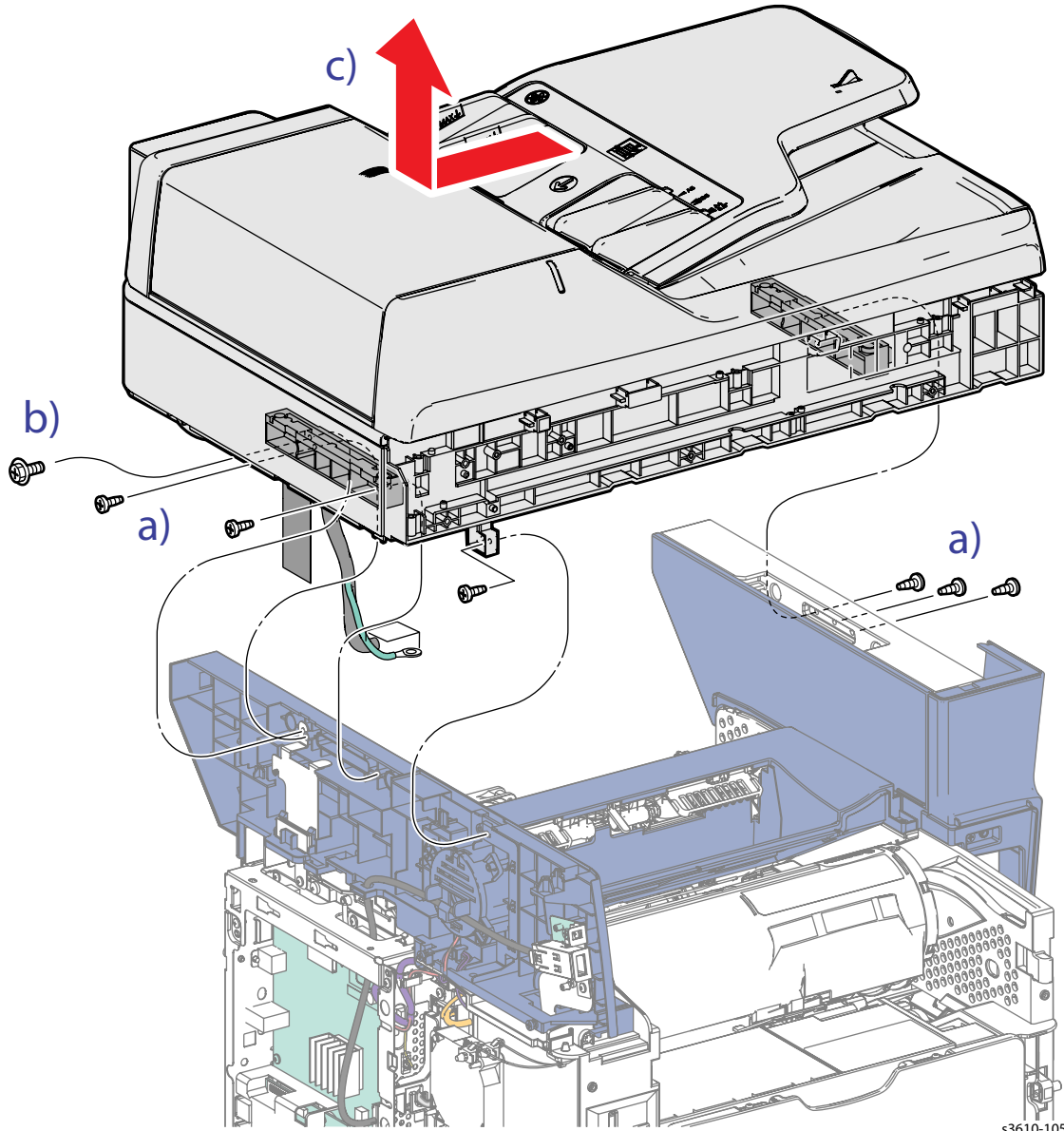

Figure 1

4. Remove the DADF Assembly. (Figure 2)
 - a. Remove 3 (silver, tapping, 8mm) on each side of the IIT Assembly.
 - b. Remove 1 screw (silver, hexagon head with flange, stud type, 10mm) on the left side.
 - c. Slide the assembly to the left to release the studs from the chassis holes, and lift to remove the IIT/DADF.



s3610-105

Figure 2

Replacement

1. Replace in reverse order.

REP 6.2 DADF

PL 6.1 IIT Scanner / DADF

Removal

1. Remove (REP 6.1 IIT Assembly).
2. Remove the DADF. (Figure 2)
 - a. Flip the IIT Assembly on its side.
 - b. While applying a little pressure to separate the DADF from the Scanner, release the pins on both DADF Hinges.

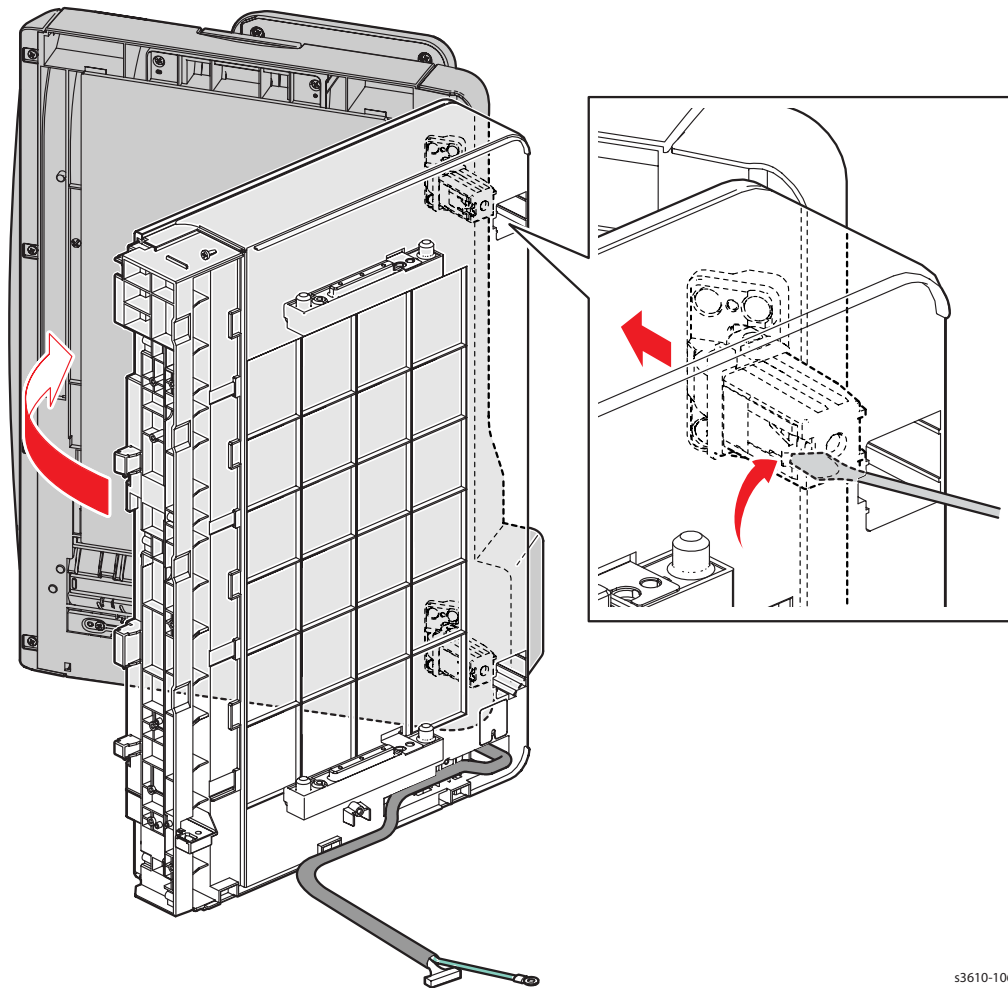

Figure 1

s3610-106

Replacement

1. Replace in reverse order.

REP 6.3 DADF Hinges

PL 6.1 IIT Scanner / DADF

Removal

1. Remove (REP 6.2 DADF).
2. Remove the DADF Hinges. (Figure 1)
 - a. Turn the DADF over.
 - b. Remove 4 screw (silver, tapping, 8mm) to remove the Right Hinge
 - c. Remove 5 screws (silver, tapping, 8mm) to remove the Left Hinge.

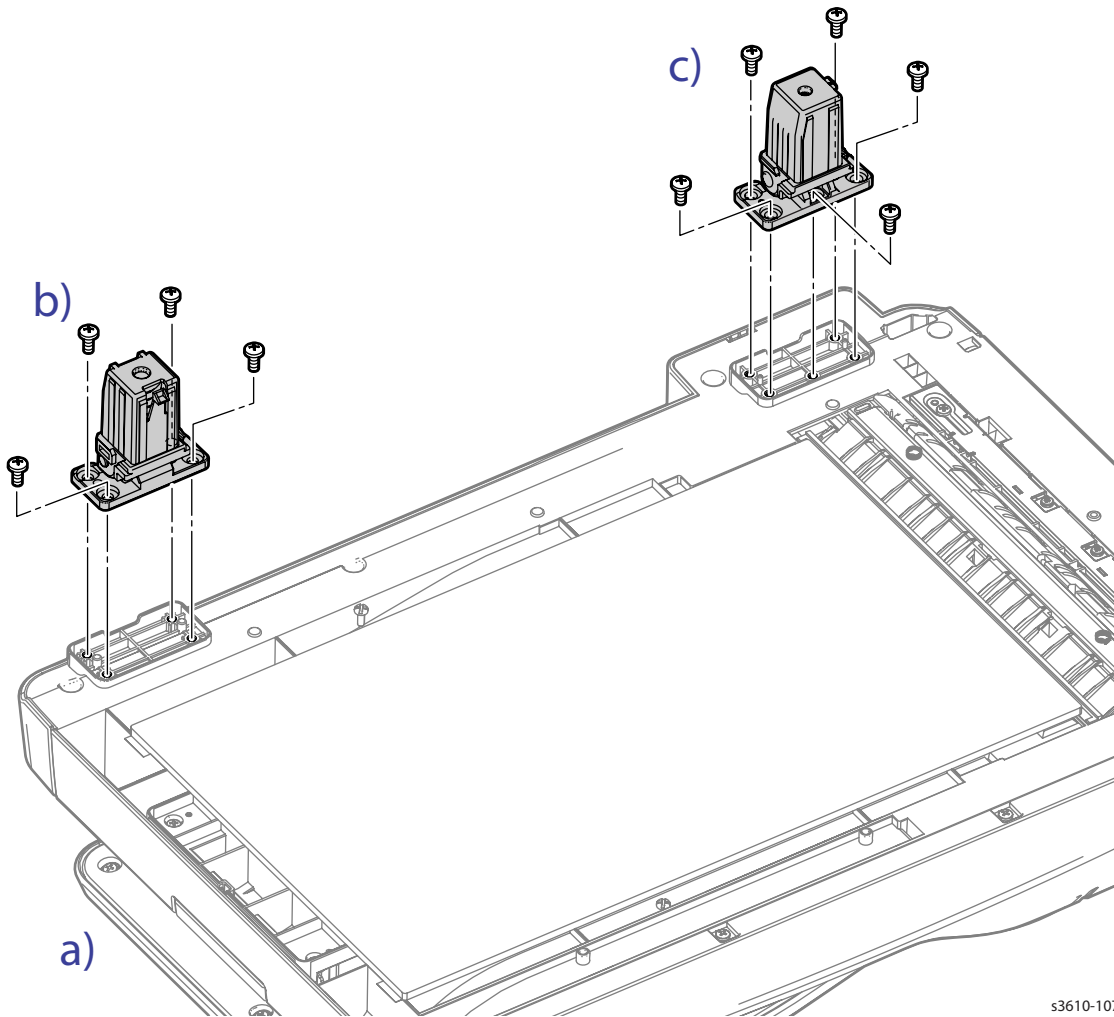

Figure 1

s3610-107

Replacement

1. Replace in reverse order.

REP 6.4 Pick-up Module Kit

PL 6.1 IIT Scanner / DADF

Removal

1. Open the DADF Cover.
2. Remove the Feed Roll Assembly. (Figure 1)
 - a. Release the paper guide on each side of the assembly.
 - b. Remove the Feed Roll Assembly.

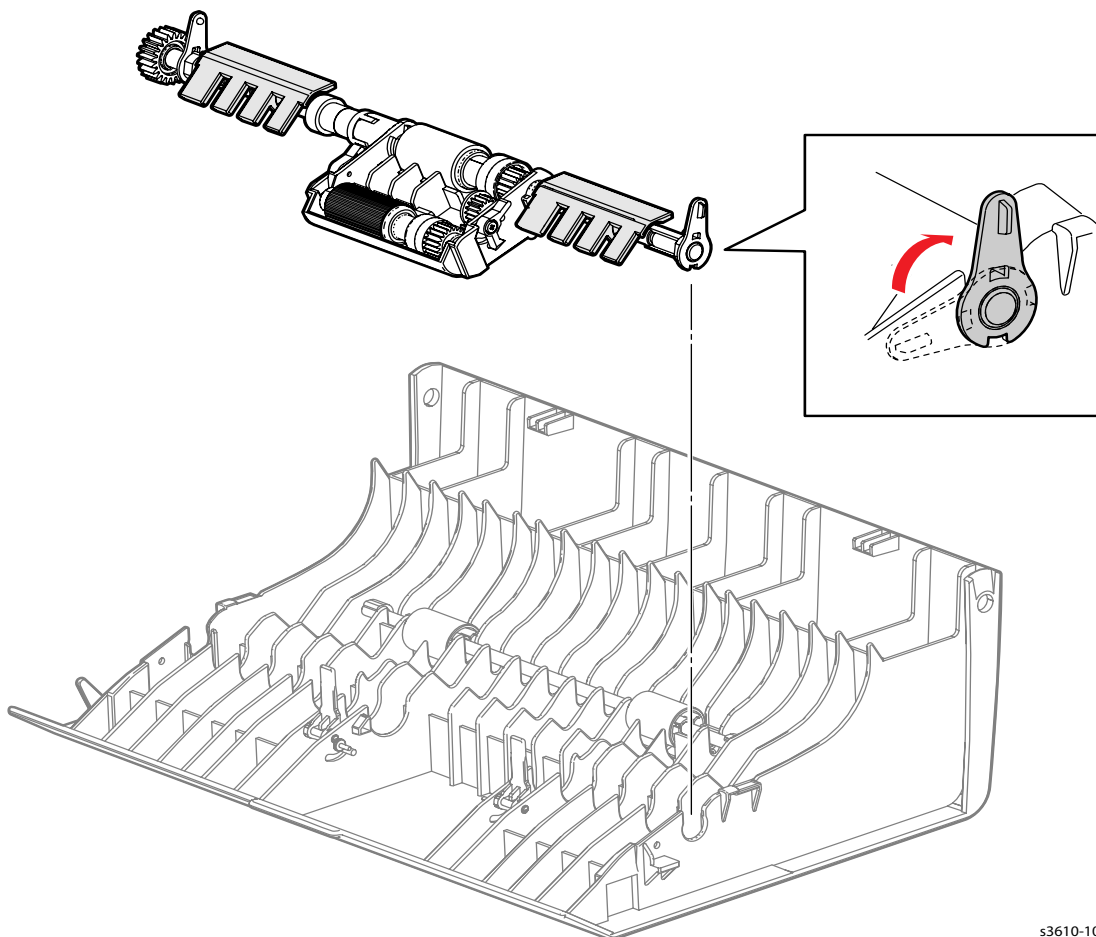
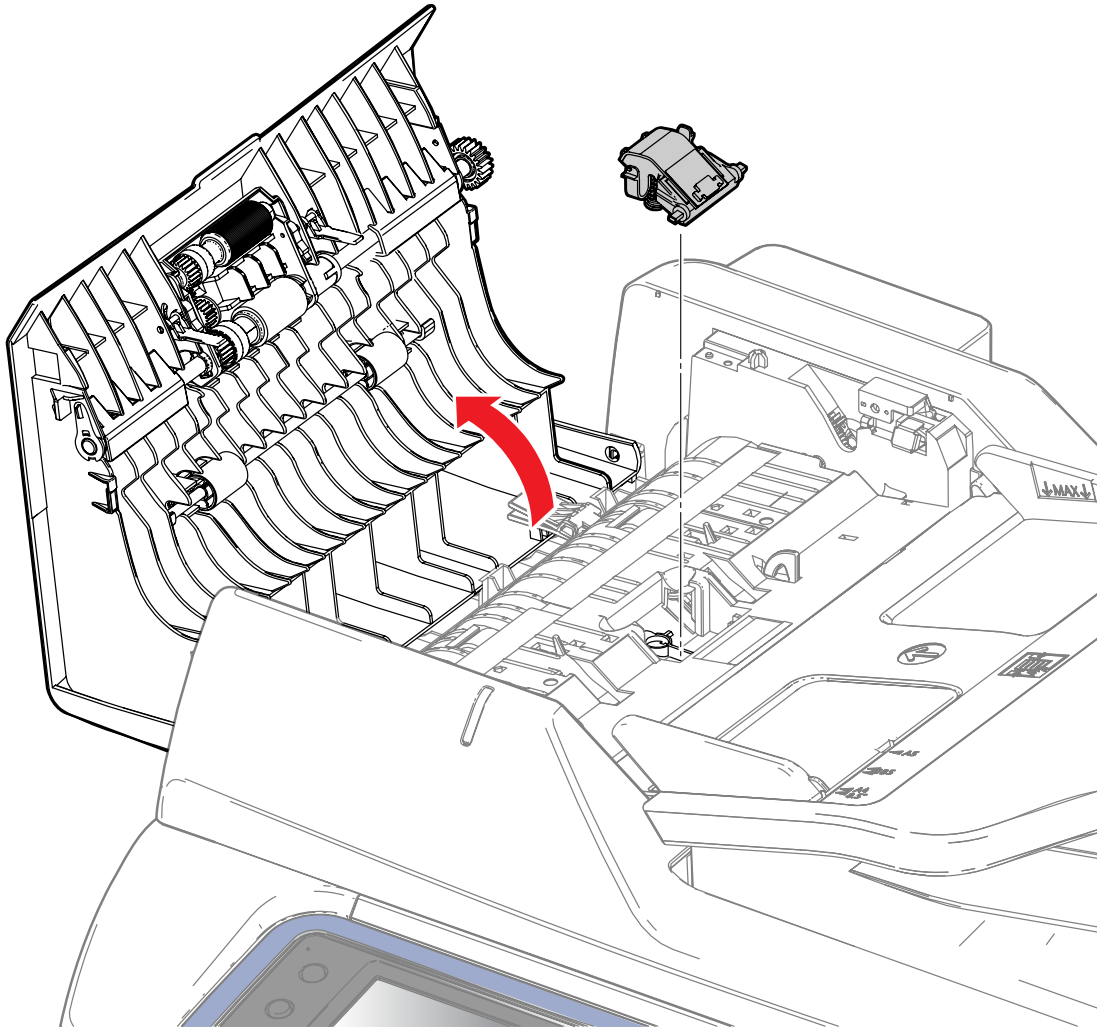

Figure 1

s3610-108

3. Release 2 clips and remove the Separation Pad. (Figure 2)



s3610-293

Figure 2

Replacement

1. Replace in reverse order.

REP 6.5 DADF Tray Assembly

PL 6.1 IIT Scanner / DADF

Removal

1. Remove (REP 6.2 DADF).
2. Remove the 4 screws from the bottom of the DADF Rear Cover and remove.
3. Remove the Tray Assembly. (Figure 1)
 - a. If present, cut the cable tie from the wire harness.
 - b. Disconnect Con 12.
 - c. Lift up slightly on the tray from the right side (wire side) and shift to the right to remove.

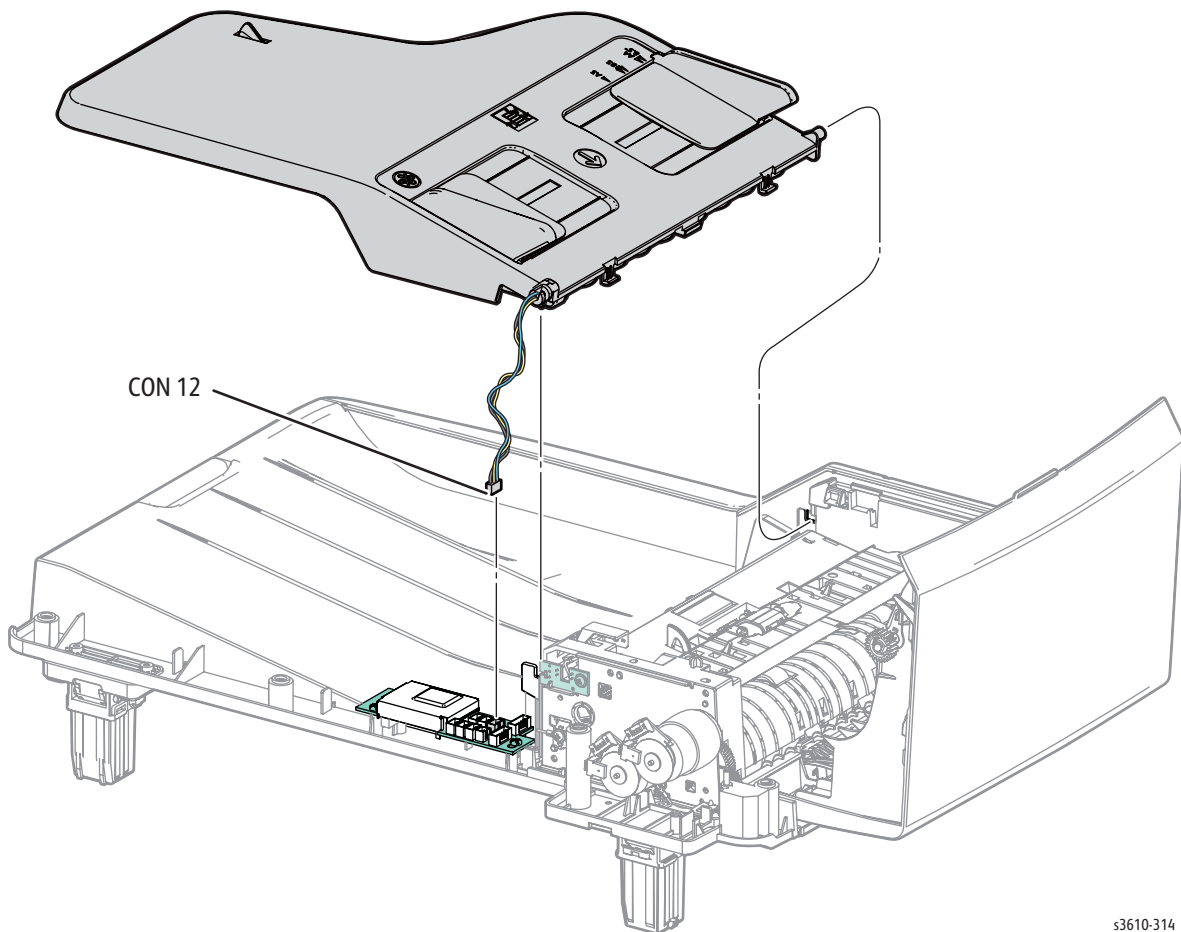

s3610-314

Figure 1

Replacement

1. Replace in reverse order.

550-Sheet Feeder Repairs

REP 7.1 550-Sheet Feeder

PL 7.1 Tray 1/Optional Tray 550-Sheet Feeder (1/4)

Removal

1. Separate the Printer from the Feeders. (Figure 1)
 - a. Remove the Bypass Tray
 - b. Remove the Tray from the 550-Sheet Feeder.
 - c. Remove 2 Screw Locks that secure the feeder to the printer.
 - d. Release 5 bosses on the feeder from the holes on the printer, then lift the printer to separate it from the feeder.

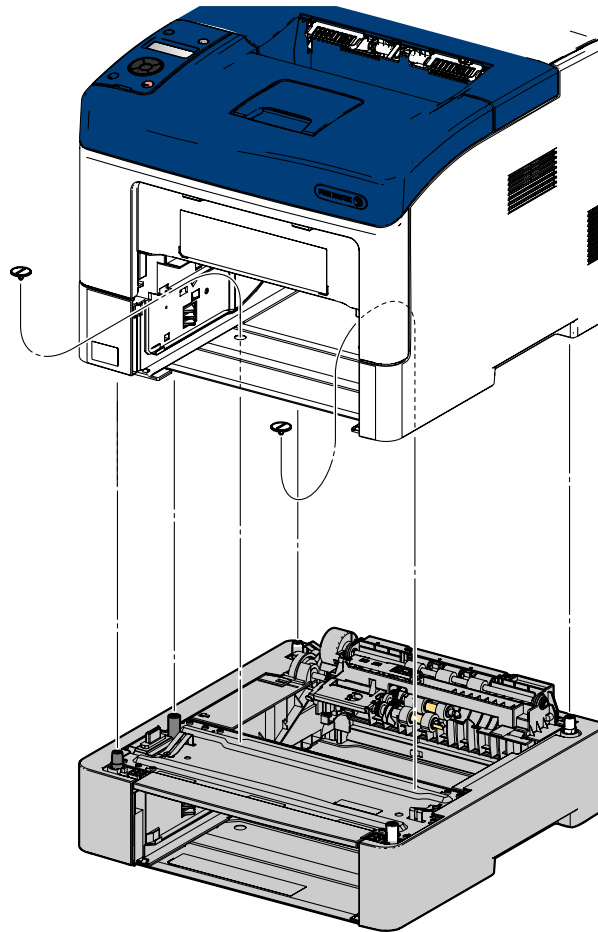

Figure 1

Replacement

1. Replace in reverse order.

REP 7.2 Left Side Cover

PL 7.1 Tray 1/Optional Tray 550-Sheet Feeder (1/4)

Removal

1. Remove the Tray from the 550-Sheet Feeder.
2. Remove ([REP 7.1 550-Sheet Feeder](#)).
3. Remove the Left Cover. (Figure 1)
 - a. Remove 1 screw (silver, tapping, 8mm),
 - b. Release 1 clip.
 - c. Release 6 bosses from the holes to remove the Left Cover.

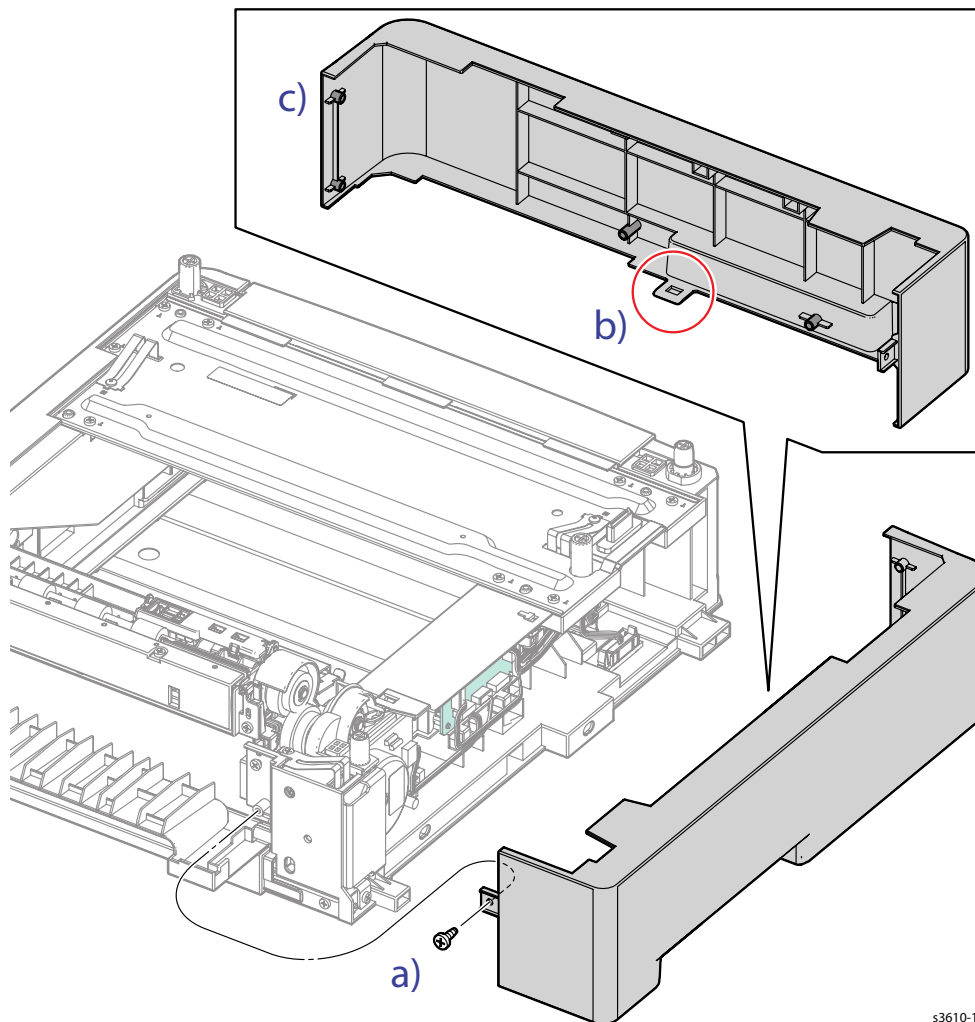

Figure 1

s3610-110

Replacement

1. Replace in reverse order.

REP 7.3 Right Side Cover

PL 7.1 Tray 1/Optional Tray 550-Sheet Feeder (1/4)

Removal

1. Remove the Tray from the 550-Sheet Feeder.
2. Remove ([REP 7.1 550-Sheet Feeder](#)).
3. Remove the Right Side Cover. (Figure 1)
 - a. Remove 1 screw (silver, tapping, 8mm)
 - b. Release 1 clip from the boss
 - c. Release 6 bosses to remove the cover

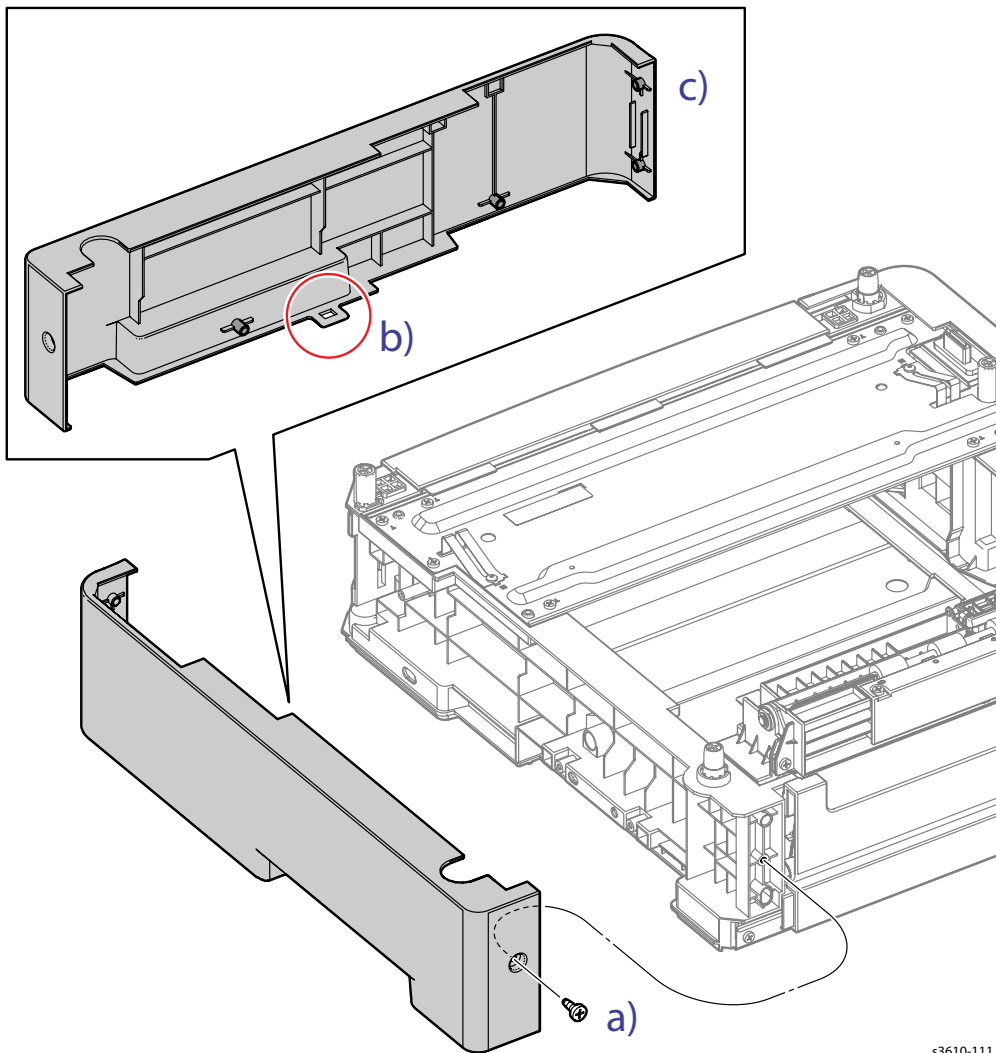

Figure 1

s3610-111

Replacement

1. Replace in reverse order.

REP 7.4 Rear Cover

PL 7.1 Tray 1/Optional Tray 550-Sheet Feeder (1/4)

Removal

1. Remove the Tray from the 550-Sheet Feeder.
2. Remove (REP 7.1 550-Sheet Feeder).
3. Remove the Rear Cover. (Figure 1)
 - a. Open the Rear Cover
 - b. Remove one side of the Rear Cover Spring from the Rear Cover.
 - c. Release the left boss to remove the Rear Cover.

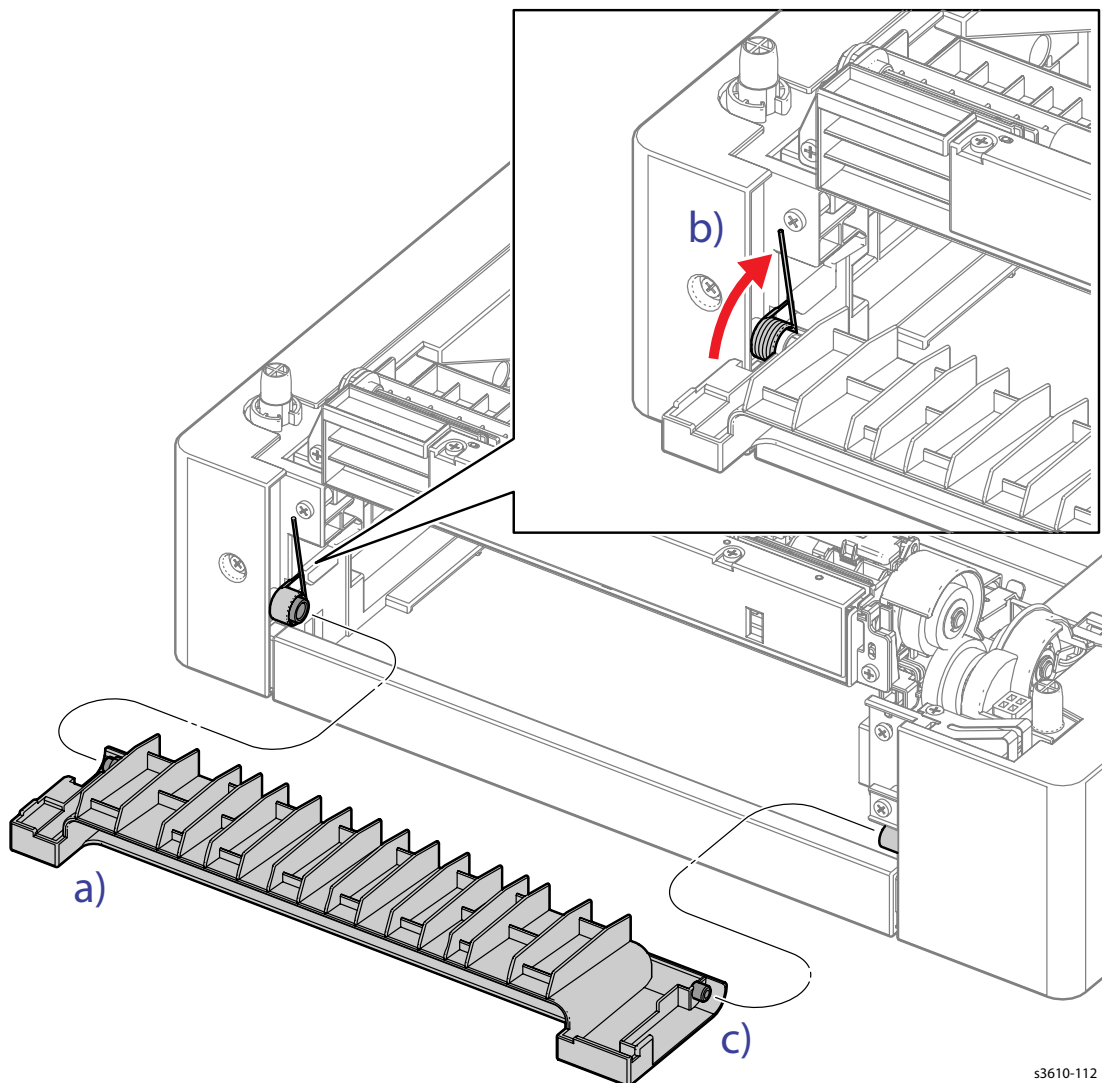

Figure 1

s3610-112

Replacement

1. Replace in reverse order.

REP 7.5 Optional Tray PWB Assembly

PL 7.1 Tray 1/Optional Tray 550-Sheet Feeder (1/4)

Removal

1. Remove the Tray from the 550-Sheet Feeder.
2. Remove ([REP 7.1 550-Sheet Feeder](#)).
3. Remove ([REP 7.2 Left Side Cover](#))
4. Remove the Optional Tray PWB Assembly. (Figure 1)
 - a. Release the harness from the clamp, and then remove the clamp from the frame.
 - b. Disconnect all connectors from the PWB Assembly.
 - c. Remove 3 screws (silver, tapping, 8mm) that secure the PWB Assembly.

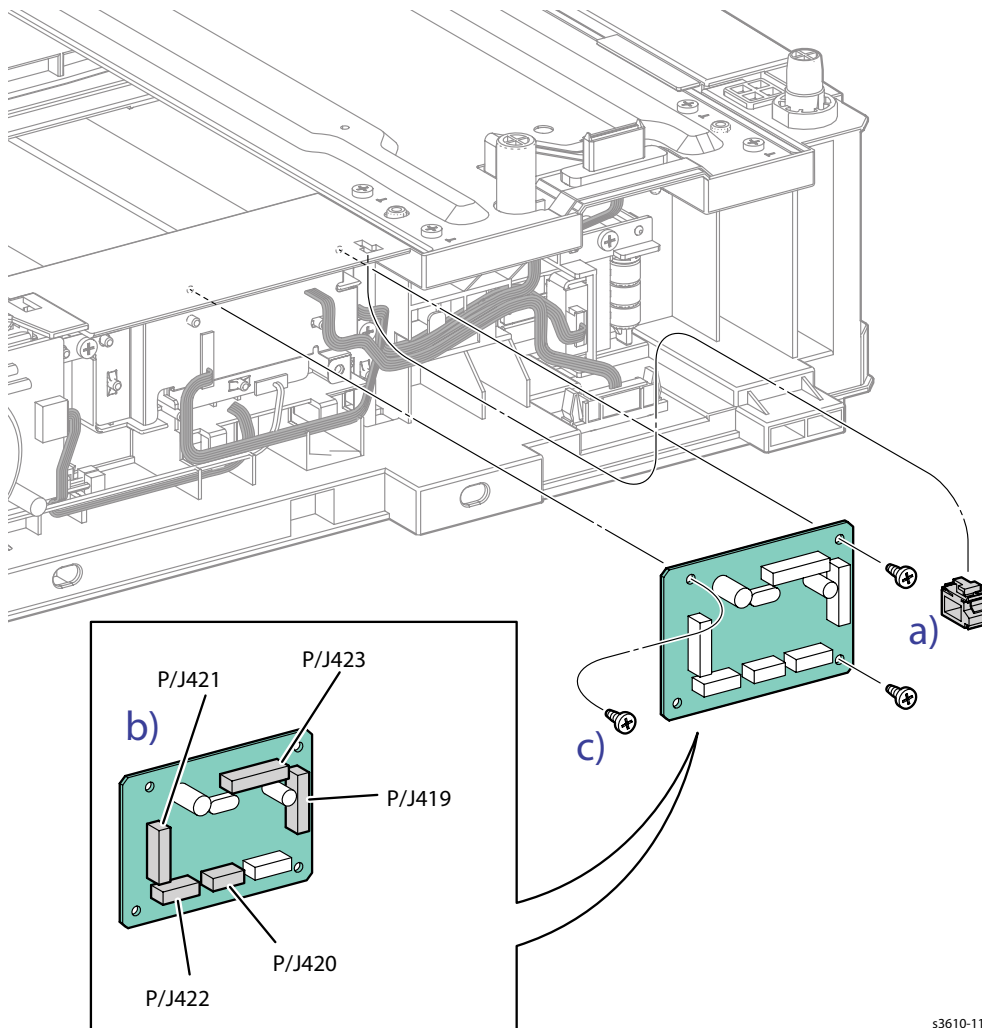

Figure 1

s3610-113

Replacement

1. Replace in reverse order.

REP 7.6 Drive Assembly

PL 7.1 Tray 1/Optional Tray 550-Sheet Feeder (1/4)

Removal

1. Remove the Tray from the 550-Sheet Feeder.
2. Remove ([REP 7.1 550-Sheet Feeder](#)).
3. Remove ([REP 7.2 Left Side Cover](#)).
4. Remove the 2 screws securing the white block (1 and 2).
5. Remove the Drive Assembly. (Figure 1)
 - a. Remove 1 screw (silver, tapping, 8mm) and lift the ground straps to remove the Cover.
 - b. Disconnect P/J4221 from the motor.
 - c. Remove 4 screws (silver, tapping, 8mm) that secure the assembly to the chassis.

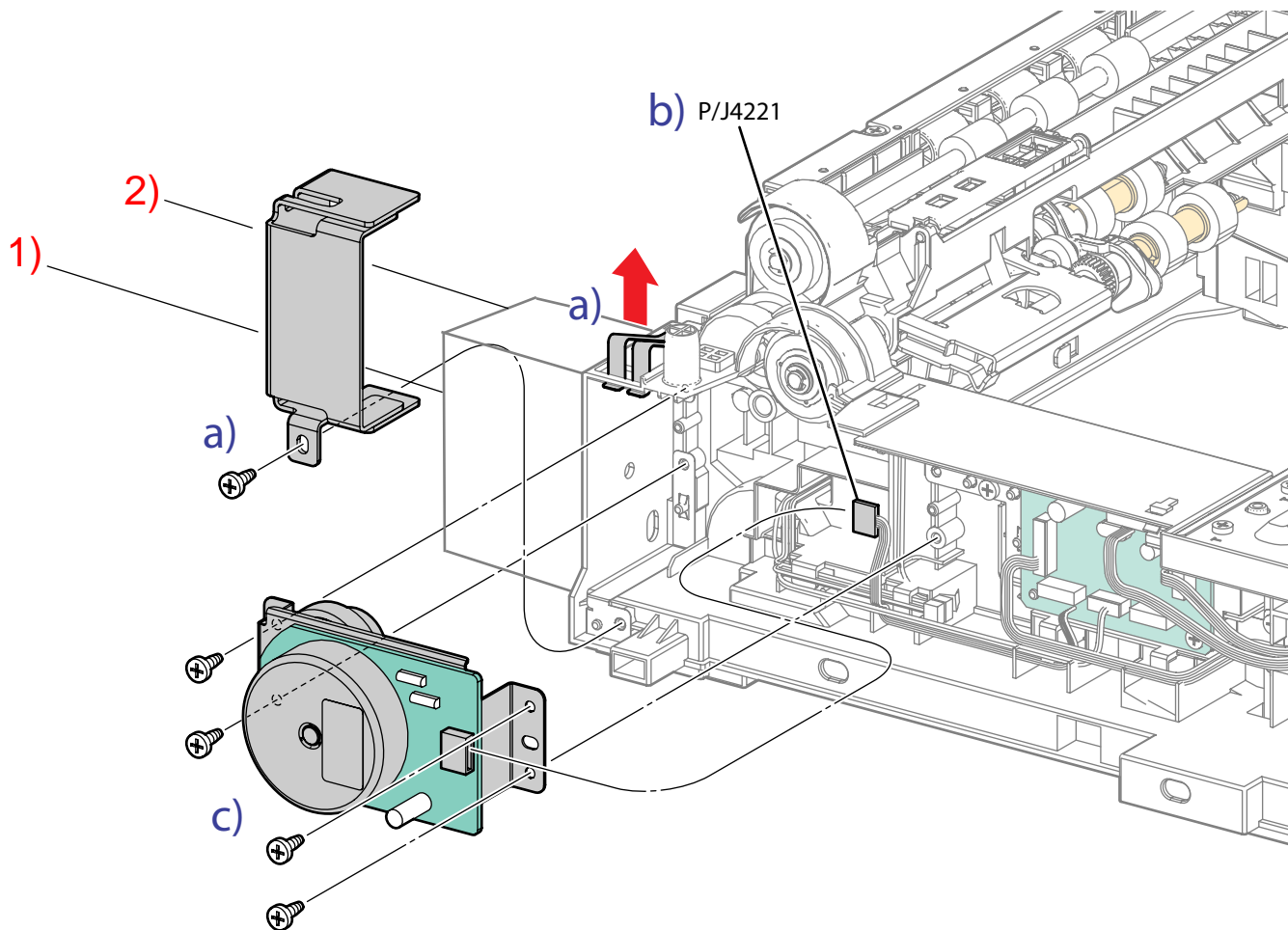

s3610-114

Figure 1

5. Remove the Drive Assembly. (Figure 2)

- a. Remove the gear
- b. Remove the 3 screws (silver, M3, 4mm) that secure the motor to the motor bracket.

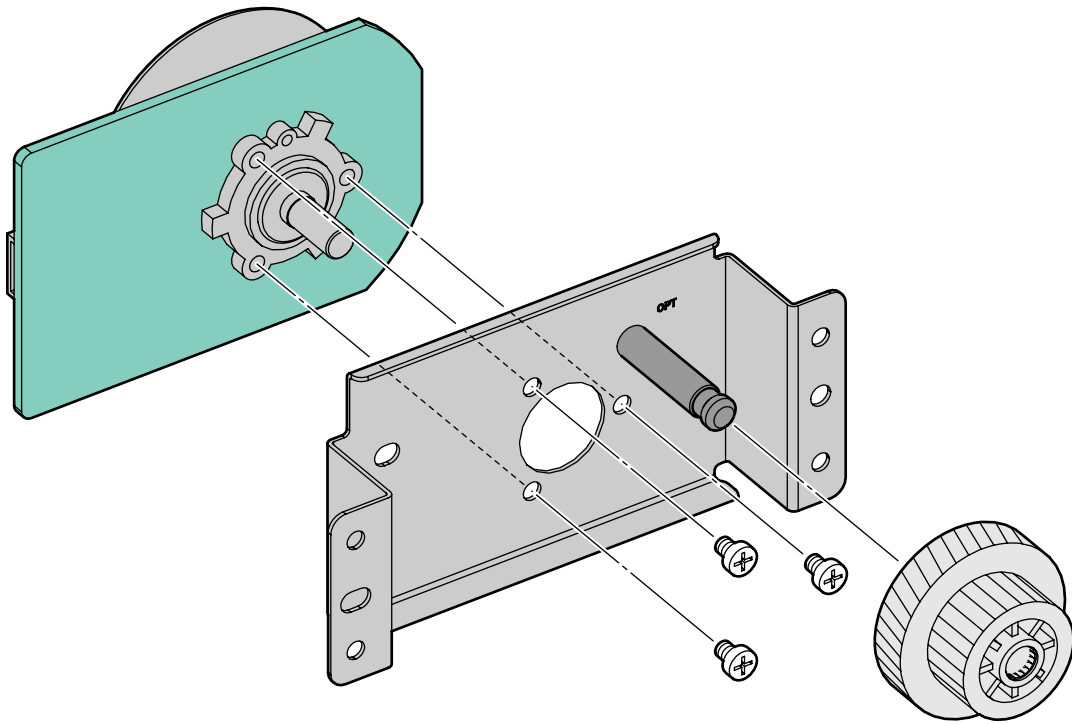

Figure 2

s3610-115

Replacement

1. Replace in reverse order.

REP 7.7 Feed Clutch Assembly

PL 7.1 Tray 1/Optional Tray 550-Sheet Feeder (1/4)

Removal

1. Remove the Tray from the 550-Sheet Feeder.
2. Remove ([REP 7.1 550-Sheet Feeder](#)).
3. Remove ([REP 7.2 Left Side Cover](#)).
4. Remove ([REP 7.6 Drive Assembly](#)).
5. Remove the Feed Clutch Assembly. (Figure 1)
 - a. Disconnect P/J4201 from the Feed Clutch Assembly,
 - b. Release the harness from the harness guide.
 - c. Remove the E-ring that secures the Feed Clutch Assembly to the shaft.

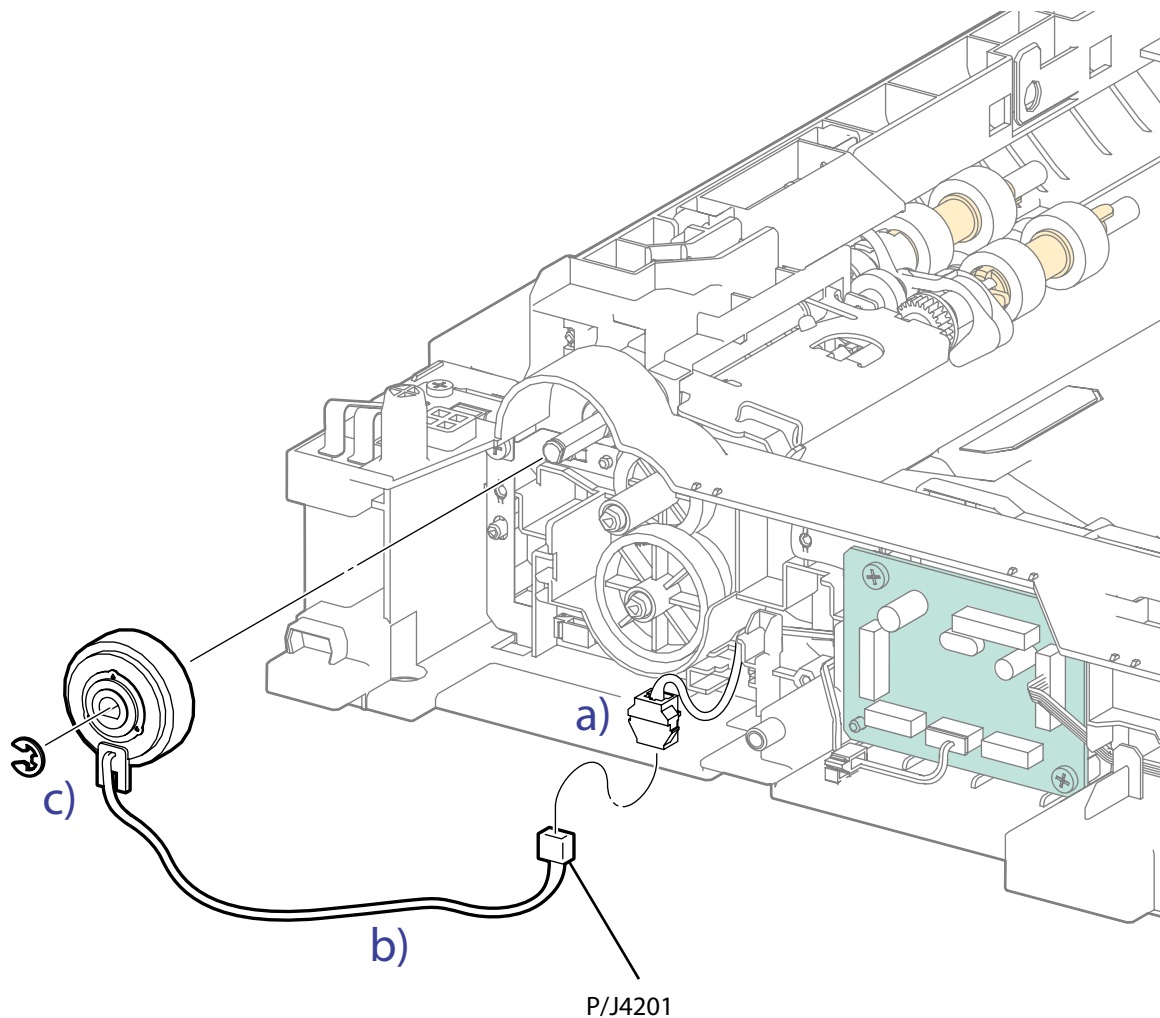

Figure 1

s3610-116

Replacement

1. Replace in reverse order.

REP 7.8 Feeder Assembly

PL 7.1 Tray 1/Optional Tray 550-Sheet Feeder (1/4)

Removal

1. Remove (REP 7.7 Feed Clutch Assembly).
2. Disconnect P/J 4202, 4213 and 4214. (Figure 1)

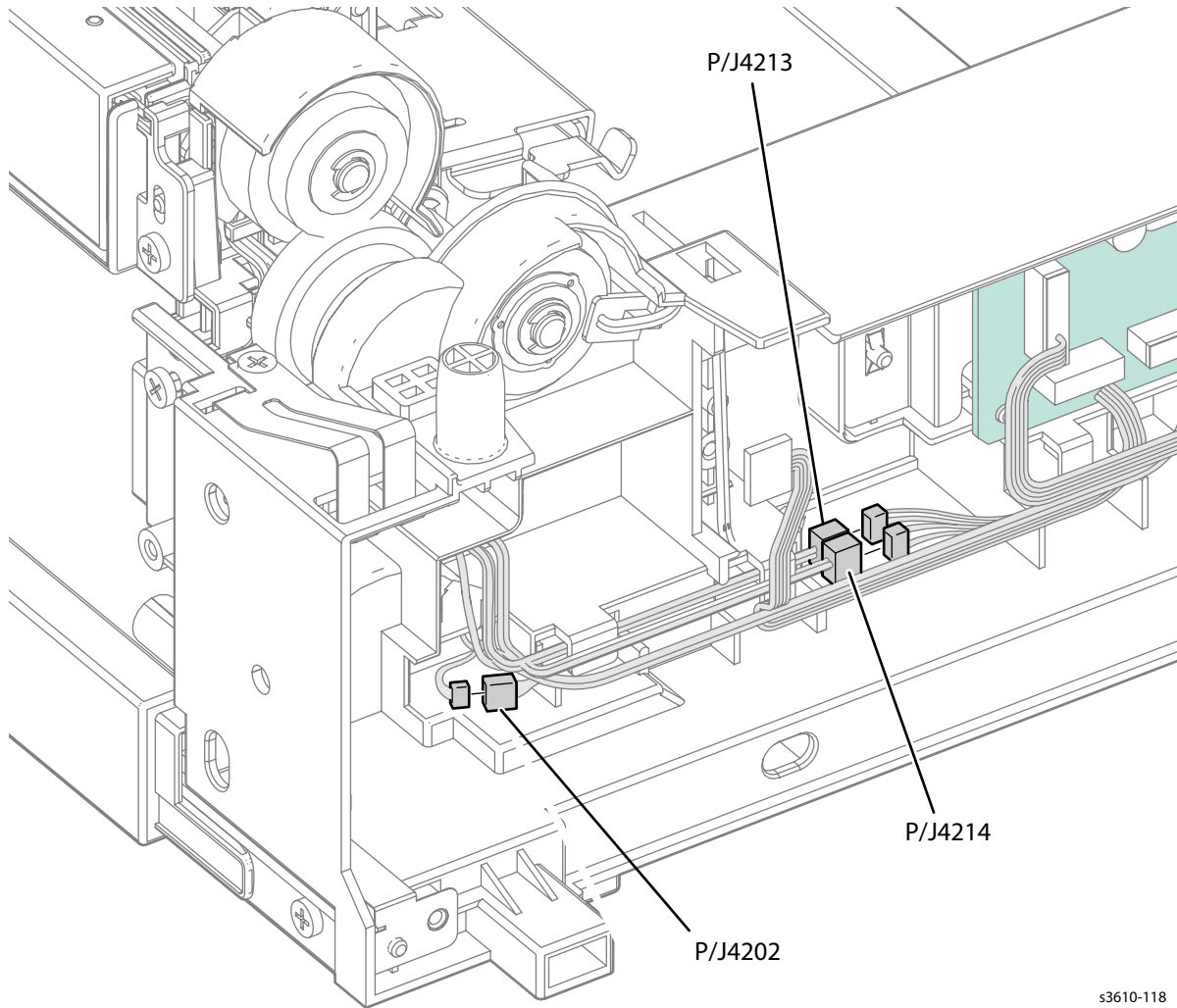

Figure 1

s3610-118

3. Release the feeder harness from the guides.
4. Remove the Feeder Assembly. (Figure 2)
 - a. 2 screws (silver, tapping, 8mm),
 - b. Remove the bearing,
 - c. Release 4 bosses to remove the Feeder Assembly.

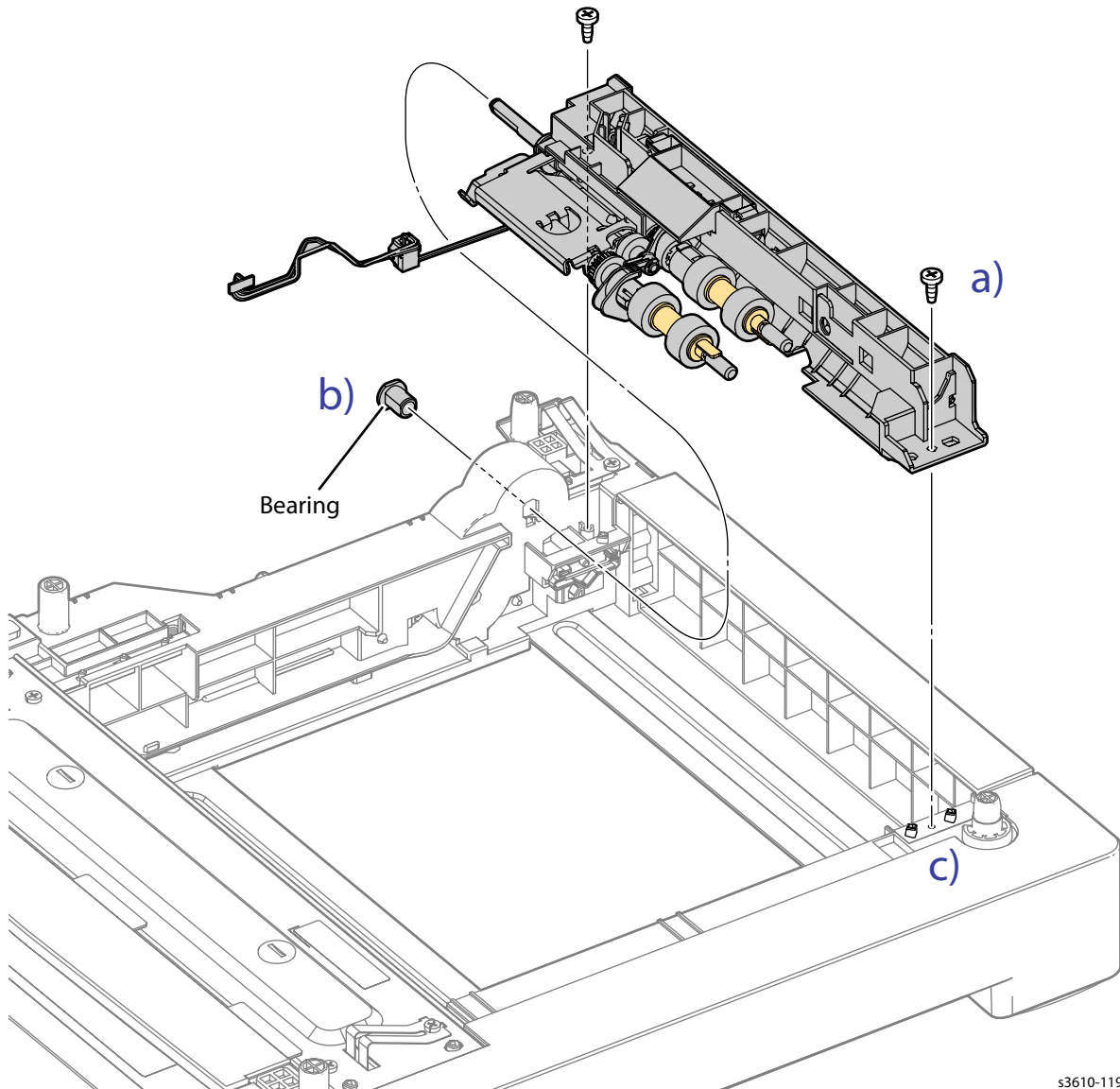

Figure 2

s3610-119

Replacement

1. Replace in reverse order.

REP 7.9 No Paper Sensor

PL 7.2 Tray 1/Optional Tray 550-Sheet Feeder (2/4)

Removal

1. Remove the Tray from the 550-Sheet Feeder.
2. Remove (REP 7.1 550-Sheet Feeder).
3. Remove the No Paper Sensor, (Figure 1)
 - a. Release 3 clips that secure the sensor holder to the Feeder Assembly.
 - b. Disconnect P/J 4203,
 - c. Release three clips that secure the sensor to the sensor holder.

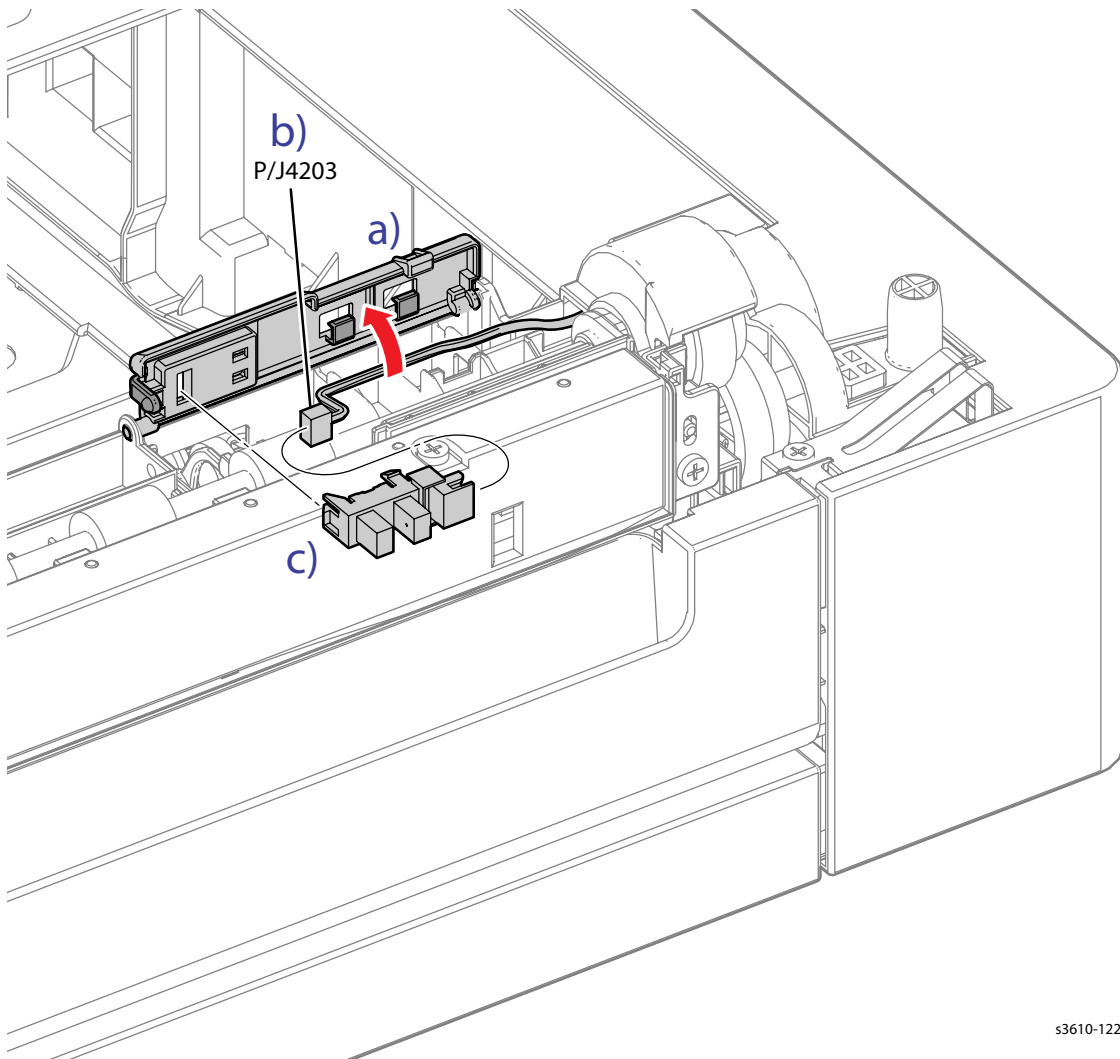

Figure 1

Replacement

1. Secure the left side of the holder to the feeder first.
2. Replace in reverse order.

REP 7.10 Registration Clutch Assembly

PL 7.2 Tray 1/Optional Tray 550-Sheet Feeder (2/4)

Removal

1. Remove (REP 7.8 Feeder Assembly).
2. Remove the Components. (Figure 1)
 - a. Remove the idler gear
 - b. Remove 1 screw (silver, tapping, 8mm) that secures the retention plate.
 - c. Remove the E-ring that secures the clutch to the shaft.

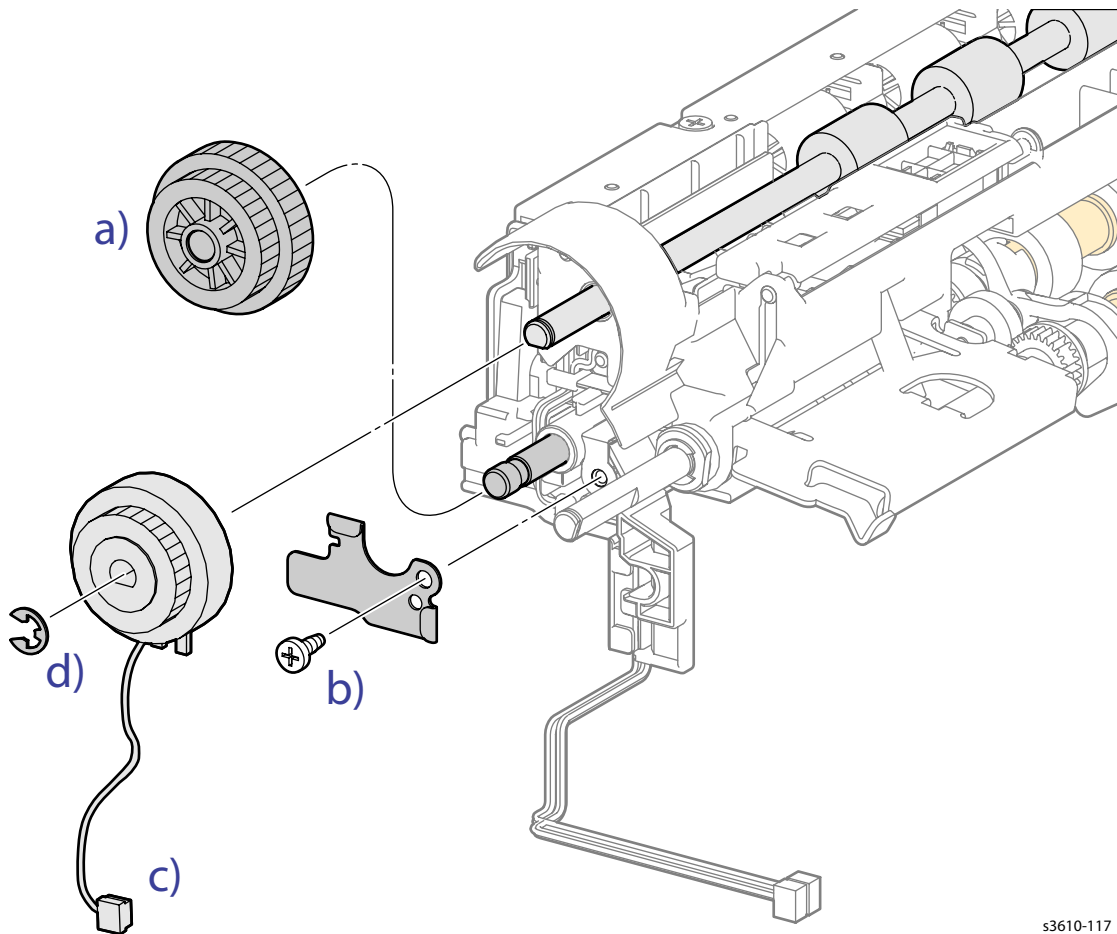

Figure 1

s3610-117

Replacement

1. Replace in reverse order.

REP 7.11 Feed Roller Assembly

PL 7.3 Tray 1/Optional Tray 550-Sheet Feeder (3/4)

Removal

1. Remove the Tray from the 550-Sheet Feeder.
2. Remove (REP 7.1 550-Sheet Feeder).
3. Release the clip that secures each roller to the shaft. (Figure 1)

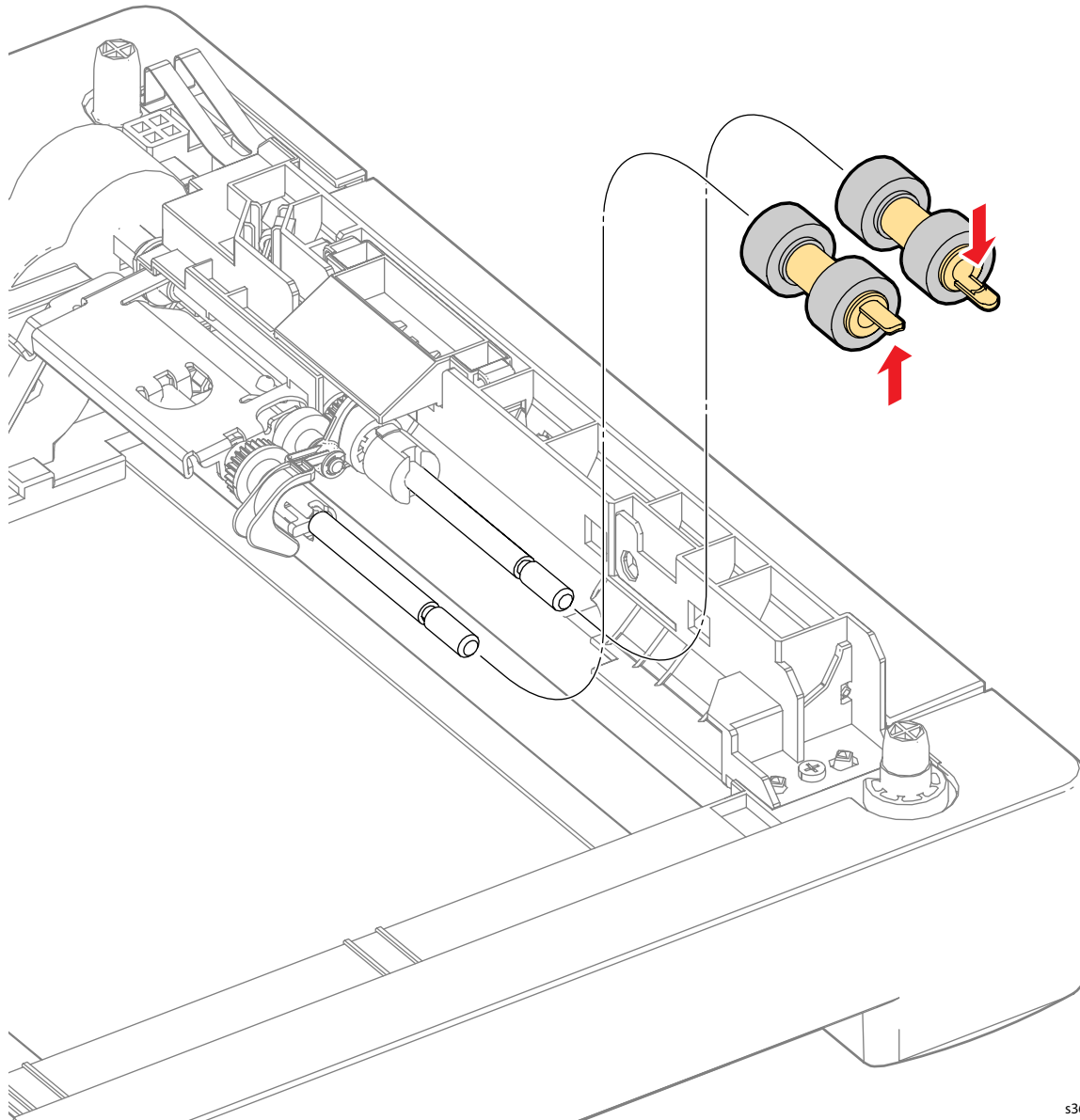

Figure 1

s3610-121

Replacement

1. Replace in reverse order.

REP 7.12 Retard Roller Assembly

PL 7.3 Tray 1/Optional Tray 550-Sheet Feeder (3/4)

Removal

1. Remove the Tray.
2. Remove the Roll Assembly. (Figure 1)
 - a. Release the clip that secures the Retard Roller Holder to the Tray,
 - b. Rotate the holder to remove the holder from the Tray.

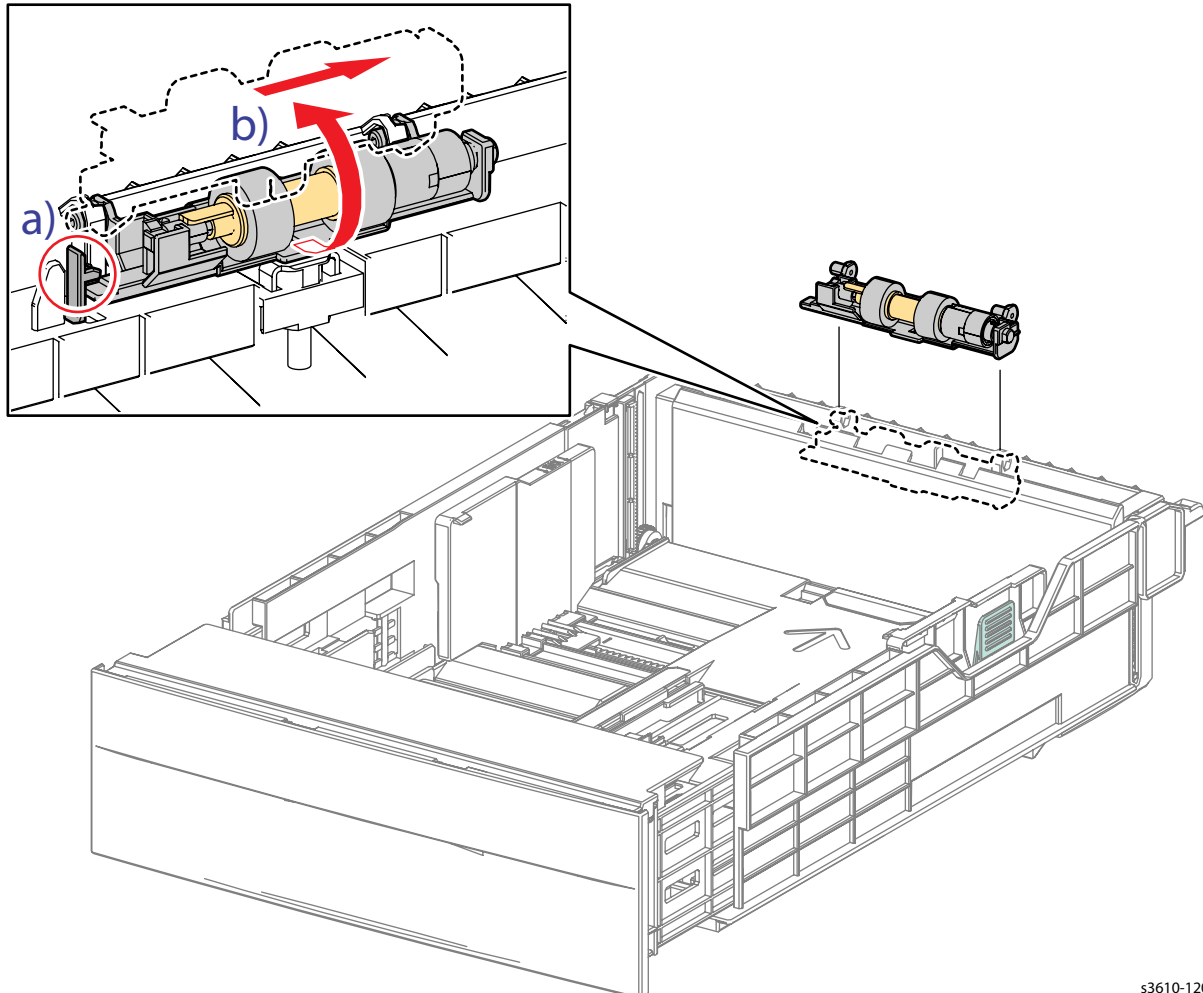

Figure 1

s3610-120

Replacement

1. Replace in reverse order.

REP 7.13 Pre-Registration Sensor

PL 7.4 Tray 1/Optional Tray 550-Sheet Feeder (4/4)

Removal

1. Remove the Tray from the 550-Sheet Feeder.
2. Remove (REP 7.1 550-Sheet Feeder).
3. Remove the Pre-Registration Sensor. (Figure 1)
 - a. Remove 2 screws (silver, tapping, 8mm).
 - b. Disconnect P/J 4212.
 - c. Release 3 clips to remove the sensor.

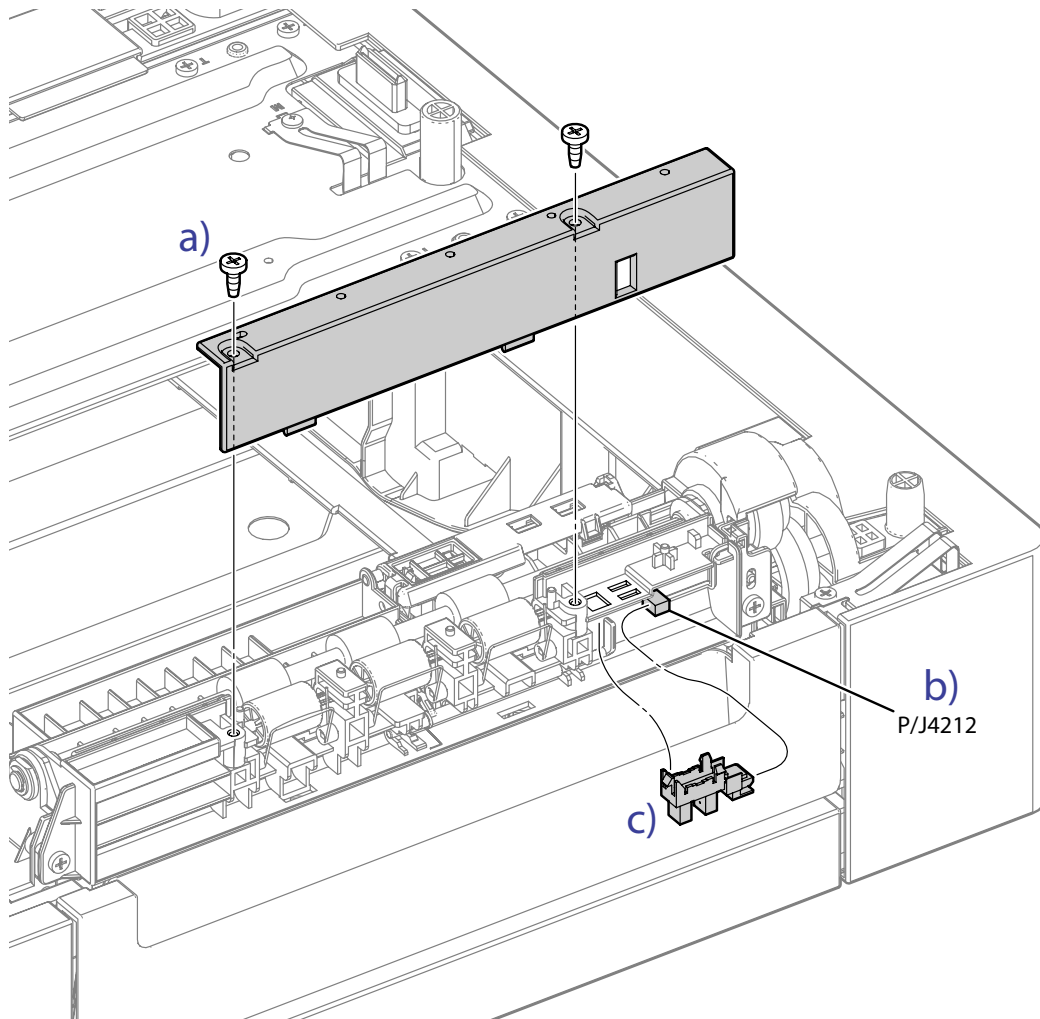

Figure 1

Replacement

1. Replace in reverse order.

REP 7.14 Take Away Roller Assembly

PL 7.4 Tray 1/Optional Tray 550-Sheet Feeder (4/4)

Removal

1. Remove (REP 7.7 Feed Clutch Assembly).
2. Remove the Roller Assembly. (Figure 1)
 - a. Remove the E-ring.
 - b. Remove the Bearing.
 - c. Remove the Roller Assembly by shifting it to the right and then out.

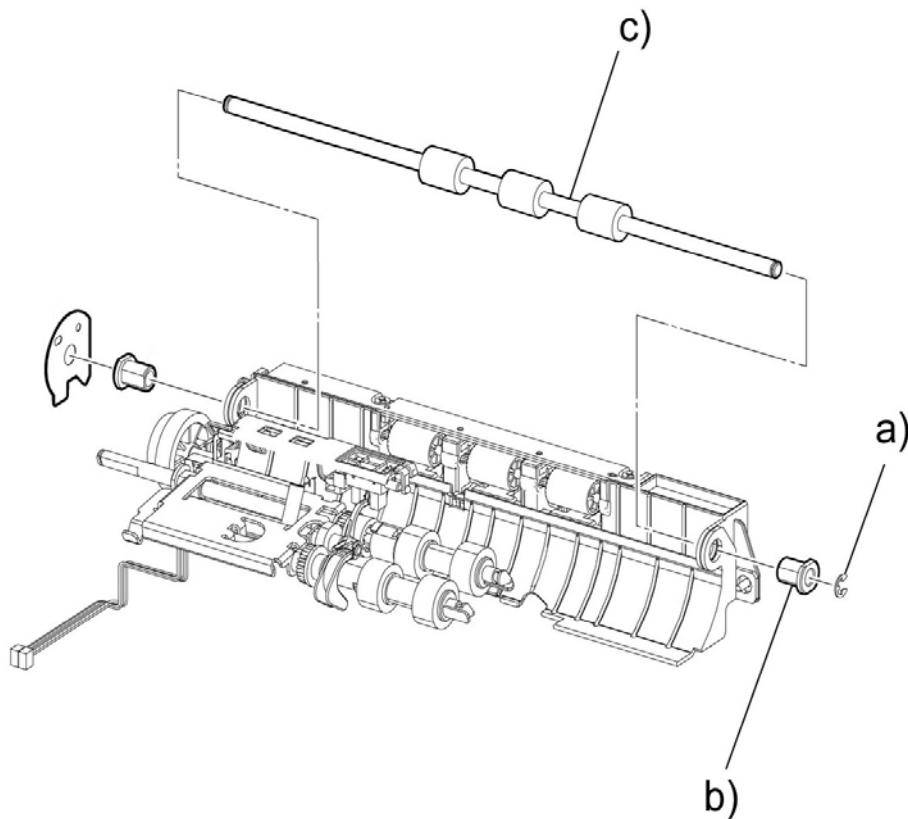

ZaS041117AA

Figure 1

Replacement

1. Replace in reverse order.

Parts List

5

In this chapter...

- [Serial Number Format](#)
- [Using the Parts List](#)
- [Parts Lists](#)
 - [PL 1.1 Covers \(3610\)](#)
 - [REP 5.6 MCU PWB](#)
 - [PL 1.3 Rear Cover Assembly](#)
 - [PL 1.4 Control Panel \(3610\)](#)
 - [PL 1.5 Control Panel \(3615\)](#)
 - [PL 2.4 Duplex Chute](#)
 - [PL 2.1 Registration](#)
 - [PL 2.3 Feed Assembly](#)
 - [PL 2.1 Registration](#)
 - [PL 2.4 Duplex Chute](#)
 - [PL 2.6 MSI](#)
 - [PL 2.7 Bypass Tray](#)
 - [PL 3.1 Xerographics](#)
 - [PL 3.2 ROS Assembly](#)
 - [PL 3.3 Toner Dispense](#)
 - [PL 3.4 Transfer Roller](#)
 - [PL 3.5 Fusing Assembly](#)
 - [PL 4.1 Drive](#)
 - [PL 4.2 NOHAD](#)
 - [PL 5.1 Electrical \(ESS PWB / LVPS\) \(3610\)](#)
 - [PL 5.2 Electrical \(ESS PWB / LVPS\) \(3615\)](#)
 - [PL 5.3 Electrical \(MCU PWB / HVPS\)](#)
 - [PL 5.4 Electrical Connections](#)
 - [PL 6.1 IIT Scanner / DADF](#)
 - [PL 7.1 Tray 1/Optional Tray 550-Sheet Feeder \(1/4\)](#)
 - [PL 7.2 Tray 1/Optional Tray 550-Sheet Feeder \(2/4\)](#)
 - [PL 7.3 Tray 1/Optional Tray 550-Sheet Feeder \(3/4\)](#)
 - [PL 7.4 Tray 1/Optional Tray 550-Sheet Feeder \(4/4\)](#)
- [Quick Reference Spares List for the 3610 and 3615](#)
- [Xerox Supplies](#)

Serial Number Format

Changes to Xerox products are made to accommodate improved components as they become available. It is important when ordering parts to include the following information:

- Component's part number
- Product type or model number
- Serial Number of the printer

The serial numbers are only reset to the starting serial number when the ending serial number is reached. At that time the revision digit will be rolled. Serial numbers below 10001 are reserved for XOG Final Integration Center (FIC) sites if re-serialization is needed.

Note: Not all of the serial number will be used. This is a buffer in case additional units are built by Fuji Xerox for each model of printer during pre-production.

110V Engine Format

The nine-digit serial number has the following format:

- **PPSSSSSS**
- **PPP** = Three digit alphanumeric product code
- **SSSSSS** = Six digit numeric serial number

Table 1: 110V Engine Format

Product	Product Code	Starting Serial Number	Ending Serial Number
Pre-Production (PP)			
xxxx_xx, 110V Engine	xxx	xxxxxx	xxxxxx
Mass Production (MP)			
xxxx_xx, 110V Engine	xxx	xxxxxx	xxxxxx
* Not all of the serial numbers will be used. This is a buffer in case additional units are built by FX during pre-production * Serial numbers between xxxxxx - xxxxxx are reserved for XOG FIC sites if re-serialization is needed. A serial number break or a new serial number range will be provided when a major product change occurs.			

220V Engine Format

- MMMSSSSSc
- **MMM** = Manufacturing Location Code, 3 digit numeric code
- **SSSSSS** = Six digit numeric serial number
- **c** = check digit

Table 2: 220V Engine Format

Product	Product Code	Manufacturing Location Code	Starting Serial Number	Ending Serial Number
Pre-Production (PP)				
xxxxx_x, 220V Engine	xxx	xxx	xxxxxx	xxxxxx
xxxxx_xx, 220V Engine	xxx	xxx	xxxxxx	xxxxxx
Mass Production (MP)				
xxxxx_x, 220V Engine	xxx	xxx	xxxxxx	xxxxxx
xxxxx_xx, 220V Engine	xxx	xxx	xxxxxx	xxxxxx
* Not all of the serial numbers will be used. This is a buffer in case additional units are built by FX during pre-production.				

Examples

110V Printer

- xxxxxxxxxx: Xerox Serial Number
- Product code for 110V printer = xxx
- Serial number for xxxx_xx = xxxxxx

220V Printer

- xxxxxxxxxx
- Manufacturing location code for 220V printer = xxx
- Serial number for xxxxx_x = xxxxxx
- Check digit = x

Serial Number Location and Layout

The serial number label is located on the frame behind the Front Cover.

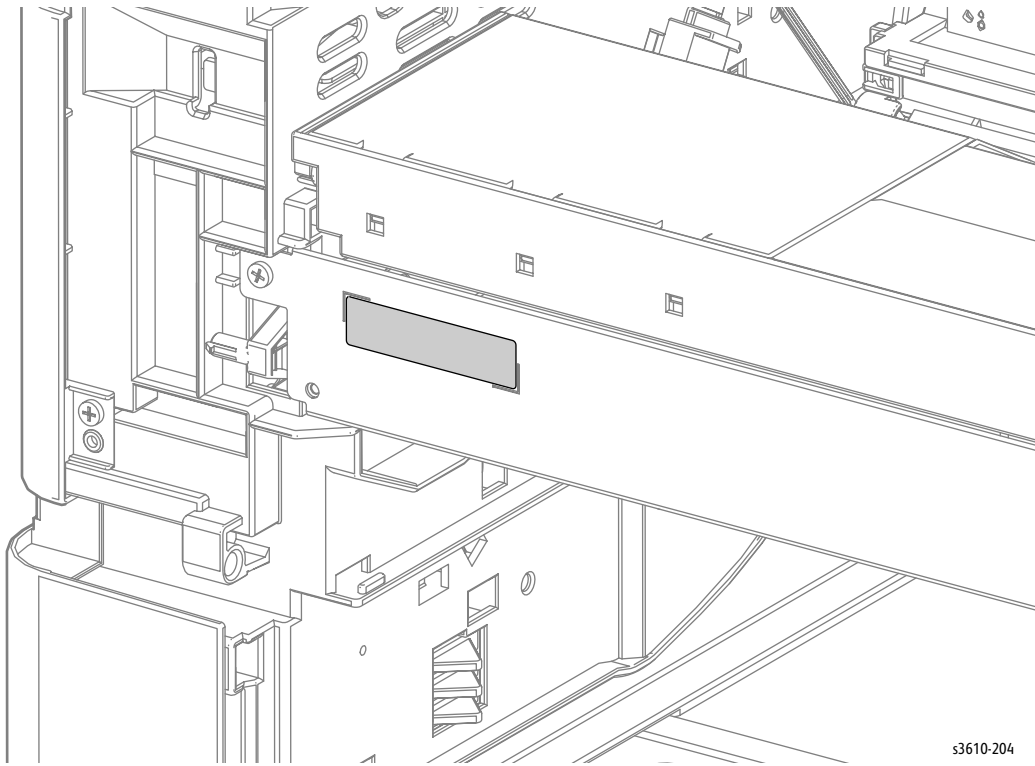

s3610-204

Using the Parts List

- ID No.: The callout number from the exploded part diagram.
- Name/ Description: The name of the part to be ordered and the number of parts supplied per order.
- Part Number: The material part number used to order that specific part.
- A black triangle preceding a number followed by a parenthetical statement in an illustrated parts list means the item is a parent assembly, made up of the individual parts called out in parentheses.
- The notation “with X~Y” following a part name indicates an assembly that is made up of components X through Y. For example, “1 (with 2~4)” means part 1 consists of part 2, part 3, and part 4.
- The notation “J1<>J2 and P2” is attached to a wire harness. It indicates that connector Jack 1 is attached to one end of the wire harness and connector J2 is attached to the other end that is plugged into P2.

Note: Only parts showing part numbers are available for ordering by support. Parts not showing part numbers are available on the parent assembly.

Parts Lists

PL 1.1 Covers (3610)

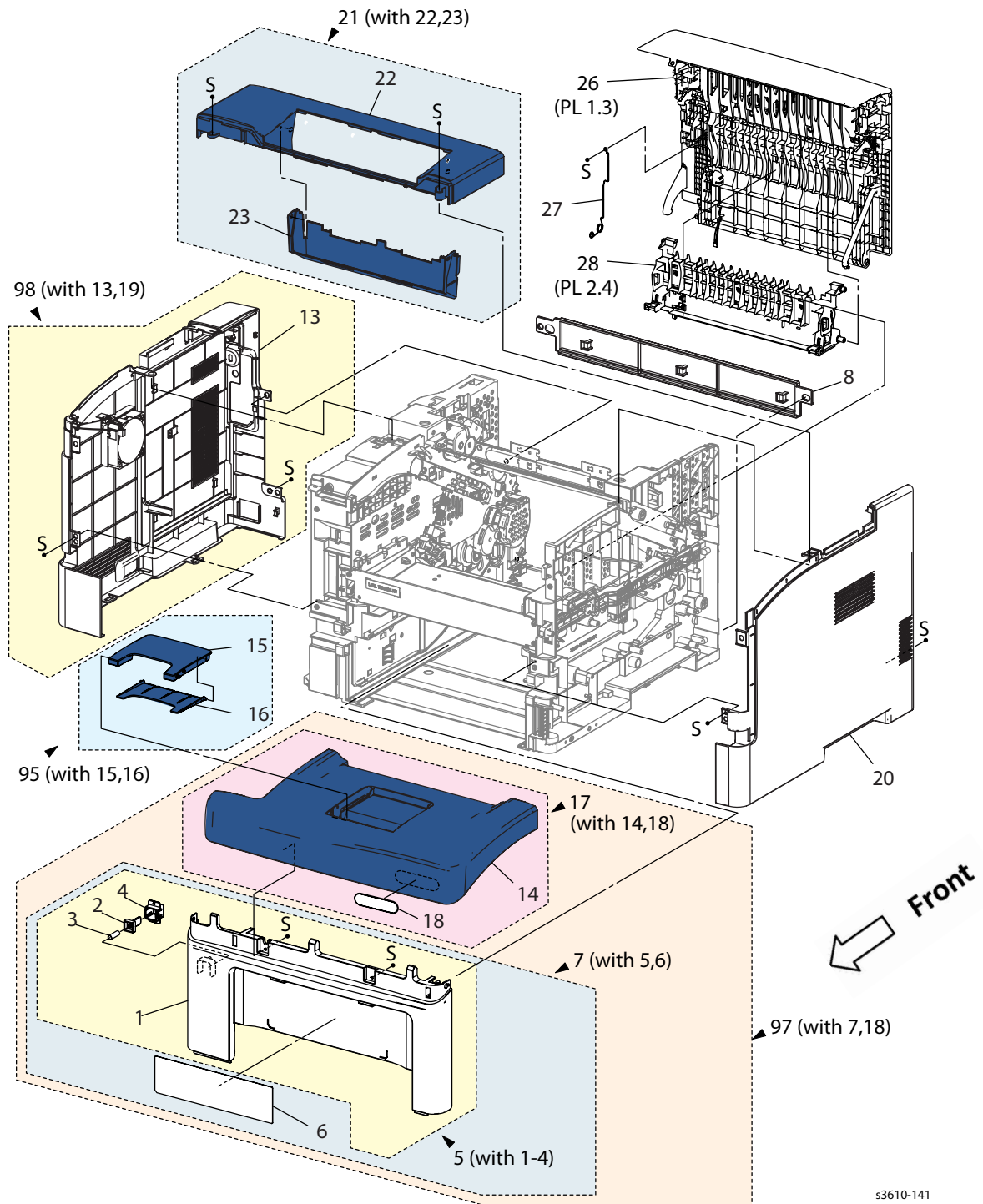

s3610-141

Parts List 1.1 Covers (3610)

Item	Description	Part Number
1.	Front Cover	
2.	Interlock Actuator	
3.	Interlock Spring	
4.	Interlock Holder	
5.	Front Cover Assembly (with 1-4)	
6.	Label MSI Instruction	
7.	Front Cover Assembly (with 5, 6) (REP 1.2)	604K85880
8.	Lower Rear Cover (REP 1.8)	848E82672
9.		
13.	Left Side Cover (REP 1.7)	848E82792
14.	Top Front Cover	
15.	Cover Extension	
16.	Cover Extension 2nd	
17.	Top Front Cover Assembly (with 14, 18) (REP 1.4)	604K84920
18.	Logo Plate Assembly	
19.		
20.	Right Side Cover (REP 1.6)	604K84941
21.	Top Cover Assembly (with 22, 23) (REP 1.4)	848K62885
22.	Top Cover (Mid)	
23.	Exit Cover (Mid)	
24.		
25.		
26.	Rear Cover Assembly (REP 1.5)	848K70060
27.	Spring-earth DTS Out	
28.	Duplex Chute Assembly (PL 2.4) (REP 2.1)	054K48100
95.	Top Front Cover Extension Assembly (with 15, 16) (REP 1.3)	604K77391
97.	Cover Assembly Front (with 7,18)	
98.	Left Side Cover Assembly (with 13, 19)	

PL 1.2 Covers (3615)

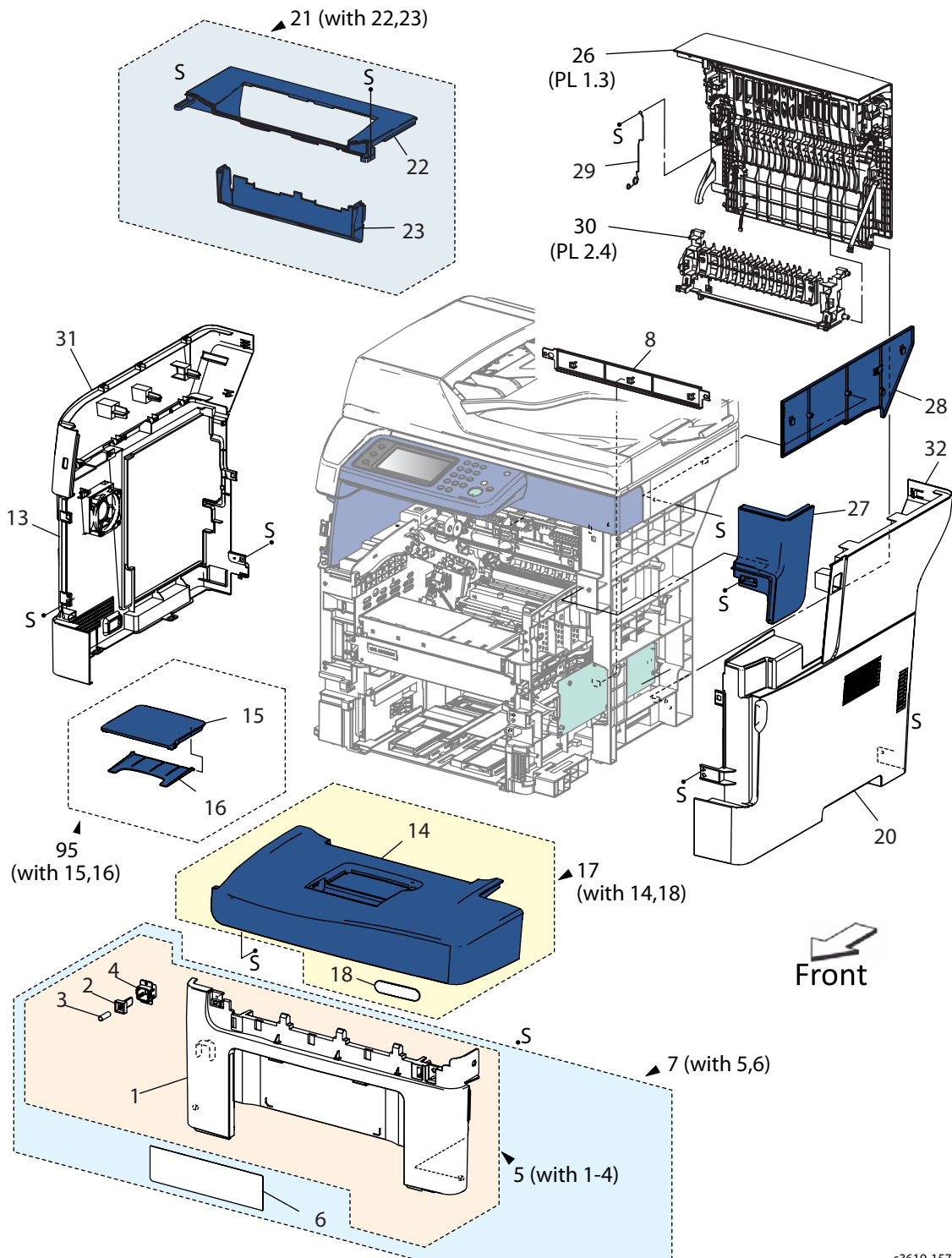

s3610-157

Parts List 1.2 Covers (3615)

Item	Description	Part Number
1.	Front Cover	
2.	Actuator Interlock	
3.	Spring Interlock	
4.	Holder Interlock	
5.	Front Cover Assembly (with 1-4)	
6.	Label MSI Instruction	
7.	Front Cover Assembly (with 5, 6) (REP 1.2)	604K85890
8.	Lower Rear Cover (REP 1.18)	848E82672
9.		
10.		
11.		
12.		
13.	Left Side Cover (REP 1.11)	848E82815
14.	Top Front Cover	
15.	Cover Extension	
16.	Cover Extension 2nd	
17.	Top Front Cover Assembly (with 14, 18) (REP 1.3)	604K84931
18.	Logo Plate	
19.		
20.	Right Side Cover (REP 1.13)	848K68342
21.	Top Cover Assembly (with 22, 23) (REP 1.15)	848K62912
22.	Top Cover	
23.	Exit Cover	
24.		
25.		
26.	Rear Cover Assembly (PL 1.3) (REP 1.8)	604K85650
27.	IIT Lower Right Cover (REP 1.13)	848E82901
28.	IIT Right Inner Cover (REP 1.14)	848E89270
29.	Earth Spring	
30.	Duplex Chute Assembly (PL 2.4) (REP 2.1)	054K48100
31.	Upper Left Side Cover (REP 1.11)	848E89213
32.	Upper Right Side Cover (REP 1.13)	848E89231
95.	Kit Cover Assembly Extension (with 15, 16) (REP 1.3)	604K85900

PL 1.3 Rear Cover Assembly

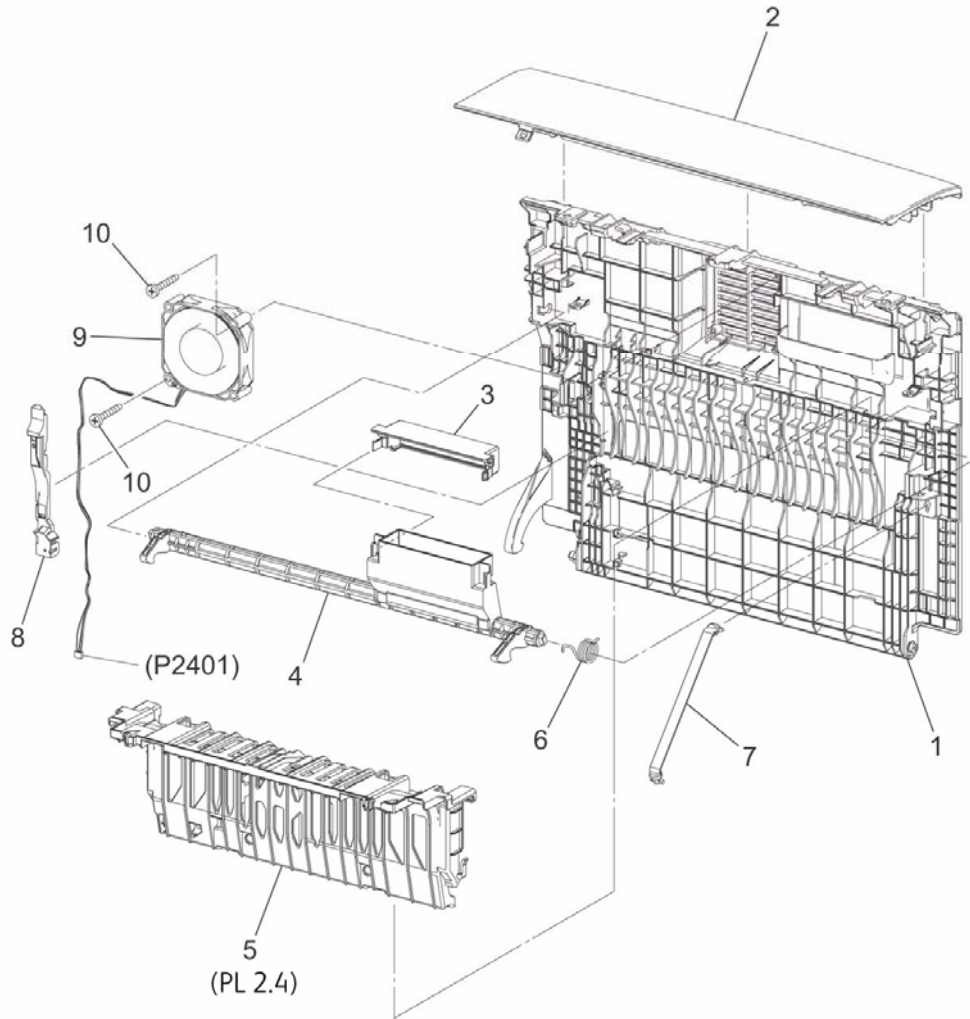



Front
ZaS051902AA

Parts List 1.3 Rear Cover Assembly

Item	Description	Part Number
1.	Rear Cover Assembly (REP 1.5) (REP 1.18)	604K85650
2.	Top Rear Cover	
3.	Rear Cover Latch	
4.	Rear Latch	
5.	Duplex Chute (PL 2.4) (REP 2.1)	054K48100
6.	Rear Latch Spring	
7.	Rear Strap	868E76893
8.	Rear Guide Harness	
9.	Rear Fan	
10.	Rear Fan Screw	

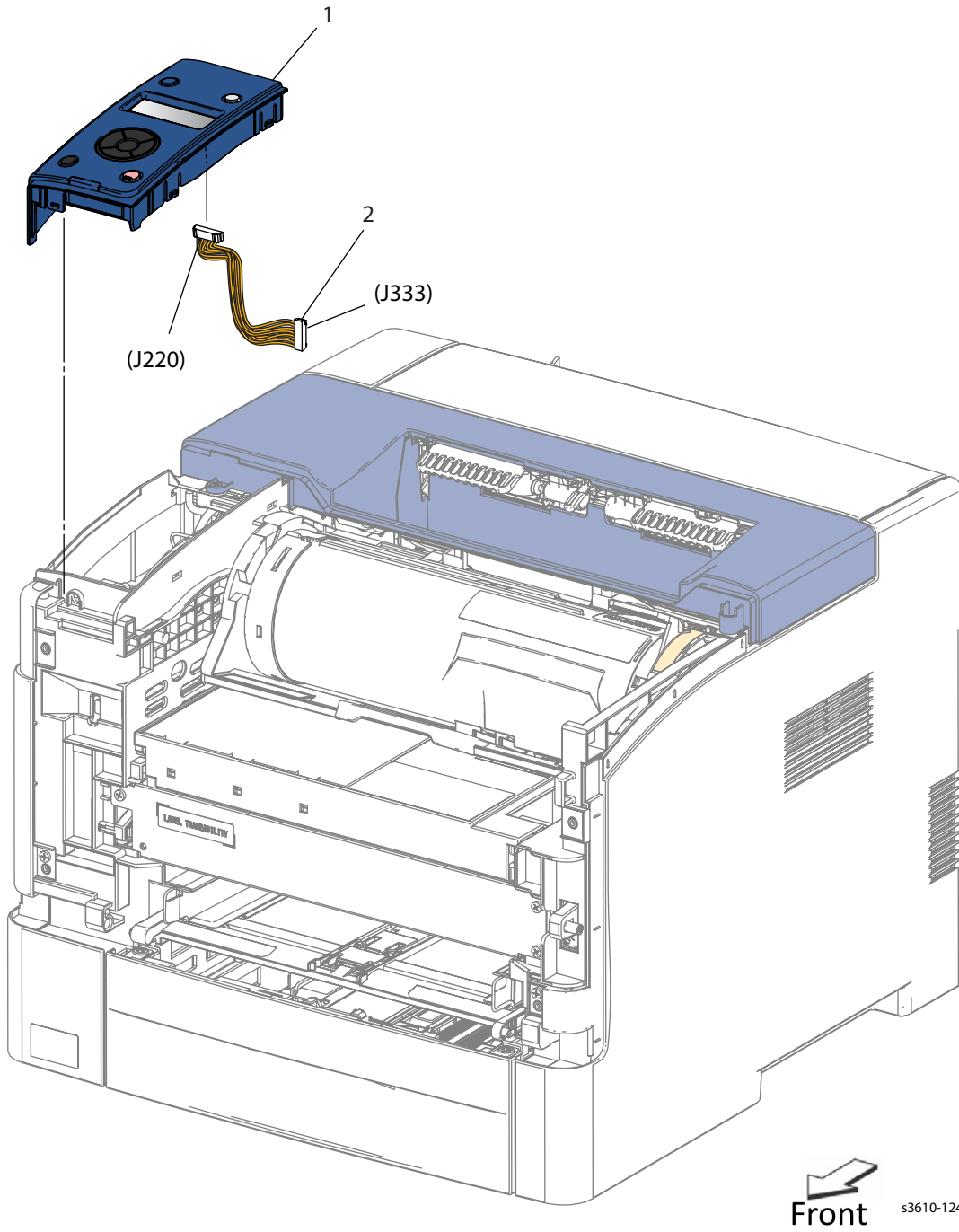
PL 1.4 Control Panel (3610)



Parts List 1.4 Control Panel

Item	Description	Part Number
1.	Control Panel (REP 1.1)	848K79123
2.	UI Harness Assembly	

PL 1.5 Control Panel (3615)

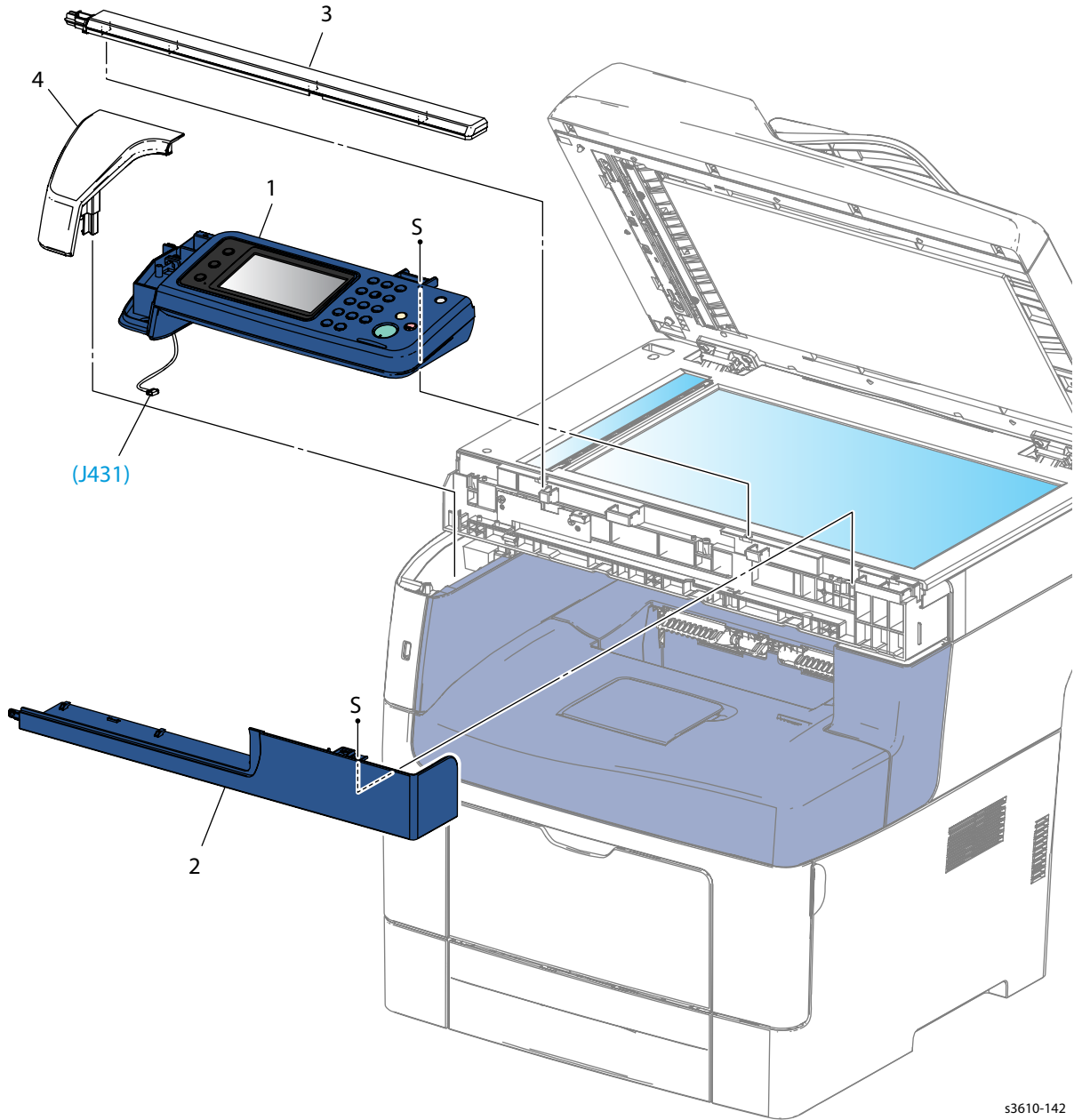

s3610-142

Parts List 1.5 IIT Control Panel

1.	Control Panel AIO 110V Control Panel AIO 220V (REP 1.12)	See attached bulletin
2.	IIT Front Bottom Cover (REP 1.10)	848E93191
3.	IIT Front Top Cover (REP 1.9)	848E93181
4.	Left Side Cover (REP 1.17)	848E93171



Parts List 2.1 Registration

Item	Description	Part Number
1.	Duplex Lower Chute Assembly (with 2, 3)	
2.	Duplex Lower Chute	
3.	Spring Wc Il	
4.	Interlock Harness Assembly	
5.		
6.	Transport Assembly (REP 2.2)	059K79334
7.		
8.	Registration Out Earth Plate	
9.	Rear Fan Connector Holder	
10.		
11.	CST Stopper (REP 2.9)	803E13351
97.	(3610) Rear Interlock Assembly (with1, 4)	604K85740
	(3615) Rear Interlock Assembly (with1, 4) (REP 2.10)	604K85750

PL 2.2 Transport Assembly

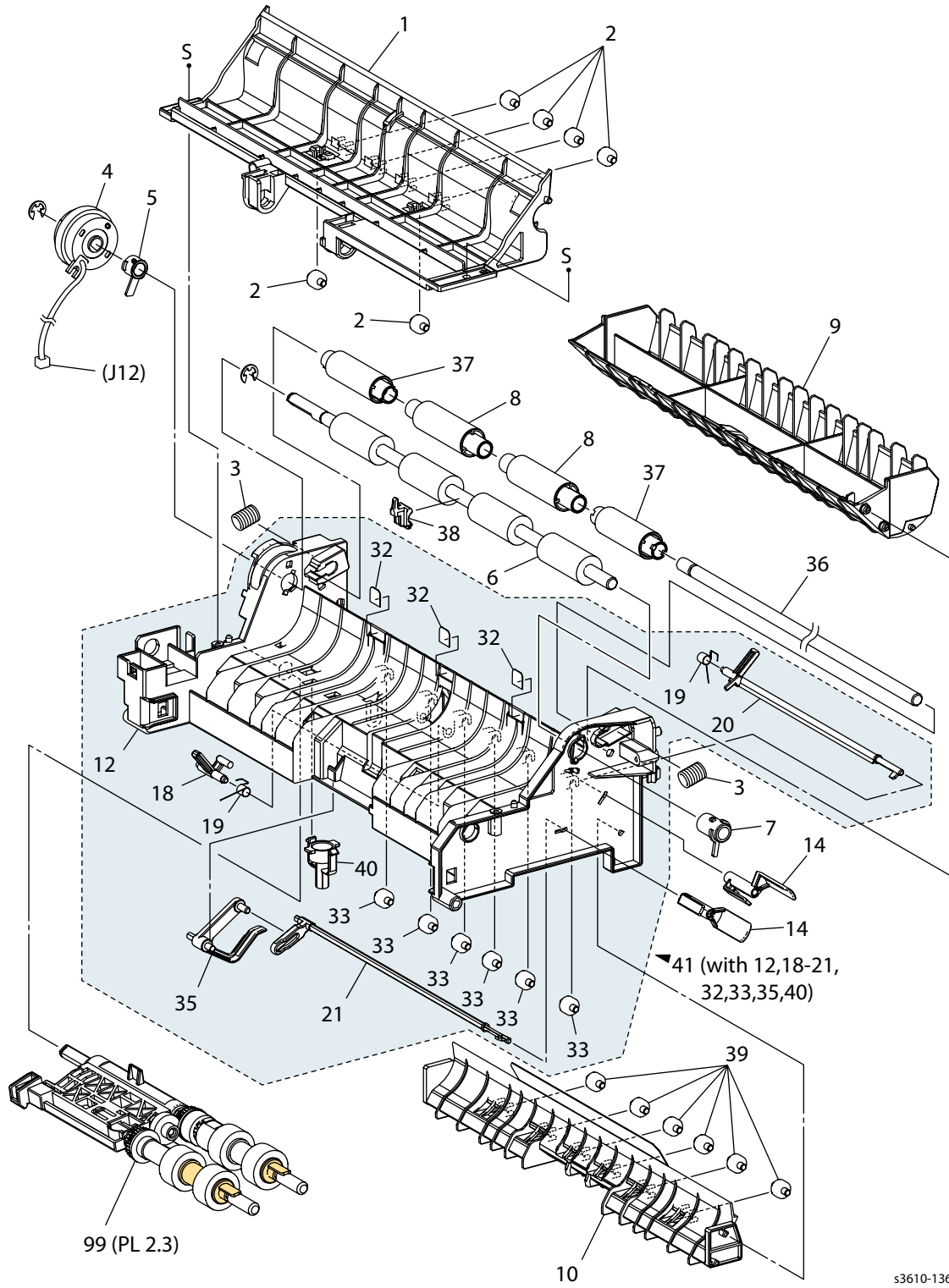

s3610-136

Parts List 2.2 Transport Assembly

Item	Description	Part Number
1.	Registration In Chute	
2.	Support Roll 2	
3.	Registration Spring	
4.	Registration Clutch (REP 2.6)	121K51870
5.	Registration Earth Bearing ZA	
6.	Rubber Roll Assembly ZA (REP 2.7)	059K74580
7.	Right Registration Bearing	
8.	Registration Pinch Roll Assembly	
9.	Registration Out Chute	
10.	Lower Feed Chute	
11.		
12.	Registration Chute	
13.		
14.	Registration Shutter Sensor (REP 2.8)	055E60433
15.		
16.		
17.		
18.	Registration Actuator MSI	
19.	Actuator Spring ZA	
20.	Actuator	
21.	No Paper Tray Actuator	
32.	Chute Guide	
33.	Support Roll 2	
34.		
35.	No Paper Tray Actuator	
36.	Registration Pinch Roll Shaft	
37.	Registration Pinch Roll	
38.	Center Bearing	
39.	Support Roll 2	
40.		
41.	Registration Chute Assembly (with 12, 18-21, 32-35)	
99.	Feeder Assembly Kit (REP 2.3)	

PL 2.3 Feed Assembly

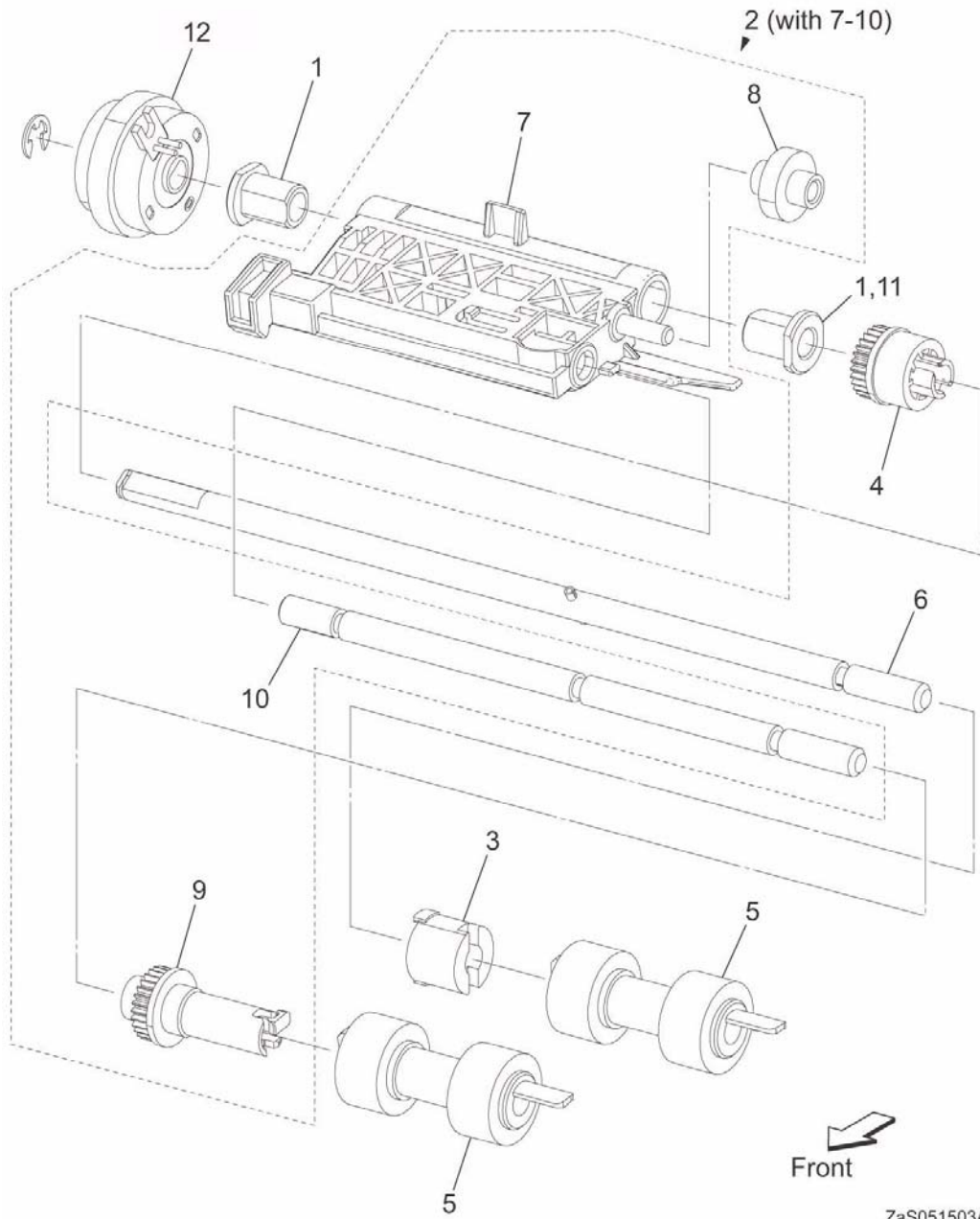

Parts List 2.3 Feed Assembly

Item	Description	Part Number
1.	Nudger Bearing	
2.	Feeder Assembly (with 7-10)	
3.	Feed Gear	
4.	One-way Feed Clutch	
5.	Feed Roll Assembly (3 pack) (REP 2.3)	604K11192
6.	Feed Shaft Assembly	
7.	Nudger Plate	
8.	Nudger Idler Gear	
9.	Nudger Gear	
10.	Nudger Shaft	
11.	Nudger Bearing	
12.	CST Feed Clutch (REP 2.5)	121K51880

PL 2.4 Duplex Chute

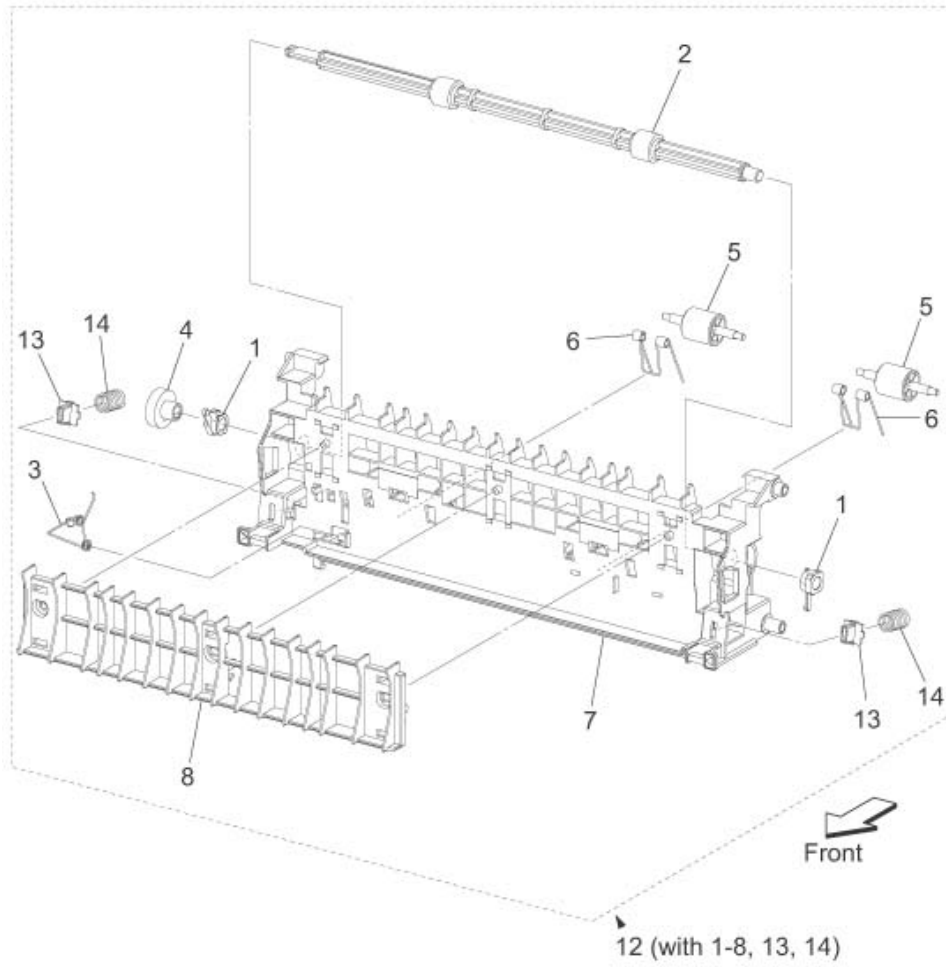

ZaS051401AA

Parts List 2.4 Duplex Chute

Item	Description	Part Number
1.	Duplex Bearing	
2.	Duplex Roll Assembly	
3.	Earth Spring	
4.	Duplex Gear	
5.	Duplex Pinch Roll	
6.	Duplex Pinch Roll Spring	
7.	Duplex In Chute	
8.	Transport Chute	
9.		
10.		
11.		
12.	Duplex Chute Assembly (with 1-8,13,14) (REP 2.1)	054K48100
13.	BTR Spring Cap	
14.	BTR Spring	

PL 2.5 Exit Chute

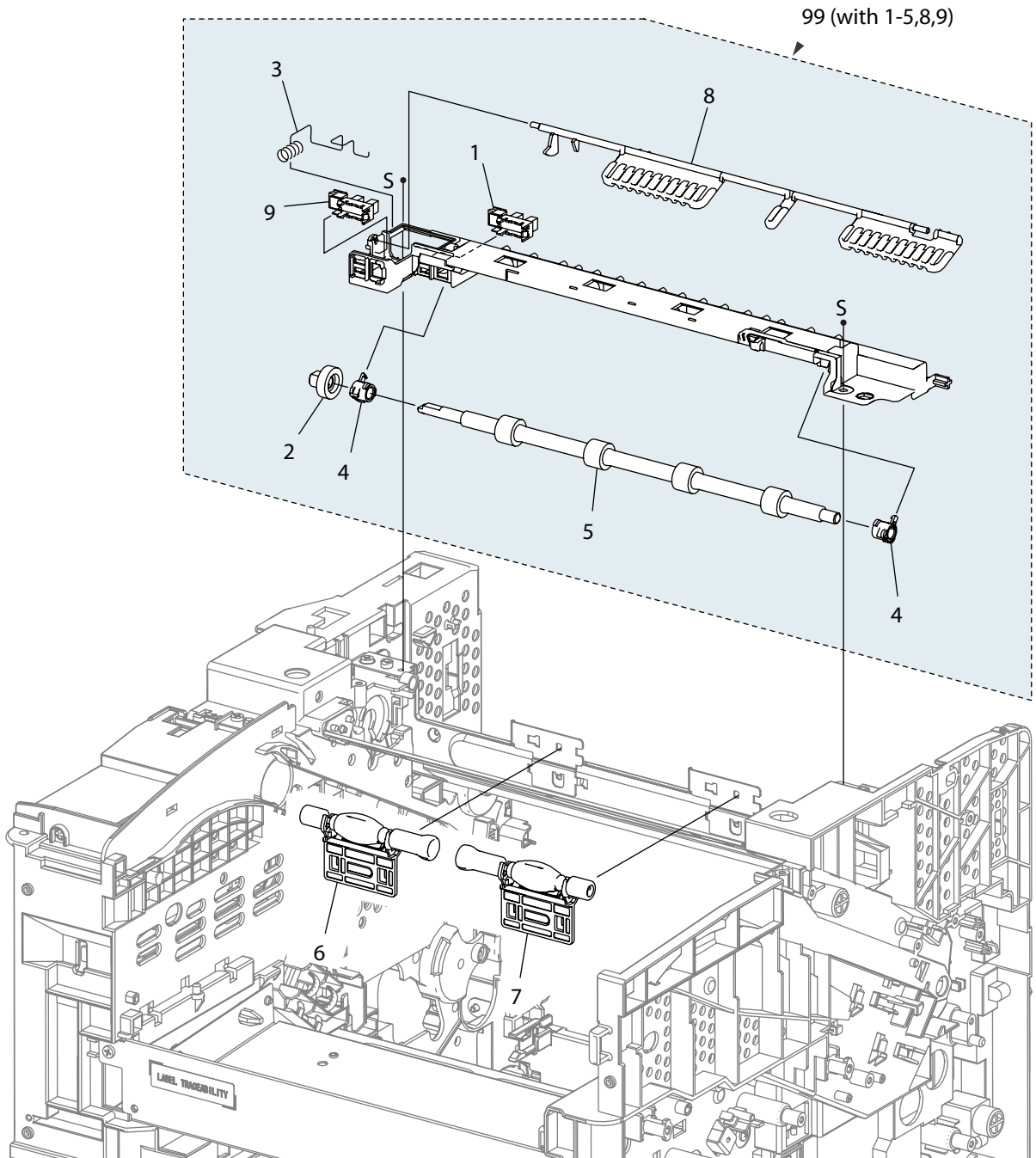

s3610-137

Parts List 2.5 Exit Chute

Item	Description	Part Number
1.	Exit Sensor	
2.	Exit Gear	
3.	Earth Sensor Spring	
4.	Exit Bearing	
5.	Exit Roll Assembly	
6.	Left Pinch Roll Assembly (REP 2.15)	604K77510
7.	Right Pinch Roll Assembly (REP 2.15)	604K77520
8.	Full Stack Actuator	
9.	Full Stack Sensor (REP 2.13)	930W00123
99.	Exit Chute Assembly (with 1-5, 8, 9) (REP 2.11)	054K48380

PL 2.6 MSI

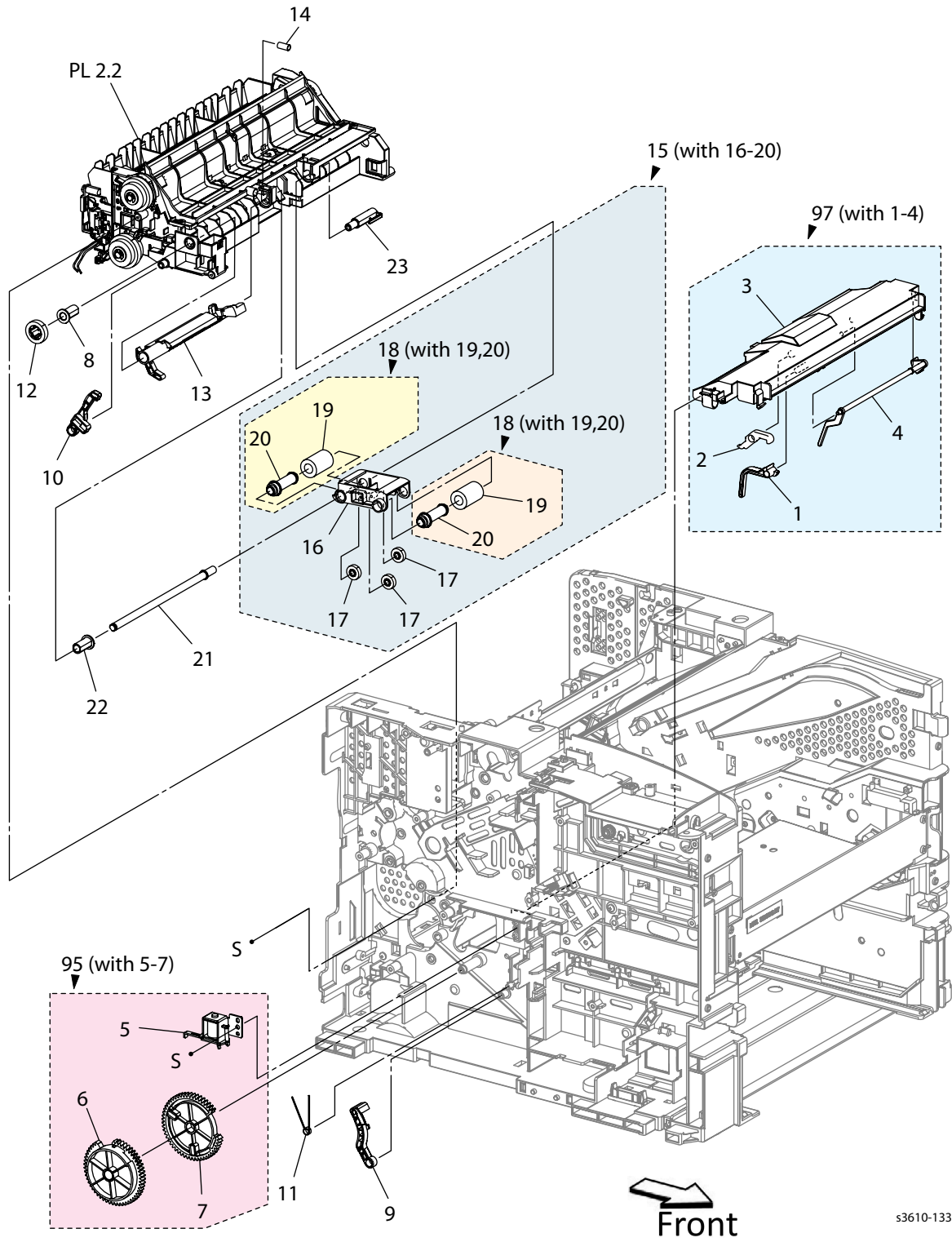

Parts List 2.6 MSI

Item	Description	Part Number
1.	MSI In Stopper	
2.	MSI In Lock	
3.	Top Frame	
4.	No Paper Actuator	
5.	Feed Solenoid (REP 2.14)	121E23570
6.	MSI 1 Segment Gear	
7.	MSI 2 Segment Gear	
8.	Feed Bearing	
9.	Arm Lifter	
10.	Stopper Lifter	
11.	Feed Spring	
12.	Feed Gear	
13.	Lifter Lever	
14.	Spring	
15.	Pick Up Holder Assembly (with 16-20) (REP 2.15)	059K78790
16.	Pick UpHolder	
17.	Idler Feeder Gear	
18.	Feed Roll Assembly (with 19, 20)	
19.	Rubber Roll	
20.	Roll Core	
21.	Feed Shaft	
22.	Feed Bearing	
23.	Pick Up Flange	
95.	MSI Solenoid Assembly (with 5-7)	121E23570
97.	Top Frame Assembly (with 1-4) (REP 2.16)	801K57914

PL 2.7 Bypass Tray

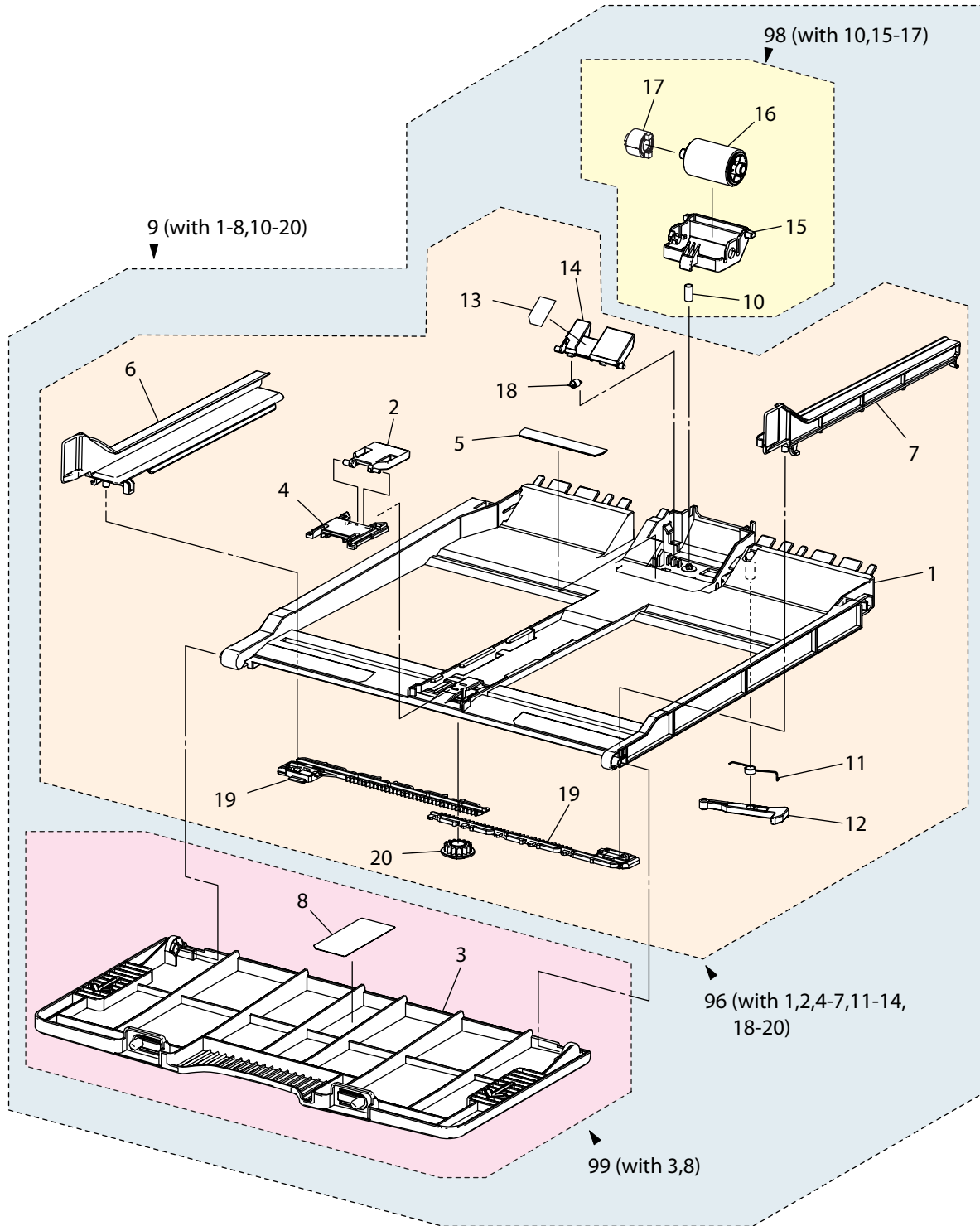

s3610-134

Parts List 2.7 Bypass Tray

Item	Description	Part Number
1.	Base Tray	
2.	End Guide	
3.	MSI Cover	
4.	Holder	
5.	MSI Pad	
6.	Left Side Guide	
7.	Right Side Guide	
8.	Label	
9.	MSI Tray Assembly (with 1-8, 10-20) (Bypass Tray)	050K71290
10.	Retard Roll Spring	
11.	Stopper Spring	
12.	Lock	
13.	MSI Mylar Guide	
14.	Stopper	
15.	Retard Roll Holder	
16.	Retard Roll Assembly	
17.	Friction Clutch Assembly	
18.	MSI Paper Stopper Spring	
19.	Side Guide Rack	
20.	Pinion Gear	
96.	MSI Frame Assembly (with 1, 2, 4-7, 11-14, 18-20)	
98.	MSI Retard Roll Assembly (with 10, 15-17) (REP 2.17)	604K78370
99.	MSI Cover Kit (with 3, 8)	

PL 3.1 Xerographics

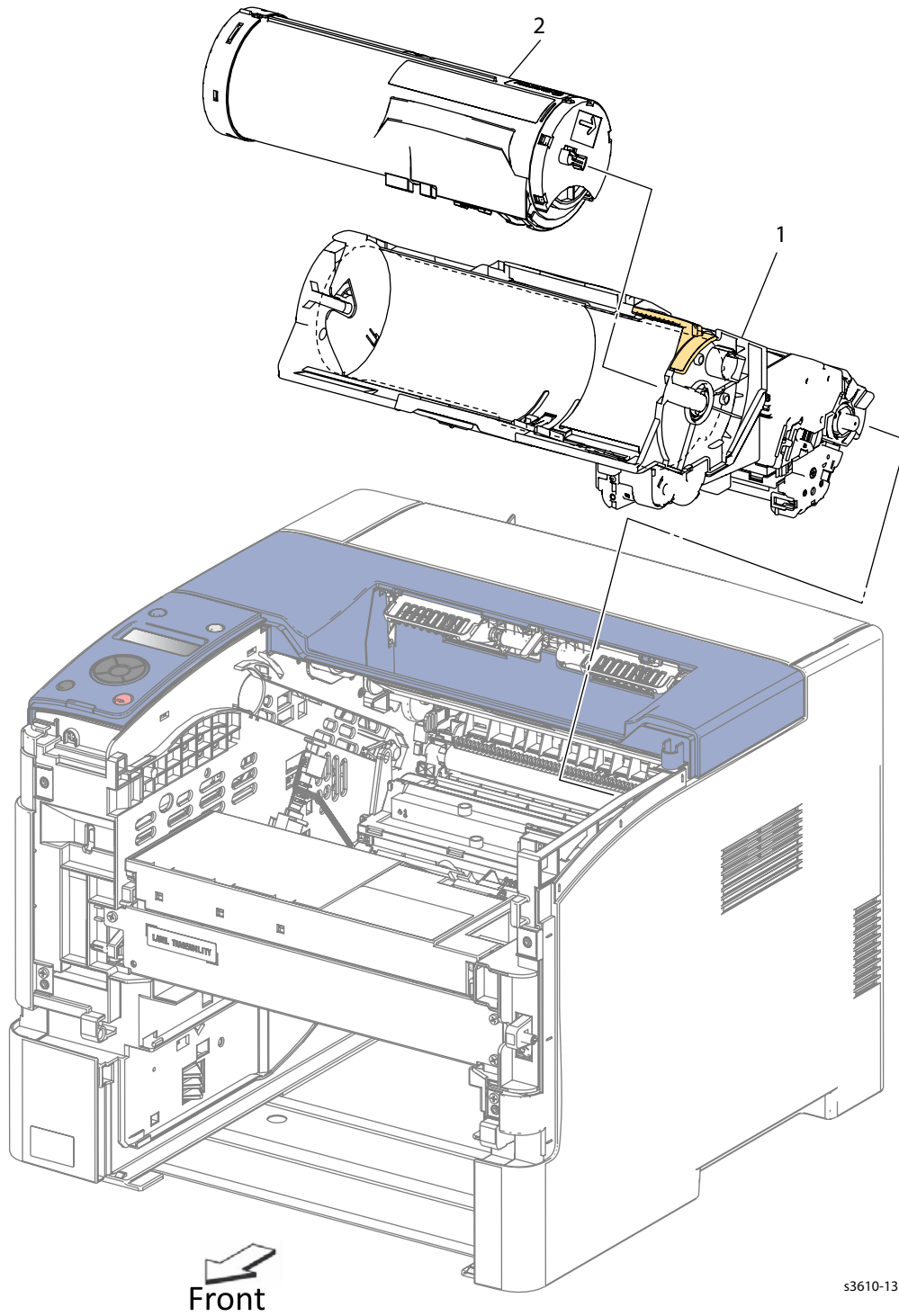

Parts List 3.1 Xerographics

Item	Description	Part Number
1.	Xerographic Assembly (Drum Cartridge)	See Consumables in Section 8
2.	Toner Cartridge Toner Cartridge (Hi capacity)	See Consumables in Section 8

PL 3.2 ROS Assembly

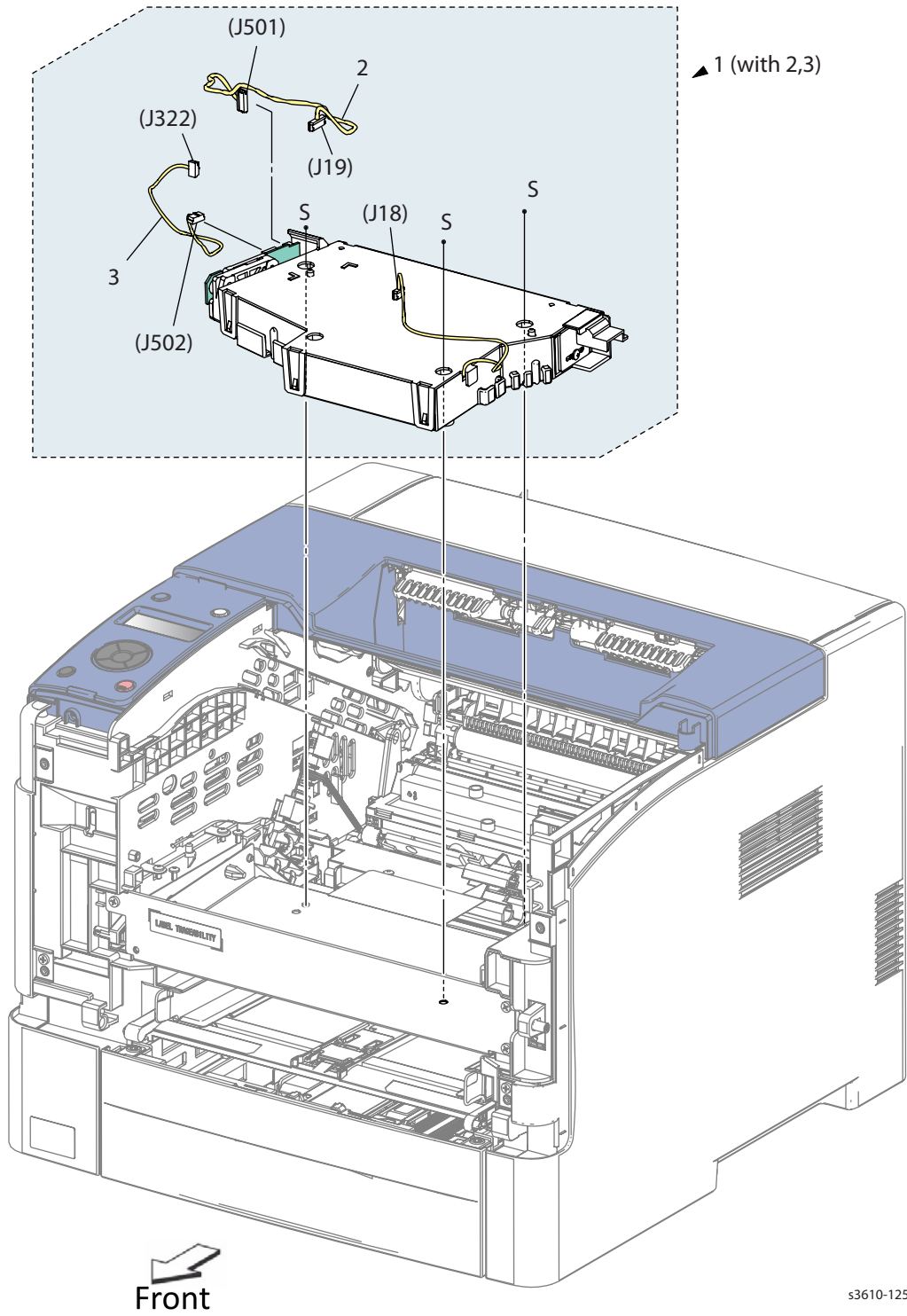

Parts List 3.2 ROS Assembly

Item	Description	Part Number
1.	ROS Assembly (with 2, 3) (REP 3.1)	062K24263
2.	ROS-MCU Harness	
3.	Video Harness	

PL 3.3 Toner Dispense

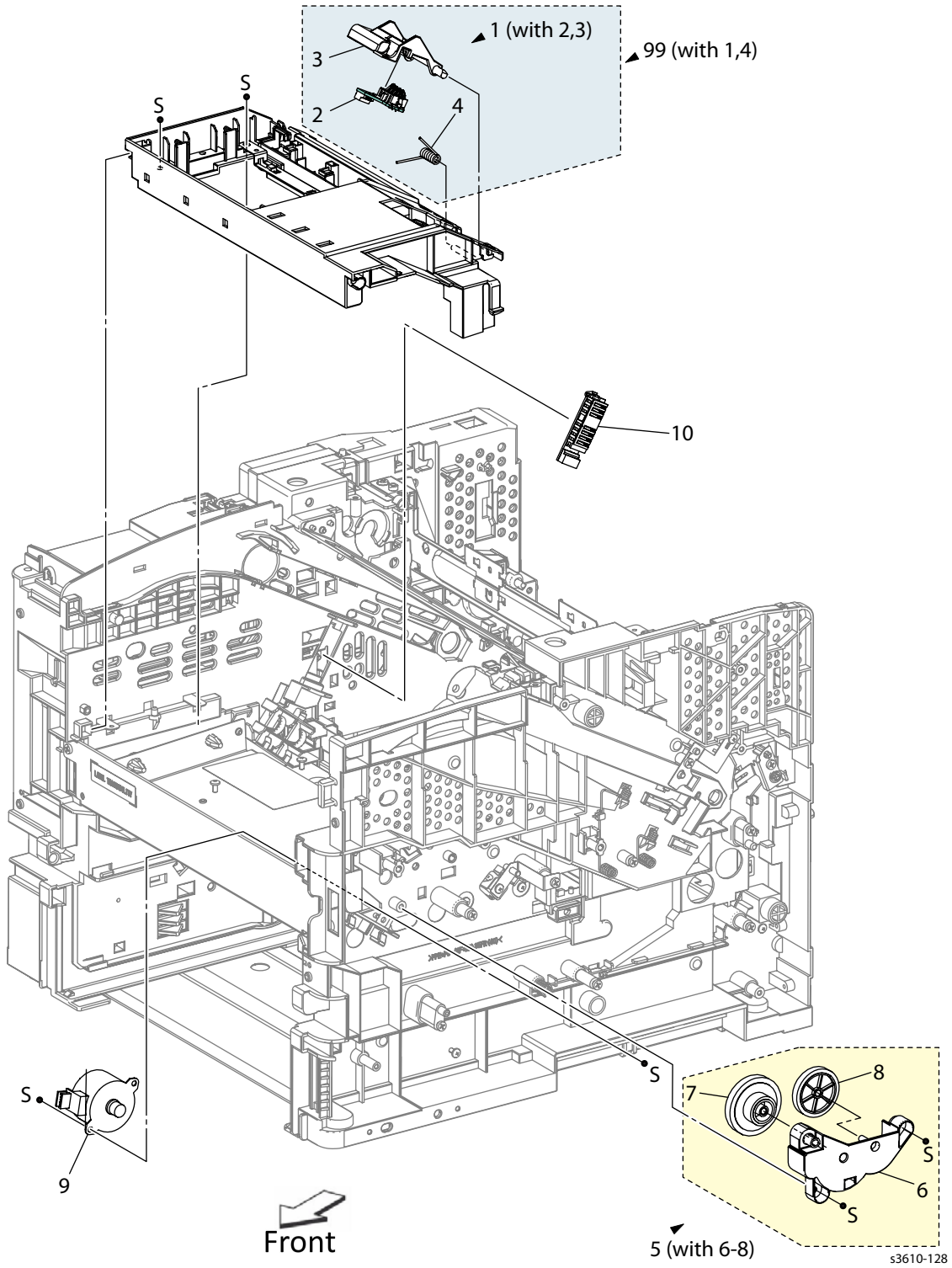

Parts List 3.3 Toner Dispense

Item	Description	Part Number
1.	CRUM Housing Assembly (with 2, 3)	
2.	CRUM Connector Assembly	
3.	CRUM Housing	
4.	CRUM Spring	
5.	Dispense Drive Assembly (with 6-8) (REP 4.6)	007K18413
6.	Dispense Housing Drive	
7.	Gear Idler Motor	
8.	Output Gear	
9.	Dispense Motor (REP 4.7)	127K52160
10.	Xerographic Connector Assembly (REP 3.3)	116K91040
99.	CRUM Assembly Kit (with 1, 4) (REP 3.2)	604K77290

PL 3.4 Transfer Roller

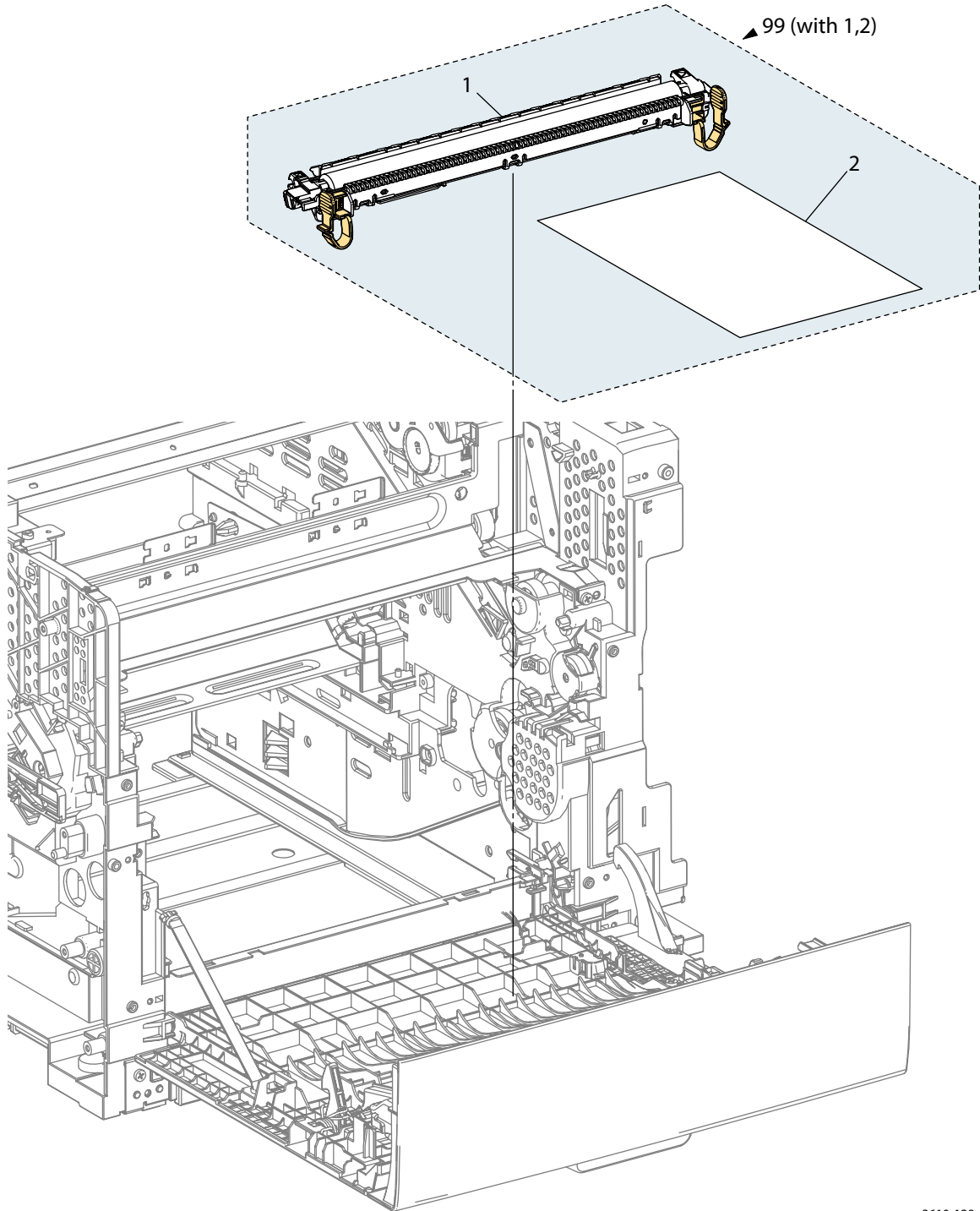

s3610-129

Parts List 3.4 Transfer Roller

Item	Description	Part Number
1.	Transfer Roll Assembly CRU (REP 3.4)	059K75560

PL 3.5 Fusing Assembly

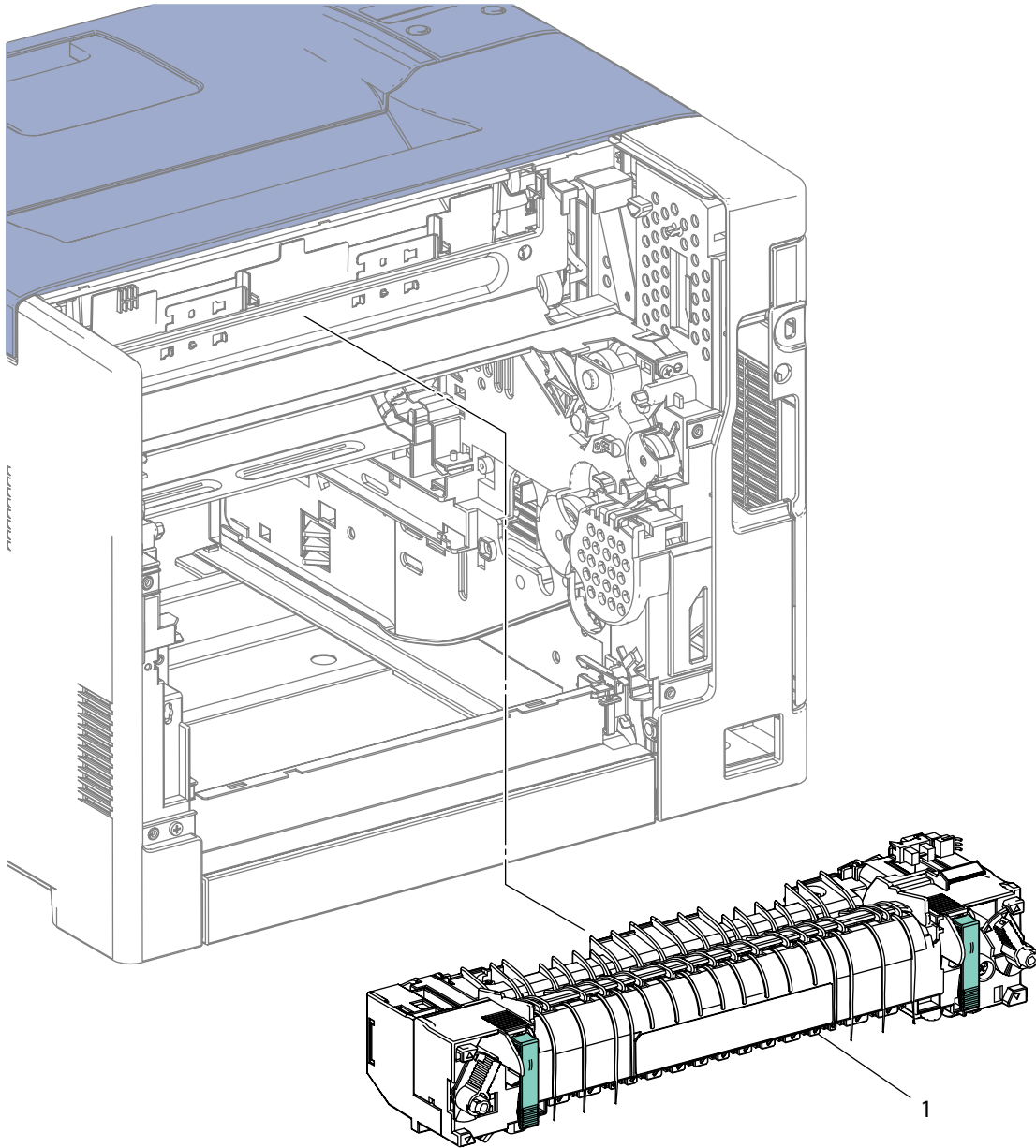

s3610-130

Parts List 3.5 Fuser

Item	Description	Part Number
1.	Fusing Assembly 110v (REP 3.5) Fusing Assembly 110v for envelopes Fusing Assembly 220v	126K30919 604K98010 126K30929

PL 4.1 Drive

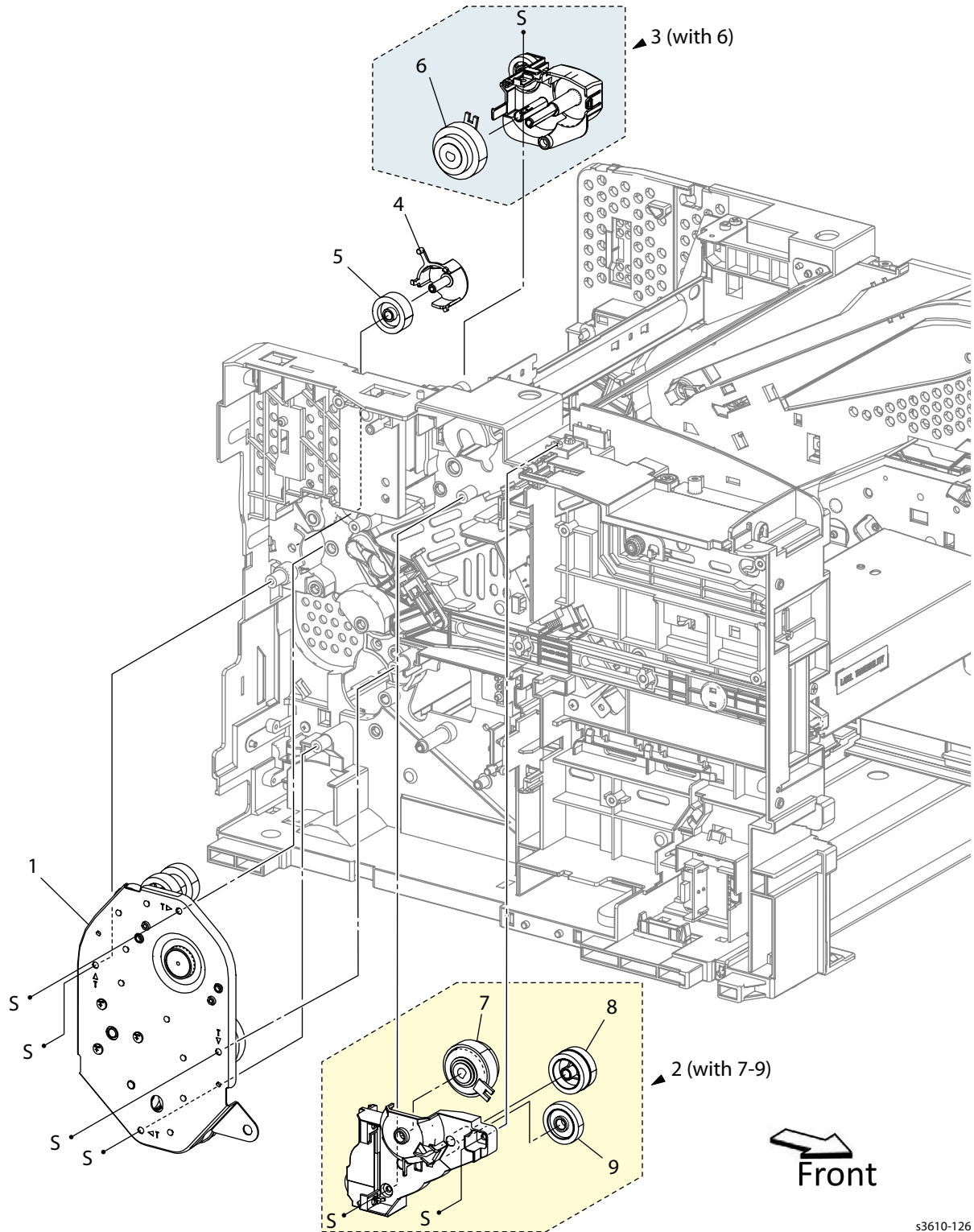

s3610-126

Parts List 4.1 Drive

Item	Description	Part Number
1.	Main Drive Assembly (REP 4.1)	007K18903
2.	Drive Exit Out Holder Assembly (with 7-9) (REP 4.2)	007K18912
3.	Drive Exit In Holder Assembly S3 (with 6) (REP 4.3)	007K18931
4.	Duplex Gear Holder (REP 4.4)	019E83450
5.	Duplex In Gear (REP 4.4)	807E38660
6.	Exit Assembly Clutch T21	
7.	Assembly Invert Clutch T24	
8.	Gear	
9.	Gear	

PL 4.2 NOHAD

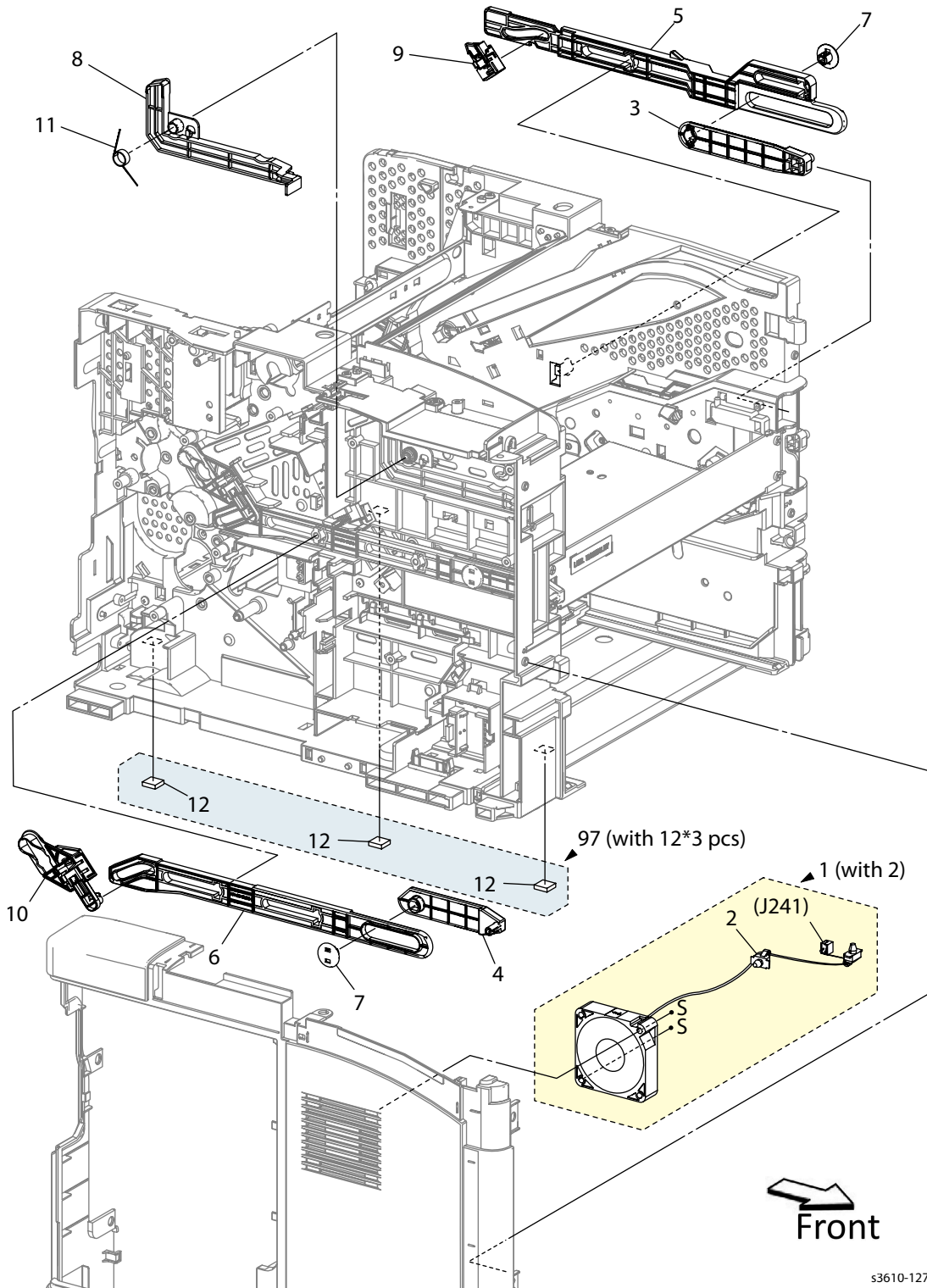

s3610-127

Parts List 4.2 NOHAD

Item	Description	Part Number
1.	LVPS Fan Assembly	127K66001
2.	Band Cable	
3.	Right Front Link (REP 4.5)	012E18133
4.	Left Front Link (REP 4.5)	012E18143
5.	Right Shaft Link	
6.	Left Shaft Link	
7.	Link Connector	012E18172
8.	Link Interlock	
9.	Right Xerographic Stopper Assembly	
10.	Left Xerographic Stopper Assembly	
11.	Interlock Spring	
12.	Foot	
97.	Foot Assembly	604K77650

PL 5.1 Electrical (ESS PWB / LVPS) (3610)

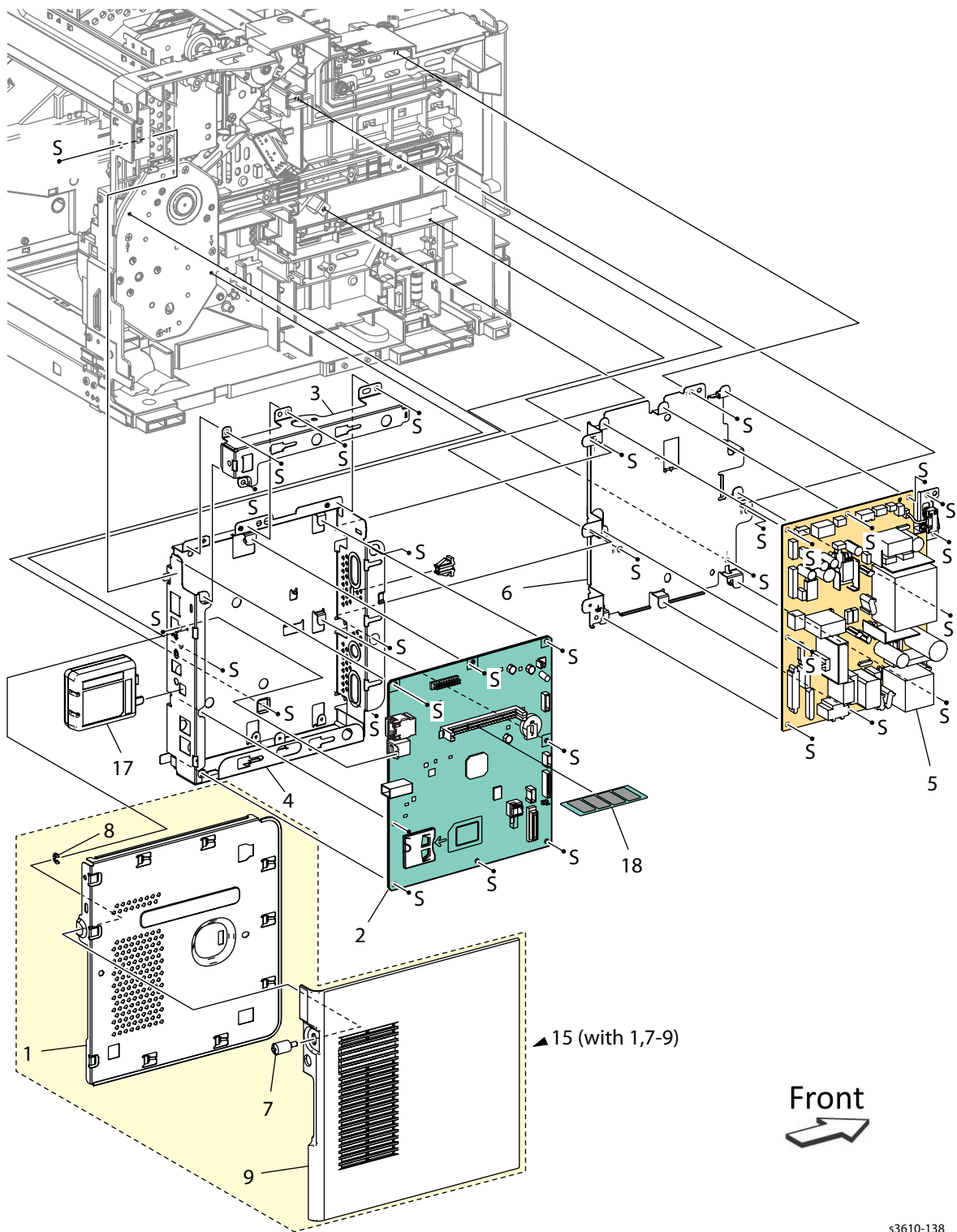

s3610-138

Parts List 5.1 Electrical (3610)

Item	Description	Part Number
1.	ESS Plate Window	
2.	ESS PWB (REP 5.1)	960K68395
3.	ESS Top Plate	
4.	ESS Housing	
5.	LVPS PWB 110 LVPS PWB 220 (REP 5.3)	604K78920 604K78930
6.	LVPS Plate	
7.	Screw	
8.	E-Ring	
9.	Cover ESS Low	
10.		
11.		
12.	ROM Font Kit	
13.		
14.		
15.	ESS Cover Assembly (REP 5.2)	848K63101
16.		
17.	Wireless Adaptor	
18.	Memory Kit (512 Mb)	

PL 5.2 Electrical (ESS PWB / LVPS) (3615)

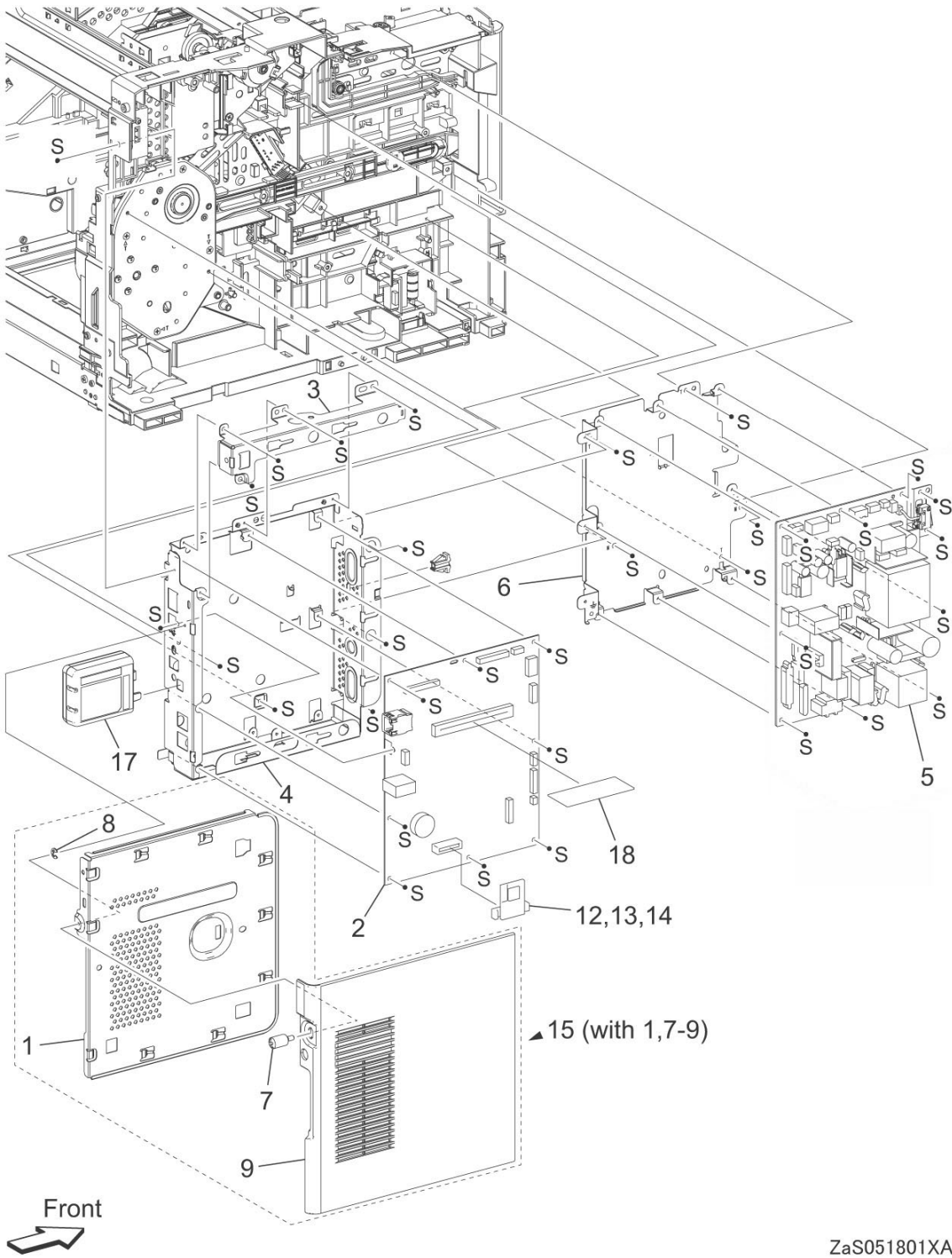

ZaS051801XA

Parts List 5.2 Electrical (3615)

Item	Description	Part Number
1.	ESS Plate Window	
2.	ESS PWB (REP 5.1)	960K69985
3.	ESS Top Plate	
4.	ESS Housing	
5.	LVPS PWB 110 LVPS PWB 220 (REP 5.3)	604K85611 604K85621
6.	LVPS Plate	
7.		
8.	Front USB Harness Assembly	
9.	FAX Guard	
10.	FAX PWB Assembly (REP 5.4)	960K67970
11.	Front USB Assembly (REP 5.5)	952K08202
12.	ESS Cover Assembly (with 1, 13-15) (REP 5.2)	848K82861
13.	Screw	
14.	E-Ring	
15.	ESS Cover	
16.	Cable Clamp	
17.	Wireless Adaptor	676K21281
18.		
19.	SD Card	497K13650
20.	Speaker Cover	
21.	Speaker Assembly	

PL 5.3 Electrical (MCU PWB / HVPS)

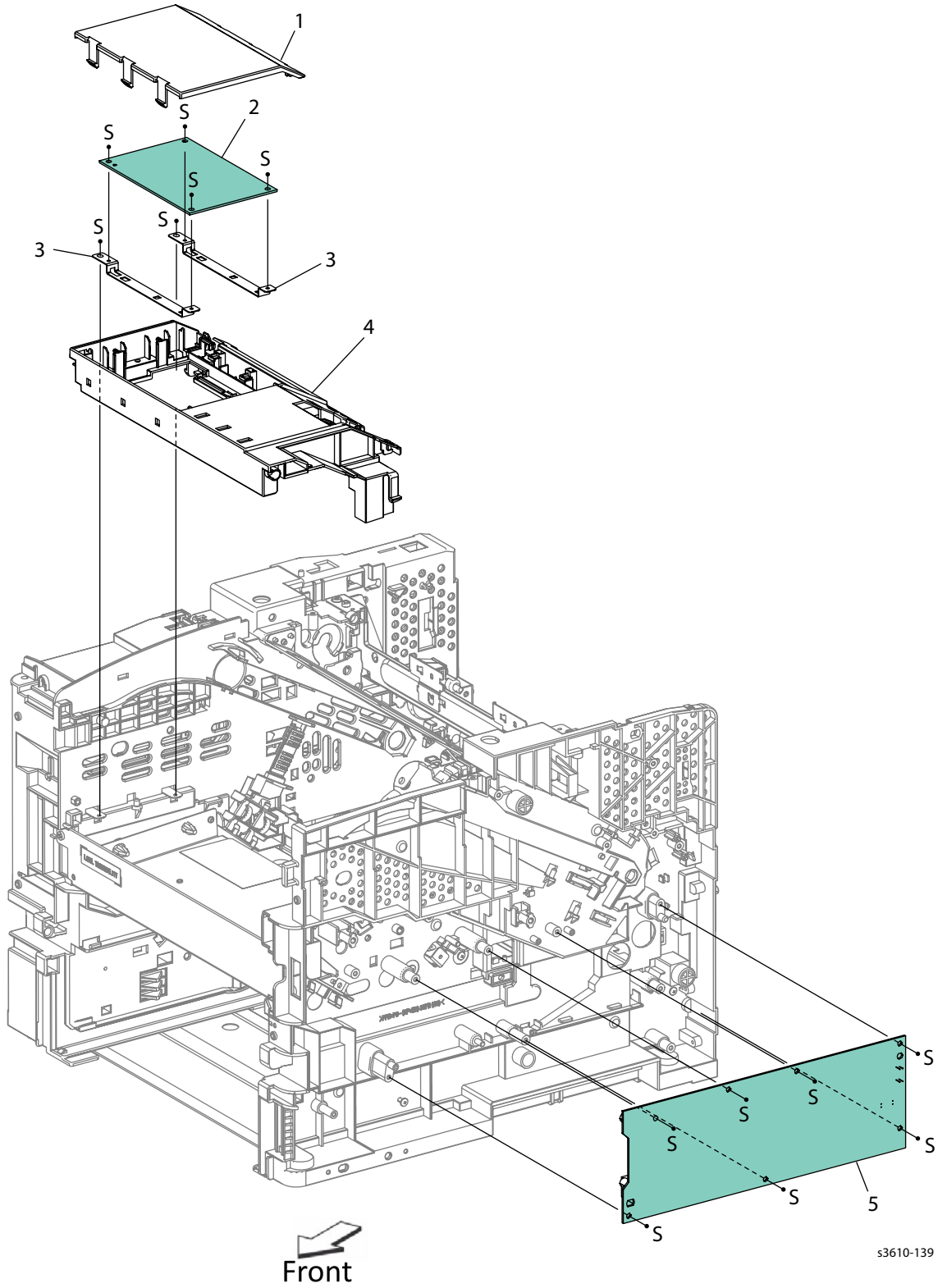

Parts List 5.3 Electrical

Item	Description	Part Number
1.	MCU Cover	
2.	MCU PWB (REP 5.6)	960K71042
3.	MCU Bracket	
4.	MCU Housing	
5.	HVPS (REP 5.7) (REP 5.8)	105K30954

PL 5.4 Electrical Connections

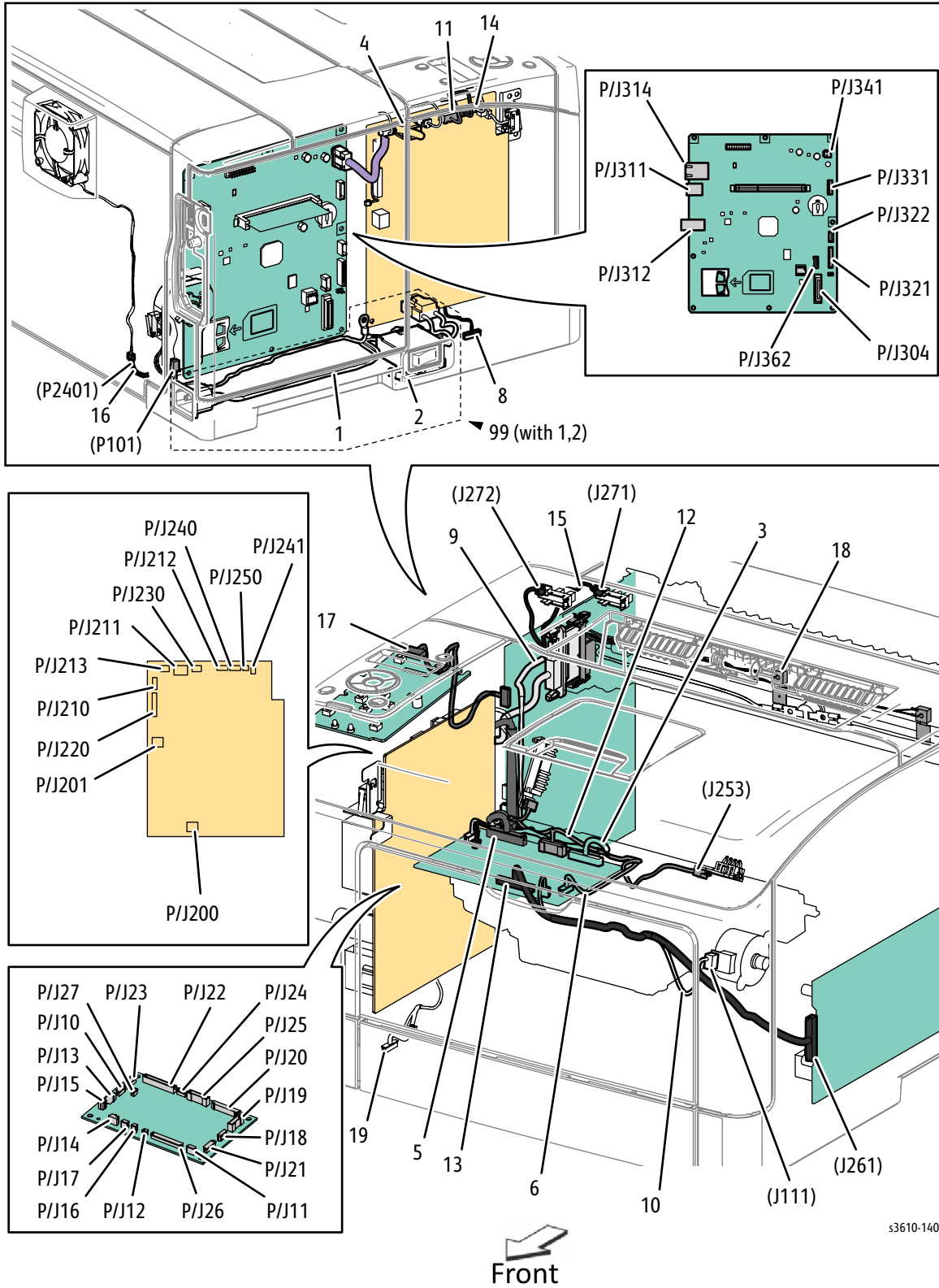

Parts List 5.4 Electrical

Item	Description	Part Number
1.	Inlet Harness Assembly 100 Inlet Harness Assembly 200	
2.	Bracket Switch	
3.	ESS Harness Assembly	
4.	ESS Power Harness Assembly SFP	
5.	Harness Assembly LV	
6.	MCU Harness Assembly 24v	
7.		
8.	OP FDR Harness Assembly	
9.	FSR Harness Assembly 100 FSR Harness Assembly 200	
10.	Dispense Motor Harness Assembly	
11.	Main Motor Harness Assembly	
12.	Xerographic Harness Assembly CRUM	
13.	Harness Assembly HV	
14.	Test Relay Harness Assembly	
15.	Exit Sensor Harness Assembly	
16.	Rear Fan Harness Assembly	
17.	Harness Assembly	
18.	Drawer Harness Assembly	
99.	(3610) AC Inlet Kit 100v (With 1, 2) (3610) AC Inlet Kit 200v (With 1, 2) (REP 5.9)	604K78900 604K78910
99.	(3615) AC Inlet Kit 100v (With 1, 2) (3615) AC Inlet Kit 200v (With 1, 2) (REP 5.9)	604K85630 604K85640

PL 6.1 IIT Scanner / DADF

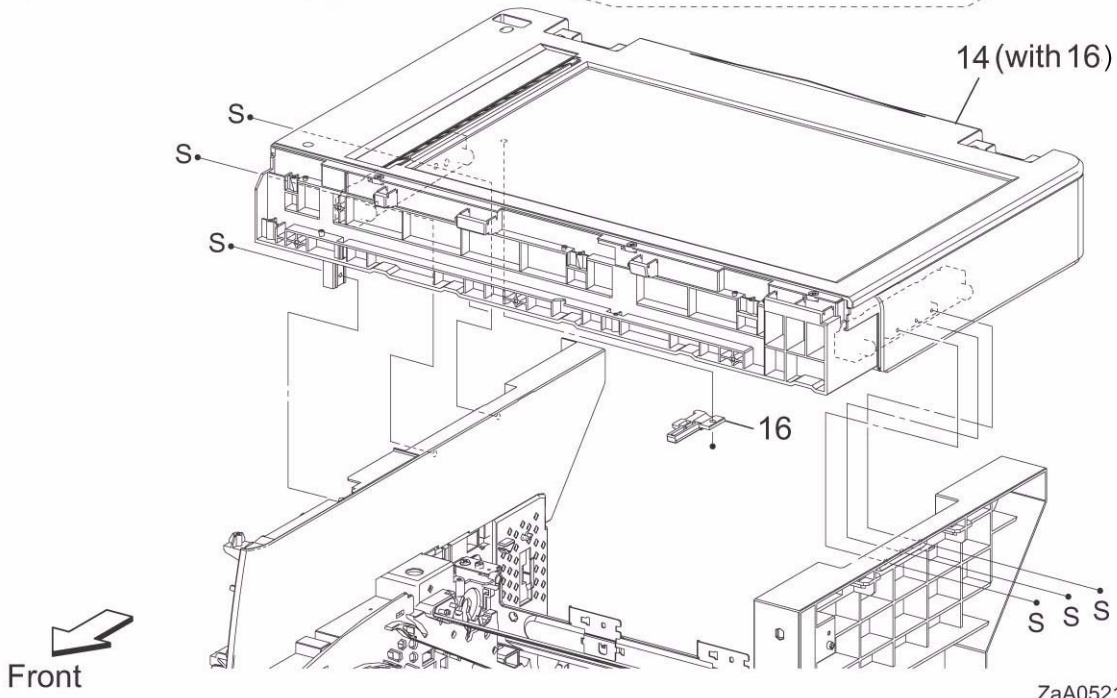
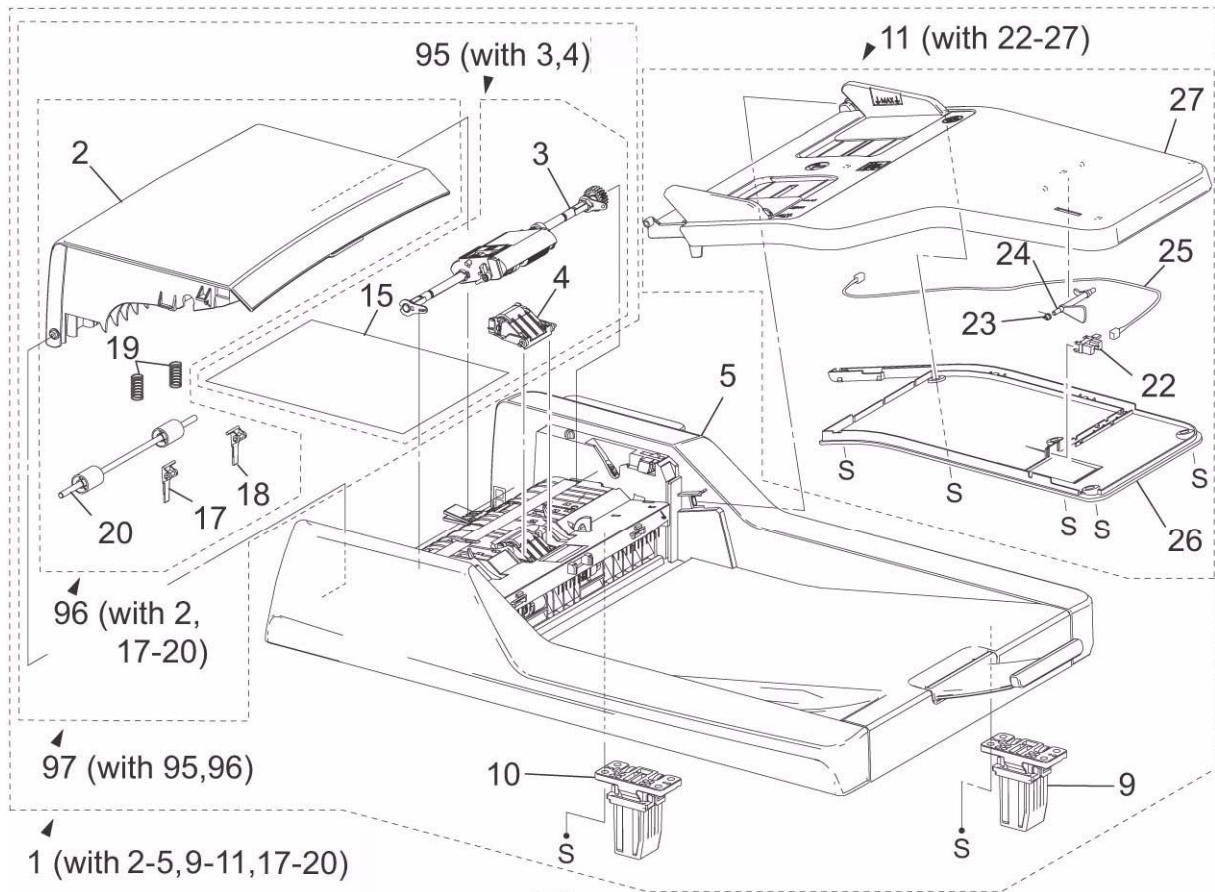

ZaA052101XB

Parts List 6.1 IIT Scanner / DADF

Item	Description	Part Number
1.	DADF Assembly (With 2-5, 9-11,17-20) (REP 6.2)	604K86162
2.	Top Cover	
3.	Roller Assembly	
4.	Separation Pad	
5.	Rear Cover	
6.		
7.		
8.		
9.	Right Hinge Assembly (REP 6.3)	003K89860
10.	Left Hinge Assembly (REP 6.3)	003K89140
11.	Tray Assembly (with 22-27) (REP 6.5)	050K71060
12.		
13.		
14.	IIT Assembly (with 16) (REP 6.1)	604K86152
15.		
16.	Harness Cover	
17.	Left Stopper Plate	
18.	Right Stopper Plate	
19.	Idle Spring	
20.	Idler Roll Assembly	
22.	Sensor	
23.	Bearing	
24.	Actuator	
25.	Harness	
26.	Bottom Plate	
27.	Top Plate	
95.	DADF Pick Up Module Kit (with 3, 4) (REP 6.4)	604K85850
96.	Top Cover Assembly (with 2, 17-20)	604K85860
97.	DADF Top Cover Kit (with 95, 96)	
98.		

PL 7.1 Tray 1/Optional Tray 550-Sheet Feeder (1/4)

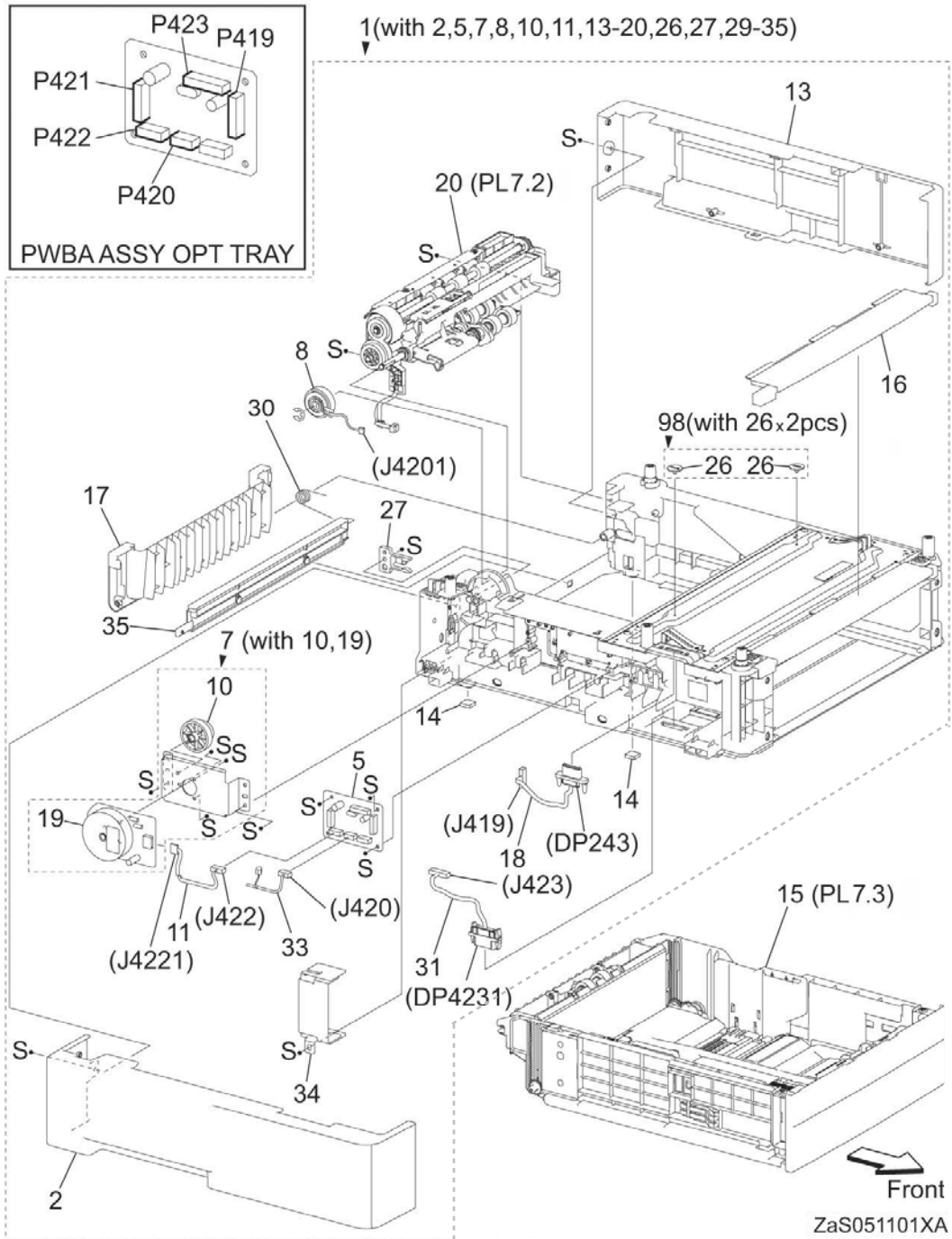

Parts List 7.1 Tray 1/Optional Tray 550-Sheet Feeder (1/4)

Item	Description	Part Number
1.	Feeder Assembly (with 2,5,7,8,10,11,13,14,16-20,26,27,29-35) (REP 7.11)	(3610) 059K82011 (3615) 059K82021
2.	Left Side Cover	
3.		
4.		
5.	Optional Tray PWB Assembly (REP 7.5)	960K67512
6.		
7.	Drive Assembly (REP 7.6)	007K18020
8.	Feed Clutch Assembly (REP 7.7)	005K83210
9.		
10.	Gear	
11.	Tray Motor Harness Assembly	
12.		
13.	Right Side Cover	
14.	Foot	
15.	Tray Assembly	050K71211
16.	Top Cover	
17.	Rear Cover	
18.	Drawer 1 Harness Assembly	
19.	Motor Assembly	
20.	Feeder Assembly 550 (REP 7.11)	059K86170
21.		
22.		
23.		
24.		
25.		
26.	Screw Locks	
27.	Stopper CST	803E10840
28.		
29.	Size Switch Assembly	
30.	Rear Spring Cover	
31.	Drawer 2 Harness Assembly	
32.		
33.	C2 Turn Harness Assembly	
34.	Locator Pin Bracket 55	
35.	Rear Under Cover	
98.	Feeder Assembly (with 26)	

PL 7.2 Tray 1/Optional Tray 550-Sheet Feeder (2/4)

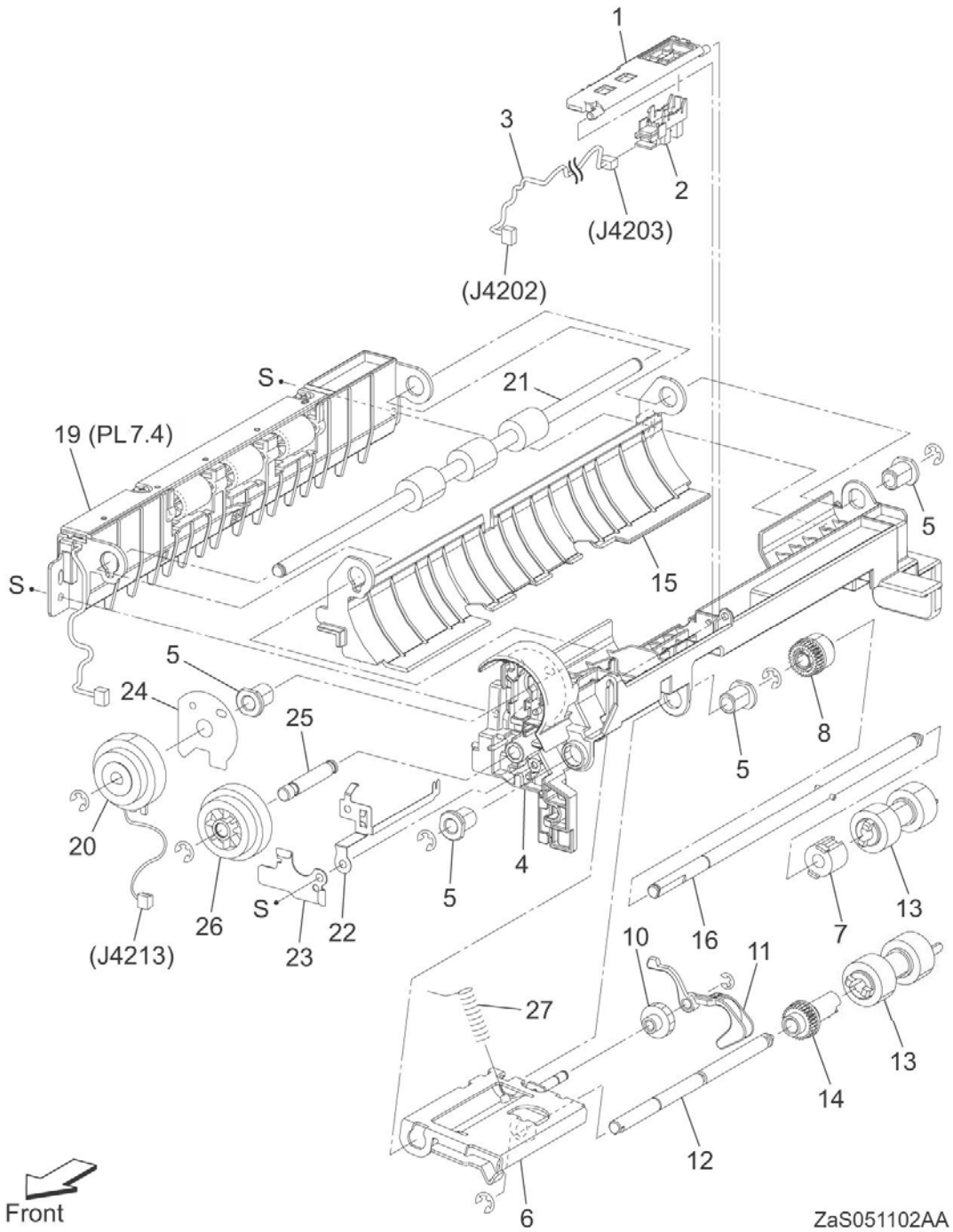

Parts List 7.2 Tray 1/Optional Tray 550-Sheet Feeder (2/4)

Item	Description	Part Number
1.	No Paper Sensor Cover	
2.	No Paper Sensor (REP 7.9)	930W00123
3.	Optional No Paper Harness Assembly	
4.	Upper Chute- Optional 550	
5.	Nudger Bearing	
6.	Nudger Assembly Support	
7.	One-way Feed Clutch	
8.	Feed Gear	
9.		
10.	Nudger Idler Gear	
11.	No Paper Actuator	
12.	Nudger Shaft	
13.	Feed Roll Assembly (3 pack) (REP 7.11)	604K11192
14.	Nudger Gear	
15.	Lower Chute Optional 550	
16.	Feed Shaft Assembly 550	
17.		
18.		
19.	Pinch Chute Assembly 550	
20.	Registration Clutch Assembly (REP 7.10)	121K48670
21.	Take Away Roll Assembly (REP 7.14)	059K71770
22.	Earth Plate	
23.	Nudger Spring Bracket	
24.	Sensor Cover Harness	
25.	Gear Shaft	
26.	Optional Feeder Gear 550	
27.	Optional Nudger Spring	

PL 7.3 Tray 1/Optional Tray 550-Sheet Feeder (3/4)

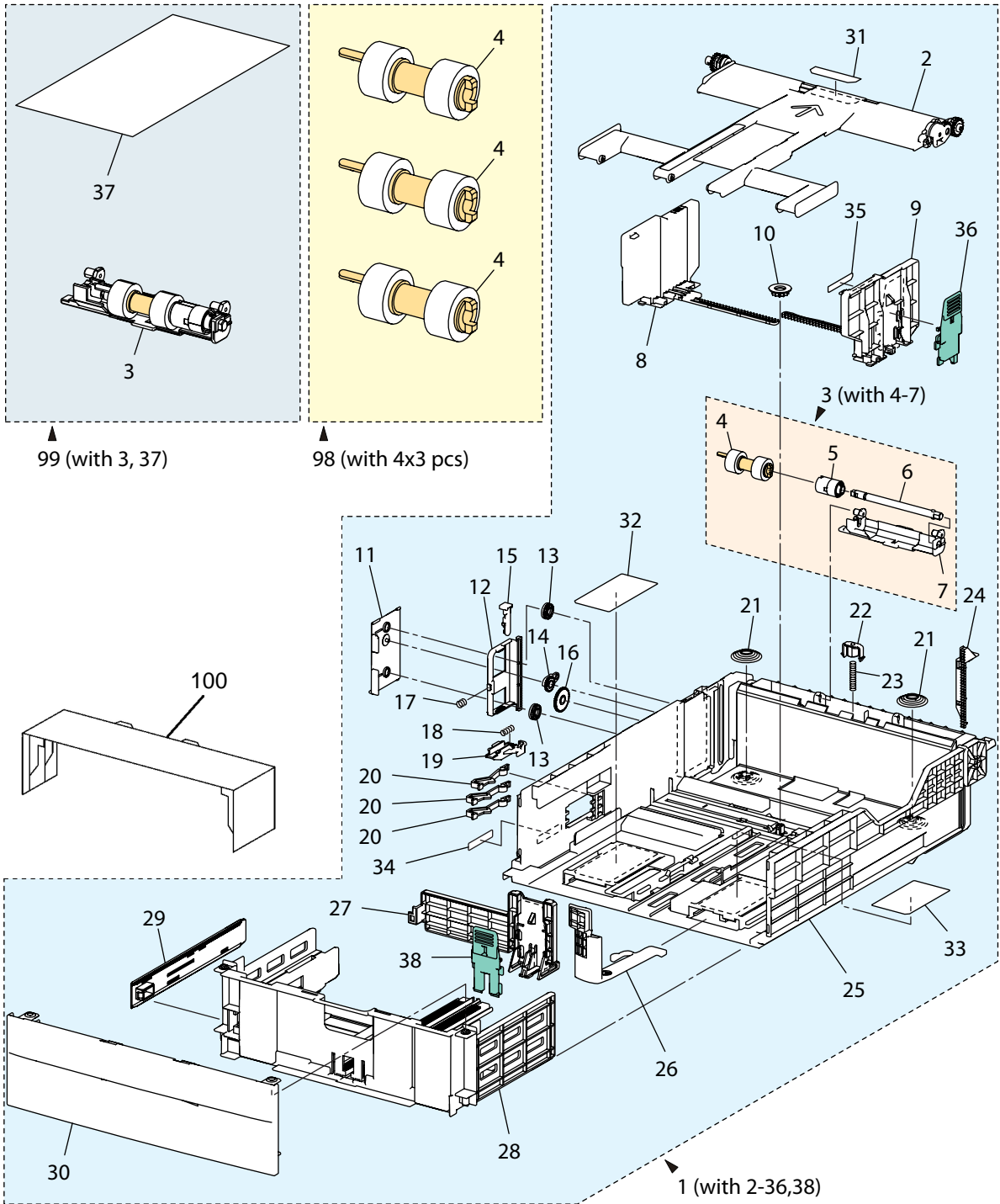

s3610-132

Parts List 7.3 Tray 1/Optional Tray 550-Sheet Feeder (3/4)

Item	Description	Part Number
1.	IOT Cassette Assembly (With 2-36,38)	050K71211
2.	Plate Bottom CST Mat X	
3.	Retard Holder Assembly CST (With 4-7)	
4.	Feed Roll Assembly	
5.	Friction Clutch	
6.	Retard Shaft CST	
7.	Retard Holder CST	
8.	Right Side Guide Assembly	
9.	Left Side Guide Assembly	
10.	Pinion Gear	
11.	Cover BTM Lock 550	
12.	Back BTM Lock 550	
13.	Pinion Gear BTM Lock	
14.	Gear Lever BTM Lock	
15.	Lever BTM Lock	
16.	Gear 40 BTM Lock	
17.	Spring BTM Lock	
18.	Spring Lock Pb	
19.	Actuator Lock Pb L	
20.		
21.	Spring BTM Up 550 A4	
22.	Retard Spring Holder	
23.	Retard Spring Cst	
24.	Rack Left Up Pb 550	
25.	Housing Base 550	
26.	Lever Ext End 550	
27.	End Guide 550	
28.	Housing End 550	
29.		
30.	Tray Handle 550	
31.	Pad Pb	
32.	Instruction Label- D	
33.	Instruction Label Ad	
34.	Tray Label	
35.	Label	
36.	Handle Gd Sd	
37.	Retard Assembly Roll Instruction	
38.	End Guide Handle	
98.	Feed Rolls (With 4*3 Pcs) (REP 7.11)	604K11192
99.	Retard Roll Assembly Kit (With 3,37) (REP 7.13)	604K78360
100.	Dust Cover	848E93660

PL 7.4 Tray 1/Optional Tray 550-Sheet Feeder (4/4)

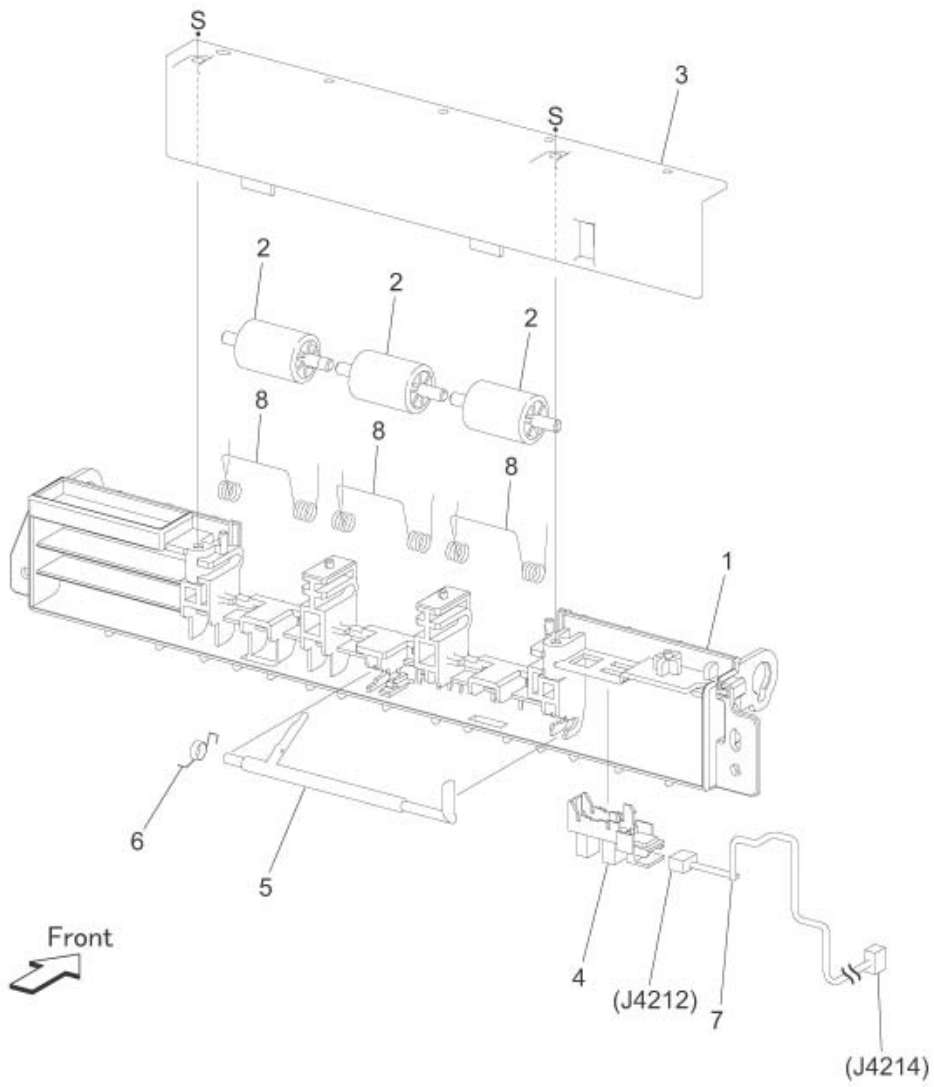

ZaS051104AA

Parts List 7.4 Tray 1/Optional Tray 550-Sheet Feeder (4/4)

Item	Description	Part Number
1.	Pinch Roll Chute	
2.	Pinch Roll	
3.	Chute Cover	
4.	Pre-Registration Sensor (REP 7.13)	930W00123
5.	Pre-Registration Actuator	
6.	Pre-Registration Sensor Spring	
7.	Harness Assembly	
8.	Pinch Roll Spring	

Quick Reference Spares List for the 3610 and 3615

SFP/MFP	Part Number	Part Description	PL Number	REP Number
SFP MFP	604K85880 604K85890	Front Cover Assembly Front Cover Assembly	PL 1.1 PL 1.2	REP 1.2
SFP MFP	848E82792 848E82815	Left Side Cover Left Side Cover	PL 1.1 PL 1.2	REP 1.7 REP 1.11
SFP MFP	604K84920 604K84931	Top Front Cover Assembly Top Front Cover Assembly	PL 1.1 PL 1.2	REP 1.3
SFP MFP	604K84941 848K68342	Right Side Cover Right Side Cover	PL 1.1 PL 1.2	REP 1.6 REP 1.13
SFP MFP	848K62885 848K62912	Top Cover Assembly Top Cover Assembly	PL 1.1 PL 1.2	REP 1.4 REP 1.15
SFP MFP	848K70060 604K85650	Rear Cover Assembly Rear Cover Assembly	PL 1.1 PL 1.2	REP 1.5 REP 1.18
SFP MFP	848E82672	Lower Rear Cover	PL 1.1 PL 1.2	REP 1.8 REP 1.18
MFP	848E82901	IIT Lower Right Cover	PL1.2	REP 1.13
MFP	848E89270	IIT Right Inner Cover	PL 1.2	REP 1.14
MFP	848E89213	Upper Left Side Cover	PL 1.2	REP 1.16
MFP	848E89231	Upper Right Side Cover	PL 1.2	REP 1.13
SFP MFP	604K77391 604K85900	Cover Extension Assembly Cover Extension Assembly	PL 1.1 PL 1.2	REP 1.3
	868E76893	Rear Strap	PL 1.3	NA
SFP	848K79123	Control Panel	PL 1.4	REP 1.1
MFP	848K75635 848K82824	Control Panel 110V Control Panel 220V	PL 1.5	REP 1.12
MFP	848E93191	IIT Front Bottom Cover	PL 1.5	REP 1.10
MFP	848E93181	IIT Front Top Cover	PL 1.5	REP 1.9
MFP	848E93171	Lower Left Side Cover	PL 1.5	REP 1.17
	059K79334	Registration Transport Assembly	PL 2.1	REP 2.2
	803E13351	Tray 1 Stopper	PL 2.1	REP 2.8

SFP/MFP	Part Number	Part Description	PL Number	REP Number
SFP MFP	604K85740 604K85750	Rear Interlock Assembly Rear Interlock Assembly	PL 2.1	REP 2.10
	121K51870	Registration Clutch	PL 2.2	REP 2.6
	059K74580	Rubber Roll Assembly	PL 2.2	REP 2.7
	055E60433	Registration Shutter Sensor	PL 2.2	REP 2.8
	604K11192	Feed Rolls (3 pack)	PL 2.3	REP 2.4
	121K51880	Feed Clutch	PL 2.3	REP 2.5
	054K48100	Duplex Chute Assembly	PL 2.4	REP 2.1
	604K77510	Exit Chute Left Pinch Roll Assembly	PL 2.5	REP 2.12
	604K77520	Exit Chute Right Pinch Roll Assembly	PL 2.5	REP 2.12
	930W00123	Exit Chute Full Stack Sensor	PL 2.5	REP 2.13
	054K48380	Exit Chute Assembly	PL 2.5	REP 2.11
	121E23570	MSI Feed Solenoid	PL 2.6	REP 2.14
	059K78790	MSI Pick Up Holder Assembly	PL 2.6	REP 2.15
	801K57914	MSI Top Frame Assembly	PL 2.6	REP 2.16
	050K71290	MSI Tray Assembly	PL 2.7	NA
	604K78370	MSI Retard Roll Assembly	PL 2.7	REP 2.17
	062K24263	ROS Assembly	PL 3.2	REP 3.1
	007K18413	Toner Dispense Drive Assembly	PL 3.3	REP 4.6
	127K52160	Toner Dispense Motor	PL 3.3	REP 4.7
	604K77290	CRUM Assembly	PL 3.3	REP 3.2
	116K91040	Xerographic Connector Assembly	PL 3.3	REP 3.3
	059K75560	Transfer Roll Assembly CRU	PL 3.4	REP 3.4
	126K30919 126K30929	Fusing Assembly 110v Fusing Assembly 220v	PL 3.5	REP 3.5
	007K18903	Main Drive Assembly	PL 4.1	REP 4.1
	007K18912	Drive Exit Out Holder Assembly	PL 4.1	REP 4.2
	007K18931	Drive Exit In Holder Assembly	PL 4.1	REP 4.3

Parts List

SFP/MFP	Part Number	Part Description	PL Number	REP Number
	019E83450	Duplex Gear Holder	PL 4.1	REP 4.4
	807E38660	Duplex In Gear	PL 4.1	REP 4.4
	127K66001	LVPS Fan Assembly	PL 4.2	NA
	012E18133	Right Front Link	PL 4.2	REP 4.5
	012E18143	Left Front Link	PL 4.2	REP 4.5
	012E18172	Link Connector	PL 4.2	NA
	604K77650	Foot Assembly	PL 4.2	NA
SFP MFP	960K68394 960K69984	ESS PWB	PL 5.1 PL5.2	REP 5.1
	848K631	ESS Cover Assembly	PL 5.1 PL 5.2	REP 5.2
SFP	604K78920 604K78930	LVPS Kit 110v LVPS Kit 220v	PL 5.1	REP 5.3
MPF	960K67970	FAX PWB Assembly	PL 5.2	REP 5.4
MPF	952K08202	Front USB Assembly	PL 5.2	REP 5.5
MPF	604K85611 604K85621	LVPS Kit 110v LVPS Kit 220v	PL 5.2	REP 5.3
	960K71042	MCU PWB	PL 5.3	REP 5.6
SFP MFP	105K30954	HVPS	PL 5.3	REP 5.7 REP 5.8
SPF	604K78900 604K78910	AC Inlet Kit (100v) AC Inlet Kit (200v)	PL 5.4	REP 5.9
MPF	604K85630 604K85640	AC Inlet Kit (100v) AC Inlet Kit (200v)	PL 5.4	REP 5.9
MFP	604K86152	IIT Assembly	PL 6.1	REP 6.1
MFP	059K86162	DADF Assembly	PL 6.1	REP 6.2
MFP	003K89860 003K89140	DADF Right Hinge Assembly DADF Left Hinge Assembly	PL 6.1	REP 6.3
MFP	050K71060	DADF Tray Assembly	PL 6.1	NA
MFP	604K85850	DADF Pick Up Module Kit	PL 6.1	REP 6.4

SFP/MFP	Part Number	Part Description	PL Number	REP Number
MFP	604K85860	DADF Top Cover Assembly	PL 6.1	NA
	960K67512	Optional Tray PWB Assembly (550)	PL 7.1	REP 7.1
	007K18020	Drive Assembly (550)	PL 7.1	REP 7.6
	005K83210	Feed Clutch Assembly (550)	PL 7.1	REP 7.7
	050K71211	Tray Assembly (550)	PL 7.1	
	059K86170	Feeder Assembly (550)	PL 7.1	REP 7.8
	803E10840	Stopper CST (550)	PL 7.1	NA
SFP MFP	059K82011 059K82021	Feeder Assembly (w/o tray)	PL 7.1	REP 7.11
	930W00123	No Paper Sensor (550)	PL 7.2	REP 7.9
	121K48670	Registration Clutch Assembly (550)	PL 7.2	REP 7.10
	059K71770	Take Away Roll Assembly (550)	PL 7.2	REP 7.14
	050K71210	IOT Cassette Assembly (550)	PL 7.3	NA
	604K11192	Feed Rolls (550)	PL 7.2	REP 7.11
	604K78360	Retard Roll Assembly Kit (550)	PL 7.3	REP 7.12
	930W00123	Pre-Registration Sensor (550)	PL 7.4	REP 7.13

Xerox Supplies

Part	Description	Capacity	Part Number
Toner Cartridge	NA / XE Sold	Standard Capacity (5.9K)	106R02720
	DMO Sold	Standard Capacity (5.9K)	106R02721
	NA / XE Sold	High Capacity (14.1K)	106R02722
	DMO Sold	High Capacity (14.1K)	106R02723
	NA / XE Sold	Extra High Capacity (25.3K)	106R02731
	DMO Sold	Extra High Capacity (25.3K)	106R02732
	Worldwide Metered / Page Pack	Extra High Capacity (25.3K)	106R02724

Yield is based on ISO / IEC 19752 Test Standard. Toner consumption will vary depending on image, area coverage and the media that is used.

Maintenance

6

This chapter includes:

- [Service Maintenance Procedure](#)
- [Cleaning](#)
- [Moving the Printers](#)
- [Resetting Counters](#)
- [Adjustments](#)
 - [ADJ 1 Adjusting Paper Type](#)
 - [ADJ 2 Adjusting the Transfer Unit](#)
 - [ADJ 3 Adjusting the Fuser](#)
 - [ADJ 4 Adjusting the Density](#)
 - [ADJ 5 Adjusting Altitude](#)
- [Firmware Update](#)
- [Tag Matrix](#)

Service Maintenance Procedure

Maintenance Safety

- Do not attempt any maintenance procedure that is not specifically described in the documentation supplied with your printer.
- Do not use aerosol cleaners. Clean the printer with a dry lint-free cloth only.
- Do not burn any consumables or routine maintenance items. For information on Xerox supplies recycling programs, go to www.xerox.com/gwa.

Perform the following procedures whenever you check, service, or repair a printer. Cleaning the printer, assures proper operation of the printer and reduces the probability of having to service the printer in the future.

Note: The frequency of use, the type of paper printed on, and operating environment are factors in determining how critical cleaning the printer is and how often it is necessary.

Recommended Materials

- Toner vacuum cleaner
- Clean water
- Clean, dry, lint-free cloth
- Black, light protective bag

Repair, Inspect, and Prevent (RIP) Procedure

Perform these routine maintenance procedures during the course of servicing the printer.

- Clean the Feed Rollers, Transfer Rollers, and Paper Guides; and replace if necessary.
- Remove and clean the paper trays.
- Print a Configuration and Error History pages; diagnose, and repair any problems as indicated.
- Check cleanliness of the interior and exterior, including Fans; if necessary, clean (dust or vacuum) these areas.
- Review proper printer operation using a customer file, if possible. Check with the customer regarding any special applications they may be using.
- Review with the customer all work that was performed and discuss proper printer care.

Cleaning

General Precautions



CAUTIONS: When cleaning your printer do not use organic or strong chemical solvents or aerosol cleaners. Do not pour fluids directly into any area. Use supplies and cleaning materials only as directed in this documentation.



WARNING:

- Keep all cleaning materials out of the reach of children.
- Do not use pressurized spray cleaning aids on or in the printer. Some pressurized sprays contain explosive mixtures and are not suitable for use in electrical applications. Use of such cleaners increase the risk of fire and explosion.
- Do not remove the covers or guards that are fastened with screws. You cannot maintain or service any parts that are behind these covers and guards. Do not attempt any maintenance procedure that is not described in the documentation supplied with your printer.
- Internal parts of the printer can be hot. Use caution when doors and covers are open.
- Do not place anything on top of the printer.
- Do not leave the covers and doors open for any length of time, especially in well-lit places. Light exposure can damage the imaging units.
- Do not open covers and doors during printing.
- Do not tilt the printer while it is in use.
- Do not touch the electrical contacts or gears. Doing so could damage the printer and cause the print quality to deteriorate.
- Ensure any parts removed during cleaning are replaced before you plug in the printer.



CAUTION: Never apply alcohol or other chemicals to any part of the printer. Never use a damp cloth to clean up toner. If you remove the Drum Cartridge, protect it from exposure to light as light exposure can quickly degrade Drum Cartridge performance and result in early failure.

General Cleaning

Perform these general cleaning steps as indicated by the printer's operating environment. Use a dry lint-free cloth or a lint-free cloth moistened with water for all cleaning unless directed otherwise in this manual. Wipe with a dry, lint-free cloth if a moistened cloth is used.

Inspect the vents on the exterior of the printer for dust. Clean as necessary.

1. Record number of sheets printed.
2. Print several sheets of paper to check for problems or defects.
3. Turn the printer power Off and disconnect the power cord.
4. Remove the following components before cleaning:
 - Rear Cover
 - Left Side Cover
 - Right Side Cover
 - Drum Cartridge

Clean the exterior of the printer once a month.

- Wipe the paper tray, output tray, control panel, and other parts with a damp, soft cloth.
- After cleaning, wipe with a dry, soft cloth.
- For stubborn stains, apply a small amount of mild detergent to the cloth and gently wipe the stain off.



CAUTION: Do not spray detergent directly on the printer. Liquid detergent could enter the printer through a gap and cause problems. Never use cleaning agents other than water or mild detergent.

Cleaning the Scanner (3615)

Clean the scanner as a standard part of service when anything is spilled on it, or when debris or dust collect on any of the surfaces. Keep the feed rollers clean to ensure the best possible copies and scans. Cleaning Procedure

1. Slightly dampen a soft, lint-free cloth with water.
2. Remove any paper or other media from the output tray.
3. Wipe the area under the scanner until it is clean.
4. Open the document cover.
5. Wipe the surface of the document glass until it is clean and dry. **Note:** For best results, use Xerox® Glass Cleaner to remove marks and streaks.
6. Wipe the white underside of the document cover until it is clean and dry.
7. With a dry, soft lint-free cloth or paper towel, wipe the DADF feed rollers until they are clean.
Note: If the DADF rollers get stained with toner or debris, they can cause stains on the documents. To remove the stains, use a soft lint-free cloth dampened with a neutral detergent or water.
8. Close the document cover.

Moving the Printers

WARNING:

- Use the power switch to turn Off the printer, and unplug all cables and cords. Do not turn the printer Off by pulling the power cord or using a power-strip with an On/Off switch.
- Always use at least two people to lift the printer.
- To prevent you from dropping the printer or injury, lift the printer firmly by gripping the recessed areas on both sides. Never lift the printer by gripping any other areas.
- Uninstall the optional 550-sheet feeder before moving the printer. If the optional 550-sheet feeder is not fixed securely to the printer, it could fall to the ground and cause injuries.
- Back injury could result if you do not lift the printers properly.

Follow these instructions when moving the printer:

1. Turn off the printer and disconnect the power cord and other cables from the back of the printer.

 **CAUTION:** If the optional Productivity Kit (HD) is not installed, ensure that the Ready LED is off before you turn off the printer. The data in the memory is cleared when the printer is turned off.

 **WARNING:** To prevent electric shock, never touch the power plug with wet hands. When removing the power cord, ensure that you pull the plug and not the cord. Pulling the cord can damage it, which can lead to fire or electric shock.

2. Remove any media from the output tray. If necessary, close the output tray extension.
3. Remove the paper from the paper tray. Keep the paper wrapped and away from humidity and dirt.
4. Lift the printer firmly by gripping the recessed areas on both sides of the printer and carry the printer to the pre-designated location.

Note: When moving the printer, do not tilt it more than 10 degrees to the front, back, left, or right. Tilting the printer more than 10 degrees can cause toner spillage.

Note: When moving the printer over a long distance, remove the imaging unit and toner cartridges to prevent toner from spilling. Pack the printer inside a box. For a repacking kit and instructions, go to [www.xerox.com/office/\(Phaser 3610 / WC3615\) support](http://www.xerox.com/office/(Phaser 3610 / WC3615) support).

 **CAUTION:** Failure to repackage the printers properly for shipment can result in damage to them. Damage to the printers caused by improper packaging are not covered by the Xerox warranty, service agreement, or Total Satisfaction Guarantee.

After moving the printer:

1. Reinstall any parts you removed.
2. Reconnect the printer to the cables and power cord.
3. Plug in and turn on the printer.

Resetting Counters

Resetting the Transfer Unit / Fuser Counters (3610)

The reset Transfer Unit / Fuser feature resets the life counter after you replace the assemblies.

1. At the printer control panel, press the **Menu** button.
Note: Note: To navigate through the menu, use the **Up** or **Down** arrow buttons.
2. Navigate to **Admin Settings**, then press **OK**.
3. Navigate to **Service Tools**, then press **OK**.
4. Navigate to **Reset Trans Unit / Fuser**, then press **OK**.
5. At the **Are you sure?** prompt, press **Yes**, then press **OK**.

After the process completes, the printer to returns to Ready.

Resetting the Transfer Roller / Fuser Assembly Counter (3615)

The reset Transfer Unit / Fuser feature resets the life counter after you replace the assemblies.

1. At the printer control panel, press the **Machine Status** button.
2. Touch **Tools**, then touch **Admin Settings**.
3. Touch **Service Tools**.
4. Touch **Reset Transfer Unit / Fuser**.
5. Touch **Reset**.
6. Touch **Yes, Reset**.

The printer displays a message, then returns to the Services Home screen.

Adjustments

ADJ 1 Adjusting Paper Type

Use Adjust Paper Type to compensate for paper thickness within a paper type. If the printed image is too light, use a heavier setting for the paper you are using. If the printed image is mottled or blotchy-looking, decrease the setting for the paper you are using.

(3610) Procedure

1. At the printer control panel, press the **Menu** button.
Note: To navigate through the menu, use the **Up** or **Down** arrow buttons.
2. Navigate to **Admin Settings**, then press **OK**.
3. Navigate to **Service Tools**, then press **OK**.
4. Select **Adjust Paper Type**, then press **OK**.
5. Select **Plain**, then press **OK**.
6. Select **Lightweight** or **Heavyweight**, then press **OK**.
7. To return to Service Tools, press the **Back** arrow button, or to return to the main menu, press the **Menu** button.

(3615) Procedure

1. At the printer control panel, press the **Machine Status** button.
2. Touch **Tools**, then touch **Admin Settings**.
3. Touch **Service Tools**.
4. Touch **Adjust Paper Type**. The default selection for Plain appears.
5. Touch **Plain**.
6. Touch **Lightweight** or **Heavyweight**, then press **OK**.

ADJ 2 Adjusting the Transfer Unit

Adjusting the Transfer Unit can decrease a mottled appearance or white spots in your prints. This adjustment is available for each paper type.

Note: This setting affects print quality. The higher the value, the darker the printed output appears.

(3610) Procedure

1. At the printer control panel, press the **Menu** button.
Note: To navigate through the menu, use the **Up** or **Down** arrow buttons.
2. Navigate to **Admin Settings**, then press **OK**.
3. Navigate to **Service Tools**, then press **OK**.
4. Navigate to the paper type for the adjustment, then press **OK**.
5. To increase or decrease the bias voltage, use the arrow buttons, then press **OK**.
6. Repeat this procedure for each paper type you need to adjust.
7. To return to Service Tools, press the **Back** arrow button, or to return to the main menu, press the **Menu** button.

(3615) Procedure

1. At the printer control panel, press the **Machine Status** button.
2. Touch **Tools**, then touch **Admin Settings**.
3. Touch **Service Tools**.
4. Touch **Adjust Transfer Unit**.
5. Touch the paper for the adjustment, touch (-) or (+), then touch **OK**.
6. Repeat this procedure for each paper type you need to adjust.
7. To return to the Services Home menu, press the **Services Home** button.

ADJ 3 Adjusting the Fuser

Use Adjust Fuser for optimum print quality across a wide range of paper types. If the toner on a print is smearing or can be rubbed off the paper, increase the offset for the paper you are using. If the toner is blistered or mottled, decrease the offset for the paper you are using.

(3610) Procedure

1. At the printer control panel, press the **Menu** button.
Note: To navigate through the menu, use the **Up** or **Down** arrow buttons.
2. Navigate to **Admin Settings**, then press **OK**.
3. Navigate to **Service Tools**, then press **OK**.
4. Select **Adjust Fuser**, then press **OK**.
5. To select the paper type for the adjustment, press the arrow buttons, then press **OK**.
6. To increase or decrease the amount of offset, press the arrow buttons, then press **OK**.
7. Repeat this procedure for each paper type you need to adjust.
8. To return to Service Tools, press the **Back** arrow button, or to return to the main menu, press the **Menu** button.

(3615) Procedure

1. At the printer control panel, press the **Machine Status** button.
2. Touch **Tools**, then touch **Admin Settings**.
3. Touch **Service Tools**.
4. Touch **Adjust Fuser**.
5. Touch the paper for the adjustment, touch (-) or (+), then touch **OK**.

ADJ 4 Adjusting the Density

The Density Adjustment feature controls how much toner is used to print. Adjust the density for lighter toner use for saving toner or heavier for making prints bolder. A positive adjustment makes the prints darker, while a negative adjustment makes the prints lighter. You can also adjust it to compensate for different paper types and thicknesses.

(3610) Procedure

1. At the printer control panel, press the **Menu** button.
Note: To navigate through the menu, use the **Up** or **Down** arrow buttons.
2. Navigate to **Admin Settings**, then press **OK**.
3. Navigate to **Service Tools**, then press **OK**.
4. Select **Adjust Density**, then press **OK**.
5. To increase or decrease the amount of offset, use the arrow buttons, then press **OK**.
6. To return to the Ready screen, press the **Menu** button.

(3615) Procedure

1. At the printer control panel, press the **Machine Status** button.
2. Touch **Tools**, then touch **Admin Settings**.
3. Touch **Service Tools**.
4. Touch **Adjust Density**.
5. Touch the desired density from Darken to Lighten, then press **OK**.

ADJ 5 Adjusting Altitude

Use Adjust Altitude to adjust the altitude to match that of the location where the printer is installed. If the altitude setting is incorrect, it can cause print-quality problems.

(3610) Procedure

1. At the printer control panel, press the **Menu** button.
Note: To navigate through the menu, use the **Up** or **Down** arrow buttons.
2. Navigate to **Admin Settings**, then press **OK**.
3. Navigate to **Service Tools**, then press **OK**.
4. Select **Adjust Altitude**, then press **OK**.
5. To select the altitude of the location of the printer, press the arrow buttons, then press **OK**.
6. To return to Service Tools, press the **Back** arrow button, or to return to the main menu, press the Menu button.

(3615) Procedure

1. At the printer control panel, press the **Machine Status** button.
2. Touch **Tools**, then touch **Admin Settings**.
3. Touch **Service Tools**.
4. Touch **Adjust Altitude**.
5. Touch the altitude of the location of the printer, then press **OK**.

Firmware Update

Note: The firmware update for Macintosh version will be available post launch.

Two methods are available for updating firmware:

- Ethernet port with Download Tool
- USB printer port with Download Tool

Before conducting a firmware update, confirm with the System Admin or authorized personnel, that the system is enabled to accept downloads.

To enable the system or check the current status, use the following procedure:

1. Open a web browser.
2. Enter the printer's IP address, and press **Enter**.
3. On the CWIS home page, select **Properties**.



4. On the left side menu field, scroll down to and expand **Security> Secure Settings**.

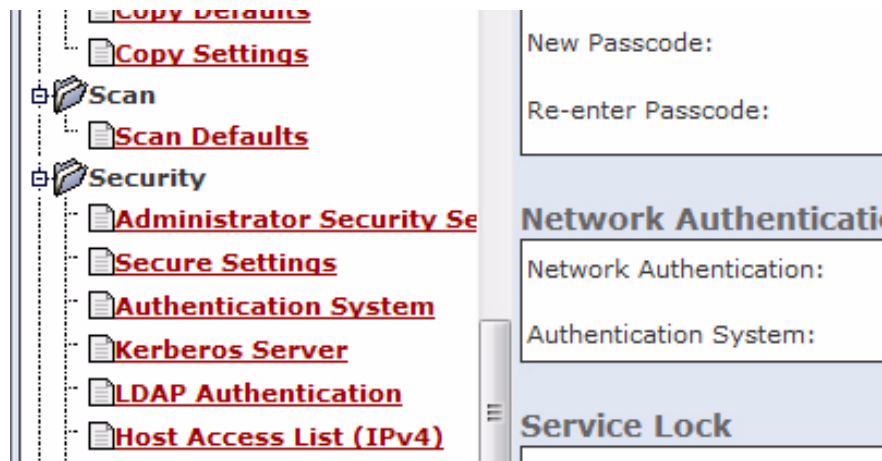

5. In the **Upgrades** window, select **Enabled** (if not selected).

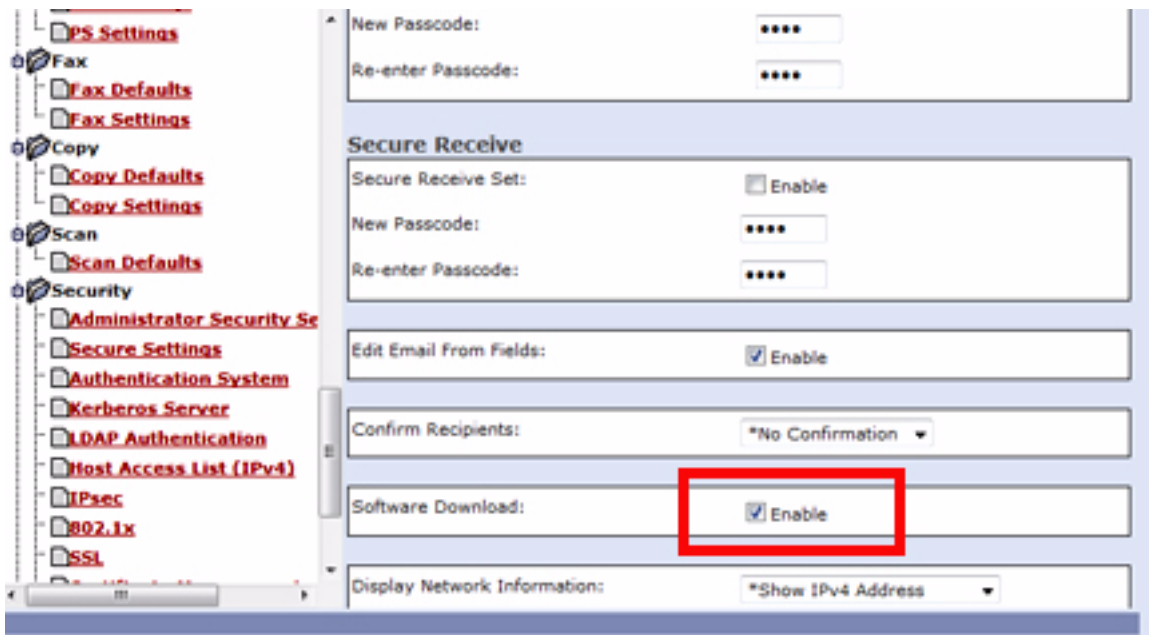

6. Click **Apply**.
7. Verify that the settings have been changed.

Upgrade Procedure

1. Make sure the printer is powered On and connected over the network or USB.
2. Print a Configuration Page or Printer Settings Report to document the current printer settings.
3. On the Computer, double-click on the xeroxfwup.exe icon located in the firmware folder.

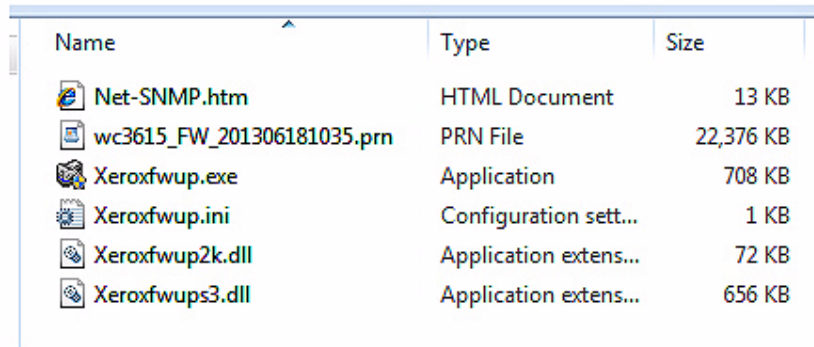

Name	Type	Size
Net-SNMP.htm	HTML Document	13 KB
wc3615_FW_201306181035.prn	PRN File	22,376 KB
Xeroxfwup.exe	Application	708 KB
Xeroxfwup.ini	Configuration sett...	1 KB
Xeroxfwup2k.dll	Application extens...	72 KB
Xeroxfwups3.dll	Application extens...	656 KB

4. The **xeroxfwup.exe** window with the connection option is displayed. Two connections are available for updating the firmware, Network or USB.

Note: When updating devices that only have USB connections, only the USB connection option will be displayed.

5. Select your connection and press **Next**.

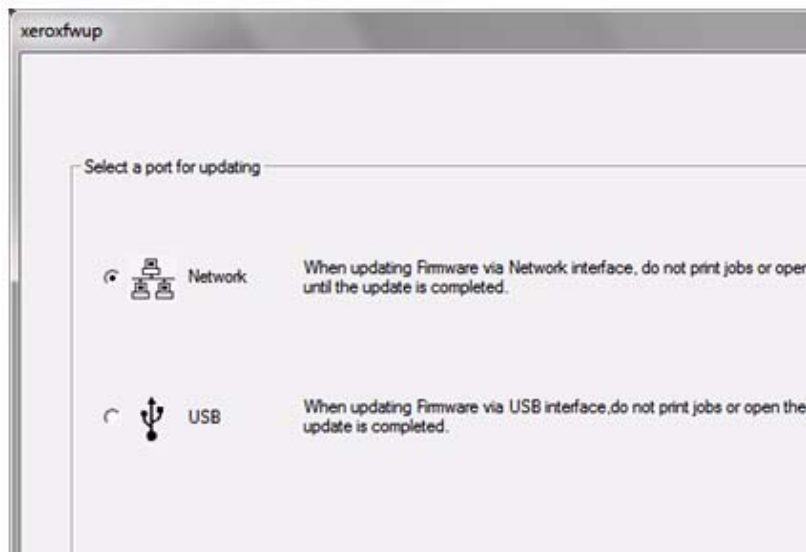

For Network Connections

If your printer IP Address is listed, check the checkbox next to the printer. Click the **Next** button.

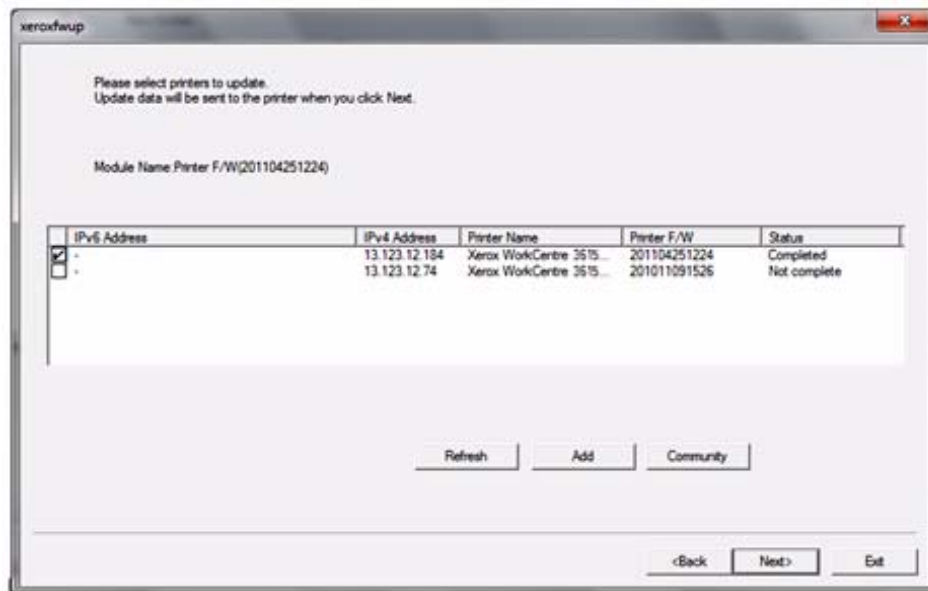

Note: If your printer IP Address is not listed, click the **Add** button. Then enter your printer IP Address and click the **OK** button.

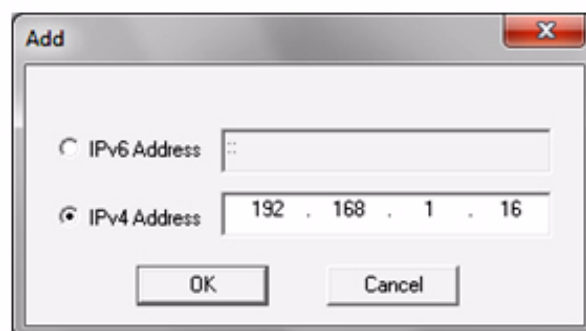

Maintenance

1. Check the checkbox next to your printer IP Address and click the **Next** button to send the firmware to your printer.

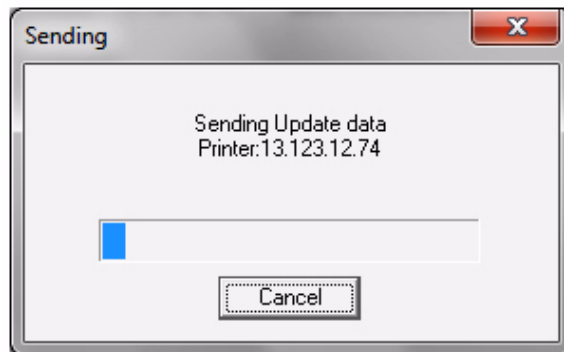

2. The following message will be displayed on your printer. These messages may vary slightly depending on the printer model, and whether you are upgrading the controller or engine firmware.
 - Receiving Data
 - Port 9100
 - Please Wait...
 - Writing Port 9100 F/W
3. The printer will reboot after the firmware is updated. Print a configuration page or printer settings page to verify the updated firmware version.
4. After the firmware upgrade is complete, click the **OK** button to exit the firmware upgrade tool.

For USB Connection

1. Check the checkbox next to your printer IP Address and click the **Next** button to send the firmware to your printer.

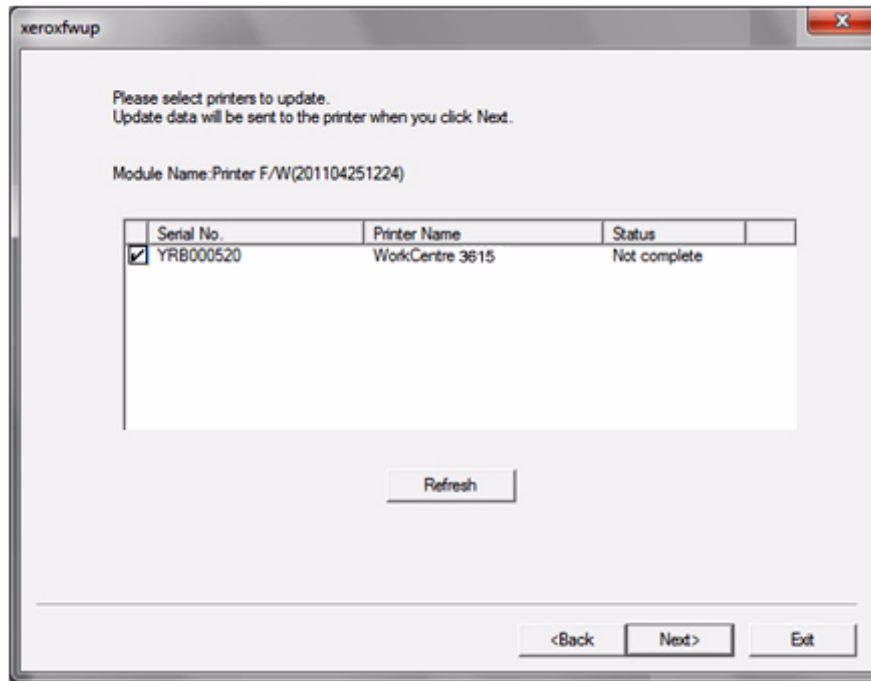

2. The following message will be displayed on your printer. These messages may vary slightly depending on the printer model, and whether you are upgrading the controller or engine firmware.
 - Receiving Data
 - USB
 - Please Wait...
 - Writing USB F/W
3. The printer will reboot after the firmware is updated. Print a configuration page or printer settings page to verify the updated firmware version.
4. After the firmware upgrade is complete, click the OK button to exit the firmware upgrade tool.

Tag Matrix

Change Tag Introduction

This section describes all of the tags associated with the machine, as well as multinational applicability, classification codes, and permanent or temporary modification information.

Important modifications to the copier are identified by a tag number which is recorded on a tag matrix. The tag matrix is on the inside of the Front Cover Assembly.

The Tag information may include:

- Tag
- Class
- Use
- Manufacturing Serial Number
- Purpose
- Name
- Kit Number
- PL Reference.

Classification Codes

A tag number may be required to identify differences between parts that cannot be interchanged, or differences in diagnostic, repair, installation, or adjustment procedures.

A tag number may also be required to identify the presence of optional hardware, special non-volatile memory programming, or whether mandatory modifications have been installed. Each tag number is given a classification code to identify the type of change that the tag has made. The classification codes and their descriptions are listed in Table 1.

Table 1 Classification Codes

Classification Code		Description
USCO Code	XE Code	
	1	Safety
M	2	Mandatory tag.
R	3	Repair tag.
O	4	Optional tag.
S	4	Situational tag
N	5	Tag not installed in the field.
	6	Refurbishing Only

There are no TAGs currently issued for this machine.

Wiring

7

This chapter includes:

- Plug/Jack Locations
 - Plug/Jack Locations for the 3610
 - Plug/Jack Locations for the 3615
 - Plug/Jack Locations for Tray 1 and the Optional Feeders
- Wire Harnessing for the Printer
- Wire Harnessing for Option Trays
- Notations Used in the Wiring Diagrams
- Wiring Diagrams
 - General Wiring Diagram for 3610
 - General Wiring Diagram for 3615
 - 1. Power
 - 2. Drive
 - 3. ROS
 - 4. Xerographics / HVPS
 - 5. Fusing
 - 6. Controller (3610)
 - 6. Controller (3615)
 - 7. Scanner
 - 8. Optional Feeder

Plug/Jack Locations

Plug/Jack Locations for the 3610

P/J (3610)	Illustration	Description
10	Illustration 02	Connects MCU PWB and MAIN MOTOR HARNESS ASSY
11	Illustration 02	Connects MCU PWB and DISP MOTOR HARNESS ASSY
12	Illustration 02	Connects MCU PWB and REGI CLUTCH
13	Illustration 02	MCU PWB (not used)
14	Illustration 02	Connects MCU PWB and CST FEED CLUTCH
15	Illustration 02	Connects MCU PWB and MSI FEED SOLENOID
16	Illustration 02	Connects MCU PWB and EXIT CLUTCH ASSY
17	Illustration 02	Connects MCU PWB and INVERT CLUTCH ASSY
18	Illustration 02	Connects MCU PWB and ROS ASSY
19	Illustration 02	Connects MCU PWB and ROS-MCU HARNESS
20	Illustration 02	Connects MCU PWB and ESS HARNESS ASSY
21	Illustration 02	Connects MCU PWB and MCU HARNESS ASSY
22	Illustration 02	Connects MCU PWB and LVPS HARNESS ASSY
23	Illustration 02	Connects MCU PWB and FUSER HARNESS ASSY
24	Illustration 02	Connects MCU PWB and OP FDR HARNESS ASSY
25	Illustration 02	Connects MCU PWB and XERO CRUM HARNESS ASSY
26	Illustration 02	Connects MCU PWB and HVPS HARNESS ASSY
27	Illustration 02	Connects MCU PWB and EXIT SENSOR HARNESS ASSY
30	Illustration 02	MCU PWB (not used)
101	Illustration 04	Connects MAIN DRIVE ASSY and MAIN MOTOR HARNESS ASSY
111	Illustration 05	Connects DISP MOTOR and DISP MOTOR HARNESS ASSY
200	Illustration 01	Connects LVPS PWB and AC INLET
201	Illustration 01	Connects LVPS PWB and FUSER HARNESS ASSY
210	Illustration 01	Connects LVPS PWB and MCU HARNESS ASSY
211	Illustration 01	Connects LVPS PWB and ESS HARNESS ASSY
212	Illustration 01	Connects LVPS PWB and MAIN MOTOR HARNESS ASSY
213	Illustration 01	Connects LVPS PWB and OP FDR HARNESS ASSY
220	Illustration 01	Connects LVPS PWB and LVPS HARNESS ASSY
220	Illustration 04	Connects CONSOLE ASSY and UI HARNESS ASSY
230	Illustration 01	Connects LVPS PWB and INTLK HARNESS ASSY

P/J (3610)	Illustration	Description
233	Illustration 04	Connects FUSING UNIT and HARNESS ASSY FSR
240	Illustration 01	Connects LVPS PWB and REAR FAN HARNESS ASSY
241	Illustration 01	Connects LVPS PWB and LVPS FAN
250	Illustration 01	Connects LVPS PWB and TEST RELAY HARNESS ASSY
251	Illustration 01	HARNESS ASSY TEST RLY Test Port
253	Illustration 05	Connects CRUM TONER CONNECTOR ASSY and XERO CRUM HARNESS ASSY
254	Illustration 05	Connects CONNECTOR ASSY XERO and XERO CRUM HARNESS ASSY
261	Illustration 02	Connects HVPS and HV HARNESS ASSY
271	Illustration 04	Connects EXIT SENSOR and EXIT HARNESS ASSY
272	Illustration 04	Connects FULL STACK SENSOR and EXIT SENSOR HARNESS ASSY
301	Illustration 01	Connects ESS PWB and MEMORY KIT
304	Illustration 01	ESS PWB (not used)
305	Illustration 01	Connects ESS PWB and SD CARD
311	Illustration 01	ESS PWB USB Port
312	Illustration 01	Connects ESS PWB and WIRELESS ADAPTER
314	Illustration 01	ESS PWB Ethernet Port
321	Illustration 01	Connects ESS PWB and ESS HARNESS ASSY
322	Illustration 01	Connects ESS PWB and VIDEO HARNESS
331	Illustration 01	Connects ESS PWB and UI HARNESS ASSY
341	Illustration 01	Connects ESS PWB and ESS HARNESS ASSY
342	Illustration 01	ESS PWB (not used)
361	Illustration 01	ESS PWB (not used)
362	Illustration 01	ESS PWB (not used)
501	Illustration 03	Connects ROS ASSY and ROS-MCU HARNESS
502	Illustration 03	Connects ROS ASSY and VIDEO HARNESS
2401	Illustration 04	Connects Rear Fan and HARNESS ASSY REAR FAN

Plug/Jack Locations for the 3615

P/J (3615)	Illustration	Description
1	Illustration 07	Connects USB PWB to ESS PWB
2	Illustration 07	Connects USB PWB to Control Panel
10	Illustration 08	Connects MCU PWB and MAIN MOTOR HARNESS ASSY
11	Illustration 08	Connects MCU PWB and DISP MOTOR HARNESS ASSY
12	Illustration 08	Connects MCU PWB and REGI CLUTCH
13	Illustration 08	MCU PWB (not used)
14	Illustration 08	Connects MCU PWB and CST FEED CLUTCH
15	Illustration 08	Connects MCU PWB and MSI FEED SOLENOID
16	Illustration 08	Connects MCU PWB and EXIT CLUTCH ASSY
17	Illustration 08	Connects MCU PWB and INVERT CLUTCH ASSY
18	Illustration 08	Connects MCU PWB and ROS ASSY
19	Illustration 08	Connects MCU PWB and ROS-MCU HARNESS
20	Illustration 08	Connects MCU PWB and ESS HARNESS ASSY
21	Illustration 08	Connects MCU PWB and MCU HARNESS ASSY
22	Illustration 08	Connects MCU PWB and LVPS HARNESS ASSY
23	Illustration 08	Connects MCU PWB and FUSER HARNESS ASSY
24	Illustration 08	Connects MCU PWB and OP FDR HARNESS ASSY
25	Illustration 08	Connects MCU PWB and XERO CRUM HARNESS ASSY
26	Illustration 08	Connects MCU PWB and HVPS HARNESS ASSY
27	Illustration 08	Connects MCU PWB and EXIT SENSOR HARNESS ASSY
30	Illustration 08	MCU PWB (not used)
101	Illustration 10	Connects MAIN DRIVE ASSY and MAIN MOTOR HARNESS ASSY
111	Illustration 11	Connects DISP MOTOR and DISP MOTOR HARNESS ASSY
200	Illustration 07	Connects LVPS PWB and AC INLET
201	Illustration 07	Connects LVPS PWB and FUSER HARNESS ASSY
210	Illustration 07	Connects LVPS PWB and MCU HARNESS ASSY
211	Illustration 07	Connects LVPS PWB and ESS HARNESS ASSY
212	Illustration 07	Connects LVPS PWB and MAIN MOTOR HARNESS ASSY
213	Illustration 07	Connects LVPS PWB and OP FDR HARNESS ASSY
220	Illustration 07	Connects LVPS PWB and LVPS HARNESS ASSY
221	Illustration 07	Connects ESS PWB and SD CARD
230	Illustration 07	Connects LVPS PWB and INTLK HARNESS ASSY

P/J (3615)	Illustration	Description
233	Illustration 10	Connects FUSING UNIT and FUSER HARNESS ASSY
240	Illustration 07	Connects LVPS PWB and REAR FAN HARNESS ASSY
241	Illustration 07	Connects LVPS PWB and LVPS FAN
250	Illustration 07	Connects LVPS PWB and TEST RELAY HARNESS ASSY
251	Illustration 07	HARNESS ASSY TEST RLY Test Port
253	Illustration 11	Connects CRUM TONER CONNECTOR ASSY and XERO CRUM HARNESS ASSY
254	Illustration 11	Connects CONNECTOR ASSY XERO and XERO CRUM HARNESS ASSY
261	Illustration 08	Connects HVPS and HVPS HARNESS ASSY
271	Illustration 10	Connects EXIT SENSOR and EXIT HARNESS ASSY
402	Illustration 07	Connects ESS PWB and FAX PWB ASSY
411	Illustration 07	ESS PWB to USB Port
412	Illustration 07	Connects ESS PWB and WIRELESS ADAPTER
414	Illustration 07	ESS PWB Ethernet Port
415	Illustration 07	Connects ESS PWB and FRONT USB ASSY
416	Illustration 07	Connects ESS PWB and UI HARNESS ASSY
421	Illustration 07	Connects ESS PWB and ESS HARNESS ASSY
422	Illustration 07	Connects ESS PWB and VIDEO HARNESS
432	Illustration 07	Connects ESS PWB and SPEAKER ASSY
441	Illustration 07	Connects ESS PWB and ESS HARNESS ASSY
451	Illustration 07	Connects ESS PWB and IIT ASSY
452	Illustration 07	Connects ESS PWB and IIT ASSY
453	Illustration 07	Connects ESS PWB and DADF ASSY
454	Illustration 07	Connects ESS PWB and IIT ASSY
462	Illustration 07	ESS PWB (not used)
501	Illustration 09	Connects ROS ASSY and ROS-MCU HARNESS
502	Illustration 09	Connects ROS ASSY and VIDEO HARNESS
2401	Illustration 10	Connects Rear Fan and REAR FAN HARNESS ASSY
CON 12	Illustration 12	Connects the Length Sensor to the DADF PWB

Plug/Jack Locations for Tray 1 and the Optional Feeders

P/J	Illustration	Description
243	Illustration 06	Connects DRAWER 1 HARNESS ASSY FDR and FDR HARNESS ASSY
419	Illustration 06	Connects OPT TRAY ASSY PWB and FDR DRAWER 1 HARNESS ASSY
420	Illustration 06	Connects OPT TRAY ASSY PWB and C2 TURN HARNESS ASSY
421	Illustration 06	Connects OPT TRAY ASSY PWB and C2 SIZE HARNESS ASSY
422	Illustration 06	Connects OPT TRAY ASSY PWB and TRAY MOTOR HARNES ASSY
423	Illustration 13	Connects OPT TRAY ASSY PWB and DRAWER 2 HARNESS ASSY
4200	Illustration 06	OPT TRAY ASSY PWB (not used)
4201	Illustration 06	Connects OPT FEED CLUTCH ASSY and HARNESS ASSY C2 TURN
4203	Illustration 13	Connects NO PAPER SENSOR and HARNESS ASSY C2 TURN
4212	Illustration 13	Connects PATH SENSOR and HARNESS ASSY
4213	Illustration 13	Connects TAKE AWAY CLUTCH and HARNESS C2 SIZE ASSY
4214	Illustration 13	Connects C2 SIZE HARNESS ASSY and HARNESS ASSY
4221	Illustration 06	Connects MOTOR ASSY and TRAY MOTOR HARNESS ASSY
4231	Illustration 13	Connects DRAWER 2 HARNESS ASSY and DRAWER 1 HARNESS ASSY

Illustration 01

ESS PWB / LVPS (3610)

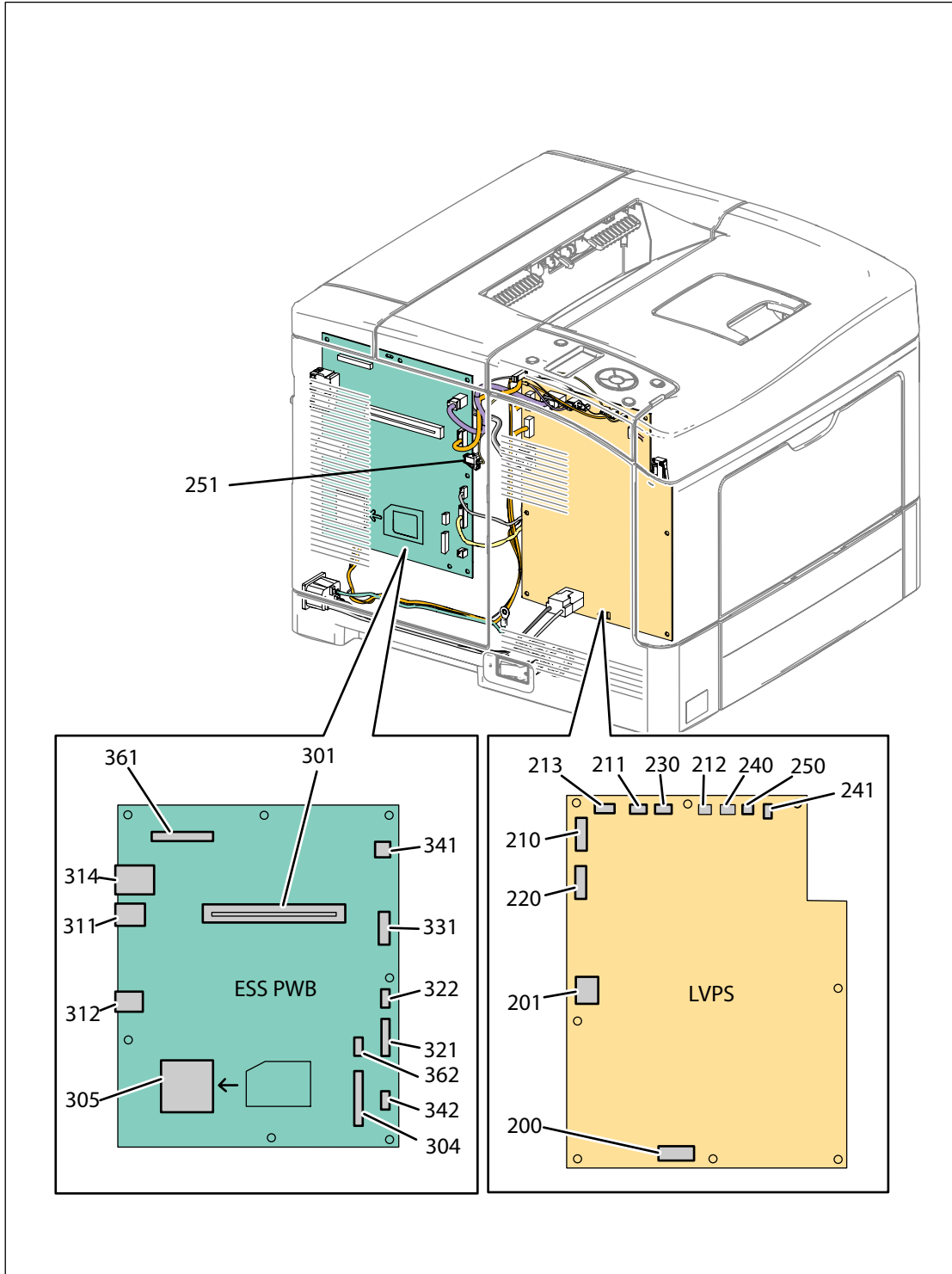

s3610-233

Illustration 02

MCU PWB / HVPS (3610)

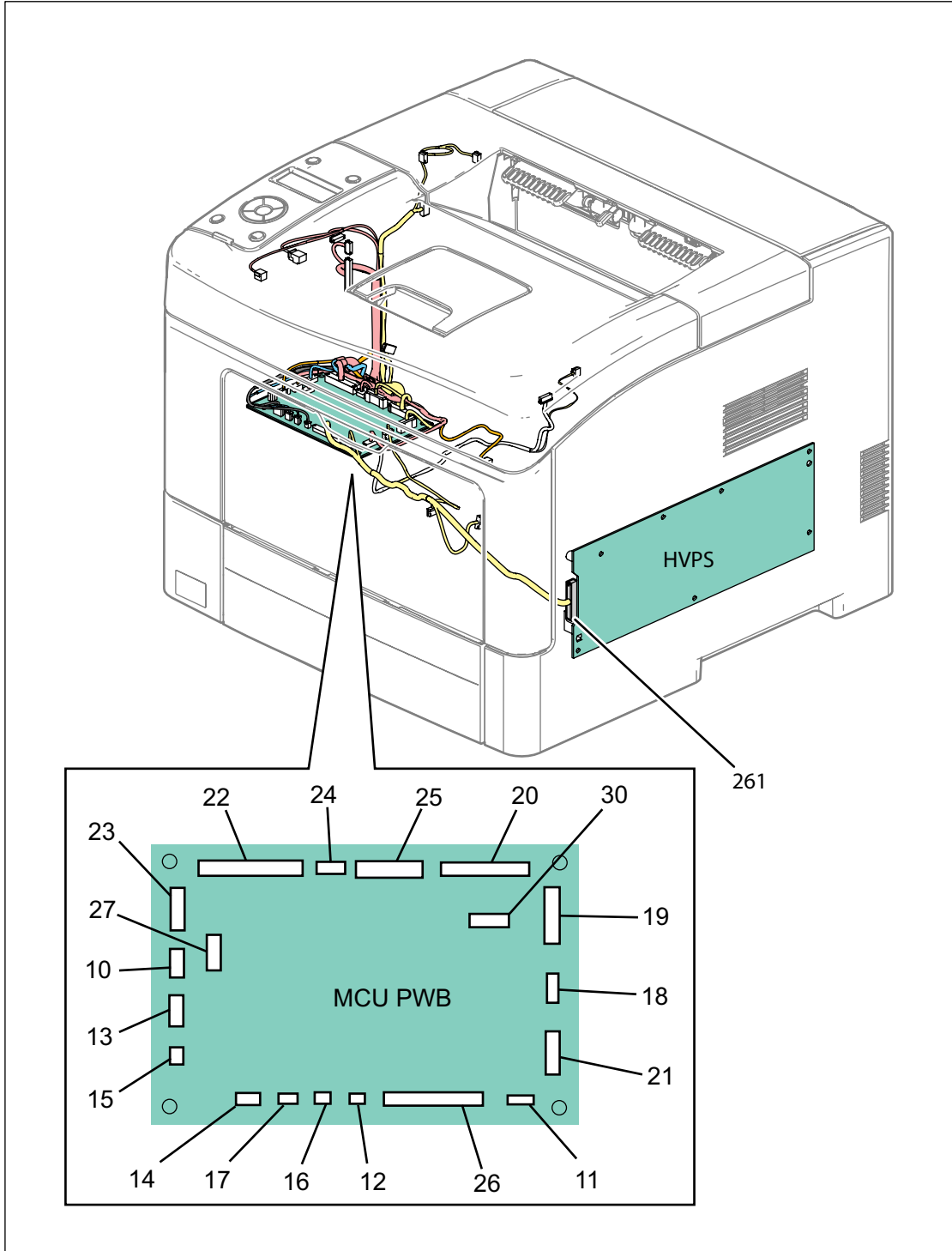

s3610-260

Illustration 03

ROS PWB (3610)

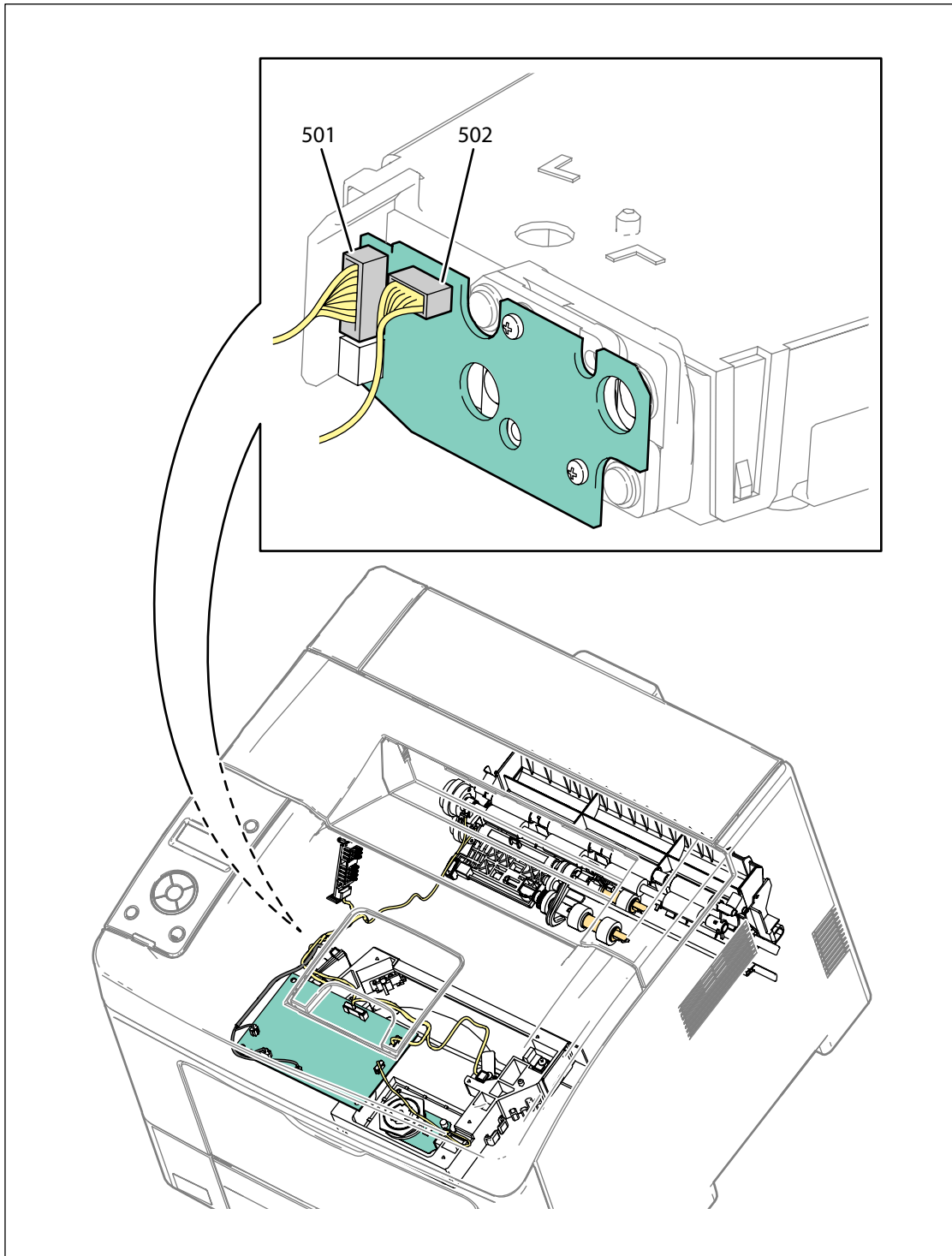

s3610-261

Illustration 04

FUSER ASSEMBLY / UI (3610)

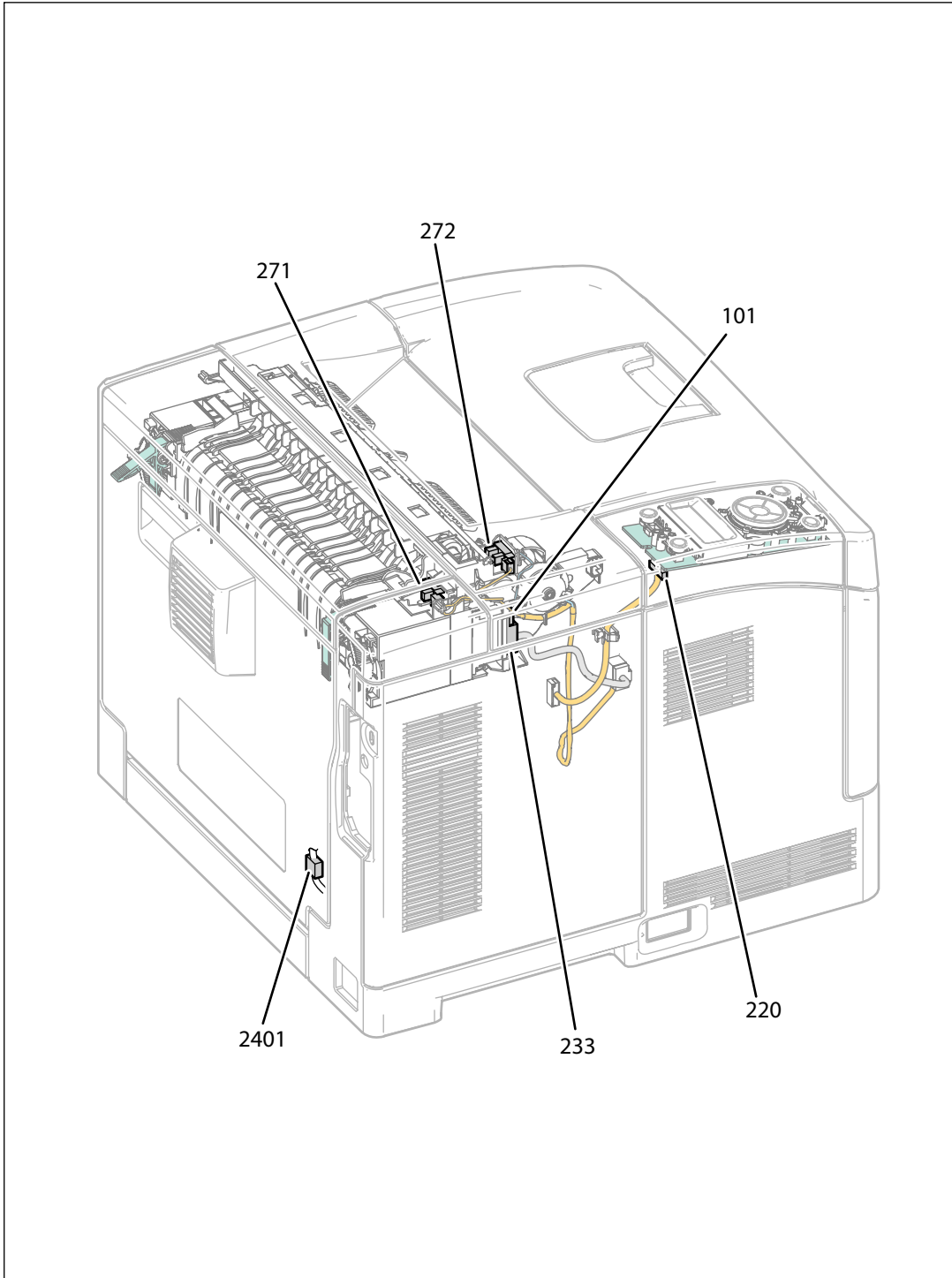

s3610-234

Illustration 05

CRUM / DRIVE ASSEMBLY (3610)

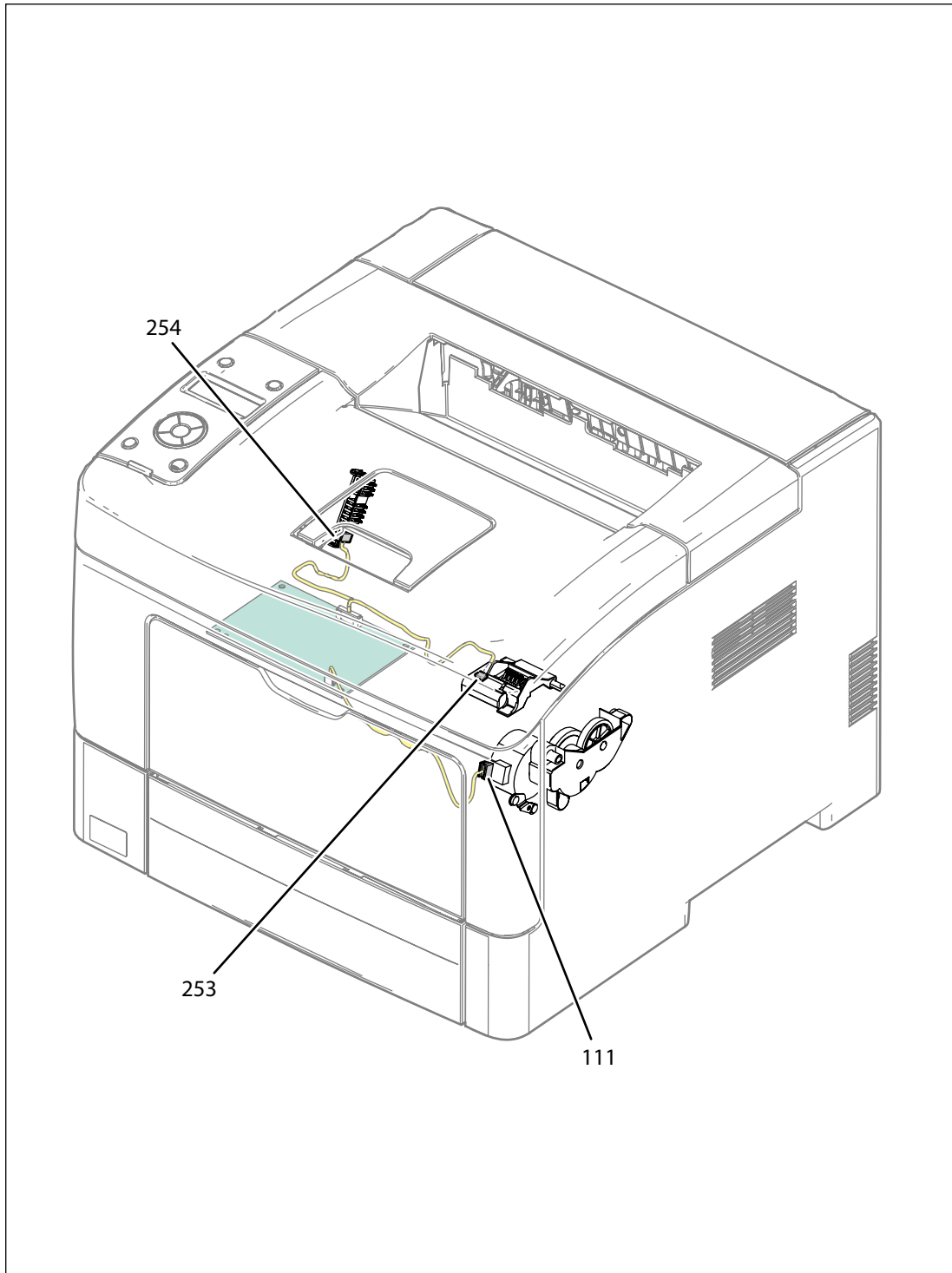

s3610-235

Illustration 06

TRAY 1

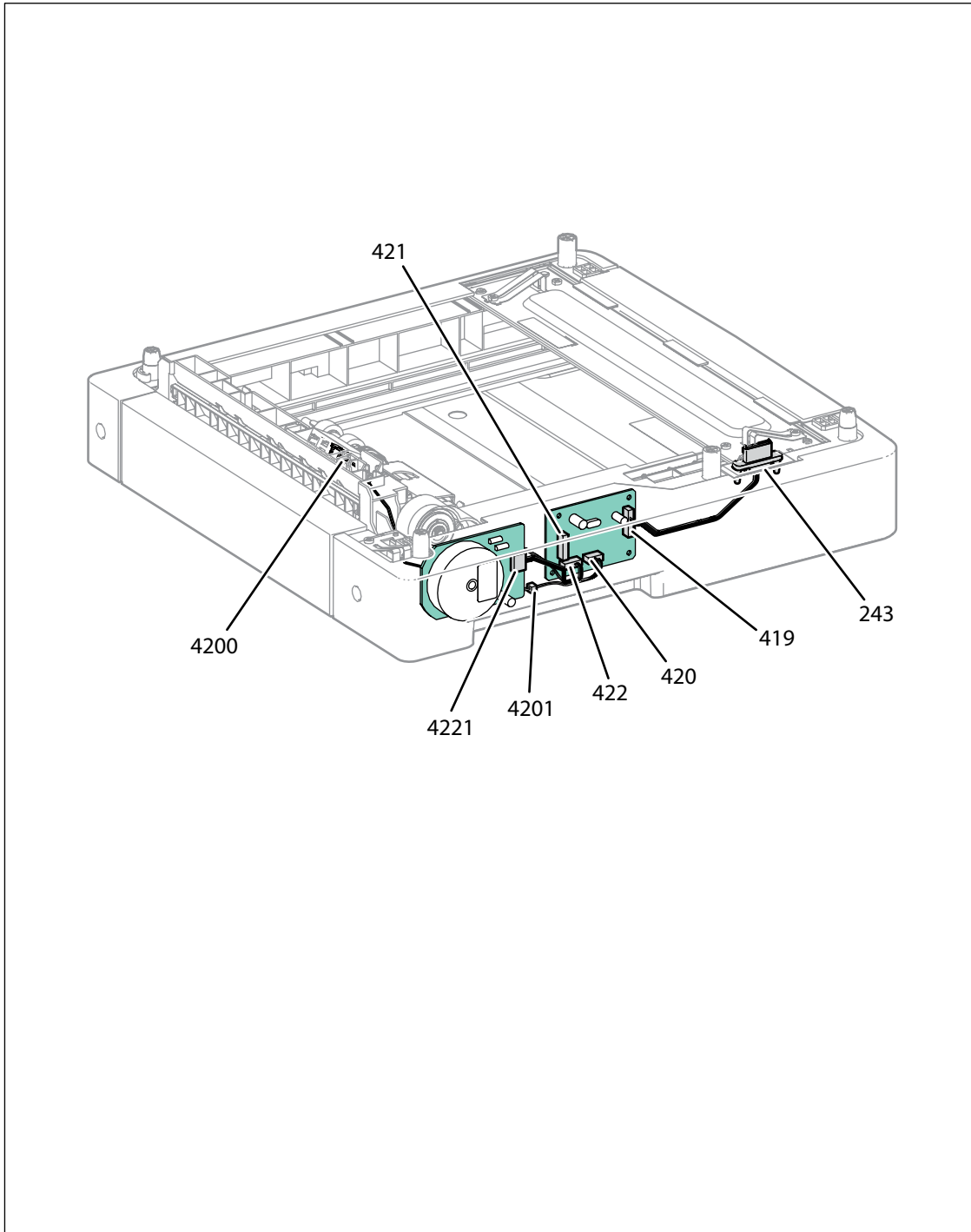

s3610-236

Illustration 07

ESS PWB / LVPS (3615)

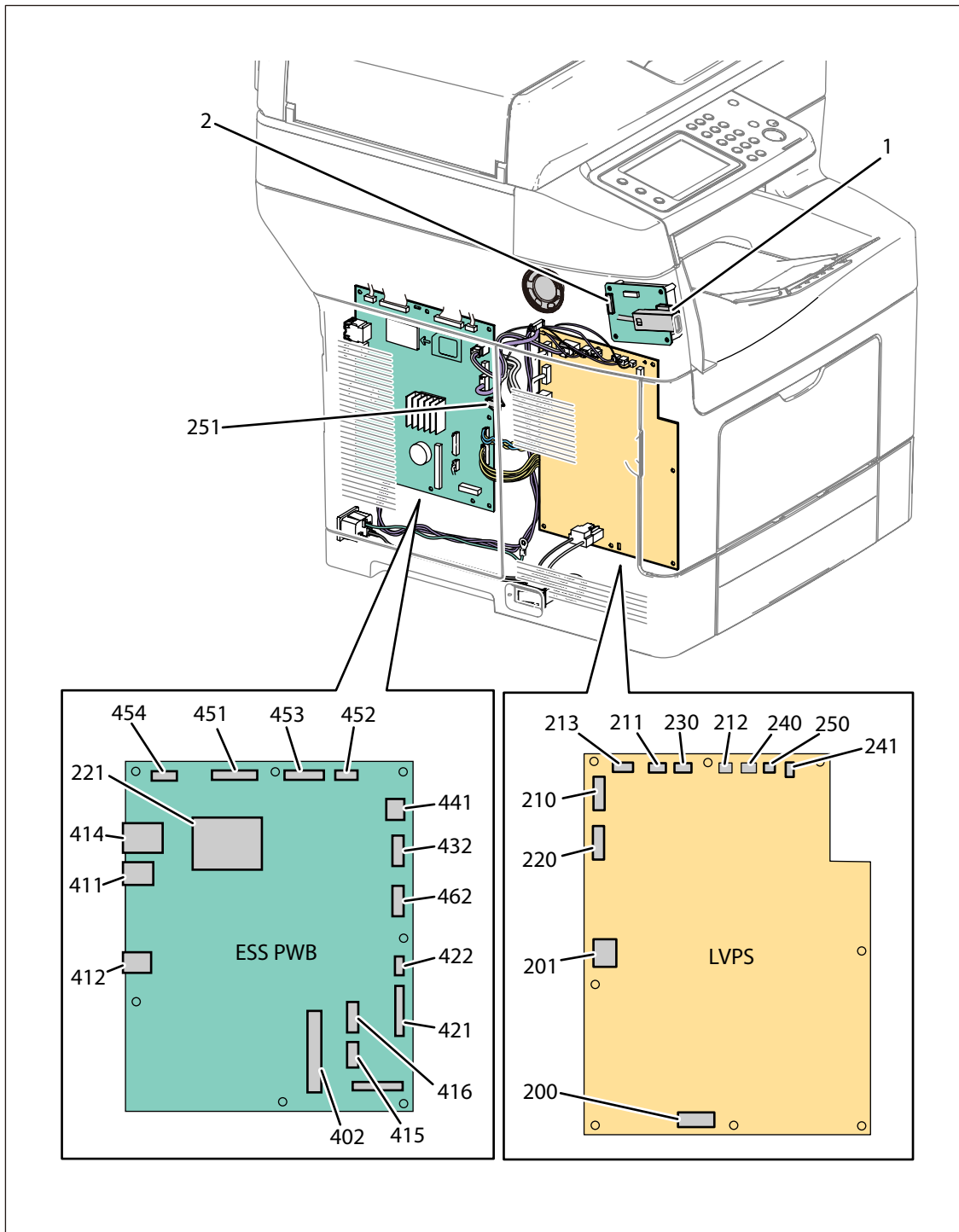

s3610-19:

Illustration 08

MCU PWB (3615)

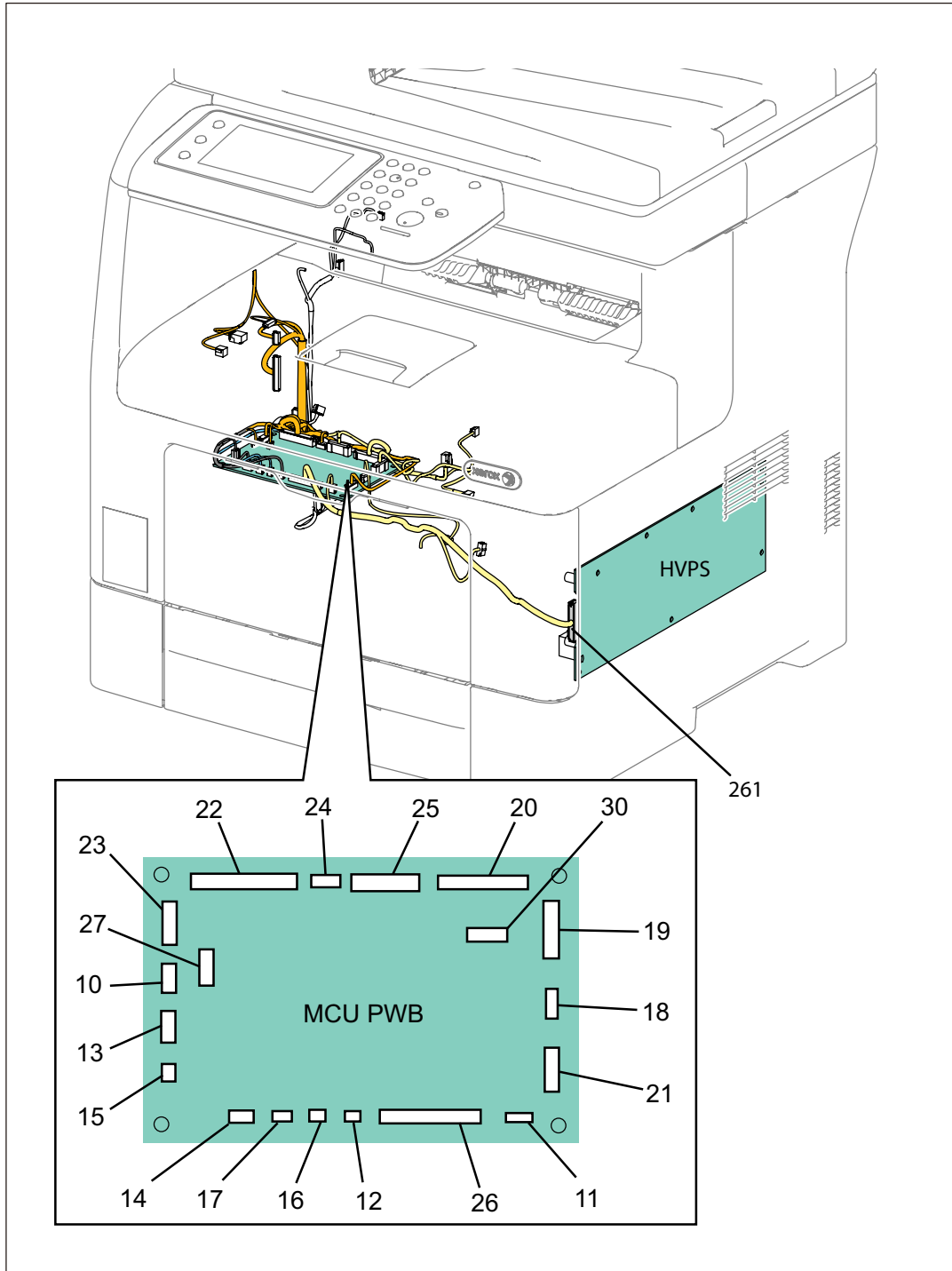

s3610-196

Illustration 09

ROS PWB (3615)

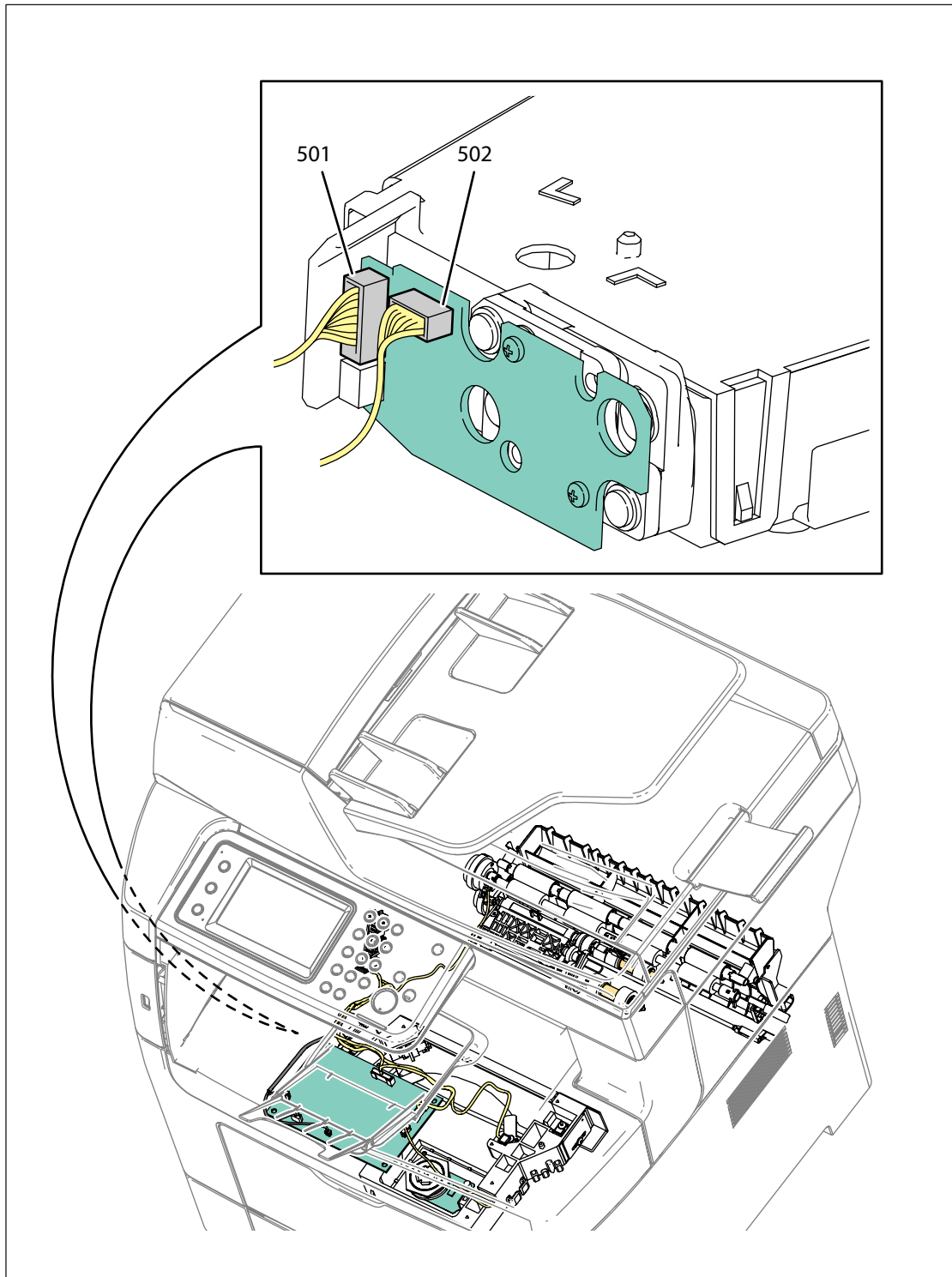

s3610-197

Illustration 10

FUSER ASSEMBLY (3615)

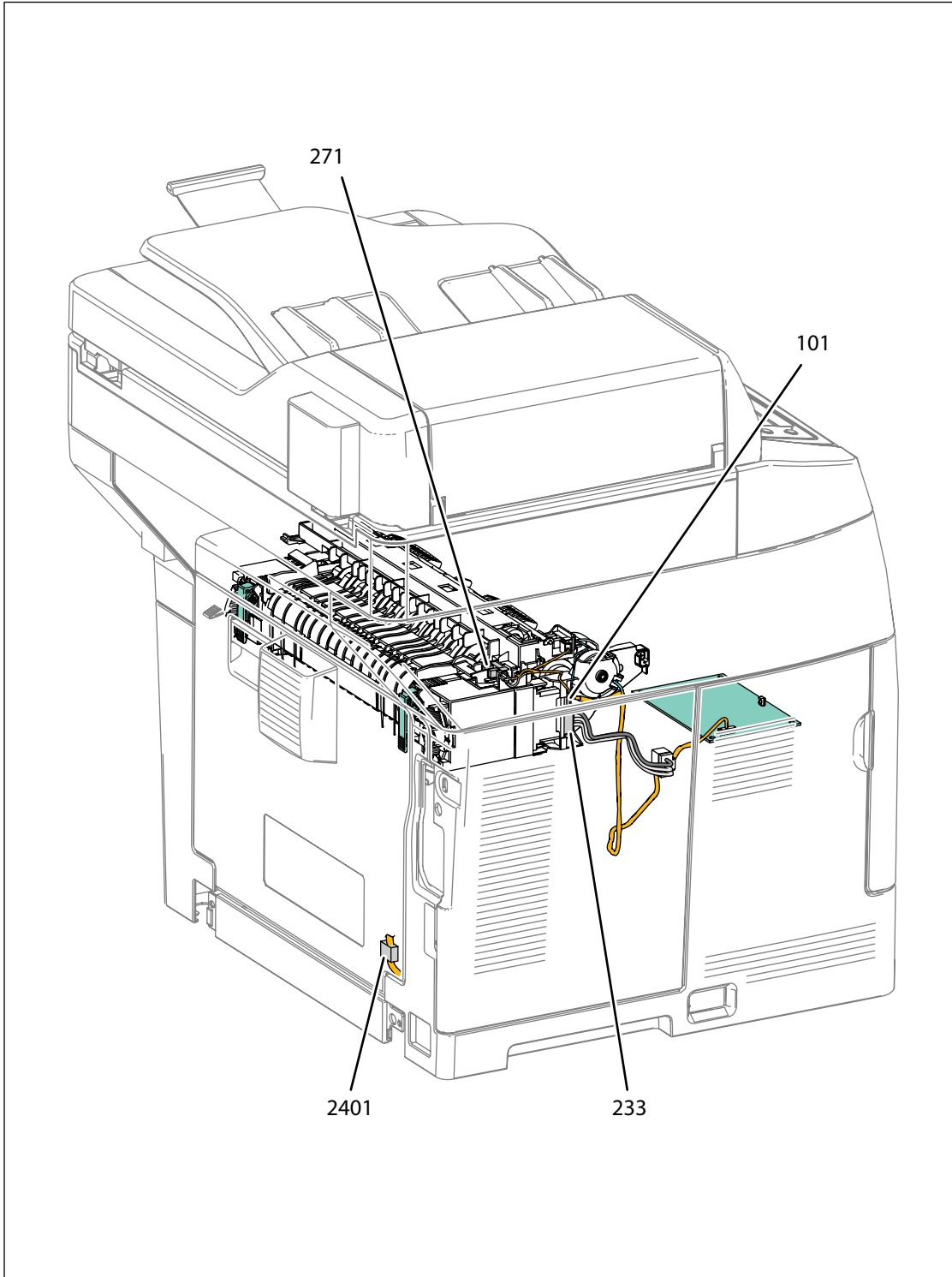

s3610-198

Illustration 11

CRUM / DRIVE ASSEMBLY (3615)

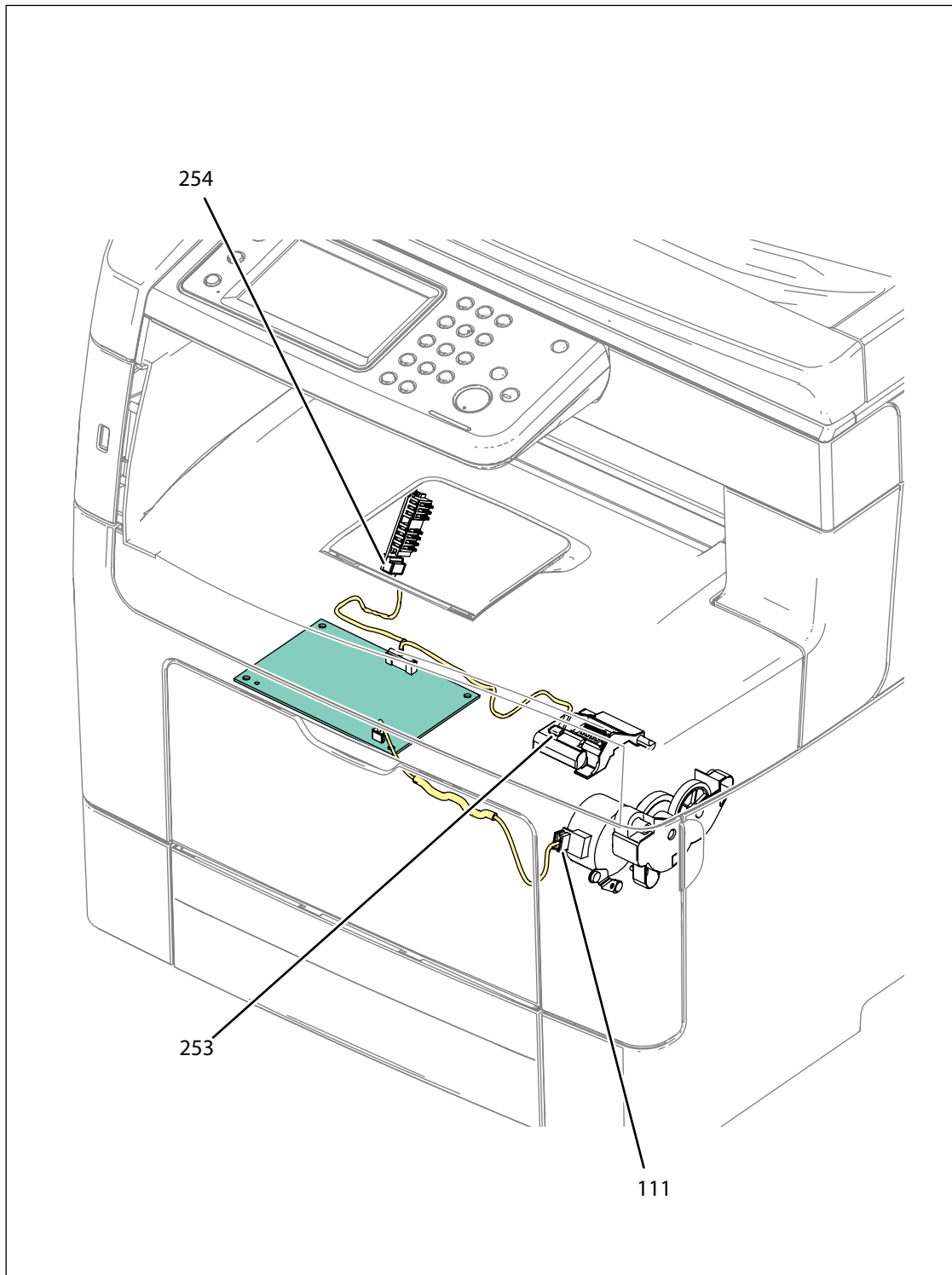

s3610-199

Illustration 12

IIT / DADF

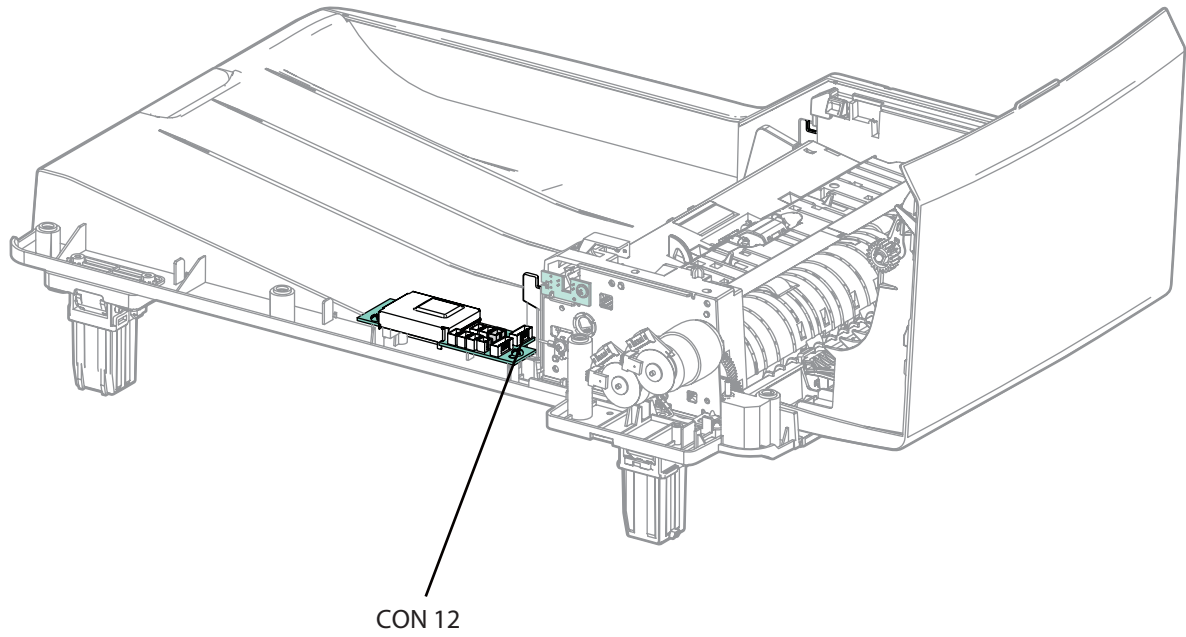

s3610-314a

Illustration 13

OPTIONAL FEEDER

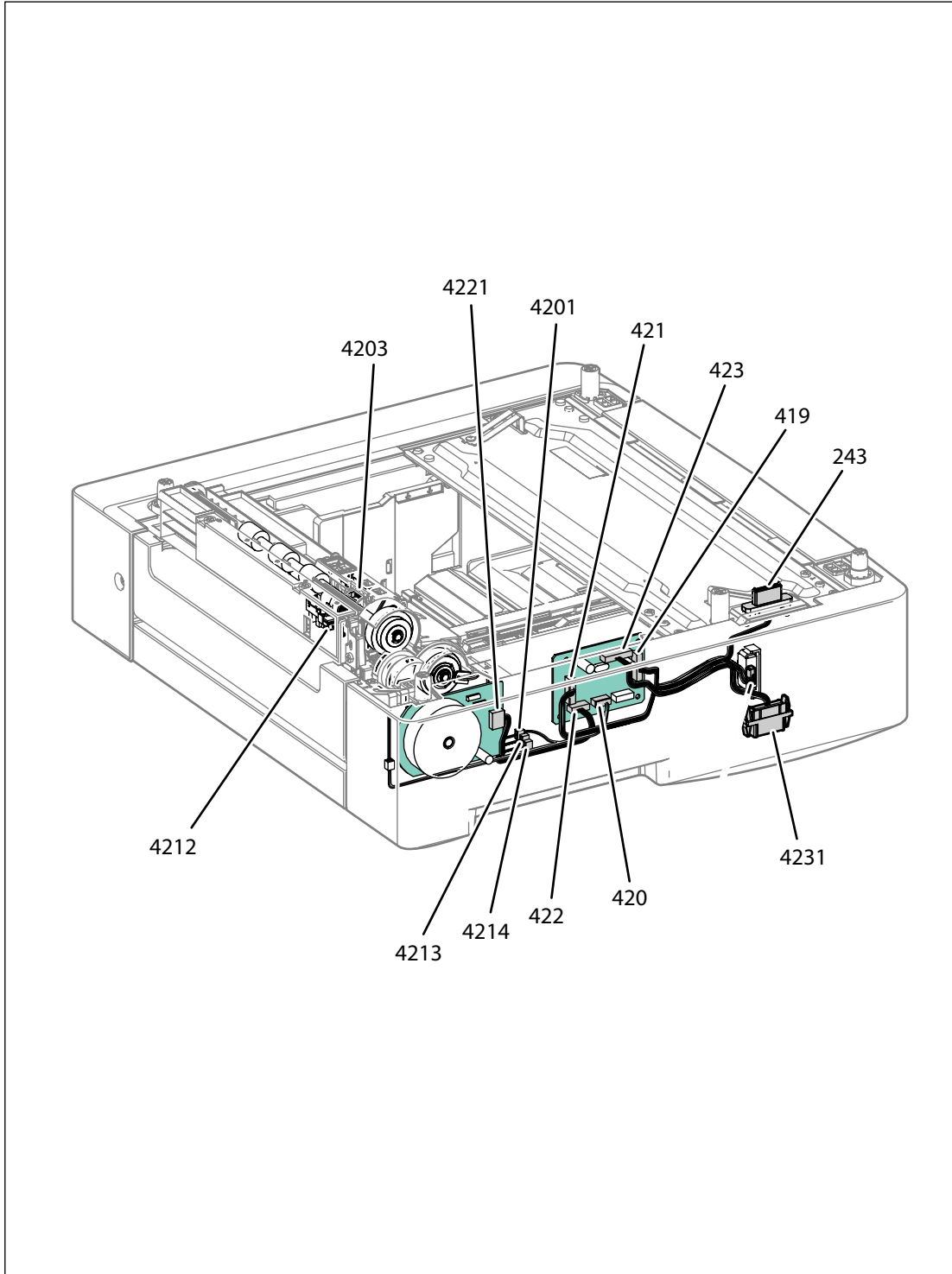

s3610-237

Wire Harnessing for the Printer

MCU PWB to HVPS / Dispense Motor Assembly

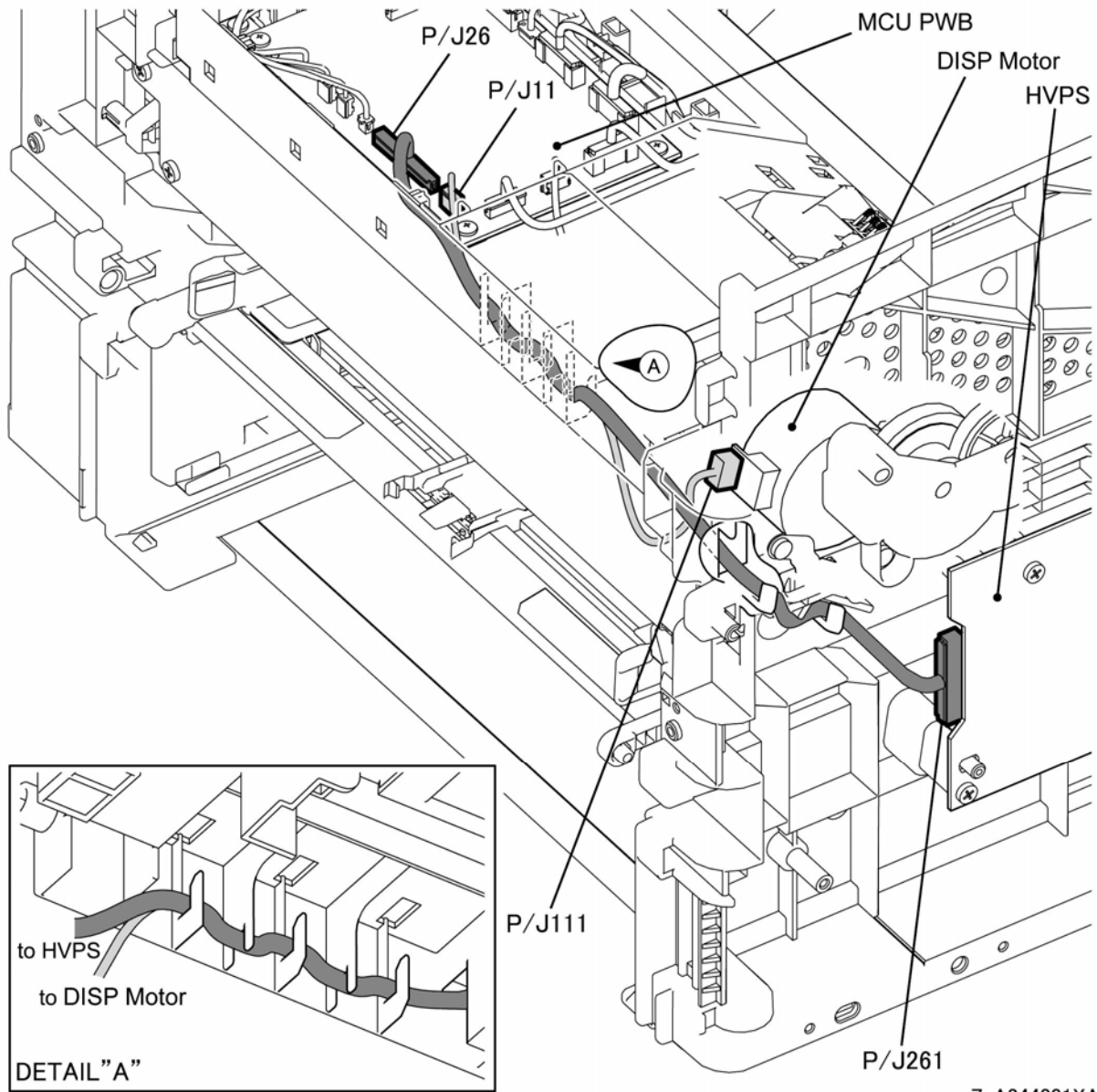

MCU PWB to Xerographic Connector Assembly

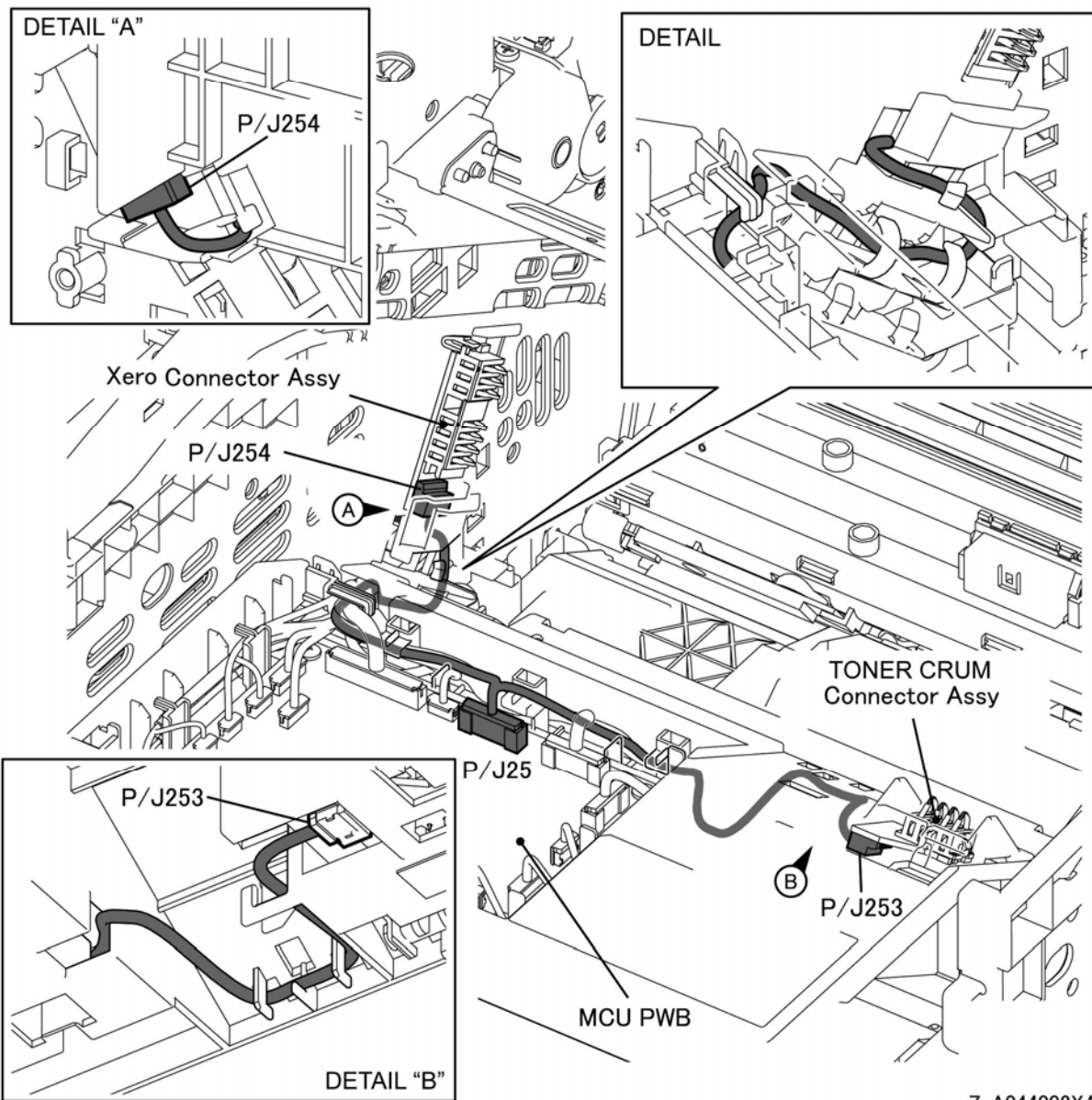

ZaA044002XA

MCU PWB to Main Motor Assembly / LVPS

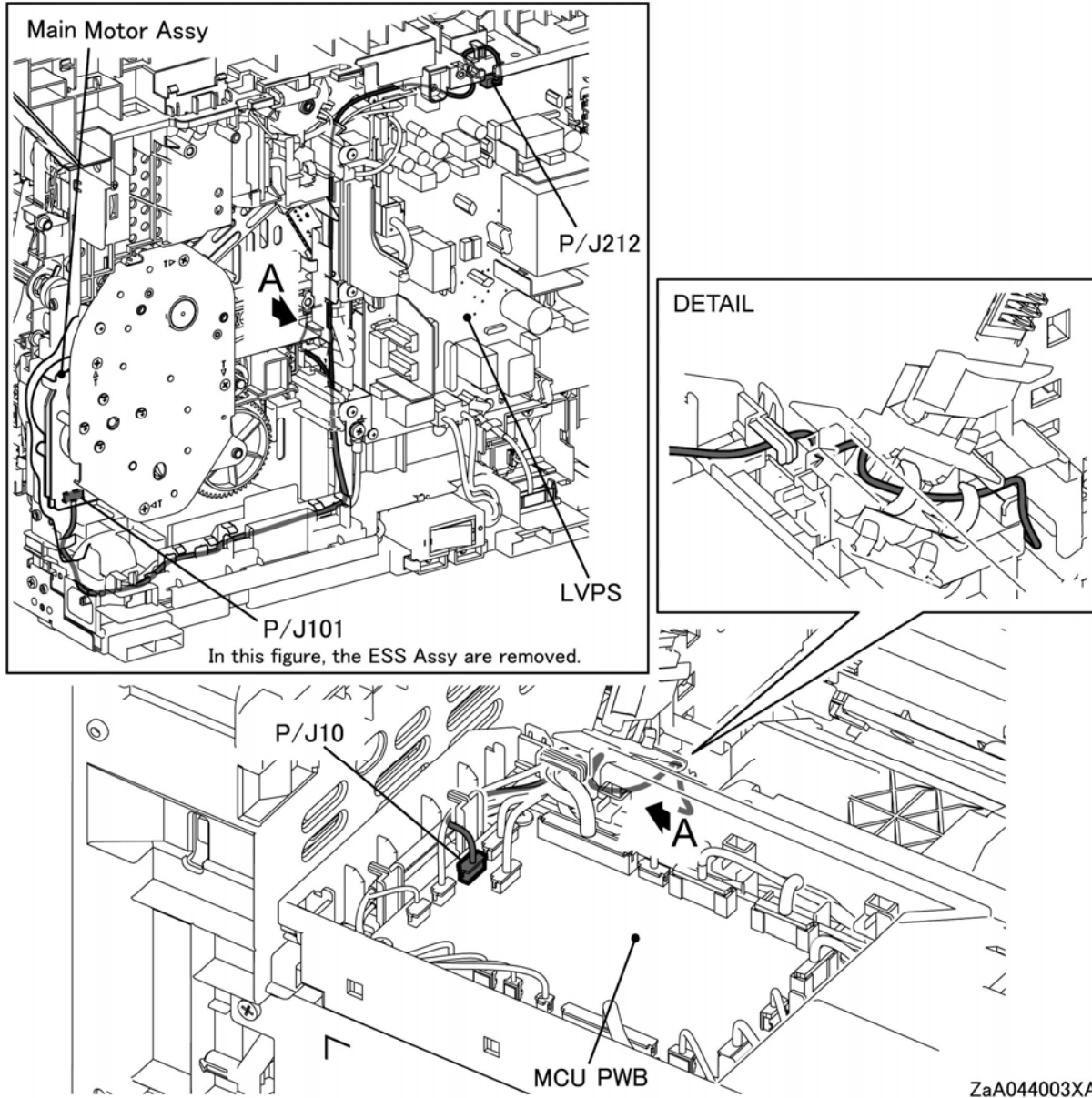

ZaA044003XA

MCU PWB to Optional Feeder Connector

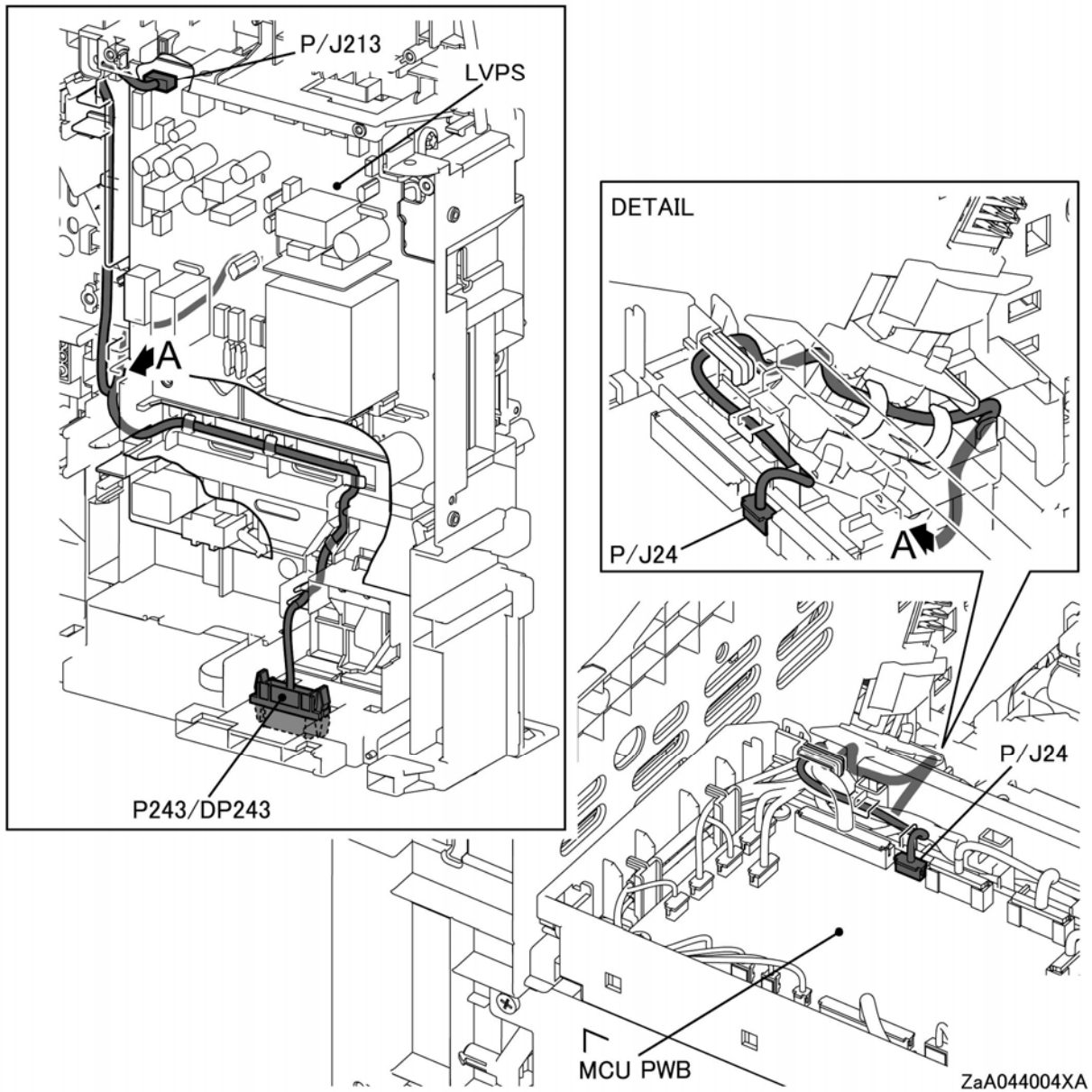

MCU PWB to the ROS Assembly

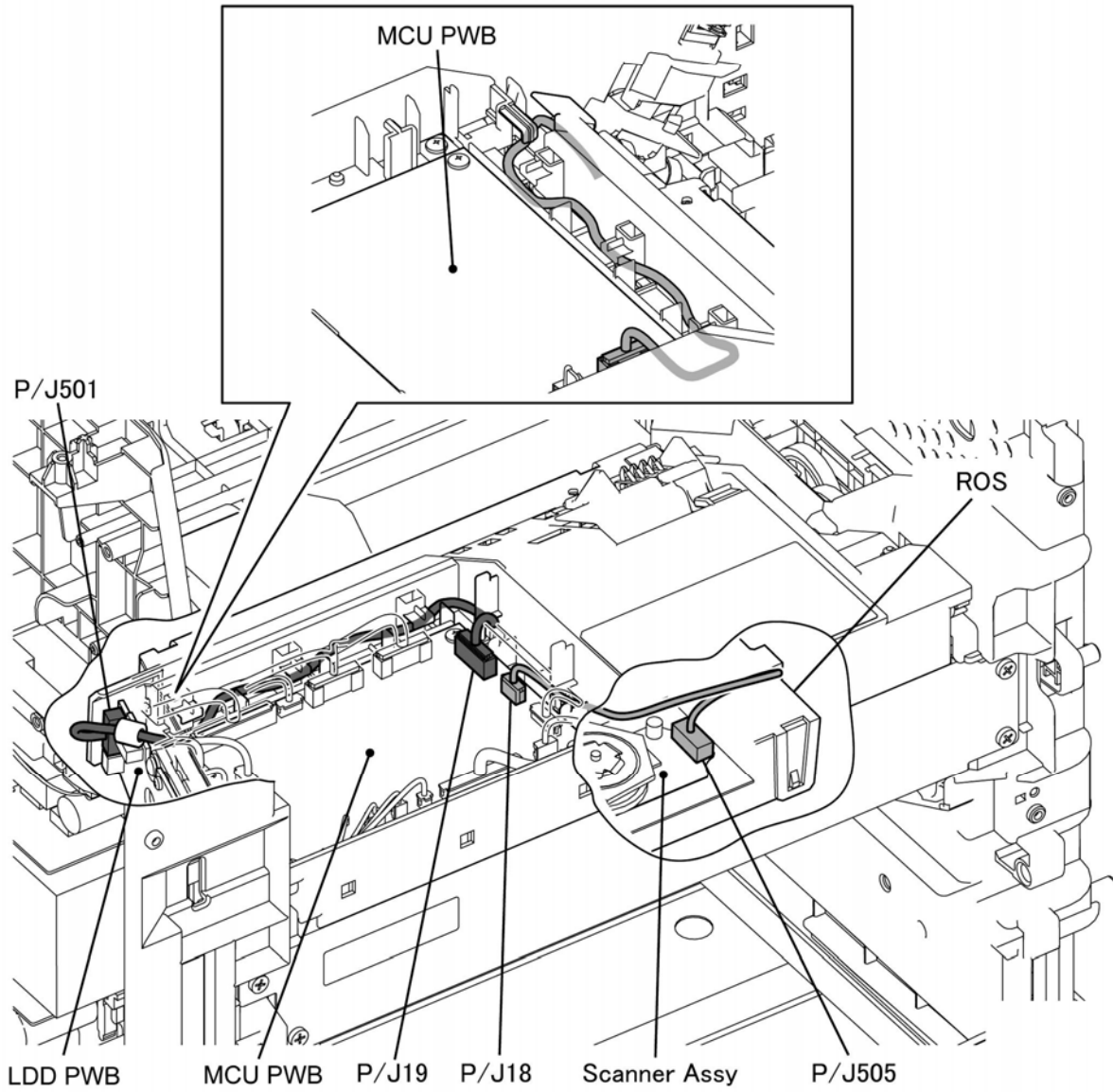

ZaA044005XA

ROS Assembly to the ESS PWB

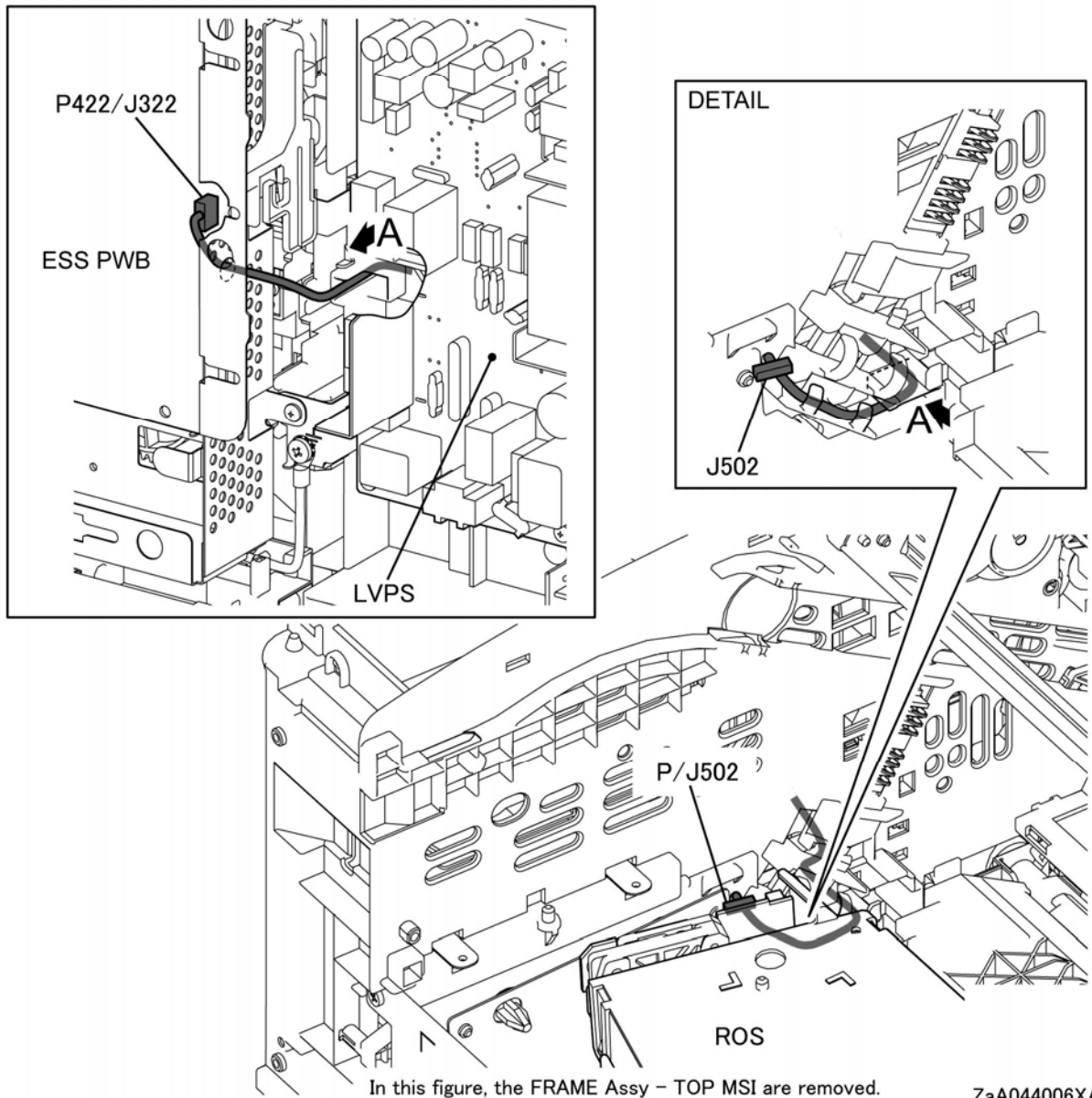

MCU PWB to the Full Stack Sensor / Exit Sensor

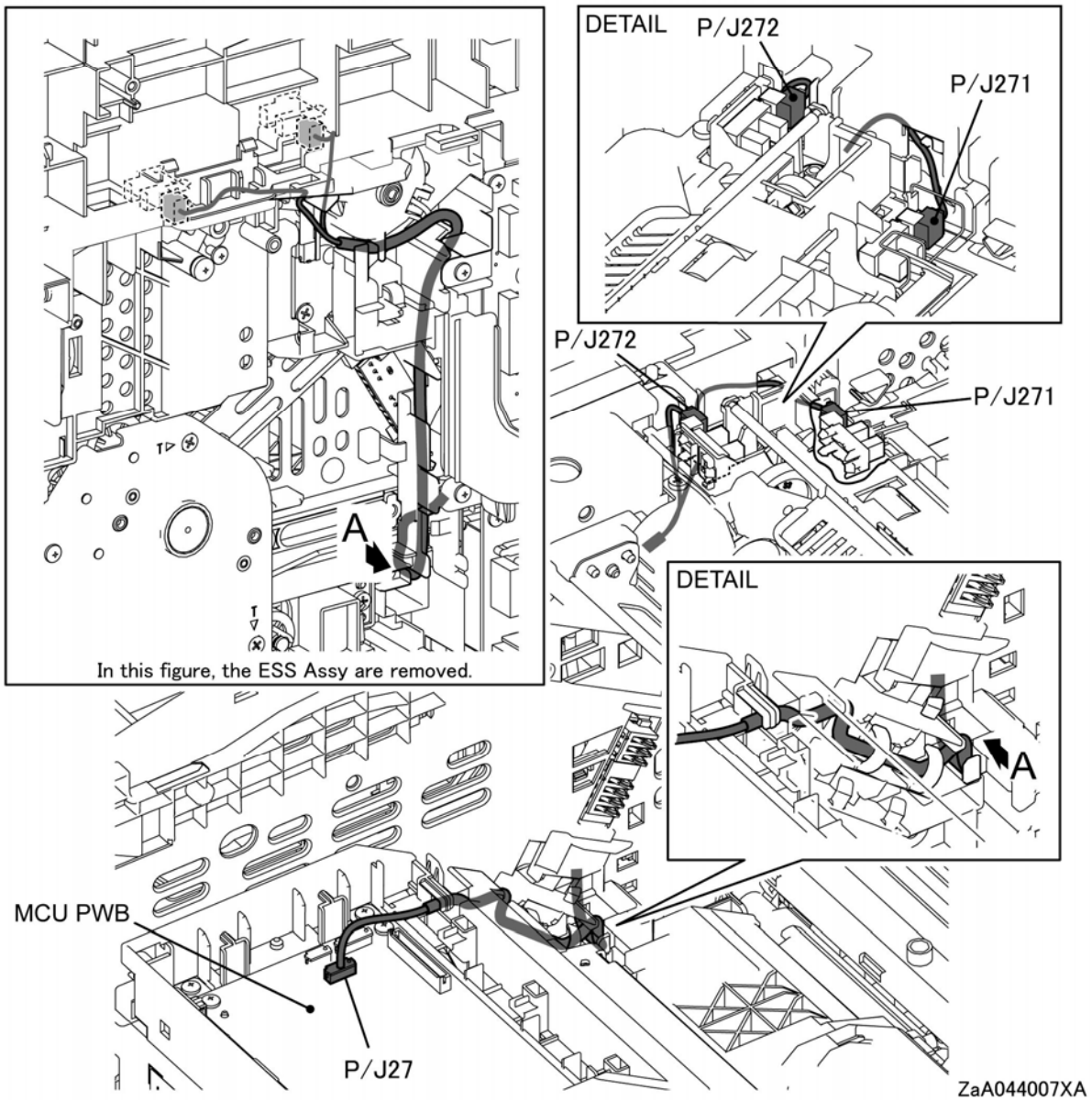

MCU PWB to the LVPS (1 of 2)

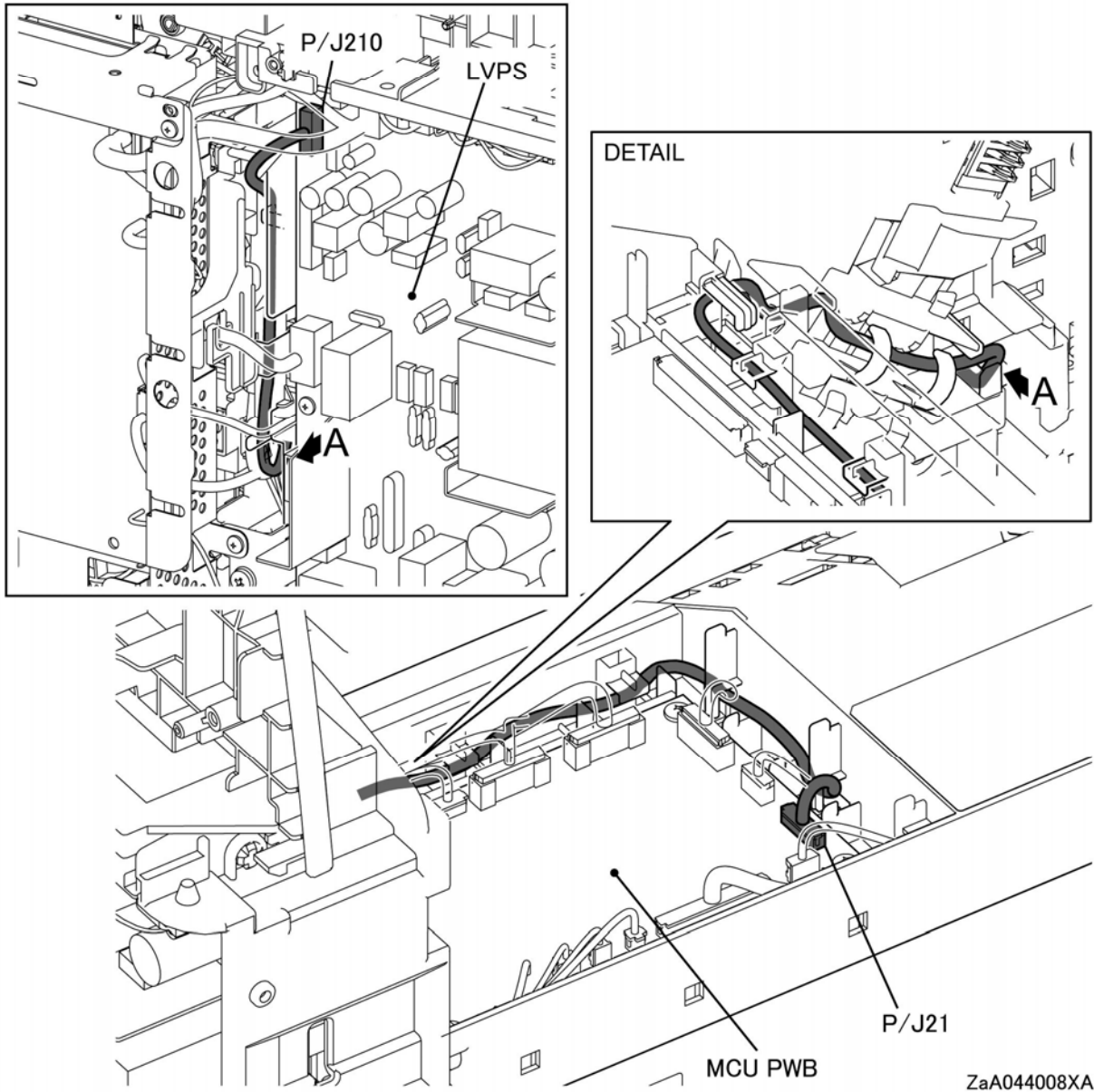

MCU PWB to the LVPS (2 of 2)

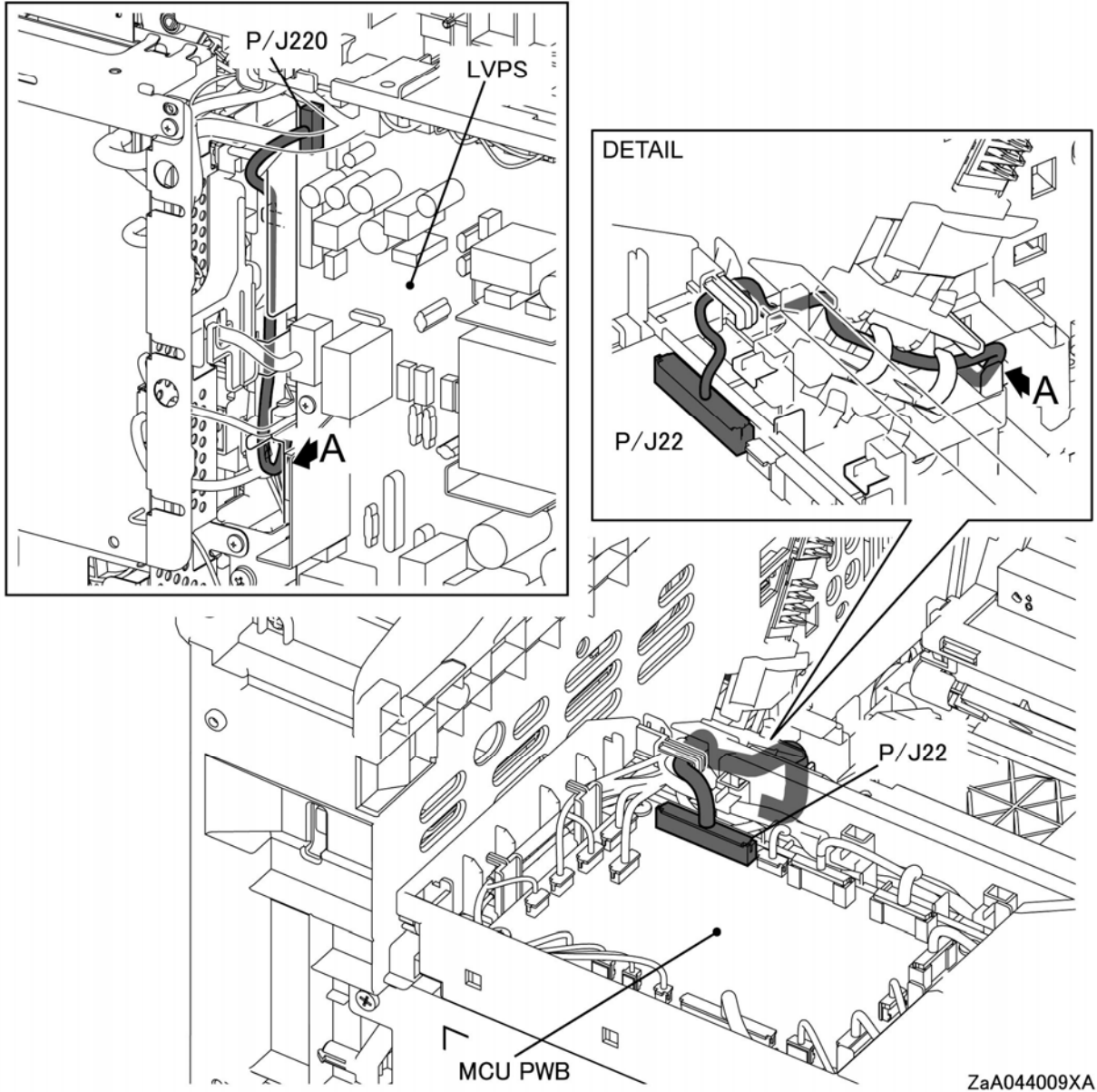

MCU PWB to ESS

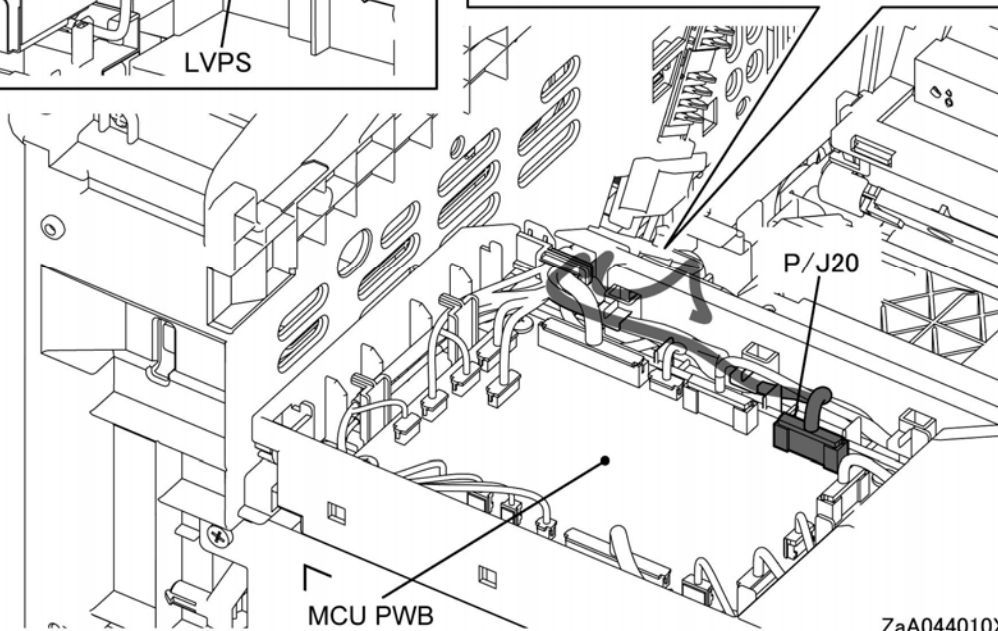
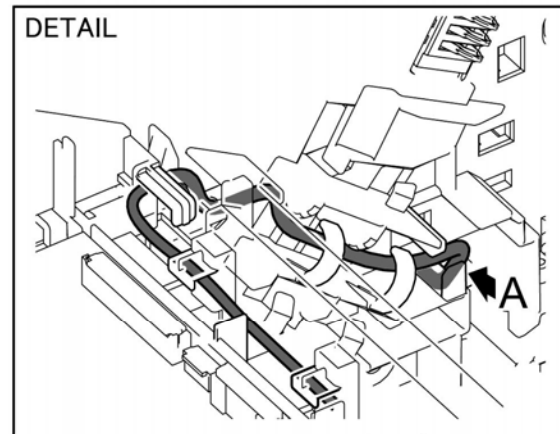
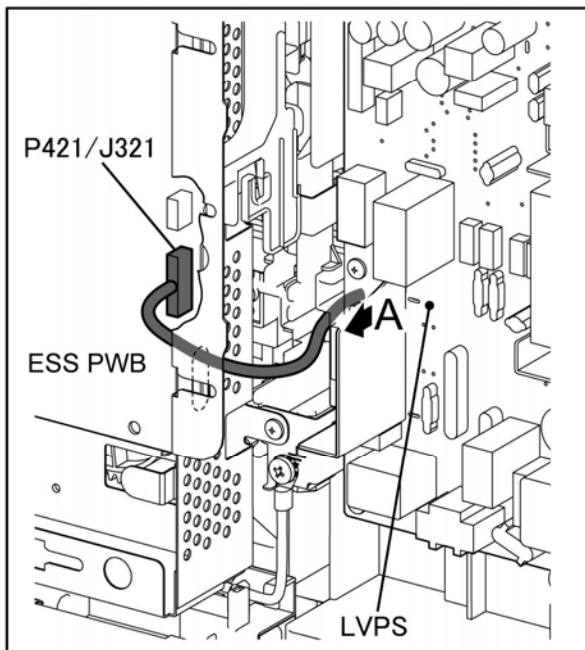

ZaA044010XA

MCU PWB to the Fusing Assembly

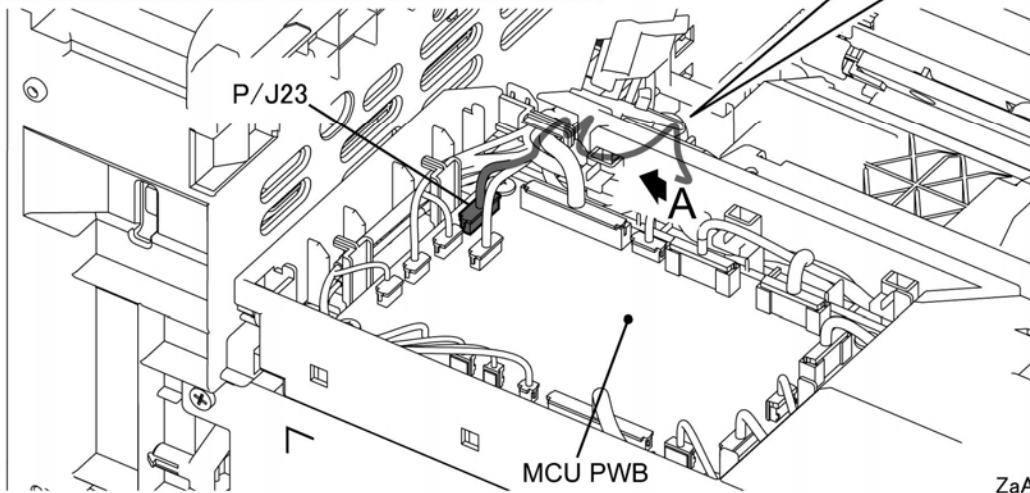
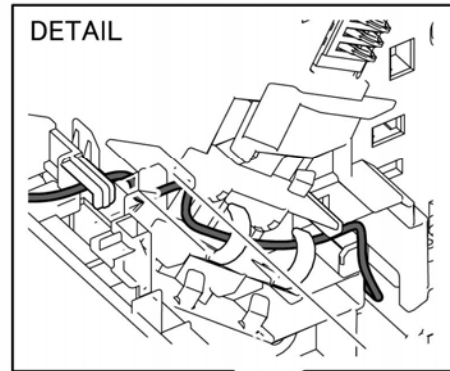
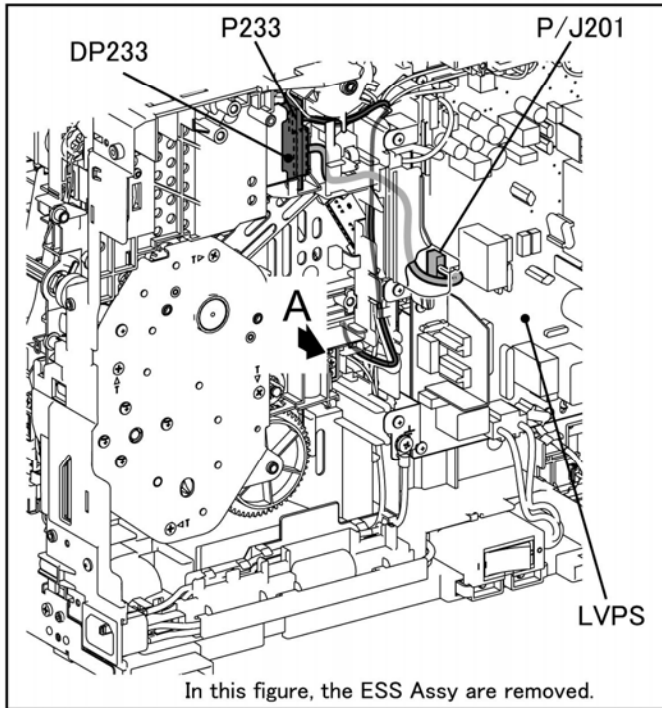

ZaA044011XA

MCU PWB to the Rear Fan Connector

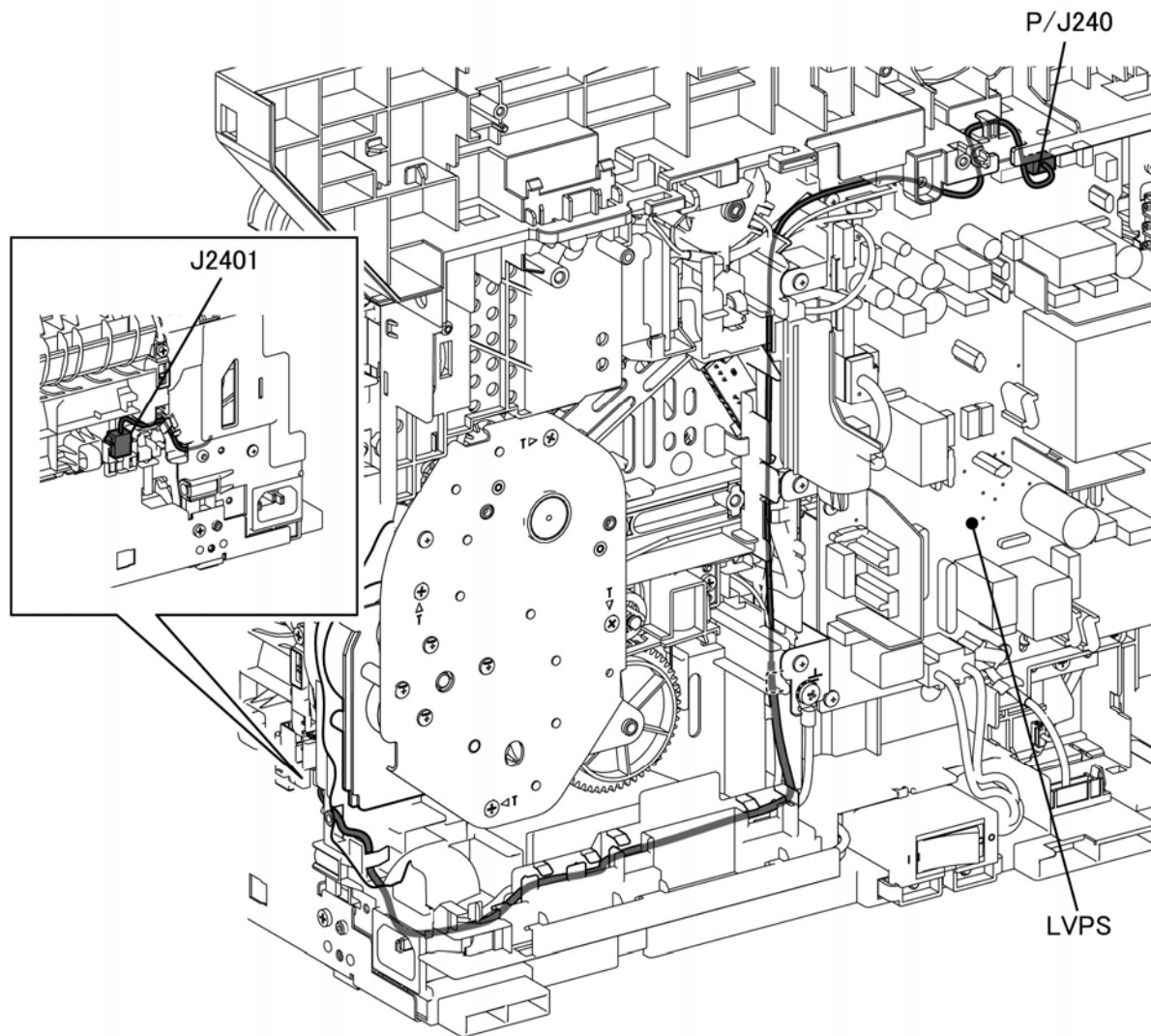

In this figure, the ESS Assy are removed.

ZaA044012XA

ESS PWB to the LVPS / UI (3610)

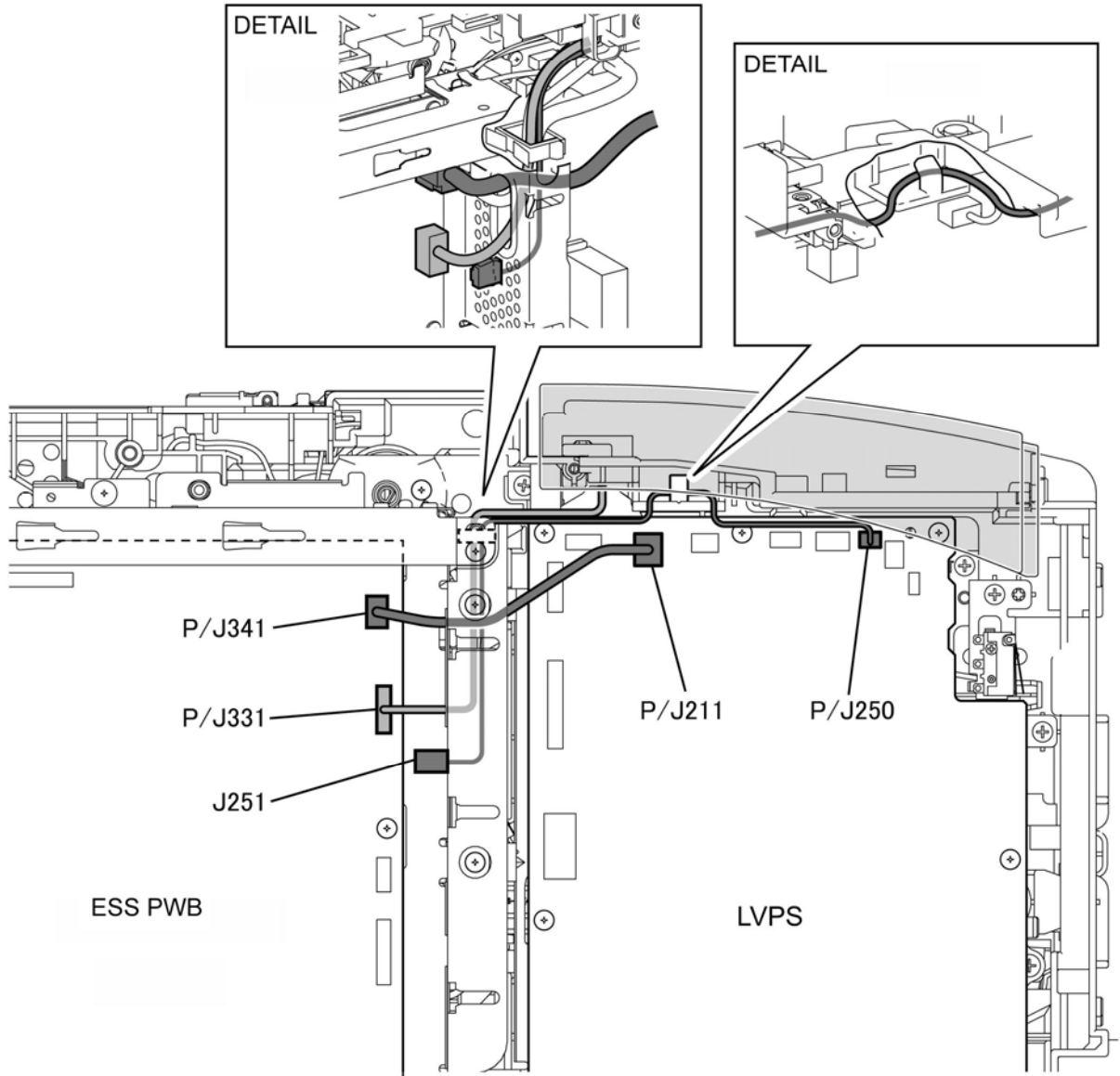

ZaS044013XA

ESS PWB to the LVPS / UI (3615)

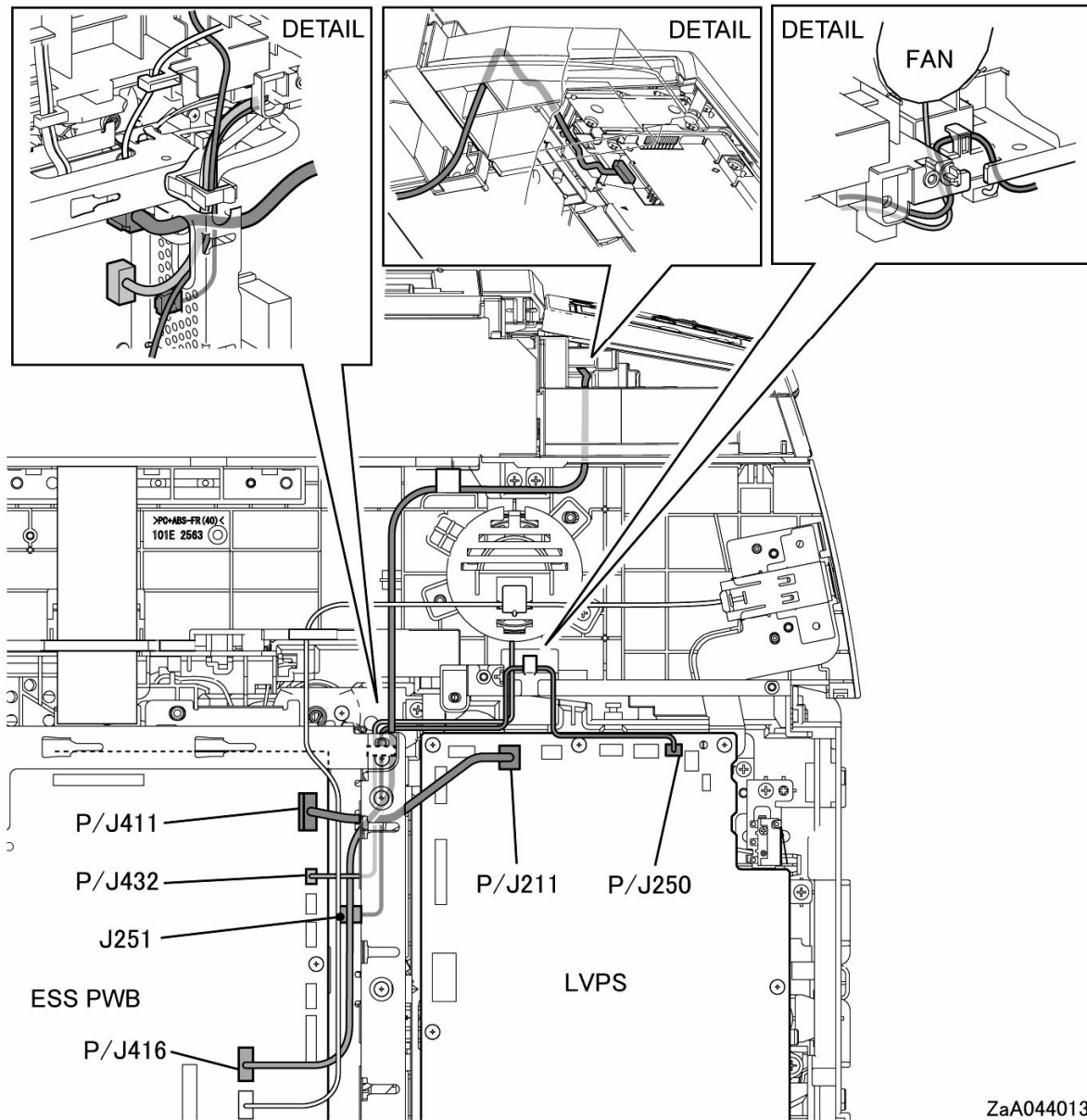

ZaA044013XB

IIT/DADF Assembly to the ESS PWBA (3615)

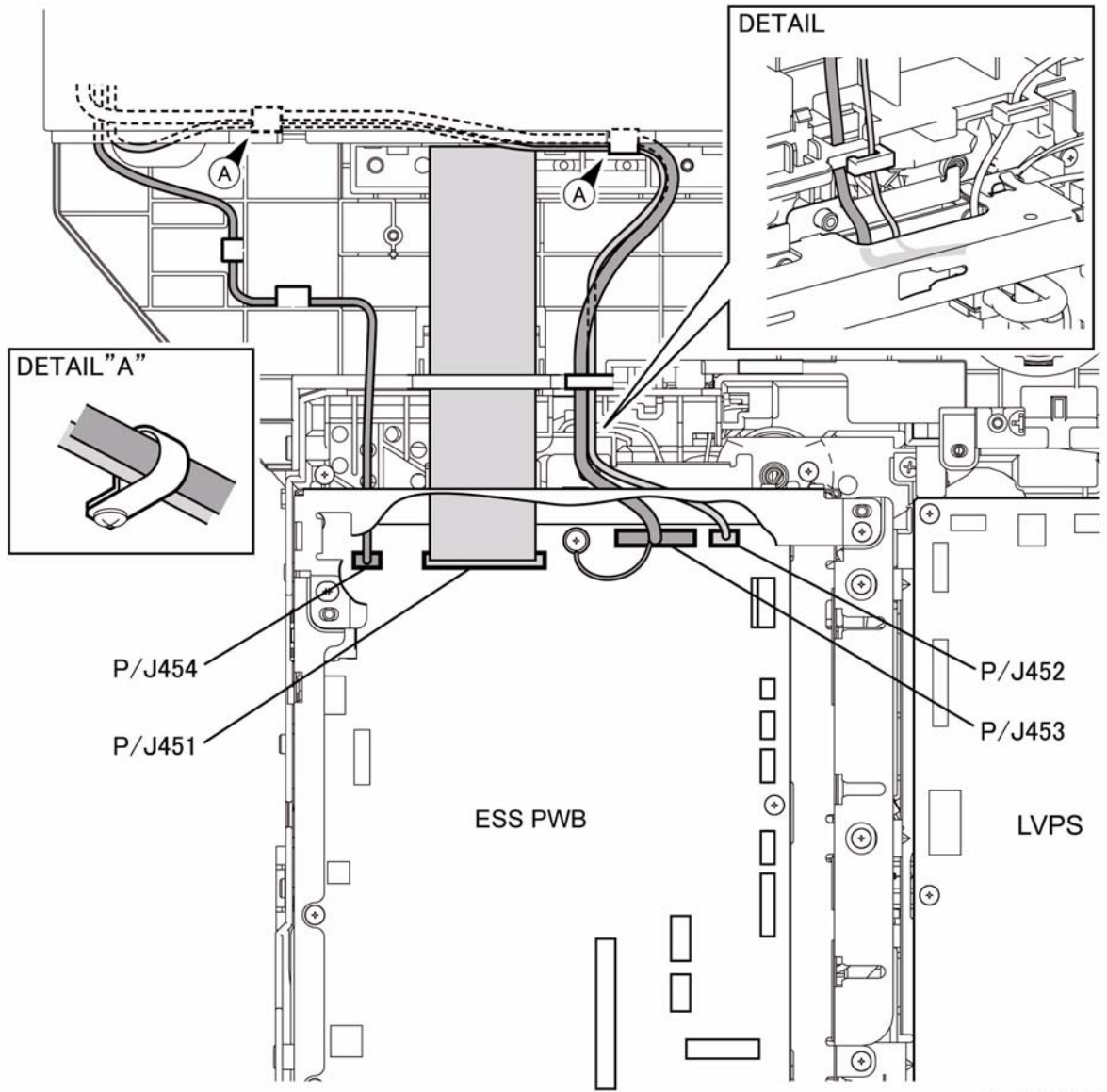

ZaA044014XB

ESS PWB to the Front USB (3615)

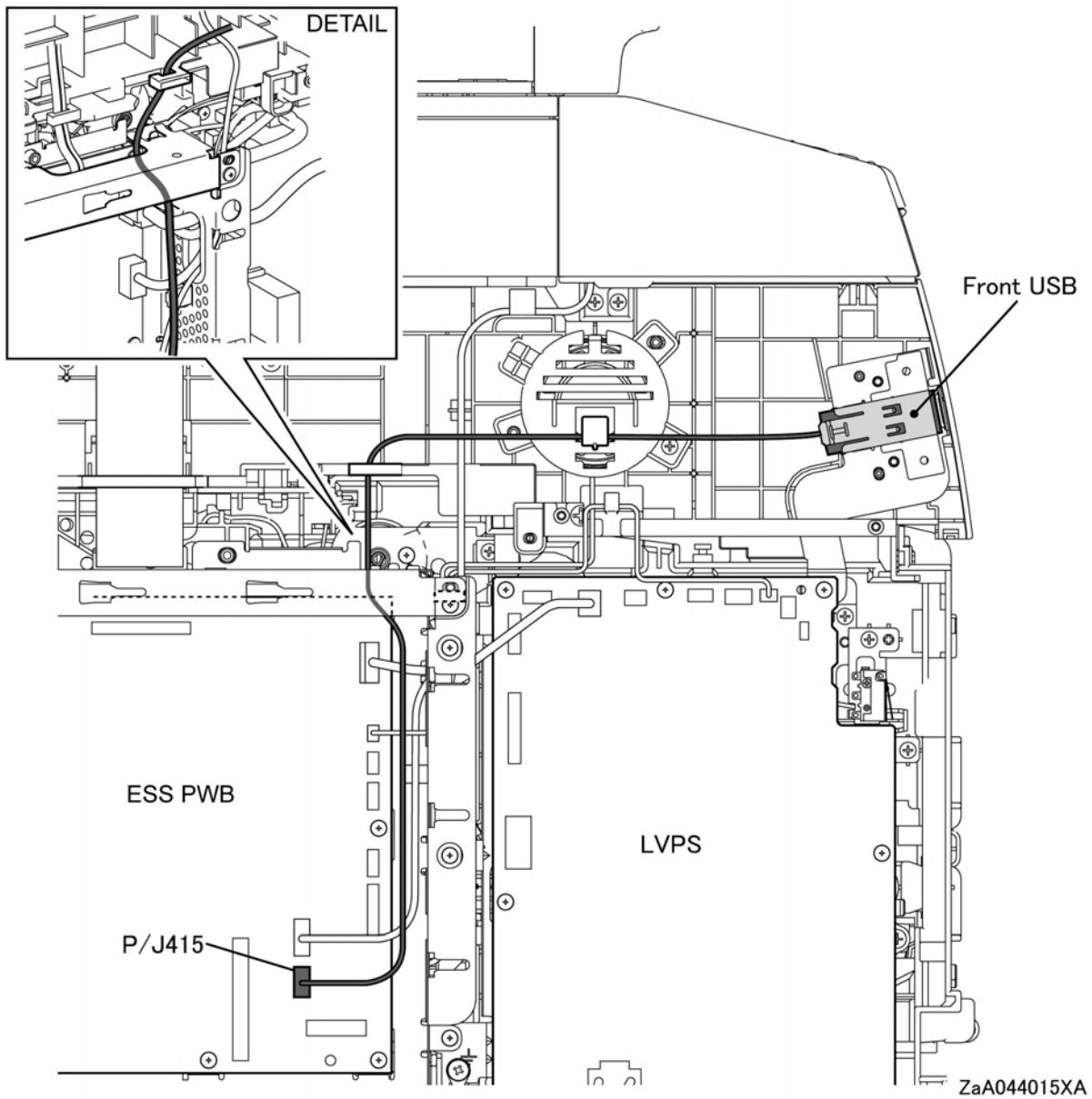

Wire Harnessing for Option Trays

No Paper Sensor

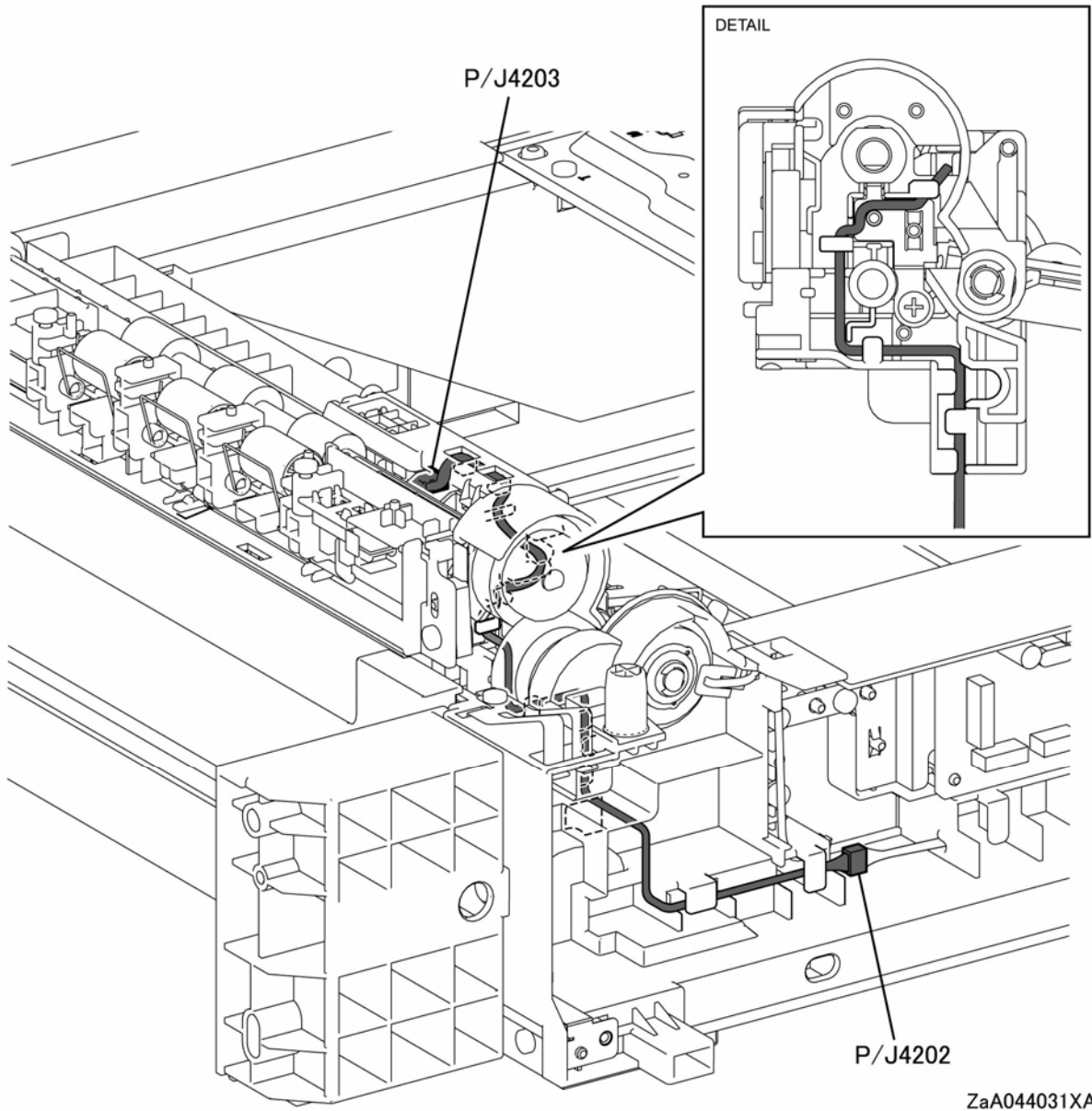

Optional Tray Pre-Registration Sensor

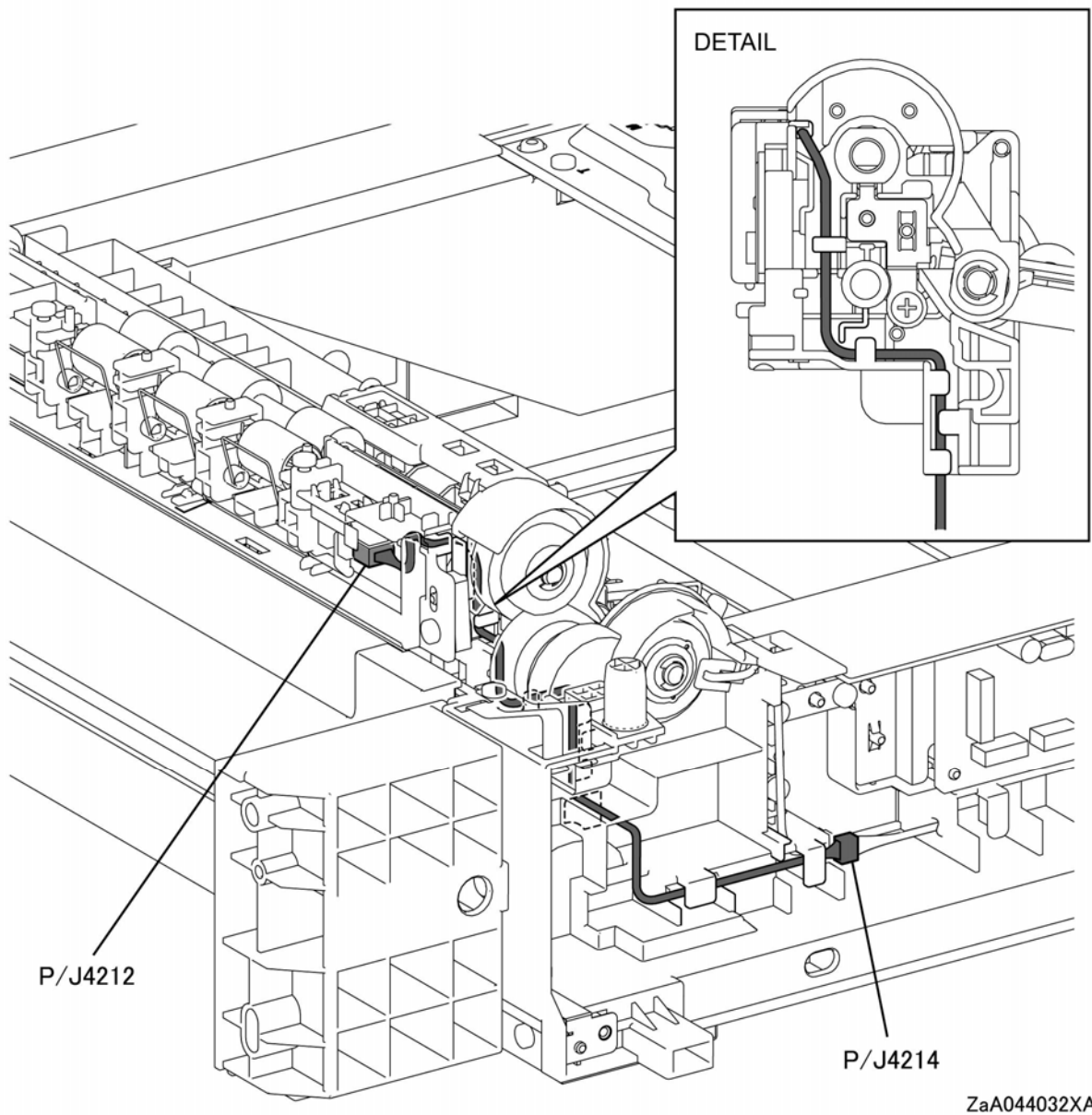

Optional Tray PWB Assembly (1 of 3)

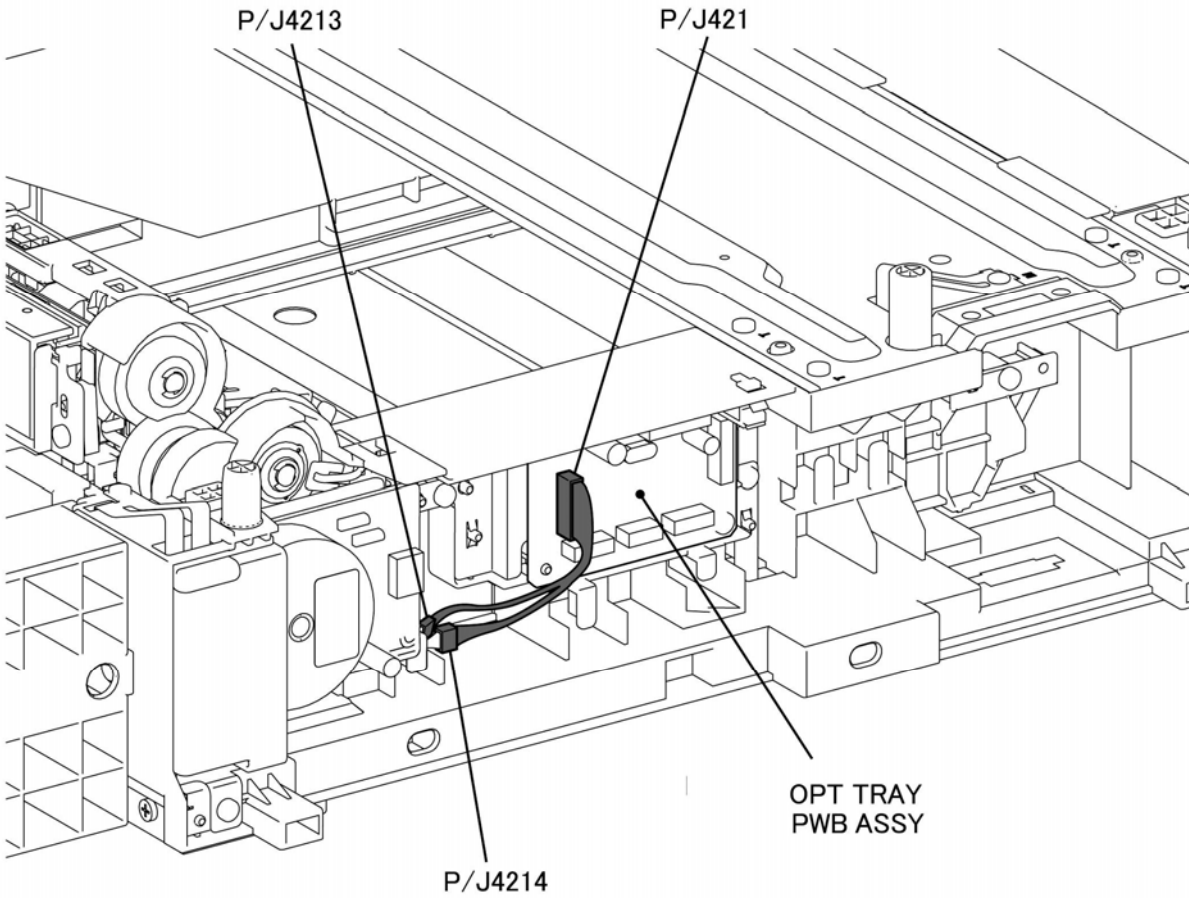

ZaA044033XA

Optional Tray PWB Assembly (2 of 3)

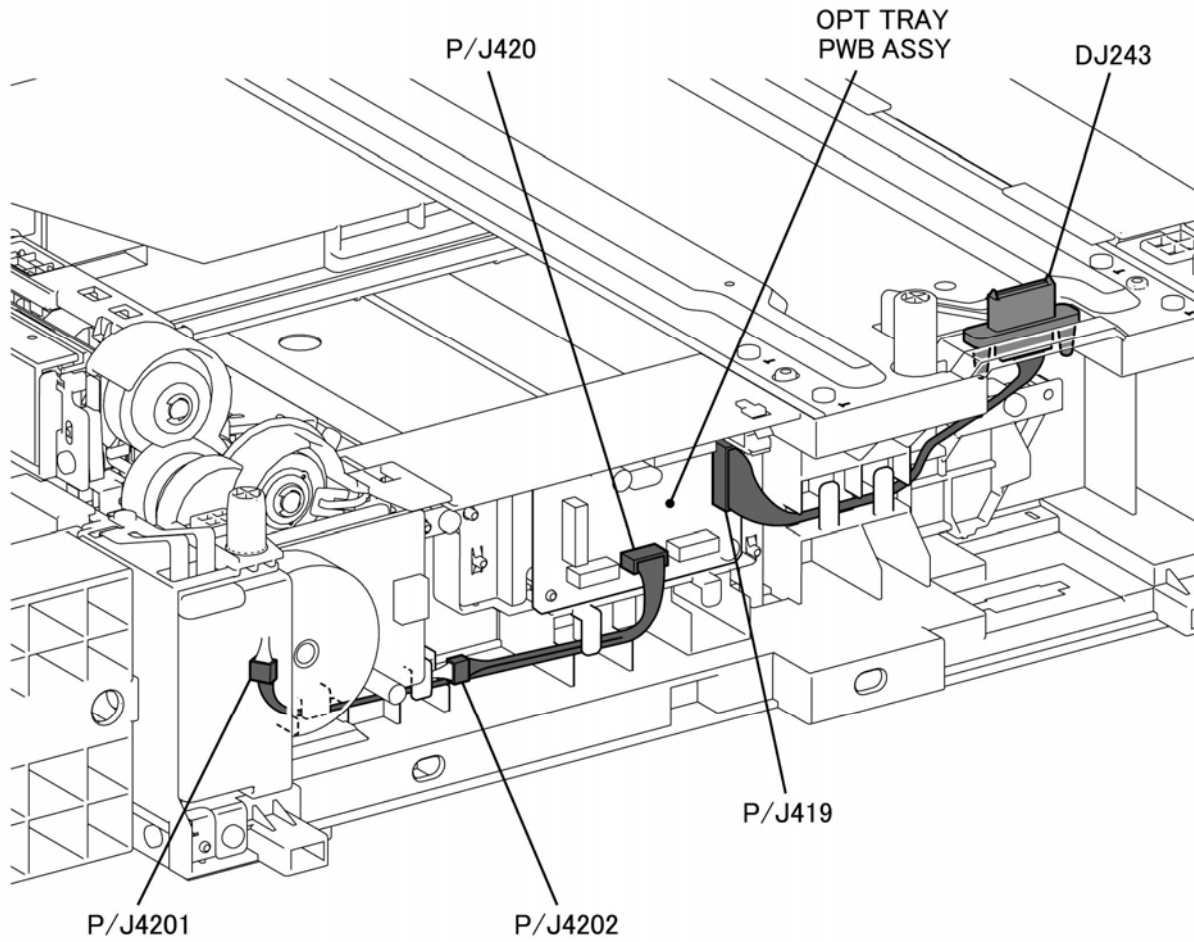

ZaA044034XA

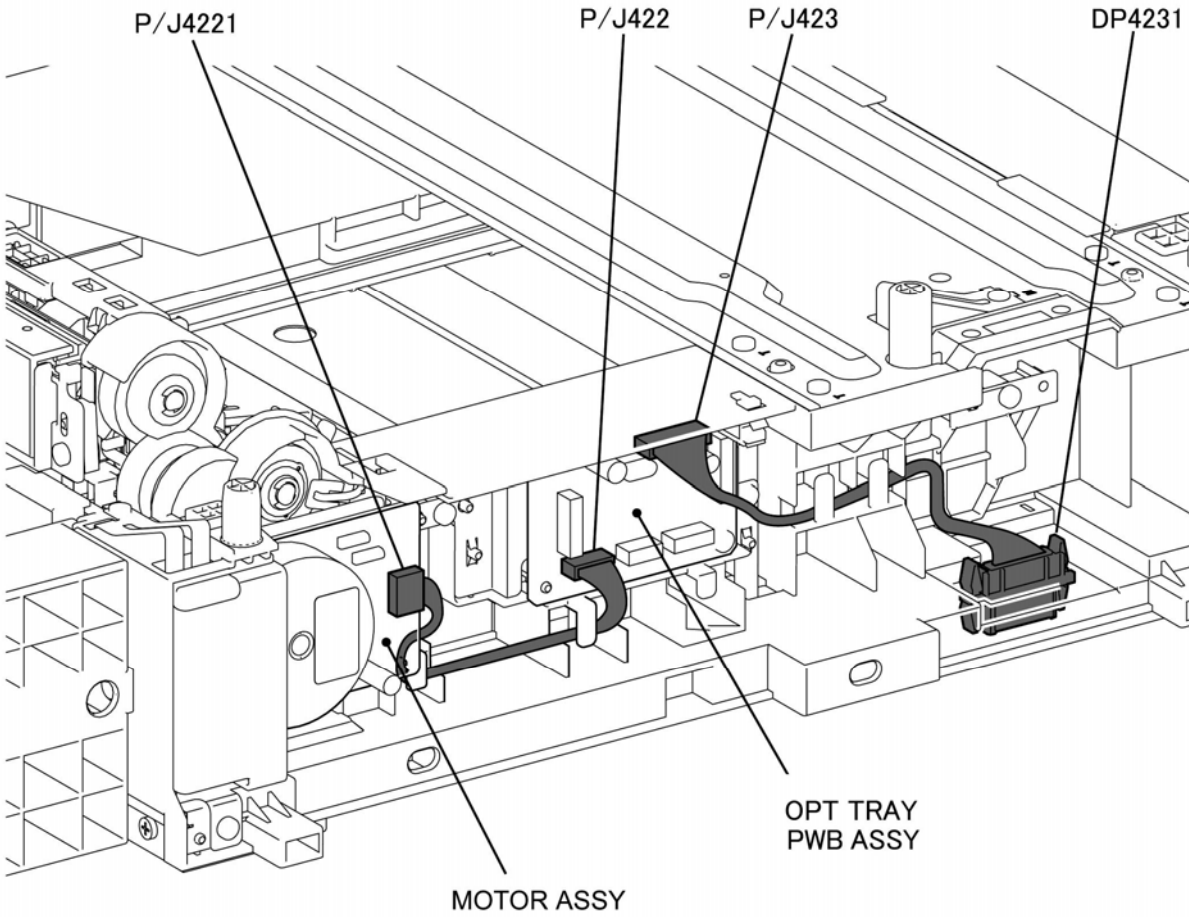

Optional Tray PWB Assembly (3 of 3)







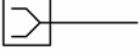





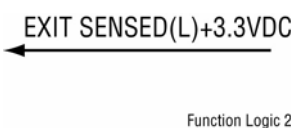
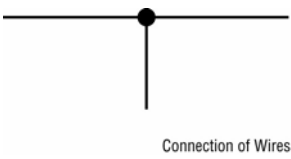
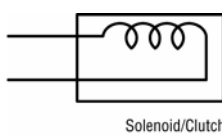
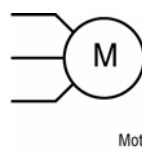

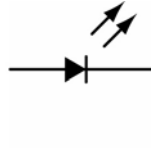
ZaA044035XA

Notations Used in the Wiring Diagrams

The following table lists the symbols used in the wiring diagrams.

Symbol	Description
 <p style="text-align: center;">Plug</p>	Denotes a Plug.
 <p style="text-align: center;">Jack</p>	Denotes a Jack.
<p style="text-align: center;">P/Jxx</p>  <p style="text-align: center;">Plug and Jack</p>	Denotes Pin yy and Jack yy of the connector Pxx and Jxx.
<p style="text-align: center;">JPxxx</p>  <p style="text-align: center;">Jumper</p>	Denotes a Jumper Point (JPxxx/xxx). Each end of the Jumper connection has a numeric designation.
<div style="border: 1px solid black; padding: 5px; width: fit-content; margin: 0 auto;"> <p>Fuser PL X.Y.Z</p> </div> <p style="text-align: center;">Subassembly 1</p>	Denotes the parts.PL X.Y.Z implies the item "Z" of plate (PL) "X.Y" in Parts List.
<div style="border: 1px dashed black; padding: 5px; width: fit-content; margin: 0 auto;"> <p>Heater</p> </div> <p style="text-align: center;">Subassembly 2</p>	Denotes functional parts attached with functional parts name.
<div style="border: 1px dashed black; padding: 5px; width: fit-content; margin: 0 auto;"> <p>Control</p> </div> <p style="text-align: center;">Subassembly 3</p>	Denotes the control and its outline in the PWB.

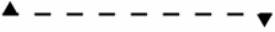
Symbol	Description
	<p>Denotes a connection between parts with harness or wires, attached with signal name/contents.</p>
	<p>Denotes the function, and logic value of the signal to operate the function (Low: L, High: H). The given voltage is for signal in high status. The arrow indicates the direction of signal.</p>
	<p>Denotes the function, and logic value of the signal when the function is operated (Low: L, High: H). The given voltage is for signal in high status. The arrow indicates the direction of signal.</p>
	<p>Denotes a connection between wires.</p>
	<p>Denotes a Clutch or Solenoid.</p>
	<p>Denotes a Motor.</p>
	<p>Denotes a Photo Sensor.</p>
	<p>Denotes an LED.</p>

Symbol	Description
 <p>Safety Interlock Switch</p>	Denotes a Safety Interlock Switch.
 <p>On Off Switch</p>	Denotes an On-Off Switch (single-pole, single-throw switch).
 <p>Temperature Switch</p>	Denotes an On-Off Switch (Temperature - normally close).
	Denotes an NPN Photo-transistor.
 <p>Interconnection</p>	Represents an interconnection between parts using wiring harness or wire.
 <p>Interconnection, Differing</p>	Represents an interconnection which differs according to the specifications.
 <p>Interconnection, Conductive Part</p>	Represents an interconnection between parts using a conductive part such as a Plate Spring.
I/L +24 VDC	Denotes DC voltage when the Interlock Switch in the MCU PWB turns On.
+5 VDC +3.3 VDC	Denotes DC voltage.
SG	Denotes signal ground.
AG	Denotes analog ground.
RTN	Denotes return.

Wiring Diagrams

General Wiring Diagram for 3610

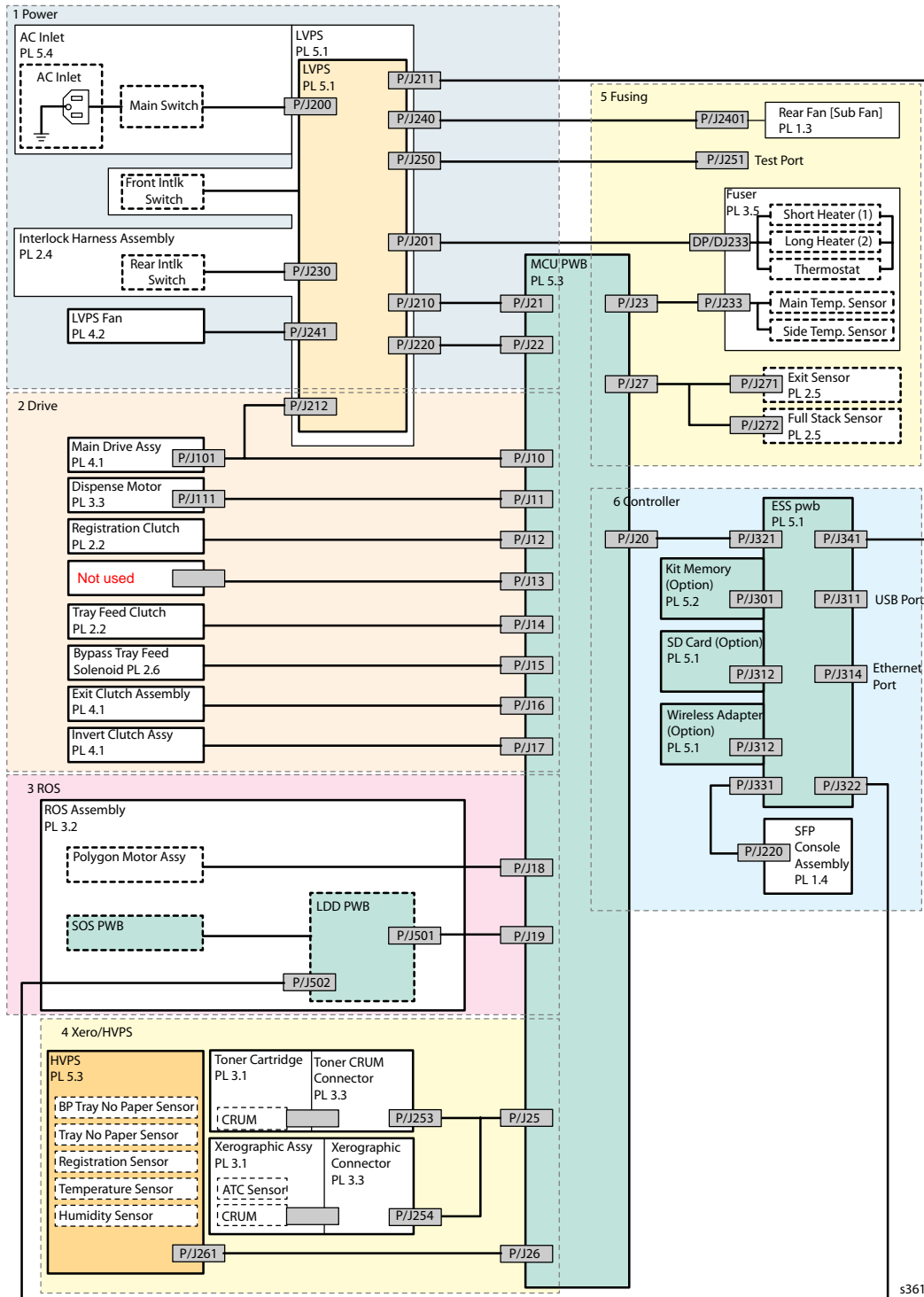

s3610-185

General Wiring Diagram for 3615

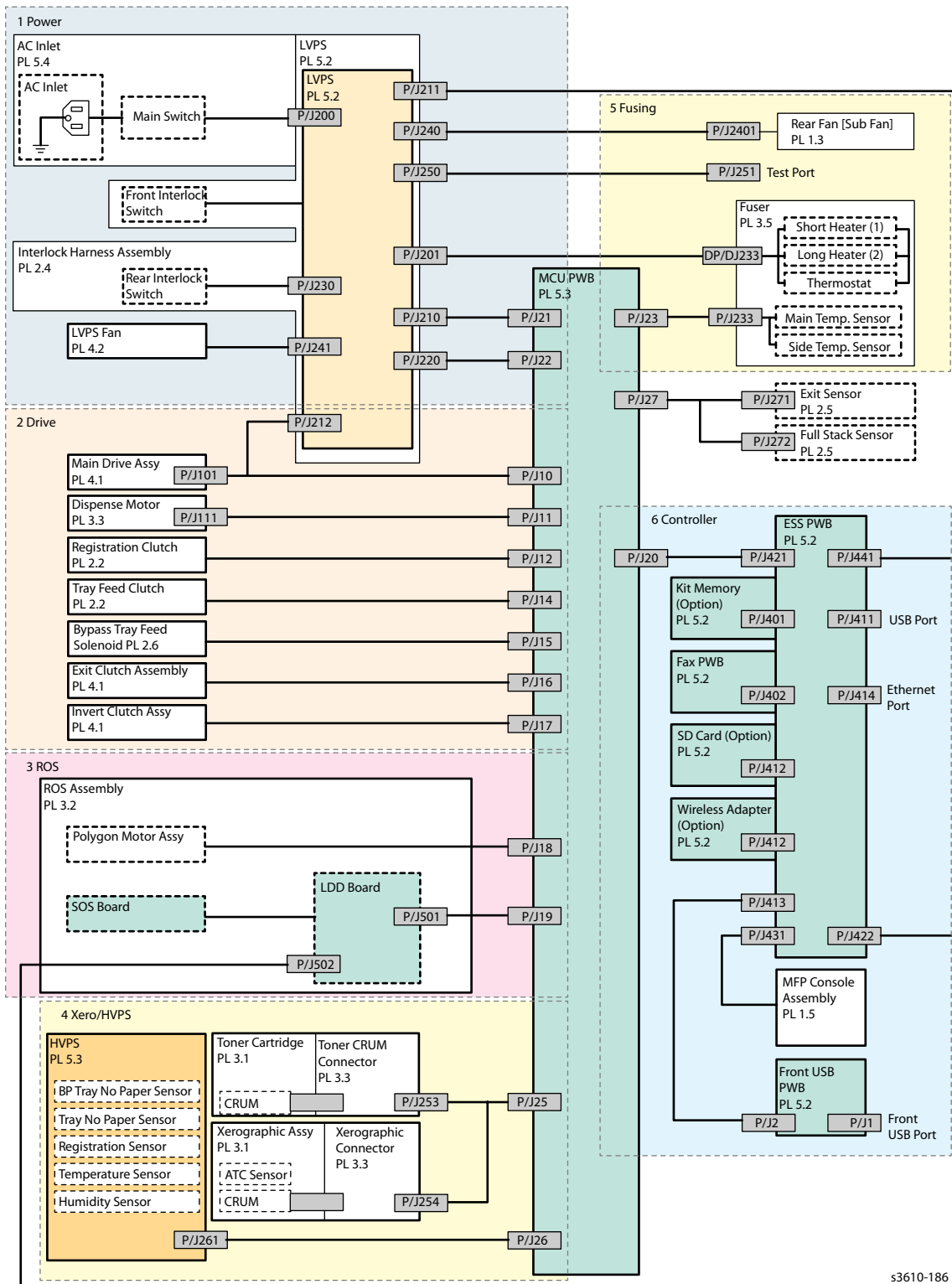

s3610-186

1. Power

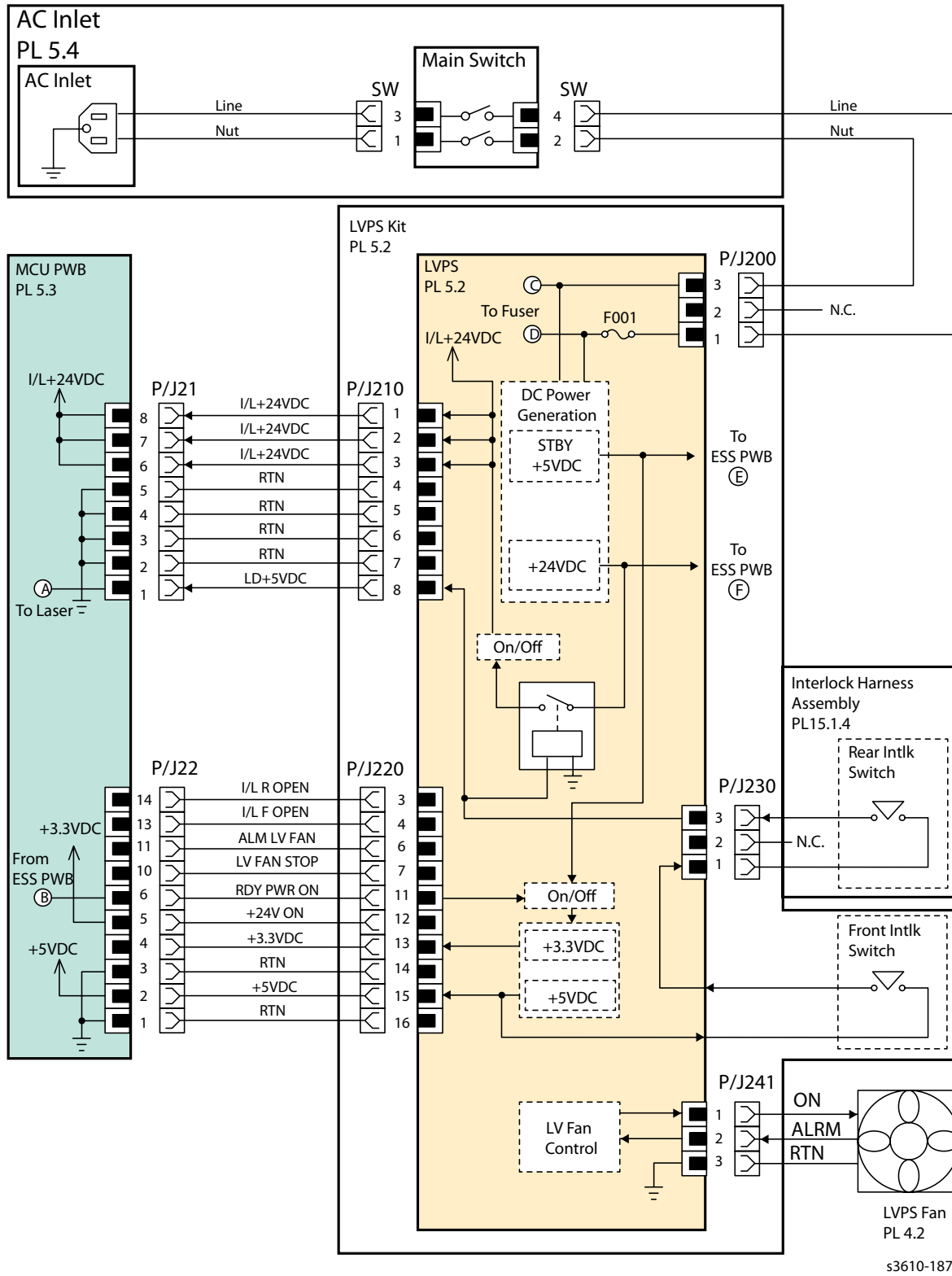

2. Drive

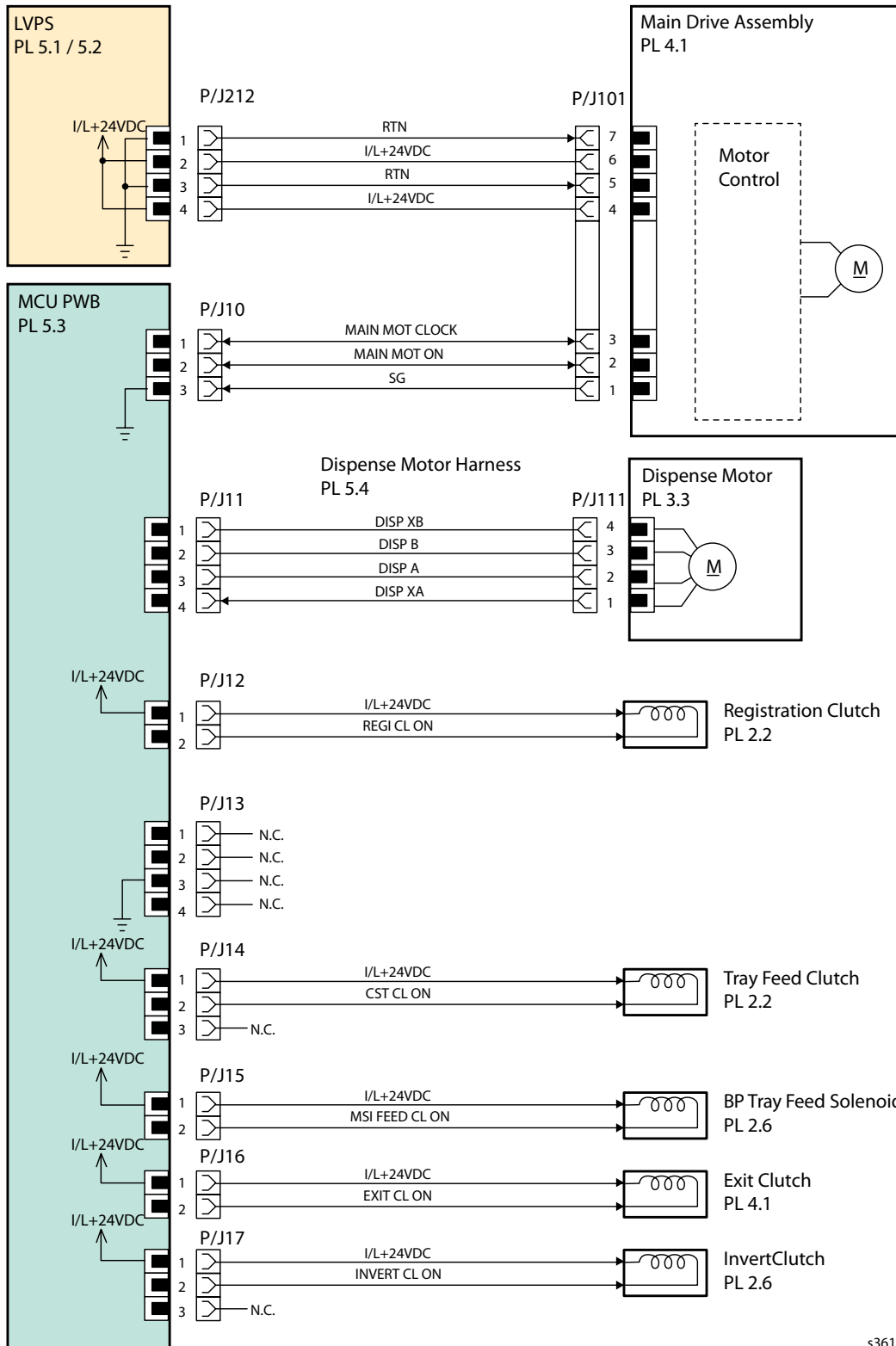

s3610-190

3. ROS

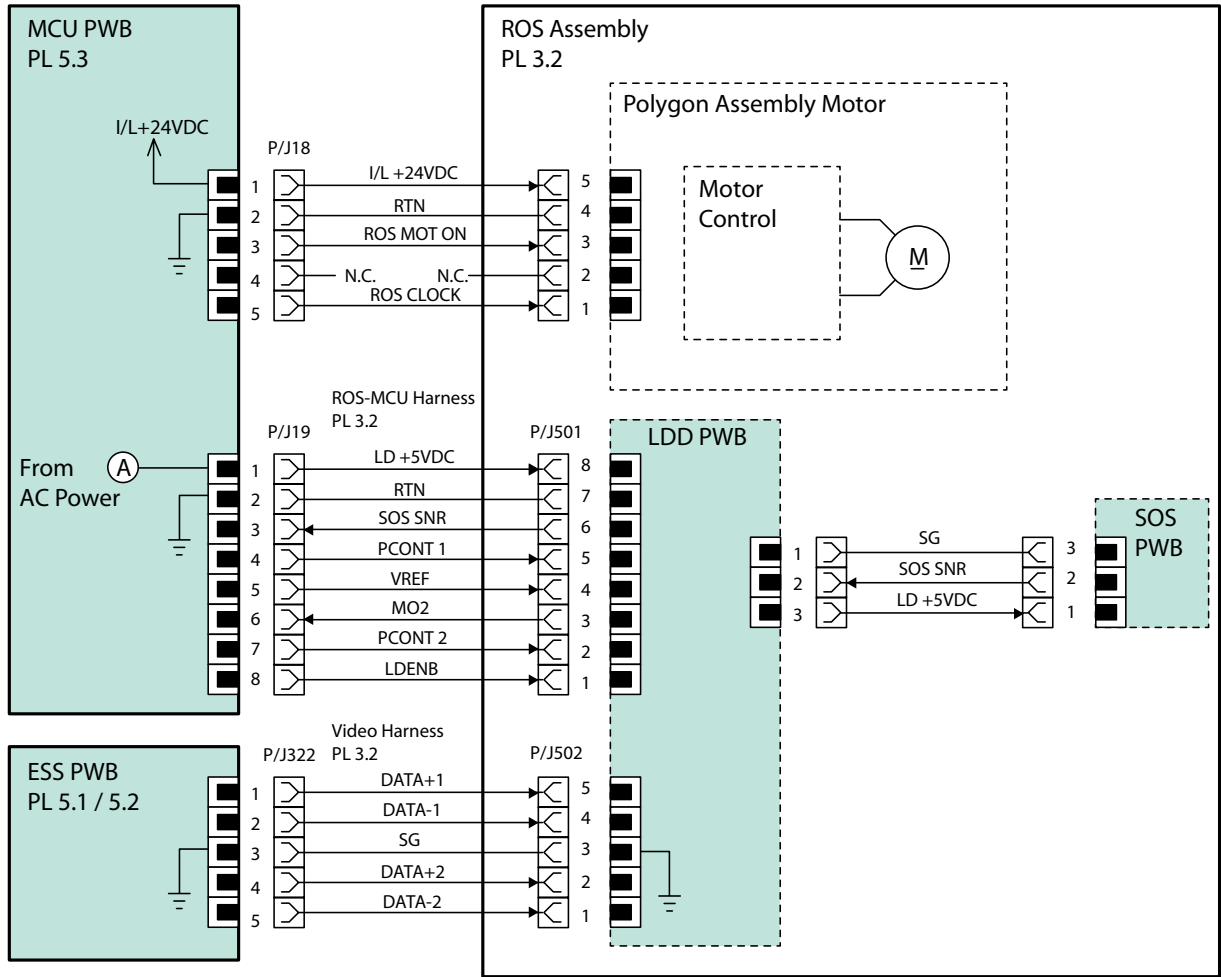

s3610-191

4. Xerographics / HVPS

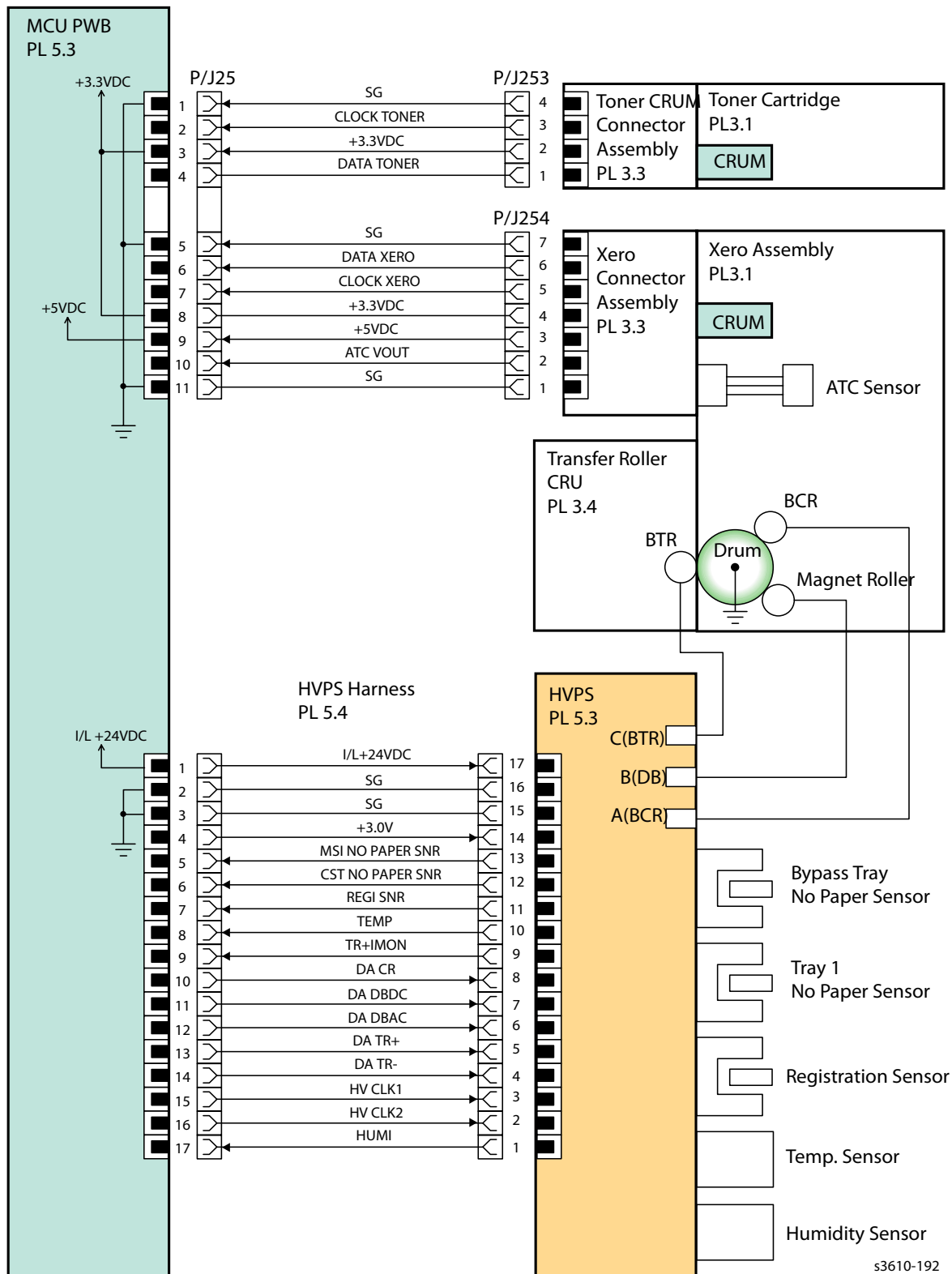

s3610-192

5. Fusing

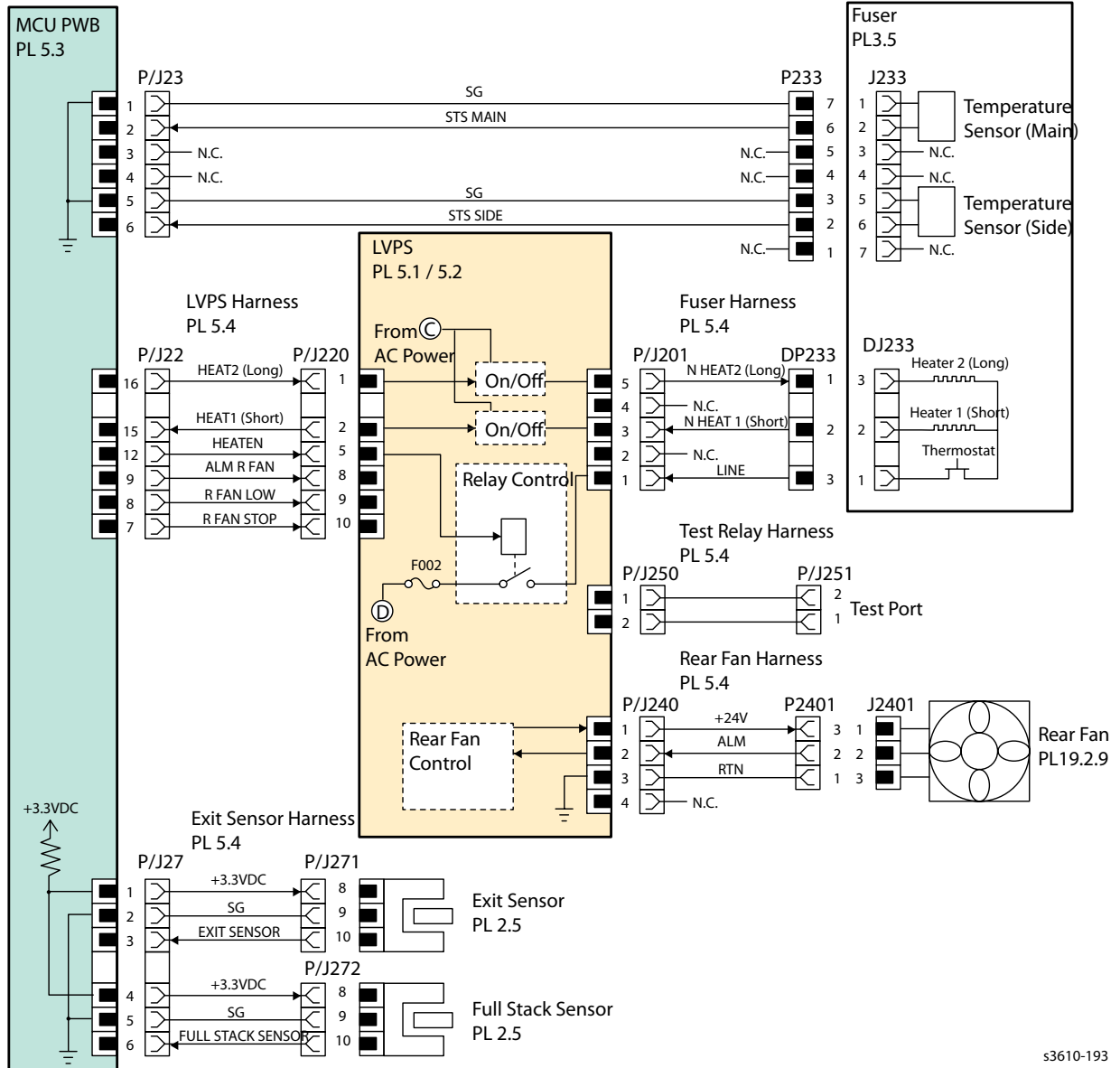

s3610-193

6. Controller (3610)

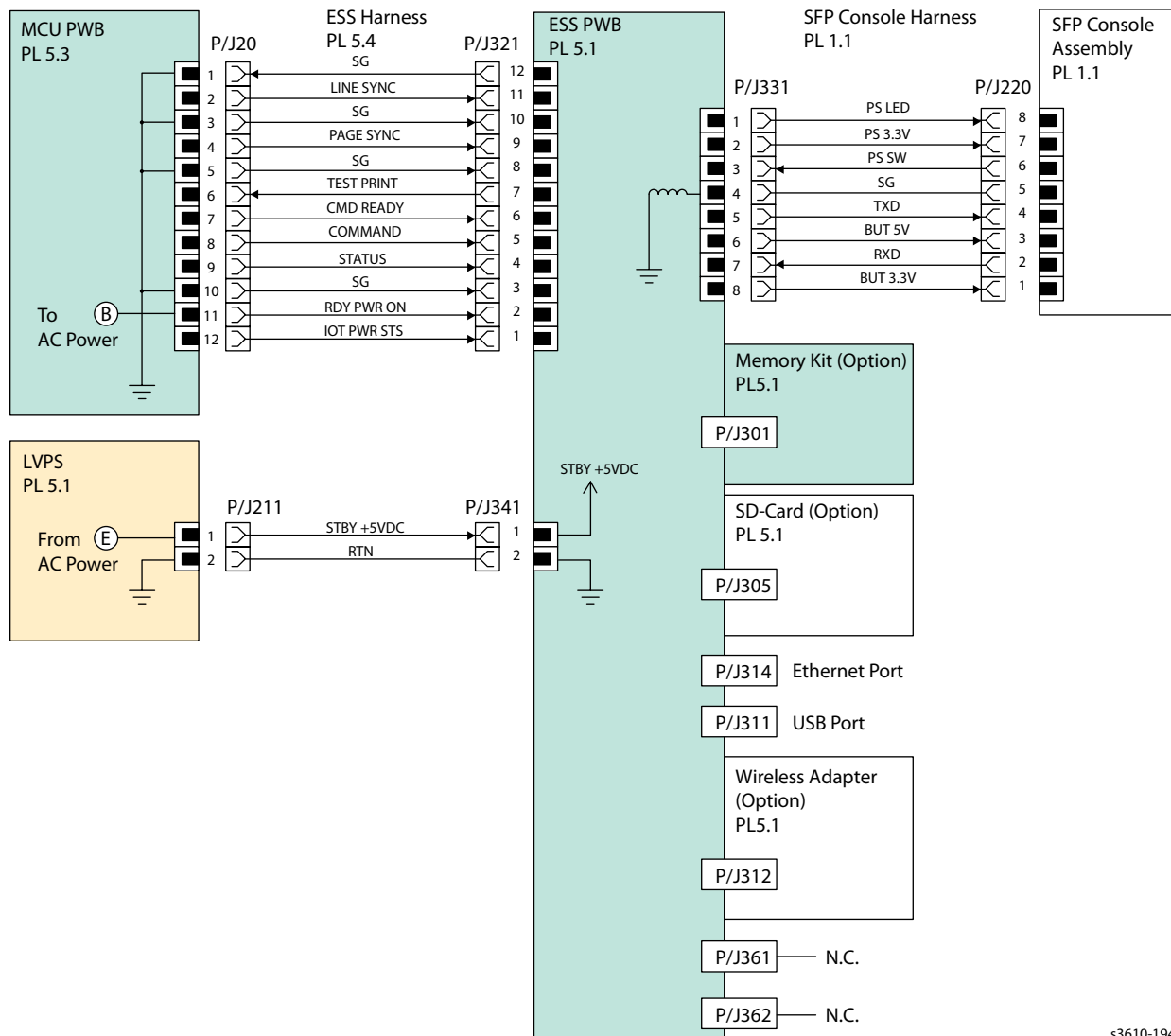

s3610-194

6. Controller (3615)

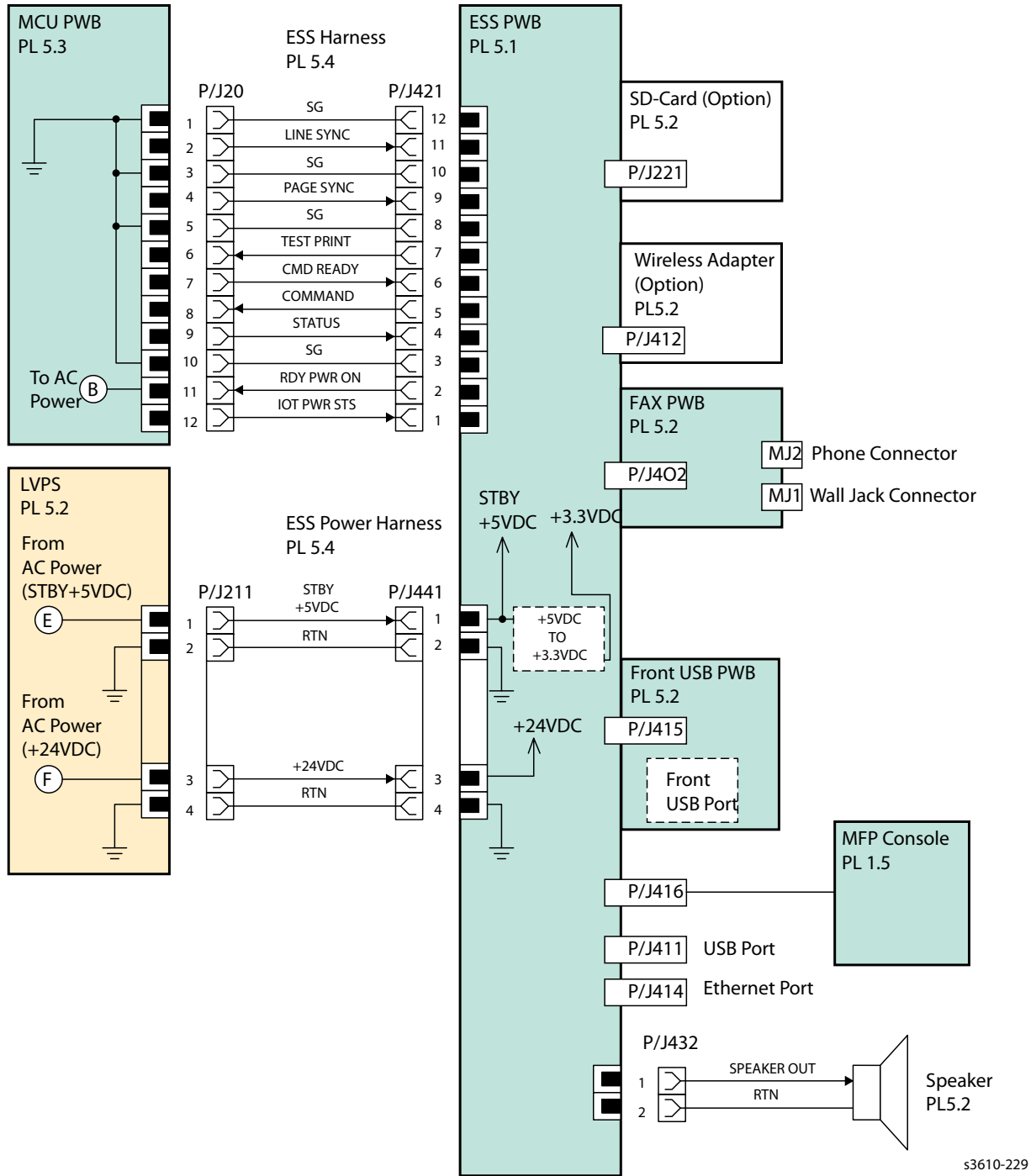

7. Scanner

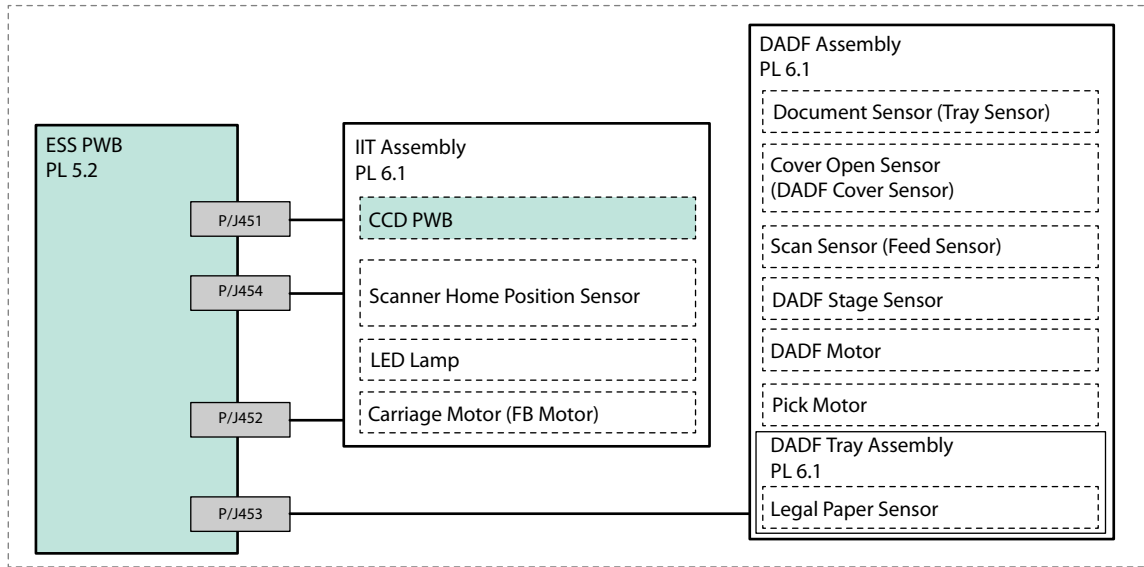

s3610-202b

8. Optional Feeder

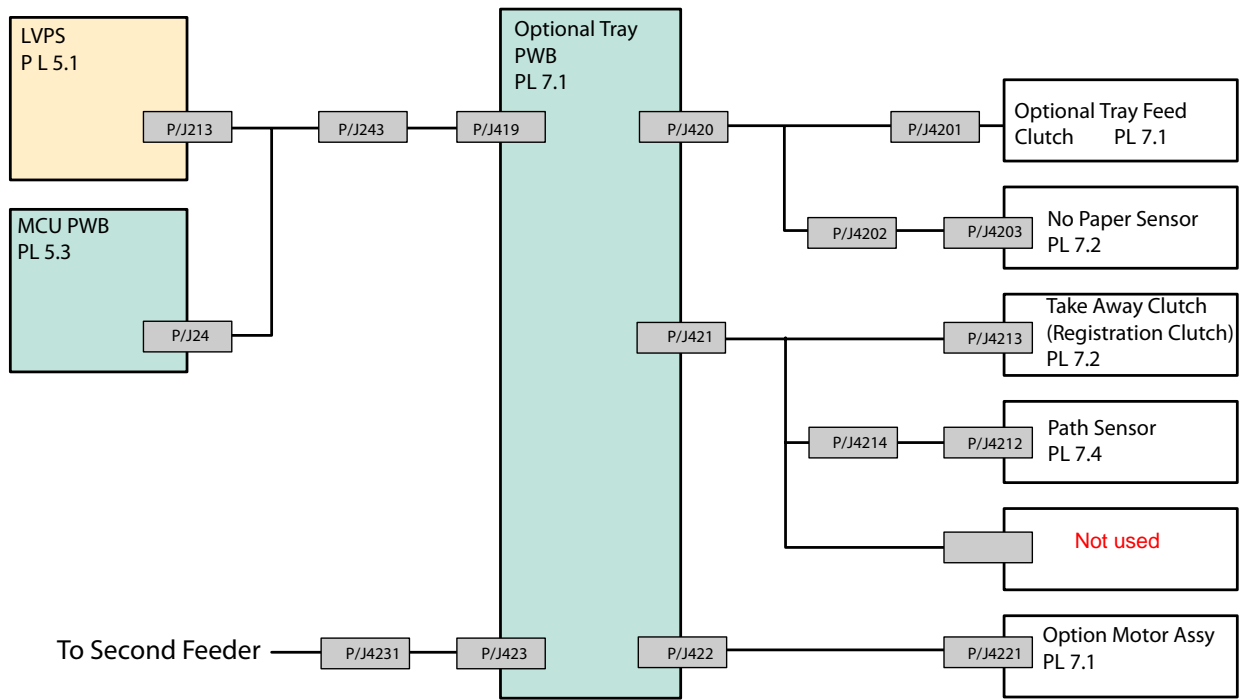

s3610-188

Specifications

8

This chapter includes:

- System Configuration for the 3610
- System Configuration for the 3615
- Electrical Properties
- Mechanical Properties
- Space Requirements for the 3610
- Space Requirements for the 3615
- Consumables
- Machine Functions
- Sleep Mode
- Deep Sleep Mode
- Machine Status for the 3610
- Machine Status for the 3615
- Warm-up Time
- FPOT (First Print Output Time)
- Operating Environment
- Safety / Environment Conditions
- Print Image Quality
- Printer Options
- ESS Specification
- IIT (Image Input Terminal) Specifications (3615)
- FAX Specifications (3615)
- Media Guidelines

Configuration of Printer

System Configuration for the 3610

IOT (Image Output Terminal):

- The IOT writes video data from each portion on paper for copying, outputting files received by the facsimile, and outputting from the printer. The Laser xerography technology engine allows for image recording on paper up to 14 in. (355.6mm) length at 600 dots/25.4mm.

Operator Panel:

- The operator panel displays various settings, instructions, and error messages for printing. It has buttons for user operation.

SFP Controller:

- The SFP controller converts print data (control code data, character code data, graphics data, image data, etc.) sent from the host computers to video data, and transfer them to IOT.

Configuration Table

Product Name	Operator Panel	Duplex	Network	Wireless	USB	Font-ROM	SD-Card	Memory
Phaser3610N	2 Line Bitmap	N	Y	Optional	1	N	Optional 1 slot	Optional 512MB
Phaser3610DN	2 Line Bitmap	Y	Y	Optional	1	N	Optional 1 slot	Optional 512MB
Phaser3610NM	2 Line Bitmap	Y	Y	Optional	1	N	Optional 1 slot	Optional 512MB
Phaser3610DNM	2 Line Bitmap	Y	Y	Optional	1	N	Optional 1 slot	Optional 512MB

Y: feature available, N: feature not available

Functional Configuration

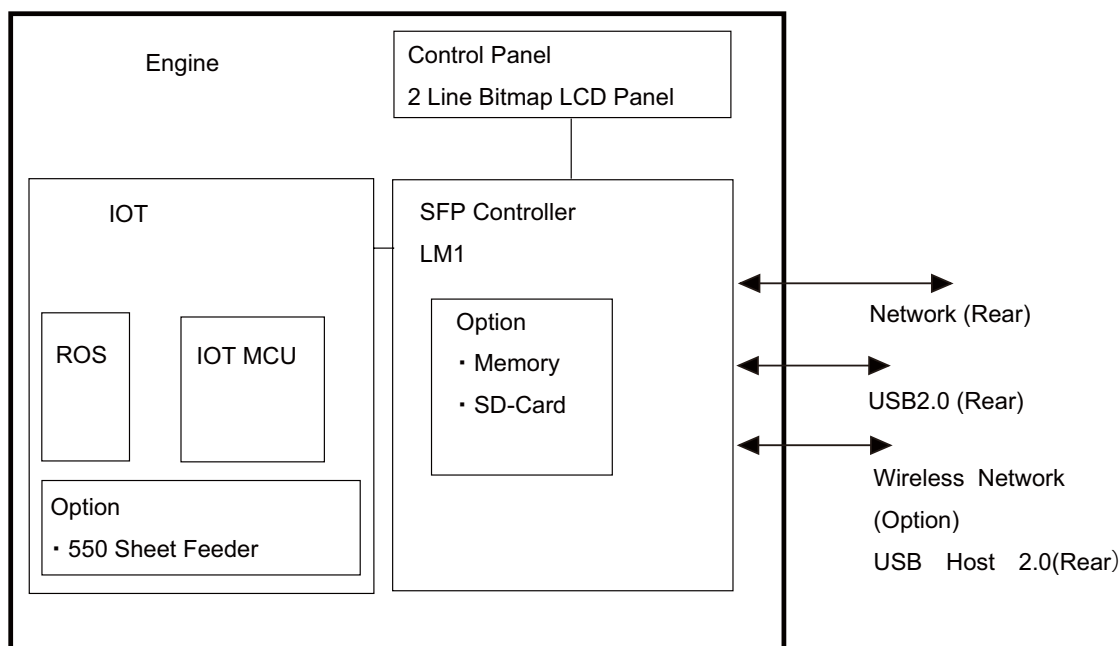

ZaS06005XB

System Configuration for the 3615

IIT (Image Input Terminal):

- The IIT is a device to scan documents for copying, facsimile (FAX) sending, and scanning. The IIT can scan documents with an optical resolution of 1200 dots/25.4mm and 1200 dots/25.4mm in the fast scan direction. The resolution in the slow scan direction is set based on the scan speed and electrical resolution conversion.
- The IIT is equipped with the DADF (Duplex Automatic Document Feeder) as standard.

IOT (Image Output Terminal):

- The IOT writes video data from each portion on paper for copying, outputting files received by the facsimile, and outputting from the printer. The Laser xerography technology engine allows for image recording on paper up to 14 in. (355.6mm) length at 600 dots/25.4mm.

Operator Panel:

- The operator panel displays various settings, instructions, and error messages for copying, sending a fax, scanning, and printing. It has touch sensor and buttons for user operations. The operator panel is also referred to as just "Panel" in this specification.

3615 Controller:

The 3615 controller performs system control for the entire machine. It processes and stores images input/output from the IIT, IOT, facsimile, and printer I/F, and also controls the panel. For FAX sending/receiving, it sends/receives data to/from the communication line via the NCU.

Configuration Table

Product Name	Operator Panel	Duplex	Network	Wireless	USB	Font - ROM	SD-Card	Memory
WorkCentre 3615DN	4.3 inch Touch Panel	Y	Y	Optional	1+1 (Host*1)	N	Optional 1 slot	N
WorkCentre 3615DNM	4.3 inch Touch Panel	Y	Y	Optional	1+1 (Host*1)	N	Optional 1 slot	N

Y: feature available, N: feature not available

*1: Direct Print Using the USB Storage Device

Functional Configuration

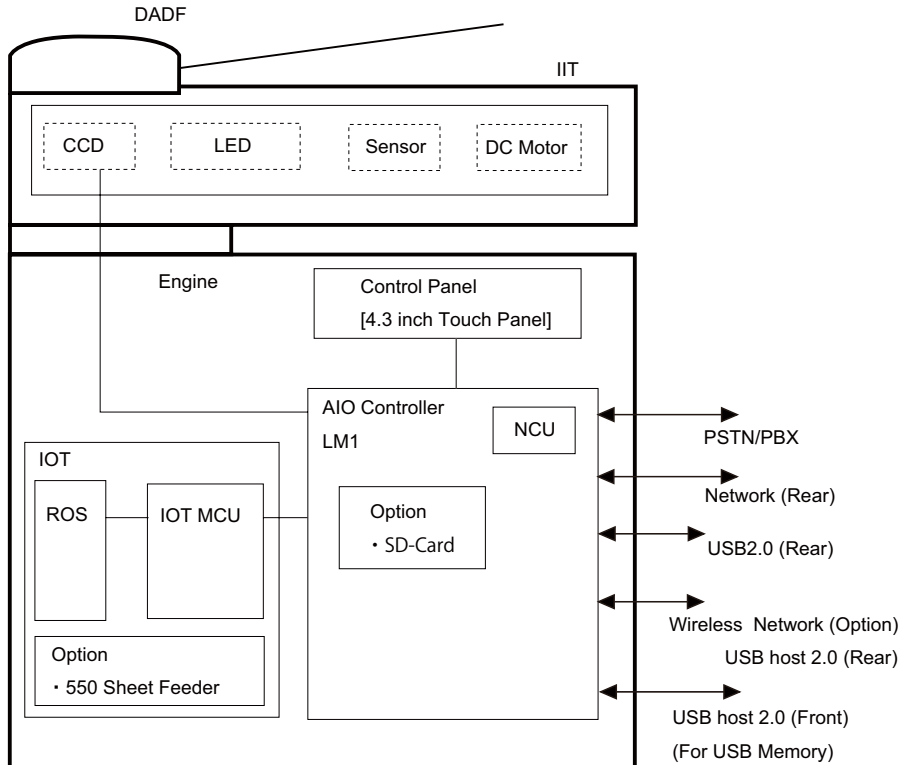

ZaA06001XB

Electrical Properties

Power Voltage and Frequency

M/C	Voltage (V)	Frequency (HZ)	Input Power (A)	Phase
110V M/C	110 to 127V +/-10 % (99 to 140V)	50/60 +/-3HZ	11A or less (110V system)	Single-phase two-wire system
220V M/C	220 to 240V +/-10 % (198 to 264V)	50/60 +/-3HZ	6A or less (220V system)	Single-phase two-wire system

Power Consumption

The following table represents the power consumption of each operation mode under rated input voltage (110, 127, 220VAC).

Operation Mode	Power Consumption
Deep Sleep	4.5 Wh/h (Ave) or less (3610) 5.5 Wh/h (Ave) or less (3615)
Sleep	13.5 Wh/h (Ave) or less (3610) 19.5 Wh/h (Ave) or less (3615)
Standby	76 Wh/h (Ave) or less (3610) 82 Wh/h (Ave) or less (3615)
During continuous printing	705 Wh/h (Ave) or less (3610) 750 Wh/h (Ave) or less (3615)
Maximum rated value	1350 W (Max) or less (3610) 1390 W (Max) or less (3615)

Surge Current

When the power switch is turned on, the surge current shall be maximum 50Amp (Cold start)/135Amp (Hot start) at first 2.5msec, and 80Amp(120V/220V/240V) / 85Amp(100V) within 10msec.

Mechanical Properties

Dimensions and Weight of Printer

	Width (in/mm) ^{*1,*2}	Depth (in/mm) ^{*1,*2,*3}	Height (in/mm)	Weight (lb/kg) ^{*4}
3610	15.47 / 393	16.7 / 426	12.4 / 315	28.2 / 12.8
3615	19.48 / 495	19.37 / 492	21.7 / 551	47.2 / 21.4

*1: Measured with the MSI cover closed.

*2: Measured with the output tray extension closed.

*3: Includes the protrusions of the Rear Fan on the Rear Cover.

*4: Includes consumables (Toner Cartridge and Drum Cartridge) but not options, power cord, or media.

Note: Allowance: Size= +/-1 %, Weight= +/-1 % kg (Uniformed to +/- 0.1 kg if 10 kg or less)

Dimensions and Weight of Optional 550 Sheet Feeder

	Optional 550 Sheet Feeder	Width (in/mm)	Depth (in/mm)	Height (in.mm) ^{*1}	Weight (lb/kg)
3610	550 Sheet Feeder	15.47 / 393	15.7 / 399	5.5 / 140	7.0 / 3.2
3615	550 Sheet Feeder	16.9 / 430	18.46 / 469	5.5 / 140	7.7 / 3.5

Note: *1: Includes the protrusions on the top of the Tray.

Dimensions and Weight of Consumables and CRUs

Toner Cartridge	Width (in/mm)	Depth (in/mm)	Height (in/mm)	Weight (lb/kg)
Toner Cartridge (Standard Capacity)	11 / 280	3.93 / 100	3.7 / 94	1.0 / 0.461
Toner Cartridge (High Capacity)	11 / 280	3.93 / 100	3.7 / 94	1.3 / 0.591

Drum Cartridge	Width (in/mm)	Depth (in/mm)	Height (in/mm)	Weight (lb/kg)
	12 / 307	10.27 / 261	5.47 / 139	3.2 / 1.471

Space Requirements for the 3610

The printer requires the minimum installation space shown below for typical operation. (Space occupied by the operator is not included.)

- Top View

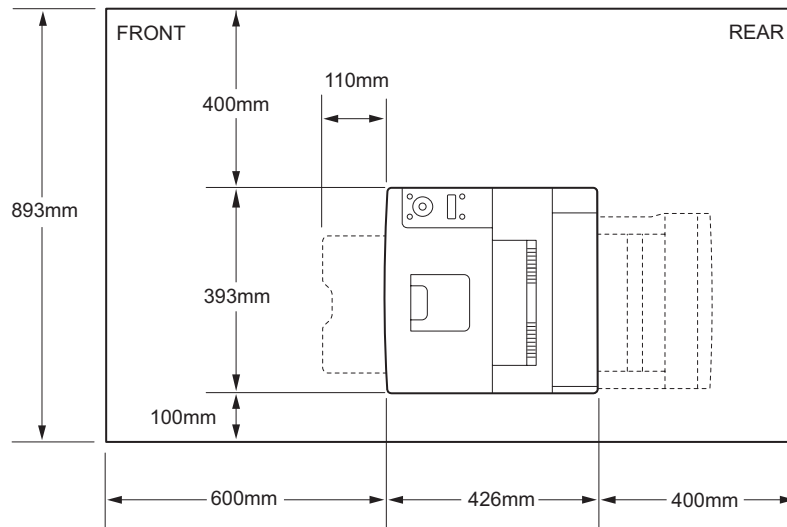

ZaS06002FA

- Right-side View

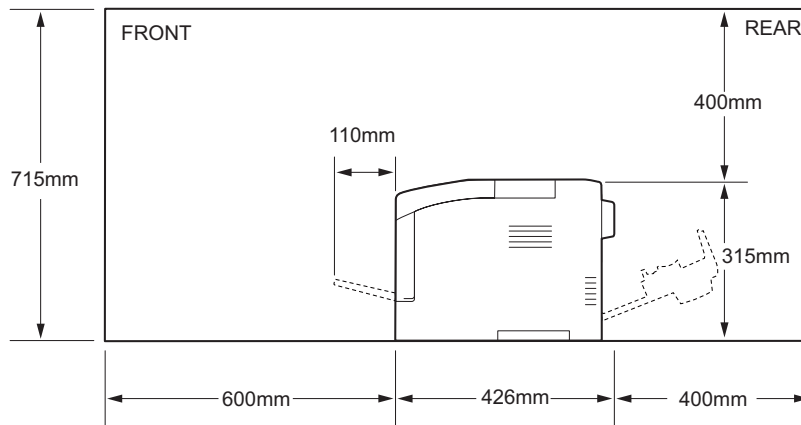

ZaS06006FA

Space Requirements for the 3615

The printer requires the minimum installation space shown below for typical operation. (Space occupied by the operator is not included.)

- Top View

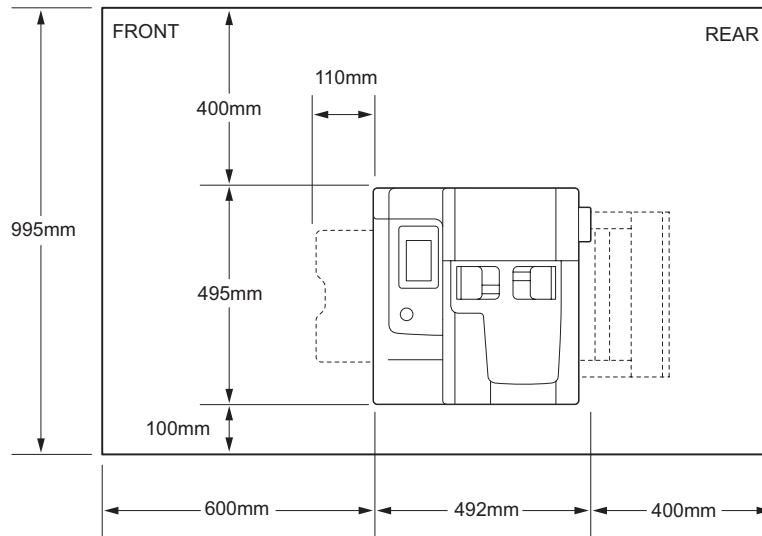

ZaA08007XA

- Right-side View

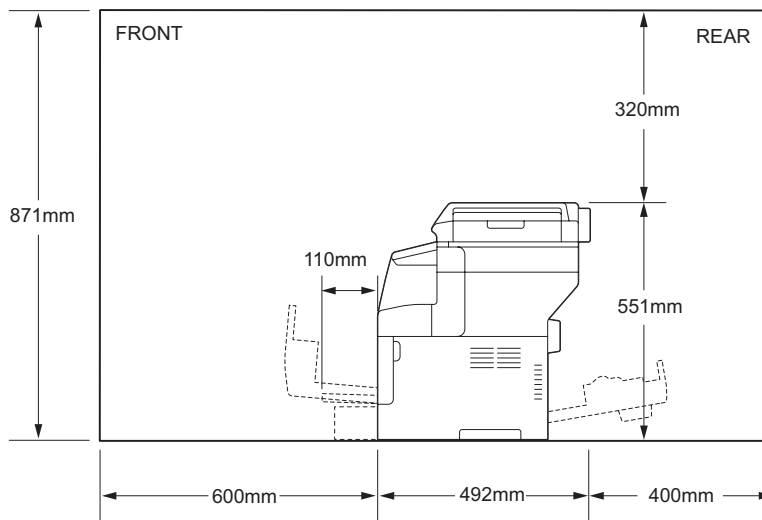

ZaA08008XA

Consumables

Each Toner Cartridge has a CRUM (Customer Replaceable Unit Meter) to record new or used cartridge and usage information. The CRUM contains a company ID, Region ID, and Xerox company name. A CRUM counts the amount of remaining toner. When toner empty is detected, Life End status will be sent to indicate toner empty. Internal counters track Consumables life usage. Life ratings are based on A-size sheets at 5% coverage.

Generally, consumables are to be replaced by the customer. It may be necessary to replace consumables for recovery from or for insulation of faults due to consumables.

Product Name	Replacement Life (reference)	CRUM Installed	Counter Reset	Remarks
Toner Cartridge (Standard Capacity)	6KPV	Yes	Auto Reset	CRU
Toner Cartridge (High Capacity)	14KPV	Yes	Auto Reset	CRU
Toner Cartridge (Meter)	25KPV	Yes	Auto Reset	CRU
Toner Cartridge (Extra High Capacity)	25KPV	Yes	Auto Reset	CRU
Drum Cartridge	100KPV	Yes	Auto Reset	CRU
Maintenance KIT(110V - Fuser / BTR)	200KPV	No	Manual	CRU
Maintenance KIT(220V - Fuser / BTR)	200KPV	No	Manual	CRU
Maintenance Kit (1 set of Feed Rolls)	100KPV	NO	NO	CRU

Machine Functions

Resolution

Line Density in Fast Scan Direction

- 600 dots /25.4mm
- 1200 dots /25.4mm

Line Density in Slow Scan Direction

- 600 dots /25.4mm fixed
- 1200 dots /25.4mm fixed

Operation Mode

Power-off Status

The power switch is off and no power is supplied. The machine does not operate.

Ready (Standby) Mode

This mode is called as "Energy Saving: Step 1" for BAM (Blue Angel Mark) standard.

When the system starts up by power-on, it shifts from the power-off status to the Standby mode.

After pressing "Power Saver button" on the operator panel, the machine enters the Sleep Mode to save more power consumption.

(for 3615) At this point, the provided functions (copying, FAX sending, network scanning) become available via the operator panel. FAX receiving, printing, Direct FAX, and local scanning also become available.

Running Mode

There are the Print mode, (3615) Scan mode, and FAX communication mode in which the IOT, IIT, and FAX communication operate respectively.

Print Mode

In this mode, the IOT is operating for printing, (3615) copying, FAX received printing, and report printing.

Scan Mode (3615)

In this mode, the IIT is operating for copy scanning, local scanning, network scanning, and FAX scanning.

FAX Communication Mode (3615)

In this mode, FAX sending/receiving is in progress.

Sleep Mode

This mode is called as "Energy Saving: Step 2" for BAM(Blue Angel Mark) standard.

When no job is executed for a certain period of time, the machine enters this mode to reduce the standby electricity consumption.

The shift time from the Standby mode to Sleep mode can be changed from the operator panel (Setting range: 1-60 min).

The factory default is 1 min.

The conditions that Sleep mode to Ready mode:

- Pressing "Energy Saver button" on the operator panel.
- Receiving a print job.
- Report printing directions from CWIS.
- (3615) Receiving a FAX Job.
- (3615) Receiving a direct FAX job.
- (3615) Start sending or polling data at the communication, if start time specified by the operator.

Deep Sleep Mode

This mode is called as "Energy Saving: Step 3" for BAM(Blue Angel Mark) standard.

After the Sleep mode has continued for a certain period of time, the machine enters the Deep Sleep Mode to save more power consumption.

The shift time from the Sleep mode to the Deep Sleep mode can be changed from the operator panel.

There is not defined Deep Sleep Mode and its menu. The shift time from the Sleep mode to the Deep

Sleep mode is fixed for 1 min.

The Deep Sleep mode is cancelled by:

- Pressing Energy Saver button on the operator panel
- Receiving a print job
- Indicate Report Print from CWIS
- Start sending or polling data at a communication start time specified by the operator
- (3615) Receiving a FAX Job.
- (3615) Receiving a direct FAX job.

Machine Status for the 3610

Status	Exposure	Developer and transfer	Fusing Unit	Cooling fan	MCU	Operation panel	Controller	Interface Port ^{*1}
Initializing	Working during calibration		Rest	Rest	Working	Working	Working	Working
Running	Working	Working	Working	Working				
Ready	Rest	Rest	Standby Temp.	Working (Half)				
Low Power			Rest	Rest	Rest	Power Saver button and Ready LED Only		
Sleep								

Note: *1: Interface Port: USB Port (Type B), Ethernet Port

Machine Status for the 3615

Status	Exposure	Developer and transfer	Fusing Unit	Cooling fan	IIT	MCU	Operation panel	Controller	Interface Port ^{*1}
Initializing	Working during calibration		Rest	Rest	Working	Working	Working	Working	Working
Running	Working	Working	Working	Working	Working				
Ready	Rest	Rest	Standby Temp.	Working (Half)	Working				
Sleep			Rest	Rest	Rest	Rest	Energy Saver button and Ready LED only		
Deep Sleep									

Note: *1: Interface Port: USB Port (Type A/Type B), Ethernet Port

Warm-up Time

The printer shall reach the Ready state within 19.9 seconds after power on.

Warm up time(s) = "FPOT from Power on"(s) - "FPOT from Ready"(s)

Event	Status transition	Warm up time	Condition
Warm up time	"FPOT from Power on"(s) -"FPOT from Ready"(s)	19.9 sec or less	22°C/60 % RH, Rated voltage.
Recovery from Sleep mode	"FPOT from Sleep mode"(s) -"FPOT from Ready"(s)		22°C/60 % RH, Rated voltage.
Recovery from Deep Sleep mode	"FPOT from deep sleep mode"(s) -"FPOT from Ready"(s)		

FPOT (First Print Output Time)

The table below shows FPOT (First Print Output Time). FPOT is defined as the time from when the printer driver issues a print request in the Standby mode until when the first printed sheet is output completely. Process control time is not included.

The job is only set by the previous job and is always kept even after Power-off/on.)

Paper Size	Paper Type	Paper Tray	FPOT (Ready mode)
A4SEF	Plain	MSI	6.5 sec. or less
A4SEF	Plain	Standard Tray (Tray 1)	
A4SEF	Plain	Optional Tray (Tray 2)	
A4SEF	Plain	Optional Tray (Tray 3)	
A4SEF	Plain	Optional Tray (Tray 4)	

Engine Status

In each mode, each system of the engine is in the status below.

	Running Mode	Ready Mode	Lower Power Mode	Sleep Mode
Fuser Assembly	Maintained at operating temperature	Maintained at ready temperature	Maintained at low temperature	Stop
Printing System (Transfer/ Development, etc.)	Operating	Stop	Stop	Stop
Exposure System	Operating	Stop	Stop	Stop
Fusing Fan	Rotate	Stop	Stop	Stop
HVPS Fan	Rotate	Stop	Stop	Stop
LVPS Fan	Rotate (High Speed)	Rotate (Low Speed)	Rotate (Low Speed)	Stop
HDD	Accessible	Accessible	Accessible	Not Accessible
ESS	Operating	Standby	Standby	Standby to receive
ESS Fan	Operating	Stop	Stop	Stop
UI	On	On	Off	Off

Operating Environment

Installation Temperature / Humidity

The temperature and non-condensing relative humidity for installation is as follows:

- **During operating:** 10 to 32°C, 10 to 85 % RH (No condensation)
- **At standby:** minus -20 to 40°C, 5 to 85 % RH (No condensation)

Installation Altitude

The machine operates normally at the altitude from 0 to 10170 ft. (0 to 3100 meters) with high-altitude settings.

Installation Horizontality

The machine operates normally when it is installed in a horizontal position and when the maximum inclination is 1 degree or less in the front to back direction and in the left-right direction.

Storage Temperature of a Toner Cartridge

The guaranteed period of an unpacked print cartridge is as follows:

- **Normal conditions:** 24 months under 0 to 35°C, 15 to 80 % RH.
- **Harsh conditions:** 1 month under -20 to 0°C and 35 to 40°C, 5 to 15 % RH, 95 % RH.

The storage altitude shall be 0 to 10,170 ft. (0 to 3100 meters). This can be extended to 0 to 49,212 ft. (0 to 15,000 meters) when shipped by air.

Note: Provided that the cargo bay is pressurized to 70.9275 Kpa or higher.

Safety / Environment Conditions

Applicable Laws and Industry Regulations

Item	M/C	Specification
Safety Standard	110-127V M/C	UL60950-1, CSA 22.2 60950
	220-240V M/C	IEC60950-1 / EN60950-1
Laser Safety Standard	110-127V M/C	FDA21CFR Chapter 1, Subchapter J, Section 1010, 1040
	220-240V M/C	IEC60825-1 Amendment 1 + Amendment 2 / EN60825-1 Amendment 1 + Amendment 2 Class 1 Laser Product

Electromagnetic Compatibility

Rated Emission and Conducted Emission.

The machine meets the following conducted emission and radiated emission standards.

M/C	Specification
110-127V M/C	FCC Part15 Subpart B, Class B
220-240V M/C	EN55022:2006, Class B

Note: Based on the standards above, the machine complies with safety regulations of each country.

Noise

Noise of printing is as follows:

- Measured according to ISO7779 and declared according to ISO9296.

Mode	Sound Power Level(Unit B ^{*1})	
	LWA	LWAD
Running (3610)	6.83 B	7.13 B
Running (3615)	7.18 B	7.48 B
Standby	5.0 B	5.3 B

Print Image Quality

Print Image Quality Guarantee Conditions

The print image quality is specified and guaranteed under the following conditions.

Environmental conditions

Environment condition for evaluating image quality.

- Temperature: 15 to 28°C
- Humidity: 20 to 70 % RH

Guaranteed paper

The image quality defined in this chapter is guaranteed when standard paper is used in the tray. FX P paper A4.

Paper condition

The image quality defined in this chapter is applied to fresh paper that is just opened after left unopened for 12 hours under the printer's operating environment.

Printer condition

The image quality defined in this chapter is guaranteed when the printer does not have any fault.

Print image quality guaranteed area

The print image quality specified in this section is guaranteed in the print image quality guaranteed area specified in the following table.

Area definition	Specification
Usable Area (maximum paper size)	8.68 (*1) x 14 in. (215.9 x 355.6mm)
Un-printable Area	Default: 4.1mm each from four edges of paper
Printable Area	8.18 x 13.68 in. (207.7 x 347.4mm)
	8.68 x 14 in. (215.9 x 355.6mm (Edge to edge mode))
Print quality guaranteed Area	8.18 x 13.68 in. (207.7 x 347.4mm)

Note: *1: Maximum width of 8.66 in. (220mm) for Envelope (DL LEF)

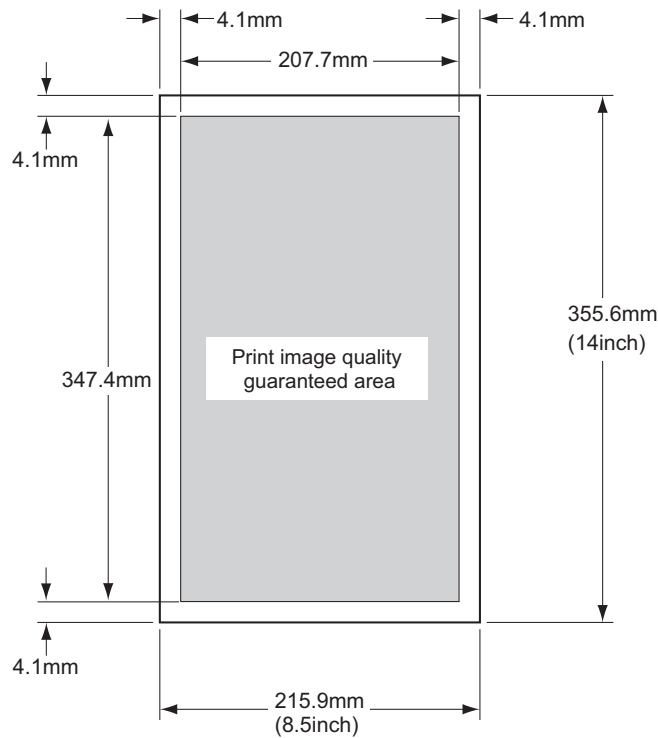

ZaS06004XA

Evaluation Criteria

The print image quality is guaranteed with the Spec. In rate = 90 % (g = 90 %).

Printer Options

Product Name	Remarks
550 Sheet Feeder SFP	<ul style="list-style-type: none"> Installed by Users. Max +3 Option Tray.
Memory DDR3	<ul style="list-style-type: none"> Installed by Users. Additional memory for SFP. To use complex/heavy data printing, increase RAM Disk for collate.
USB Wireless Adapter	<ul style="list-style-type: none"> Installed by Users. Add wireless network ability.
SD-Card	<ul style="list-style-type: none"> Installed by Users. 4 GB Add permanent Storage for job, certification, download fonts. And increase collate limit. When SD-Card is equipped, SD-Card is used for storage instead of RAM Disk.

ESS Specification

ESS-Supporting OS

The machine supports the following operation systems with the latest service pack.

- Microsoft Windows XP (32bit / 64bit)
- Microsoft Windows Server 2003 (32bit / 64bit)
- Microsoft Windows Vista (32bit / 64bit)
- Microsoft Windows Server 2008 (32bit / 64bit)
- Microsoft Windows Server 2008 R2 (64bit)
- Microsoft Windows 7 (32bit / 64bit)
- Microsoft Windows Server 2012 (64bit)
- Microsoft Windows 8 (32bit / 64bit)
- Mac OS X 10.5 (PPC/x86)
- Mac OS X 10.6/10.7/10.8 (x86/x64)
- Red Hat Enterprise Linux 5/6 Desktop (x86)
- SUSE Linux Enterprise Desktop 10/11 (x86)

Interface Port

USB Port

USB (Type-B) port

Item	Specification
Connector	One Type-B connector
Protocol	Hi-speed USB2.0 compatible

USB (Type-A) port

Item	Specification
Connector	One Type-A connector
Protocol	Hi-speed USB2.0 compatible
Supported Class	USB Mass Storage Class

Ethernet Port

Item	Specification
Connector	One RJ-45 connector
Protocol	10 Base-T / 100 Base-TX / 1000 Base-T compatible

Wireless

Wireless Adapter are required.

Item	Specification
Connectivity Technology	Wireless
Compliant Standards	IEEE802.11 n/g/b
Band width	2.4GHz
Data Transfer Rate	IEEE802.11n mode: 65 Mbps IEEE802.11g mode: 54, 48, 36, 24, 18, 12, 9, 6 Mbps IEEE802.11b mode: 11, 5.5, 2, 1 Mbps
Protocol	See " Network Protocol " for details
Device Type	Wireless Adapter
Security Protocol	64 (40-bit key)/128 (104-bit key) WEP,WPA-PSK (TKIP,AES), WPA2-PSK (AES) WPA-Enterprise (TKIP,AES), WPA2-Enterprise (AES) (EAP method supports PEAPv0 only) EAP-TLS(TBD, Need storage.)
WiFi Protected Setup (WPS)	Push Button Configuration (PBC), Personal Identification Number (PIN)

Note: Connection to a Linux machine is not guaranteed. Only for infrastructure connection and when Linux terminal is connected with Wired LAN connection.

Network Protocol

Printing Protocol

Protocol	Transport	Maximum sessions	Remarks
Port9100	TCP/IP	1	<ul style="list-style-type: none"> Windows XP/Server2003/Vista/ Server2008/ 7 /Server2008 R2/Server2012/ 8 Mac OS X
LPD	TCP/IP	10	<ul style="list-style-type: none"> Windows XP/Server2003/Vista/ Server2008/ 7 /Server2008 R2/Server2012/ 8 Mac OS X Linux
IPP IPPS*1	TCP/IP	5	<ul style="list-style-type: none"> Windows XP/Server2003/Vista/ Server2008/7/Server2008 R2/Server2012/ 8 Mac OS X
SMB	TCP/IP	5	<ul style="list-style-type: none"> Windows XP/Server2003/Vista/ Server2008/ 7/Server2008 R2/Server2012/ 8
Web Services on Devices	TCP/IP	2	<p>[Print]</p> <ul style="list-style-type: none"> Windows Vista/Server2008/ /Server2008-R2/Server2012/ 8 <p>[Scan] (3615)</p> <ul style="list-style-type: none"> Windows Vista/7/Server2012/8

Note: *1: Need SD-Card Option.

Control and Management Protocol

Protocol	Transport	Application / Usage	Remarks
HTTP/HTTPS	TCP/IP	CWIS	
SMTP	TCP/IP	E-Mail Alert	
SNMP v1/v2c/v3	UDP/IP	Driver, Installer, Management	SNMP v3 Default OFF
DHCP	UDP/IP	IP setup	
BOOTP	UDP/IP	IP setup	
RARP	TCP/IP	IP management	
AutoIP	TCP/IP	Installer (Device discovery)	
WINS	TCP/IP	IP setup	
Bonjour (mDNS)	UDP/IP	IP setup for Mac	
DNS	TCP/IP	IP management	
DDNS	TCP/IP	IP management	Default: OFF
SNTP	TCP/IP	IP management	Default: OFF
FTP	TCP/IP	IP management	
(3615) LDAP	TCP/IP	Address Book	
(3615) LDAPS	TCP/IP	Address Book	Need SD Option

MIB

The following MIBs are supported.

- RFC1213 MIB-II
- RFC1514 Host Resources
- RFC1759 Printer MIB
- Printer port monitor MIB
- XCMIB MIB

Decomposer

PDL

PDL	Interface		Remark
	USB I/F, Network	USB Storage	
PCL 5c	Yes	No	
PCL 6	Yes	No	Support OS (Driver): Windows XP / Server 2003 / Vista / Server 2008 / 7 / Server2008 R2 / Server 2012 / 8
PostScript	Yes	No	Support OS (Driver): Mac OS X (10.5/10.6/10.7/10.8), Linux, Windows XP / Server2003 / Vista / Server2008/ 7 /Server2008 R2 / Server 2012 / 8
PDF	Yes	Yes	Ver 1.6
TIFF	No	Yes	
JPEG	No	Yes	
HBPL	Yes	No	

Yes: Supported, **No:** Not supported

PCL Font

94 fonts 49 symbol sets for XC.

PostScript Font

Same as built-in PCL font.

Job Control

Print Cancel

A print job in progress can be cancelled from the operator panel.

Job Recovery

When a print job fails due to a recoverable error such as paper jam, the machine recovers the job automatically after the jammed paper is removed.

If no non-volatile storage such as SD-Card, Don't shut off a power supply.

Job Timeout

When a print job is stopped for a certain period of time (time can be changed and can also be set to unlimited on the operator panel), the print data of the job is deleted as an error.

Auditron (For XC Model supported but not public)

Auditron is a function to designate the use of print volume per user. Only the administrator can set restrictions from the CWIS.

The user name and password are embedded in the print job to confirm from whom the job is sent. In addition, the user name and password are entered by user from the printer driver.

The printer can support maximum 50 accounts.

Secure Print (Stored Print)

When the expansion memory (512MB) or SD-Card is installed, the printer holds print data in memory, including a user password (1-12 digits), a user name, and a document name specified via the printer driver. The data is not printed until the same password, user name, and document name are specified at the printer UI. The user can select whether to clear the data after printing. The data remains in the printer as long as it is not cleared. The data on the memory is cleared when the printer is turned off. The data on the SD-Card is not cleared even the printer is turned off.

Saved Job

When the memory capacity is 1GB or SD-Card is attached, the Saved job can be selected only. When print job is selected "Saved Job" in the Job Type menu on the driver, everyone cannot print job from operator panel if unknown password. And this print job remains till deleted intentionally. The data on the memory is cleared when the printer is turned off. The data on the SD-Card is not cleared even the printer is turned off.

A user can also set a password as saved job.

IP Filter

The user can select to accept or reject jobs for the specified IP address. Up to 5 IP addresses can be specified. IP filter is available only to LPD and Port 9100.

Logging

Job Logging

The machine can retain up to 20 job logs.

Job log is printed instantly by user's request or automatically when the number of the retained job logs has reached 20.

Job log includes the following information:

- Job completion date and time
- (3615) Job Type (Print/File/Fax Send/Fax Received/Copy/Scan)
- Input interface (USB, LPD, Port9100)
- Document name (File name)
- User name
- Host name (It is not displayed when XC XCPT Driver is used.)
- Number of printed sheets
- Number of printed impressions
- Paper size
- Result (Successful, Error, etc.)

Error Logging

The machine can retain the following errors.

- Fatal error: 42 errors at the maximum (10 errors at the minimum)
- Jam error: 42 errors

The user can print the error log by the panel operation.

Jam error log includes the following information.

- Date and time when a jam occurred
- Jam name

Fatal error log includes the following information:

- Date and time when error has occurred
- Error code

Billing Counter

The PV counter counts the number of sheets printed properly (Similar to Odometer).

Counter	Description
Total PV (7 digits)	Count the total number of sheets printed.

ID Print

User name can be printed. The printing position can be selected from top right, top left, bottom right, and bottom left (Only for PCL6). The user selects using the operator panel whether user name is printed or not and where it is printed.

Non-Genuine Mode

When the life of a Print cartridge has ended, the printer stops accepting print requests (the life of a Print cartridge is counted by the counter in CRUM). Taking into consideration that some users use refilled Print cartridges they get from remanufacturers, the printer can accept print requests issued by the user via the operator panel even if the life of the Print cartridge has ended. When the mode has been changed so that the printer does not stop even after the life end of the Print cartridge, the printer displays a message on the operator panel indicating e mode change. When the printer operates in this mode, print image quality is not guaranteed. Remaining toner level is not displayed, either (as CRUM data can not be guaranteed).

Cable Characteristics

With pseudo cable from 0 to 15km, the highest speed shall be guaranteed for communication with V.17, V.29, and V.27ter. For V.34, 33600bps communication speed shall be guaranteed from 0 to 2km, 31200bps or higher communication speed from 2 to 9km, and 19200bps or higher communication speed from 9 to 15km.

Communication Load Characteristics

- Data error characteristics for noise and cable loss during communication are as follows:
- Error rate (Error frequency/Total communication quantity) $\leq 1/500$

Incoming Call Level

Under ideal conditions (flat line, no noise, and no other line stress), normal communication shall be guaranteed in the range from -3 through -43dBm.

For V.17, V.29, and V.27ter, the highest speed shall be guaranteed in the range from -6 through -43dBm. For V.34, 33600bps communication speed shall be guaranteed in the range from -9 through -19dBm, and 16800bps or higher communication speed in the range from -19 through -43dBm.

For V.34, normal communication shall be guaranteed in the range from -9 through -43dBm.

IIT (Image Input Terminal) Specifications (3615)

Scanner

Scanning Method

- Platen: Document-fixed flatbed scanning method
- DADF: Carriage-fixed, document-feeding scanning method (2- side scanning)

Optical Resolution

- 1200 x 1200 dots / 25.4mm (max)

Light Source

- LED

Maximum Scanning Guarantee Area

- Platen: 8.5 x 14 in. (215.9mm x 355.6mm)
- ADF: 8.5 x 14 in. (215.9mm x 355.6mm)

Scanning Halftone Level

- Output from the CCD has the following halftone level.
- Gray: 16bit x 2ch (CDD/EVEN)
- Color: 16bit x 3ch (R/G/B)

Platen

Document Condition

Document shall be a sheet form free from damages, wrinkles, and folds.

Document Thickness

Document thickness is 3.93 in (100mm) or less when the platen cover (DADF) is opened. However, when the DADF is closed, it must remain horizontal for up to 0.78 in. (20mm) thickness of book.

Special Document (Reference)

The following documents can be scanned with the platen cover (DADF) closed.

- **Highly glossy document:** There shall be no extensive image deletion due to surface reflection even with photo folders, CD sleeves, etc.
- **Folded document:** There shall be no remarkable shadow even with 1.18 in. (30mm) or less thick book documents, half-folded/Z-folded documents, etc., excluding the binding margin portion of book documents.

Prohibited Document

It is prohibited to place the following documents on the platen.

- Document and object that weigh 5kg or more
- Document and object that contain much moisture

Document Size Detection

This function is not supported.

Platen Glass

- Size: 8.7 x 14.17 in. (221mm x 360mm) (Flat glass area)
- Withstand load: The machine operates normally when a distributed load of 49N (A4 surface load) is applied to the center of the platen.
- The platen glass shall not be broken when a book document is placed on the platen glass and 196N load is applied from the center of the closed platen cover (DADF). (The evaluation method shall comply with the operation proof stress test method of FX Product Quality Evaluation Dept.)

Document Image Area

Scanning area is as follows (Platen mode):

- Max: 8.5 x 14 in. (215.9mm x 355.6mm)

Document Setting Reference Position

Left rear corner as viewed from the front side.

DADF

Acceptable Document

Feed-able paper size:

- **Min:** Fast scan direction 5.5 in. (139.7mm) x Slow scan direction 5.5 in. (139.7mm)
- **Max:** Fast scan direction 8.5 in. (215.9mm) x Slow scan direction 14 in. (355.6mm)

Basis weight:

- **Simplex:** 50g/m² - 125g/m²
- **Duplex:** 60g/m² - 125g/m²

Paper type:

- Cut paper, plain paper

Irregular Document

The documents shown below shall not be damaged (torn) when they are fed from the DADF. However, image quality, jam rate, etc. are not guaranteed.

- Thermal paper.
- Documents with smooth surface (coating paper).
- Documents with rough surface.
- Documents immediately after printed out.
- Documents with many punch holes (Loose-leaf paper, etc.).
- Unfolded half/Z-folded documents.
- Hole-punched documents.

Prohibited Document

It is prohibited to feed the following documents from the DADF.

- Stapled or clipped documents.
- Documents with paper, tape, etc. attached on it.
- Torn documents.
- Special documents other than documents that are specified as not guaranteed in this performance specification.
- Photos.
- Transparencies.
- Documents with silicon etc. adhered to it.
- Documents that are curled by 0.4 in. (10mm) or more in height, and the height/length (h/l) ratio is 1/4 or more (See the figure below).
- Documents folded by 0.2 in. (5mm) or more in height and 0.8 in. (20mm) or less in length
- Documents of which basis weight is less than 50g/m² or more than 125g/m².
- Documents that meet more than one condition defined in this performance specification for document not guaranteed.

Document Size Detection

The device has Legal size sensor.

Feeding Method

- Feeding order: Top to bottom feed
- Document setting: Place document face up

Retention Angle / Open Angle of Platen Cover with DADF

- Maximum open angle: 70 deg or Less
- Platen cover can be retained at any angle: 15 +/- 5 through 65 +/- 5 deg
- Platen cover self-weight drop angle: 15 +/- 5 deg or less

Document Setting

Center registration

Mixed-size Document

This function is not supported.

Document Tray Capacity

- 60 sheets of standard document (about 80gsm), or document stack height is 0.3 in. (8 mm) or less.
- Document shall not be creased/folded/swollen, etc.

Output Document Stacking Reliability for Acceptable Document and Special Document

- The following conditions shall be met for up to the maximum capacity of the document setting tray.
- Output paper shall stack in the right order and shall not drop from the output tray.

Document Jam Recovery Procedure

Open the DADF left cover and pull out the document. If you cannot pull out the jammed document, lift up the lever that you can see at the front side when the left cover is opened to release the nip of the document pull-in part, and then remove the document.

FAX Specifications (3615)

FAX Communication

Communication Mode

The supported communication modes and priorities are as follows:

- Priority 1: ITU-T Super G3
- Priority 2: ITU-T G3 ECM
- Priority 3: ITU-T G3

ITU: International Telecommunication Union

ITU-T: ITU Telecommunication Standardization Sector

ECM: Error Correction Mode

Pixel transmission density

Pixel transmission density on the supported transmission path is as follows:

- R16 x 15.4 line/mm
- R8 x 15.4 line/mm
- R8 x 7.7 line/mm
- R8 x 3.85 line/mm
- 400 x 400 pixel/25.4mm (PHOTO - Grayscale)
- 300 x 300 pixel/25.4mm (SUPERFINE)
- 200 x 200 pixel/25.4mm (FINE)
- 200 x 100 pixel/25.4mm (STANDARD)

Modem Signal Processing

The following communication standards are supported:

- V.34 (33.6 /31.2 /28.8 /26.4 /24 /21.6 /19.2 /16.8 /14.4 /12 /9.6 /7.2 /4.8 /2.4kbps)
- V.17 (14.4 /12 /9.6 /7.2kbps)
- V.29 (9.6 /7.2kbps)
- V.27ter (4.8 /2.4kbps)

Halftone/Compression Method

1bit, JBIG, MMR, MR, MH encoding.

Communication Control Procedure

Complies with ITU-T recommendation T.30.

Image Data Transmission Time

Transmission time (T_p) of image data in G3 mode is as follows:

- Resolution conversion is not performed during transmission, and density is normal.
- Specified value condition: ECM (No data error)

Chart		14.4Kbps (MMR)	28.8Kbps (MMR)	33.6Kbps (JBIG)*1
IIEEJ No.4	Super Fine	56 sec. or less	29 sec. or less	22 sec. or less
	Fine	26 sec. or less	13 sec. or less	11 sec. or less
	Standard	19 sec. or less	10 sec. or less	7 sec. or less
ITU-T No.1	Super Fine	30 sec. or less	15 sec. or less	12 sec. or less
	Fine	15 sec. or less	8 sec. or less	6 sec. or less
	Standard	11 sec. or less	6 sec. or less	4 sec. or less
English Sales Text	Standard	7 sec. or less	4 sec. or less	2 sec. or less
Japanese Sales Text	Standard	9 sec. or less	5 sec. or less	4 sec. or less
IIEEJ No.1	Standard	75 sec. or less	38 sec. or less	20 sec. or less

Note: *1: Reference value

Protocol Control Time

When no data error occurs, protocol control time (T_m , T_n , T_u) is as follows:

- V.17, V.29, V.27ter

Mode	Before messages: T_m	Between messages: T_n	After messages: T_u	Total
Standard protocol	16.4 sec. or less	3.2 sec. or less	4.4 sec. or less	24.0 sec. or less

- V.34

Mode	Before messages: T_m	Between messages: T_n	After messages: T_u	Total
Standard protocol	9.9 sec. or less	1.0 sec. or less	0.9 sec. or less	11.8 sec. or less

Throughput

The sending time is calculated in the following formula:

- Sending time = Call setup time + T_m + $(N \times T_p)$ + $\{(N-1) \times T_n\}$ + T_u (sec) (N: Send quantity, T_p : Image transmission time)

Media Guidelines

Print media is paper, transparencies, labels, envelopes, coated paper and several other types. The printer prints on a variety of print media. Selecting the appropriate print media for the printer helps avoid printing problems. This chapter describes how to select, store, and load print media. For the best results in color, a 75 g/m² (20 lb.) xerographic, long grain paper is recommended. For the best results in black and white, use 90 g/m² (24 lb.) xerographic, long grain paper. When loading paper, identify the recommended print side on the paper package, and load the paper accordingly.

Paper Characteristics

The following paper characteristics affect image quality and printer reliability. Use these guidelines when evaluating the customer's paper stock.

Weight

The trays automatically feed paper weights from 60 to 220 g/m² (16 to 32 lb. bond) grain long. Paper lighter than 60 g/m² (16 lb.) might not feed properly, and could cause paper jams. For best performance, use 75 g/m² (20 lb. bond) grain long paper.

Curl

Curl is the tendency of media to curve at its edges. Excessive curl can cause feeding problems. Curl usually occurs after the paper passes through the printer, where it is exposed to high temperatures. Storing paper unwrapped in humid conditions, even in the paper tray, can contribute to curling prior to printing and cause feeding problems.

Smoothness

The degree of surface smoothness directly affects image quality. If the paper is too rough, the toner does not fuse to the paper properly, resulting in poor image quality. If the paper is too smooth, it can cause feeding problems. Smoothness between 150 and 250 Sheffield points produces the best print quality.

Moisture Content

The amount of moisture in the paper affects both print quality and the ability of the printer to feed the paper properly. Paper should remain in its original packaging until loaded. This limits the exposure of the paper to moisture changes that can degrade its performance.

Grain Direction

Grain refers to the alignment of paper fibers in a sheet of paper. Grain is either long, running the length of the paper, or short, running the width of the paper. For 60 to 135 g/m² (16 to 36 lb. bond) paper, long grain fibers are recommended. For papers heavier than 135 g/m² (36 lb. bond), short grain is preferred.

Fiber Content

Most high-quality xerographic paper is made from 100 % chemically pulped wood. Paper containing fibers such as cotton possess characteristics that can result in degraded paper handling.

Recommended Paper

Refer to the Recommended Media List (RML) for media approved for use in this product.

Unacceptable Paper

The following paper types are not recommended:

- Chemically treated papers used to make copies without carbon paper, also known as carbonless papers, carbonless copy paper (CCP), or no carbon required (NCR) paper
- Preprinted papers with chemicals affected by Fuser temperatures
- Preprinted forms that require registration (the print location on the page) greater than ±0.09 in., such as optical character recognition (OCR) forms. In some cases, the application can adjust registration to successfully print on these forms.
- Coated papers (erasable bond), synthetic papers, thermal papers
- Rough-edged, rough or heavily textured surface papers or curled papers
- Recycled papers containing more than 25 % post-consumer waste that do not meet DIN 19 309
- Multiple-part forms or documents
- Perforated or pre-cut label paper

Specifications

COPYRIGHT © 2012, XEROX CORPORATION.
ALL RIGHTS RESERVED. UNPUBLISHED
RIGHTS RESERVED UNDER THE COPYRIGHT
LAWS OF THE UNITED STATES.

PART#: 702P00566

