

Version 1.0  
November 2021  
702P08674

# Xerox® C310 Color Printer Service Manual

**Publication Information**

Product: Xerox® C310 Printer

Title: Xerox® C310 Printer Service Manual

Part Number: 702P08674

Publication Status: Launch release

Publication Date: November 2021

**Preparation Notes:**

Prepared for:

Xerox Corporation

800 Phillips Road

Webster, New York, 14580

**Copyright Statement:**

© 2021 Xerox Corporation. All Rights Reserved. Xerox®, and Xerox are trademarks of Xerox Corporation in the United States and/or other countries.

Registered Trademarks:

Other company trademarks are also acknowledged.

**NOTICE**

While every care has been taken in the preparation of this manual, no liability will be accepted by Xerox arising out of any inaccuracies or omissions.

All service documentation is supplied to Xerox external customers for informational purposes only. Xerox service documentation is intended for use by certified, product trained service personnel only. Xerox does not warrant or represent that it will notify or provide to such customer any future change to this documentation. Customer performed service of equipment, or modules, components or parts of such equipment may affect whether Xerox is responsible to fix machine defects under the warranty offered by Xerox with respect to such equipment. You should consult the applicable warranty for its terms regarding customer or third-party provided service.

# Table of Contents

1 Notices, Conventions, and Safety Information.....	11
Laser Notice.....	12
Avis Relatif À L'utilisation Du Laser .....	12
Aviso De Láser .....	12
Laser-hinweis .....	13
Avvertenza sui prodotti laser .....	13
Conventions.....	14
Conventions.....	14
Convenciones.....	14
Konventionen .....	15
Convenzioni .....	15
Safety Information .....	17
Consignes De Sécurité.....	17
Información De Seguridad .....	18
Sicherheitshinweise.....	19
Informazioni sulla sicurezza .....	20
Health and Safety Incident Reporting .....	22
2 Change History.....	25
Change History .....	26
3 General Information .....	27
Printer Model Configurations .....	28
Finding The Serial Number.....	29
Paper Support.....	30
Supported Paper Sizes.....	30
Supported Paper Types .....	33
Supported Paper Weights.....	34
Tools Required For Service .....	36
4 Diagnostics and Troubleshooting.....	37
Troubleshooting Precautions .....	38
Précautions De Dépannage.....	38
Precauciones Durante La Solución De Problemas.....	39
Vorsichtsmaßnahmen Bei Der Fehlerbehebung .....	39
Precauzioni per gli interventi di riparazione .....	40
Troubleshooting Overview.....	41
Performing The Initial Troubleshooting Check .....	41

## Table of Contents

Fixing Print Quality Issues .....	42
Initial Print Quality Check .....	42
Supplies Used To Resolve Print Quality Issues .....	42
Blurred Print Check.....	43
Misaligned Color Check.....	45
Toner Easily Rubs Off Check .....	46
Gray or Solid Background Check.....	48
Solid Color or Black Image Check .....	50
Blank or White Pages Check .....	53
Horizontal White Lines Check.....	55
Horizontal Colored Lines or Banding Check.....	57
Text or Images Cut Off Check .....	58
Mottled Print and Dots Check.....	60
Vertical White Lines Check .....	63
Ghost Images Check.....	65
Dark Print Check .....	67
Missing Color Check .....	69
Uneven Print Density Check .....	73
Repeating Defects Check .....	75
Light Print Check.....	78
Skewed Print Check.....	81
Toner Patch Sensing Service Check.....	83
Auto Alignment Service Check.....	88
Paper Jams .....	93
Avoiding Jams.....	93
Identifying Jam Locations.....	94
200 Paper Jams .....	95
202 Paper Jams .....	100
231 Paper Jams .....	107
232 Paper Jams .....	112
24y Paper Jams .....	114
User Attendance Messages .....	122
Non-Xerox Supply .....	122
Metered Supply Installed in Printer Configured For Sold .....	122
24 User Attendance Errors .....	125
31 User Attendance Errors .....	125
32 User Attendance Errors .....	126
33 User Attendance Errors .....	127
34 User Attendance Errors .....	130
42 User Attendance Errors .....	130
43 User Attendance Errors .....	131
80 User Attendance Errors .....	132
82 User Attendance Errors .....	133
84 User Attendance Errors .....	134
88 User Attendance Errors .....	135
Non-Supply User Attendance Errors .....	137
Printer Hardware Errors .....	148
100 Errors.....	148

110 Errors .....	148
120 Errors .....	150
121 Errors .....	151
126 Errors .....	158
142 Errors .....	160
151 Errors .....	162
160 Errors .....	163
161 Errors .....	165
162 Errors .....	167
163 Errors .....	168
166 Errors .....	168
167 Errors .....	169
171 Errors .....	169
600 Errors .....	171
602 Errors .....	171
620 Errors .....	172
642 Errors .....	173
651 Errors .....	173
661 Errors .....	174
662 Errors .....	175
663 Errors .....	175
666 Errors .....	176
667 Errors .....	176
Procedure Before Starting The 9yy Service Checks.....	177
900 Errors .....	178
91y Errors .....	182
938 Errors .....	184
95y Errors .....	185
96y Errors .....	189
97y Errors .....	190
980-984 Errors .....	191
99y Errors .....	192
Other Symptoms.....	195
Base Printer Symptoms .....	195
Input Option Symptoms .....	215
5 Service Menus.....	251
Using The Control Panel.....	252
Xerox C310 .....	252
Understanding The Status Of The Power Button and Indicator Light.....	253
Using The Home Screen.....	253
Configuring The Door Interlock Bypass Jumpers.....	256
Diagnostics Menu .....	258
Entering The Diagnostics Menu.....	258
Reports .....	258
Advanced Print Quality Samples.....	258
Event Log.....	258

## Table of Contents

Input Tray Quick Print .....	259
Printer Setup.....	260
Printer Diagnostics and Adjustments.....	262
Additional Input Tray Diagnostics .....	265
Configuration Menu.....	267
Service Engineer Menu.....	271
Entering The Service Engineer (SE) Menu .....	271
General SE .....	271
Network SE .....	271
Entering Invalid Engine Mode .....	273
Entering Recovery Mode .....	274
For LED Display .....	274
For 2.4- inch Display.....	274
6 Parts Removal .....	275
Data Security Notice.....	276
Identifying Printer Memory.....	276
Erasing Printer Memory.....	276
Removal Precautions.....	278
Précautions De Retrait.....	278
Precauciones Durante La Extracción .....	279
Vorsichtsmaßnahmen Bei Der Demontage.....	279
Precauzioni per la rimozione.....	280
Handling ESD-sensitive Parts.....	280
Critical Information For Controller Board or Control Panel Replacement .....	281
Restoring The Printer Configuration After Replacing The Controller Board .....	282
Restoring Solutions, Licenses, and Configuration Settings.....	282
Updating The Printer Firmware .....	284
Disconnecting Ribbon Cables .....	285
Ribbon Cable Connectors .....	286
Adjustments .....	288
Registration Adjustment .....	288
Entering The TPS Characterization Data .....	291
Removal Procedures.....	292
Left Side Removals.....	293
Left Cover Removal.....	293
Motor (drive Unit) Removal.....	294
EP Drive Assembly Removal.....	295
LVPS Removal .....	298
Sensor (fuser Exit) Removal.....	300
Speaker (CS622) Removal .....	304
Right Side Removals.....	306
Right Cover Removal.....	306
Toner Supply Door Removal .....	306
Motor (fuser Drive) Removal .....	307
TMC Card Removal .....	308

Sensors (toner Patch) Removal.....	311
Developer Unit Removal.....	313
HVPS Removal.....	314
Transfer Module Removal.....	319
Imaging Kit Removal.....	323
Toner Cartridge Contacts Removal.....	325
Waste Toner Bottle Removal.....	327
Waste Toner Bottle Contact Block Removal.....	328
Front Removals.....	330
Front Door Removal.....	330
Front Door Inner Deflector Removal.....	334
Interlock Switch Cover Assembly Removal.....	335
Control Panel Base Removal.....	337
2.4-inch Control Panel Badge Cover Removal.....	337
2.4-inch Control Panel Bezel Removal.....	338
2.4-inch Control Panel Top Cover Removal.....	338
2.4-inch Control Panel Keypad Removal.....	340
Weather Station Removal.....	341
Wireless Card Removal.....	344
Front USB Cable Removal.....	345
Fuser Removal.....	349
Exit Deflector Removal.....	352
Bottom Removals.....	355
Pick Tires Removal.....	355
Lower Left Frame Removal.....	357
Lower Right Frame Removal.....	367
Sensor (duplex) Removal.....	373
Transfer Module Guide Removal.....	375
Sensor (tray Present) Removal.....	378
Tray 1 Media Feeder Removal.....	379
Rear Side Removals.....	383
System Fan Removal.....	383
Rear Cover Removal.....	384
Controller Board Removal.....	386
Top Side Removals.....	388
Top Cover Removal.....	388
Sensor (narrow Media/output Bin Full) Removal.....	391
Narrow Media/bin Full Sensor Flag Removal.....	393
Printhead Removal.....	394
Right Output Bin Deflector Removal.....	396
Options Removals.....	397
650-sheet Duo Tray Insert Removal.....	397
650-sheet Duo Tray Removal.....	397
Dust Cover Removal.....	398
Pick Tire Removal.....	399
7 Component Locations.....	403

## Table of Contents

Printer Configurations .....	404
Controller Board Connectors.....	405
Motor Locations.....	419
Sensor Locations.....	420
8 Maintenance .....	421
Inspection Guide.....	422
Scheduled Maintenance.....	424
Maintenance Parts.....	424
Resetting The Maintenance Counter .....	425
Cleaning The Printer Parts.....	426
Cleaning The Printer .....	426
Cleaning The Printhead Lenses.....	426
9 Parts Catalog .....	429
Legend .....	430
Assembly 1: 2.4-inch Control Panel.....	431
Assembly 2: Covers .....	433
Assembly 3: Paper Path and Frame .....	435
Assembly 4: Electronics .....	437
Assembly 5: Cables and Sensors.....	439
Assembly 6: Option Trays.....	442
10 Printer Specifications .....	445
Power Consumption .....	446
Product Power Consumption .....	446
Sleep Mode.....	446
Hibernate Mode.....	447
Off Mode.....	447
Total Energy Usage.....	447
Selecting A Location For The Printer.....	448
Noise Emission Levels.....	449
Temperature Information.....	450
Enabling The Security Reset Jumper.....	451
11 Options and Features .....	453
Available Internal Options.....	454
Adding Available Options In The Print Driver.....	455
For Windows Users.....	455
For Macintosh Users.....	455
Input/output Configurations and Capacities .....	456
12 Theory Of Operation.....	457
8 Xerox® C310 Color Printer Service Manual	



Paper Path and Transport Components .....	458
Paper Path Information .....	458
Transport Components.....	459
Duplexing .....	459
Print Engine Theory.....	461
Electrophotographic Process (EP Process) .....	461
Electrophotographic Process Basics .....	461
Color Theory .....	464
Color Theory .....	464
13 Acronyms .....	469
Acronyms.....	470
14 Part Number Index .....	473
15 Part Name Index.....	477

## Table of Contents

# Notices, Conventions, and Safety Information

## Laser Notice

The printer is certified in the U.S. to conform to the requirements of DHHS 21 CFR, Chapter I, Subchapter J for Class I (1) laser products, and elsewhere is certified as a Class I laser product conforming to the requirements of IEC 60825-1: 2014.

Class I laser products are not considered to be hazardous. The laser system and printer are designed so there is never any human access to laser radiation above a Class I level during normal operation, user maintenance, or prescribed service conditions. The printer has a non-serviceable printhead assembly that contains a laser with the following specifications:

Class: IIIb (3b) AlGaInP

Nominal output power (milliwatts): 15

Wavelength (nanometers): 650–670

## Avis Relatif À L'utilisation Du Laser

Cette imprimante est certifiée conforme aux exigences de la réglementation des Etats-Unis relative aux produits laser de classe I (1) (DHHS 21 CFR, Chapitre I, Sous-chapitre J). Pour les autres pays, elle est certifiée conforme aux exigences des normes CEI 60825-1:2014 relatives aux produits laser de classe I.

Les produits laser de classe I ne sont pas considérés comme dangereux. Le système laser ainsi que l'imprimante ont été conçus de manière à ce que personne ne soit jamais exposé à des radiations laser dépassant le niveau de classe I dans le cadre d'un fonctionnement normal, de l'entretien par l'utilisateur ou de la maintenance. L'imprimante dispose d'un ensemble de têtes d'impression non réparable contenant un laser doté des caractéristiques suivantes:

Class: IIIb (3b) AlGaInP

Nominal output power (milliwatts): 15

Wavelength (nanometers): 650–670

## Aviso De Láser

Esta impresora se ha certificado en EE.UU. cumpliendo con los requisitos de DHHS 21 CFR, capítulo I, subcapítulo J para los productos láser de Clase I (1) y en otros países está certificada como un producto láser de Clase I de acuerdo con los requisitos de IEC 60825-1: 2014.

Los productos láser de Clase I no se consideran peligrosos. El sistema láser y la impresora se han diseñado para que el ser humano no acceda nunca a las radiaciones láser por encima del nivel de Clase I durante su uso normal, ni en tareas de mantenimiento o intervenciones de servicio técnico prescritas. El conjunto de cabezal de impresión de la impresora no se puede reparar y contiene un láser con las siguientes especificaciones:

Class: IIIb (3b) AlGaInP

Nominal output power (milliwatts): 15

Wavelength (nanometers): 650–670

## Laser-hinweis

Der Drucker wurde in den USA zertifiziert und entspricht den Anforderungen der Vorschriften DHHS21CFR KapitelI für Laserprodukte der KlasseI(1), andernorts ist er als Laserprodukt der KlasseI zertifiziert, das den Anforderungen von IEC60825-1 entspricht: 2014.

Laserprodukte der KlasseI werden nicht als gefährlich betrachtet. Das Lasersystem und der Drucker sind so konstruiert, dass unter normalen Betriebsbedingungen, bei der Wartung durch den Benutzer oder bei den vorgeschriebenen Wartungsbedingungen Menschen keiner Laserstrahlung ausgesetzt sind, die die Werte für KlasseI überschreitet. Der Drucker verfügt über eine Druckkopfeinheit, die nicht gewartet werden kann und mit einem Laser mit den folgenden Spezifikationen ausgestattet ist.

Class: IIIb (3b) AlGaInP

Nominal output power (milliwatts): 15

Wavelength (nanometers): 650–670

## Avvertenza sui prodotti laser

La stampante è certificata negli Stati Uniti come prodotto conforme ai requisiti DHHS 21 CFR Capitolo I, Sottocapitolo J per i prodotti laser di Classe I (1), mentre in altri paesi è certificata come prodotto laser di Classe I conforme ai requisiti IEC 60825-1: 2014.

I prodotti laser di Classe I non sono considerati pericolosi. Il sistema laser e la stampante sono stati progettati in modo da impedire l'esposizione a radiazioni laser superiori al livello previsto dalla Classe I durante le normali operazioni di stampa, manutenzione o assistenza. La stampante è dotata di un gruppo testina di stampa non riparabile che contiene un laser con le seguenti specifiche:

Classe: IIIb (3b) AlGaInP

Potenza di uscita nominale (milliwatt): 15

Lunghezza d'onda (nanometri): 650–670







## Conventions

**Note:** A *note* identifies information that could help you.

**Warning:** A *warning* identifies something that could damage the product hardware or software.

**CAUTION:** A *caution* indicates a potentially hazardous situation that could injure you.

Different types of caution statements include:

-  **CAUTION—POTENTIAL INJURY:** Indicates a risk of injury.
-  **CAUTION—SHOCK HAZARD:** Indicates a risk of electrical shock.
-  **CAUTION—HOT SURFACE:** Indicates a risk of burn if touched.
-  **CAUTION—TIPPING HAZARD:** Indicates a crush hazard.
-  **CAUTION—PINCH HAZARD:** Indicates a risk of being caught between moving parts.
-  **CAUTION—MOVING PARTS:** Indicates a risk of laceration or abrasion injuries from rotating parts.







## Conventions

**Remarque:** Une *Remarque* fournit des informations pouvant vous être utiles.

**Avertissement:** Un *Avertissement* signale un danger susceptible d'endommager le logiciel ou le matériel.

**ATTENTION:** La mention *Attention* vous signale un risque de blessure corporelle.

Il existe différentes mises en garde:

-  **ATTENTION ! DOMMAGE POTENTIEL :** Signale un risque de blessure.
-  **ATTENTION ! RISQUE D'ÉLECTROCUTION :** Signale un risque d'électrocution.
-  **ATTENTION ! SURFACE CHAUDE :** Signale un risque de brûlure de contact.
-  **ATTENTION ! RISQUE DE BASCULEMENT :** Signale un risque d'écrasement.
-  **ATTENTION ! RISQUE DE PINCEMENT :** Signale un risque de pincement entre des pièces mobiles.
-  **ATTENTION ! PIÈCES MOBILES :** Signale un risque de coupures ou de frottements à cause des pièces rotatives.







## Convenciones

**Nota:** Las *notas* señalan información que puede serle útil.

**Aviso:** Las *advertencias* indican algo que podría dañar el software o el hardware del producto.

**PRECAUCIÓN:** Las *precauciones* indican una situación de posible peligro que puede implicar lesiones para el usuario.

Estos son los tipos de avisos de precaución que existen:

-  **PRECAUCIÓN—RIESGO DE LESIONES:** Indica que existe riesgo de lesiones.
-  **PRECAUCIÓN—RIESGO DE DESCARGA:** Indica que existe riesgo de descarga eléctrica.
-  **PRECAUCIÓN—SUPERFICIE CALIENTE:** Indica que existe riesgo de sufrir quemaduras por contacto.
-  **PRECAUCIÓN—RIESGO DE CAÍDA:** Indica que existe peligro de aplastamiento.
-  **PRECAUCIÓN—RIESGO DE DESCARGA ELÉCTRICA:** Existe riesgo de atrapamiento entre las piezas en movimiento.
-  **PRECAUCIÓN—PARTES MÓVILES:** Indica que existe riesgo de lesiones por laceración o abrasión causadas por piezas giratorias.







## Konventionen

**Hinweis:** Ein *Hinweis* enthält nützliche Informationen.

**Warnung:** Durch eine *Warnung* werden Sie auf einen Umstand hingewiesen, durch den die Produkthardware oder -software beschädigt werden könnte.

**VORSICHT:** *Vorsicht* weist auf eine mögliche gefährliche Situation hin, die ein Verletzungsrisiko birgt.

Verschiedene Vorsichtshinweise:

-  **VORSICHT – VERLETZUNGSGEFAHR:** Weist auf ein Verletzungsrisiko hin.
-  **VORSICHT – STROMSCHLAGGEFAHR:** Weist auf das Risiko eines elektrischen Schlags hin.
-  **VORSICHT – HEISS:** Weist auf das Risiko von Verbrennungen bei Berührung hin.
-  **VORSICHT – KIPPGEFAHR:** Weist auf Quetschgefahr hin.
-  **VORSICHT – QUETSCHGEFAHR:** Weist auf das Risiko hin, zwischen beweglichen Komponenten eingequetscht zu werden.
-  **VORSICHT – BEWEGLICHE TEILE:** Weist auf das Risiko von Verletzungen und Abschürfungen durch sich drehende Teile hin.







## Convenzioni

**Nota:** Una *nota* identifica informazioni che potrebbero essere di aiuto.

**Avvertenza:** Un messaggio di *avvertenza* segnala qualcosa che potrebbe danneggiare l'hardware o il software del prodotto.







**ATTENZIONE:** Un messaggio di *attenzione* segnala una situazione potenzialmente pericolosa che potrebbe causare lesioni all'utente.

I diversi tipi di messaggi di attenzione sono:

-  **ATTENZIONE – PERICOLO DI LESIONI:** Indica il rischio di ferirsi.
-  **ATTENZIONE – PERICOLO DI SCOSSA ELETTRICA:** Indica il rischio di scosse elettriche.
-  **ATTENZIONE – SUPERFICIE SURRISCALDATA:**Indica il rischio di bruciarsi al contatto.
-  **ATTENZIONE – PERICOLO DI RIBALTAMENTO:** Indica il pericolo di essere schiacciati.
-  **ATTENZIONE – PERICOLO DI SCHIACCIAMENTO:** Indica il rischio di intrappolamento tra parti in movimento.
-  **ATTENZIONE – PARTI MOBILI:** Indica il rischio di lesioni da lacerazione o abrasione dovute a parti rotanti.



## Safety Information



- The safety of this product is based on testing and approvals of the original design and specific components. The manufacturer is not responsible for safety in the event of use of unauthorized replacement parts.
  - The maintenance information for this product has been prepared for use by a professional service person and is not intended to be used by others.
  - There may be an increased risk of electrical shock and personal injury during disassembly and servicing of this product. Professional service personnel should understand this risk and take necessary precautions.
-  **CAUTION—SHOCK HAZARD:** When you see this symbol on the product, there is a danger from hazardous voltage in the area of the product where you are working. Unplug the product before you begin, or use caution if the product must receive power in order to perform the task.
-  **CAUTION—POTENTIAL INJURY:** The lithium battery in this product is not intended to be replaced. There is a danger of explosion if a lithium battery is incorrectly replaced. Do not recharge, disassemble, or incinerate a lithium battery. Discard used lithium batteries according to the manufacturer's instructions and local regulations.
-  **CAUTION—POTENTIAL INJURY:** To avoid the risk of fire or electrical shock, connect the power cord to an appropriately rated and properly grounded electrical outlet that is near the product and easily accessible.
-  **CAUTION—POTENTIAL INJURY:** To avoid the risk of fire or electrical shock, use only the power cord provided with this product or the manufacturer's authorized replacement.
-  **CAUTION—POTENTIAL INJURY:** Do not use this product with extension cords, multioutlet power strips, multioutlet extenders, or UPS devices. The power capacity of these types of accessories can be easily overloaded by a laser printer and may result in a risk of fire, property damage, or poor printer performance.
-  **CAUTION—POTENTIAL INJURY:** Only a Xerox Inline Surge Protector that is properly connected between the printer and the power cord provided with the printer may be used with this product. The use of non-Xerox surge protection devices may result in a risk of fire, property damage, or poor printer performance.
-  **CAUTION—POTENTIAL INJURY:** If the printer weight is greater than 20kg (44lb), then it may require two or more people to lift it safely.

## Consignes De Sécurité

- La sécurité de ce produit est basée sur des tests et certifications de sa conception d'origine et de ses composants spécifiques. Le fabricant décline toute responsabilité en cas d'utilisation de pièces de rechange non autorisées.
- Les informations de maintenance de ce produit sont destinées à des professionnels qualifiés et ne sont pas conçues pour être utilisées par d'autres personnes.
- Il existe un risque potentiel de choc électrique et de blessures lors du démontage et de la maintenance de ce produit. Le personnel professionnel de maintenance doit comprendre les risques et prendre les précautions nécessaires.



-  **ATTENTION ! RISQUE D'ÉLECTROCUTION :** Ce symbole indique un danger lié à des niveaux de tension dangereux dans la zone du produit à manipuler. Débranchez le produit avant de commencer, ou agissez avec prudence si le produit doit être alimenté pour effectuer l'opération.
-  **ATTENTION ! DOMMAGE POTENTIEL :** La batterie lithium de ce produit n'est pas destinée à être remplacée. Si vous ne respectez pas les instructions de remplacement de la batterie, vous risquez de provoquer une explosion. Ne rechargez pas, ne désassemblez pas et ne brûlez pas la batterie au lithium. Mettez les batteries lithium usagées au rebut selon les instructions du fabricant et les réglementations locales.
-  **ATTENTION ! DOMMAGE POTENTIEL :** Pour éviter tout risque d'électrocution ou d'incendie, branchez le câble d'alimentation directement à une prise électrique répondant aux exigences requises et correctement mise à la terre, proche du produit et facile d'accès.
-  **ATTENTION ! DOMMAGE POTENTIEL :** Pour éviter tout risque d'incendie ou d'électrocution, utilisez uniquement le câble d'alimentation fourni avec ce produit ou un câble de remplacement autorisé par le fabricant.
-  **ATTENTION ! DOMMAGE POTENTIEL :** Ce produit ne doit pas être utilisé avec des rallonges, des barres multiprises, des rallonges multiprises ou des périphériques UPS. La capacité de ces types d'accessoires peut être facilement dépassée par une imprimante laser, d'où un risque de dégâts matériels, d'incendie ou de performances d'impression amoindries.
-  **ATTENTION ! DOMMAGE POTENTIEL :** Utilisez uniquement un parasurtenseur correctement raccordé à l'imprimante et au câble d'alimentation fourni avec la machine. L'utilisation de parasurtenseurs non fabriqués par Xerox comporte un risque d'incendie et de dégâts matériels, et peut amoindrir les performances de l'imprimante.
-  **ATTENTION ! DOMMAGE POTENTIEL :** Si votre imprimante pèse plus de 20kg (44lb), l'intervention d'au moins deux personnes est nécessaire pour la soulever sans risque.





## Información De Seguridad

- La seguridad de este producto se basa en las pruebas y comprobaciones del diseño original y los componentes específicos. El fabricante no se hace responsable de la seguridad en caso de uso de piezas de repuesto no autorizadas.
- La información de mantenimiento de este producto se ha preparado para su uso por parte de un profesional de asistencia técnica y no está diseñada para su uso por parte de otros usuarios.
- Es posible que haya un mayor riesgo de descarga eléctrica y daños personales durante el desmontaje y el mantenimiento de este producto. El personal de asistencia profesional debe conocer este riesgo y tomar las precauciones necesarias.
-  **PRECAUCIÓN—RIESGO DE DESCARGA:** Cuando vea este símbolo en el producto, existe peligro de tensiones peligrosas en el área del producto en la que está trabajando. Desconecte el producto antes de empezar o tenga cuidado si el producto debe recibir alimentación a fin de realizar la tarea.
-  **PRECAUCIÓN—RIESGO DE LESIONES:** La batería de litio de este producto no debe reemplazarse. Existe riesgo de explosión si se sustituye incorrectamente una batería de litio. No recargue, desmonte ni incinere una batería de litio. Deseche las baterías de litio usadas según las instrucciones del fabricante y las normativas locales.





-  **PRECAUCIÓN—RIESGO DE LESIONES:** Para evitar el riesgo de incendio o descarga eléctrica, conecte el cable de alimentación a una toma de corriente debidamente conectada a tierra con la potencia adecuada que se encuentre cerca del dispositivo y resulte fácilmente accesible.
-  **PRECAUCIÓN—RIESGO DE LESIONES:** Para evitar el riesgo de incendio o descarga eléctrica, utilice exclusivamente el cable de alimentación que se suministra junto con este producto o el repuesto autorizado por el fabricante.
-  **PRECAUCIÓN—RIESGO DE LESIONES:** No utilice este producto con cables alargadores, regletas de varias tomas, cables alargadores de varias tomas o sistemas de alimentación ininterrumpida. La potencia de este tipo de accesorios puede sobrecargarse fácilmente si se utiliza una impresora láser, lo que puede dar lugar a que el rendimiento de la impresora sea bajo, a daños materiales o a posibles incendios.
-  **PRECAUCIÓN—RIESGO DE LESIONES:** Solo debe usarse con este producto un protector de sobretensión insertable Xerox debidamente conectado entre la impresora y el cable de alimentación que con ella se suministra. El uso de protectores de sobretensión de marcas distintas a Xerox puede dar lugar a que el rendimiento de la impresora sea bajo, a daños materiales o a posibles incendios.
-  **PRECAUCIÓN—RIESGO DE LESIONES:** si el peso de la impresora es superior a 20kg (44lb), pueden ser necesarias dos o más personas para levantarla de forma segura.

## Sicherheitshinweise

- Die Sicherheit dieses Produkts basiert auf Tests und Zulassungen des Originaldesigns und der spezifischen Komponenten. Sofern nicht autorisierte Ersatzteile eingesetzt werden, übernimmt der Hersteller keinerlei Verantwortung in Bezug auf die Sicherheit dieses Produkts.
- Die Wartungsinformationen für dieses Produkt wurden für ausgebildete Servicemitarbeiter zusammengestellt und dürfen nicht von anderen verwendet werden.
- Möglicherweise besteht bei der Demontage und Wartung dieses Produkts eine erhöhte Stromschlag- und Verletzungsgefahr. Ausgebildete Servicemitarbeiter sollten sich dieser Gefahr bewusst sein und die notwendigen Vorsichtsmaßnahmen ergreifen.
-  **VORSICHT – STROMSCHLAGGEFAHR:** Wenn Sie dieses Symbol sehen, besteht eine Gefahr durch gefährliche Spannungen in dem Produktbereich, in dem Sie arbeiten. Trennen Sie das Produkt von seiner Stromverbindung, bevor Sie beginnen, oder gehen Sie vorsichtig vor, wenn das Produkt für die Durchführung der Aufgabe mit Strom versorgt werden muss.
-  **VORSICHT – VERLETZUNGSGEFAHR:** Die Lithiumbatterie in diesem Produkt darf nicht ausgetauscht werden. Wird eine Lithiumbatterie nicht ordnungsgemäß ausgetauscht, besteht Explosionsgefahr. Lithiumbatterien dürfen auf keinen Fall wieder aufgeladen, auseinander genommen oder verbrannt werden. Befolgen Sie zum Entsorgen verbrauchter Lithiumbatterien die Anweisungen des Herstellers und die örtlichen Bestimmungen.
-  **VORSICHT – VERLETZUNGSGEFAHR:** Um Feuer- und Stromschlaggefahr zu vermeiden, schließen Sie das Netzkabel direkt an eine ordnungsgemäß geerdete Steckdose an, die sich in der Nähe des Geräts befindet und leicht zugänglich ist.

-  **VORSICHT – VERLETZUNGSGEFAHR:** Um das Risiko eines Feuers oder elektrischen Schlags zu vermeiden, verwenden Sie ausschließlich das diesem Produkt beiliegende Netzkabel bzw. ein durch den Hersteller zugelassenes Ersatzkabel.
-  **VORSICHT – VERLETZUNGSGEFAHR:** Verwenden Sie das Produkt nicht mit Verlängerungskabeln, Mehrfachsteckdosen, Mehrfachverlängerungen oder Geräten für unterbrechungsfreie Stromversorgung. Die Belastbarkeit solcher Zubehörteile kann durch Laserdrucker schnell überschritten werden, was zu Brandgefahr, Beschädigung von Eigentum oder einer eingeschränkten Druckerleistung führen kann.
-  **VORSICHT – VERLETZUNGSGEFAHR:** Mit diesem Produkt darf nur ein Xerox Inline Surge Protector verwendet werden, der vorschriftsgemäß zwischen dem Drucker und dem mitgelieferten Netzkabel angeschlossen ist. Die Verwendung von nicht von Xerox stammenden Überspannungsschutzgeräten kann zu Brandgefahr, Beschädigung von Eigentum oder einer eingeschränkten Druckerleistung führen.
-  **VORSICHT – VERLETZUNGSGEFAHR:** Wenn der Drucker mehr als 20kg wiegt, sind zum sicheren Anheben mindestens zwei Personen notwendig.

## Informazioni sulla sicurezza

- La sicurezza di questo prodotto è basata sul collaudo e le approvazioni del progetto tecnico originale e di specifici componenti. Il produttore non è responsabile per la sicurezza in caso di utilizzo di parti di ricambio non autorizzate.
- Le informazioni sulla manutenzione di questo prodotto sono rivolte esclusivamente a personale di manutenzione e assistenza specializzato.
- L'intervento di smontaggio e manutenzione/riparazione di questo dispositivo potrebbe comportare un maggiore rischio di scossa elettrica o lesioni personali. Il personale di assistenza specializzato deve essere consapevole di tale rischio e assumere le necessarie precauzioni.
-  **ATTENZIONE – PERICOLO DI SCOSSA ELETTRICA:** La presenza di questo simbolo sul prodotto significa che è presente tensione pericolosa nell'area del prodotto su cui si sta lavorando. Scollegare il prodotto prima di iniziare, o prestare cautela se l'intervento richiede che il prodotto debba ricevere alimentazione.
-  **ATTENZIONE – PERICOLO DI LESIONI:** La batteria al litio presente nel prodotto non deve essere sostituita. In caso di sostituzione errata della batteria al litio, potrebbe verificarsi un'esplosione. Non ricaricare, smontare o bruciare batterie al litio. Soltare le batterie al litio usate seguendo le istruzioni del produttore e le norme locali.
-  **ATTENZIONE – PERICOLO DI LESIONI:** Per evitare il rischio di incendio o scosse elettriche, collegare il cavo di alimentazione a una presa elettrica dotata di messa a terra e con le specifiche adeguate, situata in prossimità del prodotto e facilmente accessibile.
-  **ATTENZIONE – PERICOLO DI LESIONI:** Per evitare il rischio di incendi o scosse elettriche, utilizzare solo il cavo di alimentazione fornito con il prodotto o componenti sostitutivi autorizzati dal produttore.
-  **ATTENZIONE – PERICOLO DI LESIONI:** Non utilizzare il prodotto con cavi di prolunga, prese multiple, prolunghie multipresa o gruppi di continuità. La capacità di potenza di questi tipi di accessori può essere facilmente sovraccaricata da una stampante laser e può comportare incendi, danni o scarse prestazioni della stampante.

 **ATTENZIONE – PERICOLO DI LESIONI:** Con questo prodotto può essere utilizzato solo un protettore di sovratensione in linea Xerox fornito con la stampante, correttamente collegato alla stampante e al cavo di alimentazione. L'utilizzo di protettori di sovratensione non Xerox può comportare il rischio di incendi, danni o scarse prestazioni della stampante.

 **ATTENZIONE – PERICOLO DI LESIONI:** Se la stampante pesa più di 20 kg (44 lb), potrebbe richiedere due o più persone per essere sollevata in modo sicuro.

# Health and Safety Incident Reporting

## I. Summary

This section defines requirements for notification of health and safety incidents involving Xerox products (equipment and materials) at customer locations.

## II. Scope

Xerox Corporation and subsidiaries worldwide.

## III. Objective

To enable prompt resolution of health and safety incidents involving Xerox products and to ensure Xerox regulatory compliance.

## IV. Definitions

Incident:

An event or condition occurring in a customer account that has resulted in injury, illness or property damage. Examples of incidents include machine fires, smoke generation, physical injury to an operator or service representative. Alleged events and product conditions are included in this definition.

## V. Requirements

Initial Report:

1. Xerox organizations shall establish a process for individuals to report product incidents to Xerox Environment Health and Safety within 24 hours of becoming aware of the event.
2. The information to be provided at the time of reporting is contained in Appendix A (Health and Safety Incident Report involving a Xerox product).
3. The initial notification may be made by the method that follows:
  - Email Xerox EH&S at: [usa.product.incident@xerox.com](mailto:usa.product.incident@xerox.com).
  - Fax Xerox EH&S at: 585-422-2249.



**Note:** If sending a fax, please also send the original via internal mail.

Responsibilities for resolution:

1. Business Groups/Product Design Teams responsible for the product involved in the incident shall:
  - a. Manage field bulletins, customer correspondence, product recalls, safety retrofits.
  - b. Fund all field retrofits.
2. Field Service Operations shall:
  - a. Preserve the Xerox product involved and the scene of the incident inclusive of any associated equipment located in the vicinity of the incident.
  - b. Return any affected equipment/part(s) to the location designated by Xerox EH&S and/or the Business Division.
  - c. Implement all safety retrofits.
3. Xerox EH&S shall:
  - a. Manage and report all incident investigation activities.
  - b. Review and approve proposed product corrective actions and retrofits, if necessary.
  - c. Manage all communications and correspondence with government agencies.
  - d. Define actions to correct confirmed incidents.

## VI. Appendices

The Health and Safety Incident Report involving a Xerox Product (Form # EH&S-700) is available in the following location:

- [GSN Library 1789](#)





# Change History

Change History

# Change History

November 2021

This is the launch version of the service manual.

# General Information

## Printer Model Configurations

The Xerox C310 printers are network-capable, multifunction laser printers. The printers support color and monochrome printing and are mbedded with home screen solutions and applications. All information in this service manual pertains to all models unless explicitly noted.

The printers are available in the following models:

Model	Configurations
C310	Network-ready color laser printer with 2.4" color display and internal duplex printing for small workgroups

## Finding The Serial Number

Open door A, and then find the serial number at the left side of the printer.



# Paper Support

## Supported Paper Sizes

 **Note:** Your printer model may have a 650-sheet duo tray, which consists of a 550-sheet tray and an integrated 100-sheet multipurpose feeder. The 550-sheet tray of the 650-sheet duo tray supports the same paper sizes as the optional 550-sheet tray. The integrated multipurpose feeder supports different paper sizes, types, and weights.

Paper size and dimension	Standard 250-sheet tray	Manual feeder	Optional 650-sheet duo tray		Optional 550-sheet tray	Two-sided printing
			550-sheet tray	Multipurpose feeder		
<b>A4</b> 210x297mm (8.27x11.7in.)	✓	✓	✓	✓	✓	✓
<b>A5<sup>1,2</sup></b> 148x210mm (5.83x8.27in.)	✓	✓	✓	✓	✓	X
<b>A6</b> 105x148mm (4.13x5.83in.)	✓	✓	X	✓	X	X
<b>JIS B5</b> 182x257mm (7.17x10.1in.)	✓	✓	✓	✓	✓	X
<b>Letter</b> 215.9x279.4mm (8.5x11in.)	✓	✓	✓	✓	✓	✓
<b>Legal</b> 215.9x355.6mm (8.5x14in.)	✓	✓	✓	✓	✓	✓
<b>Executive</b>	✓	✓	✓	✓	✓	X

Paper size and dimension	Standard 250-sheet tray	Manual feeder	Optional 650-sheet duo tray		Optional 550-sheet tray	Two-sided printing
			550-sheet tray	Multipurpose feeder		
184.2x266.7-mm (7.25x10.5in.)						
<b>Oficio (Mexico)</b> 215.9x340.4-mm (8.5x13.4in.)	✓	✓	✓	✓	✓	✓
<b>Folio</b> 215.9x330.2-mm (8.5x13in.)	✓	✓	✓	✓	✓	✓
<b>Statement</b> 139.7x215.9-mm (5.5x8.5in.)	✓	✓	X	✓	X	X
<b>Hagaki</b> 100x148mm (3.94x5.83in.)	✓	✓	X	✓	X	X
<b>Universal<sup>3,4</sup></b> 98.4x148mm to 215.9x355.6-mm (3.87x5.83in. to 8.5x14in.)	✓	✓	X	✓	X	X
<b>Universal<sup>3,4</sup></b> 76.2x127mm to 215.9x355.6-mm (3x5in. to 8.5x14in.)	X	✓	X	✓	X	X
<b>Universal<sup>3,4</sup></b>	✓	✓	✓	✓	✓	X

General Information

Paper size and dimension	Standard 250-sheet tray	Manual feeder	Optional 650-sheet duo tray		Optional 550-sheet tray	Two-sided printing
			550-sheet tray	Multipurpose feeder		
148x210mm to 215.9x355.6-mm (5.83x8.27in. to 8.5x14in.)						
<b>Universal</b> <sup>3,4</sup> 210x250mm to 215.9x355.6-mm (8.27x11.0in. to 8.5x14in.)	✓	✓	✓	✓	✓	✓
<b>7 3/4 Envelope</b> 98.4x190.5-mm (3.875x7.5in.)	✓	✓	X	✓	X	X
<b>9 Envelope</b> 98.4x225.4-mm (3.875x8.9in.)	✓	✓	X	✓	X	X
<b>10 Envelope</b> 104.8x241.3-mm (4.12x9.5in.)	✓	✓	X	✓	X	X
<b>DL Envelope</b> 110x220mm (4.33x8.66in.)	✓	✓	X	✓	X	X
<b>C5 Envelope</b> 162x229mm (6.38x9.01in.)	✓	✓	X	✓	X	X



Paper size and dimension	Standard 250-sheet tray	Manual feeder	Optional 650-sheet duo tray		Optional 550-sheet tray	Two-sided printing
			550-sheet tray	Multipurpose feeder		
<b>B5 Envelope</b> 176x250mm (6.93x9.84in.)	✓	✓	X	✓	X	X
<b>Monarch</b> 98.425x190.5mm (3.875x7.5in.)	✓	✓	X	✓	X	X
<b>Other Envelope<sup>5</sup></b> 98.4x162mm to 176x250mm (3.87x6.38in. to 6.93x9.84in.)	✓	✓	X	✓	X	X
<p><sup>1</sup> Load this paper size into tray 1 and the manual feeder with the long edge entering the printer first.</p> <p><sup>2</sup> Load this paper size into tray 2, tray 3, and the multipurpose feeder with the short edge entering the printer first.</p> <p><sup>3</sup> When Universal is selected, the page is formatted for 215.9x355.6mm (8.5x14 in.) unless the size is specified by the software application.</p> <p><sup>4</sup> Load narrow paper with the short edge entering the printer first.</p> <p><sup>5</sup> When Other Envelope is selected, the page is formatted for 215.9x355.6mm (8.5x14 in.) unless the size is specified by the software application.</p>						

## Supported Paper Types

### Note:

- Your printer model may have a 650-sheet duo tray, which consists of a 550-sheet tray and an integrated 100-sheet multipurpose feeder. The 550-sheet tray of the 650-sheet duo tray supports the same paper types as the 550-sheet tray. The integrated multipurpose feeder supports different paper sizes, types, and weights.
- Labels, envelopes, and card stock always print at 25 pages per minute.

Paper type	Standard 250-sheet tray	Manual feeder	Optional 650-sheet duo tray		Optional 550-sheet tray	Two-sided printing
			550-sheet tray	Multipurpose feeder		
Plain paper	✓	✓	✓	✓	✓	✓
Card stock	✓	✓	✓	✓	✓	X
Envelopes	✓	✓	X	✓	X	X
Paper labels	✓	✓	✓	✓	✓	✓
Vinyl labels	✓	✓	✓	✓	✓	X

## Supported Paper Weights

 **Note:**

- Your printer model may have a 650-sheet duo tray, which consists of a 550-sheet tray and an integrated 100-sheet multipurpose feeder. The 550-sheet tray of the 650-sheet duo tray supports the same paper types as the 550-sheet tray. The integrated multipurpose feeder supports different paper sizes, types, and weights.
- Labels, envelopes, and card stock always print at 25 pages per minute.

Paper type and weight	Standard 250-sheet tray	Manual feeder	Optional 650-sheet duo tray		Optional 550-sheet tray	Two-sided printing
			550-sheet tray	Multipurpose feeder		
<b>Light paper</b> <sup>1</sup> 60–74.9g/m <sup>2</sup> grain long (16–19.9-lb bond)	✓	✓	✓	✓	✓	✓
<b>Plain paper</b> 75–90.3g/m <sup>2</sup> grain long (20–24-lb bond)	✓	✓	✓	✓	✓	✓
<b>Heavy paper</b>	✓	✓	✓	✓	✓	✓

Paper type and weight	Standard 250-sheet tray	Manual feeder	Optional 650-sheet duo tray		Optional 550-sheet tray	Two-sided printing
			550-sheet tray	Multipurpose feeder		
90.3–105g/m <sup>2</sup> grain long (24.1–28-lb bond)						
<b>Card stock</b> 105.1–162g/m <sup>2</sup> grain long (28.1–43-lb bond)	✓	✓	✓	✓	✓	X
<b>Card stock</b> 105.1–200g/m <sup>2</sup> grain long (28.1–53-lb bond)	✓	✓	X	X	X	X
<b>Paper Labels</b> <sub>2</sub> 131g/m <sup>2</sup> (35-lb bond)	✓	✓	✓	✓	✓	✓ <sub>3</sub>
<b>Vinyl Labels</b> <sub>2</sub> 131g/m <sup>2</sup> (35-lb bond)	✓	✓	✓	✓	✓	X
<b>Envelopes</b> <sup>4,5</sup> 60–105g/m <sup>2</sup> (16–28-lb bond)	✓	✓	X	✓	X	X

<sup>1</sup> Paper less than 75g/m<sup>2</sup>(20lb) must be printed with Paper Type set to Light Paper. Failure to do so may cause excessive curl which can lead to feeding errors, especially in more humid environments.

<sup>2</sup>Labels and other specialty media are supported for occasional use and must be tested for acceptability.

<sup>3</sup> Paper labels up to 105g/m<sup>2</sup> (28-lb bond) are supported.

<sup>4</sup> 100 % cotton content maximum weight is 24-lb bond.







<sup>5</sup> 28-lb bond envelopes are limited to 25 % cotton content.

## Tools Required For Service







- Flat-blade screwdrivers, various sizes
- #1 Phillips screwdriver, magnetic
- #2 Phillips screwdriver, magnetic
- #2 Phillips screwdriver, magnetic short-blade
- Torx screwdriver (T20 head)
- Needle-nose pliers
- Diagonal side cutters
- Spring hook
- Feeler gauges
- Analog or digital multimeter
- 3-mm ball hex wrench
- Toner vacuum
- Flashlight

# Diagnostics and Troubleshooting







## Troubleshooting Precautions

-  **CAUTION—SHOCK HAZARD:** When you see this symbol on the product, there is a danger from hazardous voltage in the area of the product where you are working. Unplug the product before you begin, or use caution if the product must receive power in order to perform the task.
-  **CAUTION—SHOCK HAZARD:** This product uses an electronic power switch. It does not physically disconnect the input AC voltage. To avoid the risk of electrical shock, always remove the power cord from the printer when removal of the input AC voltage is required.
-  **CAUTION—SHOCK HAZARD:** To avoid the risk of electrical shock while troubleshooting with covers removed or doors open, do not touch the exposed wires or circuits while the printer is connected to an electrical outlet.
-  **CAUTION—SHOCK HAZARD:** To avoid the risk of electrical shock and to prevent damage to the printer, remove the power cord from the electrical outlet and disconnect all connections to any external devices before you connect or disconnect any cable, electronic board, or assembly.
-  **CAUTION—HOT SURFACE:** The inside of the printer might be hot. To reduce the risk of injury from a hot component, allow the surface to cool before touching it.
-  **CAUTION—PINCH HAZARD:** To avoid the risk of a pinch injury, use caution in areas marked with this label. Pinch injuries may occur around moving parts, such as gears, doors, trays, and covers.





## Précautions De Dépannage



-  **ATTENTION ! RISQUE D'ÉLECTROCUTION :** Ce symbole indique un danger lié à des niveaux de tension dangereux dans la zone du produit à manipuler. Débranchez le produit avant de commencer, ou agissez avec prudence si le produit doit être alimenté pour effectuer l'opération.
-  **ATTENTION ! RISQUE D'ÉLECTROCUTION :** Ce produit utilise un commutateur d'alimentation électronique. Il ne déconnecte pas physiquement la tension d'alimentation CA. Pour éviter tout risque d'électrocution, débranchez toujours le cordon d'alimentation de l'imprimante lorsque vous devez déconnecter la tension d'alimentation CA.
-  **ATTENTION ! RISQUE D'ÉLECTROCUTION :** Pour éviter tout risque d'électrocution lors du dépannage de l'imprimante avec les capots retirés ou les portes ouvertes, prenez garde de ne pas toucher les fils ou circuits dénudés si l'imprimante est connectée à une prise électrique.
-  **ATTENTION ! RISQUE D'ÉLECTROCUTION :** Pour éviter tout risque d'électrocution et éviter d'endommager l'imprimante, débranchez le cordon d'alimentation de la prise électrique et déconnectez toute connexion à tout périphérique externe avant de brancher ou débrancher des câbles ou circuits et assemblages électroniques.
-  **ATTENTION ! SURFACE CHAUDE :** L'intérieur de l'imprimante risque d'être brûlant. pour réduire le risque de brûlure, laissez la surface ou le composant refroidir avant d'y toucher.
-  **ATTENTION ! RISQUE DE PINCEMENT :** Pour éviter tout risque de blessure par pincement, agissez avec précaution au niveau des zones signalées par cette étiquette. Les blessures par pincement peuvent se produire autour des pièces mobiles telles que les engrenages, portes, tiroirs et capots.

## Precauciones Durante La Solución De Problemas







-  **PRECAUCIÓN—RIESGO DE DESCARGA:** Cuando vea este símbolo en el producto, existe peligro de tensiones peligrosas en el área del producto en la que está trabajando. Desconecte el producto antes de empezar o tenga cuidado si el producto debe recibir alimentación a fin de realizar la tarea.
-  **PRECAUCIÓN—RIESGO DE DESCARGA:** Este producto utiliza un interruptor de corriente electrónico. No desconecta físicamente la entrada de voltaje de CA. Para evitar el riesgo de descarga eléctrica, desenchufe siempre el cable de alimentación de la impresora cuando sea necesario retirar la entrada de voltaje de CA.
-  **PRECAUCIÓN—RIESGO DE DESCARGA:** Para evitar el riesgo de descarga eléctrica al solucionar problemas sin las cubiertas o con las puertas abiertas, no toque los cables ni los circuitos expuestos mientras la impresora está conectada a una toma de corriente.
-  **PRECAUCIÓN—RIESGO DE DESCARGA:** Para evitar el riesgo de descargas eléctricas y daños en la impresora, retire el cable de alimentación de la toma eléctrica y desconecte todas las conexiones a dispositivos externos antes de conectar o desconectar cualquier cable, placa electrónica o conjunto.
-  **PRECAUCIÓN—SUPERFICIE CALIENTE:** El interior de la impresora podría estar caliente. Para evitar el riesgo de heridas producidas por el contacto con un componente caliente, deje que la superficie se enfríe antes de tocarlo.
-  **PRECAUCIÓN—RIESGO DE DESCARGA ELÉCTRICA:** Para evitar el riesgo de lesión por atrapamiento, preste atención en las áreas marcadas con esta etiqueta. Las lesiones por atrapamiento se pueden producir en torno a partes móviles, tales como engranajes, puertas, bandejas y cubiertas.

## Vorsichtsmaßnahmen Bei Der Fehlerbehebung

-  **VORSICHT – STROMSCHLAGGEFAHR:** Wenn Sie dieses Symbol sehen, besteht eine Gefahr durch gefährliche Spannungen in dem Produktbereich, in dem Sie arbeiten. Trennen Sie das Produkt von seiner Stromverbindung, bevor Sie beginnen, oder gehen Sie vorsichtig vor, wenn das Produkt für die Durchführung der Aufgabe mit Strom versorgt werden muss.
-  **VORSICHT – STROMSCHLAGGEFAHR:** Dieses Produkt verwendet einen elektronischen Leistungsschalter. Er trennt die Eingangswchselspannung nicht physikalisch. Um das Risiko eines elektrischen Schlags zu vermeiden, ziehen Sie stets das Netzkabel vom Drucker ab, wenn eine Abtrennung der Eingangswchselspannung erforderlich ist.
-  **VORSICHT – STROMSCHLAGGEFAHR:** Um die Gefahr eines Stromschlags während der Fehlerbehebung bei entfernten Abdeckungen oder offenen Klappen zu vermeiden, berühren Sie die freiliegenden Drähte oder Stromkreise nicht, wenn der Drucker an eine Steckdose angeschlossen ist.
-  **VORSICHT – STROMSCHLAGGEFAHR:** Um das Risiko eines elektrischen Schlags und Schäden am Drucker zu vermeiden, ziehen Sie das Netzkabel aus der Steckdose und trennen Sie alle Verbindungen zu jeglichen externen Geräten, bevor Sie Kabel, Elektronikplatinen oder Baugruppen einstecken oder abziehen.

-  **VORSICHT – HEISS:** Das Innere des Druckers kann sehr heiß sein. Vermeiden Sie Verletzungen, indem Sie heiße Komponenten stets abkühlen lassen, bevor Sie ihre Oberfläche berühren.
-  **VORSICHT – QUETSCHGEFAHR:** Um das Risiko einer Quetschung zu vermeiden, gehen Sie in Bereichen, die mit diesem Etikett gekennzeichnet sind, mit Vorsicht vor. Quetschungen können im Bereich von beweglichen Komponenten auftreten, wie z.B. Zahnrädern, Klappen, Fächern und Abdeckungen.

## Precauzioni per gli interventi di riparazione

-  **ATTENZIONE – PERICOLO DI SCOSSA ELETTRICA:** La presenza di questo simbolo sul prodotto significa che è presente tensione pericolosa nell'area del prodotto su cui si sta lavorando. Scollegare il prodotto prima di iniziare, o prestare cautela se l'intervento richiede che il prodotto debba ricevere alimentazione.
-  **ATTENZIONE – PERICOLO DI SCOSSA ELETTRICA:** Questo prodotto utilizza un interruttore di alimentazione elettronico. Tale interruttore non scollega fisicamente la tensione CA in entrata. Per evitare il rischio di scossa elettrica, rimuovere sempre il cavo di alimentazione dalla stampante quando è necessario rimuovere la tensione CA in entrata.
-  **ATTENZIONE – PERICOLO DI SCOSSA ELETTRICA:** Per evitare il rischio di scossa elettrica quando si eseguono interventi sulla macchina con coperture rimosse e sportelli aperti, non toccare cavi o circuiti esposti quando la stampante è collegata a una presa elettrica.
-  **ATTENZIONE – PERICOLO DI SCOSSA ELETTRICA:** Per evitare il rischio di scossa elettrica e per impedire danni alla stampante, rimuovere il cavo di alimentazione dalla presa elettrica e scollegare tutti i collegamenti a eventuali dispositivi esterni prima di collegare o scollegare qualsiasi cavo, scheda elettronica o gruppo.
-  **ATTENZIONE – SUPERFICIE SURRISCALDATA:** L'area interna della stampante potrebbe surriscaldarsi. Per evitare infortuni, lasciare raffreddare la superficie dei componenti prima di toccarla.
-  **ATTENZIONE – PERICOLO DI SCHIACCIAMENTO:** Per evitare il rischio di lesioni, prestare la massima cautela quando si accede alle aree contrassegnate con questa etichetta. Potrebbero infatti verificarsi lesioni da schiacciamento in prossimità di parti in movimento, quali ad esempio ingranaggi, porte, vassoi e coperchi.



# Troubleshooting Overview

## Performing The Initial Troubleshooting Check

Before you start the troubleshooting procedures, perform the following checks:

- Use genuine Xerox supplies and parts for the best results. Third-party supplies or parts may affect the performance, reliability, or life of the printer and its imaging components.
- With the power cord unplugged from the electrical outlet, check that the cord is free from the breakage, short circuits, disconnected wires, or incorrect connections.
- Make sure the printer is properly grounded. Check the power cord ground terminal.
- Make sure the power supply line voltage is within 10 % of the rated line voltage.
- Make sure the machine is securely installed on a level surface in a well-ventilated area.
- Make sure the room temperature is between 16 and 32°C (60 and 90°F) and that the relative humidity is between 20 and 80 %.
- Avoid sites generating ammonia gas, high temperature, high humidity (near water faucets, kettles, humidifiers), cold spaces, near open flames, and dusty areas.
- Avoid sites exposed to direct sunlight.
- Make sure the paper is the recommended paper for this printer.
- Make a trial print with paper from a newly opened package, and check the result.

## Fixing Print Quality Issues

### Initial Print Quality Check

Before troubleshooting print problems, perform the following:

- Make sure that the printer is located in an area that follows the recommended operating environment and power requirement specifications.
- Check the status of supplies. Replace supplies that are low or empty.
- Load 20-lb (75-80 g/m<sup>2</sup>) plain letter or A4 paper. Make sure that the paper guides are properly set and locked. From the control panel, set the paper size and type to match the paper loaded in the tray.
- From the control panel, navigate to **Settings > Troubleshooting > Print Quality Test Pages**.
- Print and keep the Menu Settings Page. The original page is used to restore the custom settings if necessary. From the control panel, navigate to **Settings > Reports > Menu Settings Page**, and then press **OK**.
- On the Menu Settings page, check if the print resolution is set to 600 dpi and the toner darkness is set to Normal.
- Check the toner cartridges for damage, and replace if necessary.
- Make sure that the correct print driver is used to prevent print problems. If the wrong print driver is installed, then incorrect characters could print and the copy may not fit the page correctly.

### Supplies Used To Resolve Print Quality Issues

For this family of printers, the following supplies are available to resolve print quality issues:

Supply item	Part number
Imaging kits <ul style="list-style-type: none"> <li>• 125K page black imaging kit</li> <li>• 125K page black and color imaging kit</li> </ul>	Part numbers <ul style="list-style-type: none"> <li>• 013R00689</li> <li>• 013R00692</li> </ul>
Toner cartridges (NA/XE Sold) <ul style="list-style-type: none"> <li>• 3K Standard capacity black toner cartridge</li> <li>• 2K Standard capacity cyan toner cartridge</li> <li>• 2K Standard capacity magenta toner cartridge</li> <li>• 2K Standard capacity yellow toner cartridge</li> <li>• 8K High capacity black toner cartridge</li> <li>• 5.5K High capacity cyan toner cartridge</li> <li>• 5.5K High capacity magenta toner cartridge</li> <li>• 5.5K High capacity yellow toner cartridge</li> </ul>	Part numbers <ul style="list-style-type: none"> <li>• 006R04356</li> <li>• 006R04357</li> <li>• 006R04358</li> <li>• 006R04359</li> <li>• 006R04364</li> <li>• 006R04365</li> <li>• 006R04366</li> <li>• 006R04367</li> </ul>
Toner cartridges (DMO Sold) <ul style="list-style-type: none"> <li>• 3K Standard capacity black toner cartridge</li> </ul>	Part numbers <ul style="list-style-type: none"> <li>• 006R04360</li> </ul>

Supply item	Part number
<ul style="list-style-type: none"> <li>• 2K Standard capacity cyan toner cartridge</li> <li>• 2K Standard capacity magenta toner cartridge</li> <li>• 2K Standard capacity yellow toner cartridge</li> <li>• 8K High capacity black toner cartridge</li> <li>• 5.5K High capacity cyan toner cartridge</li> <li>• 5.5K High capacity magenta toner cartridge</li> <li>• 5.5K High capacity yellow toner cartridge</li> </ul>	<ul style="list-style-type: none"> <li>• 006R04361</li> <li>• 006R04362</li> <li>• 006R04363</li> <li>• 006R04368</li> <li>• 006R04369</li> <li>• 006R04370</li> <li>• 006R04371</li> </ul>
Toner cartridges (WW Metered) <ul style="list-style-type: none"> <li>• 8K Metered black toner cartridge</li> <li>• 2.3K Metered cyan toner cartridge</li> <li>• 2.3K Metered magenta print cartridge</li> <li>• 2.3K Metered yellow print cartridge</li> </ul>	Part numbers <ul style="list-style-type: none"> <li>• 006R04372</li> <li>• 006R04373</li> <li>• 006R04374</li> <li>• 006K04375</li> </ul>
Waste toner bottle	008R13325—25K pages

## Blurred Print Check

Action	Yes	No
<b>Step 1</b> From the home screen, navigate to <b>Settings &gt; Print &gt; Quality &gt; Advanced Imaging &gt; Color Adjust</b> . Does the problem remain?	Go to step 2.	The problem is solved.
<b>Step 2</b> Load paper from a fresh package. Paper absorbs moisture due to humidity. Store paper in its original wrapper until it is ready to be used. Does the problem remain?	Go to step 3.	The problem is solved.
<b>Step 3</b> 1 Remove the imaging kit. See <a href="#">Imaging kit removal</a> . 2 Clean the printhead lenses. See <a href="#">Cleaning the printhead lenses</a> . Does the problem remain?	Go to step 4.	The problem is solved.

Action	Yes	No
<p><b>Step 4</b></p> <p>1 Enter the Diagnostics menu, and then navigate to: <b>Printer diagnostics &amp; adjustments &gt; Weather Station</b></p> <p>2 Press <b>OK</b> or touch <b>Start</b>.</p> <p>Are the temperature and humidity levels reported similar to the actual temperature and humidity levels in the room?</p>	Go to step 6.	Go to step 5.
<p><b>Step 5</b></p> <p>Perform the weather station service check. See <a href="#">Weather station removal</a>.</p> <p>Does the problem remain?</p>	Go to step 6.	The problem is solved.
<p><b>Step 6</b></p> <p>Make sure that the HVPS cable is properly connected to the HVPS connector on the controller board.</p> <p>Does the problem remain?</p>	Go to step 7.	The problem is solved.
<p><b>Step 7</b></p> <p>Check the HVPS cable for continuity.</p> <p>Is there continuity?</p>	Go to step 10.	Go to step 8.
<p><b>Step 8</b></p> <p>Check the HVPS cable for damage, and replace if necessary.</p> <p>Does the problem remain?</p>	Go to step 9.	The problem is solved.
<p><b>Step 9</b></p> <p>1 Remove the transfer module. See <a href="#">Transfer module removal</a>.</p> <p>2 Make sure that the three HVPS contacts are properly positioned, and can freely move up and down.</p>	Go to step 11.	Go to step 10.

Action	Yes	No
Are the contacts properly positioned, and do they freely move up and down?		
<b>Step 10</b> 1 Reseat the HVPS. 2 Reseat the transfer module. Does the problem remain?	Go to step 11.	The problem is solved.
<b>Step 11</b> Replace the HVPS. See <a href="#">HVPS removal</a> . Does the problem remain?	Go to step 12.	The problem is solved.
<b>Step 12</b> Replace the transfer module. See <a href="#">Transfer module removal</a> . Does the problem remain?	Go to step 13.	The problem is solved.
<b>Step 13</b> Replace the controller board. See <a href="#">Controller board removal</a> . Does the problem remain?	Contact the next level of support.	The problem is solved.

## Misaligned Color Check

Action	Yes	No
<b>Step 1</b> 1 Enter the Diagnostics menu, and then navigate to: <b>Advanced Print Quality Samples &gt; Advanced Print Quality Test Pages</b> 2 Check pages G and H on the test pages to determine the color misalignment. Is there color misalignment?	Go to step 2.	The problem is solved.
<b>Step 2</b>	Go to step 3.	The problem is solved.

Action	Yes	No
<p>From the home screen, navigate to <b>Settings &gt; Print &gt; Quality &gt; Advanced Imaging &gt; Color Adjust</b>.</p> <p>Does the problem remain?</p>		
<p><b>Step 3</b></p> <p>Perform the auto alignment service check. See <a href="#">Auto alignment service check</a>.</p> <p>Does the problem remain?</p>	Go to step 4.	The problem is solved.
<p><b>Step 4</b></p> <p>Replace the printhead. See <a href="#">Printhead removal</a>.</p> <p>Does the problem remain?</p>	Contact the next level of support.	The problem is solved.

## Toner Easily Rubs Off Check



 **Note:** Before performing this print quality check, go to the home screen and navigate to **Settings > Troubleshooting > Print Quality Test Pages**, and then perform the initial print quality check. See [Initial Print Quality Check](#).

Actions	Yes	No
<p><b>Step 1</b></p> <p>Depending on your operating system, specify the paper type from the Printing Preferences or Print dialog.</p> <p> <b>Note:</b></p> <ul style="list-style-type: none"> <li>• Make sure that the setting matches the paper loaded.</li> <li>• You can also change the setting on the printer control panel.</li> </ul> <p>Does the problem remain?</p>	Go to step 2.	The problem is solved.
<p><b>Step 2</b></p> <p>Check if the paper weight is supported.</p> <p>If the weight is not supported, then load a supported one.</p> <p>Does the problem remain?</p>	Go to step 3.	The problem is solved.
<p><b>Step 3</b></p> <p>Load paper from a fresh package.</p> <p>Paper absorbs moisture due to humidity. Store paper in its original wrapper until it is ready to be used.</p> <p>Does the problem remain?</p>	Go to step 4.	The problem is solved.
<p><b>Step 4</b></p> <ol style="list-style-type: none"> <li>1 From the home screen, navigate to <b>Settings &gt; Device &gt; Maintenance &gt; Configuration Menu &gt; Reports &gt; Event Log</b></li> <li>2 Check the log history for fuser error codes.</li> </ol> <p>Are fuser error codes logged?</p>	Go to step 5.	Contact the next level of support.

Actions	Yes	No
<p><b>Step 5</b></p> <p>Perform the service check for the error code.</p> <p>Does the problem remain?</p>	Go to step 6.	The problem is solved.
<p><b>Step 6</b></p> <p>Replace the LVPS. See <a href="#">LVPS removal</a>.</p> <p>Does the problem remain?</p>	Contact the next level of support.	The problem is solved.

## Gray or Solid Background Check



 **Note:** Before performing this print quality check, go to the home screen and navigate to **Settings > Troubleshooting > Print Quality Test Pages**, and then perform the initial print quality check. See [Initial Print Quality Check](#).

Action	Yes	No
<p><b>Step 1</b></p> <p>Remove, and then insert the imaging kit. See <a href="#">Imaging kit removal</a>.</p> <p>Does the problem remain?</p>	Go to step 2.	The problem is solved.
<p><b>Step 2</b></p> <p>1 Place a narrow strip of paper over the gap between the developer units.</p> <p>Make sure that the paper stays in place when inserting the imaging kit to prevent the laser from discharging the photoconductor units.</p>	Go to step 3.	Go to step 6.



Action	Yes	No
<p>2 From the home screen, navigate to <b>Settings &gt; Reports &gt; Print Quality Pages</b>.</p> <p>3 Check the test pages for solid colors.</p> <p>Is the solid color missing where the strip of paper was placed?</p>		
<p><b>Step 3</b></p> <p>Reseat the printhead cable on the controller board.</p> <p>Does the problem remain?</p>	Go to step 4.	The problem is solved.
<p><b>Step 4</b></p> <p>Replace the printhead. See <a href="#">Printhead removal</a>.</p> <p>Does the problem remain?</p>	Go to step 5.	The problem is solved.
<p><b>Step 5</b></p> <p>Replace the controller board. See <a href="#">Controller board removal</a>.</p> <p>Does the problem remain?</p>	Contact the next level of support.	The problem is solved.
<p><b>Step 6</b></p> <p>Reseat the HVPS cable on the HVPS and on the JHVPS1 connector on the controller board.</p> <p>Does the problem remain?</p>	Go to step 7.	The problem is solved.
<p><b>Step 7</b></p> <p>Check the HVPS cable for continuity.</p> <p>Is there continuity?</p>	Go to step 9.	Go to step 8.
<p><b>Step 8</b></p> <p>Replace the HVPS cable.</p> <p>Does the problem remain?</p>	Go to step 9.	The problem is solved.
<p><b>Step 9</b></p> <p>1 Remove the transfer module. See <a href="#">Transfer module removal</a>.</p>	Go to step 11.	Go to step 10.

Action	Yes	No
<p>2 Check if the three HVPS contacts are properly positioned, and if they can freely move up and down.</p> <p>Are the contacts properly positioned, and do they freely move up and down?</p>		
<p><b>Step 10</b></p> <p>1 Reseat the HVPS. 2 Reseat the transfer module.</p> <p>Does the problem remain?</p>	Go to step 11.	The problem is solved.
<p><b>Step 11</b></p> <p>Replace the imaging kit. See <a href="#">Imaging kit removal</a>.</p> <p>Does the problem remain?</p>	Go to step 12.	The problem is solved.
<p><b>Step 12</b></p> <p>Replace the HVPS. See <a href="#">HVPS removal</a>.</p> <p>Does the problem remain?</p>	Go to step 13.	The problem is solved.
<p><b>Step 13</b></p> <p>Replace the controller board. See <a href="#">Controller board removal</a>.</p> <p>Does the problem remain?</p>	Contact the next level of support.	The problem is solved.

## Solid Color or Black Image Check



 **Note:** Before performing this print quality check, go to the home screen and navigate to **Settings > Troubleshooting > Print Quality Test Pages**, and then perform the initial print quality check. See [Initial Print Quality Check](#).

Action	Yes	No
<p><b>Step 1</b></p> <p>Remove, and then insert the imaging kit. See <a href="#">Imaging kit removal</a>.</p> <p>Does the problem remain?</p>	Go to step 2.	The problem is solved.
<p><b>Step 2</b></p> <p>1 Place a narrow strip of paper over the gap between the developer units.</p> <p>Make sure that the paper stays in place when inserting the imaging kit to prevent the laser from discharging the photoconductor units.</p> <p>2 From the home screen, navigate to <b>Settings &gt; Reports &gt; Print Quality Pages</b>.</p> <p>3 Check the test pages for solid colors.</p> <p>Is the solid color missing where the strip of paper was placed?</p>	Go to step 3.	Go to step 6.
<p><b>Step 3</b></p> <p>Reseat the printhead cable on the controller board.</p> <p>Does the problem remain?</p>	Go to step 4.	The problem is solved.
<p><b>Step 4</b></p> <p>Replace the printhead. See <a href="#">Printhead removal</a>.</p> <p>Does the problem remain?</p>	Go to step 5.	The problem is solved.
<p><b>Step 5</b></p> <p>Replace the controller board. See <a href="#">Controller board removal</a>.</p> <p>Does the problem remain?</p>	Contact the next level of support.	The problem is solved.
<p><b>Step 6</b></p> <p>Reseat the HVPS cable on the HVPS and on the JHVPS1 connector on the controller board.</p> <p>Does the problem remain?</p>	Go to step 7.	The problem is solved.

## Diagnostics and Troubleshooting

Action	Yes	No
<p><b>Step 7</b></p> <p>Check the HVPS cable for continuity.</p> <p>Is there continuity?</p>	Go to step 9.	Go to step 8.
<p><b>Step 8</b></p> <p>Replace the HVPS cable.</p> <p>Does the problem remain?</p>	Go to step 9.	The problem is solved.
<p><b>Step 9</b></p> <ol style="list-style-type: none"> <li>1 Remove the transfer module. See <a href="#">Transfer module removal</a>.</li> <li>2 Check if the three HVPS contacts are properly positioned, and if they can freely move up and down.</li> </ol> <p>Are the contacts properly positioned, and do they freely move up and down?</p>	Go to step 11.	Go to step 10.
<p><b>Step 10</b></p> <ol style="list-style-type: none"> <li>1 Reseat the HVPS.</li> <li>2 Reseat the transfer module.</li> </ol> <p>Does the problem remain?</p>	Go to step 11.	The problem is solved.
<p><b>Step 11</b></p> <p>Replace the imaging kit. See <a href="#">Imaging kit removal</a>.</p> <p>Does the problem remain?</p>	Go to step 12.	The problem is solved.
<p><b>Step 12</b></p> <p>Replace the HVPS. See <a href="#">HVPS removal</a>.</p> <p>Does the problem remain?</p>	Go to step 13.	The problem is solved.
<p><b>Step 13</b></p> <p>Replace the controller board. See <a href="#">Controller board removal</a>.</p> <p>Does the problem remain?</p>	Contact the next level of support.	The problem is solved.

# Blank or White Pages Check

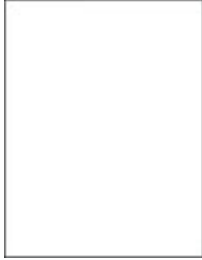

## Pre-check procedure

Make sure to perform the following pre-check procedure before performing this service check:

1. From the home screen, navigate to **Settings > Troubleshooting > Print Quality Test Pages**.
2. Check page A to determine any missing colors.
3. If any one color or black is missing, then perform the missing color check. See [Missing color check](#).

Action	Yes	No
<b>Step 1</b> Remove, and then insert the imaging kit. See <a href="#">Imaging kit removal</a> . Does the problem remain?	Go to step 2.	The problem is solved.
<b>Step 2</b> 1 Remove the imaging kit. See <a href="#">Imaging kit removal</a> . 2 Check if the developer unit and the imaging kit capacities match. The available capacities are 40K and 125K. Do the capacities match?	Go to step 4.	Go to step 3.
<b>Step 3</b> Replace the mismatched developer unit. See <a href="#">Developer unit removal</a> . Does the problem remain?	Go to step 4.	The problem is solved.
<b>Step 4</b> 1 Remove the imaging kit. See <a href="#">Imaging kit removal</a> . 2 Remove the developer units from the imaging kit. See <a href="#">Developer unit removal</a> .	Go to step 6.	Go to step 5.

## Diagnostics and Troubleshooting

Action	Yes	No
<p>3 Check the contacts between the developer units and the PCUs on the imaging kit.</p> <p>Are the contacts clean?</p>		
<p><b>Step 5</b></p> <p>Clean the contacts.</p> <p>Does the problem remain?</p>	Go to step 6.	The problem is solved.
<p><b>Step 6</b></p> <p>Check if the contacts between the developer units and the PCUs on the imaging kit are damaged.</p> <p>Are the contacts damaged?</p>	Go to step 7.	Go to step 8.
<p><b>Step 7</b></p> <p>Replace the damaged imaging kit component. See <a href="#">Supplies used to resolve print quality issues</a> .</p> <p>Does the problem remain?</p>	Go to step 8.	The problem is solved.
<p><b>Step 8</b></p> <p>Reseat the printhead cable on the JPH1 connector on the controller board.</p> <p>Does the problem remain?</p>	Go to step 9.	The problem is solved.
<p><b>Step 9</b></p> <p>Reseat the HVPS cable on the HVPS and on the JHVPS1 connector on the controller board.</p> <p>Does the problem remain?</p>	Go to step 10.	The problem is solved.
<p><b>Step 10</b></p> <p>Check the HVPS cable for continuity.</p> <p>Is there continuity?</p>	Go to step 11.	Go to step 12.
<p><b>Step 11</b></p> <p>Replace the HVPS cable.</p> <p>Does the problem remain?</p>	Go to step 12.	The problem is solved.

Action	Yes	No
<p><b>Step 12</b></p> <p>1 Remove the transfer module. See <a href="#">Transfer module removal</a>.</p> <p>2 Check if the three HVPS contacts are properly positioned, and if they can freely move up and down.</p> <p>Are the contacts properly positioned, and do they freely move up and down?</p>	Go to step 14.	Go to step 13.
<p><b>Step 13</b></p> <p>Reposition the HVPS so that the pins can freely move up and down.</p> <p>Does the problem remain?</p>	Go to step 14.	The problem is solved.
<p><b>Step 14</b></p> <p>Replace the HVPS. See <a href="#">HVPS removal</a>.</p> <p>Does the problem remain?</p>	Go to step 15.	The problem is solved.
<p><b>Step 15</b></p> <p>Replace the printhead. See <a href="#">Printhead removal</a>.</p> <p>Does the problem remain?</p>	Go to step 16.	The problem is solved.
<p><b>Step 16</b></p> <p>Replace the controller board. See <a href="#">Controller board removal</a>.</p> <p>Does the problem remain?</p>	Contact the next level of support.	The problem is solved.

## Horizontal White Lines Check



 **Note:** Before performing this print quality check, go to the home screen and navigate to **Settings > Troubleshooting > Print Quality Test Pages**, and then perform the initial print quality check. See [Initial Print Quality Check](#).

Actions	Yes	No
<p><b>Step 1</b></p> <p>Depending on your operating system, specify the paper type from the Printing Preferences or Print dialog.</p> <p> <b>Note:</b></p> <ul style="list-style-type: none"> <li>• Make sure that the setting matches the paper loaded.</li> <li>• You can also change the setting on the printer control panel.</li> </ul> <p>Does the problem remain?</p>	<p>Go to step 2.</p>	<p>The problem is solved.</p>
<p><b>Step 2</b></p> <p>Remove, and then insert the imaging kit. See <a href="#">Imaging kit removal</a>.</p> <p>Does the problem remain?</p>	<p>Go to step 3.</p>	<p>The problem is solved.</p>
<p><b>Step 3</b></p> <ol style="list-style-type: none"> <li>1 Remove the HVPS. See <a href="#">HVPS removal</a>.</li> <li>2 Check if the HVPS cable connectors are pinched or damaged.</li> </ol> <p>Are the cable connectors pinched or damaged?</p>	<p>Go to step 4.</p>	<p>Go to step 5.</p>
<p><b>Step 4</b></p> <p>Replace the HVPS cable.</p> <p>Does the problem remain?</p>	<p>Go to step 5.</p>	<p>The problem is solved.</p>



Actions	Yes	No
<p><b>Step 5</b></p> <p>Check the cables connecting the HVPS to the controller board for proper connection, and reset if necessary.</p> <p>Does the problem remain?</p>	Go to step 6.	The problem is solved.
<p><b>Step 6</b></p> <p>Replace the HVPS. See <a href="#">HVPS removal</a>.</p> <p>Does the problem remain?</p>	Contact the next level of support.	The problem is solved.

## Horizontal Colored Lines or Banding Check



 **Note:** Before performing this print quality check, go to the home screen and navigate to **Settings > Troubleshooting > Print Quality Test Pages**, and then perform the initial print quality check. See [Initial Print Quality Check](#).

Actions	Yes	No
<p><b>Step 1</b></p> <p>Depending on your operating system, specify the paper type from the Printing Preferences or Print dialog.</p> <p> <b>Note:</b></p> <ul style="list-style-type: none"> <li>• Make sure that the setting matches the paper loaded.</li> <li>• You can also change the setting on the printer control panel.</li> </ul> <p>Does the problem remain?</p>	Go to step 2.	The problem is solved.
<p><b>Step 2</b></p>	Go to step 3.	The problem is solved.

Actions	Yes	No
<p>Load paper from a fresh package.</p> <p>Paper absorbs moisture due to humidity. Store paper in its original wrapper until it is ready to be used.</p> <p>Does the problem remain?</p>		
<p><b>Step 3</b></p> <p>Remove, and then reinstall the imaging kit. See <a href="#">Imaging kit removal</a>.</p> <p>Does the problem remain?</p>	Go to step 4.	The problem is solved.
<p><b>Step 4</b></p> <p>1 Enter the Diagnostics menu, and then navigate to:</p> <p style="padding-left: 20px;"><b>Settings &gt; Troubleshooting &gt; Print Quality Test Pages</b></p> <p>2 Check the test page for lines.</p> <p>Do the lines appear in equal intervals?</p>	Go to step 5.	Contact the next level of support.
<p><b>Step 5</b></p> <p>Perform the repeating defects check. See <a href="#">Repeating defects check</a>.</p> <p>Does the problem remain?</p>	Contact the next level of support.	The problem is solved.

## Text or Images Cut Off Check



 **Note:** Before performing this print quality check, go to the home screen and navigate to **Settings > Troubleshooting > Print Quality Test Pages**, and then perform the initial print quality check. See [Initial Print Quality Check](#).

Actions	Yes	No
<p><b>Step 1</b></p> <p>Adjust the paper guides in the tray to the correct position for the paper loaded.</p> <p>Does the problem remain?</p>	Go to step 2.	The problem is solved.
<p><b>Step 2</b></p> <p>Depending on your operating system, specify the paper size from the Printing Preferences or Print dialog.</p> <p> <b>Note:</b></p> <ul style="list-style-type: none"> <li>• Make sure that the setting matches the paper loaded.</li> <li>• The paper size setting can be changed on the printer control panel.</li> </ul> <p>Does the problem remain?</p>	Go to step 3.	The problem is solved.
<p><b>Step 3</b></p> <ol style="list-style-type: none"> <li>1 Remove, and then insert the imaging kit. See <a href="#">Imaging kit removal</a>.</li> <li>2 Remove, and then insert the developer units. See <a href="#">Developer unit removal</a>.</li> </ol> <p>Does the problem remain?</p>	Go to step 4.	The problem is solved.
<p><b>Step 4</b></p> <p>Check for packing material left on the imaging components.</p> <p>Is there packing material left on the imaging components?</p>	Go to step 5.	Go to step 6.
<p><b>Step 5</b></p> <p>Remove the packing material.</p> <p>Does the problem remain?</p>	Go to step 6.	The problem is solved.
<p><b>Step 6</b></p> <ol style="list-style-type: none"> <li>1 Remove the imaging kit. See <a href="#">Imaging kit removal</a>.</li> </ol>	Go to step 8.	Go to step 7.

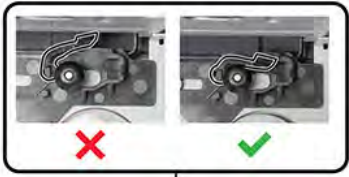
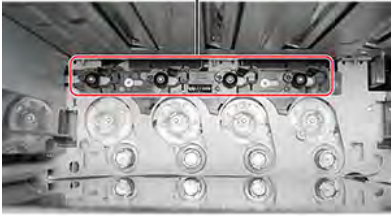
Actions	Yes	No
<p>2 Check if the developer unit hold downs are in their proper position.</p>   <p>Are the developer unit hold downs in their proper position?</p>		
<p><b>Step 7</b></p> <p>1 Return the developer unit hold downs to their proper position.</p> <p>2 Make sure that the developer unit hold downs are properly operating.</p> <p>Does the problem remain?</p>	Go to step 8.	The problem is solved.
<p><b>Step 8</b></p> <p>Replace the imaging kit. See <a href="#">Imaging kit removal</a>.</p> <p>Does the problem remain?</p>	Contact the next level of support.	The problem is solved.

## Mottled Print and Dots Check



 **Note:** Before performing this print quality check, go to the home screen and navigate to **Settings > Troubleshooting > Print Quality Test Pages**, and then perform the initial print quality check. See [Initial Print Quality Check](#).

Action	Yes	No
<p><b>Step 1</b></p> <p>Check the printer for leaked toner contamination.</p> <p>Is the printer free of leaked toner?</p>	Go to step 2.	Go to step 6.
<p><b>Step 2</b></p> <ol style="list-style-type: none"> <li>1 From the home screen, navigate to <b>Settings &gt; Paper &gt; Tray Configuration &gt; Paper Size/Type</b></li> <li>2 Check if the paper type and paper size settings match the paper loaded.</li> <li>3 Make sure that paper does not have a textured or rough finish.</li> </ol> <p>Do the settings match?</p>	Go to step 4.	Go to step 3.
<p><b>Step 3</b></p> <p>Depending on your operating system, specify the paper size and paper type from the Printing Preferences or Print dialog.</p> <p> <b>Note:</b></p> <ul style="list-style-type: none"> <li>• Make sure that the settings match the paper loaded.</li> <li>• You can also change the settings on the printer control panel.</li> </ul> <p>Does the problem remain?</p>	Go to step 4.	The problem is solved.
<p><b>Step 4</b></p> <p>Load paper from a fresh package.</p> <p>Paper absorbs moisture due to humidity. Store paper in its original wrapper until it is ready to be used.</p> <p>Does the problem remain?</p>	Go to step 5.	The problem is solved.
<p><b>Step 5</b></p>	Go to step 6.	The problem is solved.

## Diagnostics and Troubleshooting

Action	Yes	No
<p>Remove, and then insert the imaging kit. See <a href="#">Imaging kit removal</a>.</p> <p>Does the problem remain?</p>		
<p><b>Step 6</b></p> <ol style="list-style-type: none"> <li>Using a toner vacuum, clean the printer thoroughly.</li> <li>Perform a print job to clear the remaining toner from the imaging components.</li> </ol> <p>Does the problem remain?</p>	Go to step 7.	The problem is solved.
<p><b>Step 7</b></p> <p>Replace the developer unit of the leaking color. See <a href="#">Supplies used to resolve print quality issues</a> to determine which developer unit to use.</p> <p>Does the problem remain?</p>	Go to step 8.	The problem is solved.
<p><b>Step 8</b></p> <p>Replace the photoconductor unit. See <a href="#">Supplies used to resolve print quality issues</a> to determine which photoconductor unit to use.</p> <p>Does the problem remain?</p>	Go to step 9.	The problem is solved.
<p><b>Step 9</b></p> <p>Check the transfer module for proper installation and damage, and replace if necessary. See <a href="#">Transfer module removal</a>.</p> <p>Does the problem remain?</p>	Contact the next level of support.	The problem is solved.

## Vertical White Lines Check



 **Note:** Before performing this print quality check, go to the home screen and navigate to **Settings > Troubleshooting > Print Quality Test Pages**, and then perform the initial print quality check. See [Initial Print Quality Check](#).

Action	Yes	No
<p><b>Step 1</b></p> <p>Depending on your operating system, specify the paper type from the Printing Preferences or Print dialog.</p> <p> <b>Note:</b></p> <ul style="list-style-type: none"> <li>• Make sure that the setting matches the paper loaded.</li> <li>• You can also change the setting on the printer control panel.</li> </ul> <p>Does the problem remain?</p>	Go to step 2.	The problem is solved.
<p><b>Step 2</b></p> <p>Load paper source with the recommended paper type.</p> <p>Does the problem remain?</p>	Go to step 3.	The problem is solved.
<p><b>Step 3</b></p> <p>Remove, and then insert the imaging kit. See <a href="#">Imaging kit removal</a>.</p> <p>Does the problem remain?</p>	Go to step 4.	The problem is solved.
<p><b>Step 4</b></p> <ol style="list-style-type: none"> <li>1 Remove the waste toner bottle. See <a href="#">Waste toner bottle service check</a>.</li> <li>2 Remove the imaging kit. See <a href="#">Imaging kit removal</a>.</li> </ol>	Go to step 5.	The problem is solved.

Action	Yes	No
<p>3 Clean the printhead lenses. See <a href="#">Cleaning the printhead lenses</a> .</p> <p>4 From the home screen, navigate to <b>Settings &gt; Troubleshooting &gt; Print Quality Test Pages</b>.</p> <p>Does the problem remain?</p>		
<p><b>Step 5</b></p> <p>1 Check the test pages and identify the affected color.</p> <p>2 Replace the developer unit of the affected color.</p> <p>3 If vertical streaks in all colors appear on page A, then replace the transfer module. See <a href="#">Transfer module removal</a>.</p> <p>Does the problem remain?</p>	Go to step 6.	The problem is solved.
<p><b>Step 6</b></p> <p>Replace the photoconductor unit. See <a href="#">Supplies used to resolve print quality issues</a> to determine which photoconductor unit to use.</p> <p>Does the problem remain?</p>	Go to step 7.	The problem is solved.
<p><b>Step 7</b></p> <p>Check the transfer module for proper installation and damage, and replace if necessary. See <a href="#">Transfer module removal</a>.</p> <p>Does the problem remain?</p>	Go to step 8.	The problem is solved.
<p><b>Step 8</b></p> <p>Replace the printhead. See <a href="#">Printhead removal</a>.</p> <p>Does the problem remain?</p>	Contact the next level of support.	The problem is solved.



# Ghost Images Check



 **Note:** Before performing this print quality check, go to the home screen and navigate to **Settings > Troubleshooting > Print Quality Test Pages**, and then perform the initial print quality check. See [Initial Print Quality Check](#).

Action	Yes	No
<p><b>Step 1</b></p> <p>Load the tray with the correct paper type.</p> <p>Does the problem remain?</p>	Go to step 2.	The problem is solved.
<p><b>Step 2</b></p> <p>Depending on your operating system, specify the paper type from the Printing Preferences or Print dialog.</p> <p> <b>Note:</b></p> <ul style="list-style-type: none"> <li>• Make sure that the setting matches the paper loaded.</li> <li>• You can also change the setting on the printer control panel.</li> </ul> <p>Does the problem remain?</p>	Go to step 3.	The problem is solved.
<p><b>Step 3</b></p> <p>From the home screen, navigate to <b>Settings &gt; Print &gt; Quality &gt; Advanced Imaging &gt; Color Adjust</b>.</p> <p>Does the problem remain?</p>	Go to step 4.	The problem is solved.
<p><b>Step 4</b></p> <p>Remove, and then reinstall the imaging kit. See <a href="#">Imaging kit removal</a>.</p>	Go to step 5.	The problem is solved.

## Diagnostics and Troubleshooting

Action	Yes	No
Does the problem remain?		
<p><b>Step 5</b></p> <p>From the home screen, check the status of the black and color imaging kit.</p> <p>Does the status indicate OK?</p>	Go to step 6.	Go to step 7.
<p><b>Step 6</b></p> <p>Measure the distance from one point of the original image to the same point on the ghost image.</p> <p>Is the distance 43.9 mm?</p>	Go to step 8.	Go to step 7.
<p><b>Step 7</b></p> <p>Replace the developer unit of the affected color. See <a href="#">Supplies used to resolve print quality issues</a> to determine which developer unit to use.</p> <p>Does the problem remain?</p>	Go to step 8.	The problem is solved.
<p><b>Step 8</b></p> <p>Replace the imaging kit. See <a href="#">Imaging kit removal</a>.</p> <p>Does the problem remain?</p>	Go to step 9.	The problem is solved.
<p><b>Step 9</b></p> <p>1 From the home screen, navigate to <b>Settings &gt; Reports &gt; Menu Settings Page</b></p> <p>Perform this step twice to clear any debris.</p> <p>2 Check the fuser assembly for toner contamination.</p> <p>Is the fuser assembly contaminated?</p>	Go to step 10.	Contact the next level of support.
<p><b>Step 10</b></p> <p>Replace the fuser. See <a href="#">Fuser removal</a>.</p> <p>Does the problem remain?</p>	Contact the next level of support.	The problem is solved.

# Dark Print Check



**Note:** Before performing this print quality check, go to the home screen and navigate to **Settings > Troubleshooting > Print Quality Test Pages**, and then perform the initial print quality check. See [Initial Print Quality Check](#).

Action	Yes	No
<p><b>Step 1</b></p> <ol style="list-style-type: none"> <li>1 From the home screen, navigate to <b>Settings &gt; Print &gt; Quality &gt; Advanced Imaging &gt; Color Adjust</b></li> <li>2 Perform a color adjustment.</li> </ol> <p>Does the problem remain?</p>	Go to step 2.	The problem is solved.
<p><b>Step 2</b></p> <p>Depending on your operating system, reduce the toner darkness from the Printing Preferences or Print dialog.</p> <p>You can also change the setting on the printer control panel.</p> <p>Does the problem remain?</p>	Go to step 3.	The problem is solved.
<p><b>Step 3</b></p> <p>Depending on your operating system, specify the paper type from the Printing Preferences or Print dialog.</p> <p> <b>Note:</b></p> <ul style="list-style-type: none"> <li>• Make sure that the setting matches the paper loaded.</li> <li>• You can also change the setting on the printer control panel.</li> </ul> <p>Does the problem remain?</p>	Go to step 4.	The problem is solved.

## Diagnostics and Troubleshooting

Action	Yes	No
<p><b>Step 4</b></p> <p>Check if the paper is textured or has a rough finish.</p> <p>Is the paper textured or rough?</p>	Go to step 5.	Go to step 6.
<p><b>Step 5</b></p> <p>Replace textured or rough paper with plain paper.</p> <p>Does the problem remain?</p>	Go to step 6.	The problem is solved.
<p><b>Step 6</b></p> <p>Load paper from a fresh package.</p> <p>Paper absorbs moisture due to humidity. Store paper in its original wrapper until it is ready to be used.</p> <p>Does the problem remain?</p>	Go to step 7.	The problem is solved.
<p><b>Step 7</b></p> <ol style="list-style-type: none"> <li>From the home screen, navigate to <b>Settings &gt; Troubleshooting &gt; Print Quality Test Pages</b></li> <li>Check the test pages.</li> </ol> <p>Is only one color affected?</p>	Go to step 8.	Go to step 9.
<p><b>Step 8</b></p> <p>Enter the Diagnostics menu, and then navigate to:</p> <p><b>Printer diagnostics &amp; adjustments &gt; Color alignment adjust &gt; AA adjustment row</b></p> <p>Does the problem remain?</p>	Go to step 9.	The problem is solved.
<p><b>Step 9</b></p> <p>Perform the toner patch sensing service check. See <a href="#">Toner patch sensing service check</a>.</p> <p>Does the problem remain?</p>	Go to step 10.	The problem is solved.
<p><b>Step 10</b></p>	Go to step 11.	The problem is solved.

Action	Yes	No
Check the HVPS cable for proper connection, and reseat if necessary. Does the problem remain?		
<b>Step 11</b> Check the continuity of the main HVPS cable. Does the cable have continuity?	Go to step 13.	Go to step 12.
<b>Step 12</b> Replace the cable. Does the problem remain?	Go to step 13.	The problem is solved.
<b>Step 13</b> Check the contacts on the transfer module for damage. Are the contacts free of damage?	Go to step 15.	Go to step 14.
<b>Step 14</b> Replace the transfer module. See <a href="#">Transfer module removal</a> . Does the problem remain?	Go to step 15.	The problem is solved.
<b>Step 15</b> Replace the HVPS. See <a href="#">HVPS removal</a> . Does the problem remain?	Contact the next level of support.	The problem is solved.

## Missing Color Check



 **Note:** Before performing this print quality check, go to the home screen and navigate to **Settings > Troubleshooting > Print Quality Test Pages**, and then perform the initial print quality check. See [Initial Print Quality Check](#).

Action	Yes	No
<p><b>Step 1</b></p> <p>From the home screen, navigate to <b>Settings &gt; Print &gt; Quality &gt; Advanced Imaging &gt; Color Adjust</b>.</p> <p>Does the problem remain?</p>	Go to step 2.	The problem is solved.
<p><b>Step 2</b></p> <p>Remove any packing material left on the imaging kit.</p> <p>Does the problem remain?</p>	Go to step 3.	The problem is solved.
<p><b>Step 3</b></p> <ol style="list-style-type: none"> <li>1 Make sure that the toner cartridges and developer units are properly installed.</li> <li>2 Make sure that the developer units and the imaging kit match. See <a href="#">Supplies used to resolve print quality issues</a> .</li> </ol> <p>Does the problem remain?</p>	Go to step 4.	The problem is solved.
<p><b>Step 4</b></p> <ol style="list-style-type: none"> <li>1 Remove, and then insert the imaging kit. See <a href="#">Imaging kit removal</a>.</li> <li>2 Remove, and then insert the waste toner bottle. See <a href="#">Waste toner bottle removal</a> .</li> </ol> <p>Does the problem remain?</p>	Go to step 5.	The problem is solved.
<p><b>Step 5</b></p> <p>Reseat the printhead cable connector on the controller board.</p> <p>Does the problem remain?</p>	Go to step 6.	The problem is solved.
<p><b>Step 6</b></p> <ol style="list-style-type: none"> <li>1 From the home screen, navigate to <b>Settings &gt;</b></li> </ol>	Go to step 7.	Go to step 10.

Action	Yes	No
<p><b>Troubleshooting &gt; Print Quality Test Pages.</b></p> <p>2 Check the test pages.</p> <p>Is only one color missing?</p>		
<p><b>Step 7</b></p> <p>Check if the missing color is yellow.</p> <p>Is the missing color yellow?</p>	Go to step 8.	Go to step 10.
<p><b>Step 8</b></p> <p>Remove the imaging kit, and then check if the transfer module cleaning blade is in the correct position.</p>  <p>Is the cleaning blade in the correct position?</p>	Go to step 9.	Go to step 10.
<p><b>Step 9</b></p> <p>Replace the transfer module. See <a href="#">Transfer module removal</a>.</p> <p>Does the problem remain?</p>	Go to step 10.	The problem is solved.
<p><b>Step 10</b></p> <p>Check the contacts on the imaging kit and the developer unit of the missing color for dust or debris.</p> <p>Are the contacts free of dust or debris?</p>	Go to step 12.	Go to step 11.
<p><b>Step 11</b></p> <p>Clean the contacts between the developer unit and the imaging kit.</p> <p>Does the problem remain?</p>	Go to step 12.	The problem is solved.
<p><b>Step 12</b></p>	Go to step 13.	The problem is solved.

## Diagnostics and Troubleshooting

Action	Yes	No
<p>Replace the developer unit of the affected color. See <a href="#">Supplies used to resolve print quality issues</a> to determine which developer unit to use.</p> <p>Does the problem remain?</p>		
<p><b>Step 13</b></p> <p>Check if the pins in the HVPS freely move in and out with an equal amount of spring force.</p> <p>Do the pins freely move?</p>	Go to step 15.	Go to step 14.
<p><b>Step 14</b></p> <p>Replace the HVPS. See <a href="#">HVPS removal</a>.</p> <p>Does the problem remain?</p>	Go to step 15.	The problem is solved.
<p><b>Step 15</b></p> <ol style="list-style-type: none"> <li>1 Remove the imaging kit. See <a href="#">Imaging kit removal</a>.</li> <li>2 Enter the Diagnostics menu, and then navigate to: <b>Printer diagnostics &amp; adjustments &gt; Motor tests</b></li> <li>3 Go to the appropriate developer unit motor test for the missing color, and then run the test.</li> </ol> <p>Does the motor run?</p>	Go to step 17.	Go to step 16.
<p><b>Step 16</b></p> <p>Replace the defective EP drive motor. See <a href="#">Motor (drive unit) removal</a>.</p> <p>Does the problem remain?</p>	Go to step 17.	The problem is solved.
<p><b>Step 17</b></p> <ol style="list-style-type: none"> <li>1 Remove the imaging kit. See <a href="#">Imaging kit removal</a>.</li> <li>2 While manually turning the motors, check if the couplers that drive the imaging kit move.</li> </ol>	Go to step 19.	Go to step 18.



Action	Yes	No
Do the couplers move?		
<b>Step 18</b> Replace the EP drive assembly. See <a href="#">EP drive assembly removal</a> . Does the problem remain?	Go to step 19.	The problem is solved.
<b>Step 19</b> Check the Print Quality Test Pages if the black plane or the CMY plane is missing. Is the black plane or the CMY plane missing?	Go to step 20.	Go to step 21.
<b>Step 20</b> Replace the HVPS. See <a href="#">HVPS removal</a> . Does the problem remain?	Go to step 21.	The problem is solved.
<b>Step 21</b> Replace the printhead. See <a href="#">Printhead removal</a> . Does the problem remain?	Go to step 22.	The problem is solved.
<b>Step 22</b> Replace the controller board. See <a href="#">Controller board removal</a> . Does the problem remain?	Contact the next level of support.	The problem is solved.

## Uneven Print Density Check



**Note:** Before performing this print quality check, go to the home screen and navigate to **Settings > Troubleshooting > Print Quality Test Pages**, and then perform the initial print quality check. See [Initial Print Quality Check](#).

## Diagnostics and Troubleshooting

Action	Yes	No
<p><b>Step 1</b></p> <p>Remove, and then insert the imaging kit. See <a href="#">Imaging kit removal</a>.</p> <p>Does the problem remain?</p>	Go to step 2.	The problem is solved.
<p><b>Step 2</b></p> <p>From the home screen, navigate to <b>Settings &gt; Print &gt; Quality &gt; Advanced Imaging &gt; Color Adjust</b>.</p> <p>Does the problem remain?</p>	Go to step 3.	The problem is solved.
<p><b>Step 3</b></p> <ol style="list-style-type: none"> <li>1 From the home screen, navigate to <b>Settings &gt; Device &gt; Preferences</b></li> <li>2 Check if the paper type and size settings match the paper type and size set on the tray.</li> </ol> <p>Do the settings match?</p>	Go to step 5.	Go to step 4.
<p><b>Step 4</b></p> <p>Change the paper size and type, or adjust the size settings in the tray.</p> <p>Does the problem remain?</p>	Go to step 5.	The problem is solved.
<p><b>Step 5</b></p> <p>Check the paper for texture or rough finish.</p> <p>Is the paper textured or rough?</p>	Go to step 6.	Go to step 7.
<p><b>Step 6</b></p> <p>Replace the textured or rough paper with plain paper.</p> <p>Does the problem remain?</p>	Go to step 7.	The problem is solved.

Action	Yes	No
<b>Step 7</b> Clean the printhead lenses. See <a href="#">Cleaning the printhead lenses</a> . Does the problem remain?	Go to step 8.	The problem is solved.
<b>Step 8</b> Replace the imaging kit. See <a href="#">Imaging kit removal</a> . Does the problem remain?	Contact the next level of support.	The problem is solved.

## Repeating Defects Check



 **Note:** Before performing this print quality check, go to the control panel home screen and navigate to **Settings > Troubleshooting > Print Quality Test Pages**, and then perform the Initial print quality check. See [Initial Print Quality Check](#).

Action	Yes	No
<b>Step 1</b> Check the rollers in the paper path for dust or debris. Is there dust or debris on any of the rollers?	Go to step 2.	Go to step 3.
<b>Step 2</b> Clean the affected rollers. Does the problem remain?	Go to step 3.	The problem is solved.
<b>Step 3</b> 1 Print the Print Quality Test Pages. From the control panel, navigate to: <b>Settings &gt; Troubleshooting &gt; Print Quality Test Pages</b>	Go to step 4.	Contact the next level of support.

## Diagnostics and Troubleshooting

Action	Yes	No
<p>2 Measure the distance between the repeating defects on the affected color page.</p> <p>3 Check if the distance matches any of the following measurements: <b>Imaging kit</b></p> <ul style="list-style-type: none"> <li>• 94.20 mm (3.71 in.)</li> <li>• 29.80 mm (1.17 in.)</li> <li>• 23.20 mm (0.91 in.)</li> </ul> <p><b>Developer unit</b></p> <ul style="list-style-type: none"> <li>• 43.90 mm (1.73 in.)</li> <li>• 45.50 mm (1.79 in.)</li> </ul> <p><b>Transfer module</b></p> <ul style="list-style-type: none"> <li>• 37.70 mm (1.48 in.)</li> <li>• 78.50 mm (3.09 in.)</li> <li>• 55 mm (2.17 in.)</li> </ul> <p><b>Fuser</b></p> <ul style="list-style-type: none"> <li>• 79.80 mm (3.14 in.)</li> <li>• 94.30 mm (3.71 in.)</li> </ul> <p>Do the repeating defects match any of the measurements?</p>		
<p><b>Step 4</b></p> <p>Replace the component indicated by the measurement you observed in step 3. See <a href="#">Supplies used to resolve print quality issues</a> to determine which developer or imaging kit to use.</p> <p>Does the problem remain?</p>	Go to step 5.	The problem is solved.

Action	Yes	No
<p><b>Step 5</b></p> <p>Refer to the following list for additional components that can be replaced to resolve a repeating defect.</p> <p>Replace the parts one at a time in the following order, and then print a test after replacing a part.</p> <p><b>99 mm interval</b></p> <ul style="list-style-type: none"> <li>• Fuser</li> </ul> <p><b>94 mm interval</b></p> <ul style="list-style-type: none"> <li>• Imaging kit</li> </ul> <p><b>79 mm interval</b></p> <ul style="list-style-type: none"> <li>• Developer of the affected color</li> </ul> <p><b>75 mm interval</b></p> <ul style="list-style-type: none"> <li>• Fuser</li> </ul> <p><b>55-56 mm interval</b></p> <ol style="list-style-type: none"> <li>1 Developer</li> <li>2 Transfer module</li> <li>3 EP drive</li> </ol> <p><b>44-45 mm interval</b></p> <ul style="list-style-type: none"> <li>• Developer</li> </ul> <p><b>33 mm interval</b></p> <ol style="list-style-type: none"> <li>1 Developer</li> <li>2 EP drive</li> </ol> <p><b>28 mm, 24 mm, 16 mm, 12-14 mm, 9 mm, and 4-5 mm interval</b></p> <ul style="list-style-type: none"> <li>• EP drive</li> </ul> <p><b>6-7 (mm) interval</b></p> <ol style="list-style-type: none"> <li>1 Fuser motor</li> <li>2 EP drive</li> </ol> <p><b>Less than 1 mm interval</b></p> <ol style="list-style-type: none"> <li>1 EP drive</li> <li>2 Fuser motor</li> </ol> <p>If a part was replaced in the previous step, then contact the next level of support.</p> <p>Does the problem remain?</p>	<p>Contact the next level of support.</p>	<p>The problem is solved.</p>

# Light Print Check



 **Note:** Before performing this print quality check, go to the home screen and navigate to **Settings > Troubleshooting > Print Quality Test Pages**, and then perform the initial print quality check. See [Initial Print Quality Check](#).

Action	Yes	No
<p><b>Step 1</b></p> <p>From the home screen, navigate to <b>Settings &gt; Print &gt; Quality &gt; Advanced Imaging &gt; Color Adjust</b>.</p> <p>Does the problem remain?</p>	Go to step 2.	The problem is solved.
<p><b>Step 2</b></p> <p>Depending on your operating system, increase the toner darkness from the Printing Preferences or Print dialog.</p> <p>You can also change the setting on the printer control panel.</p> <p>Does the problem remain?</p>	Go to step 3.	The problem is solved.
<p><b>Step 3</b></p> <ol style="list-style-type: none"> <li>From the home screen, navigate to <b>Settings &gt; Print &gt; Quality &gt; Color Saver</b>.</li> <li>Turn off Color Saver.</li> </ol> <p>Does the problem remain?</p>	Go to step 4.	The problem is solved.
<p><b>Step 4</b></p> <p>Depending on your operating system, specify the paper type from the Printing Preferences or Print dialog.</p> <p> <b>Note:</b></p>	Go to step 5.	The problem is solved.

Action	Yes	No
<ul style="list-style-type: none"> <li>• Make sure that the setting matches the paper loaded.</li> <li>• You can also change the setting on the printer control panel.</li> </ul> <p>Does the problem remain?</p>		
<p><b>Step 5</b></p> <p>Check if the paper is textured or rough.</p> <p>Is the paper textured or rough?</p>	Go to step 6.	Go to step 7.
<p><b>Step 6</b></p> <p>Replace the textured or rough paper with plain paper.</p> <p>Does the problem remain?</p>	Go to step 7.	The problem is solved.
<p><b>Step 7</b></p> <p>Load paper from a fresh package.</p> <p>Paper absorbs moisture due to humidity. Store paper in its original wrapper until it is ready to be used.</p> <p>Does the problem remain?</p>	Go to step 8.	The problem is solved.
<p><b>Step 8</b></p> <p>Remove, and then reinstall the imaging kit. See <a href="#">Imaging kit removal</a>.</p> <p>Does the problem remain?</p>	Go to step 9.	The problem is solved.
<p><b>Step 9</b></p> <p>Remove, and then reinstall the developer unit of the affected color. See <a href="#">Developer unit removal</a>.</p> <p>Does the problem remain?</p>	Go to step 10.	The problem is solved.
<p><b>Step 10</b></p> <p>1 Enter the Diagnostics menu, and then navigate to:</p> <p><b>Printer diagnostics &amp; adjustments &gt; Motor tests</b></p>	Go to step 12.	Go to step 11.

## Diagnostics and Troubleshooting

Action	Yes	No
<p>2 Select the motor of the affected color, and then run the test.</p> <p>Does the motor run?</p>		
<p><b>Step 11</b></p> <p>Check the motor cable for proper installation, and reseal if necessary.</p> <p>Does the problem remain?</p>	Go to step 12.	The problem is solved.
<p><b>Step 12</b></p> <p>Clean the printhead lenses. See <a href="#">Cleaning the printhead lenses</a> .</p> <p>Does the problem remain?</p>	Go to step 13.	The problem is solved.
<p><b>Step 13</b></p> <p>Check the HVPS cable on the HVPS and on the JHVPS1 connector on the controller board for proper connection.</p> <p>Is the cable properly connected at both ends?</p>	Go to step 15.	Go to step 14.
<p><b>Step 14</b></p> <p>Reconnect the cable.</p> <p>Does the problem remain?</p>	Go to step 15.	The problem is solved.
<p><b>Step 15</b></p> <p>Check the cable for continuity.</p> <p>Does the cable have continuity?</p>	Go to step 17.	Go to step 16.
<p><b>Step 16</b></p> <p>Replace the HVPS cable.</p> <p>Does the problem remain?</p>	Go to step 17.	The problem is solved.
<p><b>Step 17</b></p> <p>1 Remove the transfer module. See <a href="#">Transfer module removal</a>.</p> <p>2 Check if the three contacts are visible and if they freely move.</p>	Go to step 19.	Go to step 18.



Action	Yes	No
Are the contacts visible and do they freely move?		
<b>Step 18</b> Replace imaging kit. See <a href="#">Imaging kit removal</a> . Does the problem remain?	Go to step 19.	The problem is solved.
<b>Step 19</b> Replace the transfer module. See <a href="#">Transfer module removal</a> . Does the problem remain?	Go to step 20.	The problem is solved.
<b>Step 20</b> Replace the HVPS. See <a href="#">HVPS removal</a> . Does the problem remain?	Contact the next level of support.	The problem is solved.

## Skewed Print Check



 **Note:** Before performing this print quality check, go to the home screen and navigate to **Settings > Troubleshooting > Print Quality Test Pages**, and then perform the initial print quality check. See [Initial Print Quality Check](#).

## Diagnostics and Troubleshooting

Action	Yes	No
<p><b>Step 1</b></p> <p>1 Adjust the paper guides in the tray to the correct position for the paper loaded.</p> <p>2 Make sure that the paper stack is below the maximum paper fill line.</p> <p>Does the problem remain?</p>	Go to step 2.	The problem is solved.
<p><b>Step 2</b></p> <p>Load paper from a fresh package.</p> <p>Does the problem remain?</p>	Go to step 3.	The problem is solved.
<p><b>Step 3</b></p> <p>Make sure that the paper loaded is supported.</p> <p>Does the problem remain?</p>	Go to step 4.	The problem is solved.
<p><b>Step 4</b></p> <p>Check the transfer module for proper installation and damage, and reinstall if necessary.</p> <p>Does the problem remain?</p>	Go to step 5.	The problem is solved.
<p><b>Step 5</b></p> <p>Perform the printhead adjustment. See <a href="#">Registration adjustment</a>.</p> <p>Does the problem remain?</p>	Go to step 6.	The problem is solved.

Action	Yes	No
<p><b>Step 6</b></p> <p>Check the pick rollers for dust or debris, and clean the rollers if necessary.</p> <p>Does the problem remain?</p>	Go to step 7.	The problem is solved.
<p><b>Step 7</b></p> <p>If the paper from tray 1 are straight but the paper from the other tray are skewed, then perform the following:</p> <ol style="list-style-type: none"> <li>1 Make sure that the paper guides in the tray are free to move and properly adjusted.</li> <li>2 Enter the Diagnostics menu, and then navigate to: <b>Printer diagnostics &amp; adjustments &gt; Registration adjust</b></li> <li>3 Select <b>Duplex Skew</b> or <b>Option Skew</b>.</li> </ol> <p> <b>Note:</b></p> <ul style="list-style-type: none"> <li>• Duplex Skew affects the duplex sides.</li> <li>• Option Skew affects the tray 2, tray 3, and MPF paper.</li> <li>• Raising the value of the skew setting rotates the horizontal lines clockwise while the vertical lines will remain vertical.</li> </ul> <ol style="list-style-type: none"> <li>4 Print a test page.</li> </ol> <p>Does the problem remain?</p>	Contact the next level of support.	The problem is solved.

## Toner Patch Sensing Service Check

### Pre-check procedure

 **Note:** Perform this procedure before performing the service check.

1. Enter the Diagnostics menu, and then navigate to:  
**Printer Setup > EP setup > Toner patch sensor adjust > Full calibration**
2. Navigate to **Advanced Print Quality Samples > Advanced Print Quality Test Pages**.
3. Check pages G and H on the test pages to determine the color misalignment.
4. If colors are misaligned, then navigate to **Printer diagnostics & adjustments > Color alignment adjust > Auto align**.
5. Find AA adjustment, and then press **OK** or touch **Start**.

 **Note:** This action triggers the auto align routine which performs the color alignment error corrections for the 0.42 mm, 0.84 mm, and 3 mm ranges.

6. Navigate to **Advanced Print Quality Samples > Advanced Print Quality Test Pages**.
7. Check pages G and H on the test pages to determine the color misalignment.
8. If colors are misaligned, then navigate to **Printer diagnostics & adjustments > Color alignment adjust > Auto align**.

 **Note:** Ignore the AA adjustment pre-check in this step.

Action	Yes	No
<p><b>Step 1</b></p> <p>1 From the home screen, navigate to <b>Settings &gt; Troubleshooting &gt; Print Quality Test Pages</b>.</p> <p>2 On the Device information section of the test page, check the CalSet values of the following:</p> <ul style="list-style-type: none"> <li>• C developer unit operating point</li> <li>• C laser operating point</li> <li>• C linearization stat</li> <li>• M developer unit operating point</li> <li>• M laser operating point</li> <li>• M linearization stat</li> <li>• Y developer unit operating point</li> <li>• Y laser operating point</li> <li>• Y linearization stat</li> <li>• K developer unit operating point</li> <li>• K laser operating point</li> <li>• K linearization stat</li> </ul> <p>Are the CalSet values 0?</p>	Go to step 2.	The problem is solved.
<b>Step 2</b>	Go to step 3.	Go to step 4.

Action	Yes	No
<p>Perform the blank or white pages service check. See <a href="#">Blank or white pages check</a>.</p> <p>Was an issue found and resolved?</p>		
<p><b>Step 3</b></p> <p>Perform the auto alignment service check. See <a href="#">Auto alignment service check</a>.</p> <p>Does the problem remain?</p>	Go to step 4.	The problem is solved.
<p><b>Step 4</b></p> <p>1 Enter the Diagnostics menu, and then navigate to:</p> <p style="padding-left: 20px;"><b>Printer setup &gt; EP setup &gt; Toner patch sensor adjust</b></p> <p>2 Find Sensor gain characterization, and then press <b>OK</b> or touch <b>Start</b>.</p> <p>3 Find Sensor gain verification, and then press <b>OK</b> or touch <b>Start</b>.</p> <p>4 On the TPS Sensor Characterization and Verification Information page section of the print out, check the values of following:</p> <ul style="list-style-type: none"> <li>a The PaperLeft-NDS Volts and PaperRight-DS Volts in the Patch Average from the TPS Verification Page section.</li> <li>b The Left-NDS Volts and Right-DS Volts in the High Gain Bare Belt Characterization Results section.</li> <li>c The mV value in the Amplifier Offset Characterization Result section.</li> </ul> <p>Do the results approximately match the expected values and fall within the requirements?</p>	The problem is solved.	Go to step 5.
<p><b>Step 5</b></p>	Go to step 6.	The problem is solved.

## Diagnostics and Troubleshooting

Action	Yes	No
<p>Check the cables at the JTPS1 and JTPS2 connectors on the controller board for proper connection, and reseal if necessary.</p> <p>Does the problem remain?</p>		
<p><b>Step 6</b></p> <ol style="list-style-type: none"> <li>1 Remove the transfer module. See <a href="#">Transfer module removal</a>.</li> <li>2 Make sure that the sensors (toner patch) are free of dust or debris.</li> <li>3 Perform the auto alignment service check. See <a href="#">Auto alignment service check</a>.</li> </ol> <p>Does the problem remain?</p>	Go to step 7.	The problem is solved.

Action	Yes	No
<p><b>Step 7</b></p> <ol style="list-style-type: none"> <li>1 Replace the sensors (toner patch). See <a href="#">Sensors (toner patch) removal</a> .</li> <li>2 Enter the Diagnostics menu, and then navigate to: <b>Printer setup &gt; EP setup &gt; Toner patch sensor adjust</b></li> <li>3 Find Sensor gain characterization, and then press <b>OK</b> or touch <b>Start</b>.</li> <li>4 Find Sensor gain verification, and then press <b>OK</b> or touch <b>Start</b>.</li> <li>5 On the TPS Sensor Characterization and Verification Information page section of the print out, check the values of following: <ol style="list-style-type: none"> <li>a The PaperLeft-NDS Volts and PaperRight-DS Volts in the Patch Average from the TPS Verification Page section.</li> <li>b The Left-NDS Volts and Right-DS Volts in the High Gain Bare Belt Characterization Results section.</li> <li>c The mV value in the Amplifier Offset Characterization Result section.</li> </ol> </li> </ol> <p>Do the results approximately match the expected values and fall within the requirements?</p>	The problem is solved.	Contact the next level of support.

### Post check procedure



**Note:** Perform this procedure before performing the service check.

1. Enter the Diagnostics menu, and then navigate to:  
**Printer Setup > EP setup > Toner patch sensor adjust > Full calibration**
2. Navigate to **Advanced Print Quality Samples > Advanced Print Quality Test Pages**.
3. Check pages G and H on the test pages to determine the color misalignment.

4. If colors are misaligned, then navigate to **Printer diagnostics & adjustments > Color alignment adjust > Auto align**.
5. Find AA adjustment, and then press **OK** or touch **Start**.

 **Note:** This action triggers the auto align routine which performs the color alignment error corrections for the 0.42 mm, 0.84 mm, and 3 mm ranges.

6. Navigate to **Advanced Print Quality Samples > Advanced Print Quality Test Pages**.
7. Check pages G and H on the test pages to determine the color misalignment.
8. If colors are misaligned, then navigate to **Printer diagnostics & adjustments > Color alignment adjust > Auto align**.

 **Note:** Ignore the AA adjustment pre-check in this step.

9. From the home screen, navigate to **Settings > Troubleshooting > Print Quality Test Pages**.
10. On the Device information section of the print quality test page, check the CalSet values of the following:
  - C developer unit operating point
  - C laser operating point
  - C linearization stat
  - M developer unit operating point
  - M laser operating point
  - M linearization stat
  - Y developer unit operating point
  - Y laser operating point
  - Y linearization stat
  - K developer unit operating point
  - K laser operating point
  - K linearization stat
11. If the CalSet values are not 0, then contact the next level of support.

## Auto Alignment Service Check

### Pre check procedure

 **Note:** Perform this procedure before performing the service check.

1. Enter the Diagnostics menu, and then navigate to:  
**Printer Setup > EP setup > Toner patch sensor adjust > Full calibration**
2. Navigate to **Advanced Print Quality Samples > Advanced Print Quality Test Pages**.
3. Check pages G and H on the test pages to determine the color misalignment.
4. If colors are misaligned, then navigate to **Printer diagnostics & adjustments > Color alignment adjust > Auto align**.



5. Find AA adjustment, and then press **OK** or touch **Start**.

 **Note:** This triggers the auto align routine which performs the color alignment error corrections for the 0.42 mm, 0.84 mm, and 3 mm ranges.

6. Navigate to **Advanced Print Quality Samples > Advanced Print Quality Test Pages**.

7. Check pages G and H on the test pages to determine the color misalignment.

8. If colors are misaligned, then navigate to **Printer diagnostics & adjustments > Color alignment adjust > Auto align**.

 **Note:** Ignore the AA adjustment pre check in this step.

Action	Yes	No
<p><b>Step 1</b></p> <p>1 From the home screen, navigate to <b>Settings &gt; Troubleshooting &gt; Print Quality Test Pages</b>.</p> <p>2 On the CalSet section of the test page, check the color alignment stat value.</p> <p>Is the value 0?</p>	Go to step 2.	The problem is solved.
<p><b>Step 2</b></p> <p>1 Perform the Blank or white pages check or Missing color check. See <a href="#">Blank or white pages check</a> or <a href="#">Missing color check</a>.</p> <p>2 Enter the Diagnostics menu, and then navigate to: <b>Printer setup &gt; EP setup &gt; Toner patch sensor adjust</b></p> <p>3 Find Sensor gain characterization, and then press <b>OK</b> or touch <b>Start</b>.</p> <p>4 Find Sensor gain verification, and then press <b>OK</b> or touch <b>Start</b>.</p> <p>5 On the TPS Sensor Characterization and Verification Information page section of the print out, check the values of following:</p> <ul style="list-style-type: none"> <li>a The PaperLeft-NDS Volts and PaperRight-DS Volts in the Patch Average from the TPS Verification Page section.</li> </ul>	The problem is solved.	Go to step 3.

## Diagnostics and Troubleshooting

Action	Yes	No
<p>b The Left-NDS Volts and Right-DS Volts in the High Gain Bare Belt Characterization Results section.</p> <p>c The mV value in the Amplifier Offset Characterization Result section.</p> <p>Do the results approximately match the expected values and fall within the requirements?</p>		
<p><b>Step 3</b></p> <p>Check the cables at the JTPS1 and JTPS2 connectors on the controller board for proper connection, and reseal if necessary.</p> <p>Does the problem remain?</p>	Go to step 4.	The problem is solved.

Action	Yes	No
<p><b>Step 4</b></p> <ol style="list-style-type: none"> <li>1 Remove the transfer module. See <a href="#">Transfer module removal</a>.</li> <li>2 Make sure that the sensors (toner patch) are free of dust or debris.</li> </ol> <p>Does the problem remain?</p>	Go to step 5.	The problem is solved.
<p><b>Step 5</b></p> <ol style="list-style-type: none"> <li>1 Replace the sensors (toner patch). See <a href="#">Sensors (toner patch) removal</a>.</li> <li>2 Enter the Diagnostics menu, and then navigate to: <b>Printer setup &gt; EP setup &gt; Toner patch sensor adjust</b></li> <li>3 Find Sensor gain characterization, and then press <b>OK</b> or touch <b>Start</b>.</li> <li>4 Find Sensor gain verification, and then press <b>OK</b> or touch <b>Start</b>.</li> <li>5 On the TPS Sensor Characterization and Verification Information page section of the print out, check the values of following: <ol style="list-style-type: none"> <li>a The PaperLeft-NDS Volts and PaperRight-DS Volts in the Patch Average part of the TPS Veriication Page section.</li> <li>b The Left-NDS Volts and Right-DS Volts in the High Gain Bare Belt Characterization Results section.</li> <li>c The mV value in the Amplifier Offset Characterization Result section.</li> </ol> </li> </ol> <p>Do the results approximately match the expected values and fall within the requirements?</p>	The problem is solved.	Contact the next level or support.

### Post check procedure



**Note:** Perform this procedure before performing the service check.

## Diagnostics and Troubleshooting

1. Enter the Diagnostics menu, and then navigate to:

**Printer diagnostics & adjustments > Color alignment adjust**

2. Find AA adjustment, and then press **OK** or touch **Start**.



**Note:** This action triggers the auto align routine which performs the color alignment error corrections for the 0.42 mm, 0.84 mm, and 3 mm ranges.

3. Enter the Diagnostics menu, and then navigate to:

**Printer Setup > EP setup > Toner patch sensor adjust > Full calibration**



**Note:** This action triggers the auto align routine which performs the color alignment error corrections for the 0.42 mm range only.

4. From the home screen, navigate to **Settings > Troubleshooting > Print Quality Test Pages**.
5. On the CalSet section of the test page, check if the color alignment stat value is 0. If the value is not 0, then contact the next level of support.

# Paper Jams

## Avoiding Jams

### Load Paper Properly

- Make sure that the paper lies flat in the tray.

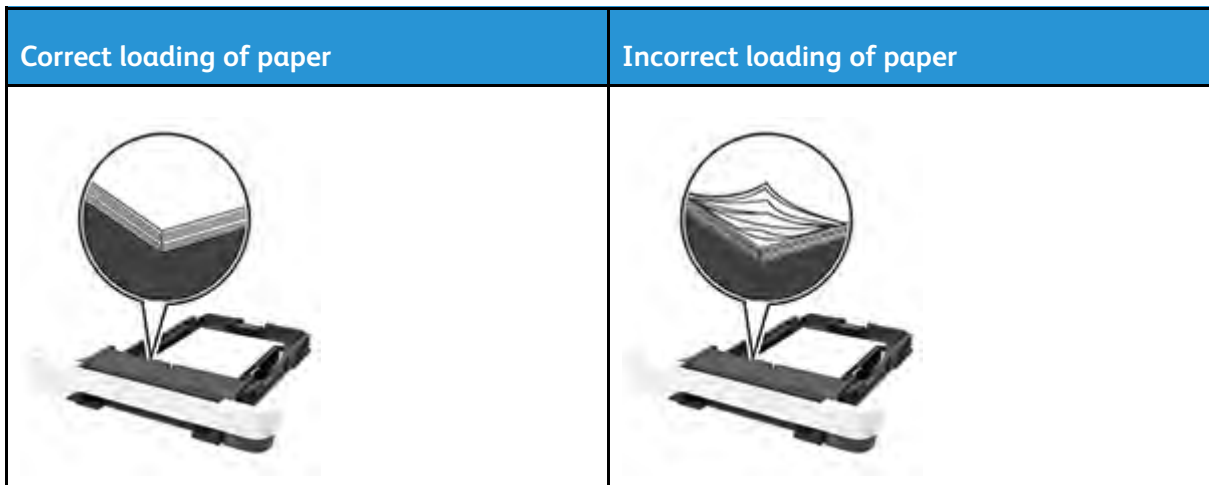

- Do not load or remove a tray while the printer is printing.
- Do not load too much paper. Make sure that the stack height is below the maximum paper fill indicator.
- Do not slide paper into the tray. Load paper as shown in the illustration.



- Make sure that the paper guides are positioned correctly and are not pressing tightly against the paper or envelopes.

- Push the tray firmly into the printer after loading paper.

### Use Recommended Paper

- Use only recommended paper or specialty media.
- Do not load paper that is wrinkled, creased, damp, bent, or curled.
- Flex, fan, and align the paper edges before loading.



- Do not use paper that has been cut or trimmed by hand.
- Do not mix paper sizes, weights, or types in the same tray.
- Make sure that the paper size and type are set correctly on the computer or printer control panel.
- Store paper according to manufacturer recommendations.

## Identifying Jam Locations

 **Note:**

- When Jam Assist is set to On, the printer flushes blank pages or pages with partial prints after a jammed page has been cleared. Check your printed output for blank pages.
- When Jam Recovery is set to On or Auto, the printer reprints jammed pages.



	Jam location
1	Standard bin
2	In the fuser
3	Below the fuser

	Jam location
4	Duplex unit
5	Trays
6	Manual feeder
7	Multipurpose feeder The multipurpose feeder is available only in some printer models.

## 200 Paper Jams

### 200 Paper Jam Messages

Error code	Description	Action
200.02	The paper fed from the MPF or manual feeder arrived at the sensor (input) earlier than expected.	See <a href="#">Sensor (input) service check</a> .
200.03	The Paper fed from the MPF did not reach the sensor (input).	
200.05	The paper fed from the MPF or manual feeder never cleared the sensor (input).	
200.06	The paper fed from the MPF was not picked. The paper did not reach the sensor (input).	
200.12	The paper fed from tray 1 arrived at the sensor (input) earlier than expected.	
200.15	The paper fed from tray 1 never cleared the sensor (input).	
200.16	The paper fed from tray 1 was not picked. The paper did not reach the sensor (input).	

Error code	Description	Action
200.22	The paper fed from tray 2 arrived at the sensor (input) earlier than expected.	
200.23	The paper fed from tray 2 did not reach the sensor (input).	
200.25	The paper fed from tray 2 never cleared the sensor (input).	
200.32	The paper fed from tray 3 arrived at the sensor (input) earlier than expected.	
200.33	The paper fed from tray 3 did not reach the sensor (input).	
200.35	The paper fed from tray 3 never cleared the sensor (input).	
200.91	The paper remains on the sensor (input) during the warm up sequence.	

## Sensor (Input) Service Check

### Note:

- If the paper source is an option tray, then make sure to perform the Option tray jam service check in addition to this check. See [Option tray jam service check](#) .
- Make sure that the tray 1 pass-through and manual feeder are free of dust or debris.
- Make sure that the duplex/manual feed sensor flag freely moves and is not obstructing the paper path.
- If a 232.x3 or 232.x5 error code appears on the display, then perform this check first at step 14, and then perform the Sensor (S1 duplex/manual feed) service check. See [Sensor \(redrive/duplex path 1\) service check](#) .



Action	Yes	No
<p><b>Step 1</b></p> <p>1 Remove the tray insert. 2 Open the front door, and then remove the jammed paper.</p> <p>Does the problem remain?</p>	Go to step 2.	The problem is solved.
<p><b>Step 2</b></p> <p>Make sure that the sensor (input) paper path and the pass-through paper paths of any installed options are free of debris or dust.</p> <p>Does the problem remain?</p>	Go to step 3.	The problem is solved.
<p><b>Step 3</b></p> <p>Check if the error code is 200.1x.</p> <p>Is the error code 200.1x?</p>	Go to step 4.	Go to step 6.
<p><b>Step 4</b></p> <p>Make sure that the pick tires are free of dust or debris.</p> <p>Does the problem remain?</p>	Go to step 5.	The problem is solved.
<p><b>Step 5</b></p> <p>Replace the pick tires. <a href="#">Pick tire removal</a>.</p> <p>Does the problem remain?</p>	Go to step 6.	The problem is solved.
<p><b>Step 6</b></p> <p>Check the sensor (input) for proper installation and damage.</p> <p>Is the sensor properly installed and free of damaged?</p>	Go to step 7.	Go to step 14.
<p><b>Step 7</b></p> <p>1 Enter the Diagnostics menu, and then navigate to: <b>Printer diagnostics &amp; adjustments &gt; Sensor tests</b></p> <p>2 Find the sensor (Input).</p>	Go to step 9.	Go to step 8.

Action	Yes	No
<p>3 Remove the tray insert, and then rotate the input sensor flag (A) to toggle the sensor.</p>  <p>The flag must freely rotate and return to its original position.</p> <p>Does the sensor status change while toggling the sensor?</p>		
<p><b>Step 8</b></p> <p>Make sure that the gray cable is properly connected to the sensor (input).</p> <p>Does the problem remain?</p>	Go to step 9.	The problem is solved.
<p><b>Step 9</b></p> <p>1 Enter the Diagnostics menu, and then navigate to:</p> <p><b>Printer diagnostics &amp; adjustments &gt; Sensor tests</b></p> <p>2 Find the sensor (Tray 1 pick).</p> <p>3 Remove the tray insert, and then rotate the smart pick encoder to toggle the sensor.</p> <p>The counter on the display must increment.</p> <p>Did the counter increment?</p>	Go to step 11.	Go to step 10.
<p><b>Step 10</b></p> <p>Make sure that the red cable is properly connected to the sensor (tray 1 pick).</p> <p>Does the problem remain?</p>	Go to step 11.	The problem is solved.
<p><b>Step 11</b></p>	Go to step 13.	Go to step 12.

Action	Yes	No
<p>1 Enter the Diagnostics menu, and then navigate to:</p> <p><b>Printer diagnostics &amp; adjustments &gt; Motor tests</b></p> <p>2 Select <b>Pick (Tray 1) Duplex</b>, and then <b>Pick (Tray 1) Picking</b>.</p> <p>Did the motors run?</p>		
<p><b>Step 12</b></p> <p>1 Turn off the printer.</p> <p>2 Remove the rear cover. See <a href="#">Rear cover removal</a>.</p> <p>3 Make sure that the JSP1 cable is properly connected on the controller board.</p> <p>Does the problem remain?</p>	Go to step 13.	The problem is solved.
<p><b>Step 13</b></p> <p>Disconnect the cable, and then check the following voltages at the JSP1 connector on the controller board:</p> <ul style="list-style-type: none"> <li>• Pin 14: 5 V dc</li> <li>• Pin 15: 3.3 V dc</li> </ul> <p>Are the voltage readings approximately the same?</p>	Go to step 14.	Go to step 15.
<p><b>Step 14</b></p> <p>Replace the motor (drive unit). See <a href="#">Motor (drive unit) removal</a>.</p> <p>Does the problem remain?</p>	Go to step 15.	The problem is solved.
<p><b>Step 15</b></p> <p>Replace the controller board. See <a href="#">Controller board removal</a>.</p> <p>Does the problem remain?</p>	Contact the next level of support.	The problem is solved.

## 202 Paper Jams

### 202 Paper Jam Messages

Error code	Description	Action
202.03	The paper fed from the MPF or manual feeder never arrived at the sensor (fuser exit).	See <a href="#">202.x3 error service check</a> .
202.04	The paper fed from the MPF or manual feeder cleared the sensor (fuser exit) earlier than expected.	See <a href="#">Sensor (fuser exit) service check</a> .
202.05	The paper fed from the MPF or manual feeder never cleared the sensor (fuser exit).	See <a href="#">202.x5 error service check</a> .
202.13	The paper fed from tray 1 never arrived at the sensor (fuser exit).	See <a href="#">202.x3 error service check</a> .
202.14	The paper fed from tray 1 cleared the sensor (fuser exit) earlier than expected.	See <a href="#">Sensor (fuser exit) service check</a> .
202.15	The paper fed from tray 1 never cleared the sensor (fuser exit).	See <a href="#">202.x5 error service check</a> .
202.23	The paper fed from tray 2 never arrived at the sensor (fuser exit).	See <a href="#">202.x3 error service check</a> .
202.24	The paper fed from tray 2 cleared the sensor (fuser exit) earlier than expected.	See <a href="#">Sensor (fuser exit) service check</a> .
202.25	The paper fed from tray 2 never cleared the sensor (fuser exit).	See <a href="#">202.x5 error service check</a> .
202.33	The paper fed from tray 3 never arrived at the sensor (fuser exit).	See <a href="#">202.x3 error service check</a> .
202.34	The paper fed from tray 3 cleared the sensor (fuser exit) earlier than expected.	See <a href="#">Sensor (fuser exit) service check</a> .

Error code	Description	Action
202.35	The paper fed from tray 3 never cleared the sensor (fuser exit).	See <a href="#">202.x5 error service check</a> .
202.91	The paper remains on the sensor (fuser exit) during the warm up sequence.	See <a href="#">Sensor (fuser exit) service check</a> .

## Sensor (Fuser Exit) Service Check

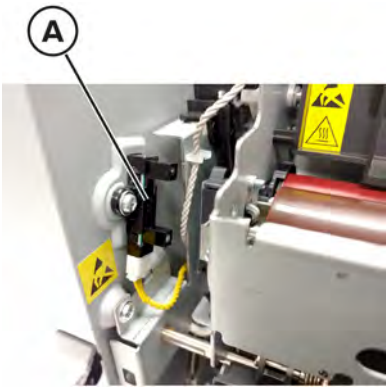

Action	Yes	No
<p><b>Step 1</b></p> <p>Open the front door to access the jam area, and then remove the jammed paper.</p> <p>Does the problem remain?</p>	Go to step 2.	The problem is solved.
<p><b>Step 2</b></p> <p>Check the sensor (A) for proper installation and damage.</p>  <p>Is the sensor properly installed and free of damage?</p>	Go to step 4.	Go to step 3.
<p><b>Step 3</b></p> <p>Replace the sensor. See <a href="#">Sensor (fuser exit) removal</a> .</p> <p>Does the problem remain?</p>	Go to step 4.	The problem is solved.
<p><b>Step 4</b></p> <p>1 Enter the Diagnostics menu, and then navigate to:</p>	Go to step 8.	Go to step 5.

Action	Yes	No
<p><b>Printer diagnostics &amp; adjustments &gt; Sensor tests</b></p> <p>2 Select <b>Sensor (Fuser exit)</b>.</p> <p>Does the sensor status change while toggling the sensor?</p>		
<p><b>Step 5</b></p> <p>1 Turn off the printer.</p> <p>2 Remove the rear cover. See <a href="#">Rear cover removal</a>.</p> <p>3 Make sure that the cable on the JBIN1 connector on the controller board is properly connected.</p> <p>Does the problem remain?</p>	Go to step 6.	The problem is solved.
<p><b>Step 6</b></p> <p>1 Disconnect the JBIN1 cable on the controller board.</p> <p>2 Perform a POR, and then check the following voltages at the JBIN1 connector on the controller board:</p> <ul style="list-style-type: none"> <li>• Pin 4: 5 V dc</li> <li>• Pin 5: 3.3 V dc</li> </ul> <p>Are values approximately the same?</p>	Go to step 7.	Go to step 12.
<p><b>Step 7</b></p> <p>Make sure that the fuser exit sensor cable is properly connected at both ends.</p> <p>Does the problem remain?</p>	Go to step 8.	The problem is solved.
<p><b>Step 8</b></p> <p>1 Make sure that the fuser exit sensor cable has continuity.</p> <p>2 Check the cable for damage, and replace if necessary.</p> <p>Does the problem remain?</p>	Go to step 9.	The problem is solved.
<p><b>Step 9</b></p> <p>Replace the sensor. See <a href="#">Sensor (fuser exit) removal</a>.</p>	Go to step 10.	The problem is solved.

Action	Yes	No
Does the problem remain?		
<b>Step 10</b> 1 Check the fuser for proper installation and damage. 2 Check the belt, rollers, and guides for wear or damage, and replace if necessary.  Is the fuser properly installed and free of damage?	Go to step 12.	Go to step 11.
<b>Step 11</b> Replace the fuser. See <a href="#">Fuser removal</a> .  Does the problem remain?	Go to step 12.	The problem is solved.
<b>Step 12</b> Replace the controller board. See <a href="#">Controller board removal</a> .  Does the problem remain?	Contact the next level of support.	The problem is solved.

## 202.x3 Error Service Check

Action	Yes	No
<b>Step 1</b> 1 Remove the imaging kit. See <a href="#">Imaging kit removal</a> . 2 Enter the Diagnostics menu, and then navigate to:  <b>Printer diagnostics &amp; adjustments &gt; Motor tests</b> 3 Select <b>K+ITM</b> .  Does the transfer belt move while the motor is running?	Go to step 6.	Go to step 2.
<b>Step 2</b> Make sure that the transfer belt coupler on the EP drive is engaged with the white transfer module links.	Go to step 6.	Go to step 3.

Action	Yes	No
<p> <b>Note:</b></p> <ul style="list-style-type: none"> <li>Do not touch the belt.</li> <li>If available, use a mirror.</li> </ul>  <p>Is the transfer belt coupler properly engaged?</p>		
<p><b>Step 3</b></p> <p>Remove, and then reinstall the transfer module. See <a href="#">Transfer module removal</a>.</p> <p>Does the problem remain?</p>	Go to step 4.	The problem is solved.
<p><b>Step 4</b></p> <p>Replace the transfer module guide. See <a href="#">Transfer module guide removal</a>.</p> <p>Does the problem remain?</p>	Go to step 5.	The problem is solved.
<p><b>Step 5</b></p> <p>Replace the EP drive. See <a href="#">EP drive assembly removal</a>.</p> <p>Does the problem remain?</p>	Go to step 6.	The problem is solved.
<p><b>Step 6</b></p> <p>Check the transfer belt for tear and damage.</p> <p>Is the belt free of tear and damage?</p>	Go to step 8.	Go to step 7.



Action	Yes	No
<p><b>Step 7</b>                      Replace the transfer module. See <a href="#">Transfer module removal</a>.                      Does the problem remain?</p>	<p>Perform the Sensor (fuser exit) service check. See <a href="#">Sensor (fuser exit) service check</a> .</p>	<p>The problem is solved.</p>
<p><b>Step 8</b></p> <ol style="list-style-type: none"> <li>1 Remove the transfer module. See <a href="#">Transfer module removal</a>.</li> <li>2 Using a pair of needle-nose pliers, turn the white coupler on the belt counter-clockwise.</li> </ol>  <p>Does the coupler turn and does the belt move without binding?</p>	<p>Perform the Sensor (fuser exit) service check. See <a href="#">Sensor (fuser exit) service check</a> .</p>	<p>Go to step 9.</p>
<p><b>Step 9</b>                      Replace the transfer module. See <a href="#">Transfer module removal</a>.                      Does the problem remain?</p>	<p>Perform the Sensor (fuser exit) service check. See <a href="#">Sensor (fuser exit) service check</a> .</p>	<p>The problem is solved.</p>

## 202.x5 Error Service Check

Action	Yes	No
<p><b>Step 1</b></p> <p>1 Fan the paper stack before loading.</p> <p>2 Make sure that the side and rear tray guides are set to the correct paper size being loaded.</p> <p>Does the problem remain?</p>	Go to step 2.	The problem is solved.
<p><b>Step 2</b></p> <p>1 Enter the diagnostics menu, and then navigate to:</p> <p><b>Printer diagnostics &amp; adjustments &gt; Sensor tests</b></p> <p>2 Find the sensor (Fuser exit).</p> <p>Does the sensor status change while toggling the sensor?</p>	Go to step 5.	Go to step 3.
<p><b>Step 3</b></p> <p>1 Make sure that the sensor cable is properly connected on both ends.</p> <p>2 Check the sensor cable for damage, and replace if necessary.</p> <p>Does the problem remain?</p>	Go to step 4.	The problem is solved.
<p><b>Step 4</b></p> <p>Replace the sensor (fuser exit). See <a href="#">Sensor (fuser exit) removal</a>.</p> <p>Does the problem remain?</p>	Go to step 5.	The problem is solved.
<p><b>Step 5</b></p> <p>Replace the fuser. See <a href="#">Fuser removal</a>.</p> <p>Does the problem remain?</p>	Contact the next level of support.	The problem is solved.



## 231 Paper Jams

### 231 Paper Jam Messages

Error code	Description	Action
231.03	The paper fed from the MPF or manual feeder did not reach the sensor (redrive/duplex path 1) during a duplex print job.	See <a href="#">Sensor (redrive/duplex path 1) service check</a> .
231.05	The paper fed from the MPF or manual feeder never cleared the sensor (redrive/duplex path 1) during a duplex print job.	
231.13	The paper fed from tray 1 did not reach the sensor (redrive/duplex path 1) during a print job.	
231.15	The paper fed from tray 1 never cleared the sensor (redrive/duplex path 1) during a duplex print job.	
231.23	The paper fed from tray 2 did not reach the sensor (redrive/duplex path 1) during a print job.	
231.25	The paper fed from tray 2 never cleared the sensor (redrive/duplex path 1) during a duplex print job.	
231.33	The paper fed from tray 3 did not reach the sensor (redrive/duplex path 1) during a print job.	
231.35	The paper fed from tray 3 never cleared the sensor (redrive/duplex path 1) during a duplex print job.	

## Sensor (Redrive/Duplex Path 1) Service Check

Action	Yes	No
<p><b>Step 1</b></p> <p>1 Make sure that the tray side guides for all the trays are properly adjusted.</p> <p>2 Make sure that the paper type and size settings match the paper type and size set on the tray.</p> <p>Does the problem remain?</p>	Go to step 2.	The problem is solved.
<p><b>Step 2</b></p> <p>Make sure that the paper size and weight are supported by the duplex. See <a href="#">Supported Paper Sizes</a> and <a href="#">Supported Paper Weights</a>.</p> <p>Are the paper size and weight supported?</p>	Go to step 4.	Go to step 3.
<p><b>Step 3</b></p> <p>Load a supported paper size and weight.</p> <p>Does the problem remain?</p>	Go to step 4.	The problem is solved.
<p><b>Step 4</b></p> <p>1 Make sure that the printer is on a hard and flat surface, so that the tray is properly seated in the printer, and the S1 actuator can properly move.</p> <p>2 Open the front door, and then remove the jammed paper.</p> <p>Does the problem remain?</p>	Go to step 5.	The problem is solved.
<p><b>Step 5</b></p> <p>Remove the tray insert, and then make sure that the sensor (A) is free of debris and obstructions.</p>	Go to step 6.	The problem is solved.

Action	Yes	No
 <p>Does the problem remain?</p>		
<p><b>Step 6</b></p> <ol style="list-style-type: none"> <li>1 Enter the Diagnostics menu, and then navigate to: <b>Printer diagnostics &amp; adjustments &gt; Sensor tests</b></li> <li>2 Find the sensor (Redrive/duplex path 1).</li> <li>3 Use a piece of paper to toggle the sensor.</li> </ol> <p>Does the sensor status change while toggling the sensor?</p>	Go to step 7.	Go to step 11.
<p><b>Step 7</b></p> <p>Check if the actuator (B) in the tray freely rotates and return to its home position.</p>  <p>Does the flag freely rotate and return to its home position?</p>	Go to step 9.	Go to step 8.
<p><b>Step 8</b></p>	Contact the next level of support.	The problem is solved.

Action	Yes	No
<p>Replace the tray insert.</p> <p>Does the problem remain?</p>		
<p><b>Step 9</b></p> <p>Turn the gear (C) to check if the manual feed shaft freely rotates.</p>  <p>Does the manual feed shaft freely rotate?</p>	Contact the next level of support.	Go to step 10.
<p><b>Step 10</b></p> <p>Replace the tray insert.</p> <p>Does the problem remain?</p>	Contact the next level of support.	The problem is solved.
<p><b>Step 11</b></p> <ol style="list-style-type: none"> <li>1 Turn off the printer.</li> <li>2 Remove the rear cover. See <a href="#">Rear cover removal</a>.</li> <li>3 Make sure that the cable on the JFUSES2 connector on the controller board is properly connected.</li> </ol> <p>Does the problem remain?</p>	Go to step 12.	The problem is solved.
<p><b>Step 12</b></p> <p>Check the cable for continuity or damage, and replace if necessary.</p> <p>Does the problem remain?</p>	Go to step 13.	The problem is solved.
<p><b>Step 13</b></p> <p>Turn on the printer, and then check for the following voltage</p>	Go to step 14.	Go to step 22.

Action	Yes	No
values at the JFUSES2 connector on the controller board: <ul style="list-style-type: none"> <li>• Pin 7: +5 V dc</li> <li>• Pin 8: Ground</li> <li>• Pin 9: +3.3 V dc</li> </ul> Are values approximately the same?		
<b>Step 14</b> Replace the sensor (redrive/duplex path 1). See <a href="#">Sensor (duplex) Removal</a> . Does the problem remain?	Go to step 15.	The problem is solved.
<b>Step 15</b> Check if the following error codes appear: <ul style="list-style-type: none"> <li>• 231.x3</li> <li>• 231.x5</li> <li>• 232.x3</li> <li>• 232.x5</li> </ul> Did any of the error codes appear?	Go to step 16.	Go to step 22.
<b>Step 16</b> Run a duplex print job from tray 1 and the option trays. Does the error only occur from an option tray?	Go to step 17.	Go to step 18.
<b>Step 17</b> Replace the defective option tray. Does the problem remain?	Go to step 18.	The problem is solved.
<b>Step 18</b> Check the fuser rollers for excessive wear or damage. Do the rollers show excessive wear or damage?	Go to step 19.	Go to step 20.
<b>Step 19</b> Replace the fuser. See <a href="#">Fuser removal</a> .	Go to step 20.	The problem is solved.

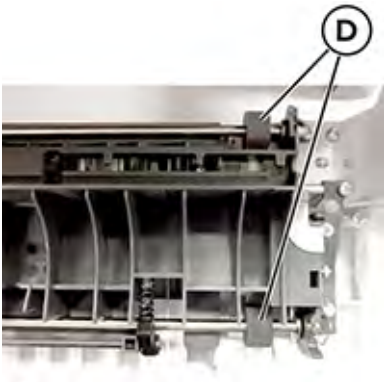
Action	Yes	No
Does the problem remain?		
<p><b>Step 20</b></p> <p>Check the two duplex aligner rollers (D) for excessive wear or damage.</p>  <p>Do the rollers show excessive wear or damage?</p>	Go to step 21.	Go to step 22.
<p><b>Step 21</b></p> <p>Replace the front door inner deflector. See <a href="#">Front Door Inner Deflector Removal</a> .</p> <p>Does the problem remain?</p>	Go to step 22.	The problem is solved.
<p><b>Step 22</b></p> <p>Replace the controller board. See <a href="#">Controller board removal</a> .</p> <p>Does the problem remain?</p>	Contact the next level of support.	The problem is solved.

## 232 Paper Jams

### 232 Paper Jam Messages

Error code	Description	Action
232.02	The paper fed from the MPF or manual feeder arrived at the sensor (input) earlier than expected during a duplex print job.	See <a href="#">Sensor (input) service check</a> .



Error code	Description	Action
232.12	The paper fed from tray 1 arrived at the sensor (input) earlier than expected during a duplex print job.	
232.22	The paper fed from tray 2 arrived at the sensor (input) earlier than expected during a duplex print job.	
232.32	The paper fed from tray 3 arrived at the sensor (input) earlier than expected during a duplex print job.	
232.03	The paper fed from the MPF or manual feeder never arrived at the sensor (input) during a duplex print job.	
232.13	The paper fed from tray 1 never arrived at the sensor (input) during a duplex print job.	
232.23	The paper fed from tray 2 never arrived at the sensor (input) during a duplex print job.	
232.33	The paper fed from tray 3 never arrived at the sensor (input) during a duplex print job.	
232.05	The paper fed from the MPF or manual feeder never cleared the sensor (input) during a duplex print job.	
232.15	The paper fed from tray 1 never cleared the sensor (input) during a duplex print job.	
232.25	The paper fed from tray 2 never cleared the sensor (input) during a duplex print job.	
232.35	The paper fed from tray 3 never cleared the sensor (input) during a duplex print job.	

## 24y Paper Jams

### 241 Paper Jam Messages

Error code	Description	Action
241.05	The paper fed from the manual feeder never cleared the sensor (redrive/duplex path 1).	See <a href="#">Sensor (redrive/duplex path 1) service check</a> .
241.82	The motor (tray 1 pick) failed to achieve the expected speed.	See <a href="#">Motor (tray 1 pick/duplex) service check</a> .
241.83	The motor (tray 1 pick) stalled.	
241.84	The motor (tray 1 pick) is running too slow.	
241.91	The paper remains on the sensor (redrive/duplex path 1) during the warm-up sequence.	See <a href="#">Sensor (redrive/duplex path 1) service check</a> .

### 242 Paper Jam Messages

Error code	Description	Action
242.05	The paper fed from the MPF never cleared the sensor (tray 2 pass-through).	See <a href="#">Option tray jam service check</a> .
242.06	The paper fed from the MPF was not picked. The paper did not reach the sensor (tray 2 pass-through).	
242.21	The paper fed from tray 2 remains detected at the sensor (tray 2 pass-through).	
242.22	The paper fed from tray 2 arrived too early at the sensor (tray 2 pass-through).	
242.25	The paper fed from tray 2 cleared the sensor (tray 2 pass-through) too late.	

Error code	Description	Action
242.26	The paper fed from the tray 2 was not picked. The paper did not reach the sensor (tray 2 pass-through).	
242.31	The paper fed from tray 3 remains detected at sensor (tray 2 pass-through).	
242.32	The paper fed from tray 3 arrived too early at the sensor (tray 2 pass-through).	
242.33	The paper fed from tray 3 did not reach the sensor (tray 2 pass-through).	
242.35	The paper fed from tray 3 cleared the sensor (tray 2 pass-through) too late.	
242.7	The motor (tray 2 pass-through) does not turn on.	See <a href="#">Option tray motor service check</a> .
242.71	The motor (tray 2 pass-through) does not turn off.	
242.72	The motor (tray 2 pass-through) failed to achieve the expected speed.	
242.73	The motor (tray 2 pass-through) stalled.	
242.74	The motor (tray 2 pass-through) is running too slow.	
242.75	The motor (tray 2 pass-through) is running too fast.	
242.76	The motor (tray 2 pass-through) moved too long.	
242.8	The motor (tray 2 pick) does not turn on.	
242.81	The motor (tray 2 pick) does not turn off.	

Error code	Description	Action
242.82	The motor (tray 2 pick) failed to achieve the expected speed.	
242.83	The motor (tray 2 pick) stalled.	
242.84	The motor (tray 2 pick) is running too slow.	
242.85	The motor (tray 2 pick) is running too fast.	
242.86	The motor (tray 2 pick) moved too long.	
242.91	The paper remains detected at the sensor (tray 2 pass-through) during the warm up sequence.	
242.92	The paper fed from an unknown source arrived too early at the sensor (tray 2 pass-through).	
242.93	The paper fed from an unknown source did not reach the sensor (tray 2 pass-through).	
242.95	The paper fed from an unknown source cleared the sensor (tray 2 pass-through) too late.	
242.96	The paper fed from an unknown source was not picked. The paper did not reach the sensor (tray 2 pass-through).	

## 243 Paper Jam Messages

Error code	Description	Action
243.31	The paper fed from tray 3 remains detected at the sensor (tray 3 pass-through).	See <a href="#">Option tray jam service check</a> .
243.32	The paper fed from tray 3 arrived too early at the sensor (tray 3 pass-through).	

Error code	Description	Action
243.35	The paper fed from tray 3 cleared the sensor (tray 3 pass-through) too late.	
243.36	The paper fed from tray 3 was not picked. The paper did not reach the sensor (tray 3 pass-through).	
243.70	The motor (tray 3 pass-through) does not turn on.	See <a href="#">Option tray motor service check</a> .
243.71	The motor (tray 3 pass-through) does not turn off.	
243.72	The motor (tray 3 pass-through) failed to achieve the expected speed.	
243.73	The motor (tray 3 pass-through) stalled.	
243.74	The motor (tray 3 pass-through) is running too slow.	
243.75	The motor (tray 3 pass-through) is running too fast.	
243.76	The motor (tray 3 pass-through) moved too long.	
243.80	The motor (tray 3 pick) does not turn on.	
243.81	The motor (tray 3 pick) does not turn off.	
243.82	The motor (tray 3 pick) failed to achieve the expected speed.	
243.83	The motor (tray 3 pick) stalled.	
243.84	The motor (tray 3 pick) is running too slow.	See <a href="#">Option tray jam service check</a> .
243.85	The motor (tray 3 pick) is running too fast.	

Error code	Description	Action
243.86	The motor (tray 3 pick) moved too long.	
243.91	The paper remains detected at the sensor (tray 3 pass-through) during the warm-up sequence.	See <a href="#">Option tray motor service check</a> .
243.92	The paper fed from an unknown source arrived too early at the sensor (tray 3 pass-through).	
243.93	The paper fed from an unknown source did not reach the sensor (tray 3 pass-through).	
243.95	The paper fed from an unknown source cleared the sensor (tray 3 pass-through) too late.	
243.96	The paper fed from an unknown source was not picked. The paper did not reach the sensor (tray 3 pass-through).	

## Option Tray Jam Service Check

Action	Yes	No
<b>Step 1</b> Check if the paper type and size settings match the paper type and size loaded on the tray. Do the settings match?	Go to step 3.	Go to step 2.
<b>Step 2</b> Change the paper size and type, or adjust the size setting in the tray. Does the problem remain?	Go to step 3.	The problem is solved.
<b>Step 3</b> Make sure that the rear and side guides in the trays are properly adjusted. Does the problem remain?	Go to step 4.	The problem is solved.

Action	Yes	No
<p><b>Step 4</b></p> <p>Make sure that the trays and the tray 1 pass-through are free of dust or debris.</p> <p>Does the problem remain?</p>	Go to step 5.	The problem is solved.
<p><b>Step 5</b></p> <ol style="list-style-type: none"> <li>1 Make sure that the tray pick tires are free of dust or debris.</li> <li>2 Check the tray pick tires for proper installation and damage, and reseal or replace if necessary.</li> </ol> <p>Does the problem remain?</p>	Go to step 6.	The problem is solved.
<p><b>Step 6</b></p> <ol style="list-style-type: none"> <li>1 Make sure that the pass-through sensors in the option trays are properly installed and free of damage, and replace if necessary.</li> <li>2 Make sure that the sensors are free of debris and obstructions.</li> </ol> <p>Does the problem remain?</p>	Go to step 7.	The problem is solved.
<p><b>Step 7</b></p> <p>Check the tray pass-through sensors and actuators for damage.</p> <p>Are the sensors and actuators free of damage?</p>	Go to step 9.	Go to step 8.
<p><b>Step 8</b></p> <p>Replace the affected tray.</p> <p>Does the problem remain?</p>	Go to step 9.	The problem is solved.
<p><b>Step 9</b></p> <ol style="list-style-type: none"> <li>1 Enter the Diagnostics menu, and then navigate to: <b>Printer diagnostics &amp; adjustments &gt; Sensor tests</b></li> <li>2 Find the sensor (Pass-through).</li> <li>3 Find the sensor (MPF media present).</li> </ol>	Go to step 11.	Go to step 10.

## Diagnostics and Troubleshooting

Action	Yes	No
Do the sensors status change while toggling the sensor?		
<p><b>Step 10</b></p> <p>Check the affected sensor for proper installation, and reset if necessary.</p> <p>Does the problem remain?</p>	Go to step 11.	The problem is solved.
<p><b>Step 11</b></p> <p>1 Enter the Diagnostics menu, and then navigate to:</p> <p><b>Additional input tray diagnostics &gt; Motor tests</b></p> <p>2 Select <b>Pick (tray x) motor test</b>, and then press <b>OK</b> or touch <b>Start</b>.</p> <p>Make sure to perform the motor test in both directions.</p> <p>3 Select <b>Pass-through (tray x) motor test</b>, and then press <b>OK</b> or touch <b>Start</b>.</p> <p>Make sure to perform the motor test in both directions.</p> <p>Did the motors run?</p>	Go to step 12.	Go to step 13.
<p><b>Step 12</b></p> <p>Perform a print test.</p> <p>Does the problem remain?</p>	Go to step 13.	The problem is solved.
<p><b>Step 13</b></p> <p>Make sure that the option connector in the subframe is properly installed in tray 2.</p> <p>Does the problem remain?</p>	Go to step 14.	The problem is solved.
<p><b>Step 14</b></p> <p>Make sure that the cable at the JOPT1 connector on the controller board is properly connected.</p> <p>Does the problem remain?</p>	Go to step 15.	The problem is solved.



Action	Yes	No
<p><b>Step 15</b></p> <p>Check the continuity of the option cable on the printer.</p> <p>Does the cable have continuity?</p>	Go to step 17.	Go to step 16.
<p><b>Step 16</b></p> <p>Replace the cable.</p> <p>Does the problem remain?</p>	Go to step 17.	The problem is solved.
<p><b>Step 17</b></p> <p>Check the tray connections for proper installation and damage, and replace the affected tray if necessary.</p> <p>Does the problem remain?</p>	Contact the next level of support.	The problem is solved.

## User Attendance Messages

### Non-Xerox Supply

The printer has detected a non-Xerox supply or part installed in the printer.

The Xerox printer is designed to function best with genuine Xerox supplies and parts. Use of third-party supplies or parts may affect the performance, reliability, or life of the printer and its imaging components.

All life indicators are designed to function with Xerox supplies and parts and may deliver unpredictable results if third-party supplies or parts are used. Imaging component usage beyond the intended life may damage the Xerox printer or associated components.

 **Warning:** Use of third-party supplies or parts can affect warranty coverage. Damage caused by the use of third-party supplies or parts may not be covered by the warranty.

If a customer accepts any and all of these risks and proceeds with the use of non-genuine supplies or parts in the printer, then instruct the customer to press and hold **X** and **#** simultaneously from the control panel for 15 seconds. Do not perform this action yourself.

If a customer does not want to accept these risks, then remove the third-party supply or part from the printer and install a genuine Xerox supply or part.

If the printer does not print after pressing and holding **X** and **#** simultaneously for 15 seconds, then instruct the customer to reset the supply usage counter.

1. From the control panel, navigate to:  
**Settings > Device > Maintenance > Configuration Menu > Supply Usage And Counters**
2. Select the part or supply to reset, and then select **Start**.
3. Read the warning message, and then select **Continue**.
4. Press and hold **X** and **#** simultaneously for 15 seconds to clear the message.

 **Note:** If the customer is unable to reset the supply usage counters, then the customer should return the item to the place of purchase.

### Metered Supply Installed in Printer Configured For Sold

The printer has detected a metered supply installed in the printer configured to use sold supply.

The printers ship with worldwide neutral toner cartridges. Initial installation of these cartridges sets the printer to worldwide neutral configuration. The first toner cartridge replacement sets the geographic differentiation code and toner cartridge type in NVM to that of the replacement cartridge. To change these NVM, a supplies plan conversion code (non-PagePack) or activation code (PagePack) code is required.

See [Supplies used to resolve print quality issues](#) for part numbers.

If an incorrect type of toner cartridge is installed, an error code is generated indicating toner incompatibility.

## Changing The Service Plan (Non-PagePack)

Contact the relevant OpCo to obtain a conversion code:

- **US:** Provide the printer Serial Number and Total Meter Read using the email template provided in Eureka Tip 1465826. A conversion PIN code is provided within 10 minutes. For any service plan conversion issues or special requests, phone Xerox Corporate Licensing Systems (XDSS), 1-800-890-3260.
- **Xerox Business Solutions (XBS):** All requests for service plan conversions must be approved by the XBS VP of Service. Request your field service manager to contact your XBS company VP of Service for direction. The XBS Core Company VP of Service will require authorization to convert the printer from sold to metered, and will provide a status of your request. Do not phone Field Engineering to request a conversion code.
- **US Authorized Service Provider (ASP):** Provide the printer Serial Number and Total Meter Read using the email template provided in Eureka Tip 1465826. A conversion PIN code is provided within 10 minutes. For any service plan conversion issues or special requests, phone Xerox Corporate Licensing Systems (XDSS), 1-800-890-3260.
- **Canada:** Provide the printer Serial Number and Total Meter Read using the email template provided in Eureka Tip 1465826. A conversion PIN code is provided within 10 minutes. For any service plan conversion issues or special requests, phone Customer Delivery Organization (CDO) field support, 1-800-647-1331.



**Note:** The service plan conversion code must be entered within 500 Total Impression counts. If this count is exceeded, a new code is required.

### Using The Control Panel

1. From the control panel, navigate to **Supplies Plan > Plan Conversion**.
2. Record the **Total Impressions** and **Device Serial Number**.
3. Contact the relevant OpCo to obtain the conversion code.
4. After receiving the conversion code, on the control panel, navigate to **Supplies Plan > Plan Conversion > Conversion Code**.
5. Enter the conversion code provided, then select **OK**.
6. Navigate to **Supplies Plan > Plan Conversion > Current Plan** to confirm the conversion is successful.

### Using The Embedded Web Server

1. Open a web browser, and then type the printer IP address. If necessary, ask the customer to enter the Admin password.
2. From the home page, navigate to **Settings > Supplies Plan > Plan Conversion**.
3. Record the **Total Impressions** and **Device Serial Number**.
4. Contact the relevant OpCo to obtain the conversion code.
5. After receiving the conversion code, on the embedded web server, navigate to **Settings > Supplies Plan > Plan Conversion > Conversion Code**.

6. Enter the conversion code provided, then click **Convert Plan**.
7. Check the **Current Plan** status to confirm the conversion is successful.

## Changing The Service Plan (PagePack)

Contact the relevant OpCo to obtain an activation code. Provide the Sequence Number and Device Serial Number.

- **EMEA (XE):** Email office.europe.page.pack.pin@xerox.com
- **EMEA (DMO-E):** Follow your local process.
- **LATAM (Latin America):** Follow your local process.



**Note:** The service plan activation code must be entered within 1000 Total Impression counts. If this count is exceeded, a new code is required.

### Using The Control Panel

1. From the control panel, navigate to **Supplies Plan > Plan Activation**.
2. Record the **Sequence Number** and **Device Serial Number**.
3. Contact the relevant OpCo to obtain the activation code.
4. After receiving the activation code, on the control panel, navigate to **Supplies Plan > Plan Activation > Activation Code**.
5. Enter the activation code provided, then select **OK**.

### Using The Embedded Web Server

1. Open a web browser, and then type the printer IP address. If necessary, ask the customer to enter the Admin password.
2. From the home page, navigate to **Settings > Supplies Plan > Plan Activation**.
3. Record the **Sequence Number** and **Device Serial Number**.
4. Contact the relevant OpCo to obtain the activation code.
5. After receiving the activation code, on the embedded web server, navigate to **Settings > Supplies Plan > Plan Activation > Activation Code**.
6. Enter the activation code provided, then click **Activate Plan**.

## 24 User Attendance Errors

### 24 User Attendance Error Messages

Error code	Description	Action
24.04	The printer tried to do a duplex print job on a sheet that was too short or too narrow for the duplex path.	Perform one of the following: <ol style="list-style-type: none"> <li>1 Load the correct paper size in the tray.</li> <li>2 From the control panel, select <b>Continue</b> to clear the message, and then print using a different tray paper source.</li> <li>3 Check the tray length and width guides, and then make sure that paper is properly loaded in the tray.</li> <li>4 Make sure that the correct paper size and type are specified in the Printing Preferences or Print dialog.</li> <li>5 Make sure that the paper size and type are specified in the Paper menu on the printer control panel.</li> <li>6 Cancel the print job.</li> </ol>

## 31 User Attendance Errors

### 31 User Attendance Error Messages

Error code	Description	Action
31.35z	Waste toner bottle smart chip or sensor problem.	See <a href="#">Waste toner bottle service check</a> .
31.40z	The printer failed to replenish due to bad auger gear and toner cartridge gear mesh.	Insert the toner cartridge of the affected color.
31.40z	Black toner cartridge smart chip or sensor problem.	See <a href="#">Missing toner cartridge, developer unit, or photoconductor unit service check</a> .
31.41z	Cyan toner cartridge smart chip or sensor problem.	

Error code	Description	Action
31.42z	Magenta toner cartridge smart chip or sensor problem.	
31.43z	Yellow toner cartridge smart chip or sensor problem.	
31.60z	Black imaging kit or photoconductor smart chip or sensor problem.	
31.65z	Black and color imaging kit smart chip or sensor problem.	

The following are the meaning of the z codes:

- A—Missing
- B—Missing Mux
- C—Read failure
- D—Write failure
- E—Device information read failure
- F—Authentication error
- G—Read failure

## 32 User Attendance Errors

### 32 User Attendance Error Messages

Error code	Description	Action
32.40J	Black Metered toner cartridge installed in printer configured for Sold	See <a href="#">Metered Supply Installed in Printer Configured For Sold</a>
32.41J	Cyan Metered toner cartridge installed in printer configured for Sold	
32.42J	Magenta Metered toner cartridge installed in printer configured for Sold	
32.43J	Yellow Metered toner cartridge installed in printer configured for Sold	

Error code	Description	Action
32.40z	Black toner cartridge unsupported error.	See <a href="#">Missing toner cartridge, developer unit, or photoconductor unit service check</a> .
32.41z	Cyan toner cartridge unsupported error.	
32.42z	Magenta toner cartridge unsupported error.	
32.43z	Yellow toner cartridge unsupported error.	
32.65z	Black and color imaging kit or photoconductor unit unsupported error.	

The following are the meaning of the z codes:

- A—Unsupported memory map version in the smart chip
- B—Failed capacity class/model compatibility check
- C—Failed OEM check
- D—Failed SWE marriage check
- E—The supply is on the revoked list
- F—The toner cartridge or imaging kit is MICR, and the firmware release does not support MICR
- J—Metered toner cartridge installed in printer configured for Sold toner cartridge

## 33 User Attendance Errors

### 33 User Attendance Error Messages

 **Note:** See [Non-Xerox supply](#).

Error code	Description	Action
33.40z	Non-Xerox black toner cartridge. The smart chip contents have been manipulated by a third party manufacturer.	See <a href="#">Missing toner cartridge, developer unit, or photoconductor unit service check</a> .
33.41z	Non-Xerox cyan toner cartridge. The smart chip contents have been manipulated by a third party manufacturer.	

Error code	Description	Action
33.42z	Non-Xerox magenta toner cartridge. The smart chip contents have been manipulated by a third party manufacturer.	
33.43z	Non-Xerox yellow cartridge. The smart chip contents have been manipulated by a third party manufacturer.	
33.50z	Non-Xerox black developer unit. The smart chip contents have been manipulated by a third party manufacturer.	
33.64z	Non-Xerox black and color imaging kit. The smart chip contents have been manipulated by a third party manufacturer.	

The following are the meaning of the z codes:

- A— Non-genuine Xerox supply
- B— Supply is exposed

## Missing Toner Cartridge, Developer Unit, or Photoconductor Unit Service Check

Action	Yes	No
<p><b>Step 1</b></p> <ol style="list-style-type: none"> <li>1 Make sure that the toner cartridge or photoconductor unit is properly installed.</li> <li>2 Check the error code on the display, and then verify if the toner cartridge, developer unit, or photoconductor unit is supported.</li> <li>3 Replace the unsupported supply.</li> </ol> <p>Does the problem remain?</p>	Go to step 2.	The problem is solved.
<p><b>Step 2</b></p> <p>Check the HVPS and pogo pin cables for proper connection, and reset if necessary.</p>	Go to step 3.	The problem is solved.



Action	Yes	No
Does the problem remain?		
<p><b>Step 3</b></p> <ol style="list-style-type: none"> <li>1 Make sure that the pogo pin contacts are free from dust or debris.</li> <li>2 Check the pogo pin contacts for damage, and replace if necessary.</li> </ol> <p>Does the problem remain?</p>	Go to step 4.	The problem is solved.
<p><b>Step 4</b></p> <p>Replace the imaging kit. See <a href="#">Imaging kit removal</a>.</p> <p>See <a href="#">Supplies used to resolve print quality issues</a> to determine which imaging kit to use.</p> <p>Does the problem remain?</p>	Go to step 5.	The problem is solved.
<p><b>Step 5</b></p> <ol style="list-style-type: none"> <li>1 Enter the Diagnostics menu, and then navigate to: <b>Printer diagnostics &amp; adjustments &gt; Sensor tests</b></li> <li>2 Find the sensor (Toner meter).</li> </ol> <p>Does the sensor status change while toggling the sensor?</p>	Go to step 7.	Go to step 6.
<p><b>Step 6</b></p> <p>Replace the TMC card. See <a href="#">TMC card removal</a>.</p> <p>Does the problem remain?</p>	Go to step 7.	The problem is solved.
<p><b>Step 7</b></p> <p>Replace the controller board. See <a href="#">Controller board removal</a>.</p> <p>Does the problem remain?</p>	Contact the next level of support.	The problem is solved.

## 34 User Attendance Errors

### 34 User Attendance Error Messages

Error code	Description	Action
34.04	The printer tried to do a duplex print job on a sheet that was too short or too narrow for the duplex path.	Perform one of the following: <ol style="list-style-type: none"> <li>1 Load the correct paper size in the tray.</li> <li>2 From the control panel, select <b>Continue</b> to clear the message, and then print using a different tray paper source.</li> <li>3 Check the tray length and width guides, and then make sure that paper is properly loaded in the tray.</li> <li>4 Make sure that the correct paper size and type are specified in the Printing Preferences or Print dialog.</li> <li>5 Make sure that the paper size and type are specified in the Paper menu on the printer control panel.</li> <li>6 Cancel the print job.</li> </ol>

## 42 User Attendance Errors

### 42 User Attendance Error Messages

Error code	Description	Action
42.xyz	Printer region mismatch.	See <a href="#">Region mismatch service check</a> .

The following are the meaning of the xyz codes:

- A b z—A is the printer region (error values 1 to 6, and 0 always matches)
- a B z—B is the cartridge region (values 0 to 6)
- a b Z—Z is the cartridge color (CMY or K)
- 0 b z—Region 0: The machine is not regionalized, and matches any regionalized cartridge
- a 0 z—Region 0: The cartridge is not regionalized, and only matches with machine region 0
- 1 1 z—Region 1: North America
- 2 2 z—Region 2: Europe Economic Area + Extras

- 3 3 z—Region 3: Asia Pacific Group
- 4 4 z—Region 4: Latin America
- 5 5 z—Region 5: Rest Of Europe, Middle East, and Africa
- 6 6 z—Region 6: Australia and New Zealand

## Region Mismatch Service Check

Action	Yes	No
<b>Step 1</b> Check the region number of the toner cartridge and the printer. Do the numbers match?	Contact the next level of support.	Go to step 2.
<b>Step 2</b> Install the appropriate toner cartridge. Does the problem remain?	Contact the next level of support.	The problem is solved.

## 43 User Attendance Errors

### 43 User Attendance Error Messages

Error code	Description	Action
43.40z	Black toner cartridge toner meter cycle error.	See <a href="#">TMC card service check</a> .
43.41z	Cyan toner cartridge toner meter cycle error.	
43.42z	Magenta toner cartridge toner meter cycle error.	
43.43z	Yellow toner cartridge toner meter cycle error.	

The following are the meaning of the yz codes:

- y—Recoverable first error
- z—Non-recoverable second error

## TMC Card Service Check

Action	Yes	No
<p><b>Step 1</b></p> <p>1 Enter the Diagnostics menu, and then navigate to:</p> <p><b>Printer diagnostics &amp; adjustments &gt; Sensor tests</b></p> <p>2 Find the sensor (Toner meter).</p> <p>Does the sensor status change while toggling the sensor?</p>	Go to step 2.	Go to step 3.
<p><b>Step 2</b></p> <p>Replace the toner cartridge.</p> <p>Does the problem remain?</p>	Go to step 3.	The problem is solved.
<p><b>Step 3</b></p> <p>Replace the TMC card. See <a href="#">TMC card removal</a>.</p> <p>Does the problem remain?</p>	Contact the next level of support.	The problem is solved.

## 80 User Attendance Errors

### 80 User Attendance Error Messages

Error code	Description	Action
80.1	The maintenance kit is low.	See <a href="#">Maintenance kit service check</a> .
80.2	The maintenance kit is very low.	
80.3	Replace the maintenance kit. Zero estimated pages remain.	
80.4		

## Maintenance Kit Service Check

Action	Yes	No
 <p>1 Replace the required maintenance kit. 2 Reset the maintenance counter.</p> <p>Does the problem remain?</p>	Contact the next level of support.	The problem is solved.

## 82 User Attendance Errors

### 82 User Attendance Error Messages

Error code	Description	Action
82.11	The waste toner bottle is nearly full. The sensor threshold has been reached.	See <a href="#">Waste toner bottle service check</a> .
82.19	The waste toner bottle is nearly full. The user-selected EWS set point has been reached.	
82.31	Replace the waste toner bottle. The sensor end of life threshold has been reached.	

### Waste Toner Bottle Service Check

Action	Yes	No
<p><b>Step 1</b></p> <p>Reseat the waste toner bottle.</p> <p>Does the problem remain?</p>	Go to step 2.	The problem is solved.
<p><b>Step 2</b></p> <p>Make sure that the printer is placed on a hard and flat surface.</p> <p>Does the problem remain?</p>	Go to step 3.	The problem is solved.

Action	Yes	No
<p><b>Step 3</b></p> <p>Make sure that the waste toner bottle contacts and waste toner bottle contact block contacts are free from dust or debris.</p> <p>Does the problem remain?</p>	Go to step 4.	The problem is solved.
<p><b>Step 4</b></p> <p>Check the waste toner bottle contact block for proper connection and damage.</p> <p>Is the waste toner bottle contact block properly connected and free of damage?</p>	Contact the next level of support.	Go to step 5.
<p><b>Step 5</b></p> <p>Replace the waste toner bottle contact block. See <a href="#">Waste toner bottle contact block removal</a>.</p> <p>Does the problem remain?</p>	Contact the next level of support.	The problem is solved.

## 84 User Attendance Errors

### 84 User Attendance Error Messages

Error code	Description	Action
84.11	The imaging kit is low.	See <a href="#">Toner cartridge or photoconductor unit service check</a> .
84.13		
84.19		
84.21	The imaging kit is very low.	
84.29		
84.31	Replace the imaging kit. Zero estimated pages remain.	
84.41	Replace the imaging kit. Zero estimated pages remain. Absolute	

Error code	Description	Action
	end of life has been reached due to the PC rev counter.	
84.43	Replace the imaging kit. Zero estimated pages remain. Absolute end of life has been reached due to page count.	
84.48	Replace the imaging kit. Zero estimated pages remain. Absolute end of life has been reached due to exhausted Quanta.	

## 88 User Attendance Errors

### 88 User Attendance Error Messages

Error code	Description	Action
88.00	The toner cartridge is nearly low.	See <a href="#">Toner cartridge or photoconductor unit service check</a>
88.10	The toner cartridge is low.	
88.19		
88.20	The toner cartridge is very low.	
88.30	Replace the toner cartridge. Zero estimated pages remain.	
88.40		
88.48		

## Toner Cartridge or Photoconductor Unit Service Check

Action	Yes	No
<p><b>Step 1</b></p> <ol style="list-style-type: none"> <li>1 Make sure that the toner cartridge or photoconductor unit is installed.</li> <li>2 Check if the toner cartridge or photoconductor unit is supported, and replace if necessary.</li> </ol> <p>Does the problem remain?</p>	Go to step 2.	The problem is solved.
<p><b>Step 2</b></p> <ol style="list-style-type: none"> <li>1 Make sure that the toner cartridge or photoconductor unit is properly installed.</li> <li>2 Make sure that the toner cartridge or photoconductor unit cables are properly connected.</li> </ol> <p>Does the problem remain?</p>	Go to step 3.	The problem is solved.
<p><b>Step 3</b></p> <ol style="list-style-type: none"> <li>1 Check the toner cartridge or photoconductor unit contacts for damage, and replace if necessary.</li> <li>2 Replace the imaging kit if necessary. See <a href="#">Imaging kit removal</a>.</li> </ol> <p>See <a href="#">Supplies used to resolve print quality issues</a> to determine which imaging kit to use.</p> <p>Does the problem remain?</p>	Go to step 4.	The problem is solved.



Action	Yes	No
<b>Step 4</b> Check the controller board pins for damage. Are the controller board pins free of damage?	Contact the next level of support.	Go to step 5.
<b>Step 5</b> Replace the controller board. See <a href="#">Controller board removal</a> . Does the problem remain?	Contact the next level of support.	The problem is solved.

## Non-Supply User Attendance Errors

### Non-Supply User Attendance Error Messages

Error code	Description	Action
35	Insufficient memory.	See <a href="#">Insufficient memory service check</a> .
36	The resolution is reduced.	N/A
37	No memory for collation, defrag, or held jobs.	See <a href="#">Insufficient memory service check</a> .
38	The memory is full.	See <a href="#">Insufficient memory service check</a> .
39	Complex page.	See <a href="#">Complex page service check</a> .
51	The flash memory is defective.	See <a href="#">Flash memory failure service check</a> .
52	The flash memory is full.	See <a href="#">Insufficient flash memory service check</a> .
53	Unformatted flash memory.	See <a href="#">Flash memory failure service check</a> .
54	Serial port or network error.	See <a href="#">Flash memory failure service check</a> .
55	The option is not supported.	See <a href="#">Unsupported internal option service check</a> .

Error code	Description	Action
56	The parallel, serial, or USB port is disabled.	See <a href="#">Disabled port service check</a> .
57	The configuration changed, and all held jobs are lost.	N/A
58	There are too many input options or trays.	See <a href="#">Excess options service check</a> .
58.xx	The optional tray is defective or incorrectly installed.	See <a href="#">Invalid input option type or ID is detected service check</a> .
59	The option or tray incompatible.	See <a href="#">Incompatible hardware option service check</a> .
61	The hard disk is defective.	See <a href="#">Hard disk failure service check</a> .
62	The hard disk is full.	
63	The hard disk is not formatted.	Format the hard disk.
64	The hard disk format is not supported.	

## Insufficient Memory Service Check

Action	Yes	No
<p><b>Step 1</b></p> <ol style="list-style-type: none"> <li>1 Perform a POR.</li> <li>2 From the home screen, navigate to <b>Settings &gt; Print &gt; Setup &gt; Download Target &gt; Disk</b>.</li> </ol> <p>Does the problem remain?</p>	Go to step 2.	The problem is solved.
<p><b>Step 2</b></p> <p>If applicable, install an extra memory card.</p> <p>Does the problem remain?</p>	Go to step 3.	The problem is solved.

Action	Yes	No
<b>Step 3</b> Check the controller board pins for damage. Are the pins free of damage?	Contact the next level of support.	Go to step 4.
<b>Step 4</b> Replace the controller board. See <a href="#">Controller board removal</a> . Does the problem remain?	Contact the next level of support.	The problem is solved.

## Complex Page Service Check

Action	Yes	No
<b>Step 1</b> 1 Perform a POR. 2 From the home screen, navigate to <b>Settings &gt; Print &gt; Setup &gt; Download Target &gt; Disk</b> . Does the problem remain?	Go to step 2.	The problem is solved.
<b>Step 2</b> Enter the Diagnostics menu, and then navigate to: <b>Input tray quick print &gt; Tray 1 &gt; Single</b> Does the problem remain?	Go to step 3.	The problem is solved.
<b>Step 3</b> Check the controller board pins for damage. Are the pins free of damage?	Contact the next level of support.	Go to step 4.
<b>Step 4</b> Replace the controller board. See <a href="#">Controller board removal</a> . Does the problem remain?	Contact the next level of support.	The problem is solved.

## Flash Memory Failure Service Check

Action	Yes	No
<p><b>Step 1</b></p> <p>1 From the home screen, navigate to <b>Settings &gt; Print &gt; Job Accounting &gt; Log Near Full Level</b>.</p> <p>2 Make sure that the value is set to the maximum.</p> <p>Does the problem remain?</p>	Go to step 2.	The problem is solved.
<p><b>Step 2</b></p> <p>Check the controller board pins for damage.</p> <p>Are the pins free of damage?</p>	Go to step 4.	Go to step 3.
<p><b>Step 3</b></p> <p>Replace the controller board. See <a href="#">Controller board removal</a>.</p> <p>Does the problem remain?</p>	Go to step 4.	The problem is solved.
<p><b>Step 4</b></p> <p>Make sure that the printer is using the latest firmware version, and update if necessary.</p> <p>Does the problem remain?</p>	Contact the next level of support.	The problem is solved.

## Insufficient Flash Memory Service Check

Action	Yes	No
<p><b>Step 1</b></p> <p>From the home screen, navigate to <b>Settings &gt; USB Drive &gt; Flash Drive Scan &gt; Format Flash</b>.</p> <p>Does the problem remain?</p>	Go to step 2.	The problem is solved.
<p><b>Step 2</b></p> <p>1 From the home screen, navigate to <b>Settings &gt; Print &gt; Job Accounting &gt; Log Near Full Level</b>.</p>	Go to step 3.	The problem is solved.

Action	Yes	No
<p>2 Make sure that the value is set to the maximum.</p> <p>Does the problem remain?</p>		
<p><b>Step 3</b></p> <p>Check the controller board pins for damage.</p> <p>Are the pins free of damage?</p>	Go to step 5.	Go to step 4.
<p><b>Step 4</b></p> <p>Replace the controller board. See <a href="#">Controller board removal</a>.</p> <p>Does the problem remain?</p>	Go to step 5.	The problem is solved.
<p><b>Step 5</b></p> <p>Make sure that the printer is using the latest firmware version, and update if necessary.</p> <p>Does the problem remain?</p>	Contact the next level of support.	The problem is solved.

## Unsupported Internal Option Service Check

Action	Yes	No
<p><b>Step 1</b></p> <p>If applicable, make sure that the option cards are supported.</p> <p>Does the problem remain?</p>	Go to step 2.	The problem is solved.
<p><b>Step 2</b></p> <p>Check the controller board pins for damage.</p> <p>Are the pins free of damage?</p>	Go to step 4.	Go to step 3.

Action	Yes	No
<p><b>Step 3</b></p> <p>Replace the controller board. See <a href="#">Controller board removal</a>.</p> <p>Does the problem remain?</p>	Go to step 4.	The problem is solved.
<p><b>Step 4</b></p> <p>Make sure that the printer is using the latest firmware version, and update if necessary.</p> <p>Does the problem remain?</p>	Contact the next level of support.	The problem is solved.

## Disabled Port Service Check

Action	Yes	No
<p><b>Step 1</b></p> <ol style="list-style-type: none"> <li>1 Make sure that the cables connected to the ports are properly installed.</li> <li>2 Check the cables for damage, and replace if necessary.</li> </ol> <p>Does the problem remain?</p>	Go to step 2.	The problem is solved.
<p><b>Step 2</b></p> <p>Enter the Network/Ports menu and make sure that the applicable port settings are enabled.</p> <p>Does the problem remain?</p>	Go to step 3.	The problem is solved.
<p><b>Step 3</b></p> <p>If applicable, make sure that the option card is supported.</p> <p>Does the problem remain?</p>	Go to step 4.	The problem is solved.
<p><b>Step 4</b></p> <p>Check the controller board pins for damage.</p> <p>Are the pins free of damage?</p>	Go to step 6.	Go to step 5.

Action	Yes	No
<b>Step 5</b> Replace the controller board. See <a href="#">Controller board removal</a> . Does the problem remain?	Go to step 6.	The problem is solved.
<b>Step 6</b> Make sure that the printer is using the latest firmware version, and update if necessary. Does the problem remain?	Contact the next level of support.	The problem is solved.

## Excess Options Service Check

Action	Yes	No
<b>Step 1</b> Perform a POR, and then resend the print job. Does the problem remain?	Go to step 2.	The problem is solved.
<b>Step 2</b> If applicable, make sure that the internal option is supported. Does the problem remain?	Go to step 3.	The problem is solved.
<b>Step 3</b> 1 If applicable, remove all internal options. 2 Perform a POR, and then resend the print job. Does the problem remain?	Go to step 6.	Go to step 4.
<b>Step 4</b> Check if the number of internal options installed is allowed, and then remove the excess option. Does the problem remain?	Go to step 5.	The problem is solved.
<b>Step 5</b>	Go to step 6.	The problem is solved.

## Diagnostics and Troubleshooting

Action	Yes	No
<p>Check the number of input options allowed, and then remove the excess input options.</p> <p>Does the problem remain?</p>		
<p><b>Step 6</b></p> <p>Check the controller board pins for damage.</p> <p>Are the pins free of damage?</p>	Contact the next level of support.	Go to step 7.
<p><b>Step 7</b></p> <p>Replace the controller board. See <a href="#">Controller board removal</a>.</p> <p>Does the problem remain?</p>	Contact the next level of support.	The problem is solved.



## Incompatible Hardware Option Service Check

Action	Yes	No
<p><b>Step 1</b></p>  <p>1 Reseat the hardware option cables. 2 Check the cables for damage, and replace if necessary.</p> <p>Does the problem remain?</p>	Go to step 2.	The problem is solved.
<p><b>Step 2</b></p> <p>Check if the firmware version of the hardware option is supported by the engine firmware, and update the firmware if necessary.</p> <p>Contact the next level of support for the correct firmware version.</p> <p>Does the problem remain?</p>	Go to step 3.	The problem is solved.
<p><b>Step 3</b></p> <p>Check the hardware option controller board pins for damage, and replace if necessary.</p> <p>Does the problem remain?</p>	Contact the next level of support.	The problem is solved.

## Hard Disk Failure Service Check

Action	Yes	No
<p><b>Step 1</b></p> <p>Delete unnecessary files.</p> <ul style="list-style-type: none"> <li>From the home screen, navigate to <b>Settings &gt; Device &gt; Maintenance &gt; Out-of-Service Erase &gt; Erase Hard Disk &gt; Sanitize all information on hard disk</b>.</li> <li>Select <b>Erase downloads (Erase all macros, fonts, PFOs, etc.)</b>, <b>Erase buffered jobs</b>, and <b>Erase held jobs &gt; All held jobs</b>.</li> <li>Touch <b>Erase</b>.</li> </ul> <p>Does the problem remain?</p>	Go to step 2.	The problem is solved.
<p><b>Step 2</b></p> <p>Make sure that the printer is using the latest firmware version.</p> <p>Does the problem remain?</p>	Go to step 3.	The problem is solved.
<p><b>Step 3</b></p> <ol style="list-style-type: none"> <li>Make sure that the hard disk cable is properly installed.</li> <li>Check the cable for damage, and replace if necessary.</li> </ol> <p>Does the problem remain?</p>	Go to step 4.	The problem is solved.
<p><b>Step 4</b></p> <ol style="list-style-type: none"> <li>Make sure that the hard disk is properly installed.</li> <li>Check the hard disk for damage, and replace if necessary.</li> </ol> <p>Does the problem remain?</p>	Go to step 5.	The problem is solved.

Action	Yes	No
<p><b>Step 5</b>                      Check the controller board pins for damage.                      Are the pins free of damage?</p>	Contact the next level of support.	Go to step 6.
<p><b>Step 6</b>                      Replace the controller board. See <a href="#">Controller board removal</a>.                      Does the problem remain?</p>	Contact the next level of support.	The problem is solved.

## Printer Hardware Errors

### 100 Errors

#### 100 Error Messages

Error code	Description	Action
100.01	The weather station data is invalid.	See <a href="#">Weather station service check</a> .
100.04D	The printhead temperature is below the range.	See <a href="#">Printhead service check</a> .
100.25	<ul style="list-style-type: none"> <li>The cavity thermistor on the sensor (toner patch) is out of range.</li> <li>The cavity and toner patch sensor thermistor reading is out of range.</li> </ul>	See <a href="#">Toner patch sensing service check</a> .

### 110 Errors

#### 110 Error Messages

Error code	Description	Action
110.20	The printhead error was detected before the motor was turned on.	See <a href="#">Printhead service check</a> .
110.21	The printhead power was off when the laser servo started.	
110.31	The printhead error (no first Hysnc) was detected.	
110.32	The printhead error (lost first Hysnc) was detected.	
110.33	The printhead error (lost first Hysnc) was detected during servo.	
110.34	The printhead error (mirror motor lost lock) was detected.	

Error code	Description	Action
110.35	The printhead error (mirror motor no first lock) was detected.	
110.36	The printhead error (mirror motor never stabilized) was detected.	
110.41	The printhead NVRAM read failure occurred.	
110.70	The printhead NVRAM values were incorrect.	
110.71	The printhead timing measurement error was detected.	
110.90	The video cable was unplugged.	
110.91	The printhead timing reading error was detected.	
110.92	The printhead NVRAM checksum mismatch occurred.	

## Printhead Service Check

Action	Yes	No
<b>Step 1</b> Perform a POR. Does the problem remain?	Go to step 2.	The problem is solved.
<b>Step 2</b> Check the cables on the printhead and on the JMIRR1 and JPH1 connectors on the controller board for proper connection. Are the cables properly connected?	Go to step 4.	Go to step 3.
<b>Step 3</b> Reconnect the cables. Does the problem remain?	Go to step 4.	The problem is solved.
<b>Step 4</b>	Go to step 5.	The problem is solved.

Action	Yes	No
Check the printhead cable for damage, and replace if necessary. Does the problem remain?		
<b>Step 5</b> Replace the printhead. See <a href="#">Printhead removal</a> . Does the problem remain?	Go to step 6.	The problem is solved.
<b>Step 6</b> Replace the controller board. See <a href="#">Controller board removal</a> . Does the problem remain?	Contact the next level of support.	The problem is solved.

## 120 Errors

### 120 Error Messages

Error code	Description	Action
120.80	The motor (fuser) does not turn on.	See <a href="#">Motor (fuser) service check</a> .
120.81	The motor (fuser) does not turn off.	
120.82	The motor (fuser) failed to achieve the expected speed.	
120.83	The motor (fuser) stalled.	
120.84	The motor (fuser) is over speeding.	
120.85	The motor (fuser) is under speeding.	
120.86	The motor (fuser) moved too long.	

## Motor (Fuser) Service Check

Action	Yes	No
<b>Step 1</b> Perform a POR. Does the problem remain?	Go to step 2.	The problem is solved.
<b>Step 2</b> Check the fuser for damage or life expiration, and replace if necessary. See <a href="#">Fuser removal</a> . Does the problem remain?	Go to step 3.	Go to step 4.
<b>Step 3</b> Check the cable at the JFUSES2 connector on the controller board for proper connection. Is the cable properly connected?	Go to step 5.	Go to step 4.
<b>Step 4</b> Reconnect the cable. Does the problem remain?	Go to step 5.	The problem is solved.
<b>Step 5</b> Check the cable for damage, and replace if necessary. Does the problem remain?	Go to step 6.	The problem is solved.
<b>Step 6</b> Replace the motor (fuser drive). See <a href="#">Motor (fuser drive) removal</a> . Does the problem remain?	Contact the next level of support.	The problem is solved.

## 121 Errors

### 121 Error Messages

Error code	Description	Action
121.00	The fuser failed to reach temperature during warm-up.	See <a href="#">Fuser service check</a> .

Error code	Description	Action
121.01	Attempting to heat the fuser, but the fuser is not installed.	
121.02	Attempting to power up the fuser while it is too warm (belt: 50°C, lamp: 76°C) to execute EWC/line voltage detection after a Wrong Fuser Installed error had been previously declared.	
121.03	Fuser hardware and driver mismatch.	
121.04	Attempting to heat the fuser but the fuser relay is open, and the fuser PIC micro controller is not reporting an error or is not responding.	
121.05	Attempting to heat the fuser but the fuser relay is open, and the fuser PIC micro controller is reporting an error condition.	
121.06	The fuser has been too cold for too long while it is powered at 100%.	
121.07	The fuser is on for more than the allowed time after a gap blowout, and the temperature is still too cold.	
121.08	The fuser is too cold while paper is in the fuser.	
121.09	The fuser fell below the minimum required temperature for motors.	
121.10	The fuser did not warm up enough to start EWC/line voltage detection (belt: 60°C, lamp: 88°C) within time-out (belt: 10 seconds, lamp: 90 seconds).	
121.11	The fuser took too long to reach the final EWC/line detection temperature (belt: 90°C, lamp: 149°C).	



Error code	Description	Action
121.12	The fuser never reached final EWC/line detection temperature (belt: 90°C, lamp: 149°C).	
121.13	The fuser heated too fast to the final EWC/line detection temperature (belt: 90°C, lamp: 149°C).	
121.15	The heater power is too high.	

Error code	Description	Action
121.16	The heater power is too low.	See <a href="#">Fuser service check</a> .
121.17	A fuser heater runaway is detected on the LV machine.	
121.18	A fuser heater runaway is detected on the HV machine.	
121.19	The fuser high power trace heated to the final EWC/line detection temperature too fast.	
121.20	The fuser high power trace heating rate from 165°C to 180°C exceeded the error threshold.	
121.20	The fuser is too cold during steady state control.  This event can occur during printing or standby modes.	
121.21	The fuser low power trace heating rate from 165°C to 180°C exceeded the error threshold.	
121.22	Open fuser relay detected.	
121.23	The fuser reached the final EWC/line detection temperature (belt: 90°C, lamp: 149°C).	
121.24	The fuser never reached the final EWC/line detection temperature (belt: 90°C, lamp: 149°C).	

## Diagnostics and Troubleshooting

Error code	Description	Action
121.25	After the line voltage detection, the controller did not roll over to the steady state control in time.	
121.26	The fuser failed to reach the temperature during warm-up.	
121.28	The fuser failed to reach the EP warm-up temperature in time.	
121.30	The fuser has been on for too long after a gap blowout, and the temperature is still too cold.	
121.31	The fuser is too hot.	
121.32	The fuser is too cold for too long while its power is at 100 %.	
121.33	The fuser is too cold when the paper is in the fuser.	

Error code	Description	Action
121.34	The fuser is too cold during steady state control when a paper is not in the fuser.  This event can occur during printing or standby modes.	See <a href="#">Fuser service check</a> .
121.35	Attempting to power up with the fuser too warm (belt: 50°C, lamp: 76°C) to execute EWC/line voltage detection after a Wrong Fuser Installed error was previously declared.	
121.36	An open fuser relay was detected with very cold, or unknown ambient temperature.	
121.37	The fuser heated to the final EWC/line detection temperature (belt: 90°C, lamp: 149°C) too fast.	
121.38	Fuser UBER defect detection.	

Error code	Description	Action
	Belt to heater temperature delta exceeded.	
121.41	Fuser mechanism did not detect the expected cam sensor signal.	
121.42	The fuser gate time is increasing out of control.	
121.48	Fuser hardware and driver mismatch.	
121.50	The fuser went over the required temperature during a global over temperature check.	
121.51	The fuser secondary heater is too hot.	
121.52	The main thermistor temperature is out of range.	
121.53	The main thermistor temperature change rate is out of range.	
121.54	The secondary thermistor temperature is out of range.	
121.55	The secondary thermistor temperature change rate is out of range.	
121.56	The middle thermistor temperature is out of range.	

Error code	Description	Action
121.57	The middle thermistor temperature change rate is out of range.	See <a href="#">Fuser service check</a> .
121.58	The edge thermistor temperature is out of range.	
121.59	The edge thermistor temperature change rate is out of range.	

## Diagnostics and Troubleshooting

Error code	Description	Action
121.60	The belt contact thermistor temperature is out of range.	
121.61	The belt contact thermistor temperature change rate is out of range.	
121.62	The belt non contact thermistor temperature is out of range.	
121.63	The belt non contact thermistor temperature change rate is out of range.	
121.64	The belt non contact 2 thermistor temperature is out of range.	
121.65	The belt non contact 2 thermistor temperature change rate is out of range.	
121.66	The narrow media thermistor temperature is out of range.	
121.67	The narrow media thermistor temperature change rate is out of range.	
121.70	The calculated heater resistance is too high.	
121.71	Open fuser main heater thermistor.	
121.72	Open fuser secondary heater thermistor.	
121.73	Open fuser middle heater thermistor.	
121.74	Open fuser edge thermistor.	
121.76	Open contact belt thermistor.	

## Fuser Service Check

Action	Yes	No
<p><b>Step 1</b></p> <p>Some of these errors are caused by a faulty component on the LVPS. Check the history file in the printer to verify other occurrences. If there are other occurrences, then replace the LVPS. See <a href="#">LVPS removal</a>.</p> <p>Does the problem remain?</p>	Go to step 2.	The problem is solved.
<p><b>Step 2</b></p> <ol style="list-style-type: none"> <li>1 Turn off the printer.</li> <li>2 Remove the rear cover. See <a href="#">Rear cover removal</a>.</li> <li>3 Check the cable on the JFUSES2 connector on the controller board for proper connection and damage, and replace if necessary.</li> </ol> <p>Does the problem remain?</p>	Go to step 3.	The problem is solved.
<p><b>Step 3</b></p> <p>Check the cable on the JLVPS1 connector on the controller board for proper connection and damage, and replace if necessary.</p> <p>Does the problem remain?</p>	Go to step 4.	The problem is solved.
<p><b>Step 4</b></p> <ol style="list-style-type: none"> <li>1 Open the front door.</li> <li>2 Remove the right cover. See <a href="#">Right cover removal</a>.</li> <li>3 Check the power cable and the thermistor cables for proper connection and damage.</li> </ol> <p>Are the cables properly connected and free of damage?</p>	Go to step 6.	Go to step 5.
<p><b>Step 5</b></p> <p>Replace the damaged cables.</p> <p>If the cables cannot be replaced, then replace the fuser. See <a href="#">Fuser removal</a>.</p>	Go to step 6.	The problem is solved.

Action	Yes	No
Does the problem remain?		
<p><b>Step 6</b></p> <p>Check the following voltage values on the JFUSES2 connector pins on the controller board:</p> <ul style="list-style-type: none"> <li>• Pin 1: +24 V dc (door closed)</li> <li>• Pin 2: +24 V dc (doors closed)</li> <li>• Pin 3: +24 V dc (doors closed)</li> <li>• Pin 4: +24 V dc (doors closed)</li> <li>• Pin 5: Between 0.6 and 3.28 V dc</li> <li>• Pin 6: Ground</li> <li>• Pin 8: Ground</li> <li>• Pin 10: Between -3 and +3.3 V dc</li> <li>• Pin 11: Ground (no wire)</li> </ul> <p>Are the voltage values approximately the same?</p>	Go to step 7.	Go to step 8.
<p><b>Step 7</b></p> <p>Replace the fuser. See <a href="#">Fuser removal</a>.</p> <p>Does the problem remain?</p>	Contact the next level of support.	The problem is solved.
<p><b>Step 8</b></p> <p>Replace the controller board. See <a href="#">Controller board removal</a>.</p> <p>Does the problem remain?</p>	Contact the next level of support.	The problem is solved.

## 126 Errors

### 126 Error Messages

Error code	Description	Action
126.05	The LVPS dropped while not sleeping.	See <a href="#">LVPS service check</a> .
126.06	An LVPS 25 V line error was detected.	

Error code	Description	Action
126.07	An LVPS 5 V rail was down during POR.	
126.10	No line frequency was detected.	
126.11	Line frequency has gone outside the operating range.	

## LVPS Service Check

Action	Yes	No
<b>Step 1</b> Perform a POR. Does the problem remain?	Go to step 2.	The problem is solved.
<b>Step 2</b> Check the cable on the JLVPS1 connector on the controller board for proper connection and damage, and replace if necessary. Does the problem remain?	Go to step 3.	The problem is solved.
<b>Step 3</b> Replace the LVPS. See <a href="#">LVPS removal</a> . Does the problem remain?	Go to step 4.	The problem is solved.
<b>Step 4</b> Replace the controller board. See <a href="#">Controller board removal</a> . Does the problem remain?	Contact the next level of support.	The problem is solved.

# 142 Errors

## 142 Error Messages

Error code	Description	Action
142.80	The motor (CMY) does not turn on.	See <a href="#">Motor (EP drive) service check</a> .
142.81	The motor (CMY) does not turn off.	
142.82	The motor (CMY) failed to achieve the expected speed.	
142.83	The motor (CMY) stalled.	
142.84	The motor (CMY) is running too slow.	
142.85	The motor (CMY) is running too fast.	
142.86	The motor (CMY) moved too long.	

## Motor (EP Drive) Service Check

Action	Yes	No
<b>Step 1</b> Perform a POR. Does the problem remain?	Go to step 2.	The problem is solved.
<b>Step 2</b> 1 Remove the imaging kit. See <a href="#">Imaging kit removal</a> . 2 Enter the Diagnostics menu, and then navigate to: <b>Printer diagnostics &amp; adjustments &gt; Motor tests &gt; CMY developer</b> 3 Press <b>OK</b> or touch <b>Start</b> . Does the motor run?	Go to step 3.	Go to step 7.
<b>Step 3</b>	Go to step 4.	Go to step 7.



Action	Yes	No
<p>1 Remove the imaging kit. See <a href="#">Imaging kit removal</a>.</p> <p>2 Remove the transfer module. See <a href="#">Transfer module removal</a>.</p> <p>3 Enter the Diagnostics menu, and then navigate to:</p> <p><b>Printer diagnostics &amp; adjustments &gt; Motor tests &gt; K/ITM developer</b></p> <p>4 Press <b>OK</b> or touch <b>Start</b>.</p> <p>Does the motor run?</p>		
<p><b>Step 4</b></p> <p>Manually turn the black developer unit and transfer module drive gears.</p> <p>Do the gears freely turn?</p>	Go to step 6.	Go to step 5.
<p><b>Step 5</b></p> <p>Replace the EP drive. See <a href="#">EP drive assembly removal</a>.</p> <p>Does the problem remain?</p>	Go to step 6.	The problem is solved.
<p><b>Step 6</b></p> <p>Check the imaging kit and transfer module for damage or life expiration, and replace if necessary. See <a href="#">Imaging kit removal</a> and <a href="#">Transfer module removal</a>.</p> <p>Does the problem remain?</p>	Contact the next level of support.	The problem is solved.
<p><b>Step 7</b></p> <p>1 Make sure that the cable on the motor (EP drive) is properly connected.</p> <p>2 Make sure that the cables on the JCARTP1 and JCARTS1 connectors on the controller board are properly connected.</p> <p>Does the problem remain?</p>	Go to step 8.	The problem is solved.

Action	Yes	No
<b>Step 8</b> Check the cables for damage and replace if necessary. Does the problem remain?	Go to step 9.	The problem is solved.
<b>Step 9</b> Replace the motor (drive unit). See <a href="#">Motor (drive unit) removal</a> . Does the problem remain?	Contact the next level of support.	The problem is solved.

## 151 Errors

### 151 Error Messages

Error code	Description	Action
151.80	The motor (K/ITM) does not turn on.	See <a href="#">Motor (EP drive) service check</a> .
151.81	The motor (K/ITM) does not turn off.	
151.82	The motor (K/ITM) failed to achieve the expected speed.	
151.83	The motor (K/ITM) stalled.	
151.84	The motor (K/ITM) is running too slow.	
151.85	The motor (K/ITM) is running too fast.	
151.86	The motor (K/ITM) moved too long.	

# 160 Errors

## 160 Error Messages

Error code	Description	Action
160.80	The motor (MPF) does not turn on.	See <a href="#">Option tray motor service check</a> .
160.81	The motor (MPF) does not turn off.	
160.82	The motor (MPF) failed to achieve the expected speed.	
160.83	The motor (MPF) stalled.	
160.84	The motor (MPF) is running too slow.	
160.85	The motor (MPF) is running too fast.	
160.86	The motor (MPF) moved too long.	

## Option Tray Motor Service Check

Action	Yes	No
<p><b>Step 1</b></p> <p>1 Enter the Diagnostics menu, and then navigate to: <b>Additional input tray diagnostics &gt; Motor Tests</b></p> <p>2 Select <b>Pick (tray x) motor test</b>, and then press <b>OK</b> or touch <b>Start</b>.  Make sure to perform the motor test in both directions.</p> <p>3 Select <b>Pass-through (tray x) motor test</b>, and then press <b>OK</b> or touch <b>Start</b>.  Make sure to perform the motor test in both directions.</p> <p>Did the motors run?</p>	Go to step 2.	Go to step 3.
<p><b>Step 2</b></p> <p>Perform a print test.</p> <p>Does the problem remain?</p>	Go to step 3.	The problem is solved.
<p><b>Step 3</b></p> <p>Make sure that the option connector in the subframe is properly connected to the tray 2 option.</p> <p>Does the problem remain?</p>	Go to step 4.	The problem is solved.
<p><b>Step 4</b></p> <p>Make sure that cable on the JOPT1 connector on the controller board is properly connected.</p> <p>Does the problem remain?</p>	Go to step 5.	The problem is solved.

Action	Yes	No
<b>Step 5</b> Check the option cable for continuity, and replace if necessary. Does the problem remain?	Go to step 6.	The problem is solved.
<b>Step 6</b> Check the option tray connections for damage, and replace the affected tray if necessary. Does the problem remain?	Contact the next level or support.	The problem is solved.

## 161 Errors

### 161 Error Messages

Error code	Description	Action
161.80	The motor (tray 1 pick) does not turn on.	See <a href="#">Motor (tray 1 pick/duplex) service check</a> .
161.81	The motor (tray 1 pick) does not turn off.	
161.82	The motor (tray 1 pick) failed to achieve the expected speed.	
161.83	The motor (tray 1 pick) stalled.	
161.84	The motor (tray 1 pick) is running too slow.	
161.85	The motor (tray 1 pick) is running too fast.	
161.86	The motor (tray 1 pick) moved too long.	

## Motor (Tray 1 Pick/Duplex) Service Check

Action	Yes	No
<p><b>Step 1</b> Perform a POR. Does the problem remain?</p>	Go to step 2.	The problem is solved.
<p><b>Step 2</b> 1 Remove tray 1. 2 Enter the Diagnostics menu, and then navigate to: <b>Printer diagnostics &amp; adjustments &gt; Motor tests &gt; Pick (tray 1) / Duplex</b> 3 Select <b>Tray 1 Picking</b>, and then press <b>OK</b> or touch <b>Start</b>. Make sure to perform the motor test in both directions. 4 Select <b>Tray 1 Duplex</b>, and then press <b>OK</b> or touch <b>Start</b>. Make sure to perform the motor test in both directions. Did the motors run?</p>	Go to step 3.	Go to step 4.
<p><b>Step 3</b> Make sure that cable on the JSP1 connector on the controller board is properly connected. Does the problem remain?</p>	Go to step 5.	The problem is solved.
<p><b>Step 4</b> Check the cable for damage. Is the cable damaged?</p>	Go to step 5.	Go to step 6.

Action	Yes	No
<b>Step 5</b> Replace the media feeder. See <a href="#">Tray 1 media feeder removal</a> . Does the problem remain?	Go to step 6.	The problem is solved.
<b>Step 6</b> Replace the controller board. See <a href="#">Controller board removal</a> . Does the problem remain?	Contact the next level of support	The problem is solved.

## 162 Errors

### 162 Error Messages

Error code	Description	Action
162.80	The motor (tray 2 pick) does not turn on.	See <a href="#">Option tray motor service check</a> .
162.81	The motor (tray 2 pick) does not turn off.	
162.82	The motor (tray 2 pick) failed to achieve the expected speed.	
162.83	The motor (tray 2 pick) stalled.	
162.84	The motor (tray 2 pick) is running too slow.	
162.85	The motor (tray 2 pick) is running too fast.	
162.86	The motor (tray 2 pick) moved too long.	

## 163 Errors

### 163 Error Messages

Error code	Description	Action
163.80	The motor (tray 3 pick) does not turn on.	See <a href="#">Option tray motor service check</a> .
163.81	The motor (tray 3 pick) does not turn off.	
163.82	The motor (tray 3 pick) failed to achieve the expected speed.	
163.83	The motor (tray 3 pick) stalled.	
163.84	The motor (tray 3 pick) is running too slow.	
163.85	The motor (tray 3 pick) is running too fast.	
163.86	The motor (tray 3 pick) moved too long.	

## 166 Errors

### 166 Error Messages

Error code	Description	Action
166.80	The motor (tray 2 transport) does not turn on.	See <a href="#">Option tray motor service check</a> .
166.81	The motor (tray 2 transport) does not turn off.	
166.82	The motor (tray 2 transport) failed to achieve the expected speed.	
166.83	The motor (tray 2 transport) stalled.	
166.84	The motor (tray 2 transport) is running too slow.	



Error code	Description	Action
166.85	The motor (tray 2 transport) is running too fast.	
166.86	The motor (tray 2 transport) moved too long.	

## 167 Errors

### 167 Error Messages

Error code	Description	Action
167.80	The motor (tray 3 transport) does not turn on.	See <a href="#">Option tray motor service check</a> .
167.81	The motor (tray 3 transport) does not turn off.	
167.82	The motor (tray 3 transport) failed to achieve the expected speed.	
167.83	The motor (tray 3 transport) stalled.	
167.84	The motor (tray 3 transport) is running too slow.	
167.85	The motor (tray 3 transport) is running too fast.	
167.86	The motor (tray 3 transport) moved too long.	

## 171 Errors

### 171 Error Messages

Error code	Description	Action
171.82	Main fan error.	See <a href="#">Main fan service check</a> .
171.83		

Error code	Description	Action
171.84		
171.85		

## Main Fan Service Check

Action	Yes	No
<p><b>Step 1</b></p> <p>Check the main fan area for obstructions.</p> <p>Is the fan area free from obstructions?</p>	Go to step 3.	Go to step 2.
<p><b>Step 2</b></p> <p>Remove the obstructions.</p> <p>Does the problem remain?</p>	Go to step 3.	The problem is solved.
<p><b>Step 3</b></p> <p>Check the cable on the JFAN2 connector on the controller board for proper connection.</p> <p>Is the cable properly connected?</p>	Go to step 5.	Go to step 4.
<p><b>Step 4</b></p> <p>Reconnect the cable.</p> <p>Does the problem remain?</p>	Go to step 5.	The problem is solved.
<p><b>Step 5</b></p> <p>Replace the main fan. See <a href="#">System fan removal</a>.</p> <p>Does the problem remain?</p>	Go to step 6.	The problem is solved.
<p><b>Step 6</b></p> <p>Replace the controller board. See <a href="#">Controller board removal</a>.</p> <p>Does the problem remain?</p>	Contact the next level of support.	The problem is solved.

## 600 Errors

### 600 Error Message

Error code	Description	Action
600.95	The printer intentionally declared a jam.  This event is typically used to prevent a kiosk user from printing free pages.	Perform a POR.

## 602 Errors

### 602 Error Messages

Error code	Description	Action
602.x8	The tray [x] timed out while waiting for the ILN command.	See <a href="#">Engine error service check</a> .
602.x9	The tray [x] failed to become the input source.	

x = tray number

## Engine Error Service Check

Action	Yes	No
<b>Step 1</b> Perform a POR. Does the problem remain?	Go to step 2.	The problem is solved.
<b>Step 2</b> 1 Remove the rear cover. See <a href="#">Rear cover removal</a> . 2 Reseat all the cables on the controller board. 3 Check the controller board contacts and pins for damage. Is the controller board free of damage?	Contact the next level of support.	Go to step 3.
<b>Step 3</b> Replace the controller board. See <a href="#">Controller board removal</a> . Does the problem remain?	Contact the next level of support.	The problem is solved.

## 620 Errors

### 620 Error Messages

Error code	Description	Action
620.80	The motor (fuser) does not turn on.	See <a href="#">Motor (fuser) service check</a> .
620.81	The motor (fuser) does not turn off.	
620.82	The motor (fuser) failed to achieve the expected speed.	
620.83	The motor (fuser) stalled.	
620.84	The motor (fuser) is running too slow.	
620.85	The motor (fuser) is running too fast.	

Error code	Description	Action
620.86	The motor (fuser) moved too long.	
621.01	The fuser heater was too cold when the paper entered the fuser nip.	See <a href="#">Fuser service check</a> .

## 642 Errors

### 642 Error Messages

Error code	Description	Action
642.80	The motor (CMY) does not turn on.	See <a href="#">Motor (EP drive) service check</a> .
642.81	The motor (CMY) does not turn off.	
642.82	The motor (CMY) failed to achieve the expected speed.	
642.83	The motor (CMY) stalled.	
642.84	The motor (CMY) is running too slow.	
642.85	The motor (CMY) is running too fast.	
642.86	The motor (CMY) moved too long.	

## 651 Errors

### 651 Error Messages

Error code	Description	Action
651.80	The motor (K/ITM) does not turn on.	See <a href="#">Motor (EP drive) service check</a> .
651.81	The motor (K/ITM) does not turn off.	

Error code	Description	Action
651.82	The motor (K/ITM) failed to achieve the expected speed.	
651.83	The motor (K/ITM) stalled.	
651.84	The motor (K/ITM) is running too slow.	
651.85	The motor (K/ITM) is running too fast.	
651.86	The motor (K/ITM) moved too long.	

## 661 Errors

### 661 Error Messages

Error code	Description	Action
661.80	The motor (tray 1 pick) does not turn on.	See <a href="#">Motor (tray 1 pick/duplex) service check</a> .
661.81	The motor (tray 1 pick) does not turn off.	
661.82	The motor (tray 1 pick) failed to achieve the expected speed.	
661.83	The motor (tray 1 pick) stalled.	
661.84	The motor (tray 1 pick) is running too slow.	
661.85	The motor (tray 1 pick) is running too fast.	
661.86	The motor (tray 1 pick) moved too long.	

## 662 Errors

### 662 Error Messages

Error code	Description	Action
662.70	The motor (tray 2 pick) does not turn on.	See <a href="#">Option tray motor service check</a> .
662.71	The motor (tray 2 pick) does not turn off.	
662.72	The motor (tray 2 pick) failed to achieve the expected speed.	
662.73	The motor (tray 2 pick) stalled.	
662.74	The motor (tray 2 pick) is running too slow.	
662.75	The motor (tray 2 pick) is running too fast.	
662.76	The motor (tray 2 pick) moved too long.	

## 663 Errors

### 663 Error Messages

Error code	Description	Action
663.70	The motor (tray 3 pick) does not turn on.	See <a href="#">Option tray motor service check</a> .
663.71	The motor (tray 3 pick) does not turn off.	
663.72	The motor (tray 3 pick) failed to achieve the expected speed.	
663.73	The motor (tray 3 pick) stalled.	
663.74	The motor (tray 3 pick) is running too slow.	

Error code	Description	Action
663.75	The motor (tray 3 pick) is running too fast.	
663.76	The motor (tray 3 pick) moved too long.	

## 666 Errors

### 666 Error Messages

Error code	Description	Action
666.70	The motor (tray 2 transport) does not turn on.	See <a href="#">Option tray motor service check</a> .
666.71	The motor (tray 2 transport) does not turn off.	
666.72	The motor (tray 2 transport) failed to achieve the expected speed.	
666.73	The motor (tray 2 transport) stalled.	
666.74	The motor (tray 2 transport) is running too slow.	
666.75	The motor (tray 2 transport) is running too fast.	
666.76	The motor (tray 2 transport) moved too long.	

## 667 Errors

### 667 Error Messages

Error code	Description	Action
667.70	The motor (tray 3 transport) does not turn on.	See <a href="#">Option tray motor service check</a> .



Error code	Description	Action
667.71	The motor (tray 3 transport) does not turn off.	
667.72	The motor (tray 3 transport) failed to achieve the expected speed.	
667.73	The motor (tray 3 transport) stalled.	
667.74	The motor (tray 3 transport) is running too slow.	
667.75	The motor (tray 3 transport) is running too fast.	
667.76	The motor (tray 3 transport) moved too long.	

## Procedure Before Starting The 9yy Service Checks

Retrieve certain information that helps your next level of support in diagnosing the problem before replacing the controller board.

 **Warning:** Do not replace the controller board unless instructed by your next level of support.

1. Collect the history information and firmware logs (Fwdebug and logs.tar.gz) from the SE menu.
2. Collect the settings from the Menu Settings Page.
3. Collect information from the user.

 **Note:** Not all of the items are retrievable from the printer that you are working on.

### A. Collecting The History Information From The SE Menu

 **Note:** Make sure that your printer is connected to a network or to a print server.

1. Open a web browser, type `http://printer_IP_address/se`, and then press **Enter**.

 **Note:**

- printer\_IP\_address is the TCP/IP address of the printer.
  - se is required to access the printer diagnostic information.
2. Click **History Information**, copy all information, and then save it as a text file.
  3. E-mail the text file to your next level of support.

## B. Collecting The Firmware Logs (fwdebug and Logs.tar.gz) From The SE Menu

 **Note:**

- Make sure that your printer is connected to a network or to a print server.
  - Some printers are designed to restart automatically after a 9yy error. On these printers, you can retrieve the secondary crash code information using the SE menu.
1. Open a web browser, type `http://printer_IP_address/se`, and then press **Enter**.
  2. Click **Logs Gzip Compressed**.

 **Note:** A logs.tar.gz file is saved to the Downloads folder. The file may take several minutes to save. You may rename the file if a logs.tar.gz already exists in the Downloads folder.

3. E-mail the logs to your next level of support.

 **Note:** To download the FWdebug log to a flash drive, see [General SE](#).

## C. Collecting The Settings From The Menu Settings Page

 **Note:** The Menu Settings Page is different for each printer. For more information, see the User's Guide. Your next level of support will tell you which page they want to see.

## D. Collecting Information From The User

Ask the user for information about the following:

- Print job being run
- Operating system being used
- Print driver being used
- Other information on what was happening when the 9yy error occurred

# 900 Errors

## 900 Error Messages

Error code	Description	Action
900.xx	Unrecoverable RIP software error/ illegal trap.	See <a href="#">900 Error Service Check</a> .

## 900 Error Service Check

Action	Yes	No
<p><b>Step 1</b></p> <ul style="list-style-type: none"> <li>Perform a POR.</li> <li>Check if a 900.xx error code appears on the display.</li> </ul> <p>Does a 900.xx error code appear?</p>	Go to step 4.	Go to step 2.
<p><b>Step 2</b></p> <p>Check if another type of error code appears instead of the 900.xx error code.</p> <p>Does a different error code appear?</p>	Go to step 3.	Go to step 4.
<p><b>Step 3</b></p> <p>See the error code and its service instructions in the printer service manual.</p> <p>Does the problem remain?</p>	Go to step 4.	The problem is solved.
<p><b>Step 4</b></p> <ul style="list-style-type: none"> <li>Turn off the printer.</li> <li>At the rear of the printer, disconnect the network cable, USB cable, and the fax line.</li> <li>Turn on the printer.</li> </ul> <p>Does the problem remain?</p>	Go to step 12.	Go to step 5.
<p><b>Step 5</b></p> <ul style="list-style-type: none"> <li>From the control panel, navigate to the <b>Reports</b> menu.</li> <li>Select <b>Device Statistics</b> and <b>Device Settings</b>.</li> </ul> <p>Does the problem remain?</p>	Go to step 12.	Go to step 6.
<p><b>Step 6</b></p> <p>Check if the printer has a scanner.</p> <p>Does the printer have a scanner?</p>	Go to step 7.	Go to step 8.
<p><b>Step 7</b></p>	Go to step 12.	Go to step 8.

## Diagnostics and Troubleshooting

Action	Yes	No
Using the scanner, perform a one-page copy job in color. Does the problem remain?		
<b>Step 8</b> <ul style="list-style-type: none"> <li>Turn off the printer.</li> <li>At the rear of the printer, connect the network cable, USB cable, and the fax line.</li> <li>Turn on the printer.</li> </ul> Does the problem remain?	Go to step 9.	Go to step 10.
<b>Step 9</b> <ul style="list-style-type: none"> <li>Start the printer in <b>Invalid engine mode</b>. See <a href="#">Entering Invalid Engine Mode</a></li> <li>Check if an <b>Invalid Engine Code</b> message appears.</li> </ul> Does the Invalid Engine Code message appear?	Go to step 10.	Contact the next level of support.
<b>Step 10</b> Using the Device Settings report that is printed in step 5, check if the firmware level is older than the latest available version. Is the firmware version older, and does the customer agree to update the firmware?	Go to step 11.	Contact the next level of support.
<b>Step 11</b> Update the firmware to the latest version. Does the problem remain?	Go to step 12.	The problem is solved.
<b>Step 12</b> <ul style="list-style-type: none"> <li>Turn off the printer.</li> <li>Make sure that all the cables on the controller board and scanner are properly connected.</li> <li>Turn on the printer.</li> <li>From the control panel, navigate to the <b>Reports</b> menu,</li> </ul>	Go to step 13.	The problem is solved.

Action	Yes	No
<p>and then select <b>Device Statistics</b> and <b>Device Settings</b>.</p> <ul style="list-style-type: none"> <li>For MFPs, perform a one-page copy and scan job in color.</li> </ul> <p>Does the problem remain?</p>		
<p><b>Step 13</b></p> <p>Check if a hard disk is installed.</p> <p>Is a hard disk installed?</p>	Go to step 14.	Go to step 17.
<p><b>Step 14</b></p> <ul style="list-style-type: none"> <li>Check for buffered print jobs, and then delete them. See <a href="#">Hard Disk Failure Service Check</a>.</li> <li>Perform a POR.</li> </ul> <p>Does the problem remain?</p>	Go to step 15.	The problem is solved.
<p><b>Step 15</b></p> <ul style="list-style-type: none"> <li>Turn off the printer.</li> <li>Uninstall the hard disk drive.</li> <li>Perform a POR.</li> </ul> <p>Does the problem remain?</p>	Go to step 17.	Go to step 16.
<p><b>Step 16</b></p> <p>Replace the hard disk.</p> <p>Does the problem remain?</p>	Go to step 17.	The problem is solved.
<p><b>Step 17</b></p> <p>Check if the printer has any of the following components installed:</p> <ul style="list-style-type: none"> <li>Memory options</li> <li>Fax card</li> <li>Modem</li> <li>Wireless and network option cards</li> </ul> <p>Is any of the components installed?</p>	Go to step 18.	Go to step 21.
<p><b>Step 18</b></p> <ul style="list-style-type: none"> <li>Turn off the printer.</li> </ul>	Go to step 21.	Go to step 19.

Action	Yes	No
<ul style="list-style-type: none"> <li>Remove all the installed components.</li> <li>Turn on the printer.</li> </ul> <p>Does the problem remain?</p>		
<p><b>Step 19</b></p> <ul style="list-style-type: none"> <li>Turn off the printer.</li> <li>Install the following components one at a time:                             <ul style="list-style-type: none"> <li>Memory options</li> <li>Fax card</li> <li>Modem</li> <li>Wireless and network option cards</li> </ul> </li> </ul> <p> <b>Note:</b> Make sure to perform a POR after installing each component.</p> <p>Does the problem remain?</p>	Go to step 20.	The problem is solved.
<p><b>Step 20</b></p> <ul style="list-style-type: none"> <li>Turn off the printer.</li> <li>Replace the components that caused the error.</li> <li>Turn on the printer.</li> </ul> <p>Does the problem remain?</p>	Go to step 21.	The problem is solved.
<p><b>Step 21</b></p> <p>Replace the controller board. See <a href="#">Controller Board Removal</a></p> <p>Does the problem remain?</p>	Contact the next level of support.	The problem is solved.

## 91y Errors

### 91y Error Messages

Error code	Description	Action
910.xx	General engine software error.	See <a href="#">91x.xx (910.xx–919.xx) Engine software service check</a> .
911.xx		

Error code	Description	Action
912.xx		
913.xx	General engine software error.	See <a href="#">913.xx error code check</a> .
914.xx	General engine software error.	See <a href="#">91x.xx (910.xx–919.xx) Engine software service check</a> .
915.xx		
916.xx		
917.xx		
918.xx		
919.xx		

### 91x.xx (910.xx–919.xx) Engine Software Service Check

Actions	Yes	No
<p><b>Step 1</b></p> <p>1 Remove the rear cover. See <a href="#">Rear cover removal</a>.</p> <p>2 Check the cables on the controller board for proper connection.</p> <p>Are the cables properly connected?</p>	Go to step 2.	Go to step 3.
<p><b>Step 2</b></p> <p>Replace the controller board. See <a href="#">Controller board removal</a>.</p> <p>Does the problem remain?</p>	Contact the next level of support.	The problem is solved.
<p><b>Step 3</b></p> <p>Reconnect the cables, and then perform a POR.</p> <p>Does the problem remain?</p>	Contact the next level of support.	The problem is solved.

## 913.xx Error Code Check

Actions	Yes	No
<p><b>Step 1</b></p> <p>1 Turn off the printer, and then remove the rear cover. See <a href="#">Rear cover removal</a>.</p> <p>2 Make sure all cable connections on the controller board are secure.</p> <p>Are all cable connections secure?</p>	Go to step 3.	Go to step 2.
<p><b>Step 2</b></p> <p>1 Reconnect any loose cables.</p> <p>2 Print multiple print tests.</p> <p>Does the problem remain?</p>	Go to step 3.	The problem is solved.
<p><b>Step 3</b></p> <p>Replace the motor (fuser drive). See <a href="#">Motor (fuser drive) removal</a>.</p> <p>Does the problem remain?</p>	Go to step 4.	The problem is solved.
<p><b>Step 4</b></p> <p>Replace the controller board. See <a href="#">Controller board removal</a>.</p> <p>Does the problem remain?</p>	Contact the next level of support.	The problem is solved.

## 938 Errors

### 938 Error Messages

Error code	Description	Action
938.01	The board level was not obtained.	See <a href="#">Controller board removal</a> .
938.02	Timed out while waiting for the bullet serial data to be updated.	
938.03	The NVM_OK was not received from the NV2 server for a successfully submitted request.	



Error code	Description	Action
938.04	An over temperature condition is detected.	

## 95y Errors

### 95y Error Messages

Error code	Description	Action
950.xx	The controller EEPROM and mirror are mismatched. <ul style="list-style-type: none"> <li>950.00 through 950.29 codes: mismatch between the controller and mirror</li> <li>950.30 through 950.60 codes: mismatch between secure NVRAM and controller</li> </ul>	See <a href="#">950.xx NVRAM Failure Service Check</a> .
951.xx	Error NV part on system board.	See <a href="#">Controller board removal</a> .
952.xx	A recoverable NVRAM Cyclic Redundancy Check (CRC) error occurred. <i>n</i> is the offset at which the error occurred.	Performing a POR clears this error.
953.xx	NVRAM chip failure with mirror. <ol style="list-style-type: none"> <li>POR the printer.</li> <li>If the problem persists, then replace the UICC card.</li> </ol>	See, <a href="#">2.4-inch Control Panel Top Cover Removal</a> .
954.xx	The NVRAM chip failure with controller part.	See <a href="#">950.xx NVRAM Failure Service Check</a> .

Error code	Description	Action
955.xx	<p>The Code ROM or NAND flash failed the Cyclic Redundancy Check (CRC) check or the NAND experienced an uncorrectable multi-bit failure. &lt;loc&gt; indicates the source of the failure and has one of the following values:</p> <ul style="list-style-type: none"> <li>• CRC Failure—The source is a failing package indicated by <math>P_n</math> where <math>n</math> is the package number. This error can occur on a controller with ROM or NAND flash and can occur as a result of the CRC check done when the machine is powered on. The range of package numbers is from 0–15.</li> <li>• Error Correction Code (ECC) Failure—The source is a failing page indicated by <math>B_n</math> where <math>n</math> is the page number. This error occurs only if a multi-bit failure is detected during the ECC execution. Single bit failures are corrected automatically and will not result in a service error. The range of page numbers is from 0–1023.</li> </ul>	
956.xx	<p>Controller board failure. Processor failure.</p> <p>Check on .02 for fan error.</p>	
957.xx	<p>Controller board failure. ASIC failure.</p>	
958.xx	<p>Printer has performed more than 100 shift and reflash operations as a result of ECC bit corrections.</p>	
959.xx	<p>Controller verification failure of system boot code.</p>	<p>See <a href="#">Invalid Firmware/controller Board Service Check</a> .</p>
959.0x	<p>System hardware failure.</p>	<p>See <a href="#">Controller board removal</a>.</p>

## 950.xx NVRAM Failure Service Check



**Warning:** When replacing any of the following components, replace only one component at a time or the printer will be inoperable:

 **Note:**

- This error indicates that the control panel and the controller board are mismatched.
- Replace the required component, enter the Diagnostics menu, and then verify that the problem is fixed before performing a POR.

Actions	Yes	No
<p><b>Step 1</b></p> <p>Check if the control panel has been replaced.</p> <p>Has the control panel been replaced?</p>	Go to step 2.	Go to step 3.
<p><b>Step 2</b></p> <p>Replace the control panel with a new, and not previously installed UICC card. See <a href="#">2.4-inch Control Panel Top Cover Removal</a>.</p> <p>Does the problem remain?</p>	Go to step 3.	The problem is solved.
<p><b>Step 3</b></p> <p>Check if the controller board has been replaced.</p> <p>Has the controller board been replaced?</p>	Go to step 4.	Go to step 5.
<p><b>Step 4</b></p> <p>Replace the controller board with a new, and not previously installed controller board. See <a href="#">Controller board removal</a>.</p> <p>Does the problem remain?</p>	Go to step 5.	The problem is solved.
<p><b>Step 5</b></p> <p>Perform a POR.</p> <p>Does the problem remain?</p>	Go to step 6.	The problem is solved.
<p><b>Step 6</b></p> <p>Clear the NVRAM of the printer:</p> <ol style="list-style-type: none"> <li>1 Turn the printer off.</li> <li>2 With the printer off, press and hold buttons <b>6</b>, <b>7</b>, and <b>8</b> on the numeric keypad.</li> <li>3 Turn on the printer.</li> </ol>	Go to step 7.	The problem is solved.

Actions	Yes	No
<p>4 When Clear NVRAM appears, release the buttons.</p> <p> <b>Note:</b></p> <ul style="list-style-type: none"> <li>• If the printer looks up on the Restoring Factory Defaults, wait for two minutes, and then turn off the printer.</li> <li>• After 10 seconds, turn on the printer.</li> </ul> <p>Does the problem remain?</p>		
<p><b>Step 7</b></p> <p>Replace the control panel. See <a href="#">2.4-inch Control Panel Top Cover Removal</a>.</p> <p>Does the problem remain?</p>	Go to step 8.	The problem is solved.
<p><b>Step 8</b></p> <p>Replace the controller board. See <a href="#">Controller board removal</a>.</p> <p>Does the problem remain?</p>	Contact the next level of support.	The problem is solved.

## Invalid Firmware/controller Board Service Check

Action	Yes	No
<p><b>Step 1</b></p> <p>Update the firmware.</p> <p>Contact the next level of support for the correct firmware level.</p> <p>Does the problem remain?</p>	Go to step 2.	The problem is solved.
<p><b>Step 2</b></p> <p>Replace the controller board. See <a href="#">Controller board removal</a>.</p> <p>Does the problem remain?</p>	Contact the next level of support.	The problem is solved.

# 96y Errors

## 96y Error Messages

Error code	Description	Action
960.xx	RAM memory error—The RAM soldered on the board is bad.	See <a href="#">Controller board removal</a> .
964.xx	<ul style="list-style-type: none"> <li>A download emulation cyclic redundancy check (CRC) failure has occurred.</li> <li>A checksum failure was detected in the emulation header or emulation file.</li> </ul>	See <a href="#">Download emulation cyclic redundancy service check</a> .

## Download Emulation Cyclic Redundancy Service Check

Action	Yes	No
<p><b>Step 1</b></p> <p>Disable the download emulation, and then program the download emulation into the firmware card again.</p> <p>Does the problem remain?</p>	Go to step 2.	The problem is solved.
<p><b>Step 2</b></p> <p>Replace the firmware card, and then download the emulation to the new card.</p> <p>Does the problem remain?</p>	Contact the next level of support.	The problem is solved.

## 97y Errors

### 97y Error Messages

Error code	Description	Action
975.xx 975.xx	Network error—Unrecognizable network port.	Replace the standard network card, or the card in the specified slot.
976.xx	Unrecoverable software or error in the network or network card [x].	See <a href="#">Standard network/network card error service check</a> .
978.xx	Bad checksum while programming the standard network or network card [x] port.	See <a href="#">Standard network/network card programming error service check</a> .
979.xx	Flash parts failed while programming the standard network or network card [x] port.	See <a href="#">Standard network/network card error service check</a> .

### Standard Network/network Card Error Service Check

Action	Yes	No
<b>Step 1</b> Check if the network card is installed. Is the network card installed?	Go to step 2.	Go to step 3.
<b>Step 2</b> Make sure that the network card is properly installed. Does the problem remain?	Contact the next level of support.	The problem is solved.
<b>Step 3</b> Replace the controller board. See <a href="#">Controller board removal</a> . Does the problem remain?	Contact the next level of support.	The problem is solved.

## Standard Network/Network Card Programming Error Service Check

Action	Yes	No
<p><b>Step 1</b></p> <p>Make sure that you downloaded the code in binary mode and not in ASCII, and then reprogram the network card.</p> <p>Does the problem remain?</p>	Go to step 2.	The problem is solved.
<p><b>Step 2</b></p> <p>Check if the network card is installed.</p> <p>Is the network card installed?</p>	Go to step 3.	Go to step 4.
<p><b>Step 3</b></p> <p>Make sure that the network card is properly installed.</p> <p>Does the problem remain?</p>	Contact the next level of support.	The problem is solved.
<p><b>Step 4</b></p> <p>Replace the controller board. See <a href="#">Controller board removal</a>.</p> <p>Does the problem remain?</p>	Contact the next level of support.	The problem is solved.

## 980-984 Errors

### 980–984 Error Messages

Error code	Description	Action
980.xx	<p>The engine is experiencing unreliable communication with the specified device.</p> <p>&lt;device&gt; can be one of the following:</p> <ul style="list-style-type: none"> <li>• Tray 2</li> <li>• Tray 3</li> </ul>	See <a href="#">Options communication error service check</a> .

Error code	Description	Action
981.xx	The specified device detects an engine protocol violation.  <device> can be one of the following: <ul style="list-style-type: none"> <li>• Tray 2</li> <li>• Tray 3</li> </ul>	
982.xx	The specified device detects a communication error.  <device> can be one of the following: <ul style="list-style-type: none"> <li>• Tray 2</li> <li>• Tray 3</li> </ul>	
983.xx	The specified device receives an invalid command.  <device> can be one of the following: <ul style="list-style-type: none"> <li>• Tray 2</li> <li>• Tray 3</li> </ul>	
984.xx	The specified device receives an invalid command parameter.  <device> can be one of the following: <ul style="list-style-type: none"> <li>• Tray 2</li> <li>• Tray 3</li> </ul>	

## 99y Errors

### 99y Error Messages

Error code	Description	Action
990.xx	An equipment check condition occurred, but the exact component failure was not determined.	See <a href="#">Options communication error service check</a> .
991.xx	An equipment check condition occurred in the controller card.	



Error code	Description	Action
992.xx	General software error.	

### Options Communication Error Service Check

Action	Yes	No
<p><b>Step 1</b></p> <ol style="list-style-type: none"> <li>1 Check if the firmware is updated, and update if necessary.</li> <li>2 Make sure that the printer supports the option. See the Printer, Option, and Stand Compatibility Guide.</li> <li>3 Make sure that the option is properly attached to the printer or adjacent option.</li> <li>4 Perform a POR.</li> </ol> <p>Does the problem remain?</p>	Go to step 2.	The problem is solved.
<p><b>Step 2</b></p> <p>Reseat the printer interface cable on the printer controller board.</p> <p>Does the problem remain?</p>	Go to step 3.	The problem is solved.
<p><b>Step 3</b></p> <p>Do the following to each option:</p> <ol style="list-style-type: none"> <li>1 Reinstall the option.</li> <li>2 Print a test page, and then check if the option is properly working.</li> </ol> <p>Are all options properly working?</p>	Go to step 4.	Contact the next level of support.

## Diagnostics and Troubleshooting

Action	Yes	No
<b>Step 4</b> Reseat the option interface cable. Does the problem remain?	Go to step 5.	The problem is solved.
<b>Step 5</b> Check the option interface cable for proper connection and damage, and replace if necessary. Does the problem remain?	Contact the next level of support.	The problem is solved.

# Other Symptoms

## Base Printer Symptoms

### Base Printer Symptoms

Symptom	Action
Printer does not have power.	See <a href="#">Dead Printer Service Check</a> .
False values for the front door appear on the display.	See <a href="#">Interlock Service Check</a> .
Bin is full or sensor (narrow media) service check.	See <a href="#">Sensor (narrow Media) Service Check</a> .
TMC card service check.	See <a href="#">TMC card service check</a> .
The printer is not communicating with the USB host.	See <a href="#">USB Service Check</a> .
The printer not communicating with the network host.	See <a href="#">Network Service Check</a> .

### Dead Printer Service Check

A dead printer is one which, when powered on from a known good electrical outlet, displays no indication of power to the printer by changes to the control panel display, or any movement of the fan or motors.

If a 650-sheet duo tray is installed, remove the tray and then check the base printer for correct operation. If the base printer operates correctly, then replace the 650-sheet duo tray.

 **Warning:** Observe all necessary ESD precautions when removing and handling the controller board or any installed option cards or assemblies.

 **Note:** Remove any input option from the printer.

Action	Yes	No
<b>Step 1</b> Turn on the printer. Did the printer turn on?	The problem is solved.	Go to step 2.
<b>Step 2</b> Check the AC power voltage. Is the line voltage correct?	Go to step 4.	Go to step 3.

## Diagnostics and Troubleshooting

Action	Yes	No
<p><b>Step 3</b></p> <p>Inform the customer of possible issues with the line voltage.</p> <p>Does the problem remain?</p>	Go to step 4.	The problem is solved.
<p><b>Step 4</b></p> <p>Check the AC power cord for damage, and replace if necessary.</p> <p>Does the problem remain?</p>	Go to step 5.	The problem is solved.
<p><b>Step 5</b></p> <p>Check the USB ground contacts on the controller board for damage, and repair if necessary.</p> <p>Does the problem remain?</p>	Go to step 6.	The problem is solved.
<p><b>Step 6</b></p> <p>Make sure that the voltage switch on the LVPS is properly set, and change if necessary.</p> <p>Does the problem remain?</p>	Go to step 7.	The problem is solved.
<p><b>Step 7</b></p> <ol style="list-style-type: none"> <li>1 Turn off the printer.</li> <li>2 Remove the rear cover. See <a href="#">Rear cover removal</a>.</li> <li>3 Check the cable connection at the JLVPS1 connector on the controller board for proper connection, and reseal if necessary.</li> </ol> <p>Does the problem remain?</p>	Go to step 8.	The problem is solved.
<p><b>Step 8</b></p> <p>Turn on the printer, and then check the following voltages at the JLVPS1 connector on the controller board:</p> <p>Test one connector pin at a time.</p> <ul style="list-style-type: none"> <li>• Pin 1: +6.5 V</li> <li>• Pin 2: Ground</li> <li>• Pin 3: +6.5 V</li> <li>• Pin 4: Ground</li> </ul>	Go to step 9.	Go to step 10.

Action	Yes	No
<ul style="list-style-type: none"> <li>• Pin 5: +6.5 V</li> <li>• Pin 6: Ground</li> <li>• Pin 7: +24 V_RAW</li> <li>• Pin 8: Ground</li> <li>• Pin 9: +24 V_RAW</li> <li>• Pin 10: Ground</li> <li>• Pin 11: +24 V_RAW</li> <li>• Pin 12: Ground</li> <li>• Pin 13: RELAY_DRIVE</li> <li>• Pin 14: PS_ZERO_XING_IN</li> <li>• Pin 15: HEAT1_ON_R</li> <li>• Pin 16: +24 V_ON_R+</li> </ul> <p>Are the voltage values approximately the same?</p>		
<p><b>Step 9</b></p> <p>Replace the controller board. See <a href="#">Controller board removal</a>.</p> <p>Does the problem remain?</p>	Contact the next level of support.	The problem is solved.
<p><b>Step 10</b></p> <p>Replace the LVPS. See <a href="#">LVPS removal</a>.</p> <p>Does the problem remain?</p>	Contact the next level of support.	The problem is solved.

## Control Panel Service Check

Action	Yes	No
<p><b>Step 1</b></p> <p>Perform a POR.</p> <p>Does the problem remain?</p>	Go to step 2.	The problem is solved.
<p><b>Step 2</b></p> <p>Check the indicator light on the control panel.</p> <p>Is the indicator light on?</p>	Go to step 3.	Go to step 4.
<p><b>Step 3</b></p> <p>Check the Ethernet and controller board LEDs on the control panel.</p>	Go to step 4.	Go to step 9.

## Diagnostics and Troubleshooting

Action	Yes	No
Are the LEDs on?		
<b>Step 4</b> Check the ribbon cable connection on the control panel and controller board. Is the cable properly connected at both ends?	Go to step 6.	Go to step 5.
<b>Step 5</b> Reconnect the cable. Does the problem remain?	Go to step 6.	The problem is solved.
<b>Step 6</b> Check the cable for damage, and replace if necessary. Does the problem remain?	Go to step 7.	The problem is solved.
<b>Step 7</b> Replace the control panel cable. Does the problem remain?	Go to step 8.	The problem is solved.
<b>Step 8</b> Replace the control panel. See <a href="#">2.4-inch Control Panel Top Cover Removal</a> . Does the problem remain?	Go to step 12.	The problem is solved.
<b>Step 9</b> Disconnect the LVPS cable from the controller board, and then measure the voltages of the red and orange wires. Is the reading on the red wire +6.5V, and the orange wire +25V?	Go to step 12.	Go to step 10.
<b>Step 10</b> Replace the LVPS cable. Does the problem remain?	Go to step 11.	The problem is solved.

Action	Yes	No
<b>Step 11</b> Replace the LVPS. See <a href="#">LVPS removal</a> . Does the problem remain?	Go to step 12.	The problem is solved.
<b>Step 12</b> Replace the controller board. See <a href="#">Controller board removal</a> . Does the problem remain?	Contact the next level of support.	The problem is solved.

## HVPS Service Check

Action	Yes	No
<b>Step 1</b> Perform a POR. Does the problem remain?	Go to step 2.	The problem is solved.
<b>Step 2</b> Check the cable at the JHVPS1 connector on the controller board for proper connection and damage, and replace if necessary. Does the problem remain?	Go to step 3.	The problem is solved.
<b>Step 3</b> 1 Remove the transfer module, and then check if the three contacts move up and down, and are making contact with the transfer module. 2 Reposition the transfer module so that the contacts move up and down. Does the problem remain?	Go to step 4.	The problem is solved.

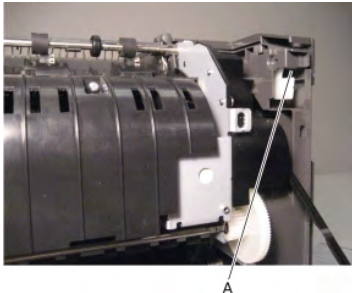

Action	Yes	No
<p><b>Step 4</b></p> <p>Replace the HVPS. See <a href="#">HVPS removal</a>.</p> <p>Does the problem remain?</p>	Go to step 5.	The problem is solved.
<p><b>Step 5</b></p> <p>Replace the controller board. See <a href="#">Controller board removal</a>.</p> <p>Does the problem remain?</p>	Contact the next level of support.	The problem is solved.

## Interlock Service Check

Action	Yes	No
<p><b>Step 1</b></p> <ol style="list-style-type: none"> <li>1 Open the front door, and then locate the sensor (Door interlock).</li> <li>2 Enter the Diagnostics menu, and then navigate to: <b>Printer diagnostics &amp; adjustments &gt; Sensor tests</b></li> <li>3 Find the sensor (Door interlock).</li> </ol> <p>Does the sensor status change while toggling the sensor?</p>	Go to step 2.	Go to step 7.
<p><b>Step 2</b></p> <ol style="list-style-type: none"> <li>1 Open the front door, and then check the thin, tall, plastic web pivot plate (A) at the top right corner of the printer.</li> </ol> 	Go to step 3.	Go to step 4.

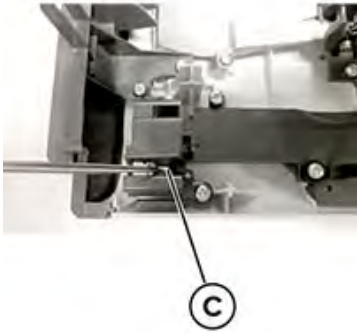

Action	Yes	No
<p>With the other covers in place and closed, the web interacts with switches in the door.</p> <p>2 Open the toner cover, and then check the motion of the web.</p> <p>Is the web loose, damaged, or missing?</p>		
<p><b>Step 3</b></p> <p>Replace the right cover. See <a href="#">Right cover removal</a>.</p> <p>Does the problem remain?</p>	Go to step 4.	The problem is solved.
<p><b>Step 4</b></p> <p>Open the toner door, and then check the vertical web (B) that pushes and rotates the pivot plate.</p>  <p>Is the web damaged?</p>	Go to step 5.	Go to step 6.
<p><b>Step 5</b></p> <p>Replace the toner cover.</p> <p>Does the problem remain?</p>	Go to step 6.	The problem is solved.
<p><b>Step 6</b></p> <p>1 Open the front door.</p> <p>2 Using a spring hook, push the metal arms (C) to check the movement of the two switches.</p>	Go to step 8.	Go to step 7.

Action	Yes	No
 <p>Are the switches and surrounding area damaged?</p>		
<p><b>Step 7</b> Check the cable connections (D) on the sensor.</p>  <p>Are the cables properly connected to the switch?</p>	Go to step 9.	Go to step 8.
<p><b>Step 8</b> Replace the interlock switch cover assembly. See <a href="#">Interlock Switch Cover Assembly Removal</a> . Does the problem remain?</p>	Go to step 9.	The problem is solved.
<p><b>Step 9</b></p> <ol style="list-style-type: none"> <li>1 Turn off the printer.</li> <li>2 Remove the rear cover. See <a href="#">Rear cover removal</a>.</li> <li>3 Turn on the printer, and then verify if the pin 1 value of the JCVR1 connector on the controller board is +25 V dc.</li> </ol>	Go to step 10.	Go to step 12.

Action	Yes	No
Is the value approximately the same?		
<p><b>Step 10</b></p> <ol style="list-style-type: none"> <li>1 Close the front door, and then close the toner door.</li> <li>2 Make sure that the right cover is in place.</li> <li>3 Turn off the printer, and then disconnect the cable at the JCVR1 connector on the controller board.</li> <li>4 Test the JCVR1 connector on the controller board under the following conditions:                             <ul style="list-style-type: none"> <li>• Close the front cover and toner door, and then test if pin 1 and pin 2 has continuity.</li> <li>• With one or both doors open, pin 1 and pin 2 should not have continuity.</li> </ul> </li> </ol> <p>Are the tests verified?</p>	Contact the next level or support.	Go to step 11.
<p><b>Step 11</b></p> <p>Replace the front door. See <a href="#">Front Door Removal</a>.</p> <p>Does the problem remain?</p>	Go to step 12.	The problem is solved.
<p><b>Step 12</b></p> <p>Replace the controller board. See <a href="#">Controller board removal</a>.</p> <p>Does the problem remain?</p>	Contact the next level or support.	The problem is solved.

## Invalid Input Option Type or ID Is Detected Service Check

Action	Yes	No
<p><b>Step 1</b></p> <ol style="list-style-type: none"> <li>1 Make sure to update to the latest printer firmware version.</li> <li>2 Make sure that the options configuration is supported.</li> <li>3 Perform a POR.</li> </ol> <p>Does the problem remain?</p>	Go to step 2.	The problem is solved.
<p><b>Step 2</b></p> <p>Check the option interface cable for proper connection and damage, and replace if necessary.</p> <p>Does the problem remain?</p>	Go to step 3.	The problem is solved.
<p><b>Step 3</b></p> <p>Check the printer interface cable and adjacent options for proper connection and damage, and replace if necessary.</p> <p>Does the problem remain?</p>	Go to step 4.	The problem is solved.
<p><b>Step 4</b></p> <p>Perform a POR.</p> <p>Does the problem remain?</p>	Contact the next level of support.	The problem is solved.

## Sensor (Narrow Media) Service Check

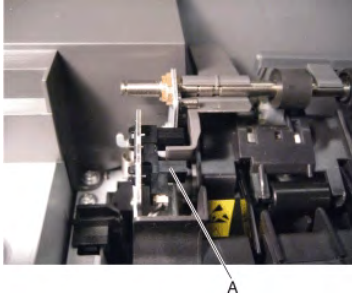
Action	Yes	No
<p><b>Step 1</b></p> <p>1 Enter the Diagnostics menu, and then navigate to:</p> <p><b>Printer diagnostics &amp; adjustments &gt; Sensor tests</b></p> <p>2 Find the sensor (Narrow media).</p> <p>3 Open the front door, and then toggle the sensor (A).</p>  <p>Does the sensor status change while toggling the sensor?</p>	Go to step 3.	Go to step 2.
<p><b>Step 2</b></p> <p>Replace the sensor (narrow media). See <a href="#">Sensor (narrow Media/output Bin Full) Removal</a>.</p> <p>Does the problem remain?</p>	Go to step 3.	The problem is solved.
<p><b>Step 3</b></p> <p>Check the sensor flag for proper installation and damage, and replace if necessary.</p> <p>Does the problem remain?</p>	Go to step 4.	The problem is solved.
<p><b>Step 4</b></p> <p>Check the sensor cable for proper connection or damage, and replace if necessary.</p> <p>Does the problem remain?</p>	Go to step 5.	The problem is solved.
<p><b>Step 5</b></p>	Contact the next level or support.	Go to step 6.

## Diagnostics and Troubleshooting

Action	Yes	No
<p>1 Enter the Diagnostics menu, and then navigate to:</p> <p><b>Printer diagnostics &amp; adjustments &gt; Sensor tests</b></p> <p>2 Find the sensor (Bin full).</p> <p>3 Open, and then close the front door to toggle the sensor.</p> <p>Does the sensor status change while toggling the sensor?</p>		
<p><b>Step 6</b></p> <p>Check the sensor cable for proper connection and damage, and replace if necessary.</p> <p>Does the problem remain?</p>	Go to step 7.	The problem is solved.
<p><b>Step 7</b></p> <p>Replace the controller board. See <a href="#">Controller board removal</a>.</p> <p>Does the problem remain?</p>	Contact your next level or support.	The problem is solved.

## USB Service Check

Actions	Yes	No
<p><b>Step 1</b></p> <p>Check if the USB cable is properly connected to the printer and host PC.</p> <p>Is the cable properly connected?</p>	Go to step 3.	Go to step 2.
<p><b>Step 2</b></p> <p>Properly connect the cable at both ends.</p> <p>Does the problem remain?</p>	Go to step 3.	The problem is solved.
<p><b>Step 3</b></p> <p>Use a different USB cable.</p> <p>Does the problem remain?</p>	Go to step 4.	The problem is solved.

Actions	Yes	No
<p><b>Step 4</b></p> <p>Connect a different device to the USB cable, and then check if the host PC detects the device.</p> <p>Did the host PC detect the device?</p>	Go to step 5.	Contact the next level of support.
<p><b>Step 5</b></p> <p>Replace the controller board. See <a href="#">Controller board removal</a>.</p> <p>Does the problem remain?</p>	Contact the next level of support.	The problem is solved.

## Network Service Check

Action	Yes	No
<p><b>Step 1</b></p> <p>Check if the printer is using an Ethernet network.</p> <p>Is the printer using an Ethernet network?</p>	Go to step 2.	Go to step 3.
<p><b>Step 2</b></p> <p>Make sure that the Ethernet cable is properly connected at both ends.</p> <p>Does the problem remain?</p>	Go to step 4.	The problem is solved.
<p><b>Step 3</b></p> <ol style="list-style-type: none"> <li>1 Make sure that the printer is not physically connected to a wired LAN.</li> <li>2 If the printer is connected using an Ethernet connection, unplug the cable from the printer, and then perform a POR to connect the printer to a wireless network.</li> </ol> <p>Does the problem remain?</p>	Go to step 4.	The problem is solved.
<p><b>Step 4</b></p> <ol style="list-style-type: none"> <li>1 From the home screen, navigate to <b>Settings</b> &gt;</li> </ol>	Go to step 6.	Go to step 5.

## Diagnostics and Troubleshooting

Action	Yes	No
<p><b>Network/Ports &gt; Active Adapters.</b></p> <p>2 Check if the adapter that appears matches the adapter used in the printer.</p> <p>Do the adapters match?</p>		
<p><b>Step 5</b></p> <p>Change the active adapter setting to match the adapter used in the printer.</p> <p>Does the problem remain?</p>	Go to step 6.	The problem is solved.
<p><b>Step 6</b></p> <p>1 Check the online status of the printer under Printers and Faxes on the host computer.</p> <p>2 Delete all print jobs in the print queue.</p> <p>Is the printer online and in the Ready state?</p>	Go to step 8.	Go to step 7.
<p><b>Step 7</b></p> <p>Change the printer status to Online.</p> <p>Does the problem remain?</p>	Go to step 8.	The problem is solved.
<p><b>Step 8</b></p> <p>Check the printer IP address on the Network Settings Page.</p> <p>Does it match the IP address in the drivers port using the printer?</p>	Go to step 13.	Go to step 9.
<p><b>Step 9</b></p> <p>Check if the printer uses a static IP address on a network.</p> <p>Is the printer using a DHCP IP address?</p>	Go to step 10.	Go to step 12.
<p><b>Step 10</b></p> <p>Check the first two segments of the IP address.</p> <p>Does the IP address start with 169.254?</p>	Go to step 11.	Go to step 12.



Action	Yes	No
<p><b>Step 11</b></p> <p>Perform a POR.</p> <p>Does the problem remain?</p>	Go to step 13.	The problem is solved.
<p><b>Step 12</b></p> <p>Reset the IP address on the printer to match the IP address on the driver.</p> <p>Does the problem remain?</p>	Go to step 13.	The problem is solved.
<p><b>Step 13</b></p> <p>Check if the printer and computer IP addresses have the same subnet address.</p> <p>Does the printer and computer IP addresses have the same subnet address?</p>	Go to step 15.	Go to step 14
<p><b>Step 14</b></p> <p>Using the subnet address supplied by the network administrator, assign a unique IP address to the printer.</p> <p>The printer IP address should match the IP address on the print driver.</p> <p>Does the problem remain?</p>	Go to step 15.	The problem is solved.
<p><b>Step 15</b></p> <p>Check if the printer is physically connected to the network.</p> <p>Is the printer physically connected to the network?</p>	Go to step 16.	Go to step 23.
<p><b>Step 16</b></p> <p>Use a different Ethernet cable.</p> <p>Does the problem remain?</p>	Go to step 17.	The problem is solved.
<p><b>Step 17</b></p> <p>Have the network administrator check the network drop for activity.</p>	Go to step 19.	Go to step 18.

## Diagnostics and Troubleshooting

Action	Yes	No
Is the network drop functioning properly?		
<b>Step 18</b> Try a known and functioning network drop. Does the problem remain?	Go to step 19.	The problem is solved.
<b>Step 19</b> Check if the built-in Ethernet port on the controller board is used to connect to the network. Is the built-in Ethernet port on the controller board used to connect to the network?	Go to step 22.	Go to step 20.
<b>Step 20</b> Make sure that the option Ethernet card is properly installed, and reseal if necessary Does the problem remain?	Go to step 21.	The problem is solved.
<b>Step 21</b> Replace the option Ethernet card. Does the problem remain?	Go to step 22.	The problem is solved.
<b>Step 22</b> Replace the controller board. See <a href="#">Controller board removal</a> . Does the problem remain?	Contact the next level of support.	The problem is solved.
<b>Step 23</b> Check if the printer is on the same wireless network as the other devices. Is the printer on the same wireless network as the other devices?	Go to step 25.	Go to step 24.
<b>Step 24</b> Assign the correct wireless network to the printer. Does the problem remain?	Go to step 25.	The problem is solved.

Action	Yes	No
<p><b>Step 25</b></p> <p>Check if the other devices on the wireless network are properly communicating.</p> <p>Are the other devices on the wireless network properly communicating?</p>	Go to step 26.	Contact the network administrator.
<p><b>Step 26</b></p> <p>Make sure that the wireless card on the printer is properly installed.</p> <p>Does the problem remain?</p>	Go to step 27.	The problem is solved.
<p><b>Step 27</b></p> <p>Check if an antenna is attached to the wireless card.</p> <p>Is an antenna attached to the wireless card?</p>	Go to step 28.	Go to step 29.
<p><b>Step 28</b></p> <p>Check the antenna for proper installation and damage, and replace if necessary.</p> <p>Does the problem remain?</p>	Go to step 29.	The problem is solved.
<p><b>Step 29</b></p> <p>Replace the wireless card. See <a href="#">Wireless card removal</a>.</p> <p>Does the problem remain?</p>	Go to step 30.	The problem is solved.
<p><b>Step 30</b></p> <p>Replace the controller board. See <a href="#">Controller board removal</a>.</p> <p>Does the problem remain?</p>	Contact the next level of support.	The problem is solved.



## TPS Service Check

Action	Yes	No
<p><b>Step 1</b></p> <p>Check the cable on the JTPS1 and JTPS2 connector on the controller board for proper connection and damage, and replace if necessary.</p> <p>Does the problem remain?</p>	Go to step 2.	The problem is solved.
<p><b>Step 2</b></p> <p>Check the cables on the left and right TPS sensors for proper connection and damage, and replace if necessary.</p> <p>Does the problem remain?</p>	Go to step 3.	The problem is solved.
<p><b>Step 3</b></p> <p>Check the left and right TPS sensors for proper installation and damage, and replace if necessary. See <a href="#">Sensors (toner patch) removal</a>.</p> <p>Does the problem remain?</p>	Go to step 4.	The problem is solved.
<p><b>Step 4</b></p> <p>Replace the controller board. See <a href="#">Controller board removal</a>.</p> <p>Does the problem remain?</p>	Contact the next level of support.	The problem is solved.

## Weather Station Service Check

Action	Yes	No
<p><b>Step 1</b></p> <p>Make sure that the cable on the JWS1 connector on the controller board is properly connected.</p> <p>Does the problem remain?</p>	Go to step 2.	The problem is solved.
<p><b>Step 2</b></p> <p>Make sure that the weather station cable is properly connected.</p> <p>Does the problem remain?</p>	Go to step 3.	The problem is solved.
<p><b>Step 3</b></p> <p>Replace the sensor (weather station). See <a href="#">Weather station removal</a>.</p> <p>Does the problem remain?</p>	Contact the next level of support.	The problem is solved.

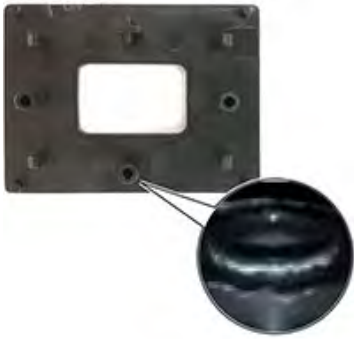
## 2.4-inch Control Panel Keypad False Navigation Key Press Service Check

Action	Yes	No
<p><b>Step 1</b></p> <ol style="list-style-type: none"> <li>1 Remove the 2.4-inch keypad from the control panel assembly. See <a href="#">2.4-inch Control Panel Keypad Removal</a>.</li> <li>2 Check the four bosses on the navigation key for excessive flashing on their ends.</li> </ol>  <p>Is there excessive flashing?</p>	<p>Go to step 2.</p>	<p>Go to step 3.</p>
<p><b>Step 2</b></p> <ol style="list-style-type: none"> <li>1 Release the four tabs (A) on the navigation key from the keypad assembly.</li> </ol> 	<p>Go to step 3.</p>	<p>The problem is solved.</p>

Action	Yes	No
2 Remove the flashing from the ends of the bosses. 3 Reinstall the keypad into the control panel assembly. Does the problem remain?		
<b>Step 3</b> Replace the 2.4-inch control panel. See <a href="#">2.4-inch Control Panel Bezel Removal</a> . Does the problem remain?	Contact the next level of support.	The problem is solved.

## Input Option Symptoms

### 550-sheet Tray and 650-Sheet Duo Tray Input Option Symptoms

Symptom	Action
The printer fails to recognize an installed option.	See <a href="#">Option and paper size not recognized service check</a> .
Tray [x] does not recognize the paper size loaded.	See <a href="#">Option and paper size not recognized service check</a> .
<ul style="list-style-type: none"> <li>• A Tray missing message appears even if the tray is installed.</li> <li>• The tray insert does not fit in the tray base.</li> </ul>	See <a href="#">Sensor (tray [x]) service check</a> .
Double feed.	See <a href="#">Double feed and printout skewed service check</a> .
The printout is skewed.	See <a href="#">Double feed and printout skewed service check</a> .
The printer failed to feed from the option tray.	See <a href="#">Failed to feed from option tray and leading edge damaged service check</a> .
The leading edge is damaged.	See <a href="#">Failed to feed from option tray and leading edge damaged service check</a> .
The printer failed to feed from the MPF.	See <a href="#">Failed to load/feed from the multipurpose feeder service check</a> .
Load MPF with plain letter-size paper.	See <a href="#">Failed to load/feed from the multipurpose feeder service check</a> .

Symptom	Action
Tray 2 or tray 3 is missing.	See <a href="#">Tray 2 or tray 3 missing service check</a> .
Tray 2 or tray 3 is not detected.	See <a href="#">Tray 2 or tray 3 not detected service check</a> .
Tray 2 or tray 3 is empty.	See <a href="#">Tray 2 or tray 3 empty service check</a> .
Incompatible tray 3.	See <a href="#">Incompatible tray 3 service check</a> .

## Sensor (Tray [x]) Service Check

Actions	Yes	No
<p><b>Step 1</b></p> <ol style="list-style-type: none"> <li>1 Perform a POR.</li> <li>2 Reseat the printer on the input option.</li> <li>3 Make sure that the input option configuration is supported. See the Printer, Option, and Stand Compatibility Guide.</li> </ol> <p>Does the problem remain?</p>	Go to step 2.	Problem resolved.
<p><b>Step 2</b></p> <p>When the printer is in the Ready state, remove and then insert the tray.</p> <p>Did a Keep the current configuration message appear?</p>	Go to step 3.	Go to step 6.
<p><b>Step 3</b></p> <p>Check the vertical wall at the left side of the tray for damage, and replace the tray if necessary.</p> <p>Does the problem remain?</p>	Go to step 4.	The problem is solved.
<p><b>Step 4</b></p> <p>Check the metal leaf (A) spring for damage.</p>	Go to step 5.	Contact the next level of support.

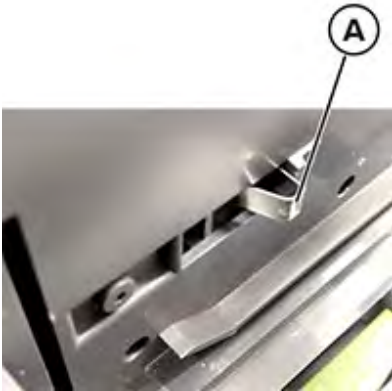

Actions	Yes	No
 <p>Is the spring damaged and unable to actuate the sensor?</p>		
<p><b>Step 5</b></p> <ul style="list-style-type: none"> <li>• If a 650-sheet duo tray insert is affected, then replace the 650-sheet duo tray.</li> <li>• If a 550-sheet tray insert is affected, then replace the 550-sheet tray.</li> </ul> <p>Does the problem remain?</p>	Go to step 6.	The problem is solved.
<p><b>Step 6</b></p> <p>Check if a Keep the current configuration message appears.</p> <p>Did a Keep the current configuration message appear?</p>	Go to step 7.	The problem is solved.

## Diagnostics and Troubleshooting

Actions	Yes	No
<p><b>Step 7</b></p> <ol style="list-style-type: none"> <li>1 Turn off the printer.</li> <li>2 Remove the rear cover. See <a href="#">Rear cover removal</a>.</li> <li>3 Disconnect the following cables on the controller board: <ul style="list-style-type: none"> <li>• JTRAY1 cable for tray 1</li> <li>• JOPT1 cable for tray 2 and tray 3</li> </ul> </li> <li>4 Turn on the printer, and then measure the following voltage values: <p>For tray 1, check the following pins on the JTRAY1 connector on the controller board:</p> <ul style="list-style-type: none"> <li>• Pin 1: +5 V dc</li> <li>• Pin 2: +5 V dc</li> <li>• Pin 3: Ground</li> </ul> <p>For tray 2, check the following pins on the JOPT1 connector on the controller board:</p> <ul style="list-style-type: none"> <li>• Pin 2: Ground</li> <li>• Pin 3: Ground</li> <li>• Pin 5: +24 V dc</li> </ul> <p>Are the voltage values approximately the same?</p> </li> </ol>	<p>The problem is solved.</p>	<p>Go to step 8.</p>
<p><b>Step 8</b></p> <p>Replace the controller board. See <a href="#">Controller board removal</a>.</p> <p>Does the problem remain?</p>	<p>Contact the next level of support.</p>	<p>The problem is solved.</p>

## Option and Paper Size Not Recognized Service Check

Action	Yes	No
<p><b>Step 1</b></p> <ol style="list-style-type: none"> <li>1 Perform a POR.</li> <li>2 Reseat the printer on the input option.</li> <li>3 Make sure that the input option configuration is supported. See the Printer, Option, and Stand Compatibility Guide.</li> </ol> <p>Does the problem remain?</p>	Go to step 2.	The problem is solved.
<p><b>Step 2</b></p> <p>Check if the printer is using both the 650-sheet duo tray and 550-sheet tray.</p> <p>Is the printer using both the 650-sheet duo tray and 550-sheet tray?</p>	Go to step 3.	Go to step 4.
<p><b>Step 3</b></p> <ol style="list-style-type: none"> <li>1 Make sure that the sequence of the option trays is correct. The 650-sheet duo tray should be tray 2, and the 550-sheet tray should be tray 3.</li> <li>2 Enter the Diagnostics menu, and then navigate to: <b>Additional input tray diagnostics &gt; Motor tests</b></li> <li>3 Select a motor, and then select <b>Start</b>.</li> </ol> <p>Does the test run successfully on each option?</p>	Go to step 9.	Go to step 4.
<p><b>Step 4</b></p> <ol style="list-style-type: none"> <li>1 Isolate the problem. Verify the problem by installing only one input option to the printer at a time.</li> <li>2 Enter the Diagnostics menu, and then navigate to: <b>Additional input tray diagnostics &gt; Motor tests</b></li> </ol>	Go to step 9.	Go to step 5.

## Diagnostics and Troubleshooting

Action	Yes	No
<p>3 Select a motor, and then select <b>Start</b>.</p> <p>Does the test run successfully on each option?</p>		
<p><b>Step 5</b></p> <p>Check the following for any damage:</p> <p>For the 550-sheet tray</p> <ul style="list-style-type: none"> <li>• Tray insert</li> <li>• Paper restraints</li> <li>• Paper dams</li> <li>• Pick pads</li> </ul> <p>For the 650-sheet duo tray</p> <ul style="list-style-type: none"> <li>• Tray insert</li> <li>• Paper restraints</li> <li>• Paper dams</li> <li>• Pick pads</li> <li>• MPF gear</li> <li>• MPF pick assembly</li> <li>• MPF tray</li> </ul> <p>Is the tray free of damage?</p>	Go to step 6.	<ul style="list-style-type: none"> <li>• If a 650-sheet duo tray insert is affected, then replace the 650-sheet duo tray.</li> <li>• If a 550-sheet tray insert is affected, then replace the 550-sheet tray.</li> </ul>
<p><b>Step 6</b></p> <p>Check the pick tires for wear, damage, contamination, and proper installation.</p> <p>Is the pick tire properly installed and free of wear or damage?</p>	Go to step 7.	Go to step 8.
<p><b>Step 7</b></p> <p>Check the tray and the following for any damage or contamination:</p> <ul style="list-style-type: none"> <li>• Top and bottom autoconnector</li> <li>• Sensor (pass-through)</li> <li>• Feed rollers</li> <li>• Input option pick assembly (if it can go down every time the tray is inserted)</li> </ul> <p>Is the tray free of damage or contamination?</p>	Go to step 9.	<ul style="list-style-type: none"> <li>• If a 650-sheet duo tray insert is affected, then replace the 650-sheet duo tray.</li> <li>• If a 550-sheet tray insert is affected, then replace the 550-sheet tray.</li> </ul>
<b>Step 8</b>	Go to step 9.	The problem is solved.

Action	Yes	No
<p>Replace the pick tire. See <a href="#">Pick tire removal</a>.</p> <p>Does the problem remain?</p>		
<p><b>Step 9</b></p> <ol style="list-style-type: none"> <li>1 Turn off the printer.</li> <li>2 Remove the printer from the optional trays.</li> <li>3 Remove the rear cover. See <a href="#">Rear cover removal</a>.</li> <li>4 Reseat the JOPT1 cable on the controller board.</li> <li>5 Check the JOPT1 cable for damage, and replace if necessary.</li> <li>6 Position the printer to partially hang on the side of a table, and then check the autoconnect/option tray cable for damage.</li> </ol> <p>Is the autoconnect/option tray cable damaged?</p>	Go to step 10.	Go to step 11.
<p><b>Step 10</b></p> <ul style="list-style-type: none"> <li>• If the printer autoconnector is damaged, then replace the tray 2 to controller board cable.</li> <li>• If the option tray autoconnector is damaged, then go to step 12.</li> </ul> <p>Does the problem remain?</p>	Go to step 12.	The problem is solved.
<p><b>Step 11</b></p> <ul style="list-style-type: none"> <li>• If a 650-sheet duo tray insert is affected, then replace the 650-sheet duo tray.</li> <li>• If a 550-sheet tray insert is affected, then replace the 550-sheet tray.</li> </ul> <p>Does the problem remain?</p>	Go to step 12.	The problem is solved.

## Diagnostics and Troubleshooting

Action	Yes	No
<p><b>Step 12</b></p> <ol style="list-style-type: none"> <li>1 Turn off the printer.</li> <li>2 Remove the rear cover. See <a href="#">Rear cover removal</a>.</li> <li>3 Disconnect the cable at the JOPT1 connector on the controller board.</li> <li>4 Turn on the printer.</li> <li>5 Measure the following voltages on the JOPT1 connector on the controller board: <ul style="list-style-type: none"> <li>• Pin 2: Ground</li> <li>• Pin 3: Ground</li> <li>• Pin 5: +24 V dc</li> <li>• Pin 6: Ground</li> <li>• Pin 7: +5 V dc</li> <li>• Pin 9: Ground</li> <li>• Pin 10: Ground</li> </ul> </li> </ol> <p>Are the voltage readings approximately the same?</p>	Contact the next level of support.	Go to step 13.
<p><b>Step 13</b></p> <p>Replace the controller board. See <a href="#">Controller board removal</a>.</p> <p>Does the problem remain?</p>	Contact the next level of support.	The problem is solved.

## Double Feed and Printout Skewed Service Check

Action	Yes	No
<p><b>Step 1</b></p> <ol style="list-style-type: none"> <li>1 Fan the paper.</li> <li>2 Verify the proper tray settings for the paper.</li> <li>3 Check the condition of all the option tray pick tires.</li> <li>4 Make sure that the tray is fully inserted.</li> <li>5 Make sure that the paper guides are properly adjusted to the paper size being loaded.</li> <li>6 Make sure that the printer and option trays are on a flat surface.</li> <li>7 Make sure that the printer is sitting flat on the option trays.</li> </ol> <p>Does the problem remain?</p>	Go to step 2.	The problem is solved.
<p><b>Step 2</b></p> <p>Check if the printer is using both the 650-sheet duo tray and 550-sheet tray.</p> <p>Is the printer using both the 650-sheet duo tray and 550-sheet tray?</p>	Go to step 3.	Go to step 4.
<p><b>Step 3</b></p> <ol style="list-style-type: none"> <li>1 Make sure that the sequence of the option trays is correct. The 650-sheet duo tray should be tray 2, and the 550-sheet tray should be tray 3.</li> <li>2 Enter the Diagnostics menu, and then navigate to: <b>Additional input tray diagnostics &gt; Motor tests</b></li> <li>3 Select a motor, and then select <b>Start</b>.</li> </ol> <p>Does the test run successfully on each option?</p>	Go to step 9.	Go to step 4.
<p><b>Step 4</b></p> <ol style="list-style-type: none"> <li>1 Isolate the problem. Verify the problem by installing only one</li> </ol>	Go to step 9.	Go to step 5.

## Diagnostics and Troubleshooting

Action	Yes	No
<p>input option to the printer at a time.</p> <p>2 Enter the Diagnostics menu, and then navigate to:</p> <p><b>Additional input tray diagnostics &gt; Motor tests</b></p> <p>3 Select a motor, and then select <b>Start</b>.</p> <p>Does the test run successfully on each option?</p>		
<p><b>Step 5</b></p> <p>Check the following for any damage:</p> <p>For the 550-sheet tray</p> <ul style="list-style-type: none"> <li>• Tray insert</li> <li>• Paper restraints</li> <li>• Paper dams</li> <li>• Pick pads</li> </ul> <p>For the 650-sheet duo tray</p> <ul style="list-style-type: none"> <li>• Tray insert</li> <li>• Paper restraints</li> <li>• Paper dams</li> <li>• Pick pads</li> <li>• MPF gear</li> <li>• MPF pick assembly</li> <li>• MPF tray</li> </ul> <p>Is the tray free of damage?</p>	Go to step 6.	<ul style="list-style-type: none"> <li>• If a 650-sheet duo tray insert is affected, then replace the 650-sheet duo tray.</li> <li>• If a 550-sheet tray insert is affected, then replace the 550-sheet tray.</li> </ul>
<p><b>Step 6</b></p> <p>Check the pick tires for wear, damage, contamination, and proper installation.</p> <p>Is the pick tire properly installed and free of wear or damage?</p>	Go to step 7.	Go to step 8.
<p><b>Step 7</b></p> <p>Check the tray and the following for any damage or contamination:</p> <ul style="list-style-type: none"> <li>• Top and bottom autoconnector</li> <li>• Sensor (pass-through)</li> <li>• Feed rollers</li> </ul>	Go to step 9.	<ul style="list-style-type: none"> <li>• If a 650-sheet duo tray insert is affected, then replace the 650-sheet duo tray.</li> <li>• If a 550-sheet tray insert is affected, then replace the 550-sheet tray.</li> </ul>



Action	Yes	No
<ul style="list-style-type: none"> <li>Input option pick assembly (if it can go down every time the tray is inserted)</li> </ul> <p>Is the tray free of damage or contamination?</p>		
<p><b>Step 8</b></p> <p>Replace the pick tire. See <a href="#">Pick tire removal</a>.</p> <p>Does the problem remain?</p>	Go to step 9.	The problem is solved.
<p><b>Step 9</b></p> <ol style="list-style-type: none"> <li>Turn off the printer.</li> <li>Remove the printer from the trays.</li> <li>Remove the rear cover. See <a href="#">Rear cover removal</a>.</li> <li>Reseat the JOPT1 cable on the controller board.</li> <li>Check the JOPT1 cable for damage, and replace if necessary.</li> <li>Position the printer to partially hang on the side of a table, and then check the autoconnect/option tray cable for damage.</li> </ol> <p>Is the autoconnect/option tray cable damaged?</p>	Go to step 10.	Go to step 11.
<p><b>Step 10</b></p> <ul style="list-style-type: none"> <li>If the printer autoconnector is damaged, then replace the tray 2 to controller board cable.</li> <li>If the option tray autoconnector is damaged, then go to step 12.</li> </ul> <p>Does the problem remain?</p>	Go to step 12.	The problem is solved.
<p><b>Step 11</b></p> <ul style="list-style-type: none"> <li>If a 650-sheet duo tray insert is affected, then replace the 650-sheet duo tray.</li> <li>If a 550-sheet tray insert is affected, then replace the 550-sheet tray.</li> </ul>	Go to step 12.	The problem is solved.

## Diagnostics and Troubleshooting

Action	Yes	No
Does the problem remain?		
<p><b>Step 12</b></p> <ol style="list-style-type: none"> <li>1 Turn off the printer.</li> <li>2 Remove the rear cover. See <a href="#">Rear cover removal</a>.</li> <li>3 Disconnect the cable at the JOPT1 connector on the controller board.</li> <li>4 Turn on the printer.</li> <li>5 Measure the following voltages on the JOPT1 connector on the controller board: <ul style="list-style-type: none"> <li>• Pin 2: Ground</li> <li>• Pin 3: Ground</li> <li>• Pin 5: +24 V dc</li> <li>• Pin 6: Ground</li> <li>• Pin 7: +5 V dc</li> <li>• Pin 9: Ground</li> <li>• Pin 10: Ground</li> </ul> </li> </ol> <p>Are the voltage readings approximately the same?</p>	Contact the next level of support.	Go to step 13.
<p><b>Step 13</b></p> <p>Replace the controller board. See <a href="#">Controller board removal</a>.</p> <p>Does the problem remain?</p>	Contact the next level of support.	The problem is solved.

## Failed To Load/Feed From The Multipurpose Feeder Service Check

Action	Yes	No
<p><b>Step 1</b></p> <ol style="list-style-type: none"> <li>1 Make sure that the 650-sheet duo tray is tray 2.</li> <li>2 Make sure that the 650-sheet duo tray is properly installed.</li> <li>3 Fan the paper.</li> <li>4 Make sure that the correct tray setting is set for the paper.</li> <li>5 Verify the paper source.</li> <li>6 Check the MPF pick tires for wear or damage, and replace if necessary.</li> <li>7 Make sure that the tray insert is fully inserted.</li> <li>8 Make sure that the paper is free from damage and defects.</li> </ol> <p>Does the problem remain?</p>	Go to step 2.	The problem is solved.
<p><b>Step 2</b></p> <p>Check if the printer is using both the 650-sheet duo tray and 550-sheet tray.</p> <p>Is the printer using both the 650-sheet duo tray and 550-sheet tray?</p>	Go to step 3.	Go to step 4.
<p><b>Step 3</b></p> <ol style="list-style-type: none"> <li>1 Make sure that the sequence of the option trays is correct. The 650-sheet duo tray should be tray 2, and the 550-sheet tray should be tray 3.</li> <li>2 Enter the Diagnostics menu, and then navigate to: <b>Additional input tray diagnostics &gt; Motor tests</b></li> <li>3 Select a motor, and the select <b>Start</b>.</li> </ol> <p>Does the test run successfully on each option?</p>	Go to step 9.	Go to step 4.
<b>Step 4</b>	Go to step 9.	Go to step 5.

Action	Yes	No
<p>1 Isolate the problem. Verify the problem by installing only one option tray to the printer at a time.</p> <p>2 Enter the Diagnostics menu, and then navigate to:</p> <p><b>Additional input tray diagnostics &gt; Motor tests</b></p> <p>3 Select a motor, and then select <b>Start</b>.</p> <p>Does the motor run on each input option?</p>		
<p><b>Step 5</b></p> <p>Check the following for any damage:</p> <ul style="list-style-type: none"> <li>• Input tray</li> <li>• Paper restrains</li> <li>• Paper dams</li> <li>• Pick pads</li> <li>• MPF gear</li> <li>• MPF pick assembly</li> <li>• MPF tray</li> </ul> <p>Is the option tray free of damage?</p>	Go to step 6.	<ul style="list-style-type: none"> <li>• If a 650-sheet duo tray insert is affected, then replace the 650-sheet duo tray.</li> <li>• If a 550-sheet tray insert is affected, then replace the 550-sheet tray.</li> </ul>
<p><b>Step 6</b></p> <p>1 Make sure that the pick tire is free of contamination.</p> <p>2 Check the pick tire for proper installation and damage.</p> <p>Is the pick tire properly installed and free of damage?</p>	Go to step 9.	Go to step 7.
<p><b>Step 7</b></p> <p>Replace the pick tire. See <a href="#">Pick tire removal</a>.</p> <p>Does the problem remain?</p>	Go to step 8.	The problem is solved.
<p><b>Step 8</b></p> <p>1 Check the tray insert for damage or contamination.</p> <p>2 Check the following for damage or contamination:</p>	Go to step 9.	<ul style="list-style-type: none"> <li>• If a 650-sheet duo tray insert is affected, then replace the 650-sheet duo tray.</li> <li>• If a 550-sheet tray insert is affected, then replace the 550-sheet tray.</li> </ul>

Action	Yes	No
<ul style="list-style-type: none"> <li>• Top and bottom autoconnector</li> <li>• Sensor (pass-through)</li> <li>• Feed rollers</li> <li>• Input option pick assembly</li> </ul> <p>Is the tray insert free of damage or contamination?</p>		
<p><b>Step 9</b></p> <ol style="list-style-type: none"> <li>1 Turn off the printer.</li> <li>2 Remove the printer from the trays.</li> <li>3 Remove the rear cover. See <a href="#">Rear cover removal</a>.</li> <li>4 Reseat the JOPT1 cable on the controller board.</li> <li>5 Check the JOPT1 cable for damage, and replace if necessary.</li> <li>6 Position the printer to partially hang on the side of a table, and then check the autoconnect/option tray cable for damage.</li> </ol> <p>Is the autoconnect/option tray cable damaged?</p>	Go to step 10.	Go to step 12.
<p><b>Step 10</b></p> <ul style="list-style-type: none"> <li>• If the printer autoconnector is damaged, then replace the tray 2 to controller board cable.</li> <li>• If the option tray autoconnector is damaged, then go to step 12.</li> </ul> <p>Does the problem remain?</p>	Go to step 11.	The problem is solved.
<p><b>Step 11</b></p> <ul style="list-style-type: none"> <li>• If a 650-sheet duo tray insert is affected, then replace the 650-sheet duo tray.</li> <li>• If a 550-sheet tray insert is affected, then replace the 550-sheet tray.</li> </ul> <p>Does the problem remain?</p>	Go to step 12.	The problem is solved.

## Diagnostics and Troubleshooting

Action	Yes	No
<p><b>Step 12</b></p> <ol style="list-style-type: none"> <li>1 Turn off the printer.</li> <li>2 Remove the rear cover. See <a href="#">Rear cover removal</a>.</li> <li>3 Disconnect the JOPT1 cable on the controller board.</li> <li>4 Turn on the printer.</li> <li>5 Measure the following voltages on the JOPT1 connector on the controller board: <ul style="list-style-type: none"> <li>• Pin 2: Ground</li> <li>• Pin 3: Ground</li> <li>• Pin 5: +24 V dc</li> <li>• Pin 6: Ground</li> <li>• Pin 7: +5 V dc</li> <li>• Pin 9: Ground</li> <li>• Pin 10: Ground</li> </ul> </li> </ol> <p>Are the voltage readings approximately the same?</p>	Contact the next level of support.	Go to step 13.
<p><b>Step 13</b></p> <p>Replace the controller board. See <a href="#">Controller board removal</a>.</p> <p>Does the problem remain?</p>	Contact the next level of support.	The problem is solved.

## Failed To Feed From Option Tray and Leading Edge Damaged Service Check

Action	Yes	No
<p><b>Step 1</b></p> <ol style="list-style-type: none"> <li>1 Fan the paper.</li> <li>2 Verify the proper tray settings for the paper.</li> <li>3 Verify the paper source.</li> <li>4 Check the MPF pick tires for wear or damage, and replace if necessary.</li> <li>5 Make sure that the tray is fully inserted.</li> <li>6 Refer to the paper specifications and check the paper condition.</li> <li>7 Make sure that the paper is free from damage and defects.</li> </ol> <p>Does the problem remain?</p>	Go to step 2.	The problem is solved.
<p><b>Step 2</b></p> <p>Check if the printer is using both the 650-sheet duo tray and 550-sheet tray.</p> <p>Is the printer using both the 650-sheet duo tray and 550-sheet tray?</p>	Go to step 3.	Go to step 4.
<p><b>Step 3</b></p> <ol style="list-style-type: none"> <li>1 Make sure that the sequence of the option trays is correct. The 650-sheet duo tray should be tray 2, and the 550-sheet tray should be tray 3.</li> <li>2 Enter the Diagnostics menu, and then navigate to: <b>Additional input tray diagnostics &gt; Motor tests</b></li> <li>3 Select a motor, and then select <b>Start</b>.</li> </ol> <p>Does the test run successfully on each option?</p>	Go to step 9.	Go to step 4.
<b>Step 4</b>	Go to step 9.	Go to step 5.

Action	Yes	No
<p>1 Isolate the problem. Verify the problem by installing only one input option to the printer at a time.</p> <p>2 Enter the Diagnostics menu, and then navigate to:</p> <p><b>Additional input tray diagnostics &gt; Motor tests</b></p> <p>3 Select a motor, and then select <b>Start</b>.</p> <p>Does the test run successfully on each option?</p>		
<p><b>Step 5</b></p> <p>Check the following for any damage:</p> <p>For the 550-sheet tray</p> <ul style="list-style-type: none"> <li>• Tray insert</li> <li>• Paper restraints</li> <li>• Paper dams</li> <li>• Pick pads</li> </ul> <p>For the 650-sheet duo tray</p> <ul style="list-style-type: none"> <li>• Tray insert</li> <li>• Paper restraints</li> <li>• Paper dams</li> <li>• Pick pads</li> <li>• MPF gear</li> <li>• MPF pick assembly</li> <li>• MPF tray</li> </ul> <p>Is the tray free of damage?</p>	Go to step 6.	<ul style="list-style-type: none"> <li>• If a 650-sheet duo tray insert is affected, then replace the 650-sheet duo tray.</li> <li>• If a 550-sheet tray insert is affected, then replace the 550-sheet tray.</li> </ul>
<p><b>Step 6</b></p> <p>Check the pick tires for wear, damage, contamination, and proper installation.</p> <p>Is the pick tire properly installed and free of wear or damage?</p>	Go to step 7.	Go to step 8.
<p><b>Step 7</b></p> <p>Check the tray and the following for any damage or contamination:</p> <ul style="list-style-type: none"> <li>• Top and bottom autoconnector</li> <li>• Sensor (pass-through)</li> </ul>	Go to step 9.	<ul style="list-style-type: none"> <li>• If a 650-sheet duo tray insert is affected, then replace the 650-sheet duo tray.</li> <li>• If a 550-sheet tray insert is affected, then replace the 550-sheet tray.</li> </ul>



Action	Yes	No
<ul style="list-style-type: none"> <li>• Feed rollers</li> <li>• Input option pick assembly (if it can go down every time the tray is inserted)</li> </ul> <p>Is the tray free of damage or contamination?</p>		
<p><b>Step 8</b></p> <p>Replace the pick tire. See <a href="#">Pick tire removal</a>.</p> <p>Does the problem remain?</p>	Go to step 9.	The problem is solved.
<p><b>Step 9</b></p> <ol style="list-style-type: none"> <li>1 Turn off the printer.</li> <li>2 Remove the printer from the trays.</li> <li>3 Remove the rear cover. See <a href="#">Rear cover removal</a>.</li> <li>4 Reseat the JOPT1 cable on the controller board.</li> <li>5 Check the JOPT1 cable for damage.</li> <li>6 Position the printer to partially hang on the side of a table, and then check the autoconnect/option tray cable for damage.</li> </ol> <p>Is the autoconnect/option tray cable damaged?</p>	Go to step 10.	Go to step 11.
<p><b>Step 10</b></p> <ul style="list-style-type: none"> <li>• If the printer autoconnector is damaged, then replace the tray 2 to controller board cable.</li> <li>• If the option tray autoconnector is damaged, then go to step 12.</li> </ul> <p>Does the problem remain?</p>	Go to step 12.	The problem is solved.
<p><b>Step 11</b></p> <ul style="list-style-type: none"> <li>• If a 650-sheet duo tray insert is affected, then replace the 650-sheet duo tray.</li> <li>• If a 550-sheet tray insert is affected, then replace the 550-sheet tray.</li> </ul>	Go to step 12.	The problem is solved.

Action	Yes	No
Does the problem remain?		
<p><b>Step 12</b></p> <ol style="list-style-type: none"> <li>1 Turn off the printer.</li> <li>2 Remove the rear cover. See <a href="#">Rear cover removal</a>.</li> <li>3 Disconnect the cable at the JOPT1 connector on the controller board.</li> <li>4 Turn on the printer.</li> <li>5 Measure the following voltages on the JOPT1 connector on the controller board:                             <ul style="list-style-type: none"> <li>• Pin 2: Ground</li> <li>• Pin 3: Ground</li> <li>• Pin 5: +24 V dc</li> <li>• Pin 6: Ground</li> <li>• Pin 7: +5 V dc</li> <li>• Pin 9: Ground</li> <li>• Pin 10: Ground</li> </ul> </li> </ol> <p>Are the voltage readings approximately the same?</p>	Contact the next level of support.	Go to step 13.
<p><b>Step 13</b></p> <p>Replace the controller board. See <a href="#">Controller board removal</a>.</p> <p>Does the problem remain?</p>	Contact the next level of support.	The problem is solved.

## Tray 2 or Tray 3 Not Detected Service Check

Action	Yes	No
<p><b>Step 1</b></p> <ol style="list-style-type: none"> <li>1 Perform a POR.</li> <li>2 Reseat the option trays.</li> </ol> <p>Does the problem remain?</p>	Go to step 2.	The problem is solved.
<p><b>Step 2</b></p> <p>Check if the printer is using both the 650-sheet duo tray and 550-sheet tray.</p>	Go to step 3.	Go to step 4.

Action	Yes	No
Is the printer using both the 650-sheet duo tray and 550-sheet tray?		
<p><b>Step 3</b></p> <p>1 Make sure that the sequence of the option trays is correct. The 650-sheet duo tray should be tray 2, and the 550-sheet tray should be tray 3.</p> <p>2 Enter the Diagnostics menu, and then navigate to:</p> <p><b>Additional input tray diagnostics &gt; Motor tests</b></p> <p>3 Select a motor, and then select <b>Start</b>.</p> <p>Does the test run successfully on each option?</p>	Go to step 9.	Go to step 4.
<p><b>Step 4</b></p> <p>1 Isolate the problem. Verify the problem by installing only one input option to the printer at a time.</p> <p>2 Enter the Diagnostics menu, and then navigate to:</p> <p><b>Additional input tray diagnostics &gt; Motor tests</b></p> <p>3 Select a motor, and then select <b>Start</b>.</p> <p>Does the test run successfully on each option?</p>	Go to step 9.	Go to step 5.
<p><b>Step 5</b></p> <p>Check the following for any damage:</p> <p>For the 550-sheet tray</p> <ul style="list-style-type: none"> <li>• Tray insert</li> <li>• Paper restraints</li> <li>• Paper dams</li> <li>• Pick pads</li> </ul> <p>For the 650-sheet duo tray</p> <ul style="list-style-type: none"> <li>• Tray insert</li> </ul>	Go to step 6.	<ul style="list-style-type: none"> <li>• If a 650-sheet duo tray insert is affected, then replace the 650-sheet duo tray.</li> <li>• If a 550-sheet tray insert is affected, then replace the 550-sheet tray.</li> </ul>

Action	Yes	No
<ul style="list-style-type: none"> <li>• Paper restraints</li> <li>• Paper dams</li> <li>• Pick pads</li> <li>• MPF gear</li> <li>• MPF pick assembly</li> <li>• MPF tray</li> </ul> <p>Is the tray free of damage?</p>		
<p><b>Step 6</b></p> <p>Check the pick tires for wear, damage, contamination, and proper installation.</p> <p>Is the pick tire properly installed and free of wear or damage?</p>	Go to step 7.	Go to step 8.
<p><b>Step 7</b></p> <p>Check the tray and the following for any damage or contamination:</p> <ul style="list-style-type: none"> <li>• Top and bottom autoconnector</li> <li>• Sensor (pass-through)</li> <li>• Feed rollers</li> <li>• Input option pick assembly (if it can go down every time the tray is inserted)</li> </ul> <p>Is the tray free of damage or contamination?</p>	Go to step 9.	<ul style="list-style-type: none"> <li>• If a 650-sheet duo tray insert is affected, then replace the 650-sheet duo tray.</li> <li>• If a 550-sheet tray insert is affected, then replace the 550-sheet tray.</li> </ul>
<p><b>Step 8</b></p> <p>Replace the pick tire. See <a href="#">Pick tire removal</a>.</p> <p>Does the problem remain?</p>	Go to step 9.	The problem is solved.
<p><b>Step 9</b></p> <ol style="list-style-type: none"> <li>1 Turn off the printer.</li> <li>2 Remove the printer from the trays.</li> <li>3 Remove the rear cover. See <a href="#">Rear cover removal</a>.</li> <li>4 Reseat the JOPT1 cable on the controller board.</li> <li>5 Check the JOPT1 cable for damage, and replace if necessary.</li> <li>6 Position the printer to partially hang on the side of a table,</li> </ol>	Go to step 10.	Go to step 11.

Action	Yes	No
<p>and then check the autoconnect/option tray cable for damage.</p> <p>Is the tray autoconnect/option tray cable damaged?</p>		
<p><b>Step 10</b></p> <ul style="list-style-type: none"> <li>• If the printer autoconnector is damaged, then replace the tray 2 to controller board cable.</li> <li>• If the option tray autoconnector is damaged, then go to step 12.</li> </ul> <p>Does the problem remain?</p>	Go to step 12.	The problem is solved.
<p><b>Step 11</b></p> <ul style="list-style-type: none"> <li>• If a 650-sheet duo tray insert is affected, then replace the 650-sheet duo tray.</li> <li>• If a 550-sheet tray insert is affected, then replace the 550-sheet tray.</li> </ul> <p>Does the problem remain?</p>	Go to step 12.	The problem is solved.

Action	Yes	No
<p><b>Step 12</b></p> <ol style="list-style-type: none"> <li>1 Turn off the printer.</li> <li>2 Remove the rear cover. See <a href="#">Rear cover removal</a>.</li> <li>3 Disconnect the cable at the JOPT1 connector on the controller board.</li> <li>4 Turn on the printer.</li> <li>5 Measure the following voltages on the JOPT1 connector on the controller board:                             <ul style="list-style-type: none"> <li>• Pin 2: Ground</li> <li>• Pin 3: Ground</li> <li>• Pin 5: +24 V dc</li> <li>• Pin 6: Ground</li> <li>• Pin 7: +5 V dc</li> <li>• Pin 9: Ground</li> <li>• Pin 10: Ground</li> </ul> </li> </ol> <p>Are the voltage readings approximately the same?</p>	Contact the next level of support.	Go to step 13.
<p><b>Step 13</b></p> <p>Replace the controller board. See <a href="#">Controller board removal</a>.</p> <p>Does the problem remain?</p>	Contact the next level of support.	The problem is solved.

## Tray 2 or Tray 3 Missing Service Check

Action	Yes	No
<p><b>Step 1</b></p> <ol style="list-style-type: none"> <li>1 Perform a POR.</li> <li>2 Reseat the option trays.</li> <li>3 Reseat the tray inserts.</li> <li>4 Make sure that the paper pick assembly can be manually triggered.</li> </ol> <p>Does the problem remain?</p>	Go to step 2.	The problem is solved.
<p><b>Step 2</b></p> <p>Check if the printer is using both the 650-sheet duo tray and 550-sheet tray.</p>	Go to step 3.	Go to step 4.

Action	Yes	No
Is the printer using both the 650-sheet duo tray and 550-sheet tray?		
<p><b>Step 3</b></p> <p>1 Make sure that the sequence of the option trays is correct. The 650-sheet duo tray should be tray 2, and the 550-sheet tray should be tray 3.</p> <p>2 Enter the Diagnostics menu, and then navigate to:</p> <p><b>Additional input tray diagnostics &gt; Motor tests</b></p> <p>3 Select a motor, and then select <b>Start</b>.</p> <p>Does the test run successfully on each option?</p>	Go to step 9.	Go to step 4.
<p><b>Step 4</b></p> <p>1 Isolate the problem. Verify the problem by installing only one input option to the printer at a time.</p> <p>2 Enter the Diagnostics menu, and then navigate to:</p> <p><b>Additional input tray diagnostics &gt; Motor tests</b></p> <p>3 Select a motor, and then select <b>Start</b>.</p> <p>Does the test run successfully on each option?</p>	Go to step 9.	Go to step 5.
<p><b>Step 5</b></p> <p>Check the following for any damage:</p> <p>For the 550-sheet tray</p> <ul style="list-style-type: none"> <li>• Tray insert</li> <li>• Paper restraints</li> <li>• Paper dams</li> <li>• Pick pads</li> </ul> <p>For the 650-sheet duo tray</p> <ul style="list-style-type: none"> <li>• Tray insert</li> </ul>	Go to step 6.	<ul style="list-style-type: none"> <li>• If a 650-sheet duo tray insert is affected, then replace the 650-sheet duo tray.</li> <li>• If a 550-sheet tray insert is affected, then replace the 550-sheet tray.</li> </ul>

Action	Yes	No
<ul style="list-style-type: none"> <li>• Paper restraints</li> <li>• Paper dams</li> <li>• Pick pads</li> <li>• MPF gear</li> <li>• MPF pick assembly</li> <li>• MPF tray</li> </ul> <p>Is the tray free of damage?</p>		
<p><b>Step 6</b></p> <p>Check the pick tires for wear, damage, contamination, and proper installation.</p> <p>Is the pick tire properly installed and free of wear or damage?</p>	Go to step 7.	Go to step 8.
<p><b>Step 7</b></p> <p>Check the tray and the following for any damage or contamination:</p> <ul style="list-style-type: none"> <li>• Top and bottom autoconnector</li> <li>• Sensor (pass-through)</li> <li>• Feed rollers</li> <li>• Input option pick assembly (if it can go down every time the tray is inserted)</li> </ul> <p>Is the tray free of damage or contamination?</p>	Go to step 9.	<ul style="list-style-type: none"> <li>• If a 650-sheet duo tray insert is affected, then replace the 650-sheet duo tray.</li> <li>• If a 550-sheet tray insert is affected, then replace the 550-sheet tray.</li> </ul>
<p><b>Step 8</b></p> <p>Replace the pick tire. See <a href="#">Pick tire removal</a>.</p> <p>Does the problem remain?</p>	Go to step 9.	The problem is solved.
<p><b>Step 9</b></p> <ol style="list-style-type: none"> <li>1 Turn off the printer.</li> <li>2 Remove the printer from the trays.</li> <li>3 Remove the rear cover. See <a href="#">Rear cover removal</a>.</li> <li>4 Reseat the JOPT1 cable on the controller board.</li> <li>5 Check the JOPT1 cable for damage, and replace if necessary.</li> <li>6 Position the printer to partially hang on the side of a table,</li> </ol>	Go to step 10.	Go to step 11.



Action	Yes	No
<p>and then check the autoconnect/option tray cable for damage.</p> <p>Is the autoconnect/option tray cable damaged?</p>		
<p><b>Step 10</b></p> <ul style="list-style-type: none"> <li>• If the printer autoconnector is damaged, then replace the tray 2 to controller board cable.</li> <li>• If the option tray autoconnector is damaged, then go to step 12.</li> </ul> <p>Does the problem remain?</p>	Go to step 12.	The problem is solved.
<p><b>Step 11</b></p> <ul style="list-style-type: none"> <li>• If a 650-sheet duo tray insert is affected, then replace the 650-sheet duo tray.</li> <li>• If a 550-sheet tray insert is affected, then replace the 550-sheet tray.</li> </ul> <p>Does the problem remain?</p>	Go to step 12.	The problem is solved.

## Diagnostics and Troubleshooting

Action	Yes	No
<p><b>Step 12</b></p> <ol style="list-style-type: none"> <li>1 Turn off the printer.</li> <li>2 Remove the rear cover. See <a href="#">Rear cover removal</a>.</li> <li>3 Disconnect the cable at the JOPT1 connector on the controller board.</li> <li>4 Turn on the printer.</li> <li>5 Measure the following voltages on the JOPT1 connector on the controller board: <ul style="list-style-type: none"> <li>• Pin 2: Ground</li> <li>• Pin 3: Ground</li> <li>• Pin 5: +24 V dc</li> <li>• Pin 6: Ground</li> <li>• Pin 7: +5 V dc</li> <li>• Pin 9: Ground</li> <li>• Pin 10: Ground</li> </ul> </li> </ol> <p>Are the voltage readings approximately the same?</p>	Contact the next level of support.	Go to step 13.
<p><b>Step 13</b></p> <p>Replace the controller board. See <a href="#">Controller board removal</a>.</p> <p>Does the problem remain?</p>	Contact the next level of support.	The problem is solved.

## Tray 2 or Tray 3 Empty Service Check

Action	Yes	No
<p><b>Step 1</b></p> <ol style="list-style-type: none"> <li>1 Add paper in the tray.</li> <li>2 Properly set the paper restraints in the tray.</li> <li>3 Perform a POR.</li> <li>4 Reseat the option trays.</li> <li>5 Refer to the paper specifications and check the condition of the paper.</li> <li>6 Make sure that the paper is free from damage and defects.</li> </ol> <p>Does the problem remain?</p>	Go to step 2.	The problem is solved.
<p><b>Step 2</b></p> <p>Check if the printer is using both the 650-sheet duo tray and 550-sheet tray.</p> <p>Is the printer using both the 650-sheet duo tray and 550-sheet tray?</p>	Go to step 3.	Go to step 4.
<p><b>Step 3</b></p> <ol style="list-style-type: none"> <li>1 Make sure that the sequence of the option trays is correct. The 650-sheet duo tray should be tray 2, and the 550-sheet tray should be tray 3.</li> <li>2 Enter the Diagnostics menu, and then navigate to: <b>Additional input tray diagnostics &gt; Motor tests</b></li> <li>3 Select a motor, and then select <b>Start</b>.</li> </ol> <p>Does the test run successfully on each option?</p>	Go to step 9.	Go to step 4.
<p><b>Step 4</b></p> <ol style="list-style-type: none"> <li>1 Isolate the problem. Verify the problem by installing only one input option to the printer at a time.</li> <li>2 Enter the Diagnostics menu, and then navigate to:</li> </ol>	Go to step 9.	Go to step 5.

Action	Yes	No
<p><b>Additional input tray diagnostics &gt; Motor tests</b></p> <p>3 Select a motor, and then select <b>Start</b>.</p> <p>Does the test run successfully on each option?</p>		
<p><b>Step 5</b></p> <p>Check the following for any damage:</p> <p>For the 550-sheet tray</p> <ul style="list-style-type: none"> <li>• Tray insert</li> <li>• Paper restraints</li> <li>• Paper dams</li> <li>• Pick pads</li> </ul> <p>For the 650-sheet duo tray</p> <ul style="list-style-type: none"> <li>• Tray insert</li> <li>• Paper restraints</li> <li>• Paper dams</li> <li>• Pick pads</li> <li>• MPF gear</li> <li>• MPF pick assembly</li> <li>• MPF tray</li> </ul> <p>Is the tray free of damage?</p>	Go to step 6.	<ul style="list-style-type: none"> <li>• If a 650-sheet duo tray insert is affected, then replace the 650-sheet duo tray.</li> <li>• If a 550-sheet tray insert is affected, then replace the 550-sheet tray.</li> </ul>
<p><b>Step 6</b></p> <p>Check the pick tires for wear, damage, contamination, and proper installation.</p> <p>Is the pick tire properly installed and free of wear or damage?</p>	Go to step 7.	Go to step 8.
<p><b>Step 7</b></p> <p>Check the tray and the following for any damage or contamination:</p> <ul style="list-style-type: none"> <li>• Top and bottom autoconnector</li> <li>• Sensor (pass-through)</li> <li>• Feed rollers</li> <li>• Input option pick assembly (if it can go down every time the tray is inserted)</li> </ul> <p>Is the tray free of damage or contamination?</p>	Go to step 9.	<ul style="list-style-type: none"> <li>• If a 650-sheet duo tray insert is affected, then replace the 650-sheet duo tray.</li> <li>• If a 550-sheet tray insert is affected, then replace the 550-sheet tray.</li> </ul>

Action	Yes	No
<p><b>Step 8</b></p> <p>Replace the pick tire. See <a href="#">Pick tire removal</a>.</p> <p>Does the problem remain?</p>	Go to step 9.	The problem is solved.
<p><b>Step 9</b></p> <ol style="list-style-type: none"> <li>1 Turn off the printer.</li> <li>2 Remove the printer from the trays.</li> <li>3 Remove the rear cover. See <a href="#">Rear cover removal</a>.</li> <li>4 Reseat the JOPT1 cable on the controller board.</li> <li>5 Check the JOPT1 cable for damage, and replace if necessary.</li> <li>6 Position the printer to partially hang on the side of a table, and then check the autoconnect/option tray cable for damage.</li> </ol> <p>Is the autoconnect/option tray cable damaged?</p>	Go to step 10.	Go to step 11.
<p><b>Step 10</b></p> <ul style="list-style-type: none"> <li>• If the printer autoconnector is damaged, then replace the tray 2 to controller board cable.</li> <li>• If the option tray autoconnector is damaged, then go to step 12.</li> </ul> <p>Does the problem remain?</p>	Go to step 12.	The problem is solved.
<p><b>Step 11</b></p> <ul style="list-style-type: none"> <li>• If a 650-sheet duo tray insert is affected, then replace the 650-sheet duo tray.</li> <li>• If a 550-sheet tray insert is affected, then replace the 550-sheet tray.</li> </ul> <p>Does the problem remain?</p>	Go to step 12.	The problem is solved.

Action	Yes	No
<p><b>Step 12</b></p> <ol style="list-style-type: none"> <li>1 Turn off the printer.</li> <li>2 Remove the rear cover. See <a href="#">Rear cover removal</a>.</li> <li>3 Disconnect the cable at the JOPT1 connector on the controller board.</li> <li>4 Turn on the printer.</li> <li>5 Measure the following voltages on the JOPT1 connector on the controller board:                             <ul style="list-style-type: none"> <li>• Pin 2: Ground</li> <li>• Pin 3: Ground</li> <li>• Pin 5: +24 V dc</li> <li>• Pin 6: Ground</li> <li>• Pin 7: +5 V dc</li> <li>• Pin 9: Ground</li> <li>• Pin 10: Ground</li> </ul> </li> </ol> <p>Are the voltage readings approximately the same?</p>	Contact the next level of support.	Go to step 13.
<p><b>Step 13</b></p> <p>Replace the controller board. See <a href="#">Controller board removal</a>.</p> <p>Does the problem remain?</p>	Contact the next level of support.	The problem is solved.

## Incompatible Tray 3 Service Check

Action	Yes	No
<p><b>Step 1</b></p> <ol style="list-style-type: none"> <li>1 Make sure that the sequence of the option trays is correct. The 650-sheet duo tray should be tray 2, and the 550-sheet tray should be tray 3.</li> <li>2 Reseat the option trays.</li> </ol> <p>Does the problem remain?</p>	Go to step 2.	The problem is solved.
<p><b>Step 2</b></p> <p>Check if the printer is using both the 650-sheet duo tray and 550-sheet tray.</p>	Go to step 3.	Go to step 4.

Action	Yes	No
Is the printer using both the 650-sheet duo tray and 550-sheet tray?		
<p><b>Step 3</b></p> <p>1 Enter the Diagnostics menu, and then navigate to:</p> <p><b>Additional input tray diagnostics &gt; Motor tests</b></p> <p>2 Select a motor, and then select <b>Start</b>.</p> <p>Does the test run successfully on each option?</p>	Go to step 7.	Go to step 4.
<p><b>Step 4</b></p> <p>1 Isolate the problem. Verify the problem by installing only one input option to the printer at a time.</p> <p>2 Enter the Diagnostics menu, and then navigate to:</p> <p><b>Additional input tray diagnostics &gt; Motor tests</b></p> <p>3 Select a motor, and then select <b>Start</b>.</p> <p>Does the test run successfully on each option?</p>	Go to step 7.	Go to step 5.
<p><b>Step 5</b></p> <p>Check the tray and the following for any damage or contamination:</p> <ul style="list-style-type: none"> <li>• Top and bottom autoconnector</li> <li>• Sensor (pass-through)</li> <li>• Feed rollers</li> <li>• Input option pick assembly (if it can go down every time the tray is inserted)</li> </ul> <p>Is the tray free of damage or contamination?</p>	Go to step 7.	<ul style="list-style-type: none"> <li>• If a 650-sheet duo tray insert is affected, then replace the 650-sheet duo tray.</li> <li>• If a 550-sheet tray insert is affected, then replace the 550-sheet tray.</li> </ul>
<p><b>Step 6</b></p> <p>Replace the pick tire. See <a href="#">Pick tire removal</a>.</p>	Go to step 7.	The problem is solved.

## Diagnostics and Troubleshooting

Action	Yes	No
Does the problem remain?		
<p><b>Step 7</b></p> <ol style="list-style-type: none"> <li>1 Turn off the printer.</li> <li>2 Remove the printer from the trays.</li> <li>3 Remove the rear cover. See <a href="#">Rear cover removal</a>.</li> <li>4 Reseat the JOPT1 cable on the controller board.</li> <li>5 Check the JOPT1 cable for damage, and replace if necessary.</li> <li>6 Position the printer to partially hang on the side of a table, and then check the autoconnect/option tray cable for damage.</li> </ol> <p>Is the autoconnect/option tray cable damaged?</p>	Go to step 8.	Go to step 9.
<p><b>Step 8</b></p> <ul style="list-style-type: none"> <li>• If the printer autoconnector is damaged, then replace the tray 2 to controller board cable.</li> <li>• If the option tray autoconnector is damaged, then go to step 12.</li> </ul> <p>Does the problem remain?</p>	Go to step 10.	The problem is solved.
<p><b>Step 9</b></p> <ul style="list-style-type: none"> <li>• If a 650-sheet duo tray insert is affected, then replace the 650-sheet duo tray.</li> <li>• If a 550-sheet tray insert is affected, then replace the 550-sheet tray.</li> </ul> <p>Does the problem remain?</p>	Go to step 10.	The problem is solved.



Action	Yes	No
<p><b>Step 10</b></p> <ol style="list-style-type: none"> <li>1 Turn off the printer.</li> <li>2 Remove the rear cover. See <a href="#">Rear cover removal</a>.</li> <li>3 Disconnect the cable at the JOPT1 connector on the controller board.</li> <li>4 Turn on the printer.</li> <li>5 Measure the following voltages on the JOPT1 connector on the controller board: <ul style="list-style-type: none"> <li>• Pin 2: Ground</li> <li>• Pin 3: Ground</li> <li>• Pin 5: +24 V dc</li> <li>• Pin 6: Ground</li> <li>• Pin 7: +5 V dc</li> <li>• Pin 9: Ground</li> <li>• Pin 10: Ground</li> </ul> </li> </ol> <p>Are the voltage readings approximately the same?</p>	Contact the next level of support.	Go to step 11.
<p><b>Step 11</b></p> <p>Replace the controller board. See <a href="#">Controller board removal</a>.</p> <p>Does the problem remain?</p>	Contact the next level of support.	The problem is solved.



# Service Menus

# Using The Control Panel

## Xerox C310



	Use the	To
1	Display	<ul style="list-style-type: none"> <li>View printer messages and supply status.</li> <li>Set up and operate the printer.</li> </ul>
2	Select button	<ul style="list-style-type: none"> <li>Select a menu option.</li> <li>Save the changes in a setting.</li> </ul>
3	Arrow buttons	<ul style="list-style-type: none"> <li>Scroll through menus or move between screens and menu options.</li> <li>Adjust the numeric value of a setting.</li> </ul>
4	Numeric keypad	Enter numbers or symbols in an input field.
5	Power button	<ul style="list-style-type: none"> <li>Turn on or turn off the printer. To turn off the printer, press and hold the power button for five seconds.</li> <li>Set the printer to Sleep or Hibernate mode.</li> <li>Wake the printer from Sleep or Hibernate mode.</li> </ul>
6	Backspace button	Move the cursor backward and delete a character in an input field.
7	Stop or Cancel button	Stop the current printer task.

	Use the	To
8	Indicator light	Check the printer status.
9	Back button	Return to the previous screen.
10	Home button	Go to the home screen.

## Understanding The Status Of The Power Button and Indicator Light

Indicator light	Printer status
Off	The printer is off or in Hibernate mode.
Blue	The printer is ready or processing data.
Red	The printer requires user intervention.

Power button light	Printer status
Off	The printer is off, ready, or processing data.
Solid amber	The printer is in Sleep mode.
Blinking amber	The printer is in Hibernate mode.

## Using The Home Screen

 **Note:** Your home screen may vary depending on your home screen customization settings, administrative setup, and active embedded solutions.

## Service Menus



Touch		To
1	Status/Supplies	<ul style="list-style-type: none"> <li>Show a warning or error message whenever the printer requires intervention to continue processing.</li> <li>View more information on the printer warning or message, and on how to clear it.</li> </ul> <p>You can also access this setting by touching the top section of the home screen.</p>
2	Job Queue	<p>Show all the current print jobs.</p> <p>You can also access this setting by touching the top section of the home screen.</p>
3	Change Language	<p>Change the language on the display.</p>
4	Settings	<p>Access the printer menus.</p>
5	Eco-Settings	<p>Manage energy consumption, noise, toner, and paper usage settings.</p>
6	Held Jobs	<p>Show the print jobs that are held in the printer memory.</p>

Touch		To
7	USB Drive	Print photos and documents from a flash drive.
8	Address Book	Manage a contact list that other applications on the printer can access.

# Configuring The Door Interlock Bypass Jumpers

 **Note:** The interlock bypass jumpers are only used with the following motors:

- Motor (fuser)
- Motor (K developer)
- Motor (transfer module)
- Motor (duplex/MPF)

The controller board has two door interlock bypass jumpers. These jumpers allow you to remove the motor cover and open the toner door to see the motors in operation while being tested in Diagnostics mode. The JMTREN1 jumper connector allows you to bypass the interlock switches, and test the motor (fuser) and motor (K developer/transfer module). The JMTREN2 jumper connector allows you to bypass the interlock switches, and test the motor (duplex/MPF).

 **Note:** If the jumpers are not set to the bypass position, and a motor test is performed while the toner door is open, then a 1yy.80 error occurs.

## Jumper configurations



Interlock bypass disabled  
(default)



Interlock bypass enabled

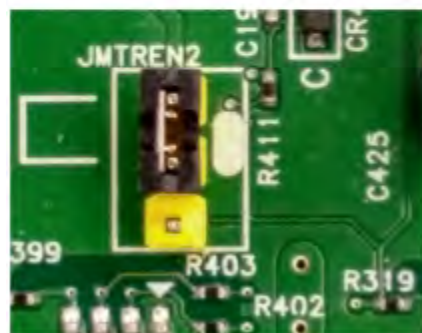

Interlock bypass disabled  
(default)



Interlock bypass enabled

## Setting the jumper

1. Turn off the printer.
2. Remove the rear cover. See [Rear cover removal](#).



3. Locate the jumper connectors on the controller board.
4. Move the jumper of the motor being tested to the bypass position.
5. From the control panel, press and hold the **3** and **6** buttons while turning on the printer to enter the Diagnostics menu.
6. Select **Printer diagnostics & adjustments > Motor tests**.
7. Select a motor, and then press **OK** or touch **Start**.
8. After the test, turn off the printer, and then move the jumpers back to the default position.



**Note:** If the jumpers are not moved to the default position, then a False door open message appears on the screen.

## Diagnostics Menu

### Entering The Diagnostics Menu

The Diagnostics menu contains tests that are used to help isolate issues with the printer. To access some of these tests, avoid POST tests that run at POR. Some POST tests can generate errors that prevent a diagnostic test from running.

To access the Diagnostics menu from the home screen, press \* \* 3 6 on the control panel.

## Reports

### Device Settings

This report lists all the current printer settings.

Enter the Diagnostics menu, and then navigate to:

**Reports > Device > Device Settings**

For non-touch-screen printer models, press  to navigate through the settings.

### Installed Licenses

This setting lists all the installed licenses and their feature data.

Enter the Diagnostics menu, and then navigate to:

**Reports > Licenses > Installed Licenses**

For non-touch-screen printer models, press  to navigate through the settings.

## Advanced Print Quality Samples

This setting prints a list of the printer settings and sample pages to check print quality.

Enter the Diagnostics menu, and then navigate to:

**Advanced Print Quality Samples > Advanced Print Quality Test Pages**

For non-touch-screen printer models, press  to navigate through the settings.

## Event Log

### Display Log

This setting displays the panel text that appears when the event occurs.

Enter the Diagnostics menu, and then navigate to:

## Event Log > Display Log

For non-touch-screen printer models, press  to navigate through the settings.

## Print Log

This setting lists an extended version of the various printer events.

1. Enter the Diagnostics menu, and then navigate to:

### Event Log > Print Log

For non-touch-screen printer models, press  to navigate through the settings.

2. Press  or touch **Start**.

 **Note:** The events that appear in the report vary depending on the operational history of the printer.

## Print Log Summary

This setting lists a brief summary of the various printer events.

1. Enter the Diagnostics menu, and then navigate to:

### Event Log > Print Log Summary

For non-touch-screen printer models, press  to navigate through the settings.

2. Press  or touch **Start**.

 **Note:** The events that appear in the report vary depending on the operational history of the printer.

## Mark Log

This setting allows you to create a service, maintenance, or custom log entry. Each log entry is added in the printer event log.

1. Enter the Diagnostics menu, and then navigate to:

### Event Log > Mark Log

For non-touch-screen printer models, press  to navigate through the settings.

2. Select a log that you want to create, and then press  or touch **Start**.

## Input Tray Quick Print

This setting lets you print a single or continuous Quick Test page in either duplex or simplex mode.

1. Enter the Diagnostics menu, and then select **Input tray quick print**.
2. Select where you want to print the pages from.
3. Select whether to print a single or continuous test page, and then select **Start**.

## Printer Setup

### Printed Page Count (mono)

This setting displays the amount of pages printed in mono.

1. Enter the Diagnostics menu, and then select **Printer Setup**.
2. View the printed page count for mono.

### Printed Page Count (color)

This setting displays the amount of pages printed in color.

1. Enter the Diagnostics menu, and then select **Printer Setup**.
2. View the printed page count for color.

### Permanent Page Count

This setting displays the total number of pages printed in mono and color. After all the print tests are completed, this value resets to zero.

1. Enter the Diagnostics menu, and then select **Printer Setup**.
2. View the permanent page count.

### Processor ID

This setting indicates the ID of the processor on the controller board.

1. Enter the Diagnostics menu, and then select **Printer Setup**.
2. View the processor ID.

### Serial Number

This setting displays a read-only value of the serial number.

1. Enter the Diagnostics menu, and then select **Printer Setup**.
2. View the serial number.

### Model Name

This setting displays the model name of the printer.

1. Enter the Diagnostics menu, and then select **Printer Setup**.

2. View the model name.

## Engine Setting [x]

 **Warning:** Do not change this setting without specific instructions from the next level of support.

This setting allows you to select a printer engine setting. Possible values are 0–255. 0 is the default.

For non-touch-screen printer models, press  to navigate through the settings.

1. Enter the Diagnostics menu, and then navigate to:  
**Printer Setup > Engine setting [x]**
2. Select a setting, enter a value, and then press  or touch **OK**.

## EP Setup

 **Warning:** Do not change these settings without specific instructions from the next level of support. Changing these settings may cause other problems to occur aside from the one being resolved.

This setting allows you to adjust the EP setup of the printer.

For non-touch-screen printer models, press  to navigate through the settings.

1. Enter the Diagnostics menu, and then navigate to:  
**Printer Setup > EP setup**
2. Select a setting.

## Charge Adjust, Developer Adjust, and Transfer Adjust

These settings enable you to adjust the high voltage levels controlling the electrophotographic process. Use these settings to compensate for unusual operating circumstances such as high humidity.

To adjust the voltage levels:

1. Select a component to adjust:
  - To adjust the photoconductor, enter the Diagnostics menu, and then navigate to:  
**Printer Setup > EP setup > Charge adjust**
  - To adjust the developer unit, enter the Diagnostics menu, and then navigate to:  
**Printer Setup > EP setup > Developer adjust**
  - To adjust the transfer module, enter the Diagnostics menu, and then navigate to:  
**Printer Setup > EP setup > Transfer adjust**
2. Select a color to adjust.

## Fuser Adjust

This adjustment can be used to help solve some customer problems with paper curl or fuse quality on certain non-standard paper or unique run modes.

To adjust the fuser temperature:

1. Enter the Diagnostics menu, and then navigate to:  
**Printer Setup > EP setup > Fuser adjust**
2. Select Normal, High, or Low. The default is Normal.

## Toner Patch Sensor Adjust

This setting allows you to calibrate or adjust the toner patch sensor settings.

To calibrate or adjust the toner patch sensor:

1. Enter the Diagnostics menu, and then navigate to:  
**Printer Setup > EP setup > Toner patch sensor adjust**
2. Select a setting to adjust or calibrate.

# Printer Diagnostics and Adjustments

## Sensor Tests

1. Enter the Diagnostics menu, and then select **Printer diagnostics & adjustments**.
2. From the Sensor tests section, select **Start**.  
A list of sensor tests appears.
3. Find, and then manually toggle the sensor.

 **Note:**

- The sensor status on the screen toggles between **1** and **0** when the sensor is properly working.
- If a sensor test fails, the test failure may not indicate a failed sensor. Further troubleshooting may be required. Check the boards and cables for possible issues.
- For the fuser exit sensor actuator, toggle it toward the rear door.

## List Of Sensor Tests

Test
Tray 1 pick
Input
Redrive/Duplex path 1
Output bin/Narrow media

Test
Fuser exit
Door interlock
K Toner meter
C Toner meter
M Toner meter
Y Toner meter
Tray present
TPS L and R
Waste Toner Bottle

## Motor Tests

For non-touch-screen printer models, press  to navigate through the settings.

1. Enter the Diagnostics menu, and then navigate to:  
**Printer diagnostics & adjustments > Motor tests**
2. Select a motor, and then press  or touch **Start**.

### Note:

- If the motor is activated, then it is properly working.
- Some motors require automatic deactivation to avoid secondary issues such as possible damage and contamination.
- Some tests require a special action to activate a motor such as removing a major component.
- If the motor fails, the test failure may not indicate a failed motor. Further troubleshooting may be required. Check the boards and cables for possible issues.
- To stop a running motor in non-touch-screen printer models, press .

## List Of Motor Tests

Test
Pick (tray 1) picking
Pick (tray 1) duplex
Fuser (fusing)
Fuser (retracting)
CMY developer
K developer-transfer
Fan (main)

## Registration Adjust

This setting lets you adjust the skew, margins, or perform a Quick Test.

For non-touch-screen printer models, press  to navigate through the settings.

1. Enter the Diagnostics menu, and then navigate to:  
**Printer diagnostics & adjustments > Registration adjust**
2. Select a setting to adjust.

## Color Alignment Adjust

This setting allows you to adjust the color alignments and to print or reset the default settings.

For non-touch-screen printer models, press  to navigate through the settings.

1. Enter the Diagnostics menu, and then navigate to:  
**Printer diagnostics & adjustments > Color alignment adjust**
2. Select a setting.

## Supply Reset

The setting resets the fuser and ITM counter values to zero.

For non-touch-screen printer models, press  to navigate through the settings.

1. Enter the Diagnostics menu, and then navigate to:  
**Printer diagnostics & adjustments > Supply reset**



2. Select a setting, and then press  or touch **Start**.

## Add-on Cards Tests

This setting allows you to test the add-on cards installed on the printer.

For non-touch-screen printer models, press  to navigate through the settings.

1. Enter the Diagnostics menu, and then navigate to:  
**Printer diagnostics & adjustments > Add-on cards tests**
2. Select a card.

## Weather Station

This setting lets you view the temperature and humidity reported by the weather station.

For non-touch-screen printer models, press  to navigate through the settings.

1. Enter the Diagnostics menu, and then touch **Printer diagnostics & adjustments**.
2. From the Weather station section, press  or touch **Start**.

## Universal Override

This setting allows the user to feed custom media sizes to a Custom Media Tray.

For non-touch-screen printer models, press  to navigate through the settings.

1. Enter the Diagnostics menu, and then navigate to:  
**Printer diagnostics & adjustments > Universal Override**
2. Select a setting to adjust.

# Additional Input Tray Diagnostics

## Sensor Tests

1. Enter the Diagnostics menu, and then select **Additional input tray diagnostics**.
2. From the Sensor tests section, press  or touch **Start**.  
A dialog listing the sensor tests appears.

3. Find, and then manually toggle the sensor.

 **Note:**

- The sensor status on the screen toggles between **1** and **0** when the sensor is properly working.
- If a sensor test fails, the test failure may not indicate a failed sensor. Further troubleshooting may be required. Check the boards and cables for possible issues.

### List Of Sensor Tests

Test
Pass-through (tray [x])
Media out (tray [x])
Media level (tray [x])
Tray present (tray [x])
MPF media present

## Motor Tests

For non-touch-screen printer models, press  to navigate through the settings.

1. Enter the Diagnostics menu, and then navigate to:  
**Additional input tray diagnostics > Motor tests**
2. Select a motor, and then press  or touch **Start**.

 **Note:**

- If the motor is activated, then it is properly working.
- Some motors require automatic deactivation in order to avoid secondary issues such as possible damage and contamination.
- Some tests require a special action to activate a motor such as removing a major component.
- If the motor fails, the test failure may not indicate a failed motor. Further troubleshooting may be required. Check the boards and cables for possible issues.

## Configuration Menu

Menu item	Description
<b>USB Configuration</b> USB PnP 1* 2	Change the USB driver mode of the printer to improve its compatibility with a personal computer.  This menu item appears only in some printer models.
<b>USB Configuration</b> USB Speed Full Auto*	Set the USB port to run at full speed and disable its high-speed capabilities.  This menu item appears only in some printer models.
<b>Tray Configuration</b> Tray Linking Automatic* Off	Set the printer to link the trays that have the same paper type and paper size settings.
<b>Tray Configuration</b> Show Tray Insert Message Off Only for unknown sizes* Always	Show the Tray Insertmessage.
<b>Tray Configuration</b> Paper Prompts Auto* Multipurpose Feeder Manual Paper	Set the paper source that the user fills when a prompt to load paper appears.  The multipurpose feeder is available only in some printer models.
<b>Tray Configuration</b> Envelope Prompts Auto* Multipurpose Feeder Manual Envelope	Set the paper source that the user fills when a prompt to load envelope appears.  The multipurpose feeder is available only in some printer models.
<b>Tray Configuration</b> Action for Prompts Prompt user* Continue	Set the printer to resolve paper- or envelope-related change prompts.

## Service Menus

Menu item	Description
Use current	
<b>Reports</b> Menu Settings Page Event Log Event Log Summary HealthCheck Statistics	Print reports about printer menu settings, status, and event logs.
<b>Supply Usage And Counters</b> Clear Supply Usage History	Reset the supply usage history, such as number of pages and days remaining, to the factory shipped level.
<b>Supply Usage And Counters</b> Reset Color Imaging Kit Counter	Reset the counter after installing a new color imaging kit.  This menu item appears only in some printer models.
<b>Supply Usage And Counters</b> Reset Maintenance Counter	Reset the counter after installing a new maintenance kit.
<b>Supply Usage And Counters</b> Tiered Coverage Ranges	Adjust the range for the amount of color coverage on the printed page.
<b>Printer Emulations</b> PPDS Emulation Off* On	Set the printer to recognize and use the PPDS data stream.
<b>Print Configuration</b> Black Only Mode Off* On	Print color content in grayscale.
<b>Print Configuration</b> Color Trapping Off 1 2* 3 4 5	Enhance the printed output to compensate for misregistration in the printer.

Menu item	Description
<b>Print Configuration</b> Font Sharpening 0–150 (24*)	Set a text point-size value below which the high-frequency screens are used when printing font data.  For example, if the value is 24, then all fonts sized 24 points or less use the high-frequency screens.
<b>Device Operations</b> Quiet Mode Off* On	Set the printer to operate in Quiet Mode.  Enabling this setting slows down the printer performance.
<b>Device Operations</b> Panel Menus Off On*	Enable access to the control panel menus.
<b>Device Operations</b> Custom Supply Levels Off* On	Let <i>printservice</i> read and edit values from the Embedded Web Server.
<b>Device Operations</b> Safe Mode Off* On	Set the printer to operate in a special mode, in which it attempts to continue offering as much functionality as possible, despite known issues.  For example, when set to On and the duplex motor is nonfunctional, the printer performs one-sided printing for a two-sided print job.
<b>Device Operations</b> Clear Custom Status	Erase user-defined strings for the Default or Alternate custom messages.
<b>Device Operations</b> Clear all remotely-installed messages	Erase messages that were remotely installed.
<b>Device Operations</b> Automatically Display Error Screens Off On*	Show existing error messages on the display after the printer remains inactive on the home screen for a length of time equal to the Screen Timeout setting.
<b>Device Operations</b> Enable Optional Parallel Port Off* On	Enable an optional parallel port.  When set to On, the printer restarts.

## Service Menus

Menu item	Description
<b>Toner patch sensor setup</b> Calibration frequency preference Disabled Fewest color adjustment Fewer color adjustment Normal* Better color accuracy Best color accuracy	Set the printer to put down the correct amount of toner to maintain color consistency.
<b>Toner patch sensor setup</b> Full calibration	Run the full color calibration.
<b>Toner patch sensor setup</b> Print TPS information page	Print a diagnostic page that contains information on toner patch sensor calibration.
An asterisk (*) next to a value indicates the factory default setting.	

# Service Engineer Menu

## Entering The Service Engineer (SE) Menu

To access the Service Engineer (SE) menu:

1. Turn on the printer.
2. When the home screen appears, press \* \* **411** on the control panel.

## General SE

This setting allows you to save a log file to a USB drive.

Enter the Service Engineer (SE) menu, and then navigate to:

**General SE > Capture Logs to USB Drive**

## Network SE

Enter the Service Engineer (SE) menu, and then touch **Network SE**.

 **Note:** Use these settings as directed by the next level of support.

Top level menu	Intermediate menu
Print SE Menus	Print SE Menus
History	<ul style="list-style-type: none"> <li>• Print History</li> <li>• Mark History</li> </ul>
MAC	<ul style="list-style-type: none"> <li>• Set Card Speed</li> <li>• LAA</li> <li>• Keep Alive</li> </ul>
NPAP	Print Alerts
TCP/IP	<ul style="list-style-type: none"> <li>• netstat</li> <li>• arp</li> <li>• Allow SNMP Set</li> <li>• MTU</li> <li>• Meditech Mode</li> <li>• RAW LPR Mode</li> </ul>
Wireless	Enable Wi-Fi Direct Sigma Control Agent

## Service Menus

Top level menu	Intermediate menu
Ping Test	<ul style="list-style-type: none"><li>• Ping</li><li>• Ping6</li></ul>
Other Actions	<ul style="list-style-type: none"><li>• ifconfig</li><li>• IPtables [Firewall Dump]</li><li>• IP6tables [Firewall Dump]</li><li>• IPsec Dump</li></ul>



## Entering Invalid Engine Mode

This mode allows the printer to load the correct firmware code.

1. Turn off the printer.
2. From the control panel, press and hold the **3**, **4**, and **6** while turning on the printer.
3. Release the buttons after 10 seconds.

## Entering Recovery Mode

This mode allows the printer to boot from a secondary set of instructions and flash firmware code. While in this mode, you can only flash firmware code through a USB cable directly connected to a PC.

Depending on your printer model, do any of the following:

### For LED Display

1. Turn off the printer.
2. Open the front door.
3. Press and hold the **Stop** button.
4. Turn on the printer.
5. When all the icons flash, release the button.

### For 2.4- inch Display

1. Turn off the printer.
2. Press and hold the **2**, **7**, and **8** buttons.
3. Turn on the printer.
4. When the display shows the following icon, release the buttons.

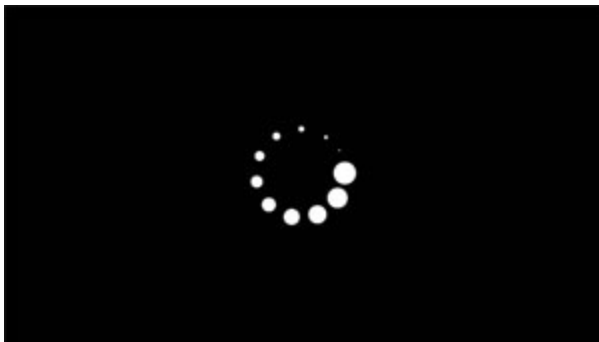

# Parts Removal

## Data Security Notice

### Identifying Printer Memory

- **Volatile memory**—The printer uses standard random access memory (RAM) to buffer user data temporarily during simple print and copy jobs.
- **Nonvolatile memory**—The printer may use two forms of nonvolatile memory: EEPROM and NAND (flash memory). Both types are used to store the operating system, printer settings, network information, scanner and bookmark settings, and embedded solutions.
- **Hard disk memory**—Some printers have a hard disk drive installed. The hard disk is designed for printer-specific functionality and cannot be used for long-term storage of data that is not print-related. The hard disk does not let users extract information, create folders, create disk or network file shares, or transfer FTP information directly from a client device. The hard disk can retain buffered user data from complex print jobs, form data, and font data.

The following parts can store memory:

- Printer control panel
- User interface controller card (UICC)
- Controller board
- Optional hard disks

 **Note:** The printer control panel and controller board contain NVRAM.

### Erasing Printer Memory

To erase volatile memory, turn off the printer.

To erase nonvolatile memory, do the following:

1. From the control panel, navigate to **Settings > Device > Maintenance > Out of Service Erase > Sanitize all information on nonvolatile memory**.
2. Select **Sanitize all information on nonvolatile memory**, and then select **ERASE**.
3. Follow the instructions on the screen.

To erase hard disk memory, do the following:

1. From the control panel, navigate to **Settings > Device > Maintenance > Out of Service Erase > Sanitize all information on hard disk**.
2. Select **Sanitize all information on hard disk**, and then select **ERASE**.
3. Follow the instructions on the screen.

 **Note:** This process can take from several minutes to more than an hour, making the printer unavailable for other tasks.

If a hard disk is replaced, then do the following:





1. Remove the hard disk, and then return it to the customer.
2. Request the customer to sign the Customer Retention form.







**Note:** You can get printed copies of the form from your Xerox partner manager.

3. Take a photo of the signed form, and then upload it to the Service Request debrief tool.
4. Fax or e-mail the signed form to the number or e-mail address shown at the bottom of the form.





## Removal Precautions

-  **CAUTION—SHOCK HAZARD:** The low-voltage power supply (LVPS) and the high-voltage power supply (HVPS) may have residual voltage present. To avoid the risk of electrical shock, do not touch their circuit components or the solder side of the board. Only handle them by their outer edges or metal housing.
-  **CAUTION—SHOCK HAZARD:** This product uses an electronic power switch. It does not physically disconnect the input AC voltage. To avoid the risk of electrical shock, always remove the power cord from the printer when removal of the input AC voltage is required.
-  **CAUTION—SHOCK HAZARD:** To avoid the risk of electrical shock and to prevent damage to the printer, remove the power cord from the electrical outlet and disconnect all connections to any external devices before you connect or disconnect any cable, electronic board, or assembly.
-  **CAUTION—HOT SURFACE:** The inside of the printer might be hot. To reduce the risk of injury from a hot component, allow the surface to cool before touching it.
-  **CAUTION—PINCH HAZARD:** To avoid the risk of a pinch injury, use caution in areas marked with this label. Pinch injuries may occur around moving parts, such as gears, doors, trays, and covers.





## Précautions De Retrait

-  **ATTENTION ! RISQUE D'ÉLECTROCUTION :** Une tension résiduelle peut être présente dans le bloc d'alimentation basse tension (LVPS) et le bloc d'alimentation haute tension (HVPS). Pour éviter tout risque d'électrocution, ne touchez pas les composants du circuit ou le côté soudure de la carte. Tenez-les uniquement par leurs extrémités ou le boîtier en métal.
-  **ATTENTION ! RISQUE D'ÉLECTROCUTION :** Ce produit utilise un commutateur d'alimentation électronique. Il ne déconnecte pas physiquement la tension d'alimentation CA. Pour éviter tout risque d'électrocution, débranchez toujours le cordon d'alimentation de l'imprimante lorsque vous devez déconnecter la tension d'alimentation CA.
-  **ATTENTION ! RISQUE D'ÉLECTROCUTION :** Pour éviter tout risque d'électrocution et éviter d'endommager l'imprimante, débranchez le cordon d'alimentation de la prise électrique et déconnectez toute connexion à tout périphérique externe avant de brancher ou débrancher des câbles ou circuits et assemblages électroniques.
-  **ATTENTION ! SURFACE CHAUDE :** L'intérieur de l'imprimante risque d'être brûlant. pour réduire le risque de brûlure, laissez la surface ou le composant refroidir avant d'y toucher.
-  **ATTENTION ! RISQUE DE PINCEMENT :** Pour éviter tout risque de blessure par pincement, agissez avec précaution au niveau des zones signalées par cette étiquette. Les blessures par pincement peuvent se produire autour des pièces mobiles telles que les engrenages, portes, tiroirs et capots.





## Precauciones Durante La Extracción

-  **PRECAUCIÓN—RIESGO DE DESCARGA:** La fuente de alimentación de bajo voltaje (LVPS) y la fuente de alimentación de alto voltaje (HVPS) pueden presentar voltaje residual. Para evitar el riesgo de descarga eléctrica, no toque los componentes del circuito ni el lateral soldado de la placa. Manipule solo los bordes exteriores o la carcasa metálica.
-  **PRECAUCIÓN—RIESGO DE DESCARGA:** Este producto utiliza un interruptor de corriente electrónico. No desconecta físicamente la entrada de voltaje de CA. Para evitar el riesgo de descarga eléctrica, desenchufe siempre el cable de alimentación de la impresora cuando sea necesario retirar la entrada de voltaje de CA.
-  **PRECAUCIÓN—RIESGO DE DESCARGA:** Para evitar el riesgo de descargas eléctricas y daños en la impresora, retire el cable de alimentación de la toma eléctrica y desconecte todas las conexiones a dispositivos externos antes de conectar o desconectar cualquier cable, placa electrónica o conjunto.
-  **PRECAUCIÓN—SUPERFICIE CALIENTE:** El interior de la impresora podría estar caliente. Para evitar el riesgo de heridas producidas por el contacto con un componente caliente, deje que la superficie se enfríe antes de tocarlo.
-  **PRECAUCIÓN—RIESGO DE DESCARGA ELÉCTRICA:** Para evitar el riesgo de lesión por atrapamiento, preste atención en las áreas marcadas con esta etiqueta. Las lesiones por atrapamiento se pueden producir en torno a partes móviles, tales como engranajes, puertas, bandejas y cubiertas.

## Vorsichtsmaßnahmen Bei Der Demontage

-  **VORSICHT – STROMSCHLAGGEFAHR:** Im Niederspannungsnetzteil (LVPS) und Hochspannungsnetzteil (HVPS) liegt unter Umständen Restspannung vor. Um das Risiko eines elektrischen Schlags zu vermeiden, berühren Sie keine umliegenden Bauteile oder die Lötseite der Platine. Fassen Sie sie nur an den Außenkanten oder am Metallgehäuse an.
-  **VORSICHT – STROMSCHLAGGEFAHR:** Dieses Produkt verwendet einen elektronischen Leistungsschalter. Er trennt die Eingangswchselspannung nicht physikalisch. Um das Risiko eines elektrischen Schlags zu vermeiden, ziehen Sie stets das Netzkabel vom Drucker ab, wenn eine Abtrennung der Eingangswchselspannung erforderlich ist.
-  **VORSICHT – STROMSCHLAGGEFAHR:** Um das Risiko eines elektrischen Schlags und Schäden am Drucker zu vermeiden, ziehen Sie das Netzkabel aus der Steckdose und trennen Sie alle Verbindungen zu jeglichen externen Geräten, bevor Sie Kabel, Elektronikplatinen oder Baugruppen einstecken oder abziehen.
-  **VORSICHT – HEISS:** Das Innere des Druckers kann sehr heiß sein. Vermeiden Sie Verletzungen, indem Sie heiße Komponenten stets abkühlen lassen, bevor Sie ihre Oberfläche berühren.
-  **VORSICHT – QUETSCHGEFAHR:** Um das Risiko einer Quetschung zu vermeiden, gehen Sie in Bereichen, die mit diesem Etikett gekennzeichnet sind, mit Vorsicht vor. Quetschungen können im Bereich von beweglichen Komponenten auftreten, wie z.B. Zahnrädern, Klappen, Fächern und Abdeckungen.

## Precauzioni per la rimozione

-  **ATTENZIONE – PERICOLO DI SCOSSA ELETTRICA:** Sull'alimentatore a bassa tensione (LVPS) e l'alimentatore ad alta tensione (HVPS) può essere presente tensione residua. Per evitare il rischio di scossa elettrica, non toccare i loro componenti elettrici o il lato saldatura della scheda. Toccarli soltanto dai bordi esterni o dall'alloggiamento in metallo.
-  **ATTENZIONE – PERICOLO DI SCOSSA ELETTRICA:** Questo prodotto utilizza un interruttore di alimentazione elettronico. Tale interruttore non scollega fisicamente la tensione CA in entrata. Per evitare il rischio di scossa elettrica, rimuovere sempre il cavo di alimentazione dalla stampante quando è necessario rimuovere la tensione CA in entrata.
-  **ATTENZIONE – PERICOLO DI SCOSSA ELETTRICA:** Per evitare il rischio di scossa elettrica e per impedire danni alla stampante, rimuovere il cavo di alimentazione dalla presa elettrica e scollegare tutti i collegamenti a eventuali dispositivi esterni prima di collegare o scollegare qualsiasi cavo, scheda elettronica o gruppo.
-  **ATTENZIONE – SUPERFICIE SURRISCALDATA:** L'area interna della stampante potrebbe surriscaldarsi. Per evitare infortuni, lasciare raffreddare la superficie dei componenti prima di toccarla.
-  **ATTENZIONE – PERICOLO DI SCHIACCIAMENTO:** Per evitare il rischio di lesioni, prestare la massima cautela quando si accede alle aree contrassegnate con questa etichetta. Potrebbero infatti verificarsi lesioni da schiacciamento in prossimità di parti in movimento, quali ad esempio ingranaggi, porte, vassoi e coperchi.

## Handling ESD-sensitive Parts



To prevent damage to the electrostatic discharge (ESD)-sensitive parts in the printer, do the following:



- Turn off the printer before removing logic boards.
- Keep the parts in their original packing material until you are ready to install them into the printer.
- Make the least-possible movements with your body to prevent an increase of static electricity from clothing fibers, carpets, and furniture.
- Use the ESD wrist strap. Connect the wrist band to the system ground point. This action discharges any static electricity in your body to the printer.
- Hold the parts by their edge connector shroud. Do not touch its pins. If you are removing a pluggable module, then use the correct tool.
- If possible, keep all parts in a grounded metal cabinet.
- Do not place the parts on the printer cover or on a metal table. If you need to put down the parts, then put them in their packing material.
- Prevent parts from being accidentally touched by other personnel. Cover the printer when you are not working on it.
- Be careful while working with the parts when cold-weather heating is used. Low humidity increases static electricity.





## Critical Information For Controller Board or Control Panel Replacement

 **CAUTION—POTENTIAL INJURY:** The lithium battery in this product is not intended to be replaced. There is a danger of explosion if a lithium battery is incorrectly replaced. Do not recharge, disassemble, or incinerate a lithium battery. Discard used lithium batteries according to the manufacturer's instructions and local regulations.

 **ATTENTION ! DOMMAGE POTENTIEL :**  La batterie lithium de ce produit n'est pas destinée à être remplacée. Il existe un risque d'explosion si une batterie lithium est placée de façon incorrecte. Ne rechargez pas, ne démontez pas et n'incinerez pas une batterie lithium. Mettez les batteries lithium usagées au rebut selon les instructions du fabricant et les réglementations locales.

 **PRECAUCIÓN—RIESGO DE LESIONES:**  La batería de litio de este producto no debe reemplazarse. Existe riesgo de explosión si se sustituye incorrectamente una batería de litio. No recargue, desmonte ni incinere una batería de litio. Deseche las baterías de litio según las instrucciones del fabricante y las normativas locales.

 **VORSICHT – VERLETZUNGSGEFAHR:**  Die Lithiumbatterie in diesem Produkt darf nicht ausgetauscht werden. Wird eine Lithiumbatterie nicht ordnungsgemäß ausgetauscht, besteht Explosionsgefahr. Lithiumbatterien dürfen auf keinen Fall wieder aufgeladen, auseinander genommen oder verbrannt werden. Befolgen Sie zum Entsorgen verbrauchter Lithiumbatterien die Anweisungen des Herstellers und die örtlichen Bestimmungen.

 **ATTENZIONE – PERICOLO DI LESIONI:** La batteria al litio presente nel prodotto non deve essere sostituita. In caso di sostituzione errata della batteria al litio, potrebbe verificarsi un'esplosione. Non ricaricare, smontare o bruciare batterie al litio. Smaltire le batterie al litio usate seguendo le istruzioni del produttore e le norme locali.

 **Warning:** Observe all precautions when handling ESD sensitive parts. See [Handling ESD-sensitive parts](#).

 **Warning:** Carefully remove the cables and connectors. Make sure they are not damaged.

 **Warning:** To avoid NVRAM mismatch issues, replace only one of the following components at a time:

- Control panel
- Controller board

To replace a component and to test whether the problem is resolved:

1. Replace the affected component.

 **Warning:** Do not perform a Power-On Reset (POR) until the problem is resolved. If a POR is performed at this point, then the replacement part can no longer be used in another printer and must be returned to the manufacturer.

2. Enter the Diagnostics menu. The Diagnostics menu allows you to temporarily use the replacement part.

 **Warning:** Some printers perform a POR automatically if the Diagnostics menu is not opened within five seconds. If a POR is performed at this point, then the replacement part can no longer be used in another printer and must be returned to the manufacturer.

3. Use the Diagnostics menu to test the replacement part. Do a feed test to check if the problem is resolved.
  - If the problem is not resolved—Turn off the printer, and then install the old part.
  - If the problem is resolved—Perform a POR.
  - If NVRAM error occurs during the replacement, then see [950.xx NVRAM Failure Service Check](#).

## Restoring The Printer Configuration After Replacing The Controller Board

Restore the printer to its correct configuration. Contact your Hardware Support Line to obtain the applicable zip file. Flash the printer settings and embedded solutions.

 **Note:** The software bundle contains the latest version of the firmware, applications, and software licenses from the Lexmark Virtual Solutions Center (VSC). The printer firmware may be at a different level from what was used before replacing the controller board.

Extract the contents of the zip file.

- Perform the install instructions on the Readme file in the exact order shown. Restart the printer only if the file says so.
- For more information on how to flash the downloaded files, see [Updating The Printer Firmware](#).
- To load the zip file, see [Restoring Solutions, Licenses, and Configuration Settings](#).

After performing the installation instructions in the Readme file, confirm that the printer is restored.

- If you are unable to access the administrative menus to verify that the printer is restored, then ask the customer for access rights.
- If a 10.00 error appears after you restart the printer, then contact the next level of support.

## Restoring Solutions, Licenses, and Configuration Settings

To load the zip files that are extracted from the Service Restore Tool, do the following:

1. Open a web browser, and then type the printer IP address.

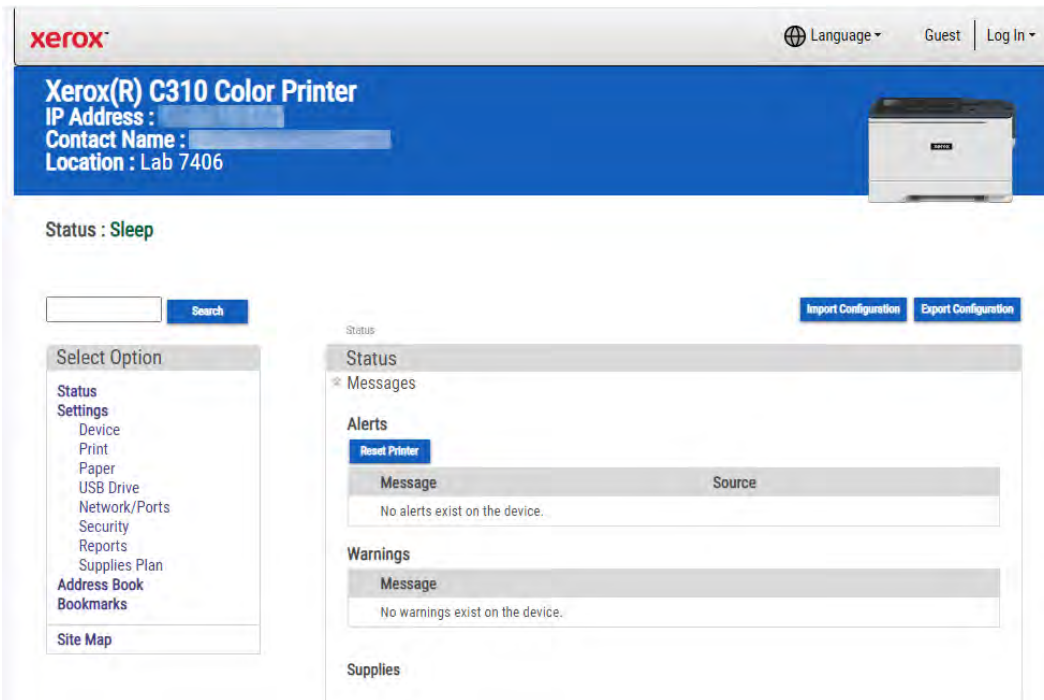

2. Click **Import Configuration**, and then click **Browse**.

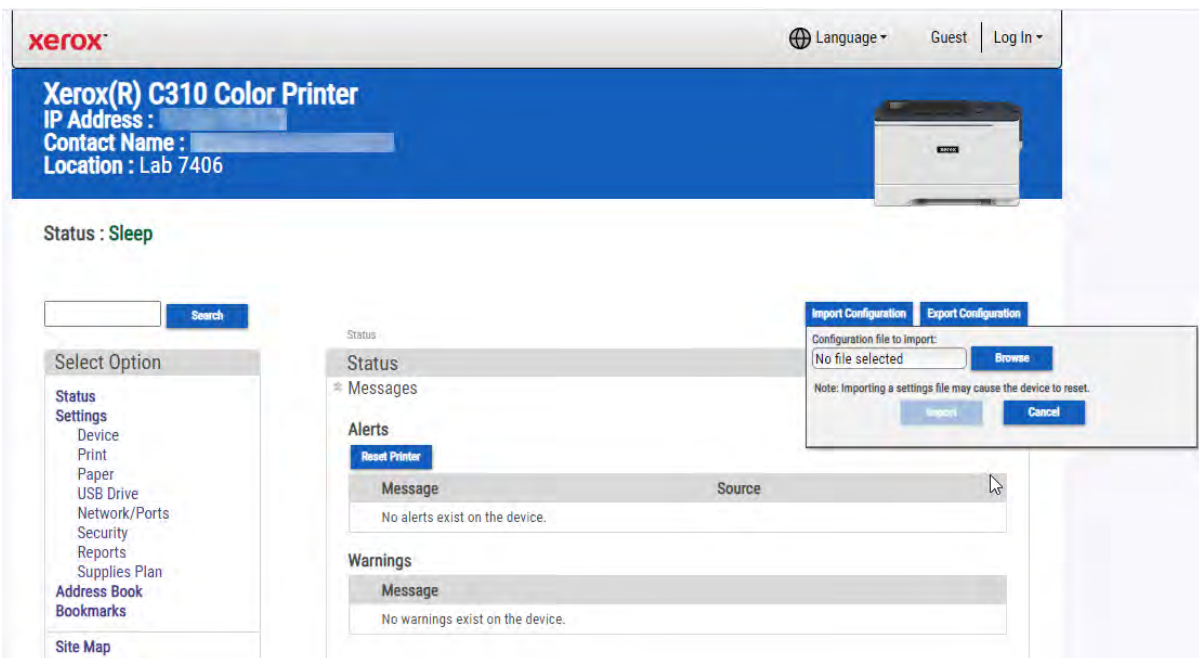

3. Navigate to the folder where the zip files are extracted from the Service Restore Tool.

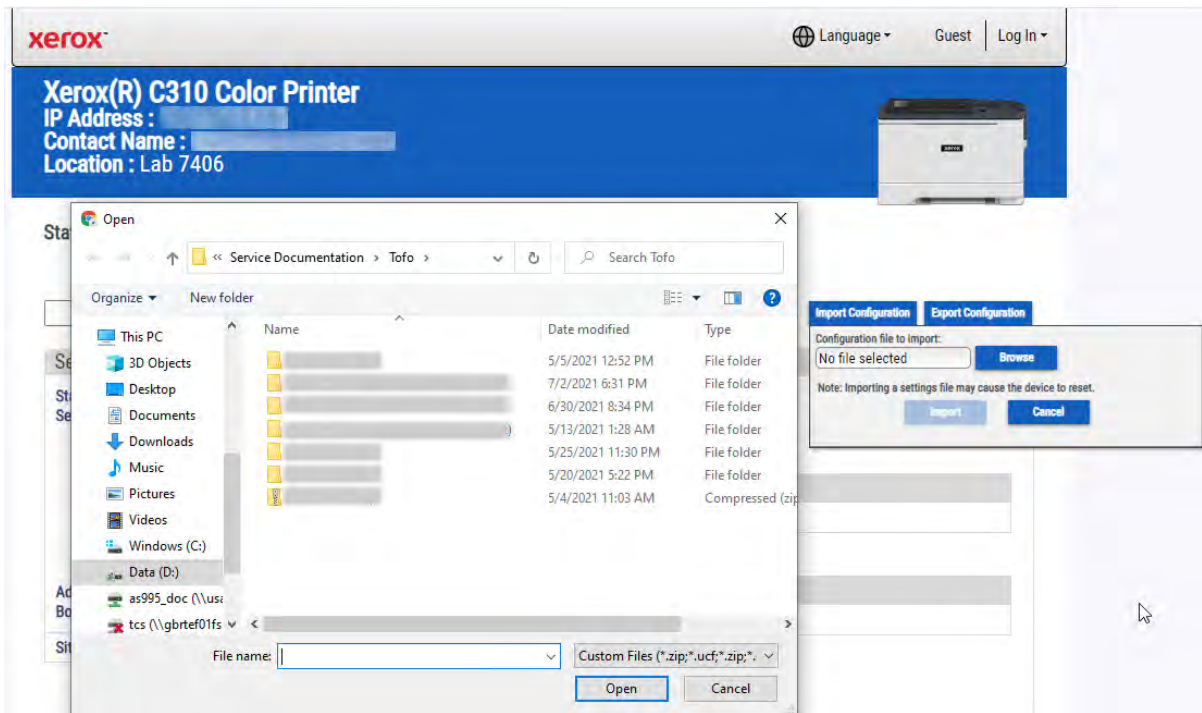

4. Select the file to import, and then click **Import**.
5. Repeat step 2 through step 4 for the other files that are included in the extracted zip file.

## Updating The Printer Firmware

**Warning:** Before updating the printer firmware, ask the next level of support for the correct code. Using an incorrect code level may damage the printer.

The printer must be in ready state to update the firmware.

### Using A Flash Drive

This procedure applies only to printer models with front USB support.

1. Insert the flash drive.  
The display shows the files on the flash drive.
2. Select the file that you need to flash.

**Note:** Do not turn off the printer while the update is going on.

## Using A Network Computer

### Using the File Transfer Protocol (FTP)

Make sure that the printer is in ready state before flashing.

1. Turn on the printer.
2. Obtain the IP address:
  - From the home screen
  - From the Network Overview section of the Network/Ports menu
3. From the command prompt of a network computer, open an FTP session to the printer IP address.
4. Use a PUT command to place the firmware file on the printer.  
The printer performs a POR sequence and terminates the FTP session.
5. Repeat step 2 through step 4 for the other files.

### Using the Embedded Web Server

Make sure that the printer is in ready state before flashing.

1. Open a web browser, and then type the printer IP address.
2. From the home page, navigate to **Settings > Device > Update Firmware**.
3. Select the file to use.  
The printer performs a POR sequence.
4. Repeat step 2 through step 4 for the other files.

## Disconnecting Ribbon Cables



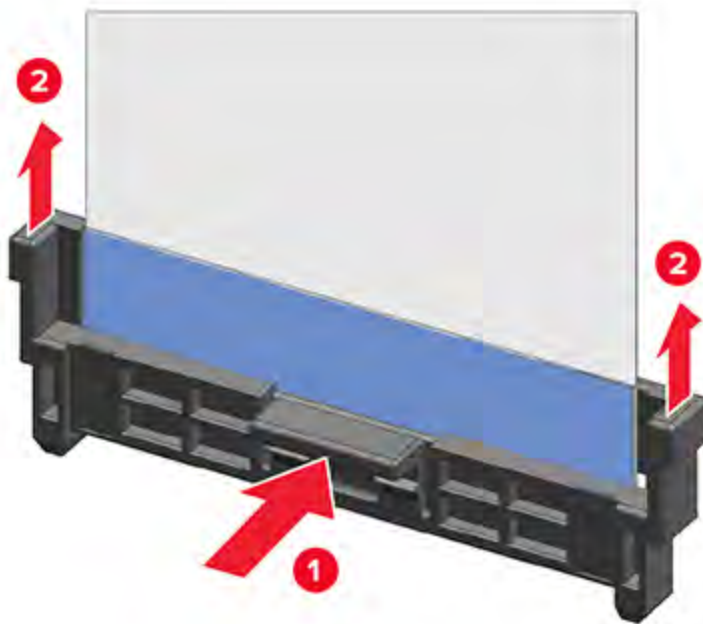

-  **Warning:** The ribbon cable and its socket may get damaged if it is not properly disconnected. When disconnecting the cable, hold its connector and press its tab before unplugging it.



## Ribbon Cable Connectors

### Zero Insertion Force (ZIF) Connectors

Zero Insertion Force (ZIF) connectors are used on the boards and cards used in this printer. Before inserting or removing a cable from these connectors, observe the following precautions.

-  **Warning:** Do not insert the cable so that the contacts are facing the locking actuator. The contacts always face away from the actuator.
-  **Warning:** Do not insert the cable diagonally into the ZIF socket. This action can damage the contacts on the cable.
-  **Warning:** Avoid using a fingernail, or sharp object to open the locking mechanism. This action can damage the cable.
-  **Warning:** Avoid pressing against the cable when opening the locking mechanism. This action can also damage the cable.

These are the types of ZIF connectors used in this printer:

- Horizontal top contact connector
- Horizontal bottom contact connector
- Vertical mount contact connector
- Horizontal sliding connector

## Horizontal Top Contact Connector

The horizontal top contact connector uses a back flip locking actuator to lock the ribbon cable into the Zero Insertion Force (ZIF) connector. The cable is inserted horizontally into the connector.

 **Warning:** When opening or closing this type of actuator, gently lift or close the two tabs located on each end of the actuator. The two tabs should be moved simultaneously. Do not close the actuator from the center of the actuator.

## Horizontal Bottom Contact Connector

The horizontal bottom contact connector uses a flip locking actuator to lock the ribbon cable into the Zero Insertion Force (ZIF) connector. The cable is inserted horizontally into the connector.

 **Warning:** When opening or closing this type of actuator, gently lift the center of the actuator using your finger. Do not use a fingernail or screwdriver to open the actuator. This can damage the ribbon cable. Do not close the actuator from the ends of the actuator.

## Vertical Mount Contact Connector

The vertical mount contact connector uses a back flip locking actuator to lock the ribbon cable into the Zero Insertion Force (ZIF) connector. The cable is inserted vertically into the connector.

 **Warning:** When opening or closing this type of actuator, gently lift the center of the actuator using your finger. Do not use a fingernail or screwdriver to open the actuator. This could damage the ribbon cable. Do not close the actuator from the ends of the actuator.

## Horizontal Sliding Contact Connector

The horizontal sliding contact connector uses a slide locking actuator to lock the ribbon cable into the Zero Insertion Force (ZIF) connector. The cable is inserted horizontally into the connector.

 **Warning:** When opening or closing this type of actuator, gently push or pull the two tabs located on each end of the actuator. Do not close the actuator from the center of the actuator. Do not use a screwdriver to open or close the actuator. Damage to the cable or connector could occur.

## Low Insertion Force (LIF) Connector

 **Warning:** When installing a cable into the LIF connector, make sure to avoid bending the edges of the cables and damaging the contacts on the cables.

# Adjustments

## Registration Adjustment

Image misalignments can occur after printhead replacement. Perform this procedure to correct the position of the image relative to the paper edges.



**Note:** You cannot perform mechanical registration or skew adjustments on this printhead.

Before performing the procedure, make sure that the tray guides are properly set and the paper settings on the printer match the paper size loaded in the tray.

## Adjusting The Skew

The skew adjustment changes the angle of the horizontal lines so that the lines can be aligned with the leading edge of the page. As the skew setting is changed, the top line on the test page stays in place at the left end, while its right end tilts up or down. All horizontal lines on the page will tilt at that same angle while the vertical lines will remain vertical. Changing the skew setting moves the right edge of the page up and down, and changes the angle of the top and bottom lines. If the skew is properly adjusted, the horizontal lines at the top of the page will be parallel to the leading edge of the page.

To check for skew:

1. Enter the Diagnostics menu, and then navigate to:  
**Printer diagnostics & adjustments > Registration adjust**



2. Select **Quick Test**, and then press **OK** or touch **Start**.

The printer prints a test page.

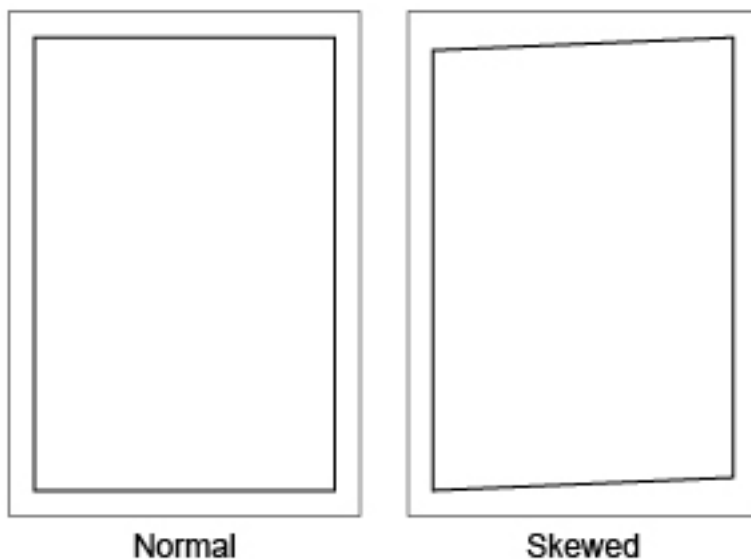

 **Note:** If there is no skew on the page, then go to Adjusting the margins. See [Registration adjustment](#).

To adjust the skew:

1. Enter the Diagnostics menu, and then navigate to:  
**Printer diagnostics & adjustments > Registration adjust > Skew**
2. Specify the value. The value range is from -100 to 100.

 **Note:**

- Raising the value of the skew rotates the horizontal lines clockwise. The left end of the line remains in the same place and the right end moves downward.
  - Decreasing the value of the skew rotates the horizontal lines counterclockwise. The left end of the line remains in the same place and the right end moves upward.
3. Select **OK**.
  4. Print a Quick test page to verify the change.
  5. Repeat steps 1 to 4 until the horizontal line is properly aligned with the leading edge of the page.
  6. Check for proper margin alignment. See [Registration adjustment](#).

## Adjusting The Margins

To check for proper margin alignment:

1. Enter the Diagnostics menu, and then navigate to:  
**Printer diagnostics & adjustments > Registration adjust**
2. Select **Quick Test**, and then press **OK** or touch **Start**.  
The printer prints a test page.
3. Check the top and bottom margins of the test page for proper alignment.

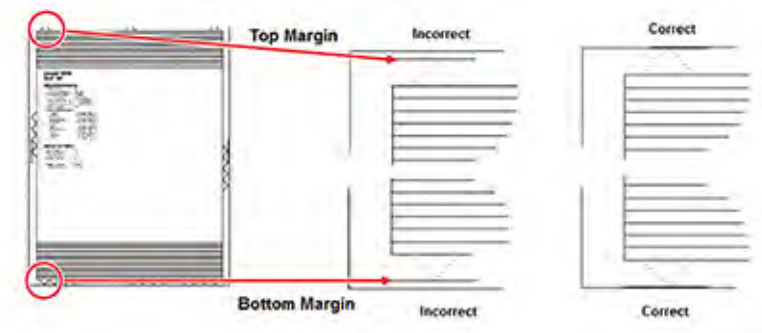

To adjust the margins:

1. Refer to the test page, and then check the arrows along the margins.

 **Note:**

- The arrows should be completely visible along the edges.
- The tip of the arrows should point to the edges of the paper.

2. Enter the Diagnostics menu, and then navigate to:  
**Printer diagnostics & adjustments > Registration adjust**
3. Select the field of the margin to adjust.
4. Specify value. The value range is from -80 to 80.

 **Note:**

- Raising the value of the top margin setting pushes the top edge of the image downward.
  - Raising the value of the bottom margin setting pushes the bottom edge of the image upward.
  - Raising the value of the left margin setting pushes the left margin to the right.
  - Raising the value of the right margin setting pushes the right margin to the left.
5. Select **OK**.
  6. Print a Quick test page to verify the change.
  7. Repeat step 3 through step 6 until the margins are properly adjusted.
  8. Check for proper color alignment. See [Registration adjustment](#).

## Adjusting The Color Alignment

1. Enter the Diagnostics menu, and then navigate to:

**Printer diagnostics & adjustments > Color alignment adjust**

On the AA Adjustment row, press **OK** or touch **Start**.



**Note:** The Color alignment procedure is performed on the cyan, magenta, and yellow colors.

2. Enter the Diagnostics menu, and then navigate to:

**Printer diagnostics & adjustments > Color alignment adjust > Cyan > Quick test**

Check the alignment markings on the test page generated. Follow the instructions on the test page to correct the color misalignment.

3. Enter the Diagnostics menu, and then navigate to:

**Printer diagnostics & adjustments > Color alignment adjust > Yellow > Quick test**

Check the alignment markings on the test page generated. Follow the instructions on the test page to correct the color misalignment.

4. Enter the Diagnostics menu, and then navigate to:

**Printer diagnostics & adjustments > Color alignment adjust > Magenta > Quick test**

Check the alignment markings on the test page generated. Follow the instructions on the test page to correct the color misalignment.

5. If color misalignment still occurs, then repeat step 1 through step 4.

## Entering The TPS Characterization Data

After installing the new left or right TPS, access the Diagnostics menu to enter the 40-character string for the left or right sensor.

To enter the Diagnostics menu:

- Press **\*\*36**.

### For 2.4-inch Control Panel

1. Enter the Diagnostics menu, and then navigate to:

**Printer setup > EP setup > Toner patch sensor adjust**

2. Select **Right TPS calibration data** or **Left TPS calibration data**, and then press **OK**.

3. Press the backspace button to clear the field.

4. Enter the 40-character string for the sensor, and then press **OK**.

## Removal Procedures

Keep the following tips in mind as you replace parts:

- Some removal procedures require removing cable ties. You must replace cable ties during reassembly to avoid pinching wires, obstructing the paper path, or restricting mechanical movement.
- Remove the toner cartridges, imaging kit, and trays before removing other printer parts. The imaging kit must be carefully set on a clean, smooth, and flat surface. It must also be protected from light while out of the printer.
- Disconnect all external cables from the printer to prevent possible damage during service.
- Unless otherwise stated, reinstall the parts in reverse order of removal.
- When reinstalling a part held with several screws, start all screws before the final tightening.
- For printers that have a soft power switch, make sure to unplug the power cord after powering off.

## Left Side Removals

### Left Cover Removal

1. Remove the tray insert.
2. Position the printer with the left side hanging over the edge of the table.
3. Remove the three screws (A).

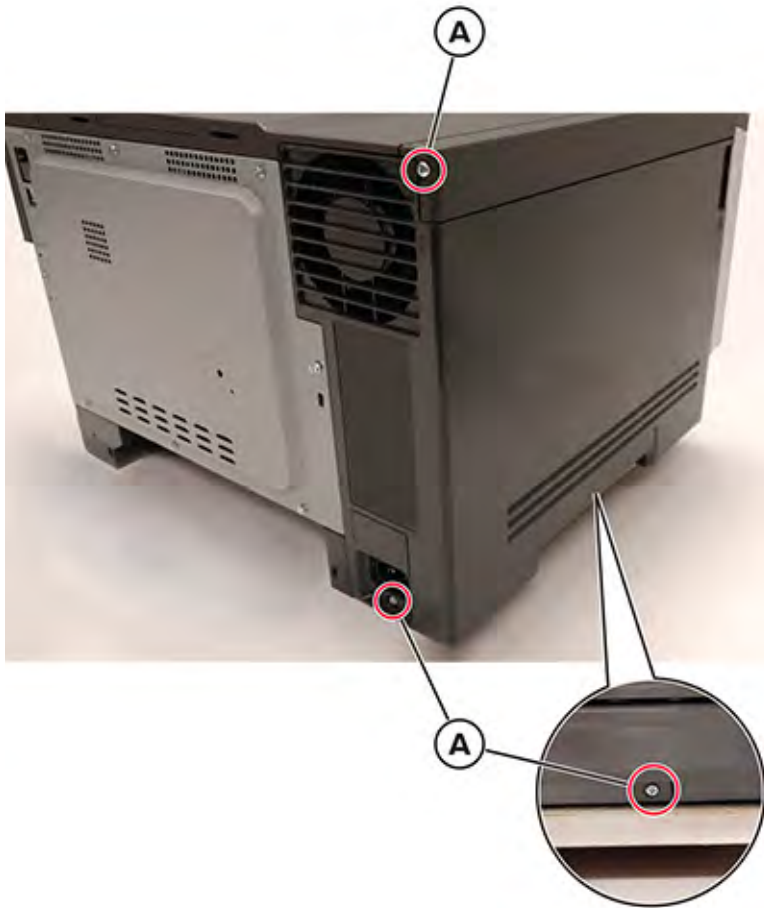

## Parts Removal

4. Flex the cover slightly to unlatch the front bottom corner tab (B), and then remove the cover.

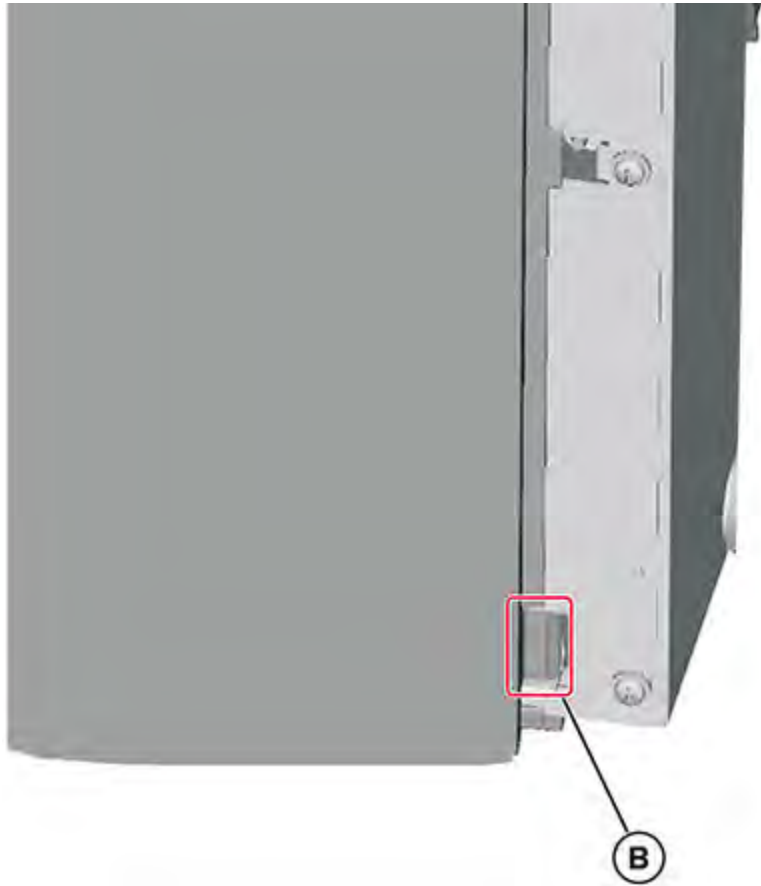

 **Note:** Installation note: When replacing the left cover, slightly flex the cover to engage the tab.

## Motor (drive Unit) Removal

 **Note:** The EP motors must be replaced in pairs.

1. Remove the left cover. See [Left cover removal](#).

2. Disconnect the cable (A), remove the four screws (B), and then remove the motor.

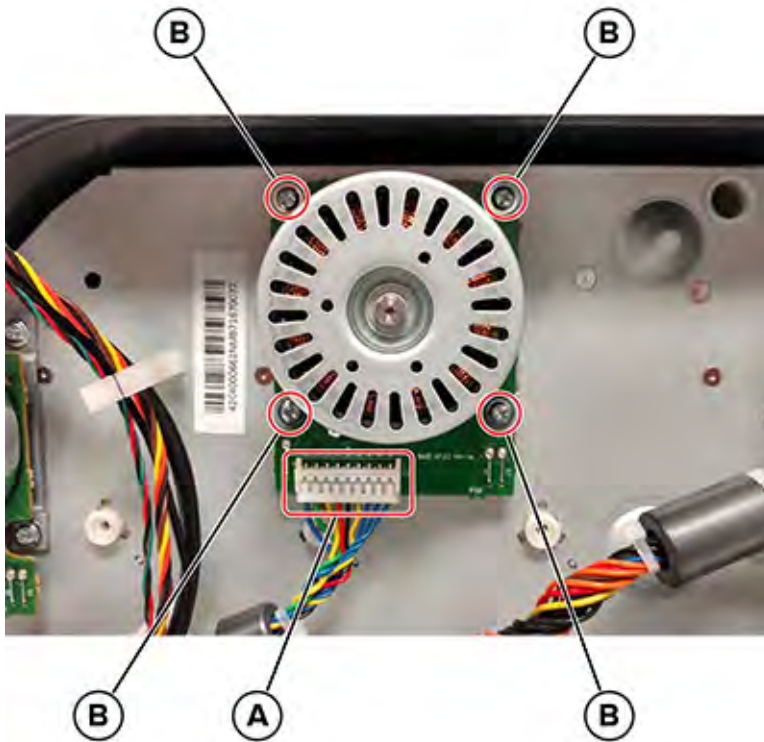

## EP Drive Assembly Removal

1. Remove the left cover. See [Left cover removal](#).
2. Remove the transfer module. See [Transfer module removal](#).

## Parts Removal

3. Disconnect the cable (A).

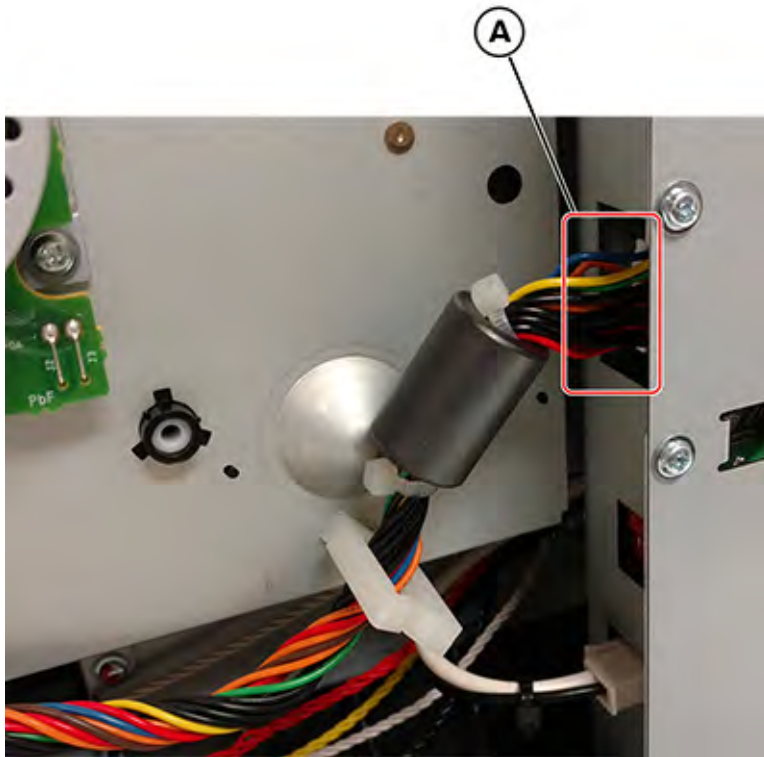

4. Disconnect the two cables from the motor (drive unit).
5. Remove the cables from the clips on the EP drive assembly, and then remove the two screws (B).

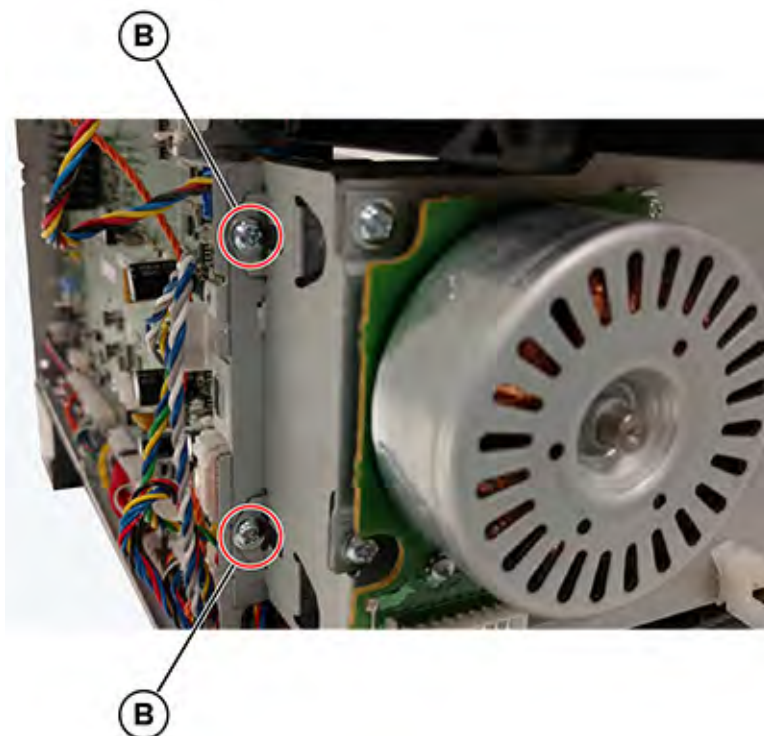



6. Remove the screw (C).

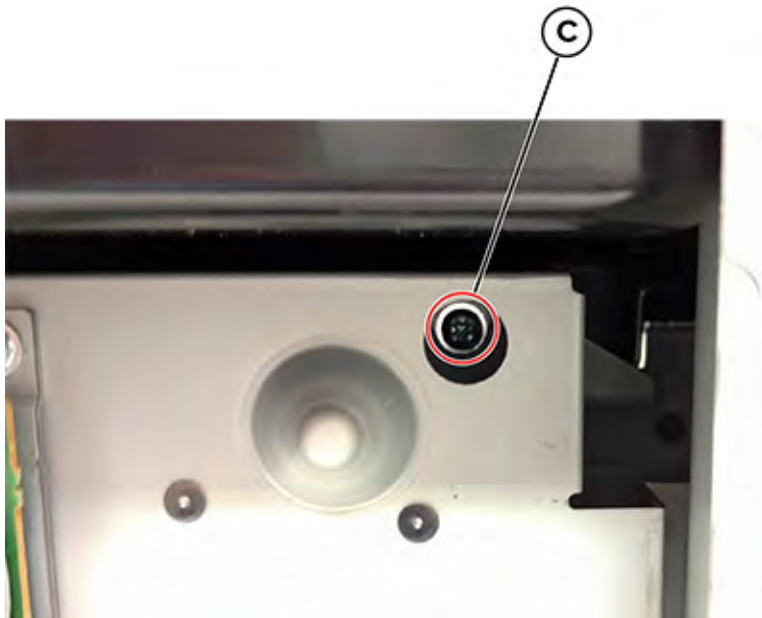

7. Remove the two screws (D).

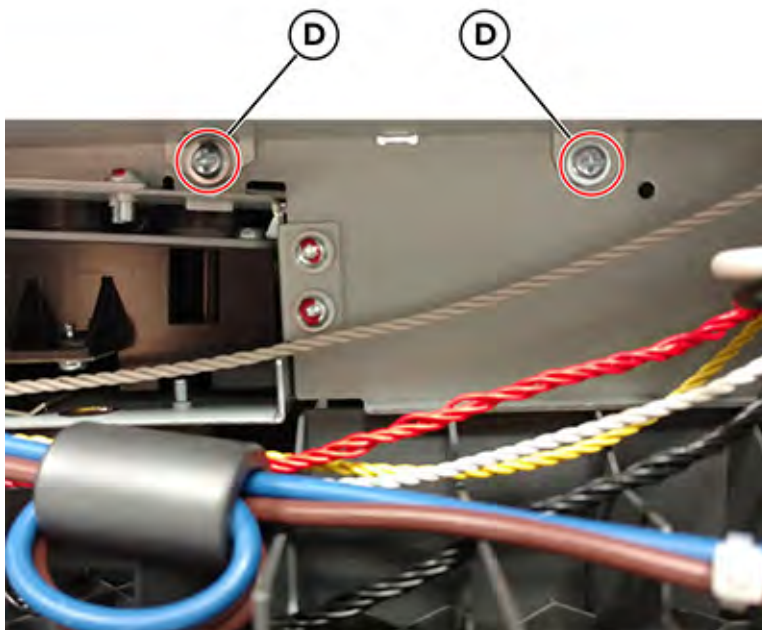

## Parts Removal

8. Remove the EP drive assembly.



## LVPS Removal

1. Turn off the printer, and then unplug the power cord.
2. Remove the left cover. See [Left cover removal](#).
3. Disconnect the three cables (A).

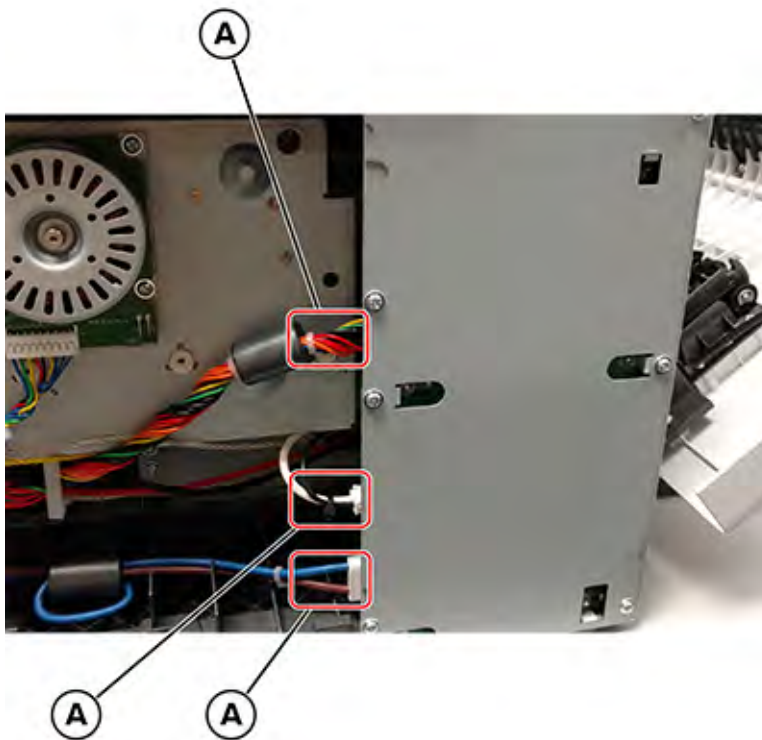

- Remove the seven screws (B), and then remove the LVPS.

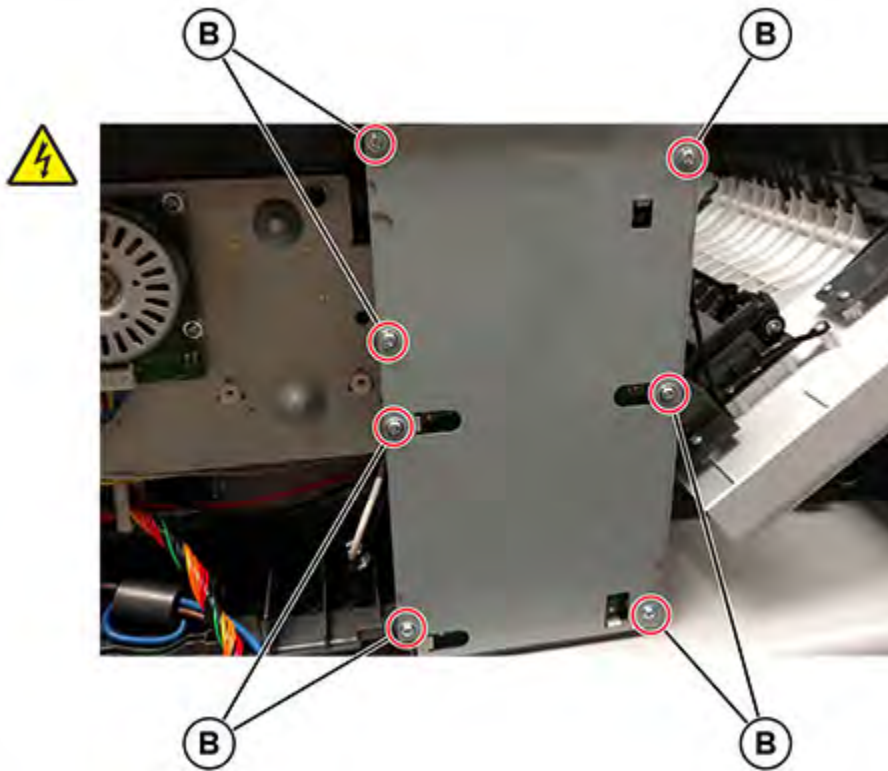

- Warning:** Make sure to set the switch (C) to the correct setting for your voltage requirements before installing the LVPS. The switch can be set to either 115V or 230V.

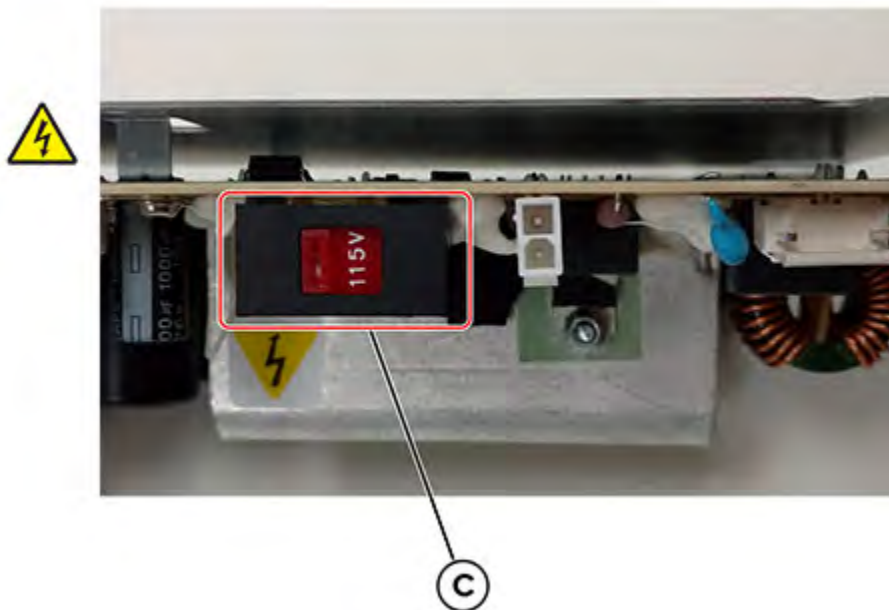

## Sensor (Fuser Exit) Removal

1. Remove the left cover. See [Left cover removal](#).
2. Press to release the tabs (A), and then rotate the deflector to remove.

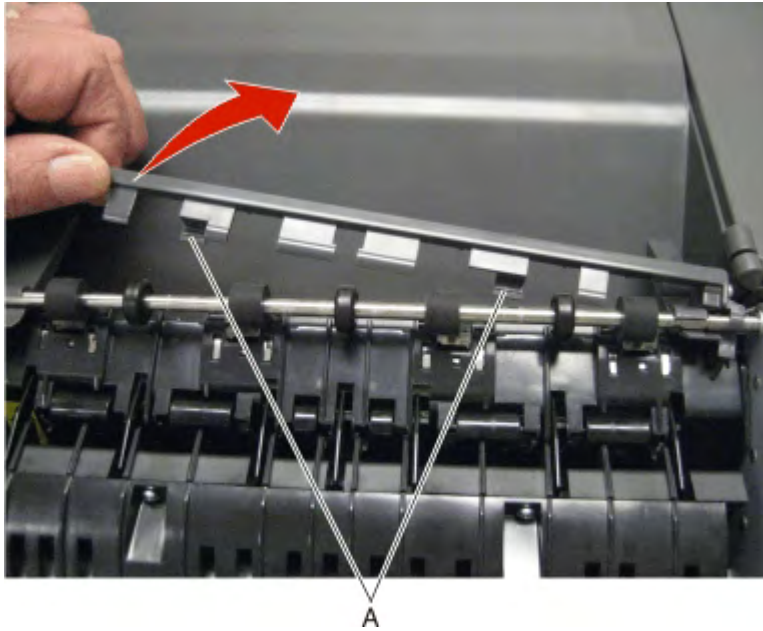

3. Remove the cable from its retainer (B).

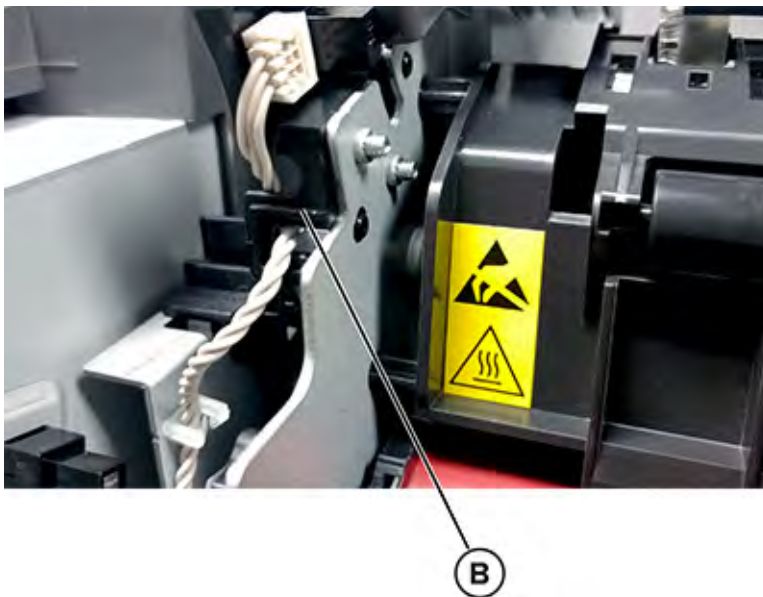

4. Disconnect the cable (C).

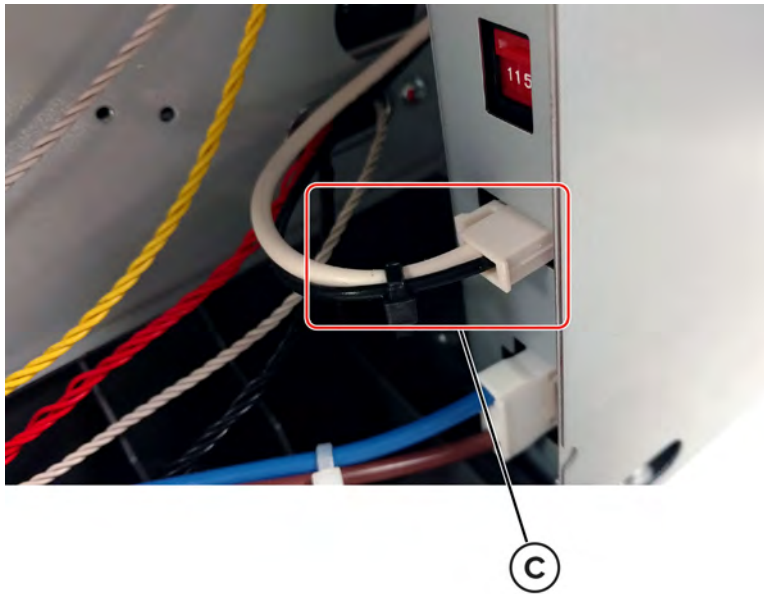

5. Disconnect the cable (D).

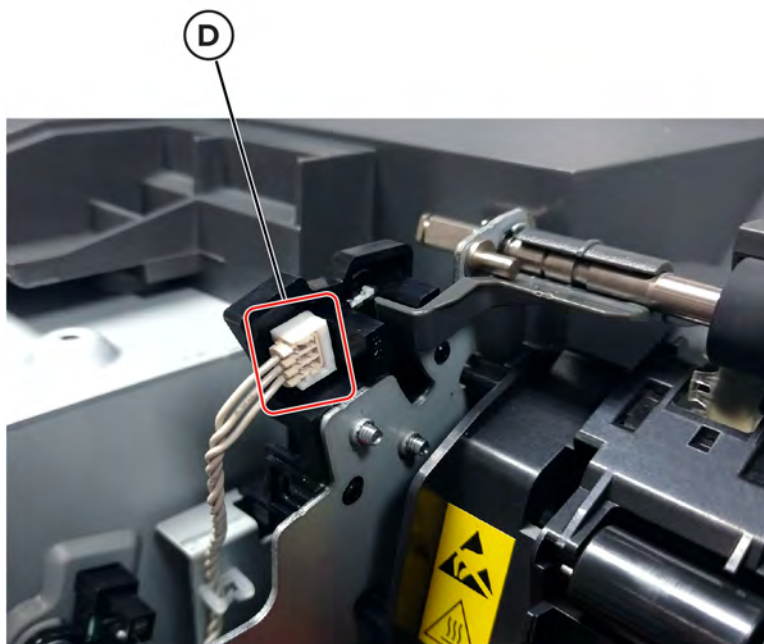



## Parts Removal

6. Unhook the two springs (E) from both sides of the fuser.

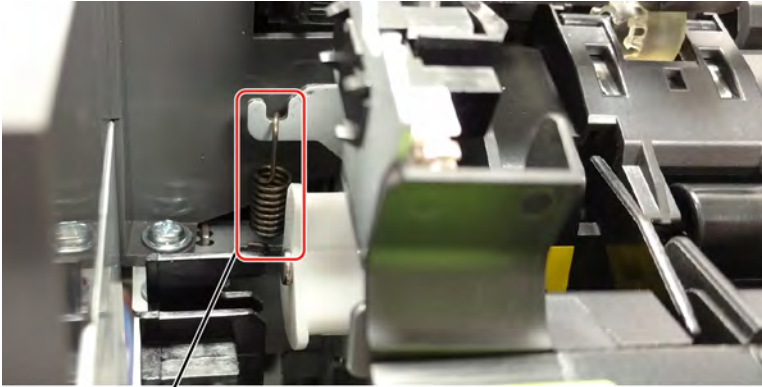

E

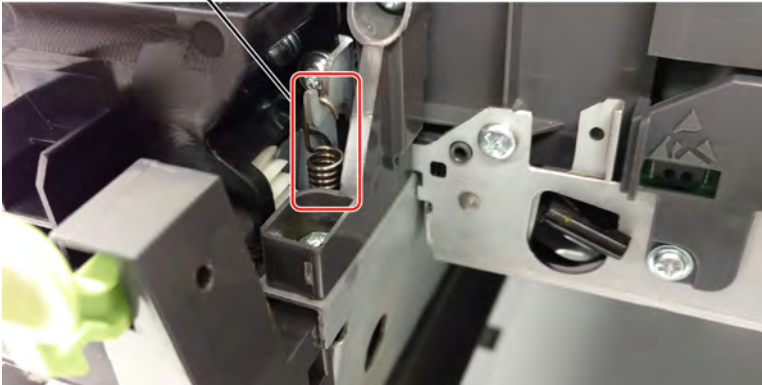

7. Disconnect the two thermistor cables (F), and then remove the screw (G).

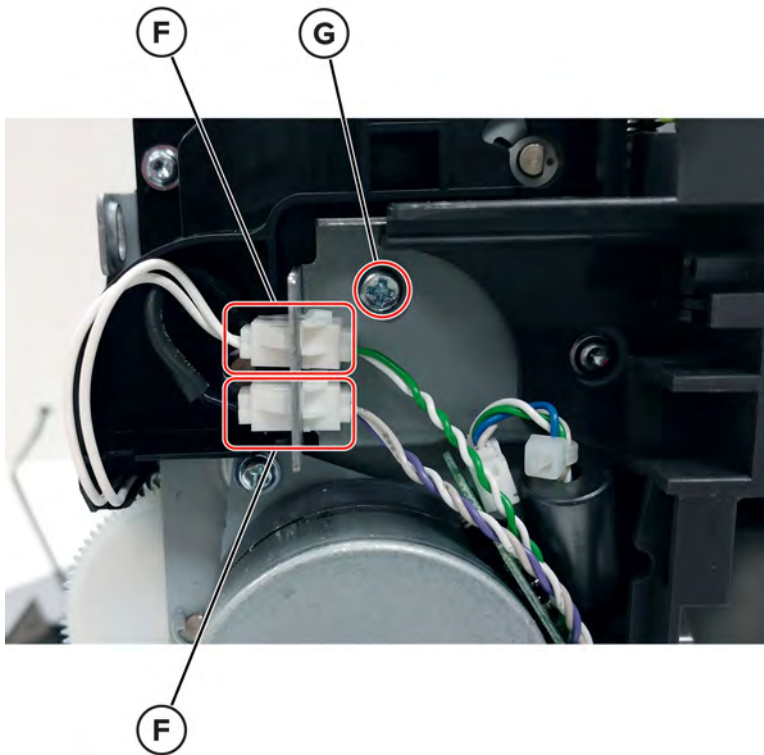

8. If the printer is an MFP, then remove the belt (H) from the pulley.

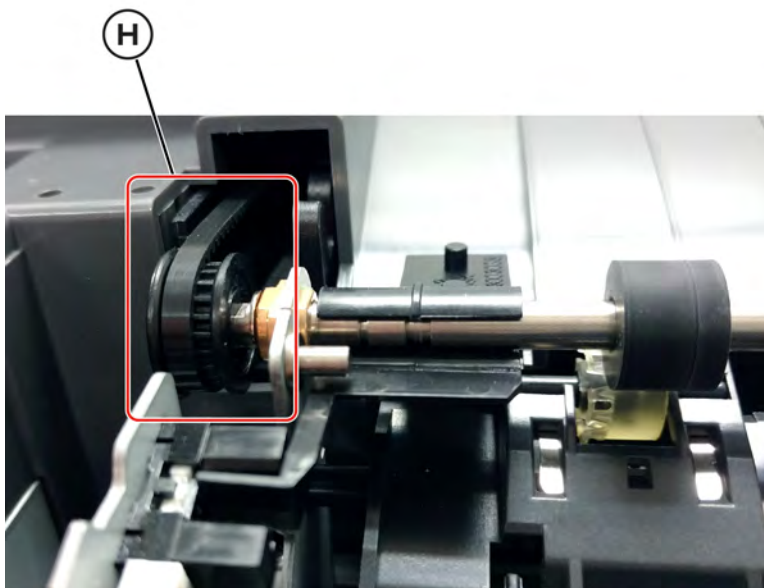

## Parts Removal

9. Rotate the fuser toward the front, disconnect the cable (I), and then remove the screw (J).

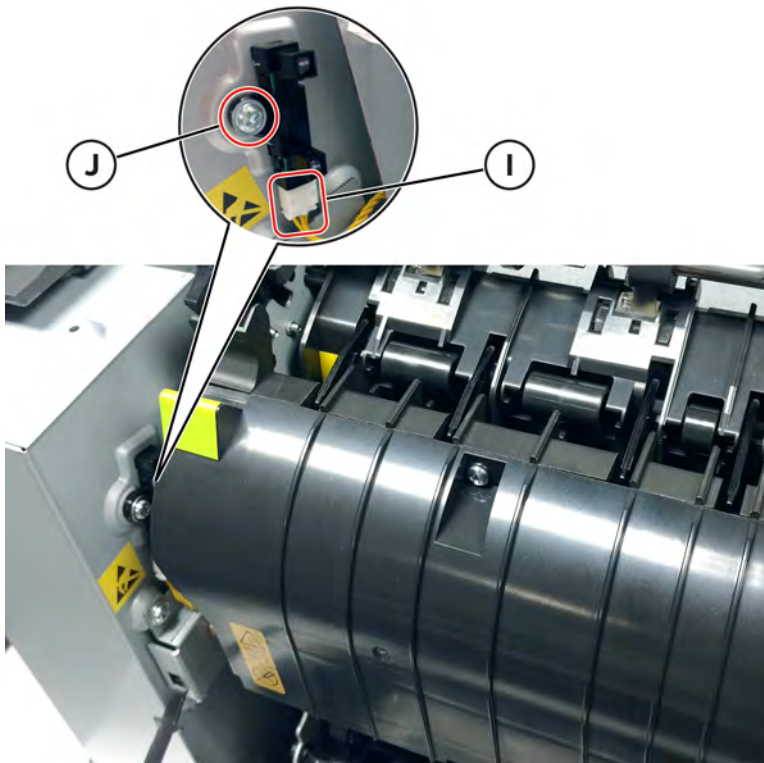

10. Using a flat-head screwdriver, remove the lower end of the sensor, and then gently pull the sensor from the frame.

## Speaker Removal

1. Remove the control panel top cover. See [2.4-inch Control Panel Top Cover Removal](#).



2. Disconnect the cable (A), remove the two screws (B), and then remove the speaker.

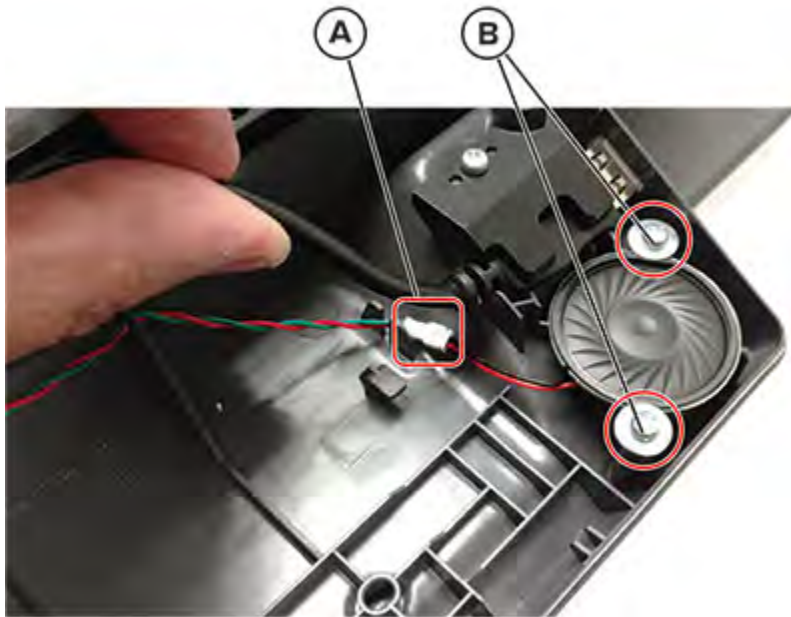

## Right Side Removals

### Right Cover Removal

1. Open the toner supply door.
2. Open the front door.
3. Release the latches (A), and then remove the cover.



### Toner Supply Door Removal

1. Open the toner supply door.

2. Remove the screw (A), and then remove the door.



## Motor (Fuser Drive) Removal

1. Remove the right cover. See [Right cover removal](#).
2. Disconnect the cable (A).

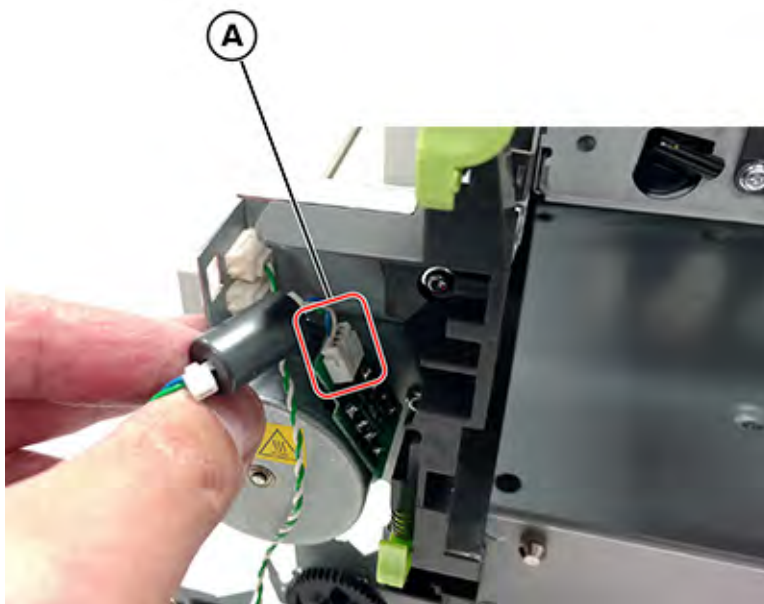

## Parts Removal

3. Remove the two screws (B), and then remove the motor.

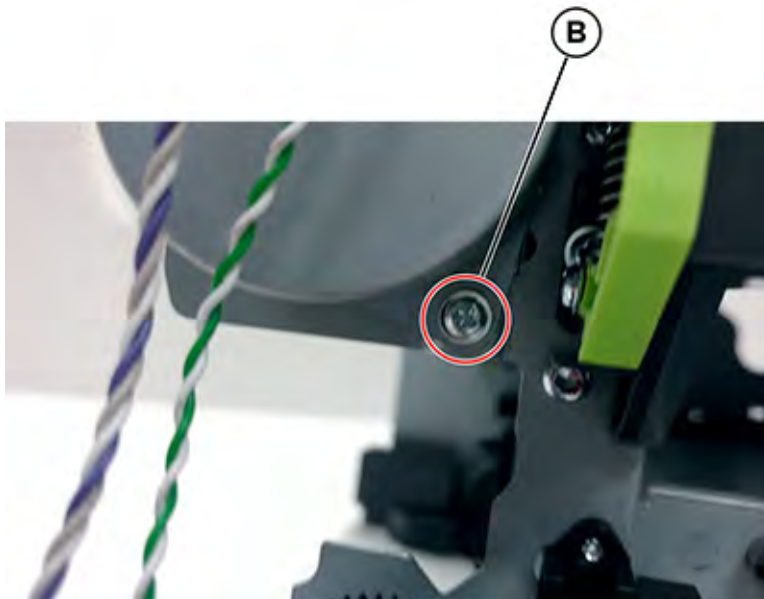
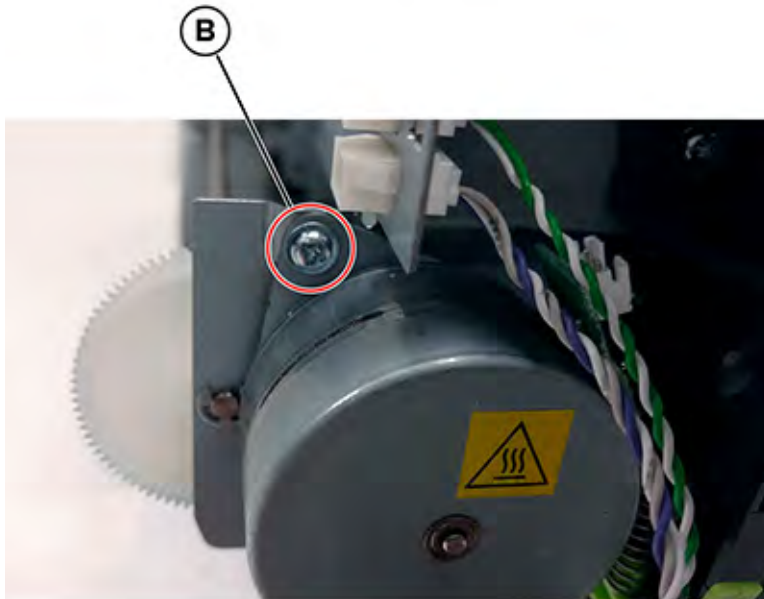

## TMC Card Removal

1. Remove the imaging kit. See [Imaging kit removal](#).
2. Remove the rear cover. See [Rear cover removal](#).

3. Disconnect the cable (A), and then push the TMC card cable through the frame opening.

 **Note:** Pay attention to the cable routing.

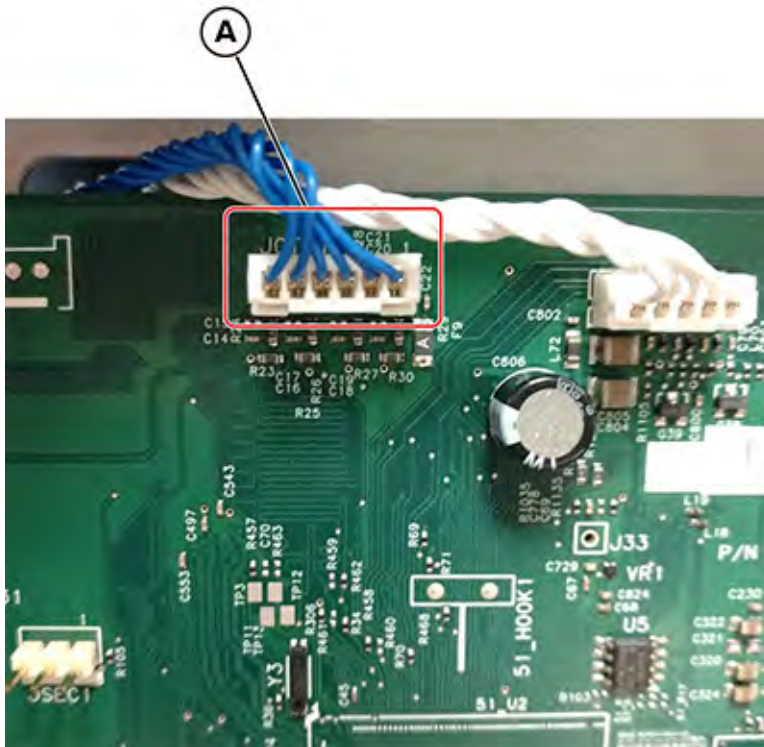

4. Remove the four screws (B).

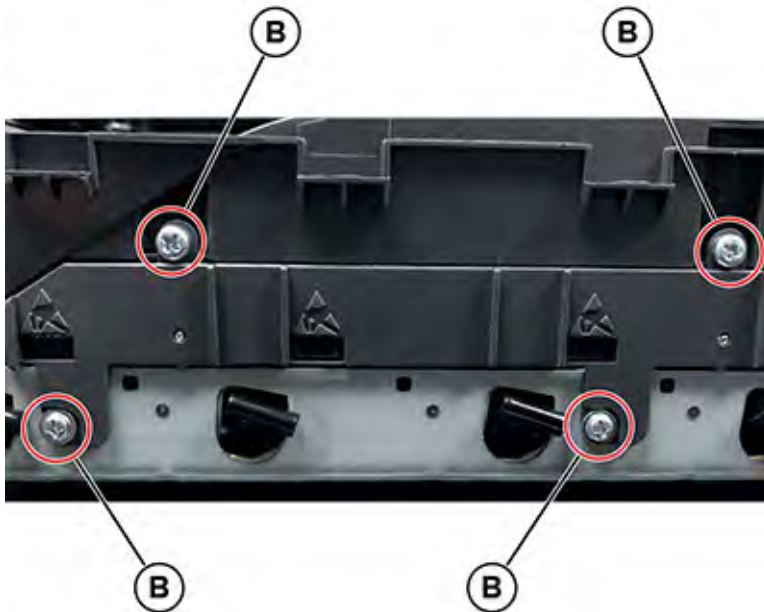



## Parts Removal

5. Insert a flat-head screwdriver into the left side of the frame, and then pry the card loose to remove it.



### Installation notes:

- Make sure to run the cable (C) through the retainer.

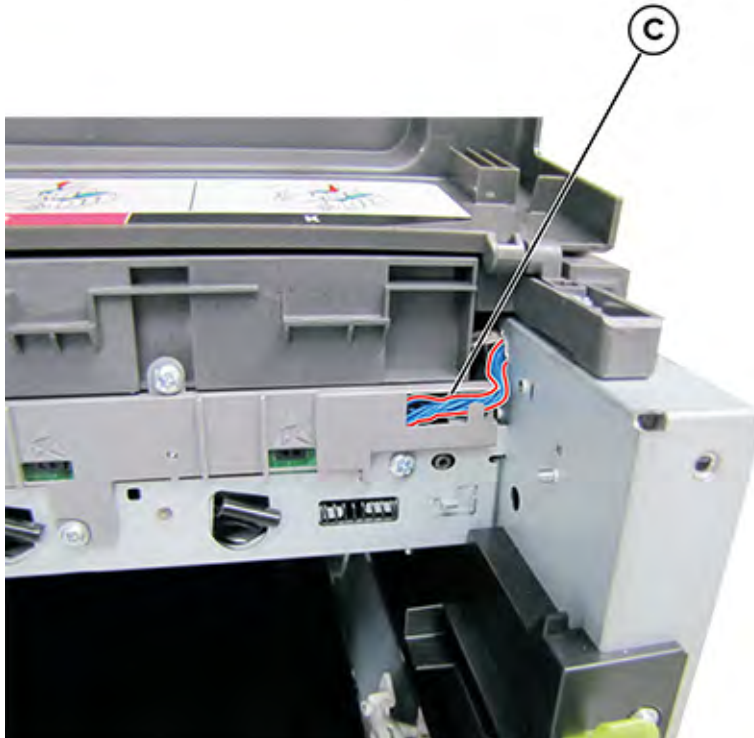

- The TMC card is a tight fit. Insert the bottom edge inside the frame first, and then push down on the top edge to clear the top cover.

## Sensors (Toner Patch) Removal

 **Note:** The left and right sensors are separate FRUs.

1. Remove the transfer module. See [Transfer module removal](#).
2. Remove the rear cover. See [Rear cover removal](#).
3. Disconnect the three cables (A) from the controller board.

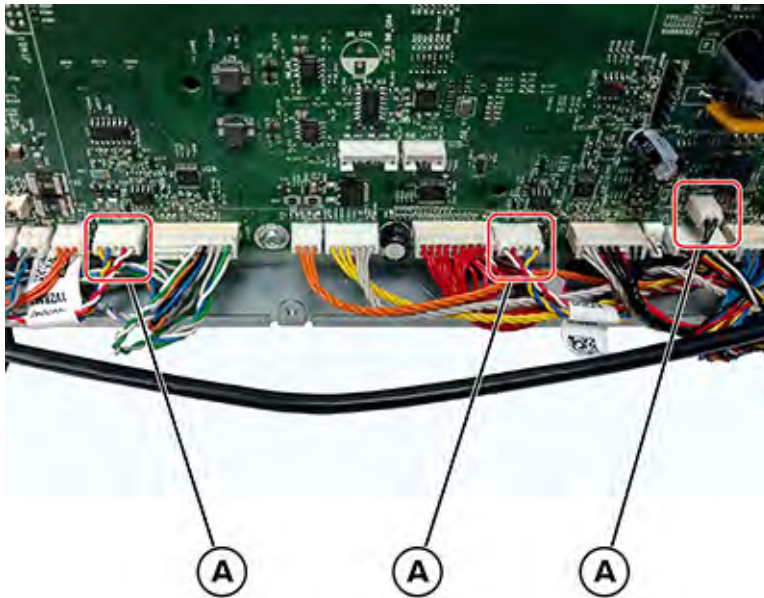

 **Note:**

- If you are removing the sensor (right toner patch), then disconnect the JTPS1 cable on the controller board.
  - If you are removing the sensor (left toner patch), then disconnect the JTPS2 cable on the controller board.
  - Pay attention to the cable routing.
4. Remove the screws at the bottom of the controller board to provide clearance for the cables.

## Parts Removal

5. Remove the two screws (B) from the left or right sensors.

 **Note:** Only remove the screws from the sensor to be replaced.

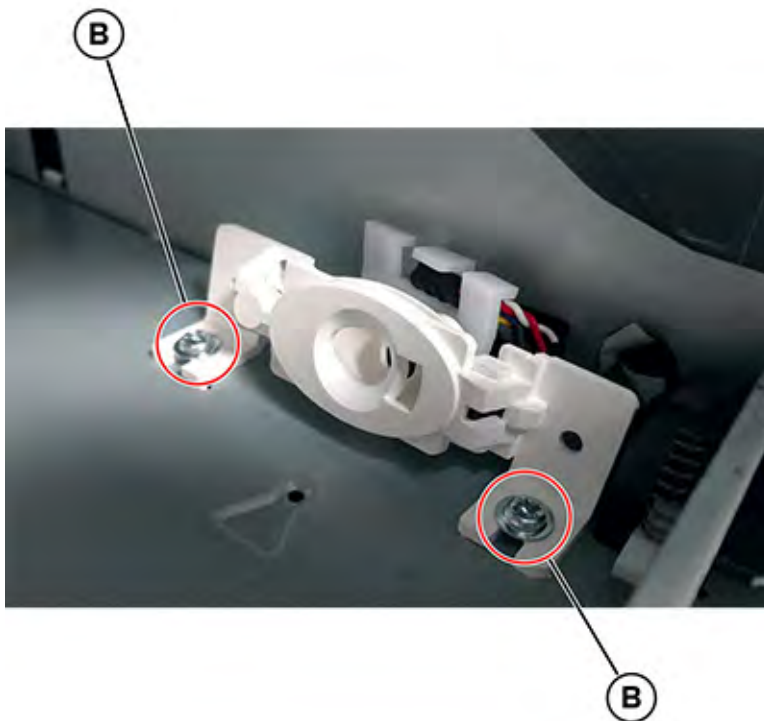
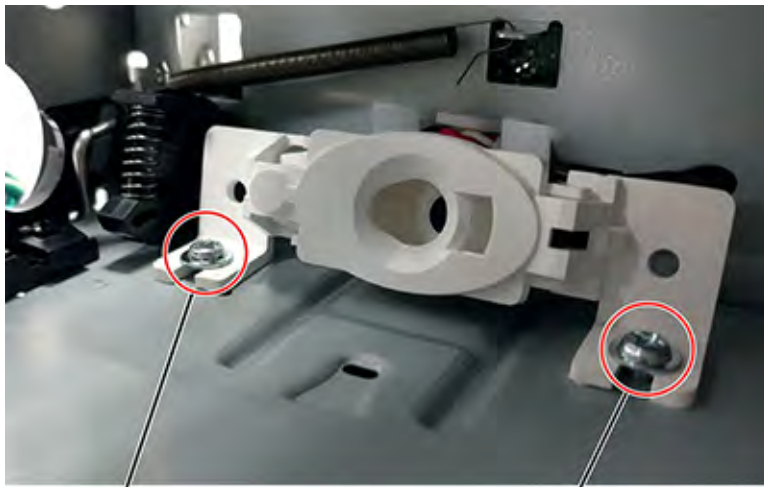

6. Remove the sensor while carefully routing the cables through the rear of the controller board cage.

 **Note:** Installation note: After installing the new sensors, make sure to enter the TPS characterization data. See [Entering the TPS characterization data](#) .



## Developer Unit Removal

 **Note:** The developer units are not FRUs.

1. Open the toner access door.
2. Remove the toner cartridges.

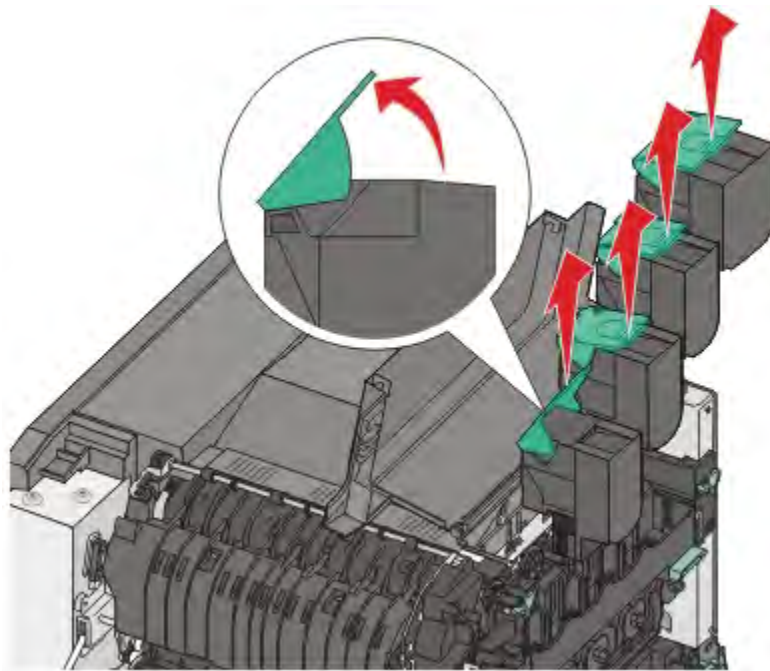

3. Remove the imaging kit. See [Imaging kit removal](#).

 **Warning:** Do not touch the underside of the imaging kit.

## Parts Removal

4. Remove the developer unit.

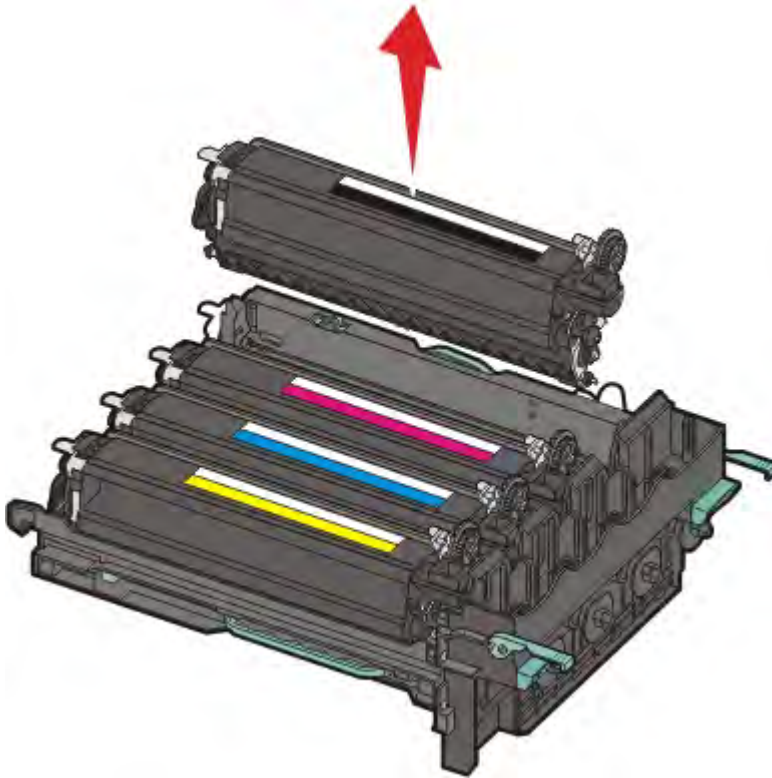

## HVPS Removal

1. Turn off the printer, and then unplug the power cord.
2. Remove the rear cover. See [Rear cover removal](#).
3. Remove the cable cover (A), and then disconnect the HVPS cable (B).

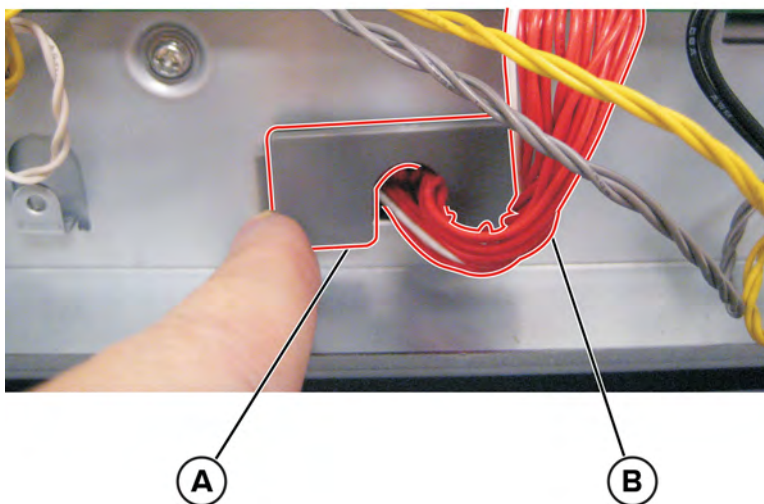

4. Tuck the HVPS cable in.



5. Remove the transfer module. See [Transfer module removal](#).
6. Remove the screw (C).

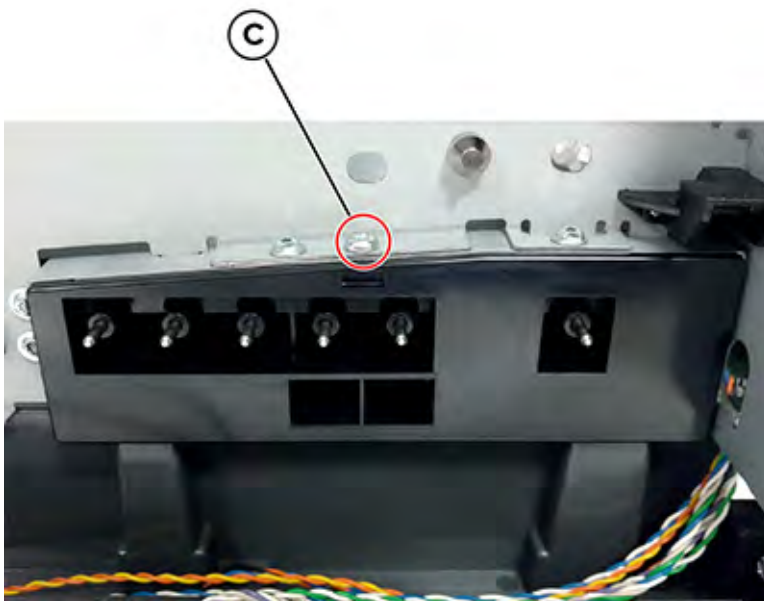

7. Remove the left cover. See [Left cover removal](#).

## Parts Removal

8. Press down and hold the three transfer module contacts.



9. While pressing down on the contacts, press down on the spring mount, and then carefully slide out the HVPS by pulling from one side and pushing from the other.

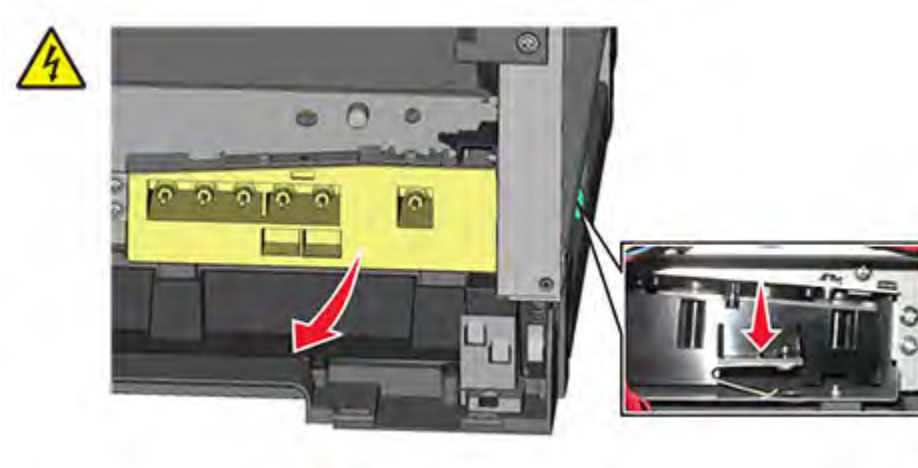

10. Release the pressure on the spring mount, and then pull and slide out the HVPS to remove it.
11. Disconnect the cable (D) from the HVPS board.

 **Warning:** After disconnecting the HVPS cable from the controller board, make sure that the HVPS connector is not damaged.

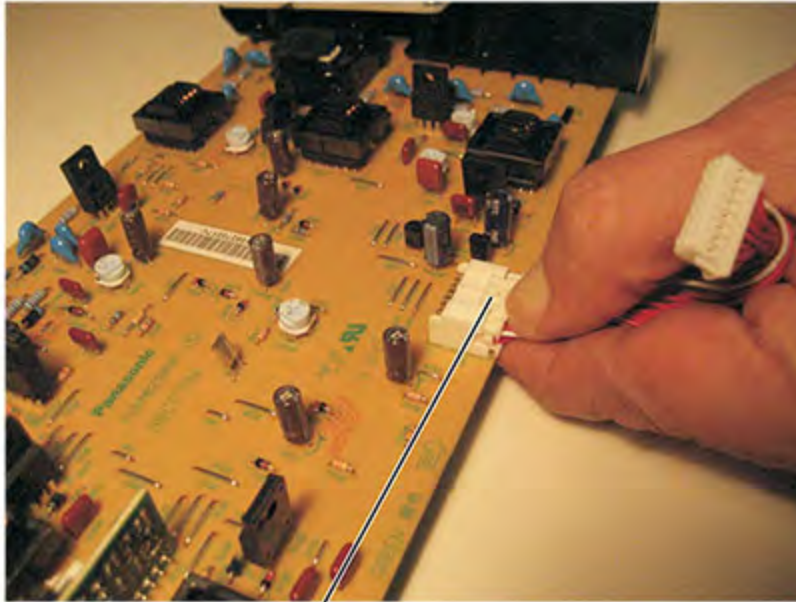

D

**Installation notes:**

- a. To install the new HVPS board, insert the spring end of the HVPS board while compressing the spring.





## Parts Removal

- b. Hold the HVPS on both sides, and then slide the it into position.

 **Warning:** Do not flex the HVPS board, and do not let it touch the cage.



- c. Hold the HVPS below the contacts, and then slide it in.



- d. Check the position of the card at the left side of the printer. The small vertical post (E) in the endcap has to be positioned in the hole above it.

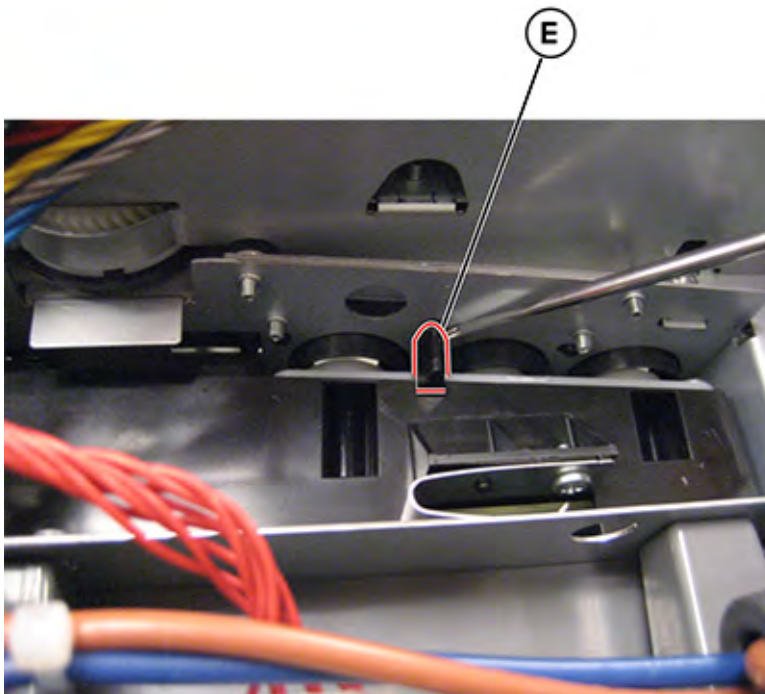

- e. Install the new cable, making sure the connector to the board is locked into position.

 **Note:** Reinstall the screw to hold the HVPS to the right side of the printer.

## Transfer Module Removal

 **Note:** For a video demonstration, see [Transfer module removal](#).

1. Remove the right cover. See [Right cover removal](#).
2. Remove the waste toner bottle. See [Waste toner bottle removal](#).
3. Remove the imaging kit. See [Imaging kit removal](#).

## Parts Removal

4. Disconnect the spring (A) on the right side.

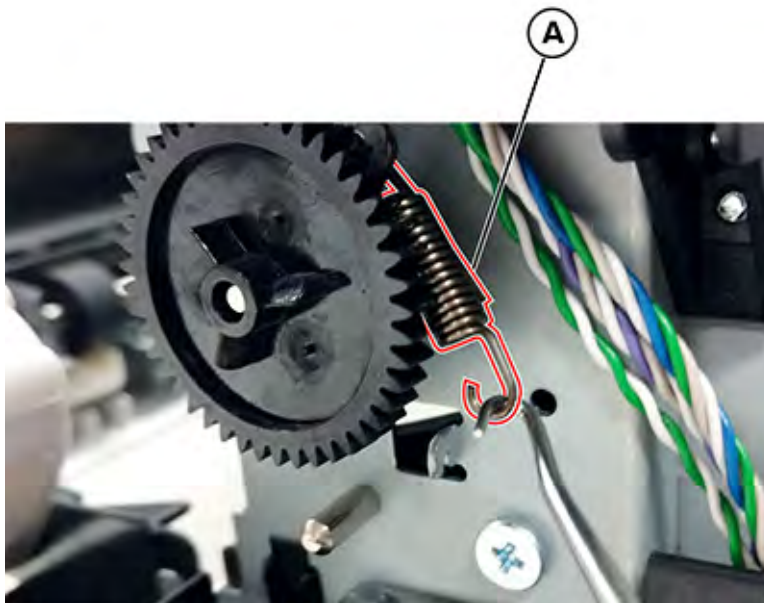

5. Release the left and right door straps (B).

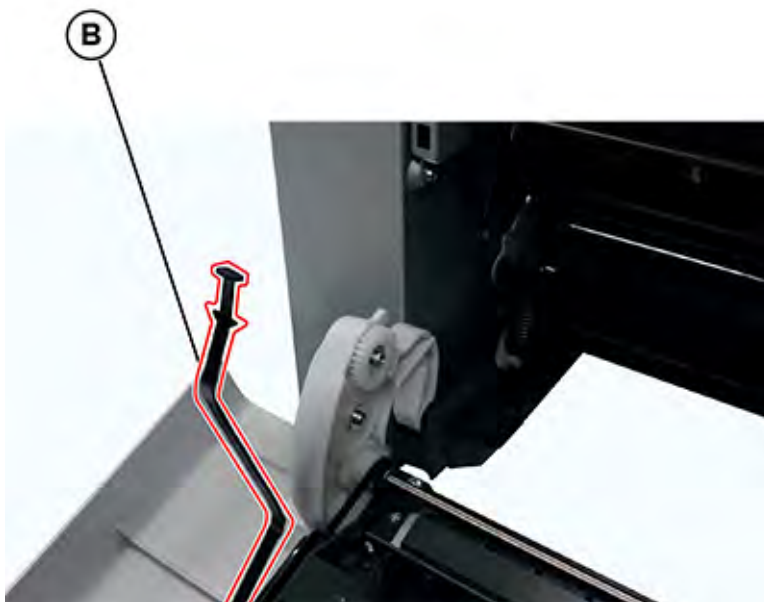



6. Disconnect the spring (C).

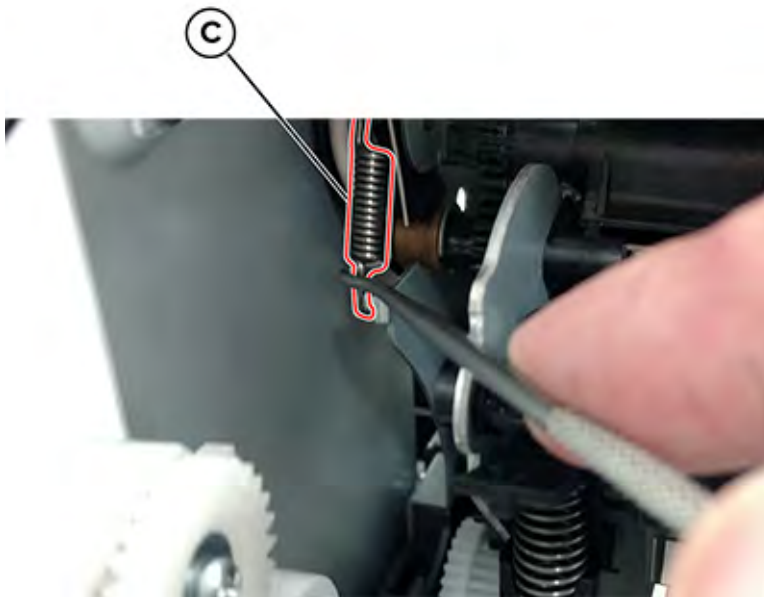

7. Raise the cam (D) and spring (E).

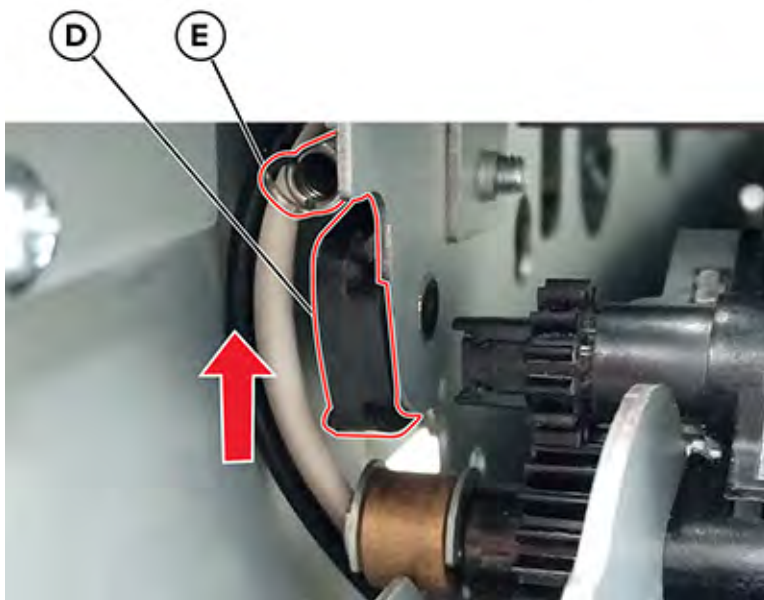

## Parts Removal

- Place the tip of a flat-head screwdriver in between the release lever (F) and the frame, and then rotate the screwdriver to rotate the release lever and decouple the transfer module while pulling it toward the front.

 **Warning:** Make sure that the lever is in the fully released position before removing the transfer module.

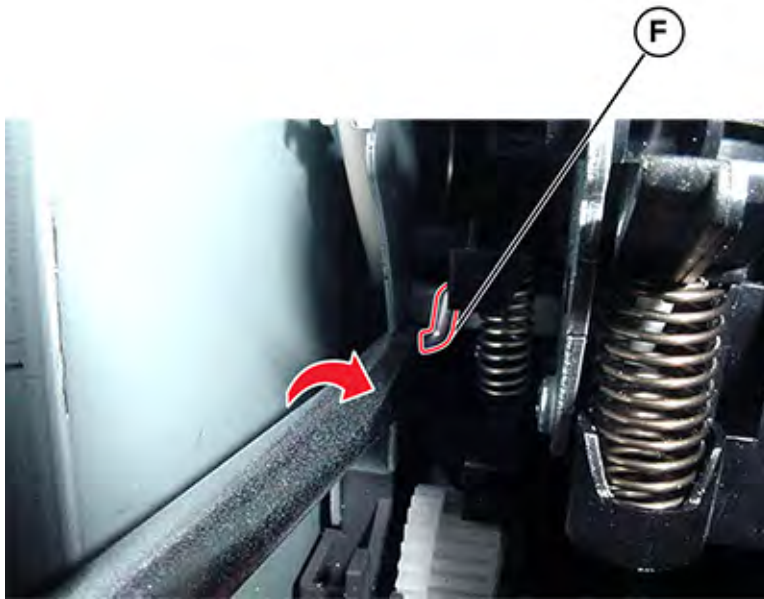

- Hold the release lever as you pull out the transfer module for the first four inches (100mm). A quick and firm pull should overcome the latch at this point.
- Remove the transfer module.



## Installation notes:

1. Do not rotate the release lever again to install the new transfer module. Doing so may cause the incorrect seating of the transfer module. The coupler is rotated out of the way as the transfer module slides in.
2. Rotate the right side spring clamp (G) and left side cam back to their original positions, and then rehook the springs.

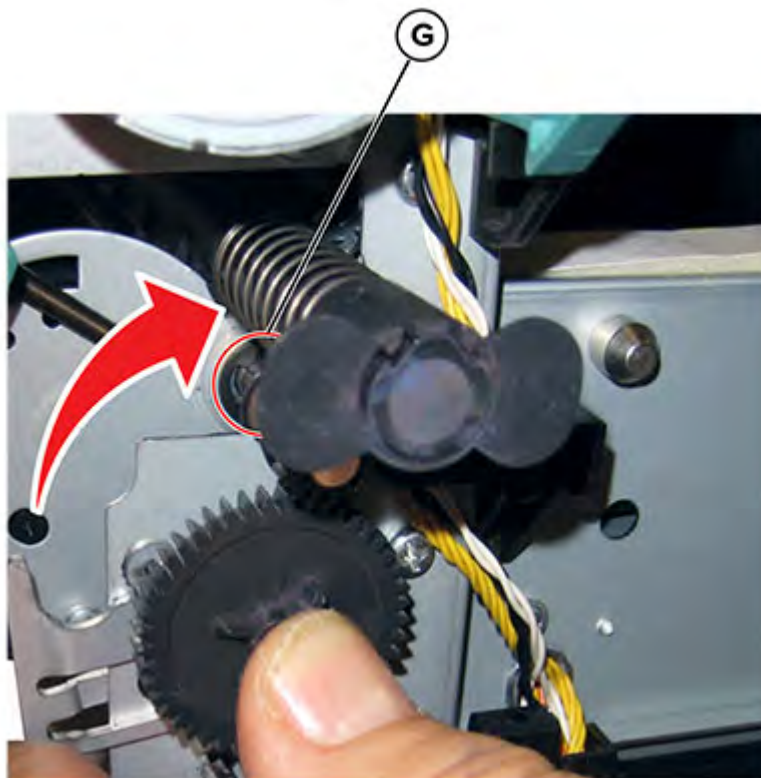

3. Make sure to reset the ITM counter after installing the new transfer module.  
Enter the Diagnostics menu, and then navigate to:  
**Printer diagnostics & adjustments > Supply reset > ITM reset**

## Imaging Kit Removal

 **Note:** This is not a FRU.

 **Note:** Installation note: The imaging kit contains the photoconductor unit and developer units. When you replace the imaging kit, you are replacing the photoconductor unit and developer units.

1. Remove the waste toner bottle. See [Waste toner bottle removal](#).
2. Remove the toner cartridges.

## Parts Removal

3. Lift the two latches (A) to unlock the imaging kit.

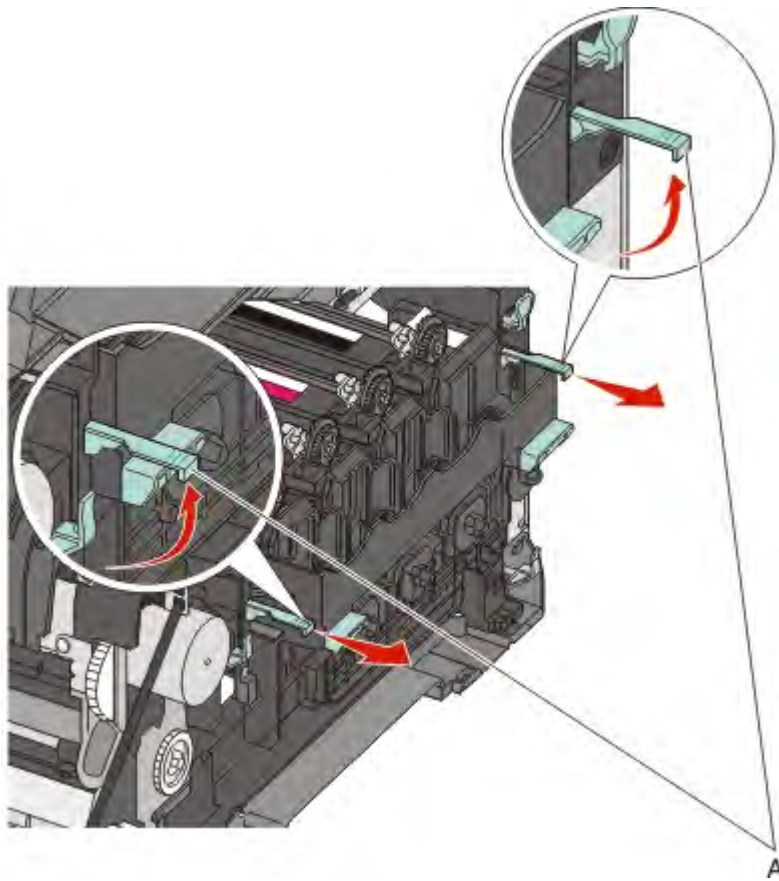

4. Pull the two latches.



5. Press and hold the two handles (B) and the latch (C), and then pull the imaging kit to remove.

 **Note:** Do not touch the underside of the imaging kit.



## Toner Cartridge Contacts Removal

1. Remove the right cover. See [Right cover removal](#).
2. Remove the waste toner bottle. See [Waste toner bottle removal](#).
3. Remove the imaging kit. See [Imaging kit removal](#).
4. Remove the rear cover. See [Rear cover removal](#).
5. Remove the screw (A) to allow access to the cable cover.

 **Note:** Do not remove the waste toner bottle contact block.



## Parts Removal

6. Remove the four screws (B), and then remove the cable cover.

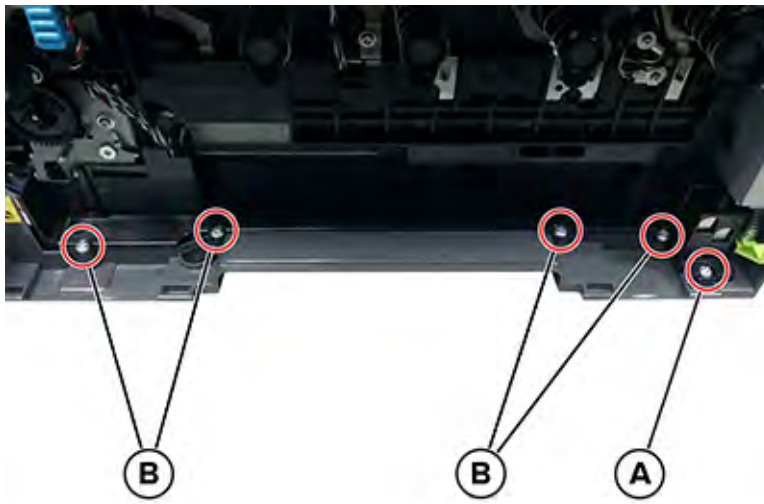

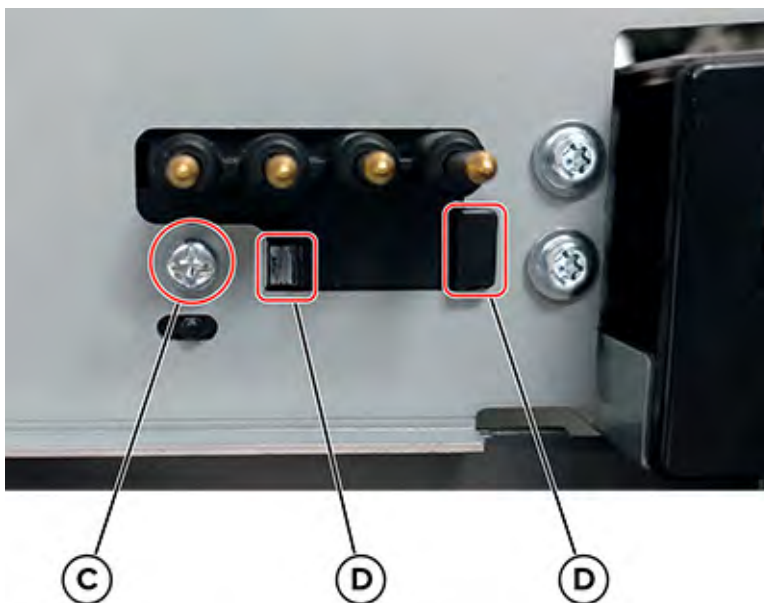

7. Place the printer on its left side.
8. Remove the screw (C), and then release the two tabs (D).

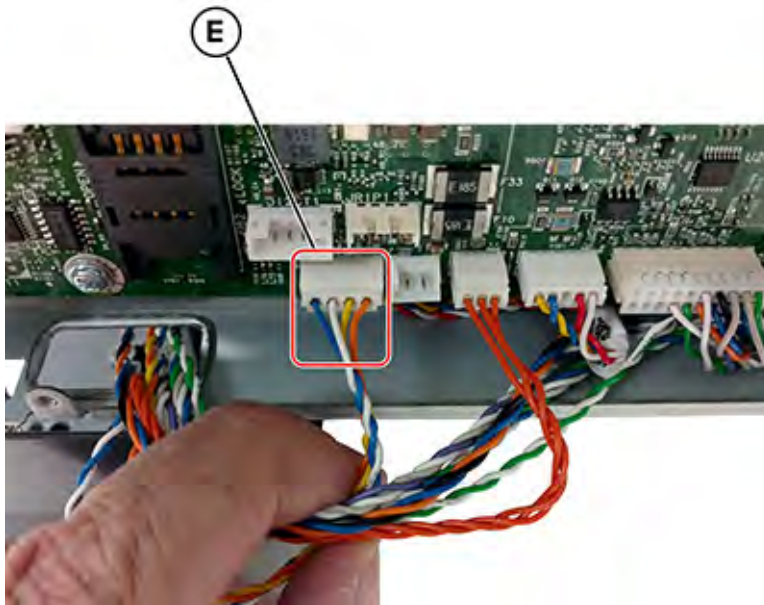

9. Slide the toner cartridge contacts to the left to remove it.

- Disconnect the cable (E) from the controller board.



 **Note:** Installation note: If used, pay attention to the assembly of the cable and toroid.

- Remove the cable from its retainer at the bottom of the printer.
- Extract the cable through the frame, and then remove the cable with the spring contacts.

 **Note:** If the cable has a toroid, unwrap the cable from the toroid, and then make sure to use the same number of wraps on the new cable.

## Waste Toner Bottle Removal

 **Note:** This is not a FRU.

- Remove the right cover. See [Right cover removal](#).
- Press the two tabs (A) to release the waste toner bottle.

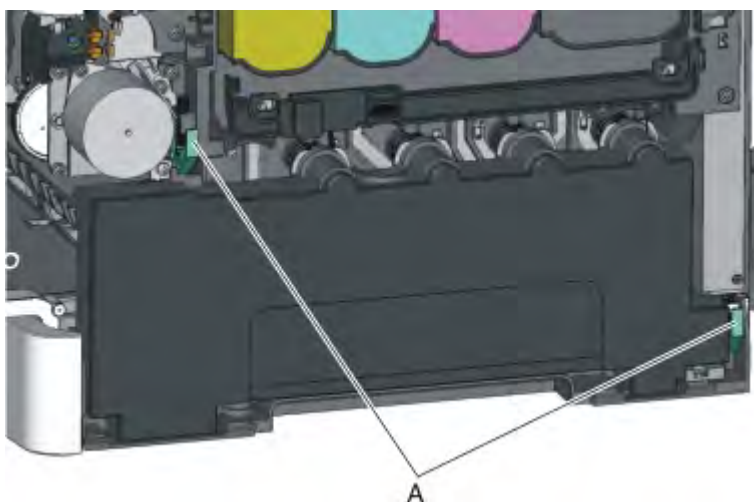

## Waste Toner Bottle Contact Block Removal

 **Note:** The waste toner bottle is not a FRU.

1. Remove the waste toner bottle. See [Waste toner bottle removal](#).
2. Remove the rear cover. See [Rear cover removal](#).
3. Remove the screw (A).

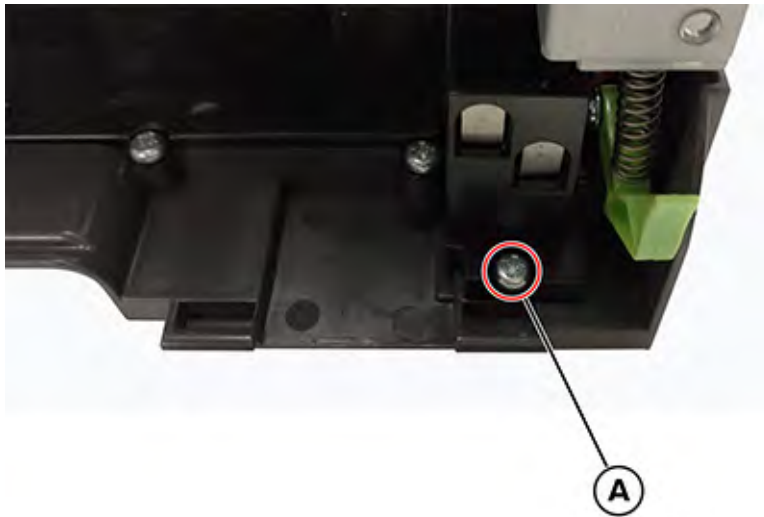

4. Disconnect the cable (B) from the controller board, and then remove the toroid from the cable.

 **Note:** Installation note: Use the toroid on the new waste toner bottle contact block.

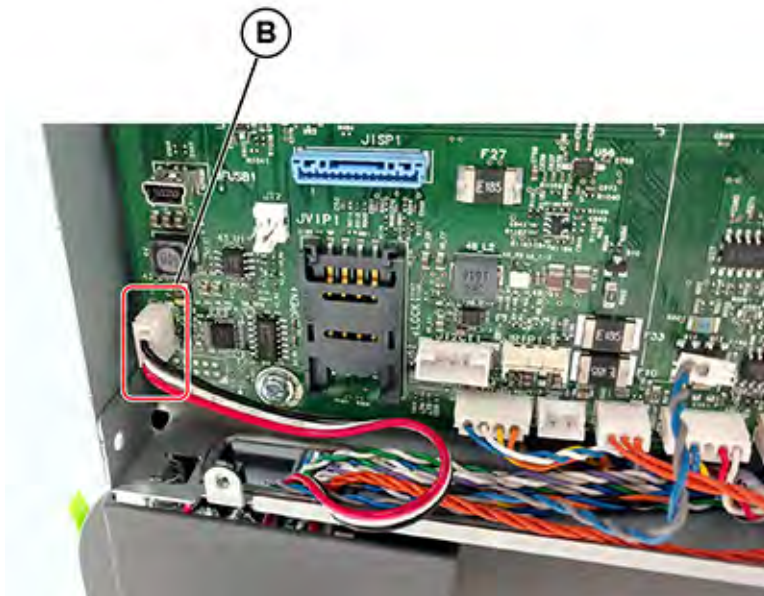



5. Remove the waste toner bottle contact block.



## Front Removals

### Front Door Removal

1. Remove the tray insert.
2. Open the front door.
3. Remove the six screws (A).

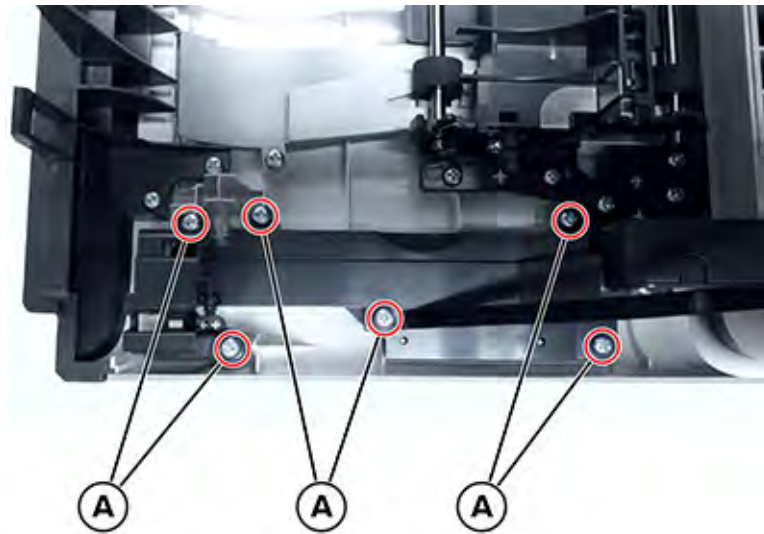

4. Remove the three screws (B).

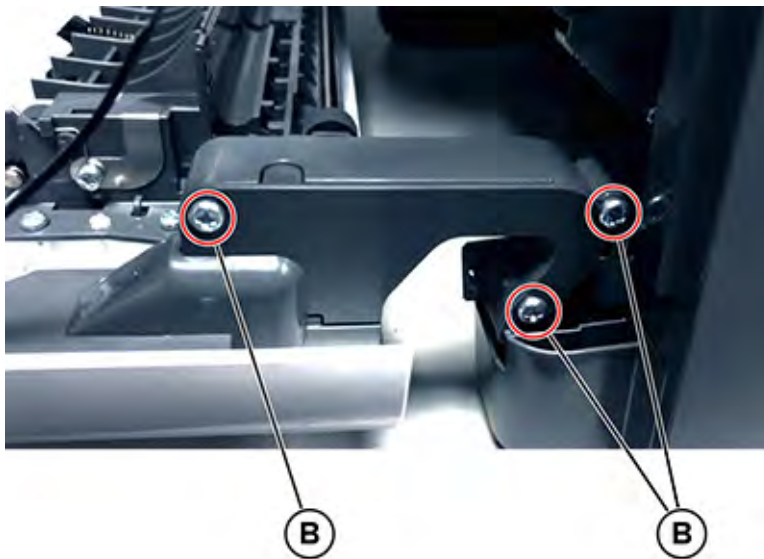

5. Remove the cable cover from the right hinge.

6. Disconnect the left and right door straps.

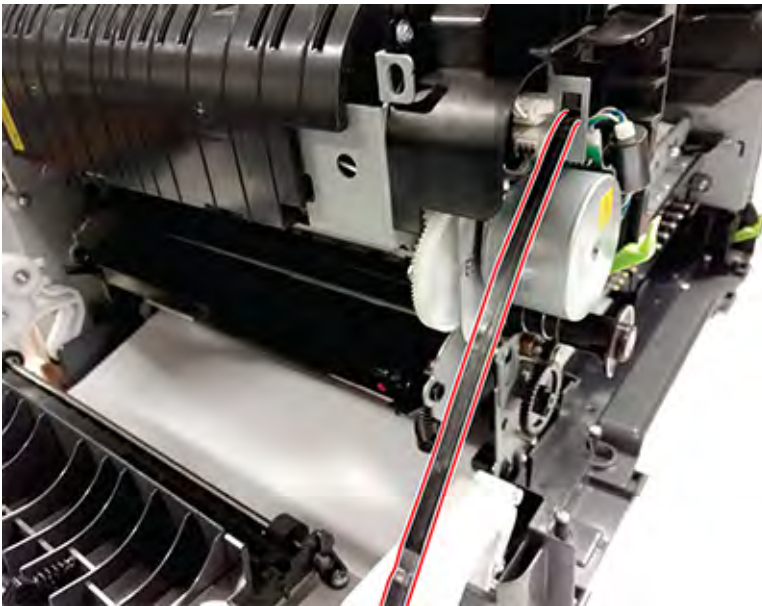

## Parts Removal

7. Route the interlock switch cover assembly away from the door.

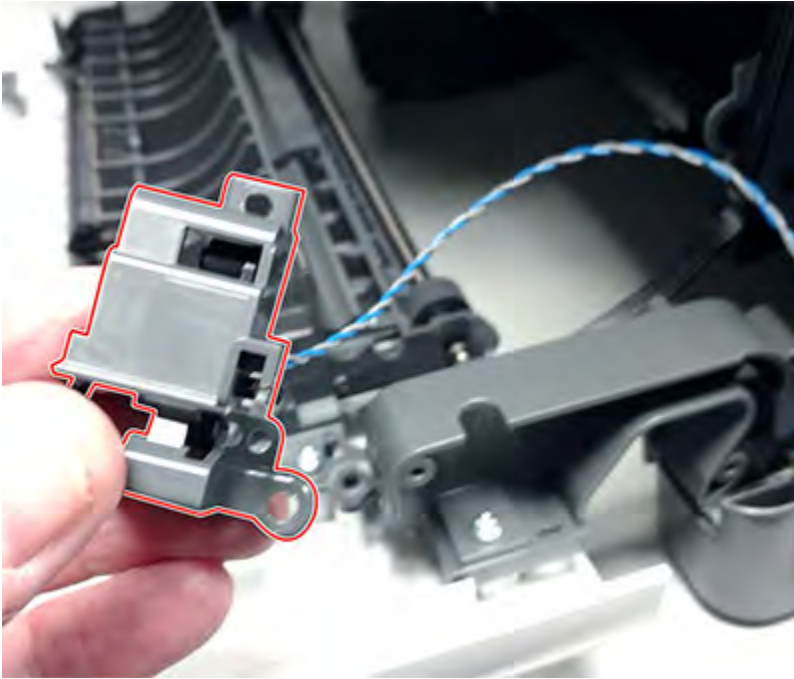

8. Remove the six screws (C).

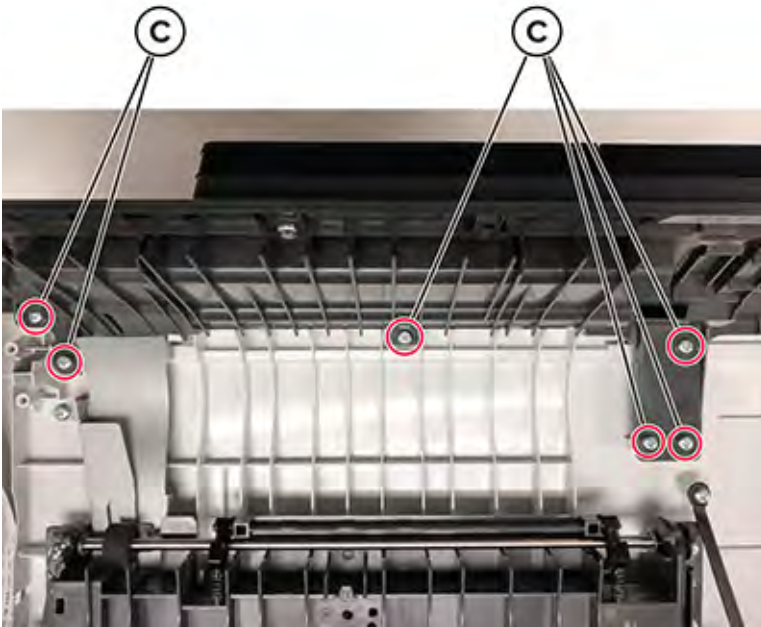

9. Pull the control panel assembly and base to the side.

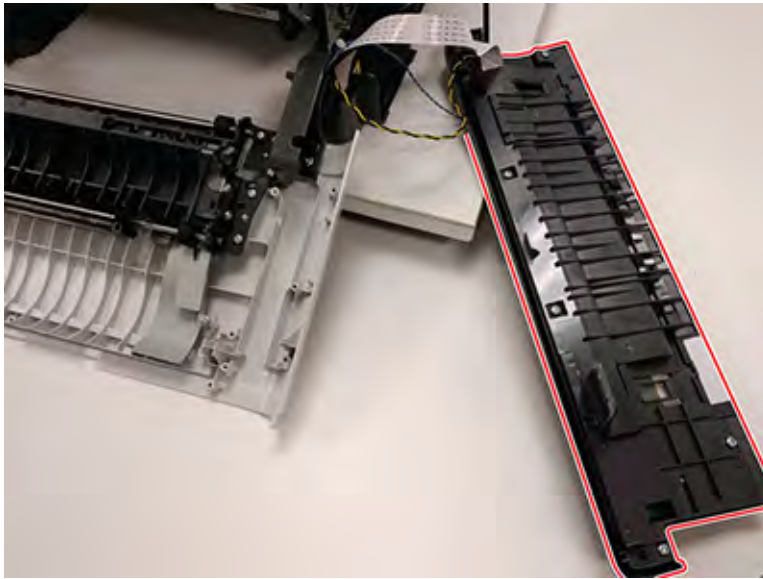

10. Remove the wireless card. See [Wireless card removal](#).
11. Remove the left hinge (D) from the left subframe.

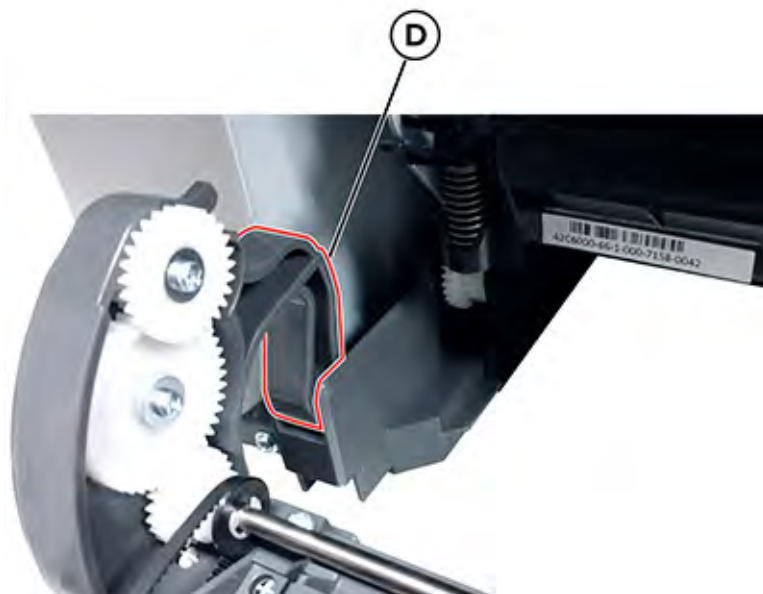



## Parts Removal

12. Remove the right hinge (E) from the right subframe.



## Front Door Inner Deflector Removal

1. Open the front door.
2. Release the two door straps (A) from the frame.

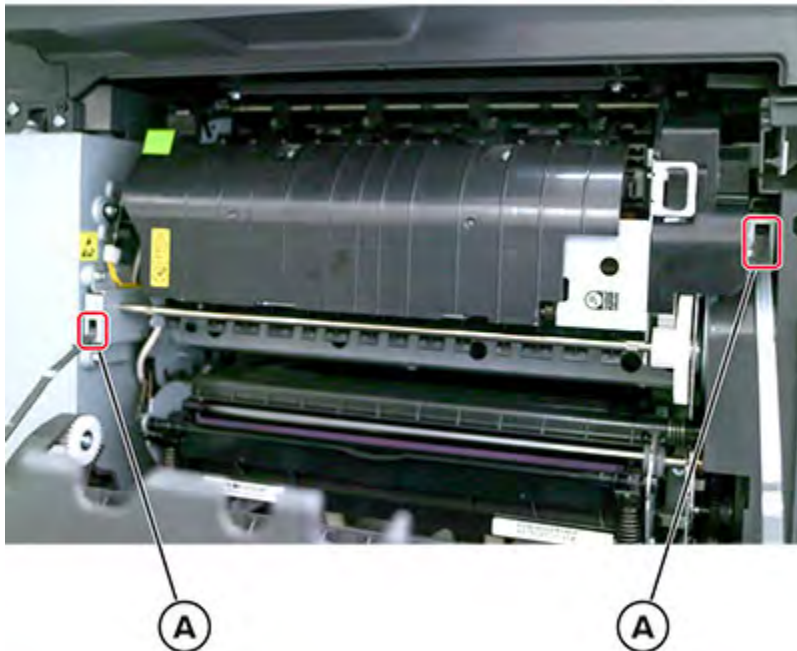

3. Remove the nine screws (B), and then remove the deflector.

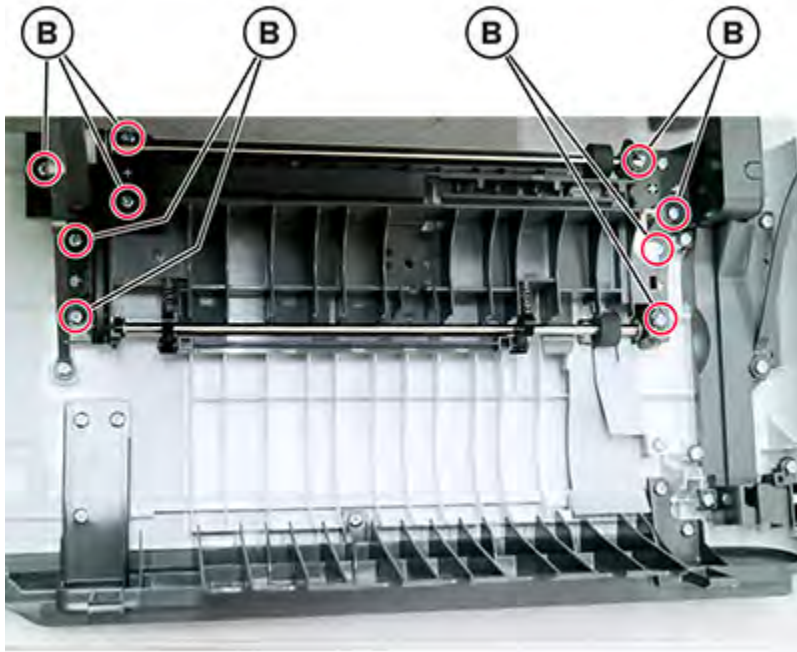

## Interlock Switch Cover Assembly Removal

1. Remove the tray insert.
2. Open the front door.
3. Remove the six screws (A).

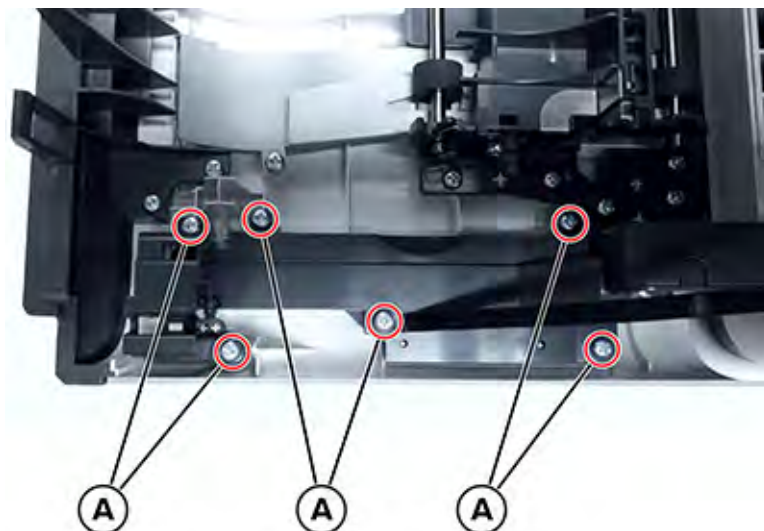

## Parts Removal

4. Remove the three screws (B).

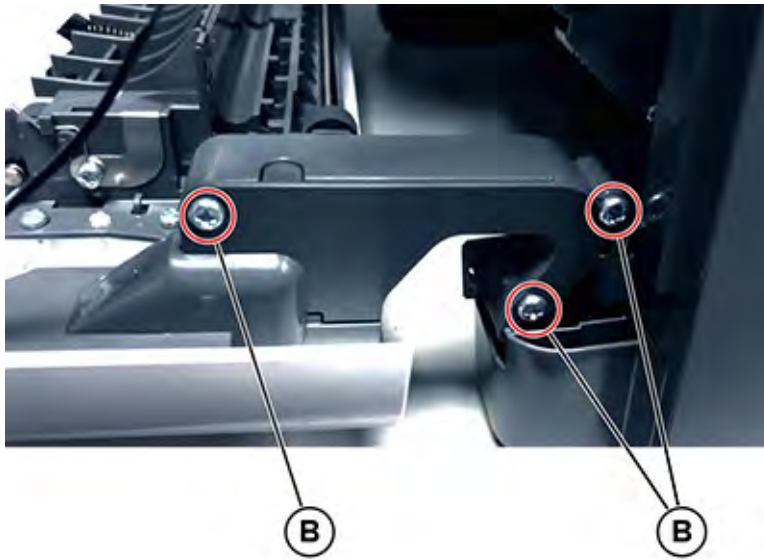

5. Remove the right cover. See [Right cover removal](#).
6. Remove the waste toner bottle. See [Waste toner bottle removal](#).
7. Remove the rear cover. See [Rear cover removal](#).
8. Remove the waste toner bottle contact block. See [Waste toner bottle contact block removal](#).
9. Remove the cable cover.
10. Disconnect the cable (C).

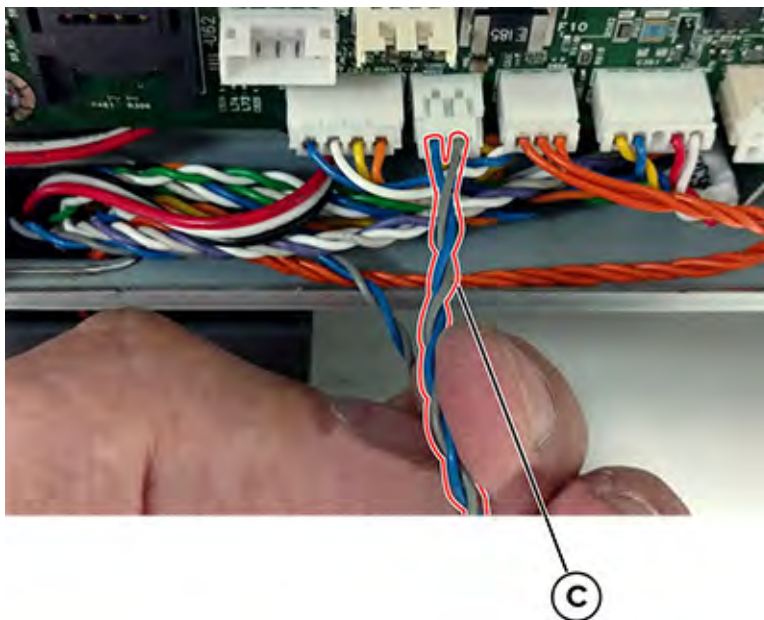

11. Route the interlock switch cover assembly out of the frame.



## Control Panel Base Removal

1. Remove the tray insert.
2. Open the front door.
3. Remove the control panel top cover. See [2.4-inch Control Panel Top Cover Removal](#)
4. Remove the six screws (A), and then remove the cover.

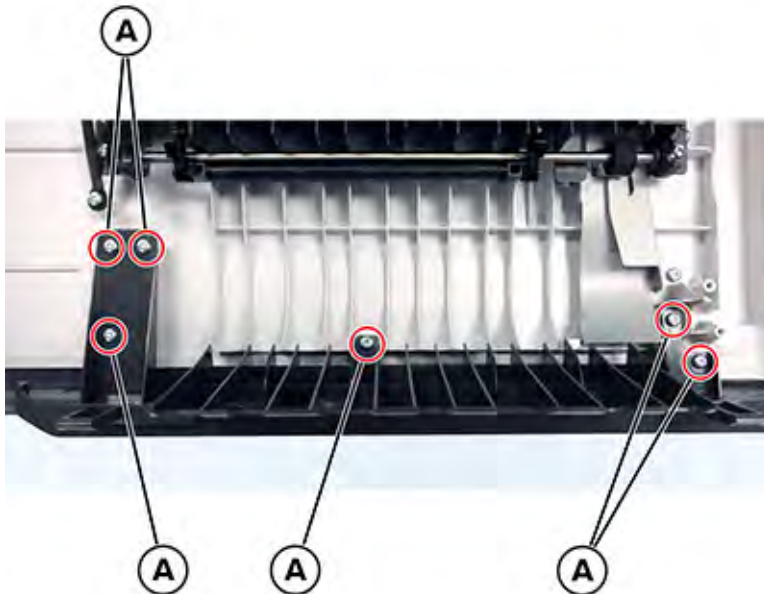

## 2.4-inch Control Panel Badge Cover Removal

Remove the badge cover (A) from the bezel.



## 2.4-inch Control Panel Bezel Removal

1. Remove the badge cover. See [2.4-inch Control Panel Badge Cover Removal](#).
2. Remove the control panel top cover. See [2.4-inch Control Panel Top Cover Removal](#).
3. Remove the six screws (A) securing the bezel to the control panel top cover.

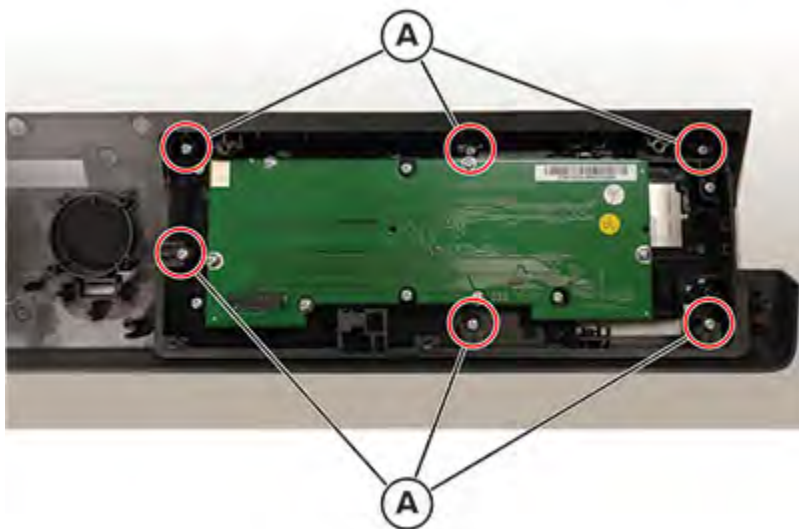

4. Remove the five screws (B) securing the control panel assembly.

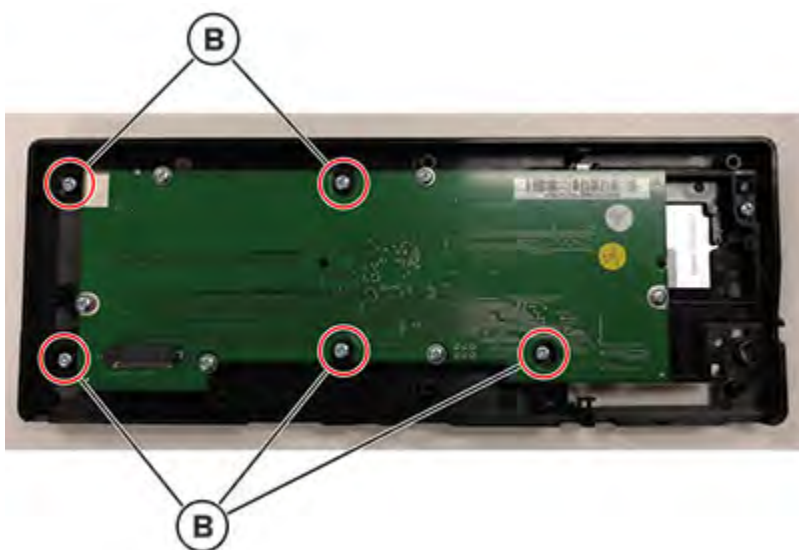

## 2.4-inch Control Panel Top Cover Removal

1. Open the front door.

2. Remove the two screws (A) securing the interlock cover assembly, and then move the cover assembly to the side.

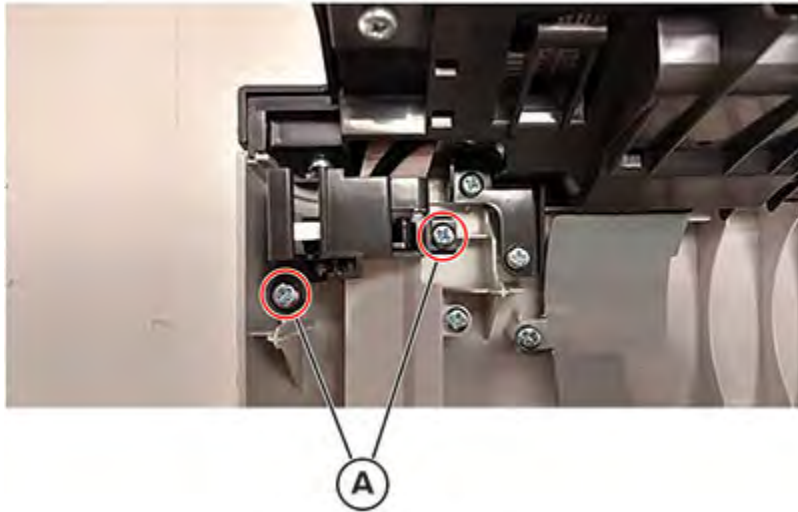

3. Remove the seven screws (B).

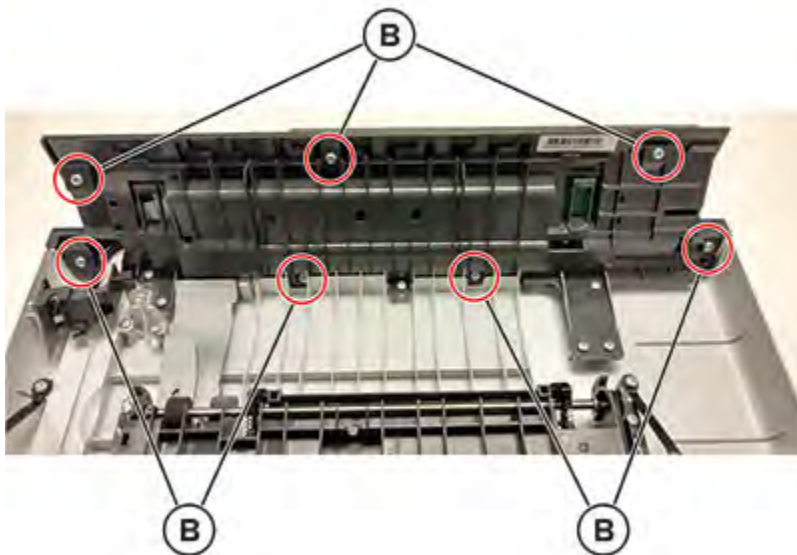

## Parts Removal

4. Disconnect the control panel ribbon cable (C.), and then remove the USB cable (D).

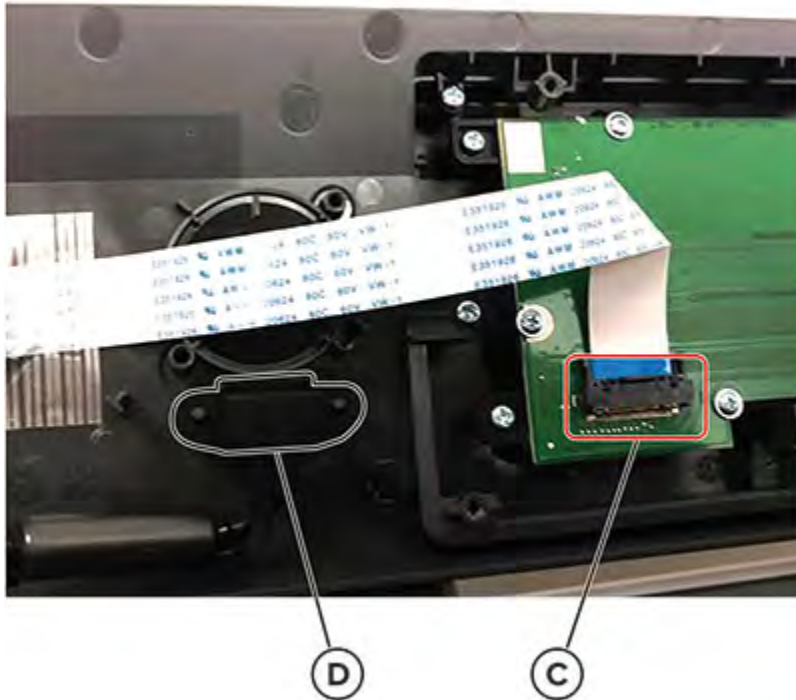

5. Remove the control panel bezel with the control panel assembly. See [2.4-inch Control Panel Bezel Removal](#).

## 2.4-inch Control Panel Keypad Removal

1. Remove the 2.4-inch control panel. See [2.4-inch Control Panel Bezel Removal](#).
2. Remove the six screws (A).

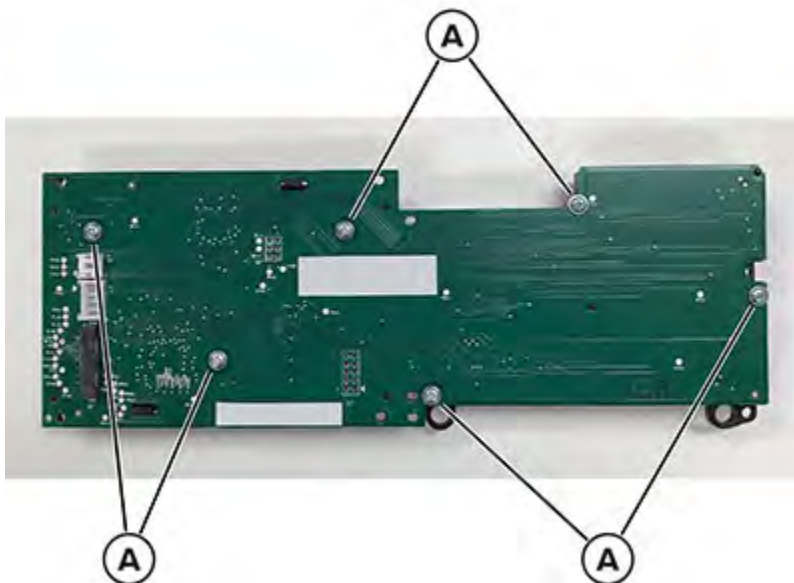

3. Disconnect the cable (B).

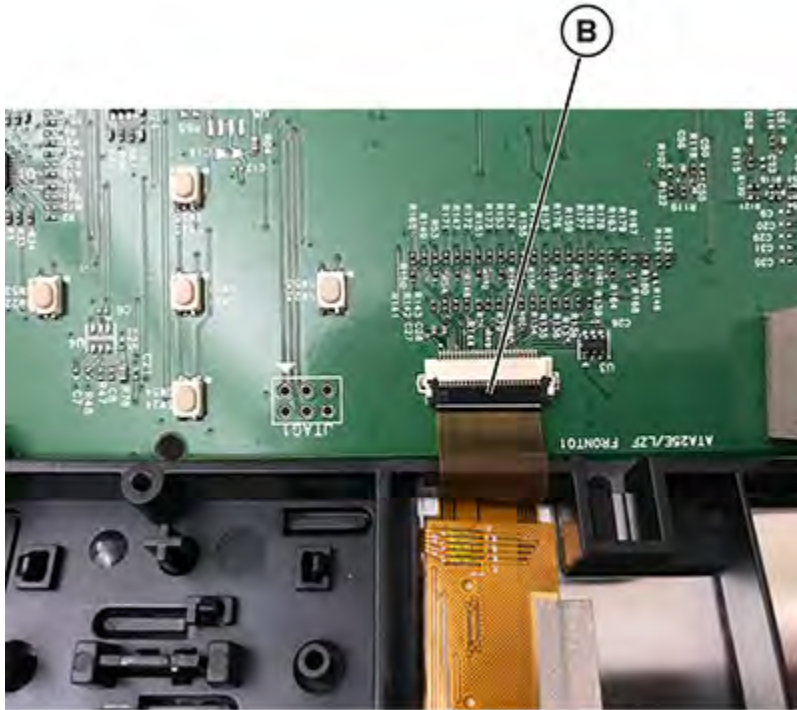

## Weather Station Removal

1. Remove the right cover. See [Right cover removal](#).
2. Remove the waste toner bottle. See [Waste toner bottle removal](#).
3. Remove the five screws (A), and then remove the cover (B).

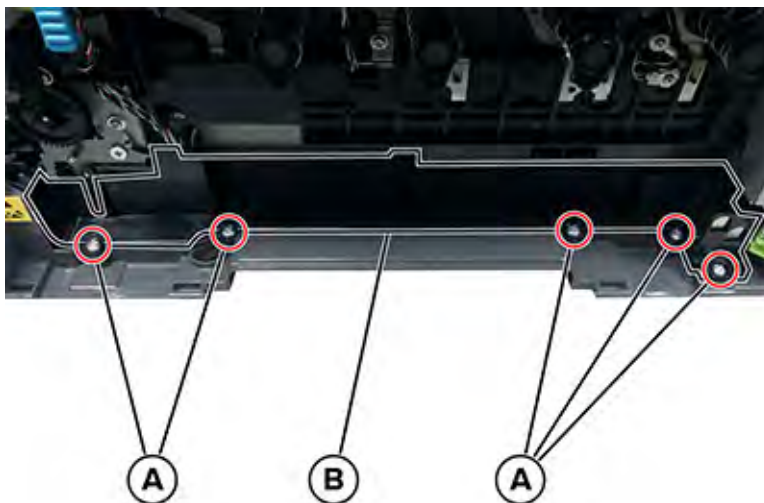

4. Open the front door.



## Parts Removal

5. Release the left and right door straps.



6. Remove the left hinge (C) from the left subframe.



7. Remove the right hinge (D) from the right subframe.



## Parts Removal

8. Remove the screw (E), and then disconnect the cable (F) from the sensor.

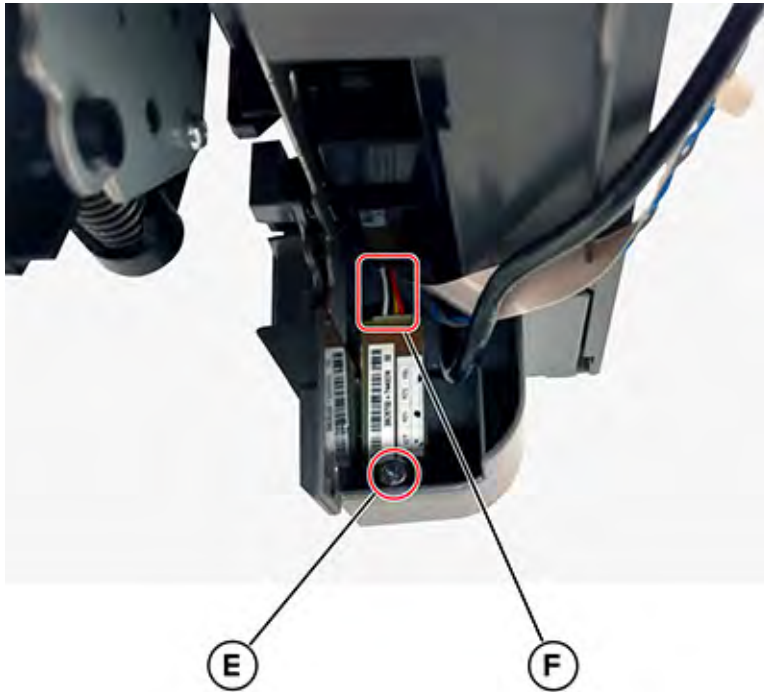

## Wireless Card Removal

1. Remove the tray.
2. Remove the six screws (A).

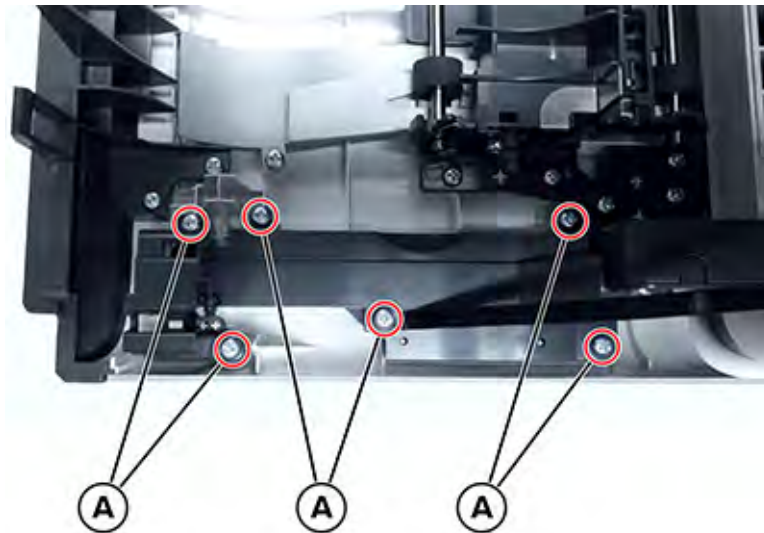



3. Remove the three screws (B).

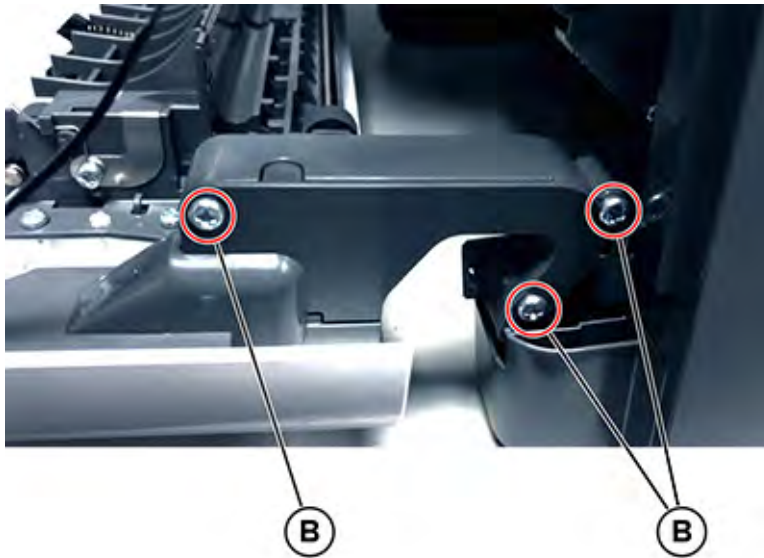

4. Disconnect the cable from the wireless card (C).



## Front USB Cable Removal

1. Open the front door.
2. Remove the tray insert.
3. Remove the rear cover. See [Rear cover removal](#).
4. Remove the right cover. See [Right cover removal](#).
5. Remove the waste toner bottle. See [Waste toner bottle removal](#).

## Parts Removal

6. Remove the six screws (A).

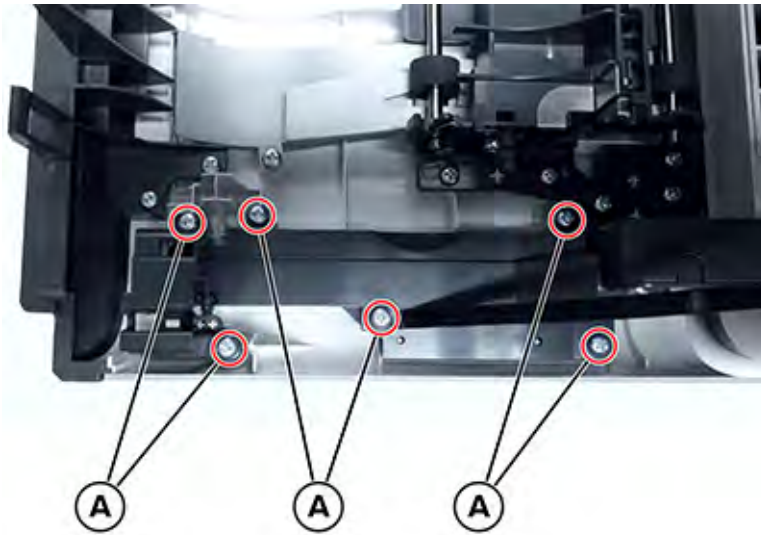

7. Remove the three screws (B).

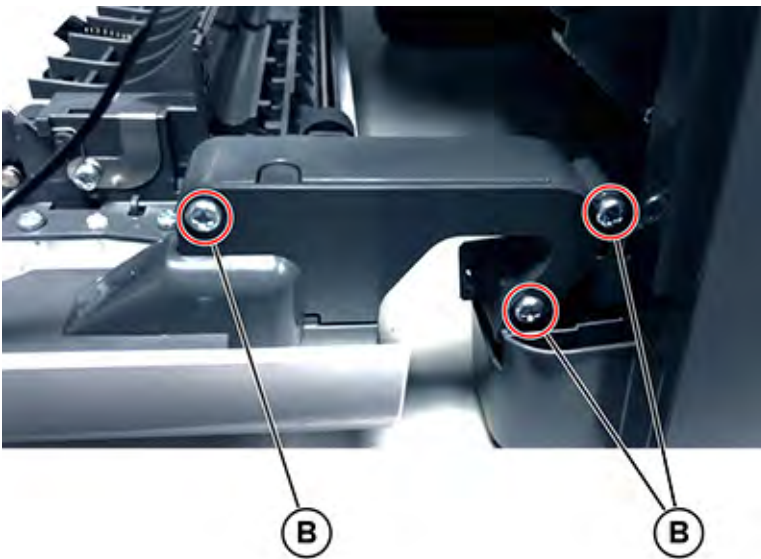

8. Remove the five screws (C).

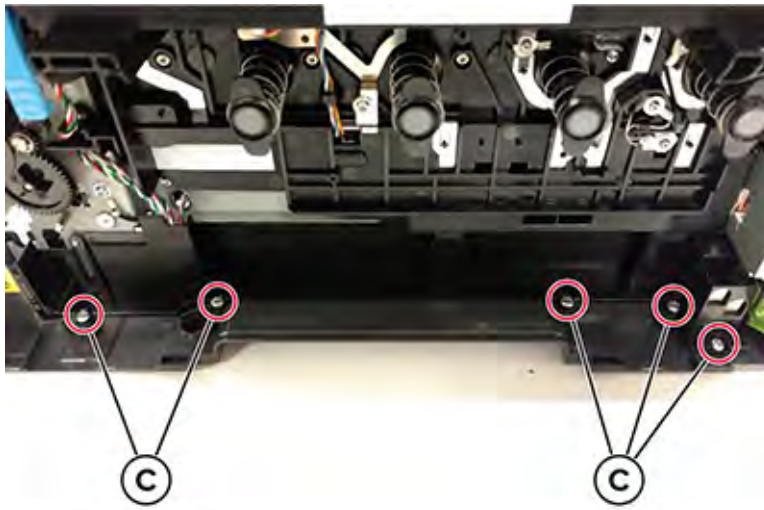

9. Disconnect the cable (D).

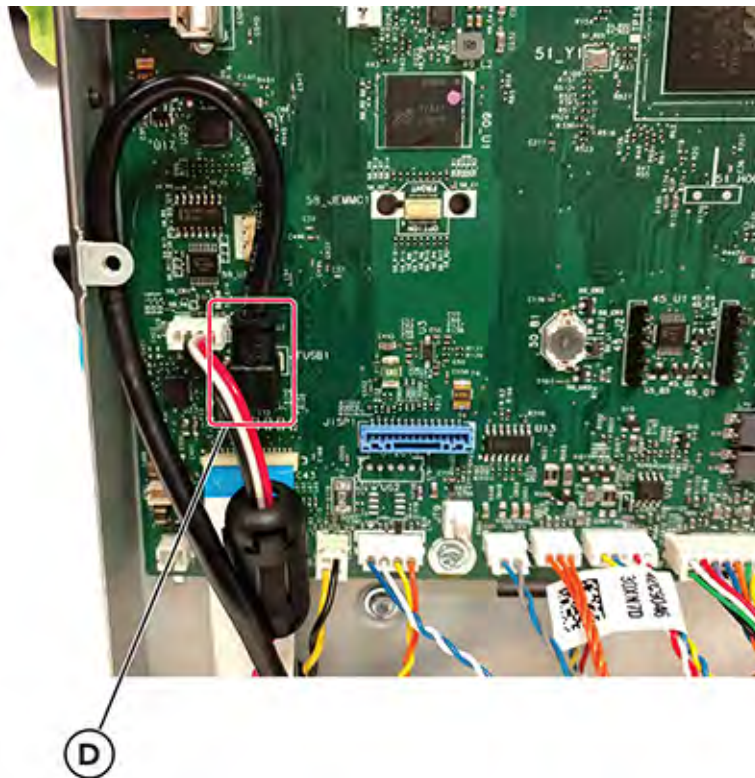

## Parts Removal

10. Remove the seven screws (E).

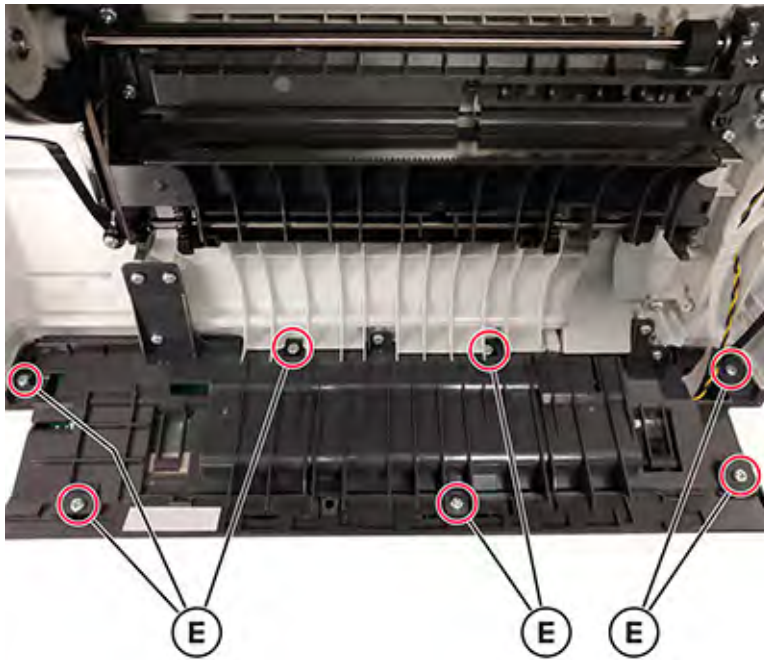



11. Route the USB cable through the rear of the printer, and then through the control panel base .

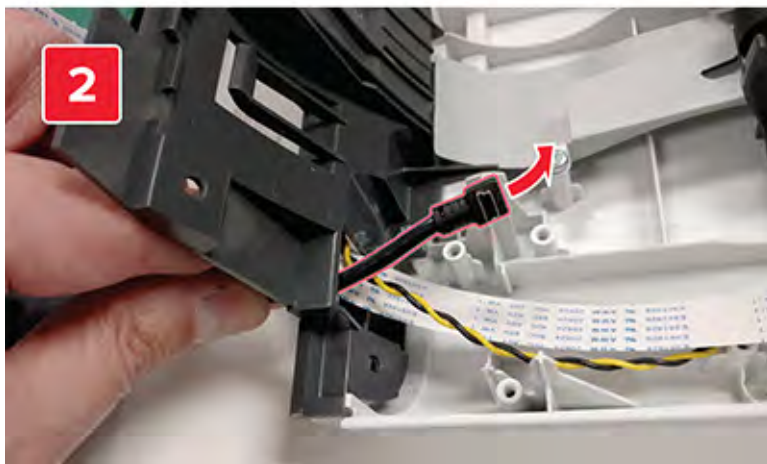

## Fuser Removal

 **Note:** For a video demonstration, see [Fuser Removal](#).

1. Remove the right cover. See [Right cover removal](#).
2. Remove the left cover. See [Left cover removal](#).
3. Disconnect the two-wire fuser cable (A) from the LVPS.

## Parts Removal

4. Position the fuser cable so that it can be pulled through from the front of the printer, and guide the cable through to the front.

 **Warning:** Be careful not to damage the cable by pulling too hard or cutting the cable insulation.

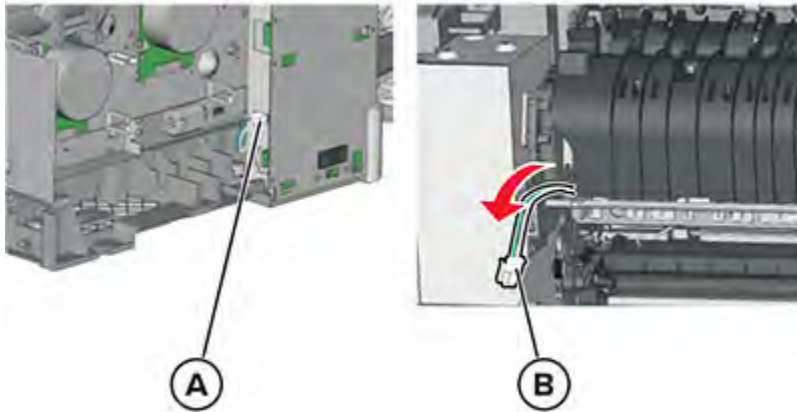

5. Remove the narrow media/exit sensor flag. See [Narrow Media/bin Full Sensor Flag Removal](#).
6. Remove the right out put bin deflector. See [Right Output Bin Deflector Removal](#).
7. Remove the exit deflector. See [Exit Deflector Removal](#).
8. Disconnect the cable (C) from the bin-full/narrow media sensor, and unroute the cable from its retainer.

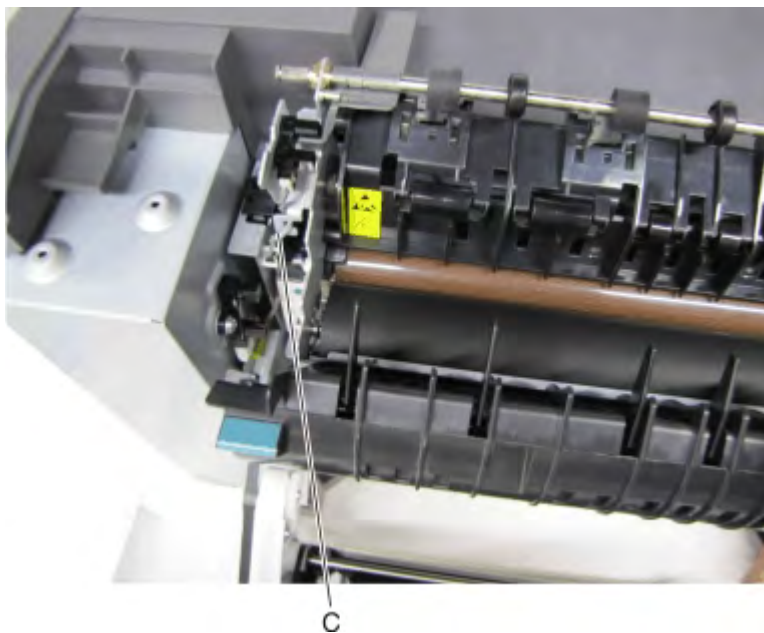

9. Unhook the springs (D) from both sides of the fuser.

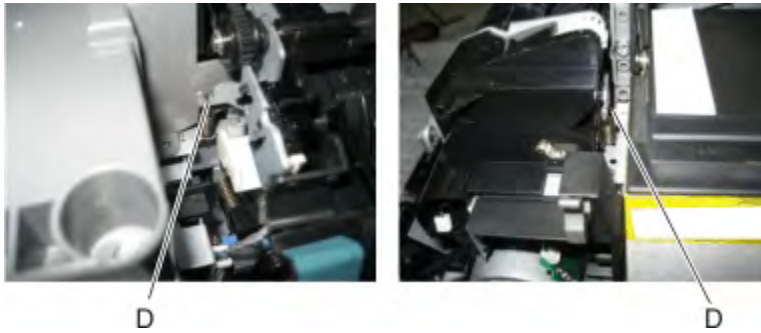

10. Disconnect the thermistor cables (E), and then pull them over the retainer.
11. Remove the screw (F).

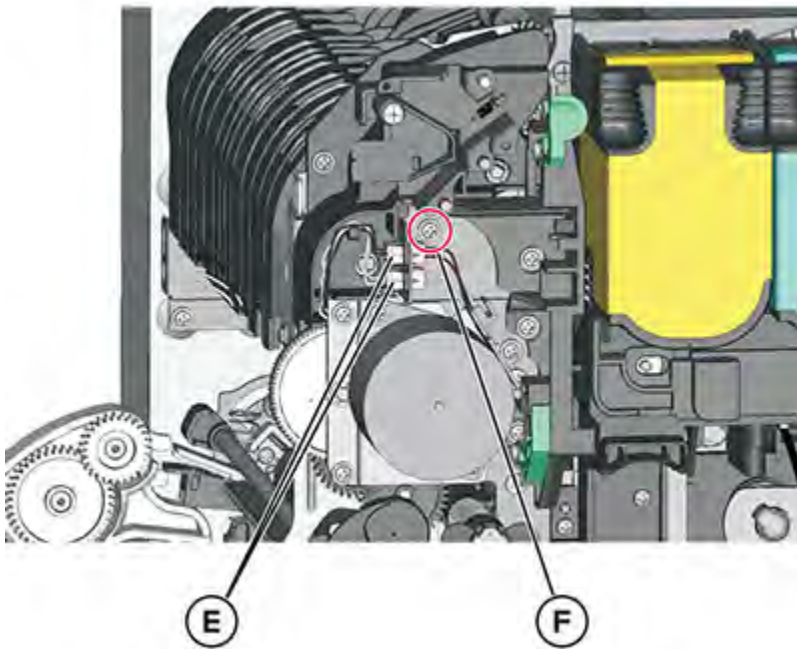

12. Rotate the top of the fuser toward the front, and then slide to the left to align the fuser side frames with the flat area of the shaft.

**⚠ Warning:** Do not damage the sensor (fuser exit) on the left of the fuser when rotating.

13. Lift, and then remove the fuser.

**Installation notes:**

## Parts Removal

- a. Install the flags (A) from the old fuser into the new fuser.

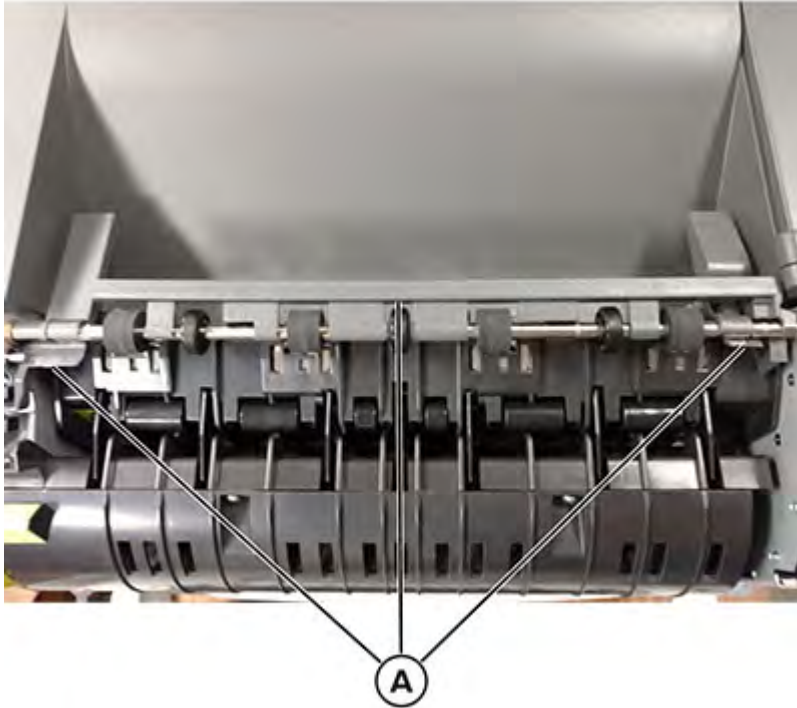

- b. Enter the Diagnostics menu, and then navigate to:  
**Printer diagnostics & adjustments > Supply Reset > Fuser Reset**
- c. Select **Start**.
- d. Print approximately 15 test pages each in simplex and duplex modes to make sure that the belt is properly working and the flags are properly installed.
- e. Pay attention to noise that may indicate an improper belt installation.
- f. If a Remove media from output bin or a 34.04 error appears, check the fuser flags for proper installation.

## Exit Deflector Removal

1. Open the front door.
2. Remove the yellow toner cartridge.



3. Remove the exit deflector ground screw (A), and then remove the cable from its retainers.

 **Note:** Be sure to pay close attention to the routing of the cables through the retainers for reinstallation.

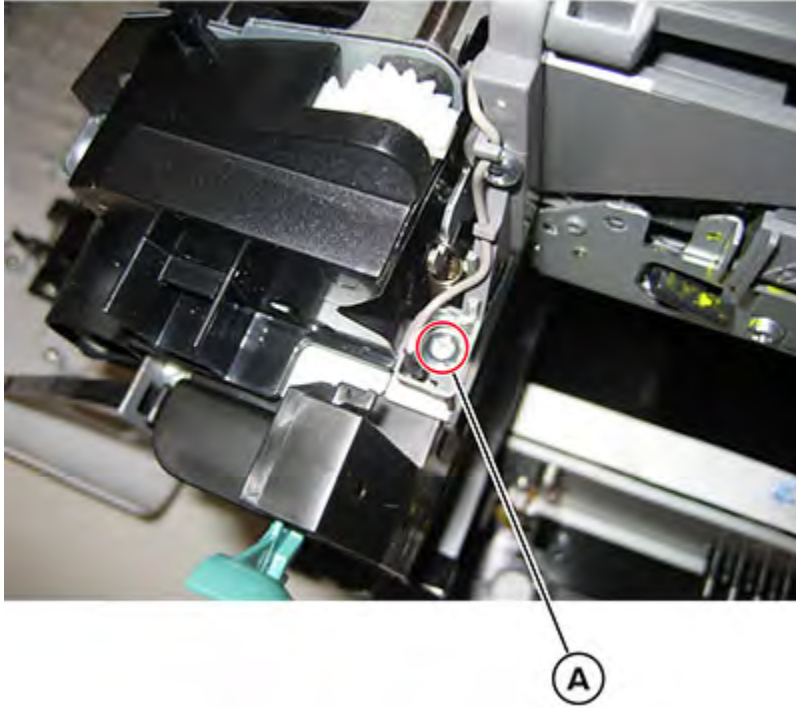

## Parts Removal

4. Press to release the tabs (B), and then rotate the deflector to remove.

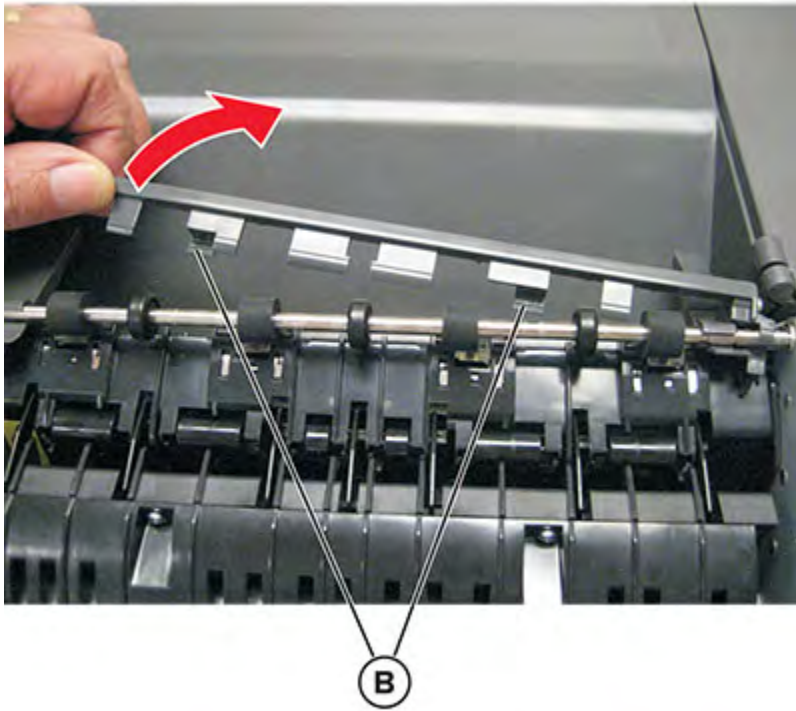

## Bottom Removals

### Pick Tires Removal

 **Warning:** Remove only the rubber tires and not the paper pick tire assembly to avoid losing small parts.

1. Lower the paper pick motor drive assembly.

## Parts Removal

2. Remove the rubber tire (A) from the pick roll assembly (B). Repeat for the other tire.

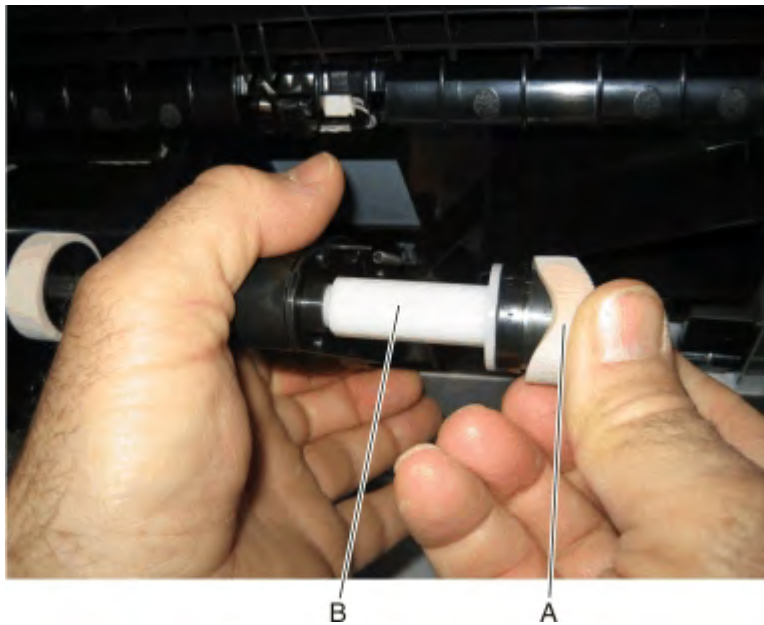

 **Note:** Installation note: Install the new rubber tires with the surface texture turning in the direction as shown in the following:

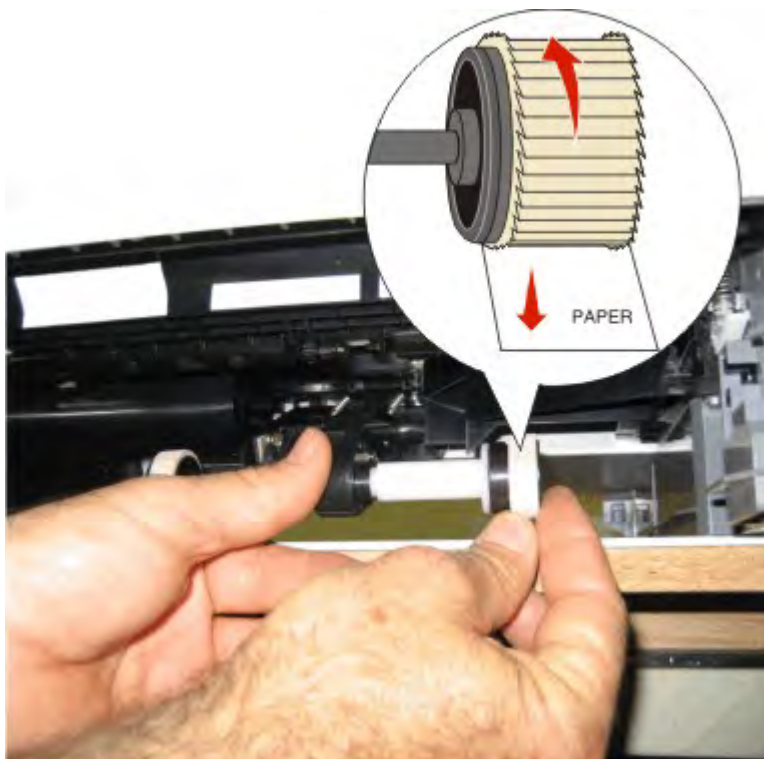

 **Note:** Feel each rubber surface to verify that it turns in the proper direction. The smoother surface pushes the paper toward the front of the printer.

## Lower Left Frame Removal

 **Note:** The right and left lower frames are in the same FRU.

1. Remove the media tray, and remove the screw (A) from the front.



2. Remove the waste toner bottle. See [Waste toner bottle removal](#).
3. Remove the imaging kit. See [Imaging kit removal](#).
4. Remove the left cover. See [Left cover removal](#).

## Parts Removal

5. Disconnect the three cables (B) from the LVPS.

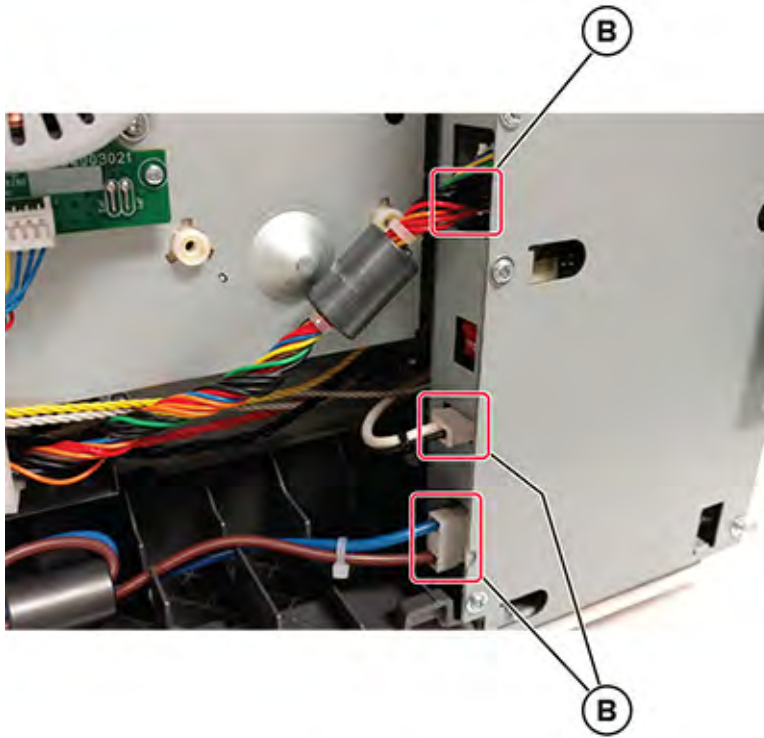

6. Remove the two screws (C).

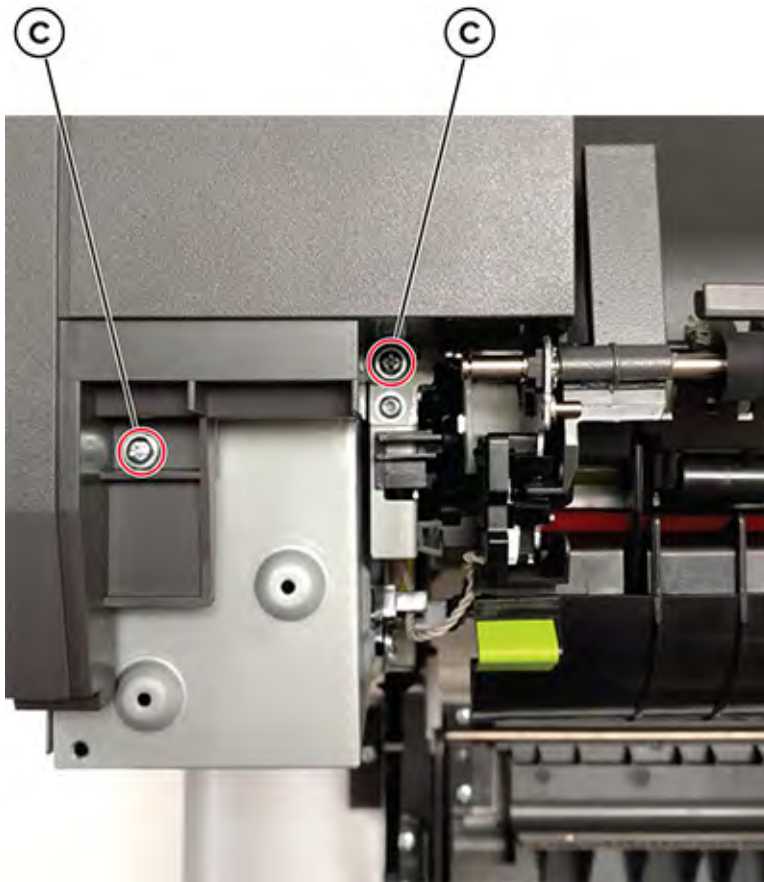



## Parts Removal

7. Position the fuser cable (D) so that it can be pulled through from the front of the printer, and then guide the cable through the front.

 **Warning:** Do not damage the cable by pulling too hard or cutting the cable insulation.

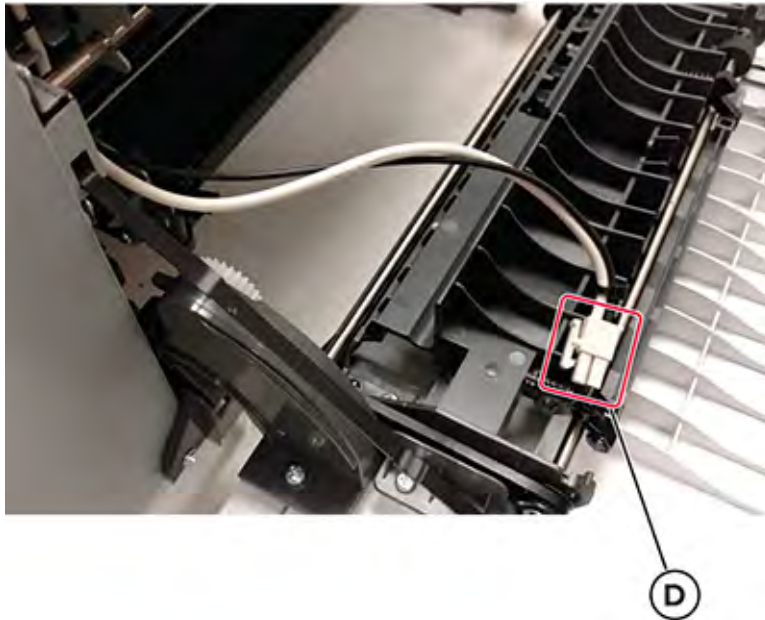

8. Remove the narrow media/exit sensor flag. See [Narrow Media/bin Full Sensor Flag Removal](#).
9. Disconnect the ground wire (E) from the front toner cover bracket, and then route it to the front of the printer.

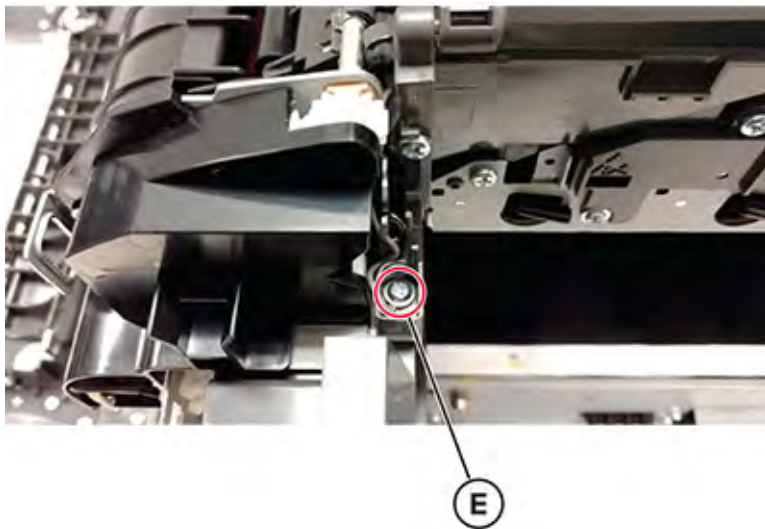



10. Release the tabs (F), and then rotate the exit deflector to remove.

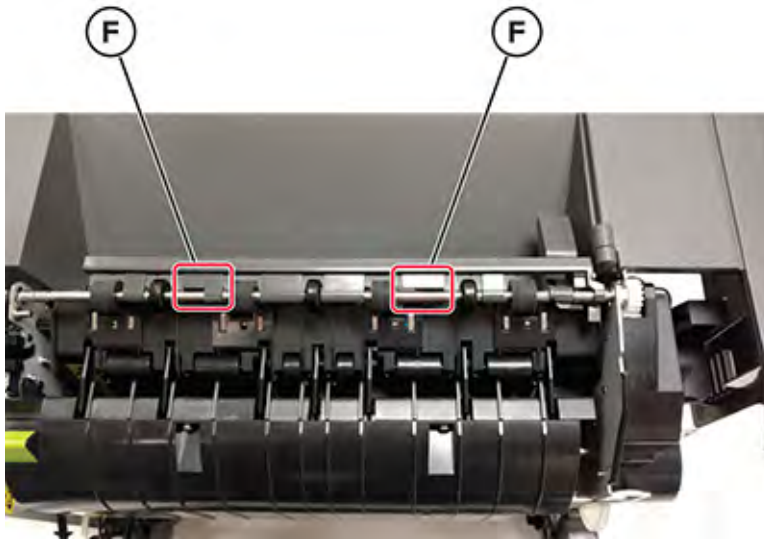

11. Remove the right out put bin deflector. See [Right Output Bin Deflector Removal](#).
12. Disconnect the cable (G) from the bin-full/narrow media sensor, and then remove the cable from its retainer.



## Parts Removal

13. Unhook the two springs (H) from both sides of the fuser.

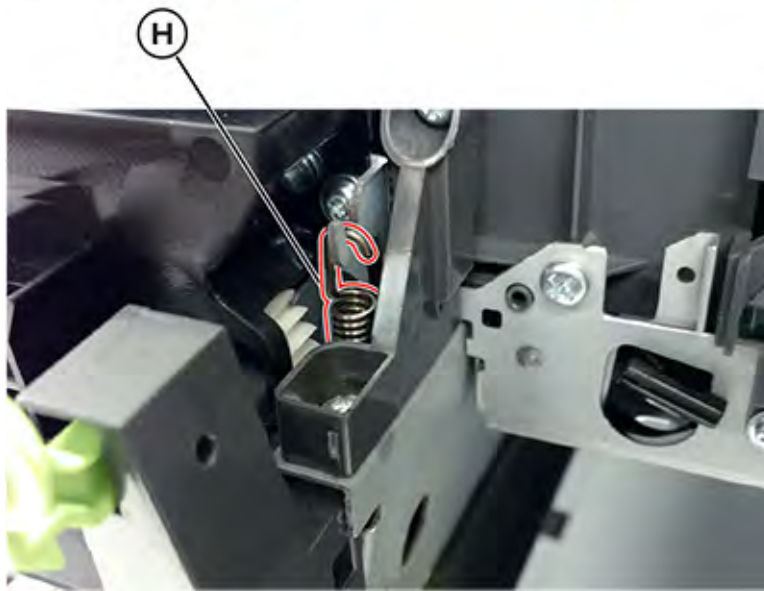
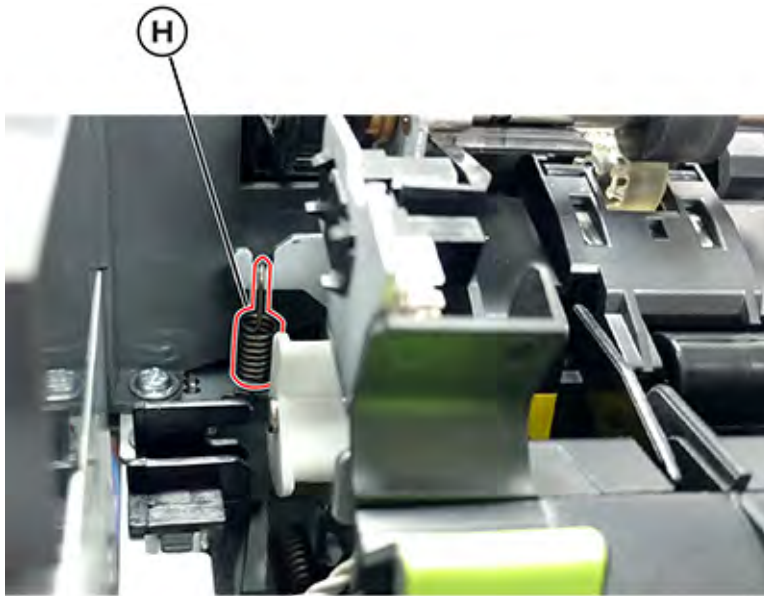

14. Disconnect the two cables (I), and then pull them over the retainer.

15. Remove the screw (J).

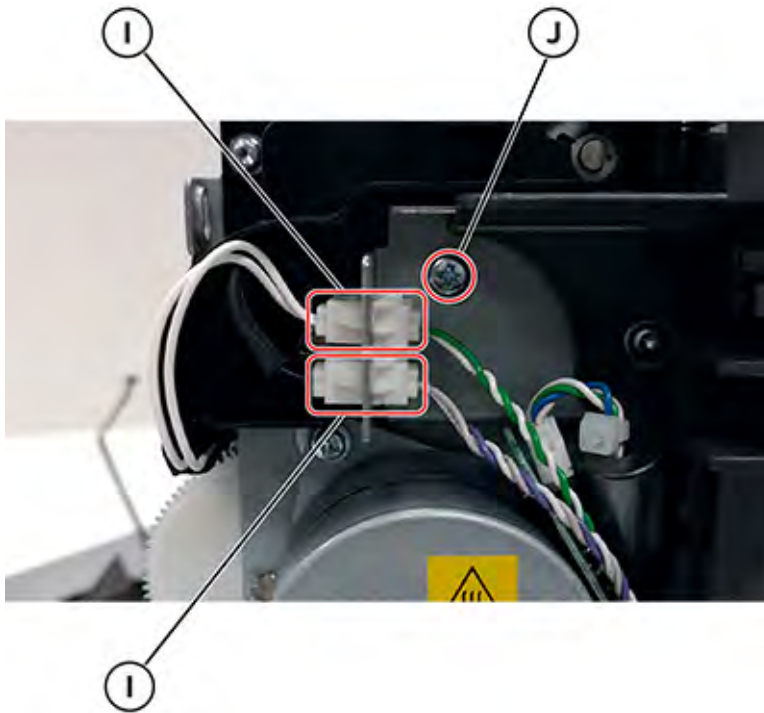

16. Remove the two screws (K).

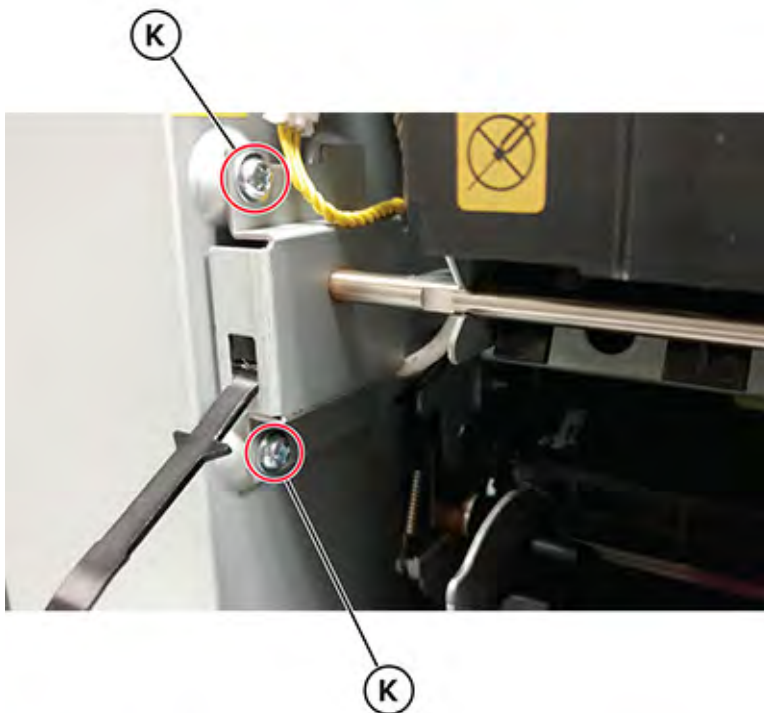

17. Rotate the top of the fuser toward the front, and then slide the fuser to the left to align the fuser side frames with the flat area of the shaft.

## Parts Removal

18. Disconnect the fuser exit sensor cable (L).



19. Lift the front left corner of the top cover, and then tilt the LVPS cage (M) to remove the cage.

 **Note:**

- There are two posts at the bottom of the cage on the left side that need to be disengaged.
- Pay attention to the sensor (fuser exit) which remains with the cage.

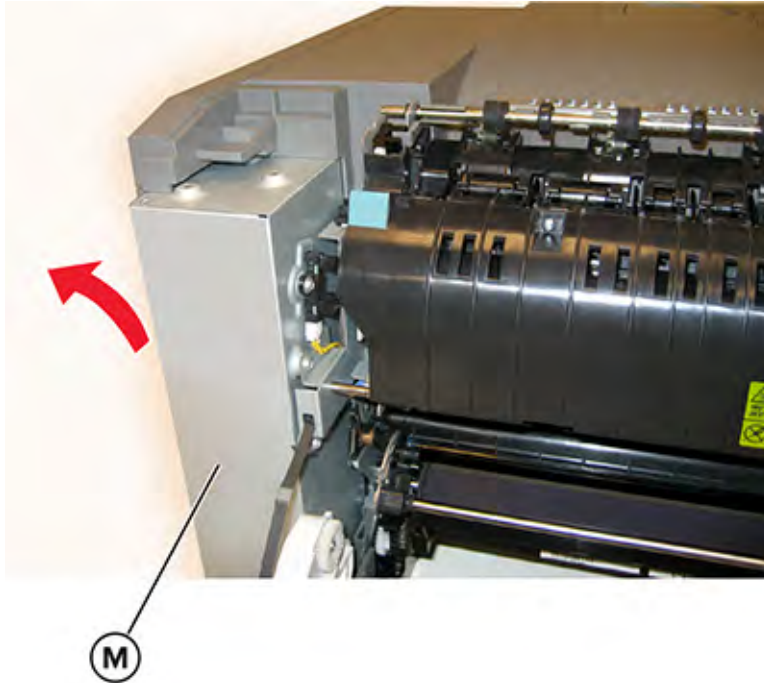

20. Place the printer on its right side.

21. Remove the connector (N).

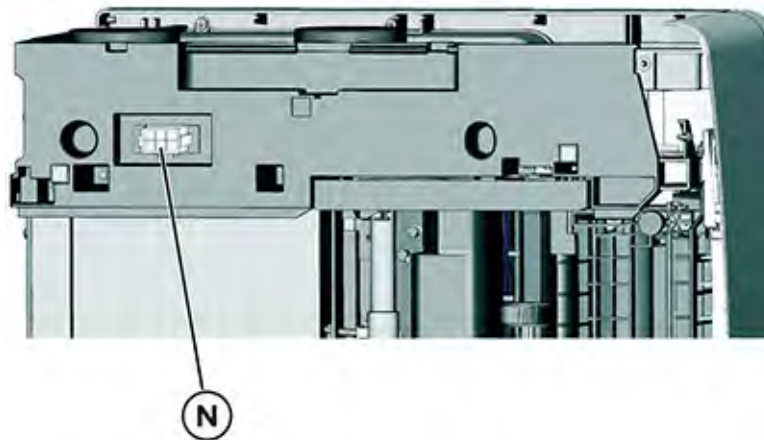



## Parts Removal

22. At the rear of the printer, remove the five screws (P).

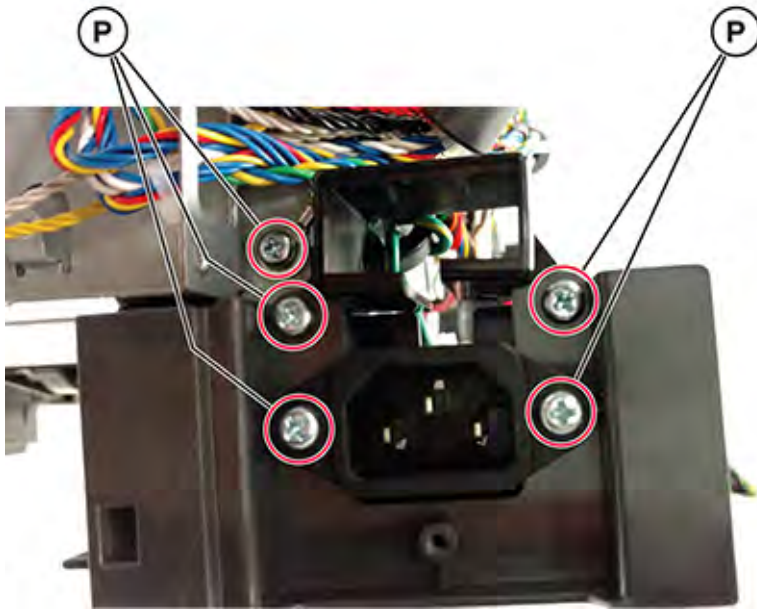

23. Remove the AC receptacle from the left lower frame.
24. Remove the three screws (Q).

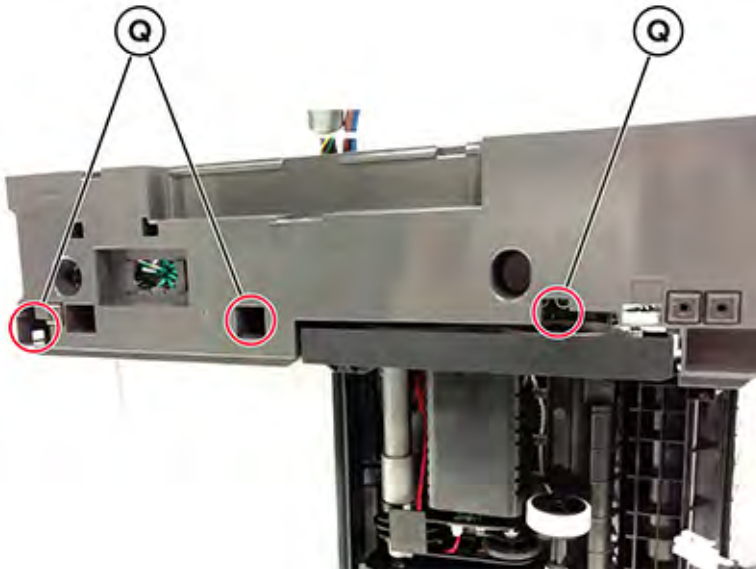

25. Tilt the front door down, disconnect the left and right door straps, and then separate the door from the frame.

26. Remove the screw (R).

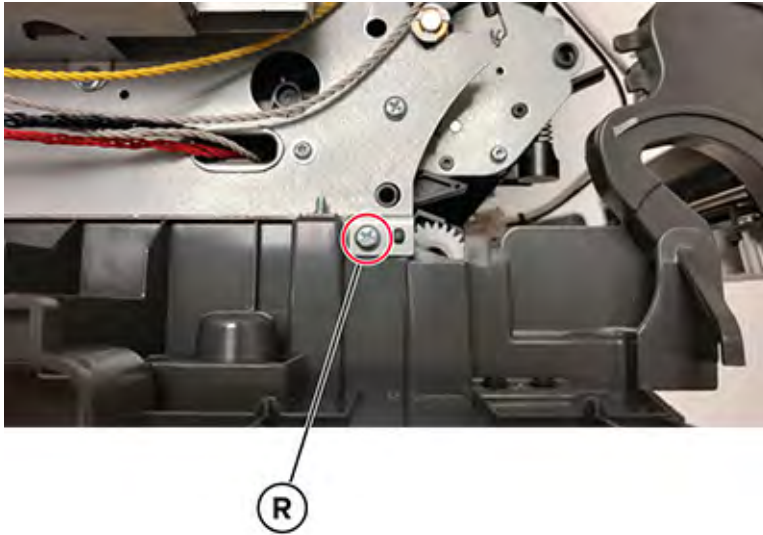

27. Swing the left lower frame away from the printer to remove.

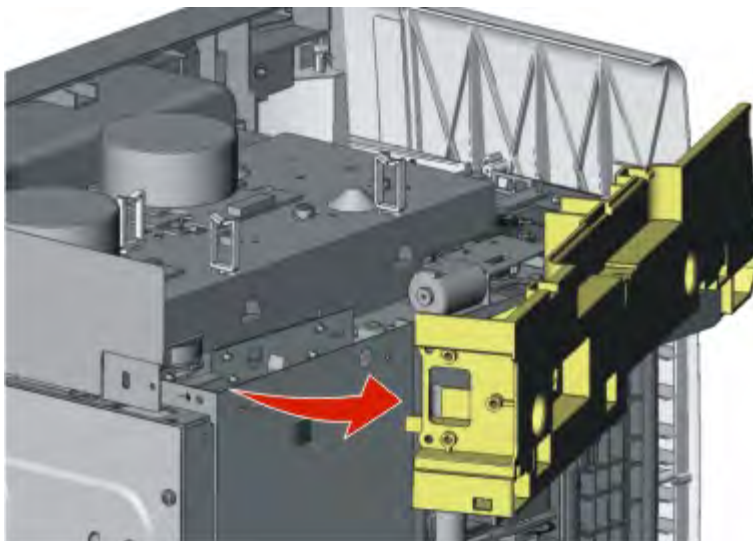

## Lower Right Frame Removal

1. Remove the tray insert.
2. Remove the waste toner bottle. See [Waste toner bottle removal](#).
3. Remove the imaging kit. See [Imaging kit removal](#).

## Parts Removal

4. Remove the screw (A), and then remove the four screws (B).

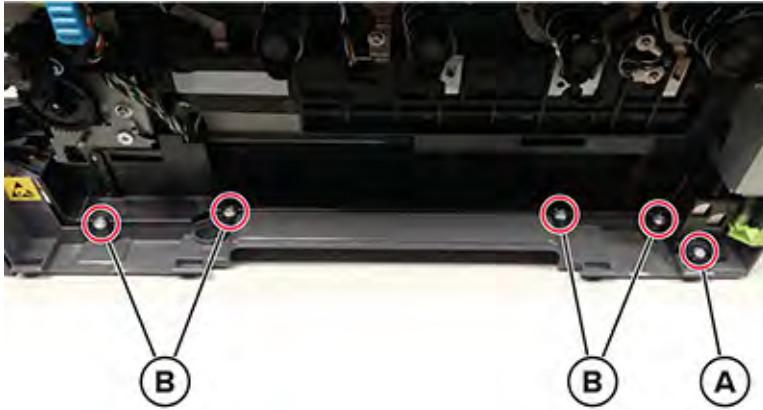

### Note:

- Do not unplug the waste toner bottle sensor contact.
  - The cable cover is part of the lower right frame.
5. Place the printer on its left side.
  6. Remove the four screws (C).

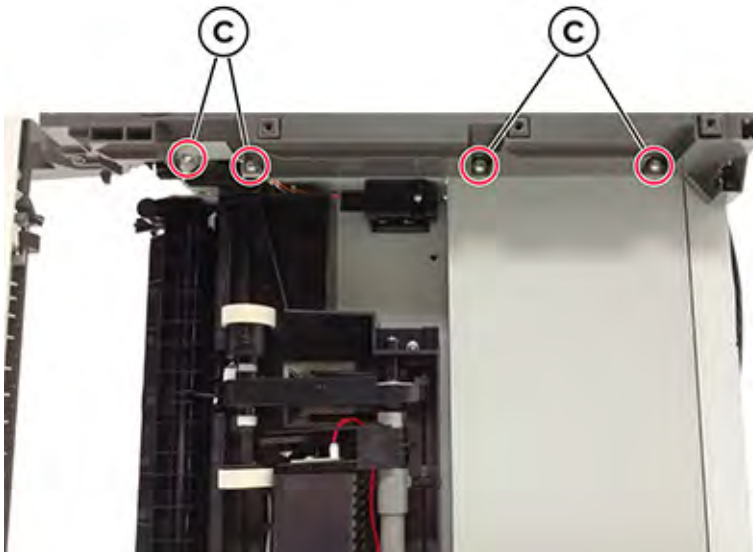



7. Lift the lower right frame pin (D) out of the hole on the printer frame.

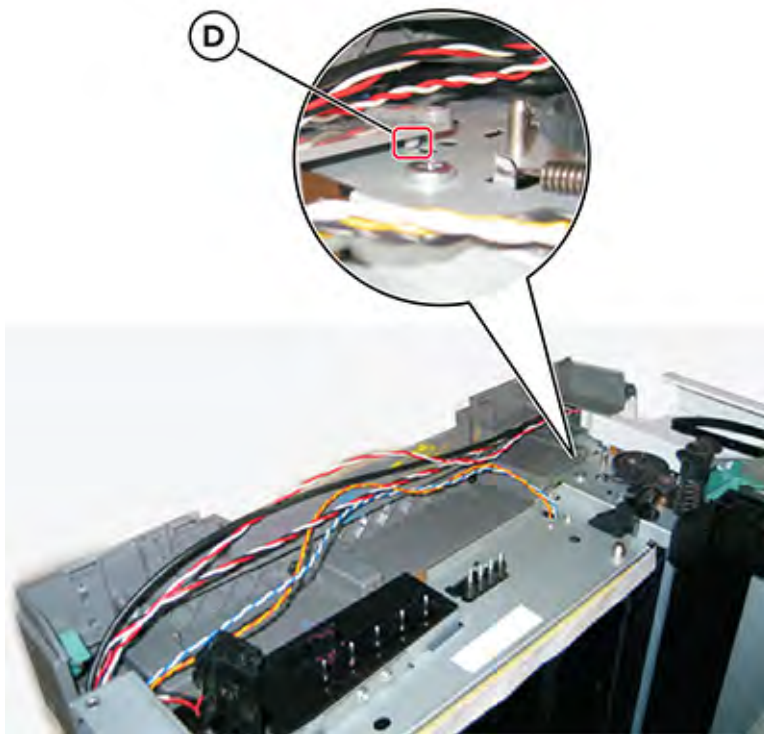

8. Remove the sensor retainer plate (E).

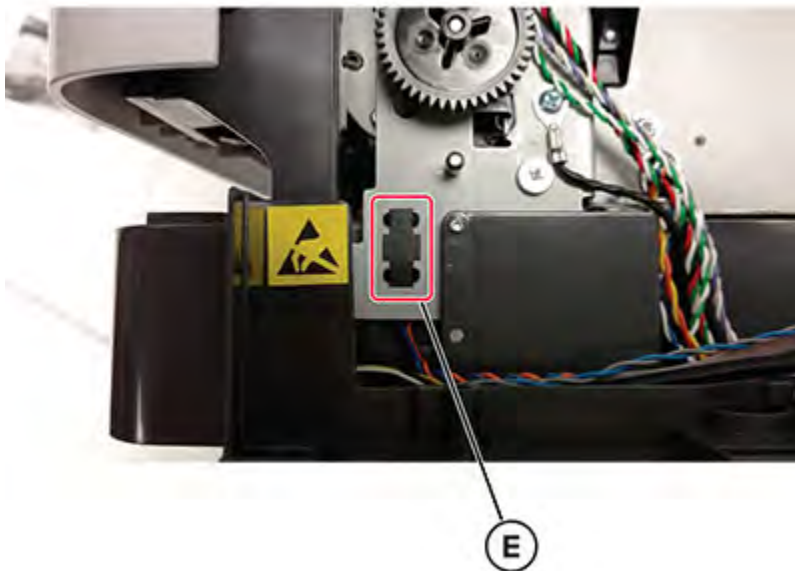

## Parts Removal

9. Remove the sensor, and then disconnect the cable (F).

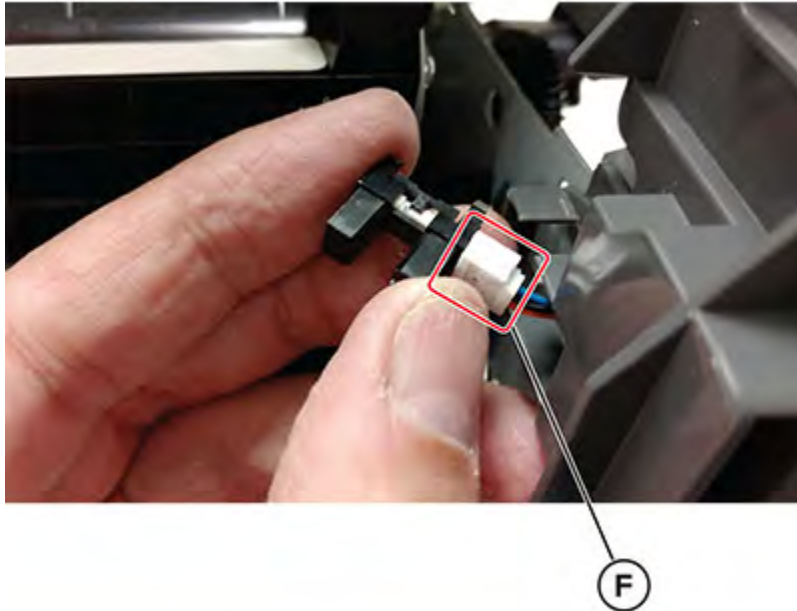

10. Swing the rear part away from the printer, and then remove the spring (G).

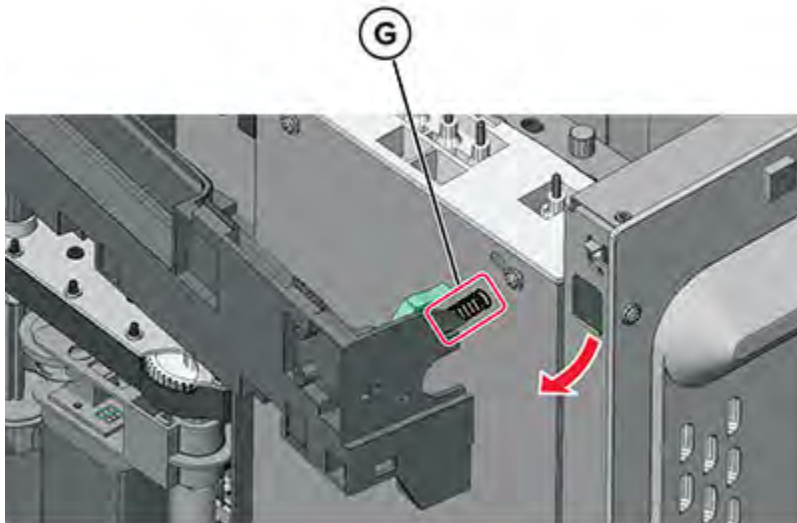

11. Disconnect the cable (H).

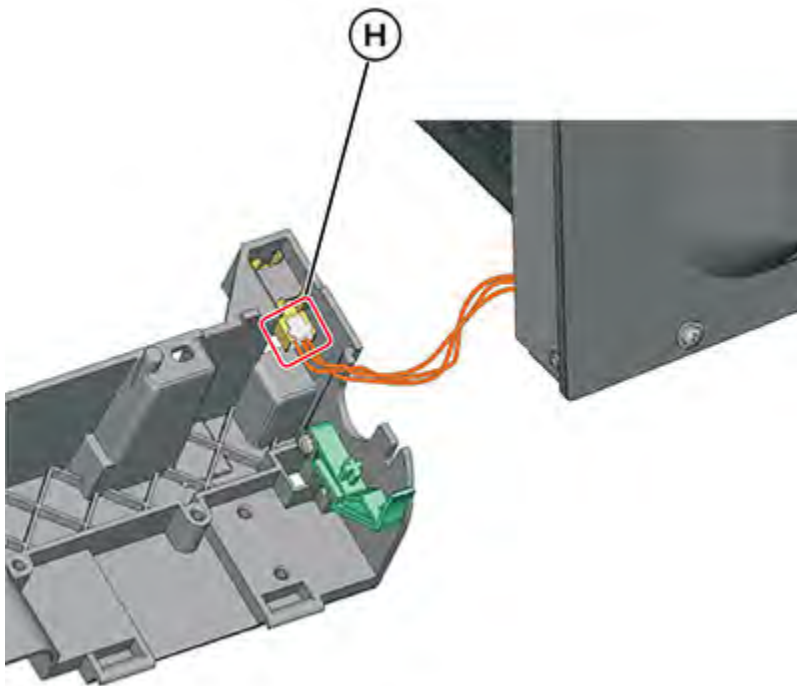

12. Swing the rear of the lower right frame away from the printer to remove it.

## Parts Removal

13. From inside the lower right frame, remove the screw (I), and then remove the spring bracket.

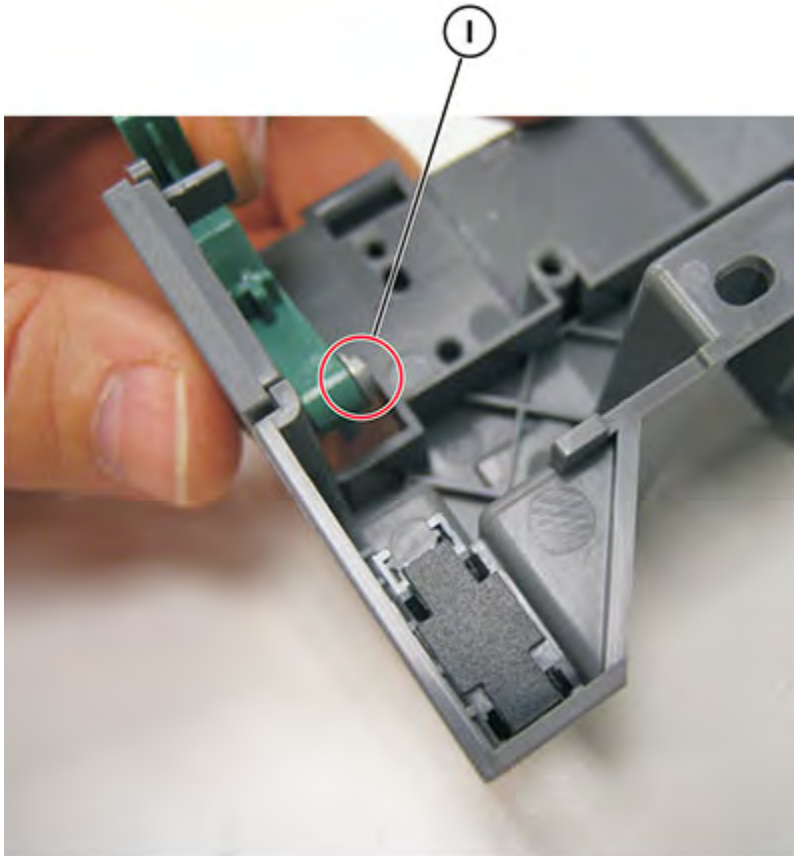

14. Disconnect the cable (J), remove the screw (K), and then remove the sensor (L).

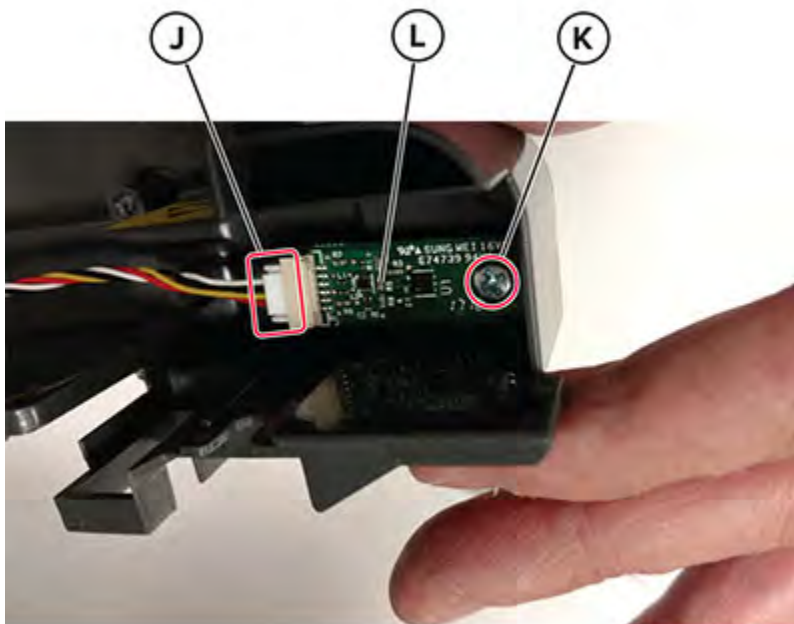

**Installation notes:**

- a. Reinstall the spring bracket and the weather station.
- b. Before installing the lower right frame, connect the cable to the sensor (tray present), and then put the spring in place.
- c. Install the weather station on the new lower right frame.

## Sensor (Duplex) Removal

1. Remove the imaging kit. See [Imaging kit removal](#).
2. Remove the two screws (A).

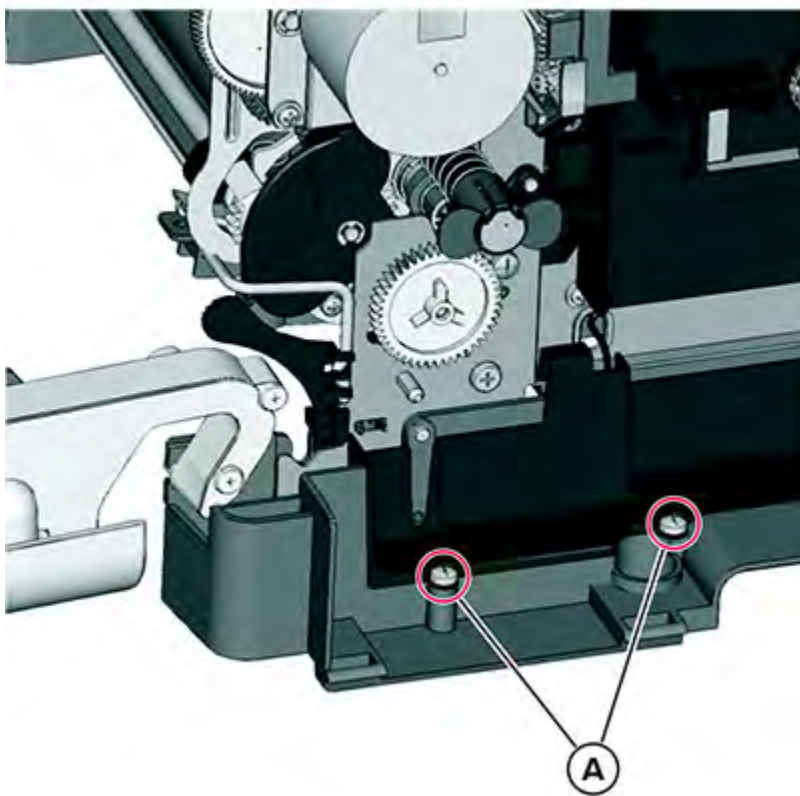

## Parts Removal

3. Pull the corner of the cable cover (B) away from the right side to access the two sensor posts (C).

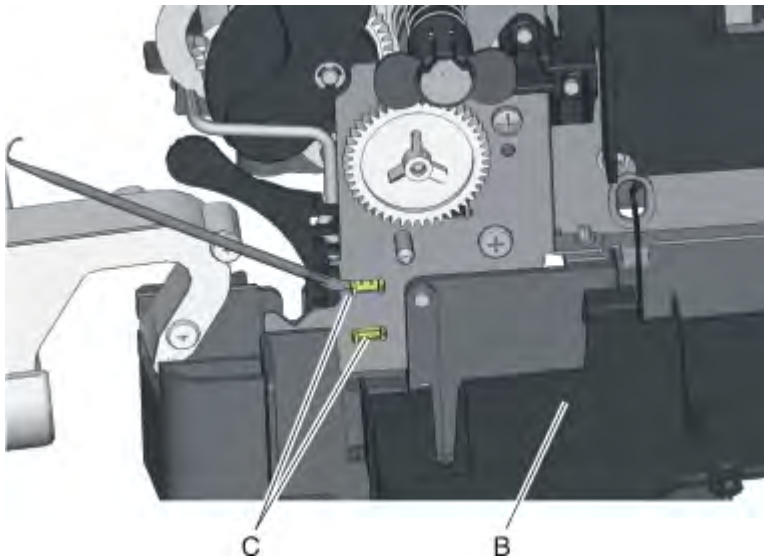

4. Remove the sensor plate (D).

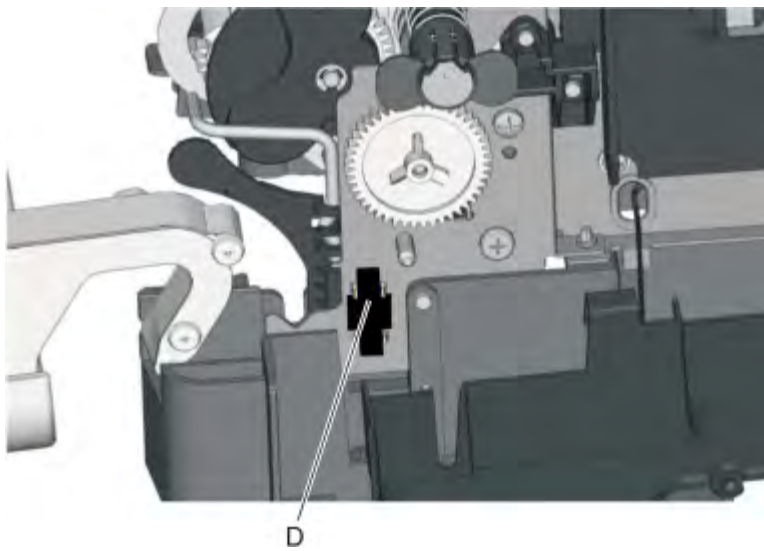

5. Press on the latches to detach the sensor from the printer frame.
6. Disconnect the cable (E).

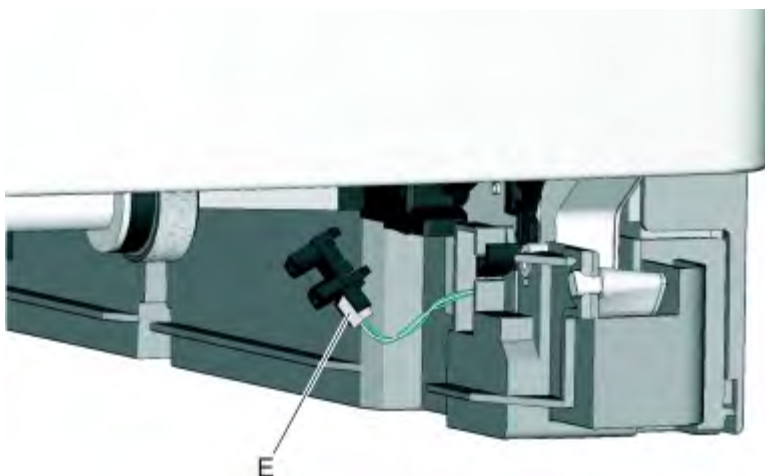

**Installation notes:**

- a. Clean the contact surface where the sensor retaining plate was removed before installing the new sensor.

 **Note:** Make sure that the clamps on the sensor legs are securely attached to the printer frame.

- b. Remove the backing from the new sensor retaining plate, and then place the plate on the surface between the sensor mounting latches.

## Transfer Module Guide Removal

1. Remove the tray insert.
2. Remove the right cover. See [Right cover removal](#).
3. Remove the waste toner bottle. See [Waste toner bottle removal](#).
4. Remove the imaging kit. See [Imaging kit removal](#).
5. Remove the transfer module. See [Transfer module removal](#).
6. Remove the fuser. See [Fuser removal](#).
7. Remove the left cover. See [Left cover removal](#).
8. Remove the LVPS. See [LVPS removal](#).
9. Remove the lower right frame. See [Lower right frame removal](#).

## Parts Removal

10. Remove the screw (A).

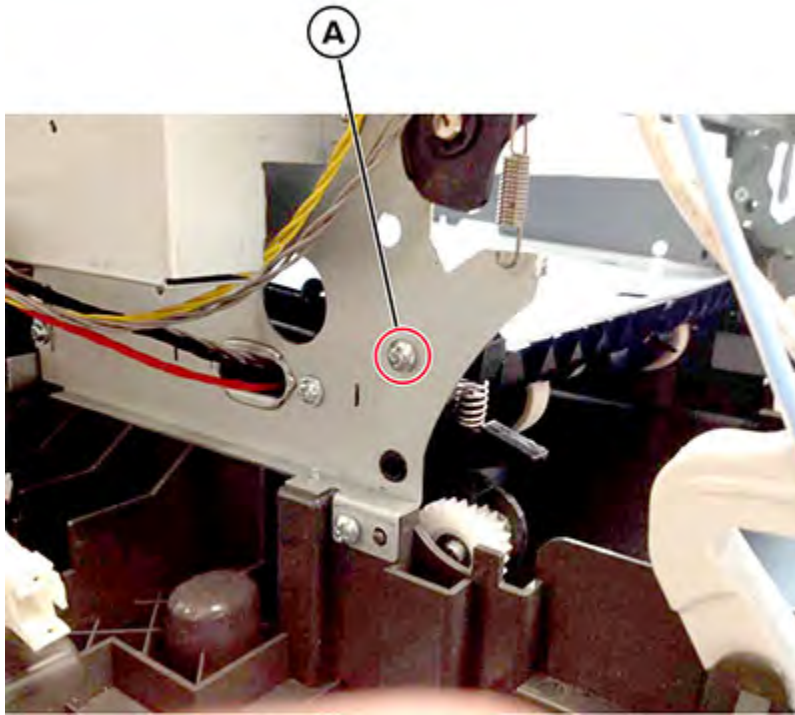

11. Remove the two screws securing the transfer module guide to the frame.

 **Note:** Use either a short #2 Phillips or a right angle screwdriver.





12. Remove the spring (B).

 **Note:** Pay attention to how the spring is attached to the bail.

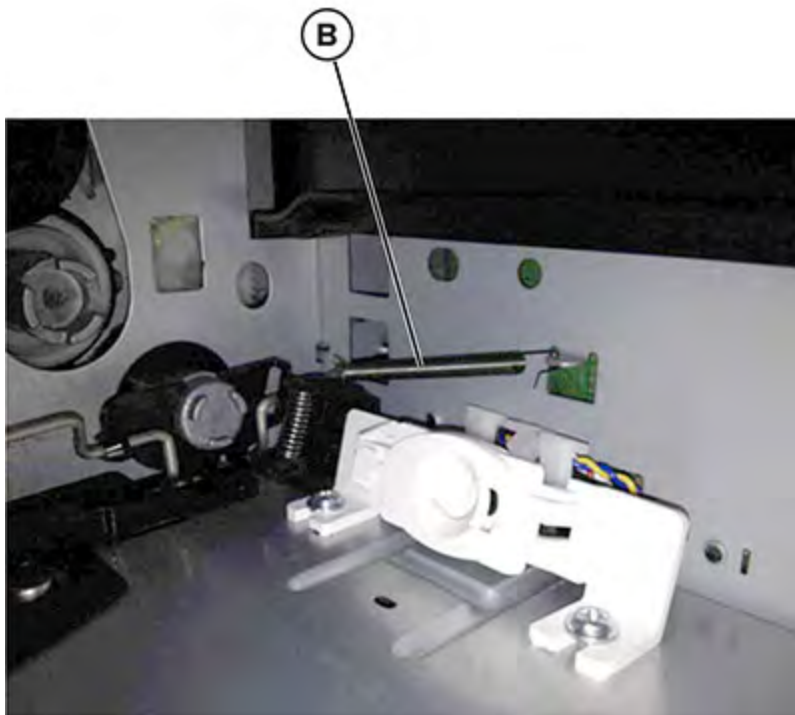

13. Using a spring hook or screwdriver, press and hold the transfer module drive coupling (C), and then tilt the guide up from the side with the screw holes to remove it.

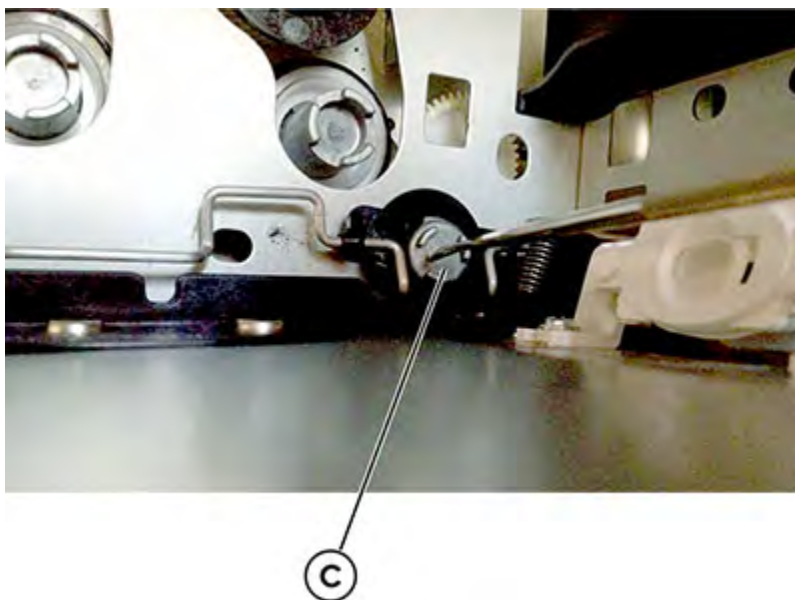

## Sensor (Tray Present) Removal

1. Remove the imaging kit. See [Imaging kit removal](#).
2. Remove the screw (A) securing the waste toner bottle sensor contact to access the cable cover.

 **Note:** Do not unplug the waste toner bottle sensor contact.

3. Remove the four screws (B), and then remove the cable cover.

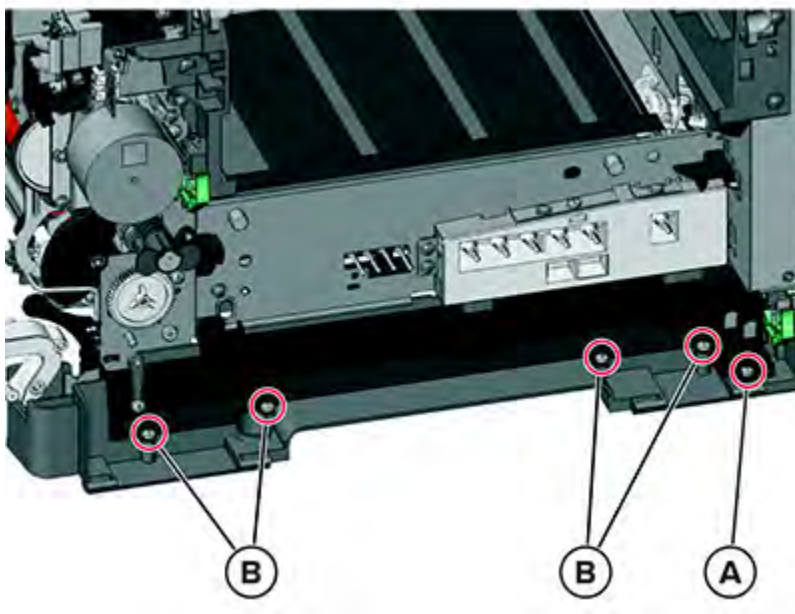

4. Remove the lower right frame. See [Lower right frame removal](#).
5. Remove the sensor retaining plate (C), and then press on the latches together to remove the sensor.

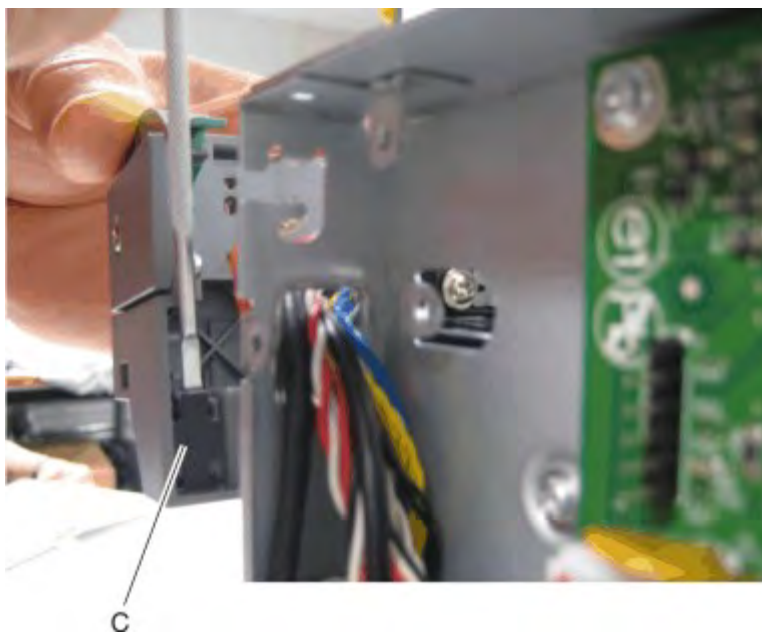

6. Disconnect the sensor cable.

**Installation notes:**

- a. Clean the contact surface where the sensor retaining plate was removed before installing the new sensor.
- b. Remove the backing from the new sensor retaining plate, and then place the plate on the surface between the sensor mounting latches.
- c. Connect the cable to the sensor.
- d. Replace the spring.

## Tray 1 Media Feeder Removal

1. Remove the waste toner bottle. See [Waste toner bottle removal](#).
2. Remove the imaging kit. See [Imaging kit removal](#).
3. Remove the left cover. See [Left cover removal](#).
4. Remove the rear cover. See [Rear cover removal](#).
5. Disconnect the cable (A) from the JSP1 connector on the controller board.
6. Route the cable through the opening (B), and then remove the cable from its retainer (C).

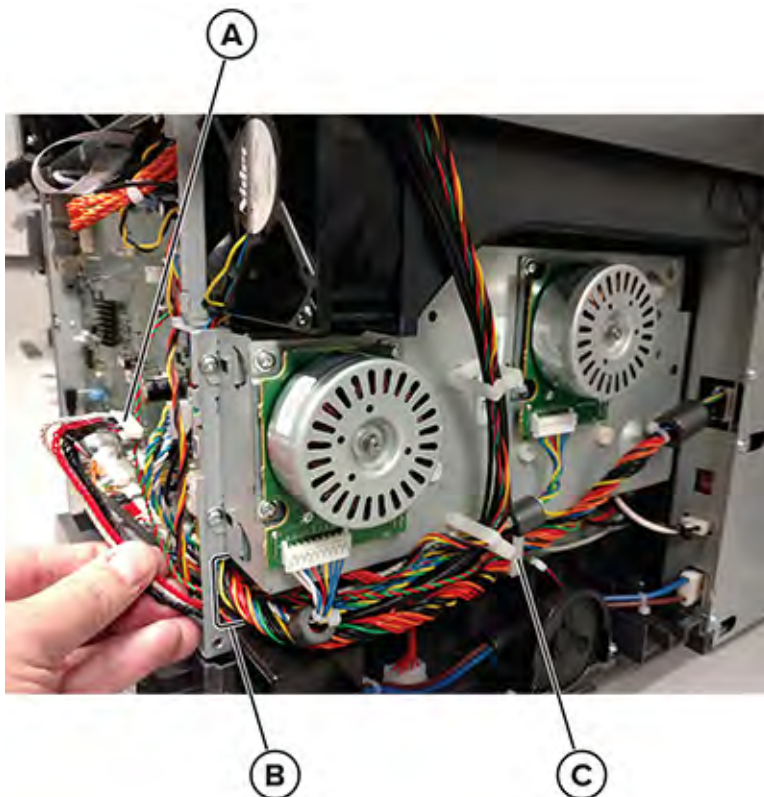

7. Partially reinstall the rear cover to protect the controller board.

## Parts Removal

8. Place the printer on its rear, and then remove the two screws (D).

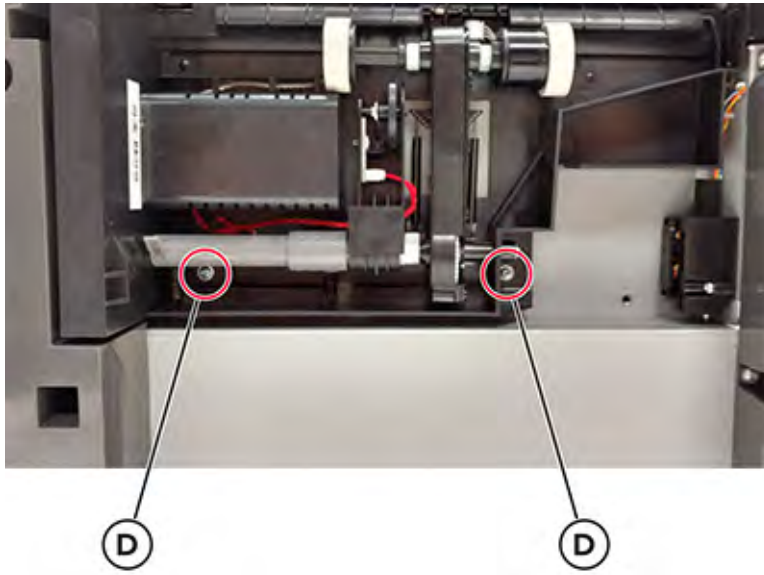

9. On the right side, loosen the screw (E) with a screwdriver, and then remove it while holding the paper feed roller assembly.

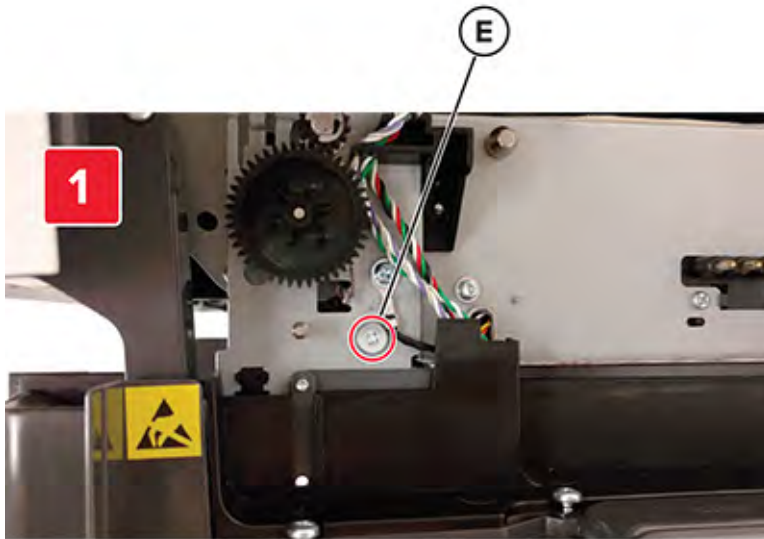

10. Move the right side of the paper feed roller assembly out to free the shaft from the opening in the frame.

 **Note:** Pay attention to the location of the shaft and the opening in the frame.

11. Remove the paper feed roller assembly.

**Installation notes:**

- a. Place the left side of the paper feed roller assembly in the printer. Make sure that the shaft on the left side aligns with the hole in the frame.
- b. Reinstall the three screws holding the paper feed roller assembly to the printer.
- c. Place the printer on the upright position.
- d. Reroute the cable, and then make sure to secure the cable in its retainer on the left side.

## Parts Removal

- e. Remove the rear cover, and then reconnect the cable on the controller board.
- f. Replace the rear cover.



## Rear Side Removals

### System Fan Removal

1. Remove the rear cover. See [Rear cover removal](#).
2. Remove the left cover. See [Left cover removal](#).
3. Disconnect system fan cable from the controller board.
4. Remove the two screws (A).



## Parts Removal

5. Detach the fan.

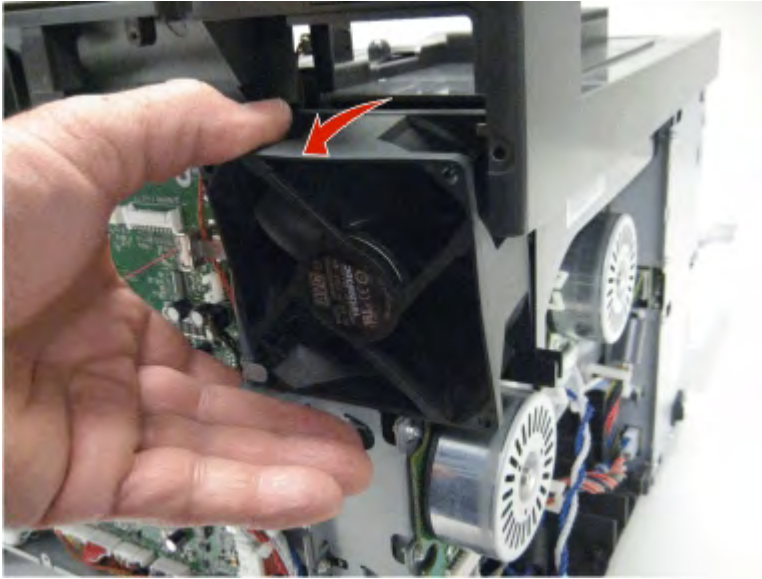

6. Lift, and then remove the fan.

## Rear Cover Removal

1. Remove the eight screws (A).

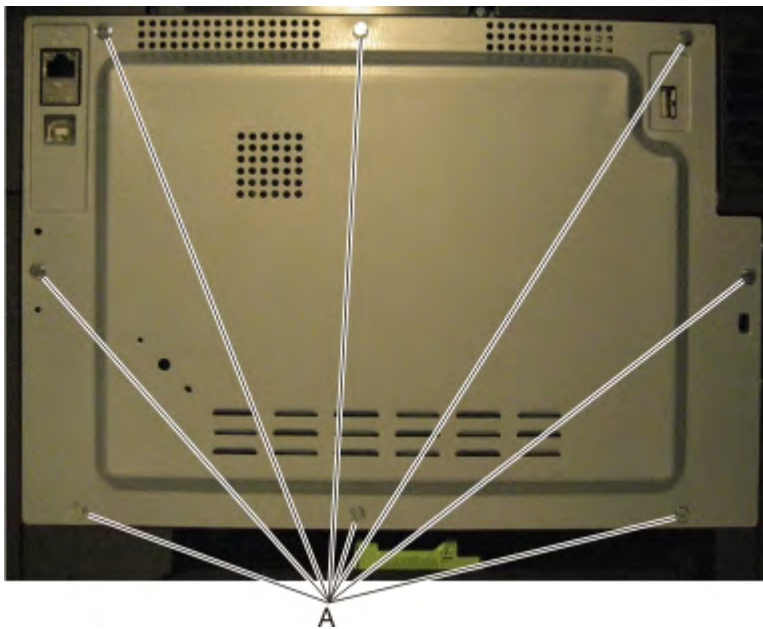



2. Swing the cover out, and then slide to the right to remove.

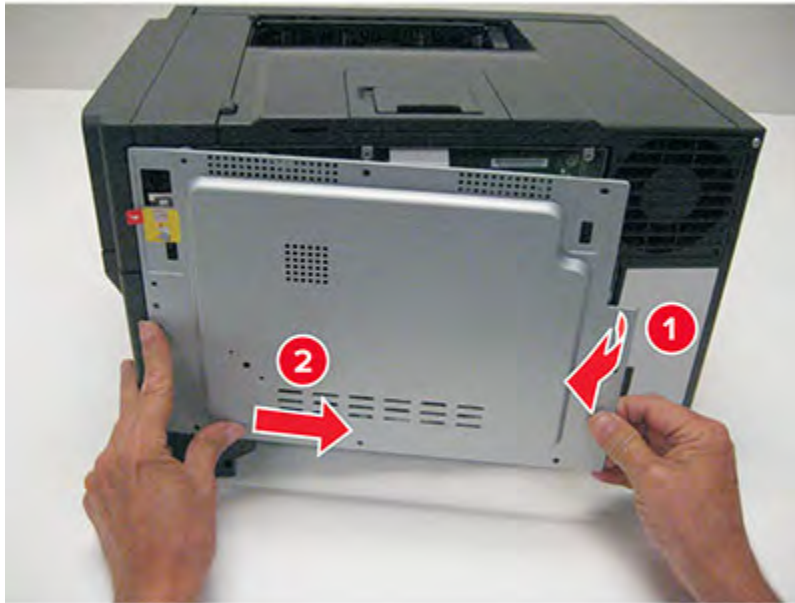

 **Note:** Installation note: When installing the rear cover, make sure that the latch (C) is inserted into the bracket (B).

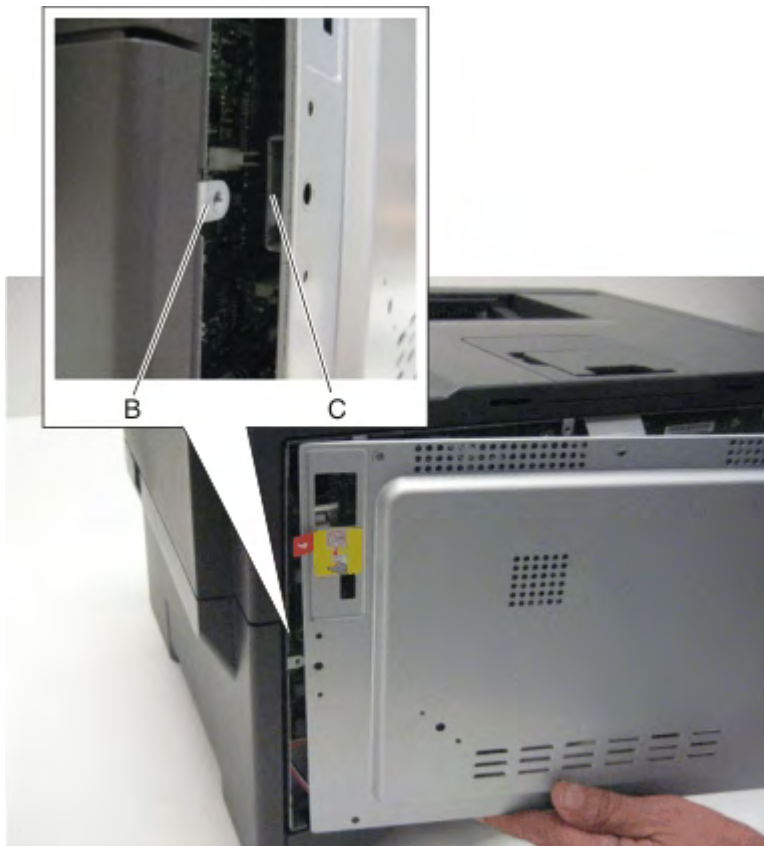

## Controller Board Removal

**Warning:** After disconnecting the HVPS cable from the controller board, make sure that the HVPS connector is not damaged.

**Warning:** Observe all precautions when handling ESD-sensitive parts. See [Handling ESD-sensitive parts](#).

**Warning:** Perform a POR after replacing one of the following components. Do not replace both components without performing a POR after installing each one.

- UICC
- Controller board

**Warning:** Do not install and remove the components listed above as a method of troubleshooting components. After one of these components is installed in the printer and the printer is powered on, the component cannot be used in another printer. The component must be returned to the manufacturer.

1. Remove the rear cover. See [Rear cover removal](#).
2. Disconnect all the cables from the controller board.
3. Remove the six screws (A).

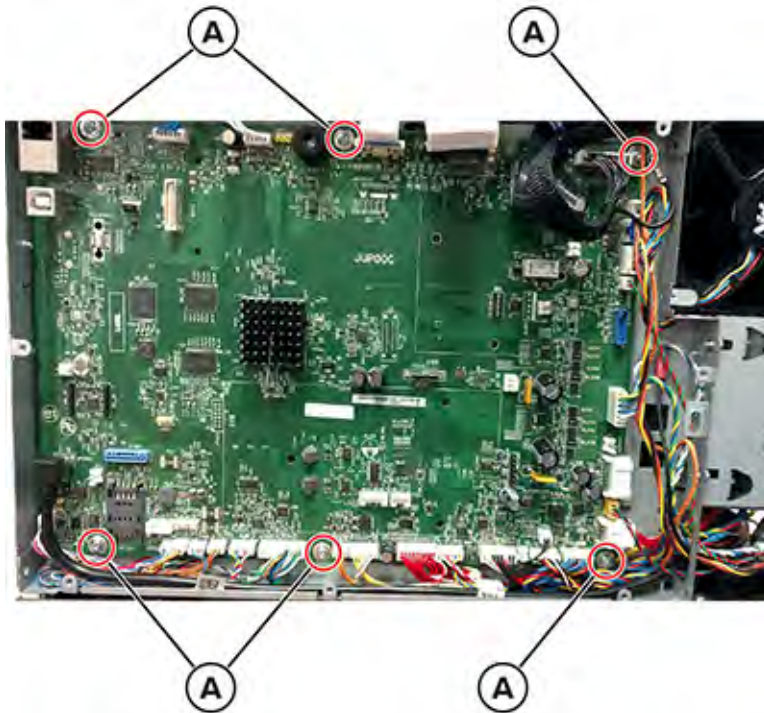

4. Remove all the USB ground clips (B) from the USB connectors.

 **Note:** Do not lose the ground clips. They will be used on the new controller board.

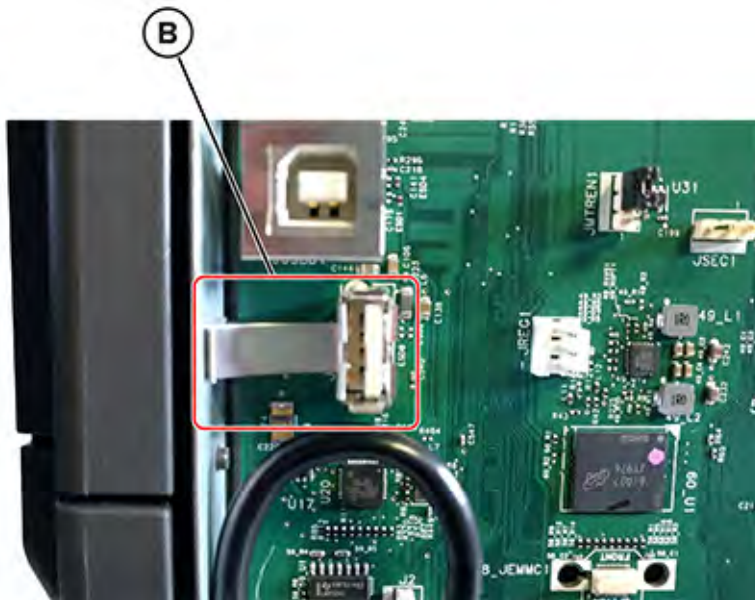

 **Note:** Installation note: Perform the printhead registration and alignment. See [Registration adjustment](#).

## Top Side Removals

### Top Cover Removal

1. Remove the right cover assembly. See [Right cover removal](#).
2. Remove the waste toner bottle. See [Waste toner bottle removal](#).
3. Remove the imaging kit. See [Imaging kit removal](#).
4. Remove the rear cover. See [Rear cover removal](#).
5. Disconnect the fan cable from JFAN1 (A) on the controller board, and then remove the screw (B).

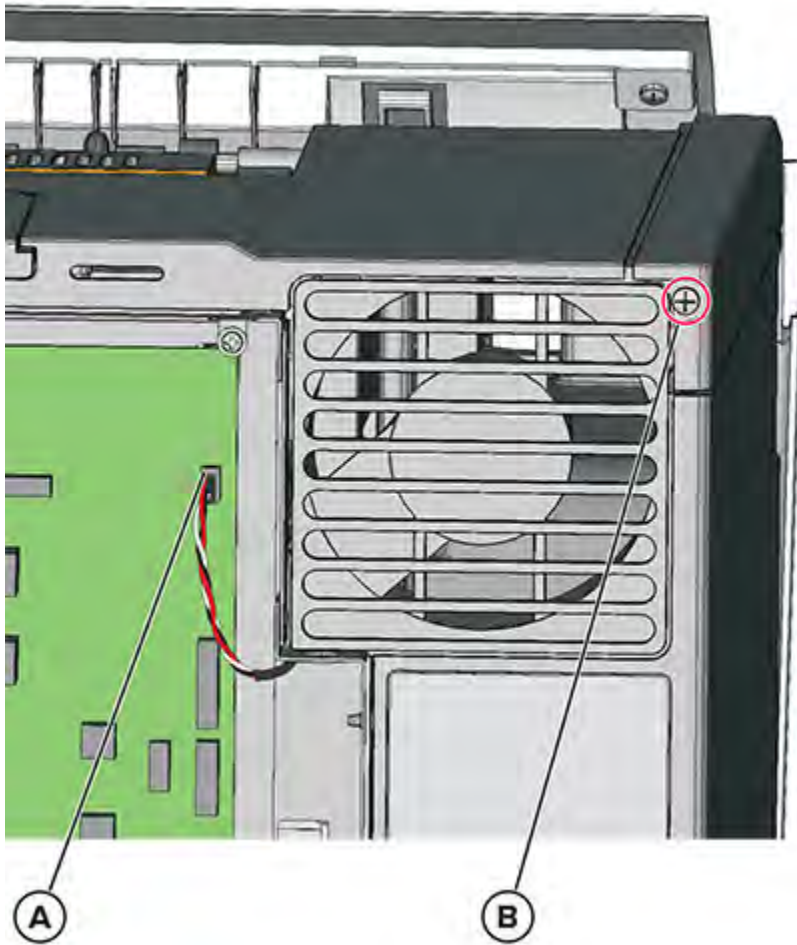

6. Remove the two screws (C), and then remove the ground cable from the cover.

7. Lift the paper stop, and then remove the screw (D).

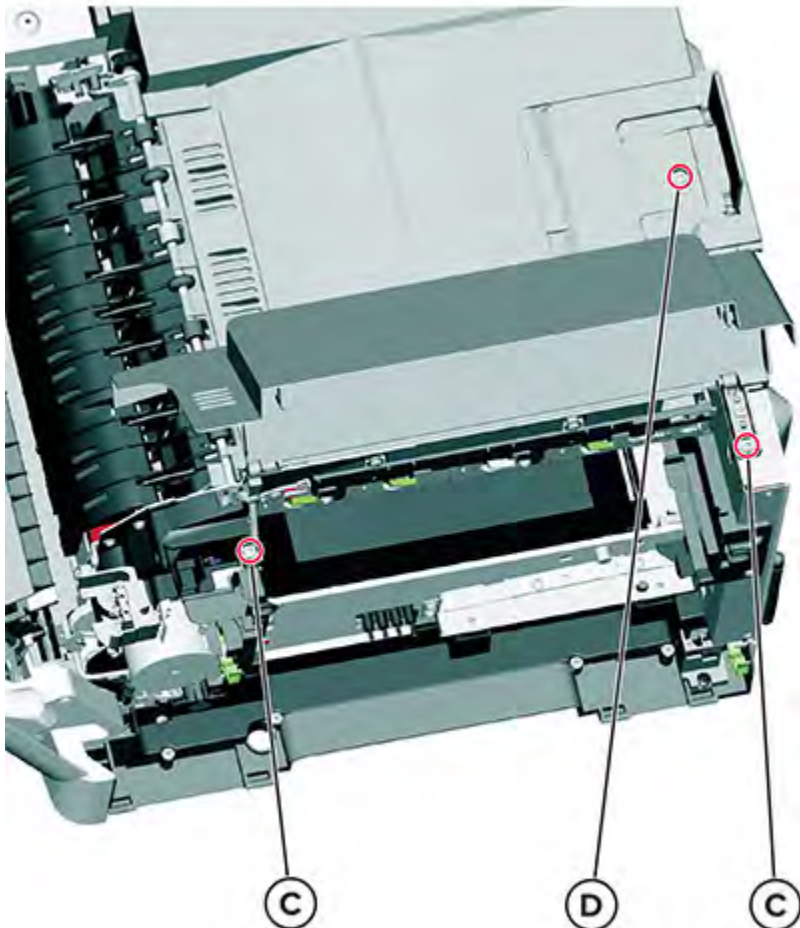

8. Remove the right output bin deflector. See [Right Output Bin Deflector Removal](#) .
9. Remove the narrow media/bin full sensor flag. See [Narrow Media/bin Full Sensor Flag Removal](#) .



## Parts Removal

10. Remove the two screws (E).

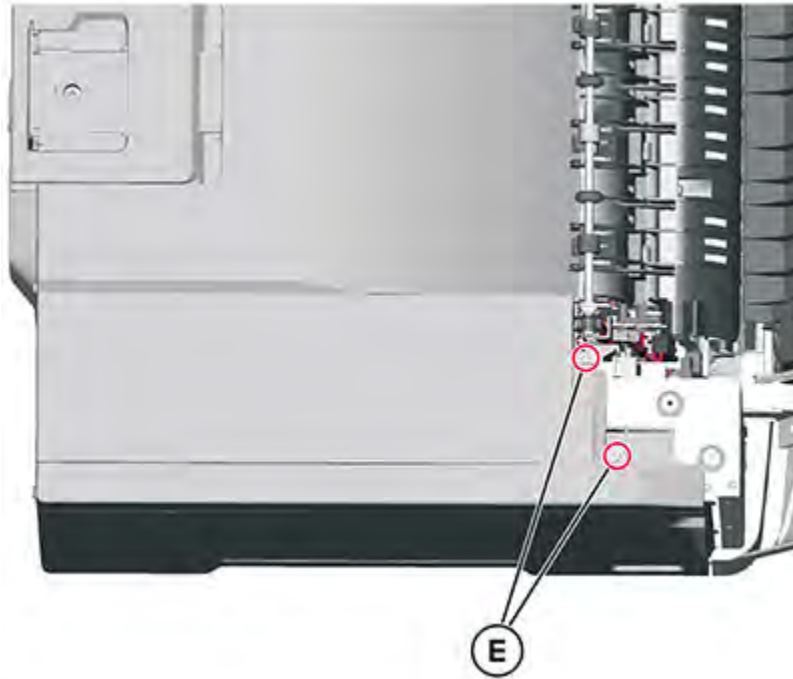

11. Remove the four screws (F), and then remove the fuser screw (G).

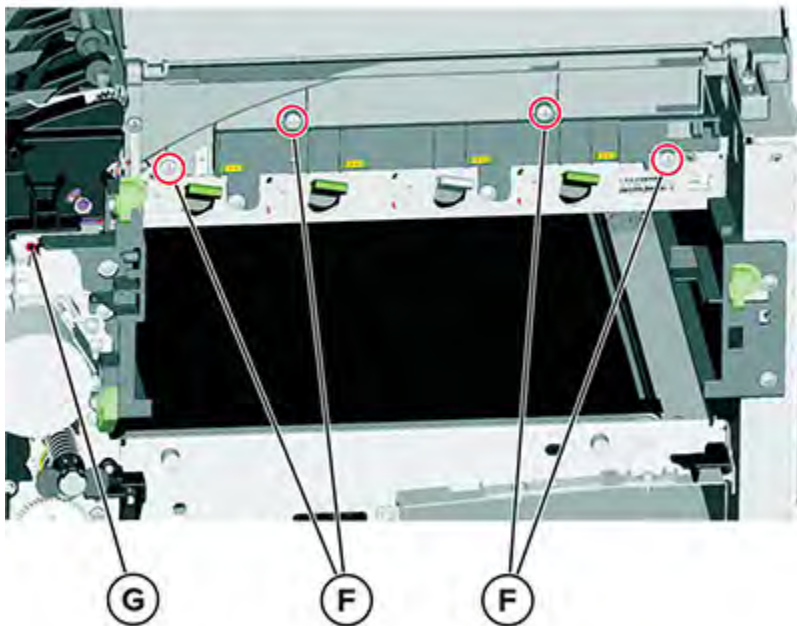

12. Push in on the cover above the locating pins (H) while lifting to disconnect the cover.

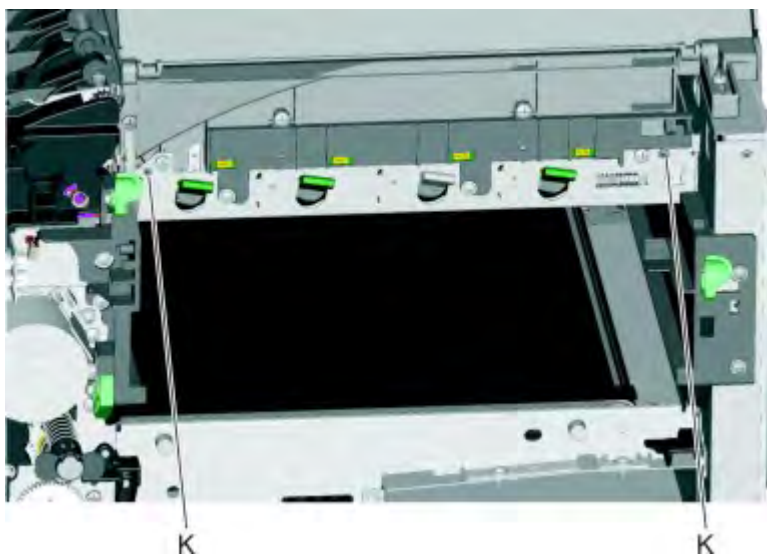

13. Carefully lift the cover while keeping it horizontal, and then guide the fan connector through the opening.

## Sensor (narrow Media/output Bin Full) Removal

1. Open the front door.

## Parts Removal

2. Remove the cable (A) from its retainer, and then disconnect it.

 **Note:** Installation note: Pay attention to the cable routing.

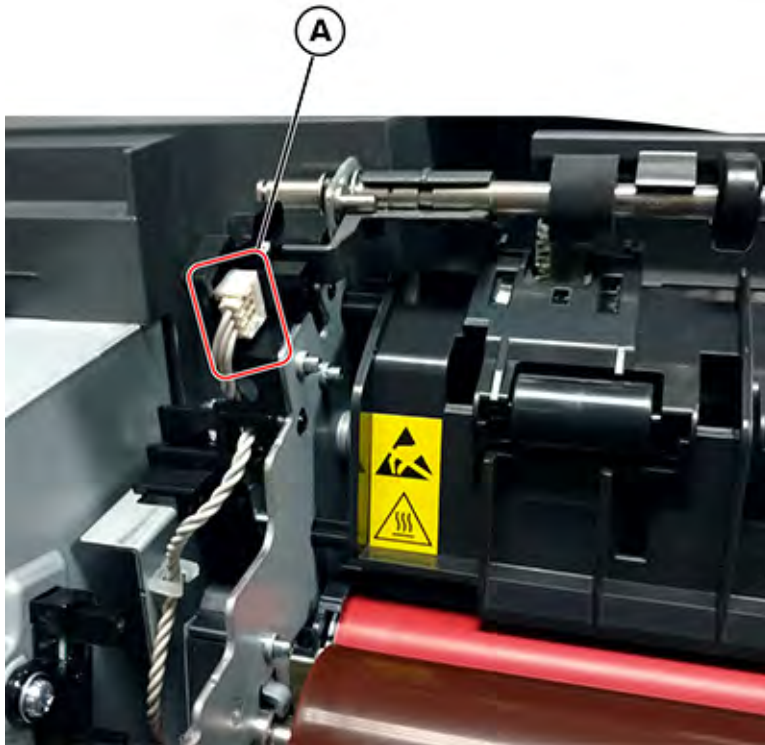

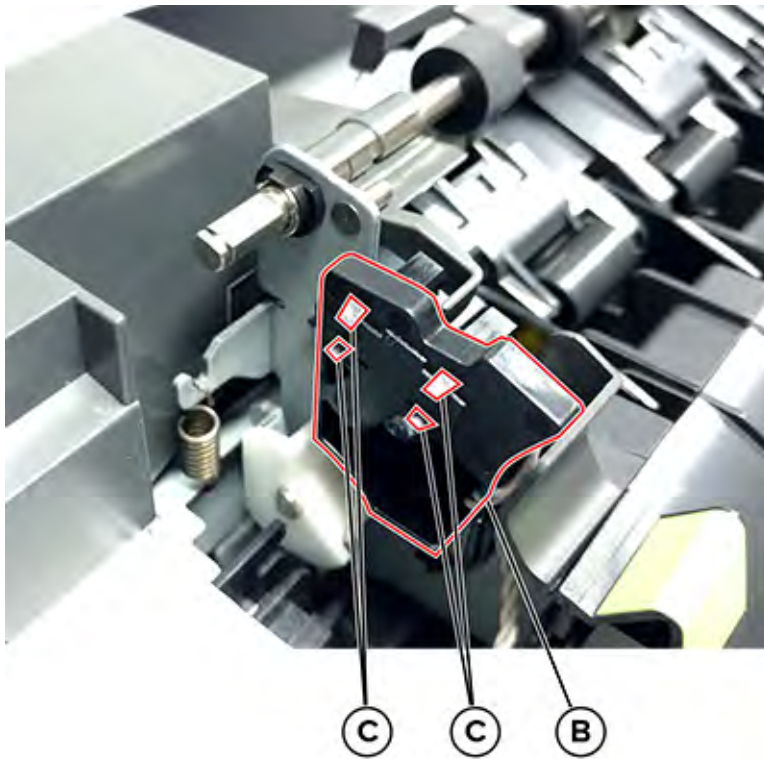

3. Remove the sensor retaining plate (B), and then pinch the four latches (C) to remove the sensor.

**Installation notes:**

- Clean the contact surface where the sensor retaining plate was removed before installing the new sensor.
- Guide the latches that hold the sensor to the bracket.
- Squeeze the latches together until they latch to the frame.
- Remove the backing from the new sensor retaining plate, and then place the plate on the surface between the sensor mounting legs.
- Reconnect the cable, and then guide the cable through its retainer.

## Narrow Media/Bin Full Sensor Flag Removal

1. Open the front door.

## Parts Removal

2. Push up on the tab to release the flag, and then remove it.

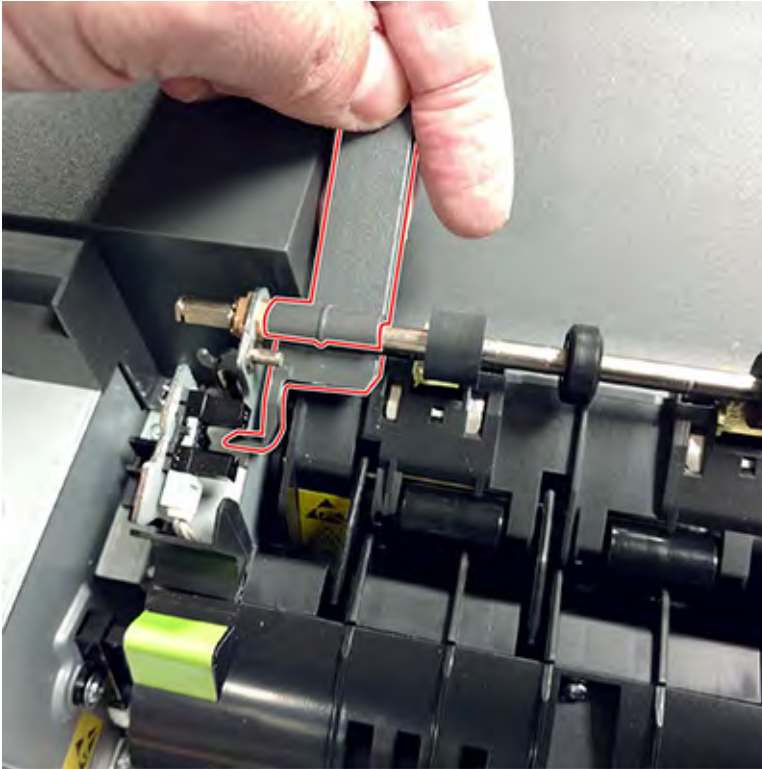

 **Note:** Be careful not to dislodge the sensor. The flag must be installed on the fuser while the fuser is out.

## Printhead Removal

1. Remove the rear cover. See [Rear cover removal](#).
2. Remove the top cover. See [Top cover removal](#).

3. Disconnect the two cables (A).

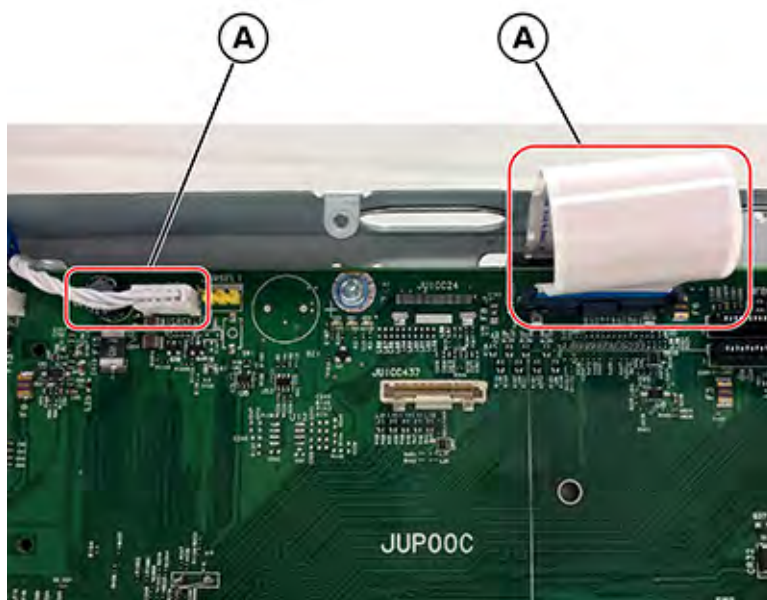

4. Remove the three screws (B), and then remove the printhead.

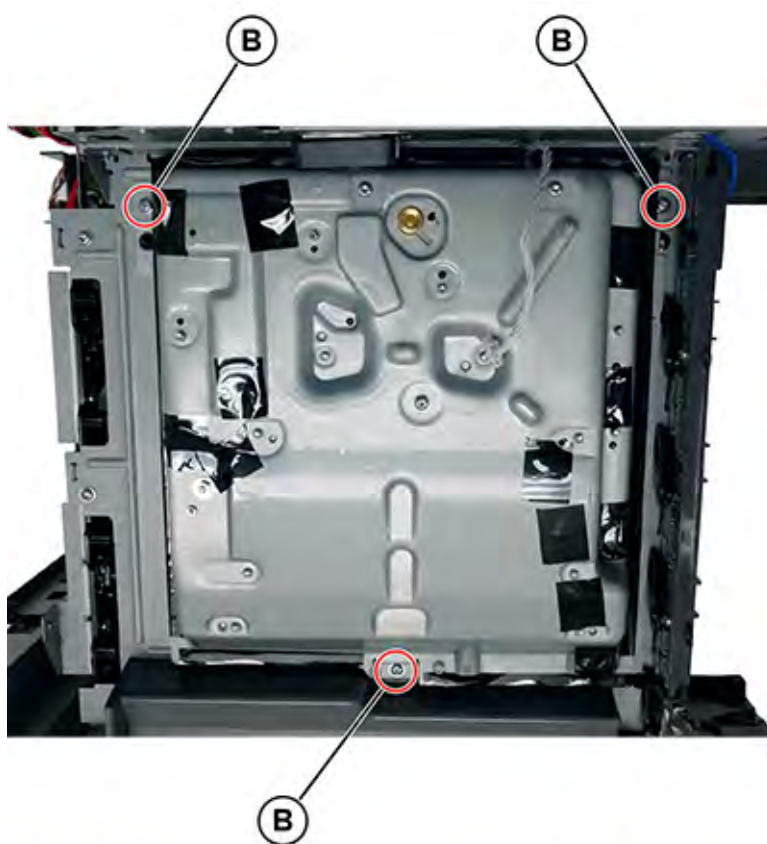

 **Note:** Installation note: Make sure to perform the registration adjustments after replacing the printhead. See [Registration adjustment](#).

## Right Output Bin Deflector Removal

1. Open the front door.
2. Remove the deflector (A).

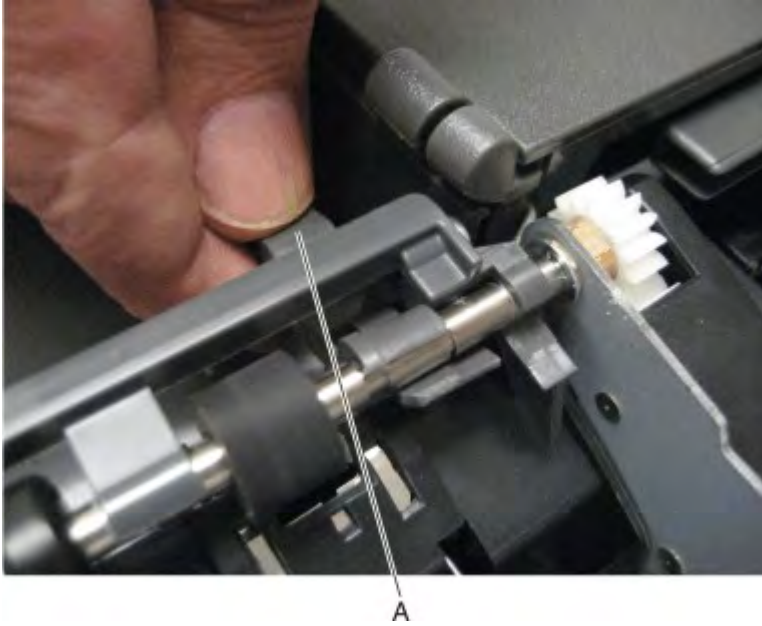

## Options Removals

### 650-sheet Duo Tray Insert Removal

Pull out to remove the tray insert.



### 650-sheet Duo Tray Removal

**⚠ Warning:** Make sure that the printer is turned off before removing the tray.

1. Carefully lift the printer, and set it aside on a flat surface.

## Parts Removal

2. Remove the tray.



## Dust Cover Removal

1. Slightly raise the dust cover.

2. Pull the dust cover to remove.

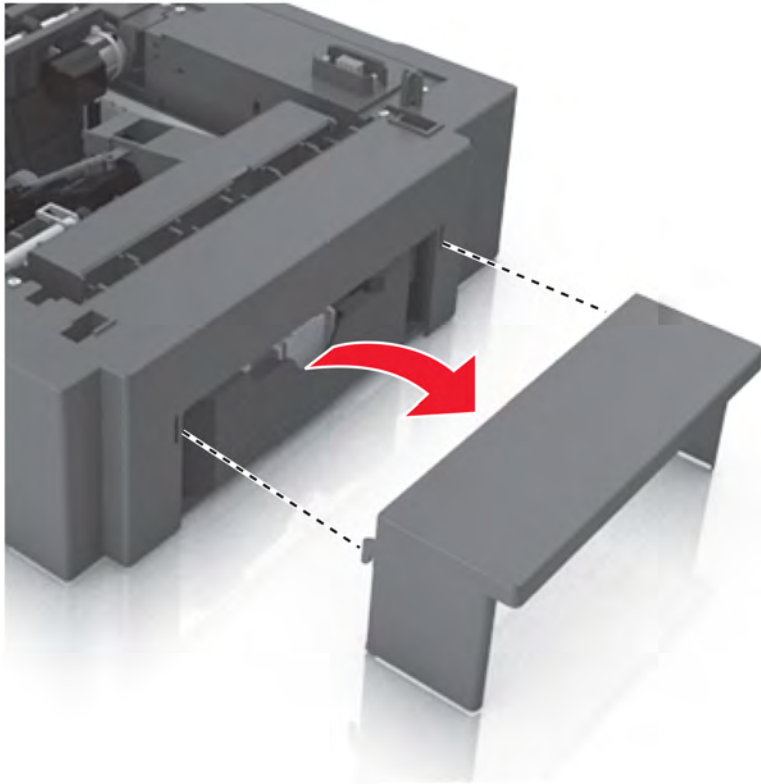

## Pick Tire Removal

1. Remove the tray insert.



## Parts Removal

2. Lower the auto compensator mechanism (A).





3. Remove the rubber tires (B) from the pick roll assembly (C). Repeat for the other tire (D).

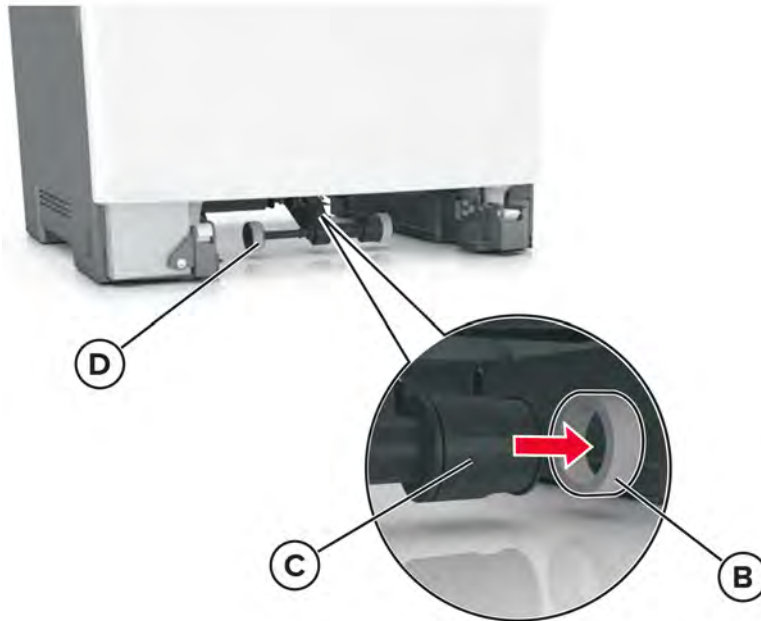

 **Note:** Installation note: Install the new rubber tire with its surface texture turning in the direction as shown.



 **Note:** Feel each rubber surface to verify it turns properly in the direction shown.



# Component Locations

## Printer Configurations



1	Control panel The appearance may vary depending on your printer model.
2	Standard bin
3	Standard 250-sheet tray
4	Manual feeder
5	Optional 650-sheet duo tray
6	Optional 550-sheet tray

## Controller Board Connectors

Connector	Connects to	Pin no.	Signal
JCTM1	Cartridge toner metering card	1	+5V_SW
		2	Cartridge Meter C
		3	Cartridge Meter M
		4	Cartridge Meter Y
		5	Cartridge Meter K
		6	GND
JMIRR1	Printhead mirror motor card	1	Mirror Mtr REF Clock
		2	Mirror Mtr Lock Signal
		3	Mirror Mtr Start Signal
		4	GND
		5	+25V
JUICC24	2.4-inch control panel	1	LED_DRV_YLW
		2	+6.5V
		3	GSPI_TXD
		4	MIR_SPI_CS-
		5	PWR_BUTTON
		6	LCD_RS
		7	LCD_TE
		8	GSPI_RDX
		9	SRDYBLE
		10	GSPI_CLK
		11	GND

## Component Locations

Connector	Connects to	Pin no.	Signal
		12	I2C1_DATA
		13	I2C1_CLK
		14	NFC_nCS
		15	UI_RESET-
		16	UI_IRQ-
		17	GND
		18	LCD_WR
		19	LCD_RD
		20	+5VL
		21	LCD_D0
		22	LCD_D1
		23	GND
		24	LCD_D2
		25	LCD_D3
		26	+5VL
		27	LCD_D4
		28	LCD_D5
		29	GND
		30	LCD_D6
		31	LCD_D7
32	+5VL		
JUICC43	4.3-inch control panel	1	LED_DRV_YLW
		2	+6.5V

Connector	Connects to	Pin no.	Signal
		3	GSPI_TXD
		4	MIR_SPI_CS-
		5	PWR_BUTTON
		6	NFC_nCS
		7	SRDYBLE
		8	GSPI_RDX
		9	+5VL
		10	GSPI_CLK
		11	GND
		12	I2C1_DATA
		13	I2C1_CLK
		14	+5VL
		15	UI_RESET-
		16	UI_IRQ-
		17	GND
		18	LCD_LVDS_D3+
		19	LCD_LVDS_D3-
		20	+5VL
		21	LCD_LVDS_CLK+
		22	LCD_LVDS_CLK-
		23	GND
		24	LCD_LVDS_D2+
		25	LCD_LVDS_D2-

## Component Locations

Connector	Connects to	Pin no.	Signal
		26	+5VL
		27	LCD_LVDS_D1+
		28	LCD_LVDS_D1-
		29	GND
		30	LCD_LVDS_D0+
		31	LCD_LVDS_D0-
		32	+5VL
JPH1	Printhead laser card	1	LADJ_D4
		2	I2C Data
		3	+3.3V
		4	I2C Clock
		5	GND
		6	SHADE_Y
		7	LADJ_D2
		8	SHADE_C
		9	LENA_CMY-
		10	LPOW_Y
		11	GND
		12	LPOW_C
		13	BOOST
		14	SHADE_M
		15	LADJ_D1
		16	SHADE_K



Connector	Connects to	Pin no.	Signal
		17	+5V_PH
		18	LPOW_M
		19	GND
		20	LPOW_K
		21	LENA_K-
		22	Printhead Thermistor
		23	GND
		24	HSYNC
		25	+5V_PH
JPH1	Printhead laser card	26	Y_DATA2-
		27	Y_DATA2+
		28	GND
		29	Y_DATA1-
		30	Y_DATA1+
		31	GND
		32	M_DATA2-
		33	M_DATA2+
		34	GND
		35	M_DATA1-
		36	M_DATA1+
		37	GND
		38	C_DATA2-
		39	C_DATA2+

## Component Locations

Connector	Connects to	Pin no.	Signal
		40	GND
		41	C_DATA1-
		42	C_DATA1+
		43	GND
		44	K_DATA2-
		45	K_DATA2+
		46	GND
		47	K_DATA1-
		48	K_DATA1+
		49	GND
		50	LADJ_D3
JUIPWR1	Control panel card	1	1. +5VL
		2	GND
JFAN1	Fan	1	GND
		2	+25V
		3	Fan Tach
		4	Fan PWM
JSPKR1	Speaker from audio DAC	1	Speaker +
		2	Speaker -
JCARTP1	K/ITM BLDC Mtr & CMY BLDC Mtr	1	K/ITM Winding W
		2	K/ITM Winding V
		3	K/ITM Winding U
		4	CMY Winding W

Connector	Connects to	Pin no.	Signal
		5	CMY Winding V
		6	CMY Winding U
JLVPS1	LVPS	1	+6.5V
		2	GND
		3	+6.5V
		4	GND
		5	+6.5V
		6	GND
		7	+25V
		8	GND
		9	+25V
		10	GND
		11	+25V
		12	GND
		13	AC Relay On/Off
		14	Zero-Xing
		15	Fuser On/Off
		16	25V On/Off
JOPT1	Tray option connector	1	Printer TXD
		2	GND
		3	GND
		4	Printer RXD
		5	+25V

## Component Locations

Connector	Connects to	Pin no.	Signal
		6	GND
		7	+5VH
		8	Input (S2) Signal
		9	GND
		10	GND
JCARTS1	K/ITM & CMY BLDC hall effect sensor	1	K/ITM Hall_U
		2	K/ITM Hall_V
		3	K/ITM Hall_W
		4	K/ITM FG
		5	GND
		6	+5V_SW
		7	CMY Hall_U
		8	CMY Hall_V
		9	CMY Hall_W
		10	CMY FG
		11	GND
		12	+5V_SW
JTHM1	TPS thermistor	1	TPS Thermistor
		2	GND
JBIN1	Fuser exit optical sensor & bin-full / narrow media optical sensor	1	BF/NM Sensor Anode
		2	BF/NM Sense Voltage
		3	GND
		4	Fsr Exit Sensor Anode

Connector	Connects to	Pin no.	Signal
		5	Fsr Exit Sense Voltage
		6	GND
JSP1	AutoComp assembly	1	Quad Encdr LED Anode
		2	Pick Mtr(+)
		3	Quad Encdr LED Cathode
		4	Pick Mtr(-)
		5	+5V_SW
		6	GND
		7	GND
		8	GND
		9	Encoder Signal A
		10	Pick Mtr Encdr Sense Voltage
		11	Encoder Signal B
		12	Pick Mtr Encdr Anode
		13	GND
		14	Input (S2) Sensor Anode
		15	Input (S2) Sense Voltage
		16	GND
JTPS2	Left side TPS sensor	1	Sensor Anode
		2	Sensor Cathode
		3	GND
		4	LED Anode
		5	LED GND

## Component Locations

Connector	Connects to	Pin no.	Signal
JHVPS1	HVPS	1	+5V from HVPS
		2	GND
		3	M_Developer PWM
		4	K_Developer PWM
		5	C_Developer PWM
		6	CMY_Charge PWM
		7	Y_Developer PWM
		8	K_Charge PWM
		9	K_Transfer PWM
		10	CMY_Transfer PWM
		11	ITM_Transfer PWM
		12	GND
		13	CMY Analog Servo Voltage
		14	K Analog Servo Voltage
		15	ITM Analog Servo Voltage
		16	HVPS ID Voltage
		17	+25V after PFET (Q32)
		18	GND
JWS1	Weather station card	1	GND
		2	I2C_Clock
		3	GND
		4	I2C_Data

Connector	Connects to	Pin no.	Signal
		5	+3.3V
		6	GND
JFUSES2	Fuser, duplex/MPF optical sensor, and bubble optical sensor	1	Fuser Stepper-Mtr PhaseA1
		2	Fuser Stepper-Mtr PhaseA2
		3	Fuser Stepper-Mtr PhaseB1
		4	Fuser Stepper-Mtr PhaseB2
		5	Fuser Hot-Roll Thermistor
		6	GND
		7	Dplx/MPF Sensor Anode
		8	GND
		9	Dplx/MPF Sense Voltage
		10	Fuser Belt Thermistor
		11	GND
		12	GND
		13	Fuser Belt ID Voltage
		14	Bubble Sensor Anode
		15	Bubble Sense Voltage
		16	GND
		17	GND
		18	GND
		19	GND
		20	GND

## Component Locations

Connector	Connects to	Pin no.	Signal
JTPS1	Right side TPS sensor	1	Sensor Anode
		2	Sensor Cathode
		3	GND
		4	LED Current Source
		5	LED GND
JTRAY1	Tray 1 present optical sensor	1	Sensor Anode
		2	Sense Voltage
		3	GND
JCVR1	Cover switch	1	25V Source
		2	25V Safety
JSC1	Image basket card	1	+3.3V_SCHIP
		2	I2C_Data
		3	I2C_Clock
		4	GND
JRIP1	FirmwWare debug (LB-Trace) port	1	GND
		2	RXD
		3	TXD
		4	+3.3V
JVIP1	Socket for viper card	1	GSPI TXD
		2	+3.3V
		3	GSPI CLK
		4	GND
		5	GSPI CS-



Connector	Connects to	Pin no.	Signal
		6	GSPI RXD
59_JWT1	Waste toner bottle	1	GND
		2	AC Supply Voltage
		3	Ref. Voltage
		4	Sense Voltage
JFUSB1	Front USB host connector	N/A	N/A
JIPS1	Internal network adapters (INA) and wireless card	1	GND
		2	No Connect
		3	No Connect
		4	GND
		5	ISP_USB_P
		6	ISP_USB_N
		7	GND
		8	+3.3V
		9	ISP_RESET-
		10	+5V_ISP
		11	I2C2_DATA
		12	+5V_ISP
		13	I2C2_CLK
		14	+5V_ISP
JSEC1	Security jumper	1	Security Jumper Signal
		2	GND
		3	GND

## Component Locations

Connector	Connects to	Pin no.	Signal
JRUSB1	Rear USB host connector	N/A	N/A
JUSB1	USB device connector	N/A	N/A
JETH1	EtherNet connector .01/ .1/1Gb	-	-
JLPWRDB1	Low Power Debug Port	1	GND
		2	RXD
		3	TXD
		4	+3.3V
JPHONE1		1	Headphone Detect
		2	Headphone -
		3	Headphone +
		4	GND

## Motor Locations

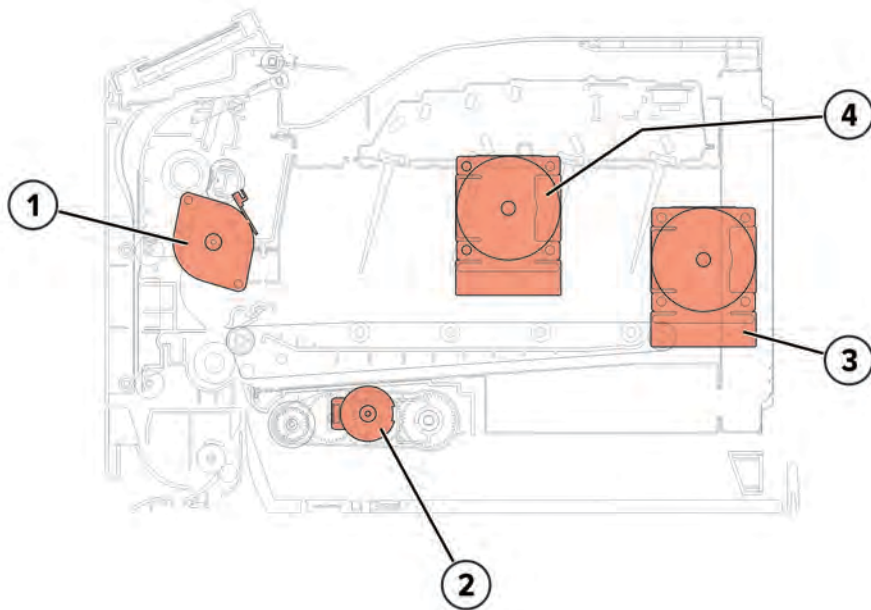

Part	Description
1	Motor (fuser)
2	Motor (tray 1 pick)
3	Motor (K drive unit)
4	Motor (CMY drive unit)

## Sensor Locations

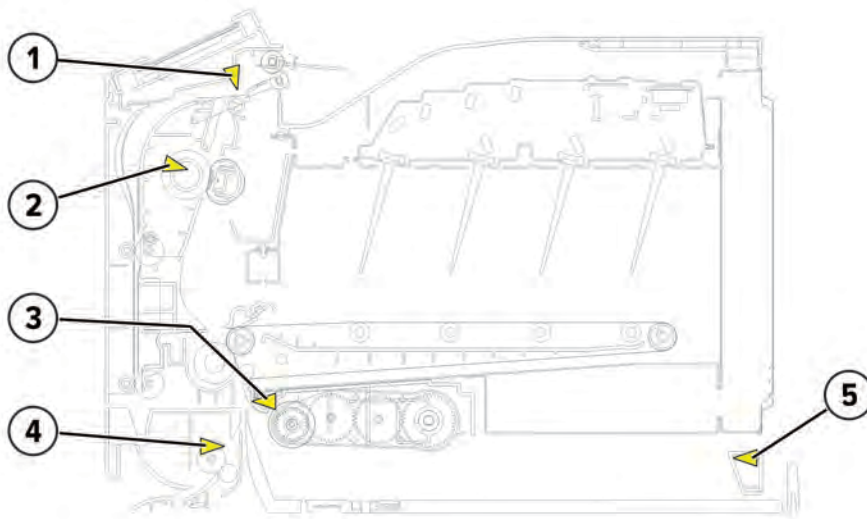

Part	Description
1	Sensor(narrow media/bin full)
2	Sensor (fuser exit)
3	Sensor (input)
4	Sensor (redrive/duplex path 1)
5	Sensor (tray present)

# Maintenance

# Inspection Guide

Use this guide in identifying the parts that must be inspected, cleaned, or replaced based on the page count.

If any unsafe condition exists, find out how serious the hazard is and if you can continue before you correct the hazard.

As you service the machine, check for the following:

- Damaged, missing, or altered parts, especially in the area of the power switch and the power supply
- Damaged, missing, or altered covers, especially in the area of the top cover and power supply cover
- Possible safety exposure from any non-Xerox components

Use the following table to determine when to inspect the following parts.:

Xerox C310	Every service call	Every 125K	Notes
<b>Tray - All</b>			
Tray side guides	Inspect		Check for correct positioning.
Tray length guides	Inspect		Check for correct positioning.
<b>Transfer module</b>	Inspect	NA	Ensure correct installation.
<b>Fuser</b>	Inspect	Replace	Ensure correct installation.
<b>Pick tires - All</b>			
Tray pick tires	Inspect and clean if needed		Clean with a damp cloth.
MPF pick tires	Inspect and clean if needed		Clean with a damp cloth.
<b>Paper path</b>			
Duplex path rollers	Inspect		<ul style="list-style-type: none"> <li>• Check for media fragments and tears.</li> <li>• Check for excessive toner build up on white rollers.</li> <li>• Clean with damp cloth if needed.</li> </ul>

Xerox C310	Every service call	Every 125K	Notes
<b>Miscellaneous</b>			
Toner spillage	Clean		Use a toner vacuum and cloth to remove the spillage.

## Scheduled Maintenance

The control panel displays an 80.xx error when it reaches certain page counts. It is necessary to replace the appropriate maintenance kit to maintain print quality and printer reliability.

 **Note:** When replacing the fuser, reset the maintenance counter.

## Maintenance Parts

After 125K printed pages (sides) the fuser and the pick roller replacement may be required. Install the correct fuser to match the type of fuser that is installed in the printer.

 **Note:**

- You can continue to run past the rated life of the fuser.
- The fuser has no hard stop and should not typically wear out with use.
- Use the Embedded Web Server to turn off the notifications for fuser life warnings.

The following error codes indicate that the fuser is nearing its end of life and requires replacement.

Error code	Description
80.0x	The maintenance kit (fuser) is nearly low.
80.1x	The maintenance kit (fuser) is low.
80.2x	The maintenance kit (fuser) is very low. Only 2000 estimated pages remain.
80.3x	The maintenance kit (fuser) is low. 0 estimated pages remain.
80.4x	The maintenance kit (fuser) is very low. 0 estimated pages remain.

When performing the scheduled maintenance procedure, clean the following areas of paper dust and toner contamination:

- Trays
- Photoconductor cartridge area
- Developer unit housing area
- Transfer roller area
- Duplex area
- Standard bin
- Bridge unit area (if equipped)
- Finisher bins (if equipped)







## Resetting The Maintenance Counter

1. Enter the Diagnostics menu, and then navigate to:  
**Printer diagnostics & adjustments > Supply Reset > Maintenance kit reset**
2. Press **OK** or touch **Start**.

## Cleaning The Printer Parts

### Cleaning The Printer

-  **CAUTION—SHOCK HAZARD:** To avoid the risk of electrical shock when cleaning the exterior of the printer, unplug the power cord from the electrical outlet and disconnect all cables from the printer before proceeding.
-  **ATTENTION ! RISQUE D'ÉLECTROCUTION :** pour éviter tout risque d'électrocution lors du nettoyage de l'extérieur de l'imprimante, débranchez le cordon d'alimentation électrique de la prise et déconnectez tous les câbles de l'imprimante avant de continuer.
-  **PRECAUCIÓN—RIESGO DE DESCARGA:** Para evitar el riesgo de descarga eléctrica al limpiar el exterior de la impresora, desconecte el cable de alimentación de la toma eléctrica y desconecte todos los cables de la impresora antes de realizar la operación.
-  **VORSICHT – STROMSCHLAGGEFAHR:** Um das Risiko eines elektrischen Schlags beim Reinigen des Druckergehäuses zu vermeiden, ziehen Sie das Netzkabel aus der Steckdose, und ziehen Sie alle Kabel vom Drucker ab, bevor Sie fortfahren.
-  **ATTENZIONE – PERICOLO DI SCOSSA ELETTRICA:** Per evitare il rischio di scosse elettriche quando si pulisce la parte esterna della stampante, scollegare il cavo di alimentazione dalla presa a muro e scollegare tutti i cavi della stampante prima di procedere.

 **Note:**

- Perform this task after every few months.
  - Damage to the printer caused by improper handling is not covered by the printer warranty.
1. Turn off the printer, and then unplug the power cord from the electrical outlet.
  2. Remove paper from the standard bin and manual feeder.
  3. Remove any dust, lint, and pieces of paper around the printer using a soft brush or vacuum.
  4. Wipe the outside of the printer with a damp, soft, lint-free cloth.

 **Note:**

- Do not use household cleaners or detergents, as they may damage the finish of the printer.
  - Make sure that all areas of the printer are dry after cleaning.
5. Connect the power cord to the electrical outlet, and then turn on the printer.

### Cleaning The Printhead Lenses

1. Remove the waste toner bottle. See [Waste toner bottle removal](#).
2. Remove the imaging kit. See [Imaging kit removal](#).

3. Using a damp, soft, lint-free cloth, wipe the printhead lenses (A).

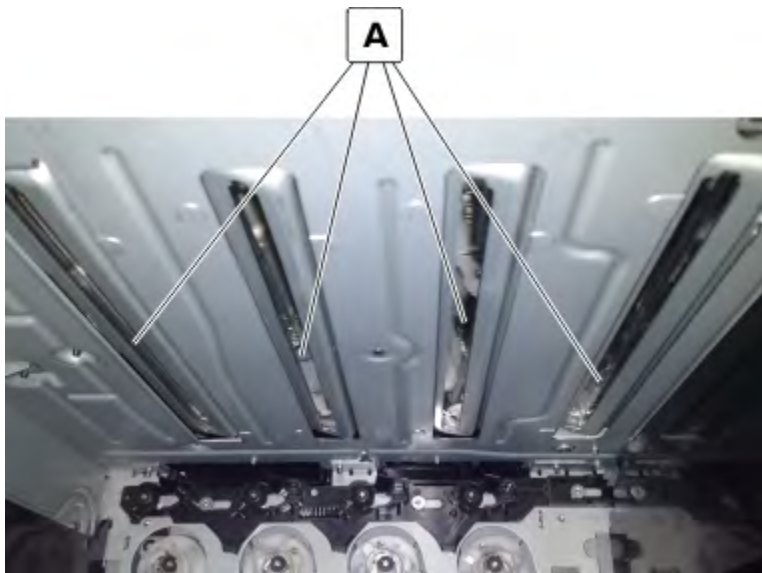



# Parts Catalog

## Legend

The following column headings are used in the parts catalog:

- **Asm-index**—Identifies the item in the illustration
- **P/N**—Identifies the part number of a FRU
- **Units/mach**—Refers to the number of units in a printer
- **Units/opt**—Refers to the number of units in an option
- **Units/FRU**—Refers to the number of units in a FRU
- **Description**—A brief description of the part

The following abbreviations are used in the parts catalog:

- **NS** (not shown) in the Asm-index column indicates that the part is procurable but is not shown in the illustration.
- **PP** (parts packet) in the Description column indicates that the part is contained in a parts packet.

## Assembly 1: 2.4-inch Control Panel

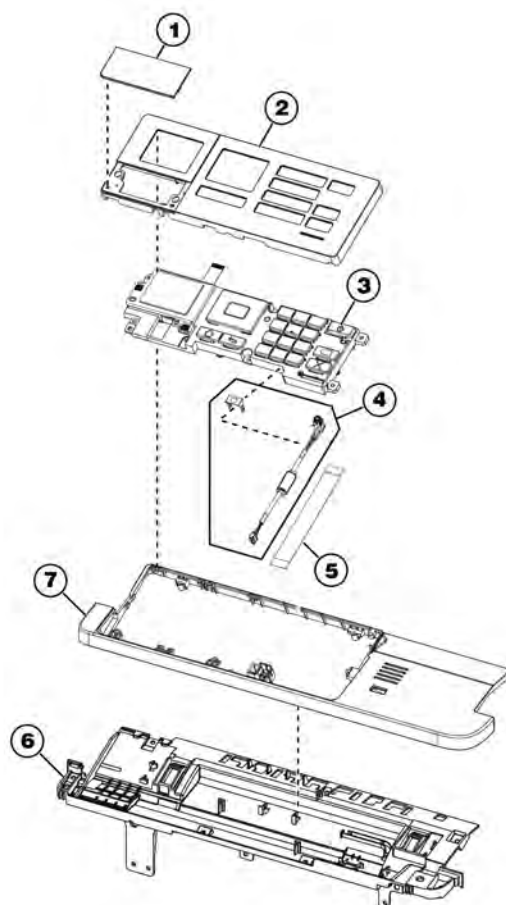

Asm-index	P/N	Units/mach	Units/FRU	Description	Removal procedure
1	002N03377	1	1	Blank control panel badge cover	<a href="#">2.4-inch Control Panel Badge Cover Removal</a>
2	056N00214	1	1	2.4-inch control panel bezel	<a href="#">2.4-inch Control Panel Bezel Removal</a>
3	002N03382	1	1	2.4-inch control panel assembly	<a href="#">2.4-inch Control Panel Top Cover Removal</a>
4	130N01898	1	1	Headphone cable	–

Parts Catalog

Asm-index	P/N	Units/mach	Units/FRU	Description	Removal procedure
5	002N03379	1	1	2.4-inch control panel FFC	<a href="#">2.4-inch Control Panel Top Cover Removal</a>
6	002N03378	1	1	Control panel base	<a href="#">Control Panel Base Removal</a>
7	—	1	1	Control panel top cover	<a href="#">2.4-inch Control Panel Top Cover Removal</a>
NS	117N02188	1	1	Control panel power cable	–



# Assembly 2: Covers

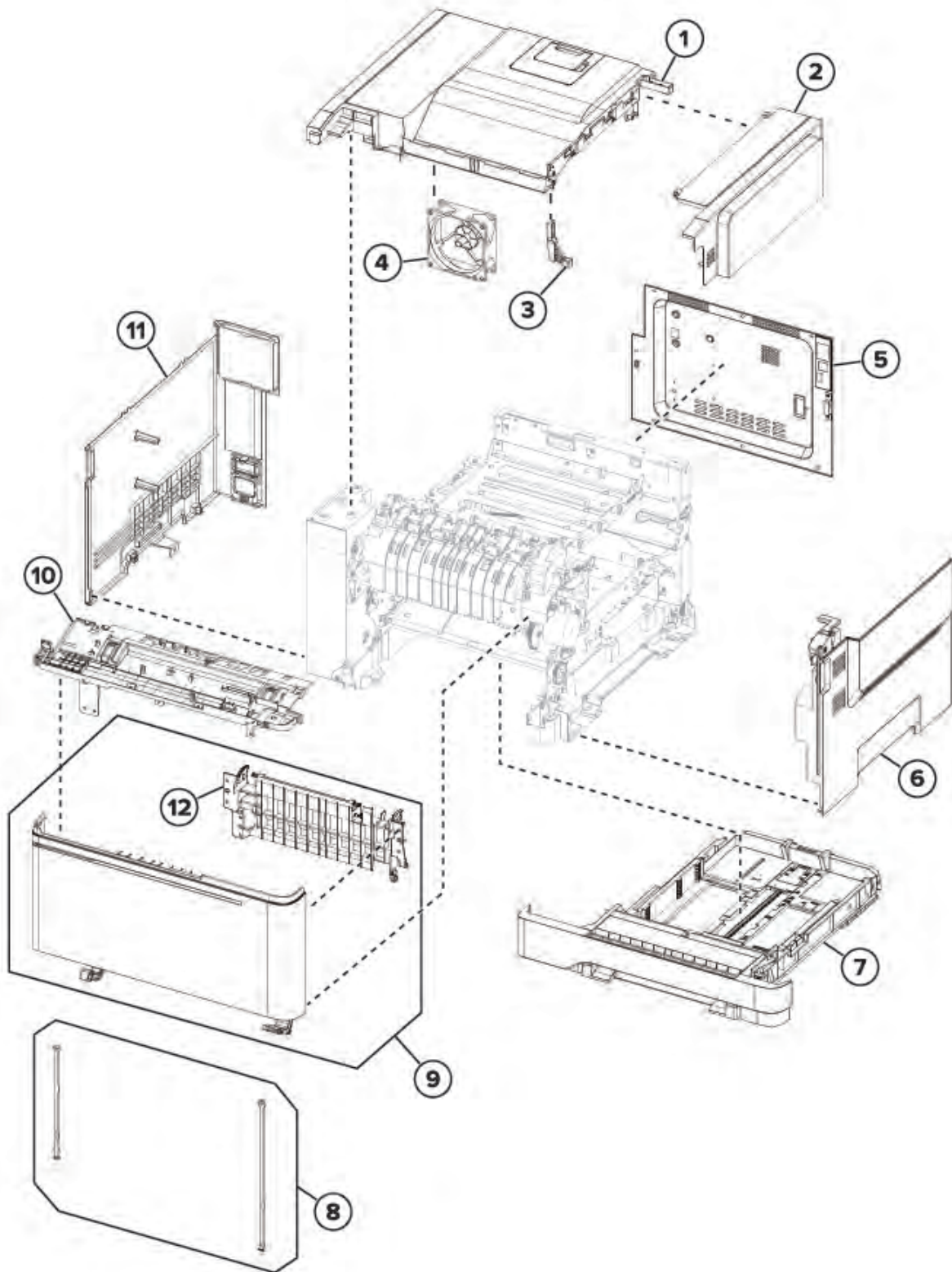

## Parts Catalog

Asm-index	P/N	Units/mach	Units/FRU	Description	Removal procedure
1	002N03414	1	1	Top cover	<a href="#">Top cover removal</a>
2	002N03415	1	1	Toner cover	–
3	030N00825	1	1	Front toner door bracket	–
4	127N07965	1	1	System fan	<a href="#">System fan removal</a>
5	002N03384	1	1	Rear cover	<a href="#">Rear cover removal</a>
6	002N03416	1	1	Right cover	<a href="#">Right cover removal</a>
7	050N00718	1	1	250-sheet tray assembly	–
8	003N01189	1	2	Door straps	–
9	002N03423	1	1	Front door assembly	<a href="#">Front Door Removal</a>
10	002N03378	1	1	Control panel base	<a href="#">Control Panel Base Removal</a>
11	002N03417	1	1	Left cover	<a href="#">Left cover removal</a>
12	055N00338	1	1	Front door inner deflector	<a href="#">Front Door Inner Deflector Removal</a>

## Assembly 3: Paper Path and Frame

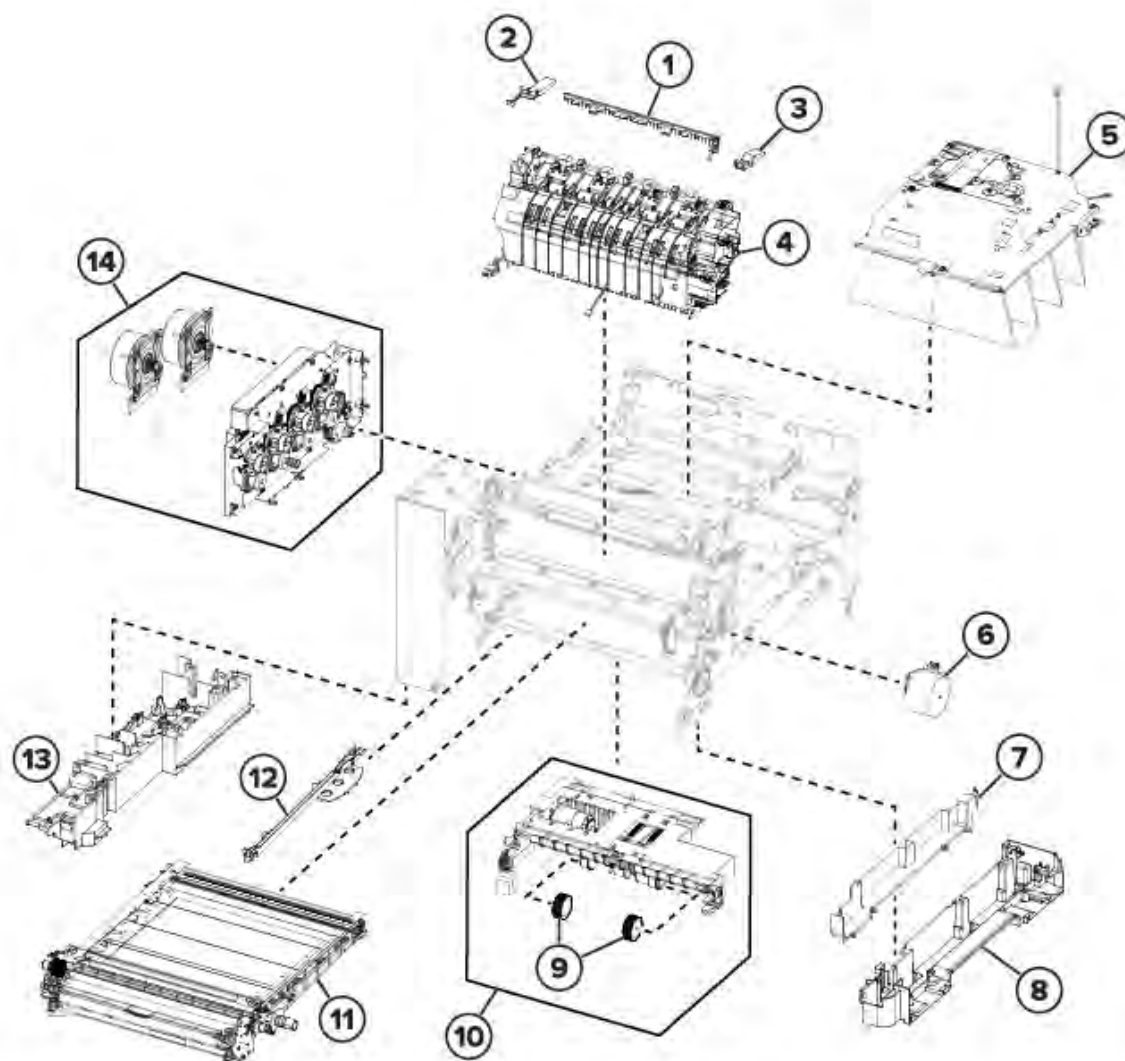

Asm-index	P/N	Units/mach	Units/FRU	Description	Removal procedure
1	126N00449	1	1	Fuser deflector	<a href="#">Exit Deflector Removal</a>
2	120N00571	1	1	Narrow media/ bin full flag	<a href="#">Narrow Media/ bin Full Sensor Flag Removal</a>
3	055N00337	1	1	Right deflector flag	<a href="#">Right Output Bin Deflector Removal</a>

## Parts Catalog

Asm-index	P/N	Units/mach	Units/FRU	Description	Removal procedure
4	126N00456	1	1	110 V Fuser	<a href="#">Fuser removal</a>
4	126N00457	1	1	220 V Fuser	<a href="#">Fuser removal</a>
5	046N00241	1	1	Printhead	<a href="#">Printhead removal</a>
6	127N07961	1	1	Motor (fuser drive)	<a href="#">Motor (fuser drive) removal</a>
7	117N02189	1	1	Subframe cable cover	–
8	001N00593	1	1	Lower right subframe	<a href="#">Lower right frame removal</a>
9	022N02894	2	2	Pick tires	<a href="#">Pick Tires Removal</a>
10	022N02898	1	1	Media feeder	<a href="#">Tray 1 media feeder removal</a>
11	133N23275	1	1	Transfer module	<a href="#">Transfer module removal</a>
12	133N23274	1	1	Transfer module guide	<a href="#">Transfer module guide removal</a>
13	001N00594	1	1	Lower left subframe	<a href="#">Lower Left Frame Removal</a>
14	007N01851	1	1	EP drive assembly	<a href="#">EP drive assembly removal</a>
NS	001N00595	4	4	Sub-frame foot	–

## Assembly 4: Electronics

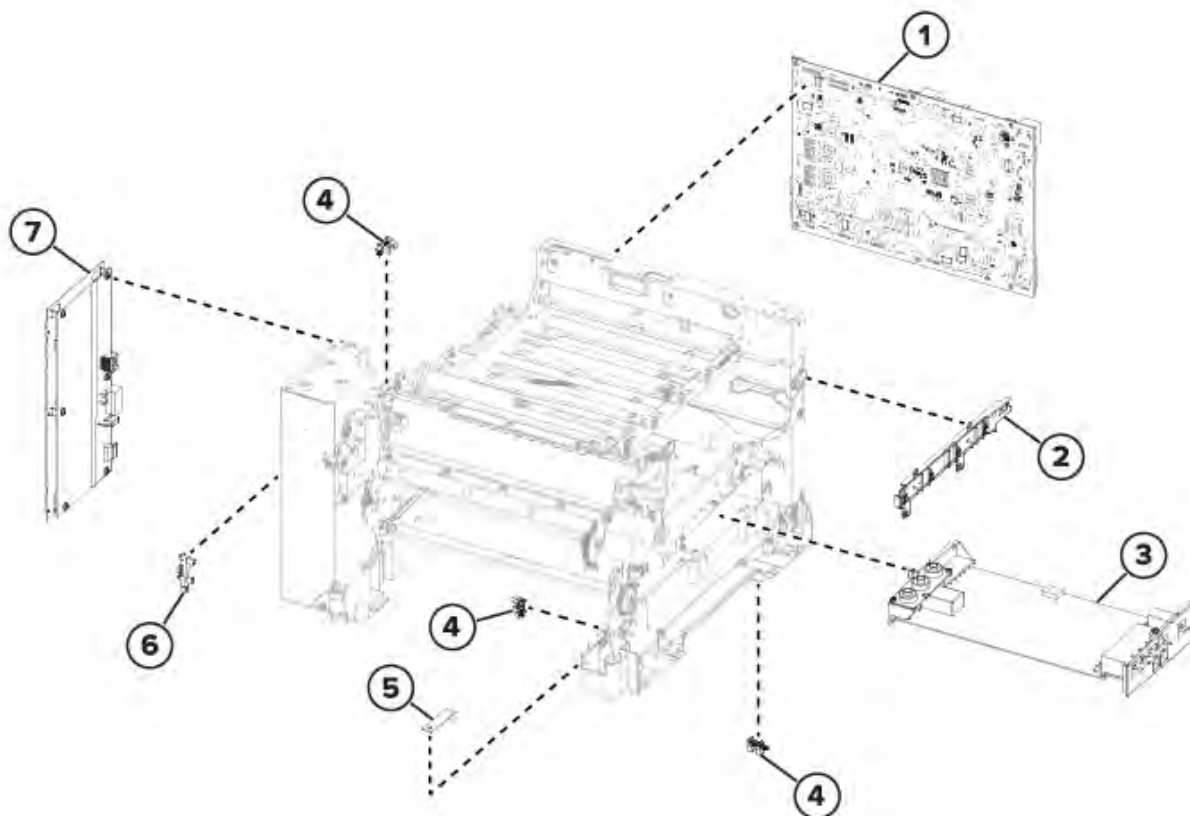

Asm-index	P/N	Units/mach	Units/FRU	Description	Removal procedure
1	109N00870	1	1	Controller board	<a href="#">Controller board removal</a>
2	128N00557	1	1	Toner meter card	<a href="#">TMC card removal</a>
3	112N00257	1	1	High voltage power supply	<a href="#">HVPS removal</a>
4	130N01896	3	1	Photo sensors: <ul style="list-style-type: none"> <li>• Sensor (tray present)</li> <li>• Sensor (duplex)</li> <li>• Sensor (narrow media/bin full)</li> </ul>	<a href="#">Sensor (tray Present) Removal</a> <a href="#">Sensor (duplex) Removal</a> <a href="#">Sensor (narrow Media/output Bin Full) Removal</a>

Parts Catalog

Asm-index	P/N	Units/mach	Units/FRU	Description	Removal procedure
5	130N01909	1	1	Weather station	<a href="#">Weather station service check</a>
6	130N01895	1	1	Sensor (fuser exit)	<a href="#">Sensor (fuser exit) removal</a>
7	105N02355	1	1	175 W low voltage power supply	<a href="#">LVPS removal</a>
NS	130N01900	1	1	Speaker	<a href="#">Speaker (CS622) Removal</a>

# Assembly 5: Cables and Sensors

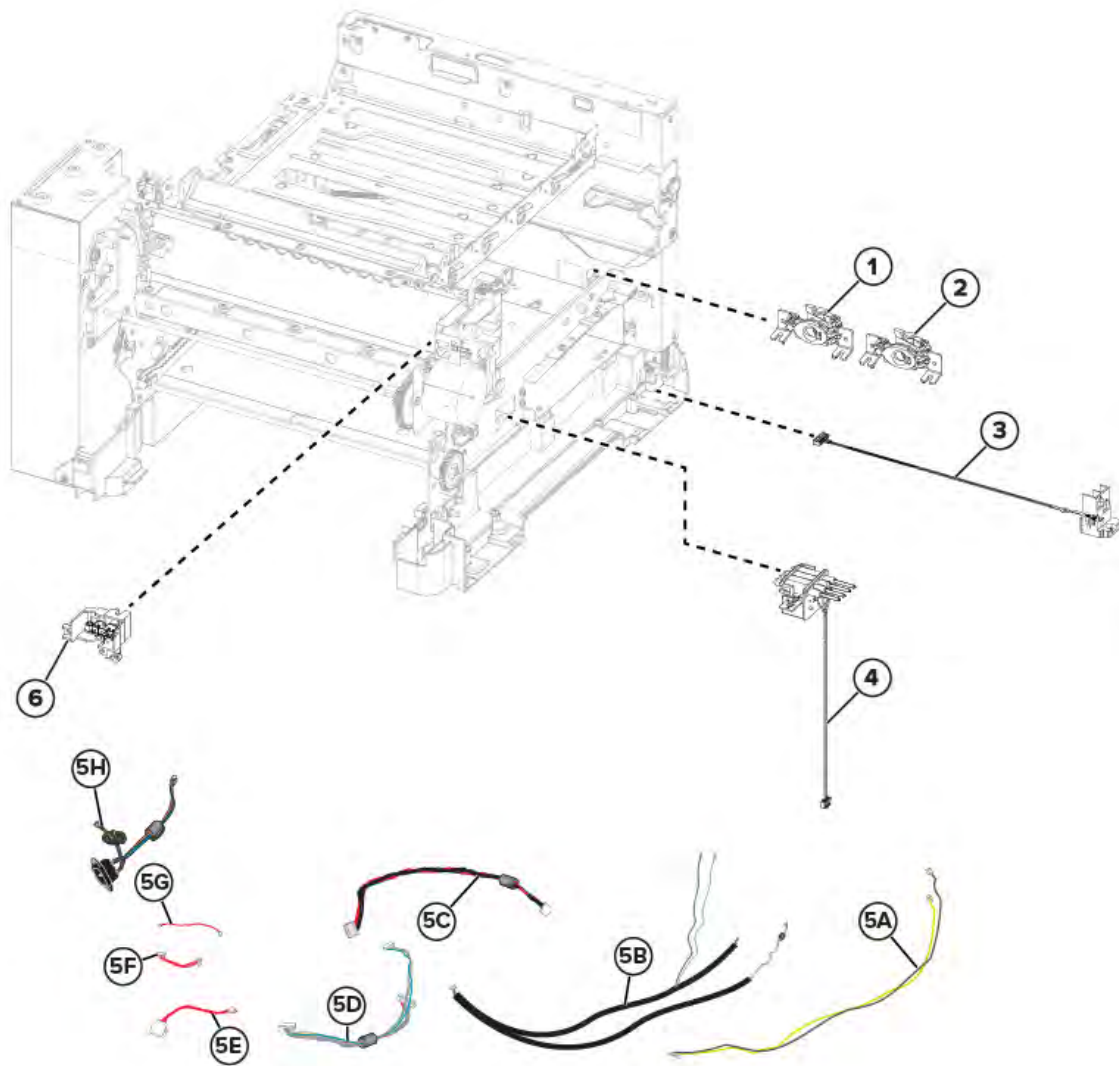

Parts Catalog

Asm-index	P/N	Units/mach	Units/FRU	Description	Removal procedure
1	130N01901	1	1	Sensor (left toner patch with thermistor)	Sensors (toner patch) removal
2	130N01903	1	1	Sensor (right toner patch with thermistor)	Sensors (toner patch) removal
3	014N00521	1	1	Waste toner bottle contact block	Waste toner bottle contact block removal
4	115N00937	4	1	Toner cartridge contact	Toner Cartridge Contacts Removal
5A	126N00450	1	1	Fuser exit narrow media to controller board	–
5B	126N00451	1	1	Fuser/input sensor cable	–
5C	117N02191	1	1	LVPS to controller board cable	–
5D	117N02190	1	1	EP motor to controller board cable	–
5E	109N00858	1	1	Tray 2 to controller board cable	–
5F	117N02193	1	1	HVPS to controller board cable	–
5G	050N00709	1	1	Tray present sensor cable	–
5H	112N00258	1	1	AC power to LVPS cable	–



Asm-index	P/N	Units/mach	Units/FRU	Description	Removal procedure
6	002N03381	1	1	Front and right side interlock switch cover assembly	<a href="#">Interlock Switch Cover Assembly Removal</a>
NS	117N02192	1	1	Weather station cable	<a href="#">Weather station removal</a>

## Assembly 6: Option Trays

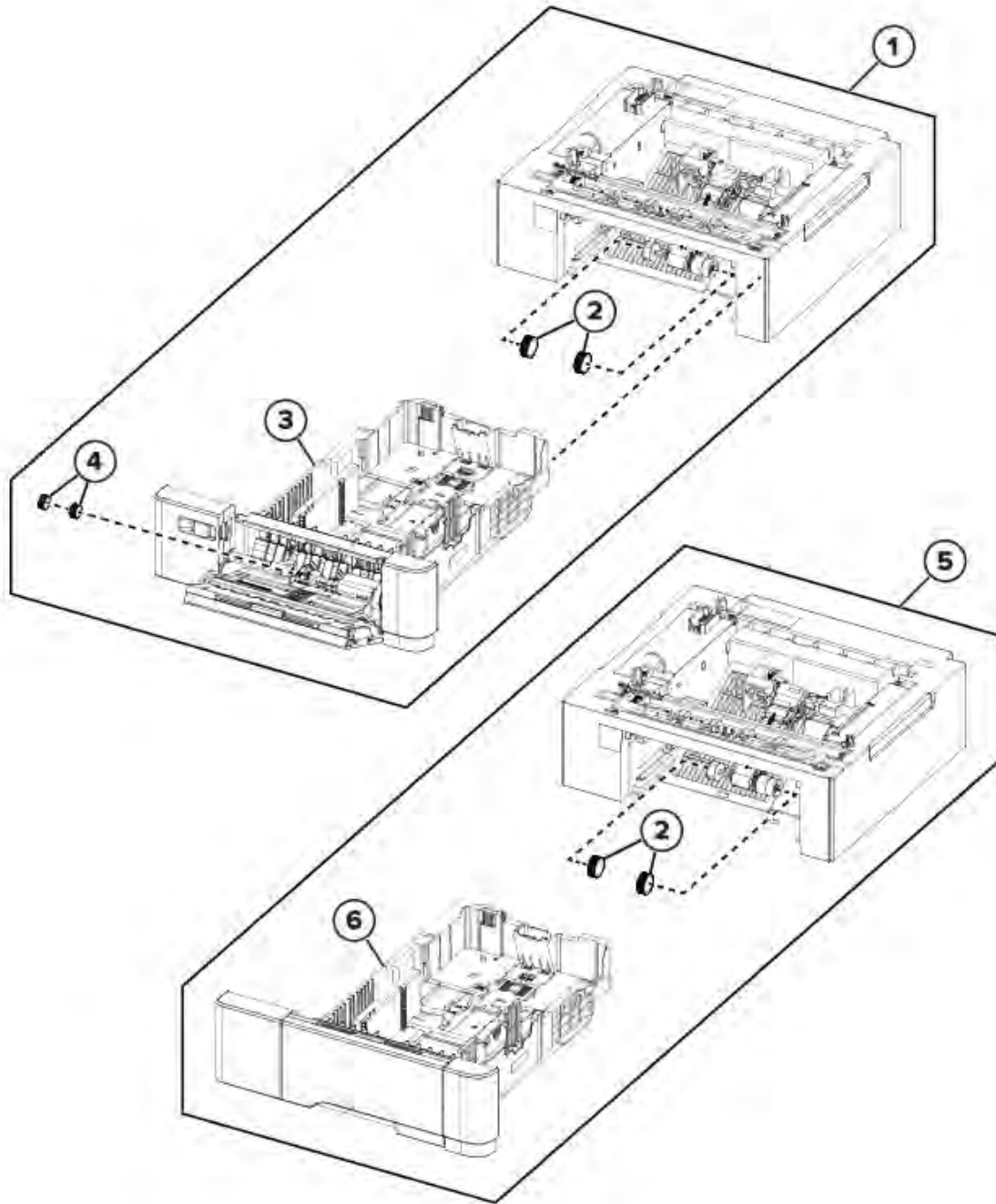

Asm-index	P/N	Units/mach	Units/FRU	Description	Removal procedure
1	—	1	1	Optional 650-sheet duo tray	<a href="#">650-sheet Duo Tray Removal</a>
2	022N02894	2	2	Pick tires	<a href="#">Pick tire removal</a>
3	016N00349	1	1	650-sheet duo tray insert	<a href="#">650-sheet Duo Tray Insert Removal</a>
4	022N02895	2	1	650-sheet duo tray MPF rollers	—
5	—	1	1	550-sheet tray	—
6	050N00719	1	1	550-sheet tray insert	—



# Printer Specifications

## Power Consumption

### Product Power Consumption

The following table documents the power consumption characteristics of the product.

 **Note:** Some modes may not apply to your product.

Mode	Description	Power consumption (Watts)
Printing	The product is generating hard-copy output from electronic inputs.	One-sided: 530 Two-sided: 360
Copy	The product is generating hard-copy output from hard-copy original documents.	N/A
Scan	The product is scanning hard-copy documents.	N/A
Ready	The product is waiting for a print job.	37.0
Sleep Mode	The product is in a high-level energy-saving mode.	1.3
Hibernate	The product is in a low-level energy-saving mode.	0.2
Off	The product is plugged into an electrical outlet, but the power switch is turned off.	0.2

The power consumption levels listed in the previous table represent time-averaged measurements. Instantaneous power draws may be substantially higher than the average.

Values are subject to change. See [www.xerox.com](http://www.xerox.com) for current values.

### Sleep Mode

This product is designed with an energy-saving mode called *Sleep Mode*. The Sleep Mode saves energy by lowering power consumption during extended periods of inactivity. The Sleep Mode is automatically engaged after this product is not used for a specified period of time, called the *Sleep Mode Timeout*.

Factory default Sleep Mode Timeout for this product (in minutes):	15
---	----

By using the configuration menus, the Sleep Mode Timeout can be modified between 1 minute and 120 minutes. Setting the Sleep Mode Timeout to a low value reduces energy consumption, but may increase the response time of the product. Setting the Sleep Mode Timeout to a high value maintains a fast response, but uses more energy.

## Hibernate Mode

This product is designed with an ultra-low power operating mode called *Hibernate mode*. When operating in Hibernate Mode, all other systems and devices are powered down safely.

The Hibernate mode can be entered in any of the following methods:

- Using the Hibernate Timeout
- Using the Schedule Power modes

Factory default Hibernate Timeout for this product in all countries or regions	3 days
--	--------

The amount of time the printer waits after a job is printed before it enters Hibernate mode can be modified between one hour and one month.

## Off Mode

If this product has an off mode which still consumes a small amount of power, then to completely stop product power consumption, disconnect the power supply cord from the electrical outlet.

## Total Energy Usage

It is sometimes helpful to estimate the total product energy usage. Since power consumption claims are provided in power units of Watts, the power consumption should be multiplied by the time the product spends in each mode in order to calculate energy usage. The total product energy usage is the sum of each mode's energy usage.

## Selecting A Location For The Printer

- Leave enough room to open trays, covers, and doors and to install hardware options.
- Set up the printer near an electrical outlet.
- Make sure that airflow in the room meets the latest revision of the ASHRAE 62 standard or the CEN Technical Committee 156 standard.
- Provide a flat, sturdy, and stable surface.
- Keep the printer:
  - Clean, dry, and free of dust
  - Away from stray staples and paper clips
  - Away from the direct airflow of air conditioners, heaters, or ventilators
  - Free from direct sunlight and humidity extremes
- Observe the temperature range.

Operating temperature	10 to 32.2°C (50 to 90°F)
-----------------------	---------------------------

- Allow the following recommended amount of space around the printer for proper ventilation:



1	Top	254 mm (10 in.)
2	Rear	102 mm (4 in.)
3	Right side	76 mm (3 in.)
4	Front	508 mm (20 in.) The minimum space needed in front of the printer is 75 mm (3 in.)
5	Left side	76 mm (3 in.)



## Noise Emission Levels

The following measurements were made in accordance with ISO 7779 and reported in conformance with ISO 9296.

 **Note:** Some modes may not apply to your product.

1-meter average sound pressure, dBA	
Printing	50
Ready	16

Values are subject to change. See [www.xerox.com](http://www.xerox.com) for current values.

## Temperature Information

Operating temperature and relative humidity	10° to 32.2° C (50° to 90° F) and 15 to 80 % RH 15.6° to 32.2° C (60° to 90° F) and 8 to 80 % RH Maximum wet-bulb temperature <sup>2</sup> : 22.8° C (73° F) Non-condensing environment
Printer / cartridge / imaging unit long-term storage <sup>1</sup>	15.6° to 32.2° C (60° to 90° F) and 8 to 80 % RH Maximum wet-bulb temperature <sup>2</sup> : 22.8° C (73° F)
Printer / cartridge / imaging unit short-term shipping	-40° to 40° C (-40° to 104° F)
<p><sup>1</sup> Supplies shelf life is approximately 2 years. This is based on storage in a standard office environment at 22° C (72° F) and 45 % humidity.</p> <p><sup>2</sup> Wet-bulb temperature is determined by the air temperature and the relative humidity.</p>	

## Enabling The Security Reset Jumper

### Note:

- Before changing the security settings, ask for permission from your administrator.
- Resetting the printer deletes all security settings.
- For MFPs, replacing the controller board deletes all security settings.
- If LDAP is used to authenticate the copy function in MFPs, then the LDAP configuration and copy function are no longer protected.
- To prevent the tampering of the jumper, secure the controller board cage with a Kensington lock. To disable the effect of the jumper reset, select **No Effect** from the Security Reset Jumper Setting section in the Security menu.
- If Enable Audit is activated from the Security Audit Log in the Miscellaneous section of the Security menu, then the printer logs a message each time the jumper is reset.

To reset the jumper:

1. Turn off the printer.
2. Access the controller board.
3. Locate the jumper at the JSEC1 connector on the controller board.
4. Move the jumper to cover the middle and exposed prongs.

 Note: The movement of the jumper triggers the reset, not the jumper position.

5. Turn on the printer.

## Printer Specifications

# Options and Features

## Available Internal Options

- Flash memory
- Font cards
- Firmware cards
  - Forms and Bar Code
  - PRESCRIBE
- Printer hard disk



**Note:** Some options are available only in some printer models. For more information, contact the place where you purchased the printer.

# Adding Available Options In The Print Driver

## For Windows Users

1. Open the printers folder.
2. Select the printer you want to update, and then do either of the following:
  - For Windows 7 or later, select **Printer properties**.
  - For earlier versions, select **Properties**.
3. Navigate to the Configuration tab, and then select **Update Now - Ask Printer**.
4. Apply the changes.

## For Macintosh Users

1. From System Preferences in the Apple menu, navigate to your printer, and then select **Options & Supplies**.
2. Navigate to the list of hardware options, and then add any installed options.
3. Apply the changes.

## Input/output Configurations and Capacities

**Table 11.1 Input sources**

Printer model	Number of standard trays	Maximum number of optional trays	Maximum number of trays
C310	2	2	4

**Table 11.2 Input capacities**

Printer model	Standard tray	Manual slot	Multipurpose feeder capacity*	Total standard capacity	Maximum input capacity
C310	250	1	100	251	1451
Paper capacity means 20-lb xerographic paper at ambient environment per sheet. * Available only when 650-sheet option tray is installed.					

**Table 11.3 Output capacities**

Printer model	Standard output capacity	Maximum output capacity
C310	125	125
Paper capacity means 20-lb xerographic paper at ambient environment per sheet.		



# Theory Of Operation

## Paper Path and Transport Components

For an image to be printed, the paper or specialty media has to be moved from an input source (such as a tray) into the printer and eventually exit into an output source.

The most important component in this process is this paper itself. Old, damaged, or out-of-specification paper can and will cause feed and transport problems. If you encounter problems, you should always check the paper first. In addition, it is always good practice to check the printer and driver settings to see if the paper being used matches the user's settings. It is not uncommon to find a user printing on cardstock with the printer programmed to print on a plain paper setting.

The printer's feed and transport components can fail and cause paper jams or other feed and transport problems. These components should be examined for damage or wear and replaced if necessary.

## Paper Path Information

The printer has a simple C-shaped paper path. The tray 1 paper is shown in red and the optional 650-sheet duo tray paper path is not shown.

Paper is fed from the rear of the printer and travels upward through the front cover.

The duplex unit is built into the front cover and Tray 1.

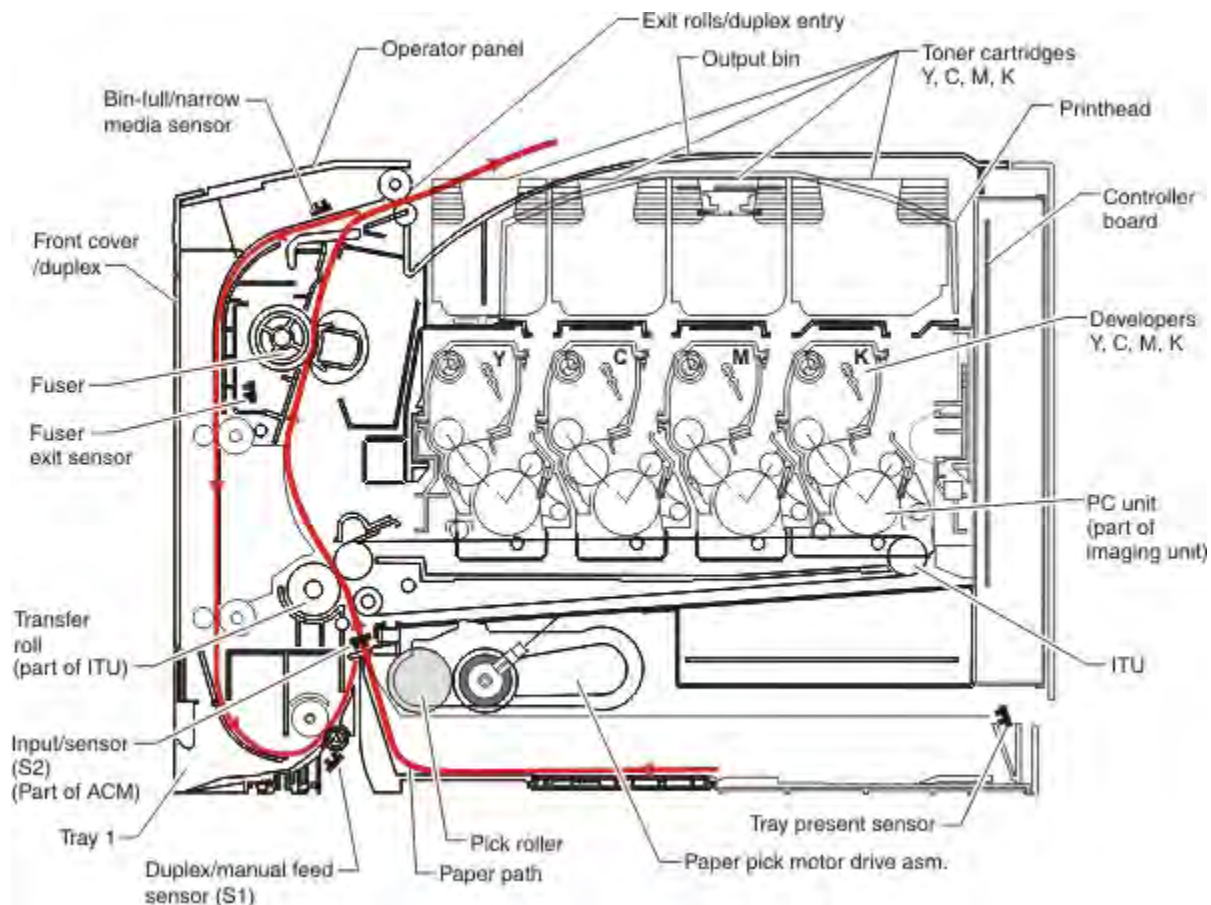

 **Note:** The ACM is also known as the paper feed roller assembly.

## Transport Components

The paper is fed from the tray into the printer by a pick roll and sent to two sets of feed rollers which time the paper to enter the Electrophotographic Process (EP Process) at just the right moment. The feed rollers push the paper to the transfer module where the image is transferred to the page.

The transfer roller moves the paper to the fuser where heat and pressure are applied to the page. The fuser rollers push the paper toward the exit bin and past the exit sensor. The exit rollers guide the paper into the output bin.

 **Note:** If the printer posts a paper jam message but no paper is found, then paper dust or paper particles may have fallen into one of the sensor eyes. Use a can of compressed air to gently clean the sensor.

## Duplexing

Printers with duplex support use a secondary paper path to print on the second side of a sheet of paper. The duplexing process is summarized as follows:

After the first side of the paper is printed and the trailing edge of the paper clears the fuser exit sensor, the fuser motor engages to reverse the paper direction and feed it into the duplex unit. The pick motor also reverses. The pick motor drives the duplex aligner rolls (A), which push the media down to the bottom turnaround in the paper tray and gate aligner (B).

 **Note:** While the sheet is being transported through the duplex unit, it is the only sheet of paper being processed by the print engine. A user should not attempt to insert a sheet of paper into the manual paper feed while a duplex job is being processed. This would cause a paper jam error.

When the trailing edge of the media clears the fuser, the fuser engine rotates forward to prepare the fuser for the page traveling through the duplex unit.

As the media reaches the gate aligner, a sensor (S1) is triggered, indicating the presence of the leading edge.

When the S1 sensor is triggered, the paper continues to the (S2) sensor. When the S2 signal is detected, the speed of the pick motor is adjusted to accommodate the speed of the transfer belt, ensuring the proper registration of the image on the media. The paper travels to the transfer module (C), and the second image is transferred to the reverse side of the media.

Once the image is transferred, the media travels to the fuser (D), the fuser exit rolls (E), and then to the output bin.

## Theory Of Operation

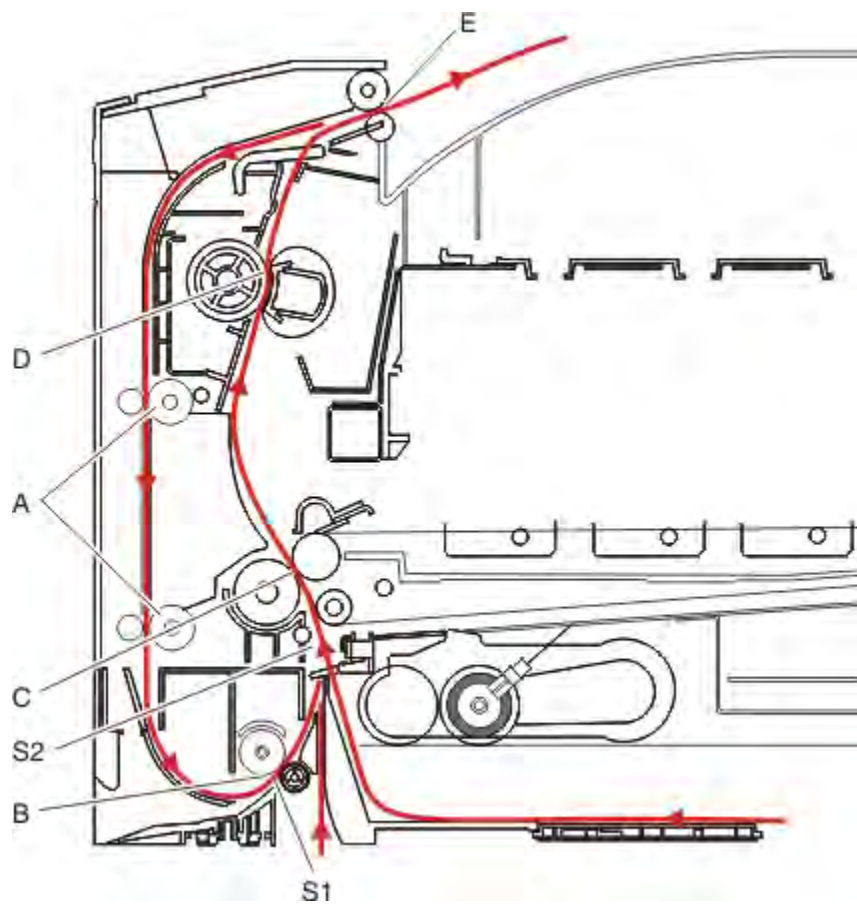

# Print Engine Theory

## Electrophotographic Process (EP Process)

The method that all laser and LED printers use to print is called the electrophotographic process. These machines use differences in charge to manipulate and move toner from the print cartridge to the printed page.

Even though the basic EP process is the same for every laser and LED printer, the specifics for each printer are different.

## Electrophotographic Process Basics

This printer is a single-laser printer that uses four print cartridges (cyan, yellow, magenta, and black) to create text and images on paper.

The printer has four photoconductor units (sometimes called a photodeveloper cartridge or PC unit) built into the print cartridges and transfer module. Each color toner is painted to its respective photoconductor unit at the same time. The transfer belt passes under the four photoconductor units and the four-color image is produced and transferred to the paper in one pass.

During the printing process, the printer follows the six basic EP process steps to create its output to the page.

1. Charge the photoconductor units.
2. Expose the photoconductor units with the laser.
3. Develop toner on the photoconductor units.
4. First transfer to the transfer module, and second transfer to the paper.
5. Fuse the toner to the paper.
6. Clean/erase the photoconductor units and the transfer module.

In summary, the printer controller board receives print data and the command to print. The controller board then initiates the print process. The controller board is the command center for the EP process and coordinates the various motors and signals.

The high-voltage power supply (HVPS) sends charge to various components in the EP process. The laser fires on the photoconductor units and alters the surface charge relative to the planned image for each photoconductor unit. Each photoconductor unit rotates past its respective developer roll, and toner is developed on the surface of each photoconductor unit. The four separate color images are then transferred to the transfer belt on the transfer module as it passes under the photoconductors. After the image is transferred to the transfer belt, the photoconductor units are cleaned and recharged.

The transfer belt carries the four-colored image towards the transfer rollers. Paper is picked up from the tray and carried to the transfer roll where the image is transferred from the transfer belt to the paper. The timing of the paper pick is determined by the speed of the transfer belt.

The paper is carried to the fuser rollers where heat and pressure are applied to the page to permanently bond the toner to the page. The fuser rollers push the paper into the output bin. The transfer unit is cleaned and the process begins again for the next page.

## Step 1: Charge

During the charge step, voltage is sent from the HVPS to the charge roller beside each of the four photoconductor units. In this printer, the charge roll is part of the photoconductor unit in the print cartridges.

The charge roller puts a uniform negative charge over the entire surface of the photoconductor unit to prepare it for the laser beam.

## Step 2: Expose

During the expose step, the laser fires a focused beam of light at the surface of each photoconductor unit and writes an invisible image, called a latent image or electrostatic image, for each color.

The laser beam discharges only the surface where the beam hits the photoconductor unit. This discharge creates a difference in charge potential between the exposed area and the rest of the photoconductor unit surface.

## Step 3: Develop

When the laser exposes the photoconductor unit, the HVPS sends charge to the developer roll. For each color, the print cartridge engages the photoconductor unit so it is in contact with the surface. Because of the charge difference between the toner on the developer roller and the electrostatic image created by the laser, the toner is attracted to areas of the photoconductor unit surface exposed by the laser.

This process is similar to using glue to write on a can and then rolling it over glitter. The glitter sticks to the glue but does not stick to the rest of the can.

## Step 4a: First Transfer

When the latent images are developed on each photoconductor unit, the HVPS sends voltage to the first transfer rollers inside the transfer module.

The charge difference between the developed toner image on the photoconductor unit surface and the first transfer roller causes the images to transfer to the surface of the transfer belt for each color. This transfer occurs during a direct surface-to-surface contact between the photoconductor units and the transfer belt.

## Step 4b: Second Transfer

When the four planes of color are transferred to the transfer belt from the photoconductor units, the image is carried toward the transfer roller, which is also part of the transfer module. Based on the speed of the transfer belt, the proper time to send the signal to pick the paper from an input source is determined. The pick is timed so that the paper passes between the transfer belt and transfer roller when the image on the belt reaches the second transfer area.

The HVPS sends voltage to the transfer roller to create a positive charge. When the image on the transfer belt reaches the transfer roller, the negatively charged toner clings to the paper, and the entire image is transferred from the transfer belt to the paper.

## Step 5: Fuse

When the image has been fully transferred to the paper, the transfer roller helps move the paper into the fuser area.

The fuser applies heat and pressure to the page to melt the toner particles and bond them permanently to the paper. The fuser moves the paper to the redrive rolls which move the paper to the output bin.

## Step 6: Clean/erase

Two main cleaning processes take place during the EP process. One process cleans the transfer belt, and the other cleans the photoconductor units.

### **Transfer module clean**

When the toner image on the transfer belt has been transferred to the page, the transfer belt rotates around and is cleaned by the cleaning blade. The cleaning occurs for every page that is printed.

After the toner is moved to the cleaning blade, the toner is moved to the waste toner area using an auger system.

### **Photoconductor clean/erase**

After each plane of color has been transferred to the transfer belt from the photoconductor units, a cleaning blade scrapes the remaining toner from the surface of each photoconductor unit.

The photoconductor unit surface is prepared to restart the EP process. This cleaning/erasing cycle happens after each plane of color is transferred to the transfer belt.

## Color Theory

### Color Theory

#### What Is RGB Color?

Red, green, and blue light can be added together in various amounts to produce a large range of colors observed in nature. For example, red and green can be combined to create yellow. Televisions and computer monitors create colors in this manner. RGB color is a method of describing colors by indicating the amount of red, green, or blue needed to produce a certain color.

#### What Is CMYK Color?

Cyan, magenta, yellow, and black inks or toners can be printed in various amounts to produce a large range of colors observed in nature. For example, cyan and yellow can be combined to create green. Printing presses, inkjet printers, and color laser printers create colors in this manner. CMYK color is a method of describing colors by indicating the amount of cyan, magenta, yellow, and black needed to reproduce a particular color.

#### How Is Color Specified In A Document To Be Printed?

Software programs typically specify document color using RGB or CMYK color combinations. They also allow users to modify the color of each object in a document. For more information, see the software program Help topics.

#### How Does The Printer Know What Color To Print?

When a user prints a document, information describing the type and color of each object is sent to the printer. The color information is passed through color conversion tables that translate the color into the appropriate amounts of cyan, magenta, yellow, and black toner needed to produce the desired color. The object information determines the application of color conversion tables. For example, one type of color conversion table can be applied to text while applying a different color conversion table to photographic images.

#### Should I Use Postscript or PCL Emulation? What Settings Produce The Best Color?

We recommend the PostScript driver for best color quality. The default settings in the PostScript driver provide the preferred color quality for the majority of printouts.

#### Why Doesn't The Printed Color Match The Color I See On The Computer Screen?

The color conversion tables used in Auto Color Correction mode generally approximate the colors of a standard computer monitor. However, because of technology differences that exist between printers and monitors, many colors can also be affected by monitor variations and lighting conditions.



## The Printed Page Appears Tinted. Can I Adjust The Color?

Sometimes a printed page may appear tinted (for example, everything looks too red). This tint can be caused by environmental conditions, paper type, lighting conditions, or user preference. Adjust the Color Balance setting to create a more preferable color. Color Balance lets the user make subtle adjustments to the amount of toner being used in each color plane. Selecting positive or negative values for cyan, magenta, yellow, and black (from the Color Balance menu) can slightly increase or decrease the amount of toner used for the chosen color. For example, if a printed page has a red tint, then decreasing both magenta and yellow can improve the color balance.

## What Is Manual Color Correction?

When manual color correction is enabled, the printer uses user-selected color conversion tables to process objects. However, Color Correction must be set to Manual, or no user-defined color conversion can be implemented. Manual color correction settings are specific to the type of object being printed (text, graphics, or images), and how the color of the object is specified in the software program (RGB or CMYK combinations).

### Note:

- Manual color correction is not useful if the software program does not specify colors with RGB or CMYK combinations. It is also not effective in situations in which the software program or the computer operating system controls the adjustment of colors.
- The color conversion tables—applied to each object when Color Correction is set to Auto—generate preferred colors for the majority of documents.

To manually apply a different color conversion table:

1. From the home screen, touch **Settings > Print > Quality > Advanced Imaging > Color Correction**.
2. Select **Manual**, and then touch **Color Correction Content**.
3. Select the appropriate color conversion table for the affected object type.

Object type	Color conversion tables
RGB Image RGB Text RGB Graphics	<ul style="list-style-type: none"> <li>• <b>Vivid</b>—Produces brighter, more saturated colors and may be applied to all incoming color formats.</li> <li>• <b>sRGB Display</b>—Produces an output that approximates the colors shown on a computer monitor. Black toner usage is optimized for printing photographs.</li> <li>• <b>Display—True Black</b>—Produces an output that approximates the colors shown on a computer monitor. Uses only black toner to create all levels of neutral gray.</li> <li>• <b>sRGB Vivid</b>—Provides an increased color saturation for the sRGB display color correction. Black toner usage is optimized for printing business graphics.</li> <li>• <b>Off</b>—No color correction is implemented.</li> </ul>
CMYK Image CMYK Text CMYK Graphics	<ul style="list-style-type: none"> <li>• <b>US CMYK</b>—Applies color correction to approximate the SWOP (Specifications for Web Offset Publishing) color output.</li> <li>• <b>Euro CMYK</b>—Applies color correction to approximate EuroScale color output.</li> <li>• <b>Vivid CMYK</b>—Increases the color saturation of the US CMYK color correction setting.</li> <li>• <b>Off</b>—No color correction is implemented.</li> </ul>

## How Can I Match A Particular Color (such As A Corporate Logo)?

From the printer Quality menu, nine types of Color Samples sets are available. These sets are also available in the Color Samples page of the Embedded Web Server. Selecting any sample set generates a multiple-page printout consisting of hundreds of colored boxes. Either a CMYK or RGB combination is located on each box, depending on the table selected. The observed color of each box is obtained by passing the CMYK or RGB combination labeled on the box through the selected color conversion table.

To print color sample pages:

1. From the home screen, touch **Settings > Print > Quality > Advanced Imaging > Color Samples > Print Color Samples**.
2. Select the appropriate color conversion table to print.

By examining Color Samples sets, a user can identify the box whose color is the closest to the desired color. The color combination labeled on the box can then be used for modifying the color of the object in a software program. For more information, see the software program Help topics. Manual color correction may be used for the selected color conversion table for the particular object.

Selecting which Color Samples set to use for a particular color-matching problem depends on the Color Correction setting being used (Auto, Off, or Manual), the type of object being printed (text, graphics, or images), and how the color of the object is specified in the software program (RGB or CMYK combinations). When the printer Color Correction setting is set to Off, the color is based on the print job information; and no color conversion is implemented.

 **Note:** The Color Samples pages are not useful if the software program does not specify colors with RGB or CMYK combinations. The software program or the computer operating system sometimes may adjust the RGB or CMYK combinations specified in the program through color management. The resulting printed color may not be an exact match of the Color Samples pages.

## What Are Detailed Color Samples and How Do I Access Them?

Detailed Color Samples sets are available in the Embedded Web Server of a network printer. A detailed Color Samples set contains a range of shades (shown as colored boxes) that are similar to a user-defined RGB or CMYK value. The likeness of the colors in the set are dependent on the value entered in the RGB or CMYK Increment box.

To access a detailed Color Samples set from the Embedded Web Server:

1. From the home screen, touch **Settings > Print > Quality > Advanced Imaging > Color Samples > Print Color Samples**.
2. Select **Advanced** to narrow the set to one color range.
3. Select the appropriate color conversion table to print.
4. Enter the RGB or CMYK color number.
5. Enter an increment value from 1 to 255.

 **Note:** The closer the value is to 1, the narrower the color sample range appears.

6. Select **Print**.



# Acronyms

# Acronyms

ASIC	Application-specific integrated circuit
BLDC	Brushless DC motor
BOR	Black only retract
C	Cyan
CCD	Charge coupled device
CCP	Carbonless copy paper
CRC	Cyclic redundancy check
CSU	Customer setup
CTLS	Capacitance toner level sensing
DIMM	Dual inline memory module
DRAM	Dynamic random access memory
EDO	Enhanced data out
EP	Electrophotography
EPROM	Erasable programmable read-only memory
ESD	Electrostatic discharge
FFC	Flat flexible cable
FRU	Field replaceable unit
GB	Gigabyte
HCF	High-capacity feeder
HCIT	High-capacity input tray
HCOF	High-capacity output finisher
HVPS	High voltage power supply

K	Black
LAA	Locally Administered Access
LCD	Liquid crystal display
LDAP	Lightweight directory access protocol
LED	Light-emitting diode
LVPS	Low voltage power supply
M	Magenta
MB	Megabyte
MFP	Multi-function product
MPF	Multipurpose feeder
MROM	Masked read only memory
MS	Microswitch
NVM	Nonvolatile memory
NVRAM	Nonvolatile random access memory
OEM	Original equipment manufacturer
OPT	Optical sensor
PC	Photoconductor
pel, pixel	Picture element
POR	Power-on reset
POST	Power-on self test
PSD	Position sensing device
PWM	Pulse width modulation
RIP	Raster imaging processor

## Acronyms

ROM	Read only memory
SDRAM	Synchronous dual random access memory
SIMM	Single inline memory module
SRAM	Static random access memory
TMC	Toner meter cycle
TPS	Toner patch sensing
UPR	Used parts return
V ac	Volts alternating current
V dc	Volts direct current
Y	Yellow



## Part Number Index

P/N	Part name
001N00593	Lower right subframe
001N00594	Lower left subframe
001N00595	Sub-frame foot
002N03382	Blank control panel badge cover
002N03378	Control panel base
002N03379	2.4-inch control panel FFC
002N03381	Front and right side interlock switch cover assembly
002N03382	2.4-inch control panel assembly
002N03384	Rear cover
002N03414	Top cover
002N03415	Toner cover
002N03416	Right cover
002N03417	Left cover
002N03423	Front door assembly
003N01189	Door straps
007N01851	EP drive assembly
014N00521	Waste toner bottle contact block
016N00349	650-sheet duo tray insert
022N02894	Pick tires
022N02895	650-sheet duo tray MPF rollers

## Part Number Index

P/N	Part name
022N02898	Media feeder
030N00825	Front toner door bracket
046N00241	Printhead
050N00709	Tray present sensor cable
050N00718	250-sheet tray assembly
050N00719	550-sheet tray insert
055N00337	Right deflector flag
055N00338	Front door inner deflector
056N00214	2.4-inch control panel bezel
105N02355	175 W low voltage power supply
109N00870	Controller board
109N00858	Tray 2 to controller board cable
112N00257	High voltage power supply
112N00258	AC power to LVPS cable
115N00937	Toner cartridge contact
117N02188	Control panel power cable
117N02189	Subframe cable cover
117N02190	EP motor to controller board cable
117N02191	LVPS to controller board cable
117N02192	Weather station cable
117N02193	HVPS to controller board cable
120N00571	Narrow media/bin full flag
126N00449	Fuser deflector

P/N	Part name
126N00450	Fuser exit narrow media to controller board
126N00451	Fuser/input sensor cable
126N00456	110 V Fuser
126N00457	220 V Fuser
127N07961	Motor (fuser drive)
127N07965	System fan
128N00557	Toner meter card
130N01896	Photo sensors
130N01898	Headphone cable
130N01900	Speaker
130N01901	Sensor (left toner patch with thermistor)
130N01903	Sensor (right toner patch with thermistor)
130N01909	Weather station
133N23274	Transfer module guide
133N23275	Transfer module

## Part Number Index

## Part Name Index

P/N	Part name
126N00456	110 V Fuser
105N02355	175 W low voltage power supply
002N03382	2.4-inch control panel assembly
056N00214	2.4-inch control panel bezel
002N03379	2.4-inch control panel FFC
126N00457	220 V Fuser
050N00718	250-sheet tray assembly
050N00719	550-sheet tray insert
016N00349	650-sheet duo tray insert
022N02895	650-sheet duo tray MPF rollers
112N00258	AC power to LVPS cable
002N03382	Blank control panel badge cover
002N03378	Control panel base
117N02188	Control panel power cable
109N00870	Controller board
003N01189	Door straps
007N01851	EP drive assembly
117N02190	EP motor to controller board cable
002N03381	Front and right side interlock switch cover assembly
002N03423	Front door assembly

## Part Name Index

P/N	Part name
055N00338	Front door inner deflector
030N00825	Front toner door bracket
126N00449	Fuser deflector
126N00450	Fuser exit narrow media to controller board
126N00451	Fuser/input sensor cable
130N01898	Headphone cable
112N00257	High voltage power supply
117N02193	HVPS to controller board cable
002N03417	Left cover
001N00594	Lower left subframe
001N00593	Lower right subframe
117N02191	LVPS to controller board cable
022N02898	Media feeder
127N07961	Motor (fuser drive)
120N00571	Narrow media/bin full flag
130N01896	Photo sensors
022N02894	Pick tires
022N02894	Pick tires
046N00241	Printhead
002N03384	Rear cover
002N03416	Right cover
055N00337	Right deflector flag
130N01901	Sensor (left toner patch with thermistor)

P/N	Part name
130N01903	Sensor (right toner patch with thermistor)
130N01900	Speaker
001N00595	Sub-frame foot
117N02189	Subframe cable cover
127N07965	System fan
115N00937	Toner cartridge contact
002N03415	Toner cover
128N00557	Toner meter card
002N03414	Top cover
133N23275	Transfer module
133N23274	Transfer module guide
109N00858	Tray 2 to controller board cable
050N00709	Tray present sensor cable
014N00521	Waste toner bottle contact block
130N01909	Weather station
117N02192	Weather station cable

## Part Name Index





