

Version 2.0
January 2022
702P08777

Xerox® B225/B235 Multifunction Printer Service Manual

Publication Information

Product: Xerox® B225/B235 Multifunction Printer

Title: Xerox® B225/B235 Multifunction Printer Service Manual

Part Number: 702P08777

Publication Status: First revision

Publication Date: January 2022

Preparation Notes:

Prepared for:

Xerox Corporation

800 Phillips Road

Webster, New York, 14580

Copyright Statement:

© 2022 Xerox Corporation. All Rights Reserved. Xerox®, and Xerox are trademarks of Xerox Corporation in the United States and/or other countries.

Registered Trademarks:

Other company trademarks are also acknowledged.

NOTICE

While every care has been taken in the preparation of this manual, no liability will be accepted by Xerox arising out of any inaccuracies or omissions.

All service documentation is supplied to Xerox external customers for informational purposes only. Xerox service documentation is intended for use by certified, product trained service personnel only. Xerox does not warrant or represent that it will notify or provide to such customer any future change to this documentation. Customer performed service of equipment, or modules, components or parts of such equipment may affect whether Xerox is responsible to fix machine defects under the warranty offered by Xerox with respect to such equipment. You should consult the applicable warranty for its terms regarding customer or third-party provided service.

Table of Contents

1 Notices, Conventions, and Safety Information.....	9
Laser Notice.....	10
Avis Relatif À L'utilisation Du Laser	10
Aviso De Láser	10
Laser-hinweis	11
Avvertenza sui prodotti laser	11
Conventions.....	12
Conventions.....	12
Convenciones.....	12
Konventionen	13
Convenzioni	13
Safety Information	15
Consignes De Sécurité.....	15
Información De Seguridad.....	16
Sicherheitshinweise.....	17
Informazioni sulla sicurezza	18
Health and Safety Incident Reporting	20
2 Change History.....	23
Change History	24
3 General Information	25
Printer Model Configurations	26
Locating the Printer Serial Number.....	27
Supported Paper Sizes, Types, and Weights	28
Supported Paper Sizes.....	28
Supported Paper Types	30
Supported Paper Weights.....	31
Tools Required For Service	32
4 Diagnostics and Troubleshooting.....	33
Troubleshooting Precautions	34
Précautions De Dépannage.....	34
Precauciones Durante La Solución De Problemas.....	35
Vorsichtsmaßnahmen Bei Der Fehlerbehebung	35
Precauzioni per gli interventi di riparazione	36
Troubleshooting Overview.....	38
Performing The Initial Troubleshooting Check	38

Table of Contents

Fixing Print Quality Issues	39
Initial Print Quality Check	39
Supplies Used to Resolve Print Quality Issues	39
Gray or Solid Background Check	40
Solid Color or Black Image Check	44
Blank or White Pages Check	47
Dark Print Check	52
Light Print Check	56
Paper Curl Check	61
Folded or Wrinkled Paper Check	63
Repeating Defects Check	65
Skewed Print Check	70
Streaked Vertical Lines Appear On Prints Check	72
Horizontal White Lines Check	76
Vertical White Lines Check	81
Vertical Colored Lines or Banding Check	85
Vertical Dark Streaks With Print Missing Check	89
White Streaks and Voided Areas Check	94
Clipped Pages or Images Check	98
Compressed Images Appear On Prints Check	103
Incorrect Margins On Prints Check	107
Toner Rubs Off Check	109
Toner Specks Appear On Prints Check	111
Paper Jams	116
Avoiding Jams	116
200 Paper Jams	117
202 Paper Jams	124
206 Paper Jams	137
232 Paper Jams	146
User Attendance Messages	152
Non-Xerox Supply	152
Metered Supply Installed in Printer Configured For Sold	153
8–12 User Attendance Messages	155
31–33 User Attendance Messages	158
34–42 User Attendance Messages	165
55 User Attendance Messages	169
71 User Attendance Messages	171
84 User Attendance Messages	173
88 User Attendance Messages	176
Non-supply User Attendance Messages	176
Printer Hardware Errors	183
111 Error Messages	183
121 Errors	184
126 Errors	189
140 Errors	191
6yy Errors	193
Procedure Before Starting The 9yy Service Checks	200
9yy Errors	201

ADF/Scanner Hardware Errors	210
84y Error Messages.....	210
Sensor (Scan) Service Check.....	210
Sensor (ADF Top Door Interlock) Service Check	213
ADF Feed Error Service Check.....	216
Scanner Disabled and Scanner Communication Error Service Check.....	219
Flatbed Home Position Service Check.....	221
Other Symptoms.....	223
Base Printer Symptoms	223
Door Switch Service Check	223
Load Tray 1 With A4 Plain Paper Service Check	224
Paper Did Not Arrive In The Bin Service Check.....	227
Tray Insert Obstructed Service Check	230
Unable To Remove Toner Cartridge Service Check	231
Fax Not Detected Service Check.....	232
No Display Service Check	233
No Power Service Check	234
ADF Cover Open Service Check.....	236
5 Service Menus.....	239
Understanding The Printer Control Panel.....	240
Using the Xerox B225 Printer Control Panel.....	240
Using the Xerox B235 Printer Control Panel.....	241
Understanding the Status of the Power Button and Indicator Light.....	242
Diagnostics Menu	243
Entering the Diagnostics Menu	243
Reports	243
Advanced Print Quality Samples.....	244
Format Fax Storage.....	244
Event Log.....	244
Input Tray Quick Print	245
Output Bin Quick Feed	245
Printer Setup.....	246
Printer Diagnostics & Adjustments	247
Scanner Diagnostics.....	249
Config Menu.....	252
Entering the Config Menu	252
Config Menu.....	252
Service Engineer Menu.....	256
Entering the Service Engineer (SE) Menu.....	256
General SE	256
Network SE	256
Fax SE.....	257
Scan SE.....	258
Entering Invalid Engine Mode	259
Entering Recovery Mode	260

Table of Contents

For LED Display	260
For 2-line Display	260
For 2.4-, 4.3-, 7-, and 10-inch Displays.....	260
For 2.8-inch Display.....	261
6 Parts Removal.....	263
Removal Precautions.....	264
Précautions De Retrait.....	264
Precauciones Durante La Extracción.....	265
Vorsichtsmaßnahmen Bei Der Demontage.....	265
Precauzioni per la rimozione.....	266
Handling ESD-sensitive Parts.....	266
Critical Information for Controller Board or Control Panel Replacement (for B235 Only)	268
Restoring The Printer Configuration After Replacing The Controller Board	269
Restoring Solutions, Licenses, and Configuration Settings.....	270
Updating The Printer Firmware	271
Ribbon Cable Connectors	272
Printhead Assembly Adjustment.....	285
Data Security Notice.....	287
Identifying Printer Memory.....	287
Erasing Printer Memory.....	287
Performing The HVPS Characterization	288
Removal Procedures.....	289
Left Side Removals.....	290
Left Cover Removal.....	290
Controller Board Removal.....	293
LVPS Removal	294
HVPS Removal	295
Right Side Removals.....	298
Right Cover Removal.....	298
Main Drive Removal.....	300
Pick Solenoid Removal	302
Fan Assembly Removal.....	302
Front Removals	305
2-line Control Panel Removal.....	305
2.8-in. Control Panel Removal.....	307
Front Door Removal.....	309
Transfer Roller Removal.....	309
Rear Removals	311
Rear Door Removal	311
Duplex Unit Removal	311
Bottom Rear Door Removal.....	312
Redrive Removal	312
Fuser Removal	313
Fuser Exit Flag Removal	315

Top Removals.....	317
Top Cover Removal	317
Printhead Removal.....	324
Bottom Removals.....	327
Sensor (Fuser Exit) Removal	327
Sensor (Paper Present) Removal.....	327
Sensor (Staging and Input) Removal.....	328
Input Sensor Flags Removal.....	330
Pick Rollers Removal.....	330
ADF and Scanner	334
Scanner Stand Removal	334
ADF Pick Assembly Removal.....	334
ADF Scanner and Flatbed Scanner Removal	336
7 Component Locations.....	343
Printer Configuration	344
Controller Board Connectors.....	345
8 Maintenance	351
Cleaning Printer Parts.....	352
Cleaning The Printer	352
Cleaning The Scanner	353
9 Parts Catalog	357
Legend	358
Assembly 1: Covers (B225)	359
Assembly 2: Covers (B235)	361
Assembly 3: Paper Path.....	363
Assembly 4: Drive.....	365
Assembly 5: Sensors	366
Assembly 6: Electronics	368
Assembly 7: Scanner	370
10 Printer Specifications	373
Power Consumption	374
Product Power Consumption	374
Sleep Mode.....	374
Hibernate Mode.....	375
Off Mode.....	375
Total Energy Usage.....	375
Selecting A Location For The Printer	376
Noise Emission Levels.....	377
Temperature Information.....	378

Table of Contents

11 Theory Of Operation.....	379
POR Sequence.....	380
Print Cycle Operation	381
Print Engine Layout.....	381
Print Cycle.....	382
Printer Operation	388
Printer Sections.....	388
Printer Paper Path.....	389
Printer Paper Path Sensors	391
Main Drive	392
ADF and Scanner Operation	394
Flatbed Scanner Drive.....	394
ADF Paper Path.....	395
ADF Paper Path Sensors.....	396
12 Part Number Index	397
13 Part Name Index.....	399
14 Wiring Diagram	401
Wiring Diagram (B225).....	402

Notices, Conventions, and Safety Information

Laser Notice

The printer is certified in the U.S. to conform to the requirements of DHHS 21 CFR, Chapter I, Subchapter J for Class I (1) laser products, and elsewhere is certified as a Class I laser product conforming to the requirements of IEC 60825-1: 2014.

Class I laser products are not considered to be hazardous. The laser system and printer are designed so there is never any human access to laser radiation above a Class I level during normal operation, user maintenance, or prescribed service conditions. The printer has a non-serviceable printhead assembly that contains a laser with the following specifications:

Class: IIIb (3b) AlGaAs

Nominal output power (milliwatts): 15

Wavelength (nanometers): 775–800

Avis Relatif À L'utilisation Du Laser

Cette imprimante est certifiée conforme aux exigences de la réglementation des Etats-Unis relative aux produits laser de classe I (1) (DHHS 21 CFR, Chapitre I, Sous-chapitre J). Pour les autres pays, elle est certifiée conforme aux exigences des normes CEI 60825-1:2014 relatives aux produits laser de classe I.

Les produits laser de classe I ne sont pas considérés comme dangereux. Le système laser ainsi que l'imprimante ont été conçus de manière à ce que personne ne soit jamais exposé à des radiations laser dépassant le niveau de classe I dans le cadre d'un fonctionnement normal, de l'entretien par l'utilisateur ou de la maintenance. L'imprimante dispose d'un ensemble de têtes d'impression non réparable contenant un laser doté des caractéristiques suivantes:

Class: IIIb (3b) AlGaAs

Nominal output power (milliwatts): 15

Wavelength (nanometers): 775–800

Aviso De Láser

Esta impresora se ha certificado en EE.UU. cumpliendo con los requisitos de DHHS 21 CFR, capítulo I, subcapítulo J para los productos láser de Clase I (1) y en otros países está certificada como un producto láser de Clase I de acuerdo con los requisitos de IEC 60825-1: 2014.

Los productos láser de Clase I no se consideran peligrosos. El sistema láser y la impresora se han diseñado para que el ser humano no acceda nunca a las radiaciones láser por encima del nivel de Clase I durante su uso normal, ni en tareas de mantenimiento o intervenciones de servicio técnico prescritas. El conjunto de cabezal de impresión de la impresora no se puede reparar y contiene un láser con las siguientes especificaciones:

Class: IIIb (3b) AlGaAs

Nominal output power (milliwatts): 15

Wavelength (nanometers): 775–800

Laser-hinweis

Der Drucker wurde in den USA zertifiziert und entspricht den Anforderungen der Vorschriften DHHS21CFR KapitelI für Laserprodukte der KlasseI(1), andernorts ist er als Laserprodukt der KlasseI zertifiziert, das den Anforderungen von IEC60825-1 entspricht: 2014.

Laserprodukte der KlasseI werden nicht als gefährlich betrachtet. Das Lasersystem und der Drucker sind so konstruiert, dass unter normalen Betriebsbedingungen, bei der Wartung durch den Benutzer oder bei den vorgeschriebenen Wartungsbedingungen Menschen keiner Laserstrahlung ausgesetzt sind, die die Werte für KlasseI überschreitet. Der Drucker verfügt über eine Druckkopfeinheit, die nicht gewartet werden kann und mit einem Laser mit den folgenden Spezifikationen ausgestattet ist.

Class: IIIb (3b) AlGaAs

Nominal output power (milliwatts): 15

Wavelength (nanometers): 775–800

Avvertenza sui prodotti laser

La stampante è certificata negli Stati Uniti come prodotto conforme ai requisiti DHHS 21 CFR Capitolo I, Sottocapitolo J per i prodotti laser di Classe I (1), mentre in altri paesi è certificata come prodotto laser di Classe I conforme ai requisiti IEC 60825-1: 2014.

I prodotti laser di Classe I non sono considerati pericolosi. Il sistema laser e la stampante sono stati progettati in modo da impedire l'esposizione a radiazioni laser superiori al livello previsto dalla Classe I durante le normali operazioni di stampa, manutenzione o assistenza. La stampante è dotata di un gruppo testina di stampa non riparabile che contiene un laser con le seguenti specifiche:

Classe: IIIb (3b) AlGaAs

Potenza di uscita nominale (milliwatt): 15

Lunghezza d'onda (nanometri): 775-800







Conventions

Note: A *note* identifies information that could help you.

Warning: A *warning* identifies something that could damage the product hardware or software.

CAUTION: A *caution* indicates a potentially hazardous situation that could injure you.

Different types of caution statements include:

-  **CAUTION—POTENTIAL INJURY:** Indicates a risk of injury.
-  **CAUTION—SHOCK HAZARD:** Indicates a risk of electrical shock.
-  **CAUTION—HOT SURFACE:** Indicates a risk of burn if touched.
-  **CAUTION—TIPPING HAZARD:** Indicates a crush hazard.
-  **CAUTION—PINCH HAZARD:** Indicates a risk of being caught between moving parts.
-  **CAUTION—MOVING PARTS:** Indicates a risk of laceration or abrasion injuries from rotating parts.







Conventions

Remarque: Une *Remarque* fournit des informations pouvant vous être utiles.

Avertissement: Un *Avertissement* signale un danger susceptible d'endommager le logiciel ou le matériel.

ATTENTION: La mention *Attention* vous signale un risque de blessure corporelle.

Il existe différentes mises en garde:

-  **ATTENTION ! DOMMAGE POTENTIEL :** Signale un risque de blessure.
-  **ATTENTION ! RISQUE D'ÉLECTROCUTION :** Signale un risque d'électrocution.
-  **ATTENTION ! SURFACE CHAUDE :** Signale un risque de brûlure de contact.
-  **ATTENTION ! RISQUE DE BASCULEMENT :** Signale un risque d'écrasement.
-  **ATTENTION ! RISQUE DE PINCEMENT :** Signale un risque de pincement entre des pièces mobiles.
-  **ATTENTION ! PIÈCES MOBILES :** Signale un risque de coupures ou de frottements à cause des pièces rotatives.







Convenciones

Nota: Las *notas* señalan información que puede serle útil.

Aviso: Las *advertencias* indican algo que podría dañar el software o el hardware del producto.

PRECAUCIÓN: Las *precauciones* indican una situación de posible peligro que puede implicar lesiones para el usuario.

Estos son los tipos de avisos de precaución que existen:

-  **PRECAUCIÓN—RIESGO DE LESIONES:** Indica que existe riesgo de lesiones.
-  **PRECAUCIÓN—RIESGO DE DESCARGA:** Indica que existe riesgo de descarga eléctrica.
-  **PRECAUCIÓN—SUPERFICIE CALIENTE:** Indica que existe riesgo de sufrir quemaduras por contacto.
-  **PRECAUCIÓN—RIESGO DE CAÍDA:** Indica que existe peligro de aplastamiento.
-  **PRECAUCIÓN—RIESGO DE DESCARGA ELÉCTRICA:** Existe riesgo de atrapamiento entre las piezas en movimiento.
-  **PRECAUCIÓN—PARTES MÓVILES:** Indica que existe riesgo de lesiones por laceración o abrasión causadas por piezas giratorias.







Konventionen

Hinweis: Ein *Hinweis* enthält nützliche Informationen.

Warnung: Durch eine *Warnung* werden Sie auf einen Umstand hingewiesen, durch den die Produkthardware oder -software beschädigt werden könnte.

VORSICHT: *Vorsicht* weist auf eine mögliche gefährliche Situation hin, die ein Verletzungsrisiko birgt.

Verschiedene Vorsichtshinweise:

-  **VORSICHT – VERLETZUNGSGEFAHR:** Weist auf ein Verletzungsrisiko hin.
-  **VORSICHT – STROMSCHLAGGEFAHR:** Weist auf das Risiko eines elektrischen Schlags hin.
-  **VORSICHT – HEISS:** Weist auf das Risiko von Verbrennungen bei Berührung hin.
-  **VORSICHT – KIPPGEFAHR:** Weist auf Quetschgefahr hin.
-  **VORSICHT – QUETSCHGEFAHR:** Weist auf das Risiko hin, zwischen beweglichen Komponenten eingequetscht zu werden.
-  **VORSICHT – BEWEGLICHE TEILE:** Weist auf das Risiko von Verletzungen und Abschürfungen durch sich drehende Teile hin.







Convenzioni

Nota: Una *nota* identifica informazioni che potrebbero essere di aiuto.

Avvertenza: Un messaggio di *avvertenza* segnala qualcosa che potrebbe danneggiare l'hardware o il software del prodotto.

ATTENZIONE: Un messaggio di *attenzione* segnala una situazione potenzialmente pericolosa che potrebbe causare lesioni all'utente.

I diversi tipi di messaggi di attenzione sono:

-  **ATTENZIONE – PERICOLO DI LESIONI:** Indica il rischio di ferirsi.
-  **ATTENZIONE – PERICOLO DI SCOSSA ELETTRICA:** Indica il rischio di scosse elettriche.
-  **ATTENZIONE – SUPERFICIE SURRISCALDATA:**Indica il rischio di bruciarsi al contatto.
-  **ATTENZIONE – PERICOLO DI RIBALTAMENTO:** Indica il pericolo di essere schiacciati.
-  **ATTENZIONE – PERICOLO DI SCHIACCIAMENTO:** Indica il rischio di intrappolamento tra parti in movimento.
-  **ATTENZIONE – PARTI MOBILI:** Indica il rischio di lesioni da lacerazione o abrasione dovute a parti rotanti.

Safety Information

- The safety of this product is based on testing and approvals of the original design and specific components. The manufacturer is not responsible for safety in the event of use of unauthorized replacement parts.
- The maintenance information for this product has been prepared for use by a professional service person and is not intended to be used by others.
- There may be an increased risk of electrical shock and personal injury during disassembly and servicing of this product. Professional service personnel should understand this risk and take necessary precautions.

 **CAUTION—SHOCK HAZARD:** When you see this symbol on the product, there is a danger from hazardous voltage in the area of the product where you are working. Unplug the product before you begin, or use caution if the product must receive power in order to perform the task.

 **CAUTION—POTENTIAL INJURY:** The lithium battery in this product is not intended to be replaced. There is a danger of explosion if a lithium battery is incorrectly replaced. Do not recharge, disassemble, or incinerate a lithium battery. Discard used lithium batteries according to the manufacturer's instructions and local regulations.

 **CAUTION—POTENTIAL INJURY:** To avoid the risk of fire or electrical shock, connect the power cord to an appropriately rated and properly grounded electrical outlet that is near the product and easily accessible.

 **CAUTION—POTENTIAL INJURY:** To avoid the risk of fire or electrical shock, use only the power cord provided with this product or the manufacturer's authorized replacement.







 **CAUTION—POTENTIAL INJURY:** Do not use this product with extension cords, multioutlet power strips, multioutlet extenders, or UPS devices. The power capacity of these types of accessories can be easily overloaded by a laser printer and may result in a risk of fire, property damage, or poor printer performance.

 **CAUTION—POTENTIAL INJURY:** Only a Xerox Inline Surge Protector that is properly connected between the printer and the power cord provided with the printer may be used with this product. The use of non-Xerox surge protection devices may result in a risk of fire, property damage, or poor printer performance.



 **CAUTION—POTENTIAL INJURY:** If the printer weight is greater than 20kg (44lb), then it may require two or more people to lift it safely.





Consignes De Sécurité

- La sécurité de ce produit est basée sur des tests et certifications de sa conception d'origine et de ses composants spécifiques. Le fabricant décline toute responsabilité en cas d'utilisation de pièces de rechange non autorisées.
- Les informations de maintenance de ce produit sont destinées à des professionnels qualifiés et ne sont pas conçues pour être utilisées par d'autres personnes.
- Il existe un risque potentiel de choc électrique et de blessures lors du démontage et de la maintenance de ce produit. Le personnel professionnel de maintenance doit comprendre les risques et prendre les précautions nécessaires.





-  **ATTENTION ! RISQUE D'ÉLECTROCUTION :** Ce symbole indique un danger lié à des niveaux de tension dangereux dans la zone du produit à manipuler. Débranchez le produit avant de commencer, ou agissez avec prudence si le produit doit être alimenté pour effectuer l'opération.
-  **ATTENTION ! DOMMAGE POTENTIEL :** La batterie lithium de ce produit n'est pas destinée à être remplacée. Si vous ne respectez pas les instructions de remplacement de la batterie, vous risquez de provoquer une explosion. Ne rechargez pas, ne désassemblez pas et ne brûlez pas la batterie au lithium. Mettez les batteries lithium usagées au rebut selon les instructions du fabricant et les réglementations locales.
-  **ATTENTION ! DOMMAGE POTENTIEL :** Pour éviter tout risque d'électrocution ou d'incendie, branchez le câble d'alimentation directement à une prise électrique répondant aux exigences requises et correctement mise à la terre, proche du produit et facile d'accès.
-  **ATTENTION ! DOMMAGE POTENTIEL :** Pour éviter tout risque d'incendie ou d'électrocution, utilisez uniquement le câble d'alimentation fourni avec ce produit ou un câble de remplacement autorisé par le fabricant.
-  **ATTENTION ! DOMMAGE POTENTIEL :** Ce produit ne doit pas être utilisé avec des rallonges, des barres multiprises, des rallonges multiprises ou des périphériques UPS. La capacité de ces types d'accessoires peut être facilement dépassée par une imprimante laser, d'où un risque de dégâts matériels, d'incendie ou de performances d'impression amoindries.
-  **ATTENTION ! DOMMAGE POTENTIEL :** Utilisez uniquement un parasurtenseur correctement raccordé à l'imprimante et au câble d'alimentation fourni avec la machine. L'utilisation de parasurtenseurs non fabriqués par Xerox comporte un risque d'incendie et de dégâts matériels, et peut amoindrir les performances de l'imprimante.
-  **ATTENTION ! DOMMAGE POTENTIEL :** Si votre imprimante pèse plus de 20kg (44lb), l'intervention d'au moins deux personnes est nécessaire pour la soulever sans risque.



Información De Seguridad

- La seguridad de este producto se basa en las pruebas y comprobaciones del diseño original y los componentes específicos. El fabricante no se hace responsable de la seguridad en caso de uso de piezas de repuesto no autorizadas.
- La información de mantenimiento de este producto se ha preparado para su uso por parte de un profesional de asistencia técnica y no está diseñada para su uso por parte de otros usuarios.
- Es posible que haya un mayor riesgo de descarga eléctrica y daños personales durante el desmontaje y el mantenimiento de este producto. El personal de asistencia profesional debe conocer este riesgo y tomar las precauciones necesarias.
-  **PRECAUCIÓN—RIESGO DE DESCARGA:** Cuando vea este símbolo en el producto, existe peligro de tensiones peligrosas en el área del producto en la que está trabajando. Desconecte el producto antes de empezar o tenga cuidado si el producto debe recibir alimentación a fin de realizar la tarea.
-  **PRECAUCIÓN—RIESGO DE LESIONES:** La batería de litio de este producto no debe reemplazarse. Existe riesgo de explosión si se sustituye incorrectamente una batería de litio. No recargue, desmonte ni incinere una batería de litio. Deseche las baterías de litio usadas según las instrucciones del fabricante y las normativas locales.







-  **PRECAUCIÓN—RIESGO DE LESIONES:** Para evitar el riesgo de incendio o descarga eléctrica, conecte el cable de alimentación a una toma de corriente debidamente conectada a tierra con la potencia adecuada que se encuentre cerca del dispositivo y resulte fácilmente accesible.
-  **PRECAUCIÓN—RIESGO DE LESIONES:** Para evitar el riesgo de incendio o descarga eléctrica, utilice exclusivamente el cable de alimentación que se suministra junto con este producto o el repuesto autorizado por el fabricante.
-  **PRECAUCIÓN—RIESGO DE LESIONES:** No utilice este producto con cables alargadores, regletas de varias tomas, cables alargadores de varias tomas o sistemas de alimentación ininterrumpida. La potencia de este tipo de accesorios puede sobrecargarse fácilmente si se utiliza una impresora láser, lo que puede dar lugar a que el rendimiento de la impresora sea bajo, a daños materiales o a posibles incendios.
-  **PRECAUCIÓN—RIESGO DE LESIONES:** Solo debe usarse con este producto un protector de sobretensión insertable Xerox debidamente conectado entre la impresora y el cable de alimentación que con ella se suministra. El uso de protectores de sobretensión de marcas distintas a Xerox puede dar lugar a que el rendimiento de la impresora sea bajo, a daños materiales o a posibles incendios.
-  **PRECAUCIÓN—RIESGO DE LESIONES:** si el peso de la impresora es superior a 20kg (44lb), pueden ser necesarias dos o más personas para levantarla de forma segura.

Sicherheitshinweise

- Die Sicherheit dieses Produkts basiert auf Tests und Zulassungen des Originaldesigns und der spezifischen Komponenten. Sofern nicht autorisierte Ersatzteile eingesetzt werden, übernimmt der Hersteller keinerlei Verantwortung in Bezug auf die Sicherheit dieses Produkts.
- Die Wartungsinformationen für dieses Produkt wurden für ausgebildete Servicemitarbeiter zusammengestellt und dürfen nicht von anderen verwendet werden.
- Möglicherweise besteht bei der Demontage und Wartung dieses Produkts eine erhöhte Stromschlag- und Verletzungsgefahr. Ausgebildete Servicemitarbeiter sollten sich dieser Gefahr bewusst sein und die notwendigen Vorsichtsmaßnahmen ergreifen.
-  **VORSICHT – STROMSCHLAGGEFAHR:** Wenn Sie dieses Symbol sehen, besteht eine Gefahr durch gefährliche Spannungen in dem Produktbereich, in dem Sie arbeiten. Trennen Sie das Produkt von seiner Stromverbindung, bevor Sie beginnen, oder gehen Sie vorsichtig vor, wenn das Produkt für die Durchführung der Aufgabe mit Strom versorgt werden muss.
-  **VORSICHT – VERLETZUNGSGEFAHR:** Die Lithiumbatterie in diesem Produkt darf nicht ausgetauscht werden. Wird eine Lithiumbatterie nicht ordnungsgemäß ausgetauscht, besteht Explosionsgefahr. Lithiumbatterien dürfen auf keinen Fall wieder aufgeladen, auseinander genommen oder verbrannt werden. Befolgen Sie zum Entsorgen verbrauchter Lithiumbatterien die Anweisungen des Herstellers und die örtlichen Bestimmungen.
-  **VORSICHT – VERLETZUNGSGEFAHR:** Um Feuer- und Stromschlaggefahr zu vermeiden, schließen Sie das Netzkabel direkt an eine ordnungsgemäß geerdete Steckdose an, die sich in der Nähe des Geräts befindet und leicht zugänglich ist.
-  **VORSICHT – VERLETZUNGSGEFAHR:** Um das Risiko eines Feuers oder elektrischen Schlags zu vermeiden, verwenden Sie ausschließlich das diesem Produkt beiliegende Netzkabel bzw. ein durch den Hersteller zugelassenes Ersatzkabel.

-  **VORSICHT – VERLETZUNGSGEFAHR:** Verwenden Sie das Produkt nicht mit Verlängerungskabeln, Mehrfachsteckdosen, Mehrfachverlängerungen oder Geräten für unterbrechungsfreie Stromversorgung. Die Belastbarkeit solcher Zubehörteile kann durch Laserdrucker schnell überschritten werden, was zu Brandgefahr, Beschädigung von Eigentum oder einer eingeschränkten Druckerleistung führen kann.
-  **VORSICHT – VERLETZUNGSGEFAHR:** Mit diesem Produkt darf nur ein Xerox Inline Surge Protector verwendet werden, der vorschriftsgemäß zwischen dem Drucker und dem mitgelieferten Netzkabel angeschlossen ist. Die Verwendung von nicht von Xerox stammenden Überspannungsschutzgeräten kann zu Brandgefahr, Beschädigung von Eigentum oder einer eingeschränkten Druckerleistung führen.
-  **VORSICHT – VERLETZUNGSGEFAHR:** Wenn der Drucker mehr als 20kg wiegt, sind zum sicheren Anheben mindestens zwei Personen notwendig.

Informazioni sulla sicurezza

- La sicurezza di questo prodotto è basata sul collaudo e le approvazioni del progetto tecnico originale e di specifici componenti. Il produttore non è responsabile per la sicurezza in caso di utilizzo di parti di ricambio non autorizzate.
- Le informazioni sulla manutenzione di questo prodotto sono rivolte esclusivamente a personale di manutenzione e assistenza specializzato.
- L'intervento di smontaggio e manutenzione/riparazione di questo dispositivo potrebbe comportare un maggiore rischio di scossa elettrica o lesioni personali. Il personale di assistenza specializzato deve essere consapevole di tale rischio e assumere le necessarie precauzioni.
-  **ATTENZIONE – PERICOLO DI SCOSSA ELETTRICA:** La presenza di questo simbolo sul prodotto significa che è presente tensione pericolosa nell'area del prodotto su cui si sta lavorando. Scollegare il prodotto prima di iniziare, o prestare cautela se l'intervento richiede che il prodotto debba ricevere alimentazione.
-  **ATTENZIONE – PERICOLO DI LESIONI:** La batteria al litio presente nel prodotto non deve essere sostituita. In caso di sostituzione errata della batteria al litio, potrebbe verificarsi un'esplosione. Non ricaricare, smontare o bruciare batterie al litio. Smaltire le batterie al litio usate seguendo le istruzioni del produttore e le norme locali.
-  **ATTENZIONE – PERICOLO DI LESIONI:** Per evitare il rischio di incendio o scosse elettriche, collegare il cavo di alimentazione a una presa elettrica dotata di messa a terra e con le specifiche adeguate, situata in prossimità del prodotto e facilmente accessibile.
-  **ATTENZIONE – PERICOLO DI LESIONI:** Per evitare il rischio di incendi o scosse elettriche, utilizzare solo il cavo di alimentazione fornito con il prodotto o componenti sostitutivi autorizzati dal produttore.
-  **ATTENZIONE – PERICOLO DI LESIONI:** Non utilizzare il prodotto con cavi di prolunga, prese multiple, prolunghe multipresa o gruppi di continuità. La capacità di potenza di questi tipi di accessori può essere facilmente sovraccaricata da una stampante laser e può comportare incendi, danni o scarse prestazioni della stampante.
-  **ATTENZIONE – PERICOLO DI LESIONI:** Con questo prodotto può essere utilizzato solo un protettore di sovratensione in linea Xerox fornito con la stampante, correttamente collegato alla stampante e al cavo di alimentazione. L'utilizzo di protettori di sovratensione non Xerox può comportare il rischio di incendi, danni o scarse prestazioni della stampante.



ATTENZIONE – PERICOLO DI LESIONI: Se la stampante pesa più di 20 kg (44 lb), potrebbe richiedere due o più persone per essere sollevata in modo sicuro.

Health and Safety Incident Reporting

I. Summary

This section defines requirements for notification of health and safety incidents involving Xerox products (equipment and materials) at customer locations.

II. Scope

Xerox Corporation and subsidiaries worldwide.

III. Objective

To enable prompt resolution of health and safety incidents involving Xerox products and to ensure Xerox regulatory compliance.

IV. Definitions

Incident:

An event or condition occurring in a customer account that has resulted in injury, illness or property damage. Examples of incidents include machine fires, smoke generation, physical injury to an operator or service representative. Alleged events and product conditions are included in this definition.

V. Requirements

Initial Report:

1. Xerox organizations shall establish a process for individuals to report product incidents to Xerox Environment Health and Safety within 24 hours of becoming aware of the event.
2. The information to be provided at the time of reporting is contained in Appendix A (Health and Safety Incident Report involving a Xerox product).
3. The initial notification may be made by the method that follows:
 - Email Xerox EH&S at: usa.product.incident@xerox.com.
 - Fax Xerox EH&S at: 585-422-2249.



Note: If sending a fax, please also send the original via internal mail.

Responsibilities for resolution:

1. Business Groups/Product Design Teams responsible for the product involved in the incident shall:
 - a. Manage field bulletins, customer correspondence, product recalls, safety retrofits.
 - b. Fund all field retrofits.
2. Field Service Operations shall:
 - a. Preserve the Xerox product involved and the scene of the incident inclusive of any associated equipment located in the vicinity of the incident.
 - b. Return any affected equipment/part(s) to the location designated by Xerox EH&S and/or the Business Division.
 - c. Implement all safety retrofits.
3. Xerox EH&S shall:
 - a. Manage and report all incident investigation activities.
 - b. Review and approve proposed product corrective actions and retrofits, if necessary.
 - c. Manage all communications and correspondence with government agencies.
 - d. Define actions to correct confirmed incidents.

VI. Appendices

The Health and Safety Incident Report involving a Xerox Product (Form # EH&S-700) is available in the following location:

- [GSN Library 1789](#)

Change History

Change History

Version No.	Month and Year	Description
02	January, 2022	<p>Updated the following topics:</p> <ul style="list-style-type: none">• 31–33 User Attendance Messages• 9yy Error Messages• Supplies Used to Resolve Print Quality Issues <p>Added the following topics:</p> <ul style="list-style-type: none">• Non-Xerox Supply• Metered Supply Installed In Printer Configured For Sold• Changing The Service Plan (Non-PagePack)• Changing The Service Plan (PagePack)• 900 Error Service Check <p>Removed the following topics:</p> <ul style="list-style-type: none">• System Software Error Service Check
01	July, 2021	This is the launch version of the service manual.

General Information

Printer Model Configurations

The Xerox B225 and B235 are small, monochrome, network-capable multifunction laser printers.

Model	Configurations
B225	Network-ready monochrome laser printer with 2-line LCD display, wireless capability, analog fax, internal duplex printing, and simplex scanning for small workgroups
B235	Network-ready monochrome laser printer with 2.8-in. LCD display, wireless capability, analog fax, internal duplex printing, and simplex scanning for small workgroups

Locating the Printer Serial Number

Follow the below steps to locate the serial number of the printer.

1. Pull out the tray.
2. Locate the serial number below the manual feeder.

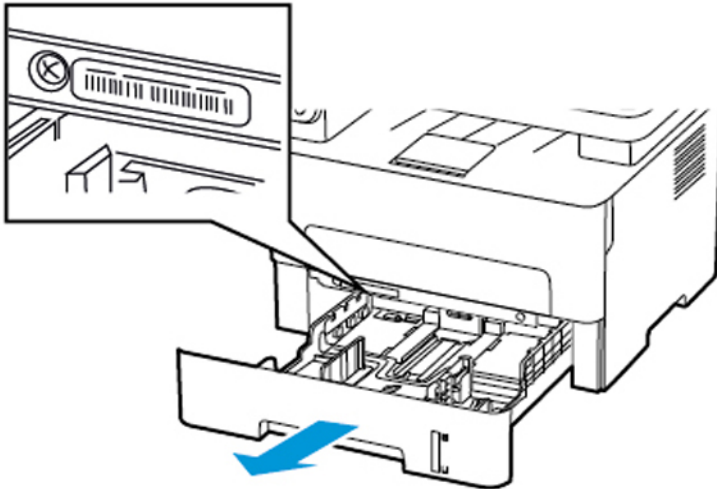

Supported Paper Sizes, Types, and Weights

Supported Paper Sizes

 **Note:**

- Paper less than 210mm (8.3in.) wide always prints at reduced speed.
- Use the manual feeder when printing on paper less than 105mm (4.1in.) wide.
- The minimum paper dimension supported for two-sided printing is 210x279.4mm (8.3x11in.).
- The maximum paper length supported by the scanner glass is 297mm (11.7in.).
- For two-sided printing on letter-, legal-, or folio-size paper, make sure that the paper size setting in the duplex unit is set to Letter.

Paper size	250-sheet tray	Manual feeder	Two-sided printing	Scanner glass	Automatic document feeder
A4 210x297mm (8.27x11.7in.)	✓	✓	✓	✓	✓
A5 (short edge feed) 148x210mm (5.83x8.27in.)	✓	✓	X	✓	✓
A5 (long edge feed) 210x148mm (8.27x5.83in.)	✓	✓	X	✓	✓
A6 105x148mm (4.13x5.83in.)	✓	✓	X	✓	✓
JIS B5 182x257mm (7.17x10.1in.)	✓	✓	X	✓	✓
Oficio (Mexico) 215.9x340.4mm (8.5x13.4in.)	✓	✓	X	X	✓
Hagaki 100x148mm (3.94x5.83in.)	X	✓	X	✓	X
Statement	✓	✓	X	✓	✓

Paper size	250-sheet tray	Manual feeder	Two-sided printing	Scanner glass	Automatic document feeder
139.7x215.9mm (5.5x8.5in.)					
Executive 184.2x266.7mm (7.25x10.5in.)	✓	✓	X	✓	✓
Letter 215.9x279.4mm (8.5x11in.)	✓	✓	✓	✓	✓
Legal 215.9x355.6mm (8.5x14in.)	✓	✓	✓	X	✓
Folio 215.9x330.2mm (8.5x13in.)	✓	✓	✓	X	✓
Universal 98x148mm (3.9x5.8in.) to 216x356mm (8.5x14in.)	X	✓	X	✓*	✓
Universal 105x148mm (4.1x5.8in.) to 216x356mm (8.5x14in.)	✓	✓	X	✓*	✓
73/4 Envelope (Monarch) 98.4x190.5mm (3.875x7.5in.)	X	✓	X	✓	X
9Envelope 98.4x225.4mm (3.875x8.9in.)	X	✓	X	✓	X
10Envelope 104.8x241.3mm (4.12x9.5in.)	X	✓	X	✓	X
DLEnvelope 110x220mm (4.33x8.66in.)	X	✓	X	✓	X

Paper size	250-sheet tray	Manual feeder	Two-sided printing	Scanner glass	Automatic document feeder
C5Envelope 162x229mm (6.38x9.01in.)	X	✓	X	✓	X
B5Envelope 176x250mm (6.93x9.84in.)	X	✓	X	✓	X
UniversalEnvelope 98.4x162mm (3.87x6.38in.) to 176x250mm (6.93x9.84in.)	X	✓	X	✓	X
* This paper source supports paper size only up to 216 x 297 mm (8.5 x 11.7 in.).					

Supported Paper Types

 **Note:** Labels, envelopes, and card stock always print at reduced speed.

Paper type	250-sheet tray	Manual feeder	Two-sided printing	Automatic document feeder
Plain paper	✓	✓	✓	✓
Card stock	X	✓	X	X
Labels	X	✓	X	X
Bond	✓	✓	✓	✓
Envelope	X	✓	X	X
Letterhead	✓	✓	✓	✓
Preprinted	✓	✓	✓	✓
Colored paper	✓	✓	✓	✓
Light	✓	✓	✓	✓
Heavy	✓	✓	✓	✓
Recycled	✓	✓	✓	✓

Supported Paper Weights







250-sheet tray	Manual feeder	Two-sided printing	Automatic document feeder
60–105g/m ² (16–28-lb bond)	60–200g/m ² (16–54-lb bond)	70–105g/m ² (18.7–28-lb bond)	60–105g/m ² (16–28-lb bond)

Tools Required For Service





- Flat-blade screwdrivers, various sizes
- #1 Phillips screwdriver, magnetic
- #2 Phillips screwdriver, magnetic
- #2 Phillips screwdriver, magnetic short-blade
- Torx screwdriver (T20 head)
- Needle-nose pliers
- Diagonal side cutters
- Spring hook
- Feeler gauges
- Analog or digital multimeter
- 3mm ball hex wrench
- Toner vacuum
- Flashlight



Diagnostics and Troubleshooting

Troubleshooting Precautions







-  **CAUTION—SHOCK HAZARD:** When you see this symbol on the product, there is a danger from hazardous voltage in the area of the product where you are working. Unplug the product before you begin, or use caution if the product must receive power in order to perform the task.
-  **CAUTION—SHOCK HAZARD:** This product uses an electronic power switch. It does not physically disconnect the input AC voltage. To avoid the risk of electrical shock, always remove the power cord from the printer when removal of the input AC voltage is required.
-  **CAUTION—SHOCK HAZARD:** To avoid the risk of electrical shock while troubleshooting with covers removed or doors open, do not touch the exposed wires or circuits while the printer is connected to an electrical outlet.
-  **CAUTION—SHOCK HAZARD:** To avoid the risk of electrical shock and to prevent damage to the printer, remove the power cord from the electrical outlet and disconnect all connections to any external devices before you connect or disconnect any cable, electronic board, or assembly.
-  **CAUTION—HOT SURFACE:** The inside of the printer might be hot. To reduce the risk of injury from a hot component, allow the surface to cool before touching it.
-  **CAUTION—PINCH HAZARD:** To avoid the risk of a pinch injury, use caution in areas marked with this label. Pinch injuries may occur around moving parts, such as gears, doors, trays, and covers.
-  **CAUTION—MOVING PARTS:** To avoid the risk of laceration or abrasion injuries, keep hands away from moving parts in areas marked with this label. Injuries from moving parts may occur around gears and other rotating parts.

Précautions De Dépannage

-  **ATTENTION ! RISQUE D'ÉLECTROCUTION :** Ce symbole indique un danger lié à des niveaux de tension dangereux dans la zone du produit à manipuler. Débranchez le produit avant de commencer, ou agissez avec prudence si le produit doit être alimenté pour effectuer l'opération.
-  **ATTENTION ! RISQUE D'ÉLECTROCUTION :** Ce produit utilise un commutateur d'alimentation électronique. Il ne déconnecte pas physiquement la tension d'alimentation CA. Pour éviter tout risque d'électrocution, débranchez toujours le cordon d'alimentation de l'imprimante lorsque vous devez déconnecter la tension d'alimentation CA.
-  **ATTENTION ! RISQUE D'ÉLECTROCUTION :** Pour éviter tout risque d'électrocution lors du dépannage de l'imprimante avec les capots retirés ou les portes ouvertes, prenez garde de ne pas toucher les fils ou circuits dénudés si l'imprimante est connectée à une prise électrique.
-  **ATTENTION ! RISQUE D'ÉLECTROCUTION :** Pour éviter tout risque d'électrocution et éviter d'endommager l'imprimante, débranchez le cordon d'alimentation de la prise électrique et déconnectez toute connexion à tout périphérique externe avant de brancher ou débrancher des câbles ou circuits et assemblages électroniques.
-  **ATTENTION ! SURFACE CHAUDE :** L'intérieur de l'imprimante risque d'être brûlant. pour réduire le risque de brûlure, laissez la surface ou le composant refroidir avant d'y toucher.







-  **ATTENTION ! RISQUE DE PINCEMENT :** Pour éviter tout risque de blessure par pincement, agissez avec précaution au niveau des zones signalées par cette étiquette. Les blessures par pincement peuvent se produire autour des pièces mobiles telles que les engrenages, portes, tiroirs et capots.
-  **ATTENTION ! PIÈCES MOBILES :** Pour éviter tout risque de coupures ou de frottements, éloignez les mains des pièces en mouvement dans les zones signalées par cette étiquette. Les pièces en mouvement autour des engrenages et autres pièces rotatives peuvent causer des blessures.

Precauciones Durante La Solución De Problemas





-  **PRECAUCIÓN—RIESGO DE DESCARGA:** Cuando vea este símbolo en el producto, existe peligro de tensiones peligrosas en el área del producto en la que está trabajando. Desconecte el producto antes de empezar o tenga cuidado si el producto debe recibir alimentación a fin de realizar la tarea.
-  **PRECAUCIÓN—RIESGO DE DESCARGA:** Este producto utiliza un interruptor de corriente electrónico. No desconecta físicamente la entrada de voltaje de CA. Para evitar el riesgo de descarga eléctrica, desenchufe siempre el cable de alimentación de la impresora cuando sea necesario retirar la entrada de voltaje de CA.
-  **PRECAUCIÓN—RIESGO DE DESCARGA:** Para evitar el riesgo de descarga eléctrica al solucionar problemas sin las cubiertas o con las puertas abiertas, no toque los cables ni los circuitos expuestos mientras la impresora está conectada a una toma de corriente.
-  **PRECAUCIÓN—RIESGO DE DESCARGA:** Para evitar el riesgo de descargas eléctricas y daños en la impresora, retire el cable de alimentación de la toma eléctrica y desconecte todas las conexiones a dispositivos externos antes de conectar o desconectar cualquier cable, placa electrónica o conjunto.
-  **PRECAUCIÓN—SUPERFICIE CALIENTE:** El interior de la impresora podría estar caliente. Para evitar el riesgo de heridas producidas por el contacto con un componente caliente, deje que la superficie se enfríe antes de tocarlo.
-  **PRECAUCIÓN—RIESGO DE DESCARGA ELÉCTRICA:** Para evitar el riesgo de lesión por atrapamiento, preste atención en las áreas marcadas con esta etiqueta. Las lesiones por atrapamiento se pueden producir en torno a partes móviles, tales como engranajes, puertas, bandejas y cubiertas.
-  **PRECAUCIÓN—PARTES MÓVILES:** Para evitar el riesgo de lesiones por laceración o abrasión, mantenga las manos lejos de las partes móviles en las zonas marcadas con esta etiqueta. Las lesiones causadas por partes móviles pueden producirse cerca de los engranajes u otras piezas giratorias.

Vorsichtsmaßnahmen Bei Der Fehlerbehebung

-  **VORSICHT – STROMSCHLAGGEFAHR:** Wenn Sie dieses Symbol sehen, besteht eine Gefahr durch gefährliche Spannungen in dem Produktbereich, in dem Sie arbeiten. Trennen Sie das Produkt von seiner Stromverbindung, bevor Sie beginnen, oder gehen Sie vorsichtig vor, wenn das Produkt für die Durchführung der Aufgabe mit Strom versorgt werden muss.

-  **VORSICHT – STROMSCHLAGGEFAHR:** Dieses Produkt verwendet einen elektronischen Leistungsschalter. Er trennt die Eingangswchselspannung nicht physikalisch. Um das Risiko eines elektrischen Schlags zu vermeiden, ziehen Sie stets das Netzkabel vom Drucker ab, wenn eine Abtrennung der Eingangswchselspannung erforderlich ist.
-  **VORSICHT – STROMSCHLAGGEFAHR:** Um die Gefahr eines Stromschlags während der Fehlerbehebung bei entfernten Abdeckungen oder offenen Klappen zu vermeiden, berühren Sie die freiliegenden Drähte oder Stromkreise nicht, wenn der Drucker an eine Steckdose angeschlossen ist.
-  **VORSICHT – STROMSCHLAGGEFAHR:** Um das Risiko eines elektrischen Schlags und Schäden am Drucker zu vermeiden, ziehen Sie das Netzkabel aus der Steckdose und trennen Sie alle Verbindungen zu jeglichen externen Geräten, bevor Sie Kabel, Elektronikplatinen oder Baugruppen einstecken oder abziehen.
-  **VORSICHT – HEISS:** Das Innere des Druckers kann sehr heiß sein. Vermeiden Sie Verletzungen, indem Sie heiße Komponenten stets abkühlen lassen, bevor Sie ihre Oberfläche berühren.
-  **VORSICHT – QUETSCHGEFAHR:** Um das Risiko einer Quetschung zu vermeiden, gehen Sie in Bereichen, die mit diesem Etikett gekennzeichnet sind, mit Vorsicht vor. Quetschungen können im Bereich von beweglichen Komponenten auftreten, wie z.B. Zahnrädern, Klappen, Fächern und Abdeckungen.
-  **VORSICHT – BEWEGLICHE TEILE:** Um das Risiko von Verletzungen und Abschürfungen zu vermeiden, halten Sie Ihre Hände von sich bewegenden Teilen in Bereichen fern, die mit diesem Hinweis gekennzeichnet sind. Verletzungen durch sich bewegende Teile treten unter Umständen im Bereich von Zahnrädern und anderen sich drehenden Teilen auf.

Precauzioni per gli interventi di riparazione

-  **ATTENZIONE – PERICOLO DI SCOSSA ELETTRICA:** La presenza di questo simbolo sul prodotto significa che è presente tensione pericolosa nell'area del prodotto su cui si sta lavorando. Scollegare il prodotto prima di iniziare, o prestare cautela se l'intervento richiede che il prodotto debba ricevere alimentazione.
-  **ATTENZIONE – PERICOLO DI SCOSSA ELETTRICA:** Questo prodotto utilizza un interruttore di alimentazione elettronico. Tale interruttore non scollega fisicamente la tensione CA in entrata. Per evitare il rischio di scossa elettrica, rimuovere sempre il cavo di alimentazione dalla stampante quando è necessario rimuovere la tensione CA in entrata.
-  **ATTENZIONE – PERICOLO DI SCOSSA ELETTRICA:** Per evitare il rischio di scossa elettrica quando si eseguono interventi sulla macchina con coperture rimosse e sportelli aperti, non toccare cavi o circuiti esposti quando la stampante è collegata a una presa elettrica.
-  **ATTENZIONE – PERICOLO DI SCOSSA ELETTRICA:** Per evitare il rischio di scossa elettrica e per impedire danni alla stampante, rimuovere il cavo di alimentazione dalla presa elettrica e scollegare tutti i collegamenti a eventuali dispositivi esterni prima di collegare o scollegare qualsiasi cavo, scheda elettronica o gruppo.
-  **ATTENZIONE – SUPERFICIE SURRISCALDATA:** L'area interna della stampante potrebbe surriscaldarsi. Per evitare infortuni, lasciare raffreddare la superficie dei componenti prima di toccarla.



ATTENZIONE – PERICOLO DI SCHIACCIAMENTO: Per evitare il rischio di lesioni, prestare la massima cautela quando si accede alle aree contrassegnate con questa etichetta. Potrebbero infatti verificarsi lesioni da schiacciamento in prossimità di parti in movimento, quali ad esempio ingranaggi, porte, vassoi e coperchi.



ATTENZIONE – PARTI MOBILI: Per evitare il rischio di lesioni da lacerazione o abrasione, tenere le mani lontano da parti in movimento nelle aree contrassegnate con questa etichetta. Le lesioni dovute a parti in movimento possono verificarsi intorno a ingranaggi e altre parti rotanti.

Troubleshooting Overview

Performing The Initial Troubleshooting Check

- With the power cord unplugged from the electrical outlet, check if the cord is free from breakage, short circuits, disconnected wires, or incorrect connections.
- Make sure that the printer is properly grounded.
- Make sure that the power supply line voltage is within 10 % of the rated line voltage.
- Make sure that the printer is securely installed on a level surface in a well-ventilated area.
- Make sure that the temperature and relative humidity are within the specifications. See [Temperature Information](#).
- Avoid locations that:
 - Generate ammonia gas
 - Are exposed to direct sunlight
 - Are near open flames
 - Are dusty
- Make sure that the recommended paper for this printer is used.
- Do a test print with paper from a newly opened package, and then check the result.

Fixing Print Quality Issues

Initial Print Quality Check

Before troubleshooting print problems, perform the following:

- Make sure that the printer is located in an area that follows the recommended operating environment and power requirement specifications.
- Check the status of supplies. Replace supplies that are low or empty.
- Load 20-lb (75-80 g/m²) plain letter or A4 paper. Make sure that the paper guides are properly set and locked. From the control panel, set the paper size and type to match the paper loaded in the tray.
- From the control panel, navigate to **Settings > Troubleshooting > Print Quality Test Pages**.
- Print and keep the Menu Settings Page. The original page is used to restore the custom settings if necessary. From the control panel, navigate to **Settings > Reports > Menu Settings Page**, and then press **OK**.
- On the Menu Settings page, check if the print resolution is set to 600 dpi and the toner darkness is set to Normal.
- Check the toner cartridges for damage, and replace if necessary.
- Make sure that the correct print driver is used to prevent print problems. If the wrong print driver is installed, then incorrect characters could print and the copy may not fit the page correctly.

Supplies Used to Resolve Print Quality Issues

For this family of printers, the following supplies are available to resolve print quality issues:

Supply Item	Part Number
Standard-Capacity Toner Cartridge (1.2K) NA/XE Sold	006R04399
High-Capacity Toner Cartridge (3K) NA/XE Sold	006R04400
Extra High-Capacity Toner Cartridge (6K) NA/XE Sold	006R04401
Standard-Capacity Toner Cartridge (1.2K) DMO Sold	006R04402
High-Capacity Toner Cartridge (3K) DMO Sold	006R04403
Extra High-Capacity Toner Cartridge (6K) DMO Sold	006R04404
World Wide Metered Toner Cartridge (6K)	006R04528
Imaging Kit (12K) Universal World Wide	013R00691

Gray or Solid Background Check

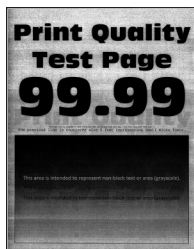

Action	Yes	No
<p>Step 1</p> <ol style="list-style-type: none"> 1 Make sure that the toner cartridge is supported. 2 Make sure that the toner cartridge and imaging unit are not empty. 3 Check if the toner cartridge is new. <p>Is the toner cartridge new?</p>	Go to step 2.	Go to step 3.
<p>Step 2</p> <p>Make sure to remove the packing material on the toner cartridge and imaging unit.</p> <p>Does the problem remain?</p>	Go to step 3.	The problem is solved.
<p>Step 3</p> <ol style="list-style-type: none"> 1 Clear the paper path of debris and contamination. 2 Remove, and then insert the imaging unit and toner cartridge. <p>Shake the toner cartridge and imaging unit before inserting them.</p> <ol style="list-style-type: none"> 3 Perform a POR. 4 Enter the Diagnostics menu, and then select Advanced Print Quality Samples. <p>Does the problem remain?</p>	Go to step 4.	The problem is solved.
<p>Step 4</p> <ol style="list-style-type: none"> 1 Make sure that the toner cartridge is properly installed and free of damage. 2 Make sure that the smart chip contacts are free of corrosion and contamination. 	Go to step 5.	The problem is solved.

Action	Yes	No
<p>3 Make sure that the developer roller surface is free of damage.</p> <p>4 Make sure that the toner HVPS contacts are free of corrosion and contamination.</p> <p>5 Enter the Diagnostics menu, and then select Advanced Print Quality Samples.</p> <p>Does the problem remain?</p>		
<p>Step 5</p> <p>Replace the toner cartridge.</p> <p>Does the problem remain?</p>	Go to step 6.	The problem is solved.
<p>Step 6</p> <p>1 Make sure that the imaging unit is properly installed and free of damage.</p> <p>2 Make sure that the smart chip contacts are free of corrosion and contamination.</p> <p>3 Make sure that the photoconductor roller surface is free of damage.</p> <p>4 Make sure that the imaging unit HVPS contacts are free of corrosion and contamination.</p> <p>5 Enter the Diagnostics menu, and then select Advanced Print Quality Samples.</p> <p>Does the problem remain?</p>	Go to step 7.	The problem is solved.
<p>Step 7</p> <p>Replace the imaging unit.</p> <p>Does the problem remain?</p>	Go to step 8.	The problem is solved.
<p>Step 8</p> <p>1 Check the HVPS toner contact spring for proper installation and damage.</p> <p>2 Check the toner smart chip contact for proper installation and damage.</p> <p>3 Check the toner contact spring for corrosion and contamination.</p> <p>Are the HVPS toner contact spring and toner smart chip contact properly installed and free of damage and contamination?</p>	Go to step 10.	Go to step 9.

Diagnostics and Troubleshooting

Action	Yes	No
<p>Step 9</p> <ol style="list-style-type: none"> 1 Make sure that the HVPS toner contact spring is in proper contact with the toner cartridge. 2 Make sure that the HVPS toner contact spring is in proper contact with the HVPS. 3 Reseat the smart chip contact cable. <p>Does the problem remain?</p>	Contact the next level of support.	The problem is solved.
<p>Step 10</p> <ol style="list-style-type: none"> 1 Check the imaging unit contact spring for damage and contamination. 2 Make sure that the imaging unit contact spring is in proper contact with the HVPS. <p>Is the imaging unit contact spring properly installed and free of damage and contamination?</p>	Contact the next level of support.	The problem is solved.
<p>Step 11</p> <ol style="list-style-type: none"> 1 Make sure that the transfer roller is properly installed and free of damage and contamination. 2 Make sure that the HVPS contact spring is properly connected to the transfer roller. 3 Make sure that the transfer roller spring is properly installed. 4 Enter the Diagnostics menu, and then select Advanced Print Quality Samples. <p>Does the problem remain?</p>	Go to step 12.	The problem is solved.
<p>Step 12</p> <ol style="list-style-type: none"> 1 Reseat the transfer roller. 2 Enter the Diagnostics menu, and then select Advanced Print Quality Samples. <p>Does the problem remain?</p>	Go to step 13.	The problem is solved.
<p>Step 13</p> <p>Replace the transfer roller. See Transfer roller removal.</p> <p>Does the problem remain?</p>	Go to step 14.	The problem is solved.

Action	Yes	No
<p>Step 14</p> <p>Adjust the toner darkness.</p> <p>Does the problem remain?</p>	Go to step 15.	The problem is solved.
<p>Step 15</p> <ol style="list-style-type: none"> 1 Check the HVPS characterization. 2 Reseat the HVPS cables. 3 Check the HVPS cables for proper installation and damage. 4 Check the HVPS spring contact for proper connection to the board. <p>Is the HVPS properly installed and free of damage?</p>	Go to step 17.	Go to step 16.
<p>Step 16</p> <p>Replace the HVPS. See HVPS removal.</p> <p>Make sure to perform the HVPS characterization when replacing the HVPS.</p> <p>Does the problem remain?</p>	Go to step 17.	The problem is solved.
<p>Step 17</p> <ol style="list-style-type: none"> 1 Reseat all the cables connected to the LVPS. 2 Check the cables for proper connection and damage. 3 Check the fuse for continuity. 4 Check the electronic components on the LVPS for damage. 5 Check the LVPS for proper installation and damage. <p>Is the LVPS properly installed and free of damage?</p>	Go to step 20.	Go to step 18.
<p>Step 18</p> <ol style="list-style-type: none"> 1 Make sure that the LVPS is compatible with the fuser and the printer. 2 Make sure that the fuser connector has voltage. 3 Make sure that the correct power input voltage is used. <p>Does the problem remain?</p>	Go to step 19.	The problem is solved.

Action	Yes	No
Step 19 Replace the LVPS. See LVPS removal . Does the problem remain?	Go to step 20.	The problem is solved.
Step 20 1 Check the controller board for proper installation and damage. 2 Reseat all the cables on the controller board. Is the controller board properly installed and free of damage?	Contact the next level of support.	Go to step 21.
Step 21 Replace the controller board. See Controller board removal . Does the problem remain?	Contact the next level of support.	The problem is solved.

Solid Color or Black Image Check



Action	Yes	No
Step 1 1 Make sure that the toner cartridge is supported. 2 Make sure that the toner cartridge and imaging unit are not empty. 3 Check if the toner cartridge is new. Is the toner cartridge new?	Go to step 2.	Go to step 3.
Step 2 Make sure to remove the packing material on the toner cartridge and imaging unit. Does the problem remain?	Go to step 3.	The problem is solved.

Action	Yes	No
<p>Step 3</p> <ol style="list-style-type: none"> 1 Clear the paper path of debris and contamination. 2 Remove, and then insert the imaging unit and toner cartridge. <p>Shake the toner cartridge and imaging unit before inserting them.</p> <ol style="list-style-type: none"> 3 Perform a POR. 4 Enter the Diagnostics menu, and then select Advanced Print Quality Samples. <p>Does the problem remain?</p>	Go to step 4.	The problem is solved.
<p>Step 4</p> <ol style="list-style-type: none"> 1 Make sure that the imaging unit is properly installed and free of damage. 2 Make sure that the smart chip contacts are free of corrosion and contamination. 3 Make sure that the photoconductor roller surface is free of damage. 4 Make sure that the imaging unit HVPS contacts are free of corrosion and contamination. 5 Enter the Diagnostics menu, and then select Advanced Print Quality Samples. <p>Does the problem remain?</p>	Go to step 5.	The problem is solved.
<p>Step 5</p> <p>Replace the imaging unit.</p> <p>Does the problem remain?</p>	Go to step 6.	The problem is solved.
<p>Step 6</p> <ol style="list-style-type: none"> 1 Check the imaging unit contact spring for damage and contamination. 2 Make sure that the imaging unit contact spring is in proper contact with the HVPS. <p>Is the imaging unit contact spring properly installed and free of damage and contamination?</p>	Contact the next level of support.	The problem is solved.
Step 7	Go to step 8.	The problem is solved.

Diagnostics and Troubleshooting

Action	Yes	No
<ol style="list-style-type: none"> 1 Make sure that the toner cartridge is properly installed and free of damage. 2 Make sure that the smart chip contacts are free of corrosion and contamination. 3 Make sure that the developer roller surface is free of damage. 4 Make sure that the toner HVPS contacts are free of corrosion and contamination. 5 Enter the Diagnostics menu, and then select Advanced Print Quality Samples. <p>Does the problem remain?</p>		
<p>Step 8</p> <p>Replace the toner cartridge.</p> <p>Does the problem remain?</p>	Go to step 9.	The problem is solved.
<p>Step 9</p> <ol style="list-style-type: none"> 1 Check the HVPS toner contact spring for proper installation and damage. 2 Check the toner smart chip contact for proper installation and damage. 3 Check the toner contact spring for corrosion and contamination. <p>Are the HVPS toner contact spring and toner smart chip contact properly installed and free of damage and contamination?</p>	Go to step 11.	Go to step 10.
<p>Step 10</p> <ol style="list-style-type: none"> 1 Make sure that the HVPS toner contact spring is in proper contact with the toner cartridge. 2 Make sure that the HVPS toner contact spring is in proper contact with the HVPS. 3 Reseat the smart chip contact cable. <p>Does the problem remain?</p>	Contact the next level of support.	The problem is solved.

Action	Yes	No
Step 11 1 Check the HVPS characterization. 2 Reseat the HVPS cables. 3 Check the HVPS cables for proper installation and damage. 4 Check the HVPS spring contact for proper connection to the board. Is the HVPS properly installed and free of damage?	Contact the next level of support.	Go to step 12.
Step 12 Replace the HVPS. See HVPS removal . Make sure to perform the HVPS characterization when replacing the HVPS. Does the problem remain?	Contact the next level of support.	The problem is solved.

Blank or White Pages Check

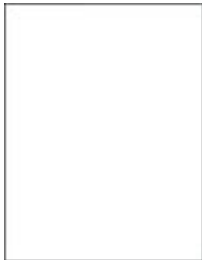

Action	Yes	No
Step 1 1 Make sure that the toner cartridge is supported. 2 Make sure that the toner cartridge and imaging unit are not empty. 3 Check if the toner cartridge is new. Is the toner cartridge new?	Go to step 2.	Go to step 3.
Step 2 Make sure to remove the packing material on the toner cartridge and imaging unit.	Go to step 3.	The problem is solved.

Diagnostics and Troubleshooting

Action	Yes	No
Does the problem remain?		
<p>Step 3</p> <ol style="list-style-type: none"> 1 Clear the paper path of debris and contamination. 2 Remove, and then insert the imaging unit and toner cartridge. Shake the toner cartridge and imaging unit before inserting them. 3 Perform a POR. 4 Enter the Diagnostics menu, and then select Advanced Print Quality Samples. <p>Does the problem remain?</p>	Go to step 4.	The problem is solved.
<p>Step 4</p> <ol style="list-style-type: none"> 1 Make sure that the imaging unit is properly installed and free of damage. 2 Make sure that the smart chip contacts are free of corrosion and contamination. 3 Make sure that the photoconductor roller surface is free of damage. 4 Make sure that the imaging unit HVPS contacts are free of corrosion and contamination. 5 Enter the Diagnostics menu, and then select Advanced Print Quality Samples. <p>Does the problem remain?</p>	Go to step 5.	The problem is solved.
<p>Step 5</p> <p>Replace the imaging unit.</p> <p>Does the problem remain?</p>	Go to step 6.	The problem is solved.
<p>Step 6</p> <ol style="list-style-type: none"> 1 Check the imaging unit contact spring for damage and contamination. 2 Make sure that the imaging unit contact spring is in proper contact with the HVPS. <p>Is the imaging unit contact spring properly installed and free of damage and contamination?</p>	Contact the next level of support.	The problem is solved.

Action	Yes	No
<p>Step 7</p> <ol style="list-style-type: none"> 1 Make sure that the transfer roller is properly installed and free of damage and contamination. 2 Make sure that the HVPS contact spring is properly connected to the transfer roller. 3 Make sure that the transfer roller spring is properly installed. 4 Enter the Diagnostics menu, and then select Advanced Print Quality Samples. <p>Does the problem remain?</p>	Go to step 8.	The problem is solved.
<p>Step 8</p> <ol style="list-style-type: none"> 1 Reseat the transfer roller. 2 Enter the Diagnostics menu, and then select Advanced Print Quality Samples. <p>Does the problem remain?</p>	Go to step 9.	The problem is solved.
<p>Step 9</p> <p>Replace the transfer roller. See Transfer roller removal.</p> <p>Does the problem remain?</p>	Go to step 10.	The problem is solved.
<p>Step 10</p> <ol style="list-style-type: none"> 1 Make sure that the toner cartridge is properly installed and free of damage. 2 Make sure that the smart chip contacts are free of corrosion and contamination. 3 Make sure that the developer roller surface is free of damage. 4 Make sure that the toner HVPS contacts are free of corrosion and contamination. 5 Enter the Diagnostics menu, and then select Advanced Print Quality Samples. <p>Does the problem remain?</p>	Go to step 11.	The problem is solved.
<p>Step 11</p> <p>Replace the toner cartridge.</p> <p>Does the problem remain?</p>	Go to step 12.	The problem is solved.

Diagnostics and Troubleshooting

Action	Yes	No
<p>Step 12</p> <ol style="list-style-type: none"> 1 Check the HVPS toner contact spring for proper installation and damage. 2 Check the toner smart chip contact for proper installation and damage. 3 Check the toner contact spring for corrosion and contamination. <p>Are the HVPS toner contact spring and toner smart chip contact properly installed and free of damage and contamination?</p>	Go to step 14.	Go to step 13.
<p>Step 13</p> <ol style="list-style-type: none"> 1 Make sure that the HVPS toner contact spring is in proper contact with the toner cartridge. 2 Make sure that the HVPS toner contact spring is in proper contact with the HVPS. 3 Reseat the smart chip contact cable. <p>Does the problem remain?</p>	Contact the next level of support.	The problem is solved.
<p>Step 14</p> <ol style="list-style-type: none"> 1 Clean the printhead lens. 2 Reseat the two printhead cables at both ends. 3 Perform a print test. <p>Does the problem remain?</p>	Go to step 15.	The problem is solved.
<p>Step 15</p> <ol style="list-style-type: none"> 1 Make sure that the printhead cables are properly connected. 2 Check the printhead for proper installation and damage. <p>Is the printhead properly installed and free of damage?</p>	Go to step 17.	Go to step 16.
<p>Step 16</p> <p>Replace the printhead. See Printhead removal.</p> <p>Does the problem remain?</p>	Go to step 17.	The problem is solved.
<p>Step 17</p> <ol style="list-style-type: none"> 1 Reseat the HVPS cables. 2 Check the cables for damage. 	Go to step 18.	Go to step 19.

Action	Yes	No
Are the cables free of damage?		
Step 18 Replace the damaged cable. Does the problem remain?	Contact the next level of support.	The problem is solved.
Step 19 1 Check the HVPS characterization. 2 Reseat the HVPS cables. 3 Check the HVPS cables for proper installation and damage. 4 Check the HVPS spring contact for proper connection to the board. Is the HVPS properly installed and free of damage?	Go to step 21.	Go to step 20.
Step 20 Replace the HVPS. See HVPS removal . Make sure to perform the HVPS characterization when replacing the HVPS. Does the problem remain?	Go to step 21.	The problem is solved.
Step 21 1 Check the controller board for proper installation and damage. 2 Reseat all the cables on the controller board. Is the controller board properly installed and free of damage?	Contact the next level of support.	Go to step 22.
Step 22 Replace the controller board. See Controller board removal . Does the problem remain?	Contact the next level of support.	The problem is solved.

Dark Print Check

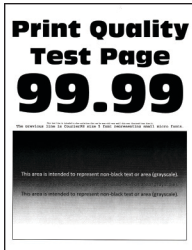

Action	Yes	No
<p>Step 1</p> <ol style="list-style-type: none"> 1 Make sure that the toner cartridge is supported. 2 Make sure that the toner cartridge and imaging unit are not empty. 3 Check if the toner cartridge is new. <p>Is the toner cartridge new?</p>	Go to step 2.	Go to step 3.
<p>Step 2</p> <p>Make sure to remove the packing material on the toner cartridge and imaging unit.</p> <p>Does the problem remain?</p>	Go to step 3.	The problem is solved.
<p>Step 3</p> <ol style="list-style-type: none"> 1 Clear the paper path of debris and contamination. 2 Remove, and then insert the imaging unit and toner cartridge. <p>Shake the toner cartridge and imaging unit before inserting them.</p> <ol style="list-style-type: none"> 3 Perform a POR. 4 Enter the Diagnostics menu, and then select Advanced Print Quality Samples. <p>Does the problem remain?</p>	Go to step 4.	The problem is solved.
<p>Step 4</p> <ol style="list-style-type: none"> 1 Make sure that the paper type is supported. 2 Make sure that the paper type and size settings match the paper type and size set on the tray. 	Go to step 5.	The problem is solved.

Action	Yes	No
<p>3 Make sure that the paper has no damage or defects.</p> <p>4 Make sure that the paper guides are properly set.</p> <p>5 Make sure that the paper size setting in the duplex unit is properly set.</p> <p>Does the problem remain?</p>		
<p>Step 5</p> <p>Adjust the toner darkness.</p> <p>Does the problem remain?</p>	Go to step 6.	The problem is solved.
<p>Step 6</p> <p>1 Make sure that the toner cartridge is properly installed and free of damage.</p> <p>2 Make sure that the smart chip contacts are free of corrosion and contamination.</p> <p>3 Make sure that the developer roller surface is free of damage.</p> <p>4 Make sure that the toner HVPS contacts are free of corrosion and contamination.</p> <p>5 Enter the Diagnostics menu, and then select Advanced Print Quality Samples.</p> <p>Does the problem remain?</p>	Go to step 7.	The problem is solved.
<p>Step 7</p> <p>Replace the toner cartridge.</p> <p>Does the problem remain?</p>	Go to step 8.	The problem is solved.
<p>Step 8</p> <p>1 Make sure that the imaging unit is properly installed and free of damage.</p> <p>2 Make sure that the smart chip contacts are free of corrosion and contamination.</p> <p>3 Make sure that the photoconductor roller surface is free of damage.</p> <p>4 Make sure that the imaging unit HVPS contacts are free of corrosion and contamination.</p> <p>5 Enter the Diagnostics menu, and then select Advanced Print Quality Samples.</p>	Go to step 9.	The problem is solved.

Diagnostics and Troubleshooting

Action	Yes	No
Does the problem remain?		
Step 9 Replace the imaging unit. Does the problem remain?	Go to step 10.	The problem is solved.
Step 10 1 Check the HVPS toner contact spring for proper installation and damage. 2 Check the toner smart chip contact for proper installation and damage. 3 Check the toner contact spring for corrosion and contamination. Are the HVPS toner contact spring and toner smart chip contact properly installed and free of damage and contamination?	Go to step 12.	Go to step 11.
Step 11 1 Make sure that the HVPS toner contact spring is in proper contact with the toner cartridge. 2 Make sure that the HVPS toner contact spring is in proper contact with the HVPS. 3 Reseat the smart chip contact cable. Does the problem remain?	Contact the next level of support.	The problem is solved.
Step 12 1 Check the imaging unit contact spring for damage and contamination. 2 Make sure that the imaging unit contact spring is in proper contact with the HVPS. Is the imaging unit contact spring properly installed and free of damage and contamination?	Contact the next level of support.	The problem is solved.
Step 13 1 Make sure that the transfer roller is properly installed and free of damage and contamination.	Go to step 14.	The problem is solved.

Action	Yes	No
<p>2 Make sure that the HVPS contact spring is properly connected to the transfer roller.</p> <p>3 Make sure that the transfer roller spring is properly installed.</p> <p>4 Enter the Diagnostics menu, and then select Advanced Print Quality Samples.</p> <p>Does the problem remain?</p>		
<p>Step 14</p> <p>1 Reseat the transfer roller.</p> <p>2 Enter the Diagnostics menu, and then select Advanced Print Quality Samples.</p> <p>Does the problem remain?</p>	Go to step 15.	The problem is solved.
<p>Step 15</p> <p>Replace the transfer roller. See Transfer roller removal.</p> <p>Does the problem remain?</p>	Go to step 16.	The problem is solved.
<p>Step 16</p> <p>1 Reseat the HVPS cables.</p> <p>2 Check the cables for damage.</p> <p>Are the cables free of damage?</p>	Go to step 17.	Go to step 18.
<p>Step 17</p> <p>Replace the damaged cable.</p> <p>Does the problem remain?</p>	Contact the next level of support.	The problem is solved.

Action	Yes	No
<p>Step 18</p> <ol style="list-style-type: none"> 1 Check the HVPS characterization. 2 Reseat the HVPS cables. 3 Check the HVPS cables for proper installation and damage. 4 Check the HVPS spring contact for proper connection to the board. <p>Is the HVPS properly installed and free of damage?</p>	Contact the next level of support.	Go to step 19.
<p>Step 19</p> <p>Replace the HVPS. See HVPS removal.</p> <p>Make sure to perform the HVPS characterization when replacing the HVPS.</p> <p>Does the problem remain?</p>	Contact the next level of support.	The problem is solved.

Light Print Check

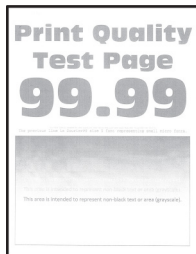

Action	Yes	No
<p>Step 1</p> <ol style="list-style-type: none"> 1 Make sure that the toner cartridge is supported. 2 Make sure that the toner cartridge and imaging unit are not empty. 3 Check if the toner cartridge is new. <p>Is the toner cartridge new?</p>	Go to step 2.	Go to step 3.
<p>Step 2</p> <p>Make sure to remove the packing material on the toner cartridge and imaging unit.</p>	Go to step 3.	The problem is solved.

Action	Yes	No
Does the problem remain?		
<p>Step 3</p> <ol style="list-style-type: none"> 1 Clear the paper path of debris and contamination. 2 Remove, and then insert the imaging unit and toner cartridge. Shake the toner cartridge and imaging unit before inserting them. 3 Perform a POR. 4 Enter the Diagnostics menu, and then select Advanced Print Quality Samples. <p>Does the problem remain?</p>	Go to step 4.	The problem is solved.
<p>Step 4</p> <ol style="list-style-type: none"> 1 Make sure that the paper type is supported. 2 Make sure that the paper type and size settings match the paper type and size set on the tray. 3 Make sure that the paper has no damage or defects. 4 Make sure that the paper guides are properly set. 5 Make sure that the paper size setting in the duplex unit is properly set. <p>Does the problem remain?</p>	Go to step 5.	The problem is solved.
<p>Step 5</p> <p>Adjust the toner darkness.</p> <p>Does the problem remain?</p>	Go to step 6.	The problem is solved.
<p>Step 6</p> <ol style="list-style-type: none"> 1 Make sure that the toner cartridge is properly installed and free of damage. 2 Make sure that the smart chip contacts are free of corrosion and contamination. 3 Make sure that the developer roller surface is free of damage. 4 Make sure that the toner HVPS contacts are free of corrosion and contamination. 	Go to step 7.	The problem is solved.

Diagnostics and Troubleshooting

Action	Yes	No
<p>5 Enter the Diagnostics menu, and then select Advanced Print Quality Samples.</p> <p>Does the problem remain?</p>		
<p>Step 7</p> <p>Replace the toner cartridge.</p> <p>Does the problem remain?</p>	Go to step 8.	The problem is solved.
<p>Step 8</p> <p>1 Make sure that the imaging unit is properly installed and free of damage.</p> <p>2 Make sure that the smart chip contacts are free of corrosion and contamination.</p> <p>3 Make sure that the photoconductor roller surface is free of damage.</p> <p>4 Make sure that the imaging unit HVPS contacts are free of corrosion and contamination.</p> <p>5 Enter the Diagnostics menu, and then select Advanced Print Quality Samples.</p> <p>Does the problem remain?</p>	Go to step 9.	The problem is solved.
<p>Step 9</p> <p>Replace the imaging unit.</p> <p>Does the problem remain?</p>	Go to step 10.	The problem is solved.
<p>Step 10</p> <p>1 Check the HVPS toner contact spring for proper installation and damage.</p> <p>2 Check the toner smart chip contact for proper installation and damage.</p> <p>3 Check the toner contact spring for corrosion and contamination.</p> <p>Are the HVPS toner contact spring and toner smart chip contact properly installed and free of damage and contamination?</p>	Go to step 12.	Go to step 11.
<p>Step 11</p> <p>1 Make sure that the HVPS toner contact spring is in proper</p>	Contact the next level of support.	The problem is solved.

Action	Yes	No
<p>contact with the toner cartridge.</p> <p>2 Make sure that the HVPS toner contact spring is in proper contact with the HVPS.</p> <p>3 Reseat the smart chip contact cable.</p> <p>Does the problem remain?</p>		
<p>Step 12</p> <p>1 Check the imaging unit contact spring for damage and contamination.</p> <p>2 Make sure that the imaging unit contact spring is in proper contact with the HVPS.</p> <p>Is the imaging unit contact spring properly installed and free of damage and contamination?</p>	Contact the next level of support.	The problem is solved.
<p>Step 13</p> <p>1 Make sure that the transfer roller is properly installed and free of damage and contamination.</p> <p>2 Make sure that the HVPS contact spring is properly connected to the transfer roller.</p> <p>3 Make sure that the transfer roller spring is properly installed.</p> <p>4 Enter the Diagnostics menu, and then select Advanced Print Quality Samples.</p> <p>Does the problem remain?</p>	Go to step 14.	The problem is solved.
<p>Step 14</p> <p>1 Reseat the transfer roller.</p> <p>2 Enter the Diagnostics menu, and then select Advanced Print Quality Samples.</p> <p>Does the problem remain?</p>	Go to step 15.	The problem is solved.
<p>Step 15</p> <p>Replace the transfer roller. See Transfer roller removal.</p> <p>Does the problem remain?</p>	Go to step 16.	The problem is solved.
<p>Step 16</p> <p>1 Clean the printhead lens.</p>	Go to step 17.	The problem is solved.

Diagnostics and Troubleshooting

Action	Yes	No
<p>2 Reseat the two printhead cables at both ends.</p> <p>3 Perform a print test.</p> <p>Does the problem remain?</p>		
<p>Step 17</p> <p>1 Make sure that the printhead cables are properly connected.</p> <p>2 Check the printhead for proper installation and damage.</p> <p>Is the printhead properly installed and free of damage?</p>	Go to step 19.	Go to step 18.
<p>Step 18</p> <p>Replace the printhead. See Printhead removal.</p> <p>Does the problem remain?</p>	Go to step 19.	The problem is solved.
<p>Step 19</p> <p>1 Reseat the HVPS cables.</p> <p>2 Check the cables for damage.</p> <p>Are the cables free of damage?</p>	Go to step 20.	Go to step 21.
<p>Step 20</p> <p>Replace the damaged cable.</p> <p>Does the problem remain?</p>	Contact the next level of support.	The problem is solved.
<p>Step 21</p> <p>1 Check the HVPS characterization.</p> <p>2 Reseat the HVPS cables.</p> <p>3 Check the HVPS cables for proper installation and damage.</p> <p>4 Check the HVPS spring contact for proper connection to the board.</p> <p>Is the HVPS properly installed and free of damage?</p>	Contact the next level of support.	Go to step 22.
<p>Step 22</p> <p>Replace the HVPS. See HVPS removal.</p> <p>Make sure to perform the HVPS characterization when replacing the HVPS.</p> <p>Does the problem remain?</p>	Contact the next level of support.	The problem is solved.

Paper Curl Check



Action	Yes	No
<p>Step 1</p> <ol style="list-style-type: none"> 1 Clear the paper path of debris and contamination. 2 Remove, and then insert the imaging unit and toner cartridge. Shake the toner cartridge and imaging unit before inserting them. 3 Perform a POR. 4 Enter the Diagnostics menu, and then select Advanced Print Quality Samples. <p>Does the problem remain?</p>	Go to step 2.	The problem is solved.
<p>Step 2</p> <ol style="list-style-type: none"> 1 Make sure that the paper type is supported. 2 Make sure that the paper type and size settings match the paper type and size set on the tray. 3 Make sure that the paper has no damage or defects. 4 Make sure that the paper guides are properly set. 5 Make sure that the paper size setting in the duplex unit is properly set. <p>Does the problem remain?</p>	Go to step 3.	The problem is solved.
<p>Step 3</p> <ol style="list-style-type: none"> 1 Check the fuser cables for proper connection and damage. 2 Check the fuser access door for damage. 3 Check if the fuser gears are in proper contact with the drive gears. 	Go to step 6.	Go to step 4.

Diagnostics and Troubleshooting

Action	Yes	No
<p>4 Make sure that the fuser is compatible with the LVPS.</p> <p>5 Check the fuser for proper installation and damage.</p> <p>Is the fuser properly installed and free of damage?</p>		
<p>Step 4</p> <p>1 Enter the Diagnostics menu, and then navigate to:</p> <p>Printer diagnostics & adjustments > Motor tests</p> <p>2 Select Motor (transport).</p> <p>3 Open the rear door, and then check if the fuser exit rollers turn.</p> <p>4 Open the fuser access door, and then check if the hot rollers turn.</p> <p>Are the rollers properly working?</p>	Go to step 6.	Go to step 5.
<p>Step 5</p> <p>Replace the fuser. See Fuser removal.</p> <p>Does the problem remain?</p>	Go to step 6.	The problem is solved.
<p>Step 6</p> <p>1 Reseat all the cables connected to the LVPS.</p> <p>2 Check the cables for proper connection and damage.</p> <p>3 Check the fuse for continuity.</p> <p>4 Check the electronic components on the LVPS for damage.</p> <p>5 Check the LVPS for proper installation and damage.</p> <p>Is the LVPS properly installed and free of damage?</p>	Contact the next level of support.	Go to step 7.

Action	Yes	No
<p>Step 7</p> <ol style="list-style-type: none"> 1 Make sure that the LVPS is compatible with the fuser and the printer. 2 Make sure that the fuser connector has voltage. 3 Make sure that the correct power input voltage is used. <p>Does the problem remain?</p>	Go to step 8.	The problem is solved.
<p>Step 8</p> <p>Replace the LVPS. See LVPS removal.</p> <p>Does the problem remain?</p>	Contact the next level of support.	The problem is solved.

Folded or Wrinkled Paper Check



Action	Yes	No
<p>Step 1</p> <ol style="list-style-type: none"> 1 Clear the paper path of debris and contamination. 2 Remove, and then insert the imaging unit and toner cartridge. <p>Shake the toner cartridge and imaging unit before inserting them.</p> <ol style="list-style-type: none"> 3 Perform a POR. 4 Enter the Diagnostics menu, and then select Advanced Print Quality Samples. <p>Does the problem remain?</p>	Go to step 2.	The problem is solved.
<p>Step 2</p> <ol style="list-style-type: none"> 1 Make sure that the paper type is supported. 2 Make sure that the paper type and size settings match the 	Go to step 3.	The problem is solved.

Diagnostics and Troubleshooting

Action	Yes	No
<p>paper type and size set on the tray.</p> <p>3 Make sure that the paper has no damage or defects.</p> <p>4 Make sure that the paper guides are properly set.</p> <p>5 Make sure that the paper size setting in the duplex unit is properly set.</p> <p>Does the problem remain?</p>		
<p>Step 3</p> <p>1 Check the fuser cables for proper connection and damage.</p> <p>2 Check the fuser access door for damage.</p> <p>3 Check if the fuser gears are in proper contact with the drive gears.</p> <p>4 Make sure that the fuser is compatible with the LVPS.</p> <p>5 Check the fuser for proper installation and damage.</p> <p>Is the fuser properly installed and free of damage?</p>	Go to step 6.	Go to step 4.
<p>Step 4</p> <p>1 Enter the Diagnostics menu, and then navigate to:</p> <p>Printer diagnostics & adjustments > Motor tests</p> <p>2 Select Motor (transport).</p> <p>3 Open the rear door, and then check if the fuser exit rollers turn.</p> <p>4 Open the fuser access door, and then check if the hot rollers turn.</p> <p>Are the rollers properly working?</p>	Go to step 6.	Go to step 5.
<p>Step 5</p> <p>Replace the fuser. See Fuser removal.</p> <p>Does the problem remain?</p>	Go to step 6.	The problem is solved.
<p>Step 6</p> <p>1 Reseat all the cables connected to the LVPS.</p>	Contact the next level of support.	Go to step 7.

Action	Yes	No
<p>2 Check the cables for proper connection and damage.</p> <p>3 Check the fuse for continuity.</p> <p>4 Check the electronic components on the LVPS for damage.</p> <p>5 Check the LVPS for proper installation and damage.</p> <p>Is the LVPS properly installed and free of damage?</p>		
<p>Step 7</p> <p>1 Make sure that the LVPS is compatible with the fuser and the printer.</p> <p>2 Make sure that the fuser connector has voltage.</p> <p>3 Make sure that the correct power input voltage is used.</p> <p>Does the problem remain?</p>	Go to step 8.	The problem is solved.
<p>Step 8</p> <p>Replace the LVPS. See LVPS removal.</p> <p>Does the problem remain?</p>	Contact the next level of support.	The problem is solved.

Repeating Defects Check



Diagnostics and Troubleshooting

Action	Yes	No
<p>Step 1</p> <ol style="list-style-type: none"> 1 Make sure that the toner cartridge is supported. 2 Make sure that the toner cartridge and imaging unit are not empty. 3 Check if the toner cartridge is new. <p>Is the toner cartridge new?</p>	Go to step 2.	Go to step 3.
<p>Step 2</p> <p>Make sure to remove the packing material on the toner cartridge and imaging unit.</p> <p>Does the problem remain?</p>	Go to step 3.	The problem is solved.
<p>Step 3</p> <ol style="list-style-type: none"> 1 Clear the paper path of debris and contamination. 2 Remove, and then insert the imaging unit and toner cartridge. <p>Shake the toner cartridge and imaging unit before inserting them.</p> <ol style="list-style-type: none"> 3 Perform a POR. 4 Enter the Diagnostics menu, and then select Advanced Print Quality Samples. <p>Does the problem remain?</p>	Go to step 4.	The problem is solved.
<p>Step 4</p> <p>Measure the distance between the horizontal defects.</p> <p>Is the distance equal to 75.4 mm or 34.7 mm?</p>	Go to step 5.	Go to step 6.
<p>Step 5</p> <p>Replace the imaging unit.</p> <p>Does the problem remain?</p>	Go to step 6.	The problem is solved.
<p>Step 6</p> <ol style="list-style-type: none"> 1 Make sure that the imaging unit is properly installed and free of damage. 2 Make sure that the smart chip contacts are free of corrosion and contamination. 	Go to step 7.	The problem is solved.

Action	Yes	No
<p>3 Make sure that the photoconductor roller surface is free of damage.</p> <p>4 Make sure that the imaging unit HVPS contacts are free of corrosion and contamination.</p> <p>5 Enter the Diagnostics menu, and then select Advanced Print Quality Samples.</p> <p>Does the problem remain?</p>		
<p>Step 7</p> <p>Replace the imaging unit.</p> <p>Does the problem remain?</p>	Go to step 8.	The problem is solved.
<p>Step 8</p> <p>Measure the distance between the horizontal defects.</p> <p>Is the distance equal to 44.6 mm, 28.3 mm, or 39.3 mm?</p>	Go to step 9.	Go to step 10.
<p>Step 9</p> <p>Replace the toner cartridge.</p> <p>Does the problem remain?</p>	Go to step 10.	The problem is solved.
<p>Step 10</p> <p>1 Make sure that the toner cartridge is properly installed and free of damage.</p> <p>2 Make sure that the smart chip contacts are free of corrosion and contamination.</p> <p>3 Make sure that the developer roller surface is free of damage.</p> <p>4 Make sure that the toner HVPS contacts are free of corrosion and contamination.</p> <p>5 Enter the Diagnostics menu, and then select Advanced Print Quality Samples.</p> <p>Does the problem remain?</p>	Go to step 11.	The problem is solved.
<p>Step 11</p> <p>Replace the toner cartridge.</p> <p>Does the problem remain?</p>	Go to step 12.	The problem is solved.
<p>Step 12</p>	Go to step 13.	Go to step 14.

Diagnostics and Troubleshooting

Action	Yes	No
<p>Measure the distance between the horizontal defects.</p> <p>Is the distance equal to 44 mm?</p>		
<p>Step 13</p> <p>Replace the transfer roller. See Transfer roller removal.</p> <p>Does the problem remain?</p>	Go to step 14.	The problem is solved.
<p>Step 14</p> <ol style="list-style-type: none"> 1 Make sure that the transfer roller is properly installed and free of damage and contamination. 2 Make sure that the HVPS contact spring is properly connected to the transfer roller. 3 Make sure that the transfer roller spring is properly installed. 4 Enter the Diagnostics menu, and then select Advanced Print Quality Samples. <p>Does the problem remain?</p>	Go to step 15.	The problem is solved.
<p>Step 15</p> <ol style="list-style-type: none"> 1 Reseat the transfer roller. 2 Enter the Diagnostics menu, and then select Advanced Print Quality Samples. <p>Does the problem remain?</p>	Go to step 16.	The problem is solved.
<p>Step 16</p> <p>Replace the transfer roller. See Transfer roller removal.</p> <p>Does the problem remain?</p>	Go to step 17.	The problem is solved.
<p>Step 17</p> <p>Measure the distance between the horizontal defects.</p> <p>Is the distance equal to 78.1 mm?</p>	Go to step 18.	Go to step 19.
<p>Step 18</p> <p>Replace the fuser. See Fuser removal.</p> <p>Does the problem remain?</p>	Go to step 19.	The problem is solved.

Action	Yes	No
<p>Step 19</p> <ol style="list-style-type: none"> 1 Check the fuser cables for proper connection and damage. 2 Check the fuser access door for damage. 3 Check if the fuser gears are in proper contact with the drive gears. 4 Make sure that the fuser is compatible with the LVPS. 5 Check the fuser for proper installation and damage. <p>Is the fuser properly installed and free of damage?</p>	Go to step 22.	Go to step 20.
<p>Step 20</p> <ol style="list-style-type: none"> 1 Enter the Diagnostics menu, and then navigate to: Printer diagnostics & adjustments > Motor tests 2 Select Motor (transport). 3 Open the rear door, and then check if the fuser exit rollers turn. 4 Open the fuser access door, and then check if the hot rollers turn. <p>Are the rollers properly working?</p>	Go to step 22.	Go to step 21.
<p>Step 21</p> <p>Replace the fuser. See Fuser removal.</p> <p>Does the problem remain?</p>	Go to step 22.	The problem is solved.
<p>Step 22</p> <ol style="list-style-type: none"> 1 Clean the printhead lens. 2 Reseat the two printhead cables at both ends. 3 Perform a print test. <p>Does the problem remain?</p>	Go to step 23.	The problem is solved.

Action	Yes	No
<p>Step 23</p> <ol style="list-style-type: none"> 1 Make sure that the printhead cables are properly connected. 2 Check the printhead for proper installation and damage. <p>Is the printhead properly installed and free of damage?</p>	Contact the next level of support.	Go to step 24.
<p>Step 24</p> <p>Replace the printhead. See Printhead removal.</p> <p>Does the problem remain?</p>	Contact the next level of support.	The problem is solved.

Skewed Print Check

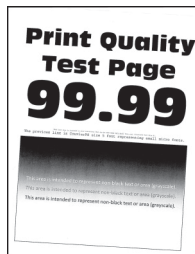

Action	Yes	No
<p>Step 1</p> <ol style="list-style-type: none"> 1 Clear the paper path of debris and contamination. 2 Remove, and then insert the imaging unit and toner cartridge. <p>Shake the toner cartridge and imaging unit before inserting them.</p> <ol style="list-style-type: none"> 3 Perform a POR. 4 Enter the Diagnostics menu, and then select Advanced Print Quality Samples. <p>Does the problem remain?</p>	Go to step 2.	The problem is solved.
<p>Step 2</p> <ol style="list-style-type: none"> 1 Make sure that the paper type is supported. 2 Make sure that the paper type and size settings match the paper type and size set on the tray. 	Go to step 3.	The problem is solved.

Action	Yes	No
<p>3 Make sure that the paper has no damage or defects.</p> <p>4 Make sure that the paper guides are properly set.</p> <p>5 Make sure that the paper size setting in the duplex unit is properly set.</p> <p>Does the problem remain?</p>		
<p>Step 3</p> <p>1 Check the tray insert for proper installation and damage.</p> <p>2 Make sure that the separator roller is free of dust and contamination.</p> <p>3 Check the lift plate for proper operation.</p> <p>4 Check the paper guides for proper operation.</p> <p>Is the tray insert properly installed and free of damage?</p>	Go to step 5.	Go to step 4.
<p>Step 4</p> <p>Replace the tray insert.</p> <p>Does the problem remain?</p>	Go to step 5.	The problem is solved.
<p>Step 5</p> <p>1 Clear the pick rollers of contamination.</p> <p>2 Reseat the pick rollers.</p> <p>3 Perform a feed test.</p> <p>Does the problem remain?</p>	Go to step 6.	The problem is solved.
<p>Step 6</p> <p>1 Check the pick rollers for proper installation and damage.</p> <p>2 Check the shaft of the pick rollers for damage.</p> <p>Are the pick rollers properly installed and free of damage?</p>	Go to step 8.	Go to step 7.
<p>Step 7</p> <p>Replace the pick rollers. See Pick rollers removal.</p> <p>Does the problem remain?</p>	Go to step 8.	The problem is solved.
<p>Step 8</p> <p>Make sure that the roller is free of dirt and contamination.</p>	Contact the next level of support.	The problem is solved.

Action	Yes	No
Does the problem remain?		
Step 9 1 Clean the printhead lens. 2 Reseat the two printhead cables at both ends. 3 Perform a print test. Does the problem remain?	Go to step 10.	The problem is solved.
Step 10 1 Make sure that the printhead cables are properly connected. 2 Check the printhead for proper installation and damage. Is the printhead properly installed and free of damage?	Contact the next level of support.	Go to step 11.
Step 11 Replace the printhead. See Printhead removal . Does the problem remain?	Contact the next level of support.	The problem is solved.

Streaked Vertical Lines Appear On Prints Check



Action	Yes	No
Step 1 1 Make sure that the toner cartridge is supported. 2 Make sure that the toner cartridge and imaging unit are not empty. 3 Check if the toner cartridge is new. Is the toner cartridge new?	Go to step 2.	Go to step 3.
Step 2	Go to step 3.	The problem is solved.

Action	Yes	No
<p>Make sure to remove the packing material on the toner cartridge and imaging unit.</p> <p>Does the problem remain?</p>		
<p>Step 3</p> <ol style="list-style-type: none"> 1 Clear the paper path of debris and contamination. 2 Remove, and then insert the imaging unit and toner cartridge. <p>Shake the toner cartridge and imaging unit before inserting them.</p> <ol style="list-style-type: none"> 3 Perform a POR. 4 Enter the Diagnostics menu, and then select Advanced Print Quality Samples. <p>Does the problem remain?</p>	Go to step 4.	The problem is solved.
<p>Step 4</p> <ol style="list-style-type: none"> 1 Clean the printhead lens. 2 Reseat the two printhead cables at both ends. 3 Perform a print test. <p>Does the problem remain?</p>	Go to step 5.	The problem is solved.
<p>Step 5</p> <ol style="list-style-type: none"> 1 Make sure that the printhead cables are properly connected. 2 Check the printhead for proper installation and damage. <p>Is the printhead properly installed and free of damage?</p>	Go to step 7.	Go to step 6.
<p>Step 6</p> <p>Replace the printhead. See Printhead removal.</p> <p>Does the problem remain?</p>	Go to step 7.	The problem is solved.
<p>Step 7</p> <ol style="list-style-type: none"> 1 Make sure that the imaging unit is properly installed and free of damage. 2 Make sure that the smart chip contacts are free of corrosion and contamination. 	Go to step 8.	The problem is solved.

Diagnostics and Troubleshooting

Action	Yes	No
<p>3 Make sure that the photoconductor roller surface is free of damage.</p> <p>4 Make sure that the imaging unit HVPS contacts are free of corrosion and contamination.</p> <p>5 Enter the Diagnostics menu, and then select Advanced Print Quality Samples.</p> <p>Does the problem remain?</p>		
<p>Step 8</p> <p>Replace the imaging unit.</p> <p>Does the problem remain?</p>	Go to step 9.	The problem is solved.
<p>Step 9</p> <p>1 Make sure that the toner cartridge is properly installed and free of damage.</p> <p>2 Make sure that the smart chip contacts are free of corrosion and contamination.</p> <p>3 Make sure that the developer roller surface is free of damage.</p> <p>4 Make sure that the toner HVPS contacts are free of corrosion and contamination.</p> <p>5 Enter the Diagnostics menu, and then select Advanced Print Quality Samples.</p> <p>Does the problem remain?</p>	Go to step 10.	The problem is solved.
<p>Step 10</p> <p>Replace the toner cartridge.</p> <p>Does the problem remain?</p>	Go to step 11.	The problem is solved.
<p>Step 11</p> <p>1 Check the HVPS toner contact spring for proper installation and damage.</p> <p>2 Check the toner smart chip contact for proper installation and damage.</p> <p>3 Check the toner contact spring for corrosion and contamination.</p> <p>Are the HVPS toner contact spring and toner smart chip contact properly installed and free of damage and contamination?</p>	Go to step 13.	Go to step 12.

Action	Yes	No
<p>Step 12</p> <ol style="list-style-type: none"> 1 Make sure that the HVPS toner contact spring is in proper contact with the toner cartridge. 2 Make sure that the HVPS toner contact spring is in proper contact with the HVPS. 3 Reseat the smart chip contact cable. <p>Does the problem remain?</p>	Contact the next level of support.	The problem is solved.
<p>Step 13</p> <ol style="list-style-type: none"> 1 Check the imaging unit contact spring for damage and contamination. 2 Make sure that the imaging unit contact spring is in proper contact with the HVPS. <p>Is the imaging unit contact spring properly installed and free of damage and contamination?</p>	Contact the next level of support.	The problem is solved.
<p>Step 14</p> <ol style="list-style-type: none"> 1 Make sure that the transfer roller is properly installed and free of damage and contamination. 2 Make sure that the HVPS contact spring is properly connected to the transfer roller. 3 Make sure that the transfer roller spring is properly installed. 4 Enter the Diagnostics menu, and then select Advanced Print Quality Samples. <p>Does the problem remain?</p>	Go to step 15.	The problem is solved.
<p>Step 15</p> <ol style="list-style-type: none"> 1 Reseat the transfer roller. 2 Enter the Diagnostics menu, and then select Advanced Print Quality Samples. <p>Does the problem remain?</p>	Go to step 16.	The problem is solved.
<p>Step 16</p> <p>Replace the transfer roller. See Transfer roller removal.</p> <p>Does the problem remain?</p>	Go to step 17.	The problem is solved.

Action	Yes	No
Step 17 1 Reseat the HVPS cables. 2 Check the cables for damage. Are the cables free of damage?	Go to step 18.	Go to step 19.
Step 18 Replace the damaged cable. Does the problem remain?	Contact the next level of support.	The problem is solved.
Step 19 1 Check the HVPS characterization. 2 Reseat the HVPS cables. 3 Check the HVPS cables for proper installation and damage. 4 Check the HVPS spring contact for proper connection to the board. Is the HVPS properly installed and free of damage?	Contact the next level of support.	Go to step 20.
Step 20 Replace the HVPS. See HVPS removal . Make sure to perform the HVPS characterization when replacing the HVPS. Does the problem remain?	Contact the next level of support.	The problem is solved.

Horizontal White Lines Check



Action	Yes	No
<p>Step 1</p> <ol style="list-style-type: none"> 1 Make sure that the toner cartridge is supported. 2 Make sure that the toner cartridge and imaging unit are not empty. 3 Check if the toner cartridge is new. <p>Is the toner cartridge new?</p>	Go to step 2.	Go to step 3.
<p>Step 2</p> <p>Make sure to remove the packing material on the toner cartridge and imaging unit.</p> <p>Does the problem remain?</p>	Go to step 3.	The problem is solved.
<p>Step 3</p> <ol style="list-style-type: none"> 1 Clear the paper path of debris and contamination. 2 Remove, and then insert the imaging unit and toner cartridge. <p>Shake the toner cartridge and imaging unit before inserting them.</p> <ol style="list-style-type: none"> 3 Perform a POR. 4 Enter the Diagnostics menu, and then select Advanced Print Quality Samples. <p>Does the problem remain?</p>	Go to step 4.	The problem is solved.
<p>Step 4</p> <ol style="list-style-type: none"> 1 Make sure that the imaging unit is properly installed and free of damage. 2 Make sure that the smart chip contacts are free of corrosion and contamination. 3 Make sure that the photoconductor roller surface is free of damage. 4 Make sure that the imaging unit HVPS contacts are free of corrosion and contamination. 5 Enter the Diagnostics menu, and then select Advanced Print Quality Samples. <p>Does the problem remain?</p>	Go to step 5.	The problem is solved.

Diagnostics and Troubleshooting

Action	Yes	No
<p>Step 5</p> <p>Replace the imaging unit.</p> <p>Does the problem remain?</p>	Go to step 6.	The problem is solved.
<p>Step 6</p> <ol style="list-style-type: none"> 1 Make sure that the toner cartridge is properly installed and free of damage. 2 Make sure that the smart chip contacts are free of corrosion and contamination. 3 Make sure that the developer roller surface is free of damage. 4 Make sure that the toner HVPS contacts are free of corrosion and contamination. 5 Enter the Diagnostics menu, and then select Advanced Print Quality Samples. <p>Does the problem remain?</p>	Go to step 7.	The problem is solved.
<p>Step 7</p> <p>Replace the toner cartridge.</p> <p>Does the problem remain?</p>	Go to step 8.	The problem is solved.
<p>Step 8</p> <ol style="list-style-type: none"> 1 Check the HVPS toner contact spring for proper installation and damage. 2 Check the toner smart chip contact for proper installation and damage. 3 Check the toner contact spring for corrosion and contamination. <p>Are the HVPS toner contact spring and toner smart chip contact properly installed and free of damage and contamination?</p>	Go to step 10.	Go to step 9.
<p>Step 9</p> <ol style="list-style-type: none"> 1 Make sure that the HVPS toner contact spring is in proper contact with the toner cartridge. 2 Make sure that the HVPS toner contact spring is in proper contact with the HVPS. 3 Reseat the smart chip contact cable. 	Contact the next level of support.	The problem is solved.

Action	Yes	No
Does the problem remain?		
<p>Step 10</p> <ol style="list-style-type: none"> 1 Check the imaging unit contact spring for damage and contamination. 2 Make sure that the imaging unit contact spring is in proper contact with the HVPS. <p>Is the imaging unit contact spring properly installed and free of damage and contamination?</p>	Contact the next level of support.	The problem is solved.
<p>Step 11</p> <ol style="list-style-type: none"> 1 Make sure that the transfer roller is properly installed and free of damage and contamination. 2 Make sure that the HVPS contact spring is properly connected to the transfer roller. 3 Make sure that the transfer roller spring is properly installed. 4 Enter the Diagnostics menu, and then select Advanced Print Quality Samples. <p>Does the problem remain?</p>	Go to step 12.	The problem is solved.
<p>Step 12</p> <ol style="list-style-type: none"> 1 Reseat the transfer roller. 2 Enter the Diagnostics menu, and then select Advanced Print Quality Samples. <p>Does the problem remain?</p>	Go to step 13.	The problem is solved.
<p>Step 13</p> <p>Replace the transfer roller. See Transfer roller removal.</p> <p>Does the problem remain?</p>	Go to step 14.	The problem is solved.
<p>Step 14</p> <ol style="list-style-type: none"> 1 Clean the printhead lens. 2 Reseat the two printhead cables at both ends. 3 Perform a print test. <p>Does the problem remain?</p>	Go to step 15.	The problem is solved.
Step 15	Go to step 17.	Go to step 16.

Diagnostics and Troubleshooting

Action	Yes	No
<ol style="list-style-type: none"> 1 Make sure that the printhead cables are properly connected. 2 Check the printhead for proper installation and damage. <p>Is the printhead properly installed and free of damage?</p>		
<p>Step 16</p> <p>Replace the printhead. See Printhead removal.</p> <p>Does the problem remain?</p>	Go to step 17.	The problem is solved.
<p>Step 17</p> <ol style="list-style-type: none"> 1 Reseat the HVPS cables. 2 Check the cables for damage. <p>Are the cables free of damage?</p>	Go to step 18.	Go to step 19.
<p>Step 18</p> <p>Replace the damaged cable.</p> <p>Does the problem remain?</p>	Contact the next level of support.	The problem is solved.
<p>Step 19</p> <ol style="list-style-type: none"> 1 Check the HVPS characterization. 2 Reseat the HVPS cables. 3 Check the HVPS cables for proper installation and damage. 4 Check the HVPS spring contact for proper connection to the board. <p>Is the HVPS properly installed and free of damage?</p>	Contact the next level of support.	Go to step 20.
<p>Step 20</p> <p>Replace the HVPS. See HVPS removal.</p> <p>Make sure to perform the HVPS characterization when replacing the HVPS.</p> <p>Does the problem remain?</p>	Contact the next level of support.	The problem is solved.

Vertical White Lines Check



Action	Yes	No
<p>Step 1</p> <ol style="list-style-type: none"> 1 Make sure that the toner cartridge is supported. 2 Make sure that the toner cartridge and imaging unit are not empty. 3 Check if the toner cartridge is new. <p>Is the toner cartridge new?</p>	Go to step 2.	Go to step 3.
<p>Step 2</p> <p>Make sure to remove the packing material on the toner cartridge and imaging unit.</p> <p>Does the problem remain?</p>	Go to step 3.	The problem is solved.
<p>Step 3</p> <ol style="list-style-type: none"> 1 Clear the paper path of debris and contamination. 2 Remove, and then insert the imaging unit and toner cartridge. <p>Shake the toner cartridge and imaging unit before inserting them.</p> <ol style="list-style-type: none"> 3 Perform a POR. 4 Enter the Diagnostics menu, and then select Advanced Print Quality Samples. <p>Does the problem remain?</p>	Go to step 4.	The problem is solved.
<p>Step 4</p> <ol style="list-style-type: none"> 1 Clean the printhead lens. 2 Reseat the two printhead cables at both ends. 3 Perform a print test. <p>Does the problem remain?</p>	Go to step 5.	The problem is solved.

Diagnostics and Troubleshooting

Action	Yes	No
<p>Step 5</p> <ol style="list-style-type: none"> 1 Make sure that the printhead cables are properly connected. 2 Check the printhead for proper installation and damage. <p>Is the printhead properly installed and free of damage?</p>	Go to step 7.	Go to step 6.
<p>Step 6</p> <p>Replace the printhead. See Printhead removal.</p> <p>Does the problem remain?</p>	Go to step 7.	The problem is solved.
<p>Step 7</p> <ol style="list-style-type: none"> 1 Make sure that the imaging unit is properly installed and free of damage. 2 Make sure that the smart chip contacts are free of corrosion and contamination. 3 Make sure that the photoconductor roller surface is free of damage. 4 Make sure that the imaging unit HVPS contacts are free of corrosion and contamination. 5 Enter the Diagnostics menu, and then select Advanced Print Quality Samples. <p>Does the problem remain?</p>	Go to step 8.	The problem is solved.
<p>Step 8</p> <p>Replace the imaging unit.</p> <p>Does the problem remain?</p>	Go to step 9.	The problem is solved.
<p>Step 9</p> <ol style="list-style-type: none"> 1 Make sure that the toner cartridge is properly installed and free of damage. 2 Make sure that the smart chip contacts are free of corrosion and contamination. 3 Make sure that the developer roller surface is free of damage. 4 Make sure that the toner HVPS contacts are free of corrosion and contamination. 5 Enter the Diagnostics menu, and then select Advanced Print Quality Samples. 	Go to step 10.	The problem is solved.

Action	Yes	No
Does the problem remain?		
Step 10 Replace the toner cartridge. Does the problem remain?	Go to step 11.	The problem is solved.
Step 11 1 Check the HVPS toner contact spring for proper installation and damage. 2 Check the toner smart chip contact for proper installation and damage. 3 Check the toner contact spring for corrosion and contamination. Are the HVPS toner contact spring and toner smart chip contact properly installed and free of damage and contamination?	Go to step 13.	Go to step 12.
Step 12 1 Make sure that the HVPS toner contact spring is in proper contact with the toner cartridge. 2 Make sure that the HVPS toner contact spring is in proper contact with the HVPS. 3 Reseat the smart chip contact cable. Does the problem remain?	Contact the next level of support.	The problem is solved.
Step 13 1 Check the imaging unit contact spring for damage and contamination. 2 Make sure that the imaging unit contact spring is in proper contact with the HVPS. Is the imaging unit contact spring properly installed and free of damage and contamination?	Contact the next level of support.	The problem is solved.
Step 14 1 Make sure that the transfer roller is properly installed and free of damage and contamination.	Go to step 15.	The problem is solved.

Diagnostics and Troubleshooting

Action	Yes	No
<p>2 Make sure that the HVPS contact spring is properly connected to the transfer roller.</p> <p>3 Make sure that the transfer roller spring is properly installed.</p> <p>4 Enter the Diagnostics menu, and then select Advanced Print Quality Samples.</p> <p>Does the problem remain?</p>		
<p>Step 15</p> <p>1 Reseat the transfer roller.</p> <p>2 Enter the Diagnostics menu, and then select Advanced Print Quality Samples.</p> <p>Does the problem remain?</p>	Go to step 16.	The problem is solved.
<p>Step 16</p> <p>Replace the transfer roller. See Transfer roller removal.</p> <p>Does the problem remain?</p>	Go to step 17.	The problem is solved.
<p>Step 17</p> <p>1 Reseat the HVPS cables.</p> <p>2 Check the cables for damage.</p> <p>Are the cables free of damage?</p>	Go to step 18.	Go to step 19.
<p>Step 18</p> <p>Replace the damaged cable.</p> <p>Does the problem remain?</p>	Contact the next level of support.	The problem is solved.

Action	Yes	No
<p>Step 19</p> <ol style="list-style-type: none"> 1 Check the HVPS characterization. 2 Reseat the HVPS cables. 3 Check the HVPS cables for proper installation and damage. 4 Check the HVPS spring contact for proper connection to the board. <p>Is the HVPS properly installed and free of damage?</p>	Contact the next level of support.	Go to step 20.
<p>Step 20</p> <p>Replace the HVPS. See HVPS removal.</p> <p>Make sure to perform the HVPS characterization when replacing the HVPS.</p> <p>Does the problem remain?</p>	Contact the next level of support.	The problem is solved.

Vertical Colored Lines or Banding Check



Action	Yes	No
<p>Step 1</p> <ol style="list-style-type: none"> 1 Make sure that the toner cartridge is supported. 2 Make sure that the toner cartridge and imaging unit are not empty. 3 Check if the toner cartridge is new. <p>Is the toner cartridge new?</p>	Go to step 2.	Go to step 3.
<p>Step 2</p> <p>Make sure to remove the packing material on the toner cartridge and imaging unit.</p>	Go to step 3.	The problem is solved.

Diagnostics and Troubleshooting

Action	Yes	No
Does the problem remain?		
<p>Step 3</p> <ol style="list-style-type: none"> 1 Clear the paper path of debris and contamination. 2 Remove, and then insert the imaging unit and toner cartridge. <p>Shake the toner cartridge and imaging unit before inserting them.</p> <ol style="list-style-type: none"> 3 Perform a POR. 4 Enter the Diagnostics menu, and then select Advanced Print Quality Samples. <p>Does the problem remain?</p>	Go to step 4.	The problem is solved.
<p>Step 4</p> <ol style="list-style-type: none"> 1 Clean the printhead lens. 2 Reseat the two printhead cables at both ends. 3 Perform a print test. <p>Does the problem remain?</p>	Go to step 5.	The problem is solved.
<p>Step 5</p> <ol style="list-style-type: none"> 1 Make sure that the printhead cables are properly connected. 2 Check the printhead for proper installation and damage. <p>Is the printhead properly installed and free of damage?</p>	Go to step 7.	Go to step 6.
<p>Step 6</p> <p>Replace the printhead. See Printhead removal.</p> <p>Does the problem remain?</p>	Go to step 7.	The problem is solved.
<p>Step 7</p> <ol style="list-style-type: none"> 1 Make sure that the imaging unit is properly installed and free of damage. 2 Make sure that the smart chip contacts are free of corrosion and contamination. 3 Make sure that the photoconductor roller surface is free of damage. 	Go to step 8.	The problem is solved.

Action	Yes	No
<p>4 Make sure that the imaging unit HVPS contacts are free of corrosion and contamination.</p> <p>5 Enter the Diagnostics menu, and then select Advanced Print Quality Samples.</p> <p>Does the problem remain?</p>		
<p>Step 8</p> <p>Replace the imaging unit.</p> <p>Does the problem remain?</p>	Go to step 9.	The problem is solved.
<p>Step 9</p> <p>1 Make sure that the toner cartridge is properly installed and free of damage.</p> <p>2 Make sure that the smart chip contacts are free of corrosion and contamination.</p> <p>3 Make sure that the developer roller surface is free of damage.</p> <p>4 Make sure that the toner HVPS contacts are free of corrosion and contamination.</p> <p>5 Enter the Diagnostics menu, and then select Advanced Print Quality Samples.</p> <p>Does the problem remain?</p>	Go to step 10.	The problem is solved.
<p>Step 10</p> <p>Replace the toner cartridge.</p> <p>Does the problem remain?</p>	Go to step 11.	The problem is solved.
<p>Step 11</p> <p>1 Check the HVPS toner contact spring for proper installation and damage.</p> <p>2 Check the toner smart chip contact for proper installation and damage.</p> <p>3 Check the toner contact spring for corrosion and contamination.</p> <p>Are the HVPS toner contact spring and toner smart chip contact properly installed and free of damage and contamination?</p>	Go to step 13.	Go to step 12.
<p>Step 12</p>	Contact the next level of support.	The problem is solved.

Diagnostics and Troubleshooting

Action	Yes	No
<p>1 Make sure that the HVPS toner contact spring is in proper contact with the toner cartridge.</p> <p>2 Make sure that the HVPS toner contact spring is in proper contact with the HVPS.</p> <p>3 Reseat the smart chip contact cable.</p> <p>Does the problem remain?</p>		
<p>Step 13</p> <p>1 Check the imaging unit contact spring for damage and contamination.</p> <p>2 Make sure that the imaging unit contact spring is in proper contact with the HVPS.</p> <p>Is the imaging unit contact spring properly installed and free of damage and contamination?</p>	Contact the next level of support.	The problem is solved.
<p>Step 14</p> <p>1 Make sure that the transfer roller is properly installed and free of damage and contamination.</p> <p>2 Make sure that the HVPS contact spring is properly connected to the transfer roller.</p> <p>3 Make sure that the transfer roller spring is properly installed.</p> <p>4 Enter the Diagnostics menu, and then select Advanced Print Quality Samples.</p> <p>Does the problem remain?</p>	Go to step 15.	The problem is solved.
<p>Step 15</p> <p>1 Reseat the transfer roller.</p> <p>2 Enter the Diagnostics menu, and then select Advanced Print Quality Samples.</p> <p>Does the problem remain?</p>	Go to step 16.	The problem is solved.
<p>Step 16</p> <p>Replace the transfer roller. See Transfer roller removal.</p> <p>Does the problem remain?</p>	Go to step 17.	The problem is solved.

Action	Yes	No
<p>Step 17</p> <p>1 Reseat the HVPS cables. 2 Check the cables for damage.</p> <p>Are the cables free of damage?</p>	Go to step 18.	Go to step 19.
<p>Step 18</p> <p>Replace the damaged cable.</p> <p>Does the problem remain?</p>	Contact the next level of support.	The problem is solved.
<p>Step 19</p> <p>1 Check the HVPS characterization. 2 Reseat the HVPS cables. 3 Check the HVPS cables for proper installation and damage. 4 Check the HVPS spring contact for proper connection to the board.</p> <p>Is the HVPS properly installed and free of damage?</p>	Contact the next level of support.	Go to step 20.
<p>Step 20</p> <p>Replace the HVPS. See HVPS removal.</p> <p>Make sure to perform the HVPS characterization when replacing the HVPS.</p> <p>Does the problem remain?</p>	Contact the next level of support.	The problem is solved.

Vertical Dark Streaks With Print Missing Check

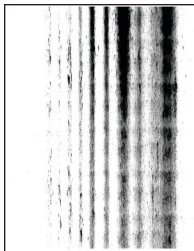

Diagnostics and Troubleshooting

Action	Yes	No
<p>Step 1</p> <ol style="list-style-type: none"> 1 Make sure that the toner cartridge is supported. 2 Make sure that the toner cartridge and imaging unit are not empty. 3 Check if the toner cartridge is new. <p>Is the toner cartridge new?</p>	Go to step 2.	Go to step 3.
<p>Step 2</p> <p>Make sure to remove the packing material on the toner cartridge and imaging unit.</p> <p>Does the problem remain?</p>	Go to step 3.	The problem is solved.
<p>Step 3</p> <ol style="list-style-type: none"> 1 Clear the paper path of debris and contamination. 2 Remove, and then insert the imaging unit and toner cartridge. <p>Shake the toner cartridge and imaging unit before inserting them.</p> <ol style="list-style-type: none"> 3 Perform a POR. 4 Enter the Diagnostics menu, and then select Advanced Print Quality Samples. <p>Does the problem remain?</p>	Go to step 4.	The problem is solved.
<p>Step 4</p> <ol style="list-style-type: none"> 1 Clean the printhead lens. 2 Reseat the two printhead cables at both ends. 3 Perform a print test. <p>Does the problem remain?</p>	Go to step 5.	The problem is solved.
<p>Step 5</p> <ol style="list-style-type: none"> 1 Make sure that the printhead cables are properly connected. 2 Check the printhead for proper installation and damage. <p>Is the printhead properly installed and free of damage?</p>	Go to step 7.	Go to step 6.
<p>Step 6</p> <p>Replace the printhead. See Printhead removal.</p>	Go to step 7.	The problem is solved.

Action	Yes	No
Does the problem remain?		
Step 7 1 Make sure that the imaging unit is properly installed and free of damage. 2 Make sure that the smart chip contacts are free of corrosion and contamination. 3 Make sure that the photoconductor roller surface is free of damage. 4 Make sure that the imaging unit HVPS contacts are free of corrosion and contamination. 5 Enter the Diagnostics menu, and then select Advanced Print Quality Samples . Does the problem remain?	Go to step 8.	The problem is solved.
Step 8 Replace the imaging unit. Does the problem remain?	Go to step 9.	The problem is solved.
Step 9 1 Make sure that the toner cartridge is properly installed and free of damage. 2 Make sure that the smart chip contacts are free of corrosion and contamination. 3 Make sure that the developer roller surface is free of damage. 4 Make sure that the toner HVPS contacts are free of corrosion and contamination. 5 Enter the Diagnostics menu, and then select Advanced Print Quality Samples . Does the problem remain?	Go to step 10.	The problem is solved.
Step 10 Replace the toner cartridge. Does the problem remain?	Go to step 11.	The problem is solved.
Step 11 1 Check the HVPS toner contact spring for proper installation and damage.	Go to step 13.	Go to step 12.

Diagnostics and Troubleshooting

Action	Yes	No
<p>2 Check the toner smart chip contact for proper installation and damage.</p> <p>3 Check the toner contact spring for corrosion and contamination.</p> <p>Are the HVPS toner contact spring and toner smart chip contact properly installed and free of damage and contamination?</p>		
<p>Step 12</p> <p>1 Make sure that the HVPS toner contact spring is in proper contact with the toner cartridge.</p> <p>2 Make sure that the HVPS toner contact spring is in proper contact with the HVPS.</p> <p>3 Reseat the smart chip contact cable.</p> <p>Does the problem remain?</p>	Contact the next level of support.	The problem is solved.
<p>Step 13</p> <p>1 Check the imaging unit contact spring for damage and contamination.</p> <p>2 Make sure that the imaging unit contact spring is in proper contact with the HVPS.</p> <p>Is the imaging unit contact spring properly installed and free of damage and contamination?</p>	Contact the next level of support.	The problem is solved.
<p>Step 14</p> <p>1 Make sure that the transfer roller is properly installed and free of damage and contamination.</p> <p>2 Make sure that the HVPS contact spring is properly connected to the transfer roller.</p> <p>3 Make sure that the transfer roller spring is properly installed.</p> <p>4 Enter the Diagnostics menu, and then select Advanced Print Quality Samples.</p> <p>Does the problem remain?</p>	Go to step 15.	The problem is solved.
<p>Step 15</p> <p>1 Reseat the transfer roller.</p>	Go to step 16.	The problem is solved.

Action	Yes	No
<p>2 Enter the Diagnostics menu, and then select Advanced Print Quality Samples.</p> <p>Does the problem remain?</p>		
<p>Step 16</p> <p>Replace the transfer roller. See Transfer roller removal.</p> <p>Does the problem remain?</p>	Go to step 17.	The problem is solved.
<p>Step 17</p> <p>1 Reseat the HVPS cables. 2 Check the cables for damage.</p> <p>Are the cables free of damage?</p>	Go to step 18.	Go to step 19.
<p>Step 18</p> <p>Replace the damaged cable.</p> <p>Does the problem remain?</p>	Contact the next level of support.	The problem is solved.
<p>Step 19</p> <p>1 Check the HVPS characterization. 2 Reseat the HVPS cables. 3 Check the HVPS cables for proper installation and damage. 4 Check the HVPS spring contact for proper connection to the board.</p> <p>Is the HVPS properly installed and free of damage?</p>	Contact the next level of support.	Go to step 20.
<p>Step 20</p> <p>Replace the HVPS. See HVPS removal.</p> <p>Make sure to perform the HVPS characterization when replacing the HVPS.</p> <p>Does the problem remain?</p>	Contact the next level of support.	The problem is solved.

White Streaks and Voiced Areas Check



Action	Yes	No
<p>Step 1</p> <ol style="list-style-type: none"> 1 Make sure that the toner cartridge is supported. 2 Make sure that the toner cartridge and imaging unit are not empty. 3 Check if the toner cartridge is new. <p>Is the toner cartridge new?</p>	Go to step 2.	Go to step 3.
<p>Step 2</p> <p>Make sure to remove the packing material on the toner cartridge and imaging unit.</p> <p>Does the problem remain?</p>	Go to step 3.	The problem is solved.
<p>Step 3</p> <ol style="list-style-type: none"> 1 Clear the paper path of debris and contamination. 2 Remove, and then insert the imaging unit and toner cartridge. <p>Shake the toner cartridge and imaging unit before inserting them.</p> <ol style="list-style-type: none"> 3 Perform a POR. 4 Enter the Diagnostics menu, and then select Advanced Print Quality Samples. <p>Does the problem remain?</p>	Go to step 4.	The problem is solved.
<p>Step 4</p> <ol style="list-style-type: none"> 1 Make sure that the imaging unit is properly installed and free of damage. 2 Make sure that the smart chip contacts are free of corrosion and contamination. 	Go to step 5.	The problem is solved.

Action	Yes	No
<p>3 Make sure that the photoconductor roller surface is free of damage.</p> <p>4 Make sure that the imaging unit HVPS contacts are free of corrosion and contamination.</p> <p>5 Enter the Diagnostics menu, and then select Advanced Print Quality Samples.</p> <p>Does the problem remain?</p>		
<p>Step 5</p> <p>Replace the imaging unit.</p> <p>Does the problem remain?</p>	Go to step 6.	The problem is solved.
<p>Step 6</p> <p>1 Make sure that the toner cartridge is properly installed and free of damage.</p> <p>2 Make sure that the smart chip contacts are free of corrosion and contamination.</p> <p>3 Make sure that the developer roller surface is free of damage.</p> <p>4 Make sure that the toner HVPS contacts are free of corrosion and contamination.</p> <p>5 Enter the Diagnostics menu, and then select Advanced Print Quality Samples.</p> <p>Does the problem remain?</p>	Go to step 7.	The problem is solved.
<p>Step 7</p> <p>Replace the toner cartridge.</p> <p>Does the problem remain?</p>	Go to step 8.	The problem is solved.
<p>Step 8</p> <p>1 Check the HVPS toner contact spring for proper installation and damage.</p> <p>2 Check the toner smart chip contact for proper installation and damage.</p> <p>3 Check the toner contact spring for corrosion and contamination.</p> <p>Are the HVPS toner contact spring and toner smart chip contact properly installed and free of damage and contamination?</p>	Go to step 10.	Go to step 9.

Diagnostics and Troubleshooting

Action	Yes	No
<p>Step 9</p> <ol style="list-style-type: none"> 1 Make sure that the HVPS toner contact spring is in proper contact with the toner cartridge. 2 Make sure that the HVPS toner contact spring is in proper contact with the HVPS. 3 Reseat the smart chip contact cable. <p>Does the problem remain?</p>	Contact the next level of support.	The problem is solved.
<p>Step 10</p> <ol style="list-style-type: none"> 1 Check the imaging unit contact spring for damage and contamination. 2 Make sure that the imaging unit contact spring is in proper contact with the HVPS. <p>Is the imaging unit contact spring properly installed and free of damage and contamination?</p>	Contact the next level of support.	The problem is solved.
<p>Step 11</p> <ol style="list-style-type: none"> 1 Make sure that the transfer roller is properly installed and free of damage and contamination. 2 Make sure that the HVPS contact spring is properly connected to the transfer roller. 3 Make sure that the transfer roller spring is properly installed. 4 Enter the Diagnostics menu, and then select Advanced Print Quality Samples. <p>Does the problem remain?</p>	Go to step 12.	The problem is solved.
<p>Step 12</p> <ol style="list-style-type: none"> 1 Reseat the transfer roller. 2 Enter the Diagnostics menu, and then select Advanced Print Quality Samples. <p>Does the problem remain?</p>	Go to step 13.	The problem is solved.
<p>Step 13</p> <p>Replace the transfer roller. See Transfer roller removal.</p> <p>Does the problem remain?</p>	Go to step 14.	The problem is solved.

Action	Yes	No
Step 14 1 Clean the printhead lens. 2 Reseat the two printhead cables at both ends. 3 Perform a print test. Does the problem remain?	Go to step 15.	The problem is solved.
Step 15 1 Make sure that the printhead cables are properly connected. 2 Check the printhead for proper installation and damage. Is the printhead properly installed and free of damage?	Go to step 17.	Go to step 16.
Step 16 Replace the printhead. See Printhead removal . Does the problem remain?	Go to step 17.	The problem is solved.
Step 17 1 Reseat the HVPS cables. 2 Check the cables for damage. Are the cables free of damage?	Go to step 18.	Go to step 19.
Step 18 Replace the damaged cable. Does the problem remain?	Contact the next level of support.	The problem is solved.

Action	Yes	No
<p>Step 19</p> <ol style="list-style-type: none"> 1 Check the HVPS characterization. 2 Reseat the HVPS cables. 3 Check the HVPS cables for proper installation and damage. 4 Check the HVPS spring contact for proper connection to the board. <p>Is the HVPS properly installed and free of damage?</p>	Contact the next level of support.	Go to step 20.
<p>Step 20</p> <p>Replace the HVPS. See HVPS removal.</p> <p>Make sure to perform the HVPS characterization when replacing the HVPS.</p> <p>Does the problem remain?</p>	Contact the next level of support.	The problem is solved.

Clipped Pages or Images Check

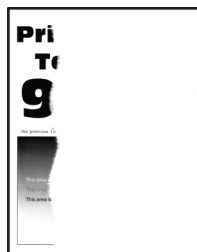

Action	Yes	No
<p>Step 1</p> <ol style="list-style-type: none"> 1 Make sure that the toner cartridge is supported. 2 Make sure that the toner cartridge and imaging unit are not empty. 3 Check if the toner cartridge is new. <p>Is the toner cartridge new?</p>	Go to step 2.	Go to step 3.
<p>Step 2</p> <p>Make sure to remove the packing material on the toner cartridge and imaging unit.</p>	Go to step 3.	The problem is solved.

Action	Yes	No
Does the problem remain?		
<p>Step 3</p> <ol style="list-style-type: none"> 1 Clear the paper path of debris and contamination. 2 Remove, and then insert the imaging unit and toner cartridge. Shake the toner cartridge and imaging unit before inserting them. 3 Perform a POR. 4 Enter the Diagnostics menu, and then select Advanced Print Quality Samples. <p>Does the problem remain?</p>	Go to step 4.	The problem is solved.
<p>Step 4</p> <ol style="list-style-type: none"> 1 Make sure that the imaging unit is properly installed and free of damage. 2 Make sure that the smart chip contacts are free of corrosion and contamination. 3 Make sure that the photoconductor roller surface is free of damage. 4 Make sure that the imaging unit HVPS contacts are free of corrosion and contamination. 5 Enter the Diagnostics menu, and then select Advanced Print Quality Samples. <p>Does the problem remain?</p>	Go to step 5.	The problem is solved.
<p>Step 5</p> <p>Replace the imaging unit.</p> <p>Does the problem remain?</p>	Go to step 6.	The problem is solved.
<p>Step 6</p> <ol style="list-style-type: none"> 1 Make sure that the toner cartridge is properly installed and free of damage. 2 Make sure that the smart chip contacts are free of corrosion and contamination. 3 Make sure that the developer roller surface is free of damage. 	Go to step 7.	The problem is solved.

Diagnostics and Troubleshooting

Action	Yes	No
<p>4 Make sure that the toner HVPS contacts are free of corrosion and contamination.</p> <p>5 Enter the Diagnostics menu, and then select Advanced Print Quality Samples.</p> <p>Does the problem remain?</p>		
<p>Step 7</p> <p>Replace the toner cartridge.</p> <p>Does the problem remain?</p>	Go to step 8.	The problem is solved.
<p>Step 8</p> <p>1 Check the HVPS toner contact spring for proper installation and damage.</p> <p>2 Check the toner smart chip contact for proper installation and damage.</p> <p>3 Check the toner contact spring for corrosion and contamination.</p> <p>Are the HVPS toner contact spring and toner smart chip contact properly installed and free of damage and contamination?</p>	Go to step 10.	Go to step 9.
<p>Step 9</p> <p>1 Make sure that the HVPS toner contact spring is in proper contact with the toner cartridge.</p> <p>2 Make sure that the HVPS toner contact spring is in proper contact with the HVPS.</p> <p>3 Reseat the smart chip contact cable.</p> <p>Does the problem remain?</p>	Contact the next level of support.	The problem is solved.
<p>Step 10</p> <p>1 Check the imaging unit contact spring for damage and contamination.</p> <p>2 Make sure that the imaging unit contact spring is in proper contact with the HVPS.</p> <p>Is the imaging unit contact spring properly installed and free of damage and contamination?</p>	Contact the next level of support.	The problem is solved.

Action	Yes	No
<p>Step 11</p> <ol style="list-style-type: none"> 1 Make sure that the transfer roller is properly installed and free of damage and contamination. 2 Make sure that the HVPS contact spring is properly connected to the transfer roller. 3 Make sure that the transfer roller spring is properly installed. 4 Enter the Diagnostics menu, and then select Advanced Print Quality Samples. <p>Does the problem remain?</p>	Go to step 12.	The problem is solved.
<p>Step 12</p> <ol style="list-style-type: none"> 1 Reseat the transfer roller. 2 Enter the Diagnostics menu, and then select Advanced Print Quality Samples. <p>Does the problem remain?</p>	Go to step 13.	The problem is solved.
<p>Step 13</p> <p>Replace the transfer roller. See Transfer roller removal.</p> <p>Does the problem remain?</p>	Go to step 14.	The problem is solved.
<p>Step 14</p> <ol style="list-style-type: none"> 1 Clean the printhead lens. 2 Reseat the two printhead cables at both ends. 3 Perform a print test. <p>Does the problem remain?</p>	Go to step 15.	The problem is solved.
<p>Step 15</p> <ol style="list-style-type: none"> 1 Make sure that the printhead cables are properly connected. 2 Check the printhead for proper installation and damage. <p>Is the printhead properly installed and free of damage?</p>	Go to step 17.	Go to step 16.
<p>Step 16</p> <p>Replace the printhead. See Printhead removal.</p> <p>Does the problem remain?</p>	Go to step 17.	The problem is solved.
<p>Step 17</p>	Go to step 18.	Go to step 19.

Diagnostics and Troubleshooting

Action	Yes	No
1 Reseat the HVPS cables. 2 Check the cables for damage. Are the cables free of damage?		
Step 18 Replace the damaged cable. Does the problem remain?	Go to step 19.	The problem is solved.
Step 19 1 Check the HVPS characterization. 2 Reseat the HVPS cables. 3 Check the HVPS cables for proper installation and damage. 4 Check the HVPS spring contact for proper connection to the board. Is the HVPS properly installed and free of damage?	Go to step 21.	Go to step 20.
Step 20 Replace the HVPS. See HVPS removal . Make sure to perform the HVPS characterization when replacing the HVPS. Does the problem remain?	Go to step 21.	The problem is solved.
Step 21 1 Reseat all the cables connected to the LVPS. 2 Check the cables for proper connection and damage. 3 Check the fuse for continuity. 4 Check the electronic components on the LVPS for damage. 5 Check the LVPS for proper installation and damage. Is the LVPS properly installed and free of damage?	Contact the next level of support.	Go to step 22.

Action	Yes	No
<p>Step 22</p> <ol style="list-style-type: none"> 1 Make sure that the LVPS is compatible with the fuser and the printer. 2 Make sure that the fuser connector has voltage. 3 Make sure that the correct power input voltage is used. <p>Does the problem remain?</p>	Go to step 23.	The problem is solved.
<p>Step 23</p> <p>Replace the LVPS. See LVPS removal.</p> <p>Does the problem remain?</p>	Contact the next level of support.	The problem is solved.

Compressed Images Appear On Prints Check

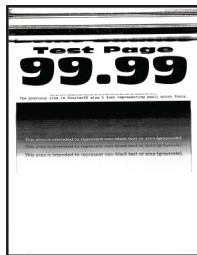

Action	Yes	No
<p>Step 1</p> <ol style="list-style-type: none"> 1 Clear the paper path of debris and contamination. 2 Remove, and then insert the imaging unit and toner cartridge. <p>Shake the toner cartridge and imaging unit before inserting them.</p> <ol style="list-style-type: none"> 3 Perform a POR. 4 Enter the Diagnostics menu, and then select Advanced Print Quality Samples. <p>Does the problem remain?</p>	Go to step 2.	The problem is solved.
<p>Step 2</p> <ol style="list-style-type: none"> 1 Make sure that the imaging unit is properly installed and free of damage. 	Go to step 3.	The problem is solved.

Diagnostics and Troubleshooting

Action	Yes	No
<p>2 Make sure that the smart chip contacts are free of corrosion and contamination.</p> <p>3 Make sure that the photoconductor roller surface is free of damage.</p> <p>4 Make sure that the imaging unit HVPS contacts are free of corrosion and contamination.</p> <p>5 Enter the Diagnostics menu, and then select Advanced Print Quality Samples.</p> <p>Does the problem remain?</p>		
<p>Step 3</p> <p>Replace the imaging unit.</p> <p>Does the problem remain?</p>	Go to step 4.	The problem is solved.
<p>Step 4</p> <p>1 Check the imaging unit drive lever for proper installation and damage.</p> <p>2 Open the right cover, and then check the lever assembly for proper installation and damage.</p> <p>Is the imaging unit drive lever properly installed and free of damage?</p>	Go to step 6.	Go to step 5.
<p>Step 5</p> <p>1 Open the front door.</p> <p>2 Remove the imaging unit.</p> <p>3 Remove the toner cartridge from the imaging unit.</p> <p>4 Slightly close the front door, and then check if the lever actuates the imaging unit drive gear.</p> <p>Did the imaging unit drive gear actuate?</p>	The problem is solved.	Contact the next level of support.
<p>Step 6</p> <p>1 Remove the imaging unit.</p> <p>2 Check the coupling drive gear for proper installation and damage.</p> <p>3 Actuate the lever, and then check if the coupling drive gear engages.</p>	Go to step 8.	Go to step 7.

Action	Yes	No
Is the coupling drive gear properly installed and free of damage?		
Step 7 Replace the main drive. See Main drive removal . Does the problem remain?	Go to step 8.	The problem is solved.
Step 8 1 Make sure that the transfer roller is properly installed and free of damage and contamination. 2 Make sure that the HVPS contact spring is properly connected to the transfer roller. 3 Make sure that the transfer roller spring is properly installed. 4 Enter the Diagnostics menu, and then select Advanced Print Quality Samples . Does the problem remain?	Go to step 9.	The problem is solved.
Step 9 1 Reseat the transfer roller. 2 Enter the Diagnostics menu, and then select Advanced Print Quality Samples . Does the problem remain?	Go to step 10.	The problem is solved.
Step 10 Replace the transfer roller. See Transfer roller removal . Does the problem remain?	Go to step 11.	The problem is solved.
Step 11 Make sure that the roller is free of dirt and contamination. Does the problem remain?	Contact the next level of support.	The problem is solved.
Step 12 1 Enter the Diagnostics menu, and then navigate to: Input tray quick print > Tray 1 > Single	Go to step 14.	Go to step 13.

Diagnostics and Troubleshooting

Action	Yes	No
<p>2 Check if the clip in the middle of the solenoid turns when the paper is transported.</p> <p>Did the clip turn?</p>		
<p>Step 13</p> <p>Reseat the deskew solenoid cable at both ends.</p> <p>Does the problem remain?</p>	Contact the next level of support.	The problem is solved.
<p>Step 14</p> <p>1 Enter the Diagnostics menu, and then navigate to:</p> <p>Printer diagnostics & adjustments > Motor tests</p> <p>2 Select Motor (transport drive).</p> <p>Did the motor run?</p>	Go to step 15.	Go to step 16.
<p>Step 15</p> <p>1 Enter the Diagnostics menu, and then navigate to:</p> <p>Input tray quick print > Tray 1 > Single</p> <p>2 Enter the Diagnostics menu, and then navigate to:</p> <p>Input tray quick print > Duplex > Single</p> <p>Does the problem remain?</p>	Go to step 16.	The problem is solved.
<p>Step 16</p> <p>1 Make sure that the main drive is properly installed and free of damage.</p> <p>2 Make sure that the main drive gears are properly installed.</p> <p>3 Make sure that the drive gears are in proper contact with the gear they are driving.</p> <p>Does the problem remain?</p>	Go to step 17.	The problem is solved.
<p>Step 17</p> <p>Replace the main drive. See Main drive removal.</p> <p>Does the problem remain?</p>	Contact the next level of support.	The problem is solved.

Incorrect Margins On Prints Check



Action	Yes	No
<p>Step 1</p> <ol style="list-style-type: none"> 1 Clear the paper path of debris and contamination. 2 Remove, and then insert the imaging unit and toner cartridge. Shake the toner cartridge and imaging unit before inserting them. 3 Perform a POR. 4 Enter the Diagnostics menu, and then select Advanced Print Quality Samples. <p>Does the problem remain?</p>	Go to step 2.	The problem is solved.
<p>Step 2</p> <ol style="list-style-type: none"> 1 Make sure that the paper type is supported. 2 Make sure that the paper type and size settings match the paper type and size set on the tray. 3 Make sure that the paper has no damage or defects. 4 Make sure that the paper guides are properly set. 5 Make sure that the paper size setting in the duplex unit is properly set. <p>Does the problem remain?</p>	Go to step 3.	The problem is solved.
<p>Step 3</p> <ol style="list-style-type: none"> 1 Check the tray insert for proper installation and damage. 2 Make sure that the separator roller is free of dust and contamination. 3 Check the lift plate for proper operation. 	Go to step 5.	Go to step 4.

Diagnostics and Troubleshooting

Action	Yes	No
<p>4 Check the paper guides for proper operation.</p> <p>Is the tray insert properly installed and free of damage?</p>		
<p>Step 4</p> <p>Replace the tray insert.</p> <p>Does the problem remain?</p>	Go to step 5.	The problem is solved.
<p>Step 5</p> <p>1 Enter the Diagnostics menu, and then navigate to:</p> <p>Printer diagnostics & adjustments > Registration adjust</p> <p>2 Select Quick test or Duplex quick test.</p> <p>3 Adjust the following margins:</p> <ul style="list-style-type: none"> • Top Margin • Bottom Margin • Left Margin • Right Margin <p>Does the problem remain?</p>	Go to step 6.	The problem is solved.
<p>Step 6</p> <p>1 Clean the printhead lens.</p> <p>2 Reseat the two printhead cables at both ends.</p> <p>3 Perform a print test.</p> <p>Does the problem remain?</p>	Go to step 7.	The problem is solved.
<p>Step 7</p> <p>1 Make sure that the printhead cables are properly connected.</p> <p>2 Check the printhead for proper installation and damage.</p> <p>Is the printhead properly installed and free of damage?</p>	Go to step 9.	Go to step 8.
<p>Step 8</p> <p>Replace the printhead. See Printhead removal.</p> <p>Does the problem remain?</p>	Go to step 9.	The problem is solved.

Action	Yes	No
Step 9 1 Check the controller board for proper installation and damage. 2 Reseat all the cables on the controller board. Is the controller board properly installed and free of damage?	Contact the next level of support.	Go to step 10.
Step 10 Replace the controller board. See Controller board removal . Does the problem remain?	Contact the next level of support.	The problem is solved.

Toner Rubs Off Check



Action	Yes	No
Step 1 1 Make sure that the toner cartridge is supported. 2 Make sure that the toner cartridge and imaging unit are not empty. 3 Check if the toner cartridge is new. Is the toner cartridge new?	Go to step 2.	Go to step 3.
Step 2 Make sure to remove the packing material on the toner cartridge and imaging unit. Does the problem remain?	Go to step 3.	The problem is solved.
Step 3 1 Clear the paper path of debris and contamination. 2 Remove, and then insert the imaging unit and toner cartridge.	Go to step 4.	The problem is solved.

Diagnostics and Troubleshooting

Action	Yes	No
<p>Shake the toner cartridge and imaging unit before inserting them.</p> <p>3 Perform a POR.</p> <p>4 Enter the Diagnostics menu, and then select Advanced Print Quality Samples.</p> <p>Does the problem remain?</p>		
<p>Step 4</p> <p>1 Make sure that the paper type and size settings match the paper type and size set on the tray.</p> <p>2 Check the fuser cables for proper connection and damage.</p> <p>3 Check the fuser access door for damage.</p> <p>4 Check if the fuser gears are in proper contact with the drive gears.</p> <p>5 Make sure that the fuser is compatible with the LVPS.</p> <p>6 Check the fuser for proper installation and damage.</p> <p>Is the fuser properly installed and free of damage?</p>	Go to step 7.	Go to step 5.
<p>Step 5</p> <p>1 Enter the Diagnostics menu, and then navigate to:</p> <p>Printer diagnostics & adjustments > Motor tests</p> <p>2 Select Motor (transport).</p> <p>3 Open the rear door, and then check if the fuser exit rollers turn.</p> <p>4 Open the fuser access door, and then check if the hot rollers turn.</p> <p>Are the rollers properly working?</p>	Go to step 7.	Go to step 6.
<p>Step 6</p> <p>Replace the fuser. See Fuser removal.</p> <p>Does the problem remain?</p>	Go to step 7.	The problem is solved.
<p>Step 7</p>	Contact the next level of support.	Go to step 8.

Action	Yes	No
<ol style="list-style-type: none"> 1 Reseat all the cables connected to the LVPS. 2 Check the cables for proper connection and damage. 3 Check the fuse for continuity. 4 Check the electronic components on the LVPS for damage. 5 Check the LVPS for proper installation and damage. <p>Is the LVPS properly installed and free of damage?</p>		
<p>Step 8</p> <ol style="list-style-type: none"> 1 Make sure that the LVPS is compatible with the fuser and the printer. 2 Make sure that the fuser connector has voltage. 3 Make sure that the correct power input voltage is used. <p>Does the problem remain?</p>	Go to step 9.	The problem is solved.
<p>Step 9</p> <p>Replace the LVPS. See LVPS removal.</p> <p>Does the problem remain?</p>	Contact the next level of support.	The problem is solved.

Toner Specks Appear On Prints Check



Diagnostics and Troubleshooting

Action	Yes	No
<p>Step 1</p> <ol style="list-style-type: none"> 1 Make sure that the toner cartridge is supported. 2 Make sure that the toner cartridge and imaging unit are not empty. 3 Check if the toner cartridge is new. <p>Is the toner cartridge new?</p>	Go to step 2.	Go to step 3.
<p>Step 2</p> <p>Make sure to remove the packing material on the toner cartridge and imaging unit.</p> <p>Does the problem remain?</p>	Go to step 3.	The problem is solved.
<p>Step 3</p> <ol style="list-style-type: none"> 1 Clear the paper path of debris and contamination. 2 Remove, and then insert the imaging unit and toner cartridge. <p>Shake the toner cartridge and imaging unit before inserting them.</p> <ol style="list-style-type: none"> 3 Perform a POR. 4 Enter the Diagnostics menu, and then select Advanced Print Quality Samples. <p>Does the problem remain?</p>	Go to step 4.	The problem is solved.
<p>Step 4</p> <ol style="list-style-type: none"> 1 Make sure that the imaging unit is properly installed and free of damage. 2 Make sure that the smart chip contacts are free of corrosion and contamination. 3 Make sure that the photoconductor roller surface is free of damage. 4 Make sure that the imaging unit HVPS contacts are free of corrosion and contamination. 5 Enter the Diagnostics menu, and then select Advanced Print Quality Samples. <p>Does the problem remain?</p>	Go to step 5.	The problem is solved.

Action	Yes	No
<p>Step 5</p> <p>Replace the imaging unit.</p> <p>Does the problem remain?</p>	Go to step 6.	The problem is solved.
<p>Step 6</p> <ol style="list-style-type: none"> 1 Make sure that the toner cartridge is properly installed and free of damage. 2 Make sure that the smart chip contacts are free of corrosion and contamination. 3 Make sure that the developer roller surface is free of damage. 4 Make sure that the toner HVPS contacts are free of corrosion and contamination. 5 Enter the Diagnostics menu, and then select Advanced Print Quality Samples. <p>Does the problem remain?</p>	Go to step 7.	The problem is solved.
<p>Step 7</p> <p>Replace the toner cartridge.</p> <p>Does the problem remain?</p>	Go to step 8.	The problem is solved.
<p>Step 8</p> <ol style="list-style-type: none"> 1 Check the HVPS toner contact spring for proper installation and damage. 2 Check the toner smart chip contact for proper installation and damage. 3 Check the toner contact spring for corrosion and contamination. <p>Are the HVPS toner contact spring and toner smart chip contact properly installed and free of damage and contamination?</p>	Go to step 10.	Go to step 9.
<p>Step 9</p> <ol style="list-style-type: none"> 1 Make sure that the HVPS toner contact spring is in proper contact with the toner cartridge. 2 Make sure that the HVPS toner contact spring is in proper contact with the HVPS. 3 Reseat the smart chip contact cable. 	Contact the next level of support.	The problem is solved.

Diagnostics and Troubleshooting

Action	Yes	No
Does the problem remain?		
<p>Step 10</p> <ol style="list-style-type: none"> 1 Check the imaging unit contact spring for damage and contamination. 2 Make sure that the imaging unit contact spring is in proper contact with the HVPS. <p>Is the imaging unit contact spring properly installed and free of damage and contamination?</p>	Contact the next level of support.	The problem is solved.
<p>Step 11</p> <ol style="list-style-type: none"> 1 Make sure that the transfer roller is properly installed and free of damage and contamination. 2 Make sure that the HVPS contact spring is properly connected to the transfer roller. 3 Make sure that the transfer roller spring is properly installed. 4 Enter the Diagnostics menu, and then select Advanced Print Quality Samples. <p>Does the problem remain?</p>	Go to step 12.	The problem is solved.
<p>Step 12</p> <ol style="list-style-type: none"> 1 Reseat the transfer roller. 2 Enter the Diagnostics menu, and then select Advanced Print Quality Samples. <p>Does the problem remain?</p>	Go to step 13.	The problem is solved.
<p>Step 13</p> <p>Replace the transfer roller. See Transfer roller removal.</p> <p>Does the problem remain?</p>	Go to step 14.	The problem is solved.
<p>Step 14</p> <ol style="list-style-type: none"> 1 Clean the printhead lens. 2 Reseat the two printhead cables at both ends. 3 Perform a print test. <p>Does the problem remain?</p>	Go to step 15.	The problem is solved.

Action	Yes	No
<p>Step 15</p> <ol style="list-style-type: none"> 1 Make sure that the printhead cables are properly connected. 2 Check the printhead for proper installation and damage. <p>Is the printhead properly installed and free of damage?</p>	<p>Contact the next level of support.</p>	<p>Go to step 16.</p>
<p>Step 16</p> <p>Replace the printhead. See Printhead removal.</p> <p>Does the problem remain?</p>	<p>Contact the next level of support.</p>	<p>The problem is solved.</p>

Paper Jams

Avoiding Jams

Load Paper Properly

- Make sure that the paper lies flat in the tray.

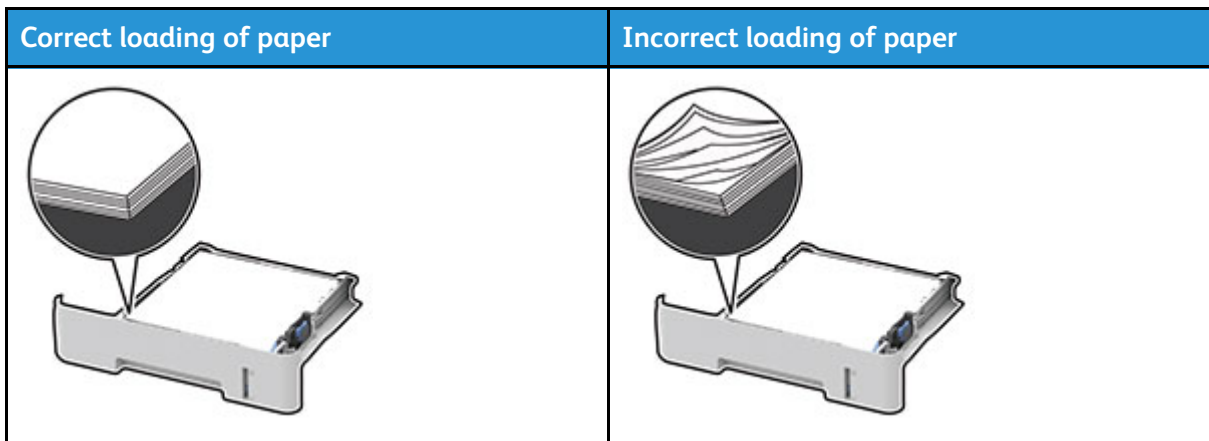

- Do not load or remove a tray while the printer is printing.
- Do not load too much paper. Make sure that the stack height is below the maximum paper fill indicator.
- Do not slide paper into the tray. Load paper as shown in the illustration.

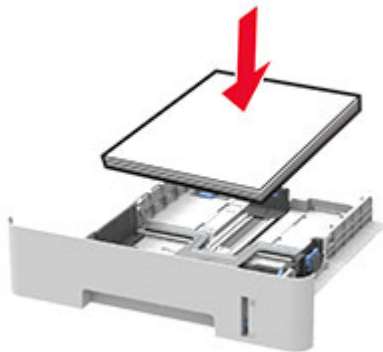

- Make sure that the paper guides are positioned correctly and are not pressing tightly against the paper or envelopes.
- Push the tray firmly into the printer after loading paper.

Use Recommended Paper

- Use only recommended paper or specialty media.
- Do not load paper that is wrinkled, creased, damp, bent, or curled.
- Flex, fan, and align the paper edges before loading.



- Do not use paper that has been cut or trimmed by hand.
- Do not mix paper sizes, weights, or types in the same tray.
- Make sure that the paper size and type are set correctly on the computer or printer control panel.
- Store paper according to manufacturer recommendations.

200 Paper Jams

200 Paper Jam Messages

Error code	Description	Action
200.04	Paper fed from the manual feeder cleared the sensor (input sensor S3) earlier than expected.	See Sensor (input sensor S3) service check .
200.05	Paper fed from the manual feeder never cleared the sensor (input sensor S3).	
200.06	Paper fed from the manual feeder was not picked. Paper did not reach the sensor (input sensor S3).	
200.07	Paper reached the sensor (input sensor S3) earlier than expected.	
200.12	Paper fed from tray 1 arrived at the sensor (input sensor S3) earlier than expected.	
200.13	Paper fed from tray 1 was detected later than expected or was never detected at the sensor (input sensor S3).	
200.14	Paper fed from tray 1 cleared the sensor (input sensor S3) earlier than expected.	
200.15	Paper fed from tray 1 never cleared the sensor (input sensor S3).	
200.91	Paper remains on the sensor (input sensor S3) during the warm up sequence.	

Sensor (Input Sensor S3) Static Jam Service Check

Action	Yes	No
<p>Step 1</p> <ol style="list-style-type: none"> 1 Make sure that the tray insert is properly inserted. 2 Make sure that the paper type and size settings match the paper type and size set on the tray. 3 Make sure that the duplex unit is properly inserted. 4 Make sure that the paper size setting in the duplex unit matches the printer setting. 5 Make sure that the front and rear doors are fully closed. 6 Make sure that the output bin is free from obstructions. <p>Does the problem remain?</p>	Go to step 2.	The problem is solved.
<p>Step 2</p> <ol style="list-style-type: none"> 1 Remove the imaging unit and toner cartridge, and then make sure that the paper path is free of jams and obstructions. 2 Clear all rollers of dirt and contamination. <p>Does the problem remain?</p>	Go to step 3.	The problem is solved.
<p>Step 3</p> <ol style="list-style-type: none"> 1 Perform a POR. 2 Enter the Diagnostics menu, and then navigate to: Input tray quick print > Tray 1 > Single <p>Does the problem remain?</p>	Go to step 4.	The problem is solved.
<p>Step 4</p> <ol style="list-style-type: none"> 1 Reseat the sensor cable. 2 Enter the Diagnostics menu, and then navigate to: Printer diagnostics & adjustments > Sensor tests 3 Find the sensor (staging sensor S2). <p>Does the sensor status change while toggling the sensor?</p>	Go to step 7.	Go to step 5.
Step 5	Go to step 7.	Go to step 6.

Action	Yes	No
1 Check the sensor for proper installation and damage. 2 Check the alignment with the sensor flag. 3 Check the sensor cable for proper connection and damage. Is the sensor properly installed and free of damage?		
Step 6 Replace the sensor. Does the problem remain?	Go to step 7.	The problem is solved.
Step 7 1 Enter the Diagnostics menu, and then navigate to: Printer diagnostics & adjustment > Sensor tests 2 Find the following sensors: <ul style="list-style-type: none"> • Sensor (media present in tray1 S1) • Sensor (input sensor S3) • Sensor (fuser exit sensor S4) Does the sensor status change while toggling the sensor?	Go to step 10.	Go to step 8.
Step 8 1 Check the sensor flags for proper installation and damage. 2 Check the sensor flags for proper alignment with the sensors. 3 Check the sensor flag springs for proper installation and damage. Are the sensor flags properly installed and free of damage?	Go to step 10.	Go to step 9.
Step 9 Replace the damaged sensor flag. Does the problem remain?	Go to step 10.	The problem is solved.
Step 10 Check the cables for proper connection and damage.	Go to step 12.	Go to step 11.

Diagnostics and Troubleshooting

Action	Yes	No
Are the cables properly connected and free of damage?		
Step 11 Replace the damaged cable. Does the problem remain?	Go to step 12.	The problem is solved.
Step 12 1 Reseat all the cables on the controller board. 2 Check if the controller board LED lights up. 3 Check the controller board for proper installation and damage. Is the controller board properly installed and free of damage?	Contact the next level of support.	Go to step 13.
Step 13 Replace the controller board. See Controller board removal . Does the problem remain?	Contact the next level of support.	The problem is solved.

Sensor (Input Sensor S3) Service Check

Action	Yes	No
Step 1 1 Make sure that the tray insert is properly inserted. 2 Make sure that the paper type and size settings match the paper type and size set on the tray. 3 Make sure that the duplex unit is properly inserted. 4 Make sure that the paper size setting in the duplex unit matches the printer setting. 5 Make sure that the front and rear doors are fully closed. 6 Make sure that the output bin is free from obstructions. Does the problem remain?	Go to step 2.	The problem is solved.
Step 2 1 Remove the imaging unit and toner cartridge, and then make	Go to step 3.	The problem is solved.

Action	Yes	No
<p>sure that the paper path is free of jams and obstructions.</p> <p>2 Clear all rollers of dirt and contamination.</p> <p>Does the problem remain?</p>		
<p>Step 3</p> <p>1 Perform a POR.</p> <p>2 Enter the Diagnostics menu, and then navigate to:</p> <p>Input tray quick print > Tray 1 > Single</p> <p>Does the problem remain?</p>	Go to step 4.	The problem is solved.
<p>Step 4</p> <p>1 Reseat the sensor cable.</p> <p>2 Enter the Diagnostics menu, and then navigate to:</p> <p>Printer diagnostics & adjustments > Sensor tests</p> <p>3 Find the sensor (staging sensor S2).</p> <p>Does the sensor status change while toggling the sensor?</p>	Go to step 7.	Go to step 5.
<p>Step 5</p> <p>1 Check the sensor for proper installation and damage.</p> <p>2 Check the alignment with the sensor flag.</p> <p>3 Check the sensor cable for proper connection and damage.</p> <p>Is the sensor properly installed and free of damage?</p>	Go to step 7.	Go to step 6.
<p>Step 6</p> <p>Replace the sensor.</p> <p>Does the problem remain?</p>	Go to step 7.	The problem is solved.
<p>Step 7</p> <p>1 Enter the Diagnostics menu, and then navigate to:</p> <p>Printer diagnostics & adjustment > Sensor tests</p> <p>2 Find the following sensors:</p>	Go to step 10.	Go to step 8.

Diagnostics and Troubleshooting

Action	Yes	No
<ul style="list-style-type: none"> • Sensor (media present in tray1 S1) • Sensor (input sensor S3) • Sensor (fuser exit sensor S4) <p>Does the sensor status change while toggling the sensor?</p>		
<p>Step 8</p> <ol style="list-style-type: none"> 1 Check the sensor flags for proper installation and damage. 2 Check the sensor flags for proper alignment with the sensors. 3 Check the sensor flag springs for proper installation and damage. <p>Are the sensor flags properly installed and free of damage?</p>	Go to step 10.	Go to step 9.
<p>Step 9</p> <p>Replace the damaged sensor flag.</p> <p>Does the problem remain?</p>	Go to step 10.	The problem is solved.
<p>Step 10</p> <ol style="list-style-type: none"> 1 Enter the Diagnostics menu, and then navigate to: Input tray quick print > Tray 1 > Single 2 Check if the clip in the middle of the solenoid turns when the paper is transported. <p>Did the clip turn?</p>	Go to step 12.	Go to step 11.
<p>Step 11</p> <p>Reseat the deskew solenoid cable at both ends.</p> <p>Does the problem remain?</p>	Contact the next level of support.	The problem is solved.
<p>Step 12</p> <p>Check the cables for proper connection and damage.</p> <p>Are the cables properly connected and free of damage?</p>	Go to step 14.	Go to step 13.
<p>Step 13</p> <p>Replace the damaged cable.</p>	Go to step 14.	The problem is solved.

Action	Yes	No
Does the problem remain?		
<p>Step 14</p> <p>1 Enter the Diagnostics menu, and then navigate to:</p> <p>Printer diagnostics & adjustments > Motor tests</p> <p>2 Select Motor (transport drive).</p> <p>Did the motor run?</p>	Go to step 15.	Go to step 16.
<p>Step 15</p> <p>1 Enter the Diagnostics menu, and then navigate to:</p> <p>Input tray quick print > Tray 1 > Single</p> <p>2 Enter the Diagnostics menu, and then navigate to:</p> <p>Input tray quick print > Duplex > Single</p> <p>Does the problem remain?</p>	Go to step 16.	The problem is solved.
<p>Step 16</p> <p>1 Make sure that the main drive is properly installed and free of damage.</p> <p>2 Make sure that the main drive gears are properly installed.</p> <p>3 Make sure that the drive gears are in proper contact with the gear they are driving.</p> <p>Does the problem remain?</p>	Go to step 17.	The problem is solved.
<p>Step 17</p> <p>Replace the main drive. See Main drive removal.</p> <p>Does the problem remain?</p>	Go to step 18.	The problem is solved.

Action	Yes	No
<p>Step 18</p> <ol style="list-style-type: none"> 1 Reseat all the cables on the controller board. 2 Check if the controller board LED lights up. 3 Check the controller board for proper installation and damage. <p>Is the controller board properly installed and free of damage?</p>	Contact the next level of support.	Go to step 19.
<p>Step 19</p> <p>Replace the controller board. See Controller board removal.</p> <p>Does the problem remain?</p>	Contact the next level of support.	The problem is solved.

202 Paper Jams

202 Paper Jam Messages

Error code	Description	Action
202.03	Paper fed from the manual feeder never arrived at the sensor (fuser exit sensor S4).	See Sensor (fuser exit sensor S4) service check .
202.05	Paper fed from the manual feeder never cleared the sensor (fuser exit sensor S4).	See Sensor (fuser exit sensor S4) never cleared service check .
202.13	Paper fed from tray 1 never arrived at the sensor (fuser exit sensor S4).	See Sensor (fuser exit sensor S4) service check .
202.15	Paper fed from tray 1 never arrived at the sensor (fuser exit sensor S4).	See Sensor (fuser exit sensor S4) never cleared service check .
202.91	Paper remains on the sensor (fuser exit sensor S4) during the warm up sequence.	See Sensor (fuser exit sensor S4) static jam service check .
202.93	Paper never arrive at the sensor (fuser exit sensor S4) which triggered a flush action.	See Sensor (fuser exit sensor S4) service check .

Sensor (Fuser Exit Sensor S4) Service Check

Action	Yes	No
<p>Step 1</p> <ol style="list-style-type: none"> 1 Make sure that the tray insert is properly inserted. 2 Make sure that the paper type and size settings match the paper type and size set on the tray. 3 Make sure that the duplex unit is properly inserted. 4 Make sure that the paper size setting in the duplex unit matches the printer setting. 5 Make sure that the front and rear doors are fully closed. 6 Make sure that the output bin is free from obstructions. <p>Does the problem remain?</p>	Go to step 2.	The problem is solved.
<p>Step 2</p> <ol style="list-style-type: none"> 1 Remove the imaging unit and toner cartridge, and then make sure that the paper path is free of jams and obstructions. 2 Clear all rollers of dirt and contamination. <p>Does the problem remain?</p>	Go to step 3.	The problem is solved.
<p>Step 3</p> <ol style="list-style-type: none"> 1 Perform a POR. 2 Enter the Diagnostics menu, and then navigate to: Input tray quick print > Tray 1 > Single <p>Does the problem remain?</p>	Go to step 4.	The problem is solved.
<p>Step 4</p> <ol style="list-style-type: none"> 1 Enter the Diagnostics menu, and then navigate to: Printer diagnostics & adjustments > Sensor tests 2 Find the sensor (fuser exit sensor S4). <p>Does the sensor status change while toggling the sensor?</p>	Go to step 7.	Go to step 5.
Step 5	Go to step 7.	Go to step 6.

Diagnostics and Troubleshooting

Action	Yes	No
<p>1 Make sure that the fuser exit sensor cable is properly connected and free of damage.</p> <p>2 Make sure that the sensor is properly aligned with the sensor flag.</p> <p>3 Check the sensor for proper installation and damage.</p> <p>Is the sensor properly installed and free of damage?</p>		
<p>Step 6</p> <p>Replace the sensor. See Sensor (fuser exit) removal .</p> <p>Does the problem remain?</p>	Go to step 7.	The problem is solved.
<p>Step 7</p> <p>1 Enter the Diagnostics menu, and then navigate to:</p> <p>Printer diagnostics & adjustment > Sensor tests</p> <p>2 Find the following sensors:</p> <ul style="list-style-type: none"> • Sensor (media present in tray1 S1) • Sensor (input sensor S3) • Sensor (fuser exit sensor S4) <p>Does the sensor status change while toggling the sensor?</p>	Go to step 10.	Go to step 8.
<p>Step 8</p> <p>1 Check the sensor flags for proper installation and damage.</p> <p>2 Check the sensor flags for proper alignment with the sensors.</p> <p>3 Check the sensor flag springs for proper installation and damage.</p> <p>Are the sensor flags properly installed and free of damage?</p>	Go to step 10.	Go to step 9.
<p>Step 9</p> <p>Replace the damaged sensor flag.</p> <p>Does the problem remain?</p>	Go to step 10.	The problem is solved.
<p>Step 10</p>	Go to step 12.	Go to step 11.

Action	Yes	No
<p>Check the rear door for proper installation and damage.</p> <p>Is the door properly installed and free of damage?</p>		
<p>Step 11</p> <p>Replace the rear door. See Rear door removal.</p> <p>Does the problem remain?</p>	Go to step 12.	The problem is solved.
<p>Step 12</p> <p>1 Enter Diagnostics menu, and then navigate to:</p> <p>Printer diagnostics & adjustments > Motor tests</p> <p>2 Select Motor (transport drive).</p> <p>3 Open the rear door, and then check if the fuser exit rollers turn.</p> <p>4 Open the fuser access door, and then check if the hot rollers turn.</p> <p>Are the rollers properly working?</p>	Go to step 13.	Go to step 14.
<p>Step 13</p> <p>1 Check the fuser cables for proper connection and damage.</p> <p>2 Check the fuser access door for damage.</p> <p>3 Check if the fuser gears are in proper contact with the drive gears.</p> <p>4 Make sure that the fuser is compatible with the LVPS.</p> <p>5 Check the fuser for proper installation and damage.</p> <p>Is the fuser properly installed and free of damage?</p>	Go to step 15.	Go to step 14.
<p>Step 14</p> <p>Replace the fuser. See Fuser removal.</p> <p>Does the problem remain?</p>	Go to step 15.	The problem is solved.
<p>Step 15</p> <p>Check the cables for proper connection and damage.</p>	Go to step 17.	Go to step 16.

Diagnostics and Troubleshooting

Action	Yes	No
Are the cables properly connected and free of damage?		
Step 16 Replace the damaged cable. Does the problem remain?	Go to step 17.	The problem is solved.
Step 17 1 Enter the Diagnostics menu, and then navigate to: Input tray quick print > Tray 1 > Single 2 Check if the clip in the middle of the solenoid turns when the paper is transported. Did the clip turn?	Go to step 19.	Go to step 18.
Step 18 Reseat the deskew solenoid cable at both ends. Does the problem remain?	Contact the next level of support.	The problem is solved.
Step 19 1 Enter the Diagnostics menu, and then navigate to: Printer diagnostics & adjustments > Motor tests 2 Select Motor (transport drive) . Did the motor run?	Go to step 20.	Go to step 21.
Step 20 1 Enter the Diagnostics menu, and then navigate to: Input tray quick print > Tray 1 > Single 2 Enter the Diagnostics menu, and then navigate to: Input tray quick print > Duplex > Single Does the problem remain?	Go to step 21.	The problem is solved.
Step 21 1 Make sure that the main drive is properly installed and free of damage.	Go to step 22.	The problem is solved.

Action	Yes	No
<p>2 Make sure that the main drive gears are properly installed.</p> <p>3 Make sure that the drive gears are in proper contact with the gear they are driving.</p> <p>Does the problem remain?</p>		
<p>Step 22</p> <p>Replace the main drive. See Main drive removal.</p> <p>Does the problem remain?</p>	Go to step 23.	The problem is solved.
<p>Step 23</p> <p>1 Reseat all the cables on the controller board.</p> <p>2 Check if the controller board LED lights up.</p> <p>3 Check the controller board for proper installation and damage.</p> <p>Is the controller board properly installed and free of damage?</p>	Contact the next level of support.	Go to step 24.
<p>Step 24</p> <p>Replace the controller board. See Controller board removal.</p> <p>Does the problem remain?</p>	Contact the next level of support.	The problem is solved.

Sensor (Fuser Exit Sensor S4) Never Cleared Service Check

Action	Yes	No
<p>Step 1</p> <ol style="list-style-type: none"> 1 Make sure that the tray insert is properly inserted. 2 Make sure that the paper type and size settings match the paper type and size set on the tray. 3 Make sure that the duplex unit is properly inserted. 4 Make sure that the paper size setting in the duplex unit matches the printer setting. 5 Make sure that the front and rear doors are fully closed. 6 Make sure that the output bin is free from obstructions. <p>Does the problem remain?</p>	Go to step 2.	The problem is solved.
<p>Step 2</p> <ol style="list-style-type: none"> 1 Remove the imaging unit and toner cartridge, and then make sure that the paper path is free of jams and obstructions. 2 Clear all rollers of dirt and contamination. <p>Does the problem remain?</p>	Go to step 3.	The problem is solved.
<p>Step 3</p> <ol style="list-style-type: none"> 1 Perform a POR. 2 Enter the Diagnostics menu, and then navigate to: Input tray quick print > Tray 1 > Single <p>Does the problem remain?</p>	Go to step 4.	The problem is solved.
<p>Step 4</p> <ol style="list-style-type: none"> 1 Enter the Diagnostics menu, and then navigate to: Printer diagnostics & adjustments > Sensor tests 2 Find the sensor (fuser exit sensor S4). <p>Does the sensor status change while toggling the sensor?</p>	Go to step 7.	Go to step 5.
Step 5	Go to step 7.	Go to step 6.

Action	Yes	No
<p>1 Make sure that the fuser exit sensor cable is properly connected and free of damage.</p> <p>2 Make sure that the sensor is properly aligned with the sensor flag.</p> <p>3 Check the sensor for proper installation and damage.</p> <p>Is the sensor properly installed and free of damage?</p>		
<p>Step 6</p> <p>Replace the sensor. See Sensor (fuser exit) removal.</p> <p>Does the problem remain?</p>	Go to step 7.	The problem is solved.
<p>Step 7</p> <p>1 Enter the Diagnostics menu, and then navigate to:</p> <p>Printer diagnostics & adjustment > Sensor tests</p> <p>2 Find the following sensors:</p> <ul style="list-style-type: none"> • Sensor (media present in tray1 S1) • Sensor (input sensor S3) • Sensor (fuser exit sensor S4) <p>Does the sensor status change while toggling the sensor?</p>	Go to step 10.	Go to step 8.
<p>Step 8</p> <p>1 Check the sensor flags for proper installation and damage.</p> <p>2 Check the sensor flags for proper alignment with the sensors.</p> <p>3 Check the sensor flag springs for proper installation and damage.</p> <p>Are the sensor flags properly installed and free of damage?</p>	Go to step 10.	Go to step 9.
<p>Step 9</p> <p>Replace the damaged sensor flag.</p> <p>Does the problem remain?</p>	Go to step 10.	The problem is solved.
<p>Step 10</p>	Go to step 12.	Go to step 11.

Diagnostics and Troubleshooting

Action	Yes	No
<p>Check the rear door for proper installation and damage.</p> <p>Is the door properly installed and free of damage?</p>		
<p>Step 11</p> <p>Replace the rear door. See Rear door removal.</p> <p>Does the problem remain?</p>	Go to step 12.	The problem is solved.
<p>Step 12</p> <p>1 Enter Diagnostics menu, and then navigate to:</p> <p>Printer diagnostics & adjustments > Motor tests</p> <p>2 Select Motor (transport drive).</p> <p>3 Open the rear door, and then check if the fuser exit rollers turn.</p> <p>4 Open the fuser access door, and then check if the hot rollers turn.</p> <p>Are the rollers properly working?</p>	Go to step 13.	Go to step 14.
<p>Step 13</p> <p>1 Check the fuser cables for proper connection and damage.</p> <p>2 Check the fuser access door for damage.</p> <p>3 Check if the fuser gears are in proper contact with the drive gears.</p> <p>4 Make sure that the fuser is compatible with the LVPS.</p> <p>5 Check the fuser for proper installation and damage.</p> <p>Is the fuser properly installed and free of damage?</p>	Go to step 15.	Go to step 14.
<p>Step 14</p> <p>Replace the fuser. See Fuser removal.</p> <p>Does the problem remain?</p>	Go to step 15.	The problem is solved.
<p>Step 15</p> <p>Check the cables for proper connection and damage.</p>	Go to step 17.	Go to step 16.

Action	Yes	No
Are the cables properly connected and free of damage?		
Step 16 Replace the damaged cable. Does the problem remain?	Go to step 17.	The problem is solved.
Step 17 1 Enter the Diagnostics menu, and then navigate to: Printer diagnostics & adjustment > Motor tests 2 Select Motor (transport) . 3 Check if the exit roller turns. Did the exit roller turn?	Go to step 20.	Go to step 18.
Step 18 1 Make sure that the redrive gears are in proper contact with the printer drive gears. 2 Check the redrive gears for proper installation and damage. 3 Check the roller for wear, contamination, and damage. Is the redrive properly installed and free of damage?	Go to step 20.	Go to step 19.
Step 19 Replace the redrive. See Redrive removal . Does the problem remain?	Go to step 20.	The problem is solved.
Step 20 1 Enter the Diagnostics menu, and then navigate to: Printer diagnostics & adjustments > Motor tests 2 Select Motor (transport drive) . Did the motor run?	Go to step 21.	Go to step 22.
Step 21 1 Enter the Diagnostics menu, and then navigate to: Input tray quick print > Tray 1 > Single	Go to step 22.	The problem is solved.

Diagnostics and Troubleshooting

Action	Yes	No
<p>2 Enter the Diagnostics menu, and then navigate to:</p> <p>Input tray quick print > Duplex > Single</p> <p>Does the problem remain?</p>		
<p>Step 22</p> <p>1 Make sure that the main drive is properly installed and free of damage.</p> <p>2 Make sure that the main drive gears are properly installed.</p> <p>3 Make sure that the drive gears are in proper contact with the gear they are driving.</p> <p>Does the problem remain?</p>	Go to step 23.	The problem is solved.
<p>Step 23</p> <p>Replace the main drive. See Main drive removal.</p> <p>Does the problem remain?</p>	Go to step 24.	The problem is solved.
<p>Step 24</p> <p>1 Reseat all the cables on the controller board.</p> <p>2 Check if the controller board LED lights up.</p> <p>3 Check the controller board for proper installation and damage.</p> <p>Is the controller board properly installed and free of damage?</p>	Contact the next level of support.	Go to step 25.
<p>Step 25</p> <p>Replace the controller board. See Controller board removal.</p> <p>Does the problem remain?</p>	Contact the next level of support.	The problem is solved.

Sensor (Fuser Exit Sensor S4) Static Jam Service Check

Action	Yes	No
<p>Step 1</p> <ol style="list-style-type: none"> 1 Make sure that the tray insert is properly inserted. 2 Make sure that the paper type and size settings match the paper type and size set on the tray. 3 Make sure that the duplex unit is properly inserted. 4 Make sure that the paper size setting in the duplex unit matches the printer setting. 5 Make sure that the front and rear doors are fully closed. 6 Make sure that the output bin is free from obstructions. <p>Does the problem remain?</p>	Go to step 2.	The problem is solved.
<p>Step 2</p> <ol style="list-style-type: none"> 1 Remove the imaging unit and toner cartridge, and then make sure that the paper path is free of jams and obstructions. 2 Clear all rollers of dirt and contamination. <p>Does the problem remain?</p>	Go to step 3.	The problem is solved.
<p>Step 3</p> <ol style="list-style-type: none"> 1 Perform a POR. 2 Enter the Diagnostics menu, and then navigate to: Input tray quick print > Tray 1 > Single <p>Does the problem remain?</p>	Go to step 4.	The problem is solved.
<p>Step 4</p> <ol style="list-style-type: none"> 1 Enter the Diagnostics menu, and then navigate to: Printer diagnostics & adjustments > Sensor tests 2 Find the sensor (fuser exit sensor S4). <p>Does the sensor status change while toggling the sensor?</p>	Go to step 7.	Go to step 5.
Step 5	Go to step 7.	Go to step 6.

Diagnostics and Troubleshooting

Action	Yes	No
<p>1 Make sure that the fuser exit sensor cable is properly connected and free of damage.</p> <p>2 Make sure that the sensor is properly aligned with the sensor flag.</p> <p>3 Check the sensor for proper installation and damage.</p> <p>Is the sensor properly installed and free of damage?</p>		
<p>Step 6</p> <p>Replace the sensor. See Sensor (fuser exit) removal .</p> <p>Does the problem remain?</p>	Go to step 7.	The problem is solved.
<p>Step 7</p> <p>1 Enter the Diagnostics menu, and then navigate to:</p> <p>Printer diagnostics & adjustment > Sensor tests</p> <p>2 Find the following sensors:</p> <ul style="list-style-type: none"> • Sensor (media present in tray1 S1) • Sensor (input sensor S3) • Sensor (fuser exit sensor S4) <p>Does the sensor status change while toggling the sensor?</p>	Go to step 10.	Go to step 8.
<p>Step 8</p> <p>1 Check the sensor flags for proper installation and damage.</p> <p>2 Check the sensor flags for proper alignment with the sensors.</p> <p>3 Check the sensor flag springs for proper installation and damage.</p> <p>Are the sensor flags properly installed and free of damage?</p>	Go to step 10.	Go to step 9.
<p>Step 9</p> <p>Replace the damaged sensor flag.</p> <p>Does the problem remain?</p>	Go to step 10.	The problem is solved.
<p>Step 10</p>	Go to step 12.	Go to step 11.

Action	Yes	No
<p>Check the cables for proper connection and damage.</p> <p>Are the cables properly connected and free of damage?</p>		
<p>Step 11</p> <p>Replace the damaged cable.</p> <p>Does the problem remain?</p>	Go to step 12.	The problem is solved.
<p>Step 12</p> <ol style="list-style-type: none"> 1 Reseat all the cables on the controller board. 2 Check if the controller board LED lights up. 3 Check the controller board for proper installation and damage. <p>Is the controller board properly installed and free of damage?</p>	Contact the next level of support.	Go to step 13.
<p>Step 13</p> <p>Replace the controller board. See Controller board removal.</p> <p>Does the problem remain?</p>	Contact the next level of support.	The problem is solved.

206 Paper Jams

206 Paper Jam Messages

Error code	Description	Action
206.15	Paper fed from tray remains on the sensor (fuser exit sensor S4).	See Sensor (staging sensor S2): Paper failed to clear service check .
206.16	Paper fed from tray 1 never arrived at the sensor (staging sensor S2).	See Sensor (staging sensor S2): Paper failed to arrive service check .

Sensor (Staging Sensor S2): Paper Failed To Clear Service Check

Action	Yes	No
<p>Step 1</p> <ol style="list-style-type: none"> 1 Make sure that the tray insert is properly inserted. 2 Make sure that the paper type and size settings match the paper type and size set on the tray. 3 Make sure that the duplex unit is properly inserted. 4 Make sure that the paper size setting in the duplex unit matches the printer setting. 5 Make sure that the front and rear doors are fully closed. 6 Make sure that the output bin is free from obstructions. <p>Does the problem remain?</p>	Go to step 2.	The problem is solved.
<p>Step 2</p> <ol style="list-style-type: none"> 1 Remove the imaging unit and toner cartridge, and then make sure that the paper path is free of jams and obstructions. 2 Clear all rollers of dirt and contamination. <p>Does the problem remain?</p>	Go to step 3.	The problem is solved.
<p>Step 3</p> <ol style="list-style-type: none"> 1 Perform a POR. 2 Enter the Diagnostics menu, and then navigate to: Input tray quick print > Tray 1 > Single <p>Does the problem remain?</p>	Go to step 4.	The problem is solved.
<p>Step 4</p> <ol style="list-style-type: none"> 1 Reseat the sensor cable. 2 Enter the Diagnostics menu, and then navigate to: Printer diagnostics & adjustments > Sensor tests 3 Find the sensor (staging sensor S2). <p>Does the sensor status change while toggling the sensor?</p>	Go to step 7.	Go to step 5.
Step 5	Go to step 7.	Go to step 6.

Action	Yes	No
<p>1 Check the sensor for proper installation and damage.</p> <p>2 Check the alignment with the sensor flag.</p> <p>3 Check the sensor cable for proper connection and damage.</p> <p>Is the sensor properly installed and free of damage?</p>		
<p>Step 6</p> <p>Replace the sensor.</p> <p>Does the problem remain?</p>	Go to step 7.	The problem is solved.
<p>Step 7</p> <p>1 Enter the Diagnostics menu, and then navigate to:</p> <p>Printer diagnostics & adjustment > Sensor tests</p> <p>2 Find the following sensors:</p> <ul style="list-style-type: none"> • Sensor (media present in tray1 S1) • Sensor (input sensor S3) • Sensor (fuser exit sensor S4) <p>Does the sensor status change while toggling the sensor?</p>	Go to step 10.	Go to step 8.
<p>Step 8</p> <p>1 Check the sensor flags for proper installation and damage.</p> <p>2 Check the sensor flags for proper alignment with the sensors.</p> <p>3 Check the sensor flag springs for proper installation and damage.</p> <p>Are the sensor flags properly installed and free of damage?</p>	Go to step 10.	Go to step 9.
<p>Step 9</p> <p>Replace the damaged sensor flag.</p> <p>Does the problem remain?</p>	Go to step 10.	The problem is solved.
<p>Step 10</p> <p>Check the cables for proper connection and damage.</p>	Go to step 12.	Go to step 11.

Diagnostics and Troubleshooting

Action	Yes	No
Are the cables properly connected and free of damage?		
Step 11 Replace the damaged cable. Does the problem remain?	Go to step 12.	The problem is solved.
Step 12 1 Enter the Diagnostics menu, and then navigate to: Input tray quick print > Tray 1 > Single 2 Check if the clip in the middle of the solenoid turns when the paper is transported. Did the clip turn?	Go to step 14.	Go to step 13.
Step 13 Reseat the deskew solenoid cable at both ends. Does the problem remain?	Contact the next level of support.	The problem is solved.
Step 14 1 Enter the Diagnostics menu, and then navigate to: Printer diagnostics & adjustments > Motor tests 2 Select Motor (transport drive) . Did the motor run?	Go to step 15.	Go to step 16.
Step 15 1 Enter the Diagnostics menu, and then navigate to: Input tray quick print > Tray 1 > Single 2 Enter the Diagnostics menu, and then navigate to: Input tray quick print > Duplex > Single Does the problem remain?	Go to step 16.	The problem is solved.
Step 16 1 Make sure that the main drive is properly installed and free of damage.	Go to step 17.	The problem is solved.

Action	Yes	No
<p>2 Make sure that the main drive gears are properly installed.</p> <p>3 Make sure that the drive gears are in proper contact with the gear they are driving.</p> <p>Does the problem remain?</p>		
<p>Step 17</p> <p>Replace the main drive. See Main drive removal.</p> <p>Does the problem remain?</p>	Go to step 18.	The problem is solved.
<p>Step 18</p> <p>1 Reseat all the cables on the controller board.</p> <p>2 Check if the controller board LED lights up.</p> <p>3 Check the controller board for proper installation and damage.</p> <p>Is the controller board properly installed and free of damage?</p>	Contact the next level of support.	Go to step 19.
<p>Step 19</p> <p>Replace the controller board. See Controller board removal.</p> <p>Does the problem remain?</p>	Contact the next level of support.	The problem is solved.

Sensor (Staging Sensor S2): Paper Failed To Arrive Service Check

Action	Yes	No
<p>Step 1</p> <ol style="list-style-type: none"> 1 Make sure that the tray insert is properly inserted. 2 Make sure that the paper type and size settings match the paper type and size set on the tray. 3 Make sure that the duplex unit is properly inserted. 4 Make sure that the paper size setting in the duplex unit matches the printer setting. 5 Make sure that the front and rear doors are fully closed. 6 Make sure that the output bin is free from obstructions. <p>Does the problem remain?</p>	Go to step 2.	The problem is solved.
<p>Step 2</p> <ol style="list-style-type: none"> 1 Remove the imaging unit and toner cartridge, and then make sure that the paper path is free of jams and obstructions. 2 Clear all rollers of dirt and contamination. <p>Does the problem remain?</p>	Go to step 3.	The problem is solved.
<p>Step 3</p> <ol style="list-style-type: none"> 1 Perform a POR. 2 Enter the Diagnostics menu, and then navigate to: Input tray quick print > Tray 1 > Single <p>Does the problem remain?</p>	Go to step 4.	The problem is solved.
<p>Step 4</p> <ol style="list-style-type: none"> 1 Reseat the sensor cable. 2 Enter the Diagnostics menu, and then navigate to: Printer diagnostics & adjustments > Sensor tests 3 Find the sensor (staging sensor S2). <p>Does the sensor status change while toggling the sensor?</p>	Go to step 7.	Go to step 5.
Step 5	Go to step 7.	Go to step 6.

Action	Yes	No
<p>1 Check the sensor for proper installation and damage.</p> <p>2 Check the alignment with the sensor flag.</p> <p>3 Check the sensor cable for proper connection and damage.</p> <p>Is the sensor properly installed and free of damage?</p>		
<p>Step 6</p> <p>Replace the sensor.</p> <p>Does the problem remain?</p>	Go to step 7.	The problem is solved.
<p>Step 7</p> <p>1 Enter the Diagnostics menu, and then navigate to:</p> <p>Printer diagnostics & adjustment > Sensor tests</p> <p>2 Find the following sensors:</p> <ul style="list-style-type: none"> • Sensor (media present in tray1 S1) • Sensor (input sensor S3) • Sensor (fuser exit sensor S4) <p>Does the sensor status change while toggling the sensor?</p>	Go to step 10.	Go to step 8.
<p>Step 8</p> <p>1 Check the sensor flags for proper installation and damage.</p> <p>2 Check the sensor flags for proper alignment with the sensors.</p> <p>3 Check the sensor flag springs for proper installation and damage.</p> <p>Are the sensor flags properly installed and free of damage?</p>	Go to step 10.	Go to step 9.
<p>Step 9</p> <p>Replace the damaged sensor flag.</p> <p>Does the problem remain?</p>	Go to step 10.	The problem is solved.
<p>Step 10</p> <p>Check the cables for proper connection and damage.</p>	Go to step 12.	Go to step 11.

Diagnostics and Troubleshooting

Action	Yes	No
Are the cables properly connected and free of damage?		
Step 11 Replace the damaged cable. Does the problem remain?	Go to step 12.	The problem is solved.
Step 12 1 Clear the pick rollers of contamination. 2 Reseat the pick rollers. 3 Enter the Diagnostics menu, and then navigate to: Input tray quick print > Tray 1 > Single. Does the problem remain?	Go to step 13.	The problem is solved.
Step 13 1 Check the pick rollers for proper installation and damage. 2 Check the shaft of the pick rollers for damage. Are the pick roller properly installed and free of damage?	Go to step 15.	Go to step 14.
Step 14 Replace the pick rollers. See Pick rollers removal . Does the problem remain?	Go to step 15.	The problem is solved.
Step 15 1 Reseat the pick solenoid cable. 2 Enter the Diagnostics menu, and then navigate to: Printer diagnostics & adjustments > Motor tests 3 Select Feed solenoid . 4 Check if the pick solenoid actuates. Did the pick solenoid actuate?	Go to step 18.	Go to step 16.
Step 16 Check the pick solenoid for proper installation and damage. Is the pick solenoid properly installed and free of damage?	Go to step 18.	Go to step 17.

Action	Yes	No
<p>Step 17</p> <p>Replace the pick solenoid. See Pick solenoid removal.</p> <p>Does the problem remain?</p>	Go to step 18.	The problem is solved.
<p>Step 18</p> <p>1 Enter the Diagnostics menu, and then navigate to:</p> <p>Printer diagnostics & adjustments > Motor tests</p> <p>2 Select Motor (transport drive).</p> <p>Did the motor run?</p>	Go to step 19.	Go to step 20.
<p>Step 19</p> <p>1 Enter the Diagnostics menu, and then navigate to:</p> <p>Input tray quick print > Tray 1 > Single</p> <p>2 Enter the Diagnostics menu, and then navigate to:</p> <p>Input tray quick print > Duplex > Single</p> <p>Does the problem remain?</p>	Go to step 20.	The problem is solved.
<p>Step 20</p> <p>1 Make sure that the main drive is properly installed and free of damage.</p> <p>2 Make sure that the main drive gears are properly installed.</p> <p>3 Make sure that the drive gears are in proper contact with the gear they are driving.</p> <p>Does the problem remain?</p>	Go to step 21.	The problem is solved.
<p>Step 21</p> <p>Replace the main drive. See Main drive removal.</p> <p>Does the problem remain?</p>	Go to step 22.	The problem is solved.

Action	Yes	No
<p>Step 22</p> <ol style="list-style-type: none"> 1 Reseat all the cables on the controller board. 2 Check if the controller board LED lights up. 3 Check the controller board for proper installation and damage. <p>Is the controller board properly installed and free of damage?</p>	Contact the next level of support.	Go to step 23.
<p>Step 23</p> <p>Replace the controller board. See Controller board removal.</p> <p>Does the problem remain?</p>	Contact the next level of support.	The problem is solved.

232 Paper Jams

232 Paper Jam Messages

Error code	Description	Action
232.13	Paper fed from tray 1 never arrived at the sensor (input sensor S3) during a duplex print job.	See Sensor (input sensor S3): Duplex failure service check .
232.15	Paper fed from tray 1 never cleared the sensor (input sensor S3) during a duplex print job.	

Sensor (Input Sensor S3): Duplex Failure Service Check

Action	Yes	No
<p>Step 1</p> <ol style="list-style-type: none"> 1 Make sure that the tray insert is properly inserted. 2 Make sure that the paper type and size settings match the paper type and size set on the tray. 3 Make sure that the duplex unit is properly inserted. 4 Make sure that the paper size setting in the duplex unit matches the printer setting. 5 Make sure that the front and rear doors are fully closed. 6 Make sure that the output bin is free from obstructions. <p>Does the problem remain?</p>	Go to step 2.	The problem is solved.
<p>Step 2</p> <ol style="list-style-type: none"> 1 Remove the imaging unit and toner cartridge, and then make sure that the paper path is free of jams and obstructions. 2 Clear all rollers of dirt and contamination. <p>Does the problem remain?</p>	Go to step 3.	The problem is solved.
<p>Step 3</p> <ol style="list-style-type: none"> 1 Perform a POR. 2 Enter the Diagnostics menu, and then navigate to: Input tray quick print > Tray 1 > Single <p>Does the problem remain?</p>	Go to step 4.	The problem is solved.
<p>Step 4</p> <ol style="list-style-type: none"> 1 Reseat the sensor cable. 2 Enter the Diagnostics menu, and then navigate to: Printer diagnostics & adjustments > Sensor tests 3 Find the sensor (staging sensor S2). <p>Does the sensor status change while toggling the sensor?</p>	Go to step 7.	Go to step 5.
Step 5	Go to step 7.	Go to step 6.

Diagnostics and Troubleshooting

Action	Yes	No
<ol style="list-style-type: none"> 1 Check the sensor for proper installation and damage. 2 Check the alignment with the sensor flag. 3 Check the sensor cable for proper connection and damage. <p>Is the sensor properly installed and free of damage?</p>		
<p>Step 6</p> <p>Replace the sensor.</p> <p>Does the problem remain?</p>	Go to step 7.	The problem is solved.
<p>Step 7</p> <ol style="list-style-type: none"> 1 Enter the Diagnostics menu, and then navigate to: Printer diagnostics & adjustment > Sensor tests 2 Find the following sensors: <ul style="list-style-type: none"> • Sensor (media present in tray1 S1) • Sensor (input sensor S3) • Sensor (fuser exit sensor S4) <p>Does the sensor status change while toggling the sensor?</p>	Go to step 10.	Go to step 8.
<p>Step 8</p> <ol style="list-style-type: none"> 1 Check the sensor flags for proper installation and damage. 2 Check the sensor flags for proper alignment with the sensors. 3 Check the sensor flag springs for proper installation and damage. <p>Are the sensor flags properly installed and free of damage?</p>	Go to step 10.	Go to step 9.
<p>Step 9</p> <p>Replace the damaged sensor flag.</p> <p>Does the problem remain?</p>	Go to step 10.	The problem is solved.
<p>Step 10</p> <ol style="list-style-type: none"> 1 Enter the Diagnostics menu, and then navigate to: 	Go to step 12.	Go to step 11.

Action	Yes	No
<p>Input tray quick print > Tray 1 > Single</p> <p>2 Check if the clip in the middle of the solenoid turns when the paper is transported.</p> <p>Did the clip turn?</p>		
<p>Step 11</p> <p>Reseat the deskew solenoid cable at both ends.</p> <p>Does the problem remain?</p>	Contact the next level of support.	The problem is solved.
<p>Step 12</p> <p>1 Clear the duplex paper path of obstructions.</p> <p>2 Load the correct paper in the tray.</p> <p>3 Make sure that the paper size setting in the duplex unit matches the paper loaded in the tray.</p> <p>4 Enter the Diagnostics menu, and then navigate to:</p> <p>Input tray quick print > Tray 1 > Duplex</p> <p>Does the problem remain?</p>	Go to step 13.	The problem is solved.
<p>Step 13</p> <p>1 Reseat the duplex unit.</p> <p>2 Check the duplex unit gears for damage.</p> <p>3 Check the rollers and belts for wear and contamination.</p> <p>Is the duplex unit properly installed and free of damage?</p>	Go to step 15.	Go to step 14.
<p>Step 14</p> <p>Replace the duplex unit.</p> <p>Does the problem remain?</p>	Go to step 15.	The problem is solved.
<p>Step 15</p> <p>Check the cables for proper connection and damage.</p> <p>Are the cables properly connected and free of damage?</p>	Go to step 17.	Go to step 16.
<p>Step 16</p>	Go to step 17.	The problem is solved.

Diagnostics and Troubleshooting

Action	Yes	No
<p>Replace the damaged cable.</p> <p>Does the problem remain?</p>		
<p>Step 17</p> <p>1 Enter the Diagnostics menu, and then navigate to:</p> <p>Printer diagnostics & adjustments > Motor tests</p> <p>2 Select Motor (transport drive).</p> <p>Did the motor run?</p>	Go to step 18.	Go to step 19.
<p>Step 18</p> <p>1 Enter the Diagnostics menu, and then navigate to:</p> <p>Input tray quick print > Tray 1 > Single</p> <p>2 Enter the Diagnostics menu, and then navigate to:</p> <p>Input tray quick print > Duplex > Single</p> <p>Does the problem remain?</p>	Go to step 19.	The problem is solved.
<p>Step 19</p> <p>1 Make sure that the main drive is properly installed and free of damage.</p> <p>2 Make sure that the main drive gears are properly installed.</p> <p>3 Make sure that the drive gears are in proper contact with the gear they are driving.</p> <p>Does the problem remain?</p>	Go to step 20.	The problem is solved.
<p>Step 20</p> <p>Replace the main drive. See Main drive removal.</p> <p>Does the problem remain?</p>	Go to step 21.	The problem is solved.

Action	Yes	No
<p>Step 21</p> <ol style="list-style-type: none"> 1 Reseat all the cables on the controller board. 2 Check if the controller board LED lights up. 3 Check the controller board for proper installation and damage. <p>Is the controller board properly installed and free of damage?</p>	Contact the next level of support.	Go to step 22.
<p>Step 22</p> <p>Replace the controller board. See Controller board removal.</p> <p>Does the problem remain?</p>	Contact the next level of support.	The problem is solved.

User Attendance Messages

Non-Xerox Supply

The printer has detected a non-Xerox supply or part installed in the printer.

The Xerox printer is designed to function best with genuine Xerox supplies and parts. Use of third-party supplies or parts may affect the performance, reliability, or life of the printer and its imaging components.

All life indicators are designed to function with Xerox supplies and parts and may deliver unpredictable results if third-party supplies or parts are used. Imaging component usage beyond the intended life may damage the Xerox printer or associated components.

 **Warning:** Use of third-party supplies or parts can affect warranty coverage. Damage caused by the use of third-party supplies or parts may not be covered by the warranty.

If a customer accepts any and all of these risks and proceeds with the use of non-genuine supplies or parts in the printer, then instruct the customer to press and hold **X** and **#** simultaneously from the control panel for 15 seconds. Do not perform this action yourself.

If a customer does not want to accept these risks, then remove the third-party supply or part from the printer and install a genuine Xerox supply or part.

If the printer does not print after pressing and holding **X** and **#** simultaneously for 15 seconds, then instruct the customer to reset the supply usage counter.

1. From the control panel, navigate to:

Settings > Device > Maintenance > Config Menu > Supply Usage And Counters

2. Select the part or supply to reset.

3. Read the warning message, and then select **Continue**.

4. Press and hold **X** and **#** simultaneously for 15 seconds to clear the message.

 **Note:** If the customer is unable to reset the supply usage counters, then the customer must return the item to the place of purchase.

 **Warning:** Supplies and parts without Return Program agreement terms may be reset and remanufactured.

Metered Supply Installed in Printer Configured For Sold

The printer has detected a metered supply installed in the printer configured to use sold supply.

The printers ship with worldwide neutral toner cartridges. Initial installation of these cartridges sets the printer to worldwide neutral configuration. The first toner cartridge replacement sets the geographic differentiation code and toner cartridge type in NVM to that of the replacement cartridge. To change these NVM, a supplies plan conversion code (non-PagePack) or activation code (PagePack) code is required.

See [supplies to resolve print quality issues](#) for part numbers.

If an incorrect type of toner cartridge is installed, an error code is generated indicating toner incompatibility.

Changing The Service Plan (Non-PagePack)

Contact the relevant OpCo to obtain a conversion code:

- **US:** Provide the printer Serial Number and Total Meter Read using the email template provided in Eureka Tip 1465823. A conversion PIN code is provided within 10 minutes. For any service plan conversion issues or special requests, phone Xerox Corporate Licensing Systems (XDSS), 1-800-890-3260.
- **Xerox Business Solutions (XBS):** All requests for service plan conversions must be approved by the XBS VP of Service. Request your field service manager to contact your XBS company VP of Service for direction. The XBS Core Company VP of Service will require authorization to convert the printer from sold to metered, and will provide a status of your request. Do not phone Field Engineering to request a conversion code.
- **US Authorized Service Provider (ASP):** Provide the printer Serial Number and Total Meter Read using the email template provided in Eureka Tip 1465823. A conversion PIN code is provided within 10 minutes. For any service plan conversion issues or special requests, phone Xerox Corporate Licensing Systems (XDSS), 1-800-890-3260.
- **Canada:** Provide the printer Serial Number and Total Meter Read using the email template provided in Eureka Tip 1465823. A conversion PIN code is provided within 10 minutes. For any service plan conversion issues or special requests, phone Customer Delivery Organization (CDO) field support, 1-800-647-1331.

 **Note:** The service plan conversion code must be entered within 500 Total Impression counts. If this count is exceeded, a new code is required.

Using The Control Panel

1. From the control panel, navigate to **Settings > Supplies Plan > Plan Conversion**.
2. Record the **Total Impressions** and **Device Serial Number**.
3. Contact the relevant OpCo to obtain the conversion code.
4. After receiving the conversion code, on the control panel, navigate to **Supplies Plan > Plan Conversion > Conversion Code**.

5. Enter the conversion code provided, then select **Convert Plan**.
6. Navigate to **Supplies Plan > Plan Conversion > Current Plan** to confirm the conversion is successful.

Using The Embedded Web Server

1. Open a web browser, and then type the printer IP address. If necessary, ask the customer to enter the Admin password.
2. From the home page, navigate to **Settings > Supplies Plan > Plan Conversion**.
3. Record the **Total Impressions** and **Device Serial Number**.
4. Contact the relevant OpCo to obtain the conversion code.
5. After receiving the conversion code, on the embedded web server, navigate to **Settings > Supplies Plan > Plan Conversion > Conversion Code**.
6. Enter the conversion code provided, then click **Convert Plan**.
7. Check the **Current Plan** status to confirm the conversion is successful.

Changing The Service Plan (PagePack)

Contact the relevant OpCo to obtain an activation code. Provide the Sequence Number and Device Serial Number.

- **EMEA (XE):** Email office.europe.page.pack.pin@xerox.com
- **EMEA (DMO-E):** Follow your local process.
- **LATAM (Latin America):** Follow your local process.



Note: The service plan activation code must be entered within 1000 Total Impression counts. If this count is exceeded, a new code is required.

Using The Control Panel

1. From the control panel, navigate to **Supplies Plan > Plan Activation**.
2. Record the **Sequence Number** and **Device Serial Number**.
3. Contact the relevant OpCo to obtain the activation code.
4. After receiving the activation code, on the control panel, navigate to **Settings > Supplies Plan > Plan Activation > Activation Code**.
5. Enter the activation code provided, then select **Activate Plan**.

Using The Embedded Web Server

1. Open a web browser, and then type the printer IP address. If necessary, ask the customer to enter the Admin password.
2. From the home page, navigate to **Settings > Supplies Plan > Plan Activation**.
3. Record the **Sequence Number** and **Device Serial Number**.

4. Contact the relevant OpCo to obtain the activation code.
5. After receiving the activation code, on the embedded web server, navigate to **Settings > Supplies Plan > Plan Activation > Activation Code**.
6. Enter the activation code provided, then click **Activate Plan**.

8–12 User Attendance Messages

8–12 User Attendance Messages

Error code	Description	Action
8.01	Close the door, cover, or latch at location A.	See Door switch service check .
8.02	Close the door, cover, or latch at location B.	
9	Auto reboot.	See Auto reboot service check .
11.1	Load tray 1.	See Load tray 1 with A4 plain paper service check .
11.8	Load the manual feeder.	See Manual feeder service check .
12.1	Change the paper in tray 1.	See Load tray 1 with A4 plain paper service check .
12.8	Change the paper in the manual feeder.	See Manual feeder service check .

Manual Feeder Service Check

Action	Yes	No
Step 1 Make sure that the imaging unit and toner cartridge are genuine Xerox supplies. Does the problem remain?	Go to step 2.	The problem is solved.
Step 2 1 Shake the toner cartridge. 2 Clean the toner cartridge smart chip contacts, and then check the contacts for damage. 3 Clean the toner cartridge spring contacts, and then check the contacts for damage. 4 Perform a print test. Does the problem remain?	Go to step 3.	The problem is solved.

Diagnostics and Troubleshooting

Action	Yes	No
<p>Step 3</p> <p>Replace the toner cartridge.</p> <p>Does the problem remain?</p>	Go to step 4.	The problem is solved.
<p>Step 4</p> <ol style="list-style-type: none"> 1 Shake the imaging unit. 2 Clean the imaging unit smart chip contacts, and then check the contacts for damage. 3 Clean the imaging unit spring contacts, and then check the contacts for damage. 4 Perform a print test. <p>Does the problem remain?</p>	Go to step 5.	The problem is solved.
<p>Step 5</p> <p>Check the smart chip for proper installation and damage.</p> <p>Is the smart chip properly installed and free of damage?</p>	Go to step 7.	Go to step 6.
<p>Step 6</p> <p>Replace the imaging unit.</p> <p>Does the problem remain?</p>	Go to step 7.	The problem is solved.
<p>Step 7</p> <ol style="list-style-type: none"> 1 From the control panel, navigate to Settings > Reports > Device > Device statistics. 2 Check if the install date reflects the date that you replaced the cartridge. 3 Check the supply level of the toner cartridge. 4 Check the supply level of the imaging unit. <p>Is there sufficient supply level, and does the install date reflect the cartridge replacement date?</p>	Go to step 8.	Go to step 10.
<p>Step 8</p> <p>Check the cables for proper connection and damage.</p> <p>Are the cables properly connected and free of damage?</p>	Go to step 10.	Go to step 9.
<p>Step 9</p> <p>Replace the damaged cable.</p>	Go to step 10.	The problem is solved.

Action	Yes	No
Does the problem remain?		
Step 10 1 Reseat all the cables on the controller board. 2 Check if the controller board LED lights up. 3 Check the controller board for proper installation and damage. Is the controller board properly installed and free of damage?	Contact the next level of support.	Go to step 11.
Step 11 Replace the controller board. See Controller board removal . Does the problem remain?	Contact the next level of support.	The problem is solved.

Auto Reboot Service Check

Action	Yes	No
Step 1 1 Turn off the printer. 2 Unplug the power cord. 3 Wait for 10 seconds, and then plug the power cord. 4 Turn on the printer. Does the problem remain?	Go to step 2.	The problem is solved.
Step 2 1 Upgrade the firmware. 2 Perform a POR. 3 Perform a print test. Does the problem remain?	Go to step 3.	The problem is solved.
Step 3 Check the cables for proper connection and damage. Are the cables properly connected and free of damage?	Go to step 5.	Go to step 4.
Step 4 Replace the damaged cable. Does the problem remain?	Go to step 5.	The problem is solved.

Action	Yes	No
<p>Step 5</p> <ol style="list-style-type: none"> 1 Reseat all the cables on the controller board. 2 Check if the controller board LED lights up. 3 Check the controller board for proper installation and damage. <p>Is the controller board properly installed and free of damage?</p>	Contact the next level of support.	Go to step 6.
<p>Step 6</p> <p>Replace the controller board. See Controller board removal.</p> <p>Does the problem remain?</p>	Contact the next level of support.	The problem is solved.

31–33 User Attendance Messages

31–33 User Attendance Messages

Error code	Description	Action
31.40	Missing black toner cartridge.	See Photoconductor and toner cartridge service check .
32.40	Unsupported toner cartridge.	See Unsupported imaging unit or toner cartridge service check .
32.40J	Metered toner cartridge installed in printer configured for Sold.	See Metered supply installed in printer configured for sold .
32.60	Unsupported imaging unit.	See Unsupported imaging unit or toner cartridge service check .
33	Non-Xerox Return Program (NLRP) codes.	See Photoconductor and toner cartridge service check .

Photoconductor and Toner Cartridge Service Check

Action	Yes	No
Step 1 Make sure that the imaging unit and toner cartridge are genuine Xerox supplies. Does the problem remain?	Go to step 2.	The problem is solved.
Step 2 1 Shake the toner cartridge. 2 Clean the toner cartridge smart chip contacts, and then check the contacts for damage. 3 Clean the toner cartridge spring contacts, and then check the contacts for damage. 4 Perform a print test. Does the problem remain?	Go to step 3.	The problem is solved.
Step 3 Replace the toner cartridge. Does the problem remain?	Go to step 4.	The problem is solved.
Step 4 1 Shake the imaging unit. 2 Clean the imaging unit smart chip contacts, and then check the contacts for damage. 3 Clean the imaging unit spring contacts, and then check the contacts for damage. 4 Perform a print test. Does the problem remain?	Go to step 5.	The problem is solved.
Step 5 Check the smart chip for proper installation and damage. Is the smart chip properly installed and free of damage?	Go to step 7.	Go to step 6.
Step 6 Replace the imaging unit. Does the problem remain?	Go to step 7.	The problem is solved.
Step 7 1 From the control panel, navigate to Settings > Reports > Device > Device statistics .	Go to step 8.	Go to step 10.

Diagnostics and Troubleshooting

Action	Yes	No
<p>2 Check if the install date reflects the date that you replaced the cartridge.</p> <p>3 Check the supply level of the toner cartridge.</p> <p>4 Check the supply level of the imaging unit.</p> <p>Is there sufficient supply level, and does the install date reflect the cartridge replacement date?</p>		
<p>Step 8</p> <p>Check the cables for proper connection and damage.</p> <p>Are the cables properly connected and free of damage?</p>	Go to step 10.	Go to step 9.
<p>Step 9</p> <p>Replace the damaged cable.</p> <p>Does the problem remain?</p>	Go to step 10.	The problem is solved.
<p>Step 10</p> <p>1 Reseat all the cables on the controller board.</p> <p>2 Check if the controller board LED lights up.</p> <p>3 Check the controller board for proper installation and damage.</p> <p>Is the controller board properly installed and free of damage?</p>	Contact the next level of support.	Go to step 11.
<p>Step 11</p> <p>Replace the controller board. See Controller board removal.</p> <p>Does the problem remain?</p>	Contact the next level of support.	The problem is solved.

Black Imaging Unit, Photoconductor Smart Chip, or Sensor Problem Service Check

Action	Yes	No
Step 1 1 Open the front door. 2 Reseat the imaging unit and toner cartridge. 3 Close the front door. Does the problem remain?	Go to step 2.	The problem is solved.
Step 2 1 Shake the toner cartridge. 2 Clean the toner cartridge smart chip contacts, and then check the contacts for damage. 3 Clean the toner cartridge spring contacts, and then check the contacts for damage. 4 Perform a print test. Does the problem remain?	Go to step 3.	The problem is solved.
Step 3 Replace the toner cartridge. Does the problem remain?	Go to step 4.	The problem is solved.
Step 4 1 Shake the imaging unit. 2 Clean the imaging unit smart chip contacts, and then check the contacts for damage. 3 Clean the imaging unit spring contacts, and then check the contacts for damage. 4 Perform a print test. Does the problem remain?	Go to step 5.	The problem is solved.
Step 5 Check the smart chip for proper installation and damage. Is the smart chip properly installed and free of damage?	Go to step 7.	Go to step 6.
Step 6 Replace the imaging unit. Does the problem remain?	Go to step 7.	The problem is solved.
Step 7	Go to step 9.	Go to step 8.

Diagnostics and Troubleshooting

Action	Yes	No
<p>1 Check the front door for proper installation and damage.</p> <p>2 Check the front door flag for damage.</p> <p>3 Check the front door hinge for damage.</p> <p>4 Check if the front door properly closes.</p> <p>Is the front door properly installed and free of damage?</p>		
<p>Step 8</p> <p>Replace the front door. See Front door removal.</p> <p>Does the problem remain?</p>	Go to step 9.	The problem is solved.
<p>Step 9</p> <p>Check the front door link for proper installation and damage.</p> <p>Is the front door link properly installed and free of damage?</p>	Go to step 11.	Go to step 10.
<p>Step 10</p> <p>Replace the printer.</p> <p>Does the problem remain?</p>	Go to step 11.	The problem is solved.
<p>Step 11</p> <p>Check the cables for proper connection and damage.</p> <p>Are the cables properly connected and free of damage?</p>	Go to step 13.	Go to step 12.
<p>Step 12</p> <p>Replace the damaged cable.</p> <p>Does the problem remain?</p>	Go to step 13.	The problem is solved.

Action	Yes	No
Step 13 1 Reseat all the cables on the controller board. 2 Check if the controller board LED lights up. 3 Check the controller board for proper installation and damage. Is the controller board properly installed and free of damage?	Contact the next level of support.	Go to step 14.
Step 14 Replace the controller board. See Controller board removal . Does the problem remain?	Contact the next level of support.	The problem is solved.

Unsupported Imaging Unit or Toner Cartridge Service Check

Action	Yes	No
Step 1 Make sure that the imaging unit and toner cartridge are genuine Xerox supplies. Does the problem remain?	Go to step 2.	The problem is solved.
Step 2 1 Shake the toner cartridge. 2 Clean the toner cartridge smart chip contacts, and then check the contacts for damage. 3 Clean the toner cartridge spring contacts, and then check the contacts for damage. 4 Perform a print test. Does the problem remain?	Go to step 3.	The problem is solved.
Step 3 Replace the toner cartridge. Does the problem remain?	Go to step 4.	The problem is solved.
Step 4 1 Shake the imaging unit. 2 Clean the imaging unit smart chip contacts, and then check the contacts for damage.	Go to step 5.	The problem is solved.

Diagnostics and Troubleshooting

Action	Yes	No
<p>3 Clean the imaging unit spring contacts, and then check the contacts for damage.</p> <p>4 Perform a print test.</p> <p>Does the problem remain?</p>		
<p>Step 5</p> <p>Check the smart chip for proper installation and damage.</p> <p>Is the smart chip properly installed and free of damage?</p>	Go to step 7.	Go to step 6.
<p>Step 6</p> <p>Replace the imaging unit.</p> <p>Does the problem remain?</p>	Go to step 7.	The problem is solved.
<p>Step 7</p> <p>Check the cables for proper connection and damage.</p> <p>Are the cables properly connected and free of damage?</p>	Go to step 9.	Go to step 8.
<p>Step 8</p> <p>Replace the damaged cable.</p> <p>Does the problem remain?</p>	Go to step 9.	The problem is solved.
<p>Step 9</p> <p>1 Reseat all the cables on the controller board.</p> <p>2 Check if the controller board LED lights up.</p> <p>3 Check the controller board for proper installation and damage.</p> <p>Is the controller board properly installed and free of damage?</p>	Contact the next level of support.	Go to step 10.
<p>Step 10</p> <p>Replace the controller board. See Controller board removal.</p> <p>Does the problem remain?</p>	Contact the next level of support.	The problem is solved.

34–42 User Attendance Messages

34–42 User Attendance Messages

Error code	Description	Action
34	Paper size mismatch (too short or too narrow).	See Load tray 1 with A4 plain paper service check .
37.1	Insufficient collation area.	See Scanner Collation Area Service Check .
37.3	Insufficient memory.	See Insufficient Memory Service Check .
38.1	Memory is full.	
39.1	Complex page.	
41.60	Toner cartridge and imaging unit mismatch.	See Unsupported imaging unit or toner cartridge service check .
42.xy	Toner cartridge region does not match the printer region. <ul style="list-style-type: none"> x = printer region y = toner cartridge region 	See Toner Cartridge Service Check .

Scanner Collation Area Service Check

Action	Yes	No
Step 1 Close all held jobs. Does the problem remain?	Go to step 2.	The problem is solved.
Step 2 1 Turn off the printer. 2 Unplug the power cord. 3 Wait for 10 seconds, and then plug the power cord. 4 Turn on the printer. Does the problem remain?	Go to step 3.	The problem is solved.
Step 3 Resend a print job or a scan job. Does the problem remain?	Go to step 4.	The problem is solved.
Step 4 1 Perform a print test. 2 Perform a copy job. Does the problem remain?	Go to step 5.	The problem is solved.

Action	Yes	No
Step 5 Reduce the number of pages to scan. Does the problem remain?	Go to step 6.	The problem is solved.
Step 6 Check if the error occurs on documents with text, graphics, or images. Did the error occur?	Go to step 7.	The problem is solved.
Step 7 Change the source document. Does the problem remain?	Go to step 8.	The problem is solved.
Step 8 1 Upgrade the firmware. 2 Perform a POR. 3 Perform a print test. Does the problem remain?	Go to step 9.	The problem is solved.
Step 9 1 Reseat all the cables on the controller board. 2 Check if the controller board LED lights up. 3 Check the controller board for proper installation and damage. Is the controller board properly installed and free of damage?	Contact the next level of support.	Go to step 10.
Step 10 Replace the controller board. See Controller board removal . Does the problem remain?	Contact the next level of support.	The problem is solved.

Insufficient Memory Service Check

Action	Yes	No
Step 1 Close all held jobs. Does the problem remain?	Go to step 2.	The problem is solved.
Step 2	Go to step 3.	The problem is solved.

Action	Yes	No
<ol style="list-style-type: none"> 1 Turn off the printer. 2 Unplug the power cord. 3 Wait for 10 seconds, and then plug the power cord. 4 Turn on the printer. Does the problem remain?		
Step 3 Resend a print job or a scan job. Does the problem remain?	Go to step 4.	The problem is solved.
Step 4 <ol style="list-style-type: none"> 1 Reduce the number of pages to print. 2 Reduce the file size of the print job. Does the problem remain?	Go to step 5.	The problem is solved.
Step 5 <ol style="list-style-type: none"> 1 Upgrade the firmware. 2 Perform a POR. 3 Perform a print test. Does the problem remain?	Go to step 6.	The problem is solved.
Step 6 <ol style="list-style-type: none"> 1 Reseat all the cables on the controller board. 2 Check if the controller board LED lights up. 3 Check the controller board for proper installation and damage. Is the controller board properly installed and free of damage?	Contact the next level of support.	Go to step 7.
Step 7 Replace the controller board. See Controller board removal . Does the problem remain?	Contact the next level of support.	The problem is solved.

Toner Cartridge Service Check

Action	Yes	No
<p>Step 1</p> <p>Make sure that the imaging unit and toner cartridge are genuine Xerox supplies.</p> <p>Does the problem remain?</p>	Go to step 2.	The problem is solved.
<p>Step 2</p> <ol style="list-style-type: none"> 1 Shake the toner cartridge. 2 Clean the toner cartridge smart chip contacts, and then check the contacts for damage. 3 Clean the toner cartridge spring contacts, and then check the contacts for damage. 4 Perform a print test. <p>Does the problem remain?</p>	Go to step 3.	The problem is solved.
<p>Step 3</p> <p>Replace the toner cartridge.</p> <p>Does the problem remain?</p>	Go to step 4.	The problem is solved.
<p>Step 4</p> <ol style="list-style-type: none"> 1 From the control panel, navigate to Settings > Reports > Device > Device statistics. 2 Check if the install date reflects the date that you replaced the cartridge. 3 Check the supply level of the toner cartridge. 4 Check the supply level of the imaging unit. <p>Is there sufficient supply level, and does the install date reflect the cartridge replacement date?</p>	Go to step 5.	Go to step 7.
<p>Step 5</p> <p>Check the cables for proper connection and damage.</p> <p>Are the cables properly connected and free of damage?</p>	Go to step 7.	Go to step 6.
<p>Step 6</p> <p>Replace the damaged cable.</p> <p>Does the problem remain?</p>	Go to step 7.	The problem is solved.

Action	Yes	No
Step 7 1 Reseat all the cables on the controller board. 2 Check if the controller board LED lights up. 3 Check the controller board for proper installation and damage. Is the controller board properly installed and free of damage?	Contact the next level of support.	Go to step 8.
Step 8 Replace the controller board. See Controller board removal . Does the problem remain?	Contact the next level of support.	The problem is solved.

55 User Attendance Messages

55 User Attendance Messages

Error code	Description	Action
55.1	Unsupported USB device.	See Unsupported USB device service check .
55.2	Unsupported USB hub.	

Unsupported USB Device Service Check

Action	Yes	No
Step 1 1 Turn off the printer. 2 Unplug the power cord. 3 Wait for 10 seconds, and then plug the power cord. 4 Turn on the printer. Does the problem remain?	Go to step 2.	The problem is solved.
Step 2 1 Check if the flash drive is set to the correct file system. 2 Check if the flash drive is detected on the computer. Is the flash drive set to the correct file system, and is it detected?	Go to step 4.	Go to step 3.

Diagnostics and Troubleshooting

Action	Yes	No
<p>Step 3</p> <p>Format the flash drive to the correct file system.</p> <p>Does the problem remain?</p>	Go to step 4.	The problem is solved.
<p>Step 4</p> <p>From the control panel, go to Settings > Device > Restore factory defaults.</p> <p>Does the problem remain?</p>	Go to step 5.	The problem is solved.
<p>Step 5</p> <p>Check the cables for proper connection and damage.</p> <p>Are the cables properly connected and free of damage?</p>	Go to step 7.	Go to step 6.
<p>Step 6</p> <p>Replace the damaged cable.</p> <p>Does the problem remain?</p>	Go to step 7.	The problem is solved.
<p>Step 7</p> <ol style="list-style-type: none"> 1 Upgrade the firmware. 2 Perform a POR. 3 Perform a print test. <p>Does the problem remain?</p>	Go to step 8.	The problem is solved.
<p>Step 8</p> <ol style="list-style-type: none"> 1 Reseat all the cables on the controller board. 2 Check if the controller board LED lights up. 3 Check the controller board for proper installation and damage. <p>Is the controller board properly installed and free of damage?</p>	Contact the next level of support.	Go to step 9.
<p>Step 9</p> <p>Replace the controller board. See Controller board removal.</p> <p>Does the problem remain?</p>	Contact the next level of support.	The problem is solved.

71 User Attendance Messages

71 User Attendance Messages

Error code	Description	Action
71.01	Fax station name is not set.	See Fax Station Name Service Check .
71.03	No analog phone line connected.	See Analog Phone Line Service Check .
71.10	The SMTP server is not set.	See Network Service Check .

Fax Station Name Service Check

Action	Yes	No
Step 1 1 Turn off the printer. 2 Unplug the power cord. 3 Wait for 10 seconds, and then plug the power cord. 4 Turn on the printer. Does the problem remain?	Go to step 2.	The problem is solved.
Step 2 1 From the control panel, go to Settings > Fax > Fax defaults > General fax settings > Fax name . 2 Enter the fax name. Does the problem remain?	Contact the next level of support.	The problem is solved.

Analog Phone Line Service Check

Action	Yes	No
Step 1 1 Turn off the printer. 2 Unplug the power cord. 3 Wait for 10 seconds, and then plug the power cord. 4 Turn on the printer. Does the problem remain?	Go to step 2.	The problem is solved.
Step 2 1 Make sure that the telephone line is properly connected to	Go to step 3.	Check with your service provider.

Diagnostics and Troubleshooting

Action	Yes	No
<p>the correct port on the fax card.</p> <p>2 Check if the telephone line is active.</p> <p>Is the telephone line active?</p>		
<p>Step 3</p> <p>Check the cables for proper connection and damage.</p> <p>Are the cables properly connected and free of damage?</p>	Contact the next level of support.	Go to step 4.
<p>Step 4</p> <p>Replace the damaged cable.</p> <p>Does the problem remain?</p>	Contact the next level of support.	The problem is solved.

Network Service Check

Action	Yes	No
<p>Step 1</p> <p>1 Turn off the printer.</p> <p>2 Unplug the power cord.</p> <p>3 Wait for 10 seconds, and then plug the power cord.</p> <p>4 Turn on the printer.</p> <p>Does the problem remain?</p>	Go to step 2.	The problem is solved.
<p>Step 2</p> <p>Make sure that the printer is properly connected to the network.</p> <p>Does the problem remain?</p>	Go to step 3.	The problem is solved.
<p>Step 3</p> <p>Contact your network administrator.</p> <p>Does the problem remain?</p>	Contact the next level of support.	The problem is solved.

84 User Attendance Messages

84 User Attendance Messages

Error code	Description	Action
84.01	The imaging unit is nearly low.	See Toner cartridge or imaging unit low service check .
84.02		
84.11	The imaging unit is low.	
84.12		
84.13		
84.19		
84.21	The imaging unit is very low.	
84.22		
84.23		
84.31	Replace the imaging unit. Zero estimated pages remain.	
84.32		
84.33	Replace the imaging unit or photoconductor. Zero estimated pages remain. Absolute end of life has been reached due to page count.	
84.41	Replace the imaging kit. Zero estimated pages remain. Absolute end of life has been reached due to the photoconductor rev counter.	
84.42	Replace the imaging unit. Zero estimated pages remain. Absolute end of life has been reached due to waste toner.	
84.43	Replace the imaging unit. Zero estimated pages remain. Absolute end of life has been reached due to page count.	

Toner Cartridge or Imaging Unit Low Service Check

Action	Yes	No
<p>Step 1</p> <p>Make sure that the imaging unit and toner cartridge are genuine Xerox supplies.</p> <p>Does the problem remain?</p>	Go to step 2.	The problem is solved.
<p>Step 2</p> <ol style="list-style-type: none"> 1 From the control panel, navigate to Settings > Reports > Device > Device statistics. 2 Check if the install date reflects the date that you replaced the cartridge. 3 Check the supply level of the toner cartridge. 4 Check the supply level of the imaging unit. <p>Is there sufficient supply level, and does the install date reflect the cartridge replacement date?</p>	Go to step 3.	Go to step 4.
<p>Step 3</p> <ol style="list-style-type: none"> 1 Enter the Diagnostics menu, and then select Advanced print quality samples. 2 Check the test pages for print quality defects. <p>Are there print quality defects?</p>	Go to step 4.	The problem is solved.
<p>Step 4</p> <ol style="list-style-type: none"> 1 Shake the toner cartridge. 2 Clean the toner cartridge smart chip contacts, and then check the contacts for damage. 3 Clean the toner cartridge spring contacts, and then check the contacts for damage. 4 Perform a print test. <p>Does the problem remain?</p>	Go to step 5.	The problem is solved.
<p>Step 5</p> <p>Replace the toner cartridge.</p> <p>Does the problem remain?</p>	Go to step 6.	The problem is solved.
<p>Step 6</p> <ol style="list-style-type: none"> 1 Shake the imaging unit. 	Go to step 7.	The problem is solved.

Action	Yes	No
<p>2 Clean the imaging unit smart chip contacts, and then check the contacts for damage.</p> <p>3 Clean the imaging unit spring contacts, and then check the contacts for damage.</p> <p>4 Perform a print test.</p> <p>Does the problem remain?</p>		
<p>Step 7</p> <p>Check the smart chip for proper installation and damage.</p> <p>Is the smart chip properly installed and free of damage?</p>	Go to step 9.	Go to step 8.
<p>Step 8</p> <p>Replace the imaging unit.</p> <p>Does the problem remain?</p>	Go to step 9.	The problem is solved.
<p>Step 9</p> <p>Check the cables for proper connection and damage.</p> <p>Are the cables properly connected and free of damage?</p>	Go to step 11.	Go to step 10.
<p>Step 10</p> <p>Replace the damaged cable.</p> <p>Does the problem remain?</p>	Go to step 11.	The problem is solved.
<p>Step 11</p> <p>1 Reseat all the cables on the controller board.</p> <p>2 Check if the controller board LED lights up.</p> <p>3 Check the controller board for proper installation and damage.</p> <p>Is the controller board properly installed and free of damage?</p>	Contact the next level of support.	Go to step 12.
<p>Step 12</p> <p>Replace the controller board. See Controller board removal.</p> <p>Does the problem remain?</p>	Contact the next level of support.	The problem is solved.

88 User Attendance Messages

88 User Attendance Messages

Error code	Description	Action
88.00	The toner cartridge is nearly low.	See Toner cartridge or imaging unit low service check .
88.09		
88.10	The toner cartridge is low.	
88.19		
88.20	The toner cartridge is very low.	
88.29		
88.30	Replace the toner cartridge. Zero estimated pages remain.	
88.40	Toner cartridge hard stop.	
88.48		

Non-supply User Attendance Messages

Non-supply User Attendance Messages

Error code	Description	Action
34B	Short paper.	See Short paper service check .
35A	Deficient memory.	See Insufficient memory service check .
37A	Insufficient collation area.	
37C	Insufficient memory.	
38A	Memory full.	
39A	Complex page.	See Complex page service check .

Fax Card Service Check

Action	Yes	No
<p>Step 1</p> <ol style="list-style-type: none"> 1 Make sure that the fax card port is free of damage. 2 Reseat the fax analog line. 3 Reseat the fax card cable on the controller board. 4 Perform a POR. <p>Does the problem remain?</p>	Go to step 2.	The problem is solved.
<p>Step 2</p> <p>Replace the top cover. See Top Cover Removal.</p> <p>Does the problem remain?</p>	Go to step 3.	The problem is solved.
<p>Step 3</p> <ol style="list-style-type: none"> 1 Reseat all the cables on the controller board. 2 Check if the controller board LED lights up. 3 Check the controller board for proper installation and damage. <p>Is the controller board properly installed and free of damage?</p>	Contact the next level of support.	Go to step 4.
<p>Step 4</p> <p>Replace the controller board. See Controller board removal.</p> <p>Does the problem remain?</p>	Contact the next level of support.	The problem is solved.

Short Paper Service Check

Action	Yes	No
<p>Step 1</p> <ol style="list-style-type: none"> 1 Make sure that the tray insert is properly inserted. 2 Make sure that the paper type and size settings match the paper type and size set on the tray. 3 Make sure that the duplex unit is properly inserted. 4 Make sure that the paper size setting in the duplex unit matches the printer setting. 5 Make sure that the front and rear doors are fully closed. 6 Make sure that the output bin is free from obstructions. <p>Does the problem remain?</p>	Go to step 2.	The problem is solved.
<p>Step 2</p> <ol style="list-style-type: none"> 1 Remove the imaging unit and toner cartridge, and then make sure that the paper path is free of jams and obstructions. 2 Clear all rollers of dirt and contamination. <p>Does the problem remain?</p>	Go to step 3.	The problem is solved.
<p>Step 3</p> <ol style="list-style-type: none"> 1 Perform a POR. 2 Enter the Diagnostics menu, and then navigate to: Input tray quick print > Tray 1 > Single <p>Does the problem remain?</p>	Go to step 4.	The problem is solved.
<p>Step 4</p> <ol style="list-style-type: none"> 1 Make sure that the separator roller is free of dust and contamination. 2 Make sure that the lift plate is properly working. 3 Make sure that the paper guides are properly working. 4 Check the tray insert for proper installation and damage. <p>Is the tray insert properly installed, and free of contamination and damage?</p>	Go to step 6.	Go to step 5.

Action	Yes	No
Step 5 Replace the tray insert. Does the problem remain?	Go to step 6.	The problem is solved.
Step 6 1 Clear the duplex paper path of obstructions. 2 Load the correct paper in the tray. 3 Make sure that the paper size setting in the duplex unit matches the paper loaded in the tray. 4 Enter the Diagnostics menu, and then navigate to: Input tray quick print > Tray 1 > Duplex Does the problem remain?	Go to step 7.	The problem is solved.
Step 7 1 Remove, and then insert the duplex unit. 2 Check the duplex unit gears for damage. 3 Check the rollers and belts for wear and contamination. Is the duplex unit properly installed and free of damage?	Go to step 9.	Go to step 8.
Step 8 Replace the duplex unit. Does the problem remain?	Go to step 9.	The problem is solved.
Step 9 1 Reseat the sensor cable. 2 Enter the Diagnostics menu, and then navigate to: Printer diagnostics & adjustments > Sensor tests 3 Find the sensor (staging sensor S2). Does the sensor status change while toggling the sensor?	Go to step 12.	Go to step 10.
Step 10 1 Check the sensor for proper installation and damage.	Go to step 12.	Go to step 11.

Diagnostics and Troubleshooting

Action	Yes	No
<p>2 Check the alignment with the sensor flag.</p> <p>3 Check the sensor cable for proper connection and damage.</p> <p>Is the sensor properly installed and free of damage?</p>		
<p>Step 11</p> <p>Replace the sensor.</p> <p>Does the problem remain?</p>	Go to step 12.	The problem is solved.
<p>Step 12</p> <p>1 Enter the Diagnostics menu, and then navigate to:</p> <p>Printer diagnostics & adjustment > Sensor tests</p> <p>2 Find the following sensors:</p> <ul style="list-style-type: none"> • Sensor (media present in tray1 S1) • Sensor (input sensor S3) • Sensor (fuser exit sensor S4) <p>Does the sensor status change while toggling the sensor?</p>	Go to step 15.	Go to step 13.
<p>Step 13</p> <p>1 Check the sensor flags for proper installation and damage.</p> <p>2 Check the sensor flags for proper alignment with the sensors.</p> <p>3 Check the sensor flag springs for proper installation and damage.</p> <p>Are the sensor flags properly installed and free of damage?</p>	Go to step 15.	Go to step 14.
<p>Step 14</p> <p>Replace the damaged sensor flag.</p> <p>Does the problem remain?</p>	Go to step 15.	The problem is solved.

Action	Yes	No
<p>Step 15</p> <ol style="list-style-type: none"> 1 Reseat all the cables on the controller board. 2 Check if the controller board LED lights up. 3 Check the controller board for proper installation and damage. <p>Is the controller board properly installed and free of damage?</p>	Contact the next level of support.	Go to step 16.
<p>Step 16</p> <p>Replace the controller board. See Controller board removal.</p> <p>Does the problem remain?</p>	Contact the next level of support.	The problem is solved.

Insufficient Memory Service Check

Action	Yes	No
<p>Step 1</p> <ol style="list-style-type: none"> 1 Perform a POR. 2 Send a print job with no image. <p>Does the problem remain?</p>	Go to step 2.	The problem is solved.
<p>Step 2</p> <ol style="list-style-type: none"> 1 Enter the Diagnostics menu, and then select Advanced print quality samples. 2 Check the test pages for print quality defects. <p>Are there print quality defects?</p>	Go to step 3.	The problem is solved.
<p>Step 3</p> <p>Make sure that the printer is using the latest firmware version, and update if necessary.</p> <p>Does the problem remain?</p>	Contact the next level of support.	The problem is solved.

Complex Page Service Check

Action	Yes	No
<p>Step 1</p> <p>1 Perform a POR.</p> <p>2 Send a print job with no image.</p> <p>Does the problem remain?</p>	Go to step 2.	The problem is solved.
<p>Step 2</p> <p>1 Enter the Diagnostics menu, and then select Advanced print quality samples.</p> <p>2 Check the test pages for print quality defects.</p> <p>Are there print quality defects?</p>	Go to step 3.	The problem is solved.
<p>Step 3</p> <p>Make sure that the printer is using the latest firmware version, and update if necessary.</p> <p>Does the problem remain?</p>	Contact the next level of support.	The problem is solved.

Printer Hardware Errors

111 Error Messages

111 Error Messages

Error code	Description	Action
111.20	Printhead error (mirror motor lock) was detected before the motor was turned on.	See Printhead error 1 service check .
111.21	No printhead power (+5V) when the laser servo started.	
111.30	The printhead failed during power-on tests.	
111.31	Printhead error (no first HSYNC) was detected.	
111.32	Printhead error (lost HSYNC) was detected.	
111.33	Printhead error (lost HSYNC) was detected during servo.	
111.34	Printhead error (mirror motor lost lock) was detected.	
111.35	Printhead error (mirror motor never got first lock) was detected.	
111.36	Printhead error (mirror motor lock never stabilized) was detected.	See Printhead error 2 service check .
111.37	Paper reached the sensor (input sensor S3) but the mirror motor was not locked.	
111.38	Paper reached the sensor (input sensor S3) but the printhead startup was not complete.	
111.40	The wrong printhead is installed.	See Printhead error 1 service check .

121 Errors

121 Error Messages

Error code	Description	Action	
121.00	The fuser failed to reach temperature during warm-up.	See Fuser service check .	
121.01	Attempting to heat the fuser, but the fuser is not installed.		
121.02	Attempting to power up the fuser while it is too warm (belt: 50°C, lamp: 76°C) to execute EWC/line voltage detection after a Wrong Fuser Installed error had been previously declared.		
121.10	The fuser did not warm up enough to start EWC/line voltage detection (belt: 60°C, lamp: 88°C) within time-out (belt: 10 seconds, lamp: 90 seconds).		
121.11	The fuser took too long to reach the final EWC/line detection temperature (belt: 90°C, lamp: 149°C).		
121.12	The fuser never reached final EWC/line detection temperature (belt: 90°C, lamp: 149°C).		
121.13	The fuser heated too fast to the final EWC/line detection temperature (belt: 90°C, lamp: 149°C).		
121.20	The fuser high power trace heating rate from 165°C to 180°C exceeded the error threshold.		
121.22	Open fuser relay detected.		
121.28	The fuser failed to reach the EP warm-up temperature in time.		
121.31	The fuser is too hot.		
121.32	The fuser is too cold for too long while its power is at 100%.		
Error code	Description		Action
121.33	The fuser is too cold when paper is in the fuser.		See Fuser service check .

Error code	Description	Action
121.34	The fuser is too cold during steady state control when paper is not in the fuser. This event can occur during printing or standby modes.	
121.50	The fuser went over the required temperature during a global over temperature check.	
121.52	The main thermistor temperature is out of range.	
121.53	The main thermistor temperature change rate is out of range.	
121.71	Open fuser main heater thermistor.	

Fuser Service Check

Action	Yes	No
<p>Step 1</p> <p>Make sure that the voltage rating of the printer matches the power supply voltage of the electrical outlet that the printer is plugged into.</p> <p>Does the problem remain?</p>	Go to step 2.	The problem is solved.
<p>Step 2</p> <ol style="list-style-type: none"> 1 Make sure that the tray insert is properly inserted. 2 Make sure that the paper type and size settings match the paper type and size set on the tray. 3 Make sure that the duplex unit is properly inserted. 4 Make sure that the paper size setting in the duplex unit matches the printer setting. 5 Make sure that the front and rear doors are fully closed. 6 Make sure that the output bin is free from obstructions. <p>Does the problem remain?</p>	Go to step 3.	The problem is solved.
<p>Step 3</p>	Go to step 4.	The problem is solved.

Diagnostics and Troubleshooting

Action	Yes	No
<p>1 Remove the imaging unit and toner cartridge, and then make sure that the paper path is free of jams and obstructions.</p> <p>2 Clear all rollers of dirt and contamination.</p> <p>Does the problem remain?</p>		
<p>Step 4</p> <p>1 Perform a POR.</p> <p>2 Enter the Diagnostics menu, and then navigate to:</p> <p style="padding-left: 20px;">Input tray quick print > Tray 1 > Single</p> <p>Does the problem remain?</p>	Go to step 5.	The problem is solved.
<p>Step 5</p> <p>1 Enter Diagnostics menu, and then navigate to:</p> <p style="padding-left: 20px;">Printer diagnostics & adjustments > Motor tests</p> <p>2 Select Motor (transport drive).</p> <p>3 Open the rear door, and then check if the fuser exit rollers turn.</p> <p>4 Open the fuser access door, and then check if the hot rollers turn.</p> <p>Are the rollers properly working?</p>	Go to step 6.	Go to step 7.
<p>Step 6</p> <p>1 Check the fuser cables for proper connection and damage.</p> <p>2 Check the fuser access door for damage.</p> <p>3 Check if the fuser gears are in proper contact with the drive gears.</p> <p>4 Make sure that the fuser is compatible with the LVPS.</p> <p>5 Check the fuser for proper installation and damage.</p> <p>Is the fuser properly installed and free of damage?</p>	Go to step 8.	Go to step 7.
<p>Step 7</p> <p>Replace the fuser. See Fuser removal.</p>	Go to step 8.	The problem is solved.

Action	Yes	No
Does the problem remain?		
Step 8 1 Enter the Diagnostics menu, and then navigate to: Printer diagnostics & adjustments > Motor tests 2 Select Fan (main) . 3 Check if the fan turns. Did the fan turn?	Go to step 9.	The problem is solved.
Step 9 1 Reseat the fan cable. 2 Make sure that the cable is properly connected. 3 Make sure that the fan and gears are properly installed. 4 Make sure that the fan is free of grease contamination. Does the problem remain?	Go to step 11.	Go to step 10.
Step 10 Replace the fan. See Fan assembly removal . Does the problem remain?	Go to step 11.	The problem is solved.
Step 11 Replace the damaged cable. Does the problem remain?	Go to step 12.	The problem is solved.
Step 12 1 Reseat the cables connected to the LVPS. 2 Check the cables for proper connection and damage. 3 Check the fuse for continuity. 4 Check the electronic components on the LVPS for damage. 5 Check the LVPS for proper installation and damage. Is the LVPS properly installed and free of damage?	Go to step 15.	Go to step 13.
Step 13 1 Make sure that the LVPS is compatible with the fuser and the printer.	Go to step 14.	The problem is solved.

Diagnostics and Troubleshooting

Action	Yes	No
<p>2 Make sure that there is voltage coming out of the fuser connector.</p> <p>3 Make sure that the correct power input voltage is applied.</p> <p>Does the problem remain?</p>		
<p>Step 14</p> <p>Replace the LVPS. See LVPS removal.</p> <p>Does the problem remain?</p>	Go to step 15.	The problem is solved.
<p>Step 15</p> <p>1 Enter the Diagnostics menu, and then navigate to:</p> <p>Printer diagnostics & adjustments > Motor tests</p> <p>2 Select Motor (transport drive).</p> <p>Did the motor run?</p>	Go to step 16.	Go to step 17.
<p>Step 16</p> <p>1 Enter the Diagnostics menu, and then navigate to:</p> <p>Input tray quick print > Tray 1 > Single</p> <p>2 Enter the Diagnostics menu, and then navigate to:</p> <p>Input tray quick print > Duplex > Single</p> <p>Does the problem remain?</p>	Go to step 17.	The problem is solved.
<p>Step 17</p> <p>1 Make sure that the main drive is properly installed and free of damage.</p> <p>2 Make sure that the main drive gears are properly installed.</p> <p>3 Make sure that the drive gears are in proper contact with the gear that they are driving.</p> <p>Does the problem remain?</p>	Go to step 18.	The problem is solved.
<p>Step 18</p> <p>Replace the main drive. See Main drive removal.</p> <p>Does the problem remain?</p>	Go to step 19.	The problem is solved.

Action	Yes	No
Step 19 1 Reseat all the cables on the controller board. 2 Check if the controller board LED lights up. 3 Check the controller board for proper installation and damage. Is the controller board properly installed and free of damage?	Contact the next level of support.	Go to step 20.
Step 20 Replace the controller board. See Controller board removal . Does the problem remain?	Contact the next level of support.	The problem is solved.

126 Errors

126 Error Messages

Error code	Description	Action
126.05	The LVPS dropped while not sleeping.	See LVPS service check .
126.06	An LVPS 25V line error was detected.	
126.07	An LVPS 5V rail was down during POR.	
126.12	LVPS mismatch. A 120V power supply is installed but the controller board reports a 220V power supply.	See LVPS service check . Go to step 3 directly.
126.13	LVPS mismatch. A 230V power supply is installed but the controller board reports a 110V or 100V power supply.	

LVPS Service Check

Action	Yes	No
<p>Step 1</p> <ol style="list-style-type: none"> 1 Remove the imaging unit and toner cartridge, and then make sure that the paper path is free of jams and obstructions. 2 Clear all rollers of dirt and contamination. <p>Does the problem remain?</p>	Go to step 2.	The problem is solved.
<p>Step 2</p> <ol style="list-style-type: none"> 1 Perform a POR. 2 Enter the Diagnostics menu, and then navigate to: Input tray quick print > Tray 1 > Single <p>Does the problem remain?</p>	Go to step 3.	The problem is solved.
<p>Step 3</p> <ol style="list-style-type: none"> 1 Reseat the cables connected to the LVPS. 2 Check the cables for proper connection and damage. 3 Check the fuse for continuity. 4 Check the electronic components on the LVPS for damage. 5 Check the LVPS for proper installation and damage. <p>Is the LVPS properly installed and free of damage?</p>	Go to step 6.	Go to step 4.
<p>Step 4</p> <ol style="list-style-type: none"> 1 Make sure that the LVPS is compatible with the fuser and the printer. 2 Make sure that there is voltage coming out of the fuser connector. 3 Make sure that the correct power input voltage is applied. <p>Does the problem remain?</p>	Go to step 5.	The problem is solved.
<p>Step 5</p> <p>Replace the LVPS. See LVPS removal.</p> <p>Does the problem remain?</p>	Go to step 6.	The problem is solved.

Action	Yes	No
Step 6 1 Reseat all the cables on the controller board. 2 Check if the controller board LED lights up. 3 Check the controller board for proper installation and damage. Is the controller board properly installed and free of damage?	Contact the next level of support.	Go to step 7.
Step 7 Replace the controller board. See Controller board removal . Does the problem remain?	Contact the next level of support.	The problem is solved.

140 Errors

140 Error Messages

Error code	Description	Action
140.82	Motor (transport drive) failure.	See Motor (transport drive) service check .

Motor (Transport Drive) Service Check

Action	Yes	No
<p>Step 1</p> <ol style="list-style-type: none"> 1 Make sure that the tray insert is properly inserted. 2 Make sure that the paper type and size settings match the paper type and size set on the tray. 3 Make sure that the duplex unit is properly inserted. 4 Make sure that the paper size setting in the duplex unit matches the printer setting. 5 Make sure that the front and rear doors are fully closed. 6 Make sure that the output bin is free from obstructions. <p>Does the problem remain?</p>	Go to step 2.	The problem is solved.
<p>Step 2</p> <ol style="list-style-type: none"> 1 Remove the imaging unit and toner cartridge, and then make sure that the paper path is free of jams and obstructions. 2 Clear all rollers of dirt and contamination. <p>Does the problem remain?</p>	Go to step 3.	The problem is solved.
<p>Step 3</p> <ol style="list-style-type: none"> 1 Perform a POR. 2 Enter the Diagnostics menu, and then navigate to: Input tray quick print > Tray 1 > Single <p>Does the problem remain?</p>	Go to step 4.	The problem is solved.
<p>Step 4</p> <ol style="list-style-type: none"> 1 Enter the Diagnostics menu, and then navigate to: Printer diagnostics & adjustments > Motor tests 2 Select Motor (transport drive). <p>Does the motor run?</p>	Go to step 6.	Go to step 5.
<p>Step 5</p> <ol style="list-style-type: none"> 1 Reseat the motor cable at both ends. 	Go to step 6.	Contact the next level of support.

Action	Yes	No
<p>2 Make sure that the motor gear is properly aligned with the drive gears.</p> <p>3 Check the motor for proper installation and damage.</p> <p>Is the motor properly installed and free of damage?</p>		
<p>Step 6</p> <p>Check the cables for proper connection and damage.</p> <p>Are the cables properly connected and free of damage?</p>	Go to step 8.	Go to step 7.
<p>Step 7</p> <p>Replace the damaged cable.</p> <p>Does the problem remain?</p>	Go to step 8.	The problem is solved.
<p>Step 8</p> <p>1 Reseat all the cables on the controller board.</p> <p>2 Check if the controller board LED lights up.</p> <p>3 Check the controller board for proper installation and damage.</p> <p>Is the controller board properly installed and free of damage?</p>	Contact the next level of support.	Go to step 9.
<p>Step 9</p> <p>Replace the controller board. See Controller board removal.</p> <p>Does the problem remain?</p>	Contact the next level of support.	The problem is solved.

6yy Errors

6yy Error Messages

Error code	Description	Action
600.01	Toner tally never received.	See Printer declared jam service check .
600.02	The printhead is not ready to image.	See Printhead error 1 service check .
600.04	Duplex paper was never picked.	See Printer declared jam service check .

Error code	Description	Action
600.05	Invalid printhead NVRAM type.	See Printhead error 1 service check .
600.06	No response from the paper port driver.	See Printer declared jam service check .
600.07	Page is at the image point before the EP is ready.	See Printhead error 2 service check .
600.08	Paper jam is caused by a printhead error.	
600.09	EP update error was detected.	Restart the print job. If the error persists, then contact the next level of support.
600.10	EP started a run-in late with less time than it takes to do the motor ramp.	See Printer declared jam service check .
600.95	The printer intentionally declared a jam. This event is typically used to prevent a kiosk user from printing free pages.	
611.02	An Input ISR error occurred and the printhead was not ready.	Restart the print job. If the error persists, then contact the next level of support.
611.32	Lost HSYNC errors were detected. Laser safety interlock system may be the cause.	
611.33	Lost HSYNC during servo.	
611.34	A mirror motor lock error was detected.	
611.35	Mirror motor never got first lock.	See Printhead error 1 service check .
611.36	Mirror motor lock never stabilized.	
611.37	Paper reached the sensor (input sensor S3) but the mirror motor was not locked.	
611.38	Paper reached the sensor (input sensor S3) but the printhead startup was not complete.	
621.01	The fuser heater was not hot enough when the paper entered the fuser nip.	Restart the print job. If the error persists, then contact the next level of support.

Printer Declared Jam Service Check

Action	Yes	No
Step 1 1 Shake the toner cartridge. 2 Clean the toner cartridge smart chip contacts, and then check the contacts for damage. 3 Clean the toner cartridge spring contacts, and then check the contacts for damage. 4 Perform a print test. Does the problem remain?	Go to step 2.	The problem is solved.
Step 2 Replace the toner cartridge. Does the problem remain?	Go to step 3.	The problem is solved.
Step 3 1 Shake the imaging unit. 2 Clean the imaging unit smart chip contacts, and then check the contacts for damage. 3 Clean the imaging unit spring contacts, and then check the contacts for damage. 4 Perform a print test. Does the problem remain?	Go to step 4.	The problem is solved.
Step 4 Check the smart chip for proper installation and damage. Is the smart chip properly installed and free of damage?	Go to step 6.	Go to step 5.
Step 5 Replace the imaging unit Does the problem remain?	Go to step 6.	The problem is solved.
Step 6 1 Turn off the printer. 2 Unplug the power cord. 3 Wait for 20 seconds, and then plug the power cord. 4 Turn on the printer. Does the problem remain?	Go to step 7.	The problem is solved.

Action	Yes	No
<p>Step 7</p> <ol style="list-style-type: none"> 1 Reseat all the cables on the controller board. 2 Check if the controller board LED lights up. 3 Check the controller board for proper installation and damage. <p>Is the controller board properly installed and free of damage?</p>	Contact the next level of support.	Go to step 8.
<p>Step 8</p> <p>Replace the controller board. See Controller board removal.</p> <p>Does the problem remain?</p>	Contact the next level of support.	The problem is solved.

Printhead Error 1 Service Check

Action	Yes	No
<p>Step 1</p> <ol style="list-style-type: none"> 1 Turn off the printer. 2 Unplug the power cord. 3 Wait for 20 seconds, and then plug the power cord. 4 Turn on the printer. <p>Does the problem remain?</p>	Go to step 2.	The problem is solved.
<p>Step 2</p> <ol style="list-style-type: none"> 1 Reseat the two printhead cables at both ends. 2 Check the printhead cables for proper connection. 3 Check the printhead for proper installation and damage. 4 Perform a print test. <p>Does the problem remain?</p>	Go to step 3.	The problem is solved.
<p>Step 3</p> <p>Make sure that the printhead lens is clean and free of contamination.</p> <p>Does the problem remain?</p>	Go to step 4.	The problem is solved.
<p>Step 4</p> <p>Replace the printhead. See Printhead removal.</p> <p>Does the problem remain?</p>	Go to step 5.	The problem is solved.

Action	Yes	No
Step 5 Check the cables for proper connection and damage. Are the cables properly connected and free of damage?	Go to step 7.	Go to step 6.
Step 6 Replace the damaged cable. Does the problem remain?	Go to step 7.	The problem is solved.
Step 7 1 Reseat all the cables on the controller board. 2 Check if the controller board LED lights up. 3 Check the controller board for proper installation and damage. Is the controller board properly installed and free of damage?	Contact the next level of support.	Go to step 8.
Step 8 Replace the controller board. See Controller board removal . Does the problem remain?	Contact the next level of support.	The problem is solved.

Printhead Error 2 Service Check

Action	Yes	No
Step 1 1 Make sure that the tray insert is properly inserted. 2 Make sure that the paper is properly loaded in the tray. 3 Make sure that the paper type and size settings match the paper type and size set on the tray. 4 Make sure that the lift plate is properly working. Does the problem remain?	Go to step 2.	The problem is solved.
Step 2 1 Reseat the sensor cable. 2 Enter the Diagnostics menu, and then navigate to:	Go to step 5.	Go to step 3.

Action	Yes	No
<p>Printer diagnostics & adjustments > Sensor tests</p> <p>3 Find the sensor (staging sensor S2).</p> <p>Does the sensor status change while toggling the sensor?</p>		
<p>Step 3</p> <p>1 Check the sensor for proper installation and damage.</p> <p>2 Check the alignment with the sensor flag.</p> <p>3 Check the sensor cable for proper connection and damage.</p> <p>Is the sensor properly installed and free of damage?</p>	Go to step 5.	Go to step 4.
<p>Step 4</p> <p>Replace the sensor.</p> <p>Does the problem remain?</p>	Go to step 5.	The problem is solved.
<p>Step 5</p> <p>1 Enter the Diagnostics menu, and then navigate to:</p> <p>Printer diagnostics & adjustment > Sensor tests</p> <p>2 Find the following sensors:</p> <ul style="list-style-type: none"> • Sensor (media present in tray1 S1) • Sensor (input sensor S3) • Sensor (fuser exit sensor S4) <p>Does the sensor status change while toggling the sensor?</p>	Go to step 8.	Go to step 6.
<p>Step 6</p> <p>1 Check the sensor flags for proper installation and damage.</p> <p>2 Check the sensor flags for proper alignment with the sensors.</p> <p>3 Check the sensor flag springs for proper installation and damage.</p> <p>Are the sensor flags properly installed and free of damage?</p>	Go to step 8.	Go to step 7.

Action	Yes	No
Step 7 Replace the damaged sensor flag. Does the problem remain?	Go to step 8.	The problem is solved.
Step 8 1 Reseat the two printhead cables at both ends. 2 Check the printhead cables for proper connection. 3 Check the printhead for proper installation and damage. 4 Perform a print test. Does the problem remain?	Go to step 9.	The problem is solved.
Step 9 Make sure that the printhead lens is clean and free of contamination. Does the problem remain?	Go to step 10.	The problem is solved.
Step 10 Replace the printhead. See Printhead removal . Does the problem remain?	Go to step 11.	The problem is solved.
Step 11 Check the cables for proper connection and damage. Are the cables properly connected and free of damage?	Go to step 13.	Go to step 12.
Step 12 Replace the damaged cable. Does the problem remain?	Go to step 13.	The problem is solved.

Action	Yes	No
Step 13 1 Reseat all the cables on the controller board. 2 Check if the controller board LED lights up. 3 Check the controller board for proper installation and damage. Is the controller board properly installed and free of damage?	Contact the next level of support.	Go to step 14.
Step 14 Replace the controller board. See Controller board removal . Does the problem remain?	Contact the next level of support.	The problem is solved.

Procedure Before Starting The 9yy Service Checks

Retrieve certain information that helps your next level of support in diagnosing the problem before replacing the controller board.

 **Warning:** Do not replace the controller board unless instructed by your next level of support.

1. Collect the history information and firmware logs (Fwdebug and logs.tar.gz) from the SE menu.
2. Collect the settings from the Menu Settings Page.
3. Collect information from the user.

 **Note:** Not all of the items are retrievable from the printer that you are working on.

A. Collecting The History Information From The SE Menu

 **Note:** Make sure that your printer is connected to a network or to a print server.

1. Open a web browser, type `http://printer_IP_address/se`, and then press **Enter**.

 **Note:**

- printer_IP_address is the TCP/IP address of the printer.
 - se is required to access the printer diagnostic information.
2. Click **History Information**, copy all information, and then save it as a text file.
 3. E-mail the text file to your next level of support.

B. Collecting The Firmware Logs (fwdebug and Logs.tar.gz) From The SE Menu

Note:

- Make sure that your printer is connected to a network or to a print server.
 - Some printers are designed to restart automatically after a 9yy error. On these printers, you can retrieve the secondary crash code information using the SE menu.
1. Open a web browser, type `http://printer_IP_address/se`, and then press **Enter**.
 2. Click **Logs Gzip Compressed**.

 **Note:** A logs.tar.gz file is saved to the Downloads folder. The file may take several minutes to save. You may rename the file if a logs.tar.gz already exists in the Downloads folder.

3. E-mail the logs to your next level of support.

 **Note:** To download the FWdebug log to a flash drive, see [General SE](#).

C. Collecting The Settings From The Menu Settings Page

 **Note:** The Menu Settings Page is different for each printer. For more information, see the printer User's Guide. Your next level of support will tell you which page they want to see.

D. Collecting Information From The User

Ask the user for information about the following:

- Print job being run
- Operating system being used
- Print driver being used
- Other information on what was happening when the 9yy error occurred

9yy Errors

9yy Error Messages

Error code	Description	Action
900.xx	Unrecoverable RIP software error/ illegal trap.	See Error Service Check .
910.xx–919.xx	An engine error occurred.	See Engine error service check .
938.04	Supplies security is not enabled.	See Black imaging unit, photoconductor smart chip, or sensor problem service check .
940	RIP to engine communication failure.	See Engine error service check .

Error code	Description	Action
941	Engine card failure.	
948	Engine card—Pel clock check failed.	
949	Engine card—Delay line calibration failure.	
950	Non-Generic FRU installed. Mismatch between system NVRAM part and mirror NVRAM part. .xx points to the setting that does not match.	
952	A recoverable NVRAM cyclic redundancy check error occurred.  Note: <ul style="list-style-type: none"> • n is the offset at which the error occurred. • Performing a POR clears the error. 	
953	NVRAM chip failure with mirror part.	
954	NVRAM chip failure with system part.	
955	The NAND flash failed the cyclic redundancy check or the NAND experienced an uncorrectable multi-bit failure. <LOC> indicates the source of the failure.	
956	RIP card failure—Processor failure.	
957	RIP card failure—ASIC failure.	
958	Controller board NAND failure.	
959	Invalid firmware—Service system board.	
960	RAM memory error—RAM soldered on the card is bad.	
961	RAM memory error—RAM in slot 1 is bad.	
962	RAM memory error—RAM in slot 2 is bad.	
963	RAM memory error—RAM in slot 3 is bad.	

Error code	Description	Action
964	Download emulation cyclic redundancy check error—Checksum failure detected in the emulation header or emulation file.	

Error code	Description	Action
975	Network error—Unrecognizable network port.	See Network software error service check .
976	Network error—Unrecoverable software error in the network port.	
978	Network error—Bad checksum while programming the network port.	
979	Network error—Flash parts failed while programming the network port.	
980	The engine is experiencing an unreliable communication.	See Engine error service check .
981	Engine protocol violation is detected.	
982	Communications error is detected.	
983	Invalid command received.	
984	Invalid command parameter received.	
985	RFID media option hardware error.	
990	An equipment check condition has occurred in the printer, but the printer is unable to identify the exact component failure.	
991	A controller board equipment check is detected.	
992	General software error.	

900 Error Service Check

Action	Yes	No
Step 1 <ul style="list-style-type: none"> Perform a POR. Check if a 900.xx error code appears on the display. Does a 900.xx error code appear?	Go to step 4.	Go to step 2.
Step 2 <p>Check if another type of error code appears instead of the 900.xx error code.</p> Does a different error code appear?	Go to step 3.	Go to step 4.
Step 3 <p>See the error code and its service instructions in the printer service manual.</p> Does the problem remain?	Go to step 4.	The problem is solved.
Step 4 <ul style="list-style-type: none"> Turn off the printer. At the rear of the printer, disconnect the network cable, USB cable, and the fax line. Turn on the printer. Does the problem remain?	Go to step 12.	Go to step 5.
Step 5 <ul style="list-style-type: none"> From the control panel, navigate to the Reports menu. Select Device Statistics and Device Settings. Does the problem remain?	Go to step 12.	Go to step 6.
Step 6 <p>Check if the printer has a scanner.</p> Does the printer have a scanner?	Go to step 7.	Go to step 8.
Step 7 <p>Using the scanner, perform a one-page copy job in color.</p> Does the problem remain?	Go to step 12.	Go to step 8.
Step 8 <ul style="list-style-type: none"> Turn off the printer. 	Go to step 9.	Go to step 10.

Action	Yes	No
<ul style="list-style-type: none"> At the rear of the printer, connect the network cable, USB cable, and the fax line. Turn on the printer. <p>Does the problem remain?</p>		
<p>Step 9</p> <ul style="list-style-type: none"> Start the printer in Invalid engine mode. See Entering Invalid Engine Mode Check if an Invalid Engine Code message appears. <p>Does the Invalid Engine Code message appear?</p>	Go to step 10.	Contact the next level of support.
<p>Step 10</p> <p>Using the Device Settings report that is printed in step 5, check if the firmware level is older than the latest available version.</p> <p>Is the firmware version older, and does the customer agree to update the firmware?</p>	Go to step 11.	Contact the next level of support.
<p>Step 11</p> <p>Update the firmware to the latest version.</p> <p>Does the problem remain?</p>	Go to step 12.	The problem is solved.
<p>Step 12</p> <ul style="list-style-type: none"> Turn off the printer. Make sure that all the cables on the controller board and scanner are properly connected. Turn on the printer. From the control panel, navigate to the Reports menu, and then select Device Statistics and Device Settings. For MFPs, perform a one-page copy and scan job in color. <p>Does the problem remain?</p>	Go to step 13.	The problem is solved.
<p>Step 13</p> <p>Check if a hard disk is installed.</p> <p>Is a hard disk installed?</p>	Go to step 14.	Go to step 17.
<p>Step 14</p>	Go to step 15.	The problem is solved.

Diagnostics and Troubleshooting

Action	Yes	No
<ul style="list-style-type: none"> • Check for buffered print jobs, and then delete them. See . • Perform a POR. <p>Does the problem remain?</p>		
<p>Step 15</p> <ul style="list-style-type: none"> • Turn off the printer. • Uninstall the hard disk drive. • Perform a POR. <p>Does the problem remain?</p>	Go to step 17.	Go to step 16.
<p>Step 16</p> <p>Replace the hard disk.</p> <p>Does the problem remain?</p>	Go to step 17.	The problem is solved.
<p>Step 17</p> <p>Check if the printer has any of the following components installed:</p> <ul style="list-style-type: none"> • Memory options • Fax card • Modem • Wireless and network option cards <p>Is any of the components installed?</p>	Go to step 18.	Go to step 21.
<p>Step 18</p> <ul style="list-style-type: none"> • Turn off the printer. • Remove all the installed components. • Turn on the printer. <p>Does the problem remain?</p>	Go to step 21.	Go to step 19.
<p>Step 19</p> <ul style="list-style-type: none"> • Turn off the printer. • Install the following components one at a time: <ul style="list-style-type: none"> – Memory options – Fax card – Modem – Wireless and network option cards <p> Note: Make sure to perform a POR after installing each component.</p>	Go to step 20.	The problem is solved.

Action	Yes	No
Does the problem remain?		
Step 20 <ul style="list-style-type: none"> Turn off the printer. Replace the components that caused the error. Turn on the printer. Does the problem remain?	Go to step 21.	The problem is solved.
Step 21 Replace the controller board. See Controller board removal Does the problem remain?	Contact the next level of support.	The problem is solved.

Engine Error Service Check

Action	Yes	No
Step 1 <ol style="list-style-type: none"> Turn off the printer. Unplug the power cord. Wait for 20 seconds, and then plug the power cord. Turn on the printer. Does the problem remain?	Go to step 2.	The problem is solved.
Step 2 Make sure that the printer is using the latest firmware version, and update if necessary. Does the problem remain?	Go to step 3.	The problem is solved.
Step 3 Check the cables for proper connection and damage. Are the cables properly connected and free of damage?	Go to step 5.	Go to step 4.
Step 4 Replace the damaged cable. Does the problem remain?	Go to step 5.	The problem is solved.

Action	Yes	No
<p>Step 5</p> <ol style="list-style-type: none"> 1 Reseat all the cables on the controller board. 2 Check if the controller board LED lights up. 3 Check the controller board for proper installation and damage. <p>Is the controller board properly installed and free of damage?</p>	Contact the next level of support.	Go to step 6.
<p>Step 6</p> <p>Replace the controller board. See Controller board removal.</p> <p>Does the problem remain?</p>	Contact the next level of support.	The problem is solved.

Network Software Error Service Check

Action	Yes	No
<p>Step 1</p> <ol style="list-style-type: none"> 1 Turn off the printer. 2 Unplug the power cord. 3 Wait for 20 seconds, and then plug the power cord. 4 Turn on the printer. <p>Does the problem remain?</p>	Go to step 2.	The problem is solved.
<p>Step2</p> <ol style="list-style-type: none"> 1 Check the network cable for proper connection and damage. 2 Make sure that the network cable contacts are free from dirt or corrosion. 3 Make sure that the network cable is active. <p>Is the network cable properly connected and free of corrosion and damage?</p>	Go to step 4.	Go to step 3.
<p>Step3</p> <p>Replace the network cable.</p> <p>Does the problem remain?</p>	Go to step 4.	The problem is solved.
<p>Step4</p> <p>Check the controller board ports and pins for damage.</p>	Go to step 5.	Go to step 9.

Action	Yes	No
Are the controller board ports and pins free of damage?		
Step5 1 Make sure that the Wi-Fi is connected to the network. 2 Make sure that the Wi-Fi setting is correct. 3 Check the Wi-Fi antenna for proper installation and damage. Is the Wi-Fi antenna properly installed and free of damage?	Go to step 6.	Go to step 9.
Step6 Make sure that the printer is using the latest firmware version, and update if necessary. Does the problem remain?	Go to step 7.	The problem is solved.
Step7 Check the cables for proper connection and damage. Are the cables properly connected and free of damage?	Go to step 9.	Go to step 8.
Step8 Replace the damaged cable. Does the problem remain?	Go to step 9.	The problem is solved.
Step9 1 Reseat all the cables on the controller board. 2 Check if the controller board LED lights up. 3 Check the controller board for proper installation and damage. Is the controller board properly installed and free of damage?	Contact the next level of support.	Go to step 10.
Step10 Replace the controller board. See Controller board removal . Does the problem remain?	Contact the next level of support.	The problem is solved.

ADF/Scanner Hardware Errors

84y Error Messages

Error code	Description	Action
840.01	The scanner is disabled by the administrator.	See Scanner Disabled and Scanner Communication Error Service Check .
840.02	The scanner is disabled for other reasons. For example, invalid license and too many hardware errors.	
842.00	Non-responsive scanner communication failure.	
842.01	Hardware protocol scanner communication failure.	
842.02	Logical protocol scanner communication failure.	
843.00	<ul style="list-style-type: none"> Scanner mechanical failure. The flatbed carriage failed to return to the home position. 	See Flatbed Home Position Service Check .

Sensor (Scan) Service Check

Action	Yes	No
<p>Step 1</p> <ol style="list-style-type: none"> Open the ADF cover, and then remove the jammed paper. Make sure that the paper path is free of obstructions. Raise the ADF assembly, and then make sure that the scan area is free of dust and obstructions. Make sure that the scanner paper setting matches the paper loaded. <p>Does the problem remain?</p>	Go to step 2.	The problem is solved.
<p>Step 2</p> <ol style="list-style-type: none"> Clean the ADF pick rollers and separator pad. Enter the Diagnostics menu, and then navigate to: <p>Scanner diagnostics > Feed test</p>	Go to step 3.	The problem is solved.

Action	Yes	No
Does the problem remain?		
Step 3 1 Check the ADF pick and feed rollers for wear, damage, and contamination. 2 Check the ADF pick separator pad for wear, damage, contamination, and spring load. 3 Check if the ADF cover properly closes. Is the ADF pick assembly properly installed and free of damage?	Go to step 5.	Go to step 4.
Step 4 Replace the ADF pick assembly. See ADF Pick Assembly Removal . Does the problem remain?	Go to step 5.	The problem is solved.
Step 5 1 Enter the Diagnostics menu, and then navigate to: Scanner diagnostics > Sensor tests 2 Find the sensor (ADF scan). Does the sensor status change while toggling the sensor?	Go to step 8.	Go to step 6.
Step 6 1 Make sure that the sensor flag is free of dust or debris. 2 Reseat all the cables on the controller board. Does the problem remain?	Go to step 7.	The problem is solved.
Step 7 Replace the ADF assembly. See ADF Scanner and Flatbed Scanner Removal . Does the problem remain?	Go to step 8.	The problem is solved.
Step 8 1 Make sure that the ADF cover properly closes. 2 Check the ADF scan sensor flag for proper installation and damage.	Go to step 10.	Go to step 9.

Diagnostics and Troubleshooting

Action	Yes	No
Is the sensor flag properly installed and free of damage?		
Step 9 Replace the ADF assembly. See ADF Scanner and Flatbed Scanner Removal . Does the problem remain?	Go to step 10.	The problem is solved.
Step 10 1 Make sure that the ADF paper path rollers are properly installed and free of damage. 2 Make sure that the rollers are free of dust and contamination. Are the rollers properly installed and free of damage?	Go to step 12.	Go to step 11.
Step 11 Replace the ADF assembly. See ADF Scanner and Flatbed Scanner Removal . Does the problem remain?	Go to step 12.	The problem is solved.
Step 12 1 Enter the Diagnostics menu, and then navigate to: Scanner diagnostics > Motor tests 2 Select Motor (ADF transport) . Does the motor run?	Go to step 14.	Go to step 13.
Step 13 1 Reseat the ADF cable. 2 Check the ADF cable for proper connection and damage. 3 Check the ADF assembly for proper installation and damage. 4 Check the ADF cover sensor for damage. Is the ADF assembly properly installed and free of damage?	Go to step 15.	Go to step 14.
Step 14	Go to step 15.	The problem is solved.

Action	Yes	No
Replace the ADF assembly. See ADF Scanner and Flatbed Scanner Removal . Does the problem remain?		
Step 15 1 Reseat all the cables on the controller board. 2 Check if the controller board LED lights up. 3 Check the controller board for proper installation and damage. Is the controller board properly installed and free of damage?	Contact the next level of support.	Go to step 16.
Step 16 Replace the controller board. See Controller board removal . Does the problem remain?	Contact the next level of support.	The problem is solved.

Sensor (ADF Top Door Interlock) Service Check

Action	Yes	No
Step 1 1 Open the ADF cover, and then remove the jammed paper. 2 Make sure that the paper path is free of obstructions. 3 Raise the ADF assembly, and then make sure that the scan area is free of dust and obstructions. 4 Make sure that the scanner paper setting matches the paper loaded. Does the problem remain?	Go to step 2.	The problem is solved.
Step 2 1 Enter the Diagnostics menu, and then navigate to: Scanner diagnostics > Sensor tests 2 Find the sensor (ADF top door interlock).	Go to step 5.	Go to step 3.

Diagnostics and Troubleshooting

Action	Yes	No
Does the sensor status change while toggling the sensor?		
Step 3 1 Make sure that the switch actuator is properly installed and free of damage. 2 Reseat all the ADF and flatbed scanner cables on the controller board. Does the problem remain?	Go to step 4.	The problem is solved.
Step 4 Replace the ADF assembly. See ADF Scanner and Flatbed Scanner Removal . Does the problem remain?	Go to step 5.	The problem is solved.
Step 5 Check the ADF cover sensor flag for proper installation and damage. Is the sensor flag properly installed and free of damage?	Go to step 7.	Go to step 6.
Step 6 Replace the ADF pick assembly. See ADF Pick Assembly Removal . Does the problem remain?	Go to step 7.	The problem is solved.
Step 7 1 Clean the ADF pick rollers and separator pad. 2 Enter the Diagnostics menu, and then navigate to: Scanner diagnostics > Feed test Does the problem remain?	Go to step 8.	The problem is solved.
Step 8 1 Check the ADF pick and feed rollers for wear, damage, and contamination. 2 Check the ADF pick separator pad for wear, damage, contamination, and spring load. 3 Check if the ADF cover properly closes.	Go to step 10.	Go to step 9.

Action	Yes	No
Is the ADF pick assembly properly installed and free of damage?		
Step 9 Replace the ADF pick assembly. See ADF Pick Assembly Removal . Does the problem remain?	Go to step 10.	The problem is solved.
Step 10 1 Enter the Diagnostics menu, and then navigate to: Scanner diagnostics > Motor tests 2 Select Motor (ADF transport) . Does the motor run?	Go to step 12.	Go to step 11.
Step 11 1 Reseat the ADF cable. 2 Check the ADF cable for proper connection and damage. 3 Check the ADF assembly for proper installation and damage. 4 Check the ADF cover sensor for damage. Is the ADF assembly properly installed and free of damage?	Go to step 13.	Go to step 12.
Step 12 Replace the ADF assembly. See ADF Scanner and Flatbed Scanner Removal . Does the problem remain?	Go to step 13.	The problem is solved.

Action	Yes	No
<p>Step 13</p> <ol style="list-style-type: none"> 1 Reseat all the cables on the controller board. 2 Check if the controller board LED lights up. 3 Check the controller board for proper installation and damage. <p>Is the controller board properly installed and free of damage?</p>	Contact the next level of support.	Go to step 14.
<p>Step 14</p> <p>Replace the controller board. See Controller board removal.</p> <p>Does the problem remain?</p>	Contact the next level of support.	The problem is solved.

ADF Feed Error Service Check

Action	Yes	No
<p>Step 1</p> <ol style="list-style-type: none"> 1 Open the ADF cover, and then remove the jammed paper. 2 Make sure that the paper path is free of obstructions. 3 Raise the ADF assembly, and then make sure that the scan area is free of dust and obstructions. 4 Make sure that the scanner paper setting matches the paper loaded. <p>Does the problem remain?</p>	Go to step 2.	The problem is solved.
<p>Step 2</p> <ol style="list-style-type: none"> 1 Enter the Diagnostics menu, and then navigate to: Scanner diagnostics > Sensor tests 2 Find the sensor (ADF media present). <p>Does the sensor status change while toggling the sensor?</p>	Go to step 5.	Go to step 3.
<p>Step 3</p> <ol style="list-style-type: none"> 1 Make sure that the paper present sensor actuator is 	Go to step 4.	The problem is solved.

Action	Yes	No
<p>properly installed and free of damage.</p> <p>2 Make sure that the actuator is properly aligned with the sensor.</p> <p>3 Reseat all the cables on the controller board.</p> <p>Does the problem remain?</p>		
<p>Step 4</p> <p>Replace the ADF assembly. See ADF Scanner and Flatbed Scanner Removal .</p> <p>Does the problem remain?</p>	Go to step 5.	The problem is solved.
<p>Step 5</p> <p>Check the ADF paper present sensor flag for proper installation and damage.</p> <p>Is the sensor flag properly installed and free of damage?</p>	Go to step 7.	Go to step 6.
<p>Step 6</p> <p>Replace the ADF assembly. See ADF Scanner and Flatbed Scanner Removal .</p> <p>Does the problem remain?</p>	Go to step 7.	The problem is solved.
<p>Step 7</p> <p>1 Clean the ADF pick rollers and separator pad.</p> <p>2 Enter the Diagnostics menu, and then navigate to:</p> <p>Scanner diagnostics > Feed test</p> <p>Does the problem remain?</p>	Go to step 8.	The problem is solved.
<p>Step 8</p> <p>1 Check the ADF pick and feed rollers for wear, damage, and contamination.</p> <p>2 Check the ADF pick separator pad for wear, damage, contamination, and spring load.</p> <p>3 Check if the ADF cover properly closes.</p> <p>Is the ADF pick assembly properly installed and free of damage?</p>	Go to step 10.	Go to step 9.

Diagnostics and Troubleshooting

Action	Yes	No
<p>Step 9</p> <p>Replace the ADF pick assembly. See ADF Pick Assembly Removal.</p> <p>Does the problem remain?</p>	Go to step 10.	The problem is solved.
<p>Step 10</p> <p>1 Enter the Diagnostics menu, and then navigate to:</p> <p style="padding-left: 20px;">Scanner diagnostics > Motor tests</p> <p>2 Select Motor (ADF transport).</p> <p>Does the motor run?</p>	Go to step 12.	Go to step 11.
<p>Step 11</p> <p>1 Reseat the ADF cable.</p> <p>2 Check the ADF cable for proper connection and damage.</p> <p>3 Check the ADF assembly for proper installation and damage.</p> <p>4 Check the ADF cover sensor for damage.</p> <p>Is the ADF assembly properly installed and free of damage?</p>	Go to step 13.	Go to step 12.
<p>Step 12</p> <p>Replace the ADF assembly. See ADF Scanner and Flatbed Scanner Removal.</p> <p>Does the problem remain?</p>	Go to step 13.	The problem is solved.
<p>Step 13</p> <p>1 Reseat all the cables on the controller board.</p> <p>2 Check if the controller board LED lights up.</p> <p>3 Check the controller board for proper installation and damage.</p> <p>Is the controller board properly installed and free of damage?</p>	Contact the next level of support.	Go to step 14.
<p>Step 14</p> <p>Replace the controller board. See Controller board removal.</p> <p>Does the problem remain?</p>	Contact the next level of support.	The problem is solved.

Scanner Disabled and Scanner Communication Error Service Check

Action	Yes	No
<p>Step 1</p> <ol style="list-style-type: none"> 1 Open the ADF cover, and then remove the jammed paper. 2 Make sure that the paper path is free of obstructions. 3 Raise the ADF assembly, and then make sure that the scan area is free of dust and obstructions. 4 Make sure that the scanner paper setting matches the paper loaded. <p>Does the problem remain?</p>	Go to step 2.	The problem is solved.
<p>Step 2</p> <ol style="list-style-type: none"> 1 Reseat all the scanner cables on the controller board. 2 Perform a POR. <p>Does the problem remain?</p>	Go to step 3.	The problem is solved.
<p>Step 3</p> <ol style="list-style-type: none"> 1 Enter the Diagnostics menu, and then navigate to: Scanner diagnostics > Motor tests 2 Select Motor (ADF transport). <p>Does the motor run?</p>	Go to step 5.	Go to step 4.
<p>Step 4</p> <ol style="list-style-type: none"> 1 Reseat the ADF cable. 2 Check the ADF cable for proper connection and damage. 3 Check the ADF assembly for proper installation and damage. 4 Check the ADF cover sensor for damage. <p>Is the ADF assembly properly installed and free of damage?</p>	Go to step 6.	Go to step 5.
<p>Step 5</p> <p>Replace the ADF assembly. See ADF Scanner and Flatbed Scanner Removal .</p> <p>Does the problem remain?</p>	Go to step 6.	The problem is solved.

Diagnostics and Troubleshooting

Action	Yes	No
<p>Step 6</p> <ol style="list-style-type: none"> 1 Reseat all the scanner cables on the controller board. 2 Enter the Diagnostics menu, and then navigate to: Scanner diagnostics > Motor tests > Flatbed scanner <p>Did the motor run?</p>	Go to step 9.	Go to step 7.
<p>Step 7</p> <ol style="list-style-type: none"> 1 Make sure that the flatbed scanner cables are properly connected and free of damage. 2 Check the flatbed scanner for proper installation and damage. <p>Is the flatbed scanner properly installed and free of damage?</p>	Go to step 9.	Go to step 8.
<p>Step 8</p> <p>Replace the flatbed scanner. See ADF Scanner and Flatbed Scanner Removal.</p> <p>Does the problem remain?</p>	Go to step 9.	The problem is solved.
<p>Step 9</p> <ol style="list-style-type: none"> 1 Reseat all the cables on the controller board. 2 Check if the controller board LED lights up. 3 Check the controller board for proper installation and damage. <p>Is the controller board properly installed and free of damage?</p>	Contact the next level of support.	Go to step 10.
<p>Step 10</p> <p>Replace the controller board. See Controller board removal.</p> <p>Does the problem remain?</p>	Contact the next level of support.	The problem is solved.

Flatbed Home Position Service Check

Action	Yes	No
<p>Step 1</p> <p>Raise the ADF assembly, and then make sure that the scan area is free of dust and obstructions.</p> <p>Does the problem remain?</p>	Go to step 2.	The problem is solved.
<p>Step 2</p> <ol style="list-style-type: none"> 1 Reseat all the scanner cables on the controller board. 2 Perform a POR. <p>Does the problem remain?</p>	Go to step 3.	The problem is solved.
<p>Step 3</p> <ol style="list-style-type: none"> 1 Reseat all the scanner cables on the controller board. 2 Enter the Diagnostics menu, and then navigate to: Scanner diagnostics > Motor tests > Flatbed scanner <p>Did the motor run?</p>	Go to step 6.	Go to step 4.
<p>Step 4</p> <ol style="list-style-type: none"> 1 Make sure that the flatbed scanner cables are properly connected and free of damage. 2 Check the flatbed scanner for proper installation and damage. <p>Is the flatbed scanner properly installed and free of damage?</p>	Go to step 6.	Go to step 5.
<p>Step 5</p> <p>Replace the flatbed scanner. See ADF Scanner and Flatbed Scanner Removal.</p> <p>Does the problem remain?</p>	Go to step 6.	The problem is solved.

Diagnostics and Troubleshooting

Action	Yes	No
Step 6 1 Reseat all the cables on the controller board. 2 Check if the controller board LED lights up. 3 Check the controller board for proper installation and damage. Is the controller board properly installed and free of damage?	Contact the next level of support.	Go to step 7.
Step 7 Replace the controller board. See Controller board removal . Does the problem remain?	Contact the next level of support.	The problem is solved.

Other Symptoms

Base Printer Symptoms

Symptom	Action
Front door is closed or open.	See Door switch service check .
Tray 1 is empty.	See Load tray 1 with A4 plain paper service check .
Paper did not arrive in the bin.	See Paper Did Not Arrive In The Bin Service Check .
Tray insert is obstructed.	See Tray Insert Obstructed Service Check .
Unable to remove the toner cartridge.	See Unable To Remove Toner Cartridge Service Check .
Fax not detected.	See Fax Not Detected Service Check .
No display.	See No Display Service Check .
No power.	See No Power Service Check .
ADF cover is open.	See ADF Cover Open Service Check .

Door Switch Service Check

Action	Yes	No
Step 1 1 Check the front door flag for damage. 2 Check the front door hinge for damage. Are the front door flag and hinge free of damage?	Go to step 3.	Go to step 2.
Step 2 Replace the front door. See Front door removal . Does the problem remain?	Go to step 3.	The problem is solved.
Step 3 1 Check the HVPS characterization. 2 Reseat the HVPS cables. 3 Check the HVPS cables for proper installation and damage. 4 Check the HVPS spring contact for proper connection to the board.	Go to step 5.	Go to step 4.

Action	Yes	No
<p>5 Check the door switch for damage and proper alignment.</p> <p>Is the HVPS properly installed and free of damage?</p>		
<p>Step 4</p> <p>Replace the HVPS. See HVPS removal.</p> <p>Make sure to perform the HVPS characterization when replacing the HVPS.</p> <p>Does the problem remain?</p>	Go to step 5.	The problem is solved.
<p>Step 5</p> <p>1 Reseat all the cables on the controller board.</p> <p>2 Check the controller board for proper installation and damage.</p> <p>3 Check if the controller board LED lights up.</p> <p>Is the controller board properly installed and free of damage?</p>	Contact the next level of support.	Go to step 6.
<p>Step 6</p> <p>Replace the controller board. See Controller board removal.</p> <p>Does the problem remain?</p>	Contact the next level of support.	The problem is solved.

Load Tray 1 With A4 Plain Paper Service Check

Action	Yes	No
<p>Step 1</p> <p>1 Make sure that the tray insert is properly inserted.</p> <p>2 Make sure that the paper is properly loaded in the tray.</p> <p>3 Make sure that the paper type and size settings match the paper type and size set on the tray.</p> <p>4 Make sure that the lift plate is properly working.</p> <p>Does the problem remain?</p>	Go to step 2.	The problem is solved.
<p>Step 2</p> <p>1 Reseat the sensor cable.</p>	Go to step 5.	Go to step 3.

Action	Yes	No
<p>2 Enter the Diagnostics menu, and then navigate to:</p> <p>Printer diagnostics & adjustments > Sensor tests</p> <p>3 Find the sensor (paper present).</p> <p>Does the sensor status change while toggling the sensor?</p>		
<p>Step 3</p> <p>1 Check the sensor for proper installation and damage.</p> <p>2 Check the alignment of the sensor with the sensor flag.</p> <p>3 Check the sensor cable for proper connection and damage.</p> <p>Is the sensor properly installed and free of damage?</p>	Go to step 5.	Go to step 4.
<p>Step 4</p> <p>Replace the sensor. See Sensor (paper present) removal.</p> <p>Does the problem remain?</p>	Go to step 5.	The problem is solved.
<p>Step 5</p> <p>1 Enter the Diagnostics menu, and then navigate to:</p> <p>Printer diagnostics & adjustment > Sensor tests</p> <p>2 Find the following sensors:</p> <ul style="list-style-type: none"> • Sensor (media present in tray1 S1) • Sensor (input sensor S3) • Sensor (fuser exit sensor S4) <p>Does the sensor status change while toggling the sensor?</p>	Go to step 8.	Go to step 6.
<p>Step 6</p> <p>1 Check the sensor flags for proper installation and damage.</p> <p>2 Check the sensor flags for proper alignment with the sensors.</p>	Go to step 8.	Go to step 7.

Diagnostics and Troubleshooting

Action	Yes	No
<p>3 Check the sensor flag springs for proper installation and damage.</p> <p>Are the sensor flags properly installed and free of damage?</p>		
<p>Step 7</p> <p>Replace the damaged sensor flag.</p> <p>Does the problem remain?</p>	Go to step 8.	The problem is solved.
<p>Step 8</p> <p>1 Make sure that the separator roller is free of dust and contamination.</p> <p>2 Make sure that the lift plate is properly working.</p> <p>3 Make sure that the paper guides are properly working.</p> <p>4 Check the tray insert for proper installation and damage.</p> <p>Is the tray insert properly installed, and free of contamination and damage?</p>	Go to step 10.	Go to step 9.
<p>Step 9</p> <p>Replace the tray insert.</p> <p>Does the problem remain?</p>	Go to step 10.	The problem is solved.
<p>Step 10</p> <p>Check the cables for proper connection and damage.</p> <p>Are the cables properly connected and free of damage?</p>	Go to step 12.	Go to step 11.
<p>Step 11</p> <p>Replace the damaged cable.</p> <p>Does the problem remain?</p>	Go to step 12.	The problem is solved.

Action	Yes	No
Step 12 1 Reseat all the cables on the controller board. 2 Check if the controller board LED lights up. 3 Check the controller board for proper installation and damage. Is the controller board properly installed and free of damage?	Contact the next level of support.	Go to step 13.
Step 13 Replace the controller board. See Controller board removal . Does the problem remain?	Contact the next level of support.	The problem is solved.

Paper Did Not Arrive In The Bin Service Check

Action	Yes	No
Step 1 1 Make sure that the tray insert is properly inserted. 2 Make sure that the paper type and size settings match the paper type and size set on the tray. 3 Make sure that the duplex unit is properly inserted. 4 Make sure that the paper size setting in the duplex unit matches the printer setting. 5 Make sure that the front and rear doors are fully closed. 6 Make sure that the output bin is free from obstructions. Does the problem remain?	Go to step 2.	The problem is solved.
Step 2 1 Remove the imaging unit and toner cartridge, and then make sure that the paper path is free of jams and obstructions. 2 Clear all rollers of dirt and contamination. Does the problem remain?	Go to step 3.	The problem is solved.
Step 3 1 Perform a POR.	Go to step 4.	The problem is solved.

Diagnostics and Troubleshooting

Action	Yes	No
<p>2 Enter the Diagnostics menu, and then navigate to:</p> <p>Input tray quick print > Tray 1 > Single</p> <p>Does the problem remain?</p>		
<p>Step 4</p> <p>Check the rear door for proper installation and damage.</p> <p>Is the door properly installed and free of damage?</p>	Go to step 6.	Go to step 5.
<p>Step 5</p> <p>Replace the rear door. See Rear door removal.</p> <p>Does the problem remain?</p>	Go to step 6.	The problem is solved.
<p>Step 6</p> <p>1 Enter the Diagnostics menu, and then navigate to:</p> <p>Printer diagnostics & adjustment > Motor tests</p> <p>2 Select Motor (transport).</p> <p>3 Check if the exit roller turns.</p> <p>Did the exit roller turn?</p>	Go to step 9.	Go to step 7.
<p>Step 7</p> <p>1 Make sure that the redrive gears are in proper contact with the printer drive gears.</p> <p>2 Check the redrive gears for proper installation and damage.</p> <p>3 Check the roller for wear, contamination, and damage.</p> <p>Is the redrive properly installed and free of damage?</p>	Go to step 9.	Go to step 8.
<p>Step 8</p> <p>Replace the redrive. See Redrive removal.</p> <p>Does the problem remain?</p>	Go to step 9.	The problem is solved.
<p>Step 9</p> <p>1 Enter the Diagnostics menu, and then navigate to:</p>	Go to step 11.	Go to step 10.

Action	Yes	No
<p>Printer diagnostics & adjustments > Motor tests</p> <p>2 Select Motor (transport drive).</p> <p>Does the motor run?</p>		
<p>Step 10</p> <p>1 Reseat the motor cable at both ends.</p> <p>2 Make sure that the motor gear is properly aligned with the drive gears.</p> <p>3 Check the motor for proper installation and damage.</p> <p>Is the motor properly installed and free of damage?</p>	Go to step 11.	Contact the next level of support.
<p>Step 11</p> <p>1 Enter the Diagnostics menu, and then navigate to:</p> <p>Input tray quick print > Tray 1 > Single</p> <p>2 Enter the Diagnostics menu, and then navigate to:</p> <p>Input tray quick print > Duplex > Single</p> <p>Does the problem remain?</p>	Go to step 12.	The problem is solved.
<p>Step 12</p> <p>1 Make sure that the main drive is properly installed and free of damage.</p> <p>2 Make sure that the main drive gears are properly installed.</p> <p>3 Make sure that the drive gears are in proper contact with the gear they are driving.</p> <p>Does the problem remain?</p>	Go to step 13.	The problem is solved.
<p>Step 13</p> <p>Replace the main drive. See Main drive removal.</p> <p>Does the problem remain?</p>	Contact the next level of support.	The problem is solved.

Tray Insert Obstructed Service Check

Action	Yes	No
<p>Step 1</p> <ol style="list-style-type: none"> 1 Make sure that the tray insert is properly inserted. 2 Make sure that the paper is properly loaded in the tray. 3 Make sure that the paper type and size settings match the paper type and size set on the tray. 4 Make sure that the lift plate is properly working. <p>Does the problem remain?</p>	Go to step 2.	The problem is solved.
<p>Step 2</p> <ol style="list-style-type: none"> 1 Make sure that the separator roller is free of dust and contamination. 2 Make sure that the lift plate is properly working. 3 Make sure that the paper guides are properly working. 4 Check the tray insert for proper installation and damage. <p>Is the tray insert properly installed, and free of contamination and damage?</p>	Contact the next level of support.	Go to step 3.
<p>Step 3</p> <p>Replace the tray insert.</p> <p>Does the problem remain?</p>	Contact the next level of support.	The problem is solved.

Unable To Remove Toner Cartridge Service Check

Action	Yes	No
<p>Step 1</p> <ol style="list-style-type: none"> 1 Check the front door for proper installation and damage. 2 Check the front door flag for damage. 3 Check the front door hinge for damage. 4 Check if the front door properly closes. <p>Is the front door properly installed and free of damage?</p>	Go to step 3.	Go to step 2.
<p>Step 2</p> <p>Replace the front door. See Front door removal.</p> <p>Does the problem remain?</p>	Go to step 3.	The problem is solved.
<p>Step 3</p> <p>Check the front door link for proper installation and damage.</p> <p>Is the front door link properly installed and free of damage?</p>	Go to step 4.	Contact the next level of support.
<p>Step 4</p> <ol style="list-style-type: none"> 1 Enter the Diagnostics menu, and then navigate to: Printer diagnostics & adjustments > Motor tests 2 Select Motor (transport drive). <p>Did the motor run?</p>	Go to step 5.	Go to step 6.
<p>Step 5</p> <ol style="list-style-type: none"> 1 Enter the Diagnostics menu, and then navigate to: Input tray quick print > Tray 1 > Single 2 Enter the Diagnostics menu, and then navigate to: Input tray quick print > Duplex > Single <p>Does the problem remain?</p>	Go to step 6.	The problem is solved.

Action	Yes	No
<p>Step 6</p> <ol style="list-style-type: none"> 1 Make sure that the main drive is properly installed and free of damage. 2 Make sure that the main drive gears are properly installed. 3 Make sure that the drive gears are in proper contact with the gear they are driving. <p>Does the problem remain?</p>	Go to step 7.	The problem is solved.
<p>Step 7</p> <p>Replace the main drive. See Main drive removal.</p> <p>Does the problem remain?</p>	Contact the next level of support.	The problem is solved.

Fax Not Detected Service Check

Action	Yes	No
<p>Step 1</p> <ol style="list-style-type: none"> 1 Reseat all the cables on the top cover. 2 Check the top cover for proper installation and damage. 3 Check the fax card cable for proper connection and damage. 4 Check the cable of the attached controller card switch for proper connection and damage. 5 Check all electronics attached to the top cover for proper installation and damage. <p>Are the top cover and all its electronic components properly installed and free of damage?</p>	Go to step 3.	Go to step 2.
<p>Step 2</p> <p>Replace the top cover. See Top Cover Removal.</p> <p>Does the problem remain?</p>	Go to step 3.	The problem is solved.

Action	Yes	No
Step 3 1 Reseat all the cables on the controller board. 2 Check if the controller board LED lights up. 3 Check the controller board for proper installation and damage. Is the controller board properly installed and free of damage?	Contact the next level of support.	Go to step 4.
Step 4 Replace the controller board. See Controller board removal . Does the problem remain?	Contact the next level of support.	The problem is solved.

No Display Service Check

Action	Yes	No
Step 1 1 Reseat all the cables on the controller board. 2 Check if the controller board LED lights up. Does the controller board LED light up?	Go to step 2.	Go to step 4.
Step 2 1 Check the control panel for proper installation and damage. 2 Check the control panel cable for proper installation and damage. Is the control panel properly installed and free of damage?	Go to step 4.	Go to step 3.
Step 3 Replace the control panel. See 2.8-in. Control Panel Removal . Does the problem remain?	Go to step 4.	The problem is solved.

Action	Yes	No
<p>Step 4</p> <ol style="list-style-type: none"> 1 Reseat all the cables on the controller board. 2 Check if the controller board LED lights up. 3 Check the controller board for proper installation and damage. <p>Is the controller board properly installed and free of damage?</p>	Contact the next level of support.	Go to step 5.
<p>Step 5</p> <p>Replace the controller board. See Controller board removal.</p> <p>Does the problem remain?</p>	Contact the next level of support.	The problem is solved.

No Power Service Check

Action	Yes	No
<p>Step 1</p> <ol style="list-style-type: none"> 1 Reseat all the cables on the controller board. 2 Check if the controller board LED lights up when the power is on. <p>Does the controller board LED light up?</p>	Go to step 5.	Go to step 2.
<p>Step 2</p> <ol style="list-style-type: none"> 1 Reseat the cables connected to the LVPS. 2 Check the cables for proper connection and damage. 3 Check the fuse for continuity. 4 Check the electronic components on the LVPS for damage. 5 Check the LVPS for proper installation and damage. <p>Is the LVPS properly installed and free of damage?</p>	Go to step 5.	Go to step 3.
<p>Step 3</p> <ol style="list-style-type: none"> 1 Make sure that the LVPS is compatible with the fuser and the printer. 	Go to step 4.	The problem is solved.

Action	Yes	No
<p>2 Make sure that there is voltage coming out of the fuser connector.</p> <p>3 Make sure that the correct power input voltage is applied.</p> <p>Does the problem remain?</p>		
<p>Step 4</p> <p>Replace the LVPS. See LVPS removal.</p> <p>Does the problem remain?</p>	Go to step 5.	The problem is solved.
<p>Step 5</p> <p>Check the cables for proper connection and damage.</p> <p>Are the cables properly connected and free of damage?</p>	Go to step 7.	Go to step 6.
<p>Step 6</p> <p>Replace the damaged cable.</p> <p>Does the problem remain?</p>	Go to step 7.	The problem is solved.
<p>Step 7</p> <p>1 Reseat all the cables on the controller board.</p> <p>2 Check if the controller board LED lights up.</p> <p>3 Check the controller board for proper installation and damage.</p> <p>Is the controller board properly installed and free of damage?</p>	Contact the next level of support.	Go to step 8.
<p>Step 8</p> <p>Replace the controller board. See Controller board removal.</p> <p>Does the problem remain?</p>	Contact the next level of support.	The problem is solved.

ADF Cover Open Service Check

Action	Yes	No
<p>Step 1</p> <ol style="list-style-type: none"> 1 Clean the ADF pick rollers and separator pad. 2 Enter the Diagnostics menu, and then navigate to: Scanner diagnostics > Feed test <p>Does the problem remain?</p>	Go to step 2.	The problem is solved.
<p>Step 2</p> <ol style="list-style-type: none"> 1 Check the ADF pick and feed rollers for wear, damage, and contamination. 2 Check the ADF pick separator pad for wear, damage, contamination, and spring load. 3 Check if the ADF cover properly closes. <p>Is the ADF pick assembly properly installed and free of damage?</p>	Go to step 4.	Go to step 3.
<p>Step 3</p> <p>Replace the ADF pick assembly. See ADF Pick Assembly Removal.</p> <p>Does the problem remain?</p>	Go to step 4.	The problem is solved.
<p>Step 4</p> <ol style="list-style-type: none"> 1 Enter the Diagnostics menu, and then navigate to: Scanner diagnostics > Motor tests 2 Select Motor (ADF transport). <p>Does the motor run?</p>	Go to step 6.	Go to step 5.
<p>Step 5</p> <ol style="list-style-type: none"> 1 Reseat the ADF cable. 2 Check the ADF cable for proper connection and damage. 3 Check the ADF assembly for proper installation and damage. 4 Check the ADF cover sensor for damage. <p>Is the ADF assembly properly installed and free of damage?</p>	Go to step 7.	Go to step 6.

Action	Yes	No
<p>Step 6</p> <p>Replace the ADF assembly. See ADF Scanner and Flatbed Scanner Removal .</p> <p>Does the problem remain?</p>	Go to step 7.	The problem is solved.
<p>Step 7</p> <ol style="list-style-type: none"> 1 Reseat all the cables on the controller board. 2 Check if the controller board LED lights up. 3 Check the controller board for proper installation and damage. <p>Is the controller board properly installed and free of damage?</p>	Contact the next level of support.	Go to step 8.
<p>Step 8</p> <p>Replace the controller board. See Controller board removal.</p> <p>Does the problem remain?</p>	Contact the next level of support.	The problem is solved.

Service Menus

Understanding The Printer Control Panel

Using the Xerox B225 Printer Control Panel

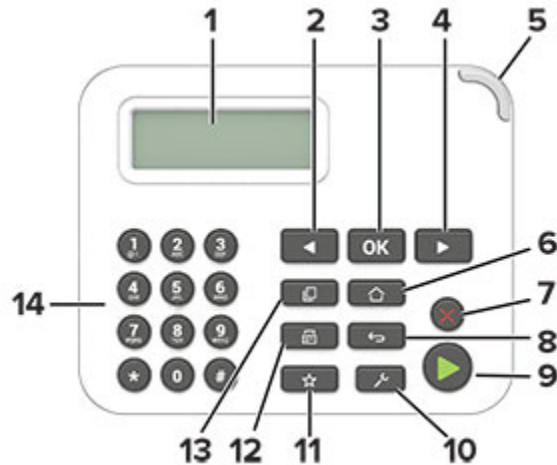

	Control panel part	Function
1	Display	<ul style="list-style-type: none"> View printer messages and supply status. Set up and operate the printer.
2	Left arrow button	<ul style="list-style-type: none"> Scroll through menus or move between screens and menu options. Decrease the numeric value of a setting.
3	Select button	<ul style="list-style-type: none"> Select a menu option. Save the changes in a setting.
4	Right arrow button	<ul style="list-style-type: none"> Scroll through menus or move between screens and menu options. Increase the numeric value of a setting.
5	Indicator light	Check the status of the printer.
6	Home button	Go to the home screen.
7	Stop or Cancel button	Stop the current job.
8	Back button	Return to the previous screen.
9	Start button	Start a job, depending on which mode is selected.
10	Menu button	Access the printer menus.

	Control panel part	Function
11	Shortcuts button	Access shortcuts to frequently used functions with previously saved settings.
12	Fax button	Enter Fax mode.
13	Copy button	Enter Copy mode.
14	Numeric keypad	Enter numbers or symbols in an input field.

Using the Xerox B235 Printer Control Panel



	Control panel part	Function
1	Home button	Go to the home screen.
2	Back button	Return to the previous screen.
3	Start button	Start a job, depending on which mode is selected.
4	Indicator light	Check the status of the printer.
5	Display	<ul style="list-style-type: none"> View printer messages and supply status. Set up and operate the printer.

Understanding the Status of the Power Button and Indicator Light

Indicator light		Printer status
B225	B235	
Off	Off	The printer is off or in Sleep mode.
Blinking green	Blinking blue	The printer is ready or processing data.
Blinking red	Blinking red	The printer requires user intervention.
	Blue	The printer is on or ready.

Power button light		Printer status
B225	B235	
Off	Off	The printer is off, ready, or processing data.
On	White	The printer is in Sleep or Hibernate mode.

Diagnostics Menu

Entering the Diagnostics Menu

The Diagnostics menu contains tests that are used to help isolate issues with the printer.

To access the Diagnostics menu in B225 printers, perform the following:

- To access the Diagnostics menu from POST, press and hold **Left arrow** and **OK** on the control panel.
- To access the Diagnostics menu from the home screen, press **Back**, **Right arrow**, **Back**, and **Right arrow** on the control panel.

To access the Diagnostics menu in B235 printers, perform the following:

- To access the Diagnostics menu from POST:
 1. Unplug the printer.
 2. Open tray 1.

 **Note:** Make sure that paper is present in the tray.

3. Plug the printer.

When the display shows the following icon, close tray 1.

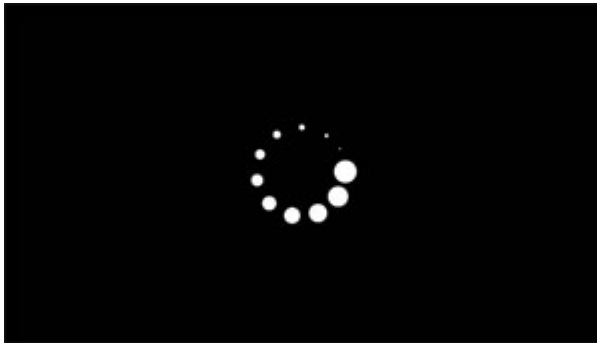

4. A menu appears on the display.
Select **Diagnostics_Mode**, and then select **Boot**.
- To access the Diagnostics menu from the home screen, press these buttons in the following sequence:
Back, Back, Start, Start

Reports

Device Settings

This report lists all the current printer settings.

Enter the Diagnostics menu, and then navigate to:

Reports > Device > Device Settings

For non-touch-screen printer models, press  to navigate through the settings.

Installed Licenses

This setting lists all the installed licenses and their feature data.

Enter the Diagnostics menu, and then navigate to:

Reports > Licenses > Installed Licenses

For non-touch-screen printer models, press  to navigate through the settings.

Advanced Print Quality Samples

This setting prints a list of the printer settings and sample pages to check print quality.

Enter the Diagnostics menu, and then select **Advanced Print Quality Samples**.

For non-touch-screen printer models, press  to navigate through the settings.

Format Fax Storage

This setting deletes stored fax jobs.

Enter the Diagnostics menu, and then navigate to:

Format Fax Storage > Format Fax Storage

For non-touch-screen printer models, press  to navigate through the settings.

Event Log

Display Log

This setting displays the panel text that appears when the event occurs.

Enter the Diagnostics menu, and then navigate to:

Event Log > Display Log

For non-touch-screen printer models, press  to navigate through the settings.

Print Log

This setting lists an extended version of the various printer events.

Enter the Diagnostics menu, and then navigate to:

Event Log > Print Log

For non-touch-screen printer models, press  to navigate through the settings.

 **Note:** The events that appear in the report vary depending on the operational history of the printer.

Print Log Summary

This setting lists a brief summary of the various printer events.

Enter the Diagnostics menu, and then navigate to:

Event Log > Print Log Summary

For non-touch-screen printer models, press  to navigate through the settings.

 **Note:** The events that appear in the report vary depending on the operational history of the printer.

Mark Log

This setting allows you to create a service, maintenance, or custom log entry. Each log entry is added in the printer event log.

1. Enter the Diagnostics menu, and then navigate to:

Event Log > Mark Log

For non-touch-screen printer models, press  to navigate through the settings.

2. Select a log that you want to create.

Input Tray Quick Print

This setting lets you print a single or continuous Quick test page in either duplex or simplex mode.

1. Enter the Diagnostics menu, and then select **Input tray quick print**.

For non-touch-screen printer models, press  to navigate through the settings.

2. Select where you want to print the pages from.
3. Select whether to print a single or continuous test page.

Output Bin Quick Feed

This setting lets you feed a single or continuous page from the standard bin.

1. Enter the Diagnostics menu, and then navigate to:

Output bin quick feed > Standard bin

For non-touch-screen printer models, press  to navigate through the settings.

2. Select whether to print a single or continuous test page.

Printer Setup

Printed Page Count (mono)

This setting displays the amount of pages printed in mono.

1. Enter the Diagnostics menu, and then navigate to:
Printer Setup > Printed page count (mono)
2. View the printed page count for mono.

Permanent Page Count

This setting displays the total number of pages printed. After all the print tests are completed, this value resets to zero.

1. Enter the Diagnostics menu, and then navigate to:
Printer Setup > Permanent page count
2. View the permanent page count.

Processor ID

This setting indicates the ID of the processor on the controller board.

1. Enter the Diagnostics menu, and then navigate to:
Printer Setup > Processor ID
2. View the processor ID.

Serial Number

This setting displays a read-only value of the printer serial number.

1. Enter the Diagnostics menu, and then navigate to:
Printer Setup > Serial number
2. View the serial number.

Model Name

This setting displays the model name of the printer.

1. Enter the Diagnostics menu, and then navigate to:
Printer Setup > Model name
2. View the model name.

Engine Setting [x]

 **Warning:** Do not change this setting without specific instructions from the next level of support.

This setting allows you to select a printer engine setting. Possible values are 0–255. 0 is the default.

For non-touch-screen printer models, press  to navigate through the settings.

1. Enter the Diagnostics menu, and then navigate to:

Printer Setup > Engine setting [x]

2. Select a setting, and then enter a value.

EP Setup

 **Warning:** Do not change this setting without specific instructions from the next level of support.

This setting allows you to adjust the EP setup of the printer.

For non-touch-screen printer models, press  to navigate through the settings.

1. Enter the Diagnostics menu, and then navigate to:

Printer Setup > EP setup

2. Select a setting.

Printer Diagnostics & Adjustments

Sensor Tests

1. Enter the Diagnostics menu, and then select **Printer diagnostics & adjustments**.

A list of sensor tests appears.

2. Find, and then manually toggle the sensor.

 **Note:**

- The sensor status on the screen toggles between **1** and **0** when the sensor is properly working.
- If a sensor test fails, the test failure may not indicate a failed sensor. Further troubleshooting may be required. Check the boards and cables for possible issues.
- For the fuser exit sensor actuator, toggle it toward the rear door.

List Of Sensor Tests

Sensor (front door)
Sensor (media present in tray1 S1)
Sensor (staging sensor S2)

Sensor (input sensor S3)
Sensor (fuser exit sensor S4)

Motor Tests

1. Enter the Diagnostics menu, and then navigate to:

Printer diagnostics & adjustments > Motor tests

For non-touch-screen printer models, press  to navigate through the settings.

2. Select a motor.

 **Note:**

- If the motor is activated, then it is properly working.
- Some motors require automatic deactivation to avoid secondary issues such as possible damage and contamination.
- Some tests require a special action to activate a motor such as removing a major component.
- If the motor fails, the test failure may not indicate a failed motor. Further troubleshooting may be required. Check the boards and cables for possible issues.
- To stop a running motor in non-touch-screen printer models, press .

List Of Motor Tests

Motor (transport drive)
Feed solenoid
Skew correction solenoid
Fan (main)

Registration Adjust

This setting lets you adjust the skew, margins, or print a Quick test page.

For non-touch-screen printer models, press  to navigate through the settings.

1. Enter the Diagnostics menu, and then navigate to:

Printer diagnostics & adjustments > Registration adjust

2. Select a setting to adjust.

Universal Override

This setting allows the user to feed custom media sizes to a Custom Media Tray.

For non-touch-screen printer models, press  to navigate through the settings.

1. Enter the Diagnostics menu, and then navigate to:
Printer diagnostics & adjustments > Universal Override
2. Select a setting to adjust.

HVPS Adjust

This setting allows the HVPS calibration data to be recovered or entered for the specific HVPS installed. The HVPS calibration data must come from the next level of support.

For non-touch-screen printer models, press  to navigate through the settings.

1. Enter the Diagnostics menu, and then navigate to:
Printer diagnostics & adjustments > HVPS adjust
2. Select a setting to adjust.

Scanner Diagnostics

Motor Tests

1. Enter the Diagnostics menu, and then navigate to:
Scanner Diagnostics > Motor Tests

For non-touch-screen printer models, press  to navigate through the settings.

2. Select a motor.

Note:

- If the motor is activated, then it is properly working.
- Some motors require automatic deactivation in order to avoid secondary issues such as possible damage and contamination.
- Some tests require a special action to activate a motor such as removing a major component.
- If the motor fails, the test failure may not indicate a failed motor. Further troubleshooting may be required. Check the boards and cables for possible issues.

List Of Motor Tests

Flatbed Scanner
ADF Transport

Sensor Tests

This test verifies the status of the scanner sensors.

1. Enter the Diagnostics menu, and then navigate to:
Scanner Diagnostics > Sensor Test

For non-touch-screen printer models, press  to navigate through the settings.

2. Select a sensor.
3. Find, and then manually toggle the sensor.

 **Note:**

- The sensor status on the screen toggles between **1** and **0** when the sensor is properly working.
- If a sensor test fails, the test failure may not indicate a failed sensor. Further troubleshooting may be required. Check the boards and cables for possible issues.

List Of Sensor Tests

Sensor (FB CCD home)
Sensor (ADF closed)
Sensor (ADF media present)
Sensor (ADF 1st scan)
Sensor (ADF top door interlock)

Feed Test

This test allows for a continuous feed from the ADF or flatbed.

1. Enter the Diagnostics menu, and then navigate to:
Scanner Diagnostics > Feed Test

For non-touch-screen printer models, press  to navigate through the settings.

2. Select a paper size.
3. Select **Feed Test**.

Scanner Calibration Reset

Before starting the test, make sure that the scanner glass and scanner glass pad are clean. For more information, see [Cleaning The Scanner](#).

1. Enter the Diagnostics menu, and then select **Scanner Diagnostics**.

For non-touch-screen printer models, press  to navigate through the settings.

2. Select **Sensor Calibration Reset**.

To verify the result, do the following:

1. Load the ADF with a document containing light and dark content.
2. Print both sides of the document.

 **Note:**

- If the back side of the copy has vertical streaks, then clean the scanner glass and scanner glass pad, and then print another copy.
- If the streaks still appear, then repeat the cleaning and verification procedure or replace the ADF.

Config Menu

Entering the Config Menu

The Config menu consists of menus, settings, and operations that are used to configure the printer.

- To access the Config menu in B225 printers, press and hold **Right arrow** and **OK** on the control panel, and then turn on the printer.
- To access the Config menu in B235 printers, from the control panel, navigate to:
Settings > Device > Maintenance > Config Menu

Config Menu

Menu item	Description
USB Configuration USB PnP 1* 2	Change the USB driver mode of the printer to improve its compatibility with a personal computer.
USB Configuration USB Scan to Local On* Off	Set whether the USB device driver enumerates as a USB Simple device (single interface) or as a USB Composite device (multiple interfaces).
USB Configuration USB Speed Full Auto*	Set the USB port to run at full speed and disable its high-speed capabilities.
Tray Configuration Show Tray Insert Message Off Only for unknown sizes* Always	Show message about the tray status.
Tray Configuration A5 Loading Short Edge* Long Edge	Specify the page orientation when loading A5 paper size.
Tray Configuration Paper Prompts	Set the paper source that the user fills when a prompt to load paper or envelope appears.

Menu item	Description
Auto* Manual Paper Envelope Prompts Auto* Manual Envelope	
Tray Configuration Action for Prompts Prompt user* Continue Use current	Set the printer to resolve paper- or envelope-related change prompts.
Reports Menu Settings Page Event Log Event Log Summary	Print reports about printer menu settings, status, and event logs.
Supply Usage And Counters Clear Supply Usage History Reset Black Cartridge Counter Reset Black Imaging Unit Counter	Reset the supply page counter or view the total printed pages.
Fax Configuration Fax Low Power Support Disable Sleep Permit Sleep Auto*	Specify the printer power setting when it is in fax mode.
Print Configuration Font Sharpening 0–150(24*)	Set a text point-size value below which the high-frequency screens are used when printing font data.
Print Configuration Print Density 1–5 (3*) Copy Density 1–5 (3*)	Adjust the toner density when printing or copying documents.
Device Operations Quiet Mode	Set the printer to reduce the amount of noise that it makes when printing.

Service Menus

Menu item	Description
On Off*	This setting slows down the overall performance of the printer.
Device Operations Panel Menus Enable* Disable	Set the printer to show the control panel menus.
Device Operations Clear Custom Status	Erase all custom messages.
Scanner Configuration Scanner Manual Registration Print Quick Test	Print a Quick Test target page. Make sure that the margin spacing on the target page is uniform all the way around the target. If it is not, then the printer margins may need to be reset.
Scanner Configuration Scanner Manual Registration Front ADF Registration Flatbed Registration	Manually register the flatbed and ADF after replacing the ADF, scanner glass, or controller board.
Scanner Configuration Edge Erase ADF Edge Erase 0–6 (3*) Flatbed Edge Erase 0–6 (3*)	Set the size, in millimeters, of the no-print area around an ADF or flatbed scan job.
Scanner Configuration Disable Scanner Enabled* Disabled ADF Disabled	Disable the scanner if it is not working properly.
Scanner Configuration Tiff Byte Order CPU Endianness* Little Endian Big Endian	Set the byte order of a TIFF-formatted scan output.

Menu item	Description
Scanner Configuration Exact Tiff Rows Per Strip On* Off	Set the RowsPerStrip tag value of a TIFF-formatted scan output.
An asterisk (*) next to a value indicates the factory default setting.	

Service Engineer Menu

Entering the Service Engineer (SE) Menu

This contains several functions that a service engineer may need in order to diagnose and fix problems on the printer.

To access the Service Engineer (SE) menu in B225 printers, perform the following:

- From the home screen, press these buttons in the following sequence:
Back, Left arrow, Back, and Left arrow

To access the Service Engineer (SE) menu in B235 printers, perform the following:

- From the home screen, press these buttons in the following sequence:
Back, Back, Home, Home

General SE

This setting allows you to save a log file to a USB drive.

Enter the Service Engineer (SE) menu, and then navigate to:

General SE > Capture Logs to USB Drive

Network SE

Enter the Service Engineer (SE) menu, and then select **Network SE**.

 **Note:** Use these settings as directed by the next level of support.

Top-level menu	Intermediate menu
Print SE Menus	Print SE Menus
History	<ul style="list-style-type: none"> • Print History • Mark History
MAC	<ul style="list-style-type: none"> • Set Card Speed • LAA • Keep Alive
NPAP	Print Alerts
TCP/IP	<ul style="list-style-type: none"> • netstat • arp • Allow SNMP Set • MTU • Meditech Mode • RAW LPR Mode
Wireless	Enable Wi-Fi Direct Sigma Control Agent

Top-level menu	Intermediate menu
Ping Test	<ul style="list-style-type: none"> • Ping • Ping6
Other Actions	<ul style="list-style-type: none"> • ifconfig • IPtables [Firewall Dump] • IP6tables [Firewall Dump] • IPsec Dump

Fax SE

Use this menu for the fax transmission and fax reception service checks.

Enter the Service Engineer (SE) menu, and then select **Fax SE**.



Note: Use these settings as directed by the next level of support.

Top-level menu	Intermediate menu
Code Levels	<ul style="list-style-type: none"> • Base: [current value] • Kernel: [current value] • Network: [current value] • Engine: [current value] • Loader: [current value] • Fax: [current value] • Scanner: [current value]
Agency Test	<ul style="list-style-type: none"> • Go Off Hook • Ring Detect • Generate Tones • Modulations
Fax Settings	<ul style="list-style-type: none"> • Line Features • Fax Modulations • Detect EOLS • Print Logs • AutoPrint T30 Logs

Top-level menu	Intermediate menu
Modem Settings	<ul style="list-style-type: none"> • Caller ID Pattern Changing the value of this setting also changes the value of the Caller ID setting in the Fax Settings. • Dial Timeout • Transmit Level • Receive Thresh • DTMF Low Level • DTMF High Level • Positive Twt Ctrl • Negative Twt Ctrl • ATRA EQM Bias • V34 PreEmph Filt • Dial Tone Thresh • Progress Thresh • Pulse Make Time • Pulse Break Time • Pulse Dial Type • Interdigit Delay • Enable CEQ • V17 TX Filter • DC Characteristic • Impedance • Caller ID Pattern • Busy Tone Cycles • Busy Tone Min On Time • Busy Tone Max On Time • Busy Tone Min Off Time • Busy Tone Max Off Time • Congest Tone Cycles • Congest Tone Min On Time • Adjust Power FSK • Pulse Fall Time • High Ring Impedance
Reboot System	After this setting is selected, the control panel displays the message: About to reboot. Press Start to reboot. Press Stop to return.

Scan SE

This setting displays the current scanner registration values for each scanner source (flatbed, ADF front, ADF rear).

Enter the Service Engineer (SE) menu, and then navigate to:

Scan SE > Scanner Info

Entering Invalid Engine Mode

This mode allows the printer to load the correct firmware code.

To access the Invalid engine mode in B225 printers, perform the following:

1. Turn off the printer.
2. From the control panel, press and hold **3**, **4**, and **6** while turning on the printer.
3. Release the buttons after 10 seconds.

To access the Invalid engine mode in B235 printers, perform the following:

1. Turn off the printer.
2. Open tray 1.

 **Note:** Make sure that paper is present in the tray.

3. Perform a POR.
4. When the display shows the following icon, close tray 1.

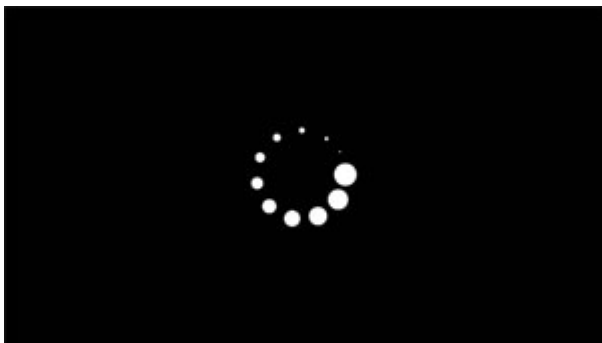

5. A menu appears on the display.
Select -> to navigate the menu, and then select **ENGINE_FLASH**.

 **Note:** ENGINE_FLASH turns green when selected.

6. Select **Boot**.

Entering Recovery Mode

This mode allows the printer to boot from a secondary set of instructions and flash firmware code. While in this mode, you can only flash firmware code through a USB cable directly connected to a PC.

Depending on your printer model, do any of the following:

For LED Display

1. Turn off the printer.
2. Open the front door.
3. Press and hold the **Stop** button.
4. Turn on the printer.
5. When all the icons flash, release the button.

For 2-line Display

1. Turn off the printer.
2. Press and hold the **OK** and **Back** buttons.
3. Turn on the printer.
4. When the display shows the following icon, release the buttons.

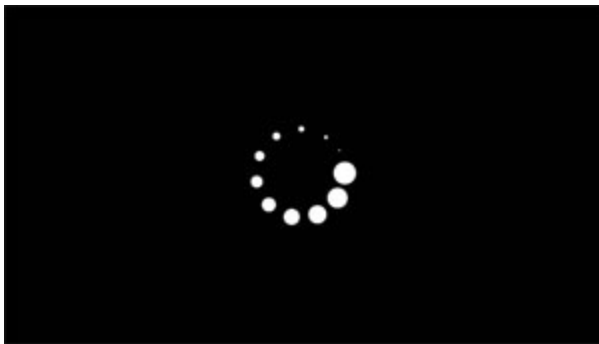

For 2.4-, 4.3-, 7-, and 10-inch Displays

1. Turn off the printer.
2. Press and hold the **2**, **7**, and **8** buttons.
3. Turn on the printer.

4. When the display shows the following icon, release the buttons.

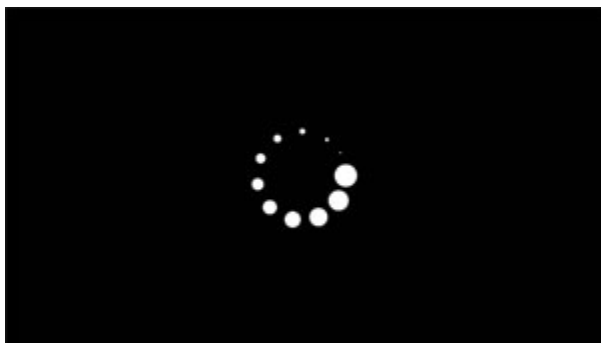

For 2.8-inch Display

1. Turn off the printer.
2. Open tray 1.
3. Make sure that paper is loaded in tray 1.
4. Turn on the printer.
5. When the display shows the following icon, close tray 1.

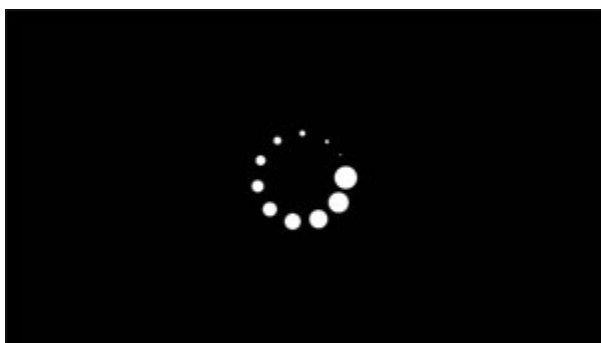







 **Note:** If tray 1 is not closed, then the printer will boot normally.

6. A screen with red selection items appears.
Touch -> to navigate to Recovery mode.
7. Touch **Boot** or **RECOVERY**.





Service Menus

Parts Removal

Removal Precautions







-  **CAUTION—SHOCK HAZARD:** The low-voltage power supply (LVPS) and the high-voltage power supply (HVPS) may have residual voltage present. To avoid the risk of electrical shock, do not touch their circuit components or the solder side of the board. Only handle them by their outer edges or metal housing.
-  **CAUTION—SHOCK HAZARD:** This product uses an electronic power switch. It does not physically disconnect the input AC voltage. To avoid the risk of electrical shock, always remove the power cord from the printer when removal of the input AC voltage is required.
-  **CAUTION—SHOCK HAZARD:** To avoid the risk of electrical shock and to prevent damage to the printer, remove the power cord from the electrical outlet and disconnect all connections to any external devices before you connect or disconnect any cable, electronic board, or assembly.
-  **CAUTION—HOT SURFACE:** The inside of the printer might be hot. To reduce the risk of injury from a hot component, allow the surface to cool before touching it.
-  **CAUTION—PINCH HAZARD:** To avoid the risk of a pinch injury, use caution in areas marked with this label. Pinch injuries may occur around moving parts, such as gears, doors, trays, and covers.
-  **CAUTION—MOVING PARTS:** To avoid the risk of laceration or abrasion injuries, keep hands away from moving parts in areas marked with this label. Injuries from moving parts may occur around gears and other rotating parts.

Précautions De Retrait



-  **ATTENTION ! RISQUE D'ÉLECTROCUTION :** Une tension résiduelle peut être présente dans le bloc d'alimentation basse tension (LVPS) et le bloc d'alimentation haute tension (HVPS). Pour éviter tout risque d'électrocution, ne touchez pas les composants du circuit ou le côté soudure de la carte. Tenez-les uniquement par leurs extrémités ou le boîtier en métal.
-  **ATTENTION ! RISQUE D'ÉLECTROCUTION :** Ce produit utilise un commutateur d'alimentation électronique. Il ne déconnecte pas physiquement la tension d'alimentation CA. Pour éviter tout risque d'électrocution, débranchez toujours le cordon d'alimentation de l'imprimante lorsque vous devez déconnecter la tension d'alimentation CA.
-  **ATTENTION ! RISQUE D'ÉLECTROCUTION :** Pour éviter tout risque d'électrocution et éviter d'endommager l'imprimante, débranchez le cordon d'alimentation de la prise électrique et déconnectez toute connexion à tout périphérique externe avant de brancher ou débrancher des câbles ou circuits et assemblages électroniques.
-  **ATTENTION ! SURFACE CHAUDE :** L'intérieur de l'imprimante risque d'être brûlant. pour réduire le risque de brûlure, laissez la surface ou le composant refroidir avant d'y toucher.
-  **ATTENTION ! RISQUE DE PINCEMENT :** Pour éviter tout risque de blessure par pincement, agissez avec précaution au niveau des zones signalées par cette étiquette. Les blessures par pincement peuvent se produire autour des pièces mobiles telles que les engrenages, portes, tiroirs et capots.



-  **ATTENTION ! PIÈCES MOBILES :** Pour éviter tout risque de coupures ou de frottements, éloignez les mains des pièces en mouvement dans les zones signalées par cette étiquette. Les pièces en mouvement autour des engrenages et autres pièces rotatives peuvent causer des blessures.

Precauciones Durante La Extracción







-  **PRECAUCIÓN—RIESGO DE DESCARGA:** La fuente de alimentación de bajo voltaje (LVPS) y la fuente de alimentación de alto voltaje (HVPS) pueden presentar voltaje residual. Para evitar el riesgo de descarga eléctrica, no toque los componentes del circuito ni el lateral soldado de la placa. Manipule solo los bordes exteriores o la carcasa metálica.
-  **PRECAUCIÓN—RIESGO DE DESCARGA:** Este producto utiliza un interruptor de corriente electrónico. No desconecta físicamente la entrada de voltaje de CA. Para evitar el riesgo de descarga eléctrica, desenchufe siempre el cable de alimentación de la impresora cuando sea necesario retirar la entrada de voltaje de CA.
-  **PRECAUCIÓN—RIESGO DE DESCARGA:** Para evitar el riesgo de descargas eléctricas y daños en la impresora, retire el cable de alimentación de la toma eléctrica y desconecte todas las conexiones a dispositivos externos antes de conectar o desconectar cualquier cable, placa electrónica o conjunto.
-  **PRECAUCIÓN—SUPERFICIE CALIENTE:** El interior de la impresora podría estar caliente. Para evitar el riesgo de heridas producidas por el contacto con un componente caliente, deje que la superficie se enfríe antes de tocarlo.
-  **PRECAUCIÓN—RIESGO DE DESCARGA ELÉCTRICA:** Para evitar el riesgo de lesión por atrapamiento, preste atención en las áreas marcadas con esta etiqueta. Las lesiones por atrapamiento se pueden producir en torno a partes móviles, tales como engranajes, puertas, bandejas y cubiertas.
-  **PRECAUCIÓN—PARTES MÓVILES:** Para evitar el riesgo de lesiones por laceración o abrasión, mantenga las manos lejos de las partes móviles en las zonas marcadas con esta etiqueta. Las lesiones causadas por partes móviles pueden producirse cerca de los engranajes u otras piezas giratorias.

Vorsichtsmaßnahmen Bei Der Demontage

-  **VORSICHT – STROMSCHLAGEFAHR:** Im Niederspannungsnetzteil (LVPS) und Hochspannungsnetzteil (HVPS) liegt unter Umständen Restspannung vor. Um das Risiko eines elektrischen Schlags zu vermeiden, berühren Sie keine umliegenden Bauteile oder die Lötseite der Platine. Fassen Sie sie nur an den Außenkanten oder am Metallgehäuse an.
-  **VORSICHT – STROMSCHLAGEFAHR:** Dieses Produkt verwendet einen elektronischen Leistungsschalter. Er trennt die Eingangswchselspannung nicht physikalisch. Um das Risiko eines elektrischen Schlags zu vermeiden, ziehen Sie stets das Netzkabel vom Drucker ab, wenn eine Abtrennung der Eingangswchselspannung erforderlich ist.
-  **VORSICHT – STROMSCHLAGEFAHR:** Um das Risiko eines elektrischen Schlags und Schäden am Drucker zu vermeiden, ziehen Sie das Netzkabel aus der Steckdose und trennen Sie alle Verbindungen zu jeglichen externen Geräten, bevor Sie Kabel, Elektronikplatinen oder Baugruppen einstecken oder abziehen.

-  **VORSICHT – HEISS:** Das Innere des Druckers kann sehr heiß sein. Vermeiden Sie Verletzungen, indem Sie heiße Komponenten stets abkühlen lassen, bevor Sie ihre Oberfläche berühren.
-  **VORSICHT – QUETSCHGEFAHR:** Um das Risiko einer Quetschung zu vermeiden, gehen Sie in Bereichen, die mit diesem Etikett gekennzeichnet sind, mit Vorsicht vor. Quetschungen können im Bereich von beweglichen Komponenten auftreten, wie z.B. Zahnrädern, Klappen, Fächern und Abdeckungen.
-  **VORSICHT – BEWEGLICHE TEILE:** Um das Risiko von Verletzungen und Abschürfungen zu vermeiden, halten Sie Ihre Hände von sich bewegenden Teilen in Bereichen fern, die mit diesem Hinweis gekennzeichnet sind. Verletzungen durch sich bewegende Teile treten unter Umständen im Bereich von Zahnrädern und anderen sich drehenden Teilen auf.

Precauzioni per la rimozione

-  **ATTENZIONE – PERICOLO DI SCOSSA ELETTRICA:** Sull'alimentatore a bassa tensione (LVPS) e l'alimentatore ad alta tensione (HVPS) può essere presente tensione residua. Per evitare il rischio di scossa elettrica, non toccare i loro componenti elettrici o il lato saldatura della scheda. Toccarli soltanto dai bordi esterni o dall'alloggiamento in metallo.
-  **ATTENZIONE – PERICOLO DI SCOSSA ELETTRICA:** Questo prodotto utilizza un interruttore di alimentazione elettronico. Tale interruttore non scollega fisicamente la tensione CA in entrata. Per evitare il rischio di scossa elettrica, rimuovere sempre il cavo di alimentazione dalla stampante quando è necessario rimuovere la tensione CA in entrata.
-  **ATTENZIONE – PERICOLO DI SCOSSA ELETTRICA:** Per evitare il rischio di scossa elettrica e per impedire danni alla stampante, rimuovere il cavo di alimentazione dalla presa elettrica e scollegare tutti i collegamenti a eventuali dispositivi esterni prima di collegare o scollegare qualsiasi cavo, scheda elettronica o gruppo.
-  **ATTENZIONE – SUPERFICIE SURRISCALDATA:** L'area interna della stampante potrebbe surriscaldarsi. Per evitare infortuni, lasciare raffreddare la superficie dei componenti prima di toccarla.
-  **ATTENZIONE – PERICOLO DI SCHIACCIAMENTO:** Per evitare il rischio di lesioni, prestare la massima cautela quando si accede alle aree contrassegnate con questa etichetta. Potrebbero infatti verificarsi lesioni da schiacciamento in prossimità di parti in movimento, quali ad esempio ingranaggi, porte, vassoi e coperchi.
-  **ATTENZIONE – PARTI MOBILI:** Per evitare il rischio di lesioni da lacerazione o abrasione, tenere le mani lontano da parti in movimento nelle aree contrassegnate con questa etichetta. Le lesioni dovute a parti in movimento possono verificarsi intorno a ingranaggi e altre parti rotanti.

Handling ESD-sensitive Parts



Many electronic products use parts that are known to be sensitive to electrostatic discharge (ESD). To prevent damage to ESD-sensitive parts, do the following:



- Turn off the printer before removing logic boards.
- Keep the parts in their original packing material until you are ready to install them into the printer.



- Make the least possible movements with your body to prevent an increase of static electricity from clothing fibers, carpets, and furniture.
- Put the ESD wrist strap on your wrist. Connect the wrist band to the system ground point. This action discharges any static electricity in your body to the printer.
- Hold the parts by their edge connector shroud. Do not touch its pins. If you are removing a pluggable module, then use the correct tool.
- If possible, keep all parts in a grounded metal cabinet.
- Do not place the parts on the printer cover or on a metal table. If you need to put down the parts, then put them into their packing material.
- Prevent parts from being accidentally touched by other personnel. Cover the printer when you are not working on it.
- Be careful while working with the parts when cold-weather heating is used. Low humidity increases static electricity.

Critical Information for Controller Board or Control Panel Replacement (for B235 Only)

 **CAUTION—POTENTIAL INJURY:** The lithium battery in this product is not intended to be replaced. There is a danger of explosion if a lithium battery is incorrectly replaced. Do not recharge, disassemble, or incinerate a lithium battery. Discard used lithium batteries according to the manufacturer's instructions and local regulations.

 **ATTENTION ! DOMMAGE POTENTIEL :**  La batterie lithium de ce produit n'est pas destinée à être remplacée. Il existe un risque d'explosion si une batterie lithium est placée de façon incorrecte. Ne rechargez pas, ne démontez pas et n'incinerez pas une batterie lithium. Mettez les batteries lithium usagées au rebut selon les instructions du fabricant et les réglementations locales.

 **PRECAUCIÓN—RIESGO DE LESIONES:**  La batería de litio de este producto no debe reemplazarse. Existe riesgo de explosión si se sustituye incorrectamente una batería de litio. No recargue, desmonte ni incinere una batería de litio. Deseche las baterías de litio según las instrucciones del fabricante y las normativas locales.

 **VORSICHT – VERLETZUNGSGEFAHR:**  Die Lithiumbatterie in diesem Produkt darf nicht ausgetauscht werden. Wird eine Lithiumbatterie nicht ordnungsgemäß ausgetauscht, besteht Explosionsgefahr. Lithiumbatterien dürfen auf keinen Fall wieder aufgeladen, auseinander genommen oder verbrannt werden. Befolgen Sie zum Entsorgen verbrauchter Lithiumbatterien die Anweisungen des Herstellers und die örtlichen Bestimmungen.

 **ATTENZIONE – PERICOLO DI LESIONI:** La batteria al litio presente nel prodotto non deve essere sostituita. In caso di sostituzione errata della batteria al litio, potrebbe verificarsi un'esplosione. Non ricaricare, smontare o bruciare batterie al litio. Smaltire le batterie al litio usate seguendo le istruzioni del produttore e le norme locali.

 **Warning:** Observe all precautions when handling ESD sensitive parts. See [Handling ESD-sensitive Parts](#).

 **Warning:** Carefully remove cables and connectors. Make sure they are not damaged.



 **Warning:** To avoid damaging the part or experience NVRAM mismatch issues, replace only one of the following components at a time:

- Control panel
- Controller board

To replace a component and to test whether the problem is resolved:

1. Replace the affected component.

 **Warning:** Do not perform a Power-On Reset (POR) until the problem is resolved. If a POR is performed at this point, then the replacement part can no longer be used in another printer and must be returned to the manufacturer.

2. Enter the Diagnostics menu. The Diagnostics menu allows you to temporarily use the replacement part.
 -  **Warning:** Some printers perform automatically a POR if the Diagnostics menu is not opened within five seconds. If a POR is performed at this point, then the replacement part can no longer be used in another printer and must be returned to the manufacturer.
3. Use the Diagnostics menu to test the replacement part. Do a feed test to check if the problem is resolved.
 - If the problem is not resolved—Turn off the printer, and then install the old part.
 - If the problem is resolved—Perform a POR.
4. To replace the controller board and the control panel simultaneously on the machine, follow the below procedure to avoid losing the printer's NVRAM settings and damaging the printer.
 - a. Replace either the controller board or the control panel on the machine. Do not replace both the parts at the same time.
 - b. Power on the printer and perform a POR.
 - c. After the printer has completed startup (printer will be either READY or post an error), power off the printer and replace the second part.
 -  **Note:** If the control panel display has failed, the printers' startup cycle is complete after the driver motor and fans shut down and the machine is quiet.
 - d. Power on the printer and allow the printer to go through a complete startup cycle and the display changes to READY.

Restoring The Printer Configuration After Replacing The Controller Board

Restore the printer to its correct configuration. Contact your Hardware Support Line to obtain the applicable zip file. Flash the printer settings and embedded solutions.

-  **Note:** The software bundle contains the latest version of the firmware, applications, and software licenses from the Lexmark Virtual Solutions Center (VSC). The printer firmware may be at a different level from what was used before replacing the controller board.

Extract the contents of the zip file.

- Perform the install instructions on the Readme file in the exact order shown. Restart the printer only if the file says so.
- For more information on how to flash the downloaded files, see [Updating The Printer Firmware](#).
- To load the zip file, see [Restoring Solutions, Licenses, and Configuration Settings](#).

After performing the installation instructions in the Readme file, confirm that the printer is restored.

- If you are unable to access the administrative menus to verify that the printer is restored, then ask the customer for access rights.
- If a 10.00 error appears after you restart the printer, then contact the next level of support.

Restoring Solutions, Licenses, and Configuration Settings

To load the zip files that you received from Hardware Support, do the following:

1. Open a web browser, and then type the printer IP address.

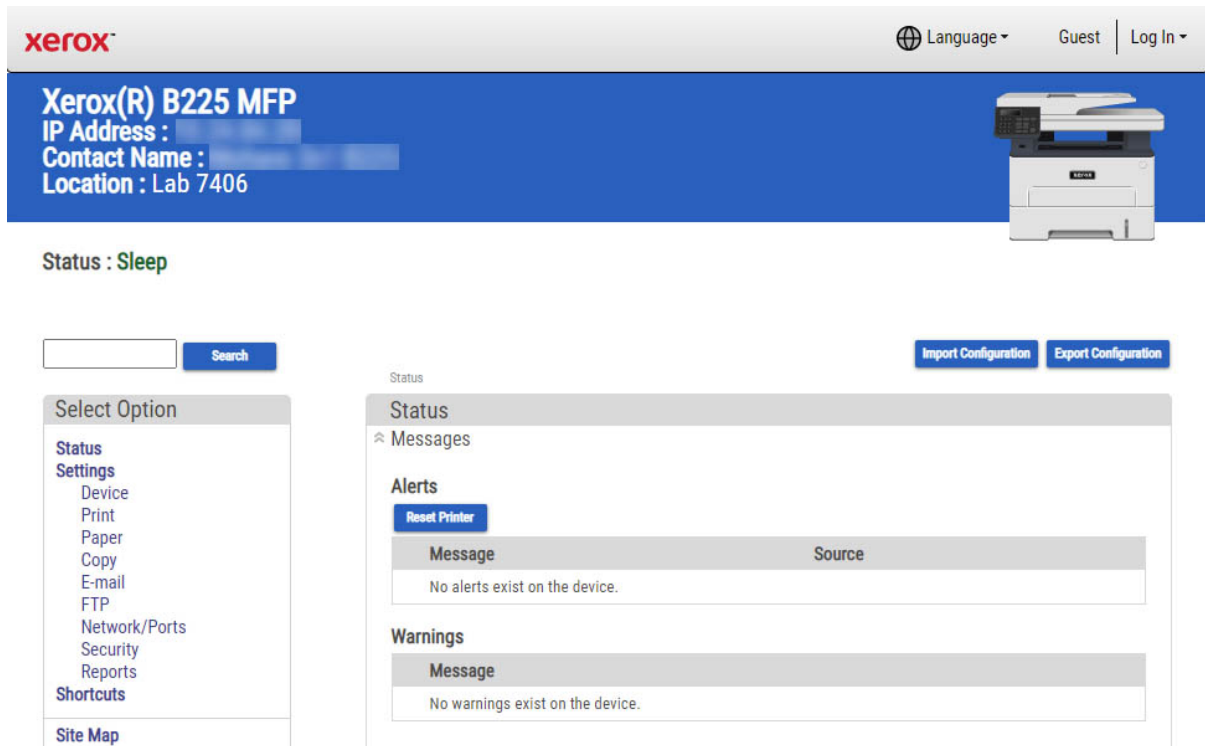

2. Click **Import Configuration**, and then click **Browse**.

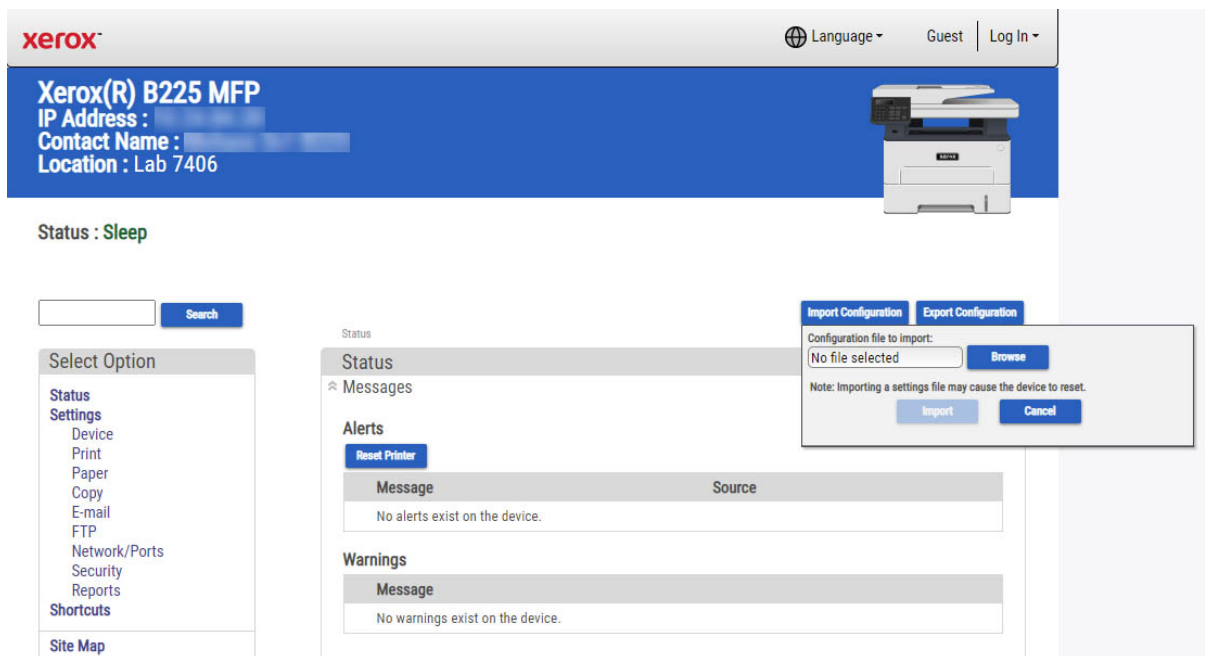

3. Navigate to the folder where the zip files are extracted.

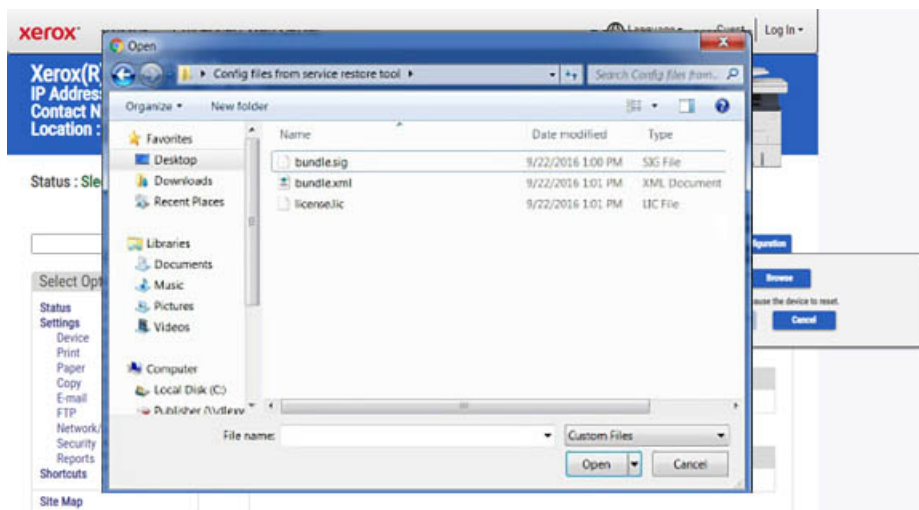

4. Select the file to import, and then click **Import**.
5. Repeat step 2 through step 4 for the other files that are included in the extracted zip file.

Updating The Printer Firmware

Warning: Before updating the printer firmware, ask the next level of support for the correct code. Using an incorrect code level may damage the printer.

Using A Flash Drive

Note: The printer must be in ready state to update the firmware.

This option is available only in printer models with front USB port.

1. Insert the flash drive into the USB port.
2. Depending on the printer model, do any of the following:
 - From the control panel, navigate to **USB Menu: Print from USB > Accept** or **OK**, and then select the file that you need to flash.
 - Select the firmware file.

Note: Do not turn off the printer while the update is going on.

Using A Network Computer

Using the File Transfer Protocol (FTP)

Note: The printer must be in ready state to update the firmware.

1. Turn on the printer.
2. Obtain the IP address from the home screen.

Parts Removal

3. From the command prompt of a network computer, open an FTP session to the printer IP address.
4. Use a PUT command to place the firmware file on the printer.
The printer performs a POR sequence and terminates the FTP session.

Using the Embedded Web Server

 **Note:** The printer must be in ready state to update the firmware.

1. Open a web browser, and then type the printer IP address.
2. Click **Settings > Device > Update Firmware**.
3. Select the file to use.
The printer performs a POR sequence and terminates the EWS session.

Using A USB Cable Connection

 **Note:** Make sure that the cable is connected to the rear USB port.

Using USB Flash Utility

1. Go to support.lexmark.com, and then download USB Flash Utility.
2. Extract, and then run the utility.
3. Click **Browse Files**, and then browse to the firmware file directory.
4. Select the firmware file.
5. Select the source printer.
6. Click **Start**.

Using USButil

1. Go to support.lexmark.com, and then download USButil.
2. Extract, and then drag and drop the firmware file onto the USButil icon.
3. A command prompt window appears briefly.

 **Note:** Make sure to disconnect other USB devices when using USButil.

Ribbon Cable Connectors

Zero Insertion Force (ZIF) Connectors

These connectors are used on the boards and cards that are installed in the printer.
To avoid damaging the connectors and their cables, observe the following:

- Do not insert the cables where the contacts are facing the locking actuator.
- Do not insert the cables diagonally into the ZIF socket.
- Avoid using a fingernail or sharp object to open the locking actuator.
- Avoid pressing against the cables when opening the locking actuator.

These are the types of the ZIF connectors that are used in this printer:

- Horizontal top contact connector
- Horizontal bottom contact connector
- Vertical mount contact connector
- Horizontal sliding connector

Horizontal Top Contact Connector

This connector uses a back flip locking actuator to lock the ribbon cable into the ZIF connector.

Warning: When opening or closing this type of actuator, lift or close the two tabs located on each end of the actuator. The two tabs should be moved simultaneously. Do not close the actuator from the center.

Removing the cable

1. Unlock the actuator.

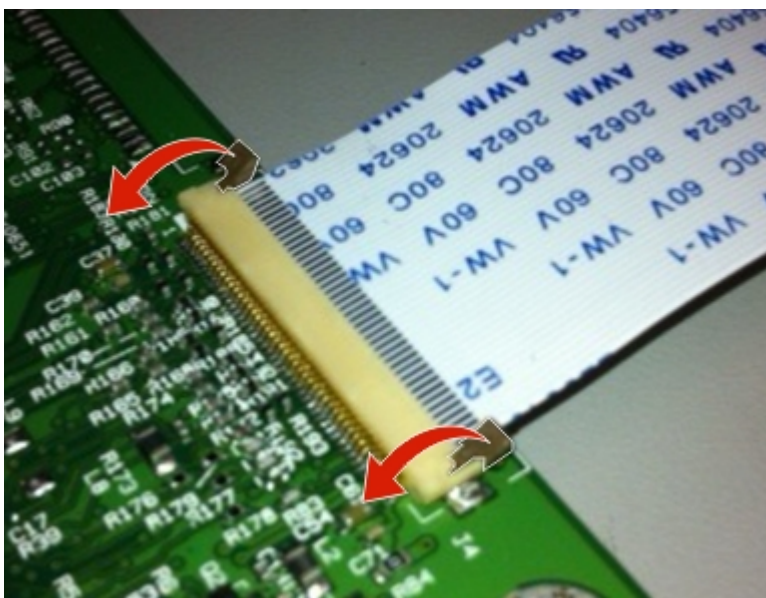

2. Remove the cable.

Inserting the cable

Make sure that the actuator is unlocked before installing the cable. The tabs are vertical when the actuator is locked.

 **Warning:** When opening or closing this type of actuator, gently lift the center of the actuator using your finger. Do not use a fingernail or screwdriver to open the actuator to avoid damaging the ribbon cable. Do not close the actuator from its ends.

Removing the cable

1. Unlock the actuator.

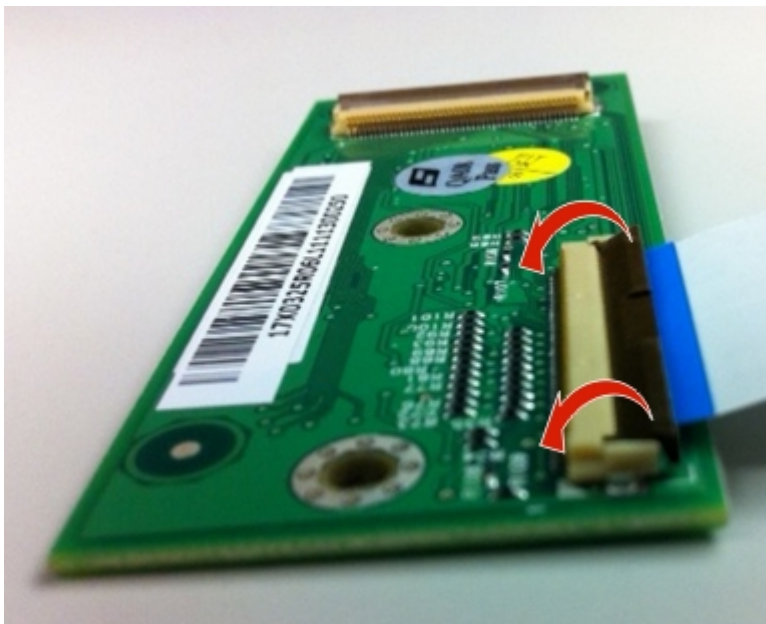

2. Remove the cable.

Inserting the cable

1. Make sure that the actuator is in the open position.



2. Insert the cable below the actuator with the contacts facing downward and away from the locking actuator.

 **Note:** Make sure that the cable is installed squarely into the connector to avoid intermittent failures.



3. Rotate the locking actuator to the locked position.



Vertical Mount Contact Connector

This connector uses a back flip locking actuator to lock the ribbon cable into the ZIF connector.

-  **Warning:** When opening or closing this type of actuator, gently lift the center of the actuator using your finger. Do not use a fingernail or screwdriver to open the actuator to avoid damaging the ribbon cable. Do not close the actuator from its ends.

Parts Removal

Removing the cable

1. Rotate the locking actuator from the center of the actuator to the unlocked position.

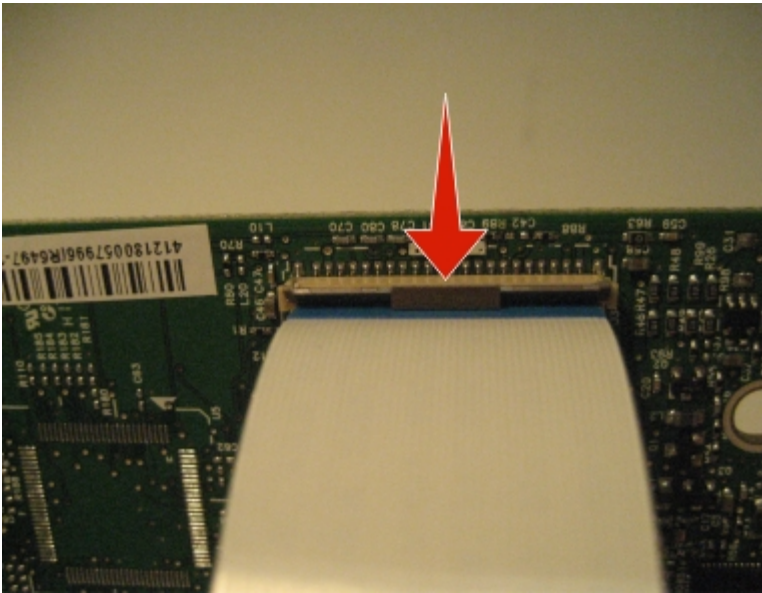

2. Remove the cable.

Inserting the cable

1. Make sure that the locking actuator is in the open position.



2. Insert the cable on top of the actuator with the contacts facing away from the locking actuator.

 **Note:** Make sure that the cable is installed squarely into the connector to avoid intermittent failures.



3. Rotate the locking actuator to the locked position.

 **Note:**

- Do not move the cable while locking the actuator.

Parts Removal

- If the cable moves, open the actuator, reposition the cable, and then close the actuator.

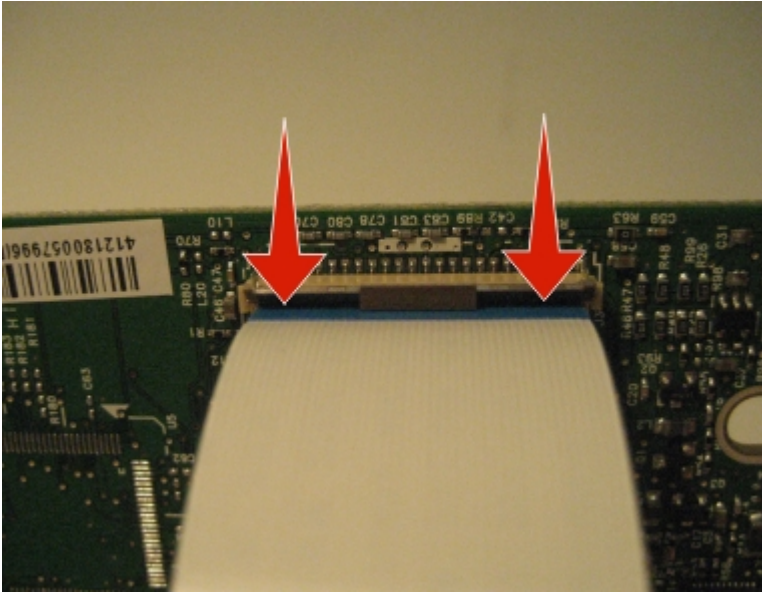

Horizontal Sliding Contact Connector

This connector uses a slide locking actuator to lock the ribbon cable into the ZIF connector.

-  **Warning:** When opening or closing this type of actuator, gently push or pull the two tabs located on each end of the actuator. Do not close the actuator from the center of the actuator. Do not use a screwdriver to open or close the actuator to avoid damage to the cable or connector.

Removing the cable

1. Slide the tabs away from the connector.

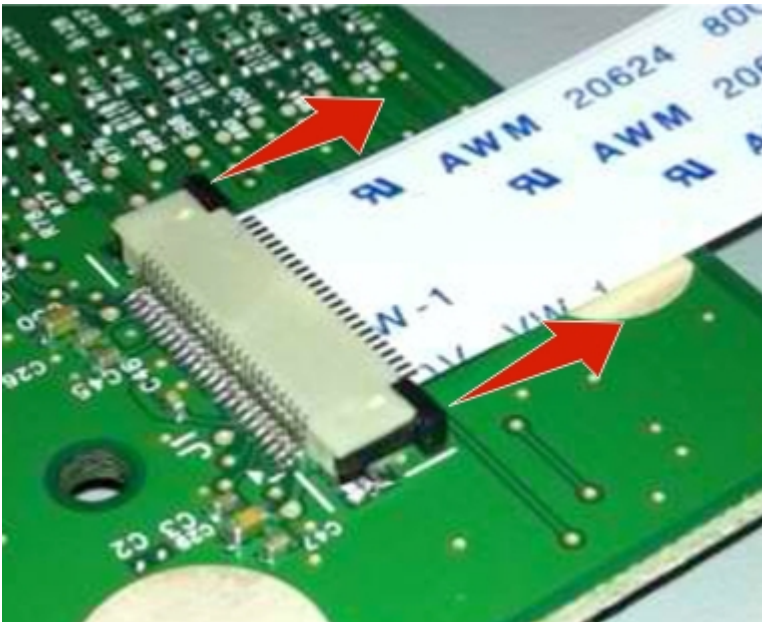

2. Remove the cable.

Inserting the cable

1. Make sure that the locking actuator is in the open position. If you are opening the connector, then pull back the end tabs using equal force to avoid breaking the connector.

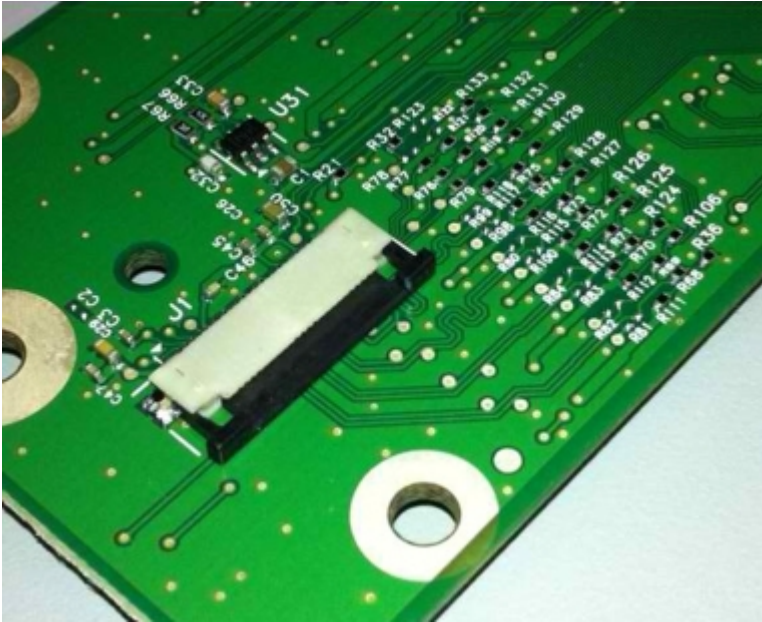

2. Insert the cable on top of the actuator with the contacts facing away from the locking actuator.



3. Slide the locking actuator toward the connector to lock the cable

 **Note:**

- Do not move the cable while locking the actuator.

- If the cable moves, open the actuator, reposition the cable, and then close the actuator.

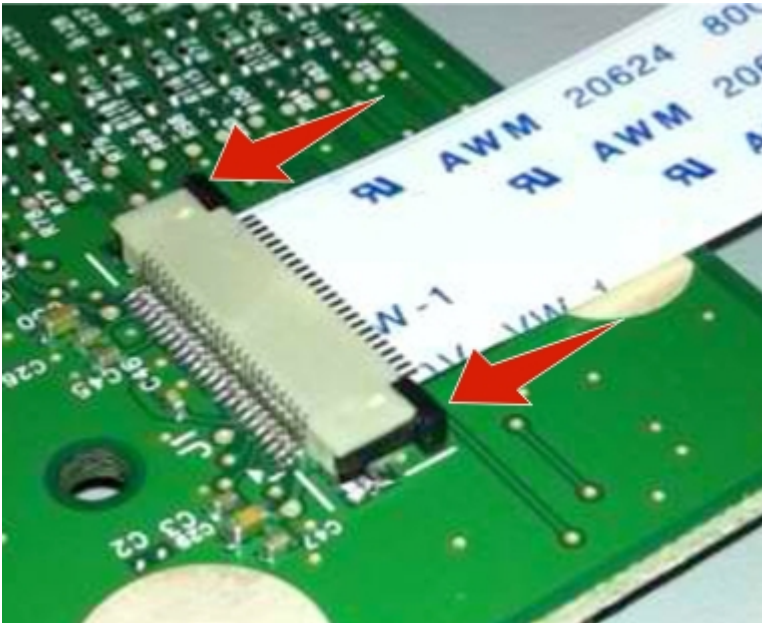

Low Insertion Force (LIF) Connector

 **Warning:** When installing a cable into an LIF connector, avoid bending the edges of the cables and damaging the contacts on the cables.

Parts Removal

Inserting the cable

1. Make sure that the contacts of the controller board and connectors are on the same side.

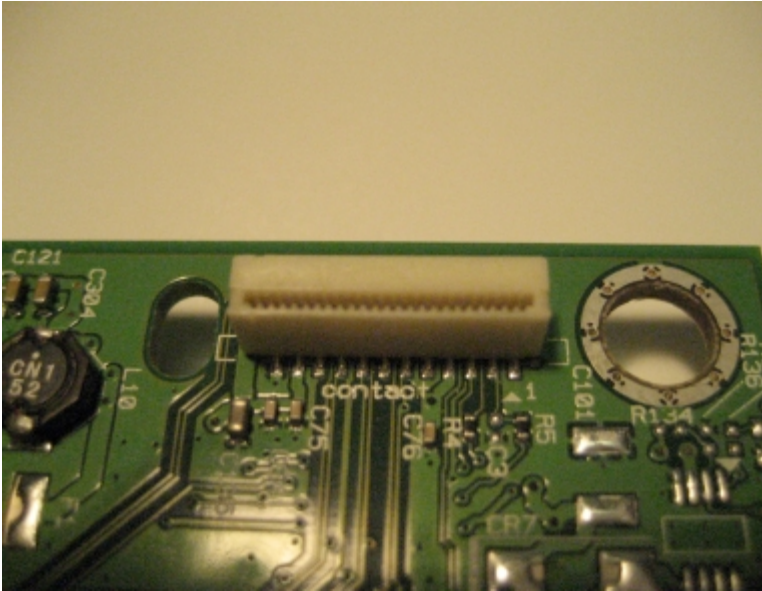

2. Insert the cable.

 **Note:** Make sure that the cable is installed straight into the connector to avoid intermittent failures.



Printhead Assembly Adjustment

A printhead must be correctly positioned after it has been removed. Use a sharp pencil or a small, flat-blade screwdriver to mark the location of the old printhead on the printer frame. Align the new printhead relative to the location of the old printhead.

 **Note:** Skew is caused by a sheet being fed through the printer while misaligned. The entire image is rotated relative to the sheet edges. However, a mechanically misaligned printhead causes the horizontal lines to appear skewed, while the vertical lines remain parallel to the vertical edges. The skew cannot be adjusted. Check the pick tires for wear, the paper path for obstructions, the fuser for proper setting, and the tray paper guides for proper setting.

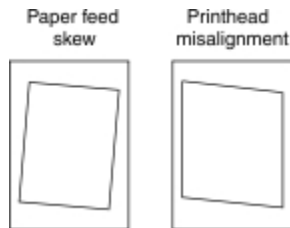

To adjust the printhead:

1. Perform a POR.
2. Enter the Diagnostics menu, and then print a Quick test page:
Diagnostics Menu > Print Tests > Tray 1 > Single
3. Fold the printed test page on the left side so that a few millimeters of grid lines wrap around the outside of the fold.
4. Make a second vertical fold near the center so that the left side top edge aligns with the right side top edge.

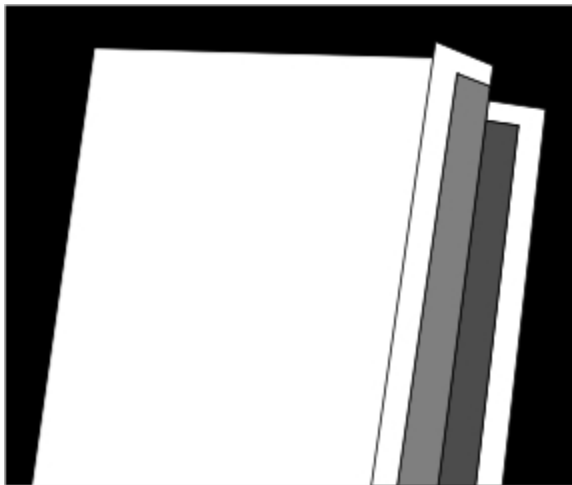

Parts Removal

5. If the grid lines of the right flap align below the corresponding lines on the left side, then adjust the printhead clockwise relative to the printer, and recheck. If the grid lines of the left flap align below the corresponding lines of the right side, then adjust the printhead counterclockwise.

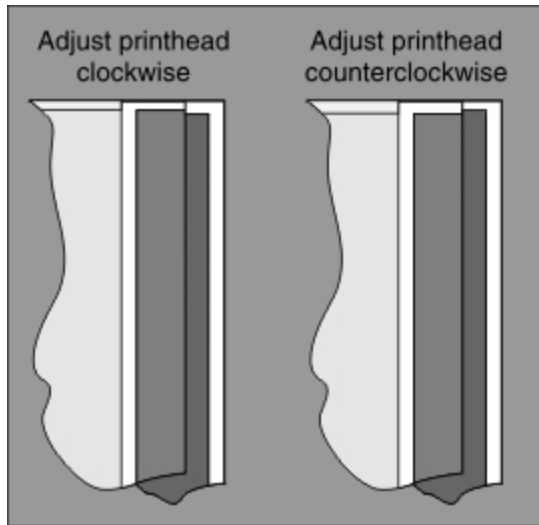

6. Print another Quick test page, and check if adjustments are still needed.
 7. After obtaining a properly adjusted image on the paper, tighten all the screws.
-  **Note:** If necessary, print a Quick test page again and perform the Registration adjust procedure to correct the skew and misalignments. See [Registration adjust](#).

Data Security Notice

Identifying Printer Memory

- **Volatile memory** – The printer uses standard random access memory (RAM) to buffer user data temporarily during simple print and copy jobs.
- **Nonvolatile memory** – The printer may use two forms of nonvolatile memory: EEPROM and NAND (flash memory). Both types are used to store the operating system, printer settings, network information, scanner and bookmark settings, and embedded solutions.

The following parts can store memory:

- Printer control panel
- User interface controller card (UICC)
- Controller board



Note: The printer control panel and controller board contain NVRAM.

Erasing Printer Memory

To erase volatile memory, turn off the printer.

To erase nonvolatile memory, do the following:

1. From the control panel, navigate to **Settings > Device > Maintenance > Out of Service Erase > Sanitize all information on nonvolatile memory**.
2. Select **Sanitize all information on nonvolatile memory**, and then select **ERASE**.
3. Follow the instructions on the screen.

Performing The HVPS Characterization

Make sure to perform the following procedure when replacing the HVPS.

1. Enter the Diagnostics menu, and then navigate to:
Reports > Device > Device settings
2. Take note of the HVPS adjust values.
3. Turn off the printer.
4. Remove the old HVPS.
5. Install the new HVPS.
6. Perform a POR.
7. Enter the Diagnostics menu, and then navigate to:
Printer diagnostics & adjustments > HVPS adjust
8. For each letter under the HVPS adjust section, enter the values as indicated on the sticker of the new HVPS.

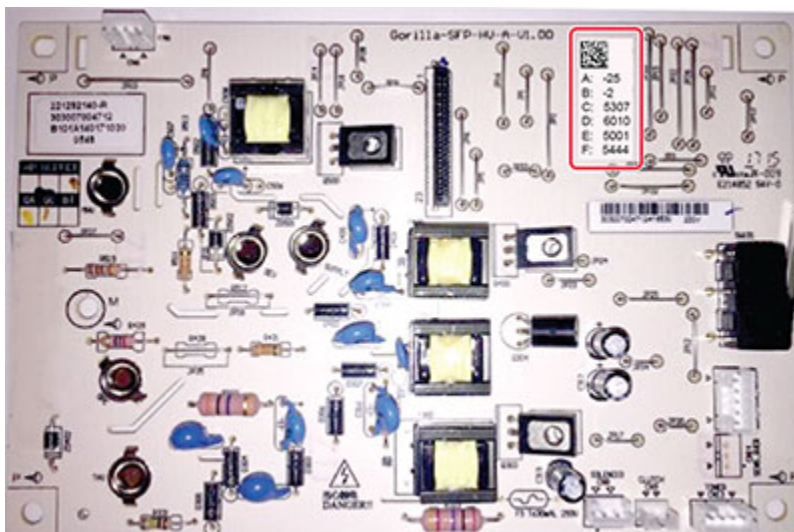

9. Perform a POR.
10. Enter the Diagnostics menu, and then navigate to:
Reports > Device > Device settings
11. Check if the new HVPS adjust values were saved.

Removal Procedures

Keep the following tips in mind as you replace parts:

- Some removal procedures require removing cable ties. You must replace cable ties during reassembly to avoid pinching wires, obstructing the paper path, or restricting mechanical movement.
- Remove the toner cartridges, imaging kit, and trays before removing other printer parts. The imaging kit must be carefully set on a clean, smooth, and flat surface. It must also be protected from light while out of the printer.
- Disconnect all external cables from the printer to prevent possible damage during service.
- Unless otherwise stated, reinstall the parts in reverse order of removal.
- When reinstalling a part held with several screws, start all screws before the final tightening.
- For printers that have a soft power switch, make sure to unplug the power cord after powering off.

Left Side Removals

Left Cover Removal

1. Remove the tray insert.
2. Remove the duplex unit.
3. Remove the rear door. See [Rear door removal](#).
4. Remove the bottom rear door. See [Bottom rear door removal](#).

5. Remove the left cover.



Parts Removal

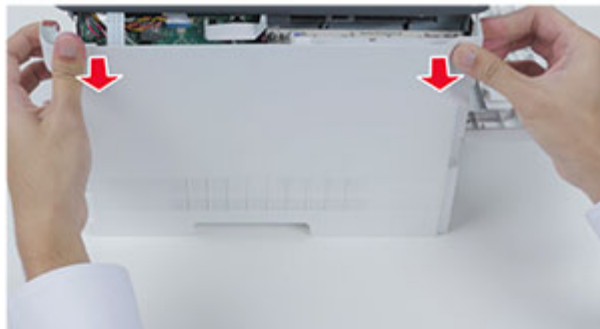

Controller Board Removal

 **Note:** For a video demonstration, see [Controller Board Removal](#)

 **Warning:** Do not replace or remove the control panel when replacing or removing the controller board. See [Critical Information for Controller Board or Control Panel Replacement \(for B235 Only\)](#).

1. Remove the tray insert.
2. Remove the duplex unit.
3. Remove the rear door. See [Rear door removal](#).
4. Remove the bottom rear door. See [Bottom rear door removal](#).
5. Remove the left cover. See [Left Cover Removal](#).
6. Disconnect all cables.





7. Remove the controller board.

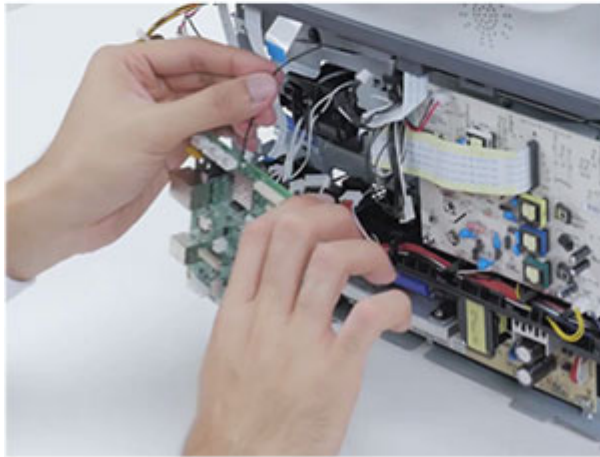
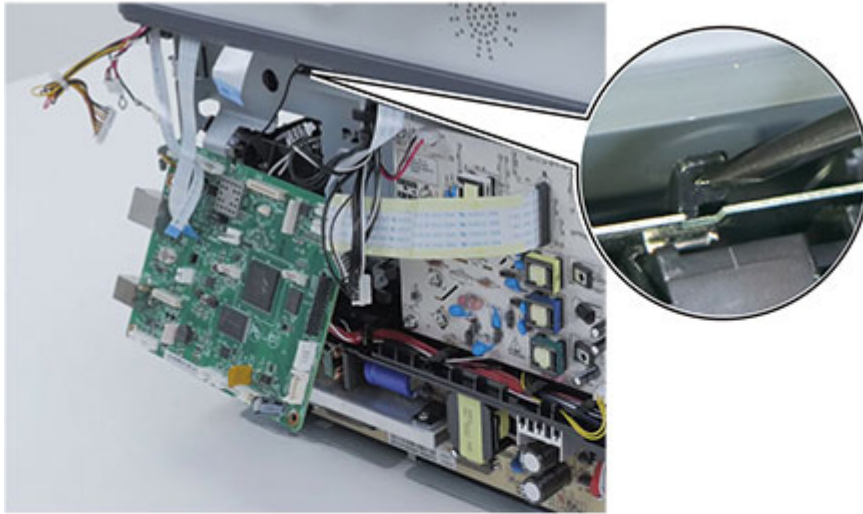

Parts Removal

8. Remove the Wi-Fi antenna.



 **Note:** Installation note: Make sure to perform a POR twice after replacing the controller board.

LVPS Removal

1. Remove the tray insert.
2. Remove the duplex unit.
3. Remove the rear door. See [Rear door removal](#).
4. Remove the bottom rear door. See [Bottom rear door removal](#).
5. Remove the left cover. See [Left Cover Removal](#).

6. Remove the LVPS.



HVPS Removal



Note: Make sure to perform the HVPS characterization when replacing the HVPS. See [Performing the HVPS characterization](#) .

1. Remove the tray insert.
2. Remove the duplex unit.
3. Remove the rear door. See [Rear door removal](#).
4. Remove the bottom rear door. See [Bottom rear door removal](#).
5. Remove the left cover. See [Left Cover Removal](#).

Parts Removal

6. Disconnect all the cables.



7. Remove the HVPS.

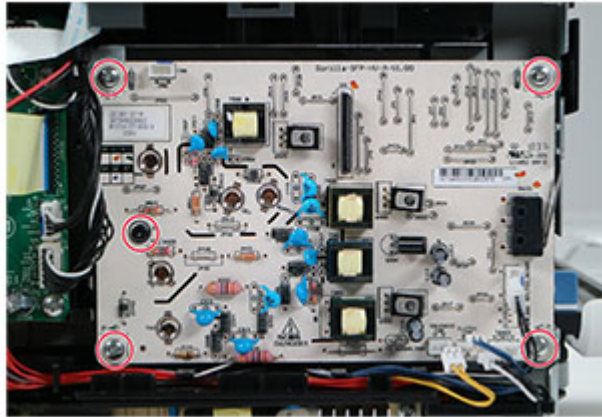

Note: Installation note: Make sure that the spring contacts on the printer (A) are properly aligned with the contacts on the HVPS (B).

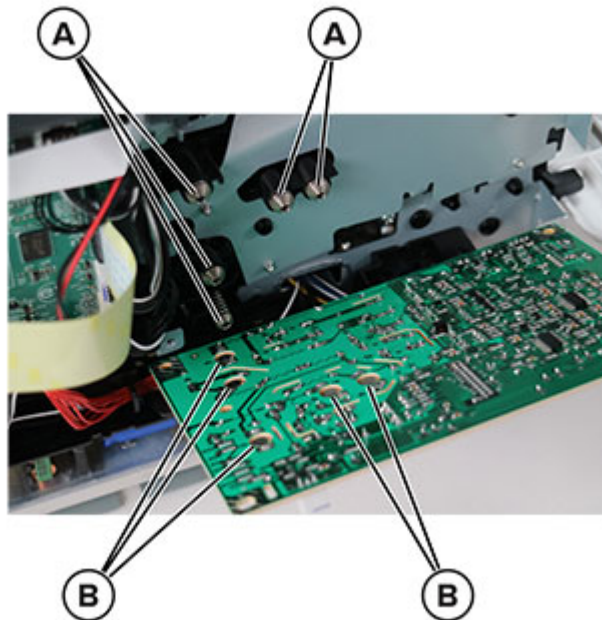

Right Side Removals

Right Cover Removal

1. Remove the tray insert.
2. Remove the duplex unit.

3. Remove the right cover.



Parts Removal



Main Drive Removal

 **Note:** For a video demonstration, see [Main Drive Removal](#).

1. Remove the tray insert.
2. Remove the duplex unit.
3. Remove the rear door. See [Rear door removal](#).
4. Remove the bottom rear door. See [Bottom rear door removal](#).
5. Remove the right cover. See [Right cover removal](#).
6. Remove the main drive.

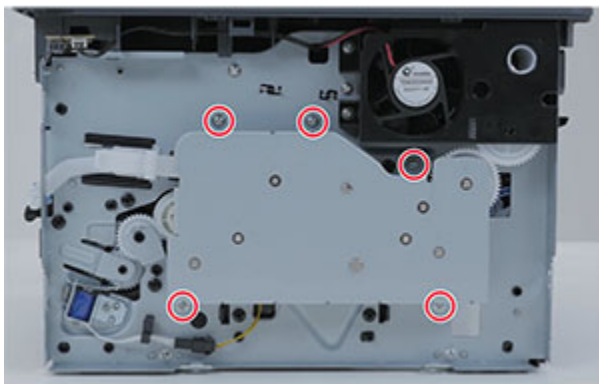

7. Remove the three gears (A).

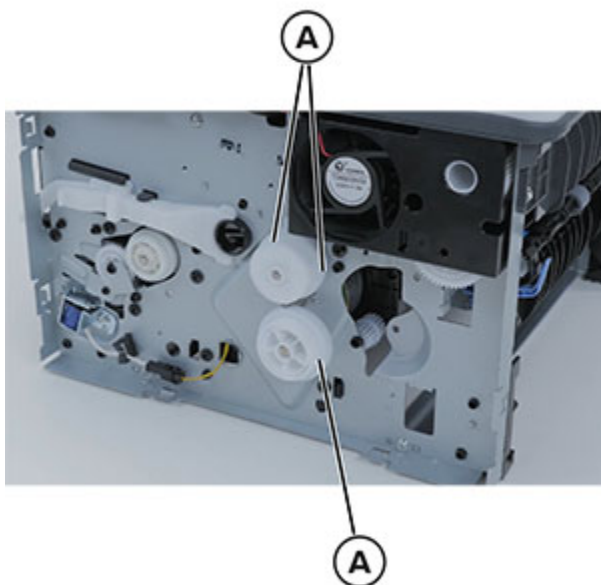

 **Note:** Installation note: Pay attention on how the gears are installed on the main drive and on the printer. Some gears may have a coupler within them. For more information, see the [Main Drive Removal](#) video.

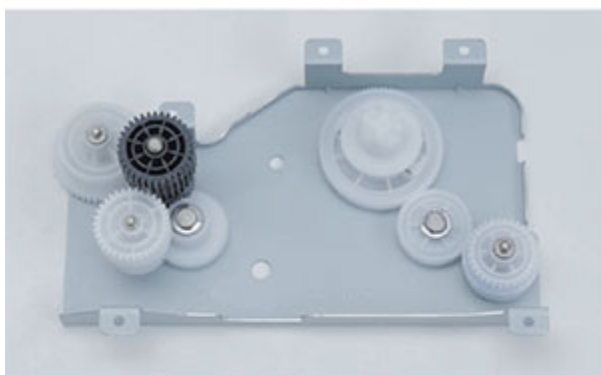

Pick Solenoid Removal

1. Remove the tray insert.
2. Remove the duplex unit.
3. Remove the right cover. See [Right cover removal](#).
4. Remove the pick solenoid.

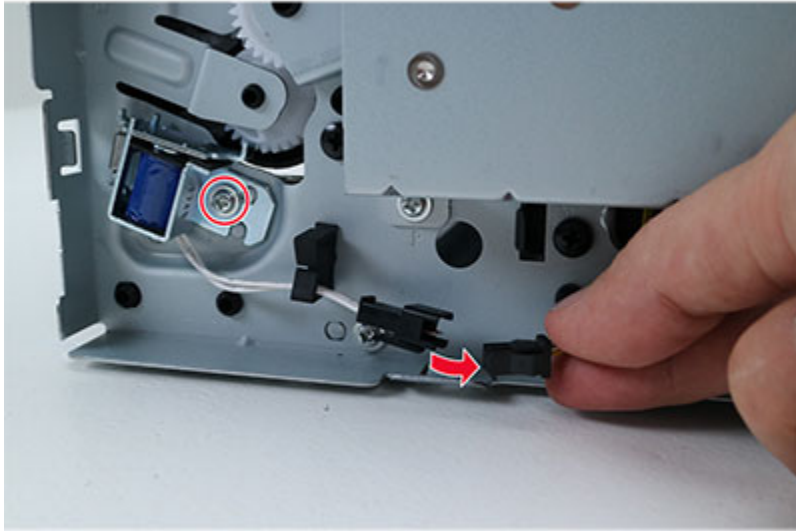

Fan Assembly Removal

1. Remove the tray insert.
2. Remove the duplex unit.
3. Remove the rear door. See [Rear door removal](#).
4. Remove the bottom rear door. See [Bottom rear door removal](#).
5. Remove the left cover. See [Left Cover Removal](#).
6. Remove the right cover. See [Right cover removal](#).
7. Remove the top cover. See [Top Cover Removal](#).

8. Disconnect the cable, and then remove it from the frame.

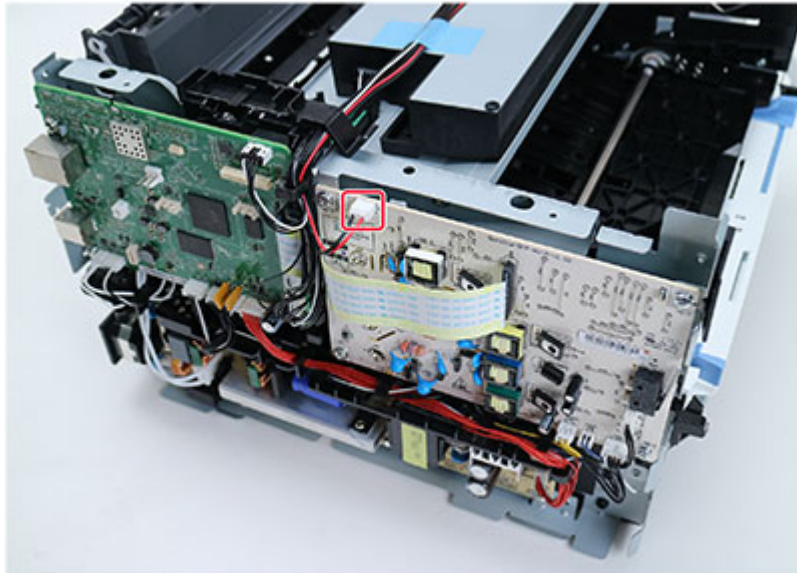

Parts Removal

9. Remove the fan, and then remove the gear.

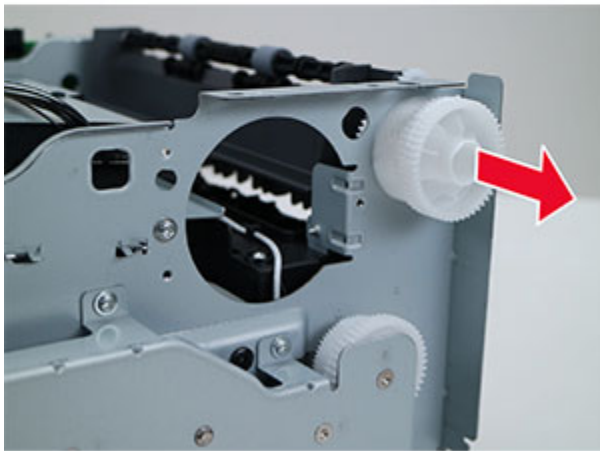
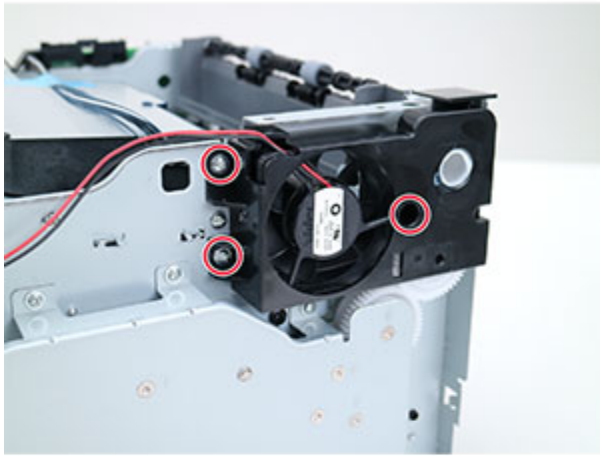

 **Note:** Installation note: Before installing the gear, make sure that it is properly greased.

Front Removals

2-line Control Panel Removal

1. Remove the tray insert.
2. Remove the duplex unit.
3. Remove the rear door. See [Rear door removal](#).
4. Remove the bottom rear door. See [Bottom rear door removal](#).
5. Remove the left cover. See [Left Cover Removal](#).
6. Remove the right cover. See [Right cover removal](#).
7. Disconnect the cable, and then detach the ADF link.



Parts Removal

8. Remove the control panel.



2.8-in. Control Panel Removal

 **Warning:** Do not replace or remove the controller board when replacing or removing the control panel. See [Critical Information for Controller Board or Control Panel Replacement \(for B235 Only\)](#).

1. Remove the tray insert.
2. Remove the duplex unit.
3. Remove the rear door. See [Rear door removal](#).
4. Remove the bottom rear door. See [Bottom rear door removal](#).
5. Remove the left cover. See [Left Cover Removal](#).
6. Remove the right cover. See [Right cover removal](#).
7. Disconnect the cable, and then detach the ADF link.



Parts Removal

8. Remove the control panel.

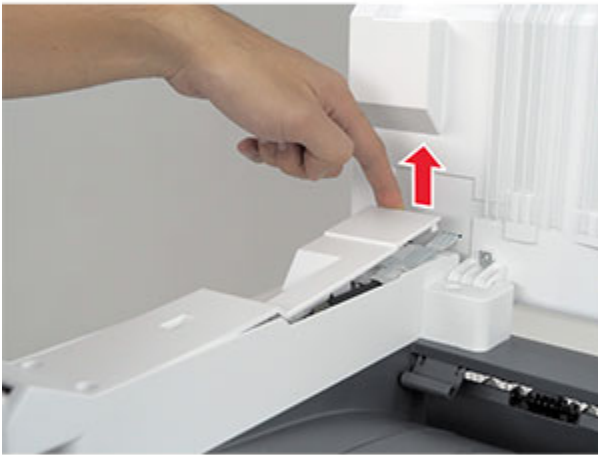

Front Door Removal

1. Detach the door strap.



2. Remove the front door.



Transfer Roller Removal

1. Remove the toner cartridge.

Parts Removal

2. Remove the transfer roller.



Installation notes:

- Do not touch the foam on the roller.
- The shaft is greased. To avoid contaminating the roller, do not touch the shaft.
- Make sure that the spring is properly installed on the right side of the roller.



Rear Removals

Rear Door Removal

1. Remove the duplex unit.
2. Detach the upper rear latch of the right cover to remove the rear door.



Duplex Unit Removal

Remove the duplex unit.



Bottom Rear Door Removal

1. Remove the duplex unit.
2. Remove the rear door. See [Rear door removal](#).
3. Remove the bottom rear door.



Redrive Removal

1. Remove the tray insert.
2. Remove the duplex unit.
3. Remove the left cover. See [Left Cover Removal](#).
4. Remove the right cover. See [Right cover removal](#).
5. Remove the rear door. See [Rear door removal](#).
6. Remove the bottom rear door. See [Bottom rear door removal](#).

7. Remove the redrive.



Fuser Removal

 **Note:** For a video demonstration, see [Fuser Removal](#).

1. Remove the tray insert.
2. Remove the duplex unit.
3. Remove the front door. See [Front door removal](#).
4. Remove the rear door. See [Rear door removal](#).
5. Remove the bottom rear door. See [Bottom rear door removal](#).
6. Remove the left cover. See [Left Cover Removal](#).
7. Remove the redrive. See [Redrive removal](#).

Parts Removal

8. Remove the fuser.

 **Note:** Installation note: Pay attention to the cable routing.

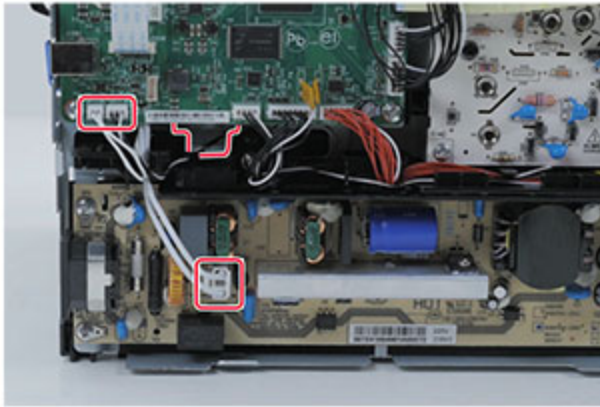

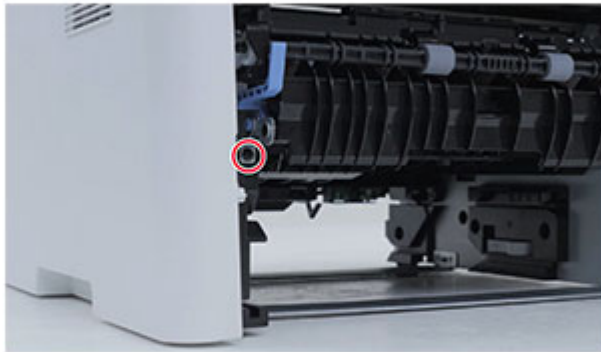

Fuser Exit Flag Removal

1. Remove the rear door. See [Rear door removal](#).
2. Open the fuser door.

Parts Removal

3. Remove the fuser exit flag.

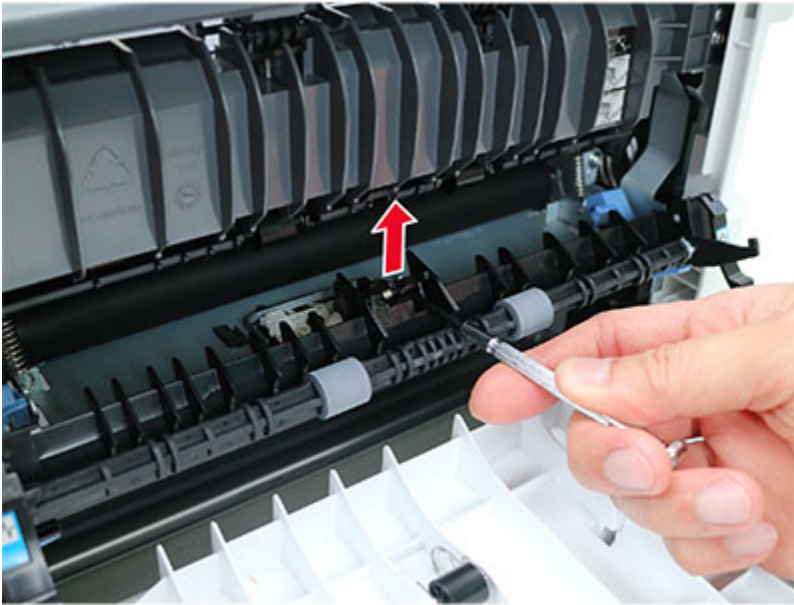

Top Removals

Top Cover Removal

B225 top cover removal

1. Remove the tray insert.
2. Remove the duplex unit.
3. Remove the front door. See [Front door removal](#).
4. Remove the rear door. See [Rear door removal](#).
5. Remove the bottom rear door. See [Bottom rear door removal](#).
6. Remove the left cover. See [Left Cover Removal](#).
7. Remove the right cover. See [Right cover removal](#).
8. Remove the ADF scanner and flatbed scanner. See [ADF Scanner and Flatbed Scanner Removal](#).
9. Remove the control panel. See [2-line Control Panel Removal](#).

Parts Removal

10. Disconnect the cable from the left and right sides of the printer.



Note: Make sure to release the right side cable from the frame.

11. Remove the top cover.





Parts Removal

B235 top cover removal

1. Remove the tray insert.
2. Remove the duplex unit.
3. Remove the front door. See [Front door removal](#).
4. Remove the rear door. See [Rear door removal](#).
5. Remove the bottom rear door. See [Bottom rear door removal](#).
6. Remove the left cover. See [Left Cover Removal](#).
7. Remove the right cover. See [Right cover removal](#).
8. Remove the ADF scanner and flatbed scanner. See [ADF Scanner and Flatbed Scanner Removal](#).
9. Remove the control panel. See [2.8-in. Control Panel Removal](#).

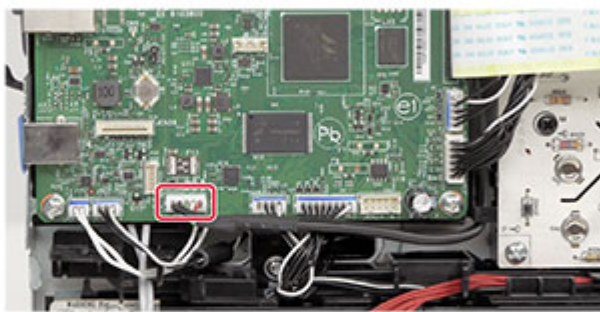
10. Disconnect the cable from the left and right sides of the printer.



 **Note:** Make sure to release the right side cable from the frame.

Parts Removal

11. Disconnect the cable, and then remove the toroids.

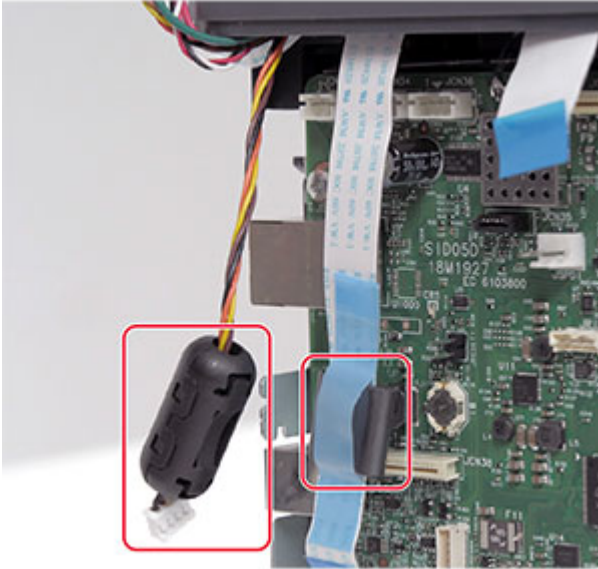

12. Remove the screws, and then remove the fax card holder (A).

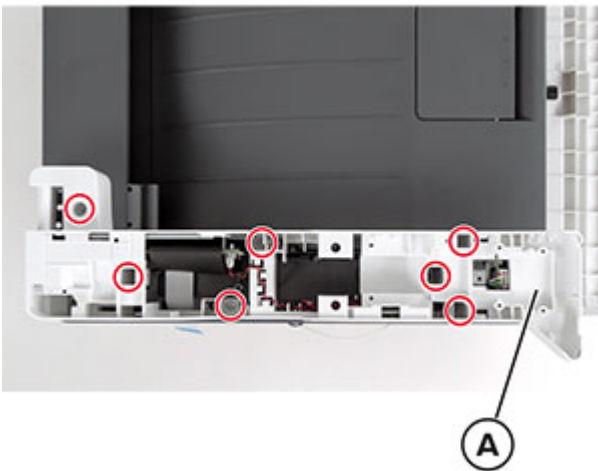

13. Remove the screws, and then remove the USB cable (B) from the guides.

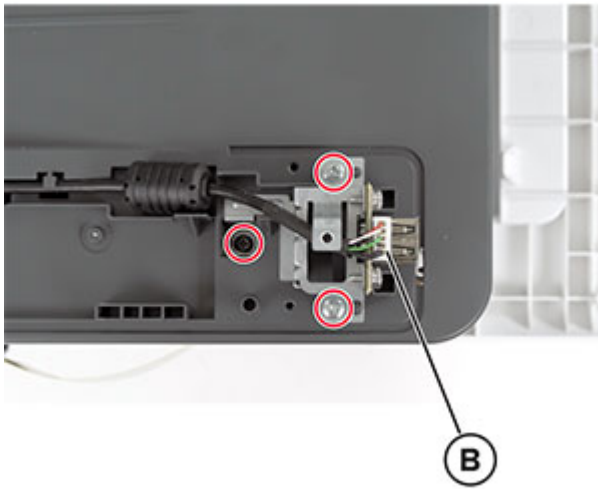

14. Remove the top cover.



 **Note:** Installation note: Remove the USB port cover.



Printhead Removal

1. Remove the tray insert.
2. Remove the duplex unit.
3. Remove the left cover. See [Left Cover Removal](#).
4. Remove the right cover. See [Right cover removal](#).
5. Remove the rear door. See [Rear door removal](#).
6. Remove the bottom rear door. See [Bottom rear door removal](#).
7. Remove the top cover. See [Top Cover Removal](#).

8. Remove the printhead.

WARNING: Class 3b invisible laser radiation when open and interlocks defeated. Avoid exposure to the beam.

AVERTISSEMENT: Rayonnement laser invisible de classe 3b - en cas d'ouverture et de verrouillage defectueux. Evitez toute exposition au faisceau.

ADVERTENCIA: Radiación láser invisible de clase 3b en caso de apertura y neutralización de la seguridad. Evitar exposición al haz.

WARNUNG: Unsichtbare Strahlung von Laser Klasse 3b wenn offen und Verriegelungen entriegelt. Kontakt mit Laserstrahl vermeiden.

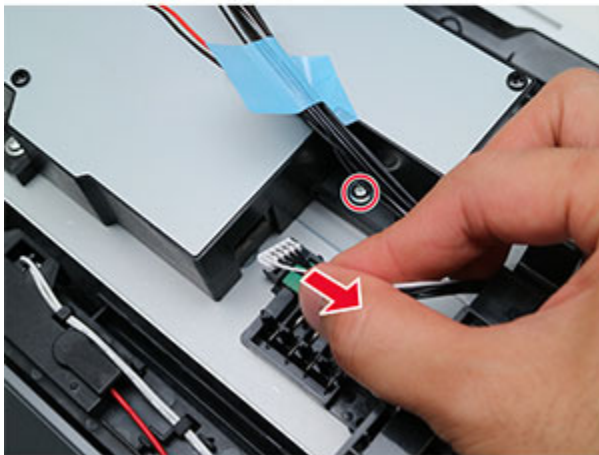

Parts Removal

9. Remove the printhead.

 **Note:** Installation note: Make sure that the EMC clip is properly installed.

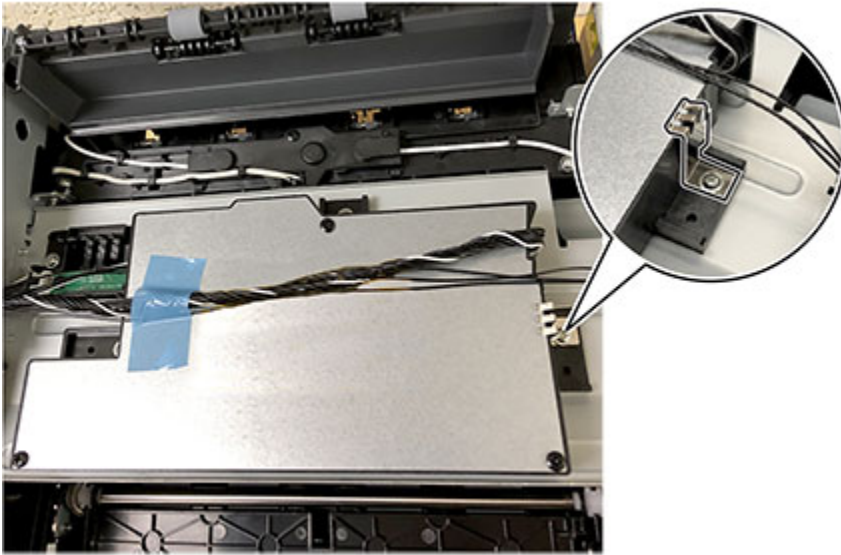

Bottom Removals

Sensor (Fuser Exit) Removal

1. Remove the tray insert.
2. Remove the duplex unit.
3. Remove the rear door. See [Rear door removal](#).
4. Remove the bottom rear door. See [Bottom rear door removal](#).
5. Place the printer on its front, and then remove the sensor.



Sensor (Paper Present) Removal

1. Remove the tray insert.
2. Remove the duplex unit.

Parts Removal

3. Place the printer on its rear, and then remove the sensor.

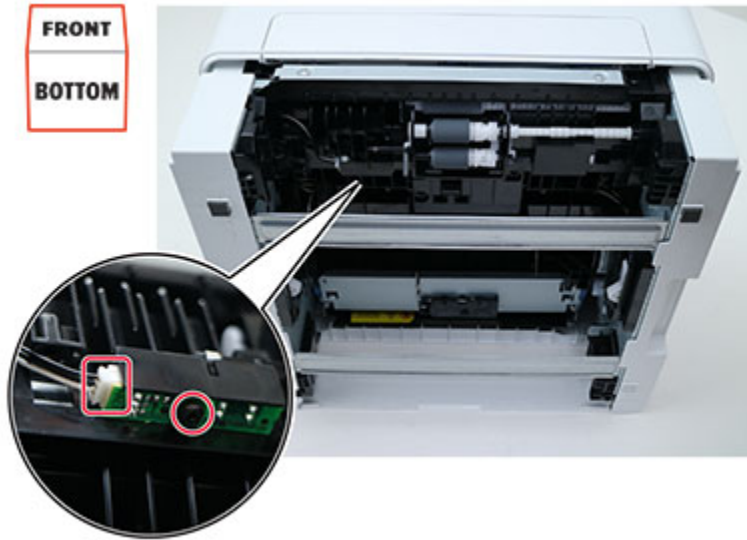

Sensor (Staging and Input) Removal

1. Remove the tray insert.
2. Remove the duplex unit.

3. Place the printer on its rear, and then remove the sensor cover.

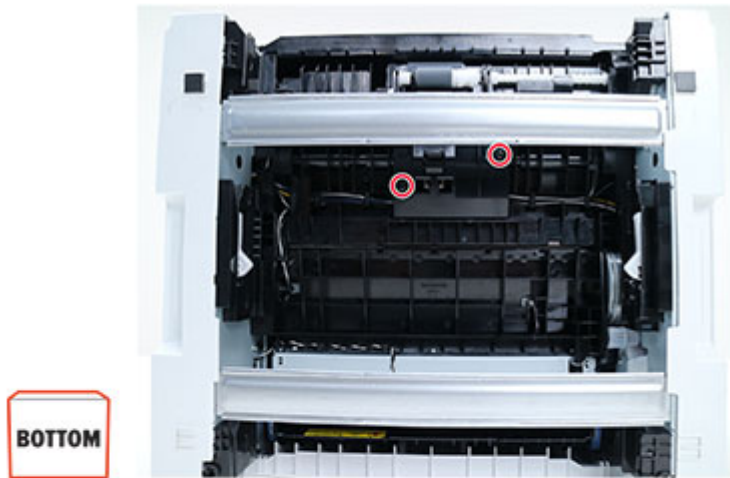

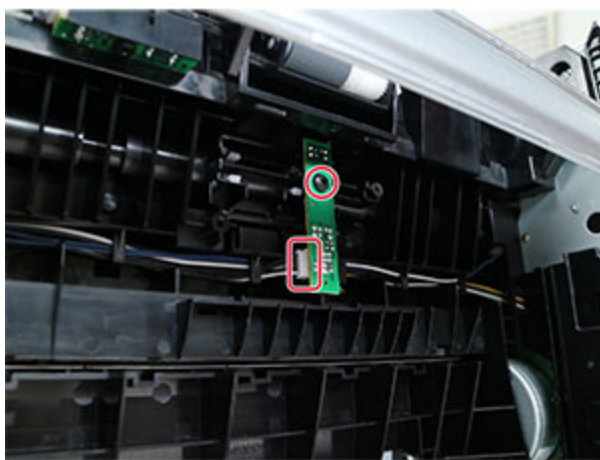

4. Remove the sensor.

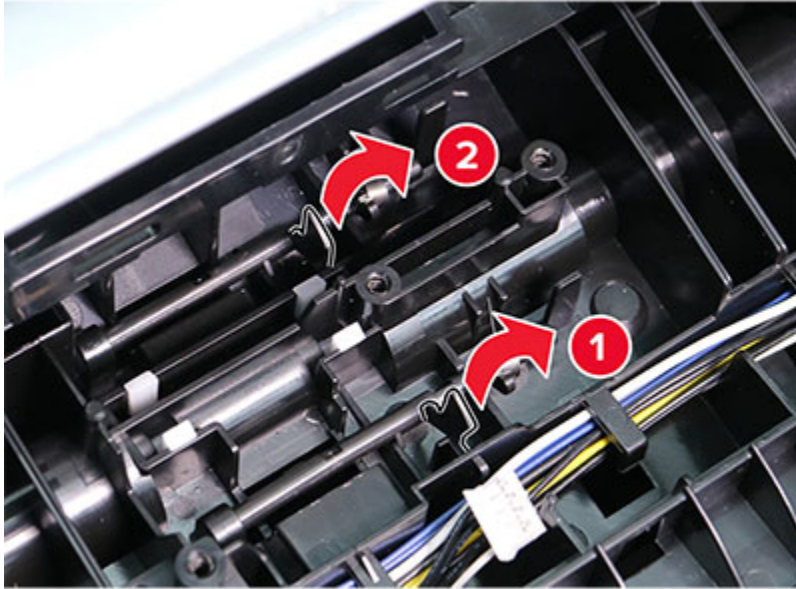

Input Sensor Flags Removal

1. Remove the tray insert.
2. Remove the duplex unit.
3. Remove the sensor (staging and input). See [Sensor \(staging and input\) removal](#).
4. Remove the two sensor flags.



 **Note:** Installation note: Pay attention to the position of the spring on each flag.

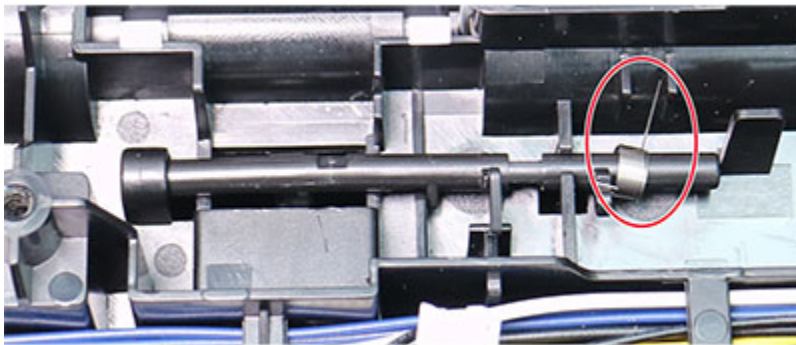

Pick Rollers Removal

 **Note:** For a video demonstration, see [Pick Roller Removal](#).

1. Remove the tray insert.

2. Place the printer on its rear.

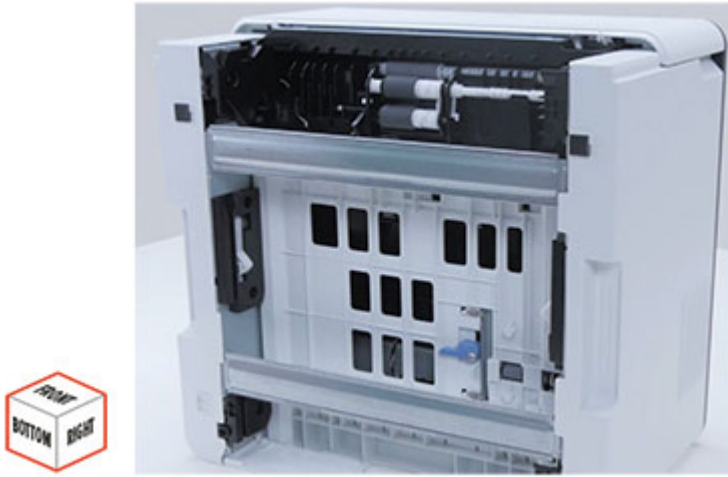

Parts Removal

3. Remove the right pick roller retainers.

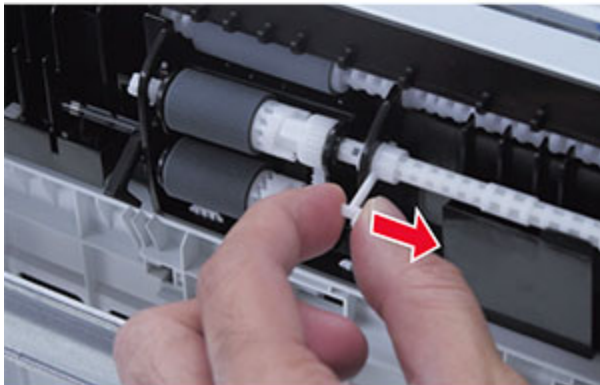
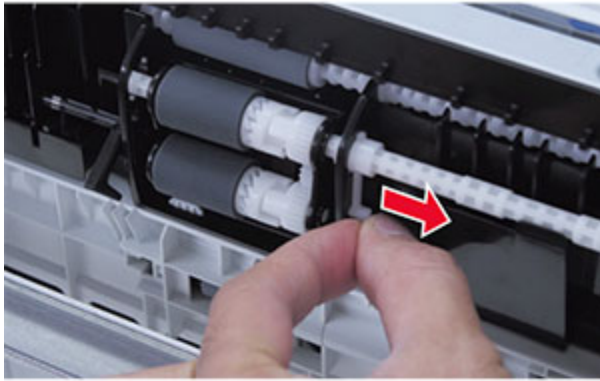

 **Note:** Perform the same procedure to remove the left pick roller retainer.

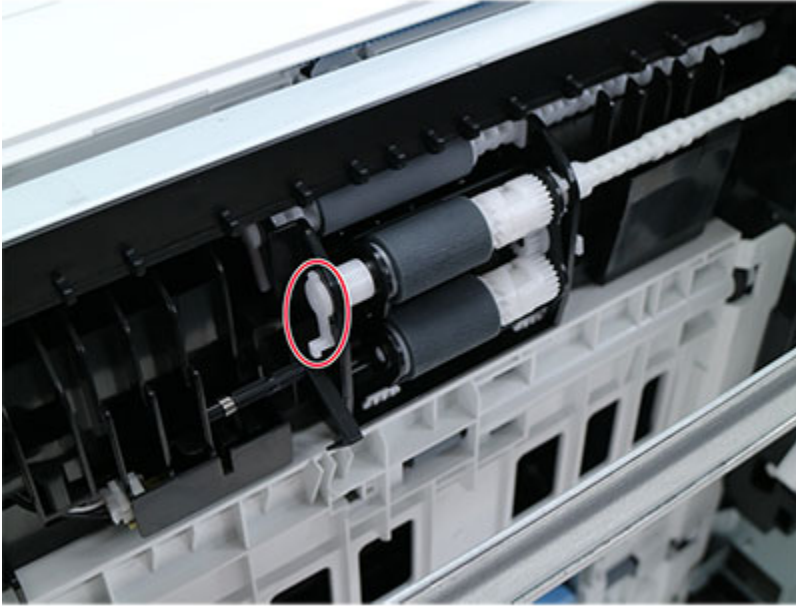

4. Remove the two pick rollers.

ADF and Scanner

Scanner Stand Removal

1. Raise the ADF and scanner assembly.
2. Remove the scanner stand.



ADF Pick Assembly Removal

1. Open the ADF cover.

2. Remove the separator pad.



 **Note:**

- Pay attention to the position of the spring under the pad.
- Do not lose the spring.

Parts Removal

3. Remove the ADF pick assembly.



ADF Scanner and Flatbed Scanner Removal

 **Note:** For a video demonstration, see [ADF/scanner assembly removal](#).

1. Remove the tray insert.
2. Remove the duplex unit.
3. Remove the rear door. See [Rear door removal](#).
4. Remove the bottom rear door. See [Bottom rear door removal](#).
5. Remove the left cover. See [Left Cover Removal](#).

6. Detach the scanner stand, and then remove the fax card cover.



Parts Removal

7. Disconnect the FFC cable, and then remove it from the frame.

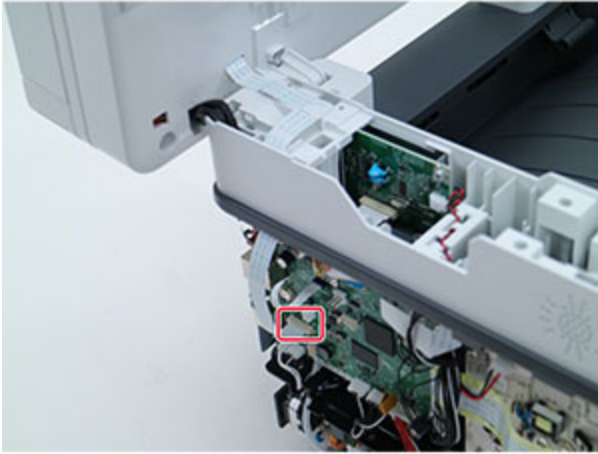

8. Disconnect the four cables, and then remove the screw securing the two ground cables.

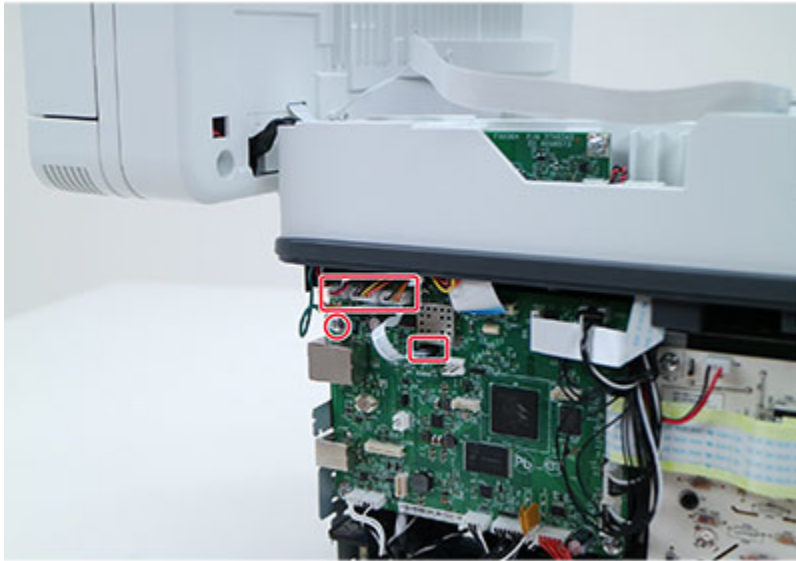

Parts Removal

9. Remove the ADF cables from the printer, and then remove the ADF scanner and flatbed scanner.

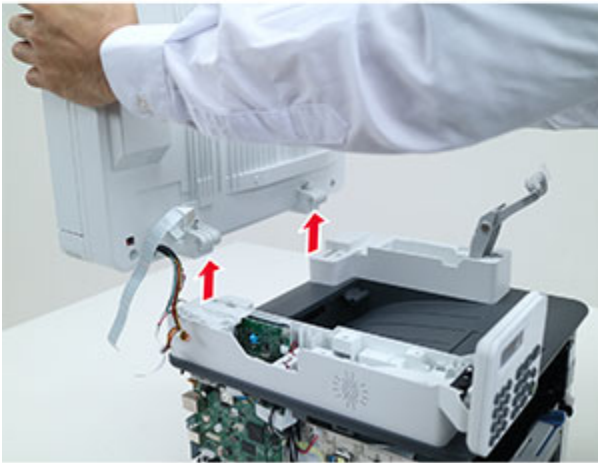

10. Detach the ADF scanner from the flatbed scanner.



 **Note:** Do not lose the two brackets.

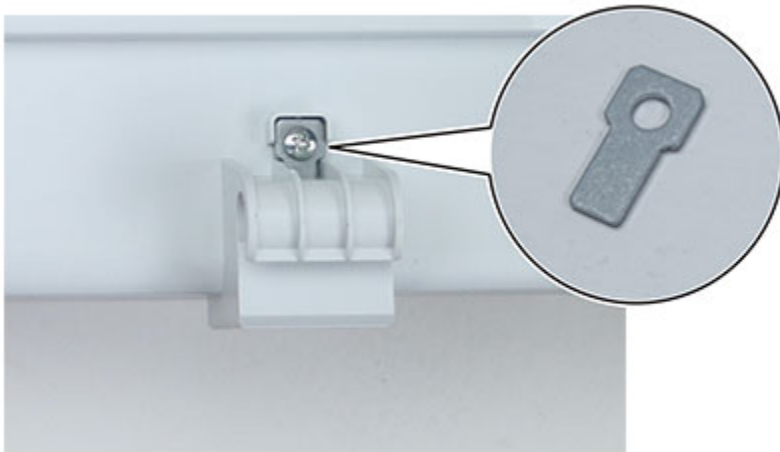

Parts Removal

11. Remove the ADF scanner from the flatbed scanner.



Component Locations

Printer Configuration



1	Automatic document feeder (ADF)
2	ADF tray
3	ADF bin
4	Standard bin
5	Power button
6	Manual feeder
7	250-sheet tray
8	Control panel

Controller Board Connectors

Connector	Connects to	Pin number	Signal
JCN37	Sensor (flatbed)	1	1.2 V
		2	GROUND
		3	FB home Sns
JCN34	Motor (ADF)	1	ADF BOUT1
		2	ADF BOUT2
		3	ADF AOUT1
		4	ADF AOUT2
		5	Not used
JCN36	Motor (flatbed)	1	FB BOUT1
		2	FB BOUT2
		3	FB AOUT1
		4	FB AOUT2
JCN35	Sensor (ADF)	1	ADF ENTRYN C
		2	ADF COVER OPEN C
		3	3 V
		4	GROUND
		5	ADF FEEDN C
JCN38	CIS scanner	1	JCIS P1
		2	GROUND
		3	GROUND
		4	3.3 V
		5	SCAN VREF
		6	JCIS P6
		7	FB CIS PCLK2
		8	5 V
		9	JCIS P9
		10	JCIS P10
		11	JCIS P11
		12	GROUND
JCN6	Fax	1	3.3 V FUSED RIP
		2	GROUND
		3	5 V FUSED

Component Locations

Connector	Connects to	Pin number	Signal		
		4	FAX POR		
		5	FAX IRQ		
		6	3.3 V FUSED RIP		
		7	GROUND		
		8	BSPI CLK FAX		
		9	GROUND		
		10	BSPI TXD FAX		
		11	GROUND		
		12	BSPI RXD		
		13	GROUND		
		14	BSP1 CS FAX		
		15	RING FAX		
		16	SLEEP		
		17	FAX RELAY		
		JCN25	Control panel	1	COL3
				2	COL2
				3	COL1
4	COL0				
5	GROUND				
6	ROW7				
7	ROW6				
8	ROW5				
9	ROW4				
10	ROW3				
11	ROW2				
12	ROW1				
13	ROW0				
14	LCD ON				
15	LCD SDA				
16	LCD SCK				
17	LCD RSTN				
18	OP PAN DETECT				
19	LCD CD				

Connector	Connects to	Pin number	Signal
		20	LCD CS
		21	LCD BK
		22	GROUND
		23	3.3 V
		24	3.3 V
JCN31	Photoconductor contact	1	3.3 V SCHIP
		2	IU SDA C
		3	IU SCL C
		4	GROUND
JCN21	Power switch	1	5 V
		2	POWER LED OUT
		3	GROUND
JCN39	HVPS	1	25 V
		2	25 V
		3	GROUND
		4	HVPS ID C
		5	3.3 V_ENG
		6	3.3 V_SCHIP
		7	CART SDA C
		8	CART SCL C
		9	FDOOR OPEN C
		10	FAN EN C
		11	3.3 V ENG SNS
		12	PICK EN C
		13	BUMP ROLL EN C
		14	INPUT SNSN C
		15	BUMP SNSN C
		16	(NO CONNECTION)
		17	UNUSED SNSN C
		18	DEV PWM C
		19	XFR PWM C
		20	CHG PWM C
		21	XFR POS C

Component Locations

Connector	Connects to	Pin number	Signal
		22	A XFR SERVO C
		23	GROUND
JCN5	Printhead	1	MMTR REFCLK C
		2	MMTR LOCKN C
		3	MMTR STARTN C
		4	GROUND
		5	25 V SW
JCN4	Printhead	1	VDO HSYNCNC
		2	GROUND
		3	VDO ADJ0N C
		4	VDO K1 -C
		5	VDO ADJ1N C
		6	VDO K1 +C
		7	VDO LENAN C
		8	GROUND
		9	VDO LPOW C
		10	VDO K0 -C
		11	VDO PWR C 3.3 V
		12	VDO K0 +C
JCN24	LVPS	1	25 V CONT
		2	25 V CONT
		3	25 V CONT
		4	GROUND
		5	GROUND
		6	GROUND
		7	LV SLEEPN C
		8	LV HEAT C
		9	25 V SW
		10	AC RELAY ON C 3 V
JCN3	Motor (main)	1	GROUND
		2	GROUND
		3	25 V SW
		4	25 V SW





Connector	Connects to	Pin number	Signal
		5	BLDC LOCKN C
		6	BLDC ENN C
		7	BLDC PWM C
		8	BLDC DIR C
JCN10	Sensor (tray empty)	1	TRAY EMPTY LED C 1.1 V
		2	TRAY EMPTY C
		3	GROUND
		4	No connection
JCN1	Sensor (fuser exit)	1	3.3 V
		2	EXIT SNS C
		3	GROUND
JCN2	Sensor (fuser)	1	A FUSER THERM C 1.8 V
		2	GROUND

Component Locations

Maintenance

Cleaning Printer Parts

Cleaning The Printer

-  **CAUTION—SHOCK HAZARD:** To avoid the risk of electrical shock when cleaning the exterior of the printer, unplug the power cord from the electrical outlet and disconnect all cables from the printer before proceeding.
-  **ATTENTION ! RISQUE D'ÉLECTROCUTION :** pour éviter tout risque d'électrocution lors du nettoyage de l'extérieur de l'imprimante, débranchez le cordon d'alimentation électrique de la prise et déconnectez tous les câbles de l'imprimante avant de continuer.
-  **PRECAUCIÓN—RIESGO DE DESCARGA:** Para evitar el riesgo de descarga eléctrica al limpiar el exterior de la impresora, desconecte el cable de alimentación de la toma eléctrica y desconecte todos los cables de la impresora antes de realizar la operación.
-  **VORSICHT – STROMSCHLAGGEFAHR:** Um das Risiko eines elektrischen Schlags beim Reinigen des Druckergehäuses zu vermeiden, ziehen Sie das Netzkabel aus der Steckdose, und ziehen Sie alle Kabel vom Drucker ab, bevor Sie fortfahren.
-  **ATTENZIONE – PERICOLO DI SCOSSA ELETTRICA:** Per evitare il rischio di scosse elettriche quando si pulisce la parte esterna della stampante, scollegare il cavo di alimentazione dalla presa a muro e scollegare tutti i cavi della stampante prima di procedere.

 **Note:**

- Perform this task after every few months.
 - Damage to the printer caused by improper handling is not covered by the printer warranty.
1. Turn off the printer, and then unplug the power cord from the electrical outlet.
 2. Remove paper from the standard bin and manual feeder.
 3. Remove any dust, lint, and pieces of paper around the printer using a soft brush or vacuum.
 4. Wipe the outside of the printer with a damp, soft, lint-free cloth.

 **Note:**

- Do not use household cleaners or detergents, as they may damage the finish of the printer.
 - Make sure that all areas of the printer are dry after cleaning.
5. Connect the power cord to the electrical outlet, and then turn on the printer.

Cleaning The Scanner

1. Open the scanner cover.



Maintenance

2. Using a damp, soft, lint-free cloth, wipe the following areas:

- ADF glass

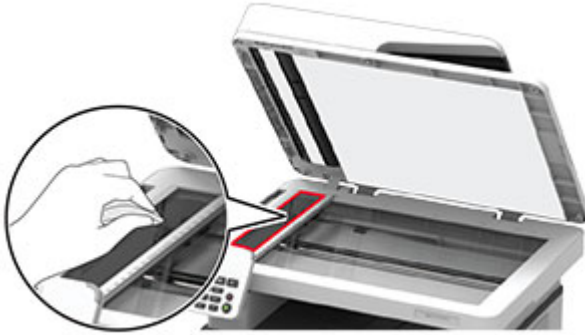

- ADF glass pad



- Scanner glass



- Scanner glass pad



3. Close the scanner cover.

Parts Catalog

Legend

The following column headings are used in the parts catalog:

- **Asm-index**—Identifies the item in the illustration.
- **Part number**—Identifies the unique number that correlates with the part.
- **Units/mach**—Refers to the number of units actually used in the base machine or product.
- **Units/FRU**—Refers to the number of units in a particular FRU.
- **Description**—Describes the part.

The following abbreviations are used in the parts catalog:

- **NS** (not shown) in the Asm-index column indicates that the part is procurable but is not pictured in the illustration.
- **PP** (parts packet) in the Description column indicates that the part is contained in a parts packet.

Assembly 1: Covers (B225)

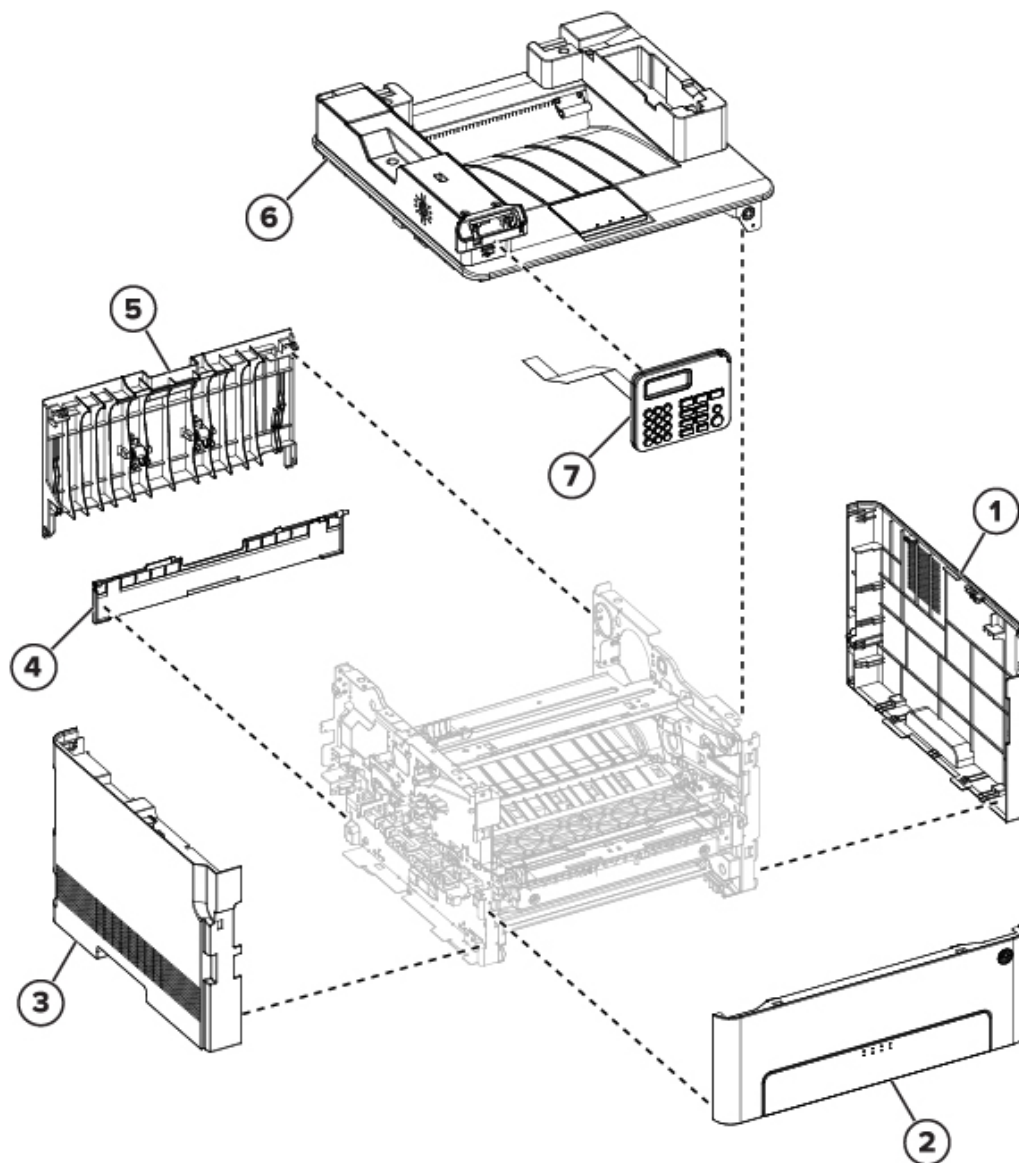

Asm-index	P/N	Units/mach	Units/FRU	Description	Removal procedure
1	002N03388	1	1	Right cover	Right cover removal
2	002N03426	1	1	Front door	Front door removal
3	002N03391	1	1	Left cover	Left Cover Removal

Parts Catalog

Asm-index	P/N	Units/mach	Units/FRU	Description	Removal procedure
4	002N03390	1	1	Bottom rear door	Bottom rear door removal
5	002N03389	1	1	Rear door	Rear door removal
6	002N03401	1	1	Top cover	Top Cover Removal
7	002N03395	1	1	2-line control panel	2-line Control Panel Removal

Assembly 2: Covers (B235)

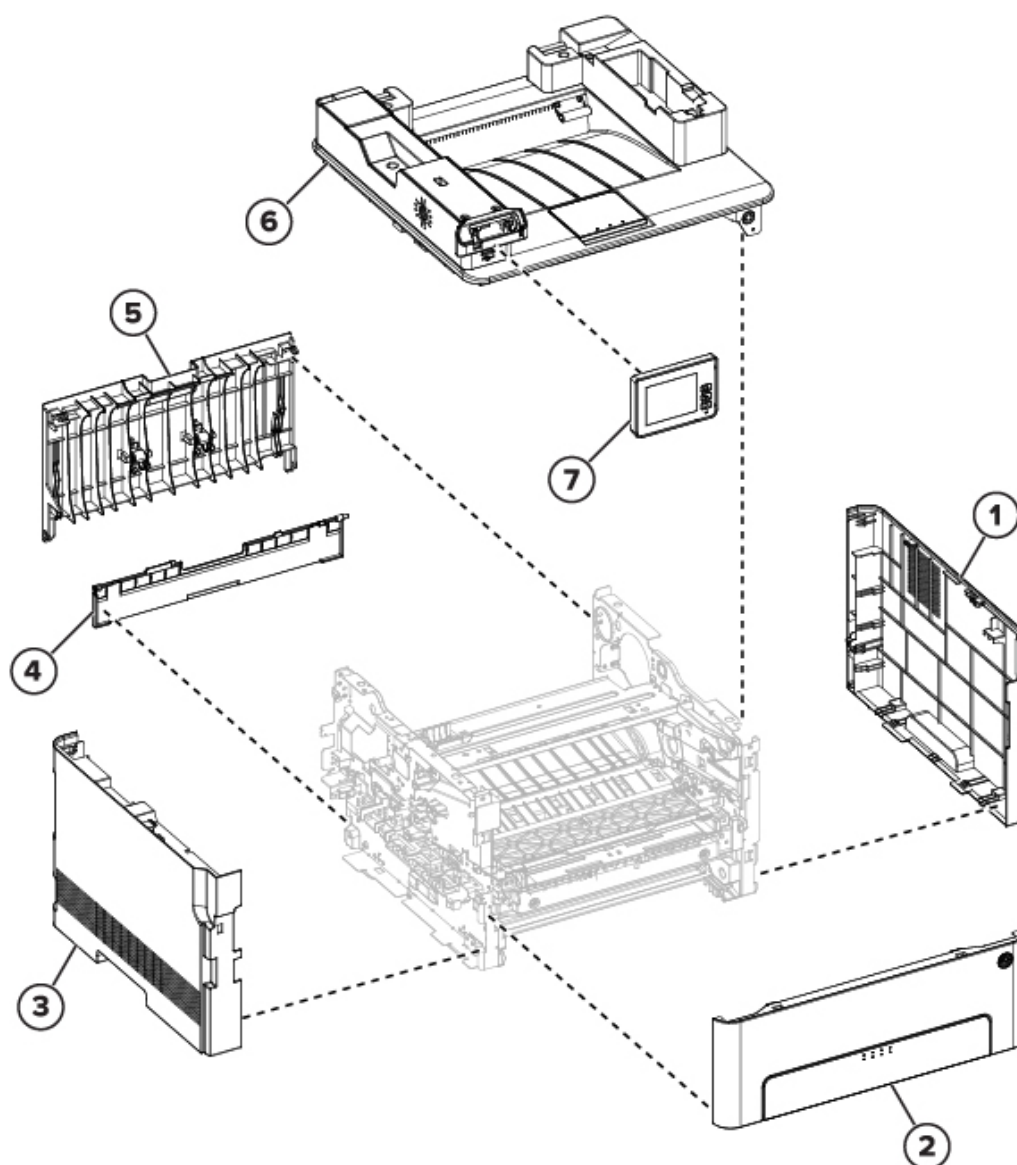

Asm-index	P/N	Units/mach	Units/FRU	Description	Removal procedure
1	002N03388	1	1	Right cover	Right cover removal
2	002N03426	1	1	Front door	Front door removal
3	002N03391	1	1	Left cover	Left Cover Removal

Parts Catalog

Asm-index	P/N	Units/mach	Units/FRU	Description	Removal procedure
4	002N03390	1	1	Bottom rear door	Bottom rear door removal
5	002N03389	1	1	Rear door	Rear door removal
6	002N03402	1	1	Top cover	Top Cover Removal
7	002N03396	1	1	2.8-in. control panel	2.8-in. Control Panel Removal

Assembly 3: Paper Path

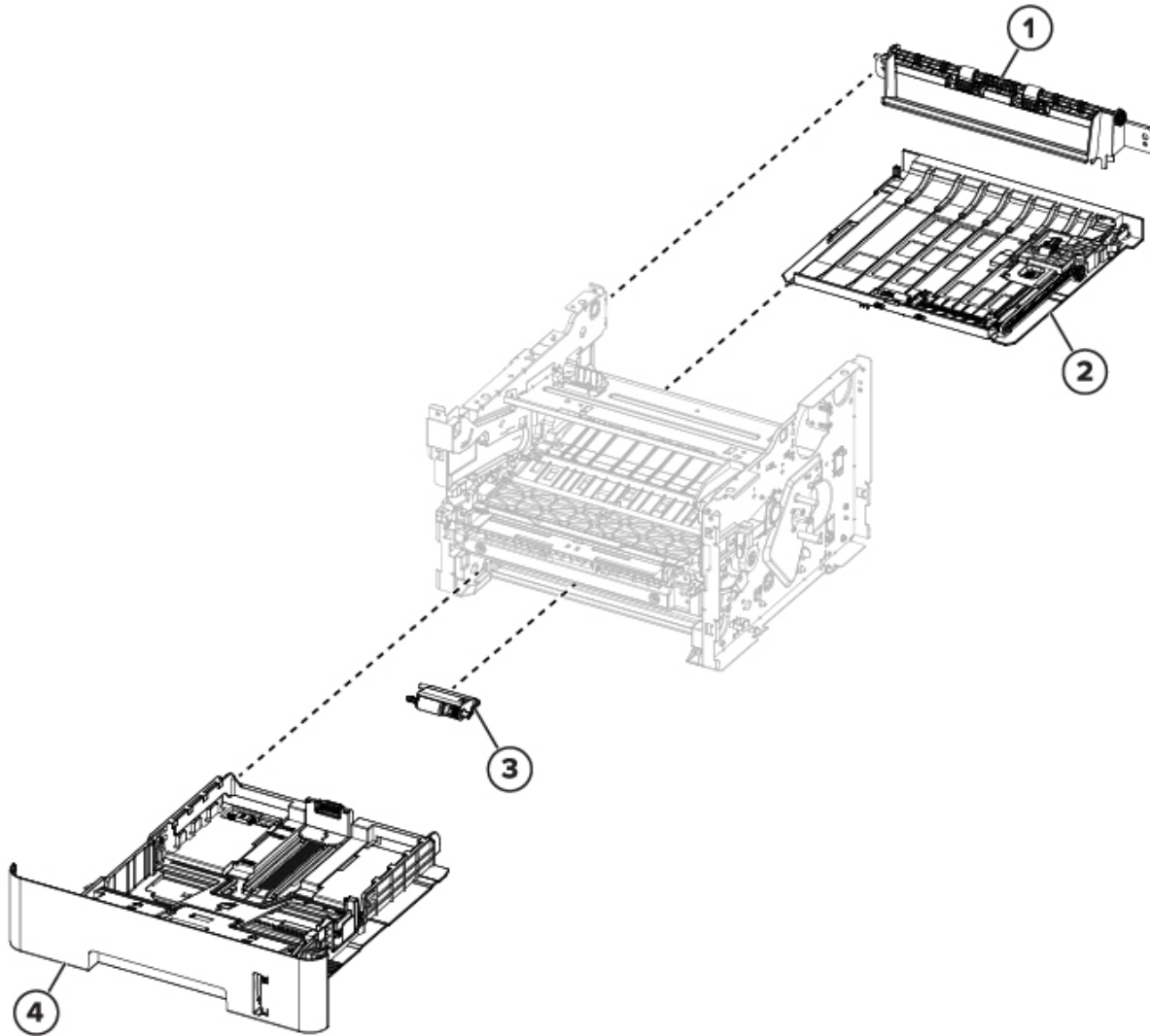

Asm-index	P/N	Units/mach	Units/FRU	Description	Removal procedure
1	007N01856	1	1	Redrive	Redrive removal
2	152N11949	1	1	Duplex unit	Duplex Unit Removal

Parts Catalog

Asm-index	P/N	Units/mach	Units/FRU	Description	Removal procedure
3	022N02900	1	1	Pick roller	Pick rollers removal
4	050N00713	1	1	Tray insert	–

Assembly 4: Drive

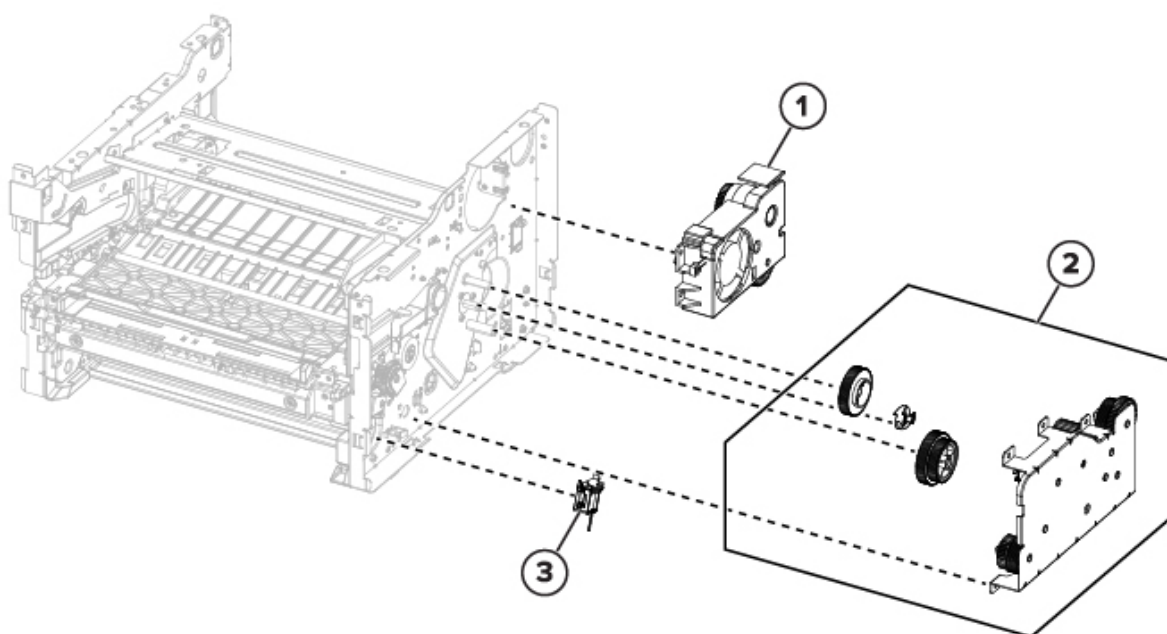

Asm-index	P/N	Units/mach	Units/FRU	Description	Removal procedure
1	127N07966	1	1	Fan assembly	Fan assembly removal
2	007N01854	1	1	Main drive	Main drive removal
3	121N01275	1	1	Pick solenoid	Pick solenoid removal

Assembly 5: Sensors

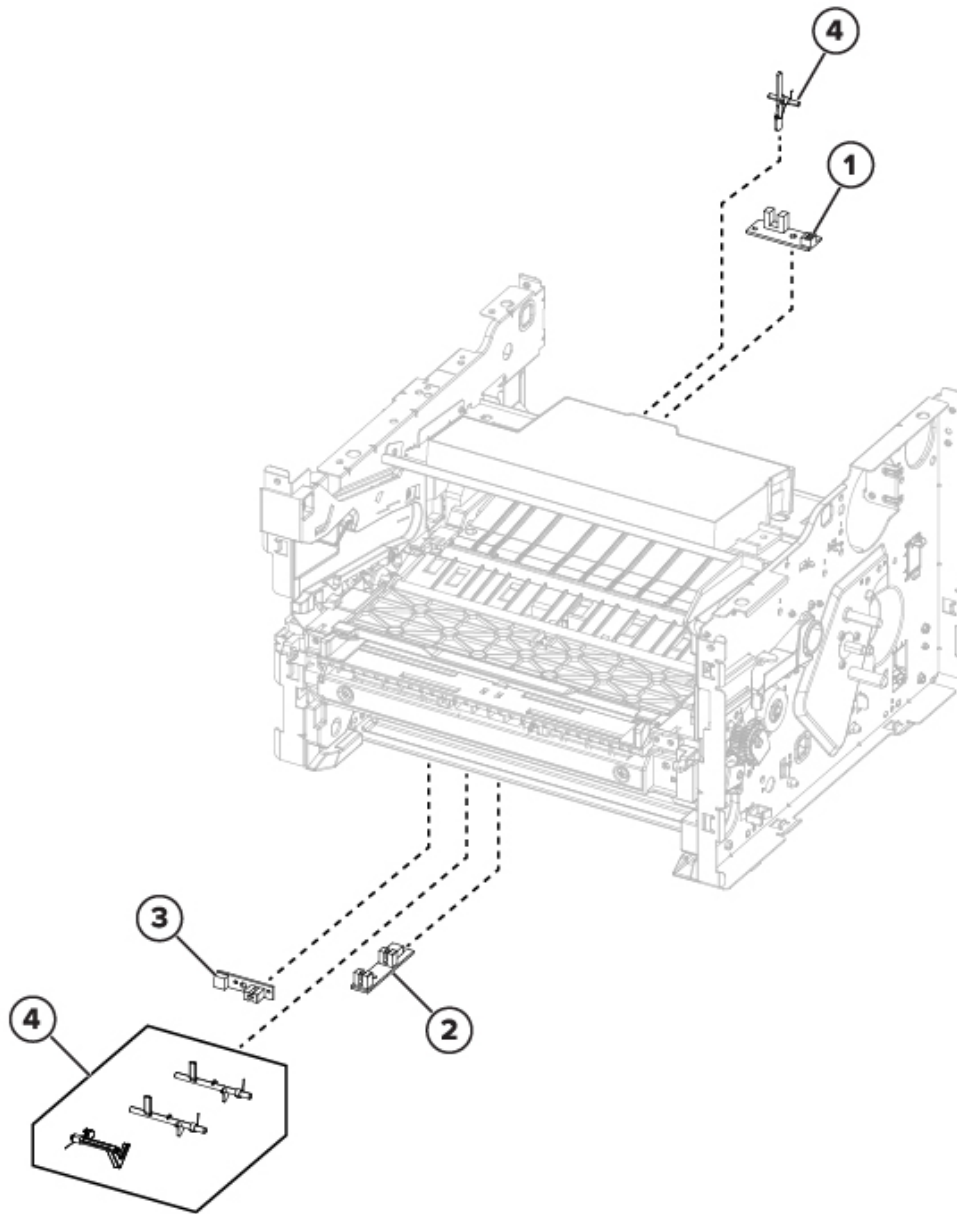

Asm-index	P/N	Units/mach	Units/FRU	Description	Removal procedure
1	130N01907	1	1	Sensor (fuser exit)	Sensor (fuser exit) removal
2	130N01906	1	1	Sensor (staging and input)	Sensor (staging and input) removal

Asm-index	P/N	Units/mach	Units/FRU	Description	Removal procedure
3	130N01905	1	1	Sensor (paper present)	Sensor (paper present) removal
4	130N01908	1	1	Sensor flags	Input Sensor Flags Removal Fuser Exit Flag Removal

Assembly 6: Electronics

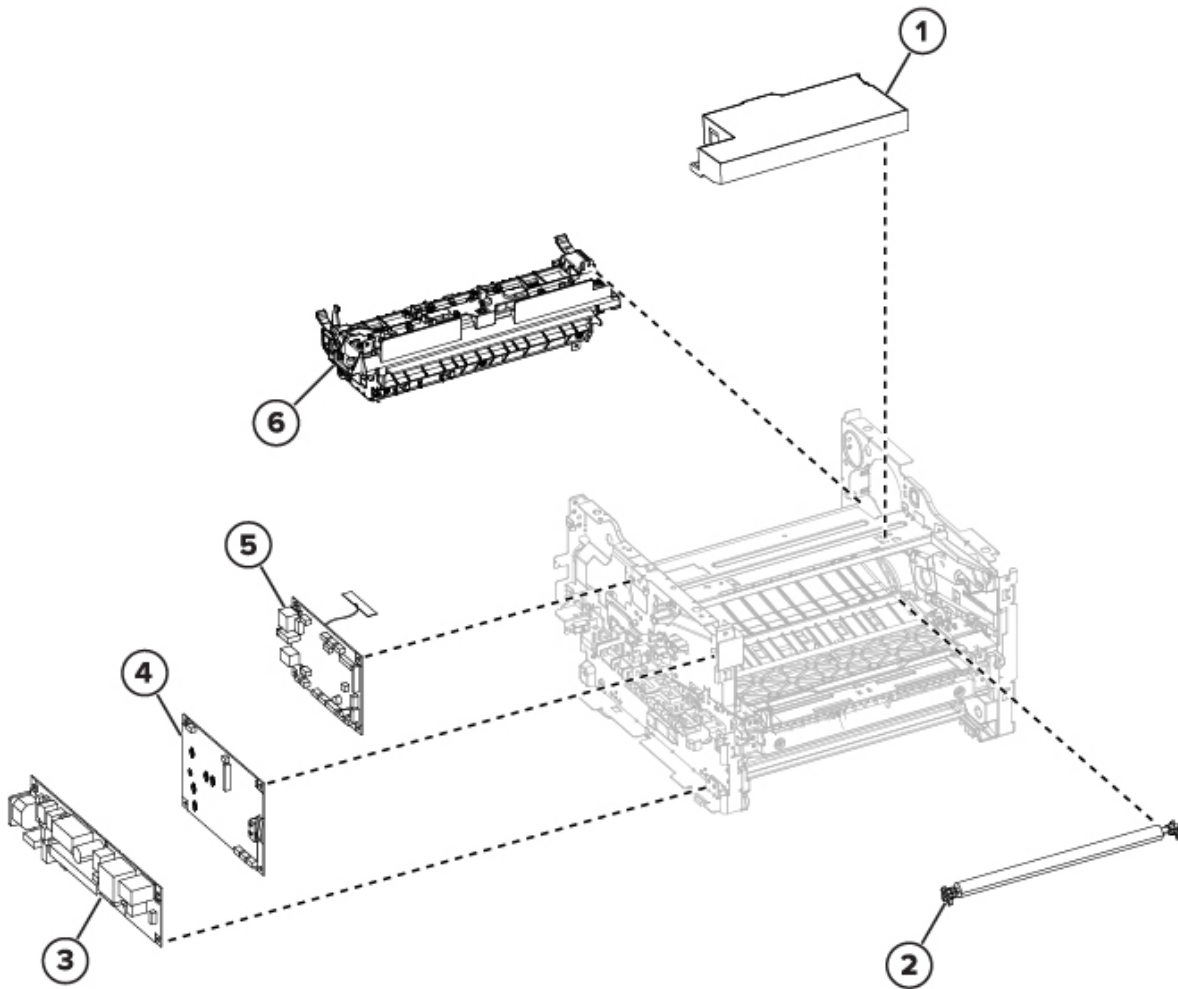

Asm-index	P/N	Units/mach	Units/FRU	Description	Removal procedure
1	046N00244	1	1	Printhead	Printhead removal
2	022N02901	1	1	Transfer roller	Transfer roller removal
3	112N00263	1	1	LVPS, 110 V	LVPS removal

Asm-index	P/N	Units/mach	Units/FRU	Description	Removal procedure
3	112N00264	1	1	LVPS, 220 V	LVPS removal
4	112N00262	1	1	HVPS	HVPS removal
5	109N00873	1	1	Controller board (B225)	Controller board removal
5	109N00862	1	1	Controller board (B235)	Controller board removal
6	126N00454	1	1	Fuser, 110 V	Fuser removal
6	126N00455	1	1	Fuser, 220 V	Fuser removal
NS	117N02196	1	1	Cable kit parts pack	–
NS	002N03394	1	1	Control panel and fax FFC cable	–
NS	117N02197	1	1	Front USB cable	–

Assembly 7: Scanner

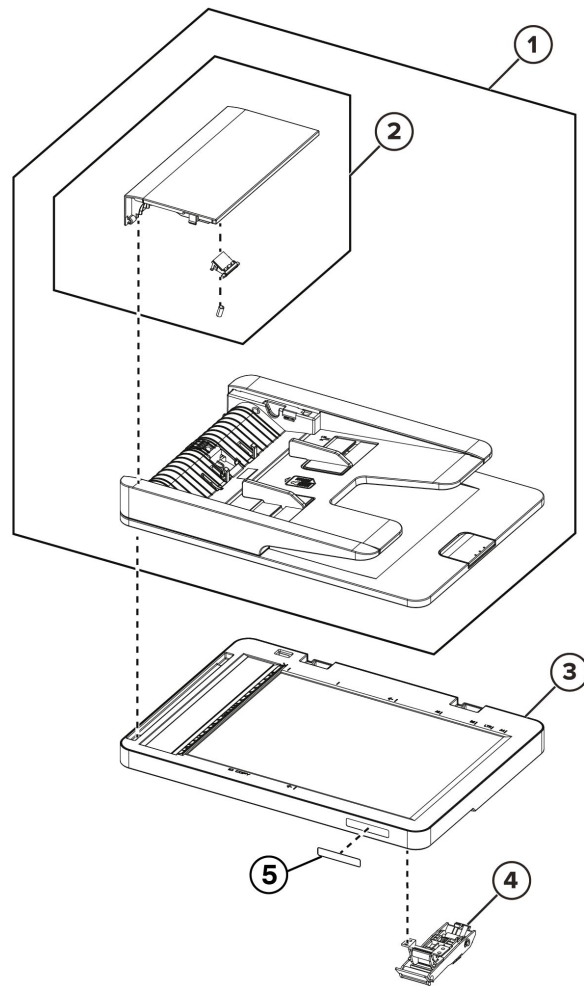

Asm-index	P/N	Units/mach	Units/FRU	Description	Removal procedure
1	062N00314	1	1	ADF scanner assembly	ADF Scanner and Flatbed Scanner Removal
2	022N02906	1	1	ADF pick assembly	ADF Pick Assembly Removal
3	109N00850	1	1	Flatbed scanner	ADF Scanner and Flatbed Scanner Removal

Asm-index	P/N	Units/mach	Units/FRU	Description	Removal procedure
4	109N00852	1	1	Scanner stand	Scanner Stand Removal
5	091N80381	1	1	Model badge label kit	

Printer Specifications

Power Consumption

Product Power Consumption

The following table documents the power consumption characteristics of the product.

 **Note:** Some modes may not apply to your product.

Mode	Description	Power consumption (Watts)	
		B225	B235
Printing	The product is generating hard-copy output from electronic inputs.	460	460
Copy	The product is generating hard-copy output from hard-copy original documents.	460	460
Scan	The product is scanning hard-copy documents.	14.5	14.5
Ready	The product is waiting for a print job.	5.5	6.0
Sleep Mode	The product is in a high-level energy-saving mode.	1.2	1.1
Hibernate	The product is in a low-level energy-saving mode.	N/A	0.2
Off	The product is plugged into an electrical outlet, but the power switch is turned off.	0.1	0.1

The power consumption levels listed in the previous table represent time-averaged measurements. Instantaneous power draws may be substantially higher than the average.

Values are subject to change. See <https://www.xerox.com> for current values.

Sleep Mode

This product is designed with an energy-saving mode called *Sleep Mode*. The Sleep Mode saves energy by lowering power consumption during extended periods of inactivity. The Sleep Mode is automatically engaged after this product is not used for a specified period of time, called the *Sleep Mode Timeout*.

Factory default Sleep Mode Timeout for this product (in minutes):	15
---	----

By using the configuration menus, the Sleep Mode Timeout can be modified between 1 minute and 120 minutes. If the print speed is less than or equal to 30 pages per minute, then you can set the timeout only up to 60 minutes. Setting the Sleep Mode Timeout to a low value reduces energy consumption, but may increase the response time of the product. Setting the Sleep Mode Timeout to a high value maintains a fast response, but uses more energy.

Hibernate Mode

This product is designed with an ultra-low power operating mode called *Hibernate mode*. When operating in Hibernate Mode, all other systems and devices are powered down safely.

The Hibernate mode can be entered in any of the following methods:

- Using the Hibernate Timeout
- Using the Schedule Power modes

Factory default Hibernate Timeout for this product in all countries or regions	3 days
--	--------

The amount of time the printer waits after a job is printed before it enters Hibernate mode can be modified between one hour and one month.

Off Mode

If this product has an off mode which still consumes a small amount of power, then to completely stop product power consumption, disconnect the power supply cord from the electrical outlet.

Total Energy Usage

It is sometimes helpful to estimate the total product energy usage. Since power consumption claims are provided in power units of Watts, the power consumption should be multiplied by the time the product spends in each mode in order to calculate energy usage. The total product energy usage is the sum of each mode's energy usage.

Selecting A Location For The Printer

- Leave enough room to open trays, covers, and doors and to install hardware options.
- Set up the printer near an electrical outlet.
- Make sure that airflow in the room meets the latest revision of theASHRAE 62 standard or the CEN Technical Committee 156 standard.
- Provide a flat, sturdy, and stable surface.
- Keep the printer:
 - Clean, dry, and free of dust
 - Away from stray staples and paper clips
 - Away from the direct airflow of air conditioners, heaters, or ventilators
 - Free from direct sunlight and humidity extremes
- Observe the temperature range.

Operating temperature	10 to 32.2°C (50 to 90°F)
-----------------------	---------------------------

- Allow the following recommended amount of space around the printer for proper ventilation:

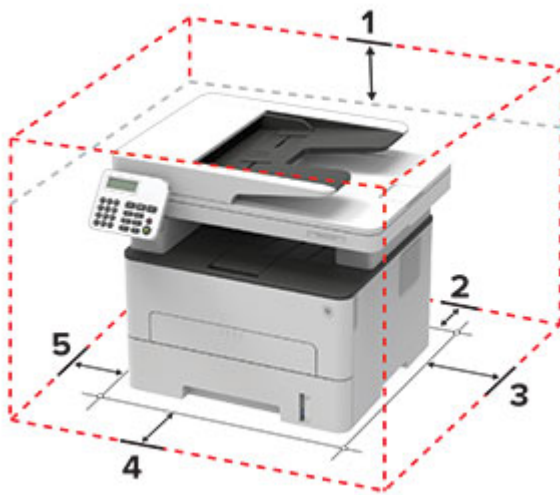

1	Top	360 mm (14 in.)
2	Rear	260 mm (10 in.)
3	Right side	200 mm (8 in.)
4	Front	550 mm (22 in.) The minimum space needed in front of the printer is 76 mm (3 in.).
5	Left side	200 mm (8 in.)

Noise Emission Levels

The following measurements were made in accordance with ISO 7779 and reported in conformance with ISO 9296.

 **Note:** Some modes may not apply to your product.

1-meter average sound pressure, dBA	
Printing	One-sided: 52; Two-sided: 50
Scanning	52
Copying	55
Ready	14

Values are subject to change. See <https://www.xerox.com> for current values.

Temperature Information

Operating temperature and relative humidity	10° to 32.2° C (50° to 90° F) and 15 to 80 % RH 15.6° to 32.2° C (60° to 90° F) and 8 to 80 % RH Maximum wet-bulb temperature ² : 22.8° C (73° F) Non-condensing environment
Printer / cartridge / imaging unit long-term storage ¹	15.6° to 32.2° C (60° to 90° F) and 8 to 80 % RH Maximum wet-bulb temperature ² : 22.8° C (73° F)
Printer / cartridge / imaging unit short-term shipping	-40° to 40° C (-40° to 104° F)
<p>¹ Supplies shelf life is approximately 2 years. This is based on storage in a standard office environment at 22° C (72° F) and 45 % humidity.</p> <p>² Wet-bulb temperature is determined by the air temperature and the relative humidity.</p>	

Theory Of Operation

POR Sequence

As the printer turns on, the engine code goes through a series of tests to verify hardware integrity. If a hardware failure is detected, then it is reported to the printer. If the POR sequence cannot be completed successfully, then the printer may post an error message. The message states that service may be needed.

Print Cycle Operation

Print Engine Layout

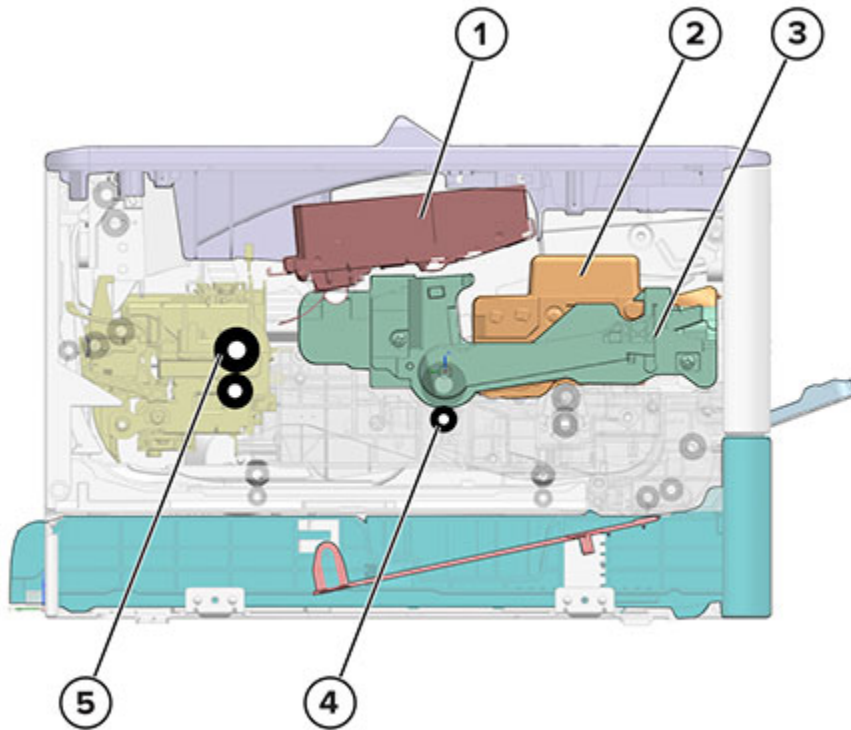

1	Printhead
2	Toner cartridge
3	Imaging unit
4	Transfer roller
5	Fuser

Print Cycle

Flowchart

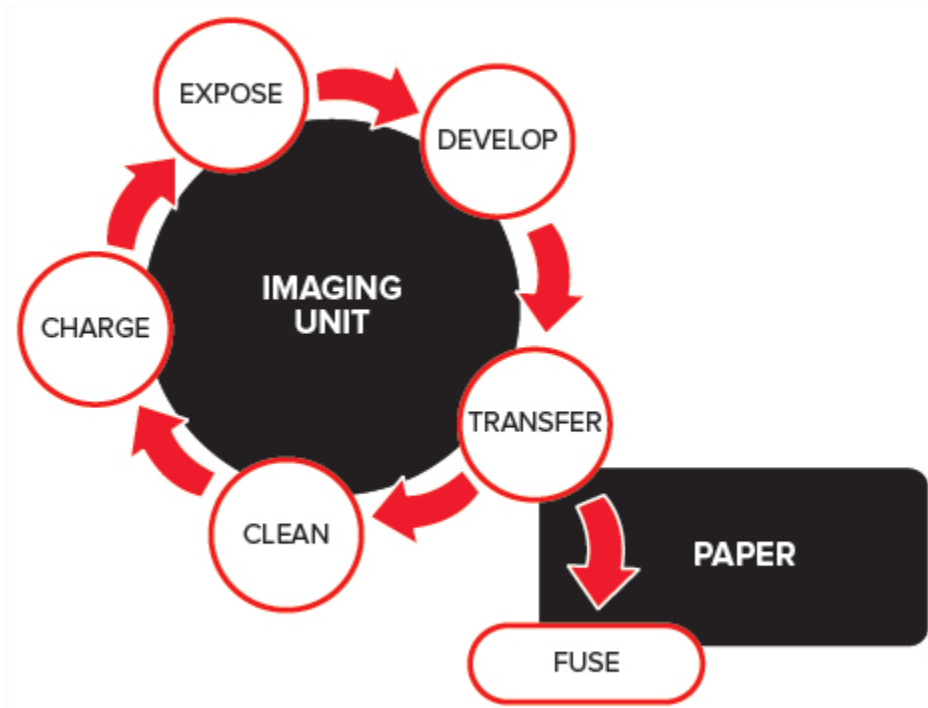

Charge

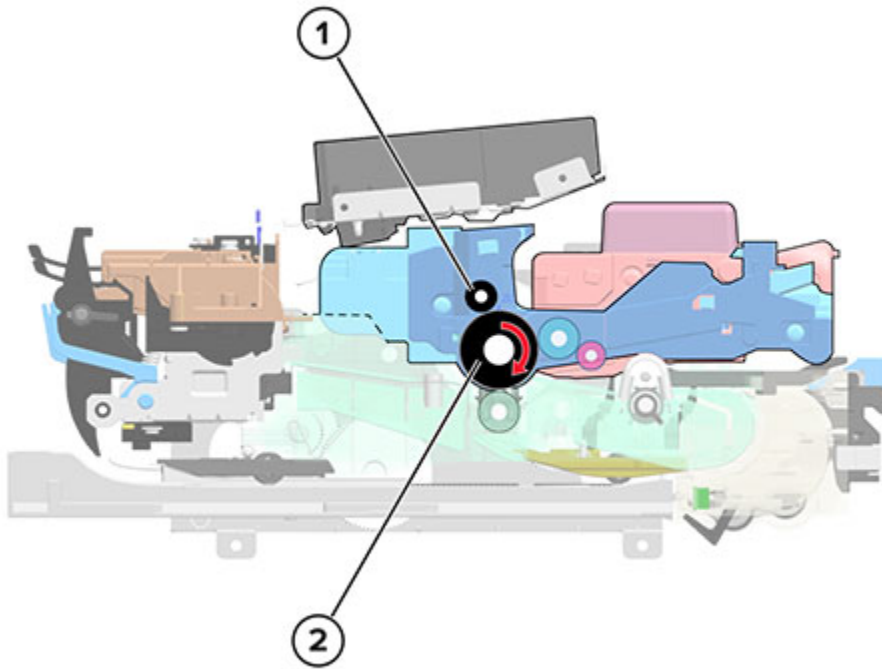

1	Charge roller
2	Photoconductor drum

The charge roller applies a uniform negative electrical charge to the surface of the photoconductor drum. The photoconductive properties of the surface material allow it to hold the charge as long as it is not exposed to light.

Expose

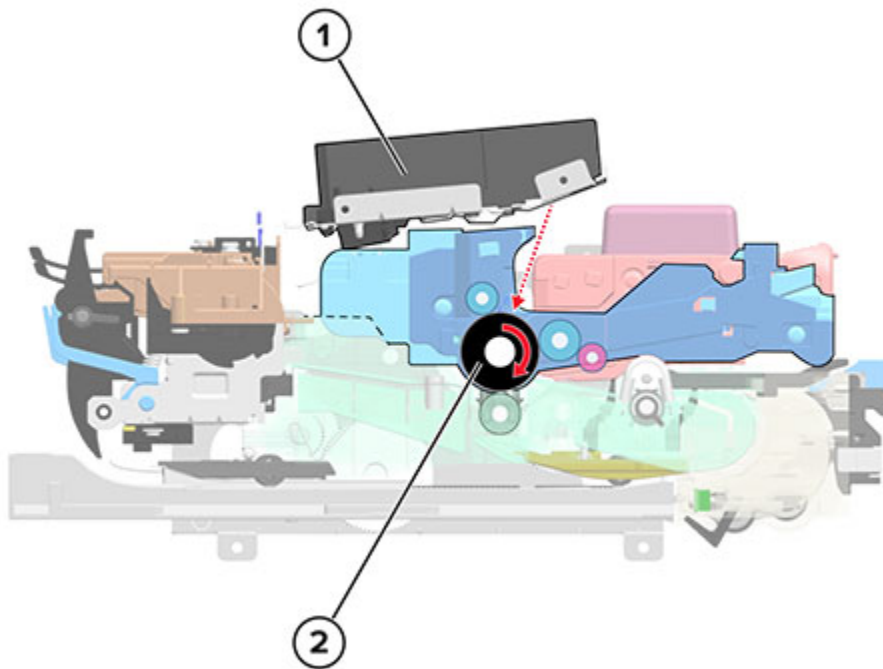

1	Printhead
2	Photoconductor drum

The printhead emits the light that contacts the surface of the photoconductor drum. The light turns on or off coinciding with the digital latent image. The light causes areas of the photoconductor drum surface to lose charge, resulting in a relative opposite polarity.

Develop

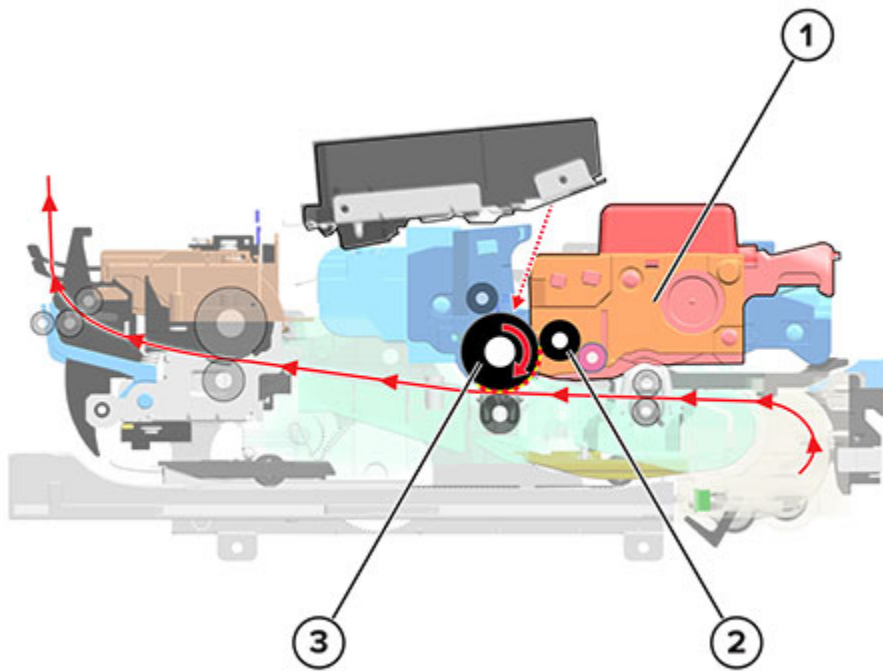

1	Toner cartridge
2	Developer roller
3	Photoconductor drum

The developer unit applies the toner from the toner cartridge to the photoconductor drum. The difference in charge causes the toner particles to attract to the photoconductor drum areas which are exposed to light.

Transfer

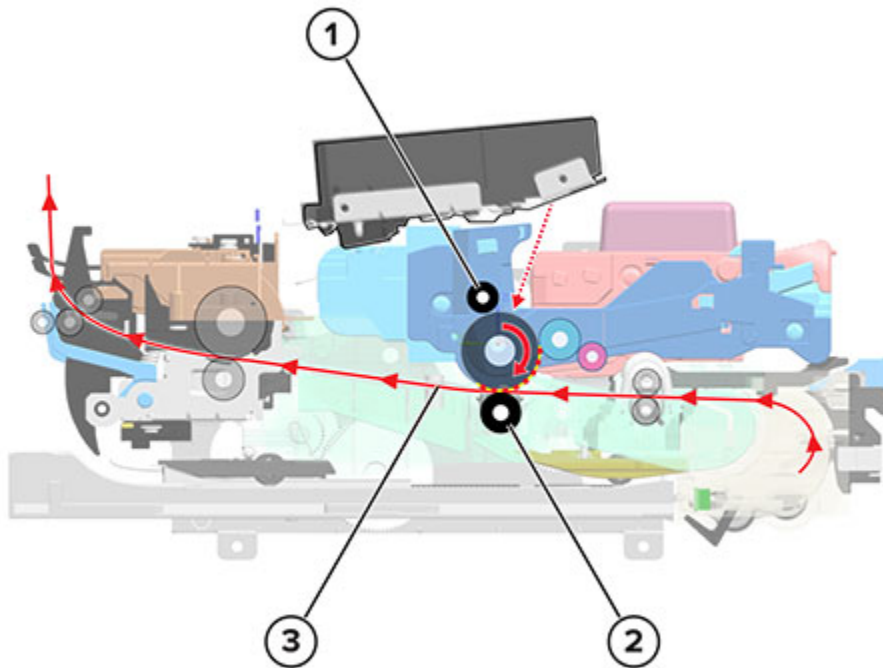

1	Charge roller
2	Transfer roller
3	Paper

The transfer roller applies a positive charge to the paper, which is pressed between the transfer roller and the photoconductor drum. Due to relative opposite polarities between the paper from the transfer roller, and the photoconductor drum from the charge roller, the charge attracts the toner to the paper.

Clean

The cleaning blade removes the residual toner from the photoconductor after the transfer. After cleaning, the process moves again to the charge process and repeats each cycle until the entire image is transferred to a side of the paper.

Fuse

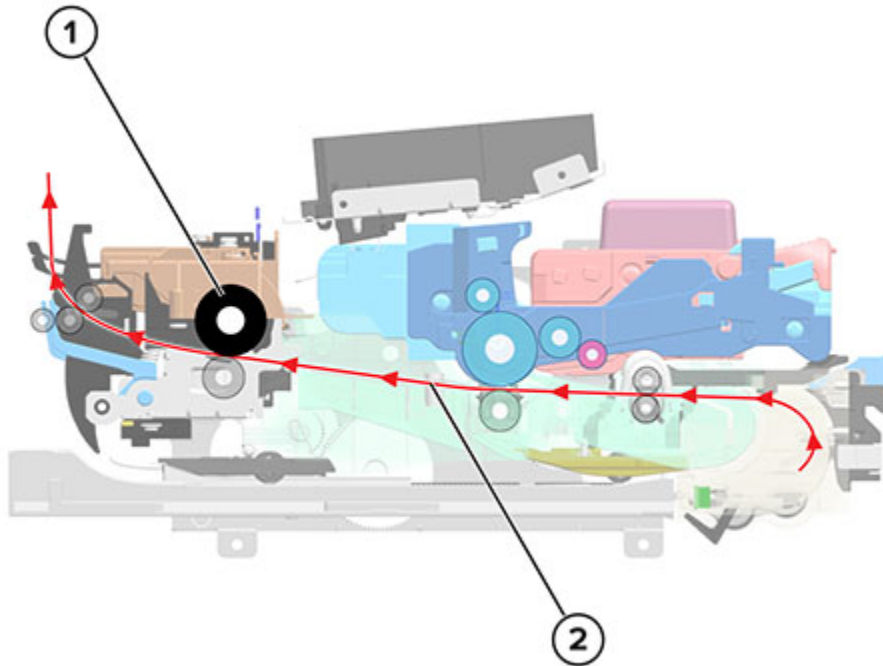

1	Fuser
2	Paper

Even if the toner image is already on the paper, the toner particles are not yet permanently bonded to the surface. For the final part of printing, the paper is transported to the fuser where heat and pressure are applied to it. As a result, the toner particles melt and permanently fuse with the paper, completing the print process. The print cycle repeats for the succeeding pages.

Printer Operation

Printer Sections

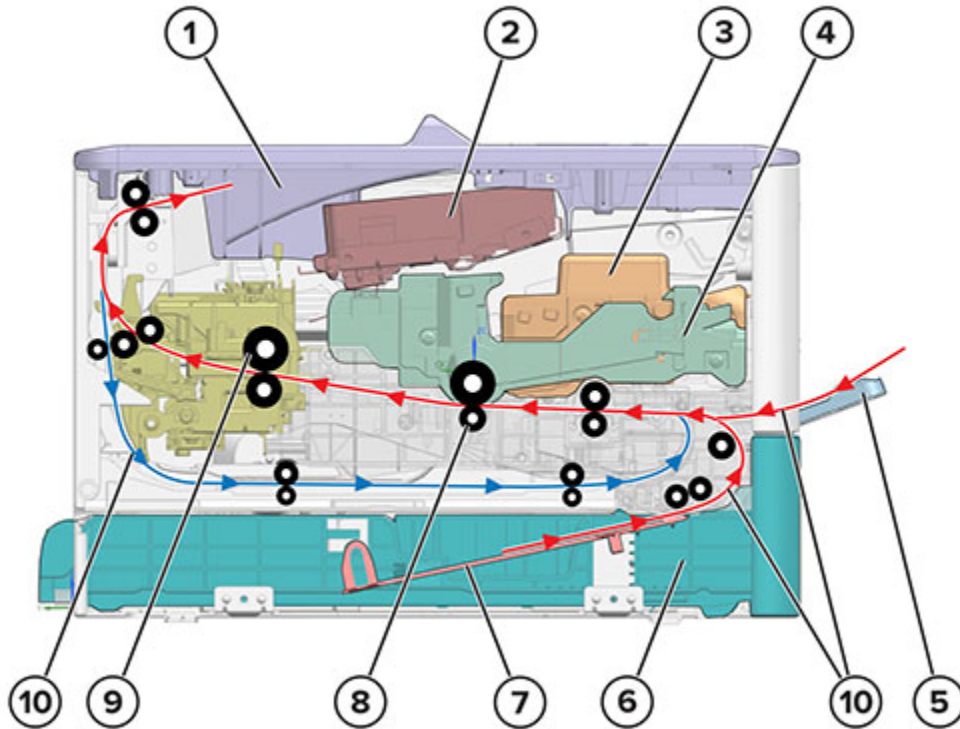

1	Output bin
2	Printhead
3	Toner cartridge
4	Imaging unit
5	Manual feeder
6	Tray
7	Lift plate
8	Transfer roller
9	Fuser
10	Paper paths

Printer Paper Path

Simplex Print Job

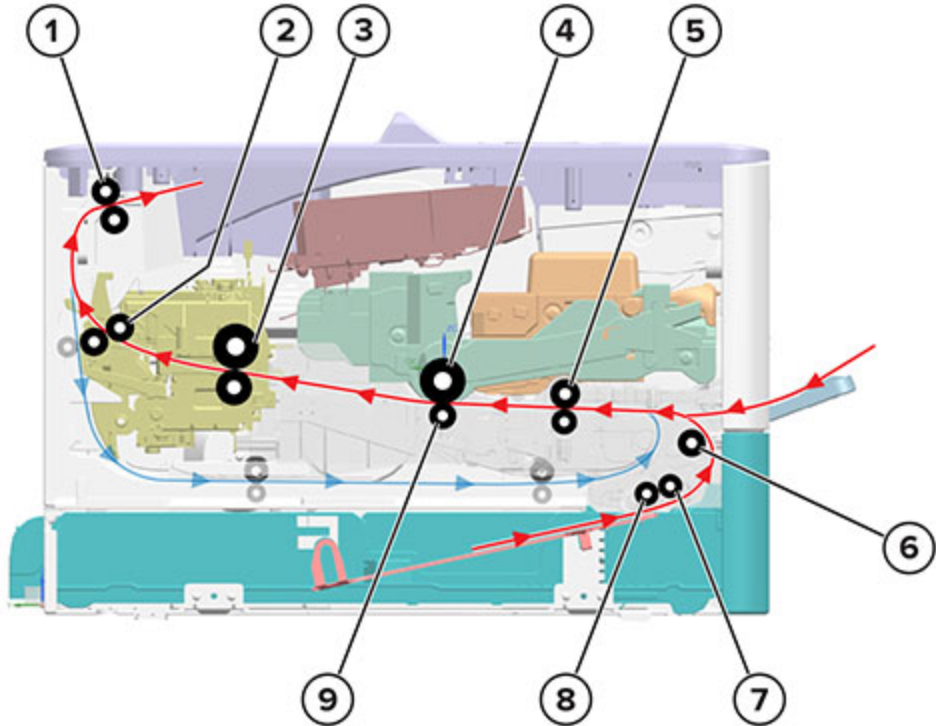

1	Paper exit roller
2	Fuser exit roller
3	Fuser
4	Photoconductor drum
5	Deskew roller
6	Transport roller
7	Feed roller
8	Pick roller
9	Transferroller

The pick and feed rollers pick the paper, and then feeds it to the transport roller. The transport roller moves the paper to the deskew roller where the paper skew is corrected.

The deskew shutter along the deskew roller corrects the paper skew.

The deskew roller feeds the paper to the transfer roller for image transfer. At the transfer roller, the photoconductor drum transfers the developed image to the paper to create the printed image.

As the paper passes the fuser, heat and pressure are applied to bond permanently the toner to the

Theory Of Operation

paper.

After the image transfer process is complete, the paper is transported to the fuser exit roller, to the paper exit roller, and then to the output bin.

Duplex Print Job

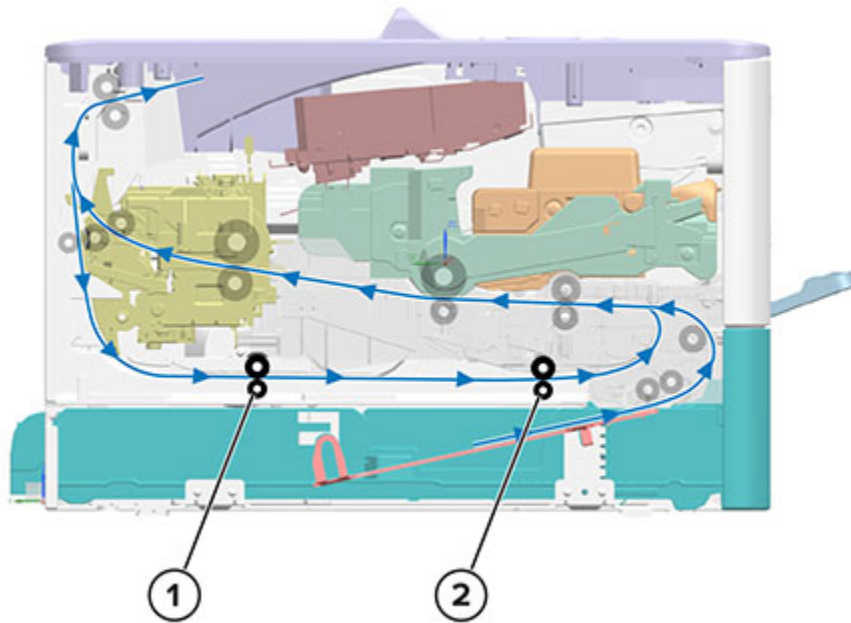

1	Duplex rear roller
2	Duplex front roller

After the first side is printed, the paper stops at the output bin while still in the exit roller. The paper is fed back into the duplex paper path to have the opposite page printed.

The paper travels along the duplex path until it reenters the second input roller. From there, the paper continues its path until the print job is done.

Printer Paper Path Sensors

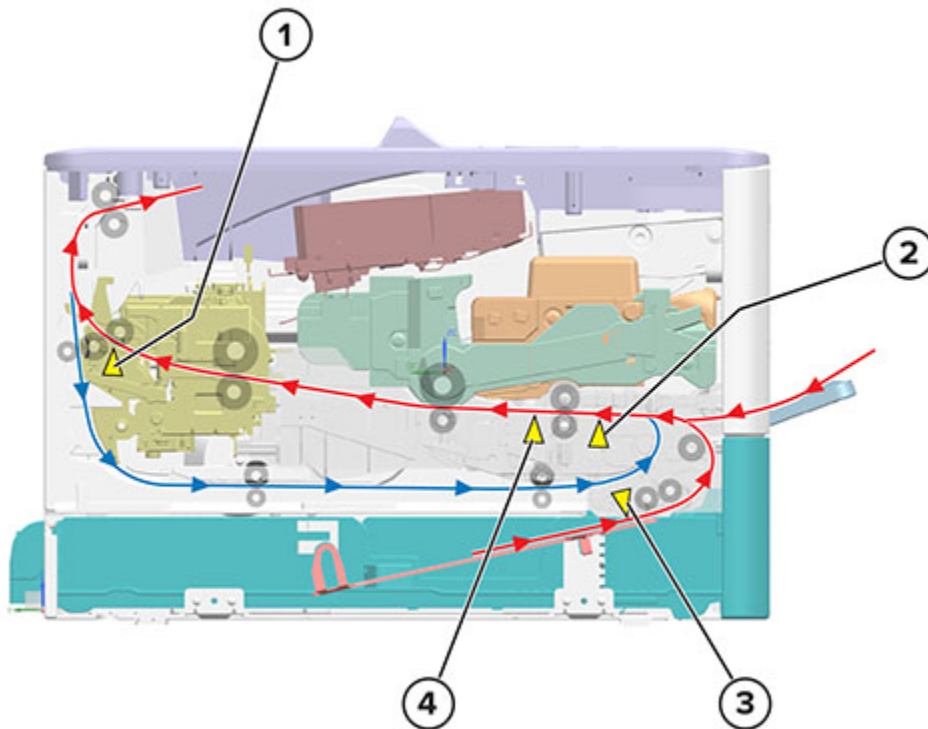

#	Sensor	Function
1	Sensor (fuser exit)	Detects the paper exiting the fuser
2	Sensor (staging)	Detects the paper travelling between the pick rollers and the deskew roller
3	Sensor (paper present)	Detects paper presence in the tray
4	Sensor (input)	Detects the paper travelling between the deskew roller and the transfer roller

Main Drive

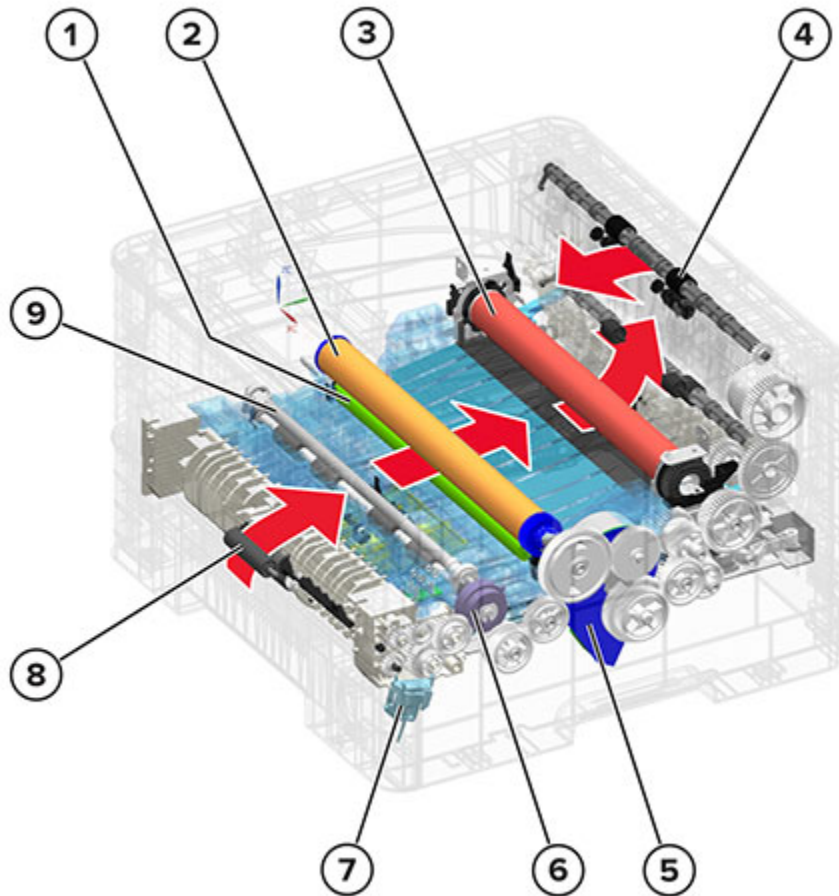

1	Transfer roller
2	Photoconductor
3	Fuser
4	Paper exit
5	Motor (main drive)
6	Deskew solenoid
7	Pick solenoid
8	Transport roller
9	Deskew roller

The motor (main drive) powers the drive mechanism of the printer. The gearbox provides mechanical power to the printer which transfers power through several gears to the following parts:

- Manual feeder
- Paper pick using the pick solenoid
- Paper feed using the deskew solenoid
- Transport roller
- Toner cartridge
- Photoconductor
- Fuser
- Duplex unit
- Redrive

ADF and Scanner Operation

Flatbed Scanner Drive

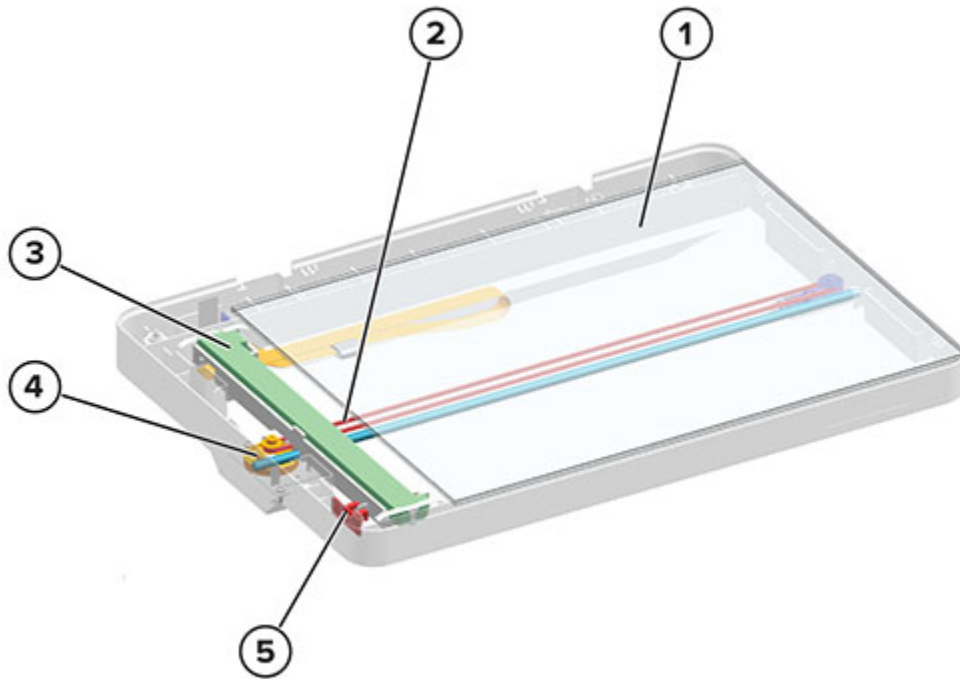

1	Scanner glass
2	Belt
3	Scanner lamp
4	Motor (scanner)
5	Sensor (scanner home)

The flatbed scanner has a scanner lamp that illuminates the surface of the document. The reflections produced are processed to create the scan image.

For flatbed scan jobs, the flatbed scanner moves across the scanner glass area to scan the front side of the document. The motor (scanner) drives the belt and controls the scanner position. The sensor (scanner home) detects the scanner at its home position.

For ADF scan jobs, the scanner lamp stays at the left side to scan the document.

ADF Paper Path

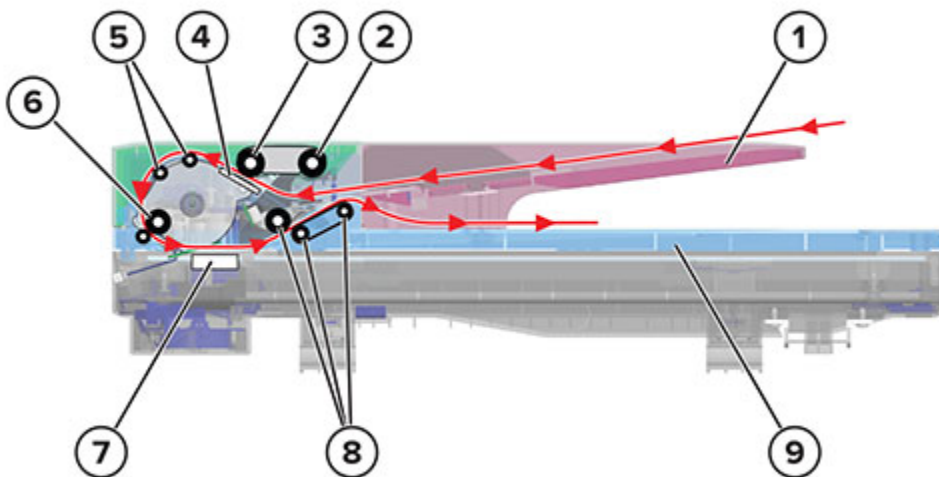

1	ADF tray
2	Pick roller
3	Feed roller
4	Separator pad
5	Transport rollers
6	Scanner roller
7	Scan area
8	Exit rollers
9	ADF bin

After the sensor (ADF paper present) detects paper in the ADF tray, the pick roller moves the paper into the ADF.

The paper passes through the feed roller and separator pad. The separator pad minimizes the possibility of feeding multiple sheets.

The paper passes through the transport rollers, and then actuates the sensor (ADF scan). The scan roller moves the paper to the scan area, and then the document is scanned.

The scan rollers continue to move the paper to the scan area until the trailing edge of the paper reaches the sensor (ADF scan). When the trailing edge of the paper reaches the sensor (ADF scan), the sensor goes to the off position. Scanning continues for a predetermined length of time.

The exit rollers move the paper into the ADF bin.

ADF Paper Path Sensors

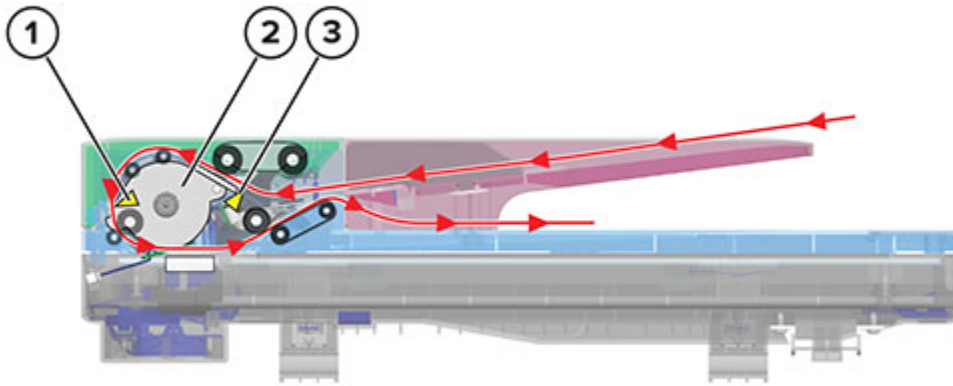

#	Sensor	Function
1	Sensor (ADF paper present)	Detects paper presence in the ADF tray
2	Motor (ADF transport)	Drives the rollers that transport paper through the ADF
3	Sensor (ADF scan)	Detects paper for scanning

Part Number Index

P/N	Part name
002N03388	Right cover (B225)
002N03388	Right cover (B235)
002N03389	Rear door (B225)
002N03389	Rear door (B235)
002N03390	Bottom rear door (B225)
002N03390	Bottom rear door (B235)
002N03391	Left cover (B225)
002N03391	Left cover (B235)
002N03394	Control panel and fax FFC cable
002N03395	2-line control panel (B225)
002N03396	2.8-in. control panel (B235)
002N03401	Top cover (B225)
002N03401	Top cover (B235)
002N03426	Front door (B225)
002N03426	Front door (B235)
007N01854	Main drive
007N01856	Redrive
022N02900	Pick roller
022N02901	Transfer roller
022N02906	ADF pick assembly
046N00244	Printhead
050N00713	Tray insert
062N00314	ADF scanner assembly
091N80381	Model badge label kit
109N00850	Flatbed scanner
109N00852	Scanner stand
109N00862	Controller board (B235)
109N00873	Controller board (B225)

Part Number Index

P/N	Part name
112N00262	HVPS
112N00263	LVPS, 110 V
112N00264	LVPS, 220 V
117N02196	Cable kit parts pack
117N02197	Front USB cable
121N01275	Pick solenoid
126N00454	Fuser, 110 V
126N00455	Fuser, 220 V
127N07966	Fan assembly
130N01905	Sensor (paper present)
130N01906	Sensor (staging and input)
130N01907	Sensor (fuser exit)
130N01908	Sensor flags
152N11949	Duplex unit

Part Name Index

P/N	Part name
002N03395	2-line control panel
002N03396	2.8-in. control panel
022N02906	ADF pick assembly
062N00314	ADF scanner assembly
002N03390	Bottom rear door (B225)
002N03390	Bottom rear door (B235)
117N02196	Cable kit parts pack
002N03394	Control panel and fax FFC cable
109N00873	Controller board (B225)
109N00862	Controller board (B235)
152N11949	Duplex unit
127N07966	Fan assembly
109N00850	Flatbed scanner
002N03426	Front door (B225)
002N03426	Front door (B235)
117N02197	Front USB cable
126N00454	Fuser, 110 V
126N00455	Fuser, 220 V
112N00262	HVPS
002N03391	Left cover (B225)
002N03391	Left cover (B235)
112N00263	LVPS, 110 V
112N00264	LVPS, 220 V
007N01854	Main drive
091N80381	Model badge label kit
022N02900	Pick roller
121N01275	Pick solenoid
046N00244	Printhead

Part Name Index

P/N	Part name
002N03389	Rear door (B225)
002N03389	Rear door (B235)
007N01856	Redrive
002N03388	Right cover (B225)
002N03388	Right cover (B235)
109N00852	Scanner stand
130N01907	Sensor (fuser exit)
130N01905	Sensor (paper present)
130N01906	Sensor (staging and input)
130N01908	Sensor flags
002N03401	Top cover (B225)
002N03401	Top cover (B235)
022N02901	Transfer roller
050N00713	Tray insert

Wiring Diagram

Wiring Diagram

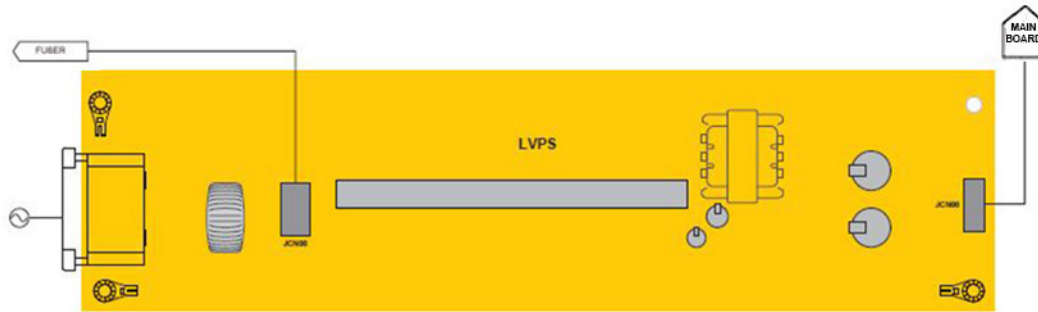

Wiring Diagram

