

**TOSHIBA**

**SERVICE MANUAL**

**MULTIFUNCTIONAL DIGITAL SYSTEMS**

**e-STUDIO167/207/237**



## Trademarks

- The official name of Windows 95 is Microsoft Windows 95 Operating System.
- The official name of Windows 98 is Microsoft Windows 98 Operating System.
- The official name of Windows Me is Microsoft Windows Millennium Edition Operating System.
- The official name of Windows 2000 is Microsoft Windows 2000 Operating System.
- The official name of Windows XP is Microsoft Windows XP Operating System.
- Microsoft, Windows, Windows NT and the brand names and product names of other Microsoft products are trademarks or registered trademarks of Microsoft Corporation in the U.S. and/or other countries.
- Molykote is a registered trademark of Dow Corning Corporation.
- Other company names and product names in this manual are the trademarks of their respective companies.

© 2007 - 2008 TOSHIBA TEC CORPORATION All rights reserved

Under the copyright laws, this manual cannot be reproduced in any form without prior written permission of TOSHIBA TEC CORPORATION. No patent liability is assumed, however, with respect to the use of the information contained herein.

# GENERAL PRECAUTIONS REGARDING THE SERVICE FOR e-STUDIO167/207/237

The installation and service should be done by a qualified service technician.

## 1) Transportation/Installation

- When transporting/installing the equipment, remove the drawer, employ two persons and be sure to hold the positions as shown in the figure. The equipment is quite heavy and weighs approximately 32.5 kg (71.65 lb), therefore pay full attention when handling it.

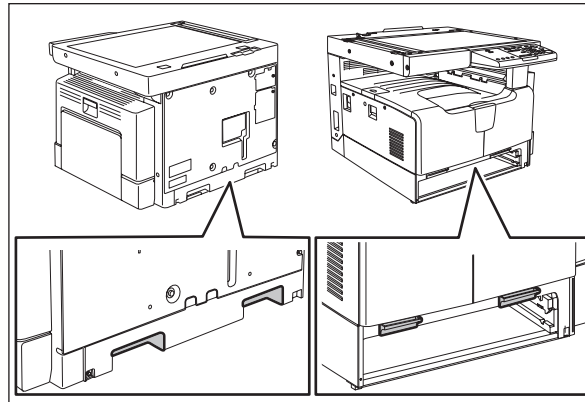

- Be sure not to hold the movable parts or units when transporting the equipment.
- Be sure to use a dedicated outlet with AC 110 V / 13.2 A, 115 V or 127 V / 12 A, 220-240 V or 240 V / 8 A for its power source.
- The equipment must be grounded for safety.
- Select a suitable place for installation. Avoid excessive heat, high humidity, dust, vibration and direct sunlight.
- Provide proper ventilation since the equipment emits a slight amount of ozone.
- To insure adequate working space for the copying operation, keep a minimum clearance of 80 cm (32") on the left, 80 cm (32") on the right and 10 cm (4") on the rear.
- The equipment shall be installed near the socket outlet and shall be easily accessible.
- Be sure to fix and plug in the power cable securely after the installation so that no one trips over it.

## 2) General Precautions at Service

- Be sure to turn the power OFF and unplug the power cable during service (except for the service should be done with the power turned ON).
- Unplug the power cable and clean the area around the prongs of the plug and socket outlet once a year or more. A fire may occur when dust lies on this area.
- When the parts are disassembled, reassembly is the reverse of disassembly unless otherwise noted in this manual or other related documents. Be careful not to install small parts such as screws, washers, pins, E-rings, star washers in the wrong places.
- Basically, the equipment should not be operated with any parts removed or disassembled.
- The PC board must be stored in an anti-electrostatic bag and handled carefully using a wristband since the ICs on it may be damaged due to static electricity.

**Caution:** Before using the wristband, unplug the power cable of the equipment and make sure that there are no charged objects which are not insulated in the vicinity.

- Avoid expose to laser beam during service. This equipment uses a laser diode. Be sure not to expose your eyes to the laser beam. Do not insert reflecting parts or tools such as a screwdriver on the laser beam path. Remove all reflecting metals such as watches, rings, etc. before starting service.
- Be sure not to touch high-temperature sections such as the exposure lamp, fuser unit, damp heater and areas around them.
- Be sure not to touch high-voltage sections such as the chargers, developer, high-voltage transformer and power supply unit. Especially, the board of these components should not be touched since the electric charge may remain in the capacitors, etc. on them even after the power is turned OFF.
- Make sure that the equipment will not operate before touching potentially dangerous places (e.g. rotating/operating sections such as gears, belts pulleys, fans and laser beam exit of the laser optical unit).
- Be careful when removing the covers since there might be the parts with very sharp edges underneath.
- When servicing the equipment with the power turned ON, be sure not to touch live sections and rotating/operating sections. Avoid exposing your eyes to laser beam.
- Use designated jigs and tools.
- Use recommended measuring instruments or equivalents.
- Return the equipment to the original state and check the operation when the service is finished.

### 3) Important Service Parts for Safety

- The breaker, door switch, fuse, thermostat, thermofuse, thermistor, batteries, IC-RAMs including lithium batteries, etc. are particularly important for safety. Be sure to handle/install them properly. If these parts are short-circuited and their functions become ineffective, they may result in fatal accidents such as burnout. Do not allow a short-circuit or do not use the parts not recommended by Toshiba TEC Corporation.

### 4) Cautionary Labels

- During servicing, be sure to check the rating plate and cautionary labels such as “Unplug the power cable during service”, “CAUTION. HOT”, “CAUTION. HIGH VOLTAGE”, “CAUTION. LASER BEAM”, etc. to see if there is any dirt on their surface and if they are properly stuck to the equipment.

### 5) Disposal of the Equipment, Supplies, Packing Materials, Used Batteries and IC-RAMs

- Regarding the recovery and disposal of the equipment, supplies, packing materials, used batteries and IC-RAMs including lithium batteries, follow the relevant local regulations or rules.

**Caution:**

Dispose of used batteries and IC-RAMs including lithium batteries according to this manual.

**Attention:**

Se débarrasser de batteries et IC-RAMs usés y compris les batteries en lithium selon ce manuel.

**Vorsicht:**

Entsorgung der gebrauchten Batterien und IC-RAMs (inclusive der Lithium-Batterie) nach diesem Handbuch.

# CONTENTS

<b>1. SPECIFICATIONS / ACCESSORIES / OPTIONS / SUPPLIES .....</b>	<b>1-1</b>
1.1 Specifications.....	1-1
1.2 Accessories .....	1-5
1.3 Options .....	1-6
1.4 Supplies.....	1-7
1.5 System List.....	1-8
<b>2. OUTLINE OF THE MACHINE .....</b>	<b>2-1</b>
2.1 Sectional View .....	2-1
2.2 Electric Parts Layout.....	2-4
2.3 Symbols and Functions of Various Components.....	2-11
2.4 General Description .....	2-15
2.4.1 System block diagram .....	2-15
2.4.2 Construction of boards .....	2-16
2.5 Disassembly and Replacement of Covers.....	2-18
2.6 Disassembly and Replacement of PC boards .....	2-23
2.7 Removal and Installation of Options.....	2-29
<b>3. COPY PROCESS .....</b>	<b>3-1</b>
3.1 General Description of Copying Process.....	3-1
3.2 Details of Copying Process.....	3-2
3.3 Comparison with e-STUDIO230/280 .....	3-13
<b>4. GENERAL OPERATION .....</b>	<b>4-1</b>
4.1 Overview of Operation .....	4-1
4.2 Description of Operation .....	4-2
4.2.1 Warming-up.....	4-2
4.2.2 Ready state (ready for copying) .....	4-2
4.2.3 Drawer feed copying .....	4-3
4.2.4 Bypass feed copying .....	4-4
4.2.5 Interruption copying.....	4-4
4.3 Detection of Abnormality.....	4-5
4.3.1 Types of abnormality .....	4-5
4.3.2 Description of abnormality .....	4-6
4.4 Flow Chart .....	4-11
4.4.1 Immediately after the power is turned ON.....	4-11
4.4.2 Automatic paper feed copying.....	4-13
<b>5. CONTROL PANEL .....</b>	<b>5-1</b>
5.1 General Description .....	5-1
5.2 Items Shown on the Display Panel .....	5-2
5.2.1 Display.....	5-2
5.2.2 Message .....	5-3
5.3 Relation between Equipment State and Operation.....	5-4
5.4 Operation.....	5-5
5.4.1 Block diagram.....	5-5
5.4.2 LED display circuit.....	5-6
5.5 Disassembly and Replacement .....	5-7
<b>6. SCANNER .....</b>	<b>6-1</b>
6.1 General Description .....	6-1
6.2 Construction.....	6-2
6.3 Functions .....	6-3
6.4 Description of Operation .....	6-5

6.4.1	Scanning operation .....	6-5
6.4.2	Scan motor drive circuit.....	6-6
6.5	Contact Image Sensor Unit Control Circuit.....	6-8
6.5.1	Exposure LED control circuit .....	6-8
6.5.2	CCD control circuit .....	6-9
6.6	Automatic Original Size Detection Circuit.....	6-12
6.6.1	Principle of original size detection .....	6-12
6.6.2	Process of detection of original size .....	6-13
6.7	Disassembly and Replacement .....	6-17
<b>7.</b>	<b>IMAGE PROCESSING .....</b>	<b>7-1</b>
7.1	General Description .....	7-1
7.2	Configuration .....	7-2
7.3	MAIN Board .....	7-3
7.3.1	Features .....	7-3
7.3.2	Functions of image processing circuit .....	7-4
<b>8.</b>	<b>LASER OPTICAL UNIT .....</b>	<b>8-1</b>
8.1	General Description .....	8-1
8.2	Structure .....	8-2
8.3	Laser Diode Control Circuit.....	8-5
8.4	Polygonal Motor Control Circuit.....	8-6
8.5	Disassembly and Replacement .....	8-7
<b>9.</b>	<b>DRIVE UNIT .....</b>	<b>9-1</b>
9.1	General Description .....	9-1
9.2	Configuration .....	9-2
9.3	Functions .....	9-3
9.4	Main Motor Control Circuit.....	9-4
9.5	Disassembly and Replacement .....	9-6
<b>10.</b>	<b>PAPER FEEDING SYSTEM.....</b>	<b>10-1</b>
10.1	General Description .....	10-1
10.2	Configuration .....	10-2
10.3	Functions .....	10-3
10.4	Operation .....	10-5
10.4.1	Drawer .....	10-5
10.4.2	Bypass tray.....	10-7
10.4.3	General operation.....	10-9
10.5	Disassembly and Replacement .....	10-10
<b>11.</b>	<b>DRUM RELATED SECTION .....</b>	<b>11-1</b>
11.1	General Description .....	11-1
11.2	Configuration .....	11-2
11.3	Functions .....	11-3
11.4	High-Voltage Output Control Circuit .....	11-5
11.4.1	General description .....	11-5
11.4.2	Description of Operation.....	11-6
11.5	Drum Temperature Detection Circuit.....	11-7
11.5.1	General description .....	11-7
11.5.2	Circuit configuration.....	11-7
11.6	Temperature/Humidity Detection Circuit.....	11-8
11.6.1	General Description.....	11-8
11.6.2	Circuit configuration.....	11-8
11.7	Disassembly and Replacement .....	11-9
<b>12.</b>	<b>DEVELOPMENT SYSTEM.....</b>	<b>12-1</b>
12.1	General Description .....	12-1

12.2 Construction.....	12-2
12.3 Functions .....	12-3
12.3.1 Function of each unit .....	12-3
12.3.2 Functions of the toner cartridge PC board (CTRG).....	12-4
12.3.3 Recovered toner supply mechanism .....	12-6
12.4 Toner Motor Control Circuit .....	12-7
12.5 Auto-Toner Circuit.....	12-8
12.5.1 General description .....	12-8
12.5.2 Function of auto-toner sensor .....	12-9
12.6 Disassembly and Replacement .....	12-11
<b>13. FUSER / EXIT UNIT .....</b>	<b>13-1</b>
13.1 General Description .....	13-1
13.2 Configurations.....	13-2
13.3 Functions .....	13-3
13.4 Operation .....	13-5
13.5 Fuser Unit Control Circuit .....	13-6
13.5.1 Configuration .....	13-6
13.5.2 Temperature detection section.....	13-7
13.6 Disassembly and Replacement .....	13-12
<b>14. AUTOMATIC DUPLEXING UNIT (ADU) (OPTION: MD-0103) .....</b>	<b>14-1</b>
14.1 General Description .....	14-1
14.1.1 Specifications of MD-0103 .....	14-2
14.2 Construction.....	14-3
14.3 Functions .....	14-4
14.4 Drive of ADU.....	14-5
14.5 Description of Operation .....	14-6
14.6 Flow Chart .....	14-11
14.7 Disassembly and Replacement .....	14-12
<b>15. POWER SUPPLY UNIT .....</b>	<b>15-1</b>
15.1 Construction.....	15-1
15.2 Operation of DC Output Circuit.....	15-2
15.3 Output Channel .....	15-3
15.4 Fuse .....	15-4
15.5 Configuration of Power Supply Unit.....	15-5
15.6 Power Supply Sequence .....	15-6
15.7 AC Wire Harness .....	15-7
<b>16. PC BOARDS .....</b>	<b>16-1</b>





# 1. SPECIFICATIONS / ACCESSORIES / OPTIONS / SUPPLIES

## 1.1 Specifications

- Copy process Indirect electrophotographic process (dry)
- Type Desktop type
- Original table Fixed type (the left rear corner used as guide to place originals)
- Accepted originals Sheet, book and 3-dimensional object. The automatic document feeder (ADF) and reversing automatic document feeder (RADF), only accepts paper which are not pasted or stapled. (Single-sided originals: 50 to 127 g/m<sup>2</sup>/13 to 34 lb. Bond) Carbon paper are not acceptable either.  
Maximum size: A3/LD

- Copy speed (Copies/min.)  
e-STUDIO167

Paper size	Drawer	Bypass feed		PFU	PFP	
		Size specified	Size not specified		Upper drawer	Lower drawer
A4, B5, LT	16	16	11	16	16	16
A5-R, ST-R	-	16	11	-	16	16
A4-R, B5-R, LT-R	15.5	15.5	11	15.5	15.5	15.5
B4, LG, FOLIO, COMPUTER	13	13	11	13	13	13
A3, LD	11	11	11	11	11	11

### e-STUDIO207

Paper size	Drawer	Bypass feed		PFU	PFP	
		Size specified	Size not specified		Upper drawer	Lower drawer
A4, B5, LT	20	20	20	20	20	20
A5-R, ST-R	-	-	20	-	20	20
A4-R, B5-R, LT-R	15.5	15.5	15.5	15.5	15.5	15.5
B4, LG, FOLIO, COMPUTER	13	13	13	13	13	13
A3, LD	11	11	11	11	11	11

### e-STUDIO237

Paper size	Drawer	Bypass feed		PFU	PFP	
		Size specified	Size not specified		Upper drawer	Lower drawer
A4, B5, LT	23	23	23	23	23	23
A5-R, ST-R	-	-	23	-	23	23
A4-R, B5-R, LT-R	17.5	17.5	17.5	17.5	17.5	17.5
B4, LG, FOLIO, COMPUTER	15	15	15	15	15	15
A3, LD	12.5	12.5	12.5	12.5	12.5	12.5

\* “-” means “Not acceptable”.

\* The copy speed in the above table are available when originals are manually placed for single side, multiple copying.

- \* When the ADF and RADF are used, the copy speed of 16/20/23 sheets per minute is only available under the following conditions:
  - Original/Mode: Single side original/A4/LT size. APS/automatic density are not selected.
  - Number of sheets: 16 or more. (e-STUDIO167)  
20 or more. (e-STUDIO207)  
23 or more. (e-STUDIO237)
  - Reproduction ratio: 100%

Copy speed for thick paper (Copies/min.)  
e-STUDIO167/207/237

Thick 1 (81 g/m<sup>2</sup> to 105 g/m<sup>2</sup>, 21.3 lb. Bond to 28 lb. Bond): Bypass feed on a sheet by sheet basis only

Thick 2 (106 g/m<sup>2</sup> to 163 g/m<sup>2</sup>, 28 lb. Bond to 90 lb. Index): Bypass feed on a sheet by sheet basis only

- Copy paper

	Drawer	PFU	PFP	ADU	Bypass copy	Remarks
Size	A3, A4, A4-R, B4, B5, B5-R, A5-R(Only for PFP), LD, LG, LT, LT-R, ST-R(Only for PFP), FOLIO, COMPUTER, 13"LG, 8K, 16K, 16K-R				A3 to A5-R, LD to ST-R, FOLIO, COMPUTER, 13"LG, 8.5" x 8.5", 8K, 16K, 16K-R (Non-standard or user-specified sizes can be set.)	
Weight	64 to 80 g/m <sup>2</sup> , 17 lb. Bond to 21.3 lb. Bond				50 to 163 g/m <sup>2</sup> (Single paper feeding) 64 to 80 g/m <sup>2</sup> (Continuous feeding)	
Special paper	-				Tracing paper, labels, OHP film (thickness: 80 µm or thicker),	These special papers recommended by Toshiba Tec

- First copy time ..... Approx. 7.6 sec.  
(A4, 100%, original placed manually, e-STUDIO167/207)  
Approx. 7.5 sec.  
(A4, 100%, original placed manually, e-STUDIO237)  
Approx. 7.7 sec.  
(LT, 100%, original placed manually, e-STUDIO167/207)  
Approx. 7.5 sec. |  
(LT, 100%, original placed manually, e-STUDIO237)  
Approx. 7.7 sec.  
(LT, 100%, original placed manually)
- Warming-up time..... Approx. 25 sec. (temperature: 20°C)
- Multiple copying ..... Up to 999 copies; Key in set numbers
- Reproduction ratio ..... Actual ratio: 100±0.5%  
Zooming: 25 to 200% in increments of 1%
- Resolution/Gradation ..... Scanning: 600 dpi x 600 dpi  
Printing: Equivalent to 2400 dpi x 600 dpi  
Gradation: 256 steps
- Eliminated portion ..... Leading edges: 3.0±2.0 mm, Side/trailing edges: 2.0±2.0 mm (copy)  
Leading / trailing edges: 5.0±2.0 mm, Side edges: 5.0±2.0 mm (print)

- Paper feeding ..... Standard drawer:  
 1 drawer (stack height 28 mm, equivalent to 250 sheets; 64 to 80 g/m<sup>2</sup> (17 to 22 lb. Bond))  
  
 Bypass feeding:  
 Stack height 11.8 mm: equivalent to 100 sheets; 64 to 80 g/m<sup>2</sup> (17 to 22 lb. Bond)  
  
 Paper Feed Unit (PFU):  
 Option (One drawer: stack height 28 mm, equivalent to 250 sheets; 64 to 80 g/m<sup>2</sup> (17 to 22 lb. Bond))  
  
 Paper Feed Pedestal (PFP):  
 Option (One drawer or two: stack height 60.5 mm, equivalent to 550 sheets; 64 to 80 g/m<sup>2</sup> (17 to 22 lb. Bond))
- Capacity of originals in the ADF/RADF (Option)  
 ..... A3 to A5-R, LD to ST-R:  
 100 sheets / 80 g/m<sup>2</sup> (Stack height 16 mm or less)
- Automatic duplexing unit (ADU: Option)  
 ..... Stackless, Switchback type
- Toner supply ..... Automatic toner density detection/supply  
 Toner cartridge replacing method (There is a recovered toner supply mechanism.)
- Density control ..... Automatic density mode and manual density mode selectable in 7 steps
- Weight..... Approximately 32.5 kg (71.65 lb.) (excluding the developer material and toner)
- Power requirements... AC 110 V / 13.2 A, 115 V or 127 V / 12 A  
 220-240 V or 240 V / 8 A (50/60 Hz)  
 \* The acceptable value of each voltage is ±10%.
- Power consumption ... 1.5 kW or less (100 V series)  
 1.6 kW or less (200 V series)  
 \* The electric power is supplied to the ADF/RADF, PFU, PFP and ADU through the equipment.
- Total counter ..... Electronical counter

- Dimensions of the equipment ..... W 600 x D 658.6 x H 462.5 (mm): See the figure below

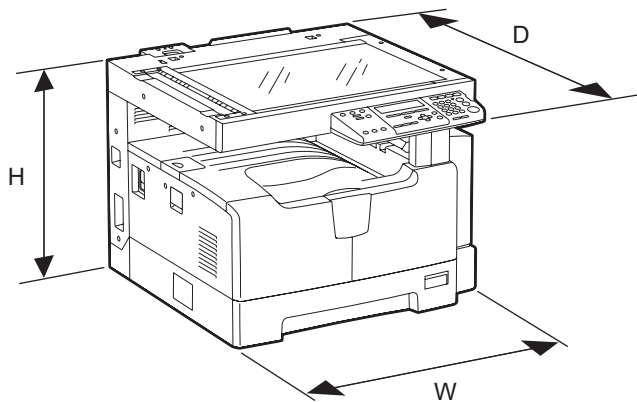

Fig. 1-1

## 1.2 Accessories

Unpacking/setup instruction	1 set
Operator's manual	1 pc.
Operator's manual pocket	1 pc. (for NAD)
Power cable	1 pc.
CD-ROM	2 pcs.
Rubber cap	6 pcs. (for MJD, ASD, ASU and SAD) 2 pcs. (for NAD, CND, AUD, TWD, KRD and ARD)
Transfer charger wire cleaner (installed inside of the transfer cover)	1 pc.
Drum (installed inside of the equipment)	1 pc.
Developer material	1 pc.
Nozzle	1 pc. (for NAD)
Toner cartridge	1 pc.
Warranty sheet	1 pc. (for NAD and CND)
Setup report	1 set (for NAD, MJD and CND)
Customer satisfaction card	1 pc. (for MJD)
Packing list	1 pc. (for CND)
Customer survey sheet	1 pc. (for CND)
Certificate of conformance	1 pc. (for CND)

\* Machine version

NAD:	North America
ASD:	Hong Kong / Latin America
AUD:	Australia
MJD:	Europe
ASU:	Asia / Saudi Arabia
SAD:	Saudi Arabia
ARD:	Latin America
CND:	China
TWD:	Taiwan
KRD:	Korea
JPD:	Japan

## 1.3 Options

Platen Cover	KA-1640PC/C
Automatic Document Feeder (ADF)	MR-2017/C
Reversing Automatic Document Feeder (RADF)	MR-3019/C
Paper Feed Unit (PFU)	MY-1027/C
Paper Feed Pedestal (PFP)	KD-1022/C
Paper Feed Controller (PFC)	GH-1060/C
Drawer Module	MY-1028/C
Automatic Duplexing Unit (ADU)	MD-0103/C
Fax Kit	GD-1220NA/EU/AU/TW/CN/KR GD-1221NA/EU/AU/TW/CN/KR
External Keyboard	GJ-1040/C/EU/KR/TW
Network Printer Kit	GA-1190/C/KR/TW
Scanner Upgrade Kit	GA-1200/C/KR/TW
Operator's manual pocket	KK-1660/C
Damp Heater	MF-1640U/E
Harness Kit	GQ-1130
Desk	MH-1640

### Notes:

- When the paper feed pedestal (KD-1022) or automatic duplexing unit (MD-0103) is installed, the paper feed controller (GH-1060) is also required to be installed.
- The external keyboard (GJ-1040) is necessary for the installation of the fax kit (GD-1220/1221) and the scanner upgrade kit (GA-1200).

## 1.4 Supplies

Drum	OD-1600 (except for China) OD-2320 (for China)
Toner cartridge	PS-ZT1640 (4) (for North America) PS-ZT1640D (4) (for Asia, Central and South America) PS-ZT1640D5K (4) (for Asia, Central and South America) PS-ZT1640C (4) (for China) PS-ZT1640C5K (4) (for China) PS-ZT1640T (4) (for Taiwan) PS-ZT1640T5 (4) (for Taiwan) PS-ZT1640E (1) (for Europe) PS-ZT1640E5K (1) (for Europe)
Developer material	D-2320 (except for China) D-2320C (for China)

## 1.5 System List

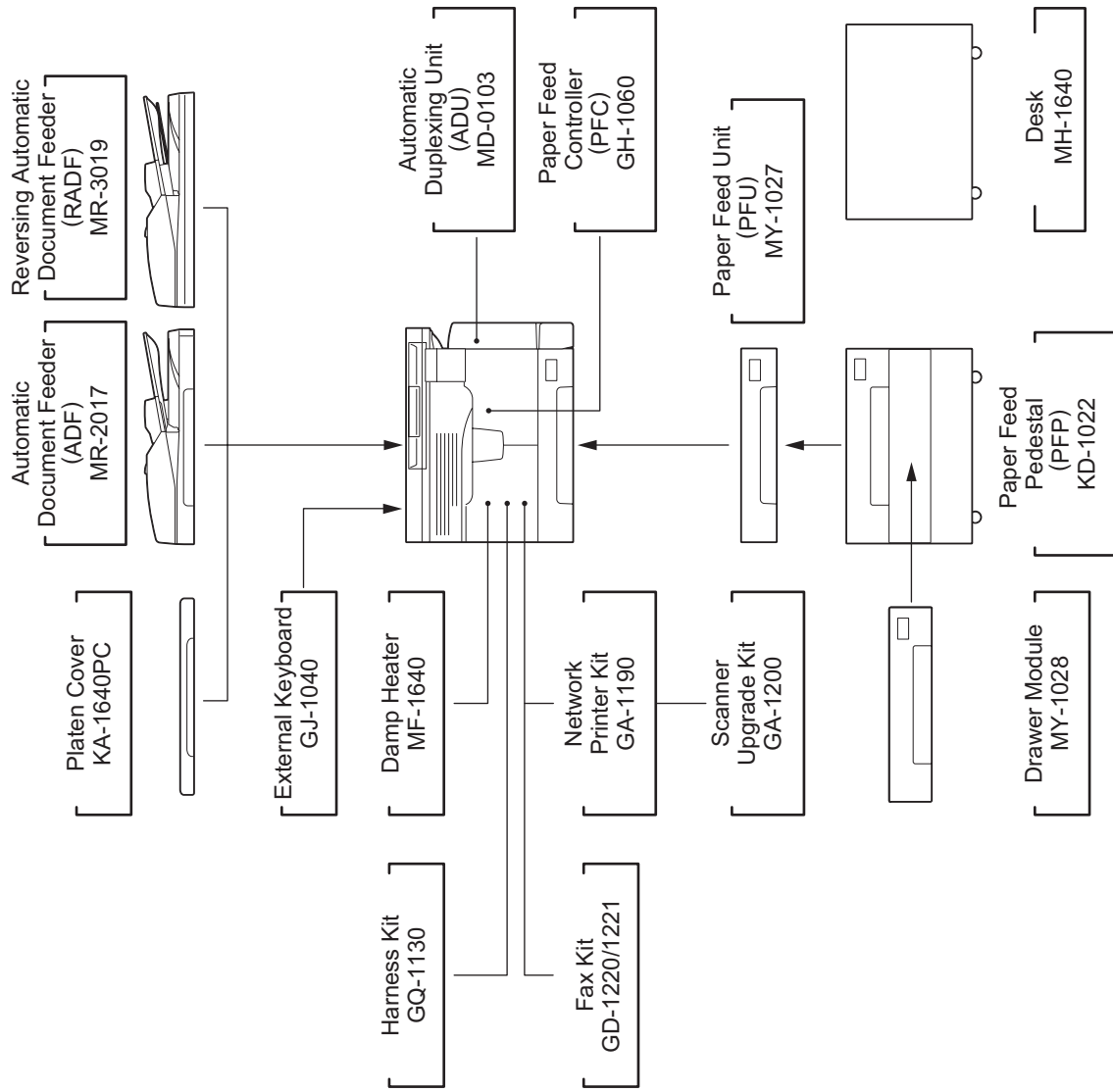

Fig. 1-2



## 2. OUTLINE OF THE MACHINE

### 2.1 Sectional View

1) Front side

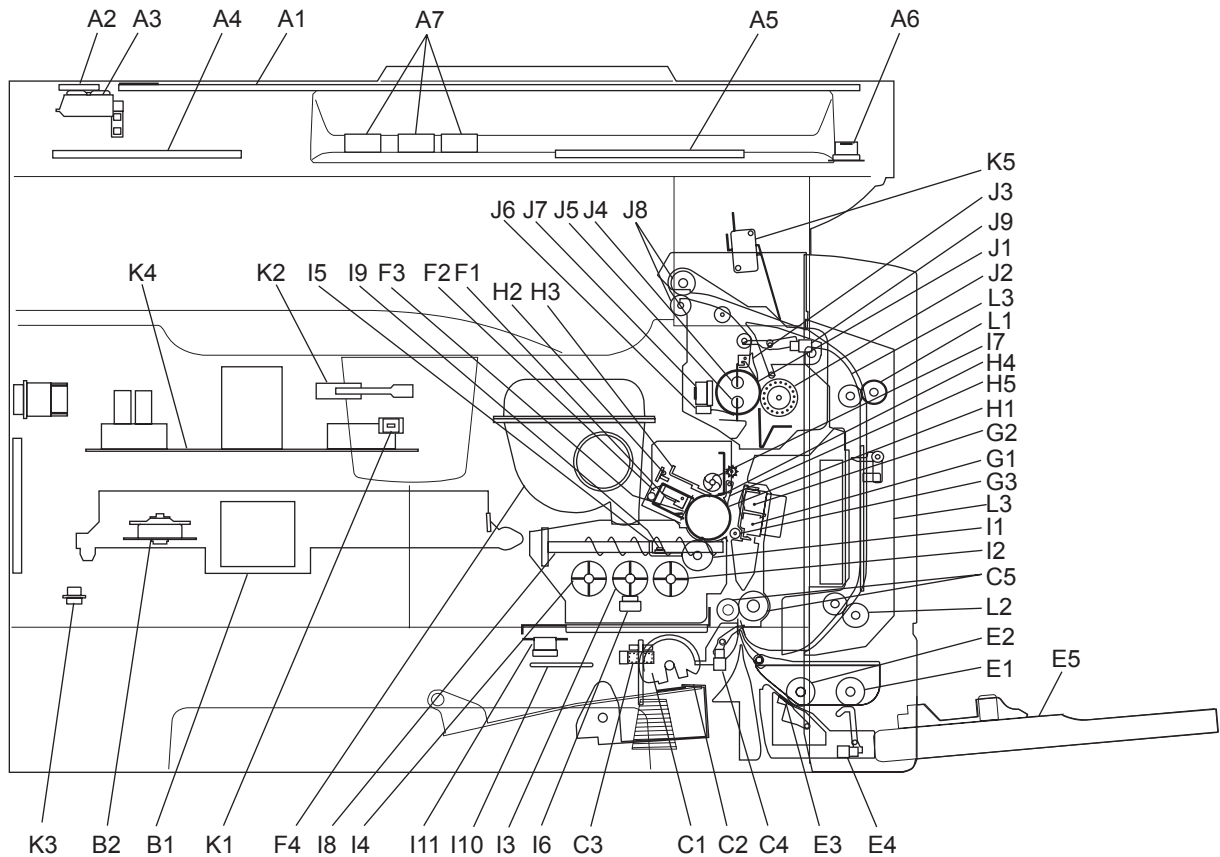

Fig. 2-1

A1	Original glass	
A2	ADF original glass	
A3	Contact image sensor unit (CIS)	
A4	Scanner damp heater (Left side)	DH1
A5	Scanner damp heater (Right side)	DH2
A6	Scanner damp heater thermostat	THMO2
A7	Automatic original detection sensor	S9-S13
B1	Laser optical unit	
B2	Polygonal motor	M4
C1	Pickup roller	
C2	Separation claw	
C3	Paper empty sensor	S7
C4	Registration sensor	S4
C5	Registration roller	
E1	Bypass pickup roller	

E2	Bypass feed roller	
E3	Bypass separation pad	
E4	Bypass paper sensor	S8
E5	Bypass tray	
F1	Needle electrode	
F2	Main charger	
F3	Main charger grid	
F4	Toner cartridge	
G1	Transfer charger wire	
G2	Separation charger wire	
G3	Transfer guide roller	
H1	Drum	
H2	Discharge LED	
H3	Drum cleaning blade	
H4	Recovery blade	
H5	Drum separation finger	
I1	Developer sleeve (Magnetic roller)	
I2	Mixer-1	
I3	Mixer-2	
I4	Mixer-3	
I5	Doctor blade	
I6	Auto-toner sensor	S6
I7	Toner recovery auger	
I8	Toner recycle auger	
I9	Drum thermistor	THMS4
I10	Drum damp heater	DH3
I11	Drum damp heater thermostat	THMO3
J1	Fuser roller	
J2	Pressure roller	
J3	Fuser roller separation finger	
J4	Center heater lamp	LAMP1
J5	Side heater lamp	LAMP2
J6	Center/Side/Edge thermistor	THMS1/2/3
J7	Fuser thermostat	THMO1
J8	Exit roller	
J9	Exit sensor	S5
K1	Front cover opening/closing switch	SW4
K2	Front cover opening/closing interlock switch	SW3
K3	Temperature/humidity sensor	S3
K4	Switching regulator	
K5	ADU cover opening/closing interlock switch	SW2
L1	ADU upper transport roller	
L2	ADU lower transport roller	
L3	ADU paper guide	

2) Rear side

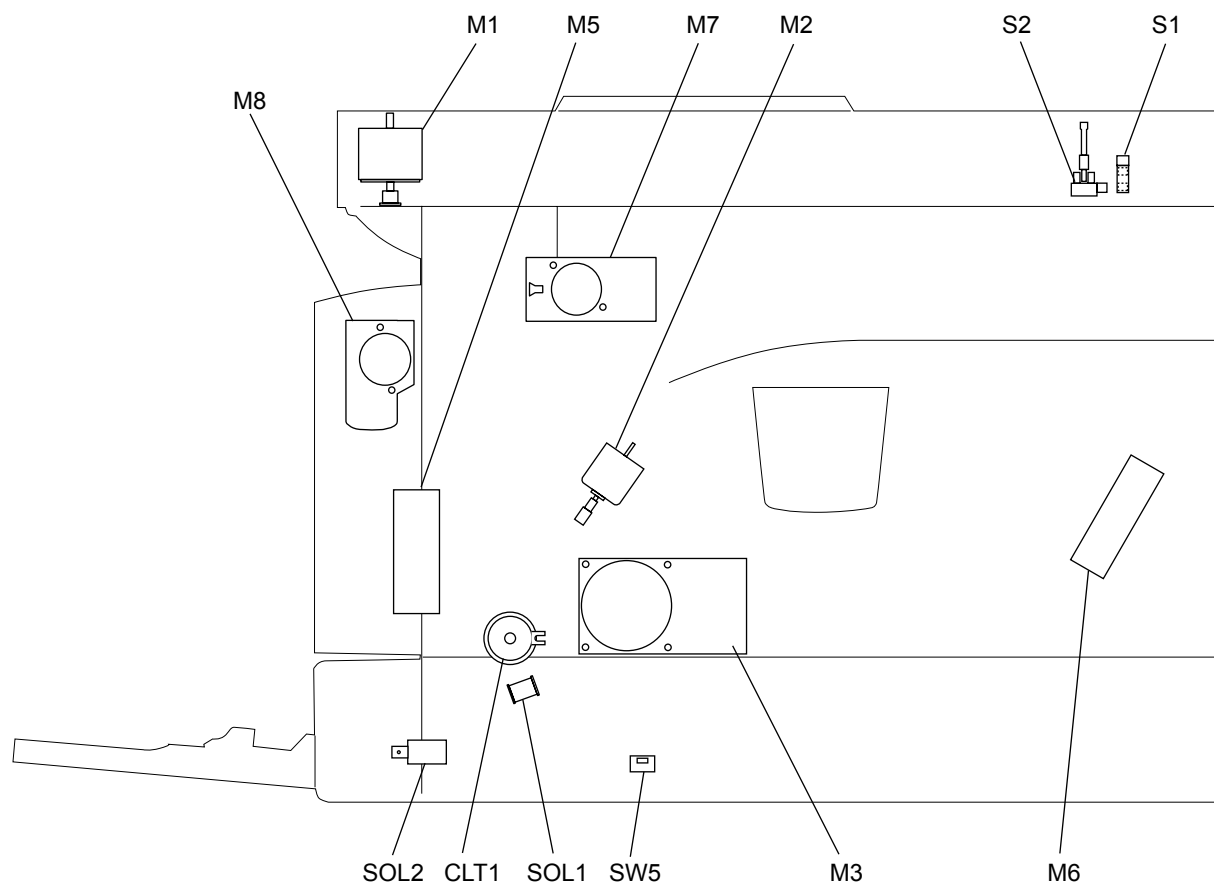

Fig. 2-2

M1	Scan motor
M2	Toner motor
M3	Main motor
M5	Exhaust fan
M6	Switching regulator cooling fan
M7	Exit motor (Option)
M8	ADU motor (Option)
S1	CIS home position sensor
S2	Platen sensor
SW5	Drawer detection switch
CLT1	Registration clutch
SOL1	Pickup solenoid
SOL2	Bypass pickup solenoid

## 2.2 Electric Parts Layout

[A] Scanner, control panel

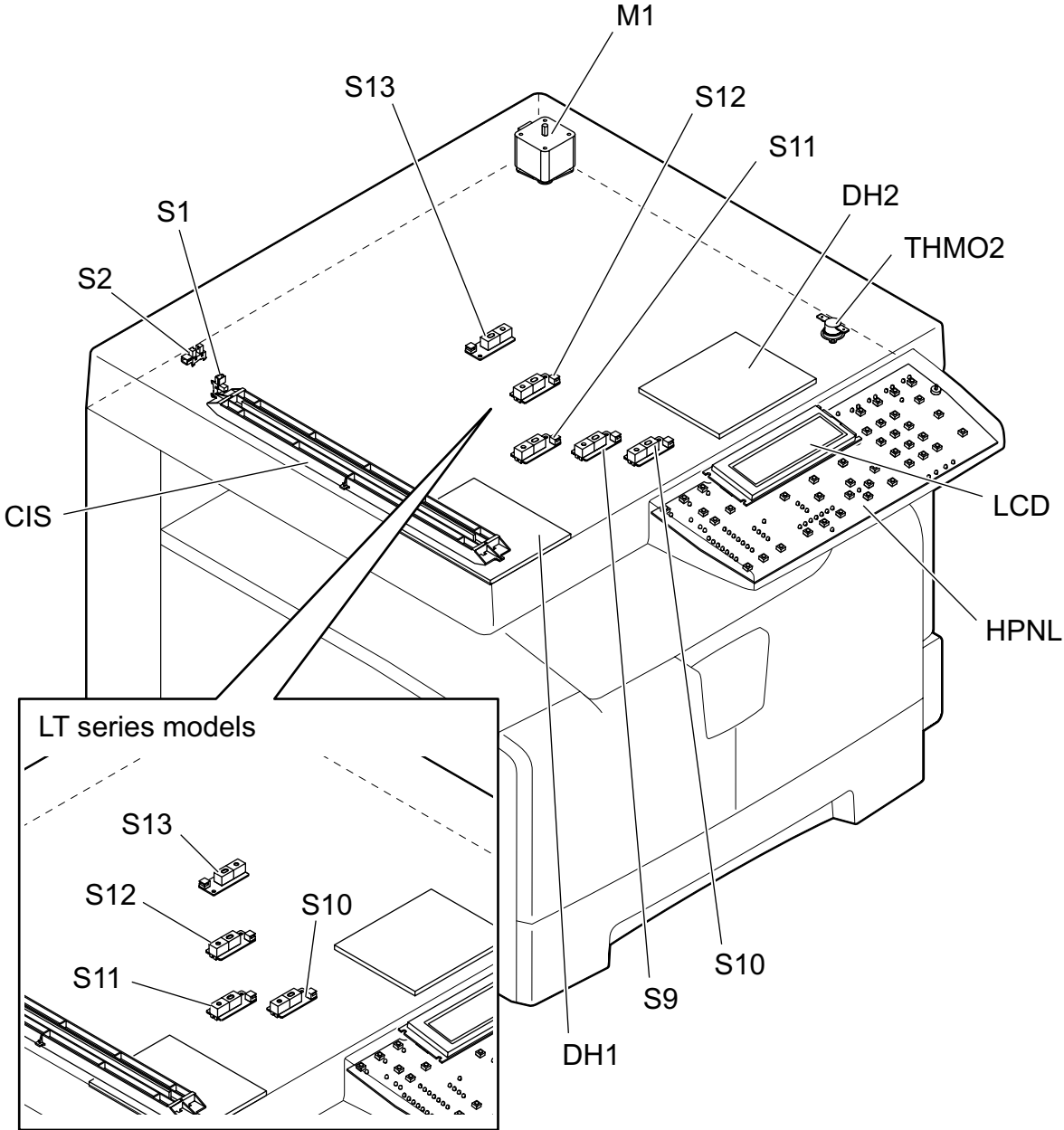

Fig. 2-3

[B] Power supply section, switches

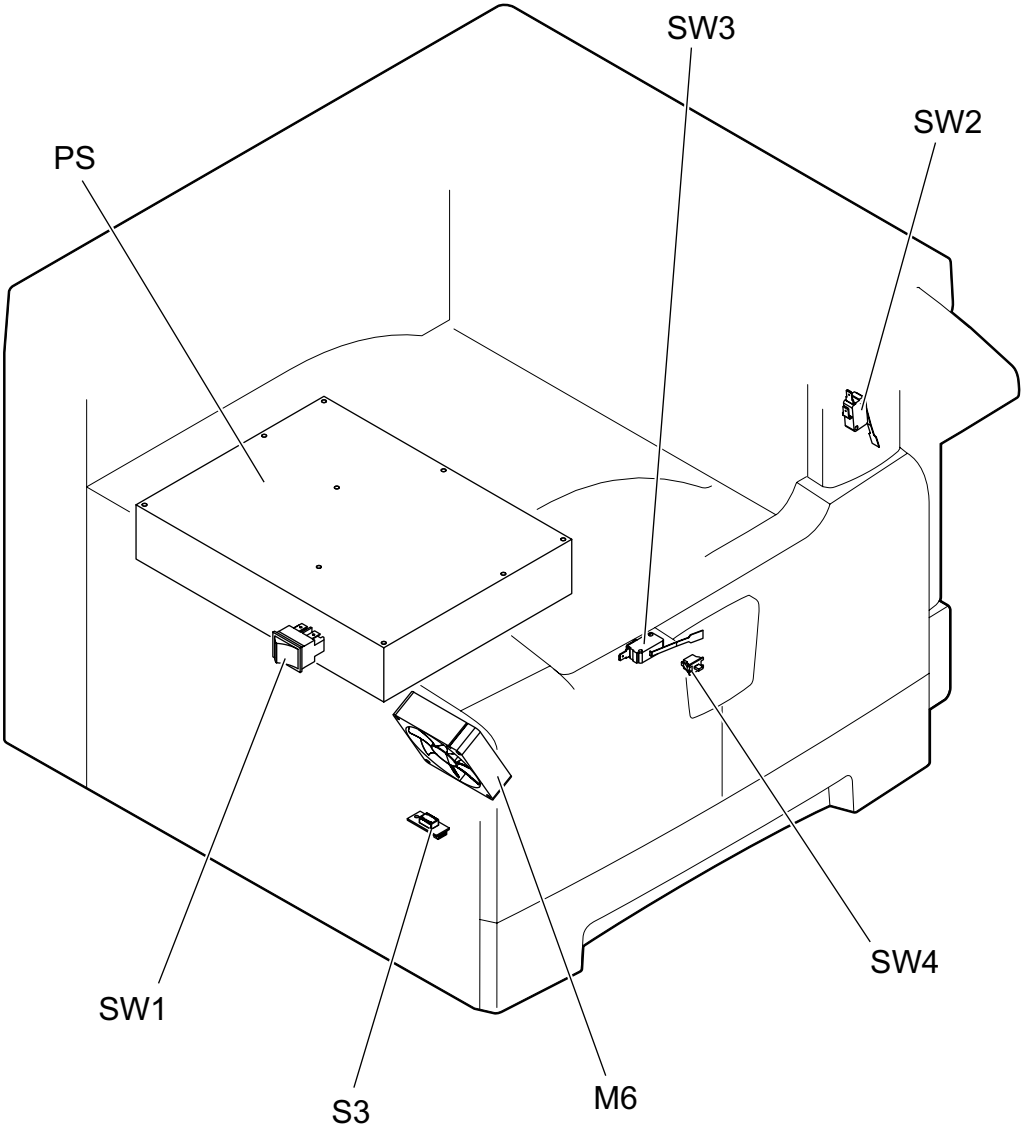

Fig. 2-4

[C] Laser optical unit, fuser unit, toner cartridge section

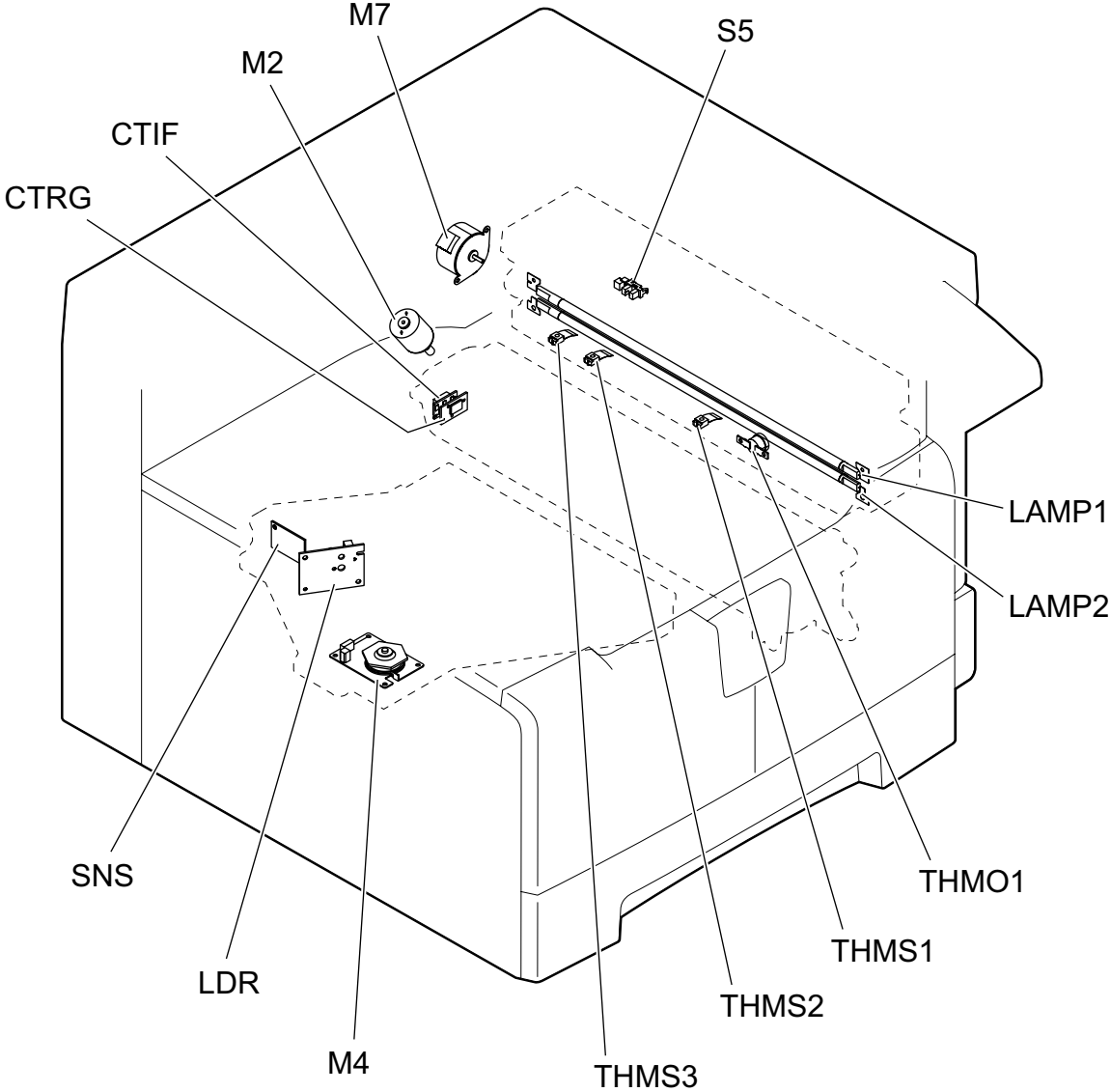

Fig. 2-5

[D] Developer unit section

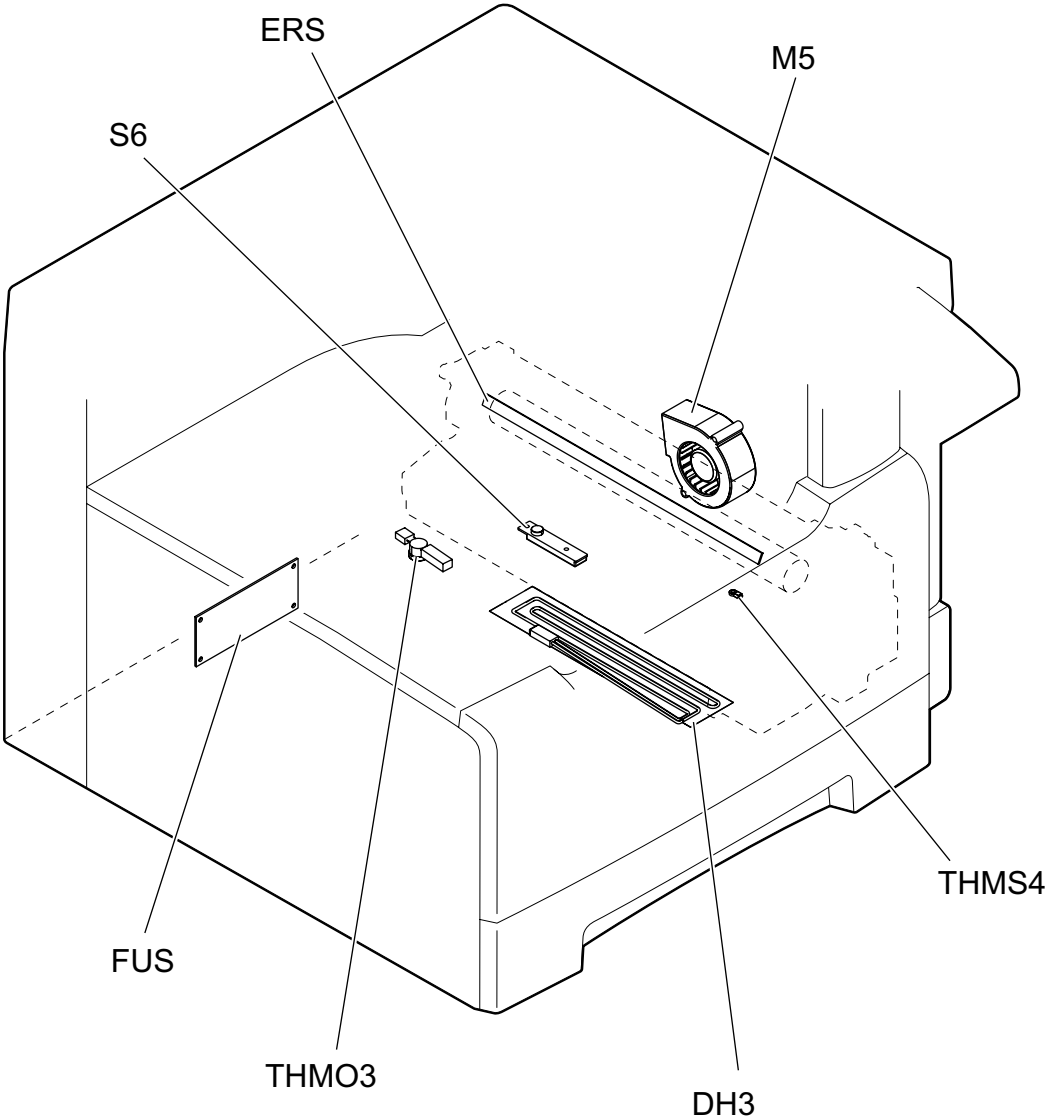

Fig. 2-6

[E] Driving section

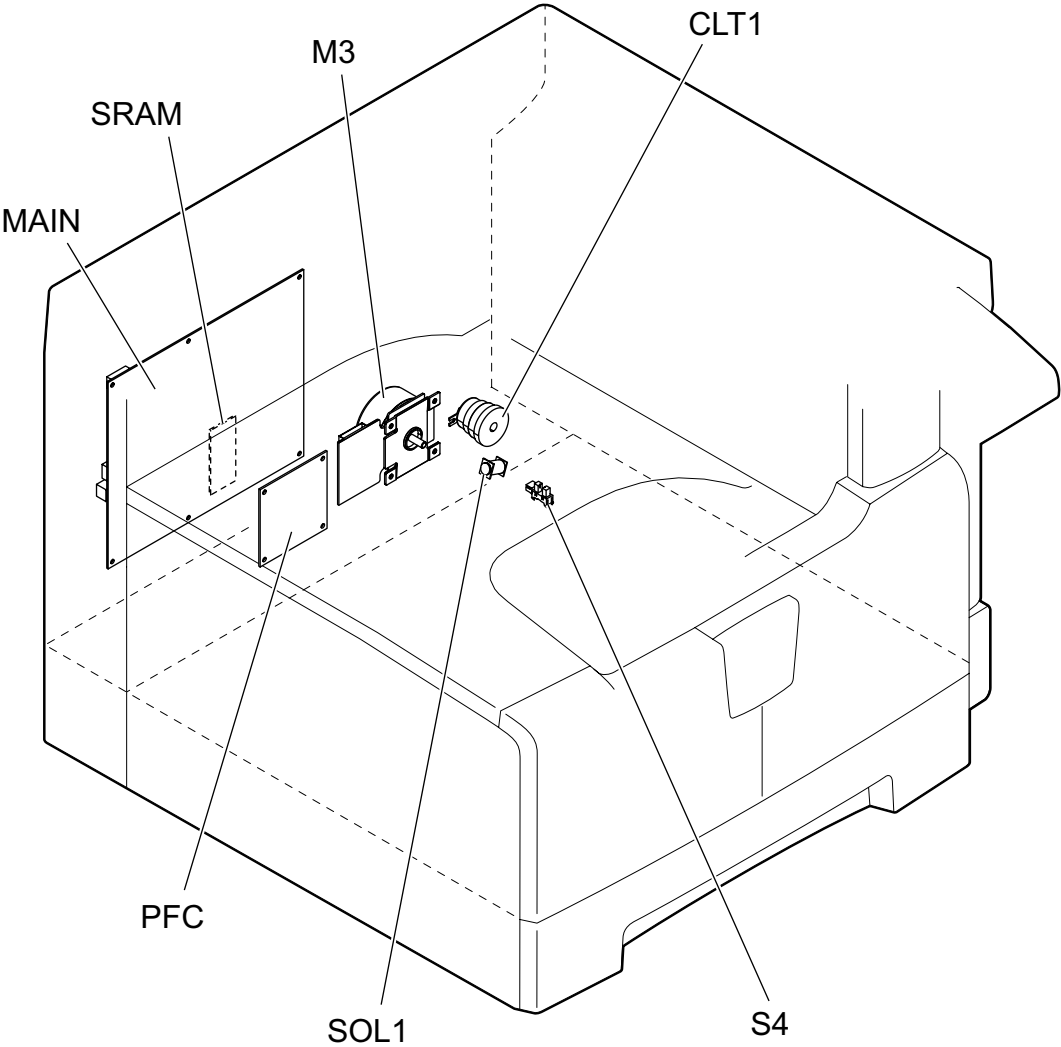

Fig. 2-7



[F] Drawer section

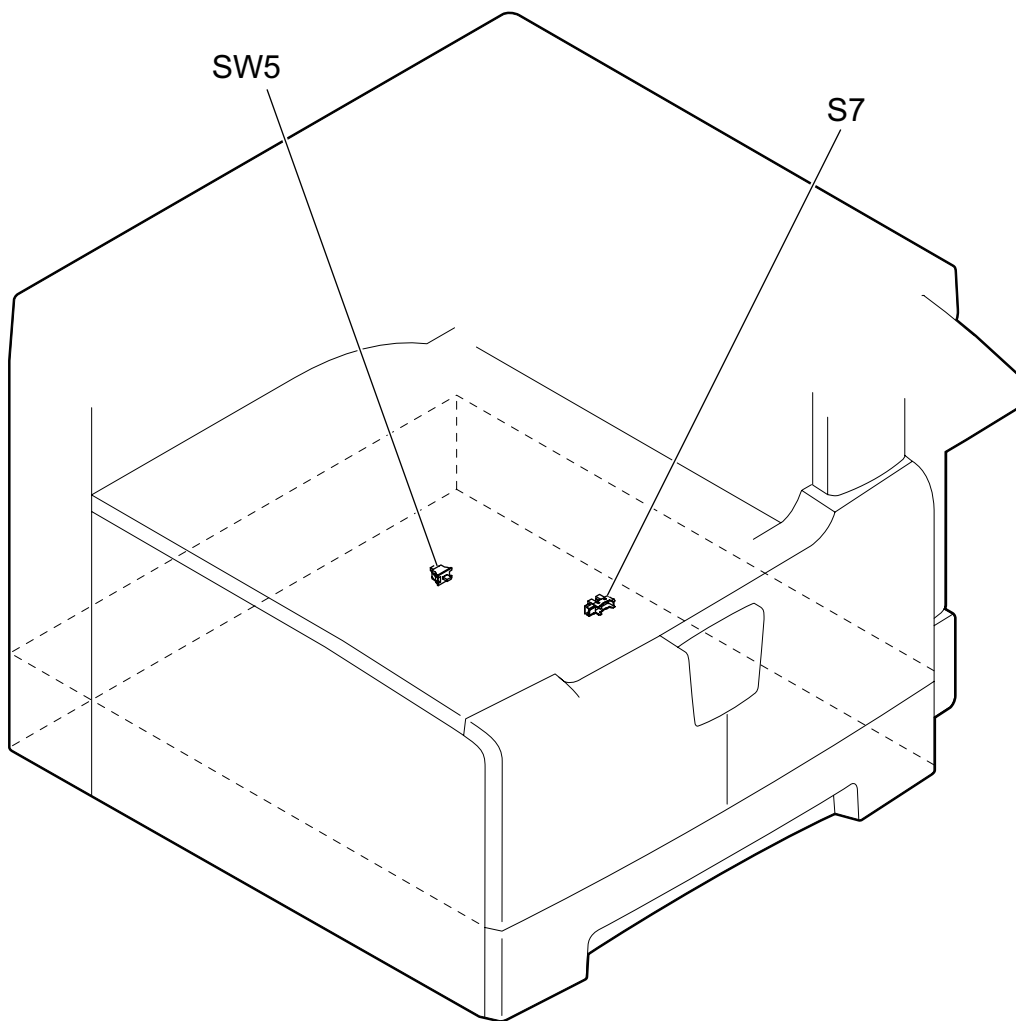

Fig. 2-8

[G] Bypass unit, automatic duplexing unit

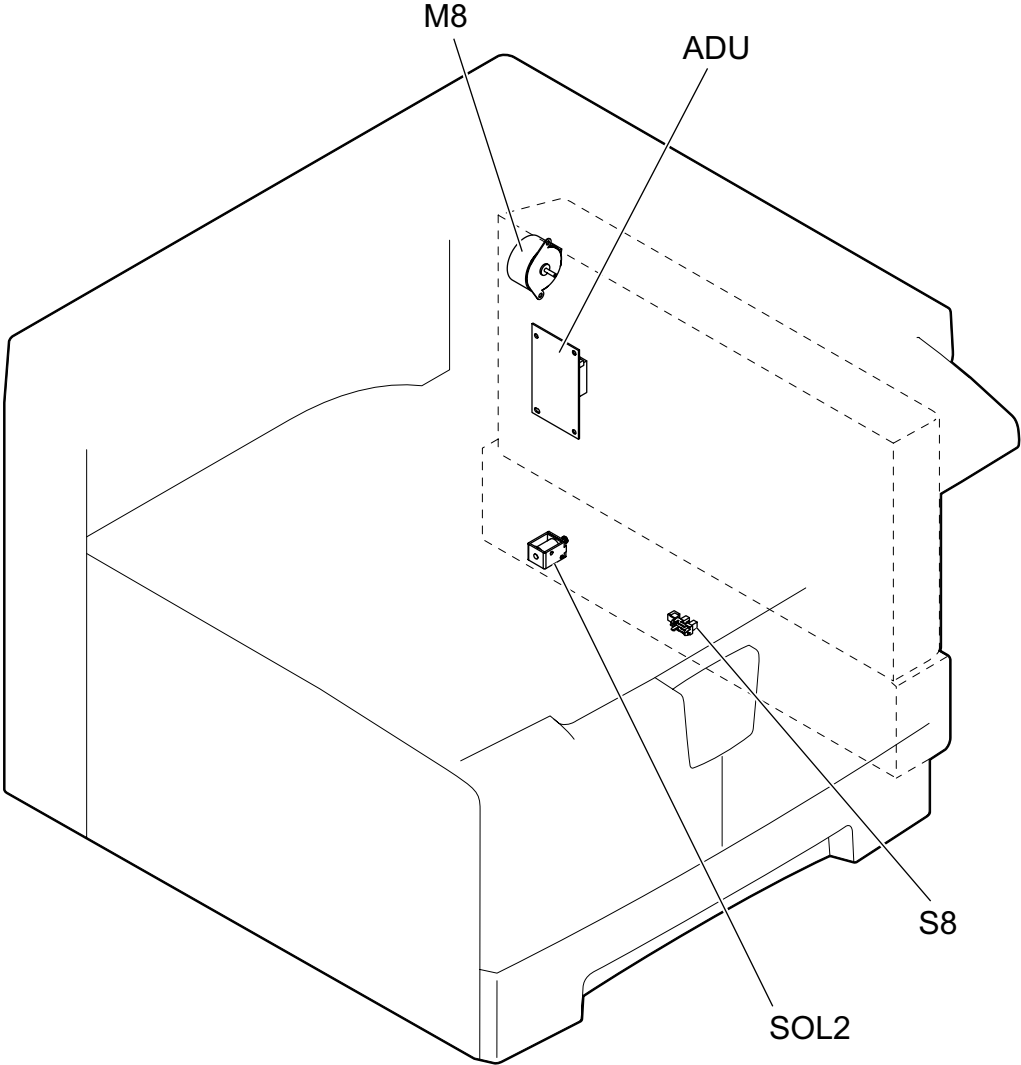

Fig. 2-9

## 2.3 Symbols and Functions of Various Components

The column "P-I" shows the page and item number in the parts list.

### 1) Motors

Symbol	Name	Function	Remarks	P-I
M1	SCAN-MOT Scan motor	Driving the CIS	Fig. 2-3	10-1
M2	TNR-MOT Toner motor	Supplying the toner	Fig. 2-5	12-15
M3	MAIN-MOT Main motor	Driving the drum, developer unit, registration roller, Pickup roller, feed roller, cleaner unit	Fig. 2-7	12-2
M4	M/DC-POL Polygonal motor	Driving the polygonal mirror	Fig. 2-5	5-13
M5	EXT-FAN-MOT Exhaust fan	Exhausting ozone and cooling down the equipment inside	Fig. 2-6	11-23
M6	PS-FAN-MOT Switching regulator cooling fan	Cooling down the switching regulator	Fig. 2-4	5-11
M7	EXIT-MOT Exit motor	Driving the fuser unit and exit roller * Option	Fig. 2-5	MD-0103 2-2
M8	ADU-MOT ADU motor	Driving the automatic duplexing unit * Option	Fig. 2-9	MD-0103 1-23

## 2) Sensors and switches

Symbol	Name	Function	Remarks	P-I
S1	HOME-SNR CIS home position sensor	Detecting CIS home position	Fig. 2-3	10-106
S2	PLTN-SNR Platen sensor	Detecting the opening/closing of platen cover or RADF	Fig. 2-3	9-101
S3	TEMP/HUMI-SNR Temperature/humidity sensor	Detecting the temperature and humidity inside the equipment	Fig. 2-4	5-16
S4	RGST-SNR Registration sensor	Detecting the transporting paper at the registration roller section	Fig. 2-7	15-107
S5	EXIT-SNR Exit sensor	Detecting the transporting paper at the exit section	Fig. 2-5	24-8
S6	ATTNR-SNR Auto-toner sensor	Detecting the density of toner in the developer unit	Fig. 2-6	21-46
S7	EMP-SNR Paper empty sensor	Detecting presence/absence of paper in the drawer	Fig. 2-8	15-107
S8	SFB-SNR Bypass paper sensor	Detecting presence/absence of paper on the bypass tray	Fig. 2-9	13-101
S9-13	APS 1-3, APS-C, APS-R Automatic original detection sensor	Detecting original size * S9: only for A4 series models	Fig. 2-3	9-9, 9-19
SW1	MAIN-SW Main switch	Turning ON/OFF of the equipment	Fig. 2-4	5-4
SW2	ADU-COV-INTLCK-SW ADU cover opening/closing interlock switch	Controlling cutoff and supply of the 24V voltage by opening/closing of the ADU cover	Fig. 2-4	6-8
SW3	FRNT-COV-INTLCK-SW Front cover opening/closing interlock switch	Controlling cutoff and supply of the 24V voltage by opening/closing of the front cover	Fig. 2-4	1-5
SW4	FRNT-COV-SW Front cover opening/closing switch	Detecting the opening/closing of the front cover	Fig. 2-4	1-101
SW5	CST-SW Drawer detection switch	Detecting presence/absence of the drawer	Fig. 2-8	16-110

## 3) Electromagnetic clutch

Symbol	Name	Function	Remarks	P-I
CLT1	RGST-CLT Registration clutch	Driving the registration roller	Fig. 2-7	16-21

## 4) Solenoids

Symbol	Name	Function	Remarks	P-I
SOL1	CST-SOL Pickup solenoid	Controlling the power transmission of the feed roller	Fig. 2-7	16-9
SOL2	SFB-SOL Bypass pickup solenoid	Controlling the power transmission of the bypass pickup roller	Fig. 2-9	14-15

## 5) PC boards

Symbol	Name	Function	Remarks	P-I
MAIN	PWA-F-MAIN Main PC board (MAIN board)	Controlling the whole system and image processing	Fig. 2-7	7-1
SRAM	PWA-F-SRAM SRAM PC board (SRAM board)	Storing the setting information of the equipment	Fig. 2-7	7-33
LDR	PWA-F-LDR Laser driving PC board (LDR board)	Driving the laser diode	Fig. 2-5	5-13
SNS	PWA-F-SNS H-sync signal detection PC board (SNS board)	Detecting the laser beam position	Fig. 2-5	5-13
HPNL	PWA-F-HPNL Control panel PC board (HPNL board)	Detecting the button entry and controlling LED and LCD on the control panel	Fig. 2-3	4-20
CTIF	PWA-F-CTIF Toner cartridge interface PC board (CTIF board)	Interface for detecting the toner cartridge (Detecting the CTRG board)	Fig. 2-5	7-30
CTRG	PWA-F-CTRG Toner cartridge PC board (CTRG board)	Storing the status of the toner cartridge	Fig. 2-5	103-3
FUS	PWA-F-FUS Fuse PC board (FUS board)	Supplying power to each damp heater * Optional for NAD/MJD/CND model, standard for other models	Fig. 2-6	7-12
PFC	PWA-F-PFC Paper feed controller PC board (PFC board)	Controlling the automatic duplexing unit and paper feed pedestal * Option	Fig. 2-7	7-35
ADU	PWA-F-ADU ADU driving PC board (ADU board)	Controlling the automatic duplexing unit * Option	Fig. 2-9	MD-0103 1-13

## 6) Lamps and heaters

Symbol	Name	Function	Remarks	P-I
LAMP1	CNTR-LAMP Center heater lamp	Heating the center section of the fuser roller	Fig. 2-5	23-12
LAMP2	SIDE-LAMP Side heater lamp	Heating the section of both sides of the fuser roller	Fig. 2-5	23-13
ERS	LP-ERS Discharge LED	Removing the residual charge from the drum surface	Fig. 2-6	20-13
DH1	SCN-DH-L Scanner damp heater (Left)	Preventing condensation in the scanner unit * Optional for NAD/MJD/CND model, standard for other models	Fig. 2-3	9-17
DH2	SCN-DH-R Scanner damp heater (Right)	Preventing condensation in the scanner unit * Optional for NAD/MJD/CND model, standard for other models	Fig. 2-3	9-18
DH3	DRM-DH Drum damp heater	Preventing condensation of the drum * Optional for NAD/MJD/CND model, standard for other models	Fig. 2-6	8-6

### 7) Thermistors and thermostats

Symbol	Name	Function	Remarks	P-I
THMS1	THMS-C-HTR Center thermistor	Detecting the surface temperature at the center of the fuser roller (for controlling the center heater lamp)	Fig. 2-5	23-6
THMS2	THMS-S-HTR Side thermistor	Detecting the surface temperature at the rear side of the fuser roller (for controlling the side heater lamp)	Fig. 2-5	23-6
THMS3	THMS-EDG-HTR Edge thermistor	Detecting the surface temperature at the edge of the rear side of the fuser roller (for preventing overheating)	Fig. 2-5	23-6
THMS4	THMS-DRM Drum thermistor	Detecting the temperature on the drum surface	Fig. 2-6	21-49
THMO1	THERMO-FSR Fuser thermostat	Preventing overheating in the fuser unit	Fig. 2-5	23-5
THMO2	THERMO-SCN-DH Scanner damp heater thermostat	Preventing overheating in the scanner damp heater * Optional for NAD/MJD/CND model, standard for other models	Fig. 2-3	9-20
THMO3	THERMO-DRM-DH Drum damp heater thermostat	Preventing overheating in the drum damp heater * Optional for NAD/MJD/CND model, standard for other models	Fig. 2-6	8-7

### 8) Others

Symbol	Name	Function	Remarks	P-I
CIS	CIS Contact image sensor unit	Reading originals	Fig. 2-3	9-8
PS	PS-ACC Switching regulator	<ul style="list-style-type: none"> <li>Generating DC voltage and supplying it to each section of the equipment</li> <li>Generating high voltage and supplying it to the main charger, developer, transfer and separation units</li> <li>Supplying AC power to the heater lamp</li> </ul>	Fig. 2-4	5-2
LCD	LCD LCD panel	Displaying each information	Fig. 2-3	4-19

## 2.4 General Description

### 2.4.1 System block diagram

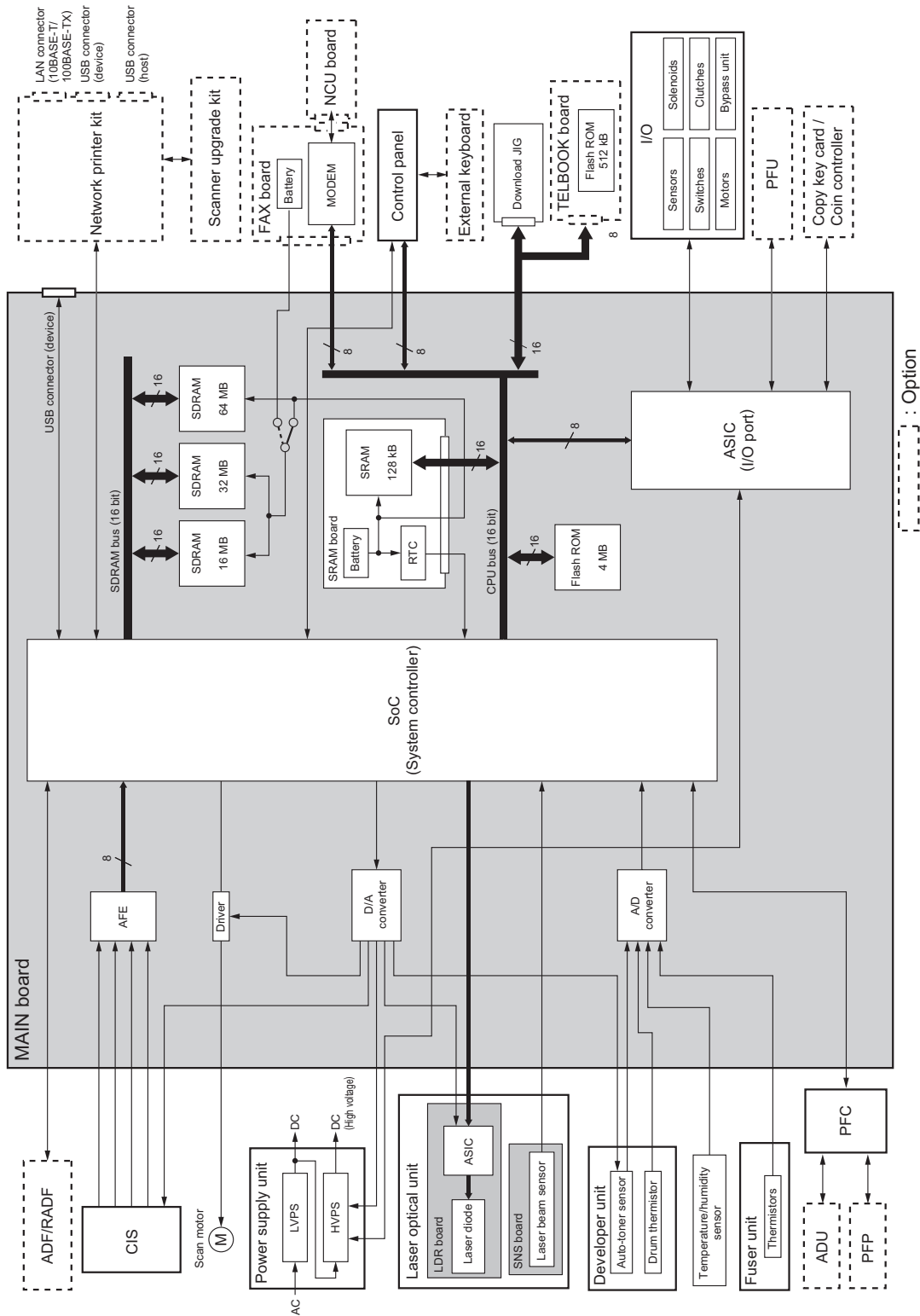

Fig. 2-10

## 2.4.2 Construction of boards

### [ 1 ] Construction diagram of boards

This system consists of the following including the MAIN board as a main board.

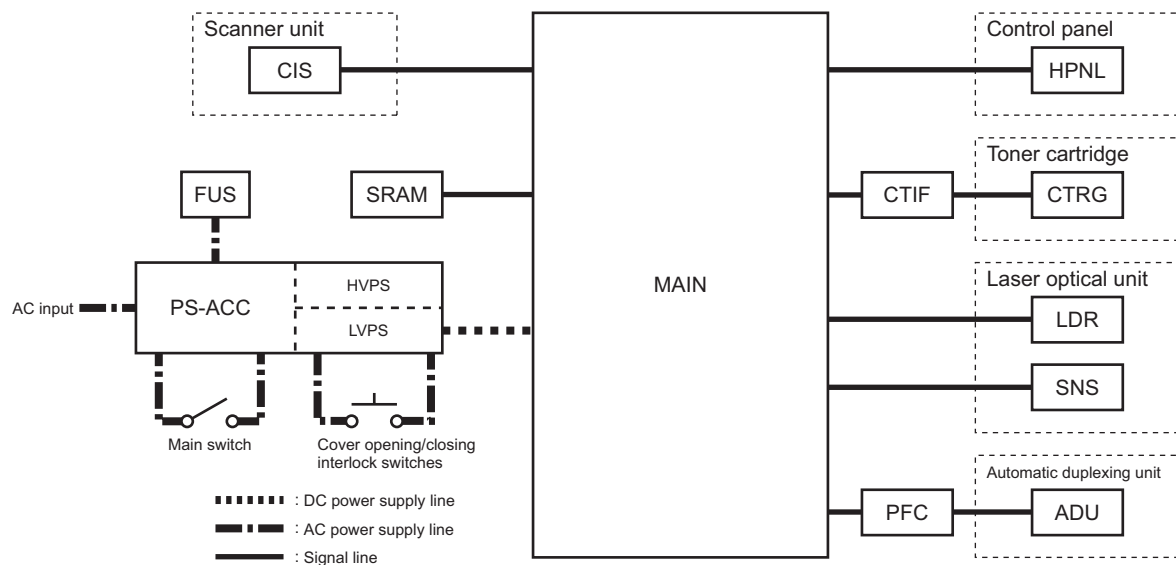

Fig. 2-11

### [ 2 ] Function of each board

- **MAIN board:**

This is the board taking the leading part in all systems. It consists of the SoC, ASIC, memory (SDRAM, Flash ROM), etc. In the SoC (System control), which is a core of this MAIN board, the functions of the CPU, image processing, page memory control, CODEC, external interface (USB) control, etc. are embedded and performed by one chip. Based on the data input from the control panel, the SoC controls each system, such as the ASIC, each memory, CIS unit and laser optical unit, and thus permitting the scanning of originals and the printing of data.
- **SRAM board:**

This is the board on which the SRAM for storing the user's setting information and counter value and its backup function are mounted. When the MAIN board is replaced, attaching this board to the new MAIN board can assume the data of the previous equipment.
- **HPNL board:**

This is the board on which each button switch and LEDs on the control panel, and the LCD control circuit are mounted.
- **CTRG board:**

This is the board on which the IC chip for storing information about the toner cartridge (number of prints, identification data, etc.) is mounted.
- **CTIF board:**

This is the interface board with the CTRG board in the toner cartridge. Information written in the IC chip on the CTRG board is read into the SoC on the MAIN board through this board.



- **LDR board:**  
This is the board on which the laser diode and the ASIC are mounted. The laser is emitted based on the image data signal output from the SoC on the MAIN board.
- **SNS board:**  
This is the board on which the light sensor for detecting the radiating position of the laser is mounted. It outputs the H-sync signal to the SoC on the MAIN board.
- **PS-ACC:**  
This is the unit to generate each DC (high/low) voltage, which is used in the equipment, from the external AC electric power input. This is then provided to each electric part.
- **FUS board:**  
This is the board to provide AC electric power for driving the damp heater.  
\* Optional for NAD/MJD/CND model, standard for other models.
- **CIS:**  
This is the unit which performs optical-to-electrical conversion to convert the light reflected by the original into the electrical signals. It consists of a light source (LEDs), optical system, CCD sensor, etc.
- **PFC board:**  
This is the board to control the optional Automatic Duplexing Unit (ADU) and optional Paper Feed Pedestal (PFP).
- **ADU board:**  
This is the board to control the optional Automatic Duplexing Unit (ADU). It detects paper feeding with a sensor mounted on the ADU board.

## 2.5 Disassembly and Replacement of Covers

### [A] Front cover

- (1) Open the front cover.
- (2) Release the upper hinge.
- (3) Take off the front cover while lifting it up.

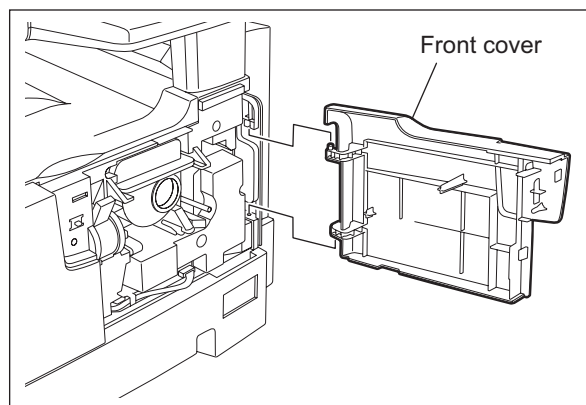

Fig. 2-12

### [B] Inner tray

- (1) Remove 2 screws and take off the Inner tray.

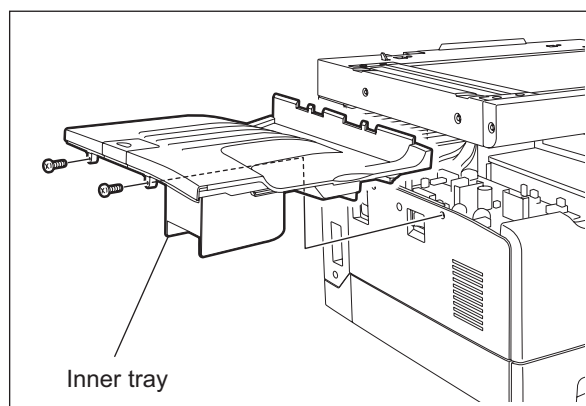
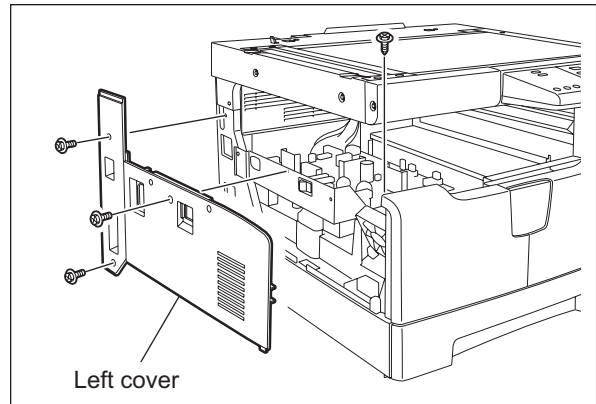

Fig. 2-13

**[C] Left cover**

- (1) Take off the Inner tray.  
📖 P.2-18 "[B] Inner tray"
- (2) Remove 4 screws and take off the left cover.

**Fig. 2-14****[D] Tray rear cover**

- (1) Take off the left cover.  
📖 P.2-19 "[C] Left cover"
- (2) Take off the tray rear cover.

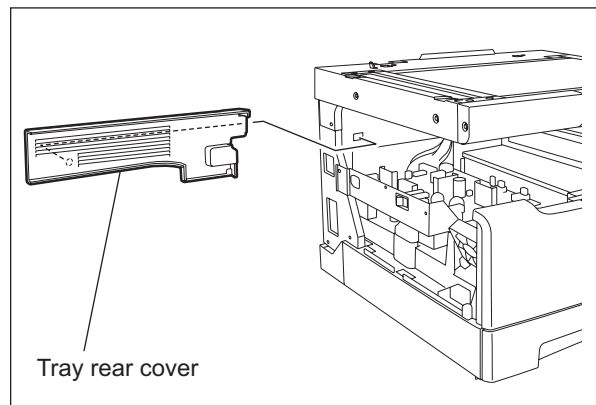
**Fig. 2-15**

### [E] Front right cover

- (1) Take off the front cover.  
📖 P.2-18 "[A] Front cover"
- (2) Pull out the toner cartridge.
- (3) Open the ADU cover.
- (4) Remove 2 screws and take off the front right cover.

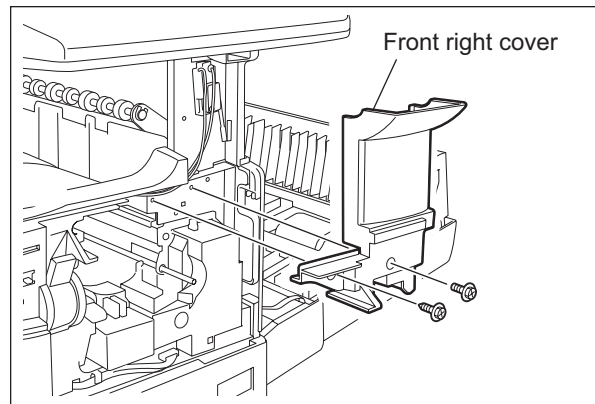

Fig. 2-16

### [F] Front upper cover

- (1) Remove 1 screw and take off the front upper cover.

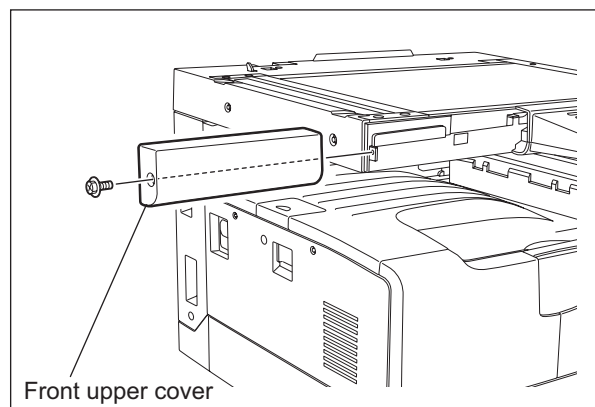

Fig. 2-17

**[G] ADU cover**

- (1) Open the bypass tray.
- (2) Open the ADU cover.
- (3) Open the transfer unit and release the ADU stopper on the front side.
- (4) Remove 1 screw and take off the ADU stopper on the rear side.

**Note:**

Be careful not to fall off the ADU cover when the screws are removed from the ADU stopper.

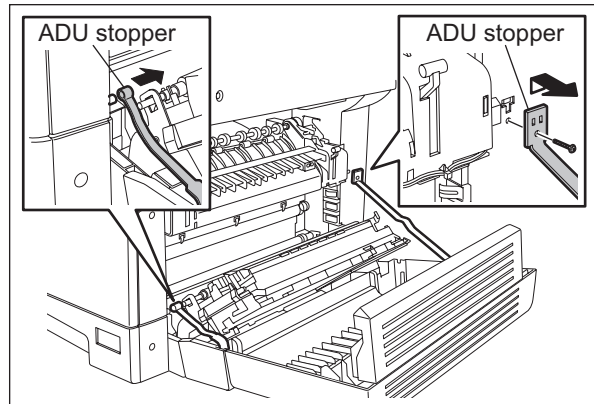

**Fig. 2-18**

- (5) Take off the ADU cover while sliding it toward the right.

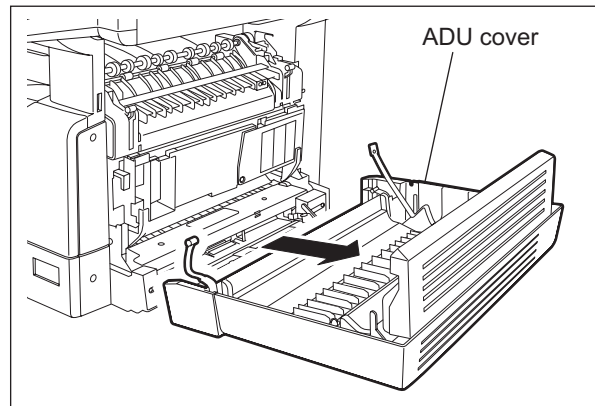

**Fig. 2-19**

**[H] Right front cover**

- (1) Take off the front cover.  
     📖 P.2-18 "[A] Front cover"
- (2) Open the ADU cover.
- (3) Pull out the drawer.
- (4) Remove 2 screws and take off the right front cover.

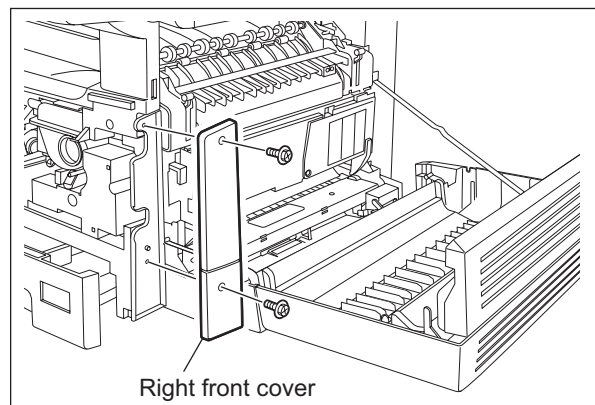

**Fig. 2-20**

### [I] Right rear cover

- (1) Open the ADU cover.
- (2) Remove 1 screw and take off the ADU stopper on the rear side.
- (3) Take off the 2 screw and take off the right rear cover.

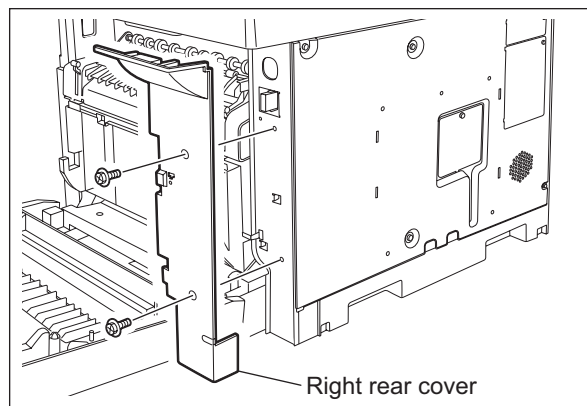

Fig. 2-21

### [J] Rear cover

- (1) Remove 5 screws and take off the rear cover.

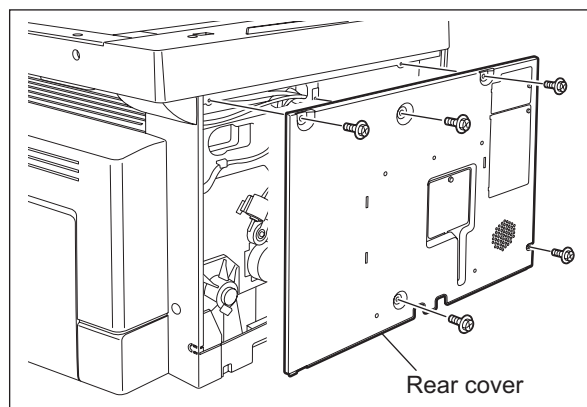



Fig. 2-22

## 2.6 Disassembly and Replacement of PC boards

### [A] MAIN board (MAIN)

- (1) Take off the rear cover.  
 P.2-22 "[J] Rear cover"
- (2) Disconnect 16 connectors.

**Note:**

Connect the flat harness to the MAIN board with its electrode side down. An error "CA2" will be displayed if the connection is incorrect.

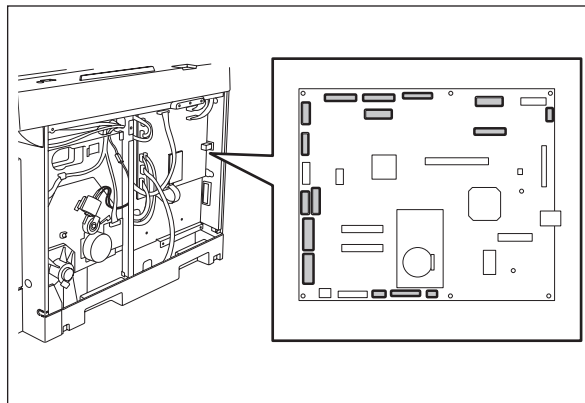

Fig. 2-23

- (3) Remove 6 screws and take off the MAIN board.

**Notes:**

1. When replacing the MAIN board, also attach the SRAM board to the new MAIN board from the old MAIN board.
2. Be sure to perform "08-389" after the SRAM board has been replaced.
3. Be sure to perform "05-310" with the platen cover or the ADF/RADF closed after replacing the MAIN board.

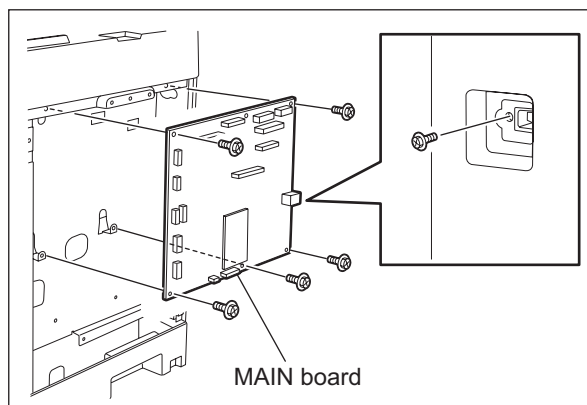

Fig. 2-24

## [B] SRAM board (SRAM)

- (1) Take off the rear cover.  
📖 P.2-22 "[J] Rear cover"
- (2) Release 1 lock support and take off the SRAM board.

### Notes:

1. Be sure to perform "08-388" after the SRAM board has been replaced.
2. Perform "05-310" with the platen cover and the ADF/RADF closed after replacing the SRAM board.

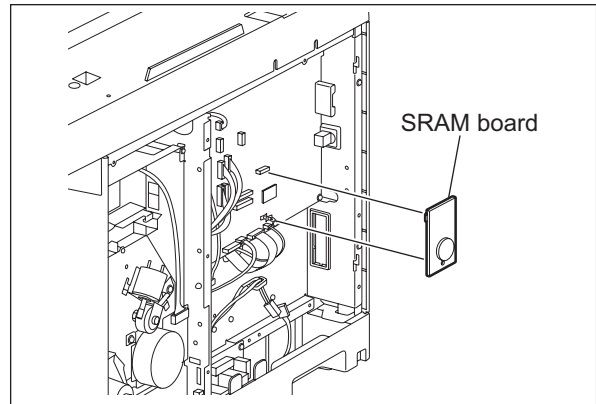

Fig. 2-25

3. Make sure that the direction of the battery on the SRAM board is correct when replacing it.

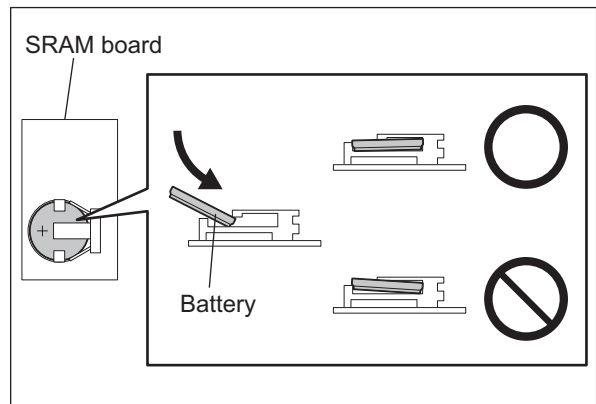

Fig. 2-26

## [C] Fuse PC board (FUS)

### Note:

This fuse PC board is copacked with the damp heater unit. (The damp heater unit is optional for NAD, CND and MJD.)

- (1) Take off the rear cover.  
📖 P.2-22 "[J] Rear cover"
- (2) Remove 2 screws and take off the cover.

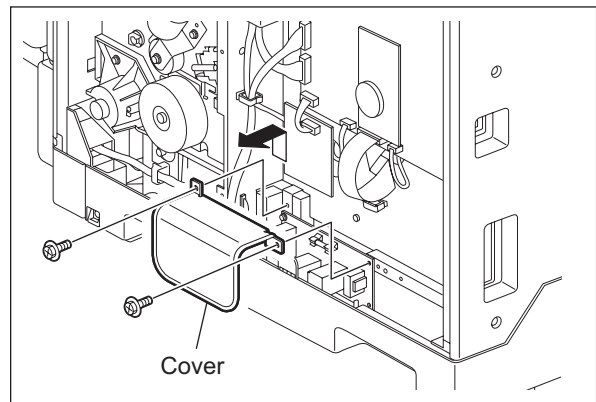

Fig. 2-27



- (3) Disconnect 2 connectors, remove 1 screw, and then take off the fuse PC board by lifting it up.

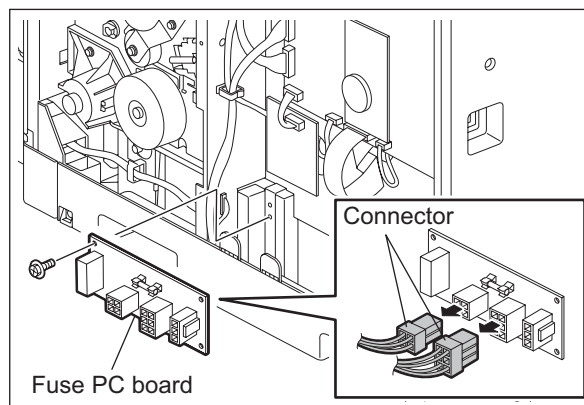

Fig. 2-28

#### [D] Paper feed controller PC board (PFC)

**Note:**

This paper feed controller PC board is optional for NAD, CND and MJD.

- (1) Take off the rear cover.  
 ☞ P.2-22 "[J] Rear cover"
- (2) Disconnect 2 connectors, remove 4 screws, and then take off the paper feed controller PC board and mylar sheet.

**Notes:**

- If the ADU (optional) is installed, disconnect 2 connectors of the ADU with other connectors at the same time before taking off the paper feed controller PC board.
- If the PFP (optional) is installed, disconnect 2 connectors of the PFP with other connectors at the same time before taking off the paper feed controller PC board.

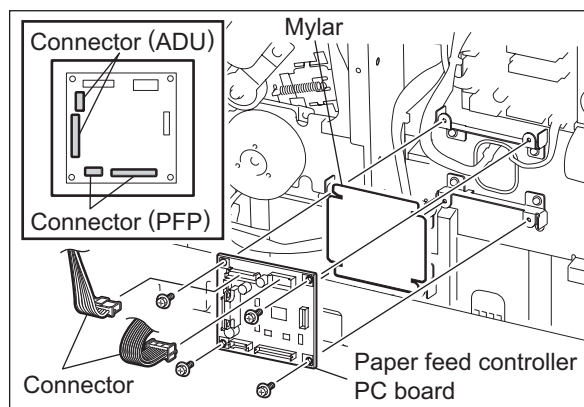

Fig. 2-29

## [E] Switching regulator unit (PS)

- (1) Take off the left cover.  
P.2-19 "[C] Left cover"
- (2) Disconnect 15 connectors.

**Note:**

The number of connectors to be disconnected is 15 when the following options are installed.

- A: Paper Feed Controller (GH-1060)  
B: Fax Kit (GD-1220/1221)

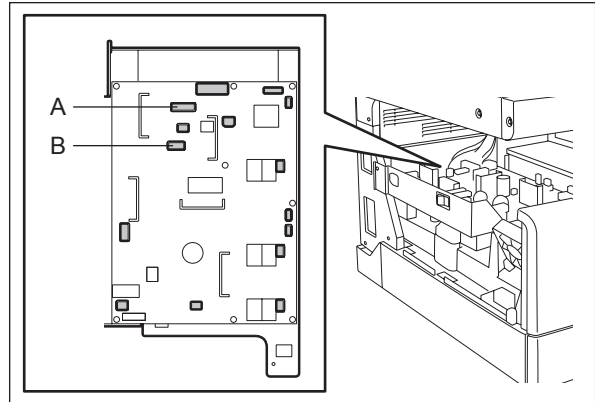

Fig. 2-30

**Note:**

Connect the connectors to the correct faston terminals on the switching regulator board.

Connector		Harness
F. Red	-	Black-thick
E. Blue	-	White-thick
D. White	-	Black-thin
C. White	-	Red-thin
B. White	-	Red-thick
A. White	-	White-thick

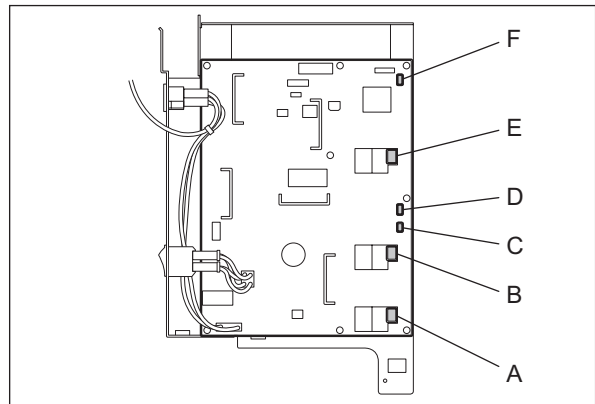

Fig. 2-31

- (3) Remove 2 screws, slide the switching regulator unit with the whole case slightly to the front, and then lift it up to take it off.

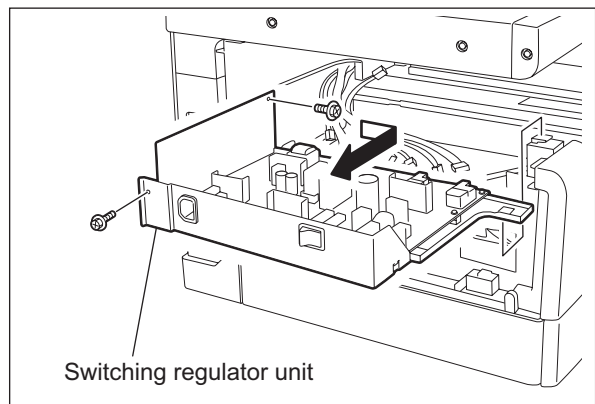

Fig. 2-32

- (4) Disconnect 7 connectors.
- (5) Remove 1 screw and 1 ground wire.

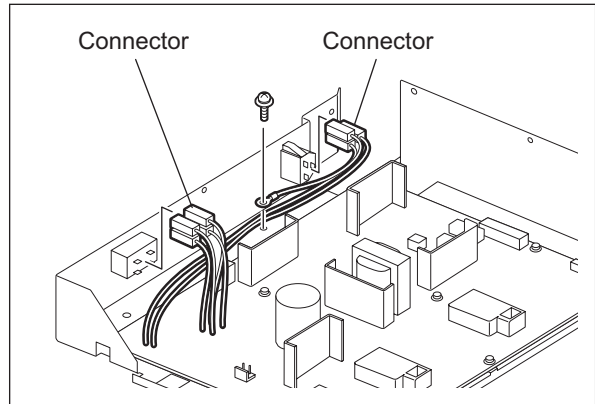

Fig. 2-33

**Note:**

Make sure that the position is correct when inserting the connector.

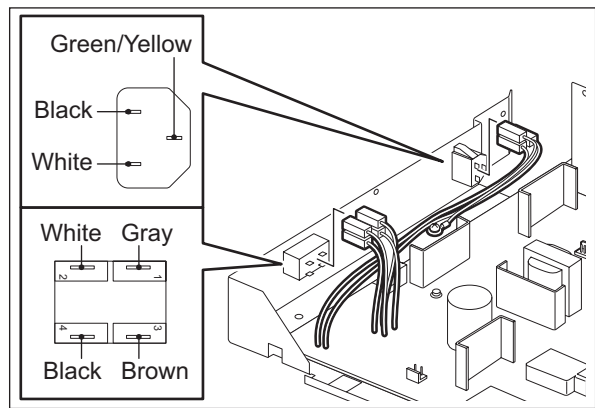

Fig. 2-34

- (6) Remove 8 screws, release 1 locking support, and take off the switching regulator board.

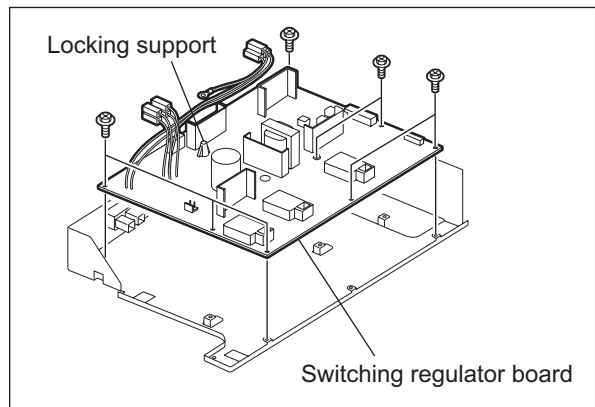

Fig. 2-35

## [F] Switching regulator cooling fan (M6)

- (1) Take off the left cover.  
📖 P.2-19 "[C] Left cover"
- (2) Disconnect 1 connector and take off the switching regulator cooling fan while sliding it upward.

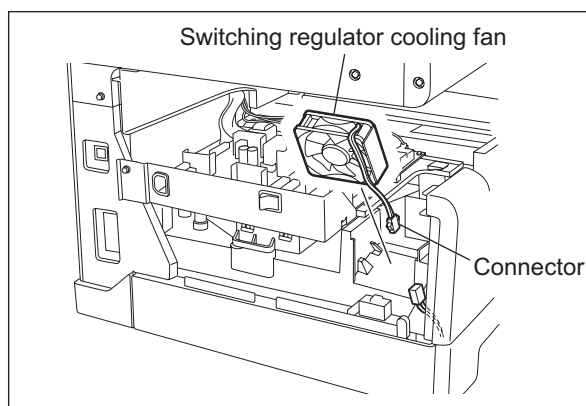

Fig. 2-36

## 2.7 Removal and Installation of Options

### [A] MR-2017 (Automatic Document Feeder (ADF))/MR-3019 (Reversing Automatic Document Feeder (RADF))

- (1) Turn the power OFF and unplug the power cable.
- (2) Remove 1 screw and take off the connector cover.

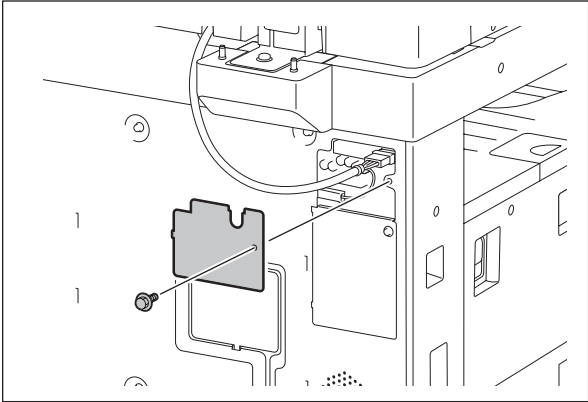

Fig. 2-37

- (3) Remove the ground wire.

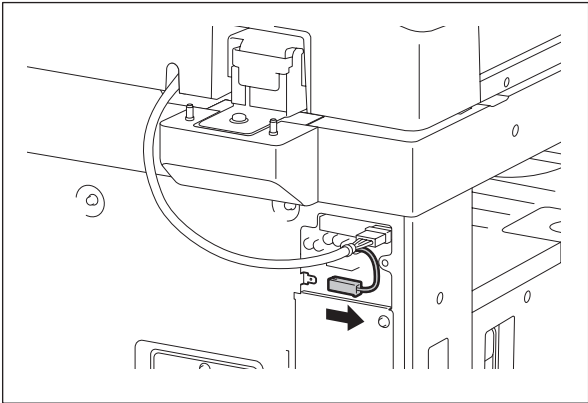

Fig. 2-38

- (4) Disconnect the connector.

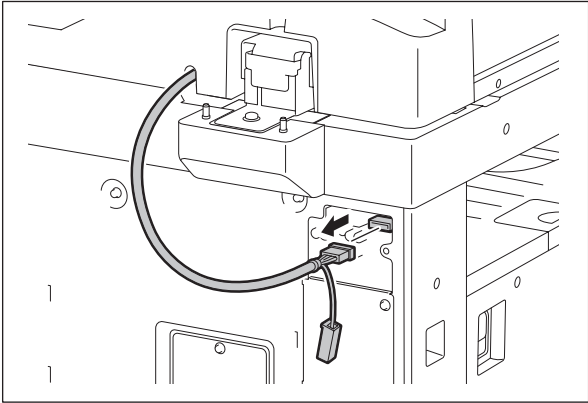
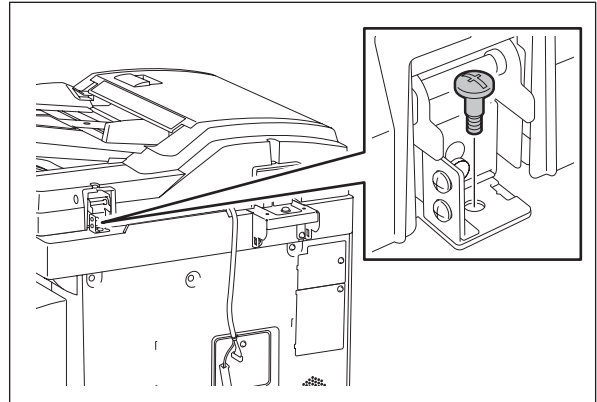

Fig. 2-39

(5) Remove 1 screw on the rear right side.



**Fig. 2-40**

(6) Remove 1 screw and 1 washer on the rear left side.

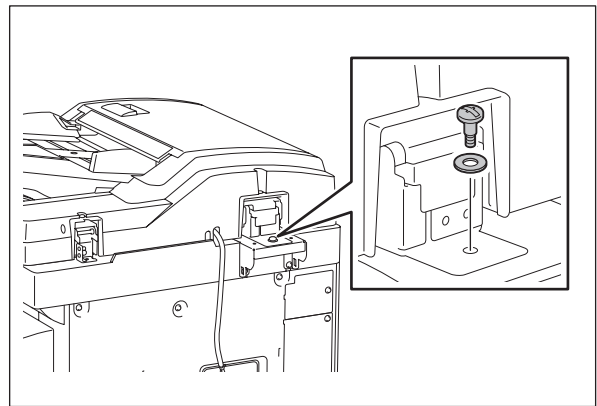

**Fig. 2-41**

(7) Open the ADF/RADF.

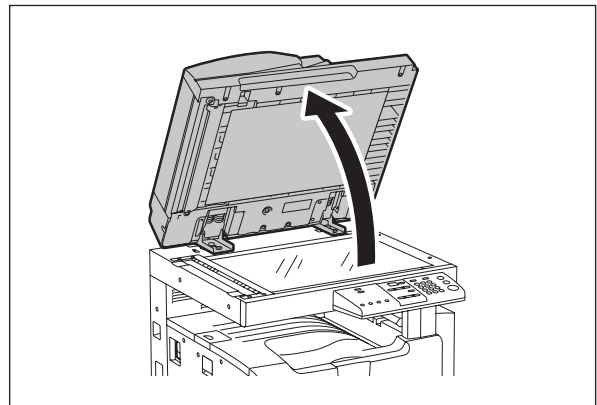

**Fig. 2-42**

- (8) Remove 2 screws on the front side.

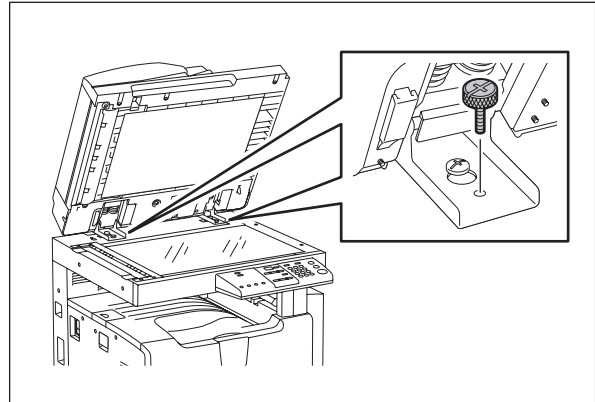

Fig. 2-43

- (9) Slide the ADF/RADF backward and take off by lifting it up.

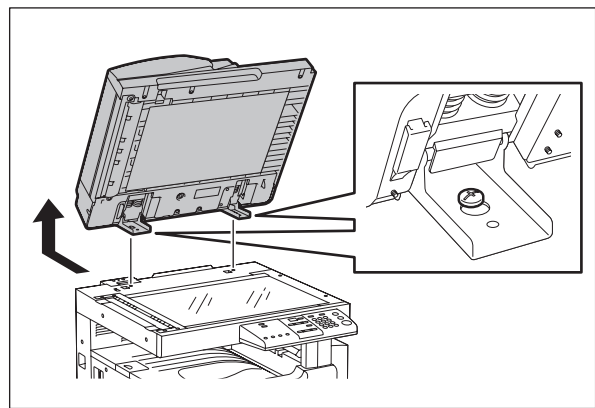

Fig. 2-44

**[B] MY-1027 (Paper Feed Unit (PFU))**

**[B-1] When PFP is not installed**

- (1) Turn the power OFF and unplug the power cable.
- (2) Remove 1 screw and take off the PFU connector cover.

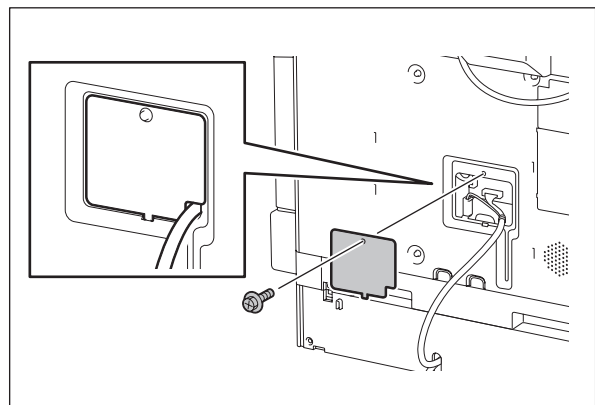
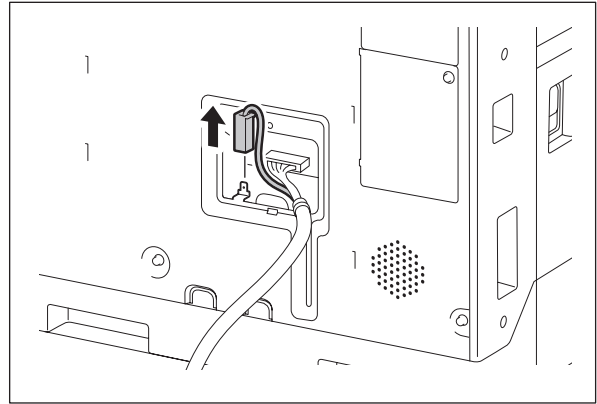

Fig. 2-45

(3) Remove the ground wire.



**Fig. 2-46**

(4) Disconnect the connector.

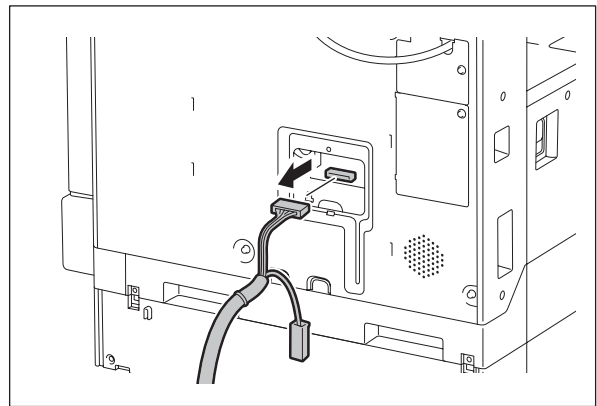

**Fig. 2-47**

(5) Install the PFU connector cover.

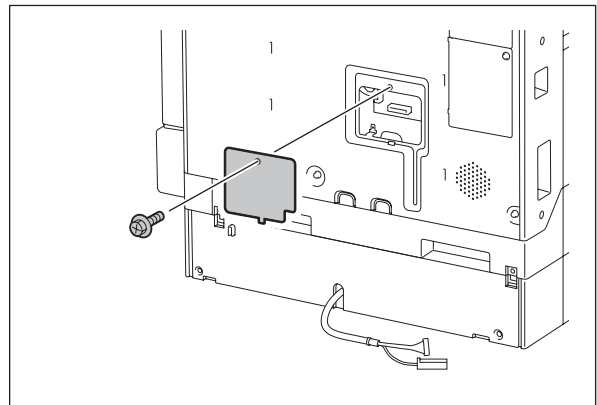

**Fig. 2-48**



- (6) Take off the rear cover.  
P.2-22 "[J] Rear cover"
- (7) Disconnect 1 connector (optional damp heater). Release the harness from the harness clamp.

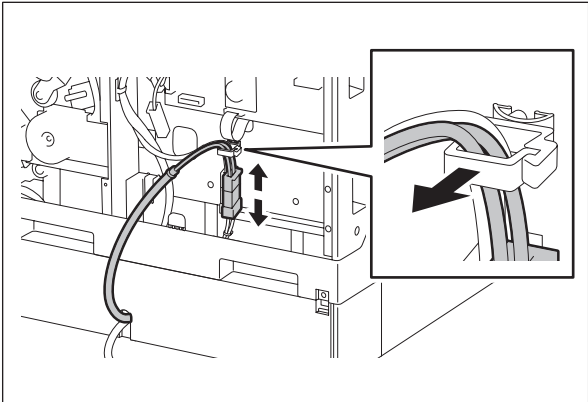

Fig. 2-49

- (8) Take off the drawer of the equipment and PFU drawer.

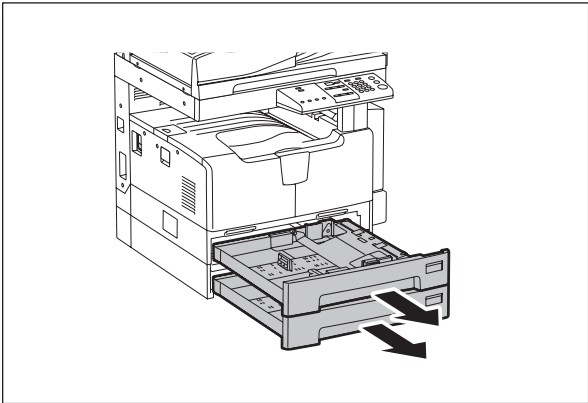

Fig. 2-50

- (9) Remove 1 screw and take off 1 fixing bracket on the front left side.

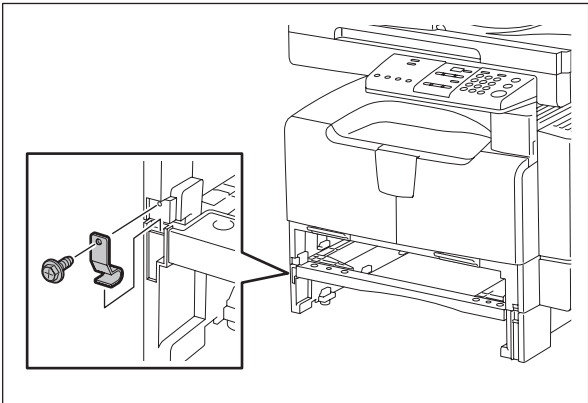
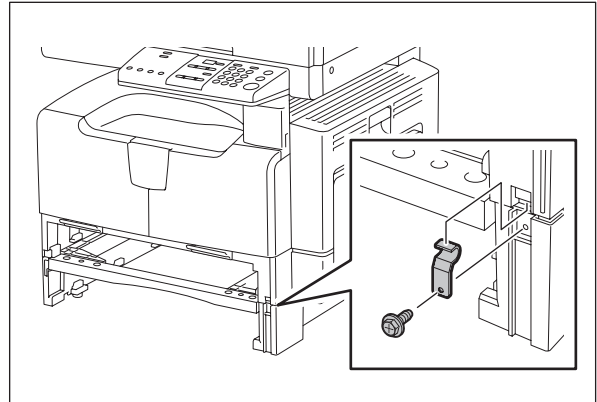

Fig. 2-51

- (10) Remove 1 screw and take off 1 fixing bracket on the front right side.



**Fig. 2-52**

- (11) Remove 1 screw and take off 1 fixing bracket on the rear left side.

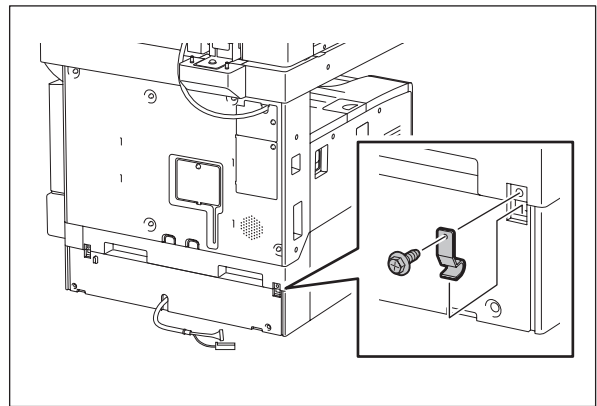

**Fig. 2-53**

- (12) Remove 1 screw and take off 1 fixing bracket on the rear right side.

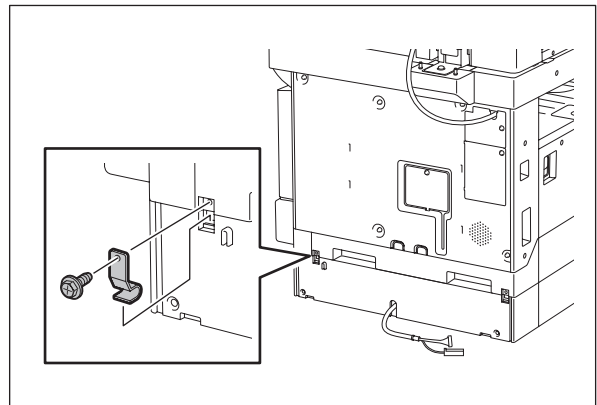

**Fig. 2-54**

(13) Lift up the equipment and take off the PFU.

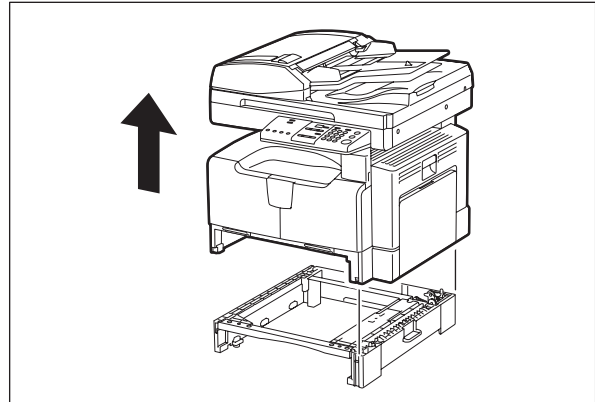

Fig. 2-55

**[B-2] When PFP is installed**

- (1) Take off the rear cover.  
P.2-22 "[J] Rear cover"
- (2) Remove 1 ground wire and 2 connectors.

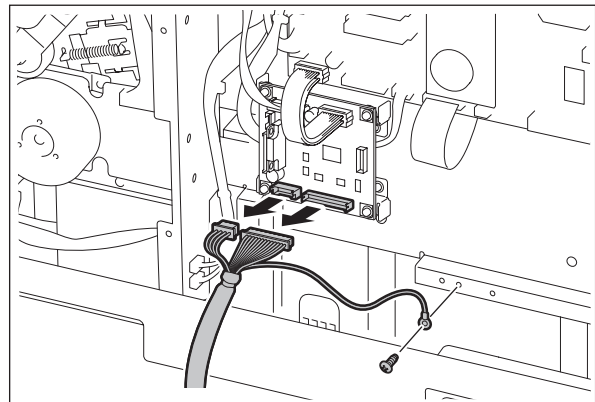

Fig. 2-56

- (3) Take off the equipment from the PFU.  
P.2-31 "[B-1] When PFP is not installed"
- (4) Take off the PFP drawer.

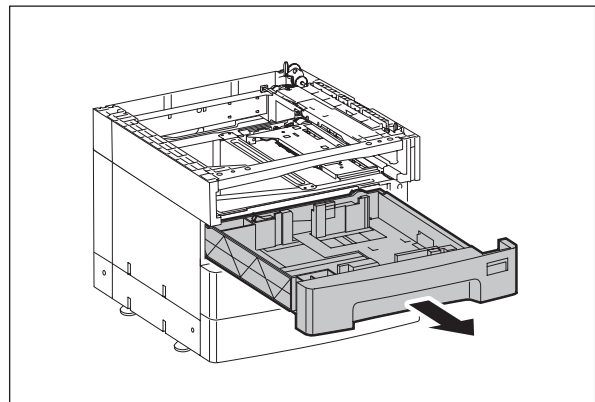
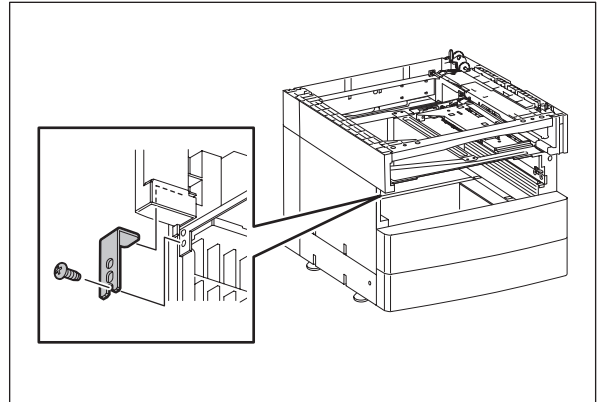

Fig. 2-57

- (5) Remove 1 screw and take off 1 fixing bracket on the front left side.



**Fig. 2-58**

- (6) Remove 1 screw and take off 1 fixing bracket on the front right side.

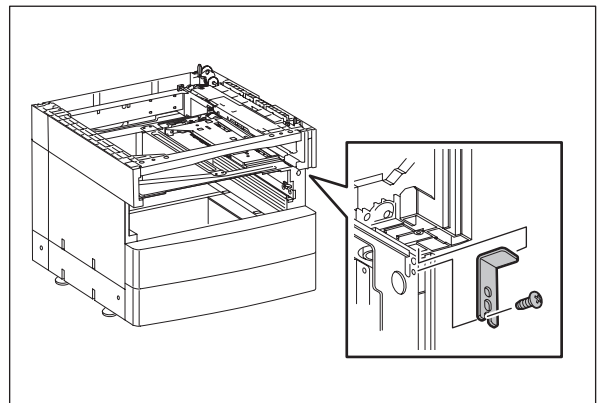

**Fig. 2-59**

- (7) Remove 1 screw and take off 1 fixing bracket on the rear left side.

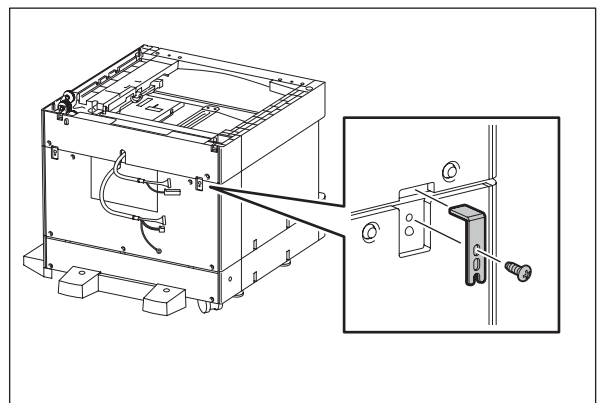

**Fig. 2-60**

- (8) Remove 1 screw and take off 1 fixing bracket on the rear right side.

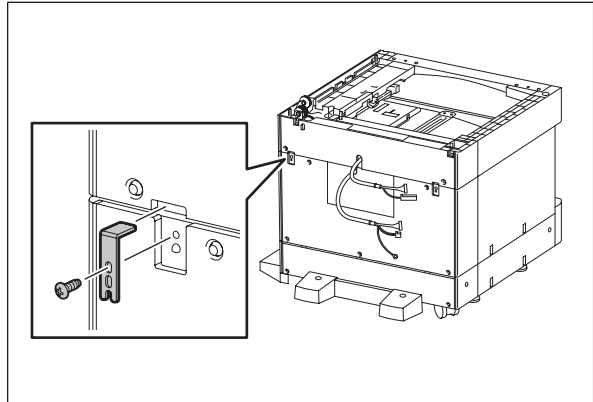

Fig. 2-61

- (9) Take off the PFU while lifting it up.

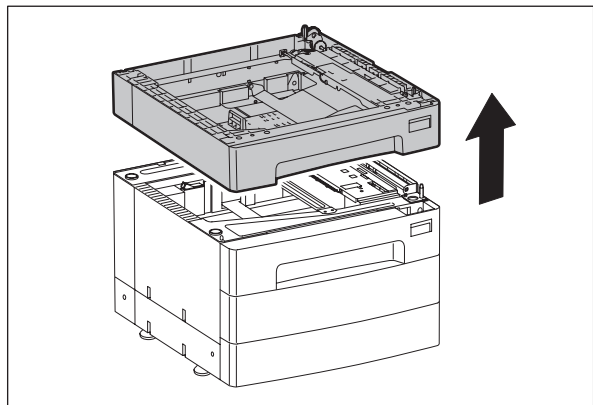



Fig. 2-62

**[C] KD-1022 (Paper Feed Pedestal (PFP))**

- (1) Take off the equipment and the PFU. Then take off the PFP.

 P.2-35 "[B-2] When PFP is installed"

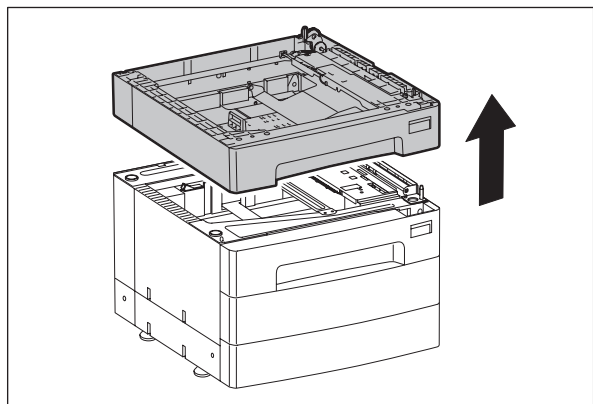

Fig. 2-63



### 3. COPY PROCESS

#### 3.1 General Description of Copying Process

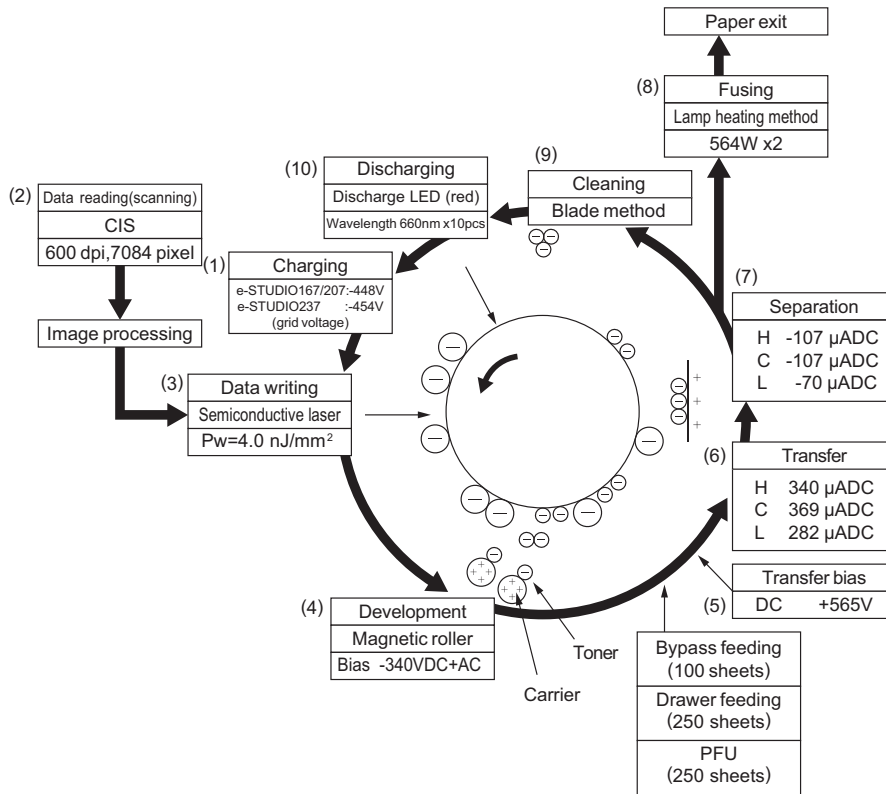

Fig. 3-1

- |  |  |
|--|--|
| <p>(1) Charging: Applies negative charge on the surface of the photoconductive drum.</p> <p style="text-align: center;">↓</p> <p>(2) Data reading: The images on the original are converted into electrical signals.</p> <p style="text-align: center;">↓</p> <p>(3) Data writing: The electrical signals are converted into light signal (laser emission) which exposes the surface of the photoconductive drum.</p> <p style="text-align: center;">↓</p> <p>(4) Development: Negatively-charged toner adheres to the photoconductive drum and forms visible image.</p> <p style="text-align: center;">↓</p> <p>(5) Transfer bias: Improves transfer efficiency.</p> <p style="text-align: center;">↓</p> <p>(6) Transfer: Transfers the visible toner image on the photoconductive drum onto paper.</p> <p style="text-align: center;">↓</p> | <p>(7) Separation: Separates paper with the toner image from the photoconductive drum.</p> <p style="text-align: center;">↓</p> <p>(8) Fusing: Fuses the toner image onto the paper by applying heat and pressure.</p> <p style="text-align: center;">↓</p> <p>(9) Cleaning: Scrapes off the residual toner from the drum.</p> <p style="text-align: center;">↓</p> <p>(10) Discharging: Eliminates the residual negative charge from the surface of the photoconductive drum.</p> |
|--|--|

## 3.2 Details of Copying Process

### 1) Photoconductive drum

The photoconductive drum consists of two layers. The outer layer is a photoconductive layer made of an organic photoconductive carrier (OPC), and the inner layer is an aluminum conductive base in a cylindrical form. The photoconductor has the following property: when it is exposed to light, the electrical resistance it possesses increases or decreases according to the strength of the light.

Example:

- Strong light  
Resistance is decreased (works as a conductor.)
- Weak light  
Resistance is increased (works as an insulator.)

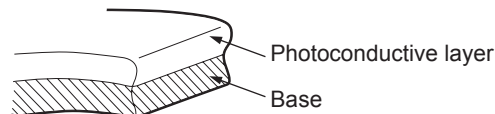

Structure of the photoconductive drum  
(Example of OPC)

Fig. 3-2

[Formation of electrostatic latent image]

In the processes of charging, data reading, data writing, discharging described later, negative potential of the areas on the drum corresponding to black areas of the original are eliminated, while the areas on the drum corresponding to white areas retains the negative charge.

As this image on the drum formed by the negative potential is not visible, it is called an "electrostatic latent image."

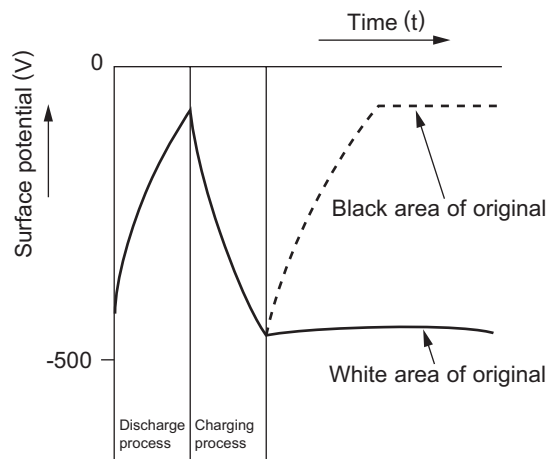

Electric potential of the photoconductive drum

Fig. 3-3



2) Charging

Charging is the process to apply charge evenly on the drum surface.

The needle electrode produces negative corona discharge is controlled by the grid, allowing the drum surface to be evenly charged with the negative potential.

The surface potential on the drum is determined by the grid potential and is controlled to a certain value by the grid control circuit.

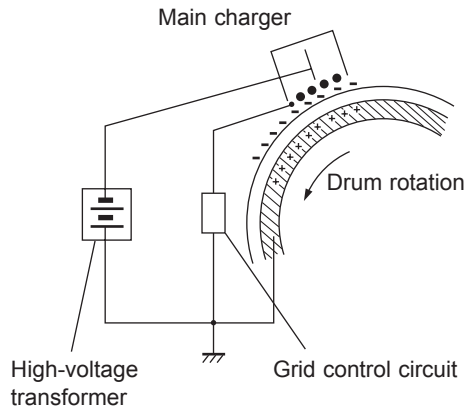

Fig. 3-4

3) Data reading (scanning)

Data reading is the process of illuminating the original with light and converting the reflected light into electrical signals.

This equipment uses the CIS (Contact Image Sensor) for data reading.

The optical image information read by the CIS is converted into electrical signals (image signals), which are then transmitted to the image processing section.

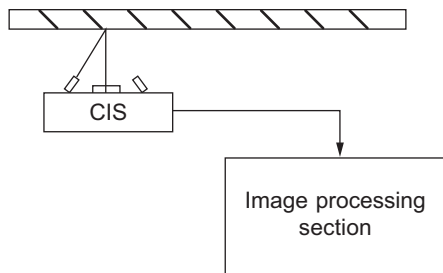

Fig. 3-5

(Example)

Light receiving amount	Value of image signals to be output
Light	255
Dark	0

} Difference between "light" and "dark" is divided into 256 steps.

Fig. 3-6

#### 4) Data writing

Data writing is the process of converting the image signals sent from the image processing section into optical signal and exposing the drum surface with the light.

Semiconductive laser element converts image signals transmitted from the image processing section into optical signal (laser emission) to expose the drum surface and form an electrostatic latent image on it.

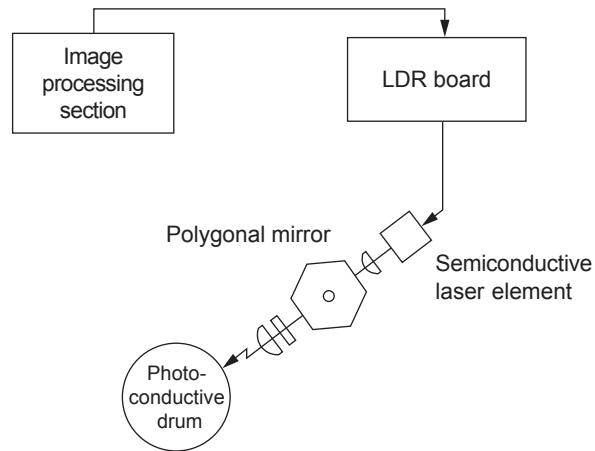

**Fig. 3-7**

5) Development

Development is the process of making the electrostatic latent images visible to the eye (visible images).

Developer material is supplied to the photoconductive drum surface by the magnetic roller. The toner in the developer material adheres to the areas on the drum surface where the potential is lower than the developer bias which is applied to the magnetic roller (reverse development method).

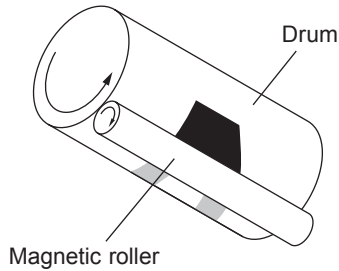

Fig. 3-8

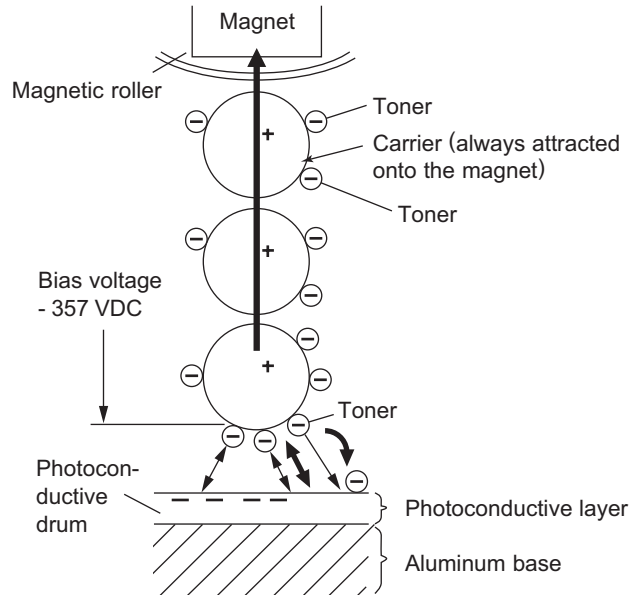

Fig. 3-9

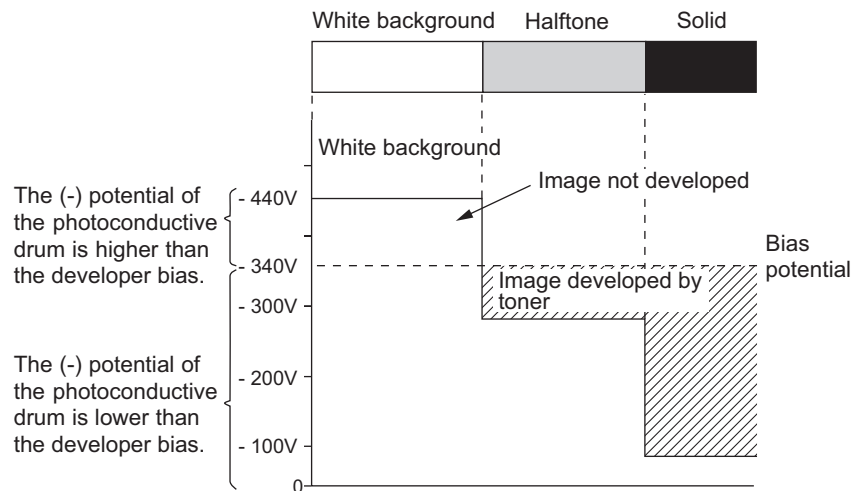

Fig. 3-10

- Charging AC bias

To obtain the stable development characteristics, AC bias (approx. 1,100 V) is charged to the development bias (DC bias).

- Developer material

The developer material consists of a mixture of the toner and carrier. The toner is charged to the negative polarity and the carrier to positive polarity due to the friction with each other caused by mixing.

- Toner: Mainly consists of the resin and carbon.  
 Carrier: Consists of the ferrite and resin coating on its surface to provide consistent frictional electrification.

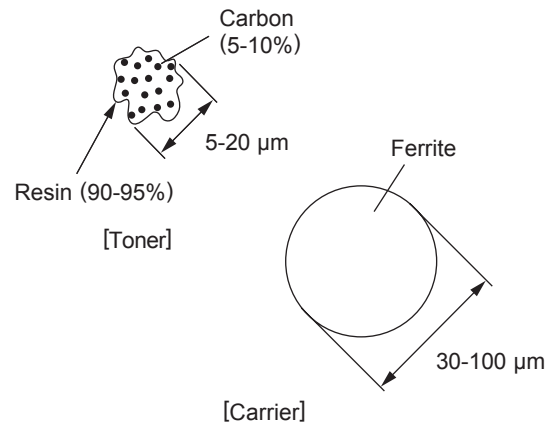

Fig. 3-11

**Note:**

If the developer material is used for a long time (beyond its normal life span), the toner is caked onto the carrier.



The charging performance of the carrier is lowered.

- Symptom: 1. Image density is lowered.  
 2. Toner scattering occurs.  
 3. Background fogging occurs.

Solution: Replace the developer material.

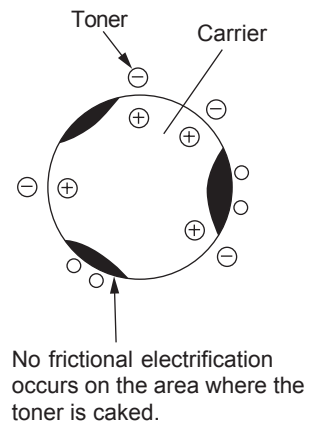

Fig. 3-12

- Magnetic roller  
Magnetic brush development  
The south and north poles are arranged inside the magnetic roller as shown in the right figure.  
The developer material forms a brush-like fluff which contacts the photoconductive drum surface.  
↓  
This is caused by the magnetic force lines between the south and north poles.

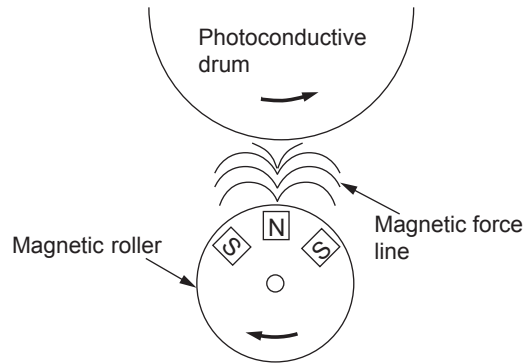

Fig. 3-13

**- Additional Explanation**

The life of the toner cartridge (number of output pages) varies depending on the following conditions.

Coverage of originals (printing image ratio of the original size) and density of original background

Size and density of originals

The existence of solid black when making prints (when a book is copied and the original cover is partially opened)

Temperature and humidity in the room when making prints.

Prints density and image quality mode

As indicated in the figure below, the life of the toner cartridge varies depending on the copy mode and coverage of originals.

In this graph, the toner consumption for copying in TEXT/PHOTO mode using chart "A" is defined as 100%.

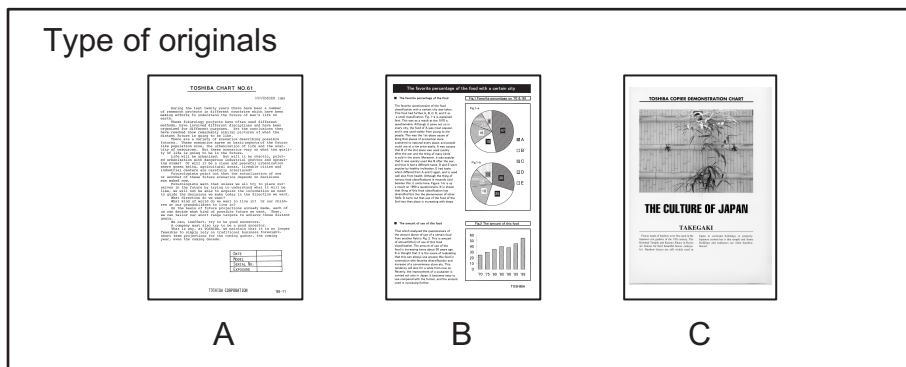
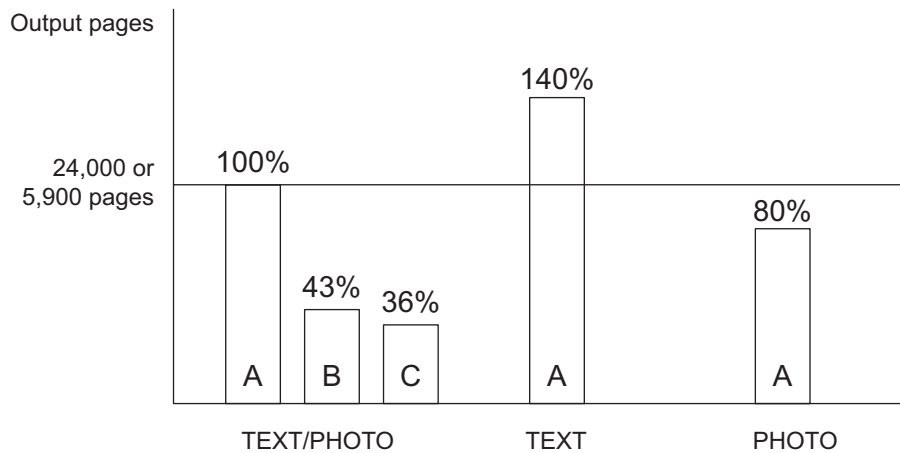

**Fig. 3-14**

6) Transfer

Transfer is the process of transferring the toner image (visible image) formed on the drum surface onto paper.

Method: A paper passing the side of the drum is charged to the opposite polarity to the that of toner by the corona discharge of the transfer charger.



The toner moves from the drum surface onto the paper.

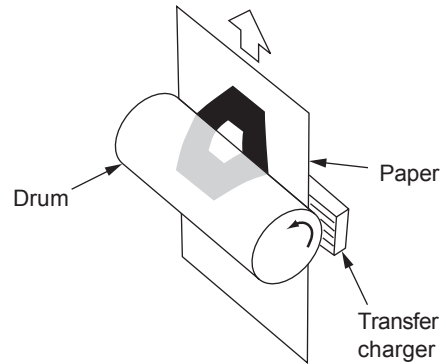

Fig. 3-15

- For smooth transfer

In the transfer bias processing of this equipment, bias voltage (+565 VDC) is applied to the registration roller and transfer unit transport guide to prevent the charge produced by the transfer charger from flowing into the transfer unit transport guide through the paper. Output is controlled as follows to realizes the desirable transfability.

Paper position against transfer point	Transfer output
From leading edge to 11 mm from leading edge	(H) 340 $\mu$ ADC
From 11 mm from leading edge to 5 mm from trailing edge	(C) 369 $\mu$ ADC
From 5 mm from trailing edge to trailing edge	(L) 282 $\mu$ ADC

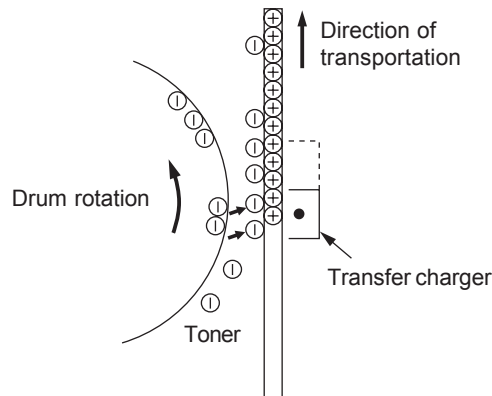

Fig. 3-16

### 7) Separation

Separation is the process of separating paper which is temporarily adhering to the drum due to the static electricity during the transfer process.

Method: Apply negative DC bias to the separation charger.

↓

The positive charge on the paper is decreased.

↓

The electrostatic adherence force between the paper and drum becomes weak.

↓

The paper is separated from the drum by its own stiffness.

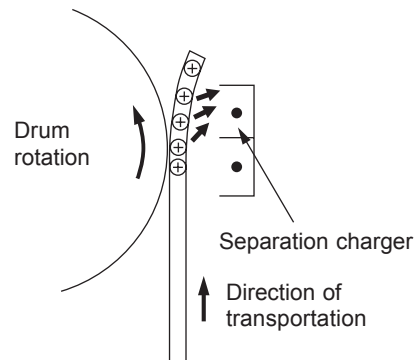

Fig. 3-17

- Output is controlled as follows to realizes the desirable separability.

Paper position against transfer point	Separation output
From leading edge to 11mm from leading edge	(H) -107 $\mu$ ADC
From 11mm from leading edge to 46mm from leading edge	(L) -70 $\mu$ ADC
From 46mm from leading edge to 48mm from trailing edge	(C) -107 $\mu$ ADC
From 48mm from trailing edge to trailing edge	(L) -70 $\mu$ ADC

Paper may not be separated from the drum surface because of moisture or malfunction of the transfer/separation charger during printing. As the result, the paper enters into the cleaner and causes jamming. To prevent this, a separation finger is used to forcibly separate the paper which was left around the drum.

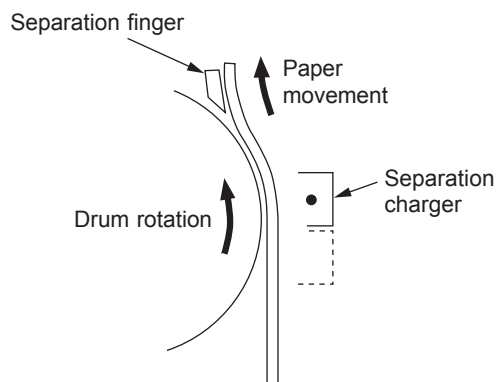

Fig. 3-18



8) Fusing

Fusing is the process of melting the toner on the paper and fixing it firmly on the paper.

Method: The melting point of the toner (main ingredient: resin) is 90-100°C.



(Heat) Toner is melted by the heat of the surface of the fuser roller.



(Pressure) The pressure roller is pressed against the fuser roller by the springs to increase the adherence of the melted toner onto the paper.



Heat and pressure are applied to the paper when it passes between the fuser roller and pressure roller.



(Fusing) The toner is fused on the paper.

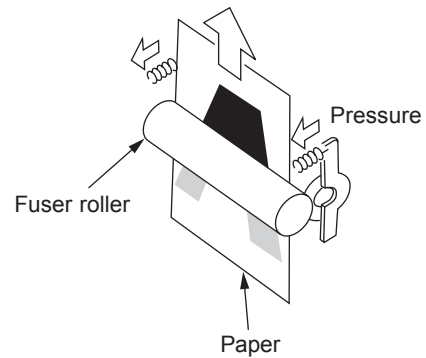

Fig. 3-19

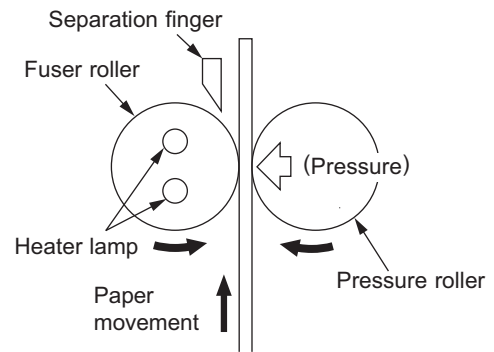

Fig. 3-20

9) Cleaning

Cleaning is the process of removing the residual toner from the photoconductive drum.

The edge of the urethane rubber cleaning blade is pressed against the photoconductive drum surface to scrape off the residual toner on it. The toner is then caught by the recovery blade.

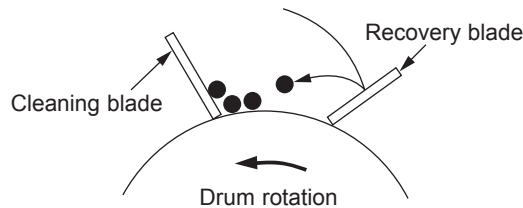

Fig. 3-21

## 10) Discharging

Discharging is the process of eliminating the negative charge remaining on the photoconductive drum before the next charging process.

If the residual charge is not eliminated, the following phenomenon occurs:

Negative charge remaining on the photoconductive drum surface causes uneven application of the charge for the next printing.



The next print will have a double image. (The preceding image appears.)



Solution:

The entire surface of the photoconductive drum is illuminated with light by the discharge LED array.



The photoconductive drum becomes electrically conductive.



All of the negative charge remaining on the photoconductive drum is conducted to the ground.



Preparation for the next printing is completed.

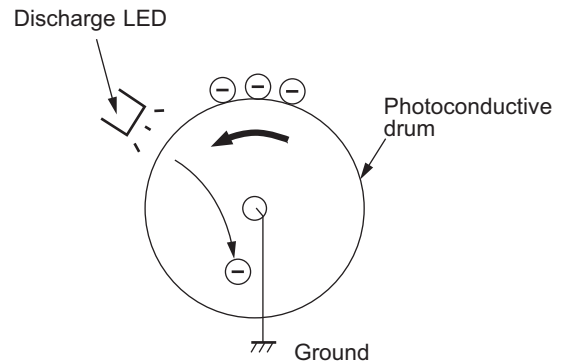

Fig. 3-22

### 3.3 Comparison with e-STUDIO230/280

Process	e-STUDIO230/280	e-STUDIO167/207/237
1. Photoconductive drum • Sensitivity • Surface potential	OD-1600 (OPC ø30) Highly sensitized/durable drum -475 V	← ← -440 V
2. Charging • Grid voltage	Scorotron method -495 V	← -448 V (e-STUDIO167/207) -454 V (e-STUDIO237)
3. Data writing • Light source • Light amount	Semiconductor laser (Adjustment not required) 4.0 nJ/mm <sup>2</sup>	←
4. Development • Magnetic roller • Auto-toner • Toner supply • Toner-empty detection • Toner • Developer material • Developer bias	One magnetic roller Magnetic bridge-circuit method Toner cartridge Density detection method T-2320, T-2320E, T-2320D, T-2320C, T-2320T D-2320, D-2320C DC-357 V Adjustable output (during printing) AC 1100 V (Adjustment not required, during printing) DC+150 V Fixed (others)	← ← ← ← T-1640, T-1640E, T-1640D T-1640C, T-1640T ← DC -340 V Adjustment output (during printing) AC 1100 V (Adjustment not required, during printing) No DC+ (positive) output
5. Transfer • Transfer bias	Adjustable output (Constant current) +600 V (Adjustment not required)	← +565 V (Adjustment not required)
6. Separation	Adjustable output (Constant current)	←
7. Discharge • Discharging position • Discharge LED	Exposure after cleaning Red LED	← ←
8. Cleaning • Method • Recovered toner	Cleaning blade Reuse (There is the recovered toner supply mechanism.)	← ←
9. Fusing • Method • Cleaning • Heater	Long-life fuser roller method Fuser roller: Thin roller coated with fluoroplastic (ø30) Pressure roller: PFA tube roller (ø30) Cleaning roller for pressure roller (ø16) Heater lamp Turned ON/OFF by thermistor	← ← Pressure roller: PFA tube roller (ø25) None ←



## 4. GENERAL OPERATION

### 4.1 Overview of Operation

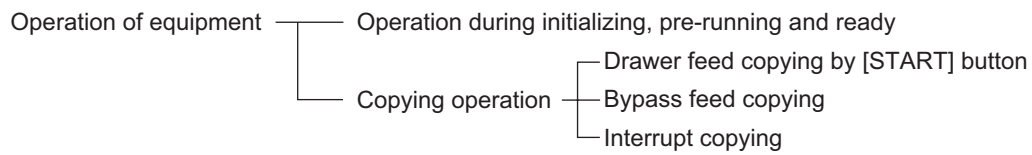

## 4.2 Description of Operation

### 4.2.1 Warming-up

#### 1) Initialization

Power ON

- Heater lamp ON
- "Please wait" is displayed
- Fan motors ON
- Initialization of scanning system
  - The CIS unit moves to the home position.
  - The CIS unit moves to the peak detection position.
  - The LED of CIS is turned ON.
  - Peak detection (white color is detected by the shading correction plate)
  - The LED of CIS is turned OFF.
  - The CIS unit moves to the home position.
- "READY (WARMING UP)" is displayed

#### 2) Pre-running operation (Only when the temperature is at 16 °C or less)

The pre-running operation is started when the temperature of the fuser roller surface reaches a certain temperature.

- The main motor is turned ON
  - Fuser roller rotated.
  - Drum rotated.
- Pre-running operation stops after 15 seconds

#### 3) When the surface temperature of the fuser roller becomes sufficient for fusing,

- "READY" is displayed

### 4.2.2 Ready state (ready for copying)

Buttons on the control panel enabled

- When no button is pressed for a certain period of time,
  - Set number "1" is displayed. Equipment returns to the normal ready state.

### 4.2.3 Drawer feed copying

- 1) Press the [START] button
  - “READY” Æ “COPYING”
  - CIS LED ON
  - Scan motor ON → CIS unit move forward
  - Polygonal motor rotates in high speed
  - Main motor and exit motor ON
  - The drum, fuser unit, developer unit and exit roller are driven.
  
- 2) Drawer paper feeding
  - Main charger, developer bias and discharge LED ON. Fans are rotated in high speed. Pickup solenoid ON.
  - Pickup roller start to rotate.
  - Pickup solenoid OFF after a certain period of time
  - Paper reaches the registration roller
  - The registration sensor is turned ON and aligning is performed.
  
- 3) After the scanning operation:
  - Registration clutch ON after a certain period of time → paper is transported to the transfer area
  - Copy counter operates
  
- 4) After the registration clutch is turned ON:
  - Transfer charger ON after a certain period of time
  - Copy counter operates
  
- 5) Completion of scanning
  - Scan motor OFF
  - CIS LED OFF
  - Registration clutch OFF (after the trailing edge of the paper passed the registration roller)
  - Ready state
  
- 6) Paper exit
  - Exit sensor detects the trailing edge of the paper
  - Main charger, developer bias and discharge LED OFF
  - Polygonal motor, main motor and exit motor OFF
  - Drum, fuser unit and developer unit stop
  - Fans return to the ready rotation
  - “READY” is displayed and the equipment enters the ready state
  
- 7) Timing chart for copying one A4 size sheet fed from the drawer

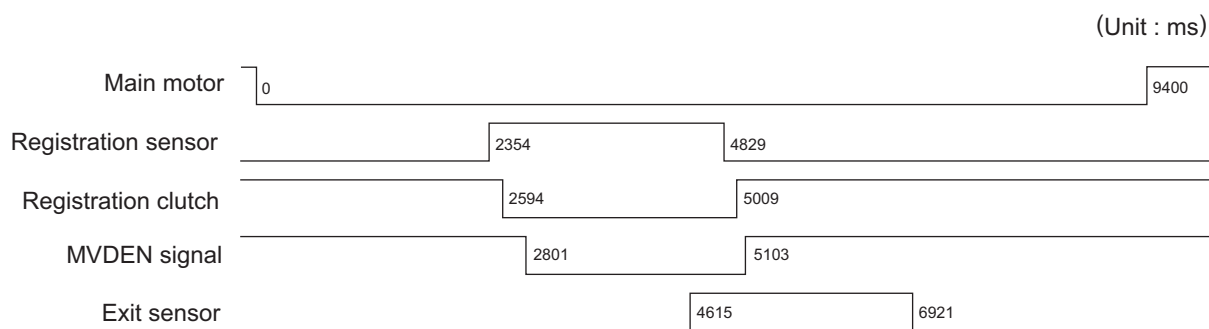

#### 4.2.4 Bypass feed copying

- 1) Insert a sheet of paper into the bypass tray.
  - Bypass paper sensor ON
  - Bypass feed priority state.
- 2) Press the [START] button
  - "READY" Æ "COPYING"
  - CIS LED ON
  - Scan motor ON → CIS unit move forward
  - Polygonal motor rotates in high speed
  - Main motor and exit motor ON
  - The drum, fuser unit, developer unit and exit roller are driven.
- 3) Bypass feeding
  - Main charger, developer bias and discharge LED ON. Fans are rotated in high speed.
  - Bypass pickup solenoid ON
  - The bypass pickup roller start to rotate.
  - The bypass pickup roller is lowered.
  - The bypass feed roller start to rotate.
  - Paper reaches the registration roller
  - Aligning operation
  - After a certain period of time, the bypass pickup solenoid OFF
- 4) Hereafter, the operation 3) through 6) of  P.4-3 "4.2.3 Drawer feed copying" is repeated.

#### 4.2.5 Interruption copying

- 1) Press the [INTERRUPT] button
  - LED "INTERRUPT" ON
  - Copying operation in progress is temporarily stopped. CIS unit return to appropriate positions
  - "Job interrupted" is displayed
  - Automatic density and reproduction ratio 100% are set (The set number remains the same)
- 2) Select the desired copy condition
- 3) After the interruption copying is finished:
  - LED "INTERRUPT" OFF by pressing the [INTERRUPT] button
  - "READY to resume job" is displayed
- 4) Press the [START] button
  - The copying operation before the interruption is resumed



## 4.3 Detection of Abnormality

When something abnormal has occurred in the equipment, the symbols corresponding to the type of abnormality are displayed.

### 4.3.1 Types of abnormality

- 1) Abnormality cleared without turning OFF the door switch
  - (A) Add paper
  - (B) Pick-up failure in bypass
  
- 2) Abnormality not cleared without turning OFF the door switch
  - (C) Misfeed in equipment
  - (D) Replace the toner cartridge
  - (E) Developer unit not installed properly
  
- 3) Abnormality not cleared without turning OFF the main switch
  - (F) Call for service

## 4.3.2 Description of abnormality

### (A) Add paper

[In cases of the equipment drawer or the PFU / PFP drawer ] (When drawer is not installed)

- Drawer empty sensor detects the presence or absence of paper.

No drawer detected



“Add paper” is displayed

The LED on the control panel corresponding to the drawer blinks (When the drawer is selected)



[START] button disabled

[In cases of the equipment drawer or the PFU drawer] (When the drawer is installed)

Drawer detected



Paper empty sensor OFF



“Add paper” is displayed

The LED on the control panel corresponding to the drawer blinks (When the drawer is selected)



[START] button disabled

[In case of the PFP drawer] (When the drawer is installed)

- When the power is turned ON or the drawer is installed  
PFP starts initialization



The detection of paper existence starts

Tray-up motor ON – Tray is raised

At this time, the tray-up sensor and paper empty sensor are OFF

→ When the tray-up sensor is not turned ON in a fixed period of time

Tray abnormality → “Add paper” is displayed regardless of the existence of paper

→ Cleared by turning the power ON and then OFF

→ The tray-up sensor is turned ON in a fixed period of time

- The tray-up motor is stopped.

At this time, if the paper empty sensor is

ON: It is judged that there is paper

OFF: It is judged that there is no paper



The lamp on the control panel corresponding to the drawer blinks (When the drawer is selected)

- When paper becomes almost empty as they fed out during copying,
  - The tray-up sensor is turned OFF.
  - The tray-up motor is turned ON – the tray is raised.
  - The tray-up sensor is turned ON.
  - The tray-up motor is stopped.
  
- When the paper empty sensor is turned OFF even if the tray-up sensor is ON during copying,
  - ↓
  - The sensor is detecting that no paper exists.
  - ↓
  - The lamp on the control panel corresponding to the drawer blinks (When the drawer is selected)
  - ↓
  - Copying is stopped

(B) Pick-up failure in bypass

- During bypass feeding
  - Bypass pickup solenoid ON
  - ↓
  - Registration sensor is not turned ON in a fixed period of time
  - ↓
  - “Misfeed in bypass“ is displayed : E12
  - ↓
  - Copying operation is disabled
  - ↓
  - Solution: The bypass paper sensor is turned OFF by removing the paper from the bypass tray.

(C) Misfeed in equipment

- Exit sensor detects jamming of the leading edge of paper.



Registration clutch ON

↓ Less than 1.808 sec.

Exit sensor ON

If the exit sensor is not turned ON after 1.808 sec.



Paper jam (E01) → The copying operation is stopped.

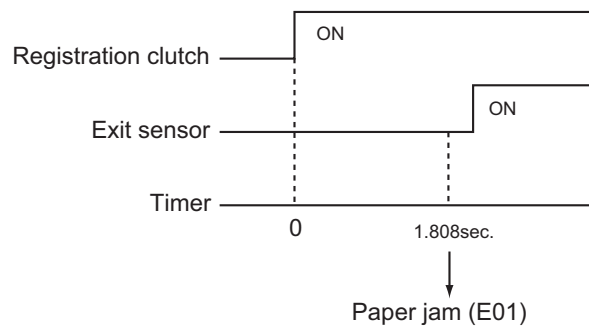

Fig. 4-1

- Exit sensor detects jamming of the tailing edge of paper.



Registration clutch OFF

↓ Less than 1.759 sec.

Exit sensor OFF

If the exit sensor is not turned OFF after 1.759 sec.



Paper jam (E02) → The copying operation is stopped.

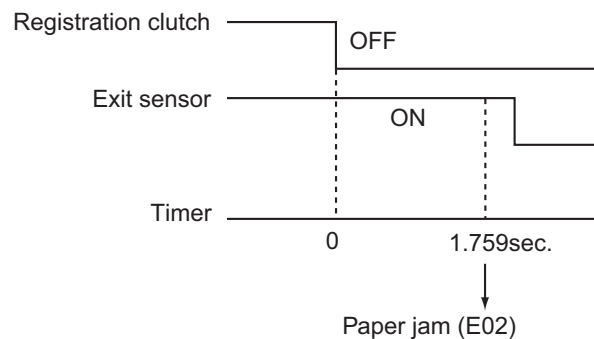

Fig. 4-2

- Immediately after the power ON



Any of all sensors on paper transport path detects paper (ON)



Paper jam (E03)

- Front cover is opened during copying



Paper jam (E41)

- The registration sensor (S4) is not turned ON in a fixed period of time when paper is fed out of the ADU.



Paper jam (E11)

- The ADU sensor (on the ADU board) does not detect paper in a fixed period of time when the paper is transported within the ADU.



Paper jam (E51)

- Registration sensor detects jamming of the leading edge of paper:  
Registration sensor is not turned ON in a fixed period of time after the feeding starts.



Paper jam (E12, E13, E21, E30 and E33)

(The error code differs depending on the paper source. Refer to the error code table in Service Handbook.)

- The PFU paper feed sensor is not turned ON in a fixed period of time after the pickup solenoid is turned ON.



Paper jam (E14)

- The PFP upper drawer feed sensor is not turned ON in a fixed period of time after the paper feed clutch is turned ON when paper is fed out of the PFP.



Paper jam (E15 and E36)

- The PFP lower drawer feed sensor is not turned ON in a fixed period of time after the paper feed clutch is turned ON when paper is fed out of the PFP.



Paper jam (E16)

- The PFU feed sensor is not turned ON in a fixed period of time after the paper feed clutch is turned ON when paper is fed out of the PFP.



Paper jam (E32 and E35)

(The error code differs depending on its paper source. Refer to the error code list in the Service Handbook.)

(D) Replace the toner cartridge

- Toner density becomes low



Auto-toner sensor detects the absence of the toner



Control circuit → The toner lamp brinks: the copying operation disabled

Solution: Open the front cover and replace the toner cartridge with a new one.

Toner is supplied → copying operation enabled.

(E) Developer unit not installed properly

- Disconnection of the connectors of the developer unit



“Set process unit” is displayed.  
[START] button disabled.



Solution: Connect the connectors of the developer unit and close the front cover.

(F) Call for service

Error code is displayed instead of the set number by pressing the [CLEAR] button and [8] button simultaneously when the service call lamp is blinking.  
Refer to the error code table in the Service Handbook.

## 4.4 Flow Chart

### 4.4.1 Immediately after the power is turned ON

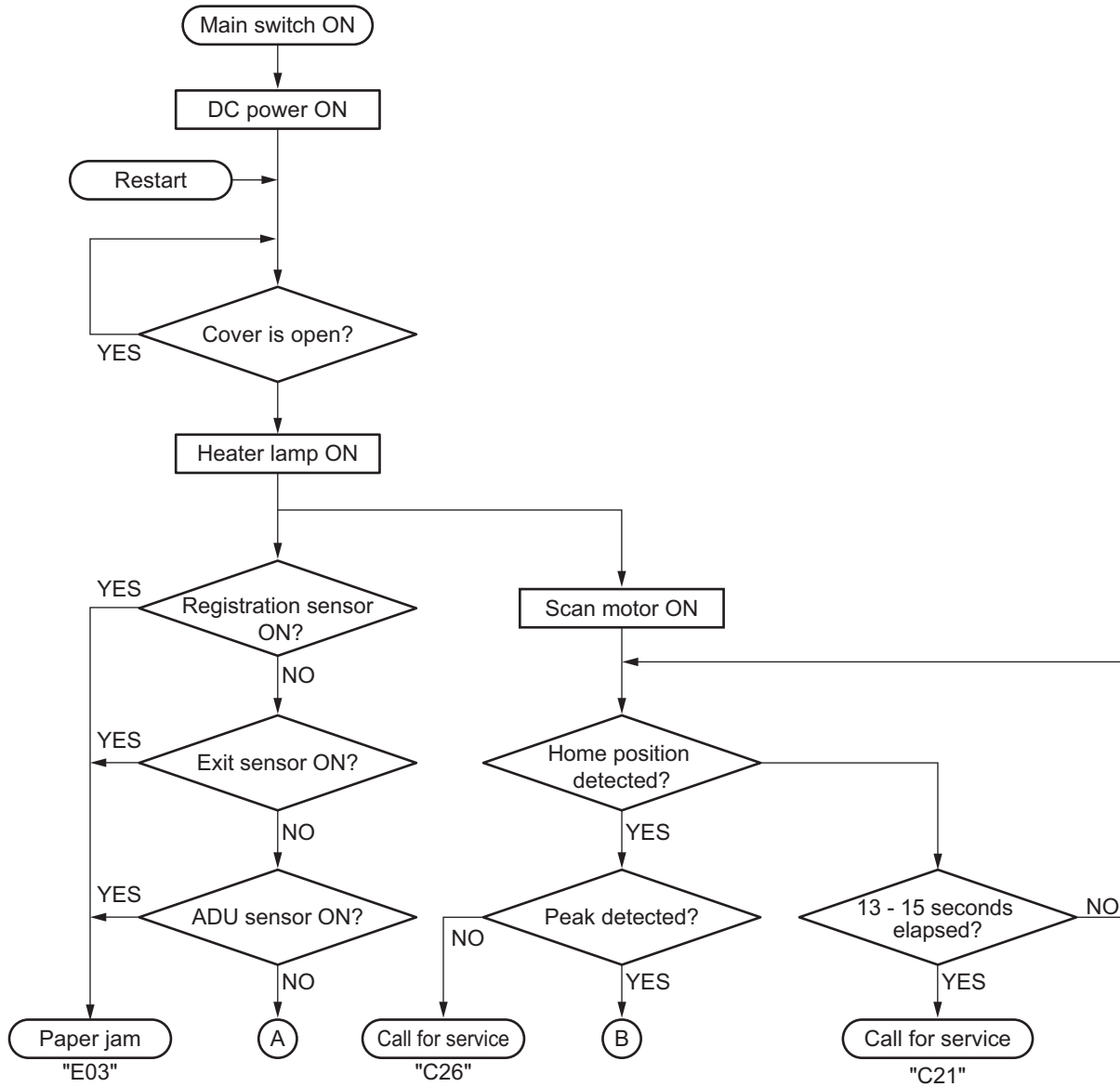

Fig. 4-3

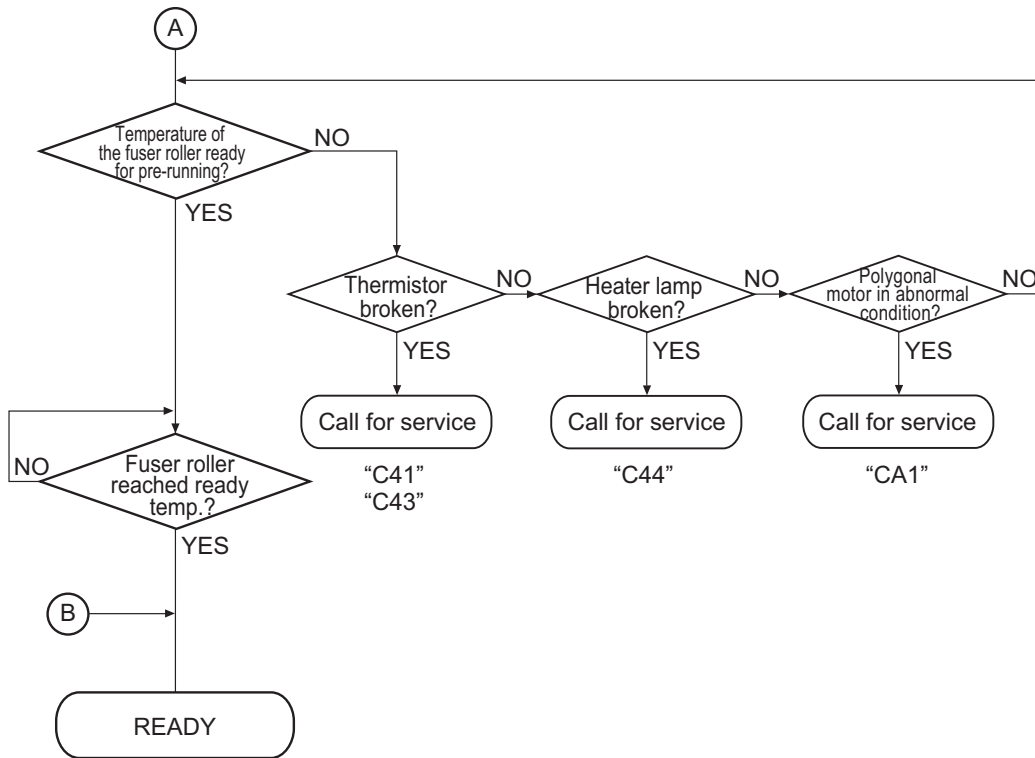

Fig. 4-4



## 4.4.2 Automatic paper feed copying

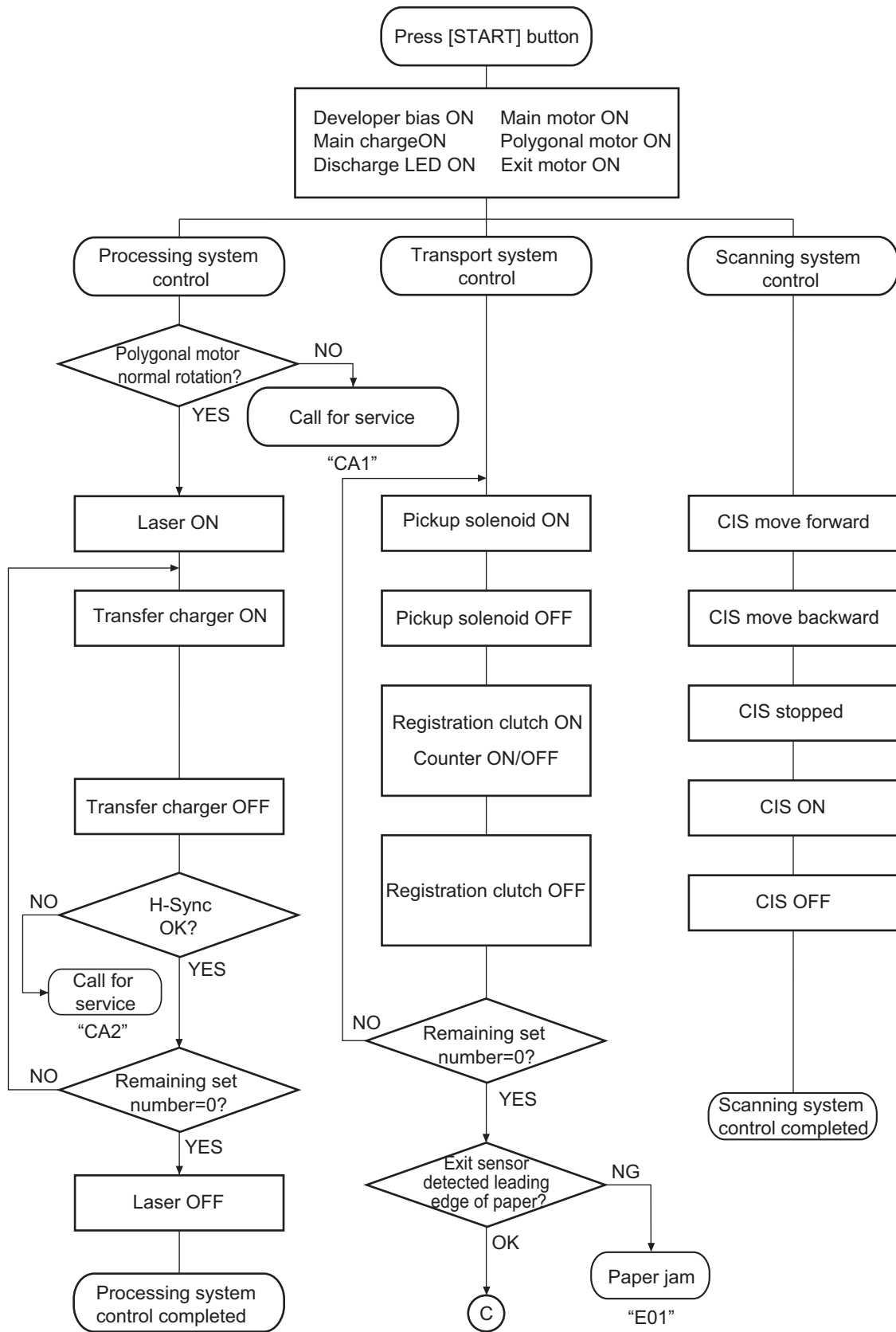

Fig. 4-5

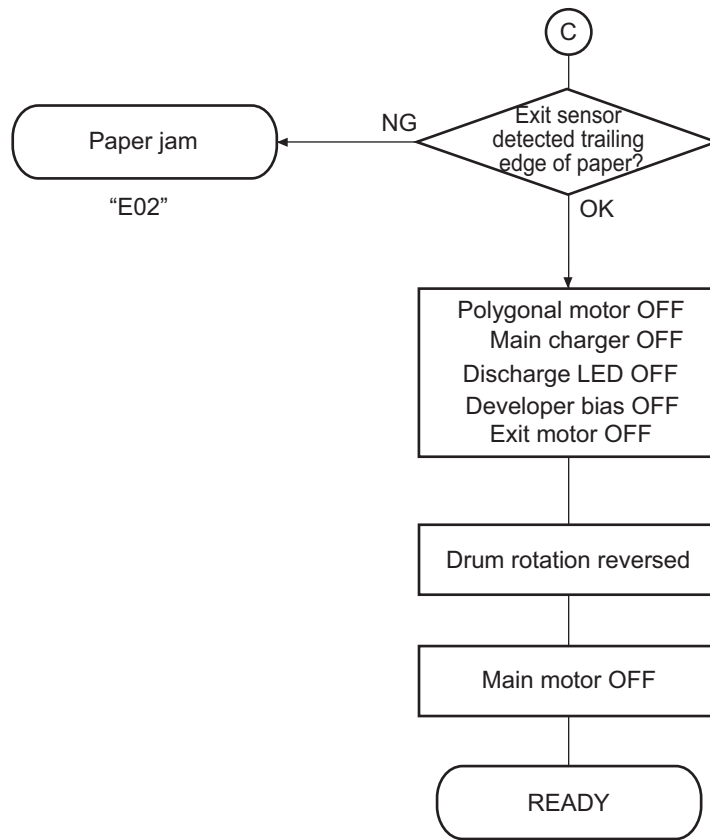

Fig. 4-6

## 5. CONTROL PANEL

### 5.1 General Description

The control panel consists of button switches to operate the equipment and select various modes, and LEDs and an LCD to display codes, values and the states (including each mode) of the equipment. The button switches, the LEDs and an LCD are mounted on the control panel PC board (HPNL) and are installed the inside of the control panel.

When the operator's attention is required, graphic symbols appear with messages explaining the condition of the equipment in the LCD panel.

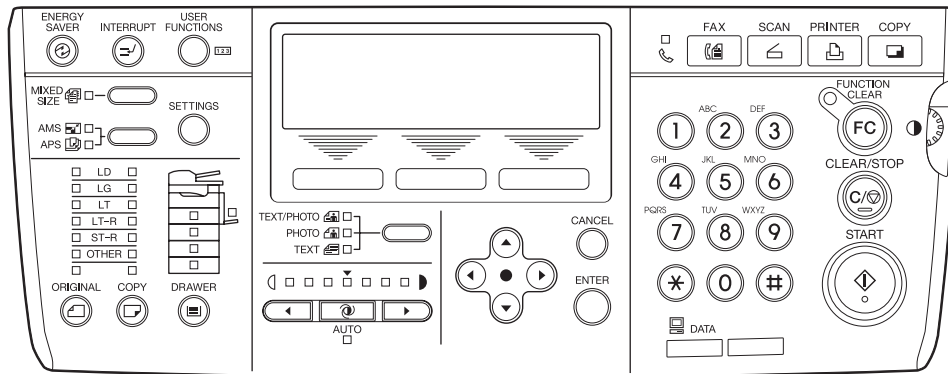

Fig. 5-1

## 5.2 Items Shown on the Display Panel

### 5.2.1 Display

1) Basic display

Displays buttons and messages.



Fig. 5-2

2) Paper jam display

Displays error code, paper jam position and paper jam release guidance.

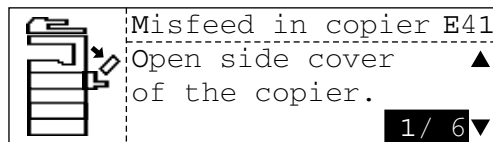

Fig. 5-3

3) Service call display

Displays error code and service call symbol.

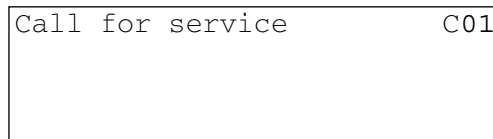

Fig. 5-4

- 4) When input values can be changed by the up or down button in the self-diagnosis mode, the LED in the center of the up, down, left and right buttons is lit.

## 5.2.2 Message

No.	Message	Condition of machine	Notes
1	Wait warming up	Being warmed up <ul style="list-style-type: none"> <li>Displayed after the main switch is turned ON up until the machine becomes ready for copying</li> </ul>	-
2	READY	Standby for copying <ul style="list-style-type: none"> <li>The machine is ready for copying and operator's instructions on copying conditions can be input</li> <li>Returns to the default condition if no key is pressed for the setting time of auto clear timer</li> </ul>	<ul style="list-style-type: none"> <li>Copy quantity indicator shows "1" When a digital key is pressed, that number indicates the set quantity</li> <li>The set quantity can be cleared to "1" by pressing the CLEAR/ STOP key</li> <li>Bypass copying is possible</li> </ul>
3	COPYING	Now copying <ul style="list-style-type: none"> <li>Displayed by pressing the START key</li> <li>Copy quantity indicator becomes "ex. 3 → 2 → 1 → 3" and copying is completed</li> </ul>	<ul style="list-style-type: none"> <li>After completion of copying, the copy quantity indicator returns to the initially set number</li> </ul>
4	Saving energy	Energy saver conditions	<ul style="list-style-type: none"> <li>Reset by pressing the any key except the ENERGY SAVER key</li> </ul>
5	Select original size	Platen sort copying standby state	<ul style="list-style-type: none"> <li>When using original cover</li> </ul>
6	-	Timer off <ul style="list-style-type: none"> <li>No message is displayed in the display panel</li> </ul>	-
7	Cassette * empty	Indication of lack of paper <ul style="list-style-type: none"> <li>Indicates when there is no paper in cassette</li> <li>Bypass copying is possible</li> </ul>	<ul style="list-style-type: none"> <li>Supply paper to the selected cassette</li> <li>Select another cassette</li> </ul>
8	Toner empty	Indication of lack of toner <ul style="list-style-type: none"> <li>The toner in the toner cartridge becomes empty</li> <li>When this message is displayed, it is not possible to copy</li> </ul>	<ul style="list-style-type: none"> <li>Reset after the toner is supplied and the front cover is closed</li> </ul>
9	Misfeed in bypass	Bypass paper jamming (SFB) <ul style="list-style-type: none"> <li>Paper jams at the bypass tray</li> </ul>	The machine returns to normal conditions automatically when the paper out is pulled from the bypass tray
10	Misfeed in copier (Copier machine)	Paper jammed in the machine	Remove the paper jammed in the copier by following the messages
11	Misfeed in doc. Feeder (ADF)	Original jammed <ul style="list-style-type: none"> <li>An original is jammed in the ADF</li> </ul>	Open the ADF jam access cover and the ADF unit, and remove the jammed original
12	Misfeed in duplexer (ADU)	Paper jammed in the ADU	Remove the paper jammed in the copier by following the message
13	Call for service	Some part of the mechanism, motors, switches or sensors is abnormal	Turn OFF the machine, remove the cause of the fault and turn the machine back ON
14	Time for maintenance	Indication of PM cycle <ul style="list-style-type: none"> <li>Displayed when it is time for preventive maintenance and inspection</li> <li>Capable of copying</li> </ul>	Maintenance and inspection by a qualified service technician

## 5.3 Relation between Equipment State and Operation

	[START]	[CLEAR /STOP]	[FUNCTION CLEAR]	[INTER-RUPT]	[ENERGY SAVER]	[COPY]	[PRINT] *1	[SCAN] *2	[FAX] *3	Other buttons/ keys
Waiting	Starts copying	Clears copy quantity	Clears each setting	Enters into interrupting copy	Enters into energy saving mode or sleep mode	---	Enters into print job list screen	Enters into SCAN screen	Enters into FAX screen	Operation acceptable
Warming up	Reserve s auto start job	Clears copy quantity	Clears each setting	---	---	---	---	---	---	Operation acceptable
Copying	---	Pauses copy job	---	Enters into interrupting copy	---	---	Enters into print job list screen	---	---	---
Pausing copy job	Resume s copy job	Cancel s copy job	Clears each setting	Enters into interrupting copy	---	---	Enters into print job list screen	---	---	---
Download- ing firm- ware	---	---	---	---	---	---	---	---	---	---
In energy saving (low power) mode	---	---	---	---	Enters into waiting state	Enters into waiting state	Enters into print job list screen	Enters into SCAN screen	Enters into FAX screen	---
In sleep mode	Enters into waiting state	Enters into waiting state	Enters into waiting state	Enters into waiting state	---	Enters into waiting state	Enters into print job list screen	Enters into SCAN screen	Enters into FAX screen	Enters into waiting state
Interrupt- ing copy job	Starts inter- rupting copy	Clears copy quantity	Cancel s inter- rupting copy	Cancel s inter- rupting copy	---	---	Enters into print job list screen	---	---	Operation acceptable
Cover open	---	Clears copy quantity	Clears each setting	---	---	---	---	---	---	Operation acceptable
Toner empty	---	---	---	---	---	---	---	---	---	Operation acceptable
Paper jam	---	---	---	---	---	---	---	---	---	---
Service call	---	---	---	---	---	---	---	---	---	---

**Note:**

- \*1 [PRINTER] button: This button is enabled when GA-1190 is installed and disabled when it is not installed.
- \*2 [SCAN] button: This button is enabled when GA-1190 and GA-1200 are installed, and disabled when they are not installed.
- \*3 [FAX] button: This button is enabled when GD-1220/1221 is installed and disabled when it is not installed.

## 5.4 Operation

### 5.4.1 Block diagram

The control panel which mainly consists of the panel controlling ASIC and LED driver transmits/receives the control signal to/from the SoC on the MAIN board, controls the LCD, detects the key pressed, and controls the ON/OFF of the LED and buzzer.

The LCD is controlled by the signal output from the panel controlling ASIC based on the information output from the SoC via the control panel data bus (OD0 to 7).

The input status of each button is output to the SoC via the data bus (OD0 to 7) by the panel controlling ASIC and detected.

Each LED is controlled to be lit by the LED driver based on the information of the serial data (OPLDSO) output from the SoC.

The buzzer is controlled by the buzzer ON signal (BZON) output from the ASIC on the MAIN board.

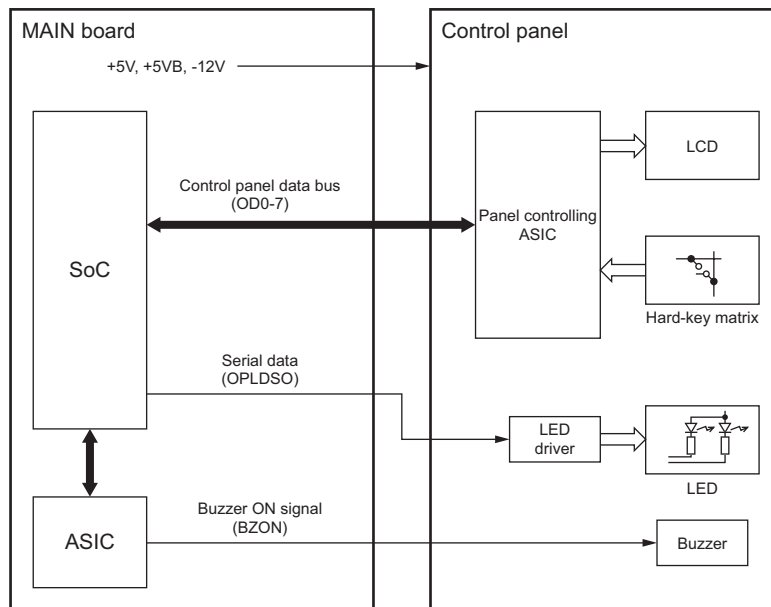

Fig. 5-5

## 5.4.2 LED display circuit

<Example> Lighting circuit method of "TEXT/PHOTO lamp"

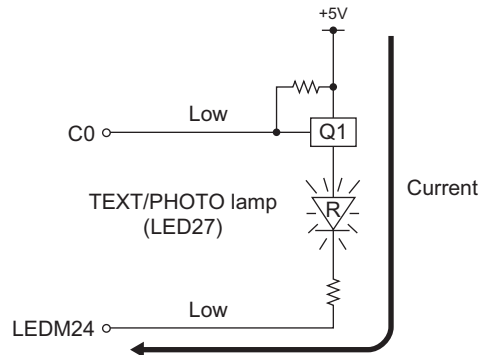

Fig. 5-6

FET (Q1) is turned ON when the FET control signal (C0) becomes "L" level.

Then when the control signal (LEDM24) of the LED driver changes to "L" level, the current flows to the cover open lamp (LED27) to turn ON the LED.

### Conditions to turn ON the LED

The LED is turned ON only when the two conditions below are met.

- 1) The FET connected to the LED anode is ON.
- 2) The cathode side of the LED is "L" level.



## 5.5 Disassembly and Replacement

### [A] Control panel unit

- (1) Remove 3 screws.

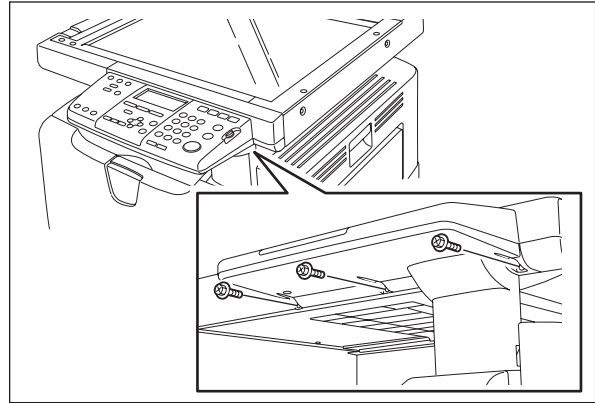

Fig. 5-7

- (2) Take off the control panel unit while lifting it up.
- (3) Disconnect 2 connector.

**Note:**

When installing the control panel unit, be sure not to have the harness being caught by the front right cover and the unit.

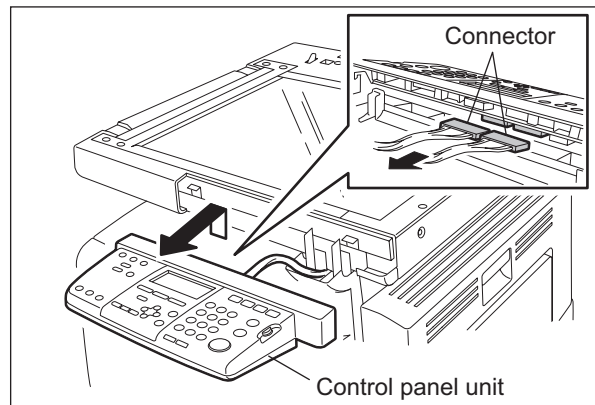
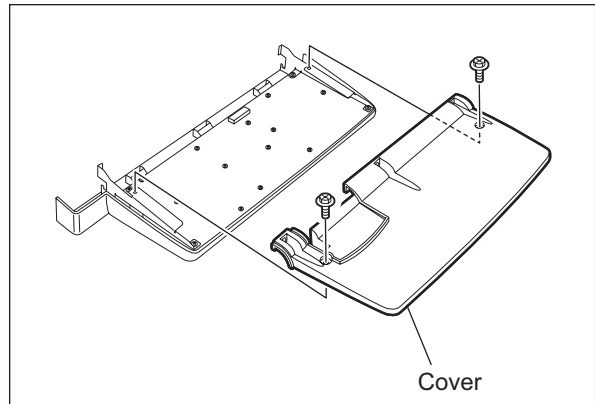

Fig. 5-8

**[B] Control panel PC board (HPNL)**

- (1) Take off the control panel unit.  
P.5-7 "[A] Control panel unit"
- (2) Remove 2 screws and take off the cover while sliding it.



**Fig. 5-9**

- (3) Take off 2 brackets by removing 2 screws each.

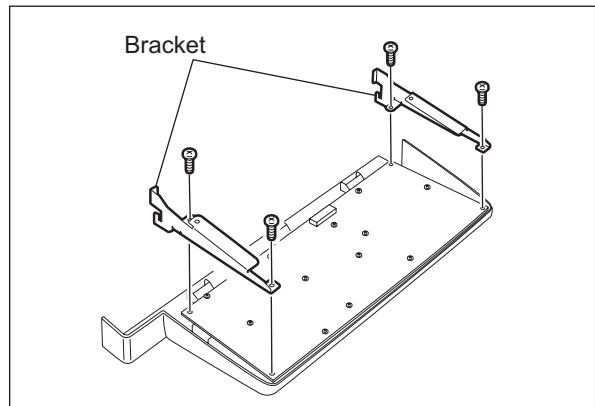

**Fig. 5-10**

- (4) Remove 11 screws, disconnect 1 connector, and then take off the control panel PC board.

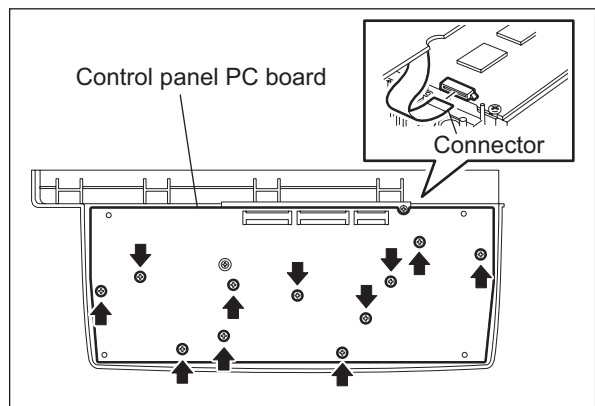

**Fig. 5-11**

### [C] LCD PC board (LCD)

- (1) Take off the control panel pc board.  
📖 P.5-8 "[B] Control panel PC board (HPNL)"
- (2) Remove 2 screws and take off the LCD PC board.

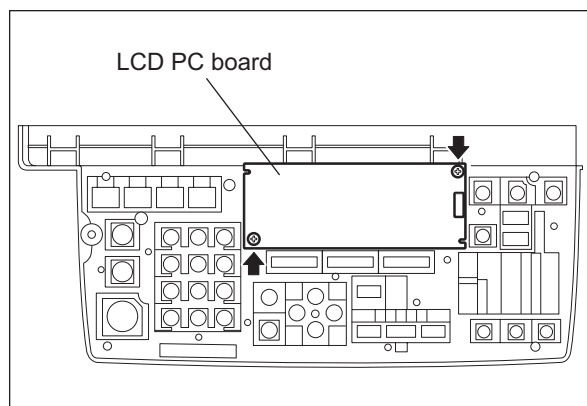

Fig. 5-12



## 6. SCANNER

### 6.1 General Description

In the scanning section, this equipment uses a CIS (Contact Image Sensor) for scanning the image. The surface of an original is irradiated with light from the LED array mounted on the CIS unit and the reflected light is scanned by the CCD where the optical image data are converted into an analog electrical signal, and then transmitted to the MAIN board. After the binarization and the various image processing operations necessary for image formation are performed on the MAIN board, the data are transmitted to the writing section.

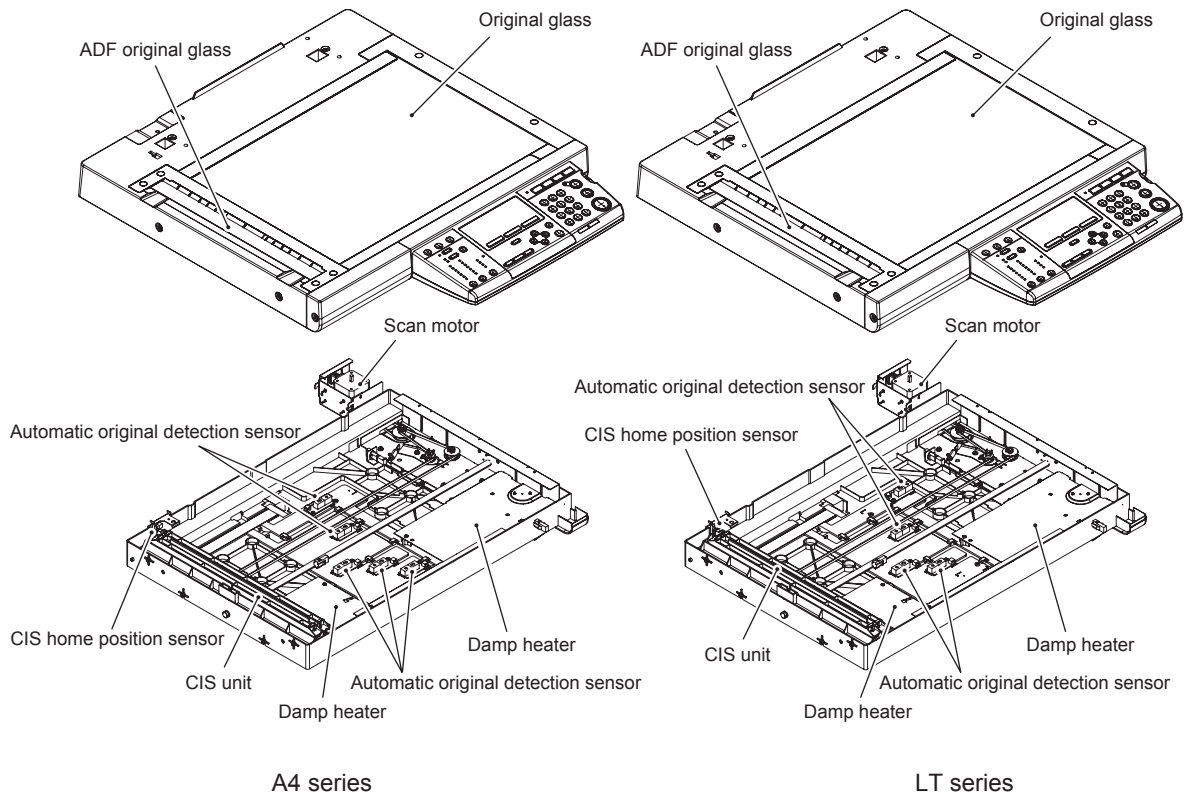

Fig. 6-1

## 6.2 Construction

Scanning section		
Original glass	Original glass	
	ADF Original glass	
CIS unit (CIS)	CCD	
	YG-LED array	
	RGB light guiding tube	
	Rod-lens array	
Drive section	Scan motor (M1)	
Automatic original detection sensor (S9-S13)		
CIS home position sensor (S1)		
Others	Damp heater (DH1, DH2)	

## 6.3 Functions

### 1) Original glass

This is a glass for placing original. Original (image) placed on the original glass is scanned by the CIS. The ADF original glass is used when original is read with the Automatic Document Feeder. Original is transported on the ADF original glass by the Automatic Document Feeder, and the transported original is read under the ADF original glass by the CIS. Do not use such solvents as alcohol when cleaning the surface of the ADF original glass, because it is coated so as not to be scratched by originals.

### 2) CIS unit (CIS)

The CIS unit (CIS) is a sensor unit which consists of an LED array, lens array and CCD sensor array of the same length as that of the original width in the primary scanning direction closely attached and unified. The original is irradiated at one time with the LED light source which consists of LEDs of RGB colors (one for each color), light guiding tube to lead each light to the original and a YG-LED array, and then the reflected light is scanned by the CCD sensor.

In the CCD method (reduction optical method), the reflected light of the exposure lamp is LED through mirrors, lens and slit to the CCD where the optical-to-electrical conversion for scanned data is performed. In contrast, in the CIS method (close-contact sensor method), those operations are processed only by the CIS unit. The CIS has characteristics of shallow depth of focus and high light-sensitivity.

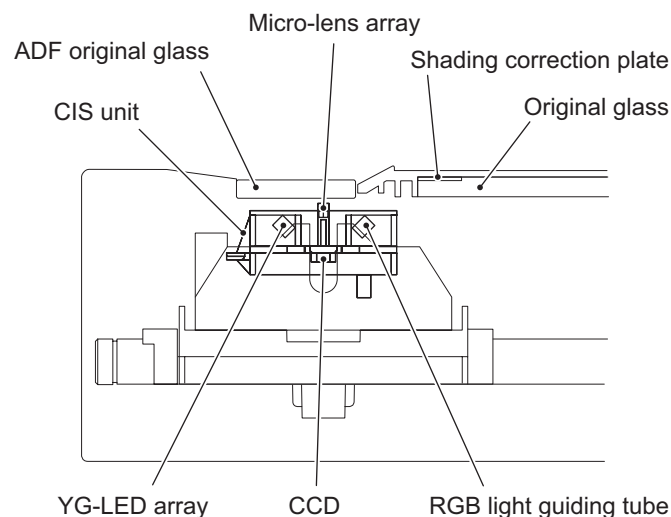

Fig. 6-2

#### - CCD

Scans the light reflected from an original and converts it to an electrical signal.

In order to realize the same-to-scale optical system of A3 width and 7084 image pixels, the equipment uses 11 CCDs (each CCD has 644 image pixels per line) to make up a CIS sensor of 600x600 dpi resolution for scanning.

#### - YG-LED array

Works as an assistant light for the RGB light guiding tube. This YG-LED array is used to reduce the shadow of the original when scanning is performed. This LED array produces the output power of 7.68W.

- RGB light guiding tube  
A light from the LED array mounted on the CIS unit (CIS) goes through the original glass and lights the original. Then, the reflected light from the original is scanned by the CCD. By adjusting each amount of R, B and YG-LED light with reference to the amount of G-LED light, it is possible to attain a light color which has nearly the same color effect as that of the YG xenon light for the light sensitivity of the CCD sensor. This LED array produces the output power of 0.125W X 3.
- 3) Scan motor (M1)  
This is a two-phase stepping motor which drives the CIS unit (CIS). The rotation of the motor is transmitted to the CIS unit through the timing belt to move the unit in the secondary scanning direction.
- 4) CIS home position sensor (S1)  
This sensor detects if the CIS unit is at its home position.
- 5) Automatic original detection sensor (S9-S13)  
The size of an original placed on the glass is instantly detected using the APS sensors fixed on the base frame.



## 6.4 Description of Operation

### 6.4.1 Scanning operation

- Scanning an original on the original glass  
The rotation of the scan motor (M1) is transmitted to the CIS unit through the timing belt to move the unit to the home position. The home position is detected when the actuator installed on the CIS case passes the CIS home position sensor (S1).

When the [START] button is pressed, the CIS unit starts scanning the original.

- Scanning an original on the ADF/RADF  
The CIS unit (CIS) stops and stays at the shading position during the shading correction, and at the scanning position during the scanning operation.

## 6.4.2 Scan motor drive circuit

The scan motor (M1) is a 2-phase stepping motor and is driven by the motor driver (IC2).

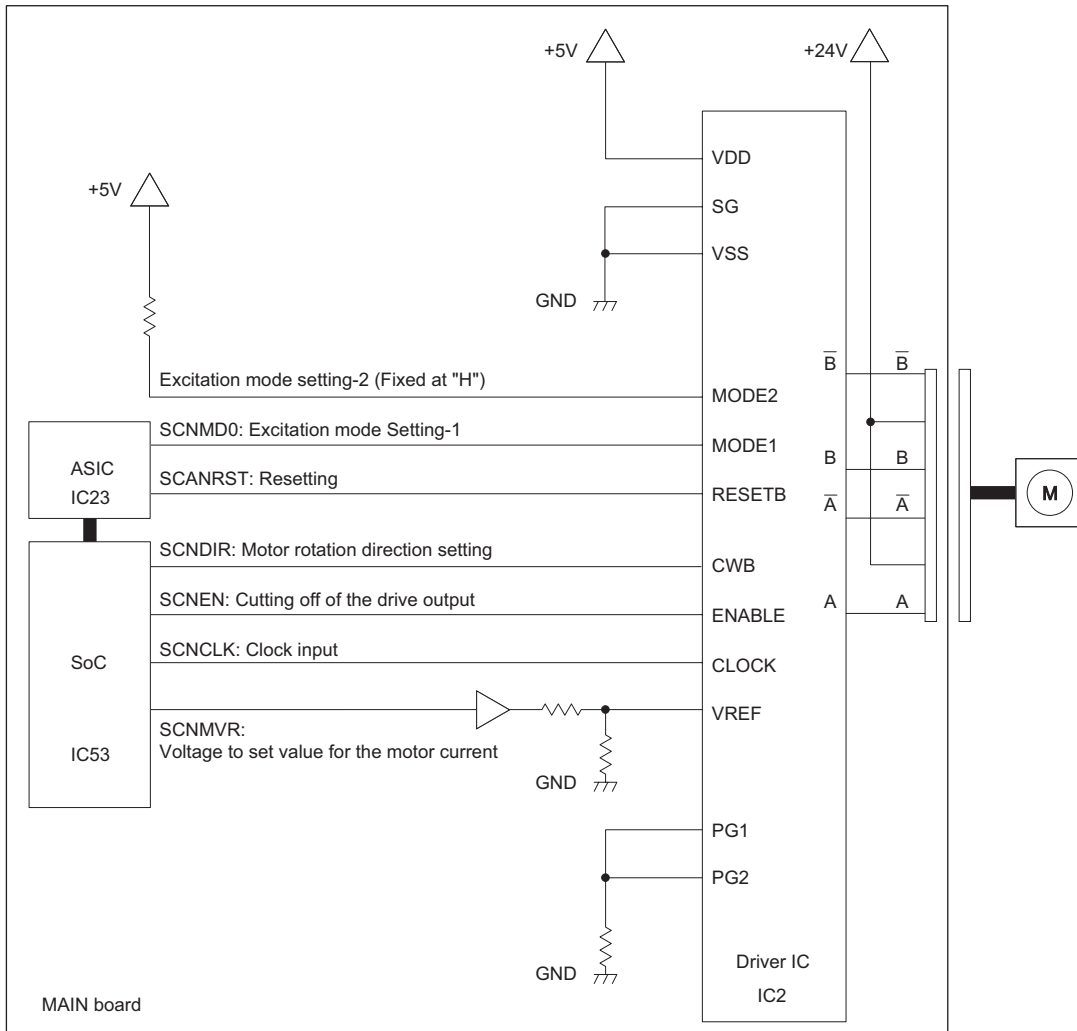

Fig. 6-3

## Description of input signal

Clock input	SCNCLK	Input	The scan motor is rotated by inputting the pulses (CLK). * Internal circuit of the motor driver works when the first pulse of the input becomes ON. * The maximum input clock is 9000 PPS.
Motor rotation direction setting	SCNDIR	Input	The direction of the motor rotation is determined by setting the level of the signal. "H": Clockwise direction "L": Counterclockwise direction * The rotation direction within 7 $\mu$ sec. before the first pulse of the CLK comes should not be changed ON and after the last pulse goes OFF.
Cutting off of the drive output	SCNEN	Input	Forcibly turn ON/OFF the excitation drive. "H": Normal operation (Excited) "L": Excitation drive is forcibly shut off (Not excited)
Excitation mode Setting-1	SCNMD0	Input	Sets the excitation mode. * The setting should not be changed within 7 $\mu$ sec. after the first pulse of the CLK comes ON.
Resetting	SCANRST	Input	Resets the whole system. "L" (10 $\mu$ sec. or more): Internal circuit of the driver is initialized. * The motor drive circuit is automatically reset when the power is turned ON.
Voltage to set value for the motor current	SCNNVR	Input	Sets the reference current value for the constant current detection. Motor wire current value can be set in the range of 0 to 2.0 (A)/phase by applying the analog voltage of 0 to 5 (V).

## 6.5 Contact Image Sensor Unit Control Circuit

### 6.5.1 Exposure LED control circuit

The cell guide mounted on the contact image sensor (CIS) unit is the main light source of the red/green/blue LEDs and is used to expose originals. Also mounted is the LED array which is the subsidiary light source of the yellow-green LEDs.

Turning each light source ON/OFF is controlled by the control signal (SCNLEDR/G/B/ASTOFF-1) output from the ASIC on the MAIN board. According to the amount of each light source, white standard generation is performed (reading the reflected light amount of the white shading correction plate). Black standard generation is also performed (reading the light amount when the light source is turned off), and according to the result, adjustment by the light amount adjustment signal (SCNLEDVR1/2/3-1) output through the D/A converter from the SoC is made. However, the light amount of the green light source is not changed because it is the standard value of the adjustment. The other light amount is changed based on the green light source; in this way the total light amount is adjusted.

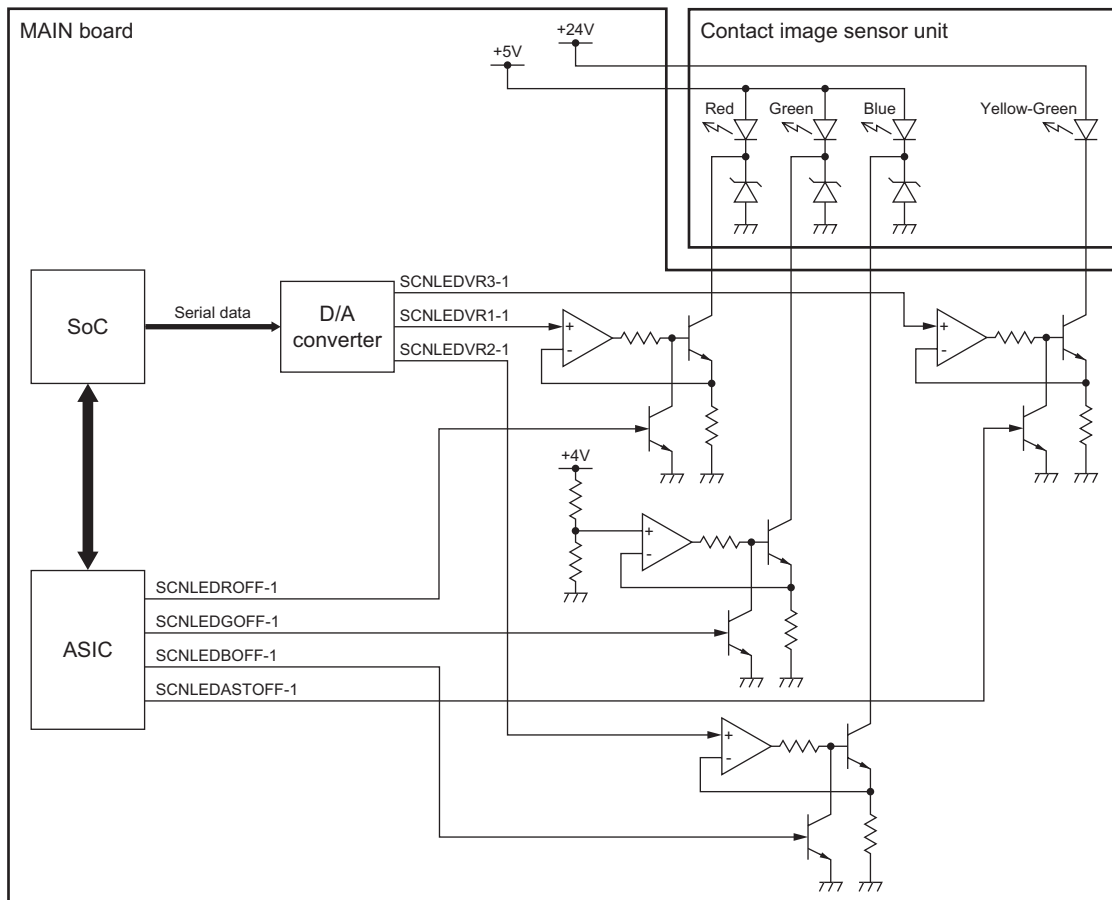

Fig. 6-4

## 6.5.2 CCD control circuit

On the contact image sensor (CIS) unit, CCD (Charge Coupled Device) with 7,084 effective pixels are mounted as the optoelectronic element for converting the light reflected on the original into electrical signals (analog signals). CCD is driven by the clock signals (TRCLCK, MCLCK, RSCLCK) output from the SoC on the MAIN board, and then it divides the photoelectric-converted analog signals into four output signals (CDIN0 to 3) and outputs to the AFE. The AFE converts the analog signals into 8-bit digital signals (SCNIMGA [0] to [7]) and outputs to the SoC.

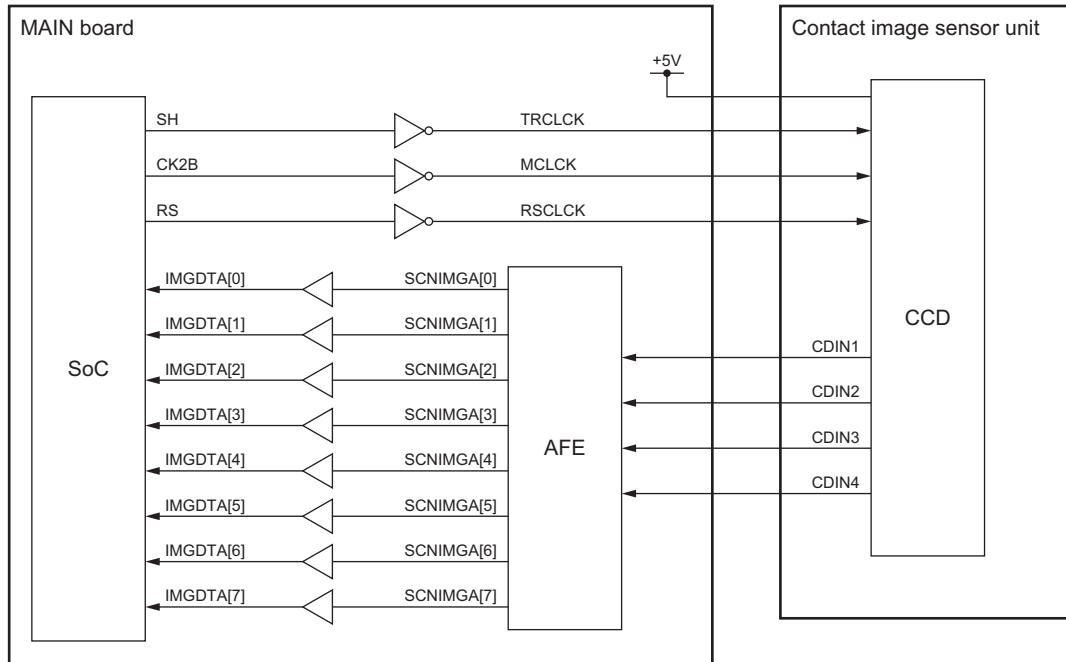

Fig. 6-5

### Optoelectronic conversion

As in the same manner as the minification optical systems in other equipments, the CCD of the contact image sensor (CIS) unit in this equipment performs photoelectronic conversion and charge transfer by the combination of its shift registers and photodiodes (light-receiving sensors) to output signals for a primary scanning direction.

Pixels of 24.0  $\mu\text{m}$  (primary scanning direction) x 40.0  $\mu\text{m}$  (secondary scanning direction), which can be scanned by 1 light-receiving sensor, are arranged at 42.3  $\mu\text{m}$  intervals in this 1:1 magnification optical system CIS. In the CCD, 1 chip consists of 644 pixels and 1 channel consists of 3 chips (only the channel 4 consists of 2 chips), and 1 line of a primary scanning direction consists of 4 channels, as shown in the figure below.

Each light-receiving sensor photoelectronically converts the received light into charge and transfers the charge to each shift register. These shift registers then transfer the charge to the direction of the arrows in the figure at the timing of transfer clocking. This transfer clock pulse is equally input into every chip, and thus all the shift registers are driven at the same timing. The charge transferred into each chip is then combined into each channel, and then output in a time division system. Furthermore the 4 channels simultaneously perform this process to output the scanning signals of these 4 systems in parallel.

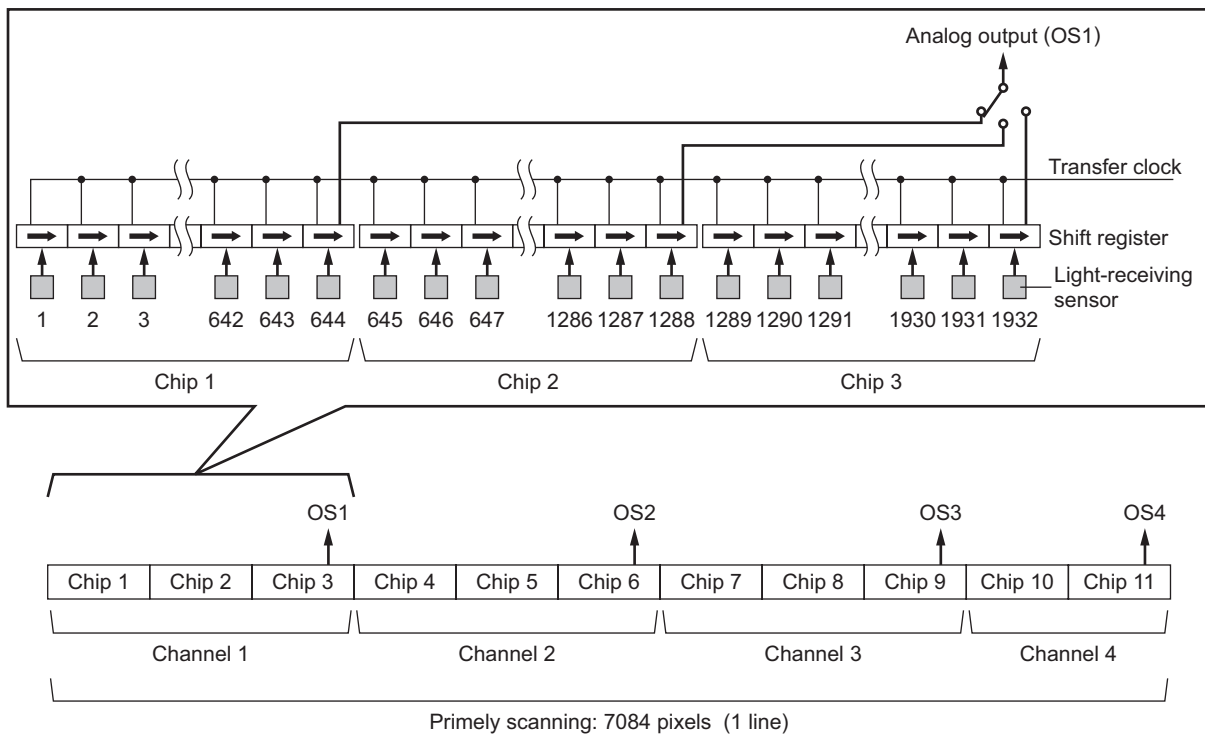

Fig. 6-6

### Shading correction

A variation is caused by the following factors in the CCD output.

- 1) The light source has a variation in its light distribution.
- 2) Each of the 7,084 elements varies in optoelectronic conversion efficiency.

These differences need to be corrected and this correction is referred to as a shading correction. The shading correction is performed by applying a normalization process using the following formula on the black data and the white data obtained in advance to correct the lighting variance and element variation of the image data.

$$I = k \times \frac{(S-K)}{(W-K)}$$

- k: Coefficient
- S: Image data before correction
- K: Black data (stored in "Black" memory)
- W: White data (stored in "White" memory)

## 6.6 Automatic Original Size Detection Circuit

This circuit detects the size of original (standard sizes only) using the reflection type photosensors arranged on the base frame of the scanner unit.

### 6.6.1 Principle of original size detection

Reflection type photosensors are placed on the base frame of the scanner unit as shown in the figure below. Each sensor consists of an infrared Light Emitting Diode (LED) on the light emitting side, and a phototransistor on the light receiving side.

When there is an original on the original glass, light beams from the LEDs are reflected by the original and led to the phototransistors. This means that the presence of the original is detected by the presence of reflection (when scanning black image).

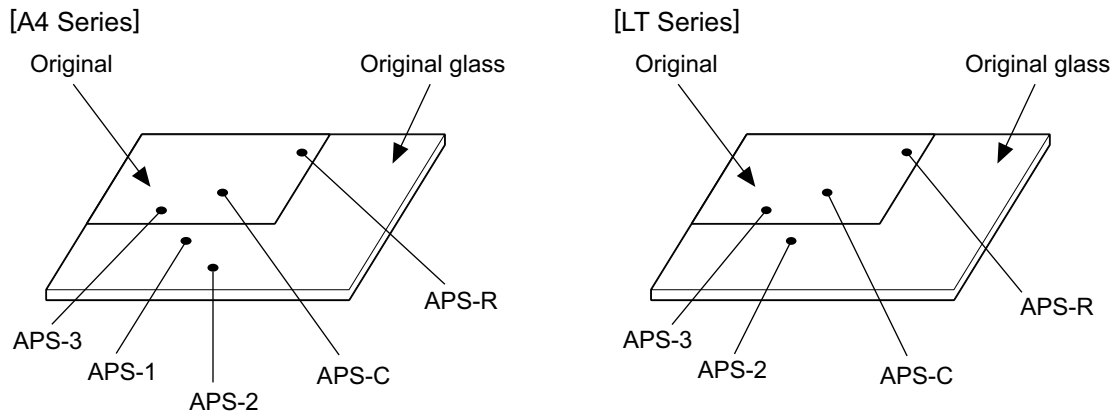

Fig. 6-7



## 6.6.2 Process of detection of original size

- 1) When the equipment is in the original size detection mode, contact image sensor unit (CIS) is set at its home position.
- 2) When the platen cover is opened, the sensors receive the light reflected from the original and if one of the matrix conditions shown in 4) for original sizes are met, the size of the original is instantly detected.
- 3) The output signal from each sensor is input to ASIC on the MAIN board to determine the size of the original.

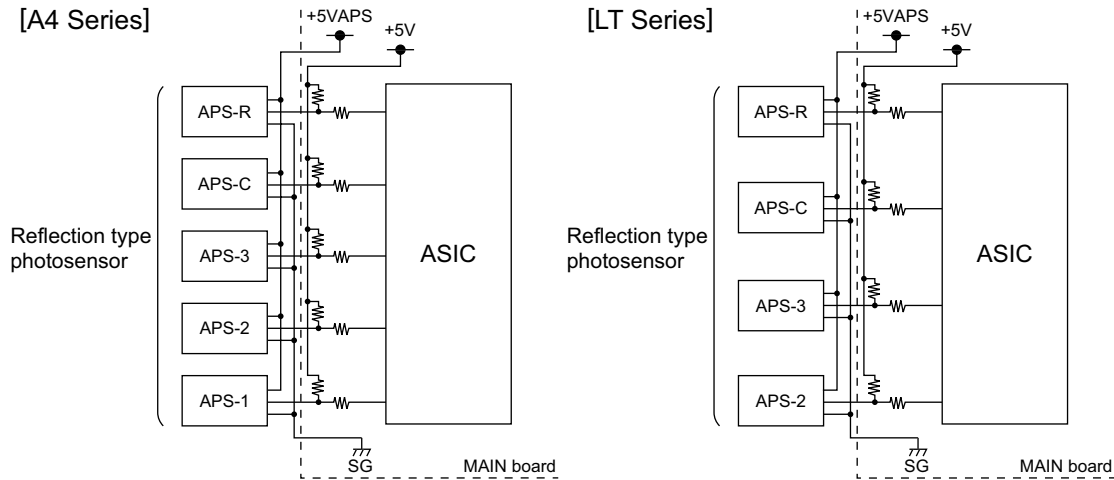
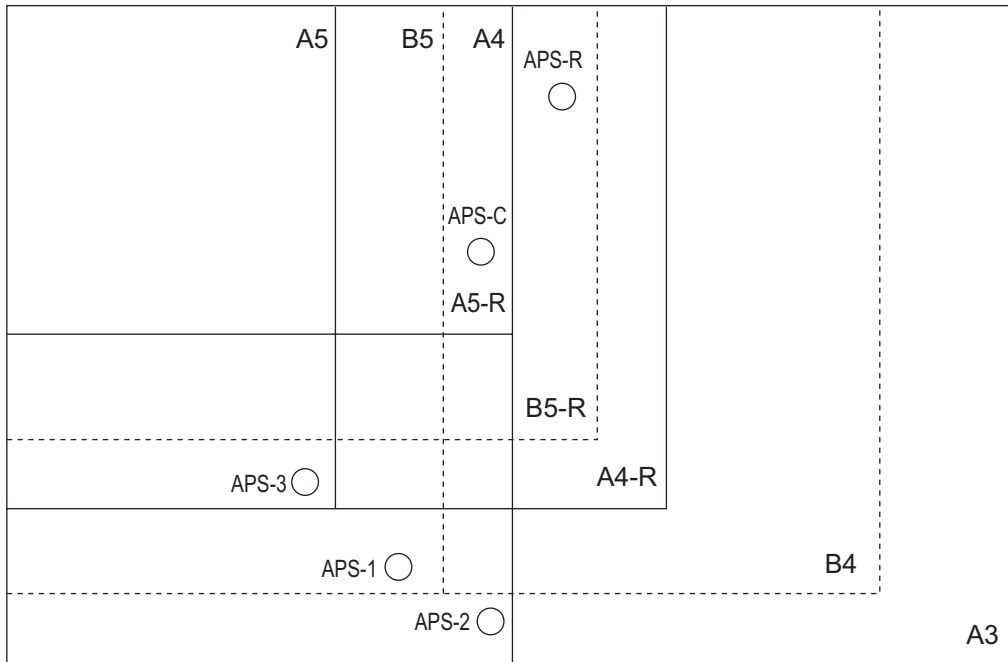

Fig. 6-8

**Sensor detection points  
[A4 Series]**



**Fig. 6-9**

**[LT Series]**

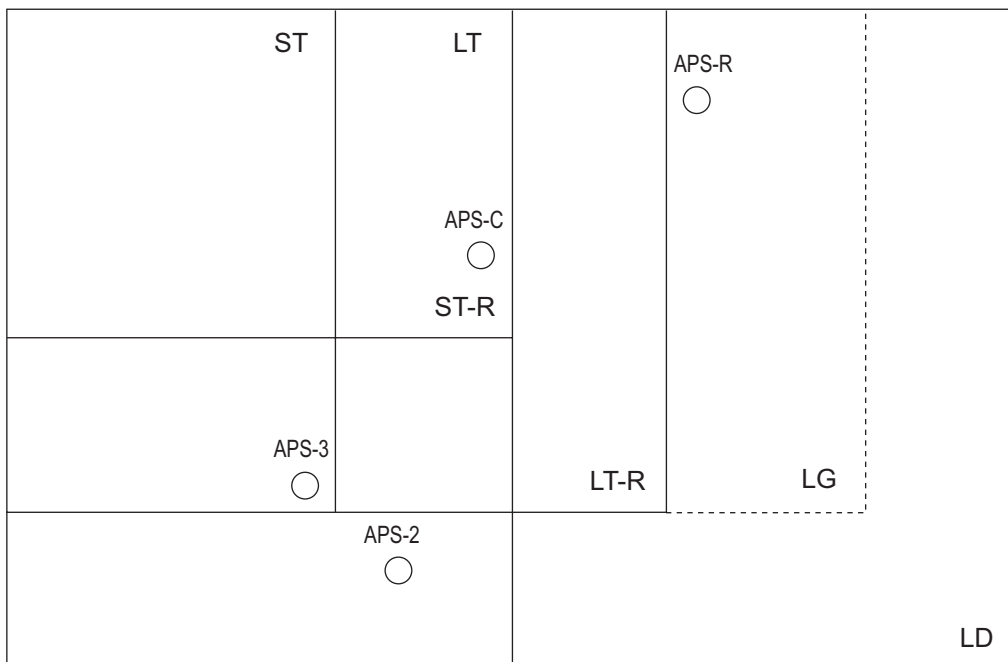

**Fig. 6-10**

- 4) Original size is determined by the combination of the signals output from each detection point.  
Combination charts for size determination of A4 series and LT series are as follows.

**[A4 Series]**

Size judgement	APS-C	APS-R	APS-1	APS-2	APS-3
A3	0	0	0	0	0
A4	0	1	0	0	0
B4	0	0	0	1	0
B5	1	1	0	1	0
A4-R	0	0	1	1	0
A5	1	1	1	1	0
B5-R	0	0	1	1	1
A5-R	0	1	1	1	1

**[LT Series]**

Size judgement	APS-C	APS-R	APS-2	APS-3
LD	0	0	0	0
LT	0	1	0	0
LG	0	0	1	0
LT-R	0	1	1	0
ST	1	1	1	0
ST-R	0	1	1	1

Code	Output signal	Original
1	H	Not available
0	L	Available

- \* When the platen sensor (S2) is OFF;
  - The followings are determined by output signals from the APS sensors.
    - Size (The combination of the signals satisfy any in the above chart)  
Size is displayed on the control panel and a specific paper or reproduction ratio is selected.
    - Size retention (The combination of the signals do not satisfy the above chart)  
The latest original size recognized (or no original state) until new paper size is recognized.
    - No original (Output from all the sensors are "H".)  
Reproduction ratio and paper are not selected.
  - Size change is always observed and detected.
  - The contact image sensor unit (CIS) stays at the standby position even if the reproduction ratio changes corresponding to the change of the original size.
- \* When the platen sensor (S2) is ON;
 

The latest original size (or no original state) recognized right before the platen sensor (S2) is turned ON is retained regardless of the status the APS sensor output signals.

### About reflection type photosensor

The reflection type photosensor is comprised of an infrared light emitting diode and a phototransistor. It uses pulse modulation to detect an original.

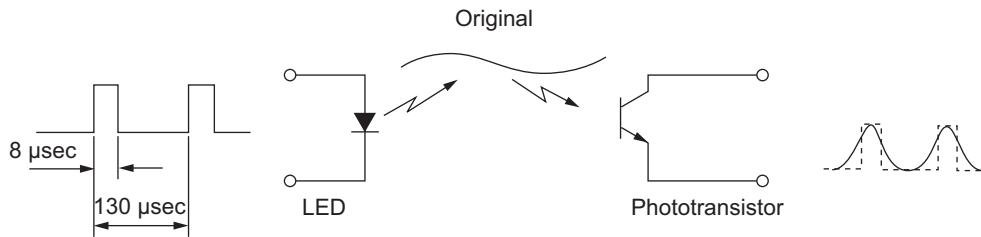

Fig. 6-11

The light emitting diode is driven by a pulse having a 130 μsec. cycle and an 8 μsec. ON time. When the phototransistor receives the same signal as this pulse, it is determined that there is an original. The pulse modulation is performed inside the reflection type phototransistor.

## 6.7 Disassembly and Replacement

### [A] Original glass

- (1) Remove 2 rubber caps and 2 screws, take off the original glass holder while sliding it to the right.

**Note:**

The rubber caps are not installed in the equipment for NAD, CND, AUD, TWD, KRD and ARD.

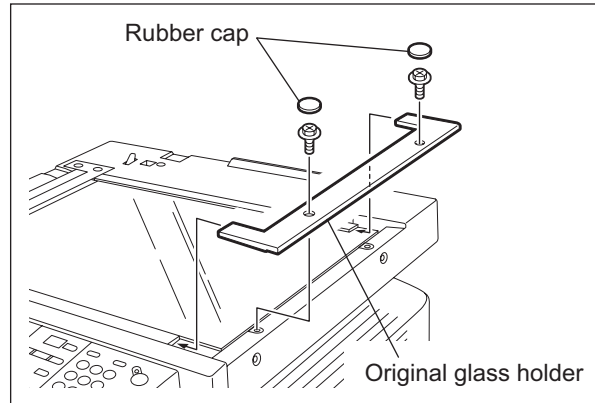

Fig. 6-12

- (2) Remove 2 rubber caps and 2 screws, take off the original glass.

**Notes:**

1. When handling the original glass, take care not to contaminate the surface with fingerprints or such.
2. Do not place the original glass directly on the floor.
3. When installing the original glass, fit 2 guides of the original glass in the groove of the scanner top cover.
4. The rubber caps are not installed in the equipment for NAD, CND, AUD, TWD, KRD and ARD.

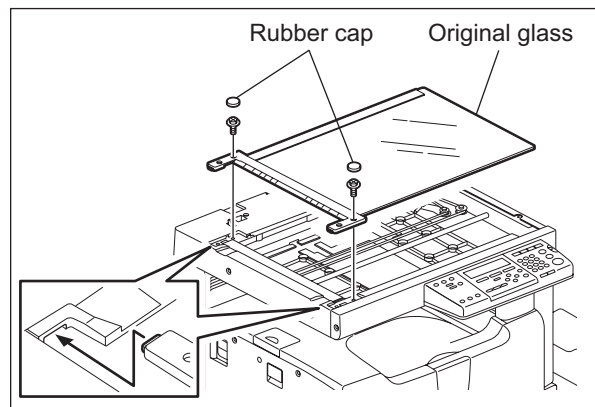

Fig. 6-13

- (3) Take off the ADF original glass.

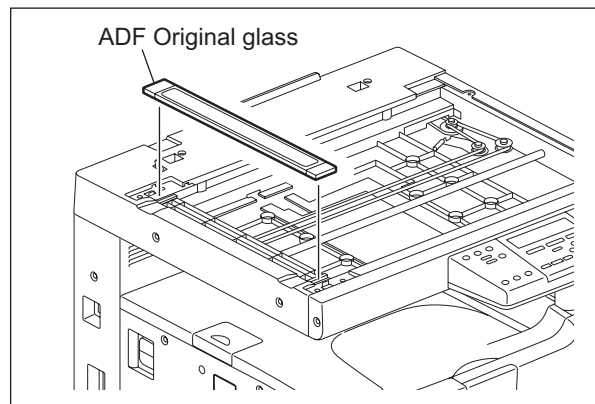
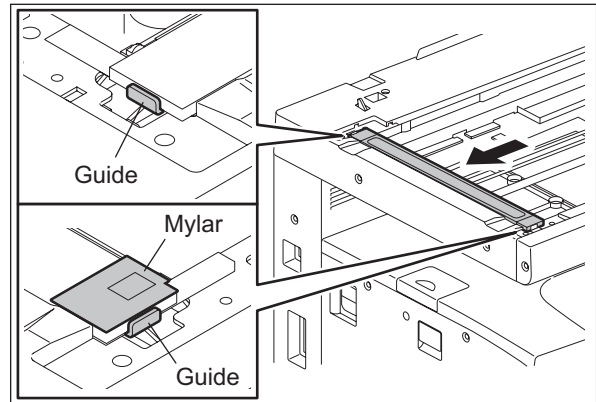

Fig. 6-14

**Notes:**

1. Install the ADF original glass so that the attached Mylar sheet is placed on the front side.
2. When installing the ADF original glass, place it between 2 small guides with its left-hand side pushed to the scanner top cover.



**Fig. 6-15**

**[B] Scanner top cover**

- (1) Take off the original glass.  
📖 P.6-17 "[A] Original glass"
- (2) Take off the front upper cover.  
📖 P.2-20 "[F] Front upper cover"
- (3) Take off the control panel unit.  
📖 P.5-7 "[A] Control panel unit"
- (4) Remove 8 screws and take off the scanner top cover.

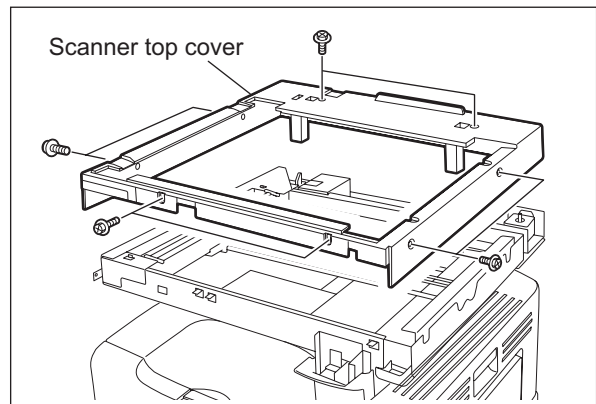

**Fig. 6-16**

### [C] Automatic original detection sensor (APS sensor)

#### [C-1] A4 series (S9-S13)

- (1) Take off the original glass.  
P.6-17 "[A] Original glass"
- (2) Disconnect 1 connector and remove 1 screw for each APS sensor. Take off 5 APS sensors.

**Note:**

When installing the automatic original detection sensor, connect the connector (yellow) to the connect one.

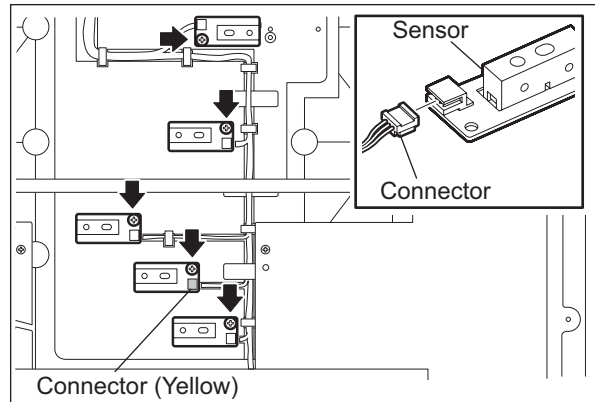

Fig. 6-17

#### [C-2] LT series (S10-S13)

- (1) Take off the original glass.  
P.6-17 "[A] Original glass"
- (2) Disconnect 1 connector and remove 1 screw for each APS sensor. Take off 4 APS sensors.

**Note:**

When installing the automatic original detection sensor, connect the connector (yellow) to the connect one.

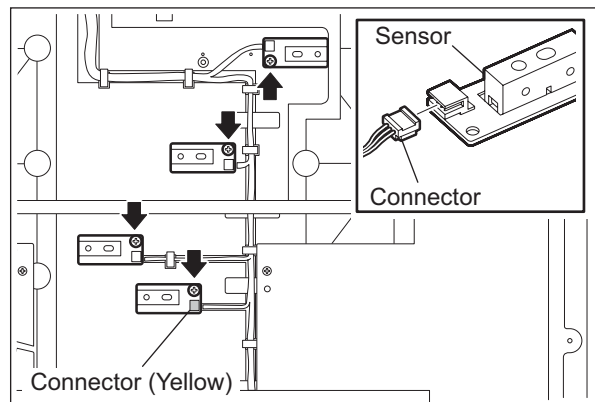

Fig. 6-18

## [D] Scan motor (M1)

- (1) Take off the scanner top cover.  
P.6-18 "[B] Scanner top cover"
- (2) Disconnect 1 connector.

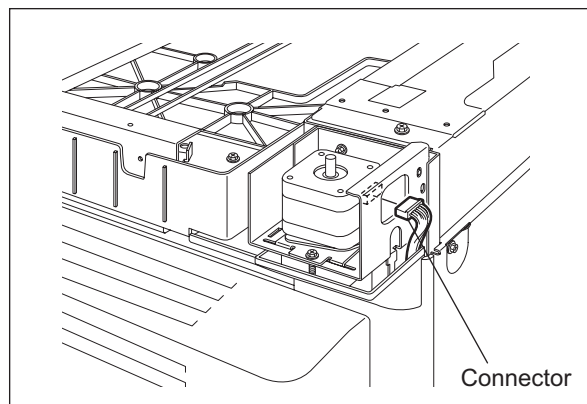

Fig. 6-19

- (3) Remove 2 screws and take off the scan motor.

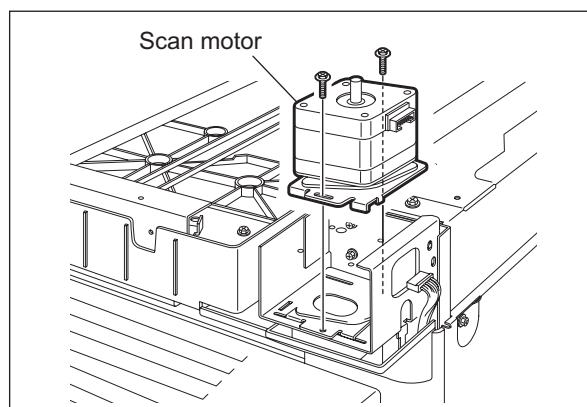
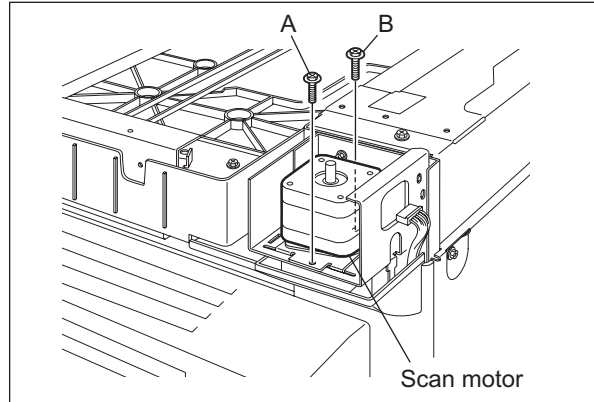

Fig. 6-20



**Notes:**

When installing the scan motor, be sure to adjust the tension of the belt using the belt tension jig. Also, be sure to take off the right rear cover when performing the adjustment. (P.2-22 "[I] Right rear cover")  
The adjustment procedure is as follows.  
1. Temporarily fix screw A and B.



**Fig. 6-21**

2. Hook the belt tension jig to the motor bracket and frame.
3. The scan motor is pulled by the belt tension jig. Fix screw A and then B at the stopped position.
4. Remove the belt tension jig.

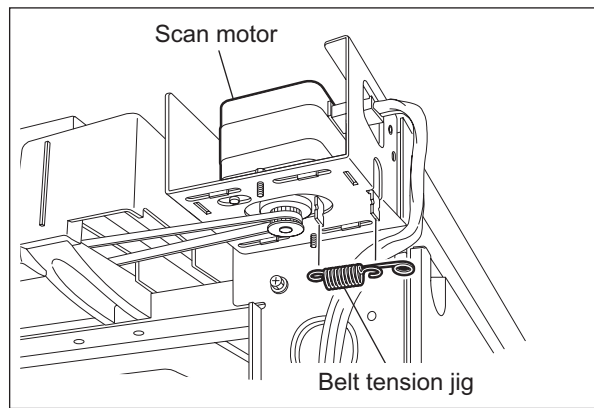

**Fig. 6-22**

**[E] CIS home position sensor (S1)**

- (1) Take off the original glass.  
P.6-17 "[A] Original glass"
- (2) Remove 1 screw and take off the CIS home position sensor with the bracket.

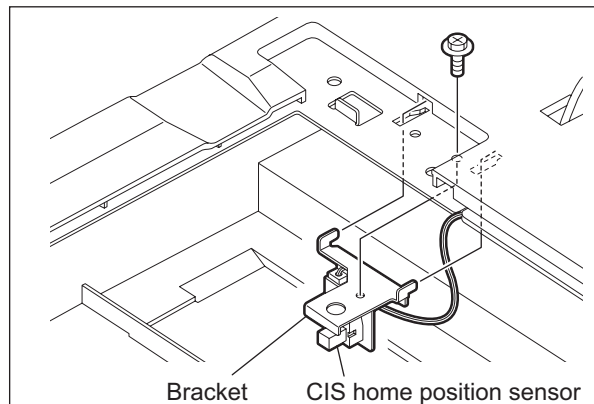

**Fig. 6-23**

- (3) Release 2 latches, take off the CIS home position sensor, release the harness from harness clamp and disconnect 1 connector.

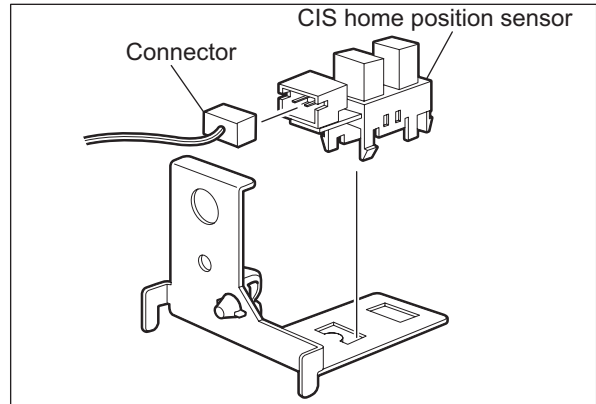

Fig. 6-24

#### [F] Platen sensor (S2)

- (1) Take off the scanner top cover.  
 P.6-18 "[B] Scanner top cover"
- (2) Remove 1 screw and take off the sensor with the bracket.
- (3) Disconnect 1 harness clamp and 1 connector.

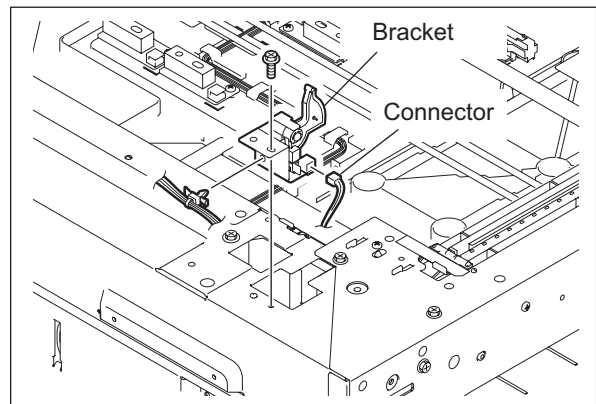

Fig. 6-25

- (4) Release 2 latches and take off the platen sensor.

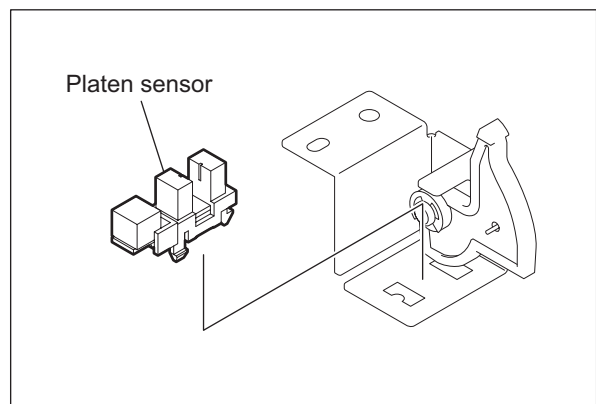

Fig. 6-26

## [G] CIS unit (CIS)

- (1) Take off the original glass.  
📖 P.6-17 "[A] Original glass"
- (2) Move the CIS unit to the right most position.

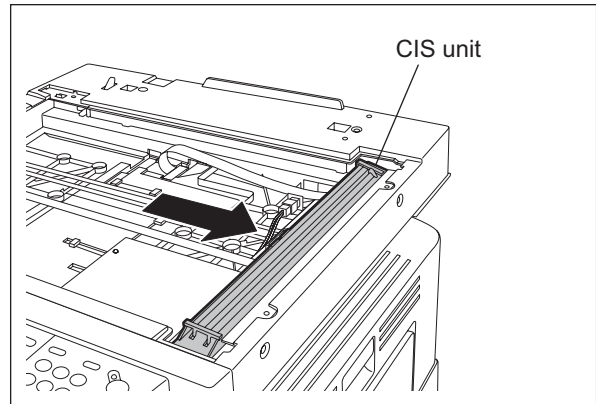

Fig. 6-27

### Notes:

- Be sure to hold the CIS unit drive belt-1 to move the CIS unit.
- When the CIS unit is moved, be sure not to touch the shaft as the silicon oil is applied on it.

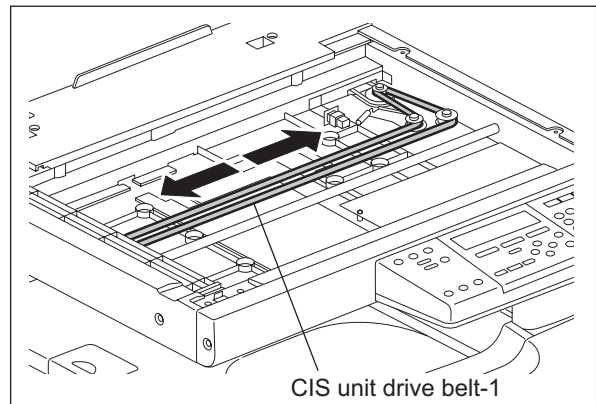

Fig. 6-28

- (3) Remove the seal which fixes the harness.

### Note:

Attach the seal by following the procedure below.

- Place the flat harness along the edge of the scanner base.
- Align the seal with the two edges of the scanner base.

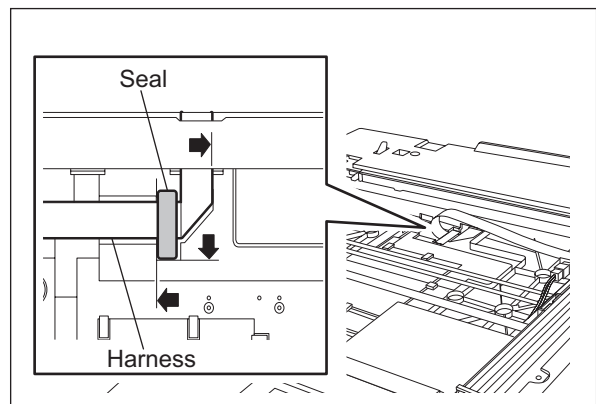
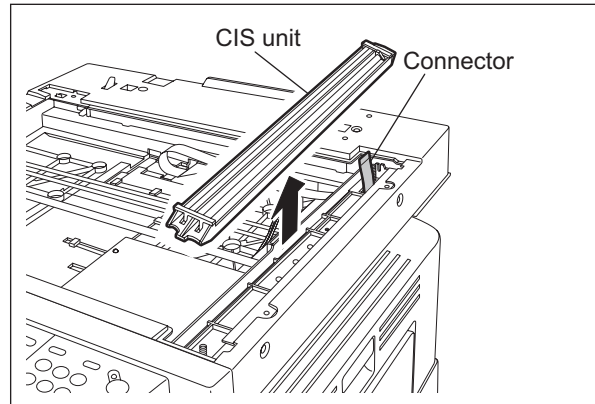

Fig. 6-29

- (4) Lift up the CIS unit, disconnect 1 connector on the bottom of the CIS unit, and then take off the CIS unit.

**Notes:**

- Take care not to contaminate the CIS unit surface with fingerprints, dust or such.
- Be sure to perform "05-310" with the platen cover or the ADF/RADF closed after replacing the CIS unit.



**Fig. 6-30**

- (5) Release 2 latches each to take off 2 original glass guides from the CIS unit.

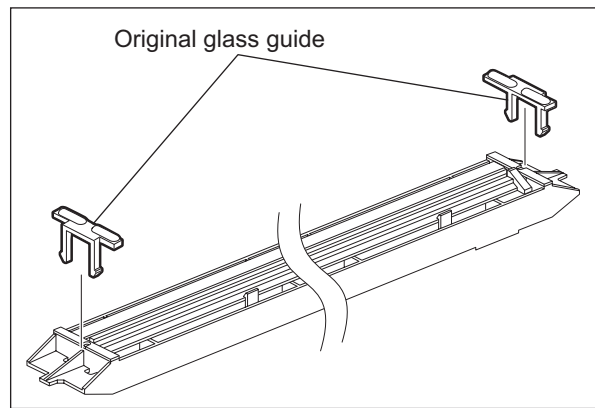

**Fig. 6-31**

**Notes:**

1. When installing the CIS unit, be sure to pass the flat harness through the harness holder of the CIS case.

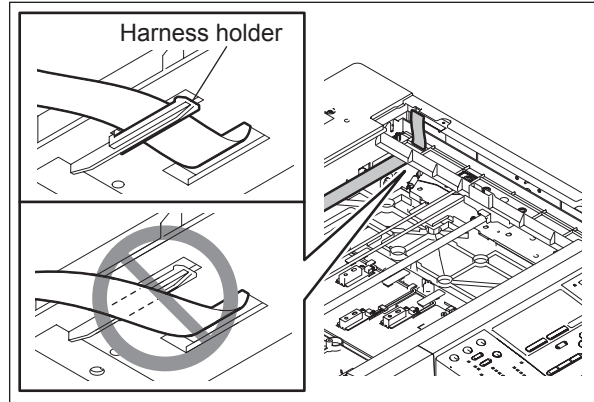

Fig. 6-32

2. Be sure to pull the flat harness so that it is not warped.

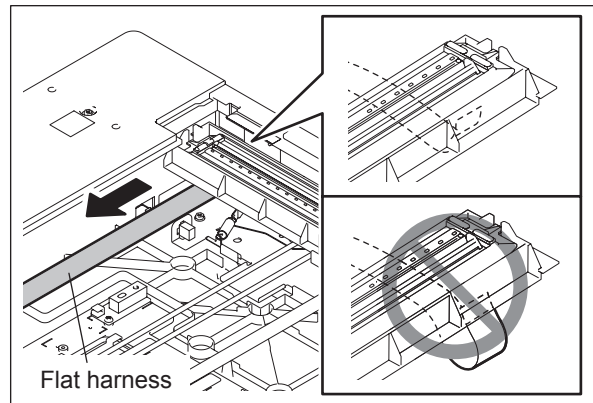

Fig. 6-33

**[H] CIS case**

- (1) Take off the CIS unit.  
P.6-23 "[G] CIS unit (CIS)"
- (2) Remove 1 screw and take off the belt stopper.

**Note:**

When installing the belt stopper, install it so that the protrusion of the stopper fits in the V-groove on the inside of the CIS unit drive belt-1.

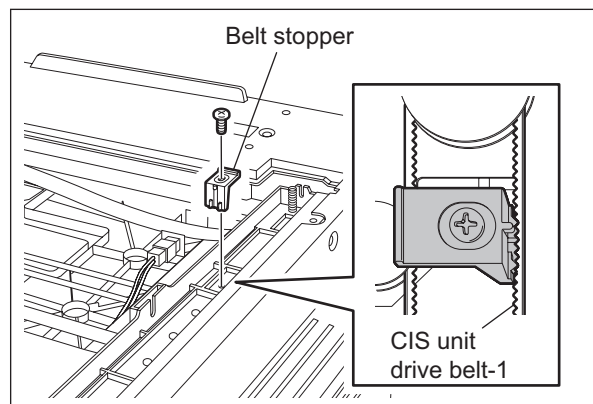

Fig. 6-34

- (3) Take off the CIS case.

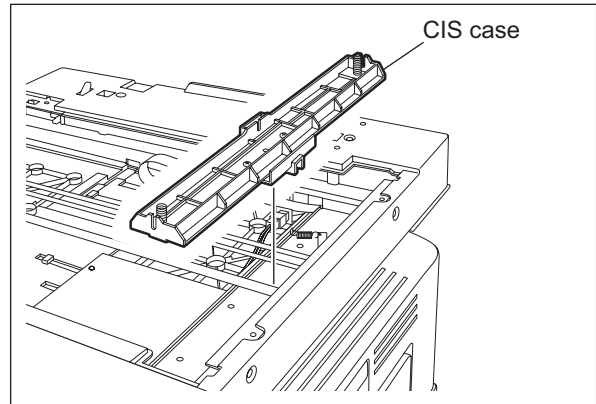

Fig. 6-35

**Notes:**

1. When installing the CIS case, be sure to fit the shaft of the equipment in the shaft guide attached on the bottom of the CIS case.
2. When installing the CIS case, install it so that the "L" shaped portion of the bottom of the CIS case comes under the CIS unit drive belt-1.

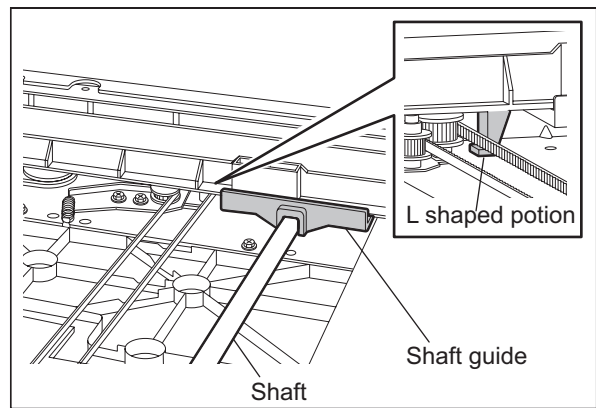

Fig. 6-36

**[I] CIS unit drive belt-1**

- (1) Take off the CIS case.  
P.6-25 "[H] CIS case"
- (2) Loosen 1 fixing screw of the tension bracket.

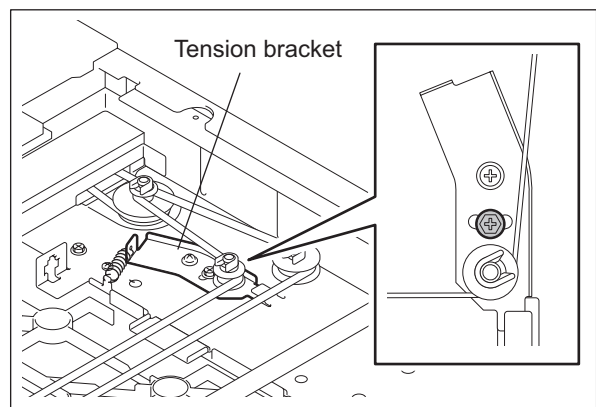

Fig. 6-37

- (3) Take off the CIS unit drive belt-1.

**Note:**

When assembling the CIS unit drive belt-1, assemble it while the fixing screw is loosened. Then tighten the fixing screw of the tension bracket.

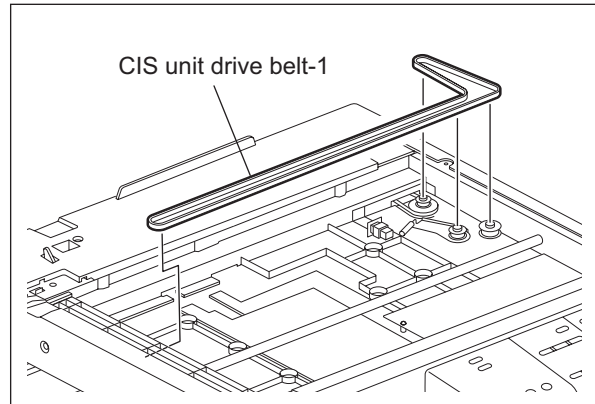

Fig. 6-38

**[J] CIS unit drive belt-2**

- (1) Take off the scanner top cover.  
P.6-18 "[B] Scanner top cover"
- (2) Take off the right rear cover.  
P.2-22 "[I] Right rear cover"
- (3) Take off the CIS unit drive belt-1.  
P.6-26 "[I] CIS unit drive belt-1"
- (4) Loosen 2 fixing screws of the scan motor.

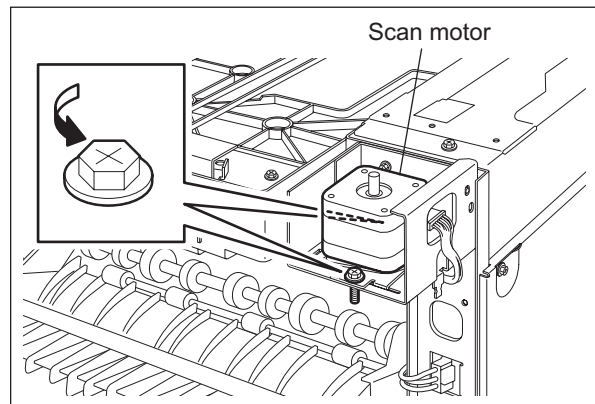

Fig. 6-39

- (5) Take off the CIS unit drive belt-2.

**Note:**

When assembling the CIS unit drive belt-2, be sure to perform the tension adjustment for the scan motor.

P.6-20 "[D] Scan motor (M1)"

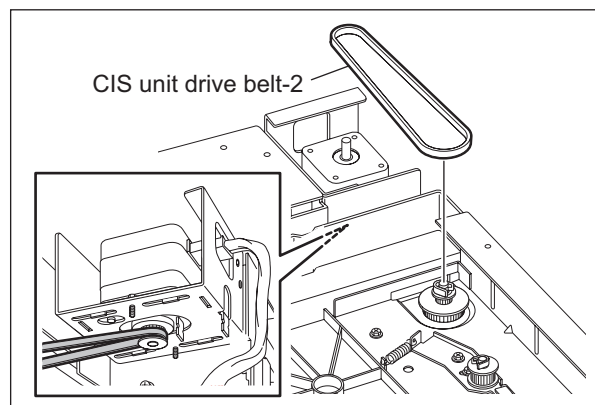

Fig. 6-40





# 7. IMAGE PROCESSING

## 7.1 General Description

The image processing section inputs the image signal from the scanning section and applies various image processing on the signal, then transmits the output result to the writing section.

Images are processed by the main board in this equipment.

The following diagram shows the process of the equipment from scanning of original to writing data on the photoconductive drum surface.

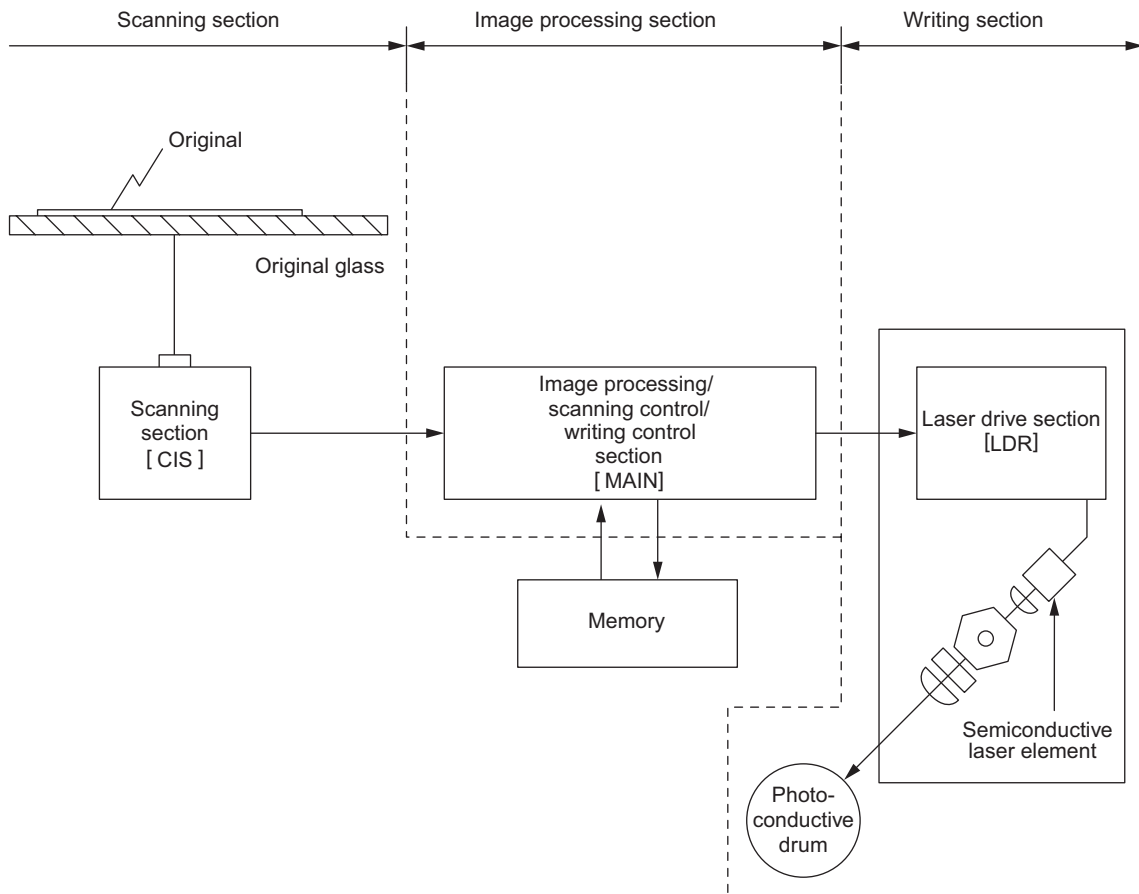

Fig. 7-1

The following is the board used for image processing.

Board	Function
MAIN board	High quality image processing, image memory editing, gamma correction, gradation processing, scanner high quality image processing, smoothing processing, image area control, laser related control and printer high quality image processing

## 7.2 Configuration

The following diagram shows the image processing section of this equipment.

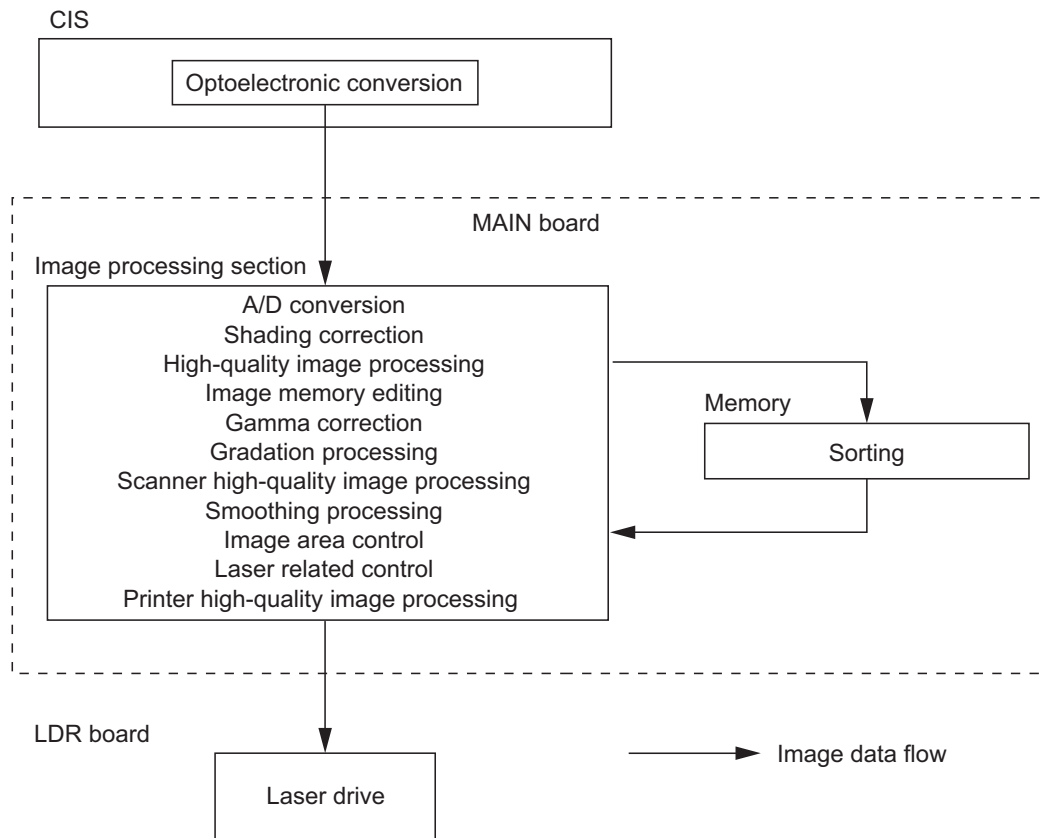

Fig. 7-2

## 7.3 MAIN Board

### 7.3.1 Features

- 1) The image processing section on the MAIN board is controlled by the CPU on the MAIN board.
- 2) The image processing section on the MAIN board realizes the following when functioning the equipment:
  - High quality image processing
  - Image memory editing
  - Gamma correction
  - Gradation processing
  - Scanner high quality image processing
  - Smoothing processing
  - Image area control
  - Laser related control
  - Printer high quality processing

## 7.3.2 Functions of image processing circuit

### 1) High quality image processing

- Background processing function (Range correction)

This function processes to remove undesirable fog from the background so that the original can be reproduced appropriately. By using this function, it is possible to cut the background density down when copying originals which have a certain level of background density, such as newspapers.

<Example>

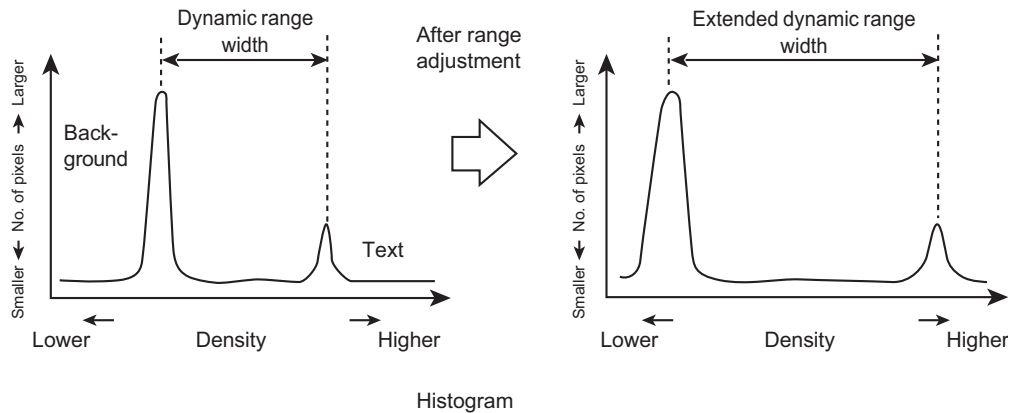

Fig. 7-3

- Filtering

This function is enabled by low-pass filter processing and high-pass filter processing.

#### Low-pass filter processing

This processing removes image/electrical noise and decreases moire by performing averaging operation between the image signals of the targeted pixel and those of the neighboring pixels to enhance the reproducibility of original.

<Example>

Density of the targeted pixel position is X. Density of pixel positions at front and back of the targeted pixel are "a" and "b" respectively. X is converted to X' through the low pass filtering.

When the matrix is (3 x 1):

$$\begin{array}{|c|c|c|} \hline a & x & b \\ \hline \end{array} \quad x' = \frac{a+b+x}{3}$$

The above averaging operation is performed for all the pixels to accomplish the high reproducibility of original.

(The following is the case that the low pass filtering is applied on the primary scanning pixel.)

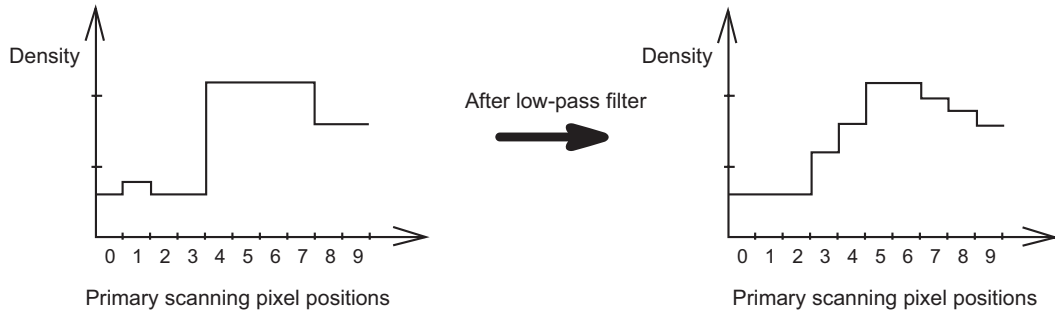

Fig. 7-4

### High-pass filter processing

Character outline blurs when the original, such as text, with big difference in density among the pixels is optically scanned and output from the CCD. Characteristic of the lens and other factors cause this phenomenon. In this equipment, processing such as edge enhancement is applied between the targeted pixel and the neighboring pixels to eliminate this phenomenon and realize high reproducibility of original.

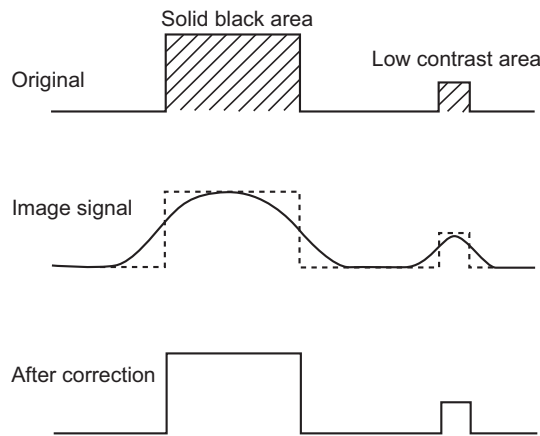

Fig. 7-5

## 2) Image memory editing

This function performs editing such as enlargement/reduction, etc., by using a line memory. Pixel data for one line in the primary scanning direction is stored in the line memory and the memory is renewed at each line.

### - Enlargement/Reduction

Enlargement/Reduction is accomplished by using the line memory control function in the process of the image processing operation.

#### <Example> Enlargement

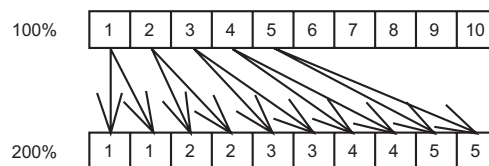

<Example> Reduction

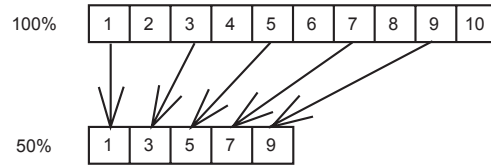

Fig. 7-6

- 3) Gamma correction  
This function corrects the input/output characteristics of the scanner/printer and adjusts the image signals so that the input/output characteristics would match with the copy mode.
- 4) Gradation processing  
This function switches the type of gradation processing depending on the copy mode: A type which selects the printer characteristics giving the priority to resolution such as for text data, and another which selects the printer characteristics giving the priority to gradation reproducibility such as for photographic images.
- 5) Scanner high quality image processing  
This function corrects the image signals scanned by the scanner and reproduces them in a higher image quality.
- 6) Smoothing processing  
This function reduces jaggy area, and output images after processing the smoothing the character outline.
- 7) Image area control  
This function sets the effective image area in horizontal and vertical directions to be output.
- 8) Laser related control  
This function performs the APC (Auto Power Control).
- 9) Printer high quality processing  
This function reproduces the image signals output from the printer controller sharper.

## 8. LASER OPTICAL UNIT

### 8.1 General Description

The laser optical unit radiates the laser beam onto the photoconductive drum responding to the digital image signals transmitted from the MAIN board. to create the latent image. Image signal is converted into the light emission signal of the laser diode on the laser driving PC board (LDR), then radiated on the drum through the optical elements such as cylinder lenses, polygonal mirror and  $f\theta$  lens. The unit must not be disassembled in the field as they are very sensitive to dust and finely adjusted at the factory.

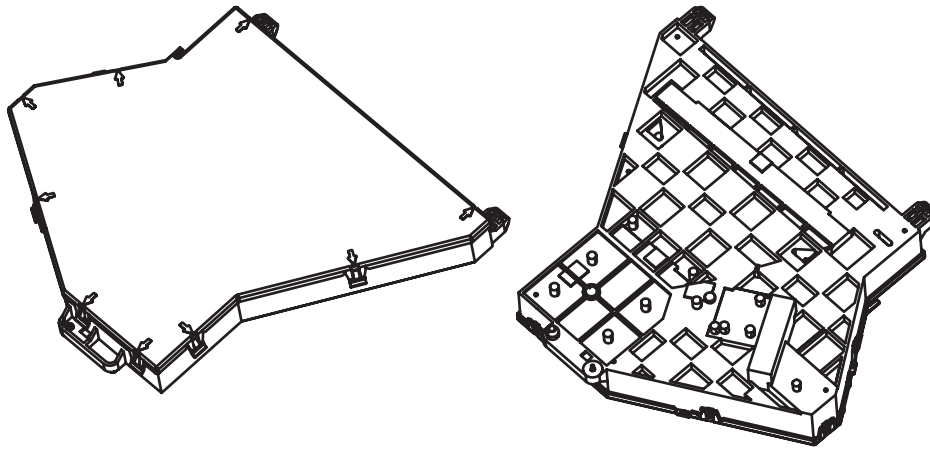

Fig. 8-1

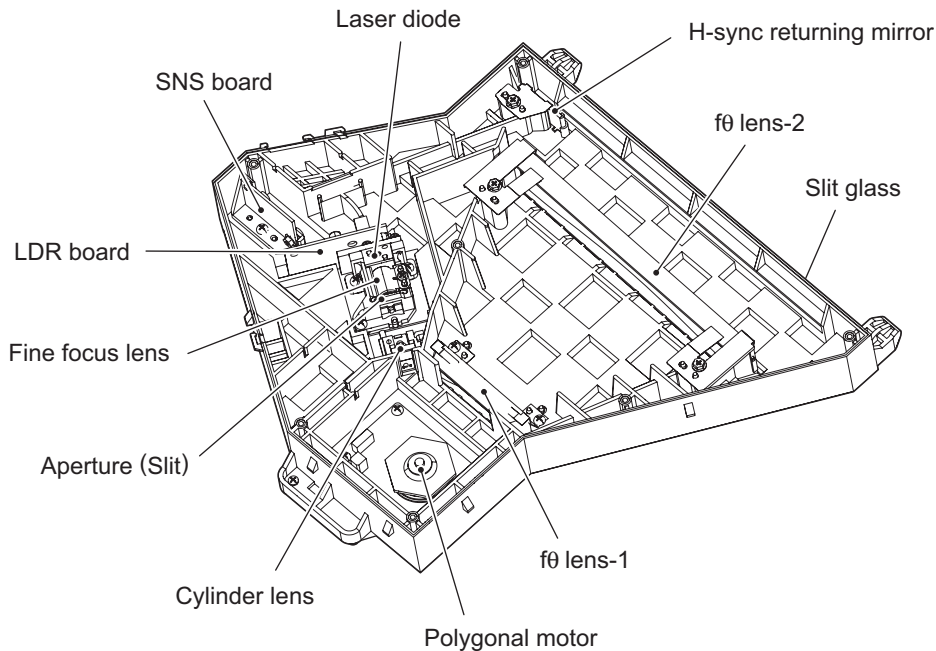

Fig. 8-2

## 8.2 Structure

Laser optical unit (1 beam)		
Laser emission unit	Laser diode	Wavelength: Approx.785 nm Output power rating: 5 mW
	Fine focus lens	
	Aperture (Slit)	
	Cylinder lens	
	Laser driving PC board (LDR)	
Polygonal motor unit	Polygonal motor (M4)	
	Polygonal mirror	6 planes
fθ lens-1		
fθ lens-2		
H-Sync returning mirror		
Slit glass		
H-sync signal detection PC board (SNS)		

### 1) Laser emission Unit

This unit consists of the laser diode, finite focus lens, aperture and cylinder lens.

#### - Laser diode

This laser diode features low droop, small laser variation and low threshold current.

Aperture determines the shape of the laser beam at laser emission position of the primary scanning and secondary scanning.

Laser diode radiates the laser beams responding to the laser emission control (ON/OFF) signals from the laser driving PC board (LDR). Laser beams which passed through the finite focus lens are focused on the drum surface.

#### - Laser precautions

A laser diode is used for this equipment and radiates an invisible laser beam.

Since it is not visible, be extremely careful when handling the laser optical unit components, performing operations or adjusting the laser beam. Also never perform the procedure with other than the specified manuals because you could be exposed to the laser radiation.

The laser optical unit is completely sealed with a protective cover. As long as only the operations of specified manuals are performed, the laser beam is not leaked and you are in no danger of being exposed to laser radiation.

The following cautionary label for the laser is attached to the front right cover (inside of the front cover).

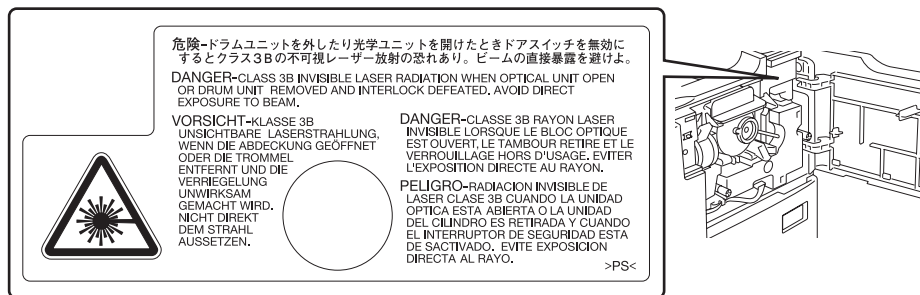

Fig. 8-3



**Cautions:**

- Avoid expose to laser beam during service. This equipment uses a laser diode. Be sure not to expose your eyes to the laser beam. Do not insert reflecting parts or tools such as a screwdriver on the laser beam path. Remove all reflecting metals such as watches, rings, etc. before starting service.
- When servicing the equipment with the power turned ON, be sure not to touch live sections and rotating/operating sections. Avoid exposing your eyes to laser beam.
- During servicing, be sure to check the rating plate and cautionary labels such as "Unplug the power cable during service", "CAUTION. HOT", "CAUTION. HIGH VOLTAGE", "CAUTION. LASER BEAM", etc. to see if there is any dirt on their surface and if they are properly stuck to the equipment.

2) Polygonal motor unit

This unit consists of the polygonal motor (M4) and polygonal mirror.

a. Polygonal motor (M4)

This motor rotates the polygonal mirror in high speed.

The DC motor controls the rotation speed of the mirror motor as follows:

During ready: 0 rpm (No rotation)

During printing

: 21,521.147 rpm (600dpi)

b. Polygonal mirror

One laser beam emitted from the laser diode is reflected by this mirror. As the polygonal mirror is rotated by the polygonal motor (M4), the reflected laser light moves in sync with the rotation. The direction of the movement is the primary scanning direction of the image. One scan is performed on one plane of the polygonal mirror.

As the polygonal mirror has six planes, six scans are performed in one rotation of the polygonal mirror.

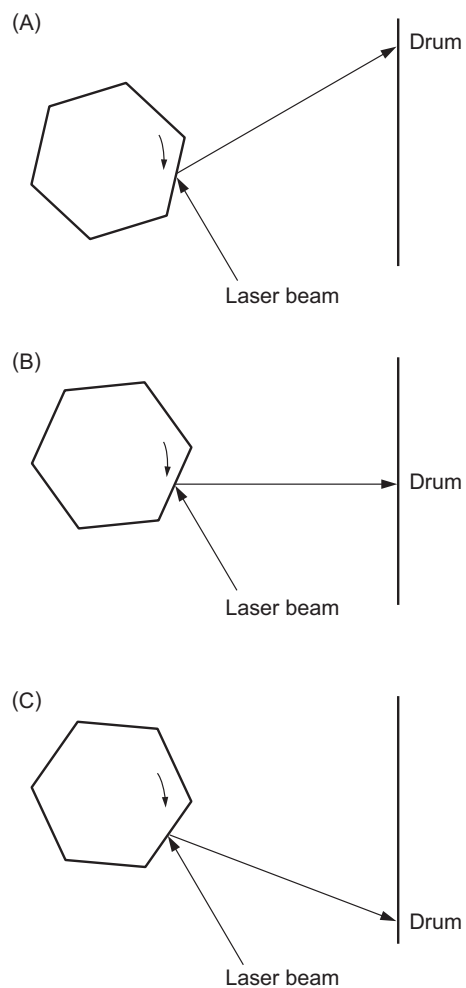

**Fig. 8-4**

One scan is completed by completion of steps (A) to (C). One scan is performed on one plane of the polygonal mirror. Six scans can be made with one rotation of the polygonal mirror.

3)  $f\theta$  lenses 1 and 2

These two lenses perform the following adjustment on the laser beams reflected by the polygonal mirror.

a. Uniform-velocity scanning

Since the polygonal mirror is rotating at a uniform velocity, the laser beam reflected from the mirror scans over the drum surface at a uniform angular velocity; namely, the pitch between the dots on the drum is wider at both ends than at the center of the scanning range. The  $f\theta$  lenses help to correct this difference, making all the dot-to-dot pitches equal on the drum surface.

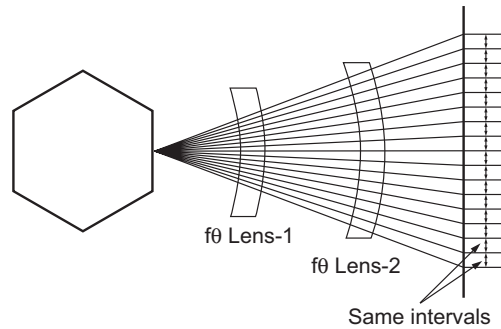
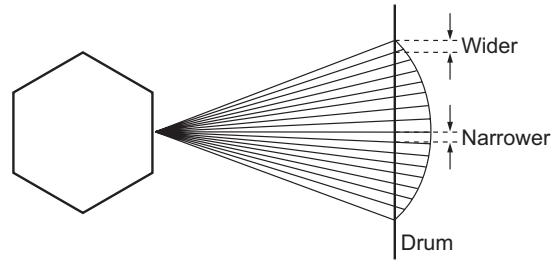

Fig. 8-5

b. Face tilt correction

The reflecting face of the polygonal mirror is tilted slightly to one side against the perfect vertical. Horizontal deviation of the laser light which is caused by the tilt is corrected.

c. Sectional shape of laser beam

The shape of the laser beam spotted on the drum is adjusted.

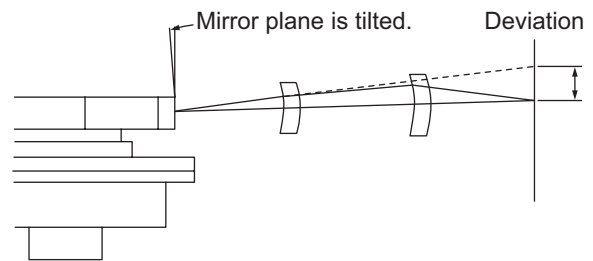

Fig. 8-6

4) H-Sync signal detection PC board (SNS)

The laser light which is started to be scanned from one of the reflected plane of the polygonal mirror is reflected by the H-Sync returning mirror and enters the PIN diode on the H-Sync signal detection PC board (SNS). The primary scanning synchronizing signal is generated based on this reflection.

5) Slit glass

Slit glass is located where the laser beams are output from the laser optical unit, and it protects the unit from dust.

### 8.3 Laser Diode Control Circuit

This equipment uses an AlGaAs type semiconductive laser with 5 mW of optical output power rating. This laser emits a beam in a single transverse mode in approx. 785 nm wavelength. PIN diode for monitoring optical output in this laser controls the laser intensity.

The relation between the forward current and optical output of a semiconductive laser is as shown below. Beam emission starts when the forward current exceeds a threshold current, and then the laser outputs a monitor current which is proportionate to the optical output. Since semiconductive lasers have an individual variability in their threshold current and monitor current, the optical output needs an adjustment to be maintained at a certain value.

The optical output of a semiconductive laser decreases as the laser temperature rises. Therefore APC (Auto Power Control) needs to be performed to maintain a constant optical output.

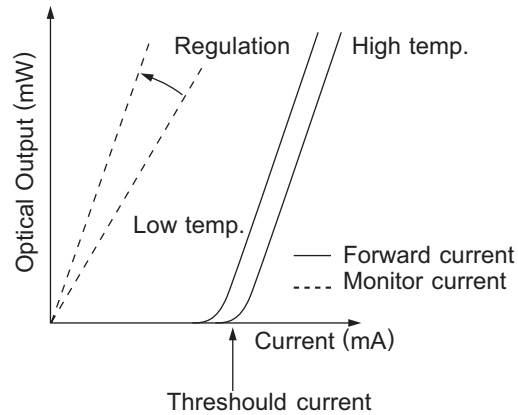

Fig. 8-7

A block diagram of the semiconductive laser control circuit is shown below. The semiconductive laser performs a monitor efficiency regulation (a process to control a monitor current for beam emission amount). The initial beam emission is adjusted to be approx. 1.6 mW (240  $\mu$ W on the drum surface). The voltage of the monitor output, which has been regulated by this adjustment, is then fed back to a laser power comparison circuit.

In the laser power comparison circuit, this voltage fed back and a laser power voltage set for the control circuit are compared for every scanning. As the result of this, a laser driver circuit increases its forward current when the laser power is insufficient and decreases it when the laser power is excessive to maintain a constant optical output.

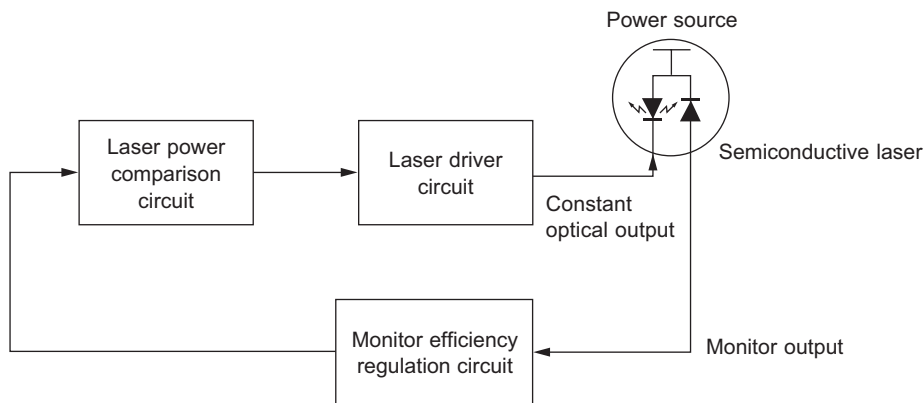

Fig. 8-8

## 8.4 Polygonal Motor Control Circuit

The polygonal motor is a DC motor rotated by a clock signal (PMTRCLK) output from the SoC. This motor is controlled under PLL (Phase Locked Loop) to realize an accurate and constant rotation. Its rotation status is converted to a status signal (PMTRSTS-0) and then output to the ASIC. PMTRSTS-0 signal moves to a low level only when the rotation status of the motor is constant. The SoC detects the rotation status with this signal, and emits a laser beam only when the rotation status is constant.

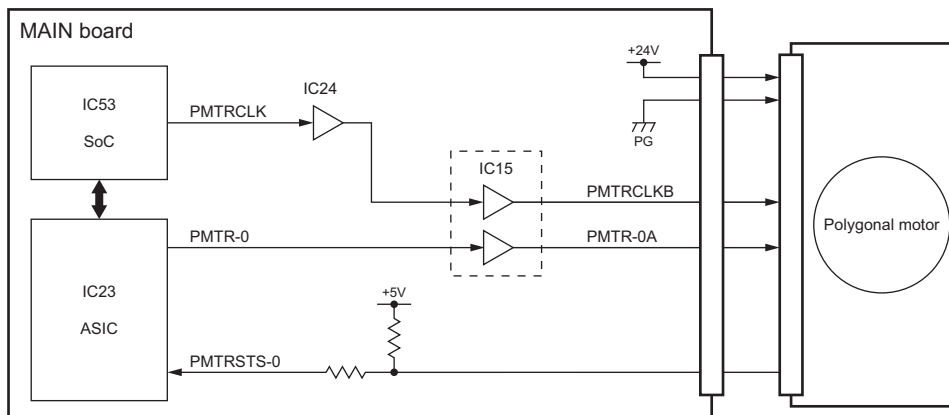

Fig. 8-9

Signal	Function	Low level	High level
PMTR-0	Polygonal motor ON signal	ON	OFF
PMTRCLK	Polygonal motor reference clock	-	-
PMTRSTS-0	Polygonal motor PLL control signal	Rotating at a constant speed	Stopping or error

## 8.5 Disassembly and Replacement

### [A] Laser optical unit

- (1) Take off the rear cover.  
P.2-22 "[J] Rear cover"
- (2) Disconnect 3 connectors from the MAIN board.

**Note:**

Connect the flat harness to the MAIN board with its electrode side down. An error "CA2" will be displayed if the connection is incorrect.

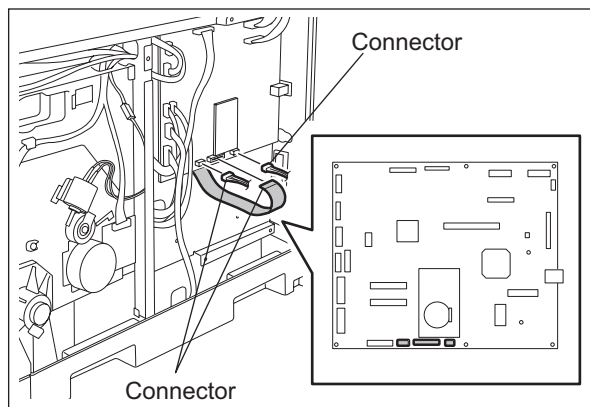

Fig. 8-10

- (3) Take off the switching regulator unit.  
P.2-26 "[E] Switching regulator unit (PS)"
- (4) Remove 1 screw.
- (5) Pull out the laser optical unit while lifting it up and take it off.

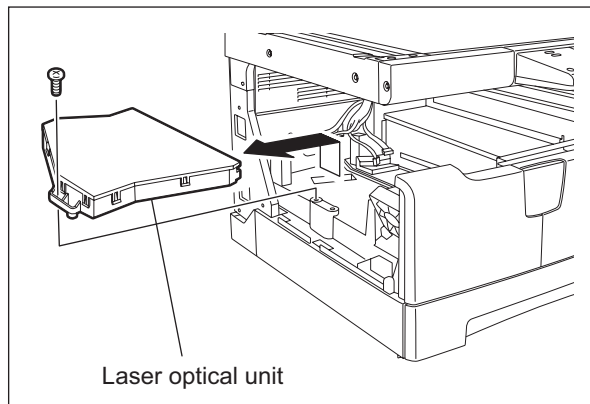

Fig. 8-11



## 9. DRIVE UNIT

### 9.1 General Description

The main motor drives the drum, developer unit, cleaner unit, fuser unit and transport rollers which transport paper (bypass feed roller, bypass pickup roller, registration roller and pickup roller).

The main motor (M3) is a brushless motor and is installed in the drive unit. The drive unit consists of gears and timing belts, and transmits the driving force of the main motor (M3) to each unit. The toner motor (M2) which drives the toner cartridge is also installed in the drive unit.

The exit roller is driven by the main motor (M3). However, when the automatic duplexing unit (ADU: optional) is installed, it is driven by the exit motor (M7).

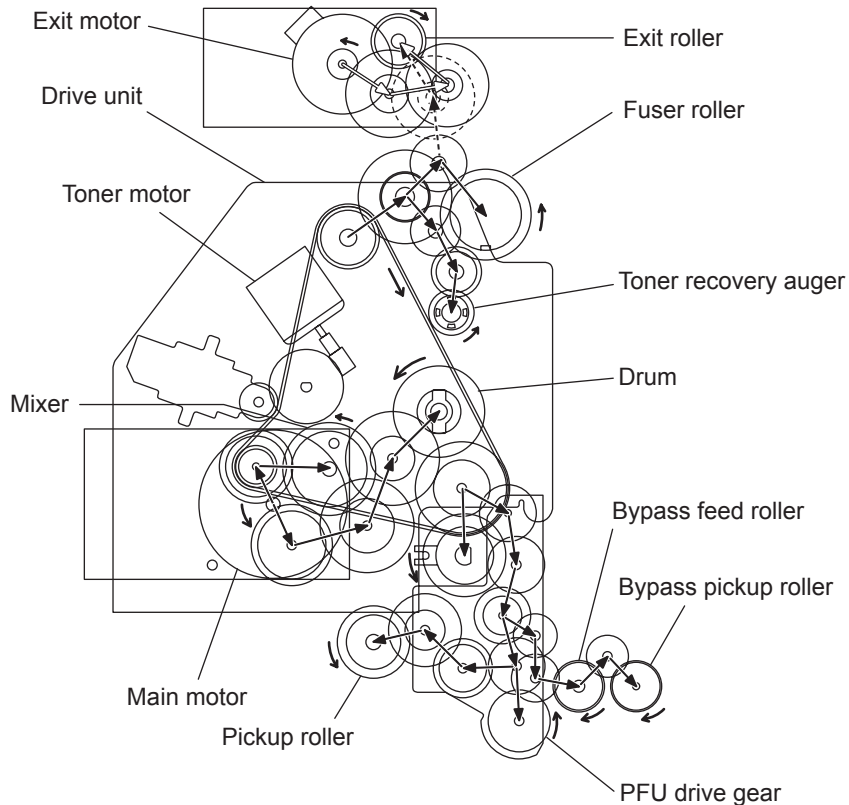

Fig. 9-1

## 9.2 Configuration

	Unit to be driven	Drive transmission
Main motor (M3)	Drum	Gears
	Developer unit (Mixer)	Gears
	Cleaner unit (Toner recovery auger)	Timing belt, gears
	Fuser unit (Fuser roller)	Timing belt, gears
	Rollers (Pickup roller, Bypass feed roller, Bypass pickup roller and PFU)	Timing belt, gears
Toner motor (M2)	Toner cartridge	Gears



## 9.3 Functions

### 1) Main motor (M3)

The main motor is a brushless motor which is controlled by control signals output from the MAIN board. The driving force of the main motor is transmitted to the drum, developer unit, cleaner unit, fuser unit and the rollers which transport the paper, via gears and timing belts.

### 2) Toner motor (M2)

The main motor is a DC motor which is controlled by control signals output from the MAIN board. The driving force of the toner motor is transmitted to the toner cartridge via gears.

## 9.4 Main Motor Control Circuit

The main motor, which is a DC motor driven by control signals from the MAIN board, drives the drum, developer unit, feed roller, transport roller and registration roller. A driving PC board is embedded in this motor to perform the following controls.

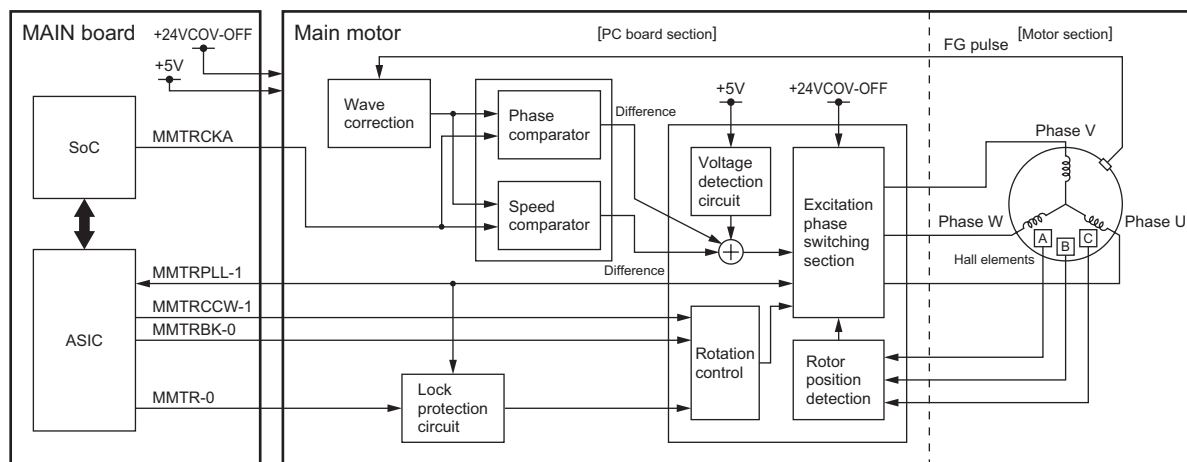

Fig. 9-2

- 1) The ASIC outputs the control signals for the main motor rotation.  
(MMTR-0 signal: Motor rotation command, MMTRCCW-1 signal: Rotation direction)
- 2) The main motor is rotated by the excitation phase-switching section exciting each phase of the main motor.
- 3) Hall elements A, B and C detect the rotation position of the motor (rotor).
- 4) The excitation phase-switching section switches the excitation of each phase.  
(The motor keeps rotating by repeating from 2 to 4.)
- 5) An FG (Frequency Generator) pulse is generated by the rotation of the motor.
- 6) The FG pulse and the reference clock (MMTRCKA) from the SoC are compared in terms of the phase and speed, and the difference is added to the excitation phase-switching section. Fluctuations in the power supply voltage are also added to the value.
- 7) According to the result of step 6, the switching timing of the excitation phase-switching section is changed and the FG pulse and the reference clock are controlled to make them equal. This will make the main motor rotate at a constant speed. (Lock range)
- 8) When the motor is in the lock range, the excitation phase-switching section outputs the MMTRPLL-1 signal in the "L" level to the ASIC.
- 9) When MMTRBK-0 signal from the ASIC becomes "L" level, the motor is braked. When the MMTR-0 signal becomes "H" level, the motor is stopped.

### **Control signal of main motor**

- **MMTR-0 signal:**  
This signal switches the ON/OFF of the main motor. When this signal becomes "L" level, the motor starts rotating, and when it becomes "H" level, the motor stops.
- **MMTRCCW-1 signal:**  
This signal switches the rotation direction of the main motor. When this signal becomes "L" level, the motor rotates clockwise seen from the rear side, and the drum and developer unit, etc. start driving.
- **MMTRCKA signal:**  
This signal is a reference clock which keeps the main motor rotation at a constant speed.
- **MMTRPLL-1 signal:**  
This is a signal to show that the main motor rotation is in the lock range. When the cyclic change of the FG pulse period against the reference clock is within (6.25%, this is defined as a lock range (the normal rotation of the motor) in the main motor. When it is within this range, this signal becomes "L" level.
- **MMTRBK-0 signal:**  
This signal applies a brake on the main motor. When this signal becomes "L" level, a brake is applied to the rotation of the motor.

## 9.5 Disassembly and Replacement

### [A] Main motor (M3)

- (1) Take off the rear cover.  
P.2-22 "[J] Rear cover"
- (2) Disconnect 1 connector, remove 2 screws, and then take off the main motor.

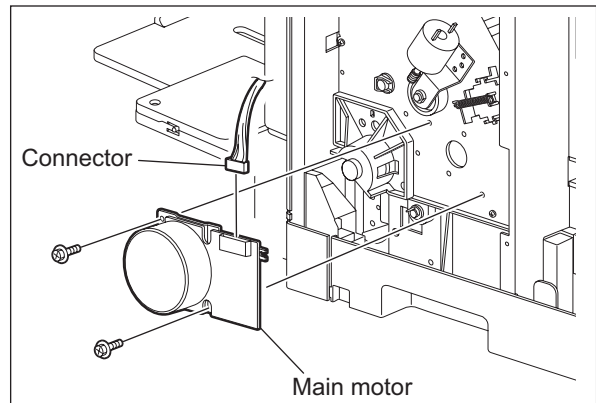

Fig. 9-3

### [B] Toner motor (M2)

- (1) Take off the rear cover.  
P.2-22 "[J] Rear cover"
- (2) Disconnect 1 connector, remove 1 screw, take off the toner motor with the bracket, and then remove 1 bushing and 1 gear.

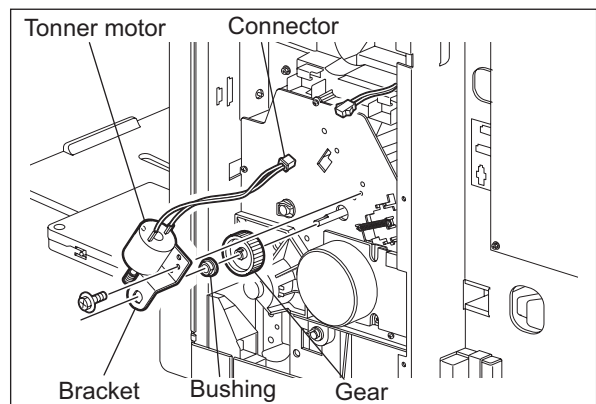

Fig. 9-4

- (3) Remove 2 screws and take off the toner motor.

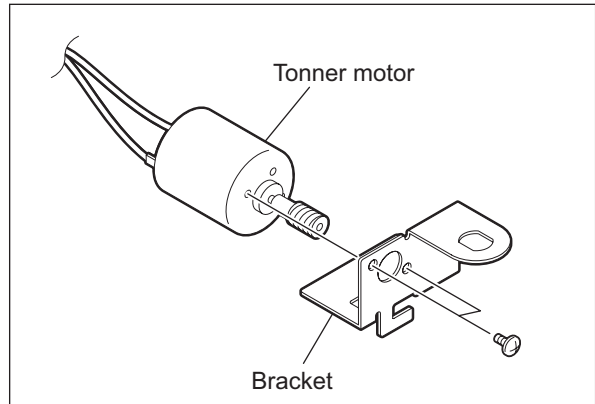

Fig. 9-5

**[C] Main motor drive unit**

- (1) Take off the Process unit.  
 P.11-9 "[A] Process unit"
- (2) Take off the toner motor with the bracket.
- (3) Remove 2 screws and take off the registration roller holder.

**Note:**

When installing the registration roller holder, align the arm of the registration roller clutch with the rotation stopper of the registration roller holder.

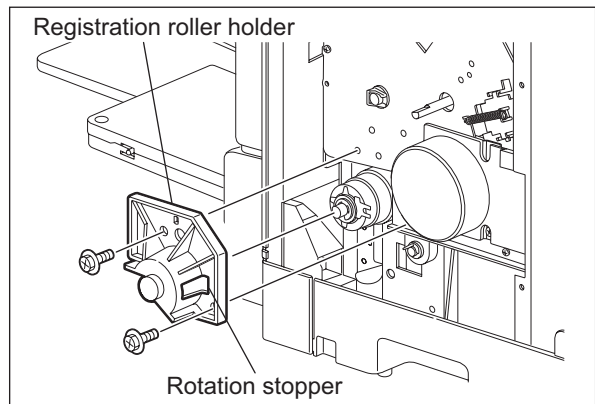

Fig. 9-6

- (4) Remove 1 clip and take off 1 bushing.

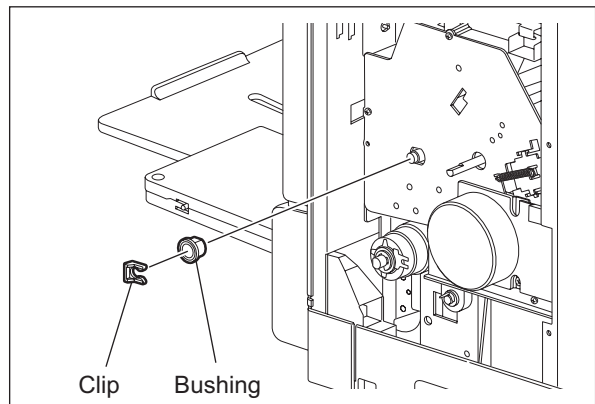
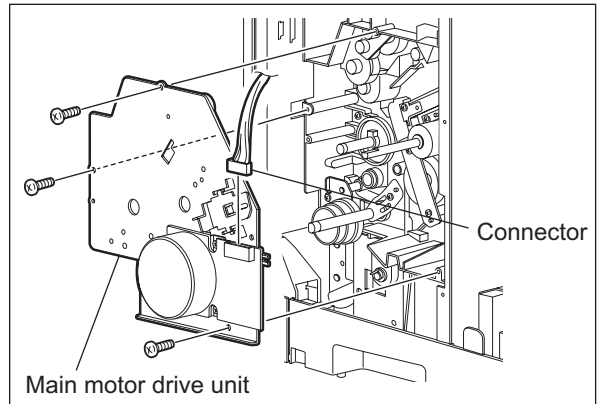

Fig. 9-7

- (5) Disconnect 1 connector, remove 3 screws and take off the main motor drive unit.



**Fig. 9-8**

- (6) Loosen 1 tensioner fixing screw and remove the tension spring.

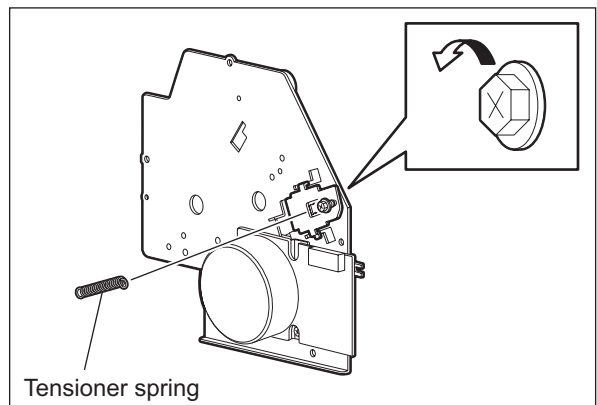

**Fig. 9-9**

- (7) Take off the gear and timing belt from the main motor drive unit.

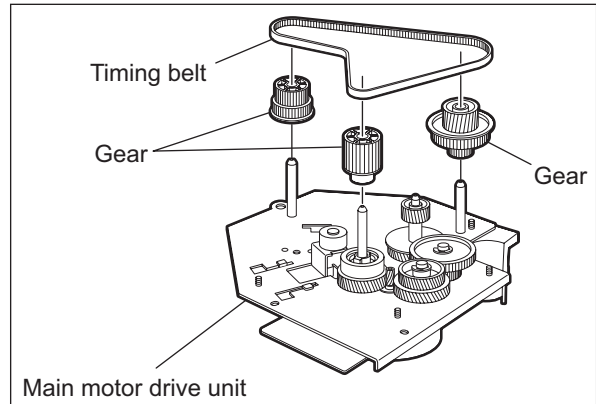

Fig. 9-10

**Notes:**

- Do not apply more tension to the belt of the main motor drive unit than that produced by the spring force.
- Follow the procedure below to perform tension adjustment when assembling the main motor drive unit.
  - Align the tensioner with the punch mark and tighten the tensioner fixing screw.
  - Hook the tensioner spring.
  - Install the main motor drive unit to the equipment.
  - Loosen the tensioner fixing screw.
  - Let the spring force produce tension for the belt, and tighten the fixing screw.

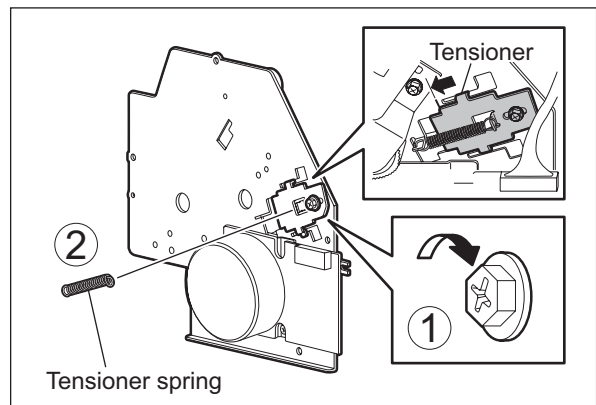

Fig. 9-11





## 10. PAPER FEEDING SYSTEM

### 10.1 General Description

The purpose of this system is to pick up a sheet of paper from the drawer or bypass tray and transport it to the transfer position. The paper feeding system mainly consists of the pickup roller, registration roller, bypass sensor, paper empty sensor, registration sensor and the drive system for these components.

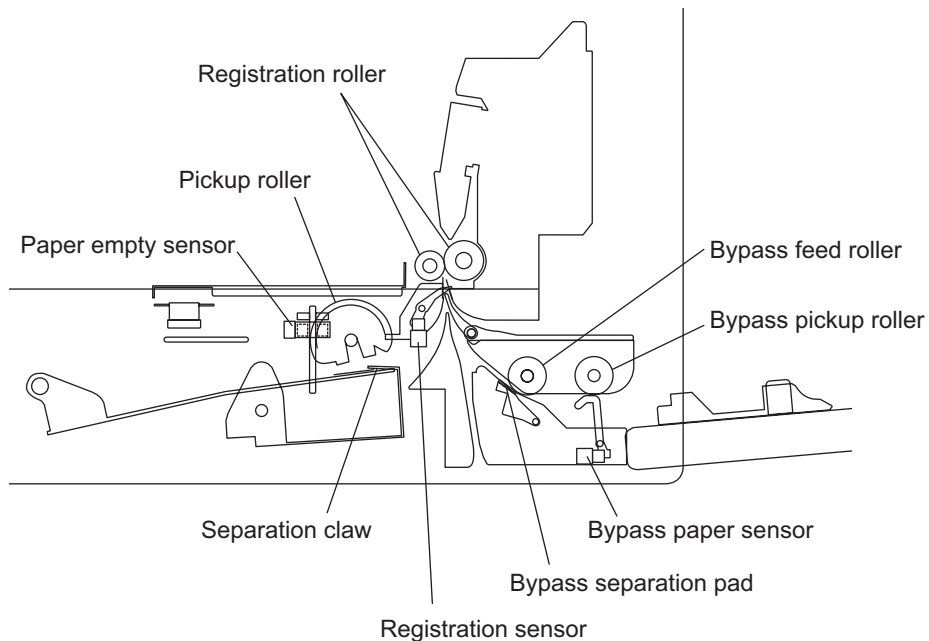

Fig. 10-1

## 10.2 Configuration

Paper feeding system		
Drawer	Pickup roller	Periodic replacement part
	Pickup solenoid (SOL1)	
	Drawer pickup clutch	
	Paper empty sensor (S7)	
Bypass unit	Bypass pickup roller	Periodic replacement part
	Bypass feed roller	Periodic replacement part
	Bypass separation pad	Periodic replacement part
	Bypass sensor (S8)	
	Bypass pickup solenoid (SOL2)	
	Bypass pickup clutch	
	Bypass feed clutch	
Registration roller		
Registration roller clutch (CLT1)		
Registration sensor (S4)		
Drawer detection switch (SW5)		

## 10.3 Functions

- 1) Pickup roller  
This roller, which has a semicircle shaped roller section, draws out a sheet of paper from the drawer and transports it to the registration roller. One rotation of the pickup roller transports one sheet of paper to the registration roller.
- 2) Pickup solenoid (SOL1)  
Starts transmission of the drive to the drawer pickup clutch. The driving force is not transmitted to the drawer pickup clutch when the pickup solenoid (SOL1) is turned OFF, but is transmitted when it is turned ON. The pickup roller rotates once for every one ON of the pickup solenoid (SOL1).
- 3) Drawer pickup clutch  
This is a spring-type mechanical one-way clutch used to transmit the drive from the main motor (M3) to the pickup roller. When the pickup solenoid (SOL1) is turned OFF, the spring tension of the one-way clutch is decreased to cut off the drive.
- 4) Paper empty sensor (S7)  
This is a transmissive-type sensor and detects the availability of paper in the drawer. When there is no paper in the drawer, the actuator blocks the light path of the sensor, and the sensor determines that there is no paper.
- 5) Bypass pickup roller  
Draws out a sheet of paper from the bypass tray, and transports it to the bypass feed roller. The roller goes down and starts rotating when the drive is transmitted.
- 6) Bypass feed roller  
Transports the paper from the bypass pickup roller to the registration roller.
- 7) Bypass separation pad  
When two or more sheets of paper are transported from the bypass pickup roller, since the resistance force of the separation pad is larger than the frictional force between the sheets, the lower sheets are not transported any further.
- 8) Bypass sensor (S8)  
Detects whether paper is set in the bypass tray or not. When paper is set in the bypass tray, bypass feeding is performed in preference to drawer feeding. And it also detects whether paper has been transported from the bypass tray or not (i.e. whether the leading/trailing edge of the paper has passed the bypass feed roller or not.). The sensor is also used to detect jams such as paper mis-sending in the bypass unit.
- 9) Bypass pickup solenoid (SOL2)  
Starts transmission of the drive to the bypass pickup clutch and bypass feed clutch. The driving force is not transmitted to the bypass pickup clutch and bypass feed clutch when the bypass pickup solenoid (SOL2) is turned OFF, and is transmitted to move down the pickup roller and rotate the bypass pickup roller and bypass feed roller when it is turned ON.
- 10) Bypass pickup clutch  
This is a spring-type mechanical one-way clutch used to transmit the drive from the main motor (M3) to the cam which moves the bypass pickup roller up and down. When the bypass pickup solenoid (SOL2) is turned OFF, the spring tension of the one-way clutch decreases so that the bypass pickup roller moves to the upper position (standby position), and moves to the lower position (operation position) when the solenoid is turned ON.

11) Bypass feed clutch

This is a spring-type mechanical one-way clutch used to transmit the drive from the main motor (M3) to the bypass feed roller and bypass pickup roller. When the bypass pickup solenoid (SOL2) is turned OFF, the spring tension of the one-way clutch decreases to cut off the drive.

12) Registration roller

Paper transported from the pickup roller or bypass feed roller is pushed against the registration roller which aligns the leading edge of the paper. Then, the registration rollers rotate to transport the paper to the transfer position.

13) Registration roller clutch (CLT1)

This is an electromagnetic clutch which drives the registration roller. When the registration roller clutch (CLT1) is turned ON, the drive is transmitted from the main motor (M3) to rotate the registration roller.

14) Registration sensor (S4)

It is used to detect that the leading edge of the paper has reached the registration roller and to control the aligning amount of the paper (the amount of the paper bend before it is transported to the registration roller). Also, it is used to detect the trailing edge of the paper has passed the registration roller.

15) Drawer detection sensor (SW5)

The switch to detect whether the drawer is fully inserted or not.

## 10.4 Operation

### 10.4.1 Drawer

#### [A] Operation of pickup roller

When the drawer is inserted into the equipment, the lock located in the center of the drawer is released, and the tray in the drawer is lifted up by the spring. This makes the paper set in the tray contact the pickup roller when it is rotated.

The driving force of the main motor (M3) is transmitted through the pickup clutch to the pickup roller. Also the drawer pickup clutch transmits the drive when the pickup solenoid (SOL1) is turned ON. The pickup roller is rotated one turn by this driving force to pull out a sheet of paper from the drawer. The pickup roller stops at its home position for each rotation. Therefore, when multiple sheets of paper are fed, the pickup solenoid (SOL1) is turned ON at each rotation. One rotation of the pickup roller, which is semicircle shaped, can transport a sheet of paper to the registration roller.

This feeding system has no mechanism specific for detecting the transported paper. Therefore, whether the paper has been transported to the registration sensor (S4) within a specified period of time or not is substituted for the paper jam detection.

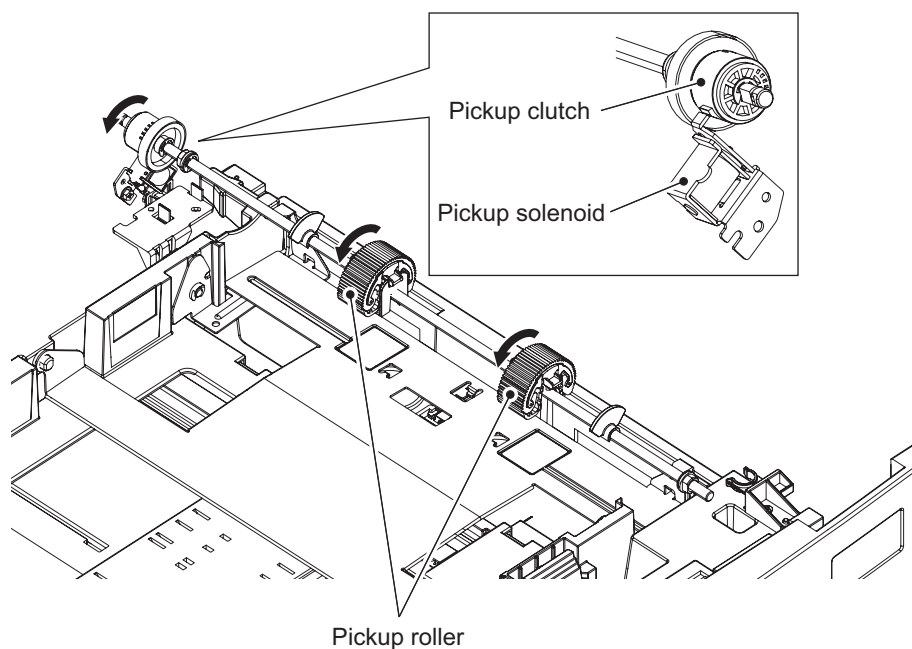
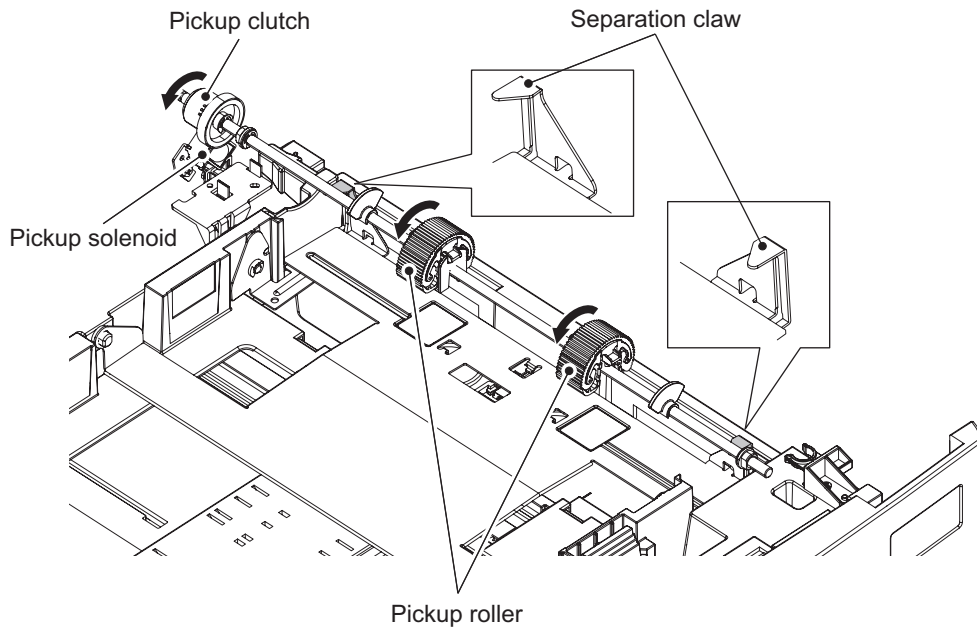

Fig. 10-2

## [B] Paper separation

This model is equipped with separation claws which work to prevent multiple paper feeding. Two separation claws are installed to hold the 2 corners of the leading edge of the paper in the drawer. When feeding starts, the pickup roller rotates. Since the friction between the pickup roller and paper is greater than the friction between two sheets, the pickup roller tries to send out a sheet of paper from the top of the stack. Because both corners of the paper stack are held by the separation claws, the paper on the top of the stack becomes bent and is sent out while the lower paper is not. When the picking up force of the roller increases, one sheet of paper is finally released from the claws. The sheet released from the separation claws is directly transported to the registration roller by the pickup roller.



**Fig. 10-3**

## 10.4.2 Bypass tray

### [A] Operation of drawer pickup roller

When the paper is set on the bypass tray, the bypass sensor (S8) detects it and judges that there is paper on the bypass tray, and the bypass feeding is performed in preference to drawer feeding.

When the bypass pickup solenoid (SOL1) is turned ON, the driving force of the main motor (M3) is transmitted to the bypass pickup clutch and bypass feed clutch. The bypass pickup roller is shifted down by the drive from the bypass pickup clutch. And then, the bypass pickup roller, as well as the bypass feed roller, is rotated by the drive from the bypass feed clutch to transport the paper on the bypass tray to the bypass feed roller.

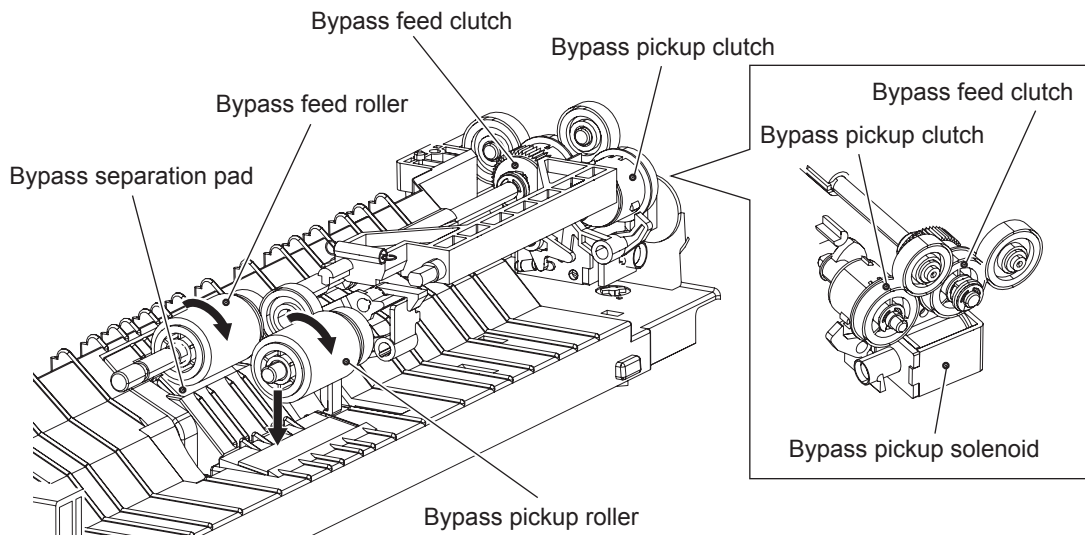

Fig. 10-4

## [B] Paper separation

This model is equipped with a separation pad which works to prevent multiple paper feeding. The separation pad is pushed to the bypass feed roller by the spring force. The bypass feed roller is rotated synchronously with the bypass pickup roller. When two or more sheets of paper are fed from the bypass pickup roller, since the friction between two sheets of paper is smaller than that between a sheet and the separation pad, the lower sheets are not transported any further while the uppermost one is transported by the feed roller.

The paper transported by the bypass feed roller reaches the registration roller. After the paper is aligned by the registration roller, the bypass pickup solenoid (SOL2) is turned OFF to stop the bypass pickup roller and bypass feed roller, and the bypass pickup roller returns to its original position.

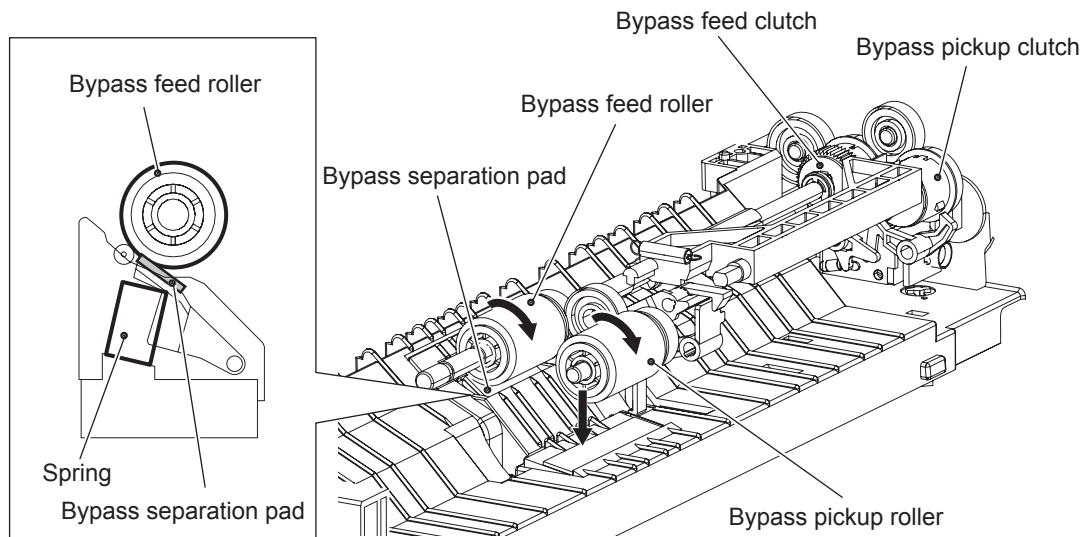

Fig. 10-5



### 10.4.3 General operation

#### [A] From power ON to standby status

- If the drawer is not completely inserted when the equipment is turned ON, it is judged by the drawer detection switch (SW5) that the drawer has not been inserted. Paper detection in the drawer cannot be performed unless the drawer is fully inserted.
- When the equipment is turned ON, if the paper empty sensor (S7) is turned OFF (L), it is judged that there is no paper in the drawer. With the sensor (S7) being ON (H), it is judged that there is paper in the drawer.
- If either of the sensors; registration sensor (S4) or exit sensor (S5) is ON (meaning there is paper on the transport path) when the equipment is turned ON, it is determined that a paper jam has occurred and no operation is enabled until the jammed paper is removed.

#### [B] Standby status

- After the availability of paper is checked as described above, the equipment enters the standby state.

#### [C] Drawer feeding

- When the pickup solenoid (SOL1) is turned ON, the driving force of the main motor (M3) is transmitted to the drawer pickup clutch to rotate the pickup roller one turn. Then, a sheet of paper is fed and transported to the registration roller.
- The leading edge of the paper turns ON the registration sensor (S4), and then the paper stops at the registration roller.
- The registration clutch (CLT1) is turned ON and the paper aligned by the registration roller is transported to the transfer unit.

#### [D] Bypass feeding

- The bypass sensor (S8) detects the availability of paper.
- When the bypass pickup solenoid (SOL2) is turned ON, the bypass pickup clutch arm and bypass feed clutch arm are pulled away from each clutch.
- The driving force of the main motor (M3) is transmitted to the bypass pickup clutch and bypass feed clutch to rotate the bypass pickup roller and bypass feed roller. At this time, the bypass pickup roller rotates and goes down simultaneously.
- Feeding starts and a sheet of paper is transported to the registration roller. The leading edge of the paper turns ON the registration sensor (S4), and then the paper stops at the registration roller.
- The bypass pickup solenoid (SOL2) is turned OFF, and the bypass pickup clutch arm and bypass feed clutch arm come in contact with each clutch. The drive for the bypass pickup roller and bypass feed roller is cut off, and the bypass pickup roller unit is lifted up.
- The registration clutch (CLT1) is turned ON and the paper aligned by the registration roller is transported to the transfer unit.

## 10.5 Disassembly and Replacement

### [A] Bypass unit

- (1) Take off the ADU cover.  
P.2-21 "[G] ADU cover"
- (2) Remove 1 screw and take off the harness cover.

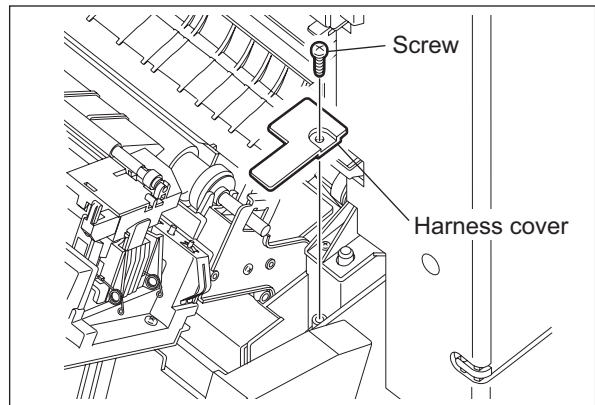

Fig. 10-6

- (3) Release the harness from the harness clamp and disconnect 1 connectors.

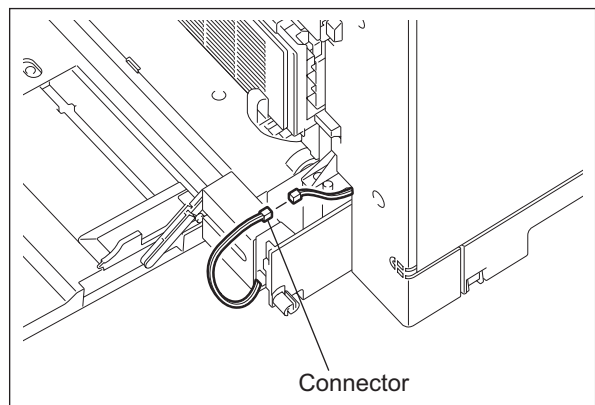

Fig. 10-7

- (4) Remove 2 screws, and take off the bypass unit by lifting it up.

**Note:**

When installing the bypass unit, place the guide behind the transfer unit.

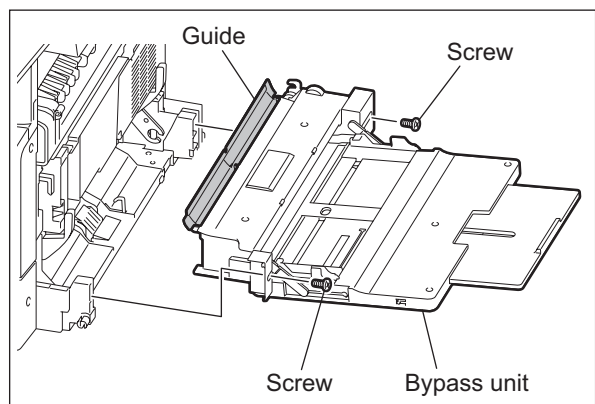

Fig. 10-8

## [B] Bypass tray

- (1) Take off the bypass unit.  
P.10-10 "[A] Bypass unit"
- (2) Release each latch to take off the front and rear tray arms.
- (3) Take off the bypass tray.

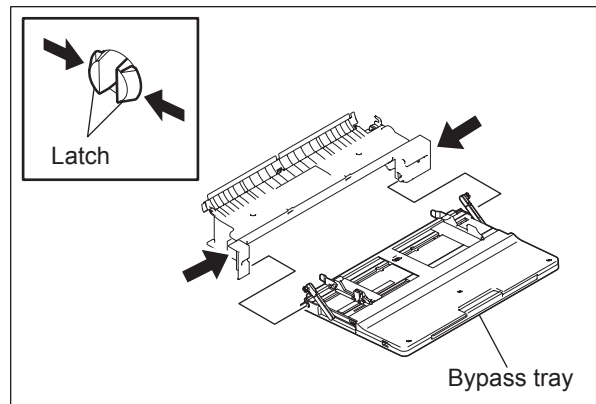

Fig. 10-9

## [C] Bypass separation pad

- (1) Take off the bypass unit.  
P.10-10 "[A] Bypass unit"
- (2) Remove 2 screws and take off the bypass separation pad unit.

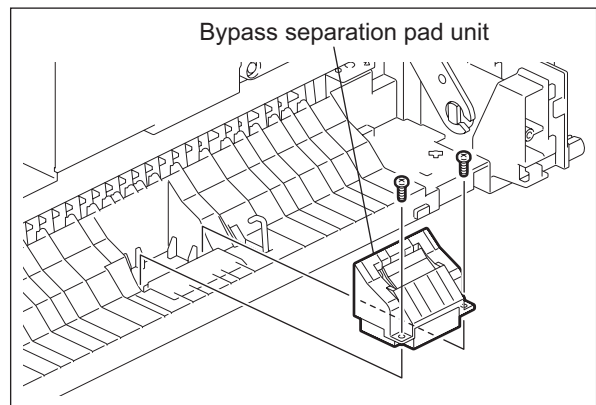

Fig. 10-10

- (3) Remove 1 screw on the bottom of the bypass separation pad unit, and take off the cover.

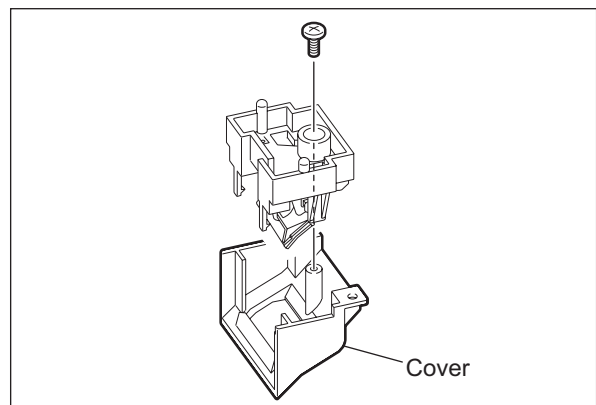

Fig. 10-11

- (4) Take off the bypass separation pad while pinching the mounting bracket.

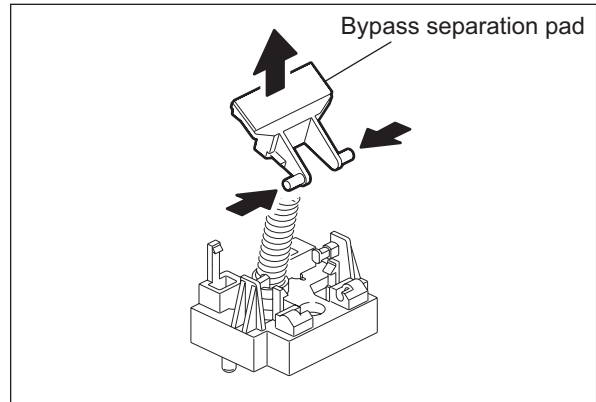

Fig. 10-12

**Note:**

When the separation pad is replaced, apply one grain of rice-sized white grease to the supporting point.

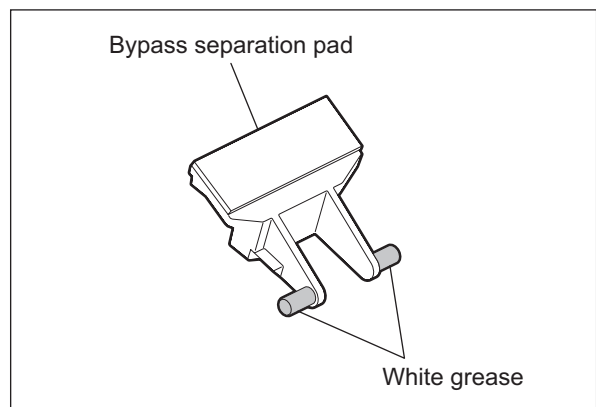

Fig. 10-13

**[D] Bypass roller unit**

- (1) Take off the bypass unit.  
P.10-10 "[A] Bypass unit"
- (2) Remove 2 screws, and take off the cover.

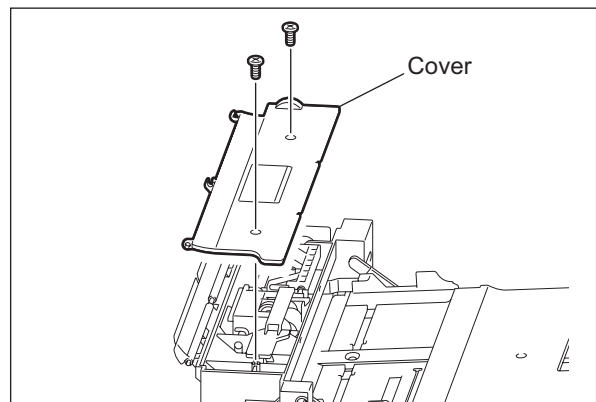

Fig. 10-14

- (3) Remove 1 spring and 2 screws. Then take off the bracket.

**Notes:**

- When installing the bracket, engage the U-shaped part of each head on both front and rear arms with each protrusion on the bypass roller unit.

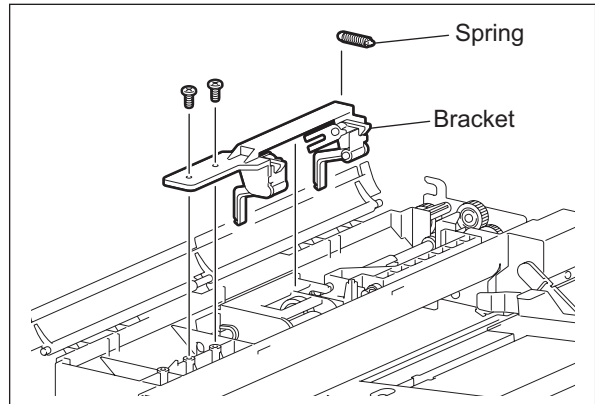

Fig. 10-15

- When the bracket is removed, place it as shown in the figure on the right to prevent the levers from coming off.

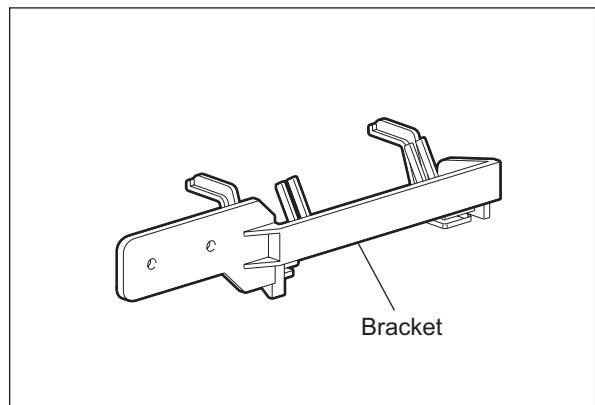

Fig. 10-16

- (4) Remove 1 clip, and take off the bypass roller unit while sliding it to the front side.

**Note:**

- When installing the bypass roller unit, insert the shaft into the coupling on the rear side.

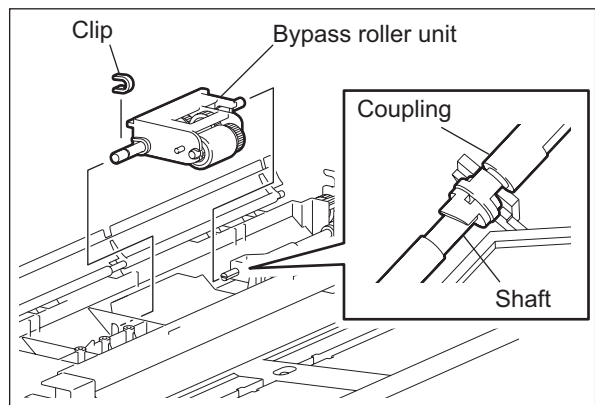
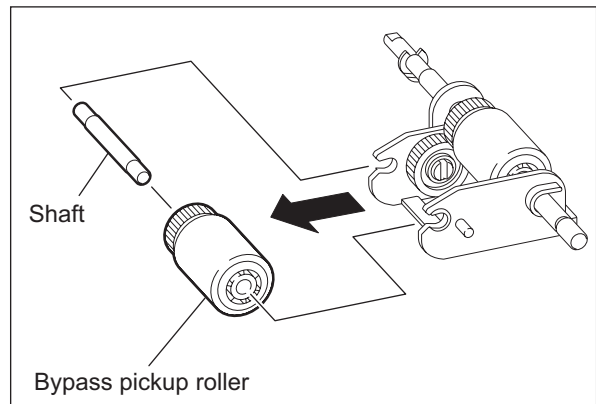

Fig. 10-17

**[E] Bypass pickup roller (PM)**

- (1) Take off the bypass roller unit.  
📖 P.10-12 "[D] Bypass roller unit"
- (2) Take off the bypass pickup roller and the shaft.



**Fig. 10-18**

**[F] Bypass feed roller (PM)**

- (1) Take off the bypass roller unit.  
📖 P.10-12 "[D] Bypass roller unit"
- (2) Remove 1 clip. Then pull out the shaft.
- (3) Take off the bypass feed roller.

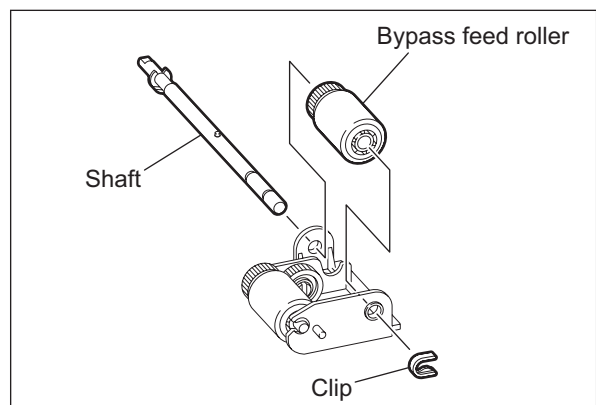

**Fig. 10-19**

**[G] Bypass sensor (S8)**

- (1) Remove 1 screw on the bottom of the equipment.
- (2) Take off the bypass sensor with the bracket.

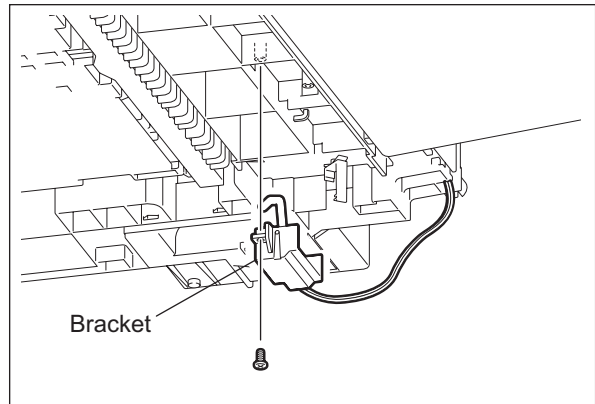

**Fig. 10-20**

- (3) Take off the actuator with the spring while pushing the bracket stays wider.

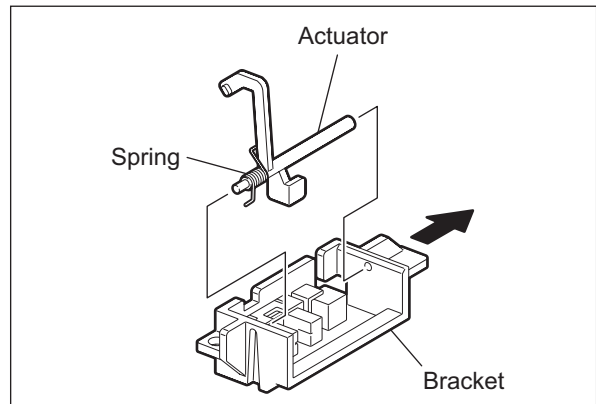

**Fig. 10-21**

- (4) Release 2 latches, take off the bypass sensor, and disconnect the connector.

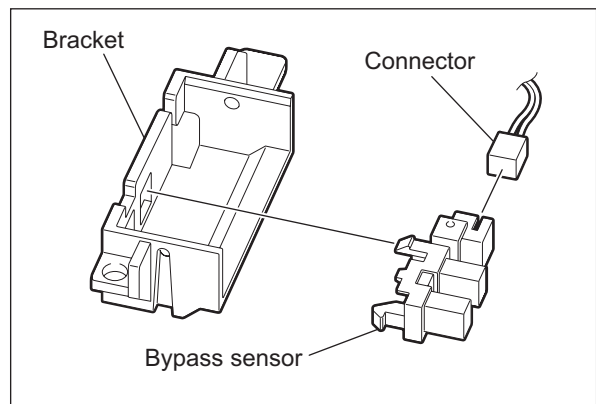

**Fig. 10-22**

## [H] Bypass pickup solenoid (SOL2)

- (1) Take off the bypass unit.  
📖 P.10-10 "[A] Bypass unit"
- (2) Remove 1 screw.

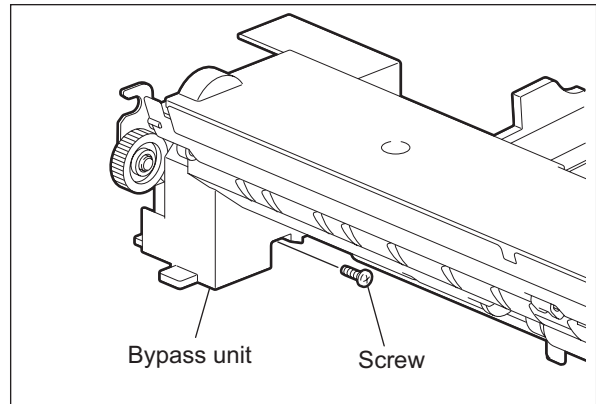

Fig. 10-23

- (3) Release the harness from the harness clamp and slide the pickup solenoid with the spring upward to take it off.

### Note:

When installing the bypass pickup solenoid, be sure to place the spring between the arm and the solenoid.

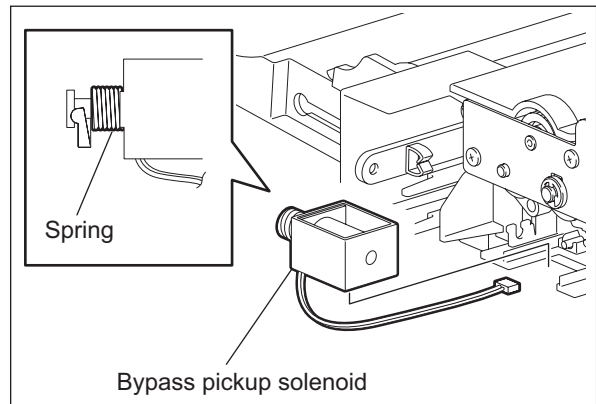

Fig. 10-24

## [I] Bypass pickup clutch / Bypass feed clutch

- (1) Take off the bypass unit.  
📖 P.10-10 "[A] Bypass unit"
- (2) Remove 1 E-ring, 1 bushing and 2 screws. Then take off the 1 bracket and 2 gears.

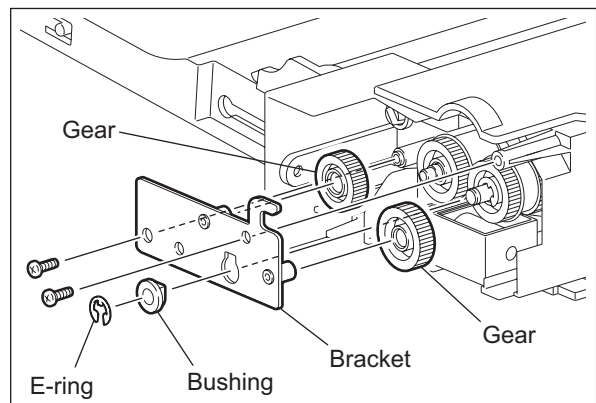

Fig. 10-25



- (3) Take off the bypass pickup clutch with its shaft.

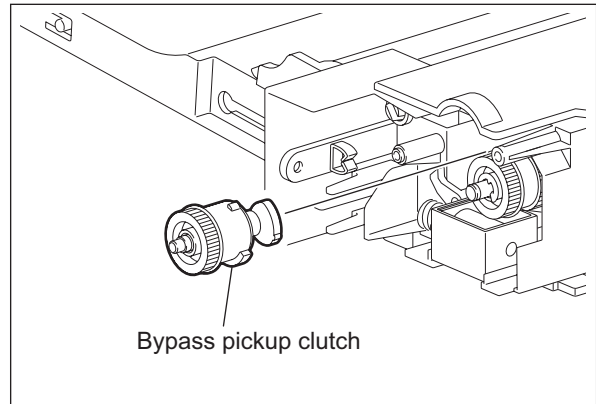

Fig. 10-26

- (4) Remove 2 E-rings. Then remove the gear, cover, spring and cam out of the shaft.

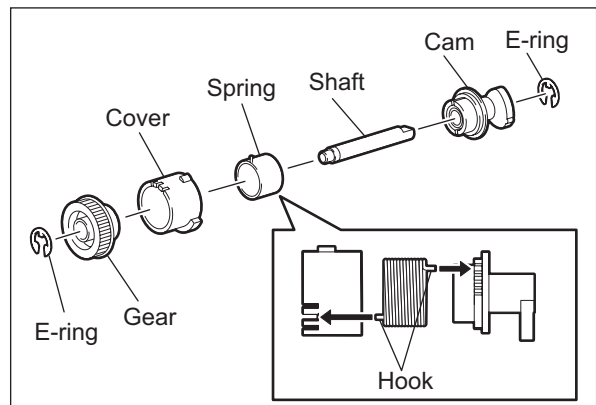

Fig. 10-27

**Note:**

When assembling the bypass pickup clutch, be sure to adjust the position of the hook of the spring and cover so that the center slit of the cover and the center of the cam are aligned.

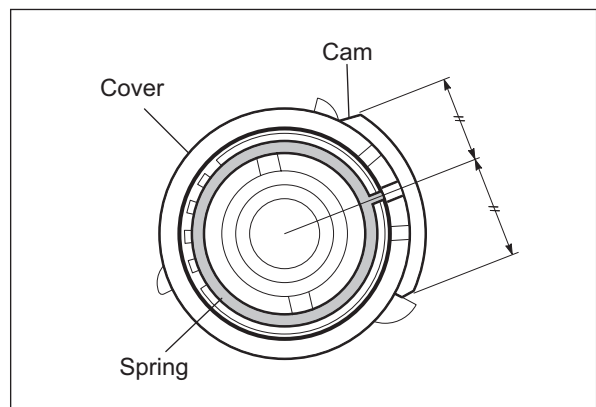
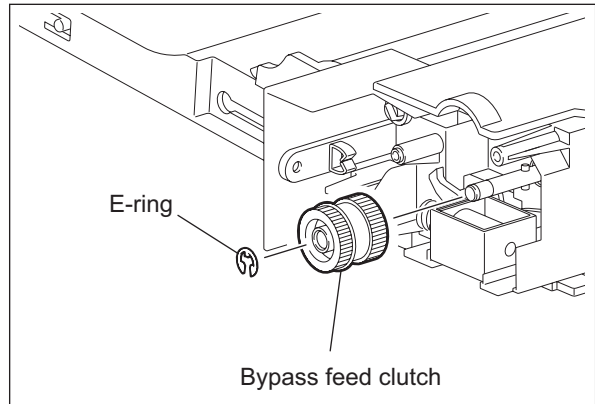

Fig. 10-28

- (5) Remove 1 E-ring, and take off the bypass feed clutch.



**Fig. 10-29**

- (6) Remove the gear, cover, spring and cap.

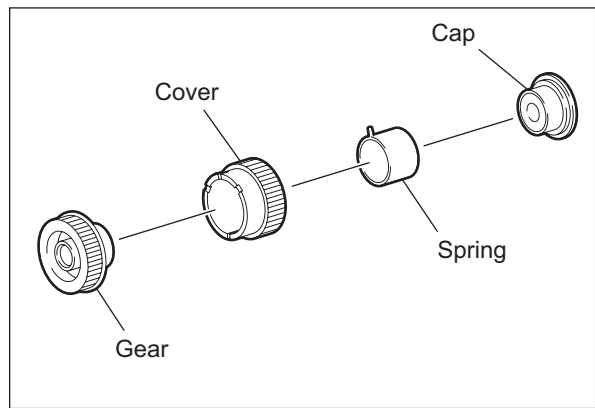

**Fig. 10-30**

## [J] Damp heater unit (DH3) / Dummy plate

### Notes:

- This damp heater unit is optional for NAD, CND and MJD.
- The dummy plate is attached to the equipment in which the damp heater unit is not installed. To take it off, perform the procedure from step (3).

- (1) Take off the rear cover.  
P.2-22 "[J] Rear cover"
- (2) Release the harness from the harness clamp and disconnect the connector.

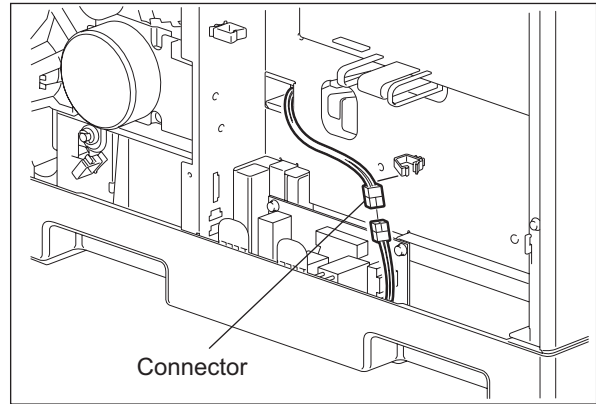

Fig. 10-31

- (3) Take off the process unit.  
P.11-9 "[A] Process unit"
- (4) Remove 1 screw and take off the damp heater unit or dummy plate while sliding it to the rear side and lifting it up.

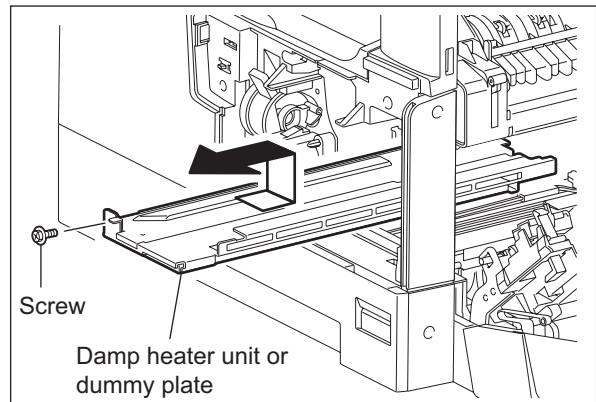

Fig. 10-32

## [K] Paper empty sensor (S7)

- (1) Take off the drawer.
- (2) Take off the damp heater unit or dummy plate.  
P.10-19 "[J] Damp heater unit (DH3) / Dummy plate"
- (3) Disconnect 1 connector, remove 1 screw, and take off the bracket of the paper empty sensor.

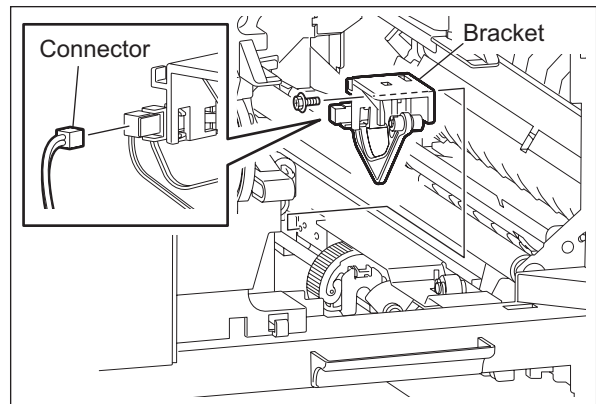

Fig. 10-33

- (4) Release 2 latches and take off the paper empty sensor from the bracket.

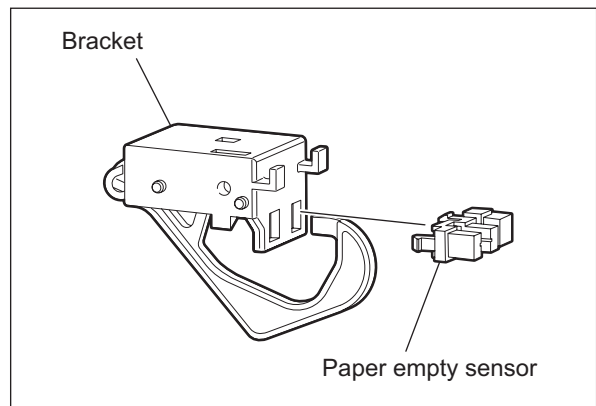

Fig. 10-34

## [L] Pickup roller

- (1) Take off the drawer.
- (2) Rotate the pickup roller shaft counterclockwise to make the rubber surface of the roller facing down.

### Note:

Because the tension is applied to the pickup roller shaft by the pickup clutch when it is rotated counter-clockwise, be sure to hold the shaft while replacing the roller.

- (3) Push 2 latches each to take off 2 pickup rollers.

### Notes:

- Be sure to install the pickup roller in the correct direction when reassembling it.
- When it is difficult to take off the pickup roller, alternatively follow the procedure below to remove it.
  1. Take off the damp heater unit or dummy plate.  
 P.10-19 "[J] Damp heater unit (DH3) / Dummy plate"
  2. Take off 2 pickup rollers by releasing 2 latches each.

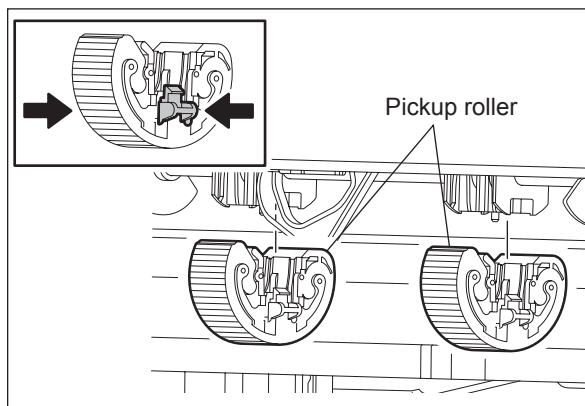

Fig. 10-35

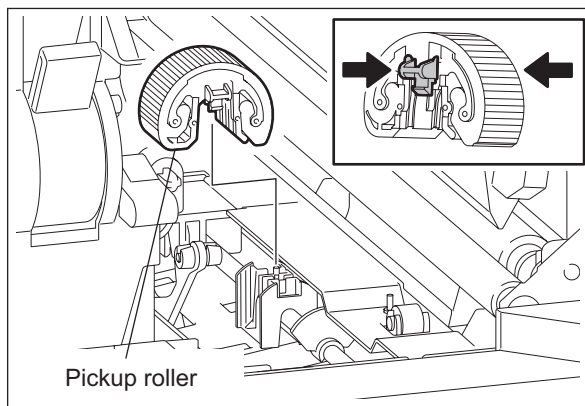



Fig. 10-36

## [M] Registration roller clutch (CLT1)

- (1) Take off the rear cover.  
 P.2-22 "[J] Rear cover"
- (2) Remove 2 screws and take off registration roller holder.

### Note:

When installing the registration roller holder, engage the arm of the registration roller clutch with the rotation stopper of the registration roller holder.

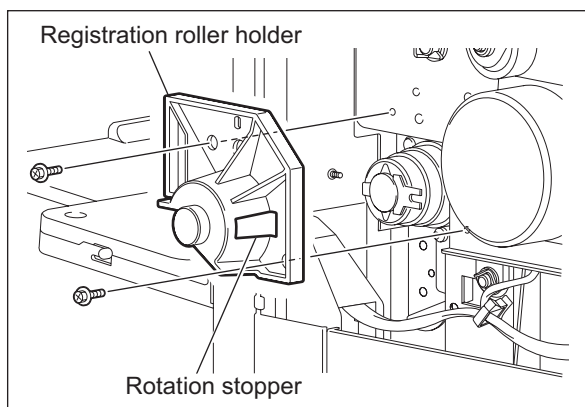

Fig. 10-37

- (3) Release the harness from the harness clamp, disconnect 1 connector and take off the registration roller clutch.

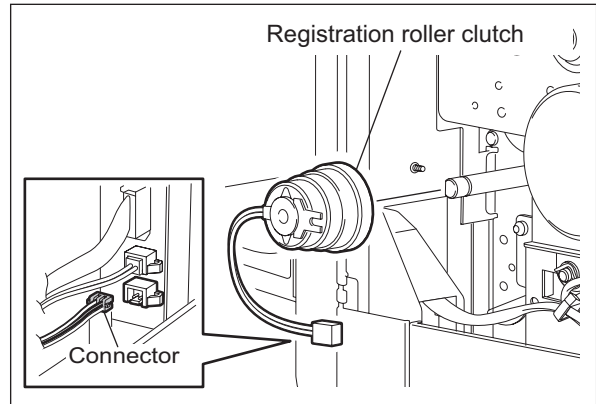

Fig. 10-38

**[N] Pickup solenoid (SOL1)**

- (1) Take off the rear cover.  
 P.2-22 "[J] Rear cover"
- (2) Release the harness from the harness clamp and disconnect 1 connector.

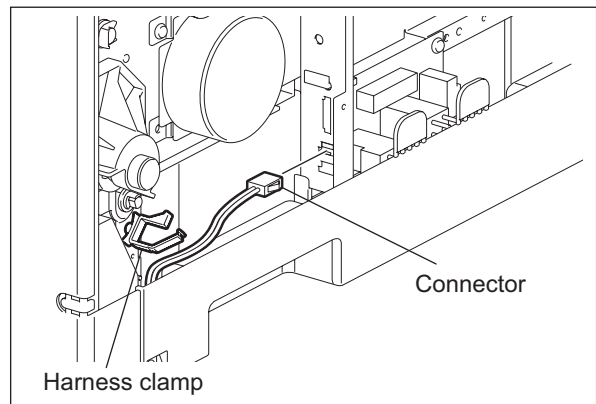

Fig. 10-39

- (3) Remove 1 screw and take off the pickup solenoid bracket.

**Note:**  
 Be sure not to drop the bushing.

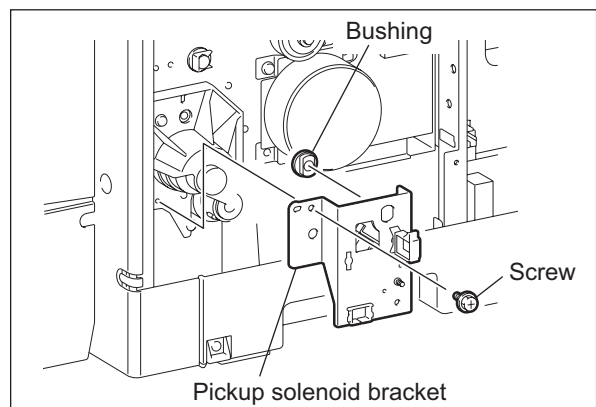

Fig. 10-40

- (4) Remove 1 screw and take off the pickup solenoid from the bracket.

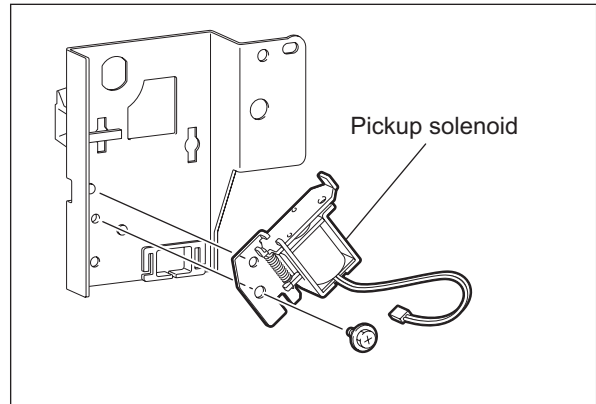

Fig. 10-41

**[O] Drawer pickup clutch**

- (1) Take off the main motor drive unit.  
 📖 P.9-7 "[C] Main motor drive unit"
- (2) Take off the pickup solenoid bracket.  
 📖 P.10-22 "[N] Pickup solenoid (SOL1)"
- (3) Remove 1 E-ring, and take off the drawer pickup clutch.

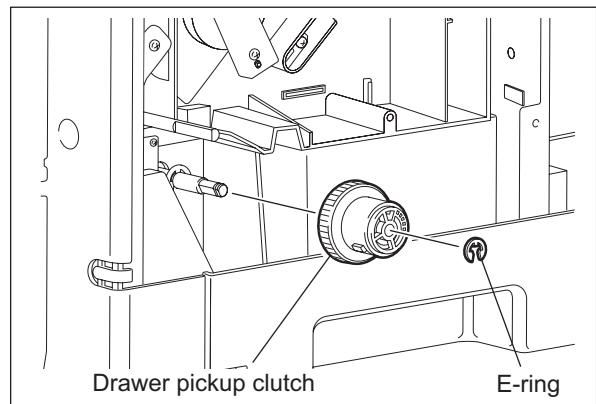

Fig. 10-42

- (4) Take off the cover-A, cover-B, spring and flange.

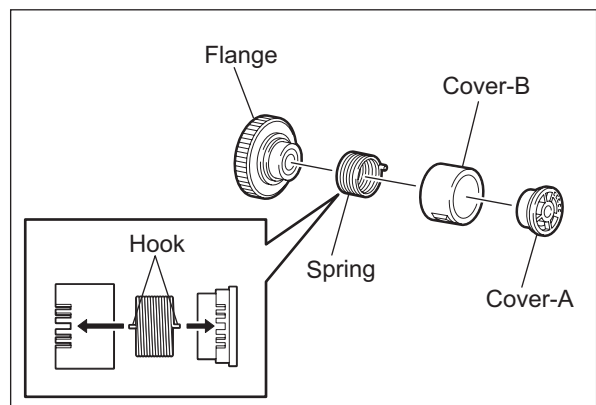

Fig. 10-43

**Note:**

When assembling the drawer pickup clutch, adjust the position of the hook of the spring and the covers so that the stopper of the cover-B and the center of the rib of the cover-A are aligned.

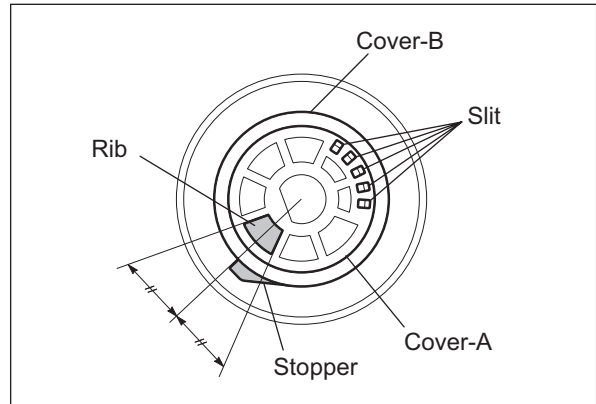

Fig. 10-44

**[P] Registration roller (rubber)**

- (1) Take off the transfer/separation charger.  
P.11-16 "[L] Transfer/Separation charger"
- (2) Remove 1 clip and take off 1 gear and the registration roller (rubber) while sliding them to the front side.

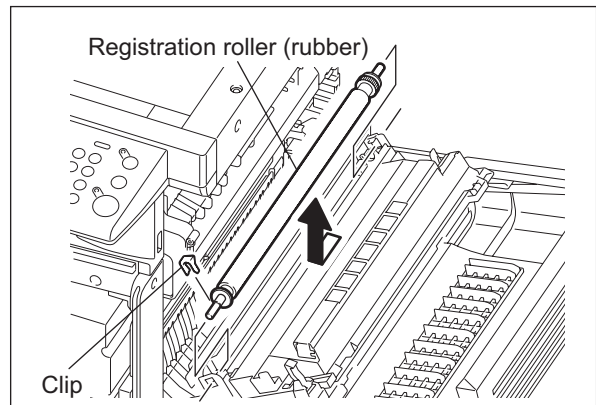

Fig. 10-45

- (3) Remove 2 washers, 1 E-ring, 1 gear, and 1 pin from the registration roller.

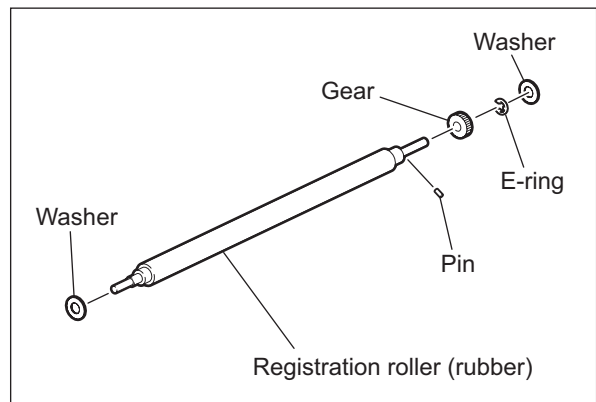

Fig. 10-46



## [Q] Registration roller (metal)

- (1) Take off the Process unit.  
P.11-9 "[A] Process unit"
- (2) Take off the transfer unit.  
P.11-17 "[N] Transfer unit"
- (3) Take off the registration roller clutch.  
P.10-21 "[M] Registration roller clutch (CLT1)"
- (4) Remove 1 clip, 1 bushing and then take off the registration roller (metal) while sliding it to the rear side.

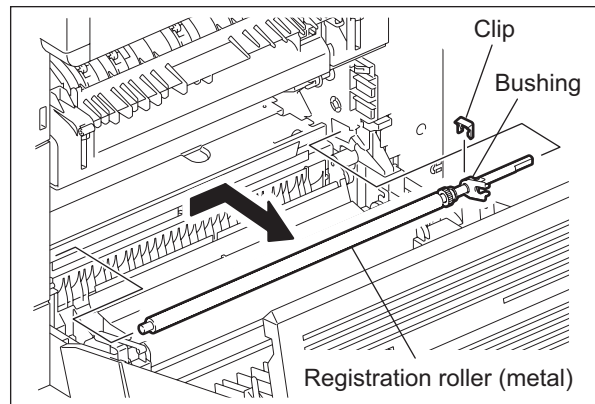

Fig. 10-47

- (5) Remove 1 bushing, 1 E-ring and then take off 1 gear and 1 pin.

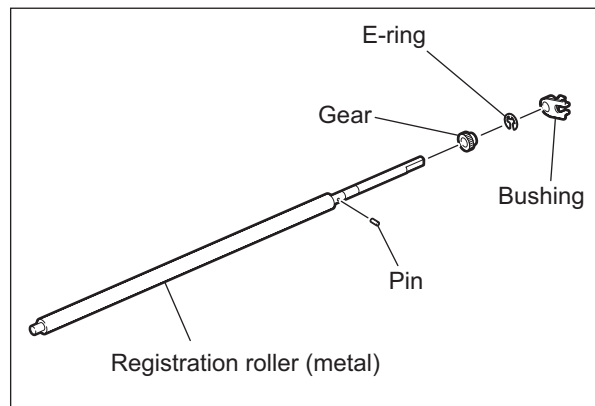

Fig. 10-48

## [R] Feed gear unit

- (1) Take off the main motor drive unit.  
P.9-7 "[C] Main motor drive unit"
- (2) Take off the registration roller clutch.  
P.10-21 "[M] Registration roller clutch (CLT1)"
- (3) Take off the pickup solenoid bracket.  
P.10-22 "[N] Pickup solenoid (SOL1)"
- (4) Remove 2 screws, and then take off the feed gear unit.

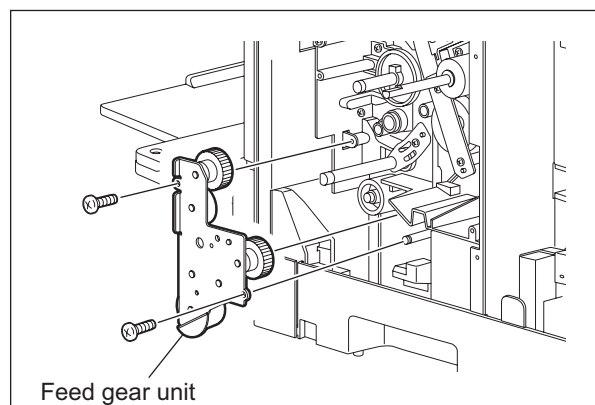

Fig. 10-49

### [S] Drawer detection switch (SW5)

- (1) Take off the damp heater unit or dummy plate.  
P.10-19 "[J] Damp heater unit (DH3) / Dummy plate"
- (2) Release the latch, take off the bracket while lifting it up, and then disconnect the connector.

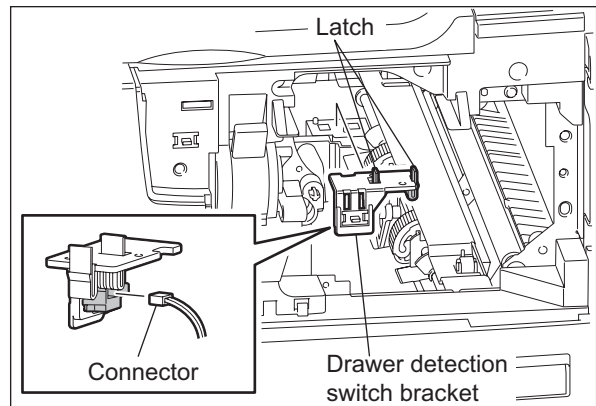

Fig. 10-50

- (3) Release the latch and take off the drawer detection switch from the bracket.

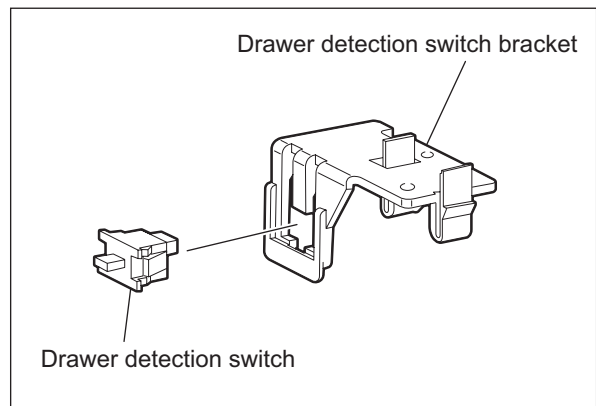

Fig. 10-51

### [T] Registration sensor (S4)

- (1) Take off the rear cover.  
P.2-22 "[J] Rear cover"
- (2) Release the harness from the harness clamp and disconnect 1 connector.

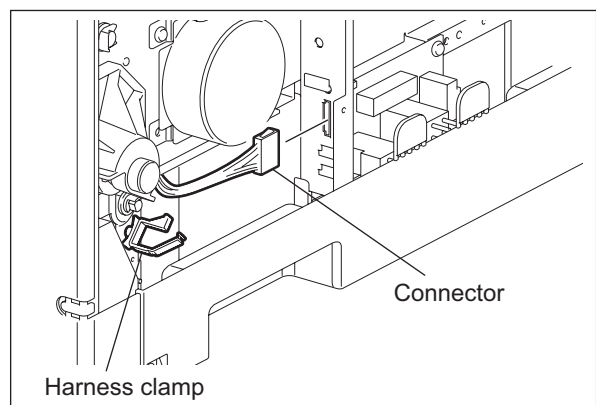

Fig. 10-52

- (3) Take off the damp heater unit or dummy plate.  
 ☞ P.10-19 "[J] Damp heater unit (DH3) / Dummy plate"
- (4) Take off the registration roller (metal).  
 ☞ P.10-25 "[Q] Registration roller (metal)"
- (5) Remove 1 screw.

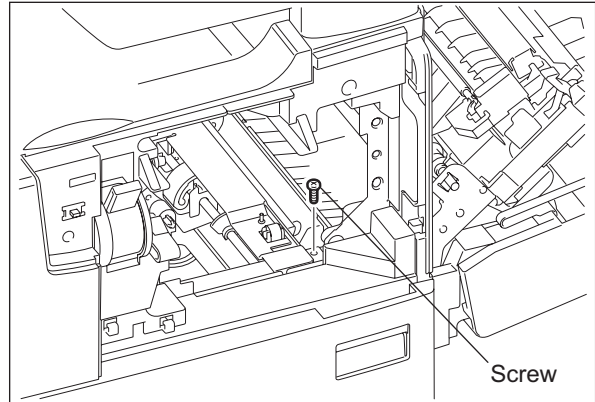

Fig. 10-53

- (6) Take off the registration guide while lifting it up. Release the latch and take off the drawer detection switch bracket.

**Note:**

Be careful not to break the harness which connects the registration guide unit with the drawer detection switch when taking off the unit.

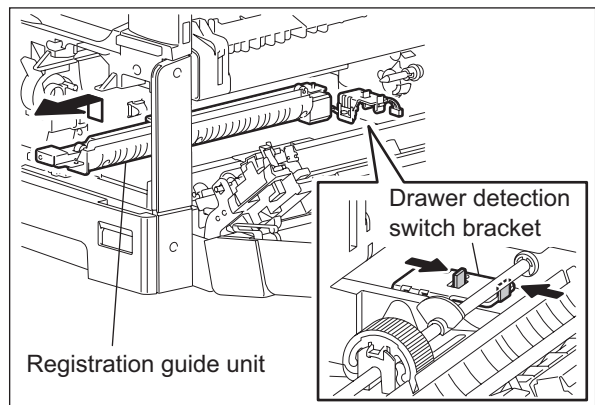

Fig. 10-54

- (7) Take off the bracket of paper empty sensor.  
 ☞ P.10-20 "[K] Paper empty sensor (S7)"
- (8) Release the harness from the harness clamp, disconnect the connector, remove 3 screws, and then take off the registration guide.

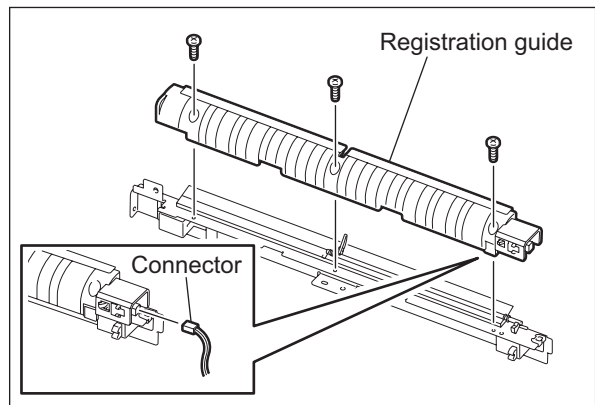

Fig. 10-55

- (9) Remove the seal, release 2 latches, and take off the registration sensor.

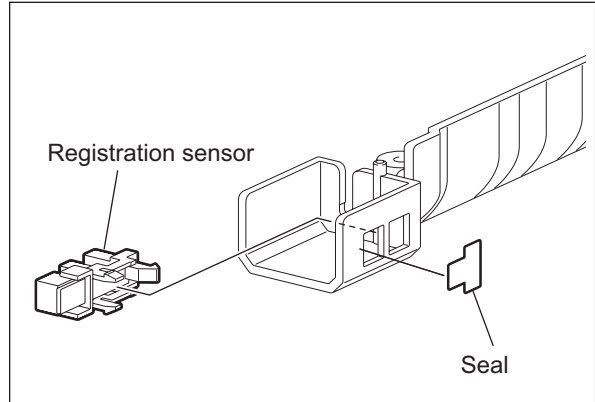

Fig. 10-56

# 11. DRUM RELATED SECTION

## 11.1 General Description

This chapter explains about the area around the drum, drum itself, image processing, their parts and control circuits.

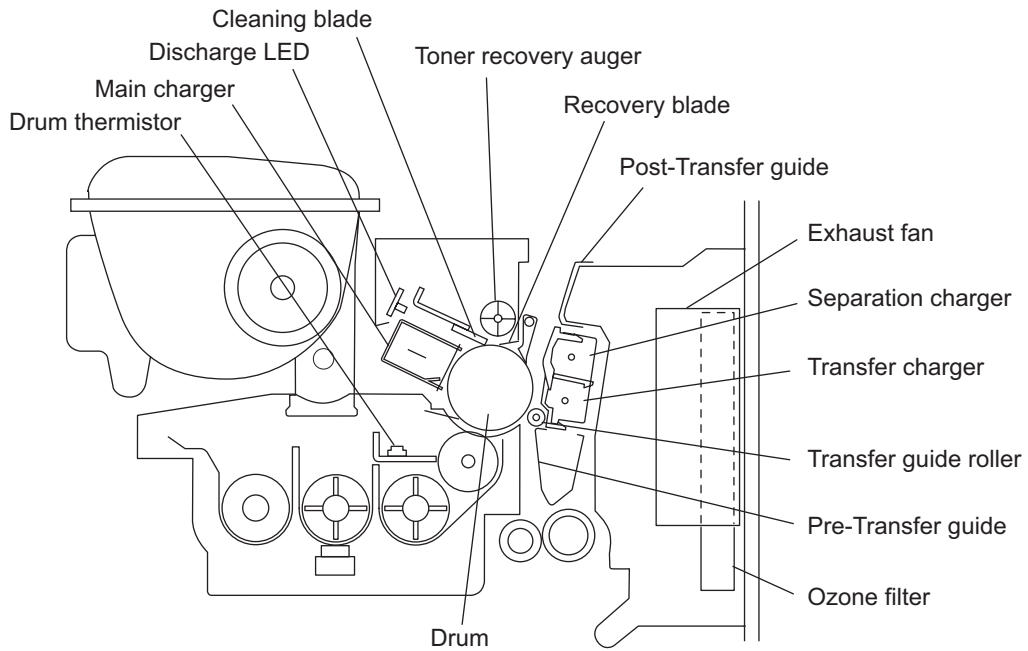

Fig. 11-1

## 11.2 Configuration

Drum cleaner unit	Drum		PM parts
	Drum separation finger		PM parts
	Drum cleaning blade		PM parts
	Recovery blade		PM parts
	Drum thermistor (THM4)		
Discharge LED (ERS)			
Main charger	Needle electrode		PM parts
	Main charger grid		PM parts
Transfer unit	Transfer/Separation charger	Transfer charger wire	PM parts
		Separation charger wire	PM parts
	Exhaust fan (M5)		
	Ozone filter		PM parts
	Transport guide		
Temperature/humidity sensor (S3)			
Switching regulator (PS)			

## 11.3 Functions

### 1) Drum

The drum is made of a cylindrical aluminum base coated with thin film of organic photoconductive substance.

The photoconductive object becomes insulative (the electrical resistance is high) when it is not exposed to the light and electrically conductive (the electrical resistance is low) when it is exposed to the light. This object is called a photoconductor.

### 2) Main charger

The main charger in this equipment consists of a metal rod with U-shaped section, insulated blocks at both ends of the rod and a needle electrode attached between them.

When a high voltage is applied to the needle electrode, the air around it is charged (ionized). The ionized air then flows into the drum causing it to be charged. This phenomenon is called "corona discharge". At the same time, a control bias is applied to the main charger grid to control the charging amount.

In a dark place, negative charge is evenly applied onto the drum surface by the corona discharge and this grid. In addition, a cleaner is installed to clean up the dust attached on the needle electrode.

#### - Needle electrode

The needle electrode has aligned needles and their points perform the corona discharge. These points (electrodes) discharge toward the drum in one direction to realize the more efficient discharging comparing to the charger wire which discharges in a radial direction. Therefore, the needle electrode enables to reduce the ozone amount.

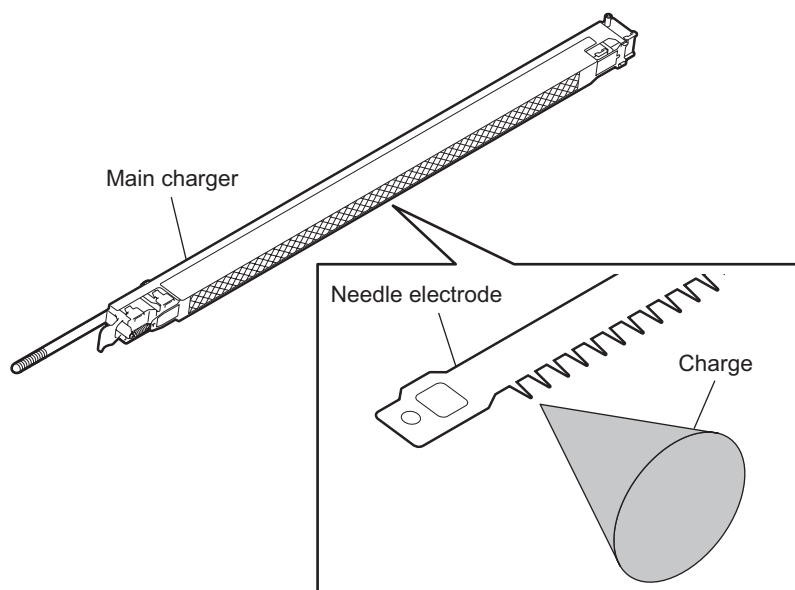

Fig. 11-2

- 3) Drum cleaner
  - Cleaning blade  
This blade is pressed against the drum surface and scrapes off the residual toner from the drum surface.
  - Recovery blade  
This blade catches the toner scraped off by the cleaning blade.
  - Toner recovery auger  
This auger carries the residual toner scraped off to the developer unit and reuses the toner.
- 4) Transfer/Separation charger
  - Transfer guide  
This guide leads the paper transported from the feeding unit to the transfer section. Positive (+) bias voltage is applied to the registration roller and post-transfer guide to prevent the transferability from being lowered under conditions such as high humidity.
  - Transfer charger  
The transfer charger applies a charge (positive (+) charge) which is contrary to the charging polarity of the toner to the back of the paper. The toner image is transferred electrostatically on the paper by performing this corona discharge.
  - Separation charger  
After the transfer process, the corona discharge applies a negative charge (DC) on the back of the paper to separate the paper adhering to the drum surface by an electrostatic force.
- 5) Exhaust fan (M5)  
The exhaust fan (M5) cools down the inside of the equipment. The air to exhaust includes the ozone generated by the corona discharge, and this ozone is removed by the ozone filter. The exhaust fan (M5) also helps the paper separation by absorbing the paper to post-transfer guide.
- 6) Discharge LED (ERS)  
Discharging is a process to decrease or eliminate the electrical potential of the drum surface. The electrical resistance of the photosensitive layer is decreased by the light irradiation, and the residual charge on the drum surface is neutralized and eliminated. The electrical potential of the drum surface is fixed to a certain amount before the drum is charged.
- 7) Drum thermistor (THMS4)  
The drum thermistor (THMS4) detects the drum surface temperature, and thus the rotation speed of the exhaust fan (M5) is controlled when the equipment is in the ready status.
- 8) Switching regulator (PS)  
This is a board to generate the output control voltage of the main charger, main charger grid, transfer charger, separation charger, developer bias and pre/post-transfer guide bias.
- 9) Temperature/Humidity sensor (S3)  
This sensor and drum thermistors (THMS1, THMS2) detect the temperature and humidity inside of the equipment since the drum, developer material and paper are affected by environmental elements such as temperature or humidity. Thus the main charger grid, transfer/separation charger, transfer guide bias, developer bias, laser output and auto-toner output are controlled to be at their optimum states.



## 11.4 High-Voltage Output Control Circuit

### 11.4.1 General description

In this equipment, the high-voltage generation circuit is included in the switching regulator. It is controlled by the ON/OFF signal of each bias output from the ASIC on the MAIN board and reference voltage  $V_c$  of each bias output from the SoC via the D/A converter. It generates the output current and voltage of each bias according to the +24VCOV-OFF input from the low-voltage generation circuit of the switching regulator.

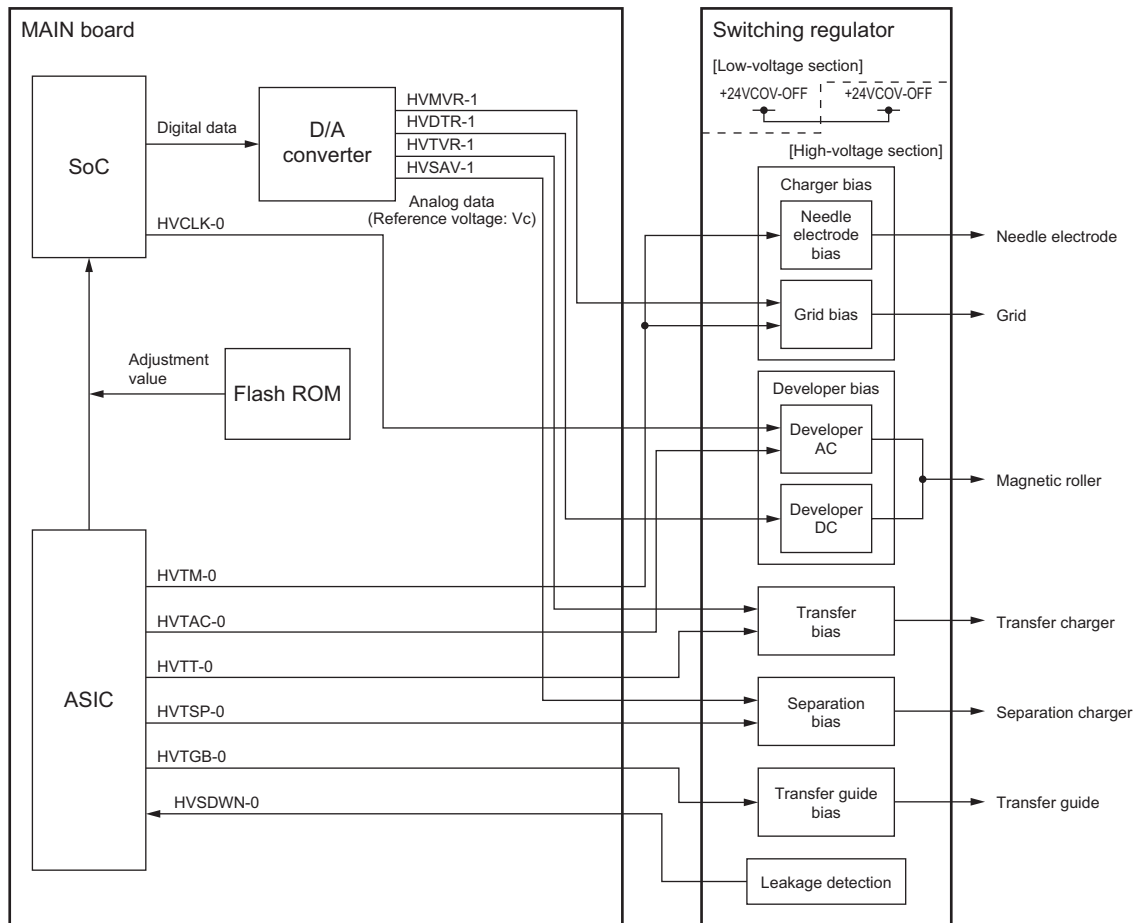

Fig. 11-3

## 11.4.2 Description of Operation

The function and operation of each signal are as follows:

ON/OFF signals (HVTM-0, HVTAC-0, HVTT-0, HVTSP-0, HVTGB-0):

These are for the charge grid (needle electrode / grid), developer bias (AC), transfer charger, transfer guide bias and separation charger. When these signals become "L" level, the generation circuit of each bias on the switching regulator is turned ON to generate an output current/voltage.

- \* The negative DC component of the developer bias is turned ON/OFF by switching the reference voltage (HVDTR-0) separately. The positive DC component of the developer bias is output only when the reference voltage (HVDTR-0) is 0.6 V or less and also the developer bias ON/OFF signal (HVTAC-0) is ON.

Reference voltages Vc (HVMVR-1, HVDTR-1, HVTVR-1, HVSAV-1):

These are analog voltages which are the reference of each output of the charge grid, developer bias, transfer charger and separation charger. Each bias output can be linearly changed by switching these reference voltages.

The output operation of the reference voltage is as follows:

- 1) The adjustment values of the main charger, developer, transfer and separation bias in the Flash ROM are output to the SoC.
  - 2) The reference voltage data are output from the SoC to D/A converter.
  - 3) Converted to analog data by the D/A converter
  - 4) The reference voltage Vc of each bias is output to the high-voltage generation circuit.
  - 5) The high-voltage generation circuit generates the output current/voltage which is proportional to the reference voltage.
- \* The reference voltage is adjusted in the Adjustment Mode (05).
  - \* The output values of the main charger and transfer guide bias are fixed when the high-voltage transformer is shipped from the factory.

Developer bias (AC) generation clock (HVCLK-0):

This clock signal is a reference of the AC component of the developer bias.

High-voltage generation circuit leakage detection signal (HVSDWN-0):

This signal is for leakage detection of the high-voltage generation circuit. This signal becomes "L" level at the occurrence of such an abnormality.

## 11.5 Drum Temperature Detection Circuit

### 11.5.1 General description

To prevent the print quality from varying depending on the temperature, the temperature of the drum surface and around the drum is detected by the drum thermistor. Based on the result of the detection, this circuit corrects the output of the main charger bias, developer bias, transfer bias and separation bias as well as the output of the auto-toner sensor and the laser.

### 11.5.2 Circuit configuration

The configuration of the drum surface temperature detection circuit is shown below. The voltage output from the drum thermistor is converted by the A/D converter in the Main board and is input into the SoC. The drum thermistor is a device whose resistance decreases as the temperature rises; thus, the voltage input to the A/D converter becomes smaller along with the rise of the temperature.

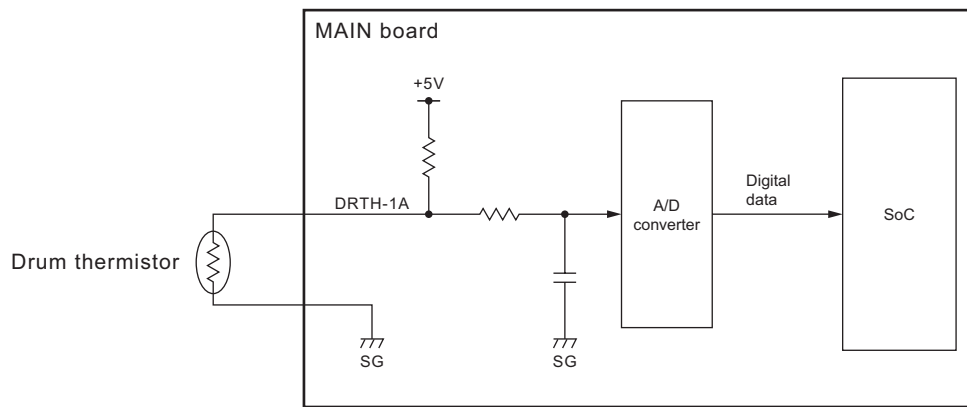

Fig. 11-4

## 11.6 Temperature/Humidity Detection Circuit

### 11.6.1 General Description

To prevent the print quality from varying depending on the temperature and humidity of the place where the equipment is installed, the temperature and humidity of the outside air taken into the equipment are detected. Based on the result of the detection, this circuit corrects the output of the main charger bias, developer bias, transfer bias and separation bias as well as the output of the auto-toner sensor and the laser.

### 11.6.2 Circuit configuration

The configuration of the temperature/humidity detection circuit is shown below. The voltage output from the temperature/humidity sensor is converted digitally by the A/D converter on the MAIN board and is input into the SoC. The higher the temperature or the humidity is, the higher the output voltage of this sensor becomes.

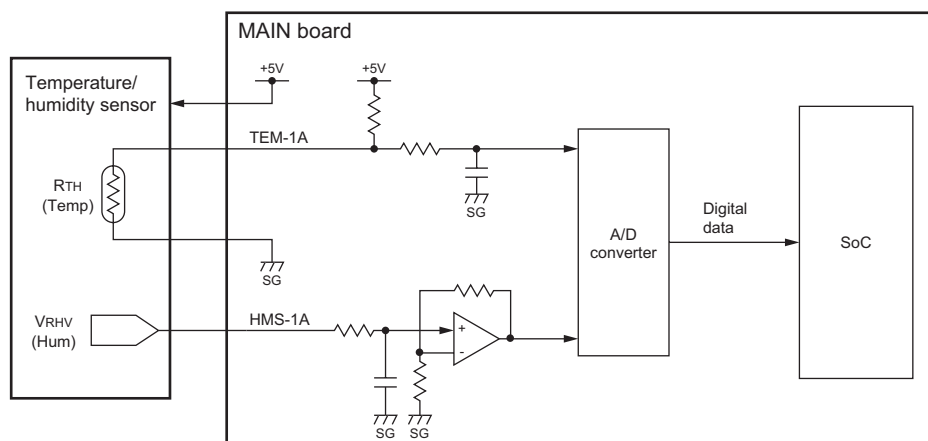

Fig. 11-5

## 11.7 Disassembly and Replacement

### [A] Process unit

- (1) Open the ADU cover and transfer unit.
- (2) Open the front cover and take off the toner cartridge.
- (3) Disconnect 1 connector. Loosen 2 screws and pull out the process unit.

**Note:**

When installing the process unit, make sure that the connector (harness) is not caught under the developer unit.

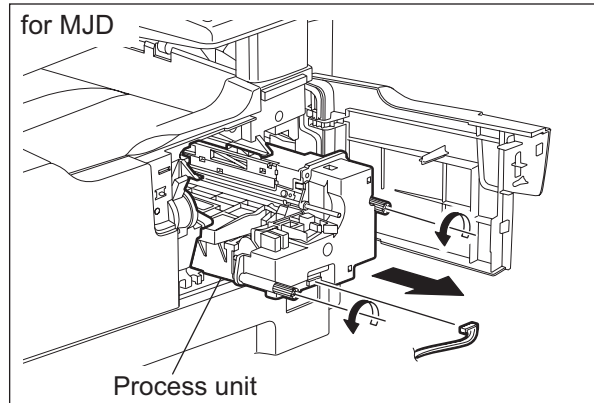

Fig. 11-6

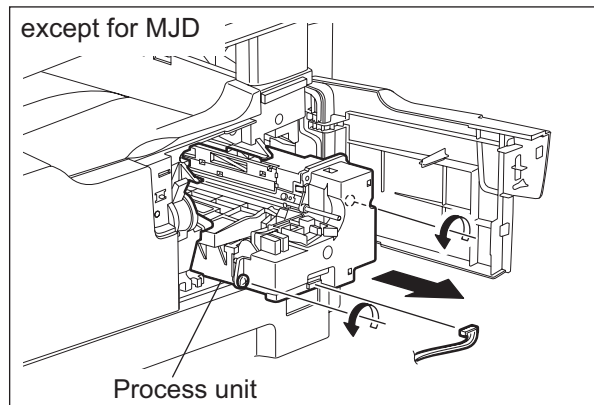

Fig. 11-7

## [B] Drum cleaner unit

- (1) Take out the process unit.  
P.11-9 "[A] Process unit"
- (2) Disconnect 2 connectors and remove 2 screws.
- (3) Release 1 latch. Then pull out the process unit front cover and take it off.

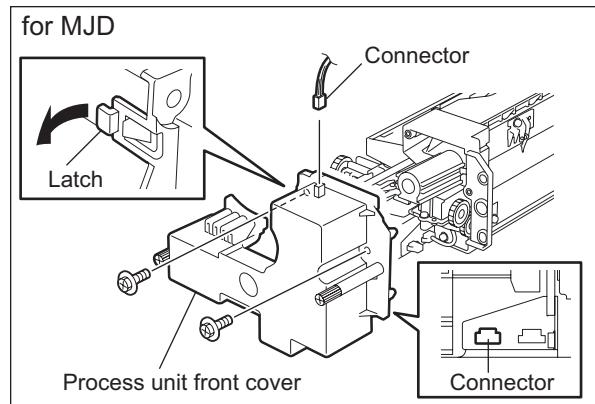

Fig. 11-8

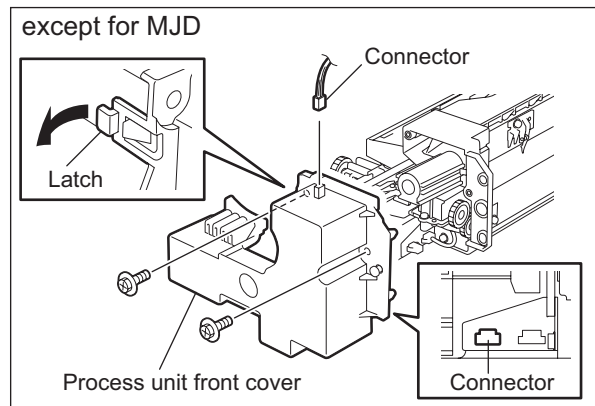

Fig. 11-9

### Note:

When installing the process unit front cover, wire the harness correctly in order not to contact the gears and harness of the process unit front cover each other.

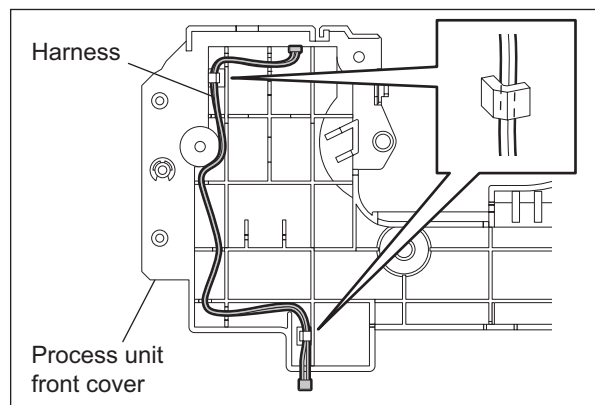

Fig. 11-10

- (4) Lift up the drum cleaner unit and take it off.

**Notes:**

1. Be careful not to touch or scratch the drum surface at this time.

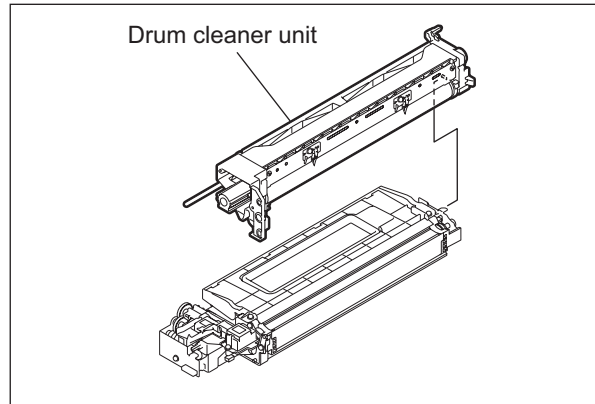

Fig. 11-11

2. Do not deform the guide mylar by touching this.

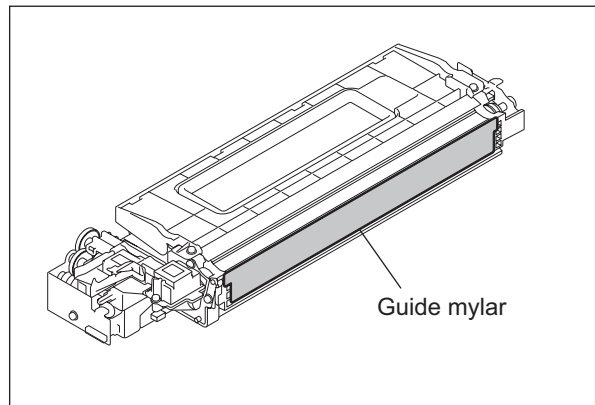

Fig. 11-12

**[C] Discharge LED (ERS)**

- (1) Take off the drum cleaner unit.  
P.11-10 "[B] Drum cleaner unit"
- (2) Release 1 latch and take off the discharge LED unit.

**Note:**

Be careful not to touch or scratch the drum surface at this time.

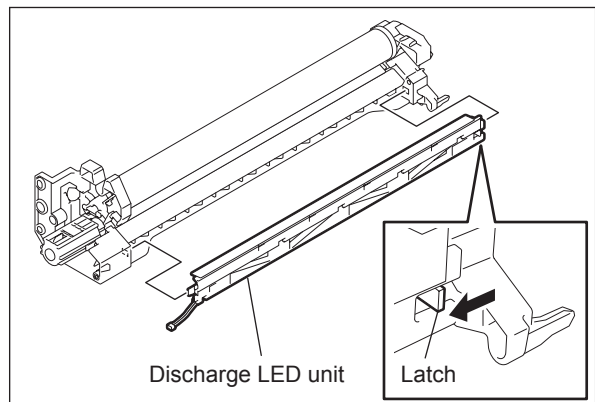

Fig. 11-13

- (3) Release the harness from the harness clamp and pull out the discharge LED.

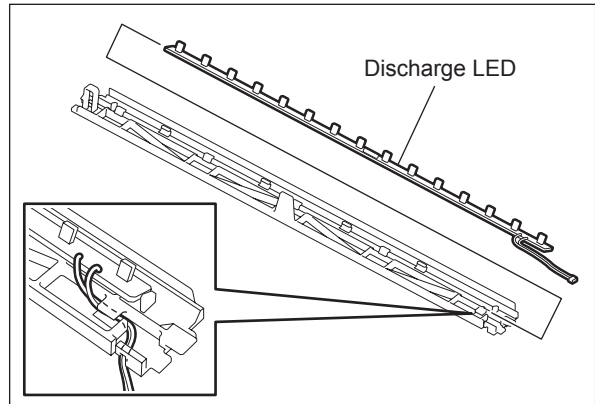

Fig. 11-14

**[D] Main charger**

- (1) Take off the discharge LED unit.  
     📖 P.11-11 "[C] Discharge LED (ERS)"
- (2) Pull out the main charger and take it off by sliding it to the rear side.

**Note:**  
 Be careful not to touch or scratch the drum surface at this time.

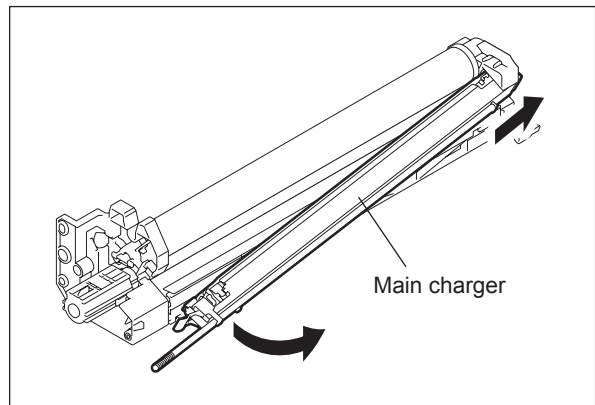

Fig. 11-15

**[E] Main charger grid** 

- (1) Take off the main charger.  
     📖 P.11-12 "[D] Main charger"
- (2) Remove the spring and take off the main charger grid.

**Note:**  
 Do not touch the mesh area of the grid.

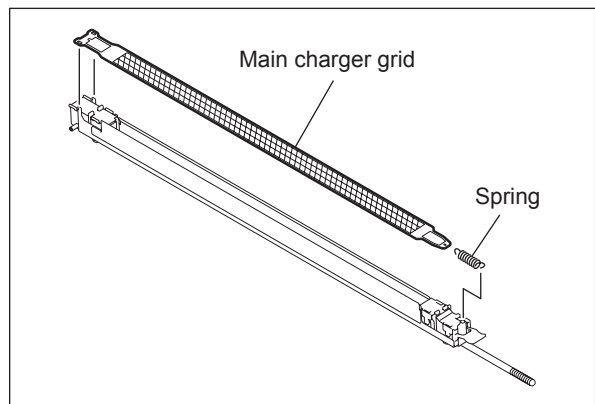

Fig. 11-16



## [F] Main charger cleaner

- (1) Take off the main charger.  
📖 P.11-12 "[D] Main charger"
- (2) Release the hook of the cleaning shaft. Then rotate the shaft at 90 degrees to take it off.

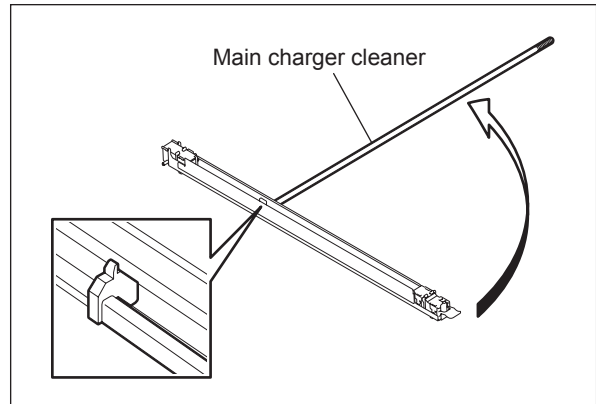

Fig. 11-17

## [G] Needle electrode

- (1) Take off the main charger grid and main charger cleaner.  
📖 P.11-12 "[E] Main charger grid"  
📖 P.11-13 "[F] Main charger cleaner"
- (2) Take off the terminal covers of both front and rear sides.

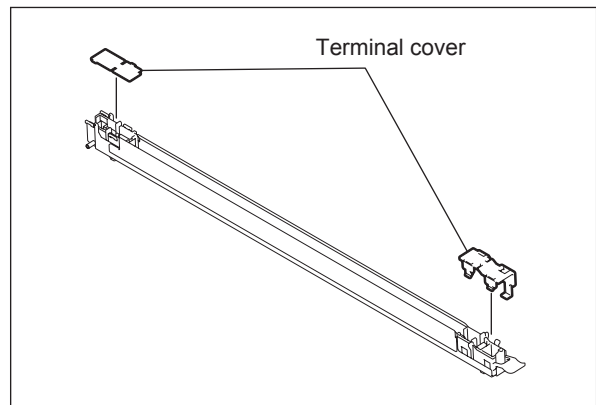

Fig. 11-18

- (3) Remove the terminal and spring. Then take off the needle electrode.

### Notes:

1. Do not touch the needle electrode directly with bare hands.
2. Make sure not to hold or bend the needle electrode.

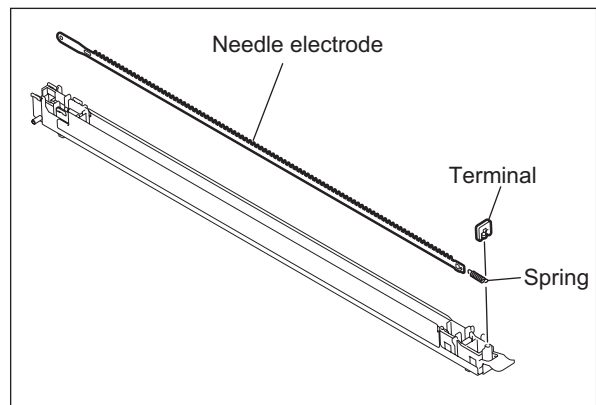



Fig. 11-19

## [H] Drum

- (1) Take off the main charger.  
 P.11-12 "[D] Main charger"
- (2) Rotate the lever while pushing its latch and pull it out.
- (3) Take off the drum.

### Notes:

1. Be careful not to touch, spit or scratch the drum surface.
2. Avoid direct light. Place the drum in a dark place immediately after taking off.
3. Be careful not to touch or scratch the edge of the cleaning blade.

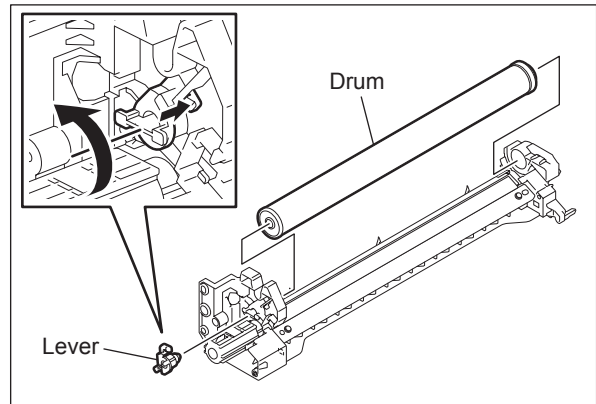



Fig. 11-20

## [I] Drum cleaning blade

- (1) Take off the drum.  
 P.11-14 "[H] Drum"
- (2) Remove 2 screws and take off the drum cleaning blade.

### Note:

Be careful not to touch or scratch the edge of the drum cleaning blade.

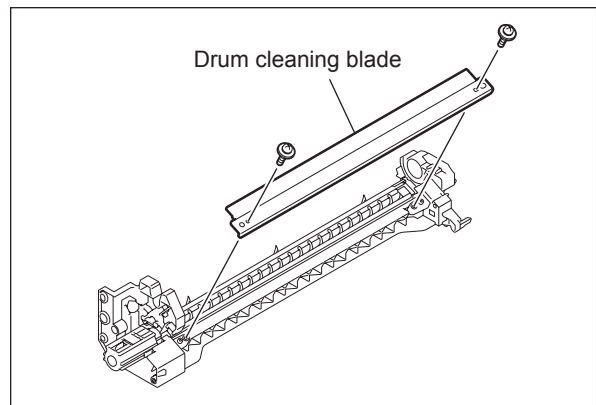



Fig. 11-21

## [J] Drum separation finger

- (1) Take off the drum.  
 P.11-14 "[H] Drum"
- (2) Take off 2 drum separation finger units by removing 1 screw each.

### Note:

When replacing the drum separation fingers, make sure that the drum has been taken off first since the fingers may scratch the drum surface.

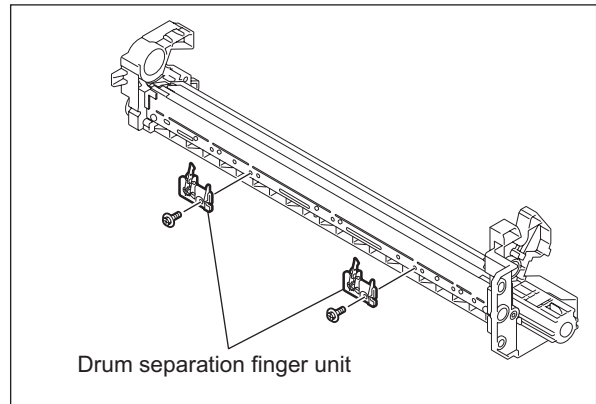

Fig. 11-22

- (3) Take off the drum separation finger with the spring.

### Note:

When the drum separation fingers have been replaced, check if the pressure movement is normal by moving them with your hands.

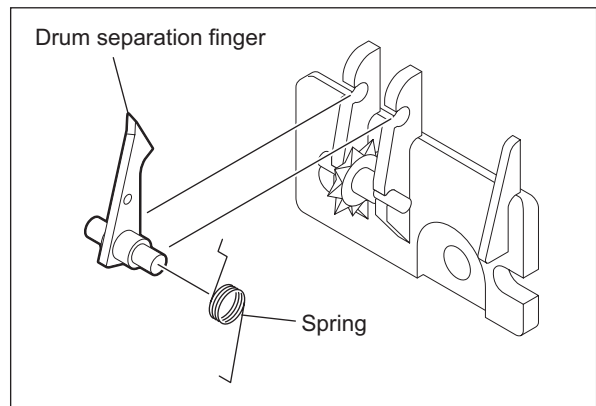



Fig. 11-23

## [K] Recovery blade

- (1) Take off 2 drum separation finger units.  
 P.11-15 "[J] Drum separation finger"
- (2) Remove 2 screws, and take off the whole recovery blade with the bracket.

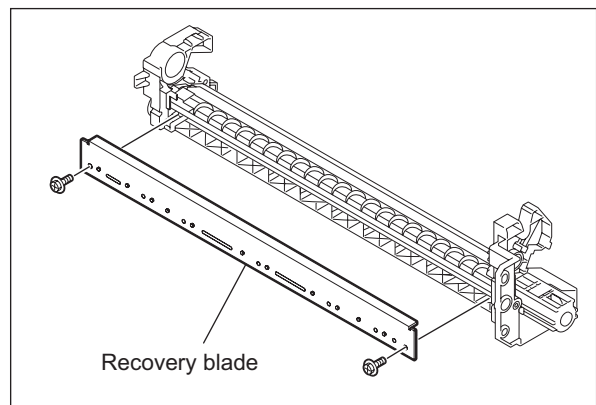

Fig. 11-24

## [L] Transfer/Separation charger

- (1) Open the ADU cover and transfer unit.
- (2) Release the latch and take off the transfer and separation chargers.

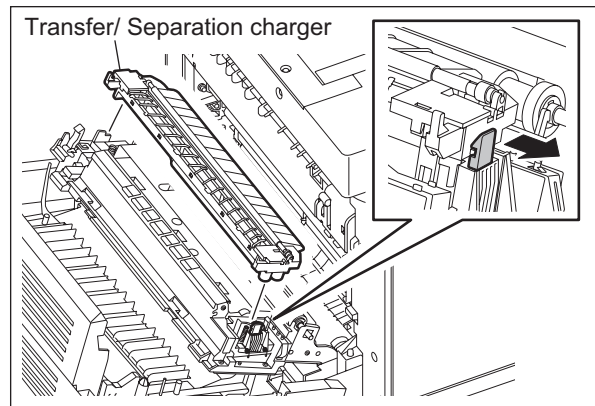



Fig. 11-25

## [M] Charger wire

\* Length: 353 mm (tungsten wire), diameter: 0.06 mm

- (1) Take off the transfer/separation charger.  
 P.11-16 "[L] Transfer/Separation charger"
- (2) Release 9 latches and take off the separation supporter.

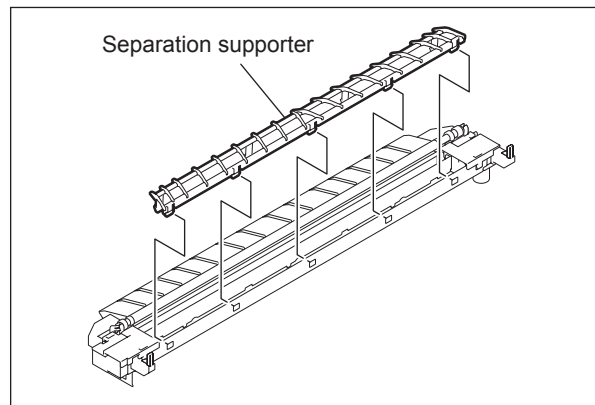

Fig. 11-26

- (3) Release 2 latches and take off the terminal cover on the front side.
- (4) Release 2 latches and take off the terminal cover on the rear side.

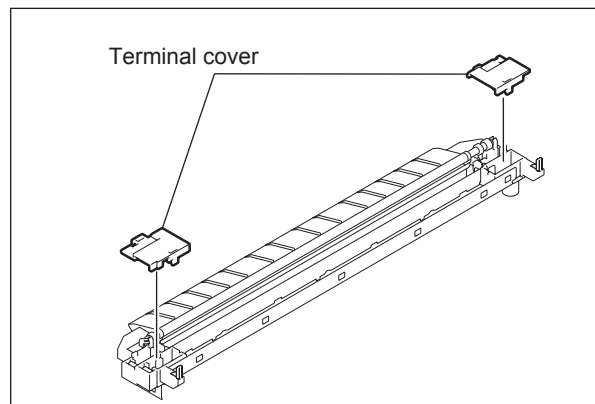

Fig. 11-27

- (5) Remove the terminal and spring. Then take off the transfer charger wire.
- (6) Remove the cushioning material, disconnect the terminal and remove the spring. Then take off the separation charger wire.

**Notes:**

1. Insert the wire securely into the V-grooves of the front and rear sides.
2. Do not twist the wire.
3. Do not touch the wire directly with bare hands.

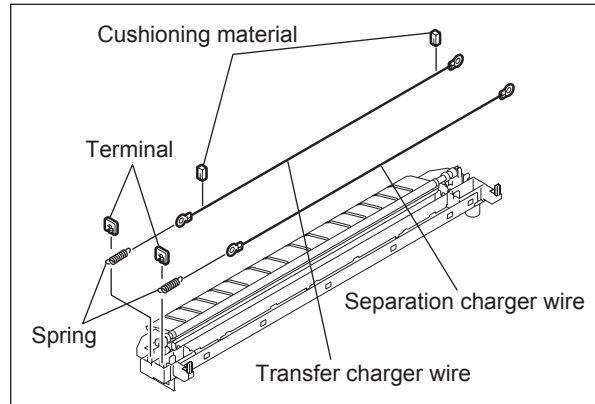

Fig. 11-28

**[N] Transfer unit**

**Note:**

When taking off the transfer unit, take off the process unit first to prevent the drum from light.

- (1) Open off the ADU cover.
- (2) Take off 2 guides.

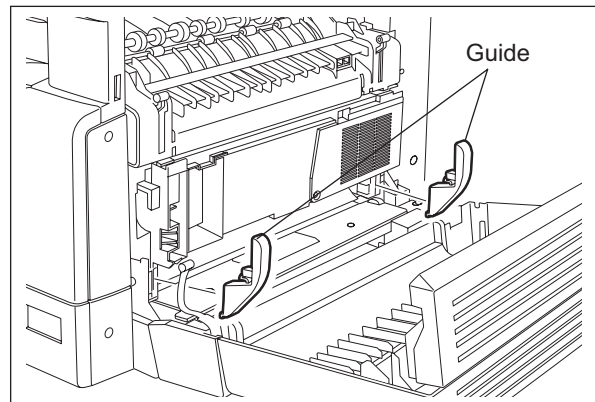

Fig. 11-29

- (3) Take off the transfer unit while pulling the lever.

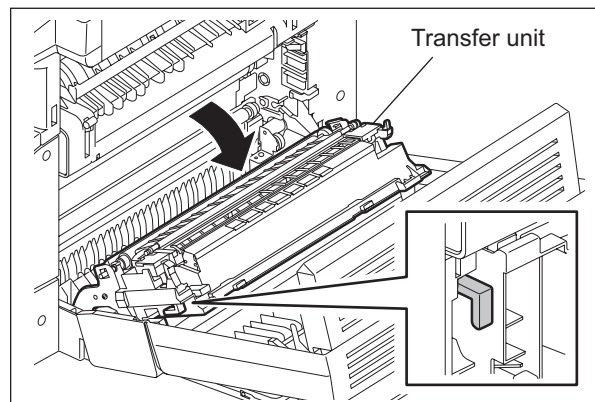

Fig. 11-30

- (4) Remove 1 screw and take off the harness cover.

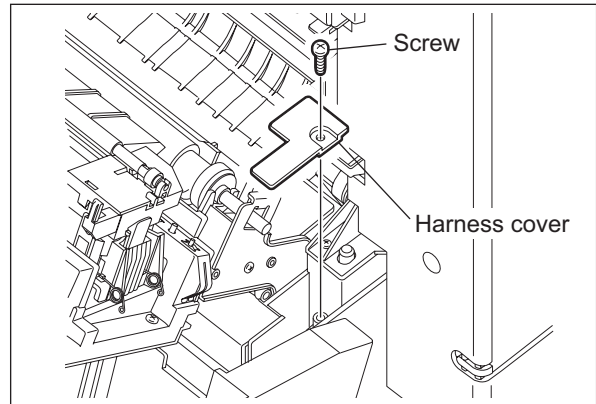

Fig. 11-31

- (5) Disconnect 1 connector.

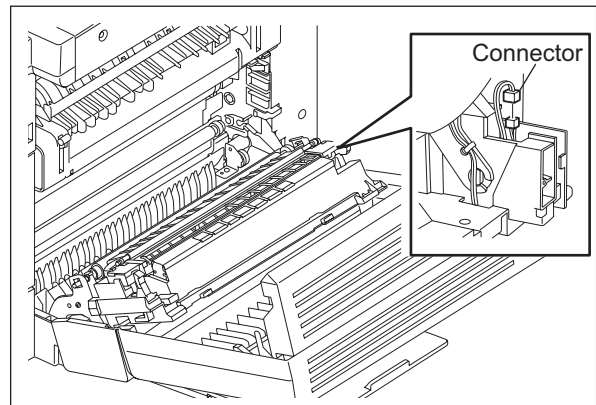

Fig. 11-32

- (6) Take off the transfer unit while lifting it up.

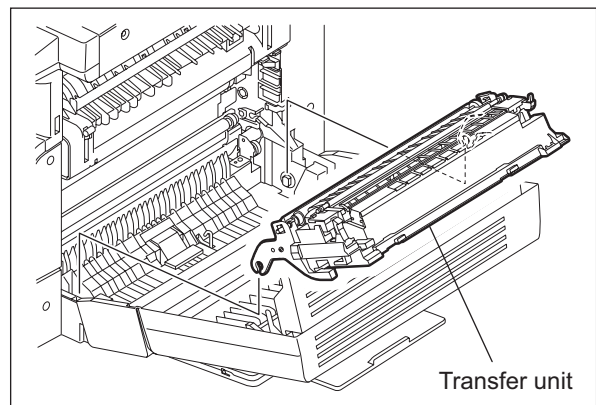

Fig. 11-33

## [O] Ozone filter

- (1) Open the ADU cover.
- (2) Release 1 latch and take off the rear side guide.

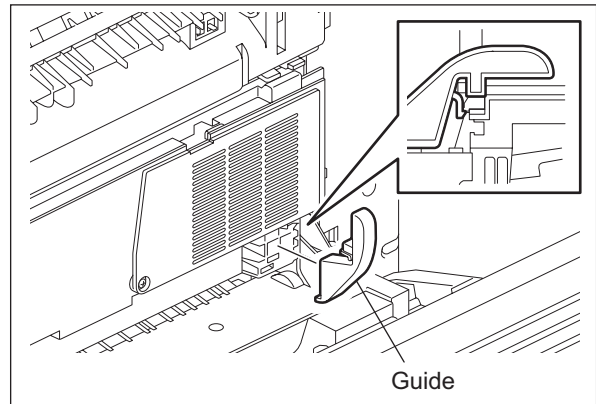

Fig. 11-34

- (3) Remove 1 screw and take off the ozone filter cover.
- (4) Take off the ozone filter.

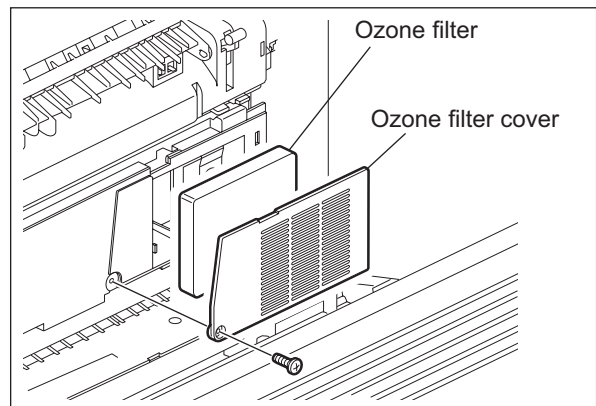



Fig. 11-35

## [P] Exhaust fan (M5)

- (1) Take off the transfer unit.  
 P.11-17 "[N] Transfer unit"
- (2) Take off the transfer/separation charger.  
 P.11-16 "[L] Transfer/Separation charger"
- (3) Remove 1 screw and take off the post transfer guide.

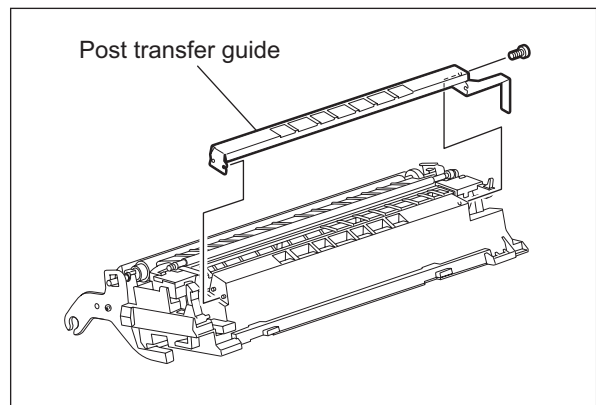

Fig. 11-36

- (4) Remove 4 screws.

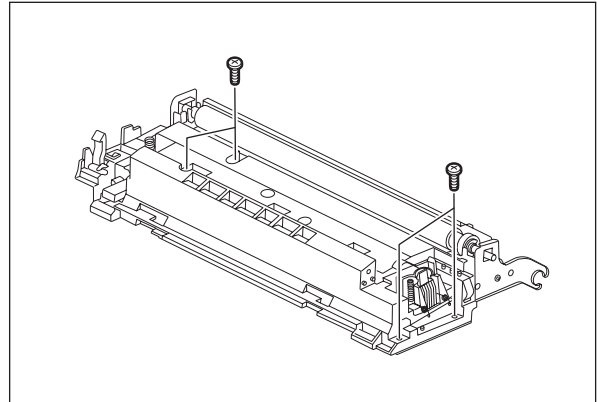

Fig. 11-37

- (5) Remove 1 strap, release the harness from the harness clamp, and take off the exhaust fan with the duct.

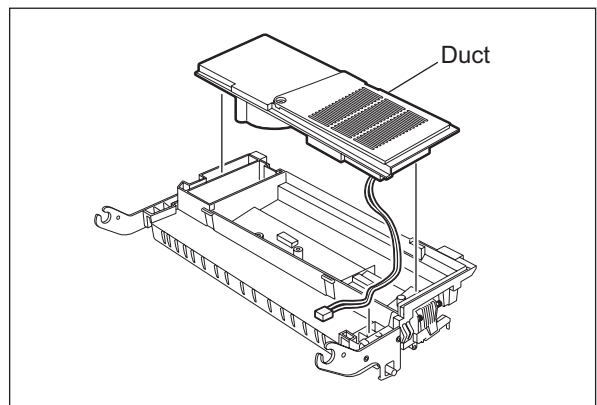

Fig. 11-38

- (6) Release the harness from the harness clamp, remove the two-sided tape and take off the exhaust fan.

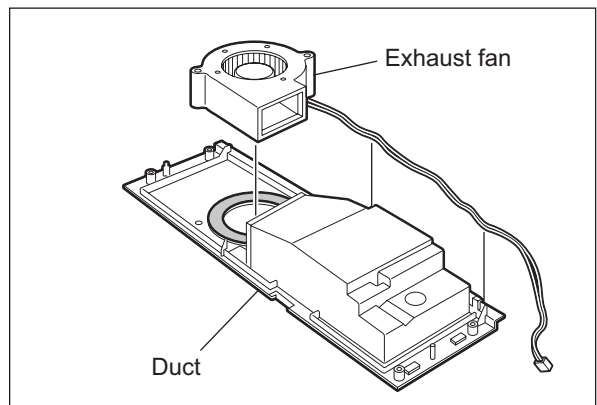

Fig. 11-39



### [Q] Temperature/humidity sensor (S3)

- (1) Take off the left cover.  
📖 P.2-19 "[C] Left cover"
- (2) Disconnect 1 connector, remove 1 screw, and then take off the temperature/humidity sensor.

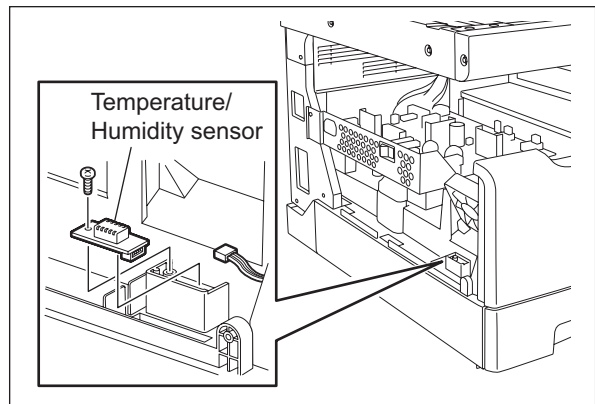

Fig. 11-40

### [R] Toner cartridge interface PC board (CTIF)

- (1) Take off the process unit.  
📖 P.11-17 "[N] Transfer unit"
- (2) Take off the inner tray.  
📖 P.2-18 "[B] Inner tray"
- (3) Disconnect 1 connector, remove 1 screw and then take off the toner cartridge interface PC board.

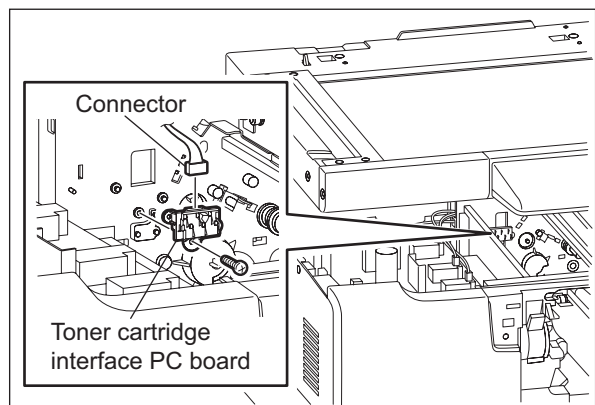

Fig. 11-41



## 12. DEVELOPMENT SYSTEM

### 12.1 General Description

Development is the process of converting electrostatic latent images into visible images. The developer material is supplied onto the photoconductive drum surface by the developer sleeve (magnet roller). Then the toner in the developer material adheres to this drum surface to form images. This process is performed in the developer unit.

This chapter explains about the units, parts and control circuits related to development.

The developer unit in this equipment has a recovered toner supply mechanism which recycles the recovered toner scraped off by the drum cleaning blade. The developer unit is driven by the main motor (M3) to rotate the mixers and the developer sleeve.

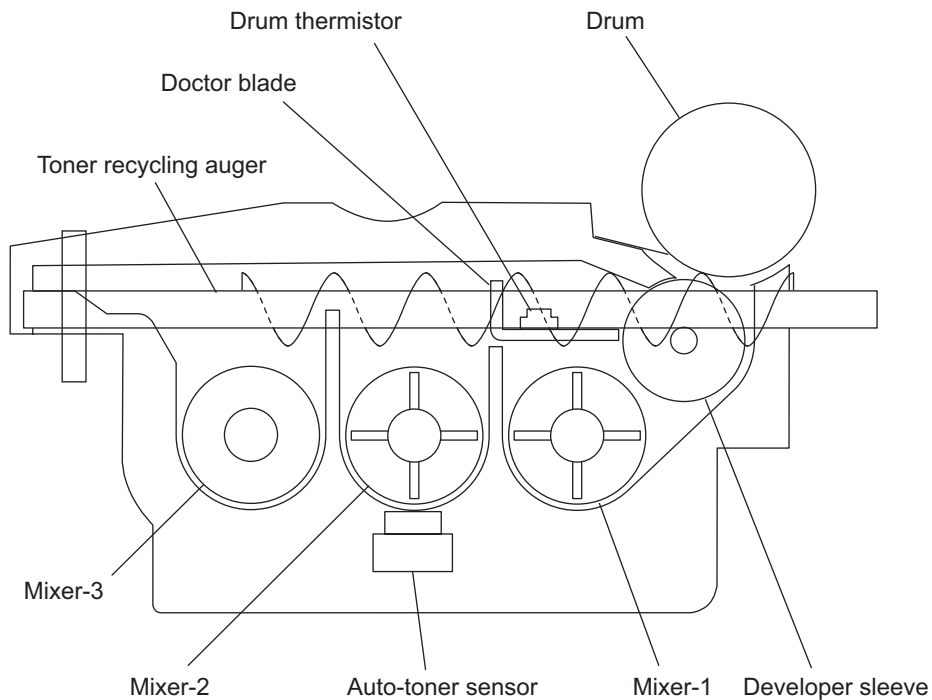

Fig. 12-1

## 12.2 Construction

Developer unit	Developer material	Periodic replacement required
	Mixers-1, -2 and -3	
	Developer sleeve (Magnet roller)	
	Doctor blade	
	Auto-toner sensor	S6
	Drum thermistor	THMS4
	Recovered toner supply mechanism (Toner recycling auger)	
Toner cartridge	Toner cartridge PC board	CTRG
	Toner cartridge interface PC board	CTIF
Toner motor		M2 (Ch. 9)

## 12.3 Functions

### 12.3.1 Function of each unit

#### [ 1 ] Developer unit

- Developer material  
This consists of carrier and toner. The carrier is electrically conductive ferrite whose particle size is 30-100  $\mu\text{m}$ , and the toner is resin whose particle size is 5-20  $\mu\text{m}$ . The developer material requires a periodic replacement since it deteriorates with long-term use.
- Mixers-1, -2 and -3  
Mixing the developer material generates a friction of the carrier and the toner. The carrier is then positively charged and the toner is negatively charged, and the charged carrier and toner adhere on the drum surface by their static electricity. The mixer-3 is mounted exclusively for the recovered toner to mix it in a sufficient period of time.
- Developer sleeve (Magnet roller)  
This aluminum roller includes a magnet inside. The developer sleeve absorbs the developer material using this magnet to form a magnetic brush. The magnet is fixed therefore the only sleeve is rotated. This rotation makes the magnetic brush of the developer sleeve sweep over the drum surface, and thus development is performed.
- Doctor blade  
This controls the amount of the developer material transported from the developer sleeve so that the magnetic brush of the developer material can properly contact with the drum surface.
- Auto-toner sensor (S6)  
To print out normal images, a constant ratio of the carrier and the toner in the developer material (= toner density) must be maintained. The auto-toner sensor (S6) detects the content ratio of the toner in the developer material with its magnetic bridge circuit. When this sensor detects the insufficient status of the toner, it drives the toner motor (M2) to supply the toner from the toner cartridge.
- Drum thermistor (THMS4)  
This is installed in the developer unit to detect the ambient temperature of the drum.
- Recovered toner supply mechanism (Toner recycling auger)  
The recovered toner, transported from the drum cleaner, is then transported into the developer unit by the toner recycling auger mounted on the front side of this unit. The drive of the toner recycling auger is transmitted from the mixer-3.

#### [ 2 ] Toner cartridge

This is filled with the toner and this supplies the toner to the developer unit by the drive of the toner motor (M2). The toner cartridge in this equipment mounts the toner cartridge PC board (CTRG), and the data identifying recommended TOSHIBA toner cartridges and the counter values determining that the cartridge is nearly empty are written in this board. These data are read out by the toner cartridge interface PC board (CTIF) in this equipment, and data related to toner supply are also written in the toner cartridge PC board (CTRG). The toner cartridge interface PC board (CTIF) also detects whether the toner cartridge is installed or not.

#### [ 3 ] Toner motor (M2)

This drives the toner cartridge with gears.

## 12.3.2 Functions of the toner cartridge PC board (CTRG)

The toner cartridge in this equipment mounts the toner cartridge PC board (CTRG). An IC chip is embedded in this board, and the data identifying the recommended TOSHIBA toner cartridge and thresholds to determine if the cartridge is nearly empty are written in this chip.

To measure the amount of toner remaining in the cartridge, when the value of counter for period of toner cartridge rotation time (08-1410) is updated, this equipment writes the updated value into the toner cartridge PC board (CTRG).

These data written in the toner cartridge PC board (CTRG) enable the functions below, and accordingly this equipment operates as shown below. Data reading is performed every time the power of this equipment is turned ON and the front cover is closed.

[Data read by the toner cartridge PC board (CTRG)]

- Data to identify recommended TOSHIBA toner cartridges
- Thresholds to determine if the toner cartridge is nearly empty
- Value of counter for period of toner cartridge rotation time

[Functions]

- Cartridge detecting function  
This function checks whether the toner cartridge is inserted correctly or not, and whether the recommended toner cartridge is used or not.
- Toner remaining check function  
This function notifies the user of the near-empty status of toner. Normally, the message "Toner is low" is displayed when the toner is running out, and "Toner empty" when the toner cartridge is empty.
- Toner remaining check notification function  
Upon detecting the near-empty status of toner, this function automatically notifies your service representative.

[Operations]

Toner cartridge	Recommended cartridge	Recommended cartridge refilled with new toner	Non-recommended cartridge
Cartridge detecting function	Enabled "Toner not recognized" is displayed when no cartridge is installed.	Enabled "Toner not recognized" is displayed when no cartridge is installed.	Disabled "Toner not recognized" is displayed even when the cartridge is installed.
Toner remaining check function	Enabled "Toner is low" is displayed when the cartridge is nearly empty.	Disabled "Toner is low" is displayed even when a new cartridge is installed.	Disabled This function does not operate.
Toner remaining check notification function	Enabled	Disabled	Disabled

A sign of the status that the toner cartridge is nearly empty (= the behavior of the toner lamp) appears when the value of counter for period of toner cartridge rotation time has exceeded the thresholds previously written in the toner cartridge PC board (CTRG). When a used cartridge refilled with new toner is used, that is the value of counter for period of toner cartridge rotation time in the toner cartridge PC board (CTRG) had already exceeded the threshold to determine the near-empty status of the toner at this moment, the sign of the near-empty status appears immediately after the installation of this cartridge. When a non-recommended toner cartridge is used, the toner lamp is lit by the cartridge detecting function because its data cannot be read out.

The toner near-empty status threshold setting (08-971) is provided to adjust the timing for displaying the toner near-empty status as follows.

The toner near-empty status threshold setting (08-971)

- 0: The period from the appearance of the toner near-empty sign to the actual complete consumption of the toner is set long.
- 1: Normal (Default)
- 2: The period from the appearance of the toner near-empty sign to the actual complete consumption of the toner is set short.
- 3: The sign of the status that the cartridge is nearly empty does not appear.

Note that the shorter the period described above is set, the more frequently the toner in the cartridge may run out before the sign of the near-empty status of the toner appears because the way the toner remains in the cartridge differs every time.

When the value of the toner near-empty status threshold setting (08-971) is set at "3", the toner remaining check function is disabled.

When the cartridge detecting function is set to OFF (08-695 is set at "0"), the value of the toner near-empty status threshold setting (08-971) is automatically set at "3" and the toner remaining check function is disabled.

When the cartridge detecting function is set to ON (08-695 is set at "1"), the value of the toner near-empty status threshold setting (08-971) is automatically set at "1" and the toner remaining check function is enabled.

### 12.3.3 Recovered toner supply mechanism

The toner scraped off by the drum cleaning blade is transported by the toner recovery auger and the toner recycling auger to be recycled, and then returned into the developer unit. Then the recovered toner in the developer unit is mixed by the developer material using the mixer-3. The mixer-3 is mounted exclusively for the recovered toner to mix it in a sufficient period of time. On the other hand, the (fresh) toner transported from the toner cartridge into the developer unit is mixed by the mixer-2. Then the (fresh) toner and the recovered toner are mixed together and further transported to the mixer-1. They are further mixed by the mixer-1 and transported to the developer sleeve.

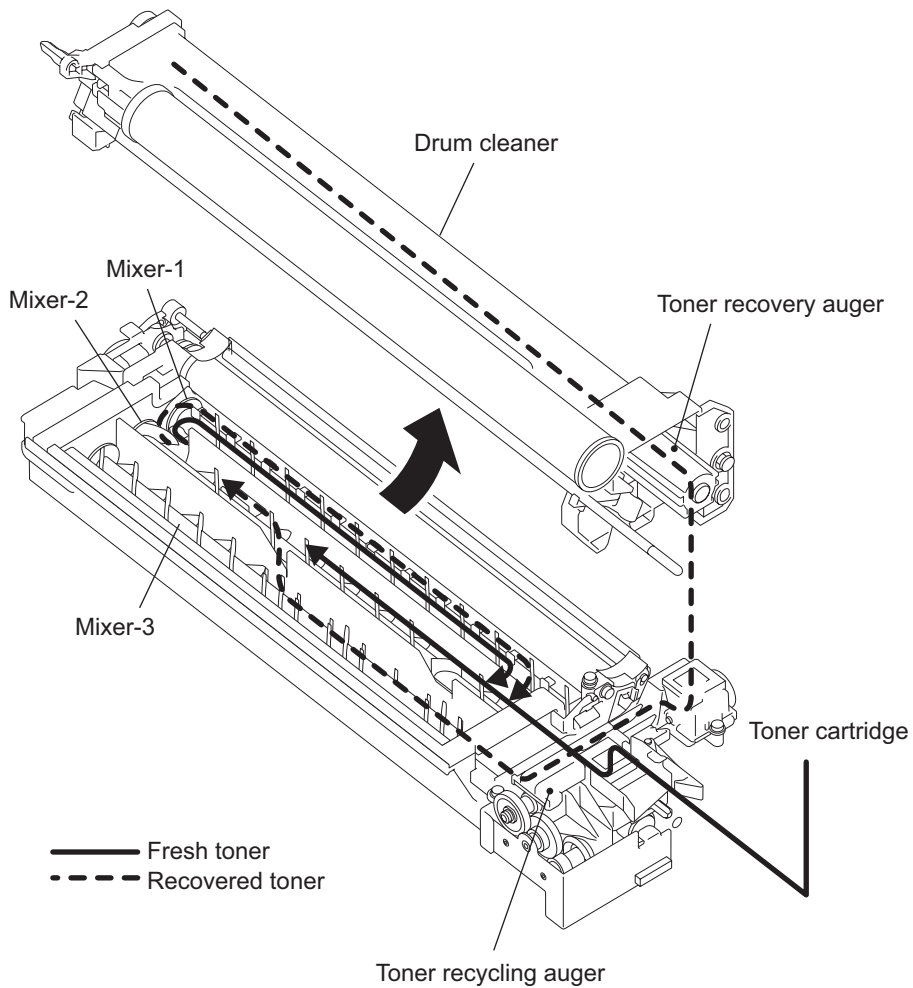

Fig. 12-2



## 12.4 Toner Motor Control Circuit

The toner motor, which is a DC motor driven by control signals from the ASIC on the MAIN board, supplies toner to the developer unit by means of rotating the paddle and angle in the toner cartridge. The toner motor is driven when the ON/OFF signal (TNRMTON-0) output from the ASIC becomes "L" level.

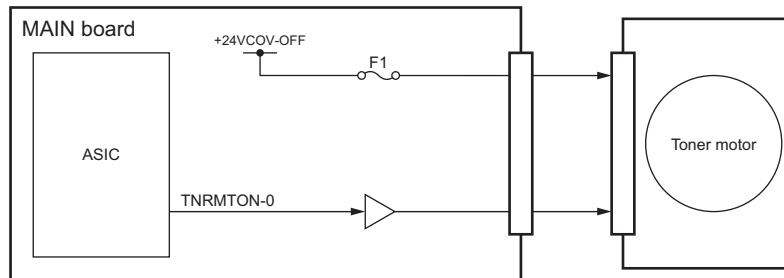

Fig. 12-3

## 12.5 Auto-Toner Circuit

### 12.5.1 General description

1) Function of the auto-toner circuit

- Detects the toner density in the developer material, and supplies toner when the density is lowered to a certain level.
- Detects that there is no toner left in the cartridge (toner-empty detection).

2) The auto-toner circuit consists of the following:

- Auto-toner sensor:  
Detects the toner density.
- Control section:  
Controls the toner density so that the toner in the developer material is fixed to certain ratio.
- Toner motor:  
Supplies toner to the developer material.
- Control panel:  
Indicates toner-empty information.
- Recovered toner supply section:  
The main motor supplies the recovered toner to the developer unit from the recovered toner supply mechanism.

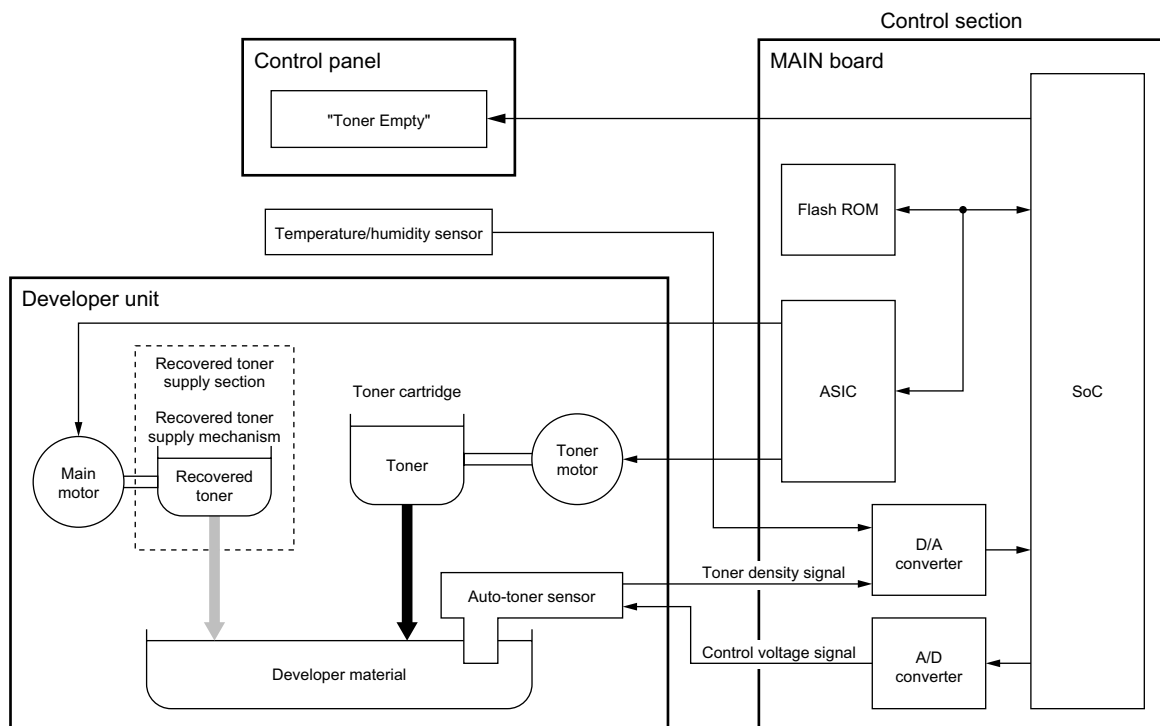

Fig. 12-4

## 12.5.2 Function of auto-toner sensor

### 1) Function

- Initialization adjustment function - At the first use of the equipment or when the developer material is replaced with a new one.

Automatically adjusts the output value of the auto-toner sensor responding to humidity (input value to the A/D converter) for the toner density of the new developer material so that it stays in range of 2.34 to 2.46 V.

- Stabilizing the toner density - During the printing operation  
Maintains the toner density to a certain ratio as follows.

Toner is consumed.

→ The toner density is lowered.

→ Change in the auto-toner sensor output responding to humidity is detected.

→ The toner motor is driven.

→ Toner is supplied from the toner cartridge to the developer unit.

- Toner-empty detection and recovery:

Detects that there is no toner in the toner cartridge:

The toner motor is driven.

→ The auto-toner sensor output does not change.

→ The toner density does not change.

→ It is determined there is no toner in the cartridge (toner empty).

Recovering from the toner-empty state:

The toner motor is driven.

→ Toner is supplied from toner cartridge.

→ The auto-toner sensor output changes.

→ The toner density returns to normal value.

→ The toner-empty state is cleared.

## 2) Function of auto-toner sensor

- The auto-toner sensor consists of the following circuits:

### Drive winding:

A magnetic head (primary side) with a high-frequency magnetic field, which forms a magnetic circuit in the developer material.

### Detection winding:

Receives the change in the magnetic resistance of the developer material through the magnetic circuit (secondary side).

### DC conversion circuit:

Converts a high-frequency output from the detection winding into a DC signal (auto-toner output  $V_{ATS}$ ).

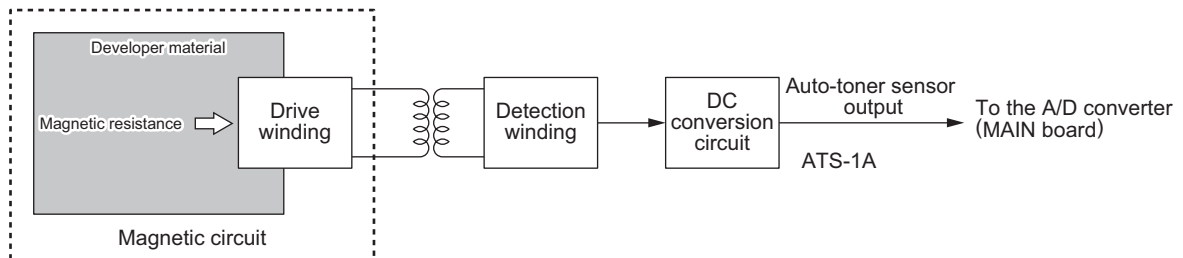

Fig. 12-5

- When the toner density is low

The ratio of the toner against the carrier in the developer material decreases.

- The magnetic resistance decreases.
- The detection output increases.
- The auto-toner output  $V_{ATS}$  increases.

- When the toner density is high

The ratio of the toner against the carrier in the developer material increases.

- The magnetic resistance increases.
- The detection output decreases.
- The auto-toner output  $V_{ATS}$  decreases.

## 12.6 Disassembly and Replacement

### [A] Developer unit

**Note:**

Make sure to perform "05-280" and take off the process unit before the developer material is replaced.

- (1) Take off the Process unit.  
📖 P.11-9 "[A] Process unit"
- (2) Take off the drum cleaner unit from the process unit so that only the developer unit will be left.  
📖 P.11-10 "[B] Drum cleaner unit"

**Notes:**

1. Be careful not to touch or scratch the drum surface at this time.

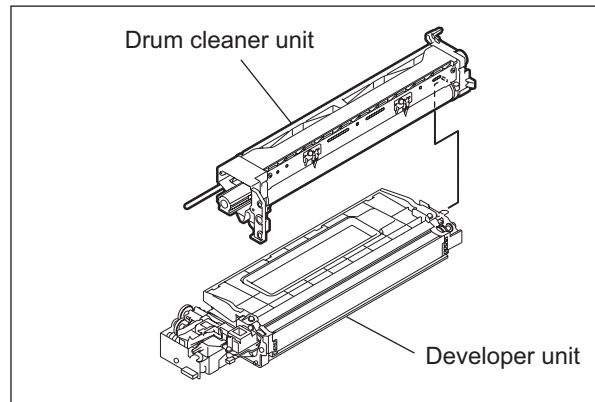

Fig. 12-6

2. Do not deform the Guide Mylar by touching this.

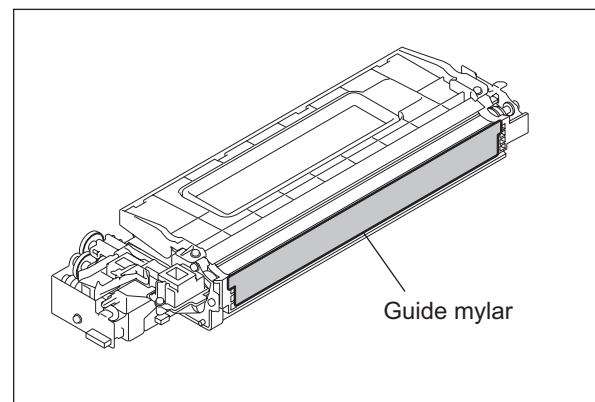
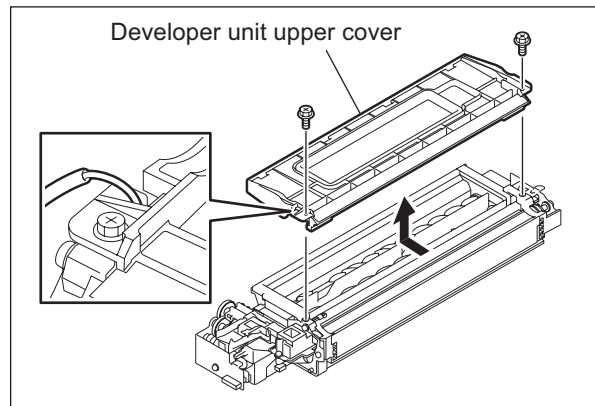

Fig. 12-7

**[B] Developer material (PM)**

- (1) Take out the developer unit  
P.12-11 "[A] Developer unit".
- (2) Remove 2 screws and slide the developer unit upper cover to the direction of the arrow and take it off.



**Fig. 12-8**

**Note:**

When installing the developer unit upper cover, make sure that the side seal comes between the developer unit upper cover and rubber seal on the cover.

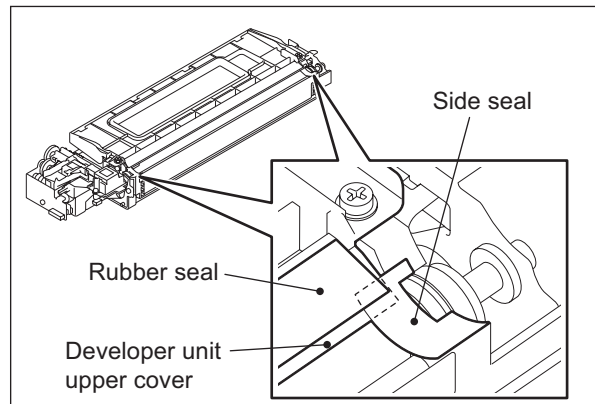
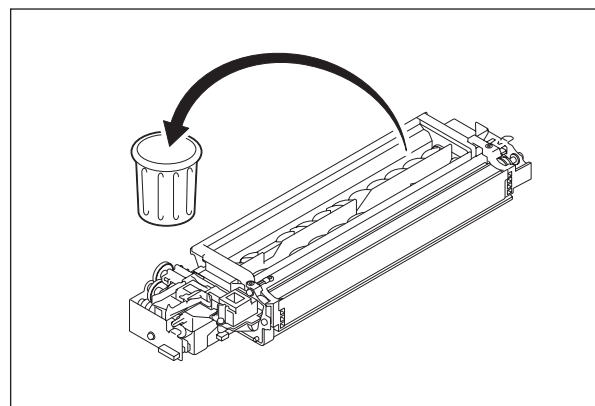

**Fig. 12-9**

- (3) Remove the developer material from rear side.

**Note:**

When removing the developer material, be careful not to drop the developer material on the gears of the developer unit.



**Fig. 12-10**

### [C] Filling developer unit with developer material

- (1) Rotate the gear on the rear side of the developer unit to the direction of the arrow while filling the developer unit with the developer material. Spread out the developer material over the developer sleeve.

- Attach the nozzle as required.

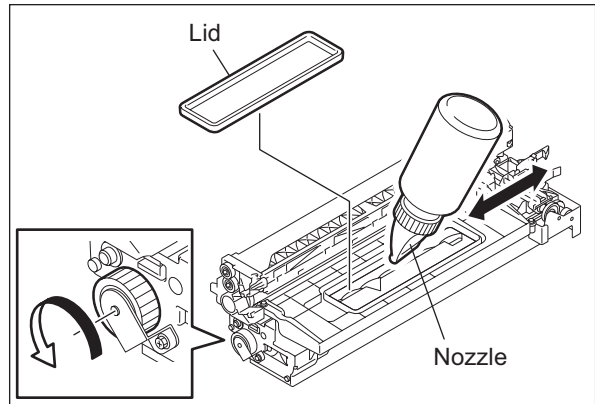

Fig. 12-11

### [D] Auto-toner sensor (S6)

- (1) Remove the developer material.  
P.12-12 "[B] Developer material"
- (2) Place the developer unit upside down. Disconnect 1 connector, release 1 latch, and then rotate the auto toner sensor counter-clockwise to take it off.

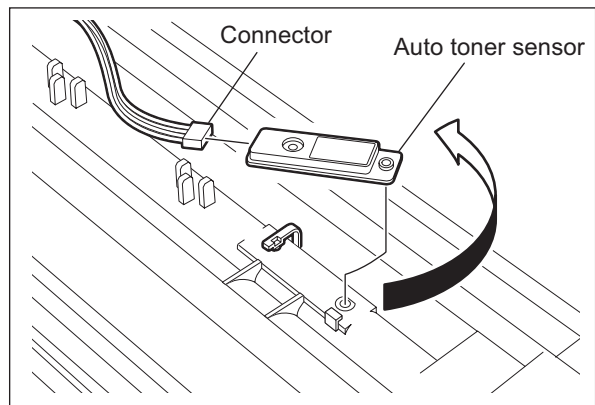

Fig. 12-12

### [E] Drum thermistor (THMS4)

- (1) Remove the developer material.  
P.12-12 "[B] Developer material"
- (2) Disconnect 1 connector, remove 1 screw and take off the drum thermistor.

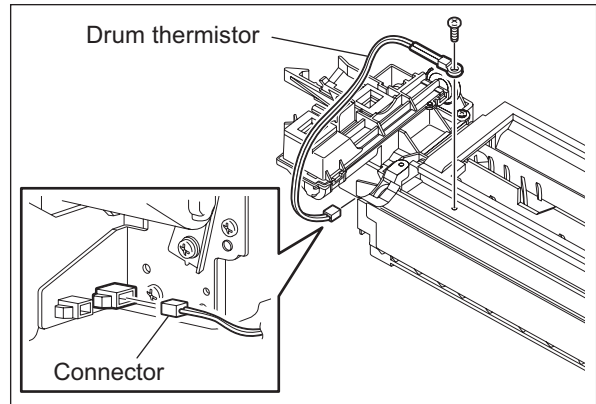

Fig. 12-13

### [F] Guide roller / Developer sleeve

- (1) Remove the developer material.  
P.12-12 "[B] Developer material"
- (2) Remove 2 screws and take off the recovered toner supply unit.

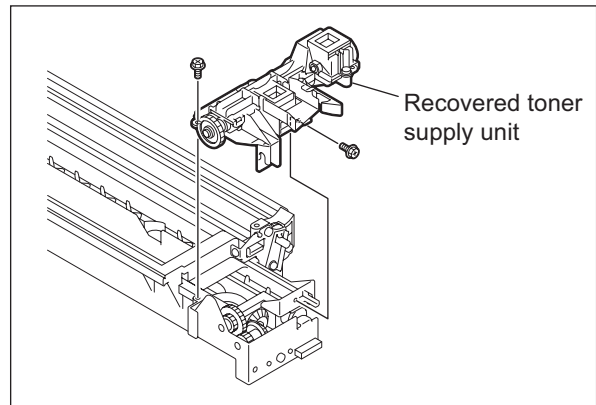

Fig. 12-14

- (3) Remove 1 screw. Disconnect 1 connector while taking off the recovered toner drive unit. Remove 1 gear.

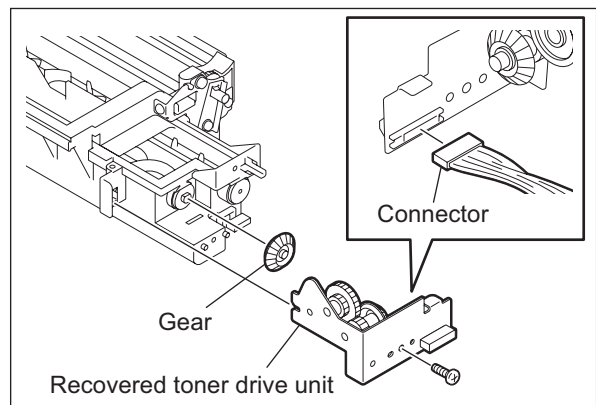

Fig. 12-15



- (4) Remove 2 plate springs fixing the doctor sleeve on its both ends.

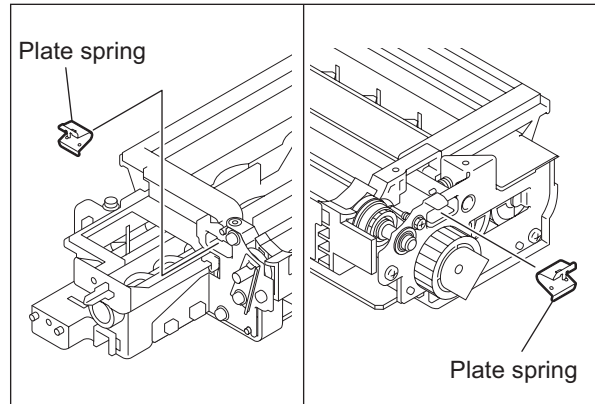

Fig. 12-16

- (5) Remove 2 screws on both ends of the doctor sleeve and remove 2 coil springs.

**Note:**

When the screws on both ends of the doctor sleeve are removed, be sure to adjust the doctor sleeve gap ( $0.45 \pm 0.05$  mm) after assembling.  
(Refer to Service Handbook Chap.3.8)

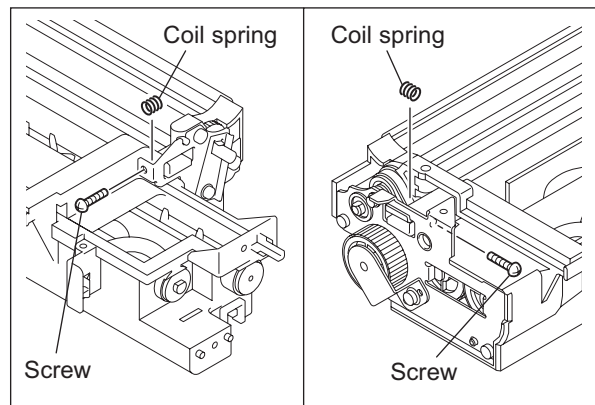

Fig. 12-17

- (6) Remove 1 screw and take off the polarity adjustment lever.

**Note:**

Make a note of the position where the polarity adjustment lever is pointing. (Mark the position if needed.) When reassembling, match the polarity adjustment lever with the previously marked position on the scale.

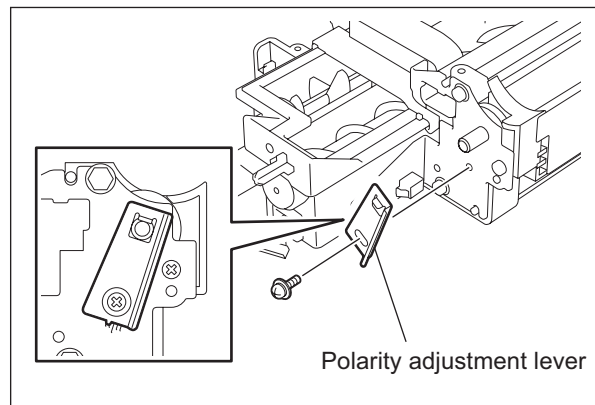

Fig. 12-18

- (7) Disconnect 2 connectors, remove 3 screws and take off the bracket.

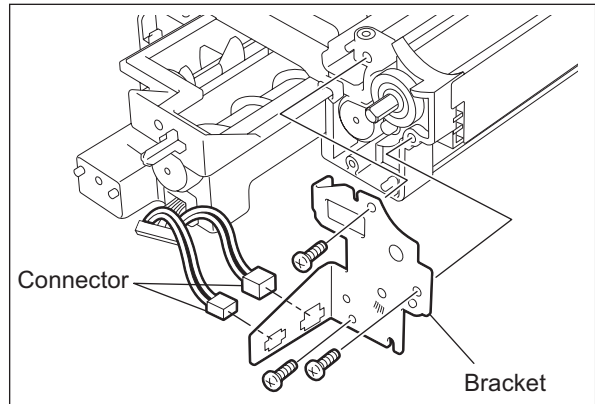

Fig. 12-19

- (8) Remove 1 E-ring and take off the guide roller on the front side.

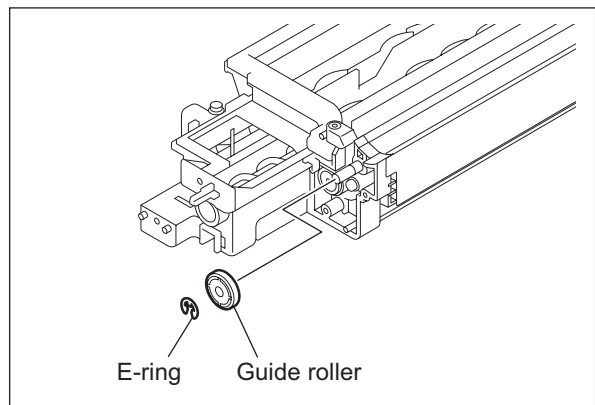

Fig. 12-20

- (9) Remove 1 screw and the gear.

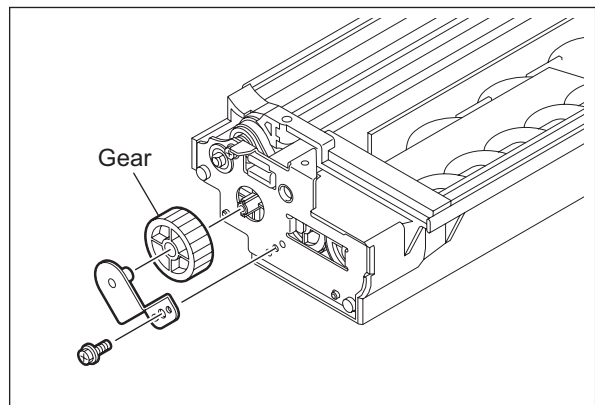

Fig. 12-21

- (10) Remove 3 screws. Take off 1 bearing and the bracket.

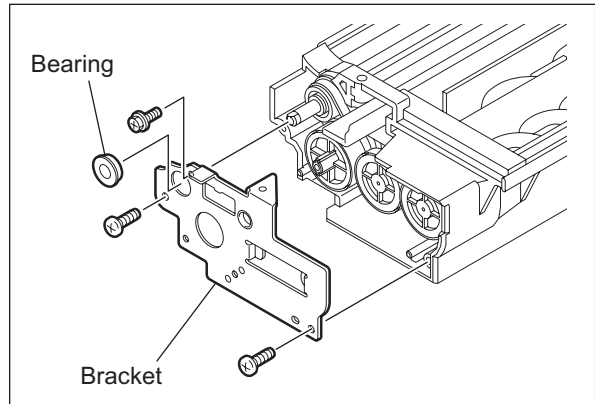

Fig. 12-22

- (11) Take off 4 gears and 1 timing belt.

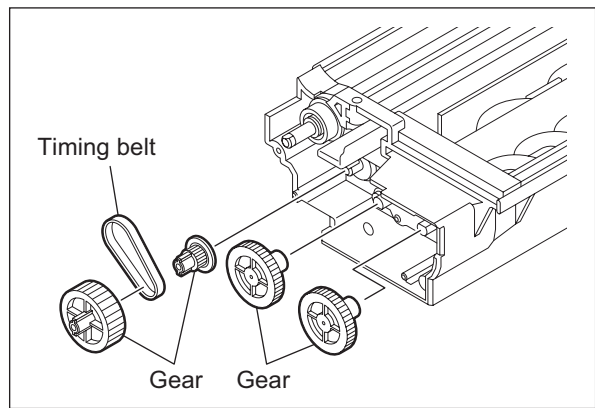

Fig. 12-23

- (12) Remove 1 E-ring, 1 pin and 1 pulley.  
(13) Take off the guide roller on the rear side.

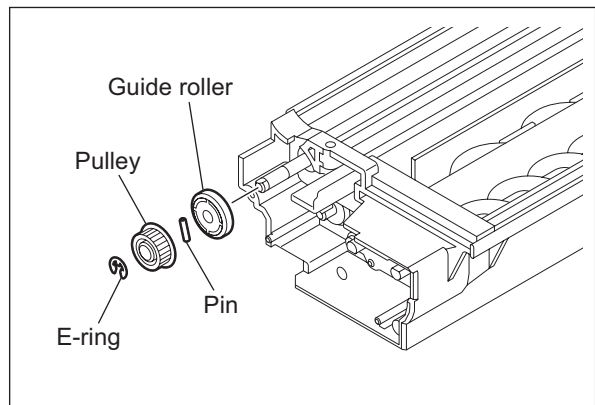

Fig. 12-24

- (14) Remove the seal on the front side. Remove 1 E-ring and 1 bushing.

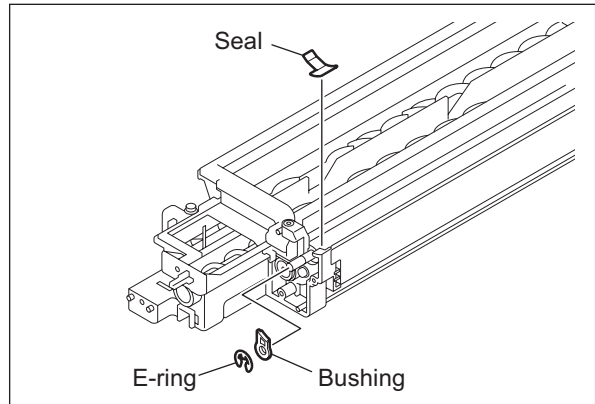

Fig. 12-25

- (15) Take off the developer sleeve.

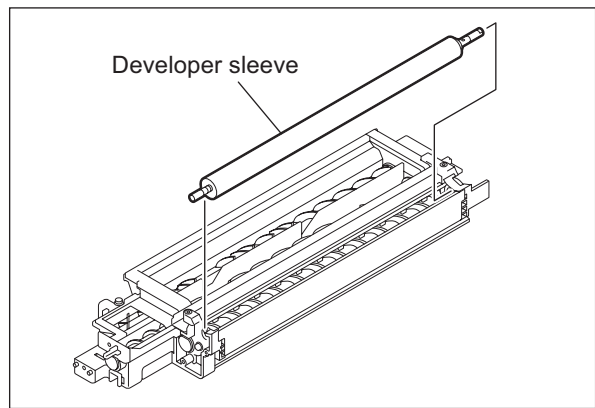

Fig. 12-26

### [G] Mixer

- (1) Take off the developer sleeve.  
P.12-14 "[F] Guide roller / Developer sleeve"  
(2) Take off the doctor sleeve.

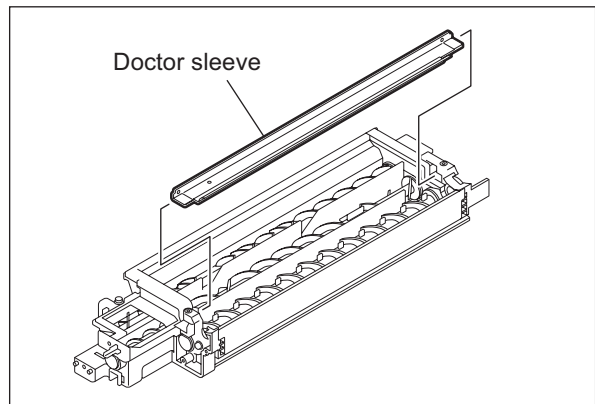

Fig. 12-27

- (3) Remove 1 screw and take off the tensioner bracket.
- (4) Remove 2 screws and take off the holder.

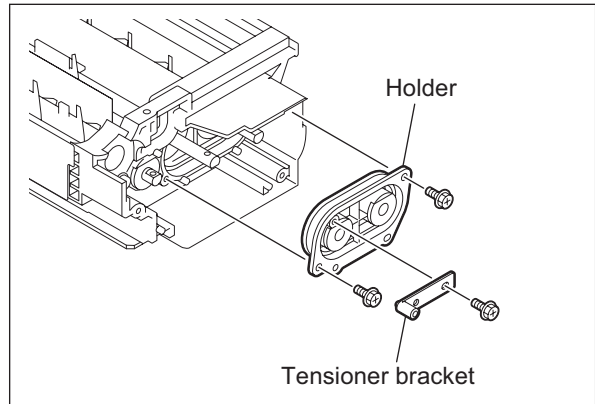

Fig. 12-28

- (5) Remove 2 bushings and 2 oil seals from the holder.  
 (Replacement of Oil seal: P.12-21 "[H] Replacement of Oil Seal")

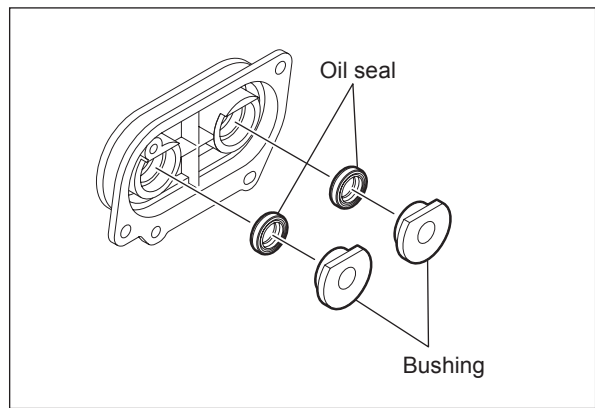

Fig. 12-29

- (6) Take off the mixers-2 and -3.

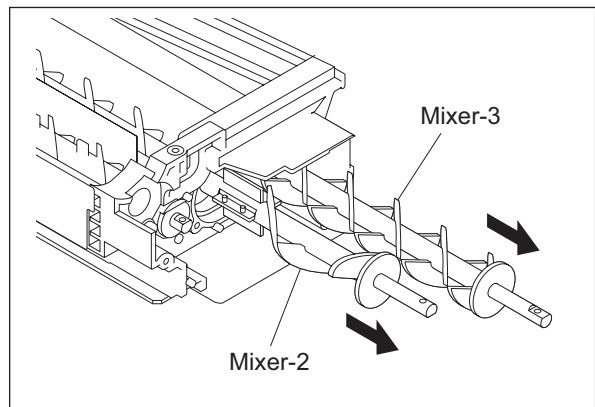

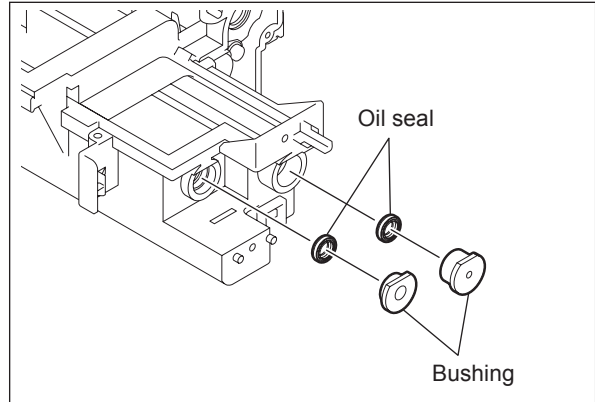



Fig. 12-30

- (7) Remove 2 bushings and 2 oil seals on the rear side.  
 (Replacement of Oil seal:  P.12-21 "[H] Replacement of Oil Seal")



**Fig. 12-31**

- (8) Remove the end section of the mixer-1.  
 (9) Remove the bushing and oil seal.  
 (Replacement of Oil seal:  P.12-21 "[H] Replacement of Oil Seal")

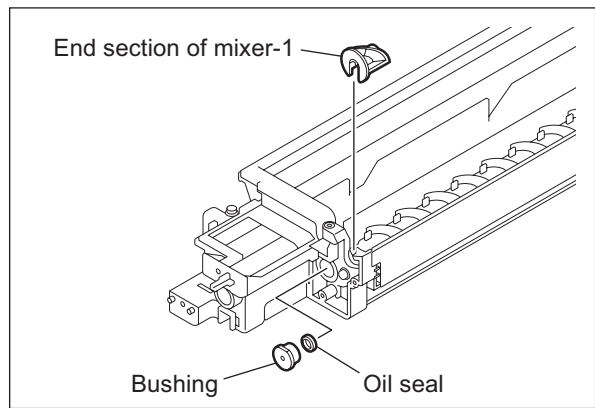

**Fig. 12-32**

- (10) Take off the mixer-1.

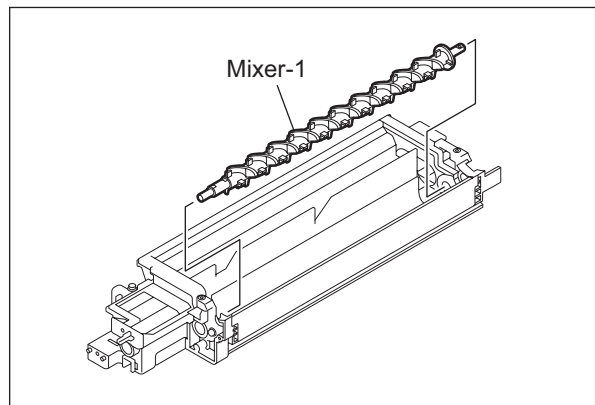

**Fig. 12-33**

- (11) Remove the bushing on the rear side.
- (12) Remove the oil seal.
- (Replacement of Oil seal:  P.12-21 "[H] Replacement of Oil Seal")

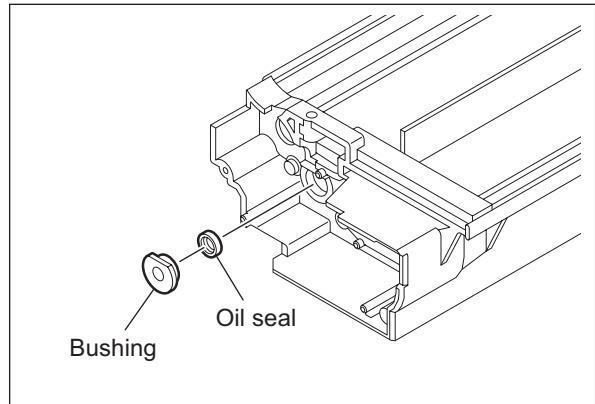

Fig. 12-34

### [H] Replacement of Oil Seal

- (1) Insert a fine screwdriver into the depression of the oil seal to take it out.
- (2) Push in a new oil seal parallel to the frame or bushing (shown figure at right).
- (3) Apply the grease (Alvania No.2; amount of 2 rice grains) on entire surface of the oil seal evenly.

**Note:**

Wipe off the excessive grease.

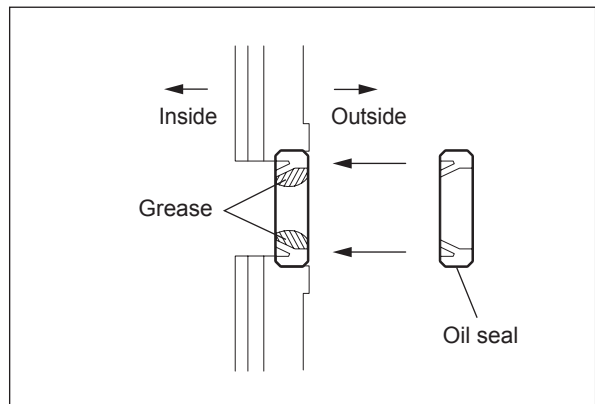

Fig. 12-35





## 13. FUSER / EXIT UNIT

### 13.1 General Description

In the equipment, the fuser unit which fuses toner on the paper and the paper exit section (exit roller) which outputs the paper with the fused toner to the inner tray are combined together to make up the fuser/exit unit.

In the fuser unit, toner is fused by applying heat and pressure on the transferred image on the transported paper. The paper is then transported to the exit tray after the completion of fusing. The fuser/exit unit is driven by the main motor (M3), and the heat roller and exit roller are rotated by the main motor (M3).

When the automatic duplexing unit (ADU: optional) is installed, it is driven by the exit motor (M7).

Other than the above rollers, the fuser/exit unit consists of the heater lamps, separation fingers, thermistors (THMS1/THMS2/THMS3), fuser thermostat (THMO1), paper transport guide and the exit sensor which detects the status of the paper transport, etc.

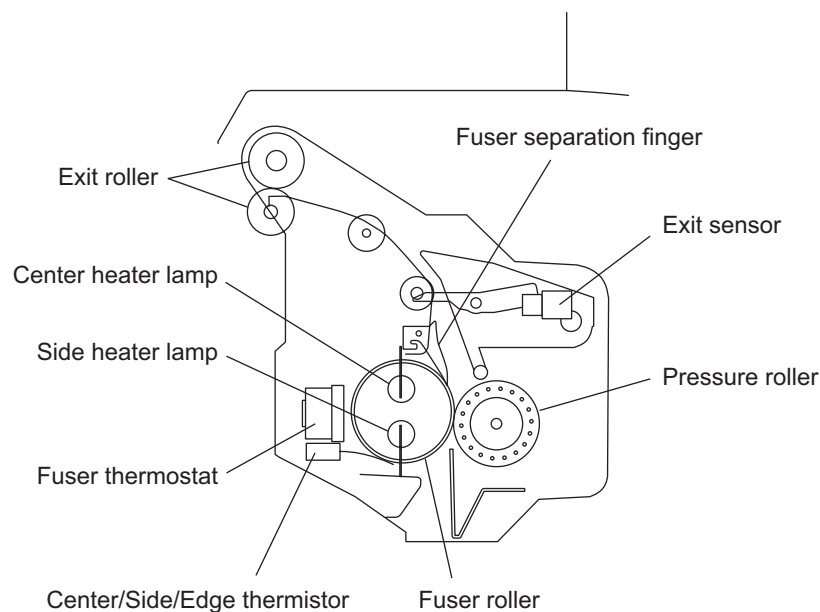

Fig. 13-1

## 13.2 Configurations

Fuser / exit unit		
Pressure roller unit	Pressure roller	PFA tube sponge roller (φ25) Periodic replacement part
	Exit sensor (S5)	
Fuser roller unit	Fuser roller	Fluoro-plastic coated roller (φ30) Periodic replacement part
	Heater lamp (LAMP1, LAMP2)	564W+564W
	Thermistor (THM1, 2, 3)	
	Fuser thermostat (THMO1)	Non-contact type (170°C)
	Separation finger	Periodic replacement part
	Exit roller	
Exit motor (M7)		Stepping motor: option

## 13.3 Functions

### 1) Pressure roller

The pressure roller is a sponge roller which assures the nip amount of the fuser roller. The pressure from the spring presses the paper onto the fuser roller to fuse toner onto the paper efficiently.

### 2) Exit sensor (S5)

The exit sensor detects if the leading or trailing edge of the paper is passing through the pressure roller and the fuser roller. This sensor is used for the detection of paper jams in the fuser/exit unit as well.

### 3) Fuser roller

The fuser roller applies heat onto the paper and is heated by the heater lamps installed inside of the fuser roller. The heat from this roller fuses toner onto the paper. The fuser roller in this equipment is a thin roller which enhances heat conduction, and thus the warming-up time is shortened.

### 4) Heater lamp (LAMP1/LAMP2)

The heater lamps are halogen lamps to apply heat to the fuser roller. The fuser unit in this equipment has 2 heater lamps (564W+564W) with different functions each other. One has a coil wound up on its center and this part generates heat. The other one has coils wound up on its both ends and these parts generate heat. The one has a coil on its center is called the center heater lamp (LAMP1) and the one has coils on its both ends is called the side heater lamp (LAMP2).

The heater lamps are fixed on the inside of the fuser roller to heat it up. The heater lamps do not rotate even when the fuser roller is rotating.

### 5) Sensor thermistor (THMS1) / Side thermistor (THMS2)

This thermistor detects the temperature of the fuser roller to maintain it in a certain temperature range (actually around 170°C) between the lower limit causing the poor fusing and the upper limit causing the high temperature offsetting. When the temperature of the fuser roller is lower than the preset temperature, it turns ON the power supply to the heater lamps, and when it is higher than the preset temperature, it cuts off the supply.

The center thermistor (THMS1) detects the temperature of the center part of the fuser roller, and the side thermistor (THMS2) detects the temperature of one side of fuser roller and control the both sides.

### 6) Edge thermistor (THMS3)

Both the ends of the fuser roller may be overheated without heat absorption by the paper since it does not pass through this area. The edge thermistor (THMS3) detects any temperature abnormality of this area caused by overheating of the fuser roller. Therefore this thermistor is not used for temperature control of the fuser roller.

### 7) Fuser thermostat (THMO1)

The fuser thermostat (THMO1) cuts off the power supply to the heater lamps (LAMP1/LAMP2) by opening itself if the fuser roller becomes abnormally hot as a result of the problem such as thermistor malfunction. The fuser thermostat (THMO1) for this equipment is used to prevent abnormal operation. When the fuser thermostat (THMO1) detects any abnormality, it must be replaced as well as the other damaged parts in the fuser unit.

### 8) Separation finger

Five separation fingers are installed above the fuser roller, in order to separate paper adhering to each roller.

### 9) Exit roller

The exit roller, which transports the paper to the inner tray, is driven by the main motor (M3). It is driven by the exit motor (M7) when the ADU (optional) is installed.

#### 10)Exit motor (M7)

The exit motor is a stepping motor which drives the exit roller. This motor rotates reversely to switch-back the exit roller when the paper is transported to the ADU. Install this exit motor (M7) when the ADU (optional) is installed.

## 13.4 Operation

The fuser roller is pressed by the pressure roller with the spring force. The fuser roller is rotated by the main motor drive, and the pressure roller is rotated by the rotation of the fuser roller. In addition, the heater lamps in the fuser roller do not structurally rotate.

2 heater lamps having different functions are installed; one applies heat to the center part of the fuser roller and the other applies heat to both ends of the roller. In this equipment, the surface temperature of the fuser roller at any paper size can be maintained by controlling the turning ON/OFF of the 2 heater lamps. The thermistors control the temperature of the fuser roller and detect temperature abnormalities. If the temperature becomes excessively high, the thermostat is opened to stop the power supply to the heater lamps.

Then the paper transported to the fuser unit is held between the fuser roller and pressure roller, and toner is fused on the paper with heat and pressure. After this, the separation fingers separate the paper from the fuser roller. Then the paper is transported to the inner tray through the exit roller. The paper transport status of the fuser/exit unit is detected by the exit sensor.

When the power is turned ON, the warming up of the fuser unit is started: the heater lamps are turned ON. If the temperature of the fuser roller does not reach or exceeds a specified temperature within a specified period of time, it is judged that the heater is abnormal. When the specified temperature has been reached normally, the equipment goes into the ready state.

When printing is not performed within a specified period of time during ready, the equipment enters the Auto Power Save Mode and turns the 2 heater lamps OFF or lowers the control temperature to save power consumption. And if printing is not performed within another specified period of time after the equipment has entered the Auto Power Save Mode, the equipment then enters the Auto Shut Off mode to turn OFF the 2 heater lamps.

## 13.5 Fuser Unit Control Circuit

### 13.5.1 Configuration

In this equipment, the surface temperature of the fuser roller is controlled by turning ON/OFF 2 heater lamps (center and side) which have different heat-generating positions with the command from the SoC on the MAIN board. The surface temperature of the fuser roller is detected by 3 thermistors (center, side and edge) and then the information of the temperature is transmitted to the SoC and each control circuit. Based on the detected temperature, the SoC transmits the control signal of the heater lamp to the control circuit (TRC: Triac) of each heater lamp on the switching regulator. The power supply to each fuser roller is thus controlled by driving TRC. The SoC detects the overheating of the fuser roller. In case that the surface temperature of the fuser roller has exceeded the specified temperature, the SoC turns the heater lamp OFF.

If the SoC does not function for some reason and the fuser roller is abnormally overheated as the result, a forcible power-OFF circuit transmits a relay-OFF signal to the switching regulator to shut off the power supply to the heater lamp by opening the relay. In addition, if these control circuits do not function with thermistor abnormality or other reasons and the fuser roller is abnormally overheated as the result, thermostat shut off the power supply to the heater lamps to protect the equipment.

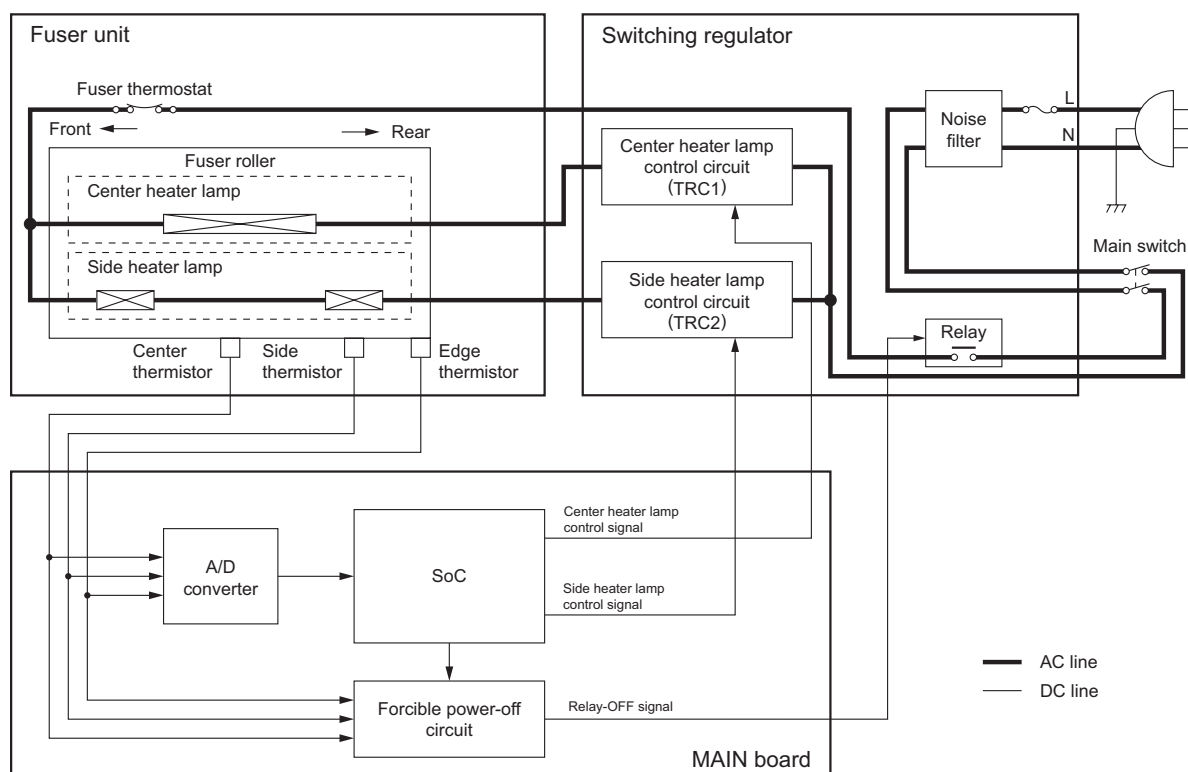

Fig. 13-2

## 13.5.2 Temperature detection section

To maintain the surface temperature of the fuser roller at a certain level, 3 thermistors (center, side and edge) detect the surface temperature of the fuser roller to turn ON/OFF and control 2 heater lamps (center and side).

1) Relation between the thermistor output voltage and surface temperature of the fuser roller

Output voltages of thermistors [V]	Surface temperatures of fuser roller [°C]
Approx. 0.5	40
Approx. 1.9	100
Approx. 3.7	170

2) Control of the surface temperature of the fuser roller

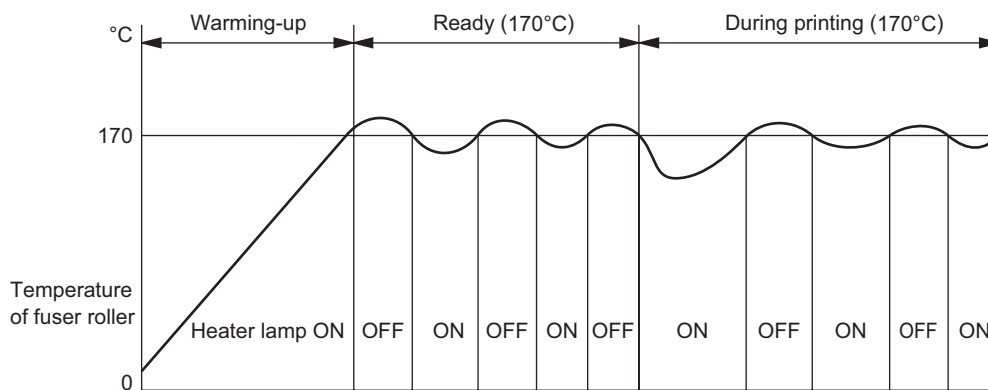

Fig. 13-3

### Remark:

During warming-up, 2 heater lamps (center and side) are turned ON to raise the surface temperature of the fuser roller. During ready and printing status, each heater lamp is turned ON/OFF alternately to maintain the surface temperature of the fuser roller at a certain level (setting temperature of each status).

3) Temperature control for the both ends of the fuser roller

During continuous printing, the temperature of the end of the fuser roller (area where the paper does not pass on) generally tends to be higher than that of other areas (areas where the paper passes on). For this reason, the edge thermistor detects the temperature of the end of the fuser roller. When this thermistor detects the abnormal temperature (Approx. 235°C), the heater lamp is turned OFF regardless of the temperature of the area where the paper passes on.

#### 4) Temperature control at Energy Saving Mode

This equipment has the following two types of temperature control for saving energy and returns to ready status to perform printing in each mode upon printing request.

The period of time from the printing request to this mode can be set in Setting Mode (08).

##### **Auto Power Save Mode (08-205):**

When the printing is not performed in a specified period of time (default: 15 min.) after the previous printing is completed, the equipment enters to Auto Power Save Mode to turn OFF the heater lamp.

\* When a value other than OFF is set for the "Fuser roller temperature in Auto Power Save Mode (code 08-409/448)", the equipment controls to maintain the fuser roller temperature at the preset value by turning the 2 heater lamps ON/OFF alternately.

##### **Auto Shut Off Mode (08-206):**

When no operation is performed in a specified period of time (default: 15 min.) after the equipment entered to Auto Power Save Mode, the equipment then enters Auto Shut Off Mode to be in the OFF state (e.g. turns off the unnecessary displays on the control panel, etc.).

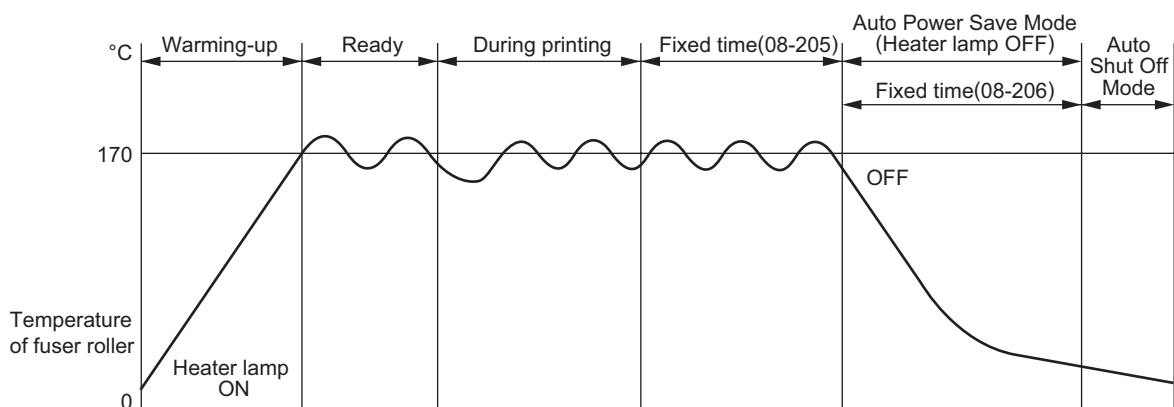

Fig. 13-4



## 5) Fuser unit error status counter control

- To enhance the safety of the fusing section unit, SoC provides the following protection: When the third [C41] error has occurred after two consecutive [C41] errors, the heater lamp is not turned ON and error [C41] is displayed immediately even if an operator turns OFF the power and back ON. However, if the equipment goes into a ready state normally with the fuser unit error status counter "1" or below, the counter is cleared to "0".
- If the error codes [C41] to [C45] are displayed and still not cleared even though the thermistor, thermostat and heater lamp have been repaired (and the power ON/OFF does not clear the error), check the Setting Mode (08-400) to set the fuser unit error status counter to "0".

### Remark:

The fuser unit error status counter (Setting Mode (08-400)) never has values other than 0-19.

- If the heater lamp does not turn ON and the service call [C41] is displayed immediately after the power is ON, ensure the fuser unit error status counter is "2" or over. If it is "2" or over, be sure to check the thermistor, thermostat and heater lamp. Reset the counter to "0" after repairing them, then turn ON the power.
- If the fuser unit error status counter is "20" or over (e.g., 31), the data in SRAM or SRAM itself may possibly have been ruined due to causes such as leakage from the chargers. Check the bias, high-voltage transformers and charge wires to see if any of them is defective, and also look through all the data in the SRAM.
- When the thermistors detect overheating, the SoC decides the error code and counter value of the fuser unit error status, and turns OFF each output (the heater lamp, control panel display, motors and so on) to protect the fuser unit.

Error code: C44 ([CLEAR/STOP] and [8])

Counter value of the fuser unit error status: 9 (08-400)

Thermistors continue detecting the abnormal temperature even after the error codes and counter values are decided. Even if the power is turned ON immediately, the heater lamp is automatically turned OFF again when the surface temperature of the fuser roller is still higher than the abnormal temperature detected.

Wait until the surface temperature of the fuser roller is lowered enough, and turn ON the power to check the counter value. After confirming that it is the fuser unit abnormality, correct the abnormality and reset the counter value (08-400) to "0" to start up the equipment normally.

## 6) Temperature detection configuration

Thermistor is a device whose resistance decreases as it detects a higher temperature. Thus its input voltage to A/D converter changes and then SoC judges whether this change is normal or abnormal. If one of the fuser roller thermistors is broken, the control circuit judges that the fuser roller temperature is extremely low and keeps turning the heater lamp ON. As a result, the fuser roller temperature rises, and possibly activates the thermostat which is a safety protection device. To prevent this in advance, SoC works to detect whether each thermistor is broken or not.

Also, the thermistors constantly check the temperature of heater lamp to prevent it from excessive heating by MAIN circuit abnormality or thermistor abnormality. The thermistors automatically turn OFF the power when the temperature of heater lamp exceeds the specified temperature.

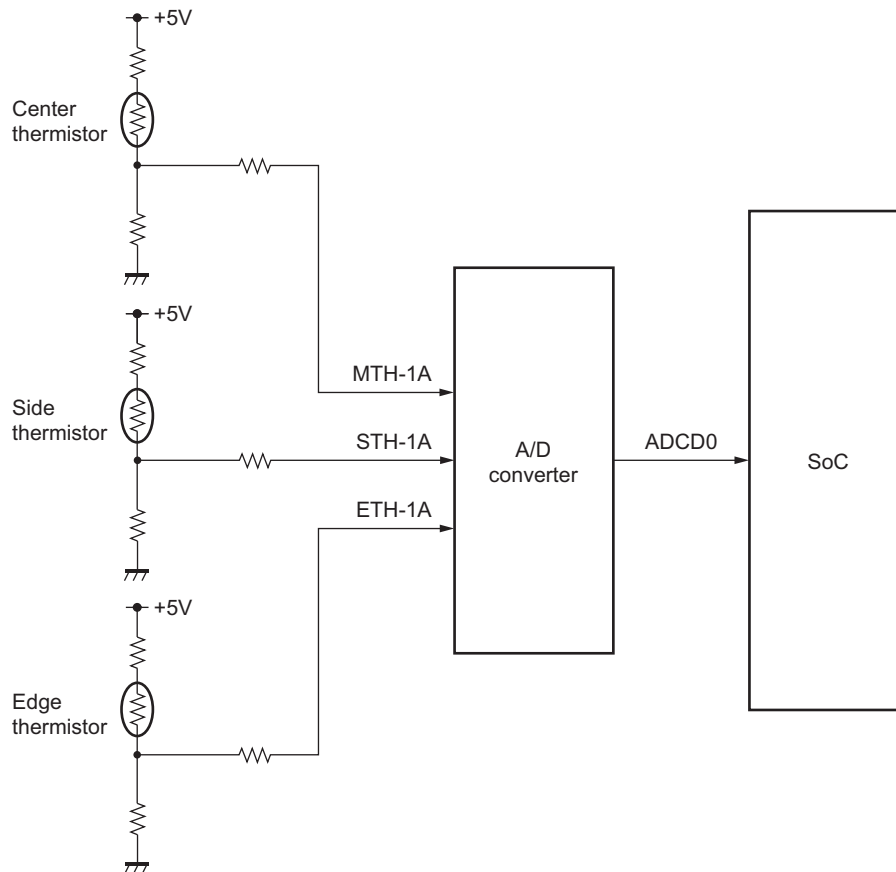

Fig. 13-5

7) Abnormality detection by the thermistors

The following table shows the conditions judging the fuser roller temperature abnormality and detecting timing.

Checking timing	Priority	Temperature judged			Error-judging timing	Error code
		Center thermistor	Side thermistor	Edge thermistor		
On usual	1	230°C or above	-	-	On usual	C44
		-	230°C or above	-		
		-	-	230°C or above		
Detecting 40°C	1	40°C or below	-	-	Specified time	C41
		-	40°C or below	-		
Detecting 100°C	1	100°C or below	-	-	Specified time	C44
		-	100°C or below	-		
	2	40°C or below	150°C or above	-	On usual	C43
		150°C or above	40°C or below	-		
Detecting warming-up temperature	1	Warming-up temp. or below	-	-	Specified time	C44
		-	Warming-up temp. or below	-		
	2	40°C or below	150°C or above	-	On usual	C43
		150°C or above	40°C or below	-		
		-	150°C or above	40°C or below		
During ready status	1	40°C or below	150°C or above	-	On usual	C43
		150°C or above	40°C or below	-		
		-	150°C or above	40°C or below		
	2	40°C or below	-	-		C44
		-	40°C or below	-		
During copying	1	40°C or below	-	-	On usual	C44
		-	40°C or below	-		
	2	-	-	40°C or below		C45

\* The figures in the "priority" section denote the priority of error checking.

## 13.6 Disassembly and Replacement

### [A] Fuser / Exit unit

- (1) Take off the right rear cover.  
P.2-22 "[I] Right rear cover"
- (2) Lay down the transfer unit.
- (3) Disconnect 3 connectors, remove 2 screws, and then take off the fuser/paper exit unit.

**Note:**

Be careful because the fuser/paper exit unit is hot.

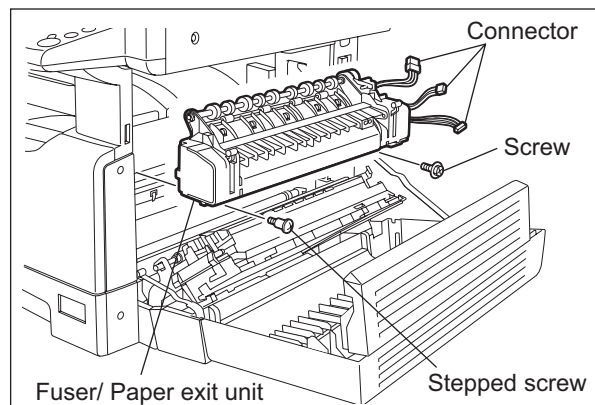

Fig. 13-6

### [B] Pressure roller unit / Fuser roller unit

- (1) Take off the fuser/paper exit unit.  
P.13-12 "[A] Fuser / Exit unit"
- (2) Remove 1 spring and 2 screws.
- (3) Separate the pressure roller unit from the fuser roller unit.

**Note:**

If the ADU (optional) is installed, the spring has already been removed.

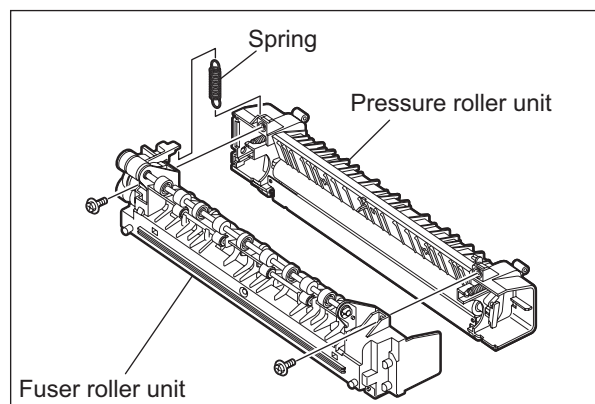

Fig. 13-7

**Note:**

Separate the pressure roller and the heat roller while pressing the thermistor ground leaf spring.

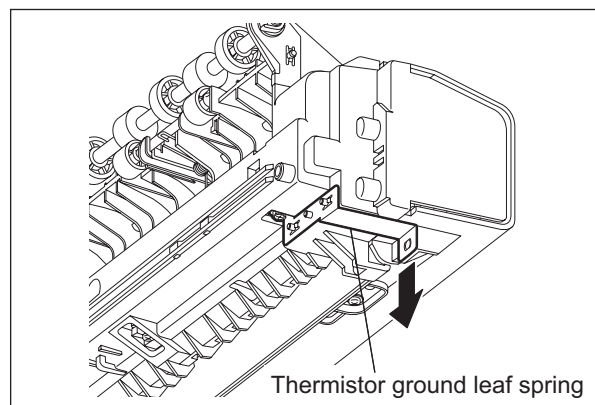

Fig. 13-8

### [C] Exit roller

- (1) Take off the fuser roller unit.  
P.13-12 "[B] Pressure roller unit / Fuser roller unit"
- (2) Release the latch and take off the gear-A.

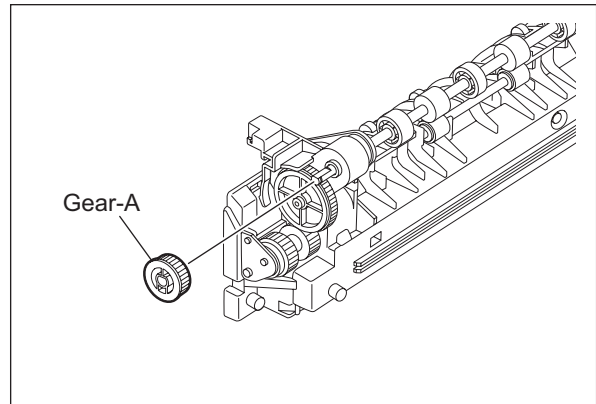

Fig. 13-9

- (3) Take off the gear-B.

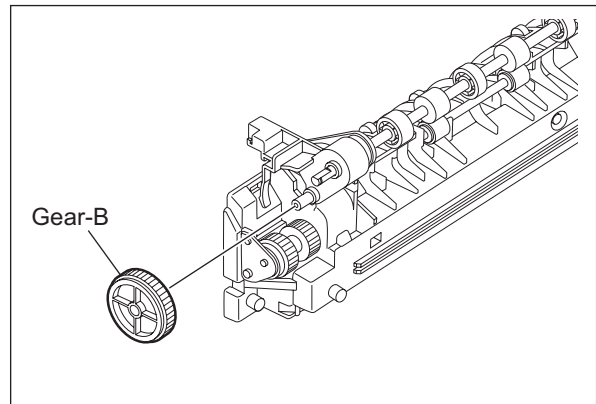

Fig. 13-10

- (4) Remove the bracket.

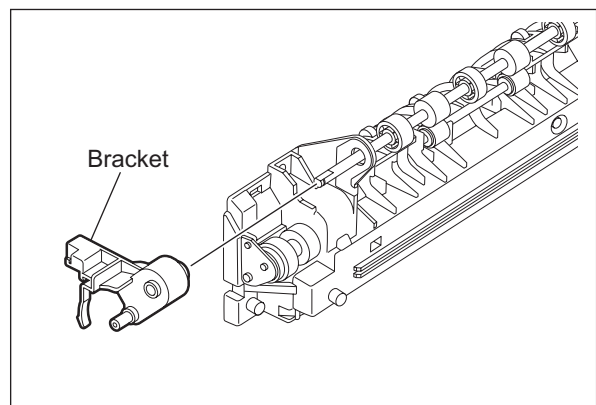

Fig. 13-11

- (5) Remove 1 clip and 1 bushing.
- (6) Take off the exit roller by sliding it to the rear side.

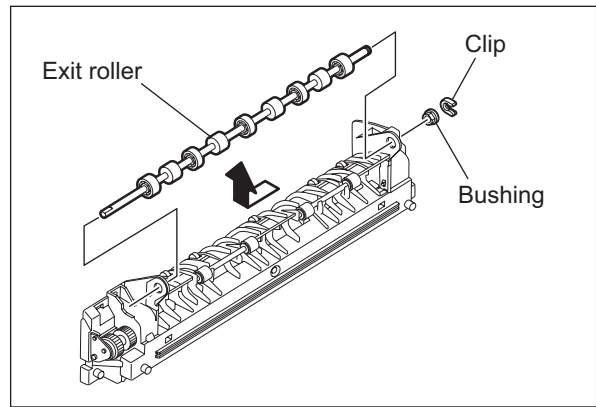

Fig. 13-12

#### [D] Exit sensor (S5)

- (1) Take off the fuser/paper exit unit.  
 P.13-12 "[A] Fuser / Exit unit"
- (2) Release the stopper using a flathead screwdriver.

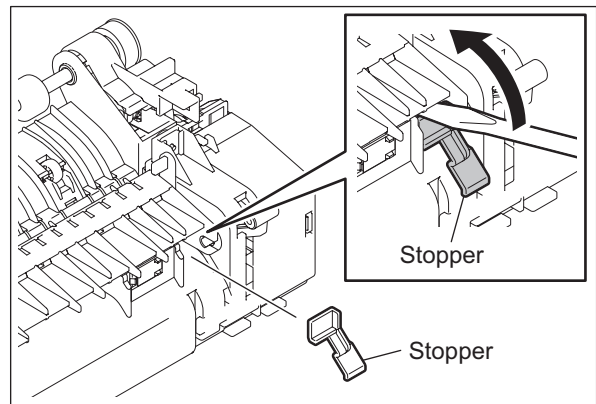

Fig. 13-13

- (3) Open the guide and slide it to the front side. Then slide its rear hinge downward.

**Note:**

Keep the guide being slid to the front side during the steps (3) and (4).

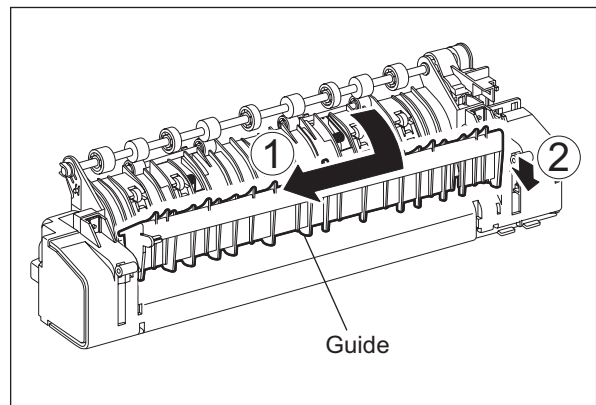

Fig. 13-14

- (4) Close the guide, and then take off the guide by sliding its rear hinge to the right side.

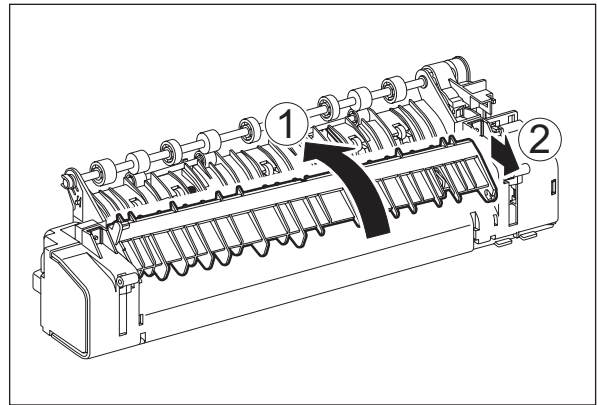

Fig. 13-15

- (5) Remove 1 spring and take off the guide while the guide is being slid to the rear side.

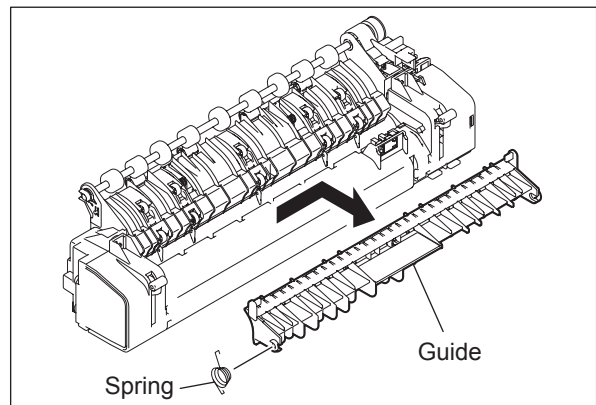

Fig. 13-16

- (6) Remove the Mylar.  
(7) Disconnect 1 connector, release 2 latches, and then take off the exit sensor.

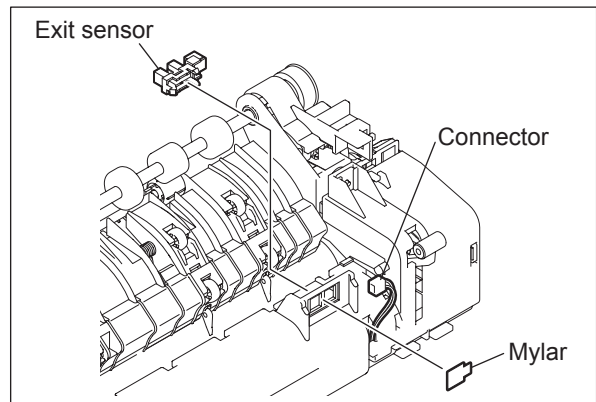

Fig. 13-17

**Note:**

When installing the guide, secure the spring to the hook of the fuser unit and the other end of the spring to the guide.

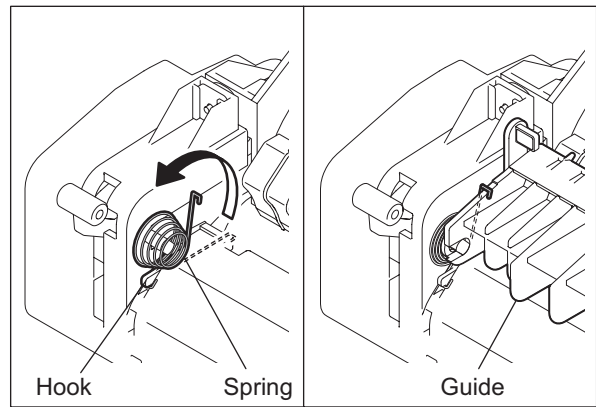



Fig. 13-18

**[E] Separation finger **

- (1) Take off the fuser roller unit.  
 P.13-12 "[B] Pressure roller unit / Fuser roller unit"
- (2) Remove 3 screws and take off the sub guide.

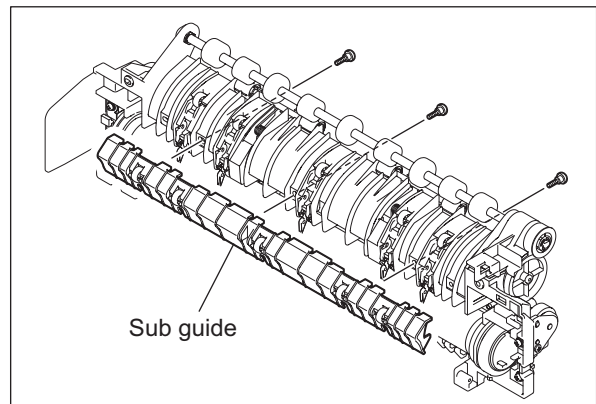

Fig. 13-19

- (3) Remove 5 springs from the hooks.

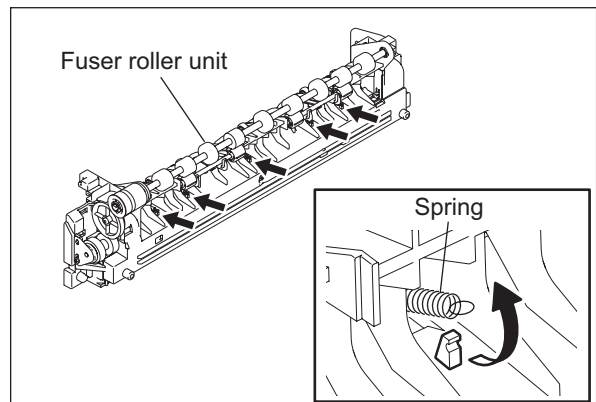

Fig. 13-20



- (4) Remove 5 drum separation fingers with the springs.

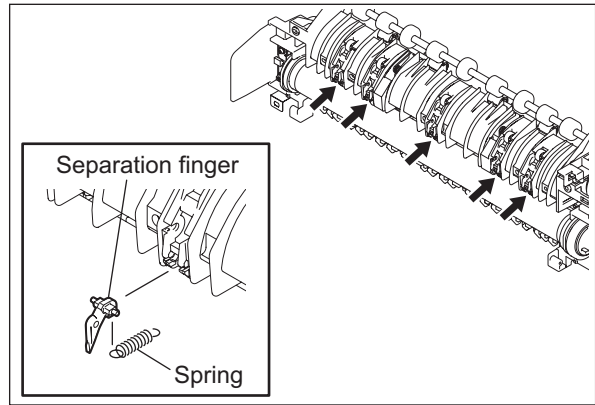

Fig. 13-21

**[F] Center heater lamp / Side heater lamp (LAMP1/LAMP2)**

- (1) Take off the fuser roller unit.  
P.13-12 "[B] Pressure roller unit / Fuser roller unit"
- (2) Remove 2 screws on each terminal of both center heater lamp and side heater lamp.

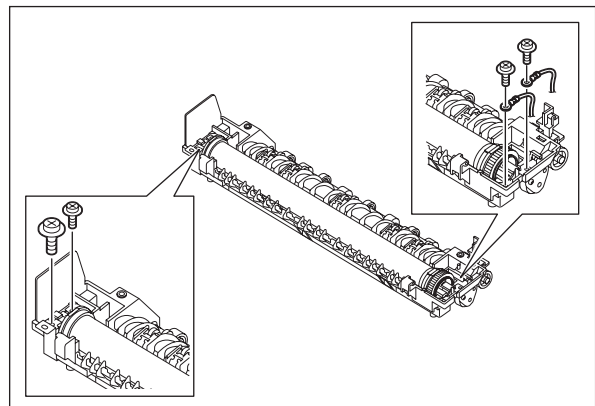

Fig. 13-22

- (3) Pull out the center heater lamp and side heater lamp.

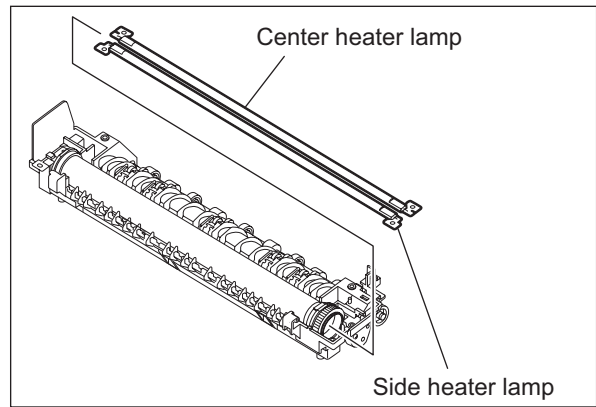

Fig. 13-23

**Notes:**

- When installing the heater lamps, be sure not to mix up the upper heater lamp and the lower heater lamp. The upper heater lamp has a coil wound up on its center part, and the lower heater lamp has coils wound up on its both edges.
- When installing the heater lamps, be sure to face up their weld sides.
- Do not touch the lamps directly with your hands.
- The connector on each end of the harness which connects to the center heater lamp has a small screw hole. The connector on each end of the harness which connects to the side heater lamp has a big one.

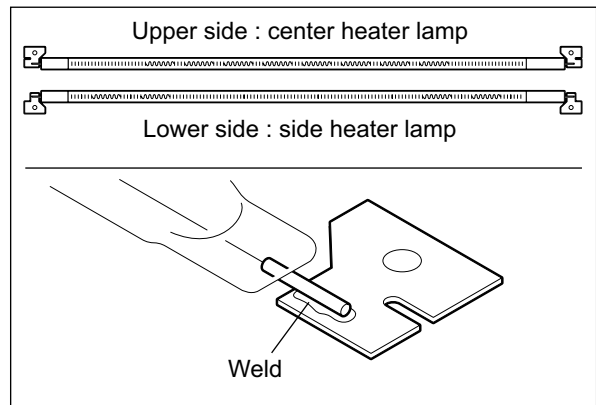



Fig. 13-24

**[G] Fuser roller **

- (1) Take off the center heater lamp and the side heater lamp.  
 P.13-17 "[F] Center heater lamp / Side heater lamp (LAMP1/LAMP2)"
- (2) Take off the separation fingers.  
 P.13-16 "[E] Separation finger"
- (3) Take out the fuser roller upward.

**Notes:**

- When installing the fuser roller, slide each bushing on both edges of the roller outward so that the bushings will engage with the frame and the installation will be secured.
- Do not apply force onto the roller because it may be deformed.

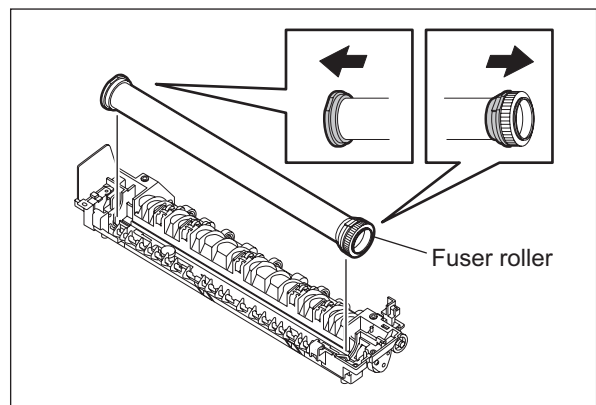

Fig. 13-25

- (4) Remove 1 C-ring and 1 bushing on the front side of the fuser roller.
- (5) Remove 1 C-ring, 1 gear and 1 bushing on the rear side of the fuser roller.

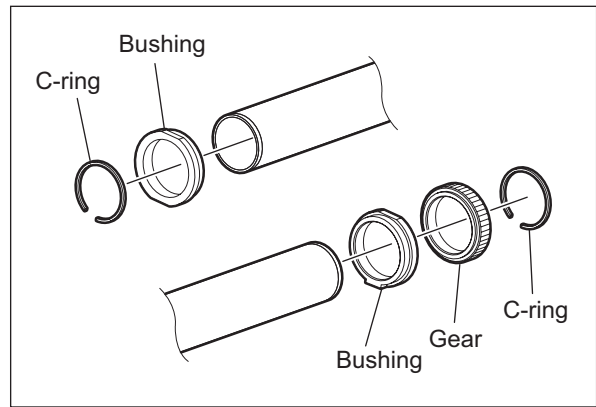



Fig. 13-26

**[H] Pressure roller **

- (1) Take off the pressure roller unit.  
 P.13-12 "[B] Pressure roller unit / Fuser roller unit"
- (2) Remove 3 screws, and then take off the fuser unit entrance guide.

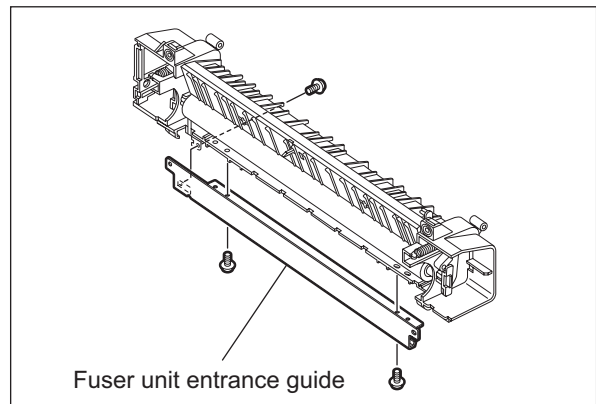

Fig. 13-27

- (3) Remove 2 springs.

**Note:**

When installing the spring, be sure to hang the spring on the upper hook.

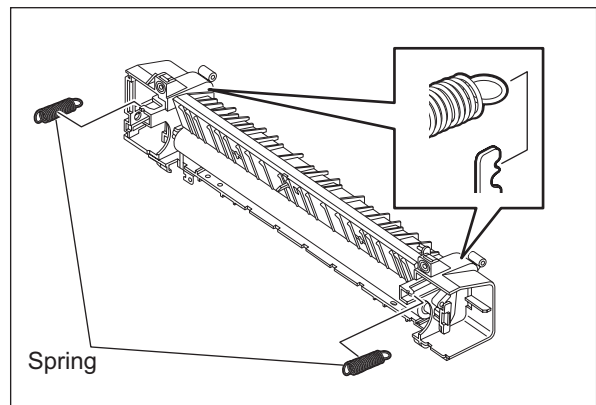

Fig. 13-28

- (4) Take off each 1 pressure lever on both front and rear sides.

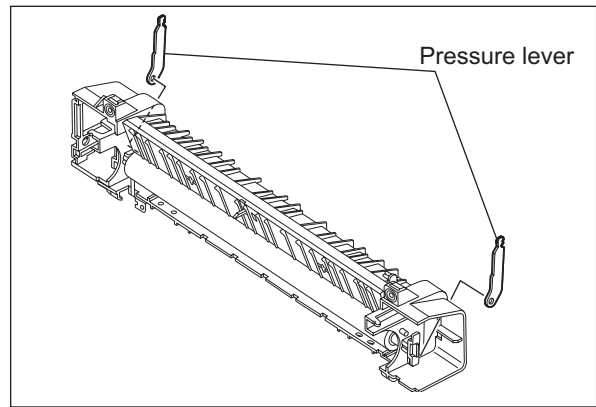

Fig. 13-29

- (5) Take off 2 bushings and then take off the pressure roller while sliding the pressure roller to the rear side.

**Notes:**

- Do not drop the pressure roller when you lift it up because it is quite heavy.
- Be sure to install the pressure roller from the rear side (pressure roller ground plate side) in order not to deform the pressure roller ground plate.

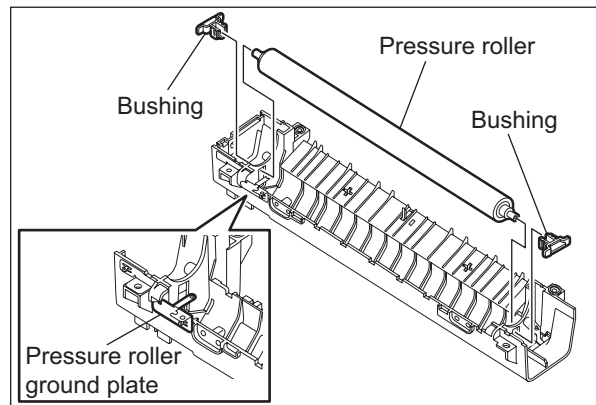

Fig. 13-30

**[I] Center thermistor / Side thermistor / Edge thermistor (THMS1/THMS2/THMS3)**

- (1) Take off the fuser roller.  
 ☞ P.13-18 "[G] Fuser roller"
- (2) Remove each 1 screw of the thermistors, and then take off each thermistor by releasing its harness out of the harness clamp.

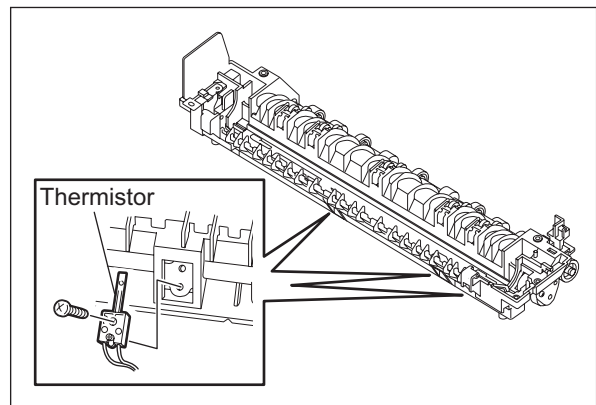

Fig. 13-31

**Note:**

When installing the thermistors, do not mix up the installation positions of the side thermistor and the edge thermistor by telling them apart by the length of their harnesses.

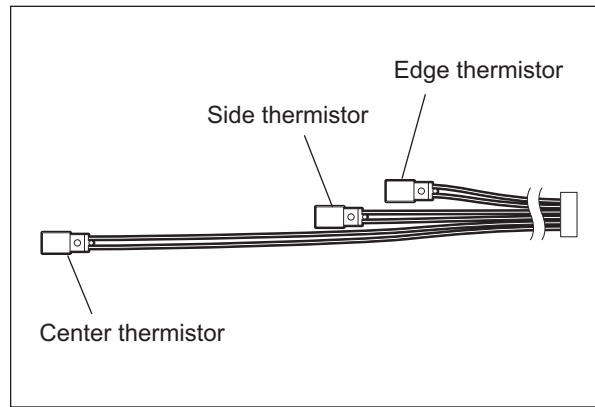

Fig. 13-32

**[J] Fuser thermostat (THMO1)**

- (1) Take off the fuser roller.  
📖 P.13-18 "[G] Fuser roller"
- (2) Remove 2 screws and take off the fuser thermostat.

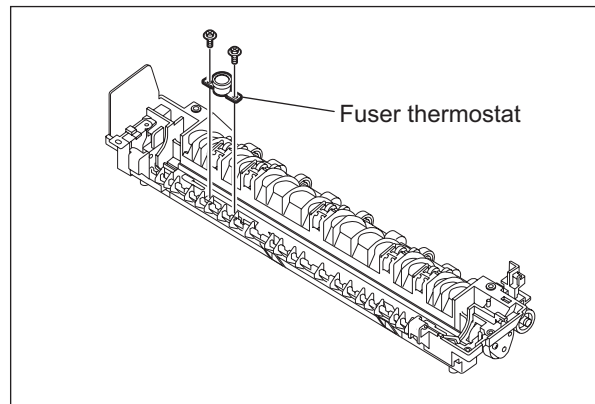

Fig. 13-33

**[K] Exit motor (M7): Option**

- (1) Take off the rear cover.  
📖 P.2-22 "[J] Rear cover"
- (2) Disconnect 1 connector, remove 1 screw, and then take off the exit motor with the bracket while sliding it toward the right.

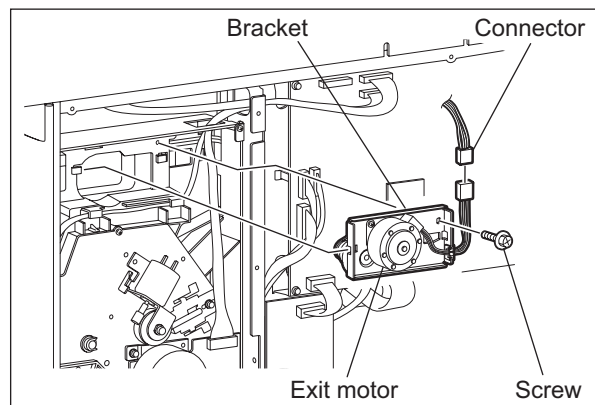
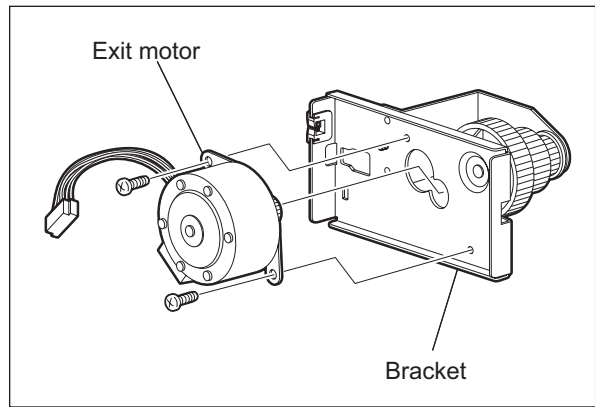

Fig. 13-34

- (3) Release the harness from harness clamp, remove 2 screws, and then takeoff the exit motor.



**Fig. 13-35**

## 14. AUTOMATIC DUPLEXING UNIT (ADU) (OPTION: MD-0103)

### 14.1 General Description

The Automatic Duplexing Unit (ADU) is a unit to reverse a sheet of paper at duplex copying. A switchback method using the exit roller is adopted for the ADU of this equipment. Immediately after the printing of one side (fusing process) is completed, the paper is switchbacked by the exit roller. The paper being reversed is then transported to the registration roller for the printing of the other side. The ADU mainly consists of the transport rollers and their drive section, the paper guides and the ADU driving PC board (ADU).

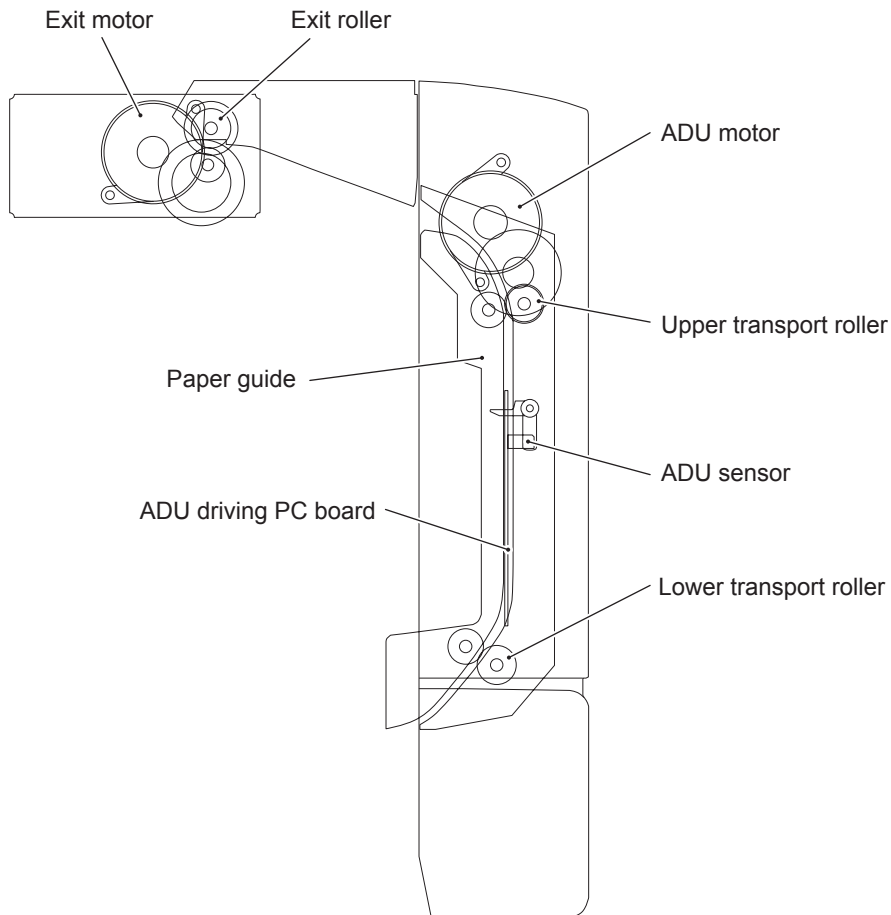

Fig. 14-1

## 14.1.1 Specifications of MD-0103

Item	Specification	Remarks
Reversal method	Stackless switchback method	
Paper size	A3, A4, A4-R, A5-R, B4, B5, B5-R, FOLIO, LD, LG, LT, LT-R, ST-R, COMPUTER, 13" LG, 8.5"x8.5" SQ, 8K, 16K, 16K-R	
Paper weight	64 to 80g/m <sup>2</sup> 17 to 22 lb. Bond	
Dimensions	W466 x D55 x H244 (mm) W307 x D50 x H200 (mm) W61 x D50 x H101 (mm)	Paper guide (outside) Paper guide (inside) Motor unit
Weight	Approx. 1.2 kg Approx. 2.65 lb.	Total weight of paper guide (outside), paper guide (inside) and motor unit
Power supply	DC 24V, DC 5V	Supplied from the equipment
Bundled	Unpacking instruction Paper guide (outside) Paper guide (inside) Motor unit Wire harness Screws (M3 x 8) Screw (M3 x 6)	1 pc 1 pc 1 pc 1 pc 1 pc 5 pcs 1 pc
Option	Paper feed controller (GH-1060)	MD-0103 and GH-1060 are to be installed together.



## 14.2 Construction

Automatic Duplexing Unit (ADU)	
ADU motor (M8)	Stepping motor
ADU driving PC board (ADU)	
ADU sensor	Mounted on the ADU driving PC board (ADU)
Upper transport roller	
Lower transport roller	

## 14.3 Functions

- 1) ADU motor (M8)  
This motor drives the ADU transport rollers (upper and lower).
- 2) ADU driving PC board (ADU)  
The sensor on this board drives the ADU motor and detects paper being transported within the ADU.
- 3) ADU sensor  
This sensor is mounted on the ADU driving PC board to detect paper being transported within the ADU.
- 4) Upper transport roller / Lower transport roller  
These rollers transport paper within the ADU.

## 14.4 Drive of ADU

When the ADU motor (M8) rotates in the direction A, the transport rollers (upper and lower) rotate to transport paper through the drive of the gear and the belt.

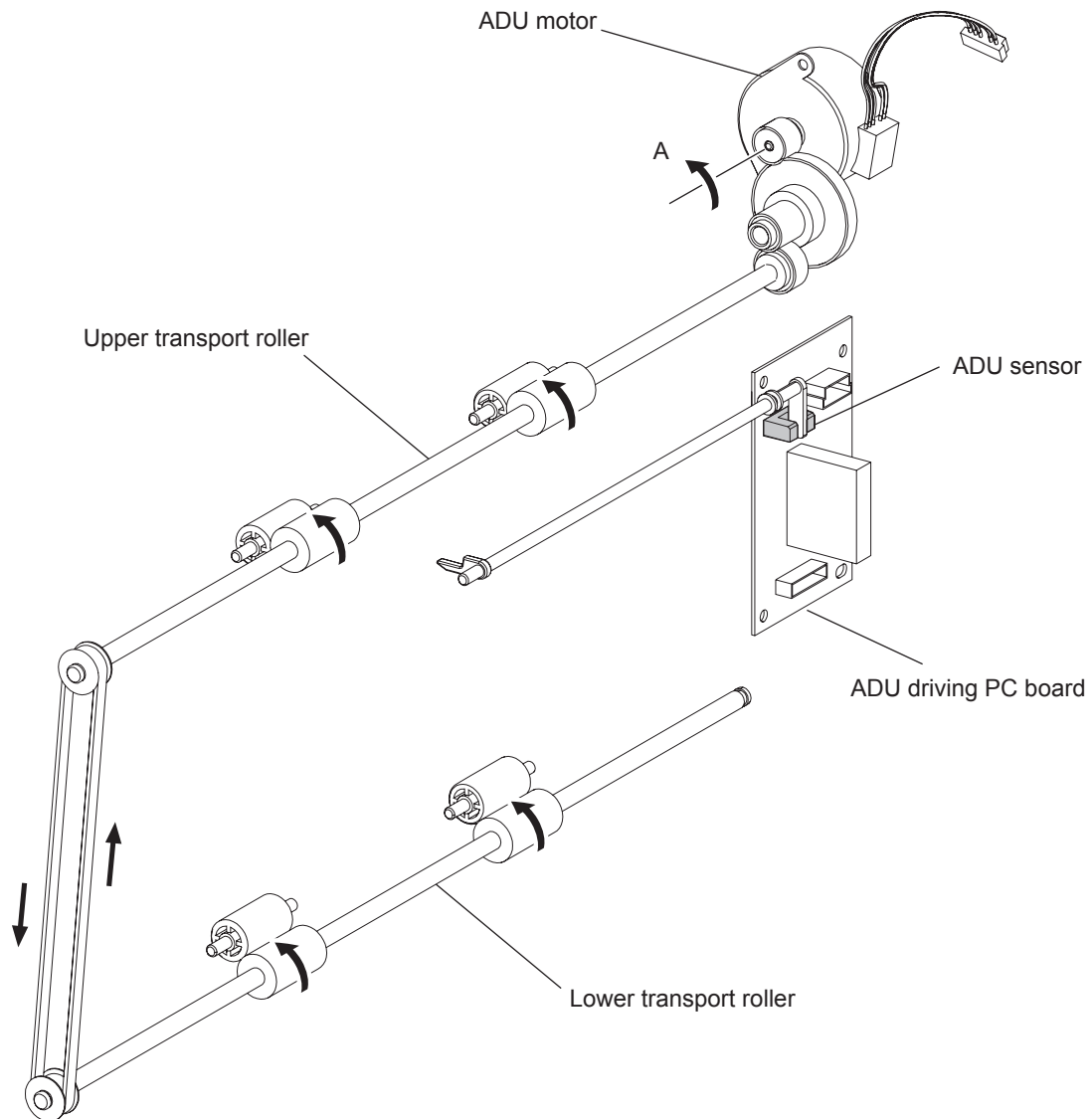

Fig. 14-2

## 14.5 Description of Operation

The back side printing (recording data of the back side of paper) is performed first by selecting duplex printing mode and pressing the [START] button. When the trailing edge of the paper passes the exit gate, the paper is switchbacked by the exit roller and transported into the ADU.

The front side printing (recording data of the front side of paper) is performed at the registration section. The paper passes through the exit gate again and is transported to the inner tray to complete duplex printing.

The detection of paper jam is performed in two methods. In one method the paper jam is judged by whether the ADU sensor is turned ON or not within a specified period of time after the paper started to be switchbacked to the ADU (error code: E51), and in another method, it is judged by whether the registration sensor (S4) is turned ON or not within a specified period of time after the paper started to be fed out of the ADU to the equipment (error code: E11).

ADU open jam (error code: E43) occurs when the ADU is opened during the duplex printing and thus the ADU motor is stopped.

The equipment is never to be stopped during printing by interruption in any case except paper jam or service call.

The operation of the duplex printing differs depending on the size of the paper; single-paper circulation and alternateness circulation. The figures in the following pages show the circulating operations during duplex copying. The numbers in the figures indicate the page numbers.

1) Single-paper circulation

With the paper larger than A4/LT size, duplex printing (back-side printing → front-side printing) is performed for one sheet at a time as shown below.

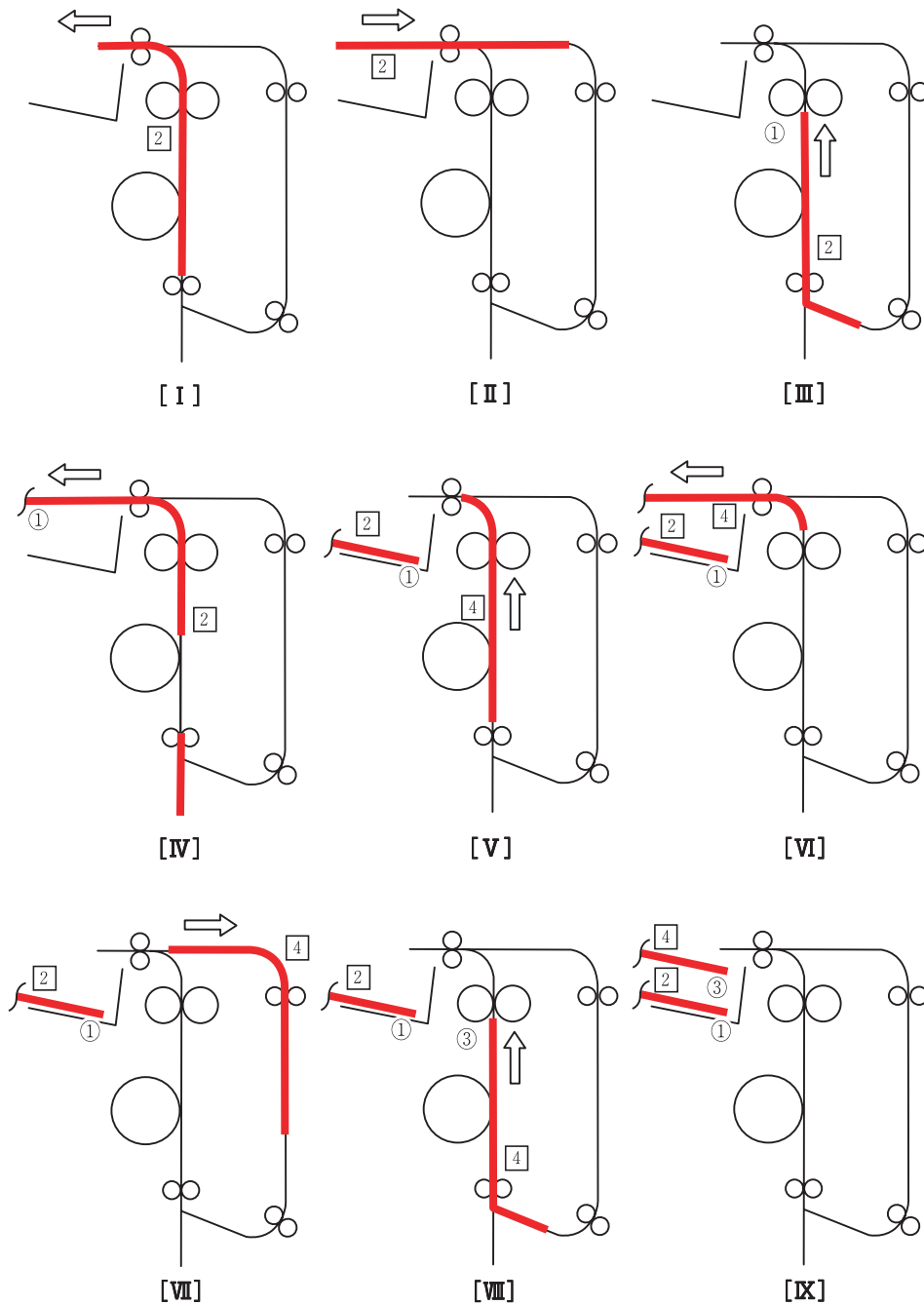

Fig. 14-3

2) Double-paper alternateness circulation

With A4/LT size paper or smaller, duplex printing is performed for two sheets at a time as shown below.

Back side of the 1st sheet → Back side of the 2nd sheet → Front side of the 1st sheet → Front side of the 2nd sheet

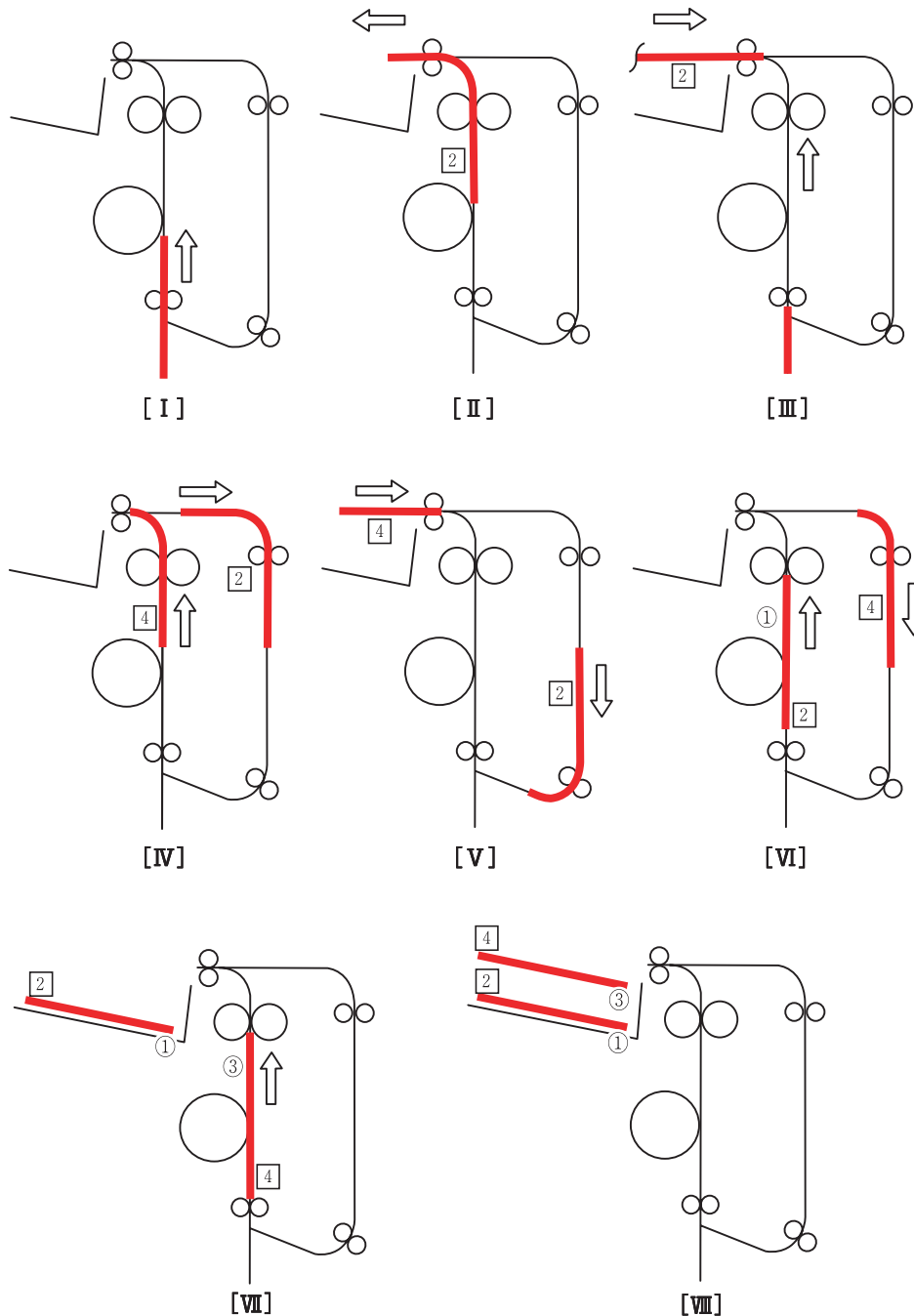

Fig. 14-4

Timing chart for duplex copying from upper drawer (A4, 4 sheets)

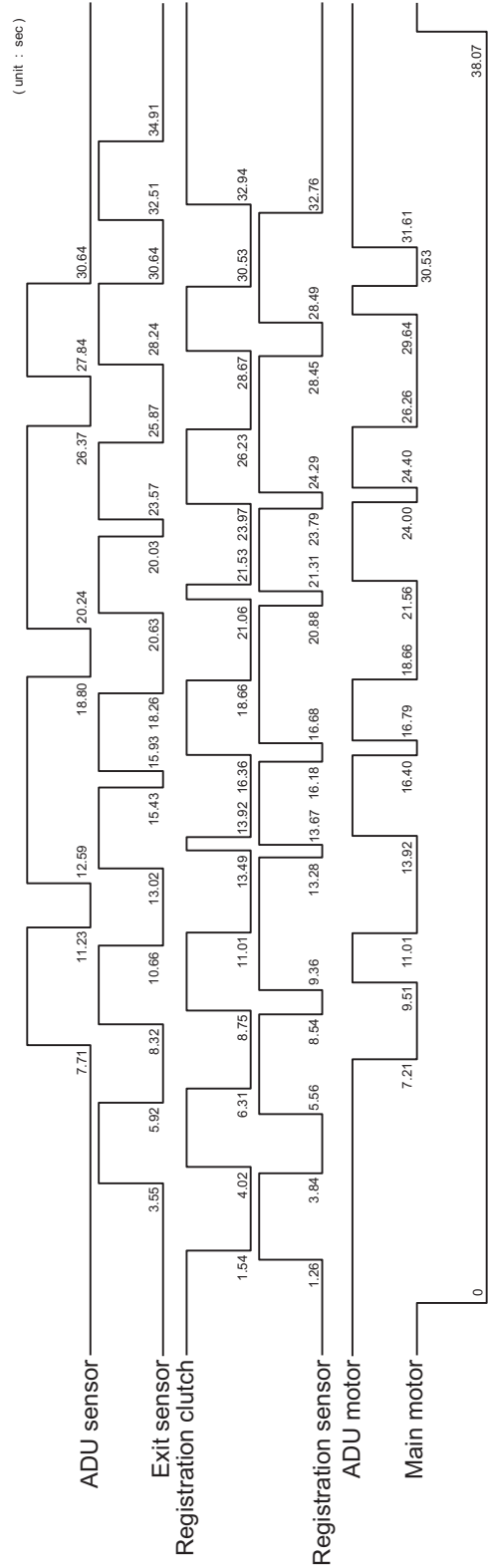

Fig. 14-5

Timing chart for duplex copying from upper drawer (A3, 1 sheet)

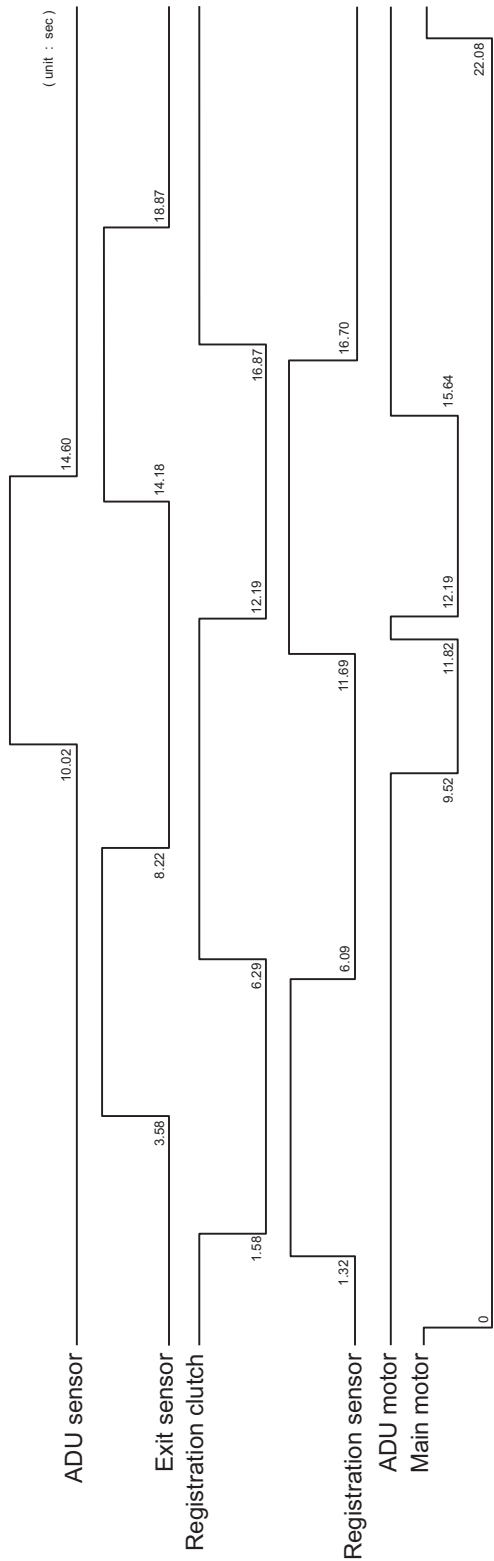

Fig. 14-6



## 14.6 Flow Chart

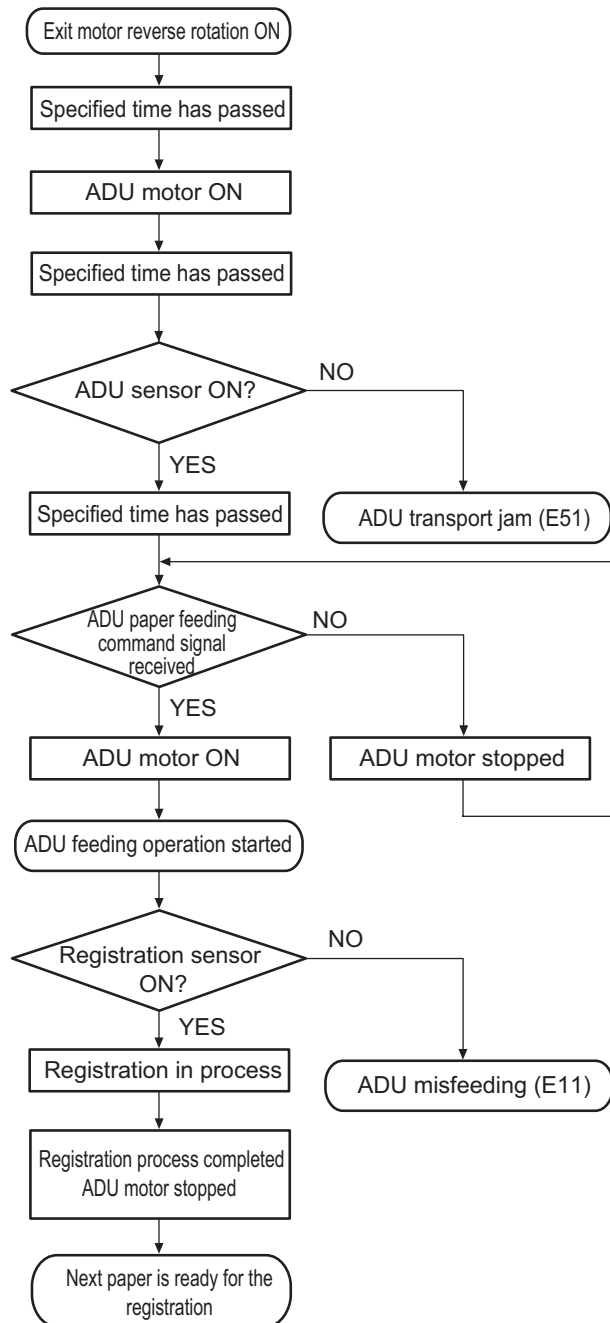

Fig. 14-7

## 14.7 Disassembly and Replacement

### [A] Automatic Duplexing Unit (ADU)

- (1) Take off the right rear cover.  
P.2-22 "[I] Right rear cover"
- (2) Remove 1 screw and 1 ground wire.
- (3) Disconnect 1 connector.

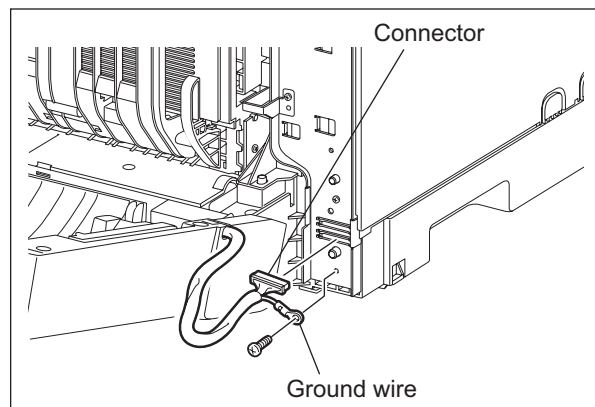

Fig. 14-8

- (4) Open the transfer unit and release the ADU stopper.
- (5) Take off the ADU cover while sliding it toward the right.

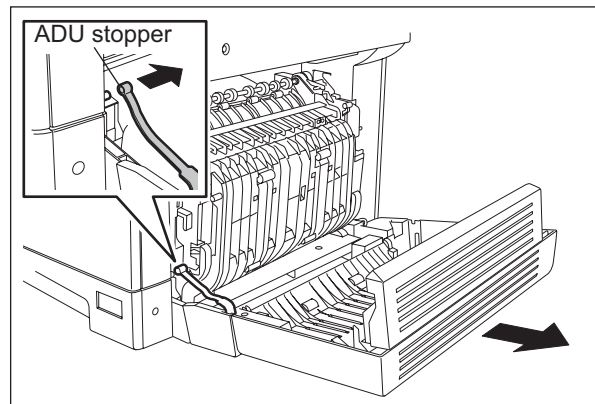

Fig. 14-9

- (6) Remove 4 screws and take off the ADU.

**Note:**

When installing the ADU, be sure to put the ADU stopper on the rear side through the rear slit of the ADU.

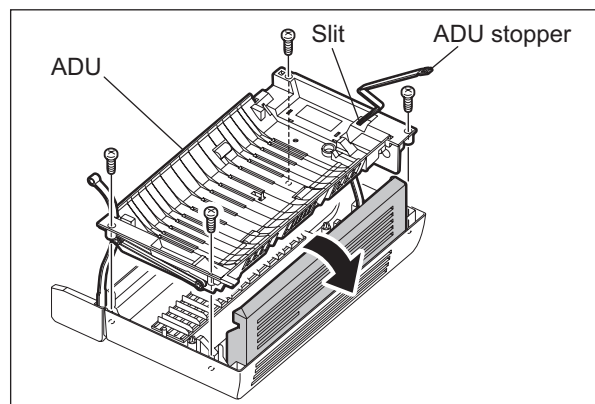

Fig. 14-10

## [B] ADU driving PC board (ADU)

- (1) Take off the ADU.  
P.14-12 "[A] Automatic Duplexing Unit (ADU)"
- (2) Disconnect 2 connectors, release the latch and take off the ADU driving PC board.

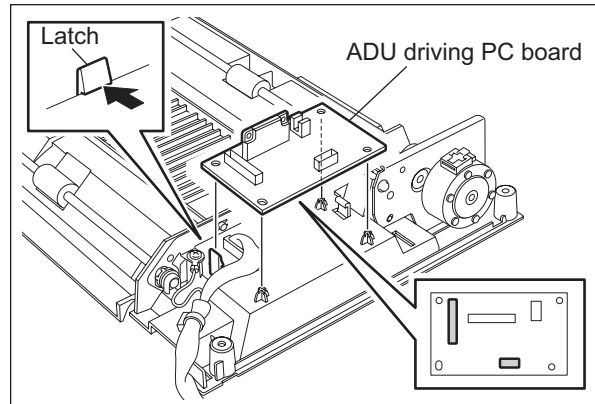

Fig. 14-11

## [C] ADU motor (M8)

- (1) Take off the ADU.  
P.14-12 "[A] Automatic Duplexing Unit (ADU)"
- (2) Disconnect 1 connector, remove 2 screws and take off the ADU motor with the bracket.

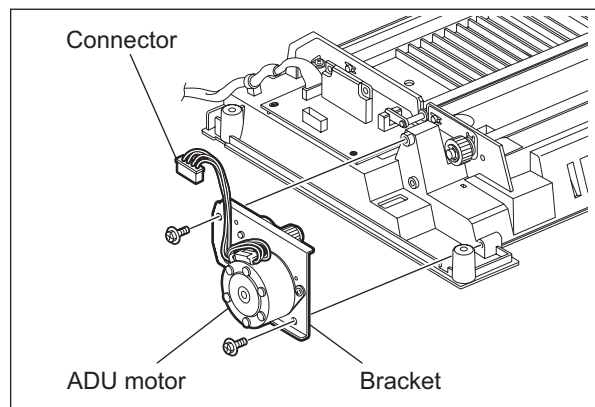

Fig. 14-12

- (3) Remove the gear.
- (4) Remove 2 screws and take off the ADU motor.

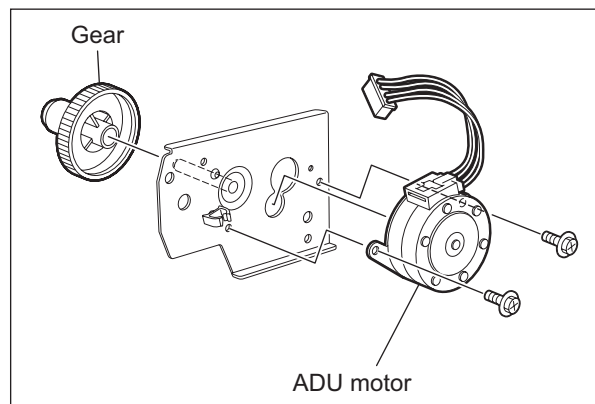

Fig. 14-13

#### [D] Upper transport roller

- (1) Take off the ADU.  
P.14-12 "[A] Automatic Duplexing Unit (ADU)"
- (2) Take off the ADU motor.  
P.14-13 "[C] ADU motor (M8)"
- (3) Remove 2 E-rings, 2 pulleys and 2 pins, and then take off the timing belt.

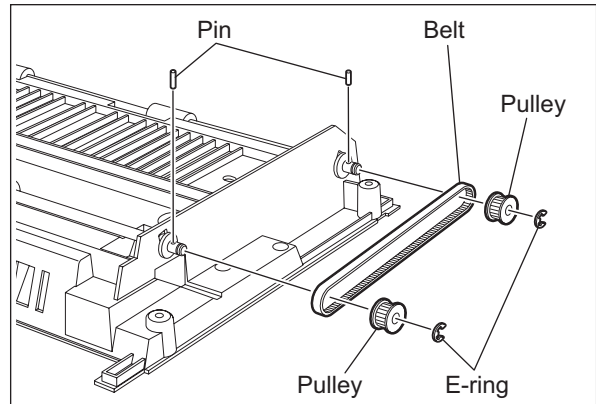

Fig. 14-14

- (4) Remove 1 E-ring, 1 gear and 2 bushings, and then take off the upper transport roller.

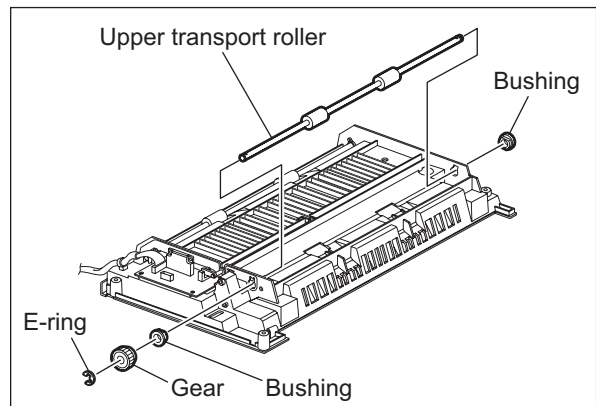

Fig. 14-15

#### [E] Lower transport roller

- (1) Take off the ADU.  
P.14-12 "[A] Automatic Duplexing Unit (ADU)"
- (2) Remove 2 E-rings, 2 pulleys and 2 pins, and then take off the timing belt.

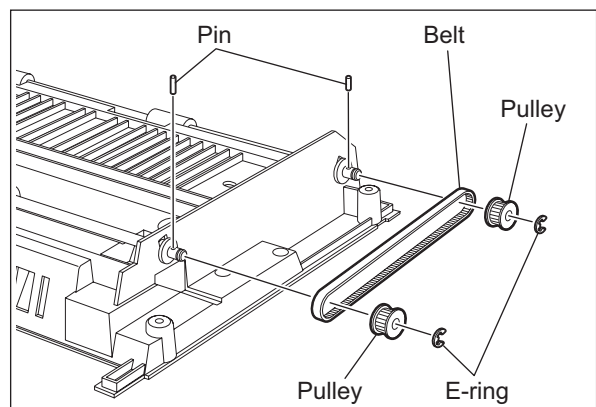

Fig. 14-16

- (3) Remove 1 clip and 2 bushings, and then take off the lower transport roller.

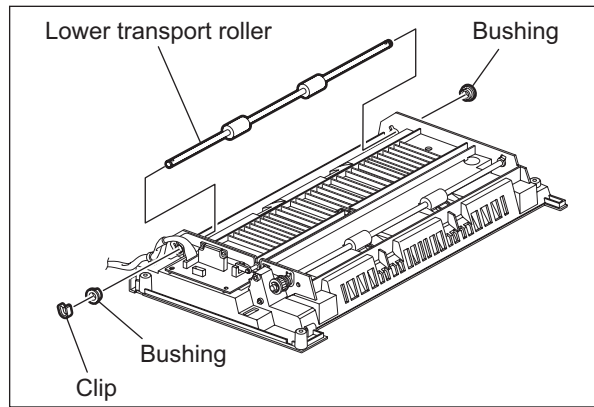

Fig. 14-17

**[F] Paper guide**

- (1) Open the ADU cover.
- (2) Release 1 latch and take off the guide on the front side.

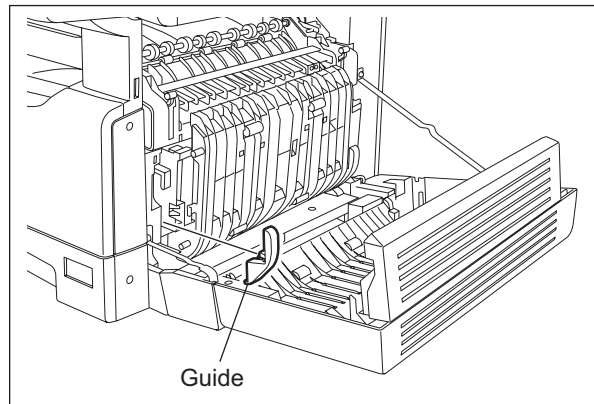

Fig. 14-18

- (3) Release 1 latch and take off the paper guide while sliding it toward the front.

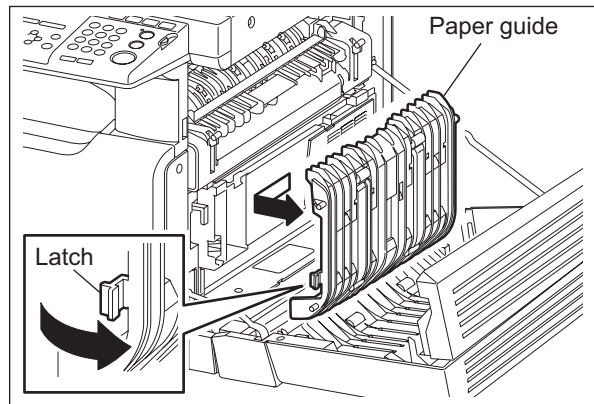

Fig. 14-19



## 15. POWER SUPPLY UNIT

### 15.1 Construction

The power supply unit consists of the AC filter, insulated-side DC output circuit, high-voltage output circuit, and heater lamp control circuit.

1) AC filter

Eliminates noise from the outside and prevents the noise generated by the equipment from leaking to the outside.

2) DC output circuit (Low-voltage output circuit)

Converts AC voltage input from outside to DC voltage and supplies it to each electric part. The DC voltage is divided into the following two lines.

a. Main switch line: Power supply used in the entire equipment during the image forming process. Six kinds of voltage (+5V, +5VB, +12V, -12V, +24V and +24VDF) are output when the main switch of the equipment is turned ON.

b. Cover switch line: Power supply used in the entire equipment during the image forming process. It is supplied via the cover switch. This voltage (+24VCOV-OFF) is output only when both the main switch of the equipment and the cover interlock switches are turned ON (when the front and ADU covers are closed).

\* When the equipment is in Energy Saving Mode (Auto Shut Off Mode), only the +5VB for the main switch line is supplied.

3) High-voltage output circuit

Generates the output currents/voltages for the charger, developer, transfer and separation biases, based on the +24V voltage which is generated by the DC output circuit. For details of the high-voltage output circuit, see the following.

 P.11-5 "11.4 High-Voltage Output Control Circuit"

4) Heater lamp control circuit

TRC (Triac) is driven by the heater control signal (HTON1B/HTON2B) from the MAIN board and then AC power is supplied to each heater lamp (center and side) in the fuser unit. For details of the heater lamp control circuit, see the following.

 P.13-6 "13.5 Fuser Unit Control Circuit"

## 15.2 Operation of DC Output Circuit

### 1) Starting line output

When the power of the equipment is turned ON, all the voltages start being supplied. However, they start being supplied only when both the front cover and the ADU cover are closed.

### 2) Stopping line output

When the power of the equipment is turned OFF, the power-OFF (PWRDWN-1) signal is output after the end of the instantaneous outage insurance time (20 ms or more), and then the supply of each voltage stops. If the supply of voltage of the +5VB line stops earlier than the 24V line does, it may cause damage to the electron device on each control circuit. To prevent this, the supply of the +5VB voltage stops after the power-OFF signal is output and the minimum retaining time (50 ms or more) has elapsed.

### 3) Output protection

Each output system includes an overcurrent and overvoltage protection circuit (a fuse and internal protection circuit). This is to prevent defects (damage or abnormal operation of the secondary circuit) which may be caused by an overcurrent due to a short circuit or an overvoltage resulting from short-circuiting between different voltages. If the protection circuit is activated (except when the fuse is blown), repair the causes such as short-circuiting. Turn ON the power again 1 minute later to clear the overcurrent protection.



## 15.3 Output Channel

The following are 6 output channels for the main switch line.

- 1) +5V  
+5V: CN104 Pin 3  
Output to the MAIN board  
  
+5V: CN112 Pins 3 and 4  
Output to the PFC board, ADU (via PFC board), PFP (via PFC board)  
  
+5VB: CN104 Pin 8  
Output to the FUS board  
  
+5VB: CN104 Pins 9 and 10  
Output to the MAIN board
- 2) +12V  
+12V: CN110 Pin 3  
Output to the FAX unit
- 3) -12V  
-12V: CN104 Pin 2  
Output to the control panel (via MAIN board)  
  
-12V: CN110 Pin 2  
Output to the FAX unit
- 4) +24V  
+24V: CN104 Pins 19 and 20  
Output to the MAIN board, PFU (via MAIN board)  
  
+24V: CN112 Pins 1 and 2  
Output to the PFC board, ADU (via PFC board), PFP (via PFC board)  
  
+24VDF: CN104 Pins 17 and 18  
Output to the RADF/ADF (via MAIN board)

The following is an output channel for the cover switch line.

- 1) +24V  
+24VCOV-OFF: CN104 Pins 23 and 24  
Output to the MAIN board

## 15.4 Fuse

When the power supply secondary fuse is blown out, confirm that there is no abnormality with each part using the following table.

Voltage	Board/Unit	Part		Fuse type
+24V	MAIN board	Scan motor	M1	F203: 4A
		Polygonal motor	M4	
		Switching regulator cooling fan	M6	
		Registration clutch	CLT1	
		Pickup solenoid	SOL1	
		Bypass pickup solenoid	SOL2	
		Contact image sensor unit	CIS	
	PFC board	Exit motor	M7	
	ADU board	ADU motor	M8	
		PFU		
	PFP			
+24VDF	ADF			
+24VCOV-OFF	MAIN board	Toner motor	M2	F201: 4A
		Main motor	M3	
		Exhaust fan	M5	
		Auto-toner sensor	S6	
		Discharge LED	ERS	
	Coin controller			



## 15.6 Power Supply Sequence

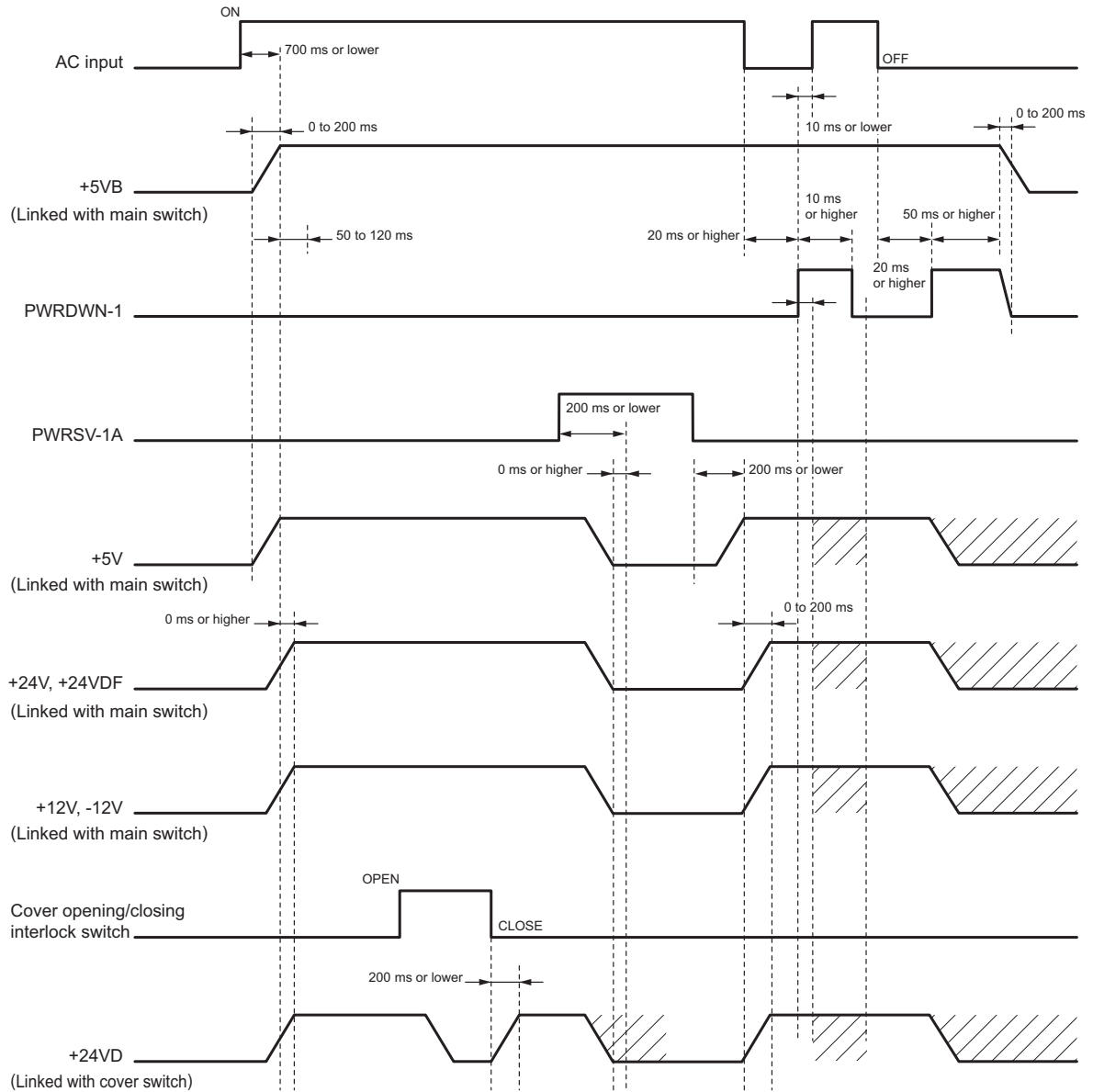

Fig. 15-2

# 15.7 AC Wire Harness

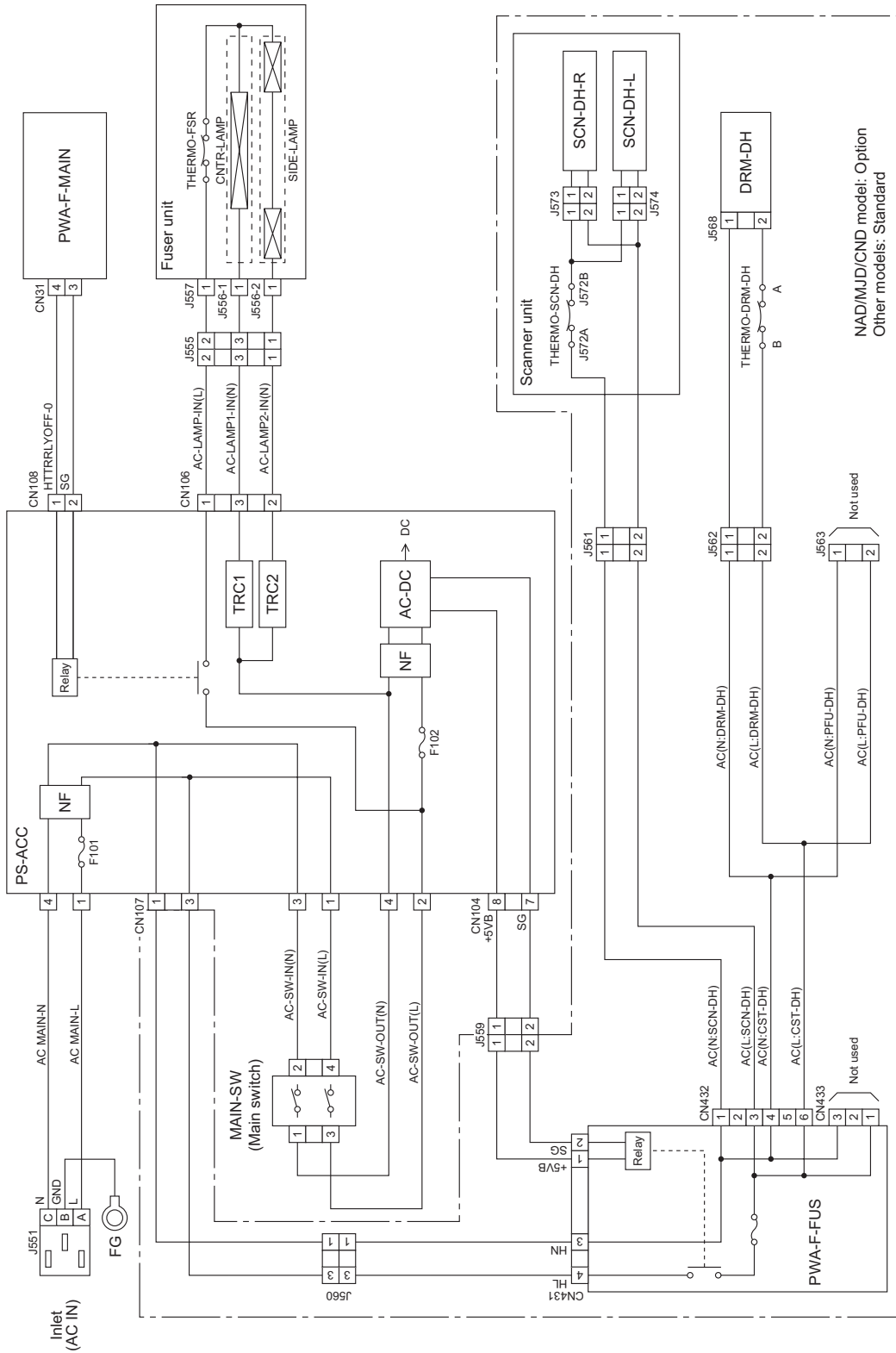

Fig. 15-3



# 16. PC BOARDS

## 1) PWA-F-MAIN

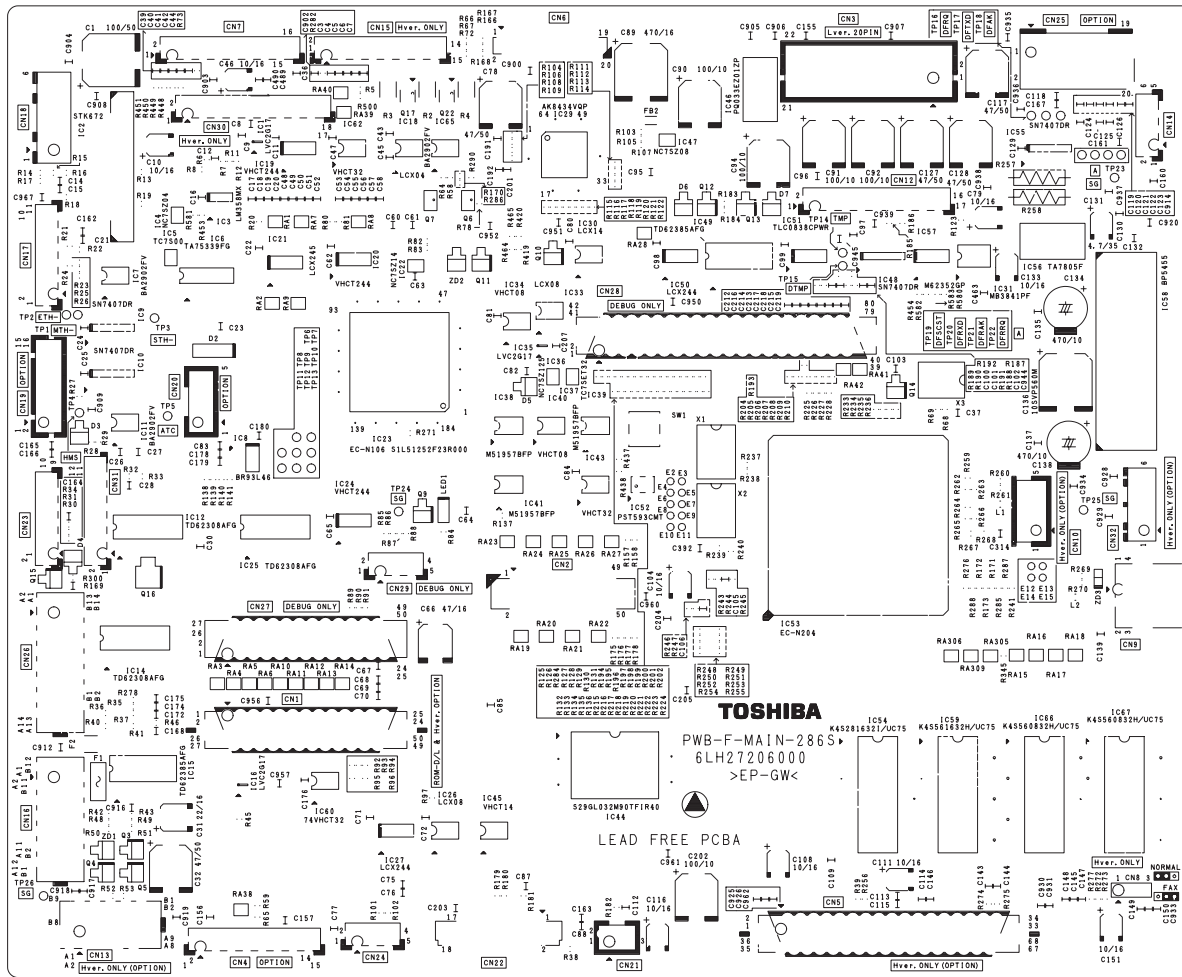

Fig. 16-1

## 2) PWA-F-SRAM

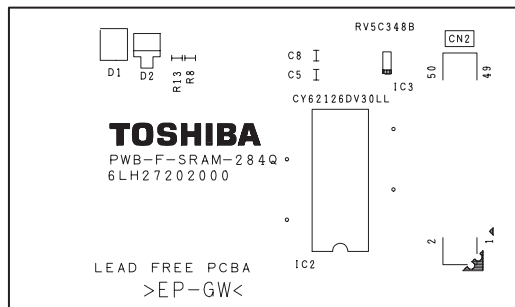

Fig. 16-2





6) PWA-F-FUS

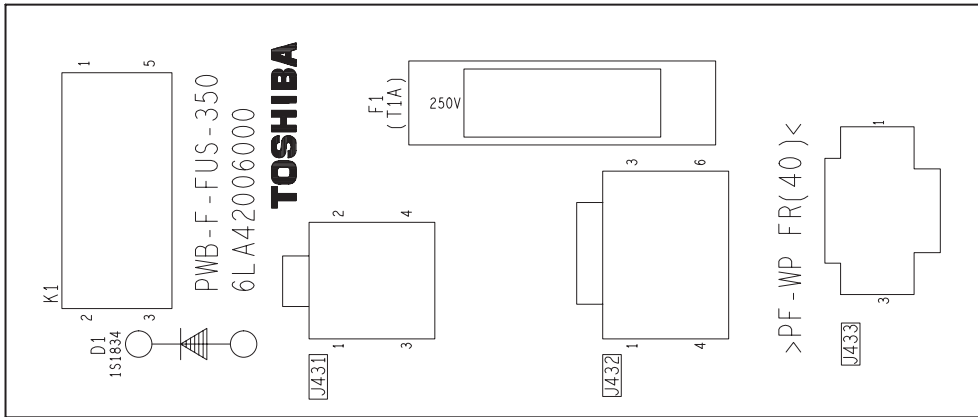

Fig. 16-6

7) PWA-F-PFC

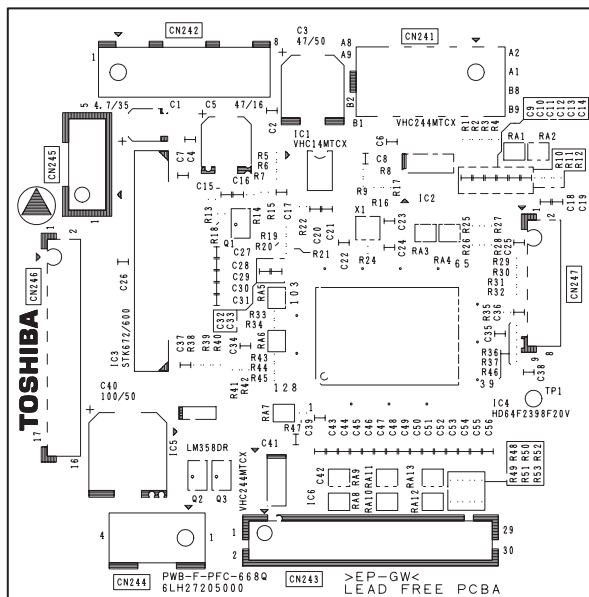

Fig. 16-7

8) PWA-F-ADU

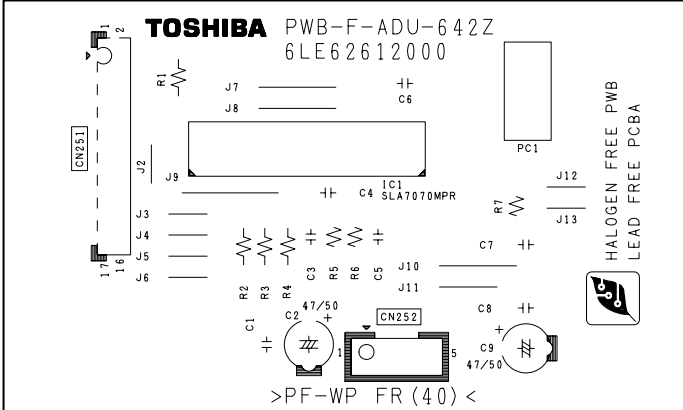

Fig. 16-8



# **TOSHIBA**

**TOSHIBA TEC CORPORATION**

2-17-2, HIGASHIGOTANDA, SHINAGAWA-KU, TOKYO, 141-8664, JAPAN

*WWW.SERVICE-MANUAL.NET*