

TOSHIBA

SERVICE PARTS LIST

MULTIFUNCTIONAL DIGITAL SYSTEMS

e-STUDIO0901/1101/1351

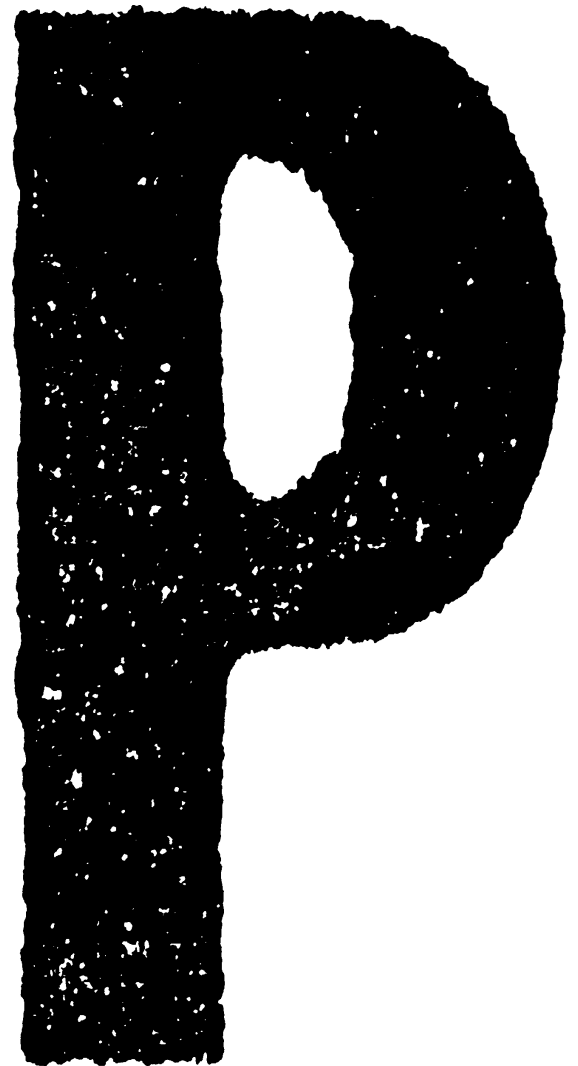

© 2006 TOSHIBA TEC CORPORATION All rights reserved

Under the copyright laws, this manual cannot be reproduced in any form without prior written permission of TOSHIBA TEC CORPORATION. No patent liability is assumed, however, with respect to the use of the information contained herein.

EXPLANATION OF SERVICE-PARTS LIST

1. HOW TO READ THE PARTS LIST

- (1) Number of pieces
The number of pieces in the list denotes total pieces used per unit. But the numbers in the list for PACKING MATERIAL and ACCESSORY denote total pieces used per machine.
- (2) One pack of screws in the list includes 50 pieces.
- (3) ABBREVIATED CODES

QTY/PAC

- QTY.....one piece
- PAC.....one pack
- 1/P.....one piece packed in polyethylene bag
- 1/S.....one piece packed in special pack
- 1/C.....one piece packed in carton box
- 1/PP.....one piece packed in paper and polyethylene bag
- 1/KP.....one piece packed in polyethylene bag with cardboard
- 1/D.....one piece packed in polyethylene-cushion bag
- 1/SB.....one piece packed in shielding bag
- N/A.....not available

P.....PURPOSE

- A.....ADD
- B.....DELETE
- C.....CHANGE
- D.....QTY, CHANGE
- E.....MISENTRY
- F.....OMISSION

I.....INTERCHANGEABILITY STATUS

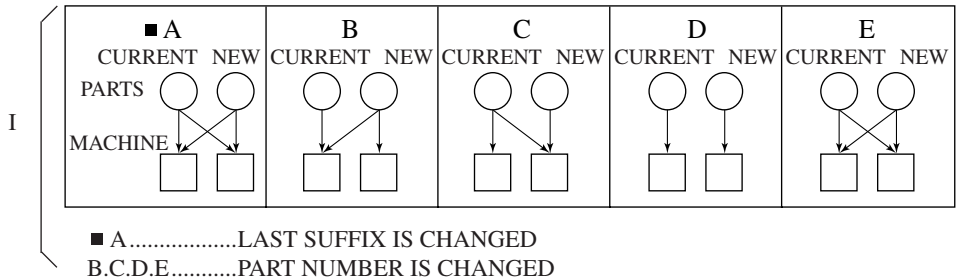

2. HOW TO PLACE ORDER FOR PARTS

- (1) The parts handled as service parts are only those with their "QTY/PACK" column listed with a quantity other than "N/A***" or "SUPPLY".
Those parts with "N/A***" are listed only for the purpose of showing the mechanical construction, those listed with "SUPPLY" are handled only as a sales item, and therefore both types of parts are not supplied as service parts.
- (2) Orders for any parts which form a component of a semi-assembled unit are not acceptable.
Note: All the screws and nuts used are ISO standard.

3. REGION

NAD.....115V
50/60Hz, NORTH AMERICA, SOUTH AMERICA

TWD.....110/220V
50/60Hz, TAIWAN

SAD.....127V/60Hz, SAUDI ARABIA

ASD.....220-240V
50/60Hz, ASIA, SOUTH AMERICA, etc.

ASU.....220-240V
50/60Hz, ASIA, etc.

AUD.....220-240V
50/60Hz, AUSTRALIA

MJD.....220-240V
50/60Hz, EUROPE

CND.....220-240V
50/60Hz, CHINA

KRD.....220-240V
50/60Hz, KOREA

CONTENTS

EXTERIOR 1	1	TRANSFER BELT UNIT 2	45
EXTERIOR 2	2	FUSING UNIT 1	46
EXTERIOR 3	3	FUSING UNIT 2	47
OPERATION PANEL	4	FUSING UNIT 3	48
DF EXTERIOR	5	FUSING UNIT 4	49
ORIGINAL FEED 1	6	PAPER EXIT SECTION 1	50
ORIGINAL FEED 2	7	PAPER EXIT SECTION 2	51
ORIGINAL FEED 3	8	PAPER EXIT SECTION 3	52
ORIGINAL TRANSPORT	9	DUPLEX UNIT 1	53
ORIGINAL EXIT 1	10	DUPLEX UNIT 2	54
ORIGINAL EXIT 2	11	DUPLEX UNIT 3	55
DF DRIVE SECTION 1	12	DUPLEX UNIT 4	56
DF DRIVE SECTION 2	13	DUPLEX UNIT 5	57
DF FRAME SECTION	14	DUPLEX UNIT 6	58
OPTICS SECTION 1	15	DRIVE SECTION 1	59
OPTICS SECTION 2	16	DRIVE SECTION 2	60
OPTICS SECTION 3	17	DRIVE SECTION 3	61
OPTICS SECTION 4	18	DRIVE SECTION 4	62
LASER UNIT	19	DRIVE SECTION 5	63
TANDEM TRAY 1	20	DRIVE SECTION 6	64
TANDEM TRAY 2	21	DRIVE SECTION 7	65
TANDEM TRAY 3	22	ELECTRICAL SECTION 1	66
UNIVERSAL TRAY	23	ELECTRICAL SECTION 2	67
PAPER FEED UNIT 1	24	ELECTRICAL SECTION 3	68
PAPER FEED UNIT 2	25	ELECTRICAL SECTION 4	69
PAPER FEED UNIT 3	26	ELECTRICAL SECTION 5	70
VERTICAL TRANSPORT	27	ELECTRICAL SECTION 6	71
PAPER REGISTRATION 1	28	ELECTRICAL SECTION 7	72
PAPER REGISTRATION 2	29	CONTROLLER UNIT	73
PAPER REGISTRATION 3	30	FRAME SECTION 1	74
TONER BANK UNIT 1	31	FRAME SECTION 2	75
TONER BANK UNIT 2	32	FRAME SECTION 3	76
TONER SUPPLY UNIT 1	33	FRAME SECTION 4	77
TONER SUPPLY UNIT 2	34	FRAME SECTION 5	78
TONER HOPPER SECTION	35	FRAME SECTION 6	79
CHARGE CORONA UNIT 1	36	BCU BOARD	80
CHARGE CORONA UNIT 2	37	IO BOARD	81
DEVELOPMENT UNIT 1	38	IPU BOARD	82
TONER COLLECTION BOTTLE	39	CONTROLLER BOARD	83
PCU 1	40	DECAL AND DOCUMENT 1	84
PCU 2	41	DECAL AND DOCUMENT 2	85
CLEANING UNIT 1	42	DECAL AND DOCUMENT 3	86
CLEANING UNIT 2	43	SPECIAL TOOLS	87
TRANSFER BELT UNIT 1	44		

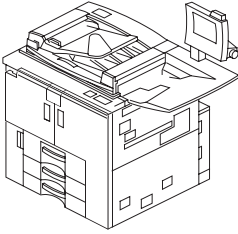
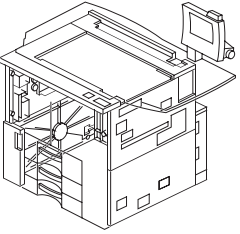
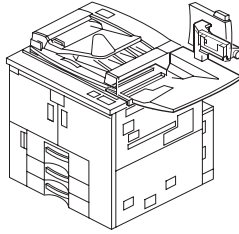
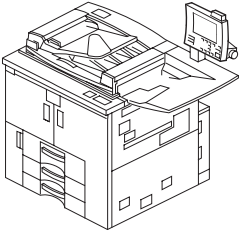
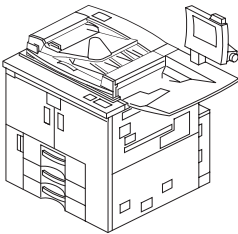
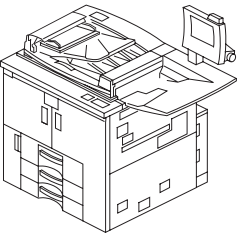
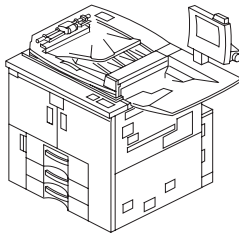
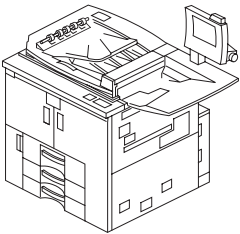
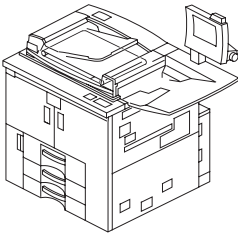
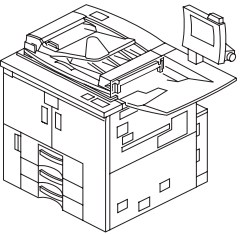
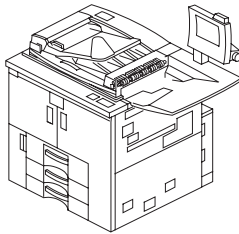
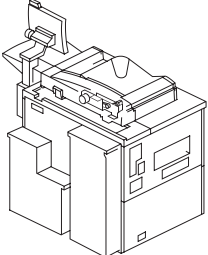
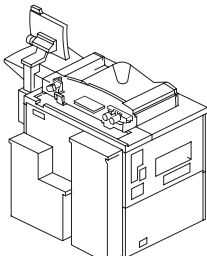
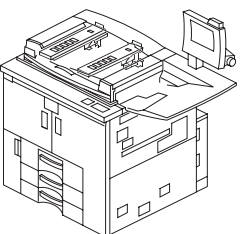
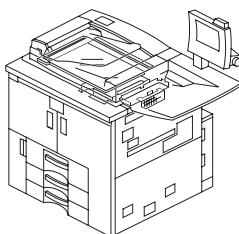
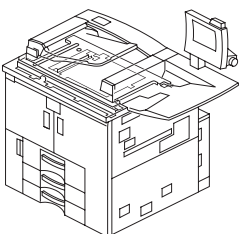
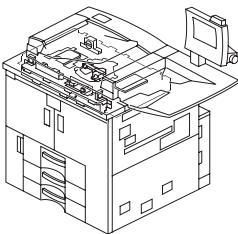
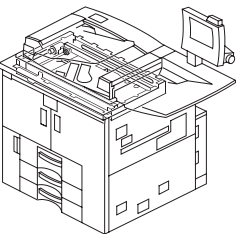
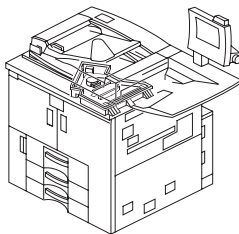
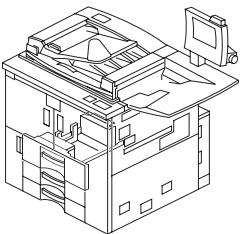
<p>1. EXTERIOR 1</p> 	<p>2. EXTERIOR 2</p> 	<p>3. EXTERIOR 3</p> 	<p>4. OPERATION PANEL</p> 
<p>5. DF EXTERIOR</p> 	<p>6. ORIGINAL FEED 1</p> 	<p>7. ORIGINAL FEED 2</p> 	<p>8. ORIGINAL FEED 3</p> 
<p>9. ORIGINAL TRANSPORT</p> 	<p>10. ORIGINAL EXIT 1</p> 	<p>11. ORIGINAL EXIT 2</p> 	<p>12. DF DRIVE SECTION 1</p> 
<p>13. DF DRIVE SECTION 2</p> 	<p>14. DF FRAME SECTION</p> 	<p>15. OPTICS SECTION 1</p> 	<p>16. OPTICS SECTION 2</p> 
<p>17. OPTICS SECTION 3</p> 	<p>18. OPTICS SECTION 4</p> 	<p>19. LASER UNIT</p> 	<p>20. TANDEM TRAY 1</p> 

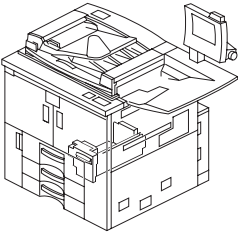
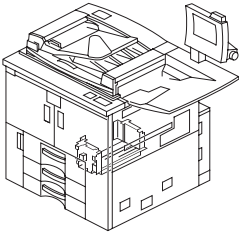
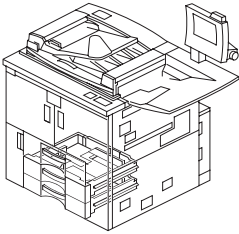
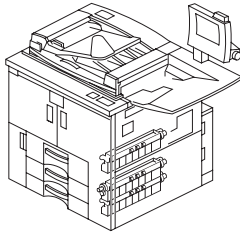
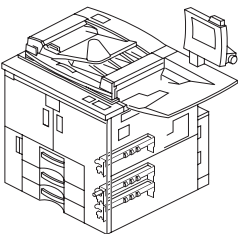
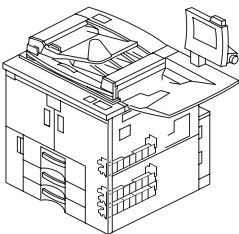
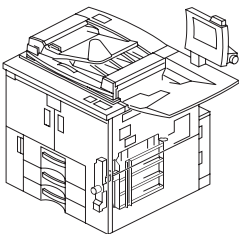
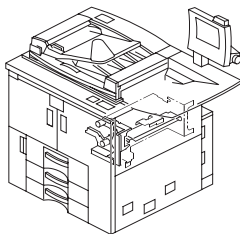
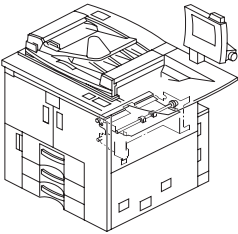
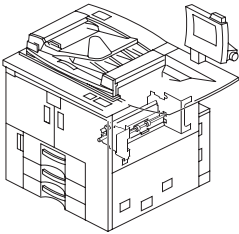
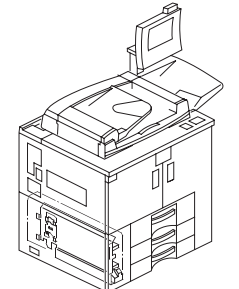
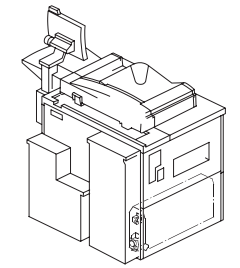
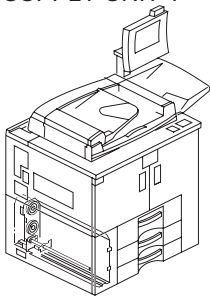
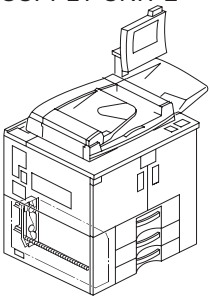
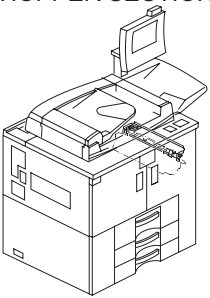
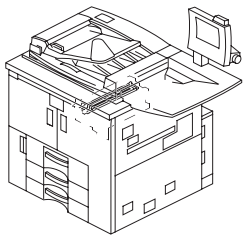
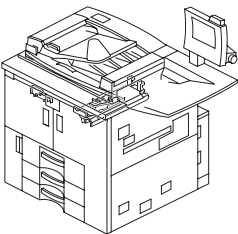
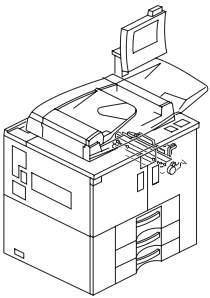
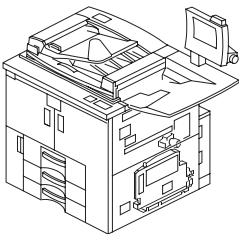
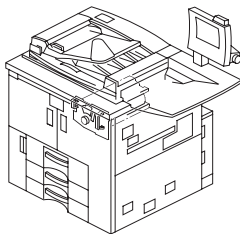
<p>21. TANDEM TRAY 2</p> 	<p>22. TANDEM TRAY 3</p> 	<p>23. UNIVERSAL TRAY</p> 	<p>24. PAPER FEED UNIT 1</p> 
<p>25. PAPER FEED UNIT 2</p> 	<p>26. PAPER FEED UNIT 3</p> 	<p>27. VERTICA TRANSPORT</p> 	<p>28. PAPER REGISTRATION 1</p> 
<p>29. PAPER REGISTRATION 2</p> 	<p>30. PAPER REGISTRATION 3</p> 	<p>31. TONER BANK UNIT 1</p> 	<p>32. TONER BANK UNIT 2</p> 
<p>33. TONER SUPPLY UNIT 1</p> 	<p>34. TONER SUPPLY UNIT 2</p> 	<p>35. TONER HOPPER SECTION</p> 	<p>36. CHARGE CORONA UNIT 1</p> 
<p>37. CHARGE CORONA UNIT 2</p> 	<p>38. DEVELOPMENT UNIT 1</p> 	<p>39. TONER COLLECTION BOTTLE</p> 	<p>40. PCU 1</p> 

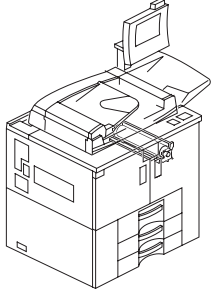
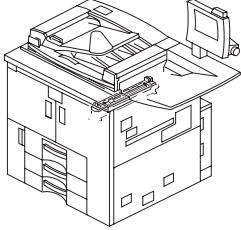
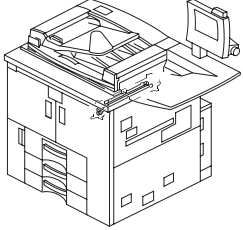
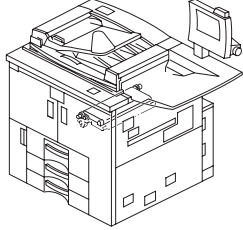
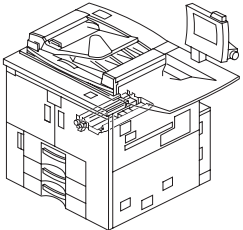
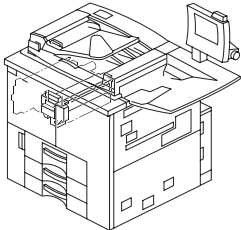
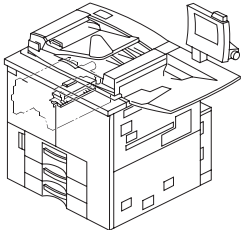
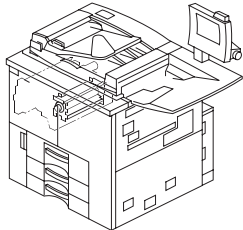
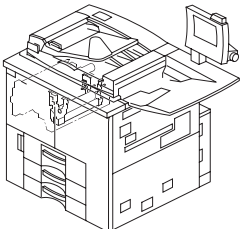
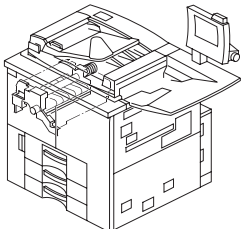
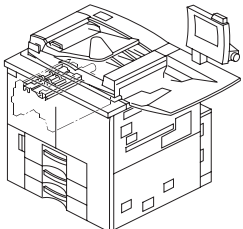
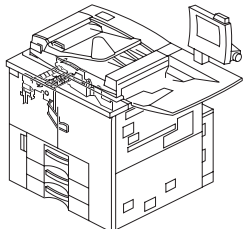
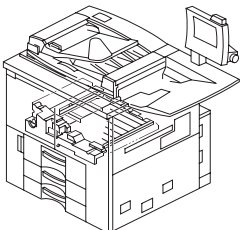
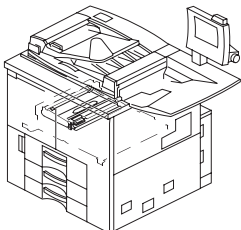
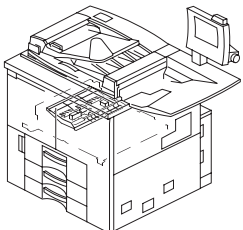
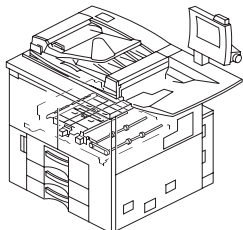
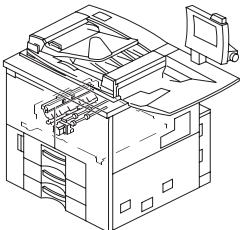
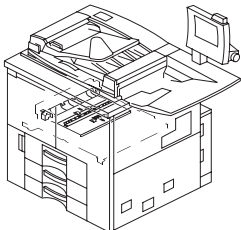
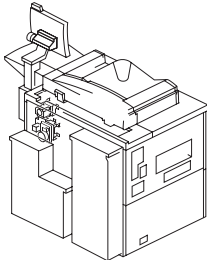
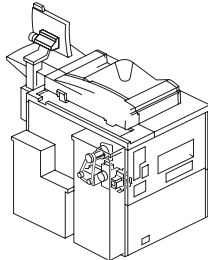
<p>41. PCU 2</p> 	<p>42. CLEANING UNIT 1</p> 	<p>43. CLEANING UNIT 2</p> 	<p>44. TRANSFER BELT UNIT 1</p> 
<p>45. TRANSFER BELT UNIT 2</p> 	<p>46. FUSING UNIT 1</p> 	<p>47. FUSING UNIT 2</p> 	<p>48. FUSING UNIT 3</p> 
<p>49. FUSING UNIT 4</p> 	<p>50. PAPER EXIT SECTION 1</p> 	<p>51. PAPER EXIT SECTION 2</p> 	<p>52. PAPER EXIT SECTION 3</p> 
<p>53. DUPLEX UNIT 1</p> 	<p>54. DUPLEX UNIT 2</p> 	<p>55. DUPLEX UNIT 3</p> 	<p>56. DUPLEX UNIT 4</p> 
<p>57. DUPLEX UNIT 5</p> 	<p>58. DUPLEX UNIT 6</p> 	<p>59. DRIVE SECTION 1</p> 	<p>60. DRIVE SECTION 2</p> 

61. DRIVE SECTION 3

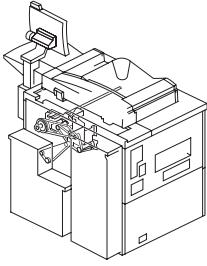

62. DRIVE SECTION 4

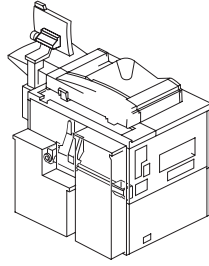

63. DRIVE SECTION 5

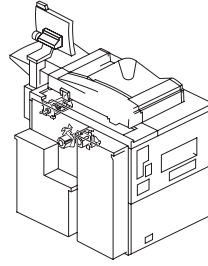

64. DRIVE SECTION 6

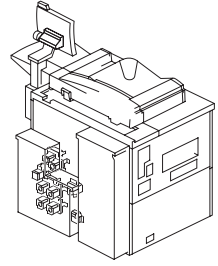

65. DRIVE SECTION 7

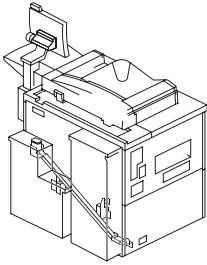

66. ELECTRICAL SECTION 1

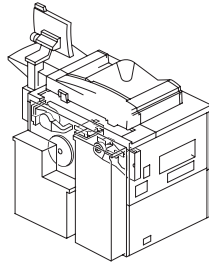

67. ELECTRICAL SECTION 2

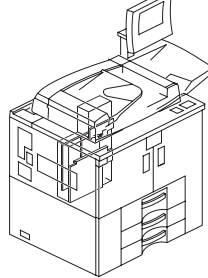

68. ELECTRICAL SECTION 3

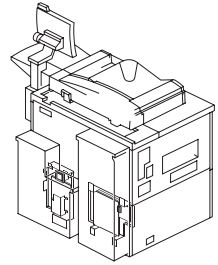

69. ELECTRICAL SECTION 4

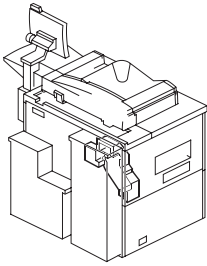

70. ELECTRICAL SECTION 5

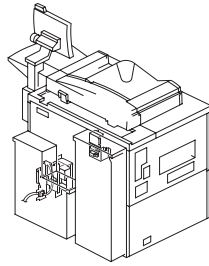

71. ELECTRICAL SECTION 6

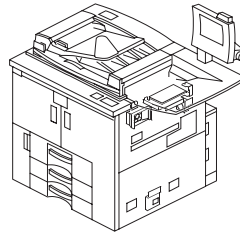

72. ELECTRICAL SECTION 7

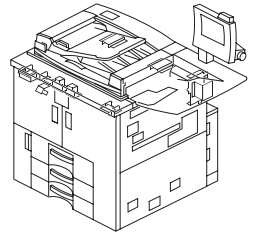

73. CONTROLLER UNIT

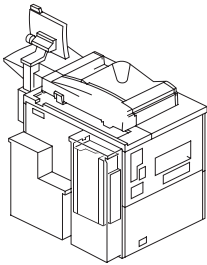

74. FRAME SECTION 1

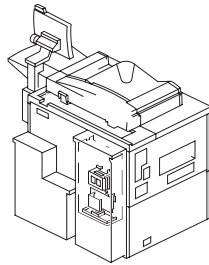

75. FRAME SECTION 2

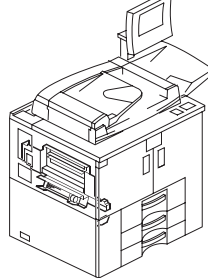

76. FRAME SECTION 3

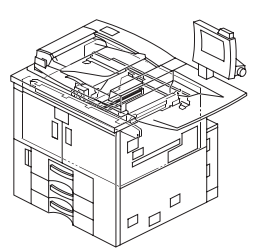

77. FRAME SECTION 4

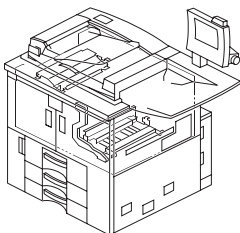

78. FRAME SECTION 5

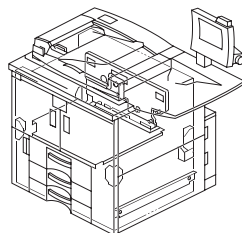

79. FRAME SECTION 6

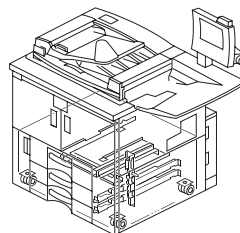

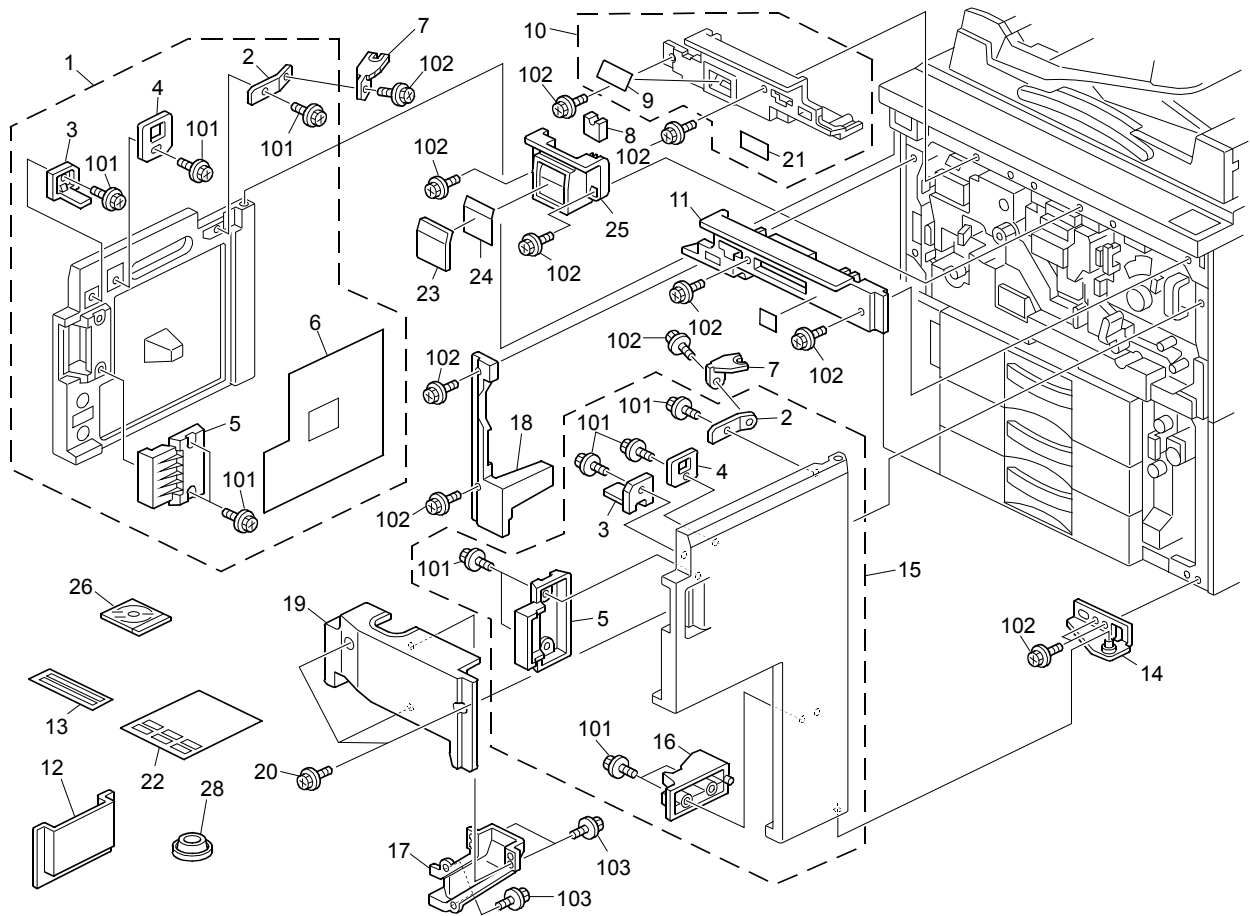

ITEM NO.	PARTS NO.	PARTS NAME	Q'TY / PAGE	Q'TY / PACK	P	I	R	B S I NO.	T O	T	F R O M	S E R I A L NO.	R E M A R K S	C
1	B2341277	Door - Front Left	1											
2	A2941282	Front Door Spcer Bracket	2											
3	B2341293	Lever - Safety Switch	2											
4	B2341296	Plate:Magnet Catch	2											
5	B2341281	Cover Grip	2											
6	B2341300	Decal - Misfeed Removal	1											
7	A0791406	Upper Door Spacer	2											
8	B1321529	Sponge:SD-Card:Plate	1											
9	B2341378	Decal - Total Counter	1											
10	B2341372	Inner Cover - Upper Left	1											
11	B2341375	Inner Cover - Upper Right	1											
12	B1548521	Holder:Operating Instruct	1											
13	B0701307	Decal:Caution Chart:Paper	1											
14	A2941356	Lower Right Hinge	1											
15	B2341253	Door - Front Right	1											
16	B2341294	Stopper - Vertical Transp	1											
17	B2342344	Duct	1											
18	B2341380	Inner Cover - Left	1											
19	B2342342	Inner Cover	1											
20	B2342390	Flanged Hexagonal Head Bo	3											
21	B2344136	Decal - Warning (high Tem	1											
22	B2348510	Decal:Size Indication:Mul	1											
23	B1321531	Panel:Logo	1											
24A	B2346940	Sheet - TEC 901	1										e-STUDIO901	
24B	B2356940	Logo Sheet - TEC 1101	1										e-STUDIO1101	
24C	B2366940	Logo Sheet - TEC 1351	1										e-STUDIO1351	
25	B2341367	Cover - Logo	1											
26	B2357451	IC:Manual:TEC	1											
27	B2341306	Decal:Multie:Misfeed Remo	1											
28	B1321226	Holder:Stand	4											
101	0450008N	Tapping Screw - M4x8												
102	0451008N	Tapping Screw:4x8												
103	0450008N	Tapping Screw - M4x8												

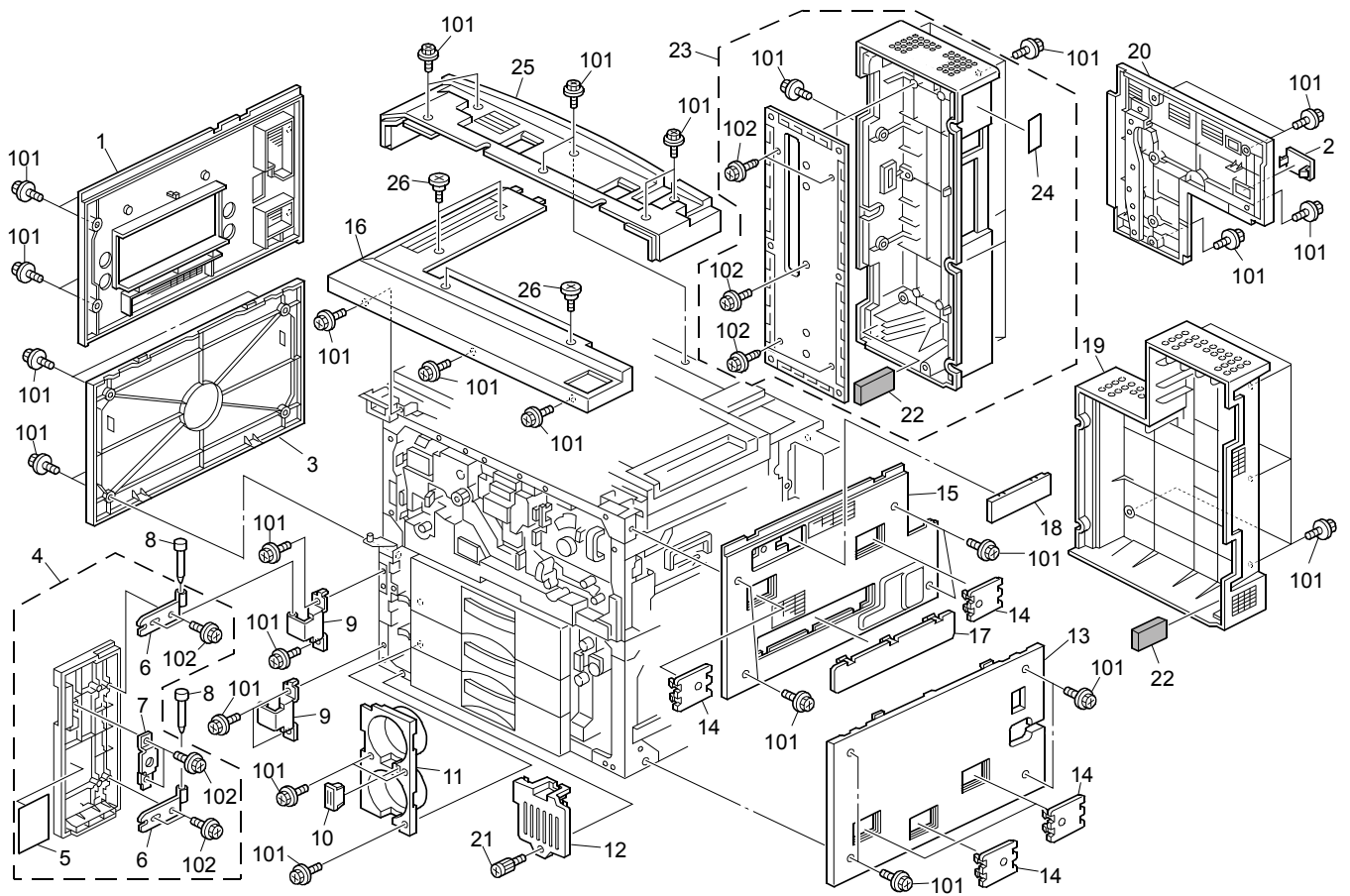

ITEM NO.	PARTS NO.	PARTS NAME	Q'TY / PAGE	Q'TY / PACK	P I R	B S I NO.	T O	T	F R O M	S E R I A L NO.	R E M A R K S	C
1	B2341320	Cover - Left Upper	1									
2	B2341341	Cap:Connector	2									
3	B2341326	Cover - Left Lower	1									
4	B2341267	Door - Front Lower	1									
5	B2341272	Decal - Toner Bank	1									
6	A2941270	Lower Front Hinge	2									
7	A2941268	Door Catch - Front Lower	1									
8	C2442187	Shaft:Flange:Master:Right	2									
9	A2941271	Hinge - Lower Front Door	2									
10	AA021035	Magnetic:Cover	1									
11	B2343491	Inner Cover - Upper	1									
12	B2343492	Inner Cover - Lower	1									
13	B2341316	Cover - Right Lower	1									
14	B0701312	Cap:Joint:Large Capacity	4									
15	B2341311	Cover - Right Upper	1									
16	B2341258	Cover - Upper	1									
17	B2341313	Cover - Large Capacity Tr	1									
18	B0701331	Cap:Key Counter:C2	1									
19	B2347576	Cover - Power Supply Unit	1									
20	B2341329	Cover - Rear	1									
21	AA143865	Screw - M4X10	1									
22	B0706840	Filter:C/T Box	2									
23	B2346838	Cover:C/T Box	1									
24	B2346851	Decal - Caption Interface	1									
25	B2341261	Cover - Upper Rear	1									
26	AA143560	Stepped Screw - M4	4									
101	0451008N	Tapping Screw:4x8										
102	0450008N	Tapping Screw - M4x8										

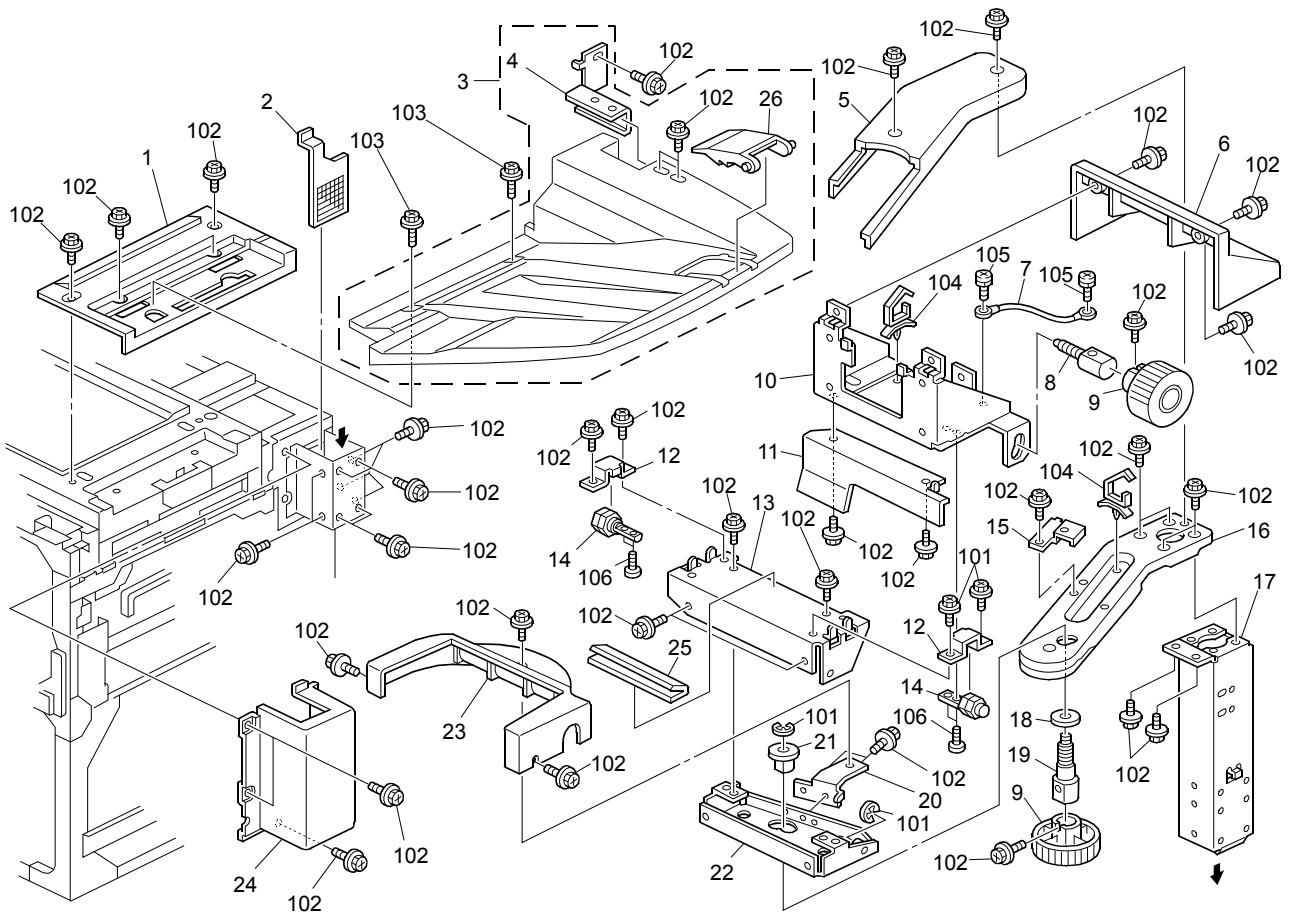

ITEM NO.	PARTS NO.	PARTS NAME	Q'TY / PAGE	Q'TY / PACK	P	I	R	B S I NO.	T O	T	F R O M	S E R I A L NO.	R E M A R K S	C
1	B2341262	Cover - Upper Right	1											
2	B0702123	Filter:Entrance:Around Th	1											
3	B2341260	ADF Exit Tray	1											
4	A2941266	Exit Bracket	1											
5	B2341424	Cover - Arm	1											
6	B2341422	Support Cover - Upper	1											
7	B0705147	Harness:Ground Wire:Opera	1											
8	B2341447	Knob Shaft - Operation Pa	1											
9	B0701440	Knob:Operation Sub-unit	2											
10	A2941439	Operation Unit Fixing Pla	1											
11	B0701430	Cover:Operation Panel:Rea	1											
12	A2941438	Hinge Fixing Plate	2											
13	A2941437	Supporting Plate - Operat	1											
14	A2941429	Hinge - Operation Unit	2											
15	A2941446	Bracket - Arm Cover	1											
16	A2941425	Operation Unit Arm	1											
17	B2341433	Frame:Arm:Operation Sub-u	1											
18	A2941441	Spacer - Operation Panel	1											
19	B2341448	Knob Shaft - Operation Pa	1											
20	A2941445	Bracket - Cover	1											
21	A2941449	Bushing - Operation Panel	1											
22	A2941434	Lower Support	1											
23	B2341423	Support Cover - Lower	1											
24	B2341421	Cover - Holder	1											
25	B0701436	Gasket:Operation Sub-unit	1											
26	B2341263	Stopper - ADF Exit Tray	1											
101	0720060E	Retaining Ring - M6												
102	0451008N	Tapping Screw:4x8												
103	0451012N	Tapping Screw:4x12												
104	11050508	Harness Clamp - LWS-0711												
105	0950008N	Screw:Spring Washer:M4x8												
106	0313080N	Pan Head Screw:M3x8												

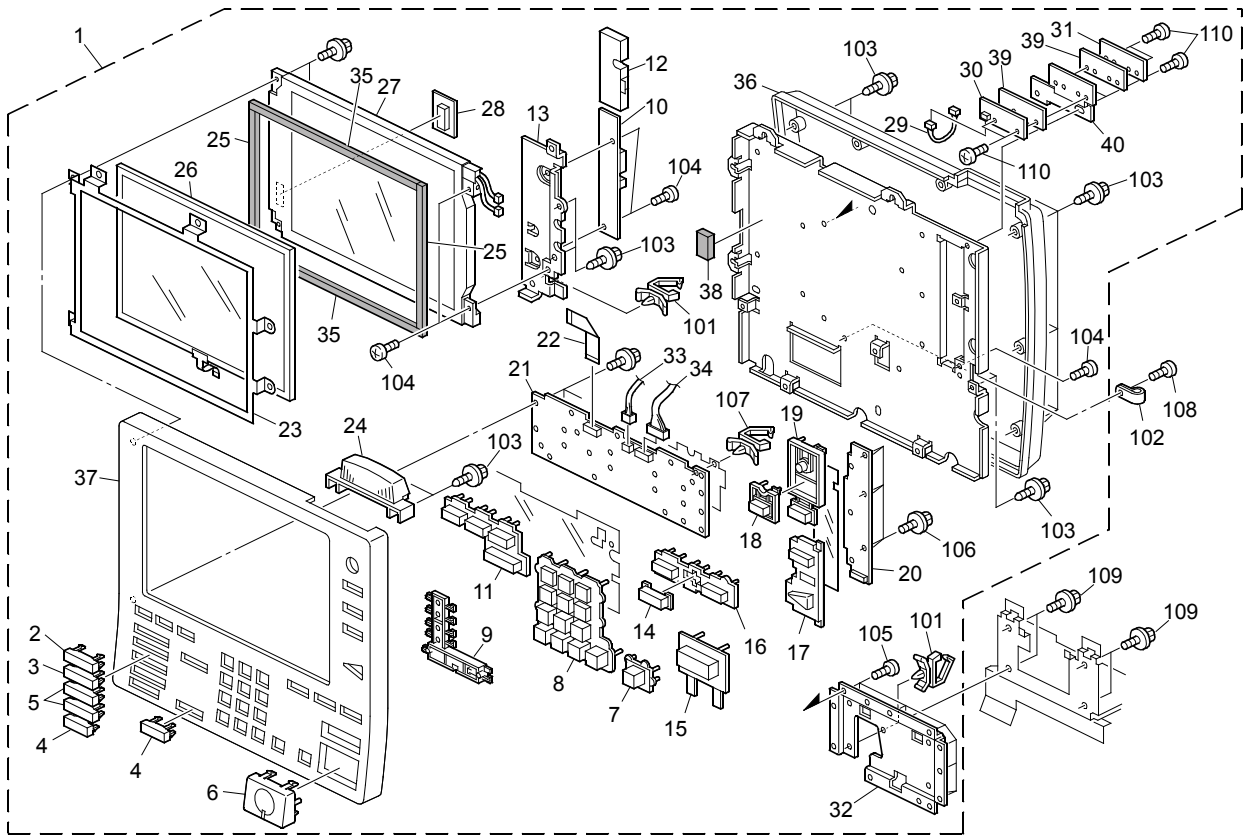

ITEM NO.	PARTS NO.	PARTS NAME	Q'TY / PAGE	Q'TY / PACK	P I R	B S I NO.	T O	T	F R O M	S E R I A L NO.	R E M A R K S	C
1	B2341451	Operation Panel Unit	1									
2	B2341569	Keytop - Copy NA	1									
3	B2341570	Keytop - Docbox NA	1									
4	B2341523	Keytop - Application Blan	2									
5	B2341526	Keytop - Application Blan	2									
6	B2341505	Keytop - Start	1									
7	B2341508	Keytop - Try Print	1									
8	B2341507	Keytop - 10key	1									
9	B2341515	Keytop - Spacer Applicati	1									
10	B2341480	Invertor S-vga	1									
11	B2341558	Keytop - Counter NA	1									
12	B2341539	Insulator - Invertor	1									
13	B2341534	LCD Bracket	1									
14	B2341559	Keytop - Reset Switch	1									
15	B2341506	Keytop - Stop	1									
16	B2341517	Keytop - Program	1									
17	B2341520	Keytop - Interrupt	1									
18	B2341521	Keytop - Login_logout	1									
19	B2341519	Keytop - Power Source	1									
20	B2341463	PCB Key Sub	1									
21	B2341460	PCB - Key Main	1									
22	B2341478	Cable - FFC/LCD	1									
23	B2341531	Shadeing Plate	1									
24	B2341504	Cover - Pilot Lamp	1									
25	B2341543	Spacer - Touch Panel S	2									
26	B2341479	Touch Panel S-vga	1									
27	RC010070	LCD - LQ104S1DG21A	1									
28	B2341472	PCB LCD	1									
29	B2341477	Harness - LED	1									
30	B2341466	PCB LED F	1									
31	B2341469	PCB LED R	1									
32	B2341533	Arm Stay Bracket	1									
33	B2341476	Harness - INV	1									
34	B2341475	Harness - SUB	1									
35	B2341542	Spacer - Touch Panel L	2									
36	B2341502	Cover:Rear	1									
37	B2341501	Cover:Front	1									
38	B2341544	Cushion - Plate Lcdpcb	1									
39	B2341538	Sheet:Heat	2									
40	B2341535	LED Heat Sink	1									
101	11050508	Harness Clamp - LWS-0711										
102	11050530	Nylon Clamp-ent-4n										
103	0450010N	Tapping Screw - M3x10										
104	0353060N	Bind Screw - M3x6										
105	0354060N	Screw-m4x6										
106	0360008N	Screw:M3x8										
107	11050511	Harness Clamp - LWS-0306Z										
108	0314060N	Screw - M4x6										
109	0451008N	Tapping Screw:4x8										
110	0353040P	Screw - M3X4										

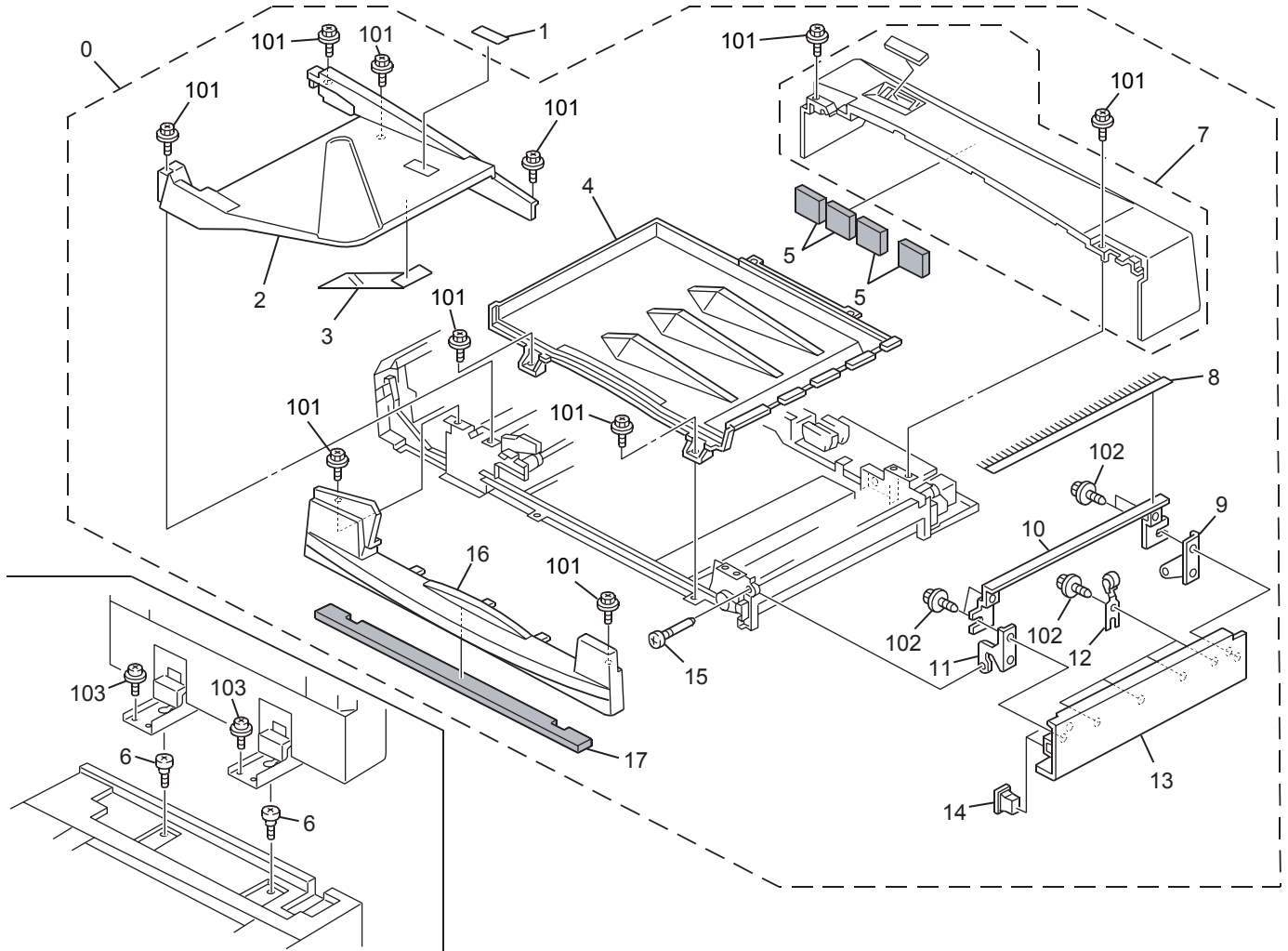

ITEM NO.	PARTS NO.	PARTS NAME	Q'TY / PAGE	Q'TY / PACK	P	I	R	B S I NO.	T O	T	F R O M	S E R I A L NO.	R E M A R K S	C
0	B2347000	Ardf Unit	1											
1	B4774431	Decal - Original Table	1											
2	B3011826	Original Table:RIC:Printi	1											
3	B3011835	Original Holder	1											
4	B3011796	Cover:Original Table:Lowe	1											
5	B3014428	Sound Proofing Material -	4											
6	A8597211	Stepped Screw	2											
7	B3011726	Cover:Rear:RIC:Ass'y	1											
8	B3011919	Discharge Brush - Exit	1											
9	A8063261	Inner Back Cover Bracket	1											
10	A8063266	Discharge Brush Bracket	1											
11	A8063251	Exit Cover Bracket	1											
12	A6631241	Exit Roller:Driven :AS	4											
13	B3011786	Cover:Exit:RIC	1											
14	G0121531	Magnet	2											
15	AA143788	Pin:Guide Plate:Paper Fee	1											
16	B3011716	Cover:Front	1											
17	B3014415	Sound Proofing Material -	1											
101	0451008N	Tapping Screw:4x8												
102	0450012N	Tapping Screw:4x12												
103	0951008N	Screw:Polished Round:M5X8												

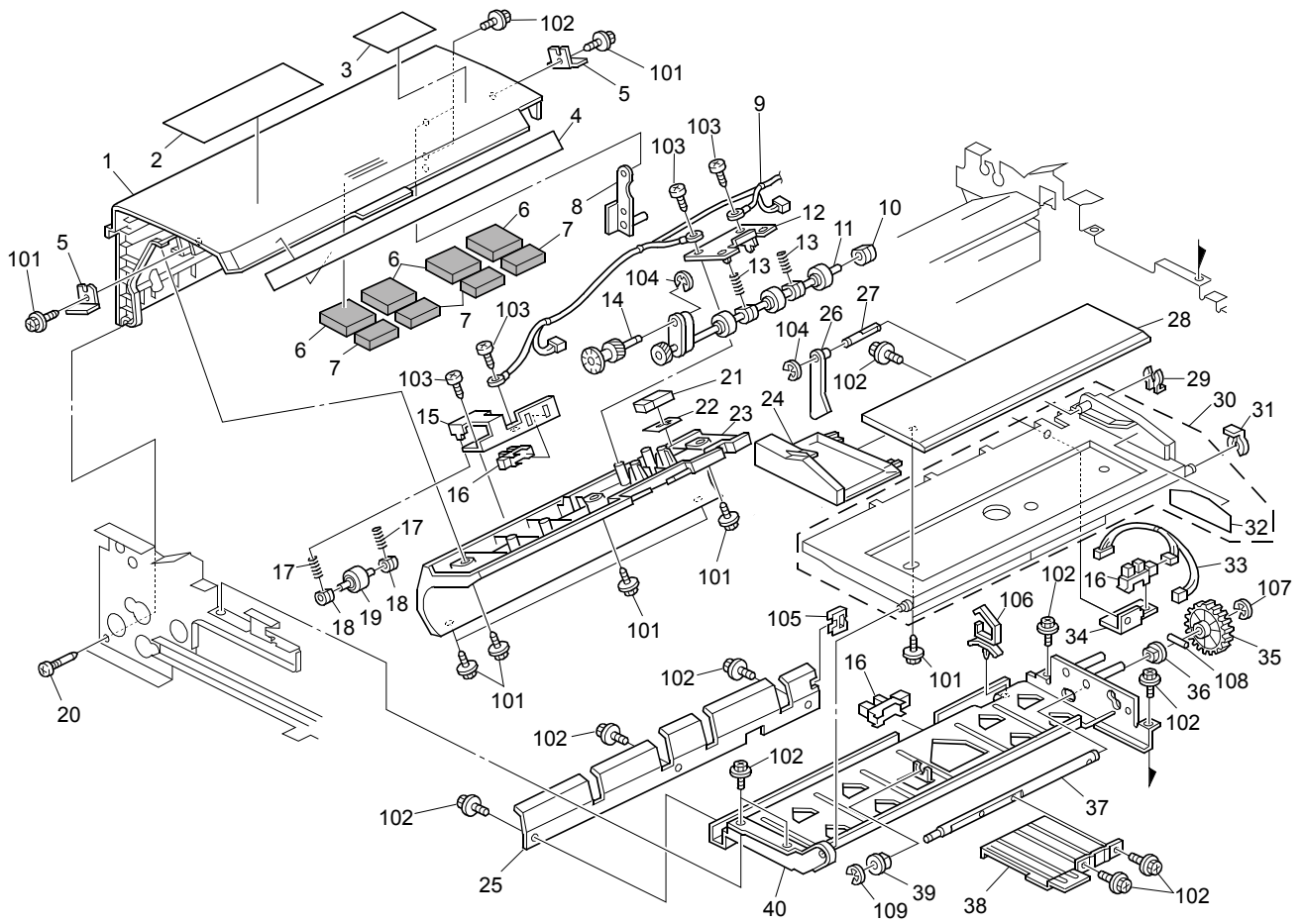

ITEM NO.	PARTS NO.	PARTS NAME	Q'TY / PAGE	Q'TY / PACK	P I R	B S I NO.	T O	T	F R O M	S E R I A L NO.	R E M A R K S	C
1	B3011766	Paper Feed Cover	1									
2	B3014316	Decal: Misfeed Removal	1									
3	B3014356	Decal: Paper Feed	1									
4	B3014336	Decal: Size: Original: RIC	1									
5	A8061371	Magnet Catch - Paper Feed	2									
6	B3014426	Sound Proofing Material -	4									
7	B3014427	Sound Proofing Material -	4									
8	A8061361	Cover Bracket	1									
9	B3015405	DC Relay Harness	1									
10	A6801661	Bushing - 4mm	1									
11	B3011191	Pull-out Driven Roller	1									
12	A8061181	Pressure Roller Bracket -	1									
13	B3014211	Spring	2									
14	B3011195	Gear - 19Z	1									
15	B3011188	Sensor Bracket	1									
16	AW020141	Photointerruptor	3									
17	B3014222	Spring	2									
18	B3011192	Bushing - 4x6x6	2									
19	B3011198	Pull-out Driven Roller-Fr	1									
20	AA143788	Pin: Guide Plate: Paper Fee	1									
21	AW010109	Photo Refiection Sensor:P	1									
22	A8064251	Grounding Plate	1									
23	B3011171	Pulley Cover	1									
24	B3011876	Side Fence: Table: Ass'y	1									
25	A8061335	Original Table Guide Plat	1									
26	B3011351	Original Feeler	1									
27	A8061353	Feeler Stud	1									
28	G5644151	Rail - Side Fence	1									
29	52062686	Snap Ring	1									
30	B3011856	Base: Original Table: Ass'y	1									
31	52152621	Snap Ring - M6	1									
32	B4774311	Decal - Original Base	1									
33	B3015241	Harness - Original Sensor	1									
34	A8061356	Original Sensor Bracket	1									
35	A8062281	Gear - Z47	1									
36	50530223	Bushing - 8mm	1									
37	A8061346	Base Shaft	1									
38	A8061342	Base Lever	1									
39	50530447	Bushing - 6mm	1									
40	A8061331	Original Table Stay	1									
101	0450008N	Tapping Screw - M4x8										
102	0451008N	Tapping Screw: 4x8										
103	0452008N	Tapping Screw: M4x8										
104	0720030E	Retaining Ring - M3										
105	11050328	Harness Clamp - ES-0505										
106	11050511	Harness Clamp - LWS-0306Z										
107	0720060E	Retaining Ring - M6										
108	0632140G	Parallel Pin										
109	0720040E	Retaining Ring - M4										

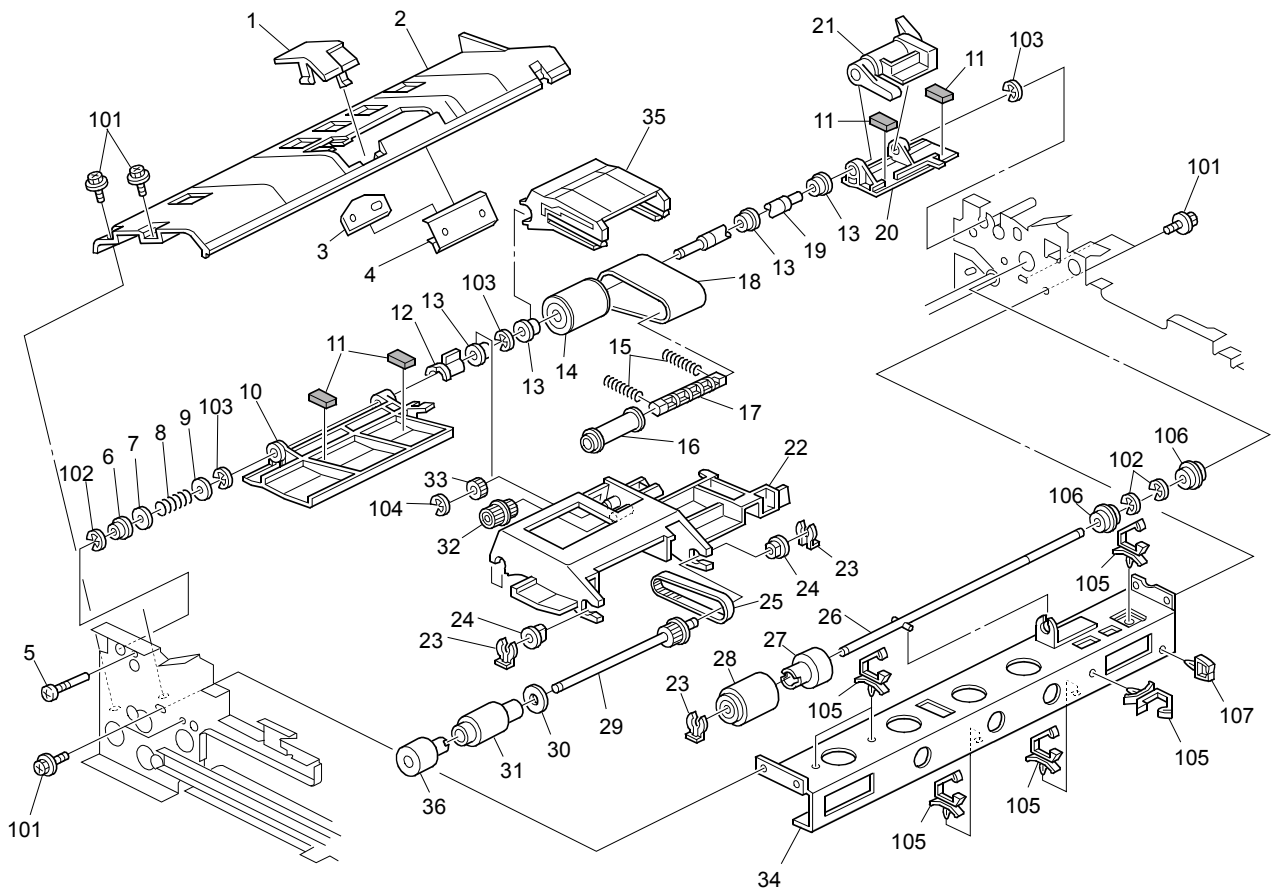

ITEM NO.	PARTS NO.	PARTS NAME	Q'TY / PAGE	Q'TY / PACK	P	I	R	B S I NO.	T O	T	F R O M	S E R I A L NO.	R E M A R K S	C
1	A8061152	Upper Guide Plate	1											
2	A8061153	Upper Guide Plate	1											
3	B3011155	Separation Support Pad	1											
4	B3011156	Separation Pad Holder	1											
5	AA143789	Shaft:Cleaner	1											
6	B3011286	Bushing - 6x10x6	1											
7	A4181158	Spacer - M6.5x1	1											
8	AA063435	Compression Spring:Paper	1											
9	AA132013	Spacer	1											
10	A8061161	Entrance Guide Plate - Fr	1											
11	A8061163	Guide Plate Cushion	4											
12	A6801621	Feed-in Unit Stopper	1											
13	A6281225	Bushing - 8mm	4											
14	A8061293	Feed Belt Drive Roller	1											
15	A8064261	Spring Belt Guide Roller	2											
16	A8061294	Feed Belt Driven Roller	1											
17	A8061298	Transport Belt Roller Sha	1											
18	A8061295	Feed Belt	1											
19	A8061282	Separation Drive Shaft	1											
20	A8061162	Entrance Guide Plate - In	1											
21	A8061328	Release Lever	1											
22	B3011314	Pick-up Roller Bracket	1											
23	54472681	Snap Ring	3											
24	50530447	Bushing - 6mm	2											
25	A8064118	Timing Belt - B40S2M148	1											
26	B3012511	Reverse Roller Shaft	1											
27	A2946700	Torque Limiter - 53mmxm	1											
28	A8592241	Reverse Roller	1											
29	A8062153	Timing Pulley - T27 S2M	1											
30	AA132171	Spacer - 6x20x1	1											
31	B4772225	Pick-up Roller	1											
32	A8062151	Timing Pulley - T19/Z23 S	1											
33	A8062271	Gear - Z18	1											
34	A8061141	Reverse Roller Stay	1											
35	A8061292	Feed Belt Bracket	1											
36	B4772226	Pickup Roller:Coupling	1											
101	0451008N	Tapping Screw:4x8												
102	0720040E	Retaining Ring - M4												
103	0720060E	Retaining Ring - M6												
104	0720030E	Retaining Ring - M3												
105	11050516	Clamp												
106	07413506	Ball Bearing - 6x12x4mm												
107	11050231	Clamp												

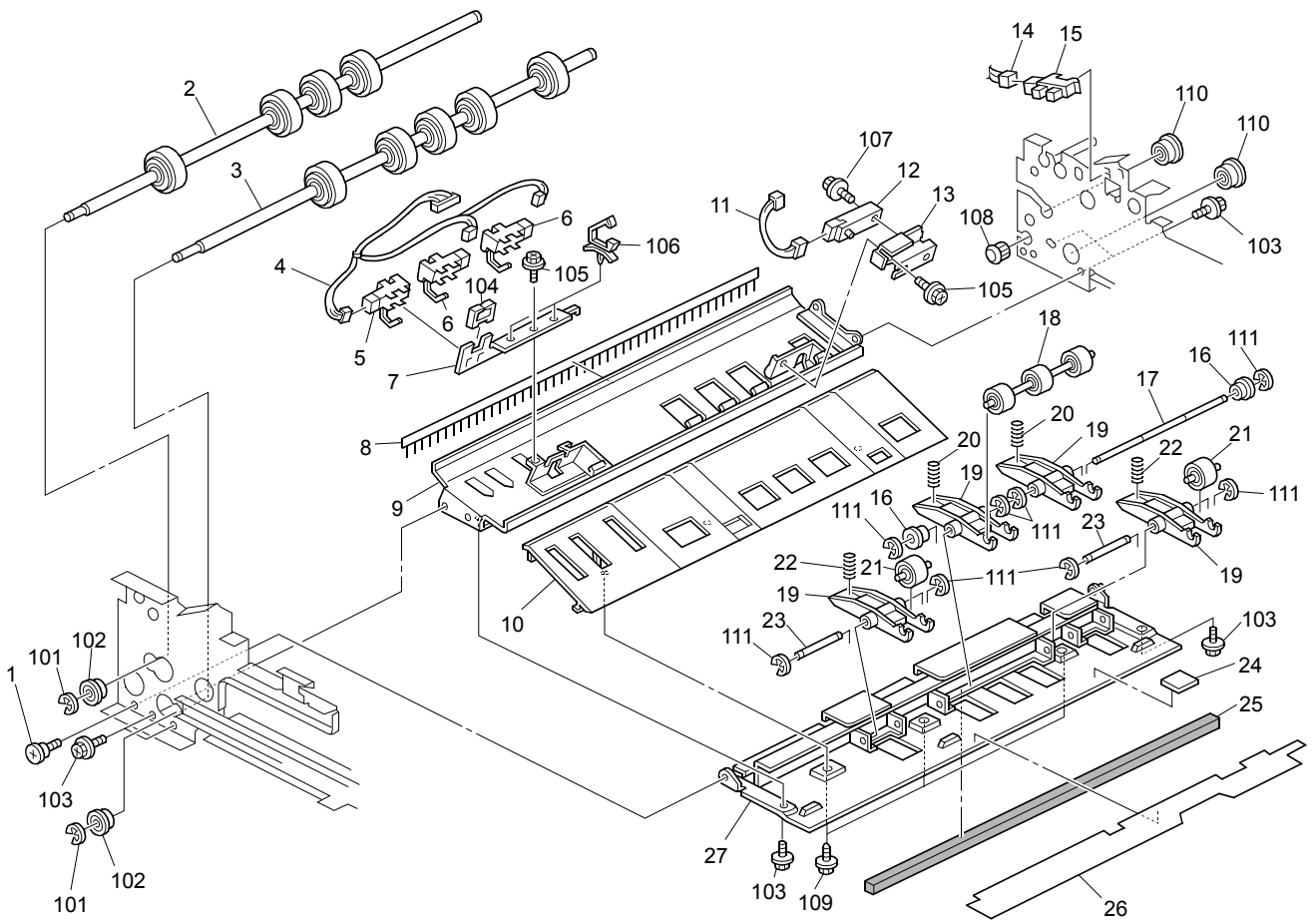

ITEM NO.	PARTS NO.	PARTS NAME	Q'TY / PAGE	Q'TY / PACK	P	I	R	B S I NO.	T O	T	F R O M	S E R I A L NO.	R E M A R K S	C
1	AA143857	Screw - M4X5	1											
2	A8061271	Pull Out Drive Roller	1											
3	A8061276	Transport Drive Roller	1											
4	B3015244	Harness - Paper Size Sens	1											
5	AW020155	Photointerruptor:Paper Si	1											
6	AW020154	Photointerruptor:Entrance	2											
7	A8061226	Paper Size Sensor Bracket	1											
8	B3011216	Discharge Brush	1											
9	A8061211	Middle Guide Plate	1											
10	A8061241	Lower Guide Plate	1											
11	B3015243	Harness - Registration Se	1											
12	AW010109	Photo Refiection Sensor:P	1											
13	A8061221	Registration Sensor Brack	1											
14	B3015231	Harness - Paper Feed Sens	1											
15	AW020141	Photointerruptor	1											
16	53241658	Bushing- 4x8x4.5mm	2											
17	A8061256	Middle Shaft - Roller Arm	1											
18	A8061261	Middle Driven Roller	1											
19	A8061251	Transport Roller Arm	4											
20	A8064221	Compression Spring	2											
21	A8061266	Driven Roller	2											
22	B3014226	Spring	2											
23	A8061257	Roller Arm Shaft	2											
24	A4221063	Seal - 0.7x13x20	1											
25	B3014417	Sound Proofing Material -	1											
26	B3011247	Entrance Guide	1											
27	B3011232	Base:Paper Feed	1											
101	0720040E	Retaining Ring - M4												
102	07413506	Ball Bearing - 6x12x4mm												
103	0451008N	Tapping Screw:4x8												
104	11050328	Harness Clamp - ES-0505												
105	0451006N	Tapping Screw - 3x6												
106	11050511	Harness Clamp - LWS-0306Z												
107	0451012N	Tapping Screw:4x12												
108A	0951006N	Screw - M3X6												
108B	11060193	Bushing - 7.9mm												
109	0450008N	Tapping Screw - M4x8												
110	07423808	Ball Bearing - 8x16x5												
111	0720030E	Retaining Ring - M3												

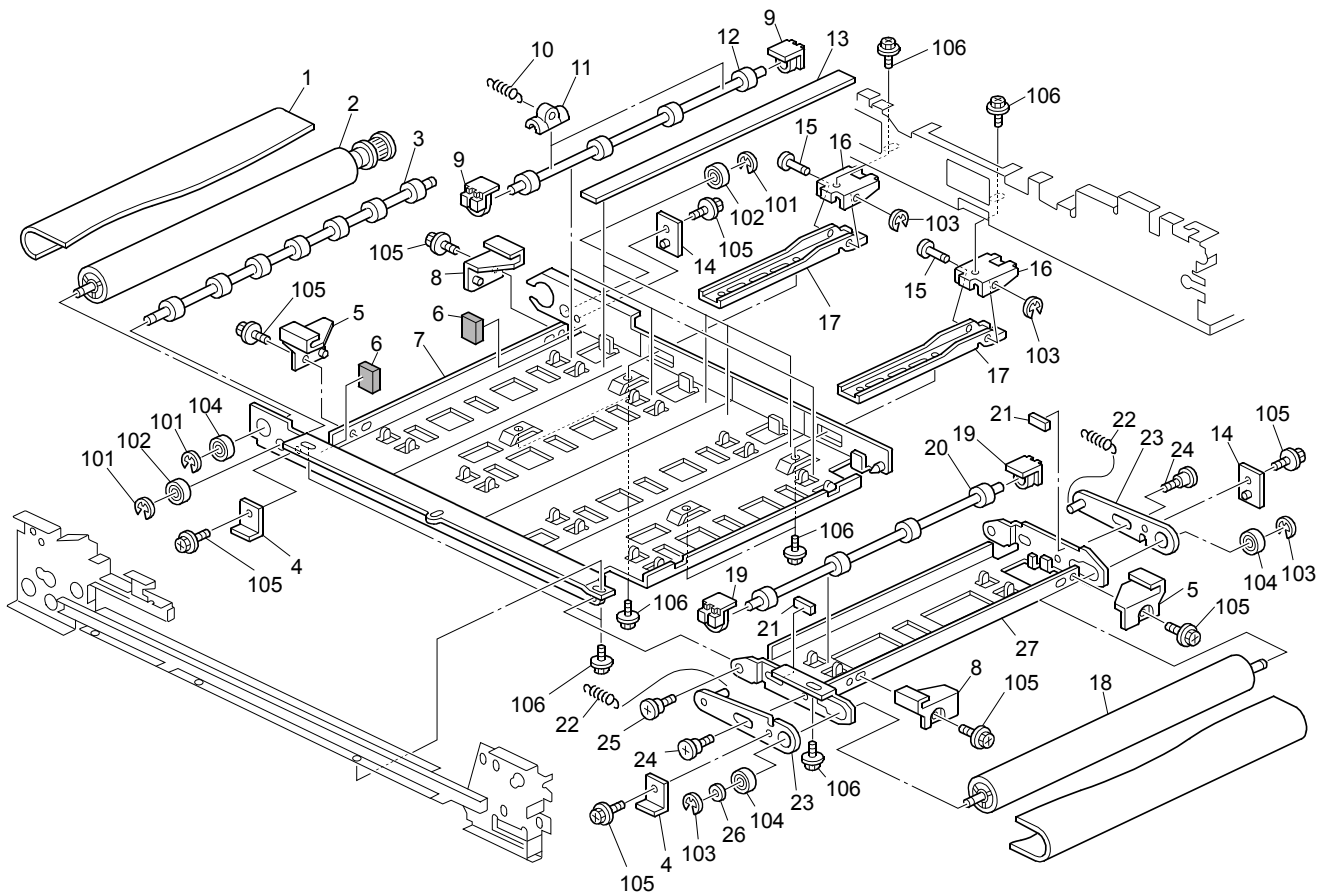

ITEM NO.	PARTS NO.	PARTS NAME	Q'TY / PAGE	Q'TY / PACK	P I R	B S I NO.	T O	T	F R O M	S E R I A L NO.	R E M A R K S	C
1	B3011442	Transport Belt	1									
2	B3011432	Belt Drive Roller	1									
3	B3011451	Belt Pressure Roller	1									
4	B3011449	Front Spacer	2									
5	B3011443	Transport Belt Stopper -	2									
6	B3011141	Rubber Cushion	2									
7	B3011412	Transport Belt Plate	1									
8	B3011444	Transport Belt Stopper -	2									
9	A6102136	Bushing	8									
10	AA062587	Tension Spring:Pressure	8									
11	A6102132	Pressure Bushing	8									
12	B3011481	Belt Pressure Roller	4									
13	B3014431	Vibration Absorbing Pad	4									
14	B3011445	Rear Spacer	2									
15	A6801443	Arm Shaft	2									
16	A6801446	Transport Unit Arm	2									
17	A5481442	Transport Arm	2									
18	B3011436	Transport Belt Roller	1									
19	A6102137	Pressure Roller Bushing	2									
20	B3012161	Roller:Pressure:Belt:Mm24	1									
21	AA161138	Cushion - 1.1	2									
22	AA062345	Tension Spring	2									
23	B3011491	Tension Bracket	2									
24	AA143831	Screw	2									
25	B1883575	Screw:Lever:Release:Blade	1									
26	A0287878	Arm Spacer	1									
27	B3011422	Transport Stay	1									
101	0720040E	Retaining Ring - M4										
102	07413706	Ball Bearing - 6x10x3										
103	0720030E	Retaining Ring - M3										
104	07413506	Ball Bearing - 6x12x4mm										
105	0451008N	Tapping Screw:4x8										
106	0451006N	Tapping Screw - 3x6										

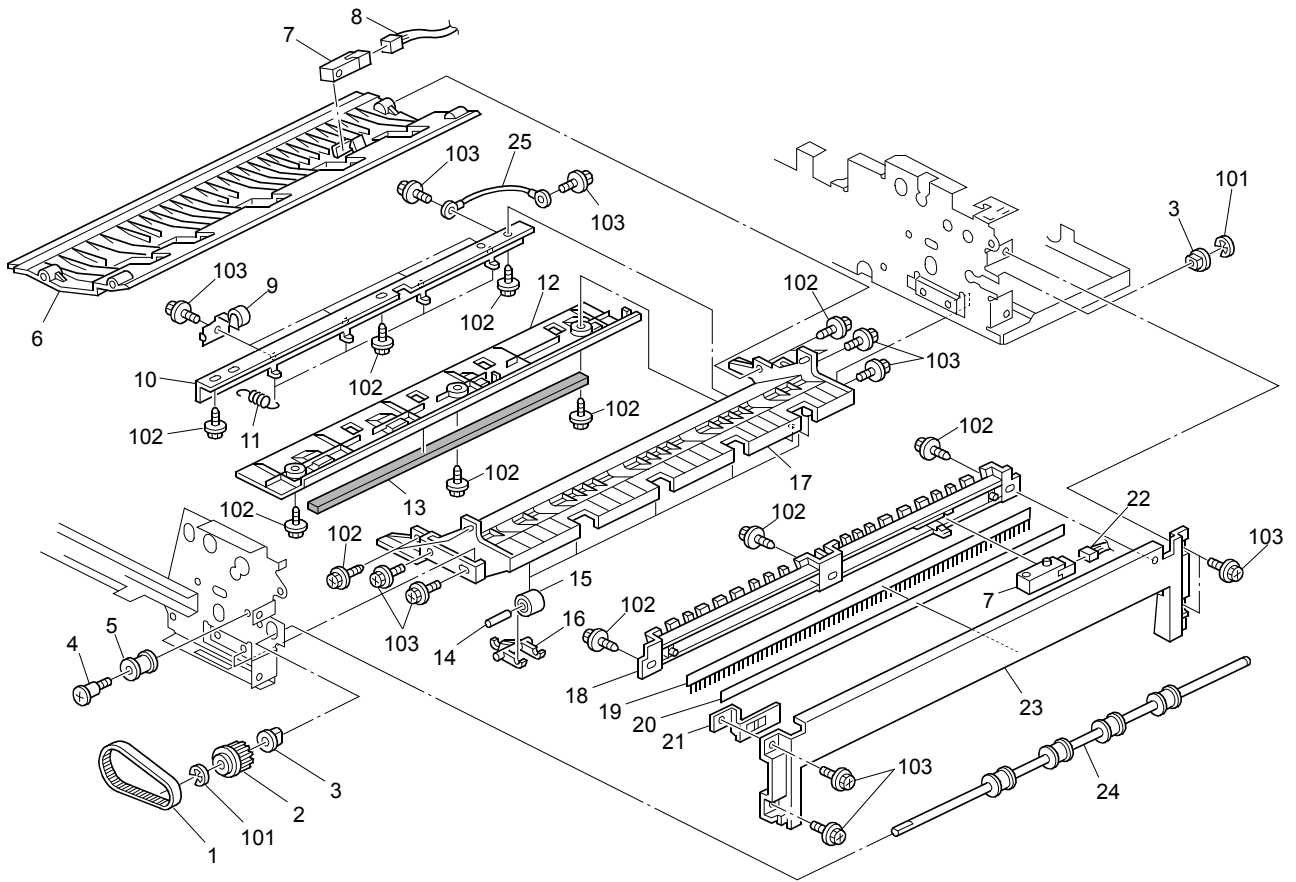

ITEM NO.	PARTS NO.	PARTS NAME	Q'TY / PAGE	Q'TY / PACK	P	I	R	B S I NO.	T O	T	F R O M	S E R I A L NO.	R E M A R K S	C
1	AA043548	Timing Belt - B40S3M150	1											
2	A8063281	Timing Pulley - T14 S3M	1											
3	50530447	Bushing - 6mm	2											
4	AA143842	Screw:Dia6:14.5:M4	1											
5	A3513459	Idler	1											
6	B3013161	Left Exit Guide	1											
7	AW010109	Photo Refiection Sensor:P	2											
8	B3015251	Harness - Exit Sensor	1											
9	A8063151	Driven Exit Roller	4											
10	A8063142	Guide Plate Bracket	1											
11	B3013135	Spring	4											
12	A8063171	Lower Exit Cover	1											
13	B3014417	Sound Proofing Material -	1											
14	B3013185	Driven Roller Shaft	5											
15	B3013184	Reverse Driven Roller	5											
16	A5481234	Driven Roller Arm	5											
17	B3013132	Lower Guide Plate	1											
18	A8063211	Right Exit Guide Plate	1											
19	B3011919	Discharge Brush - Exit	1											
20	A8063222	Seal	1											
21	A8063221	Exit Ground Plate	1											
22	B3015252	Harness - Sensor	1											
23	B3011926	Cover:Right	1											
24	A8063111	Drive Exit Roller	1											
25	B3015475	Grounding Wire	1											
101	0720040E	Retaining Ring - M4												
102	0450008N	Tapping Screw - M4x8												
103	0451008N	Tapping Screw:4x8												

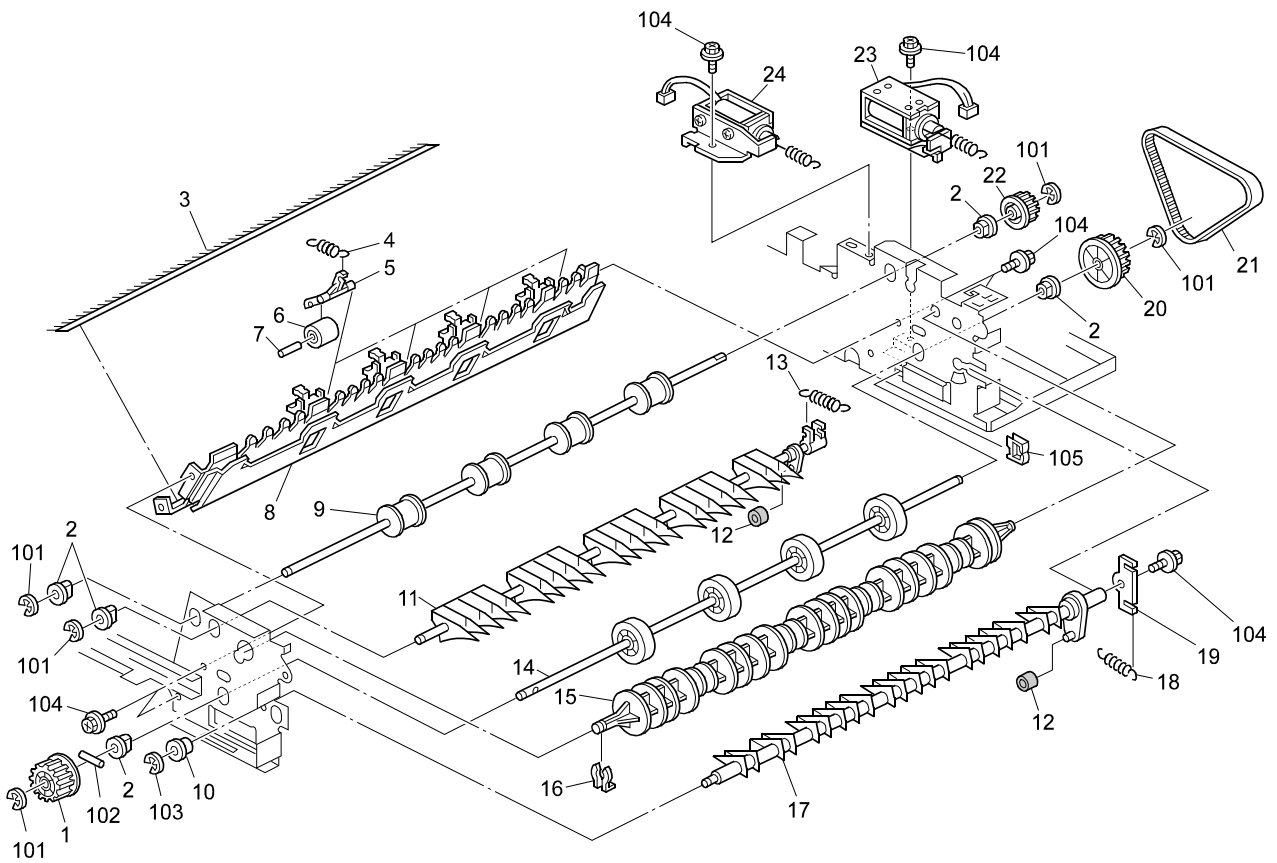

ITEM NO.	PARTS NO.	PARTS NAME	Q'TY / PAGE	Q'TY / PACK	P	I	R	B S I NO.	T O	T	F R O M	S E R I A L NO.	R E M A R K S	C
1	A6802321	Pulley - 30T	1											
2	50530447	Bushing - 6mm	5											
3	B3013188	Discharge Brush	1											
4	B3013186	Spring	4											
5	A5481234	Driven Roller Arm	4											
6	B3013184	Reverse Driven Roller	4											
7	B3013185	Driven Roller Shaft	4											
8	B3013181	Invertor Guide Plate	1											
9	A5481261	Exit Roller	1											
10	53241658	Bushing- 4x8x4.5mm	1											
11	A5481321	Exchange Pawl	1											
12	A5481317	Lever Cushion	2											
13	AA062589	Tension Spring:Reverse	1											
14	B3013271	Reverse Drive Roller	1											
15	A5481231	Guide Roller	1											
16	52152621	Snap Ring - M6	1											
17	B3013191	Exit Junction Gate	1											
18	AA062588	Tension Spring:Exit	1											
19	B3013192	Lever - Exit Junction Gat	1											
20	B3013286	Pulley - 30Z	1											
21	AA043547	Timing Belt - B40S3M213	1											
22	A5482137	Timing Pulley - 18Z	1											
23	B3013311	Reverse DC Solenoid	1											
24	B3013301	Paper Exit Solenoid	1											
101	0720040E	Retaining Ring - M4												
102	0632120G	Parallel Pin - 2x12												
103	0720030E	Retaining Ring - M3												
104	0451008N	Tapping Screw:4x8												
105	11050328	Harness Clamp - ES-0505												

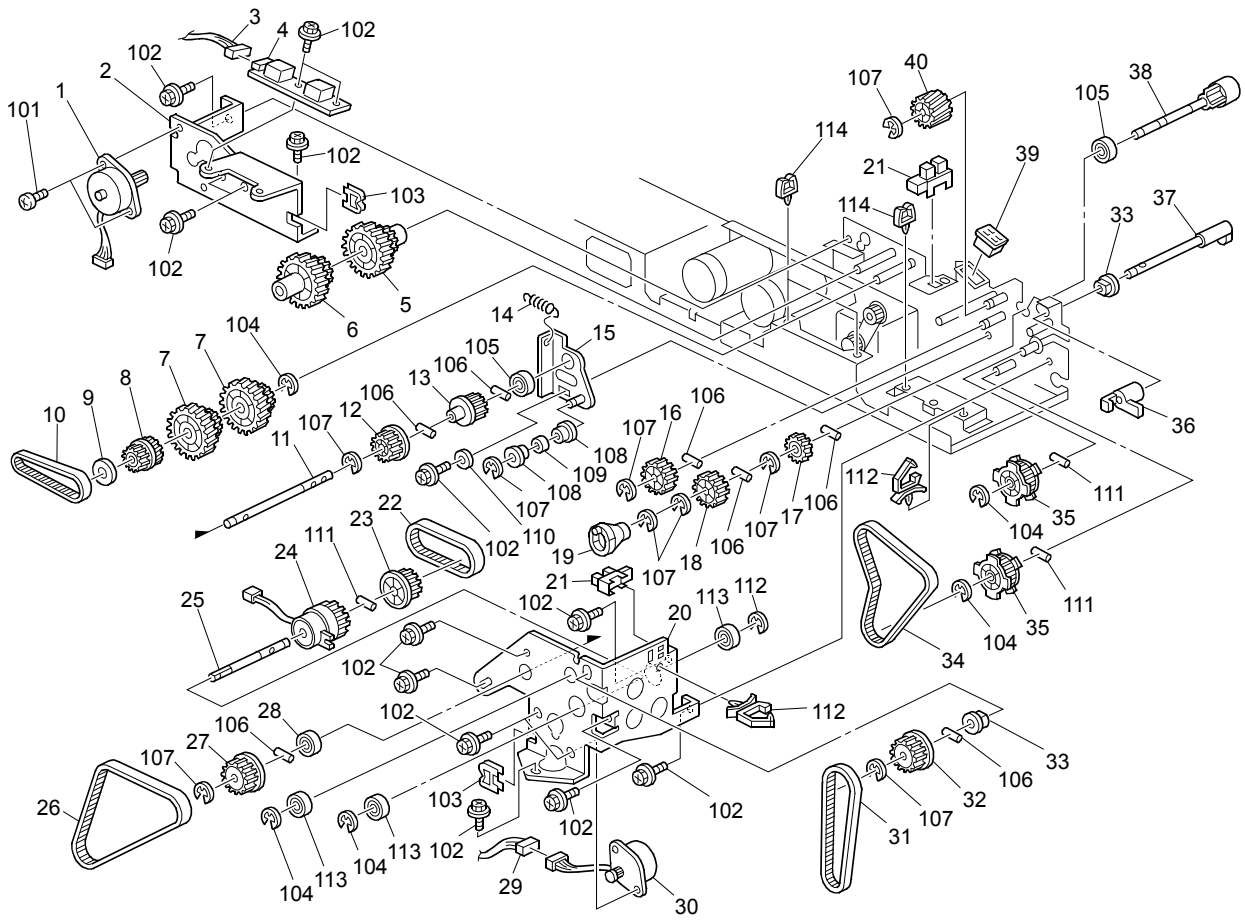

ITEM NO.	PARTS NO.	PARTS NAME	Q'TY / PAGE	Q'TY / PACK	P I R	B S I NO.	T O	T	F R O M	S E R I A L NO.	R E M A R K S	C
1	B6522911	Stepper Motor:Base:Rise:A	1									
2	B3012367	Motor Bracket	1									
3	B3015270	Harness - Display	1									
4	B3015190	PCB Display	1									
5	A8062285	Gear - Z20/Z47	1									
6	A8062287	Gear - Z20/Z47	1									
7	A8062283	Gear - Z20/Z47	2									
8	A8062161	Timing Pulley - T30/Z20 S	1									
9	AA132152	Spacer - 8x20x1	1									
10	A8064117	Timing Belt - B40S2M158	1									
11	B3012122	Shaft	1									
12	B3012213	Pulley - 20Z	1									
13	B3012211	Pulley - 20/19Z	1									
14	AA060590	Pressure Spring	1									
15	B3012281	Tension Bracket	1									
16	B3012221	Gear - 31Z	1									
17	B3012244	Gear - 23Z	1									
18	B3012243	Gear - 29Z	1									
19	A8062244	Separation Shaft Stopper	1									
20	B3012336	Side Plate	1									
21	AW020141	Photointerruptor	2									
22	AA043535	Timing Belt - B60S3M195	1									
23	B3012273	Pulley - 32Z	1									
24	AX200294	Magnetic Clutch - 38z	1									
25	B3012271	Shaft	1									
26	AA043534	Timing Belt - B60S3M216	1									
27	B3012123	Pulley - 24Z	1									
28	A8592230	Ball Bearing - 6x13x5	1									
29	B3015220	Harness - Pick Up Motor	1									
30	AX040139	Stepper Motor:MM42:0.95A:	1									
31	AA043537	Timing Belt - B40S2M206	1									
32	B3012141	Pulley - 39Z	1									
33	50530447	Bushing - 6mm	2									
34	AA043536	Timing Belt - B60S3M279	1									
35	B3012261	Pulley - 36Z	2									
36	A6802262	Feeler - Pick-up Roller C	1									
37	B3012422	Cam - Pick-up Roller	1									
38	B3012242	Shaft	1									
39	AG070515	Magnet Catch:13n	1									
40	B3012222	Gear - 20Z	1									
101	0353050N	Screw-m3x5										
102	0451008N	Tapping Screw:4x8										
103	11050328	Harness Clamp - ES-0505										
104	0720060E	Retaining Ring - M6										
105	07413506	Ball Bearing - 6x12x4mm										
106	0632120G	Parallel Pin - 2x12										
107	0720040E	Retaining Ring - M4										
108	07413706	Ball Bearing - 6x10x3										
109	08053507	Bushing - 6mm										
110	0701030N	Washer Dia3										
111	0632160G	Parallel Pin-M2x16										
112	11050328	Harness Clamp - ES-0505										
113	07423808	Ball Bearing - 8x16x5										
114	11050231	Clamp										

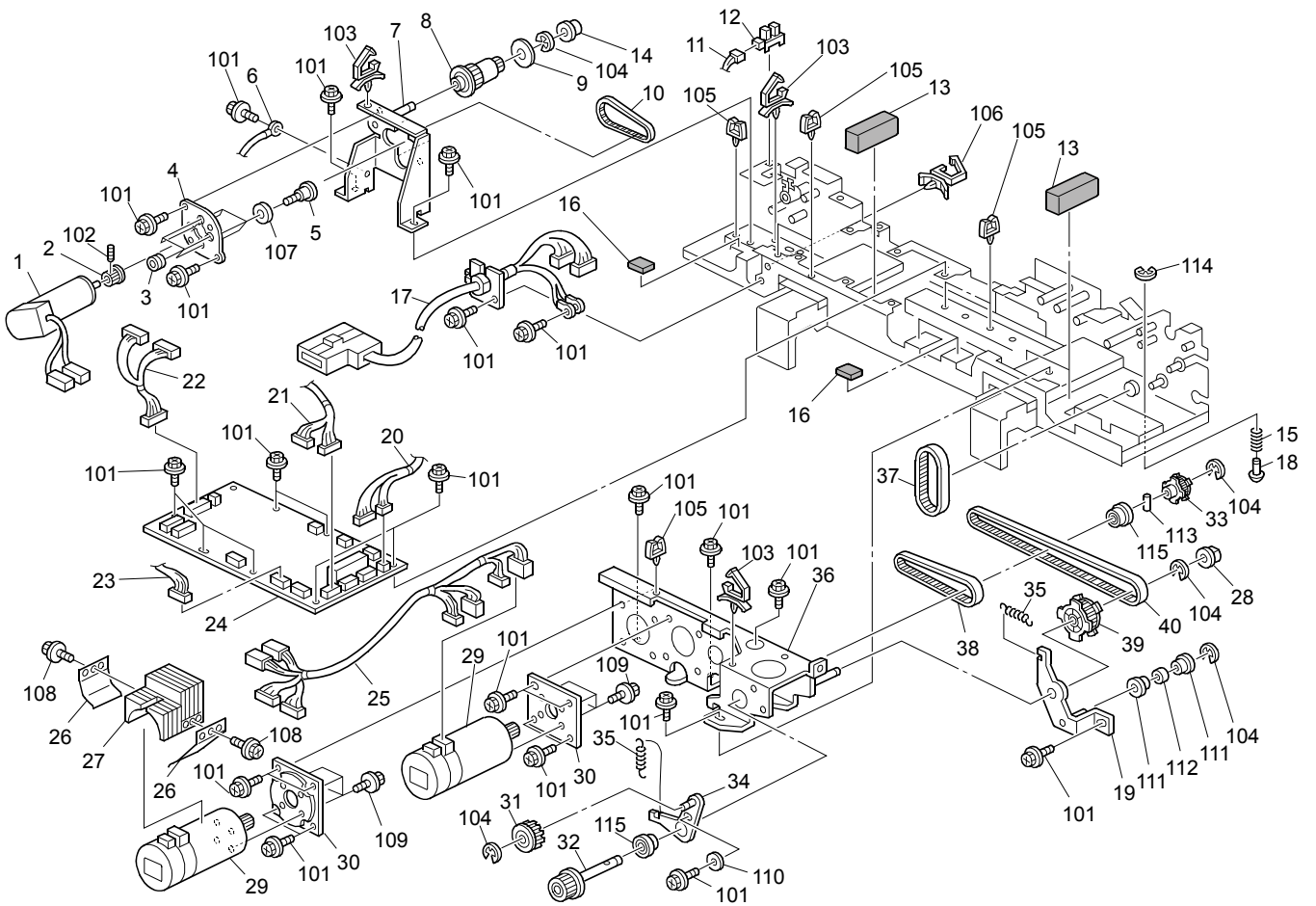

ITEM NO.	PARTS NO.	PARTS NAME	Q'TY / PAGE	Q'TY / PACK	P	I	R	B S I NO.	T O	T	F R O M	S E R I A L NO.	R E M A R K S	C
1	AX060321	DC Motor 24V 27W	1											
2	A6103532	Timing Pulley - 18Z	1											
3	B3013246	Motor Bushing - 4x9x5.2	4											
4	B3013345	Exit Motor Guide Plate	1											
5	AA143379	Stepped Screw	4											
6	B3015475	Grounding Wire	1											
7	B3013341	Exit Motor Bracket	1											
8	A6802311	Pulley - 18T/32T	1											
9	A3003812	Spacer - 6x22x1.5	1											
10	AA043539	Timing Belt - B40S2M104	1											
11	B3015252	Harness - Sensor	1											
12	AW020141	Photointerruptor	1											
13	B3014418	Sound Proofing Material -	3											
14	50530447	Bushing - 6mm	1											
15	B6521134	Compression Spring	1											
16	B3011141	Rubber Cushion	3											
17	B3015200	Harness - Interface	1											
18	B6521133	Shaft:Slider	1											
19	B3012376	Tension Bracket	1											
20	B3015230	Harness - Paper Feed Rear	1											
21	B3015240	Harness - Middle	1											
22	B3015250	Harness - Paper Exit	1											
23	B3015260	Harness - Sensor On Off D	1											
24	B3015100	PCB ADF Main Control	1											
25	B3015210	Harness - DC Motor	1											
26	B3012320	Heat Sink Holder	2											
27	B3012319	Heat Sink - DC Motor	1											
28	59362321	Rubber Bushing - Vibratio	1											
29	AX060320	DC Motor:54w	2											
30	B3012172	Cushion	2											
31	AB030354	Pulley - 20T	1											
32	B3012113	Pulley - 19Z	1											
33	B3012111	Pulley - 30Z	2											
34	B3012327	Holder Bracket	1											
35	AA060590	Pressure Spring	2											
36	B3012371	Motor Bracket	1											
37	AA043538	Timing Belt - B60S3M174	1											
38	AA043533	Timing Belt - B0S2M256	1											
39	B3012231	Pulley - 58/20Z	1											
40	AA043546	Timing Belt - B60S2M474	1											
101	0451008N	Tapping Screw:4x8												
102	0574050E	Hexagon Headless Set Scre												
103	11050328	Harness Clamp - ES-0505												
104	0720040E	Retaining Ring - M4												
105	11050231	Clamp												
106	11050516	Clamp												
107	08073035	Washer - 4.1x10x0.5												
108	0451005N	Tapping Screw:M3x5												
109	0451006N	Tapping Screw - 3x6												
110	0701030N	Washer Dia3												
111	07413706	Ball Bearing - 6x10x3												
112	08053507	Bushing - 6mm												
113	0632120G	Parallel Pin - 2x12												
114	0720030E	Retaining Ring - M3												
115	07423906	Ball Bearing - 6x14x5mm												

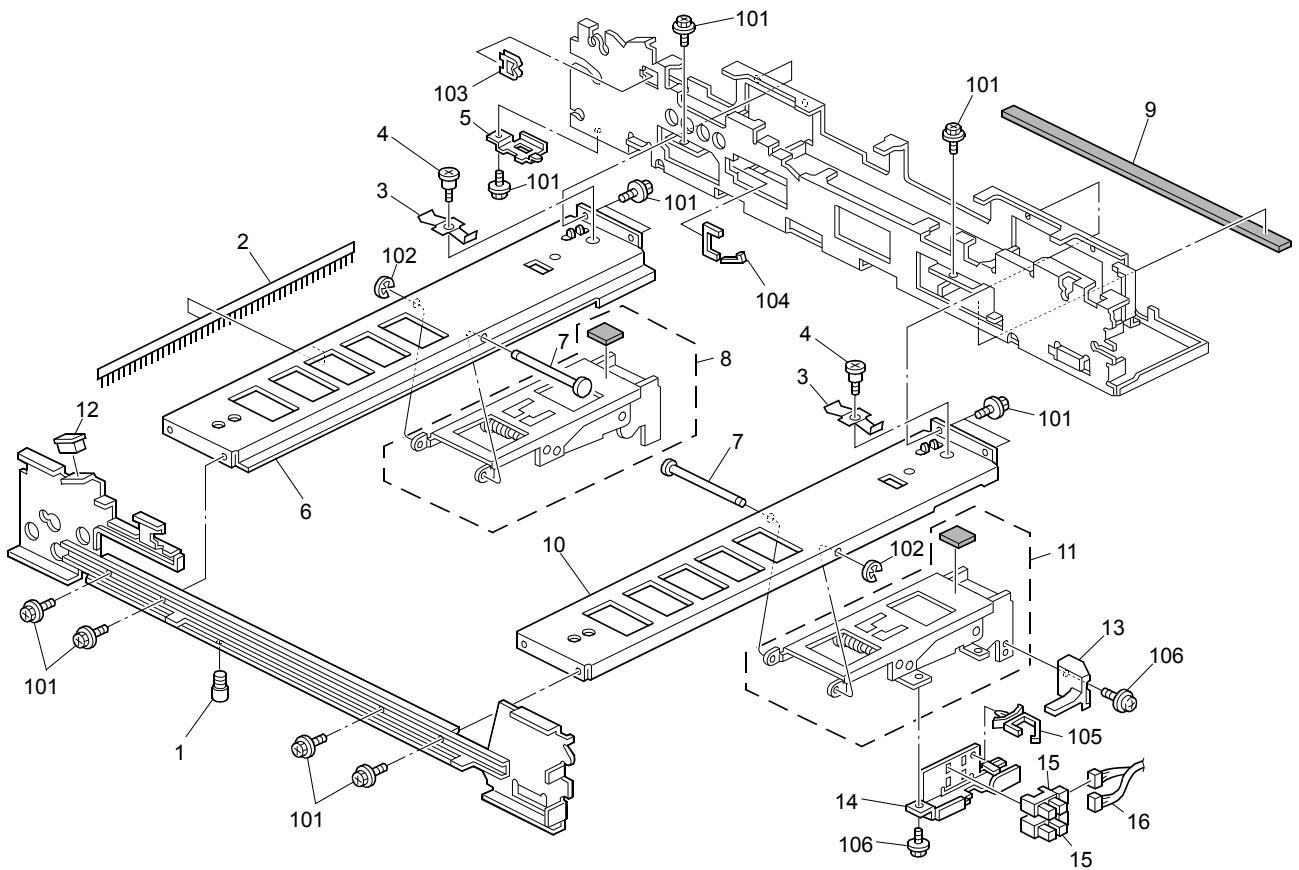

ITEM NO.	PARTS NO.	PARTS NAME	Q'TY / PAGE	Q'TY / PACK	P	I	R	BSI NO.	TO	T	FROM	SERIAL NO.	REMARKS	C
1	54101291	Pin	1											
2	B6523157	Discharge Brush:Long	1											
3	B3011136	Spring Plate - 0.4mm	2											
4	AA143832	Release Spring Holder	2											
5	B3011137	Pulley Cover	1											
6	B3011631	Rear Side Plate	1											
7	A8061135	Contact Point Shaft	2											
8	B3011550	Hinge - Left	1											
9	B3014416	Sound Proofing Material -	1											
10	B3011633	Right Stay	1											
11	B3011560	Hinge - Right	1											
12	G0121531	Magnet	1											
13	A5481531	Safety Switch Feeler	1											
14	B3011543	Sensor Bracket	1											
15	AW020141	Photointerruptor	2											
16	B3015260	Harness - Sensor On Off D	1											
101	0451008N	Tapping Screw:4x8												
102	0720030E	Retaining Ring - M3												
103	11050328	Harness Clamp - ES-0505												
104	11050334	Edge - 17												
105	11050511	Harness Clamp - LWS-0306Z												
106	0451006N	Tapping Screw - 3x6												

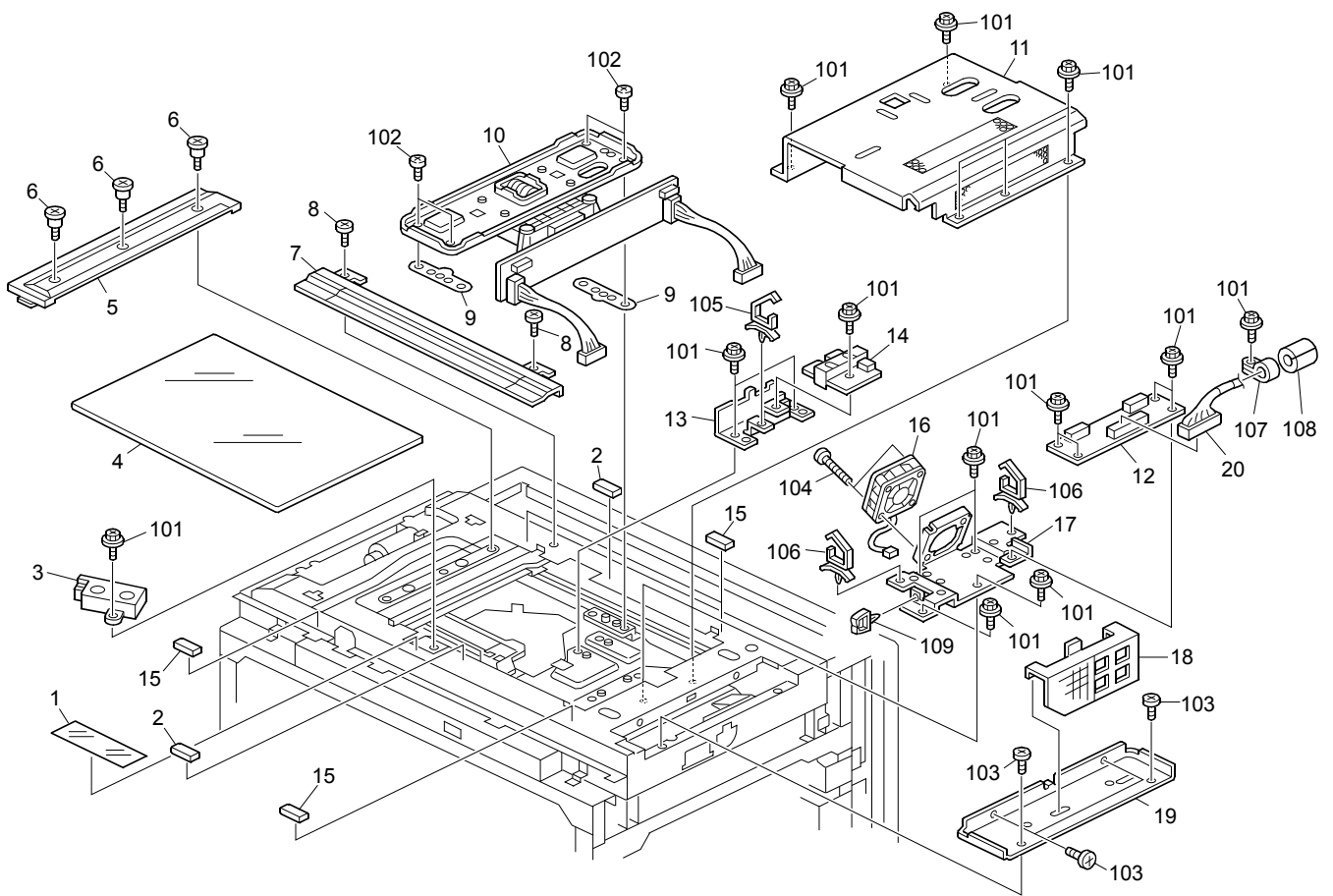

ITEM NO.	PARTS NO.	PARTS NAME	Q'TY / PAGE	Q'TY / PACK	P	I	R	B S I NO.	T O	T	F R O M	S E R I A L NO.	R E M A R K S	C
1	A2941788	Sheet - Upper Frame	1											
2	A1761737	Exposure Glass Cushion	2											
3	AW010130	Original Sensor:H=3-80	1											
4	B0701790	Exposure Glass:Ass'y	1											
5	AC042172	Scale:Left:Printing	1											
6	52062684	Shoulder Screw - M3	3											
7	B2341795	Scale:Rear:Ass'y	1											
8	AA143573	Shoulder Screw - M4x4	2											
9	B2341782	Lens Unit Stay Spacer	2											
10	B2341721	Lens Unit	1											
11	B2341779	Cover - Lens SBU	1											
12	B2345107	PCB CNB	1											
13	B2341747	Original Sensor Holder	2											
14	AW010116	Original Sensor:H=1-66	2											
15	AA161138	Cushion - 1.1	4											
16	GX640028	Fan Motor DC24V 1.92W	1											
17	B2341766	CNB Bracket	1											
18	B2341845	Filter:Ass'y	1											
19	A2941799	Right Stay - Optical Hous	1											
20	B2345168	Interface Cable - Scanner	1											
101	0360006N	Screw - M3X6												
102	0314080N	Philips Pan Head Screw -												
103	0354060N	Screw-m4x6												
104	0354200N	Screw:M4X20												
105	11050487	Harness Clamp												
106	11050488	Harness Clamp												
107	11050559	Clamp:EMT-5N												
108	16070912	Ferrite Core:Tr-25-15-12												
109	11050650	Clamp - MS-0709												

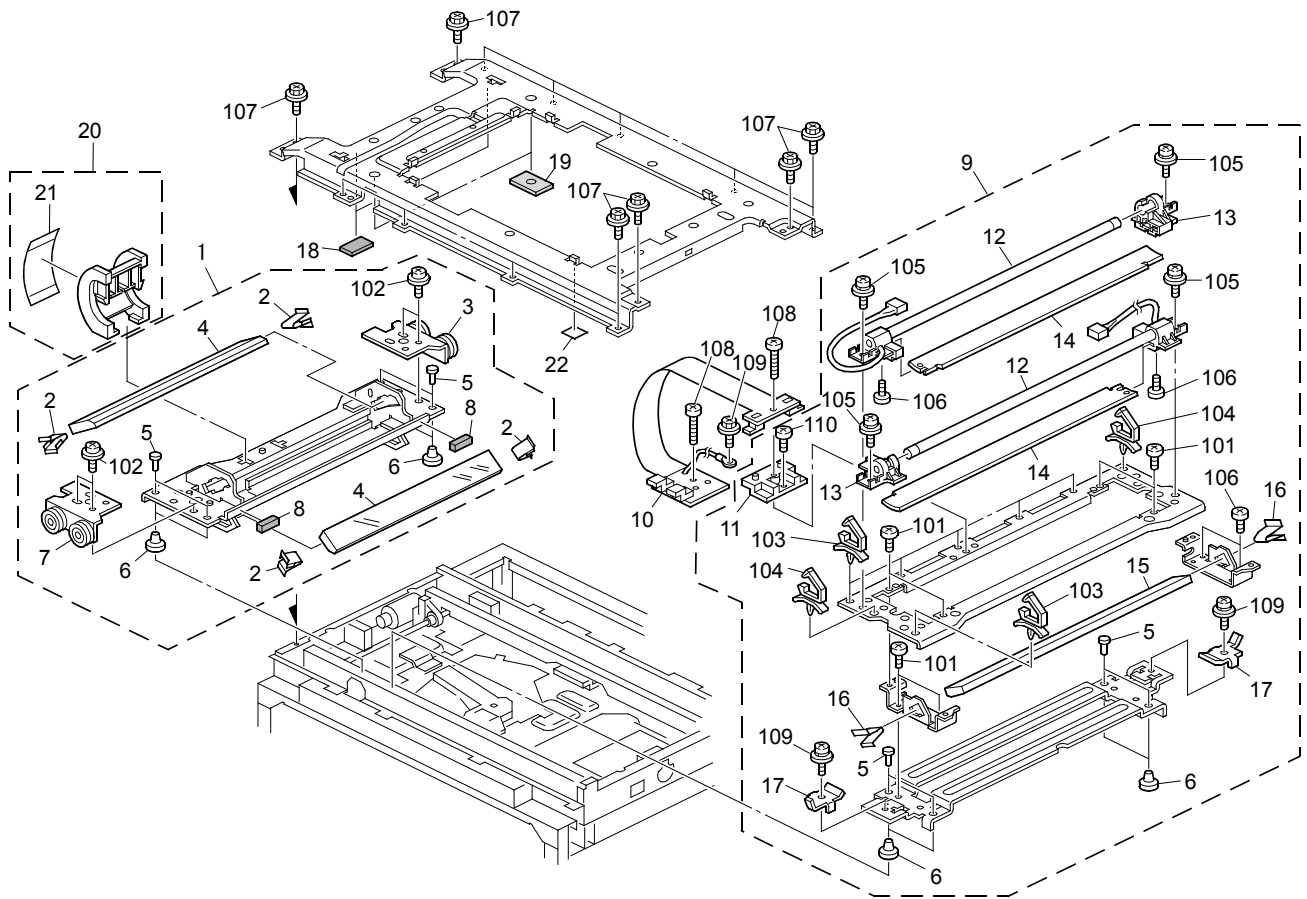

ITEM NO.	PARTS NO.	PARTS NAME	Q'TY / PAGE	Q'TY / PACK	P	I	R	B S I NO.	T O	T	F R O M	S E R I A L NO.	R E M A R K S	C
1	B2341732	Scanner No.2 Unit	1											
2	G4042810	Spring Plate - 2nd Mirror	4											
3	B2341739	Scanner No.2 Bracket - Re	1											
4	B2341640	Mirror No.2	2											
5	B1321820	Scanner Shoe Pin	8											
6	A0691883	Shoe - Scanner	8											
7	B2341726	Scanner No.2 Bracket - Fr	1											
8	A2941743	Cushion - 5x20x4	2											
9	B2341701	Scanner No.1 Unit	1											
10	B2345500	Flexible Board - Xenon La	1											
11	B2341713	Harness Holder No.1	1											
12	AX510011	Xenon Lamp	2											
13	B2341712	Lamp Holder - Rear	2											
14	B2341707	Reflector	2											
15	B2341706	Mirror No.1	1											
16	A1931767	1st Mirror Holder	2											
17	B2341709	Wire Stay	2											
18	B2341793	Cushion:Scanner:No.2:Uppe	2											
19	B2341688	Cushion:Scanner:No.1:Uppe	2											
20	B2341630	Guide:Harness:No.2:Unit	1											
21	B2341621	Sheet:Guide:Harness:Ass'y	1											
22	B2341681	Seal:Harness	1											
101	0453006N	Tapping Screw - M3x6												
102	0951004N	Screw:Polished Round:M3x4												
103	11050511	Harness Clamp - LWS-0306Z												
104	11050534	Clamp												
105	0954008N	Screw - M3X8												
106	0452004N	Screw - 2X4												
107	0451006N	Tapping Screw - 3x6												
108	0313120N	Pan Head Screw:M3x12												
109	0954008N	Screw - M3X8												
110	0313060N	Screw - M3X6												

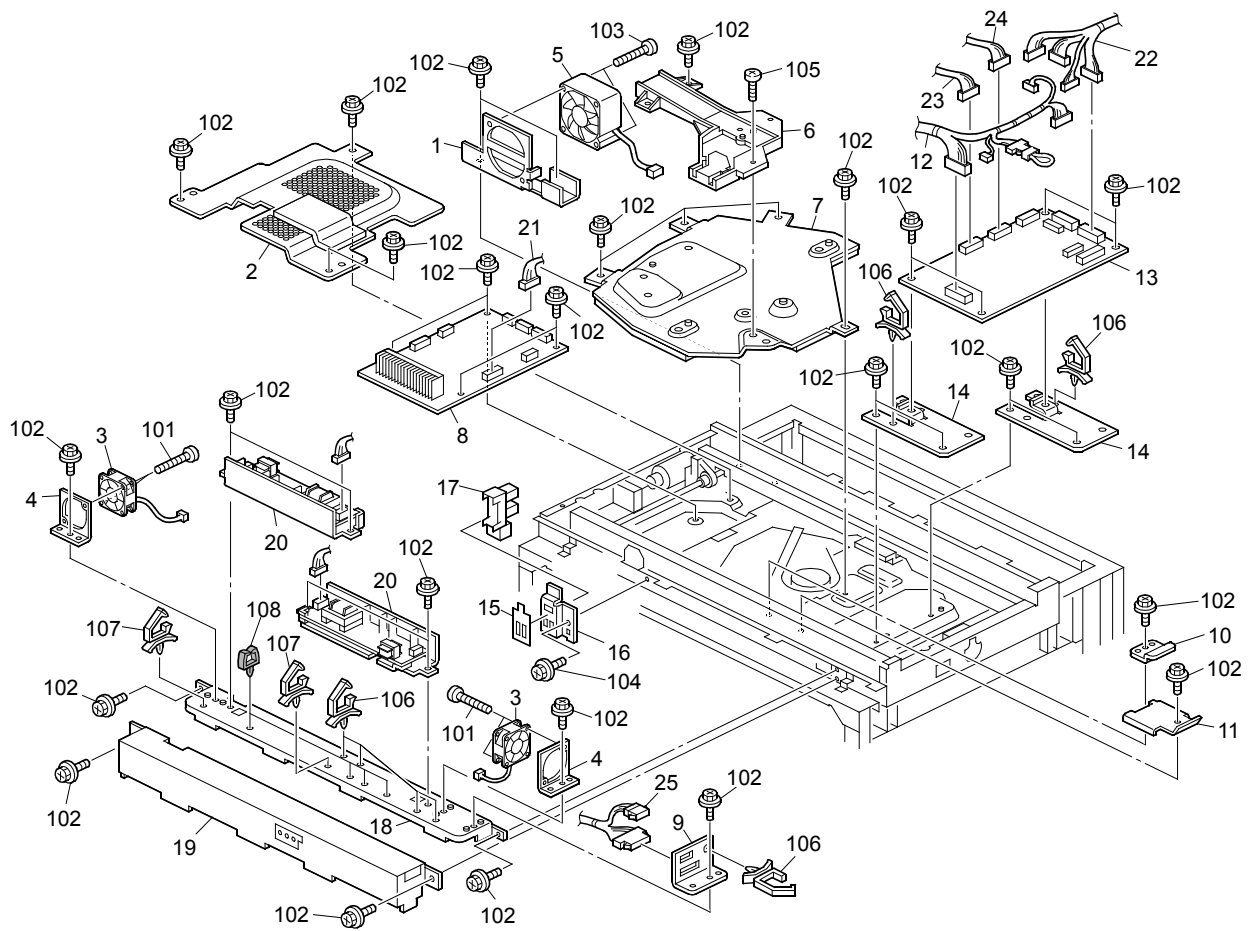

ITEM NO.	PARTS NO.	PARTS NAME	Q'TY / PAGE	Q'TY / PACK	P I R	B S I NO.	T O	T	F R O M	S E R I A L NO.	R E M A R K S	C
1	B2341765	Fan Motor Bracket	1									
2	B2341669	Cover - IC	1									
3	GX640028	Fan Motor DC24V 1.92W	2									
4	B2341699	Fan Motor Bracket	2									
5	GX640021	Fan Motor DC24V 1.92W	1									
6	B2341744	Harness Guide	1									
7	B2341811	Cover - LD Unit	1									
8	B2345116	Scanner Motor Board	1									
9	B2341696	Duct Bracket	1									
10	B2341674	Cover Plate - Sync Detect	1									
11	B2341817	Cover - Sync Detector Boa	1									
12	B2345158	Harness - SIB Fan Motor	1									
13	B2345122	PCB SIB	1									
14	B2341697	SIB Bracket	2									
15	A2671820	Sheet - Photointerrupter	1									
16	B2341825	Home Position Sensor Brac	1									
17	AW020160	Paper Feed Sensor	1									
18	B2341676	Stabilizer Bracket	1									
19	B2341670	Stabilizer Duct	1									
20	AZ500071	Stabilizer	2									
21	B2345153	Harness - MCU Sensor	1									
22	B2345152	Harness - Scanner Main	1									
23	B2345156	Harness - SBU Power Sourc	1									
24	B2345157	Harness - SBU	1									
25	B2345160	Harness - Lamp Regulator	1									
101	0354200N	Screw:M4X20										
102	0360006N	Screw - M3X6										
103	0354300N	Screw:M4x30										
104	0451006N	Tapping Screw - 3x6										
105	0313120N	Pan Head Screw:M3x12										
106	11050488	Harness Clamp										
107	11050487	Harness Clamp										
108	11050650	Clamp - MS-0709										

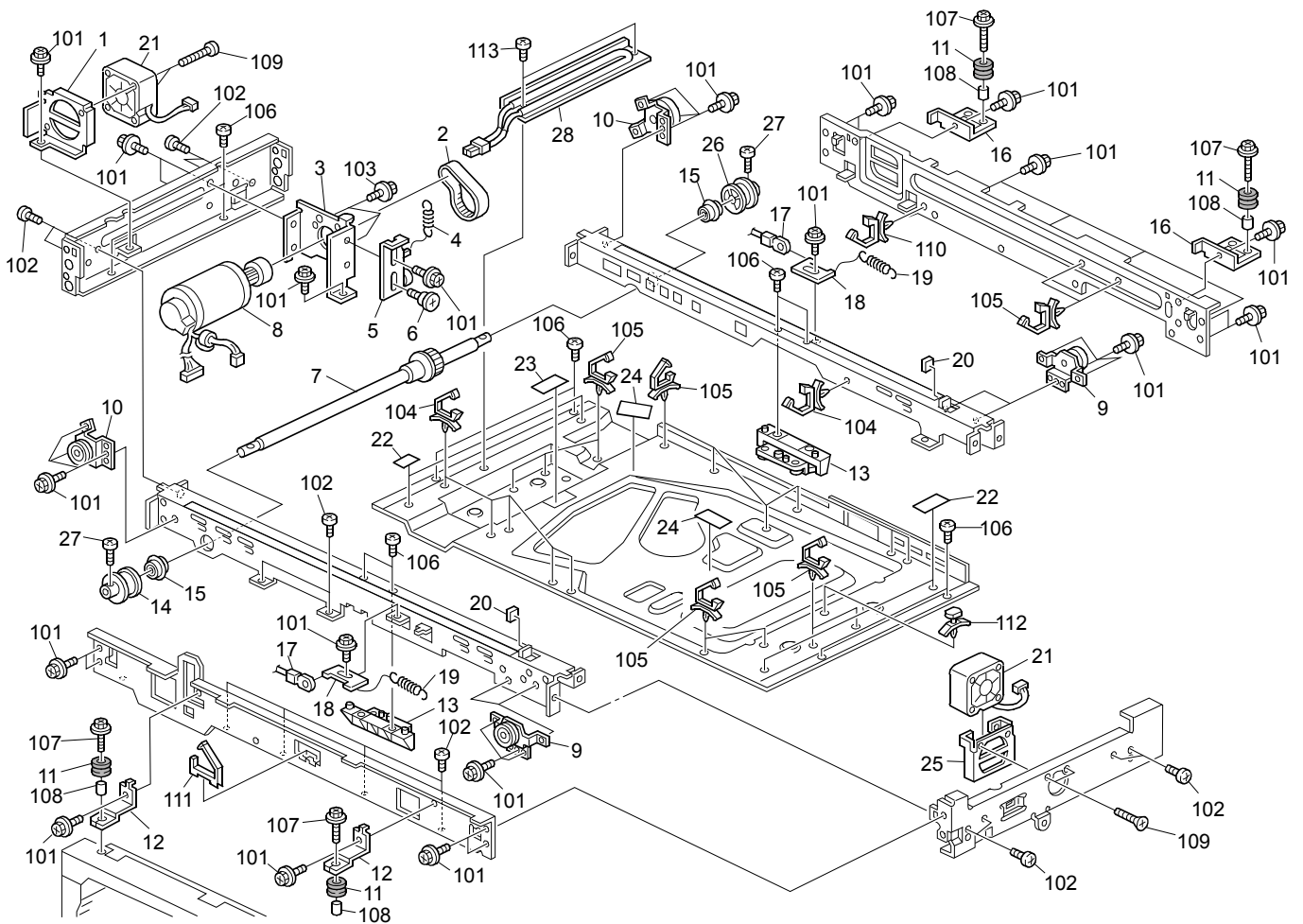

ITEM NO.	PARTS NO.	PARTS NAME	Q'TY / PAGE	Q'TY / PACK	P I R	B S I NO.	T O	T	F R O M	S E R I A L NO.	R E M A R K S	C
1	B2341764	Fan Motor Bracket	1									
2	A2941747	Timing Belt - Scanner	1									
3	B2341748	Scanner Motor Bracket	1									
4	A2941756	Spring - Scanner Motor	1									
5	A2941752	Pulley:Tension:Timing Bel	1									
6	AA143802	Screw:6x1.7	1									
7	B2341749	Scanner Drive Shaft	1									
8	B2341774	DC Motor:Scanner:DC27V 50	1									
9	B2341683	Scanner Pulley Bracket	2									
10	B2341723	Scanner Pulley Bracket -	2									
11	AA161104	Cushion - Motor	4									
12	A2941673	Front Stay	2									
13	B2341781	Holder Lensstay Lens Unit	2									
14	AB032069	Pulley	1									
15	A1931829	Ball Bearing - M8	2									
16	B2341690	Image Reading Unit Stay:F	2									
17	B2341759	Drive Were	2									
18	B2341746	Tension Wire Bracket	2									
19	B2341758	Tension Spring	2									
20	A2941688	Cushion	2									
21	GX640021	Fan Motor DC24V 1.92W	1									
22	AA150332	Seal - 0.19x18x22	4									
23	A2941667	Sheet - Optical Housing	1									
24	G0291982	LD - Decal	2									
25	B2341828	Scanning Fan Bracket	1									
26	AB032070	Pulley	1									
27	B1321719	Screw:Mechanical Drive Se	2									
101	0451006N	Tapping Screw - 3x6										
102	0453006N	Tapping Screw - M3x6										
103	0451008N	Tapping Screw:4x8										
104	11050487	Harness Clamp										
105	11050488	Harness Clamp										
106	0314080N	Philips Pan Head Screw -										
107	0451012N	Tapping Screw:4x12										
108	0707050N	Bushing - 4x5										
109	0324300N	Screw - M4X30										
110	11050489	Harness Clamp - LWS 1316										
111	11050522	Edge Saddle - Les0510										
112	11060383	Supporter - P.C.B.										
113	0314060N	Screw - M4x6										

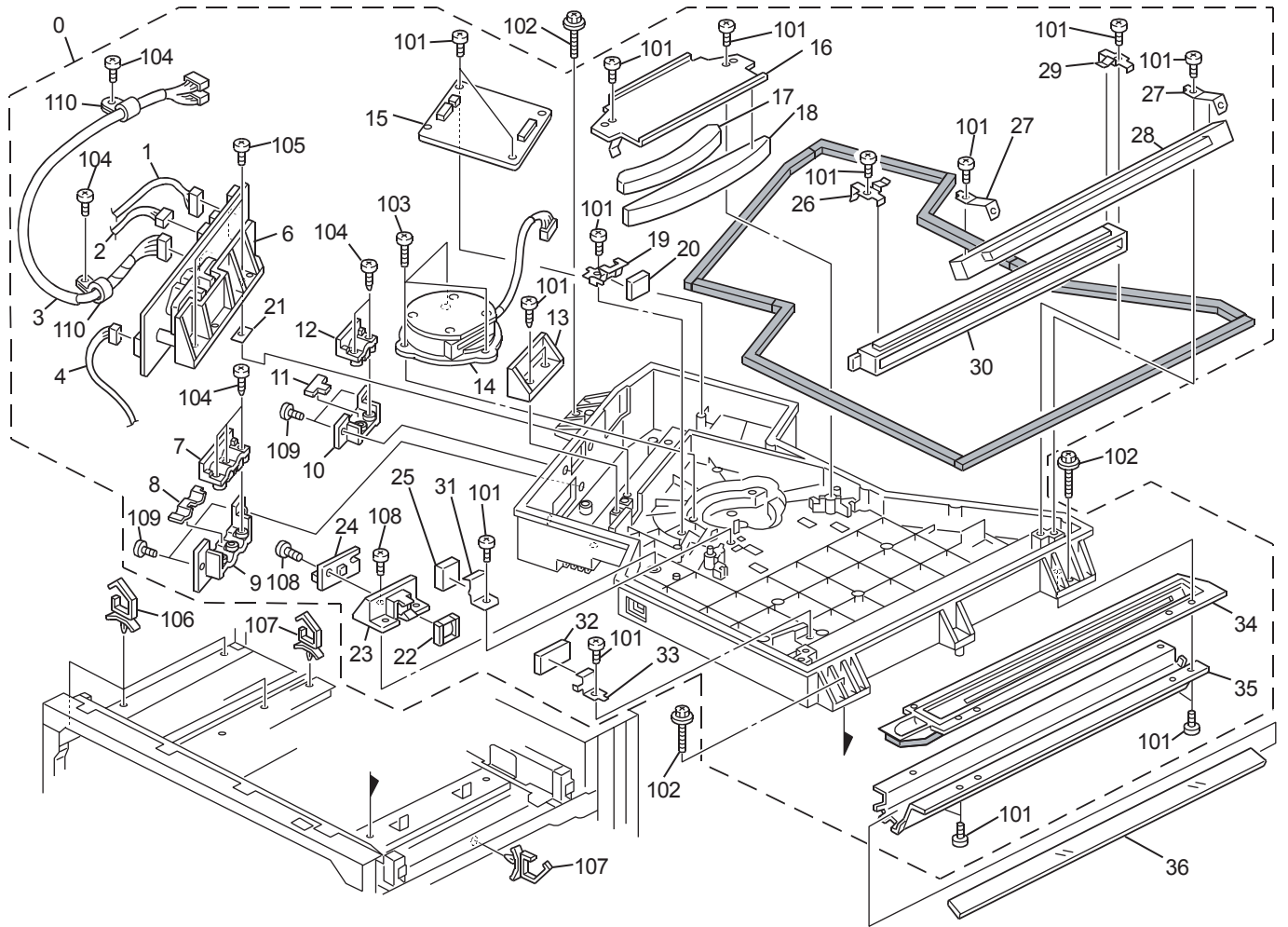

ITEM NO.	PARTS NO.	PARTS NAME	Q'TY / PAGE	Q'TY / PACK	P	I	R	B S I NO.	T O	T	F R O M	S E R I A L NO.	R E M A R K S	C
0	B2341851	Imaging Unit	1											
1	B2345351	Harness - LDB Control	1											
2	B2345350	Harness - Power Source:LD	1											
3	B2345352	Cable - LVDS LDB 18p	1											
4	B0705165	Harness:LDB:Sync Detector	1											
6	B2341910	Laser Diode Unit	1											
7	B0701985	Upper Laser Harness Holde	1											
8	B2341984	Harness Cushion 1	1											
9	B0701983	Lower Laser Harness Holde	1											
10	B0701987	Holder:Harness:Power Sour	1											
11	B2341988	Harness Cushion 2	1											
12	B0701989	Holder:Harness:Power Sour	1											
13	B0701917	Aperture	1											
14	AX060325	Polygon Mirror Motor	1											
15	B2345380	Motor Control Board	1											
16	A2572102	F-theta Lens Plate	1											
17	AC022012	F-theta Lens 1	1											
18	AC022013	F-theta Lens 2	1											
19	AC035055	Sync Detector Mirror Plat	1											
20	AC030078	Sync Detector Mirror	1											
21A	B0701921	Spacer:Laser Diode Unit:2	1											
21B	B0701922	Spacer:Laser Diode Unit:5	1											
21C	B0701923	Spacer:Laser Diode Unit:7	1											
21D	B0701924	Spacer:Laser Diode Unit:1	1											
22	G0291975	Cylindrical Lens	1											
23	A2941942	Holder - Sync Detector Bo	1											
24	B2345365	PCB Sync Detector	1											
25	AC030150	Mirror:No.2	1											
26	A2572077	Rear Lens Plate	1											
27	B2341934	Mirror Holder	2											
28	B0701932	No.1 Mirror Ass'y	1											
29	A2572076	Front Lens Plate	1											
30	A2941931	Btlens Ass'y	1											
31	AC035056	Plate:Mirror:No.2	1											
32	AC024008	Lens:Cylindrical Lens	1											
33	B0701925	Plate:Cylindrical Lens	1											
34	B2341944	Shield Glass Holder	1											
35	B0701949	Bracket:Shield Glass	1											
36	AC015030	Toner Shield Glass - 366x	1											
101	0353060N	Bind Screw - M3x6												
102	0451010N	Tapping Screw:4x10												
103	0354100N	Screw - M4X10												
104	0452010N	Binding Self-tapping Scre												
106	11050508	Harness Clamp - LWS-0711												
107	11050489	Harness Clamp - LWS 1316												
108	0452006N	Binding Self-tapping Scre												
109	0353080N	Screw:M3x8												
110	11050529	Nylon Clamp-ent-3n												

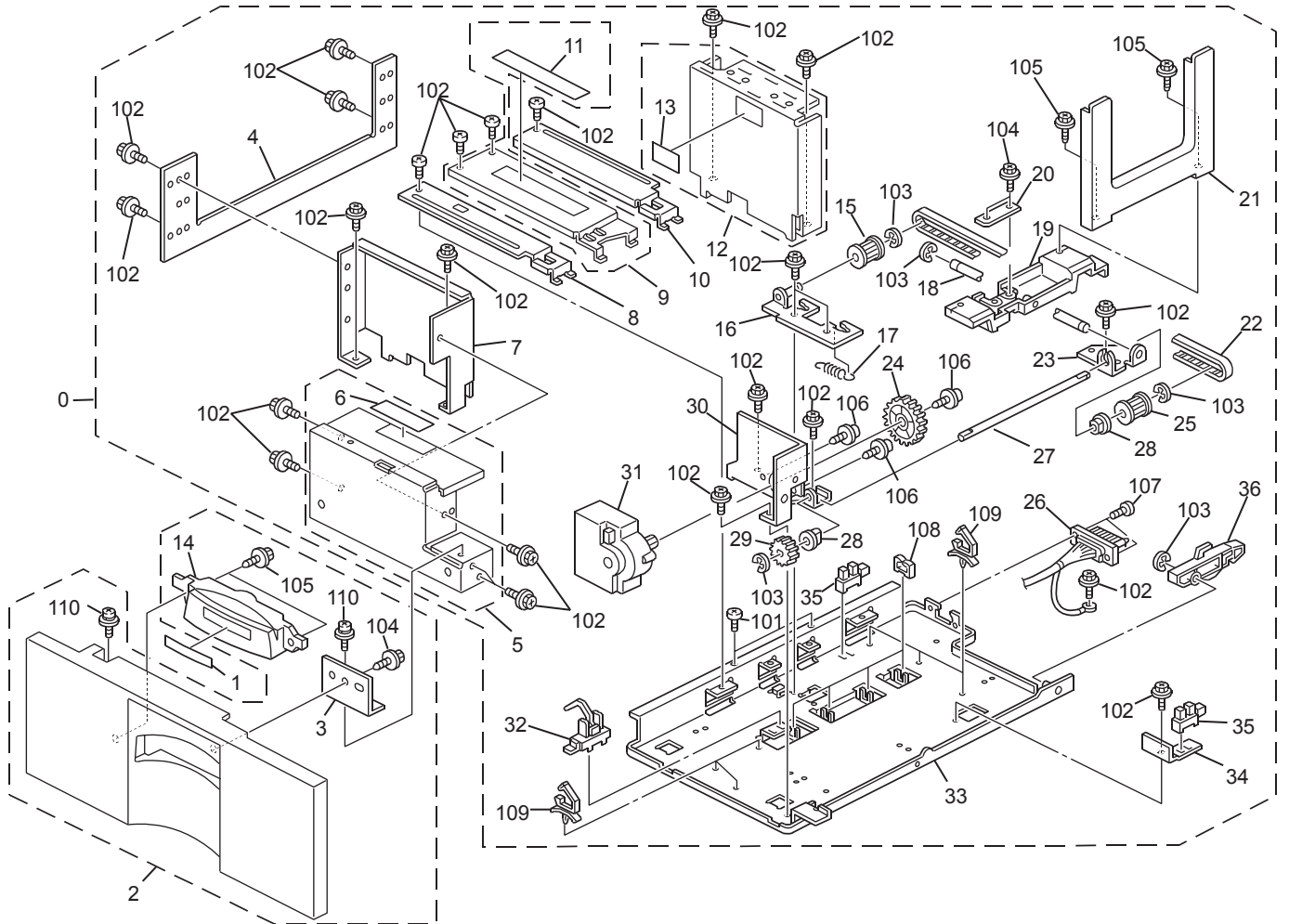

ITEM NO.	PARTS NO.	PARTS NAME	Q'TY / PAGE	Q'TY / PACK	P	I	R	B S I NO.	T O	T	F R O M	S E R I A L NO.	R E M A R K S	C
0	B2346616	Tandem LCT Unit - Left	1											
1	AA003211	Decal:Paper Tray:Display:	1											
2	B2346784	Cover - Tandem LCT	1											
3	B2346788	Bracket:Cover:Tandem LCT	1											
4	A2946645	Left Side Plate	1											
5	B0706516	Bracket:Cover:Tandem LCT:	1											
6	B0656846	Decal - Paper Set - Left	1											
7	A2946643	Left Front Fence	1											
8	B1327540	Tray Bottom Plate:Left Fr	1											
9	B0986639	Tray Bottom Plate:Left Mi	1											
10	B1327541	Tray Bottom Plate:Left Re	1											
11	A0966678	Decal - Left Paper Set	1											
12	A2946630	Left Rear Fence	1											
13	AA002010	Decal - Paper Level	1											
14	B2476634	Grip - Paper Tray Cover	1											
15	AB033085	Timing Pulley - 15T	1											
16	B2476951	Bracket:Pulley:Driven:Ass	1											
17	AA060987	Tension Spring:Timing Bel	1											
18	B2476950	Shaft:Slider:Back Fence	1											
19	B1327564	Slider:Back Fence:Left	1											
20	B0656823	Timing Belt Cover	1											
21	B1327561	Back Fence:Left	1											
22	AA043271	Timing Belt S3M 196T	1											
23	B0656830	Pulley Bracket	1											
24	AB019475	Gear - 48T	1											
25	AB033084	Timing Pulley - 15T	1											
26	B0705473	DC Harness - Left	1											
27	AA140686	Shaft - Timing Pulley	1											
28	50530447	Bushing - 6mm	2											
29	AB013798	Gear - Z18	1											
30	B0706666	Left DC Motor Bracket	1											
31	AX040145	DC Motor:Tandem LCT	1											
32	AW020163	Paper Feed Sensor	1											
33	B2476970	Base:Tandem LCT:Left:Ass'	1											
34	B0656831	Sensor Bracket	1											
35	AW020145	Photointerruptor:Flat	2											
36	A2486615	Coupling Lever - Left	1											
101	0353040N	Screw - M3X4												
102	0451006N	Tapping Screw - 3x6												
103	0720040E	Retaining Ring - M4												
104	0452008N	Tapping Screw:M4x8												
105	0450010N	Tapping Screw - M3x10												
106	0450008N	Tapping Screw - M4x8												
107	0313080N	Pan Head Screw:M3x8												
108	11050328	Harness Clamp - ES-0505												
109	11050516	Clamp												
110	0951008N	Screw:Polished Round:M5X8												

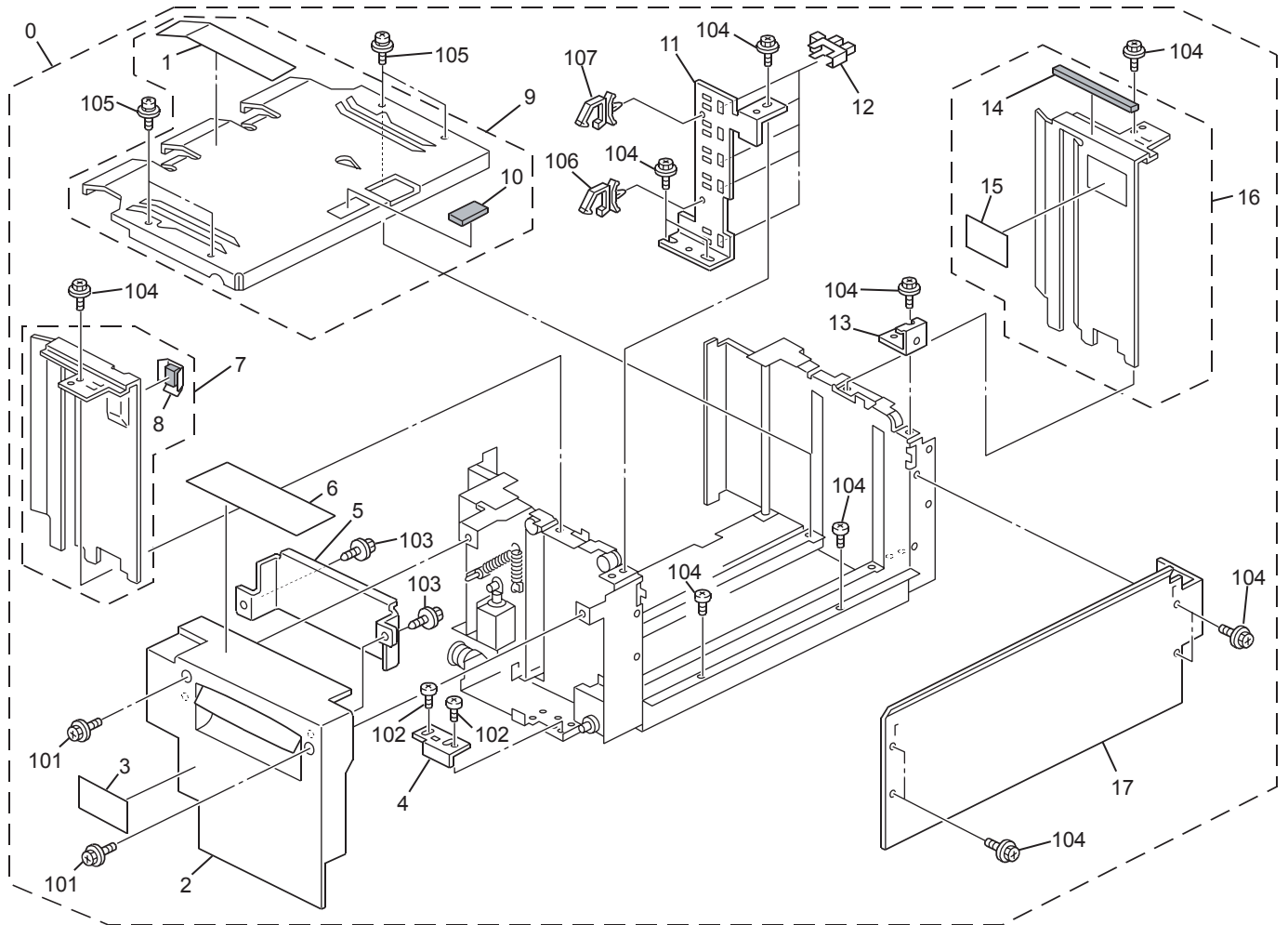

ITEM NO.	PARTS NO.	PARTS NAME	Q'TY / PAGE	Q'TY / PACK	P	I	R	B S I NO.	T O	T	F R O M	S E R I A L NO.	R E M A R K S	C
0	B2346615	Tandem LCT Unit - Right	1											
1	A0966677	Decal - Right Paper Set	1											
2	B1327586	Inner Cover:Tandem LCT	1											
3	AA002246	Decal - Caution	1											
4	B0656859	Right Stopper	1											
5	B0656875	Protection -inner Cover	1											
6	B0656877	Decal - Paper Set - Right	1											
7	B2346686	Side Fence - Right Front	1											
8	B2346690	Plate:Paper	1											
9	B1327543	Base:Tandem LCT:Right	1											
10	52012858	Friction Pad	1											
11	B2346606	Sensor Bracket	1											
12	AW020145	Photointerruptor:Flat	5											
13	A1766695	Misfeed Removal Guide	1											
14	B4756855	Shield:Tandem Lct:Rear Ri	1											
15	AA002010	Decal - Paper Level	2											
16	B1327576	Side Fence:Tandem LCT:Rig	1											
17	B2346667	Side Plate - Side	1											
101	0951008N	Screw:Polished Round:M5X8												
102	0314060N	Screw - M4x6												
103	0452008N	Tapping Screw:M4x8												
104	0434060N	Pan Self-tapping Screw:M4												
105	0951006N	Screw - M3X6												
106	11050488	Harness Clamp												
107	11050534	Clamp												

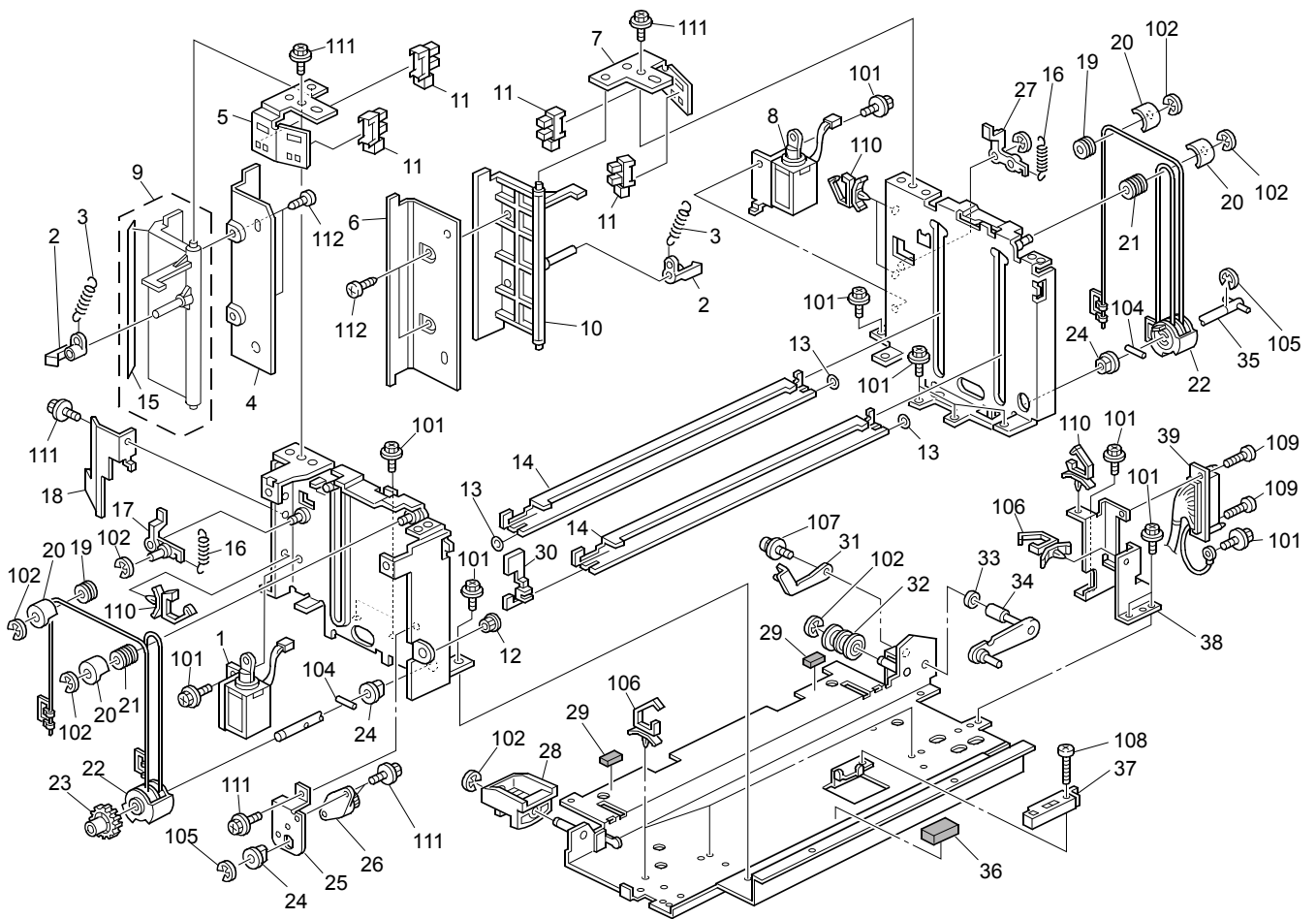

ITEM NO.	PARTS NO.	PARTS NAME	Q'TY / PAGE	Q'TY / PACK	P I R	B S I NO.	T O	T	F R O M	S E R I A L NO.	R E M A R K S	C
1	B1327547	DC Solenoid:End Fence:Fro	1									
2	A2486713	Hook - Tension Sprong	2									
3	AA060757	Tension Spring - Long	2									
5	B2346620	On Off Detector Bracket -	1									
7	B2346621	On Off Detector Bracket -	1									
8	B1327571	DC Solenoid:End Fence:Rea	1									
9	B2346612	End Fence - Front	1									
10	B2346625	End Fence - Rear	1									
11	AW020145	Photointerruptor:Flat	4									
12	B2346141	Positioning Sleeve - Inne	1									
13	A2486694	Wire Ring	2									
14	B0656870	Stay -rightbase	2									
15	A2946713	Shield - Front Side Fence	1									
16	AA060758	Tension Spring - Short	2									
17	B0706683	Lever:Release:Front	1									
18	B0706667	End Fence Cover Front	1									
19	AB032058	Wire Pulley - M10	2									
20	A2486695	Guide - Pulley	4									
21	AB032719	Pulley - M10	2									
22	B1327550	Cover:Pulley:Drive Were	2									
23	AB013781	Gear - 30Z	1									
24	50530223	Bushing - 8mm	3									
25	B0656872	Oil Damper Bracket	1									
26	A2486701	Oil Damper	1									
27	B0706684	Side Plate:Tandem:Right F	1									
28	A2946655	Front Roller - Slide Rail	1									
29	AA161130	Cushion - Small	2									
30	A2946690	Feeler - Paper Height Sen	1									
31	B0656864	Small Lever	1									
32	AF022105	Roller - Slide Rail	1									
33	AA132203	Spacer - 6mm	1									
34	B0656862	Large Lever	1									
35	A2486687	Right Drive Shaft	1									
36	AA161129	Cushion - Large	1									
37	AW010113	Sensor	1									
38	B1327575	Bracket:Connector:Tandem	1									
39	B2345673	Harness - Tandem LCT Righ	1									
101	0434060N	Pan Self-tapping Screw:M4										
102	0720040E	Retaining Ring - M4										
103	11050328	Harness Clamp - ES-0505										
104	0633200G	Pin - M3x20										
105	0720060E	Retaining Ring - M6										
106	11050488	Harness Clamp										
107	0951006N	Screw - M3X6										
108	0313120N	Pan Head Screw:M3x12										
109	0313080N	Pan Head Screw:M3x8										
110	11050488	Harness Clamp										
111	0451008N	Tapping Screw:4x8										
112	0452006N	Binding Self-tapping Scre										

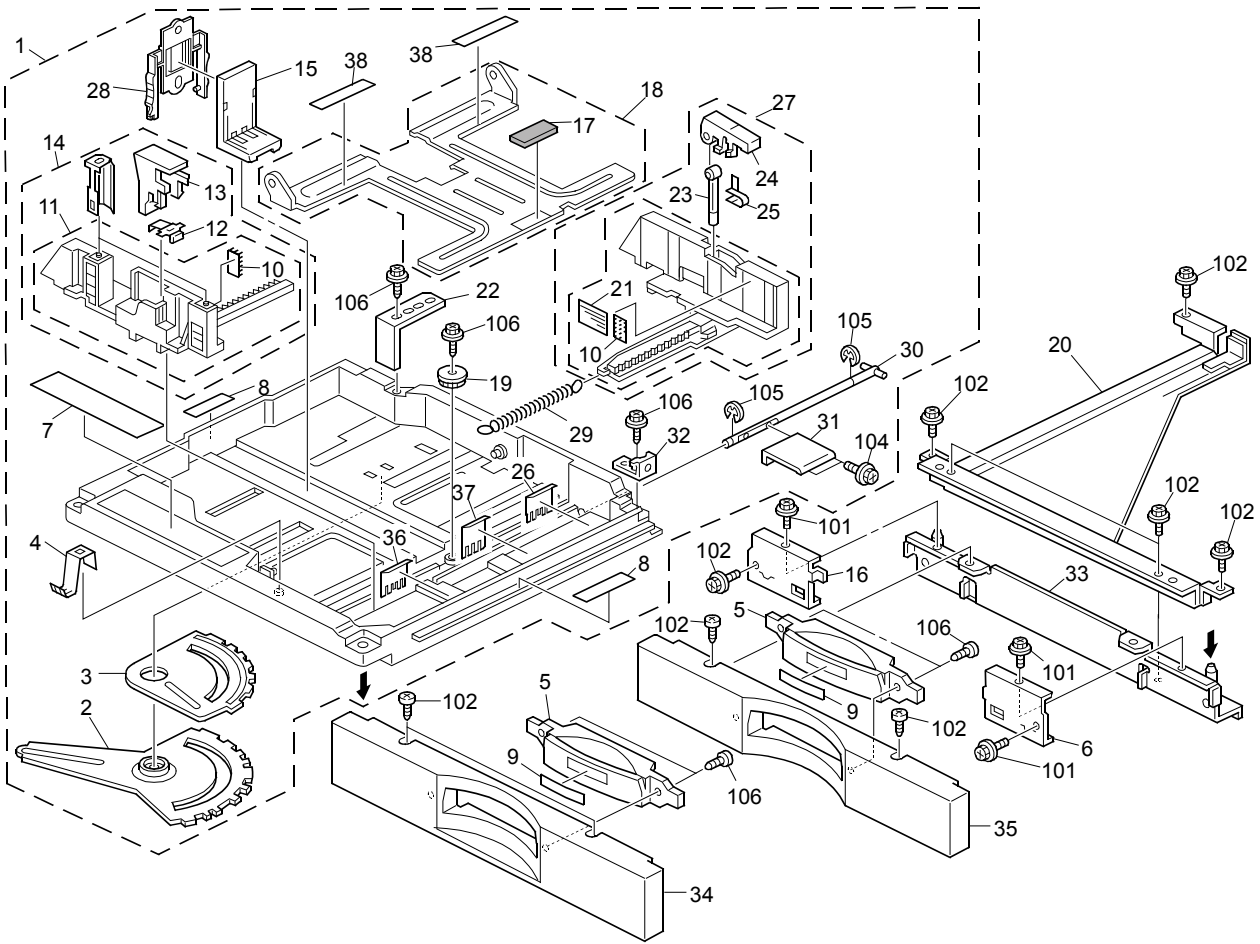

ITEM NO.	PARTS NO.	PARTS NAME	Q'TY / PAGE	Q'TY / PACK	P I R	B S I NO.	T O	T	F R O M	S E R I A L NO.	R E M A R K S	C
1	B2346770	Paper Tray:Universal:Unit	1									
2	B1326788	Link:End Fence	1									
3	B1326789	Link:Side Fence	1									
4	B1326798	Spring Plate:Paper Tray:E	1									
5	B2476634	Grip - Paper Tray Cover	1									
6	B0656588	Right Support Plate	1									
7	B1326786	Decal:Paper Tray:Paper Se	1									
8	B0656545	Decal - Positioning	2									
9A	AA003212	Decal:Paper Tray:Display:	1									
9B	AA003213	Decal:Paper Tray:Display:	1									
10	A0966553	Side Fence Pad	2									
11	B1326791	Plate:Side Fence	1									
12	A1342978	Spring Plate	1									
13	B0656538	Positioning Stopper Lever	1									
14	B1326793	Side Fence:Front:Ass'y	1									
15	AF017032	End Fence	1									
16	B0656589	Left Support Plate	1									
17	AF013005	Bottom Plate Pad	1									
18	B1326785	Tray Bottom Plate:Ass'y	1									
19	AB012327	Gear:16z	1									
20	B0656591	Paper Tray Holder Base	1									
21	AA002010	Decal - Paper Level	1									
22	B1326797	Side Fence:Rear:Auxiliary	1									
23	A2672859	Side Fence Stopper	1									
24	A2672860	Rear Lever Stopper	1									
25	A2672857	Spring Plate - Side Fence	1									
26	B2346497	Guide:Rear:Paper Tray	1									
27	B1326795	Side Fence:Rear:Ass'y	1									
28	B1326783	Arm:End Fence:Lock	1									
29	AA060961	Tension Spring:Side Fence	1									
30	B0656524	Bottom Plate Lift Shaft	1									
31	B0656526	Lift Lever	1									
32	A1766695	Misfeed Removal Guide	1									
33	B0656581	Paper Tray Holder Stay	1									
34	B2346644	Paper Tray Cover - Long	1									
35	B2346643	Paper Tray Cover - Short	1									
36	B2346495	Guide:Front:Paper Tray	1									
37	B2346496	Guide:Middle:Paper Tray	1									
38	B2346498	Sheet:Tray Bottom Plate	1									
101	0451008N	Tapping Screw:4x8										
102	0451008N	Tapping Screw:4x8										
104	0360008N	Screw:M3x8										
105	0720060E	Retaining Ring - M6										
106	0450008N	Tapping Screw - M4x8										

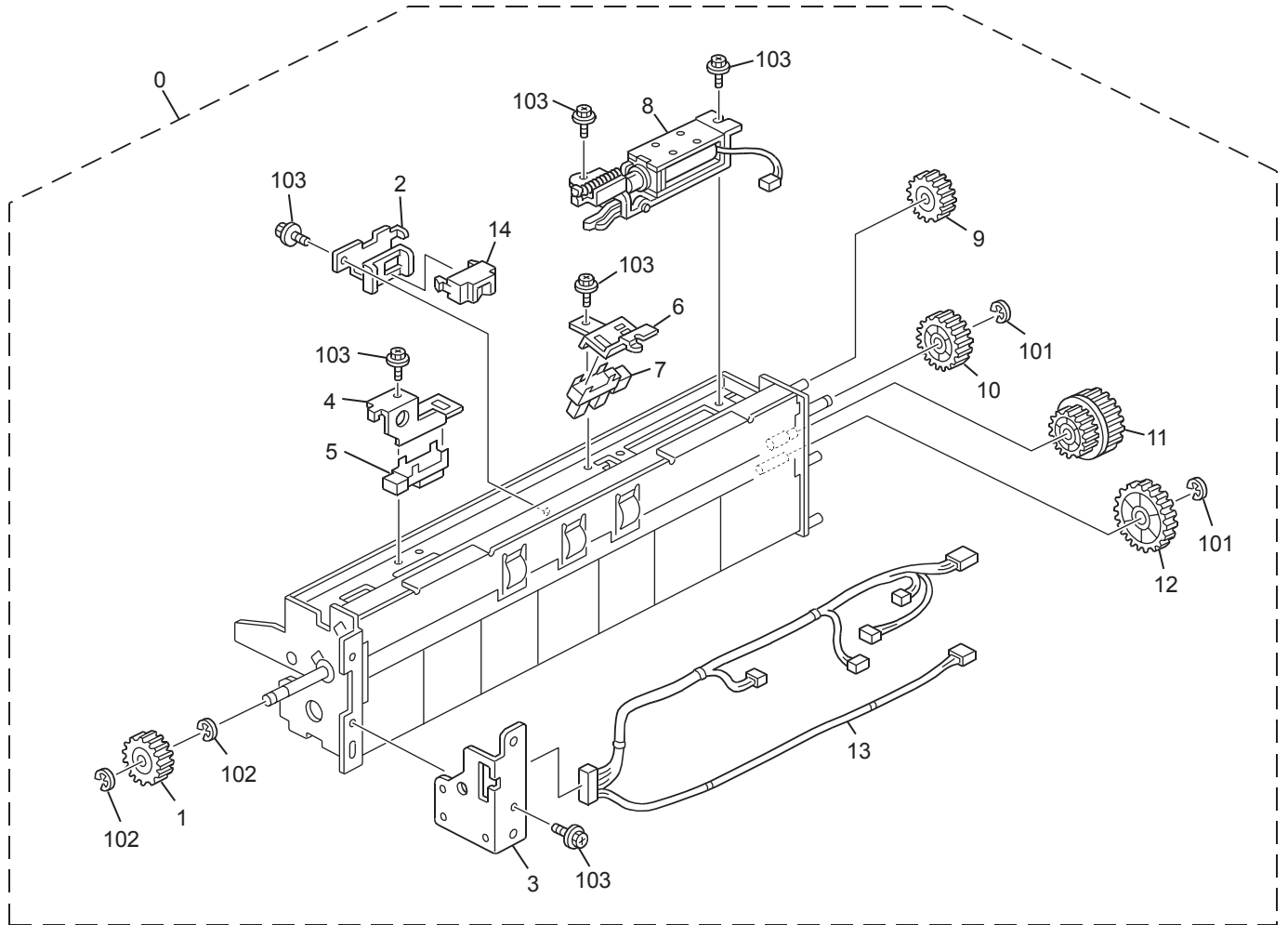

ITEM NO.	PARTS NO.	PARTS NAME	Q'TY / PAGE	Q'TY / PACK	P	I	R	B S I NO.	T O	T	F R O M	S E R I A L NO.	R E M A R K S	C
0	B2346200	Paper Feed Unit	1											
1	BB013007	Gear - 20Z	1											
2	B2346286	Sensor Bracket - Vertical	1											
3	B2346208	Paper Feed Unit Stay	1											
4	B2346287	Sensor Bracket - Paper Fe	1											
5	AW010107	Paper Feed Sensor	1											
6	B2346288	Bsensor Bracket - Sensor	1											
7	AW020145	Photointerruptor:Flat	1											
8	B2346282	Pickup DC Solenoid	1											
9	BB013010	Gear - 18Z	1											
10	BB013019	Gear - 23Z	1											
11	AB017724	Gear - 23Z/28Z	1											
12	BB013008	Gear - 31Z	1											
13	B2345670	Harness - Paper Feed Unit	1											
14	AW010122	Paper Feed Sensor	1											
101	0720060E	Retaining Ring - M6												
102	0720040E	Retaining Ring - M4												
103	0451006N	Tapping Screw - 3x6												

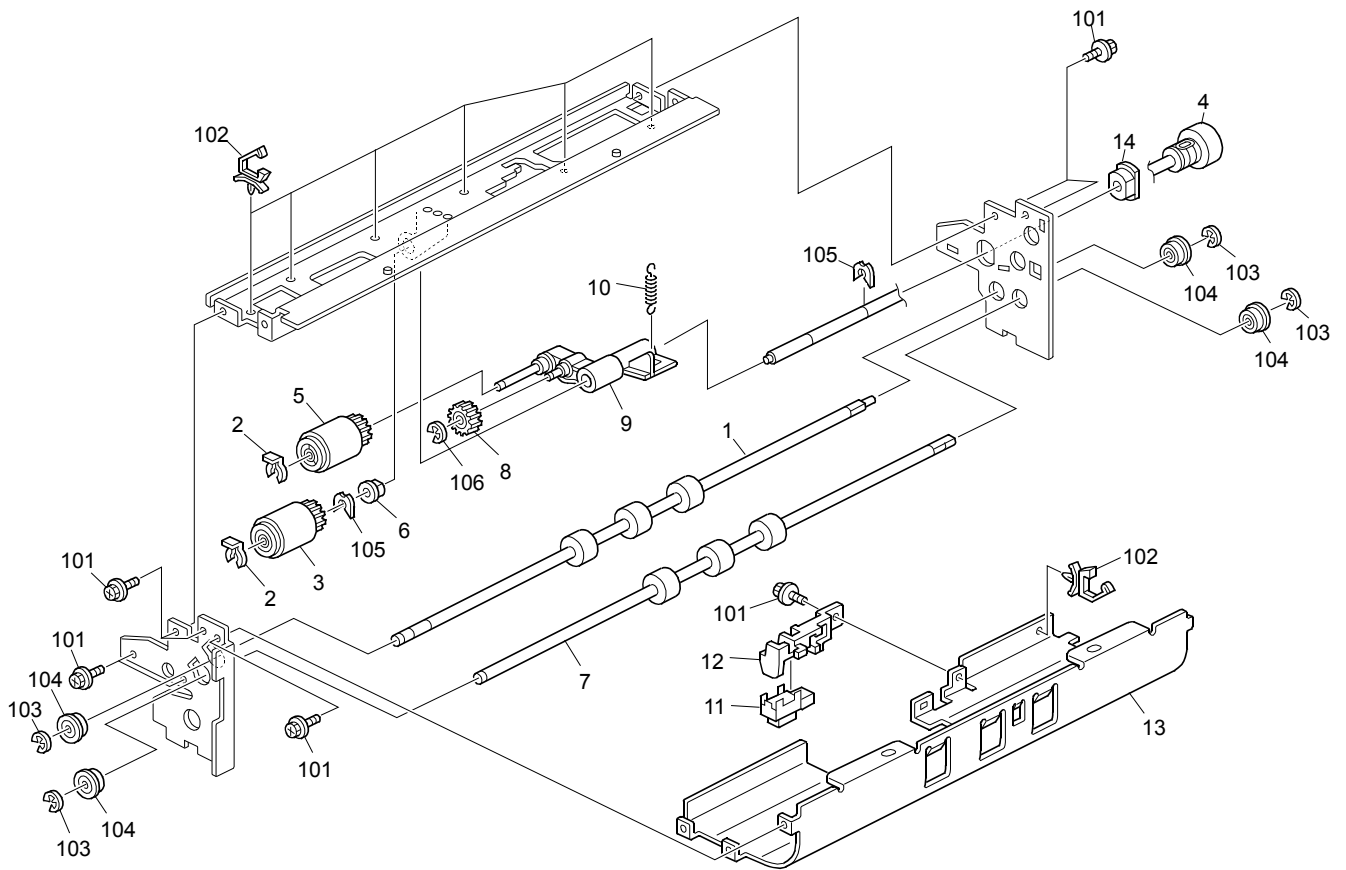

ITEM NO.	PARTS NO.	PARTS NAME	Q'TY / PAGE	Q'TY / PACK	P	I	R	B S I NO.	T O	T	F R O M	S E R I A L NO.	R E M A R K S	C
1	AF020683	Transport Roller No.1 - D	1											
2	54472681	Snap Ring	1											
3	AF031080	Paper Feed Roller:Feed	1											
4	B2346272	Feed Shaft	1											
5	AF030080	Paper Feed Roller:Pickup	1											
6	B2342624	Ball Bearing - 8x12x5	1											
7	AF020684	Transport Roller No.2 - D	1											
8	54472706	Gear - 15T	1											
9	B2346275	Pickup Arm	1											
10	AA060523	Pick-up Pressure Spring	1											
11	AW010107	Paper Feed Sensor	1											
12	B0656345	Paper End Sensor Bracket	1											
13	B2346254	Guide Plate - Feed	1											
14	AA083009	Clutch Roller - 8x18x11	1											
101	0434060N	Pan Self-tapping Screw:M4												
102	11050511	Harness Clamp - LWS-0306Z												
103	0720060E	Retaining Ring - M6												
104	07423808	Ball Bearing - 8x16x5												
105	08050088	Retaining Ring - M6												
106	0720040E	Retaining Ring - M4												

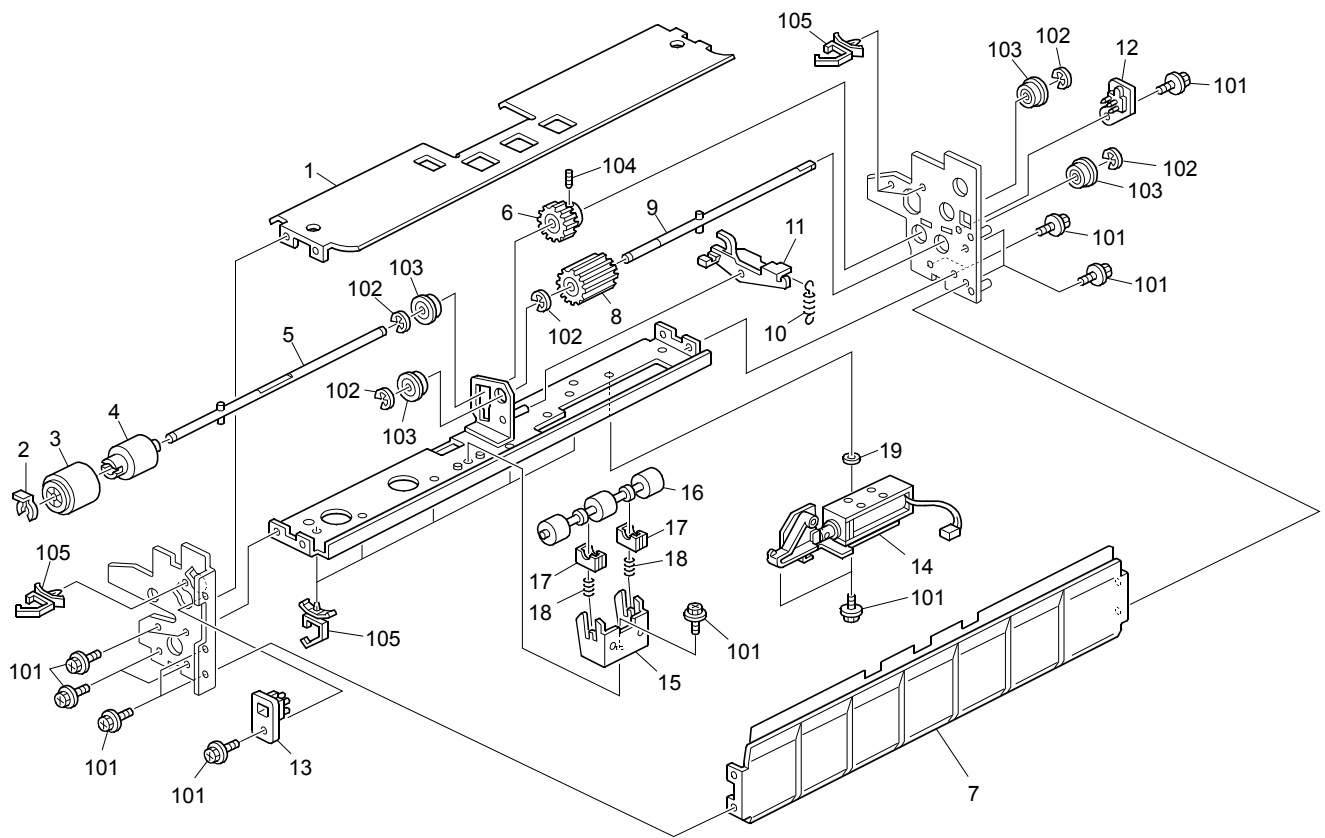

ITEM NO.	PARTS NO.	PARTS NAME	Q'TY / PAGE	Q'TY / PACK	P	I	R	B S I NO.	T O	T	F R O M	S E R I A L NO.	R E M A R K S	C
1	B2346253	Guide Plate - Reverse	1											
2	54472681	Snap Ring	1											
3	AF032080	Paper Feed Roller:Separat	1											
4	B2346300	Torque Limiter	1											
5	B2346223	Driven Reverse Shaft	1											
6	AB011591	Gear:Reverse	1											
7	B2346245	Guide Plate - Vertical Tr	1											
8	AB011392	Drive Reverse Gear - 24z	1											
9	B2346222	Reverse Drive Shaft	1											
10	AA061000	Spring - 1.42n	1											
11	B2346212	Reverse Lever	1											
12	B2346256	Guide - Rear	1											
13	B2346255	Guide - Front	1											
14	B2346232	DC Solenoid	1											
15	B2346242	Guide - Roller:Driven Pre	1											
16	AF020672	Transport Roller - Driven	1											
17	AA084059	Ball Bearing Holder	2											
18	AA063674	Spring - 8n	2											
19	B2346237	Spacer:Dia5xdial2x0.5	2											
101	0434060N	Pan Self-tapping Screw:M4												
102	0720040E	Retaining Ring - M4												
103	07413506	Ball Bearing - 6x12x4mm												
104	0573030E	Hexagon Headless Set Scre												
105	11050511	Harness Clamp - LWS-0306Z												

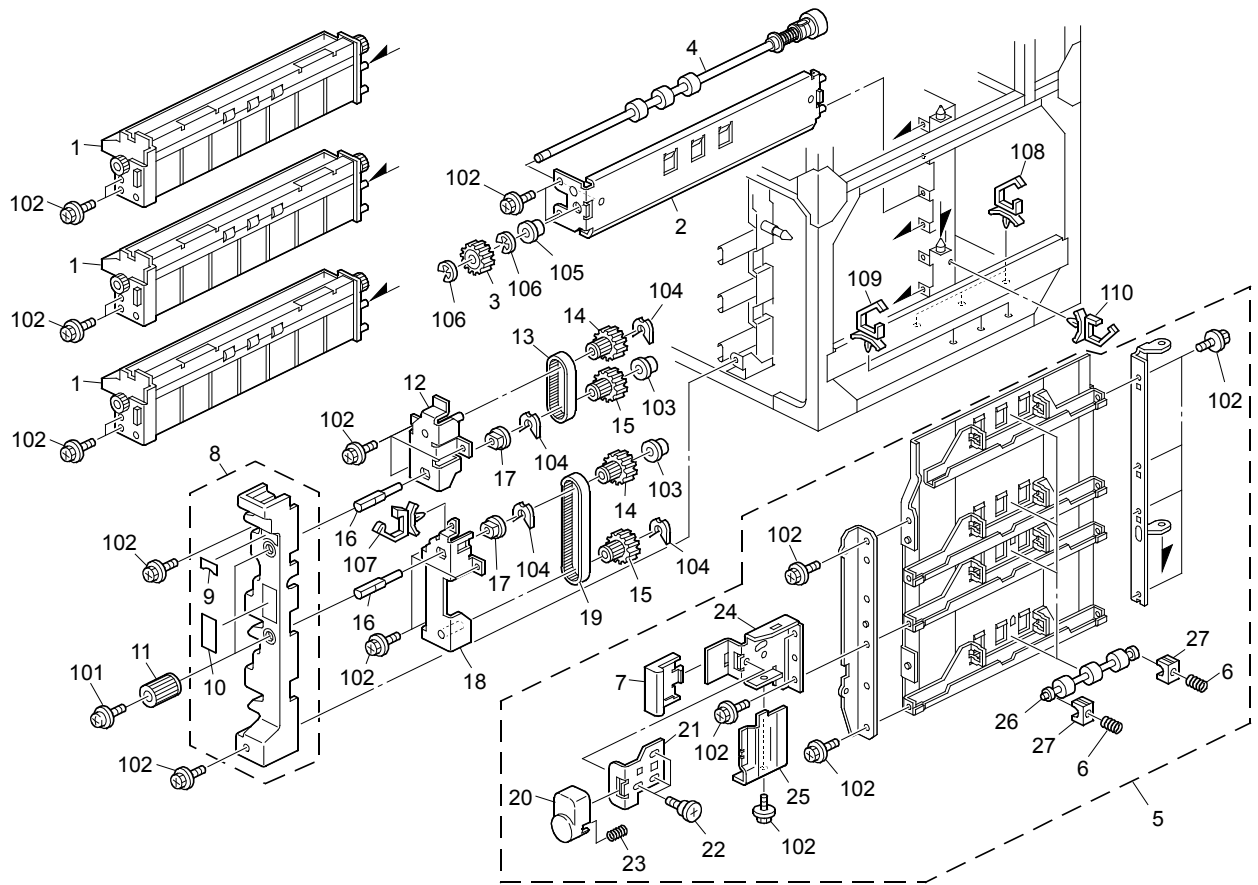

ITEM NO.	PARTS NO.	PARTS NAME	Q'TY / PAGE	Q'TY / PACK	P	I	R	BSI NO.	TO	T	FROM	SERIAL NO.	REMARKS	C
1	B2346200	Paper Feed Unit	3											
2	B2346355	Guide Plate - Joint Unit	1											
3	BB013007	Gear - 20Z	1											
4	B2346360	Transport Roller:Joint Un	1											
5	B2346400	Vertical Transport Unit	1											
6	AA063679	Spring - 10n	8											
7	B2346424	Release Grip	1											
8	B2346122	Inner Cover	1											
9	AA003046	Decal - Vertical Transpor	1											
10	AA003045	Decal - Misfeed Removal	1											
11	AG050101	Knob - Misfeed Removal	1											
12	B2346455	Bracket - Upper	1											
13	AA043324	Timing Belt - B40S2M152	1											
14	AB017725	Gear/timing Pulley - 20Z/	2											
15	AB017726	Gear/timing Pulley - 20Z/	2											
16	AA143570	Misfeed Removal Shaft	2											
17	AA080265	Bushing:6x8x5	2											
18	B2346475	Bracket - Lower	1											
19	AA043325	Timing Belt - B40S2M250	1											
20	B0656428	Release Button - Vertical	1											
21	B2346423	Release Lever	1											
22	AA143560	Stepped Screw - M4	3											
23	AA063878	Spring	1											
24	B2346426	Bracket:Release:Vertical	1											
25	B2346427	Cover:Release:Vertical Tr	1											
26	AF022166	Transport Roller - Driven	4											
101	0951008N	Screw:Polished Round:M5X8												
102	0451008N	Tapping Screw:4x8												
103	08053386	Bushing - 8mm												
104	08050088	Retaining Ring - M6												
105	07413708	Ball Bearing - 8x12x3.5mm												
106	0720060E	Retaining Ring - M6												
107	11050516	Clamp												
108	11050489	Harness Clamp - LWS 1316												
109	11050487	Harness Clamp												
110	11050488	Harness Clamp												

ITEM NO.	PARTS NO.	PARTS NAME	Q'TY / PAGE	Q'TY / PACK	P I R	B S I NO.	T O	T	F R O M	S E R I A L NO.	R E M A R K S	C
0	B2342512	Paper Feed Unit	1									
1	AG050100	Knob - Transport Roller	2									
2	AA001466	Decal - Paper Feed (C2)	1									
3	B2342850	Inner Cover	1									
4	AA001462	Decal - Paper Feed (B1)	1									
5	AA001464	Decal - Paper Feed (B3)	1									
6	B2342793	Button	1									
7	B2342792	Slider	1									
8	AA143802	Screw:6x1.7	1									
9	AA063677	Spring	1									
10	B2342785	DC Solenoid	1									
11	B2342781	Paper Feed Sensor Bracket	1									
12	AW010107	Paper Feed Sensor	2									
13	B2342726	Paper Feed Sensor Bracket	1									
14	B2342776	Guide Plate - Lower	1									
15	AF022165	Transport Roller - Driven	1									
16	AA084059	Ball Bearing Holder	2									
17	AA063674	Spring - 8n	2									
18	AA001465	Decal - Paper Feed (B4)	1									
19	AA161165	Cushion	1									
20	AG051141	Release Lever	1									
21	54472681	Snap Ring	1									
22	B2342750	Contact Image Sensor	1									
23	B2342731	Positioning Sensor Bracke	1									
24	B2342736	Positioning Sensor Stay	1									
25	B2345679	Harness - CIS CRB	1									
26	B2345675	Harness - Paper Feed Unit	1									
101	0951008N	Screw:Polished Round:M5X8										
102	0451008N	Tapping Screw:4x8										
103	0451006N	Tapping Screw - 3x6										
104	0313040N	Screw:M3x4										
105	11050511	Harness Clamp - LWS-0306Z										

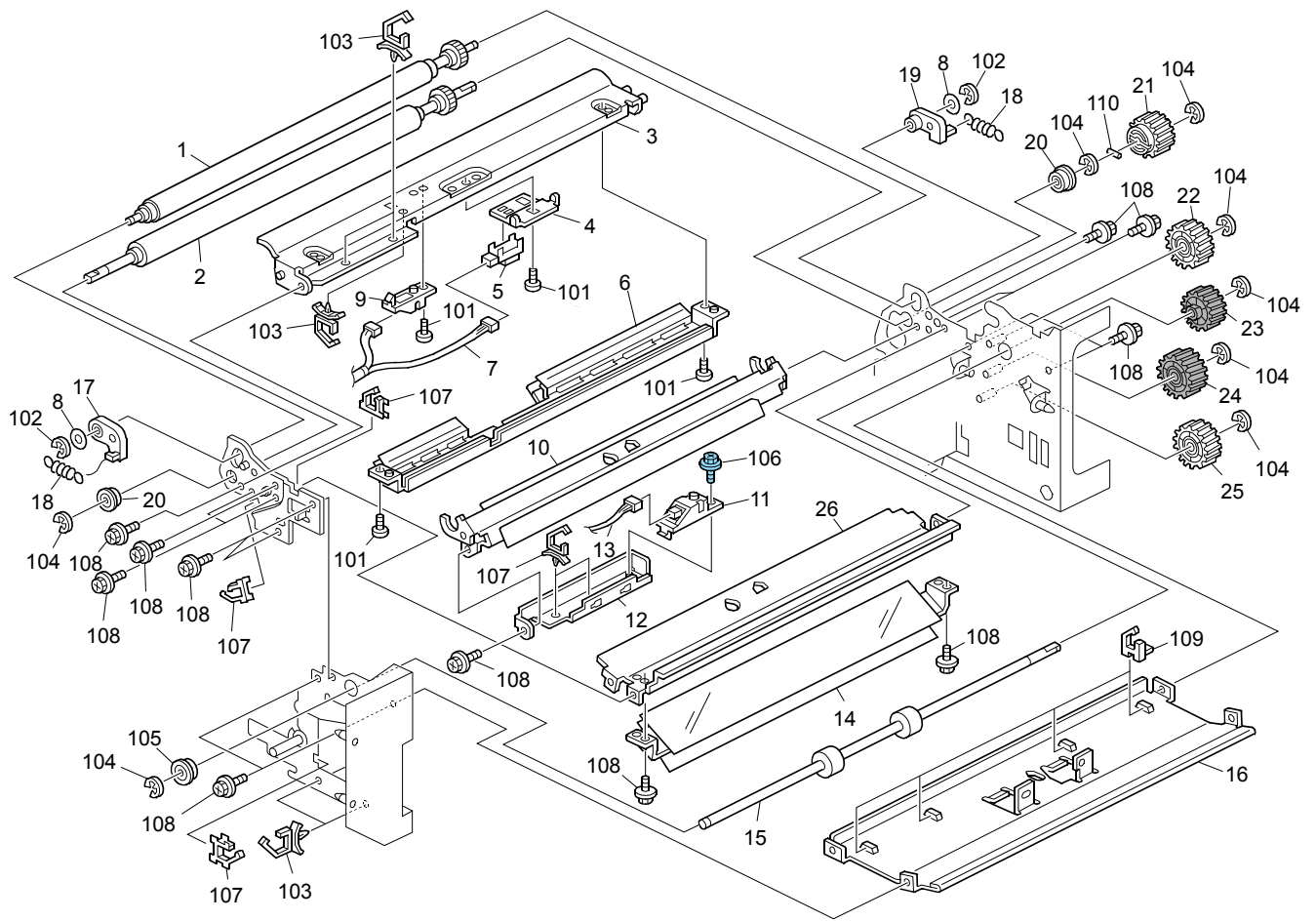

ITEM NO.	PARTS NO.	PARTS NAME	Q'TY / PAGE	Q'TY / PACK	P	I	R	B S I NO.	T O	T	F R O M	S E R I A L NO.	R E M A R K S	C
1	B2342626	Registration Roller - Dri	1											
2	B2342621	Registration Roller - Dri	1											
3	B2342652	Registration Cover	1											
4	B2342658	Registration Sensor Brack	1											
5	AW010107	Paper Feed Sensor	1											
6	B2342660	Remove Paper Dust Case	1											
7	B2345676	Harness - Sensor	1											
8	AA132025	Spacer - 1x8x12	2											
9	AW000010	Optics Sensor:Photo	1											
10	B2342632	Guide Plate - Lower	1											
11	AX560011	LED:Radiate	1											
12	B2342637	LED Bracket	1											
13	B2345678	Harness - Double Feed Sen	1											
14	B2342643	Guide Plate - Entrance	1											
15	AF020671	Transport Roller - Drive	1											
16	B2342770	Guide Plate - Upper	1											
17	B2342628	Ball Bearing - Front	1											
18	AA062329	Pressure Spring	2											
19	B2342629	Ball Bearing - Rear	1											
20	B2342624	Ball Bearing - 8x12x5	2											
21	AB011501	Gear - 30Z	1											
22	AB011502	Gear - 30Z	1											
23	AB011503	Gear - 30Z	1											
24	AB011504	Gear - 33Z	1											
25	AB011505	Gear - 35Z	1											
26	B2342642	Guide Plate - Upper	1											
101	0353040N	Screw - M3X4												
102	0720040E	Retaining Ring - M4												
103	11050511	Harness Clamp - LWS-0306Z												
104	0720060E	Retaining Ring - M6												
105	07423808	Ball Bearing - 8x16x5												
106	0454006Q	Tapping Screw - M3x6												
107	11050551	Clamp:LES-0505												
108	0451006N	Tapping Screw - 3x6												
109	11050568	Clamp:LWSS-0504												
110	0633180G	Parallel Pin - 3x18mm												

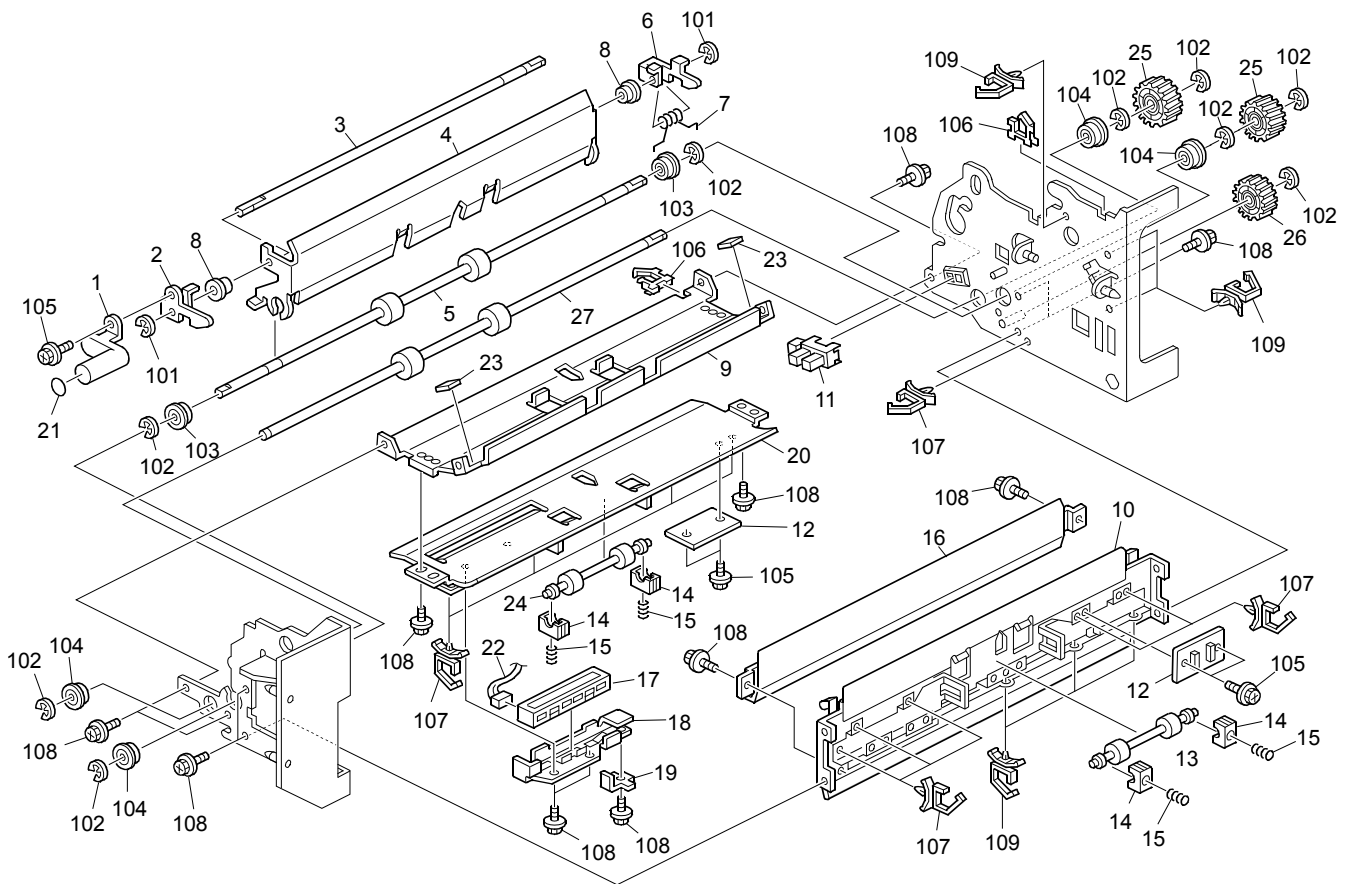

ITEM NO.	PARTS NO.	PARTS NAME	Q'TY / PAGE	Q'TY / PACK	P	I	R	B S I NO.	T O	T	F R O M	S E R I A L NO.	R E M A R K S	C
1	B2342707	Lock Lever	1											
2	B2342705	Lock Pawl - Front	1											
3	AA140779	Lock Shaft	1											
4	B2342704	Guide Plate	1											
5	AF020669	Transport Roller	1											
6	B2342706	Lock Pawl - Rear	1											
7	AA066372	Spring	1											
8	54432668	Bushing - 4x6x7mm	2											
9	B2342761	Guide Plate - Upper	1											
10	B2342712	Guide Plate:Middle:Right:	1											
11	AW020145	Photointerruptor:Flat	1											
12	B2345280	PCB CRB	2											
13	AF022165	Transport Roller - Driven	2											
14	AA084059	Ball Bearing Holder	4											
15	AA063674	Spring - 8n	4											
16	B2342720	Guide Plat - Left Lower	1											
17	B2342750	Contact Image Sensor	1											
18	B2342731	Positioning Sensor Bracke	1											
19	B2342736	Positioning Sensor Stay	1											
20	B2342765	Guide Plate - Lower	1											
21	AA001463	Decal - Paper Feed:B2	1											
22	B2345679	Harness - CIS CRB	1											
23	A4692123	Rubber Cushion - 1x10x10m	1											
24	AF022168	Transport Roller - Driven	1											
25	AB011504	Gear - 33Z	2											
26	AB011505	Gear - 35Z	1											
27	AF020670	Transport Roller - Drive	1											
101	0720030E	Retaining Ring - M3												
102	0720060E	Retaining Ring - M6												
103	07413708	Ball Bearing - 8x12x3.5mm												
104	07423808	Ball Bearing - 8x16x5												
105	0451006N	Tapping Screw - 3x6												
106	11050551	Clamp:LES-0505												
107	11050511	Harness Clamp - LWS-0306Z												
108	0451006N	Tapping Screw - 3x6												
109	11050516	Clamp												

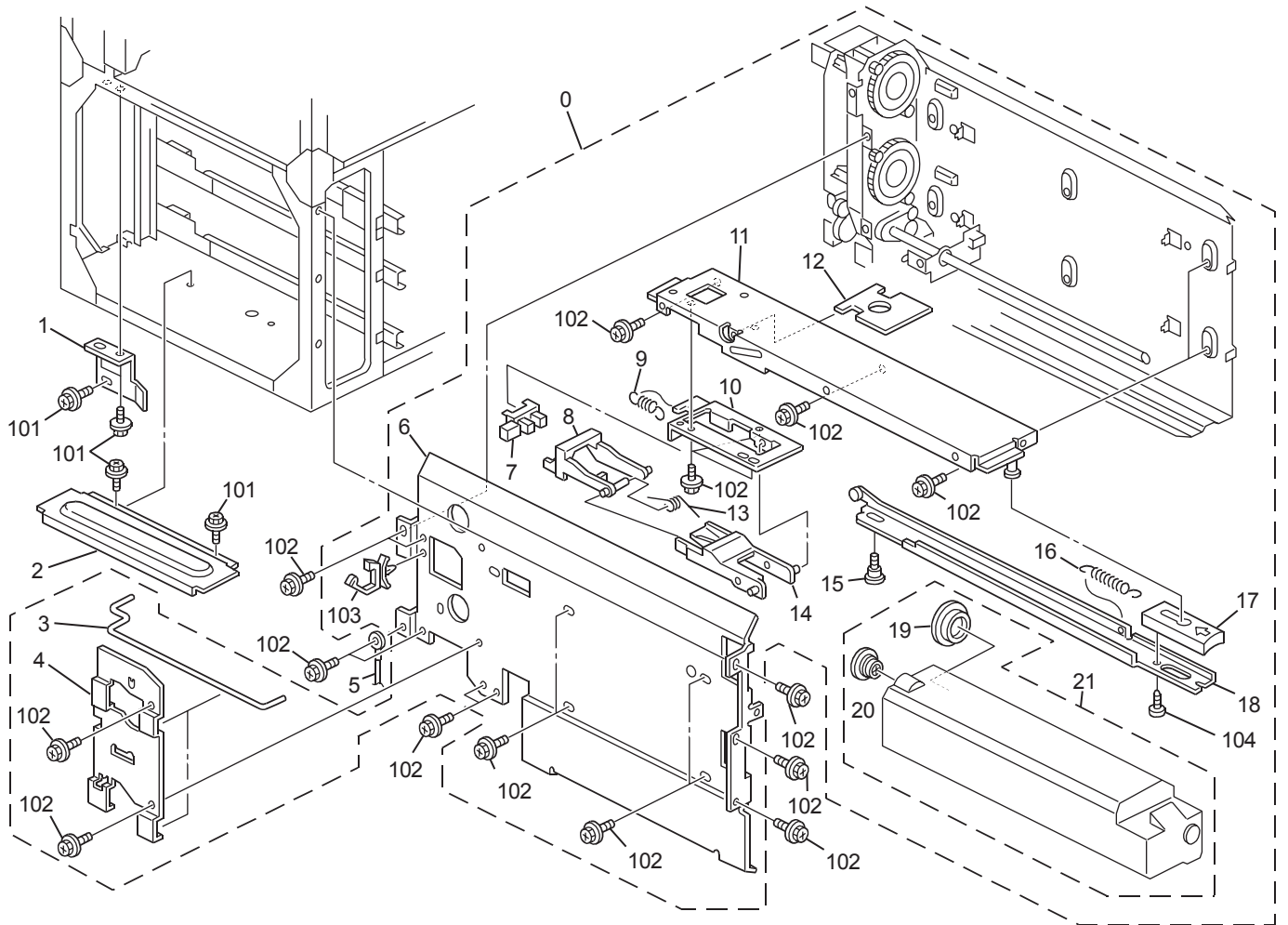

ITEM NO.	PARTS NO.	PARTS NAME	Q'TY / PAGE	Q'TY / PACK	P I R	B S I NO.	T O	T	F R O M	S E R I A L NO.	R E M A R K S	C
0	B2343037	Toner Bank - TEC	1									
1	A2943495	Fixing Plate	1									
2	B0703496	Supporter:Toner Bank	1									
3	A2943461	Lever Rack Joint	1									
4	B0703462	Plate:Joint:Rack:Lever	1									
5	A2945489	Ground Harness - Toner Ba	1									
6	B0703436	Left Side Plate - Toner B	1									
7	AW020145	Photointerruptor:Flat	1									
8	A2943447	Toner Bottle Set Feeler	2									
9	AA060812	Lever Tension Spring	2									
10	A2943445	Stopper Support Plate	2									
11	A2943442	Toner Bottle Guide Plate	2									
12	A2943454	Lever Stopper	2									
13	AA066320	Feeler Tortion Spring	2									
14	A2943446	Toner Bottle Stopper	2									
15	AA143562	Screw:M4:Dia6x1.2	2									
16	AA060811	Tension Spring - Stopper	2									
17	A2943453	Toner Bottle Release Leve	2									
18	A2943451	Lever Holder	2									
19	A0073751	Large Cap - Toner Collect	1									
20	A0073785	Toner Collection Bottle C	1									
21	B2343468	Collection Bottle	1									
101	0451008N	Tapping Screw:4x8										
102	0451006N	Tapping Screw - 3x6										
103	11050511	Harness Clamp - LWS-0306Z										
104	0451006N	Tapping Screw - 3x6										

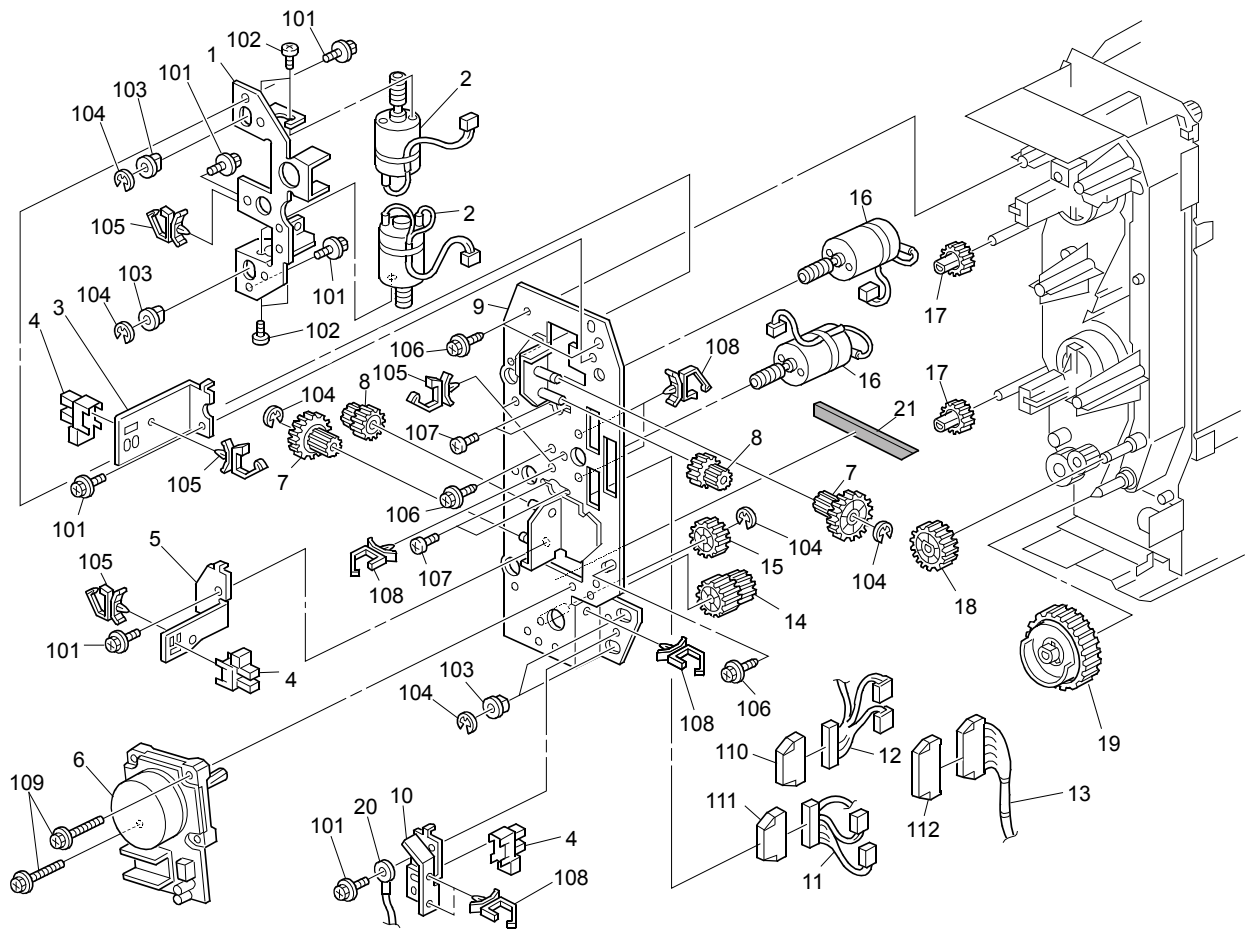

ITEM NO.	PARTS NO.	PARTS NAME	Q'TY / PAGE	Q'TY / PACK	PIR	BSI NO.	TO	T	FROM	SERIAL NO.	REMARKS	C
1	A2943371	Motor Bracket	1									
2	B2343372	DC Motor:Toner Bottle:DC2	2									
3	A2943378	Position Sensor Bracket -	1									
4	AW020145	Photointerruptor:Flat	3									
5	A2943379	Position Sensor Bracket -	1									
6	B2343420	Brushless Motor:DC24V 5.1	1									
7	AB017514	Double Gear - 12/27z	2									
8	AB017515	Double Gear - 12/23z	2									
9	B0703362	Toner Bottle Bracket	1									
10	A2943377	Sensor Bracket	1									
11	B2345681	Harness:Toner Bank:Bottle	1									
12	B2345680	Harness:Toner Bank:Bottle	1									
13	B2345682	Harness - Toner Bank Main	1									
14	AB017732	Gear:Idler:Z16/Z47:PRESS	1									
15	AB012006	Gear - 23Z	1									
16	B2343375	DC Motor:Drive:Chuck:DC21	2									
17	AB012008	Gear - 23Z	2									
18	AB012004	Gear - 27Z	1									
19	A2943423	Gear - Toner Collection C	1									
20	A2945489	Ground Harness - Toner Ba	1									
21	B0703364	Shield:Bracket:Chuck	1									
101	0451006N	Tapping Screw - 3x6										
102	0312060N	Screw - M2.5X6										
103	08053480	Bushing - 6mm										
104	0720040E	Retaining Ring - M4										
105	11050511	Harness Clamp - LWS-0306Z										
106	0450006N	Tapping Screw:4x6										
107	0312050N	Screw - M2.5X5										
108	11050516	Clamp										
109	0451012N	Tapping Screw:4x12										
110	11026253	Relay Connector										
111	11026267	Connector - 10P										
112	11033507	Connector:55482-1919										

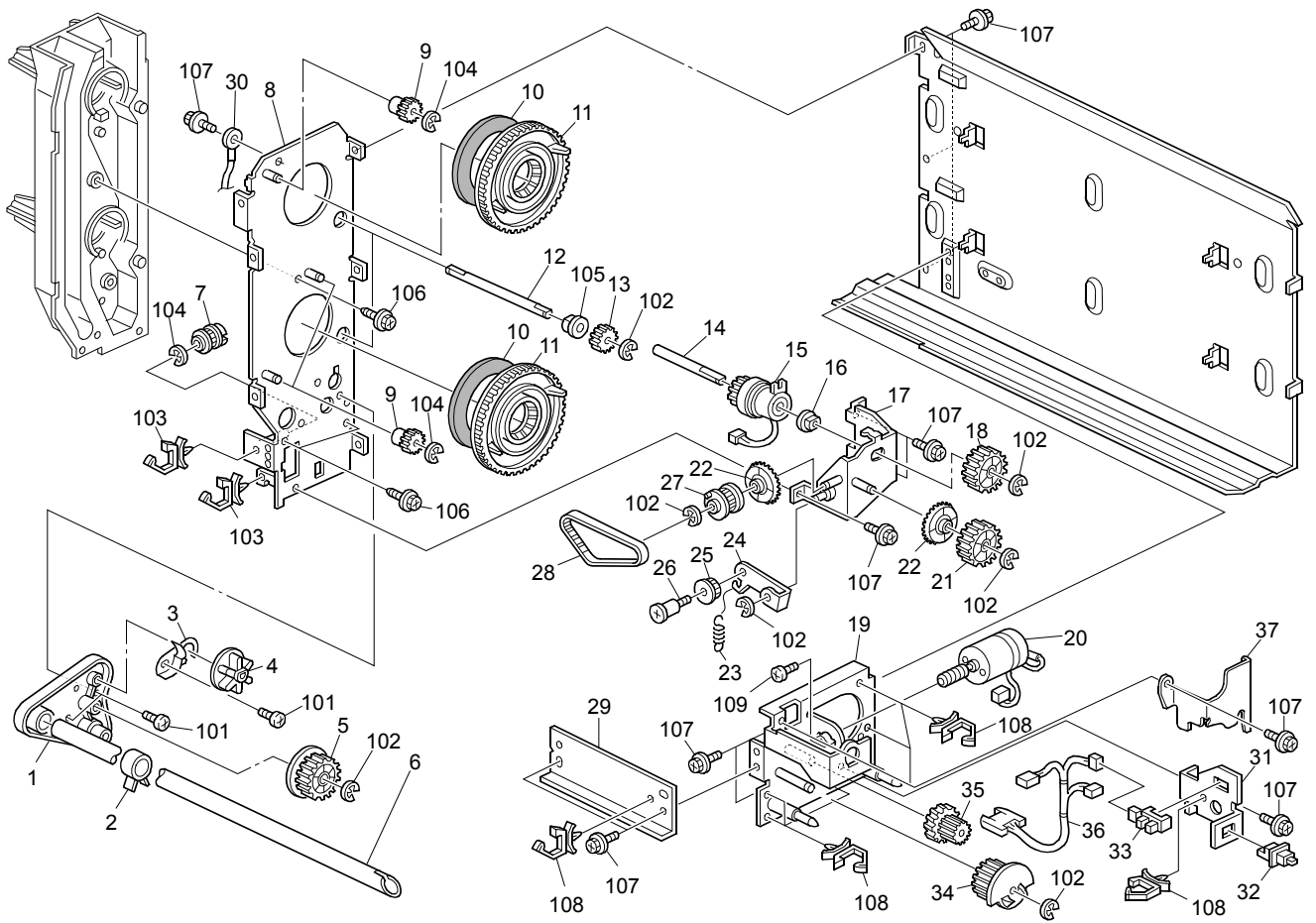

ITEM NO.	PARTS NO.	PARTS NAME	Q'TY / PAGE	Q'TY / PACK	P I R	B S I NO.	T O	T	F R O M	S E R I A L NO.	R E M A R K S	C
1	A2943386	Driving Case	1									
2	A2943422	Pipe Stopper-toner Collec	1									
3	A2943195	Cam Stopper	1									
4	A2943390	Spring Shaft Cam	1									
5	A2943391	Gear - 32Z	1									
6	B2343499	Pipe	1									
7	AB030643	Pulley - 23Z	1									
8	B0703346	Toner Bank Side Plate	1									
9	AB012005	Gear - 13Z	2									
10	AA152299	Bottle Hold Seal	2									
11	A2943294	Gear - 108Z USA	2									
12	A2943382	Toner Bottle Drive Shaft	2									
13	AB012007	Gear - 14Z	2									
14	A2943406	Clutch Shaft	1									
15	AX200301	Magnetic Clutch:25NCM	1									
16	AA082058	Bushing - 6x10x9mm	1									
17	A2943402	Clutch Bracket	1									
18	AB012009	Gear - 34Z	1									
19	B2343452	Bracket:Dc Motor:Collecti	1									
20	B2343372	DC Motor:Toner Bottle:DC2	1									
21	AB012010	Gear - 34Z	1									
22	A2941163	Gear - 30Z	2									
23	AA060950	Tension Spring	1									
24	A2943408	Tightener Bracket	1									
25	AB030317	Gate Tightener	1									
26	AA143444	Stepped Screw	1									
27	B2343424	Torque Limiter - 50t	1									
28	B2343283	Timing Belt - B50S2M208	1									
29	B2343467	Stay - DC Motorbracket	1									
30	A2945489	Ground Harness - Toner Ba	1									
31	B2343461	Used Toner Sensor Bracket	1									
32	AW500023	Push Switch	1									
33	AW020145	Photointerruptor:Flat	1									
34	B2343458	Gear - 27Z	1									
35	B2343457	Gear - 23Z	1									
36	B2345689	Harness - Toner Bank Sub	1									
37	B2343460	Cover:Drive:Agitator	1									
101	0354060N	Screw-m4x6										
102	0720040E	Retaining Ring - M4										
103	11050516	Clamp										
104	0720040E	Retaining Ring - M4										
105	08053480	Bushing - 6mm										
106	0450008N	Tapping Screw - M4x8										
107	0451006N	Tapping Screw - 3x6										
108	11050511	Harness Clamp - LWS-0306Z										
109	0312050N	Screw - M2.5x5										

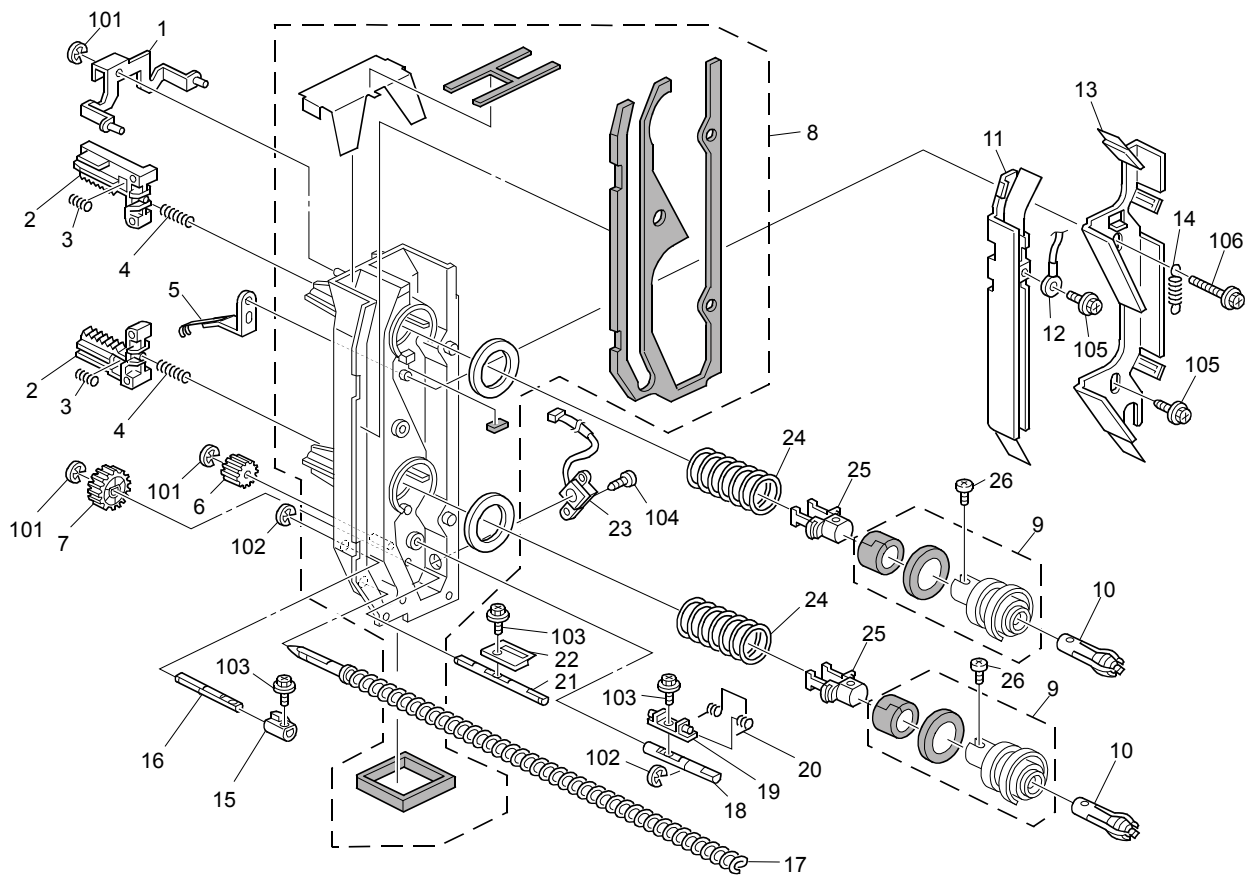

ITEM NO.	PARTS NO.	PARTS NAME	Q'TY / PAGE	Q'TY / PACK	PIR	BSI NO.	TO	T	FROM	SERIAL NO.	REMARKS	C
1	A2943341	Vibrating Plate Link Brac	1									
2	A2943354	Rack - 10z	2									
3	AA063601	Rack Spring	2									
4	AA063602	Chuck Spring	2									
5	A2943225	Ground Plate - Vibrating	1									
6	AB012003	Gear - 16Z	1									
7	AB012004	Gear - 27Z	1									
8	B2343311	Case:Toner Bank:Unit	1									
9	A2943292	Toner Bank Slider	2									
10	A1343180	Bottle Chuck	2									
11	A2943327	Toner Collection Vibratio	1									
12	A2945488	Ground Harness - Vibratin	1									
13	A2943323	Vibration Plate	1									
14	AA060810	Tension Spring - Vibratin	1									
15	A2943337	Vibration Plate Cam	1									
16	A2943336	Cam Shaft	1									
17	B2343494	Toner Collection Coil	1									
18	A2943339	Spring Shaft	1									
19	B2343400	Cylinder Unit	1									
20	AA066319	Tortion Spring	1									
21	A2943333	Agitator Shaft	1									
22	A2943331	Toner Bank Agitator	1									
23	AW310008	Toner End Sensor	1									
24	AA063392	Chuck Spring	2									
25	B2343356	Joint:Chuck:Toner Bottle	2									
26	AA143816	Flat Screw:Chuck: Bottle	2									
101	0720040E	Retaining Ring - M4										
102	0720030E	Retaining Ring - M3										
103	0353060N	Bind Screw - M3x6										
104	0452008N	Tapping Screw:M4x8										
105	0450008N	Tapping Screw - M4x8										
106	0360014N	Screw - M3X14										
107	08053480	Bushing - 6mm										

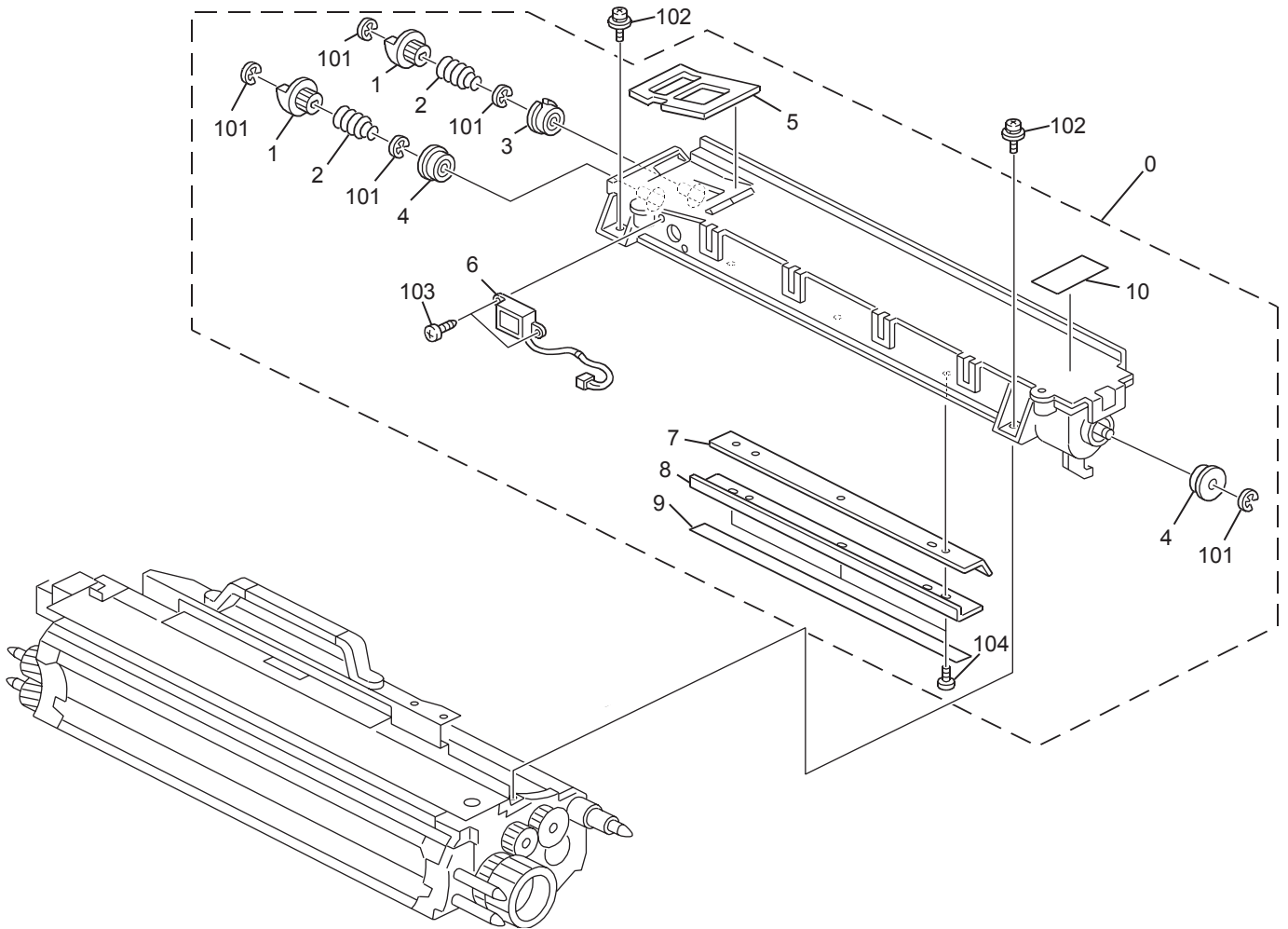

ITEM NO.	PARTS NO.	PARTS NAME	Q'TY / PAGE	Q'TY / PACK	P	I	R	B S I NO.	T O	T	F R O M	S E R I A L NO.	R E M A R K S	C
0	B2343200	Toner Supply Unit	1											
1	B2343239	Joint:Toner Hopper	2											
2	B1321278	Compression Spring:Drive	2											
3	B2473175	Bushing 8x14x8	1											
4	B2473176	Boss:Bearing:Agitator:Pre	2											
5	B2343216	Seal:Toner Hopper:Upper	1											
6	AW310009	Toner End Sensor	1											
7	B2343221	Slitter	1											
8	B2343222	Plate Nut	1											
9	B2343223	Slitter Cover	1											
10	B2343214	Decal:Display:Caution:Dev	1											
101	0720040E	Retaining Ring - M4												
102	0951006N	Screw - M3X6												
103	0452008N	Tapping Screw:M4x8												
104	0354060N	Screw-m4x6												

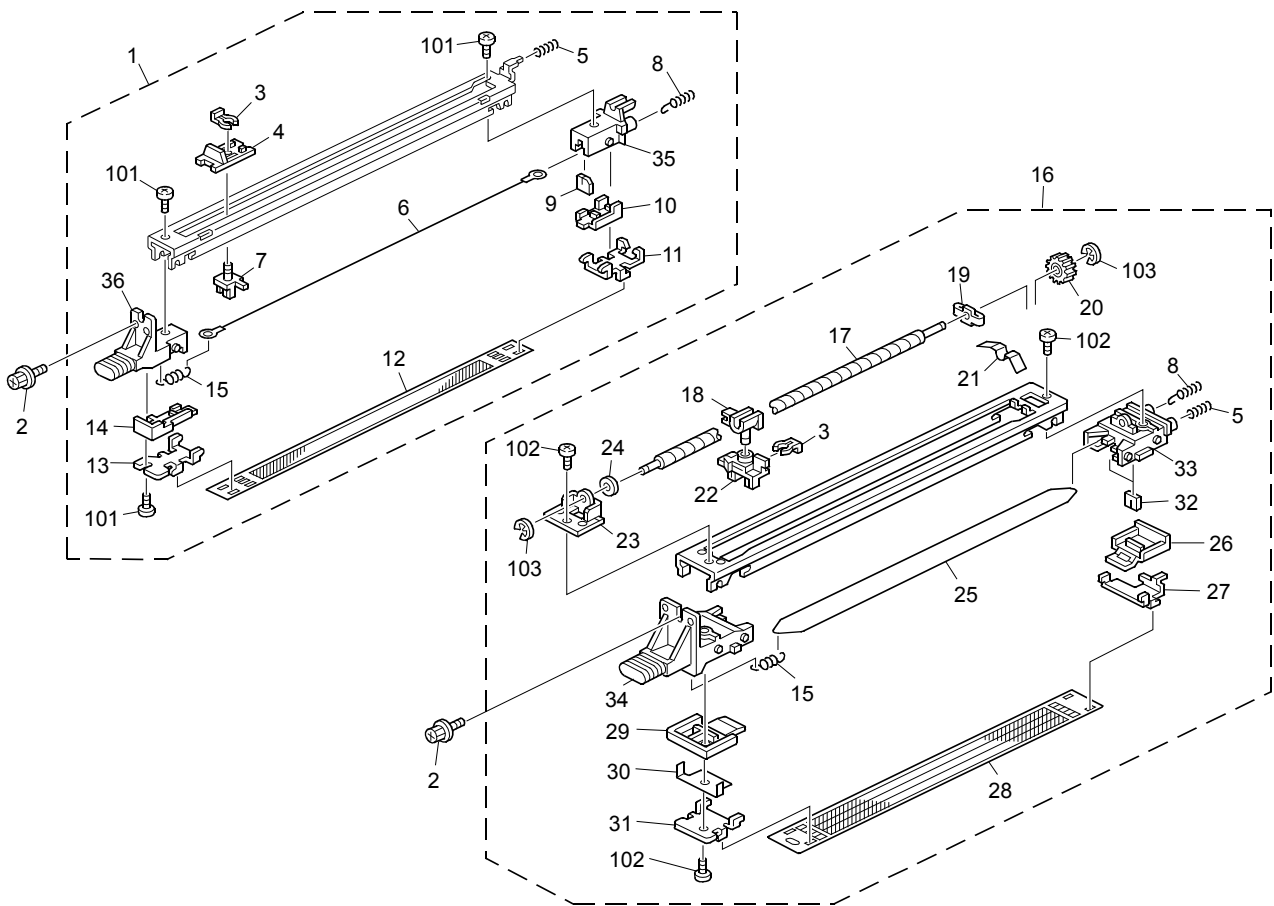

ITEM NO.	PARTS NO.	PARTS NAME	Q'TY / PAGE	Q'TY / PACK	P I R	B S I NO.	T O	T	F R O M	S E R I A L NO.	R E M A R K S	C
1	B2342140	Pre Charge Corona	1									
2	B2342390	Flanged Hexagonal Head Bo	2									
3	A0962065	Slider Ring	2									
4	B2342148	Cleaner Slider	1									
5	B2342125	Spring - Grid	2									
6	B2342156	Charge Corona Wire	1									
7	B2342149	Cleaner	1									
8	B2342124	Spring - Charge Corona	1									
9	B2342154	Wire Cushion	2									
10	B2342145	End Block Cover - Rear	1									
11	B2342152	Grid Stay - Rear	1									
12	B2342155	Charge Corona Grid	1									
13	B2342151	Grid Stay - Front	1									
14	B2342144	End Block Cover - Front	1									
15	AA062284	Pressure Spring	2									
16	B2342111	Charge Corona Unit	1									
17	B2342116	Screw Shaft	1									
18	A0962062	Wire Cleaner Slider	1									
19	AA080147	Front Bushing	1									
20	B2342119	Gear - 14Z	1									
21	B2342115	Earth Spring Plate	1									
22	A0962063	Corona Wire Cleaner	1									
23	B2342117	Bushing - Screw Shaft	1									
24	B2342118	Spacer Cushion	1									
25	B2342128	Wire:Charge Corona	1									
26	B2342127	End Block Cover - Rear	1									
27	A0962051	Rear Grid Anchor	1									
28	B2342113	Charge Corona Grid	1									
29	B2342126	End Block Cover - Front	1									
30	B2342114	Electrode Plate	1									
31	B2342112	Grid Stay - Front	1									
32	B2342123	Cushion - Wire	1									
33	B2342121	End Block:Charge Corona:R	1									
34	B2342120	End Block:Charge Corona:F	1									
35	B2342142	End Block:Rear	1									
36	B2342141	End Block:Front	1									
101	0452006N	Binding Self-tapping Scre										
102	0354080N	Screw:M4x8										
103	0720025E	Retaining Ring - M2.5										

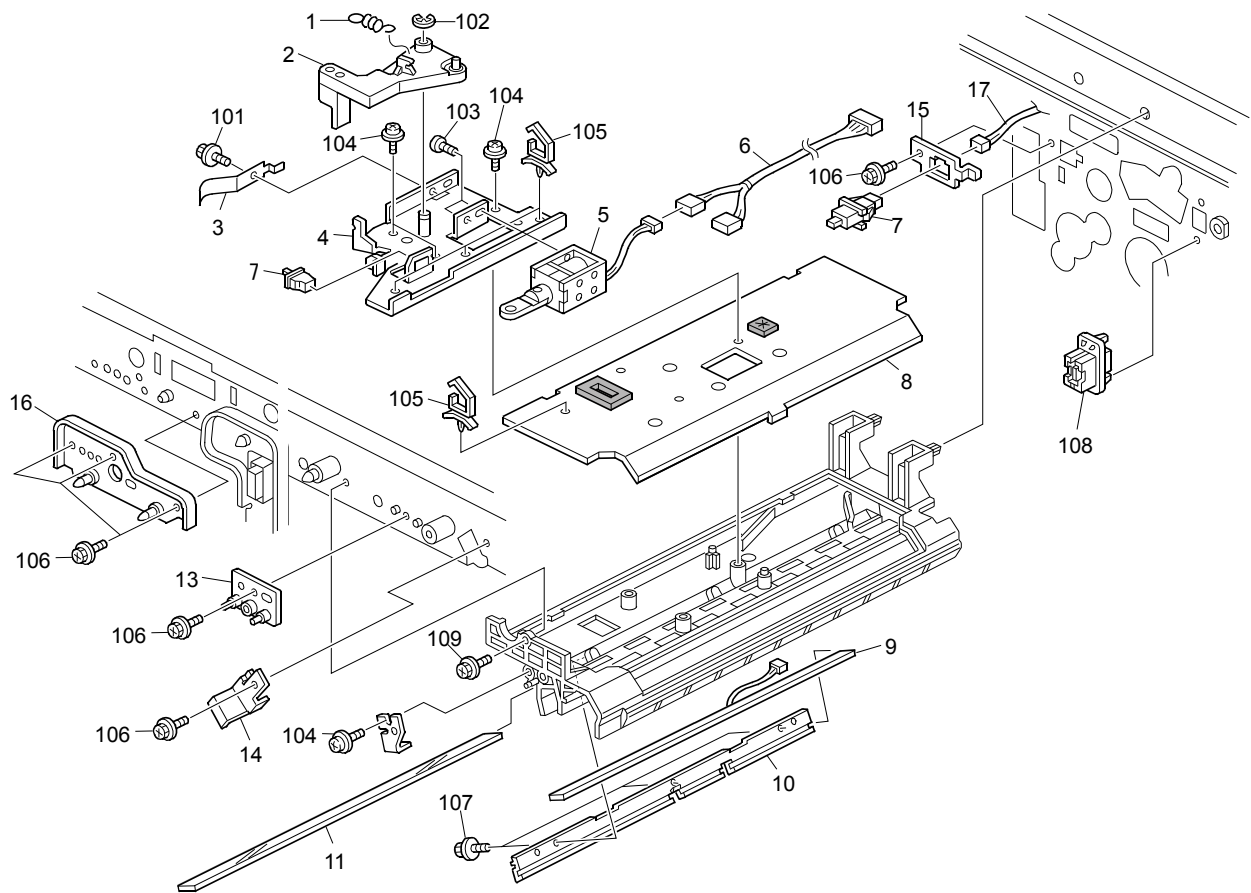

ITEM NO.	PARTS NO.	PARTS NAME	Q'TY / PAGE	Q'TY / PACK	P	I	R	B S I NO.	T O	T	F R O M	S E R I A L NO.	R E M A R K S	C
1	B2342412	Tension Spring	1											
2	B2342411	Arm	1											
3	B2342431	Ground Plate	1											
4	B2342406	Release Blade Base No.2	1											
5	B2342404	DC Solenoid	1											
6	B2345667	Harness - Ql On-off Solen	1											
7	AW500023	Push Switch	2											
8	B2342434	Cover - Around The Photoc	1											
9	B2342440	LED Array - QL	1											
10	B2342427	Seal - Ql	1											
11	B2342422	Shadeing Plate - Discharg	1											
12	B2342423	Cover - Shield Glass	1											
13	B2342129	Charge Corona Bracket	1											
14	B2341991	Cover - Shield Glass	1											
15	B2343786	Push Switch Holder	1											
16	B2344080	Positioning Pin Bracket -	1											
17	B2345668	Harness - Set Sensor	1											
101	0451006N	Tapping Screw - 3x6												
102	0720060E	Retaining Ring - M6												
103	0353040N	Screw - M3X4												
104	0951008N	Screw:Polished Round:M5X8												
105	11050511	Harness Clamp - LWS-0306Z												
106	0451008N	Tapping Screw:4x8												
107	0450008N	Tapping Screw - M4x8												
108	11029785	Connector:55949-1819												
109	0451012N	Tapping Screw:4x12												

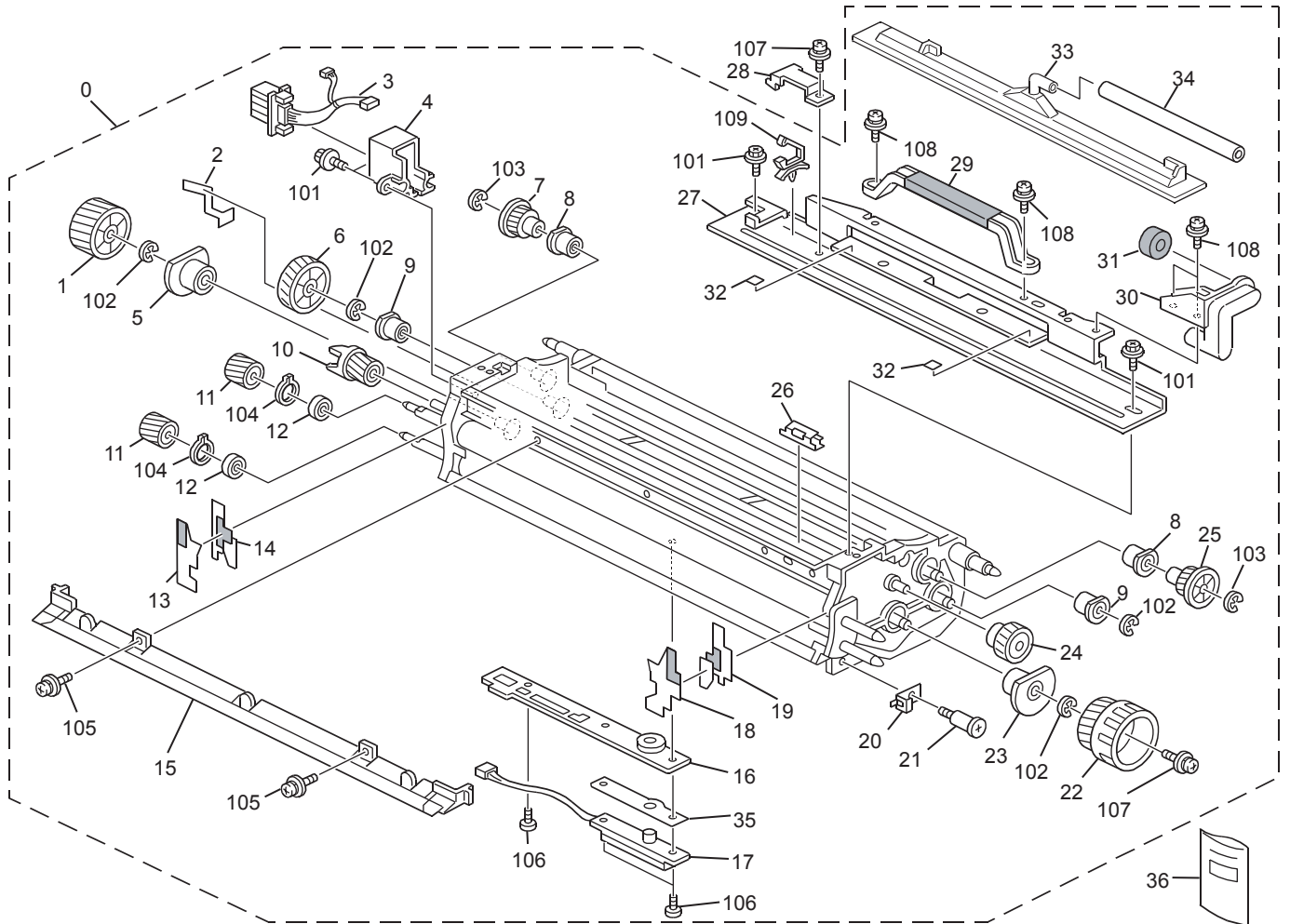

ITEM NO.	PARTS NO.	PARTS NAME	Q'TY / PAGE	Q'TY / PACK	P I R	B S I NO.	T O	T	F R O M	S E R I A L NO.	R E M A R K S	C
0	B2343102	Development Unit	1									
1	B2343165	Gear - 42Z	1									
2	B2343187	Seal:Side Plate:Rear	1									
3	B2343139	Harness - Development Uni	1									
4	B2343138	Connector Holder	1									
5	A2943145	Ball Bearing Case - 8x19x	1									
6	B2343167	Gear - 34Z	1									
7	B2343166	Gear - 20Z	1									
8	B2343118	Bushing:Transport Screw:D	1									
9	B0653069	Bushing - 8mm	1									
10	B2343163	Gear - 23Z	1									
11	B0703180	Gear:Development Roller:Z	2									
12	A2473089	Ball Bearing - 9x17x5	2									
13	B2343192	Shield:Drum:Rear	1									
14	B2343180	Shield:Development Roller	1									
15	B2343171	Entrance Seal:Ass'y	1									
16	B2343125	Density Sensor Guide	1									
17	AW230022	Density Sensor	1									
18	B2343191	Shield:Drum:Front	1									
19	B2343179	Shield:Development Roller	1									
20	A2943126	Casing Electrode	1									
21	AA143426	Stopped Screw - M4x17	1									
22	B2343168	Knob - Development	1									
23	B0703170	Bearing Case:8:Front:Ass'	1									
24	B0703184	Gear:Idler:Z29:M=0.8:Ass'	1									
25	B2343170	Gear - 31Z	1									
26	A2943124	Ground Plate:Doctor Blade	1									
27	B2343157	Development Guide	1									
28	B2343188	Harness Cover	1									
29	B2343175	Grip	1									
30	B2343158	Tube:Duct Joint	1									
31	B2343190	Seal:Joint	1									
32	B2343177	Decal:Positioning Display	2									
33	B2343151	Duct	1									
34	B2343154	Tube	1									
35	B2343126	Sheet:Guide:Density Senso	1									
36	B2349650	Developer	1									
101	0450008N	Tapping Screw - M4x8										
102	0720060E	Retaining Ring - M6										
103	0720040E	Retaining Ring - M4										
104	0727090E	Retaining Ring C - M9										
105	0951008N	Screw:Polished Round:M5X8										
106	0353050N	Screw-m3x5										
107	0951006N	Screw - M3X6										
108	0951006N	Screw - M3X6										
109	11050511	Harness Clamp - LWS-0306Z										

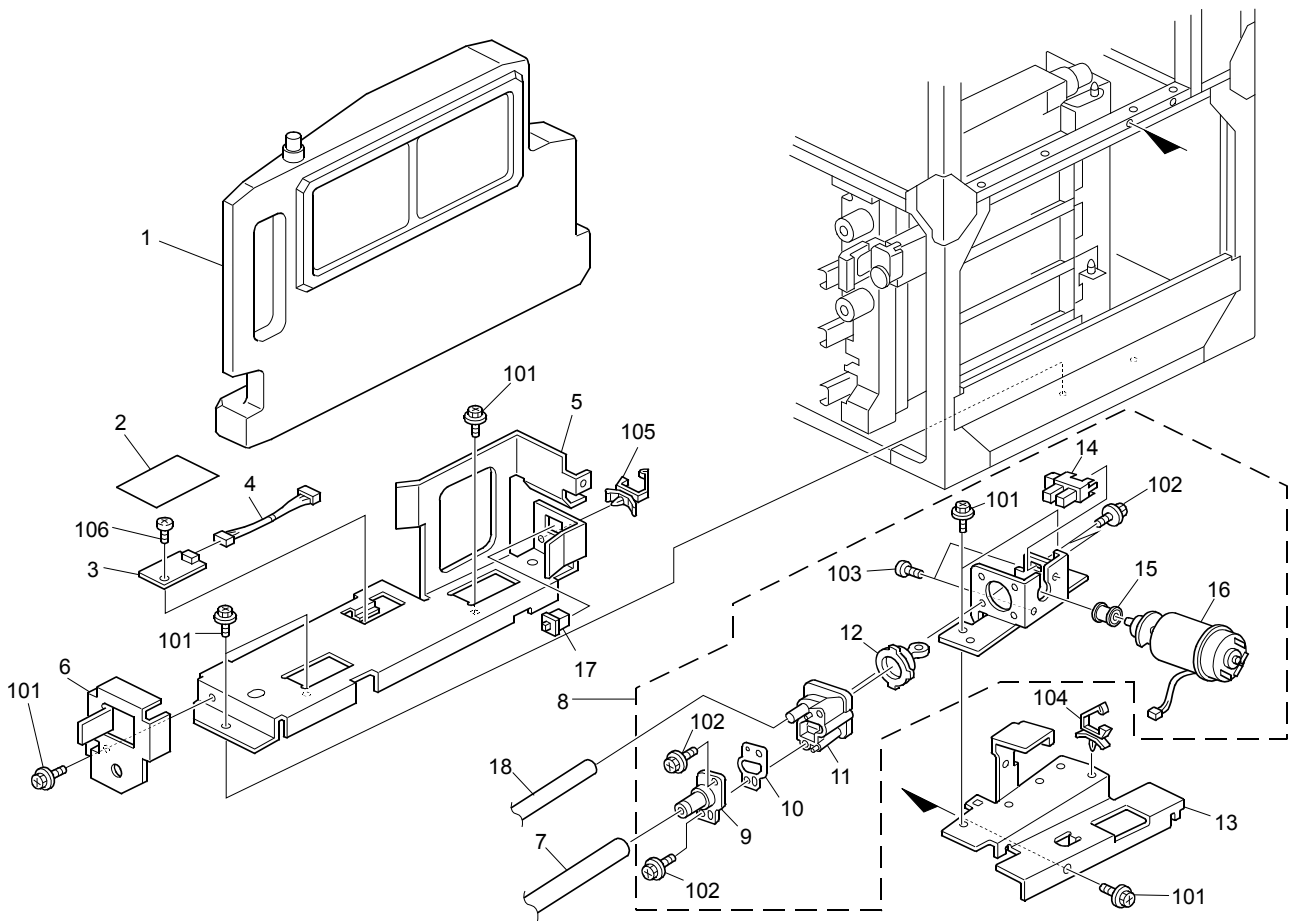

ITEM NO.	PARTS NO.	PARTS NAME	Q'TY / PAGE	Q'TY / PACK	P	I	R	BSI NO.	TO	T	FROM	SERIAL NO.	REMARKS	C
1	B2343701	Collection Bottle	1											
2	B2343712	Sensor Cover	1											
3	AW140014	Temperature & Humidity Se	1											
4	B2345688	Harness - Sensor	1											
5	B2343711	Supporter	1											
6	B2343714	Stopper	1											
7	B2343079	Tube - Collection Bottle	1											
8	B2343094	Air Pump Unit	1											
9	A2943726	Cap:Pump:Mm12	1											
10	A2943085	Pump Seal	1											
11	A2943081	Air Pump	1											
12	A2943086	Toner Supply Pump	1											
13	B2343076	Pump Unit Bracket	1											
14	AW020160	Paper Feed Sensor	1											
15	A2943084	Coller - 4x7x8	1											
16	B2343095	DC Motor 24V 5.85W	1											
17	AW500023	Push Switch	1											
18	B2343162	Tube - Joint	1											
101	0451008N	Tapping Screw:4x8												
102	0450008N	Tapping Screw - M4x8												
103	0313050N	Philips Pan Head Screw -												
104	11050508	Harness Clamp - LWS-0711												
105	11050511	Harness Clamp - LWS-0306Z												
106	0353060N	Bind Screw - M3x6												

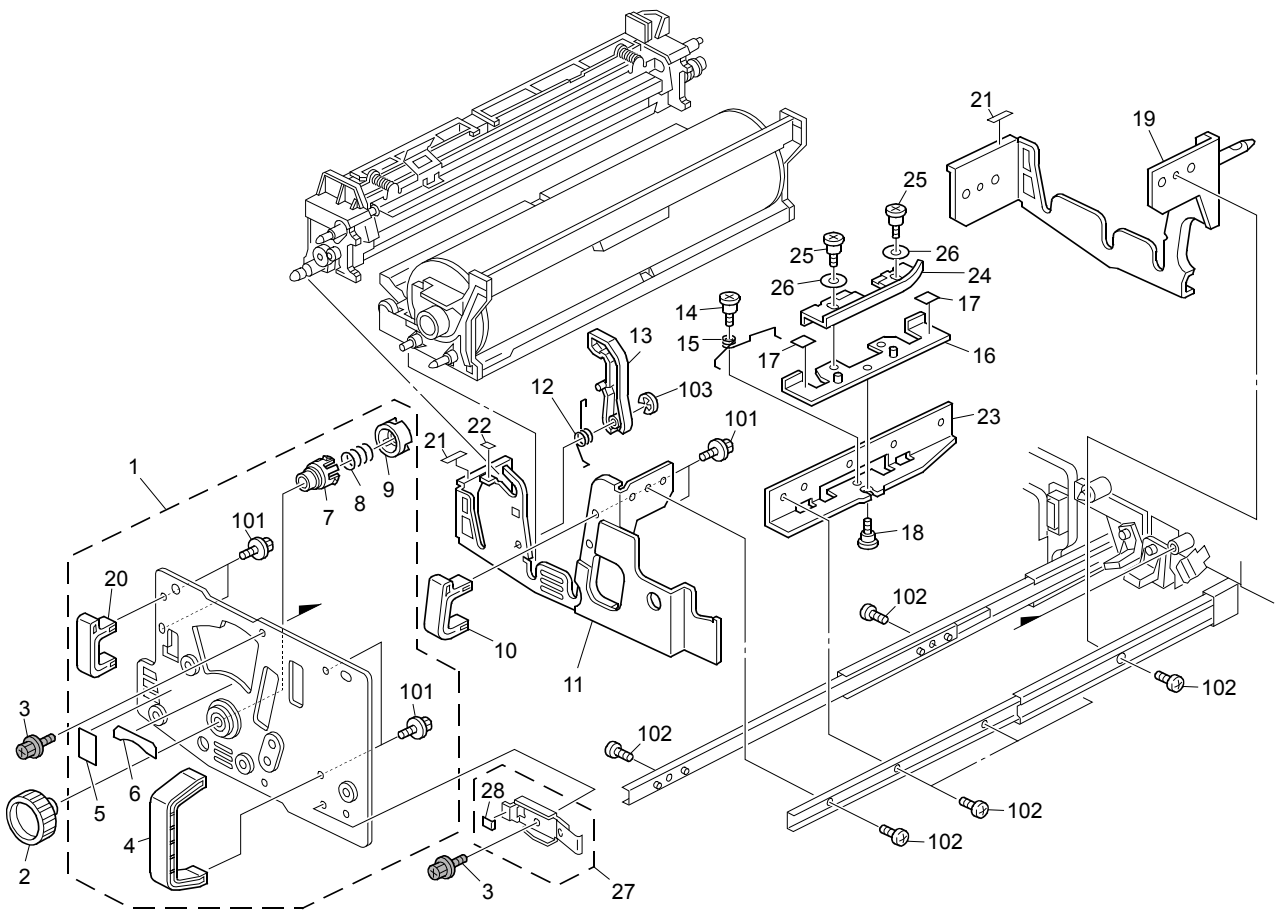

ITEM NO.	PARTS NO.	PARTS NAME	Q'TY / PAGE	Q'TY / PACK	P	I	R	BSI NO.	TO	T	FROM	SERIAL NO.	REMARKS	C
1	B2342330	Drum Stay	1											
2	A0962330	Drum Shaft Knob	1											
3	B2342390	Flanged Hexagonal Head Bo	1											
4	B2342326	Grip - Right	1											
5	B2342338	Decal:Drum Stay	1											
6	B2342332	Decal:Knob:English	1											
7	B2342323	Holder	1											
8	B2342325	Compression Spring	1											
9	B2342324	Cover	1											
10	B2342327	Grip - Tray Unit	1											
11	B2342461	Side Plate:Tray Unit:Fron	1											
12	B2343785	Torsion Spring	1											
13	B2343784	Cleaning Arm	1											
14	AA143444	Stepped Screw	1											
15	B2343093	Torsion Spring	1											
16	B2343090	Holder - Development Unit	1											
17	B2343177	Decal:Positioning Display	2											
18	AA143810	Development Cover Screw	1											
19	B2342471	Side Plate - Rear	1											
20	B2342327	Grip - Tray Unit	1											
21	B2342467	Decal:Side Plate:Tray Uni	1											
22	B2342468	Decal:Side Plate:Tray Uni	1											
23	B2343089	Stay:Holder:Development U	1											
24	B2343084	Release Plate	1											
25	AA143863	Shoulder Screw - M3	1											
26	B7004652	Spacer:Dia4.5	1											
27	B2343196	Spring Plate:Drum Stay	1											
28	B2343593	Decal:Frame:Cleaning	1											
101	0450008N	Tapping Screw - M4x8												
102	0354060N	Screw-m4x6												
103	0720040E	Retaining Ring - M4												

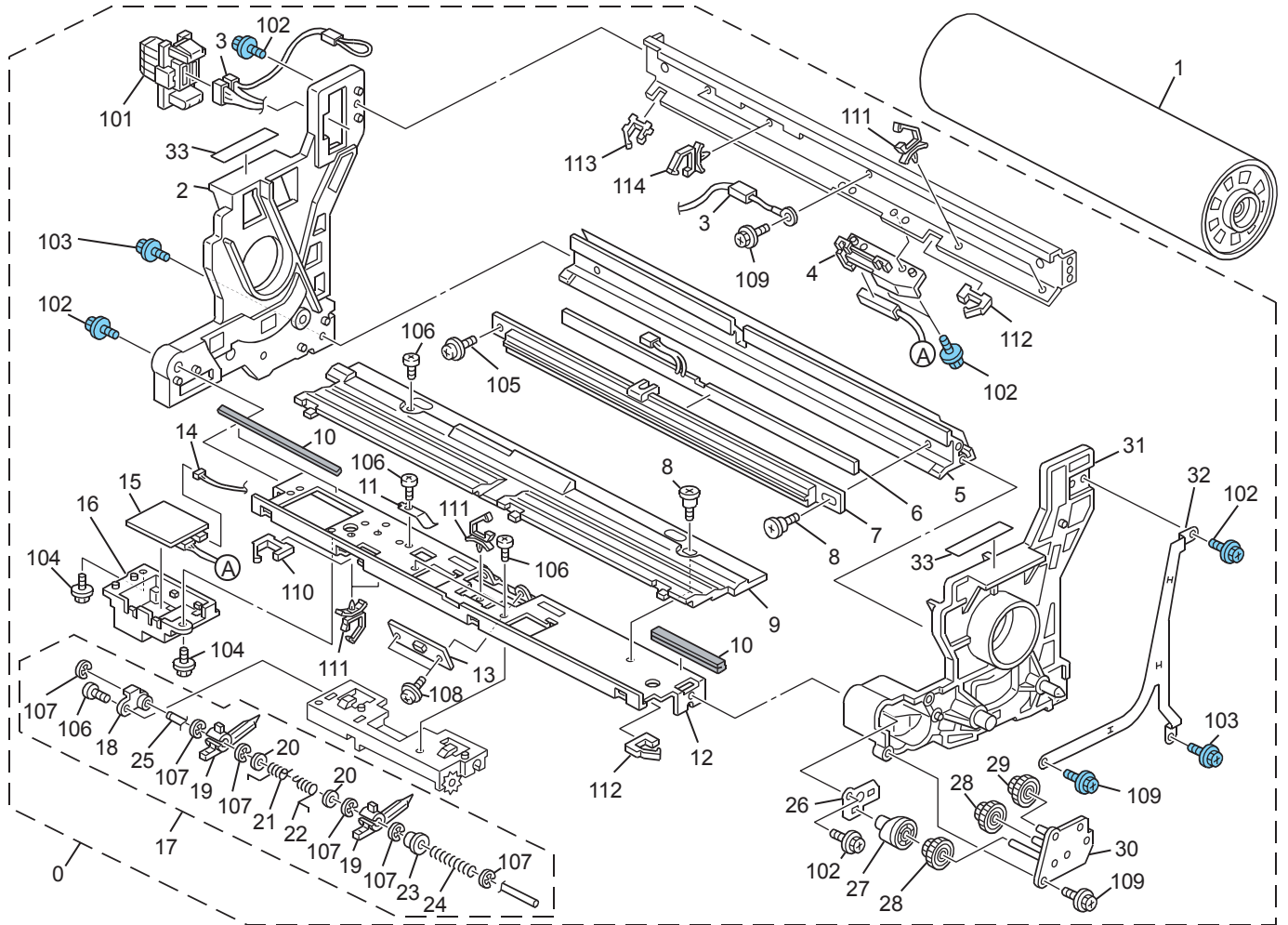

ITEM NO.	PARTS NO.	PARTS NAME	Q'TY / PAGE	Q'TY / PACK	P I R	B S I NO.	T O	T	F R O M	S E R I A L NO.	R E M A R K S	C
0	B2342309	Drum Unit	1									
1	B2349510	OPC Drum	1									
2	B2342310	Side Plate - Rear	1									
3	B2345665	Harness - Drum Uni	1									
4	B2342263	Electric Potential Sensor	1									
5	B2342273	Stay - Pre-transfer Lamp	1									
6	B2342270	LED Array	1									
7	B1402382	Pre-transfer Lamp Case As	1									
8	52062684	Shoulder Screw - M3	2									
9	B2342293	Cover - Pickoff Pawl Stay	1									
10	B0703657	Magnetic:Cleaning	1									
11	B2342278	Ground Plate	1									
12	B2342276	Pickoff Pawl Stay	1									
13	B2342279	Density Sensor P	1									
14	B2345666	Harness - Sensor	1									
15	B2342264	Electric Potential Sensor	1									
16	B2342291	Electric Potential Sensor	1									
17	B2342281	Pickoff Pawl Unit	1									
18	B2342287	Bushing - Rear	1									
19	AD025022	Pick-off Pawl	2									
20	A3522138	Slide Collar - 0.6x4.5x6	2									
21	B2342289	Pawl Spring - Rear	1									
22	B2342288	Pawl Spring - Front	1									
23	53241658	Bushing- 4x8x4.5mm	1									
24	B2342282	Spring:Pickoff Pawl:Swive	1									
25	B2342284	Shaft	1									
26	B2342382	Ground Plate - Pickoff Pa	1									
27	B2342303	Gear - 32Z	1									
28	B2342302	Gear - 14Z/32Z	2									
29	B2342301	Gear - 17Z/18Z	1									
30	B2342296	Bracket	1									
31	B2342305	Side Plate - Front	1									
32	B2342381	Ground Plate - Front	1									
33	B2342311	Decal:Grip:Drum	2									
101	11029782	Connector:51405-1819										
102	0454008Q	Tapping Screw:3x8										
103	0454006Q	Tapping Screw - M3x6										
104	0451006N	Tapping Screw - 3x6										
105	0951008N	Screw:Polished Round:M5X8										
106	0353060N	Bind Screw - M3x6										
107	0720030E	Retaining Ring - M3										
108	0951005N	Screw:Polished Round:M3x5										
109	0450008N	Tapping Screw - M4x8										
110	11050518	Edge Saddle - Les-1010										
111	11050511	Harness Clamp - LWS-0306Z										
112	11050522	Edge Saddle - Les0510										
113	11050551	Clamp:LES-0505										
114	11050534	Clamp										

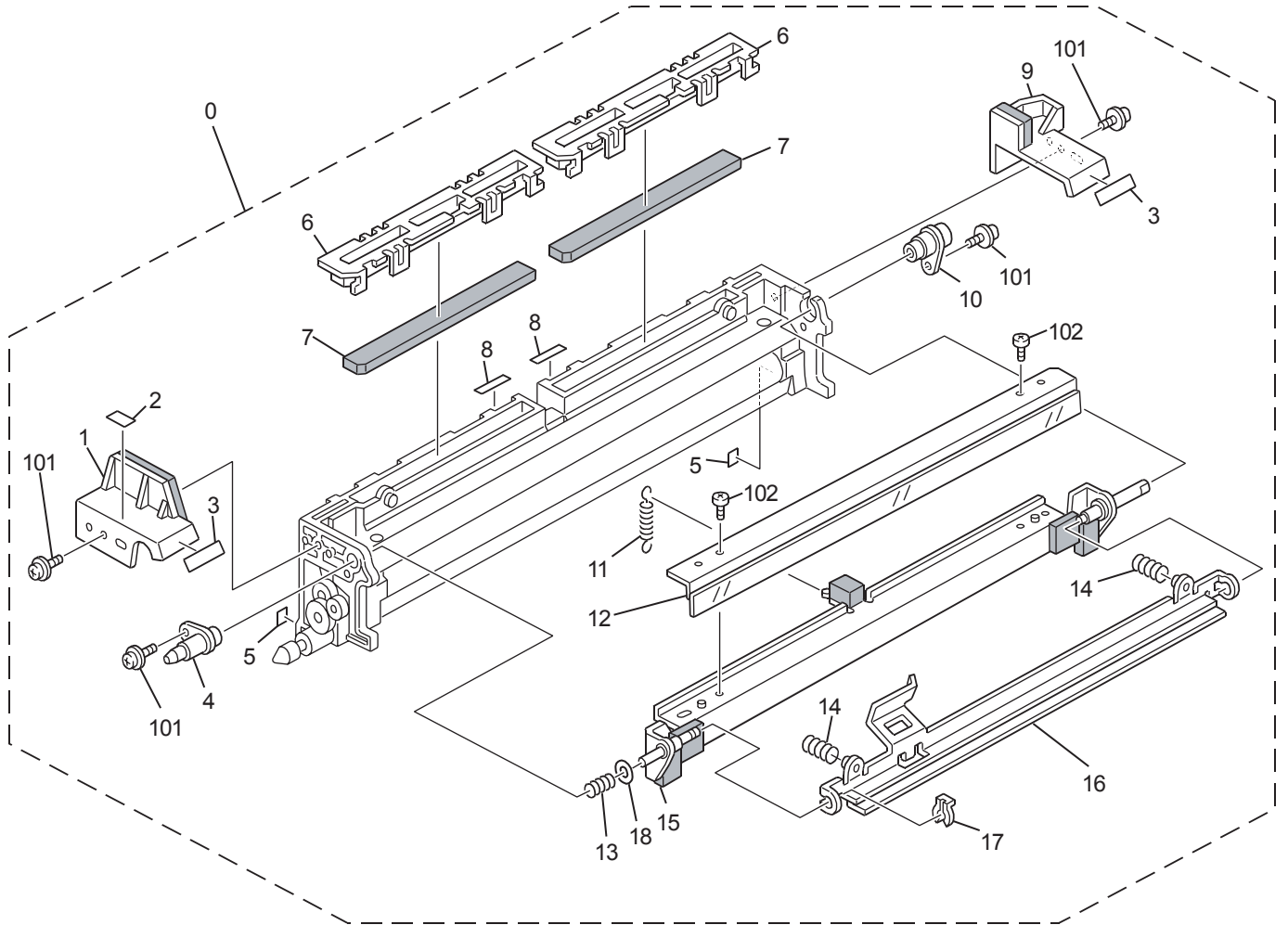

ITEM NO.	PARTS NO.	PARTS NAME	Q'TY / PAGE	Q'TY / PACK	P	I	R	B S I NO.	T O	T	F R O M	S E R I A L NO.	R E M A R K S	C
0	B2343502	Cleaning Unit	1											
1	B2343641	Case:Cleaning:Front:Ass'y	1											
2	B2343654	Decal:Positioning Display	1											
3	B2343655	Decal:Positioning Display	2											
4	B2343562	Bushing - Front	1											
5	B2343592	Decal:Positioning Display	2											
6	B2343636	Case - Upper	2											
7	B2343637	Filter - Cleaning	2											
8	B2343644	Decal:Case:Middle:Cleanin	2											
9	B2343646	Case:Cleaning:Inner Back:	1											
10	B2343556	Bushing - Rear	1											
11	B2343561	Spring	1											
12	B2343564	Cleaning Blade	1											
13	B2343579	Spring - 16mm	1											
14	B2343585	Compression Spring	2											
15	B2343567	Cleaning Blade Bracket	1											
16	B2343586	Cleaning Blade:No.2:Ass'y	1											
17	G0652681	Snap Ring - M6	1											
18	AA132080	Spacer - Cleaning Brush	1											
101	0951006N	Screw - M3X6												
102	0314040N	Pan Head Screw - M4x4												

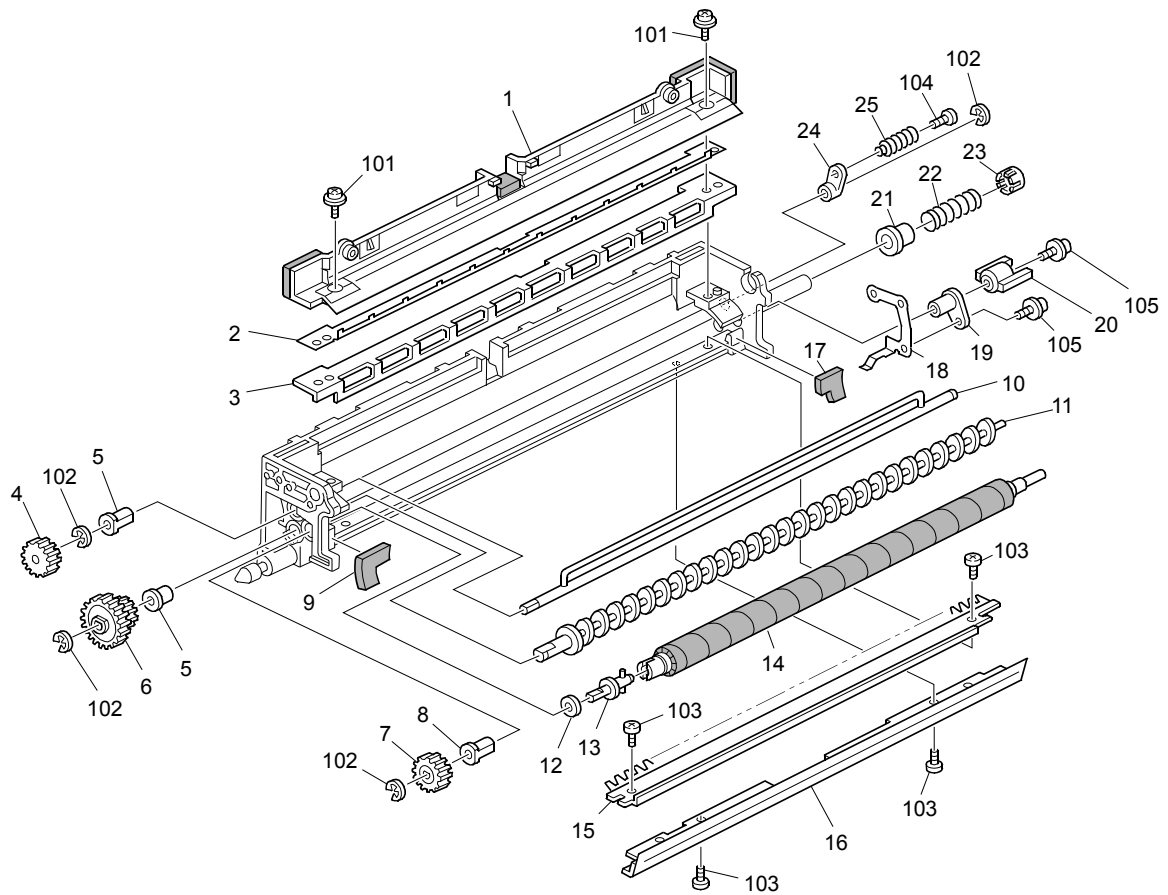

ITEM NO.	PARTS NO.	PARTS NAME	Q'TY / PAGE	Q'TY / PACK	P	I	R	B S I NO.	T O	T	F R O M	S E R I A L NO.	R E M A R K S	C
1	B2343627	Case:Middle:Cleaning:Ass'	1											
2	B2343638	Spring Plate:Brush Roller	1											
3	B2343639	Holder:Spring Plate:Brush	1											
4	B2343601	Gear - 15Z	1											
5	AA082095	Bushing - Toner Collectio	2											
6	B2343602	Gear - 15Z/43Z	1											
7	B2343666	Gear - 23Z	1											
8	AA082094	Bushing - Brush Roller	1											
9	B2343658	Drum Seal - Front	1											
10	B2343603	Agitator	1											
11	B2343607	Toner Collection Coil	1											
12	AA132024	Spacer - M6	1											
13	A0963586	Cleaning Brush Drive Shaf	1											
14	B2343590	Cleaningbrush Roller	1											
15	B2343615	Vibrating Plate	1											
16	B2343656	Entrance Seal:Cleaning:As	1											
17	B2343659	Seal:Drum:Rear	1											
18	B2343606	Ground Plate - Brush Roll	1											
19	AA082045	Cleaning Brush Bushing	1											
20	B2343763	Joint	1											
21	B2343651	Toner Catchpan	1											
22	B2343653	Spring	1											
23	B2343652	Cap	1											
24	AA082059	Agitator Bushing	1											
25	B1323634	Compression Spring - Eart	1											
101	0951008N	Screw:Polished Round:M5X8												
102	0720040E	Retaining Ring - M4												
103	0452008N	Tapping Screw:M4x8												
104	0452010N	Binding Self-tapping Scre												
105	0951006N	Screw - M3X6												

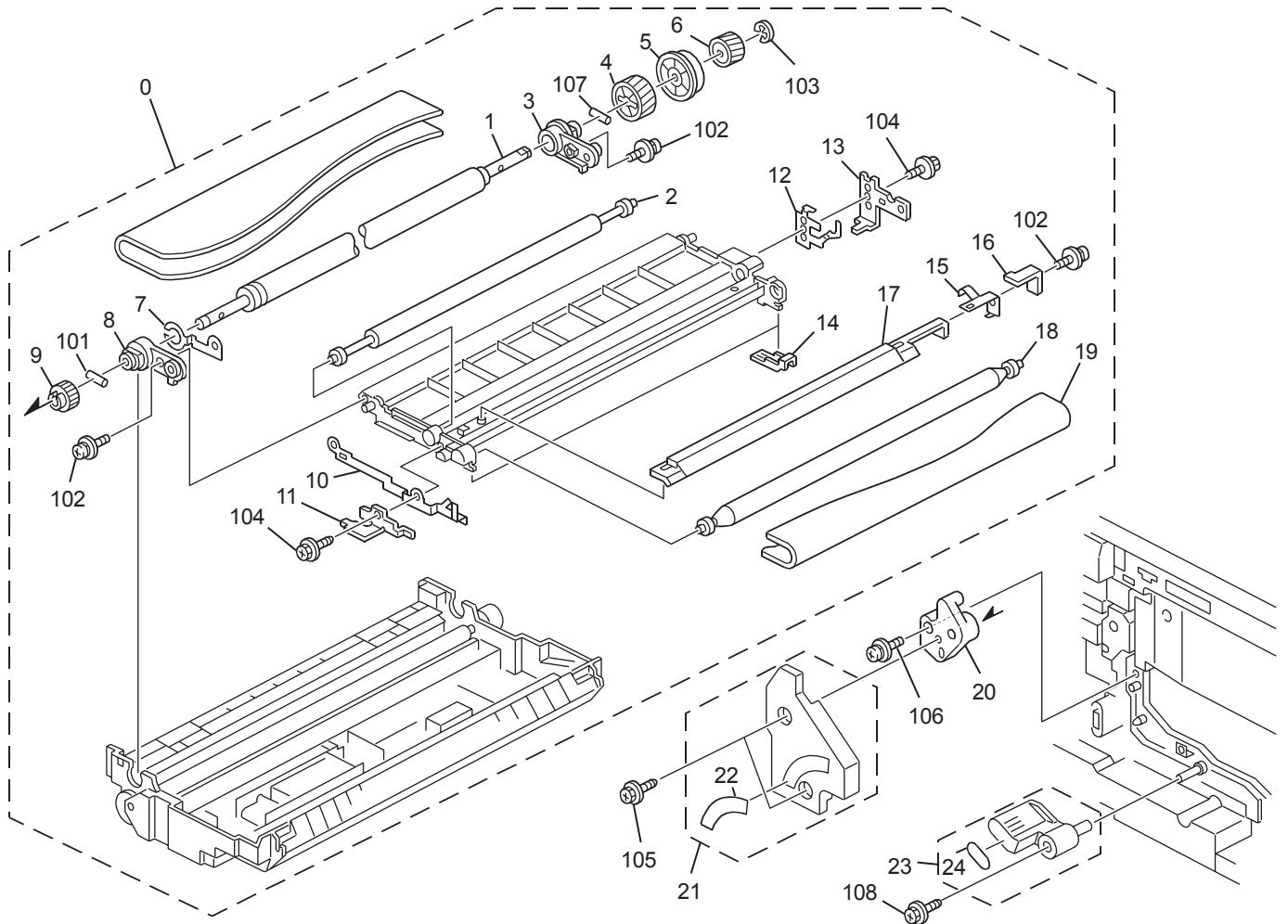

ITEM NO.	PARTS NO.	PARTS NAME	Q'TY / PAGE	Q'TY / PACK	P	I	R	BSI NO.	TO	T	FROM	SERIAL NO.	REMARKS	C
0	B2343900	Transfer Unit	1											
1	B2343956	Roller - Drive	1											
2	B2343960	Roller: Bias	1											
3	A2293862	Rear Arm	1											
4	B2343962	Gear - 50Z	1											
5	A2943869	Rear Positioning Plate	1											
6	A2933871	Gear - 20Z	1											
7	A2293875	Drive Electrode	1											
8	A2293861	Front Arm	1											
9	B0653873	Toner Collection Gear	1											
10	B0653874	Electrode Plate	1											
11	B0653875	Terminal	1											
12	B2473980	Electrode: Bias	1											
13	B2343966	Bias Terminal	1											
14	B0653868	Pressure Arm	1											
15	B2343967	Bias Electrode	1											
16	B2343981	Cover - Electrode Plate	1											
17	B2343975	Transfer Belt Brush	1											
18	B2343951	Roller - Driven	1											
19	B2343971	Transfer Belt	1											
20	B2343860	Guide Plate	1											
21	B2343890	Inner Cover - Transfer	1											
22	B2343892	Decal - Lever Release Tra	1											
23	B0653832	Transfer Unit Lever	1											
24	B0653833	Decal - Transfer Unit Lev	1											
101	0623120E	Spring Pin - M3x12												
102	0951008N	Screw: Polished Round: M5X8												
103	0720060E	Retaining Ring - M6												
104	0450008N	Tapping Screw - M4x8												
105	0451008N	Tapping Screw: 4x8												
106	0951014N	Screw: Polished Round: M4x1												
107	0633180G	Parallel Pin - 3x18mm												
108	0360008N	Screw: M3x8												

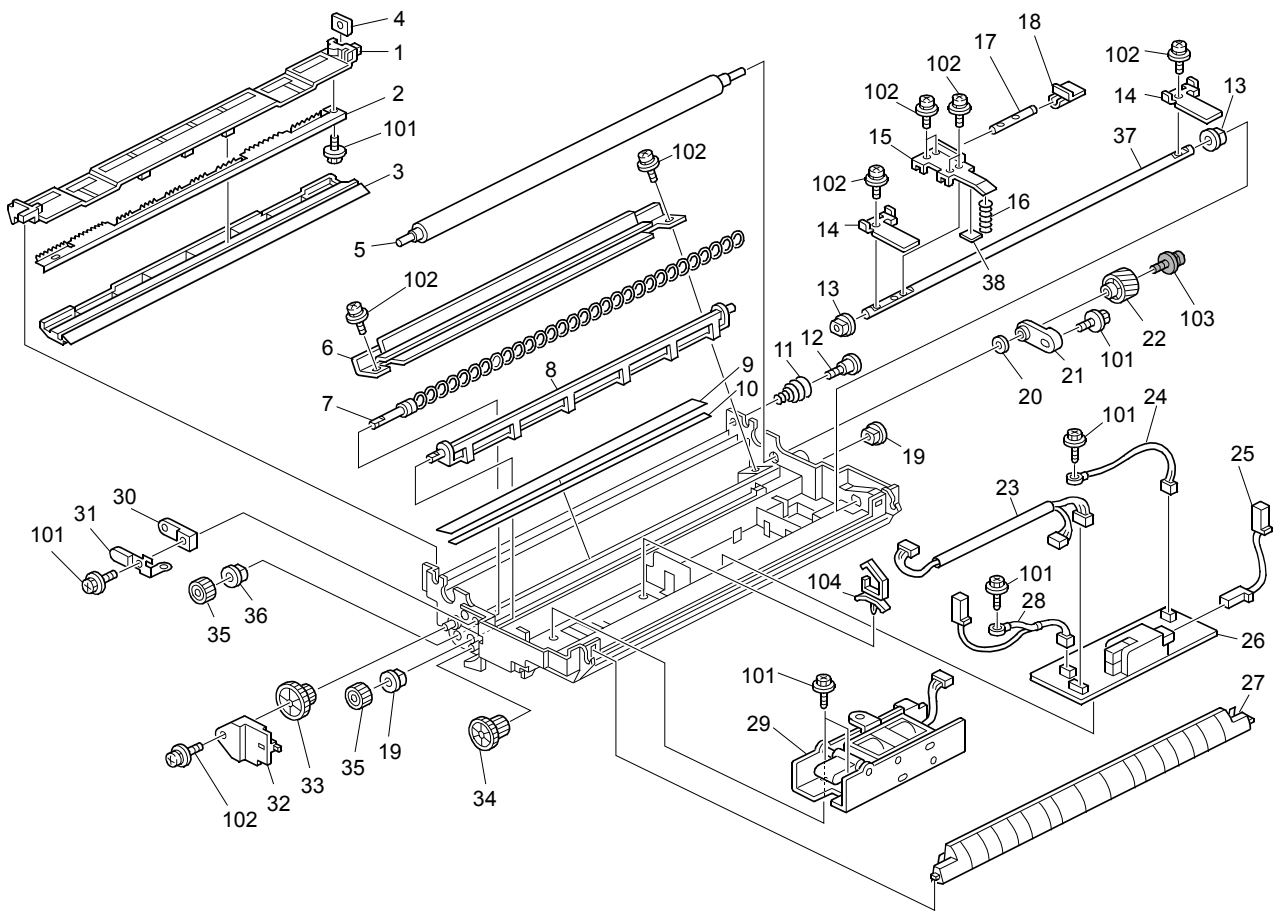

ITEM NO.	PARTS NO.	PARTS NAME	Q'TY / PAGE	Q'TY / PACK	P I R	B S I NO.	T O	T	F R O M	S E R I A L NO.	R E M A R K S	C
1	B2343933	Guide Plate - Exit	1									
2	B2343939	Electrode Plate - Transfe	1									
3	B2343935	Entrance Seal Holder	1									
4	B2343940	Earth Bracket	1									
5	B2343922	Cleaning Roller	1									
6	B2343916	Transfer Belt Cleaning Bl	1									
7	B2343911	Toner Collection Coil	1									
8	B2343913	Agitator	7									
9	B2343907	Seal	1									
10	B2343908	Tape	1									
11	B2343947	Spring	1									
12	H0531150	Stepped Screw - Locking	1									
13	B2343949	Bushing	2									
14	B2343946	Spring Plate	2									
15	B0653963	Lever	1									
16	AA063877	Spring	1									
17	B2473965	Lever Shaft	1									
18	B0653964	Bushing	1									
19	AA082101	Bushing - 6X10X6	2									
20	AA132024	Spacer - M6	1									
21	B2343926	Bushing - Rear	1									
22	B2343924	Gear - 37Z	1									
23	B2345691	Harness - Transfer Belt U	1									
24	B2345621	High Voltage Supply Cord	1									
25	B2345620	High Voltage Supply Cord	1									
26	AZ320156	Power Pack	1									
27	B2343941	Guide Plate - Entrance	1									
28	B2345622	Ground Wire	1									
29	B2343944	DC Solenoid	1									
30	B2343925	Bushing - Front	1									
31	B2343927	Bias Terminal	1									
32	B0653922	Electrode Plate Cover	1									
33	B0653920	Idle Gear - 1	1									
34	B0653921	Idle Gear - 2	1									
35	B0653918	Toner Collection Gear Coi	1									
36	AA082058	Bushing - 6x10x9mm	1									
37	B2343943	On-off Shaft	1									
38	B2343932	Cushion:On-off:Transfer B	1									
101	0450008N	Tapping Screw - M4x8										
102	0951006N	Screw - M3X6										
103	0951004P	Screw:Polished Round:M3x4										
104	11050601	Clamp:LWSM-0511-2M										
105	0951006N	Screw - M3X6										

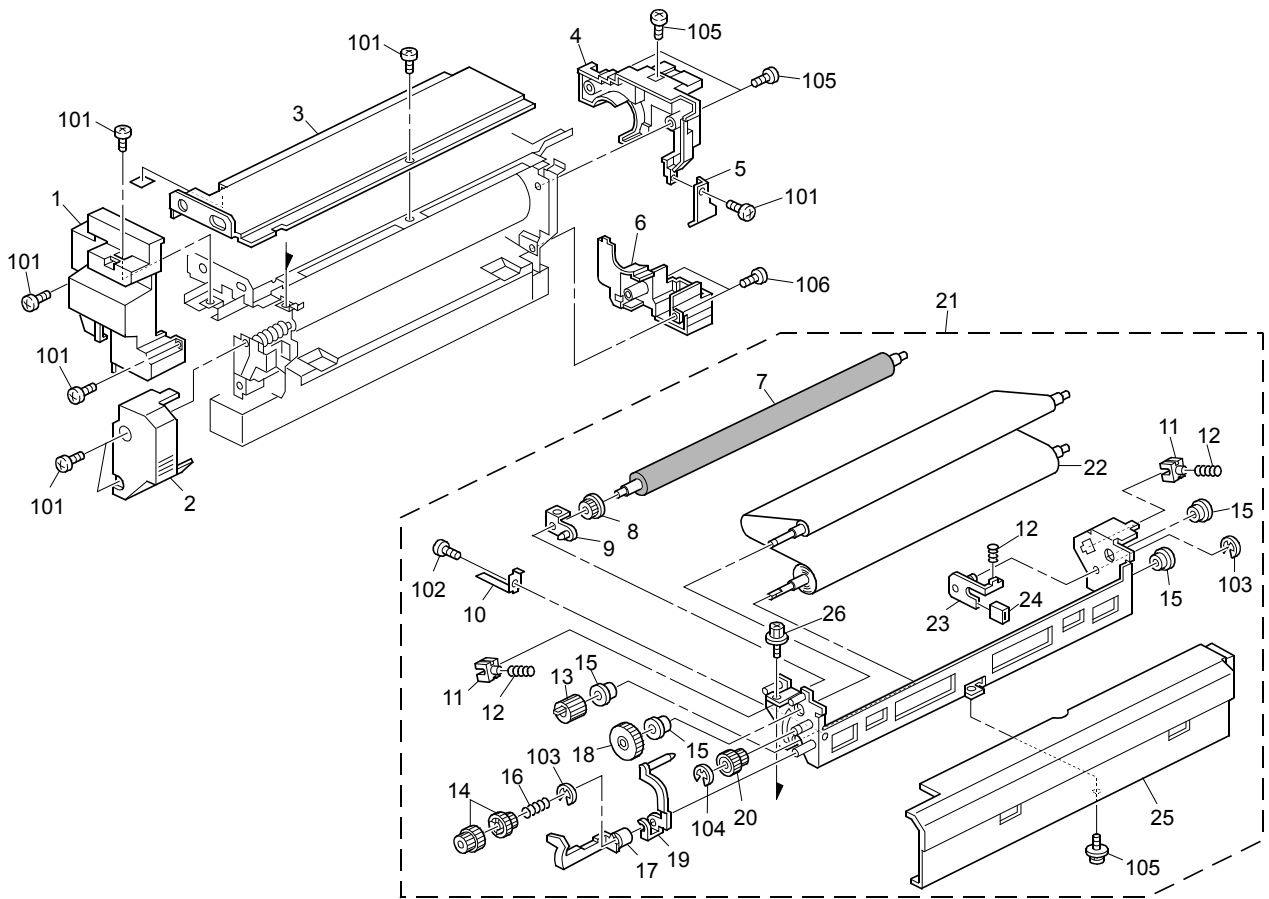

ITEM NO.	PARTS NO.	PARTS NAME	Q'TY / PAGE	Q'TY / PACK	P	I	R	BSI NO.	TO	T	FROM	SERIAL NO.	REMARKS	C
0A	B2344012	Fusing Unit (208V)(B234/B	1										e-STUDIO90	
0B	B2364012	Fusing Unit (208V)(B236)	1										1/1101	
1	B2344056	Inner Cover - Front Upper	1										e-STUDIO13	
2	B2344062	Inner Cover - Right Upper	1										51	
3A	B2344152	Cover:Fusing:Upper:Typeab	1										e-STUDIO90	
3B	B2344249	Cover:Fusing:Upper:Typec	1										1/1101	
4	B2344059	Cover - Rear Upper	1										e-STUDIO13	
5	B2344065	Cover - Rear Upper No.2	1										51	
6	B2344064	Cover - Rear Lower	1											
7	AE040067	Roller - Cleaning Felt	1											
8	A2944116	Plate Ratchet	1											
9	B2344109	Bracket:Stopper:Ass'y	1											
10	A2944433	Web Spring Plate	1											
11	AE031026	Bushing - Oil Supply Roll	2											
12	AA063652	Spring-oil Supply Roller	3											
13	A2944156	Gear - 23Z	1											
14	A2944158	Coupled Gear - 25z/32z	2											
15	AE031032	Bushing - 6x9x6.5	4											
16	AA063851	Pressure Spring	1											
17	A2944434	Web End Feeler	1											
18	B2344244	Gear - 50Z	1											
19	B2344112	Feeler - Cleaning Felt	1											
20	A2944171	Coupled Gear - 17z/32z	1											
21	B2344111	Web Unit	1											
22	AE045054	Web Roller	1											
23	A2944412	Web Brake Pad Bracket	1											
24	B0704418	Web Brake Pad	1											
25	B2344115	Fusing Entrance Guide Pla	1											
26	B2342390	Flanged Hexagonal Head Bo	1											
101	0354060N	Screw-m4x6												
102	0354040N	Screw-m4x4												
103	0720040E	Retaining Ring - M4												
104	0720030E	Retaining Ring - M3												
105	0954008N	Screw - M3X8												
106	0450008N	Tapping Screw - M4x8												

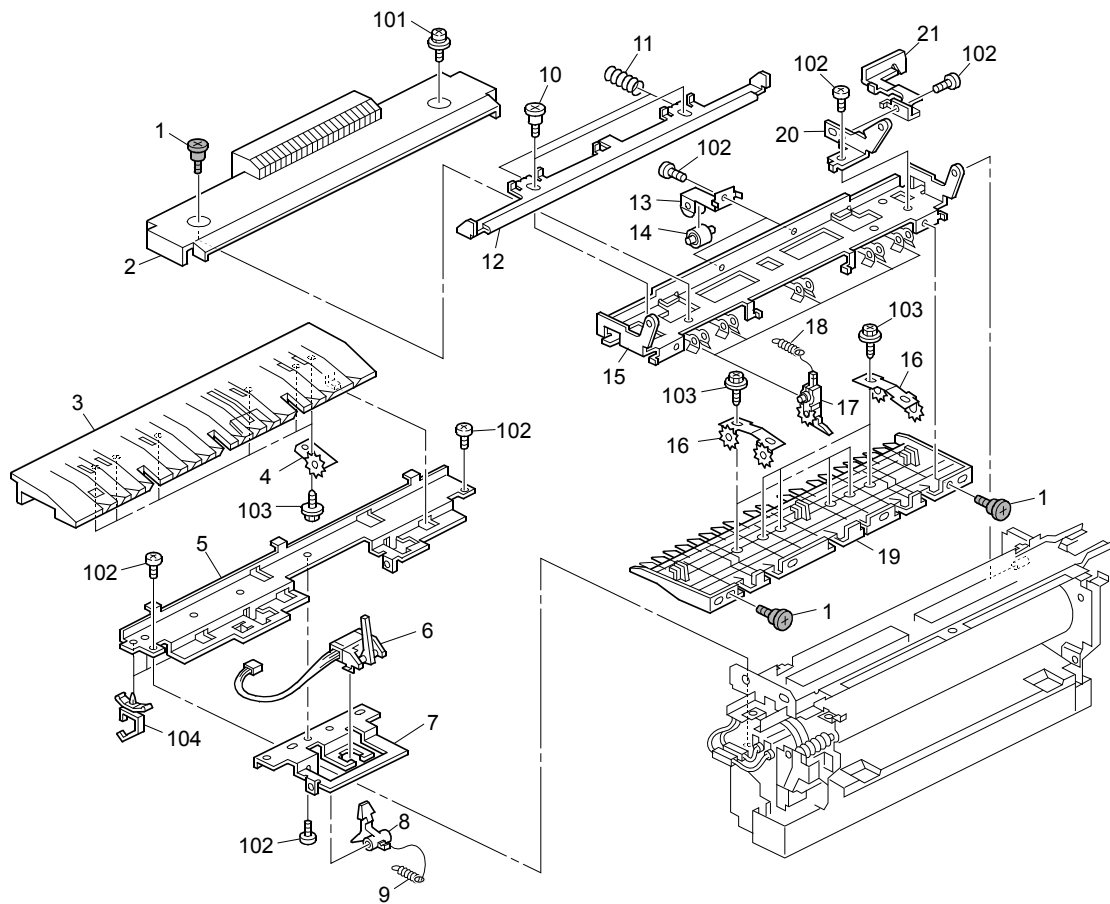

ITEM NO.	PARTS NO.	PARTS NAME	Q'TY / PAGE	Q'TY / PACK	P	I	R	BSI NO.	TO	T	FROM	SERIAL NO.	REMARKS	C
1	AA143810	Development Cover Screw	3											
2	B2344160	Cover - Left Upper	1											
3	B2344204	Guide Plate - Lower	1											
4	B0704084	Holder:Ring:Lower:Ass'y	6											
5	B2344207	Fusing Exit Bracket - Low	1											
6	AW200009	Paper Feed Sensor:Fusing	1											
7	B2344205	Bracket	1											
8	AE044042	Pressure Roller Stripper	1											
9	AA062350	Tension Spring:Pickoff Pa	1											
10	AA143852	Screw	2											
11	AA063853	Pressure Spring	2											
12	B2344199	Pickoff Pawl Release Slid	1											
13	A2944164	Roller Spring Plate	2											
14	AF040561	Fusing Exit Roller - Uppe	2											
15	B2344165	Bracket - Upper	1											
16	B0704475	Holder:Ring:Fusing Exit:A	6											
17	AE044044	Stripper Pawls:Ring:Ass'y	5											
18	AA060539	Stripper Pawl Spring	5											
19	B2344163	Guide Plate - Upper	1											
20	B2344167	Supporting Plate - Upper	1											
21	B2344170	Stopper - Upper	1											
101	0954008N	Screw - M3X8												
102	0353060N	Bind Screw - M3x6												
103	0450006N	Tapping Screw:4x6												
104	11050511	Harness Clamp - LWS-0306Z												

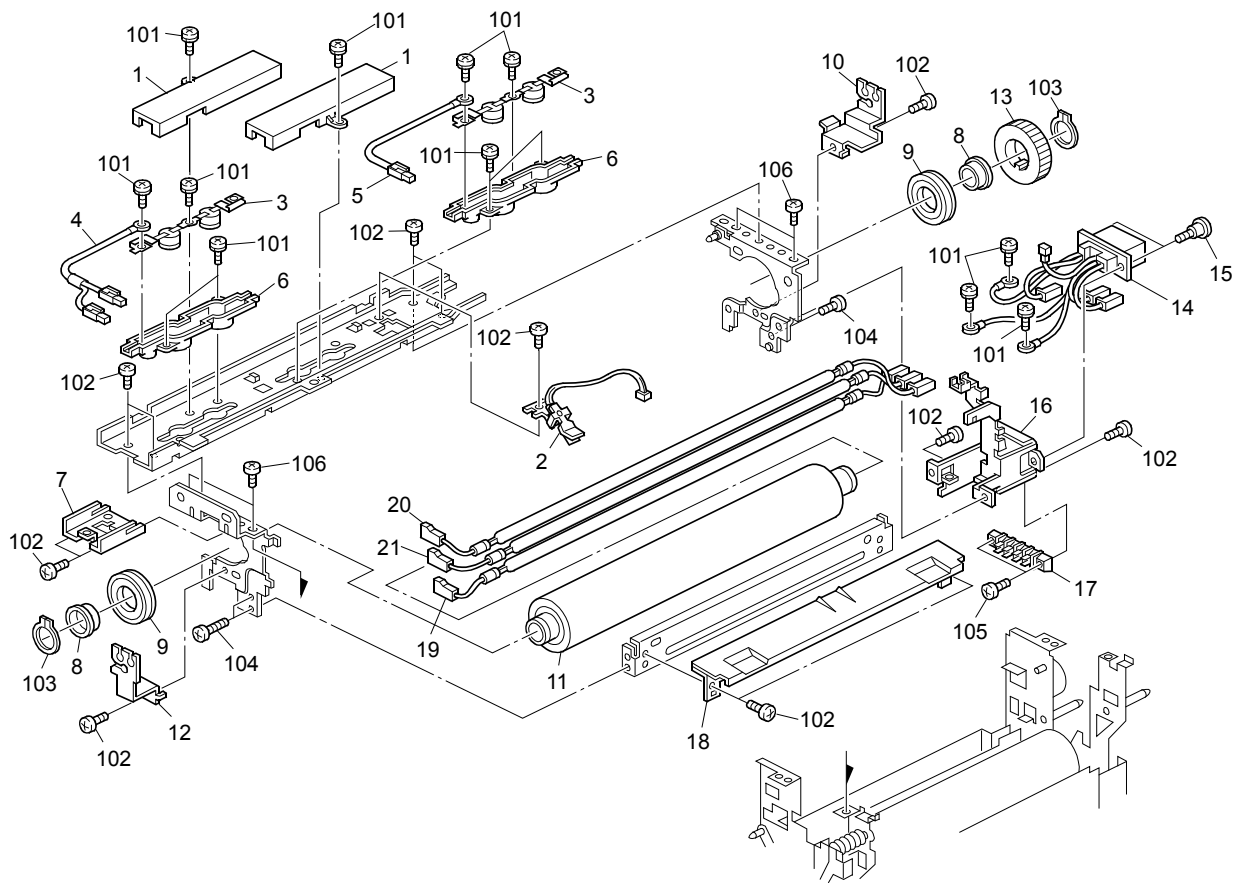

ITEM NO.	PARTS NO.	PARTS NAME	Q'TY / PAGE	Q'TY / PACK	P	I	R	B S I NO.	T O	T	F R O M	S E R I A L NO.	R E M A R K S	C
1	B0704091	Housing:Thermostat:Upper	2											
2	B2344131	Thermistor:Fusing:Ass'y	1											
3	B2344090	Thermostat:198/199c:No.1	2											
4	B2344149	Harness - Thermostat Fron	1											
5	B2344150	Harness - Thermostat Fron	1											
6	B2344241	Housing:Thermostat:Lower	2											
7	B2344182	Grip - Front	1											
8	AE032021	Bushing - 34.3x39.9x15.5	2											
9	AE030031	Ball Bearing - 40x62x12	2											
10	A2944057	Rear Heater Holder	1											
11A	AE011108	Hot Roller (B234/B235)	1										e-STUDIO90 1/1101	
11B	AE011110	Hot Roller - Dia80 C (B23	1										e-STUDIO13 51	
12	A2944056	Front Heater Holder	1											
13	A2944061	Gear - 67Z	1											
14A	B2345611	Harness - Fusing Unit Upp	1										e-STUDIO90 1/1101	
14B	B2365611	Harness - Fusing Unit Upp	1										e-STUDIO13 51	
15	B2135843	Screw:Inner Cover:Joint U	2											
16	B2344192	Harness Bracket - Upper	1											
17	A2474249	Connector - 3P	1											
18	B2344237	Fusing Entrance Guide Pla	1											
19	AX440240	Heater - 208V/900V	1											
20	AX440242	Heater - 208V/900W	1											
21A	AX440241	Heater - 208V/600W (B234/	1										e-STUDIO90 1/1101	
21B	AX440243	Heater - 208V/600W (B236)	1										e-STUDIO13 51	
101	0950006N	Screw - M4X6												
102	0354060N	Screw-m4x6												
103	08050098	Ring - M35												
104	0354100N	Screw - M4X10												
105	0314120N	Screw - M4X12												
106	0315080N	Pan Head Screw:M5x8												

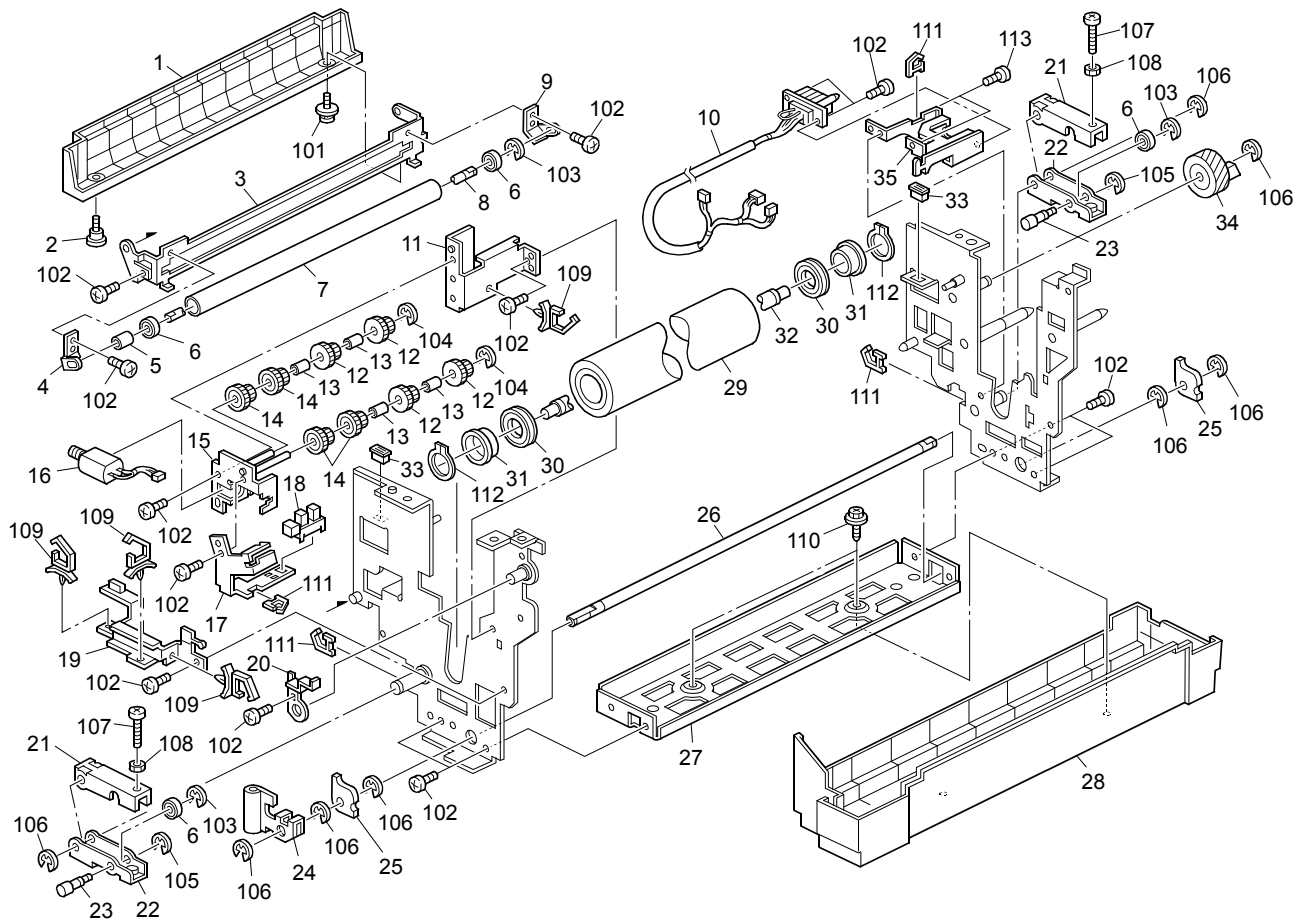

ITEM NO.	PARTS NO.	PARTS NAME	Q'TY / PAGE	Q'TY / PACK	P I R	B S I NO.	T O	T	F R O M	S E R I A L NO.	R E M A R K S	C
1	B2344076	Cover:Cleaning Unit:Press	1									
2	AA143810	Development Cover Screw	1									
3	B2344083	Pressure Roller Bracket	1									
4	A2944077	Left Holder	1									
5	AA132209	Spacer - 8x10x13.5	1									
6	AE030035	Ball Bearing - 6x16x5	4									
7	AE042090	Cleaning Roller	1									
8	B2344075	Cleaning Roller Shaft	1									
9	A2944078	Right Holder	1									
10	B2345686	Harness - Fusing Unit Low	1									
11	B2344235	Cleaning Drive Bracket -	1									
12	AB014229	Coupledgear - 17z/32z	4									
13	AE031037	Bushing - M4	4									
14	A2944171	Coupled Gear - 17z/32z	4									
15	B2344230	Cleaning Drive Bracket	1									
16	AX040147	DC Motor:Cleaner	1									
17	B2344234	Photointerruptor Bracket	1									
18	AW020160	Paper Feed Sensor	1									
19	B2344189	Pressure Roller Bracket -	1									
20	B2344247	Fusing Cleaning Bracket -	1									
21	A2944103	Upper Pressure Lever	2									
22	A2944107	Lower Pressure Lever	2									
23	B2344106	Shaft:Pressure	2									
24	B2344185	Guide Plate - Lever	1									
25	A0794097	Pressure Cam	2									
26	B2344186	Pressure Roller Shaft	1									
27	B2344228	Stay - Lower	1									
28	B2344233	Cover - Lower	1									
29	AE020159	Pressure Roller - Dia80	1									
30	AE030031	Ball Bearing - 40x62x12	2									
31	AE032029	Thermal Insulating Bushin	2									
32	B2344135	Pressure Roller Shaft	1									
33	AA021031	Magnetic Catch	2									
34	AB013587	Gear - 41Z	1									
35	B2344196	Harness Bracket	1									
101	0954008N	Screw - M3X8										
102	0354060N	Screw-m4x6										
103	0720060E	Retaining Ring - M6										
104	0720030E	Retaining Ring - M3										
105	0720040E	Retaining Ring - M4										
106	0720080E	Retaining Ring - M8										
107	0585351N	Hexagonal Head Bolt:M5x35										
108	0710050N	Hexagonal Nut:M5										
109	11050511	Harness Clamp - LWS-0306Z										
110	0450008N	Tapping Screw - M4x8										
111	11050522	Edge Saddle - Les0510										
112	0725200E	Retaining Ring C - M20										
113	0353080N	Screw:M3x8										

ITEM NO.	PARTS NO.	PARTS NAME	Q'TY / PAGE	Q'TY / PACK	P I R	B S I NO.	T O	T	F R O M	S E R I A L NO.	R E M A R K S	C
1	B2344251	Cooling Transport Belt	4									
2	B2344499	Transport Roller - Coolin	1									
3	B2344252	Transport Roller - Heat P	1									
4	B2344254	Transport Roller Shaft	1									
5	B2344498	Transport Roller - Coolin	4									
6	B2344284	Inner Cover	1									
7	AA001473	Decal - Paper Exit Unit (1									
8	AA001472	Decal - Paper Exit Unit (1									
9	AG050103	Knob - Fusing/Paper Exit	1									
10	B2344460	Discharge Brush - L=341 S	1									
11	B3522650	Magnet Catch - 5n	1									
12	B2344138	Decal - Warning (high Tem	1									
13	AA120097	Antistatic Brush	1									
14	B2344438	Heat Sink Bracket	1									
15	H0722216	Compression Spring	2									
16	B0704294	Cap - Heat Pipe	2									
17	AA143444	Stepped Screw	2									
18	B2344137	Decal:Warning:High Temper	1									
19	AA043326	Timing Belt - B60S3M474	1									
20	AB030804	Pulley - 30T	1									
21	BB013015	Gear - 28Z	1									
22	BB013014	Gear - 43Z	1									
23	B2344139	Decal:Positioning Display	1									
24	AB030805	Pulley:Coupling:30T	1									
101	0720060E	Retaining Ring - M6										
102	0454008Q	Tapping Screw:3x8										
103	07423808	Ball Bearing - 8x16x5										
104	0720080E	Retaining Ring - M8										
105	0353060N	Bind Screw - M3x6										
106	0451006N	Tapping Screw - 3x6										
107	0951008N	Screw:Polished Round:M5X8										
108	0453006N	Tapping Screw - M3x6										

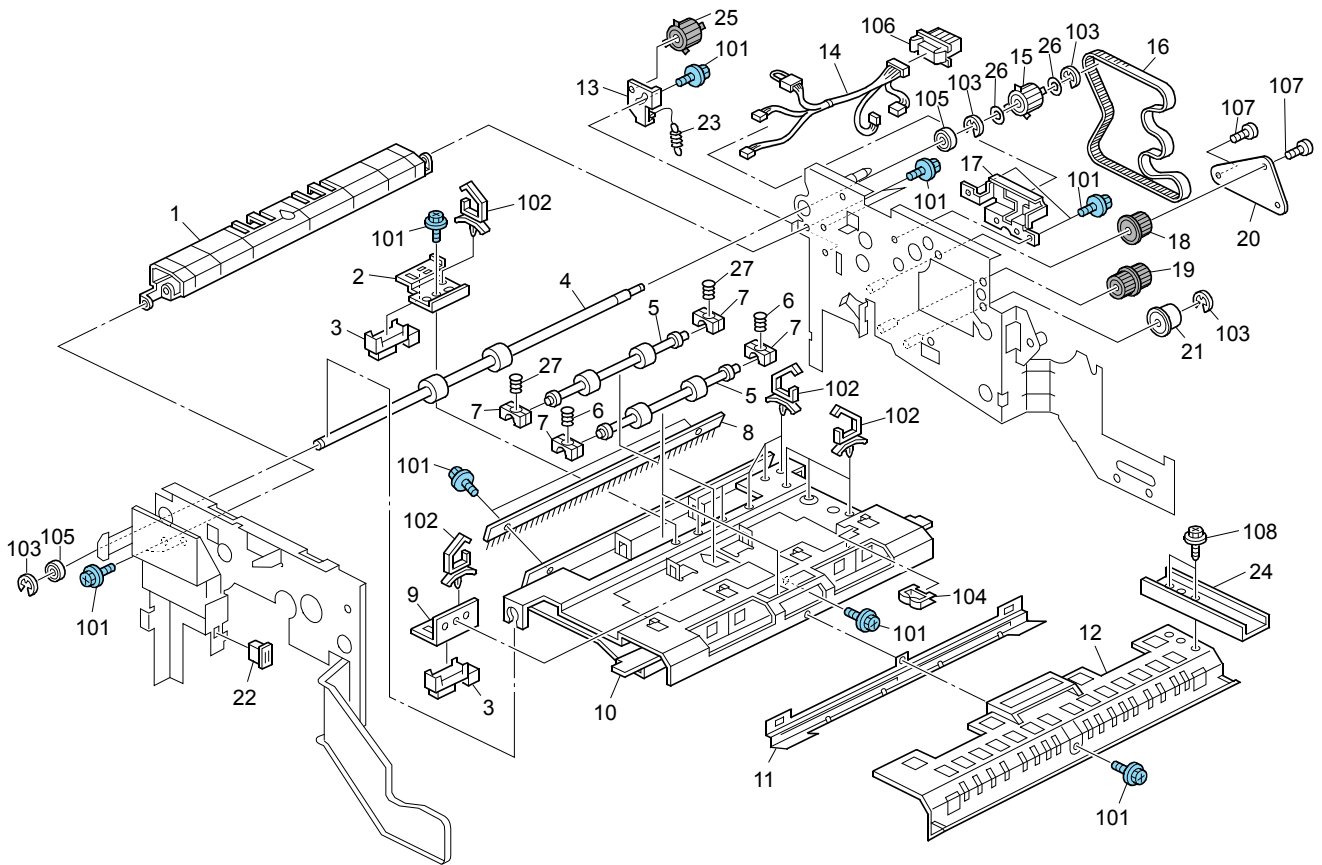

ITEM NO.	PARTS NO.	PARTS NAME	Q'TY / PAGE	Q'TY / PACK	P	I	R	B S I NO.	T O	T	F R O M	S E R I A L NO.	R E M A R K S	C
1	B2344464	Exit Guide Plate - Lower	1											
2	B2344469	Paper Feed Sensor Bracket	1											
3	AW010107	Paper Feed Sensor	2											
4	AF040622	Exit Roller - Exit	1											
5	AF022167	Transport Roller - Driven	3											
6	AA063676	Spring:Pressure:2n	4											
7	AA084059	Ball Bearing Holder	6											
8	B2344460	Discharge Brush - L=341 S	1											
9	B2344470	Photo Refiection Sensor B	1											
10	B2344441	Exit Guide Plate - Upper	1											
11	B2344468	Guide - Auxiliary	1											
12	B2344360	Entrance Cooling Guide -	1											
13	B2344446	Tightener - Left	1											
14	B2345685	Harness - Paper Exit Unit	1											
15	AB030807	Timing Pulley - 20T	1											
16	AA043327	Timing Belt - B60DS3M453	1											
17	B2344415	Connector Bracket	1											
18	AB030806	Pulley - 19T	1											
19	AB033088	Pulley - 20T/20T	1											
20	B2344420	Drum Stay - Drive Unit	1											
21	AB030310	Tightener Pulley	1											
22	B3522650	Magnet Catch - 5n	1											
23	AA060950	Tension Spring	1											
24	B2344445	Bracket - Guide Plate Sto	1											
25	AB030808	Timing Pulley - 20T	1											
26	B4783569	Spacer	2											
27	AA063680	Pressure Spring - 5x10.5	2											
101	0454008Q	Tapping Screw:3x8												
102	11050511	Harness Clamp - LWS-0306Z												
103	0720060E	Retaining Ring - M6												
104	11050328	Harness Clamp - ES-0505												
105	07423808	Ball Bearing - 8x16x5												
106	11029782	Connector:51405-1819												
107	0353060N	Bind Screw - M3x6												
108	0450008N	Tapping Screw - M4x8												

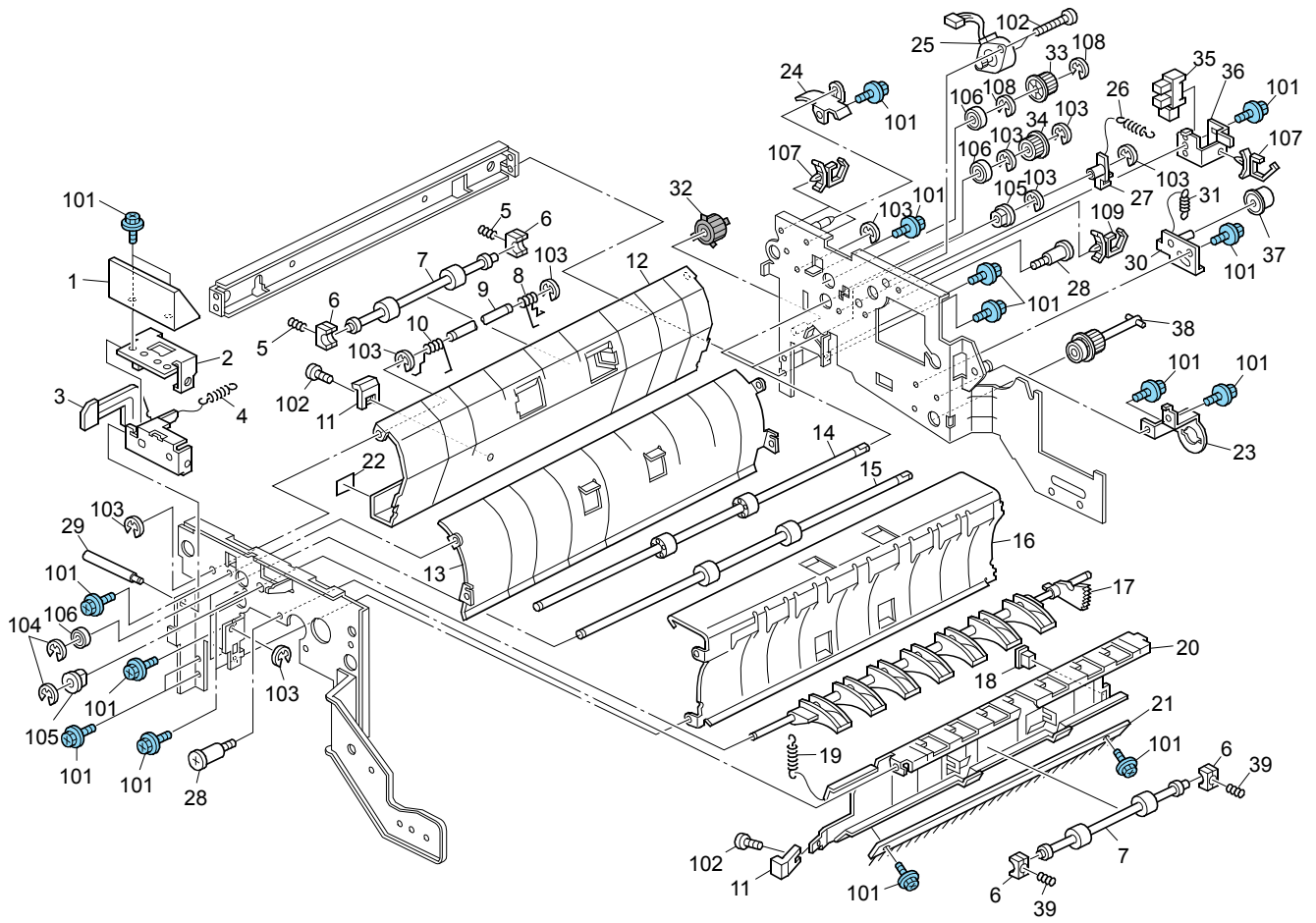

ITEM NO.	PARTS NO.	PARTS NAME	Q'TY / PAGE	Q'TY / PACK	P I R	B S I NO.	T O	T	F R O M	S E R I A L NO.	R E M A R K S	C
1	B2344347	Release Grip	1									
2	B2344423	Lever Bracket	1									
3	B2344349	Lock Lever	1									
4	AA060590	Pressure Spring	1									
5	AA063675	Spring - 5n	4									
6	AA084059	Ball Bearing Holder	4									
7	AF022168	Transport Roller - Driven	2									
8	AA066321	Rear Guide Plate Spring	1									
9	B2344473	Contact Point Shaft	1									
10	AA066322	Front Guide Plate Spring	1									
11	AG051141	Release Lever	1									
12	B2344467	Guide Plate - Exit	1									
13	B2344466	Exit Guide	1									
14	AF040624	Exit Roller - Reverse	1									
15	AF040623	Exit Roller - Horizontal	1									
16	B2344465	Entrance Guide	1									
17	B2344455	Gate Pawl	1									
18	B3522650	Magnet Catch - 5n	1									
19	AA060360	Tension Spring	1									
20	B2344442	Guide Plate - Entrance	1									
21	B2344460	Discharge Brush - L=341 S	1									
22	AA001417	Decal - D6	1									
23	B2344419	Drum Stay - Coupling	1									
24	B2344416	Harness Guard Bracket	1									
25	B2344497	Stepper Motor DC24V 2.6W	1									
26	AA061015	Tension Spring - 5x25	1									
27	B2344454	Feeler	1									
28	AA143862	Screw - M4X5	2									
29	B2344474	Lever Shaft	1									
30	B2344447	Tightener - Right	1									
31	AA060950	Tension Spring	1									
32	AB030808	Timing Pulley - 20T	1									
33	AB030081	Pulley - 20Z	1									
34	AB030807	Timing Pulley - 20T	1									
35	AW020145	Photointerruptor:Flat	1									
36	B2344417	Photointerruptor Bracket	1									
37	AB030310	Tightener Pulley	1									
38	B2344256	Drive Shaft	1									
39	AA063678	Spring - 3.5n	1									
101	0454008Q	Tapping Screw:3x8										
102	0353060N	Bind Screw - M3x6										
103	0720040E	Retaining Ring - M4										
104	0720030E	Retaining Ring - M3										
105	08053384	Bushing - 5mm										
106	07423808	Ball Bearing - 8x16x5										
107	11050511	Harness Clamp - LWS-0306Z										
108	0720060E	Retaining Ring - M6										
109	11050516	Clamp										

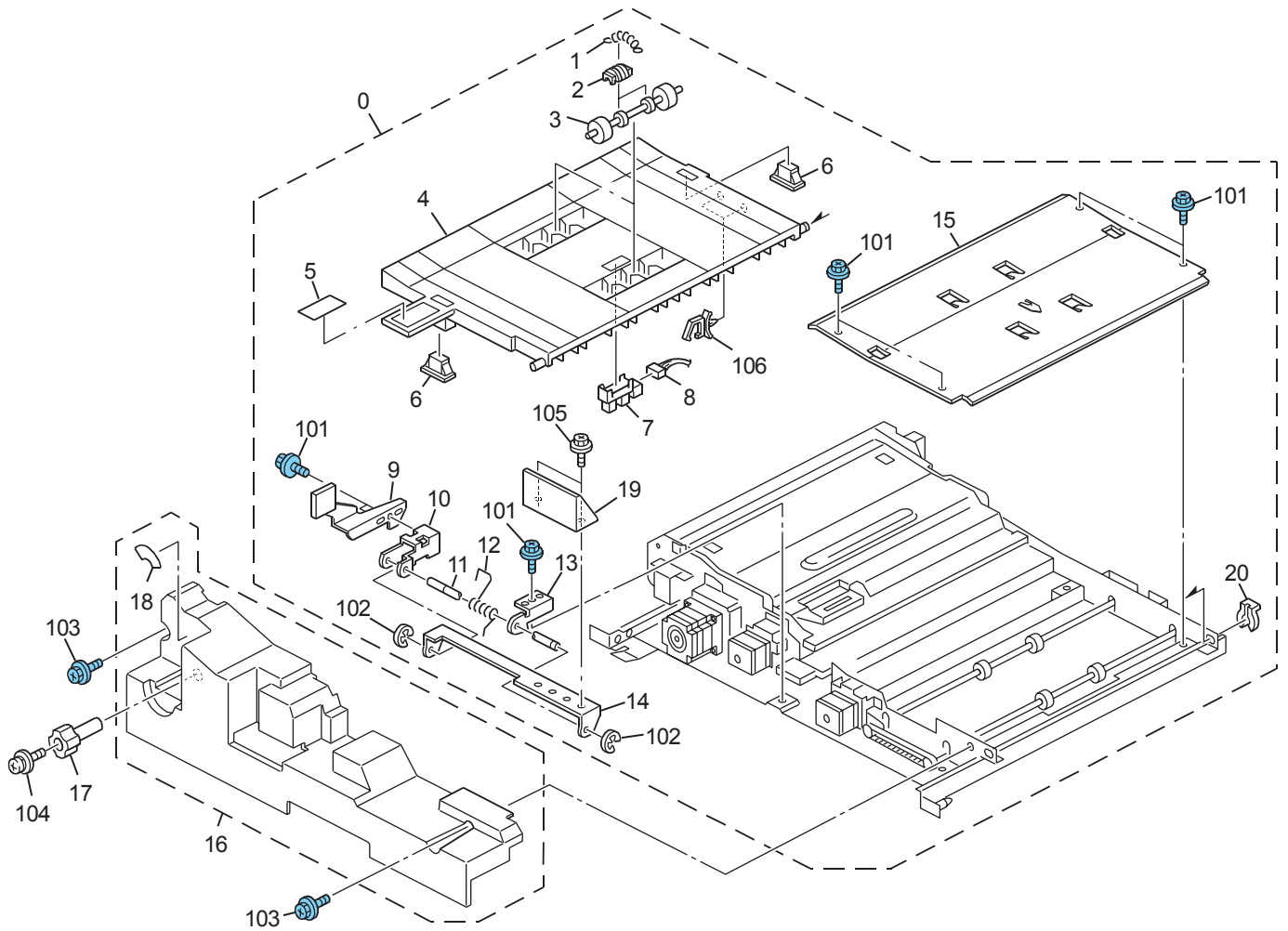

ITEM NO.	PARTS NO.	PARTS NAME	Q'TY / PAGE	Q'TY / PACK	P	I	R	B S I NO.	T O	T	F R O M	S E R I A L NO.	R E M A R K S	C
0	B2344500	Duplex Unit	1											
1	B2344859	Tension Spring	4											
2	B2344858	Driven Roller Holder	4											
3	AF022169	Transport Roller - Driven	2											
4	B2344857	Guide Plate - Right	1											
5	AA001476	Decal - Duplex Unit (Z5)	1											
6	AG070513	Magnet Catch	2											
7	AW010107	Paper Feed Sensor	1											
8	B2345696	Harness - Duplex Unit Rig	1											
9	B2344651	Lock Lever	1											
10	A2944843	Lock Arm	1											
11	B2344654	Release Lever Shaft	1											
12	AA066378	Grip Spring	1											
13	B2344653	Release Guide Plate	1											
14	B2344652	Release Bracket	1											
15	B2344871	Guide Plate - Right Lower	1											
16	B2344995	Inner Cover	1											
17	AG050102	Knob - Duplex	1											
18	AA001474	Decal - Duplex Unit (Z2)	1											
19	B2344656	Release Grip	1											
20	54472681	Snap Ring	1											
101	0454006Q	Tapping Screw - M3x6												
102	0720040E	Retaining Ring - M4												
103	0454008Q	Tapping Screw:3x8												
104	0951008N	Screw:Polished Round:M5X8												
105	0451006N	Tapping Screw - 3x6												
106	11050534	Clamp												

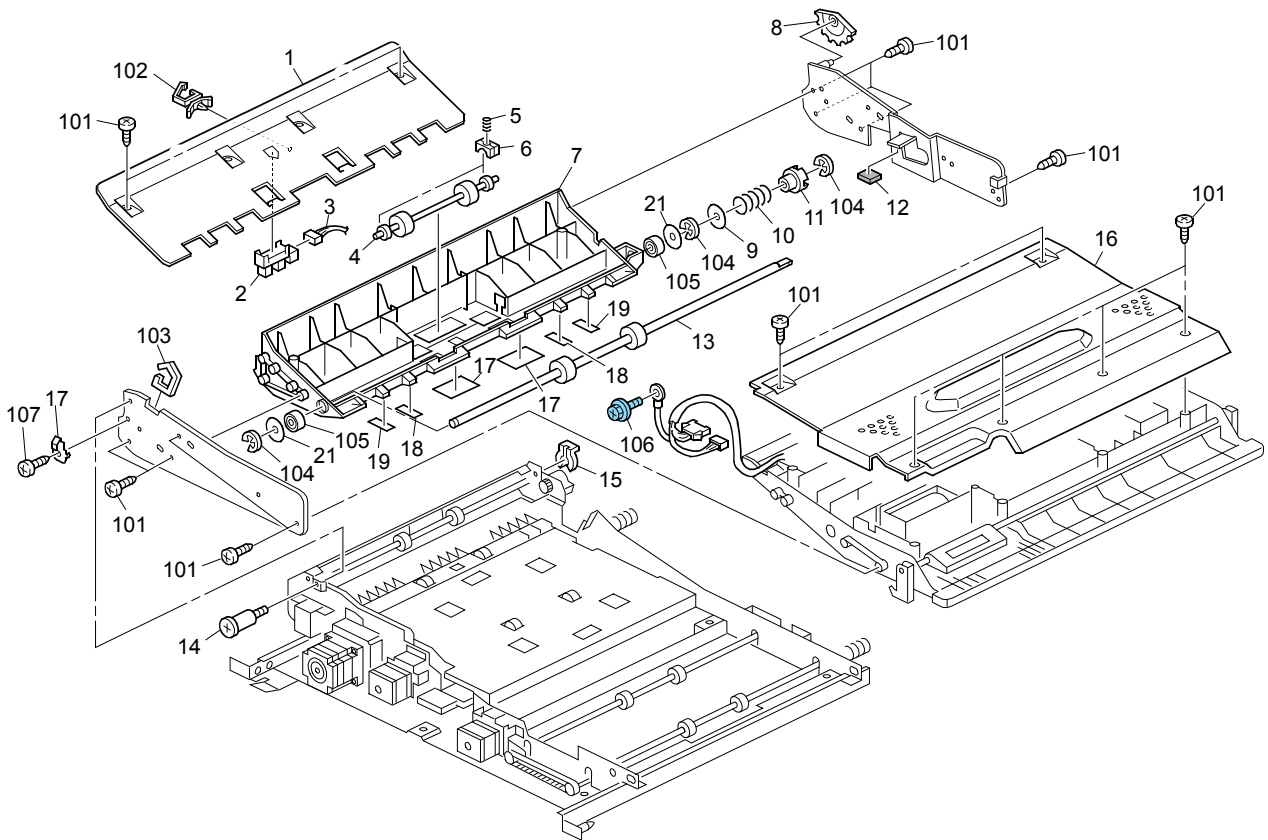

ITEM NO.	PARTS NO.	PARTS NAME	Q'TY / PAGE	Q'TY / PACK	P	I	R	B S I NO.	T O	T	F R O M	S E R I A L NO.	R E M A R K S	C
1	B2344814	Entrance Guide Plate	1											
2	AW010107	Paper Feed Sensor	1											
3	B2345699	Harness - Duplex Unit	1											
4	AF020681	Transport Roller - Driven	1											
5	AA063674	Spring - 8n	2											
6	AA084059	Ball Bearing Holder	2											
7	B2344817	Guide Plate - Lower	1											
8	B2344649	Gear:Sector:Duplex:Entran	1											
9	B1253230	Spacer - 0.3	1											
10	B2344826	Compression Spring	1											
11	B2344819	Drive Joint	1											
12	B2344884	Gate Pawl Cushion	1											
13	AF020676	Transport Roller - Drive	1											
14	AA143426	Stopped Screw - M4x17	1											
15	54472681	Snap Ring	1											
16	B2344834	Cover - Duplex	1											
17	B2344591	Sheet:Duplex:28	2											
18	B2344592	Sheet:Duplex:10.5	2											
19	B2344593	Sheet:Duplex:7	2											
20	B2344891	Harness Clamp:Duplex:Entr	1											
21	AA132025	Spacer - 1x8x12	2											
101	0452006N	Binding Self-tapping Scre												
102	11050511	Harness Clamp - LWS-0306Z												
103	11050522	Edge Saddle - Les0510												
104	0720060E	Retaining Ring - M6												
105	07413708	Ball Bearing - 8x12x3.5mm												
106	0454006Q	Tapping Screw - M3x6												
107	0353060N	Bind Screw - M3x6												

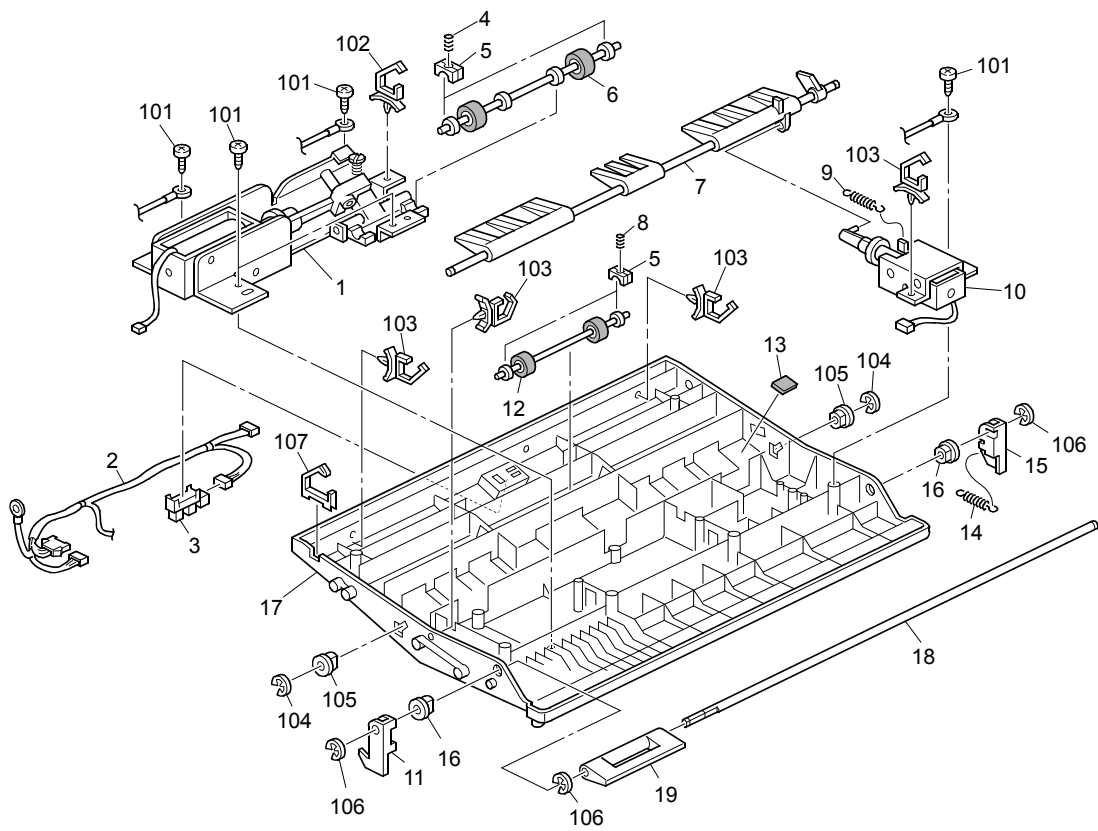

ITEM NO.	PARTS NO.	PARTS NAME	Q'TY / PAGE	Q'TY / PACK	P	I	R	B S I NO.	T O	T	F R O M	S E R I A L NO.	R E M A R K S	C
1	B2344835	On-off DC Solenoid	1											
2	B2345697	Harness - Duplex Unit Lef	1											
3	AW010107	Paper Feed Sensor	1											
4	AA063674	Spring - 8n	2											
5	AA084059	Ball Bearing Holder	4											
6	AF020682	Transport Roller - Driven	1											
7	B2344828	Gate Pawl - Switchback	1											
8	B2344818	Compression Spring	2											
9	B2344833	Tension Spring	1											
10	B2344830	DC Solenoid	1											
11	B2344822	Lock Pawl - Front	1											
12	AF020681	Transport Roller - Driven	1											
13	B2344884	Gate Pawl Cushion	1											
14	B2344847	Tension Spring	1											
15	B2344823	Lock Pawl - Rear	1											
16	AA080344	Bushing - Dia5	2											
17	B2344813	Entrance Guide Plate - Up	1											
18	B2344821	Guide Plate Lock Shaft	1											
19	B2344824	Grip	1											
101	0452006N	Binding Self-tapping Scre												
102	11050511	Harness Clamp - LWS-0306Z												
103	11050534	Clamp												
104	0720040E	Retaining Ring - M4												
105	08053384	Bushing - 5mm												
106	0720030E	Retaining Ring - M3												
107	11050522	Edge Saddle - Les0510												

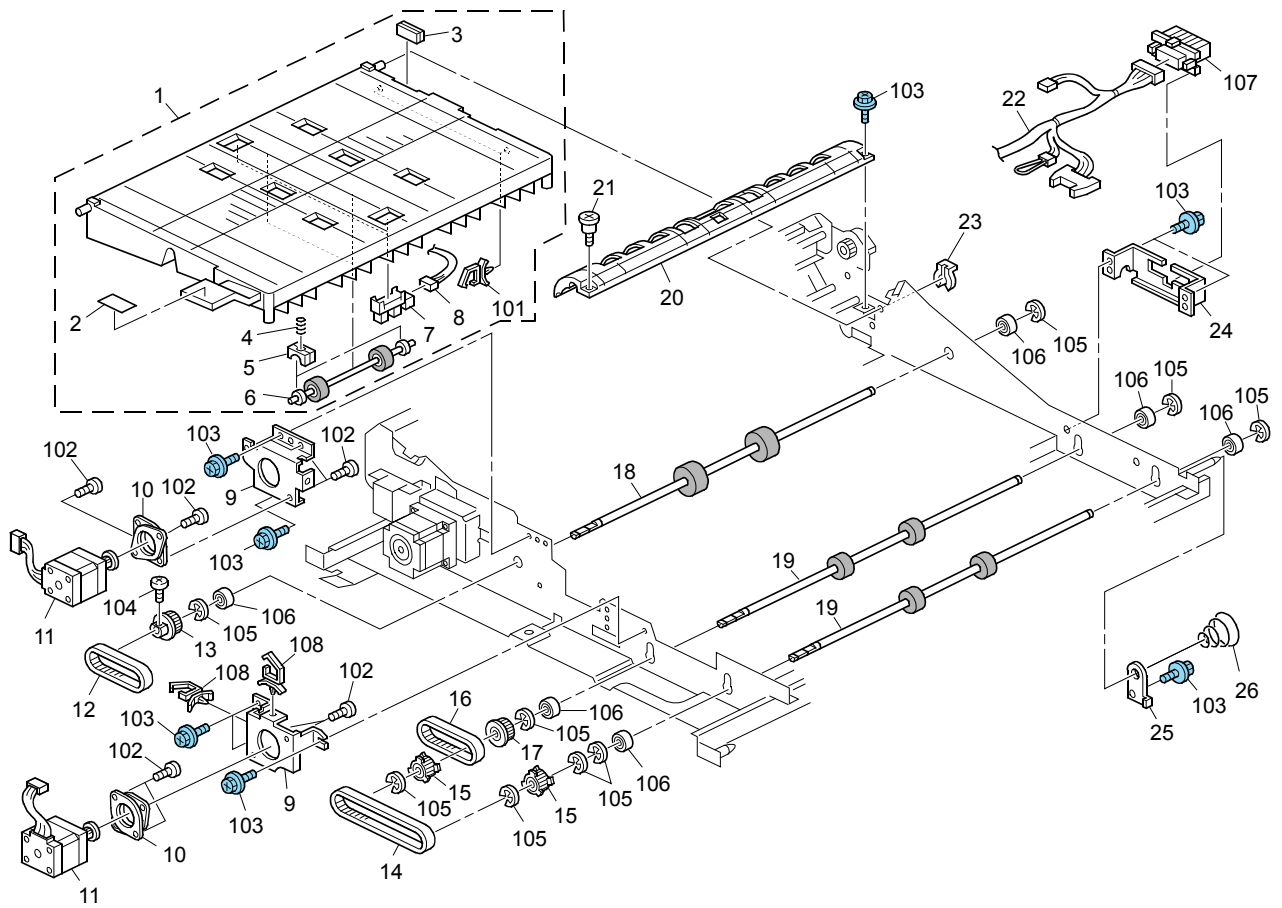

ITEM NO.	PARTS NO.	PARTS NAME	Q'TY / PAGE	Q'TY / PACK	P	I	R	B S I NO.	T O	T	F R O M	S E R I A L NO.	R E M A R K S	C
1	B2344850	Guide Plate:Duplex:Left:U	1											
2	AA001475	Decal - Duplex Unit (Z4)	1											
3	AG070514	Magnet Catch	1											
4	AA063675	Spring - 5n	4											
5	AA084059	Ball Bearing Holder	4											
6	AF022167	Transport Roller - Driven	2											
7	AW010107	Paper Feed Sensor	2											
8	B2345698	Harness - Duplex Unit Lef	1											
9	B2344736	Stepper Motor Bracket	2											
10	A2324666	Cushion - Stepper Motor	2											
11	AX040158	Stepper Motor DC2.64V 6.3	2											
12	B2346523	Timing Belt - S2M100	1											
13	AB030803	Timing Pulley - 25T	1											
14	AA043651	Timing Belt - B60S2M264	1											
15	AB030802	Timing Pulley - 24T	2											
16	B7027210	Timing Belt:B60S2M122	1											
17	B2346507	Timing Pulley - 25T	1											
18	AF020675	Transport Roller - Drive	1											
19	AF020680	Transport Roller - Drive	2											
20	B2344866	Guide Plate - Upper	1											
21	AA143811	Stepped Screw - M3x4	1											
22	B2345695	Harness - Duplex Unit	1											
23	54472681	Snap Ring	1											
24	B2344636	Drawer Bracket	1											
25	B2344632	Positioning Pin Bracket -	1											
26	B2344635	Compression Spring	1											
101	11050534	Clamp												
102	0353050N	Screw-m3x5												
103	0454006Q	Tapping Screw - M3x6												
104	0353060N	Bind Screw - M3x6												
105	0720060E	Retaining Ring - M6												
106	07413708	Ball Bearing - 8x12x3.5mm												
107	11029781	Connector:51405-3919												
108	11050516	Clamp												

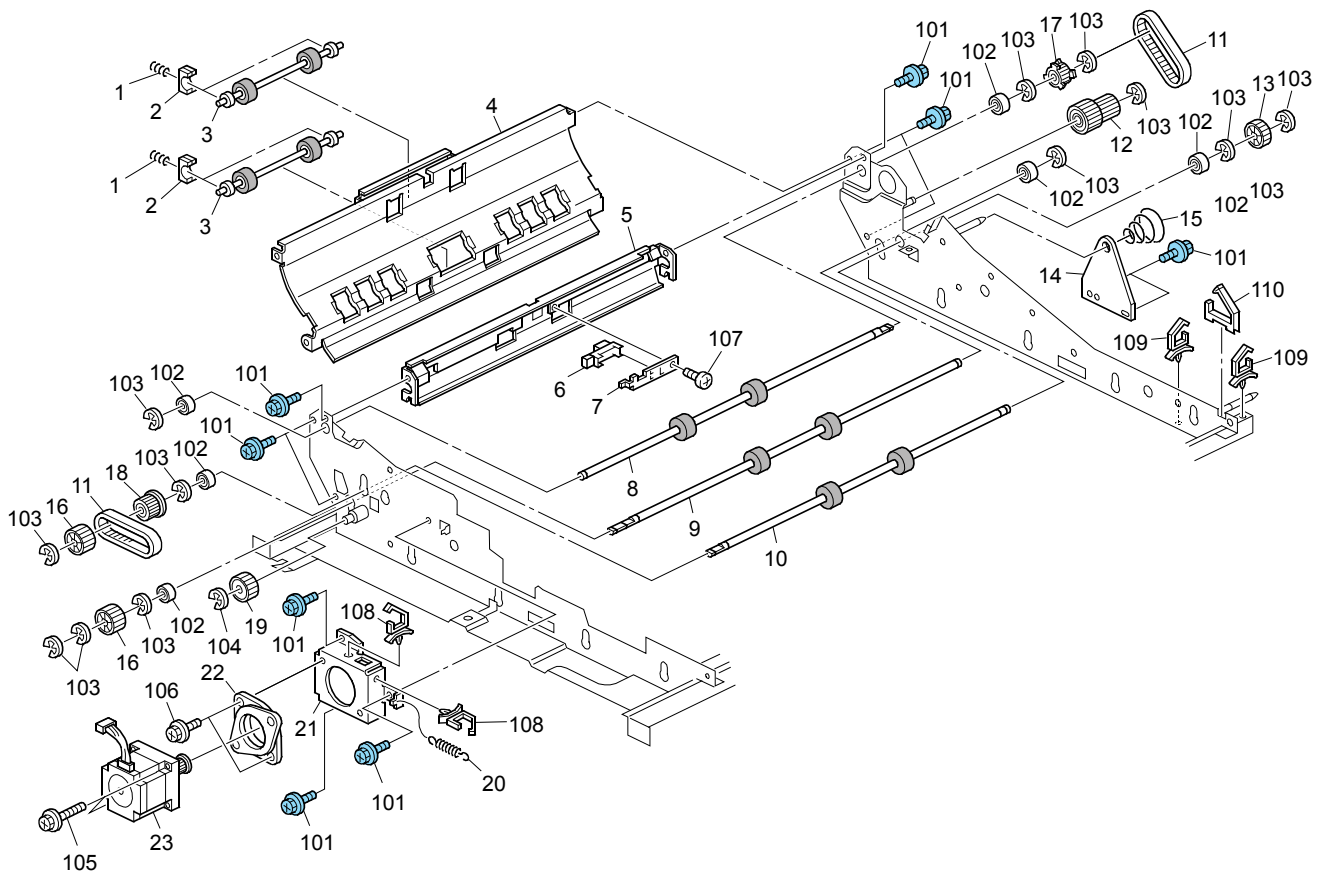

ITEM NO.	PARTS NO.	PARTS NAME	Q'TY / PAGE	Q'TY / PACK	P	I	R	B S I NO.	T O	T	F R O M	S E R I A L NO.	R E M A R K S	C
1	AA063674	Spring - 8n	4											
2	AA084059	Ball Bearing Holder	4											
3	AF020681	Transport Roller - Driven	2											
4	B2344861	Guide Plate - Exit	1											
5	B2344873	Guide Plate - Exit	1											
6	AW010107	Paper Feed Sensor	1											
7	B2344876	Sensor Bracket	1											
8	AF020677	Transport Roller - Exit	1											
9	AF020674	Transport Roller - Lower	1											
10	AF020673	Transport Roller - Upper	1											
11	AA043621	Timing Belt - 60S2M156	1											
12	AB017727	Gear - 27Z/30Z	1											
13	BB013012	Gear - 28Z	1											
14	B2344631	Positioning Pin Bracket -	1											
15	B2344635	Compression Spring	1											
16	BB013011	Gear - 22Z	2											
17	AA043621	Timing Belt - 60S2M156	1											
18	B2346506	Timing Pulley - 30T	1											
19	BB013013	Gear - 21Z	1											
20	B2346508	Tension Spring	1											
21	B2344721	Stepper Motor Bracket	1											
22	AA161122	Motor Cushion	1											
23	AX040157	Stepper Motor DC1.68V 6.7	1											
101	0454006Q	Tapping Screw - M3x6												
102	07413708	Ball Bearing - 8x12x3.5mm												
103	0720060E	Retaining Ring - M6												
104	0720040E	Retaining Ring - M4												
105	0451010N	Tapping Screw:4x10												
106	0451006N	Tapping Screw - 3x6												
107	0353060N	Bind Screw - M3x6												
108	11050516	Clamp												
109	11050511	Harness Clamp - LWS-0306Z												
110	11050598	Clamp:LWSS-1N												

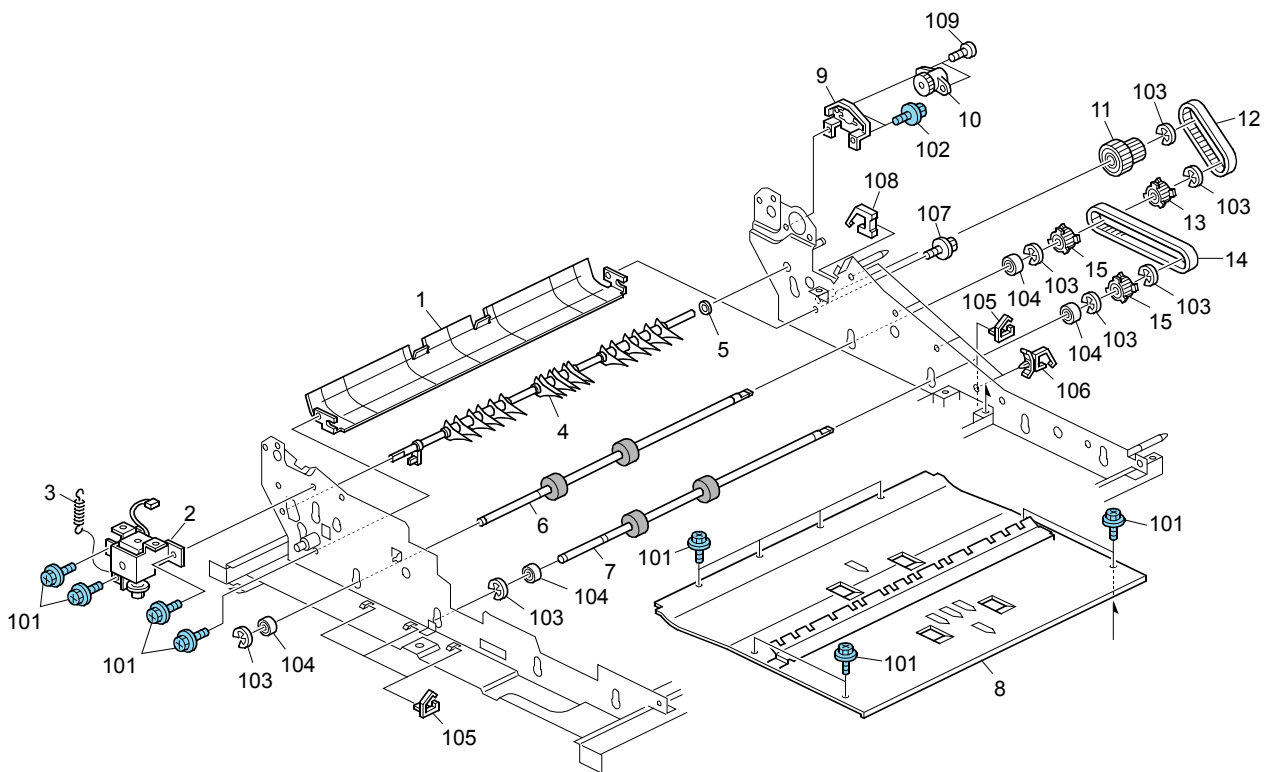

ITEM NO.	PARTS NO.	PARTS NAME	Q'TY / PAGE	Q'TY / PACK	P	I	R	B S I NO.	T O	T	F R O M	S E R I A L NO.	R E M A R K S	C
1	B2344867	Guide Plate - Lower	1											
2	B2344881	DC Solenoid	1											
3	B2344844	Tension Spring	1											
4	B2344888	Gate Pawl:Duplex	1											
5	AA082118	Bushing - M6	1											
6	AF020678	Transport Roller - Drive	1											
7	AF020679	Transport Roller - Drive	1											
8	B2344868	Guide Plate - Left Lower	1											
9	B2344647	Bracket:Plate:Damper:Open	1											
10	B2344646	Damper:Open And Close	1											
11	AB017728	Gear: - 30Z/30T	1											
12	B6523135	Timing Belt:B60S2M172	1											
13	AB030801	Timing Pulley - 28T	1											
14	AA043650	Timing Belt - B60S2M290	1											
15	AB030802	Timing Pulley - 24T	2											
101	0454006Q	Tapping Screw - M3x6												
102	0454006Q	Tapping Screw - M3x6												
103	0720060E	Retaining Ring - M6												
104	07413708	Ball Bearing - 8x12x3.5mm												
105	11050598	Clamp:LWSS-1N												
106	11050516	Clamp												
107	0451006N	Tapping Screw - 3x6												
108	11050511	Harness Clamp - LWS-0306Z												
109	0353060N	Bind Screw - M3x6												

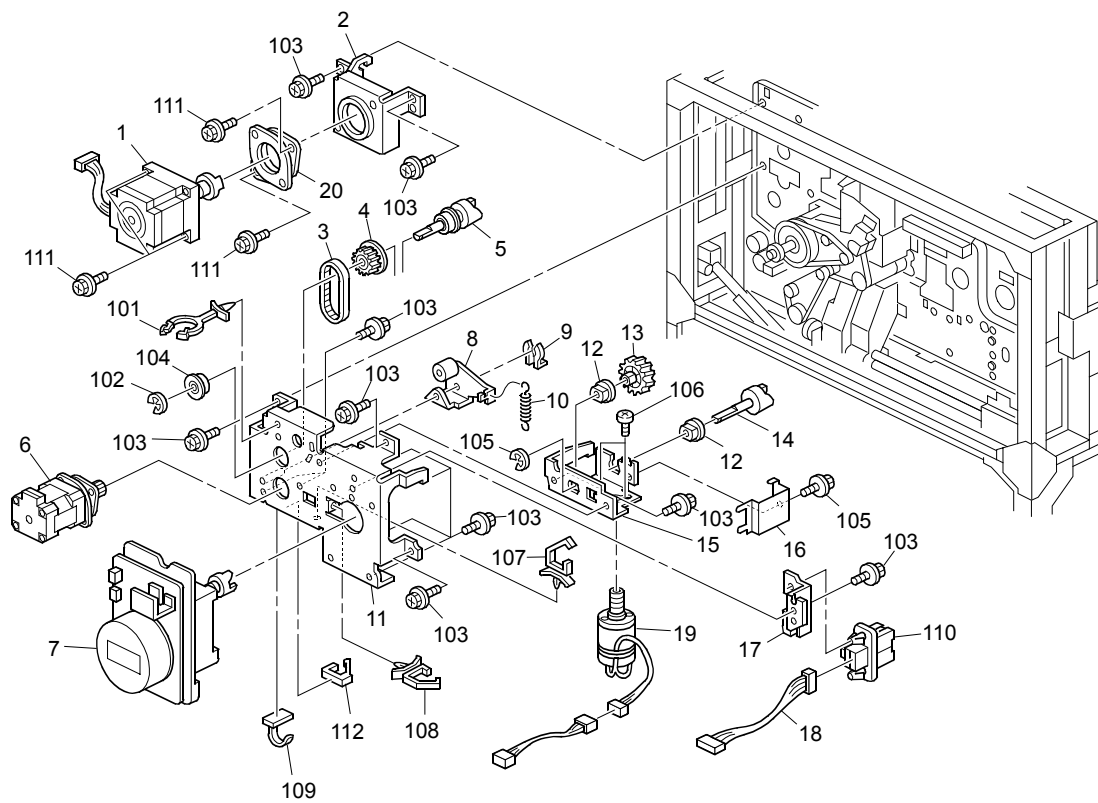

ITEM NO.	PARTS NO.	PARTS NAME	Q'TY / PAGE	Q'TY / PACK	P I R	B S I NO.	T O	T	F R O M	S E R I A L NO.	R E M A R K S	C
1	B2343293	Stepper Motor DC3.6V 7.2W	1									
2	B2343291	Stepper Motor Bracket	1									
3	AA043974	Timing Belt - B60S2M112	1									
4	B7893126	Timing Pulley - 25T	1									
5	B2343062	Shaft - Toner Supply Roll	1									
6	B2343055	Stepper Motor DC12.6V 12.	1									
7	B2343051	Brushless Motor DC24V 33W	1									
8	B2343065	Tightener	1									
9	52062686	Snap Ring	1									
10	B2343067	Spring	1									
11	B2343056	Bracket	1									
12	AA082101	Bushing - 6X10X6	2									
13	B2343072	Gear - 30Z	1									
14	B2343070	Agitator Drive Shaft	1									
15	B2343069	Agitator Bracket	1									
16	B2343073	Cover	1									
17	B2343074	Drawer Bracket	1									
18	B2345684	Harness - Drawer	1									
19	B2343372	DC Motor:Toner Bottle:DC2	1									
20	AA161122	Motor Cushion	1									
101	11050517	Harness Clamp - LWS-2111Z										
102	0720060E	Retaining Ring - M6										
103	0451008N	Tapping Screw:4x8										
104	07423808	Ball Bearing - 8x16x5										
105	0451006N	Tapping Screw - 3x6										
106	0312060N	Screw - M2.5X6										
107	11050516	Clamp										
108	11050511	Harness Clamp - LWS-0306Z										
109	11050568	Clamp:LWSS-0504										
110	11029785	Connector:55949-1819										
111	0451010N	Tapping Screw:4x10										
112	11050522	Edge Saddle - Les0510										

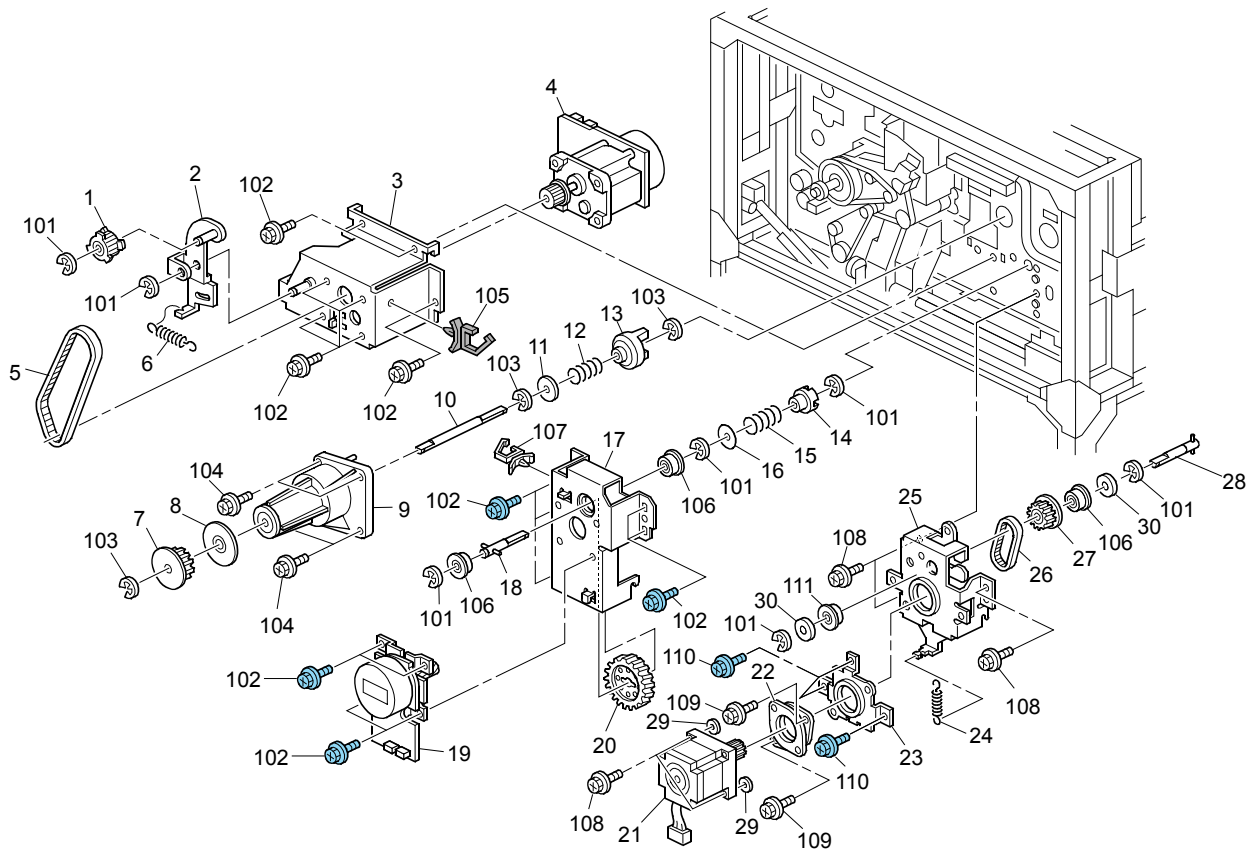

ITEM NO.	PARTS NO.	PARTS NAME	Q'TY / PAGE	Q'TY / PACK	P	I	R	B S I NO.	T O	T	F R O M	S E R I A L NO.	R E M A R K S	C
1	B2341158	Pulley - 23T	1											
2	B2341128	Tightener	1											
3	B2341125	Brushless Motor Bracket	1											
4	AX060329	Brushless Motor DC24V 50.	1											
5	AA043977	Timing Belt:Drive:Fusing	1											
6	AA062346	Tension Spring:Tension	1											
7	AB030794	Pulley - 40Z	1											
8	B2341135	Pulley Flange	1											
9	B2341130	Fusing Drive Unit Bracket	1											
10	B2341134	Drive Shaft	1											
11	A0791203	Fusing Drive Stopper	1											
12	B2341132	Spring:Joint:Ffusing	1											
13	A0791201	Fusing Drive Joint	1											
14	B2344398	Joint Drive	1											
15	AA063636	Compression Spring - 6.5n	1											
16	B2344458	Spacer - 8x20x0.3t	1											
17	B2344425	Brushless Motor Bracket	1											
18	B2344283	Motor Drive Shaft	1											
19	B2344325	Brushless Motor DC24V 20W	1											
20	B2344396	Gear - 66Z	1											
21	AX040157	Stepper Motor DC1.68V 6.7	1											
22	AA161122	Motor Cushion	1											
23	B2344663	Stepper Motor Bracket	1											
24	B2346508	Tension Spring	1											
25	B2344662	Stepper Motor Bracket	1											
26	AA043652	Timing Belt - B60S2M130	1											
27	B2346506	Timing Pulley - 30T	1											
28	B2344667	Pulley Drive Shaft	1											
29	B2344668	Cushion:Bracket:Duplex:En	1											
30	AA132025	Spacer - 1x8x12	2											
101	0720060E	Retaining Ring - M6												
102	0451008N	Tapping Screw:4x8												
103	0720080E	Retaining Ring - M8												
104	0451012N	Tapping Screw:4x12												
105	11050601	Clamp:LWSM-0511-2M												
106	07423808	Ball Bearing - 8x16x5												
107	11050487	Harness Clamp												
108	0451006N	Tapping Screw - 3x6												
109	0451010N	Tapping Screw:4x10												
110	0951008N	Screw:Polished Round:M5X8												
111	07413708	Ball Bearing - 8x12x3.5mm												

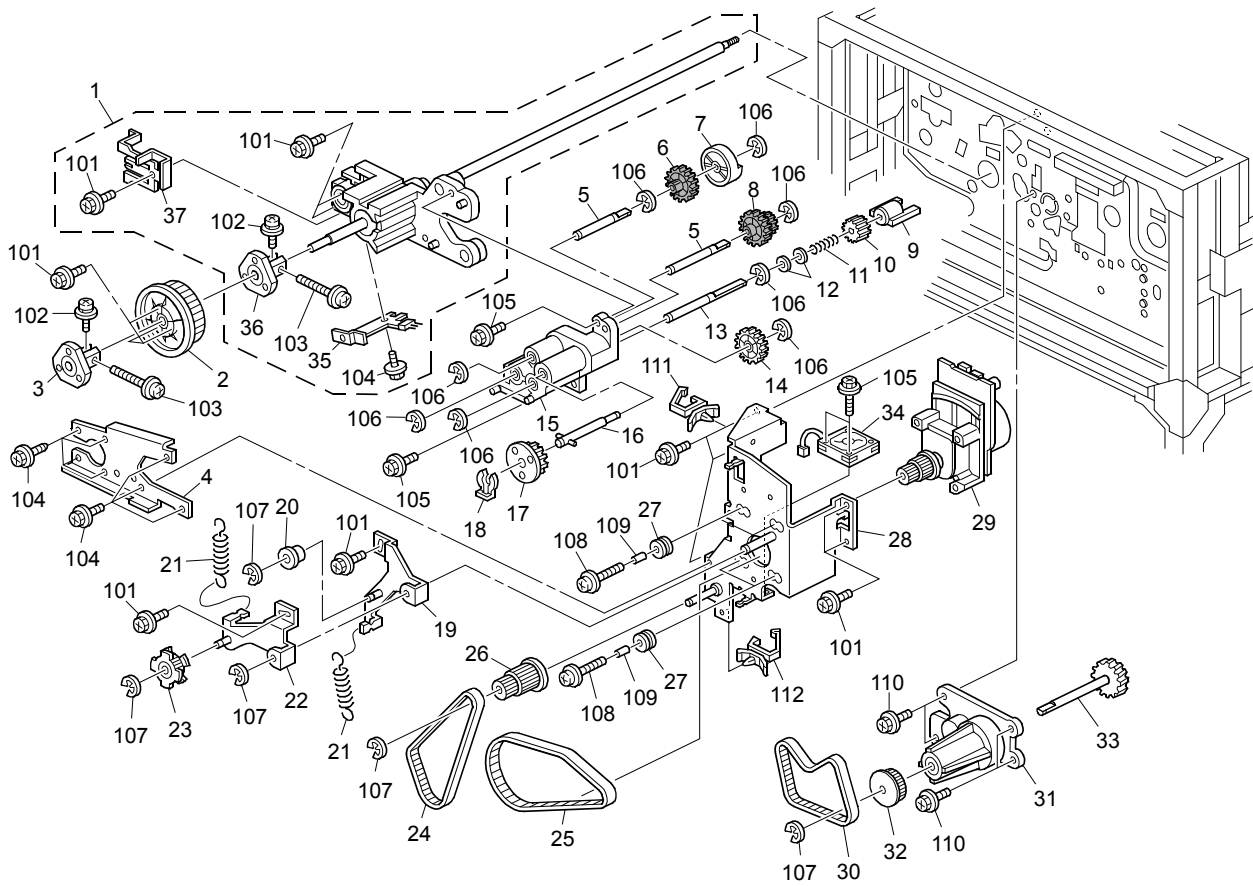

ITEM NO.	PARTS NO.	PARTS NAME	Q'TY / PAGE	Q'TY / PACK	P I R	B S I NO.	T O	T	F R O M	S E R I A L NO.	R E M A R K S	C
1	B2342350	Drum Shaft	1									
2	AB030793	Pulley - 125T	1									
3	B2341118	Fly Wheel Flange	1									
4	B2343078	Supporting Plate - Drum S	1									
5	B2343757	Shaft - Swivel	2									
6	B2343759	Gear - 32Z	1									
7	B2343764	Cam	1									
8	B2343758	Gear - 13Z/29Z	1									
9	B2343763	Joint	1									
10	B2343762	Gear - 16Z	1									
11	AA063604	Pressure Spring	1									
12	AA132024	Spacer - M6	2									
13	B2343756	Shaft - Cleaning	1									
14	B2343768	Gear - 22Z	1									
15	B2343765	Cleaning Drive Unit Stay	1									
16	B2343761	Drive Shaft - Cleaning	1									
17	B2343760	Pulley - 39T	1									
18	52152621	Snap Ring - M6	1									
19	B2341110	Tightener	1									
20	B2341112	Pulley	1									
21	AA062346	Tension Spring:Tension	2									
22	B2341106	Tightener	1									
23	B2341114	Pulley:Tightener:Drum:ASS	1									
24	AA043972	Timing Belt - B60S3M435	1									
25	AA043970	Timing Belt - B60S3M426	1									
26	AB033093	Idle Pulley - 25t/20t	1									
27	AA161072	Cushion - DC Motor	4									
28	B2341101	Brushless Motor Bracket	1									
29	AX060328	Brushless Motor DC24V 72W	1									
30	AA043971	Timing Belt - B60S3M363	1									
31	B2341140	Transfer Drive Bracket	1									
32	AB030795	Pulley - 29T	1									
33	B2341144	Drive Shaft	1									
34	GX640028	Fan Motor DC24V 1.92W	1									
35	B2342360	Electrode Plate:Drum Shaf	1									
36	B2341117	Holder:Pulley:Drum	1									
37	B2343087	Terminal:Development Vias	1									
101	0451008N	Tapping Screw:4x8										
102	0951008N	Screw:Polished Round:M5X8										
103	0951020N	Screw - M4X20										
104	0450008N	Tapping Screw - M4x8										
105	0451020N	Tapping Screw - M4x20										
106	0720040E	Retaining Ring - M4										
107	0720060E	Retaining Ring - M6										
108	0951010N	Screw:Polished Round:M4x1										
109	0707050N	Bushing - 4x5										
110	0451012N	Tapping Screw:4x12										
111	11050511	Harness Clamp - LWS-0306Z										
112	11050487	Harness Clamp										

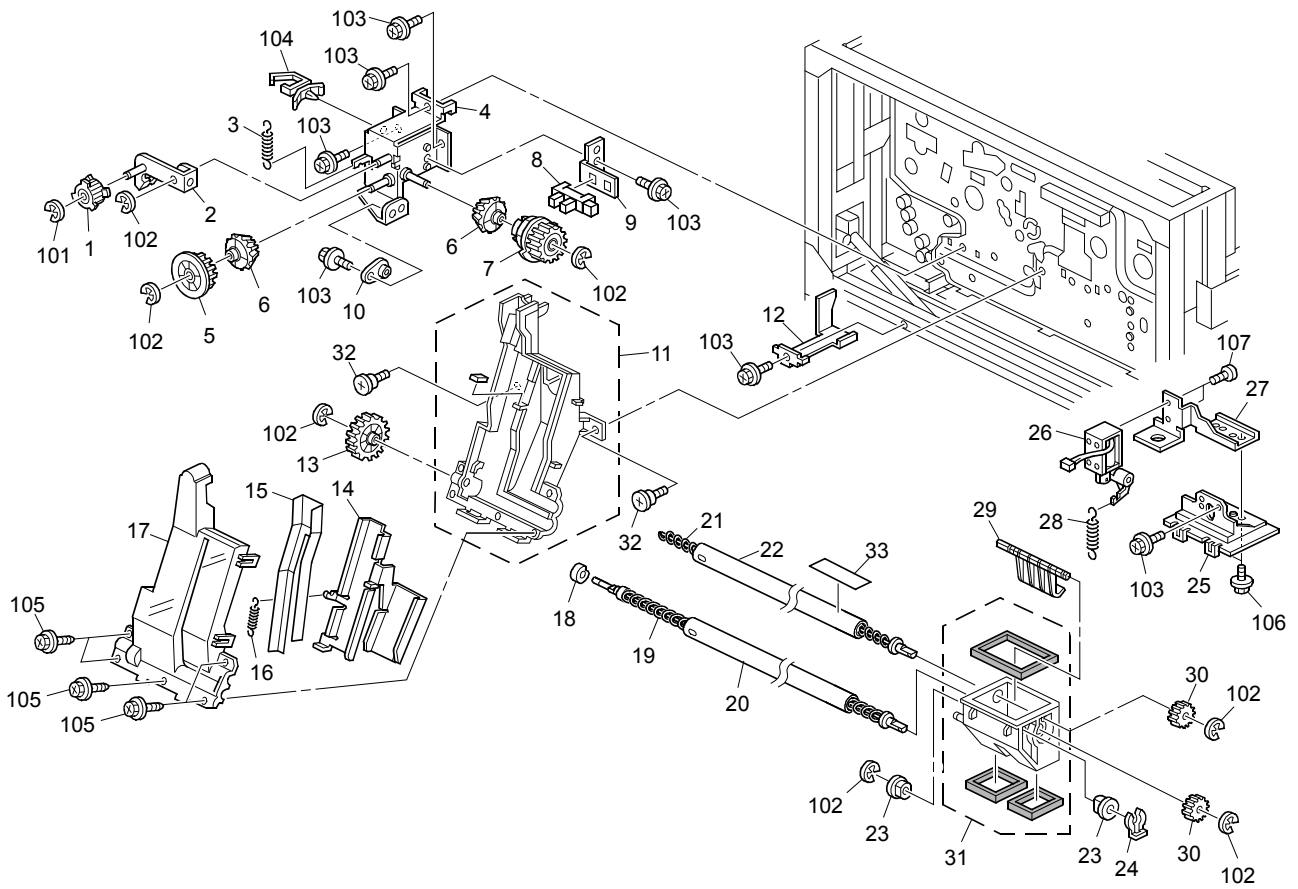

ITEM NO.	PARTS NO.	PARTS NAME	Q'TY / PAGE	Q'TY / PACK	P I R	B S I NO.	T O	T	F R O M	S E R I A L NO.	R E M A R K S	C
1	B2341158	Pulley - 23T	1									
2	B2341156	Tightener	1									
3	AA062346	Tension Spring:Tension	1									
4	B2341150	Toner Recycling Unit Driv	1									
5	B2341154	Pulley - 40T	1									
6	A2941163	Gear - 30Z	2									
7	B2343782	Torque Limiter Gear - 24z	1									
8	AW020145	Photointerruptor:Flat	1									
9	B2343781	Positioning Sensor Bracke	1									
10	A2941158	Transport Screw Bushing	1									
11	B2343705	Case - Lower	1									
12	B2343783	Harness Guard Bracket	1									
13	A2943621	Gear - 44Z	1									
14	B2343722	Vibrating Plate	1									
15	B2343723	Guide - Lower	1									
16	A1841760	Cam Spring	1									
17	B2343704	Case - Upper	1									
18	A2943618	Vibrating Plate Cam	1									
19	B2343744	Transport Screw:Toner Rec	1									
20	B2343733	Pip - Dial4	1									
21	B2343731	Transport Screw	1									
22	B2343730	Pipe	1									
23	50530447	Bushing - 6mm	2									
24	AA100014	Retaining Ring C - Separa	1									
25	B0703636	Case:Classification:Upper	1									
26	B2343741	DC Solenoid	1									
27	B2343743	Solenoid Bracket	1									
28	B0703647	Tension Spring:Arm:Toner	1									
29	B0703646	Arm:Toner Recycling	1									
30	A2943626	Gear - 17Z	2									
31	B0703630	Case:Classification:Lower	1									
32	AA143545	Screw:M4	2									
33	B2343736	Heat Insulation	1									
101	0720060E	Retaining Ring - M6										
102	0720040E	Retaining Ring - M4										
103	0451008N	Tapping Screw:4x8										
104	11050488	Harness Clamp										
105	0450008N	Tapping Screw - M4x8										
106	0451006N	Tapping Screw - 3x6										
107	0353040N	Screw - M3X4										

ITEM NO.	PARTS NO.	PARTS NAME	Q'TY / PAGE	Q'TY / PACK	P I R	B S I NO.	T O	T	F R O M	S E R I A L NO.	R E M A R K S	C
1	B2343260	Pump Unut	1									
2	AW020145	Photointerruptor:Flat	1									
3	B2345692	Harness - Pump Sensor	1									
4	B2343267	Drive Shaft	1									
5	B2343269	Feeler	1									
6	B2343268	Gear - 24Z	1									
7	B2343266	Drive Joint	1									
8	B2342830	DC Solenoid	1									
9	AB017723	Gear/pulley - 31Z/31T	1									
10	B2343279	Gear - 36Z	1									
11	B2343277	Compression Spring	1									
12	B2342495	Roller Bracket	1									
13	B2342494	Torsion Spring	1									
14	B2342491	Roller Bracket	1									
15	AB017722	Gear/pulley - 31Z/31T	1									
16	AA043308	Timing Belt - S2M114 9MM	1									
17	B2342813	Drive Unit Bracket	1									
18	B2346508	Tension Spring	2									
19	B2342812	Stepper Motor Bracket	2									
20	AA161122	Motor Cushion	2									
21	AX040157	Stepper Motor DC1.68V 6.7	2									
22	B2342821	Drive Unit Bracket	1									
23	B2343282	Tube - Dia6	1									
101	0451008N	Tapping Screw:4x8										
102	08053480	Bushing - 6mm										
103	0720040E	Retaining Ring - M4										
104	11050511	Harness Clamp - LWS-0306Z										
105	0451010N	Tapping Screw:4x10										
106	0951008N	Screw:Polished Round:M5X8										
107	0451008N	Tapping Screw:4x8										
108	0720060E	Retaining Ring - M6										

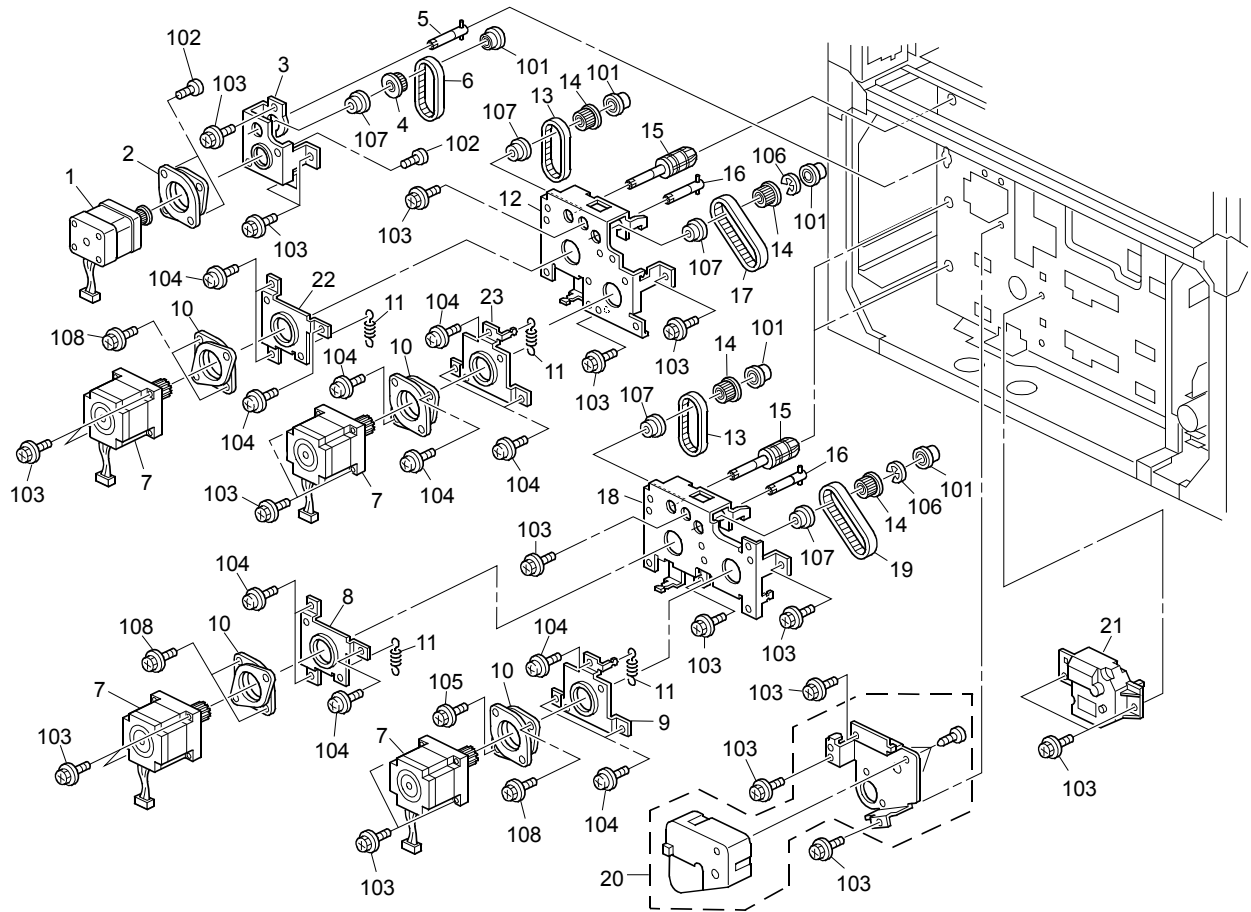

ITEM NO.	PARTS NO.	PARTS NAME	Q'TY / PAGE	Q'TY / PACK	P	I	R	B S I NO.	T O	T	F R O M	S E R I A L NO.	R E M A R K S	C
1	AX040158	Stepper Motor DC2.64V 6.3	1											
2	A2324666	Cushion - Stepper Motor	1											
3	B2346520	Bracket	1											
4	B2346507	Timing Pulley - 25T	1											
5	B2346543	Drive Shaft	1											
6	B2346523	Timing Belt - S2M100	1											
7	AX040157	Stepper Motor DC1.68V 6.7	4											
8	B2346531	Tightener Bracket	2											
9	B2346532	Tightener Bracket	2											
10	AA161122	Motor Cushion	4											
11	B2346508	Tension Spring	4											
12	B2346510	Tandem LCT Bracket	1											
13	B2346514	Timing Belt - S2M126	2											
14	B2346506	Timing Pulley - 30T	4											
15	B2346542	Grip Drive Shaft	2											
16	B2346541	Feed Drive Shaft	2											
17	B2346513	Timing Belt - S2M180	1											
18	B2346530	Bracket	1											
19	B2346533	Timing Belt - S2M152	1											
20	B1326759	DC Motor:Rise:Tandem LCT:	1											
21	AX040144	DC Motor:Rise:Paper Tray	2											
22	B2346512	Tightener Bracket	1											
23	B2346511	Tightener Bracket	1											
101	07423808	Ball Bearing - 8x16x5												
102	0353050N	Screw-m3x5												
103	0451008N	Tapping Screw:4x8												
104	0951006N	Screw - M3X6												
105	0451010N	Tapping Screw:4x10												
106	0720060E	Retaining Ring - M6												
107	07413708	Ball Bearing - 8x12x3.5mm												
108	0451006N	Tapping Screw - 3x6												

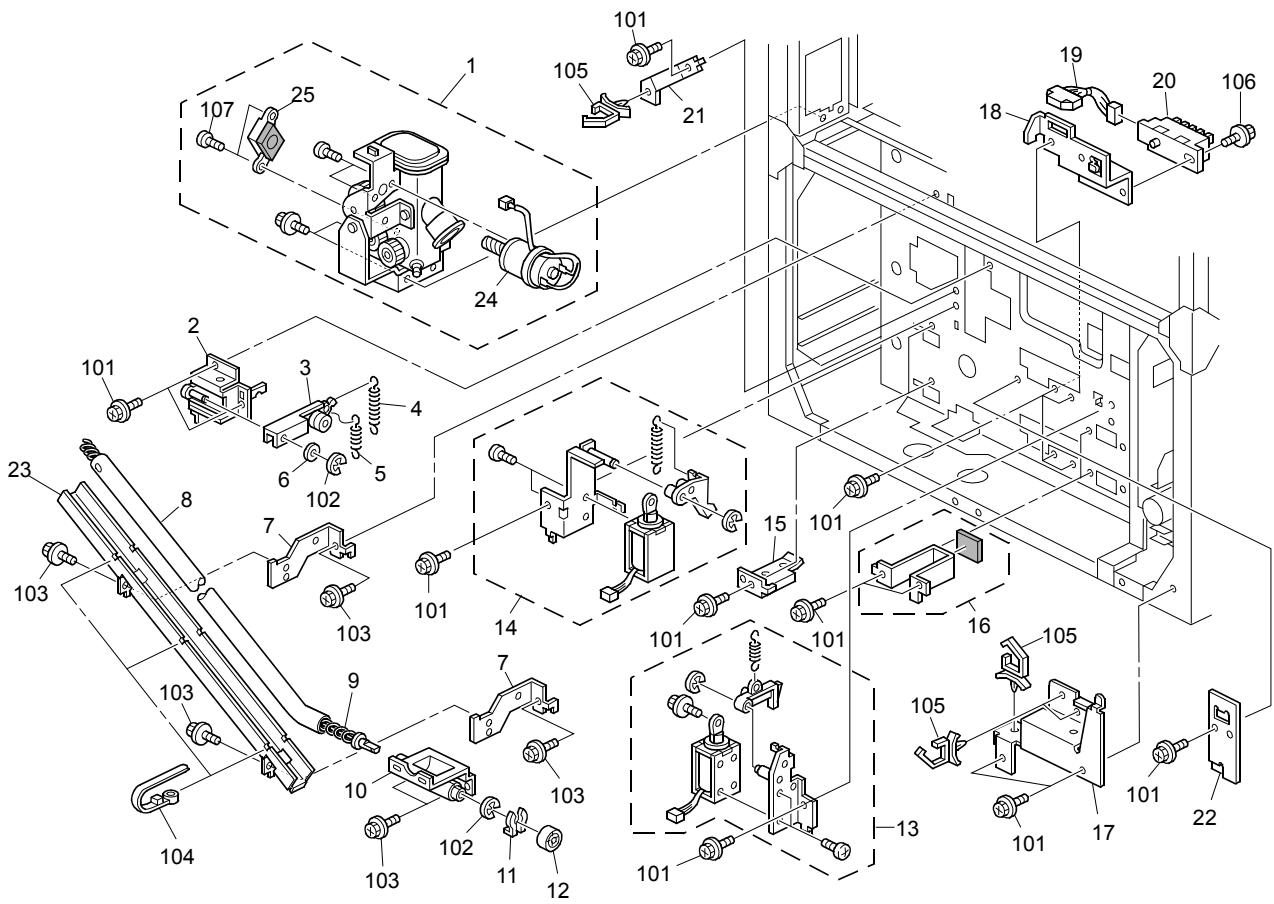

ITEM NO.	PARTS NO.	PARTS NAME	Q'TY / PAGE	Q'TY / PACK	P I R	B S I NO.	T O	T	F R O M	S E R I A L NO.	R E M A R K S	C
1	B2343400	Cylinder Unit	1									
2	B1326726	Bracket:Arm:Ass'y	1									
3	B0656769	Lock Arm	1									
4	B2476753	Lock Spring - Large	1									
5	B2476754	Lock Spring - Small	1									
6	AA132203	Spacer - 6mm	1									
7	B2343446	Supporter Bracket	2									
8	A2943475	Tube - 12x14x835	1									
9	A2943477	Toner Transport Screw	1									
10	B0703471	Toner Transport Screw Cas	1									
11	54472681	Snap Ring	1									
12	A2943480	Driving Joint	1									
13	B1326765	DC Solenoid:Lock:Ass'y	1									
14	B1326762	DC Solenoid:Coupling:Ass'	1									
15	B2346120	Bracket:Positioning:Paper	2									
16	B0656172	Paper Tray Stopper	2									
17	B2346831	Bracket - Harness Clamp	1									
18	B2346151	Paper Size Sensor Bracket	1									
19	B2345671	Harness - Paper Size Sens	1									
20	AW500010	Push Switch	1									
21	B2346565	Harness Clamp Bracket	1									
22	B2346198	Cover - Spaper Size Senso	1									
23	A2943482	Tube Guide Rail	1									
24	B2343372	DC Motor:Toner Bottle:DC2	1									
25	AW310008	Toner End Sensor	1									
101	0451008N	Tapping Screw:4x8										
102	0720040E	Retaining Ring - M4										
103	0451006N	Tapping Screw - 3x6										
104	11050408	Wire Binder:T18MR-HS										
105	11050489	Harness Clamp - LWS 1316										
106	0451008N	Tapping Screw:4x8										
107	0353060N	Bind Screw - M3x6										

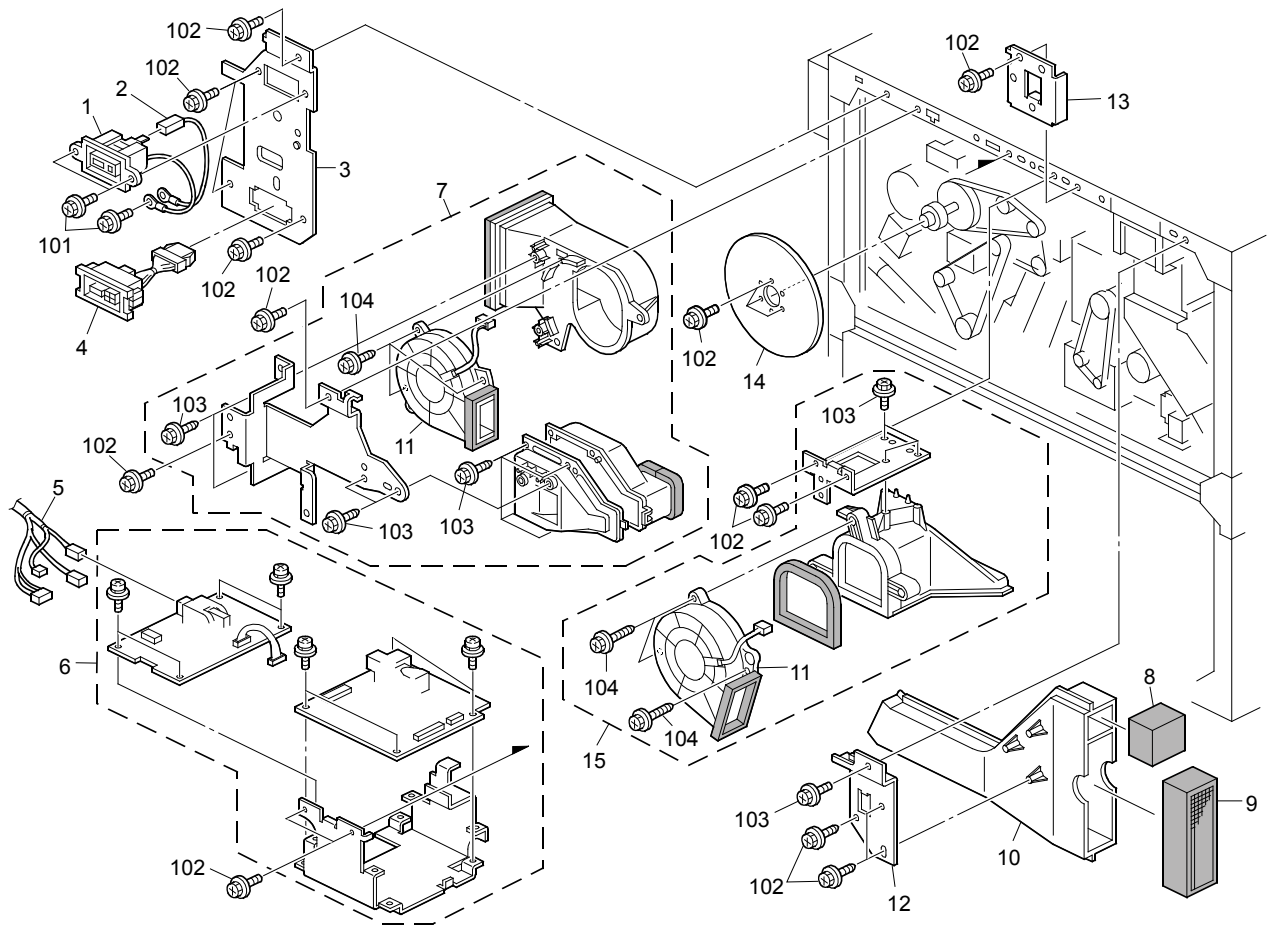

ITEM NO.	PARTS NO.	PARTS NAME	Q'TY / PAGE	Q'TY / PACK	P	I	R	B S I NO.	T O	T	F R O M	S E R I A L NO.	R E M A R K S	C
1	B2345659	Harness - Ground Wire	1											
2	B0705460	Interface Grounding Harne	1											
3	B2347554	ADF Plug Bracket	1											
4	B2345632	Harness - Power Source	1											
5	B2345625	High Voltage Supply Cord	1											
6	AZ320155	Power Pack - Development	1											
7	B2342051	Vacuum Duct Unit	1											
8	B0702098	Shield:Duct:Ozone Unit	1											
9	B0702076	Ozone Filter:50x150x40	1											
10	B0702072	Duct:Exhaust	1											
11	B2341097	Fan Motor DC24V 9.6W	2											
12	B0702075	Bracket:Duct:Exhaust	1											
13	B0706831	Bracket:Standard:C/T Box	1											
14	A2941119	Fly Wheel	1											
15	B2342165	Rear Duct Unit	1											
101	0451008N	Tapping Screw:4x8												
102	0451008N	Tapping Screw:4x8												
103	0450008N	Tapping Screw - M4x8												
104	0450016N	Tapping Screw - M4x16												

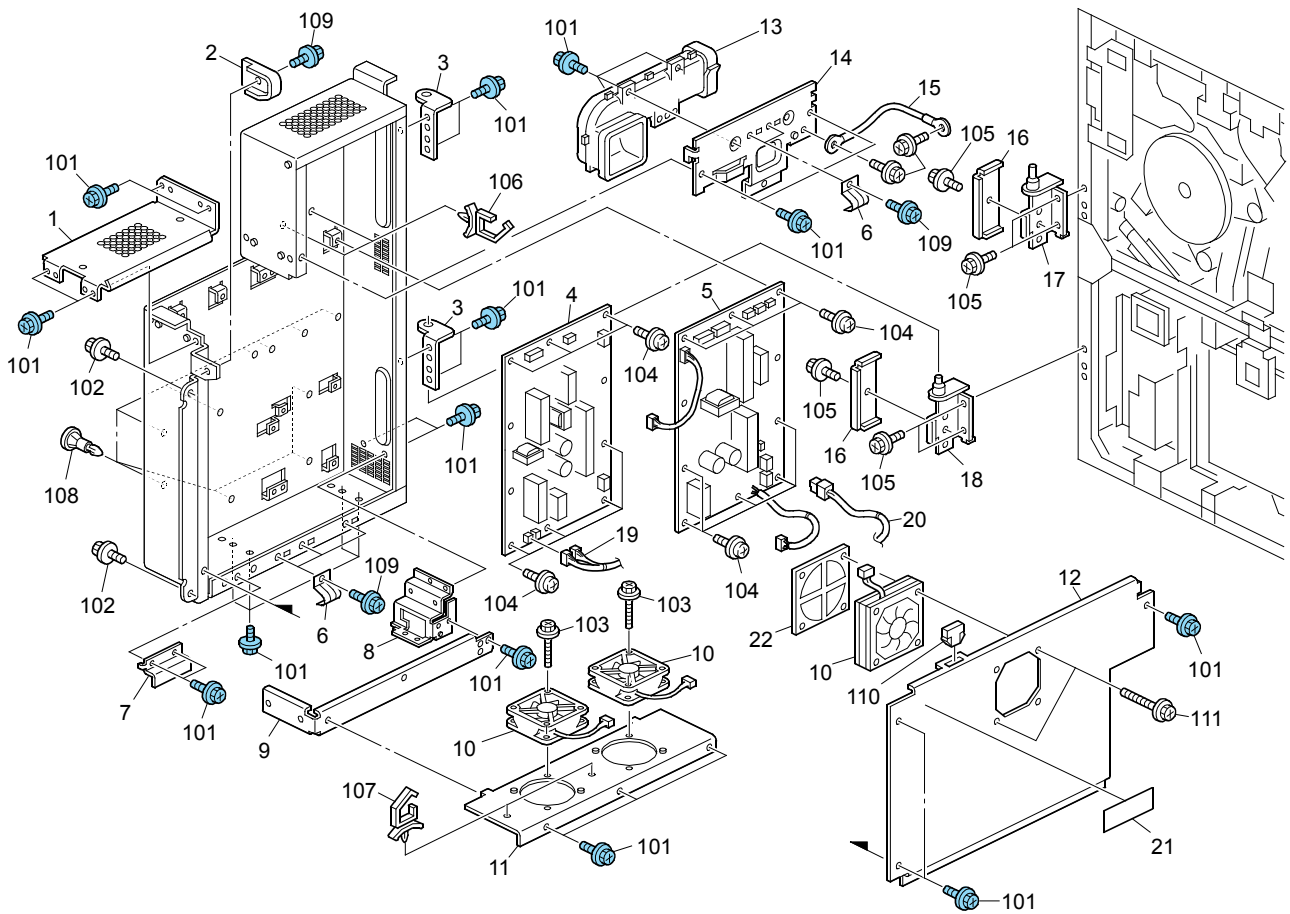

ITEM NO.	PARTS NO.	PARTS NAME	Q'TY / PAGE	Q'TY / PACK	P	I	R	B S I NO.	T O	T	F R O M	S E R I A L NO.	R E M A R K S	C
1	B2347570	Bracket:Power Supply Unit	1											
2	B0706849	Guide:Positioning	1											
3	B2347565	Hinge Bracket - Case	2											
4	AZ260003	Power Supply Unit B	1											
5	AZ260001	Power Supply Unit A	1											
6	A2677586	Grounding Plate	4											
7	B2347568	Receive Bracket - Lower	1											
8	B2347583	Stay:Power Supply Unit:Lo	1											
9	B2347582	Stay:Power Supply Unit:Mi	1											
10	AX640159	Fan Motor MM80	3											
11	B2347592	Bracket:Fan:Power Supply	1											
12	B2347593	Power Supply Unit Cover -	1											
13	B2347512	Duct - Vacuum	1											
14	B2347569	Bracket:Power Supply Unit	1											
15	B0705522	Harness - Ground Wire IEM	1											
16	B2346827	Cover - Hinge	2											
17	B2347566	Hinge Bracket - Upper	1											
18	B2347562	Hinge Bracket - Lower	1											
19	B2345634	Harness - Power Supply Un	1											
20	B2345601	Harness - AC Paper Bank	1											
21	B2347598	Decal:Caution Chart:PSU:S	1											
22	B0706854	Bracket:Fan:Cooling	1											
101	0454008Q	Tapping Screw:3x8												
102	0954008N	Screw - M3X8												
103	0451030N	Tapping Screw:M4x30												
104	0954008N	Screw - M3X8												
105	0451008N	Tapping Screw:4x8												
106	11050490	Harness Clamp - IWS-2218												
107	11050487	Harness Clamp												
108	11050637	Harness Clamp - KGLS-10RT												
109	0454006Q	Tapping Screw - M3x6												
110	11026246	Relay Connector - 4P												
111	0451035N	Tapping Screw:4x35												

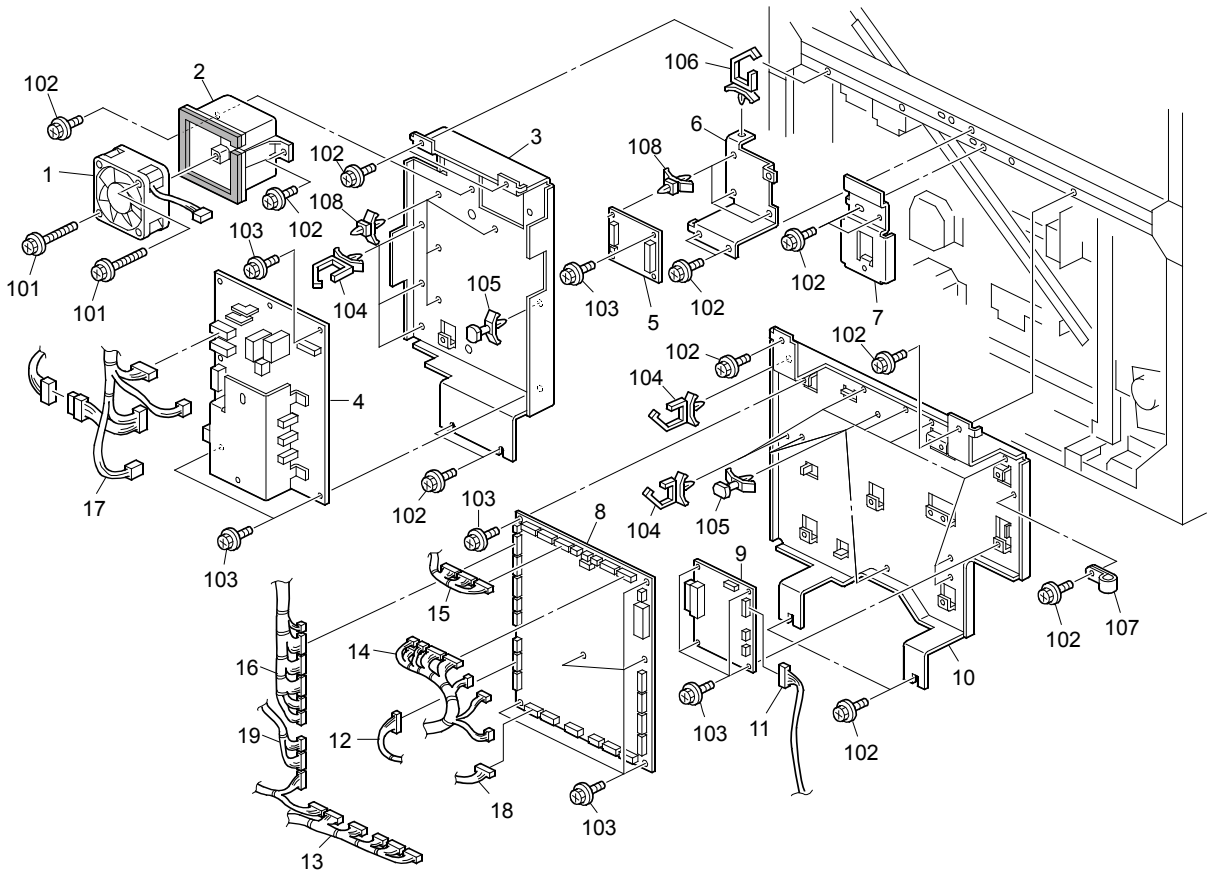

ITEM NO.	PARTS NO.	PARTS NAME	Q'TY / PAGE	Q'TY / PACK	P	I	R	B S I NO.	T O	T	F R O M	S E R I A L NO.	R E M A R K S	C
1	AX640178	Fan Motor DC24V 3.36W	1											
2	B2347580	Vacuum Duct - Inner Back	1											
3	B2347557	Bracket - AC Drive Board	1											
4	B2345410	PCB AC Drive	1											
5	B2345440	PCB Relay Safety Switch	1											
6	B2347556	Safety Switch Bracket	1											
7	B2346830	Stay - Rear	1											
8	B2345241	PCB IOB	1											
9	B2345220	PCB BCU	1											
10	B2347558	Bracket:IOB	1											
11	B2345657	Cable - IPU BCU	1											
12	B2345653	Harness - Paper Bank Left	1											
13	B2345654	Harness - Paper Bank Midd	1											
14	B2345650	Harness - Machine Or Copi	1											
15A	B2345651	Harness - Machine Or Copi	1										e-STUDIO901	
15B	B2355651	Harness - Machine Or Copi	1										e-STUDIO1101	
15C	B2365651	Harness - Machine Or Copi	1										e-STUDIO1351	
16	B2345660	Harness:Machine Or Copier	1											
17	B2345601	Harness - AC Paper Bank	1											
18	B2345655	Harness - Paper Bank Righ	1											
19	B2345662	Harness:Main:Stepper Moto	1											
101	0450035N	Tapping Screw:4x35												
102	0451008N	Tapping Screw:4x8												
103	0451006N	Tapping Screw - 3x6												
104	11050490	Harness Clamp - IWS-2218												
105	11050367	Spacer												
106	11050487	Harness Clamp												
107	11050529	Nylon Clamp-ent-3n												
108	11050192	Locking Support												

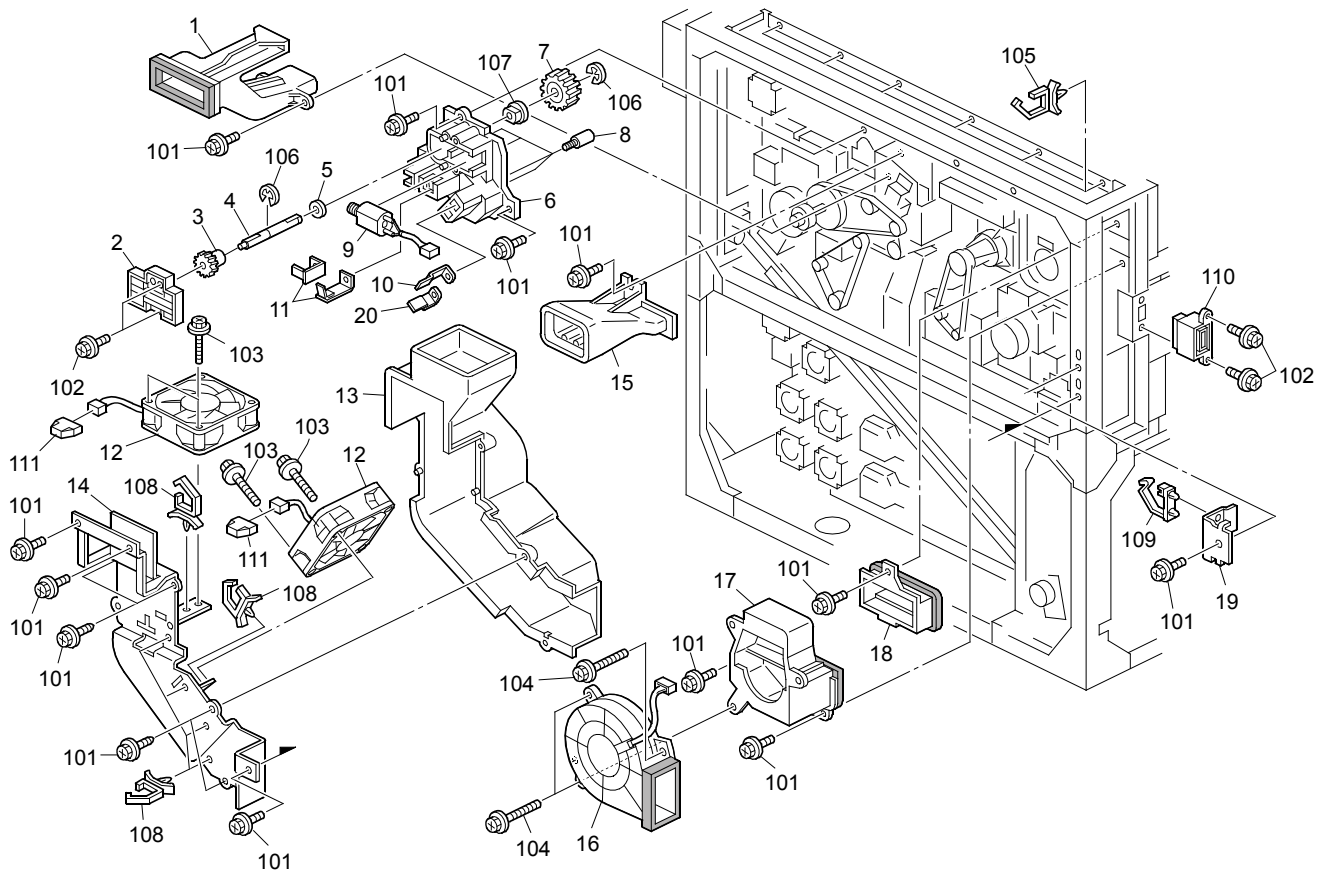

ITEM NO.	PARTS NO.	PARTS NAME	Q'TY / PAGE	Q'TY / PACK	P	I	R	B S I NO.	T O	T	F R O M	S E R I A L NO.	R E M A R K S	C
1	B2342065	Drum Duct	1											
2	B2342101	Cover - Motor	1											
3	B2342097	Gear - 20Z	1											
4	B2342100	Drive Shaft	1											
5	A2323077	Spacer - M5	1											
6	B2342091	Charge Receptacle	1											
7	B2342098	Gear - 14Z	1											
8	B2342092	Terminal Pin	4											
9	AX040147	DC Motor:Cleaner	1											
10	B2342093	Terminal - Pre G	1											
11	A2942122	Receptalce Connector C	2											
12	AX640185	Fan Motor DC24V 4.8W	2											
13	B2344379	Duct - Heat Pipe	1											
14	B2344394	Cover - Duct	1											
15	B2342071	Charge Duct	1											
16	B2341097	Fan Motor DC24V 9.6W	1											
17	B2341182	Duct - Exhaust Fusing Exi	1											
18	B2344395	Duct - Coupling	1											
19	B0706834	Bracket:Clamp	1											
20	B2342096	Terminal - Pre C	1											
101	0451008N	Tapping Screw:4x8												
102	0451008N	Tapping Screw:4x8												
103	0450010N	Tapping Screw - M3x10												
104	0450016N	Tapping Screw - M4x16												
105	11050490	Harness Clamp - IWS-2218												
106	0720030E	Retaining Ring - M3												
107	08053384	Bushing - 5mm												
108	11050511	Harness Clamp - LWS-0306Z												
109	11050211	FCS-3015												
110	11028502	Connector - 54679-1615												
111	11026245	Relay Connector - 2P												

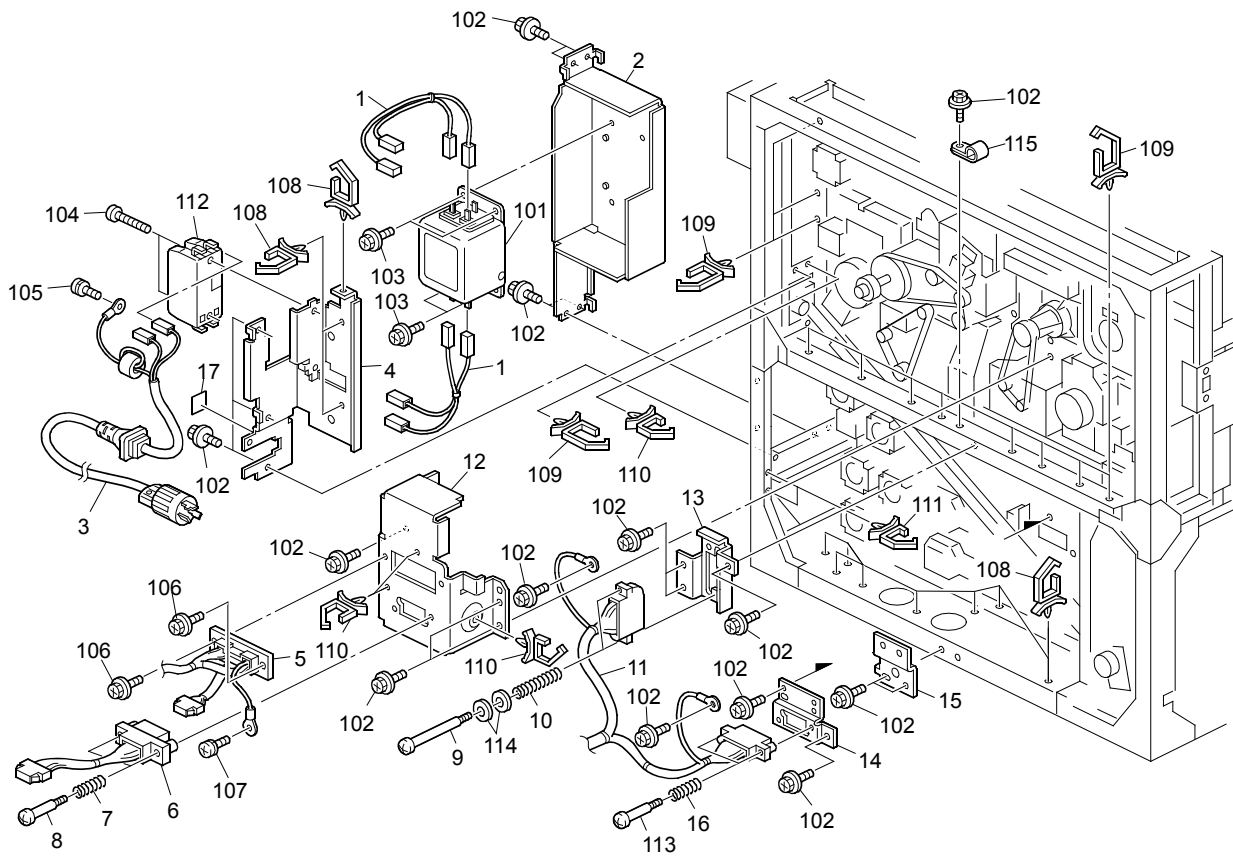

ITEM NO.	PARTS NO.	PARTS NAME	Q'TY / PAGE	Q'TY / PACK	P	I	R	BSI NO.	TO	T	FROM	SERIAL NO.	REMARKS	C
1	B2345604	Harness - AC Noise Filter	2											
2	B2347551	Noise Filter Bracket	1											
3	AZ000109	Power Supply Cord NA	1											
4	B2347587	Power Supply Cord Bracket	1											
5	B2345600	Harness - AC Machine Or C	1											
6	B2345687	Harness - Fusing Lower	1											
7	AA063670	Spring Connector:9.8n	2											
8	AA143797	Connector Guide Pin	2											
9	AA143550	Screw:DIA4:M3	2											
10	AA063583	Spring	2											
11	B2345656	Harness - Paper Bank Tand	1											
12	B2344239	Connector Bracket	1											
13	B1326764	Bracket:Connector:Right	1											
14	B1326763	Bracket:Connector:Left	1											
15	B2346832	Stay - Rear Lower	1											
16	AA063268	Connector Spring	2											
17	AA001190	Decal - Ground	1											
101	16071799	Filter - SUP-ET20-ER-0												
102	0451008N	Tapping Screw:4x8												
103	0451006N	Tapping Screw - 3x6												
104	0434200N	Pan Self-tapping Screw:4x												
105	0950010N	Screw:Spring Washer:M5X10												
106	0451012N	Tapping Screw:4x12												
107	0950006N	Screw - M4X6												
108	11050489	Harness Clamp - LWS 1316												
109	11050490	Harness Clamp - IWS-2218												
110	11050488	Harness Clamp												
111	11050487	Harness Clamp												
112	11071169	Fuse - Bjs201100fcrk												
113	08030058	Stepped Screw												
114	0701040N	Washer:Dia4												
115	11050009	Nylon Clamp - 5n												

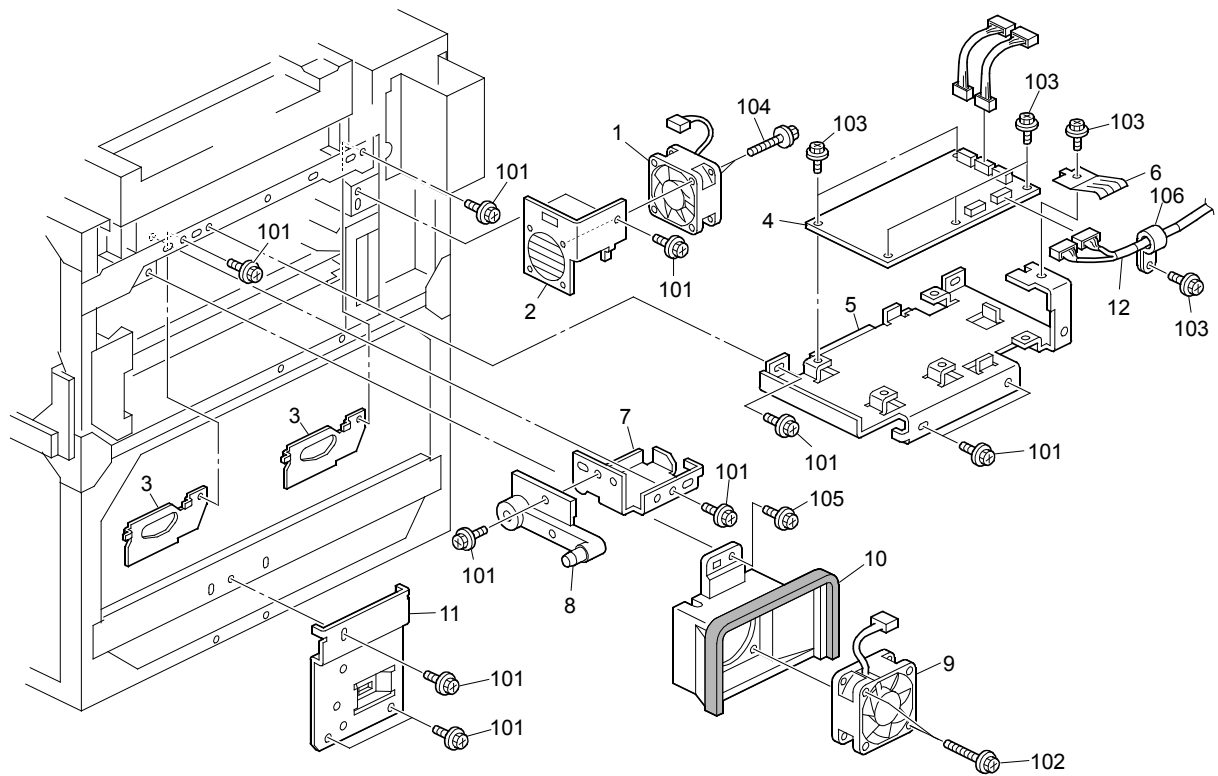

ITEM NO.	PARTS NO.	PARTS NAME	Q'TY / PAGE	Q'TY / PACK	P	I	R	B S I NO.	T O	T	F R O M	S E R I A L NO.	R E M A R K S	C
1	AX640164	Fan Motor:15mm:24V	1											
2	B2343086	Fan Motor Bracket	1											
3	A2943093	Air Block Plate	2											
4	B2345314	PCB:OPU:TEC:Ass'y	1											
5	B2347555	OPU Bracket	1											
6	A2941838	Ground Plate - Lens Stay	1											
7	B2343255	Tube Joint Bracket	1											
8	B2343256	Tube Joint	1											
9	AX640158	Fan Motor MM60/15mm:24V	1											
10	B2343081	Duct:Fan:Ass'y	1											
11	B2347559	Connector Bracket	1											
12	B2345658	Cable - Operation Panel O	1											
101	0451008N	Tapping Screw:4x8												
102	0450025N	Tapping Screw:4x25												
103	0451006N	Tapping Screw - 3x6												
104	0451020N	Tapping Screw - M4x20												
105	0451012N	Tapping Screw:4x12												
106	11050530	Nylon Clamp-ent-4n												

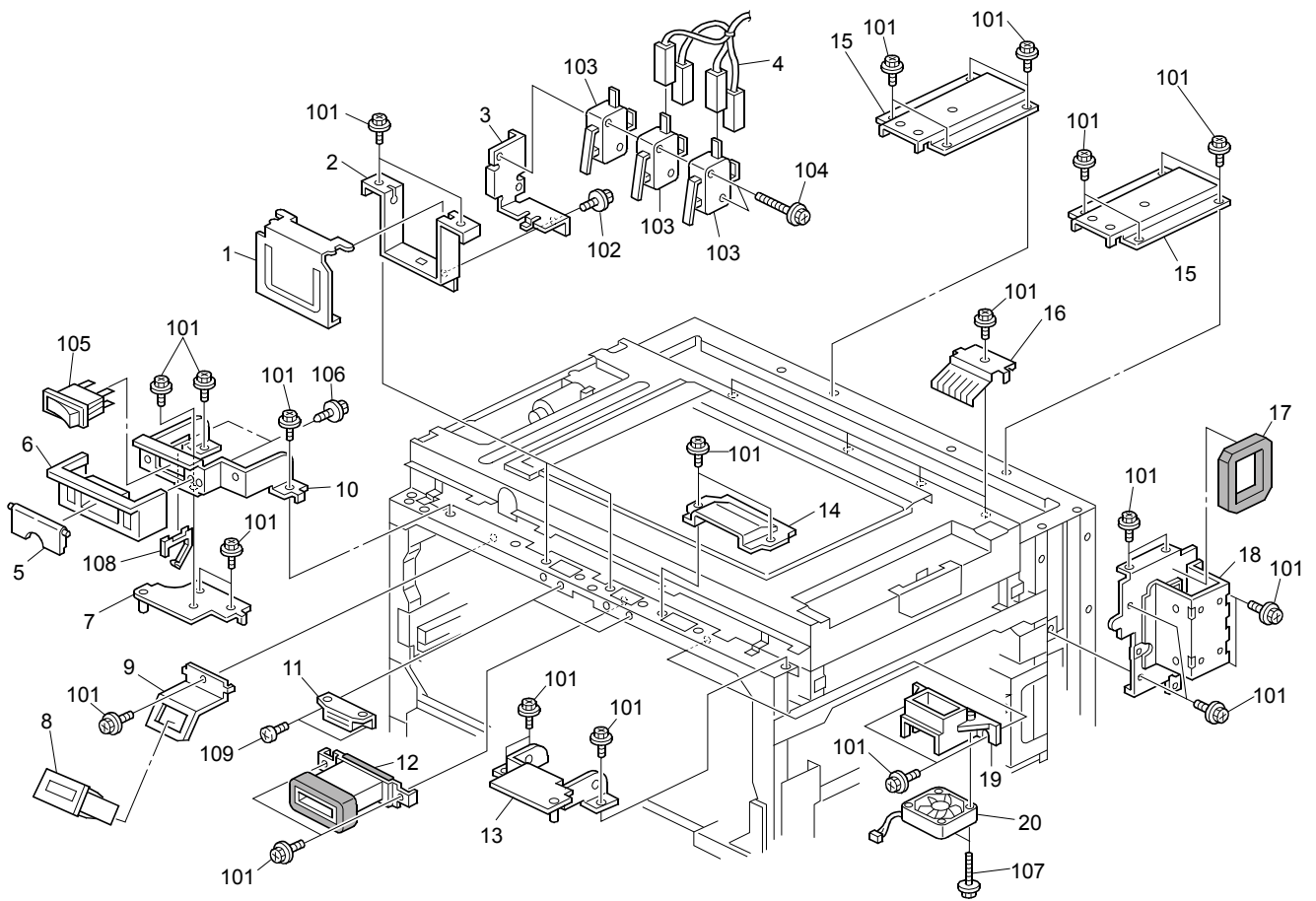

ITEM NO.	PARTS NO.	PARTS NAME	Q'TY / PAGE	Q'TY / PACK	P	I	R	B S I NO.	T O	T	F R O M	S E R I A L NO.	R E M A R K S	C
1	B2347653	Safety Switch Lever	1											
2	B2347651	Safety Switch Bracket A	1											
3	B2347652	Safety Switch Bracket B	1											
4	B2345355	Harness - Safety Switch	1											
5	B0701350	Cover:Main Switch	1											
6	B2341349	Cover - Main Switch	1											
7	B2341360	Hinge:Left Upper:Ass'y	1											
8	AX310047	Total Counter:7FIG:24V:MI	1											
9	A2941347	Bracket - Total Counter	1											
10	B2341354	Bracket:Main Switch	1											
11	AG070504	Magnet Catch:44.In	1											
12	B2341977	Imaging Unit Duct	1											
13	B2341352	Hinge:Right Upper:Ass'y	1											
14	B2342377	Duct - Upper	1											
15	B2341686	ADF Bracket	2											
16	A2941837	Ground Plate - Rear Frame	4											
17	A2942124	Seal - Operation Frame	1											
18	A2941442	Frame - Operation Panel	1											
19	B2342372	Cleaning Fan Holder	1											
20	AX640158	Fan Motor MM60/15mm:24V	1											
101	0451008N	Tapping Screw:4x8												
102	0451008N	Tapping Screw:4x8												
103	12042521	Micro Switch												
104	0451035N	Tapping Screw:4x35												
105	12042614	Switch AC250V/16A												
106	0450006N	Tapping Screw:4x6												
107	0450025N	Tapping Screw:4x25												
108	11050522	Edge Saddle - Les0510												
109	0314080N	Philips Pan Head Screw -												

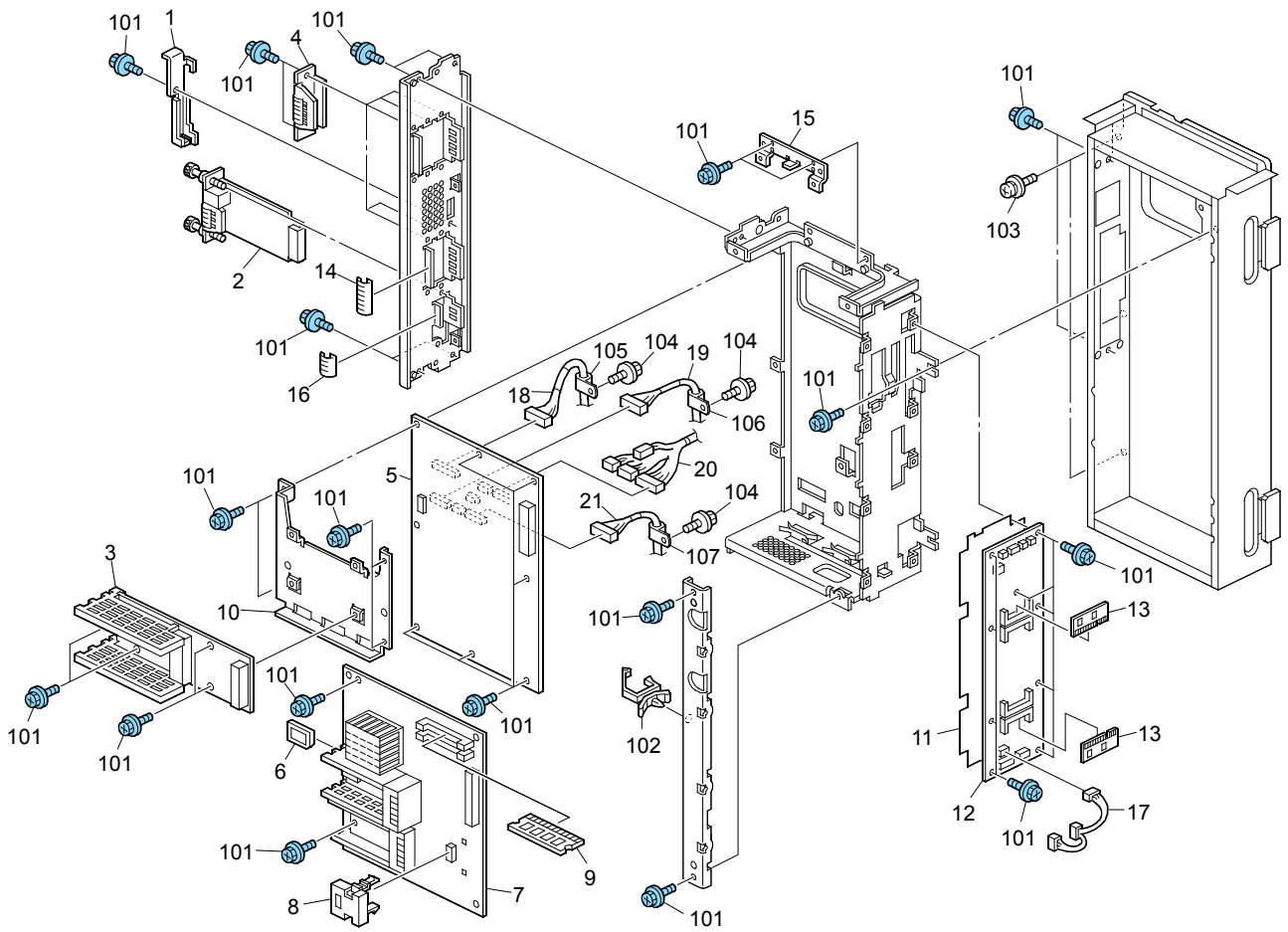

ITEM NO.	PARTS NO.	PARTS NAME	Q'TY / PAGE	Q'TY / PACK	P I R	B S I NO.	T O	T	F R O M	S E R I A L NO.	R E M A R K S	C
1	B2346900	Cover - SD-Card	1									
2	B7365660	PCB:NIC+USB	1									
3	B2345505	PCB Inter Face	1									
4	B1015993	Interface Panel	1									
5	B2345450	PCB IPU	1									
6	B2345535	SD-Card:Copy:B-C3:TEC	1									
7	B2345510	PCB Type-AX2D	1									
8	B2349590	Counter:PCB:Novita 2.2	1									
9	G3325720	PCB:SDRAM-DIMM:256Mb	1									
10	B2346875	Supporter Bracket - Upper	1									
11	B2346868	Insulating Sheet	1									
12	B2345562	PCB Vectra	1									
13	B2345563	PCB DDR-DIMM 128Mb	2									
14	B0706877	Large Drum Stay Ground Pl	1									
15	B2346879	Base Bracket - ICIB-2	1									
16	B0706879	Ground Plate:Drum Stay:Sm	1									
17	B2345585	Harness:HDD:Power Source	1									
18	B2345168	Interface Cable - Scanner	1									
19	B2345357	Cable - LVDS 18p	1									
20	B2345356	Harness - LDB Opu BCU Gwb	1									
21	B2345657	Cable - IPU BCU	1									
101	0454006Q	Tapping Screw - M3x6										
102	11050511	Harness Clamp - LWS-0306Z										
103	0954008N	Screw - M3X8										
104	0451008N	Tapping Screw:4x8										
105	11050559	Clamp:EMT-5N										
106	11050530	Nylon Clamp-emt-4n										
107	11050529	Nylon Clamp-emt-3n										

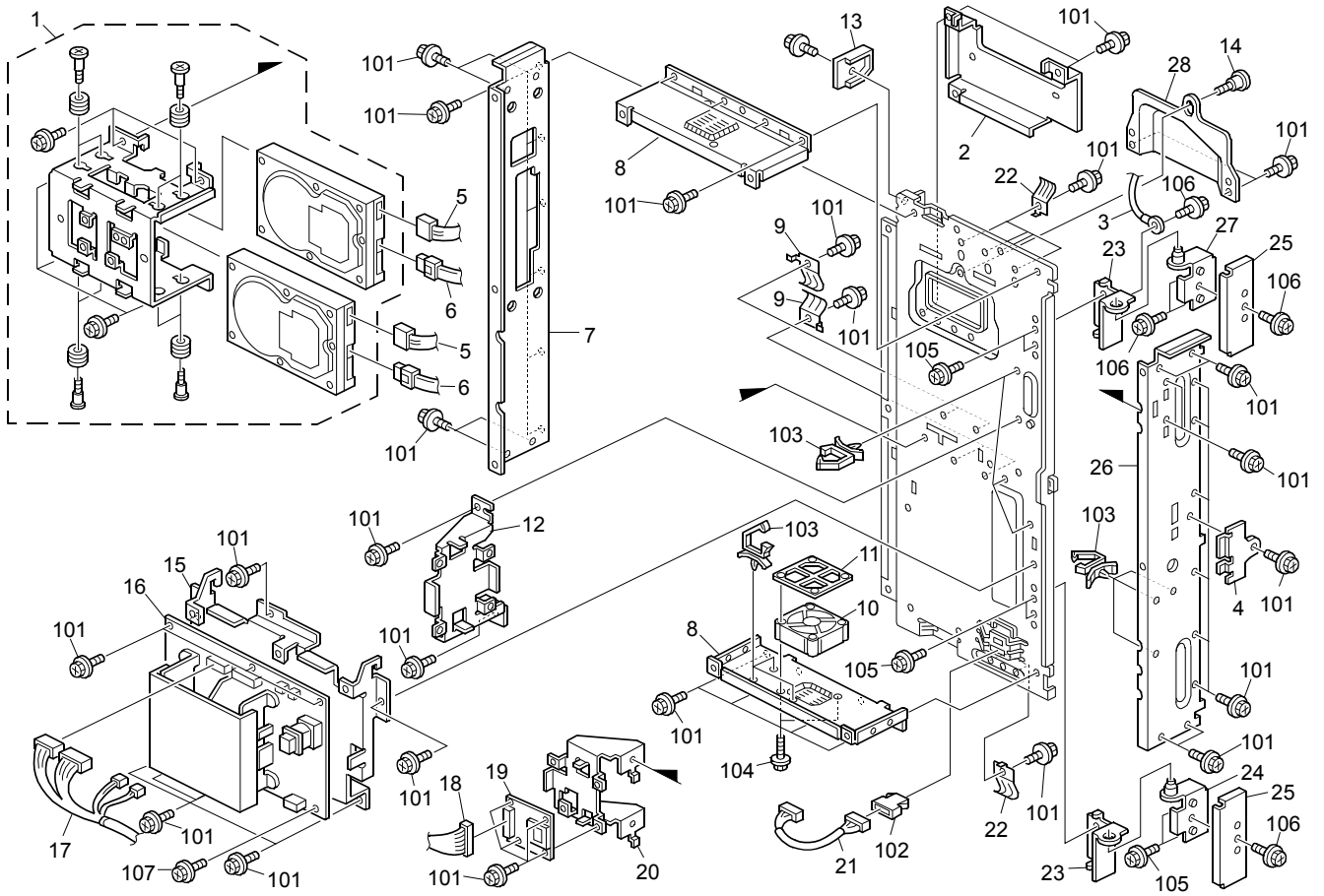

ITEM NO.	PARTS NO.	PARTS NAME	Q'TY / PAGE	Q'TY / PACK	P I R	B S I NO.	T O	T	F R O M	S E R I A L NO.	R E M A R K S	C
1	B2346880	HDD Unit	1									
2	B0706855	Cover:Harness	1									
3	B0705522	Harness - Ground Wire IBM	1									
4	B0706757	CSS Cover	1									
5	B2345522	Cable:HDD:S-ATA:Gray:Rohs	2									
6	B2345521	Cable:HDD:S-ATA:Red:Rohs	2									
7	B2346859	Side Plate:C/T Box:Right	1									
8	B0706856	Side Plate:C/T Box:Upper	2									
9	A2677586	Grounding Plate	4									
10	AX640177	Fan Motor DC12V 3.6W	1									
11	B0706854	Bracket:Fan:Cooling	1									
12	B0706887	Bracket:CSS	1									
13	B0706849	Guide:Positioning	1									
14	54472768	Stepped Screw - M3	1									
15	B0706884	Bracket:Power Supply Unit	1									
16	AZ230195	Power Supply Unit (208V)	1									
17	B2345631	Harness - Power Source	1									
18	B2345592	Harness - SD-Card	1									
19	B2345564	PCB Screwdriver	1									
20	B2346867	PCB Bracket	1									
21	B2345603	Harness - AC Control Sect	1									
22	A2941838	Ground Plate - Lens Stay	1									
23	B0706837	Bracket:Hinge:C/T Box	2									
24	B0706820	Bracket:Hinge:Lower	1									
25	B2346827	Cover - Hinge	2									
26	B0706851	Side Plate:C/T Box:Left	1									
27	B0706821	Bracket:Hinge:Upper	1									
28	B0706852	Cover:Base:C/T Box	1									
101	0454006Q	Tapping Screw - M3x6										
102	11026246	Relay Connector - 4P										
103	11050488	Harness Clamp										
104	0451035N	Tapping Screw:4x35										
105	0434060N	Pan Self-tapping Screw:M4										
106	0451008N	Tapping Screw:4x8										
107	0954008N	Screw - M3X8										

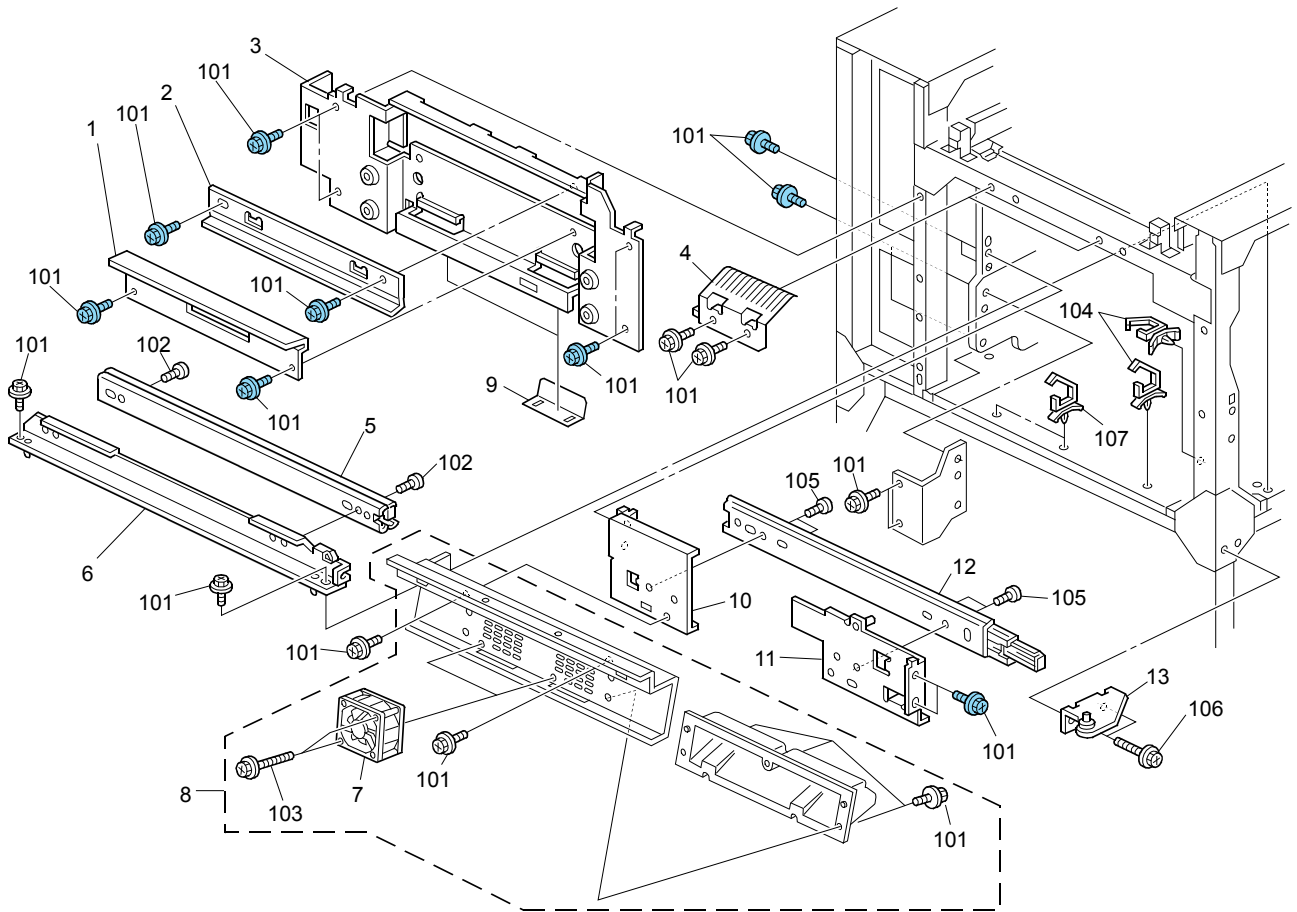

ITEM NO.	PARTS NO.	PARTS NAME	Q'TY / PAGE	Q'TY / PACK	P	I	R	BSI NO.	TO	T	FROM	SERIAL NO.	REMARKS	C
1	B2344403	Exit Guide Plate - Lower	1											
2	B2344404	Exit Guide:Upper	1											
3	B2344335	Drum Stay - Coupling Fini	1											
4	B2341836	Ground Plate - Left Frame	2											
5	AA070081	Slide Rail - Duplex	1											
6	B2344952	Slide Rail Stay - Left	1											
7	AX640178	Fan Motor DC24V 3.36W	1											
8	B2344901	Fan Motor Unit	1											
9	B2344457	Seal - Left	2											
10	B2344409	Slide Rail Bracket	1											
11	B2344407	Slide Rail Bracket	1											
12	B2344490	Slide Rail - Fusing/paper	1											
13	A2941363	Lower Left Hinge	1											
101	0451008N	Tapping Screw:4x8												
102	0434080N	Pan Self-tapping Screw:M4												
103	0451030N	Tapping Screw:M4x30												
104	11050508	Harness Clamp - LWS-0711												
105	0453006N	Tapping Screw - M3x6												
106	0451012N	Tapping Screw:4x12												
107	11050489	Harness Clamp - LWS 1316												

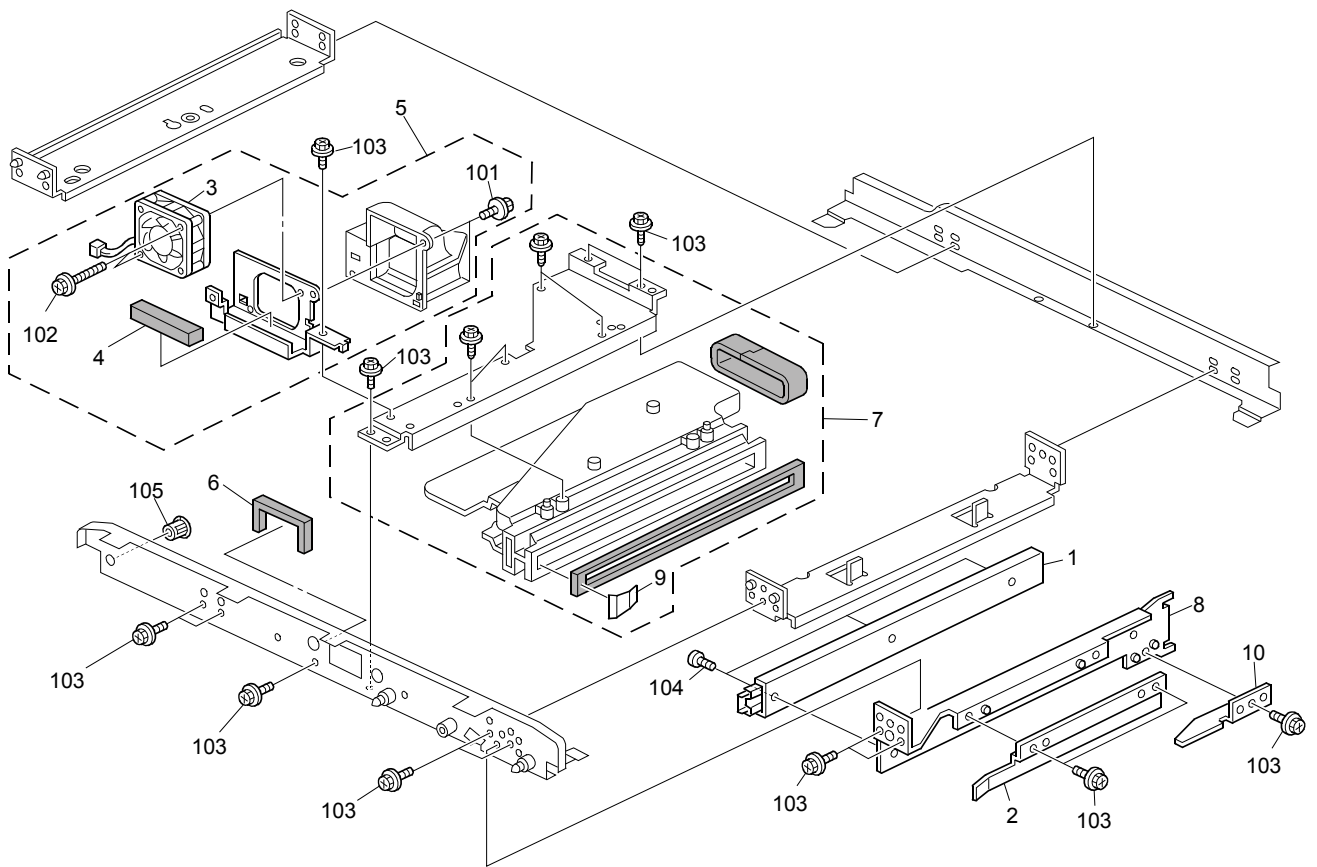

ITEM NO.	PARTS NO.	PARTS NAME	Q'TY / PAGE	Q'TY / PACK	P	I	R	B S I NO.	T O	T	F R O M	S E R I A L NO.	R E M A R K S	C
1	B2342485	Slide Rail	1											
2	B2343097	Guide Plate - Development	1											
3	AX640150	Fan Motor:MM60:25mm:24V	1											
4	B2341975	Fan Motor Seal - Lower	1											
5	B2361970	Fan:Imaging Unit:Unit:DC2	1											
6	B2341976	Fan Motor Seal - Upper	1											
7	B2342170	Machine Or Copier Duct	1											
8	B2343096	Tray Unit Stay - Right	1											
9	A2942109	Entrance Duct Slider	1											
10	B2343098	Guide Plate - Rail Develo	1											
101	0451006N	Tapping Screw - 3x6												
102	0451030N	Tapping Screw:M4x30												
103	0451008N	Tapping Screw:4x8												
104	0354060N	Screw-m4x6												
105	11060200	Bushing - 19.44mm												

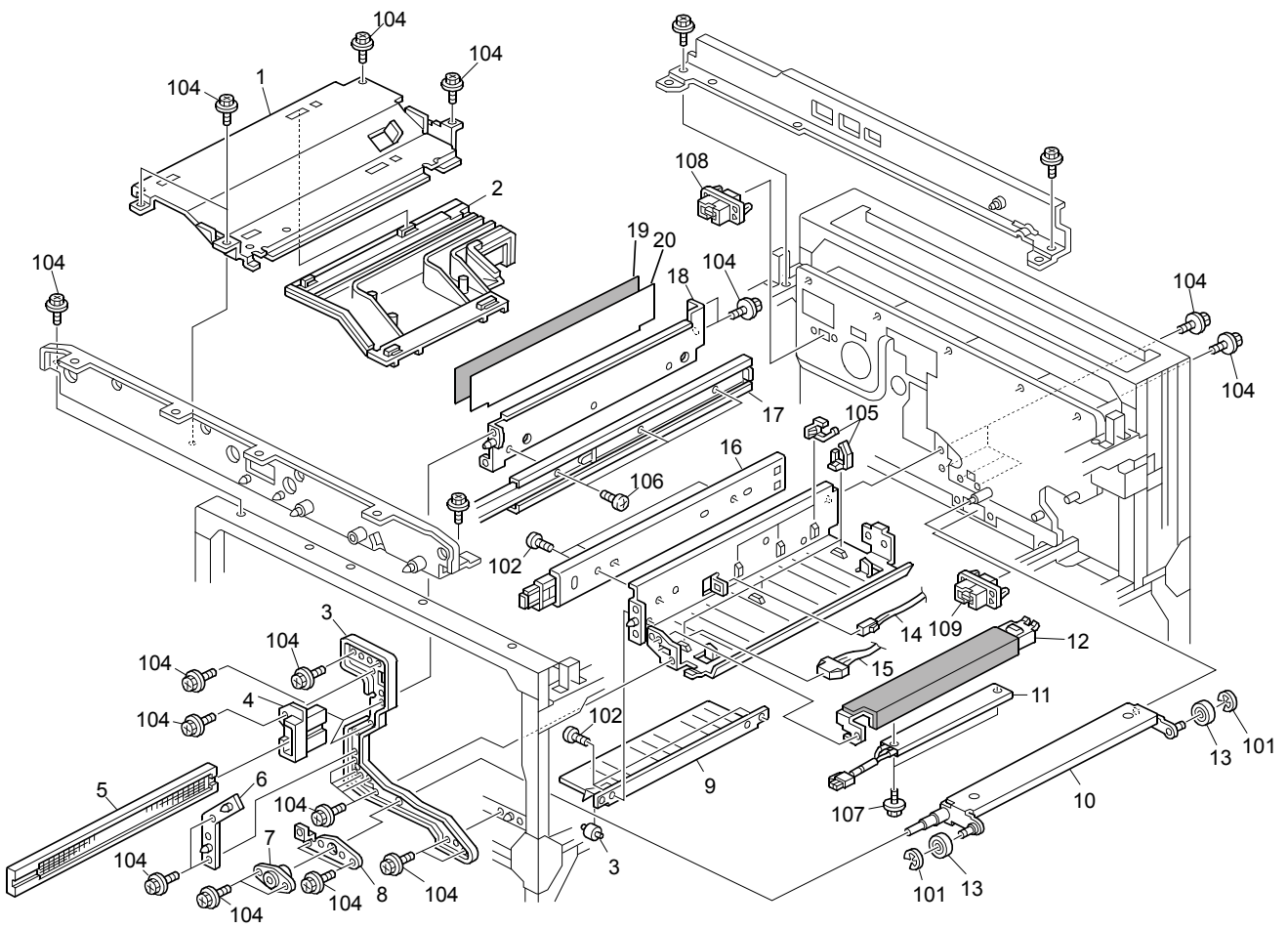

ITEM NO.	PARTS NO.	PARTS NAME	Q'TY / PAGE	Q'TY / PACK	P	I	R	B S I NO.	T O	T	F R O M	S E R I A L NO.	R E M A R K S	C
1	B2344378	Stay:Upper:Duct	1											
2	B2344299	Duct:Exhaust:Upper:Unit	1											
3	AF022154	Roller:Horizontal:Transpo	1											
4	B2342157	Filter Guide	1											
5	B2342158	Filter	1											
6	B2343854	Positioning Plate - Trans	1											
7	AA082064	Bushing - 10mm	1											
8	B2343863	Positioning Plate	1											
9	B2344961	Guide Plate - Duplex Uppe	1											
10	B2343858	Handle Stay	1											
11	AX400198	Heater - 240V/9W	1											
12	B2343871	Heater - Transfer	1											
13	67542866	Roller - Positioning Guid	2											
14	B2345606	Harness - AC Heater	1											
15	B2345690	Harness - Transfer Belt	1											
16	B2344490	Slide Rail - Fusing/paper	1											
17	B2342485	Slide Rail	1											
18	B2342481	Tray Unit Stay - Left	1											
19	B2342487	Stay Heat Insulation - Le	1											
20	B2342486	Guard Bracket - Upper	1											
101	0720040E	Retaining Ring - M4												
102	0453008N	Binding Self Tapping Scre												
103	0360008N	Screw:M3x8												
104	0451008N	Tapping Screw:4x8												
105	11050598	Clamp:LWSS-1N												
106	0354060N	Screw-m4x6												
107	0360006N	Screw - M3X6												
108	11029785	Connector:55949-1819												
109	11029783	Connector:55949-3919												

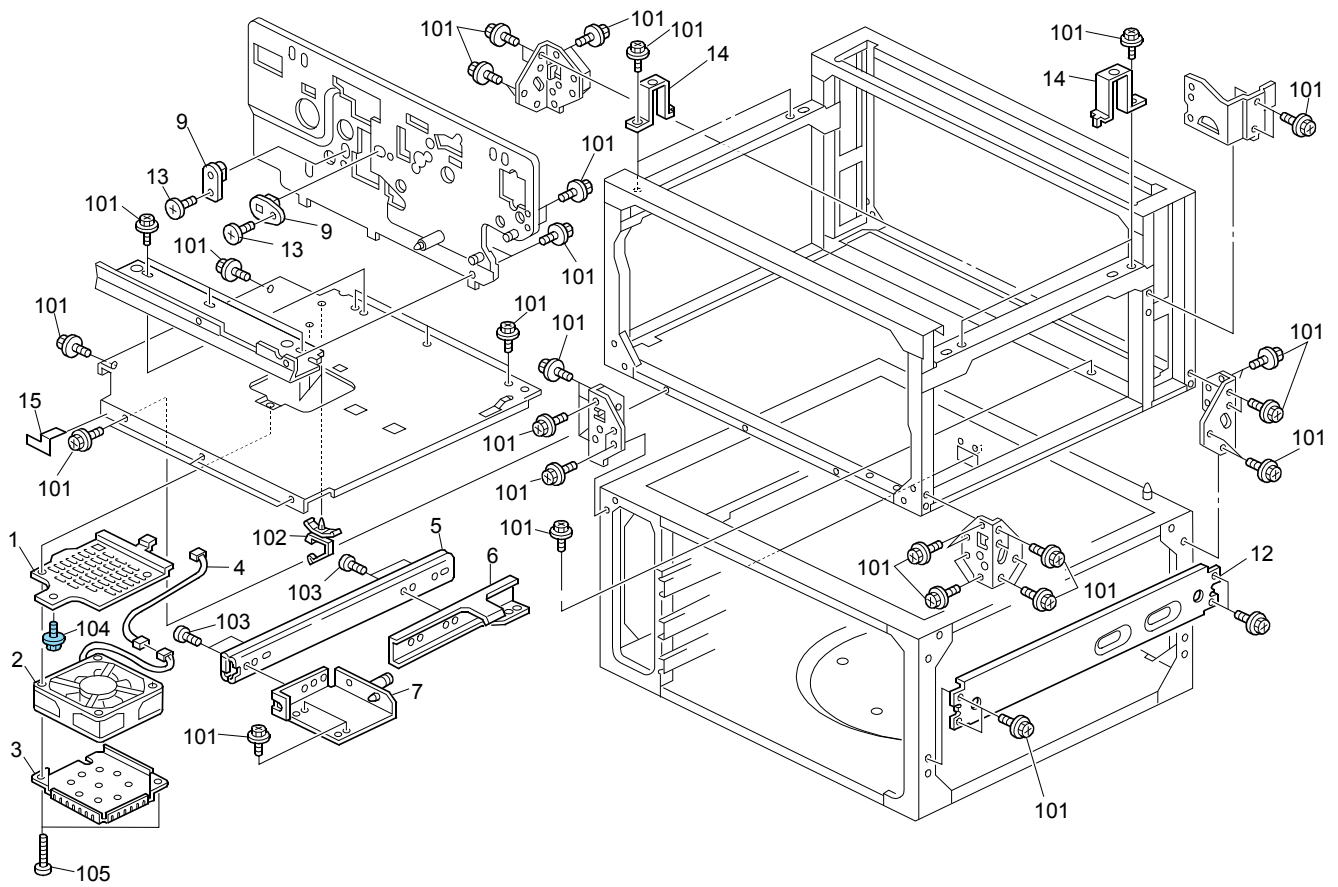

ITEM NO.	PARTS NO.	PARTS NAME	Q'TY / PAGE	Q'TY / PACK	P	I	R	B S I NO.	T O	T	F R O M	S E R I A L NO.	R E M A R K S	C
1	B0704911	Fan Motor Bracket	1											
2	AX640184	Fan Motor DC24V 3.1W	1											
3	B0704912	Cover:Fan:Duplex:Lower	1											
4	B2345693	Harness: - Duplex Fan Mot	1											
5	AA070081	Slide Rail - Duplex	1											
6	B2344957	Slide Rail Stay - Right R	1											
7	B2341080	Channel Bracket - Middle	1											
8	B2344155	Positioning Pin No.2	1											
9	B2344154	Positioning Pin No.1	1											
12	B0701041	Stay:Right Sideways:Lower	1											
13	55066197	Screw - Knife Cam - Leadi	2											
14	B2341099	Holder:Base:Image Reading	1											
15	B2344954	Shoe:Duplex Unit:Left Fro	1											
101	0451008N	Tapping Screw:4x8												
102	11050511	Harness Clamp - LWS-0306Z												
103	0434080N	Pan Self-tapping Screw:M4												
104	08025281	Tapping Screw - M4x6												
105	0354200N	Screw:M4X20												
106	0314040N	Pan Head Screw - M4x4												

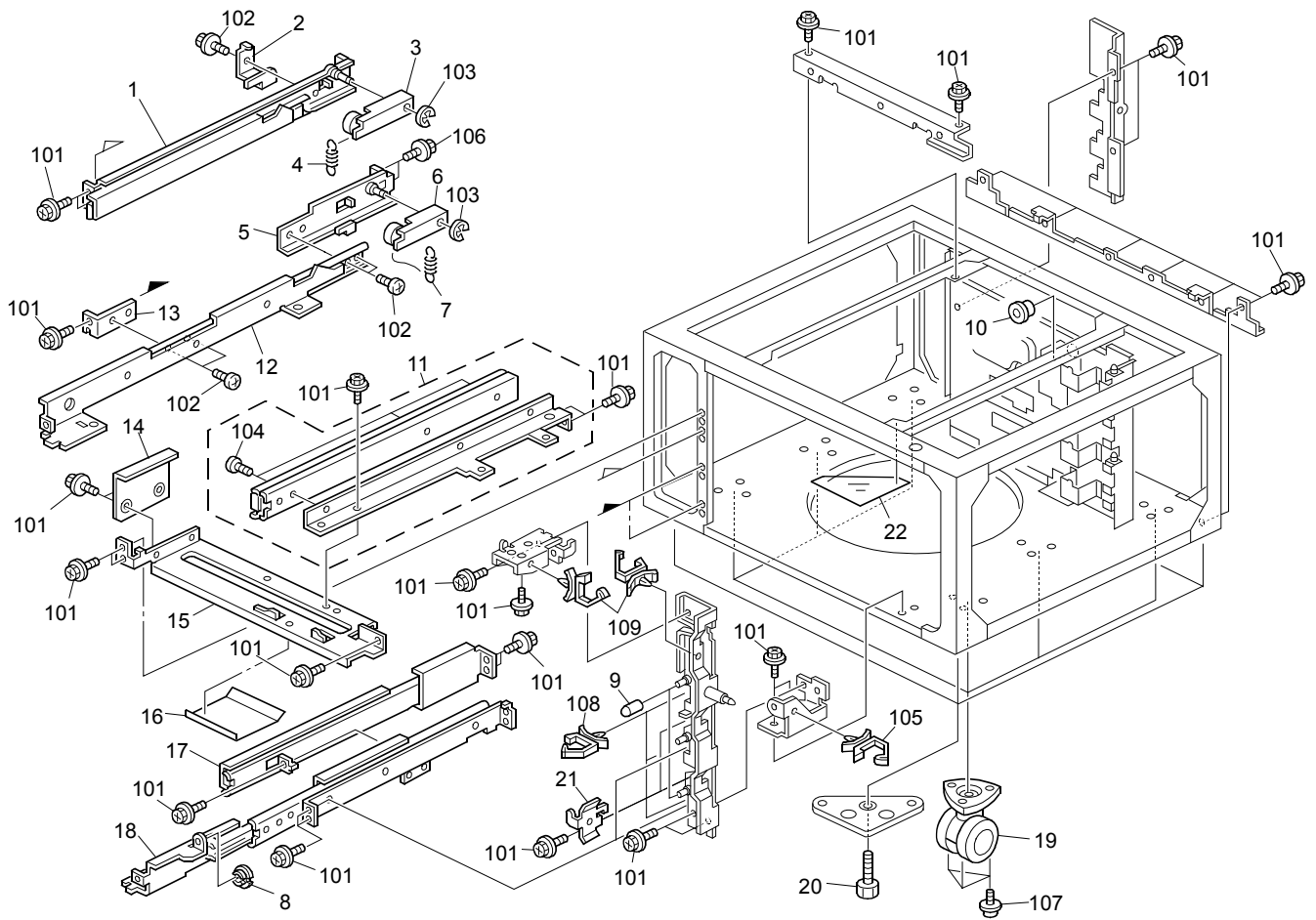

ITEM NO.	PARTS NO.	PARTS NAME	Q'TY / PAGE	Q'TY / PACK	P I R	B S I NO.	T O	T	F R O M	S E R I A L NO.	R E M A R K S	C
1	B2346160	Tandem LCT Rail - Left	1									
2	B1326742	Left Rail Bracket	1									
3	B0656135	Lock Arm - Tandem Tray	1									
4	AA060761	Spring	1									
5	B2346173	Rail Stay - Left	1									
6	B0656136	Tray Lock Arm	1									
7	AA060534	Tray Lock Spring - 19mm	1									
8	B2346188	Slide Sleeve Positioning	1									
9	B0042995	Cap - Positioning	1									
10	B2346141	Positioning Sleeve - Inne	1									
11	B2346138	Rail - Tandem LCT	1									
12	B1326692	Slide Rail:Left:Sub-ass'y	2									
13	B2346170	Slide Rail Bracket - Left	2									
14	B0656777	Supporting Plate	1									
15	B2346169	Stay - Tandem LCT	1									
16	AA150406	Seal - Misfeed Removal	1									
17	B1327591	Rail:Paper Tray:Ass'y	1									
18	B2346181	Slide Rail - Right	2									
19	AH012031	Caster:1470N	6									
20	AA143798	Hexagonal Bolt:M12x35	4									
21	B2346125	Harness Guide Bracket	1									
22	A0966693	Paper Guide Sheet	1									
101	0451008N	Tapping Screw:4x8										
102	0314060N	Screw - M4x6										
103	0720040E	Retaining Ring - M4										
104	0314040N	Pan Head Screw - M4x4										
105	11050508	Harness Clamp - LWS-0711										
106	0451006N	Tapping Screw - 3x6										
107	0951012N	Screw - M6X12										
108	11050516	Clamp										
109	11050487	Harness Clamp										

CAPACITOR

SYMBOL NO.	INDEX NO.	SYMBOL NO.	INDEX NO.	SYMBOL NO.	INDEX NO.	SYMBOL NO.	INDEX NO.	SYMBOL NO.	INDEX NO.	SYMBOL NO.	INDEX NO.	SYMBOL NO.	INDEX NO.
C101	132	C111	132	---	---	---	---	C141	132	C151	129	C161	153
C102	127	C112	130	---	---	C132	132	C142	130	C152	132	C162	132
C103	134	C113	132	C123	130	C133	132	C143	132	C153	130	C163	133
C104	127	C114	130	C124	132	C134	130	C144	130	C154	132	---	---
C105	132	C115	129	C125	130	C135	132	---	---	C155	132	C165	132
C106	132	C116	132	C126	130	C136	132	C146	128	C156	129	C166	132
C107	132	C117	132	C127	130	C137	130	C147	132	C157	130	C167	132
C108	132	C118	130	C128	130	C138	132	C148	132	C158	130	C168	132
C109	130	C119	136	C129	132	C139	132	C149	132	---	---	C169	135
C110	132	C120	131	C130	128	C140	132	C150	132	---	---	---	---

CA

SYMBOL NO.	INDEX NO.
CA101	137
CA102	137

CONNECTOR

SYMBOL NO.	INDEX NO.
CN251	102
CN252	104
---	---
CN254	103
CN255	105
---	---
CN256	101
CN257	106

DIONE

SYMBOL NO.	INDEX NO.
D101	107
D102	108

IC

SYMBOL NO.	INDEX NO.
IC101	120
IC102	155
IC103	113
---	---
IC105	154
IC106	119
---	---
IC108	115
IC109	115
IC110	118
IC111	118

JP

SYMBOL NO.	INDEX NO.
JP101	142
JP102	142

LED

SYMBOL NO.	INDEX NO.
LED101	109
LED102	110
LED103	111

OSC

SYMBOL NO.	INDEX NO.
OSC101	123

RESISTOR

SYMBOL NO.	INDEX NO.	SYMBOL NO.	INDEX NO.	SYMBOL NO.	INDEX NO.	SYMBOL NO.	INDEX NO.	SYMBOL NO.	INDEX NO.	SYMBOL NO.	INDEX NO.	SYMBOL NO.	INDEX NO.
R101	146	---	---	---	---	R131	152	R141	146	R151	143	---	---
R102	144	R112	150	R122	143	R132	146	R142	149	R152	143	R162	146
R103	144	R113	150	R123	149	R133	152	R143	146	R153	143	R163	146
R104	144	R114	146	R124	149	R134	149	R144	149	R154	143	---	---
R105	146	---	---	---	---	R135	145	R145	145	R155	147	---	---
---	---	R116	150	R126	146	R136	146	R146	145	R156	146	---	---
R107	148	R117	146	R127	151	R137	150	R147	143	R157	146	---	---
R108	145	R118	150	R128	146	R138	145	R148	143	---	---	R168	145
---	---	R119	150	R129	145	R139	146	R149	143	R159	146	R169	146
---	---	---	---	R130	152	R140	146	R150	143	---	---	R170	145

RESISTOR

SYMBOL NO.	INDEX NO.	SYMBOL NO.	INDEX NO.	SYMBOL NO.	INDEX NO.	SYMBOL NO.	INDEX NO.	SYMBOL NO.	INDEX NO.	SYMBOL NO.	INDEX NO.	SYMBOL NO.	INDEX NO.
R171	146	R181	143	---	---	---	---	RN101	139	---	---	RN121	124
R172	145	R182	143	R192	145	REG101	122	RN102	139	RN112	124	RN122	138
---	---	R183	143	R193	146	---	---	RN103	141	---	---	RN123	138
---	---	R184	143	R194	146	---	---	RN104	141	RN114	124	RN124	139
---	---	R185	150	R195	146	---	---	RN105	141	RN115	125	RN125	139
---	---	R186	150	R196	150	---	---	RN106	138	RN116	138	RN126	138
R177	143	---	---	R197	145	---	---	RN107	139	RN117	138	RN127	126
R178	143	R188	145	R198	149	---	---	RN108	138	---	---	RN128	124
R179	143	---	---	---	---	---	---	RN109	138	RN119	124	RN129	140
R180	143	R190	145	---	---	---	---	---	---	---	---	RN130	140

REG

SYMBOL NO.	INDEX NO.
REG101	122

RN

SYMBOL NO.	INDEX NO.	SYMBOL NO.	INDEX NO.	SYMBOL NO.	INDEX NO.	SYMBOL NO.	INDEX NO.
RN101	139	---	---	RN116	138	RN121	124
RN102	139	RN112	124	RN117	138	RN122	138
RN103	141	---	---	---	---	RN123	138
RN104	141	RN114	124	---	---	RN124	139
RN105	141	RN115	125	RN119	124	RN125	139
RN106	138	---	---	---	---	RN126	138
RN107	139	---	---	---	---	RN127	126
RN108	138	---	---	---	---	RN128	124
RN109	138	---	---	---	---	RN129	140
---	---	---	---	---	---	RN130	140

RN

SYMBOL NO.	INDEX NO.
RN131	140
RN132	140
RN133	140
RN134	139
RN135	139
---	---
RN137	125
RN138	138

ITEM NO.	PARTS NO.	PARTS NAME	Q'TY / PAGE	Q'TY / PACK	P I R	B S I NO.	T O	T	F R O M	S E R I A L NO.	R E M A R K S	C
0	B2345220	PCB BCU	1									
101	11026297	Connector - 4P										
102	11027699	Connector:TX24-50R-LT-H1E										
103	11028091	Connector - 53505-4010										
104	11028474	Connector:55447-1080										
105	11028475	Connector:55447-1180										
106	11033427	Connector:Fh12-49S-0.5Sv(
107	14021336	Diode - 1SS355										
108	14021565	Diode:RB521S-30										
109	14030953	LED - SML-310MT										
110	14030978	LED:SML-310DT										
111	14030996	LED - SML-310VT										
112	14075353	IC - SN74LV244APW										
113	14075366	IC - 74LVC08A TSSOP										
114	14075392	IC:SN74LV541APW										
115	14075463	IC - SN74LV245APW										
116	14075469	IC - SN74LV07APW										
117	14075511	IC - SN74LV14APW										
118	14075633	IC:SN74LV574APW										
119	14076166	IC - ESOC										
120	14081730	IC - MM1096BF										
121	14081736	Operational Amplifier:LMV										
122	14081818	Series Regulator:LM1117MP										
123	15031215	Crystal Oscillator - 17.5M										
124	16017752	Resistor Array - 10K OHM										
125	16017867	Resistor - 33 OHM +-5% 1/										
126	16017871	Resistor - 68OHM +-5% 1/1										
127	16044894	Capacitor:100UF:+-20%:16V										
128	16051202	Capacitor - 15PF +-5% 50V										
129	16051208	Capacitor:100pf:+-5%:50v										
130	16051212	Capacitor - 470PF +-10% 5										
131	16051214	Capacitor - 1000PF +-10%										
132	16051221	Capacitor - 0.1 UF+80-20%										
133	16051234	Capcitor:4700pf:+-10%:50V										
134	16051281	Capacitor - 0.22UF +-10%										
135	16051291	Capacitor:2.2uf:+-10%:10v										
136	16051454	Capacitor:0.33UF:+-10%:6.										
137	16051483	Capacitor:0.01UF:+-20%:25										
138	16090005	Resistor:33 Ohm:+-5%:1/16										
139	16090006	Resistor:10k Ohm:+-5%:1/1										
140	16090016	Resistor:56OHM:+-5%:1/16W										
141	16090020	Resistor:10 Ohm:+-5%:1/16										
142	16340000	Resistor - 0 OHM 1/16W										
143	16504100	Resistor - 10OHM +-5% 1/1										
144	16504101	Resistor - 100OHM+-5%1/10										
145	16504102	Resistor - 1KOHM +-5% 1/1										
146	16504103	Resistor - 10KOHM +-5% 1/										
147	16504104	Resistor - 100KOHM+-5%1/1										
148	16504105	Resistor - 1MOHM +-5% 1/1										
149	16504222	Resistor - 2.2KOHM+-5%1/1										
150	16504330	Chip Resistor - 33ohm +-5										
151	16504560	Chip Resistor - 56ohm +-5										
152	16504681	Resistor - 680OHM +-5% 1/										
153	16604103	Capacitor - 10000pf - +-1										
154	19070013	SDRAM:256M:4MX16X4:133Mhz										
155	19060101	Flash Memory:S29G1032A90T										

CAPACITOR

SYMBOL NO.	INDEX NO.	SYMBOL NO.	INDEX NO.	SYMBOL NO.	INDEX NO.	SYMBOL NO.	INDEX NO.	SYMBOL NO.	INDEX NO.	SYMBOL NO.	INDEX NO.	SYMBOL NO.	INDEX NO.
C101	185	C111	186	C121	240	C131	237	C141	236	C151	239	C161	239
C102	240	C112	239	C122	239	C132	239	C142	239	C152	239	C162	239
C103	185	C113	186	C123	240	C133	240	C143	238	C153	239	C163	181
C104	183	C114	185	C124	235	C134	185	C144	238	C154	189	C164	240
C105	239	C115	186	C125	235	C135	184	C145	239	C155	238	C165	240
C106	239	C116	239	C126	186	C136	183	C146	239	C156	240	C166	240
C107	239	C117	186	C127	240	C137	190	---	---	C157	182	C167	190
C108	239	C118	185	---	---	C138	190	---	---	C158	239	C168	190
C109	240	C119	185	C129	239	C139	236	C149	187	C159	239	C169	240
C110	186	C120	239	C130	239	C140	239	C150	187	C160	181	C170	240

CAPACITOR

SYMBOL NO.	INDEX NO.	SYMBOL NO.	INDEX NO.	SYMBOL NO.	INDEX NO.	SYMBOL NO.	INDEX NO.	SYMBOL NO.	INDEX NO.	SYMBOL NO.	INDEX NO.	SYMBOL NO.	INDEX NO.
C171	240	C181	240	C191	240	C201	240	C211	186	C221	239	C231	240
C172	239	C182	186	C192	240	C202	240	C212	240	C222	186	C232	240
C173	239	C183	240	C193	240	C203	240	C213	186	C223	240	C233	240
C174	239	C184	186	C194	186	C204	186	C214	240	C224	186	C234	186
C175	240	C185	240	C195	240	C205	240	C215	239	C225	240	C235	186
C176	239	C186	186	C196	186	C206	186	C216	240	C226	186	C236	186
C177	239	C187	240	C197	186	C207	240	C217	239	C227	240	C237	186
C178	238	C188	240	C198	186	C208	240	C218	240	C228	240	C238	186
C179	238	C189	186	C199	186	C209	186	C219	239	C229	186	C239	240
C180	239	C190	240	C200	240	C210	240	C220	239	C230	240	C240	240

CAPACITOR

SYMBOL NO.	INDEX NO.	SYMBOL NO.	INDEX NO.	SYMBOL NO.	INDEX NO.	SYMBOL NO.	INDEX NO.	SYMBOL NO.	INDEX NO.	SYMBOL NO.	INDEX NO.	SYMBOL NO.	INDEX NO.
C241	240	C251	240	C261	239	C271	240	C281	240	C291	188	CA101	191
C242	240	C252	186	C262	240	C272	239	C282	239	C292	188	CA102	194
C243	186	C253	240	C263	239	C273	240	C283	240	C293	188	CA103	192
C244	240	C254	239	C264	240	C274	186	C284	239	C294	188	CA104	192
C245	186	C255	240	C265	239	C275	240	C285	240	C295	190	CA105	192
C246	240	C256	239	C266	239	C276	239	C286	239			CA106	192
C247	240	C257	239	C267	239	C277	240	C287	240			CA107	192
C248	186	C258	240	C268	236	C278	239	C288	240			---	---
C249	240	C259	239	C269	236	C279	240	C289	188			CA109	192
C250	186	C260	240	C270	236	C280	239	C290	188			CA110	192

CA

CA

SYMBOL NO.	INDEX NO.	SYMBOL NO.	INDEX NO.	SYMBOL NO.	INDEX NO.	SYMBOL NO.	INDEX NO.	SYMBOL NO.	INDEX NO.	SYMBOL NO.	INDEX NO.		
CA111	192	CA121	192	CA131	192	CN301	110	CN311	117	CN321	112	CN331	101
CA112	192	CA122	192	CA132	192	CN302	118	---	---	CN322	114		
CA113	192	CA123	192	CA133	192	CN303	116	CN313	111	CN323	105		
CA114	192	CA124	192			CN304	113	CN314	109	CN324	107		
CA115	192	CA125	193			CN305	102	CN315	116	CN325	104		
CA116	192	CA126	193			CN306	119	CN316	117	CN326	105		
CA117	192	CA127	193			CN307	118	CN317	119	CN327	115		
CA118	192	CA128	193			CN308	103	CN318	105	CN328	108		
CA119	192	CA129	193			CN309	117	CN319	104	CN329	106		
CA120	192	CA130	193			CN310	105	CN320	115	CN330	117		

CONNECTOR

DIODE

SYMBOL NO.	INDEX NO.
D101	145
D102	145
D103	148
D104	140
D105	143
D106	143
D107	143
D108	145
D109	142
D110	141

SYMBOL NO.	INDEX NO.
D111	144
D112	144
D113	144
D114	145
---	---
D116	147
D117	144
D118	145
D119	145
D120	147

SYMBOL NO.	INDEX NO.
D121	145
D122	145
D123	145
D124	145
---	---
D126	148
D127	148
D128	145

DA

SYMBOL NO.	INDEX NO.
DA101	148
DA102	144

SYMBOL NO.	INDEX NO.
FU101	122
FU102	121
FU103	121
FU104	120
FU105	122
FU106	122
FU107	122

IC

SYMBOL NO.	INDEX NO.
IC101	162
IC102	162
IC103	162
IC104	152
IC105	162
IC106	151
IC107	159
IC108	151
IC109	157
IC110	150

SYMBOL NO.	INDEX NO.
IC111	162
IC112	162
IC113	162
IC114	161
IC115	155
IC116	1
IC117	155
IC118	152
IC119	152
IC120	162

IC

SYMBOL NO.	INDEX NO.
IC121	162
IC122	164
IC123	156
IC124	168
IC125	160
IC126	160
IC127	167
IC128	162
IC129	162
IC130	152

SYMBOL NO.	INDEX NO.
IC131	159
IC132	154
IC133	169
IC134	160
IC135	160
IC136	162
IC137	162
IC138	162
IC139	150
IC140	156

SYMBOL NO.	INDEX NO.
IC141	158
IC142	155
IC143	151
IC144	166
IC145	151
IC146	151
IC147	163
IC148	163
IC149	155
IC150	163

SYMBOL NO.	INDEX NO.
IC151	152
IC152	153
IC153	163

LED

SYMBOL NO.	INDEX NO.
LED101	149
LED102	149

OSC

SYMBOL NO.	INDEX NO.
OSC101	171

Q

SYMBOL NO.	INDEX NO.
---	---
---	---
Q103	128
Q104	128
Q105	134
Q106	134
Q107	137
Q108	137
Q109	126
Q110	126

SYMBOL NO.	INDEX NO.
Q111	135
Q112	135
Q113	135
Q114	128
Q115	128
Q116	124
Q117	126
Q118	126
Q119	138
Q120	126

Q

SYMBOL NO.	INDEX NO.
Q121	133
Q122	137
Q123	128
---	---
Q125	139
Q126	165
Q127	131
Q128	131
Q129	129
Q130	129

SYMBOL NO.	INDEX NO.
Q131	125
Q132	126
Q133	128
Q134	128
Q135	132
Q136	132
Q137	132
Q138	128
Q139	128
Q140	128

SYMBOL NO.	INDEX NO.
Q141	134
---	---
Q143	132
Q144	132
Q145	150
Q146	150
Q147	137
Q148	137
Q149	136
Q150	127

SYMBOL NO.	INDEX NO.
Q151	130
Q152	134
Q153	137
Q154	137
Q155	137
---	---
Q157	134
Q158	130

RESISTOR

SYMBOL NO.	INDEX NO.
R101	206
R102	205
R103	206
R104	206
R105	206
R106	204
R107	206
R108	204
R109	206
R110	204

SYMBOL NO.	INDEX NO.
R111	173
R112	173
R113	173
R114	212
R115	206
R116	212
R117	206
R118	212
R119	212
R120	212

SYMBOL NO.	INDEX NO.
R121	212
R122	206
R123	212
R124	206
R125	212
R126	212
R127	206
R128	212
R129	204
R130	206

RESISTOR

SYMBOL NO.	INDEX NO.
R131	232
R132	206
R133	205
R134	232
R135	234
R136	200
R137	200
R138	200
R139	200
R140	172

SYMBOL NO.	INDEX NO.
R141	206
R142	200
R143	204
R144	205
R145	208
---	---
R147	206
R148	206
---	---
R150	205

SYMBOL NO.	INDEX NO.
R151	208
R152	215
R153	220
R154	209
R155	209
R156	206
R157	215
R158	215
R159	199
R160	199

SYMBOL NO.	INDEX NO.
R161	199
R162	204
R163	206
R164	206
R165	204
R166	206
R167	209
R168	210
R169	206
R170	206

SYMBOL NO.	INDEX NO.
R171	206
R172	217
---	---
R174	212
R175	206
---	---
R177	205
R178	214
R179	206
R180	216

SYMBOL NO.	INDEX NO.
R181	216
R182	206
R183	201
R184	206
R185	201
---	---
R187	202
R188	202
R189	202
R190	202

SYMBOL NO.	INDEX NO.
R191	202
R192	202
R193	202
R194	202
R195	206
R196	205
R197	206
R198	206
R199	205
R200	203

RESISTOR

SYMBOL NO.	INDEX NO.	SYMBOL NO.	INDEX NO.	SYMBOL NO.	INDEX NO.	SYMBOL NO.	INDEX NO.	SYMBOL NO.	INDEX NO.	SYMBOL NO.	INDEX NO.	SYMBOL NO.	INDEX NO.
R201	203	R211	211	---	---	R231	231	R241	211	---	---	R261	232
R202	203	R212	211	---	---	R232	205	R242	211	R252	206	R262	226
R203	203	R213	206	R223	218	R233	208	R243	205	---	---	---	---
R204	212	R214	212	R224	204	R234	206	R244	206	R254	229	R264	206
R205	206	R215	204	R225	206	R235	206	R245	206	R255	232	---	---
R206	206	R216	206	R226	204	R236	205	R246	206	R256	226	R266	229
R207	212	R217	204	R227	206	R237	207	R247	215	---	---	R267	232
R208	212	R218	206	R228	208	R238	205	R248	209	R258	206	R268	226
R209	207	R219	204	R229	207	R239	207	R249	206	---	---	R269	208
R210	207	R220	206	R230	205	R240	206	R250	209	R260	229	R270	205

RESISTOR

SYMBOL NO.	INDEX NO.	SYMBOL NO.	INDEX NO.	SYMBOL NO.	INDEX NO.	SYMBOL NO.	INDEX NO.	SYMBOL NO.	INDEX NO.	SYMBOL NO.	INDEX NO.	SYMBOL NO.	INDEX NO.
R271	208	R281	232	---	---	---	---	R311	232	R321	204	R331	229
R272	205	R282	228	R292	226	R302	206	---	---	R322	206	R332	232
R273	206	---	---	R293	232	---	---	R313	207	R323	204	R333	226
R274	204	R284	206	R294	229	R304	221	R314	206	R324	206	R334	206
R275	205	---	---	---	---	R305	232	---	---	R325	204	---	---
R276	232	R286	233	R296	206	---	---	R316	206	R326	205	---	---
---	---	R287	232	---	---	---	---	R317	204	R327	205	R337	233
R278	206	R288	228	R298	223	R308	206	R318	204	R328	205	R338	232
---	---	---	---	R299	232	---	---	R319	204	R329	206	R339	228
R280	233	R290	206	R300	224	R310	219	R320	204	---	---	---	---

RESISTOR

SYMBOL NO.	INDEX NO.	SYMBOL NO.	INDEX NO.	SYMBOL NO.	INDEX NO.	SYMBOL NO.	INDEX NO.
R341	206	R351	213	R361	221	R371	206
R342	198	R352	212	---	---	R372	206
R343	230	R353	206	R363	206	R373	206
R344	227	R354	204	---	---	R374	222
---	---	R355	206	R365	233	R375	212
R346	206	---	---	R366	232	R376	212
---	---	R357	206	R367	228	R377	215
R348	232	---	---	R368	212	---	---
R349	225	---	---	R369	206	---	---
---	---	R360	232	R370	206	---	---

REG

SYMBOL NO.	INDEX NO.
REG101	170

RN

SYMBOL NO.	INDEX NO.	SYMBOL NO.	INDEX NO.
RN101	175	RN111	175
RN102	175	RN112	177
RN103	175	RN113	175
RN104	175	RN114	175
RN105	195	RN115	175
RN106	196	RN116	175
RN107	174	RN117	178
RN108	177	RN118	175
RN109	177	RN119	175
RN110	178	RN120	195

RN

SYMBOL NO.	INDEX NO.	SYMBOL NO.	INDEX NO.	SYMBOL NO.	INDEX NO.	SYMBOL NO.	INDEX NO.	SYMBOL NO.	INDEX NO.	SYMBOL NO.	INDEX NO.		
RN121	195	RN131	197	RN141	175	RN151	197	RN161	195	RN171	180	RN181	177
RN122	197	RN132	197	RN142	195	RN152	197	RN162	195	RN172	196	RN182	175
RN123	180	RN133	195	RN143	195	RN153	175	RN163	197	RN173	180	RN183	195
RN124	175	RN134	197	RN144	197	RN154	197	RN164	195	RN174	196	RN184	197
RN125	175	RN135	195	RN145	195	RN155	195	RN165	195	RN175	175	RN185	195
RN126	176	RN136	195	RN146	195	RN156	195	RN166	175	RN176	195	RN186	195
RN127	175	RN137	197	RN147	197	RN157	197	RN167	175	RN177	195	RN187	175
RN128	195	RN138	195	RN148	175	RN158	195	RN168	196	RN178	195	RN188	175
RN129	195	RN139	195	RN149	179	RN159	195	RN169	195	RN179	195	RN189	175
RN130	197	RN140	175	RN150	175	RN160	197	RN170	175	RN180	175	RN190	177

RN

SYMBOL NO.	INDEX NO.
RN191	175
RN192	177

SW

SYMBOL NO.	INDEX NO.
SW101	123

ZD

SYMBOL NO.	INDEX NO.
ZD101	146
ZD102	146

ITEM NO.	PARTS NO.	PARTS NAME	Q'TY / PAGE	Q'TY / PACK	PIR	BSI NO.	TO	T	FROM	SERIAL NO.	REMARKS	C
0	B2345241	PCB IOB	1									
1	B2345285	IC:PED	1									
101	11023822	Connector - 20P										
102	11025301	Connector - 2P										
103	11025326	Connector - 4P										
104	11026299	Connector - 6P										
105	11026305	Connector - 12P										
106	11026306	Connector - 13P										
107	11026319	Connector - 12P										
108	11026403	Connector - 30P										
109	11026596	Connector										
110	11027701	Connector - 50P										
111	11028467	Connector - 55447-0370										
112	11028480	Connector - 55447-1610										
113	11028488	Connector - 5451-2810										
114	11028490	Connector:55451-3210										
115	11028492	Connector - 55451-3610										
116	11028493	Connector - 55451-3810										
117	11028494	Connector - 55451-4010										
118	11029547	Connector :55451-1870										
119	11033663	Connector:55451-1670										
120	11090007	IC - MINISMDCL100-02										
121	11090016	Circuit Protector - SMD07										
122	11090018	Circuit Protector - SMD10										
123	12041537	Dip Switch										
124	14000715	Transistor - 2SB1197KR										
125	14000731	Transistor - 2SD1766										
126	14000769	Transistor - 2SA1576A										
127	14000781	Transistor:2SB1132R										
128	14000811	Transistor:DTA144TUA										
129	14000909	Transistor - DTA143EUA										
130	14000918	Transistor - DTC123JUA										
131	14000920	Transistor - DTC143EUA										
132	14000953	Transistor - 2SC4081S										
133	14000968	Transistor : DTA123JUA										
134	14001012	Transistor:2SD2656										
135	14011022	FET:2SK2009										
136	14011135	Fet:2SK3019										
137	14011156	Fet:2SK2231(TE16L1 NQ)										
138	14011233	Fet:SSM3J14T										
139	14011301	Fet:2SK2615										
140	14021057	Diode Array - DAP202U										
141	14021142	Diode Array - DAN217										
142	14021236	Diode - ERA83-006										
143	14021322	Diode Array - DAN202U										
144	14021336	Diode - 1SS355										
145	14021343	Diode - RB106L-40										
146	14021663	Diode - ZTP12B										
147	14021700	Diode - ZTP12B										
148	14021748	Diode:RB481K										
149	14030953	LED - SML-310MT										
150	14071535	IC - TD62308AP										
151	14072187	TTLIC - SN74LS07NS										
152	14072231	IC - TD62308AF										
153	14074687	IC - TA8083F										
154	14075344	IC - SN74LV02APW										
155	14075351	IC - SN74LV14APW										
156	14075353	IC - SN74LV244APW										
157	14075364	IC - SN74AHCT244PW										
158	14075376	IC - SN74LV32APW										
159	14075469	IC - SN74LV07APW										
160	14076167	IC - EIO										
161	14076389	Motor Control IC:SLA7072M										
162	14076611	Motor Control IC:SLA7073M										
163	14080826	IC - TA8428K										
164	14080827	IC - TA8429H										
165	14081206	Transistor-array - TD62M4										
166	14081779	IC - R3112Q281A										
167	14081829	OpA AMP - LM358PW										

ITEM NO.	PARTS NO.	PARTS NAME	Q'TY / PAGE	Q'TY / PACK	PIR	BSI NO.	TO	T	FROM	SERIAL NO.	REMARKS	C
168	14081911	Comparator - LM2903PW										
169	14082007	Operational Amplifier:LM32										
170	14082393	Series Regulator:R1172H33										
171	15031274	Crystal Oscilator:19.85MH										
172	16015277	Resistor - 3.9 OHM +-5% 2										
173	16015532	Resistor - 91OHM +-5% 2W										
174	16017751	Resistor - 4.7KOHM +-5%										
175	16017752	Resistor Array - 10K OHM										
176	16017781	Resistor - 10 OHM +-5%										
177	16017791	Resistor Array - 1K OHM +										
178	16017796	Resistor										
179	16017871	Resistor - 68OHM +-5% 1/1										
180	16017899	Resister Array - 56 Ohm +										
181	16044661	Capacitor - 100MF +-20% 5										
182	16044708	Capacitor - 10MF +-20% 50										
183	16044838	Capacitor:47Uf:+-20%:10V										
184	16044925	Resistor - 100UF +-20% 10										
185	16045375	Capacitor:220Uf:+-20%:50V										
186	16051137	Capacitor - 470PF +-10% 5										
187	16051200	Capacitor - 10PF +-0.5PF										
188	16051208	Capacitor:100pf:+-5%:50v										
189	16051406	Capacitor - 10UF +-10% 6.										
190	16051419	Capacitor:4.7Uf:+-10%:16V										
191	16051479	Capacitor - 47PF +-10%:50										
192	16051483	Capacitor:0.01Uf:+-20%:25										
193	16051530	Capacitor :10PF:+-1PF:50V										
194	16051531	Capacitor:470Pf:+-20%:50V										
195	16090006	Resistor:10k Ohm:+-5%:1/1										
196	16090016	Resistor:56OHM:+-5%:1/16W										
197	16090020	Resistor:10 Ohm:+-5%:1/16										
198	16340000	Resistor - 0 OHM 1/16W										
199	16502121	Resistor:120OHM:+-5%:1/4W										
200	16502151	Resistor - 150OHM +-5% 1/										
201	16502472	Chip Resistor-4.7K										
202	16503221	Resistor - 220OHM+-5%1/8W										
203	16503331	Resistor:330ohm:+-5%:1/8W										
204	16504100	Resistor - 10OHM +-5% 1/1										
205	16504102	Resistor - 1KOHM +-5% 1/1										
206	16504103	Resistor - 10KOHM +-5% 1/										
207	16504104	Resistor - 100KOHM+-5%1/1										
208	16504105	Resistor - 1MOHM +-5% 1/1										
209	16504154	Resistor 150kohm +-5% 1/1										
210	16504162	Resistor - 1.6KOHM +-5% 1										
211	16504221	Resistor - 220OHM+-5%1/10										
212	16504222	Resistor - 2.2KOHM+-5%1/1										
213	16504223	Resistor - 22KOHM+-5%1/10										
214	16504393	Resistor - 39KOHM+-5%1/10										
215	16504472	Resistor - 4.7KOHM +-5% 1										
216	16504560	Chip Resistor - 56ohm +-5										
217	16521000	Chip Resistor:100ohm:+-1%										
218	16541003	Resistor - 100KOHM+-1%1/1										
219	16541500	Resistor - 150OHM+-1 %1/1										
220	16541601	Chip Resistor - 1.6kohm+-										
221	16541690	Chip Resistor:169 OHM:+-1										
222	16541780	Chip Resistor:178ohm:+-1%										
223	16542050	Resistor:205 Ohm:+-1%:1/1										
224	16542152	Resistor:21.5K Ohm:+-1%:1										
225	16542200	Resistor:220OHM:+-1%:1/10										
226	16542700	Resistor:270:Ohm:+-1%:1/1										
227	16543000	Chip Resistor:300ohm:+-1%										
228	16543090	Resistor:309 Ohm:+-1%:1/1										
229	16543742	Resistor:37.4KOHM:+-1%:1/										
230	16544701	Resistor - 4.7KOHM+-1% 1/										
231	16544702	Chip Resistor - 47kohm+-1										
232	16545231	Resistor - 5.23KOHM+-1%1/										
233	16546192	Chip Resistor:61.9Kohm:+-										
234	16547680	Chip Resistor:768ohmu:1/1										
235	16602150	Capacitor - 15PF +-5% 50V										
236	16602471	Capacitor - 470pf - +-5%										

ITEM NO.	PARTS NO.	PARTS NAME	Q'TY / PAGE	Q'TY / PACK	P I R	B S I NO.	T O	T	F R O M	S E R I A L NO.	R E M A R K S	C
237	16604102	Capacitor - 1000PF +-10%										
238	16604472	Capacitor - 4700PF+-10% 5										
239	16606103	Capacitor - 10000pf - +80										
240	16608104	Capacitor - 0.1UF +80-20%										

CAPACITOR

SYMBOL NO.	INDEX NO.	SYMBOL NO.	INDEX NO.	SYMBOL NO.	INDEX NO.	SYMBOL NO.	INDEX NO.	SYMBOL NO.	INDEX NO.	SYMBOL NO.	INDEX NO.	SYMBOL NO.	INDEX NO.
C1	175	C11	171	C21	203	C31	169	C41	185	C51	243	C61	199
C2	185	C12	250	C22	204	---	---	C42	172	C52	243	C62	196
C3	250	C13	203	C23	175	C33	169	C43	201	C53	243	C63	199
C4	185	C14	203	C24	185	C34	196	C44	250	C54	250	C64	244
C5	175	C15	204	C25	185	C35	200	C45	250	C55	196	C65	245
C6	250	C16	187	C26	175	C36	169	C46	250	C56	243	C66	243
C7	250	C17	203	C27	193	C37	179	C47	250	C57	246	C67	202
C8	250	C18	203	C28	250	C38	201	C48	250	---	---	---	---
C9	172	C19	204	C29	199	C39	178	C49	250	C59	178	C69	188
C10	172	C20	203	C30	250	C40	183	C50	243	C60	196	C70	250

CAPACITOR

SYMBOL NO.	INDEX NO.	SYMBOL NO.	INDEX NO.	SYMBOL NO.	INDEX NO.	SYMBOL NO.	INDEX NO.	SYMBOL NO.	INDEX NO.	SYMBOL NO.	INDEX NO.	SYMBOL NO.	INDEX NO.
C71	173	C81	250	C91	172	---	---	C111	177	C121	195	C131	177
C72	170	---	---	---	---	---	---	C112	177	C122	188	C132	188
---	---	---	---	---	---	---	---	C113	188	C123	177	C133	188
---	---	---	---	---	---	C104	189	C114	178	C124	178	C134	178
---	---	C85	184	C95	185	C105	188	C115	195	C125	195	C135	195
C76	182	---	---	---	---	C106	188	C116	177	C126	189	C136	173
C77	190	---	---	---	---	C107	195	C117	188	C127	177	C137	177
C78	178	C88	172	C98	250	C108	177	C118	195	C128	188	C138	178
C79	172	C89	203	C99	250	C109	195	C119	189	C129	177	C139	195
C80	172	C90	188	---	---	C110	178	C120	189	C130	178	C140	178

CAPACITOR

SYMBOL NO.	INDEX NO.	SYMBOL NO.	INDEX NO.	SYMBOL NO.	INDEX NO.	SYMBOL NO.	INDEX NO.	SYMBOL NO.	INDEX NO.	SYMBOL NO.	INDEX NO.	SYMBOL NO.	INDEX NO.
C141	177	C151	191	C161	197	C171	188	C181	188	C191	194	C201	189
C142	188	C152	191	C162	189	C172	191	C182	188	C192	174	C202	198
C143	172	C153	188	C163	191	C173	197	C183	191	C193	198	C203	191
C144	178	C154	188	C164	188	C174	189	C184	191	C194	189	C204	248
C145	249	C155	178	C165	186	C175	178	C185	178	C195	188	C205	176
C146	197	C156	191	C166	189	C176	186	C186	178	C196	196	C206	186
C147	193	C157	188	C167	176	C177	189	C187	178	C197	191	C207	191
C148	189	C158	176	C168	249	C178	188	C188	196	C198	248	C208	186
C149	193	C159	186	C169	186	C179	191	C189	250	C199	196	C209	176
C150	249	C160	178	C170	193	C180	178	C190	178	C200	248	C210	191

CAPACITOR

SYMBOL NO.	INDEX NO.	SYMBOL NO.	INDEX NO.	SYMBOL NO.	INDEX NO.	SYMBOL NO.	INDEX NO.	SYMBOL NO.	INDEX NO.	SYMBOL NO.	INDEX NO.	SYMBOL NO.	INDEX NO.
C211	248	C221	248	C231	248	C241	248	C251	248	C261	176	C271	198
C212	248	C222	196	C232	191	C242	191	C252	186	C262	248	C272	188
C213	191	C223	248	C233	188	C243	196	C253	176	C263	191	C273	178
C214	176	C224	191	C234	189	C244	248	C254	176	C264	196	C274	194
C215	186	C225	191	C235	198	C245	191	C255	186	C265	248	C275	174
C216	196	C226	191	C236	174	C246	191	C256	248	C266	191	---	---
C217	186	C227	248	C237	194	C247	248	C257	191	C267	191	C277	250
C218	176	C228	198	C238	178	C248	176	C258	198	C268	248	C278	174
C219	248	C229	189	---	---	C249	186	C259	189	C269	196	C279	188
C220	191	C230	196	C240	196	C250	191	C260	186	C270	189	C280	198

CAPACITOR

SYMBOL NO.	INDEX NO.	SYMBOL NO.	INDEX NO.	SYMBOL NO.	INDEX NO.	SYMBOL NO.	INDEX NO.	SYMBOL NO.	INDEX NO.	SYMBOL NO.	INDEX NO.	SYMBOL NO.	INDEX NO.
C281	189	C291	248	C301	176	C311	191	C321	248	C331	191	C341	191
C282	194	C292	176	C302	186	C312	191	C322	189	C332	248	C342	248
C283	189	C293	186	C303	196	C313	250	C323	198	C333	248	C343	196
C284	198	C294	196	C304	186	C314	194	C324	191	C334	191	C344	248
C285	191	C295	186	C305	176	C315	188	C325	248	C335	176	C345	191
C286	191	C296	176	C306	248	C316	198	C326	176	C336	186	C346	191
C287	248	C297	191	C307	191	C317	191	C327	186	C337	196	C347	191
C288	196	C298	248	C308	248	C318	191	C328	196	C338	186	C348	196
C289	248	C299	248	C309	196	C319	248	C329	186	C339	176	C349	248
C290	191	C300	191	C310	248	C320	196	C330	176	C340	248	C350	191

CAPACITOR

SYMBOL NO.	INDEX NO.	SYMBOL NO.	INDEX NO.	SYMBOL NO.	INDEX NO.	SYMBOL NO.	INDEX NO.	SYMBOL NO.	INDEX NO.	SYMBOL NO.	INDEX NO.	SYMBOL NO.	INDEX NO.
C351	248	C361	176	C371	185	C381	184	C391	184	C401	185	C411	184
C352	176	C362	186	C372	184	C382	185	C392	185	C402	184	C412	185
C353	186	C363	186	C373	185	C383	185	C393	184	C403	185	C413	185
C354	196	C364	176	C374	184	C384	184	C394	185	C404	185	C414	185
C355	186	C365	248	C375	184	C385	184	C395	192	C405	192	C415	184
C356	176	C366	191	C376	185	C386	185	C396	185	C406	185	C416	185
C357	191	C367	196	C377	184	C387	185	C397	185	C407	184	C417	184
C358	248	C368	248	C378	185	C388	185	C398	184	C408	184	C418	184
C359	248	C369	191	C379	185	C389	184	C399	184	C409	184	C419	185
C360	191	C370	184	C380	184	C390	184	C400	184	C410	185	C420	184

CAPACITOR

SYMBOL NO.	INDEX NO.	SYMBOL NO.	INDEX NO.	SYMBOL NO.	INDEX NO.	SYMBOL NO.	INDEX NO.	SYMBOL NO.	INDEX NO.	SYMBOL NO.	INDEX NO.	SYMBOL NO.	INDEX NO.
C421	185	C431	185	C441	177	C451	177	C461	189	C471	195	C481	189
C422	184	C432	184	C442	195	C452	177	C462	178	C472	177	C482	174
C423	185	C433	185	C443	178	C453	177	C463	178	C473	178	C483	189
C424	184	C434	184	C444	195	C454	195	C464	195	C474	195	C484	250
C425	185	C435	195	C445	178	C455	178	C465	177	C475	178	C485	250
C426	184	C436	177	C446	177	C456	189	C466	177	C476	195	C486	185
C427	185	C437	189	C447	195	C457	178	C467	177	C477	178	C487	199
C428	184	C438	177	C448	189	C458	177	C468	178	C478	177	C488	199
C429	185	C439	178	C449	177	C459	177	C469	177	C479	178	C489	196
C430	184	C440	178	C450	178	C460	177	C470	189	C480	177	C490	196

CAPACITOR

SYMBOL NO.	INDEX NO.	SYMBOL NO.	INDEX NO.	SYMBOL NO.	INDEX NO.	SYMBOL NO.	INDEX NO.	SYMBOL NO.	INDEX NO.	SYMBOL NO.	INDEX NO.	SYMBOL NO.	INDEX NO.
C491	202	C501	243	C511	196	C521	196	C531	199	C541	196	---	---
C492	196	C502	196	C512	199	C522	199	C532	250	C542	199	---	---
C493	196	C503	177	C513	196	C523	199	C533	177	C543	199	C553	195
C494	243	C504	177	C514	202	C524	177	C534	196	C544	196	C554	189
C495	196	C505	196	C515	199	C525	196	C535	196	C545	196	C555	177
C496	177	C506	243	C516	196	C526	177	C536	177	C546	199	C556	195
C497	177	C507	195	C517	195	C527	196	C537	196	C547	199	C557	178
C498	196	C508	243	C518	199	C528	195	C538	196	---	---	C558	195
C499	199	C509	195	C519	196	C529	247	C539	243	---	---	C559	178
C500	199	C510	199	C520	196	C530	199	C540	196	---	---	C560	177

CAPACITOR

SYMBOL NO.	INDEX NO.	SYMBOL NO.	INDEX NO.	SYMBOL NO.	INDEX NO.	SYMBOL NO.	INDEX NO.	SYMBOL NO.	INDEX NO.	SYMBOL NO.	INDEX NO.	SYMBOL NO.	INDEX NO.
C561	195	C571	178	C581	177	C591	178	C601	202	C611	185	C621	185
C562	189	C572	177	C582	178	C592	177	C602	243	C612	185	C622	196
C563	177	C573	177	C583	177	C593	177	C603	243	C613	185	C623	185
C564	178	C574	177	C584	189	C594	189	C604	177	C614	185	C624	185
C565	177	C575	189	C585	195	---	---	C605	185	C615	185	C625	185
C566	177	C576	178	C586	177	C596	178	C606	185	C616	185	C626	185
C567	177	C577	178	C587	178	C597	250	C607	185	C617	185	C627	185
C568	195	C578	195	C588	195	C598	243	C608	185	C618	185	C628	185
C569	178	C579	177	C589	178	---	---	C609	185	C619	185	C629	185
C570	189	C580	177	C590	195	C600	178	C610	185	C620	185	C630	185

CAPACITOR

SYMBOL NO.	INDEX NO.
C631	185
C632	185
C633	185
C634	185
C635	185
C636	185
C637	185
C638	185
C639	181
C640	180

SYMBOL NO.	INDEX NO.
C641	183
C642	183
C643	203
C644	178

CA

SYMBOL NO.	INDEX NO.
CA1	205
CA2	205
CA3	205
CA4	205
CA5	205
CA6	205
CA7	205
CA8	205
CA9	205
CA10	205

CONNECTOR

SYMBOL NO.	INDEX NO.
---	---
---	---
---	---
---	---
---	---
---	---
---	---
---	---
---	---
---	---
CN450	108

SYMBOL NO.	INDEX NO.
CN451	109
CN452	102
CN453	101
CN454	104
---	---
CN456	107
CN457	105
CN458	106
CN459	103

DIODE

SYMBOL NO.	INDEX NO.
D1	113
D2	113
D3	113
D4	113
D5	114
D6	114
D7	114
D8	114
D9	114
D10	114

SYMBOL NO.	INDEX NO.
---	---
---	---
---	---
D44	113

FIL

SYMBOL NO.	INDEX NO.
FIL1	207
FIL2	206
FIL3	207
FIL4	206
FIL5	206
FIL6	206
FIL7	206
FIL8	206
FIL9	206
FIL10	206

SYMBOL NO.	INDEX NO.
FIL11	206
FIL12	206
FIL13	206
FIL14	206
FIL15	206
FIL16	206
FIL17	206
FIL18	206
FIL19	206
FIL20	207

SYMBOL NO.	INDEX NO.
FIL21	206
FIL22	206
FIL23	206
FIL24	207

IC

SYMBOL NO.	INDEX NO.
IC1	134
IC2	133
IC3	130
IC4	117
IC5	124
IC6	124
---	---
IC8	150
IC9	149
IC10	136

SYMBOL NO.	INDEX NO.
IC11	2
IC12	121
IC13	145
IC14	2
IC15	125
IC16	120
IC17	146
IC18	130
IC19	120
IC20	126

SYMBOL NO.	INDEX NO.
IC21	122
IC22	121
IC23	123
IC24	123
IC25	120
IC26	125
IC27	137
IC28	140
IC29	128
---	---

SYMBOL NO.	INDEX NO.
---	---
---	---
IC33	125
IC34	135
IC35	135
IC36	135
IC37	138
IC38	140
IC39	135
---	---

IC

SYMBOL NO.	INDEX NO.
---	---
---	---
---	---
---	---
IC45	118
IC46	135
IC47	130
IC48	133
---	---
---	---

SYMBOL NO.	INDEX NO.
---	---
---	---
IC53	139
IC54	119
IC55	1
IC56	140
IC57	125
IC58	125
IC59	125
IC60	131

SYMBOL NO.	INDEX NO.
IC61	132
IC62	125
IC63	133
IC64	125
IC65	125
IC66	133
IC67	133
IC68	133
IC69	127
IC70	123

SYMBOL NO.	INDEX NO.
IC71	129
IC72	121
---	---
---	---
---	---
---	---
---	---
IC78	121
IC79	119
IC80	136

SYMBOL NO.	INDEX NO.
IC81	127
IC82	131
IC83	131
IC84	119

L

SYMBOL NO.	INDEX NO.
---	---
---	---
L3	209
---	---
---	---
---	---
L7	208
L8	208
L9	208

LED

SYMBOL NO.	INDEX NO.
LED1	115
LED2	115
LED3	116
LED4	116
LED5	116
LED6	115
LED7	116

OSC		Q		RESISTOR		RESISTOR		RESISTOR		RESISTOR		RESISTOR	
SYMBOL NO.	INDEX NO.	SYMBOL NO.	INDEX NO.	SYMBOL NO.	INDEX NO.	SYMBOL NO.	INDEX NO.	SYMBOL NO.	INDEX NO.	SYMBOL NO.	INDEX NO.	SYMBOL NO.	INDEX NO.
OSC1	152	Q1	112	---	---	R11	230	---	---	R31	233	R41	214
OSC2	153	Q2	112	---	---	R12	230	R22	219	R32	219	R42	219
---	---	Q3	112	R3	219	R13	229	R23	219	R33	215	R43	214
OSC4	154	Q4	111	R4	230	R14	215	R24	227	R34	227	R44	215
OSC5	155	Q5	111	R5	230	R15	215	R25	230	R35	230	R45	225
		Q6	110	---	---	R16	232	R26	214	R36	219	R46	214
		Q7	110	---	---	R17	237	R27	233	R37	214	R47	241
		Q8	111	R8	228	R18	238	R28	233	R38	214	R48	231
		Q9	110	R9	227	R19	219	R29	233	R39	214	R49	231
				R10	230	---	---	R30	214	R40	214	R50	231

RESISTOR

SYMBOL NO.	INDEX NO.	SYMBOL NO.	INDEX NO.	SYMBOL NO.	INDEX NO.	SYMBOL NO.	INDEX NO.	SYMBOL NO.	INDEX NO.	SYMBOL NO.	INDEX NO.	SYMBOL NO.	INDEX NO.
R51	231	R61	231	R71	231	R81	214	---	---	---	---	R111	213
R52	214	R62	215	R72	231	R82	232	---	---	R102	211	R112	211
R53	215	R63	215	R73	231	R83	232	R93	212	R103	212	R113	216
R54	215	R64	211	R74	219	R84	232	R94	212	---	---	R114	213
R55	215	R65	215	R75	240	R85	232	R95	212	R105	216	R115	216
R56	215	R66	215	R76	219	R86	232	R96	212	R106	216	R116	213
R57	231	R67	224	R77	227	R87	232	R97	212	R107	213	R117	216
R58	219	R68	215	R78	212	R88	232	---	---	R108	216	R118	213
R59	231	R69	211	R79	227	R89	219	---	---	R109	213	R119	216
R60	231	R70	231	R80	219	R90	219	---	---	R110	216	R120	213

RESISTOR

SYMBOL NO.	INDEX NO.	SYMBOL NO.	INDEX NO.	SYMBOL NO.	INDEX NO.	SYMBOL NO.	INDEX NO.	SYMBOL NO.	INDEX NO.	SYMBOL NO.	INDEX NO.	SYMBOL NO.	INDEX NO.
R121	216	R131	216	R141	232	R151	215	R161	226	---	---	R181	226
R122	213	R132	213	R142	232	R152	215	R162	219	---	---	R182	223
R123	216	R133	216	R143	232	R153	211	R163	211	R173	214	---	---
R124	213	R134	213	R144	217	R154	211	---	---	R174	211	R184	215
R125	216	R135	216	R145	215	R155	219	R165	226	R175	226	R185	231
R126	213	R136	213	R146	215	R156	226	R166	215	R176	234	R186	212
R127	216	R137	216	R147	215	R157	215	R167	219	R177	215	R187	219
R128	213	R138	213	R148	215	R158	215	---	---	R178	226	R188	219
R129	216	R139	219	R149	214	R159	215	---	---	R179	223	R189	222
R130	213	R140	232	R150	215	R160	215	---	---	R180	231	R190	222

RESISTOR

SYMBOL NO.	INDEX NO.	SYMBOL NO.	INDEX NO.	SYMBOL NO.	INDEX NO.	SYMBOL NO.	INDEX NO.	SYMBOL NO.	INDEX NO.	SYMBOL NO.	INDEX NO.	SYMBOL NO.	INDEX NO.
R191	223	R201	226	---	---	R221	232	---	---	R241	223	R251	215
---	---	R202	226	---	---	R222	215	R232	222	---	---	R252	215
---	---	R203	226	---	---	R223	215	R233	222	R243	215	---	---
R194	214	R204	226	---	---	R224	226	R234	222	---	---	R254	232
R195	227	R205	226	---	---	R225	236	---	---	---	---	---	---
R196	223	R206	226	---	---	R226	232	---	---	R246	236	R256	236
R197	223	R207	226	---	---	R227	232	R237	215	---	---	R257	215
R198	214	R208	214	---	---	R228	232	R238	215	R248	214	R258	211
R199	215	---	---	R219	214	R229	232	R239	215	R249	219	---	---
R200	211	R210	211	R220	232	---	---	R240	215	R250	219	---	---

RESISTOR

SYMBOL NO.	INDEX NO.	SYMBOL NO.	INDEX NO.	SYMBOL NO.	INDEX NO.	SYMBOL NO.	INDEX NO.	SYMBOL NO.	INDEX NO.	SYMBOL NO.	INDEX NO.	SYMBOL NO.	INDEX NO.
---	---	R271	215	R281	215	R291	215	R301	210	R311	227	R321	219
R262	223	R272	215	R282	215	R292	232	R302	210	R312	214	R322	215
---	---	R273	215	R283	215	R293	226	R303	211	R313	230	R323	219
---	---	R274	215	R284	215	R294	211	R304	210	---	---	R324	230
R265	215	R275	215	R285	215	R295	211	R305	210	R315	219	R325	215
R266	215	R276	236	R286	214	R296	210	R306	211	R316	219	R326	214
R267	236	R277	215	R287	215	R297	210	R307	211	R317	219	R327	219
R268	232	R278	219	R288	215	R298	210	R308	211	R318	215	R328	219
R269	232	R279	219	R289	215	R299	211	R309	229	R319	215	R329	219
R270	232	R280	215	R290	215	R300	211	R310	229	R320	227	R330	219

RESISTOR

SYMBOL NO.	INDEX NO.	SYMBOL NO.	INDEX NO.	SYMBOL NO.	INDEX NO.	SYMBOL NO.	INDEX NO.	SYMBOL NO.	INDEX NO.	SYMBOL NO.	INDEX NO.	SYMBOL NO.	INDEX NO.
R331	214	R341	240	R351	231	R361	215	R371	215	R381	214	R391	240
R332	214	R342	218	R352	241	R362	211	R372	214	R382	219	R392	215
R333	219	R343	214	R353	231	R363	241	R373	214	R383	219	R393	224
R334	219	R344	215	R354	231	R364	214	R374	219	R384	233	R394	214
R335	219	R345	219	R355	215	R365	218	R375	215	R385	225	R395	228
R336	219	R346	214	R356	215	R366	227	R376	219	R386	223	R396	242
R337	219	R347	223	R357	215	R367	230	---	---	---	---	R397	233
R338	214	R348	240	R358	211	R368	215	R378	230	R388	212	R398	239
R339	215	R349	241	R359	220	R369	215	R379	219	R389	211	R399	235
R340	215	R350	231	R360	215	R370	215	R380	215	R390	211	R400	214

RESISTOR

SYMBOL NO.	INDEX NO.	SYMBOL NO.	INDEX NO.	SYMBOL NO.	INDEX NO.	SYMBOL NO.	INDEX NO.	SYMBOL NO.	INDEX NO.	SYMBOL NO.	INDEX NO.	REG	INDEX NO.
R401	214	R411	227	R421	219	R431	227	---	---	---	---	REG1	142
R402	224	R412	230	R422	221	R432	215	---	---	---	---	REG2	147
R403	215	R413	230	R423	226	R433	211	R483	214	---	---	REG3	151
R404	215	R414	230	---	---	R434	211	---	---	---	---	REG4	141
R405	224	R415	230	R425	229	R435	211	---	---	---	---	REG5	144
R406	215	R416	217	R426	229	R436	211	---	---	---	---	REG6	148
R407	211	R417	221	R427	228	---	---	---	---	---	---	REG7	143
R408	211	R418	221	R428	214	---	---	---	---	---	---	REG7	148
R409	211	R419	221	R429	211	---	---	---	---	---	---	REG8	148
R410	230	---	---	R430	219	---	---	---	---	---	---	REG9	148

RN

SYMBOL NO.	INDEX NO.	SYMBOL NO.	INDEX NO.	SYMBOL NO.	INDEX NO.	SYMBOL NO.	INDEX NO.	SYMBOL NO.	INDEX NO.	SYMBOL NO.	INDEX NO.	SYMBOL NO.	INDEX NO.
RN1	162	RN11	160	RN21	164	RN31	168	RN41	164	RN51	164	RN61	163
RN2	162	RN12	164	RN22	168	RN32	168	RN42	164	RN52	164	RN62	163
RN3	162	RN13	164	RN23	168	RN33	164	RN43	164	RN53	164	RN63	163
RN4	162	RN14	164	RN24	168	RN34	164	RN44	164	RN54	158	RN64	163
RN5	162	RN15	164	RN25	163	RN35	164	RN45	164	RN55	158	RN65	164
RN6	162	RN16	164	RN26	163	RN36	164	RN46	164	RN56	164	RN66	164
RN7	162	RN17	164	RN27	168	RN37	164	RN47	162	RN57	164	RN67	164
RN8	156	RN18	164	RN28	168	RN38	164	RN48	162	RN58	163	RN68	164
RN9	156	RN19	164	RN29	168	RN39	164	RN49	164	RN59	163	RN69	164
RN10	156	RN20	164	RN30	168	RN40	164	RN50	164	RN60	157	RN70	164

RN

SYMBOL NO.	INDEX NO.	SYMBOL NO.	INDEX NO.	SYMBOL NO.	INDEX NO.	SYMBOL NO.	INDEX NO.	SYMBOL NO.	INDEX NO.	SYMBOL NO.	INDEX NO.	SYMBOL NO.	INDEX NO.
RN71	165	RN81	164	RN91	164	RN101	166	RN111	166	RN121	164	---	---
---	---	RN82	164	RN92	164	RN102	166	RN112	166	RN122	161	---	---
RN73	164	RN83	164	RN93	164	RN103	166	RN113	166	RN123	161	---	---
RN74	164	RN84	164	RN94	164	RN104	166	RN114	166	RN124	161	---	---
RN75	164	RN85	164	RN95	164	RN105	166	RN115	166	RN125	161	---	---
---	---	---	---	---	---	---	---	---	---	---	---	---	---
RN76	164	RN86	164	RN96	164	RN106	166	RN116	166	RN126	161	---	---
RN77	164	RN87	164	RN97	164	RN107	166	RN117	162	RN127	161	RN137	166
RN78	164	RN88	164	RN98	161	RN108	166	RN118	164	RN128	161	RN138	166
RN79	164	RN89	164	RN99	166	RN109	166	RN119	164	---	---	RN139	166
RN80	164	RN90	164	RN100	166	RN110	166	RN120	164	RN130	161	RN140	166

RN

SYMBOL NO.	INDEX NO.	SYMBOL NO.	INDEX NO.	SYMBOL NO.	INDEX NO.	SYMBOL NO.	INDEX NO.	SYMBOL NO.	INDEX NO.	SYMBOL NO.	INDEX NO.	SYMBOL NO.	INDEX NO.
RN141	166	RN151	164	RN161	164	---	---	RN181	161	---	---	RN201	161
RN142	166	RN152	164	RN162	162	RN172	161	RN182	161	---	---	RN202	161
RN143	166	RN153	164	RN163	164	---	---	RN183	161	RN193	164	RN203	161
RN144	166	RN154	164	RN164	162	---	---	RN184	161	RN194	164	RN204	161
RN145	166	RN155	164	RN165	161	---	---	RN185	161	RN195	164	RN205	161
---	---	---	---	---	---	---	---	---	---	---	---	---	---
RN146	166	RN156	162	RN166	161	---	---	RN186	162	RN196	164	RN206	161
RN147	166	RN157	164	RN167	161	RN177	164	---	---	RN197	162	---	---
RN148	166	RN158	162	RN168	164	RN178	164	RN188	161	RN198	164	---	---
RN149	166	RN159	164	RN169	161	RN179	162	---	---	RN199	164	---	---
RN150	166	RN160	162	RN170	161	RN180	162	---	---	RN200	162	---	---

RN

SYMBOL NO.	INDEX NO.	SYMBOL NO.	INDEX NO.	SYMBOL NO.	INDEX NO.	SYMBOL NO.	INDEX NO.	SYMBOL NO.	INDEX NO.	SYMBOL NO.	INDEX NO.	SYMBOL NO.	INDEX NO.
RN211	164	RN221	164	RN231	164	RN241	162	RN251	162	RN261	162	RN271	168
RN212	164	RN222	164	RN232	164	RN242	162	RN252	162	RN262	162	RN272	168
RN213	164	RN223	164	RN233	164	RN243	162	RN253	162	RN263	162	RN273	168
RN214	164	RN224	164	RN234	162	RN244	162	RN254	162	RN264	158	RN274	168
RN215	164	RN225	164	RN235	162	RN245	162	RN255	162	RN265	158	RN275	168
---	---	---	---	---	---	---	---	---	---	---	---	---	---
RN216	164	RN226	164	RN236	162	RN246	164	RN256	162	RN266	168	RN276	168
RN217	164	RN227	164	RN237	162	RN247	164	RN257	162	RN267	168	RN277	168
RN218	164	RN228	164	RN238	162	RN248	162	RN258	162	RN268	168	RN278	168
RN219	164	RN229	164	RN239	162	RN249	162	RN259	162	RN269	168	RN279	168
RN220	164	RN230	164	RN240	162	RN250	162	RN260	162	RN270	168	RN280	164

RN

SYMBOL NO.	INDEX NO.	SYMBOL NO.	INDEX NO.	SYMBOL NO.	INDEX NO.	SYMBOL NO.	INDEX NO.	SYMBOL NO.	INDEX NO.	SYMBOL NO.	INDEX NO.	SYMBOL NO.	INDEX NO.
RN281	164	RN291	162	RN301	164	---	---	RN331	168	RN341	164	RN351	162
RN282	164	RN292	162	RN302	164	---	---	RN332	168	RN342	164	RN352	162
RN283	164	RN293	162	RN303	163	---	---	RN333	168	RN343	162	RN353	159
RN284	164	RN294	162	RN304	163	---	---	RN334	164	RN344	162	---	---
RN285	164	RN295	167	RN305	163	RN325	168	RN335	164	RN345	167	---	---
---	---	---	---	---	---	---	---	---	---	---	---	---	---
RN286	164	RN296	167	RN306	163	RN326	168	RN336	164	RN346	162	---	---
---	---	RN297	164	RN307	156	RN327	168	RN337	164	RN347	164	RN387	164
RN288	164	RN298	163	---	---	---	---	RN338	164	RN348	162	---	---
RN289	164	RN299	164	---	---	---	---	RN339	164	RN349	162	---	---
RN290	164	RN300	163	---	---	RN330	168	RN340	164	RN350	162	---	---

ITEM NO.	PARTS NO.	PARTS NAME	Q'TY / PAGE	Q'TY / PACK	PIR	BSI NO.	TO	T	FROM	SERIAL NO.	REMARKS	C
0	B2345450	PCB IPU	1									
1	B1015160	IC:MB87M1480175	1									
2	B1885350	LSI:MB87M4290	2									
101	11025302	Connector - 3P										
102	11026317	Connector - 53324-1062										
103	11026397	Box Header										
104	11026895	Connector - 40P										
105	11028091	Connector - 53505-4010										
106	11028473	Connector - 55447-0910										
107	11028489	Connector - 55451-3010										
108	11028560	Connector - KX14-60K5D1E										
109	11029535	Connector - 200PS-JUK-G-B										
110	14000688	Transistor -DTC143ZUA										
111	14000948	Transistor:DTC143ZE										
112	14011203	Fet:HAT1048R										
113	14021336	Diode - 1SS355										
114	14021546	Diode - RB081										
115	14030953	LED - SML-310MT										
116	14030996	LED - SML-310VT										
117	14074919	IC - 74VHCT244 TSSOP										
118	14075334	IC - CMOS LOGIC 74LVC244A										
119	14075346	IC - SN74LS74ANS										
120	14075353	IC - SN74LV244APW										
121	14075392	IC:SN74LV541APW										
122	14075394	IC:SN74LV138APW										
123	14075463	IC - SN74LV245APW										
124	14075469	IC - SN74LV07APW										
125	14075483	IC - SN74AHC1G125DCK										
126	14075592	CMOS Logic:SN74LV139APW										
127	14075772	IC - SN74AHC2G32HDCT										
128	14076123	IC SN74LVC2G125DCU										
129	14076132	IC:SN74LVC1G08DCK										
130	14076187	CMOS Logic - SN74LVC1G07D										
131	14076201	CMOS Logic SN74LVC1G125DC										
132	14076204	CMOS Logic:SN74LVC2G07DCK										
133	14076205	CMOS Logic - SN74LVC1G06D										
134	14076259	CMOS Logic - SN74AHCT1G04										
135	14076280	Controller - RB5V870										
136	14076335	CMOS Logic:SN74LVC1G17DCK										
137	14076447	Custom IC - GAVD Type-W										
138	14076520	Custom IC - GARAC-C										
139	14076545	Custom IC - RB5C661										
140	14076613	ICS7152M-01										
141	14081454	Series Regulator - LM1085										
142	14081507	Regulator - PQ5VY3H3Z										
143	14081515	DC/DC Converter - R1223N3										
144	14081744	Regulator - PQ018EH01Z										
145	14081790	IC - R3112Q301A										
146	14081879	IC:R3112Q281C-FA										
147	14082015	Series Regulator - PQ018E										
148	14082016	Regulator - R1114Q181B-FA										
149	14082286	DCDC Controller IC - R122										
150	14082287	DCDC Controller IC - R122										
151	14082321	R1172H121B										
152	15031111	Crystal Oscilator:14Mhz										
153	15031260	Crystal Oscilator - 23.8M										
154	15031303	Crystal Oscilator - 65Mhz										
155	15031317	Crystal Oscilator:35MHZ										
156	16017751	Resistor - 4.7KOHM +-5%										
157	16017752	Resistor Array - 10K OHM										
158	16017759	Resistor Array - 100K OHM										
159	16017791	Resistor Array - 1K OHM +										
160	16017867	Resistor - 33 OHM +-5% 1/										
161	16017877	Resistor Array 4.7k Ohm +										
162	16017887	Resistor Array - 10K OHM										
163	16017896	Resistor Array - 56 OHM +										
164	16017898	Resistor Array										
165	16017899	Resister Array - 56 Ohm +										
166	16017943	Resistor Array - 68 OHM +										

ITEM NO.	PARTS NO.	PARTS NAME	Q'TY / PAGE	Q'TY / PACK	PIR	BSI NO.	TO	T	FROM	SERIAL NO.	REMARKS	C
167	16017959	Resistor										
168	16017981	Resistor Array - 100K OHM										
169	16042331	Capacitor - 47UF +-20% 10										
170	16042332	Capacitor - 10UF +-20% 16										
171	16044355	Capacitor - 47UF +-20% 25										
172	16044728	Capacitor - 100UF +-20% 1										
173	16045187	Capacitor - 10UF +-20% 16										
174	16051002	Capacitor - 2700PF +-10%										
175	16051034	Ceramic Capacitor:1000pf:										
176	16051135	Capacitor - 0.47UF +-1% 1										
177	16051137	Capacitor - 470PF +-10% 5										
178	16051148	Capacitor - 0.1UF +80-20%										
179	16051161	Capacitor - 0.33UF +-10%										
180	16051200	Capacitor - 10PF +-0.5PF										
181	16051204	Capacitor-PF50V										
182	16051205	Capacitor - 33PF +-5% 50V										
183	16051208	Capacitor:100pf:+-5%:50v										
184	16051214	Capacitor - 1000PF +-10%										
185	16051221	Capacitor - 0.1 UF+80-20%										
186	16051224	Capacitor 4.7uf +-10% 6.3										
187	16051234	Capcitor:4700pf:+-10%:50V										
188	16051240	Capacitor - 0.01UF +-10%										
189	16051289	Capacitor - 0.1UF +-10% 1										
190	16051293	Capacitor - 27PF+-5%50V										
191	16051294	Resistor - 1000PF +-5% 50										
192	16051295	Capacitor:10uf:++80-20%:10										
193	16051296	Capacitor - 330PF +-10% 5										
194	16051300	Capacitor - 270PF +-5% 50										
195	16051306	Capacitor - 1UF +-10% 10V										
196	16051353	Capacitor - 0.1UF +-10% 2										
197	16051358	Capacitor - 10UF +-10% 10										
198	16051391	Capacitor - 22UF:+-20%:6.										
199	16051406	Capacitor - 10UF +-10% 6.										
200	16051447	Resistor - 470PF +-5% 50V										
201	16051453	Capacitor:0.022uf:+-10%:1										
202	16051455	Capacitor - 10000PF +-5%										
203	16051464	Resistor - 10UF +-20% 25V										
204	16051474	Capacitor - 47UF +-20% 6.										
205	16051480	Capacitor - 100PF +-10% 5										
206	16070861	Filter - BK2125HS101										
207	16071351	Filter BLM21PG221SN1B										
208	16071426	Inductor:RLF12560-2R7N110										
209	16071546	Inductor - SLF6028-220MR7										
210	16330000	Resistor - 0 OHM 1/10W										
211	16340000	Resistor - 0 OHM 1/16W										
212	16504100	Resistor - 100OHM +-5% 1/1										
213	16504101	Resistor - 100OHM+-5%1/10										
214	16504102	Resistor - 1KOHM +-5% 1/1										
215	16504103	Resistor - 10KOHM +-5% 1/										
216	16504104	Resistor - 100KOHM+-5%1/1										
217	16504220	Chip Resistor - 22ohm +-5										
218	16504223	Resistor - 22KOHM+-5%1/10										
219	16504330	Chip Resistor - 33ohm +-5										
220	16504331	Resistor - 330OHM+-5%1/10										
221	16504470	Resistor - 47OHM+-5%1/10W										
222	16504471	Resistor - 470OHM+-5%1/10										
223	16504472	Resistor - 4.7KOHM +-5% 1										
224	16504511	Resistor - 510OHM+-5%1/10										
225	16504560	Chip Resistor - 56ohm +-5										
226	16504680	Resistor - 68OHM+-5%1/10W										
227	16505102	Chip Resistor - 1kohm+-5%										
228	16505103	Chip Resistor - 10kohm+-5										
229	16505104	Chip Resistor - 100kohm+-										
230	16505330	Chip Resistor - 33ohm+-5%										
231	16541000	Resistor - 100OHM +-1% 1/										
232	16541002	Resistor - 10KOHM+-5%1/10										
233	16541003	Resistor - 100KOHM+-1%1/1										
234	16541300	Resistor - 130OHM+-1% 1/1										
235	16542001	Chip Resistor - 2kohm +-1										

ITEM NO.	PARTS NO.	PARTS NAME	Q'TY / PAGE	Q'TY / PACK	P I R	B S I NO.	T O	T	F R O M	S E R I A L NO.	R E M A R K S	C
236	16542700	Resistor:270:Ohm:+-1%:1/1										
237	16542701	Resistor - 2.7KOHM+-1% 1/										
238	16542741	Resistor - 2.74K OHM +-1%										
239	16543321	Resistor - 3.32K OHM +-1%										
240	16544700	Resistor - 470OHM+-1%1/10										
241	16544701	Resistor - 4.7KOHM+-1% 1/										
242	16550000	Chip Resistor - 0ohm+-0%1										
243	16602101	Capacitor - 100pf - +-10%										
244	16602120	Capacitor - 12 PF +-5% 50										
245	16602150	Capacitor - 15PF +-5% 50V										
246	16602331	Capacitor - 330PF +-5% 50										
247	16602680	Capacitor - 68PF +-5% 50V										
248	16604103	Capacitor - 10000pf - +-1										
249	16604332	Capacitor - 3300pf - +-10										
250	16608104	Capacitor - 0.1UF +80-20%										

BAT

SYMBOL NO.	INDEX NO.
BAT1	114

CAPACITOR

SYMBOL NO.	INDEX NO.
---	---
C2	199
C3	170
C4	191
C5	191
C6	195
C7	201
C8	201
C9	170
C10	191

SYMBOL NO.	INDEX NO.
C11	195
C12	201
C13	201
C14	201
C15	201
C16	201
C17	201
C18	195
C19	195
C20	199

SYMBOL NO.	INDEX NO.
C21	201
---	---
C23	187
C24	189
C25	179
C26	187
C27	182
C28	191
C29	191
C30	201

SYMBOL NO.	INDEX NO.
C31	178
C32	177
C33	201
C34	201
C35	189
C36	171
C37	187
C38	201
C39	209
C40	185

SYMBOL NO.	INDEX NO.
C41	201
C42	187
C43	171
C44	195
C45	186
C46	187
C47	201
C48	195
C49	171
C50	189

SYMBOL NO.	INDEX NO.
C51	189
C52	189
C53	189
C54	200
C55	188
C56	201
C57	199
C58	199
C59	199
C60	201

CAPACITOR

SYMBOL NO.	INDEX NO.
C61	201
C62	186
C63	189
C64	189
C65	189
C66	198
C67	192
---	---
C69	189
C70	189

SYMBOL NO.	INDEX NO.
C71	189
C72	189
C73	189
C74	189
C75	199
C76	189
C77	189
C78	189
C79	189
C80	189

SYMBOL NO.	INDEX NO.
C81	189
C82	189
C83	189
C84	189
C85	191
C86	201
C87	187
C88	191
C89	201
C90	172

SYMBOL NO.	INDEX NO.
C91	194
C92	192
C93	189
---	---
C95	189
C96	199
C97	202
C98	195
C99	195
C100	195

SYMBOL NO.	INDEX NO.
C101	189
C102	189
C103	189
C104	189
C105	189
C106	189
C107	202
C108	199
C109	199
C110	199

SYMBOL NO.	INDEX NO.
C111	201
C112	201
C113	199
C114	172
C115	201
C116	201
C117	172
C118	189
C119	189
---	---

SYMBOL NO.	INDEX NO.
C121	173
C122	189
C123	171
C124	171
C125	171
C126	171
C127	171
C128	171
C129	171
C130	171

CAPACITOR

SYMBOL NO.	INDEX NO.
C131	184
C132	184
C133	173
C134	173
C135	205
C136	182
C137	171
C138	171
C139	171
C140	189

SYMBOL NO.	INDEX NO.
C141	189
C142	189
C143	181
C144	199
C145	201
C146	199
C147	201
C148	201
C149	199
C150	182

SYMBOL NO.	INDEX NO.
C151	182
C152	197
C153	184
C154	184
C155	187
C156	187
C157	187
C158	201
C159	201
C160	176

SYMBOL NO.	INDEX NO.
C161	176
C162	201
C163	201
---	---
C165	189
---	---
C167	187
C168	201
C169	171
C170	195

SYMBOL NO.	INDEX NO.
C171	187
C172	198
C173	198
C174	209
C175	171
C176	201
C177	187
C178	198
C179	189
C180	199

SYMBOL NO.	INDEX NO.
C181	189
C182	199
C183	189
C184	201
C185	201
C186	201
C187	201
C188	201
C189	201
C190	201

SYMBOL NO.	INDEX NO.
C191	201
C192	201
C193	190
C194	189
C195	189
C196	189
C197	189
C198	189
C199	173
C200	201

CAPACITOR

SYMBOL NO.	INDEX NO.
C201	187
C202	187
C203	189
C204	189
C205	173
C206	201
C207	187
C208	187
C209	173
C210	201

SYMBOL NO.	INDEX NO.
C211	187
C212	187
---	---
C214	189
C215	189
C216	189
C217	189
C218	200
C219	170
C220	207

SYMBOL NO.	INDEX NO.
C221	207
C222	207
C223	202
---	---
---	---
C226	202
C227	171
C228	192
C229	207
C230	171

SYMBOL NO.	INDEX NO.
---	---
C232	175
---	---
---	---
C235	195
C236	195
C237	197
C238	197
---	---
---	---

SYMBOL NO.	INDEX NO.
C241	207
---	---
---	---
C244	195
C245	207
C246	187
C247	199
C248	199
C249	199
C250	199

SYMBOL NO.	INDEX NO.
C251	201
C252	191
---	---
---	---
C255	201
C256	201
C257	201
C258	201
C259	187
C260	204

SYMBOL NO.	INDEX NO.
C261	187
C262	312
C263	187
C264	189
C265	187
C266	187
---	---
C268	199
---	---
C270	171

CAPACITOR

SYMBOL NO.	INDEX NO.	SYMBOL NO.	INDEX NO.	SYMBOL NO.	INDEX NO.	SYMBOL NO.	INDEX NO.	SYMBOL NO.	INDEX NO.	SYMBOL NO.	INDEX NO.	SYMBOL NO.	INDEX NO.
C271	189	C281	174	C291	174	C301	189	---	---	C321	189	C331	189
C272	189	C282	174	C292	189	C302	171	C312	187	C322	189	C332	189
C273	199	C283	189	C293	174	C303	189	C313	201	C323	189	C333	189
C274	189	C284	199	C294	189	C304	189	C314	189	C324	189	C334	189
C275	189	C285	189	C295	189	C305	171	C315	189	C325	189	C335	189
C276	199	C286	174	C296	199	C306	199	C316	187	---	---	C336	189
C277	189	C287	174	C297	189	C307	197	C317	187	---	---	C337	174
C278	189	C288	189	C298	189	C308	196	C318	201	C328	195	C338	174
C279	199	C289	189	C299	189	C309	181	C319	201	C329	209	C339	174
C280	189	C290	199	C300	199	C310	183	C320	201	C330	189	C340	174

CAPACITOR

SYMBOL NO.	INDEX NO.	SYMBOL NO.	INDEX NO.	SYMBOL NO.	INDEX NO.	SYMBOL NO.	INDEX NO.	SYMBOL NO.	INDEX NO.	SYMBOL NO.	INDEX NO.	SYMBOL NO.	INDEX NO.
C341	174	C351	174	C361	174	C371	189	---	---	C391	171	C401	201
C342	174	C352	189	C362	189	C372	171	C382	201	C392	189	C402	201
C343	189	C353	174	C363	189	---	---	C383	201	C393	199	C403	201
C344	174	C354	189	C364	189	---	---	C384	199	C394	189	C404	201
C345	174	C355	174	C365	189	C375	199	C385	199	C395	171	C405	173
C346	189	C356	174	C366	189	C376	199	C386	189	C396	195	C406	173
C347	199	C357	174	C367	189	C377	201	C387	171	C397	195	C407	201
C348	189	C358	174	C368	208	C378	201	C388	189	C398	189	C408	199
C349	199	C359	174	C369	189	---	---	C389	189	C399	189	C409	199
C350	174	C360	174	C370	189	---	---	C390	189	C400	201	C410	173

CAPACITOR

SYMBOL NO.	INDEX NO.	SYMBOL NO.	INDEX NO.	SYMBOL NO.	INDEX NO.	SYMBOL NO.	INDEX NO.	SYMBOL NO.	INDEX NO.	SYMBOL NO.	INDEX NO.	SYMBOL NO.	INDEX NO.
C411	201	C421	189	C431	189	C441	189	C451	189	C461	199	C471	189
C412	201	C422	199	C432	189	C442	189	C452	203	C462	199	C472	189
C413	173	C423	189	C433	189	C443	189	C453	203	C463	201	C473	189
C414	201	C424	189	C434	189	C444	189	C454	203	---	---	C474	189
C415	201	C425	199	C435	189	C445	199	C455	189	C465	199	C475	189
C416	199	C426	189	C436	199	C446	189	C456	189	C466	189	C476	189
C417	199	C427	201	C437	199	C447	189	C457	189	C467	199	C477	189
C418	199	C428	201	C438	189	C448	189	C458	189	C468	189	C478	189
C419	199	C429	189	C439	189	C449	189	C459	189	C469	189	C479	189
C420	189	C430	189	C440	199	C450	189	C460	189	C470	189	C480	201

CAPACITOR

SYMBOL NO.	INDEX NO.	SYMBOL NO.	INDEX NO.	SYMBOL NO.	INDEX NO.	SYMBOL NO.	INDEX NO.	SYMBOL NO.	INDEX NO.	SYMBOL NO.	INDEX NO.	SYMBOL NO.	INDEX NO.
C481	189	C491	189	---	---	C511	181	C521	189	C531	189	C541	203
C482	173	C492	201	C502	199	C512	189	C522	189	C532	203	C542	186
C483	189	C493	189	C503	199	C513	189	C523	199	C533	199	C543	189
C484	189	C494	201	C504	201	C514	189	C524	199	C534	189	C544	189
C485	199	C495	189	C505	201	C515	189	C525	203	C535	189	C545	189
C486	189	C496	199	C506	192	C516	181	C526	189	C536	189	C546	189
---	---	C497	189	C507	199	C517	189	C527	189	C537	189	C547	189
C488	189	C498	199	---	---	C518	189	C528	189	C538	189	C548	186
C489	189	C499	189	C509	189	C519	189	C529	189	C539	189	---	---
C490	180	C500	189	C510	203	C520	189	C530	189	C540	203	C550	189

CAPACITOR

SYMBOL NO.	INDEX NO.	SYMBOL NO.	INDEX NO.	SYMBOL NO.	INDEX NO.	SYMBOL NO.	INDEX NO.	SYMBOL NO.	INDEX NO.	SYMBOL NO.	INDEX NO.	SYMBOL NO.	INDEX NO.
C551	201	C561	189	C571	201	C581	189	C591	189	C601	180	C611	189
C552	189	C562	189	C572	171	C582	193	C592	180	C602	189	C612	201
C553	189	C563	189	C573	180	C583	189	C593	189	C603	189	C613	201
C554	189	C564	189	C574	189	C584	189	C594	189	C604	171	C614	201
C555	189	C565	189	C575	189	C585	199	---	---	---	---	C615	189
C556	189	---	---	C576	180	C586	202	C596	189	C606	189	C616	201
C557	189	C567	189	C577	189	---	---	C597	189	C607	203	C617	201
C558	189	C568	189	C578	189	C588	189	C598	189	C608	201	C618	189
C559	189	C569	189	C579	180	C589	189	C599	189	C609	201	C619	189
C560	189	C570	201	C580	180	C590	189	C600	199	C610	201	C620	203

CAPACITOR

SYMBOL NO.	INDEX NO.	SYMBOL NO.	INDEX NO.	SYMBOL NO.	INDEX NO.	SYMBOL NO.	INDEX NO.	SYMBOL NO.	INDEX NO.	SYMBOL NO.	INDEX NO.	SYMBOL NO.	INDEX NO.
C621	189	C631	171	C641	201	C651	201	C661	202	C671	172	CN520	102
C622	189	C632	201	C642	199	C652	200	---	---	C672	172	CN521	102
C623	189	C633	187	C643	199	C653	201	C663	189	C673	172	CN522	104
C624	202	---	---	C644	199	C654	200	---	---	C674	206	CN523	104
C625	189	C635	195	C645	199	C655	201	---	---	C675	206	CN524	104
C626	189	C636	171	C646	199	C656	200	C666	189	---	---	CN525	105
---	---	C637	201	C647	199	C657	189	---	---	---	---	CN526	107
---	---	C638	187	C648	200	C658	199	---	---	---	---	CN527	103
C629	201	C639	201	C649	201	C659	199	---	---	---	---	CN528	108
C630	195	C640	200	C650	200	C660	199	---	---	---	---	CN530	106

CONNECTOR

CONNECTOR

SYMBOL NO.	INDEX NO.
CN532	101

DIODE

SYMBOL NO.	INDEX NO.
D1	133
D2	133
D3	130
D4	134
D5	134
D6	134
D7	134
D8	134
D9	132
D10	133

FILTER

SYMBOL NO.	INDEX NO.
D11	133
---	---
D13	135
---	---
D15	135
---	---
---	---
D18	131

FILTER

SYMBOL NO.	INDEX NO.
FIL1	211
---	---
FIL3	211
---	---
FIL5	213

FUSE

SYMBOL NO.	INDEX NO.
FU1	109

IC

SYMBOL NO.	INDEX NO.	SYMBOL NO.	INDEX NO.
---	---	IC11	139
IC2	157	---	---
IC3	159	IC13	158
IC4	157	IC14	160
IC5	147	IC15	139
IC6	144	---	---
IC7	145	IC17	1
IC8	138	IC18	152
IC9	145	IC19	141
IC10	141	IC20	147

IC

SYMBOL NO.	INDEX NO.
IC21	156
IC22	140
IC23	153
IC24	160
IC25	158
IC26	154
IC27	147
IC28	147
IC29	2
---	---

SYMBOL NO.	INDEX NO.
IC31	162
IC32	138
IC33	151
IC34	149
IC35	151
IC36	148
IC37	143
IC38	143
IC39	142
---	---

SYMBOL NO.	INDEX NO.
IC41	150
IC42	140
IC43	146
IC44	146
IC45	140
IC46	161
IC47	161
IC48	160

J

SYMBOL NO.	INDEX NO.
J1	221
J2	221
J3	221
J4	221
---	---
---	---
---	---
---	---
---	---

SYMBOL NO.	INDEX NO.
---	---
---	---
J13	221
J14	221
J15	221
J16	221

JP

SYMBOL NO.	INDEX NO.
JP5	259
JP6	259
JP7	259
JP8	259
JP9	259
JP10	259
---	---
JP12	259
JP18	259

L

SYMBOL NO.	INDEX NO.
L1	212
L2	214
L3	212
L4	215
L5	216
L6	210

LED		OSC		Q							
SYMBOL NO.	INDEX NO.	SYMBOL NO.	INDEX NO.	SYMBOL NO.	INDEX NO.	SYMBOL NO.	INDEX NO.	SYMBOL NO.	INDEX NO.	SYMBOL NO.	INDEX NO.
LED1	137	OSC1	163	Q1	128	Q11	129	Q21	121	Q31	126
LED2	137	OSC2	165	Q2	119	---	---	Q22	121	---	---
LED3	137	OSC3	164	Q3	119	Q13	123	Q23	118	---	---
LED4	137			Q4	122	Q14	126	Q24	117	---	---
LED5	137			Q5	121	Q15	127	Q25	127	Q35	126
LED6	137			Q6	118	Q16	125	Q26	126	---	---
LED7	137			Q7	118	Q17	120	Q27	127	Q37	118
LED8	137			Q8	118	---	---	Q28	124	---	---
LED9	137			Q9	121	---	---	Q29	124	Q39	115
LED10	136			Q10	116	Q20	116	Q30	127	---	---
										Q44	118
										Q45	115
										Q46	118
										Q47	129

RESISTOR

SYMBOL NO.	INDEX NO.	SYMBOL NO.	INDEX NO.	SYMBOL NO.	INDEX NO.	SYMBOL NO.	INDEX NO.	SYMBOL NO.	INDEX NO.	SYMBOL NO.	INDEX NO.	SYMBOL NO.	INDEX NO.
---	---	R11	259	---	---	R31	257	R41	259	R51	259	R61	257
---	---	R12	226	---	---	R32	241	R42	226	R52	259	R62	257
R3	248	---	---	R23	226	R33	226	R43	226	R53	259	R63	257
---	---	R14	241	R24	248	R34	241	---	---	R54	257	R64	257
R5	241	R15	226	R25	226	R35	257	R45	256	R55	241	---	---
R6	241	R16	252	R26	257	R36	226	R46	241	R56	241	R66	223
R7	269	R17	225	R27	248	R37	257	R47	226	R57	241	---	---
R8	260	R18	226	R28	226	R38	228	R48	259	R58	241	R68	223
R9	248	R19	226	R29	226	R39	228	R49	259	R59	257	R69	241
R10	248	R20	226	R30	257	R40	257	R50	259	R60	257	R70	241

RESISTOR

SYMBOL NO.	INDEX NO.	SYMBOL NO.	INDEX NO.	SYMBOL NO.	INDEX NO.	SYMBOL NO.	INDEX NO.	SYMBOL NO.	INDEX NO.	SYMBOL NO.	INDEX NO.	SYMBOL NO.	INDEX NO.
R71	241	R81	241	R91	226	R101	257	R111	257	R121	226	R131	241
R72	241	R82	226	R92	248	R102	257	R112	257	R122	226	---	---
R73	241	R83	226	---	---	R103	225	R113	226	R123	226	---	---
---	---	R84	226	---	---	R104	248	R114	251	R124	241	R134	226
R75	223	R85	226	R95	257	R105	243	R115	251	R125	226	---	---
R76	241	R86	226	R96	257	R106	257	R116	251	R126	241	R136	226
---	---	R87	226	R97	257	R107	238	R117	226	R127	262	R137	226
R78	223	---	---	R98	257	R108	257	---	---	R128	259	R138	223
R79	226	R89	259	R99	257	R109	257	R119	226	R129	241	---	---
R80	226	---	---	R100	257	R110	257	R120	226	R130	241	R140	226

RESISTOR

SYMBOL NO.	INDEX NO.	SYMBOL NO.	INDEX NO.	SYMBOL NO.	INDEX NO.	SYMBOL NO.	INDEX NO.	SYMBOL NO.	INDEX NO.	SYMBOL NO.	INDEX NO.	SYMBOL NO.	INDEX NO.
R141	223	R151	236	R161	226	R171	224	R181	226	---	---	R201	226
R142	226	R152	236	R162	226	R172	225	R182	226	R192	259	R202	226
R143	223	R153	236	R163	248	R173	225	R183	226	R193	241	R203	226
R144	259	R154	236	R164	248	R174	226	R184	225	R194	241	R204	226
R145	223	R155	246	R165	241	R175	225	R185	226	R195	226	R205	236
R146	236	R156	246	R166	241	R176	225	---	---	---	---	R206	236
R147	236	R157	223	R167	241	R177	225	R187	226	R197	226	R207	236
R148	236	R158	223	R168	241	R178	222	R188	226	R198	226	R208	236
R149	236	R159	226	R169	241	R179	222	R189	227	R199	226	R209	236
R150	236	R160	226	R170	226	R180	226	---	---	R200	226	R210	259

IC		JP		IC		JP		JP		LED		OSC	
SYMBOL NO.	INDEX NO.	SYMBOL NO.	INDEX NO.	SYMBOL NO.	INDEX NO.	SYMBOL NO.	INDEX NO.	SYMBOL NO.	INDEX NO.	SYMBOL NO.	INDEX NO.	SYMBOL NO.	INDEX NO.
R211	259	R221	259	R231	292	R241	292	R251	226	R261	259	R271	224
R212	226	R222	226	R232	305	R242	286	---	---	R262	259	R272	241
R213	226	R223	279	R233	292	R243	299	R253	259	R263	259	---	---
R214	226	R224	264	R234	299	---	---	R254	259	R264	259	---	---
R215	226	R225	301	R235	299	R245	259	R255	227	R265	259	R275	277
R216	223	R226	263	R236	299	R246	286	R256	227	R266	259	R276	239
R217	223	R227	231	R237	299	R247	257	R257	227	R267	259	R277	239
R218	223	R228	232	R238	299	R248	286	R258	226	R268	259	R278	239
R219	259	R229	225	R239	286	R249	226	R259	224	R269	259	R279	239
R220	259	R230	225	R240	286	R250	275	R260	226	R270	259	R280	239

Q		RESISTOR		Q		RESISTOR		RESISTOR		RESISTOR		RESISTOR	
SYMBOL NO.	INDEX NO.	SYMBOL NO.	INDEX NO.	SYMBOL NO.	INDEX NO.	SYMBOL NO.	INDEX NO.	SYMBOL NO.	INDEX NO.	SYMBOL NO.	INDEX NO.	SYMBOL NO.	INDEX NO.
R281	239	R291	226	---	---	R311	226	R321	293	R331	256	R341	232
R282	239	R292	224	---	---	---	---	R322	304	R332	250	R342	244
R283	239	R293	224	---	---	R313	256	R323	286	R333	253	R343	244
R284	277	---	---	R304	220	R314	256	R324	256	R334	301	R344	240
R285	277	R295	226	R305	229	R315	259	R325	256	R335	240	R345	240
R286	226	---	---	R306	227	R316	259	R326	256	R336	237	R346	301
R287	259	---	---	R307	233	R317	241	R327	256	R337	249	R347	258
R288	259	R298	224	R308	234	R318	241	R328	256	R338	231	R348	258
R289	226	R299	224	R309	224	---	---	R329	256	R339	237	R349	226
R290	226	---	---	R310	292	R320	304	R330	256	R340	226	---	---

RESISTOR

SYMBOL NO.	INDEX NO.	SYMBOL NO.	INDEX NO.	SYMBOL NO.	INDEX NO.	SYMBOL NO.	INDEX NO.	SYMBOL NO.	INDEX NO.	SYMBOL NO.	INDEX NO.	SYMBOL NO.	INDEX NO.
R351	226	R361	226	R371	236	R381	226	R391	226	R401	311	R411	225
---	---	R362	226	R372	236	R382	282	R392	226	R402	270	R412	225
R353	248	R363	226	R373	236	R383	226	R393	226	R403	231	R413	225
R354	257	R364	226	R374	236	R384	226	R394	226	R404	231	R414	274
R355	259	R365	226	R375	236	R385	226	R395	223	R405	265	R415	274
R356	259	R366	226	R376	236	R386	226	R396	223	R406	311	R416	293
R357	261	R367	236	R377	226	R387	226	R397	223	R407	270	R417	307
R358	272	R368	236	R378	226	R388	226	R398	281	R408	225	R418	307
R359	273	R369	236	R379	226	R389	226	R399	285	R409	232	R419	242
---	---	R370	236	R380	226	R390	226	R400	222	R410	232	R420	242

RESISTOR

SYMBOL NO.	INDEX NO.	SYMBOL NO.	INDEX NO.	SYMBOL NO.	INDEX NO.	SYMBOL NO.	INDEX NO.	SYMBOL NO.	INDEX NO.	SYMBOL NO.	INDEX NO.	SYMBOL NO.	INDEX NO.
R421	309	R431	236	R441	226	R451	236	R461	226	R471	301	R481	286
R422	309	R432	223	R442	226	R452	236	---	---	R472	226	R482	311
R423	250	R433	223	---	---	R453	236	---	---	R473	226	R483	270
R424	226	R434	248	R444	226	R454	248	R464	248	R474	226	R484	259
R425	226	---	---	R445	226	R455	226	R465	248	R475	226	R485	280
R426	226	R436	223	R446	226	R456	277	R466	224	R476	225	R486	308
R427	226	R437	223	R447	226	R457	227	R467	224	R477	293	R487	223
R428	226	R438	223	---	---	R458	225	R468	248	R478	286	R488	223
R429	236	R439	267	R449	223	R459	223	R469	248	R479	304	R489	223
R430	236	R440	289	R450	236	R460	226	R470	224	R480	304	---	---

RESISTOR

SYMBOL NO.	INDEX NO.	SYMBOL NO.	INDEX NO.	SYMBOL NO.	INDEX NO.	SYMBOL NO.	INDEX NO.	SYMBOL NO.	INDEX NO.	SYMBOL NO.	INDEX NO.	SYMBOL NO.	INDEX NO.
R491	257	R501	251	R511	257	R521	259	R531	257	R541	303	R551	284
---	---	R502	255	R512	257	R522	288	R532	257	R542	270	R552	259
R493	257	R503	255	R513	257	R523	284	R533	257	R543	302	R553	278
---	---	R504	255	R514	257	R524	224	R534	257	R544	260	R554	294
R495	257	R505	255	R515	257	R525	287	R535	257	R545	310	R555	284
---	---	R506	241	R516	251	R526	297	R536	277	R546	296	R556	223
R497	257	R507	255	R517	241	R527	268	R537	226	R547	310	R557	223
---	---	R508	241	---	---	R528	226	R538	226	R548	260	R558	223
R499	257	R509	257	R519	284	R529	257	R539	307	---	---	R559	223
---	---	R510	255	R520	259	---	---	R540	257	R550	298	R560	223

RESISTOR

SYMBOL NO.	INDEX NO.	SYMBOL NO.	INDEX NO.	SYMBOL NO.	INDEX NO.	SYMBOL NO.	INDEX NO.	SYMBOL NO.	INDEX NO.	SYMBOL NO.	INDEX NO.	SYMBOL NO.	INDEX NO.
R561	226	R571	257	R581	241	R601	241	R611	299	---	---	R631	223
R562	226	R572	260	R582	226	R602	241	R612	299	---	---	R632	223
R563	226	R573	266	R583	225	R603	241	R613	299	---	---	R633	223
R564	226	R574	248	R584	257	R604	260	R614	299	R624	217	R634	223
R565	226	R575	284	R585	257	R605	259	R615	299	R625	219	R635	223
R566	226	R576	257	---	---	R606	259	R616	299	R626	220	R636	223
R567	225	R577	284	---	---	R607	226	R617	299	R627	223	---	---
R568	225	---	---	---	---	---	---	R618	299	R628	223	R638	226
R569	226	R579	248	R599	241	R609	299	R619	235	R629	223	---	---
R570	257	R580	225	R600	226	R610	299	R620	235	R630	223	R640	226

RESISTOR

SYMBOL NO.	INDEX NO.	SYMBOL NO.	INDEX NO.	SYMBOL NO.	INDEX NO.	SYMBOL NO.	INDEX NO.	SYMBOL NO.	INDEX NO.	SYMBOL NO.	INDEX NO.	SYMBOL NO.	INDEX NO.
R641	261	R651	283	R661	241	R671	241	R681	241	R691	257	R701	241
R642	295	R652	290	R662	241	R672	241	R682	241	R692	241	R702	241
R643	261	R653	290	---	---	R673	241	R683	259	R693	245	R703	241
R644	261	R654	300	---	---	R674	241	---	---	R694	254	R704	226
R645	261	R655	306	---	---	R675	241	R685	241	R695	257	R705	241
R646	271	R656	306	R666	241	R676	241	R686	241	R696	226	R706	226
R647	271	R657	218	R667	241	R677	241	R687	241	R697	226	---	---
R648	261	R658	241	R668	241	R678	241	R688	241	R698	241	---	---
R649	291	R659	241	R669	241	R679	241	R689	241	R699	241	R709	223
R650	276	R660	241	R670	241	R680	241	R690	257	R700	241	R710	226

RESISTOR

SYMBOL NO.	INDEX NO.	SYMBOL NO.	INDEX NO.	SYMBOL NO.	INDEX NO.	SYMBOL NO.	INDEX NO.	SYMBOL NO.	INDEX NO.	SYMBOL NO.	INDEX NO.	SYMBOL NO.	INDEX NO.
R711	226	---	---	---	---	R741	226	R751	257	R761	259	R771	227
R712	226	R722	259	---	---	R742	226	---	---	---	---	---	---
---	---	---	---	---	---	R743	259	---	---	---	---	---	---
---	---	R724	259	---	---	R744	237	---	---	---	---	R774	223
---	---	R725	223	---	---	R745	237	R755	257	R765	222	R775	223
R716	226	R726	223	---	---	R746	247	R756	257	R766	222	R776	299
---	---	R727	223	---	---	R747	259	R757	257	R767	222	---	---
R718	259	R728	223	R738	226	R748	237	---	---	R768	227	R778	226
---	---	R729	223	R739	226	R749	237	R759	226	---	---	R779	230
---	---	---	---	---	---	R750	247	R760	226	---	---	---	---

RESISTOR

SYMBOL NO.	INDEX NO.
---	---
---	---
---	---
---	---
R785	241
---	---
---	---
R788	241
R789	236
R790	236

SYMBOL NO.	INDEX NO.
R791	223
R792	223
R793	223
R794	223
R795	226
---	---
R796	226
---	---
---	---
R799	241
R800	241

SYMBOL NO.	INDEX NO.
R801	241
R802	241
R803	226
R804	226
R805	226
---	---
R807	222
R808	226
R809	226
R810	226

SYMBOL NO.	INDEX NO.
R811	226
R812	225
R813	225

REG

SYMBOL NO.	INDEX NO.
REG1	155

RN

SYMBOL NO.	INDEX NO.
RN1	167
RN2	167
RN3	167
RN4	167
RN5	167
---	---
RN6	167
RN7	167
RN8	167
RN9	167
RN10	169

SYMBOL NO.	INDEX NO.
RN11	169
RN12	169
RN13	167
RN14	167
RN15	167
---	---
RN16	169
RN17	168
RN18	168
RN19	168
RN20	168

RN

SYMBOL NO.	INDEX NO.
RN21	168
RN22	168
RN23	168
RN24	168
RN25	168
---	---
---	---
RN28	169
RN29	169
RN30	169

SYMBOL NO.	INDEX NO.
RN31	169
RN32	166
RN33	166

SW

SYMBOL NO.	INDEX NO.
SW1	113
SW2	111
SW3	112
SW4	110
SW5	110

ITEM NO.	PARTS NO.	PARTS NAME	Q'TY / PAGE	Q'TY / PACK	PIR	BSI NO.	TO	T	FROM	SERIAL NO.	REMARKS	C
0	B2345510	PCB Type-AX2D	1									
1	B2345595	BIOS:B-C3:AX2	1									
2	B2385720	Asic:Shaker5.5	1									
101	11027615	Connector - B8B-XH-A										
102	11028832	Connector - DM-3D4-B3210										
103	11029079	Connector - RHM-88PL-SDK1										
104	11029336	Connector:FPS009-2300-0										
105	11029337	Connector:14016PS-JUK-G-B										
106	11029456	Connector - 20 5078 050 5										
107	11029686	Connector - RHM-176P-SDK1										
108	11029887	Connector:52588-3090										
109	11071095	Fuse - Sst 2										
110	12041385	Push Switch										
111	12041422	DIP Switch - 51D-0401										
112	12041542	DIP Switch										
113	12041543	DIP Switch										
114	12060114	Primary Lithium Cell:CR23										
115	14000715	Transistor - 2SB1197KR										
116	14000730	Transistor - 2SD1782K										
117	14000769	Transistor - 2SA1576A										
118	14000775	Transistor - 2SC4081										
119	14000810	Transistor:DTC114EUA										
120	14000981	Transistor - 2SC3052										
121	14010902	Fet:2SK1590										
122	14011181	Fet - 2SK2157-AZ										
123	14011192	Fet - 2SK1764										
124	14011209	IC - HAT2093R										
125	14011228	Fet:SI3433DV-E3										
126	14011317	Fet - HAT2197R										
127	14011318	Fet - HAT2198R										
128	14011319	Fet - TPC8105-H										
129	14011320	Fet - TPC8107										
130	14021336	Diode - 1SS355										
131	14021343	Diode - RB106L-40										
132	14021398	Diode - RB050L-40										
133	14021530	Diode - RB520S-30										
134	14021698	Diode - RB										
135	14021709	Diode:EC21QS06G										
136	14030953	LED - SML-310MT										
137	14030996	LED - SML-310VT										
138	14075439	CMOS Logic:SN74AHC2G66HDC										
139	14075482	IC - SN74LVCO7APW										
140	14075640	CMOS Logic:SN74AHC1G14HDC										
141	14075684	CMOS Logic - SN74AHC1G08H										
142	14075733	IC:SN74ALVC244PW										
143	14075734	CMOS Logic - SN74ALVC245P										
144	14075790	CMOS Logic - SN74AHC2G08H										
145	14075803	IC:SN741V132APW										
146	14075927	CMOS Logic - SN74LVC1G14D										
147	14076101	IC - SN74LVC2G17DCK										
148	14076126	Clock Generator - ICS9508										
149	14076127	Clock Generator:ICS960008										
150	14076245	CMOS Logic - SN74CBTLV325										
151	14076248	EEPROM - M24256-BWMN6										
152	14076278	ICH3 - NH82801CAM(SL7A7)										
153	14076279	GMCH - NN82830MP(SL7A6)										
154	14076526	CPU - NK80530MZ866256(S17										
155	14081664	Series Regulator:LM1117MP										
156	14081778	IC:R3112Q101A										
157	14081779	IC - R3112Q281A										
158	14081815	IC - R3112Q151A										
159	14081825	IC - R3112Q121A										
160	14081826	IC - R3112Q421A										
161	14081956	IC:LTC3728LXCUH#TRPBF										
162	14082057	IC - LTC3714EG#TRPBF										
163	15030773	Crystal Oscillator:32.768K										
164	15030842	Oscillator - 14.31818MHZ										
165	15030947	Crystal Oscillator:25Mhz										
166	16017898	Resistor Array										

ITEM NO.	PARTS NO.	PARTS NAME	Q'TY / PAGE	Q'TY / PACK	PIR	BSI NO.	TO	T	FROM	SERIAL NO.	REMARKS	C
167	16017909	Resistor Array - 10 OHM +										
168	16017913	Resistor 22 Ohm +-5% 1/32										
169	16017943	Resistor Array - 68 OHM +										
170	16045357	Resistor - 560UF +-20% 4V										
171	16050976	Capacitor - 1MF +80% -20%										
172	16051034	Ceramic Capacitor:1000pf:										
173	16051124	Capacitor - 4.7UF +80 -20										
174	16051176	Ceramic Capacitor 0.47uf										
175	16051194	Capacitor:3pf:+-0.25pf:50										
176	16051195	Capacitor:4pf:+-0.25pf:50										
177	16051196	Capacitor - 5PF:+-0.25PF:										
178	16051197	Capacitor - 6PF +-0.5PF 5										
179	16051205	Capacitor - 33PF +-5% 50V										
180	16051206	Capacitor - 47PF +-5% 50V										
181	16051207	Capacitor - 68PF +-5% 50V										
182	16051208	Capacitor:100pf:+-5%:50v										
183	16051209	Capacitor - 150PF +-5% 50										
184	16051210	Capacitor:180pf:+-5%:50V										
185	16051211	Capacitor - 220PF +-10% 5										
186	16051212	Capacitor - 470PF +-10% 5										
187	16051214	Capacitor - 1000PF +-10%										
188	16051216	Capacitor - 2200PF+-10%50										
189	16051221	Capacitor - 0.1 UF+80-20%										
190	16051225	Capacitor - 0.1UF +-10% 5										
191	16051234	Capcitor:4700pf:+-10%:50V										
192	16051240	Capacitor - 0.01UF +-10%										
193	16051249	Capacitor:0.047uf:+-10%:1										
194	16051281	Capacitor - 0.22UF +-10%										
195	16051282	Capacitor:22uf:+80-20%:10										
196	16051283	Capacitor - 680PF +-10% 5										
197	16051284	Capacitor:1500pf:+-10%:50										
198	16051289	Capacitor - 0.1UF +-10% 1										
199	16051295	Capacitor:10uf:+80-20%:10										
200	16051296	Capacitor - 330PF +-10% 5										
201	16051303	Capacitor - 0.01UF +80-20										
202	16051306	Capacitor - 1UF +-10% 10V										
203	16051352	Resistor - 82PF +-5% 50V										
204	16051354	Capacitor:1200pf:+-5%:50V										
205	16051416	Capacitor - 1800PF:+-5%:5										
206	16051417	Capacitor:47uf:+80-20%:10										
207	16051432	Resistor - 100UF +-20% 6.										
208	16051450	Resistor - 22UF +-10% 6.3										
209	16051464	Resistor - 10UF +-20% 25V										
210	16071322	Inductor:LB2012B4R7M										
211	16071489	Filter - MMZ1608B301C										
212	16071556	Inductor:RLF7030-1R5N6R1										
213	16071637	Coil:ACM2012-900-2P										
214	16071650	Inductor:RLF7030-6R8M2R8										
215	16071651	Inductor - HM73-101R0LF										
216	16071657	Inductor - HM73-10R68LF										
217	16101733	Resistor - 0.01 OHM +-1%										
218	16101775	Resistor - 0.03 OHM +-1%										
219	16101804	Resistor:0.006 Ohm:+-1%:1										
220	16101805	Resistor - 0.003 OHM +-2%										
221	16320000	Resistor - 0 OHM 1/8W										
222	16330000	Resistor - 0 OHM 1/10W										
223	16505100	Chip Resistor - 10 Ohm+-5										
224	16505101	Chip Resistor - 100 Ohm+-										
225	16505102	Chip Resistor - 1kohm+-5%										
226	16505103	Chip Resistor - 10kohm+-5										
227	16505104	Chip Resistor - 100kohm+-										
228	16505106	Resistor - 10M OHM +-5% 1										
229	16505109	Chip Resistor 1ohm +-5% 1										
230	16505122	Chip Resistor - 1.2kohm+-										
231	16505151	Resistor - 150OHM +-5% 1/										
232	16505152	Chip Resistor:1.5kohm:+-5										
233	16505153	Chip Resistor - 15kohm +-										
234	16505202	Chip Resistor:2kohm:+-5%:										
235	16505204	Chip Resistor - 200kohm+-										

ITEM NO.	PARTS NO.	PARTS NAME	Q'TY / PAGE	Q'TY / PACK	P I R	B S I NO.	T O	T	F R O M	S E R I A L NO.	R E M A R K S	C
236	16505220	Resistor - 220HM +-5% 1/1										
237	16505221	Chip Resistor - 220ohm+-5										
238	16505222	Resistor - 2.2KOHM +-5% 1										
239	16505229	Resistor:2.2 Ohm:+-5%:1/1										
240	16505241	Resistor - 240 OHM +-5% 1										
241	16505330	Chip Resistor - 33ohm+-5%										
242	16505331	Resistor - 330OHM +-5% 1/										
243	16505332	Resistor - 3.3KOHM +-5% 1										
244	16505390	Resistor - 39OHM +-5% 1/1										
245	16505393	Resistor - 39KOHM +-5% 1/										
246	16505470	Chip Resistor 47ohm +-5%										
247	16505471	Chip Resistor - 470ohm -5										
248	16505472	Chip Resistor:4.7kohm:+-5										
249	16505511	Resistor - 510OHM +-5% 1/										
250	16505513	Chip Resistor:51kohm:+-5%										
251	16505560	Chip Resistor 56ohm +-5%										
252	16505562	Chip Resistor:5.6kohm:+-5										
253	16505569	Resistor - 5.6OHM +-5% 1/										
254	16505623	Resistor - 62KOHM +-5% 1/										
255	16505680	Resistor - 68OHM +-5% 1/1										
256	16505681	Chip Resistor:680ohm:+-5%										
257	16505822	Chip Resistor:8.2kohm:+-5										
258	16505823	Chip Resistor:82kohm:+-5%										
259	16550000	Chip Resistor - 0ohm+-0%1										
260	16551001	Chip Resistor - 1kohm +-1										
261	16551002	Chip Resistor - 10kohm+-1										
262	16551009	Resistor - 10OHM +-1% 1/1										
263	16551100	Resistor - 110OHM +-1% 1/										
264	16551370	Resistor - 137OHM +-1% 1/										
265	16551409	Resistor - 14OHM +-1% 1/1										
266	16551502	Resistor - 15KOHM +-1% 1/										
267	16551800	Chip Resistor:180ohm:+-1%										
268	16551829	Resistor - 18.2OHM +-1% 1										
269	16552000	Resistor - 200OHM +-1% 1/										
270	16552001	Resistor - 2KOHM +-1% 1/1										
271	16552002	Chip Resistor - 20kohm+-1										
272	16552003	Chip Resistor - 200kohm+-										
273	16552052	Resistor - 20.5KOHM +-1%										
274	16552209	Resistor - 22OHM +-1% 1/1										
275	16552210	Resistor - 221OHM +-1% 1/										
276	16552402	Resistor - 24KOHM +-1% 1/										
277	16552433	Resistor - 243KOHM +-1% 1										
278	16552490	Resistor - 249OHM +-1% 1/										
279	16552679	Resistor - 26.7OHM +-1% 1										
280	16552749	Resistor - 27.4OHM +-1% 1										
281	16552803	Resistor - 280KOHM +-1% 1										
282	16553000	Chip Resistor:300ohm:+-1%										
283	16553002	Chip Resistor - 30kohm+-1										
284	16553010	Resistor - 301OHM +-1% 1/										
285	16553303	Resistor - 330KOHM +-1% 1										
286	16553329	Resistor - 33.2OHM +-1% 1										
287	16553480	Resistor - 348OHM +-1% 1/										
288	16553659	Resistor - 36.5OHM +-1% 1										
289	16553900	Resistor:390 Ohm:+-1%:1/1										
290	16554321	Resistor:4.32k Ohm:+-1%:1										
291	16554701	Chip Resistor - 4.7kohm+-										
292	16554709	Resistor - 47OHM +-1% 1/1										
293	16554750	Resistor - 475OHM +-1% 1/										
294	16554999	Resistor - 49.9OHM +-1% 1										
295	16555101	Resistor - 5.1KOHM +-1% 1										
296	16555109	Resistor - 51OHM +-1% 1/1										
297	16555119	Resistor - 51.1OHM +-1% 1										
298	16555499	Resistor - 54.9OHM +-1% 1										
299	16555609	Resistor - 56OHM +-1% 1/1										
300	16555621	Resistor - 5.62KOHM +-1%										
301	16555629	Resistor - 56.2OHM +-1% 1										
302	16555760	Resistor - 576OHM +-1% 1/										
303	16556049	Resistor - 60.4OHM +-1% 1										
304	16556199	Resistor - 61.9OHM +-1% 1										

ITEM NO.	PARTS NO.	PARTS NAME	Q'TY / PAGE	Q'TY / PACK	P	I	R	BSI NO.	TO	T	FROM	SERIAL NO.	REMARKS	C
305	16556209	Resistor - 620HM +-1% 1/1												
306	16556342	Resistor:63.4k Ohm:+-1%:1												
307	16556809	Chip Resistor - 68ohm+-1%												
308	16558062	Resistor - 80.6KOHM +-1%												
309	16558063	Resistor - 806KOHM +-1% 1												
310	16558209	Resistor - 820HM +-1% 1/1												
311	16559100	Resistor - 910OHM +-1% 1/												
312	16602121	Capacitor - 120PF +-5% 50												

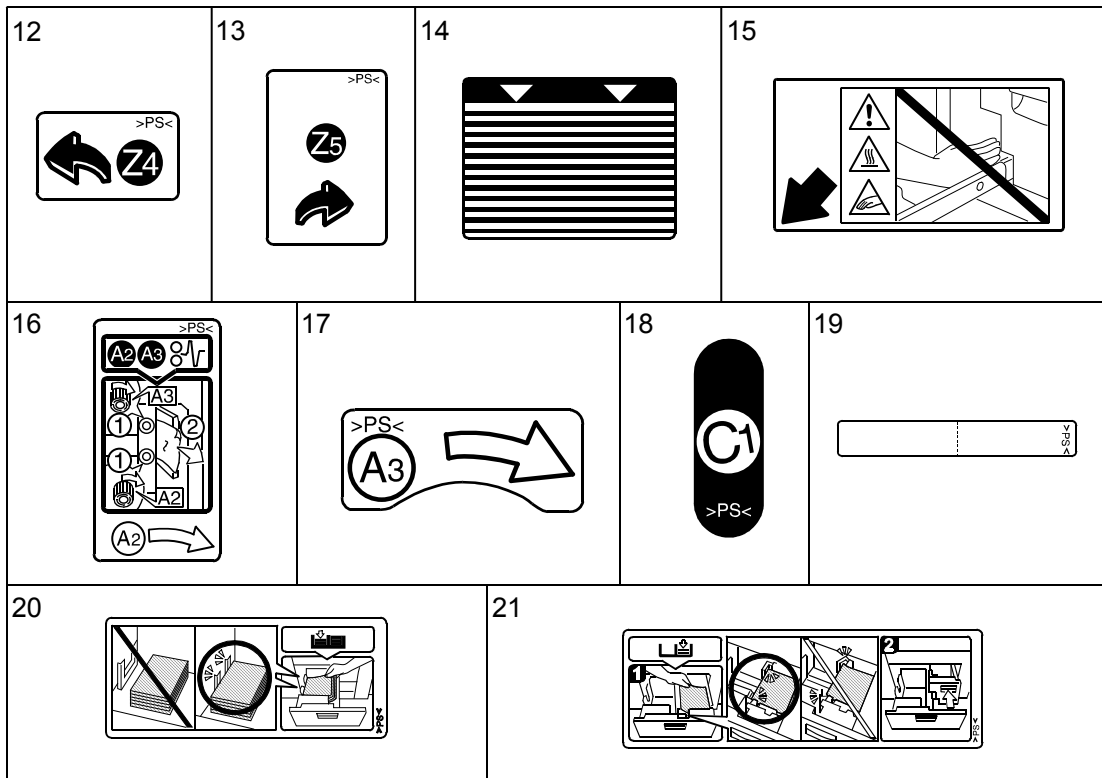
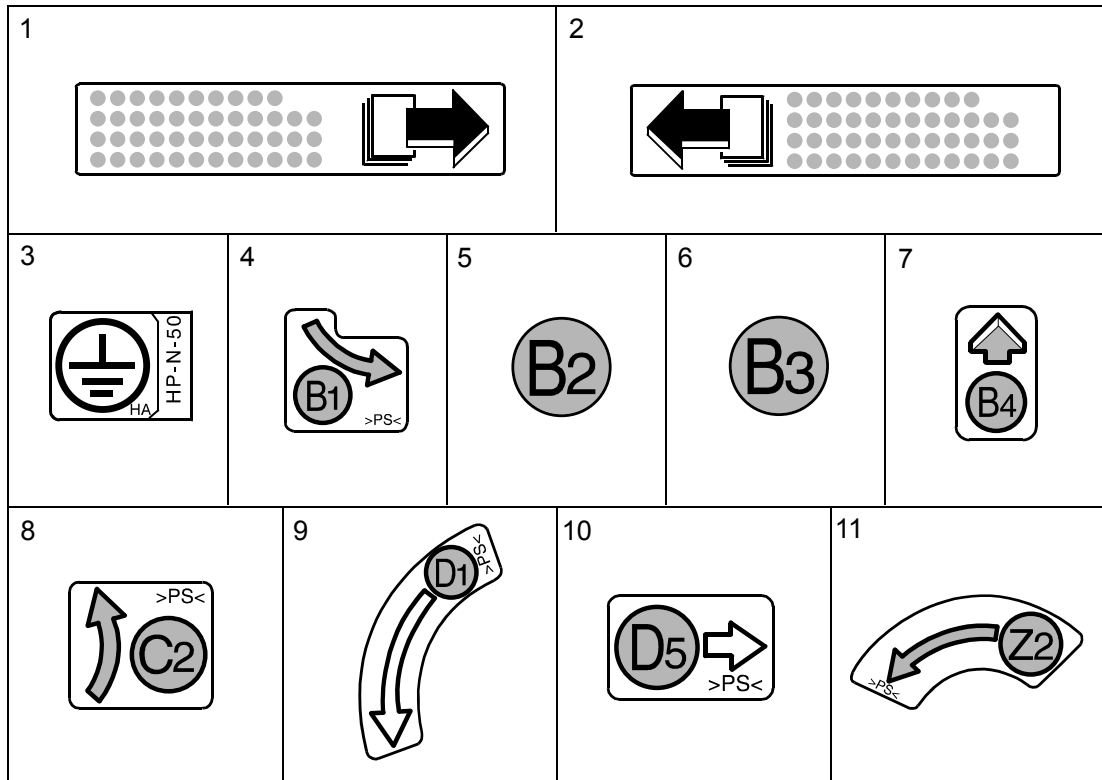

ITEM NO.	PARTS NO.	PARTS NAME	Q'TY / PAGE	Q'TY / PACK	P	I	R	B S I NO.	T O	T	F R O M	S E R I A L NO.	R E M A R K S	C
1	A0966677	Decal - Right Paper Set	1											
2	A0966678	Decal - Left Paper Set	1											
3	AA001190	Decal - Ground	1											
4	AA001462	Decal - Paper Feed (B1)	1											
5	AA001463	Decal - Paper Feed:B2	1											
6	AA001464	Decal - Paper Feed (B3)	1											
7	AA001465	Decal - Paper Feed (B4)	1											
8	AA001466	Decal - Paper Feed (C2)	1											
9	AA001472	Decal - Paper Exit Unit (1											
10	AA001473	Decal - Paper Exit Unit (1											
11	AA001474	Decal - Duplex Unit (Z2)	1											
12	AA001475	Decal - Duplex Unit (Z4)	1											
13	AA001476	Decal - Duplex Unit (Z5)	1											
14	AA002010	Decal - Paper Level	1											
15	AA002246	Decal - Caution	1											
16	AA003045	Decal - Misfeed Removal	1											
17	AA003046	Decal - Vertical Transpor	1											
18	B0653833	Decal - Transfer Unit Lev	1											
19	B0656545	Decal - Positioning	1											
20	B0656846	Decal - Paper Set - Left	1											
21	B0656877	Decal - Paper Set - Right	1											

22

24

25

23

1		B5	11×17	8×13
		8½×11	11×17	8¼×13
	A4			
A3	B5	8½×14	10×14	
A3	B5	8½×14	11×15	
B4	A5	8½×11	×	
B4	A5	8½×11	×	
A4	A5	8½×11	F	
A4	レター	8½×11	*	
A4	レター	8½×13		
A4	5½×8½	8×10½		
B5	5½×8½	8×10		

26

27

Caution: When Turning Off the Main Power

Do not turn off the main power switch while the On indicator is lit or blinking.

Before turning off main power switch, lower the exposure glass cover ADF and press the operation switch. The On indicator should go out indicating that it is safe to turn off the main power switch.

>PS<







28

>PS<



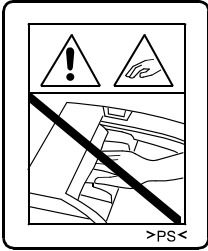

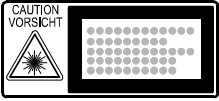
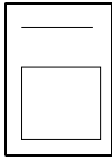

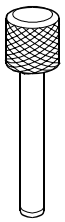
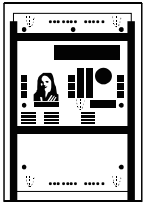
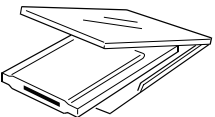

29

>PS<

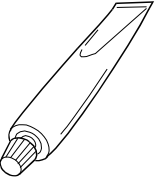
ITEM NO.	PARTS NO.	PARTS NAME	Q'TY / PAGE	Q'TY / PACK	P	I	R	B S I NO.	T O	T	F R O M	S E R I A L NO.	R E M A R K S	C
22	B0701307	Decal:Caution Chart:Paper	1											
23A	B0701308	Decal:Size Indication:Pap	1											
23B	B2348510	Decal:Size Indication:Mul	1											
24	B1326786	Decal:Paper Tray:Paper Se	1											
25	B2341272	Decal - Toner Bank	1											
26	B2341300	Decal - Misfeed Removal	1											
27	B2341357	Decal - Power Source Off	1											
28	B2341378	Decal - Total Counter	1											
29	B2343892	Decal - Lever Release Tra	1											

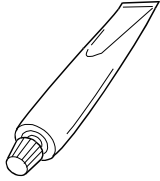
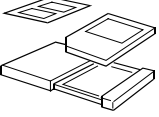
<p>30</p> 	<p>32</p> 																								
<p>31</p> <table border="1" data-bbox="331 878 507 1091"> <tr> <td></td> <td>IF Card Slot</td> </tr> <tr> <td>A1</td> <td>Tandem</td> </tr> <tr> <td>A2</td> <td>External CTL</td> </tr> <tr> <td>A3</td> <td>File Format Converter</td> </tr> <tr> <td>B1</td> <td>USB-Host</td> </tr> <tr> <td>B2</td> <td>Option</td> </tr> <tr> <td>B3</td> <td>Ethernet & USB(2.0)</td> </tr> <tr> <td></td> <td>SD Card Slot</td> </tr> <tr> <td>C1</td> <td>System</td> </tr> <tr> <td>C2</td> <td>Option</td> </tr> <tr> <td>C3</td> <td>Service</td> </tr> </table> <p style="text-align: right;">>PS<</p>		IF Card Slot	A1	Tandem	A2	External CTL	A3	File Format Converter	B1	USB-Host	B2	Option	B3	Ethernet & USB(2.0)		SD Card Slot	C1	System	C2	Option	C3	Service	<p>33</p> 	<p>34</p> 	<p>35</p> 
	IF Card Slot																								
A1	Tandem																								
A2	External CTL																								
A3	File Format Converter																								
B1	USB-Host																								
B2	Option																								
B3	Ethernet & USB(2.0)																								
	SD Card Slot																								
C1	System																								
C2	Option																								
C3	Service																								
<p>36</p> <table border="1" data-bbox="347 1136 496 1400"> <tr> <td>Face UP</td> </tr> <tr> <td>Face imprimée dessus</td> </tr> <tr> <td>Mit der Schriftseite nach oben</td> </tr> <tr> <td>Faccia in su</td> </tr> <tr> <td>Boca arriba</td> </tr> </table>	Face UP	Face imprimée dessus	Mit der Schriftseite nach oben	Faccia in su	Boca arriba	<p>37</p> 	<p>38</p> 	<p>39</p> 																	
Face UP																									
Face imprimée dessus																									
Mit der Schriftseite nach oben																									
Faccia in su																									
Boca arriba																									

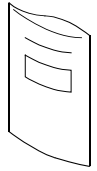
ITEM NO.	PARTS NO.	PARTS NAME	Q'TY / PAGE	Q'TY / PACK	P	I	R	B S I NO.	T O	T	F R O M	S E R I A L NO.	R E M A R K S	C
30	B2344138	Decal - Warning (high Tem	1											
31	B2346851	Decal - Caption Interface	1											
32	B3014316	Decal: Misfeed Removal	1											
33	B3014336	Decal: Size: Original: RIC	1											
34	B3014356	Decal: Paper Feed	1											
35	B4774311	Decal - Original Base	1											
36	B4774431	Decal - Original Table	1											
37	G0291982	LD - Decal	1											
38A	B2357607	Operating Instructions: Co	1											
38B	B2357707	Operating Instructions: Tr	1											
38C	B2357737	Operating Instructions: Th	1											
38D	B2357907	Operating Instructions: Se	1											
39A	B2342333	Decal: Knob: German	1											
39B	B2342334	Decal: Knob: French	1											
39C	B2342335	Decal: Knob: Italian	1											
39D	B2342336	Decal: Knob: Spanish	1											

1 	2 	3 	4 	5 
6 	7 	8 	9 	10 
11 			14 	

ITEM NO.	PARTS NO.	PARTS NAME	Q'TY / PAGE	Q'TY / PACK	P	I	R	B S I NO.	T O	T	F R O M	S E R I A L NO.	R E M A R K S	C
1	A0069104	Scanner Positioning Pin (1											
2	A2929500	Test Chart - S5S (10 Pcs/	1											
3	B6456700	SD-Card:Adapter:BN-SDAA2	1											
4	B6456800	SD-Card:USB:Writer:BN-SDC	1											
5	A2579300	Grease Barrierta - S552R	1											
6	52039502	Grease 501	1											
7	G0049668	Grease - KS660 - SHIN-ETS	1											
8	B6455010	SD-Card:Ass'y	1											
9	54479078	Heat Resisting Grease MT-	1											
10	54429103	Launa Oil 40	1											
11	B2349640	Developer	1											
14	B2348614	Setting Powder	1											

TOSHIBA

TOSHIBA TEC CORPORATION

2-17-2, HIGASHIGOTANDA, SHINAGAWA-KU, TOKYO, 141-8664, JAPAN