

TOSHIBA

SERVICE MANUAL

MULTIFUNCTIONAL DIGITAL SYSTEMS

e-STUDIO6529A/7529A/ 9029A

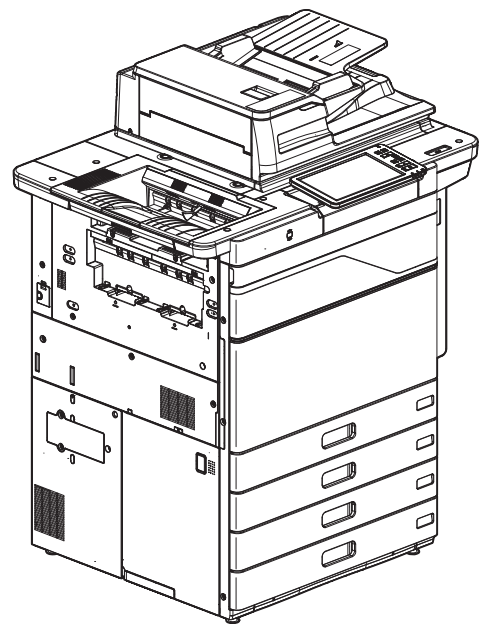

Model: DP-6529A/7529A/9029A
Publish Date: November 2022
File No. SME21003700
R220421Z0300-TTEC
Ver00 F 2022-11

Trademarks

- Microsoft, Windows, Windows NT, and the brand names and product names of other Microsoft products are trademarks of Microsoft Corporation in the US and other countries.
- Apple, AppleTalk, Macintosh, Mac, Safari, and TrueType are trademarks of Apple Inc.
- Adobe[®], Acrobat[®], Acrobat Reader[®], and PostScript[®] are trademarks or registered trademarks of Adobe Inc.
- Mozilla, Firefox and the Firefox logo are trademarks or registered trademarks of Mozilla Foundation in the U.S. and other countries.
- The official name of Windows[®] 10 is Microsoft Windows 10 Operating System.
- The official name of Windows[®] 11 is Microsoft Windows 11 Operating System.
- The official name of Windows Server[®] 2012 is Microsoft Windows Server 2012 Operating System.
- The official name of Windows Server[®] 2016 is Microsoft Windows Server 2016 Operating System.
- The official name of Windows Server[®] 2019 is Microsoft Windows Server 2019 Operating System.
- The official name of Windows Server[®] 2022 is Microsoft Windows Server 2022 Operating System.
- FLOIL[®] is a registered trademark of Kanto Kasei CO., Ltd.
- MOLYKOTE[®] is a registered trademark of DDP SPECIALTY ELECTRONIC MATERIALS US, INC..
- ALVANIA[®] is a registered trademark of Shell Brands International AG.
- VNC is a registered trademark of RealVNC Ltd. in the United States and other countries.
- e-STUDIO, e-BRIDGE, and TopAccess are trademarks of Toshiba Tec Corporation.
- Other company names and product names in this manual are the trademarks of their respective companies.

© 2022 Toshiba Tec Corporation All rights reserved

Under the copyright laws, this manual cannot be reproduced in any form without prior written permission of Toshiba Tec Corporation.

GENERAL PRECAUTIONS REGARDING THE SERVICE FOR THIS EQUIPMENT

The installation and service shall be done by a qualified service technician.

1. Transportation/Installation

- When transporting/installing the MFP, employ two or more persons and be sure to move it by the casters while lifting the stoppers.
The MFP is quite heavy and weighs approximately 194 kg (427.70 lb.), therefore pay full attention when handling it.
- Be sure not to hold the movable parts or units (e.g.: the control panel, ADU or DSDF) when transporting the MFP.
- Be sure to use a dedicated outlet with AC 120 V / 16 A, 220-240 V / 10 A for its power source.
- The MFP must be grounded for safety.
- Select a suitable place for installation. Avoid excessive heat, high humidity, dust, vibration and direct sunlight.
- Provide proper ventilation since the MFP emits a slight amount of ozone.
- To insure adequate working space for the copying operation, keep a minimum clearance of 30 cm (11.8") on the left, 80 cm (32") on the right and 10 cm (4") on the rear.
- The MFP shall be installed near the socket outlet and shall be easily accessible.
- Be sure to fix and plug in the power cable securely after the installation so that no one trips over it.
- If the unpacking place and where the MFP is to be installed differ, perform image quality adjustment (automatic gamma adjustment) according to the temperature and humidity of the place of installation and the paper to be used.
- When the equipment is used after the option is removed, be sure to install the parts or the covers which have been taken off so that the inside of the equipment is not exposed.
- Do not use an ozone generator near the MFP. Or, place any ozone generator as far away from the MFP as possible.
- Do not use an ultrasonic humidifier near the MFP.
Components such as chlorinate and mineral will be atomized by an ultrasonic humidifier and they will adhere to electric parts in the MFP. This could cause malfunctions.
- Unpacking and installation of an MFP should be performed by following the Unpacking Instructions co-packed with it. After the installation is completed, be sure to check the operations and images.
- Be sure to change the service password from the initial value (factory shipment value).
- When the LAN cable, USB cable or telephone line is connected, be sure to wire the cable or line by passing it through the clamp of the rear cover.
Otherwise, they will be caught when the duplexing unit is opened/closed and thus may be damaged.

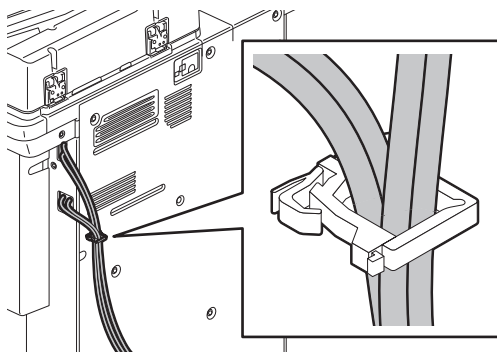

2. General Precautions at Service

- Be sure to turn the power OFF and unplug the power cables during service (except for the service should be done with the power turned ON).
- After the power cable is disconnected, an electric charge may remain in the boards of the MFP. Therefore, be sure to disconnect or connect the connectors when about 1 minute (e.g.: the time for taking off the rear cover) has passed after the power cable is disconnected.
- Generally, the fuse is embedded so that it would be on the live side. However, it could be on the neutral side depending on the type of the power plug to be used. Therefore, in order to disconnect and de-energize of the phase conductors, unplug the power plug.
- Unplug the power cable and clean the area around the prongs of the plug and socket outlet once a year or more. A fire may occur when dust lies on this area.
- When the parts are disassembled, reassembly is the reverse of disassembly unless otherwise noted in this manual or other related documents. Be careful not to install small parts such as screws, washers, pins, E-rings, star washers, harnesses in the wrong places.
- Basically, the equipment should not be operated with any parts removed or disassembled.
- The PC board must be stored in an anti-electrostatic bag and handled carefully using an antistatic wrist strap since the ICs on it may be damaged due to static electricity.

Caution: Before using the antistatic wrist strap, unplug the power cable of the equipment and make sure that there are no charged objects which are not insulated in the vicinity.

- Avoid expose to laser beam during service. This MFP uses a laser diode. Be sure not to expose your eyes to the laser beam. Do not insert reflecting parts or tools such as a screwdriver on the laser beam path. Remove all reflecting metals such as watches, rings, etc. before starting service.
- Be sure not to touch high-temperature sections such as the fuser unit, damp heater and areas around them.
- Be sure not to touch high-voltage sections such as the chargers, transfer belt, 2nd transfer roller, developer, IH board, high-voltage transformer and power supply unit. Especially, the board of these components should not be touched since the electric charge may remain in the capacitors, etc. on them even after the power cable is disconnected.
- Make sure that the equipment will not operate before touching potentially dangerous places (e.g.: rotating/operating sections such as gears, belts pulleys, fans and laser beam exit of the laser optical unit).
- Be careful when removing the covers since there might be the parts with very sharp edges underneath.
- When servicing the MFP with the power turned ON, be sure not to touch live sections and rotating/operating sections. Avoid exposing your eyes to laser beam.
- Use designated jigs and tools.
- Use recommended measuring instruments or equivalents.
- Return the equipment to the original state and check the operation when the service is finished.
- Be very careful to treat the touch panel gently and never hit it. Breaking the surface could cause malfunctions.
- Do not leave plastic bags where children can get at them. This may cause an accident such as suffocation if a child puts his/her head into a bag. Plastic bags of options or service parts must be brought back.
- There is a risk of an electric shock or fire resulting from the damage to the harness covering or conduction blockage. To avoid this, be sure to wire the harness in the same way as that before disassembling when the equipment is assembled/disassembled.

3. General operations

- Check the procedures and perform them as described in the Service Manual.
- Make sure you do not lose your balance.
- Avoid exposure to your skin and wear protective gloves as needed.

4. Important Service Parts for Safety

The breaker, IH coil, door switch, fuse, thermostat, thermofuse, thermistor, batteries, IC-RAMs including lithium batteries, etc. are particularly important for safety. Be sure to handle/install them properly. If these parts are short-circuited and their functions become ineffective, they may result in fatal accidents such as explosion or burnout. Avoid short-circuiting and do not use parts not recommended by Toshiba Tec Corporation.

5. Cautionary Labels

During servicing, be sure to check the rating plate and cautionary labels to see if there is any dirt on their surface and if they are properly stuck to the MFP.

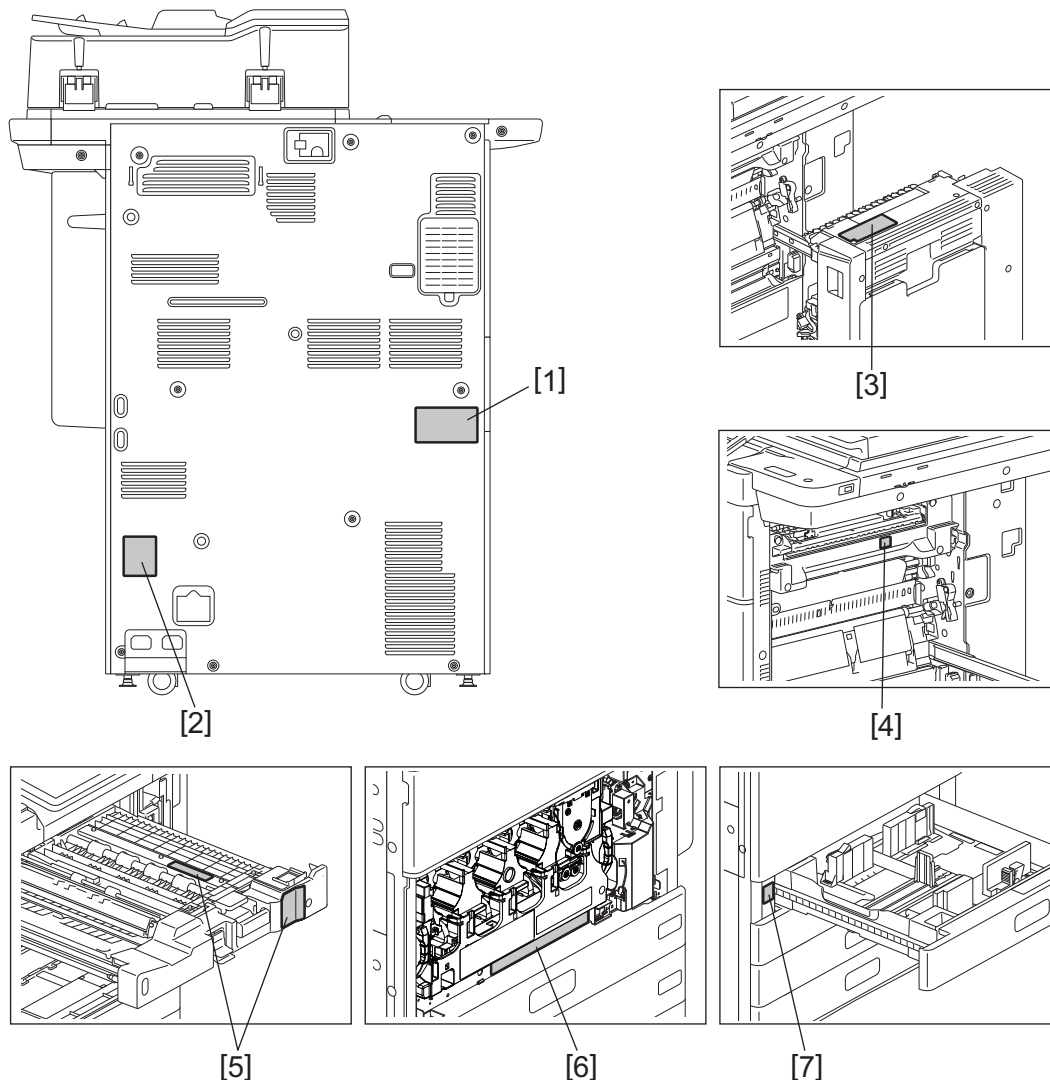

- [1] Identification label
- [2] Laser class label
- [3] Warning for power cable
- [4] Warning for high temperature area
- [5] Warning for high temperature area
- [6] Warning for high temperature area
- [7] Warning for laser
- [8] Warning for damp heater (for TWD)

6. Disposal of the Equipment, Supplies and Packing Materials

Regarding the recovery and disposal of the equipment, supplies and packing materials including, follow the relevant local regulations or rules.

7. Precautions regarding IC-RAMs with a battery or a lithium battery embedded

- Be very careful not to replace this with an incorrect type. This will result in an explosion or fire.
- Regarding the collection and disposal of used IC-RAMs with a battery or a lithium battery embedded, follow relevant local regulations or rules.

1. Precautions for Transporting Equipment Once Unpacked

1.1 General Description

It is recommended to follow the procedure below when you transport equipment that has already been unpacked but has not been packed again. Note that the following procedure cannot guarantee the operation of the transported equipment.

| | Item | Content |
|-----|------------------|---|
| (1) | Scanning section | Fix the scanning section. |
| (2) | Drum | Install the drum protection sheet and the drum fixing holder. |
| (3) | Toner | Install sealing material on the toner supply opening of each toner cartridge. |

Remarks:

- Keep packing material removed at unpacking to reuse it in steps (1) and (2) above.

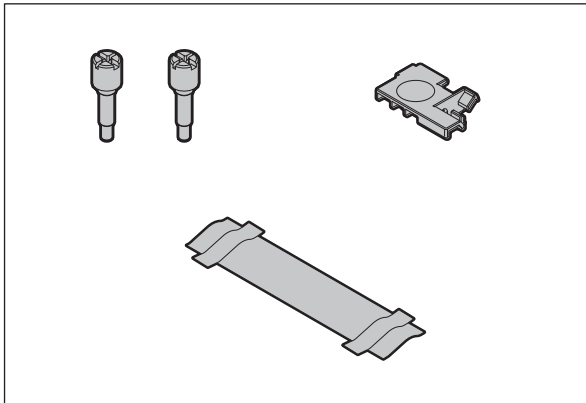

- Use a service jig PLATE-TONER-SEAL (6LJ06917000) as sealing material to be used in step (3) above.
- Do not install the accessories shown below when unpacking the equipment.

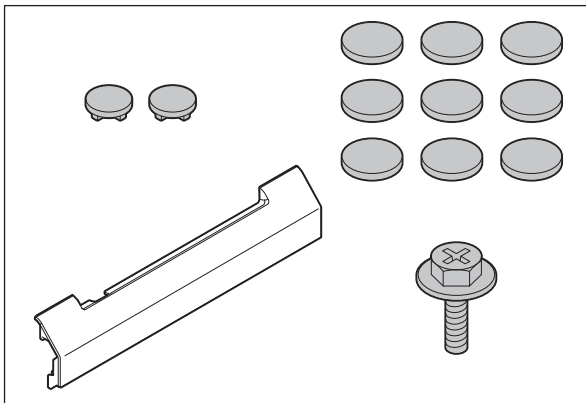

2. Precautions and Procedures for Transporting Equipment

2.1 Installing the sealing material in toner supply opening

1. Open the front cover and the toner cover. Then take off the toner cartridge.

Notes:

Entry of the self-diagnostic code is required in order to open the toner cover. For details, refer to the Self-Diagnosis Code or the Service Manual.

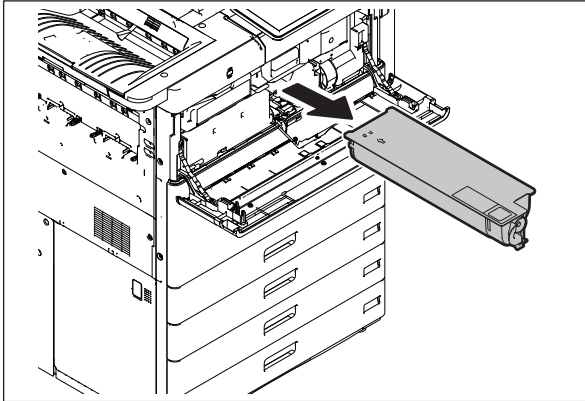

2. While the toner cover and front cover are opened, shut down the equipment.
3. Install PLATE-TONER-SEAL-4P (6LH035950) in the toner supply opening of the toner cartridge. Check that PLATE-TONER-SEAL-4P (6LH035950) is firmly inserted to the end and then close the toner cover and front cover.

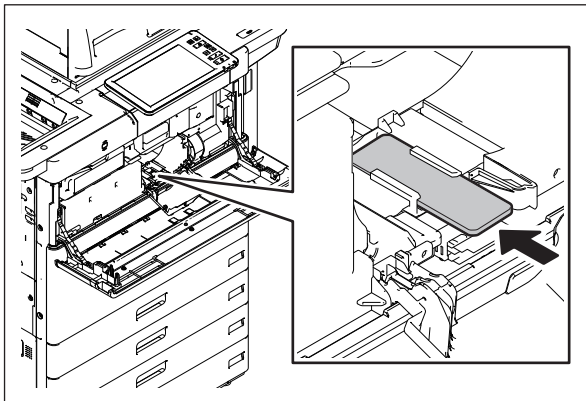

Notes:

- Pay attention to prevent dust from entering into the toner supply openings.
- When installing PLATE-TONER-SEAL-4P (6LH035950), be careful not to scratch or remove the sponge that is already attached to the toner supply openings.
- The toner cartridge must not be installed while the equipment is being transported. Pack it separately from the equipment.

2.2 Install the drum protection sheet and the drum fixing holder.

1. Pull out the EPU tray.
📖 P. 4-124 “4.6.1 Pulling out of the process unit (EPU tray)”
2. Attach a drum protection sheet to the drum.
Be sure to fix the drum protection sheet with pieces of tape. (Be careful not to let the tape contact the drum during this.)

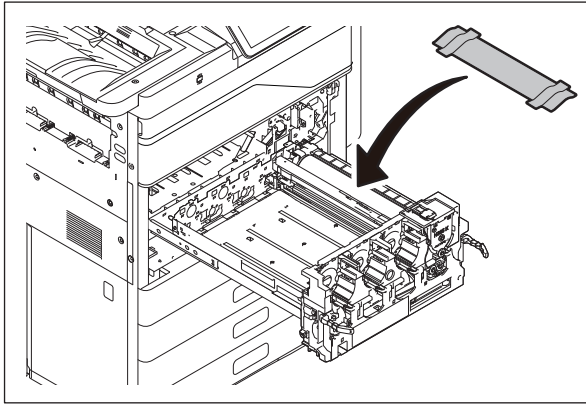

3. Place the drum fixing holder on the specified position and press it in until a sound is heard.

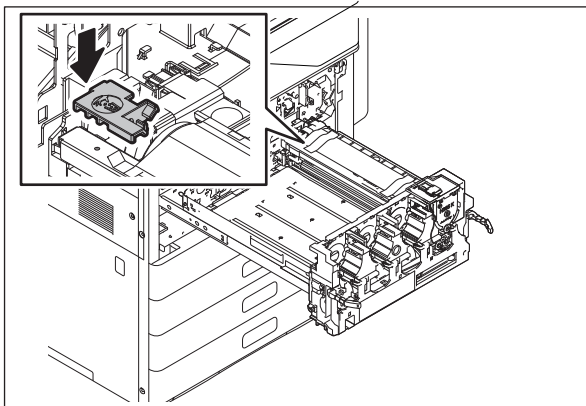

4. Push the EPU tray in, and then reassemble the equipment in the procedure reverse to disassembly.

Notes:

- It is recommended to keep the drum protection sheet and the drum fixing holder removed at unpacking.
- Store the drum protection sheet in a place without high temperature and humidity, direct sunlight or dust.
- Do not scratch or bend the drum protection sheet. Avoid adhesion of dust, dirt or foreign matter, especially things that may damage the surface of the drum or the transfer belt (e.g. hard matter or matter that is highly adhesive, organic or chemical matter, grease) to the drum protection sheet.
- Do not use a drum protection sheet that is damaged or deformed, or one with any abnormality.

2.3 Fixing the scanning section

1. Move carriage-1 until it touches the left side of the frame. Then move it back to the right for 3 mm.

Notes:

Rotate a drive pulley by hand to move carriage-1.

📖 P. 4-38 “4.3.10 Carriage-1”

2. Reinstall 2 screws that were removed when unpacking the equipment.

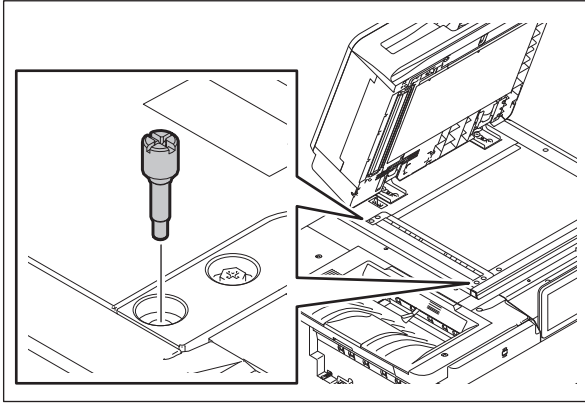

Notes:

- The installation of rubber caps for covering the holes of the scanner fixing screws, which is described in the Unpacking Instructions, must not be performed when the equipment is unpacked but must be when it is reinstalled at a user's office. (Large: 9 pcs. , Small: 2 pcs.)

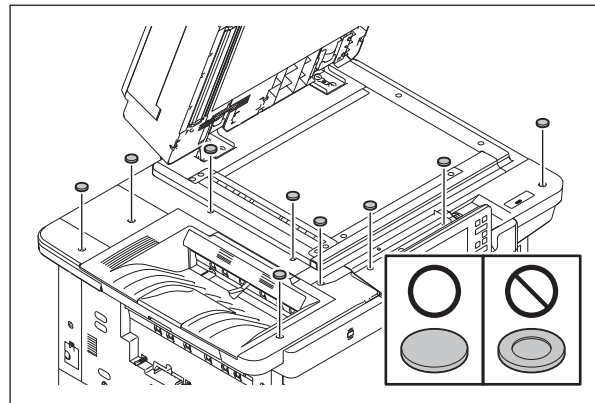
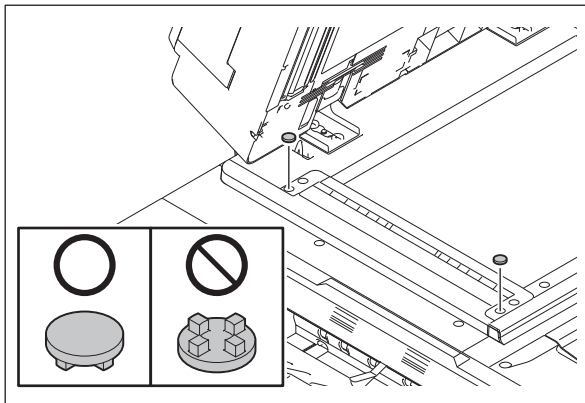

- The installation of the front lower cover, which is described in the Unpacking Instructions, must not be performed when the equipment is unpacked but must when it is set up at a user's office.

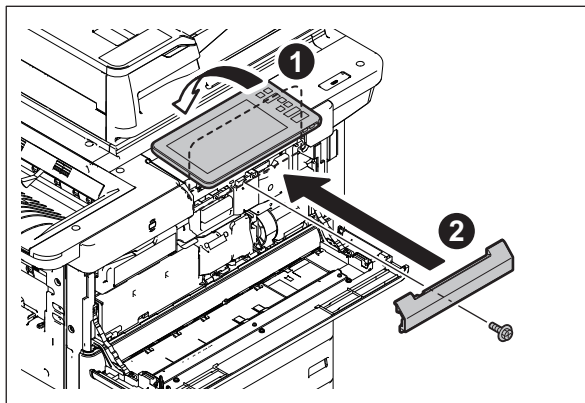

2.4 Attach the cushioning material of the scanning section

When transporting the equipment with the DSDF installed, be sure to attach the cushioning material as below to prevent the cover in the scanner section from being scratched by the protrusion of the DSDF cover.

1. Fold the cushioning material (packing material) in two. (Utilize the packing material used in the DSDF section, if available.) Place it on the upper surface of the scanner section so that it is covered.

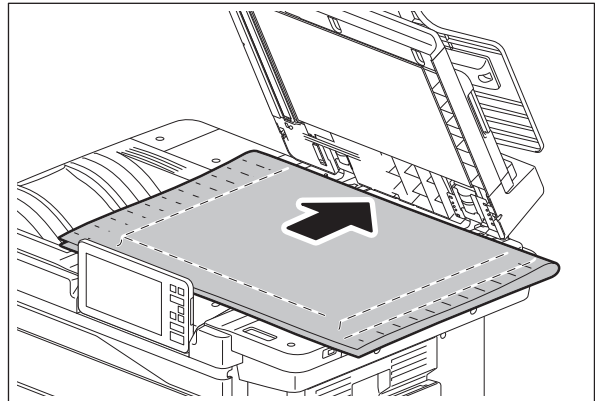
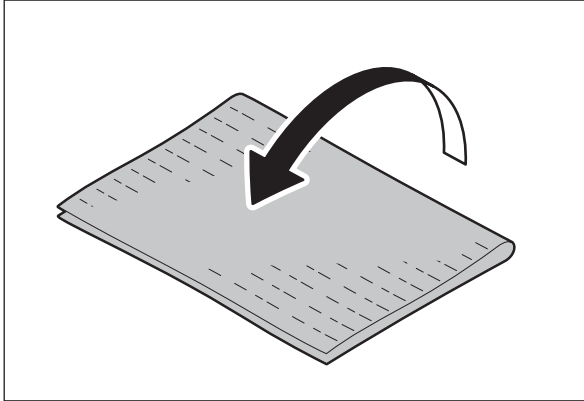

2. While paying attention to ensure that the cushioning material is not moved, slowly close the DSDF.

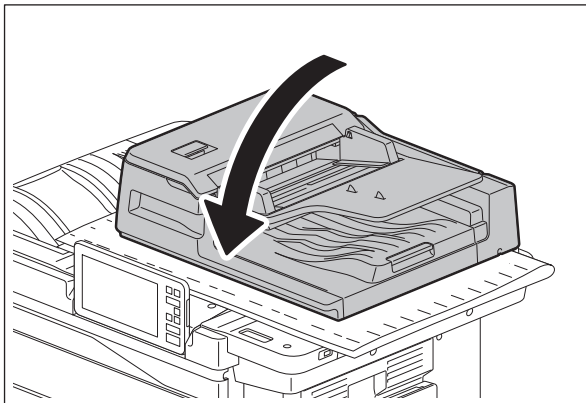

2.5 Attaching packaging tape to the accessory tray

When an optional accessory tray is installed, be sure to fix it with packaging tape.

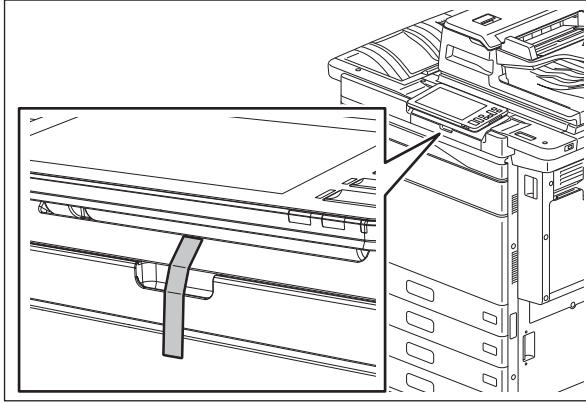

ALLGEMEINE SICHERHEITSMASSNAHMEN IN BEZUG AUF DIE WARTUNG

Die Installation und die Wartung sind von einem qualifizierten Service-Techniker durchzuführen.

1. Transport/Installation

- Zum Transportieren/Installieren des Gerätes werden 2 Personen benötigt. Bewegen Sie es mit den Rollen, während Sie die Absperrvorrichtungen heben. Das Gerät ist sehr schwer und wiegt etwa 194 kg; deshalb muss bei der Handhabung des Geräts besonders aufgepasst werden
- Beim Transportieren des Geräts nicht an den beweglichen Teilen oder Einheiten (z.B. das Bedienungsfeld, die Duplexeinheit oder die automatische Dokumentenzuführung) halten.
- Eine spezielle Steckdose mit Stromversorgung von AC 120 V / 16 A, 220-240 V / 10 A als Stromquelle verwenden.
- Das Gerät ist aus Sicherheitsgründen zu erden.
- Einen geeigneten Standort für die Installation wählen. Standorte mit zuviel Hitze, hoher Luftfeuchtigkeit, Staub, Vibration und direkter Sonneneinstrahlung sind zu vermeiden.
- Für ausreichende Belüftung sorgen, da das Gerät etwas Ozon abgibt.
- Um einen optimalen Kopierbetrieb zu gewährleisten, muss ein Abstand von mindestens 80 cm links, 80 cm rechts und 10 cm dahinter eingehalten werden.
- Das Gerät ist in der Nähe der Steckdose zu installieren; diese muss leicht zu erreichen sein.
- Nach der Installation muss das Netzkabel richtig hineingesteckt und befestigt werden, damit niemand darüber stolpern kann.
- Falls der Auspackungsstandort und der Installationsstandort des Geräts verschieden sind, die Bildqualitätsjustierung (automatische Gammajustierung) je nach der Temperatur und Luftfeuchtigkeit des Installationsstandorts und der Papiersorte, die verwendet wird, durchführen.
- Wenn das Gerät nach der Entfernung der Extras verwendet wird, die entfernten Teile oder Abdeckungen anbringen, damit das Innere des Gerät nicht freiliegt.
- Betreiben Sie keinen Ultraschall-Luftbefeuchter in der Nähe des MFP. Chlorat- und mineralhaltige Komponenten werden von einem Ultraschallbefeuchter zerstäubt und die Partikel können sich an den elektrischen Teilen innerhalb des MFP anlagern. Dies kann zu Fehlfunktionen führen.
- Wenn LAN-Kabel, USB-Kabel oder die Telefonleitung angeschlossen sind, müssen diese Kabel durch die Klemme an der Rückwand verlegt werden. Ansonsten können sie beim Öffnen/Schließen der Duplexeinheit eingeklemmt und beschädigt werden.

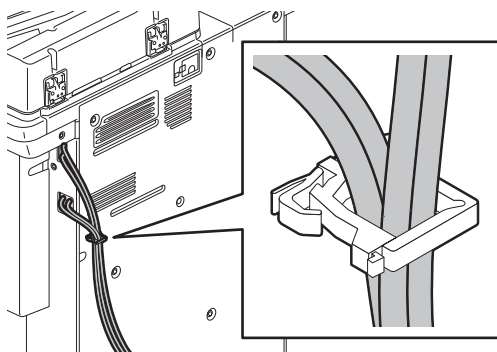

2. Allgemeine Sicherheitsmassnahmen in bezug auf die Wartung

- Während der Wartung das Gerät ausschalten und das Netzkabel herausziehen (ausser Wartung, die bei einem eingeschalteten Gerät, durchgeführt werden muss).
- Das Netzkabel herausziehen und den Bereich um die Steckerpole und die Steckdose die Umgebung in der Nähe von den Steckerzacken und der Steckdose wenigstens einmal im Jahr reinigen. Wenn Staub sich in dieser Gegend ansammelt, kann dies ein Feuer verursachen.
- Die Sicherung kann eingeschaltet bleiben. Der Stromstecker sollte jedoch gezogen werden, damit die internen Leiter von der Phase getrennt sind.
- Wenn die Teile auseinandergenommen werden, wenn nicht anders in diesem Handbuch usw erklärt, ist das Zusammenbauen in umgekehrter Reihenfolge durchzuführen. Aufpassen, dass kleine Teile wie Schrauben, Dichtungsringe, Bolzen, E-Ringe, Stern-Dichtungsringe, Kabelbäume nicht an den verkehrten Stellen eingebaut werden.
- Grundsätzlich darf das Gerät mit entfernten oder auseinandergenommenen Teilen nicht in Betrieb genommen werden.
- Das PC-Board muss in einer Anti-elektrostatischen Hülle gelagert werden. Nur Mit einer Manschette bei Betätigung eines Armbandes anfassen, sonst könnte es sein, dass die integrierten Schaltkreise durch statische Elektrizität beschädigt werden.

Vorsicht: Vor Benutzung der Manschette der Betätigung des Armbandes, das Netzkabel des Gerätes herausziehen und prüfen, dass es in der Nähe keine geladenen Gegenstände, die nicht isoliert sind, gibt.

- Setzen Sie sich während der Wartungsarbeiten nicht dem Laserstrahl aus. Dieses Gerät ist mit einer Laserdiode ausgestattet. Es ist unbedingt zu vermeiden, direkt in den Laserstrahl zu blicken. Keine reflektierenden Teile oder Werkzeuge, wie z. B. Schraubendreher, in den Pfad des Laserstrahls halten. Vor den Wartungsarbeiten sämtliche reflektierenden Metallgegenstände, wie Uhren, Ringe usw., entfernen.
- Auf keinen Fall Hochtemperaturbereiche, wie die Belichtungslampe, die Fixiereinheit, die Heizquelle und die umliegenden Bereiche, berühren.
- Auf keinen Fall Hochspannungsbereiche, wie die Ladeeinheiten, das Transferband, die zweite Transferwalze, die Entwicklereinheit, den Hochspannungstransformator und das Netzgerät, berühren. Insbesondere sollten die Platinen dieser Komponenten nicht berührt werden, da die Kondensatoren usw. auch nach dem Ausschalten des Geräts noch elektrisch geladen sein können.
- Vor dem Berühren potenziell gefährlicher Bereiche (z. B. drehbare oder betriebsrelevante Bereiche, wie Zahnräder, Riemen, Riemenscheiben, Lüfter und die Laseraustrittsöffnung der optischen Lasereinheit) sicherstellen, dass das Gerät sich nicht bedienen lässt.
- Beim Entfernen von Abdeckungen vorsichtig vorgehen, da sich darunter scharfkantige Komponenten befinden können.
- Bei Wartungsarbeiten am eingeschalteten Gerät dürfen keine unter Strom stehenden, drehbaren oder betriebsrelevanten Bereiche berührt werden. Nicht direkt in den Laserstrahl blicken.
- Ausschließlich vorgesehene Werkzeuge und Hilfsmittel verwenden.
- Empfohlene oder gleichwertige Messgeräte verwenden.
- Nach Abschluss der Wartungsarbeiten das Gerät in den ursprünglichen Zustand zurück versetzen und den einwandfreien Betrieb überprüfen.
- Das berührungsempfindliche Bedienungsfeld stets vorsichtig handhaben und keinen Stößen aussetzen. Wenn die Oberfläche beschädigt wird, kann dies zu Funktionsstörungen führen.
- Bewahren Sie Kunststofftüten kindersicher auf. Es besteht Erstickungsgefahr, wenn sich Kinder beim Spielen eine Kunststofftüte über den Kopf ziehen. Bitte nehmen Sie die Kunststofftüten von Optionen oder Serviceparts wieder zurück.
- Wenn der Schutzmantel eines Kabels oder die Steckerisolierung beschädigt werden, besteht Brandgefahr oder die Gefahr eines elektrischen Schlags. Um dies zu vermeiden, sollten Kabel in der gleichen Weise verlegt werden, wie sie vor der Demontage/dem Transport verlegt waren.

3. Allgemeine Sicherheitsmassnahmen

- Die Verfahren sind zu überprüfen und wie im Wartungshandbuch beschrieben durchzuführen.
- Vorsichtig, dass Sie nicht umfallen.
- Um Kontakt zur Haut zu vermeiden, tragen Sie wenn nötig Schutzhandschuhe.

4. Sicherheitsrelevante Wartungsteile

- Der Leistungsschutzschalter, die IH-Spule, der Türschalter, die Sicherung, der Thermostat, die Thermosicherung, der Thermistor, die Akkus, die IC-RAMs einschließlich der Lithium-Batterie sind besonders sicherheitsrelevant. Sie müssen unbedingt korrekt gehandhabt und installiert werden. Wenn diese Teile kurzgeschlossen und funktionsunfähig werden, kann dies zu schwerwiegenden Schäden, wie einer Explosion oder einem Abbrand, führen. Kurzschlüsse sind zu vermeiden, und es sind ausschließlich Teile zu verwenden, die von der Toshiba TEC Corporation empfohlen sind.

5. Warnetiketten

- Im Rahmen der Wartung unbedingt das Leistungsschild und die Etiketten mit Warnhinweisen überprüfen, um sicherzustellen, dass sie nicht verschmutzt sind und korrekt am Gerät angebracht sind.

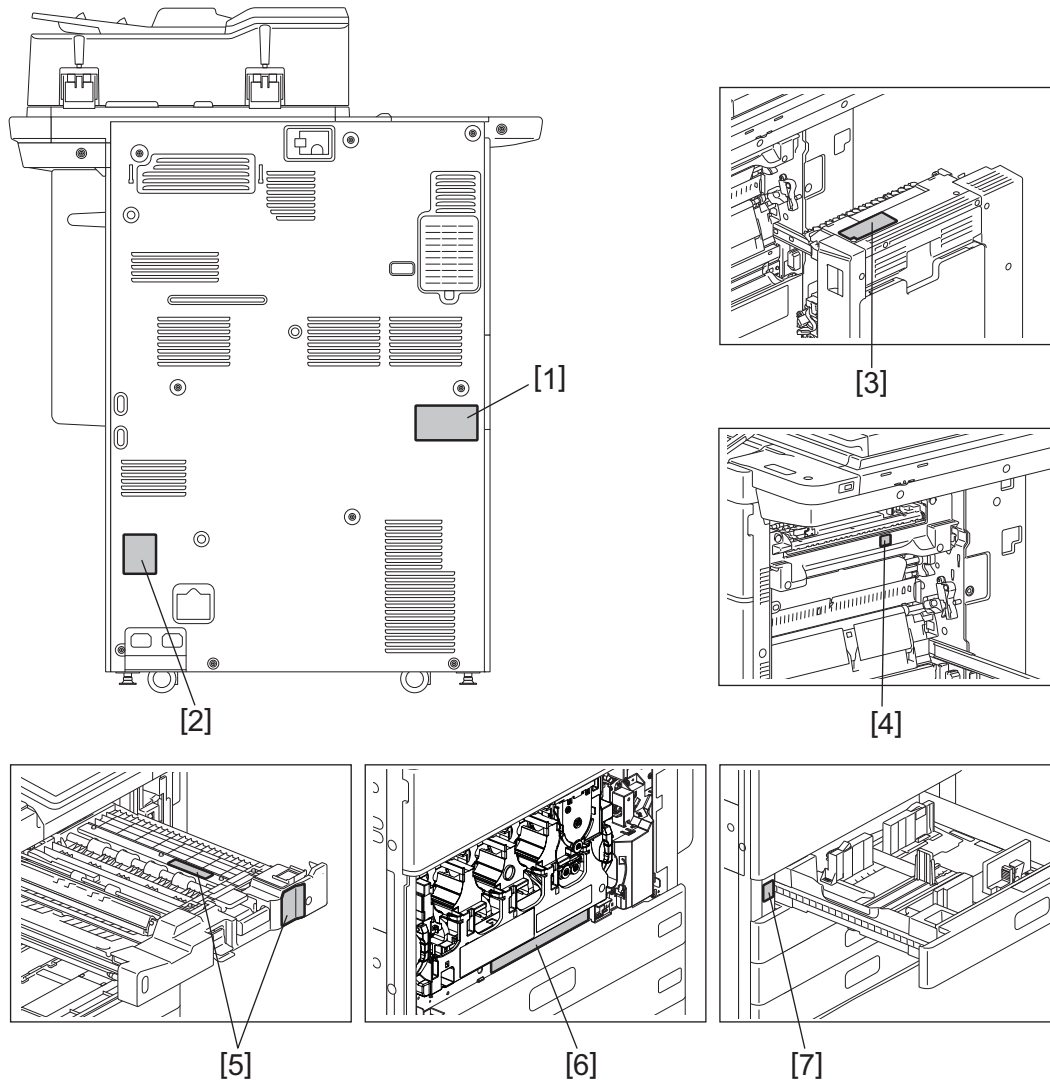

- 1) Erkennungsetikett
- 2) Warnung für den Laser
- 3) Warnung für das Stromkabel
- 4) Warnung für Bereiche mit hohen Temperaturen
- 5) Warnung für Bereiche mit hohen Temperaturen
- 6) Warnung für Bereiche mit hohen Temperaturen
- 7) Warnung für den Laser
- 8) Warnung für die Anti-Kondensationsheizung (für TWD)

6. Entsorgung des Geräts, der Verbrauchs- und Verpackungsmaterialien, alter Akkus und IC-RAMs

- In Bezug auf die Entsorgung und Wiederverwertung des Geräts, der Verbrauchs- und Verpackungsmaterialien, alter Akkus und IC-RAMs, einschließlich Lithiumakkus, sind die einschlägigen nationalen oder regionalen Vorschriften zu befolgen.

Caution:

Dispose of used batteries and IC-RAMs including lithium batteries according to this manual.

Attention:

Se débarrasser de batteries et IC-RAMs usés y compris les batteries en lithium selon ce manuel.

Vorsicht:

Entsorgung der gebrauchten Batterien und IC-RAMs (inclusive der Lithium-Batterie) nach diesem Handbuch.

- Laseremissionseinheit

Diese Einheit besteht aus der Laserdiode, dem Fokussierungsobjektiv, der Blende und dem Zylinderobjektiv.

Laserdiode

Diese Laserdiode zeichnet sich durch eine geringe Regeldifferenz, eine kleine Laservariation und einen niedrigen Schwellenstrom aus.

Die Blende der Laseremissionseinheit ist unter dem Fokussierobjektiv angeordnet, um die Form der Laserstrahlen in der primären und sekundären Scanrichtung festzulegen.

Die Laserdiode gibt Laserstrahlen als Reaktion auf die Signale der Laseremissionssteuerung (ein/aus) von der Lasertreiber-PC-Platine (LDR) aus. Die durch das Fokussierobjektiv geführten Laserstrahlen werden auf die Trommeloberfläche fokussiert.

Vorsichtsmaßnahmen im Zusammenhang mit Lasern

Dieses Gerät enthält eine Laserdiode, die einen unsichtbaren Laserstrahl emittiert.

Da man diesen Laserstrahl nicht sehen kann, ist bei der Handhabung der Komponenten der optischen Lasereinheit, bei der Durchführung von Arbeiten und bei der Justierung des Laserstrahls äußerste Vorsicht geboten. Arbeiten dürfen niemals anhand anderer als den vorgeschriebenen Anleitungen durchgeführt werden; andernfalls kann es zu einer Schädigung durch Laserstrahlung kommen.

Die Lasereinheit ist vollständig mit einer Schutzabdeckung versiegelt. Solange ausschließlich die Arbeitsschritte der vorgeschriebenen Anleitungen durchgeführt werden, tritt der Laserstrahl nicht aus, und es besteht keine Gefahr, der Laserstrahlung ausgesetzt zu werden.

Das folgende Laser-Warnetikett ist an der Abdeckung vorne rechts angebracht.

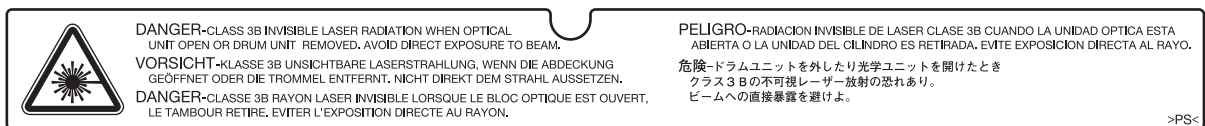
**Warnhinweise:**

Setzen Sie sich während der Wartungsarbeiten nicht dem Laserstrahl aus.

Dieses Gerät ist mit einer Laserdiode ausgestattet. Es ist unbedingt zu vermeiden, direkt in den Laserstrahl zu blicken. Keine reflektierenden Teile oder Werkzeuge, wie z. B. Schraubendreher, in den Pfad des Laserstrahls halten. Vor den Wartungsarbeiten sämtliche reflektierenden Metallgegenstände, wie Uhren, Ringe usw., entfernen.

Bei Wartungsarbeiten am eingeschalteten Gerät dürfen keine unter Strom stehenden, drehbaren oder betriebsrelevanten Bereiche berührt werden. Nicht direkt in den Laserstrahl blicken.

Im Rahmen der Wartung unbedingt das Leistungsschild und die Etiketten mit Warnhinweisen überprüfen [z. B. „Unplug the power cable during service“ („Netzkabel vor Beginn der Wartungsarbeiten abziehen“), „CAUTION. HOT“ („VORSICHT, HEISS“), „CAUTION. HIGH VOLTAGE“ („VORSICHT, HOCHSPANNUNG“), „CAUTION. LASER BEAM“ („VORSICHT, LASER“) usw.], um sicherzustellen, dass sie nicht verschmutzt sind und korrekt am Gerät angebracht sind.

CONTENTS

| | |
|--|------------|
| 1. DIFFERENCES BETWEEN MODELS | 1-1 |
| 2. SPECIFICATIONS, ACCESSORIES, OPTIONS AND CONSUMABLES | 2-1 |
| 2.1 Specifications | 2-1 |
| 2.1.1 General | 2-1 |
| 2.1.2 Copy | 2-5 |
| 2.1.3 Printer | 2-10 |
| 2.1.4 Scan | 2-10 |
| 2.1.5 Internet Fax | 2-11 |
| 2.1.6 Network Fax (optional) | 2-11 |
| 2.2 Accessories | 2-12 |
| 2.3 System List | 2-13 |
| 2.4 Option List | 2-15 |
| 2.5 Supplies | 2-17 |
| 2.5.1 For JPC | 2-17 |
| 2.5.2 Other than JPC | 2-17 |
| 3. OVERVIEW | 3-1 |
| 3.1 Sectional View | 3-1 |
| 3.1.1 Front side | 3-1 |
| 3.1.2 Rear side | 3-3 |
| 3.2 Electric Parts Layout | 3-6 |
| 3.3 Symbols and Functions of Various Components | 3-32 |
| 3.3.1 Motor | 3-32 |
| 3.3.2 Fan | 3-33 |
| 3.3.3 Sensor | 3-35 |
| 3.3.4 Switch | 3-39 |
| 3.3.5 Clutch | 3-40 |
| 3.3.6 Solenoid | 3-40 |
| 3.3.7 PC board | 3-41 |
| 3.3.8 Lamp, coil and heater | 3-42 |
| 3.3.9 Thermistor and thermostat | 3-42 |
| 3.3.10 Transformer | 3-42 |
| 3.3.11 Others | 3-43 |
| 3.4 Copy Process | 3-44 |
| 3.5 Comparison with e-STUDIO5518A/6518A/7518A/8518A | 3-46 |
| 3.6 General Operation | 3-48 |
| 3.6.1 Operation description | 3-48 |
| 3.6.2 Detection of abnormality | 3-52 |
| 3.6.3 Hibernation function | 3-54 |
| 3.7 Control Panel | 3-55 |
| 3.7.1 Overview | 3-55 |
| 3.8 Scanning Section | 3-57 |
| 3.8.1 Overview | 3-57 |
| 3.8.2 Composition | 3-58 |
| 3.8.3 Functions | 3-59 |
| 3.8.4 Operation description | 3-61 |
| 3.8.5 Process of original size detection | 3-62 |
| 3.9 Data Writing Section | 3-64 |
| 3.9.1 Overview | 3-64 |
| 3.9.2 Laser precautions | 3-65 |
| 3.9.3 Slit glass cleaning mechanism | 3-66 |
| 3.10 Paper Feeding Section | 3-67 |
| 3.10.1 Overview | 3-67 |
| 3.10.2 Composition | 3-69 |
| 3.10.3 Functions | 3-70 |

| | | |
|-----------|--|------------|
| 3.10.4 | Operation description..... | 3-72 |
| 3.11 | Process Unit Related Section | 3-80 |
| 3.11.1 | Overview..... | 3-80 |
| 3.11.2 | Composition..... | 3-82 |
| 3.11.3 | Functions | 3-83 |
| 3.11.4 | Electric circuit description | 3-86 |
| 3.11.5 | Toner cover..... | 3-87 |
| 3.11.6 | Functions of the toner cartridge PC board (CTRG)..... | 3-88 |
| 3.12 | Transfer Unit | 3-91 |
| 3.12.1 | Overview..... | 3-91 |
| 3.12.2 | Composition..... | 3-92 |
| 3.12.3 | Self-steering mechanism | 3-93 |
| 3.13 | Image Quality Control | 3-94 |
| 3.13.1 | Overview..... | 3-94 |
| 3.14 | Fusing Section | 3-95 |
| 3.14.1 | Overview..... | 3-95 |
| 3.14.2 | Composition..... | 3-97 |
| 3.14.3 | Pressure mechanism | 3-98 |
| 3.14.4 | Electric circuit description | 3-99 |
| 3.15 | Paper Exit Unit, Reverse Unit, Duplexing Unit..... | 3-102 |
| 3.15.1 | Overview..... | 3-102 |
| 3.15.2 | Composition..... | 3-105 |
| 3.15.3 | Operation description..... | 3-107 |
| 3.16 | Dual Scan Document Feeder (DSDF)..... | 3-110 |
| 3.16.1 | Overview..... | 3-110 |
| 3.16.2 | Original transport path | 3-112 |
| 3.16.3 | Driving motor | 3-113 |
| 3.16.4 | DSDF paper feed motor..... | 3-114 |
| 3.16.5 | DSDF separation motor | 3-115 |
| 3.16.6 | DSDF registration motor | 3-116 |
| 3.16.7 | DSDF read motor..... | 3-117 |
| 3.16.8 | DSDF original exit motor..... | 3-118 |
| 3.16.9 | Original size detection | 3-119 |
| 3.16.10 | DSDF tray original width sensor, DSDF tray original length sensors-1 and -2..... | 3-120 |
| 3.16.11 | DSDF tray original width detection sensors-1, -2, DSDF registration sensor | 3-121 |
| 3.16.12 | Multiple feeding detection | 3-124 |
| 3.17 | Power supply unit..... | 3-125 |
| 3.17.1 | Overview..... | 3-125 |
| 3.17.2 | Composition..... | 3-125 |
| 3.17.3 | Operation of DC output circuits..... | 3-126 |
| 3.17.4 | Output channel | 3-128 |
| 4. | DISASSEMBLY AND REPLACEMENT..... | 4-1 |
| 4.1 | Cover..... | 4-1 |
| 4.1.1 | Front lower cover | 4-1 |
| 4.1.2 | Front cover..... | 4-1 |
| 4.1.3 | Top right cover..... | 4-2 |
| 4.1.4 | Right top cover..... | 4-3 |
| 4.1.5 | Front right cover (control panel right cover)..... | 4-3 |
| 4.1.6 | Front top cover (control panel top cover)..... | 4-4 |
| 4.1.7 | Front lower cover (control panel lower cover)..... | 4-4 |
| 4.1.8 | Front left cover (control panel left cover) | 4-5 |
| 4.1.9 | Top front cover..... | 4-5 |
| 4.1.10 | Top left cover | 4-6 |
| 4.1.11 | Left rear cover..... | 4-6 |
| 4.1.12 | Top rear left cover..... | 4-7 |
| 4.1.13 | Exit tray..... | 4-7 |

| | | |
|--------|---|------|
| 4.1.14 | Left middle cover | 4-8 |
| 4.1.15 | Left top cover | 4-8 |
| 4.1.16 | Left lower cover | 4-9 |
| 4.1.17 | Bypass unit (removal of the tray arm)..... | 4-10 |
| 4.1.18 | Duplexing unit front cover | 4-10 |
| 4.1.19 | Duplexing unit rear cover | 4-11 |
| 4.1.20 | Paper feed cover | 4-11 |
| 4.1.21 | Right rear cover | 4-12 |
| 4.1.22 | Rear cover | 4-12 |
| 4.1.23 | Top rear cover | 4-13 |
| 4.1.24 | Left corner cover | 4-13 |
| 4.1.25 | Right corner cover | 4-14 |
| 4.2 | Control Panel | 4-15 |
| 4.2.1 | Control panel unit..... | 4-15 |
| 4.2.2 | Hinge cover..... | 4-17 |
| 4.2.3 | Signal harness | 4-18 |
| 4.2.4 | Key PC board, Button | 4-19 |
| 4.2.5 | Display PC board | 4-21 |
| 4.3 | Scanner Section..... | 4-23 |
| 4.3.1 | Original glass | 4-23 |
| 4.3.2 | Lens cover | 4-29 |
| 4.3.3 | Automatic original detection sensor-1 (S1)..... | 4-29 |
| 4.3.4 | Automatic original detection sensor-2 (S2)..... | 4-30 |
| 4.3.5 | Lens unit (CCD driving PC board) | 4-30 |
| 4.3.6 | Carriage home position sensor (S3)..... | 4-32 |
| 4.3.7 | Exposure lamp (EXP) | 4-33 |
| 4.3.8 | Scan motor (M1)..... | 4-35 |
| 4.3.9 | Platen sensor-1 (S4), Platen sensor-2 (S5)..... | 4-36 |
| 4.3.10 | Carriage-1 | 4-38 |
| 4.3.11 | Carriage wire, Carriage-2 | 4-41 |
| 4.3.12 | Scanner damp heater (DH1)..... | 4-46 |
| 4.3.13 | Scanner damp heater thermostat (THMO1) | 4-47 |
| 4.4 | Data Writing Section | 4-48 |
| 4.4.1 | Laser optical unit..... | 4-48 |
| 4.4.2 | Laser optical unit cooling fan (front) (F22)..... | 4-52 |
| 4.4.3 | Laser optical unit cooling fan (rear) (F23)..... | 4-54 |
| 4.4.4 | Shutter | 4-55 |
| 4.4.5 | Shutter motor (M38)..... | 4-56 |
| 4.4.6 | Shutter sensor (home position) (S24)..... | 4-57 |
| 4.4.7 | Shutter sensor (end position) (S25)..... | 4-57 |
| 4.5 | Paper Feeding Section..... | 4-58 |
| 4.5.1 | Bypass tray | 4-58 |
| 4.5.2 | Bypass unit | 4-59 |
| 4.5.3 | Bypass pickup solenoid (SOL8)..... | 4-60 |
| 4.5.4 | Bypass tray paper sensor (S71) | 4-61 |
| 4.5.5 | Bypass tray pickup roller..... | 4-62 |
| 4.5.6 | Bypass upper unit | 4-63 |
| 4.5.7 | Bypass tray paper feed roller | 4-64 |
| 4.5.8 | Bypass tray transport roller | 4-65 |
| 4.5.9 | Bypass tray motor (M12) | 4-66 |
| 4.5.10 | Bypass tray separation roller | 4-68 |
| 4.5.11 | Bypass tray paper feed sensor (S72) | 4-70 |
| 4.5.12 | Paper width detection PC board (SFBB) | 4-70 |
| 4.5.13 | Paper feed unit | 4-72 |
| 4.5.14 | Paper feed roller | 4-73 |
| 4.5.15 | Pickup roller | 4-74 |
| 4.5.16 | Separation roller | 4-74 |
| 4.5.17 | Drawer transport roller | 4-75 |

| | | |
|--------|---|-------|
| 4.5.18 | Drawer detection sensor (S73, S81, S89, S97)..... | 4-78 |
| 4.5.19 | Drawer paper feed sensor (S78, S86, S94, S102) | 4-79 |
| 4.5.20 | Drawer transport sensor (S77, S85, S93, S101) | 4-80 |
| 4.5.21 | Drawer paper empty sensor (S75, S83, S91, S99) | 4-81 |
| 4.5.22 | Drawer tray-up sensor (S76, S84, S92, S100) | 4-81 |
| 4.5.23 | Drawer bottom sensor (S74, S82, S90, S98) | 4-82 |
| 4.5.24 | Registration roller (rubber)..... | 4-82 |
| 4.5.25 | Registration guide | 4-84 |
| 4.5.26 | Registration sensor (S52) | 4-85 |
| 4.5.27 | Registration roller (metal) | 4-86 |
| 4.5.28 | 2nd transfer side paper clinging detection sensor (S51) | 4-87 |
| 4.5.29 | Paper feed cover sensor (S114)..... | 4-88 |
| 4.5.30 | Drawer | 4-89 |
| 4.5.31 | Drawer paper width detection sensor, Drawer paper length detection sensor (S79, S80, S87, S88, S95, S96, S103, S104) | 4-90 |
| 4.5.32 | Registration motor (M39)..... | 4-91 |
| 4.5.33 | Paper feed/transport drive unit | 4-92 |
| 4.5.34 | Transport motor-1 (M40)..... | 4-93 |
| 4.5.35 | Transport motor-2 (M41)..... | 4-93 |
| 4.5.36 | 1st/2nd drawer paper feed motor (M42) | 4-94 |
| 4.5.37 | 3rd/4th drawer/T-LCF paper feed motor (M43)..... | 4-94 |
| 4.5.38 | Paper feed drive unit..... | 4-95 |
| 4.5.39 | 3rd drawer transport clutch (CLT4), 3rd drawer paper feed clutch (CLT5) | 4-96 |
| 4.5.40 | 4th drawer transport clutch (CLT6), 4th drawer paper feed clutch (CLT7) | 4-98 |
| 4.5.41 | 1st drawer tray-up motor (M44), 2nd drawer tray-up motor (M49) | 4-100 |
| 4.5.42 | 3rd drawer tray-up motor (M45), 4th drawer tray-up motor (M50) | 4-102 |
| 4.5.43 | Transfer belt paper clinging detection sensor (S47) | 4-104 |
| 4.5.44 | T-LCF tray-up motor (M46) (NAD, ARD, GSA, AUD, MJD, ASD, CND)..... | 4-105 |
| 4.5.45 | T-LCF end fence motor (M47) | 4-107 |
| 4.5.46 | Tandem LCF standby unit | 4-108 |
| 4.5.47 | Tandem LCF paper feed unit..... | 4-109 |
| 4.5.48 | T-LCF stopper opening/closing solenoid (front) (SOL10), T-LCF stopper opening/closing detection sensor (front) (S110)..... | 4-110 |
| 4.5.49 | T-LCF stopper opening/closing solenoid (rear) (SOL11), T-LCF stopper opening/closing detection sensor (rear) (S111)..... | 4-111 |
| 4.5.50 | T-LCF bottom sensor (S107) | 4-112 |
| 4.5.51 | T-LCF standby side tray paper amount detection sensor (S106) | 4-113 |
| 4.5.52 | T-LCF end fence home position sensor (S112)..... | 4-115 |
| 4.5.53 | T-LCF end fence stop position sensor (S113)..... | 4-116 |
| 4.5.54 | T-LCF standby side paper empty sensor (S109)..... | 4-117 |
| 4.5.55 | T-LCF standby side tray detection sensor (S108) | 4-118 |
| 4.5.56 | T-LCF pickup solenoid (SOL9) | 4-119 |
| 4.5.57 | 1st drawer idling roller..... | 4-119 |
| 4.5.58 | Soft-close unit (4-drawer model)..... | 4-121 |
| 4.5.59 | Soft-close unit (Tandem LCF model)..... | 4-122 |
| 4.6 | Process Unit Related Section | 4-124 |
| 4.6.1 | Pulling out of the process unit (EPU tray)..... | 4-124 |
| 4.6.2 | Drum cleaner unit | 4-128 |
| 4.6.3 | Drum | 4-130 |
| 4.6.4 | Drum cleaning blade | 4-131 |
| 4.6.5 | Blade side seal | 4-132 |
| 4.6.6 | Main charger unit | 4-133 |
| 4.6.7 | Main charger grid | 4-133 |
| 4.6.8 | Needle electrode cleaner | 4-134 |
| 4.6.9 | Needle electrode..... | 4-134 |
| 4.6.10 | Discharge LED (K) (ERS-K) | 4-135 |
| 4.6.11 | Sub-hopper | 4-135 |
| 4.6.12 | Sub-hopper toner sensor (K) (S38) | 4-136 |

| | | |
|--------|--|-------|
| 4.6.13 | EPU cover..... | 4-137 |
| 4.6.14 | Sub-hopper toner motor (K) (M19) | 4-138 |
| 4.6.15 | Drum surface potential sensor control PC board (V0S board) (9029A only) | 4-139 |
| 4.6.16 | Auger lock detection sensor (S42)..... | 4-139 |
| 4.6.17 | Drum unit side vertical duct | 4-140 |
| 4.6.18 | Ozone mixing fan (K) (F17) | 4-141 |
| 4.6.19 | Needle electrode cleaner detection sensor (K) (S30)..... | 4-141 |
| 4.6.20 | Needle electrode cleaner motor (K) (M23) | 4-142 |
| 4.6.21 | V0 sensor shutter solenoid (K) (SOL4) (9029A only) | 4-144 |
| 4.6.22 | Drum surface potential (V0) sensor (K) (S34) (9029A only)..... | 4-146 |
| 4.6.23 | Drum thermistor (K) (THM1) | 4-147 |
| 4.6.24 | Developer unit..... | 4-148 |
| 4.6.25 | Developer material..... | 4-151 |
| 4.6.26 | Mixer-1, Mixer-2..... | 4-155 |
| 4.6.27 | Developer sleeve | 4-159 |
| 4.6.28 | Auto-toner sensor (K) (S26)..... | 4-162 |
| 4.6.29 | Drum developer drive unit..... | 4-163 |
| 4.6.30 | Drum motor (K) (M27)..... | 4-164 |
| 4.6.31 | Developer unit motor (K) (M30) | 4-164 |
| 4.6.32 | Developer unit mixer motor (K) (M29) | 4-165 |
| 4.6.33 | EPU tray developer unit cooling duct..... | 4-165 |
| 4.6.34 | TBU cleaner side vertical duct | 4-167 |
| 4.6.35 | EPU tray waste toner horizontal transport unit | 4-167 |
| 4.6.36 | Waste toner box..... | 4-168 |
| 4.6.37 | Waste toner box nearly full detection sensor (S13) | 4-169 |
| 4.6.38 | Waste toner box full detection sensor (S14)..... | 4-171 |
| 4.6.39 | Waste toner box detection sensor (S16) | 4-171 |
| 4.6.40 | Ozone filter-1 | 4-172 |
| 4.6.41 | Ozone filter-2 | 4-173 |
| 4.6.42 | Power supply unit cooling fan (F37) | 4-174 |
| 4.6.43 | Toner filter..... | 4-175 |
| 4.6.44 | Toner guide..... | 4-176 |
| 4.6.45 | Toner cover solenoid (K) (SOL12)..... | 4-178 |
| 4.6.46 | Toner motor (K) (M15)..... | 4-180 |
| 4.6.47 | Waste toner transport motor (M33)..... | 4-183 |
| 4.6.48 | Waste toner transport unit | 4-184 |
| 4.6.49 | Ozone suctioning fan (F24) | 4-185 |
| 4.6.50 | Fuser insulation fan (F21)..... | 4-187 |
| 4.6.51 | Temperature/humidity sensor (S12) | 4-188 |
| 4.6.52 | Toner motor interlock switch (SW3)..... | 4-189 |
| 4.6.53 | Developer unit cooling fan (F14)..... | 4-191 |
| 4.6.54 | Scattered toner suctioning fan (F25) | 4-192 |
| 4.7 | Transfer Unit | 4-195 |
| 4.7.1 | Pulling out of the transfer belt unit | 4-195 |
| 4.7.2 | 2nd transfer facing roller cleaning pad..... | 4-198 |
| 4.7.3 | Transfer belt cleaner unit | 4-199 |
| 4.7.4 | Transfer belt cleaning blade | 4-200 |
| 4.7.5 | Transfer belt cleaner side seal..... | 4-200 |
| 4.7.6 | Transfer belt unit (TBU) | 4-201 |
| 4.7.7 | Transfer belt..... | 4-203 |
| 4.7.8 | 1st transfer roller | 4-207 |
| 4.7.9 | Cleaning facing roller | 4-208 |
| 4.7.10 | Tension roller | 4-209 |
| 4.7.11 | 2nd transfer facing roller | 4-210 |
| 4.7.12 | 2nd transfer unit (TRU)..... | 4-211 |
| 4.7.13 | 2nd transfer roller..... | 4-212 |
| 4.7.14 | 2nd transfer unit rear guide..... | 4-213 |

| | | |
|---------|--|-------|
| 4.7.15 | Transfer belt motor (M13)..... | 4-215 |
| 4.7.16 | Transfer belt motor unit..... | 4-215 |
| 4.8 | Image Quality Control Section | 4-217 |
| 4.8.1 | Image quality control unit..... | 4-217 |
| 4.8.2 | Image position aligning/image quality sensor (center) (S21)..... | 4-218 |
| 4.8.3 | Image quality shutter solenoid (SOL3) | 4-218 |
| 4.9 | Fusing Section | 4-220 |
| 4.9.1 | Fuser unit..... | 4-221 |
| 4.9.2 | Pressure roller cover..... | 4-221 |
| 4.9.3 | Fuser unit transport guide..... | 4-222 |
| 4.9.4 | Entrance guide cover..... | 4-222 |
| 4.9.5 | Separation guide..... | 4-223 |
| 4.9.6 | Separation plate..... | 4-225 |
| 4.9.7 | Fuser belt..... | 4-226 |
| 4.9.8 | Fuser belt lubricating sheet, Fuser belt pad..... | 4-236 |
| 4.9.9 | Rear fuser cover oil recovery sheet..... | 4-238 |
| 4.9.10 | Front fuser belt oil recovery sheet | 4-239 |
| 4.9.11 | Rear fuser belt oil recovery sheet | 4-240 |
| 4.9.12 | Rear fuser gear oil recovery sheet..... | 4-241 |
| 4.9.13 | Fuser belt center thermistor (THM5), Fuser belt edge thermistor (THM6), Fuser belt thermostat (THMO4)..... | 4-243 |
| 4.9.14 | Pressure roller | 4-249 |
| 4.9.15 | Fuser belt rotation detection sensor (S49)..... | 4-250 |
| 4.9.16 | Pressure roller contact/release detection sensor (S48)..... | 4-251 |
| 4.9.17 | IH coil (IH-COIL) | 4-253 |
| 4.9.18 | Fuser motor (M6) | 4-255 |
| 4.9.19 | Pressure roller contact/release motor (M48) | 4-255 |
| 4.9.20 | IH board cooling fan (suction) (F8) | 4-257 |
| 4.9.21 | IH board cooling fan (exhaust) (F9)..... | 4-258 |
| 4.9.22 | VOC filter | 4-260 |
| 4.10 | Paper Exit Unit, Reverse Unit, Duplexing Unit..... | 4-261 |
| 4.10.1 | Upper paper exit section cooling fan (rear) (F32) | 4-261 |
| 4.10.2 | Lower paper exit section cooling fan (rear) (F34), Lower paper exit section cooling fan (front) (F35) | 4-261 |
| 4.10.3 | Lower paper exit section cooling fan (bottom) (F36) | 4-262 |
| 4.10.4 | Paper exit motor (M2)..... | 4-263 |
| 4.10.5 | Upper paper exit sensor (S61), Upper exit tray paper full detection sensor (S62)..... | 4-264 |
| 4.10.6 | Lower paper exit sensor (S63)..... | 4-265 |
| 4.10.7 | Reverse section paper transport detection sensor (S60) | 4-266 |
| 4.10.8 | Reverse path cover switch (SW5) | 4-267 |
| 4.10.9 | Upper paper exit roller | 4-268 |
| 4.10.10 | Lower paper exit roller | 4-270 |
| 4.10.11 | Bridge unit..... | 4-271 |
| 4.10.12 | Bridge unit front cover..... | 4-272 |
| 4.10.13 | Bridge unit lower cover | 4-273 |
| 4.10.14 | Bridge unit transport entrance motor (M4), Reverse motor (M3)..... | 4-274 |
| 4.10.15 | Bridge unit transport exit motor (M5) | 4-275 |
| 4.10.16 | Bridge unit upper cover..... | 4-277 |
| 4.10.17 | Bridge unit transport roller-1 | 4-278 |
| 4.10.18 | Bridge unit transport roller-2 | 4-280 |
| 4.10.19 | Bridge unit transport roller-3 | 4-282 |
| 4.10.20 | Reverse roller | 4-284 |
| 4.10.21 | Bridge unit paper exit roller-1..... | 4-285 |
| 4.10.22 | Bridge unit paper exit roller-2..... | 4-286 |
| 4.10.23 | Transport path switching solenoid (bridge unit/reverse section) (SOL1) | 4-287 |
| 4.10.24 | Transport path switching solenoid (upper/lower paper exit) (SOL2)..... | 4-288 |
| 4.10.25 | Bridge unit path entrance sensor (S55)..... | 4-289 |

| | | |
|---------|---|-------|
| 4.10.26 | Bridge unit path exit sensor (S56) | 4-290 |
| 4.10.27 | Reverse sensor (S59) | 4-291 |
| 4.10.28 | Reverse section stationary jam detection sensor (S58) | 4-292 |
| 4.10.29 | Bridge unit cooling fan (F6) | 4-294 |
| 4.10.30 | Front cover opening/closing detection switch (SW9), Bridge unit connecting detection switch (SW8) | 4-297 |
| 4.10.31 | Duplexing bridge unit | 4-297 |
| 4.10.32 | Duplexing unit opening/closing detection sensor (S64) | 4-298 |
| 4.10.33 | Reverse path sensor (S57) | 4-299 |
| 4.10.34 | Duplexing bridge transport roller | 4-301 |
| 4.10.35 | Duplexing unit upper cover | 4-302 |
| 4.10.36 | Duplexing unit front side cover | 4-303 |
| 4.10.37 | Duplexing unit rear side cover | 4-304 |
| 4.10.38 | Reversed paper cooling fan (F11) | 4-304 |
| 4.10.39 | ADU transport motor (M7) | 4-306 |
| 4.10.40 | ADU original feed motor (M8) | 4-307 |
| 4.10.41 | ADU board (ADU) | 4-308 |
| 4.10.42 | ADU transport roller-1 | 4-309 |
| 4.10.43 | ADU transport roller-2 | 4-312 |
| 4.10.44 | ADU transport roller-3 | 4-314 |
| 4.10.45 | Duplexing unit path exit sensor (S67) | 4-315 |
| 4.10.46 | Fuser transport sensor (S65) | 4-316 |
| 4.10.47 | Duplexing unit path exit sensor (S66) | 4-317 |
| 4.10.48 | Duplexing unit cover opening/closing detection switch (SW7) | 4-319 |
| 4.10.49 | IH interlock switch (SW4) | 4-320 |
| 4.10.50 | Interlock switch (SW2), Duplexing unit interlock switch (SW10) | 4-321 |
| 4.10.51 | Fuser unit exhaust heat fan (F2), Bridge unit exhaust heat fan (F1) | 4-323 |
| 4.10.52 | Upper discharge brush | 4-324 |
| 4.10.53 | Lower discharge brush | 4-325 |
| 4.11 | Dual Scan Document Feeder (DSDF) | 4-326 |
| 4.11.1 | Removal of the DSDF | 4-326 |
| 4.11.2 | Installing of the DSDF | 4-328 |
| 4.11.3 | DSDF pickup unit | 4-330 |
| 4.11.4 | DSDF separation roller | 4-331 |
| 4.11.5 | DSDF pickup roller | 4-335 |
| 4.11.6 | DSDF original feed roller | 4-336 |
| 4.11.7 | DSDF rear cover | 4-337 |
| 4.11.8 | DSDF front cover | 4-338 |
| 4.11.9 | Original jam access cover | 4-339 |
| 4.11.10 | DSDF left cover | 4-340 |
| 4.11.11 | DSDF-LED PC board (LEDD) | 4-341 |
| 4.11.12 | DSDF control PC board (DLGD) | 4-341 |
| 4.11.13 | DSDF relay PC board (DFRLY) | 4-342 |
| 4.11.14 | DSDF multiple feeding detection relay PC board (DLGRLY) | 4-343 |
| 4.11.15 | Original tray | 4-344 |
| 4.11.16 | DSDF tray original length sensor-1 (SD1), DSDF tray original length sensor-2 (SD2) | 4-345 |
| 4.11.17 | DSDF tray original width sensor (SD3) | 4-346 |
| 4.11.18 | DSDF original empty sensor (SD4) | 4-348 |
| 4.11.19 | DSDF original feed sensor (SD5), DSDF tray lift upper limit sensor (SD9) | 4-349 |
| 4.11.20 | DSDF tray original width detection sensor-1 (SD7), DSDF tray original width detection sensor-2 (SD8) | 4-350 |
| 4.11.21 | DSDF registration sensor (SD6) | 4-352 |
| 4.11.22 | DSDF cooling fan motor (FD1) | 4-354 |
| 4.11.23 | DSDF upper cover interlock switch (SWD2) | 4-355 |
| 4.11.24 | DSDF upper cover opening/closing detection sensor (SD16) | 4-356 |
| 4.11.25 | DSDF registration motor (MD3) | 4-358 |
| 4.11.26 | DSDF read motor (MD4) | 4-360 |

| | | |
|-----------|---|------------|
| 4.11.27 | Paper original exit motor (MD5) | 4-362 |
| 4.11.28 | DSDF lower cover interlock switch (SWD1) | 4-364 |
| 4.11.29 | DSDF original feed motor (MD1) | 4-365 |
| 4.11.30 | DSDF separation motor (MD2) | 4-365 |
| 4.11.31 | Intermediate transport unit | 4-366 |
| 4.11.32 | DSDF read-in sensor-1 (SD11), DSDF read-in sensor-2 (SD12) | 4-368 |
| 4.11.33 | DSDF original exit sensor (SD13), DSDF tray lift lower limit sensor (SD10) | 4-369 |
| 4.11.34 | Lower transport unit | 4-371 |
| 4.11.35 | DSDF shading sheet HP sensor (SD14) | 4-372 |
| 4.11.36 | DSDF lower cover opening/closing detection sensor (SD15) | 4-373 |
| 4.11.37 | Multiple feeding detection sensor (reception side) (SD18) | 4-374 |
| 4.11.38 | Multiple feeding detection sensor (transmission side) (SD17) | 4-375 |
| 4.11.39 | DSDF-CCD module (CCDD) | 4-376 |
| 4.11.40 | Right hinge | 4-378 |
| 4.11.41 | Left hinge | 4-379 |
| 4.12 | Film Attachment Reference | 4-383 |
| 4.12.1 | Registration films (F), (R) | 4-383 |
| 4.12.2 | Films with a spacer | 4-384 |
| 4.13 | Removal and Installation of Options | 4-385 |
| 4.13.1 | External Large Capacity Feeder (2.5K) (Ex-LCF) | 4-385 |
| 4.13.2 | LCF Connector | 4-387 |
| 4.13.3 | When 2 External Large Capacity Feeder (2.5K) (Ex-LCF) units are installed | 4-391 |
| 4.13.4 | External Large Capacity Feeder (2.0K) (Ex-LCF) | 4-392 |
| 4.13.5 | Finisher, Saddle Stitch Finisher | 4-393 |
| 4.13.6 | Hole Punch Unit | 4-394 |
| 5. | SELF-DIAGNOSTIC MODE | 5-1 |
| 5.1 | Overview | 5-1 |
| 5.2 | Description Rule for Each Menu and Mode | 5-4 |
| 5.3 | Service UI | 5-7 |
| 5.3.1 | Overview | 5-7 |
| 5.3.2 | Operation procedure | 5-7 |
| 5.3.3 | Starting the FS Menu from the normal mode | 5-7 |
| 5.4 | 03 TEST MODE | 5-8 |
| 5.4.1 | Output check | 5-8 |
| 5.4.2 | Input check | 5-8 |
| 5.5 | 04 TEST PRINT MODE | 5-9 |
| 5.6 | 05 ADJUSTMENT MODE | 5-9 |
| 5.6.1 | TEST COPY | 5-9 |
| 5.6.2 | TEST PRINT | 5-9 |
| 5.7 | 08 SETTING MODE | 5-9 |
| 5.8 | 20 PM SUPPORT MODE | 5-9 |
| 5.9 | 30 LIST PRINT MODE | 5-10 |
| 5.9.1 | List output table | 5-10 |
| 5.9.2 | Operation procedure | 5-11 |
| 5.9.3 | Samples of the output | 5-11 |
| 5.10 | FAX | 5-32 |
| 5.10.1 | 11 FAX CLEAR MODE | 5-32 |
| 5.10.2 | 12 FAX LIST PRINT MODE | 5-33 |
| 5.10.3 | 13 FAX FUNCTION MODE | 5-33 |
| 5.10.4 | 19 RAM EDIT MODE | 5-33 |
| 5.11 | 35 DATA BACKUP/RESTORE MODE | 5-34 |
| 5.12 | 36 CLONING | 5-34 |
| 5.13 | 37 LICENSE MANAGEMENT | 5-34 |
| 5.14 | 38 DEACTIVATE RELEASE MODE | 5-34 |
| 5.15 | 01 Control Panel Check | 5-35 |
| 5.15.1 | Screen transition | 5-35 |

| | | |
|--------|---|------|
| 5.15.2 | Checking of the LCD back light and LEDs..... | 5-36 |
| 5.15.3 | Checking of the LCD display, hard keys and digital keys..... | 5-36 |
| 5.15.4 | Checking of the LCD touch sensor and USB storage device connection..... | 5-37 |
| 5.16 | 73 Firmware Assist..... | 5-38 |
| 5.16.1 | Overview..... | 5-38 |
| 5.16.2 | Operation procedure..... | 5-38 |
| 5.16.3 | Functions..... | 5-39 |
| 5.17 | 74 Storage Assist Mode..... | 5-43 |
| 5.17.1 | Overview..... | 5-43 |
| 5.17.2 | Operation procedure..... | 5-43 |
| 5.17.3 | Functions..... | 5-43 |
| 5.18 | 75 File System Recovery..... | 5-44 |
| 5.18.1 | Overview..... | 5-44 |
| 5.18.2 | Operation procedure..... | 5-44 |
| 5.18.3 | Functions..... | 5-44 |
| 5.19 | 76 SRAM Maintenance..... | 5-47 |
| 5.19.1 | Overview..... | 5-47 |
| 5.19.2 | Operation procedure..... | 5-47 |
| 5.19.3 | Functions..... | 5-47 |
| 5.20 | 77 Detach Release..... | 5-49 |
| 5.21 | 78 Option Storage Assist..... | 5-49 |
| 5.22 | TPM Restore..... | 5-50 |
| 5.23 | Batch Setting for Self-Diagnostic Codes..... | 5-51 |
| 5.23.1 | Overview..... | 5-51 |
| 5.23.2 | Setting files..... | 5-51 |
| 5.23.3 | Result files..... | 5-51 |
| 5.23.4 | Operation procedure..... | 5-52 |

6. SETTING AND ADJUSTMENT..... 6-1

| | | |
|--------|---|------|
| 6.1 | Image Related Adjustment..... | 6-1 |
| 6.1.1 | Adjustment order..... | 6-1 |
| 6.1.2 | Auto-toner sensor adjustment..... | 6-2 |
| 6.1.3 | Image quality control adjustment..... | 6-4 |
| 6.1.4 | Alignment position adjustment..... | 6-5 |
| 6.1.5 | Image dimensional adjustment at the printing section..... | 6-9 |
| 6.1.6 | Image dimensional adjustment at the scanning section..... | 6-18 |
| 6.1.7 | Automatic gamma adjustment..... | 6-26 |
| 6.1.8 | Density Unevenness Correction..... | 6-27 |
| 6.1.9 | Scanning and paper feeding direction instruction patterns superposition function..... | 6-30 |
| 6.2 | Image Related Adjustment (Overview)..... | 6-31 |
| 6.2.1 | List..... | 6-31 |
| 6.2.2 | Operation procedure..... | 6-31 |
| 6.3 | Image Quality Adjustment (Copying Function)..... | 6-32 |
| 6.3.1 | Density adjustment..... | 6-32 |
| 6.3.2 | Gamma balance adjustment..... | 6-32 |
| 6.3.3 | Background adjustment..... | 6-33 |
| 6.3.4 | Blank page judgment threshold adjustment..... | 6-33 |
| 6.3.5 | Void amount adjustment for blank page judgment..... | 6-33 |
| 6.3.6 | Sharpness adjustment..... | 6-34 |
| 6.3.7 | Range correction adjustment..... | 6-34 |
| 6.3.8 | Smudged/faint text adjustment..... | 6-34 |
| 6.3.9 | Emission level adjustment..... | 6-35 |
| 6.3.10 | Background offset adjustment (DF)..... | 6-35 |
| 6.3.11 | Background offset adjustment on the back side of paper (DSDF)..... | 6-36 |
| 6.3.12 | Drop out color adjustment..... | 6-36 |
| 6.3.13 | Scanning streak reduction..... | 6-36 |
| 6.3.14 | Background removal level adjustment..... | 6-37 |
| 6.3.15 | Low density text reproduction adjustment..... | 6-37 |

| | | |
|--------|--|------|
| 6.4 | Image Quality Adjustment (Printing Function)..... | 6-38 |
| 6.4.1 | Gamma balance adjustment..... | 6-38 |
| 6.4.2 | Text density adjustment..... | 6-39 |
| 6.4.3 | Density upper limit value adjustment in toner saving mode..... | 6-39 |
| 6.4.4 | Fine line enhancement switching..... | 6-40 |
| 6.4.5 | Sharpness adjustment..... | 6-41 |
| 6.4.6 | Thin line width lower limit adjustment..... | 6-42 |
| 6.4.7 | Background adjustment..... | 6-42 |
| 6.4.8 | Emission level adjustment..... | 6-42 |
| 6.4.9 | Graphic line density adjustment (1200 dpi)..... | 6-43 |
| 6.4.10 | Gradation reproduction switching for Text..... | 6-43 |
| 6.4.11 | Smudged text in black adjustment..... | 6-43 |
| 6.4.12 | Halftone setting..... | 6-44 |
| 6.4.13 | White void correction around the text..... | 6-44 |
| 6.5 | Image Quality Adjustment (Scanning Function)..... | 6-45 |
| 6.5.1 | Gamma balance adjustment..... | 6-45 |
| 6.5.2 | RGB color balance adjustment..... | 6-45 |
| 6.5.3 | Density adjustment..... | 6-46 |
| 6.5.4 | Background adjustment..... | 6-47 |
| 6.5.5 | ACS judgment threshold..... | 6-47 |
| 6.5.6 | Void amount adjustment for ACS judgment..... | 6-47 |
| 6.5.7 | Blank page judgment threshold adjustment..... | 6-48 |
| 6.5.8 | Void amount adjustment for blank page judgment..... | 6-48 |
| 6.5.9 | Sharpness adjustment..... | 6-48 |
| 6.5.10 | Contrast adjustment..... | 6-48 |
| 6.5.11 | Black density fine adjustment..... | 6-49 |
| 6.5.12 | RGB conversion method selection..... | 6-49 |
| 6.5.13 | Saturation adjustment..... | 6-49 |
| 6.5.14 | SlimPDF capacity and image quality adjustment..... | 6-50 |
| 6.5.15 | Surrounding void amount adjustment..... | 6-50 |
| 6.5.16 | JPEG compression level adjustment..... | 6-51 |
| 6.5.17 | Scanning streak reduction..... | 6-51 |
| 6.5.18 | Background offset adjustment (DF)..... | 6-51 |
| 6.5.19 | Background offset adjustment on the back side of paper (DSDF)..... | 6-51 |
| 6.5.20 | Low density text reproduction process adjustment..... | 6-51 |
| 6.6 | Image Quality Adjustment (Fax Function)..... | 6-52 |
| 6.6.1 | Density adjustment..... | 6-52 |
| 6.6.2 | Emission level adjustment..... | 6-52 |
| 6.6.3 | Background offset adjustment (DF)..... | 6-52 |
| 6.6.4 | Background offset adjustment on the back side of paper (DSDF)..... | 6-52 |
| 6.7 | Scanning Section..... | 6-53 |
| 6.7.1 | Carriage-1 position adjustment..... | 6-53 |
| 6.7.2 | Lens unit position adjustment..... | 6-54 |
| 6.7.3 | Belt tension adjustment of the scan motor..... | 6-54 |
| 6.8 | Paper feeding section..... | 6-55 |
| 6.8.1 | Adjustment of the clearance of the paper and side guide..... | 6-55 |
| 6.8.2 | Separation roller pressure force adjustment (drawer)..... | 6-56 |
| 6.8.3 | Separation roller pressure force adjustment (bypass unit)..... | 6-58 |
| 6.8.4 | Paper transport sideways deviation adjustment (drawer)..... | 6-61 |
| 6.8.5 | Bypass unit paper transport sideways deviation adjustment..... | 6-65 |
| 6.8.6 | Paper transport sideways deviation adjustment (T-LCF)..... | 6-66 |
| 6.9 | Process Unit Related Section..... | 6-67 |
| 6.9.1 | Auto-toner sensor adjustment..... | 6-67 |
| 6.9.2 | Doctor-to-sleeve gap adjustment (developer unit)..... | 6-67 |
| 6.10 | Image Quality Control Section..... | 6-69 |
| 6.10.1 | Image quality control related adjustment..... | 6-69 |
| 6.11 | Fusing Section..... | 6-70 |
| 6.11.1 | Separation plate gap adjustment..... | 6-70 |

| | | |
|-----------|--|------------|
| 6.11.2 | Separation guide gap adjustment | 6-75 |
| 6.12 | Control Panel Calibration | 6-81 |
| 6.12.1 | Overview | 6-81 |
| 6.12.2 | Operation procedure | 6-81 |
| 6.13 | Dual Scan Document Feeder (DSDF)..... | 6-84 |
| 6.13.1 | Position adjustment | 6-84 |
| 6.13.2 | Height adjustment..... | 6-88 |
| 6.13.3 | Skew adjustment | 6-90 |
| 6.13.4 | Leading edge position adjustment | 6-94 |
| 6.13.5 | Sideways deviation adjustment | 6-96 |
| 6.13.6 | Reproduction ratio adjustment..... | 6-99 |
| 6.13.7 | DSDF read-in sensor-1 adjustment | 6-100 |
| 6.13.8 | Platen sheet..... | 6-102 |
| 6.13.9 | DSDF separation roller pressure force adjustment..... | 6-103 |
| 7. | PREVENTIVE MAINTENANCE (PM)..... | 7-1 |
| 7.1 | Overview | 7-1 |
| 7.2 | PM Display | 7-1 |
| 7.2.1 | Overview | 7-1 |
| 7.2.2 | PM display condition | 7-1 |
| 7.2.3 | PM display content | 7-2 |
| 7.2.4 | Counter clearing | 7-3 |
| 7.3 | PM Procedure | 7-4 |
| 7.4 | 20 PM SUPPORT MODE..... | 7-5 |
| 7.4.1 | Overview | 7-5 |
| 7.4.2 | Operation flow..... | 7-5 |
| 7.4.3 | Operation screen | 7-6 |
| 7.4.4 | Access tree | 7-11 |
| 7.5 | Part Replacement Workflow..... | 7-13 |
| 7.6 | Preventive Maintenance Checklist | 7-15 |
| 7.6.1 | Scanner | 7-16 |
| 7.6.2 | Paper feeding section | 7-17 |
| 7.6.3 | Bypass unit | 7-19 |
| 7.6.4 | Main charger..... | 7-20 |
| 7.6.5 | Drum, cleaner unit, filter..... | 7-21 |
| 7.6.6 | Developer unit..... | 7-26 |
| 7.6.7 | Waste toner box..... | 7-29 |
| 7.6.8 | Transfer belt unit, Transfer belt cleaning unit | 7-30 |
| 7.6.9 | Image quality control unit..... | 7-32 |
| 7.6.10 | 2nd Transfer Unit | 7-33 |
| 7.6.11 | Fuser unit..... | 7-35 |
| 7.6.12 | Duplexing unit | 7-38 |
| 7.6.13 | Bridge Unit | 7-39 |
| 7.6.14 | Paper exit unit..... | 7-40 |
| 7.6.15 | DSDF | 7-41 |
| 7.7 | Machine Refreshing Checklist..... | 7-43 |
| 7.8 | Storage of Supplies and Replacement Parts | 7-44 |
| 7.9 | PM Kit..... | 7-45 |
| 7.10 | Maintenance Parts | 7-46 |
| 7.10.1 | How to attach the DSDF stopper jig | 7-47 |
| 7.11 | Grease List..... | 7-48 |
| 8. | ERROR CODE AND TROUBLESHOOTING | 8-1 |
| 8.1 | Overview | 8-1 |
| 8.1.1 | If a problem continues even after performing all troubleshooting | 8-2 |
| 8.1.2 | Collection of debug logs with a USB storage device | 8-3 |
| 8.1.3 | Traceability label..... | 8-5 |
| 8.1.4 | Detach function | 8-5 |
| 8.2 | Error Code List..... | 8-6 |

| | | |
|--------|---|-------|
| 8.2.1 | Paper misfeeding..... | 8-6 |
| 8.2.2 | Service call | 8-14 |
| 8.2.3 | Error in Internet fax and scanning functions | 8-22 |
| 8.2.4 | Printer function error | 8-31 |
| 8.2.5 | TopAccess related error, Communication error with external application | 8-33 |
| 8.2.6 | MFP access error | 8-34 |
| 8.2.7 | Maintenance error..... | 8-38 |
| 8.2.8 | Network error | 8-52 |
| 8.2.9 | Notification | 8-56 |
| 8.2.10 | FAX error | 8-59 |
| 8.2.11 | Error history | 8-67 |
| 8.3 | Analysis from Error Codes | 8-69 |
| 8.3.1 | Check item | 8-69 |
| 8.3.2 | Connector number, input check, output check | 8-69 |
| 8.3.3 | Paper misfeeding (E series errors)..... | 8-77 |
| 8.3.4 | Service call (C series errors) | 8-173 |
| 8.3.5 | Service call (F series errors)..... | 8-229 |
| 8.3.6 | Internet fax and scanning functions error | 8-275 |
| 8.3.7 | Printer function error | 8-301 |
| 8.3.8 | TopAccess related error, Communication error with external application | 8-308 |
| 8.3.9 | MFP access error | 8-312 |
| 8.3.10 | Maintenance error..... | 8-316 |
| 8.3.11 | Network error | 8-337 |
| 8.3.12 | FAX error | 8-350 |
| 8.4 | Other Errors | 8-382 |
| 8.4.1 | DSDF | 8-382 |
| 8.4.2 | Drum surface potential (V0) sensor (K) control related troubleshooting (9029A only) | 8-389 |
| 8.4.3 | Troubleshooting at unpacking..... | 8-392 |
| 8.4.4 | Drum surface potential (V0) sensor (K) control related troubleshooting at unpacking and setting up (9029A only) | 8-393 |
| 8.4.5 | MFP operation disabled after the installation of option(s)..... | 8-395 |
| 8.4.6 | Wireless LAN connection disabled | 8-395 |
| 8.4.7 | When the duplexing unit cover open display cannot be released..... | 8-395 |
| 8.4.8 | Troubleshooting for one-time dongle | 8-396 |
| 8.4.9 | Countermeasure to staining on the back side of the paper | 8-396 |
| 8.4.10 | Countermeasure to exiting paper sideways deviation | 8-397 |
| 8.4.11 | Problems in paper exiting | 8-399 |
| 8.4.12 | Error code "M00" displayed while updating firmware..... | 8-400 |
| 8.4.13 | "Latch the developer unit" remains displayed | 8-401 |
| 8.4.14 | Countermeasure to stains (stripe-shaped) on the back side of the paper occurring immediately after the drum cleaner unit is removed and then reinstalled..... | 8-402 |
| 8.4.15 | Error check by the LEDs on the LGC board | 8-403 |
| 8.4.16 | The MFP does not start after the power has been turned ON..... | 8-404 |
| 8.4.17 | Countermeasure to sudden power failure..... | 8-410 |
| 8.4.18 | The drawer is not automatically inserted. | 8-411 |
| 8.4.19 | Troubleshooting for operation abnormality | 8-412 |
| 8.4.20 | The waiting time for printing is too long. | 8-413 |
| 8.4.21 | "Fax line1 is out of order." or "Fax line2 is out of order." displayed | 8-413 |
| 8.4.22 | Ethernet disabled in half-duplex communication | 8-413 |
| 8.4.23 | Toner cartridge unrecognized..... | 8-413 |
| 8.4.24 | "Invalid Department Code" displayed | 8-414 |
| 8.4.25 | Paper cannot be fed from the Ex-LCF | 8-414 |
| 8.5 | Troubleshooting for the Image | 8-415 |
| 8.5.1 | Uneven pitch and jitter image | 8-415 |
| 8.5.2 | Black spots | 8-417 |
| 8.5.3 | Poor image density and gray balance | 8-418 |
| 8.5.4 | Background fogging..... | 8-420 |

| | | |
|--------|--|-------|
| 8.5.5 | Moiré, lack of sharpness | 8-422 |
| 8.5.6 | Toner offset..... | 8-423 |
| 8.5.7 | Toner offset (shadow image) at the edges | 8-424 |
| 8.5.8 | Blurred image | 8-427 |
| 8.5.9 | Poor fusing..... | 8-428 |
| 8.5.10 | Blank print..... | 8-429 |
| 8.5.11 | Solid print..... | 8-431 |
| 8.5.12 | White banding and white void (in the feeding direction) | 8-432 |
| 8.5.13 | White banding (at right angles to the feeding direction) | 8-434 |
| 8.5.14 | Skew (slantwise copying) | 8-436 |
| 8.5.15 | Black banding (in feeding direction)..... | 8-437 |
| 8.5.16 | Black banding (at right angles to feeding direction)..... | 8-439 |
| 8.5.17 | White spots | 8-440 |
| 8.5.18 | Poor transfer | 8-442 |
| 8.5.19 | Uneven image density 1 | 8-444 |
| 8.5.20 | Uneven image density 2 | 8-445 |
| 8.5.21 | Faded image (low density)..... | 8-447 |
| 8.5.22 | Image dislocation in leading edge | 8-449 |
| 8.5.23 | Image jittering | 8-450 |
| 8.5.24 | Poor cleaning | 8-451 |
| 8.5.25 | Uneven light distribution | 8-452 |
| 8.5.26 | Blotched image | 8-453 |
| 8.5.27 | Stain on the paper back side | 8-454 |
| 8.5.28 | White void in halftone | 8-457 |
| 8.5.29 | Paper wrinkle | 8-458 |
| 8.5.30 | Toner scattering..... | 8-459 |
| 8.5.31 | Residual image | 8-460 |
| 8.5.32 | Feathered image..... | 8-462 |
| 8.5.33 | Low density image (rear side)..... | 8-464 |
| 8.5.34 | Image distortion (dogleg image) | 8-466 |
| 8.5.35 | Shadow in copied/scanned images when using the DSDF | 8-468 |
| 8.5.36 | The exit paper surface feels rough like sand is adhering to it (carrier offset) | 8-470 |
| 8.5.37 | Scanned image abnormality | 8-472 |
| 8.5.38 | If an image-related problem continues after performing all troubleshooting .. | 8-474 |

9. REPLACEMENT OF PC BOARDS, SSD 9-1

| | | |
|--------|---|------|
| 9.1 | Removal and Installation of PC Boards/SSD | 9-1 |
| 9.1.1 | SYS board cover..... | 9-1 |
| 9.1.2 | SYS board (SYS)..... | 9-1 |
| 9.1.3 | SRAM | 9-4 |
| 9.1.4 | SSD | 9-4 |
| 9.1.5 | Optional HDD..... | 9-5 |
| 9.1.6 | Optional SSD | 9-5 |
| 9.1.7 | SYS board case (MJD, ASD, AUD, JPC, CND) | 9-6 |
| 9.1.8 | SYS board case (NAD, ARD) | 9-8 |
| 9.1.9 | SYS board cooling fan (F27) | 9-10 |
| 9.1.10 | LGC board (LGC) | 9-10 |
| 9.1.11 | Sub EEPROM..... | 9-12 |
| 9.1.12 | LGC/PFC board case | 9-13 |
| 9.1.13 | PFC board (PFC)..... | 9-16 |
| 9.1.14 | Switching regulator (PS)..... | 9-17 |
| 9.1.15 | High-voltage transformer (HVT)..... | 9-19 |
| 9.1.16 | FIL-AC board | 9-20 |
| 9.1.17 | FIL-IH board (9029A models of JPC only)..... | 9-21 |
| 9.1.18 | DAMP PC board (ASD, AUD, ARD, JPC, CND)..... | 9-22 |
| 9.1.19 | DSDF I/F board..... | 9-23 |
| 9.1.20 | IH board | 9-23 |
| 9.1.21 | DRV board | 9-26 |

| | | |
|------------|--|-------------|
| 9.1.22 | CTIF board..... | 9-26 |
| 9.2 | Precautions, Procedures and Settings for Replacing PC Boards and Storage Device... | 9-27 |
| 9.2.1 | Precautions when replacing PC boards..... | 9-27 |
| 9.2.2 | Storage device fault diagnosis..... | 9-28 |
| 9.2.3 | Precautions and procedures when replacing the storage device | 9-31 |
| 9.2.4 | Precautions and procedures when replacing the SYS board | 9-36 |
| 9.2.5 | Precautions and procedure when replacing the SRAM | 9-39 |
| 9.2.6 | Procedures when replacing the LGC board..... | 9-43 |
| 9.2.7 | Procedures and settings when replacing the Sub EEPROM..... | 9-44 |
| 9.2.8 | Procedures and settings when replacing the lens unit | 9-48 |
| 9.2.9 | Firmware confirmation after the PC board/storage device replacement..... | 9-48 |
| 9.2.10 | License re-registration using the one-time dongle..... | 9-49 |
| 9.3 | Precautions when Disposing of the Storage Devices and PC Boards | 9-51 |
| 9.3.1 | Precautions when disposing of the storage devices | 9-51 |
| 9.3.2 | Precautions when disposing of the SYS board..... | 9-51 |
| 9.3.3 | Precautions when disposing of the SRAM..... | 9-51 |
| 10. | REMOTE SERVICE..... | 10-1 |
| 10.1 | Auto Supply Order..... | 10-1 |
| 10.1.1 | Overview..... | 10-1 |
| 10.1.2 | Setting item..... | 10-2 |
| 10.1.3 | Setting procedure | 10-3 |
| 10.1.4 | Supply Order sheet format..... | 10-13 |
| 10.2 | Service Notification | 10-15 |
| 10.2.1 | Overview..... | 10-15 |
| 10.2.2 | Setting..... | 10-15 |
| 10.2.3 | Items to be notified | 10-23 |
| 10.3 | Remote Panel (VNC) | 10-38 |
| 10.3.1 | Overview..... | 10-38 |
| 10.3.2 | Setting..... | 10-38 |
| 10.3.3 | Operation | 10-39 |
| 10.4 | Remote Assistant Menu | 10-40 |
| 10.4.1 | Overview..... | 10-40 |
| 10.4.2 | Displaying of the [Remote Assistant Menu] icon | 10-40 |
| 10.4.3 | Logs Transmission..... | 10-40 |
| 10.4.4 | Remote Service | 10-43 |
| 10.4.5 | Remote Panel Operation | 10-44 |
| 11. | FIRMWARE UPDATING | 11-1 |
| 11.1 | Overview | 11-1 |
| 11.2 | Firmware Updating with a USB Storage Device | 11-2 |
| 11.2.1 | Updating methods..... | 11-2 |
| 11.2.2 | File configuration of a USB storage device..... | 11-3 |
| 11.2.3 | Firmware type and data file for updating | 11-4 |
| 11.2.4 | Updating procedure | 11-6 |
| 12. | MANAGEMENT OF MFP INFORMATION..... | 12-1 |
| 12.1 | Cloning (HS Menu)..... | 12-1 |
| 12.1.1 | Overview..... | 12-1 |
| 12.1.2 | Precautions | 12-1 |
| 12.1.3 | Backup files | 12-2 |
| 12.1.4 | Cloning procedure | 12-2 |
| 12.2 | Cloning (FS Menu)..... | 12-4 |
| 12.2.1 | Overview..... | 12-4 |
| 12.2.2 | Precautions | 12-4 |
| 12.2.3 | Clone file creation procedure..... | 12-6 |
| 12.2.4 | Clone file installation procedure..... | 12-6 |
| 12.3 | Backing Up and Restoring Data..... | 12-7 |
| 12.3.1 | Overview..... | 12-7 |
| 12.3.2 | Applicable data | 12-7 |

| | | |
|------------|--|-------------|
| 12.3.3 | Precautions | 12-8 |
| 12.3.4 | Backup file creation procedure | 12-9 |
| 12.3.5 | Restore procedure | 12-10 |
| 12.3.6 | Management of the backup function..... | 12-11 |
| 12.4 | TPM..... | 12-13 |
| 12.4.1 | Overview | 12-13 |
| 12.4.2 | Confirmation Method | 12-13 |
| 12.4.3 | Precautions for MFPs with TPM enabled | 12-13 |
| 12.5 | High Security Mode..... | 12-14 |
| 12.5.1 | Overview | 12-14 |
| 12.5.2 | Prior confirmation..... | 12-14 |
| 12.5.3 | Back up data in HDD | 12-14 |
| 12.5.4 | Procedure for entering the High Security mode..... | 12-15 |
| 12.5.5 | Restore user information and data in HDD..... | 12-15 |
| 12.5.6 | Precautions | 12-16 |
| 12.6 | Decommissioning..... | 12-17 |
| 12.6.1 | Overview | 12-17 |
| 12.6.2 | Function | 12-17 |
| 12.6.3 | Precautions | 12-17 |
| 12.6.4 | Procedures of decommissioning..... | 12-17 |
| 13. | WIRE HARNESS CONNECTION..... | 13-1 |
| 13.1 | AC Wire Harness | 13-1 |
| 13.1.1 | 100V model (6529A)..... | 13-1 |
| 13.1.2 | 100V model (9029A)..... | 13-2 |
| 13.1.3 | 120V model..... | 13-3 |
| 13.1.4 | 220-240V model | 13-4 |
| 13.2 | DC Wire Harness / Electric Parts Layout | 13-5 |
| 13.2.1 | DC Wire Harness..... | 13-5 |
| 13.2.2 | Electric Parts Layout..... | 13-6 |
| 13.3 | DSDL Harness Diagram | 13-7 |
| 14. | APPENDIX | 14-1 |
| 14.1 | External Counters | 14-1 |
| 14.1.1 | Overview | 14-1 |
| 14.1.2 | Connector | 14-1 |
| 14.1.3 | Coin controller..... | 14-1 |
| 14.1.4 | Key copy counter | 14-4 |
| 14.1.5 | Precautions | 14-5 |
| 14.2 | Optional Storage Device | 14-6 |
| 14.2.1 | Overview | 14-6 |
| 14.2.2 | Disabling setting | 14-6 |
| 14.2.3 | Security setting | 14-6 |
| 14.2.4 | Precautions for disposal | 14-6 |
| 14.2.5 | Data overwriting function | 14-6 |
| 14.3 | Pixel Counter..... | 14-7 |
| 14.3.1 | Overview | 14-7 |
| 14.4 | Notes for the installation of a card reader | 14-15 |
| 14.5 | Usable USB storage device | 14-16 |
| 14.6 | License..... | 14-17 |
| 14.6.1 | Types and categories..... | 14-17 |
| 14.6.2 | How to activate the license..... | 14-17 |
| 14.6.3 | How to deactivate the license..... | 14-21 |
| 14.6.4 | How to delete the license..... | 14-21 |
| | REVISION RECORD..... | 1 |

1. DIFFERENCES BETWEEN MODELS

This section describes the differences between the models and items which have been changed from the former ones.

| | 6526AC 6527AC 7527AC | 6529A 7529A 9029A |
|--|---|---|
| Copy speed | - | Addition of 90 ppm model |
| DSDF | Multiple feeding detection function added | Multiple feeding detection function added |
| Main power switch | Not installed | Not installed |
| Process unit | YMCK | K only |
| Toner replacing in the middle prevention mechanism | Addition of new mechanisms | Addition of new mechanisms |
| Drawer automatic pull-in mechanism | Addition of new mechanisms | Addition of new mechanisms |
| Drawer tray-up mechanism | Embedded in each drawer | Embedded in each drawer |
| Maximum paper weight | 300 g/m ² | 300 g/m ² |
| Main memory capacity | 6 GB (GST: 8 GB) | 6 GB (GSA: 8 GB) |
| Storage medium | SSD 128 GB (GST: SSD 128 GB, HDD 320 GB) | SSD 128 GB (GSA: SSD 128 GB, HDD 320 GB) |
| Motion sensor | Equipped as the standard | None |
| Ex-LCF | 2 units of the Ex-LCF installation possible | 2 units of the Ex-LCF installation possible |

2. SPECIFICATIONS, ACCESSORIES, OPTIONS AND CONSUMABLES

In this document, a model name is replaced with an alias as follows: Moreover, the availability of the model configurations depending on the destination and the standard specification of drawers are also described.

| Model name | Alias | Availability | | | | | | | | |
|---------------|-------|--------------|-----|-----|-----|-----|-----|-----|-----|-----|
| | | NAD | GSA | ARD | AUD | MJD | ASD | CND | TWD | JPC |
| e-STUDIO6529A | 6529A | Yes | No | Yes | No | Yes | Yes | Yes | No | Yes |
| e-STUDIO7529A | 7529A | Yes | No | No | Yes | Yes | Yes | Yes | Yes | No |
| e-STUDIO9029A | 9029A | Yes | Yes | Yes | Yes | Yes | Yes | Yes | No | Yes |

| Drawers | Availability | | | | | | | | |
|---------------------|--------------|-----|-----|-----|-----|-----|-----|-----|-----|
| | NAD | GSA | ARD | AUD | MJD | ASD | CND | TWD | JPC |
| 4 drawers | - | - | - | - | - | - | - | - | Yes |
| 2 drawers and T-LCF | Yes | Yes | Yes | Yes | Yes | Yes | Yes | Yes | - |

For details about the destination, see "destination" in the following reference.

☞ P. 2-1 "2.1.1 General"

2.1 Specifications

2.1.1 General

| | | |
|---------------------------|---|--|
| Type | Console type | |
| Copy process | Indirect electro-photographic method (dry) | |
| Developing system | 2-component magnetic brush developing (Self-refreshing development) | |
| Fusing system | Belt fusing system with external IH | |
| Photo conductive type | OPC | |
| Original glass | - | Fixed |
| | Original scanning system | Flat surface scanning system (the left rear corner used as guide to place originals) |
| | Original scanning sensor | CCD sensor |
| | Scanning light source | LED |
| | Original type | Sheets and books |
| | Original size | Max. A3, LD |
| Resolution | Scanning | 600 dpi × 600 dpi |
| | Writing | 600 dpi x 600 dpi, 1 bit 2,400 dpi (equivalent) x 600 dpi (when smoothing processing is applied) |
| Gradation | 256 | |
| Dual Scan Document Feeder | Original scanning system | Fixed scanning system by feeding the original (the center used as guide to place originals) |
| | Original type | Plain paper, Recycled paper (The following types of paper are unacceptable.: duplicative draft, back carbon paper, bonded paper, stapled paper, high-transparency paper, photo, catalog, coated paper, etc.) |
| | Original size | A3, A4, A4-R, A5-R, B4, B5, B5-R, FOLIO, LD, LG, LT, LT-R, ST-R, COMPUTER |
| | Original paper weight*1 | 35 g/m ² to 209 g/m ² (9.3 lb. Bond to 77.3 lb. Cover) |
| | Original capacity | Stacking height: 38 mm, equivalent to 300 sheets of 80 g/m ² (21.3 lb. Bond) plain paper |

| | | |
|---------------------------|--|--|
| Paper feeding system | | 4 drawers and bypass tray 4 drawers, bypass tray and Ex-LCF (2.5K) 4 drawers, bypass tray, Ex-LCF (2.0K) and Ex-LCF (2.5K) 2 drawers, bypass tray and T-LCF 2 drawers, bypass tray, T-LCF and Ex-LCF (2.5K) 2 drawers, bypass tray, T-LCF, Ex-LCF (2.0K) and Ex-LCF (2.5K) |
| Paper supply | Drawer | Stacking height: 60 mm • Plain: Approx. 540 sheets (80 g/m ² , 21.3 lb. Bond) • Thick: Approx. 500 sheets (105 g/m ² , 28 lb. Bond) |
| | Bypass tray | Stacking height: 13 mm • Plain: Approx. 120 sheets (80 g/m ² , 21.3 lb. Bond) • Thick: Approx. 80 sheets (105 g/m ² , 28 lb. Bond) • Envelope: Approx. 10 sheets |
| | T-LCF | Stacking height: 132.5 mm (Left), 137.5 mm (Right) • Plain: Approx. 2,320 sheets (80 g/m ² , 21.3 lb. Bond) • Thick: Approx. 2,000 sheets (105 g/m ² , 28 lb. Bond) |
| | Ex-LCF(2.0K) | Stacking height: 230 mm • Plain: Approx. 2,000 sheets (80 g/m ² , 21.3 lb. Bond) • Thick: Approx. 1,700 sheets (105 g/m ² , 28 lb. Bond) |
| | Ex-LCF(2.5K) | Stacking height: 290 mm • Plain: Approx. 2,500 sheets (80 g/m ² , 21.3 lb. Bond) • Thick: Approx. 2,200 sheets (105 g/m ² , 28 lb. Bond) |
| Paper size | Drawer | A3, A4, A4-R, A5-R, B4, B5, B5-R, FOLIO, 8K, 16K, 16K-R, A3 Wide (305 mm x 457 mm), SRA3 (320 mm x 450 mm), 320 x 460 mm, LD, LG, LT, LT-R, ST-R, COMPUTER, 13"LG, 8.5" x 8.5", Full Bleed (12" x 18") Non-standard ² : Paper size whose width is within 140 mm to 297 mm and length is 210 mm to 432 mm |
| | Bypass tray | A3, A4, A4-R, A5-R, B4, B5, B5-R, Postcard, FOLIO, 8K, 16K, 16K-R, A3 Wide (305 mm x 457 mm), SRA3 (320 mm x 450 mm), 320 mm x 460 mm, 330 x 483 mm ^{*3} , LD, LG, LT, LT-R, ST-R, COMPUTER, 13"LG, 8.5" x 8.5", Full Bleed (12" x 18"), 13" x 19" ^{*3} , Cho-3, You-4, DL, COM10, Monarch, KAKU-2 Non-standard ² : Paper size whose width is within 100 mm to 297 mm and length is 148 mm to 432 mm |
| | T-LCF Ex-LCF(2.0K) Ex-LCF(2.5K) | A4, LT |
| Paper type ^{*4} | Drawer T-LCF Ex-LCF(2.0K) Ex-LCF(2.5K) | Plain, Recycled paper, Thick, Thick 1, Thick 2, Thick 3, Thick 4 |
| | Bypass tray | Plain, Recycled paper, Thick, Thick 1, Thick 2, Thick 3, Thick 4, Special 1 (Waterproof paper), Special 2 (Waterproof paper), Transparency, Label, Tab paper, Postcard, Envelope, Extra large paper |
| Paper weight | Drawer Bypass tray T-LCF Ex-LCF(2.0K) Ex-LCF(2.5K) | 60 g/m ² to 300 g/m ² (16 lb. Bond to 110 lb. Cover) |
| Automatic duplexing unit | Paper re-feeding/reversing system | Stack-less, Switchback type |
| | Acceptable paper size | A3, A4, A4-R, A5-R, B4, B5, B5-R, FOLIO, 8K, 16K, 16K-R, A3 Wide (305 mm x 457mm), LD, LG, LT, LT-R, ST-R, COMPUTER, 13"LG, 8.5" x 8.5", Full Bleed (12" x 18") |
| | Acceptable paper weight | 60 g/m ² to 256 g/m ² (16 lb. Bond to 140 lb. Index) |
| Toner supply system | | Toner cartridge exchange type |
| Density adjustment system | | Magnetic auto-toner system (non-contact) with pixel count system |
| Total counter | | Electronic counter displayed in 7-digit |

| | | |
|------------------------------------|-------------|--|
| Memory capacity | Main memory | 6 GB (GSA: 8 GB) |
| | Page Memory | Included in the main memory |
| Standard storage device size | | SSD 128 GB (HDD 320 GB is also equipped as the standard for GSA.) |
| Registrable user account number | | 10,000 |
| Registrable department code number | | 1,000 |
| Warm-up time*5 | | Normal start-up (Stand-alone) (temperature: 20°C): <ul style="list-style-type: none"> • 6529A: Approx. 24 sec. • 7529A: Approx. 20 sec. • 9029A (JPC): Approx. 30 sec. • 9029A (other than JPC): Approx. 25 sec. Start-up with hibernation: Approx. 40 sec. (Stand-alone) (temperature:20°C) |
| Recovery from sleep*5 | | <ul style="list-style-type: none"> • 6529A, 7529A: Approx. 15.4 sec. (stand-alone) (temperature: 20°C) • 9029A (JPC): Approx. 25.4 sec. (stand-alone) (temperature: 20°C) • 9029A (other than JPC): Approx. 20 sec. (stand-alone) (temperature: 20°C) |
| Power source | | 6529A: <ul style="list-style-type: none"> • AC 100 V (±10%), 15 A (common for 50/60 Hz) • AC 120 V (±10%), 16 A (common for 50/60 Hz) • AC 220 V to 240 V (±10%), 10 A (common for 50/60 Hz) 7529A: <ul style="list-style-type: none"> • AC 120 V (±10%), 16 A (common for 50/60 Hz) • AC 220 V to 240 V (±10%), 10 A (common for 50/60 Hz) 9029A: <ul style="list-style-type: none"> • AC 100 V (±10%), 8 A + 12 A (IH) (common for 50/60 Hz) • AC 120 V (±10%), 16 A (common for 50/60 Hz) • AC 220 V to 240 V (±10%), 10 A (common for 50/60 Hz) |
| Power consumption*6 | | 6529A: <ul style="list-style-type: none"> • 1.5 kW or less (100 V) • 2.0 kW or less (120 V) • 2.4 kW or less (220 V to 240 V) 7529A (TWD): <ul style="list-style-type: none"> • 2.2 kW or less (220 V to 240 V) 7529A (other than TWD): <ul style="list-style-type: none"> • 2.0 kW or less (120 V) • 2.4 kW or less (220 V to 240 V) 9029A: <ul style="list-style-type: none"> • 2.0 kW or less (100 V) • 2.0 kW or less (120 V) • 2.4 kW or less (220 V to 240 V) |
| Dimensions (MFP only) | | W 955 x D 698 x H 1,227 mm (When the tilt angle of the control panel is 90 degrees.) W 955 x D 737 x H 1,227 mm (When the tilt angle of the control panel is 7 degrees.)  |
| Weight | | 194 kg |

Fig. 2-1

| | |
|-------------|--|
| Destination | NAD, GSA: North America, Brazil ARD: Argentina AUD: Australia MJD: Europe ASD: Asia, Others CND: China TWD: Taiwan JPC: Japan |
|-------------|--|

- *1 Show-through will occur when a 2-sided thin-paper original such as 35 g/m² (9.3 lb. Bond) is scanned.
- *2 Image deviation, image void, skewing, image tilting, corner folding or wrinkling may occur on non-standard size paper.
- *3 Staining on the back side of the paper may occur.
- *4 Pre-punched paper is unacceptable.
- *5 This may vary depending on the quality maintenance behavior, such as the settings, conditions of use and toner refill.
- *6 Power for the options is supplied through the MFP.

2.1.2 Copy

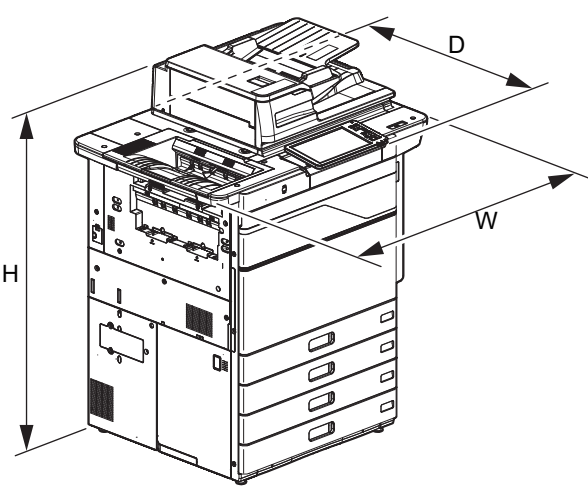
[1] Copy specifications

| | |
|--------------------|---|
| Storage capacity | Max. 1000 sheets or until the memory is full |
| Eliminated portion | Leading edges: 4.2 +2.8/-1.2 mm, Trailing edges: 3.0 ±2.0 mm, Side edges: 2.0 ±2.0 mm |
| Multiple copying | Up to 9,999 copies (Entered by the digital keys) |
| Density control | The automatic density mode and the manual density mode are selectable in 11 steps. |

[2] First copy time

| | |
|-------|------------------|
| 6529A | Approx. 5.2 sec. |
| 7529A | Approx. 4.5 sec. |
| 9029A | Approx. 4.1 sec. |

[3] Copy speed (sheets/min.)

The measurement conditions of the copying speed are as below.

- When originals are manually placed for single-sided, continuous copying.
- When the DSDF is used, the copy speed of the MFP is only possible under the following conditions: Original: A4 or LT (single-sided), Mode: APS selected, Automatic density not selected, Plain selected. Reproduction ratio: 100%
- “-” means “Not acceptable”.
- “Wait” may be displayed or the copy speed may decrease depending on the usage environment or print settings.

[3-1] Plain, Recycled Paper

- Plain, Recycled Paper: 60 g/m² to 80 g/m² (1.6 lbs. Bond to 21.3 lbs. Bond)

6529A (Plain, Recycled paper)

| Paper size | Paper supply | Drawer | Bypass feed Size specified | T-LCF | Ex-LCF (2.0K) | Ex-LCF (2.5K) |
|--------------------------------|--------------|--------|----------------------------|-------|---------------|---------------|
| A4, LT | | 65 | 48 | 65 | 65 | 65 |
| B5 | - | | | - | | |
| 16K, A5-R, ST-R, 8.5" x 8.5" | - | | | - | | |
| A6-R (other than JPC) | | - | 48 | - | - | - |
| Postcard (for JPC only) | | - | - | - | - | - |
| A4-R, B5-R, LT-R, 16K-R | | 46 | 36 | - | - | - |
| B4, FOLIO, LG, COMPUTER, 13"LG | | 31 | 28 | - | - | - |
| A3, LD, 8K | | 30 | 25 | - | - | - |
| A3 Wide, SRA3 | | 27 | 21 | - | - | - |
| 330 mm x 483 mm | | - | | - | - | - |

7529A (Plain, Recycled paper)

| Paper size | Paper supply | Drawer | Bypass feed Size specified | T-LCF | Ex-LCF (2.0K) | Ex-LCF (2.5K) |
|--------------------------------|--------------|--------|----------------------------|-------|---------------|---------------|
| A4, LT | | 75 | 52 | 75 | 75 | 75 |
| B5 | - | | | - | | |
| 16K, A5-R, ST-R, 8.5" x 8.5" | - | | | - | | |
| A6-R (other than JPC) | | - | 52 | - | - | - |
| Postcard (for JPC only) | | - | - | - | - | - |
| A4-R, B5-R, LT-R, 16K-R | | 54 | 38 | - | - | - |
| B4, FOLIO, LG, COMPUTER, 13"LG | | 39 | 30 | - | - | - |
| A3, LD, 8K | | 37 | 27 | - | - | - |
| A3 Wide, SRA3 | | 31 | 23 | - | - | - |
| 330 mm x 483 mm | | - | | - | - | - |

9029A (Plain, Recycled paper)

| Paper size | Paper supply | Drawer | Bypass feed Size specified | T-LCF | Ex-LCF (2.0K) | Ex-LCF (2.5K) |
|--------------------------------|--------------|--------|----------------------------|-------|---------------|---------------|
| A4, LT | | 90 | 56 | 90 | 90 | 90 |
| B5 | - | | | - | | |
| 16K, A5-R, ST-R, 8.5" x 8.5" | - | | | - | | |
| A6-R (other than JPC) | | - | 56 | - | - | - |
| Postcard (for JPC only) | | - | - | - | - | - |
| A4-R, B5-R, LT-R, 16K-R | | 61 | 42 | - | - | - |
| B4, FOLIO, LG, COMPUTER, 13"LG | | 46 | 38 | - | - | - |
| A3, LD, 8K | | 40 | 34 | - | - | - |
| A3 Wide, SRA3 | | 33 | 30 | - | - | - |
| 330 mm x 483 mm | | - | | - | - | - |

[3-2] Thick

- Thick: 81 g/m² to 105 g/m² (22 lb. Bond to 28 lb. Bond)

6529A (Thick)

| Paper size | Paper supply | Drawer | Bypass feed Size specified | T-LCF | Ex-LCF (2.0K) | Ex-LCF (2.5K) |
|--------------------------------|--------------|--------|----------------------------|-------|---------------|---------------|
| A4, LT | | 65 | 48 | 65 | 65 | 65 |
| B5 | - | | | - | | |
| 16K, A5-R, ST-R, 8.5" x 8.5" | - | | | - | | |
| A6-R (other than JPC) | | - | 48 | - | - | - |
| Postcard (for JPC only) | | - | - | - | - | - |
| A4-R, B5-R, LT-R, 16K-R | | 46 | 36 | - | - | - |
| B4, FOLIO, LG, COMPUTER, 13"LG | | 31 | 28 | - | - | - |
| A3, LD, 8K | | 30 | 25 | - | - | - |
| A3 Wide, SRA3 | | 27 | 21 | - | - | - |
| 330 mm x 483 mm | | - | | - | - | - |

7529A (Thick), 9029A (JPC) (Thick)

| Paper size | Paper supply | Drawer | Bypass feed Size specified | T-LCF | Ex-LCF (2.0K) | Ex-LCF (2.5K) |
|--------------------------------|--------------|--------|----------------------------|-------|---------------|---------------|
| A4, LT | | 75 | 52 | 75 | 75 | 75 |
| B5 | - | | | - | | |
| 16K, A5-R, ST-R, 8.5" x 8.5" | - | | | - | | |
| A6-R (other than JPC) | | - | 52 | - | - | - |
| Postcard (for JPC only) | | - | - | - | - | - |
| A4-R, B5-R, LT-R, 16K-R | | 54 | 38 | - | - | - |
| B4, FOLIO, LG, COMPUTER, 13"LG | | 39 | 30 | - | - | - |
| A3, LD, 8K | | 37 | 27 | - | - | - |
| A3 Wide, SRA3 | | 31 | 23 | - | - | - |
| 330 mm x 483 mm | | - | | - | - | - |

9029A (other than JPC) (Thick)

| Paper size | Paper supply | Drawer | Bypass feed Size specified | T-LCF | Ex-LCF (2.0K) | Ex-LCF (2.5K) |
|--------------------------------|--------------|--------|----------------------------|-------|---------------|---------------|
| A4, LT | | 90 | 56 | 90 | 90 | 90 |
| B5 | | 75 | 52 | - | - | 75 |
| 16K, A5-R, ST-R, 8.5" x 8.5" | | | | - | - | |
| A6-R (other than JPC) | | - | 52 | - | - | - |
| Postcard (for JPC only) | | - | - | - | - | - |
| A4-R, B5-R, LT-R, 16K-R | | 54 | 38 | - | - | - |
| B4, FOLIO, LG, COMPUTER, 13"LG | | 39 | 30 | - | - | - |
| 8K | | 37 | 27 | - | - | - |
| A3, LD | | 40 | 34 | - | - | - |
| A3 Wide, SRA3 | | 33 | 30 | - | - | - |
| 330 mm x 483 mm | | - | | - | - | - |

[3-3] Thick 1, Thick 2

- Thick 1: 106 g/m² to 163 g/m² (90 lb. Index)
- Thick 2: 164 g/m² to 209 g/m² (110 lb. Index)

| Paper size | Paper supply | Drawer | Bypass feed Size specified | T-LCF | Ex-LCF (2.0K) | Ex-LCF (2.5K) |
|--------------------------------|--------------|--------|----------------------------|-------|---------------|---------------|
| A4, LT | | 32 | 26 | 32 | 32 | 32 |
| B5 | | | | - | - | |
| 16K, A5-R, ST-R, 8.5" x 8.5" | | | | - | - | |
| A6-R (other than JPC) | | - | 26 | - | - | - |
| Postcard (for JPC only) | | - | 26 | - | - | - |
| A4-R, B5-R, LT-R, 16K-R | | 23 | 20 | - | - | - |
| B4, FOLIO, LG, COMPUTER, 13"LG | | 15.5 | 13 | - | - | - |
| A3, LD, 8K | | 13.5 | 11 | - | - | - |
| A3 Wide, SRA3 | | 12 | 9 | - | - | - |
| 330 mm x 483 mm | | - | | - | - | - |

[3-4] Thick 3, Thick 4

- Thick 3: 210 g/m² to 256 g/m² (140 lb. Index)
- Thick 4: 257 g/m² to 300 g/m² (110 lb. Cover)

| Paper size | Paper supply | Drawer | Bypass feed Size specified | T-LCF | Ex-LCF (2.0K) | Ex-LCF (2.5K) |
|--------------------------------|--------------|--------|----------------------------|-------|---------------|---------------|
| A4, LT | | 32 | 26 | 32 | 32 | 32 |
| B5 | - | | | - | | |
| 16K, A5-R, ST-R, 8.5" x 8.5" | - | | | - | | |
| A6-R (other than JPC) | | - | 26 | - | - | - |
| Postcard (for JPC only) | | - | 26 | - | - | - |
| A4-R, B5-R, LT-R, 16K-R | | 23 | 20 | - | - | - |
| B4, FOLIO, LG, COMPUTER, 13"LG | | 15.5 | 13 | - | - | - |
| A3, LD, 8K | | 13.5 | 11 | - | - | - |
| A3 Wide, SRA3 | | 12 | 9 | - | - | - |
| 330 mm x 483 mm | | - | | - | - | - |

[3-5] Special 1

| Paper size | Paper supply | Drawer | Bypass feed Size specified | T-LCF | Ex-LCF (2.0K) | Ex-LCF (2.5K) |
|--|--------------|--------|----------------------------|-------|---------------|---------------|
| A4, LT, B5, 16K, ST-R, A5-R, 8.5" x 8.5" | | - | 6 | - | - | - |
| A6-R (other than JPC) | | - | 6 | - | - | - |
| Postcard (for JPC only) | | - | 6 | - | - | - |
| A4-R, B5-R, LT-R, 16K-R | | - | 4.5 | - | - | - |
| B4, FOLIO, LG, COMPUTER, 13"LG | | - | 3 | - | - | - |
| A3, LD, 8K | | - | 2.5 | - | - | - |
| A3 Wide, SRA3, 330 mm x 483 mm | | - | 2 | - | - | - |

[3-6] Special 2

| Paper size | Paper supply | Drawer | Bypass feed Size specified | T-LCF | Ex-LCF (2.0K) | Ex-LCF (2.5K) |
|--|--------------|--------|----------------------------|-------|---------------|---------------|
| A4, LT, B5, 16K, ST-R, A5-R, 8.5" x 8.5" | | - | 17 | - | - | - |
| A6-R (other than JPC) | | - | 17 | - | - | - |
| Postcard (for JPC only) | | - | 17 | - | - | - |
| A4-R, B5-R, LT-R, 16K-R | | - | 13 | - | - | - |
| B4, FOLIO, LG, COMPUTER, 13"LG | | - | 9.5 | - | - | - |
| A3, LD, 8K | | - | 8 | - | - | - |
| A3 Wide, SRA3, 330 mm x 483 mm | | - | 6 | - | - | - |

[3-7] Transparency

| Paper size | Paper supply | Drawer | Bypass feed Size specified | T-LCF | Ex-LCF (2.0K) | Ex-LCF (2.5K) |
|------------|--------------|--------|----------------------------|-------|---------------|---------------|
| A4, LT | | - | 17 | - | - | - |

[3-8] Envelope

| Paper size | Paper supply | Drawer | Bypass feed Size specified | T-LCF | Ex-LCF (2.0K) | Ex-LCF (2.0K) Ex-LCF (2.5K) |
|---------------------------|--------------|--------|----------------------------|-------|---------------|--------------------------------|
| Cho-3 (120 mm x 235 mm) | | - | 13 | - | - | - |
| You-4 (235 mm x105 mm) | | - | | - | - | - |
| DL (110 mm x 220 mm) | | - | | - | - | - |
| monarch (3 7/8" x 7 1/2") | | - | | - | - | - |
| COM10 (4 1/8" x 9 1/2") | | - | | - | - | - |
| KAKU-2 (240 mm x 332 mm) | | - | 8 | - | - | - |

[4] System copy speed (Copies/min.)

| Copy mode | | Sec. | | |
|--------------------------|--------|--------|--------|-------|
| | | 6529A | 7529A | 9029A |
| Single-sided originals | 1 set | 14.78 | 13.83 | 14.26 |
| | 3 sets | 37.50 | 31.29 | 26.51 |
| ↓ Single-sided copies | 5 sets | 53.18 | 48.45 | 39.68 |
| Single-sided originals | 1 set | 19.95 | 19.41 | 18.66 |
| | 3 sets | 41.62 | 40.08 | 34.28 |
| ↓ Double-sided copies | 5 sets | 63.95 | 56.67 | 50.12 |
| Double-sided originals | 1 set | 31.25 | 30.59 | 25.49 |
| | 3 sets | 74.41 | 69.37 | 59.04 |
| ↓ Double-sided copies | 5 sets | 119.36 | 105.25 | 93.73 |
| Double-sided originals | 1 set | 26.92 | 26.68 | 20.99 |
| | 3 sets | 63.55 | 59.52 | 48.39 |
| ↓ Single-sided copies | 5 sets | 110.66 | 88.70 | 74.06 |

- The table shows the period of time when 10 sheets of an A4 or LT size original are set on the DSDF and one of the copy modes above is selected.
- The period of time is from when the [START] button is pressed until "Ready" is displayed.
- When the following settings are specified: Automatic density, APS, AMS: OFF, Text/Photo: Selected
Paper supply: Drawer 1, Sort: Selected
- No finisher, saddle stitch finisher and hole punch unit are installed.

2.1.3 Printer

| | | |
|--|----------------|---|
| Page Description Language (Printer Driver) | | PCL6, PostScript3 (emulation) |
| Page Description Language (MFP) | | PCL6, PostScript3 (emulation), XPS, PCL5e, PCL5c, PDF (emulation), JPEG |
| Supported Client OS | | Windows Server 2012, Windows 10, Windows Server 2016, Windows Server 2019, Windows 11, Windows Server 2022 Mac OS X 10.12 or later Sun Solaris 11.2 HP-UX Version 11iv3 IBM AIX 7.x Fedora 21/22 Red Hat Enterprise Linux 5.x/6.x/7.x SUSE Linux Enterprise Server 11/12 Open SUSE 13.2/13.3 Ubuntu 14.04LTS/15.04 Debian 7/8 CUPS V1.1.15 |
| Resolution | | 600 dpi x 600 dpi, 1-bit All PDL 2,400 dpi (equivalent) x 600 dpi (when smoothing processing is applied) All PDL 1,200 dpi x 1,200 dpi, 2-bit (3,600 dpi (equivalent) x 1,200 dpi) PS only |
| Eliminated portion | | Leading edge: 4.2 mm +2.8/-1.2 mm Trailing edge: 4.2 mm +1.2/-2.8 mm Side edges: 4.2 mm ±2.0 mm |
| Interface | Standard | Ethernet (10BASE-T/100BASE-TX/1000BASE-T) USB 2.0 High Speed (480 Mbps) |
| | Optional*1 | Wireless LAN (IEEE 802.11b/g/n/a/ac) Bluetooth V4.2 (HCRP/BIP/OPP/FTP/HID) |
| Paper size*2 | Drawer | Paper size whose width is within 140 mm to 313.4 mm and length is 210 mm to 460 mm |
| | Bypass feeding | Paper size whose width is within 100 mm to 313.4 mm and length is 148 mm to 1,200 mm |

*1 Equipped as the standard for JPC only

*2 When printing is performed by using a printer driver, the available paper sizes may differ from the listed ones depending on the specifications of the printer driver.

2.1.4 Scan

| | | |
|--------------------|------|---|
| Scanning speed*1*2 | DSDF | 100 dpi, 150 dpi, 200 dpi, 300 dpi: Simplex 120 spm +14/-1 spm, Duplex 240 spm +28/-2 spm 400 dpi: Simplex 80 spm or larger, Duplex 160 spm or larger 600 dpi: Simplex 70 spm +8/-0.6 spm, Duplex 120 spm or larger |
| Resolution | | 100, 150, 200, 300, 400 and 600 dpi |
| Color mode | | Black, Gray scale, Full color, ACS (Auto Color Selection) |
| File format | | JPEG, TIFF-Multi/Single page, PDF-Multi/Single Page, Slim PDF-Multi/Single Page, XPS-Multi/Single Page |

*1 When single-sided A4/LT landscape originals are scanned continuously or scanning is completed

*2 Common for Black, Gray scale, Full color

2.1.5 Internet Fax

[1] Transmission

| | | |
|-----------------------|-------------------------|--|
| Resolution | TX <dots/mm> | Standard (8 x 3.85) Fine (8 x 7.7) U-Fine (16 x 15.4)* |
| Scanning | Original size | A3, B4, A4, A4-R, A5, B5, B5-R, A5-R, LT, LT-R, LG, LD, ST, ST-R, COMPUTER, FOLIO |
| | Speed | 0.7sec. (per page/A4) Max.50 spm (ITU-T No.1, A4, 8 x 3.85, Text mode) |
| | Gray scale | 256 levels (Error Diffusion) |
| Address book | Address list | 3,000 stations |
| | Group list | Max. 200 stations |
| Transmission features | Broadcast transmission | Max. 400 destinations/job. (A fax number and an e-mail address registered in same job are available.) |
| | Message size limitation | Max. 100M Byte |
| | Message division | Page by page |

* If U-Fine is selected in TX resolution, data is converted to Fine resolution in RX.







[2] Reception

| | |
|------------------|---------------------------|
| Reception format | TIFF-FX (Profile S, F, J) |
|------------------|---------------------------|

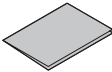
2.1.6 Network Fax (optional)

| | | |
|------------------------|--------------------|--|
| Compatible standards | | Super G3, G3 (ITU-T.30) Internet Fax (Simple mode) (ITU-T.37) |
| TX Resolution | PSTN | Standard: 200 dpi x 100 dpi Fine: 200 dpi x 200 dpi Super Fine: 200 dpi x 400 dpi Ultra Fine: 400 dpi x 400 dpi |
| | Internet Fax | 200 dpi x 200 dpi |
| Original size | | A3, B4, A4, B5, A5, LT, LG, LD, ST, FOLIO, COMPUTER |
| Mail Box | User defined | Max. 300 boxes |
| Routed document format | Send to e-Filing | MMR |
| | Send to File (SMB) | Single TIFF, Multi-TIFF, Single PDF, Multi PDF |
| | Send to FTP | Single TIFF, Multi-TIFF, Single PDF, Multi PDF |
| | Send to E-mail | Single TIFF, Multi-TIFF, Single PDF, Multi PDF |
| | Send to I-Fax | TIFF-S |
| | Send to PSTN-Fax | MMR, MR, MH, JBIG |

2.2 Accessories

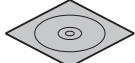
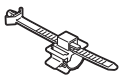
| Name | | Q'ty | Availability |
|--|---|--------------------------------|------------------------------|
| Unpacking/Setup instruction |  | 1 set | For all destinations |
| Operator's manual • Safety Information: 1 • Quick Start Guide: 1 |  | 1 set | For all destinations |
| Cleaning cloth | | 1 pc. | For all destinations |
| Cloth holder | | 1 pc. | For all destinations |
| Drum | | 1 pc. | For all destinations |
| Developer cartridge |  | 1 pc. | For all destinations |
| Toner cartridge | | 1 pc. | For all destinations |
| Waste toner box | | 1 pc. | For all destinations |
| Power cable | | None (Fixed to the MFP) | NAD, GSA |
| | | 1 pc. | ARD, AUD, MJD, ASD, CND, TWD |
| | | 2 pcs. | JPC |
| Rubber plug |  | Large: 9 pcs. Small: 2 pcs. | For all destinations |
| Harness clamp |  | 1 pc. | For all destinations |
| Front lower cover (control panel lower cover), Screw (M4 x 8, BK) |  | 1 pc. each | For all destinations |
| Service information sheets | | 1 pc. | For all destinations |
| Information of customer | | 1 pc. | For all destinations |
| DVD (Client Utilities / User Documentation DVD) |  | 1 pc. | ARD, MJD, ASD, CND, TWD, JPC |
| Warranty sheet | | 1 pc. | NAD, GSA, ARD |
| Setup report | | 1 pc. | NAD, GSA, ARD |
| PM sticker | | 1 pc. | MJD |
| TESS warranty sheet | | 1 pc. | CND |
| CCC certificate | | 1 pc. | CND |
| Accessories list | | 1 pc. | CND |
| Business card case | | 1 set | JPC |
| Paper precaution sheet | | 1 pc. | JPC |
| Warning sheet | | 1 pc. | JPC |
| Cord clamp |  | 1 pc. | JPC |
| Ground wire | | 1 pc. | JPC |

Notes:

Check that the above accessories are correctly co-packed at the time of unpacking.

2.3 System List

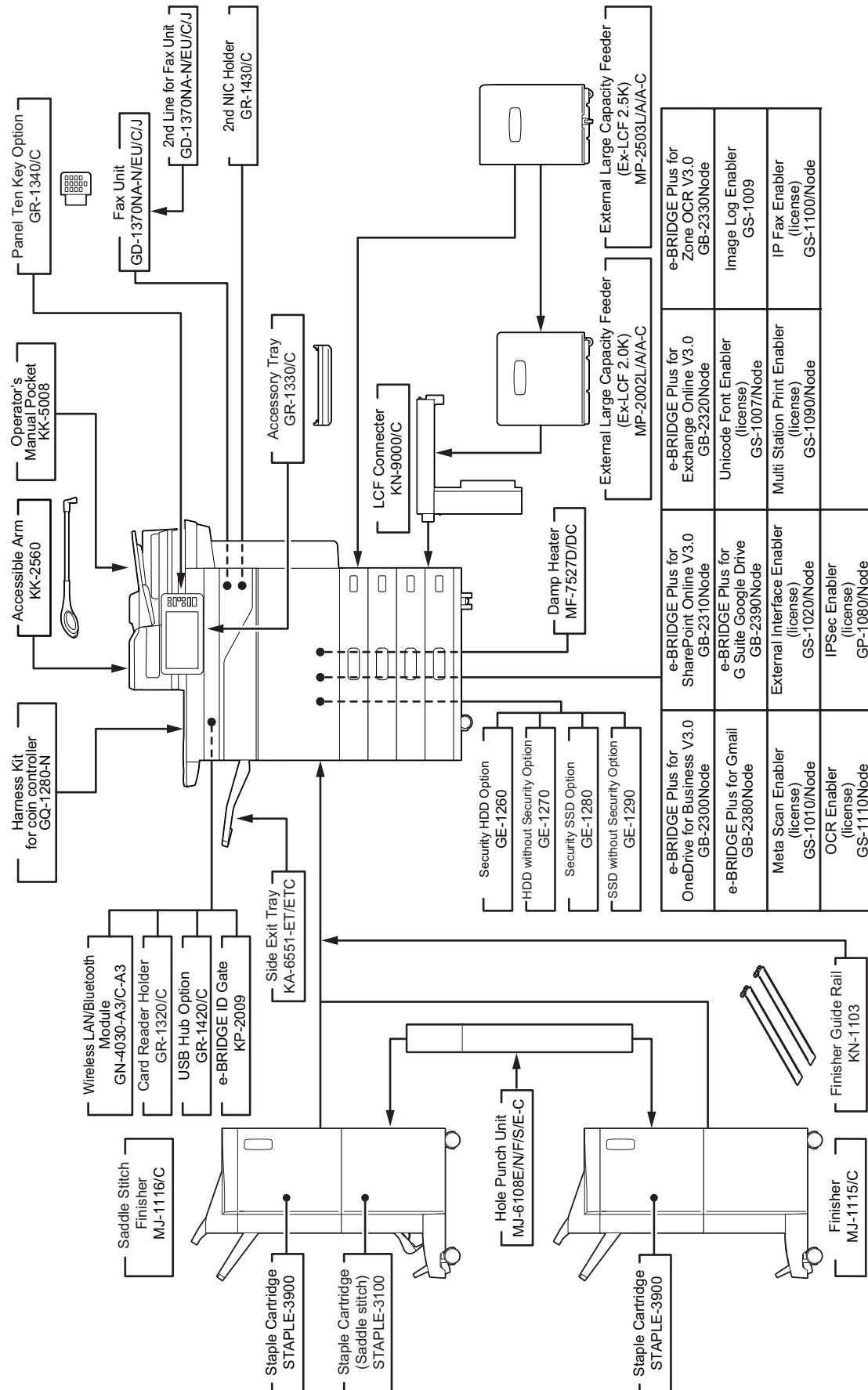

Fig. 2-2

Notes:

- The finisher (MJ-1115/C, MJ-1116/C) is necessary for installation of the hole punch unit (MJ-6108E/N/F/S/E-C).
- The LCF Connector (KN-9000/C) and Ex-LCF 2.5K (MP-2503L/A/A-C) are necessary when the Ex-LCF 2.0K (MP-2002L/A/A-C) is installed.
- Only either the 2nd NIC Holder (GR-1430/C) or the 2nd Line for the FAX Unit (GD-1370NA-N/EU/C/J) can be installed.
- Only one of GE-1260, GE-1270, GE-1280 or GE-1290 can be installed for an optional storage device.

2.4 Option List

| Option | Model name | Availability | | | | | |
|--|--------------------|-------------------|-------------------|-------------------|-----|-----|-----|
| | | NAD GSA | ARD AUD | MJD ASD | CND | TWD | JPC |
| External Large Capacity Feeder (Ex-LCF 2.0K) | MP-2002L/A/A-C | Yes | Yes | Yes | Yes | Yes | Yes |
| External Large Capacity Feeder (Ex-LCF 2.5K) | MP-2503L/A/A-C | Yes | Yes | Yes | Yes | Yes | Yes |
| LCF Connector | KN-9000/C | Yes | Yes | Yes | Yes | Yes | Yes |
| Side Exit Tray | KA-6551-ET/ETC | Yes | Yes | Yes | Yes | Yes | Yes |
| Operator's Manual Pocket | KK-5008 | No | No | No | No | No | Yes |
| Accessible Arm | KK-2560 | Yes | Yes | Yes | Yes | Yes | Yes |
| Finisher | MJ-1115/C | Yes | Yes | Yes | Yes | Yes | Yes |
| Saddle Stitch Finisher | MJ-1116/C | Yes | Yes | Yes | Yes | Yes | Yes |
| Finisher Guide Rail | KN-1103 | Yes | Yes | Yes | Yes | Yes | Yes |
| Hole Punch Unit (for MJ-1115/C, MJ-1116/C) | MJ-6108E/N/F/S/E-C | Yes | Yes | Yes | Yes | Yes | Yes |
| Staple Cartridge (for MJ-1116/C Saddle Stitch) | STAPLE-3100 | Yes | Yes | Yes | Yes | Yes | Yes |
| Staple Cartridge (staples for 65 sheets for MJ-1115/C, MJ-1116/C) | STAPLE-3900 | Yes | Yes | Yes | Yes | Yes | Yes |
| Damp Heater Kit | MF-7527D/DC | No | Yes | Yes ^{*1} | Yes | Std | Std |
| Fax Unit (2nd Line for Fax Unit) | GD-1370NA-N/EU/C/J | Yes | Yes | Yes | Yes | Yes | Yes |
| Card Reader Holder | GR-1320/C | Yes | Yes | Yes | Yes | Yes | No |
| Accessory Tray | GR-1330/C | Yes | Yes | Yes | Yes | Yes | No |
| Panel Ten Key Option | GR-1340/C | Yes | Yes | Yes | Yes | Yes | Yes |
| USB Hub Option | GR-1420/C | Std | Yes ^{*2} | Yes | Yes | Yes | Yes |
| 2nd NIC Holder | GR-1430/C | Yes | Yes | Yes | Yes | Yes | Yes |
| Wireless LAN / Bluetooth Module | GN-4030-A3/C-A3 | Yes | Yes ^{*3} | Yes | Yes | No | Std |
| Harness Kit for coin controller | GQ-1280-N | Yes | Yes | Yes | Yes | Yes | Yes |
| e-BRIDGE ID Gate | KP-2009 | No | No | No | No | No | Yes |
| Security HDD Option ^{*4} | GE-1260 | Yes ^{*5} | Yes | Yes | No | Yes | Yes |
| HDD without Security Option | GE-1270 | No | No | No | Yes | No | No |
| Security SSD Option | GE-1280 | Yes | Yes | Yes | No | Yes | No |
| SSD without Security Option | GE-1290 | No | No | No | Yes | No | No |
| IPSec Enabler (License) | GP-1080/Node | Yes | Yes | Yes | No | Yes | Yes |
| Unicode Font Enabler (license) | GS-1007/Node | Yes | Yes | Yes | Yes | Yes | Yes |
| Image Log Enabler | GS-1009 | No | No | No | Yes | No | No |
| Meta Scan Enabler (license) | GS-1010/Node | Yes | Yes | Yes | Yes | Yes | Yes |
| External Interface Enabler (license) | GS-1020/Node | Std | Std | Std | Std | Yes | Yes |
| Multi Station Print Enabler (license) | GS-1090/Node | Yes | Yes | Yes | Yes | Yes | Yes |
| IP Fax Enabler (license) | GS-1100/Node | Yes | Yes | Yes | Yes | Yes | Yes |
| OCR Enabler (license) | GS-1110Node | Std | Std | Std | Std | Std | Yes |
| Embedded Applications For Office365 • e-BRIDGE Plus for OneDrive for Business V3.0 (Node) | GB-2300Node | Yes | Yes | Yes | No | Yes | Yes |
| Embedded Applications For Office365 • e-BRIDGE Plus for SharePoint Online V3.0 (Node) | GB-2310Node | Yes | Yes | Yes | No | Yes | Yes |
| Embedded Applications For Office365 • e-BRIDGE Plus for Exchange Online V3.0 (Node) | GB-2320Node | Yes | Yes | Yes | No | Yes | Yes |

| Option | Model name | Availability | | | | | |
|---|-------------|--------------|------------|-------------------|-----|-----|-----|
| | | NAD GSA | ARD AUD | MJD ASD | CND | TWD | JPC |
| e-BRIDGE Plus for Zone OCR V3.0 (Node) | GB-2330Node | Yes | Yes | Yes | Yes | Yes | Yes |
| e-BRIDGE Plus for Gmail (Node) | GB-2380Node | Yes | Yes | Yes | No | Yes | Yes |
| e-BRIDGE Plus for G Suite Google Drive (Node) | GB-2390Node | Yes | Yes | Yes | No | Yes | Yes |
| Power Cable for UK | GE-1300 | No | No | Yes ^{*6} | No | No | No |

*1 MJD not applicable

*2 Equipped as the standard for ARD

*3 ARD not applicable

*4 FIPS supported

*5 Equipped as the standard for GSA

*6 ASD not applicable

Remarks:



- Letters of the alphabet added to the end of the model name mainly indicates the destination or region. For example, “C” indicates “China” and “J” indicates “Japan”. Moreover, “L” and “LT” indicate Letter series models, while “A” and “A4” indicate A4 series models.
- The options indicated with “Std” are equipped as the standard.

2.5 Supplies

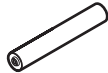
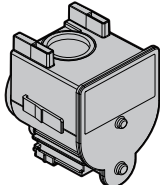
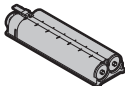
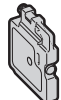
2.5.1 For JPC

| | | |
|--|-----------------|-----|
| Drum  | PS-ODFC556 | JPC |
| Developer cartridge  | PS-ZDFC556K | |
| Toner cartridge  | PS-ZTFC727JK(1) | |
| Waste toner box  | PS-TBFC55J(1) | |

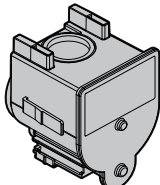
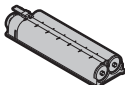
2.5.2 Other than JPC

| | | |
|--|---------------|-----------------------------------|
| Drum  | OD-FC556 | |
| Developer cartridge  | D-FC556K | |
| Toner cartridge  | PS-ZT9029U(1) | NAD, GSA, ARD |
| | PS-ZT9029E(1) | MJD |
| | PS-ZT9029P(1) | AUD, ASD, TWD |
| | PS-ZT9029C(1) | CND |
| Waste toner box  | PS-TBFC55 | NAD, GSA, ARD, AUD, MJD, ASD, TWD |
| | PS-TBFC55C | CND |

3. OVERVIEW

3.1 Sectional View

3.1.1 Front side

4-drawer model

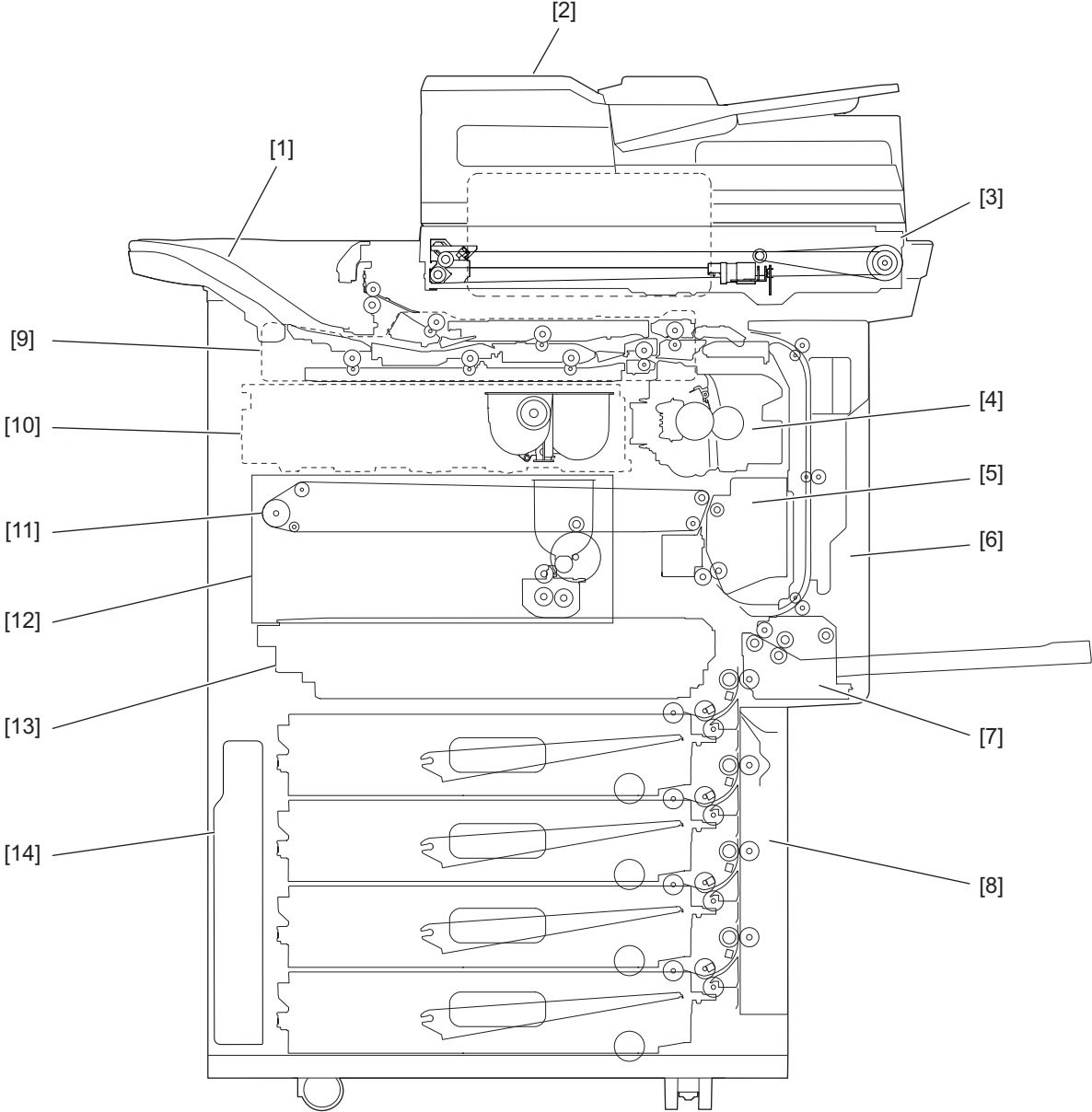

Fig. 3-1

Tandem LCF model

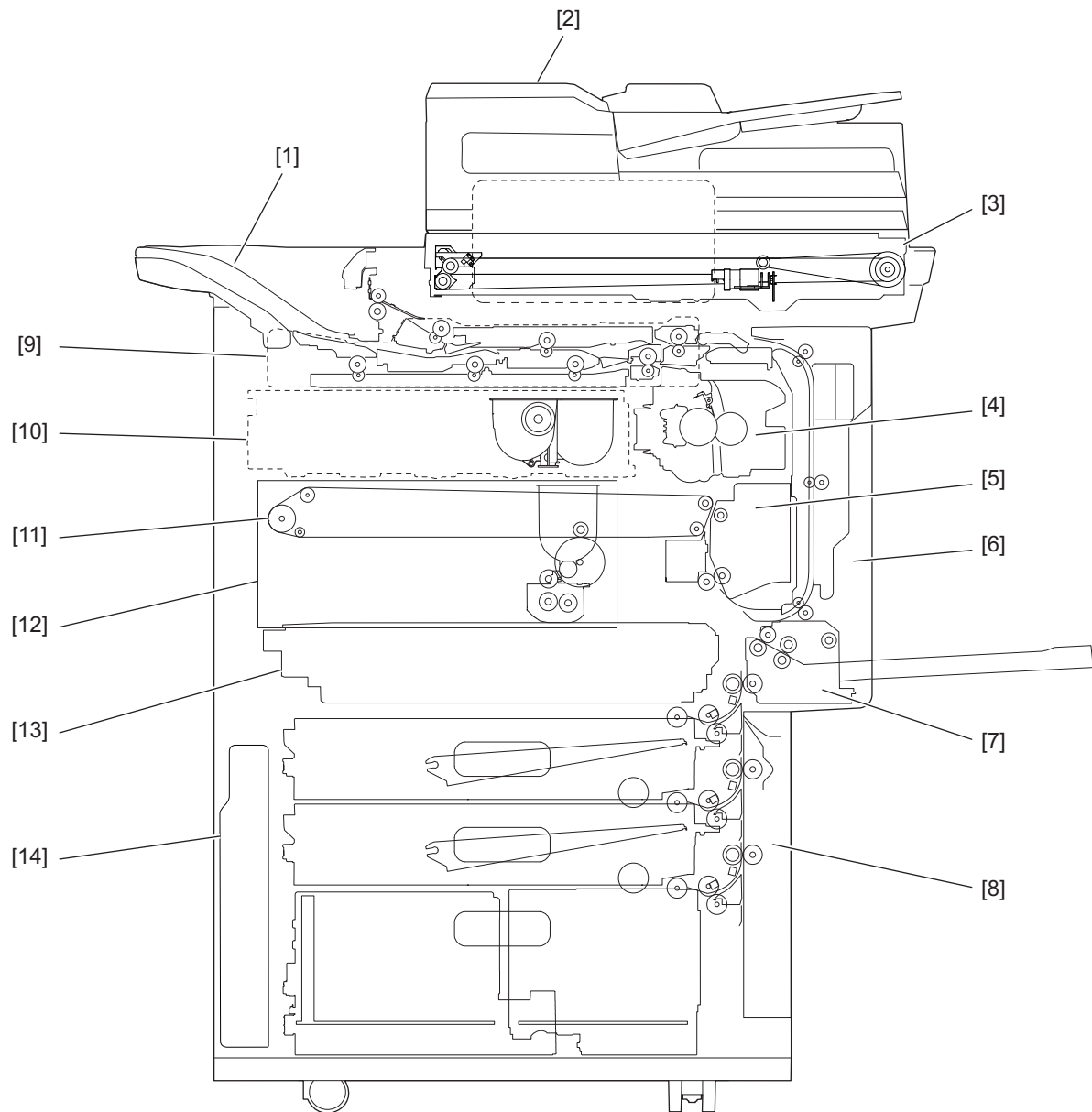

Fig. 3-2

| | | | |
|-----|----------------------------------|------|-------------------------------------|
| [1] | Exit tray | [8] | Paper Feeding Section |
| [2] | Dual Scan Document Feeder (DSDF) | [9] | Paper exit section, reverse section |
| [3] | Scanning section (scanner) | [10] | Toner cartridge |
| [4] | Fusing Section | [11] | Transfer belt unit |
| [5] | 2nd transfer section | [12] | Process Unit Related Section |
| [6] | Duplexing unit | [13] | Data writing section |
| [7] | Bypass unit section | [14] | Waste toner box |

3.1.2 Rear side

4-drawer model

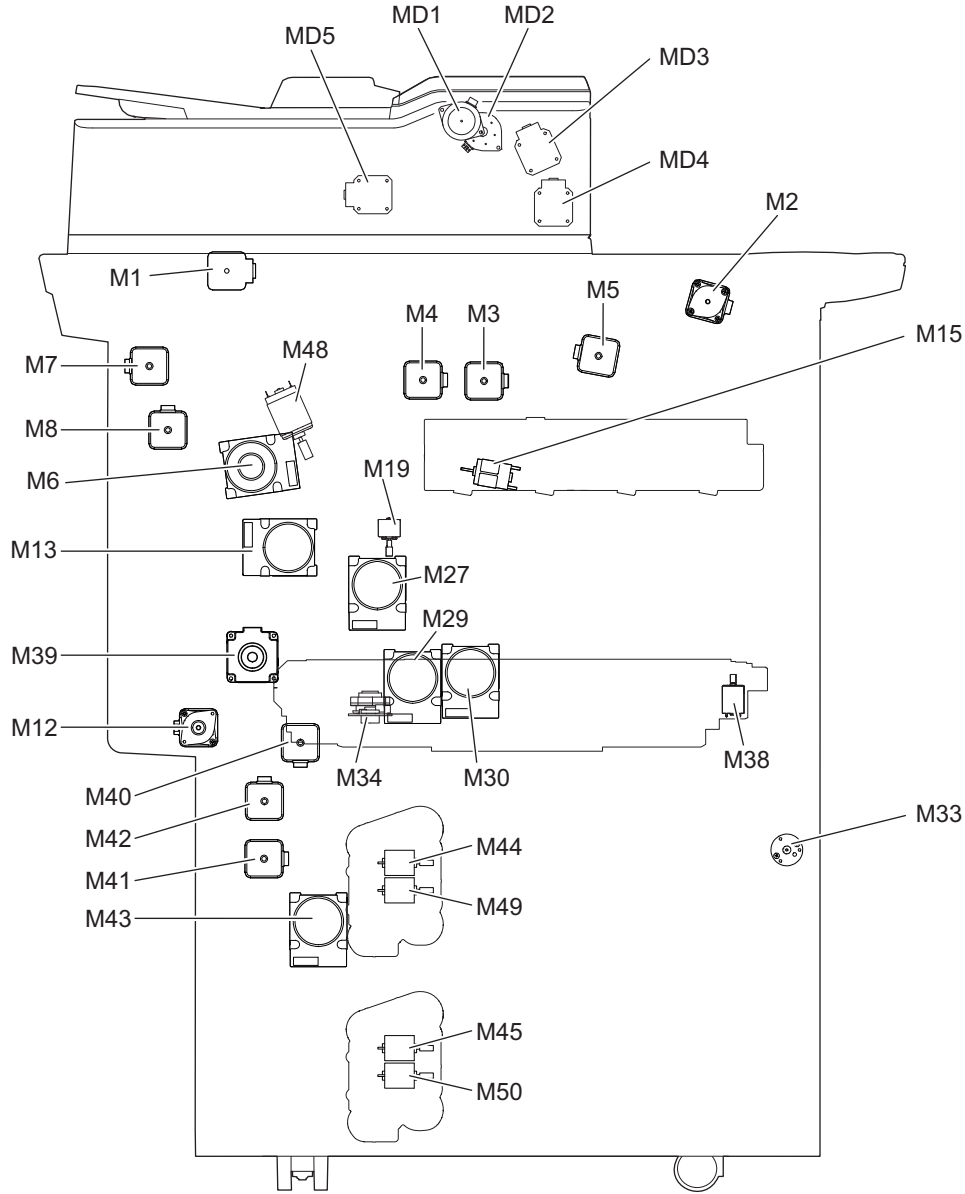

Fig. 3-3

Tandem LCF model

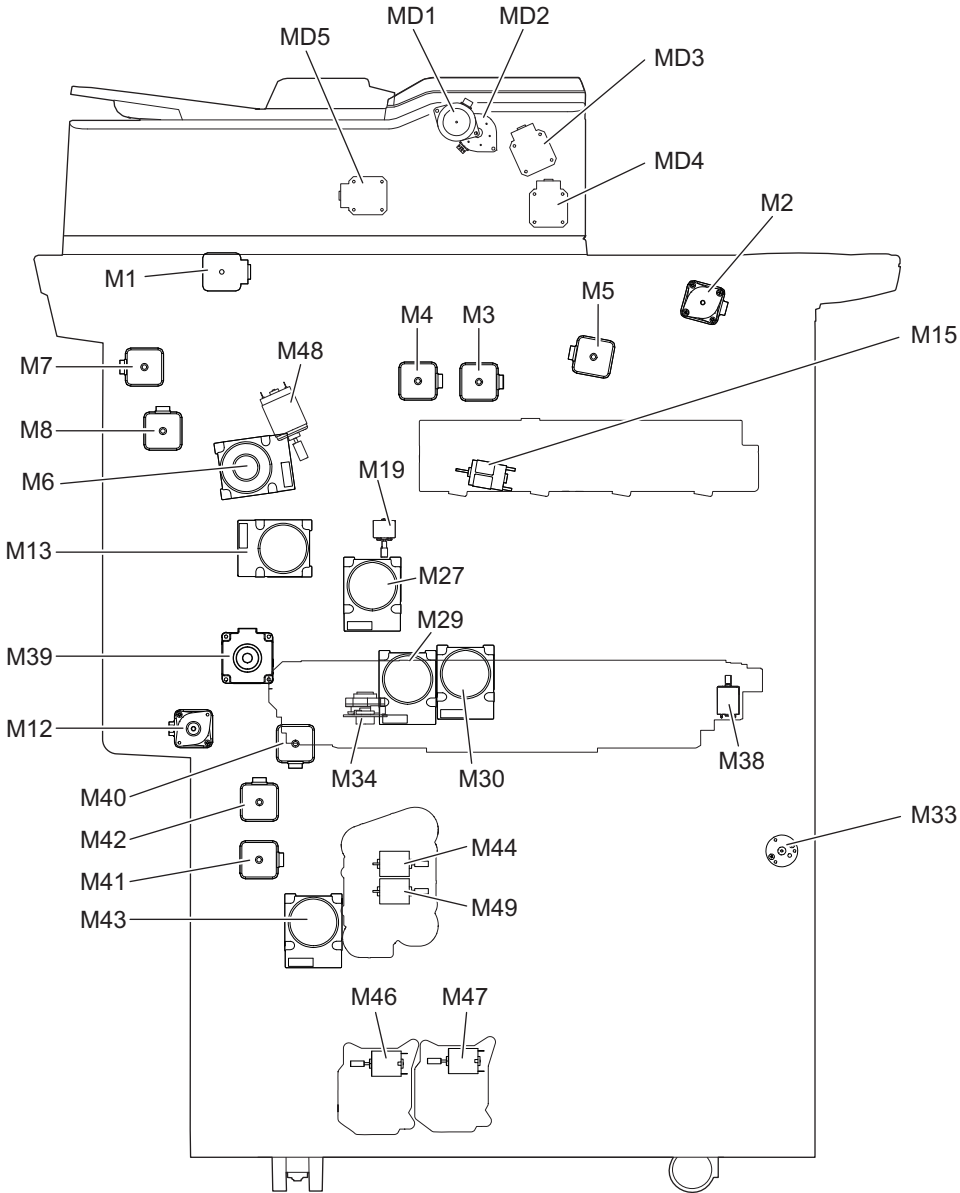

Fig. 3-4

| | | | |
|-----|--------------------------------------|-----|---------------------------------------|
| MD1 | DSDF paper feed motor | M29 | Developer unit mixer motor (K) |
| MD2 | DSDF separation motor | M30 | Developer unit motor (K) |
| MD3 | DSDF registration motor | M33 | Waste toner transport motor |
| MD4 | DSDF read motor | M34 | Polygonal motor |
| MD5 | DSDF original exit motor | M38 | Shutter motor |
| M1 | Scan motor | M39 | Registration motor |
| M2 | Paper exit motor | M40 | Transport motor-1 |
| M3 | Reverse motor | M41 | Transport motor-2 |
| M4 | Bridge unit transport entrance motor | M42 | 1st/2nd drawer paper feed motor |
| M5 | Bridge unit transport exit motor | M43 | 3rd/4th drawer/T-LCF paper feed motor |
| M6 | Fuser motor | M44 | 1st drawer tray-up motor |
| M7 | ADU transport motor | M45 | 3rd drawer/LCF tray-up motor |
| M8 | ADU paper feed motor | M46 | T-LCF tray-up motor |
| M12 | Bypass tray motor | M47 | T-LCF end fence motor |
| M13 | Transfer belt motor | M48 | Pressure roller contact/release motor |
| M15 | Toner motor (K) | M49 | 2nd drawer tray-up motor |
| M19 | Sub-hopper toner motor (K) | M50 | 4th drawer/LCF tray-up motor |
| M27 | Drum motor (K) | | |

3.2 Electric Parts Layout

[A] Dual Scan Document Feeder (DSDF)

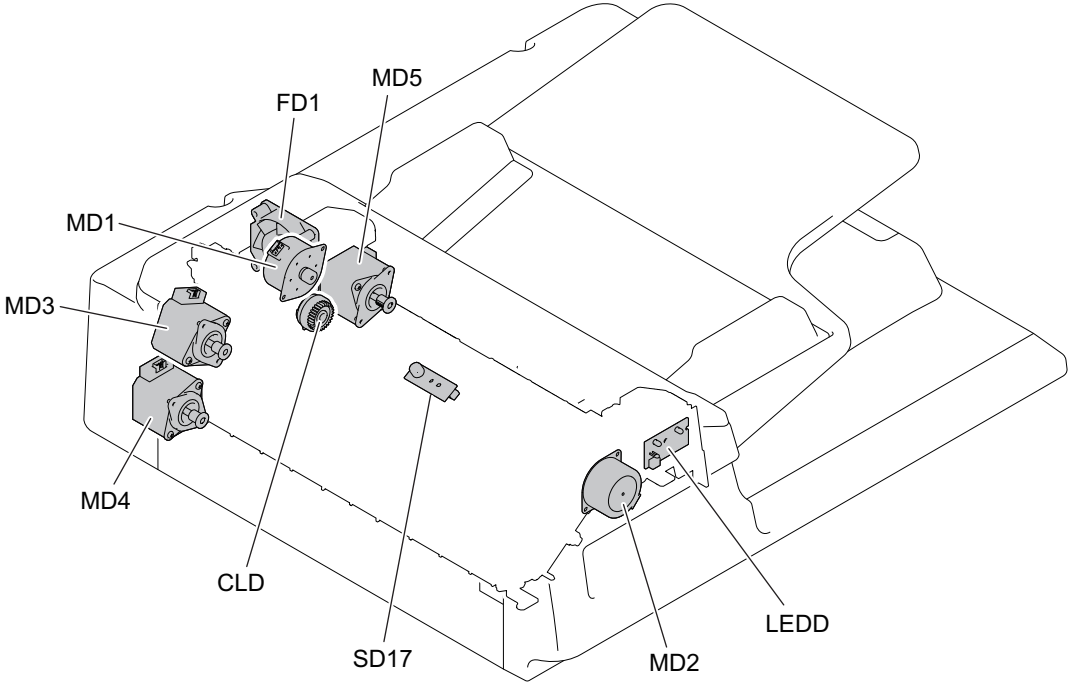

Fig. 3-5

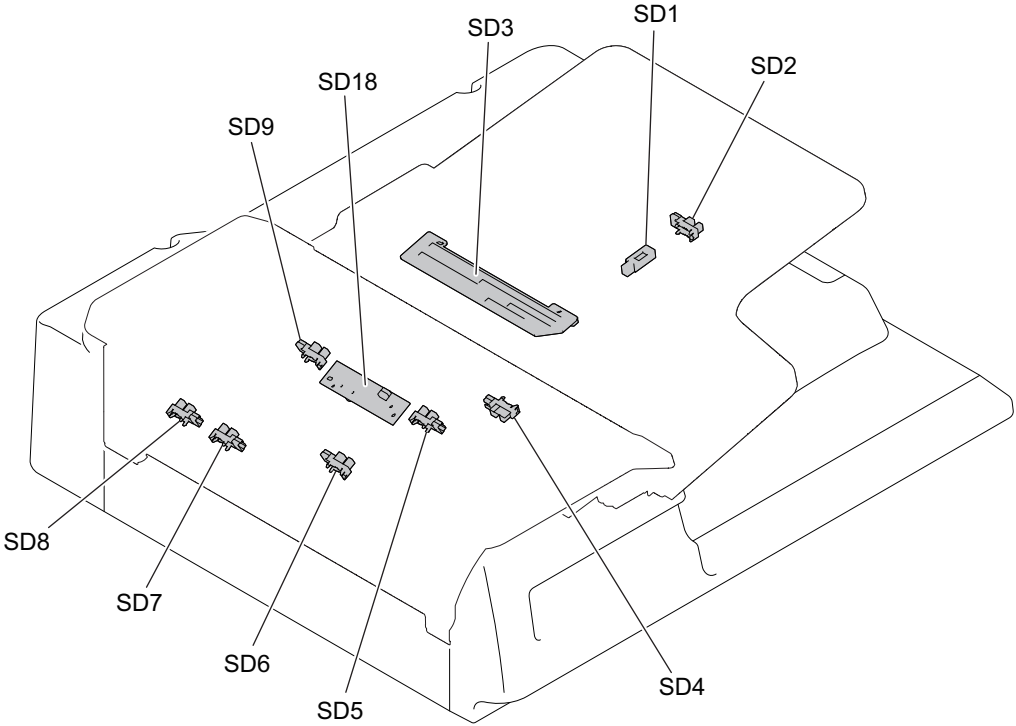

Fig. 3-6

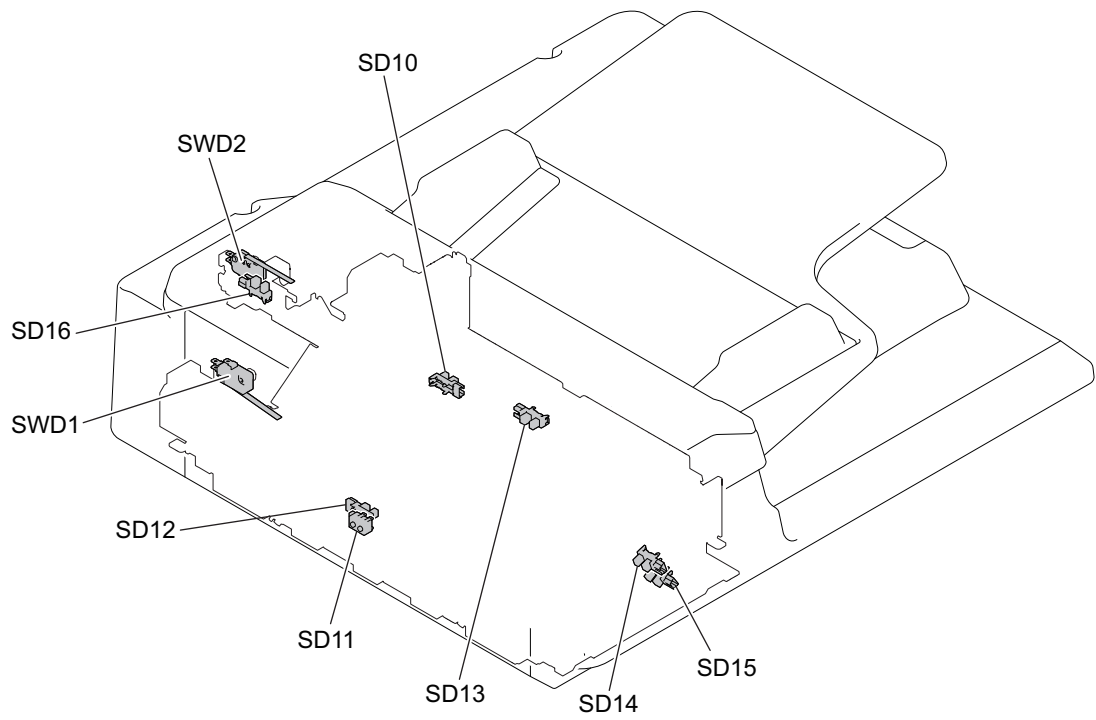

Fig. 3-7

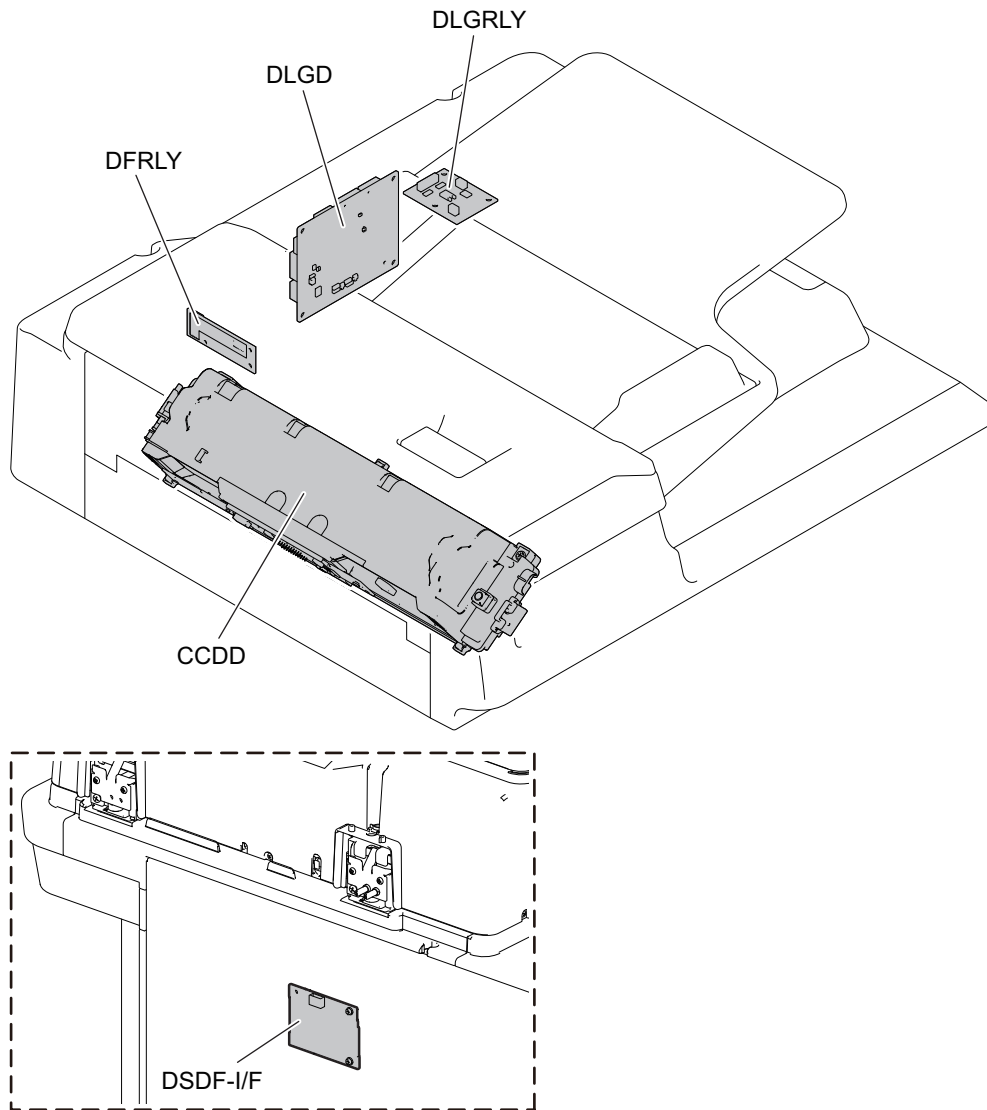

Fig. 3-8

[B] Scanner unit and control panel

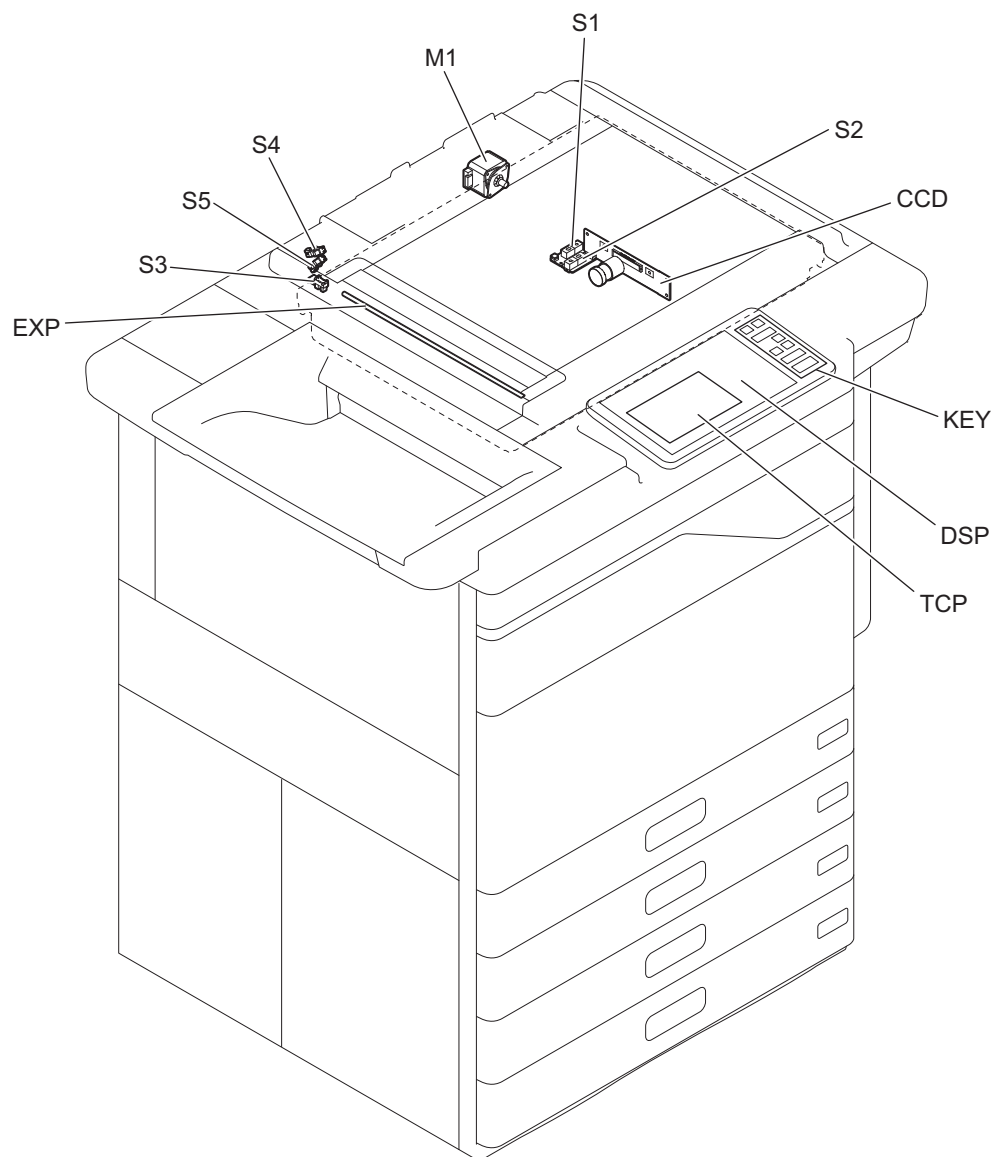

Fig. 3-9

[C] Bridge unit and paper exit section

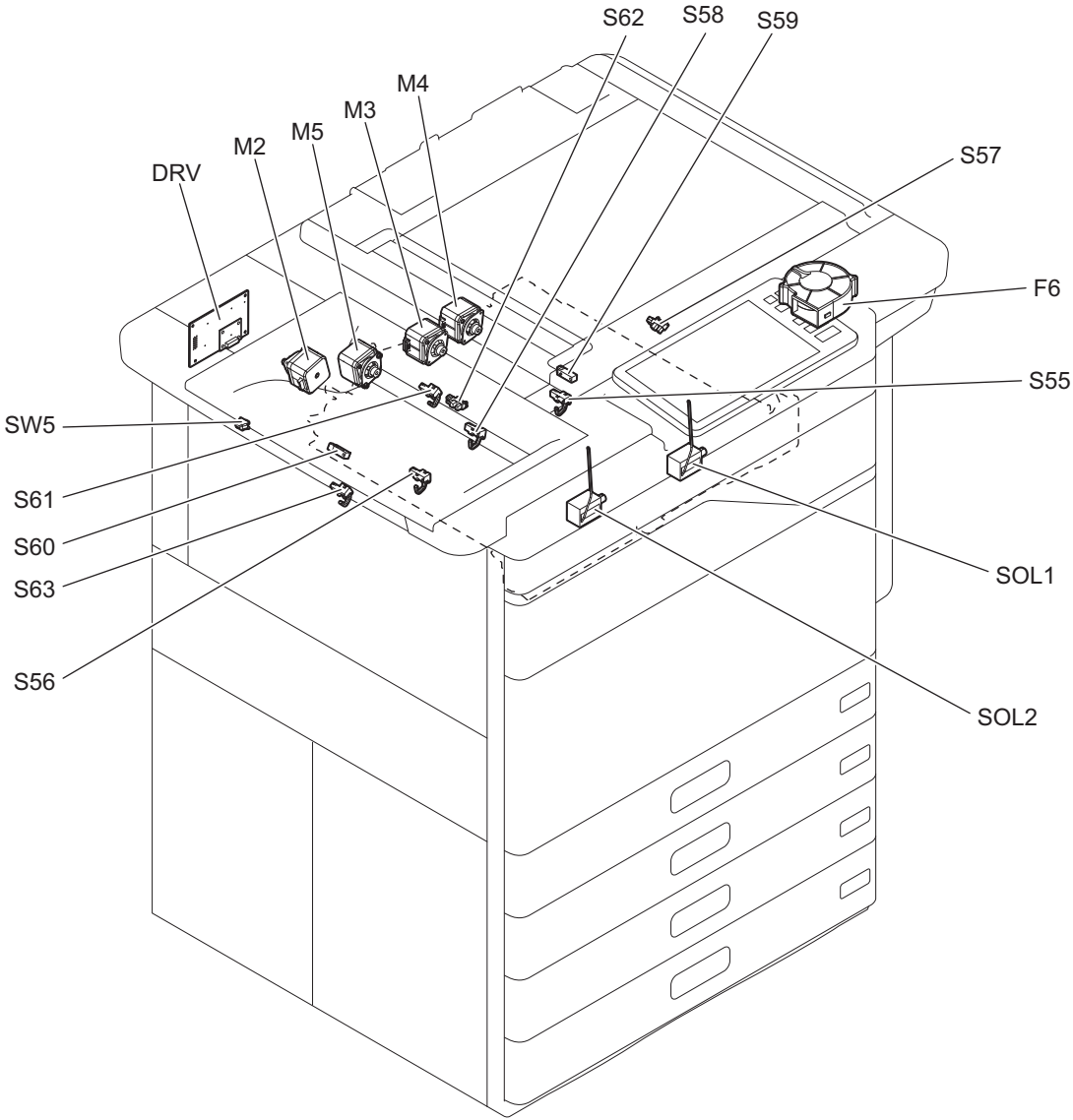

Fig. 3-10

[D] Fuser unit section

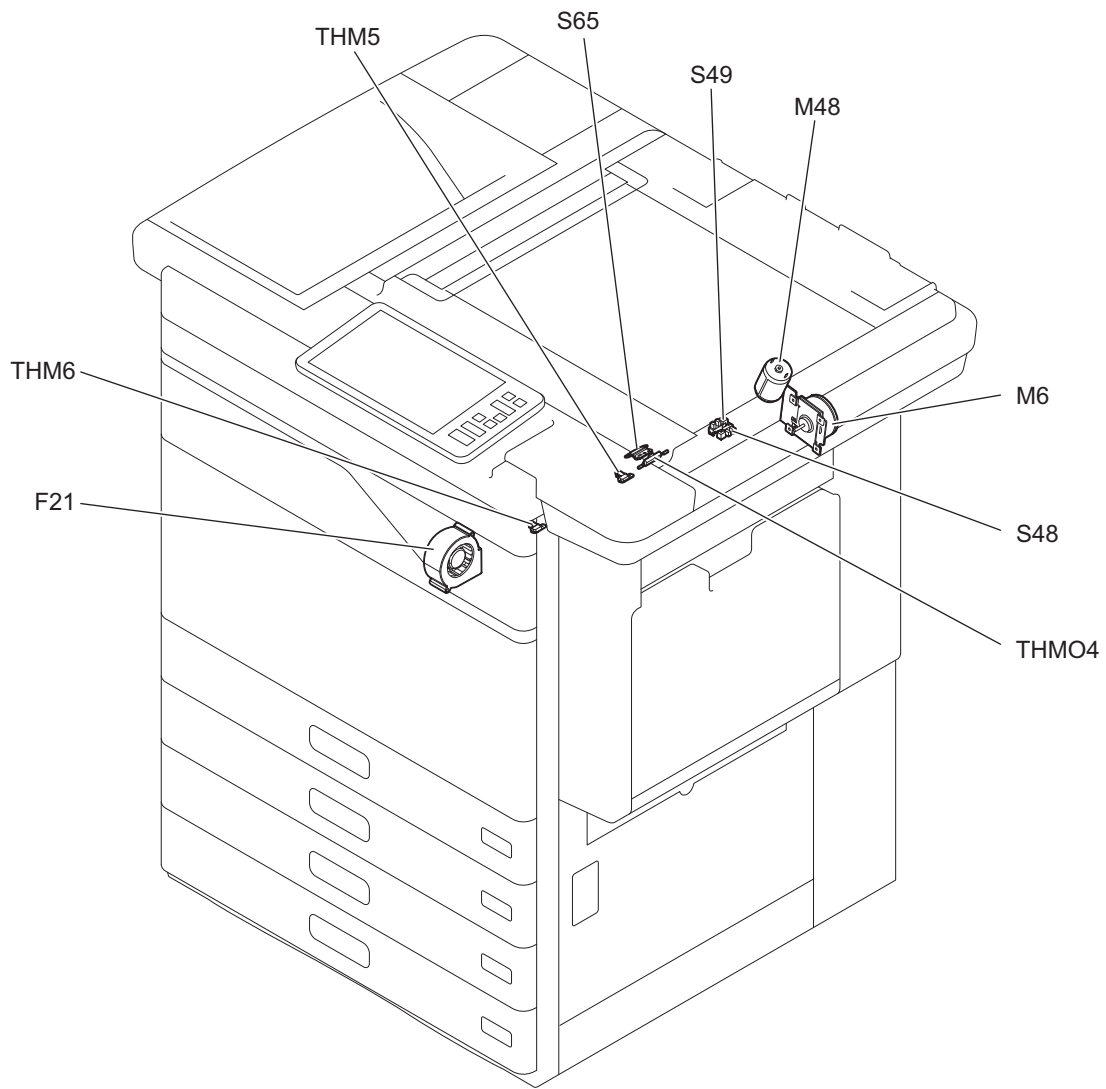

Fig. 3-11

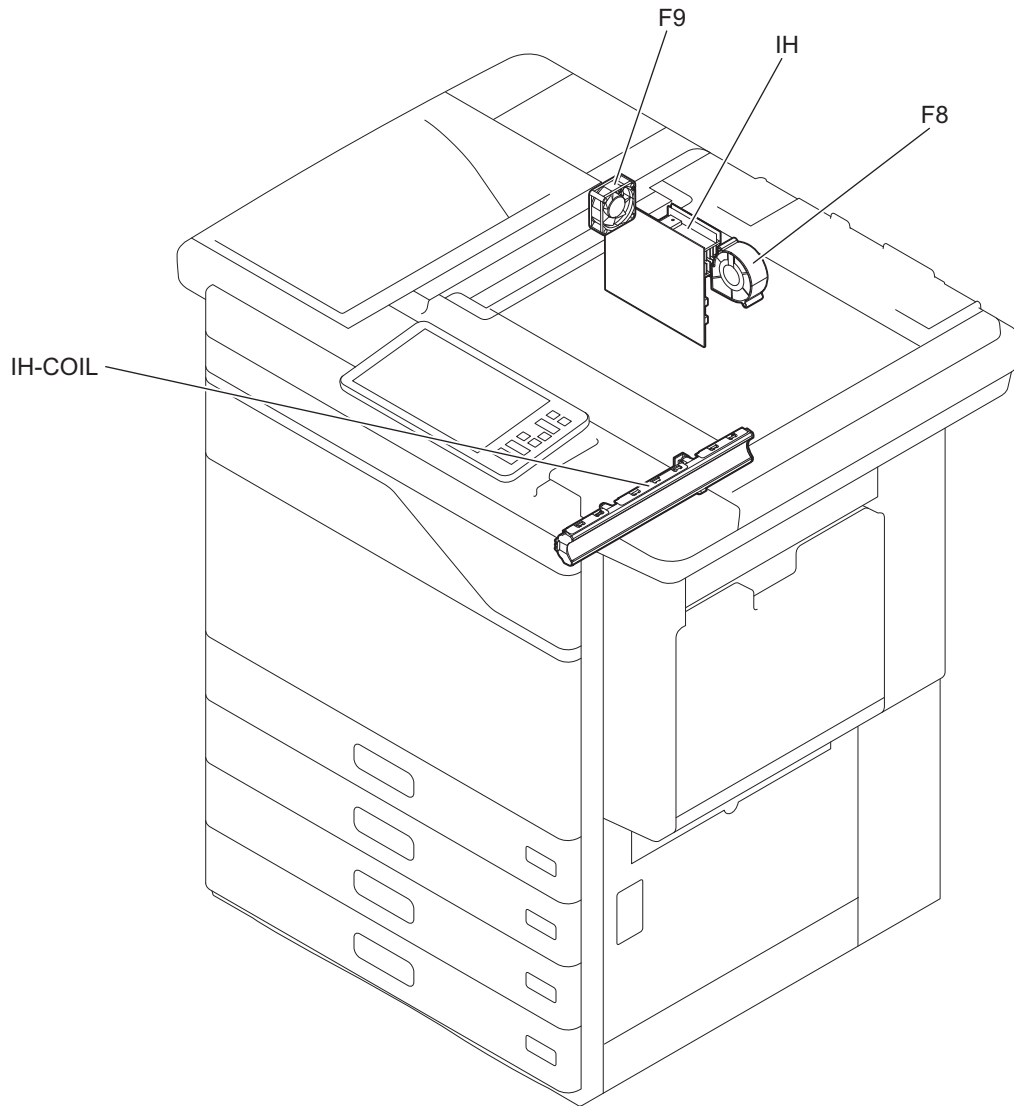

Fig. 3-12

[E] Developer unit

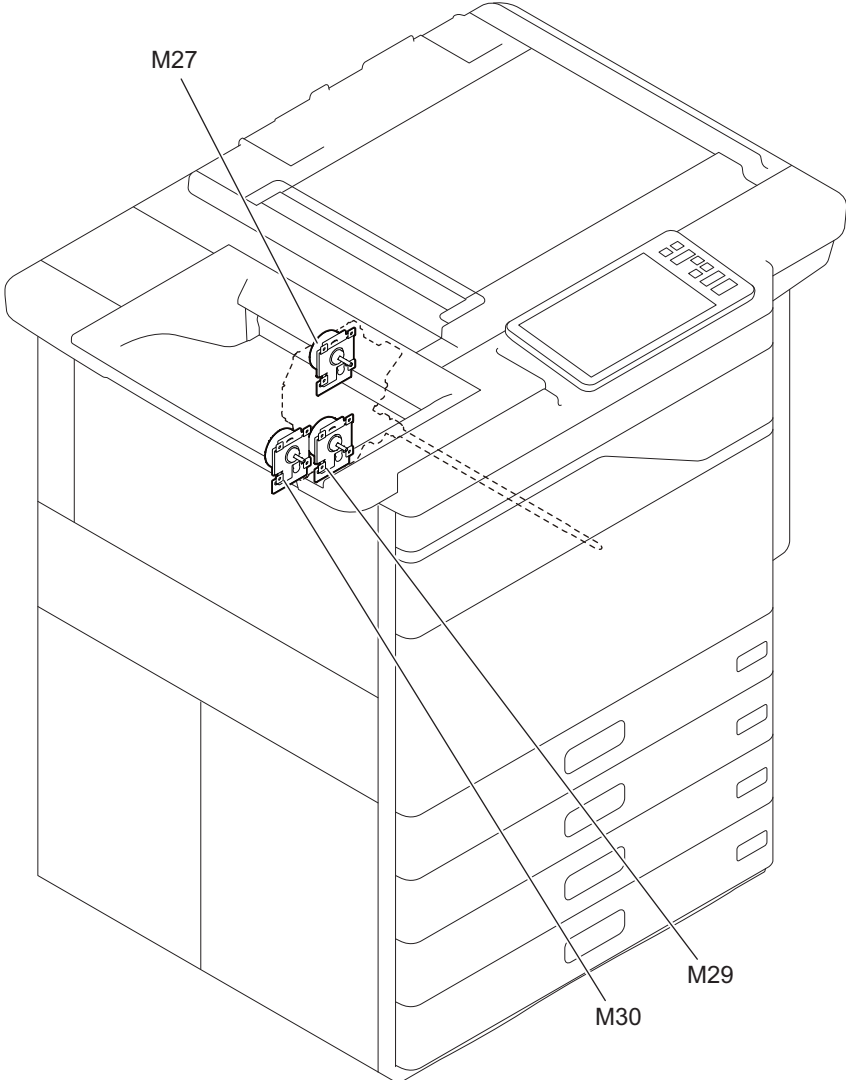

Fig. 3-13

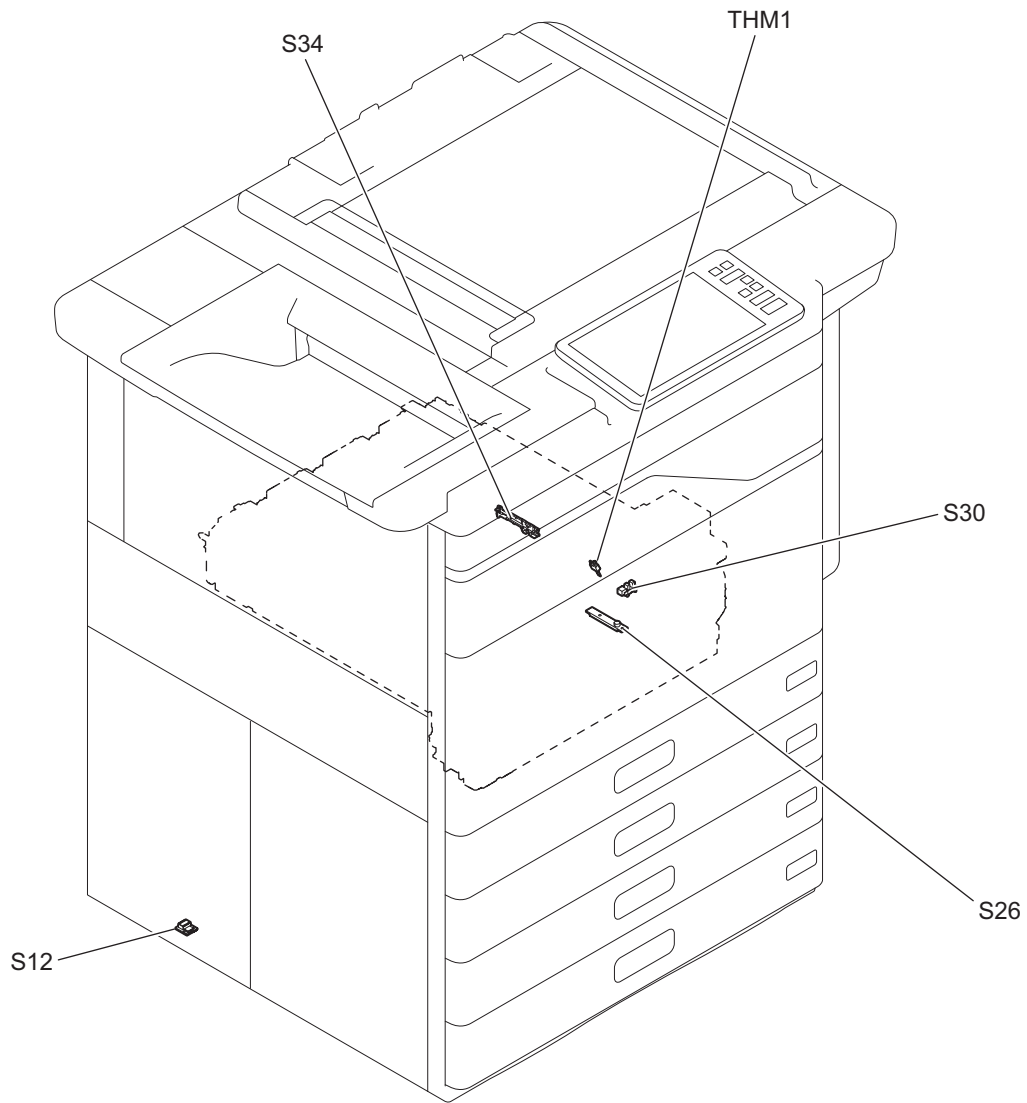

Fig. 3-14

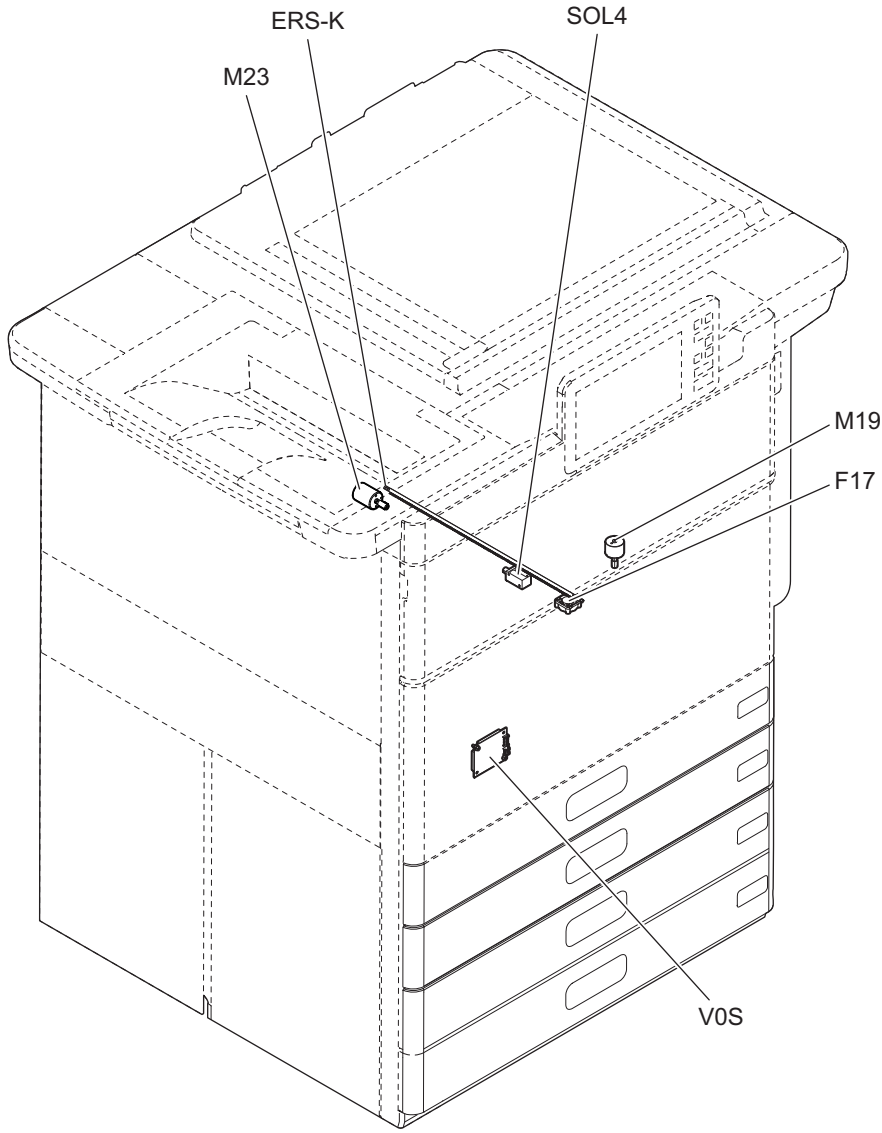

Fig. 3-15

[F] Transfer belt unit

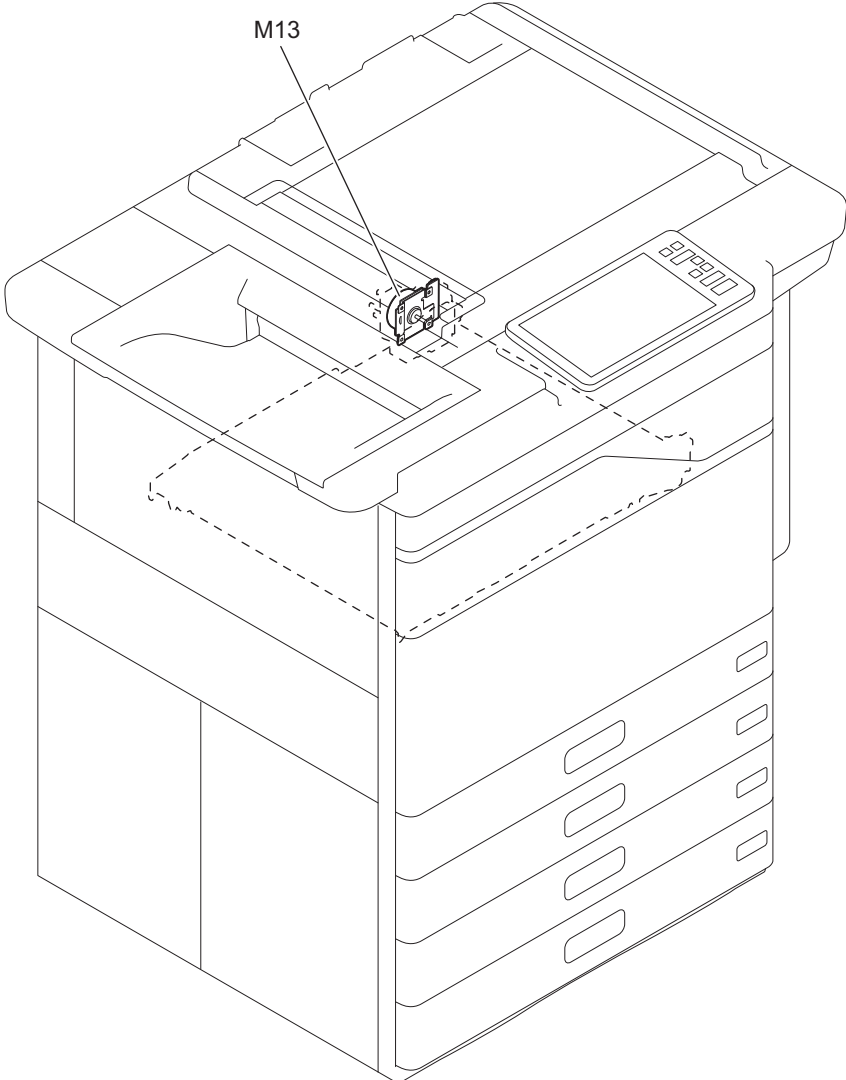

Fig. 3-16

[G] Transfer Unit

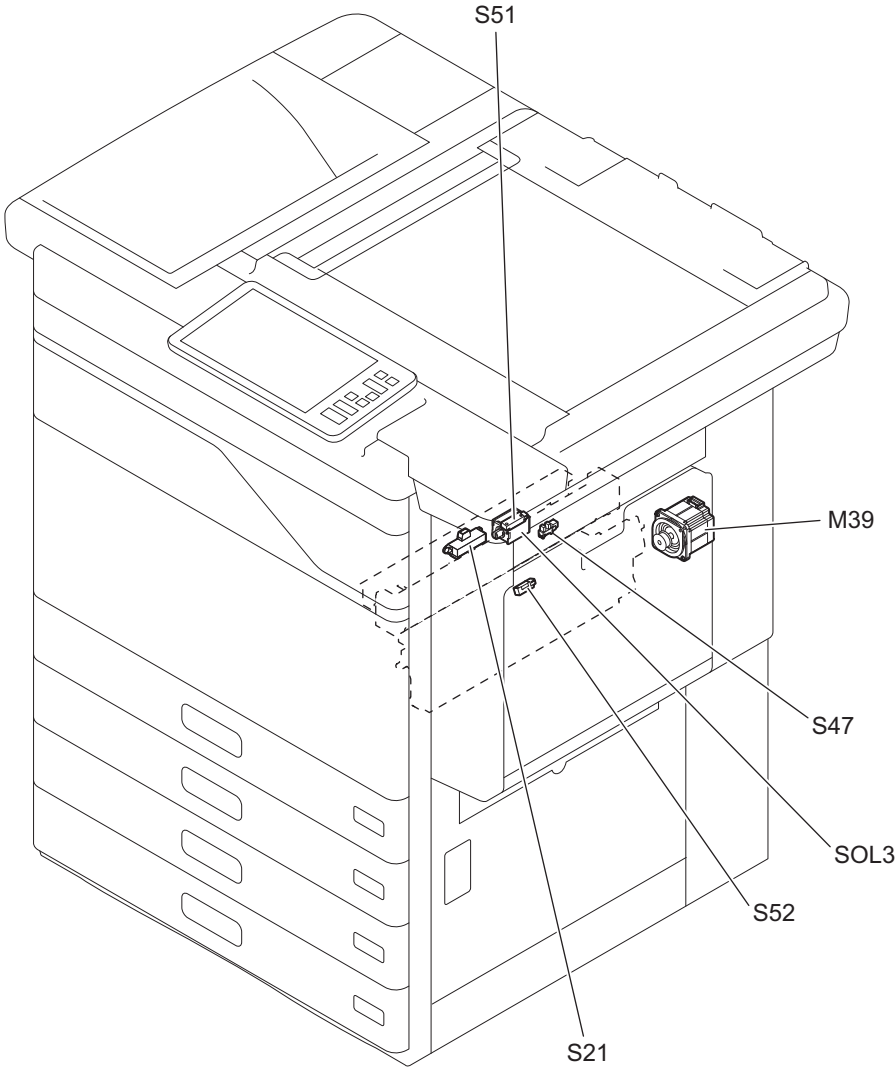

Fig. 3-17

[H] Laser optical unit

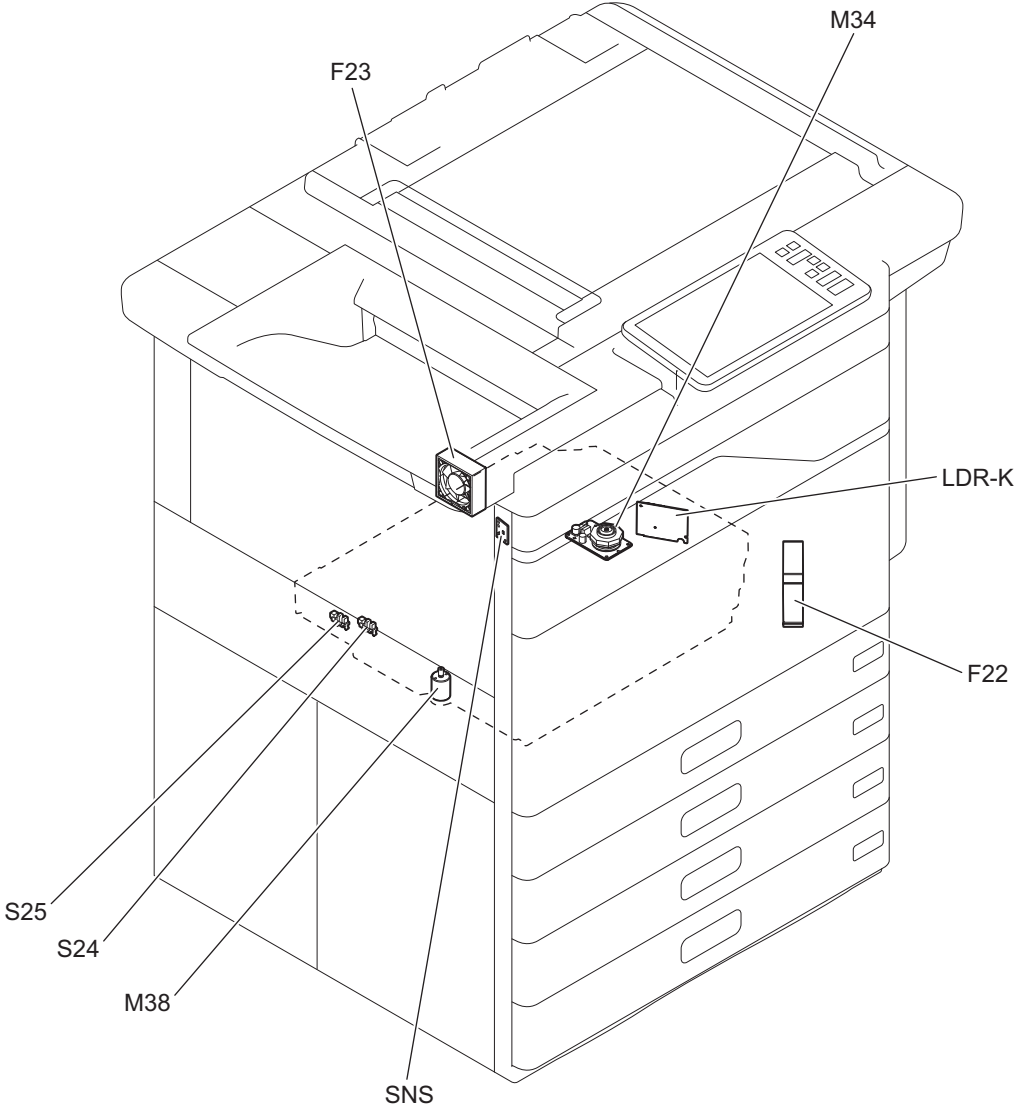

Fig. 3-18

[I] Toner cartridge and waste toner box

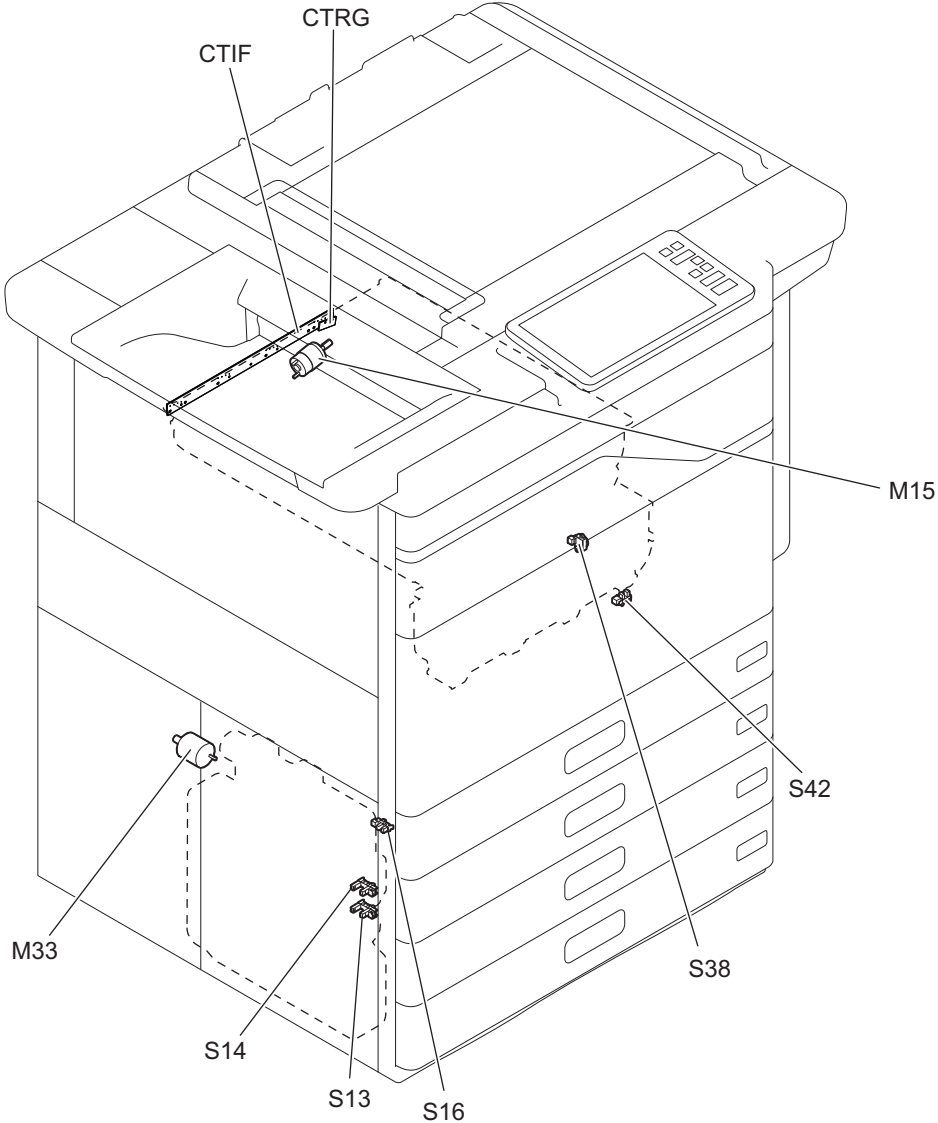

Fig. 3-19

[J] Duplexing unit

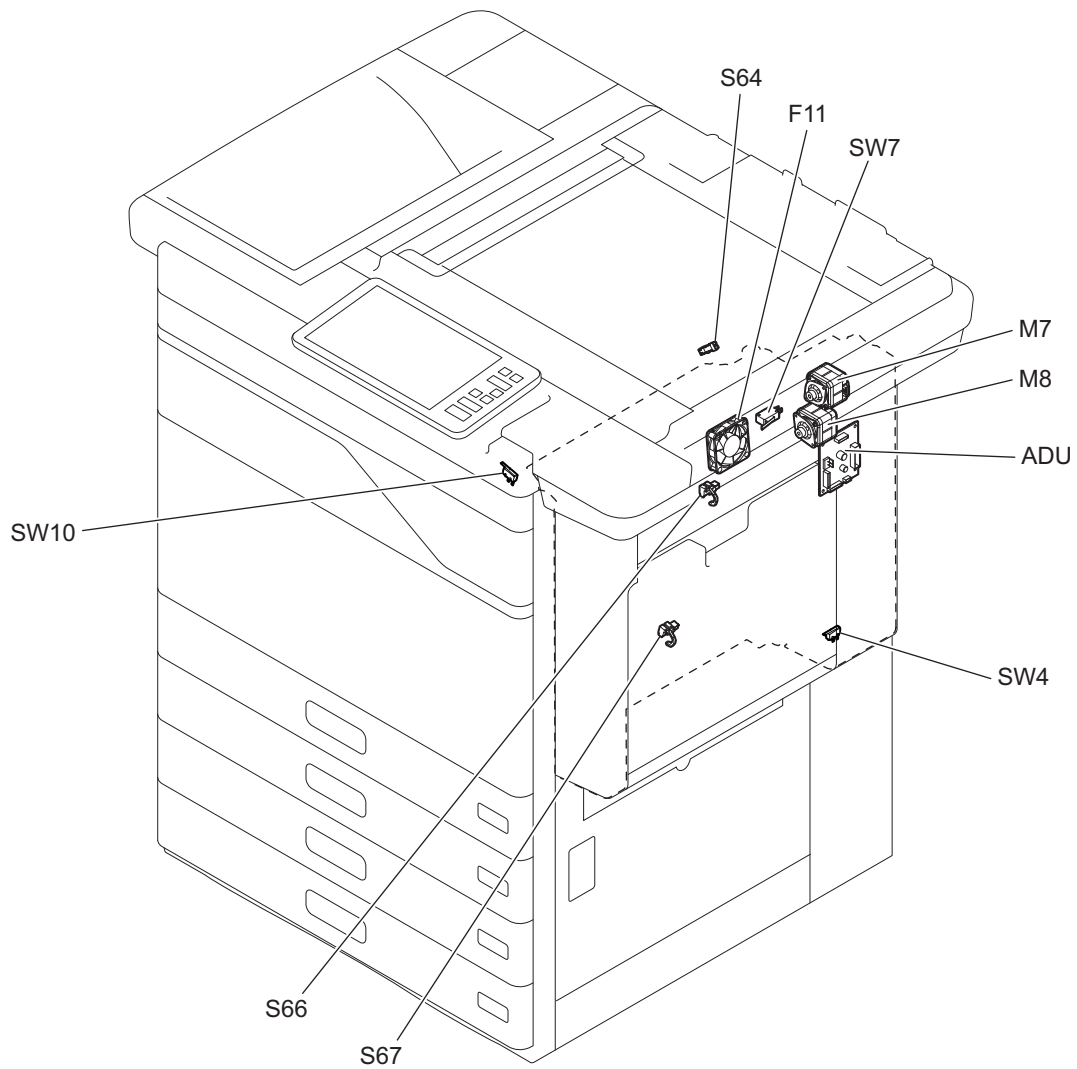

Fig. 3-20

[K] Cover switch and cover sensor

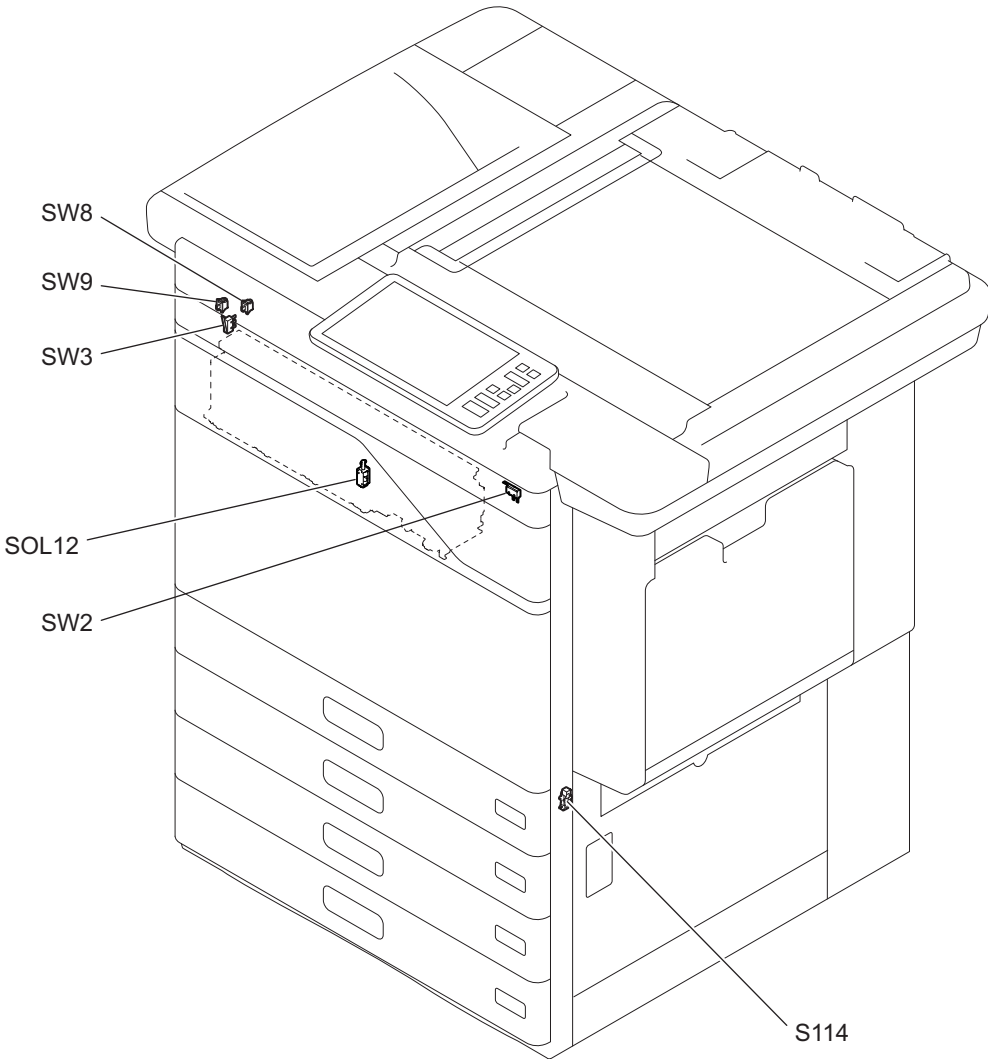

Fig. 3-21

[L] Bypass unit

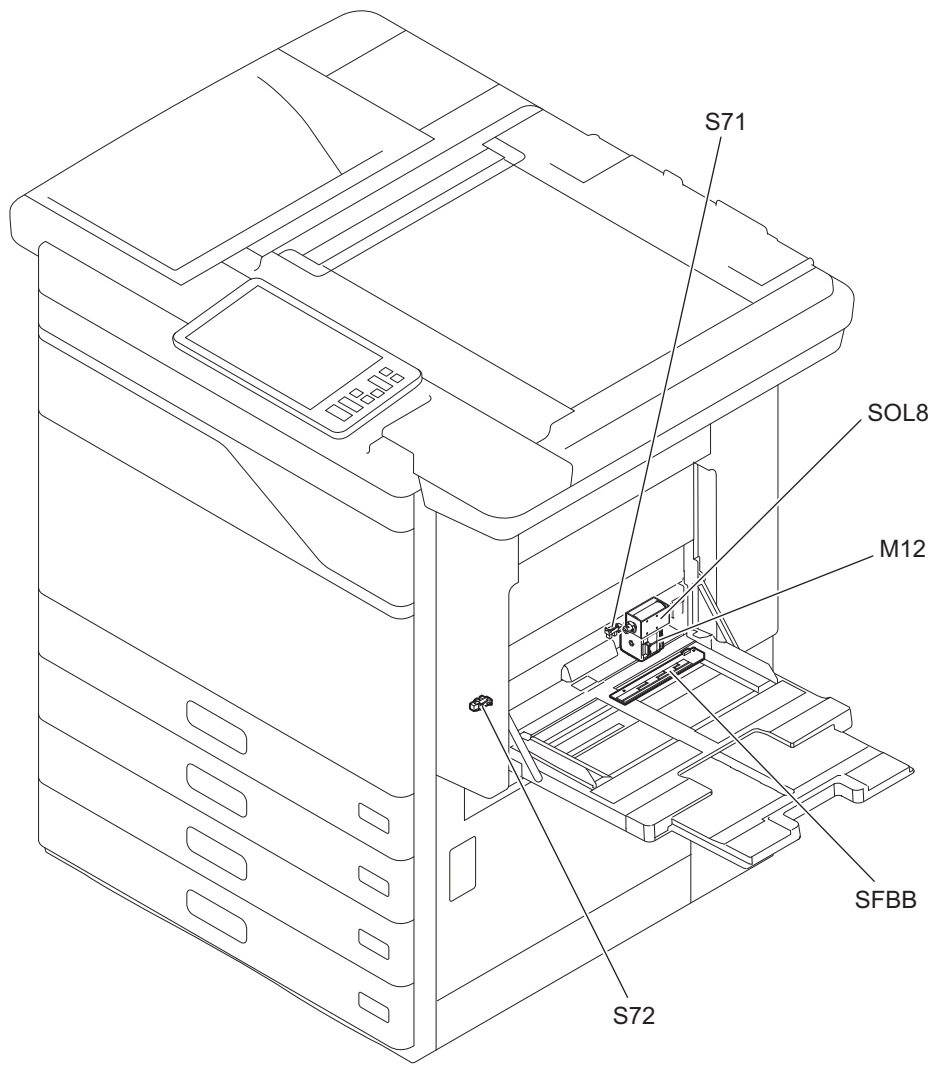

Fig. 3-22

**[M] Paper feeding section
4-drawer model**

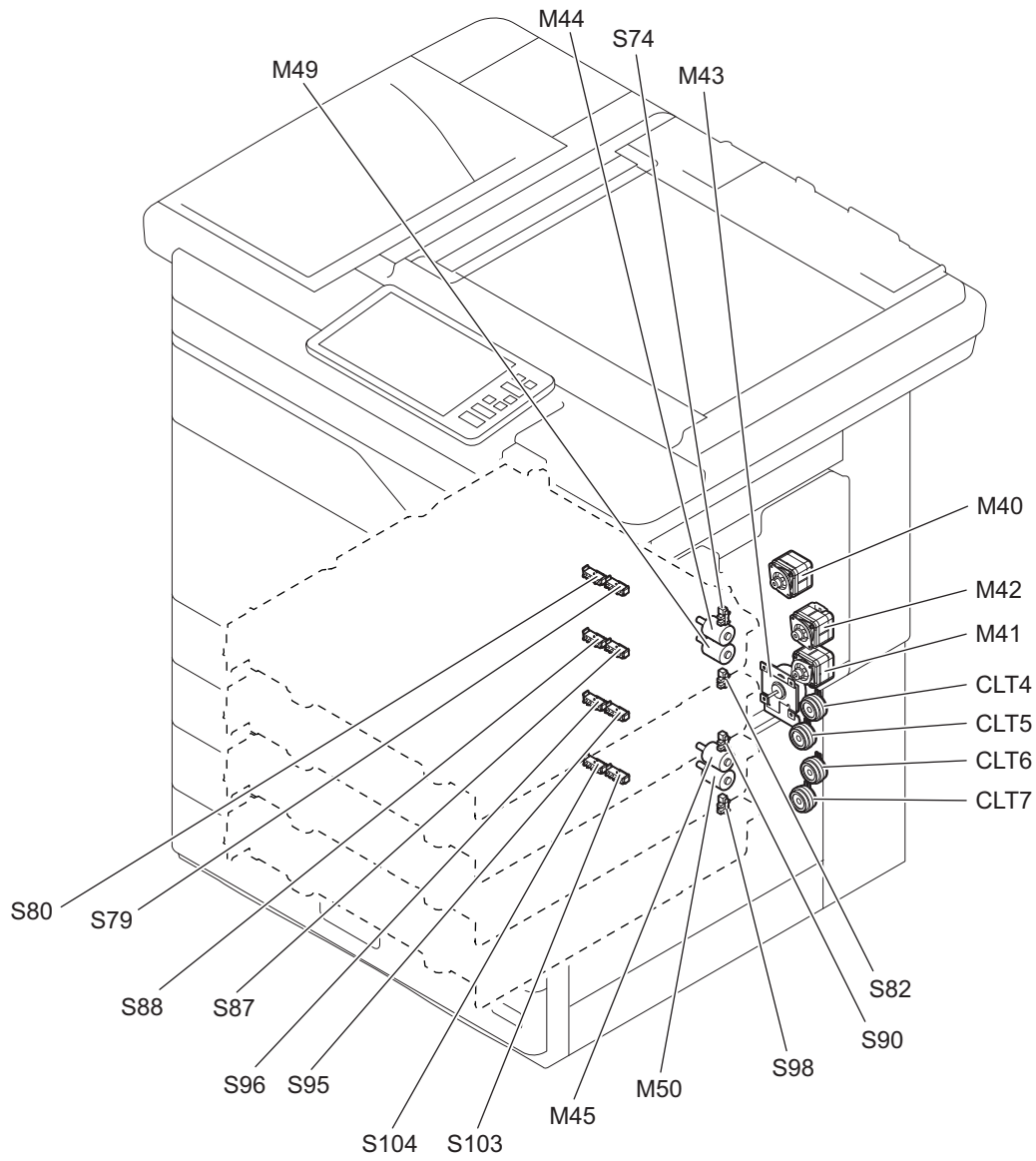

Fig. 3-23

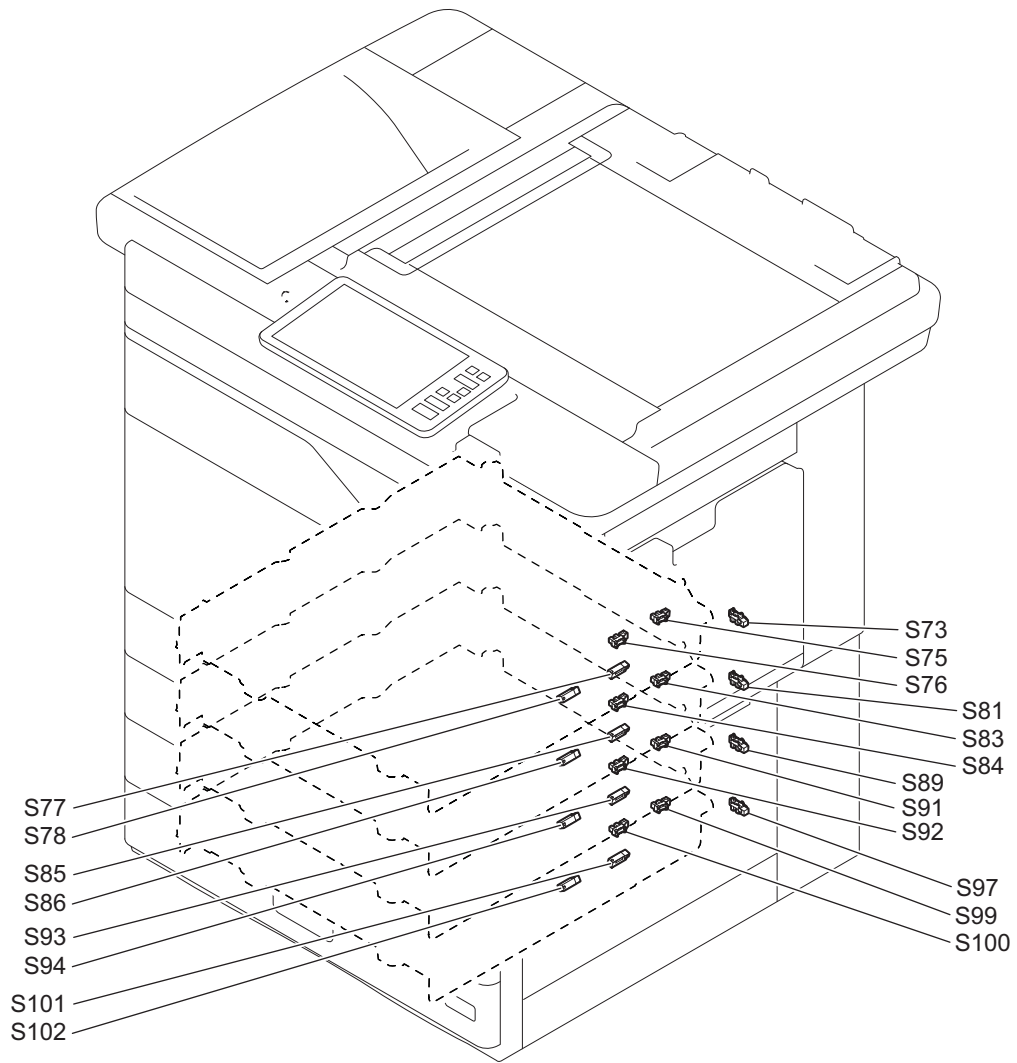

Fig. 3-24

Tandem LCF model

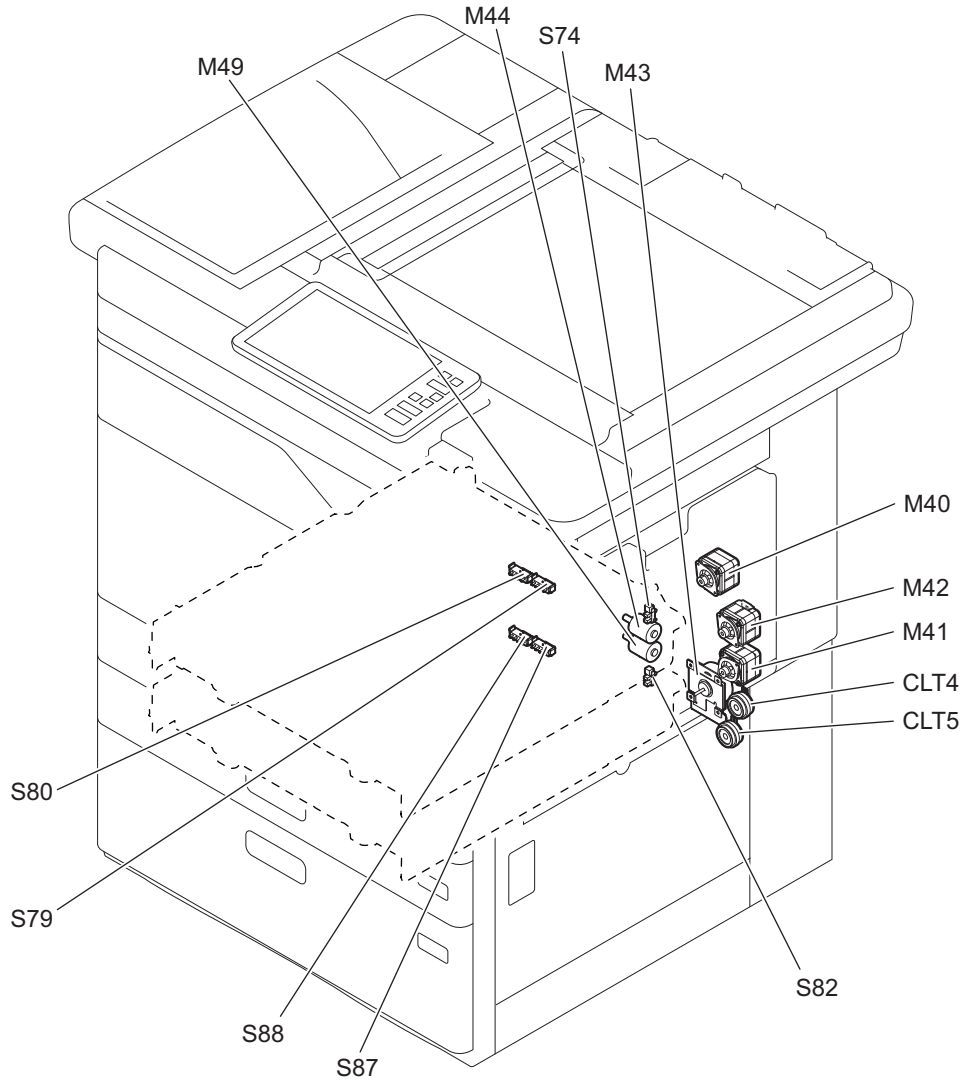

Fig. 3-25

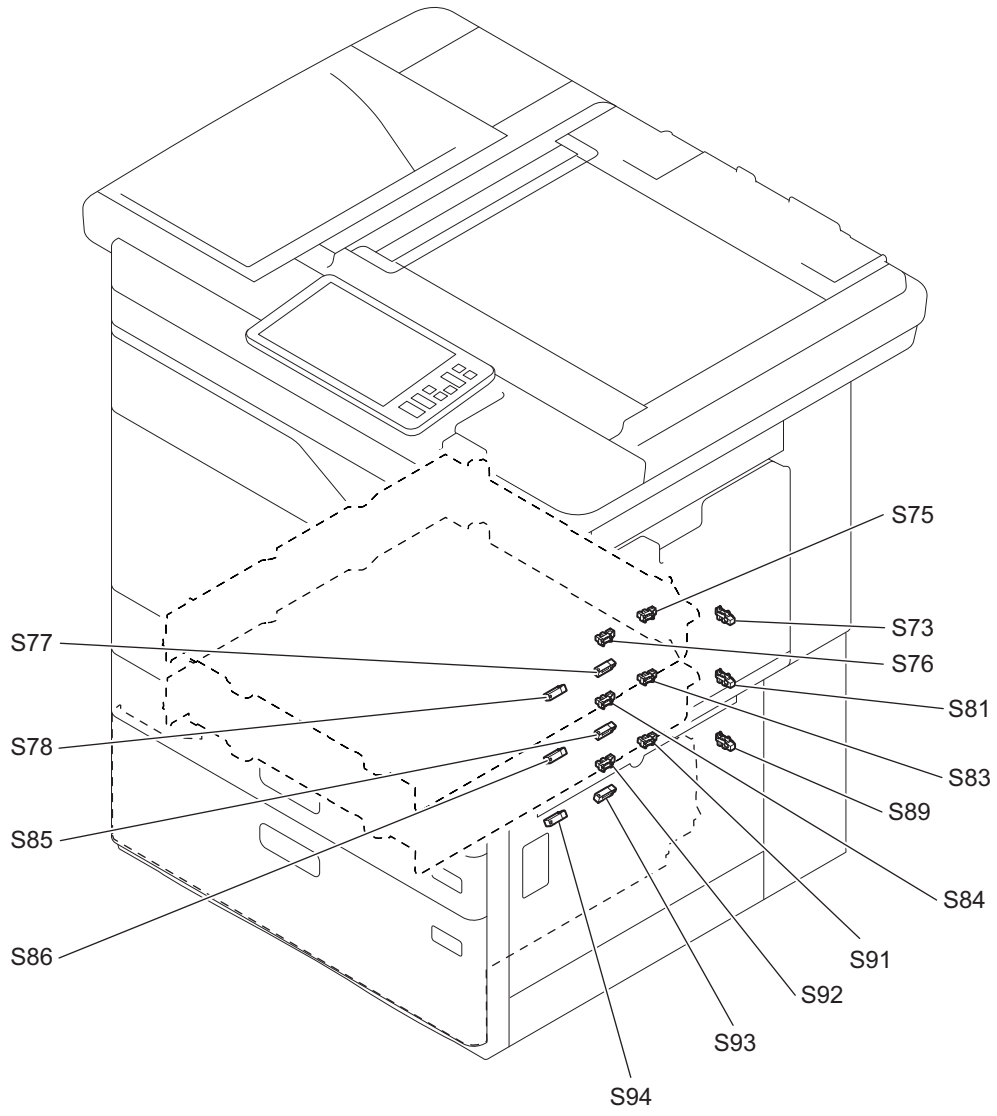

Fig. 3-26

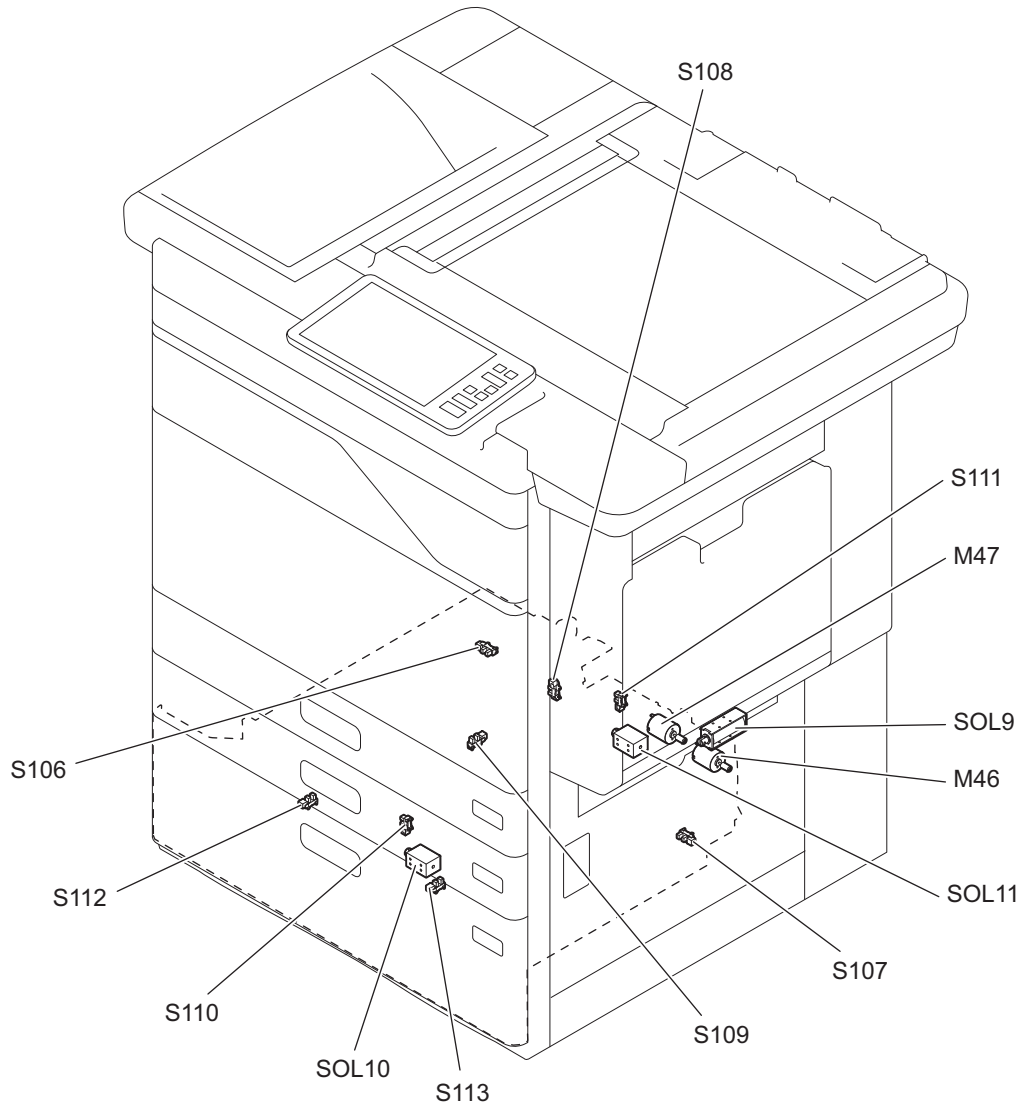

Fig. 3-27

[N] PC board

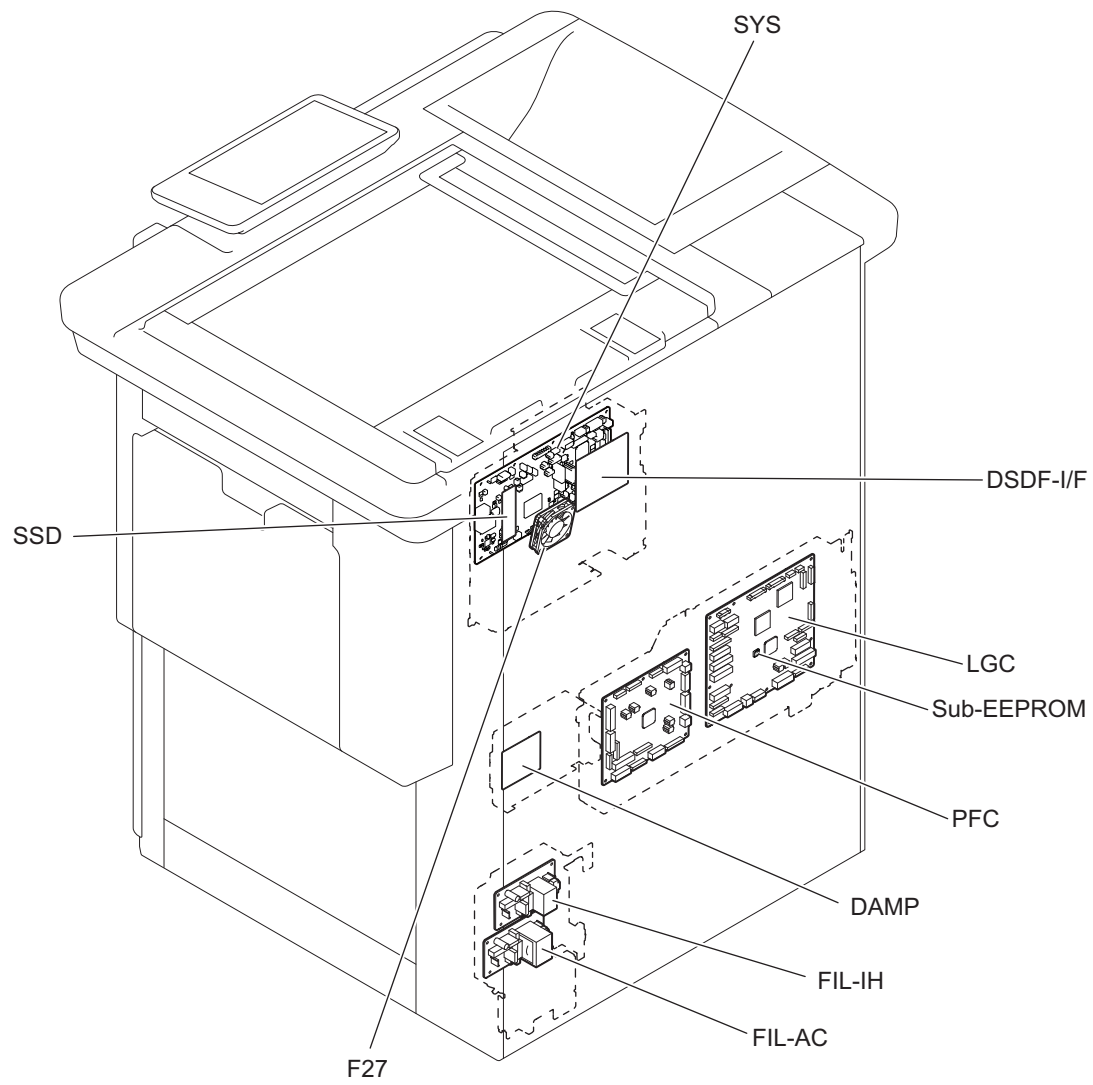

Fig. 3-28

[O] Power supply

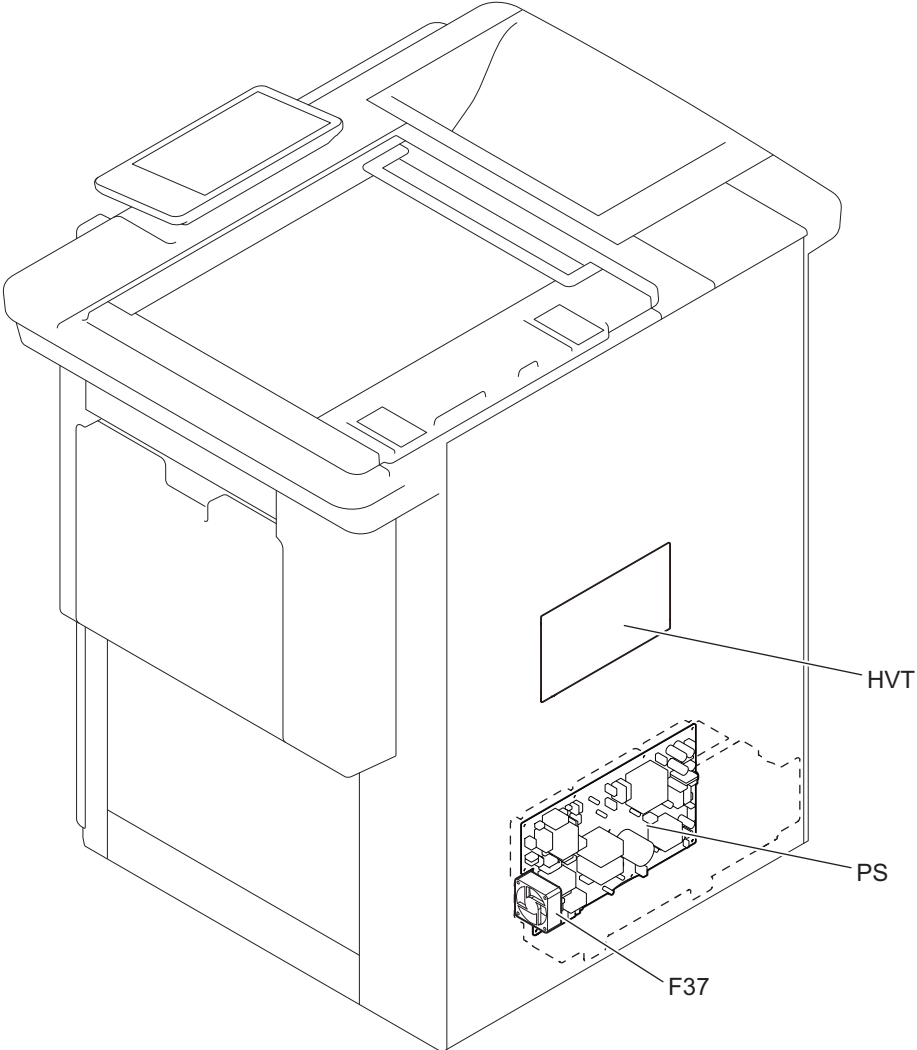

Fig. 3-29

[P] Fan

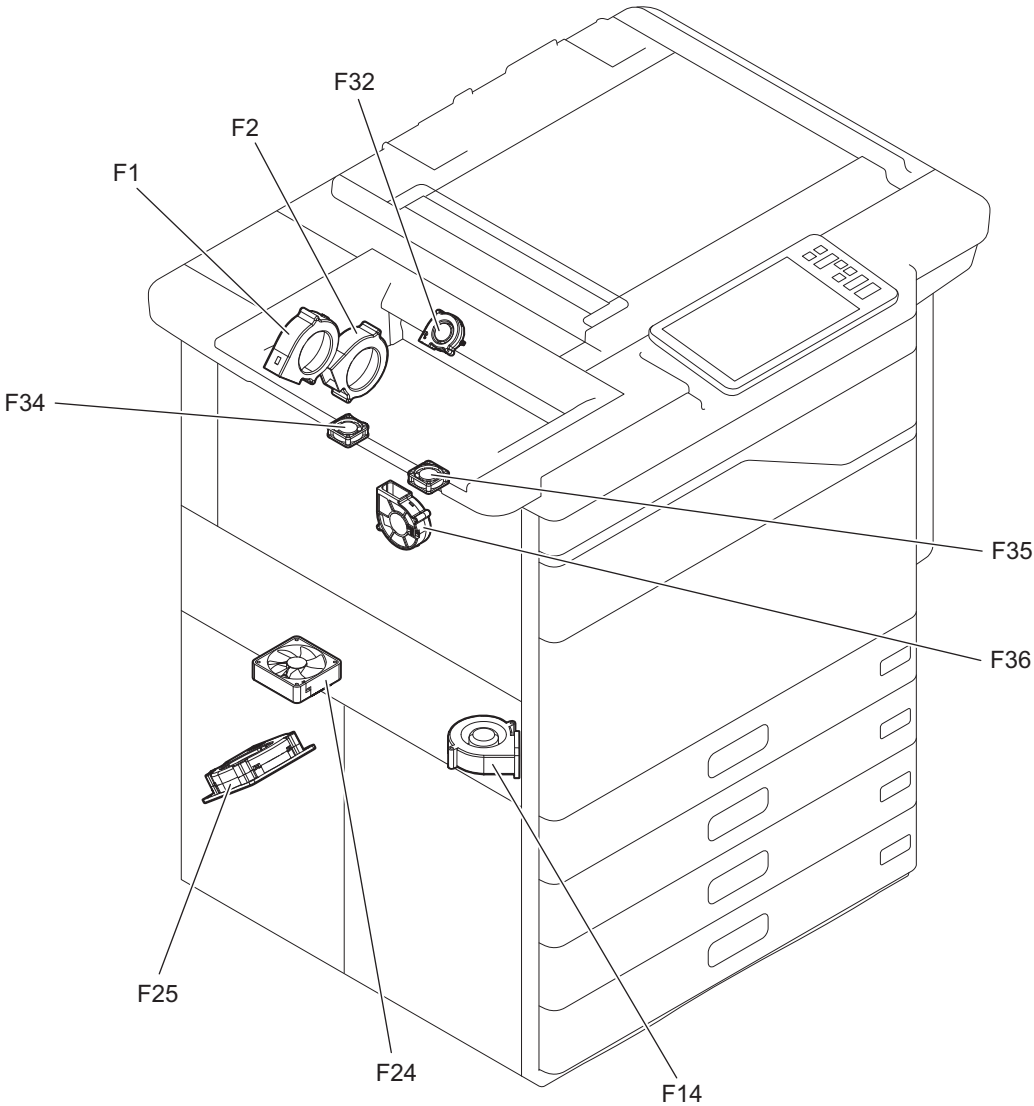

Fig. 3-30

[Q] Damp heater

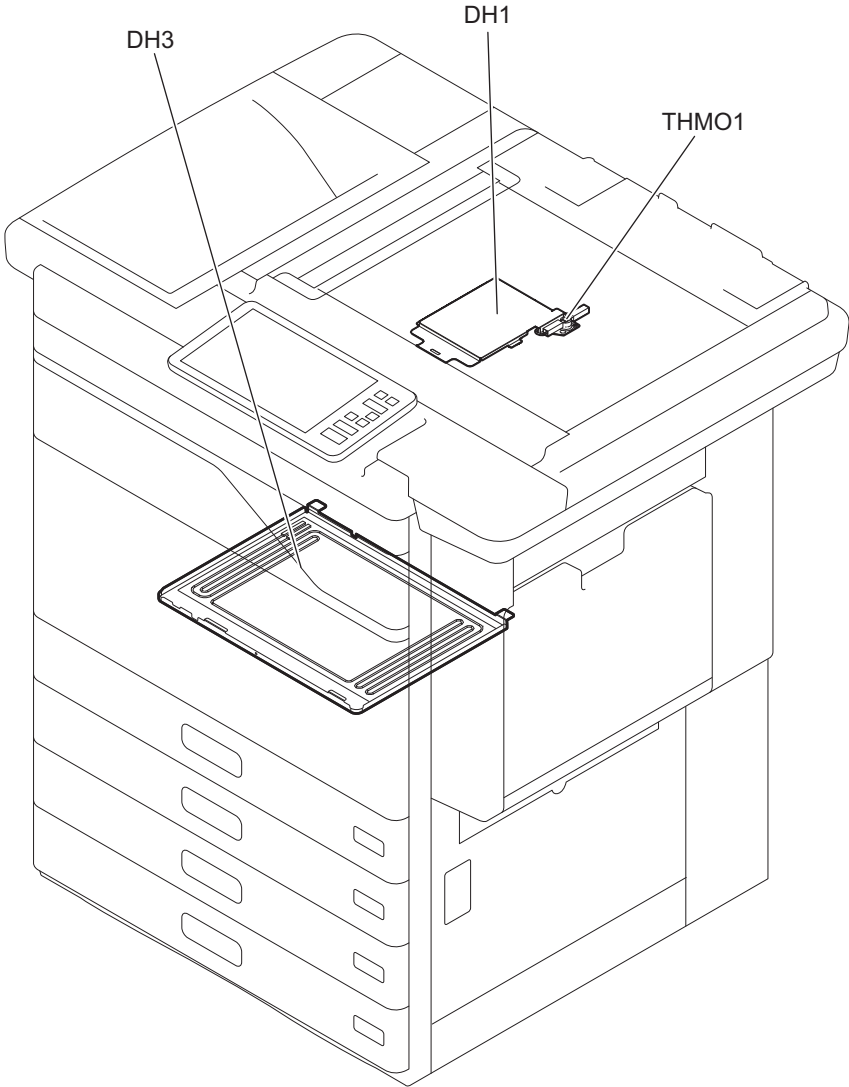

Fig. 3-31

3.3 Symbols and Functions of Various Components

The column "P-I" shows the page and item number in the parts list.

3.3.1 Motor

| Symbol | Name | Function | Remarks | P-I |
|--------|--------------------------------------|--|--|-------|
| MD1 | DSDF original feed motor | Drives the DSDF pickup roller and DSDF original feed roller. | [A] Dual Scan Document Feeder (DSDF) Fig. 3-5 | 86-8 |
| MD2 | DSDF separation motor | Performs the reverse operation of the DSDF separation roller and moves (upward/downward) the original tray lift. | [A] Dual Scan Document Feeder (DSDF) Fig. 3-5 | 85-10 |
| MD3 | DSDF registration motor | Drives the DSDF registration roller. | [A] Dual Scan Document Feeder (DSDF) Fig. 3-5 | 86-4 |
| MD4 | DSDF read motor | Drives the pre-read roller-1, post-read roller-1, pre-read roller-2 and post-read roller-2. | [A] Dual Scan Document Feeder (DSDF) Fig. 3-5 | 90-5 |
| MD5 | DSDF original exit motor | Drives the DSDF original exit roller and rotates the shading sheet. | [A] Dual Scan Document Feeder (DSDF) Fig. 3-5 | 90-5 |
| M1 | Scan motor | Drives the carriages. | [B] Scanner unit and control panel Fig. 3-9 | 51-8 |
| M2 | Paper exit motor | Drives the paper exit roller. | [C] Bridge unit and paper exit section Fig. 3-10 | 37-6 |
| M3 | Reverse motor | Drives the reverse section. | [C] Bridge unit and paper exit section Fig. 3-10 | 23-36 |
| M4 | Bridge unit transport entrance motor | Drives the transport roller of the entrance section of the bridge unit. | [C] Bridge unit and paper exit section Fig. 3-10 | 23-36 |
| M5 | Bridge unit transport exit motor | Drives the transport roller of the exit section of the bridge unit. | [C] Bridge unit and paper exit section Fig. 3-10 | 23-36 |
| M6 | Fuser motor | Drives the fuser unit. | [D] Fuser unit section Fig. 3-11 | 39-20 |
| M7 | ADU transport motor | Drives the paper transportation of the duplexing unit. | [J] Duplexing unit Fig. 3-20 | 18-2 |
| M8 | ADU paper feed motor | Drives the paper feeding of the duplexing unit. | [J] Duplexing unit Fig. 3-20 | 18-2 |
| M12 | Bypass tray motor | Feeds and transports paper in the bypass tray. | [L] Bypass unit Fig. 3-22 | 15-77 |
| M13 | Transfer belt motor | Drives the transfer belt. | [F] Transfer belt unit Fig. 3-16 | 28-11 |
| M15 | Toner motor (K) | Supplies the toner from the toner cartridge to the sub-hopper. | [I] Toner cartridge and waste toner box Fig. 3-19 | 45-79 |
| M19 | Sub-hopper toner motor (K) | Mixes the toner in the sub-hopper (K) and supplies the toner from the sub-hopper (K) to the developer unit (K). | [E] Developer unit Fig. 3-15 | 60-20 |
| M23 | Needle electrode cleaner motor (K) | Drives the needle electrode cleaner. | [E] Developer unit Fig. 3-15 | 59-11 |
| M27 | Drum motor (K) | Drives the drum. | [E] Developer unit Fig. 3-13 | 56-17 |

| Symbol | Name | Function | Remarks | | P-I |
|--------|---------------------------------------|---|---|------------------------|-------|
| M29 | Developer unit mixer motor (K) | Mixes the developer material. | [E] Developer unit | Fig. 3-13 | 56-19 |
| M30 | Developer unit motor (K) | Drives the developer sleeve (magnetic roller) of the developer unit and toner recovery auger. | [E] Developer unit | Fig. 3-13 | 56-19 |
| M33 | Waste toner transport motor | Transports waste toner. | [I] Toner cartridge and waste toner box | Fig. 3-19 | 65-37 |
| M34 | Polygonal motor | Drives the polygonal mirror. | [H] Laser optical unit | Fig. 3-18 | 48-1 |
| M38 | Shutter motor | Drives the protective shutter of the laser emission outlet (slit glass). | [H] Laser optical unit | Fig. 3-18 | 48-1 |
| M39 | Registration motor | Drives the registration roller. | [G] Transfer Unit | Fig. 3-17 | 10-22 |
| M40 | Transport motor-1 | Drives the intermediate transport roller-1. | [M] Paper feeding section | Fig. 3-23 Fig. 3-25 | 8-3 |
| M41 | Transport motor-2 | Drives the intermediate transport roller-2. | [M] Paper feeding section | Fig. 3-23 Fig. 3-25 | 8-3 |
| M42 | 1st/2nd drawer paper feed motor | Drives the paper feed rollers and pickup rollers in the 1st and 2nd drawers. | [M] Paper feeding section | Fig. 3-23 Fig. 3-25 | 8-3 |
| M43 | 3rd/4th drawer/T-LCF paper feed motor | Drives the paper feed rollers, pickup rollers and transport rollers in the 3rd and 4th drawers or the tandem LCF. | [M] Paper feeding section | Fig. 3-23 Fig. 3-25 | 9-50 |
| M44 | 1st drawer tray-up motor | Lifts up the tray in the 1st drawer. | [M] Paper feeding section | Fig. 3-23 Fig. 3-25 | 66-7 |
| M45 | 3rd drawer/LCF tray-up motor | Lifts up the tray in the 3rd drawer. | [M] Paper feeding section | Fig. 3-23 | 66-7 |
| M46 | T-LCF tray-up motor | Lifts up the tray in the tandem LCF. | [M] Paper feeding section | Fig. 3-27 | 12-19 |
| M47 | T-LCF end fence motor | Drives the end fence in the tandem LCF. | [M] Paper feeding section | Fig. 3-27 | 12-19 |
| M48 | Pressure roller contact/release motor | Drives the contacting and releasing operation of the pressure roller. | [D] Fuser unit section | Fig. 3-11 | 39-3 |
| M49 | 2nd drawer tray-up motor | Lifts up the tray in the 2nd drawer. | [M] Paper feeding section | Fig. 3-23 Fig. 3-25 | 39-3 |
| M50 | 4th drawer/LCF tray-up motor | Lifts up the tray in the 4th drawer. | [M] Paper feeding section | Fig. 3-23 | 39-3 |

3.3.2 Fan

| Symbol | Name | Function | Remarks | | P-I |
|--------|---------------------------------|--|--|-----------|------|
| FD1 | DSDf cooling fan motor | Cools down inside of the DSDf. | [A] Dual Scan Document Feeder (DSDf) | Fig. 3-5 | 85-1 |
| F1 | Bridge unit heat exhausting fan | Exhausts heat from the bridge unit and cools down the motors installed in the bridge unit. | [P] Fan | Fig. 3-30 | 49-6 |
| F2 | Fuser unit heat exhausting fan | Exhausts heat from the upper side of the fuser unit, prevents paper from getting wet, and exhausts heat from the toner cartridge area. | [P] Fan | Fig. 3-30 | 49-6 |
| F6 | Bridge unit cooling fan | Cools down the bridge unit and scanner unit. Prevents paper from getting wet. | [C] Bridge unit and paper exit section | Fig. 3-10 | 49-6 |

| Symbol | Name | Function | Remarks | | P-I |
|--------|---|---|------------------------|-----------|--------|
| F8 | IH board cooling fan (suction) | Cools down the IH board. | [D] Fuser unit section | Fig. 3-12 | 38-29 |
| F9 | IH board cooling fan (exhaust) | Cools down the IH board. | [D] Fuser unit section | Fig. 3-12 | 38-33 |
| F11 | Reversed paper cooling fan | Cools down the reversed paper. | [J] Duplexing unit | Fig. 3-20 | 18-26 |
| F14 | Developer unit cooling fan | Cools down the developer unit. | [P] Fan | Fig. 3-30 | 49-6 |
| F17 | Ozone mixing fan (K) | Mixes the ozone of the main charger. | [E] Developer unit | Fig. 3-15 | 59-2 |
| F21 | Fuser insulation fan | Insulates the heat and cools down the toner cartridge. | [D] Fuser unit section | Fig. 3-11 | 49-35 |
| F22 | Laser optical unit cooling fan (front) | Cools down the polygonal motor. | [H] Laser optical unit | Fig. 3-18 | 48-8 |
| F23 | Laser optical unit cooling fan (rear) | Cools down the polygonal motor and the 1st/2nd drawer paper feed motor. | [H] Laser optical unit | Fig. 3-18 | 49-13 |
| F24 | Ozone suctioning fan | Suctions ozone generated at charging. | [P] Fan | Fig. 3-30 | 49-32 |
| F25 | DEV-FAN-MOT Scattered toner suctioning fan | Suctions scattered toner. | [P] Fan | Fig. 3-30 | 49-30 |
| F27 | SYS board cooling fan | Cools down the SYS board. | [N] PC board | Fig. 3-28 | 68-5 |
| F32 | Upper paper exit section cooling fan (rear) | Cools down the paper exiting on the upper exit tray. | [P] Fan | Fig. 3-30 | 36-101 |
| F34 | Lower paper exit section cooling fan (rear) | Cools down the paper exiting on the lower paper exit section. | [P] Fan | Fig. 3-30 | 35-45 |
| F35 | Lower paper exit section cooling fan (front) | | [P] Fan | Fig. 3-30 | 35-45 |
| F36 | Lower paper exit section cooling fan (bottom) | | [P] Fan | Fig. 3-30 | 49-43 |
| F37 | Power supply unit cooling fan | Cools down the power supply unit. | [O] Power supply | Fig. 3-29 | 70-1 |

3.3.3 Sensor

| Symbol | Name | Function | Remarks | P-I | |
|--------|---|--|--------------------------------------|----------|-------|
| SD1 | DSDF tray original length sensor-1 | Detects the original size (length) set on the original tray. | [A] Dual Scan Document Feeder (DSDF) | Fig. 3-6 | 82-30 |
| SD2 | DSDF tray original length sensor-2 | Detects the original size (length) set on the original tray. | [A] Dual Scan Document Feeder (DSDF) | Fig. 3-6 | 82-4 |
| SD3 | DSDF tray original width sensor | Detects the original size (width) set on the original tray. | [A] Dual Scan Document Feeder (DSDF) | Fig. 3-6 | 82-12 |
| SD4 | DSDF original empty sensor | Detects whether there is an original on the original tray or not. | [A] Dual Scan Document Feeder (DSDF) | Fig. 3-6 | 82-4 |
| SD5 | DSDF original feed sensor | Detects the original in the original feeding section. | [A] Dual Scan Document Feeder (DSDF) | Fig. 3-6 | 84-7 |
| SD6 | DSDF registration sensor | Detects the paper transportation at the DSDF registration roller section as well as the original size (length). | [A] Dual Scan Document Feeder (DSDF) | Fig. 3-6 | 84-7 |
| SD7 | DSDF original width detection sensor-1 | Detects the original size (width). | [A] Dual Scan Document Feeder (DSDF) | Fig. 3-6 | 83-11 |
| SD8 | DSDF original width detection sensor-2 | Detects the original size (width). | [A] Dual Scan Document Feeder (DSDF) | Fig. 3-6 | 83-11 |
| SD9 | DSDF tray lift upper limit sensor | Detects the upper limit position of the original tray lift. | [A] Dual Scan Document Feeder (DSDF) | Fig. 3-6 | 84-7 |
| SD10 | DSDF tray lift lower limit sensor | Detects the lower limit position of the original tray lift. | [A] Dual Scan Document Feeder (DSDF) | Fig. 3-7 | 91-5 |
| SD11 | DSDF read-in sensor-1 | Detects the original leading edge position at the original scanning section of the MFP. | [A] Dual Scan Document Feeder (DSDF) | Fig. 3-7 | 94-14 |
| SD12 | DSDF read-in sensor-2 | Detects the original leading edge position at the CCD module original scanning section of the DSDF. | [A] Dual Scan Document Feeder (DSDF) | Fig. 3-7 | 94-15 |
| SD13 | DSDF original exit sensor | Detects the original in the original exit section. | [A] Dual Scan Document Feeder (DSDF) | Fig. 3-7 | 91-5 |
| SD14 | DSDF shading sheet HP sensor | Detects the home position of the DSDF shading sheet. | [A] Dual Scan Document Feeder (DSDF) | Fig. 3-7 | 95-8 |
| SD15 | DSDF lower cover opening/closing detection sensor | Detects the opening and closing status of the DSDF lower cover. | [A] Dual Scan Document Feeder (DSDF) | Fig. 3-7 | 95-8 |
| SD16 | DSDF upper cover opening/closing detection sensor | Detects the opening and closing status of the DSDF upper cover. | [A] Dual Scan Document Feeder (DSDF) | Fig. 3-7 | 86-22 |
| SD17 | Multiple feeding detection sensor (transmission side) | Detects multiple feeding of the originals. This works by means of the combination of the transmission and reception sides. | [A] Dual Scan Document Feeder (DSDF) | Fig. 3-5 | 86-22 |
| SD18 | Multiple feeding detection sensor (reception side) | Detects multiple feeding of the originals. This works by means of the combination of the transmission and reception sides. | [A] Dual Scan Document Feeder (DSDF) | Fig. 3-6 | 86-22 |

| Symbol | Name | Function | Remarks | | P-I |
|--------|--|--|---|-----------|-------|
| S1 | Automatic original detection sensor-1 | Detects the original size. | [B] Scanner unit and control panel | Fig. 3-9 | 50-12 |
| S2 | Automatic original detection sensor-2 | Detects the original size. (for LT) | [B] Scanner unit and control panel | Fig. 3-9 | 50-12 |
| S3 | Carriage home position sensor | Detects the home position of the carriage. | [B] Scanner unit and control panel | Fig. 3-9 | 50-5 |
| S4 | Platen sensor-1 | Detects the opening and closing status of the platen cover or DSDF. | [B] Scanner unit and control panel | Fig. 3-9 | 51-13 |
| S5 | Platen sensor-2 | Detects the opening and closing status of the platen cover or DSDF. | [B] Scanner unit and control panel | Fig. 3-9 | 51-13 |
| S12 | Temperature/humidity sensor | Detects the ambient temperature and humidity of the MFP. | [E] Developer unit | Fig. 3-14 | 5-29 |
| S13 | Waste toner box nearly full detection sensor | Detects the nearly full status of the waste toner in the waste toner box. | [I] Toner cartridge and waste toner box | Fig. 3-19 | 65-45 |
| S14 | Waste toner box full detection sensor | Detects the full status of the waste toner in the waste toner box. | [I] Toner cartridge and waste toner box | Fig. 3-19 | 65-45 |
| S16 | Waste toner box detection sensor | Detects whether there is a waste toner box or not as well as the opening and closing status of the waste toner box cover. | [I] Toner cartridge and waste toner box | Fig. 3-19 | 5-17 |
| S21 | Image quality sensor | Detects the density of a toner image (test pattern) developed on the transfer belt surface. | [G] Transfer Unit | Fig. 3-17 | 6-5 |
| S24 | Shutter sensor (home position) | Detects the home position of the laser emission outlet (slit glass) protective shutter. | [H] Laser optical unit | Fig. 3-18 | 48-1 |
| S25 | Shutter sensor (end position) | Detects the end position of the laser emission outlet (slit glass) protective shutter. | [H] Laser optical unit | Fig. 3-18 | 48-1 |
| S26 | Auto-toner sensor (K) | Detects the toner density in the developer unit. | [E] Developer unit | Fig. 3-14 | 62-41 |
| S30 | Needle electrode cleaner detection sensor (K) | Detects the cleaning operation for the needle electrode. (Detects that the needle electrode cleaner has reached the limit position.) | [E] Developer unit | Fig. 3-14 | 59-4 |
| S34 | Drum surface potential (V0) sensor (K) | Detects the surface potential of the drum at charging. (9029A only) | [E] Developer unit | Fig. 3-14 | 59-22 |
| S38 | Sub-hopper toner sensor (K) | Detects the toner amount in the sub-hopper. | [I] Toner cartridge and waste toner box | Fig. 3-19 | 58-23 |
| S42 | Auger lock detection sensor | Detects the auger operation in the waste toner transport unit. | [I] Toner cartridge and waste toner box | Fig. 3-19 | 61-19 |
| S47 | Transfer belt paper clinging detection sensor | Detects paper clinging to the lower side of the transfer belt. | [G] Transfer Unit | Fig. 3-17 | 28-18 |
| S48 | Pressure roller contact/release detection sensor | Detects the contacting and releasing status of the fuser unit. | [D] Fuser unit section | Fig. 3-11 | 40-17 |
| S49 | Fuser belt rotation detection sensor | Detects the rotation of the fuser belt. | [D] Fuser unit section | Fig. 3-11 | 40-17 |

| Symbol | Name | Function | Remarks | P-I | |
|--------|---|---|--|------------------------|-------|
| S51 | 2nd transfer side paper clinging detection sensor | Detects paper clinging on the 2nd transfer roller side. | [G] Transfer Unit | Fig. 3-17 | 29-14 |
| S52 | Registration sensor | Detects the paper transportation at the registration roller section. | [G] Transfer Unit | Fig. 3-17 | 10-13 |
| S55 | Bridge unit path entrance sensor | Detects the paper transportation at the entrance section of the bridge unit. | [C] Bridge unit and paper exit section | Fig. 3-10 | 23-7 |
| S56 | Bridge unit path exit sensor | Detects the paper transportation inside of the bridge unit. | [C] Bridge unit and paper exit section | Fig. 3-10 | 23-7 |
| S57 | Reverse path sensor | Detects the reversed paper. | [C] Bridge unit and paper exit section | Fig. 3-10 | 20-28 |
| S58 | Reverse section stationary jam detection sensor | Detects paper misfeeding at the reverse section. | [C] Bridge unit and paper exit section | Fig. 3-10 | 25-8 |
| S59 | Reverse sensor | Detects the transportation of the reversed paper. | [C] Bridge unit and paper exit section | Fig. 3-10 | 26-25 |
| S60 | Reverse section paper transport detection sensor | Detects the paper transportation at the reverse section. | [C] Bridge unit and paper exit section | Fig. 3-10 | 37-16 |
| S61 | Upper paper exit sensor | Detects paper exiting to the exit tray. | [C] Bridge unit and paper exit section | Fig. 3-10 | 36-11 |
| S62 | Upper exit tray paper full detection sensor | Detects the full status of paper exiting to the exit tray. | [C] Bridge unit and paper exit section | Fig. 3-10 | 36-10 |
| S63 | Lower paper exit sensor | Detects paper exiting to the side exit tray. | [C] Bridge unit and paper exit section | Fig. 3-10 | 35-11 |
| S64 | Duplexing unit opening/closing detection sensor | Detects the opening and closing status of the duplexing unit. | [J] Duplexing unit | Fig. 3-20 | 20-28 |
| S65 | Fuser transport sensor | Detects the paper transportation at the fuser unit. | [D] Fuser unit section | Fig. 3-11 | 22-19 |
| S66 | Duplexing unit path entrance sensor | Detects the paper transportation at the entrance section of the duplexing unit. | [J] Duplexing unit | Fig. 3-20 | 21-45 |
| S67 | Duplexing unit path exit sensor | Detects the paper transportation inside of the duplexing unit. | [J] Duplexing unit | Fig. 3-20 | 21-45 |
| S71 | Bypass tray paper sensor | Detects the paper loading level on the bypass tray. | [L] Bypass unit | Fig. 3-22 | 15-65 |
| S72 | Bypass tray paper feed sensor | Detects the paper transportation fed from the bypass tray. | [L] Bypass unit | Fig. 3-22 | 16-65 |
| S73 | 1st drawer detection sensor | Detects the opening and closing status of the 1st drawer. | [M] Paper feeding section | Fig. 3-24 Fig. 3-26 | 11-7 |
| S74 | 1st drawer bottom sensor | Detects the lowering status of the tray in the 1st drawer. | [M] Paper feeding section | Fig. 3-23 Fig. 3-25 | 47-7 |
| S75 | 1st drawer paper empty sensor | Detects the paper loading level in the 1st drawer. | [M] Paper feeding section | Fig. 3-24 Fig. 3-26 | 11-7 |
| S76 | 1st drawer tray-up sensor | Detects the lifting status of the tray in the 1st drawer. | [M] Paper feeding section | Fig. 3-24 Fig. 3-26 | 11-7 |
| S77 | 1st drawer transport sensor | Detects the paper transportation at the 1st drawer paper feed section. | [M] Paper feeding section | Fig. 3-24 Fig. 3-26 | 11-45 |
| S78 | 1st drawer paper feed sensor | Detects the paper feeding status of the 1st drawer. | [M] Paper feeding section | Fig. 3-24 Fig. 3-26 | 11-45 |
| S79 | 1st drawer paper width detection sensor | Detects the width of paper in the 1st drawer. | [M] Paper feeding section | Fig. 3-23 Fig. 3-25 | 46-20 |

| Symbol | Name | Function | Remarks | | P-I |
|--------|---|---|---------------------------|------------------------|-------|
| S80 | 1st drawer paper length detection sensor | Detects the length of paper in the 1st drawer. | [M] Paper feeding section | Fig. 3-23 Fig. 3-25 | 46-20 |
| S81 | 2nd drawer detection sensor | Detects the opening and closing status of the 2nd drawer. | [M] Paper feeding section | Fig. 3-24 Fig. 3-26 | 11-7 |
| S82 | 2nd drawer bottom sensor | Detects the lowering status of the tray in the 2nd drawer. | [M] Paper feeding section | Fig. 3-23 Fig. 3-25 | 47-7 |
| S83 | 2nd drawer paper empty sensor | Detects the paper loading level in the 2nd drawer. | [M] Paper feeding section | Fig. 3-24 Fig. 3-26 | 11-7 |
| S84 | 2nd drawer tray-up sensor | Detects the lifting status of the tray in the 2nd drawer. | [M] Paper feeding section | Fig. 3-24 Fig. 3-26 | 11-7 |
| S85 | 2nd drawer transport sensor | Detects the paper transportation at the 2nd drawer paper feed section. | [M] Paper feeding section | Fig. 3-24 Fig. 3-26 | 11-45 |
| S86 | 2nd drawer paper feed sensor | Detects the paper feeding status of the 2nd drawer. | [M] Paper feeding section | Fig. 3-24 Fig. 3-26 | 11-45 |
| S87 | 2nd drawer paper width detection sensor | Detects the width of paper in the 2nd drawer. | [M] Paper feeding section | Fig. 3-23 Fig. 3-25 | 46-20 |
| S88 | 2nd drawer paper length detection sensor | Detects the length of paper in the 2nd drawer. | [M] Paper feeding section | Fig. 3-23 Fig. 3-25 | 46-20 |
| S89 | 3rd drawer/T-LCF detection sensor | Detects the opening and closing status of the 3rd drawer or the tandem LCF. | [M] Paper feeding section | Fig. 3-24 Fig. 3-26 | 11-7 |
| S90 | 3rd drawer bottom sensor | Detects the lowering status of the tray in the 3rd drawer. | [M] Paper feeding section | Fig. 3-23 | 47-7 |
| S91 | 3rd drawer/T-LCF paper empty sensor | Detects the paper loading level in the 3rd drawer or the tandem LCF. | [M] Paper feeding section | Fig. 3-24 Fig. 3-26 | 11-7 |
| S92 | 3rd drawer/T-LCF tray-up sensor | Detects the lifting status of the tray in the 3rd drawer or the tandem LCF. | [M] Paper feeding section | Fig. 3-24 Fig. 3-26 | 11-7 |
| S93 | 3rd drawer/T-LCF transport sensor | Detects the paper transportation at the paper feed section of the 3rd drawer or the tandem LCF. | [M] Paper feeding section | Fig. 3-24 Fig. 3-26 | 11-45 |
| S94 | 3rd drawer/T-LCF paper feed sensor | Detects the paper feeding status of the 3rd drawer or the tandem LCF. | [M] Paper feeding section | Fig. 3-24 Fig. 3-26 | 11-45 |
| S95 | 3rd drawer paper width detection sensor | Detects the width of paper in the 3rd drawer. | [M] Paper feeding section | Fig. 3-23 | 46-20 |
| S96 | 3rd drawer paper length detection sensor | Detects the length of paper in the 3rd drawer. | [M] Paper feeding section | Fig. 3-23 | 46-20 |
| S97 | 4th drawer detection sensor | Detects the opening and closing status of the 4th drawer. | [M] Paper feeding section | Fig. 3-27 | 11-7 |
| S98 | 4th drawer bottom sensor | Detects the lowering status of the tray in the 4th drawer. | [M] Paper feeding section | Fig. 3-23 | 47-7 |
| S99 | 4th drawer paper empty sensor | Detects the paper loading level in the 4th drawer. | [M] Paper feeding section | Fig. 3-24 | 11-7 |
| S100 | 4th drawer tray-up sensor | Detects the lifting status of the tray in the 4th drawer. | [M] Paper feeding section | Fig. 3-24 | 11-7 |
| S101 | 4th drawer transport sensor | Detects the paper transportation at the 4th drawer paper feed section. | [M] Paper feeding section | Fig. 3-24 | 11-45 |
| S102 | 4th drawer paper feed sensor | Detects the paper feeding status of the 4th drawer. | [M] Paper feeding section | Fig. 3-24 | 11-45 |
| S103 | 4th drawer paper width detection sensor | Detects the width of paper in the 4th drawer. | [M] Paper feeding section | Fig. 3-23 | 46-20 |
| S104 | 4th drawer paper length detection sensor | Detects the length of paper in the 4th drawer. | [M] Paper feeding section | Fig. 3-23 | 46-20 |
| S106 | T-LCF standby side tray paper amount detection sensor | Detects the remaining amount of paper on the standby side tray in the tandem LCF. | [M] Paper feeding section | Fig. 3-27 | 13-15 |

| Symbol | Name | Function | Remarks | P-I | |
|--------|--|--|-----------------------------------|-----------|-------|
| S107 | T-LCF bottom sensor | Detects the lowering status of the tray in the tandem LCF. | [M] Paper feeding section | Fig. 3-27 | 14-32 |
| S108 | T-LCF standby side tray detection sensor | Detects the opening and closing status of the standby side tray in the tandem LCF. | [M] Paper feeding section | Fig. 3-27 | 13-27 |
| S109 | T-LCF standby side paper empty sensor | Detects the paper loading level of the standby side in the tandem LCF. | [M] Paper feeding section | Fig. 3-27 | 13-15 |
| S110 | T-LCF stopper opening/closing detection sensor (front) | Detects the opening and closing status of the front stopper in the tandem LCF. | [M] Paper feeding section | Fig. 3-27 | 14-32 |
| S111 | T-LCF stopper opening/closing detection sensor (rear) | Detects the opening and closing status of the rear stopper in the tandem LCF. | [M] Paper feeding section | Fig. 3-27 | 14-32 |
| S112 | T-LCF end fence home position sensor | Detects the home position of the end fence in the tandem LCF. | [M] Paper feeding section | Fig. 3-27 | 13-15 |
| S113 | T-LCF end fence stop position sensor | Detects the stop position of the end fence in the tandem LCF. | [M] Paper feeding section | Fig. 3-27 | 13-15 |
| S114 | Paper feed cover sensor | Detects the opening and closing status of the paper feed cover. | [K] Cover switch and cover sensor | Fig. 3-21 | 7-4 |

3.3.4 Switch

| Symbol | Name | Function | Remarks | P-I | |
|--------|---|--|--|-----------|-------|
| SWD1 | DSDf lower cover interlock switch | Shuts off the 24 V power by opening the DSDf lower cover. | [A] Dual Scan Document Feeder (DSDf) | Fig. 3-7 | 96-5 |
| SWD2 | DSDf upper cover interlock switch | Shuts off the 24 V power by opening the DSDf upper cover. | [A] Dual Scan Document Feeder (DSDf) | Fig. 3-7 | 86-19 |
| SW2 | Interlock switch | Supplies and shuts off the AC power to the switching regulator (voltage-generating circuit interlocked with the cover) according to the opening and closing of the front cover. (Cover open: Shut off) | [K] Cover switch and cover sensor | Fig. 3-21 | 44-18 |
| SW3 | Toner motor interlock switch | Supplies and shuts off the power to the toner motor according to the opening and closing of the front cover. (Cover open: Shut off) | [K] Cover switch and cover sensor | Fig. 3-21 | 44-5 |
| SW4 | IH interlock switch | Supplies and shuts off the IH power according to the opening and closing of the duplexing unit. (Unit open: Shut off) | [J] Duplexing unit | Fig. 3-20 | 46-6 |
| SW5 | Reverse path cover switch | Opens and closes the reverse path cover. | [C] Bridge unit and paper exit section | Fig. 3-10 | 37-13 |
| SW7 | Duplexing unit cover opening/closing detection switch | Detects the opening and closing status of the cover of the duplexing unit. | [J] Duplexing unit | Fig. 3-20 | 18-40 |
| SW8 | Bridge unit connecting detection switch | Detects the connection of the bridge unit. | [K] Cover switch and cover sensor | Fig. 3-21 | 44-4 |
| SW9 | Front cover opening/closing detection switch | Detects the opening and closing status of the front cover. | [K] Cover switch and cover sensor | Fig. 3-21 | 44-4 |

| Symbol | Name | Function | Remarks | P-I |
|--------|---------------------------------|---|---------------------------------|------|
| SW10 | Duplexing unit interlock switch | Supplies and shuts off the AC power to the switching regulator (voltage-generating circuit interlocked with the unit) according to the opening and closing of the duplexing unit. (Unit open: Shut off) | [J] Duplexing unit Fig. 3-20 | 44-4 |

3.3.5 Clutch

| Symbol | Name | Function | Remarks | P-I |
|--------|---|--|---|-------|
| CLD | DSDF tray-up clutch | Transmits the driving force to move upward or downward the original tray. | [A] Dual Scan Document Feeder (DSDF) Fig. 3-5 | 88-13 |
| CLT4 | CST3-TR-CLT 3rd drawer transport clutch | Drives the transport roller of the 3rd drawer or the tandem LCF. | [M] Paper feeding section Fig. 3-23 Fig. 3-25 | 9-42 |
| CLT5 | CST3-FEED-CLT 3rd drawer paper feed clutch | Drives the separation roller, paper feed roller and pickup roller of the 3rd drawer or the tandem LCF. | [M] Paper feeding section Fig. 3-23 Fig. 3-25 | 9-42 |
| CLT6 | CST4-TR-CLT 4th drawer transport clutch | Drives the transport roller of the 4th drawer. | [M] Paper feeding section Fig. 3-23 | 9-42 |
| CLT7 | CST4-FEED-CLT 4th drawer paper feed clutch | Drives the separation roller, paper feed roller and pickup roller of the 4th drawer. | [M] Paper feeding section Fig. 3-23 | 9-42 |

3.3.6 Solenoid

| Symbol | Name | Function | Remarks | P-I |
|--------|---|---|---|-------|
| SOL1 | Transport path switching solenoid (bridge unit/reverse section) | Drives the switching operation of the paper transport path of the bridge unit. | [C] Bridge unit and paper exit section Fig. 3-10 | 24-28 |
| SOL2 | Transport path switching solenoid (upper/lower paper exit) | Drives the switching operation of the paper transport path of the bridge unit. | [C] Bridge unit and paper exit section Fig. 3-10 | 24-28 |
| SOL3 | Image quality shutter solenoid | Drives the shutter of the image position aligning/image quality sensor (center). | [G] Transfer Unit Fig. 3-17 | 6-11 |
| SOL4 | V0 sensor shutter solenoid (K) | Drives the opening and closing operation of the shutter of the drum surface potential (V0) sensor (K). (9029A only) | [E] Developer unit Fig. 3-15 | 59-33 |
| SOL8 | Bypass pickup solenoid | Drives the upward and downward movement of the bypass tray pickup roller. | [L] Bypass unit Fig. 3-22 | 15-5 |
| SOL9 | T-LCF pickup solenoid | Drives the upward and downward movement of the tandem LCF pickup roller. | [M] Paper feeding section Fig. 3-27 | 11-62 |
| SOL10 | T-LCF stopper opening/closing solenoid (front) | Drives the opening and closing operation of the front stopper in the tandem LCF. | [M] Paper feeding section Fig. 3-27 | 14-28 |
| SOL11 | T-LCF stopper opening/closing solenoid (rear) | Drives the opening and closing operation of the rear stopper in the tandem LCF. | [M] Paper feeding section Fig. 3-27 | 14-28 |
| SOL12 | Toner cover solenoid (K) | Opens the toner cover (K). | [K] Cover switch and cover sensor Fig. 3-21 | 14-28 |

3.3.7 PC board

| Symbol | Name | Function | Remarks | P-I |
|---------|--|---|--|-------|
| DLGD | DSDf control PC board | Controls the DSDf. | [A] Dual Scan Document Feeder (DSDf) Fig. 3-8 | 96-1 |
| LEDD | DSDf-LED PC board | Lights the LED when an original is set or an abnormality occurs. | [A] Dual Scan Document Feeder (DSDf) Fig. 3-5 | 85-9 |
| DFRLY | DSDf relay PC board | Relays signals between the DSDf-CCD module and the DSDf control PC board. | [A] Dual Scan Document Feeder (DSDf) Fig. 3-8 | 96-28 |
| DLGRL Y | DSDf multiple feeding detection relay PC board | Relays signals between the multiple feeding detection sensors (transmission and reception sides) and the DSDf control PC board. | [A] Dual Scan Document Feeder (DSDf) Fig. 3-8 | 17-1 |
| CCD | CCD driving PC board (CCD board) | Controls the scanning of an original with a CCD. | [B] Scanner unit and control panel Fig. 3-9 | 50-9 |
| DSP | Display PC board (DSP board) | Controls the whole control panel. | [B] Scanner unit and control panel Fig. 3-9 | 3-15 |
| KEY | Key PC board (KEY-1 board) | Controls the key switches and LEDs. | [B] Scanner unit and control panel Fig. 3-9 | 3-14 |
| CTIF | Toner cartridge interface PC board (CTIF board) | Interface for detecting the toner cartridge (Detects the CTRG board.) | [I] Toner cartridge and waste toner box Fig. 3-19 | 45-85 |
| CTRG | Toner cartridge PC board (CTRG board) | Maintains the information of the toner cartridge. • The CTRG board is installed in the toner cartridge. | [I] Toner cartridge and waste toner box Fig. 3-19 | - |
| SYS | System control PC board (SYS board) | Controls the whole system and image processing. | [N] PC board Fig. 3-28 | 68-10 |
| LGC | Logic PC board (LGC board) | Controls the print engine section. | [N] PC board Fig. 3-28 | 69-4 |
| LDR-K | Laser driving PC board (K) (LDR-K board) | Drives the laser diode. | [H] Laser optical unit Fig. 3-18 | 48-1 |
| V0S | Drum surface potential sensor control PC board (V0S board) | Controls the drum surface potential (V0) sensor (K). (9029A only) | [E] Developer unit Fig. 3-15 | 59-22 |
| PFC | Paper feeding control PC board (PFC board) | Controls paper feeding. | [N] PC board Fig. 3-28 | 69-3 |
| ADU | ADU control PC board (ADU board) | Controls the duplexing unit. | [J] Duplexing unit Fig. 3-20 | 18-35 |
| DRV | DRV PC board | Controls the driving of the motors (M2, M3, M4, M5). | [C] Bridge unit and paper exit section Fig. 3-10 | 46-60 |
| IH | Heater control PC board (IH board) | Controls the IH coil of the fuser unit. | [D] Fuser unit section Fig. 3-12 | 38-28 |
| DAMP | DAMP PC board (DAMP board) | Supplies the power to each damp heater of the scanner and the drum. | [N] PC board Fig. 3-28 | 69-18 |
| FIL-AC | Filter PC board (AC) | Eliminates the AC power noise. (For power supply) | [N] PC board Fig. 3-28 | 71-7 |
| FIL-IH | Filter PC board (IH) | Eliminates the AC power noise. (For IH) (9029A (JPC) only) | [N] PC board Fig. 3-28 | 71-7 |
| SFBB | Paper width detection PC board (SFB board) | Detects the paper width on the bypass tray. | [L] Bypass unit Fig. 3-22 | 17-14 |

| Symbol | Name | Function | Remarks | | P-I |
|----------|------------------------------|--|--------------|-----------|------|
| DSDF-I/F | DSDF I/F PC board (DSDF-I/F) | Relays signals between the DSDF-CCD module and the SYS control PC board. | [N] PC board | Fig. 3-28 | 68-3 |

3.3.8 Lamp, coil and heater

| Symbol | Name | Function | Remarks | | P-I |
|---------|---------------------|--|------------------------------------|-----------|-------|
| EXP | Exposure lamp | Exposes an original. | [B] Scanner unit and control panel | Fig. 3-9 | 52-3 |
| ERS-K | Discharge LED (K) | Eliminates residual charge on the drum surface. | [E] Developer unit | Fig. 3-15 | 64-20 |
| IH-COIL | IH coil | Heats the fuser belt. | [D] Fuser unit section | Fig. 3-12 | 38-4 |
| DH1 | Scanner damp heater | Prevents condensation of the carriage mirror. (JPC only) | [Q] Damp heater | Fig. 3-31 | 50-17 |
| DH3 | Drum damp heater | Prevents condensation of the drum. (JPC only) | [Q] Damp heater | Fig. 3-31 | 5-20 |

3.3.9 Thermistor and thermostat

| Symbol | Name | Function | Remarks | | P-I |
|--------|--------------------------------|--|------------------------|-----------|-------|
| THM1 | Drum thermistor (K) | Detects the surface temperature of the drum. | [E] Developer unit | Fig. 3-14 | 59-27 |
| THM5 | Fuser belt center thermistor | Detects the surface temperature of the center of the fuser belt. | [D] Fuser unit section | Fig. 3-11 | 42-21 |
| THM6 | Fuser belt edge thermistor | Detects the surface temperature of the edge of the fuser belt. | [D] Fuser unit section | Fig. 3-11 | 42-21 |
| THMO1 | Scanner damp heater thermostat | Controls the temperature of the scanner damp heater. | [Q] Damp heater | Fig. 3-31 | 50-17 |
| THMO4 | Fuser belt thermostat | Detects the surface temperature of the fuser belt. | [D] Fuser unit section | Fig. 3-11 | 42-21 |

3.3.10 Transformer

| Symbol | Name | Function | Remarks | | P-I |
|--------|--------------------------|--|------------------|-----------|------|
| HVT | High-voltage transformer | Generates the high voltage and supplies it to the following sections. <ul style="list-style-type: none"> • Main charger needle electrode • Main charger grid • Developer bias • 1st transfer bias • 2nd transfer bias | [O] Power supply | Fig. 3-29 | 70-5 |

3.3.11 Others

| Symbol | Name | Function | Remarks | P-I |
|------------|---------------------|---|--|-------|
| CCDD | DSDF-CCD module | Scans the back side of the original in the DSDF. | [A] Dual Scan Document Feeder (DSDF) Fig. 3-8 | 85-22 |
| TCP | Touch panel | Displays and enters various kinds of information. | [B] Scanner unit and control panel Fig. 3-9 | 3-1 |
| Sub-EEPROM | Sub-EEPROM | Stores the setting and adjustment values, etc. used for the control by the LGC board. | [N] PC board Fig. 3-28 | 3-1 |
| SRAM | SRAM | Stores the programs, etc. used for the control by the SYS board. | [N] PC board Fig. 3-28 | 3-1 |
| SSD | SSD | Stores various data and programs. | [N] PC board Fig. 3-28 | 68-19 |
| PS | Switching regulator | Generates the DC voltage and supplies it to each section of the MFP. | [O] Power supply Fig. 3-29 | 70-1 |

3.4 Copy Process

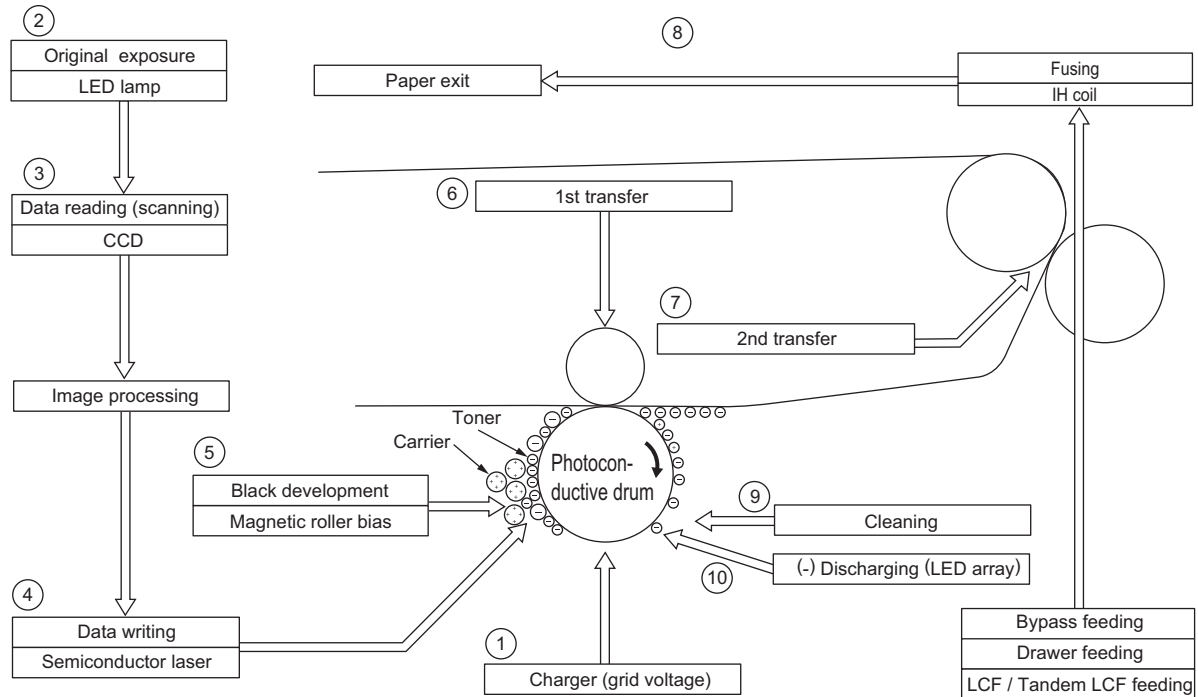

Fig. 3-32

- (1) Charging:
Places a negative charge on the surface of the photoconductive drum.
- (2) Original exposure:
Converts images on the original into optical signals.
- (3) Data reading:
Converts optical signals into electrical ones.
- (4) Data writing:
Converts the electrical signals into optical signals (by laser emission) and exposes the surface of the photoconductive drum.
- (5) Development:
Allows the negatively-charged toner on the photoconductive drum to adhere and form a visible image.
- (6) 1st transfer:
Transfers the visible image (toner) on the photoconductive drum to the transfer belt.
- (7) 2nd transfer:
Transfers the visible image (toner) on the transfer belt to the paper.
- (8) Fusing:
Fuses the toner image to the paper by applying heat and pressure.
- (9) Cleaning:
Forcibly scrapes off the residual toner remaining on the photoconductive drum by means of the blade.

(10) (-) discharging:

Eliminates the residual negative charge from the surface of the photoconductive drum.

3.5 Comparison with e-STUDIO5518A/6518A/7518A/8518A

| Process | | e-STUDIO5518A/6518A/7518A/8518A | e-STUDIO6529A/7529A/9029A |
|----------------------------------|--------------------|---|---|
| 1. Photoconductive drum | Drum | PS-ODFC556 (OPC drum) | ← |
| | Sensitivity | Ultrasensitive drum (ø60) | ← |
| 2. Charging | | Scorotron type -250 to -1200 V (Grid voltage) (adjustment by image quality control) (Feedback control with the surface potential sensor only for e-STUDIO8518A) | ← (Feedback control with the surface potential sensor only for e-STUDIO9029A) |
| 3. Data writing | Light source | Semiconductor laser | ← |
| 4. Image control | | Image quality control by the image quality sensor | ← |
| 5. Development | Magnetic roller | One magnetic roller | ← |
| | Auto-toner | Magnetic permeability circuit method | ← |
| | Toner supply | Toner cartridge replacement method (No toner recycle system) | ← |
| | Toner empty | Density detection method | ← |
| | Cartridge empty | Sub-hopper toner remaining amount detection method | ← |
| | Toner | JPC PS-ZT6518J(1) NAC, NAD PS-ZT6518U(1) MJC, MJD PS-ZT6518E(1) CND PS-ZT6518C(1) Others PS-ZT6518P(1) PS-ZT6518T(1) | JPC PS-ZTFC727JK(1) NAD, GSA, ARD PS-ZT9029U(1) MJD PS-ZT9029E(1) CND PS-ZT9029C(1) Others PS-ZT9029P(1) |
| | Developer material | JPC PS-ZDFC556K Others D-FC556K | ← |
| | Developer bias | DC -100 to -900 V (adjustment by image quality control) AC 1000 V/8 to 13 kHz | ← |
| 6. Transfer | | 1st transfer: Transfer belt method | ← |
| | | 2nd transfer: Transfer roller method | ← |
| 7. Separation | | Self-separation by the transfer belt and the 2nd transfer roller | ← |
| 8. Photoconductive drum cleaning | Method | Blade | ← |
| | Recovered toner | Non-usable | ← |
| 9. Transfer belt cleaning | | Blade cleaning method (no contact/release mechanism) | ← |
| 10. Discharging | | LED array (red) | ← |

| Process | | e-STUDIO5518A/6518A/7518A/8518A | e-STUDIO6529A/7529A/9029A |
|------------|------------------|--|---------------------------|
| 11. Fusing | Method | Belt fusing system with external IH | ← |
| | | Fuser belt: PFA tube belt (φ40) IH coil: <ul style="list-style-type: none"> • 200 to 1240 W (MJC/MJD) • 200 to 1100 W (NAC/NAD, ASD, ARD, AUD, JPC, CND) Pressure roller: Silicon rubber roller Surface-PFA tube (φ40) | ← |
| | Cleaning | None | ← |
| | Heat temperature | ON/OFF control and power control by the thermistor | ← |
| | Heater | IH coil (Induction heating system) | ← |

3.6 General Operation

3.6.1 Operation description

By using the copying function for the explanation purposes, the performance carried out from warming up to the ready status and the one by means of the operation are described.

[1] Warming-up

1. Initialization

- The power is turned ON.
- The IH coil (IH-COIL) is turned ON.
- The set number "1" and "Wait Warming Up" are displayed.
- The fan motor is turned ON.
- Initialization of the laser optical system starts.
- The polygonal motor (M34) rotates at high speed.
- Initialization of the paper feeding system starts.
- Each drawer tray goes up.
- The tray in the tandem LCF goes up. (Other than JPC models)
- The pre-running operation stops after five seconds.
- Initialization of the process unit system (process unit related section) starts.
- The transfer belt moves to the releasing position.
- The needle electrode cleaner moves to its home position.
- Cleaning of the transfer belt starts.*1
- The drum motor (M27) is turned ON.
- The transfer belt motor (M13) is turned ON.
- (Performs image quality control.) *1
- Initialization of the scanning system starts.
- The carriage moves to its home position and stops.
- The carriage moves to the peak detection position.
- The exposure lamp (EXP) is turned ON.
- Peak detection (white color is detected by the shading correction plate)
- The exposure lamp (EXP) is turned OFF.
- The polygonal motor (M34) rotates at low speed.
- The set number "1" and "READY (WARMING UP)" are displayed.

2. Pre-running operation

The pre-running operation is started at the corresponding starting timing.

- The fuser motor (M6) is turned ON.
- When the temperature of the fuser belt becomes sufficient for fusing,

3. When the temperature of the fuser belt becomes sufficient for fusing,

- The IH coil (IH-COIL) is turned OFF.
- The set number "1" and "READY" are displayed.
- The polygonal motor (M34) rotates at high speed for 30 seconds.

*1 Color registration control and image quality control should be performed only at a change of environment or periodical performance timing.

[2] Ready (ready for copying)

- Buttons on the control panel are enabled.
- When no button is pressed for a certain period of time, Set number “1” and reproduction ratio “100%” are displayed. The MFP returns to the normal ready status.
- The fuser unit repeats rotation and stopping

[3] Drawer feed copying by the [START] button (1st drawer paper feeding)

1. Press the [START] button.
 - “READY” changes to “COPYING”.
 - The exposure lamp (EXP) is turned ON.
 - The scan motor (M1) is turned ON. → The carriage-1 and -2 move forward.
 - The polygonal motor (M34) rotates at high speed.
 - The drum motor (K) (M27), transfer belt motor (M13), transport motors (M40, M41), developer unit mixer motor (K) (M29), developer unit motor (K) (M30), fuser motor (M6) and paper exit motor (M2) are turned ON.
 - The drum, transfer belt, fuser unit, developer unit and paper exit roller are driven.
2. Paper feeding from the drawer

The fans rotate at high speed and the 1st/2nd drawer paper feed motor (M42) is turned ON.

 - The pickup roller, paper feed roller, separation roller and transport roller start to rotate.
 - Paper reaches the 1st drawer paper feed sensor (S78).
 - The 1st drawer paper feed sensor (S78) is turned ON.
 - Paper reaches the registration roller.
 - The registration sensor (S52) is turned ON and aligning is performed.
 - After a certain period of time, the 1st/2nd drawer paper feed motor (M42) is turned OFF.
3. A certain period of time passed after the carriage operation
 - The registration motor (M39) is turned ON. → Paper is transported to the transfer area.
 - The copy counter operates.
4. Completion of scanning
 - The exposure lamp (EXP) is turned OFF.
 - The scan motor (M1) is turned OFF.
 - The registration motor (M39) is turned OFF after the trailing edge of the paper has passed the registration roller.
 - “READY (PRINTING)” is displayed.
5. Printing operation
 - The drum motor (K) (M27), transfer belt motor (M13) and discharge LED (K) are turned ON.
 - The main charger bias is turned ON.
 - The 2nd transfer bias is turned ON.
 - The developer bias (K) (DC), developer unit mixer motor (K)(M29) and developer unit motor (K) (M30) are turned ON.
 - The developer bias (K) (AC) is turned ON.
 - Laser emission (black image)
 - The 1st transfer bias (K) is turned ON.
 - The 1st transfer of black images (Black images are transferred to the transfer belt.)
 - The 1st transfer bias (K) is turned OFF.
 - The 2nd transfer of black images (Black images on the transfer belt are transferred to the paper.)
 - The main charger bias is turned OFF.
 - The developer unit mixer motor (K) (M29), developer unit motor (K) (M30) and developer bias (K) are turned OFF.
 - The drum motor (K), transfer belt motor and discharge LED (K) are turned OFF.
 - The 2nd transfer bias is turned OFF.

6. Paper exiting operation

- The paper exit sensors (S61, S63) detect the passing of the trailing edge of the paper.
- The toner recovery auger and discharge LED (ERS) are turned OFF.
- The drum motor (K) (M27), transfer belt motor (M13), transport motors (M40, M41), developer unit mixer motor (K) (M29), developer unit motor (K) (M30), fuser motor (M6) and paper exit motor (M2) are turned OFF. The polygonal motor (M34) rotates at low speed.
- The drum, fuser unit and developer unit are stopped. Each fan returns to rotate at the normal rotation speed.
- “READY” is displayed and the MFP enters into the ready mode.

[4] Bypass feed copying

1. Place A4 or LT paper on the bypass tray.
 - The bypass tray paper sensor (S71) is turned ON.
 - “Ready for bypass feeding” is displayed.
 - The carriage moves to its home position.
2. Press the [START] button.
 - “Ready for bypass feeding” changes to “COPYING”.
 - The exposure lamp (EXP) is turned ON.
 - The scan motor (M1) is turned ON. → The carriage-1 and -2 move forward.
 - The drum motor (K) (M27), transfer belt motor (M13), transport motors (M40, M41), developer unit mixer motor (K) (M29), developer unit motor (K) (M30), fuser motor (M6) and paper exit motor (M2) are turned ON.
 - The drum, transfer belt, fuser unit, developer unit and paper exit roller are driven.
3. Paper feeding from the bypass tray
 - Each fan rotates at high speed.
 - The bypass tray motor (M12) is turned ON.
 - The bypass tray pickup roller and bypass tray paper feed roller start rotating.
 - The bypass pickup solenoid (SOL8) is turned ON.
 - The bypass tray pickup roller move downward.
 - Aligning is performed.
 - Paper reaches the registration roller.
 - After a certain period of time, the bypass tray motor (M12) is turned OFF.
4. Hereafter, operations (3) through (6) of “[3] Drawer feed copying by the [START] button (1st drawer paper feeding)” are repeated.

[5] Interrupt copying

1. Press [Interrupt].
The "INTERRUPT" LED is turned ON.
 - The copying operation in progress is temporarily stopped and the carriage-1 and -2 return to the appropriate positions.
 - "Job interrupted job 1 saved" is displayed.
 - Automatic density and reproduction ratio 100% are set. The set number remains the same.
2. Select the desired copy condition
3. After interruption copying is finished:
 - "Press interrupt to resume job 1" is displayed.
 - The "INTERRUPT" LED is turned OFF by pressing [Interrupt] and the MFP returns to the status before the interruption.
 - "Ready to resume job 1" is displayed.
4. Press the [START] button.
The copying operation before the interruption is resumed.

3.6.2 Detection of abnormality

When something abnormal has occurred in the MFP, symbols corresponding to the type of abnormality are displayed.

[1] Types of abnormality

1. Abnormality which can be cleared even if the power is not turned off by the door switch
 - (A) Add paper
 - (B) Abnormal paper feeding from the bypass tray
 - (C) Toner supply
2. Abnormality which can be cleared if the power is turned off by the door switch
 - (D) Paper misfeeding
 - (E) Waste toner box replacement
3. Abnormality which can be cleared if the power is turned OFF by the [ON/OFF] button
 - (F) Call for service

[2] Description of abnormality

[2-1] Add paper

Instructions how to place more paper are displayed when there is no paper in the appropriate drawer or the tandem LCF, or it is not installed in the MFP.

In this situation, the [START] button is disabled.

[2-2] Abnormality in the drawer or tandem LCF

When the power is turned ON or the drawer or tandem LCF is inserted, the tray-up motor is turned ON, resulting in the lifting up of the tray.

When the tray-up sensor is turned ON within a certain period of time, the tray-up motor stops. At this moment, it is judged that there is paper in the drawer or tandem LCF if the paper empty sensor is turned ON. If the paper empty sensor is turned OFF, it is judged that there is no paper in the drawer or tandem LCF.

When the tray-up sensor is not turned ON within a certain period of time, it is judged that an abnormality has occurred. As a result, "NO PAPER" appears and then the tray-up motor stops.

[2-3] Abnormal paper feeding from the bypass tray

If the bypass tray paper feed sensor (S72) is not turned ON within a certain period of time during paper feeding from the bypass tray or after the start of paper feeding from the bypass tray, it is judged that a paper misfeed has occurred.

[2-4] Paper misfeeding

Detection of misfeeding of the leading edge of the paper by the fuser transport sensor (S65):

When the registration motor (M39) is turned ON but the fuser transport sensor (S65) is not, even if a certain period of time has passed, it is judged that a paper misfeed (E010) has occurred and the operation has stopped as a result.

Detection of misfeeding of the trailing edge of the paper by the paper exit sensors (S61, S63):

When the registration motor (M39) is turned OFF but the paper exit sensors (S61, S63) are not, even if a certain period of time has passed, it is judged that a paper misfeed (E020) has occurred and the operation has stopped as a result.

Other paper misfeeding:

- Immediately after the power is turned ON, if any one of all the sensors on the paper transport path detects paper (ON), it is judged that a paper misfeed (E030) has occurred.
- When the registration motor (M39) and transfer belt paper clinging detection sensor (S47) are turned ON but the 2nd transfer side paper clinging detection sensor (S51) is not, even if a certain period of time has passed, it is judged that a paper misfeed (E011) has occurred and the copying operation has stopped as a result.
- If the registration sensor (S52) is not turned ON within a certain period of time after the leading edge of the paper has passed the transport roller, it is judged that a paper misfeed (E200, E210, E270, E300, E330, E3C0) has occurred.
- If the registration sensor (S52) is not turned ON within a certain period of time after the ADU motors (M7, M8) are turned ON during paper feeding from the ADU, it is judged that a paper misfeed (E110) has occurred.
- If the duplexing unit path entrance sensor (S66) and duplexing unit path exit sensor (S67) do not detect the paper at a certain timing during paper transporting from the ADU, it is judged that a paper misfeed (E510, E520) has occurred.
- If the drawer transport sensors (S77, S85, S93, S101) is not turned ON within a certain period of time after the paper feed clutch is turned ON during paper feeding from the MFP, it is judged that a paper misfeed (E220, E310, E320, E340 to E360, E3D0, E3E0) has occurred. (A different error code appears depending on the paper source.)

[2-5] Toner supply

If the toner density is low, the toner empty status will occur, resulting in the copying operation becoming impossible. In order to avoid this, sub-hoppers are embedded.

After the toner in the sub-hopper has decreased, the toner cartridge empty status is displayed and it is necessary to replace the toner cartridge. When this timing has come, replace the toner cartridge.

[2-6] Waste toner box replacement

When the full status of the waste toner box is detected by the waste toner box full detection sensor (S14), a message to advise that it be replaced is displayed. When a full of the waste toner box is detected during printing, the operation is stopped after the paper being printed has exited. In such a case, replace the waste toner box with a new one and close the front cover to solve this problem.

[2-7] Call for service

Check the error code displayed on the touch panel when “Call for service” appears and then deal with the abnormality in accordance with the error code table.

 P. 8-6 “8.2 Error Code List”

3.6.3 Hibernation function

A hibernation function is embedded in this MFP. This function allows the MFP to store the last status of the system in the SSD immediately before the power is turned OFF and to restart from this stored status at the next boot-up. The MFP starts up in the specified time described in the warming-up time after the execution of the 2nd hibernation when the power is turned OFF and then back ON correctly. For the warming-up time, see the following reference.

 P. 2-1 “2.1.1 General”

If hibernation is not performed when the power is turned OFF or the MFP boots up immediately after the settings, warming-up takes longer. This differs depending on the usage conditions; warming-up will take approx. 30 to 150 seconds.

The following are the conditions which necessitate a longer warming-up time.

- Rebooting from TopAccess
- At the first booting after a power failure
- At the first booting after a self-diagnostic code is changed in the Service UI
- When options or finishers are installed
- At the first booting after an option or a finisher is removed
- During the toner supply mode
- Operating while “READY (WARMING-UP)” is still on the touch panel
- At the first booting when the power is turned OFF during the network initialization
- At the first booting after the power is turned OFF in a procedure other than the correct one described in the Quick Start Guide.

3.7 Control Panel

3.7.1 Overview

The control panel consists of the touch panel, buttons and LEDs indicating the state of the MFP, including various modes.

Pictorial symbols and messages are displayed either by lighting or blinking to advise the user of the notification. When a paper misfeed or service call has occurred, the corresponding error code is also displayed.

The [ON/OFF] button on the control panel is usually used to turn the power ON and OFF. Press this button to turn the power of the MFP ON and OFF.

Method: Color LCD with a touch panel

Touch panel: Resistance film type multi touch panel

Size: 10.1 inches

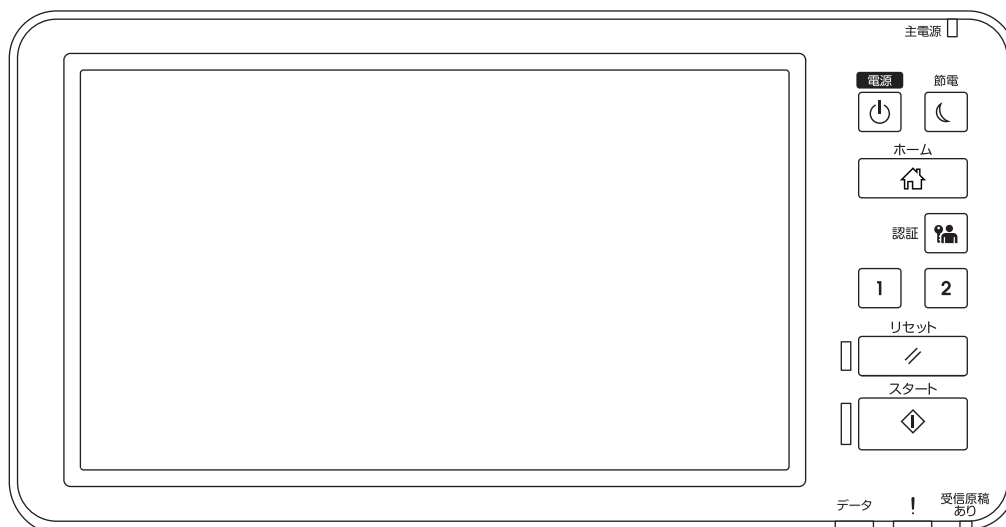

Fig. 3-33

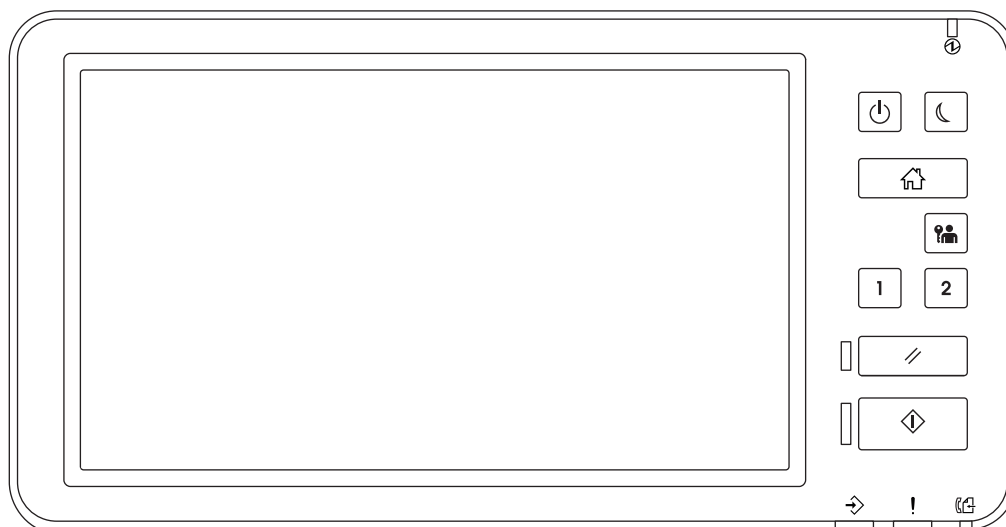

Fig. 3-34

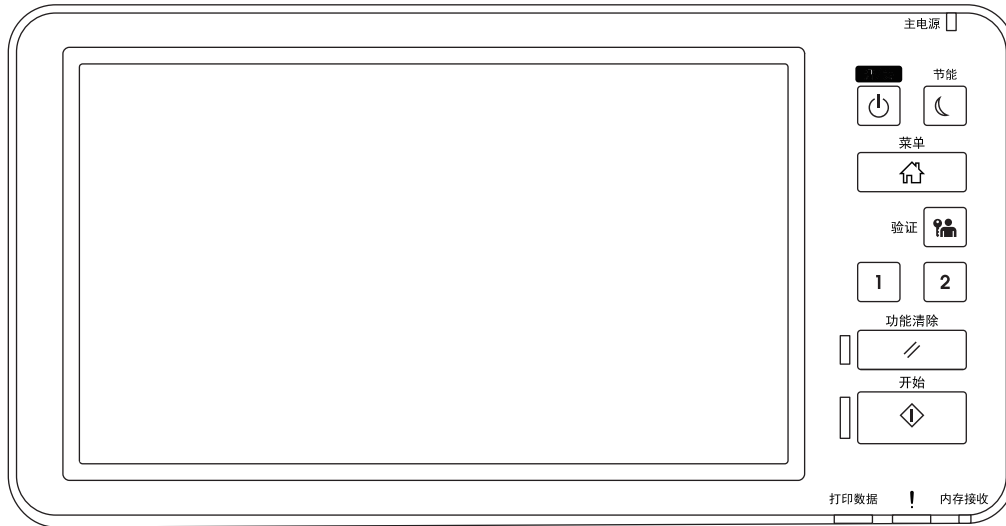

Fig. 3-35

3.8 Scanning Section

3.8.1 Overview

In the scanning section of this MFP, the surface of an original is irradiated with a direct light and the reflected light is led through mirrors, a lens and a slit to the CCD. This CCD performs optical-to-electrical conversion to convert the optical image data into an electrical (analog) signal. This analog signal is converted to a digital signal, which then undertakes various corrective processes necessary for image formation. After that, arithmetic operation is performed on the digital signal, which is then transmitted to the data writing section.

In this MFP, a reduction-type 3-line CCD for color processing is used. How this CCD differs from black-and-white CCDs is that its devices are arranged in 3 lines and covered with color filters (Red, Green and Blue). The color separation is arranged by means of these filters.

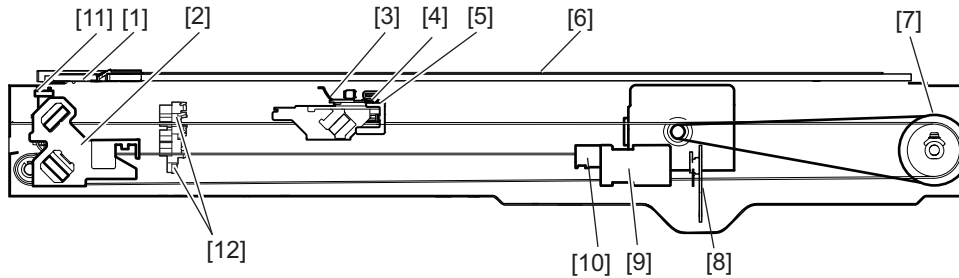

Fig. 3-36

- [1] ADF original glass
- [2] Carriage-2
- [3] Reflector
- [4] Exposure lamp
- [5] Carriage-1
- [6] Original glass
- [7] Drive pulley
- [8] CCD board
- [9] Lens
- [10] Automatic original detection sensor
- [11] Home position sensor
- [12] Platen sensor

3.8.2 Composition

| | | |
|---|------------------------------------|--|
| Scanning Section | | |
| Original glass | Original glass | |
| | ADF original glass | |
| Carriage-1 | Exposure lamp (EXP) | |
| | Reflector | |
| | Mirror-1 | |
| Carriage-2 | Mirror-2 | |
| | Mirror-3 | |
| Lens unit | Lens | |
| | CCD driving PC board (CCD) | |
| Automatic original detection sensor (S1, S2*) | | |
| Driving Section | Scan motor (M1) | <ul style="list-style-type: none"> • 2-phase stepping motor • Drives the carriage-1 and carriage-2 |
| Others | Carriage home position sensor (S3) | |
| | Platen sensor-1 (S4) | |
| | Platen sensor-2 (S5) | |

* S2 is for LT.

3.8.3 Functions

The following shows the construction and purpose of the scanning system:

1. Original glass

This is the glass for placing an original. The light from the exposure lamp (EXP) is irradiated to the original through this original glass. The ADF original glass is used when an original is read with the Automatic Document Feeder. The original is transported on the ADF original glass by the Automatic Document Feeder and the transported original is scanned under the ADF original glass by the carriage. The surface of the ADF original glass is coated so as not to be scratched by originals. Therefore, do not use such solvents as alcohol when cleaning the surface of the ADF original glass.

2. Carriage-1

The carriage-1 consists of the exposure lamp (EXP), reflector, mirror-1, etc. The carriage-1 is driven by the scan motor (M1) and scans an original on the glass.

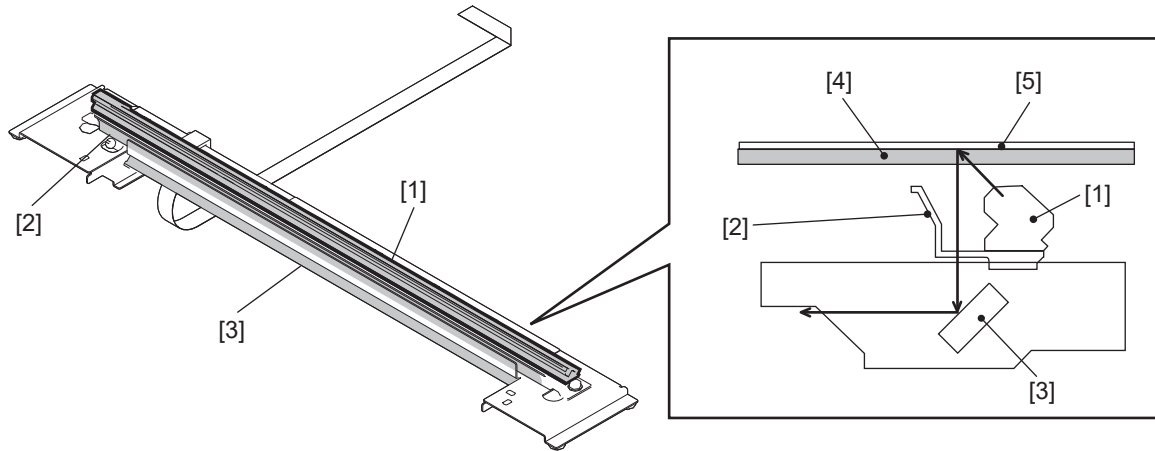

Fig. 3-37

- [1] Exposure lamp
- [2] Reflector
- [3] Mirror-1
- [4] Original glass
- [5] Original

- Exposure lamp (EXP)
This lamp is the light source to irradiate the original on the glass. An LED lamp is used in this MFP.
- Reflector
This is a plate to direct the light from efficiently the exposure lamp (EXP) to the surface of the original on the glass.
- Mirror-1
This mirror directs the light reflected from the original to the mirror-2, which will be described later.

3. Carriage-2

The carriage-2 mainly consists of the mirror-2, mirror-3, etc. and directs the reflected light from the mirror-1 through the mirrors-2 and -3 to the lens.

This carriage is driven by the same scan motor (M1) as that for the carriage-1 at half the scanning speed of the carriage-1. (The scanning distance is also half that of the carriage-1.)

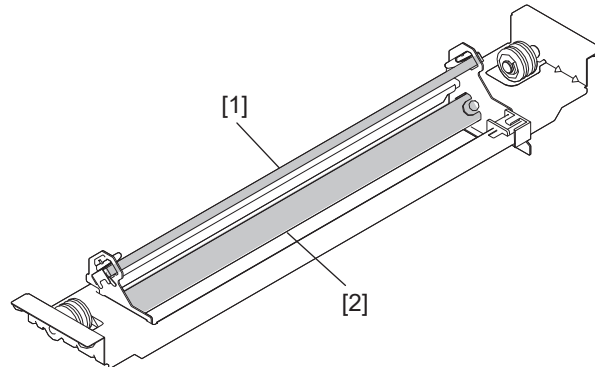

Fig. 3-38

[1] Mirror-2

[2] Mirror-3

4. Lens unit

The light reflected from the mirror-3 is led to the CCD placed at the focal point of the lens which is fixed in a position.

5. CCD driving PC board (CCD)

Processes such as signal amplification, signal integration and A/D conversion are applied on the electrical signal which was converted by the CCD.

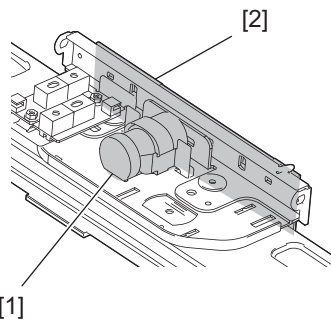

Fig. 3-39

[1] Lens unit

[2] CCD driving PC board

6. Automatic original detection sensors (S1, S2)

The size of the original placed on the glass is instantly detected using the automatic original detection sensors (S1, S2) fixed on the base frame without moving the carriage-1.

3.8.4 Operation description

[1] Scanning operation

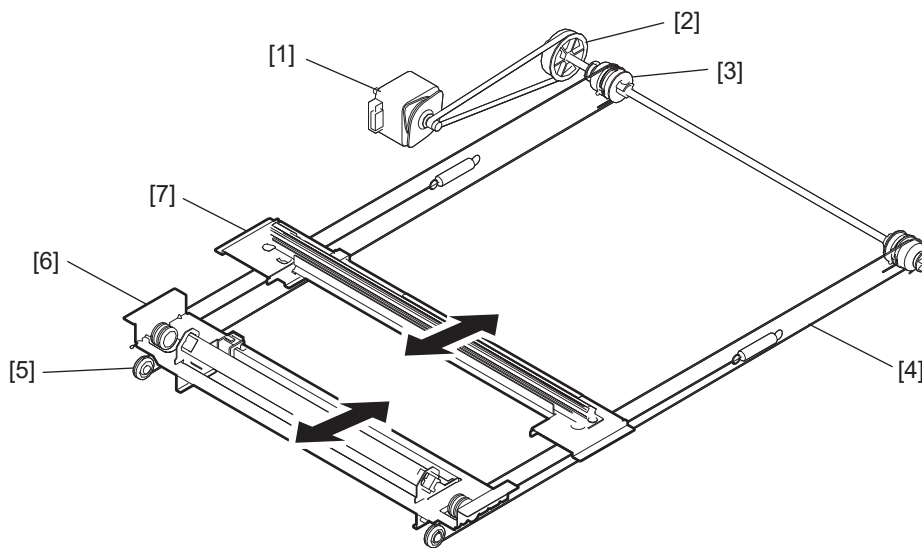

Fig. 3-40

- [1] Scan motor
- [2] Drive pulley
- [3] Wire pulley
- [4] Wire
- [5] Idler pulley
- [6] Carriage-2
- [7] Carriage-1

- Scanning of an original placed on the original glass
The scan motor (M1) drives the carriages-1 and -2 through the timing belt and carriage wire. First, the scan motor drives the carriages-1 and -2 to their respective home positions. The home positions are detected when the carriage-1 passes the home position sensor (S3). When the [START] button is pressed, both carriages start to move and scan the original on the glass.
- Scanning of an original placed on the DSDF
The carriage-1 stays at the shading position during shading correction and at the scanning position during scanning operation.
- Carriage speed
The carriage speed of the original placed on the original glass in the color mode is the same as that in the black mode.

3.8.5 Process of original size detection

In this MFP, detection of the original sizes is performed with the combination of the CCD and automatic original detection sensors-1 and -2 (S1, S2).

The size in the primary scanning direction is detected by the CCD while that in the secondary scanning direction is detected by the sensors.

[1] Original size detection procedure

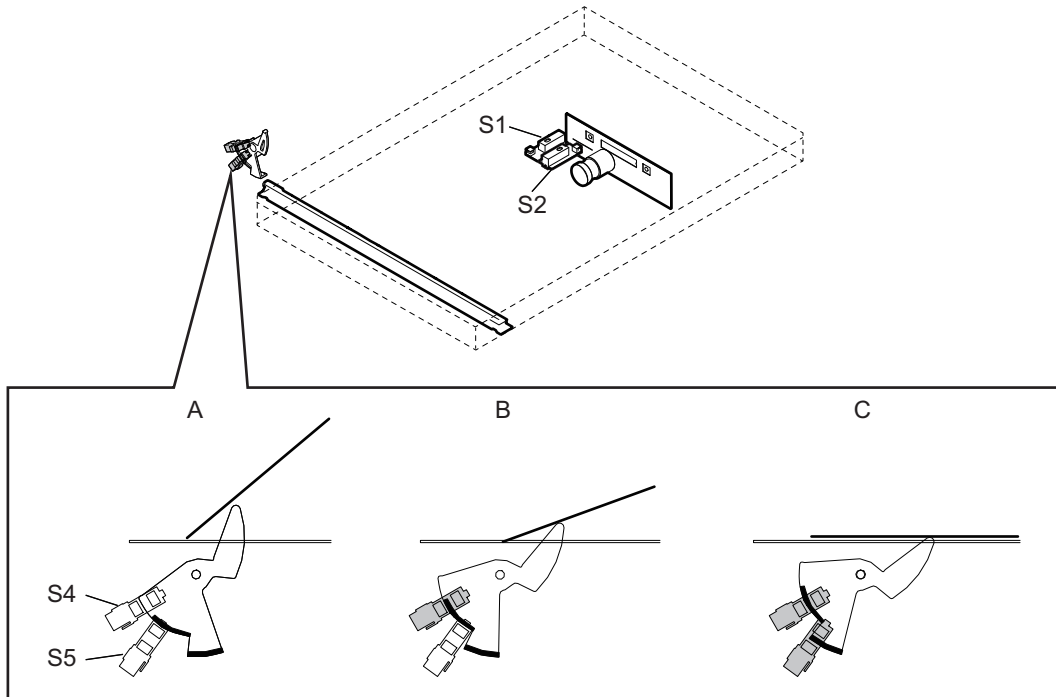

Fig. 3-41

A: DSDF fully opened

When the DSDF is fully opened, the original size is not detected.

B: DSDF opened by 25 degrees: Detected by the platen sensor-1 (S4)

When this status is detected, the exposure lamp of the scanner emits light and the presence/absence of the original in the secondary scanning direction and the paper size of the original in the primary scanning direction are detected by the automatic original detection sensor. (As for the LT series, two automatic original detection sensors are used.)

C: DSDF closed: Detected by the platen sensors-1 and -2 (S4, S5)

This status is detected by the platen sensor-1 (S4) and platen sensor-2 (S5).

The exposure lamp of the scanner emits light for a short time and the sensors detect the length of the original in the primary scanning direction again.

Remarks:

When the DSDF is fully closed or closed by 25 degrees or less, the exposure lamp emits light as follows.

Light emitted → OFF → light emitted → OFF → carriage moved

If the connectors are connected to the platen sensors-1 (S4) and -2 (S5) in reverse, the exposure lamp emits light as follows.

Light emitted → OFF → carriage moved → light emitted

When the following phenomena have occurred, the platen sensor-1 (S4) may be damaged. In such a case, check the sensors and the harnesses.

- The exposure lamp does not emit light even when the platen cover is opened by 25 degrees.
- The detected paper size of the original is not correct.

[2] Detection points

The detection points in the primary and secondary scanning directions are as follows.

- **Sensor detection points (A4 and K Series)**

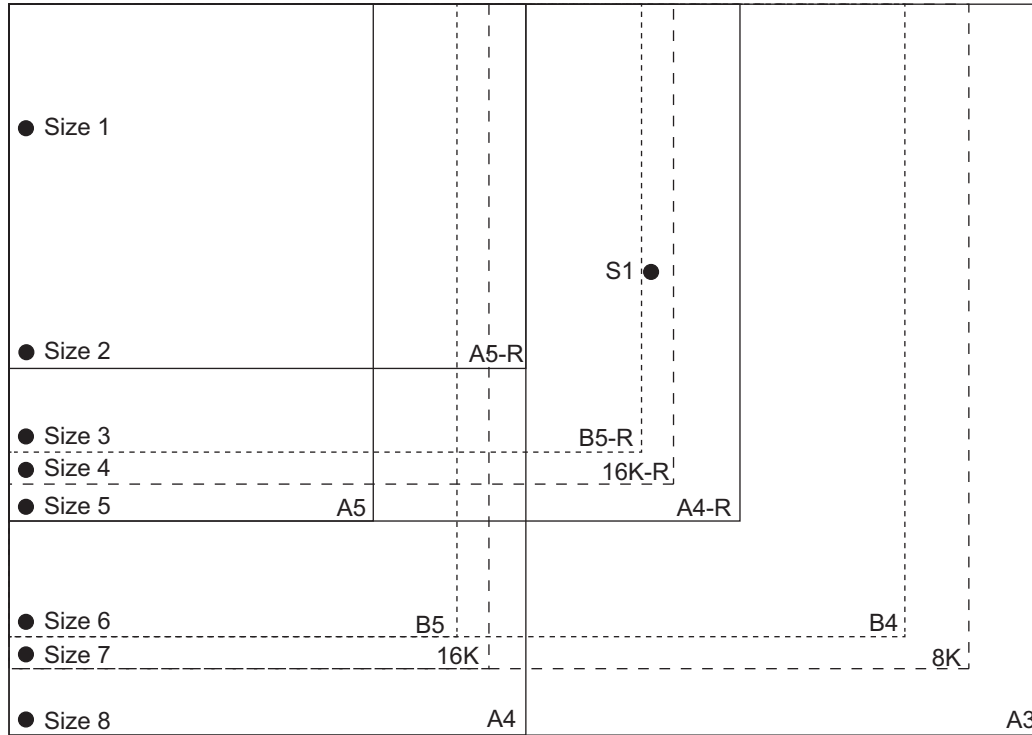

Fig. 3-42

- **Sensor detection points (LT Series)**

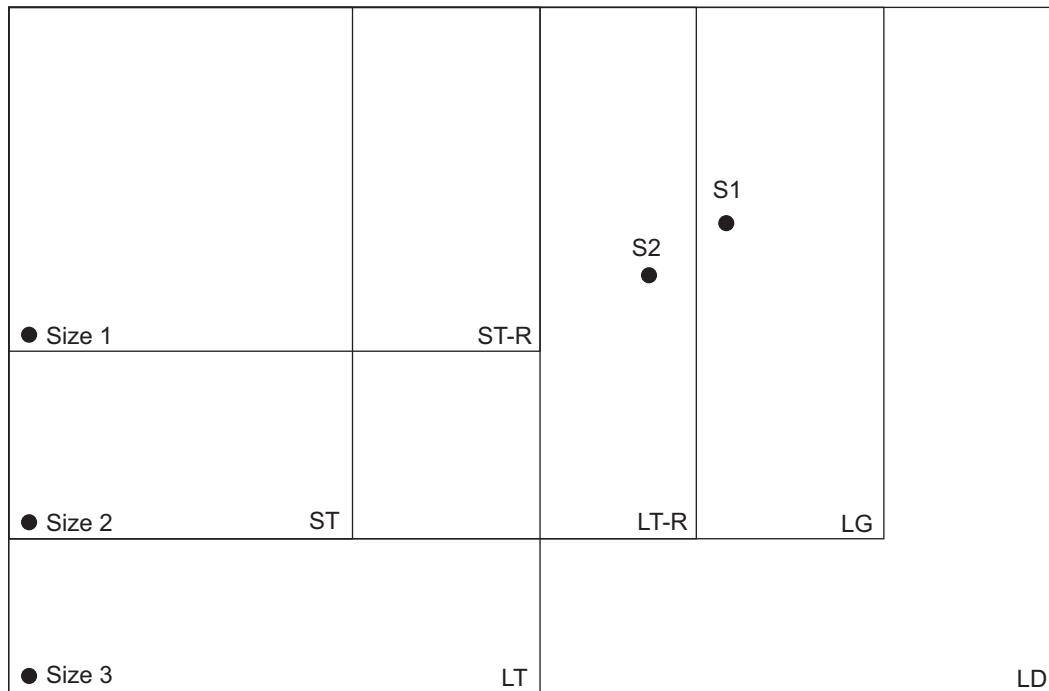

Fig. 3-43

3.9 Data Writing Section

3.9.1 Overview

In the data writing section, the laser optical unit radiates the laser beam onto the photoconductive drum in response to the digital image signals transmitted from the scanner, USB storage device, network, etc. to create a latent image. The image signal is converted into the light emission signal of the laser diode on the laser driving PC board (LDR), then radiated on the photoconductive drum through optical elements such as a polygonal mirror (polygonal motor) and a lens. They are very sensitive to dust and are finely adjusted at the factory. The units must not be disassembled in the field.

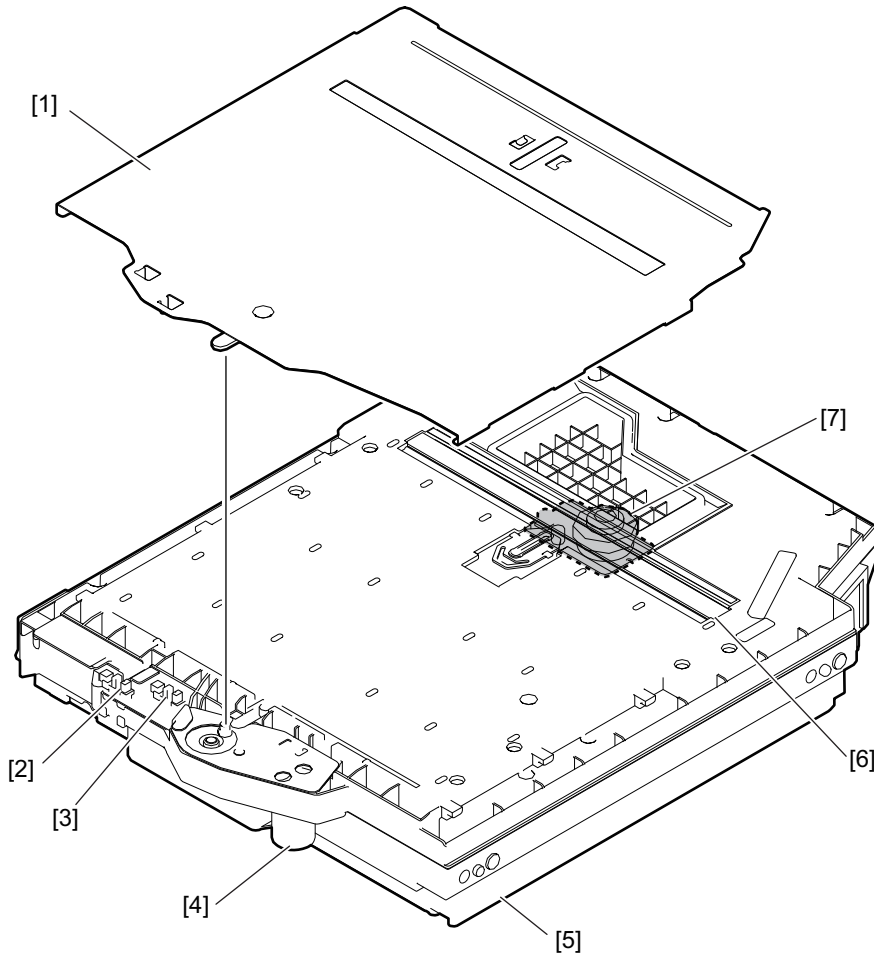

Fig. 3-44

- [1] Shutter
- [2] Shutter sensor (end position)
- [3] Shutter sensor (home position)
- [4] Shutter motor
- [5] Laser optical unit
- [6] Slit glass
- [7] Polygonal motor

3.9.2 Laser precautions

A laser diode is used for this MFP and radiates an invisible laser beam.

Since it is not visible, be extremely careful when handling the laser optical unit components, performing operations or adjusting the laser beam. Also, never perform the procedure with other than the specified manuals because you could be exposed to laser radiation.

The laser optical unit is completely sealed with a protective cover. As long as only the operations of specified manuals are performed, the laser beam does not leak and you are in no danger of being exposed to laser radiation.

The following cautionary label for the laser is attached to the frame inside of the front lower cover.

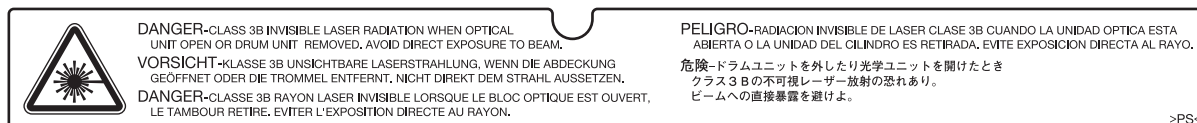

Fig. 3-45

Notes:

- Avoid exposure to the laser beam during service. This MFP uses a laser diode. Be sure not to expose your eyes to the laser beam. Do not insert reflecting parts or tools such as screwdrivers into the laser beam path. Remove all reflecting metals such as watches, rings, etc. before starting service.
- When servicing the MFP with the power turned ON, be sure not to touch live sections and rotating/operating sections. Avoid exposing your eyes to the laser beam.
- During servicing, be sure to check the rating plate and cautionary labels such as “Unplug the power cable during service”, “CAUTION. HOT”, “CAUTION. HIGH VOLTAGE”, “CAUTION. LASER BEAM”, etc. to see if there is any dirt on their surface and if they are properly stuck to the MFP.

3.9.3 Slit glass cleaning mechanism

The laser optical unit has a protective shutter on its upper section. This shutter is opened or closed with the drive from the shutter motor (M38). Two shutter sensors (S24 for the home position and S25 for the end position) detect the phase of the shutter when it is opened or closed. When the shutter is closed, the shutter sensor (home position) (S24) is turned ON.

A cleaning brush installed inside of the shutter cleans the slit glass when the shutter is opened or closed. The shutter performs cleaning by opening or closing itself every time the power is turned ON, printing starts, printing ends or image quality control is performed.

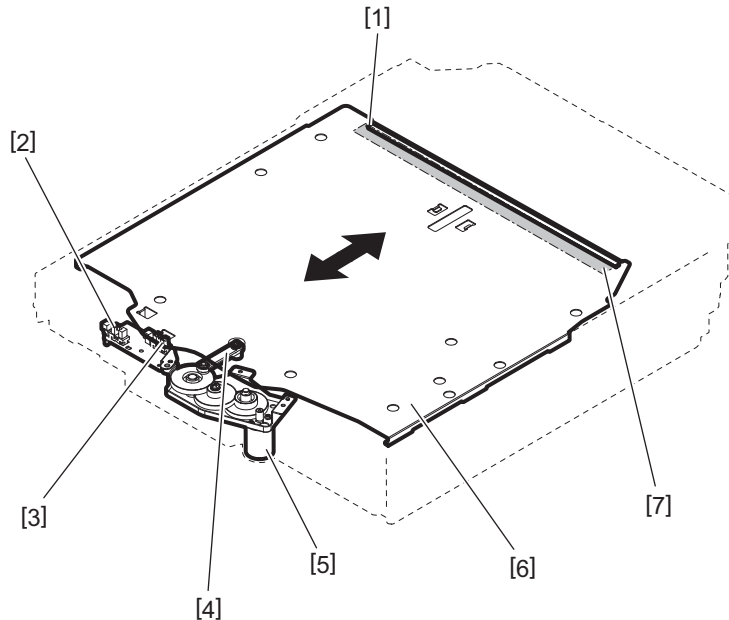

Fig. 3-46

- [1] Brush
- [2] Shutter sensor (end position)
- [3] Shutter sensor (home position)
- [4] Link
- [5] Shutter motor
- [6] Shutter
- [7] Slit glass

3.10 Paper Feeding Section

3.10.1 Overview

This chapter explains how the system works to pick up paper from the drawer or bypass tray and transport it to the 2nd transfer position.

The paper feeding section mainly consists of the pickup roller, paper feed roller, separation roller, transport roller, registration roller, bypass tray paper sensor, drawer paper empty sensor, paper nearly empty sensor, bypass tray paper feed sensor, drawer paper feed sensor, registration sensor and the drive system for these components. The transport motor-1, transport motor-2, 1st/2nd drawer paper feed motor, 3rd/4th drawer/T-LCF paper feed motor and registration motor drive the above rollers.

4-drawer model

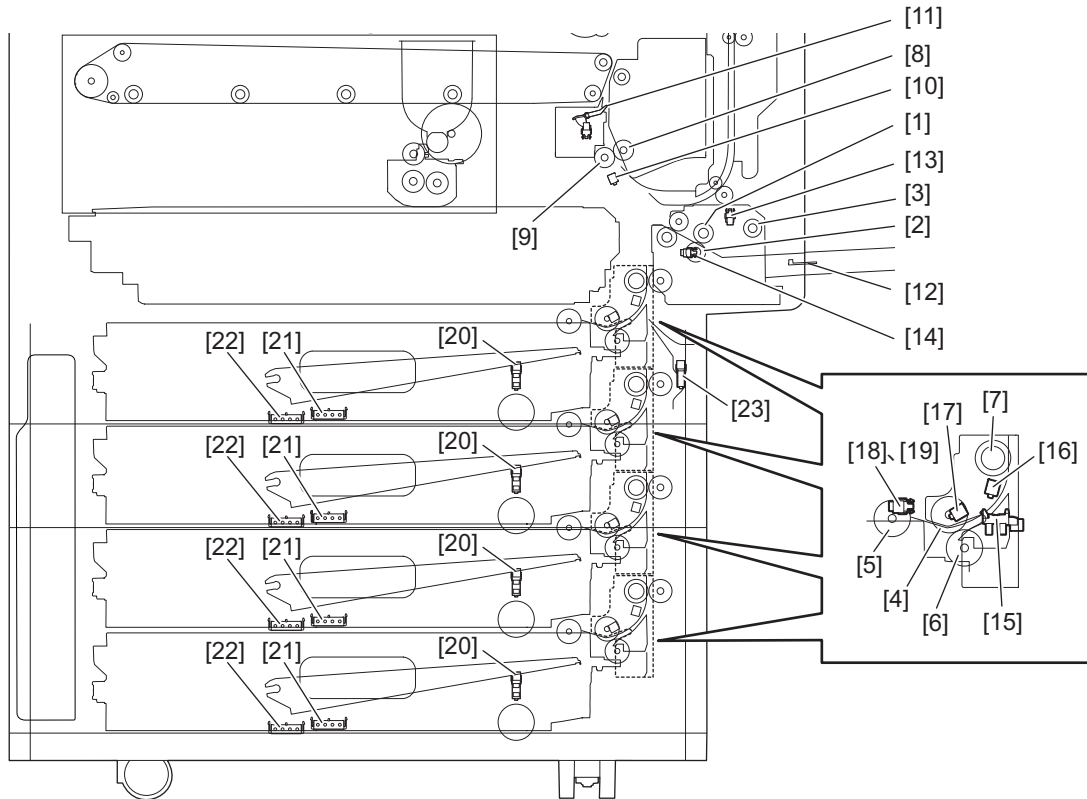

Fig. 3-47

| Symbol | Name | Symbol | Name |
|--------|--|--------|---|
| 1 | Bypass tray paper feed roller | 13 | Bypass tray paper sensor |
| 2 | Bypass tray separation roller | 14 | Bypass tray paper feed sensor |
| 3 | Bypass tray pickup roller | 15 | 1st / 2nd / 3rd / 4th drawer detection sensor |
| 4 | 1st / 2nd / 3rd / 4th drawer paper feed roller | 16 | 1st / 2nd / 3rd / 4th drawer transport sensor |
| 5 | 1st / 2nd / 3rd / 4th drawer pickup roller | 17 | 1st / 2nd / 3rd / 4th drawer paper feed sensor |
| 6 | 1st / 2nd / 3rd / 4th drawer separation roller | 18 | 1st / 2nd / 3rd / 4th drawer paper empty sensor |
| 7 | 1st / 2nd / 3rd / 4th drawer transport roller | 19 | 1st / 2nd / 3rd / 4th drawer tray-up sensor |
| 8 | Registration roller (rubber) | 20 | 1st / 2nd / 3rd / 4th drawer bottom sensor |
| 9 | Registration roller (metal) | 21 | 1st / 2nd / 3rd / 4th drawer paper width detection sensor |
| 10 | Registration sensor | 22 | 1st/2nd/3rd/4th drawer paper length detection sensor |
| 11 | Transfer belt paper clinging detection sensor | 23 | Paper feed cover sensor |
| 12 | SFB PC board | | |

Tandem LCF model

The composition of the 1st and 2nd drawers of the tandem LCF model is the same as that of the 4-drawer model.

The 3rd and the 4th drawers are not installed but instead the tandem LCF is installed.

Tandem LCF sectional view (front side)

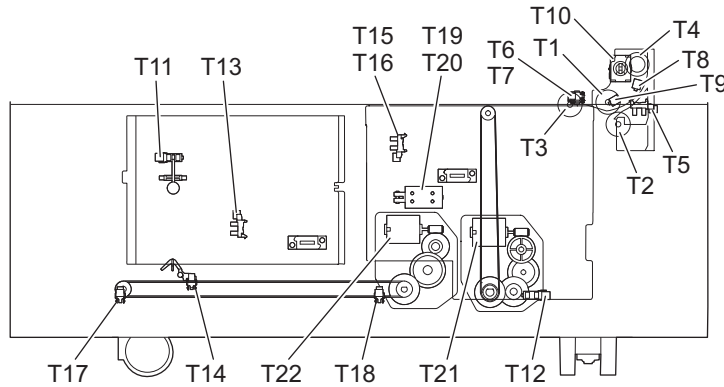

Fig. 3-48

| Symbol | Name | Symbol | Name |
|--------|---|--------|--|
| T1 | Paper feed roller | T12 | T-LCF bottom sensor |
| T2 | Separation roller | T13 | T-LCF standby side tray detection sensor |
| T3 | Pickup roller | T14 | T-LCF standby side paper empty sensor |
| T4 | Transport roller | T15 | T-LCF stopper opening/closing detection sensor (front) |
| T5 | 3rd drawer/T-LCF detection sensor | T16 | T-LCF stopper opening/closing detection sensor (rear) |
| T6 | 3rd drawer/T-LCF paper empty sensor | T17 | T-LCF end fence home position sensor |
| T7 | T-LCF tray-up sensor | T18 | T-LCF end fence stop position sensor |
| T8 | 3rd drawer/T-LCF transport sensor | T19 | T-LCF stopper opening/closing solenoid (front) |
| T9 | 3rd drawer/T-LCF paper feed sensor | T20 | T-LCF stopper opening/closing solenoid (rear) |
| T10 | T-LCF pickup solenoid | T21 | T-LCF tray-up motor |
| T11 | T-LCF standby side tray paper amount detection sensor | T22 | T-LCF end fence motor |

3.10.2 Composition

| Paper feeding section | | |
|--|--|---------------------|
| 1st/2nd/3rd/4th drawer paper feed unit | 1st / 2nd / 3rd / 4th drawer pickup roller | |
| | 1st / 2nd / 3rd / 4th drawer paper feed roller | |
| | 1st / 2nd / 3rd / 4th drawer separation roller | |
| | 1st / 2nd / 3rd / 4th drawer transport roller | |
| | 1st / 2nd / 3rd / 4th drawer paper feed sensor | S78, S86, S94, S102 |
| | 1st / 2nd / 3rd / 4th drawer transport sensor | S77, S85, S93, S101 |
| | 1st / 2nd / 3rd / 4th drawer tray-up sensor | S76, S84, S92, S100 |
| | 1st / 2nd / 3rd / 4th drawer paper empty sensor | S75, S83, S91, S99 |
| | 1st / 2nd / 3rd / 4th drawer detection sensor | S73, S81, S89, S97 |
| Bypass unit | Bypass tray pickup roller | |
| | Bypass tray paper feed roller | |
| | Bypass tray separation roller | |
| | Bypass tray paper sensor | S71 |
| | Bypass tray paper feed sensor | S72 |
| | Bypass pickup solenoid | SOL8 |
| | Paper width detection PC board | SFBB |
| | Bypass tray motor | M12 |
| Driving section, others | 3rd drawer transport clutch, 4th drawer transport clutch | CLT4, CLT6 |
| | 3rd drawer paper feed clutch, 4th drawer paper feed clutch | CLT5, CLT7 |
| | Transport motor-1, Transport motor-2 | M40, M41 |
| | 1st/2nd drawer paper feed motor | M42 |
| | 3rd/4th drawer/T-LCF paper feed motor | M43 |
| | Registration motor | M39 |
| | Registration roller | |
| | Registration sensor | S52 |
| | Transfer belt paper clinging detection sensor | S47 |
| 1st / 2nd / 3rd / 4th drawer tray-up motor | M44, M49, M45, M50 | |
| Tandem LCF | Tandem LCF pickup roller | |
| | Tandem LCF paper feed roller | |
| | Tandem LCF separation roller | |
| | Tandem LCF transport roller | |
| | T-LCF paper feed sensor | S94 |
| | T-LCF transport sensor | S93 |
| | T-LCF pickup solenoid | SOL9 |
| | T-LCF end fence motor | M47 |
| | T-LCF tray-up motor | M46 |

3.10.3 Functions

1. Pickup roller (drawers and bypass tray)
This roller moves up and down to draw out a sheet of paper from the bypass tray or drawer and transport it to the paper feed roller.
2. Paper feed roller (drawers and bypass tray)
The paper feed roller is facing to the separation roller. It transports the paper transported from the pickup roller to the transport roller.
3. Separation roller (drawers and bypass tray)
This roller is facing to the paper feed roller. When two or more sheets of paper are transported from the pickup roller, the load of the torque limiter of the separation roller is greater than the frictional force between the sheets. As the result, the separation roller is stopped and the lower sheet of paper is not transported any further.
When only one sheet of paper is transported from the pickup roller, the separation roller is forced to rotate following the paper feed roller.
4. Transport roller (drawers and bypass tray)
This roller transports the paper transported from the paper feed roller to the registration roller.
5. Registration roller
Paper transported from the transport roller is pushed against the registration roller (which is not being rotated) which aligns the leading edge of the paper. Then the registration roller rotates to transport the paper to the transfer unit.
6. Bypass tray paper sensor (S71)
This sensor detects that paper is set on the bypass tray. If paper is set on the bypass tray, bypass feeding always takes priority before drawer feeding.
7. Drawer paper empty sensor (S75, S83, S91, S99)
This is a transmissive-type sensor which detects the availability of paper in the drawer by using an actuator. When there is no paper in the drawer, the actuator blocks the light path of the sensor, and the sensor determines that there is no paper.
8. Drawer paper empty sensor (S78, S86, S94, S102)
This sensor detects that the leading edge and trailing edge of the paper has passed the paper feed roller. This sensor is also utilized to detect the jams such as paper misfeeding.
9. Drawer transport sensor (S77, S85, S93, S101)
This is a reflective sensor whose purpose is to directly detect if paper is set or not, without using any device such as a sensor arm.
This sensor detects that the leading edge and trailing edge of the paper has passed the transport roller. This sensor is also utilized to detect the jams such as paper misfeeding.
10. Registration sensor (S52)
This sensor detects that the leading edge of the paper has reached the registration roller. This sensor also detects that the trailing edge of the paper has passed the registration roller.
11. Drawer tray-up sensor (S76, S84, S92, S100)
This sensor stops the tray at the specified height when it is being lifted up. When this sensor is turned ON, the tray-up motor stops lifting up the tray.
12. Drawer detection sensor (S73, S81, S89, S97)
This sensor detects if the drawer is fully inserted.
13. 3rd drawer paper feed clutch, 4th drawer paper feed clutch (CLT5, CLT7)
This clutch transmits the drive from the 3rd/4th drawer/T-LCF paper feed motor to the pickup roller and paper feed roller.

14. 3rd drawer transport clutch, 4th drawer transport clutch (CLT4, CLT6)
This clutch transmits the drive from the 3rd/4th drawer/T-LCF paper feed motor to the transport roller. When the clutch is turned ON, the transport roller rotates at high speed to transport paper.
15. 3rd/4th drawer/T-LCF paper feed motor (M43)
This motor drives the pickup rollers, paper feed rollers and transport rollers of the drawers and T-LCF.
16. Registration motor (M39)
This motor drives the registration roller. This stepping motor transports paper in the transfer direction in time with the image transfer to align the paper with the leading edge of the image.
17. 1st drawer tray-up motor, 2nd drawer tray-up motor, 3rd drawer tray-up motor, 4th drawer tray-up motor (M44, M49, M45, M50)
This motor lifts up the tray in the drawer.
18. Bypass tray motor (M12)
This is a stepping motor to drive the pickup roller, paper feed roller and transport roller in the bypass tray.
19. Bypass pickup solenoid (SOL8)
This solenoid moves down the bypass tray pickup roller.
20. Paper width detection PC board (SFBB)
This sensor works directly with the side guides of the bypass tray to detect the paper width on it.
21. Drawer paper width detection sensor, Drawer paper length detection sensor (S79, S80, S87, S88, S95, S96, S103, S104)
These sensors detect the size of the paper placed in each drawer.
The paper sizes can be detected with the combination of switch signals that are sent by the movement of the end and side guides in each drawer.
For the detection operation, refer to the operation description section.

3.10.4 Operation description

[1] Driving the rollers

The drive of the each motor in the paper feeding section is transmitted to the paper transport rollers as below.

4-drawer model

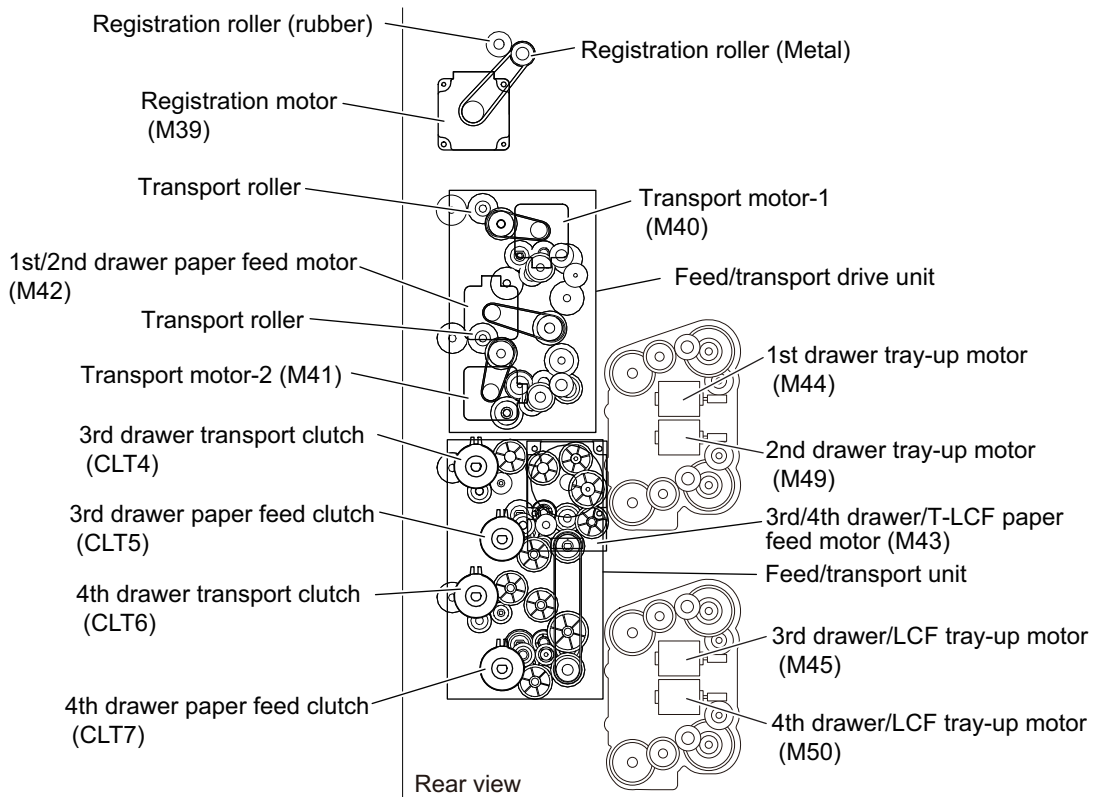
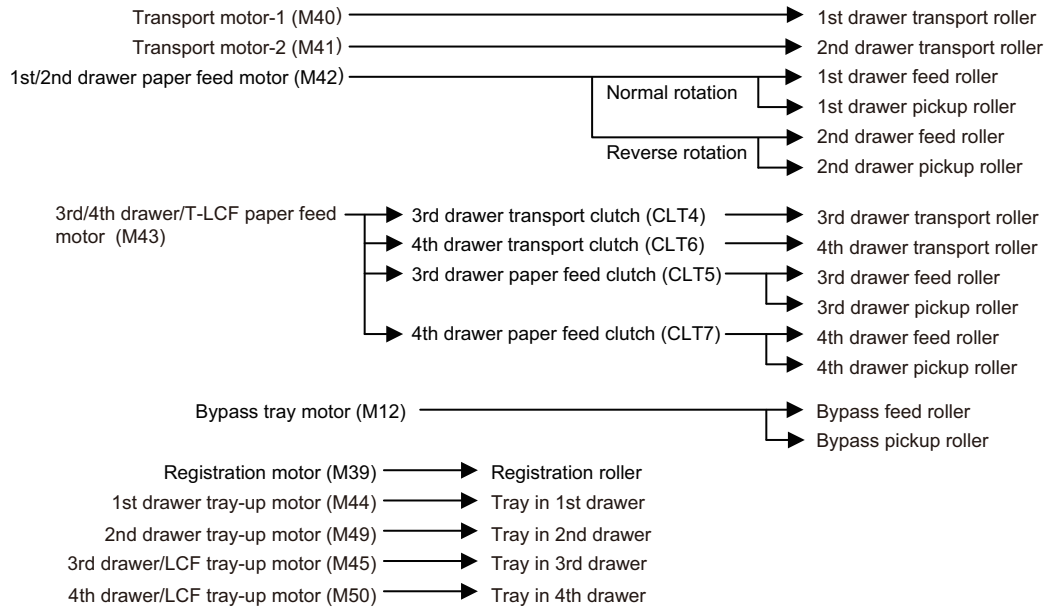

Fig. 3-49

Tandem LCF model

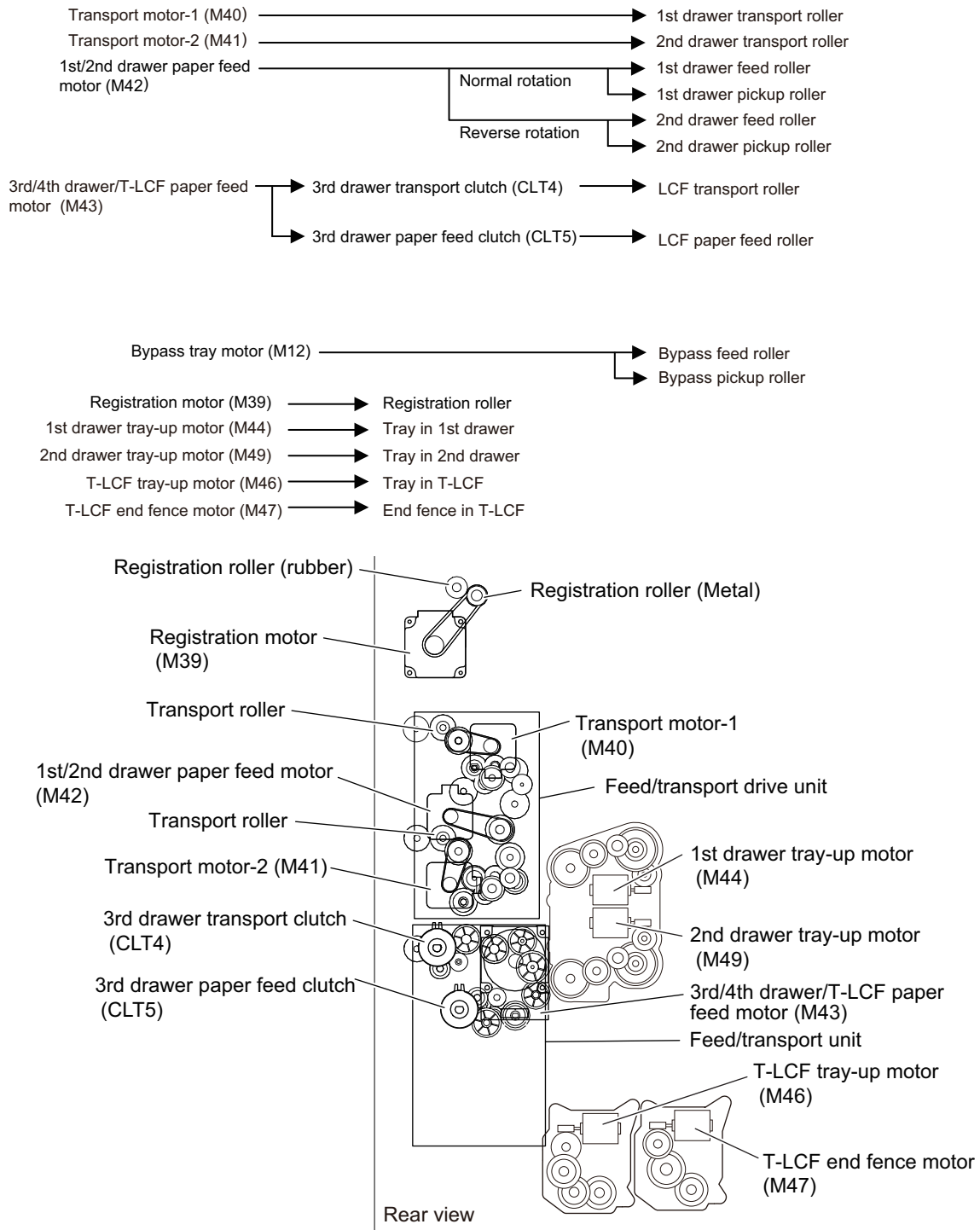

Fig. 3-50

[2] Driving of the bypass tray pickup roller

When the bypass pickup solenoid (SOL8) is turned ON, the plunger is pulled and then the lever is rotated. The pickup arm is then brought down with its own weight. When the bypass pickup solenoid (SOL8) is turned OFF, the pickup arm is brought up by the spring force.

The driving force transmitted through the bypass tray motor (M12) is transmitted to the bypass tray paper feed roller through the shaft and then to the bypass tray pickup roller through the timing belt. The roller is rotated by this driving force.

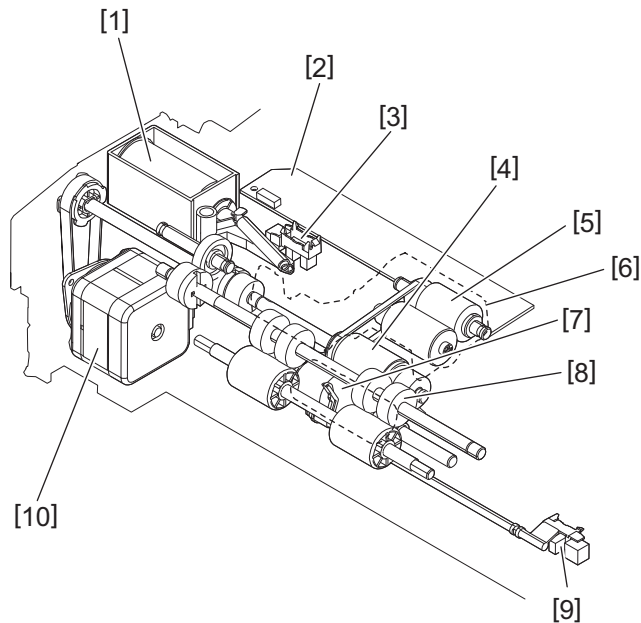

Fig. 3-51

- [1] Bypass pickup solenoid
- [2] Paper width detection PC board
- [3] Bypass tray paper sensor
- [4] Bypass tray paper feed roller
- [5] Bypass tray pickup roller
- [6] Pickup arm
- [7] Bypass tray separation roller
- [8] Bypass tray transport roller
- [9] Bypass tray paper feed sensor
- [10] Bypass tray motor

[3] Driving of the drawer pickup roller

When the drawer is inserted, the protrusion at the rear side of the drawer pushes the lever in the direction of A. Then the pickup roller and roller holder are lowered by the spring force.

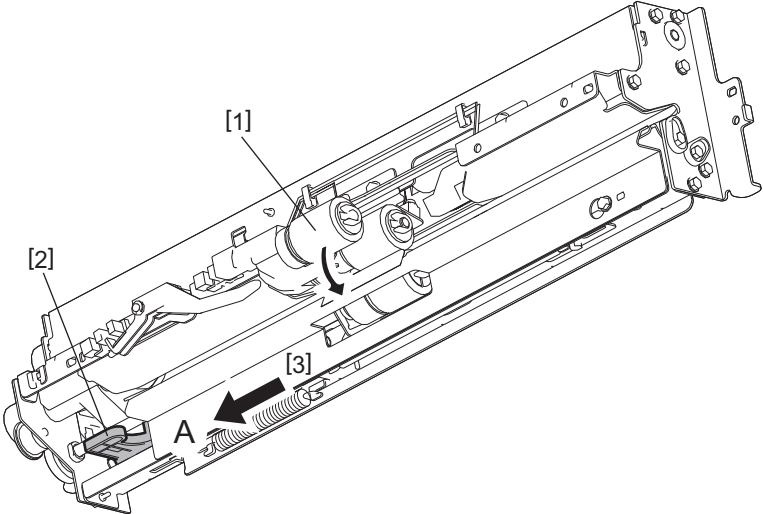

Fig. 3-52

- [1] Pickup roller
- [2] Lever
- [3] Drawer insertion direction

[4] Paper size detection in the drawers

This MFP automatically detects the size of the paper placed in each drawer.

The end and side guides in each drawer are moved according to the paper size and a pusher moves together with those guides.

Then the protrusion of this pusher pushes each button of the drawer paper width detection sensor and the drawer paper length detection sensor.

Thus the paper size is detected with the combination of the pushing statuses of these sensors.

The drawer paper width detection sensor detects the movement of the side guides while the drawer paper length detection sensor detects that of the end guide.

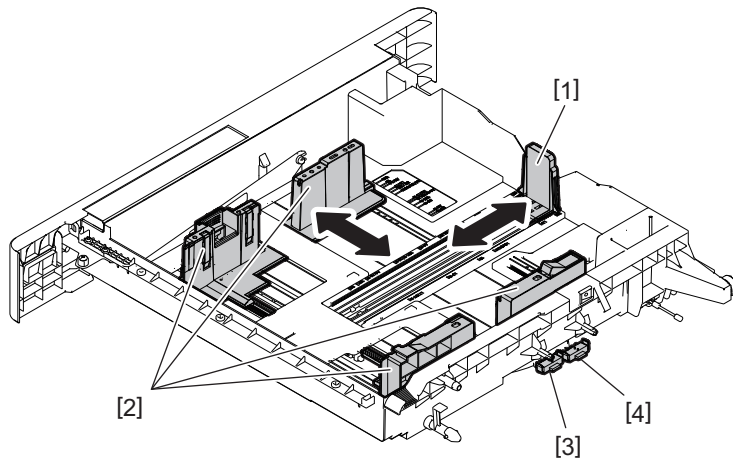

Fig. 3-53

The positions of the guides and the pusher in the cases of A3 and A4-R are shown below as examples

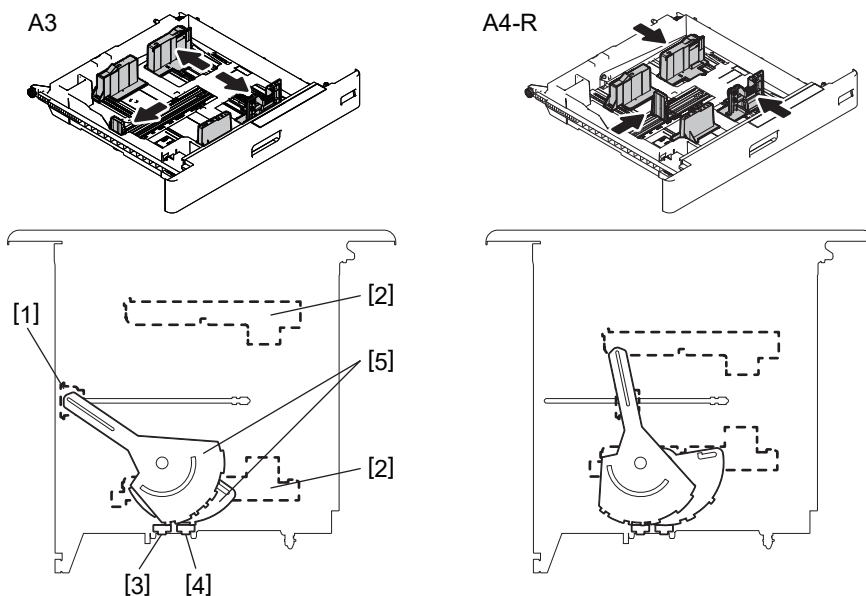

Fig. 3-54

- [1] End guide
- [2] Side guide
- [3] Drawer paper width detection switch
- [4] Drawer paper length detection switch
- [5] Pusher

[5] Drawer automatic pull-in mechanism

When the drawer is inserted, it is slowly pulled in by means of the damper and soft-close unit installed in it.

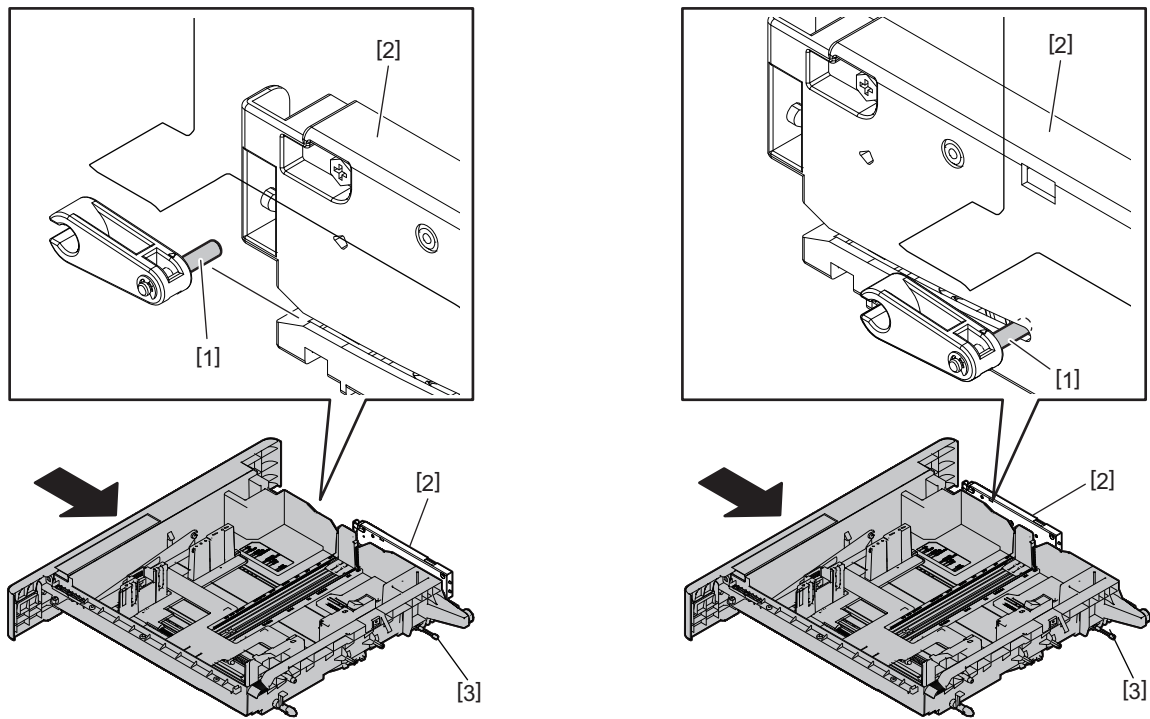

Fig. 3-55

- [1] Drawer (PIN)
- [2] Soft-close unit
- [3] Damper

[6] General Operation

[A] From power-ON to ready status

1. When the MFP is turned ON, the tray-up motors (M44, M45, M49, M50) in each drawer are activated and the drawer trays in each drawer start to rise. When the tray-up sensors (S76, S84, S92, S100) in each drawer are turned ON (L→H), the tray-up motors (M44, M45, M49, M50) in each drawer are turned OFF to stop the trays. At this time, if the paper empty sensors (S75, S83, S91, S99) in each drawer are OFF (L), it is judged that there is no paper in the drawer. If the sensors are ON (H), it is judged that there is paper in the drawer. The tray stops at the raised position regardless of the availability of paper.
2. If the drawer is pulled out when the MFP is turned ON, the tray for that drawer is not raised. When the drawer is inserted completely, the tray is raised and checks for the availability of paper.
3. If either of the sensors on the transport path is ON (meaning there is paper on the transport path) when the MFP is turned ON, it is determined that a paper misfeed has occurred and no operation is enabled until the paper is removed.

[B] Ready status

- After the tray is moved up and the availability of paper is checked as described above, the MFP enters the ready status. At the ready status, the tray remains at the raised position.
- When a drawer is inserted or pulled out at the ready status, the tray is raised again to check for the availability of paper.

[C] Paper feeding from the bypass tray

- The bypass tray paper sensor (S71) detects the paper on the bypass tray.
- When the bypass pickup solenoid (SOL8) is turned ON, the bypass tray pickup roller moves downward.
- The bypass tray motor (M12) is turned ON and then the bypass tray pickup roller, bypass tray paper feed roller and bypass tray transport roller are rotated and start feeding.
- When the leading edge of the paper turns the bypass tray paper feed sensor (S72) ON, the bypass pickup solenoid (SOL8) is turned OFF and then the bypass tray pickup roller is raised.
- The leading edge of the paper turns the registration sensor (S52) ON and the paper is aligned by the registration rollers.
- The bypass tray motor (M12) is turned OFF and then the bypass tray pickup roller, bypass tray paper feed roller and bypass tray transport roller are stopped.
- The registration motor (M39) is turned ON and the paper is transported to the transfer position.

[D] Paper feeding from the drawer

[D-1] 2nd drawer

- The 1st and 2nd drawer paper feed motors and transfer motors are turned ON and the pickup rollers, paper feed rollers and transport rollers are rotated to start feeding paper.
- Passing of the leading edge of the paper turns ON the 2nd drawer paper feed sensor and then the 2nd transport sensor is turned ON.
- The leading edge of the paper turns the registration sensor ON and the paper is aligned by the registration rollers.
- The transport motor is turned OFF and the transport roller is stopped.
- The registration motor (M39) and transport roller are turned ON and the paper is transported to the transfer position.

[D-2] 1st drawer

- The 1st and 2nd drawer paper feed motors and transfer motors are turned ON and the pickup rollers, paper feed rollers and transport rollers are rotated to start feeding paper.
- The passing of the leading edge of the paper turns ON the 1st drawer paper feed sensor and then the 1st transport sensor is turned ON.
- The leading edge of the paper turns the registration sensor ON and the paper is aligned by the registration rollers.
- The transport motor is turned OFF and the transport roller is stopped.
- The registration motor (M39) and transport roller are turned ON and the paper is transported to the transfer position.

3.11 Process Unit Related Section

3.11.1 Overview

There are cleaner, main charger and developer unit in this MFP.

This chapter explains about the process unit and parts around this unit which are provided for image formation.

The toner is supplied to the developer unit from the toner cartridge via the sub-hopper.

This enables printing to be performed using the toner charged in the sub-hopper even if the toner cartridge is replaced during the operation.

The developer material, which is comprised of a mixture of the carrier and toner, is filled in the developer unit. The carrier is charged to a positive polarity and the toner to a negative polarity due to the mutual friction caused by the mixing in the developer unit. The charged toner is supplied to the photoconductive drum surface by means of a magnetic roller, allowing it to adhere to the areas on the drum surface where the potential is lower than the developer bias which is applied to the magnetic roller. Through this process, latent images are formed on the photoconductive drum surface.

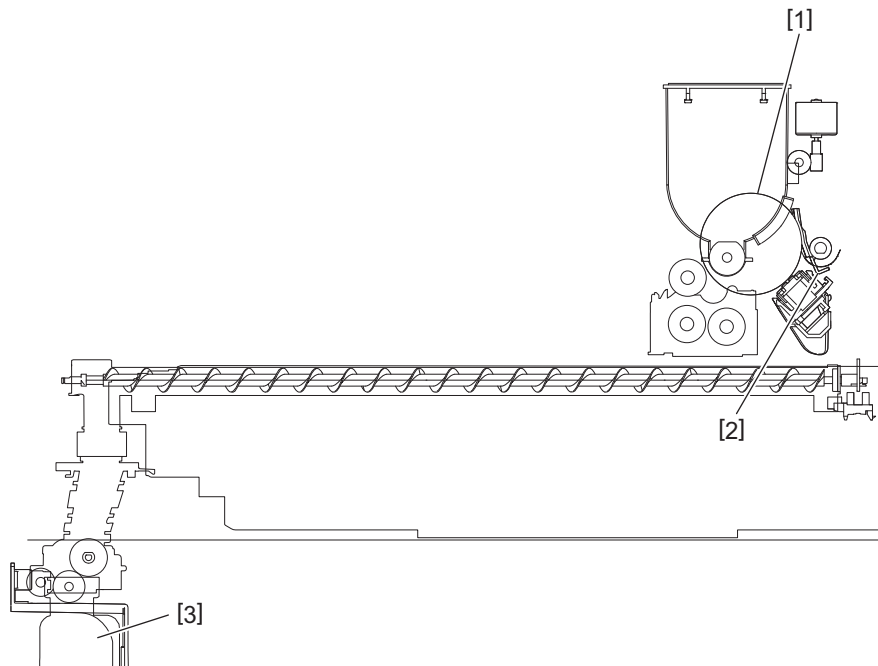

Fig. 3-56

[1] Drum

[2] Drum cleaner

[3] Waste toner box

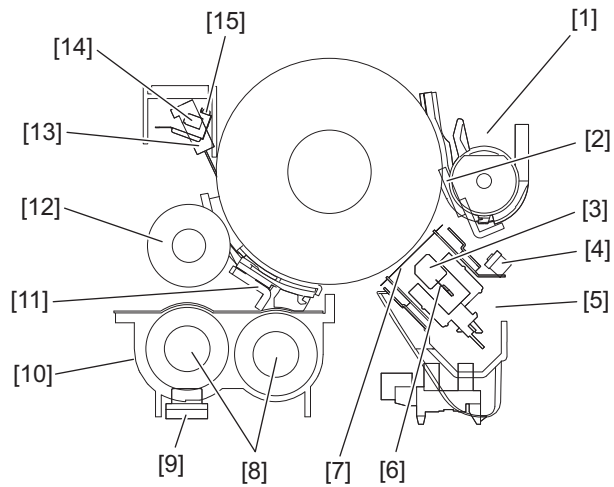

Fig. 3-57

- [1] Drum cleaner unit
 - [2] Cleaning blade
 - [3] Needle electrode cleaner
 - [4] Discharge LED
 - [5] Main charger unit
 - [6] Needle electrode
 - [7] Grid
 - [8] Mixer
 - [9] Auto-toner sensor
 - [10] Development unit
 - [11] Doctor blade
 - [12] Developer sleeve (Magnetic roller)
 - [13] Drum thermistor
 - [14] Drum surface potential (V0) sensor (K) *1
 - [15] Shutter *1
- *1 : 9029A only

3.11.2 Composition

| | | | |
|-------------------------|------------------------------------|---|-------|
| Process unit | Drum cleaner unit | Drum | |
| | | Cleaning blade | |
| | | Recovery blade | |
| | | Blade side seal | |
| | | Toner recovery auger | |
| | Main charger unit | Grid | |
| | | Needle electrode | |
| | | Needle electrode cleaner | |
| | | Discharge LED | ERS-K |
| | Drum surface potential sensor unit | Drum surface potential (V0) sensor (K) (9029A only) | S34 |
| | | V0 sensor shutter solenoid (K) (9029A only) | SOL4 |
| | | Drum thermistor (K) | THM1 |
| | | Needle electrode cleaner motor (K) | M23 |
| | | Needle electrode cleaner detection sensor (K) | S30 |
| | | Ozone mixing fan (K) | F17 |
| | | Auger lock detection sensor | S42 |
| | Developer unit | Developer material | |
| | | Auto-toner sensor | S26 |
| | | Developer sleeve (Magnetic roller) | |
| | | Doctor blade | |
| Mixer | | | |
| Driving section, others | Temperature/humidity sensor | S12 | |
| | Ozone filter-1, Ozone filter-2 | | |
| | Toner filter | | |
| | Ozone suctioning fan | F24 | |
| | High-voltage transformer | HVT | |
| | Developer unit mixer motor (K) | M29 | |
| | Developer unit motor (K) | M30 | |
| | Drum motor (K) | M27 | |
| | Developer unit cooling fan | F14 | |
| | Scattered toner suctioning fan | F25 | |

3.11.3 Functions

1. Drum

A drum is made of a cylindrical aluminum base coated with a thin film of organic photoconductive substance. A photoconductive object becomes insulative (high electrical resistance) when it is not exposed to light and becomes conductive (low electrical resistance) when it is exposed to light. This object is called a photoconductor.

2. Drum cleaner unit

- Cleaning blade
Upon the pressure spring, this blade is pressed against the drum surface with a constant force and scrapes off the residual toner on the drum surface.
- Recovery blade
This blade prevents the toner which was scraped off by the cleaning blade from being scattered to the outside.
- Toner recovery auger
This auger carries the residual toner scraped off to the waste toner box.

3. Main charger

The main charger in this MFP consists of insulated terminals having a U-shaped section and a needle electrode attached between them. When a high voltage is applied to the needle electrode, the air around it is charged (ionized). The ionized air then flows into the drum causing it to be charged. This phenomenon is called "corona discharge". At the same time, a control bias is applied to the main charger grid to control the charging amount. In a dark place, negative charge is evenly applied onto the drum surface by the corona discharge and the main charger grid. In addition, a cleaner is installed to clean up the stains adhering to the needle electrode.

- Needle electrode
The needle electrode has aligned needles and their points perform the corona discharge. These points (electrodes) discharge toward the drum in one direction to realize more efficient discharging compared to a charger wire which discharges in a radial direction. Therefore, the needle electrode enables a reduction in the ozone amount.

4. Drum thermistor (K) (THM1)

The photoconductive characteristic of the drum surface changes depending on its temperature. Therefore, the drum thermistor detects the temperature of the drum surface and exercises control to achieve the charging potential according to the environment.

5. Discharge LED (K) (ERS-K)

Discharge is a process to decrease or eliminate the static electricity on the drum surface. The electrical resistance of the photosensitive layer is decreased by the light, and the residual charge on the drum surface is neutralized and eliminated (cleaned). The electrical potential of the drum surface is fixed to a certain amount before the drum is charged.

6. Temperature/humidity sensor (S12)

This sensor measures the environment inside the MFP. The values of the temperature and humidity detected inside the MFP are output to the LGC board.

7. Ozone filter

Ozone produced by corona discharge of the main charger is exhausted through this filter. The catalyzer of the ozone filter degrades the ozone.

8. Ozone suctioning fan (F24)

This fan sucks in air containing ozone generated by the main charger and exhausts it through the ozone filter-1.

9. High-voltage transformer (HVT)

This board generates the output control voltage of the main charger unit, main charger grid bias, 1st transfer roller bias, 2nd transfer roller bias and developer bias.

10. Drum motor (K)

This motor drives the drum (K).

The drive of the motor is transmitted with the gear from the drum motor to the drum (K).

11. Developer unit motor (K)

This motor drives the auger to carry the waste toner gathered with the developer magnetic roller and cleaning blade to the waste toner transport path.

To maintain the rotational speeds of the photoconductive drum and the developer magnetic roller at a specified ratio, the developer unit motor rotates at a speed proportionate to the paper transport speed for special modes such as the thick paper mode.

The drive of the motor is transmitted with the gear and the motor is connected to the developer unit with a coupling.

12. Developer unit mixer motor (K)

This motor drives a mixer to mix and transport the developer material (K).

The rotational speed of this motor is constant in any mode because the transport amount of the developer material must be stable in any special mode such as the thick paper mode.

The drive of the motor is transmitted with the gear and the motor is connected to the developer unit with a coupling.

13. Developer material

The developer material consists of the carrier and toner. Normally, developer material does not need to be replaced periodically. However, replacement may be necessary depending on the conditions of use.

14. Mixer

The carrier and toner are frictionized each other when the developer material is stirred. Then the carrier is positively charged (+) and the toner is negatively charged (–), and the toner is adhered by the electrostatic force.

15. Developer sleeve (Magnetic roller)

These aluminum rollers have magnets inside. The developer material is pulled by these magnets to form a magnetic brush. The magnets are fixed at their position so only the sleeve rotates. By this rotation, the developer material is transported to the development section. Then the magnetic brush formed at the developer sleeve sweeps over the drum surface and thus development is performed.

16. Doctor blade

The doctor blade controls the amount of the developer material from the developer sleeve so that the magnetic brush of the developer material can contact with the drum surface properly.

17. Auto-toner sensor (K) (S26)

To output a precise image, the proportion (toner density ratio) of the carrier and the toner in the developer material always needs to be constant. The magnetic permeability circuit in the auto-toner sensor detects the toner ratio in the developer material. Toner is supplied from the sub-hopper when the toner contained in the developer material is running out.

18. Toner motor (K) (M15)

These motors drive the paddles and the auger in the toner cartridge and transport the toner filled in the cartridge to the sub-hopper.

19. Sub-hopper toner motor (K) (M19)

This motor transports toner in the sub-hopper to the developer unit.

20. Waste toner transport motor (M33)

This motor rotates the auger in the corresponding unit and transports the waste toner which exits from each developer unit and the transfer belt cleaner unit, as well as the waste developer material which exits from each developer unit.

21. Auger lock detection sensor (S42)

This sensor detects locking of the waste toner transport auger.

When the waste toner transport auger is locked due to an overload or malfunction of the motor, this sensor detects it and a service call (CD71) occurs.

22. Waste toner box nearly full detection sensor (S13)

This is a transmissive sensor to detect the amount of waste toner in the waste toner box.

This sensor detects when the amount of waste toner has reached approx. 80% of the toner-full status.

23. Waste toner box full detection sensor (S14)

This is a transmissive sensor to check the sensor section at the side of the waste toner box. When the waste toner box becomes full of waste toner and the accumulated waste toner shields the sensor path, this sensor detects that the waste toner box is full.

24. Waste toner box

This collects the residual toner scraped off on the drum surface by the cleaning blade and that scraped off from the transfer belt by the transfer belt cleaning blade.

Developer material discharged in SR development is also recovered into the waste toner box.

25. Waste toner box detection sensor (S16)

This sensor detects whether there is a waste toner box or not as well as the opening and closing status of the waste toner box cover.

26. Toner filter

This collects toner scattered out of the developer unit (developer sleeve).

27. Scattered toner suctioning fan (F25)

This fan sucks in toner scattered out of the developer unit (developer sleeve) and collects it through the toner filter.

3.11.4 Electric circuit description

[1] Drum surface potential (V0) sensor (K) control circuit

[1-1] Overview

The drum surface potential (V0) sensor (K) measures the surface potential of the drum when the drum is charged. Based on the measured value, this sensor controls the main charger grid bias voltage, and thus can control the drum surface potential accurately.

[1-2] Composition

The configuration of this control circuit is shown below.

- Drum surface potential (V0) sensor (K):
Measures the surface potential of the drum.
- Drum surface potential (V0) sensor (K) shutter:
Prevents toner and developer material from adhering to the drum surface potential (V0) sensor (K).
- Control section (LGC board):
Calculates the main charger grid bias voltage to be applied when the image quality control is performed, then controls the high-voltage transformer to adjust its bias voltage output.
- High-voltage transformer:
Generates and supplies the bias voltage of the main charger grid.

3.11.5 Toner cover

In this MFP, a toner cover is attached to the toner cartridge in order to prevent it from being replaced by mistake if it still contains toner.

The toner cover is normally locked; however, it is unlocked accordingly when the front cover is opened at the time of a toner empty status.

The toner cover is locked by a spring and slider. When the toner cover solenoid is turned ON, the slider is pulled down and then the toner cover is opened.

To open the toner cover for a maintenance operation, perform FS-05-4914.

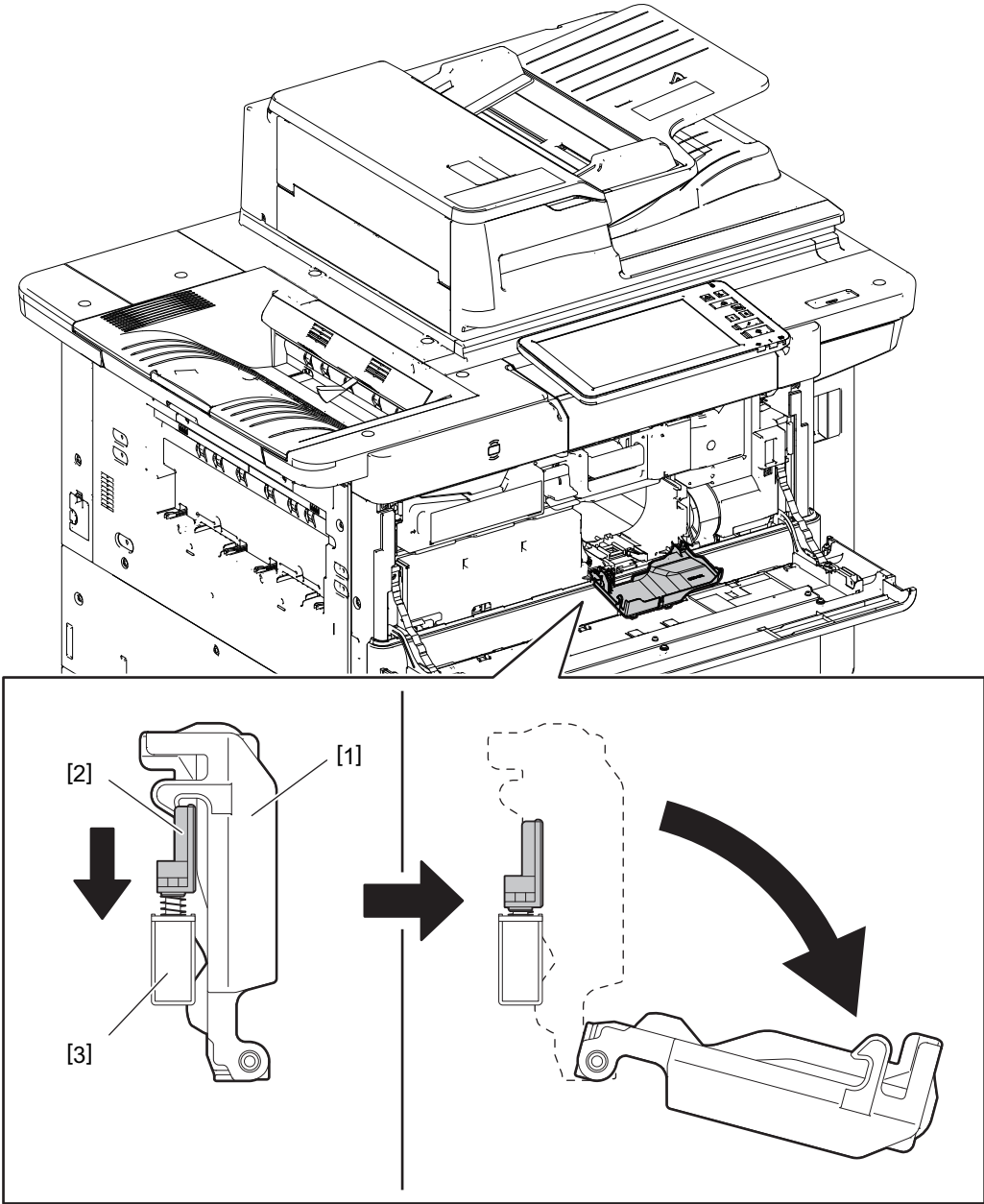

Fig. 3-58

- [1] Toner cover
- [2] Slider
- [3] Toner cover solenoid

3.11.6 Functions of the toner cartridge PC board (CTRG)

The toner cartridge PC board (CTRG) is equipped in the toner cartridge of this MFP. An IC chip is embedded in this board. Data such as the identification information for the recommended TOSHIBA toner cartridge, thresholds to determine if the cartridge is nearly empty, and controlling data for the image quality to be optimal according to the toner characteristics are written in this chip.

To measure the amount of toner remaining in the cartridge, when the value of the counter for the period of the toner cartridge rotation time is updated, this MFP writes the updated value into the toner cartridge PC board (CTRG).

These data written in the toner cartridge PC board (CTRG) enable the functions below and accordingly this MFP operates as shown below. Data reading is performed every time when the power is turned ON, the front cover is closed, a job is finished and the MFP has recovered from the sleep mode.

[1] Data read by the toner cartridge PC board (CTRG)

- Data to identify recommended TOSHIBA toner cartridges
- Thresholds to determine if the toner cartridge is nearly empty
- Value of the counter for the period of the toner cartridge rotation time
- Data for optimizing the image quality
- Threshold of toner remaining displays

[2] Function

- Toner cartridge check function
This function checks whether the toner cartridge is inserted correctly or not, and whether the recommended toner cartridge is used or not.
- Toner remaining check function
This function notifies the user of the nearly-empty status of the toner. Normally, "Toner is low" is displayed when the toner is running out and "Toner empty" when the toner cartridge becomes empty.
- Toner remaining check notification function
Upon detecting the nearly-empty status of the toner, this function automatically notifies your service representative.
- Image optimization function
This function controls the quality of images to be optimal according to the characteristics of the toner used.
- Toner remaining display function
This function displays the remaining toner amount from 0% to 100%.

[3] Function

A sign indicating that the toner cartridge is nearly empty appears in the following cases:

- The counter value for the toner cartridge rotation time has exceeded the threshold previously written in the toner cartridge PC board (CTRG). (Related code: FS-08-5155)
- The remaining amount of toner is equal to or less than the set amount (percentage or number of sheets). (Related codes: FS-08-5155, FS-08-5810, FS-08-5811)

When a used cartridge refilled with a new toner is used, a sign indicating that the toner cartridge is empty appears because information for determining the empty status has already been written in the toner cartridge PC board (CTRG).

When a non-recommended toner cartridge is used, "Toner not recognized" appears on the control panel, and then the MFP may stop normal operations. The toner remaining display function, the toner remaining check function, the automatic remote supply order to Toshiba service representatives and the image optimization function may also be disabled.

The self-diagnostic codes to adjust the timing for displaying the toner nearly-empty status are as follows.

- Toner near empty threshold setting (FS-08-5155)
<Setting value>
 - 0: The period from the appearance of the toner nearly-empty indication to the actual complete consumption of the toner is set to long.
 - 1: Normal (Default)
 - 2: The period from the appearance of the toner nearly-empty indication to the actual complete consumption of the toner is set to short.
 - 4: Toner nearly-empty status threshold value (%)
 - 5: Toner nearly-empty status threshold value (Number of sheets)
- Toner nearly-empty status threshold value setting (%) (FS-08-5810)
Use this code to specify the threshold value (unit: %) for displaying the toner nearly-empty status. This code is used when the value of FS-08-5155 is set to "4".
- Toner nearly-empty status threshold value setting (number of sheets) (FS-08-5811)
Use this code to specify the threshold value (unit: number of sheets) for displaying the toner nearly-empty status. This code is used when the value of FS-08-5155 is set to "5".
- Fine adjustment of threshold value for displaying the toner remaining amount / toner nearly-empty (FS-08-5156-3)
This code performs fine adjustment of the threshold value for displaying the toner remaining amount and toner nearly-empty.
Display threshold value = Default threshold value x setting value/100 (Unit: %)

[4] Display adjustment of toner nearly-empty and toner empty

The toner empty indication appears when the sub-hopper toner sensor in the sub-hopper detects the actual amount of toner in the sub-hopper has become low. The toner remaining amount is displayed by means of calculating it by counting the value of the counter for the period of the toner motor rotation time. Then the toner nearly-empty indication appears when the calculated toner remaining amount has reached the specified value (the toner amount which can print approx. 2,000 sheets of paper when an image whose print ratio is 6% is printed with the A4 or LT equivalent paper size).

The relationship between the period of the toner motor rotation time and the actual toner consumption amount varies depending on the printed images and usage conditions. Therefore, the displaying of the toner remaining amount can be adjusted by the codes shown below. However, it is recommended to handle the toner remaining amount as the reference since the printed images and usage conditions are always unstable and there will be variations in the systems.

1. Fine adjustment of the toner remaining amount display
When the displayed toner remaining amount is decreased more quickly than that for the actual toner (when "1%" is being displayed for a long time), set a value in FS-08-5156 larger than the default one. When the displayed toner remaining amount is decreased more slowly than that for the actual toner (when the toner nearly-empty indication appears before "1%" is displayed), set a value in FS-08-5156 than smaller the default one.
2. Toner nearly-empty setting change
 - Setting change of the period from the toner nearly-empty to the toner empty
When the period is made longer, set "0" in FS-08-5155. When the period is made shorter, set "2" in FS-08-5155.
 - Setting change of the toner nearly-empty threshold value
When the threshold value (default: printing approx. 2,000 sheets of paper is available when an image whose print ratio is 6% is printed with the A4 or LT equivalent paper size) used to designate toner nearly-empty is changed, perform the following setting change.

When the change is made by using the toner remaining amount (%), set “4” in FS-08-5155 and exchange the value of FS-08-5810. In order to designate the toner nearly-empty status while the toner remaining amount is greater than the default value, set a larger value in FS-08-5810. When the change is made by using the available remaining number of print sheets, set “5” in FS-08-5155 and exchange the value of FS-08-5811. In order to designate the toner nearly-empty status while the available remaining number of print sheets is greater than the default value (printing approx. 2,000 sheets of paper is available when an image whose print ratio is 6% is printed with the A4 or LT equivalent paper size), set a larger value in FS-08-5811.

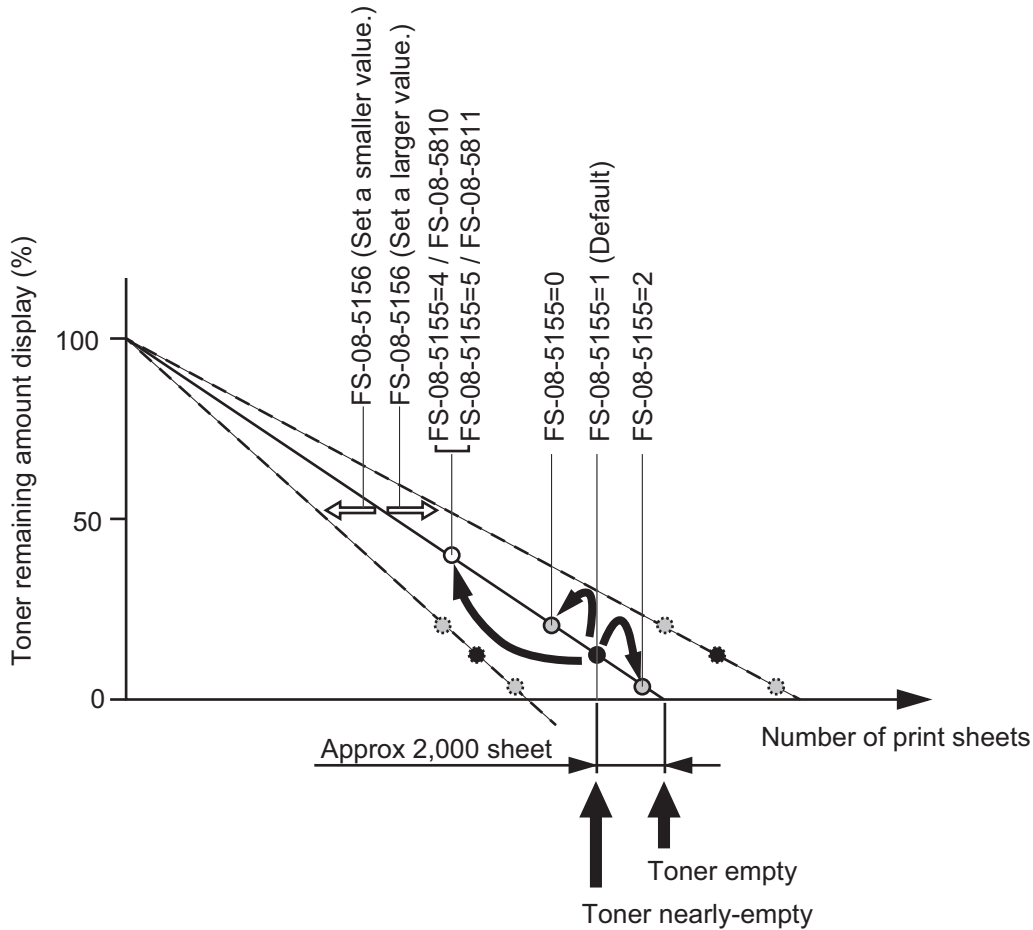

Fig. 3-59

Notes:

- Do not perform the change operations 1 (Fine adjustment of the toner remaining amount display) and 2 (Toner nearly-empty setting change) simultaneously. If the change is required by the combination of the operations 1 (Fine adjustment of the toner remaining amount display) and 2 (Toner nearly-empty setting change), only perform either of them first. Then change the setting for another one while checking the results.
- The values of the toner remaining amount and the number of print sheets are the reference. They will vary depending on the printed images and usage conditions.

3.12 Transfer Unit

3.12.1 Overview

Transfer is a process of decaling a toner image from the photoconductive drum onto the paper. A toner image formed on the photoconductive drum is temporarily transferred onto the transfer belt. The toner image is then transferred from the transfer belt onto the paper. The first transfer from the photoconductive drum to the transfer belt is called the 1st transfer. The second transfer from the transfer belt to paper is called the 2nd transfer.

After the completion of the 2nd transfer, the residual toner on the transfer belt is scraped off by the transfer belt cleaning blade and then transported to the waste toner box.

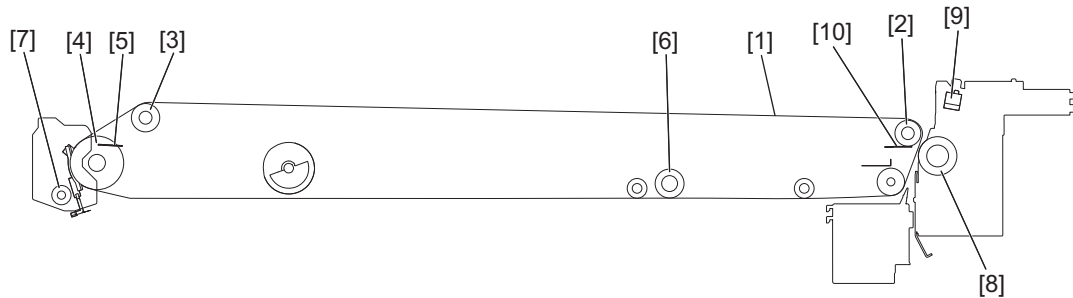

Fig. 3-60

- [1] Transfer belt
- [2] 2nd transfer facing roller
- [3] Tension roller
- [4] Cleaning facing roller
- [5] Cleaning facing roller cleaning pad
- [6] 1st transfer roller
- [7] Waste toner auger
- [8] 2nd transfer roller
- [9] 2nd transfer side paper clinging detection sensor
- [10] 2nd transfer facing roller cleaning pad

3.12.2 Composition

| | | |
|---|---|-----|
| Transfer belt unit | Transfer belt | |
| | 1st transfer roller | |
| | Cleaning facing roller | |
| | Tension roller | |
| | 2nd transfer facing roller | |
| | Idling roller | |
| | 2nd transfer facing roller cleaning pad | |
| | Cleaning facing roller cleaning pad | |
| Transfer belt cleaner | Transfer belt cleaning blade | |
| | Transfer belt cleaner side seal | |
| Transfer belt motor | | M13 |
| 2nd transfer unit | 2nd Transfer Roller | |
| | 2nd transfer side paper clinging detection sensor | S51 |
| Image position aligning/image quality sensor (center) | | S21 |

3.12.3 Self-steering mechanism

This MFP has a self-steering mechanism to prevent the transfer belt from leaning to one side. The configuration of this mechanism is shown below.

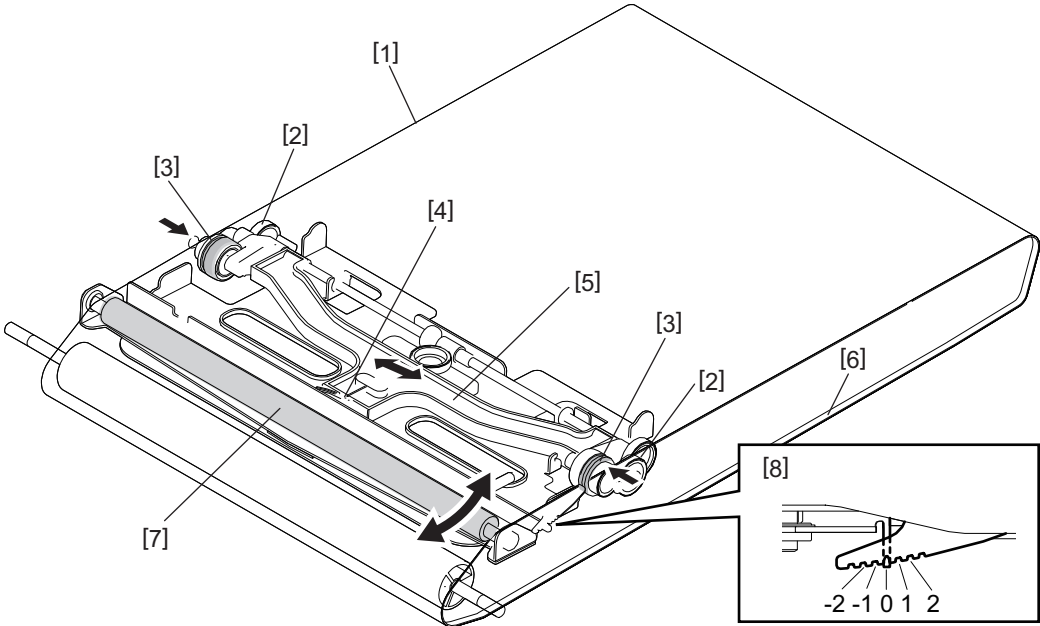

Fig. 3-61

- [1] Transfer belt
- [2] Gear
- [3] Guide roller
- [4] Rack and pinion
- [5] Slider
- [6] Rib
- [7] Steering roller
- [8] Cutting angle indicator

Operation flow

1. The transfer belt is inclined to the front or rear side.
2. The rib of the inclined belt contacts with either of the guide rollers and thus makes the gears rotate.
3. The gears rotate and thus their lead screws make the slider shift forward or backward.
4. The steering roller is inclined with a rack and pinion mechanism.
5. The inclined steering roller moves the inclined transfer belt to the original position.
6. The steering roller stops the leaning at a position in which the rib of the belt no longer contacts with the guide roller.

Notes:

- The tolerance for the cutting angle of the self-steering mechanism is normally ± 2 degrees.
- If the cutting angle does not fall within the acceptable range, check and correct the following:
 - Is the MFP installed on a flat surface? Is the MFP installed slantwise?
 - Is the transfer belt unit assembled correctly?
 - Is the transfer belt installed correctly?

3.13 Image Quality Control

3.13.1 Overview

The image position aligning/image quality sensor (center) is mounted inside of the pre-2nd transfer guide beneath the transfer belt.

At this control, image forming conditions are automatically adjusted so as to minimize the change in the image density or tone reproduction caused by a fluctuation in the working environment or the life of the supply items.

At first, the image quality/position aligning sensor (center) operates to output the reflected light amount voltage when no toner image is formed on the transfer belt. The output voltage is then converted analog-to-digital to be output as the reflected light amount signal. The light source amount voltage of the sensor is adjusted to correspond with the value set in advance and the output value of the reflected light amount signal at this adjustment is stored. This output value is considered as the reading of the belt surface. Next, the sensor outputs the reflected light amount signal when a test pattern is developed on the transfer belt. This output value is considered as the reading of the toner image. The difference between the reading of the transfer belt and that of the toner image is defined as the toner adhesion amount. Image forming conditions are determined in approximating this toner adhesion amount to the value set in advance.

In addition, a shutter operated by the Image quality shutter solenoid (SOL3) is equipped on the light receiving/emitting surfaces to prevent stain to the sensor.

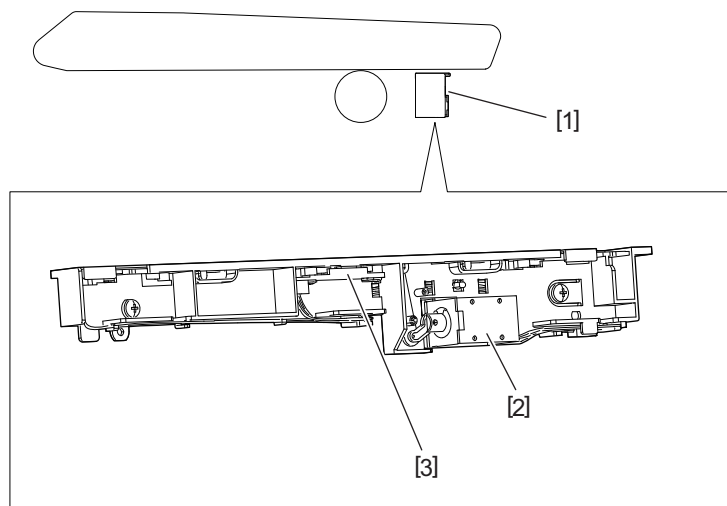

Fig. 3-62

- [1] Image quality control unit
- [2] Image quality shutter solenoid
- [3] Image position aligning/image quality sensor (center)

3.14 Fusing Section

3.14.1 Overview

Toner is fused by applying heat and pressure on the transferred image on the paper which is transported to the fuser unit. The paper is then transported to the bridge unit. The fuser unit consists of the fuser belt, IH coil, pressure roller, separation plate, thermistors, thermostats, sensors, etc. The fuser belt and pressure roller in the fuser unit are driven by the fuser motor.

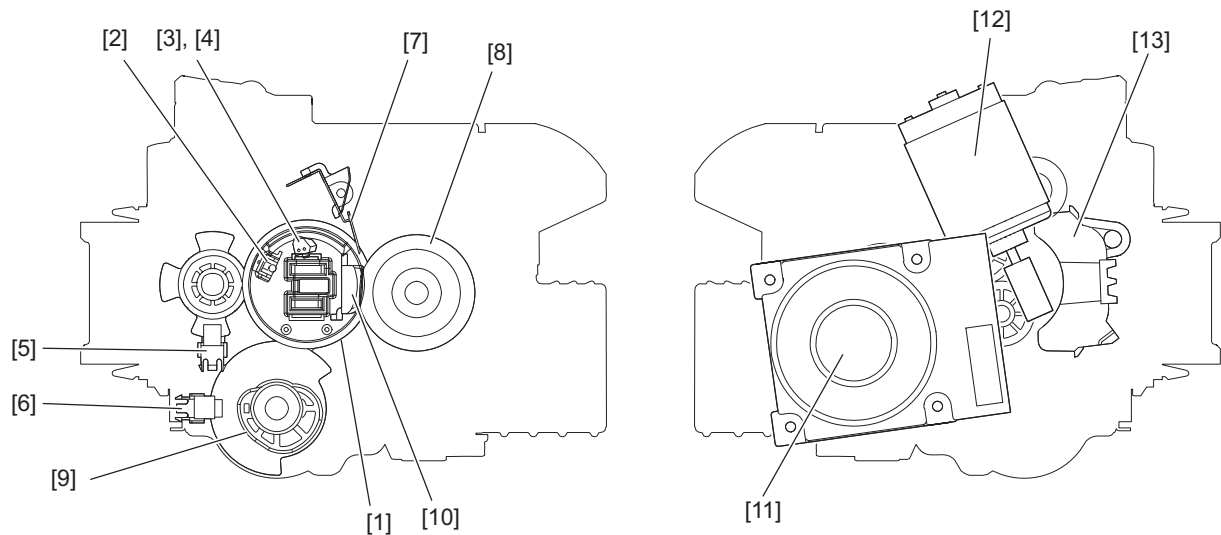

Fig. 3-63

- [1] Fuser belt
- [2] Fuser belt thermostat
- [3] Fuser belt center thermistor
- [4] Fuser belt edge thermistor
- [5] Fuser belt rotation detection sensor
- [6] Pressure roller contact/release detection sensor
- [7] Separation plate
- [8] Pressure roller
- [9] Pressure roller contact/release cam
- [10] Fuser belt pad
- [11] Fuser motor
- [12] Pressure roller contact/release motor
- [13] IH coil

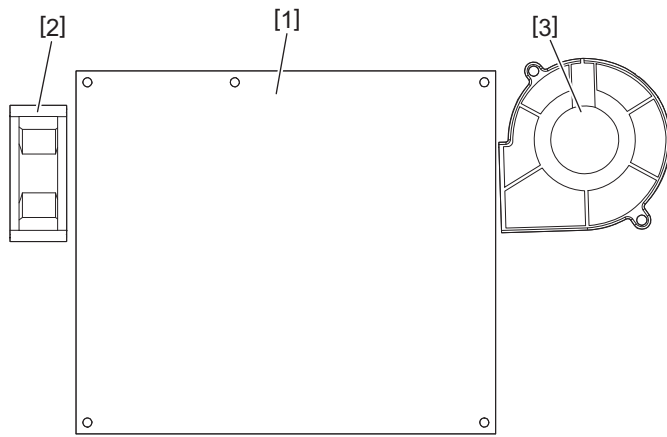

Fig. 3-64

- [1] IH board
- [2] IH board cooling fan (exhaust)
- [3] IH board cooling fan (suction)

3.14.2 Composition

| | | |
|-------------------------|--|---------|
| Fuser belt section | Fuser belt | |
| | Fuser belt thermostat | THMO4 |
| | Fuser belt edge thermistor | THM6 |
| | Fuser belt center thermistor | THM5 |
| | Fuser belt rotation detection sensor | S49 |
| | Separation plate | |
| Pressure roller section | Pressure roller | |
| | Separation guide | |
| | Pressure roller contact/release detection sensor | S48 |
| IH coil section | IH coil | IH COIL |
| | IH board | IH |
| | IH board cooling fan (suction) | F8 |
| | IH board cooling fan (exhaust) | F9 |
| Driving section, others | Fuser motor | M6 |

3.14.3 Pressure mechanism

In the MFP, when “Envelope” is selected from the menu on the touch panel screen, the pressure roller contact/release cam rotates and come to the semi-contact position (envelope position).

The pressure to the fuser belt [4] is adjusted by moving the arm [2] retaining the pressure roller [3] by means of the position of the pressure roller contact/release cam [1]. Moreover, the pressure is applied by using the force of the spring [5].

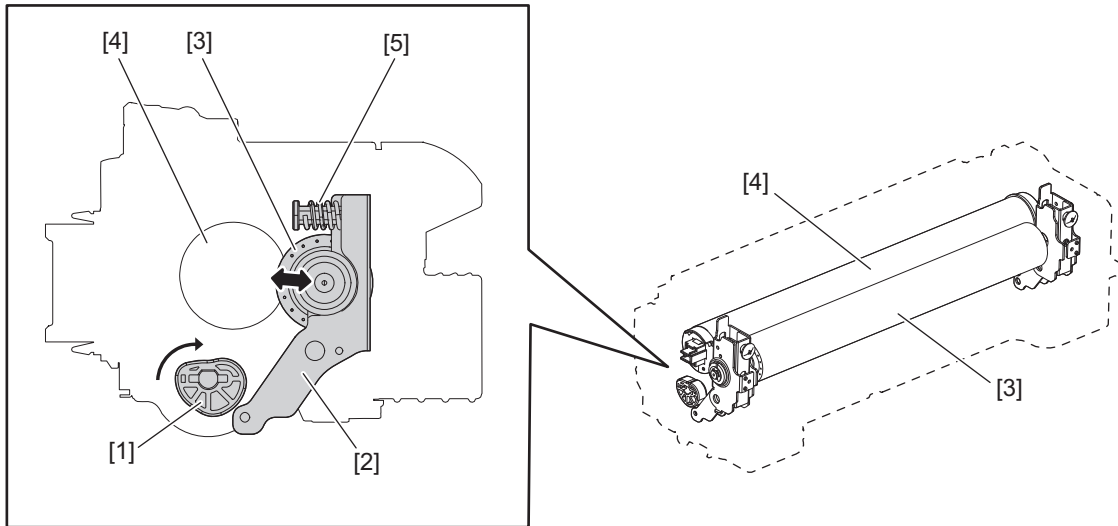

Fig. 3-65

- [1] Pressure roller contact/release cam
- [2] Arm
- [3] Pressure roller
- [4] Fuser belt
- [5] Spring

3.14.4 Electric circuit description

[1] Fuser unit control circuit

[1-1] Configuration

This MFP employs an external IH coil unit for heating the fuser belt. The IH coil in the IH coil unit generates a magnetic field to heat the fuser unit with a high-frequency current carried its inside. The surface temperature of the fuser belt is detected with the center and edge thermistors. The detected temperature data are sent to the CPU on the LGC board. Based on the received temperature data, the CPU on the LGC board then controls the electricity of the IH. The forcible power OFF circuit detects overheating with each thermistor. When the surface temperature of the fuser belt exceeds the preset one, this circuit sends an overheating signal to the CPU on the LGC board as well as a relay OFF signal and then shuts OFF the power supply to the IH drive circuit. If the circuit noted above does not operate due to problems such as a thermistor malfunction and therefore the fuser belt is abnormally heated, the thermostat shuts OFF the power supply to the IH coil to protect the MFP.

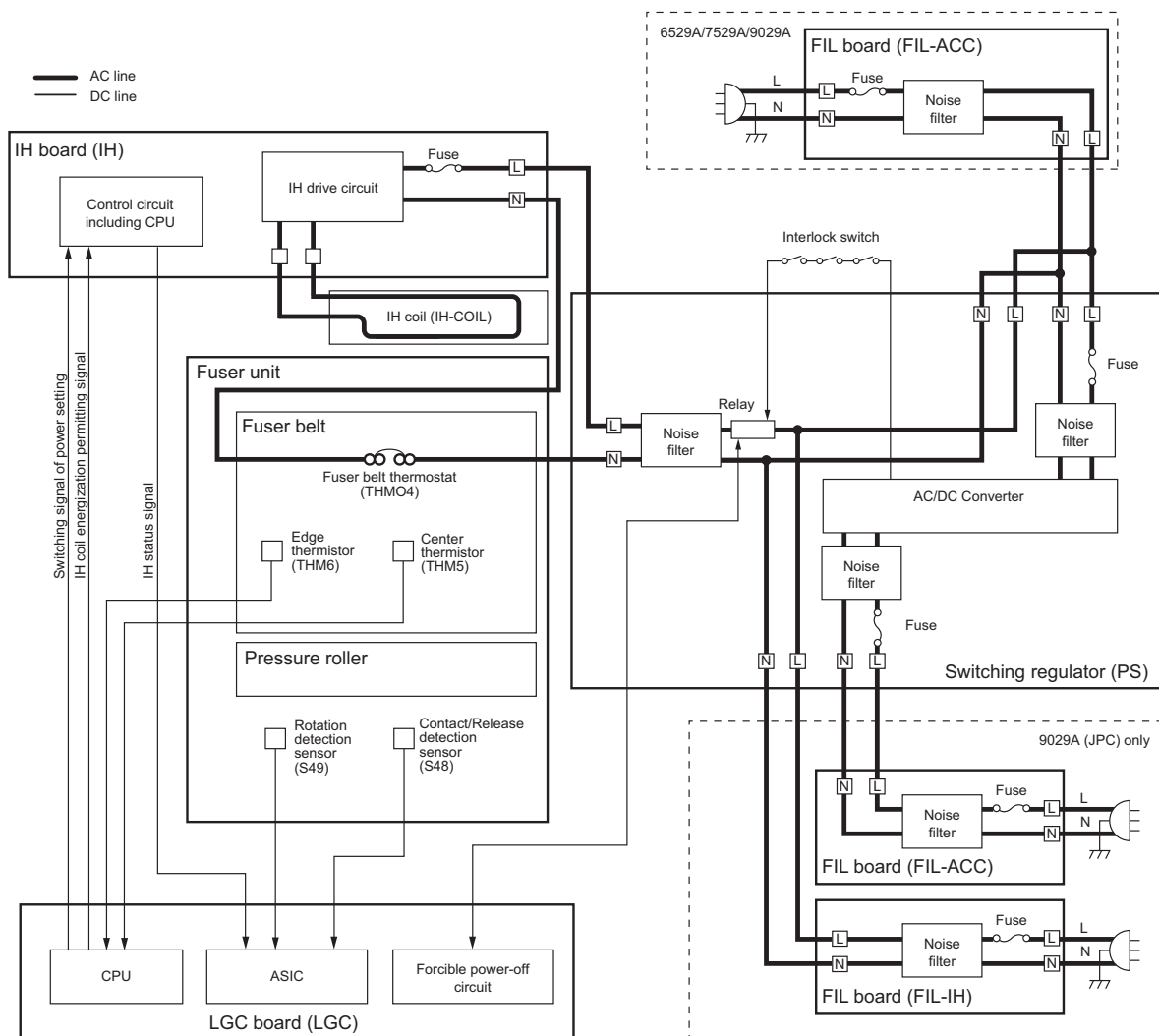

Fig. 3-66

[1-2] Temperature detection section

Fuser unit error status counter control

- To enhance the safety of the fuser unit section, the following protection is provided: When a [C445] error has occurred two or more times in a row, the IH coil is not turned ON after the third error and an error code [C446] is displayed immediately even if the operator turns the power OFF and then back ON. However, if the MFP goes into the ready state normally with the fuser unit error status counter value "5", the counter is cleared to "0".
If any of the error codes [C445] to [C449] is displayed but the error is still not cleared and the IH coil is not turned ON even after the thermistor or thermostat was repaired, check the value of FS-08-2002 (fuser unit error status counter) to clear it to "0".

Remarks:

The fuser unit error status counter (FS-08-2002) never has any values other than 0 to 70. If the counter value is "71" or over, data in EEPROM may possibly have been ruined due to causes such as leakage from the chargers. In this case, check the bias, high-voltage transformers and needle electrodes to see if any of them is defective, and also recheck all the data in the EEPROM.

- When the thermistors detect overheating, the engine CPU determines an error code and the fuser unit error status counter value. Then to protect the fuser unit, each output (fusing relay, motors and so on) is turned OFF and "Call for service" appears.

Error Code: C449

FS-08-2002 (Fuser unit error status counter): 9, 22, 23, 25, 27, 29, 59, 61, 67, 68, 69, 70

The thermistors continue detecting abnormal temperatures even after an error code and a counter value are determined. Even if the power is turned ON immediately, "Call for service" appears on the panel unless the surface temperature of the fuser belt goes lower than the abnormal temperature detected. In such a case, therefore, wait until the surface temperature of the fuser belt becomes lower than the abnormal temperature detected. Then turn the power ON and check the counter value. After confirming that it is a fuser unit abnormality, correct the corresponding part in the unit and clear the counter value of this code to "0" so that the MFP can be started up normally.

Temperature detection circuit

A thermistor is a device whose resistance varies according to the detected temperature. The CPU on the LGC board detects voltages output from this device, and judges whether the operation of the fuser unit is normal or abnormal from the changes in the voltages.

If any of the thermistors is broken, the control circuit judges that the surface temperature of the fuser belt and pressure roller is extremely low and keeps turning the IH circuit ON. As a result, the surface temperature of the fuser belt rises and this possibly activates a thermostat which is a safety protection device. To prevent this in advance, the CPU on the LGC board detects whether each thermistor is broken or not.

Also, the control circuit constantly monitors the surface temperature of the fuser belt to prevent it from excessive heating caused by abnormalities in circuits or thermistors. It automatically turns off the fusing relay when the surface temperature exceeds the preset temperature.

Then it controls not to turn on the fusing relay until the power is turned OFF and then back ON.

Abnormality detection by the thermistors

The following table shows the conditions for judging the temperature abnormality of the fuser belt and the detecting timing.

| Timing | Code | Counter | Center | Edge |
|-----------------------|------|--------------|---|----------------|
| During warming up | C449 | 22 Not fixed | 220°C or above | 237°C or above |
| | C449 | 61 Not fixed | IH OFF signal: H | |
| | C445 | 5 Not fixed | Ready temperature or below | - |
| | C446 | 6 Fixed | | |
| At Ready | C449 | 23 Not fixed | 220°C or above | 237°C or above |
| | C449 | 67 Not fixed | IH OFF signal: H | |
| | C447 | 7 Fixed | 0°C or below | - |
| | C447 | 63 Fixed | - | 0°C or below |
| During printing | C449 | 25 Not fixed | 220°C or above | 237°C or above |
| | C449 | 68 Not fixed | IH OFF signal: H | |
| | C440 | 35 Fixed | The low-temperatures WAIT is 2 minutes or more. | |
| | C447 | 24 Fixed | 0°C or below | - |
| | C447 | 64 Fixed | - | 0°C or below |
| | C447 | 65 Fixed | 40°C or below | - |
| | C447 | 66 Fixed | - | 40°C or below |
| At energy saving mode | C449 | 27 Not fixed | 220°C or above | 237°C or above |
| | C449 | 69 Not fixed | IH OFF signal: H | |
| At paper misfeeding | C449 | 29 Not fixed | 220°C or above | 237°C or above |
| | C449 | 70 Not fixed | IH OFF signal: H | |
| Others | C449 | 9 Not fixed | 220°C or above | 237°C or above |
| | C449 | 59 Not fixed | IH OFF signal: H | |

3.15 Paper Exit Unit, Reverse Unit, Duplexing Unit

3.15.1 Overview

In the paper exit section, paper transported from the bridge unit is transported to the upper exit tray or the lower exit tray.

The bridge unit transports paper transported from the fuser unit to the paper exit section. For duplex printing, the bridge unit makes paper switchbacked to the duplexing unit.

The duplexing unit reverses paper for duplex printing. When printing on one side of paper is finished, the paper is transported from the bridge unit to the duplexing unit, and then the duplexing unit reverses and transports the paper to the registration roller with the other side up.

- Paper exit unit

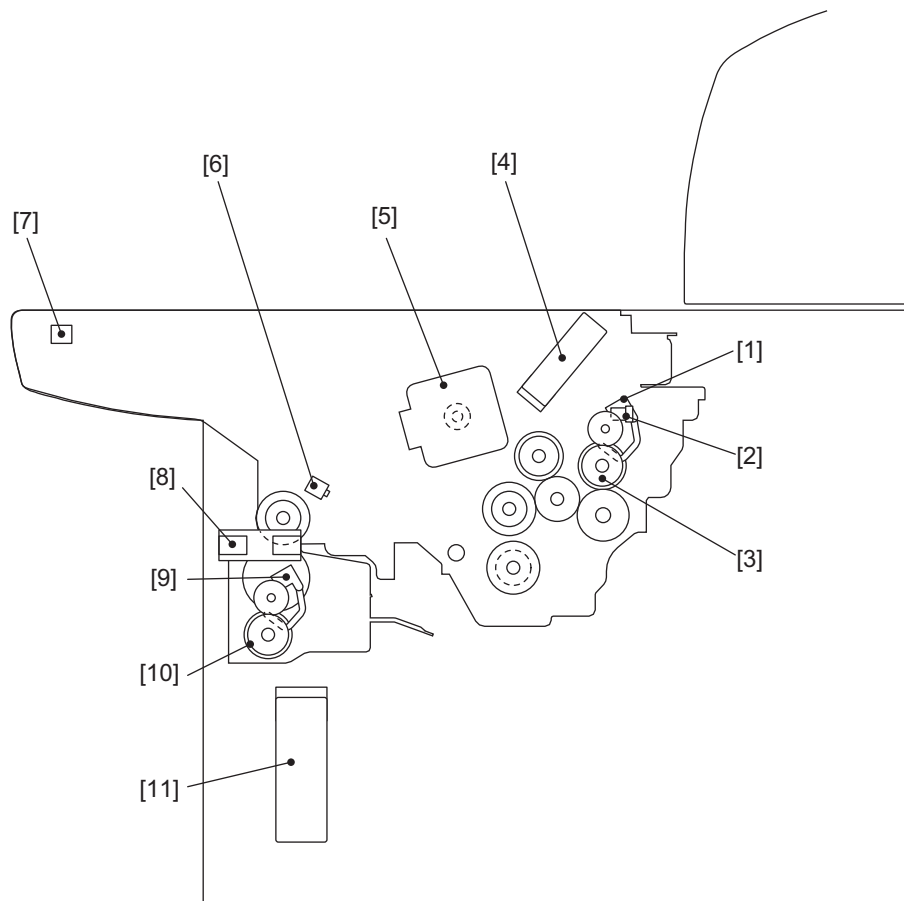
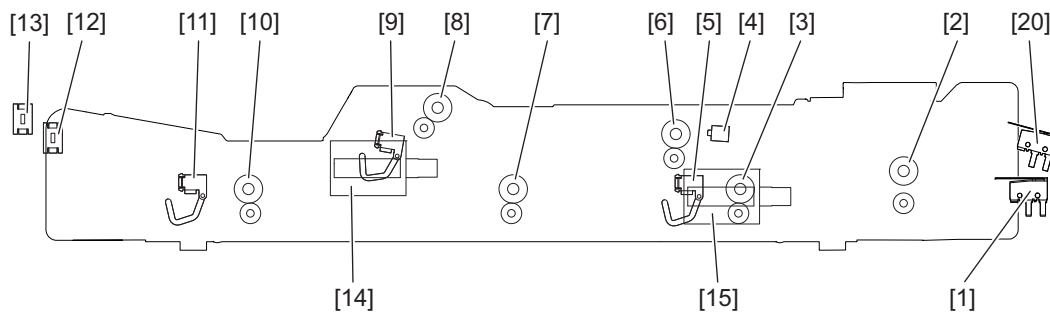

Fig. 3-67

- [1] Upper paper exit sensor
- [2] Upper exit tray paper full detection sensor
- [3] Upper paper exit roller
- [4] Upper paper exit section cooling fan (rear)
- [5] Paper exit motor
- [6] Reverse section paper transport detection sensor
- [7] Reverse path cover switch
- [8] Lower paper exit section cooling fan (front) (rear)
- [9] Lower paper exit sensor
- [10] Lower paper exit roller
- [11] Lower paper exit section cooling fan (bottom)

- Bridge unit

[A]



[B]

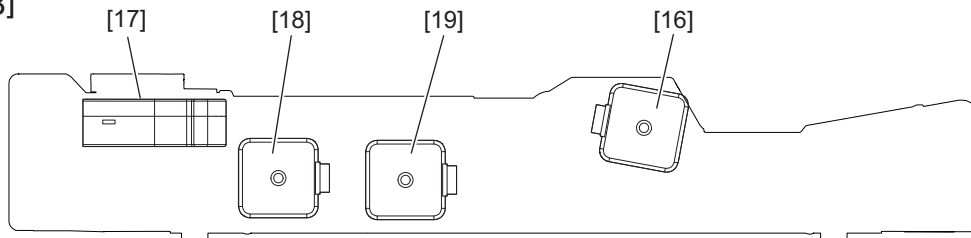

Fig. 3-68

[A] Front side

[B] Rear side

- [1] Interlock switch
- [2] Bridge unit transport roller-1
- [3] Bridge unit transport roller-2
- [4] Reverse sensor
- [5] Bridge unit path entrance sensor
- [6] Reverse roller
- [7] Bridge unit transport roller-3
- [8] Bridge unit paper exit roller-1
- [9] Reverse section stationary jam detection sensor
- [10] Bridge unit paper exit roller-2
- [11] Bridge unit path exit sensor
- [12] Bridge unit connecting detection switch
- [13] Front cover opening/closing detection switch
- [14] Transport path switching solenoid (upper/lower paper exit)
- [15] Transport path switching solenoid (bridge unit/reverse section)
- [16] Bridge unit transport exit motor
- [17] Bridge unit cooling fan
- [18] Bridge unit transport entrance motor
- [19] Reverse motor
- [20] Duplexing unit interlock switch

- Duplexing bridge unit, Duplexing unit

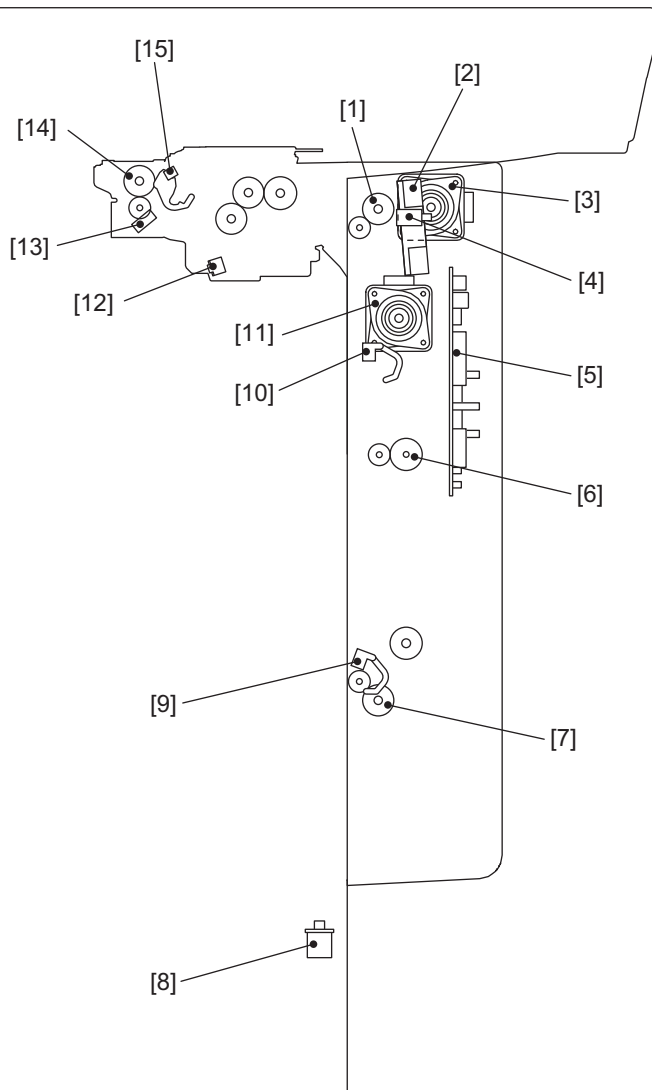

Fig. 3-69

- [1] ADU transport roller-1
- [2] Reversed paper cooling fan
- [3] ADU transport motor
- [4] Duplexing unit cover opening/closing detection switch
- [5] ADU board
- [6] ADU transport roller-2
- [7] ADU transport roller-3
- [8] IH interlock switch
- [9] Duplexing unit path exit sensor
- [10] Duplexing unit path entrance sensor
- [11] ADU original feed motor
- [12] Fuser transport sensor
- [13] Duplexing unit opening/closing detection sensor
- [14] Duplexing bridge transport roller
- [15] Reverse path sensor

3.15.2 Composition

| | | |
|---|--|----------------------------------|
| Paper exit unit | Upper paper exit sensor | S61 |
| | Upper exit tray paper full detection sensor | S62 |
| | Lower paper exit sensor | S63 |
| | Reverse section paper transport detection sensor | S60 |
| | Reverse path cover switch | SW5 |
| | Upper paper exit roller | |
| | Lower paper exit roller | |
| | Upper paper exit section cooling fan (rear) | F32 |
| | Lower paper exit section cooling fan (rear) | F34 |
| | Lower paper exit section cooling fan (front) | F35 |
| | Lower paper exit section cooling fan (bottom) | F36 |
| | Paper exit motor | M2 |
| | Bridge unit | Bridge unit path entrance sensor |
| Bridge unit path exit sensor | | S56 |
| Reverse section stationary jam detection sensor | | S58 |
| Reverse sensor | | S59 |
| Interlock switch | | SW2 |
| Bridge unit connecting detection switch | | SW8 |
| Front cover opening/closing detection switch | | SW9 |
| Transport path switching solenoid (bridge unit/ reverse section) | | SOL1 |
| Transport path switching solenoid (upper/lower paper exit) | | SOL2 |
| Bridge unit cooling fan | | F6 |
| Bridge unit transport roller-1 | | |
| Bridge unit transport roller-2 | | |
| Bridge unit transport roller-3 | | |
| Reverse roller | | |
| Bridge unit paper exit roller-1 | | |
| Bridge unit paper exit roller-2 | | |
| Bridge unit transport entrance motor | | M4 |
| Bridge unit transport exit motor | | M5 |
| Reverse motor | M3 | |
| Duplexing bridge unit | Duplexing unit opening/closing detection sensor | S64 |
| | Reverse path sensor | S57 |
| | Duplexing bridge transport roller | |

| | | |
|----------------|---|------|
| Duplexing unit | Duplexing unit path entrance sensor | S66 |
| | Duplexing unit path exit sensor | S67 |
| | IH interlock switch | SW4 |
| | Duplexing unit cover opening/closing detection switch | SW7 |
| | Duplexing unit interlock switch | SW10 |
| | ADU control PC board | ADU |
| | Reversed paper cooling fan | F11 |
| | ADU transport roller-1 | |
| | ADU transport roller-2 | |
| | ADU transport roller-3 | |
| | ADU transport motor | M7 |
| | ADU paper feed motor | M8 |
| | Fuser transport sensor | S65 |

3.15.3 Operation description

Paper brought from the fuser unit to the bridge unit is then transported to either the upper or lower exit tray of the paper exit unit by means of the bridge unit transport rollers-1, -2 and -3, and the bridge unit transport rollers-1 and -2. To transport paper to the upper exit tray, the transport path switching solenoid (bridge unit/reverse section) (SOL1) and transport path switching solenoid (upper exit/lower exit) (SOL2) are turned ON in order to lower the flappers-1 and -2. To transport it to the lower exit tray, only transport path switching solenoid (bridge unit/reverse section) (SOL1) is turned OFF in order not to lower the flapper-1. The paper transported from the bridge unit to the paper exit unit is then made to exit by the upper or lower paper exit roller.

When the duplex printing mode is selected, first the print data of the back side of the original are printed on the back side of the fed paper, and then the printed paper is transported from the fuser unit to the bridge unit. At this time, the transport path switching solenoid (bridge unit/reverse section) (SOL1) is turned ON in order to lower the flapper-1, and the transport path switching solenoid (upper exit/lower exit) (SOL2) is turned OFF in order not to lower the flapper-2, so that the paper will be transported to the reverse path section.

When the reverse sensor (S59) of the bridge unit detects the trailing edge of the paper, the reverse roller is driven to switch back the paper to the duplexing unit via the duplexing bridge unit. Then the print data of the front side of the original are printed on the front side of the paper that was transported from the duplexing unit to the registration section. After printing on the both sides of the paper is completed, the paper is made to exit by the bridge unit and the paper exit unit.

Paper misfeeding on the upper transport path is detected by means of the reverse sensor (S59) of the bridge unit and the upper paper exit sensor (S61) of the paper exit unit. Paper misfeeding on the lower transport path is detected by means of the bridge unit path entrance sensor (S55), bridge unit path exit sensor (S56) and lower paper exit sensor (S63).

Paper misfeeding on the reverse path is detected by means of the reverse path sensor (S57). The reverse section paper transport detection sensor (S60) of the bridge unit and reverse section stationary jam detection sensor (S58) of the paper exit unit detect where the jammed paper lies on the reverse path.

[1] Paper transport paths

1. Upper paper exit section

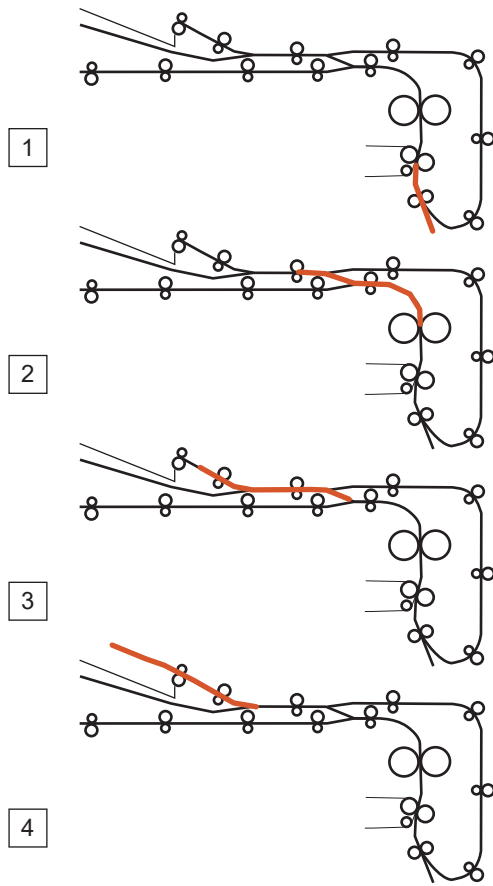

Fig. 3-70

2. Lower paper exit section

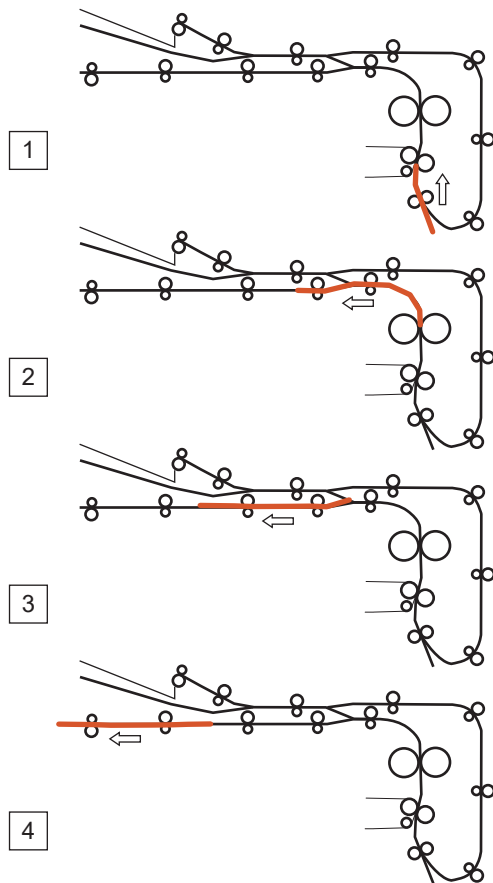

Fig. 3-71

3.16 Dual Scan Document Feeder (DSDF)

3.16.1 Overview

The Dual Scan Document Feeder (DSDF) scans both sides of a sheet type original at the same time. The original is transported to the ADF original glass. Its front side is scanned by the CCD of the MFP and the back side is scanned by the DSDF-CCD module of the DSDF. Due to this, no reversing of the original will take place.

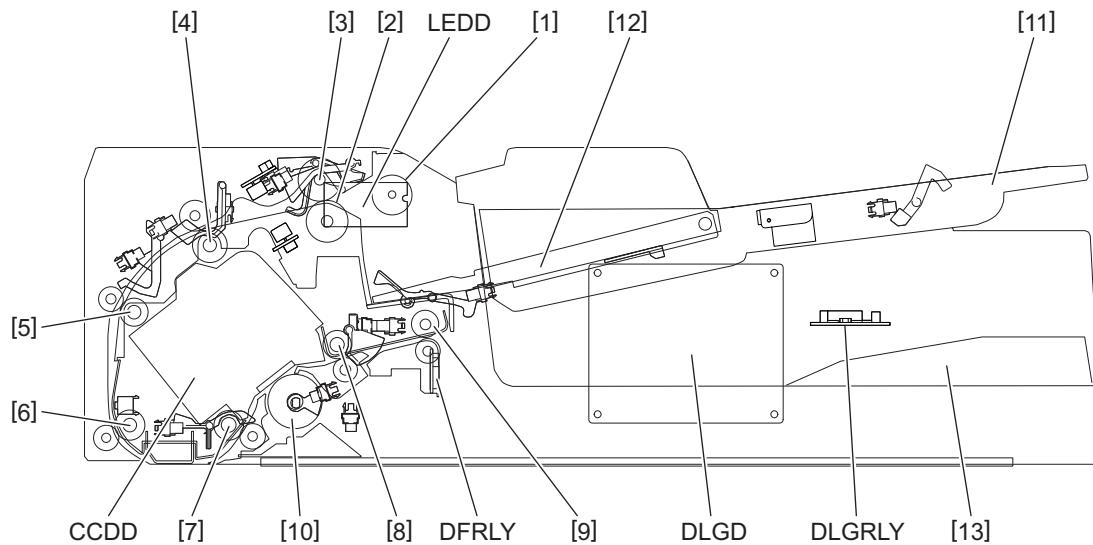

Fig. 3-72

| Symbol | Name | Symbol | Name |
|--------|---------------------------|--------|--|
| LEDD | DSDF-LED PC board | 7 | Pre-read roller-2 |
| CCDD | DSDF-CCD module | 8 | Post-read roller-2 |
| DLGD | DSDF control PC board | 9 | DSDF original exit roller |
| 1 | DSDF pickup roller | 10 | DSDF shading sheet |
| 2 | DSDF separation roller | 11 | Original tray |
| 3 | DSDF original feed roller | 12 | Original tray lift |
| 4 | DSDF registration roller | 13 | Original exit tray |
| 5 | Pre-read roller-1 | DFRLY | DSDF relay PC board |
| 6 | Post-read roller-1 | DLGRLY | DSDF multiple feeding detection relay PC board |

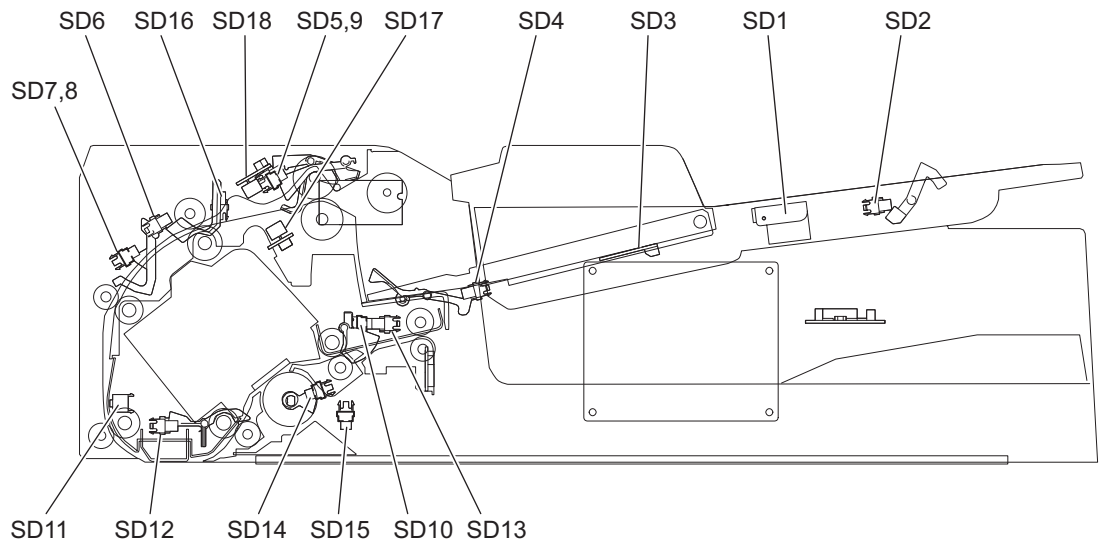

Fig. 3-73

| Symb ol | Name | Symb ol | Name |
|---------|--|---------|---|
| SD1 | DSDF tray original length sensor-1 | SD10 | DSDF tray lift lower limit sensor |
| SD2 | DSDF tray original length sensor-2 | SD11 | DSDF read-in sensor-1 |
| SD3 | DSDF tray original width sensor | SD12 | DSDF read-in sensor-2 |
| SD4 | DSDF original empty sensor | SD13 | DSDF original exit sensor |
| SD5 | DSDF original feed sensor | SD14 | DSDF shading sheet HP sensor |
| SD6 | DSDF registration sensor | SD15 | DSDF lower cover opening/closing detection sensor |
| SD7 | DSDF original width detection sensor-1 | SD16 | DSDF upper cover opening/closing detection sensor |
| SD8 | DSDF original width detection sensor-2 | SD17 | Multiple feeding detection sensor (transmission side) |
| SD9 | DSDF tray lift upper limit sensor | SD18 | Multiple feeding detection sensor (reception side) |

3.16.2 Original transport path

An original is transported by each transport roller via the path shown in the figure. The front side of the original is scanned by the CCD (DF original glass section) of the MFP and the back side is scanned by the DSDF-CCD module embedded in the DSDF.

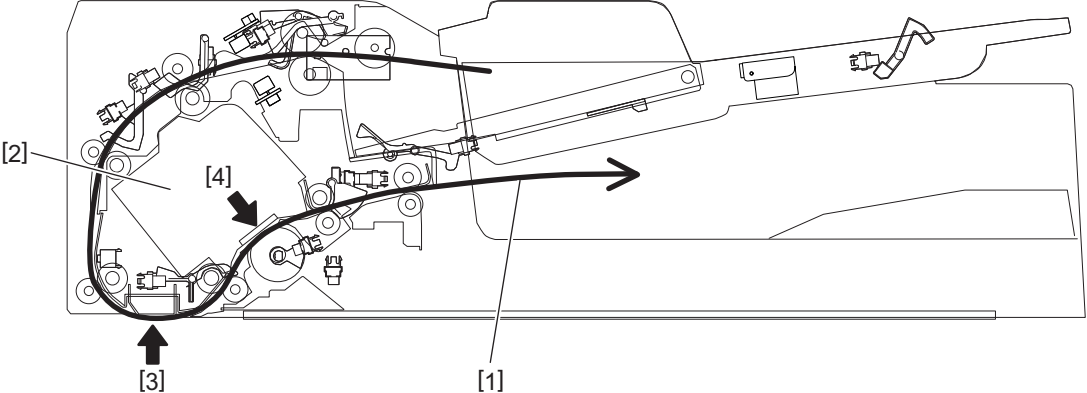

Fig. 3-74

- [1] Transport path
- [2] DSDF-CCD module
- [3] Front side scanning section (DF original glass section)
- [4] Back side scanning section (DSDF-CCD module scanning section)

3.16.3 Driving motor

Transportation of originals is operated by the DSDF original feed motor, DSDF read motor and DSDF original exit motor.

The role for each motor is as below.

| Motor | Rotation direction | Function |
|--------------------------|--------------------|---|
| DSDF paper feed motor | Clockwise | Drives the DSDF pickup roller and DSDF original feed roller. |
| DSDF separation motor | Clockwise | Moves downward the original tray lift. |
| | Counterclockwise | Performs the reverse operation of the DSDF separation roller and moves upward the original tray lift. |
| DSDF registration motor | Counterclockwise | Drives the DSDF registration roller. |
| DSDF read motor | Counterclockwise | Drives the pre-read roller-1, post-read roller-1, pre-read roller-2 and post-read roller-2. |
| DSDF original exit motor | Clockwise | Rotates the DSDF shading sheet. |
| | Counterclockwise | Drives the DSDF original exit roller. |

3.16.4 DSDF paper feed motor

When the feed signal from the MFP is received, feeding and transporting of an original will start. The DSDF original feed motor starts rotating to drive the DSDF pickup roller and the DSDF original feed roller to transport the original to the registration roller.

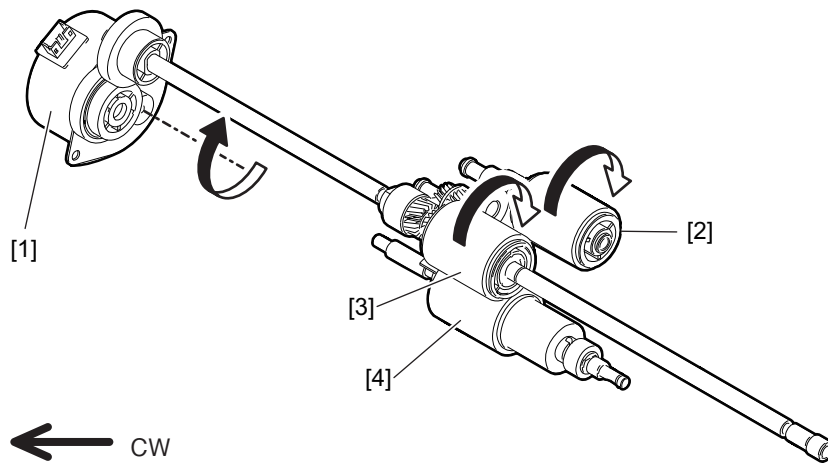

Fig. 3-75

- [1] DSDF original feed motor
- [2] DSDF pickup roller
- [3] DSDF original feed roller
- [4] DSDF separation roller

3.16.5 DSDF separation motor

The DSDF separation motor performs the reverse operation of the original separation roller and moves (upward/downward) the original tray lift.

When original feeding starts, the DSDF separation motor rotates clockwise to perform the reverse operation of the original separation roller.

This will prevent multiple feeding of an original.

Moreover, when the DSDF original empty sensor is turned ON, the DSDF separation motor rotates counterclockwise, resulting in the original tray lift going up.

When the DSDF original empty sensor is turned OFF, the DSDF separation motor rotates counterclockwise, resulting in the original tray lift lowering.

Transmitting the driving force from the DSDF separation motor to the original tray lift is controlled by the DSDF tray-up clutch.

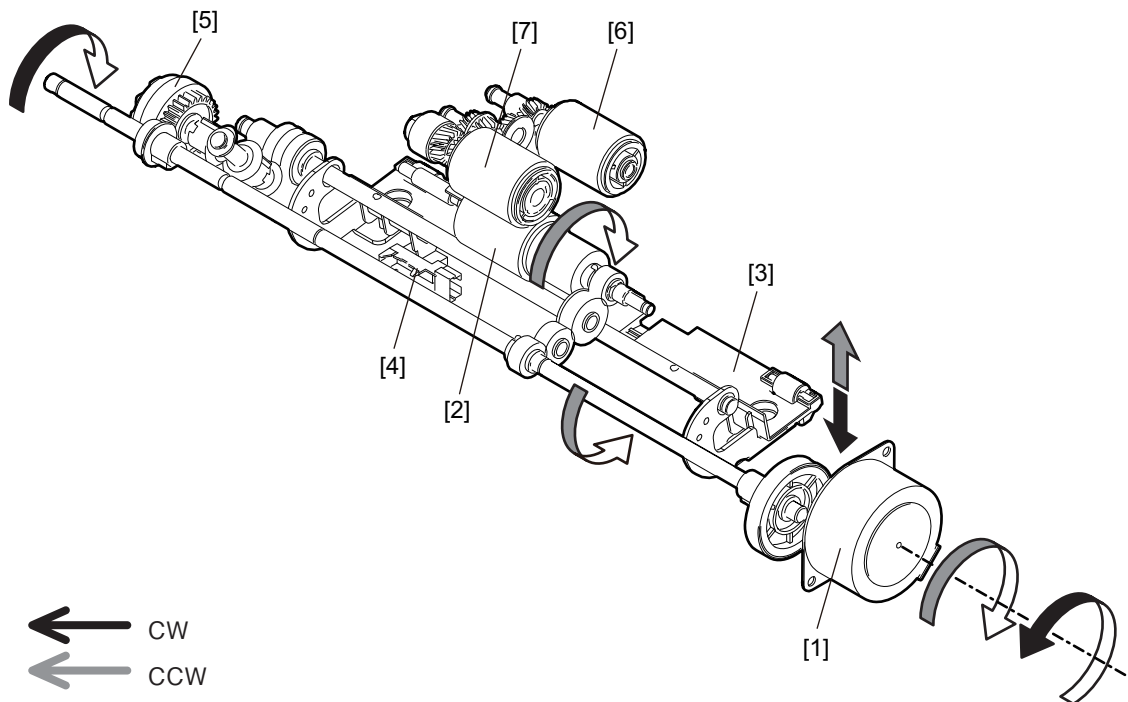

Fig. 3-76

- [1] DSDF separation motor
- [2] DSDF separation roller
- [3] Original tray lift
- [4] DSDF tray lift lower limit sensor
- [5] DSDF tray-up clutch
- [6] DSDF pickup roller
- [7] DSDF original feed roller

3.16.6 DSDF registration motor

The DSDF registration motor rotates the DSDF registration roller.
The DSDF registration roller aligns the paper and transports it to the pre-read roller-1.

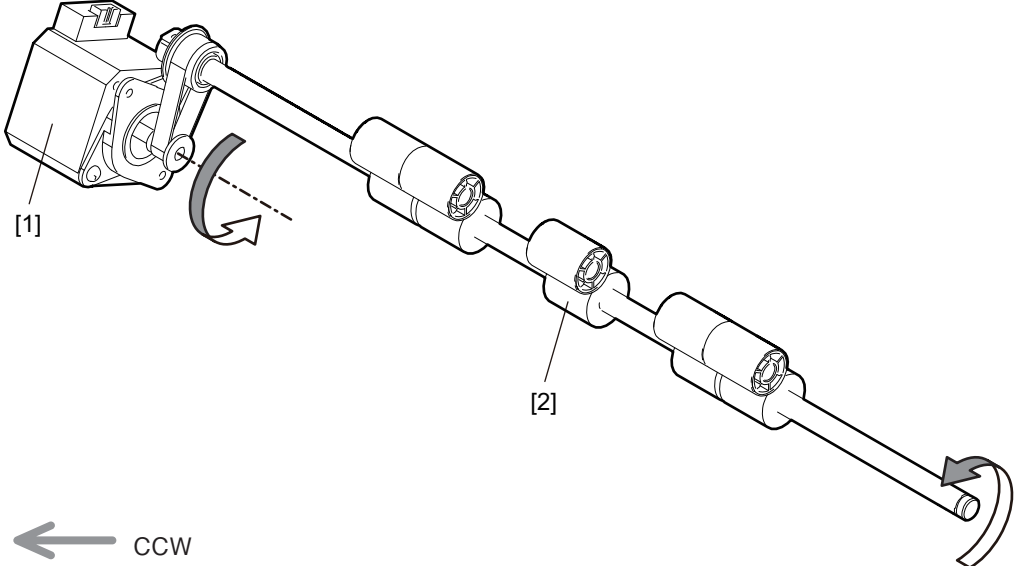

Fig. 3-77

- [1] DSDF registration motor
- [2] DSDF registration roller

3.16.7 DSDF read motor

The DSDF read motor drives four rollers; the pre-read roller-1, post-read roller-1, pre-read roller-2 and post-read roller-2, by means of the timing belt.

The pre-read roller-1 and the post-read roller-1 perform paper transporting at the scanning section of the ADF original glass. The pre-read roller-2 and the post-read roller-2 perform paper transporting at the scanning section of the DSDF-CCD module.

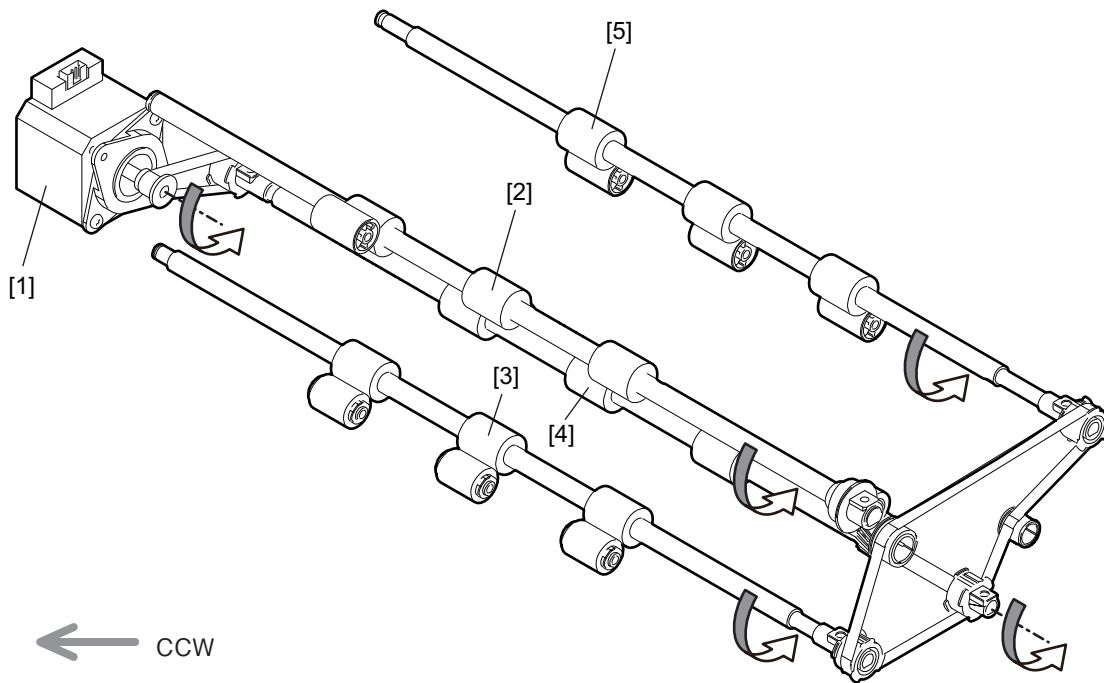

Fig. 3-78

- [1] DSDF read motor
- [2] Pre-read roller-1
- [3] Post-read roller-1
- [4] Pre-read roller-2
- [5] Post-read roller-2

3.16.8 DSDF original exit motor

When the DSDF original exit motor rotates counterclockwise, the DSDF original exit roller starts rotating to exit an original.

When the DSDF original exit motor rotates clockwise, the guide covering the DSDF shading sheet starts rotating and then it appears.

The home position of the guide covering the DSDF shading sheet is detected by the DSDF shading sheet HP sensor.

The DSDF shading sheet is used to correct the values of the background peak of the DSDF-CCD module.

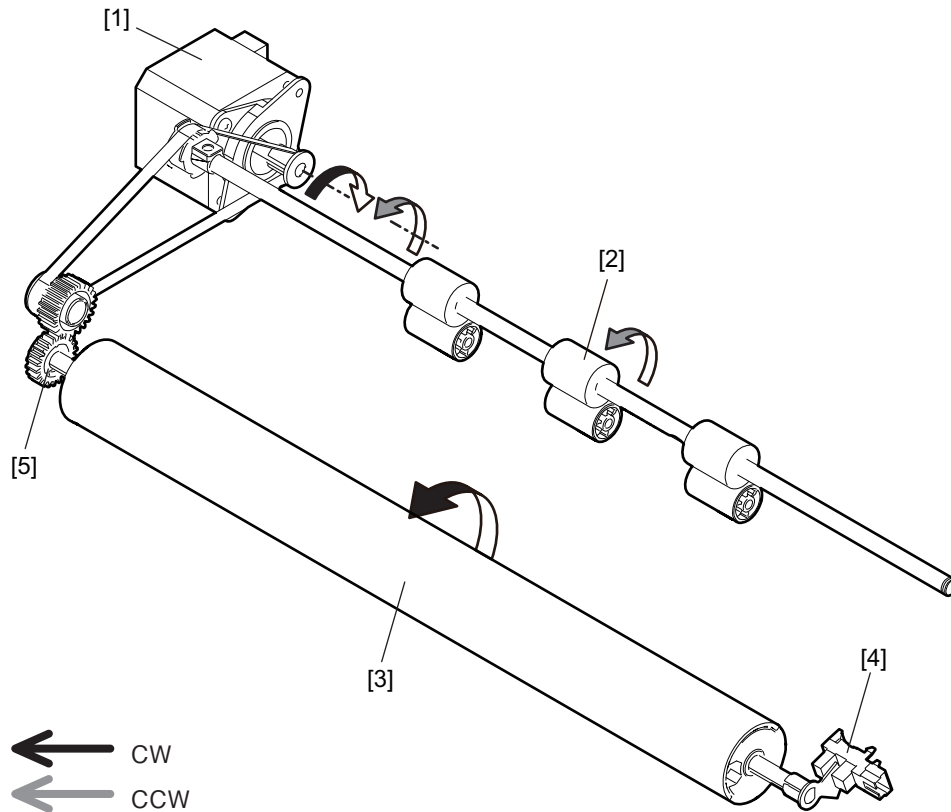

Fig. 3-79

- [1] DSDF original exit motor
- [2] DSDF original exit roller
- [3] DSDF shading sheet
- [4] DSDF shading sheet HP sensor
- [5] One-way clutch

3.16.9 Original size detection

The size of the original on the original tray is detected by the combination of the DSDF tray original width sensor, DSDF tray original length sensors-1 and -2.

In the original mixed size mode, after the original on the original tray has been fed and transported, the original size is detected again by the combination of the DSDF original width detection sensors-1 and -2 and the DSDF registration sensor to determine the paper size.

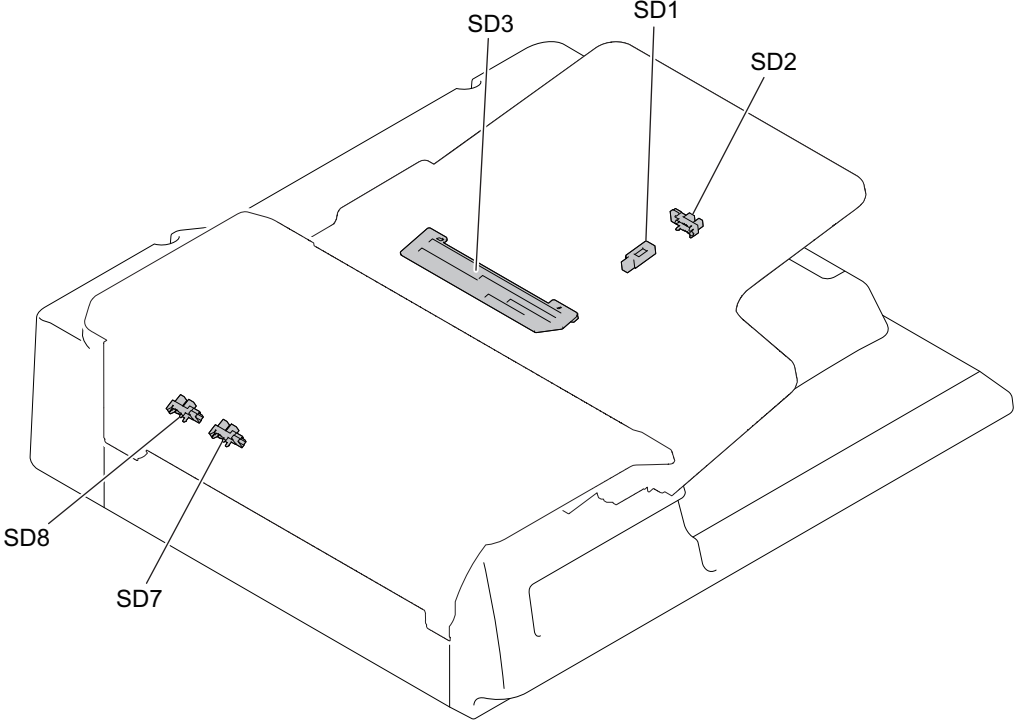

Fig. 3-80

| Symbol | Name | Symbol | Name |
|--------|------------------------------------|--------|--|
| SD1 | DSDF tray original length sensor-1 | SD7 | DSDF original width detection sensor-1 |
| SD2 | DSDF tray original length sensor-2 | SD8 | DSDF original width detection sensor-2 |
| SD3 | DSDF tray original width sensor | | |

3.16.10 DSDF tray original width sensor, DSDF tray original length sensors-1 and -2

The DSDF tray original width sensor, DSDF tray original length sensors-1 and -2 detect the size of an original placed on the original tray.

It is detected by the brush attached to the rack moving on the DSDF original tray width sensor, which is a board with the different length of the patterns written. This brush is moved accordingly as the original width guide is shifted. Signals (TWID0S, TWID1S, TWID2S) are opened and shorted to SG by this movement. The combination of these short (= low level) and open (= high level) can determine the width of the original.

The size of the original is determined by the combination of the DSDF tray original width sensor, DSDF tray original length sensors-1 and -2. Therefore, if the sensors cannot perform the detection properly when dealing with a folded or bent original, an incorrect original size may be detected.

Sizes detectable in combination of these opening and shorting of the signals are as follows.

| DSDF tray original width sensor | | | DSDF tray original length sensor-1 | DSDF tray original length sensor-2 | Original width size (A series) | Original width size (LT series) |
|---------------------------------|--------|--------|------------------------------------|------------------------------------|--------------------------------|---------------------------------|
| TWID2S | TWID1S | TWID0S | | | | |
| L | L | H | * | * | Business card | Business card |
| H | H | L | * | * | B5-R | - |
| H | L | H | * | * | A5-R | ST-R |
| H | L | L | OFF | OFF | A4 | LT |
| | | | * | ON | A3 | LD |
| L | H | L | OFF | OFF | A4-R | 8.5" x 8.5" |
| | | | ON | OFF | | LT-R |
| | | | * | ON | FOLIO | LG |
| L | L | L | OFF | OFF | B5 | COMPUTER |
| | | | * | ON | B4 | |

H: Open

L: Short

* There is no concern between ON and OFF.

3.16.11 DSDF tray original width detection sensors-1, -2, DSDF registration sensor

In the original mixed size mode, the size of the original is determined by being based on the original size detected by the DSDF tray original width sensor, DSDF tray original length sensors-1 and -2 located on the original tray by adding the size detected again (second detection) during the transporting of the original.

The second detection is carried out by the combination of the ON/OFF status of the DSDF original width detection sensors-1 and -2 and the time when the DSDF is turned ON (transportation time) to determine the original size.

Sizes detectable in combination of these sensors are as follows:

A4 series

| Original size on the tray | DSDF original width detection sensor-1 | DSDF original width detection sensor-2 | DSDF registration sensor turned ON time | Determined size |
|--|--|--|--|-----------------|
| A3 | *1 | ON | Longer than transporting A4 size paper | A3 |
| | | | Less than transporting A4 size paper | A4 |
| | ON | OFF | Longer than transporting A4 size paper | B4 |
| | | | Less than transporting A4 size paper | B5 |
| | OFF | OFF | Longer than transporting A4-R size paper | FOLIO |
| | | | Longer than transporting B5-R size paper Less than transporting A4-R size paper | A4-R |
| Less than transporting B5-R size paper | | | B5-R | |
| A4 | *1 | ON | *2 | A4 |
| | ON | OFF | Longer than transporting A4 size paper | A4 |
| | | | Less than transporting A4 size paper | B5 |
| | OFF | OFF | *2 | A4 |
| B4 | ON | *1 | Longer than transporting A4 size paper | B4 |
| | | | Less than transporting A4 size paper | B5 |
| | OFF | OFF | Longer than transporting A4-R size paper | FOLIO |
| | | | Longer than transporting B5-R size paper Less than transporting A4-R size paper | A4-R |
| | | | Longer than transporting A4 size paper Less than transporting B5-R size paper | B5-R |
| | | | Less than transporting A4 size paper | A5-R |
| B5 | *1 | *1 | *2 | B5 |

| Original size on the tray | DSDF original width detection sensor-1 | DSDF original width detection sensor-2 | DSDF registration sensor turned ON time | Determined size |
|---------------------------|--|--|--|-----------------|
| FOLIO | ON | *1 | Longer than transporting A4-R size paper | FOLIO |
| | | | Less than transporting A4-R size paper | A4-R |
| | OFF | OFF | Longer than transporting A4 size paper | B5-R |
| | | | Less than transporting A4 size paper | A5-R |
| A4-R | ON | *1 | *2 | A4-R |
| | OFF | OFF | Longer than transporting A4 size paper | B5-R |
| | | | Less than transporting A4 size paper | A5-R |
| B5-R | *1 | *1 | Longer than transporting A4 size paper | B5-R |
| | | | Less than transporting A4 size paper | A5-R |
| A5-R | *1 | *1 | *2 | A5-R |

*1 : There is no concern between ON and OFF.

*2 : There is no concern in the transportation time.

LT series

| Original size on the tray | DSDF original width detection sensor-1 | DSDF original width detection sensor-2 | DSDF registration sensor turned ON time | Determined size |
|---------------------------|--|--|--|-----------------|
| LD | *1 | ON | Longer than transporting LT size paper | LD |
| | | | Less than transporting LT size paper | LT |
| | OFF | OFF | Longer than transporting 13" LG size paper | LG |
| | | | Longer than transporting LT-R size paper Less than transporting 13" LG size paper | 13" LG |
| | | | Longer than transporting LT size paper Less than transporting LT-R size paper | LT-R |
| | | | Less than transporting LT size paper | 8.5" SQ |
| LT | *1 | ON | *2 | LT |
| | OFF | OFF | Longer than transporting LT size paper | LT |
| | | | Less than transporting LT size paper | 8.5" SQ |

| Original size on the tray | DSDF original width detection sensor-1 | DSDF original width detection sensor-2 | DSDF registration sensor turned ON time | Determined size |
|---------------------------|--|--|--|-----------------|
| COMP | ON | *1 | *2 | COMP |
| | OFF | OFF | Longer than transporting 13" LG size paper | LG |
| | | | Longer than transporting LT-R size paper Less than transporting 13" LG size paper | 13" LG |
| | | | Longer than transporting LT size paper Less than transporting LT-R size paper | LT-R |
| | | | Less than transporting LT size paper | 8.5" SQ |
| LG | ON | *1 | Longer than transporting 13" LG size paper | LG |
| | | | Longer than transporting LT-R size paper Less than transporting 13" LG size paper | 13" LG |
| | | | Longer than transporting LT size paper Less than transporting LT-R size paper | LT-R |
| | | | Less than transporting LT size paper | 8.5" SQ |
| | OFF | OFF | *2 | ST-R |
| LT-R | ON | *1 | Longer than transporting LT size paper | LT-R |
| | | | Less than transporting LT size paper | 8.5" SQ |
| | OFF | OFF | *2 | ST-R |
| ST-R | OFF | OFF | *2 | ST-R |

*1 : There is no concern between ON and OFF.

*2 : There is no concern in the transportation time.

3.16.12 Multiple feeding detection

The DSDF has a transmissive ultrasonic sensor to detect multiple feeding of sheets of an original. When multiple sheets of the original are fed together, it is determined as multiple feeding. Then an alert is generated and then the operation is stopped.

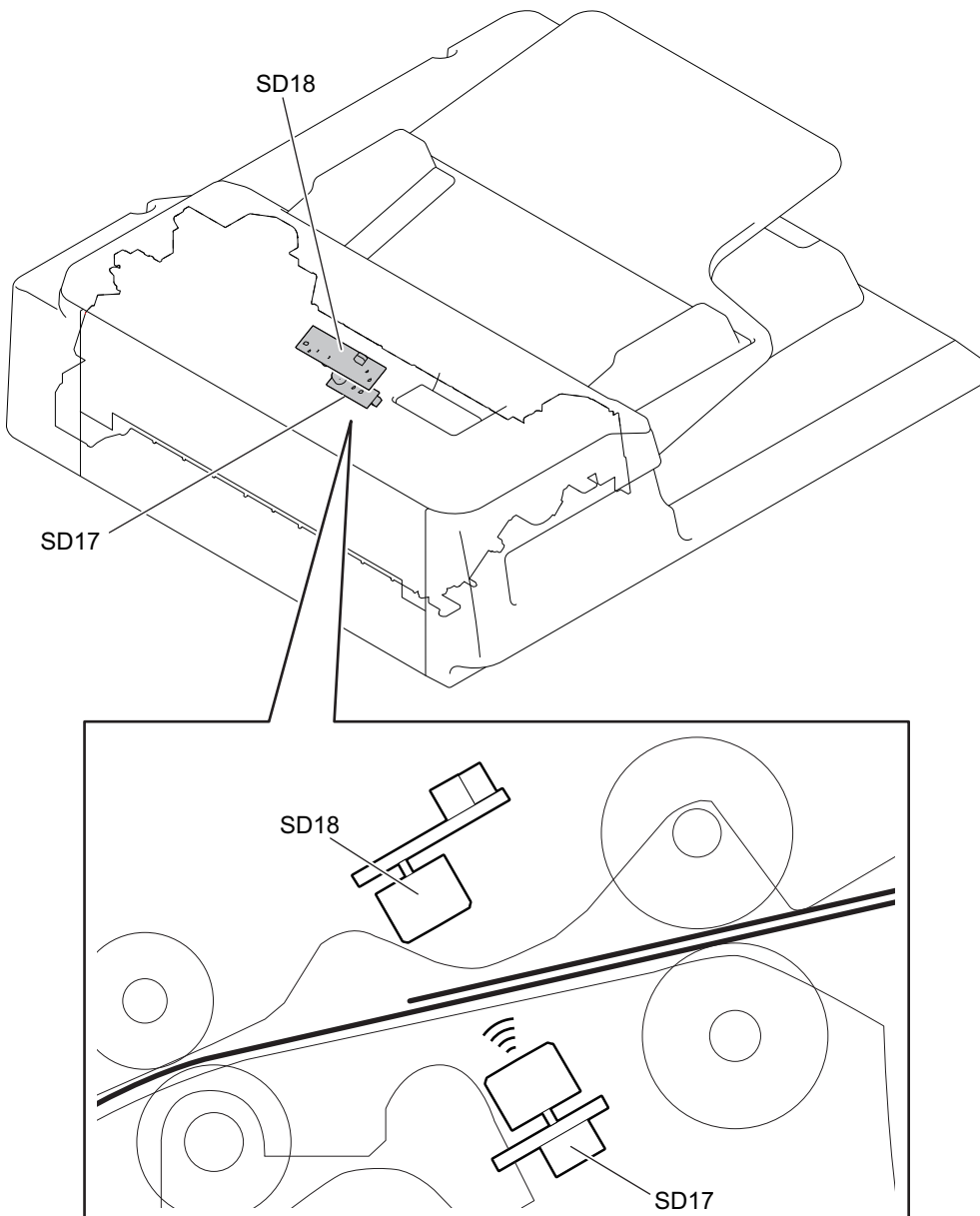

Fig. 3-81

| Symbol | Name |
|--------|---|
| SD17 | Multiple feeding detection sensor (transmission side) |
| SD18 | Multiple feeding detection sensor (reception side) |

3.17 Power supply unit

3.17.1 Overview

The power supply unit consists of the AC filter and insulation type DC output circuit.

Notes:

In a model with 2 power cables, the total current capacity to be used should not exceed the breaker rating.

3.17.2 Composition

[1] Functions

1. AC filter

Eliminates noise from the outside and prevents the noise generated by the MFP from leaking to the outside.

2. DC output circuits

Converts AC voltage input from outside to DC voltage and supplies it to each electric part. The DC voltage is divided into the following two lines.

a. Power switch line: Power supply used in the entire MFP during the image forming process. Two kinds of voltage (+12 VS and +12 VA) are output when the power is turned ON.

b. Cover switch line: Power supply used in the entire MFP during the image forming process, being supplied via the cover switch. The voltage (+24 VD) is output only when the power is turned ON and the front cover and the duplexing unit cover are closed.

3.17.3 Operation of DC output circuits

1. Start-up operation of the MFP

Once the power cable of the MFP is plugged into an outlet, only +12 VS power is supplied to the power supply control circuits on the SYS board. When the power is turned ON by pressing the [ON/OFF] button on the control panel, the supplying of all the voltages is started. However, the voltage for the cover switch line starts being supplied only when the front cover and duplexing unit cover are closed.

2. Stopping line output

When a power failure has occurred or the power cable is unplugged, the PWR-DN signal is output after the instantaneous outage insurance time elapses and then the supply of each voltage stops. If the voltage supply of the main line (+12 VS, +12 VA) stops earlier than the 24 V line does, it may cause damage to the electron device on each control circuit. To prevent this, the supply of these voltages stops after the PWR-DN signal is output and the minimum retaining time elapses.

3. Output protection

Each output system includes an overcurrent and an overvoltage protection circuit (an internal protection circuit). This is to prevent defects (damage or abnormal operation of the secondary circuit) which may be caused by an overcurrent due to a short circuit or an overvoltage due to a short circuit between different voltages. If the protection circuit is activated, remove the causes such as the short circuit. Turn ON the power again to clear the overcurrent protection.

4. Recovering from the super sleep mode (normal startup)

When the [Energy Saver] button on the control panel is pressed during the super sleep mode, its shifting or recovering signal (SYS-EN) is output from the SYS board and then voltage starts being supplied to all the lines, if no error was detected.

5. Recovering from the super sleep mode (when receiving a packet)

When a packet from a network is received during the super sleep mode, it is shifted to the sleep mode.

When they are received frequently, a control is performed to keep the sleep mode for a specified period. The sleep mode holding time by means of this control will not be affected by the setting of the self-diagnostic code.

6. Shifting to the super sleep mode (normal startup)

When the [ENERGY SAVER] button on the control panel is pressed while the power is turned ON, a super sleep mode shifting/recovering signal (SYS-EN) is output from the SYS board after the initialization is finished and then all lines for the output voltage except +12 VS are closed.

In the following cases, the MFP does not shift into the super sleep mode.

- When the super sleep mode is set to be disabled on the control panel, TopAccess and with the code FS-08-8543
- When the e-BRIDGE ID Gate (for JPC only), Overwrite Enabler, USB storage device, Fingerprint reader or 2nd NIC is installed
- When the IPsec Enabler is installed and its function is set to be enabled
- When the operation is being performed in the self-diagnostic mode (Disabled until the power is turned OFF)
- When the VNC setting is set to be enabled
- When the Wi-Fi Direct function is set to be enabled
- When the Multi Station print function is set to be enabled
- When the [Assume this MFP is the Primary Server] check box is selected in the [Home Setting] screen
- When the license of the IP Fax is installed
- When any of the recovery settings of [Screen Control] is set to be enabled
- When a background application is being started
- The MFP is being operated on TopAccess (during the retaining of the session)

7. State of the power supply

- Power is not supplied.
The power cable is unplugged from an outlet.

- Power OFF
When the MFP is shut down, a DC voltage is supplied only to the circuits on the SYS board which are monitoring the [ON/OFF] button, but the MFP is not operable.

- Normal state (including the energy saving mode)
The power is turned ON and a DC voltage is supplied to each board. When the cover of the MFP is closed, a 24 V DC voltage is supplied and the MFP enters into the ready or printing state.

- Sleep mode
The 12 VS and 12 VA power are supplied to the SYS board which operates normally. No power is supplied to the LGC board. In addition, the DC power supply of 24 V series is not supplied either.

- Super sleep mode
Only the 12 VS power is supplied to the SYS board, but the 12 VA power is not. The CPU on the SYS board stops operating and monitors a recovery event only. No power is supplied to the LGC board. In addition, the DC power supply of 24 V series is not supplied either.

3.17.4 Output channel

Power switch line

| Connector | Pin No. | Voltage | Destination |
|-----------|---------|---------|-------------------|
| CN511 | 2 | +12 VA | LGC board (CN316) |
| | 3 | +12 VA | SYS board (CN105) |
| | 4 | +12 VA | SYS board (CN105) |
| | 8 | +12 VS | SYS board (CN105) |

Cover switch line

| Connector | Pin No. | Voltage | Destination |
|-----------|---------|---------|-------------------------|
| CN514 | 1 | +24 VD4 | LGC board (CN317) |
| | 2 | +24 VD3 | LGC board (CN317) |
| | 3 | +24 VD2 | PFC board (CN351) |
| | 4 | +24 VD1 | PFC board (CN351) |
| CN515 | 1 | +24 VB2 | Finisher (J717) |
| | 3 | +24 VB1 | SYS board, DSDF (CN125) |

Output list for each connector

| Connector | Destination | Voltage | Remarks |
|-----------|-------------------------|------------------|-------------------|
| CN316 | LGC board | +12 VA | Power switch line |
| CN105 | SYS board | +12 VA, +12 VS | |
| CN317 | LGC board | +24 VD3, +24 VD4 | Cover switch line |
| CN351 | PFC board | +24 VD1, +24 VD2 | |
| CN125 | SYS board, DSDF | +24 VD5 | |
| J717 | Finisher | +24 VD3 | |
| CN501 | AC input (power supply) | | AC line |
| CN521 | AC input (for IH) | | |
| CN522 | IH output | | |

4. DISASSEMBLY AND REPLACEMENT

4.1 Cover

4.1.1 Front lower cover

- (1) Pull out the 1st drawer.
- (2) Loosen 2 screws.
- (3) Take off the front lower cover [1].



Fig. 4-1

4.1.2 Front cover

- (1) Take off the front lower cover.
📖 P. 4-1 “4.1.1 Front lower cover”
- (2) Open the front cover.
- (3) Remove 2 screws [2] of the cover support [1].

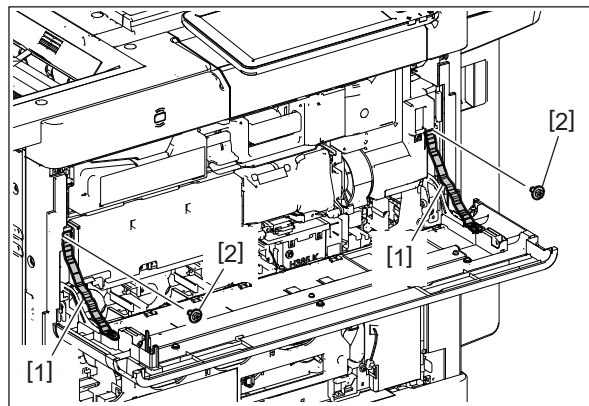

Fig. 4-2

- (4) Remove the clip [3].

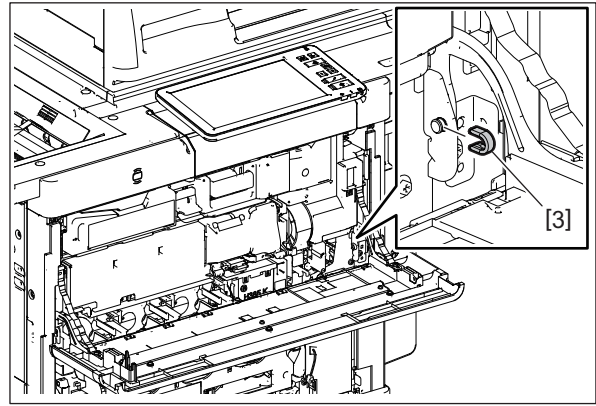

Fig. 4-3

- (5) Lift up the supporting point of the left side hinge [4] and move the front cover [5] to the right side to take it off.

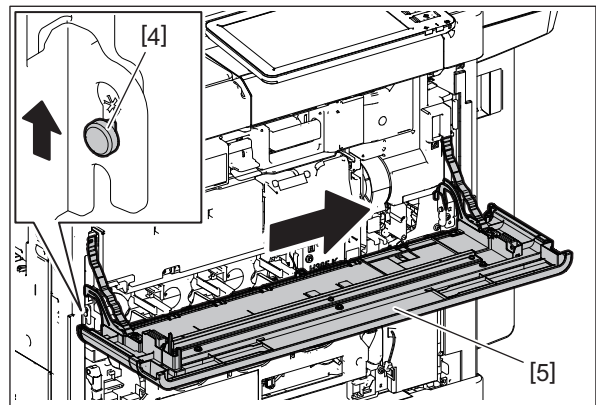

Fig. 4-4

4.1.3 Top right cover

- (1) Open the DSDF.
- (2) Take off the front right cover (control panel right cover).
 P. 4-3 "4.1.5 Front right cover (control panel right cover)"
- (3) Remove 2 screws and take off the top right cover [1].



Fig. 4-5

4.1.4 Right top cover

- (1) Open the duplexing unit.
- (2) Take off the top right cover [1].
📖 P. 4-2 "4.1.3 Top right cover"
- (3) Remove 3 screws and take off the right top cover [1].

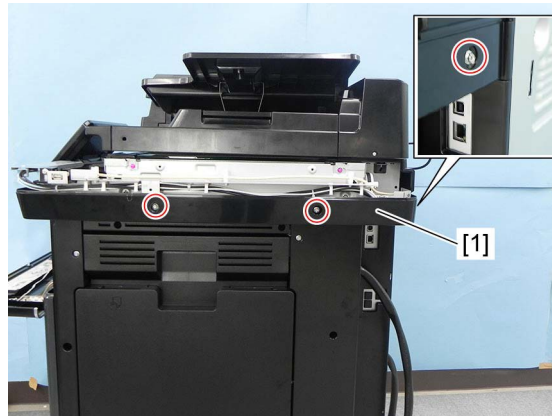

Fig. 4-6

4.1.5 Front right cover (control panel right cover)

- (1) Open the front cover.
- (2) Remove 1 cap.
- (3) Remove 2 screws and take off the front right cover [1].

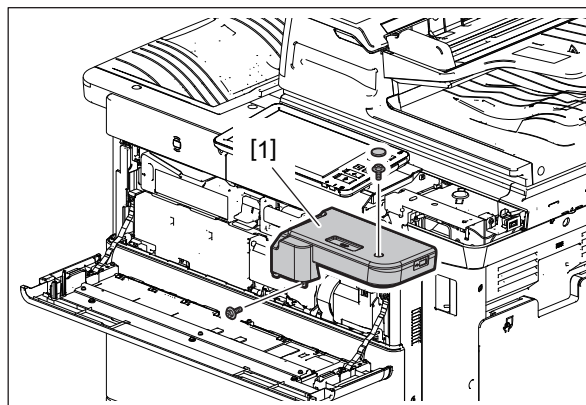

Fig. 4-7

4.1.6 Front top cover (control panel top cover)

- (1) Take off the front left cover (control panel left cover).
📖 P. 4-5 "4.1.8 Front left cover (control panel left cover)"
- (2) Raise the control panel [1].

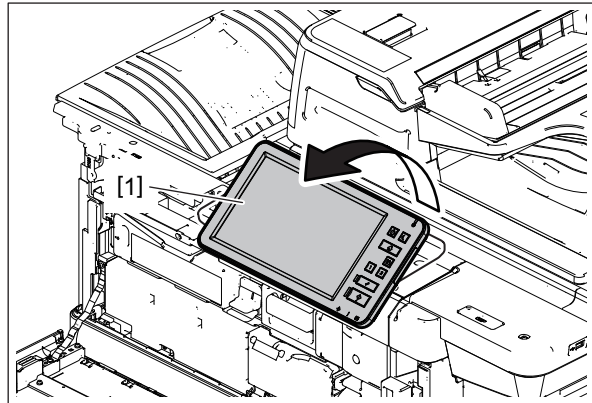

Fig. 4-8

- (3) Remove 2 caps.
- (4) Remove 2 screws and take off the front top cover [2].

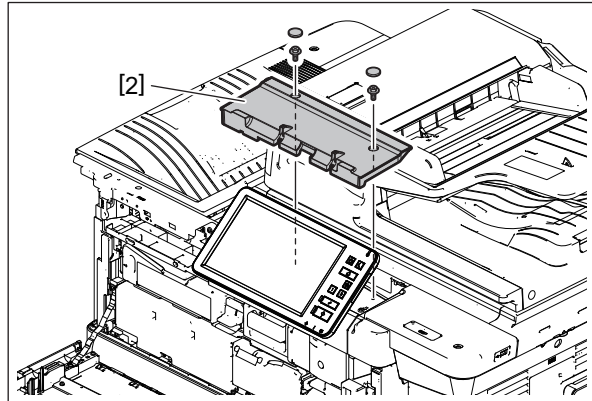

Fig. 4-9

4.1.7 Front lower cover (control panel lower cover)

- (1) Open the front cover.
- (2) Make the control panel [1] level.

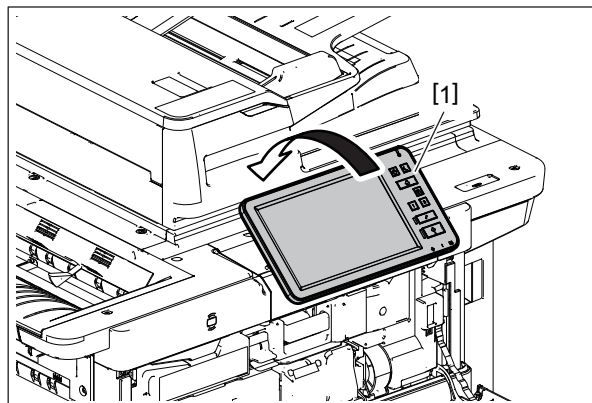

Fig. 4-10

- (3) Remove 1 screw and take off the front lower cover [2].

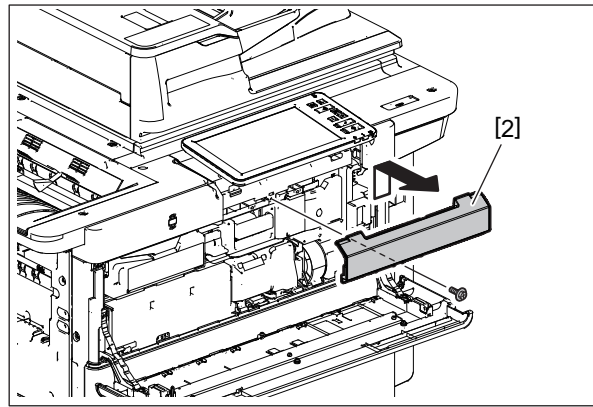

Fig. 4-11

4.1.8 Front left cover (control panel left cover)

- (1) Open the front cover.
- (2) Remove 2 caps.
- (3) Remove 3 screws and take off the front left cover [1].

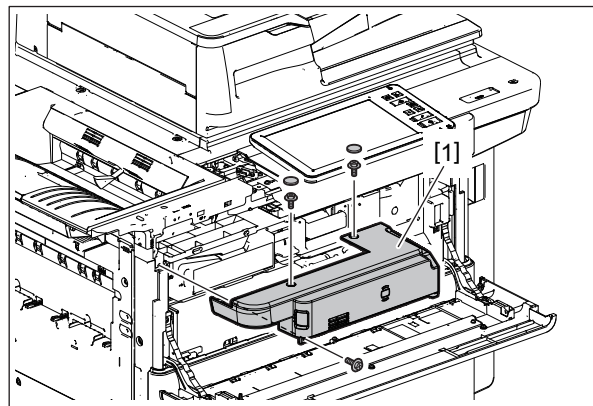

Fig. 4-12

4.1.9 Top front cover

- (1) Open the DSDF.
- (2) Take off the front top cover (control panel top cover).
📖 P. 4-4 “4.1.6 Front top cover (control panel top cover)”
- (3) Take off the front left cover (control panel left cover).
📖 P. 4-5 “4.1.8 Front left cover (control panel left cover)”
- (4) Take off the front right cover (control panel right cover).
📖 P. 4-3 “4.1.5 Front right cover (control panel right cover)”

- (5) Remove 2 screws and take off the top front cover [1].

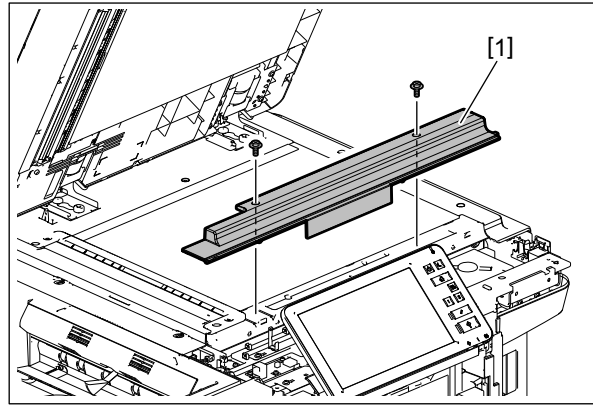

Fig. 4-13

4.1.10 Top left cover

- (1) Open the DSDF.
(2) Remove 2 caps.
(3) Remove 2 screws and take off the top left cover [1].

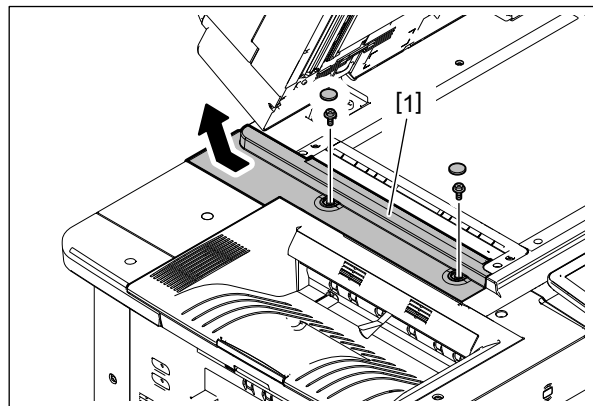

Fig. 4-14

4.1.11 Left rear cover

- (1) Remove 1 cap.
(2) Remove 4 screws and take off the left rear cover [1].

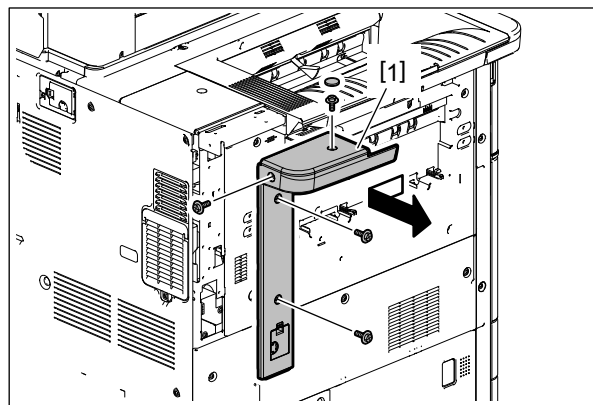

Fig. 4-15

4.1.12 Top rear left cover

- (1) Take off the top left cover.
P. 4-6 "4.1.10 Top left cover"
- (2) Take off the left rear cover.
P. 4-6 "4.1.11 Left rear cover"
- (3) Remove 1 cap.
- (4) Remove 1 screw and take off the top rear left cover [1].

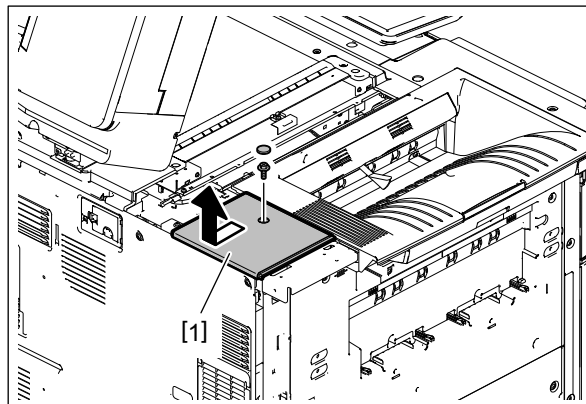

Fig. 4-16

4.1.13 Exit tray

- (1) Take off the front left cover (control panel left cover).
P. 4-5 "4.1.8 Front left cover (control panel left cover)"
- (2) Take off the top left cover.
P. 4-6 "4.1.10 Top left cover"
- (3) Open the reverse path cover [1].



Fig. 4-17

- (4) Remove 2 screws and take off the exit tray [2].

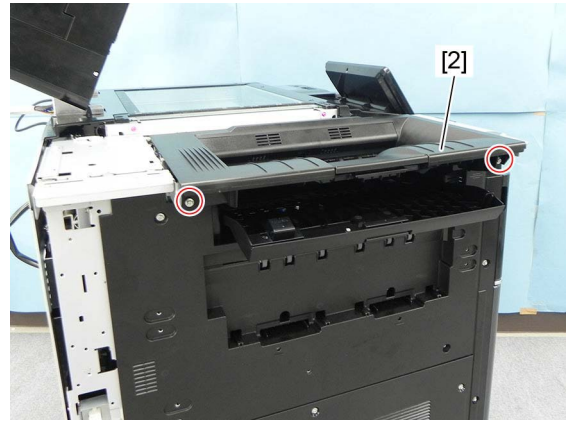

Fig. 4-18

4.1.14 Left middle cover

- (1) Remove 3 screws and take off the left middle cover [1].



Fig. 4-19

4.1.15 Left top cover

- (1) Take off the exit tray.
📖 P. 4-7 “4.1.13 Exit tray”
- (2) Take off the left middle cover.
📖 P. 4-8 “4.1.14 Left middle cover”
- (3) Remove 2 screws and take off the fan cover [1].

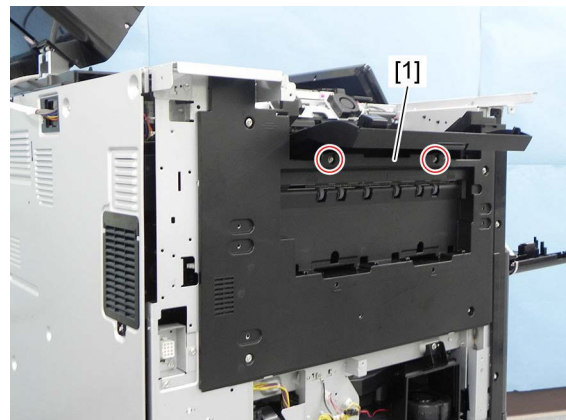

Fig. 4-20

- (4) Remove 6 screws and take off the left top cover [2].

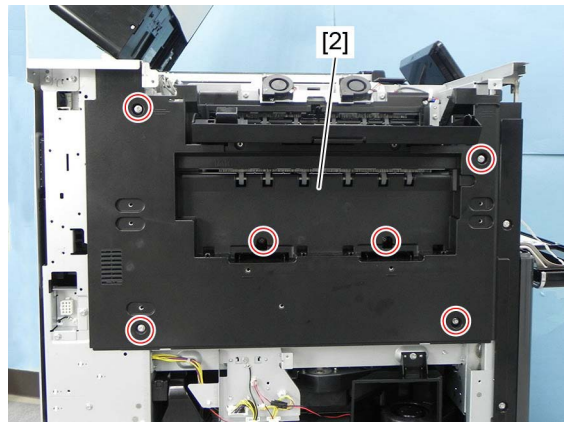

Fig. 4-21

4.1.16 Left lower cover

- (1) Take off the left middle cover.
P. 4-8 "4.1.14 Left middle cover"
- (2) Remove 2 screws and take off the filter cover [1].



Fig. 4-22

- (3) Remove 1 screw and take off the left lower cover [2].



Fig. 4-23

4.1.17 Bypass unit (removal of the tray arm)

- (1) Open the bypass tray.
- (2) Secure the sliding section [2] of the tray arm [1], and then remove it by pulling its joint [3] up. The tray arm can be easily taken out by lifting up its leading edge [4] with the sliding section [2] secured.

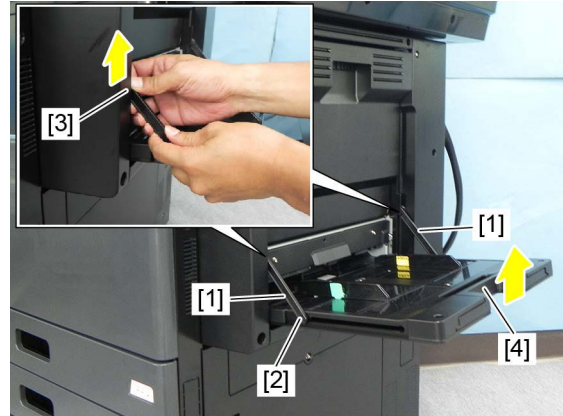

Fig. 4-24

4.1.18 Duplexing unit front cover

- (1) Open the duplexing unit.
- (2) Remove the tray arms.
 P. 4-10 "4.1.17 Bypass unit (removal of the tray arm)"
- (3) Remove 3 screws and take off the duplexing unit front cover [1].



Fig. 4-25

4.1.19 Duplexing unit rear cover

- (1) Open the duplexing unit.
- (2) Remove the tray arms.
 P. 4-10 "4.1.17 Bypass unit (removal of the tray arm)"
- (3) Remove 3 screws and take off the duplexing unit rear cover [1].



Fig. 4-26

4.1.20 Paper feed cover

- (1) Open the duplexing unit.
- (2) Open the paper feed cover [1].
- (3) Remove 1 clip and take off the paper feed cover [1].

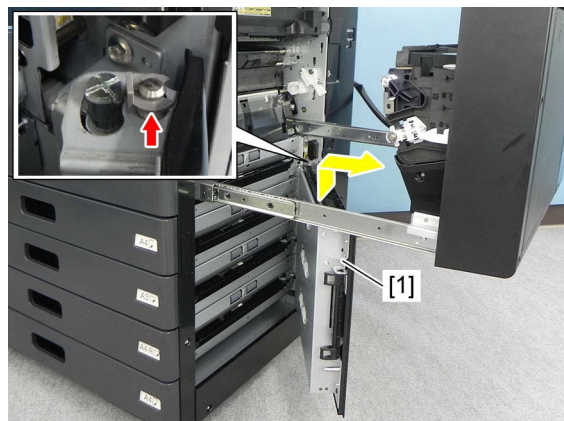

Fig. 4-27

4.1.21 Right rear cover

- (1) Take off the right top cover.
📖 P. 4-3 "4.1.4 Right top cover"
- (2) Remove 4 screws and take off the right rear cover [1].



Fig. 4-28

4.1.22 Rear cover

- (1) Remove 9 screws and take off the rear cover [1].

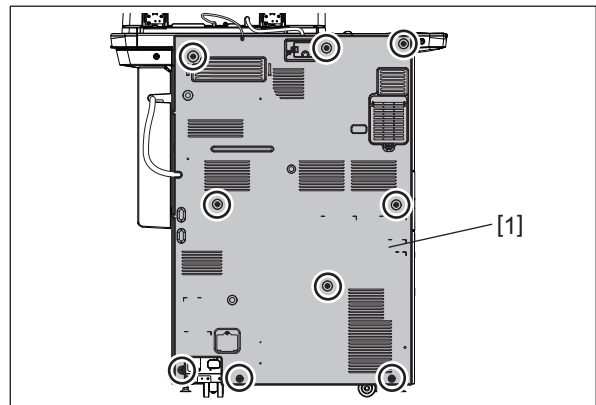

Fig. 4-29

Notes:

When installing, be careful not to let the harness get caught in it.

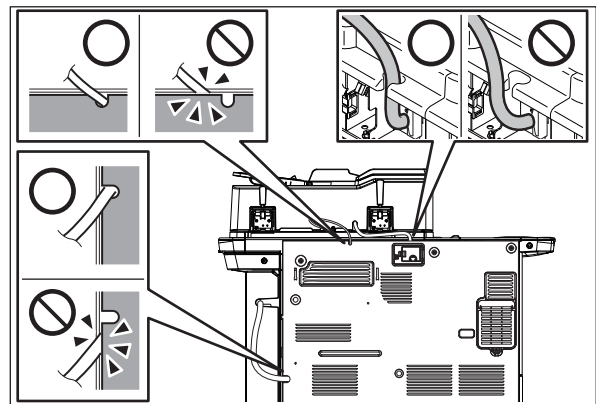

Fig. 4-30

4.1.23 Top rear cover

- (1) Take off the DSDF.
☞ P. 4-326 "4.11.1 Removal of the DSDF"
- (2) Take off the top left cover.
☞ P. 4-6 "4.1.10 Top left cover"
- (3) Remove 3 screws and take off the top rear cover [1].

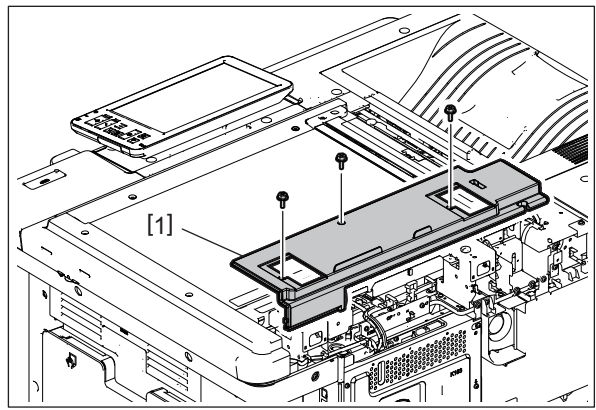

Fig. 4-31

4.1.24 Left corner cover

- (1) Take off the front lower cover.
☞ P. 4-1 "4.1.1 Front lower cover"
- (2) Take off the front left cover (control panel left cover).
☞ P. 4-5 "4.1.8 Front left cover (control panel left cover)"
- (3) Pull out all the drawers.
- (4) Remove 3 screws and take off the left corner cover [1].

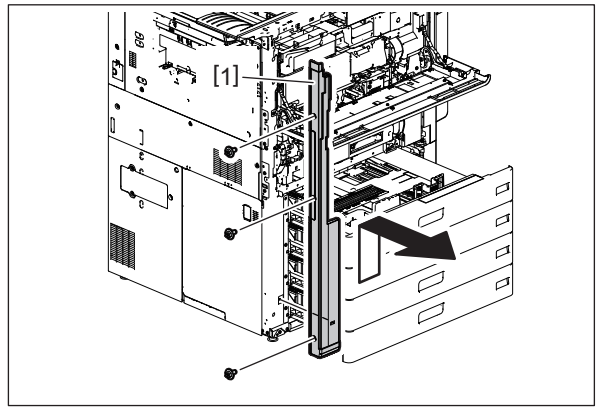

Fig. 4-32

4.1.25 Right corner cover

- (1) Pull out all the drawers.
- (2) Take off the front lower cover.
📖 P. 4-1 "4.1.1 Front lower cover"
- (3) Open the front cover.
- (4) Take off the right top cover.
📖 P. 4-3 "4.1.4 Right top cover"
- (5) Take off the front right cover (control panel right cover).
📖 P. 4-3 "4.1.5 Front right cover (control panel right cover)"
- (6) Open the paper feed cover.
- (7) Remove 2 screws and take off the right corner cover [1].

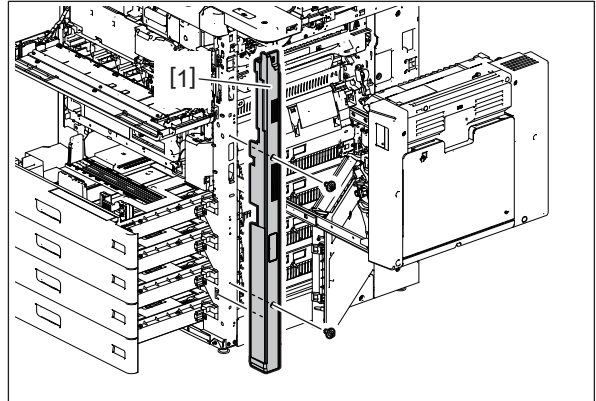

Fig. 4-33

4.2 Control Panel

4.2.1 Control panel unit

- (1) Take off the Dual Scan Document Feeder (DSDF).
📖 P. 4-326 “4.11.1 Removal of the DSDF”
- (2) Take off the top rear cover.
📖 P. 4-13 “4.1.23 Top rear cover”
- (3) Take off the front left cover (control panel left cover).
📖 P. 4-5 “4.1.8 Front left cover (control panel left cover)”
- (4) Take off the front lower cover (control panel lower cover).
📖 P. 4-4 “4.1.7 Front lower cover (control panel lower cover)”
- (5) Take off the top front cover.
📖 P. 4-5 “4.1.9 Top front cover”
- (6) Take off the top left cover.
📖 P. 4-6 “4.1.10 Top left cover”
- (7) Disconnect 1 connector.

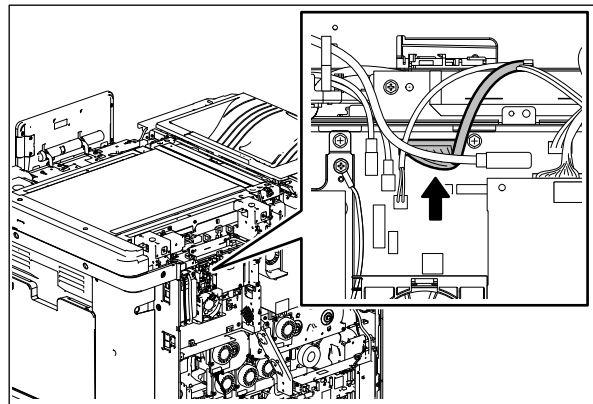

Fig. 4-34

- (8) Release the harnesses [1] from 5 harness clamps.

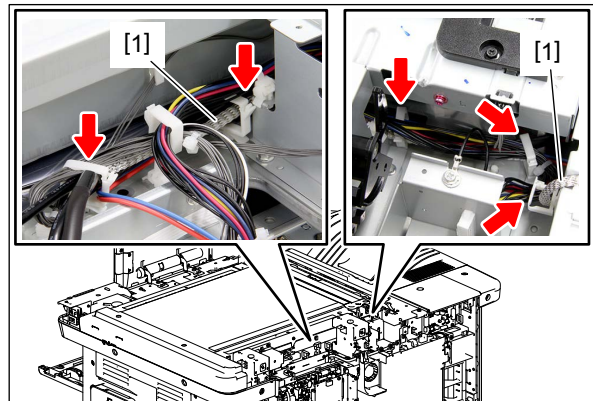

Fig. 4-35

(9) Release the harnesses [1] from 2 harness clamps.

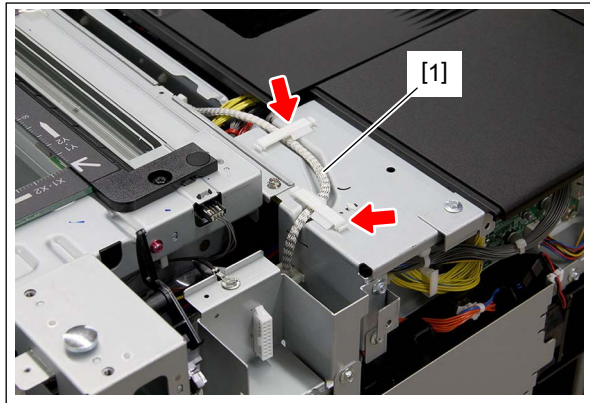

Fig. 4-36

(10) Release the harnesses [1] from 3 harness clamps.

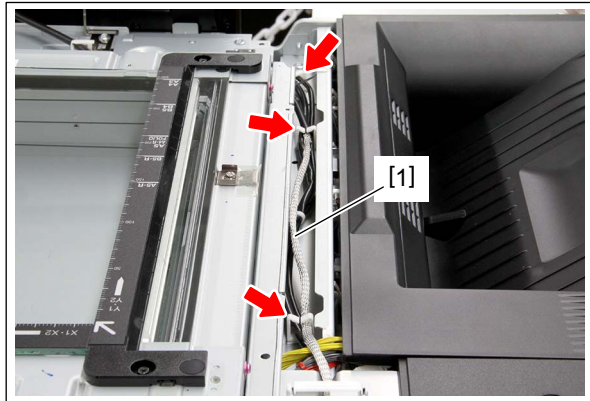

Fig. 4-37

(11) Release the harnesses [1] from 4 harness clamps.

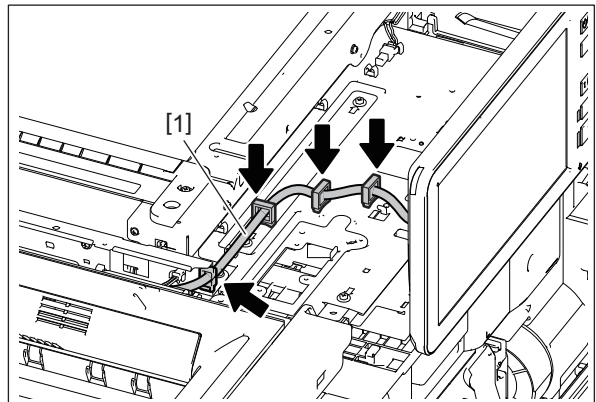

Fig. 4-38

(12) Remove 2 screws. Take off the control panel unit [2] by sliding it to the rear side.

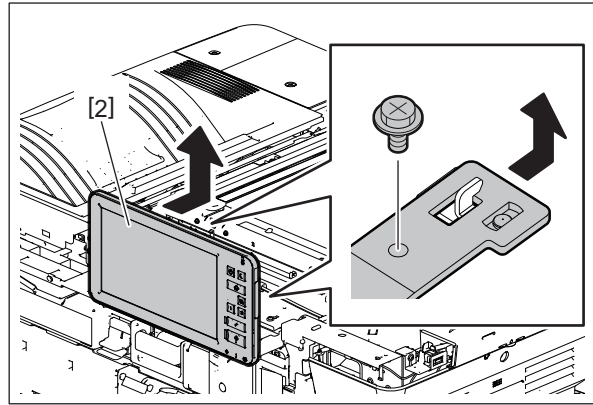

Fig. 4-39

4.2.2 Hinge cover

- (1) Take off the control panel unit.
P. 4-15 "4.2.1 Control panel unit"
- (2) Push 2 hinges downward.

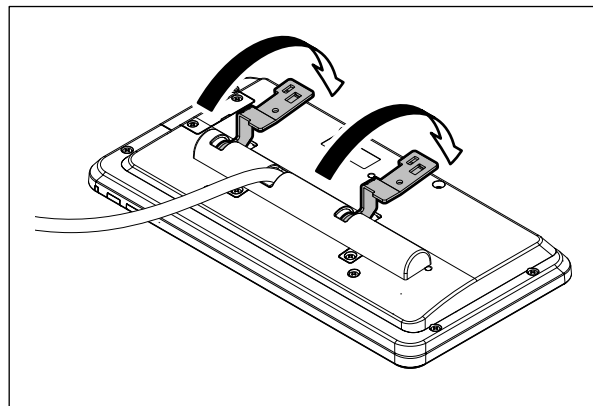

Fig. 4-40

- (3) Remove 2 screws and take off the hinge cover [1].

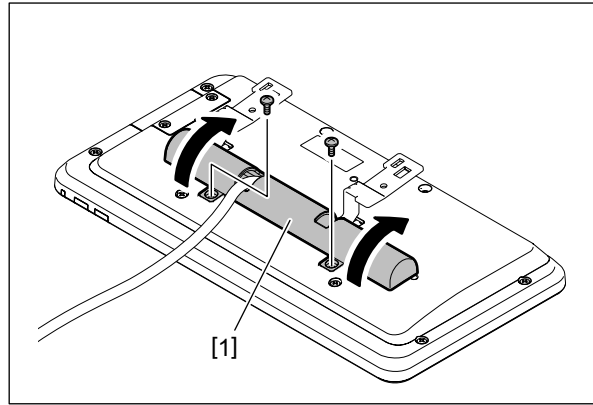

Fig. 4-41

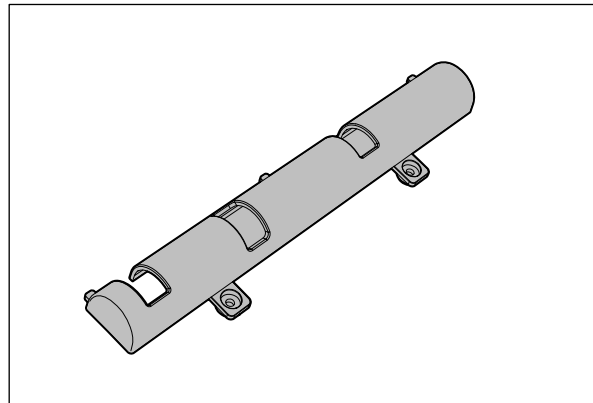

Fig. 4-42

4.2.3 Signal harness

- (1) Take off the hinge cover.
📖 P. 4-17 "4.2.2 Hinge cover"
- (2) Remove 9 screws and open the control panel rear cover [1].

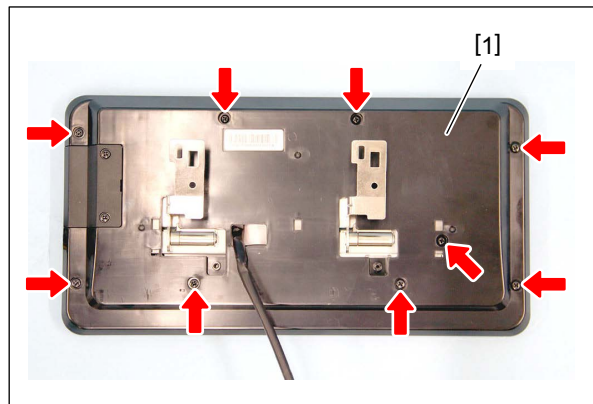

Fig. 4-43

- (3) Release the harness from 1 hook and disconnect the signal harness [2].

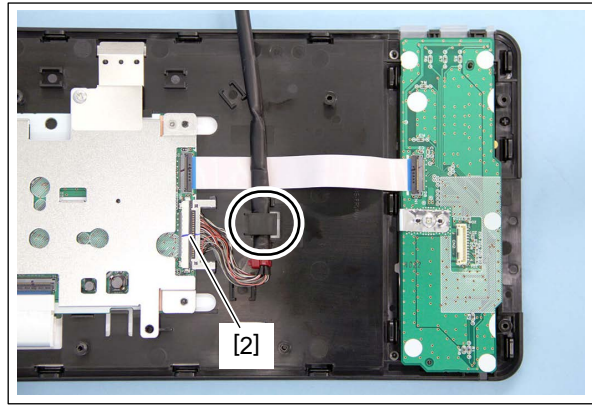

Fig. 4-44

Notes:

When disconnecting the connector [2], release the lock in advance.

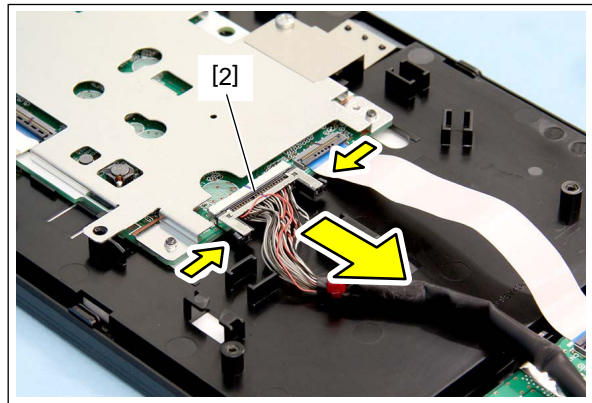

Fig. 4-45

4.2.4 Key PC board, Button

- (1) Take off the control panel unit.
P. 4-15 "4.2.1 Control panel unit"
- (2) Take off the control panel rear cover.
P. 4-18 "4.2.3 Signal harness"
- (3) Disconnect 1 flat cable [1], remove 1 screw and take off the key PC board [2].

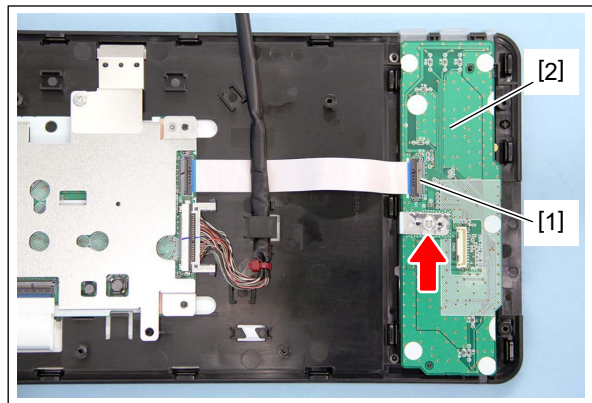

Fig. 4-46

Notes:

When disconnecting the flat cable [1], release the lock in advance by raising the flap.

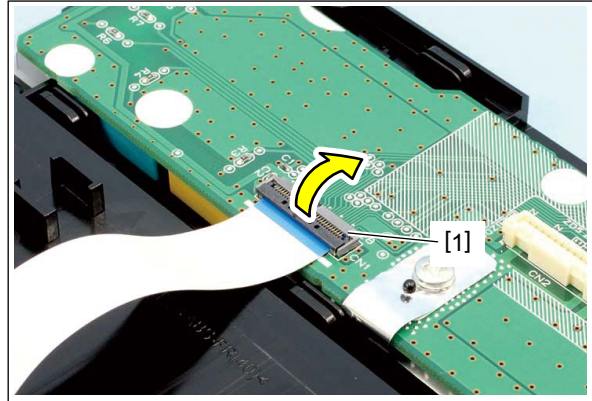

Fig. 4-47

(4) Remove 6 buttons [3].

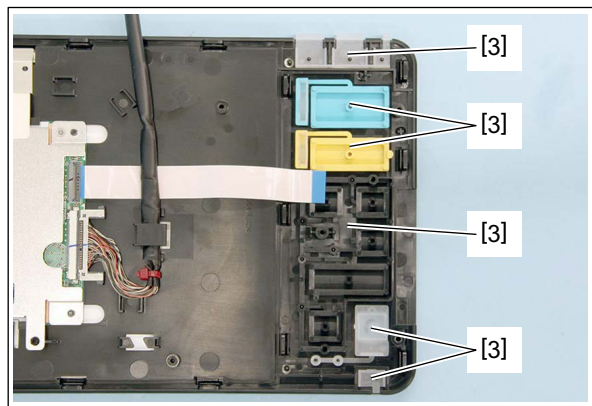



Fig. 4-48



Fig. 4-49

4.2.5 Display PC board

- (1) Take off the control panel unit.
 P. 4-15 "4.2.1 Control panel unit"
- (2) Remove the signal harness.
 P. 4-18 "4.2.3 Signal harness"
- (3) Remove 2 screws and take off the ground plate [1].
- (4) Disconnect the flat cables [2], [3] and [4].

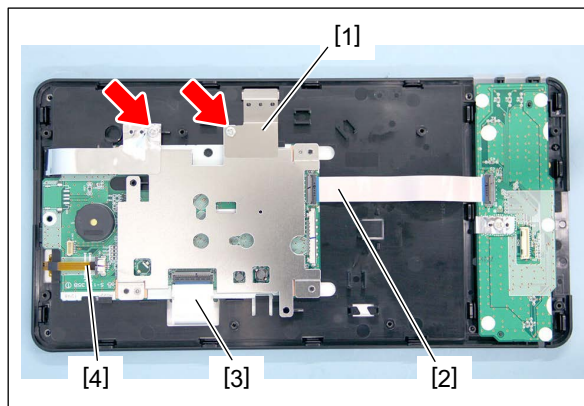

Fig. 4-50

Notes:

- When disconnecting the flat cable [2], release the lock in advance by raising the flap [5].

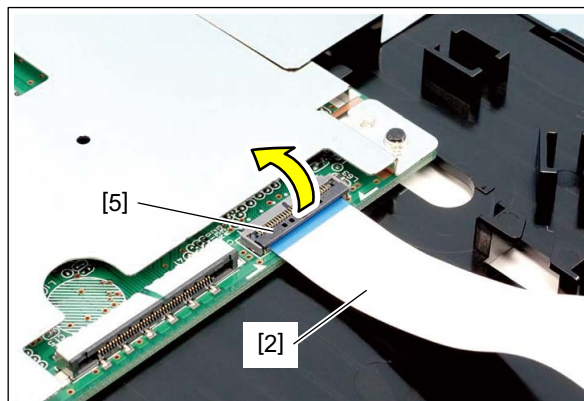

Fig. 4-51

- When disconnecting the flat cable [3], release the lock in advance by raising the flap [6].

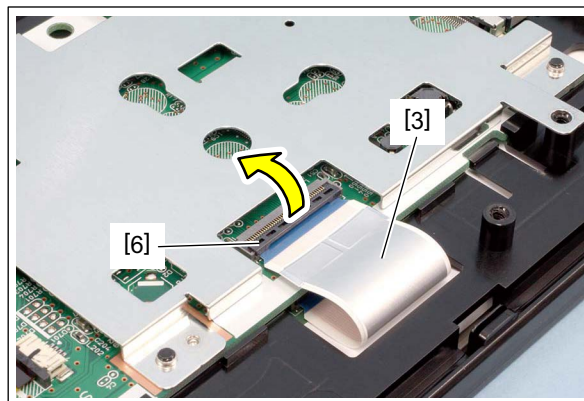

Fig. 4-52

- When disconnecting the flat cable [4], release the lock [7] in advance.

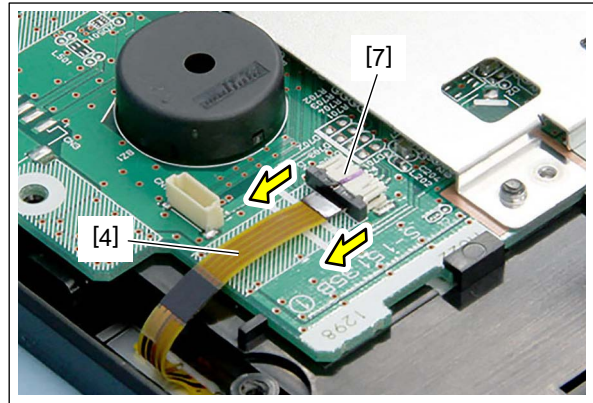

Fig. 4-53

- (5) Release 2 latches [8] and take off the display PC board [7] in the direction of the arrow.

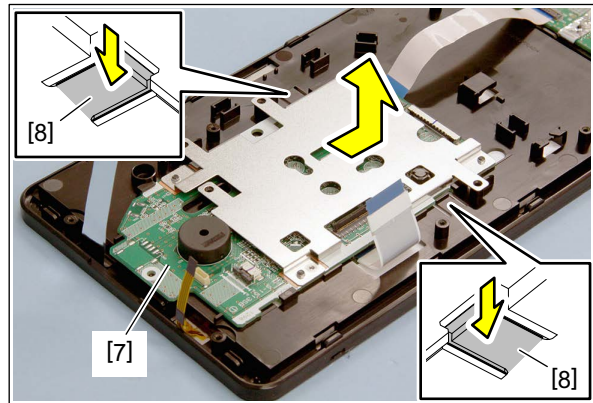

Fig. 4-54

Notes:

When the display PC board has been replaced, perform FS-08-9050 (panel calibration execution) before starting the MFP in the normal mode.

 P. 6-81 "6.12 Control Panel Calibration"

4.3 Scanner Section

Notes:

Since the scanner section is assembled with high precision, be sure not to perform any disassembling other than that instructed in the Service Manual.

4.3.1 Original glass

- (1) Open the DSDF.
- (2) Take off the top right cover [1].
 P. 4-2 "4.1.3 Top right cover"
- (3) Remove 2 screws and take off the original glass [1] and the ADF original glass [2].

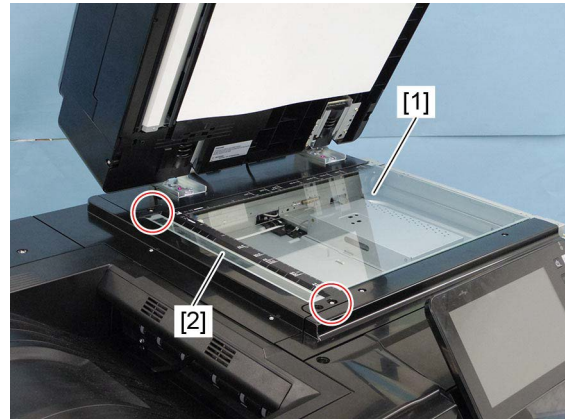

Fig. 4-55

Notes:

- When installing, make sure that the ADF original glass [2] is securely inserted into the groove of the fixing part of the original glass [1].
- Securely insert 2 pins of the original glass [1] into the holes of the frame.

[A] Removal of the original glass

- (1) Remove 4 screws and take off 2 brackets [1].
- (2) Open the DSDF.

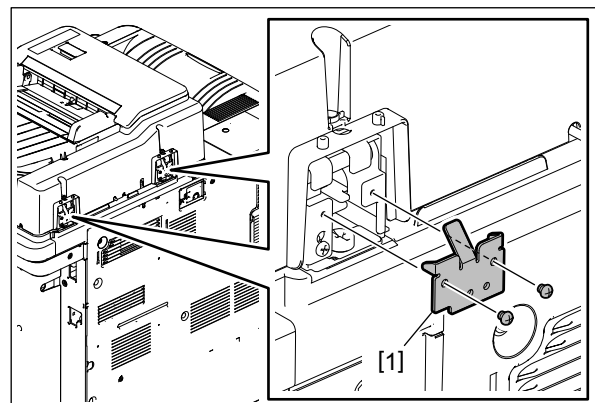

Fig. 4-56

- (3) Take off the top right cover.
📖 P. 4-2 "4.1.3 Top right cover"
- (4) Remove 2 screws and take off the original glass [2] and the ADF original glass [3].

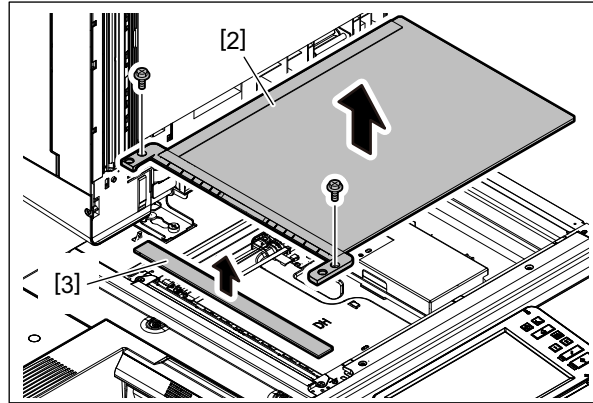

Fig. 4-57

Notes:

- When installing, make sure that the ADF original glass [3] is securely inserted into the groove of the fixing part of the original glass [2].
- Securely insert 2 pins of the original glass [2] into the holes of the frame.

[B] Installation of the original glass

- (1) While taking care not to crush the cushion at the edge of the ADF original glass [3], slide it to the left side and then install the original glass [2].
- (2) Secure the original glass with 2 screws.

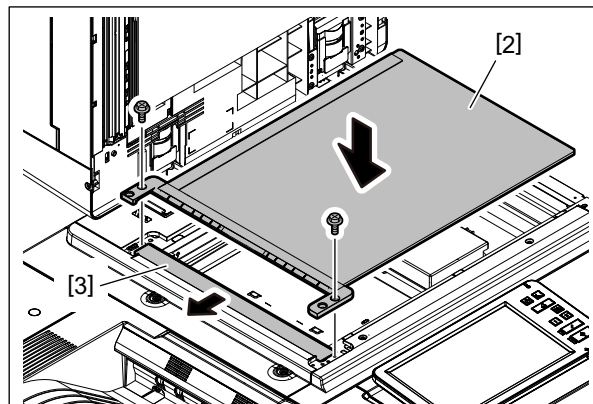

Fig. 4-58

[C] Replacement of the original glass and the ADF original glass

- (1) Remove 2 caps.
- (2) Remove 2 screws and take off the top right cover [4].

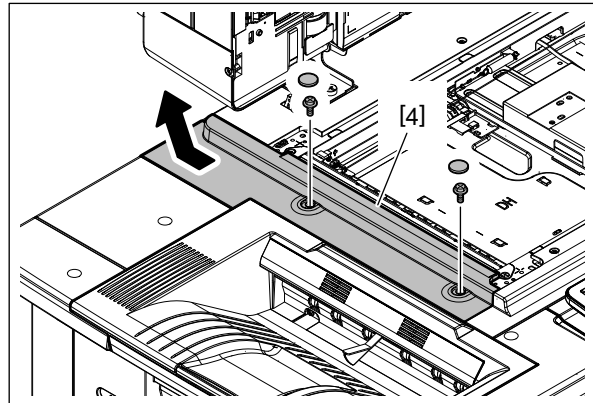

Fig. 4-59

- (3) Remove the film [5] and dispose of it.

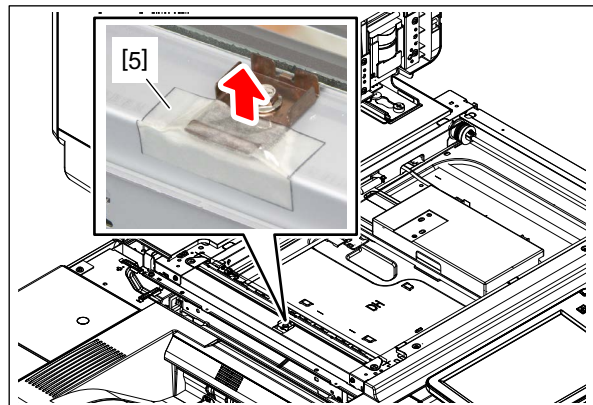

Fig. 4-60

- (4) Loosen 1 fixing screw of the leaf spring. Slide the leaf spring [6] by 1 mm in the direction indicated by the arrow and tighten the fixing screw temporarily.

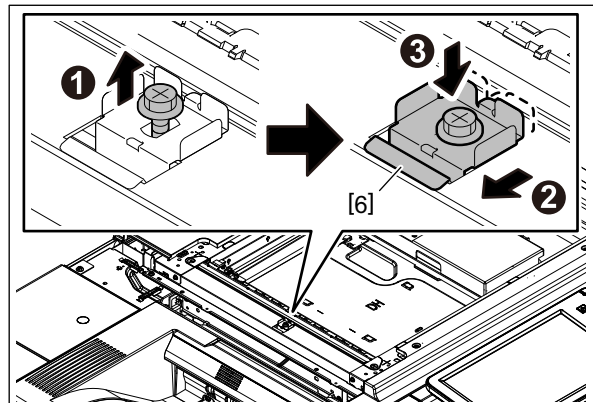

Fig. 4-61

- (5) Place a new ADF original glass [3] and set its position by aligning it to the mark-off lines.

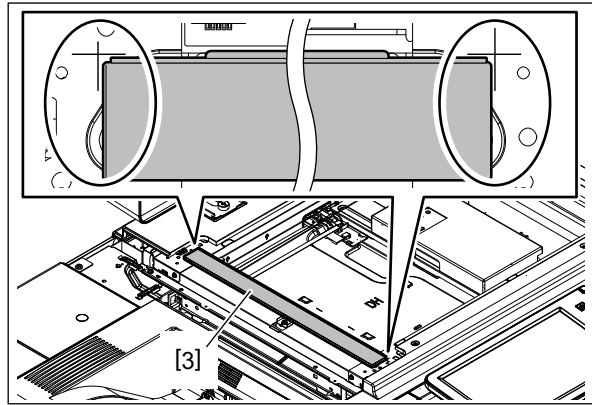

Fig. 4-62

- (6) Place a new original glass [2].

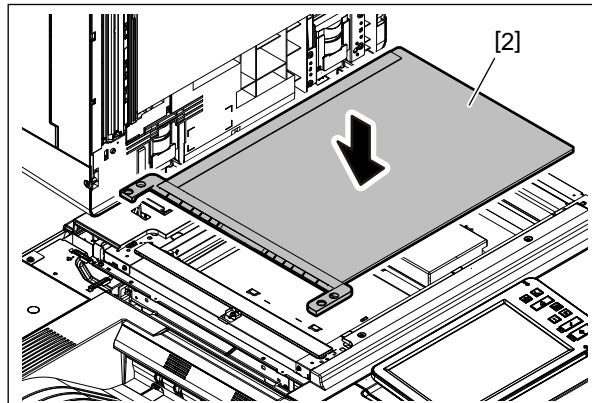

Fig. 4-63

Notes:

- Do not attach the screws of the original glass until step (10).
- While taking care not to crush the cushion at the edge of the ADF original glass, install the original glass.

- (7) Loosen the fixing screw of the leaf spring. By means of the tension of the leaf spring, press the ADF original glass against the original glass. Tighten the fixing screw of the leaf spring.

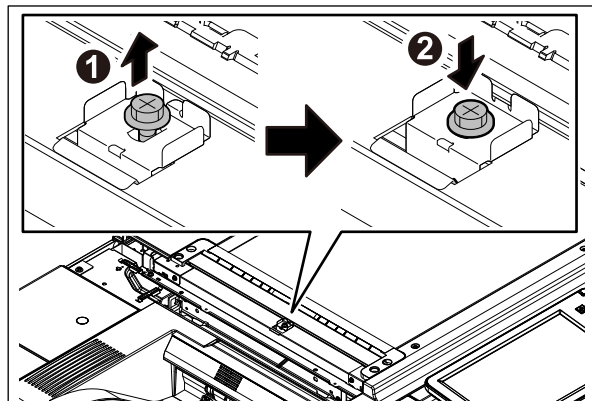

Fig. 4-64

(8) Attach a new film [7] to the scanner frame.

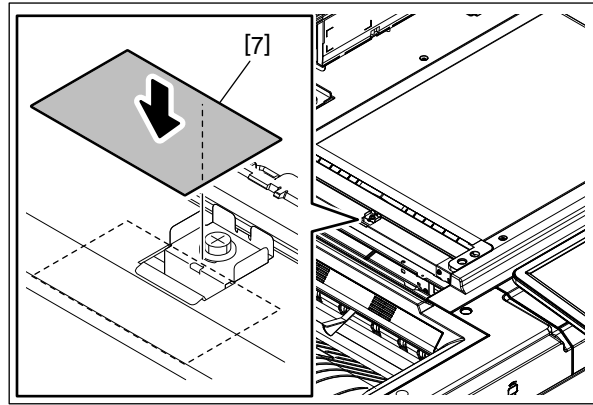

Fig. 4-65

Notes:

- Before attaching, use alcohol to clean the attachment surfaces and wait until they have dried.
- Be sure to align the film [7] to the leaf spring [6] as shown in the figure.
- Be sure to attach the film [7] securely to the leaf spring [6].

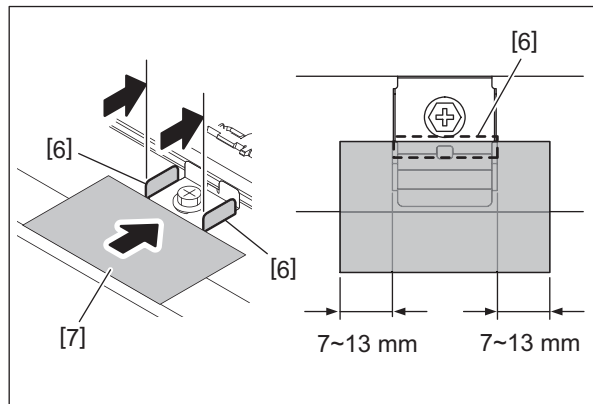

Fig. 4-66

(9) Fold the film [7] by aligning to the corner of the scanner frame and attach it. When the film is folded, lifting will be generated at the both edges on the folded portion. Therefore, in order to remove this lifting, pinch the folded portions of the film with your fingers so that its adhesive surfaces are stuck to each other.

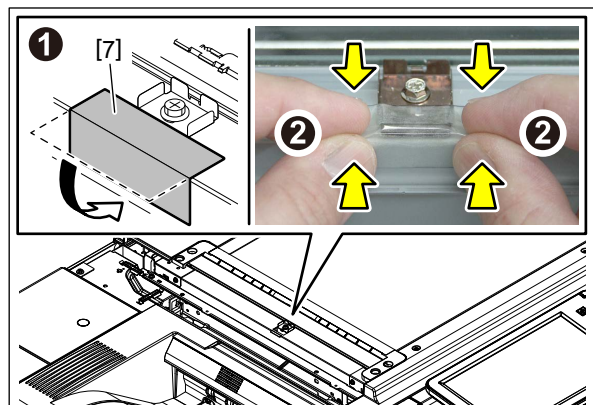

Fig. 4-67

Notes:

Confirm that the film is attached firmly.

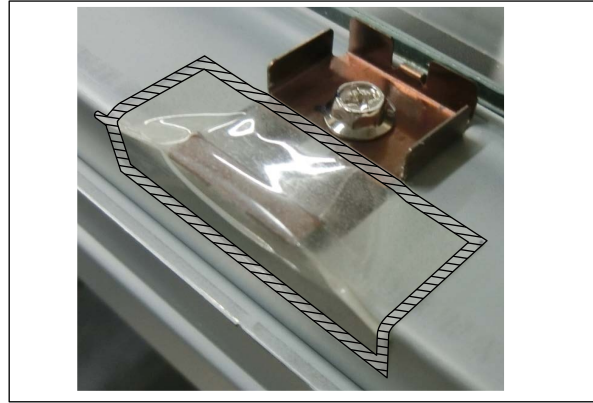

Fig. 4-68

(10) Secure the original glass [2] with 2 screws.

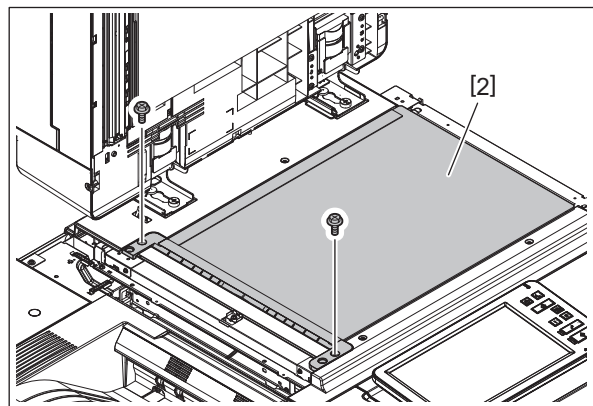

Fig. 4-69

(11) Secure the left top cover [4] with 2 screws. Attach 2 caps.

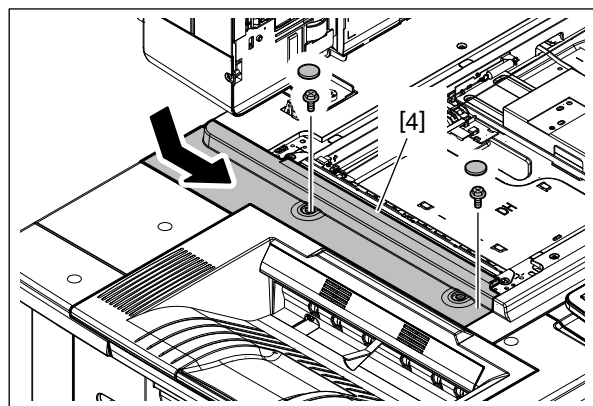



Fig. 4-70

4.3.2 Lens cover

- (1) Take off the original glass.
 P. 4-23 "4.3.1 Original glass"
- (2) Remove 1 screw and take off the lens cover [1] as shown in the figure.

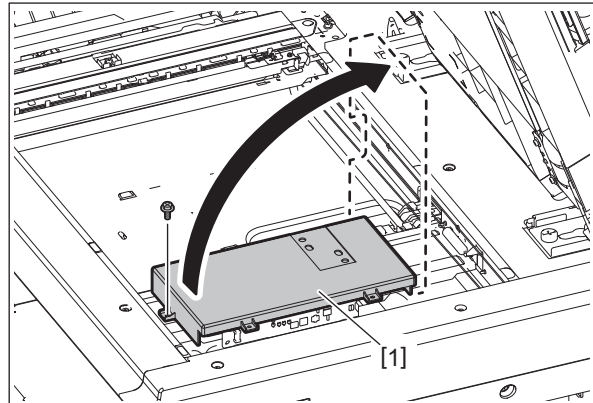



Fig. 4-71

4.3.3 Automatic original detection sensor-1 (S1)

- (1) Take off the lens cover.
 P. 4-29 "4.3.2 Lens cover"
- (2) Remove 1 screw. Disconnect 1 connector [1] and take off the automatic original detection sensor-1 [2].

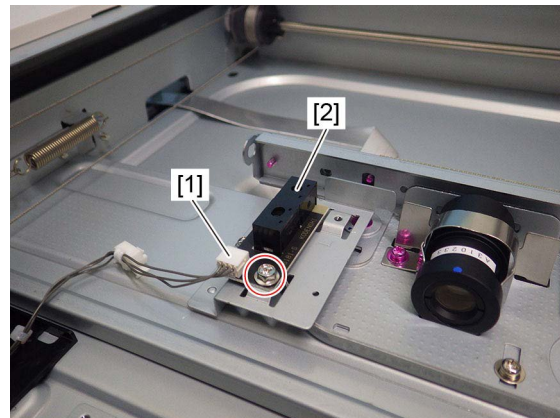

Fig. 4-72

4.3.4 Automatic original detection sensor-2 (S2)

- (1) Take off the lens cover.
📖 P. 4-29 “4.3.2 Lens cover”
- (2) Remove 1 screw. Disconnect 1 connector [1] and take off the automatic original detection sensor-2 [2].

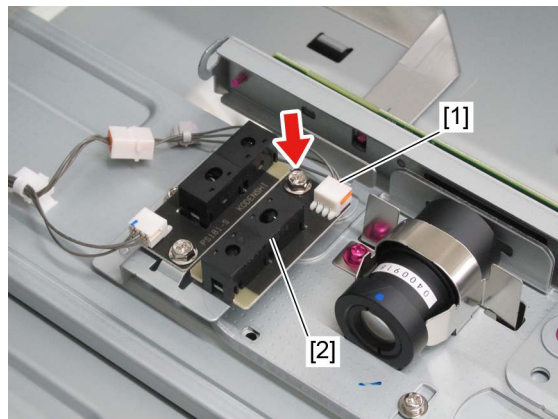

Fig. 4-73

4.3.5 Lens unit (CCD driving PC board)

- (1) Take off the lens cover.
📖 P. 4-29 “4.3.2 Lens cover”
- (2) Remove 1 screw and take off the automatic original detection sensor with the bracket [1].

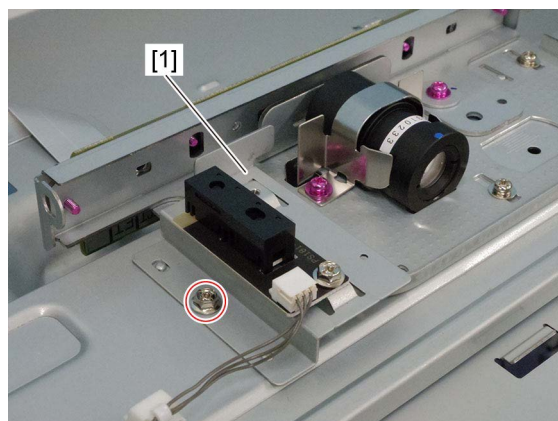

Fig. 4-74

- (3) Remove 1 HDMI cable [2].

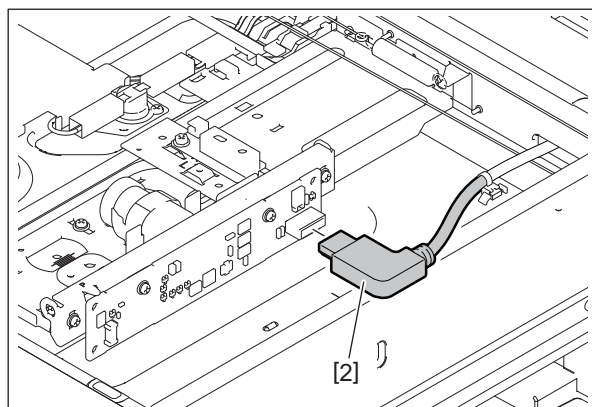

Fig. 4-75

(4) Remove 3 screws and take off the CCD lens unit [3].

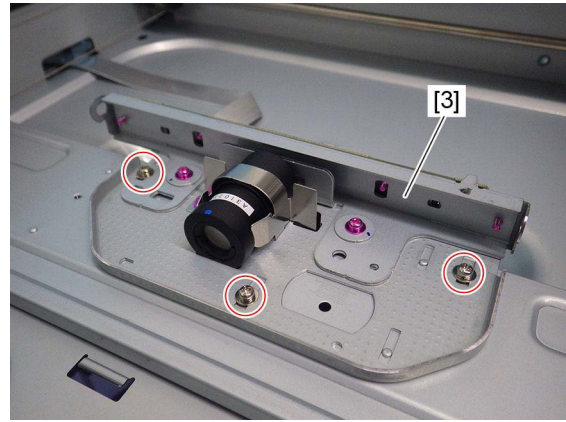

Fig. 4-76

Notes:

- The CCD lens unit is adjusted finely, so the re-adjustment or replacement of some parts are impossible in the field. The lens unit must be replaced on a unit basis.
- Handle the lens unit with care. Do not hold the adjustment unit or lens.
- Count the number of lines [4] and write it down for later reference before removing the CCD lens unit. When installing the CCD lens unit, the same number of lines needs to be visible.

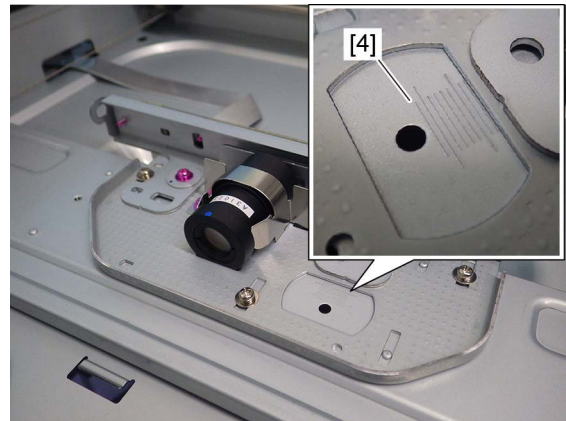

Fig. 4-77

- When replacing the CCD lens unit, do not touch the screws (7 places).

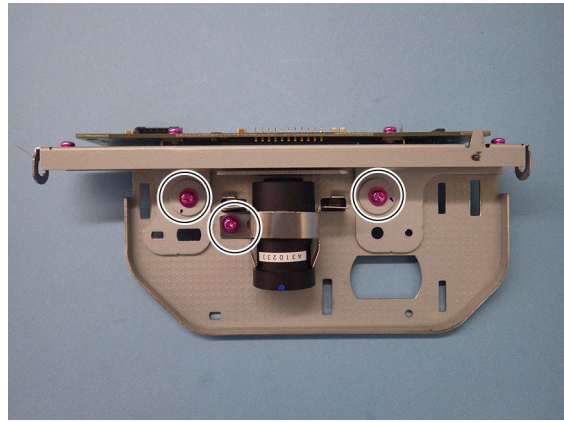

Fig. 4-78

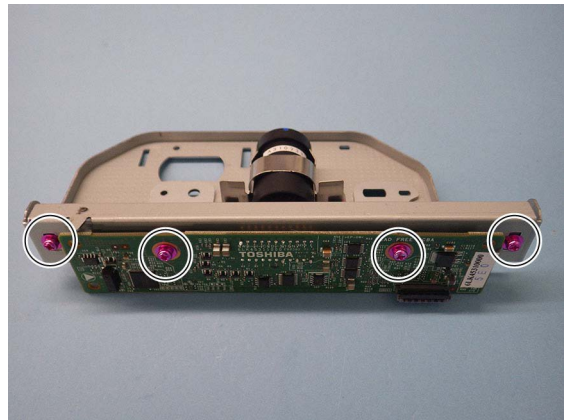

Fig. 4-79

4.3.6 Carriage home position sensor (S3)

- (1) Take off the original glass.
 📖 P. 4-23 “4.3.1 Original glass”
- (2) Take off the top rear cover.
 📖 P. 4-13 “4.1.23 Top rear cover”
- (3) Remove 1 film [1] and disconnect the connector [2]. Release 3 latches and take off the carriage home position sensor [3].

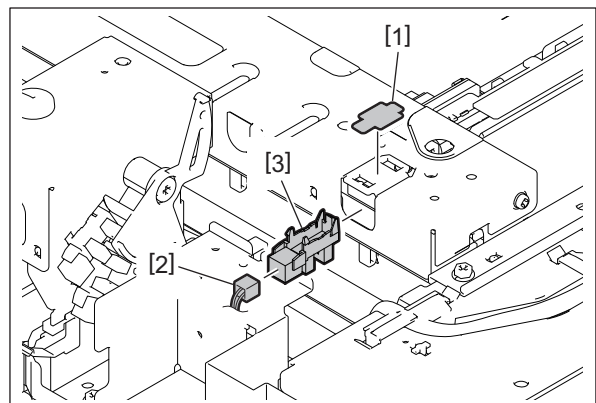

Fig. 4-80

4.3.7 Exposure lamp (EXP)

- (1) Take off the original glass.
📖 P. 4-23 "4.3.1 Original glass"
- (2) Take off the top front cover.
📖 P. 4-5 "4.1.9 Top front cover"
- (3) Take off the top rear cover.
📖 P. 4-13 "4.1.23 Top rear cover"
- (4) Move the carriage-1 [1] to a place where you can see the exposure lamp mounting screw through the frame hole.

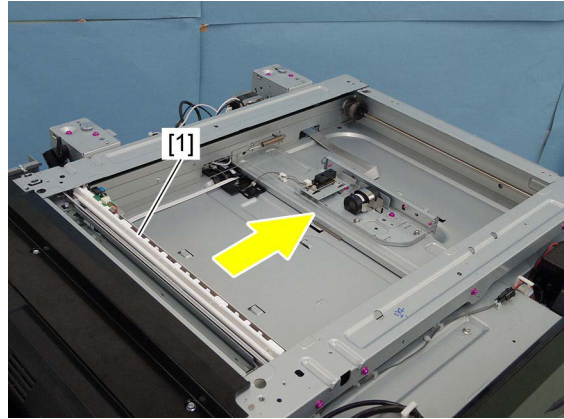

Fig. 4-81

Notes:

- Move the carriage until the screw at the front side can be seen.
- To move the carriage, manually rotate the drive pulley.

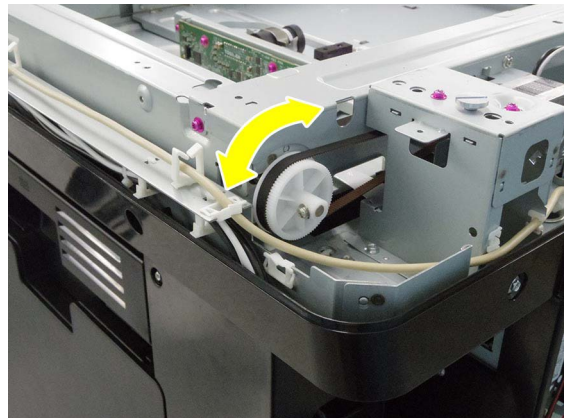

Fig. 4-82

(5) Remove 1 screw.

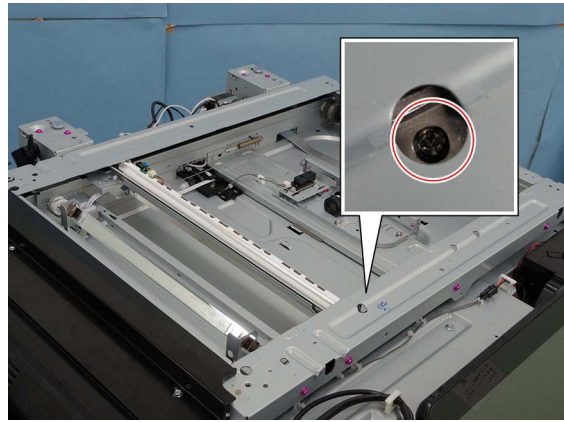

Fig. 4-83

(6) Slide the front side of the exposure lamp [2] in the direction of the arrow and remove the flat cable [3]. Take off the exposure lamp [2] from the front side.

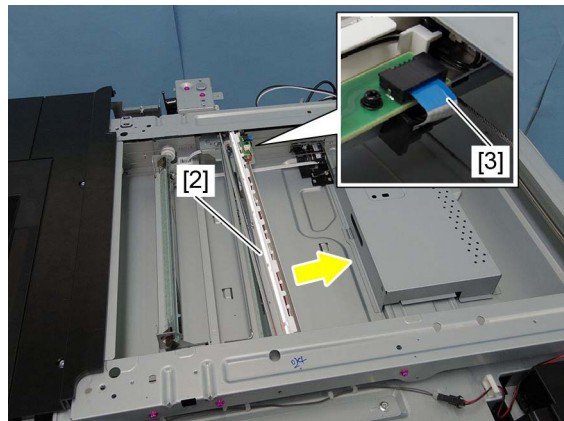

Fig. 4-84



Fig. 4-85

Notes:

After replacing the exposure lamp, be sure to perform FS-05-3270.

4.3.8 Scan motor (M1)

- (1) Take off the top rear cover.
 P. 4-13 "4.1.23 Top rear cover"
- (2) Disconnect 1 connector.

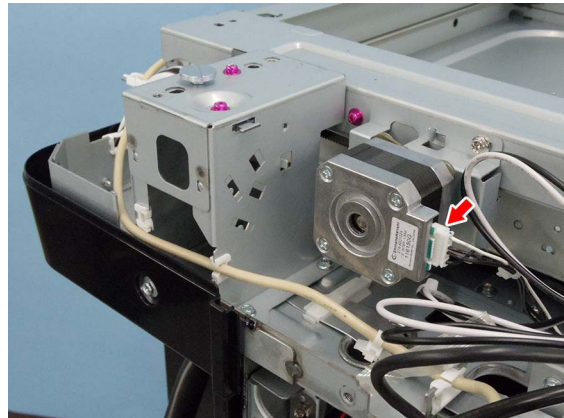

Fig. 4-86

- (3) Remove 2 screws and take off the scan motor assembly [1].

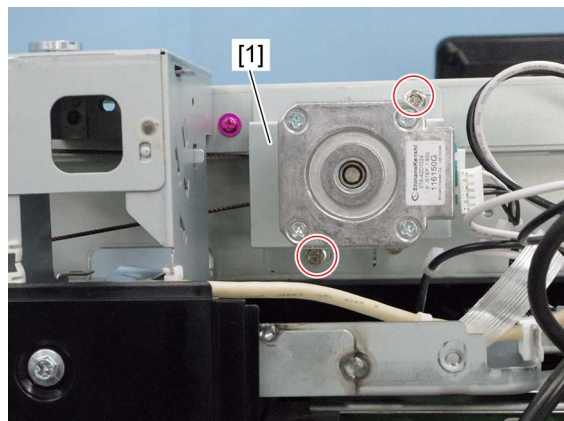



Fig. 4-87

Notes:

When installing the scan motor, use the belt tension jig.
 P. 6-54 "6.7.3 Belt tension adjustment of the scan motor"

- (4) Remove 2 screws and take off the scan motor [2].

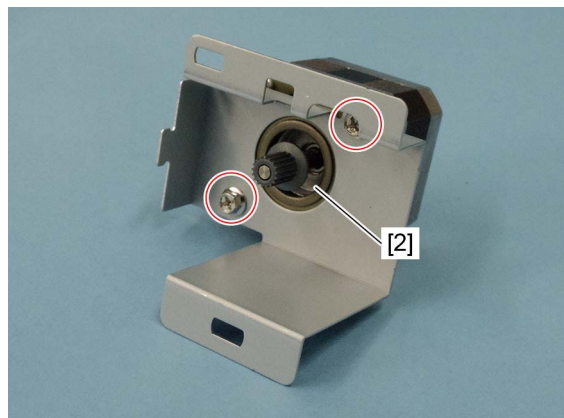

Fig. 4-88

4.3.9 Platen sensor-1 (S4), Platen sensor-2 (S5)

- (1) Take off the top rear cover.
P. 4-13 "4.1.23 Top rear cover"
- (2) Remove 5 screws.

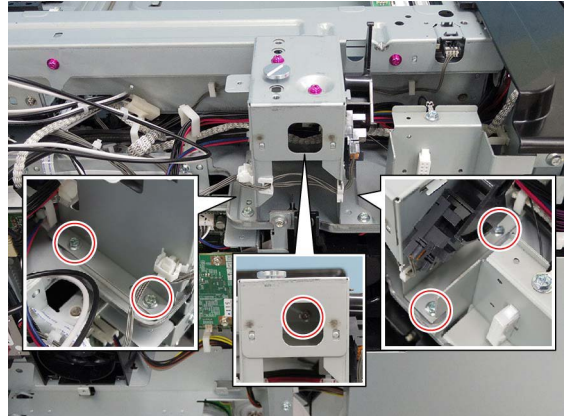

Fig. 4-89

- (3) Remove 1 harness clamp [1]. Release the harnesses [2] from 2 harness clamps [3]. Disconnect 2 connectors.

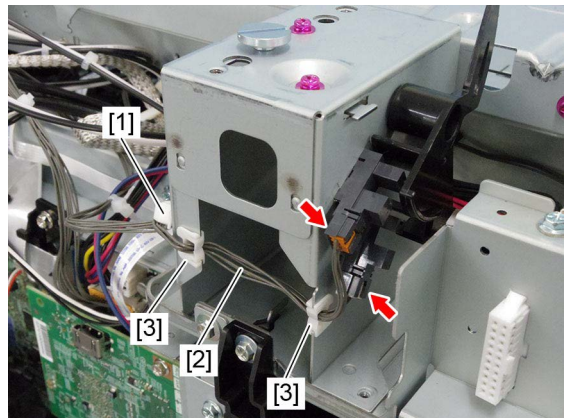

Fig. 4-90

- (4) Remove 2 harness clamps and take off the platen sensor assembly [4].

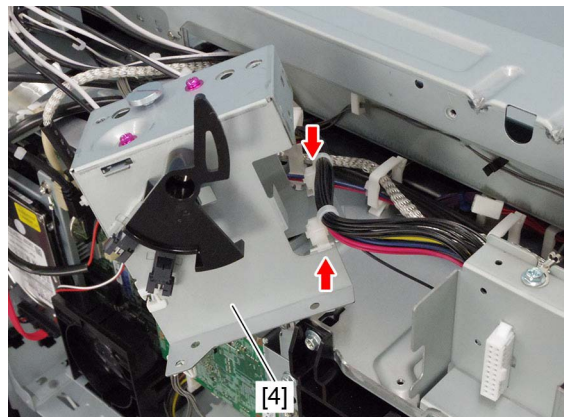

Fig. 4-91

Notes:

When installing, be careful not to connect each different connector.

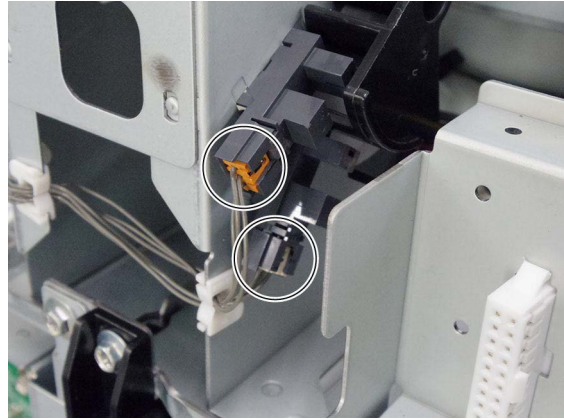

Fig. 4-92

- (5) Release each 3 latch and take off the platen sensor-1 [5] and platen sensor-2 [6].

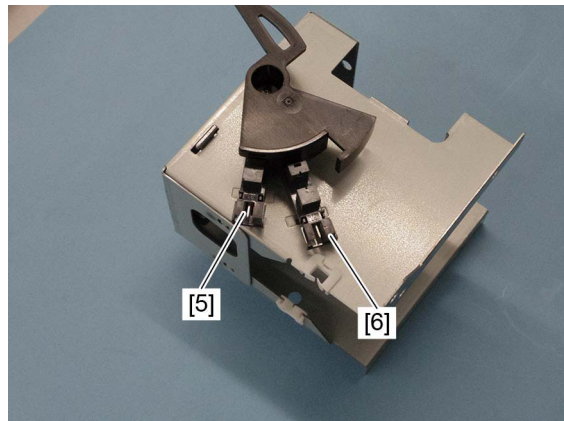

Fig. 4-93

4.3.10 Carriage-1

- (1) Take off the original glass.
📖 P. 4-23 "4.3.1 Original glass"
- (2) Take off the top rear cover.
📖 P. 4-13 "4.1.23 Top rear cover"
- (3) Take off the top front cover.
📖 P. 4-5 "4.1.9 Top front cover"
- (4) Move the carriage-1 [1] to the leftmost side. Make sure that the screws on the carriage-1 are showing from the holes of the frame. Remove 2 screws.

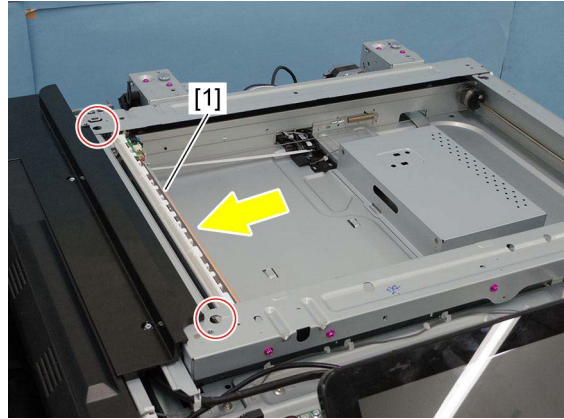

Fig. 4-94

Notes:

To move the carriage-1, manually rotate the drive pulley.

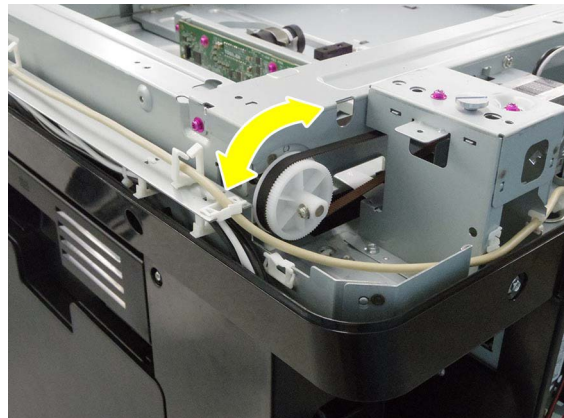

Fig. 4-95

- (5) Slide the front of the carriage-1 [1] in the direction of the arrow shown in the figure, while trying not to touch the mirror [2].

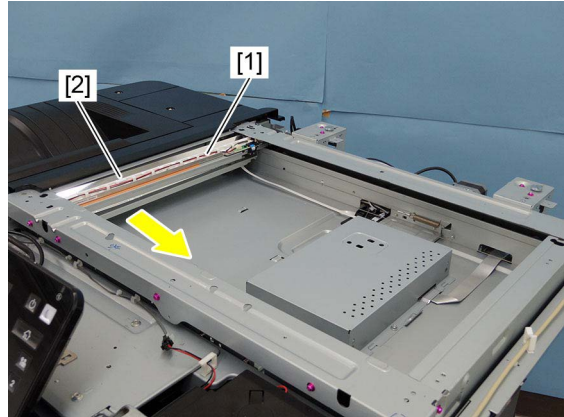

Fig. 4-96

- (6) Release the harness from 3 harness guides [3] and disconnect the connector [4]. Remove the carriage-1 [1].

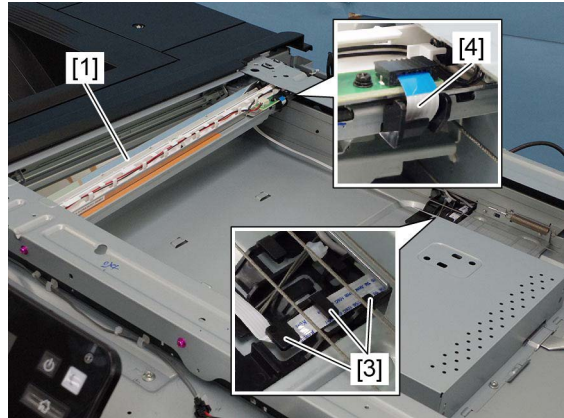

Fig. 4-97

Notes:

- After installing, move the carriage-1 to the leftmost side and check the exposure lamp harness for any twists.
- When installing the carriage-1, make sure that the wires are placed on the front and rear notches of the carriage-1 and fix them with screws.



Fig. 4-98

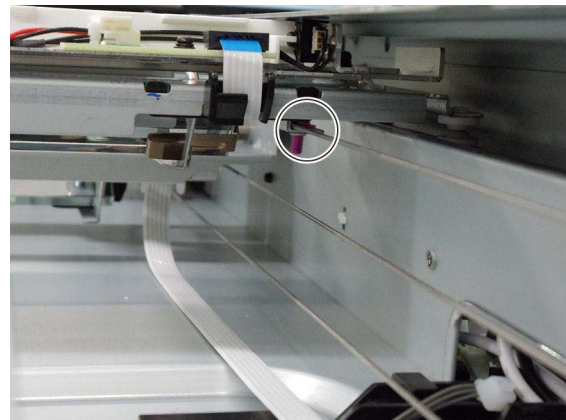

Fig. 4-99

4.3.11 Carriage wire, Carriage-2

Notes:

- When replacing the carriage wires with new ones, exchange those on the front and rear sides together.
- When the carriage wires are replaced with new ones, set the value of FS-08-6123 to "0".

[A] Carriage wire, Carriage-2

- (1) Remove the carriage-1.
📖 P. 4-38 "4.3.10 Carriage-1"
- (2) Attach the wire holder jig [1] to the wire pulley to prevent the wire from coming loose.

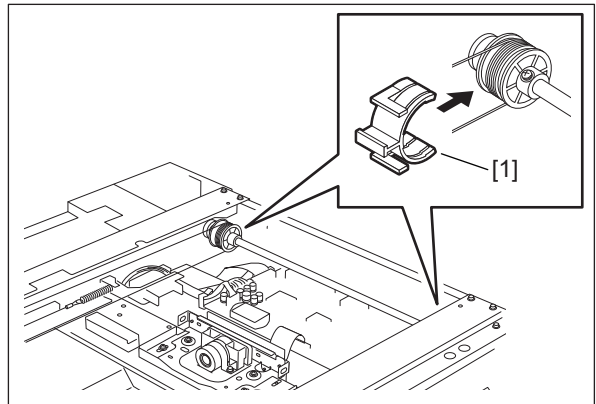

Fig. 4-100

Notes:

- When attaching the wire holder jig [1], make sure that the wire has not shifted or become loose.
- The wire should come out of the slot of the wire holder jig [1] and be passed under the jig arm [2].

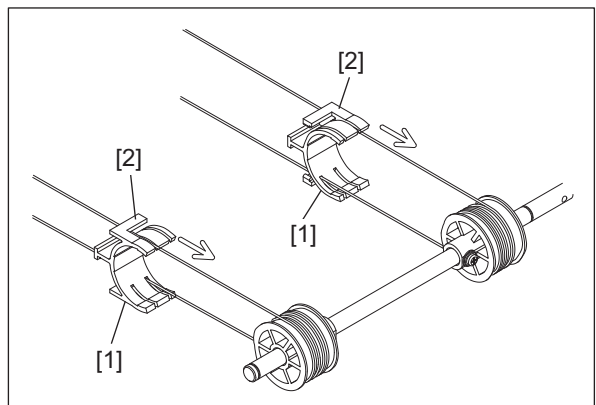

Fig. 4-101

- (3) Remove the tension springs [3] in the front and rear sides.
- (4) Remove the carriage wire.

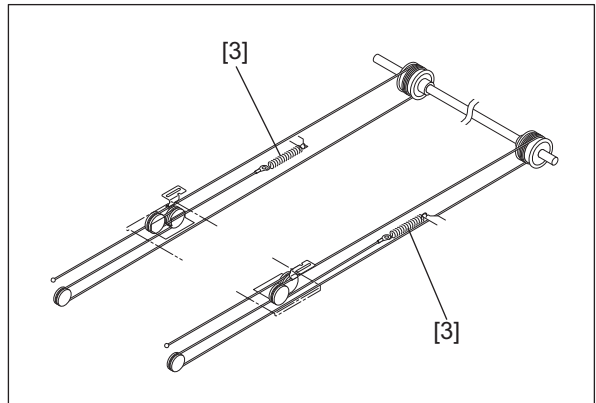

Fig. 4-102

- (5) Rotate the carriage-2 [4] in the direction shown in the figure, while trying not to touch the mirror. Then remove carriage-2 [4].

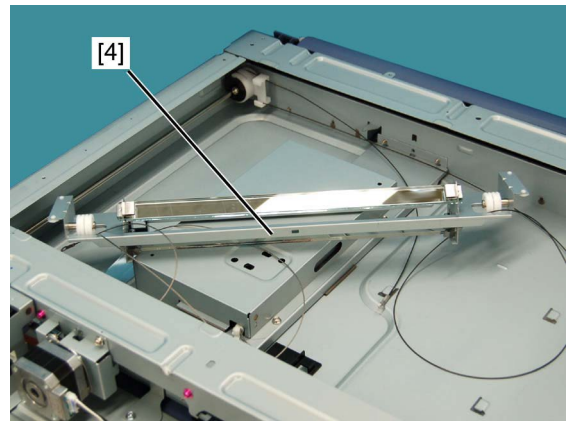

Fig. 4-103

Notes:

Replace the mirror-2 and -3 together with the carriage-2 [4]. Do not remove the mirror-2 and -3.

[B] Installing the carriage wire

(1) As shown in the figure, replace the carriage wire and install a new wire.

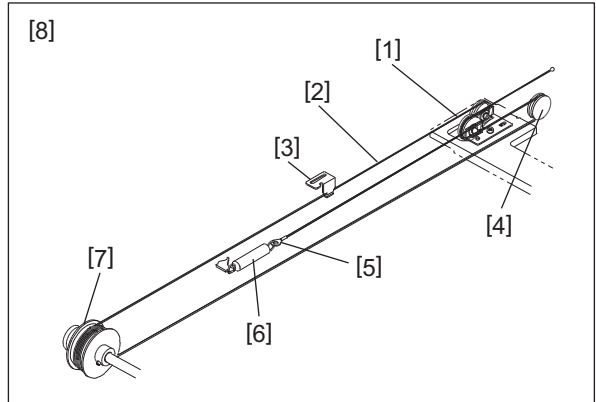

Fig. 4-104

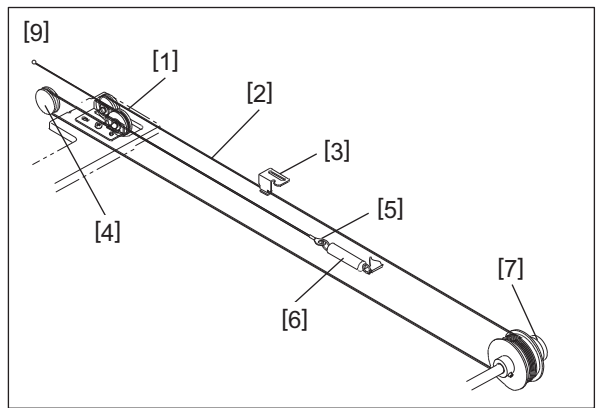

Fig. 4-105

- [1] Carriage-2
- [2] Carriage wire
- [3] Carriage-1 bracket
- [4] Idler pulley
- [5] Hook
- [6] Tension spring
- [7] Wire pulley
- [8] Front side
- [9] Rear side

Notes:

Make sure that the tension applied to the wire is normal.

[C] Winding on the wire pulley

- (1) Pull the $\varnothing 3$ ball terminal [1] located at the center of the wire into a hole on the wire pulley. One end of the wire with the hook [2] attached comes to the outside.
- (2) Wind the wires around the wire pulleys of the front side [3] and rear side [4]. The number of turns to be wound are as follows: 2 toward the opposite side (outside) of the pulley boss [5], and 4 toward the pulley boss side (inside) [6].

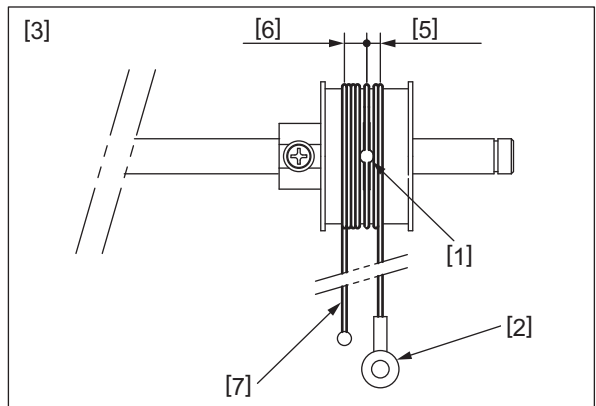

Fig. 4-106

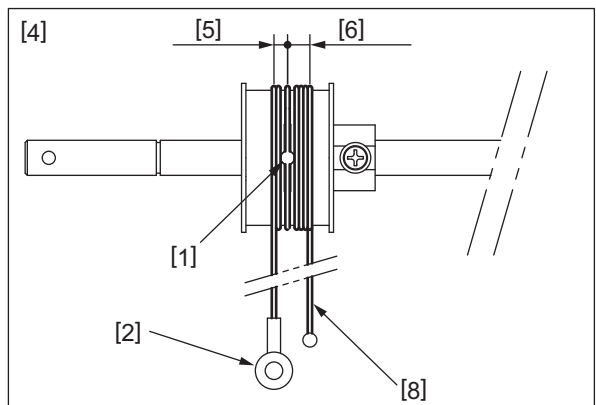

Fig. 4-107

- [7] Black
[8] Sliver

Notes:

When winding the wire onto the pulley, be sure to note the following.

- Do not twist the wire.
- Wind the wires tightly so that they are in complete contact with the surface of the pulleys.
- Each turn should be pushed against the previously wound turn so that there is no space between them.

- (3) After winding the wires around the pulleys, attach the wire holder jigs [3] to prevent the wire from coming loose.

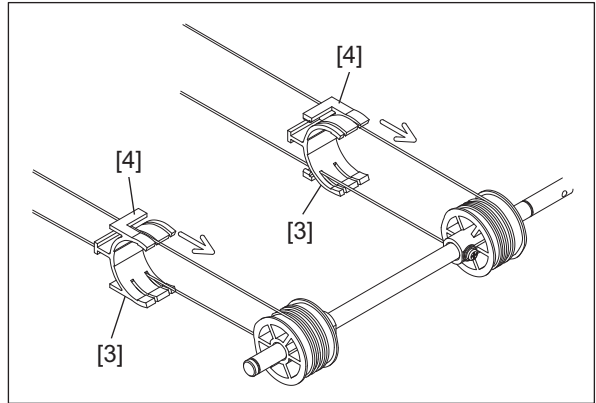



Fig. 4-108

Notes:

- When attaching the wire holder jig [3], make sure that the wire has not shifted or become loose.
- The wire should come out of the slot of the wire holder jig [3] and be passed under the jig arm [4].
- When installing the wire holder jig, be careful of its orientation.

4.3.12 Scanner damp heater (DH1)

- (1) Take off the rear cover.
 P. 4-12 "4.1.22 Rear cover"
- (2) Take off the original glass.
 P. 4-23 "4.3.1 Original glass"
- (3) Disconnect 1 connector.

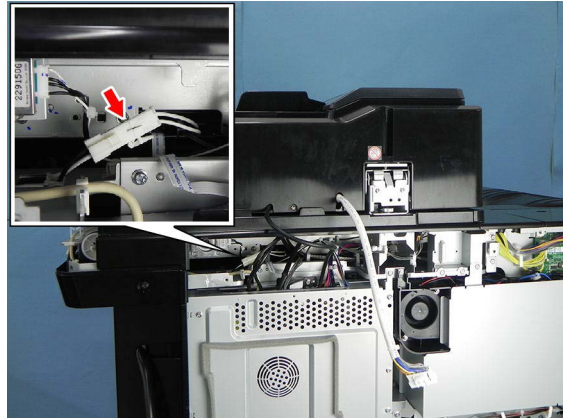

Fig. 4-109

- (4) Take off the scanner damp heater [1].

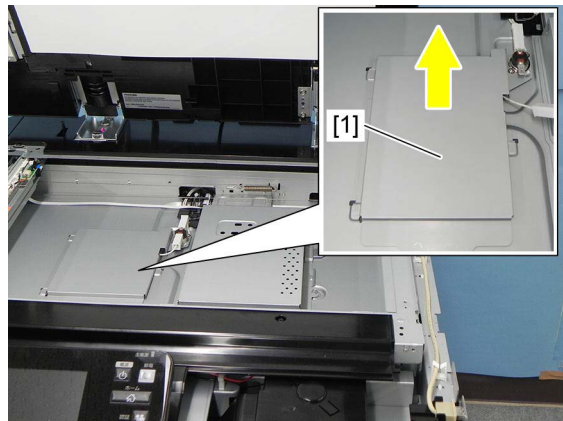

Fig. 4-110

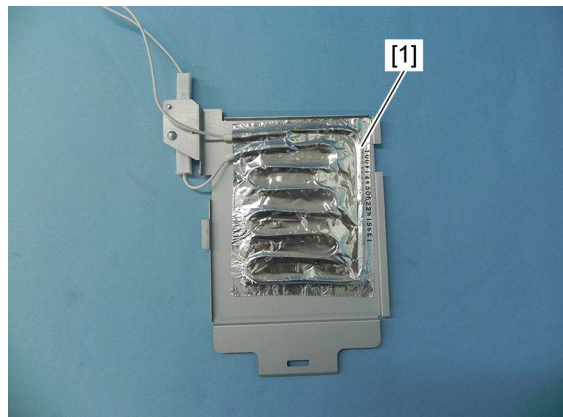

Fig. 4-111

4.3.13 Scanner damp heater thermostat (THMO1)

Notes:

If the DAMP PC board is not installed appropriately when it is replaced or removed, a serious accident such as fire or damage to the product may occur. Therefore, to avoid this, be sure to carry out the correct handling and installation.

- (1) Take off the scanner damp heater.
📖 P. 4-46 “4.3.12 Scanner damp heater (DH1)”
- (2) Remove 2 screws. Disconnect 2 connectors and take off the scanner damp heater thermostat [1].

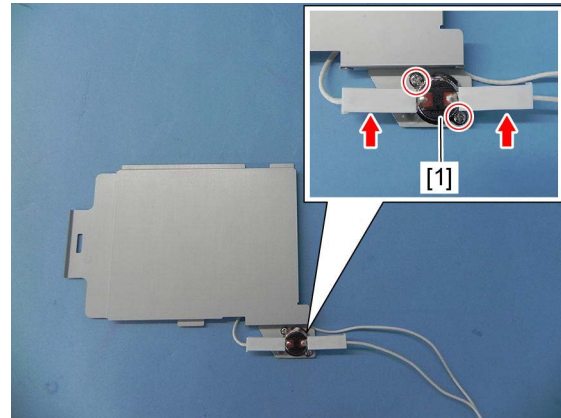

Fig. 4-112

4.4 Data Writing Section

4.4.1 Laser optical unit

- (1) Take off the front lower cover.
📖 P. 4-1 “4.1.1 Front lower cover”
- (2) Take off the rear cover.
📖 P. 4-12 “4.1.22 Rear cover”
- (3) Take off the left middle cover.
📖 P. 4-8 “4.1.14 Left middle cover”

Notes:

When installing the laser optical unit, attach the left middle cover before the rear cover since the former may catch the flat cable.

- (4) Disconnect 3 connectors and release the harness from 2 harness clamps [1].
- (5) Remove 2 harness clamps [2].

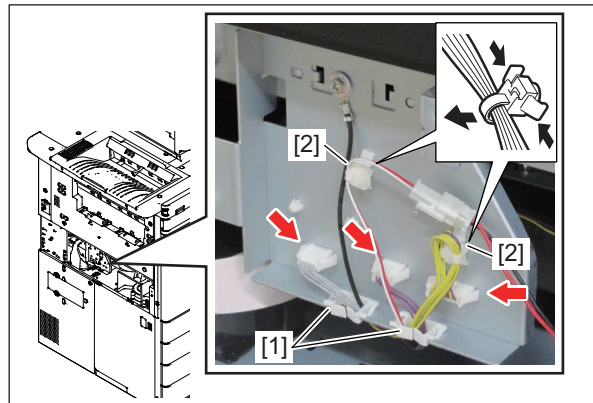

Fig. 4-113

- (6) Disconnect 1 connector. Remove 1 harness clamp [3]. Remove 1 screw and the ground terminal [4]. Then take off the bracket [5].

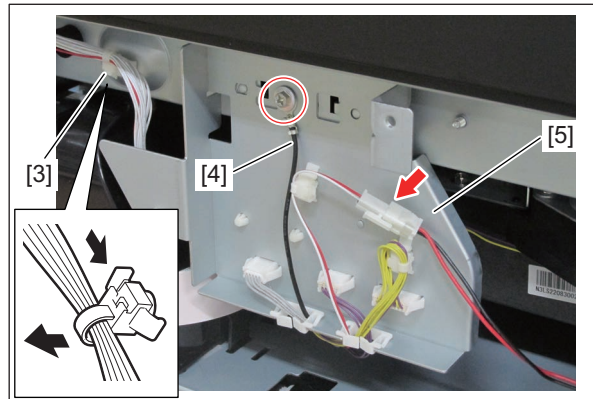

Fig. 4-114

Notes:

Install the removed harness clamp [3] in the hole [6] of the frame, so that you can remove the laser optical unit easily.

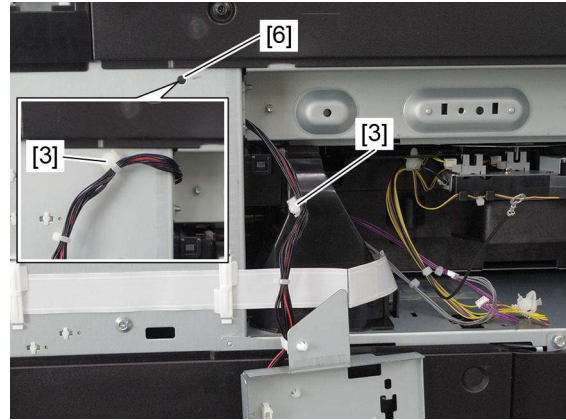

Fig. 4-115

- (7) Release the lock by tilting the flap and disconnect 1 flat cable from the LGC board.

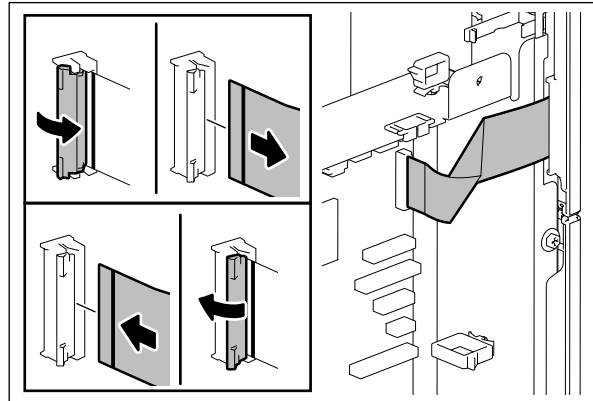

Fig. 4-116

- (8) Release the flat cable from 2 harness clamps.

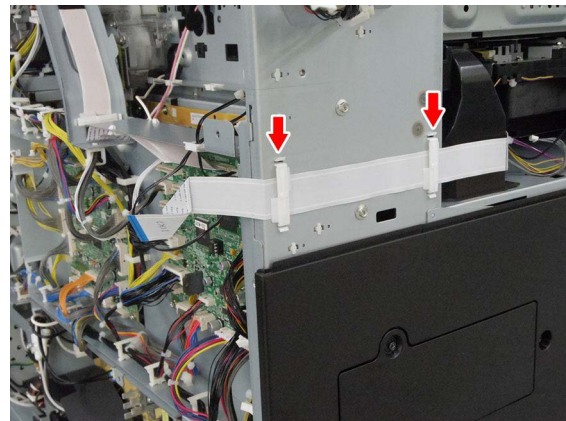

Fig. 4-117

- (9) Remove 2 screws and take off the duct [7] of the developer unit cooling fan.

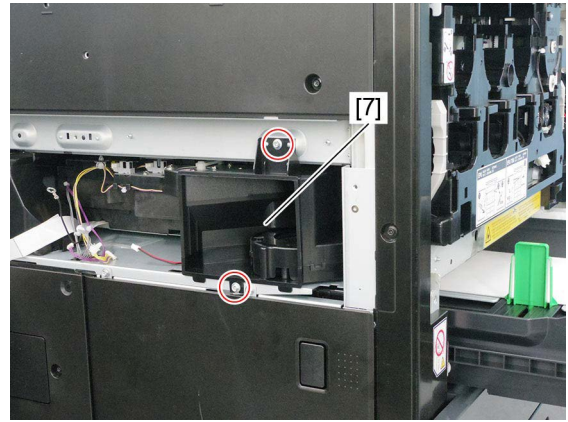

Fig. 4-118

- (10) Release 1 latch and take off the duct [8] of the ozone exhaust fan.

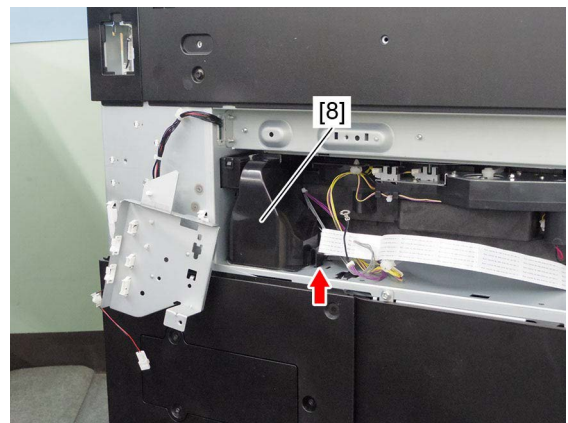

Fig. 4-119

- (11) Pull out the EPU together with the transfer belt.
P. 4-195 "4.7.1 Pulling out of the transfer belt unit"
- (12) Remove 2 screws.

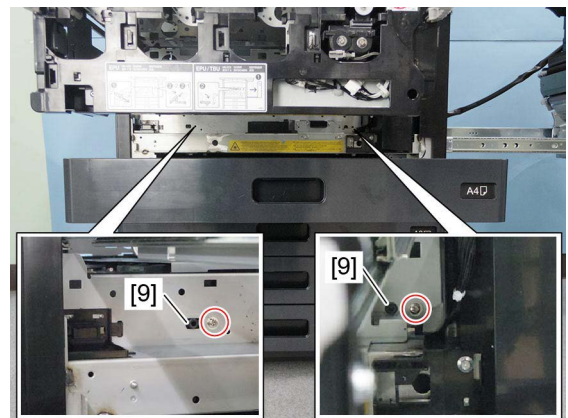

Fig. 4-120

Notes:

When reassembling, make sure the bosses of the laser optical unit are securely inserted into the holes [9] of the plate.

- (13) Slide the laser optical unit [10] to the rear side and then quietly pull out the unit towards the paper exit side.

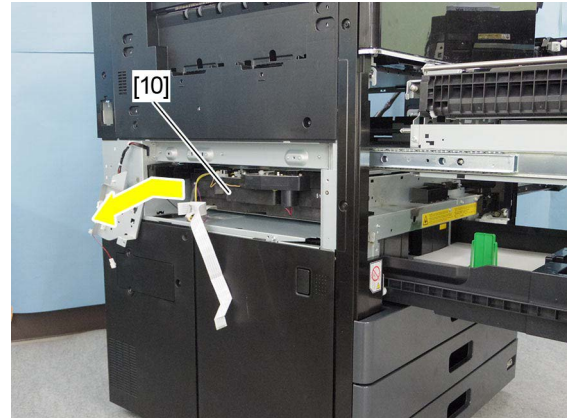

Fig. 4-121

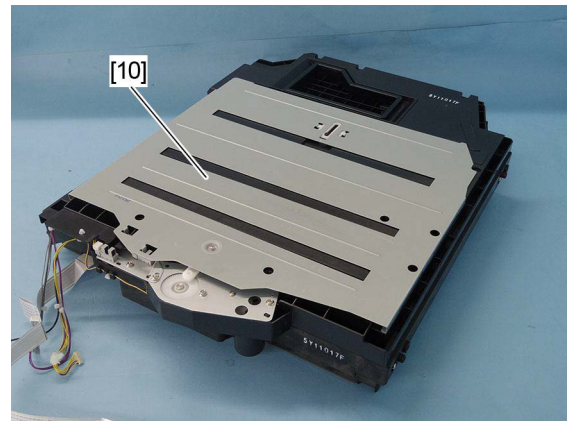

Fig. 4-122

Notes:

- Do not leave fingerprints or stains on the slit glass of the laser optical unit.
- Pay close attention not to make an impact or vibration on the laser optical unit because it is a precise apparatus.
- Place the removed laser optical unit so as not to load on the polygonal motor.
- Do not disassemble the laser optical unit in the field because it is precisely adjusted and very sensitive to dust and stains.
- Horizontally hold the parts A and B shown in the figure to handle the laser optical unit. Do not press the top of the unit where the slit glass and polygonal motor (cover) are installed with your hands or other things.
- When the laser optical unit has been taken off, keep the shutter closed unless otherwise required.

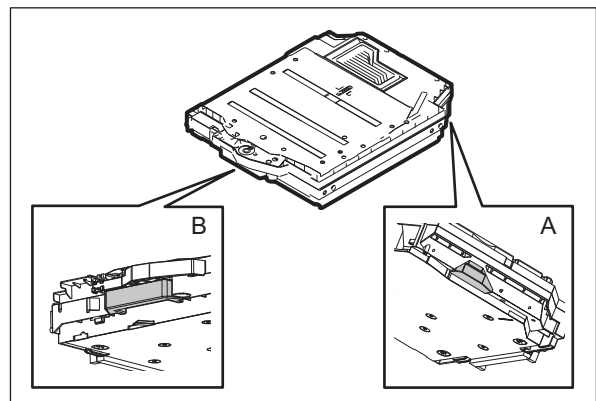



Fig. 4-123

4.4.2 Laser optical unit cooling fan (front) (F22)

- (1) Take off the right corner cover.
 P. 4-14 “4.1.25 Right corner cover”
- (2) Pull out the process unit.
 P. 4-124 “4.6.1 Pulling out of the process unit (EPU tray)”
- (3) Disconnect 3 connectors and release the harness from 1 harness clamp [1].

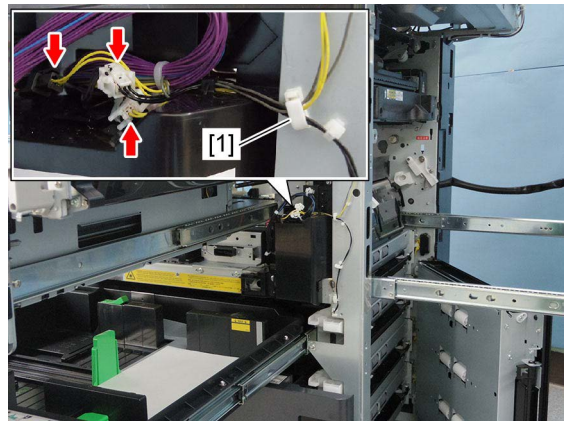

Fig. 4-124

- (4) Remove 1 harness clamp.

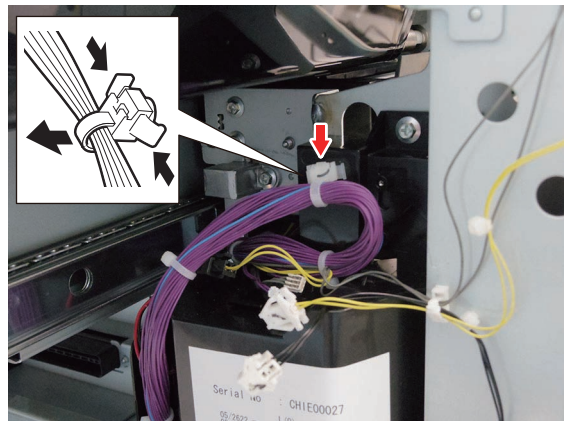

Fig. 4-125

- (5) Remove 2 screws.



Fig. 4-126

- (6) Take off the laser optical unit cooling duct [2] by rotating it as shown in the figure.

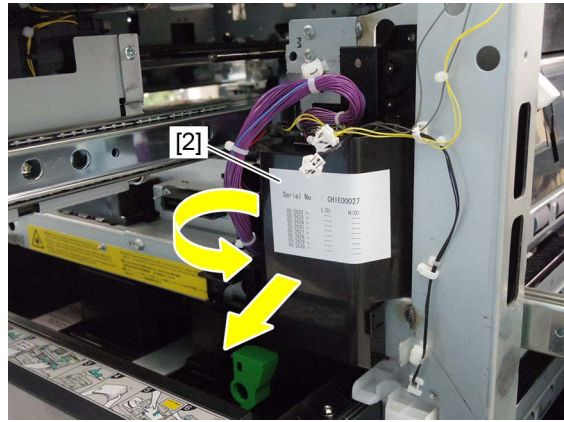

Fig. 4-127

Notes:

When installing the laser optical unit cooling duct in the MFP, set its harness as shown in the figure.

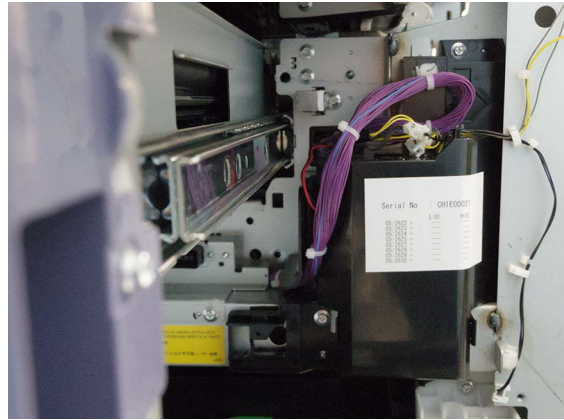

Fig. 4-128

- (7) Release 4 latches and take off the case [3].

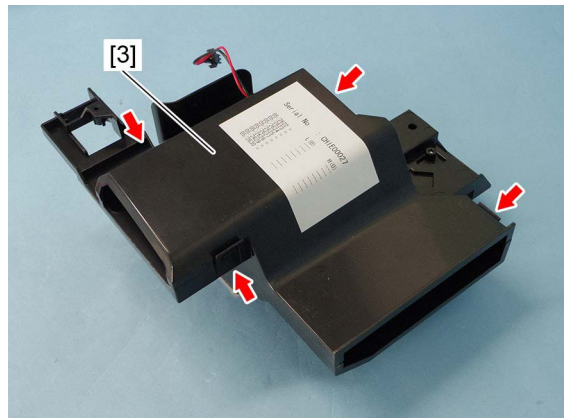

Fig. 4-129

Notes:

When taking off the case, do not pull the harness which is coming out of the hole in the case.

- (8) Take off the laser optical unit cooling fan (front) [4].

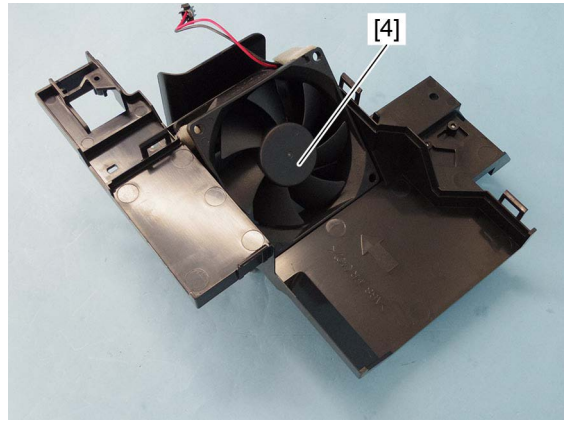

Fig. 4-130

4.4.3 Laser optical unit cooling fan (rear) (F23)

- (1) Take off the rear cover.
P. 4-12 “4.1.22 Rear cover”
- (2) Remove 2 screws and disconnect 6 connectors. Release the harness from 8 harness clamps [1] and the bracket [2].

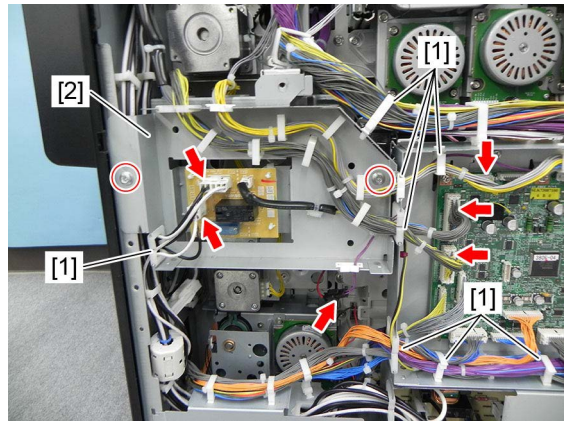

Fig. 4-131

- (3) Remove 2 screws and take off the laser optical unit cooling duct [3].

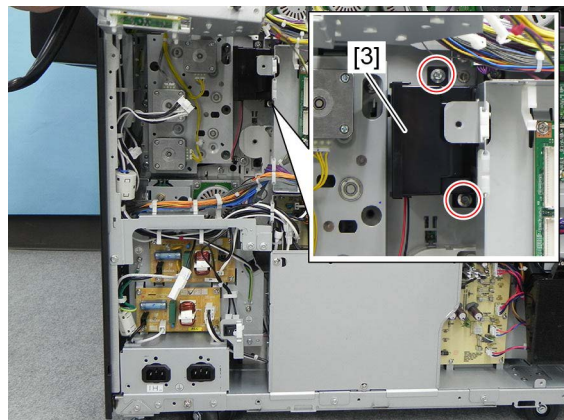

Fig. 4-132

- (4) Release 2 latches and take off the duct cover [4].
- (5) Take off the laser optical unit cooling fan (rear) [5].

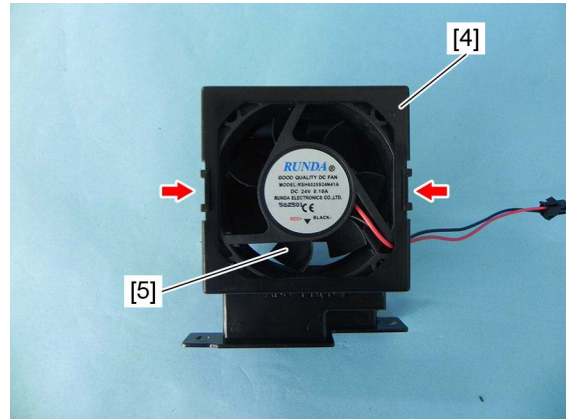

Fig. 4-133

4.4.4 Shutter

- (1) Take off the laser optical unit.
 P. 4-48 "4.4.1 Laser optical unit"
- (2) If the shutter [1] is closed, rotate the shutter motor section to open it.
 A: Shutter closed
 B: Shutter opened

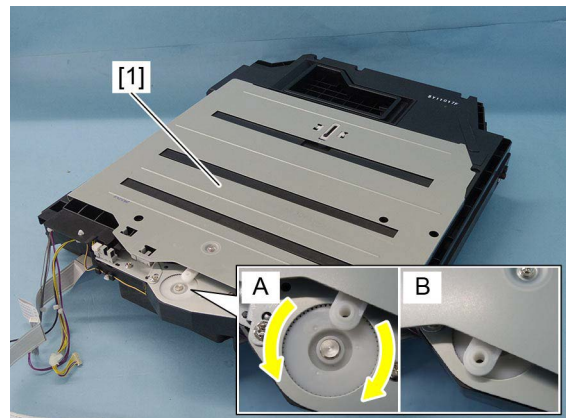

Fig. 4-134

- (3) Remove the shutter [1].

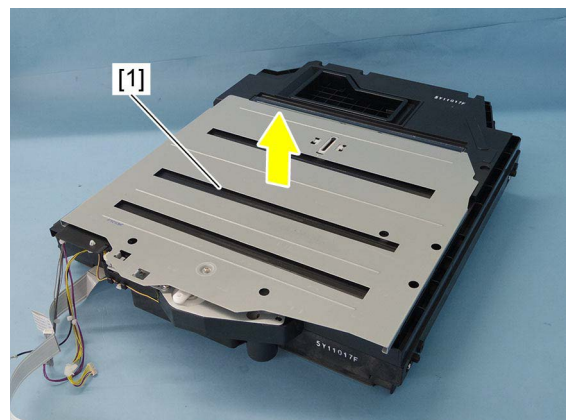

Fig. 4-135

4.4.5 Shutter motor (M38)

- (1) Take off the laser optical unit.
P. 4-48 "4.4.1 Laser optical unit"

Notes:

Check that the shutter is closed.

- (2) Remove 2 screws.



Fig. 4-136

- (3) Disconnect 1 connector and take off the shutter motor [1].

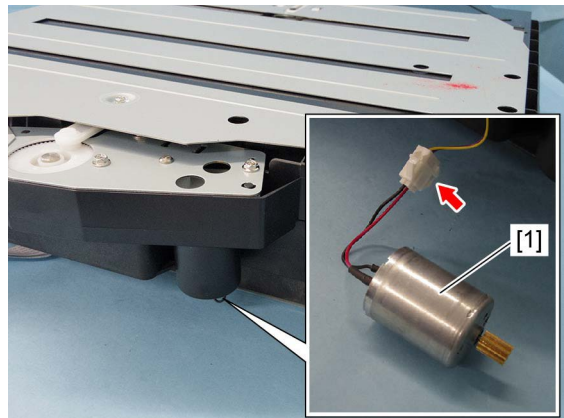

Fig. 4-137

Notes:

Pay attention to the size and length of the screws. If you use the wrong ones, the motor could be damaged.

4.4.6 Shutter sensor (home position) (S24)

- (1) Take off the laser optical unit.
📖 P. 4-48 “4.4.1 Laser optical unit”
- (2) Remove the shutter.
📖 P. 4-55 “4.4.4 Shutter”
- (3) Disconnect 1 connector.
- (4) Release 3 latches and take off the shutter sensor (home position) [1].

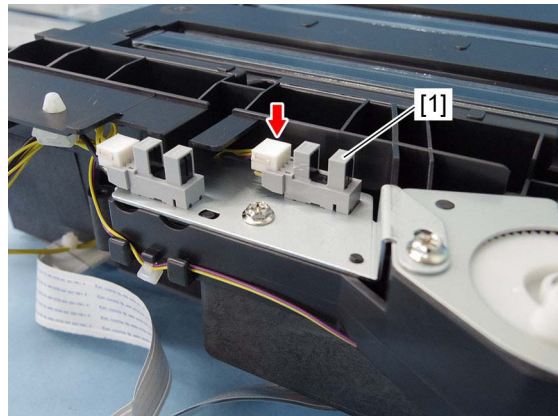

Fig. 4-138

4.4.7 Shutter sensor (end position) (S25)

- (1) Take off the laser optical unit.
📖 P. 4-48 “4.4.1 Laser optical unit”

Notes:

Check that the shutter is closed.

- (2) Remove 1 harness clamp [1]. Disconnect 1 connector.
- (3) Release 3 latches and take off the shutter sensor (end position) [2].

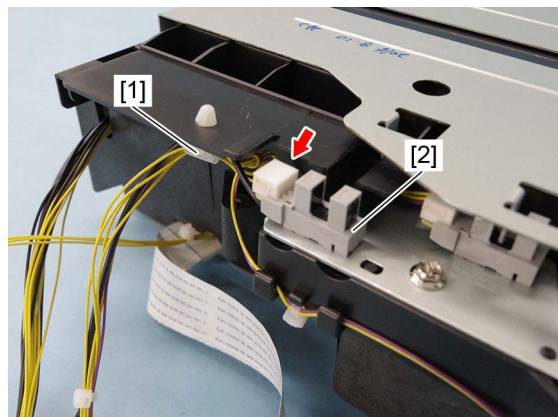

Fig. 4-139

4.5 Paper Feeding Section

4.5.1 Bypass tray

- (1) Take off the duplexing unit front cover.
📖 P. 4-10 “4.1.18 Duplexing unit front cover”
- (2) Take off the duplexing unit rear cover.
📖 P. 4-11 “4.1.19 Duplexing unit rear cover”
- (3) Disconnect 1 connector and remove 1 screw.

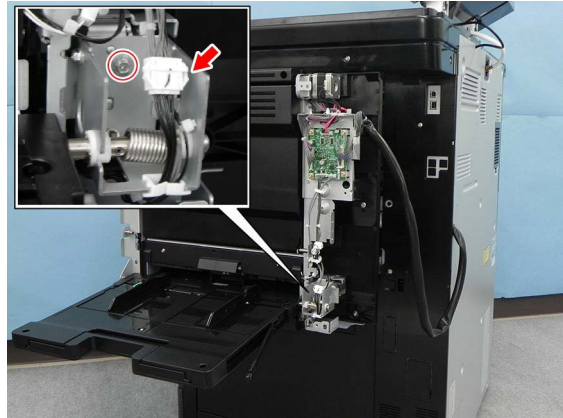

Fig. 4-140

- (4) Lift up the hinge [1] slightly and take off the bypass tray [2].

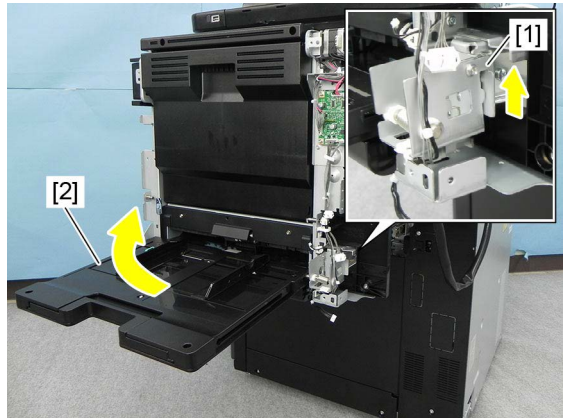

Fig. 4-141

Notes:

When installing or taking off the bypass tray, keep it setting up because it is tensed with a spring.

4.5.2 Bypass unit

- (1) Take off the bypass tray.
P. 4-58 "4.5.1 Bypass tray"
- (2) Open the duplexing unit.
- (3) Remove 1 screw and take off the SFB lower cover [1].

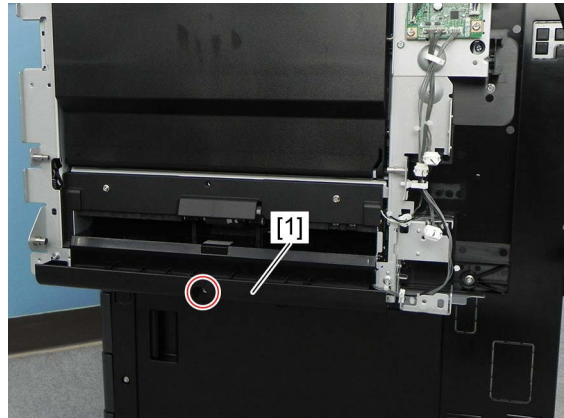

Fig. 4-142

Notes:

When the optional LCF is installed, be sure to attach the cover with the duplexing unit opened wider than the LCF.

- (4) Disconnect 4 connectors, remove 2 screws and take off the bypass unit [2].

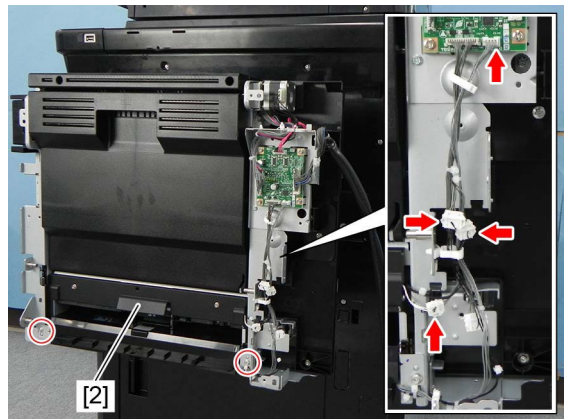

Fig. 4-143

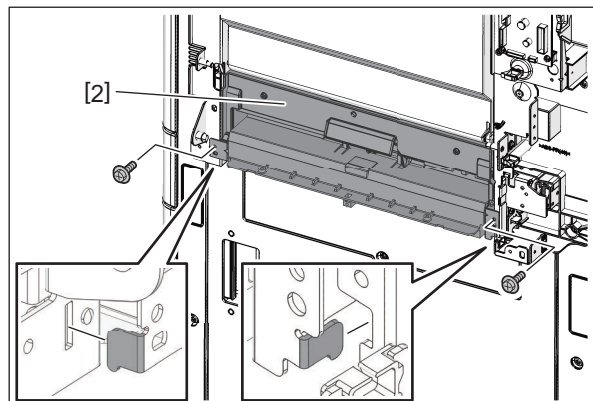

Fig. 4-144

Notes:

- Before installing the bypass unit, check that the belt [4] is attached correctly.
- When installing the bypass unit, exercise care not to let the belt [4] come off by letting it hang from the frame.

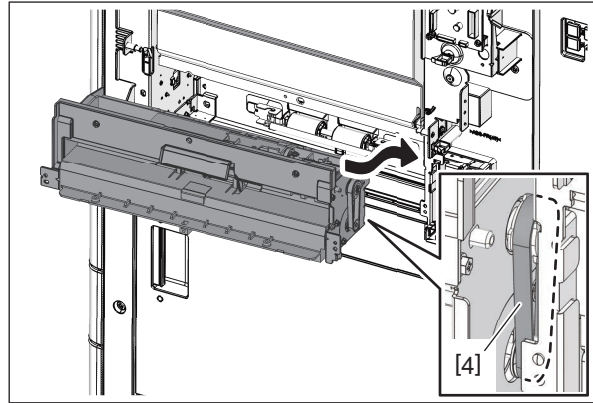

Fig. 4-145

4.5.3 Bypass pickup solenoid (SOL8)

- (1) Take off the bypass unit.
📖 P. 4-59 "4.5.2 Bypass unit"
- (2) Remove 2 screws and take off the SFB upper cover [1].

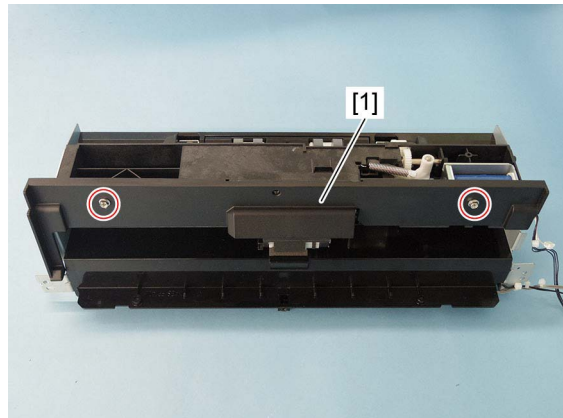

Fig. 4-146

- (3) Remove 1 spring [2]. Remove 2 screws and take off the bypass pickup solenoid [3].

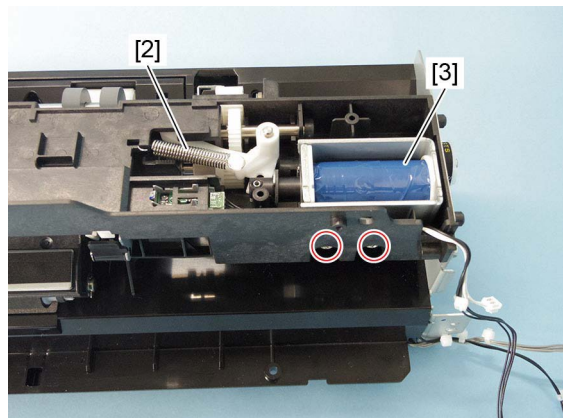

Fig. 4-147

4.5.4 Bypass tray paper sensor (S71)

- (1) Take off the bypass pickup solenoid.
📖 P. 4-60 "4.5.3 Bypass pickup solenoid (SOL8)"
- (2) Remove the actuator [1].

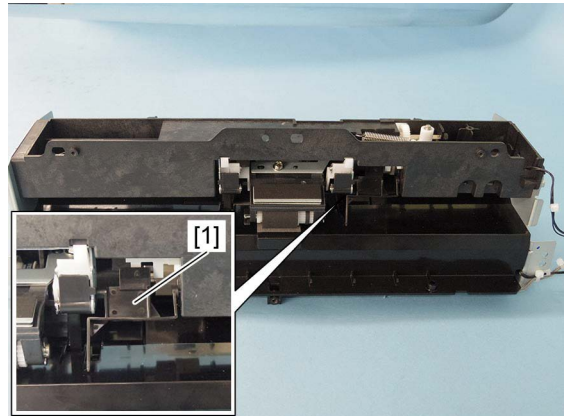

Fig. 4-148

- (3) Release 3 latches and take off the bypass tray paper sensor [2].

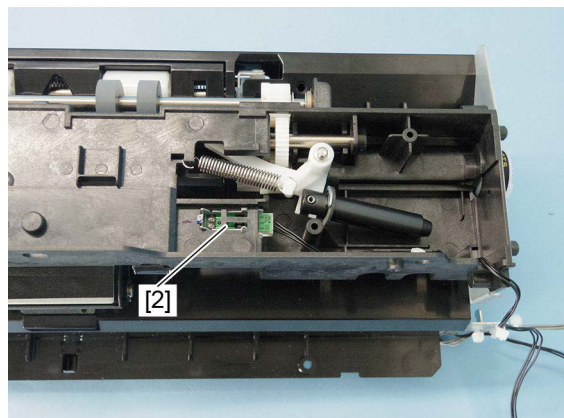

Fig. 4-149

- (4) Disconnect 1 connector.

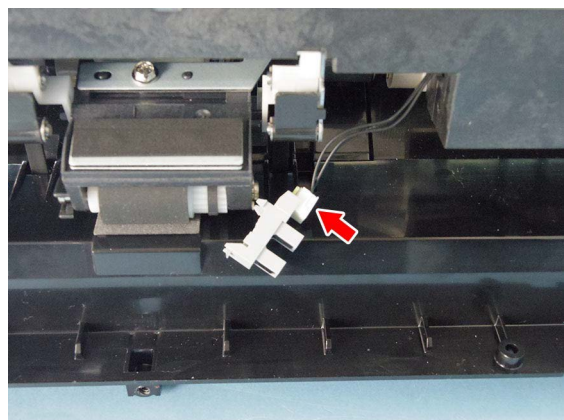

Fig. 4-150

4.5.5 Bypass tray pickup roller

- (1) Open the bypass tray.
- (2) Remove 2 screws and take off the SFB upper cover [1].

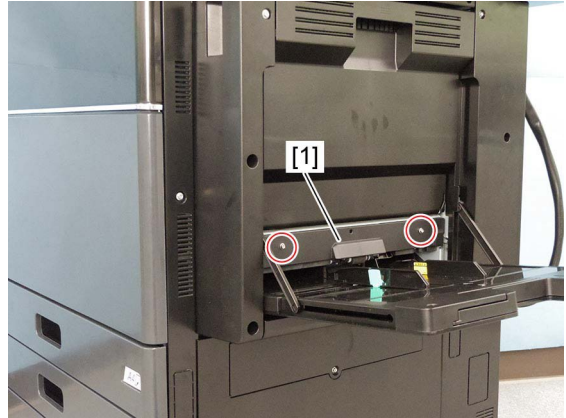

Fig. 4-151

- (3) Remove 1 clip. Remove the shaft and take off the bypass tray pickup roller [2].

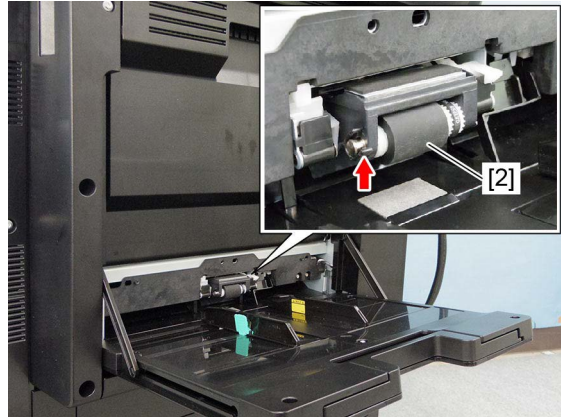



Fig. 4-152



Fig. 4-153

4.5.6 Bypass upper unit

- (1) Take off the bypass unit.
 P. 4-59 "4.5.2 Bypass unit"
- (2) Remove 2 screws and take off the SFB upper cover [1].

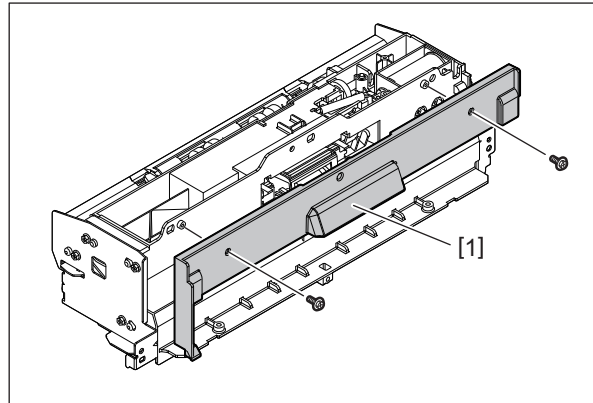

Fig. 4-154

- (3) Remove 4 screws and take off the bracket [2].

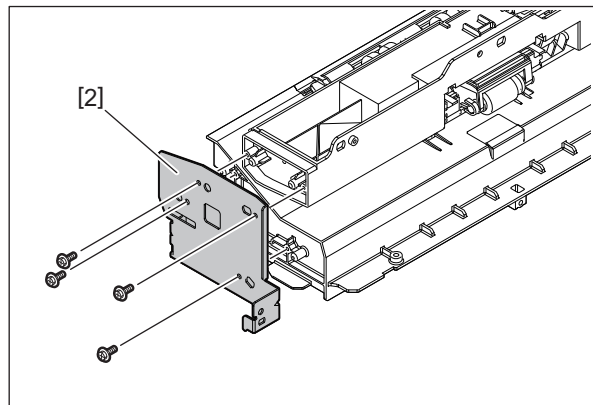

Fig. 4-155

- (4) Remove 1 E-ring [3], 1 belt [4], 1 gear [5], 1 pin [6] and 1 bushing [7].

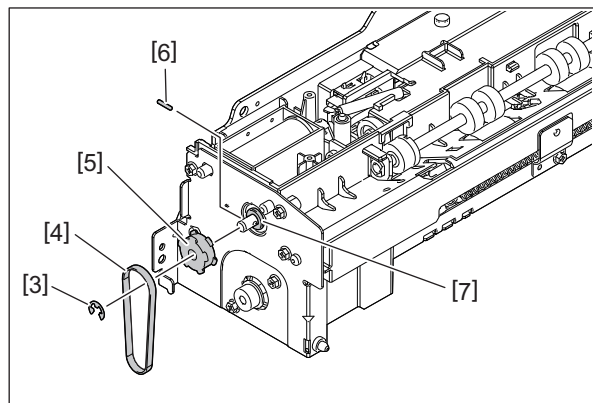

Fig. 4-156

- (5) Remove 2 screws and take off the bypass upper unit [8].

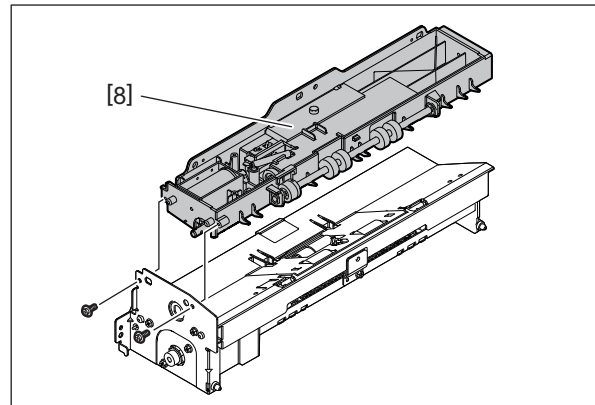



Fig. 4-157

4.5.7 Bypass tray paper feed roller

- (1) Take off the bypass upper unit.
 P. 4-63 “4.5.6 Bypass upper unit”
- (2) Remove the clip [1] and take off the bypass tray paper feed roller [2].

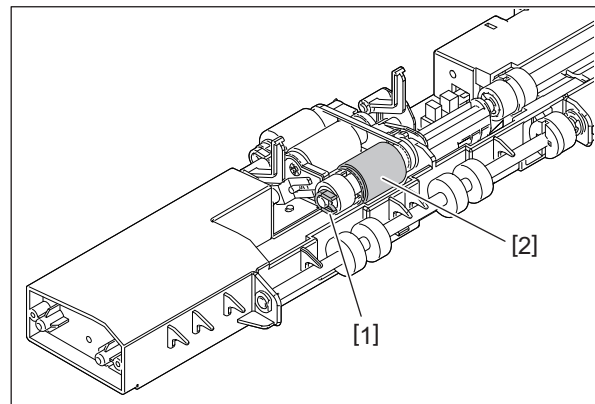

Fig. 4-158

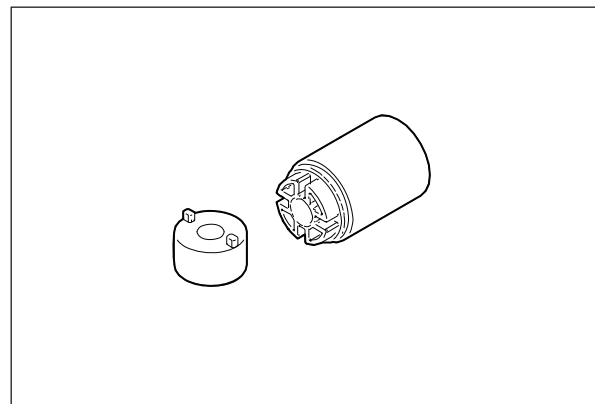

Fig. 4-159

Notes:

When reassembling the bypass tray paper feed roller, pay attention to the following items.

- Set the timing belt to the pulley securely.
- Do not set the timing belt in the wrong position.
- Be sure to insert the clip into the groove of shaft.
- Check that there are no stains, such as oil on the surface of the timing belt, the pulley and the roller.

- Install the bypass tray pickup roller and the bypass unit feed roller in the correct direction.

4.5.8 Bypass tray transport roller

- (1) Take off the bypass unit.
📖 P. 4-59 “4.5.2 Bypass unit”
- (2) Remove 1 E-ring and move the bushing [1] to the inner side.
- (3) Move the shaft [2] to the right side and remove the left bushing [3]. Then take off the bypass tray transport roller [4].

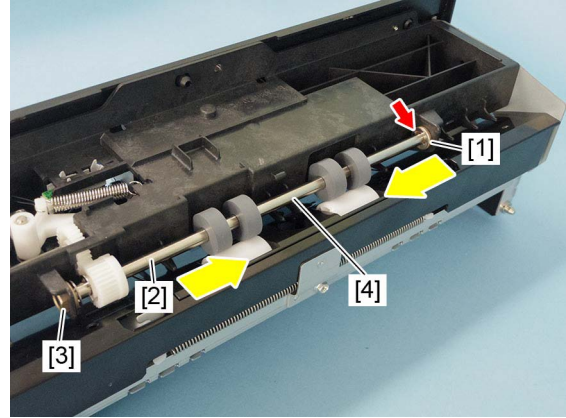

Fig. 4-160



Fig. 4-161

4.5.9 Bypass tray motor (M12)

- (1) Take off the bypass unit.
P. 4-59 "4.5.2 Bypass unit"
- (2) Remove 1 E-ring [1], 1 belt [2], 1 gear [3], 1 pin [7] and 1 bushing [8].

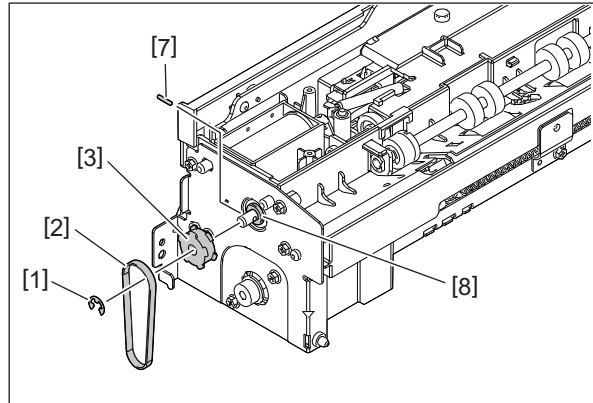

Fig. 4-162

- (3) Release the ground wire [4] from 1 harness clamp. Remove 1 screw and take off the ground wire [4].

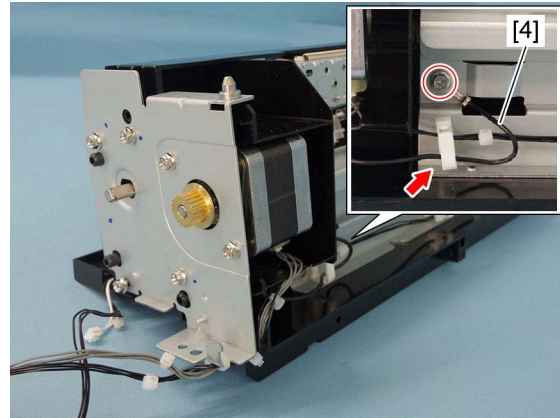

Fig. 4-163

- (4) Remove 4 screws and take off the bracket [5].

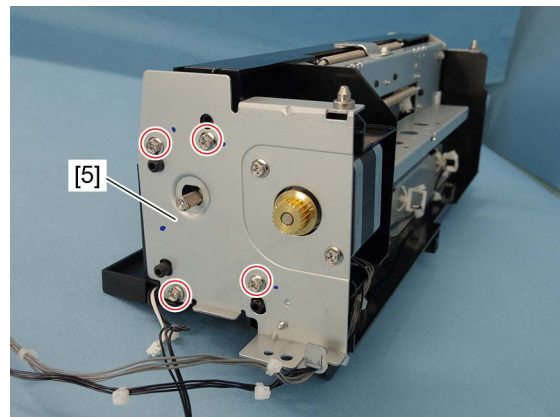

Fig. 4-164

(5) Remove 2 screws.

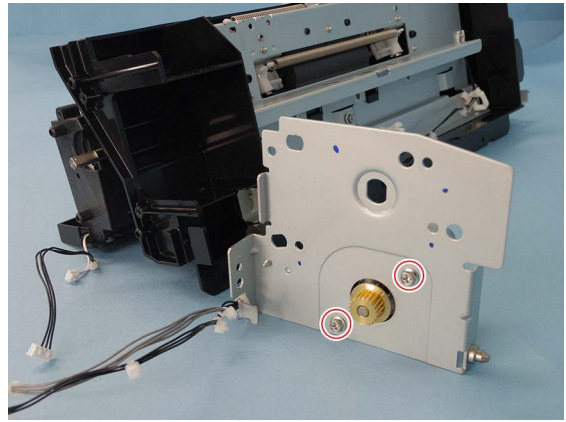

Fig. 4-165

(6) Disconnect 1 connector and take off the bypass tray motor [6].

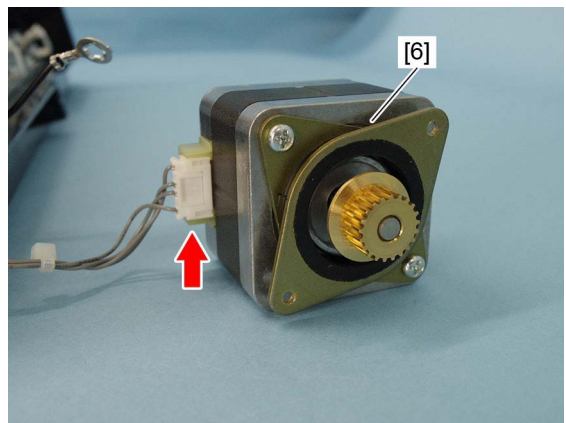



Fig. 4-166

4.5.10 Bypass tray separation roller

- (1) Take off the bypass unit.
 P. 4-59 “4.5.2 Bypass unit”
- (2) Remove 1 screw and take off the bracket [1].

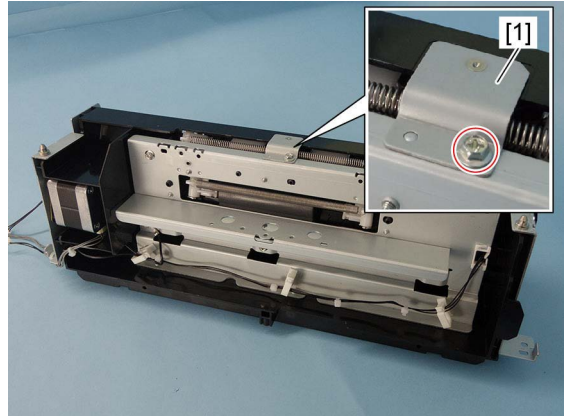

Fig. 4-167

- (3) Release the harnesses from 4 harness clamps. Remove 4 screws and take off the SFB lower unit [2].

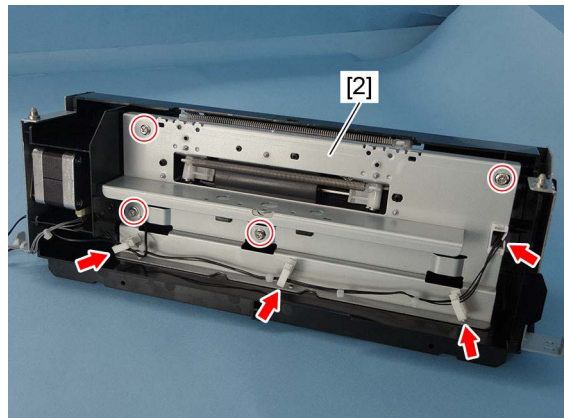

Fig. 4-168

- (4) Remove 2 screws and take off the SFB lower guide [3].

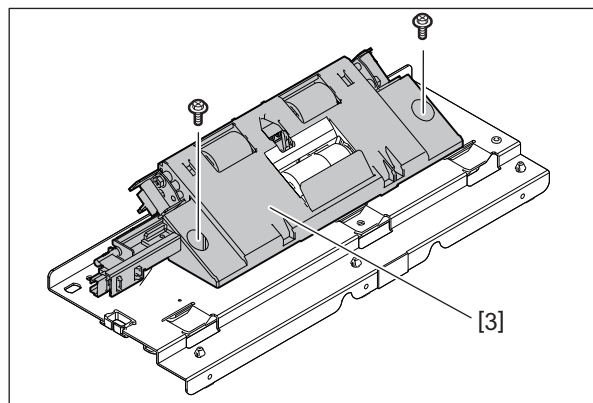

Fig. 4-169

- (5) Lift up the shaft [4] and then take off the bypass tray separation roller [5].

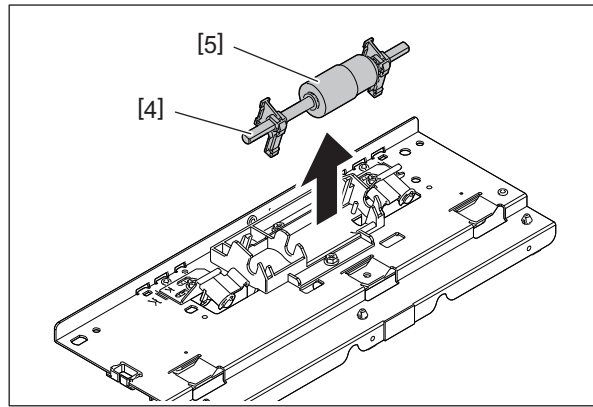

Fig. 4-170

- (6) Remove 2 arbors [6] and 1 washer [7] from the shaft [4].

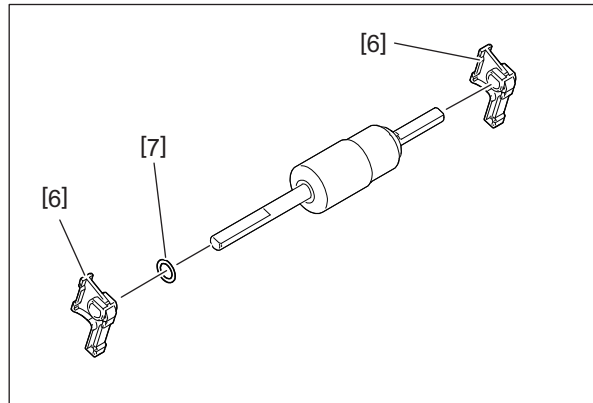

Fig. 4-171

Notes:

Make sure not to damage the latch [7] of the holder.

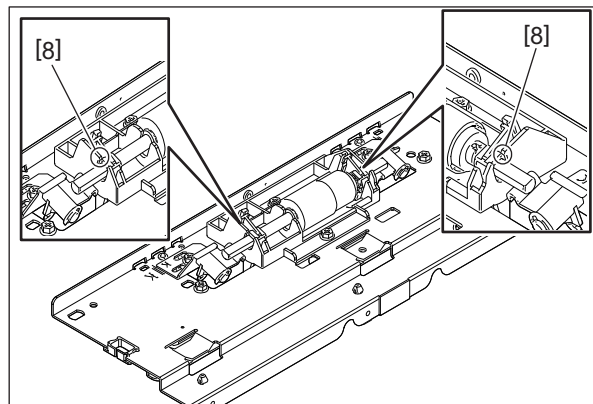

Fig. 4-172

4.5.11 Bypass tray paper feed sensor (S72)

- (1) Take off the SFB lower unit.
📖 P. 4-68 “4.5.10 Bypass tray separation roller”
- (2) Disconnect 1 connector and release 3 latches. Take off the bypass tray paper feed sensor [2] by pushing its actuator [1].

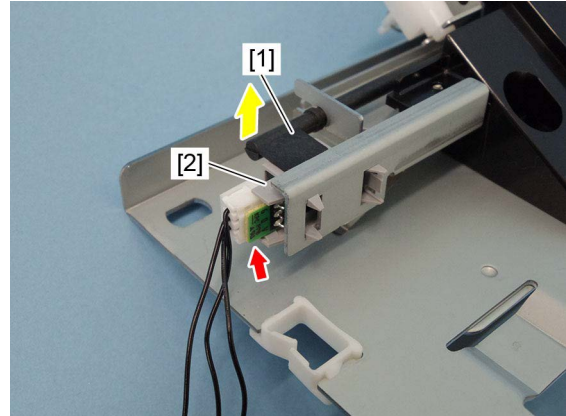

Fig. 4-173

4.5.12 Paper width detection PC board (SFBB)

- (1) Take off the bypass tray.
📖 P. 4-58 “4.5.1 Bypass tray”
- (2) Remove 5 screws and take off the upper tray [1].

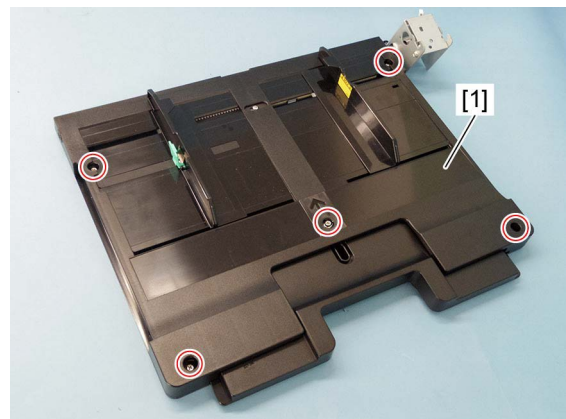

Fig. 4-174

(3) Remove 1 screw and the leaf spring [2].

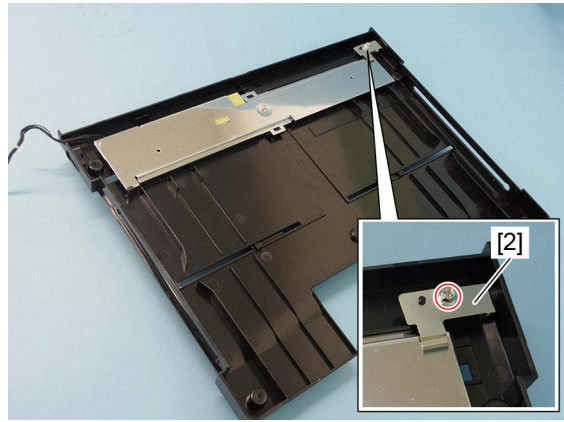

Fig. 4-175

(4) Remove 1 screw and take off the bracket [3].

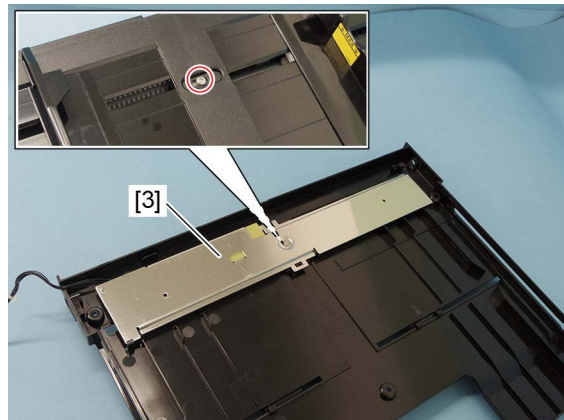

Fig. 4-176

(5) Disconnect 1 connector, remove 1 screw and take off the paper width detection PC board [4].

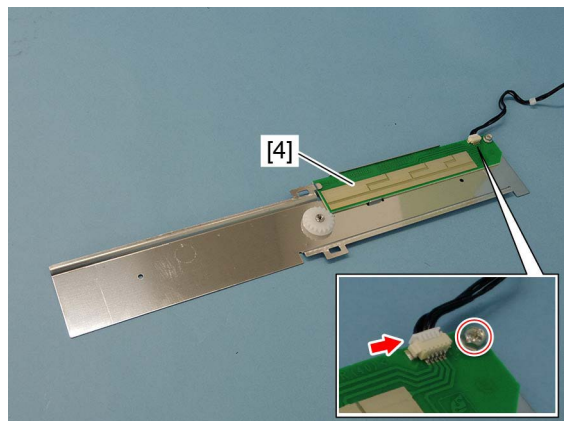



Fig. 4-177

4.5.13 Paper feed unit

- (1) Take off the paper feed cover.
 P. 4-11 "4.1.20 Paper feed cover"
- (2) Pull out the drawer.
- (3) Disconnect 1 connector, remove 2 screws and take off the paper feed unit [1].

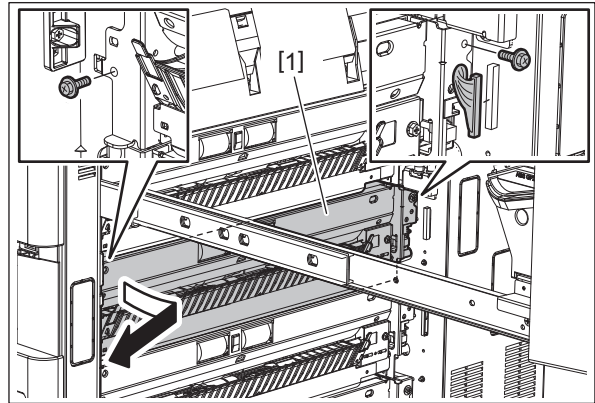

Fig. 4-178

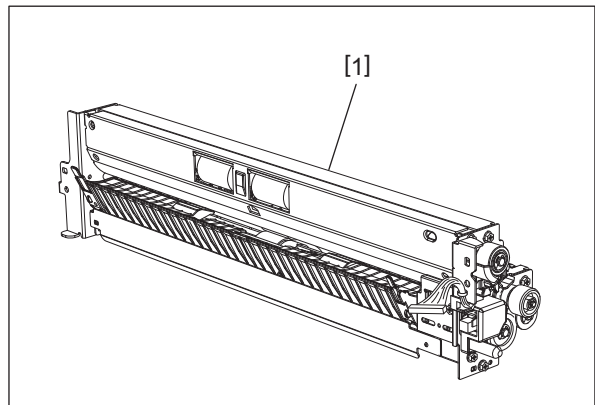

Fig. 4-179

Notes:

- When removing the 1st drawer paper feed unit, take off the connector cover [2].

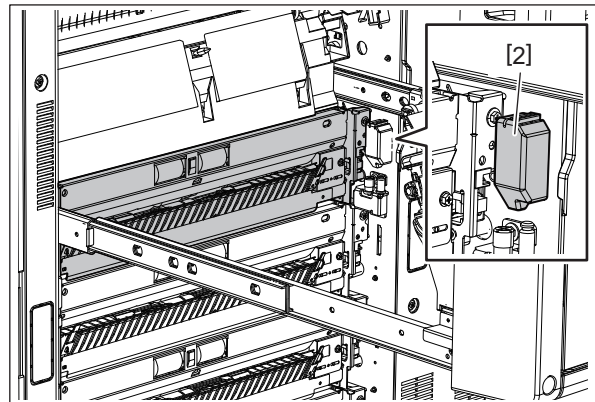

Fig. 4-180

- Install the paper feed unit [1] as shown in the figure.

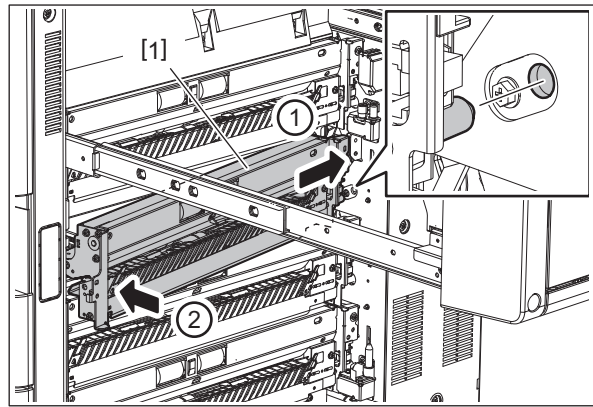

Fig. 4-181

- When installing the paper feed unit [1], move it to the front side and then secure it with the screws in the order of the rear and front sides.

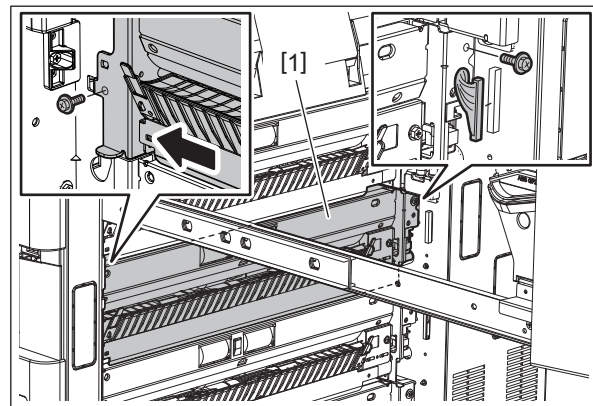



Fig. 4-182

4.5.14 Paper feed roller

- (1) Remove the paper feed unit.
 P. 4-72 “4.5.13 Paper feed unit”
- (2) Remove 1 clip [3]. Press down the lever [1] and take off the paper feed roller [2].

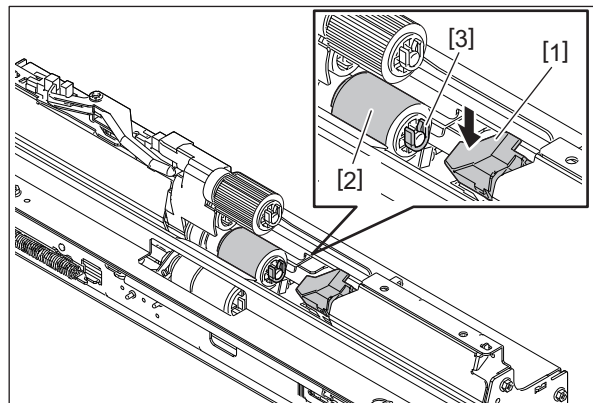



Fig. 4-183

4.5.15 Pickup roller

- (1) Remove the paper feed unit.
 P. 4-72 "4.5.13 Paper feed unit"
- (2) Remove 1 clip [2] and take off the pickup roller [1].

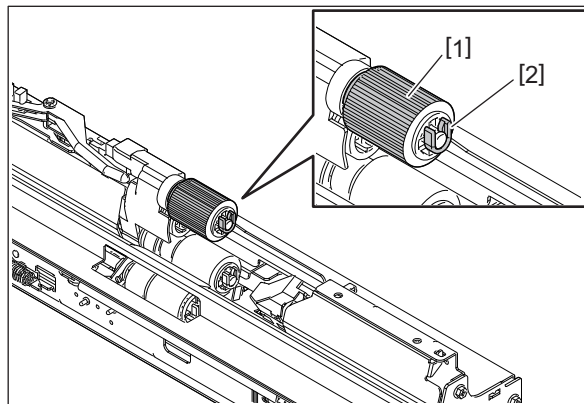



Fig. 4-184

4.5.16 Separation roller

- (1) Remove the paper feed unit.
 P. 4-72 "4.5.13 Paper feed unit"
- (2) Remove 2 screws and take off the paper guide A [1].

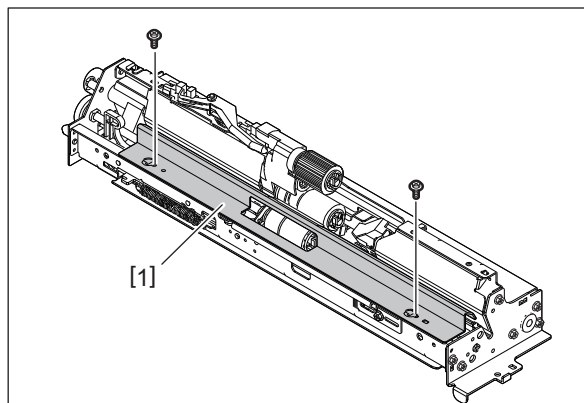

Fig. 4-185

- (3) Remove 1 clip [2] and take off the separation roller [3].

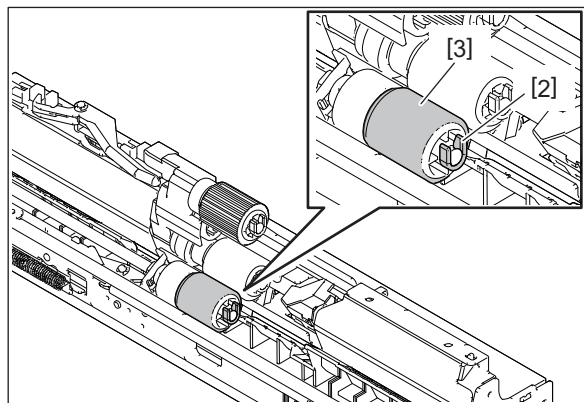

Fig. 4-186

4.5.17 Drawer transport roller

- (1) Remove the paper feed unit.
P. 4-72 "4.5.13 Paper feed unit"
- (2) Remove 2 screws and take off the paper guide A [1].
P. 4-74 "4.5.16 Separation roller"
- (3) Remove 1 screw and slide the bracket [2] to the rear side. Then take off the paper guide B [3] and then the bracket [2].

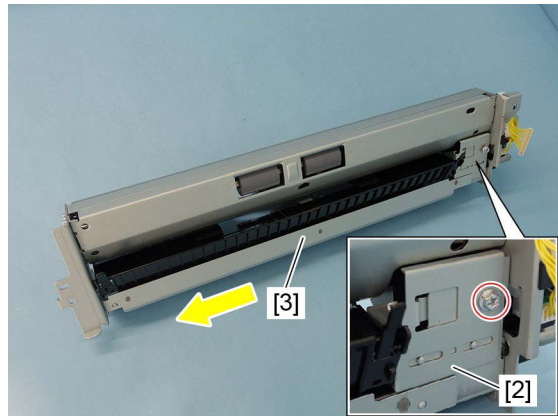

Fig. 4-187

- (4) Release the harnesses [4] from 5 harness clamps. Disconnect 1 connector [5], remove 1 screw and take off the sensor cover [6].

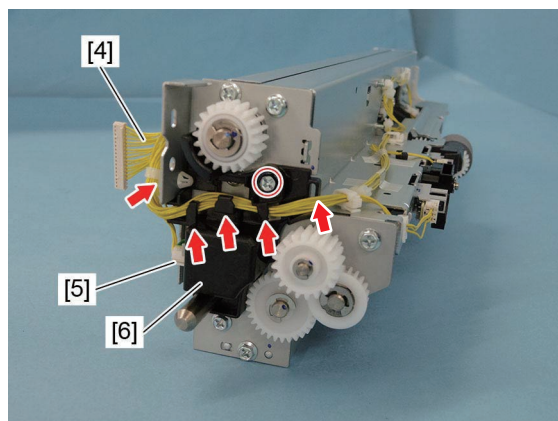

Fig. 4-188

- (5) Remove 1 E-ring and the gear [7].

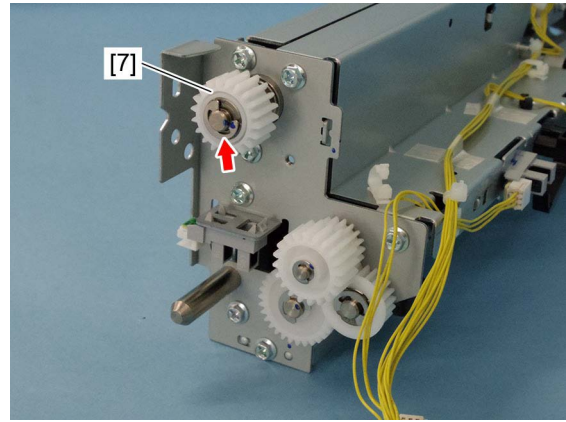

Fig. 4-189

Notes:

When installing the gear, pay attention to the orientation of the one-way clutch.

- (6) Remove 1 E-ring.

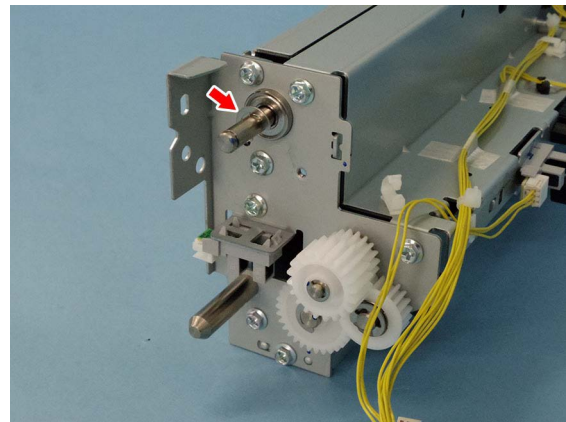

Fig. 4-190

- (7) Remove 4 screws and take off the paper guide C [8].

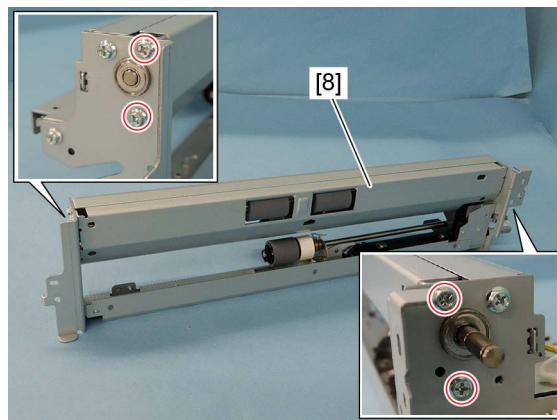

Fig. 4-191

Notes:

When reassembling, make sure the bosses of the paper guide are securely inserted into the holes of the plate.

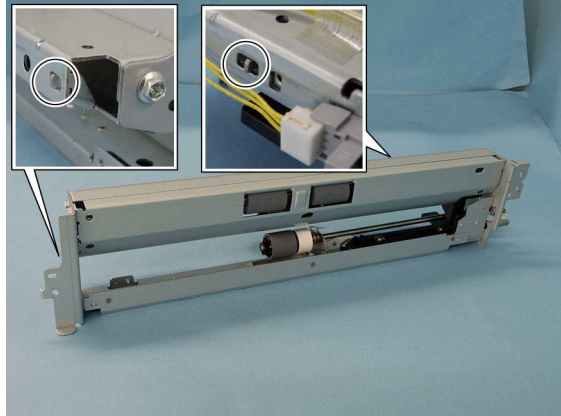

Fig. 4-192

- (8) Remove 1 E-ring and slide the bearing [9] to the inner side. Then take off the drawer transport roller [10].

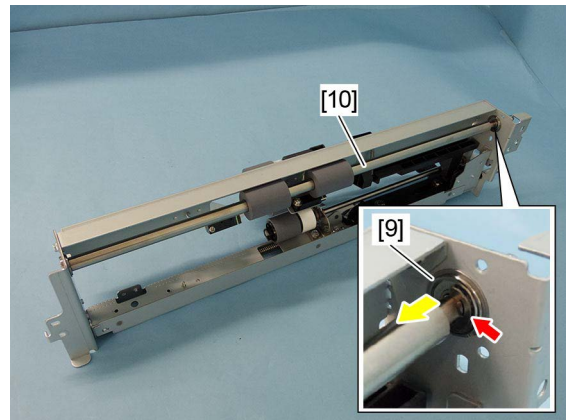

Fig. 4-193



Fig. 4-194

4.5.18 Drawer detection sensor (S73, S81, S89, S97)

- (1) Remove the paper feed unit.
P. 4-72 "4.5.13 Paper feed unit"
- (2) Release the harnesses [1] from 5 harness clamps. Disconnect 1 connector [2], remove 1 screw and take off the sensor cover [3].

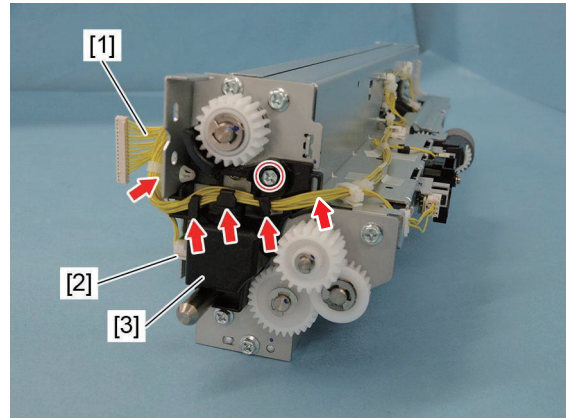

Fig. 4-195

- (3) Release 3 latches and take off the drawer detection sensor [4].

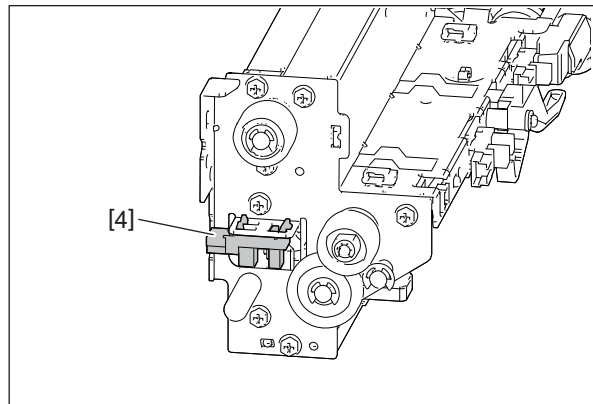

Fig. 4-196

4.5.19 Drawer paper feed sensor (S78, S86, S94, S102)

- (1) Remove the paper feed unit.
P. 4-72 "4.5.13 Paper feed unit"
- (2) Release the harnesses [1] from 1 harness clamp. Remove 1 screw and take off the sensor bracket [2].

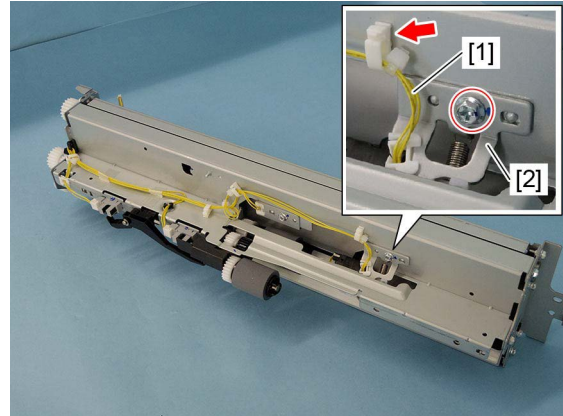

Fig. 4-197

- (3) Release the harnesses [1] from 1 harness clamp. Disconnect 1 connector [3], remove 1 screw and take off the drawer paper feed sensor [4].

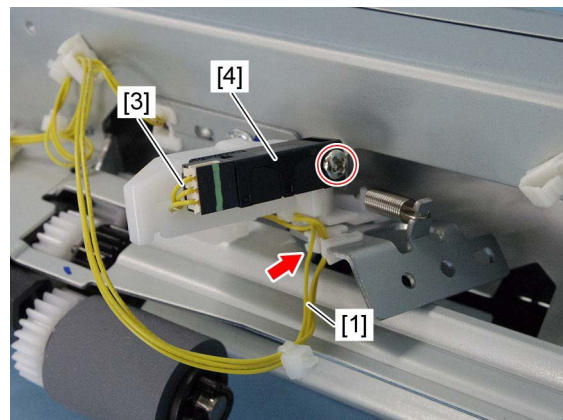

Fig. 4-198

Notes:

When installing, make sure that the protrusion of each sensor is inserted into the hole of the bracket securely.

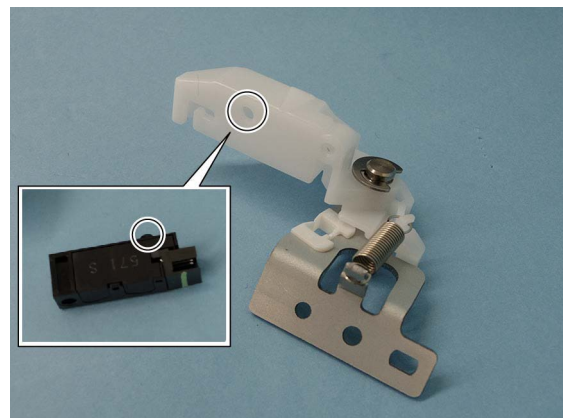

Fig. 4-199

4.5.20 Drawer transport sensor (S77, S85, S93, S101)

- (1) Remove the paper feed unit.
P. 4-72 "4.5.13 Paper feed unit"
- (2) Release the harnesses [1] from 1 harness clamp. Remove 1 screw and take off the sensor bracket [2].

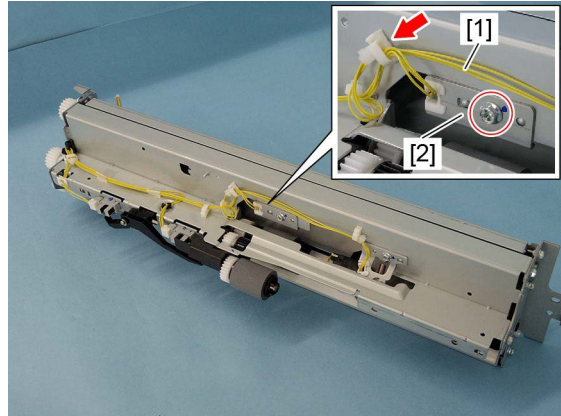

Fig. 4-200

- (3) Disconnect 1 connector, remove 1 screw and take off the drawer transport sensor [3].

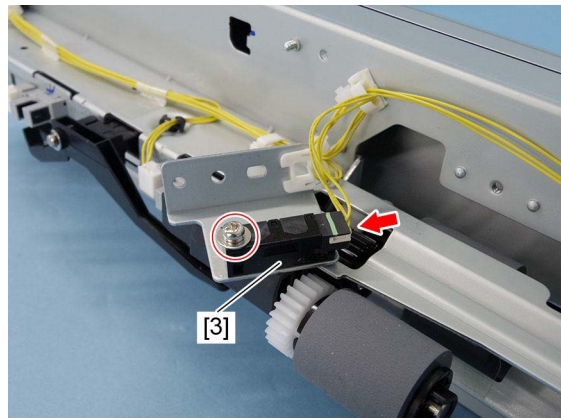

Fig. 4-201

Notes:

When installing, make sure that the protrusion of each sensor is inserted into the hole of the bracket securely.

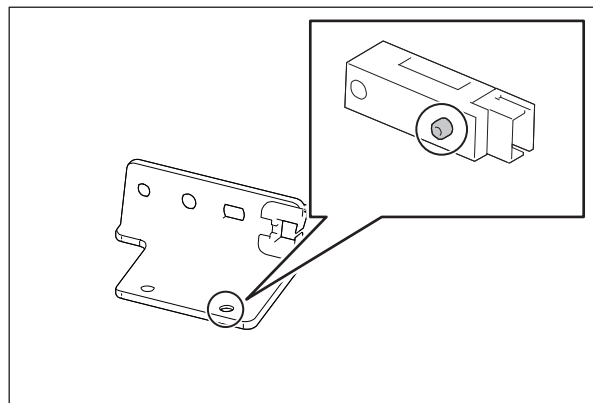

Fig. 4-202

4.5.21 Drawer paper empty sensor (S75, S83, S91, S99)

- (1) Remove the paper feed unit.
P. 4-72 "4.5.13 Paper feed unit"
- (2) Release the harnesses [1] from 1 harness clamp. Disconnect 1 connector [2]. Release 3 latches and take off the drawer paper empty sensor [3].

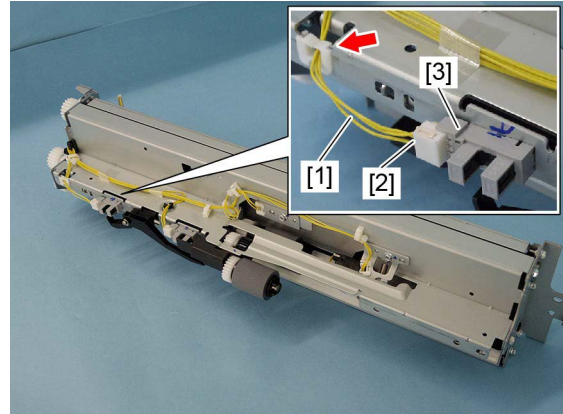

Fig. 4-203

4.5.22 Drawer tray-up sensor (S76, S84, S92, S100)

- (1) Remove the paper feed unit.
P. 4-72 "4.5.13 Paper feed unit"
- (2) Disconnect 1 connector. Release 3 latches and take off the drawer tray-up sensor [1].

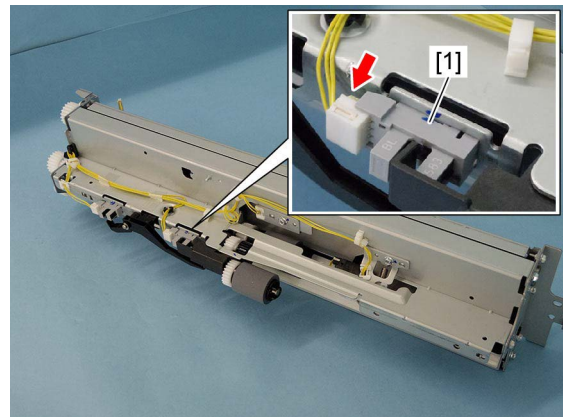

Fig. 4-204

4.5.23 Drawer bottom sensor (S74, S82, S90, S98)

- (1) Take off all the drawers.
📖 P. 4-89 “4.5.30 Drawer”
- (2) Disconnect 1 connector. Release 3 latches and take off the drawer bottom sensor [1].
There are 4 drawer bottom sensors in total.

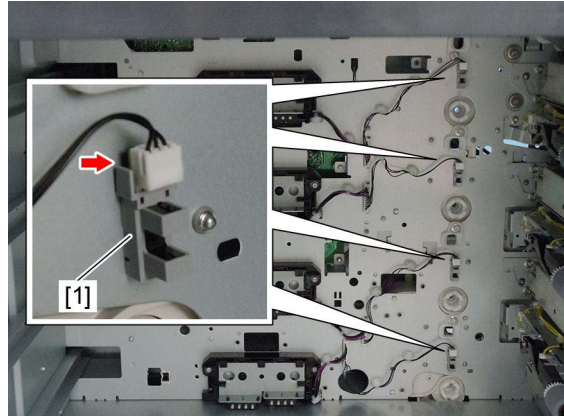

Fig. 4-205

4.5.24 Registration roller (rubber)

- (1) Take off the 2nd transfer unit.
📖 P. 4-211 “4.7.12 2nd transfer unit (TRU)”
- (2) Remove 1 screw. Remove 1 spring [1] and take off the holder [2] on the front side.

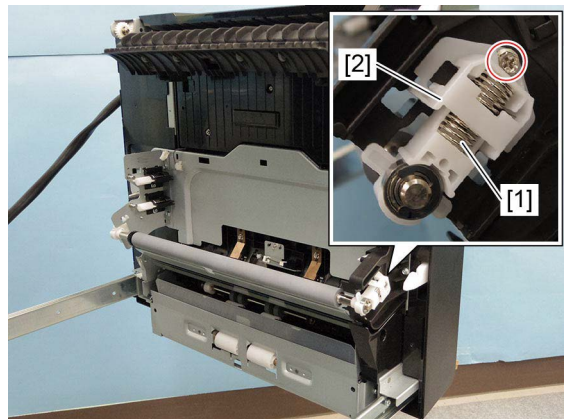

Fig. 4-206

- (3) Remove 1 screw. Remove 1 spring [3] and take off the holder [4] on the rear side. Take off the registration roller (rubber) [5].

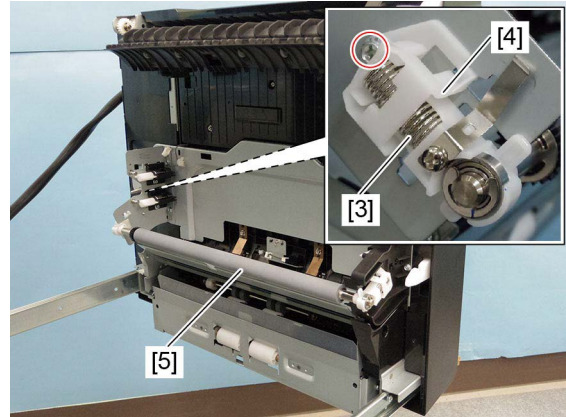

Fig. 4-207

- (4) Remove 3 E-rings [6], 2 holders [7], 1 gear [8] and 1 pin.

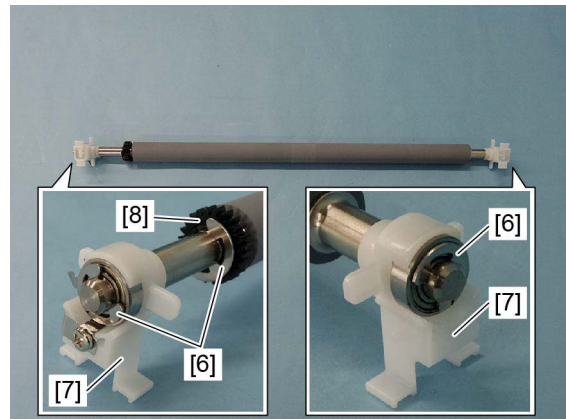

Fig. 4-208

Notes:

Make sure that the holders are installed in a correct position because those for the front side differ from those for the rear side.

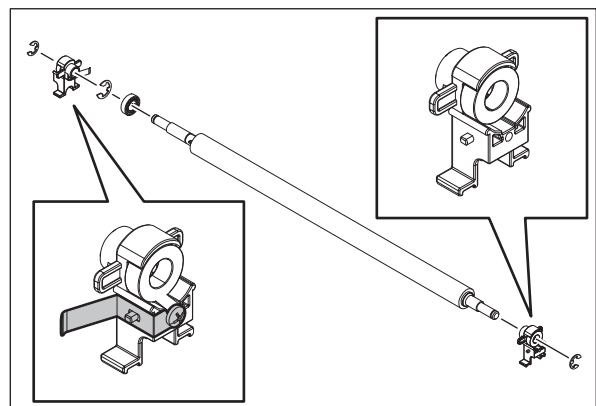

Fig. 4-209

4.5.25 Registration guide

- (1) Open the duplexing unit.
- (2) Remove 3 screws and slide the registration guide [1] slightly to the rear side to release the front hook.

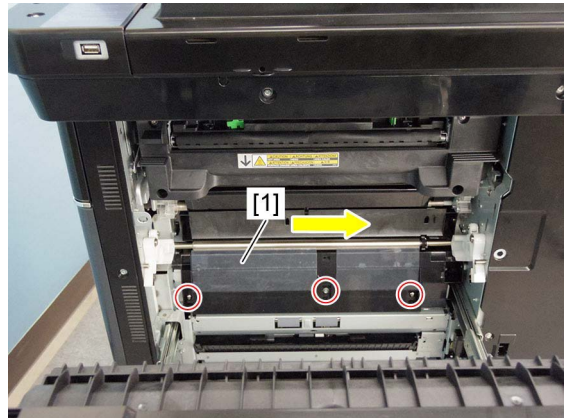

Fig. 4-210

- (3) Disconnect 1 connector and take off the registration guide [1].

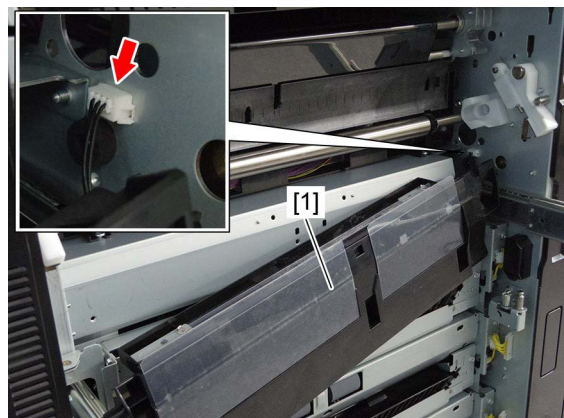

Fig. 4-211

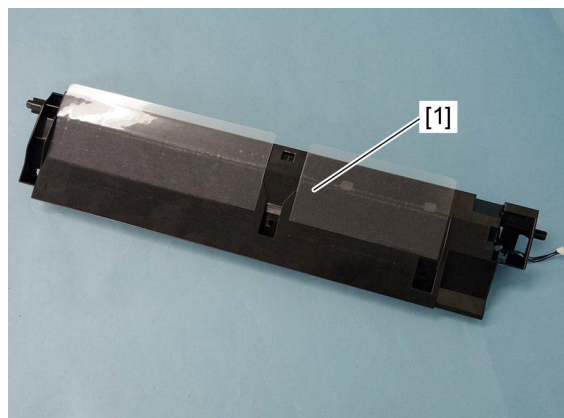

Fig. 4-212

4.5.26 Registration sensor (S52)

- (1) Take off the registration guide.
P. 4-84 "4.5.25 Registration guide"
- (2) Remove 3 screws and take off the paper dust holder [1].

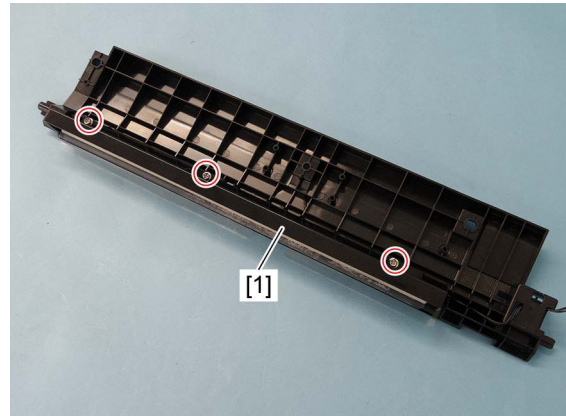

Fig. 4-213

- (3) Disconnect 1 connector, remove 1 screw and take off the registration sensor [2].

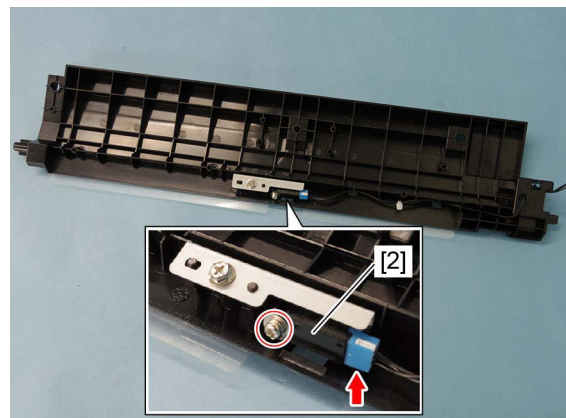

Fig. 4-214

Notes:

When installing, make sure that the protrusion of the sensor is inserted into the hole of the bracket securely.



Fig. 4-215

4.5.27 Registration roller (metal)

- (1) Take off the registration guide.
📖 P. 4-84 “4.5.25 Registration guide”
- (2) Take off the registration motor.
📖 P. 4-91 “4.5.32 Registration motor (M39)”
- (3) Take off the laser unit cooling duct.
📖 P. 4-52 “4.4.2 Laser optical unit cooling fan (front) (F22)”
- (4) Remove 1 E-ring and the bearing [1] on the front side.

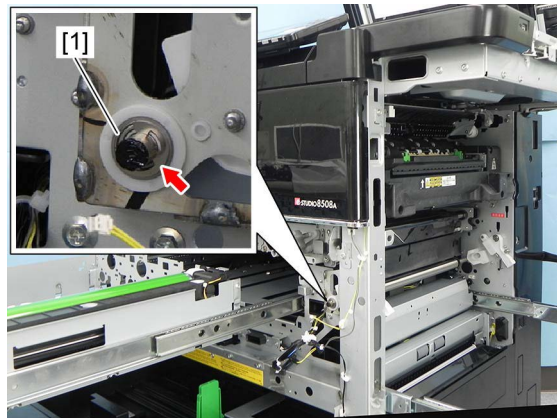

Fig. 4-216

- (5) Take off the registration roller (metal) [2] by sliding it to the rear side and pulling it out toward you.

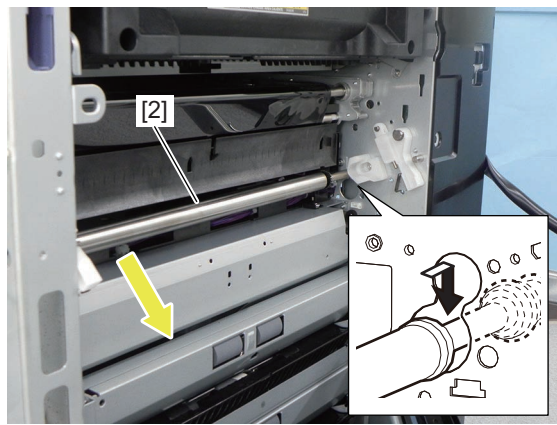

Fig. 4-217

Notes:

When taking off the registration roller (metal) [2], be careful not to hit the roller gear on the rear side to the frame because it may scratch the roller.

4.5.28 2nd transfer side paper clinging detection sensor (S51)

- (1) Take off the 2nd transfer unit.
📖 P. 4-211 “4.7.12 2nd transfer unit (TRU)”
- (2) Remove 1 screw and take off the sensor holder [1].

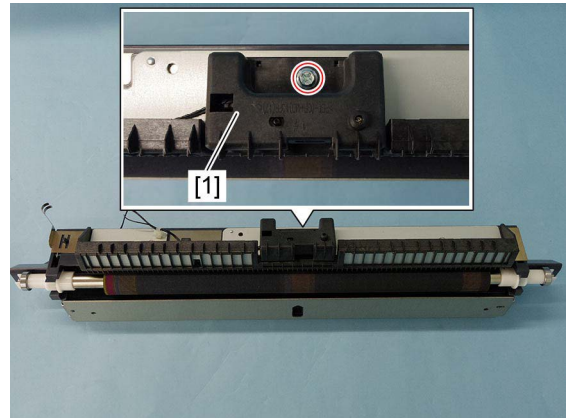

Fig. 4-218

- (3) Remove 1 screw. Disconnect 1 connector and take off the 2nd transfer side paper clinging detection sensor [2].

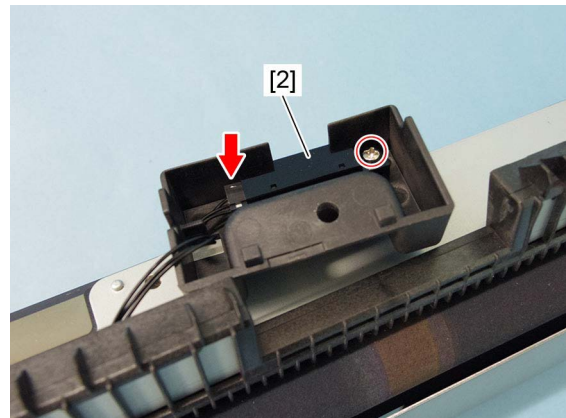

Fig. 4-219

Notes:

When installing, make sure that the protrusion of the sensor is inserted into the hole of the holder securely.

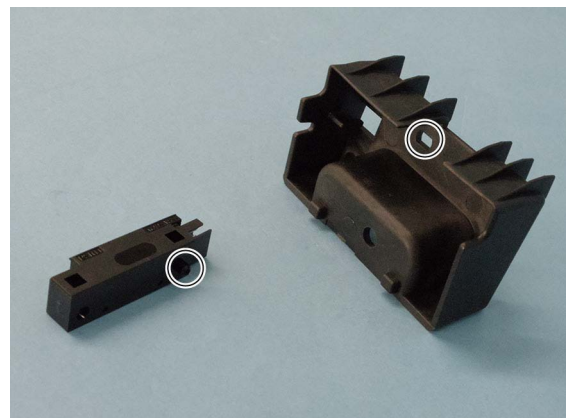

Fig. 4-220

4.5.29 Paper feed cover sensor (S114)

- (1) Open the duplexing unit.
- (2) Open the paper feed cover.
- (3) Take off the sensor cover [1] by pushing the latch on its upper side.

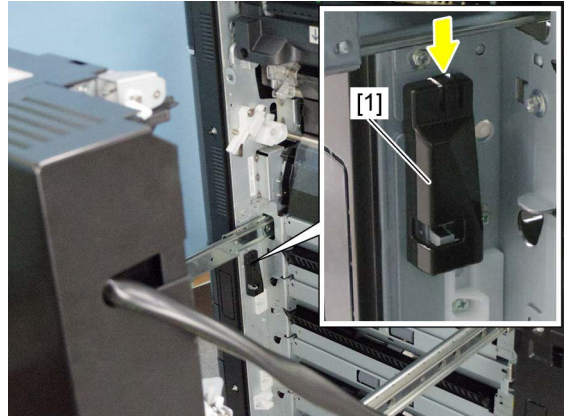

Fig. 4-221

Notes:

When installing, insert the latch on its lower side into the hole of the frame first.

- (4) Disconnect 1 connector. Release 3 latches and take off the paper feed cover sensor [2].

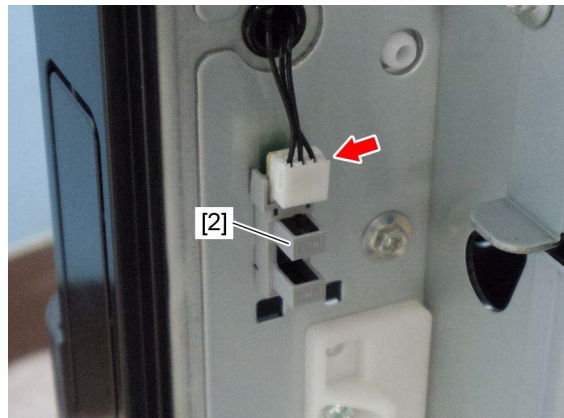

Fig. 4-222

4.5.30 Drawer

- (1) Pull out the drawer and remove paper in it.
- (2) Remove 3 screws and take off the drawer [1].

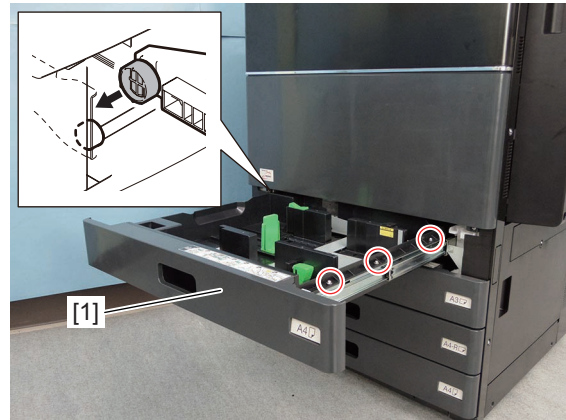

Fig. 4-223

Notes:

When installing, engage the left roller of the drawer with the rail of the MFP, and then place the right roller on the rail.

4.5.31 Drawer paper width detection sensor, Drawer paper length detection sensor (S79, S80, S87, S88, S95, S96, S103, S104)

- (1) Take off all the drawers.
P. 4-89 "4.5.30 Drawer"
- (2) Disconnect 1 connector [1] and remove 2 screws.

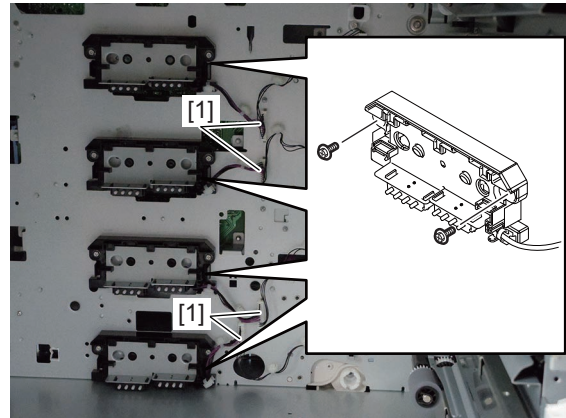

Fig. 4-224

- (3) Release 2 latches and take off the sensor holder.

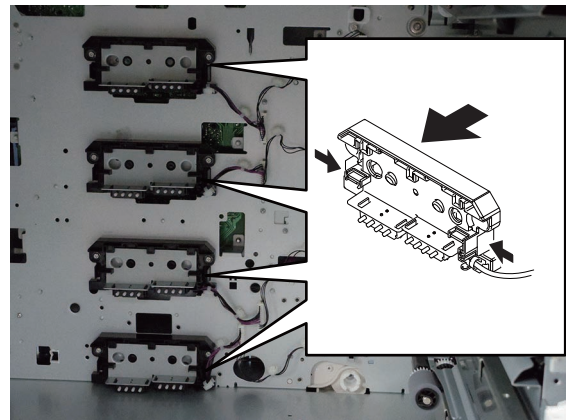

Fig. 4-225

- (4) Release 2 latches. Take off the drawer paper width detection sensor [2] and the drawer paper length detection sensor [3]. Then disconnect the connector [4].

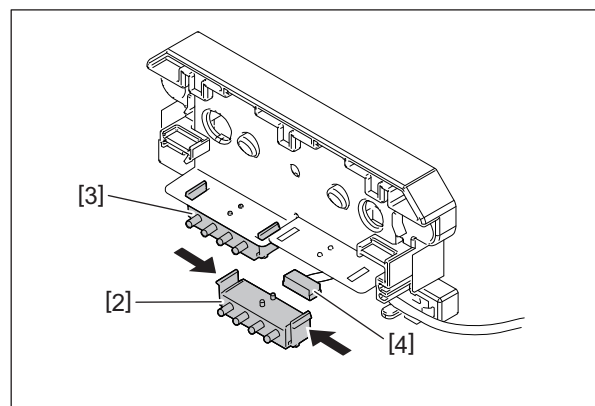

Fig. 4-226

4.5.32 Registration motor (M39)

- (1) Take off the rear cover.
P. 4-12 "4.1.22 Rear cover"
- (2) Remove 1 harness clamp.

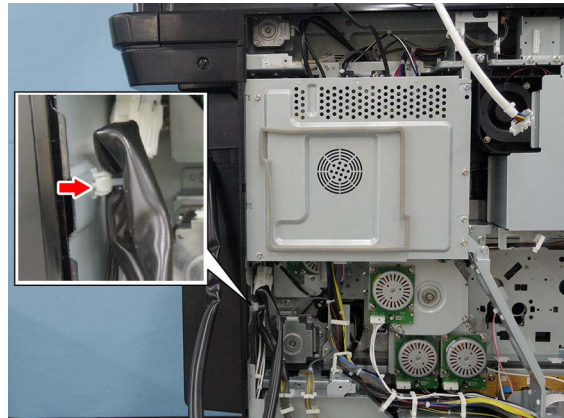

Fig. 4-227

- (3) Disconnect 1 connector, remove 3 screws and take off the registration motor [1] with the bracket.

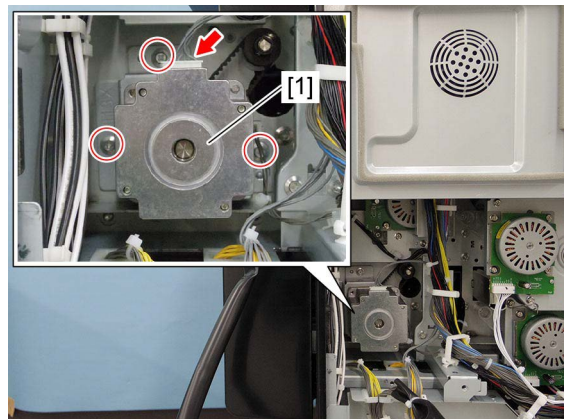

Fig. 4-228

Notes:

When installing, make sure that the belt is hung on the pulley of the motor securely.

- (4) Remove 2 screws and take off the registration motor [1].

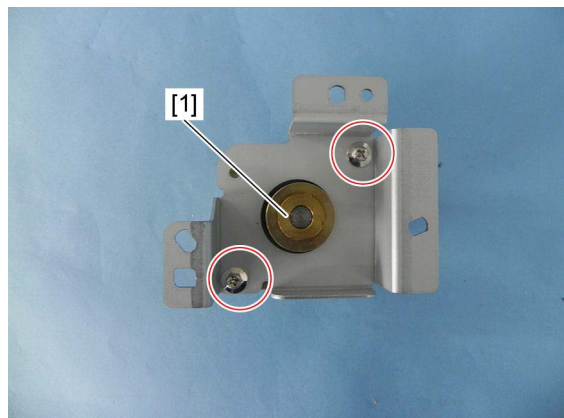

Fig. 4-229

4.5.33 Paper feed/transport drive unit

- (1) Take off the LGC/PFC board case.
📖 P. 9-13 "9.1.12 LGC/PFC board case"
- (2) Remove 2 harness clamps [1].
- (3) Disconnect 3 connectors [2], remove 4 screws and take off the paper feed/transport drive unit [3].

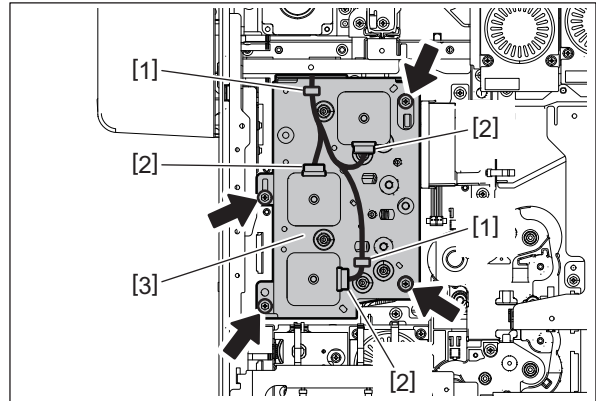

Fig. 4-230

Remarks:

- [A] Transport motor-1 (M40)
- [B] Transport motor-2 (M41)
- [C] 1st/2nd drawer paper feed motor (M42)

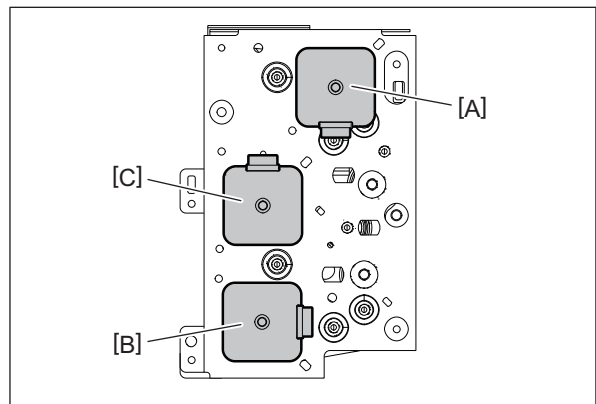

Fig. 4-231

4.5.34 Transport motor-1 (M40)

- (1) Take off the paper feed/transport drive unit.
📖 P. 4-92 "4.5.33 Paper feed/transport drive unit"
- (2) Remove 4 screws and take off the plate [1].

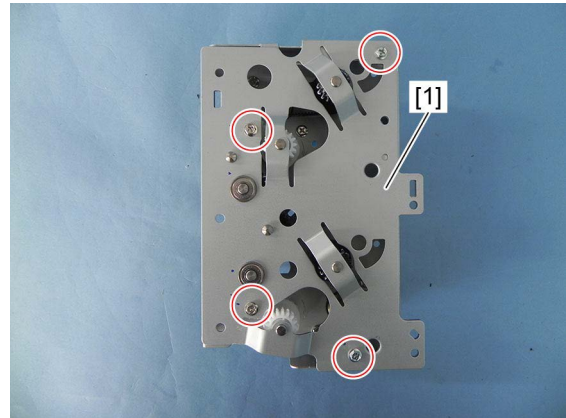

Fig. 4-232

- (3) Remove 2 screws and take off the transport-1 motor [2].

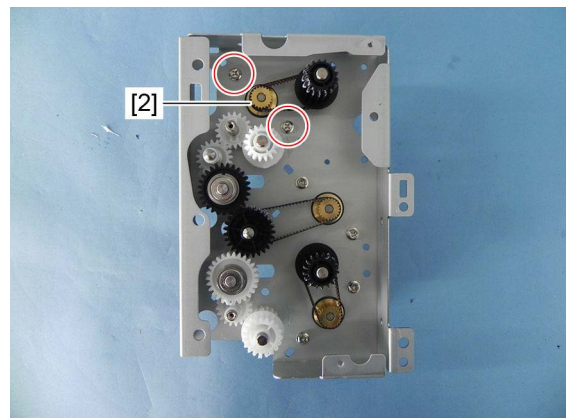

Fig. 4-233

4.5.35 Transport motor-2 (M41)

- (1) Take off the plate.
📖 P. 4-93 "4.5.34 Transport motor-1 (M40)"
- (2) Remove 2 screws and take off the transport-2 motor [1].

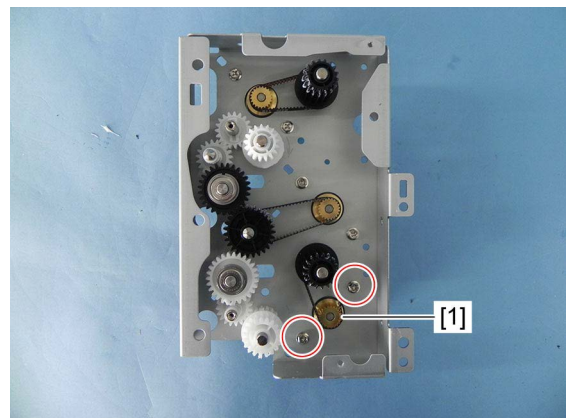



Fig. 4-234

4.5.36 1st/2nd drawer paper feed motor (M42)

- (1) Take off the plate.
 P. 4-93 "4.5.34 Transport motor-1 (M40)"
- (2) Remove 2 screws and take off the 1st/2nd drawer paper feed motor [1].

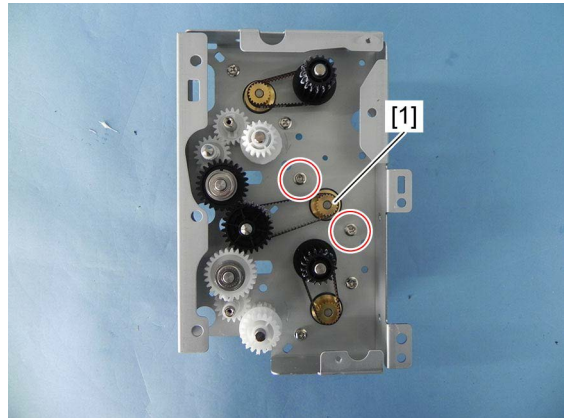



Fig. 4-235

4.5.37 3rd/4th drawer/T-LCF paper feed motor (M43)

- (1) Release the bracket.
 P. 4-95 "4.5.38 Paper feed drive unit"
- (2) Remove 4 screws [1], disconnect 1 connector and take off the 3rd/4th drawer/T-LCF paper feed motor [2].

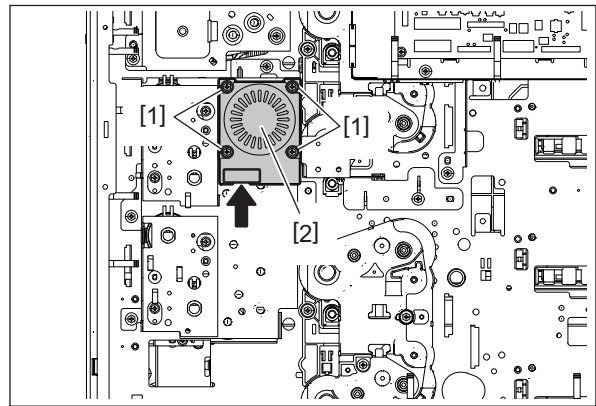

Fig. 4-236

4.5.38 Paper feed drive unit

- (1) Take off the switching regulator case.
📖 P. 9-17 "9.1.14 Switching regulator (PS)"
- (2) Take off the FIL-AC board.
📖 P. 9-20 "9.1.16 FIL-AC board"
- (3) Take off the FIL-IH board.
📖 P. 9-21 "9.1.17 FIL-IH board (9029A models of JPC only)"
- (4) Release the harnesses from 3 harness clamps.

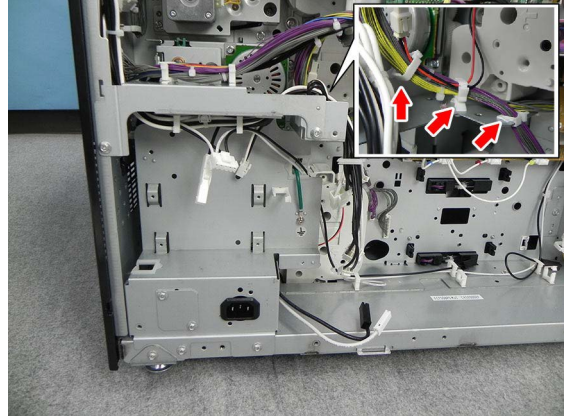

Fig. 4-237

- (5) Release the harnesses from 6 harness clamps. Remove 4 screws [2] and release the bracket [1].

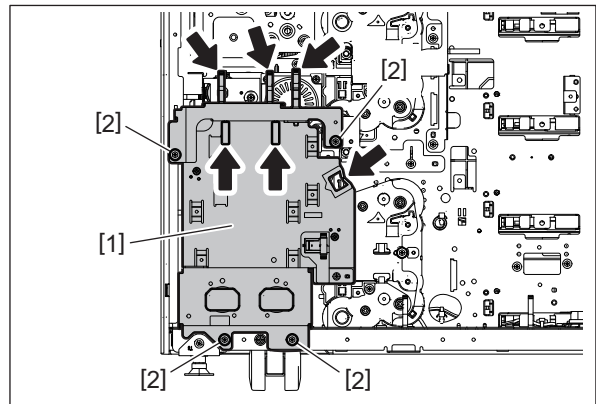

Fig. 4-238

- (6) Remove 4 screws and take off the paper feed drive unit [3].

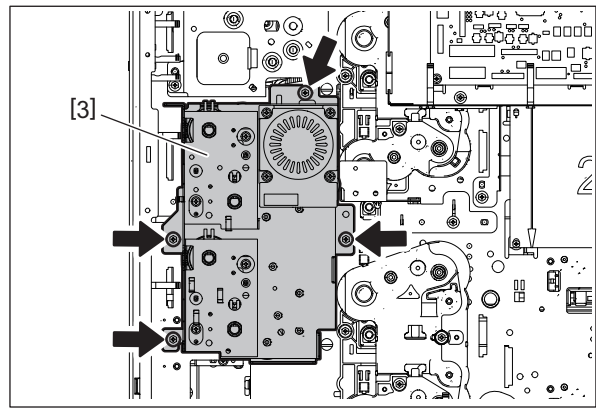

Fig. 4-239

Notes:

The number of clutches in the paper feed drive unit of the Tandem LCF model differs from that of the 4-drawer model.

4.5.39 3rd drawer transport clutch (CLT4), 3rd drawer paper feed clutch (CLT5)

- (1) Take off the paper feed drive unit.
P. 4-95 "4.5.38 Paper feed drive unit"
- (2) Disconnect 1 connector [1] and release the harness from 4 harness clamps. Remove the harness clamp [2].
- (3) Remove 2 screws and take off the bracket [3].

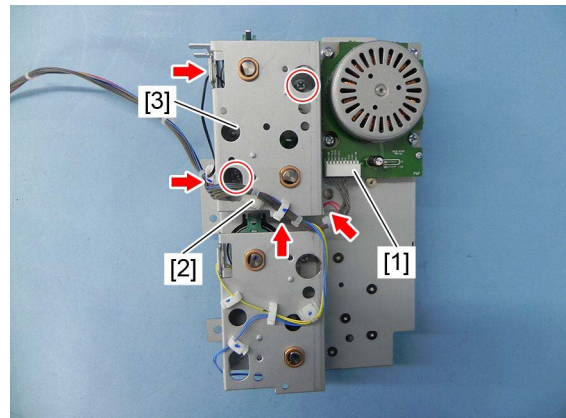

Fig. 4-240

- (4) Disconnect 1 connector.
Remove 1 bushing [4] and 2 clips [5]. Remove the 3rd drawer transport clutch [6] from the shaft.

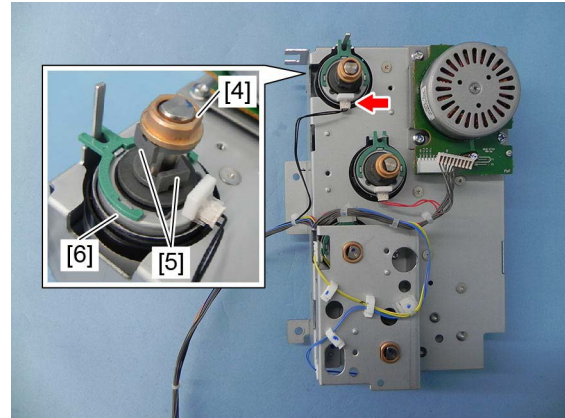

Fig. 4-241

- (5) Disconnect 1 connector.
Remove 1 bushing [7] and 2 clips [8]. Remove the 3rd drawer paper feed clutch [9] from the shaft.

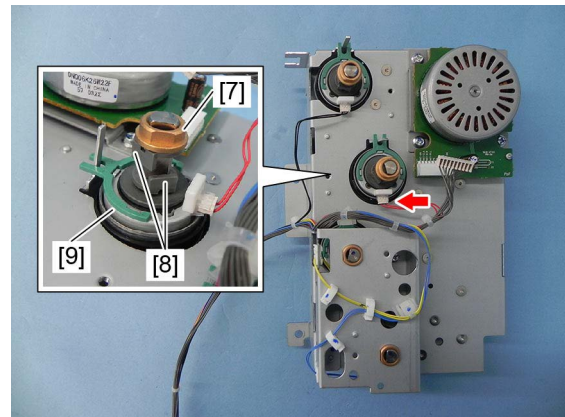

Fig. 4-242

Notes:

- When reassembling, be sure to align the protrusion of the clutch to the position shown in the figure.
- The color of the harnesses for the drawer transport clutch and for the drawer paper feed clutch is different. When installing, be sure to attach the corresponding harness.
- Black: 3rd drawer transport clutch harness [10]
- Red: 3rd drawer paper feed clutch harness [11]

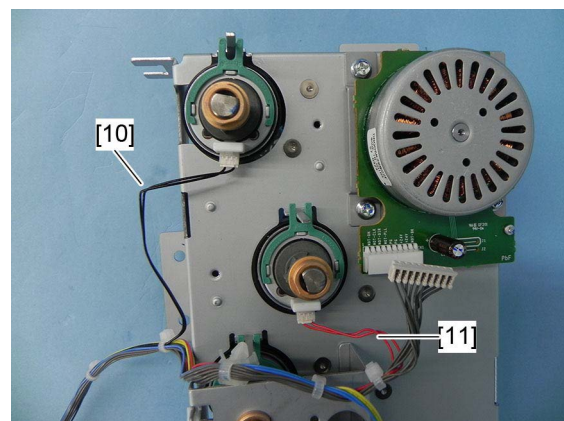

Fig. 4-243

4.5.40 4th drawer transport clutch (CLT6), 4th drawer paper feed clutch (CLT7)

- (1) Take off the paper feed drive unit.
P. 4-95 “4.5.38 Paper feed drive unit”
- (2) Release the harness from 5 harness clamps. Remove the harness clamp [1].
- (3) Remove 2 screws and take off the bracket [2].

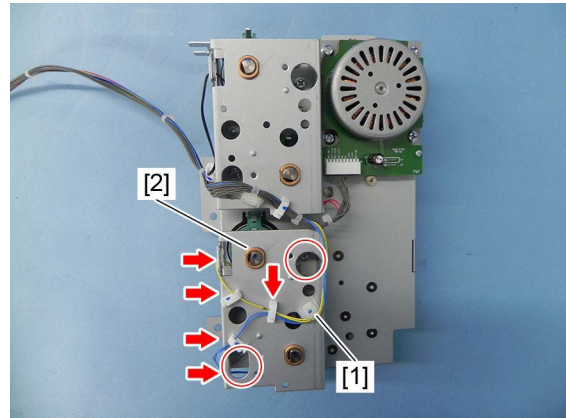

Fig. 4-244

- (4) Disconnect 1 connector.
Remove 1 bushing [3] and 2 clips [4]. Remove the 4th drawer transport clutch [5] from the shaft.

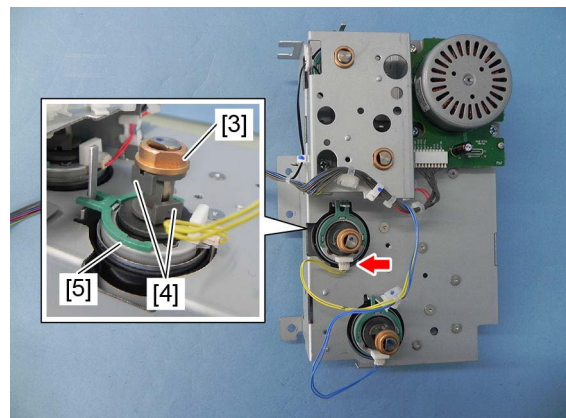

Fig. 4-245

- (5) Disconnect 1 connector.
Remove 1 bushing [6] and 2 clips [7]. Remove the 4th drawer paper feed clutch [8] from the shaft.

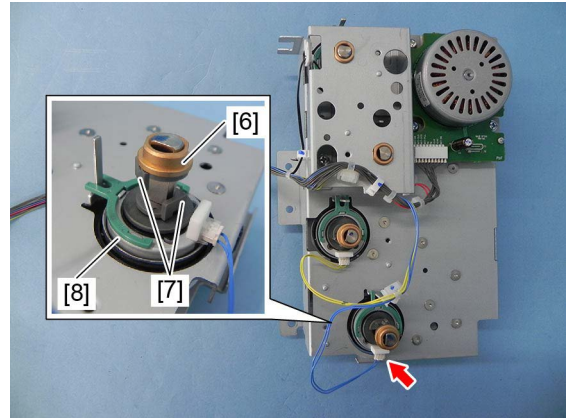

Fig. 4-246

Notes:

- When reassembling, be sure to align the protrusion of the clutch to the position shown in the figure.
- The color of the harnesses for the drawer transport clutch and for the drawer paper feed clutch is different. When installing, be sure to attach the corresponding harness.
- Yellow: 4th drawer transport clutch harness [9]
- Blue: 4th drawer paper feed clutch harness [10]

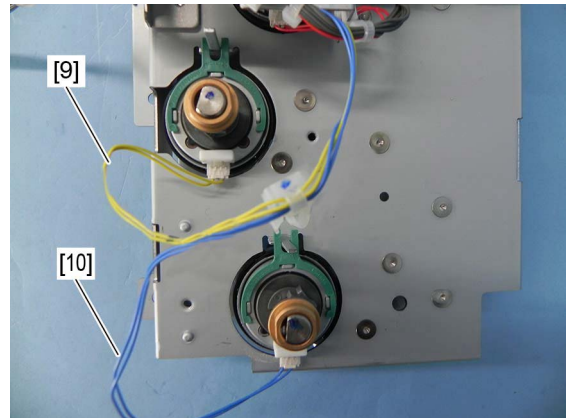

Fig. 4-247

4.5.41 1st drawer tray-up motor (M44), 2nd drawer tray-up motor (M49)

- (1) Pull out the 1st and 2nd drawers.
- (2) Take off the LGC/PFC board case.
📖 P. 9-13 "9.1.12 LGC/PFC board case"
- (3) Take off the switching regulator case.
📖 P. 9-17 "9.1.14 Switching regulator (PS)"
- (4) Disconnect 2 connectors [1].
- (5) Remove 3 screws [9] and take off the tray drive unit [2].

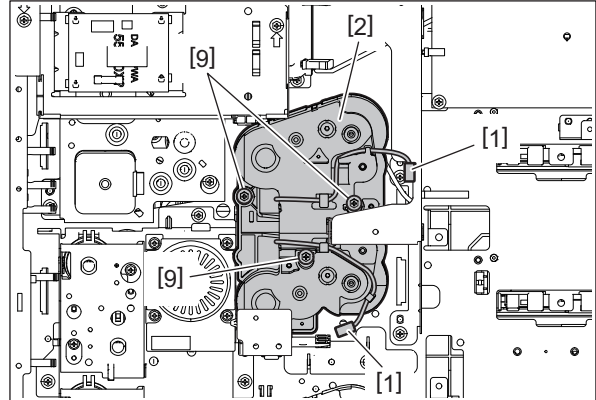

Fig. 4-248

- (6) Release 6 latches and take off the cover [3].

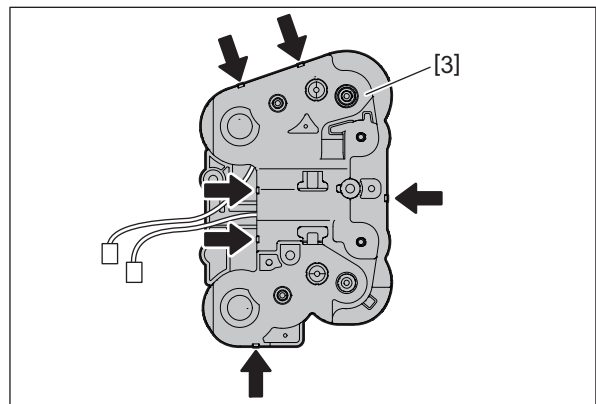

Fig. 4-249

Notes:

Be careful in taking off the cover because there is a spring in the tray drive unit.

(7) Take off the 1st drawer tray-up motor [4] and 2nd drawer tray-up motor [5].

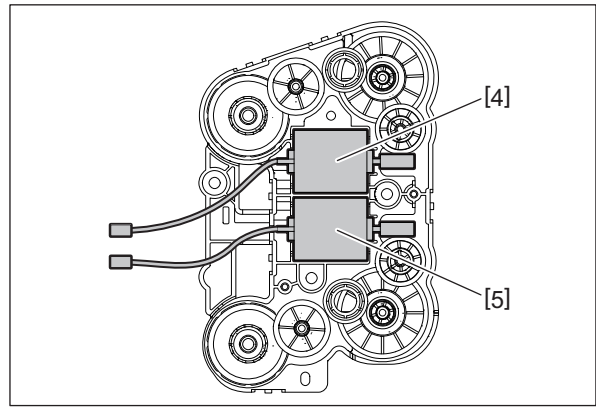

Fig. 4-250

Notes:

When reassembling, align the hole of the gear [6] with the boss [7] of the cover [8].

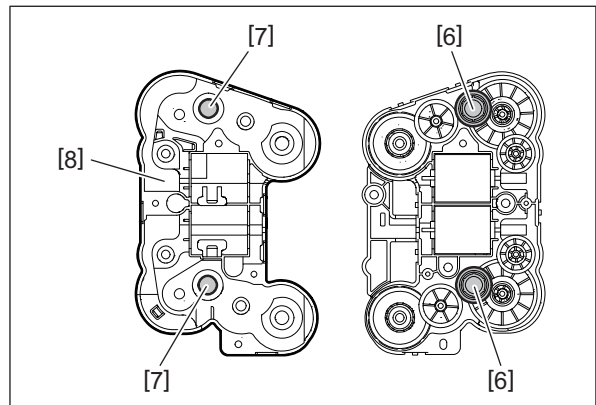





Fig. 4-251

4.5.42 3rd drawer tray-up motor (M45), 4th drawer tray-up motor (M50)

- (1) Pull out the 3rd and 4th drawers.
- (2) Take off the switching regulator case.
 P. 9-17 "9.1.14 Switching regulator (PS)"
- (3) Take off the FIL-AC board.
 P. 9-20 "9.1.16 FIL-AC board"
- (4) Take off the FIL-IH board.
 P. 9-21 "9.1.17 FIL-IH board (9029A models of JPC only)"
- (5) Release the harnesses from 6 harness clamps. Remove 4 screws [2] and release the bracket [1].

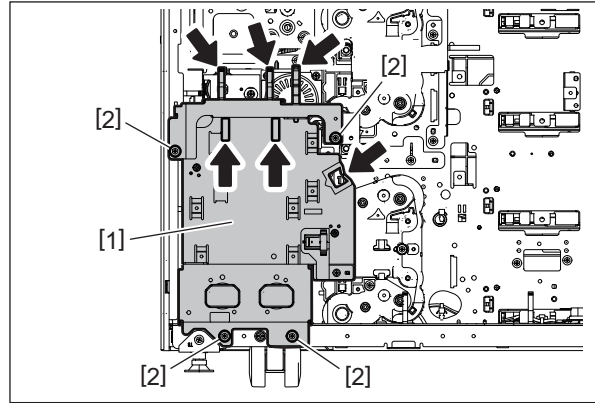

Fig. 4-252

- (6) Disconnect 2 connectors [11]. Remove 3 screws [9] and take off the tray drive unit [10].

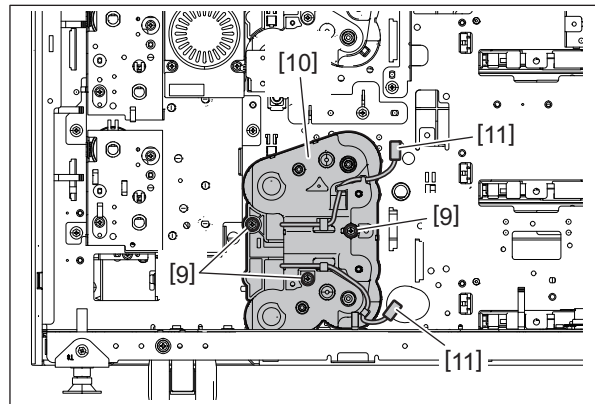

Fig. 4-253

- (7) Release 6 latches and take off the cover [3].

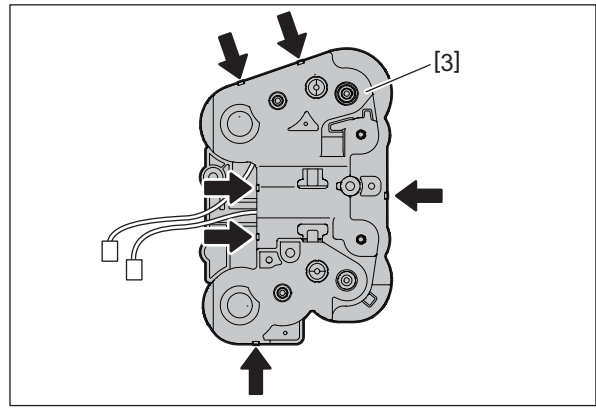

Fig. 4-254

Notes:

Be careful in taking off the cover because there is a spring in the tray drive unit.

- (8) Take off the 3rd drawer tray-up motor [4] and 4th drawer tray-up motor [5].

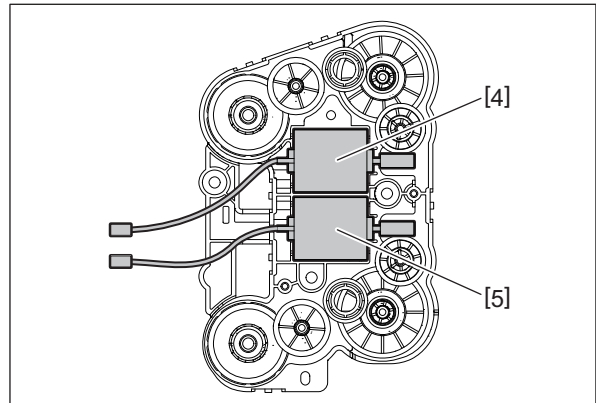

Fig. 4-255

Notes:

When reassembling, align the hole of the gear [6] with the boss [7] of the cover [8].

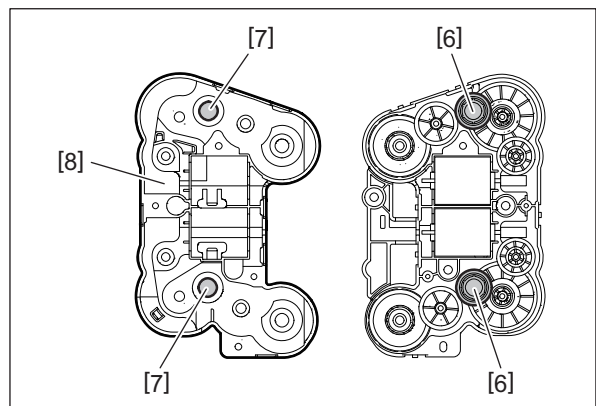



Fig. 4-256

4.5.43 Transfer belt paper clinging detection sensor (S47)

- (1) Pull out the transfer belt unit.
 P. 4-195 "4.7.1 Pulling out of the transfer belt unit"
- (2) Remove 2 screws and lift up the middle guide [1].

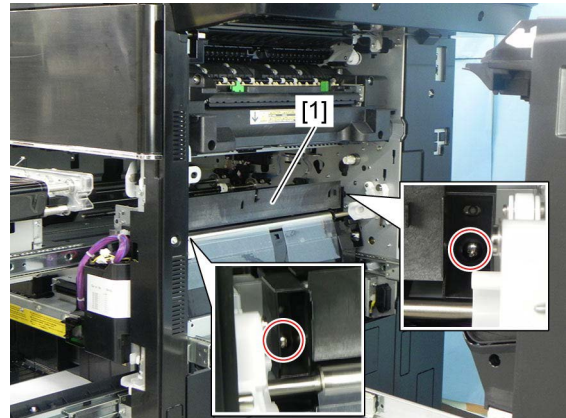

Fig. 4-257

- (3) Disconnect 1 connector and take off the middle guide [1].

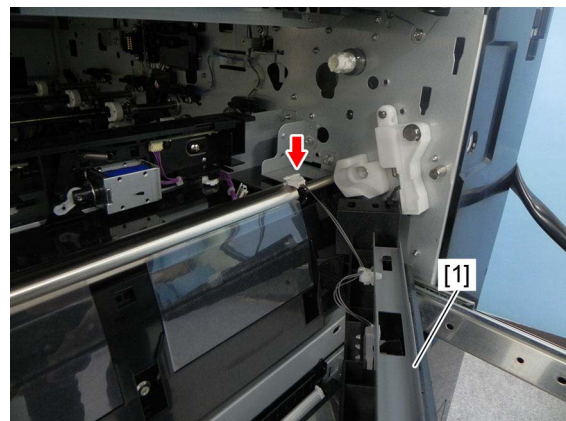

Fig. 4-258

- (4) Remove 1 screw and 1 harness clamp. Slide the metal plate [2] and take it off.

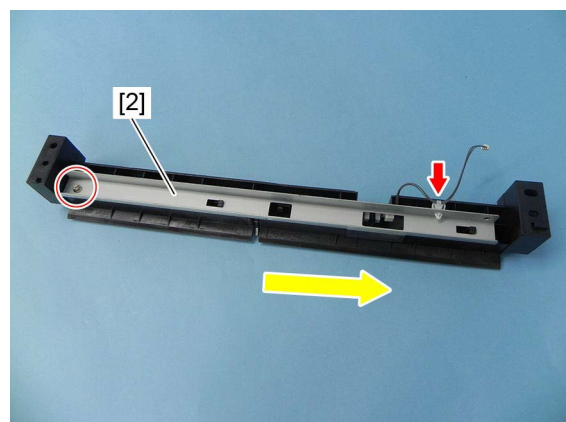

Fig. 4-259

- (5) Disconnect 1 connector and take off the transfer belt paper clinging detection sensor [3].

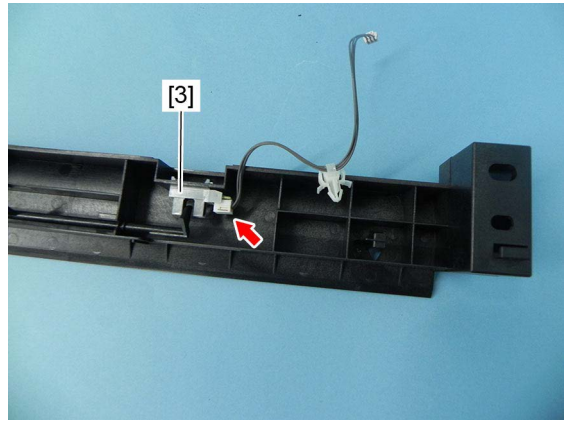

Fig. 4-260

4.5.44 T-LCF tray-up motor (M46) (NAD, ARD, GSA, AUD, MJD, ASD, CND)

- (1) Pull out the tandem LCF.
- (2) Take off the switching regulator case.
📖 P. 9-17 "9.1.14 Switching regulator (PS)"
- (3) Release the bracket.
📖 P. 4-95 "4.5.38 Paper feed drive unit"
- (4) Disconnect 1 connector, remove 3 screws and take off the T-LCF tray-up motor unit [1].

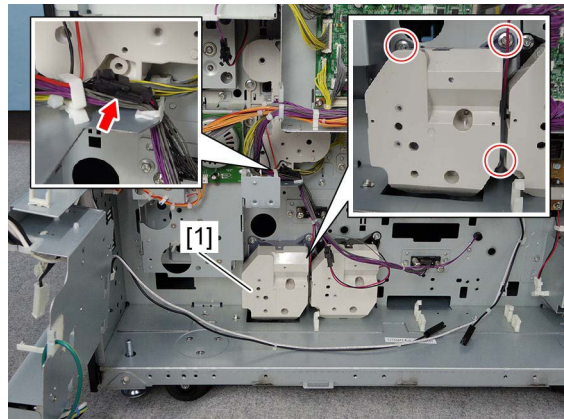

Fig. 4-261

Notes:

Do not mix the T-LCF tray-up motor unit [1] and the T-LCF end fence motor unit when installing them.

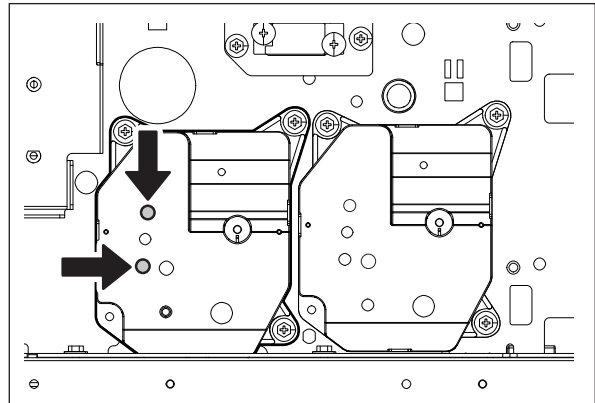

Fig. 4-262

- (5) Release 2 latches and remove the coupling [2] and spring [3].

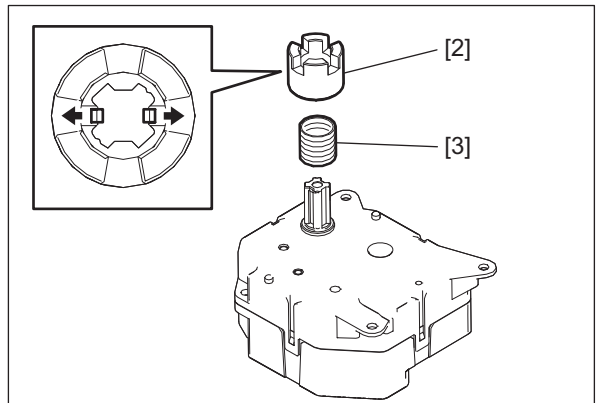

Fig. 4-263

- (6) Release 4 latches and take off the T-LCF tray-up motor [4].

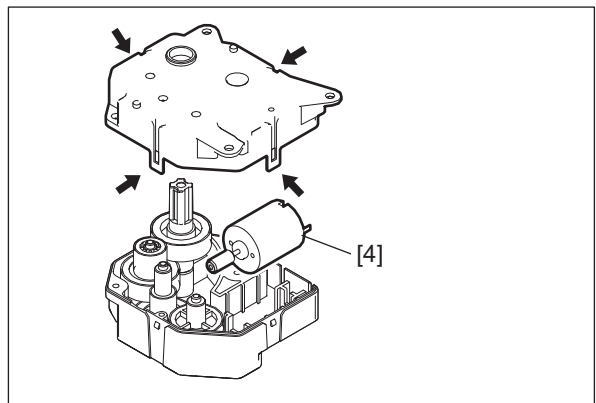



Fig. 4-264

4.5.45 T-LCF end fence motor (M47)

- (1) Pull out the tandem LCF.
- (2) Take off the switching regulator case.
 P. 9-17 "9.1.14 Switching regulator (PS)"
- (3) Disconnect 1 connector, remove 3 screws and take off the T-LCF end fence motor unit [1].

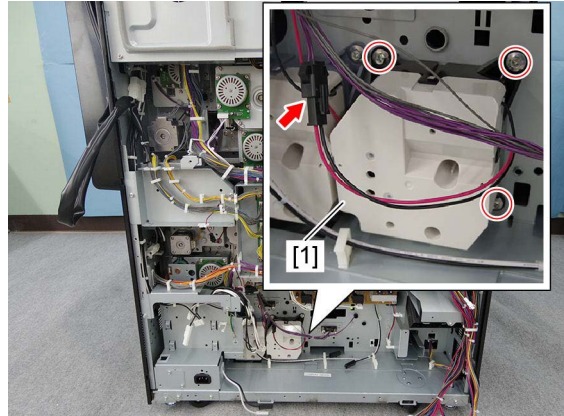

Fig. 4-265

Notes:

Do not mix the T-LCF tray-up motor unit and the T-LCF end fence motor unit [1] when installing them.

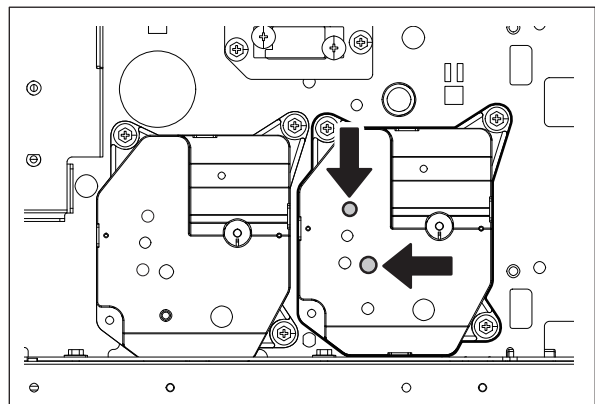

Fig. 4-266

- (4) Release 2 latches and remove the coupling [2] and spring [3].

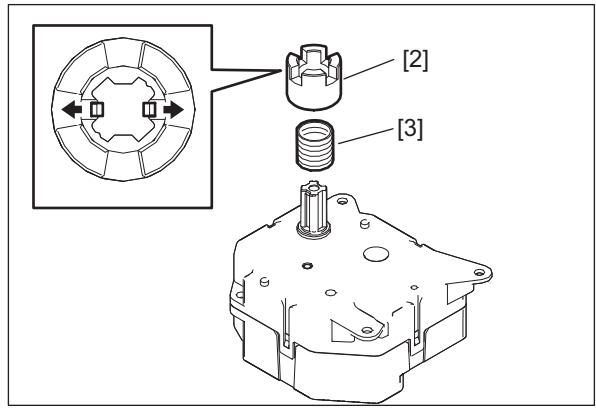

Fig. 4-267

- (5) Release 4 latches and take off the T-LCF end fence motor [4].

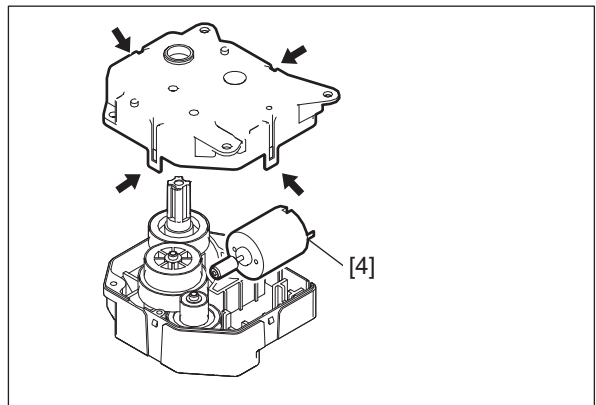

Fig. 4-268

4.5.46 Tandem LCF standby unit

- (1) Pull out the tandem LCF.
(2) Remove 2 screws and take off the stopper plate [1].

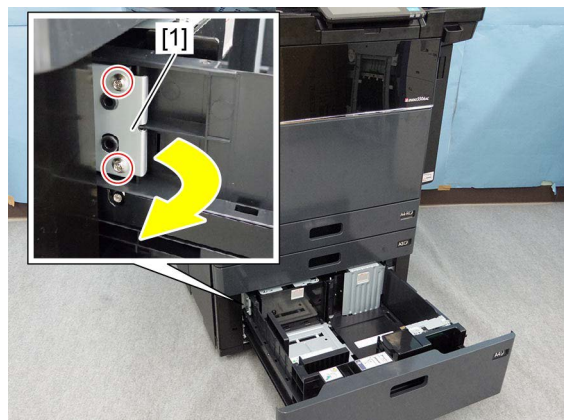

Fig. 4-269

- (3) Insert the tandem LCF paper feed unit [2].



Fig. 4-270

- (4) Remove 3 screws and take off the Tandem LCF standby unit [3].

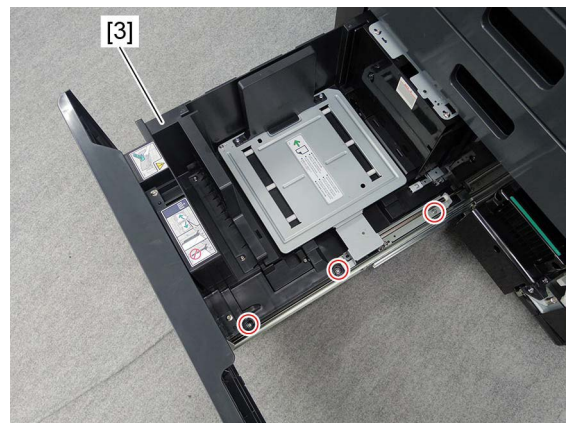

Fig. 4-271

4.5.47 Tandem LCF paper feed unit

- (1) Take off the Tandem LCF standby unit.
P. 4-108 "4.5.46 Tandem LCF standby unit"
- (2) Remove 3 screws and take off the Tandem LCF paper feed unit [1].



Fig. 4-272

4.5.48 T-LCF stopper opening/closing solenoid (front) (SOL10), T-LCF stopper opening/closing detection sensor (front) (S110)

- (1) Take off the Tandem LCF paper feed unit.
P. 4-109 "4.5.47 Tandem LCF paper feed unit"
- (2) Remove 4 screws and take off the paper feed unit front cover [1].

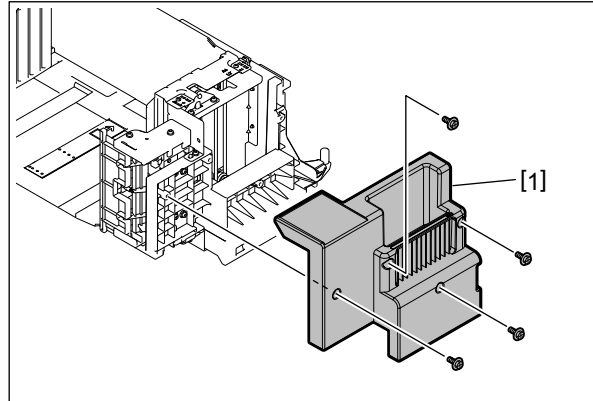

Fig. 4-273

- (3) Remove 2 screws. Release 2 hooks and take off the stopper unit [2].

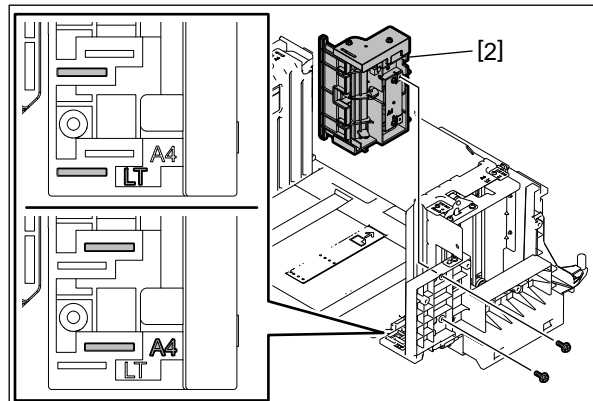

Fig. 4-274

Notes:

The position of the hook differs depending on the destination.

- (4) Remove 2 screws and take off the plate [3].

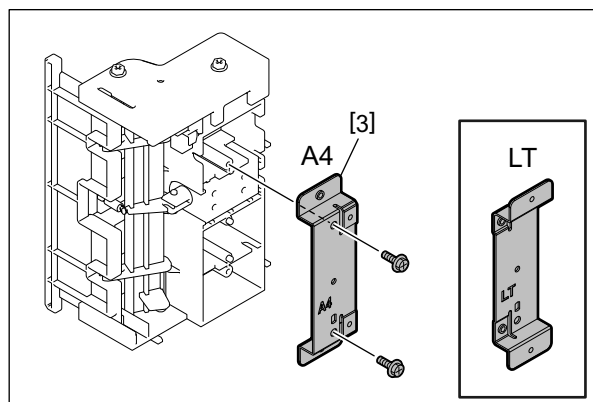

Fig. 4-275

Notes:

The direction of the plate differs depending on the destination (A4/LT).

- (5) Disconnect 1 connector and take off the T-LCF stopper opening/closing solenoid (front) [4].
- (6) Disconnect 1 connector. Release 3 latches and take off the T-LCF stopper opening/closing detection sensor (front) [5].

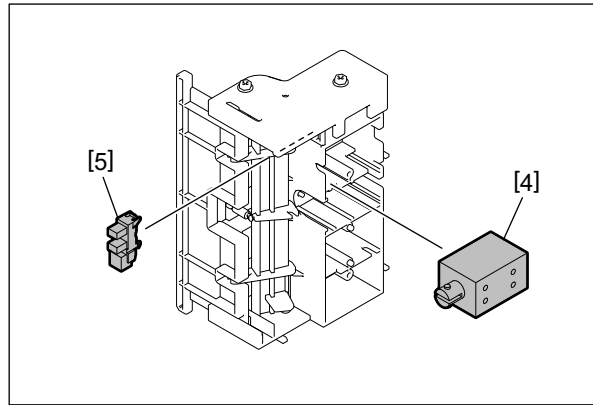

Fig. 4-276

4.5.49 T-LCF stopper opening/closing solenoid (rear) (SOL11), T-LCF stopper opening/closing detection sensor (rear) (S111)

- (1) Take off the Tandem LCF paper feed unit.
 P. 4-109 "4.5.47 Tandem LCF paper feed unit"
- (2) Remove 2 screws. Release 2 hooks and take off the stopper unit [1].

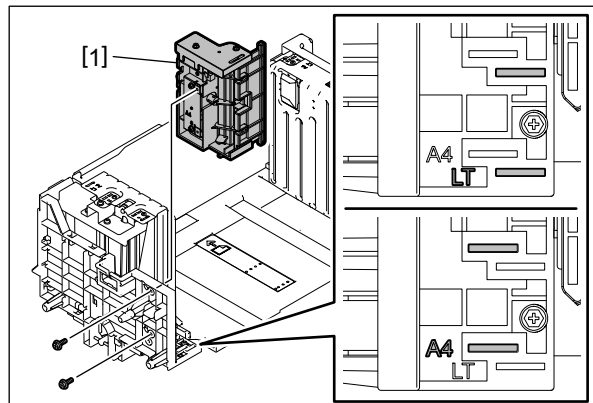

Fig. 4-277

Notes:

The position of the hook differs depending on the destination.

- (3) Remove 2 screws and take off the plate [2].

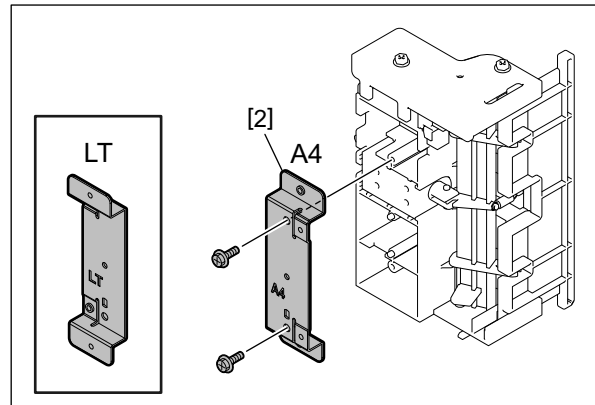

Fig. 4-278

Notes:

The direction of the plate differs depending on the destination (A4/LT).

- (4) Disconnect 1 connector and take off the T-LCF stopper opening/closing solenoid (rear) [3].
- (5) Disconnect 1 connector. Release 3 latches and take off the T-LCF stopper opening/closing detection sensor (rear) [4].

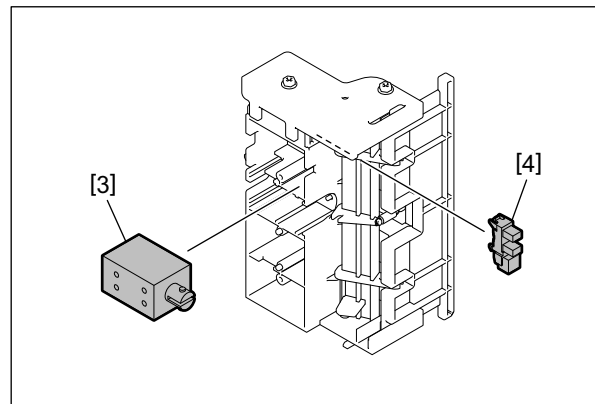

Fig. 4-279

4.5.50 T-LCF bottom sensor (S107)

- (1) Take off the Tandem LCF paper feed unit.
P. 4-109 "4.5.47 Tandem LCF paper feed unit"
- (2) Remove 6 screws and take off the paper feed side tray [1].

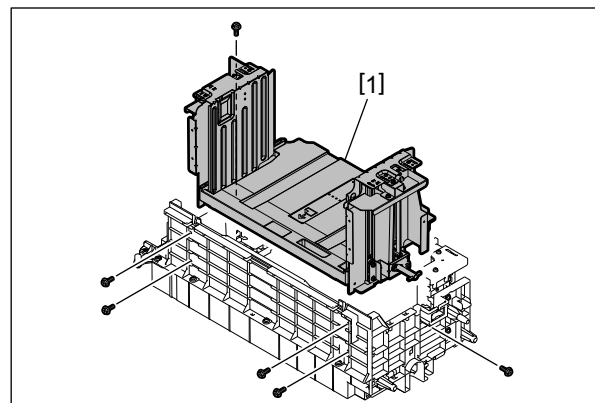

Fig. 4-280

- (3) Disconnect 1 connector. Release 3 latches and take off the T-LCF bottom sensor [2].

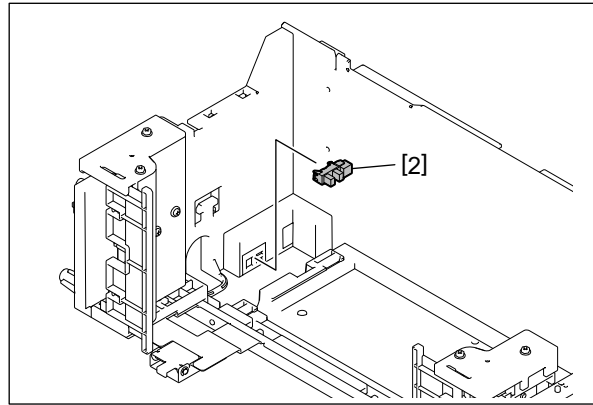

Fig. 4-281

4.5.51 T-LCF standby side tray paper amount detection sensor (S106)

- (1) Take off the Tandem LCF standby unit.
P. 4-108 "4.5.46 Tandem LCF standby unit"
- (2) Remove 4 screws and take off the plate [1]. (The type of the screws differs.)

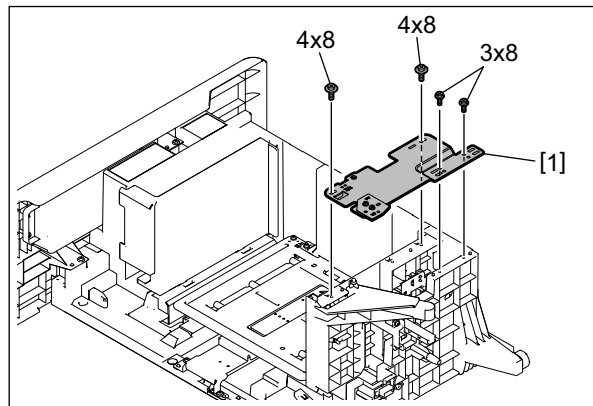

Fig. 4-282

- (3) Remove 3 screws and take off the link arm [2].

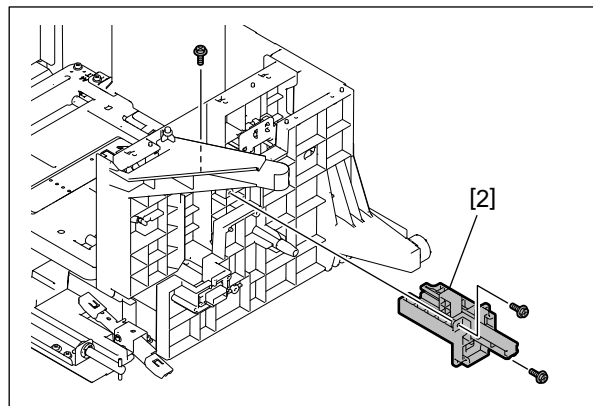

Fig. 4-283

- (4) Remove 1 screw and take off the rear fence [3].

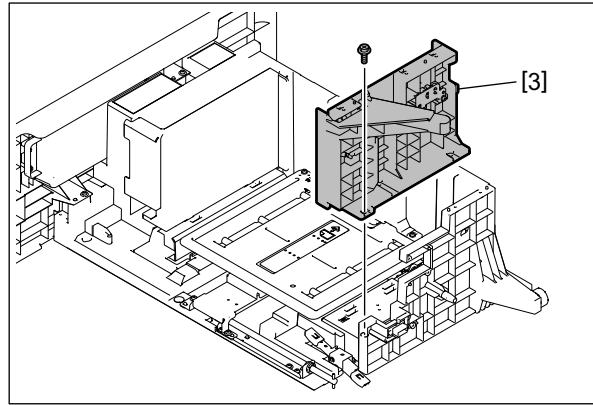

Fig. 4-284

- (5) Remove 2 screws and take off the bracket [4].

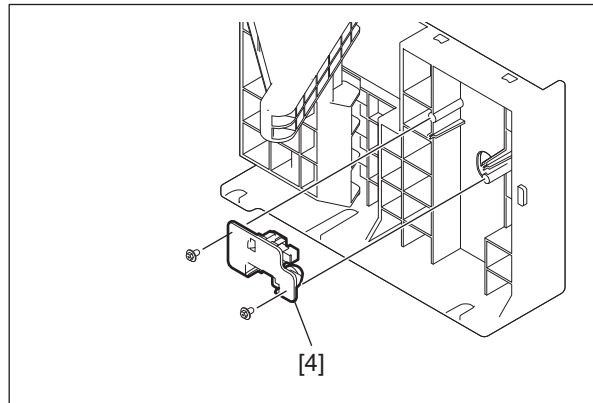

Fig. 4-285

- (6) Disconnect 1 connector. Release 3 latches and take off the T-LCF standby side tray paper amount detection sensor [5].

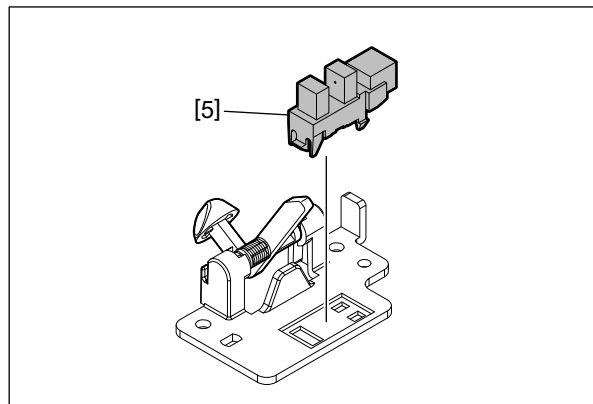

Fig. 4-286

4.5.52 T-LCF end fence home position sensor (S112)

- (1) Pull out the standby unit and slide the standby tray [1] to the paper feed side.

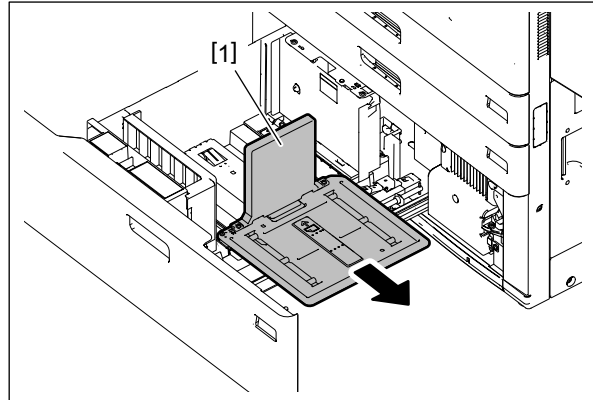

Fig. 4-287

- (2) Remove 1 screw and take off the sensor cover [2].

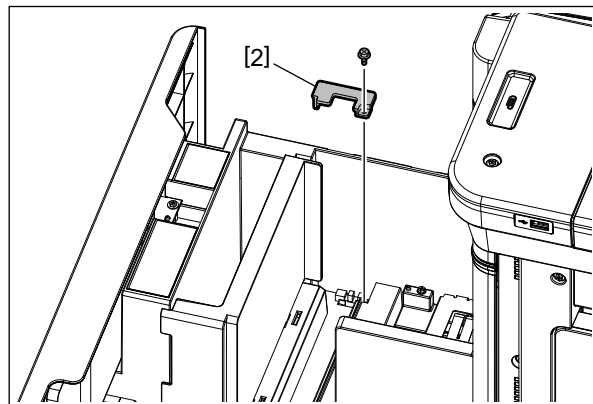

Fig. 4-288

- (3) Disconnect 1 connector. Release 3 latches and take off the T-LCF end fence home position sensor [3].

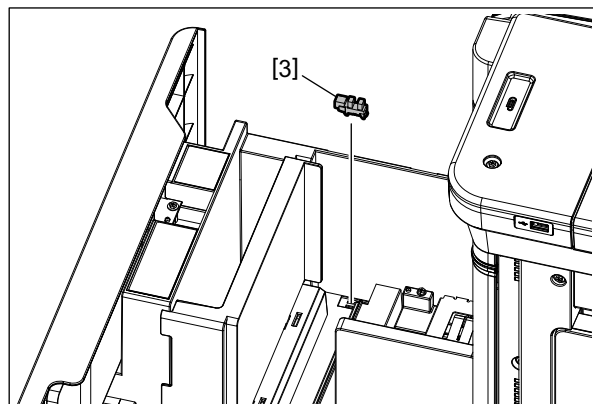

Fig. 4-289

4.5.53 T-LCF end fence stop position sensor (S113)

- (1) Pull out the standby unit.
- (2) Remove 2 screws and take off the front fence [1].

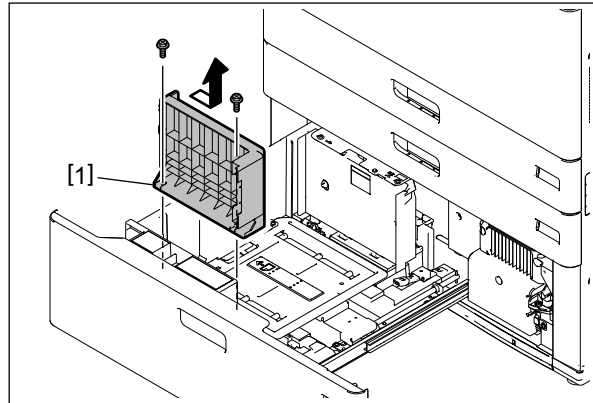

Fig. 4-290

- (3) Remove 1 screw and take off the sensor cover [2].

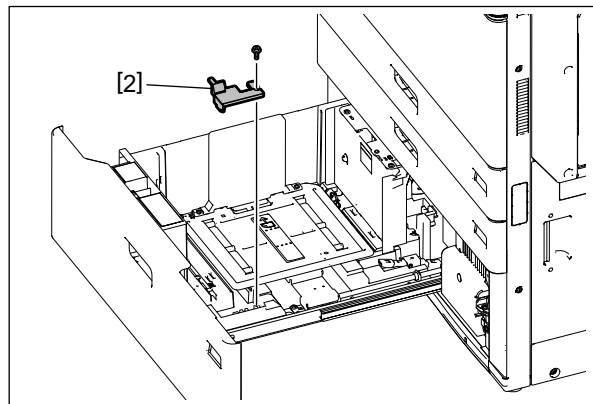

Fig. 4-291

- (4) Disconnect 1 connector. Release 3 latches and take off the T-LCF end fence stop position sensor [3].

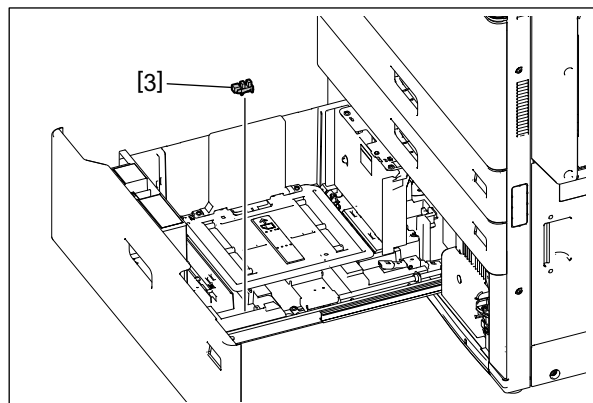

Fig. 4-292

4.5.54 T-LCF standby side paper empty sensor (S109)

- (1) Take off the Tandem LCF standby unit.
P. 4-108 "4.5.46 Tandem LCF standby unit"
- (2) Take off the rear fence.
P. 4-113 "4.5.51 T-LCF standby side tray paper amount detection sensor (S106)"
- (3) Move the standby tray [1] to the paper feed side.
- (4) Remove 1 screw and take off the sensor cover [2].

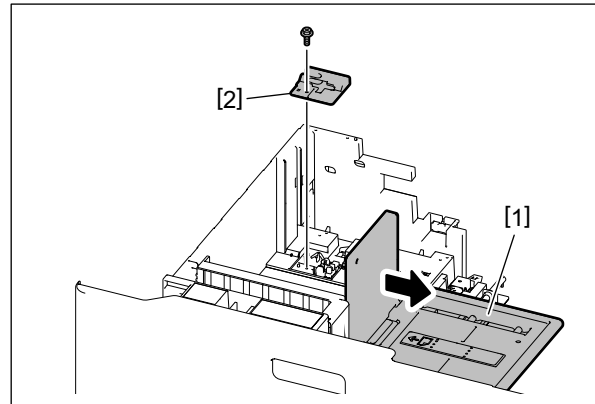

Fig. 4-293

- (5) Remove 2 screws and take off the sensor bracket [3].
- (6) Disconnect 1 connector. Release 3 latches and take off the T-LCF standby side paper empty sensor [4].

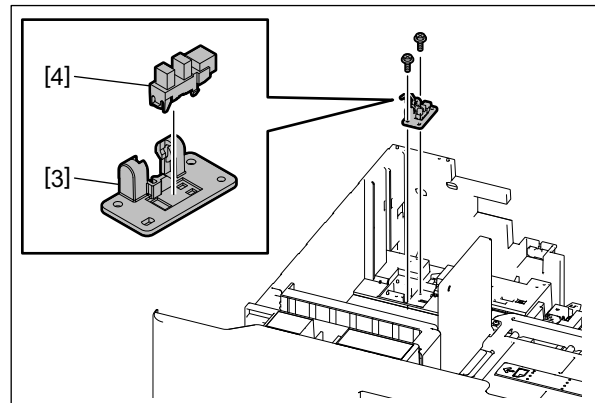

Fig. 4-294

4.5.55 T-LCF standby side tray detection sensor (S108)

- (1) Take off the Tandem LCF standby unit.
P. 4-108 "4.5.46 Tandem LCF standby unit"
- (2) Remove 1 screw and take off the sensor bracket [1].

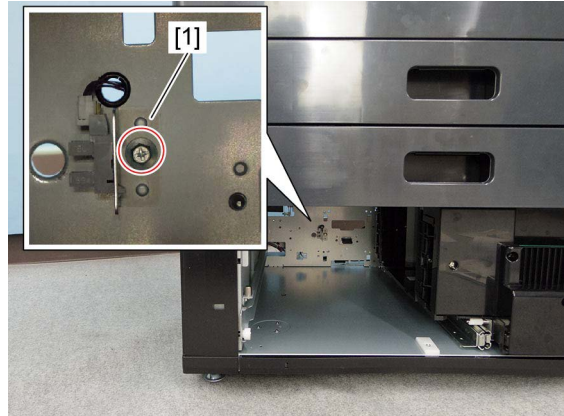

Fig. 4-295

- (3) Disconnect 1 connector and take off the T-LCF standby side tray detection sensor [2].

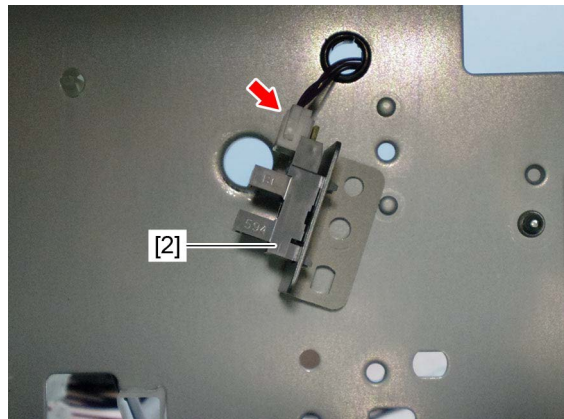

Fig. 4-296

4.5.56 T-LCF pickup solenoid (SOL9)

- (1) Take off the paper feed cover.
 P. 4-11 "4.1.20 Paper feed cover"
- (2) Pull out the tandem LCF.
- (3) Remove 2 screws. Disconnect 1 connector and take off the paper feed unit [1].



Fig. 4-297

- (4) Remove 2 screws. Disconnect 1 connector and take off the T-LCF pickup solenoid [2].

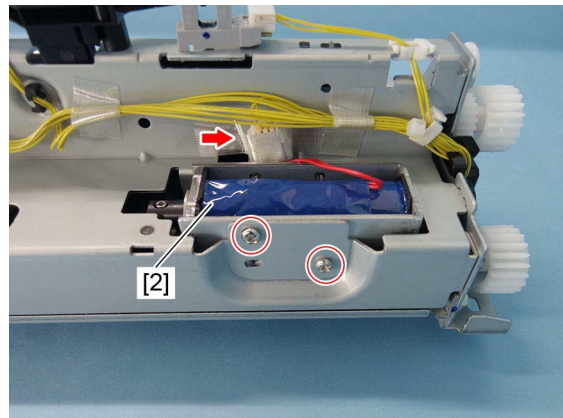



Fig. 4-298

4.5.57 1st drawer idling roller

- (1) Take off the bypass unit.
 P. 4-59 "4.5.2 Bypass unit"
- (2) Remove 1 spring [1] and take off the 1st drawer idling roller unit assembly [2].

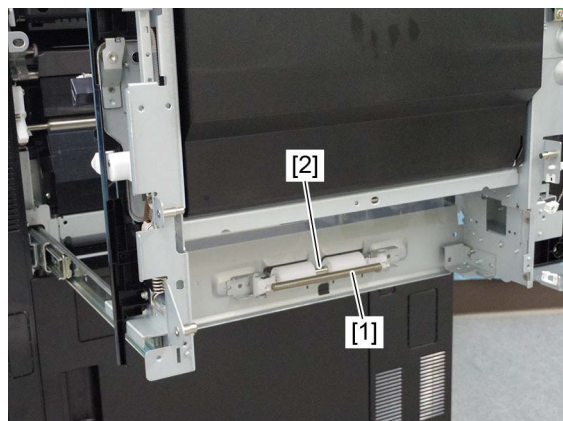

Fig. 4-299

(3) Remove 2 E-rings and 2 bushings [3].

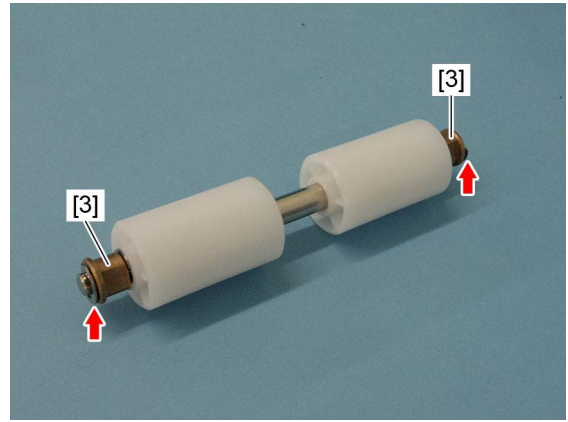

Fig. 4-300

(4) Remove 2 E-rings and take off the 1st drawer idling roller [4].

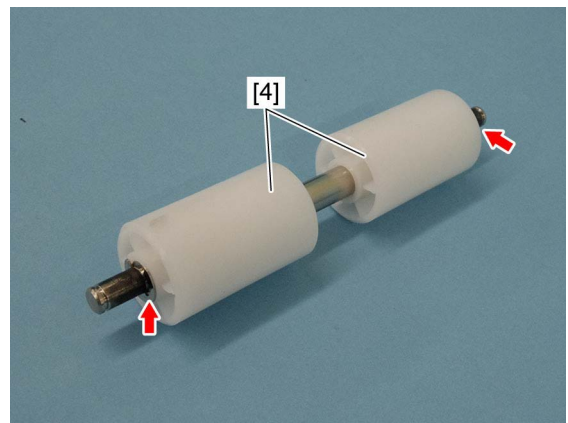

Fig. 4-301

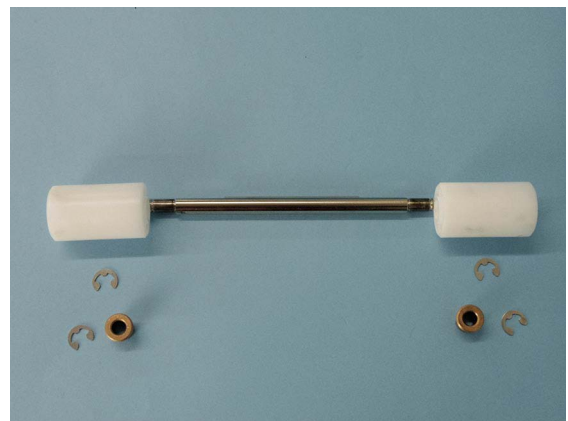

Fig. 4-302

4.5.58 Soft-close unit (4-drawer model)

- (1) Take off all the drawers.
P. 4-89 "4.5.30 Drawer"
- (2) Remove 1 screw [1] and take off the soft-close unit [2].

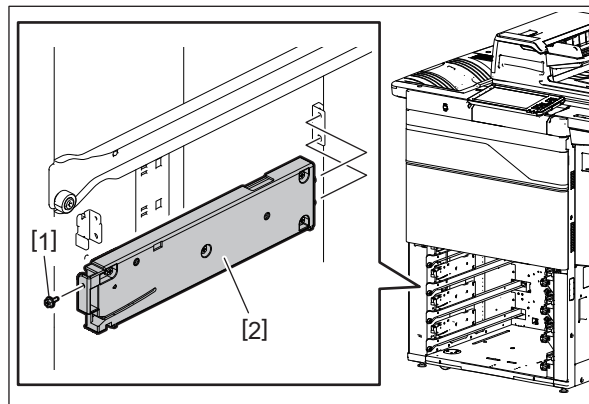

Fig. 4-303

Notes:

Do not disassemble the soft-close units since a spring with a strong force is used and this will be dangerous.

Operation when replacing the soft-close unit for the first time

- (1) Pull out the drawer with the soft-close unit replaced.
- (2) Turn the lever to release the lock.

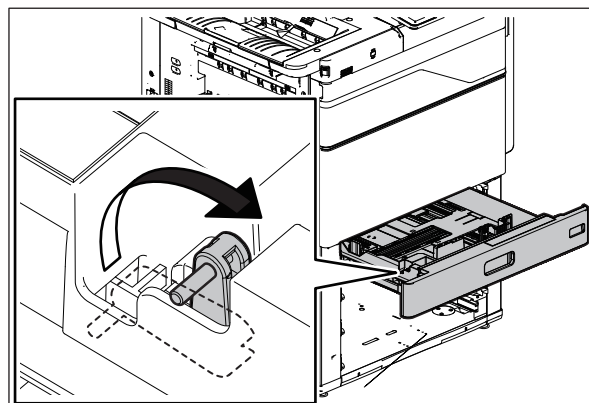

Fig. 4-304

- (3) Lift up the lever to take it off and then insert it into the pocket.

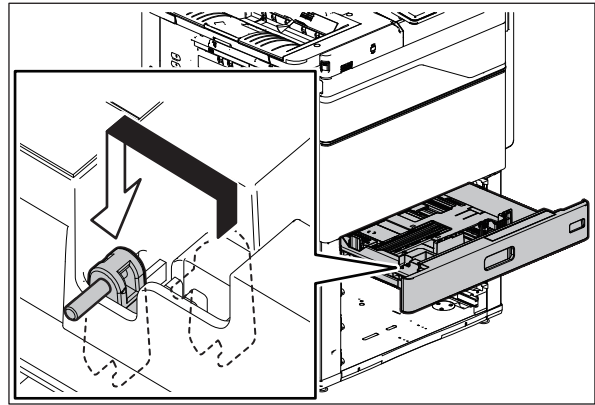

Fig. 4-305

- (4) Insert the drawer all the way in.
- (5) Check if the drawer is automatically inserted by removing and then reinstalling it.
- (6) Take out the lever from the pocket and attach it to the original position.

Notes:

When the lever is attached to its original position, be sure to return it to be locked. (Status before unlocking in step (2))

If the lever is not returned to be locked, the drawer will not be pulled in correctly.

4.5.59 Soft-close unit (Tandem LCF model)

- (1) Take off the 1st and 2nd drawers.
P. 4-89 "4.5.30 Drawer"
- (2) Remove 1 screw [1] and take off the soft-close unit [2].

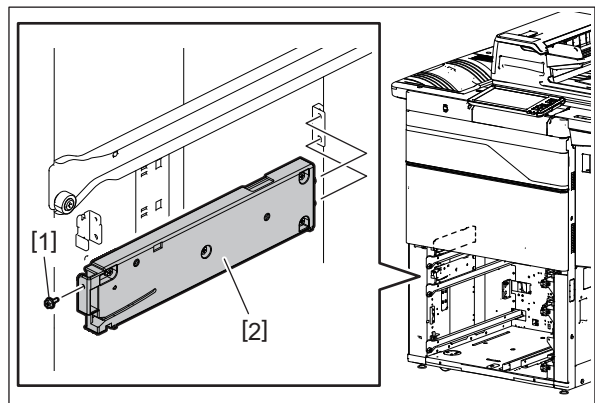

Fig. 4-306

Notes:

Do not disassemble the soft-close units since a spring with a strong force is used and this will be dangerous.

Operation when replacing the soft-close unit for the first time

- (1) Pull out the drawer with the soft-close unit replaced.
- (2) Turn the lever to release the lock.

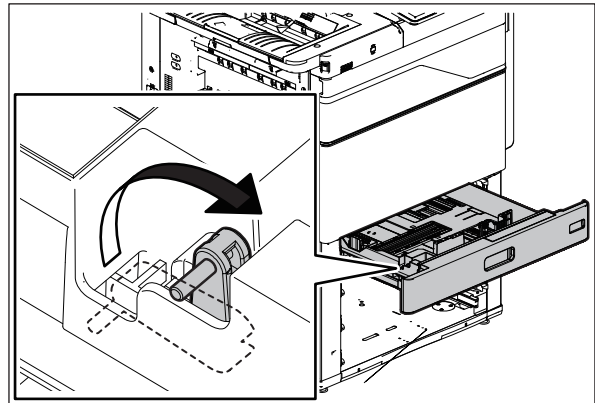

Fig. 4-307

- (3) Lift up the lever to take it off and then insert it into the pocket.

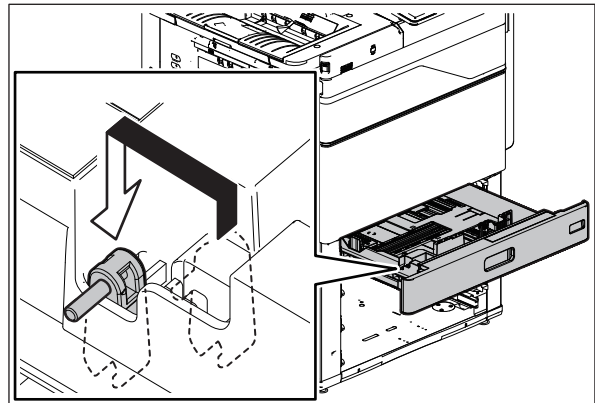

Fig. 4-308

- (4) Insert the drawer all the way in.
- (5) Check if the drawer is automatically inserted by removing and then reinstalling it.
- (6) Take out the lever from the pocket and attach it to the original position.

Notes:

When the lever is attached to its original position, be sure to return it to be locked. (Status before unlocking in step (2))

If the lever is not returned to be locked, the drawer will not be pulled in correctly.

4.6 Process Unit Related Section

4.6.1 Pulling out of the process unit (EPU tray)

- (1) Take off the front lower cover.
 P. 4-1 “4.1.1 Front lower cover”
- (2) Loosen the fixing screw of the TBU lifting lever right [1] to release it.



Fig. 4-309

- (3) Pull out the TBU lifting lever left [2] toward you until it reaches to the mark [3].

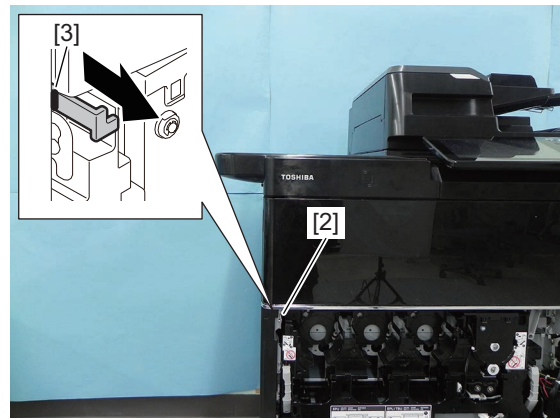

Fig. 4-310

- (4) Turn the TBU lifting lever right [1] to the left for 90 degrees.
- (5) Turn the TBU locking lever [4] to the right for 45 degrees.

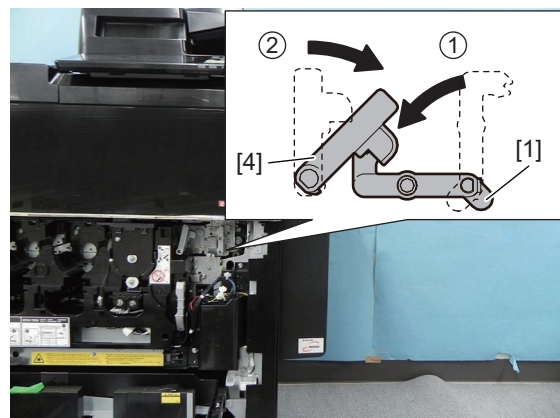

Fig. 4-311

(6) Lift up the EPU locking lever [5].

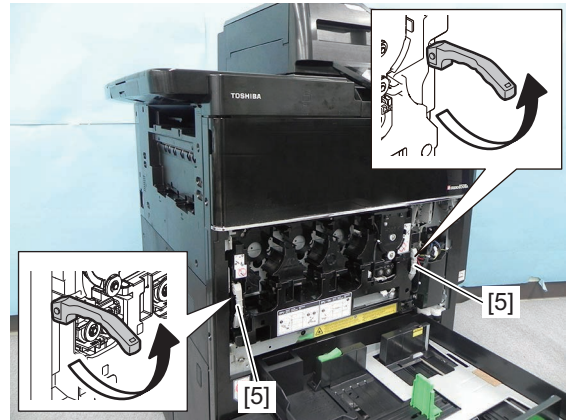

Fig. 4-312

(7) Turn the EPU locking lever [5] for 90 degrees.

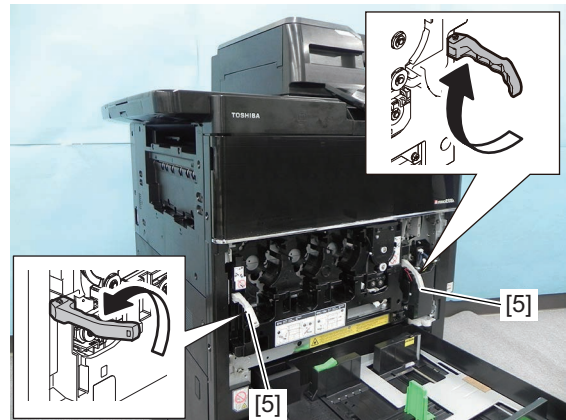

Fig. 4-313

(8) Pull out the process unit [6] by holding the EPU locking levers [5].

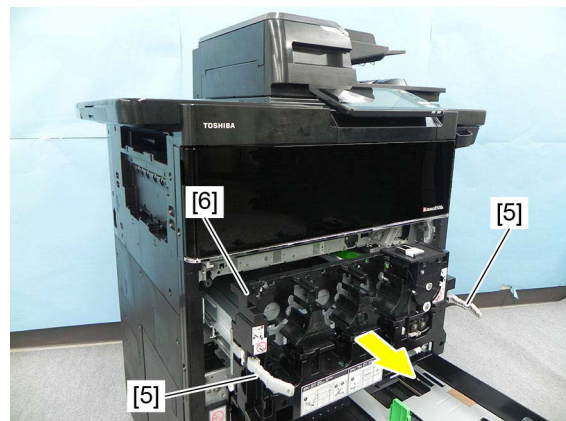

Fig. 4-314

Notes:

- When the process unit is pulled out, be sure to close the shutter [7] of the sub-hopper to prevent dust from entering into the unit.



Fig. 4-315

- When the process unit is pulled out, clean toner or dirt on the entrance of the waste toner transport path on the MFP side or on the toner supply opening of the sub-hopper and stay, if there is any.

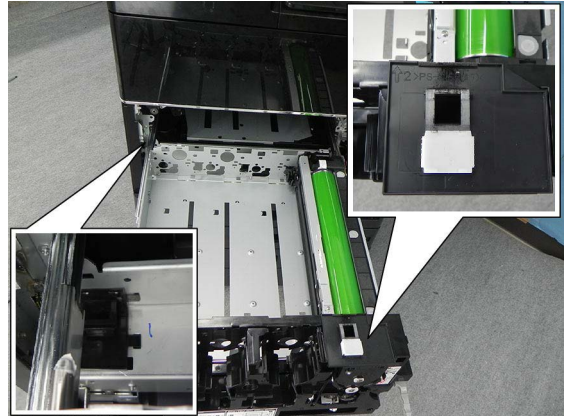

Fig. 4-316

- Before you push the process unit back, make sure that each lever is set as shown in the figure.
[1] TBU lifting lever right
[2] TBU lifting lever left
[3] Mark
[4] TBU locking lever

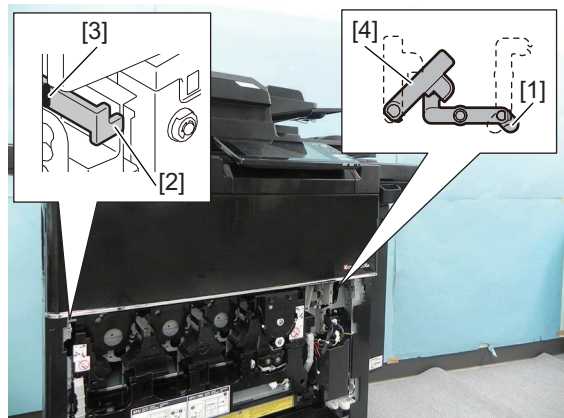

Fig. 4-317

- Turn the TBU lifting lever right downward to unlock the TBU locking lever.
- Do not install the process unit with too much force. Follow the procedure below when installing the process unit.
- Hold the levers on both sides and insert the process unit slowly until it seems to stop. (The stud [8] should be inserted into the hole [9] of the frame.) In this case, the levers face the inside.

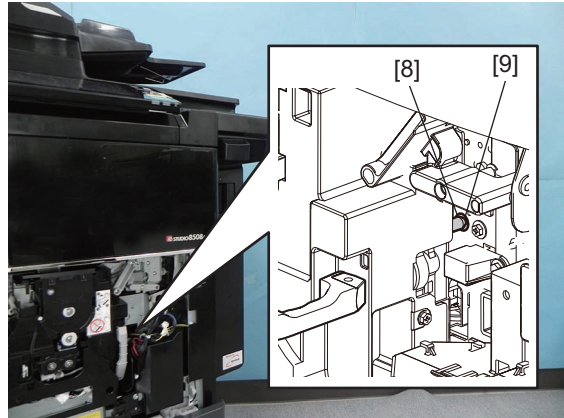

Fig. 4-318

- Place your hands in the position indicated by the arrows below, and push them well.



Fig. 4-319

- Turn both levers outside by 90 degrees and push them down.

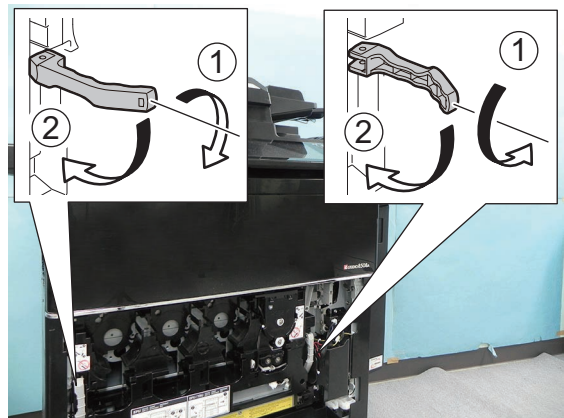



Fig. 4-320

4.6.2 Drum cleaner unit

- (1) Pull out the process unit (EPU).
 P. 4-124 “4.6.1 Pulling out of the process unit (EPU tray)”
- (2) Take off the drum cleaner unit [1] quietly not to hit the drum to the surrounding parts.

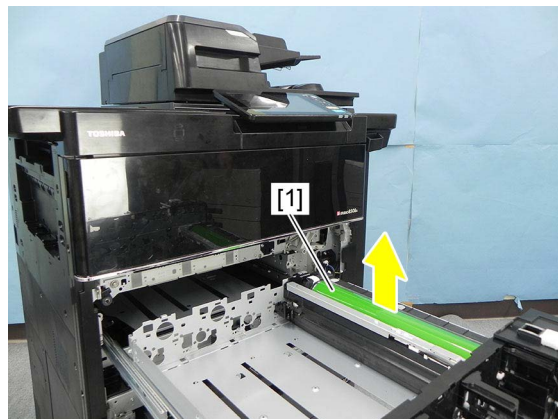

Fig. 4-321

Notes:

- When you hold the drum cleaner unit, hold the part [A] shown in the figure. Do not touch the part [B] because grease will adhere to your hands.

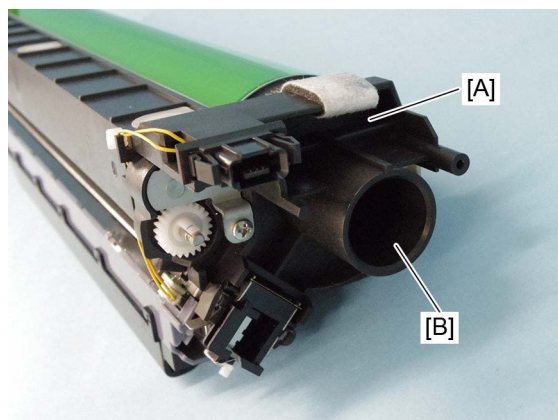

Fig. 4-322

- When installing, place the drum cleaner unit by keeping it horizontal.
- Confirm that the unit is placed horizontally by holding 4 sections (shown in the figure) securely and checking that no lifting is found at each section.

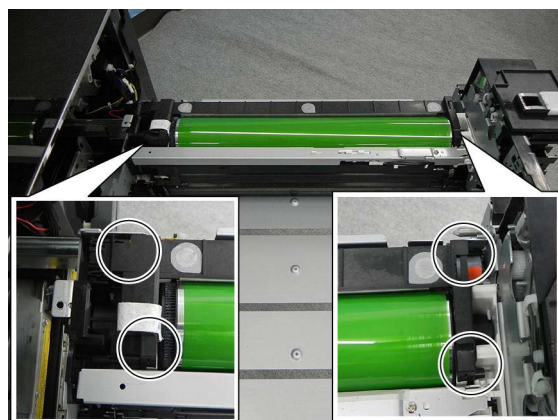

Fig. 4-323

- When installing the drum cleaner unit, be sure that the orange label attached on the shutter is clearly seen.

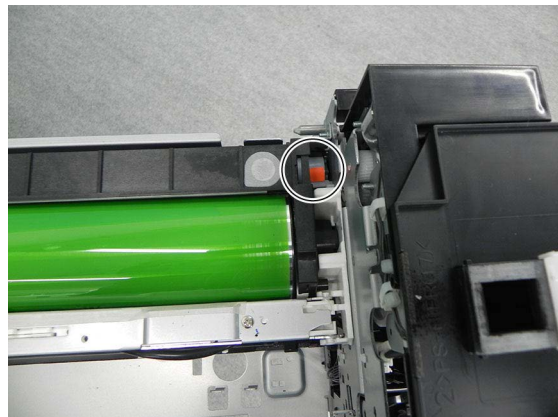



Fig. 4-324

4.6.3 Drum

- (1) Take off the drum cleaner unit.
 P. 4-128 “4.6.2 Drum cleaner unit”
- (2) Take off the main charger unit.
 P. 4-133 “4.6.6 Main charger unit”
- (3) Remove 2 drum holders [1].
- (4) Take off the drum [2] by lifting it up straight.

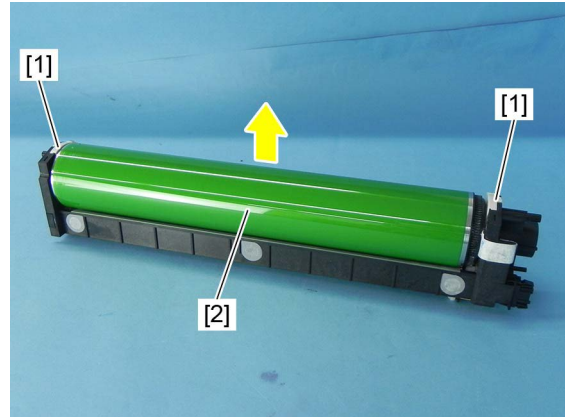

Fig. 4-325

Notes:

- Do not install the drum in a wrong direction.
- Do not touch the drum flanges on the front [3] and rear [4] sides because grease will adhere to your hands.

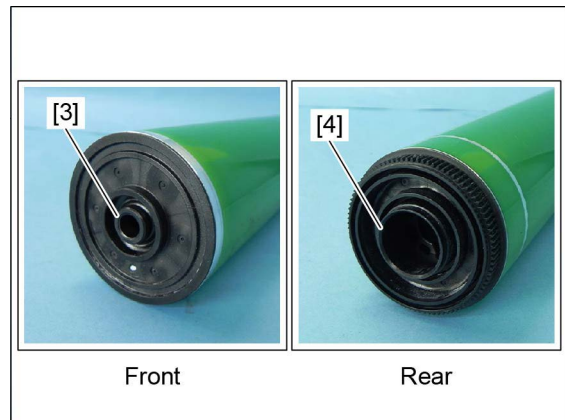



Fig. 4-326

4.6.4 Drum cleaning blade

- (1) Take off the main charger unit.
 P. 4-133 “4.6.6 Main charger unit”
- (2) Take off the drum.
 P. 4-130 “4.6.3 Drum”
- (3) Remove 2 screws and take off the drum cleaning blade [1].

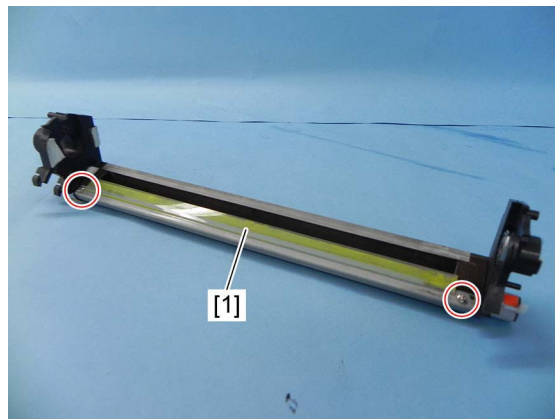



Fig. 4-327

Notes:

When replacing the drum cleaning blade, replace the blade side seal too if the conditions of the blade side seal are as follows:

- If the flock on the surface layer of the blade side seal has peeled off and the sponge of the layer below protrudes
- If the blade side seal has not been attached appropriately (not following the attachment reference) or if the blade has caught or come over the blade side seal when the blade retaining bracket was removed

 P. 4-132 “4.6.5 Blade side seal”

4.6.5 Blade side seal

- (1) Take off the drum cleaning blade.
P. 4-131 “4.6.4 Drum cleaning blade”
- (2) Remove 2 blade side seals [1].

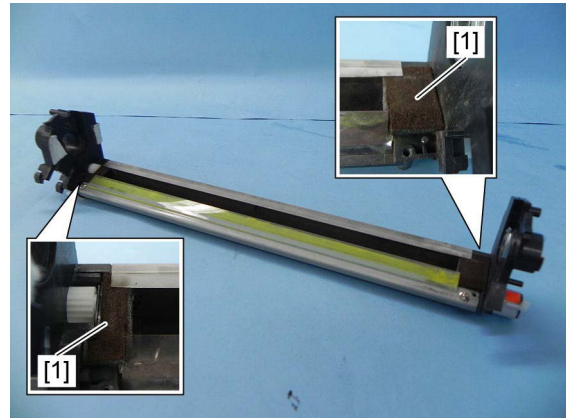

Fig. 4-328

Notes:

When replacing the blade side seals, follow the procedure below.

- Move the blade [2] toward the front side and secure it with 2 screws.
- By following the attachment reference in the figure below, attach the blade side seal [1].

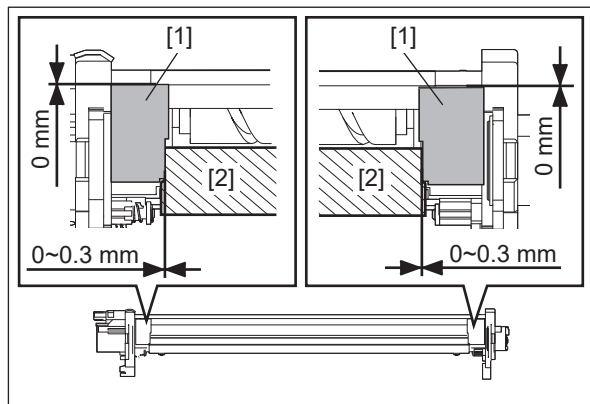

Fig. 4-329

- After the blade side seals [1] are attached, move the blade retaining bracket and check that it is neither caught by the blade [2] nor does it come up on to the blade side seal.

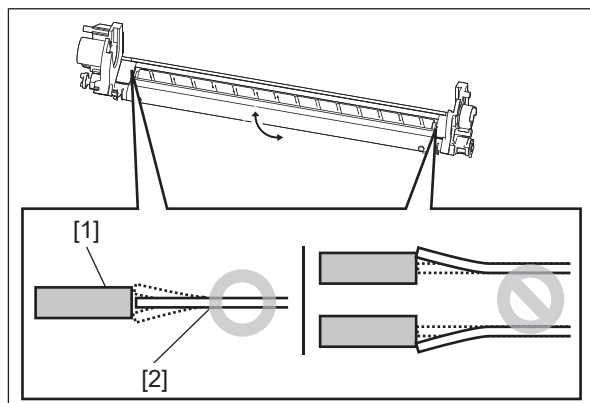

Fig. 4-330

4.6.6 Main charger unit

- (1) Take off the drum cleaner unit.
P. 4-128 "4.6.2 Drum cleaner unit"
- (2) Disconnect 1 connector.

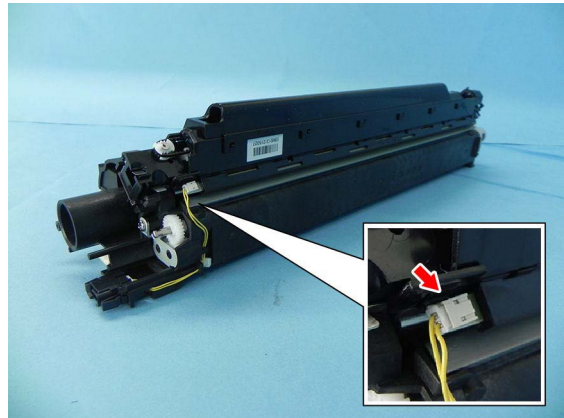

Fig. 4-331

- (3) Release 2 latches and take off the main charger unit [1].

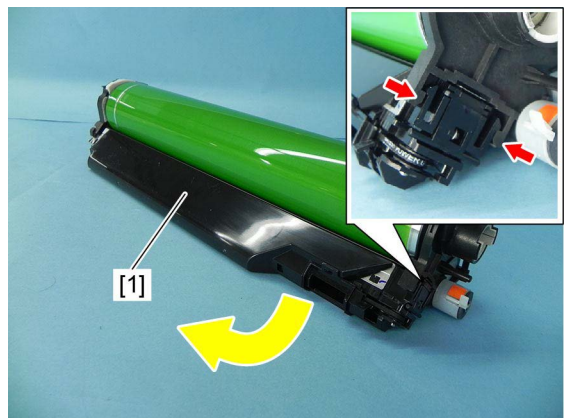

Fig. 4-332

4.6.7 Main charger grid

- (1) Take off the main charger unit.
P. 4-133 "4.6.6 Main charger unit"
- (2) Remove the main charger grid [1] by pulling the lever of the holder.

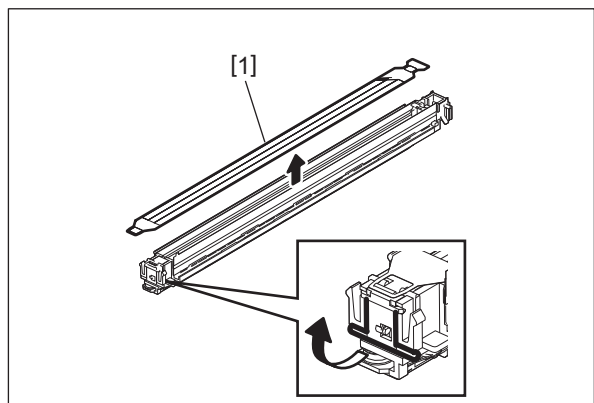



Fig. 4-333

4.6.8 Needle electrode cleaner

- (1) Take off the main charger grid.
 P. 4-133 “4.6.7 Main charger grid”
- (2) Remove the needle electrode cleaner [1].

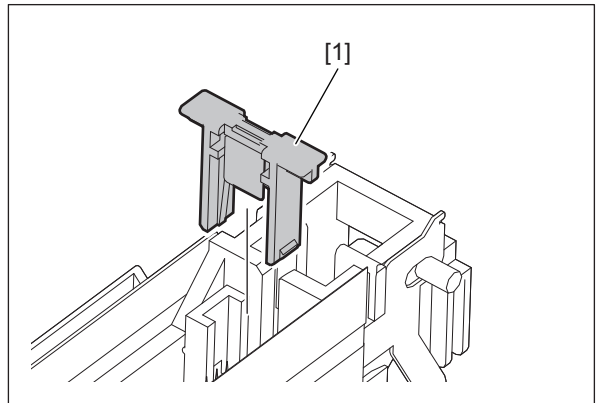



Fig. 4-334

4.6.9 Needle electrode

- (1) Take off the needle electrode cleaner.
 P. 4-134 “4.6.8 Needle electrode cleaner”
- (2) Remove the holder and take off the needle electrode [1].

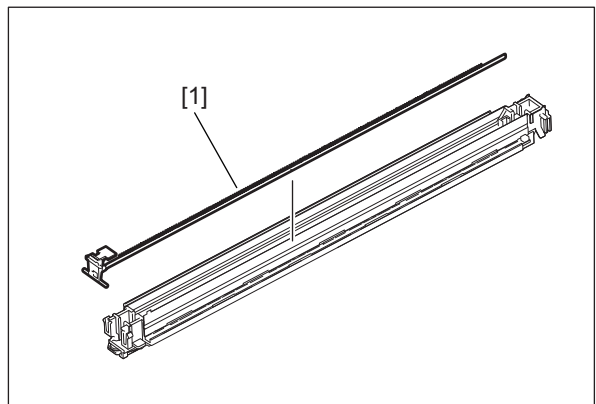

Fig. 4-335

4.6.10 Discharge LED (K) (ERS-K)

- (1) Take off the main charger unit.
📖 P. 4-133 "4.6.6 Main charger unit"
- (2) Remove the discharge LED (K) [1] from the protrusion of the charger case and take it off by sliding it.

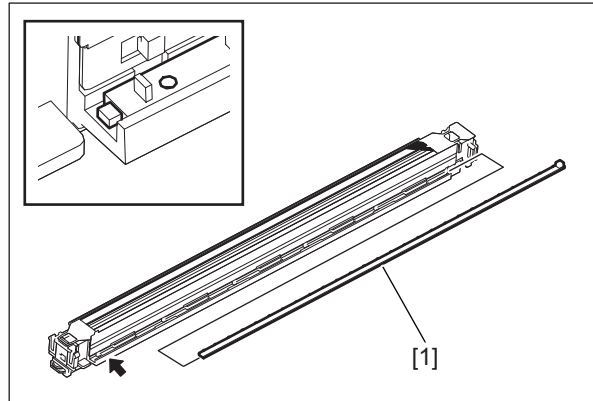

Fig. 4-336

4.6.11 Sub-hopper

- (1) Pull out the process unit.
📖 P. 4-124 "4.6.1 Pulling out of the process unit (EPU tray)"
- (2) Disconnect 1 connector.



Fig. 4-337

- (3) Release 1 hook on the rear side.

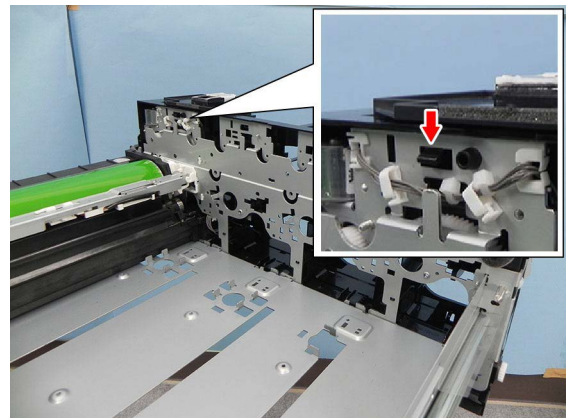

Fig. 4-338

- (4) Release 2 hooks on the both sides.
- (5) Remove the sub-hopper [1].

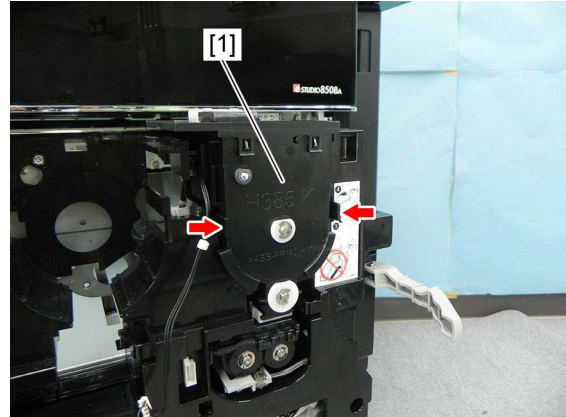



Fig. 4-339

4.6.12 Sub-hopper toner sensor (K) (S38)

- (1) Remove the sub-hopper.
 P. 4-135 "4.6.11 Sub-hopper"
- (2) Discharge toner.

Notes:

When taking off the sensor while toner is still in the sub-hopper, be careful not to spill the toner out of the sub-hopper.

If the toner surface is higher than the sensor installation position, it is recommended to mix the toner by rotating the gear.

- (3) Release 1 hook and remove the holder [1].



Fig. 4-340

- (4) Disconnect 1 connector, remove 1 screw and then take off the sub-hopper toner sensor (K) [2].

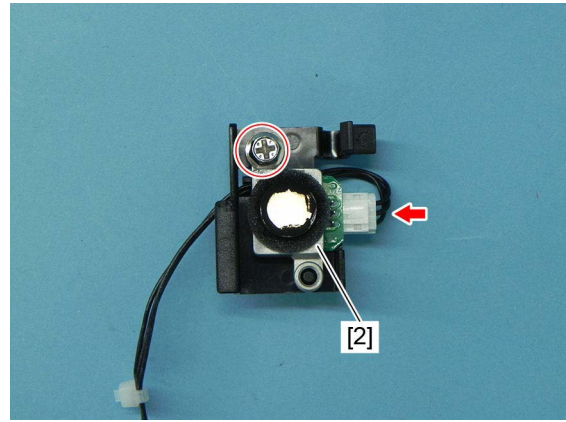

Fig. 4-341

4.6.13 EPU cover

- (1) Remove the sub-hopper.
📖 P. 4-135 "4.6.11 Sub-hopper"
- (2) Remove 6 screws and release 5 latches. Pull out the EPU cover [1] toward you.

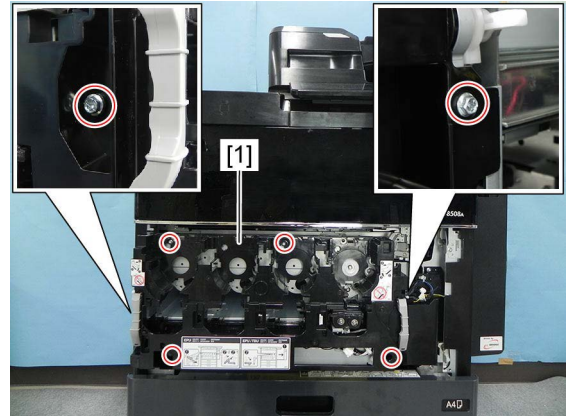

Fig. 4-342

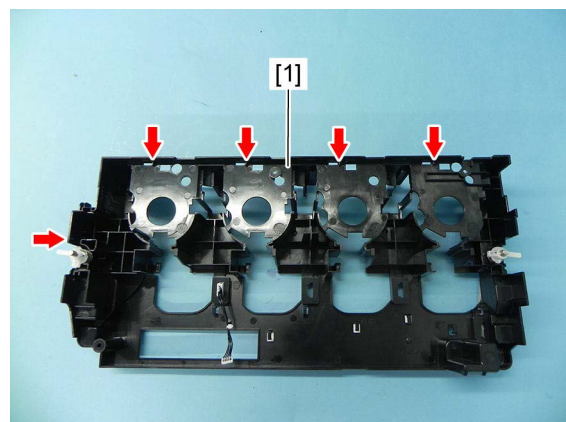

Fig. 4-343

- (3) Disconnect 1 connector and take off the EPU cover [1].

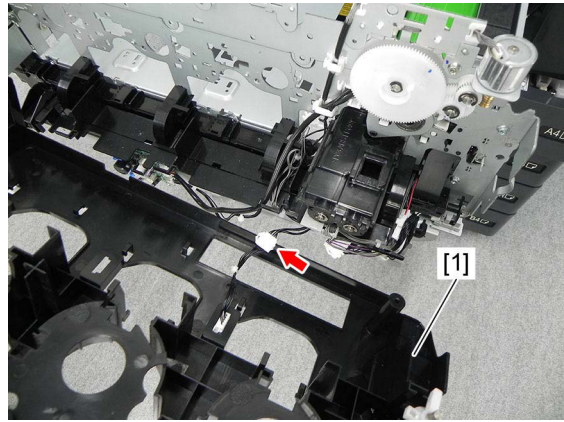

Fig. 4-344

4.6.14 Sub-hopper toner motor (K) (M19)

- (1) Take off the EPU cover.
P. 4-137 "4.6.13 EPU cover"
- (2) Remove 2 screws. Disconnect 1 connector and take off the motor bracket [1].

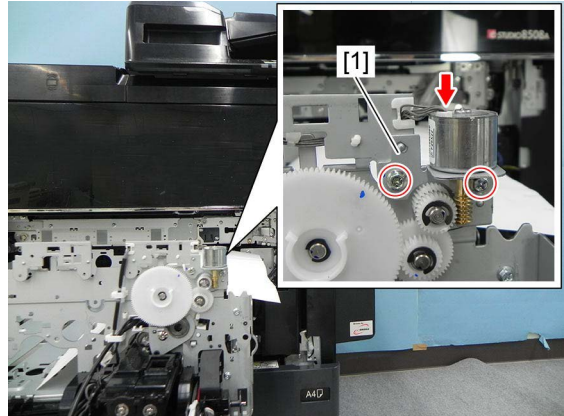

Fig. 4-345

- (3) Remove 2 screws and take off the sub-hopper toner motor (K) [2].

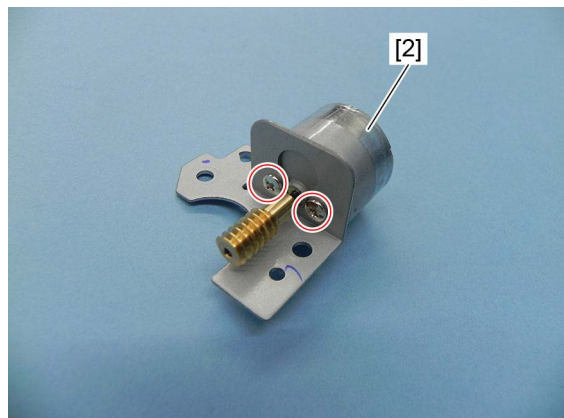

Fig. 4-346

Notes:

Pay attention to the size and length of the screws. If you use the wrong ones, the motor could be damaged.

4.6.15 Drum surface potential sensor control PC board (V0S board) (9029A only)

- (1) Take off the EPU cover.
P. 4-137 “4.6.13 EPU cover”
- (2) Disconnect 2 connectors.
- (3) Remove 2 screws and take off the drum surface potential sensor control PC board [1].

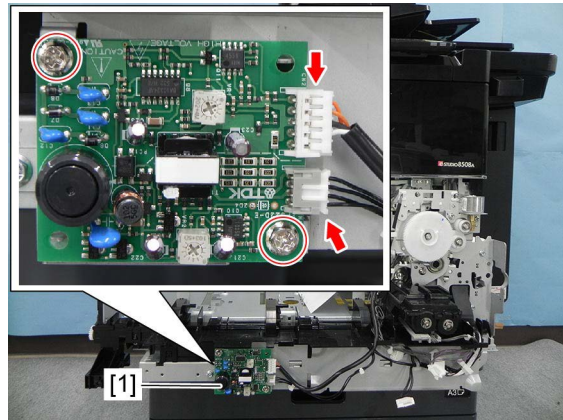

Fig. 4-347

4.6.16 Auger lock detection sensor (S42)

- (1) Take off the EPU cover.
P. 4-137 “4.6.13 EPU cover”
- (2) Rotate the auger [1] to escape the actuator [2] from the auger lock detection sensor [3].

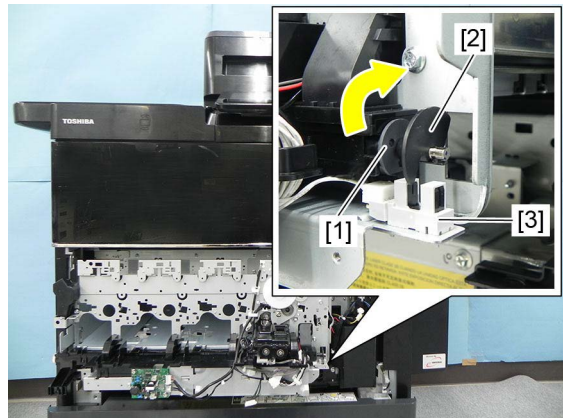

Fig. 4-348

- (3) Disconnect 1 connector and remove the auger lock detection sensor [3].

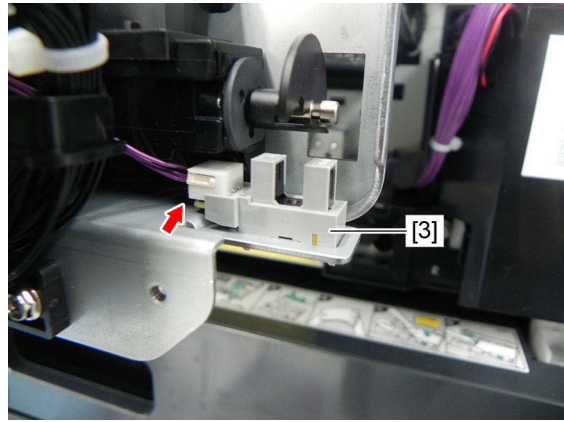

Fig. 4-349

4.6.17 Drum unit side vertical duct

- (1) Take off the drum cleaner unit.
📖 P. 4-128 "4.6.2 Drum cleaner unit"
- (2) Take off the EPU cover.
📖 P. 4-137 "4.6.13 EPU cover"
- (3) Release 2 latches and remove the drum unit side vertical duct [1].

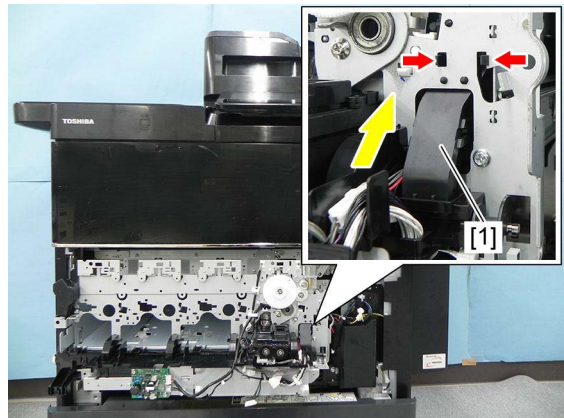

Fig. 4-350

4.6.18 Ozone mixing fan (K) (F17)

- (1) Take off the drum unit side vertical duct.
📖 P. 4-140 "4.6.17 Drum unit side vertical duct"
- (2) Disconnect 1 connector and take off the ozone mixing fan (K) [1] by sliding it.

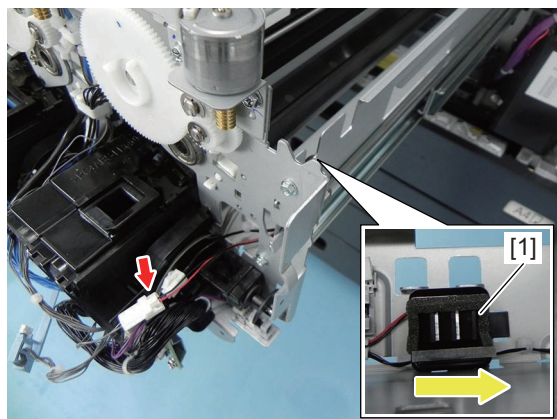

Fig. 4-351

4.6.19 Needle electrode cleaner detection sensor (K) (S30)

- (1) Take off the drum cleaner unit.
📖 P. 4-128 "4.6.2 Drum cleaner unit"
- (2) Disconnect 1 connector and release 3 latches. Take off the needle electrode cleaner detection sensor (K) [1].

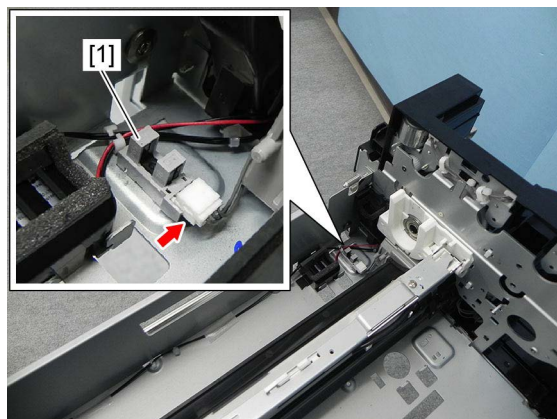

Fig. 4-352

4.6.20 Needle electrode cleaner motor (K) (M23)

- (1) Take off the developer unit.
P. 4-148 “4.6.24 Developer unit”
- (2) Release 2 latches and lift up the motor holder [1].

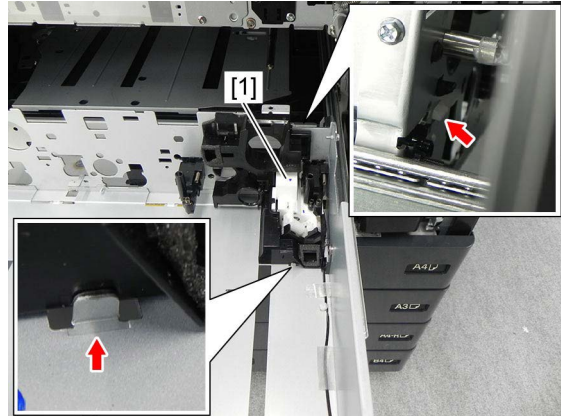

Fig. 4-353

- (3) Disconnect 1 connector and take off the motor holder [1].

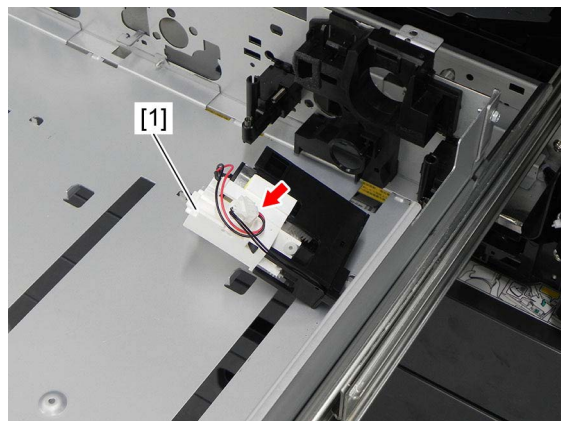

Fig. 4-354

- (4) Release 2 hooks and take off the duct [2].

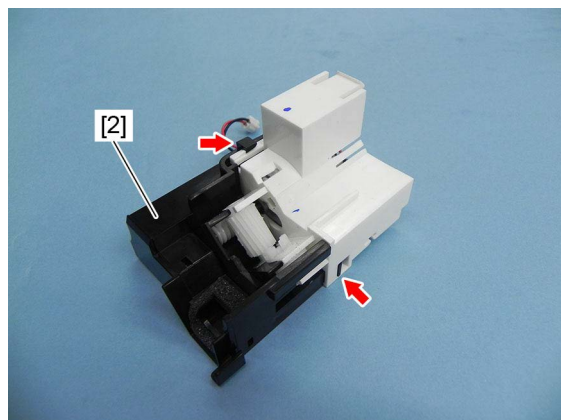

Fig. 4-355

(5) Remove 2 gears [3].

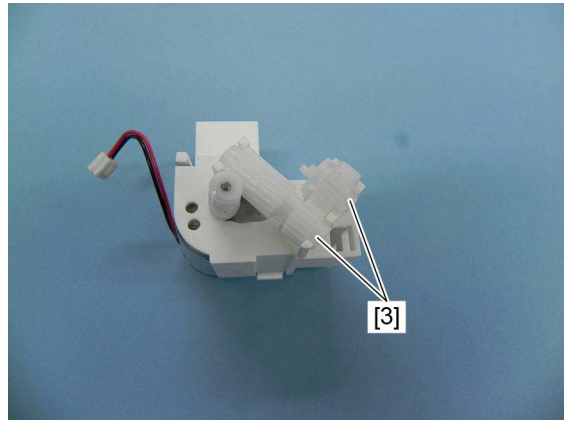

Fig. 4-356

(6) Release 1 lock and remove the needle electrode cleaner motor (K) [4].

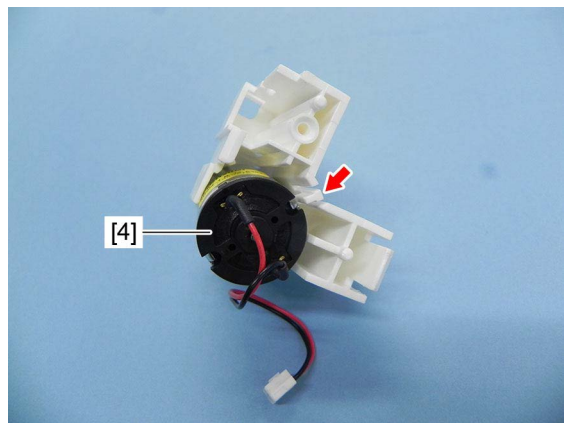

Fig. 4-357

Notes:

When installing the motor, engage the locking part with the recessed part of the motor.

4.6.21 V0 sensor shutter solenoid (K) (SOL4) (9029A only)

- (1) Take off the EPU cover.
📖 P. 4-137 “4.6.13 EPU cover”
- (2) Disconnect 3 connectors.

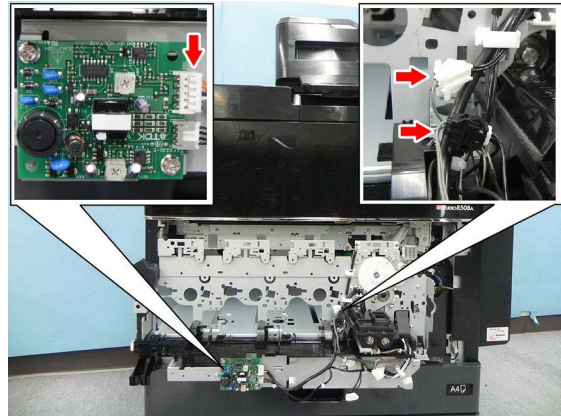

Fig. 4-358

- (3) Release 1 hook and remove the stay [1] by raising it.

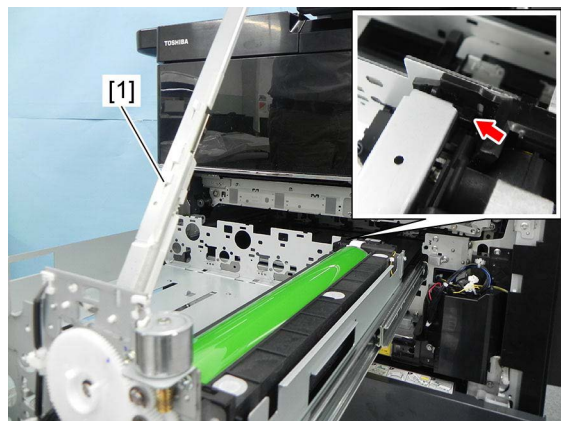

Fig. 4-359

Notes:

Hold the upper side of the stay. Avoid touching its shutter.

- (4) Remove 1 screw and take off the solenoid holder [2] by sliding it.

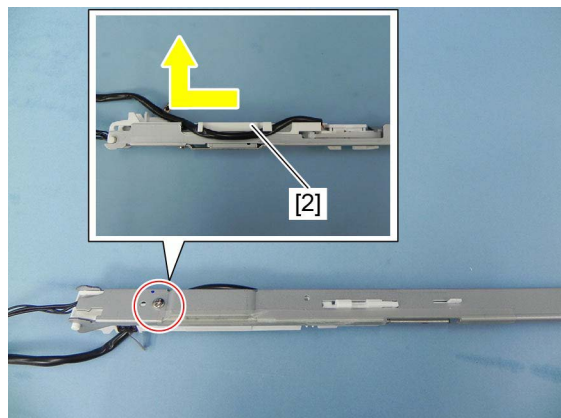

Fig. 4-360

(5) Disconnect the joint of the link arm [3].

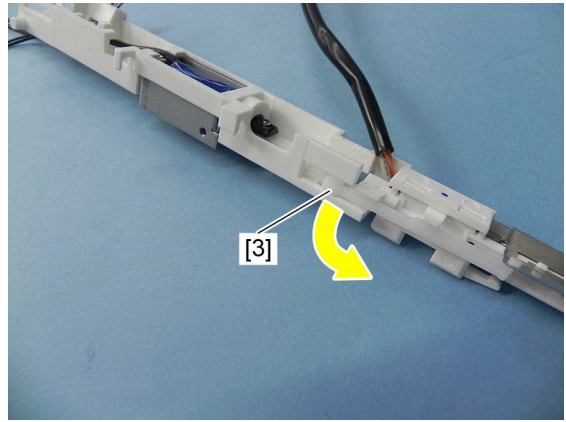

Fig. 4-361

(6) Remove the link arm [4].

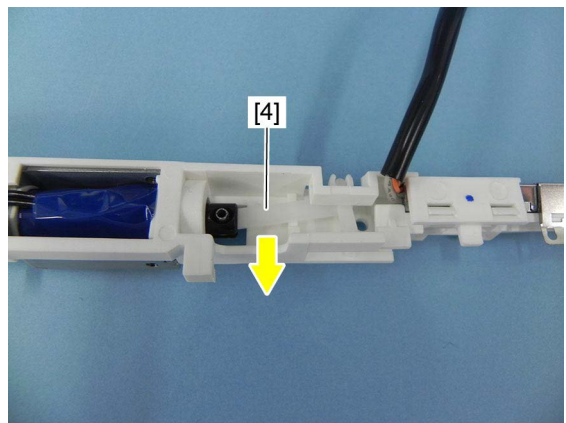

Fig. 4-362

(7) Release the harness from the hook of the harness holder and remove the V0 sensor shutter solenoid (K) [5].

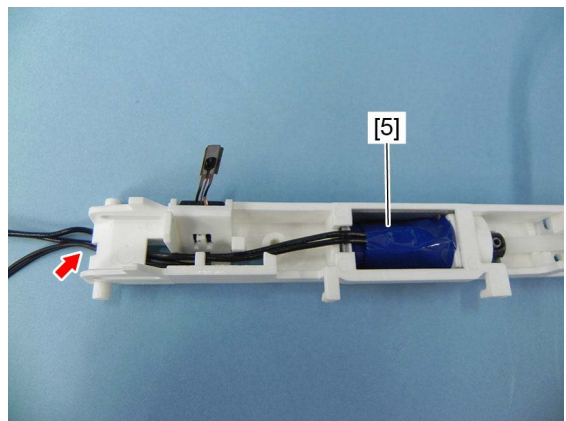



Fig. 4-363

4.6.22 Drum surface potential (V0) sensor (K) (S34) (9029A only)

- (1) Remove the solenoid holder.
 P. 4-144 "4.6.21 V0 sensor shutter solenoid (K) (SOL4) (9029A only)"
- (2) Remove the link arm [1].

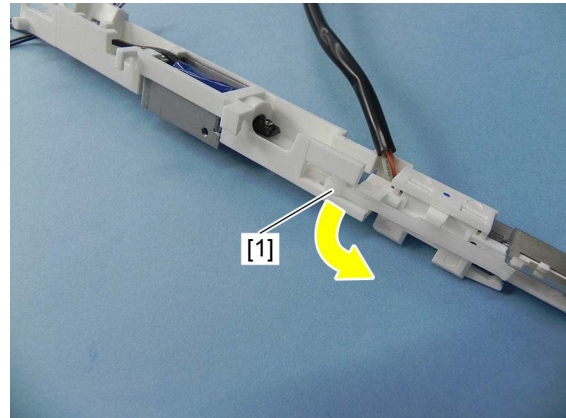

Fig. 4-364

- (3) Remove 1 spring [2].

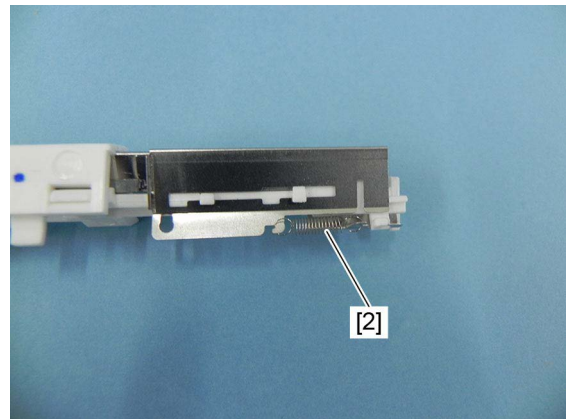

Fig. 4-365

- (4) Remove the shutter [4] by sliding it while lifting the edge [3] of the shutter.

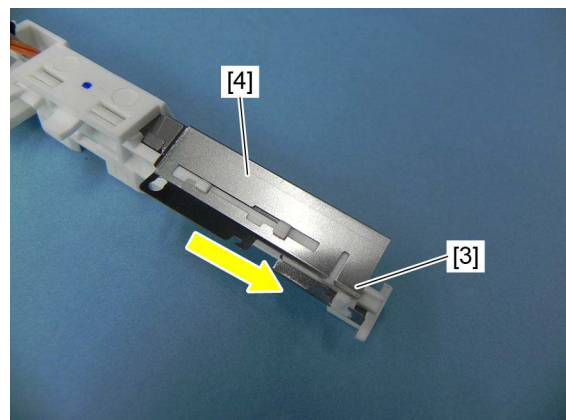

Fig. 4-366

- (5) Release 2 hooks.

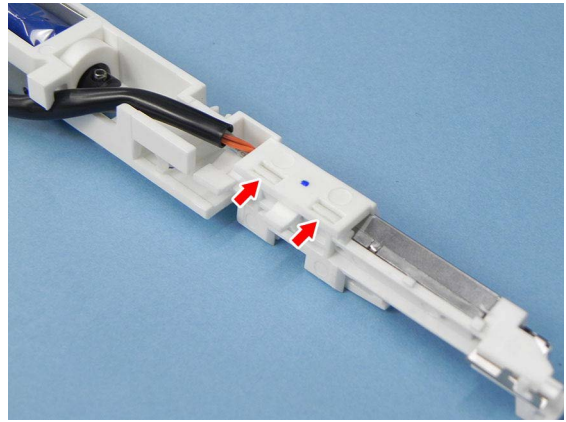

Fig. 4-367

- (6) Release the harness from the harness guide and remove the Drum surface potential (V0) sensor (K) [5].

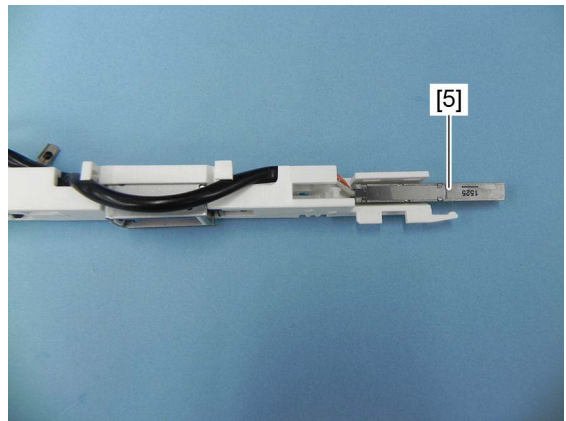

Fig. 4-368

4.6.23 Drum thermistor (K) (THM1)

- (1) Remove the solenoid holder.
P. 4-144 “4.6.21 V0 sensor shutter solenoid (K) (SOL4) (9029A only)”
- (2) Remove the drum thermistor (K) [1].

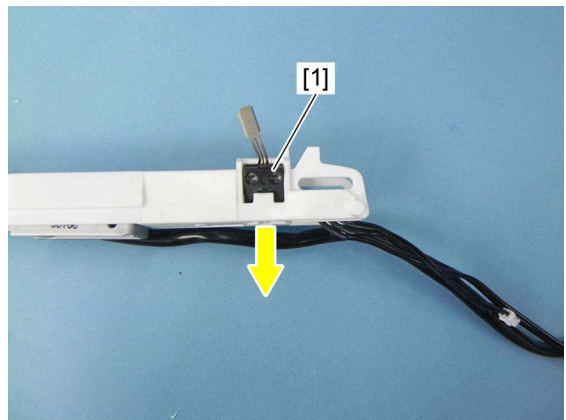

Fig. 4-369

4.6.24 Developer unit

- (1) Take off the front cover.
📖 P. 4-1 “4.1.2 Front cover”
- (2) Take off the drum cleaner unit.
📖 P. 4-128 “4.6.2 Drum cleaner unit”
- (3) Remove the sub-hopper.
📖 P. 4-135 “4.6.11 Sub-hopper”
- (4) Take off the connector holder [1].

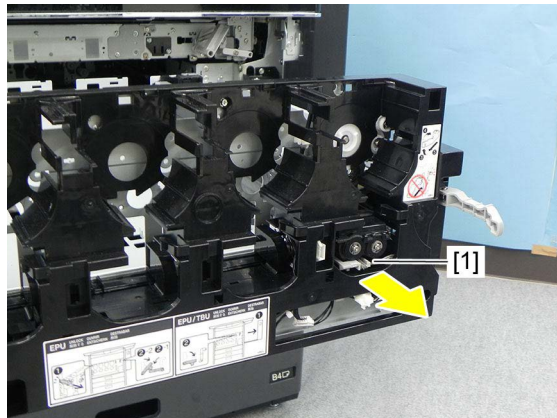

Fig. 4-370

- (5) Remove 1 screw and the developer unit locking [2].

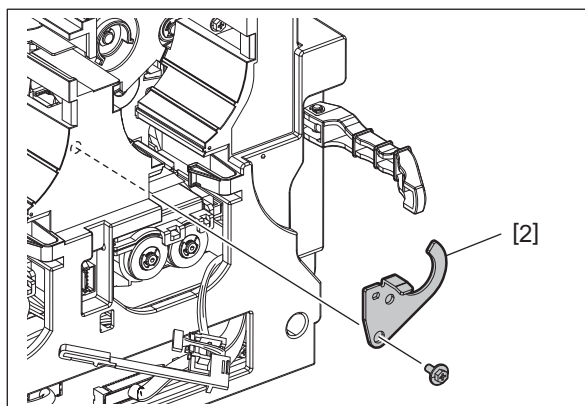

Fig. 4-371

Notes:

Be sure not to drop screws into the toner inlet.

- (6) Release 1 lock [3] to set up a stay [4].

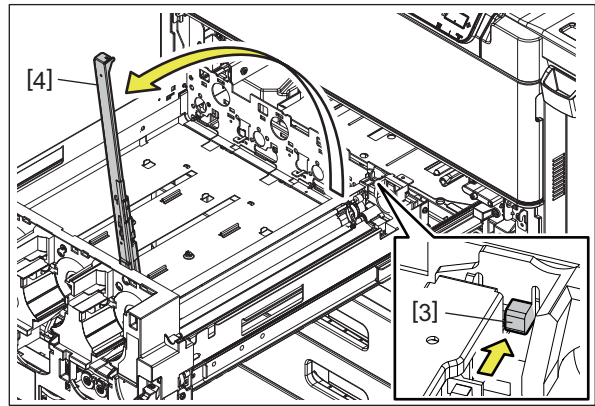

Fig. 4-372

Notes:

Hold the upper side of the stay. Avoid touching its shutter.

- (7) Remove the duct [5].

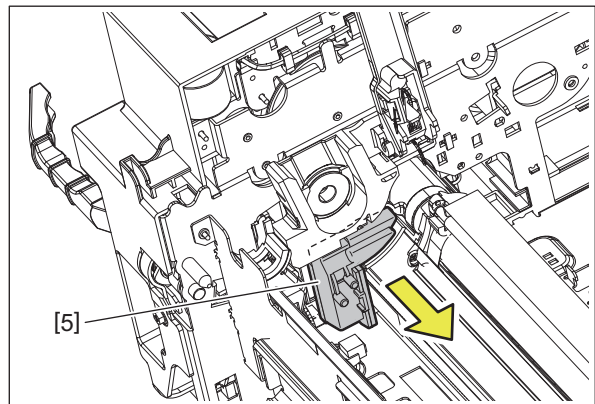

Fig. 4-373

- (8) Slide the developer unit toward the front.

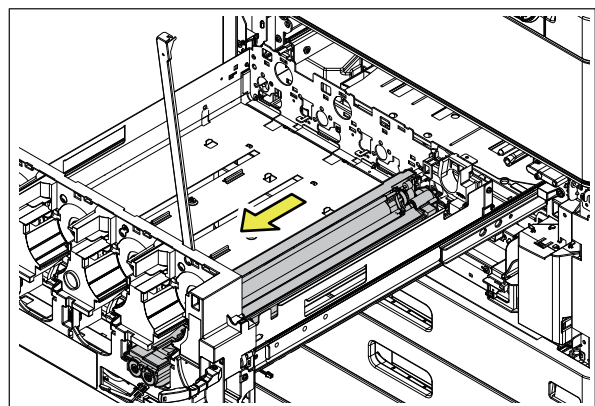

Fig. 4-374

(9) While lifting the rear side of the developer unit [6], slide it toward the rear and remove it.

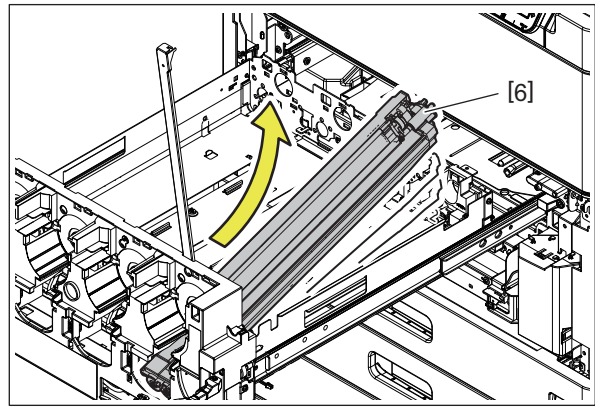

Fig. 4-375

Notes:

- When installing or taking off the developer unit, be careful not to hit the unit to the surrounding parts, especially to a sensor at the bottom of the EPU tray.
- Never turn the coupling [7] behind the developer unit in a direction opposite to the one shown with the arrow.

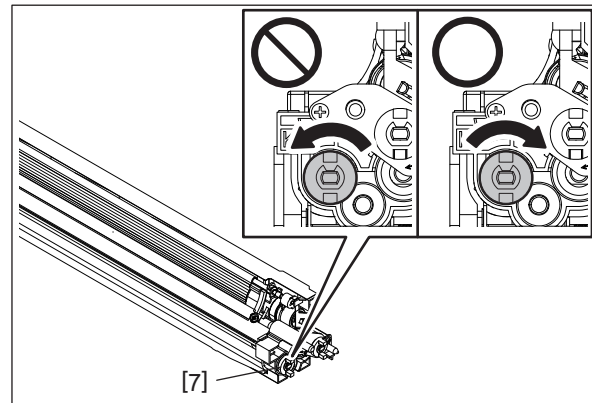

Fig. 4-376

4.6.25 Developer material

Remarks:

Normally developer material does not need to be replaced. If there is a need for replacement, follow the procedure below.

- (1) Take off the developer unit.
📖 P. 4-148 “4.6.24 Developer unit”
- (2) Release 2 hooks and remove the developer unit front cover by sliding it.

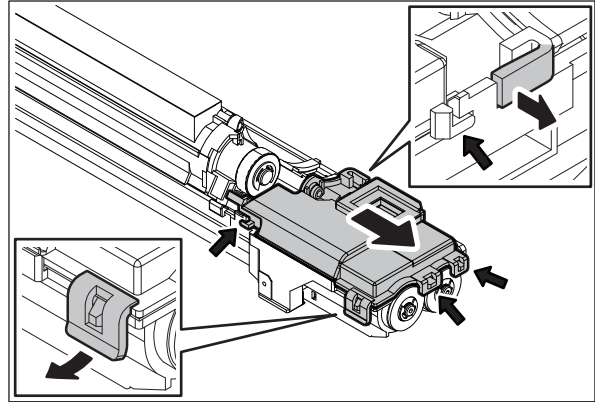

Fig. 4-377

- (3) Remove the developer upper unit [2] by sliding it.

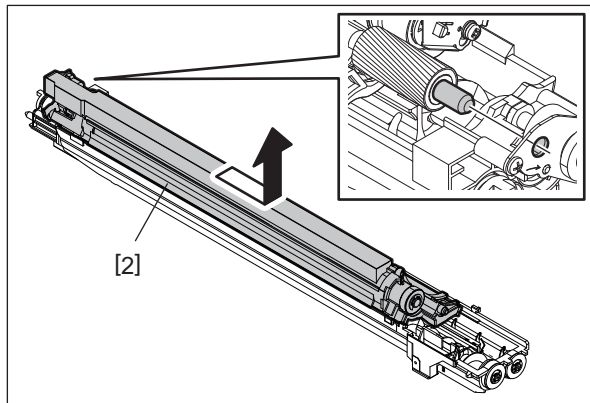

Fig. 4-378

- (4) Discharge the developer material.



Fig. 4-379

- (5) Scrape off any developer material adhering to the magnet sleeve by rotating the gear, too.

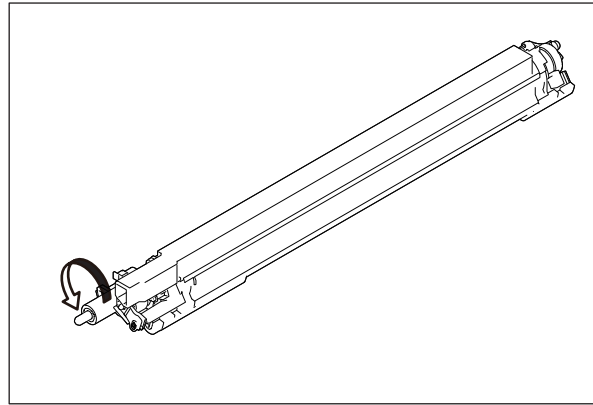

Fig. 4-380

Notes:

- When removing the developer upper unit, be sure not to lose the springs.

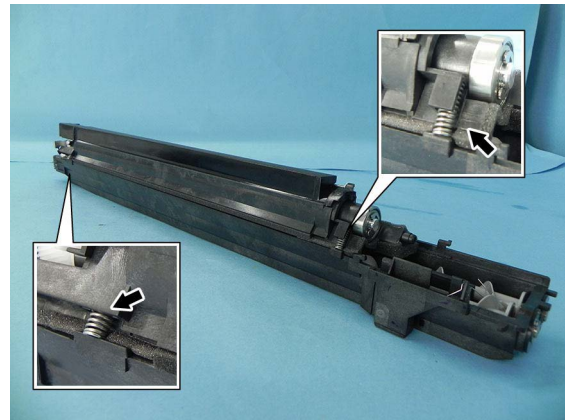

Fig. 4-381

- When discharging the developer material, be careful not to let it drop on the gears of the developer unit.
- When installing the developer upper unit, insert its rear side into the developer unit first and then its front side downward, while paying attention that the sponge does not end up inside the case.
If the sponge ends up inside the case, it may cause the leakage of the developer material.

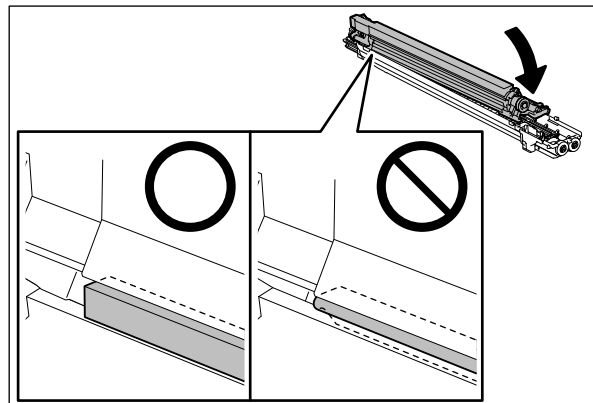

Fig. 4-382

- Never turn the coupling [3] behind the developer unit in a direction opposite to the one shown with the arrow.

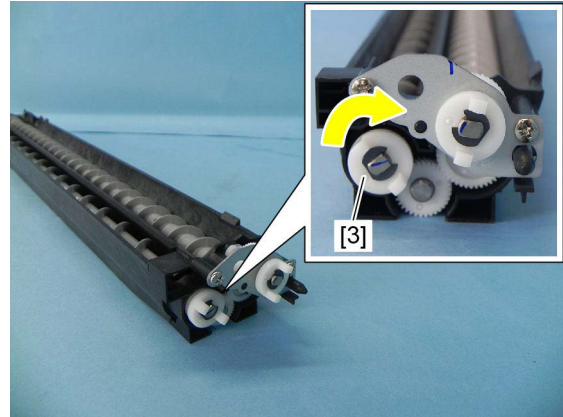

Fig. 4-383

- Be sure not to lose the scraper [4] in the developer. Make sure that the scraper is installed passing through the hole [5], and check if the coupling can be turned in the direction of the arrow in the figure.

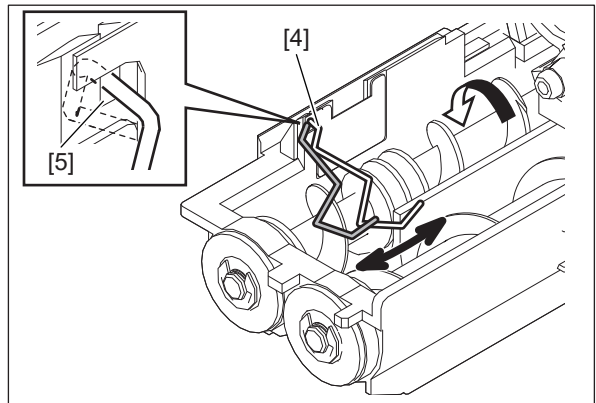



Fig. 4-384

- Be sure that there is no developer material adhering to the driving gear [6] in the developer unit.



Fig. 4-385

- (6) Install the developer unit in the MFP and take off the sub-hopper.
 P. 4-135 "4.6.11 Sub-hopper"
- (7) Attach a developer cartridge of the corresponding color to the position where the sub-hopper was installed. (Do not install the toner cartridge.)
- (8) Perform the auto-toner adjustment.
FS-05-2400
- (9) After the developer material has been filled up, take off the developer cartridge and the reinstall the sub-hopper.

Remarks:

When the developer material is replaced, perform "Forced performing of image quality closed-loop control" and then "Automatic gamma adjustment".

 P. 6-1 "6.1 Image Related Adjustment"

4.6.26 Mixer-1, Mixer-2

- (1) Take off the developer unit.
 P. 4-148 "4.6.24 Developer unit"
- (2) Remove the scraper.

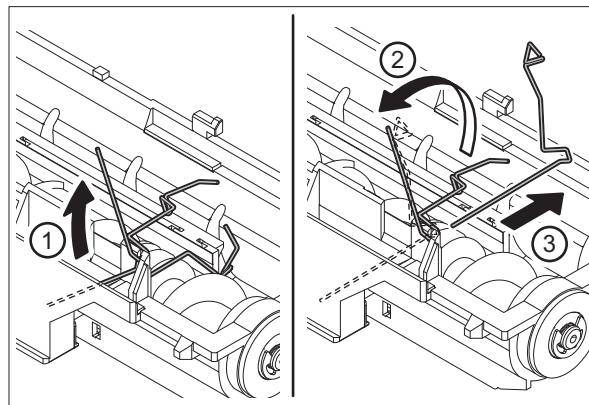

Fig. 4-386

Notes:

- When attaching the scraper [1], pass it through the hole [2].
- The scraper [1] is moved in the direction of the arrow when the coupling is rotated clockwise.
- Do not rotate the coupling counterclockwise.

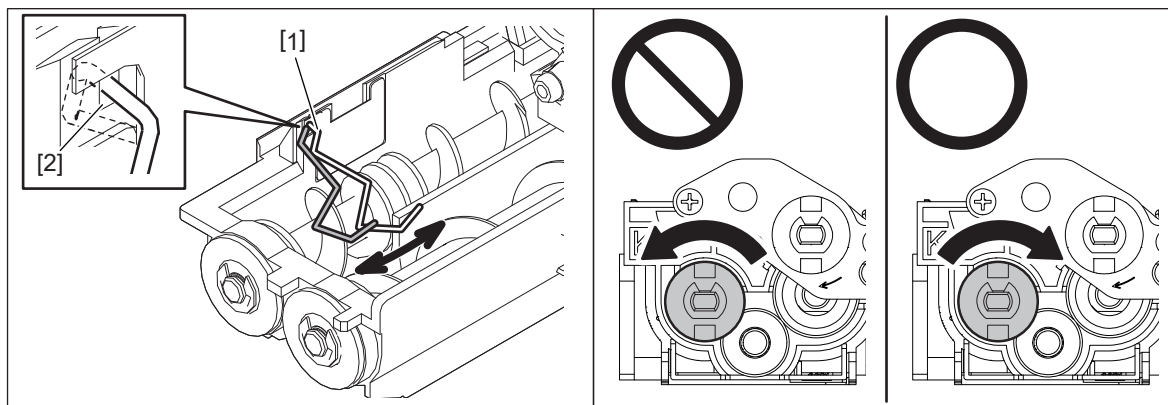

Fig. 4-387

- (3) Remove the E-ring [3], coupling [4] and gear [5].

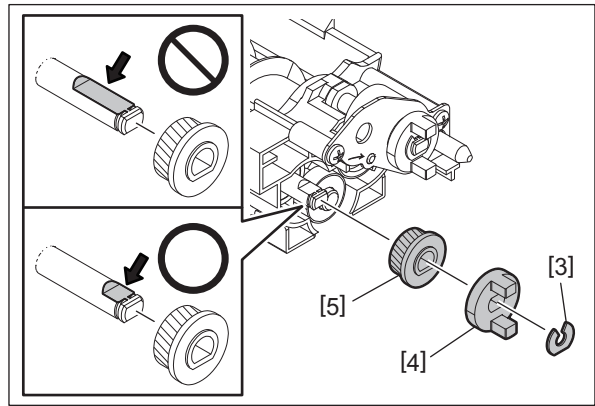

Fig. 4-388

Notes:

Be sure to attach gear [5] to the shaft as shown in the figure.

- (4) Remove ball bearing [6] and oil seal [7].

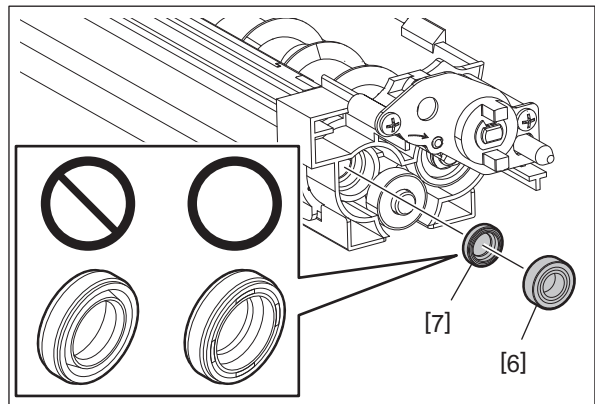

Fig. 4-389

- (5) Remove the mixer-1 [8].

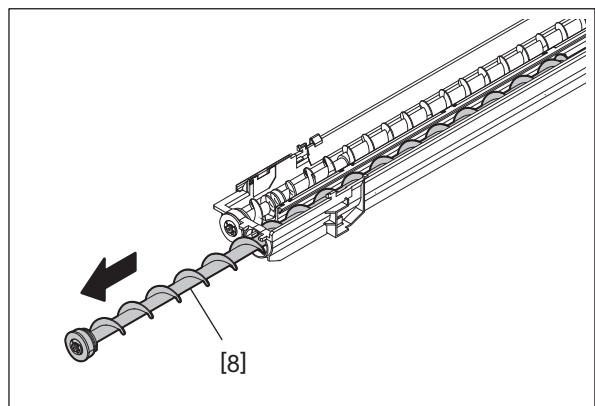

Fig. 4-390

- (6) Remove the E-ring [9], ball bearing [10], oil seal [11] and bushing [12].

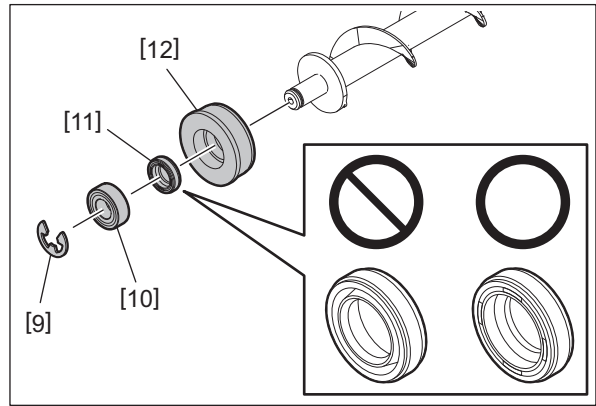

Fig. 4-391

Notes:

Be sure to attach the oil seal [11] in the direction shown in the figure.

- (7) Remove the 2 screws and take off the gear unit [13].

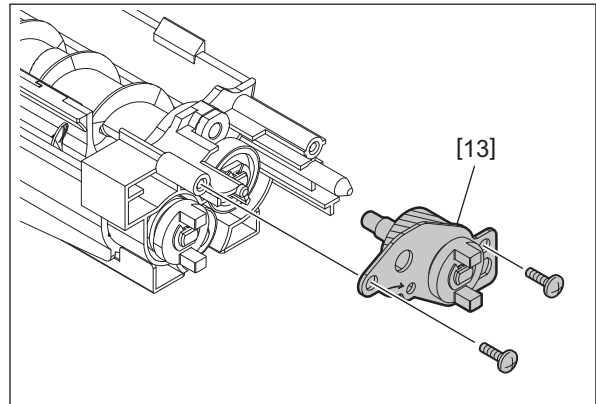

Fig. 4-392

- (8) Remove the E-ring [14], gear [15] and bushing [16].

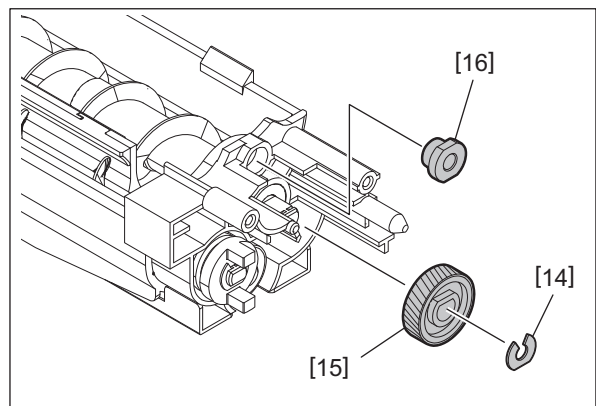

Fig. 4-393

(9) Remove the ball bearing [17] and oil seal [18].

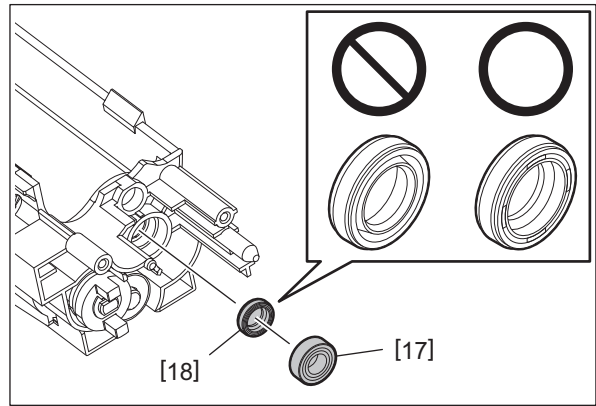

Fig. 4-394

Notes:

Be sure to attach the oil seal [18] in the direction shown in the figure.

(10) Remove the mixer-2 [19].

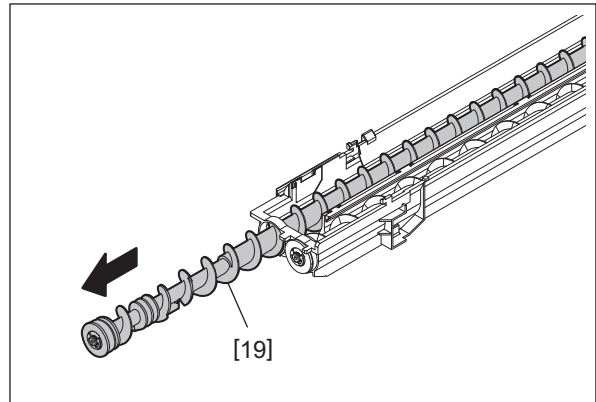

Fig. 4-395

(11) Remove the E-ring [20], ball bearing [21], oil seal [22] and bushing [23].

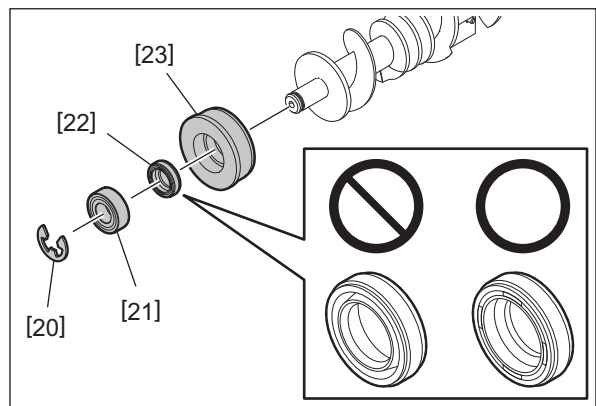

Fig. 4-396

Notes:

- Be sure to attach the oil seal [22] in the direction shown in the figure.

- Be sure to attach the oil seal [22] parallel to the bushing.

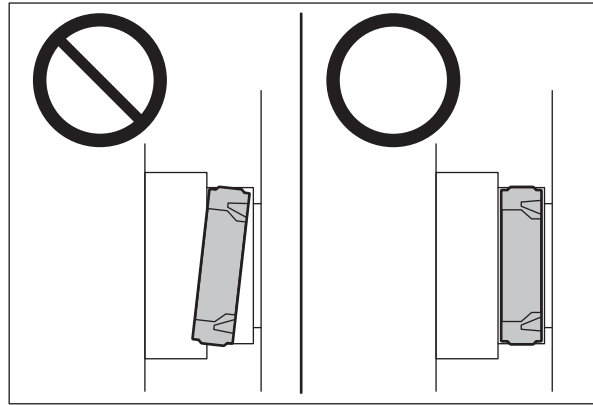

Fig. 4-397

4.6.27 Developer sleeve

When the developer sleeve has been replaced or taken off, adjust the gap between the developer sleeve and the doctor blade.

☞ P. 6-67 “6.9.2 Doctor-to-sleeve gap adjustment (developer unit)”

- (1) Take off the developer unit.
☞ P. 4-148 “4.6.24 Developer unit”
- (2) Release 2 latches and take off the cover [1].

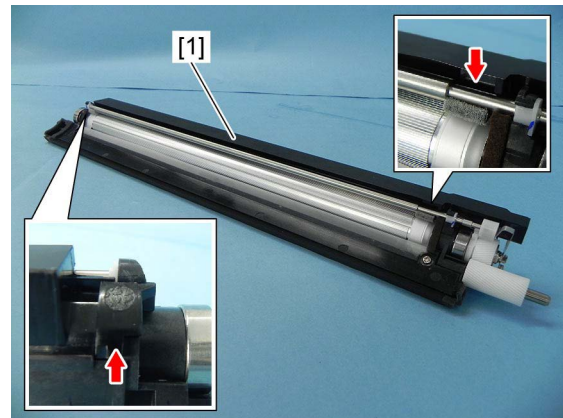

Fig. 4-398

(3) Release 1 latch and remove the recovery roller [2].

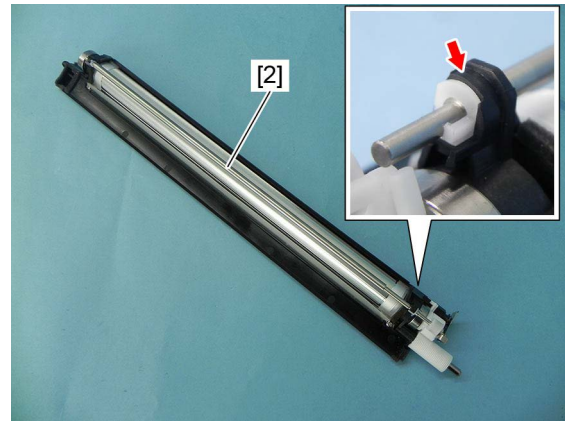

Fig. 4-399

(4) Remove 1 screw and take off the pole position adjustment plate [3].

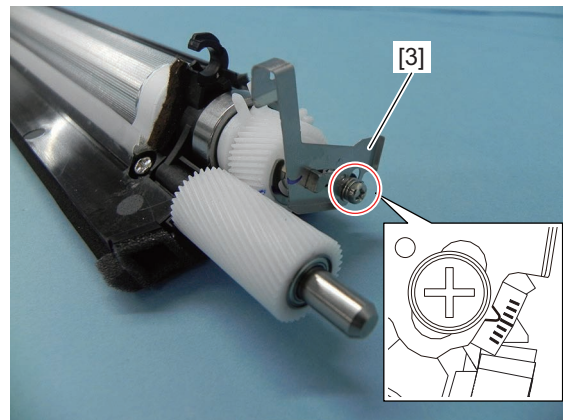

Fig. 4-400

Notes:

- Before disassembling, record (mark if any) the scale pointed by the polarity adjustment lever. Then match the polarity adjustment plate at the scale previously recorded when reassembling.
- When installing the polarity adjustment plate, make sure that the shaft of the developer sleeve and the polarity adjustment plate [3] are stable.

(5) Remove the E-ring and ball bearing [4] on the front side.



Fig. 4-401

(6) Remove the E-ring and gear [5] on the rear side.



Fig. 4-402

(7) Remove 2 screws.



Fig. 4-403

(8) Remove the blade cover [7] which is fixed with adhesive tape [6].



Fig. 4-404

Notes:

Be careful not to damage seals when taking off the blade cover.

- (9) Remove 2 ball bearings [8].
- (10) Take off the developer sleeve [9].



Fig. 4-405

4.6.28 Auto-toner sensor (K) (S26)

- (1) Remove the corresponding developer unit and discharge the developer material out of the unit.
 - ☞ P. 4-148 "4.6.24 Developer unit"
 - ☞ P. 4-151 "4.6.25 Developer material"
- (2) Remove 1 screw and disconnect 1 connector. Take off the auto-toner sensor [1].



Fig. 4-406

4.6.29 Drum developer drive unit

- (1) Pull out the process unit.
📖 P. 4-124 “4.6.1 Pulling out of the process unit (EPU tray)”
- (2) Remove the drum motor.
📖 P. 4-164 “4.6.30 Drum motor (K) (M27)”
- (3) Take off the developer unit motor.
📖 P. 4-164 “4.6.31 Developer unit motor (K) (M30)”
- (4) Take off the developer unit mixer motor.
📖 P. 4-165 “4.6.32 Developer unit mixer motor (K) (M29)”
- (5) Remove 4 screws and take off the drum developer drive unit [1].

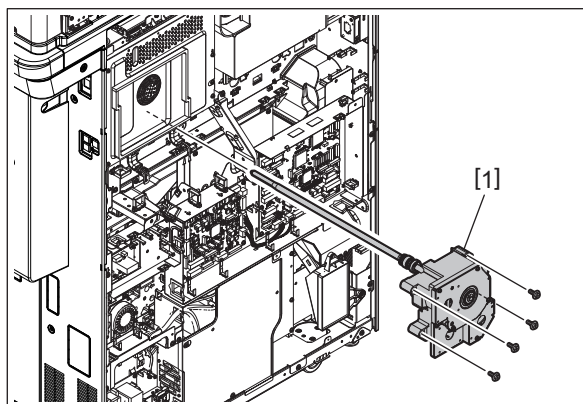

Fig. 4-407

Notes:

Be careful not to hit the edge and the coupling (circled in the figure) of the drum drive unit. When you place the unit, set it up as shown in the figure.

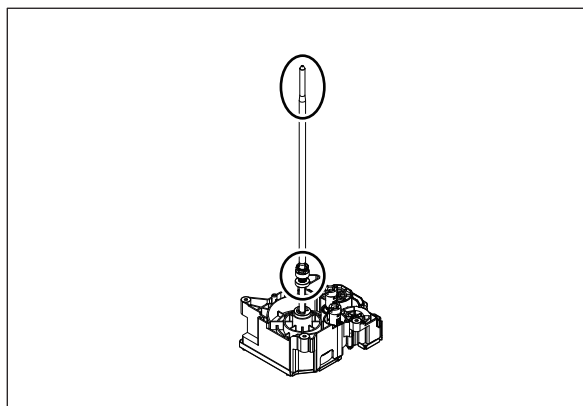

Fig. 4-408

4.6.30 Drum motor (K) (M27)

- (1) Take off the rear cover.
📖 P. 4-12 "4.1.22 Rear cover"
- (2) Disconnect 1 connector, remove 4 screws and take off the drum motor (K) [1].

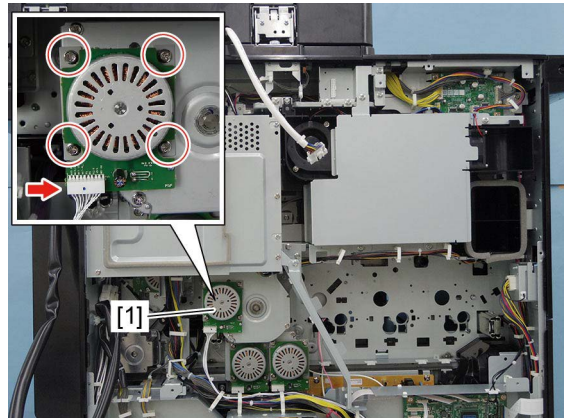

Fig. 4-409

4.6.31 Developer unit motor (K) (M30)

- (1) Take off the rear cover.
📖 P. 4-12 "4.1.22 Rear cover"
- (2) Remove 3 screws. Disconnect 1 connector and take off the developer unit motor (K) [1].

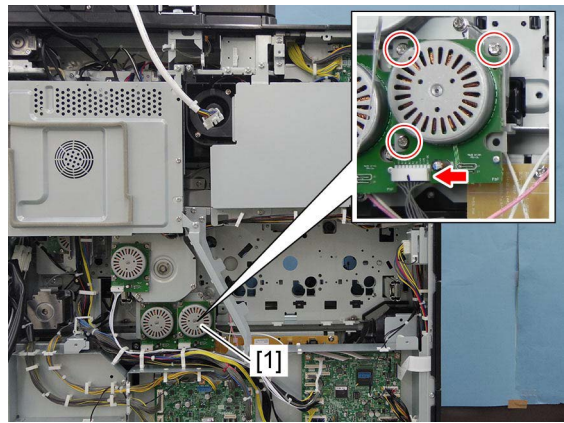



Fig. 4-410

4.6.32 Developer unit mixer motor (K) (M29)

- (1) Take off the rear cover.
 P. 4-12 “4.1.22 Rear cover”
- (2) Remove 3 screws. Disconnect 1 connector and take off the developer unit mixer motor (K) [1].

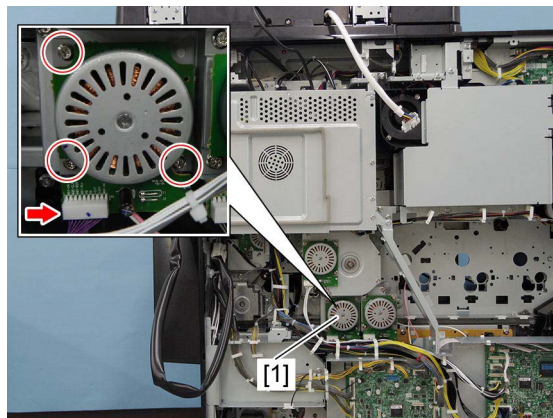



Fig. 4-411

4.6.33 EPU tray developer unit cooling duct

- (1) Take off the developer unit.
 P. 4-148 “4.6.24 Developer unit”
- (2) Take off the drum unit side vertical duct.
 P. 4-140 “4.6.17 Drum unit side vertical duct”
- (3) Disconnect all connectors connected to the drum surface potential sensor control PC board [1] (9029 only).

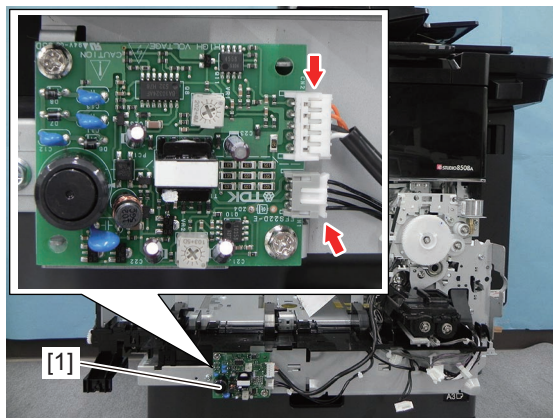

Fig. 4-412

(4) Remove 1 screw and take off the bracket [2] by sliding it.

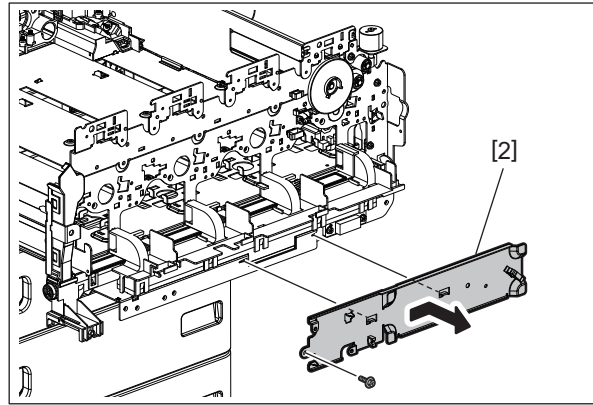

Fig. 4-413

(5) Remove the EPU tray developer unit cooling duct [3] by sliding it.

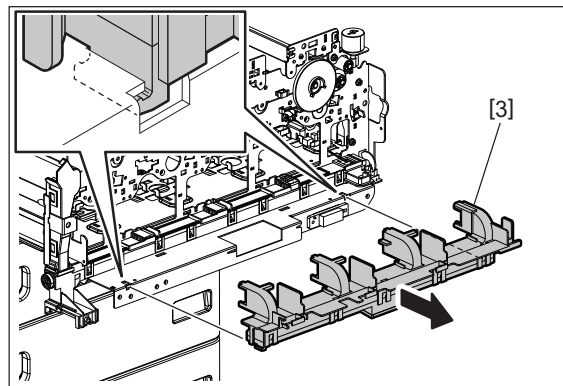

Fig. 4-414

4.6.34 TBU cleaner side vertical duct

- (1) Remove the EPU tray developer unit cooling duct.
📖 P. 4-165 "4.6.33 EPU tray developer unit cooling duct"
- (2) Remove 1 screw and take off the metal plate [1].

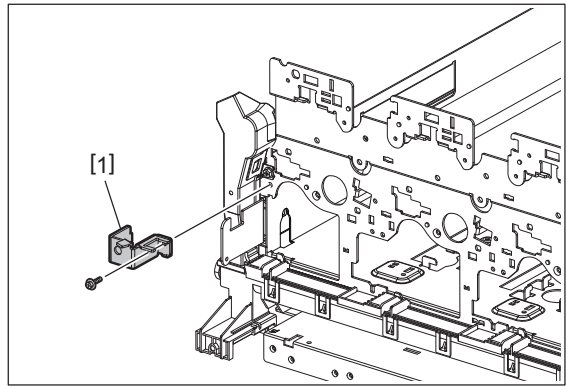

Fig. 4-415

- (3) Remove 1 screw and take off the TBU cleaner side vertical duct [2].

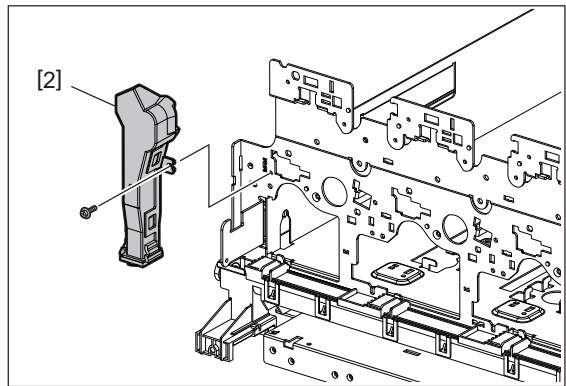

Fig. 4-416

4.6.35 EPU tray waste toner horizontal transport unit

- (1) Remove the TBU cleaner side vertical duct.
📖 P. 4-167 "4.6.34 TBU cleaner side vertical duct"
- (2) Remove the auger lock detection sensor.
📖 P. 4-139 "4.6.16 Auger lock detection sensor (S42)"
- (3) Remove 2 screws and take off the EPU tray waste toner horizontal transport unit [1].

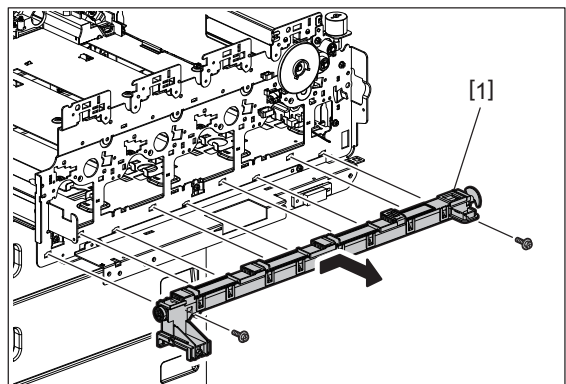

Fig. 4-417

4.6.36 Waste toner box

- (1) Open the waste toner cover [1].

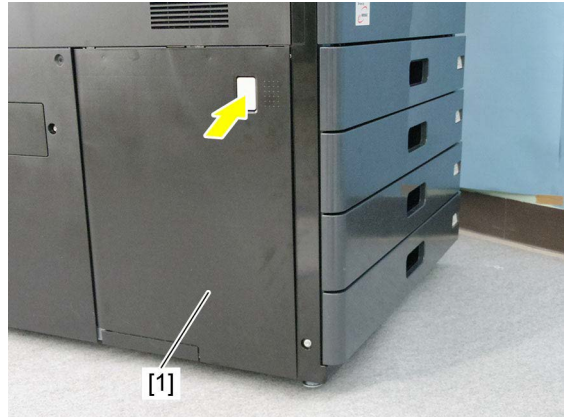

Fig. 4-418

- (2) Take out the waste toner box [2].

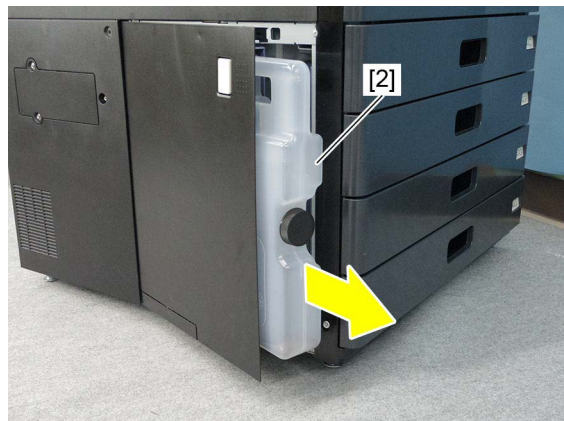

Fig. 4-419

- (3) Attach the cap [3].

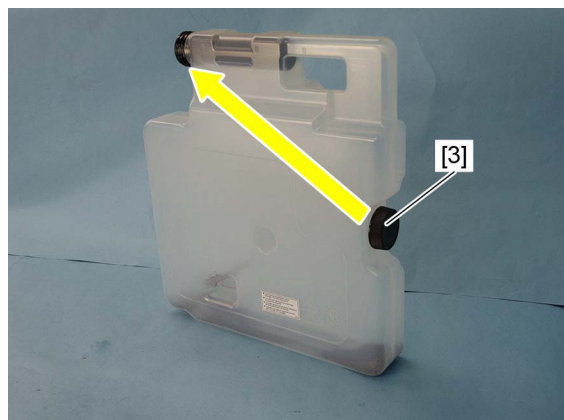

Fig. 4-420

4.6.37 Waste toner box nearly full detection sensor (S13)

- (1) Take off the left lower cover.
P. 4-9 "4.1.16 Left lower cover"
- (2) Remove 1 screw and take off the bracket [1].

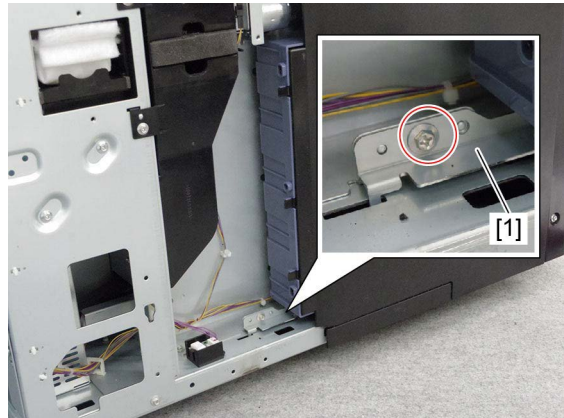

Fig. 4-421

- (3) Lower the dowel [2] located at the upper of the waste toner case.

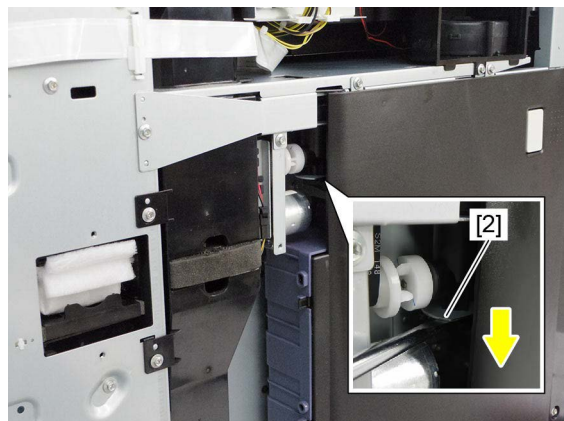

Fig. 4-422

- (4) Hold up the bottom of the waste toner case [3] and remove the dowel [2]. Remove the waste toner case [3] by lowering it.



Fig. 4-423

(5) Release 1 hook and remove the sensor cover [4].

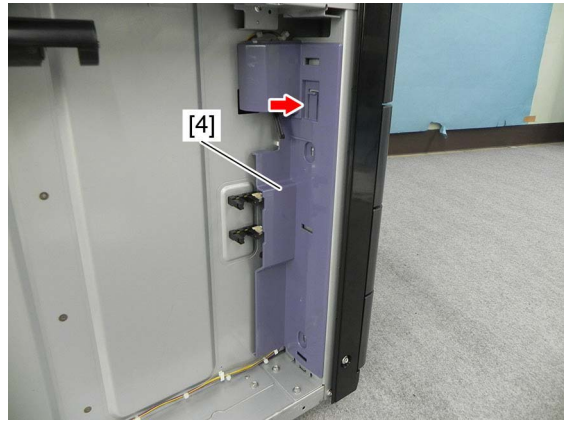

Fig. 4-424

(6) Disconnect 1 connector and release 3 latches. Remove the waste toner box nearly full detection sensor [5].

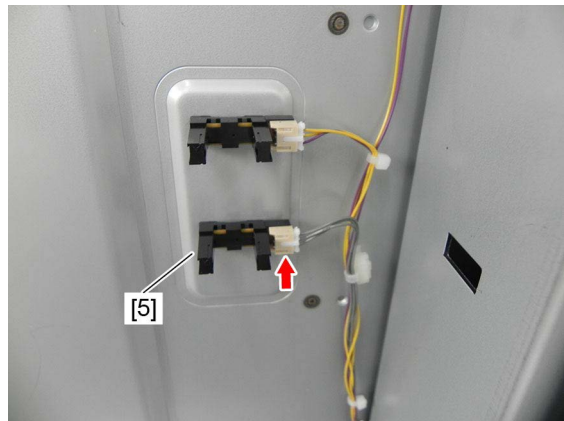



Fig. 4-425

4.6.38 Waste toner box full detection sensor (S14)

- (1) Take off the sensor cover.
 P. 4-169 “4.6.37 Waste toner box nearly full detection sensor (S13)”
- (2) Disconnect 1 connector and release 3 latches. Remove the waste toner box full detection sensor [1].

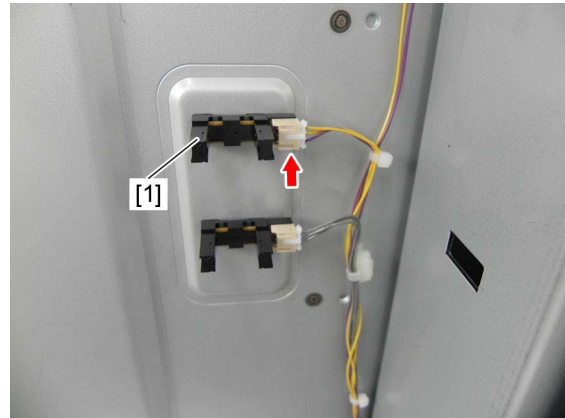



Fig. 4-426

4.6.39 Waste toner box detection sensor (S16)

- (1) Take off the sensor cover.
 P. 4-169 “4.6.37 Waste toner box nearly full detection sensor (S13)”
- (2) Disconnect 1 connector and release 3 latches. Remove the waste toner box detection sensor [1].

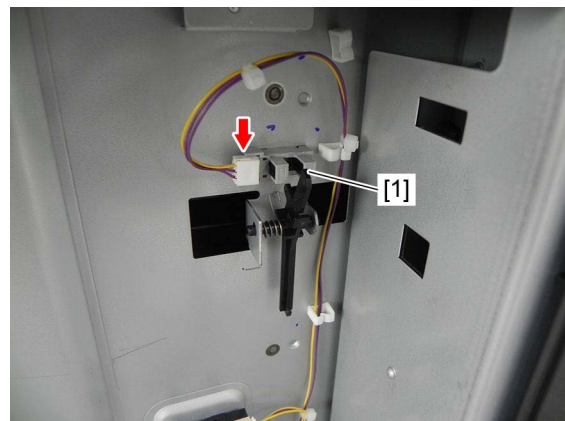

Fig. 4-427

4.6.40 Ozone filter-1

- (1) Remove 2 screws and take off the filter cover [1].



Fig. 4-428

- (2) Remove the ozone filter-1 [2].



Fig. 4-429

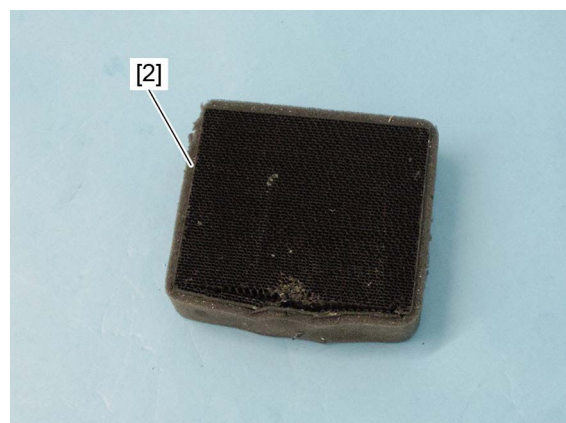

Fig. 4-430

4.6.41 Ozone filter-2

- (1) Remove 2 screws and take off the filter cover [1].



Fig. 4-431

- (2) Remove the ozone filter-2 [2].



Fig. 4-432



Fig. 4-433

4.6.42 Power supply unit cooling fan (F37)

- (1) Take off the switching regulator.
P. 9-17 "9.1.14 Switching regulator (PS)"
- (2) Pull out the harness from the window [1] of the frame and then release it from 2 harness clamps [2].

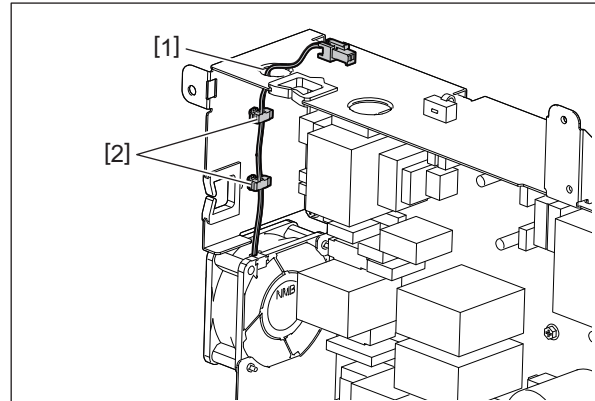

Fig. 4-434

- (3) Remove 2 screws and take off the power supply unit cooling fan [3].

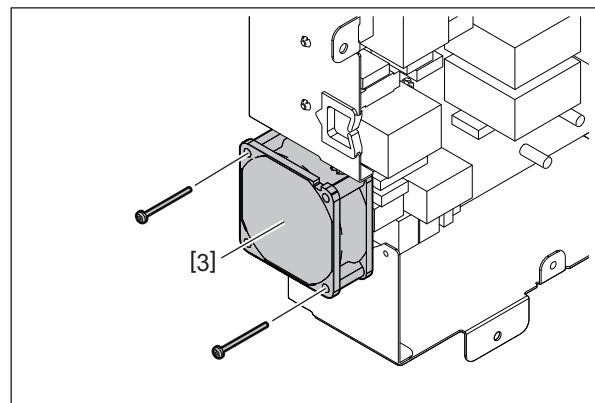

Fig. 4-435

4.6.43 Toner filter

- (1) Remove 2 screws and take off the filter cover [1].



Fig. 4-436

- (2) Remove the toner filter [2].



Fig. 4-437

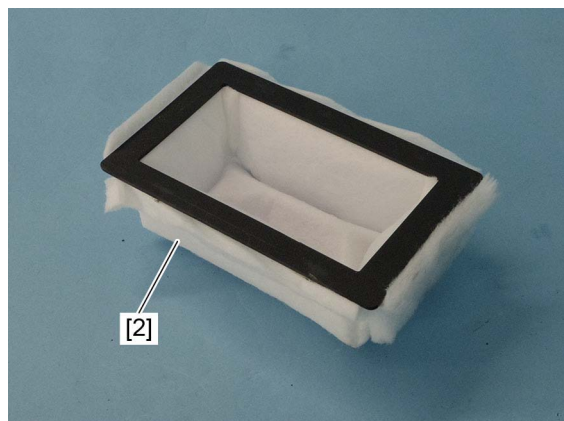





Fig. 4-438

4.6.44 Toner guide

- (1) Perform FS-05-4914 and then pull out the toner cartridge.
- (2) Take off the front cover.
 P. 4-1 “4.1.2 Front cover”
- (3) Take off the exit tray.
 P. 4-7 “4.1.13 Exit tray”
- (4) Take off the switch cover.
 P. 4-189 “4.6.52 Toner motor interlock switch (SW3)”
- (5) Pull out the process unit (EPU tray).
 P. 4-124 “4.6.1 Pulling out of the process unit (EPU tray)”
- (6) Disconnect 1 connector [1].

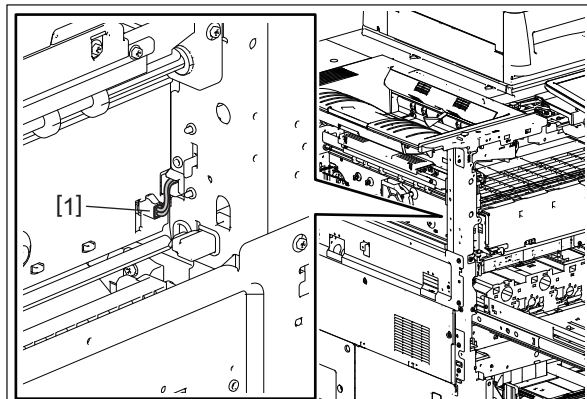

Fig. 4-439

- (7) Remove 2 screws and take off the toner guide [2] by sliding it to the left-hand side and then pulling it toward you.

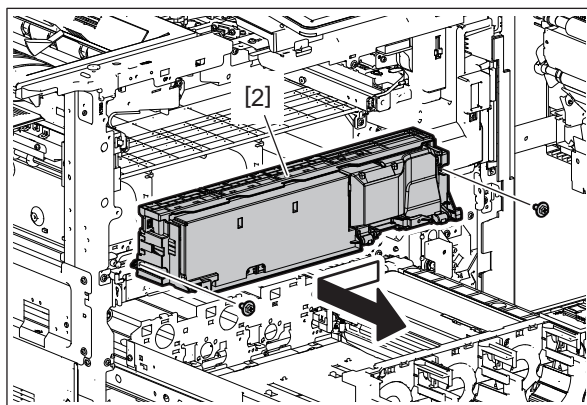

Fig. 4-440

Notes: Film attached to the toner guide

- Replace the film [3] with a new one if it is deformed, damaged or is dirty because of toner sticking to the adhesive surface.
- If the film [3] is peeled off, it may damage the harness. Therefore, be sure to attach the film [3] securely so that it does not become peeled off.
- When installing the film [3], be careful not to let the harness come over from it.

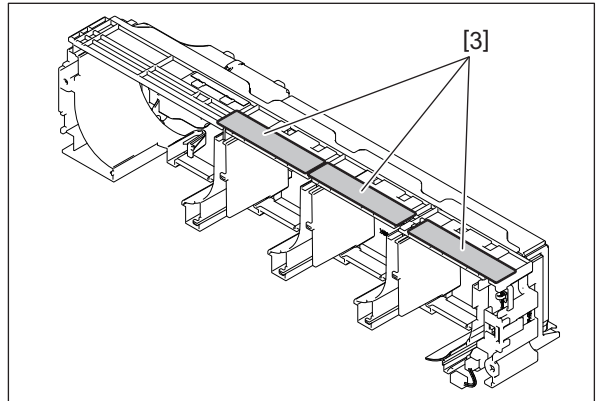



Fig. 4-441

4.6.45 Toner cover solenoid (K) (SOL12)

- (1) Remove the toner guide.
 P. 4-176 "4.6.44 Toner guide"
- (2) Release the slider [1] and open the toner cover [2].

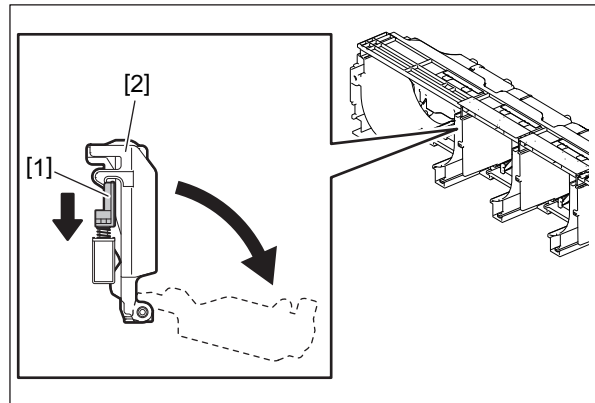

Fig. 4-442

- (3) Release the lock [3] and take off the toner cover [2].

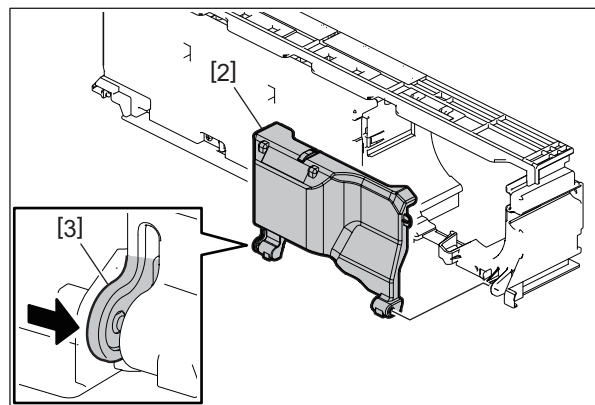

Fig. 4-443

- (4) Remove 2 screws and take off the inner cover [4].

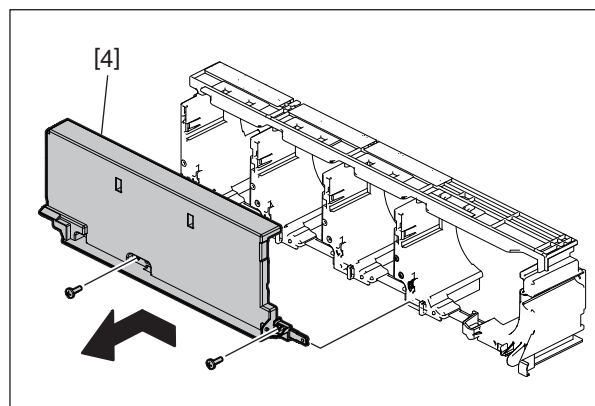

Fig. 4-444

- (5) Remove 2 screws. Disconnect the connector [5] and remove the toner cover solenoid (K) [6].

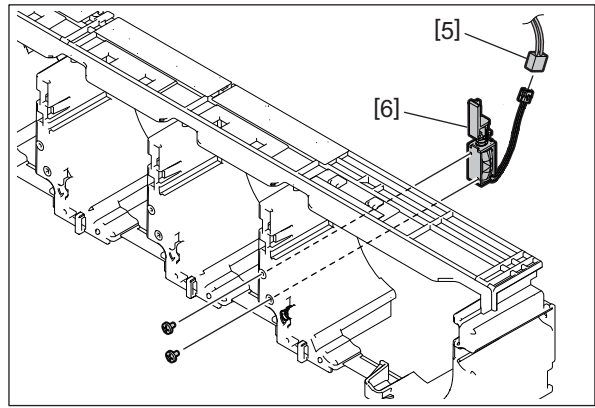

Fig. 4-445

- (6) Remove the slider [1] and the spring [7] from the toner cover solenoid (K) [6].

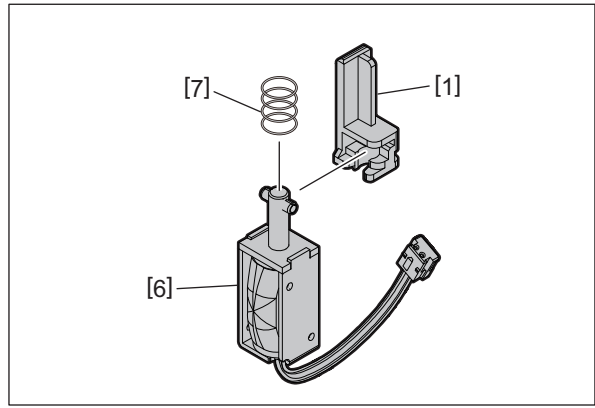



Fig. 4-446

4.6.46 Toner motor (K) (M15)

- (1) Remove the toner guide.
 P. 4-176 "4.6.44 Toner guide"
- (2) Remove 2 screws and release the hook by sliding the toner cover [2] slightly toward you. Take off the toner cover [2] by lifting it up slightly.

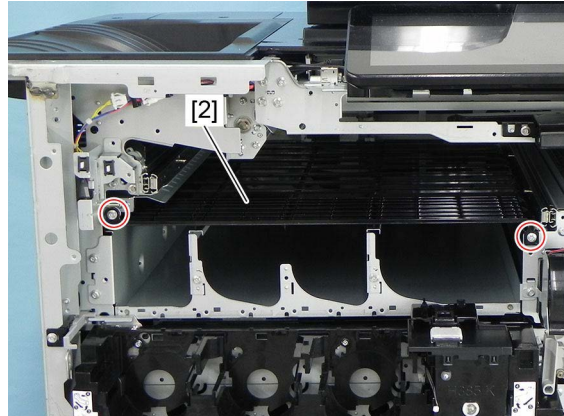

Fig. 4-447

- (3) Remove 2 screws and take off 2 stays [3].

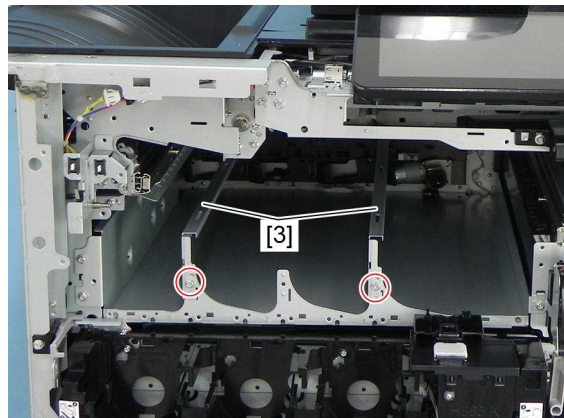

Fig. 4-448

- (4) Remove 2 screws. Release the harness from 2 harness clamps [4] and disconnect 1 connector.

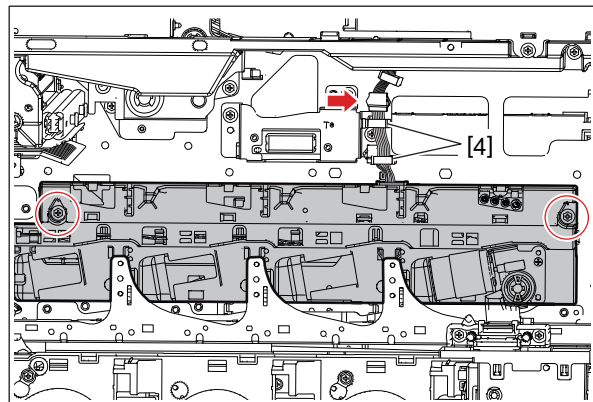

Fig. 4-449

- (5) Disconnect 1 connector and take off the toner motor assembly [5].

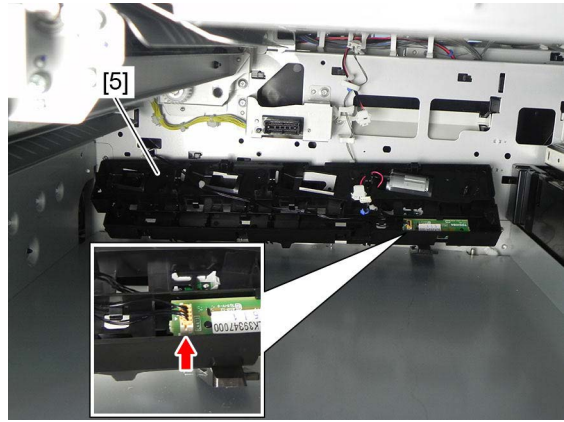

Fig. 4-450

- (6) Disconnect 1 connector.

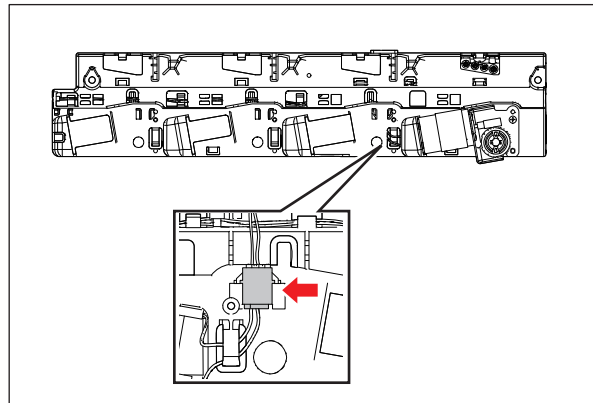

Fig. 4-451

- (7) Release 2 hooks and remove the gear [6].

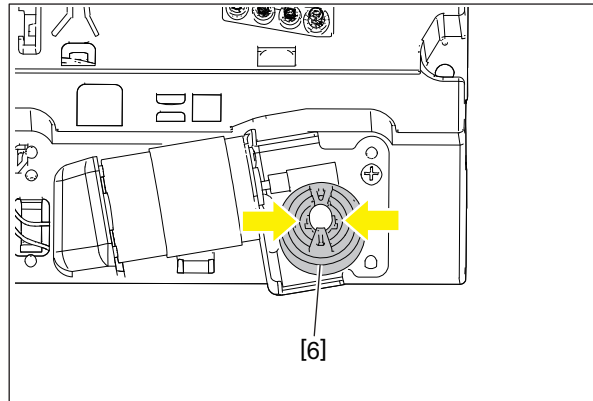

Fig. 4-452

(8) Remove the spring [7]. Remove 1 screw and take off the toner motor bracket [8].

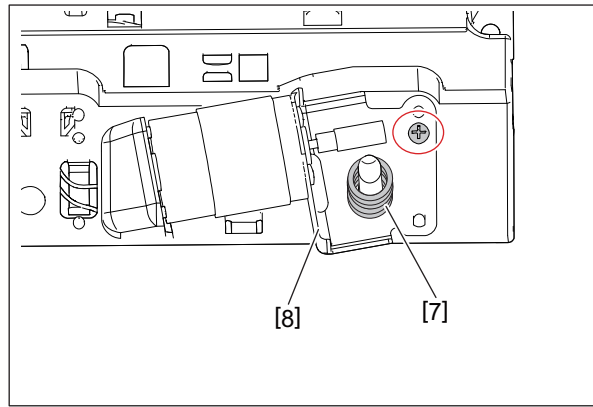

Fig. 4-453

(9) Remove 2 screws and take off the toner motor (K) [9].

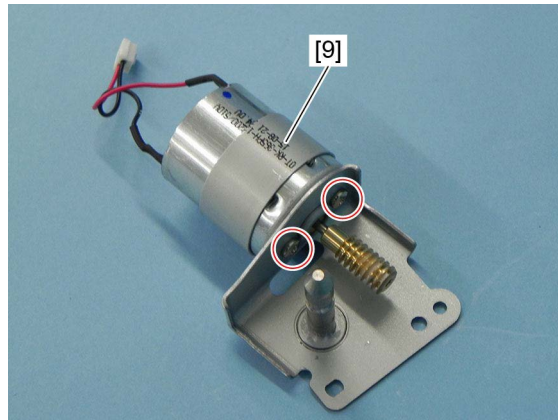

Fig. 4-454

Notes:

Pay attention to the size and length of the screws. If you use the wrong ones, the motor could be damaged.

4.6.47 Waste toner transport motor (M33)

- (1) Take off the left lower cover.
📖 P. 4-9 "4.1.16 Left lower cover"
- (2) Remove the stay.
📖 P. 4-185 "4.6.49 Ozone suctioning fan (F24)"
- (3) Disconnect 1 connector and release the harness from 2 harness clamps [1].
- (4) Remove 2 screws and separate the belt [2] from the pulley, and then take off the motor drive unit [3].

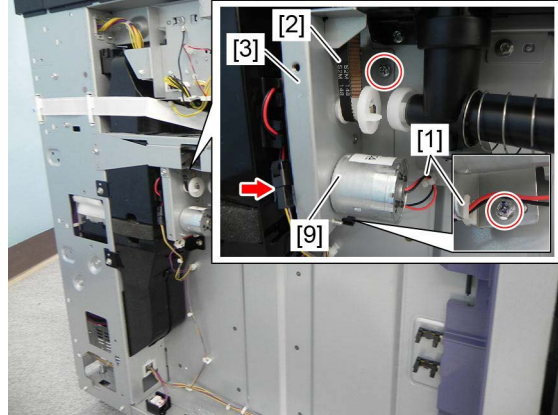

Fig. 4-455

- (5) Remove 2 screws, 1 C-ring [4] and 1 bushing [5], and then take off the bracket [6].

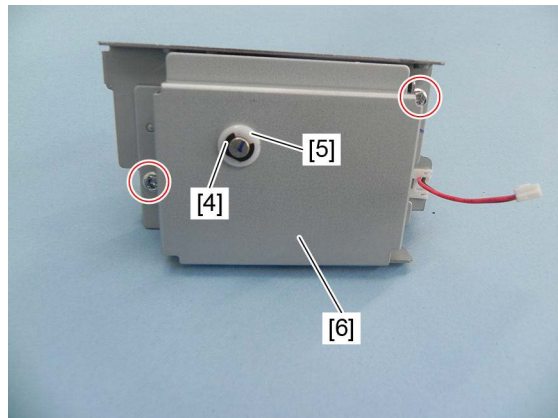

Fig. 4-456

- (6) Remove 2 screws and take off the belt [7]. Release the harness from the harness clamp [8] and remove the waste toner transport motor [9].

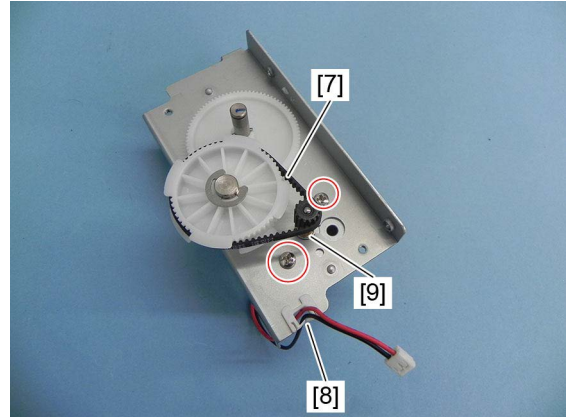



Fig. 4-457

4.6.48 Waste toner transport unit

- (1) Take off the motor drive unit.
 P. 4-183 "4.6.47 Waste toner transport motor (M33)"
- (2) Remove the stay.
 P. 4-185 "4.6.49 Ozone suctioning fan (F24)"
- (3) Remove 5 screws and take off the waste toner transport unit [1].

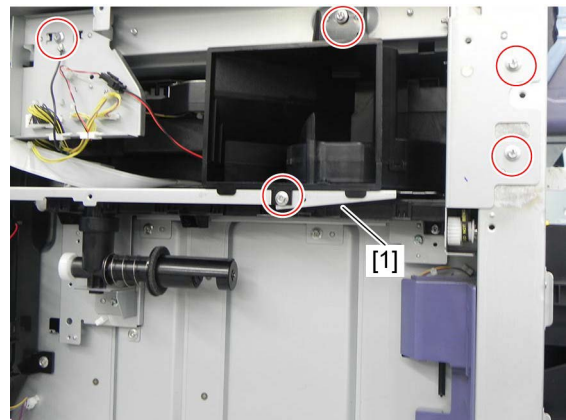

Fig. 4-458

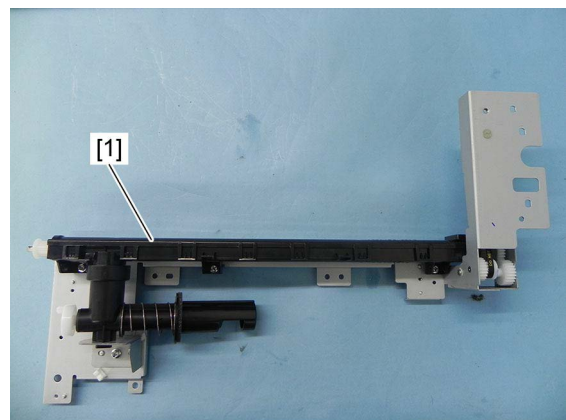

Fig. 4-459

Notes:

When you reinstall the removed belt of the waste toner drive unit, check that the belt [3] does not contact a metal plate [2].

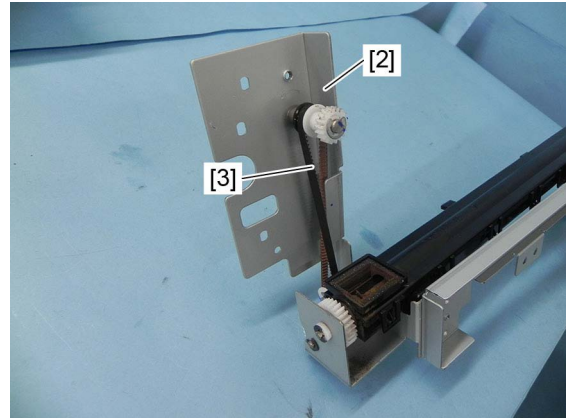

Fig. 4-460

4.6.49 Ozone suctioning fan (F24)

- (1) Take off the left lower cover.
📖 P. 4-9 “4.1.16 Left lower cover”
- (2) Remove the ozone filter-1.
📖 P. 4-172 “4.6.40 Ozone filter-1”
- (3) Take off the waste toner case.
📖 P. 4-169 “4.6.37 Waste toner box nearly full detection sensor (S13)”
- (4) Remove 5 screws and take off the stay [1].



Fig. 4-461

(5) Remove 3 screws. Disconnect 1 connector and take off the duct [2].

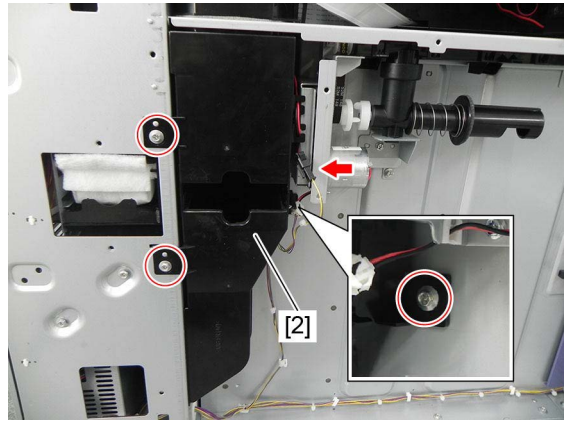

Fig. 4-462

(6) Release 7 latches and separate the duct [2].

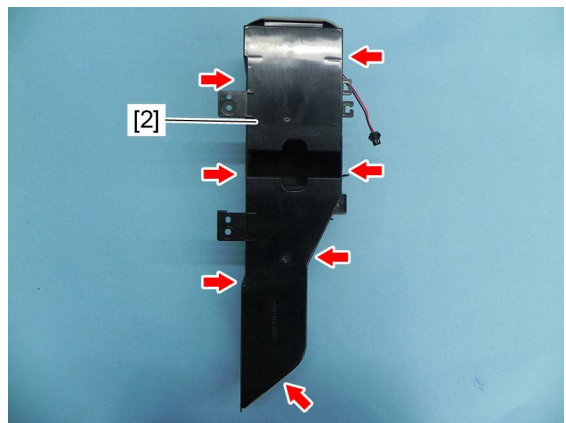

Fig. 4-463

(7) Release the harness from 2 harness guides and remove the ozone suctioning fan [3].

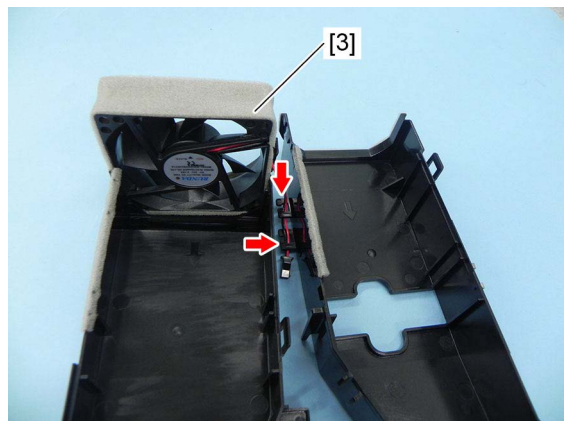



Fig. 4-464

4.6.50 Fuser insulation fan (F21)

- (1) Remove the toner guide.
 P. 4-176 "4.6.44 Toner guide"
- (2) Remove 2 screws and take off the right inner cover [1].

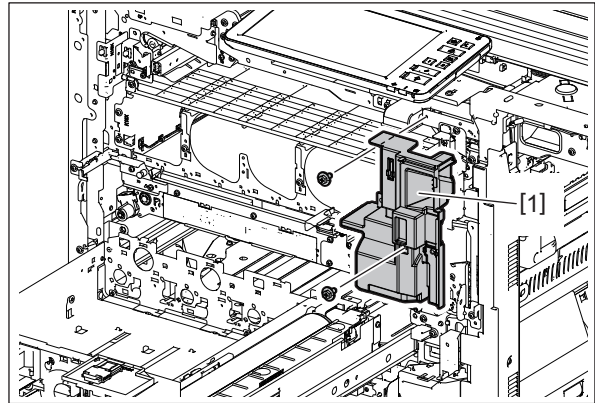

Fig. 4-465

- (3) Remove 1 screw. Disconnect 1 connector and take off the duct [6].

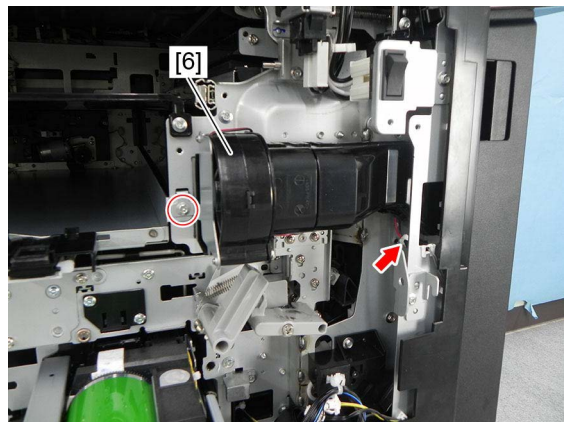

Fig. 4-466

- (4) Remove 2 screws and take off the fuser insulation fan [7]. Release the harness from the harness guide.

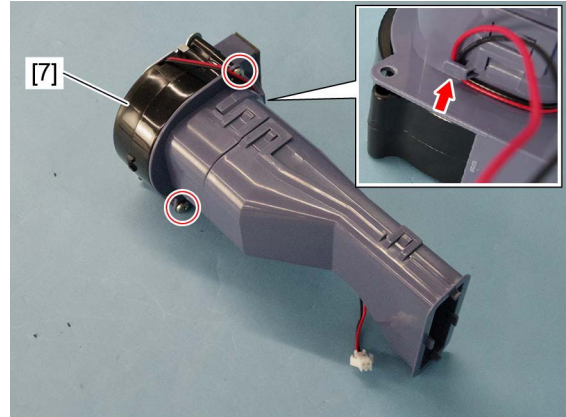

Fig. 4-467

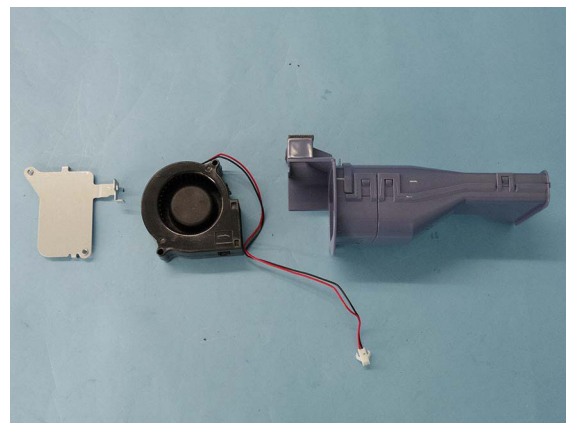

Fig. 4-468

4.6.51 Temperature/humidity sensor (S12)

- (1) Take off the left lower cover.
P. 4-9 “4.1.16 Left lower cover”
- (2) Release 2 latches.

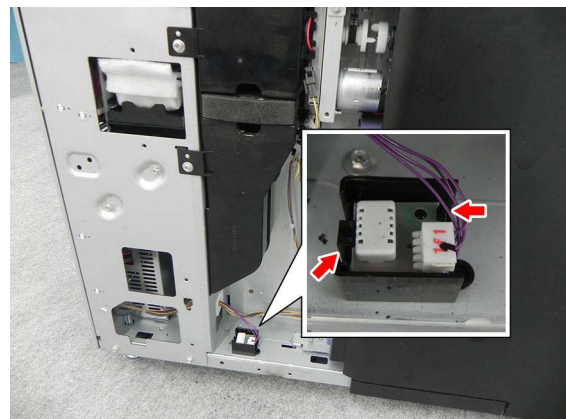

Fig. 4-469

- (3) Disconnect 1 connector and take off the temperature/humidity sensor [1].

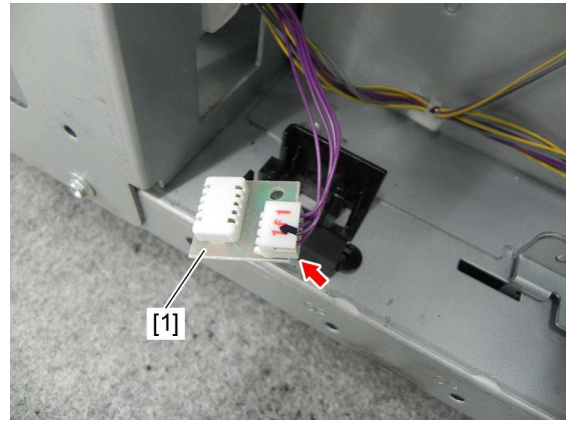

Fig. 4-470

4.6.52 Toner motor interlock switch (SW3)

Notes:

- When the toner motor interlock switch (SW3) is replaced or removed, be sure to perform the operation check with the input check (test mode 03).
- If the interlock switch is not installed appropriately, it may not work normally. If you carry out the maintenance of the MFP in such a situation, you could get an electric shock by touching live sections or be injured by touching moving sections. Therefore, to avoid this, be sure to perform correct handling and installation.

- (1) Take off the front right cover (control panel right cover).
📖 P. 4-3 “4.1.5 Front right cover (control panel right cover)”
- (2) Take off the front lower cover (control panel lower cover).
📖 P. 4-4 “4.1.7 Front lower cover (control panel lower cover)”
- (3) Take off the left corner cover.
📖 P. 4-13 “4.1.24 Left corner cover”
- (4) Take off the bridge unit.
📖 P. 4-271 “4.10.11 Bridge unit”
- (5) Insert the rails all the way in.
- (6) Remove 3 screws and take off the stay [2] and inner cover [3].

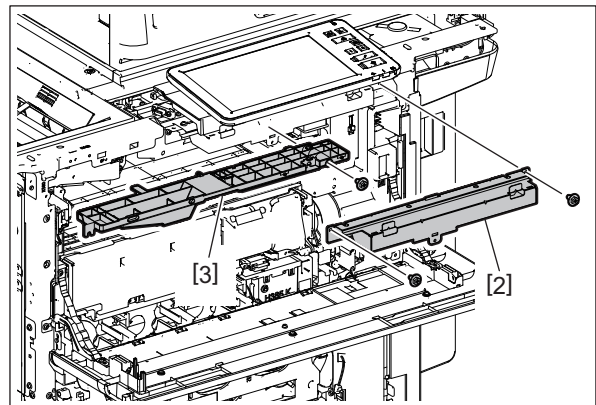

Fig. 4-471

(7) Remove 2 screws and take off the switch cover [4].

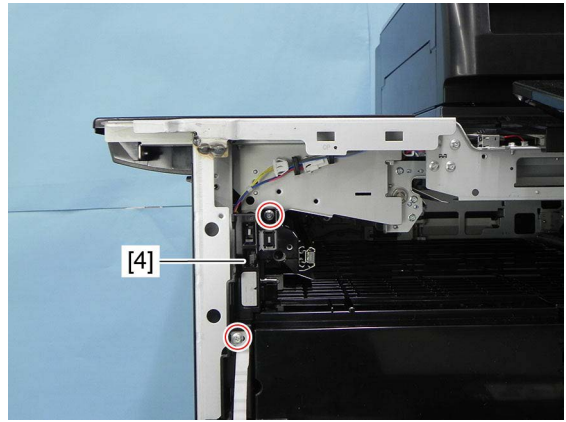

Fig. 4-472

(8) Disconnect 2 connectors and release the harness from the harness clamp [5].

(9) Remove 2 screws and take off the switch bracket [6].

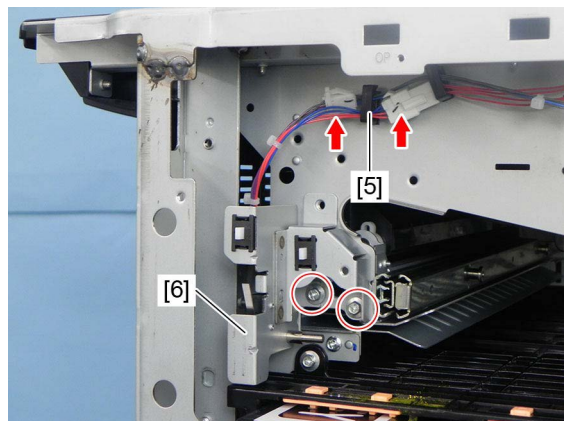

Fig. 4-473

(10) Disconnect 2 connectors, remove 2 screws and take off the toner motor interlock switch [7].

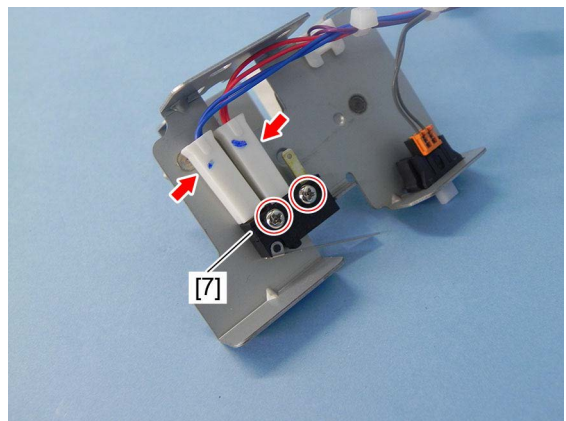

Fig. 4-474

4.6.53 Developer unit cooling fan (F14)

- (1) Remove the duct of the developer unit cooling fan.
P. 4-48 "4.4.1 Laser optical unit"
- (2) Release 6 latches. Then take off the developer unit cooling fan [1].

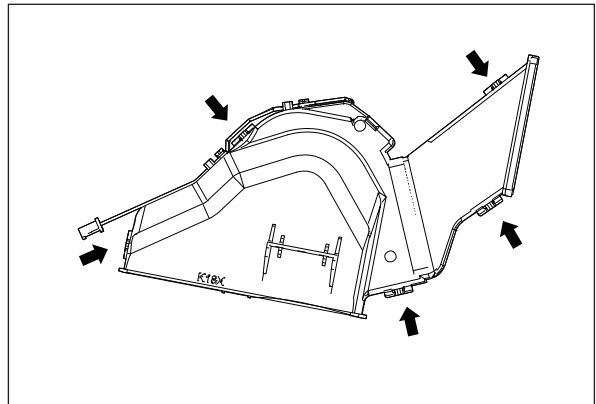

Fig. 4-475

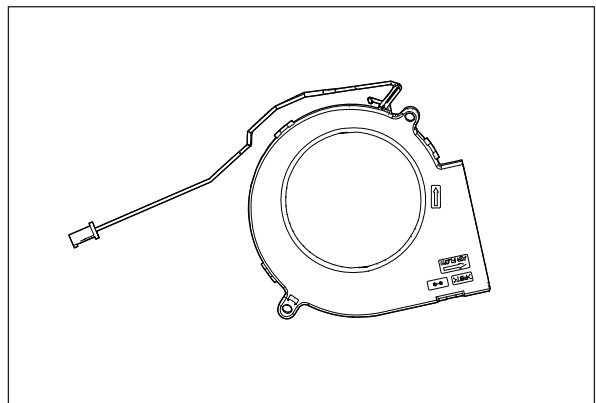

Fig. 4-476

4.6.54 Scattered toner suctioning fan (F25)

- (1) Take off the LGC/PFC board case.
📖 P. 9-13 "9.1.12 LGC/PFC board case"
- (2) Take off the switching regulator case.
📖 P. 9-17 "9.1.14 Switching regulator (PS)"
- (3) Take off the left lower cover.
📖 P. 4-9 "4.1.16 Left lower cover"
- (4) Remove 2 screws.

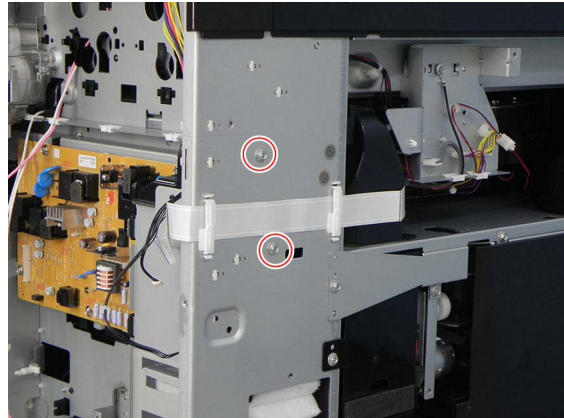

Fig. 4-477

- (5) Remove 2 screws and take off the bracket [2] and duct [1].

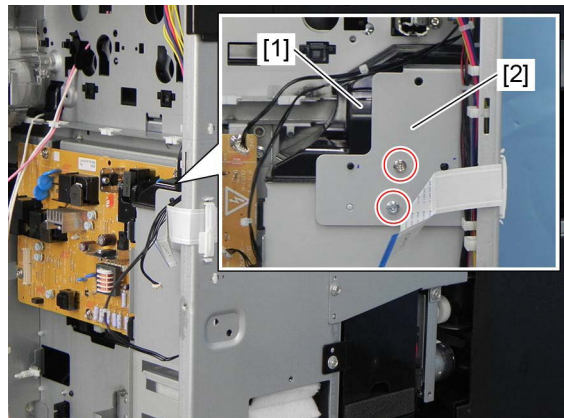

Fig. 4-478

- (6) Rotate 2 harness clamps by 90 degrees to take them off.

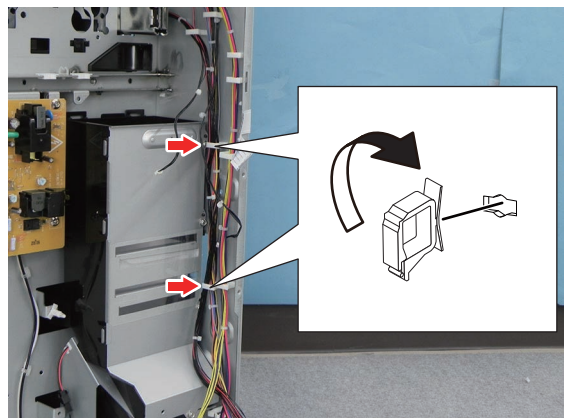

Fig. 4-479

(7) Disconnect 1 connector.

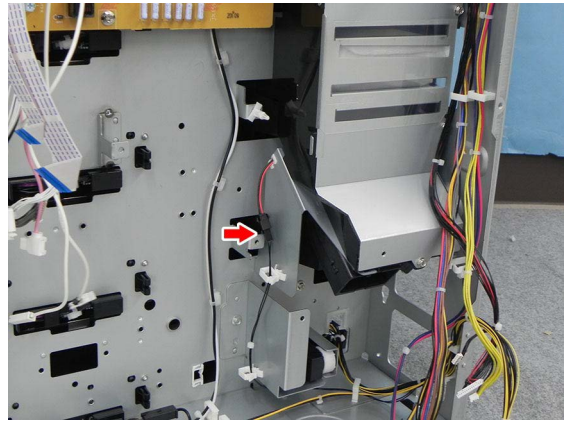

Fig. 4-480

(8) Remove 2 screws.

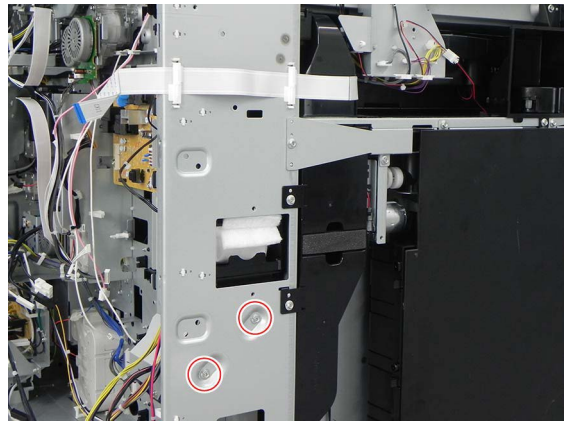

Fig. 4-481

(9) Remove the duct [3].

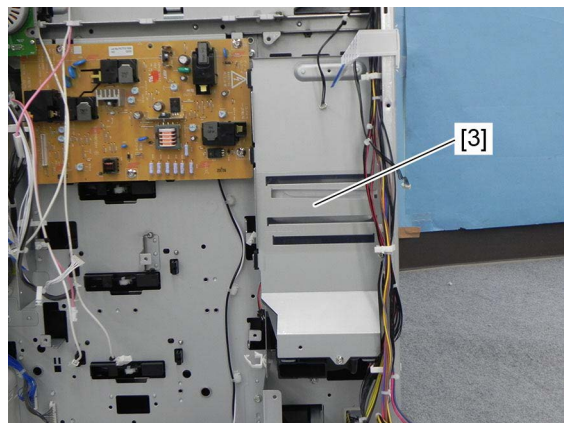

Fig. 4-482

(10) Release the harnesses from 1 harness clamp. Remove 2 screws and take off the scattered toner suctioning fan [4].

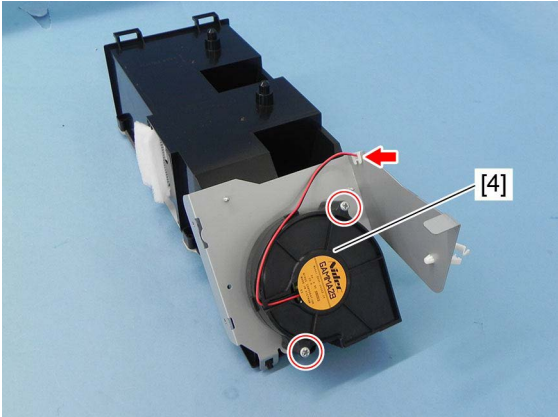

Fig. 4-483

4.7 Transfer Unit

4.7.1 Pulling out of the transfer belt unit

- (1) Fully open the duplexing unit until it stops.

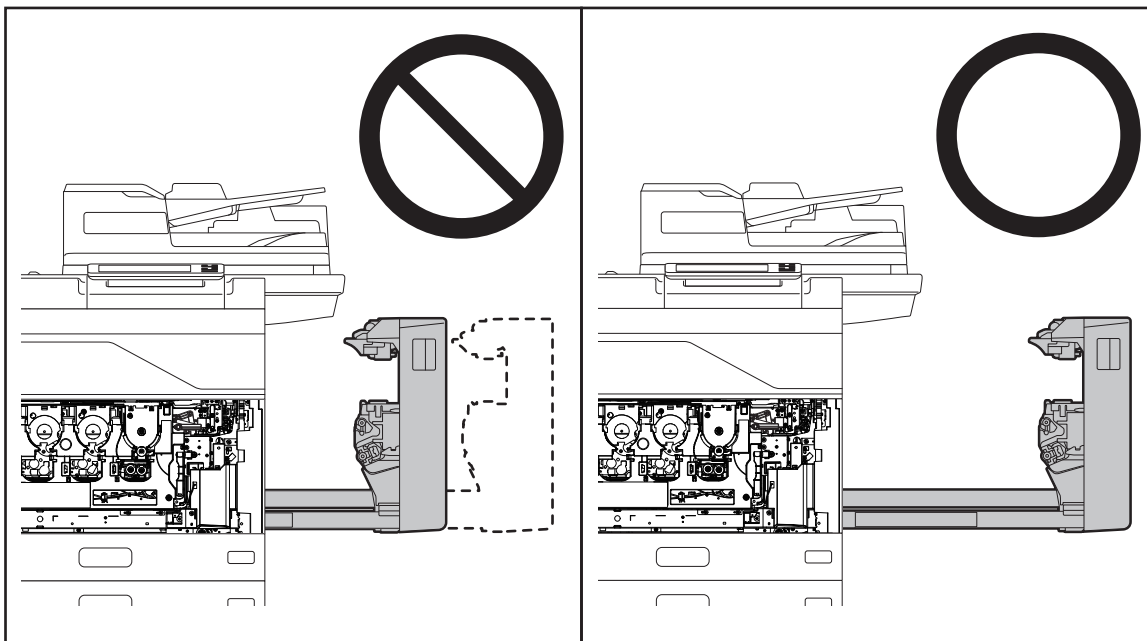

Fig. 4-484

- (2) Take off the front lower cover.
📖 P. 4-1 "4.1.1 Front lower cover"
- (3) Turn the TBU locking lever [1] for 90 degrees.

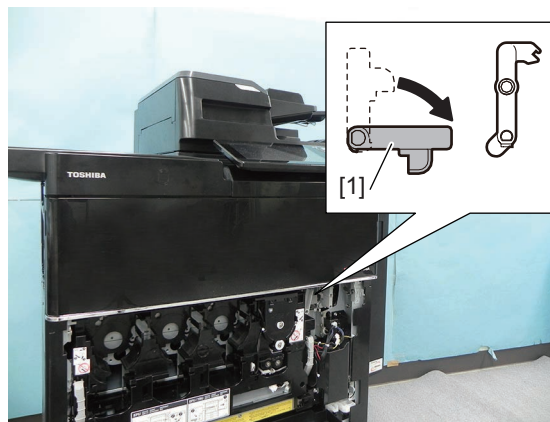

Fig. 4-485

(4) Lift up the EPU locking lever [2].

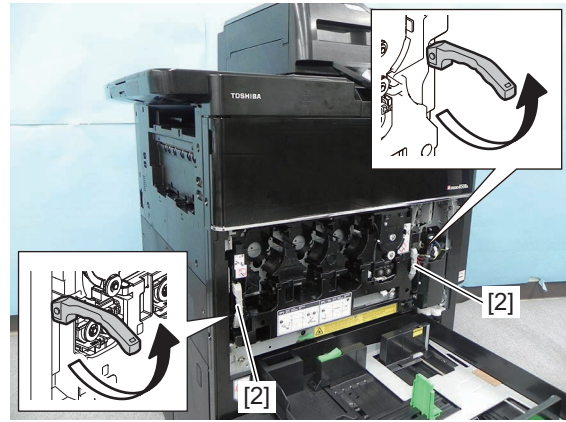

Fig. 4-486

(5) Turn the EPU locking lever [2] for 90 degrees.

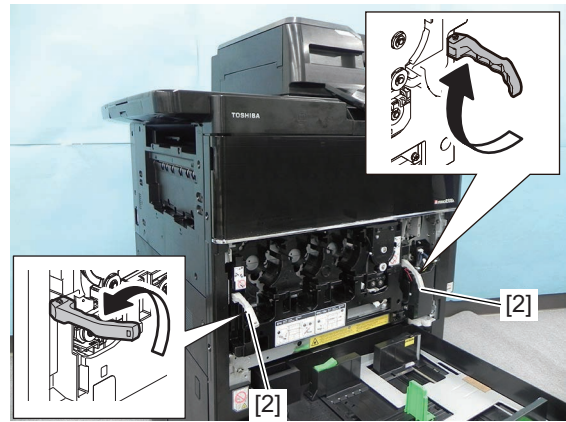

Fig. 4-487

(6) Pull out the transfer belt unit [3] by holding the EPU locking levers [2].

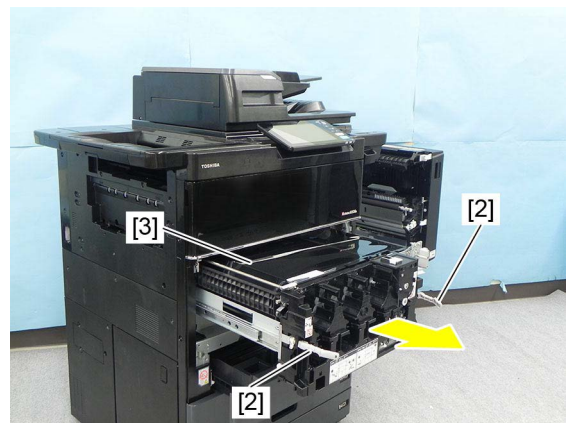

Fig. 4-488

Notes:

When installing or removing the transfer belt unit (EPU tray), make sure that the duplexing unit is pulled out fully. Moreover, check that the transfer belt unit is completely set before the duplexing unit is closed.

If the transfer belt unit and duplexing unit are under the following states, parts may be damaged.

1. When the duplexing unit is opened or closed without fully pulling out or closing the transfer belt unit (EPU unit)
2. When the transfer belt unit is pulled out or closed without fully opening the duplexing unit
 - The clips on both edges of the 2nd transfer roller may fall off.
 - The 2nd transfer unit front guide may be damaged.
 - The transfer belt may be damaged.
 - The 2nd transfer roller may be damaged.
 - The bearings on both edges of the 2nd transfer roller may fall off.
 - The 2nd transfer unit (TRU) may fall off.

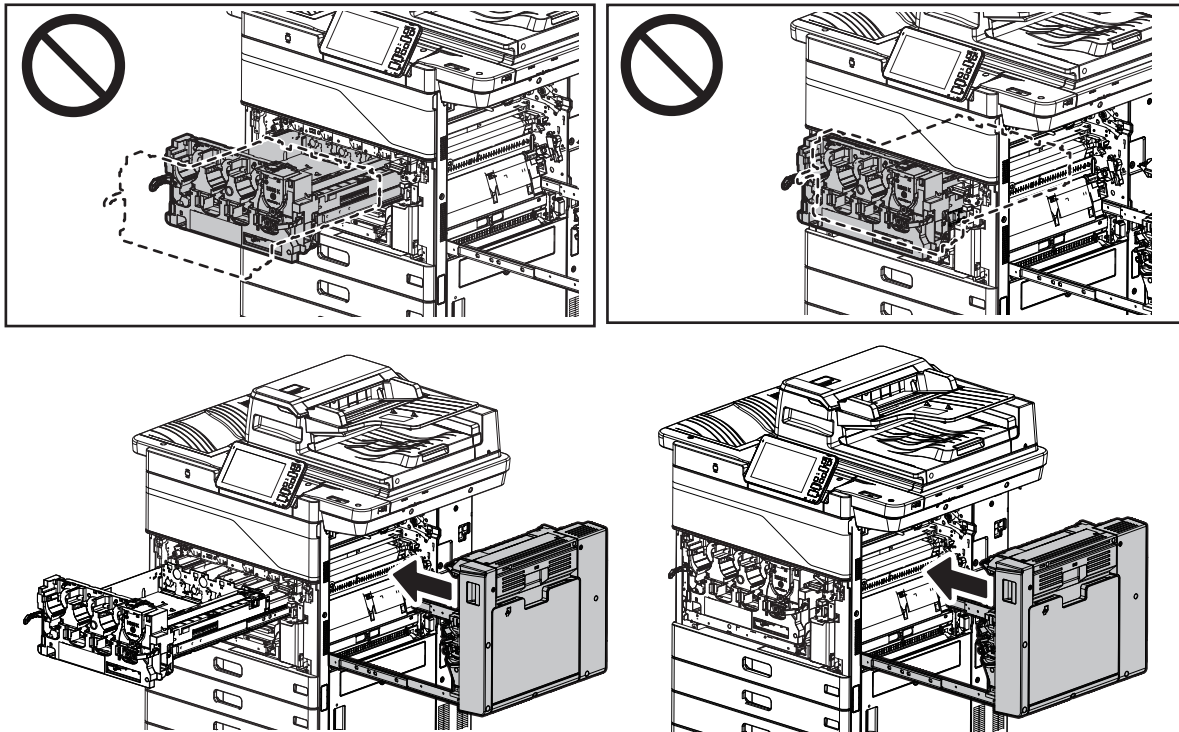



Fig. 4-489

4.7.2 2nd transfer facing roller cleaning pad

- (1) Take off the front lower cover.
 P. 4-1 “4.1.1 Front lower cover”
- (2) Remove 1 screw and then take off the 2nd transfer facing roller cleaning pad [1].

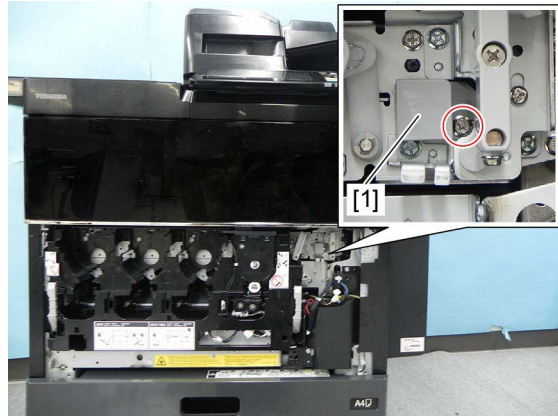

Fig. 4-490

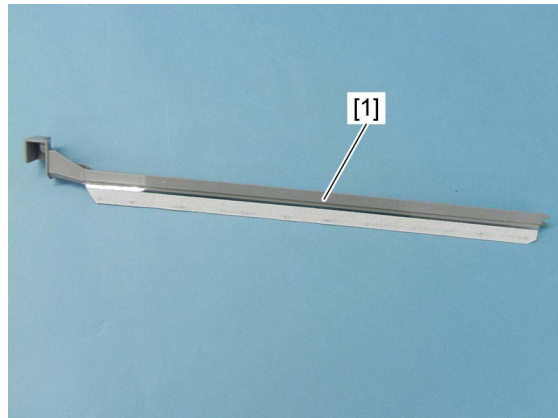

Fig. 4-491

4.7.3 Transfer belt cleaner unit

- (1) Pull out the transfer belt unit.
📖 P. 4-195 "4.7.1 Pulling out of the transfer belt unit"
- (2) Loosen 2 screws.

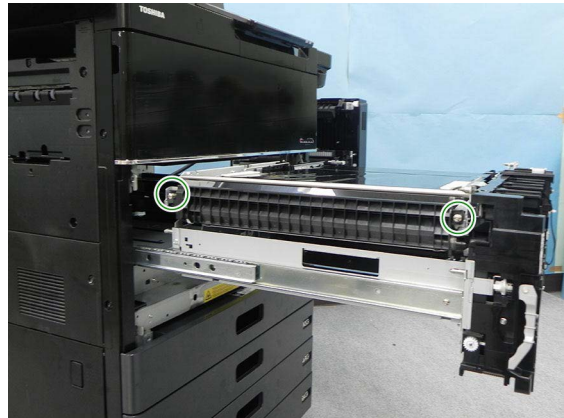

Fig. 4-492

- (3) Remove the transfer belt cleaner unit [2] while pushing the lever [1] on the front side.

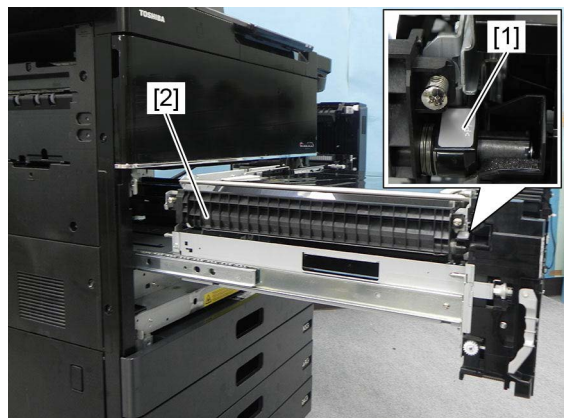

Fig. 4-493

Notes:

When taking off the TBU cleaner, clean it if it is dusty or stained [3]. When taking off the TBU cleaner, clean it if the film [4] sheet indicated by the figure gets dusty or stained [3].

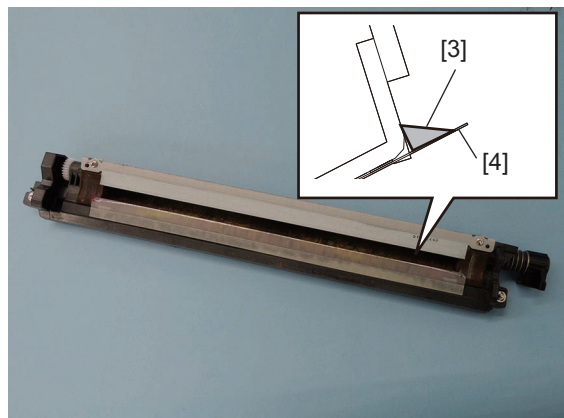



Fig. 4-494

4.7.4 Transfer belt cleaning blade

- (1) Take off the transfer belt cleaner unit.
 P. 4-199 “4.7.3 Transfer belt cleaner unit”
- (2) Remove 2 screws and take off the transfer belt cleaning blade [1].

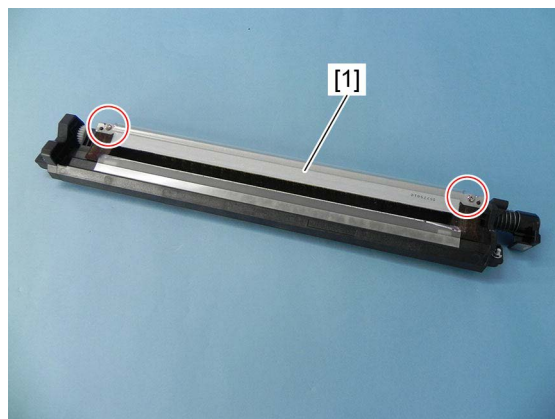



Fig. 4-495

Notes:

- When taking off the transfer belt cleaning blade, be sure to check the back side and clean it if it is dirty.
- When taking off the transfer belt cleaning blade, clean the image quality control unit.
 P. 7-32 “7.6.9 Image quality control unit”

4.7.5 Transfer belt cleaner side seal

- (1) Turn up a recovery blade and then remove the transfer belt cleaner side seals [1] on both sides.

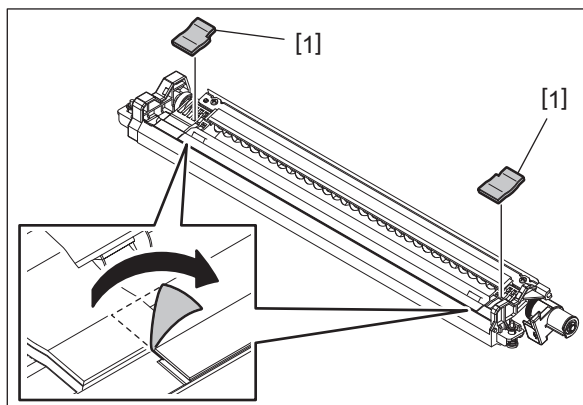

Fig. 4-496

Notes:

- When taking off the transfer belt cleaner side seal, clean the image quality control unit.
📖 P. 7-32 “7.6.9 Image quality control unit”
- When installing the transfer belt cleaner side seals, install them following the standard shown in the figure. Install 2 transfer belt cleaner side seals following the standard shown in the figure.

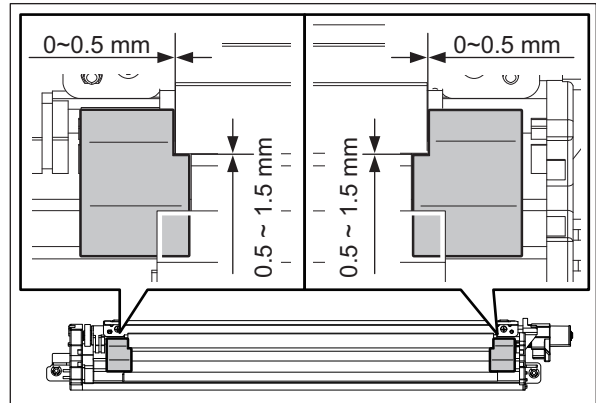

Fig. 4-497

- After the transfer belt cleaning blade is attached, check that the blade does not come over transfer belt cleaner side seal.

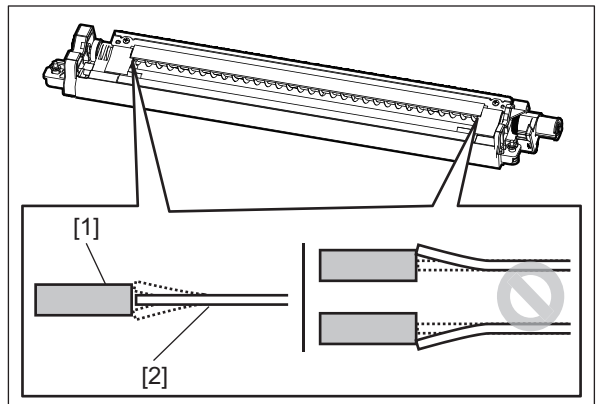

Fig. 4-498

4.7.6 Transfer belt unit (TBU)

- (1) Take off the transfer belt cleaner unit.
📖 P. 4-199 “4.7.3 Transfer belt cleaner unit”
- (2) Hold 2 handles [1] and take off the transfer belt unit [2].

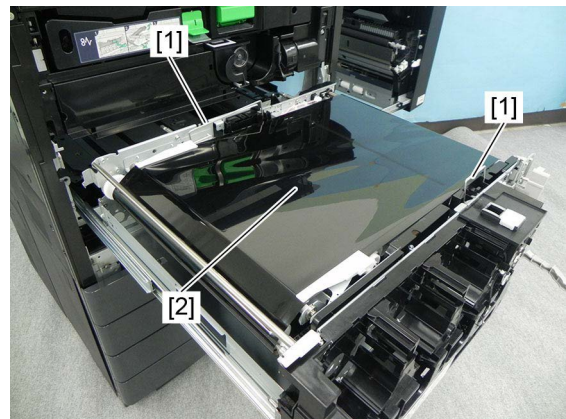

Fig. 4-499

Notes:

- Make sure that 2 sections shown in the figure are properly set.



Fig. 4-500

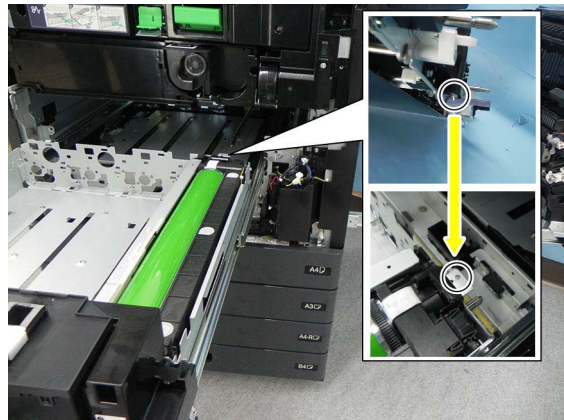

Fig. 4-501

- The power supply spring shown in the figure supplies high-voltage bias from the MFP to each roller. If any of these springs is dirty, clean it. If it is deformed, replace it with a new one.
 - [1] 1st transfer roller
 - [2] 2nd transfer facing roller
 - [3] Power supply spring (1st transfer roller)
 - [4] Power supply spring (2nd transfer facing roller)

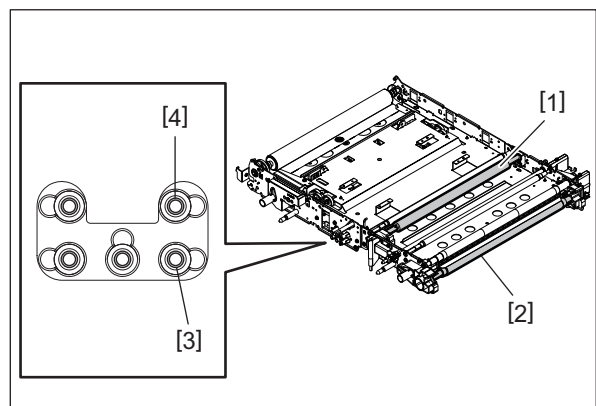



Fig. 4-502

- When installing the TBU, install it securely and close the duplexing unit. If you close the duplexing unit without having securely installed the TBU, this may damage the transfer belt or the 2nd transfer roller, deform the 2nd transfer front guide or cause the bearing on both ends of the 2nd transfer roller to fall off.
- Make sure that the process unit is installed securely.
- Check that the TBU locking lever is locked.

4.7.7 Transfer belt

Notes:

You are recommended to wear gloves so that you do not touch the surface of the transfer belt with bare hands.

- (1) Take off the transfer belt unit.
 P. 4-201 "4.7.6 Transfer belt unit (TBU)"
- (2) Pull up the belt guides [1] by approx. 20 degrees and then pull them out to take them off.

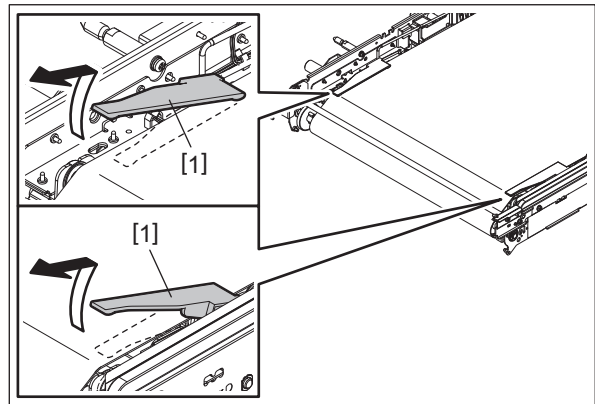

Fig. 4-503

Notes:

When installing the belt guide [1], tilt it by approx. 20 degrees and insert it to the shaft, and then let it go down under its own weight. When it does not go down under its weight, reinstall it because the belt [2] might get on the rib [3] of the guide.

[4] Pulley

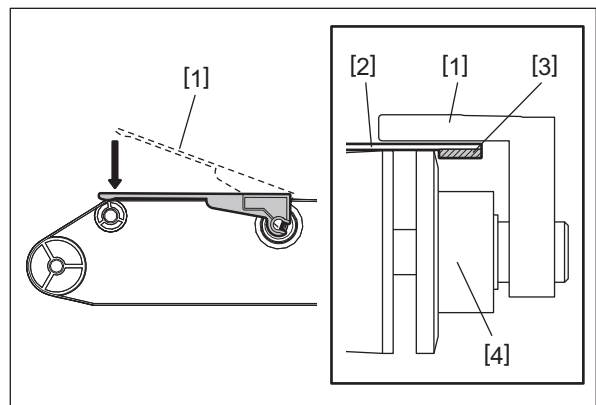

Fig. 4-504

- (3) Remove 1 screw and take off the stay [5].

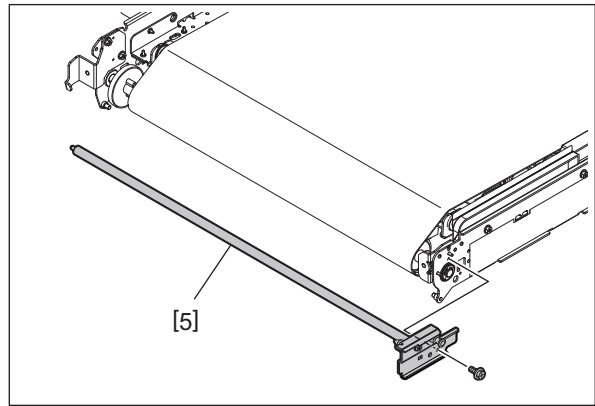

Fig. 4-505

- (4) Remove 2 screws and take off the fixing bracket [6] on the front side.
(5) Remove 2 screws and take off the fixing bracket [7] on the rear side.

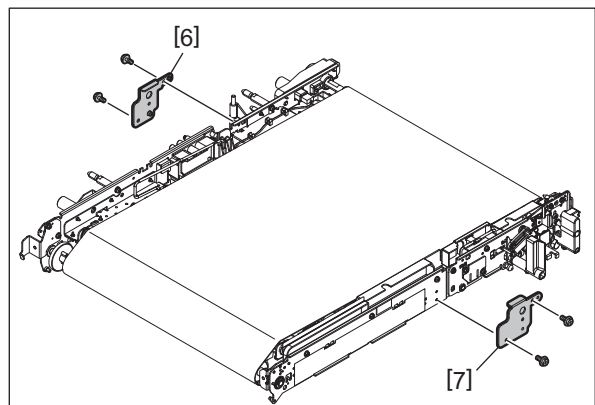

Fig. 4-506

- (6) Fold the frame with its rear side down.
(7) Pull out the transfer belt [8] upward to take it off.

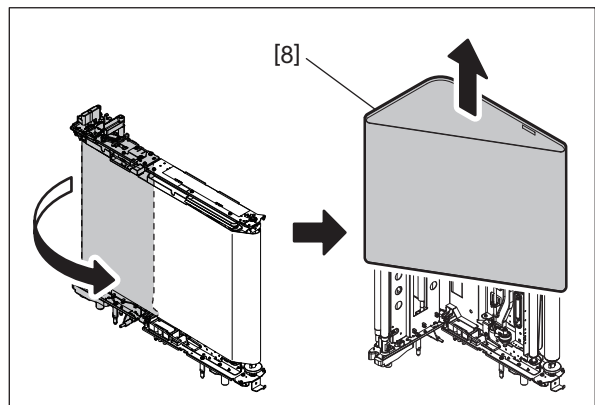

Fig. 4-507

Notes:

- When taking off the transfer belt, clean the image quality control unit.
📖 P. 7-32 “7.6.9 Image quality control unit”
- When replacing the transfer belt, check the cleaning facing roller, 2nd transfer facing roller and tension roller, and clean them with alcohol. If the 1st transfer roller has foreign matter adhering to it, remove this before installing the transfer belt.
- Install the transfer belt in the middle so that it does not move to one side.
- When installing, be sure that the serial number [9] indicated the inside of the belt is shown at the front side.

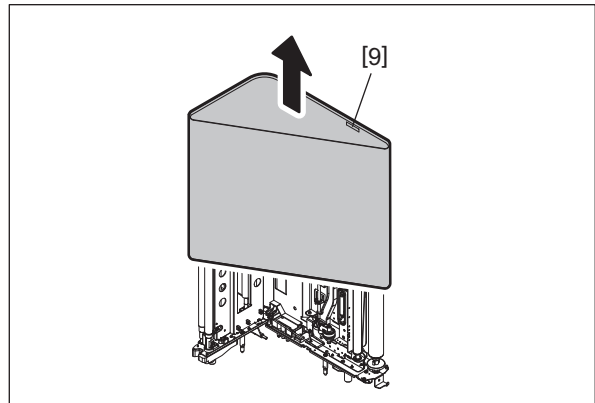

Fig. 4-508

- Do not touch the belt surface directly with bare hands.
- Be sure not to scratch the belt surface.
- When replacing the transfer belt, clean the cleaning facing roller, 2nd transfer facing roller, tension roller and idling roller with alcohol.
- Attach a belt guide so that the rib of the transfer belt will not be run on the detection roller.
- After the transfer belt is installed, rotate the cleaning facing roller in the direction of the arrow to set the value of the cutting angle indicator to 0 ± 0.5 degree.

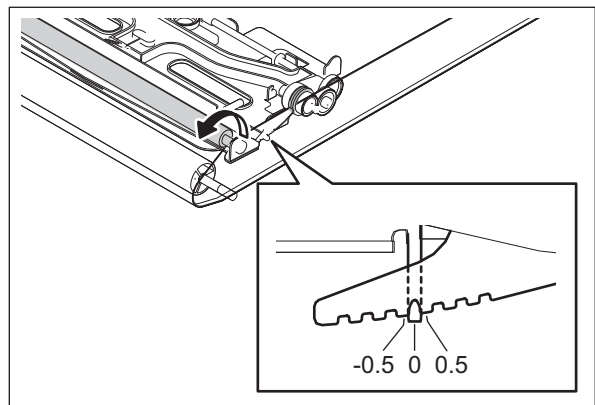

Fig. 4-509

- Clean 2 portions on the control plate [10] on the cleaner unit facing roller side, 2 portions on the control plate [11] on the guide roller side as well as 2 portions on the control plate [12] on the 2nd transfer facing roller side.

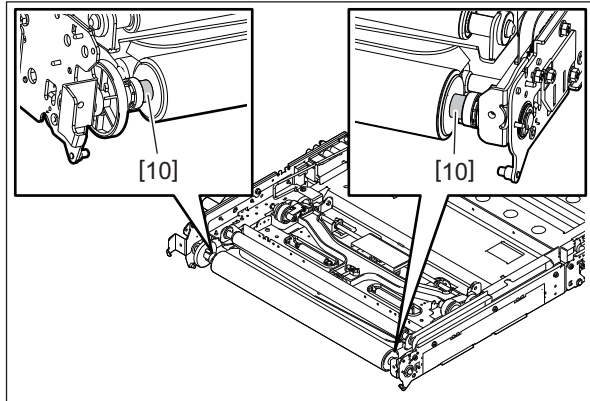

Fig. 4-510

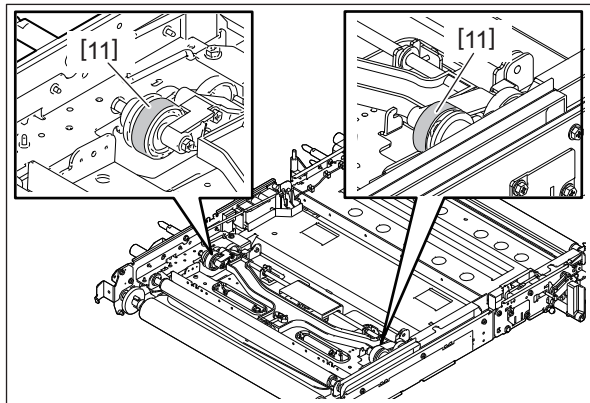

Fig. 4-511

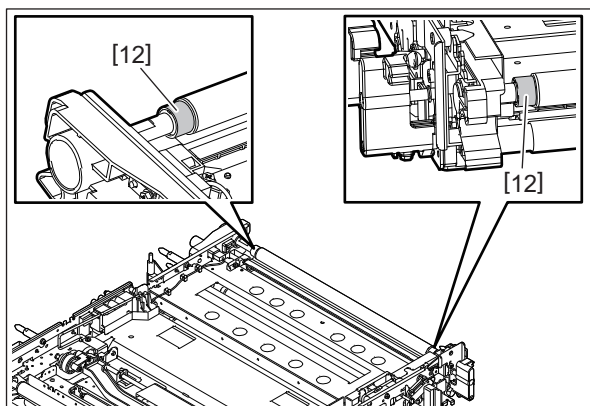

Fig. 4-512

4.7.8 1st transfer roller

- (1) Take off the transfer belt.
P. 4-203 "4.7.7 Transfer belt"
- (2) Remove 2 screws and take off the holder [1].

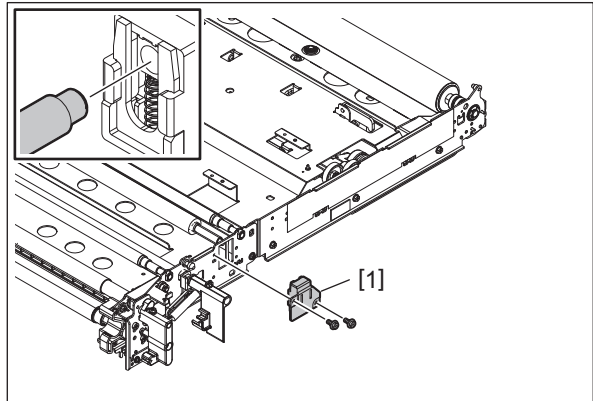

Fig. 4-513

- (3) Take off the 1st transfer roller [2].

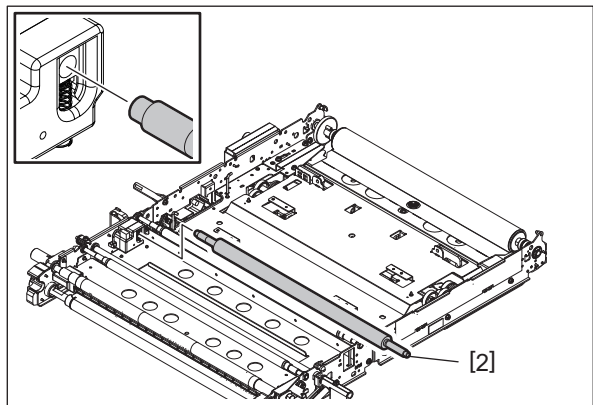



Fig. 4-514

4.7.9 Cleaning facing roller

- (1) Take off the transfer belt.
 P. 4-203 "4.7.7 Transfer belt"
- (2) Remove 1 E-ring and 1 ball bearing [1].

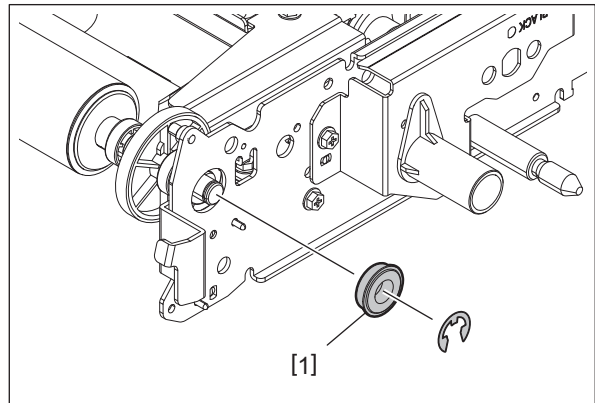

Fig. 4-515

- (3) Remove 1 E-ring and 1 ball bearing [2].

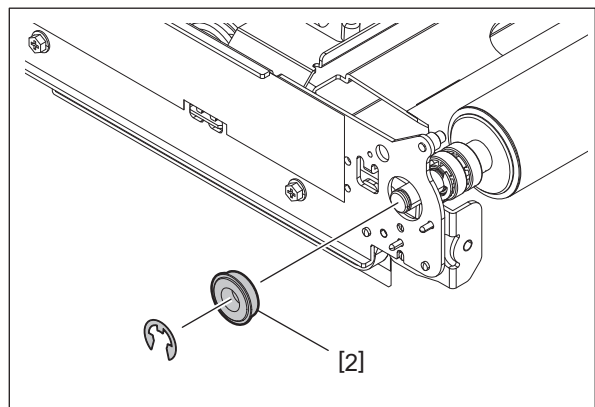

Fig. 4-516

- (4) Take off the cleaning facing roller assembly [3].

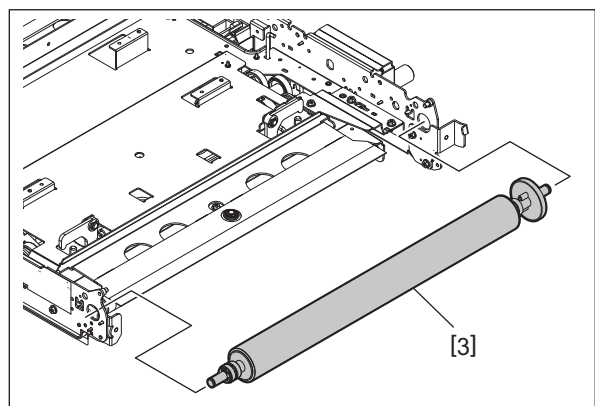

Fig. 4-517

- (5) Remove 2 E-rings, 4 bearings [5], 1 gear [6] and 1 pin [7] from the cleaning facing roller [4].

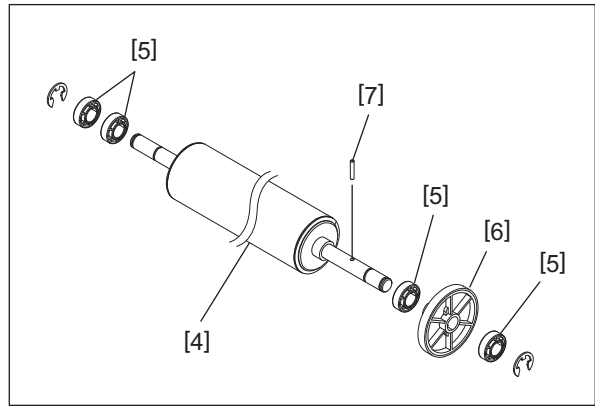

Fig. 4-518

4.7.10 Tension roller

- (1) Take off the transfer belt.
P. 4-203 "4.7.7 Transfer belt"
- (2) Remove 2 collars [1].

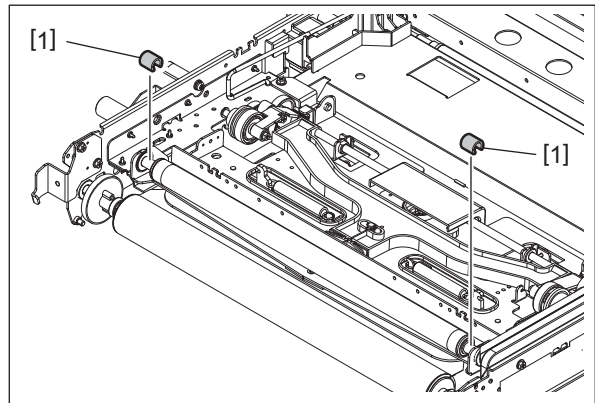

Fig. 4-519

- (3) Move the ball bearings [2] to the inner side and then take off the tension roller [3].

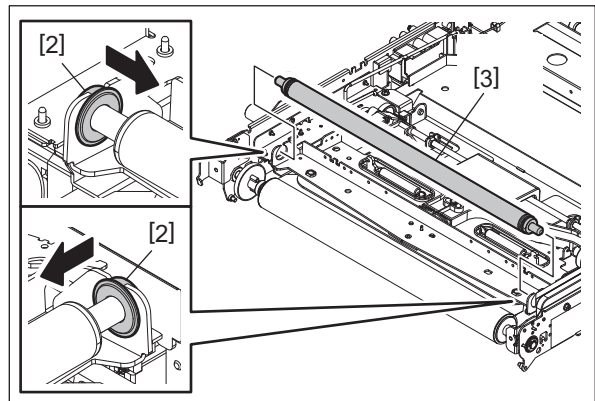

Fig. 4-520

4.7.11 2nd transfer facing roller

- (1) Take off the transfer belt.
P. 4-203 "4.7.7 Transfer belt"
- (2) Disconnect 1 connector [1].

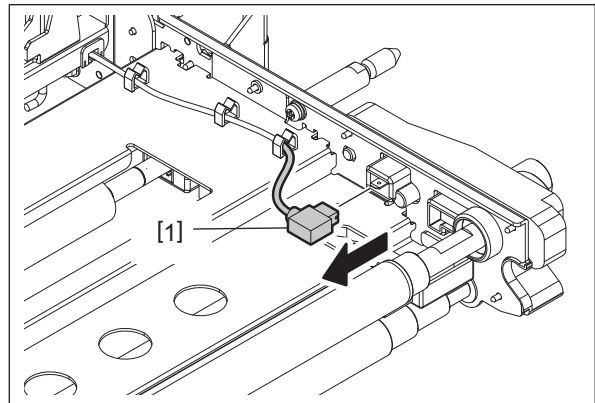

Fig. 4-521

- (3) Remove 3 screws and take off the holder [2].

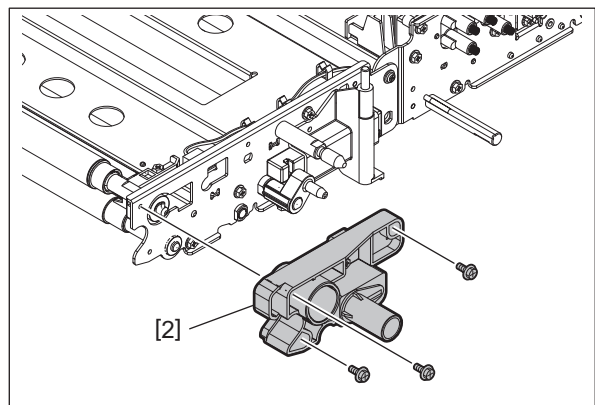

Fig. 4-522

- (4) Take off the 2nd transfer facing roller [3].

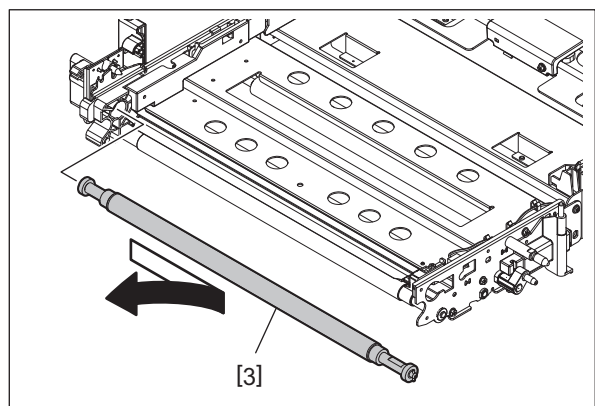

Fig. 4-523

4.7.12 2nd transfer unit (TRU)

- (1) Open the duplexing unit.
P. 4-195 "(1) Fully open the duplexing unit until it stops."
- (2) Remove 1 screw and take off the cover [1].

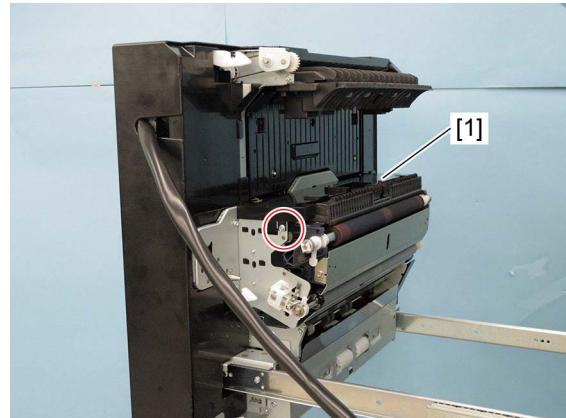

Fig. 4-524

- (3) Disconnect 1 connector and remove the clip [2].

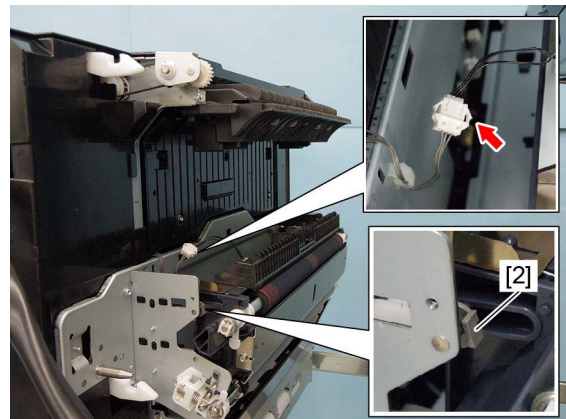

Fig. 4-525

- (4) Remove the 2nd transfer unit [3] not to hit it to the registration roller or other parts.

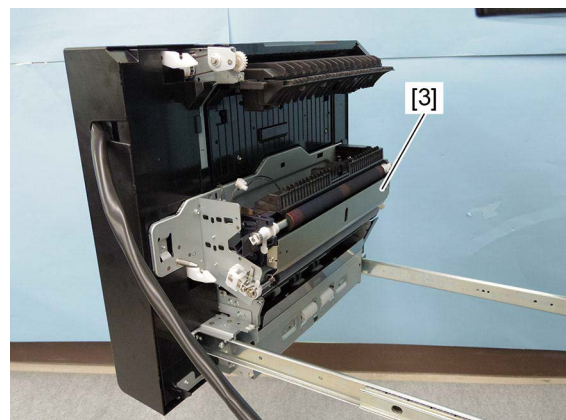

Fig. 4-526

Notes:

- When installing, make sure that 2 pins [4] on the rear side are inserted to the rectangular holes [5] of the 2nd transfer unit.
- Be sure to take off the 2nd transfer roller before the paper guide of the TRU is removed. Moreover, be sure to install the paper guide of the TRU before the 2nd transfer roller is attached. If they are installed in the incorrect order, this will cause an error due to a conduction failure or a defective image.

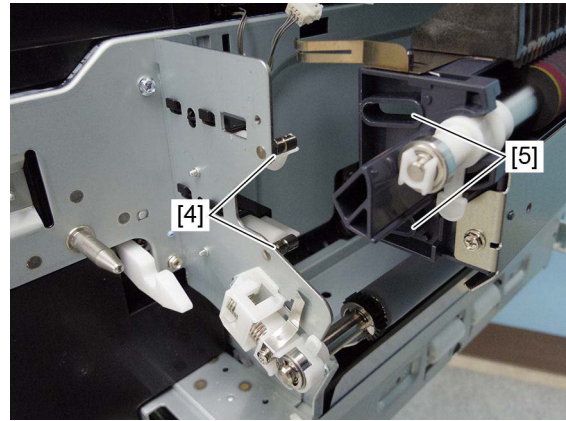

Fig. 4-527

4.7.13 2nd transfer roller

- (1) Pull 2 levers [1] toward you and take off the 2nd transfer roller unit [2].

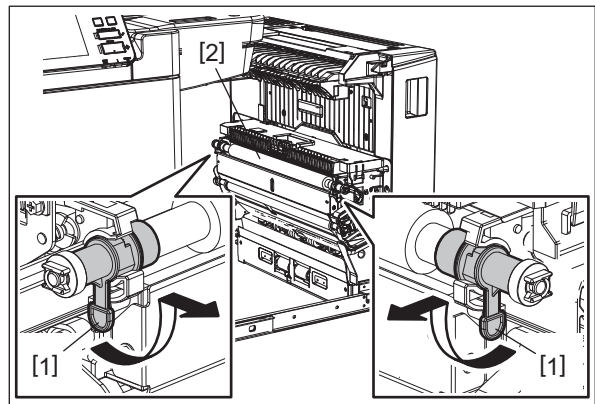

Fig. 4-528

- (2) Remove 1 clip [3], 1 ball bearing [4] and 1 bushing [5] on the rear side.
- (3) Remove 1 clip [6], 1 bearing [7] and 1 bushing [8] on the front side.

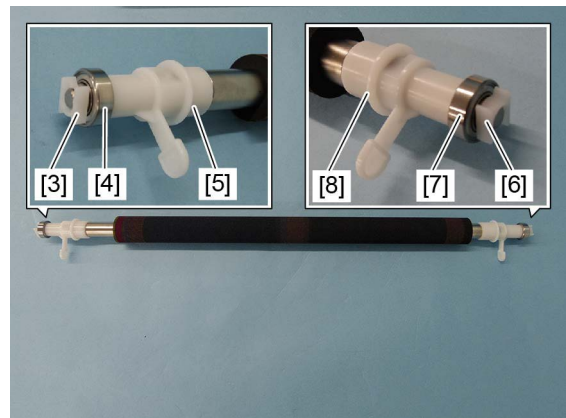

Fig. 4-529

Notes:

Since the ball bearings [9] are press-fitted in the bushings [5] and [8], be sure to remove them in a straight direction, so that the bearings do not fall off.

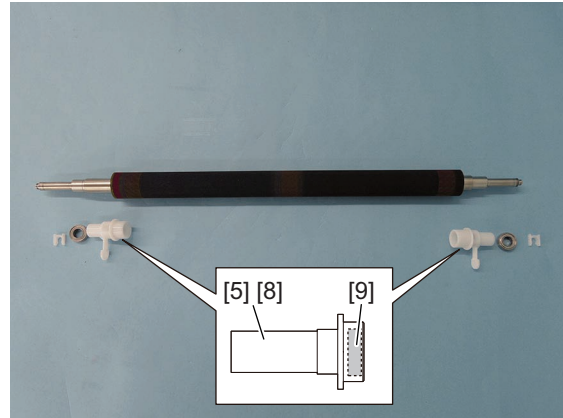

Fig. 4-530

4.7.14 2nd transfer unit rear guide

- (1) Take off the 2nd transfer unit.
P. 4-211 "4.7.12 2nd transfer unit (TRU)"
- (2) Pull 2 levers [1] toward you and remove the 2nd transfer roller [2].
P. 4-212 "4.7.13 2nd transfer roller"

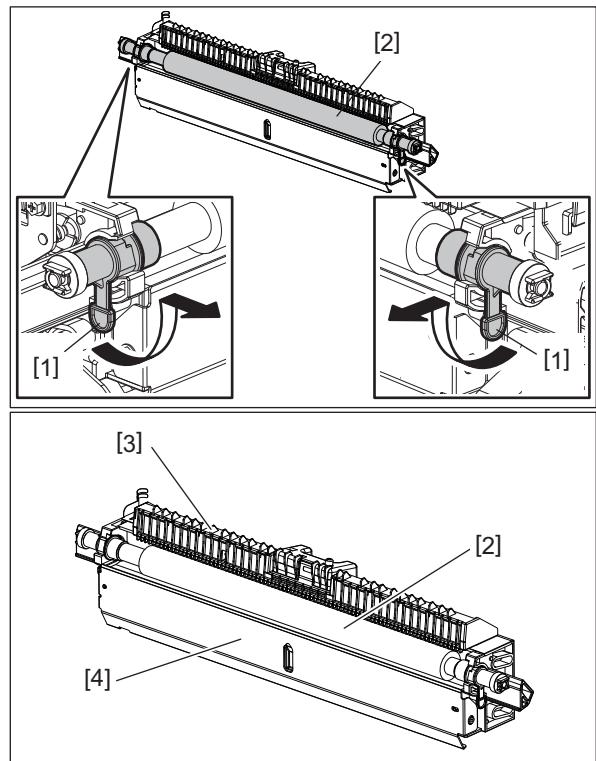

Fig. 4-531

- [2] 2nd transfer roller
- [3] 2nd transfer unit rear guide
- [4] 2nd transfer unit front guide

- (3) Remove 2 screws and take off the 2nd transfer unit rear guide [3].

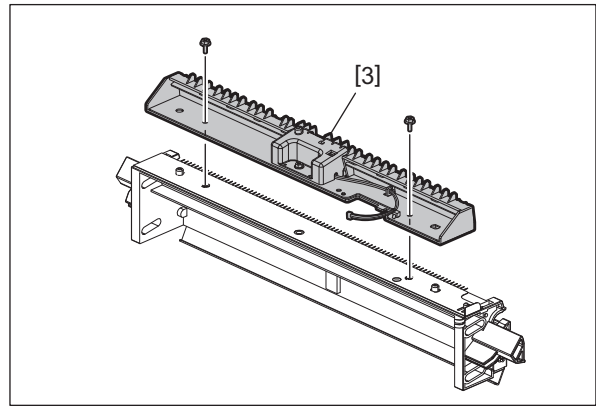

Fig. 4-532

Notes:

Be sure to take off the 2nd transfer roller [2] before the 2nd transfer unit rear guide [3] is removed. Moreover, be sure to install the 2nd transfer unit rear guide [3] before the 2nd transfer roller [2] is attached. If they are installed in the incorrect order, this will cause an error due to a conduction failure or a defective image.

- (4) Release the harness from the hook of the 2nd transfer unit rear guide [3].
(5) Remove the 2nd transfer unit rear guide from the metal plate [5].

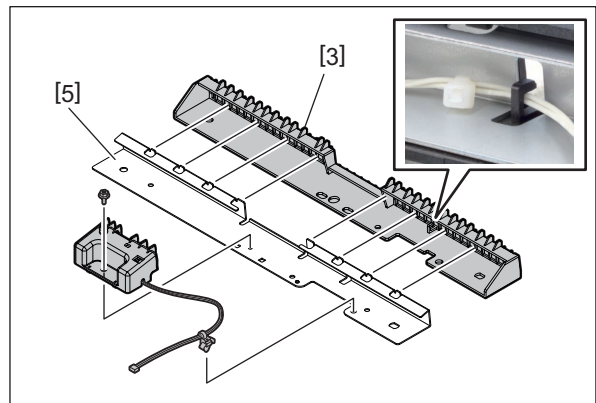

Fig. 4-533

4.7.15 Transfer belt motor (M13)

- (1) Take off the SYS board case.
📖 P. 9-6 “9.1.7 SYS board case (MJD, ASD, AUD, JPC, CND)”
- (2) Remove 2 screws and release the bracket [1].

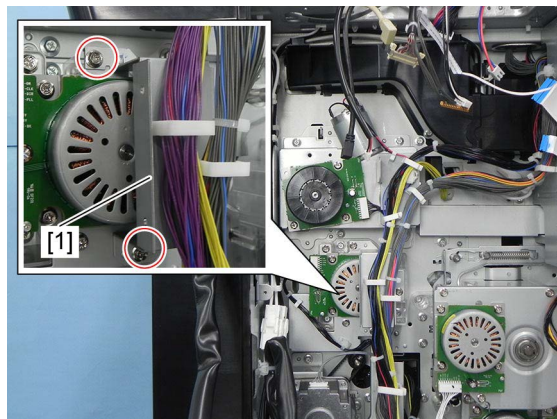

Fig. 4-534

- (3) Disconnect 1 connector and remove 4 screws. Take off the transfer belt motor [2].

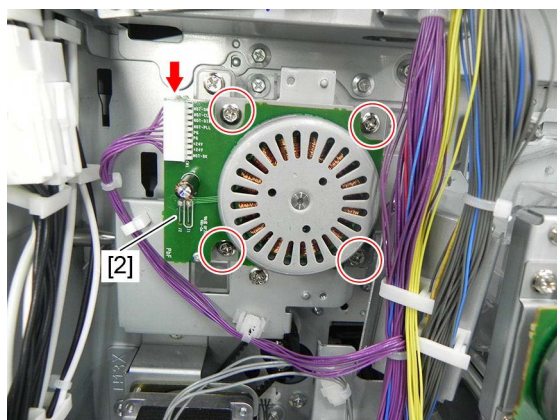

Fig. 4-535

4.7.16 Transfer belt motor unit

- (1) Take off the SYS board case.
📖 P. 9-6 “9.1.7 SYS board case (MJD, ASD, AUD, JPC, CND)”
- (2) Release the harnesses from 2 harness clamps.

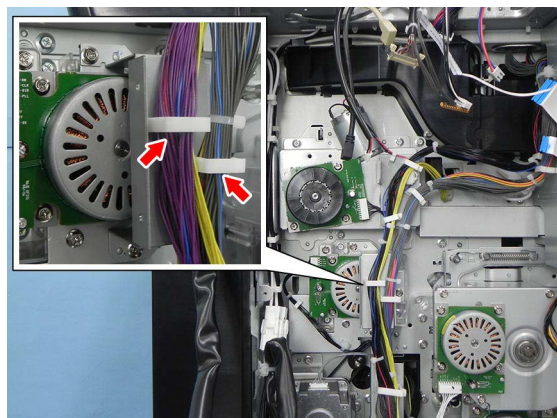

Fig. 4-536

(3) Remove 2 screws and take off the bracket [1].

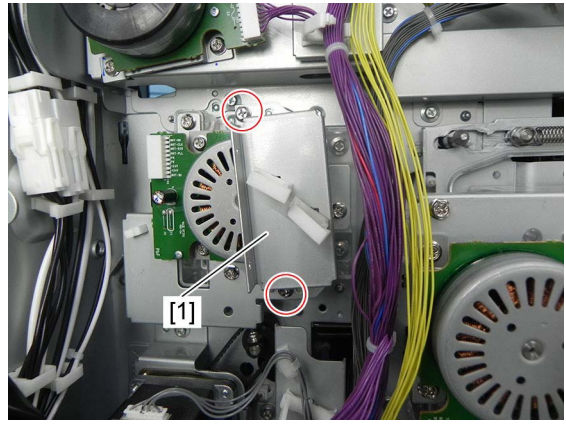

Fig. 4-537

(4) Disconnect 1 connector and release the harness from 1 harness clamp [2]. Remove 1 harness clamp [3] and take off the transfer belt motor unit [4].

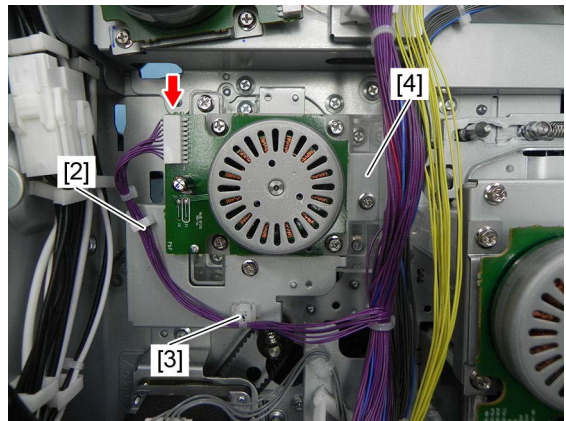

Fig. 4-538

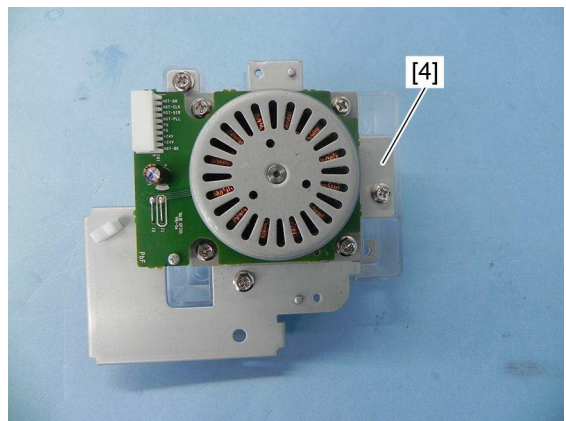



Fig. 4-539

4.8 Image Quality Control Section

4.8.1 Image quality control unit

- (1) Remove the middle guide.
 P. 4-104 "4.5.43 Transfer belt paper clinging detection sensor (S47)"
- (2) Remove 2 shoulder screws.

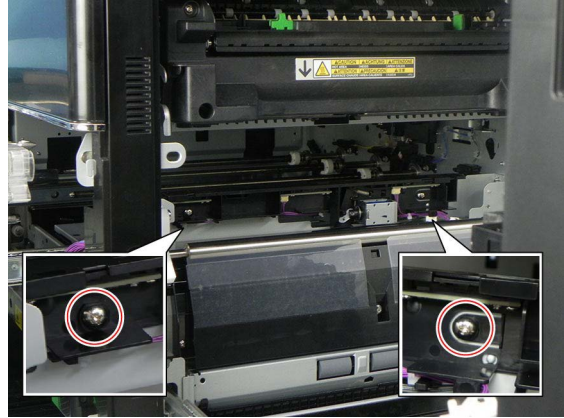

Fig. 4-540

- (3) Disconnect 1 connector and remove the image quality control unit [1].

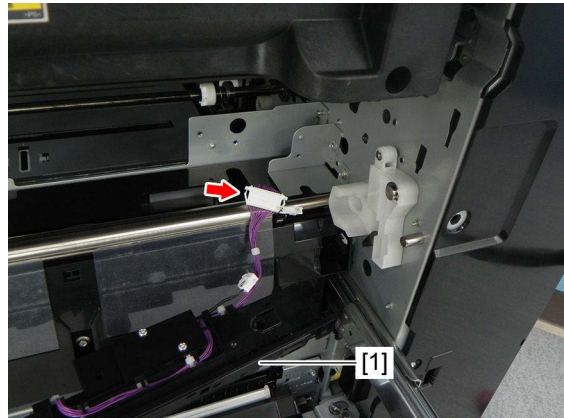

Fig. 4-541



Fig. 4-542

4.8.2 Image position aligning/image quality sensor (center) (S21)

- (1) Take off the image quality control unit.
📖 P. 4-217 “4.8.1 Image quality control unit”
- (2) Remove 2 screws and disconnect 1 connector. Take off the image position aligning/image quality sensor (center) [1].

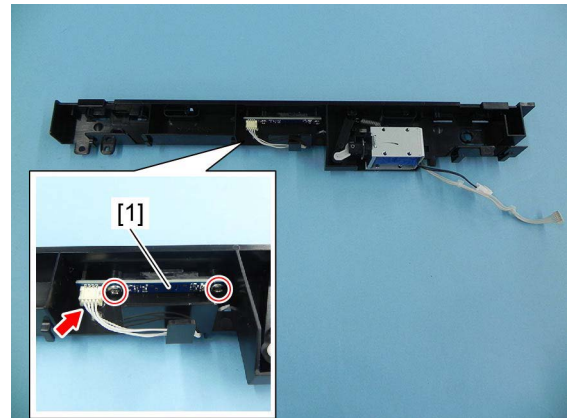

Fig. 4-543

4.8.3 Image quality shutter solenoid (SOL3)

- (1) Take off the image quality control unit.
📖 P. 4-217 “4.8.1 Image quality control unit”
- (2) Remove 2 screws and disconnect 1 connector. Take off the image quality shutter solenoid [1].

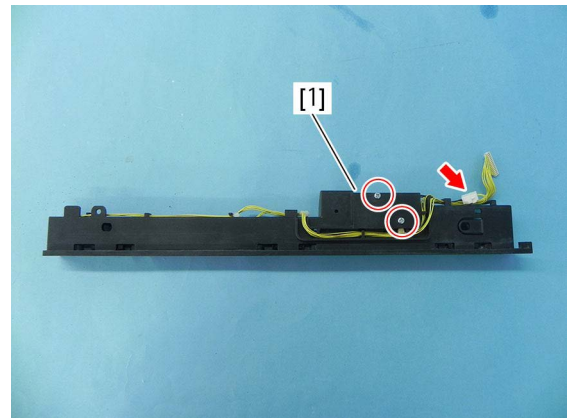

Fig. 4-544

(3) Remove the link arm [2] of the image quality shutter solenoid [1].

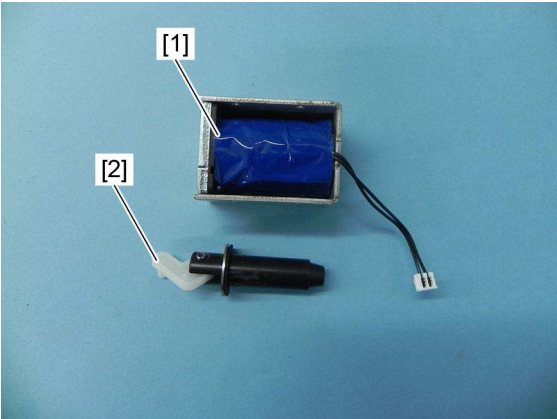

Fig. 4-545

4.9 Fusing Section

Notes:

- Be sure that the temperature of the fuser unit has lowered enough before removing it. If the unit still heated should be removed, wear a pair of gloves before working.
- When a new fuser unit is installed, be sure that the fuser-related life counter values are reset in the list print mode (FS-30), PM support mode (FS-20) or setting mode (FS-08).
- When assembling the fuser unit, wire the following harness through all of the clamps to prevent it from being caught by the cover.

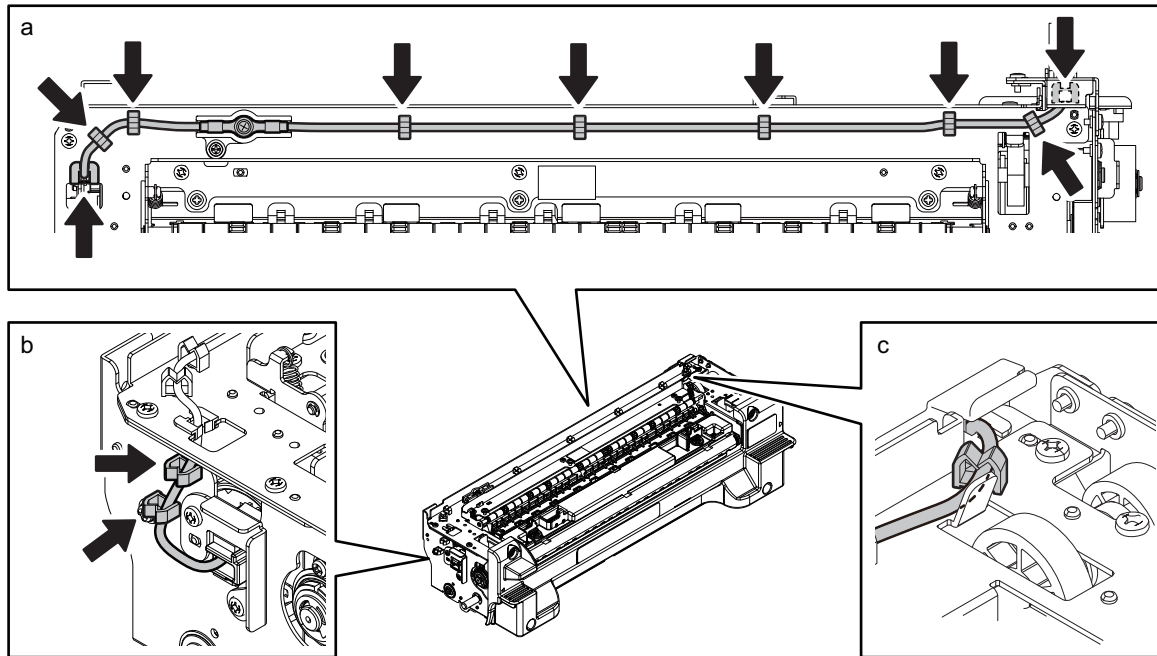

Fig. 4-546

4.9.1 Fuser unit

- (1) Open the duplexing unit.
- (2) Lower 2 levers [1] and take off the fuser unit [2].

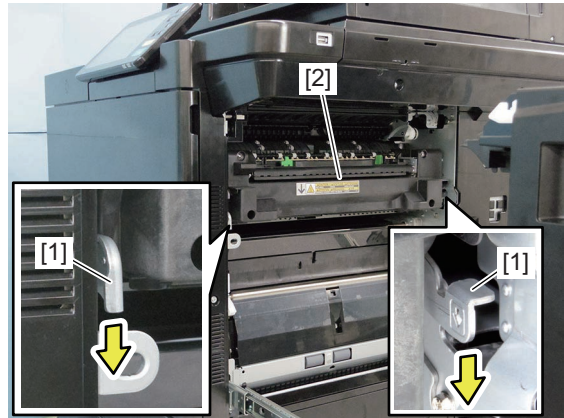



Fig. 4-547

Notes:

- When installing the fuser unit, be sure to press it in until the lever is made to go up by the setting of the plates on both sides of the unit onto the guide of the MFP. If the lever goes down, the fuser unit has not been correctly installed.
- The oil inside the fuser unit may leak when it is tilted. Therefore, keep the fuser unit in a horizontal position while it is assembled/disassembled.

4.9.2 Pressure roller cover

- (1) Take off the fuser unit.
 P. 4-221 “4.9.1 Fuser unit”
- (2) Remove 4 screws and take off the pressure roller cover [1].

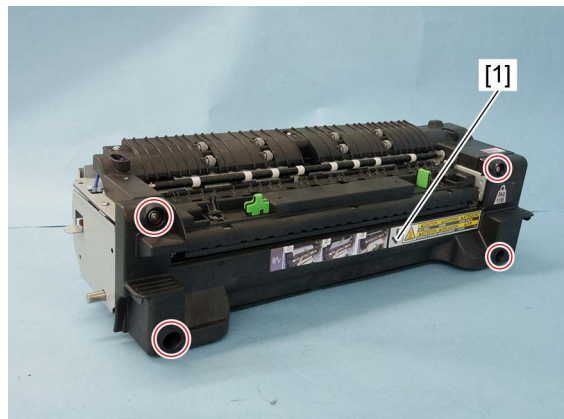

Fig. 4-548

4.9.3 Fuser unit transport guide

- (1) Take off the fuser unit.
📖 P. 4-221 "4.9.1 Fuser unit"
- (2) Remove 2 screws and take off the fuser unit transport guide [1].

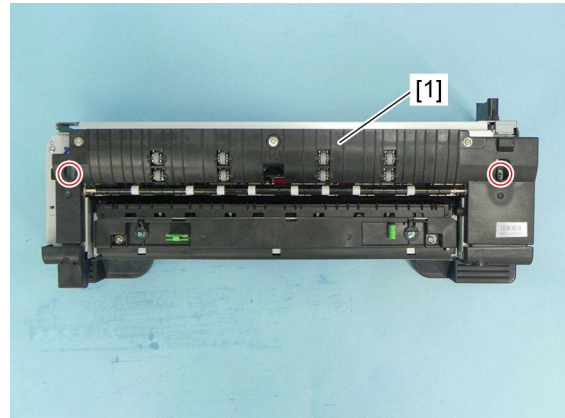

Fig. 4-549

4.9.4 Entrance guide cover

- (1) Take off the fuser unit.
📖 P. 4-221 "4.9.1 Fuser unit"
- (2) Take off the pressure roller cover.
📖 P. 4-221 "4.9.2 Pressure roller cover"
- (3) Remove 2 screws and take off the entrance guide cover [1].

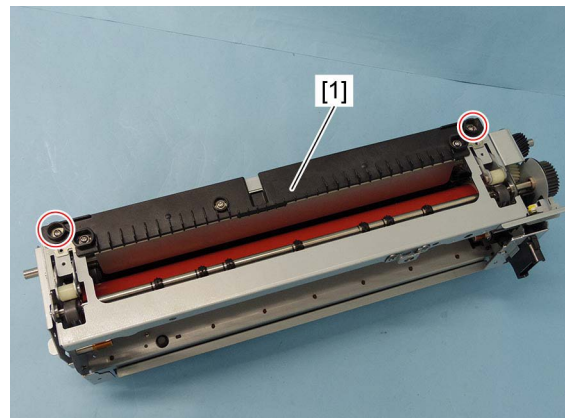

Fig. 4-550

Notes:

- If toner adheres to the entrance guide cover or the star wheel, wipe it off with dry cloth.
- Fix the screw in the position as shown in the figure unless paper wrinkle or paper jams occur at the entrance of the fuser unit.



Fig. 4-551

4.9.5 Separation guide

Notes:

When the separation guide has been replaced or taken off, adjust the gap between the guide and the fuser belt.

📖 P. 6-75 “6.11.2 Separation guide gap adjustment”

- (1) Take off the fuser unit.
📖 P. 4-221 “4.9.1 Fuser unit”
- (2) Open the separation guide cover [1].

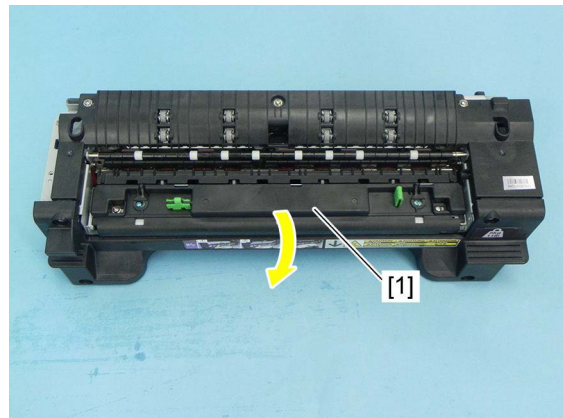

Fig. 4-552

(3) Remove 3 screws and take off the separation guide [2].

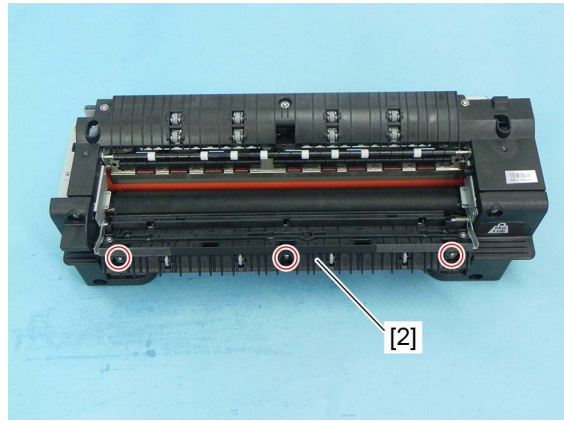

Fig. 4-553

Notes:

- The shoulder screws are used on the front side and rear side. When installing, pay attention not to confuse them with other kinds of screws.
- Make sure that the pieces of tapes attached to the separation guide are adhering properly and moreover that they are not dirty.
- If toner adheres to the separation guide, wipe it off with a dry cloth.

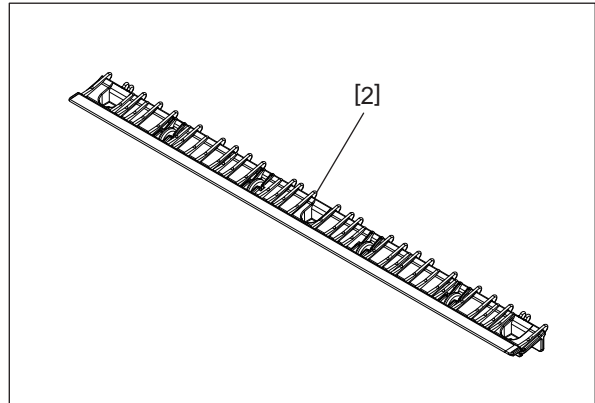



Fig. 4-554

4.9.6 Separation plate

Notes:

When the separation plate has been replaced or taken off, adjust the gap between the plate and the fuser belt.

 P. 6-70 “6.11.1 Separation plate gap adjustment”

- (1) Take off the fuser unit transport guide.
 P. 4-222 “4.9.3 Fuser unit transport guide”
- (2) Remove 3 screws and take off the separation plate unit [1].

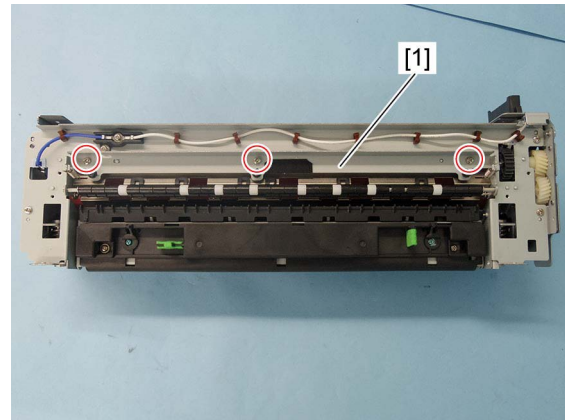

Fig. 4-555

- (3) Remove 2 springs [2] and take off the separation plate [3].

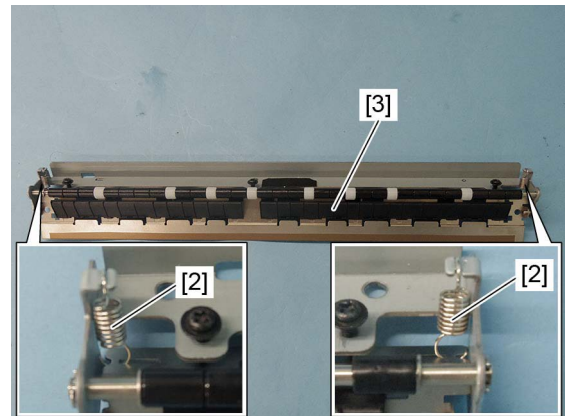

Fig. 4-556

Notes:

Make sure that the pieces of tapes [4] attached to the separation plate are adhering properly and moreover that they are not dirty.

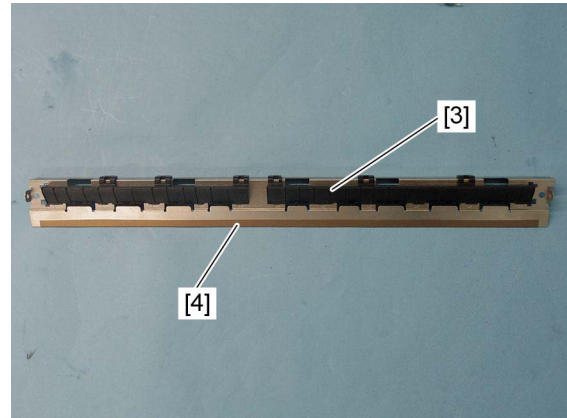

Fig. 4-557

4.9.7 Fuser belt^{PM}

- (1) Take off the fuser unit transport guide.
📖 P. 4-222 “4.9.3 Fuser unit transport guide”
- (2) Remove 1 screw. Release the harnesses from 7 harness clamps.

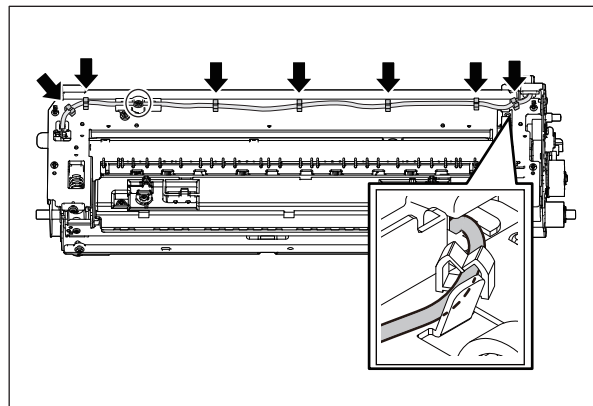

Fig. 4-558

- (3) Remove 4 screws and take off the metal plate [1].

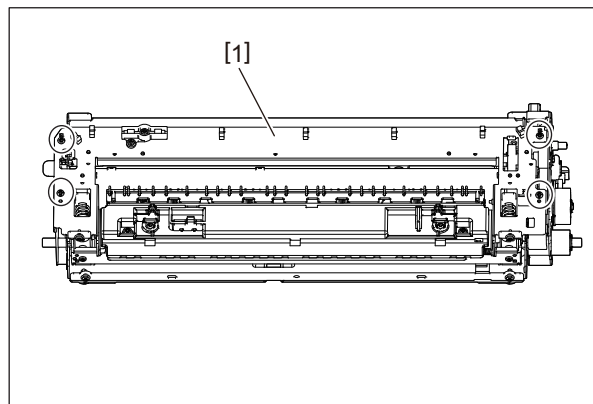

Fig. 4-559

- (4) Remove 2 screws and take off the metal plate [2].

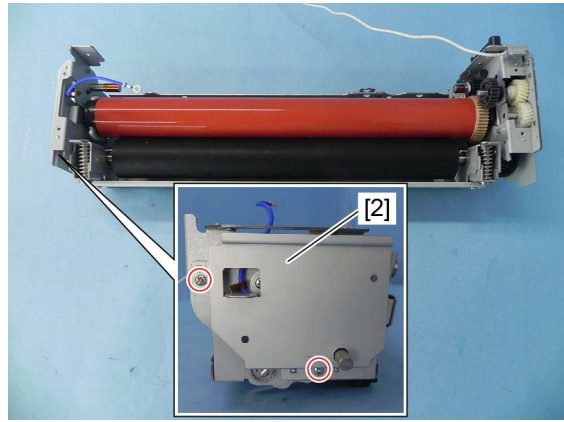

Fig. 4-560

- (5) Release the harness from 2 harness clamps. Remove 2 screws and take off the bracket [3].

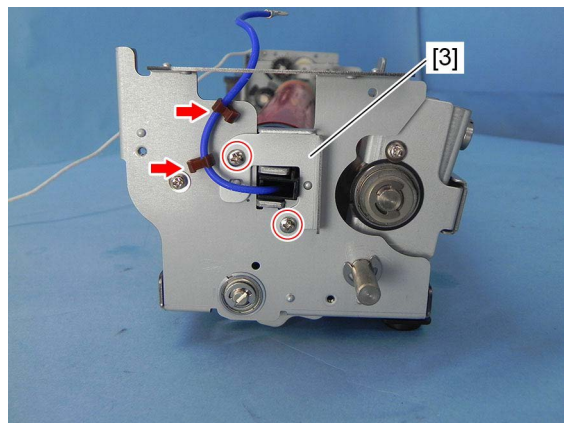

Fig. 4-561

- (6) Remove 1 E-ring, and then take off the pressure roller contact/release cam [4] and 1 pin. Remove 1 E-ring and the gear [5].

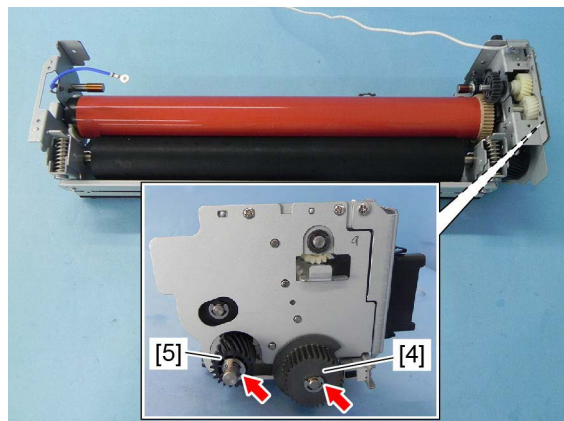

Fig. 4-562

(7) Remove 3 screws and 1 bushing. Take off the metal plate [6].

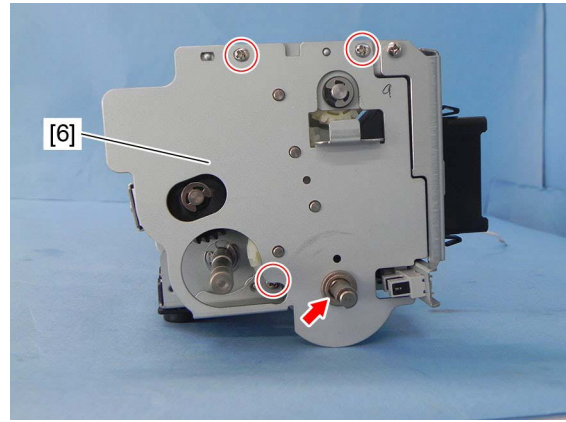

Fig. 4-563

(8) Remove 1 E-ring and the gear [7]. Remove 2 screws and take off the bracket [8]. Remove the harness cover [9].

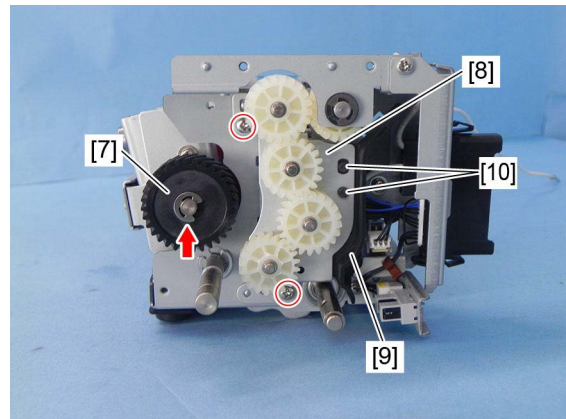

Fig. 4-564

Notes:

- When removing the bracket, be careful not to drop the gears.
- When installing the bracket, check that its holes match with 2 bosses [10].

(9) Remove 1 screw and release the harness from the harness holder [11].

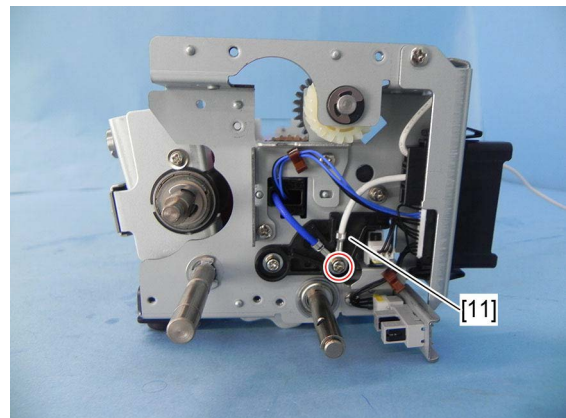

Fig. 4-565

Notes:

Pay attention to the following points when attaching the fuser belt unit to the fuser unit. While pulling the lead wire [20] of the thermostat at the rear side, fold it near the exit of the bushing [21] and then secure the terminal [22]. Note that when securing the terminal [22], be sure to place it in the position as shown in the figure so as not to allow the lead wire to become sagged.

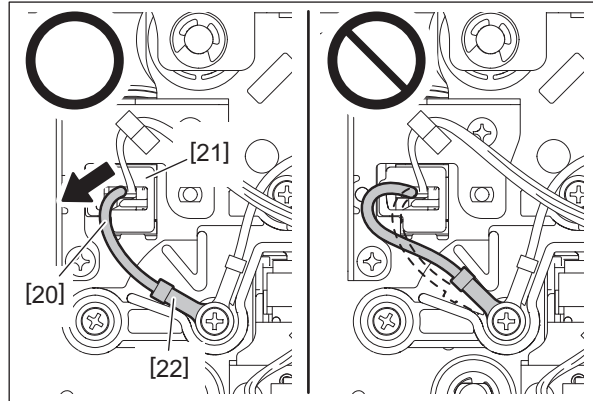

Fig. 4-566

- (10) Remove 1 screw and take off the sensor cover [20] and the sensor bracket [12]. Release the harnesses from 1 harness clamp.

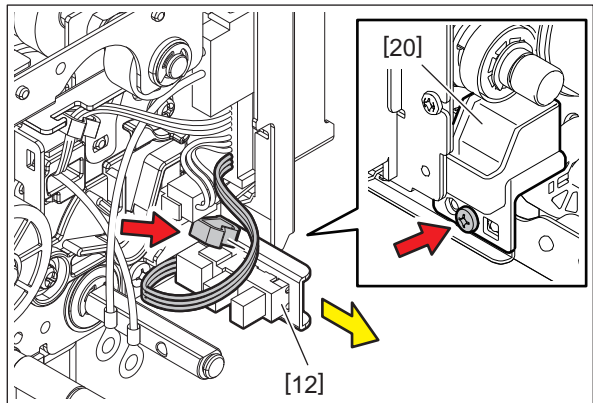

Fig. 4-567

Notes:

If oil has adhered to the sensor cover and around the sensor, wipe it off cleanly.

- (11) Disconnect 1 connector.

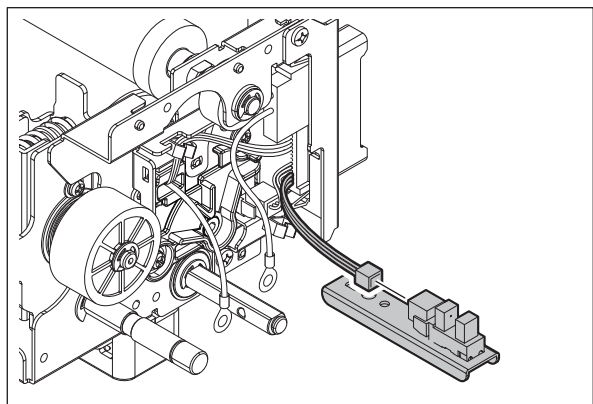

Fig. 4-568

(12) Disconnect 1 connector.

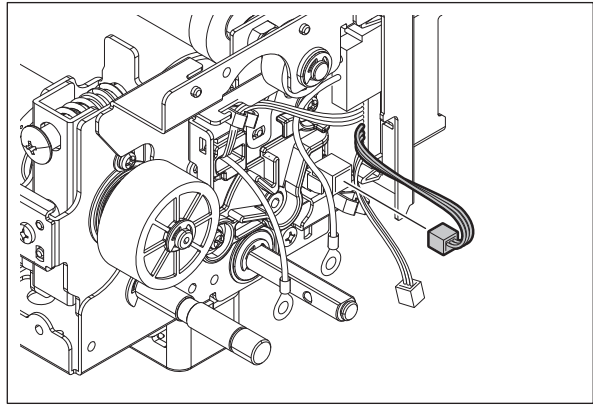

Fig. 4-569

(13) Remove 2 screws and take off the connector bracket [13].

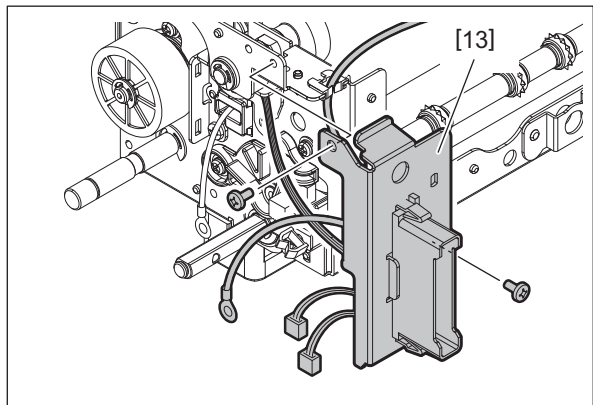

Fig. 4-570

(14) Release the harness from 1 harness clamp.



Fig. 4-571

(15) Disconnect 1 connector.

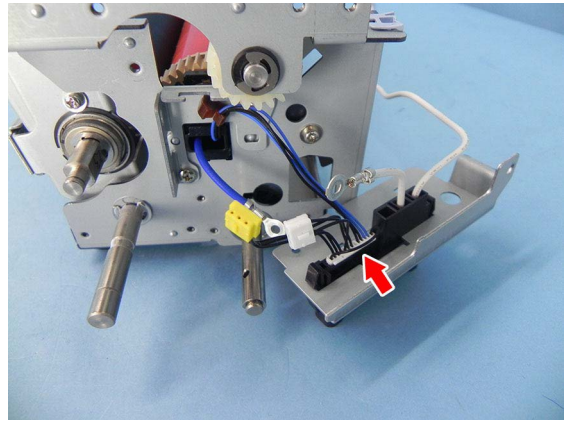

Fig. 4-572

(16) Release the harnesses from 1 harness clamp. Remove 2 screws and take off the bracket [14].

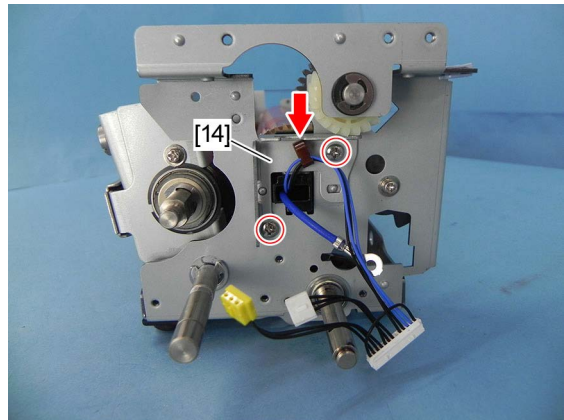

Fig. 4-573

(17) Take off the fuser belt unit [15] by sliding it.

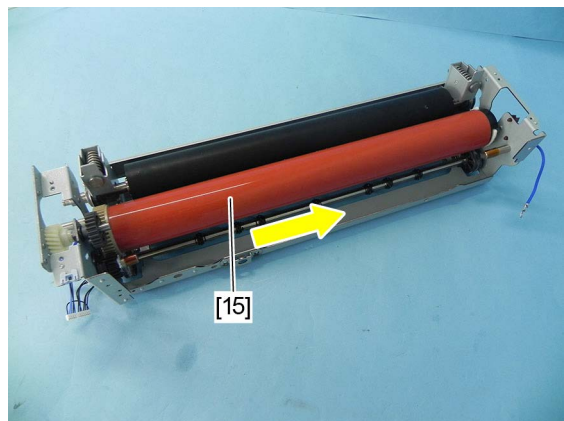

Fig. 4-574

Notes:

Take care so that no damage or stains are detected on the fuser belt.

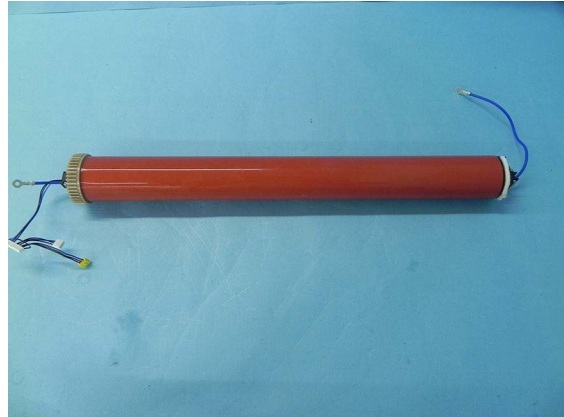

Fig. 4-575

(18) Remove the collar [16] and take off the fuser belt [17] from the front side.

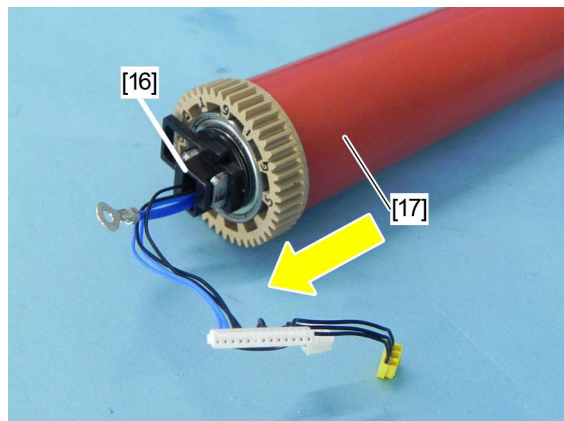

Fig. 4-576

Notes:

- Be sure to hold the gear sections of the fuser belt not to damage the belt.
- The fuser belt supplied as a service part consists of the following parts. When replacing the fuser belt, exchange them all in a set. An application of silicon oil to the inside of the fuser belt is required.
- Fuser belt
- Fuser belt lubricating sheet
- Oil recovery sheets (4 types)
- Silicon oil



Fig. 4-577

- Be careful that the thermistor [18] of the fuser unit is not deformed when it is placed after the removal of the fuser belt. The thermistor may be deformed if it is made to come to the lower side by turning the fuser unit.

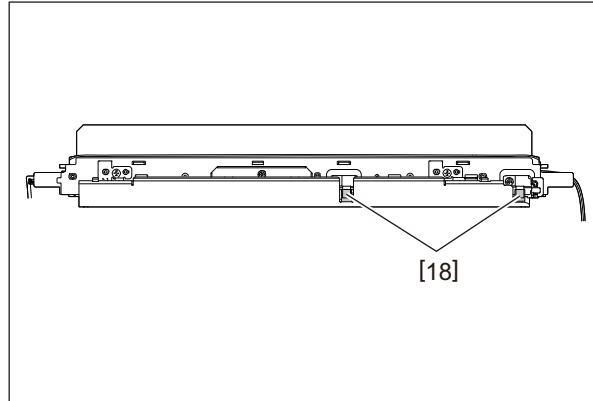

Fig. 4-578

- Be sure to hold the portions shown in the figure when handling the magnetic metal plate [19] to prevent it from deforming.

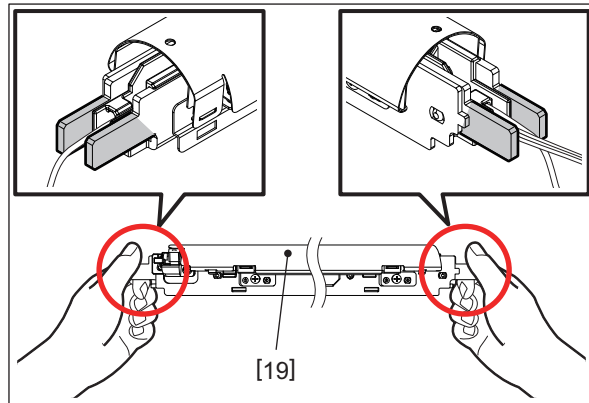

Fig. 4-579

[1] Installing of the fuser belt

- (1) When attaching the fuser belt, prepare some paper so that no silicon oil adheres to the harness and the connector.
Make the paper round and create a cylinder with the diameter of your little finger. Then, fix the 2 places indicated with some tape.

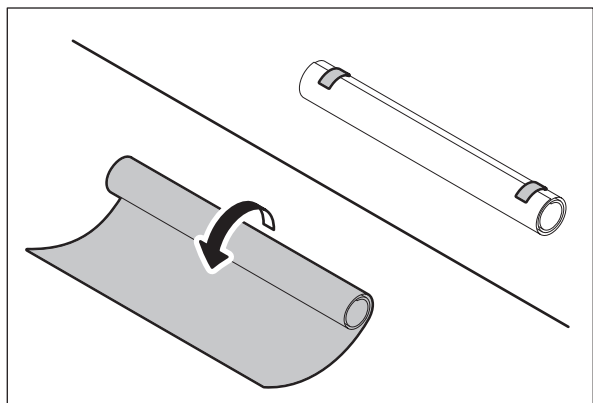

Fig. 4-580

- (2) Use the cylinder to cover the harness and the connector [1] of the fuser belt unit.

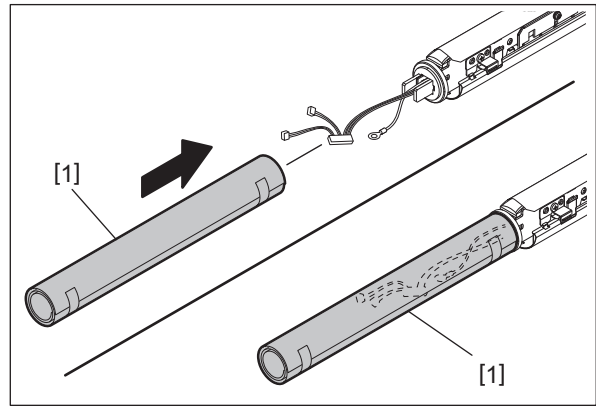

Fig. 4-581

- (3) Tilt the gear side of the fuser belt [3] downward. Pour the entire amount of silicon oil [2] into the fuser belt [3] without spilling. This should be done from the rear side where there is no gear.

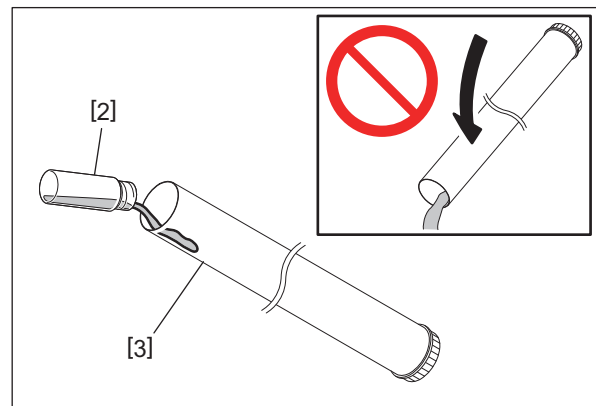

Fig. 4-582

Notes:

- Be sure to hold the gear sections of the fuser belt not to damage the belt.
- Pour the entire amount without leaving any of silicon oil.
- Silicon oil has a low viscosity and is easy to spill. Therefore, do not tilt it downwards at the no-gear side.

- (4) To spread silicon oil inside the fuser belt [3], rotate it a few times.

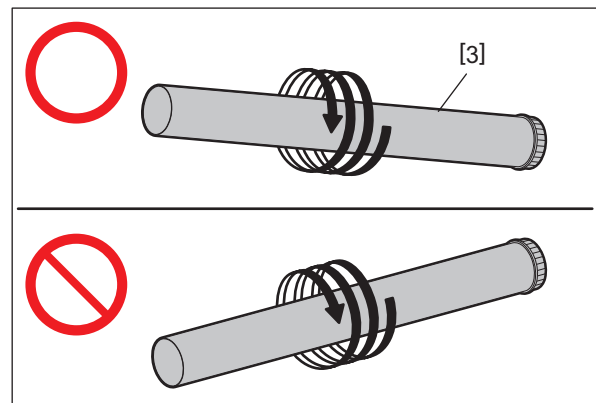

Fig. 4-583

Notes:

Silicon oil has a low viscosity and is easy to spill. Therefore, do not tilt it downwards at the no-gear side.

- (5) Gently place a hand on the magnetic metal plate [4] and insert the fuser belt [3] slowly while rotating it clockwise.

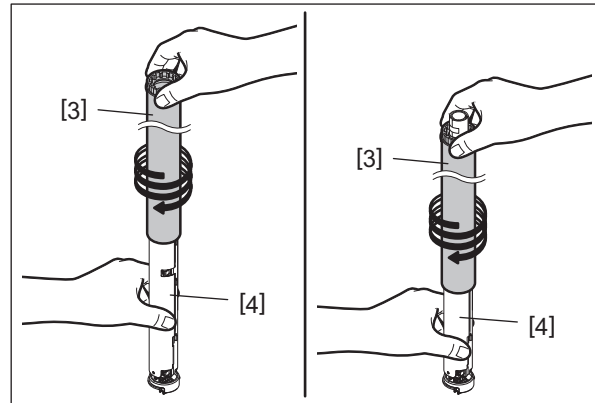

Fig. 4-584

Notes:

- Take care so that no damage or stains are detected on the fuser belt.
- When attaching the fuser belt, gently press the fuser belt thermistor [5] with your fingers to prevent its deformation.

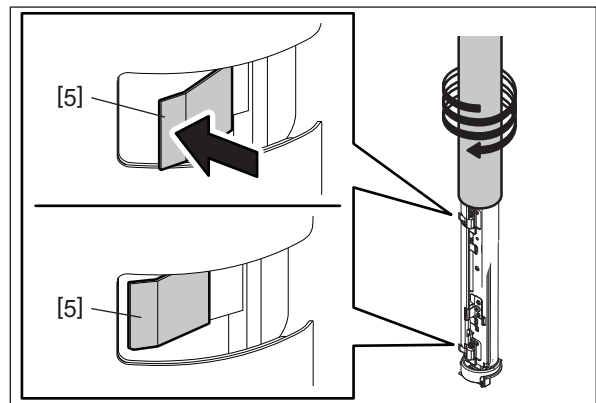



Fig. 4-585

- After reassembling the fuser belt, check that there is no scratch on the surface and the edges of the belt, and check that the grease has not adhered on the belt surface. If silicon oil is running over more than 25 mm from the edge of the fuser belt, wipe it off using alcohol. If 25 mm or less, wipe it off with a dry cloth.

4.9.8 Fuser belt lubricating sheet, Fuser belt pad

- (1) Take off the fuser belt.
 P. 4-226 “4.9.7 Fuser belt”
- (2) Remove 3 screws and take off the metal plate [1].

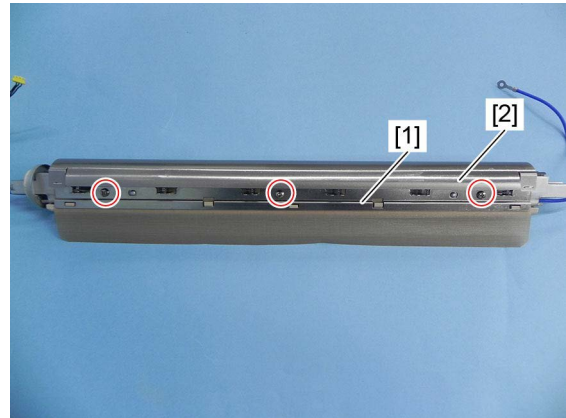

Fig. 4-586

Notes:

- When handling the inside of the fuser belt unit, position a towel or cushion so that no pressure is applied to the magnetic metal plate [2].
- Tighten the screws securely. Otherwise they come off and this will cause the damage of the fuser belt.

- (3) Remove the fuser belt lubricating sheet [3].

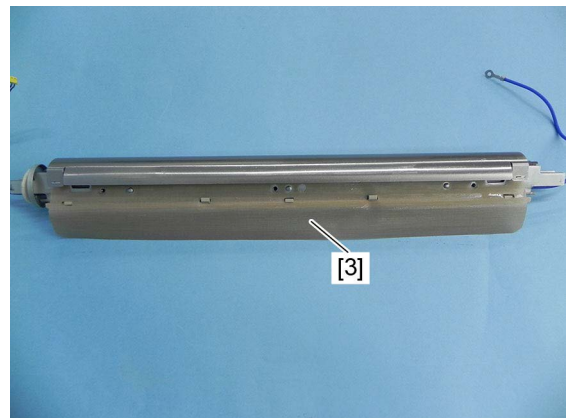

Fig. 4-587

(4) Remove the fuser belt pad [4].

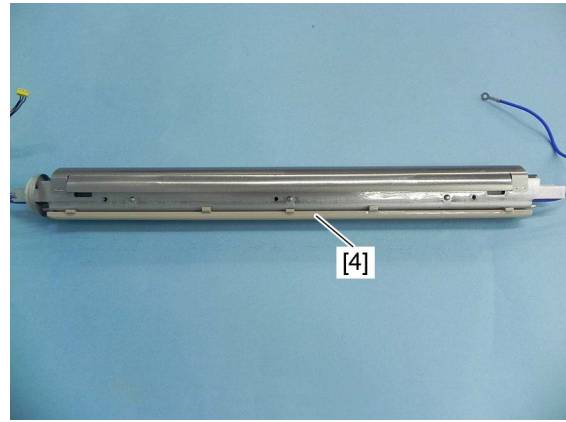

Fig. 4-588

Notes:

- When installing the fuser belt pad, align 5 latches to the holes of the fuser belt lubricating sheet.

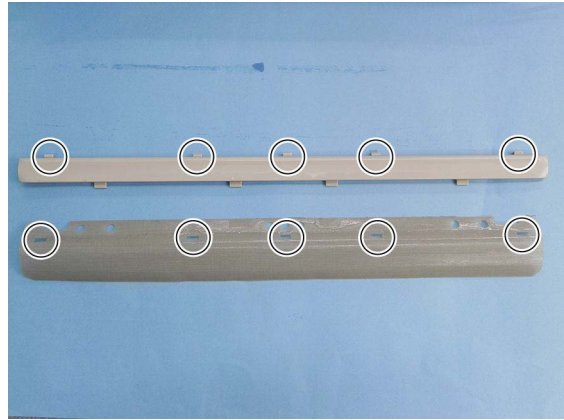

Fig. 4-589

- When installing the fuser belt lubricating sheet, align 4 latches with the latches of the fuser belt unit.

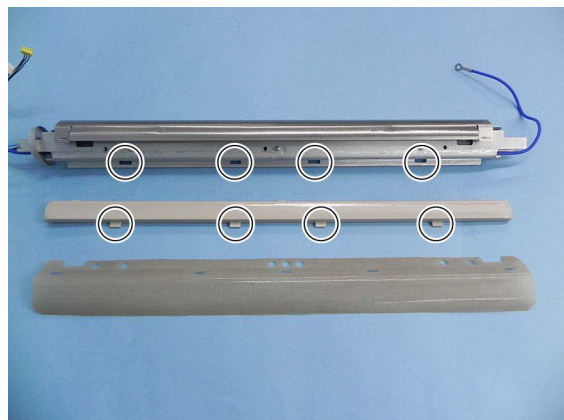

Fig. 4-590

4.9.9 Rear fuser cover oil recovery sheet

- (1) Take off the fuser unit.
P. 4-221 "4.9.1 Fuser unit"
- (2) Remove 1 screw and take off the cover [1].

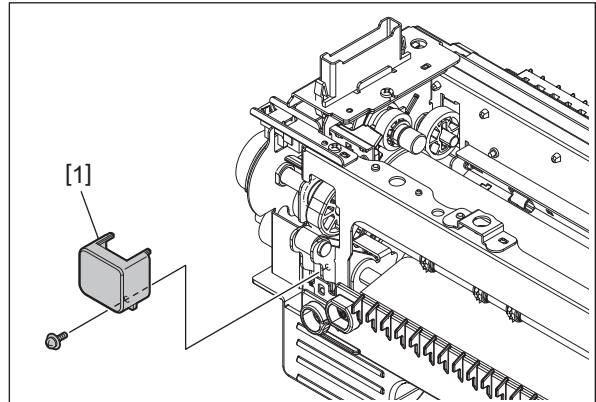

Fig. 4-591

Notes:

Do not tilt the cover too much. Otherwise, the accumulated silicon oil will flow out.

- (3) Remove the rear fuser cover oil recovery sheet [2] from the cover.

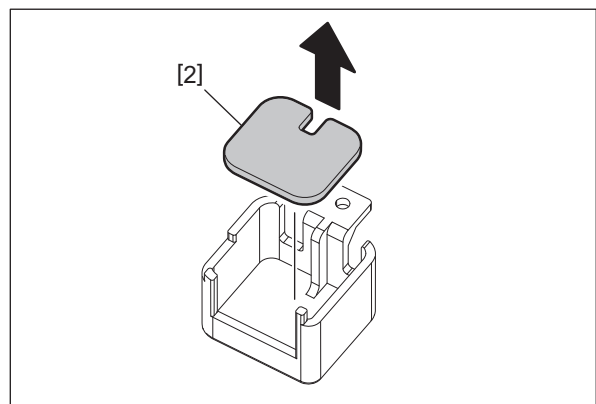

Fig. 4-592

Notes:

When installing the new rear fuser cover oil recovery sheet, pay attention to the following items.

- Clean the attachment surface of the cover.

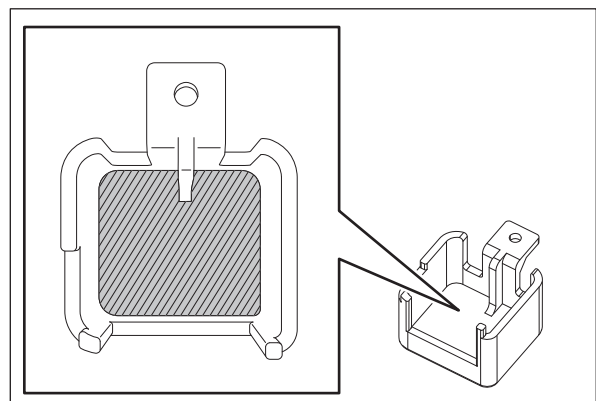

Fig. 4-593

- Remove the protection sheet [3] from the double-sided adhesive tape of the rear fuser cover oil recovery sheet.

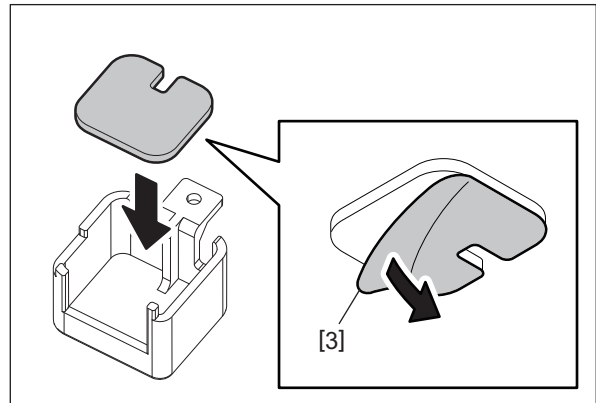

Fig. 4-594

4.9.10 Front fuser belt oil recovery sheet

- Take off the fuser belt unit.
 P. 4-226 "4.9.7 Fuser belt"
- Remove 1 screw and then take off the bracket [1] and the front fuser belt oil recovery sheet [2].

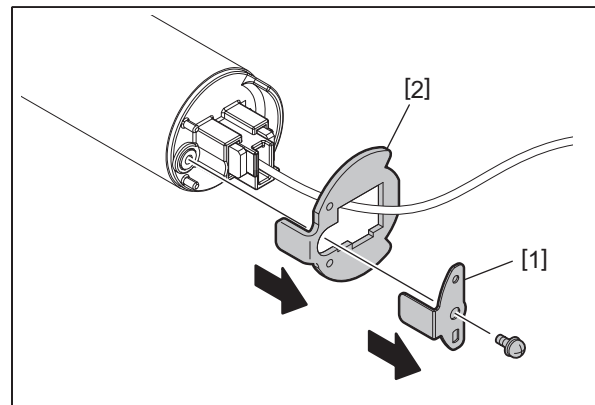

Fig. 4-595

Notes:

When installing the front fuser belt oil recovery sheet, pay attention to the following items.

- Be sure to align 2 holes in the front fuser belt oil recovery sheet to the dowels [3].

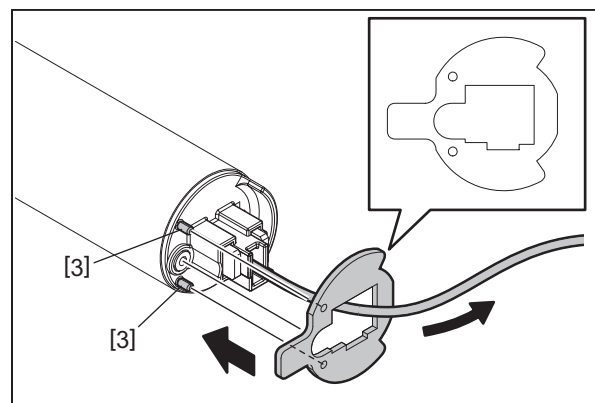

Fig. 4-596

- Fix the front fuser belt oil recovery sheet [4] under the convex portion [5] of the fuser belt unit and then attach the bracket [6] to the unit.

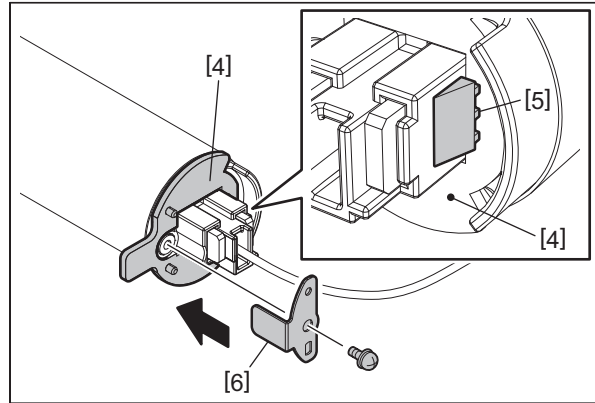

Fig. 4-597

4.9.11 Rear fuser belt oil recovery sheet

- (1) Take off the fuser belt unit.
 P. 4-226 "4.9.7 Fuser belt"
- (2) Remove the rear fuser belt oil recovery sheet [1].

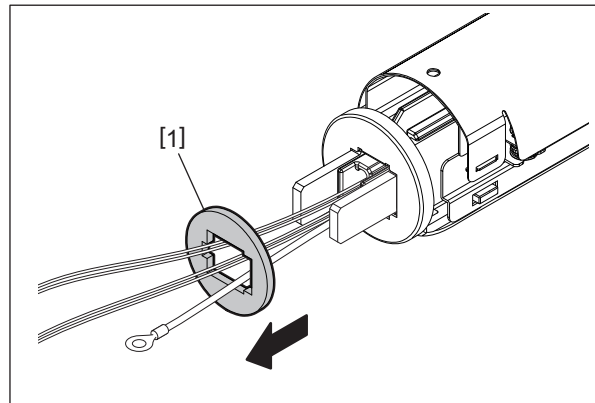

Fig. 4-598

Notes:

When installing the rear fuser belt oil recovery sheet, the positions of its holes must be oriented as shown below.

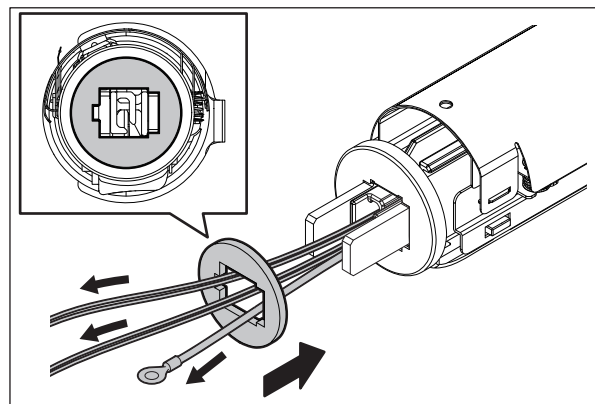

Fig. 4-599

4.9.12 Rear fuser gear oil recovery sheet

- (1) Take off the fuser belt unit.
P. 4-226 "4.9.7 Fuser belt"
- (2) Remove 1 screw and then take off 1 gear [1] and the actuator [2].

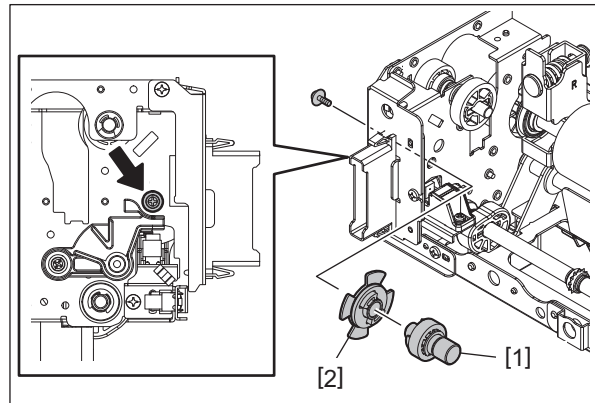

Fig. 4-600

- (3) Remove the rear fuser gear oil recovery sheet [3] from the actuator.

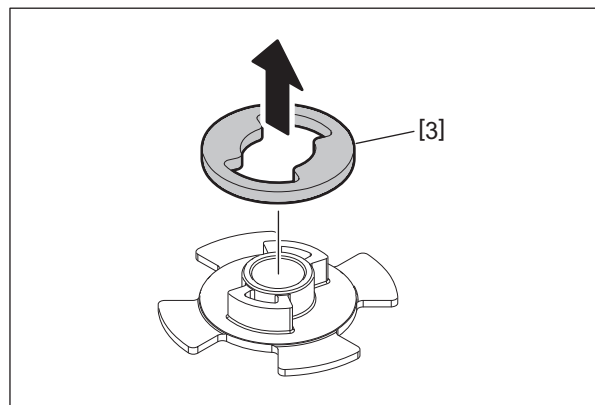

Fig. 4-601

Notes:

When installing the new rear fuser gear oil recovery sheet, pay attention to the following items.

- Clean the attachment surface of the actuator.

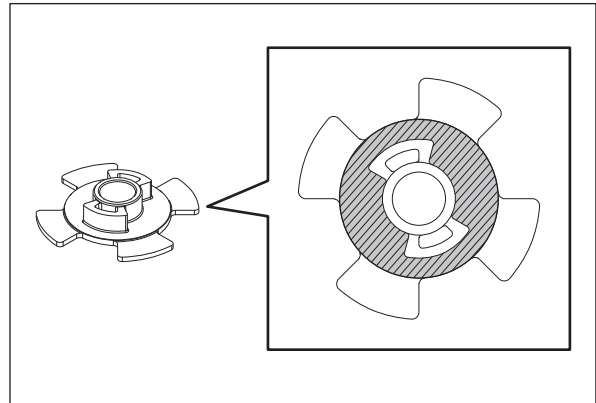

Fig. 4-602

- Remove the protection sheet [4] from the double-sided adhesive tape of the rear fuser gear oil recovery sheet.

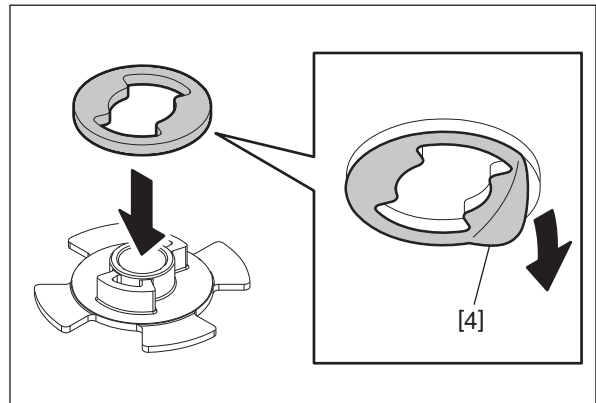

Fig. 4-603

4.9.13 Fuser belt center thermistor (THM5), Fuser belt edge thermistor (THM6), Fuser belt thermostat (THMO4)

Notes:

- If the thermistor is not installed appropriately when it is replaced or installed, it may not work normally. If you carry out the maintenance of the MFP in such a situation, they may result in fatal accidents such as explosion or fire. Therefore, to avoid this, be sure to perform correct handling and installation.

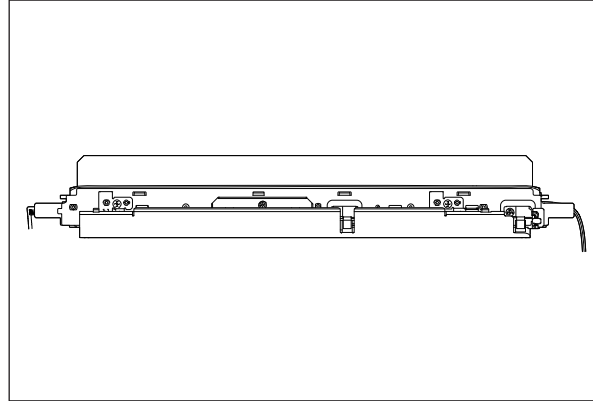

Fig. 4-604

- When handling them, be careful not to deform the thermistor and the magnetic metal plate. It is recommended to prepare stands with a height of 2 cm or more and place both edges of the fuser belt unit on them for the operation.

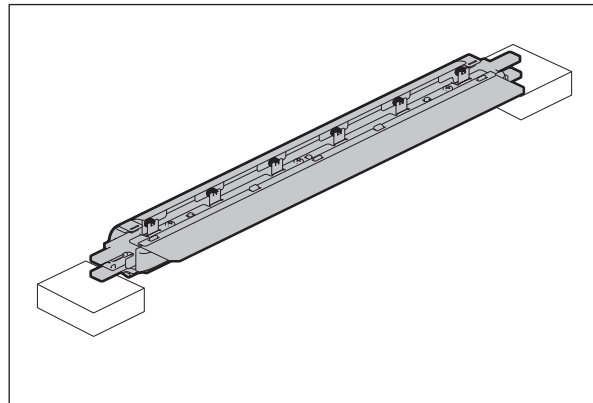

Fig. 4-605

- (1) Remove 3 screws and take off the plate [1].

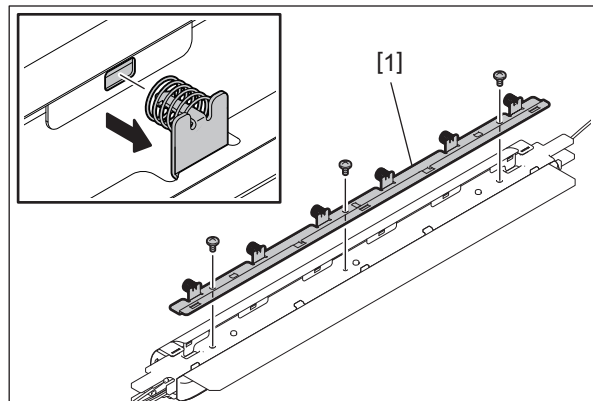

Fig. 4-606

(2) Take off the fuser belt pad [2] and the fuser belt lubricating sheet [3].

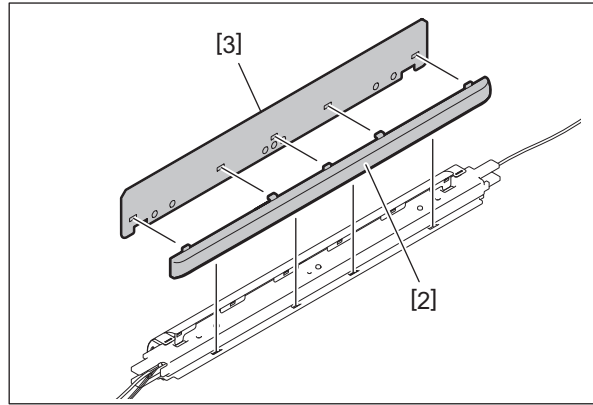

Fig. 4-607

(3) Remove 2 screws and take off 2 brackets [4].

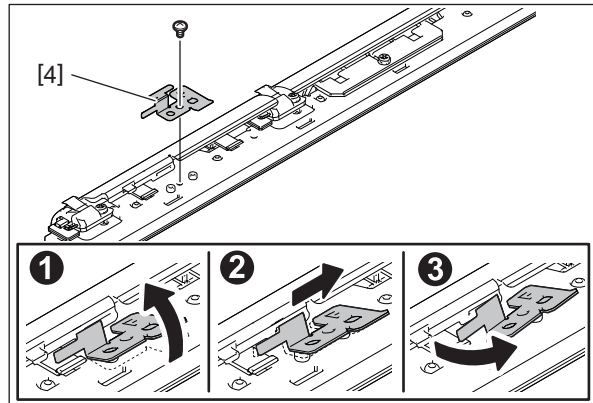

Fig. 4-608

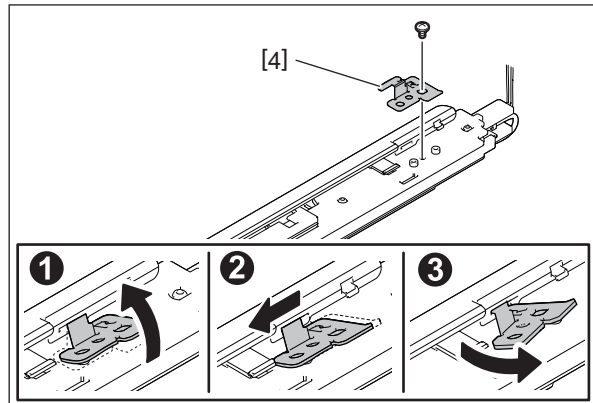

Fig. 4-609

(4) Take off the magnetic plate [5].

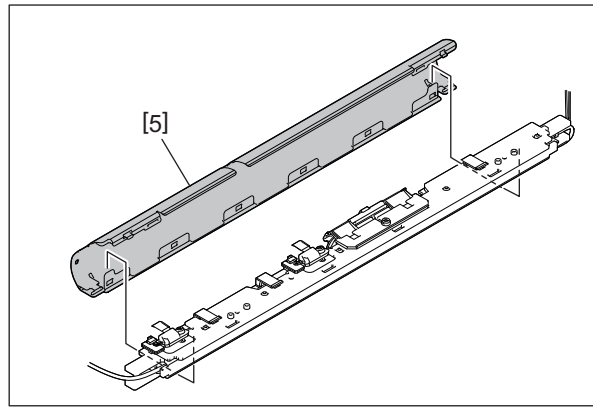

Fig. 4-610

Notes:

- No dents, scratches and deformation.

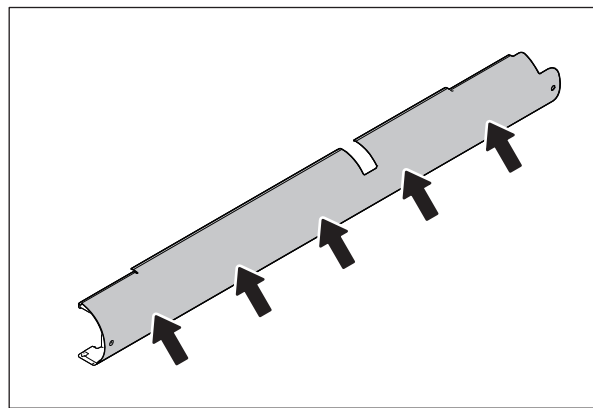

Fig. 4-611

- No misalignment between the front and the rear being viewed from the side.
 - No misalignment in all 6 portions being viewed from the side.
 - Do not wipe off the oil which has been applied to the magnetic plate.
- In addition, pay attention that no dust or foreign matter adheres during the service.

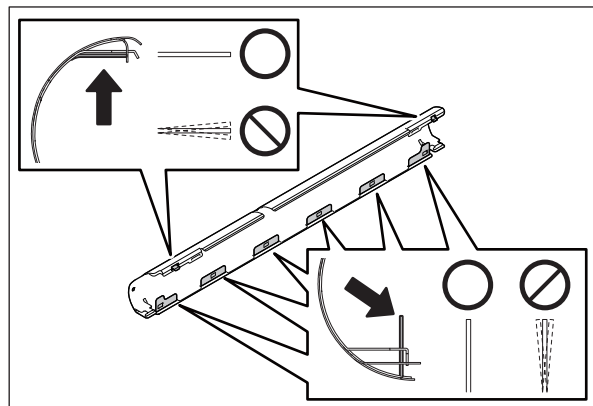

Fig. 4-612

- (5) Remove 2 screws and then take off the fuser belt edge thermistor [6] and the fuser belt center thermistor [7].

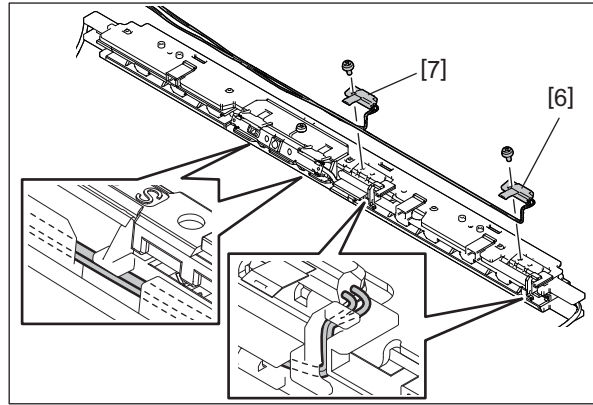

Fig. 4-613

Notes:

- The harness of the thermistor should be wired inside the latches.
- Since the detection portion of the thermistor is easily deformed, be very careful that this does not happen.
- After installing the thermistor, the dimension "A" in the figure below should be within 2 to 3 mm as a guide.

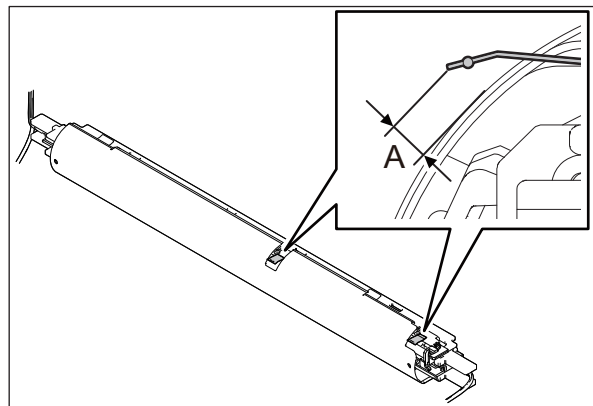

Fig. 4-614

- (6) Lift up 2 latches and take off the harness guide [8].
(7) Lift up 1 latch and take off the harness guide [9].

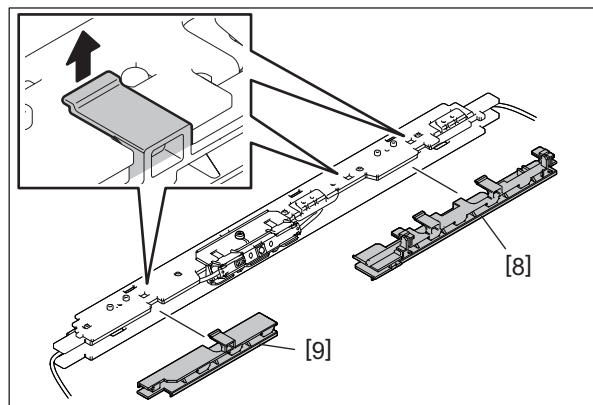

Fig. 4-615

(8) Release 4 latches and then take off the cover [10] of the thermostat.

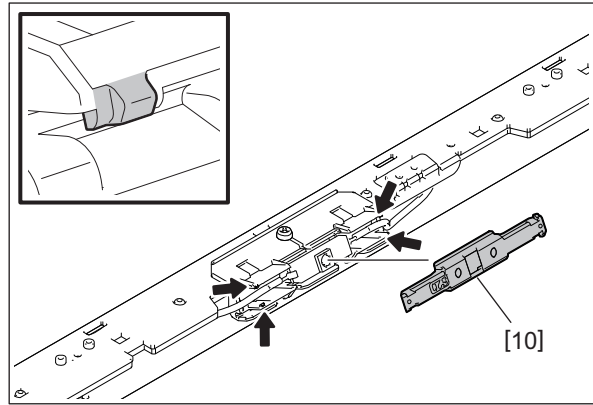

Fig. 4-616

(9) Take off the fuser belt thermostat [11].

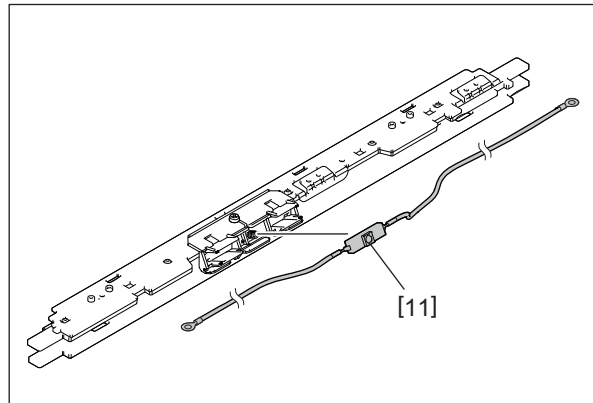

Fig. 4-617

Notes:

- Do not apply a load to the harness of the thermostat.

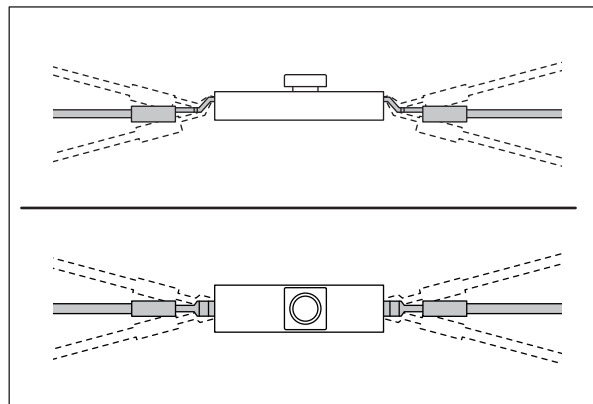

Fig. 4-618

- The spring [12] is mounted inside of the holder of the thermostat. If this spring has come off, insert its tip to the hole of the holder as shown in the figure.

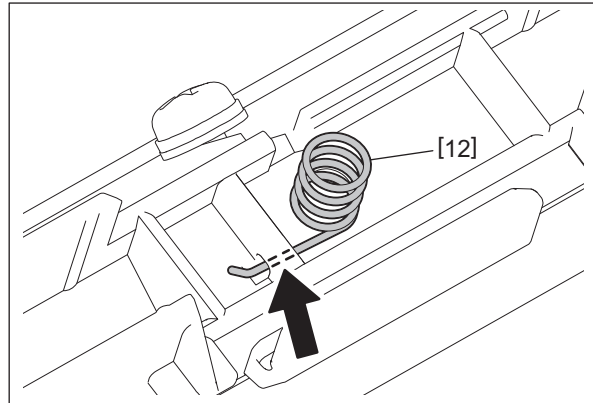

Fig. 4-619

- When installing the cover [10] of the thermostat, first hook 2 latches at the left side and then those at the right side.
- Make sure that 4 latches are hooked securely.

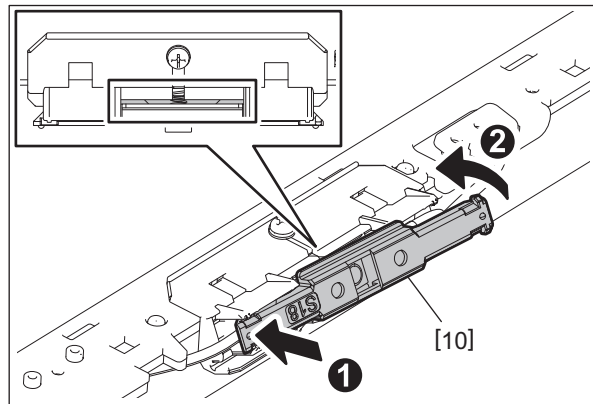

Fig. 4-620

- After installing the cover, there should be an even space between the cover and the holder.
If there is no space or it is uneven, the cover and the spring are not installed correctly.

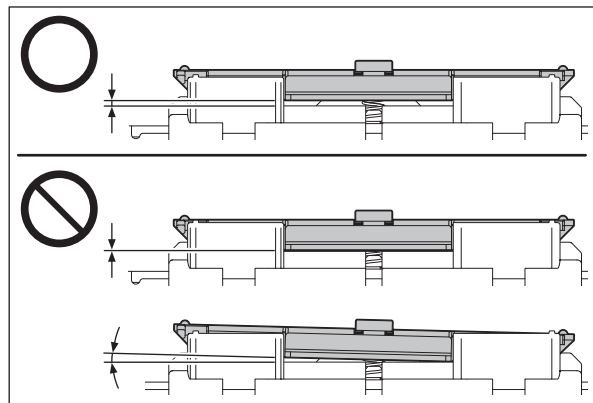

Fig. 4-621

4.9.14 Pressure roller

- (1) Take off the fuser belt unit.
P. 4-226 "4.9.7 Fuser belt"
- (2) Remove 2 screws, 2 E-rings [1], 2 washers [2] and 2 bushings [3].

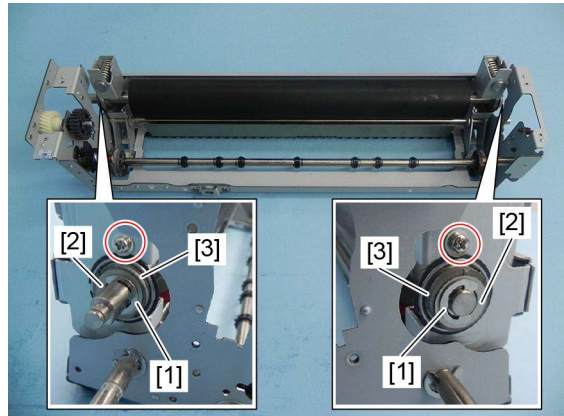

Fig. 4-622

- (3) Remove the pressure roller [4] by sliding it.

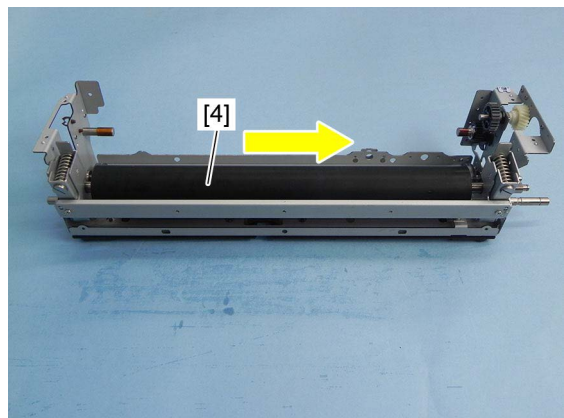

Fig. 4-623



Fig. 4-624

Notes:

Take care so that no damage or stains are detected on the fuser belt.

4.9.15 Fuser belt rotation detection sensor (S49)

- (1) Remove the pressure roller contact/release sensor.
P. 4-251 "4.9.16 Pressure roller contact/release detection sensor (S48)"
- (2) Take off the fuser belt unit.
P. 4-226 "4.9.7 Fuser belt"
- (3) Remove 1 screw and then take off the gear [1] and actuator [2].

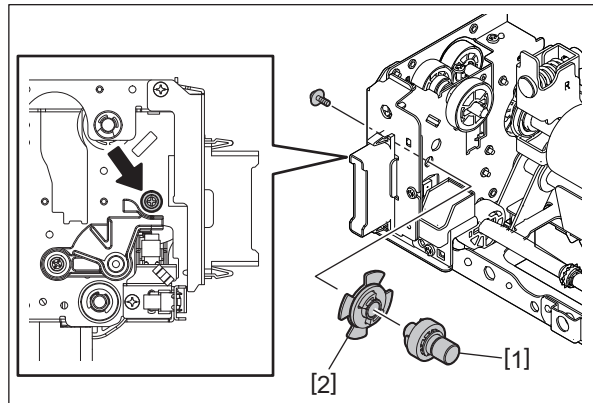

Fig. 4-625

- (4) Remove 1 screw and take off the sensor cover [3].

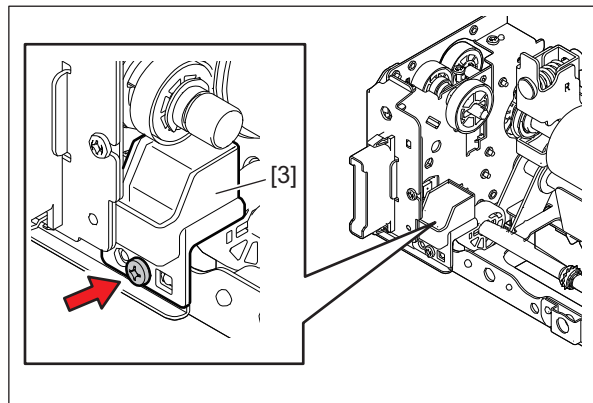

Fig. 4-626

- (5) Remove 1 screw and take off the sensor bracket [4].

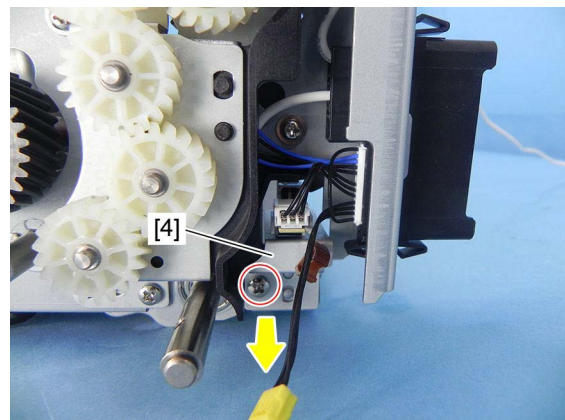

Fig. 4-627

- (6) Disconnect 1 connector. Release 3 latches and remove the fuser belt rotation detection sensor [5].

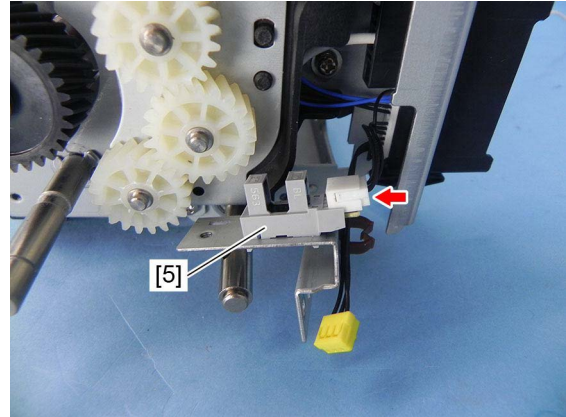

Fig. 4-628

4.9.16 Pressure roller contact/release detection sensor (S48)

- (1) Take off the fuser unit transport guide.
P. 4-222 "4.9.3 Fuser unit transport guide"
- (2) Remove 1 E-ring, and then take off the pressure roller contact/release cam [1] and 1 pin. Remove 1 E-ring and the gear [2].

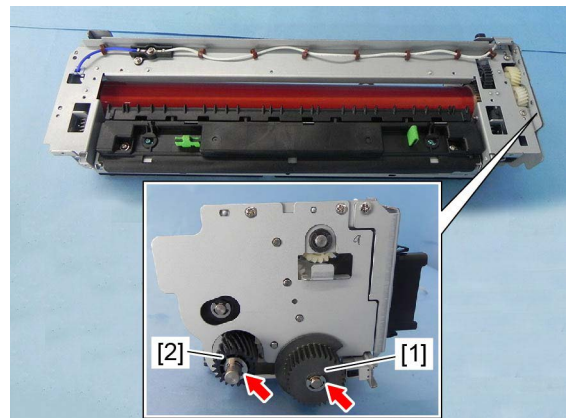

Fig. 4-629

- (3) Remove 3 screws and 1 bushing. Take off the metal plate [3].

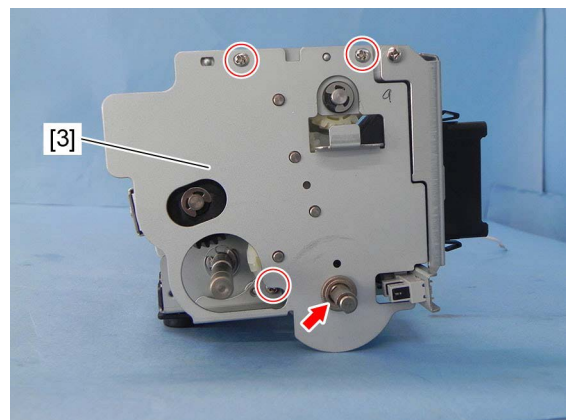

Fig. 4-630

- (4) Remove 1 screw and take off the sensor cover [20] and the sensor bracket [12]. Release the harnesses from 1 harness clamp.

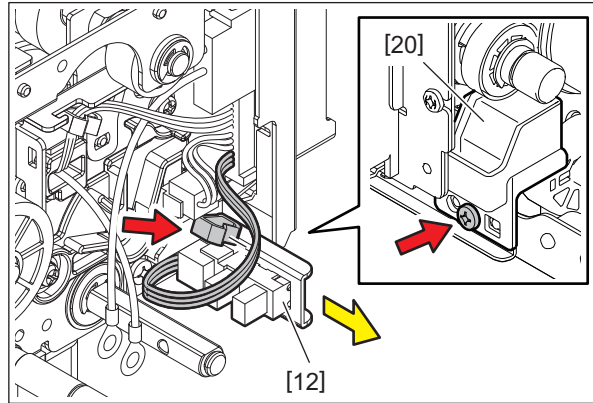

Fig. 4-631

Notes:

If oil has adhered to the sensor cover and around the sensor, wipe it off cleanly.

- (5) Disconnect 1 connector. Release 3 latches and take off the pressure roller contact/release sensor [5].

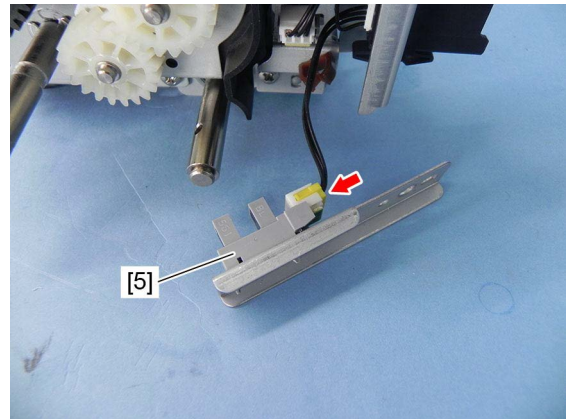

Fig. 4-632

4.9.17 IH coil (IH-COIL)

- (1) Take off the fuser unit.
📖 P. 4-221 “4.9.1 Fuser unit”
- (2) Take off the SYS board case.
📖 P. 9-6 “9.1.7 SYS board case (MJD, ASD, AUD, JPC, CND)”
- (3) Take off the IH board cover.
📖 P. 9-23 “9.1.20 IH board”
- (4) Remove 2 screws and release the harness [1] of the IH coil.

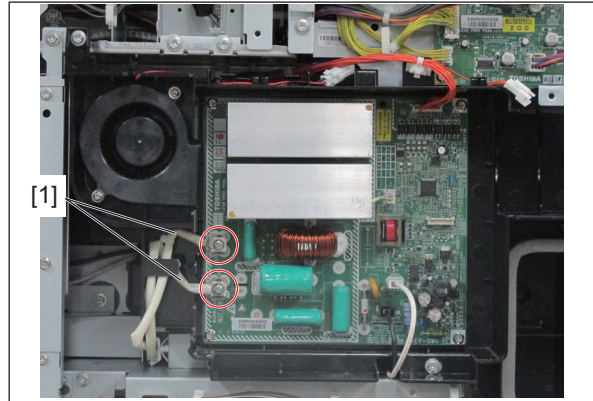

Fig. 4-633

- (5) Remove 2 screws and take off the harness cover [2].

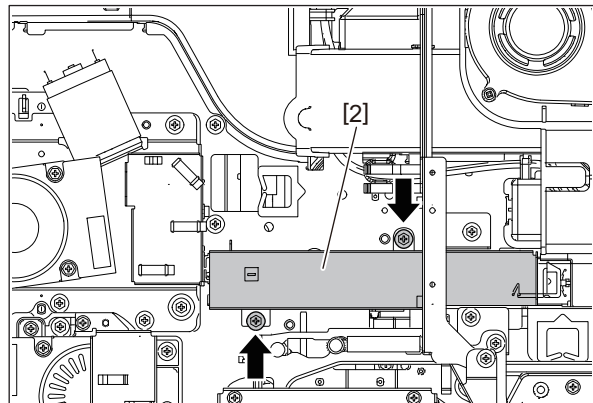

Fig. 4-634

- (6) Release the harnesses from 3 harness clamps.

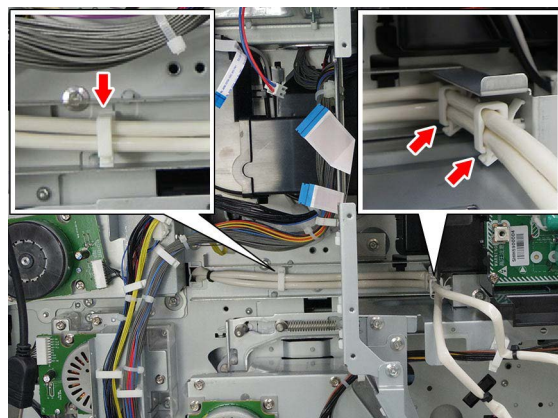

Fig. 4-635

(7) Remove 1 screw and take off the harness cover [3].

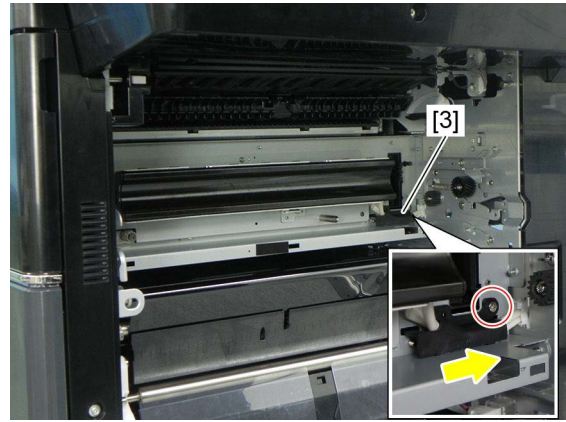

Fig. 4-636

Notes:

When installing the harness cover, check that the IH coil can be moved by pushing it with your finger. If not, loosen the tension of the harness in the IH coil.

(8) Remove 3 screws and take off the IH coil [4].

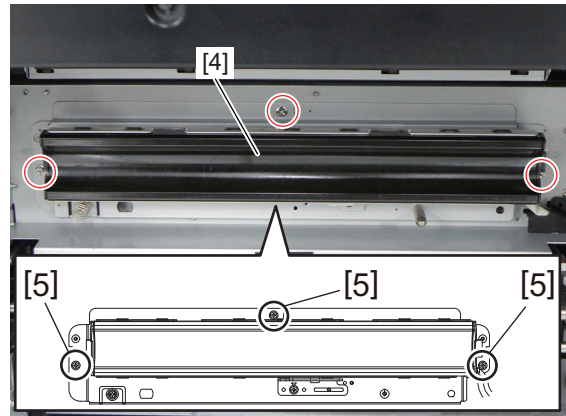

Fig. 4-637

Notes:

- The gap of the IH coil is adjusted, so be sure not to remove any other 3 screws [5] other than those from the bracket.
- Count the number of lines [6] and write it down for later reference before removing the IH coil. When installing the IH coil, the same number of lines needs to be visible.

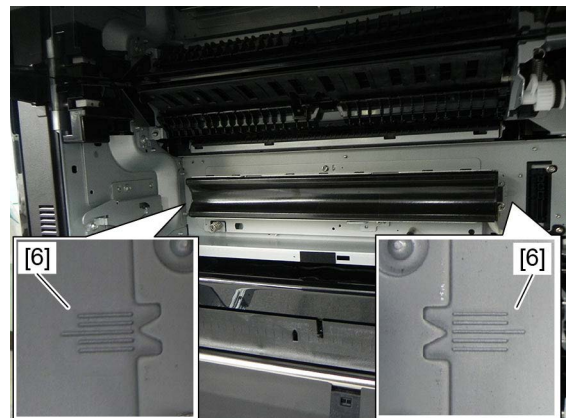

Fig. 4-638

4.9.18 Fuser motor (M6)

- (1) Take off the SYS board case.
📖 P. 9-6 "9.1.7 SYS board case (MJD, ASD, AUD, JPC, CND)"
- (2) Remove 3 screws. Disconnect 1 connector and take off the fuser motor [1].

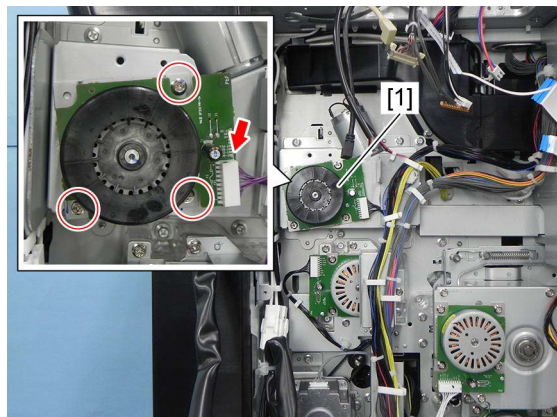

Fig. 4-639

4.9.19 Pressure roller contact/release motor (M48)

- (1) Take off the fuser unit.
📖 P. 4-221 "4.9.1 Fuser unit"
- (2) Take off the SYS board case.
📖 P. 9-6 "9.1.7 SYS board case (MJD, ASD, AUD, JPC, CND)"
- (3) Release the harnesses from 3 harness clamps.

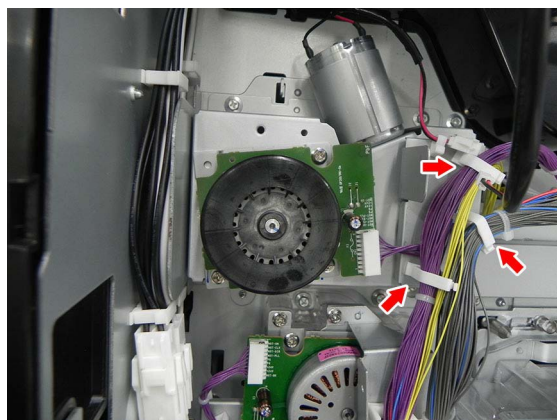

Fig. 4-640

- (4) Remove 4 screws and take off the fuser drive unit [1].

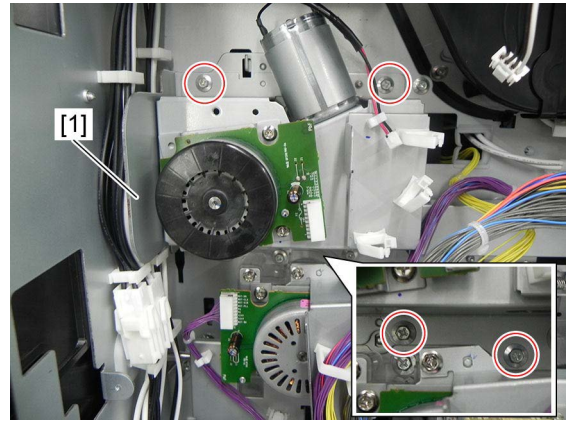

Fig. 4-641

- (5) Remove 1 screw, the gear [2] and 1 pin.
Remove 1 screw and the gear [3].
Remove 2 screws and take off the bracket [4].

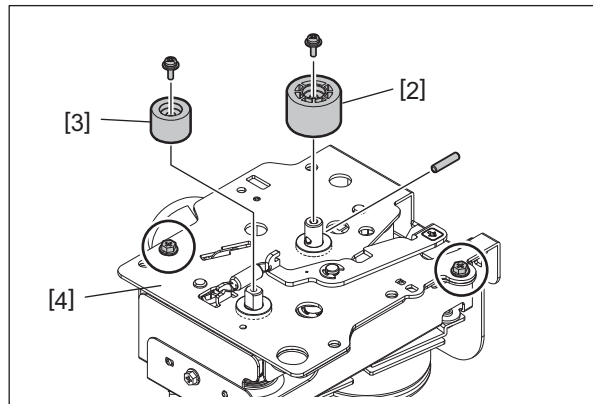

Fig. 4-642

Notes:

Pay attention not to drop the pin when removing the gear [2].

- (6) Remove 2 ball bearings [5] and the gears [6], [7], [8] and [9].

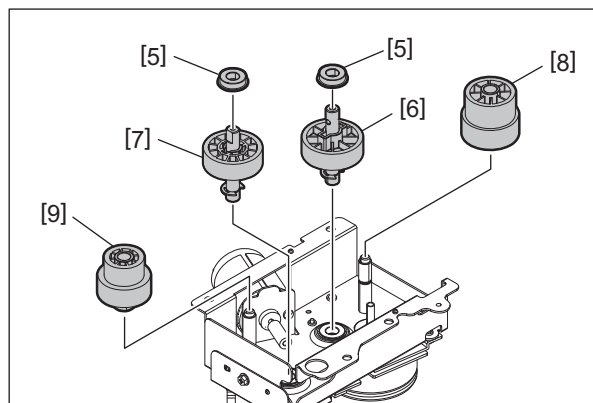

Fig. 4-643

Notes:

When replacing the parts, apply an appropriate amount of white grease (Molykote EM-30L) to the tooth surface of the gears.

- (7) Remove 2 screws and take off the pressure roller contact/release motor [10].

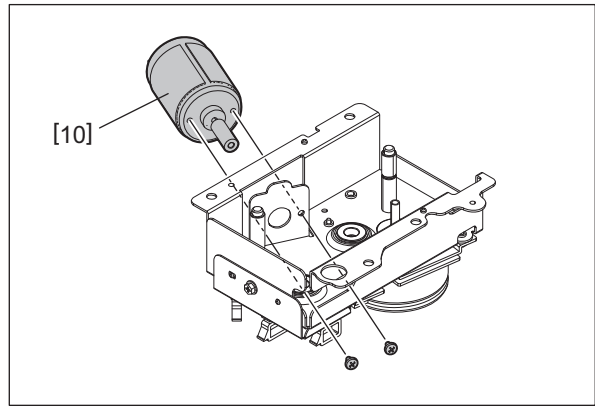

Fig. 4-644

Notes:

- Pay attention to the size and length of the screws. If you use the wrong ones, the motor could be damaged.
- When disassembling the fuser unit drive section, apply white grease (Molykote EM-30L) on the shafts and the tooth surfaces of the gears shown in the figure.

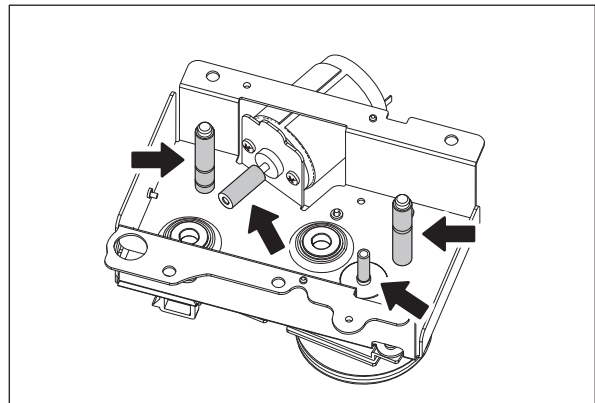

Fig. 4-645

4.9.20 IH board cooling fan (suction) (F8)

- (1) Take off the rear cover.
P. 4-12 “4.1.22 Rear cover”
- (2) Remove 4 screws. Disconnect 1 connector and take off the IH board cover [1].

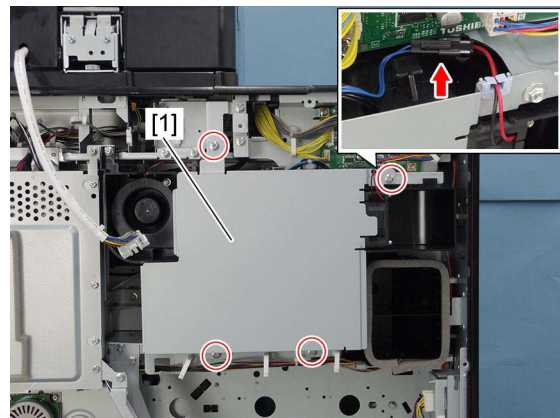

Fig. 4-646

- (3) Disconnect 1 connector and release the harness from the harness guides [2].

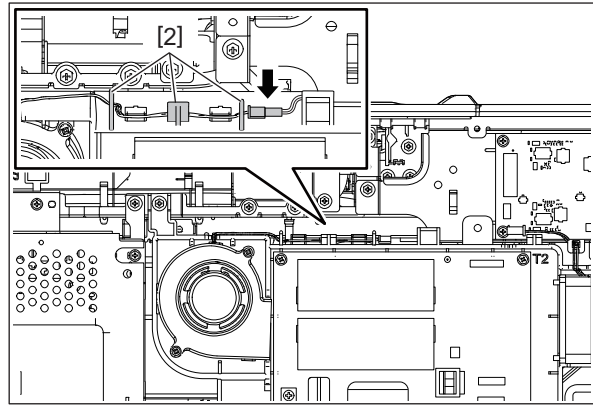

Fig. 4-647

- (4) Remove 2 screws and take off the IH board cooling fan (suction) [3].

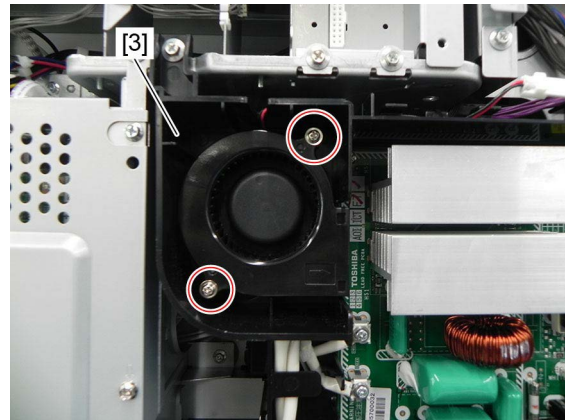

Fig. 4-648

4.9.21 IH board cooling fan (exhaust) (F9)

- (1) Take off the rear cover.
P. 4-12 "4.1.22 Rear cover"
- (2) Remove 4 screws. Disconnect 1 connector and take off the IH board cover [1].

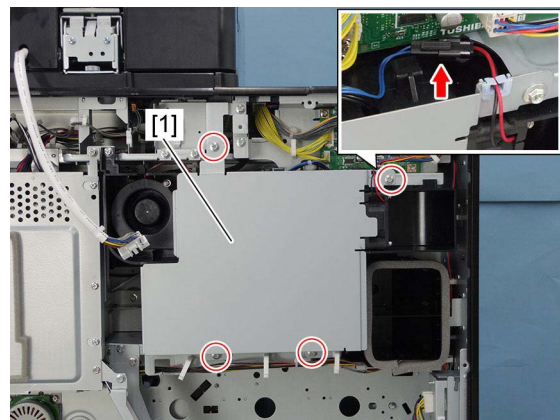

Fig. 4-649

- (3) Release the harnesses from 1 harness clamp. Remove 2 screws and take off the IH board cooling fan (exhaust) [2].

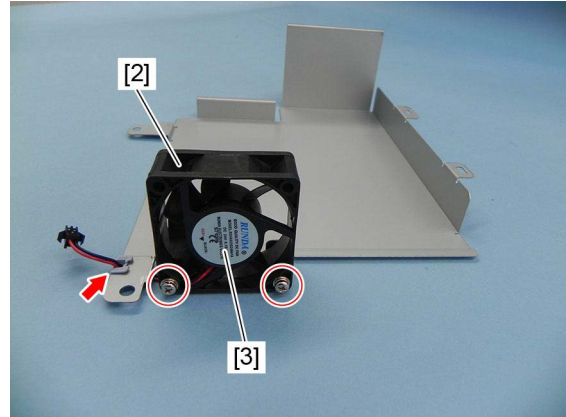

Fig. 4-650

Notes:

When installing the fan, be sure that the surface with the label [3] is shown at the outside.

4.9.22 VOC filter

- (1) Remove 1 screw and take off the filter cover [1].

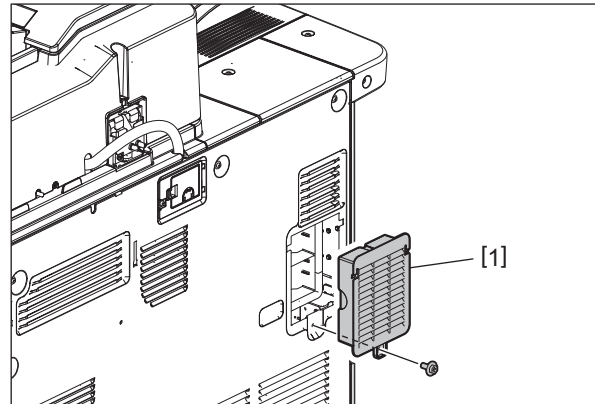

Fig. 4-651

- (2) Remove the VOC filter [2].

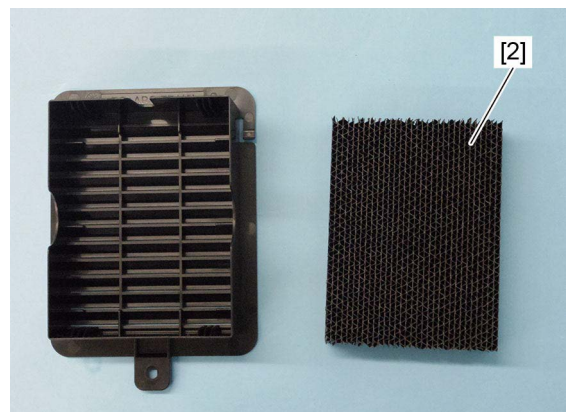

Fig. 4-652

Notes:

- Do not take out the new filter from the bag until just before replacement.
- Insert the filter between 2 ribs.
- Install without breaking the filter cell.

4.10 Paper Exit Unit, Reverse Unit, Duplexing Unit

4.10.1 Upper paper exit section cooling fan (rear) (F32)

- (1) Take off the exit tray.
P. 4-7 “4.1.13 Exit tray”
- (2) Remove 2 screws and disconnect 1 connector.
- (3) Release the harness from 2 harness clamps. Remove the upper paper exit section cooling fan (rear) [1].

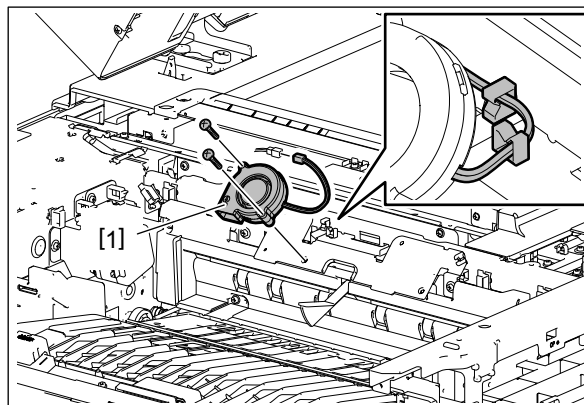

Fig. 4-653

4.10.2 Lower paper exit section cooling fan (rear) (F34), Lower paper exit section cooling fan (front) (F35)

- (1) Take off the exit tray.
P. 4-7 “4.1.13 Exit tray”
- (2) Take off the left top cover.
P. 4-8 “4.1.15 Left top cover”
- (3) Lift up the reverse path cover. Remove 2 screws and disconnect 1 connector for each fan.

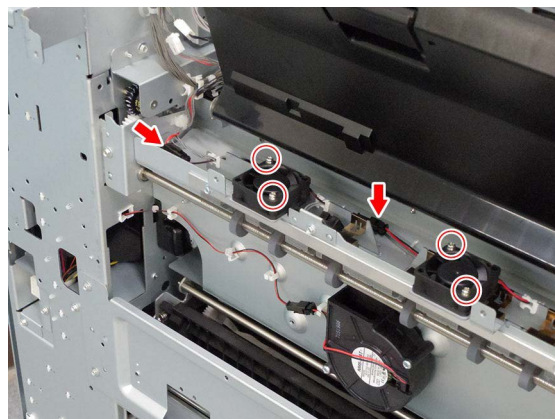

Fig. 4-654

- (4) Release the harness from 5 harness clamps. Remove the lower paper exit section cooling fan (rear) [1] and the lower paper exit section cooling fan (front) [2].

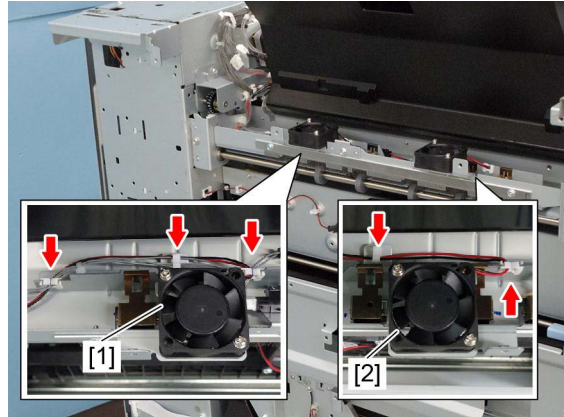

Fig. 4-655

4.10.3 Lower paper exit section cooling fan (bottom) (F36)

- (1) Take off the left top cover.
P. 4-8 "4.1.15 Left top cover"
- (2) Release the harness from 1 harness clamp [1] and disconnect 1 connector.
- (3) Remove 2 screws and take off the lower paper exit section cooling fan (bottom) [2].

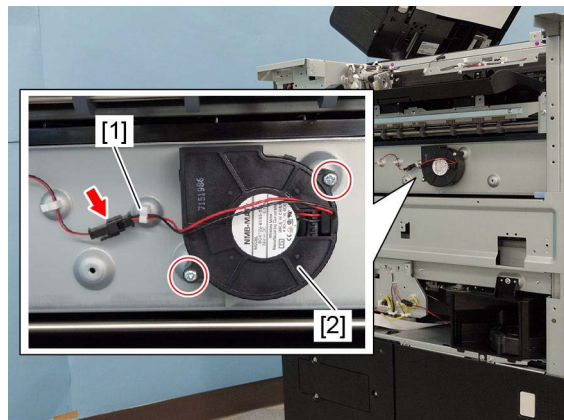

Fig. 4-656

4.10.4 Paper exit motor (M2)

- (1) Take off the exit tray.
📖 P. 4-7 "4.1.13 Exit tray"
- (2) Take off the left top cover.
📖 P. 4-8 "4.1.15 Left top cover"
- (3) Release the harnesses from 2 harness clamps.

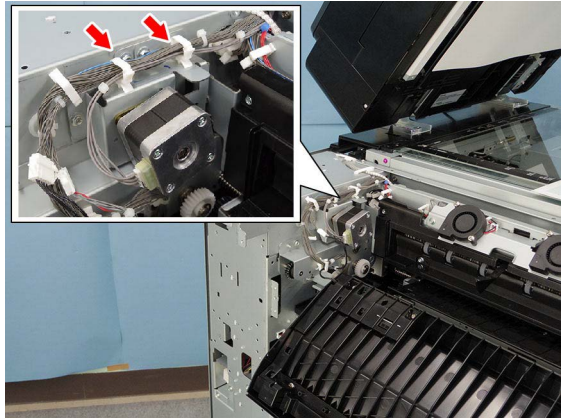

Fig. 4-657

- (4) Remove 2 screws. Disconnect 1 connector and take off the paper exit motor [1] with the bracket [2],

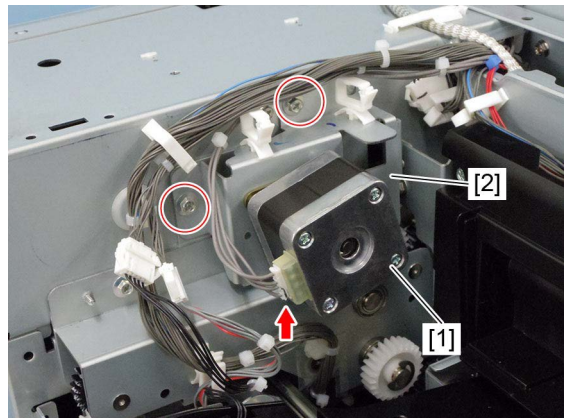

Fig. 4-658

- (5) Remove 2 screws and the belt [3], and then take off the paper exit motor [1].

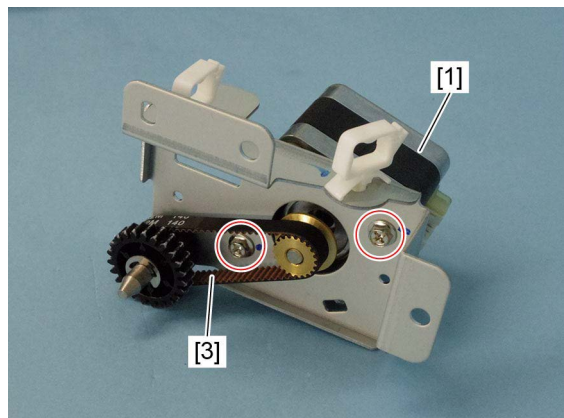

Fig. 4-659

4.10.5 Upper paper exit sensor (S61), Upper exit tray paper full detection sensor (S62)

- (1) Take off the upper paper exit section cooling fan (rear).
📖 P. 4-261 "4.10.1 Upper paper exit section cooling fan (rear) (F32)"
- (2) Take off the paper exit motor.
📖 P. 4-263 "4.10.4 Paper exit motor (M2)"
- (3) Remove 4 screws and take off the paper exit cover [1].

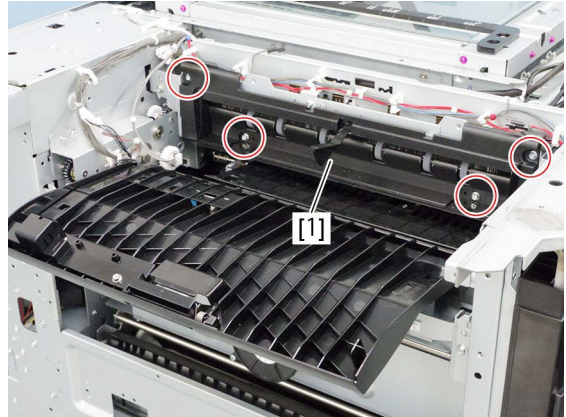

Fig. 4-660

- (4) Remove 2 screws. Disconnect 1 connector [1] and take off the upper paper exit roller unit [2].

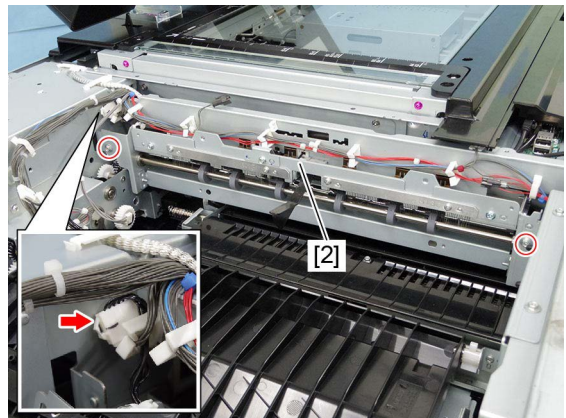

Fig. 4-661

- (5) Release the harnesses from 1 harness clamp [3]. Disconnect 1 connector [4] and take off the upper exit tray paper full detection sensor [5].
- (6) Remove 1 screw and disconnect 1 connector [6]. Take off the sensor bracket [7].

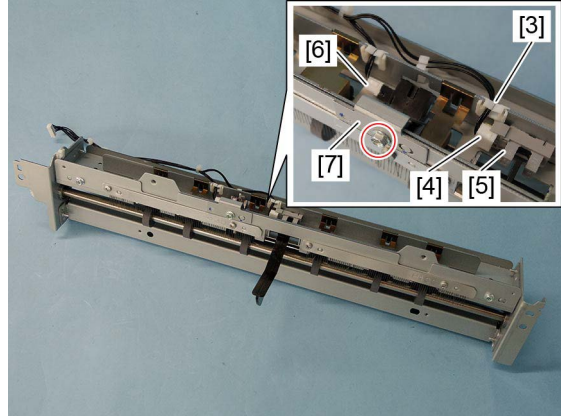

Fig. 4-662

- (7) Remove the upper paper exit sensor [8] from the sensor bracket [7].

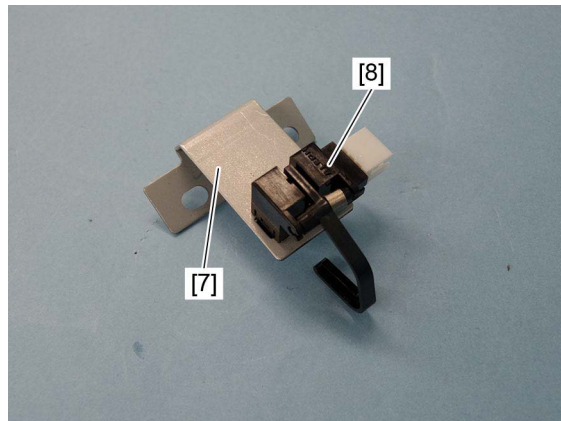

Fig. 4-663

4.10.6 Lower paper exit sensor (S63)

- (1) Take off the left top cover.
 📖 P. 4-8 “4.1.15 Left top cover”
- (2) Lift up the reverse path cover. Remove 1 screw and disconnect the connector. Take off the sensor bracket [1].

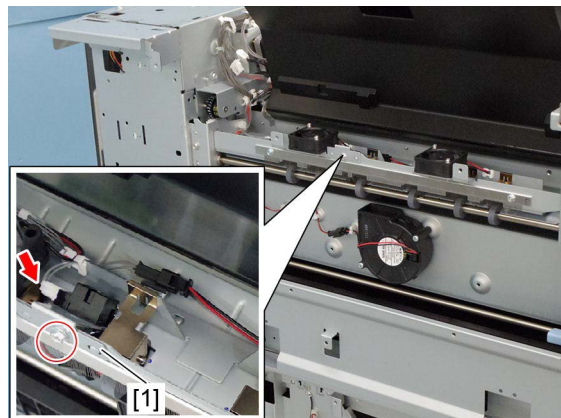

Fig. 4-664

- (3) Remove the lower paper exit sensor [2] from the sensor bracket [1].

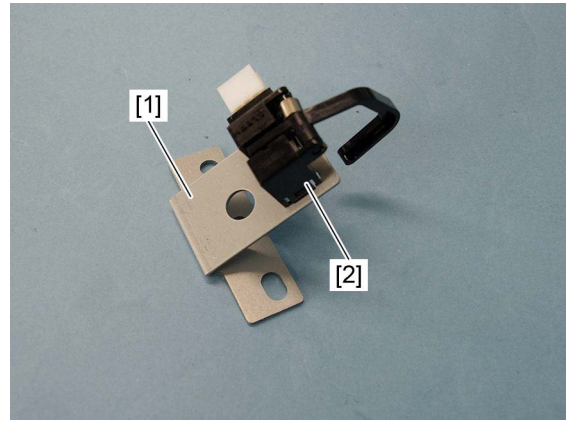

Fig. 4-665

4.10.7 Reverse section paper transport detection sensor (S60)

- (1) Take off the exit tray.
📖 P. 4-7 “4.1.13 Exit tray”
- (2) Remove 2 screws and take off the sensor bracket [1].

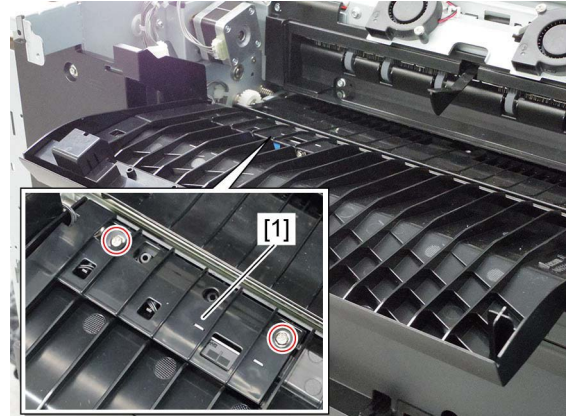

Fig. 4-666

- (3) Release the harness from 3 hooks [2] and disconnect the connector.
- (4) Remove 2 screws and take off the reverse section paper transport detection sensor [4] from the sensor bracket [3].

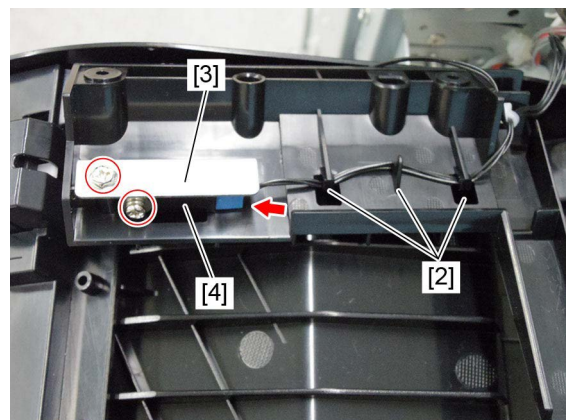

Fig. 4-667

4.10.8 Reverse path cover switch (SW5)

- (1) Take off the exit tray.
P. 4-7 "4.1.13 Exit tray"
- (2) Remove 2 screws and take off the sensor bracket [1].

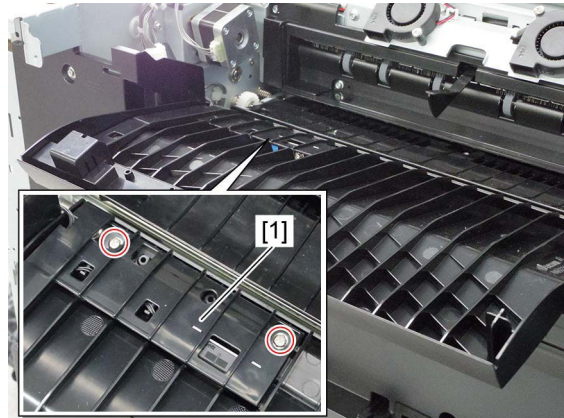

Fig. 4-668

- (3) Take off the sensor cover [2]. Remove 2 screws and take off the sensor bracket [3].

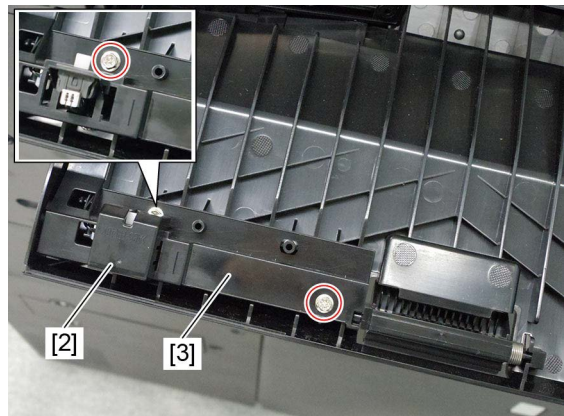

Fig. 4-669

Notes:

When installing the sensor bracket, be careful not to let the harness get caught in it.

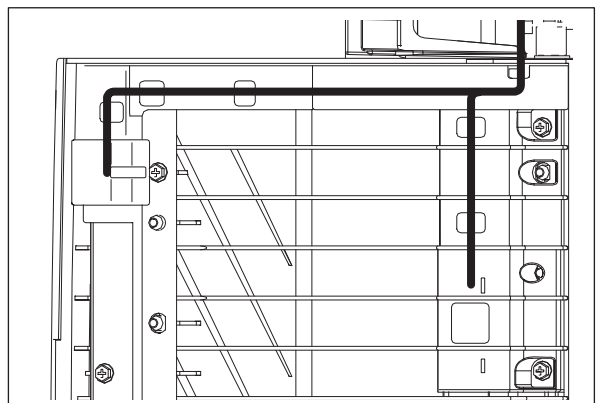

Fig. 4-670

- (4) Release the harness from 3 hooks [4].
- (5) Remove the reverse path cover switch (SW5) [5] from the sensor bracket.
- (6) Disconnect the connector from the reverse path cover switch [5].

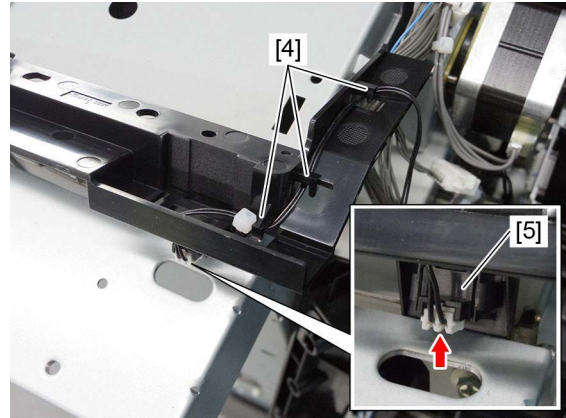

Fig. 4-671

4.10.9 Upper paper exit roller

- (1) Take off the upper paper exit roller unit.
P. 4-264 "4.10.5 Upper paper exit sensor (S61), Upper exit tray paper full detection sensor (S62)"
- (2) Remove the E-ring and gear [1] on the rear side.

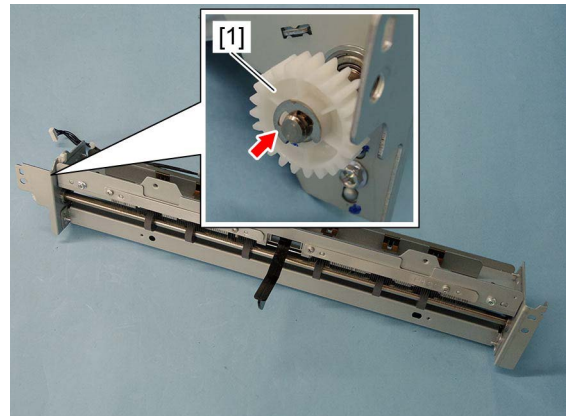

Fig. 4-672

- (3) Remove 2 E-rings from the rear and front sides.
- (4) Remove 2 ball bearings [2] from the rear and front sides. Take off the upper paper exit roller [3].

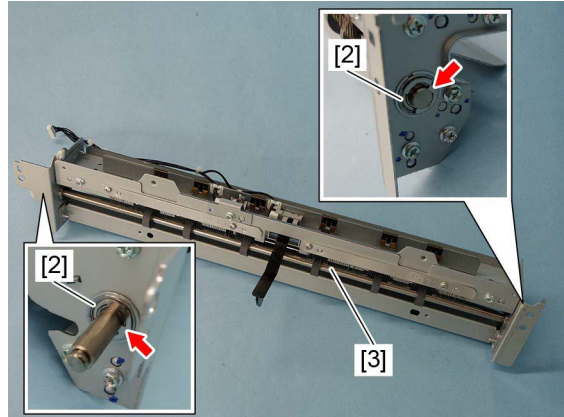

Fig. 4-673



Fig. 4-674

4.10.10 Lower paper exit roller

- (1) Take off the left top cover.
P. 4-8 "4.1.15 Left top cover"
- (2) Lift up the reverse path cover. Remove 2 screws and disconnect the connector. Take off the lower paper exit roller unit [1].

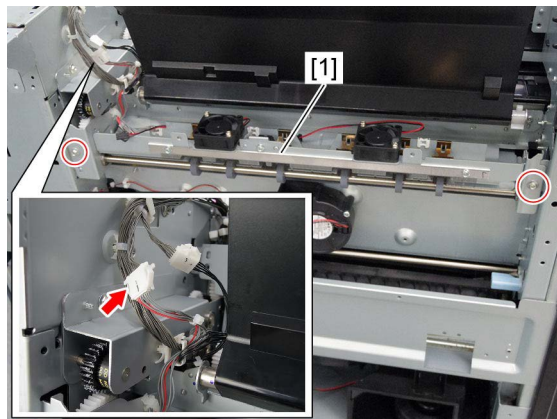

Fig. 4-675

- (3) Remove 2 E-rings and 2 gears [2].

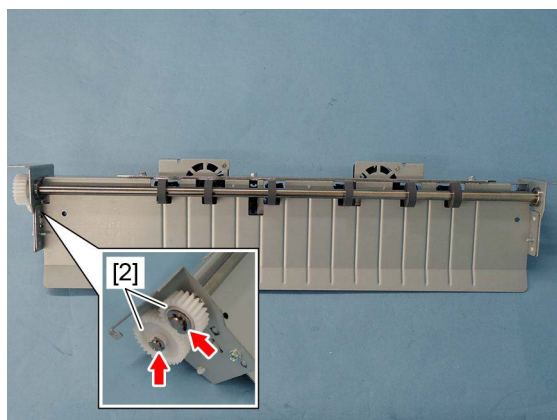

Fig. 4-676

- (4) Remove 1 E-ring and 2 ball bearings [3]. Take off the lower paper exit roller [4].

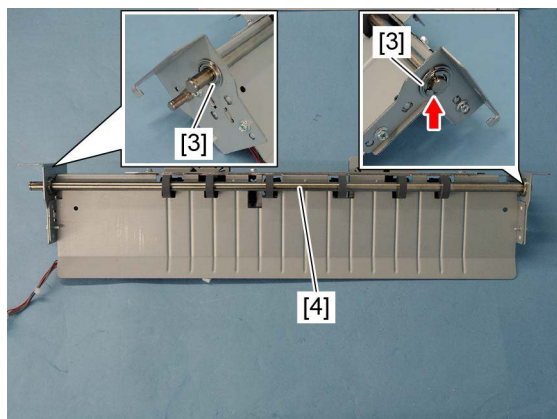

Fig. 4-677

4.10.11 Bridge unit

- (1) Open the front cover and pull out the bridge unit [1].



Fig. 4-678

- (2) Remove 4 screws from the rail.
- (3) Take off the bridge unit [1].



Fig. 4-679

Notes:

When installing the bridge unit, engage the dent of the unit with the 4 bosses of the rail.



Fig. 4-680

4.10.12 Bridge unit front cover

- (1) Open the front cover and pull out the bridge unit.
- (2) Open the bridge unit lower cover [1] and remove 3 screws from the bridge unit front cover [2].

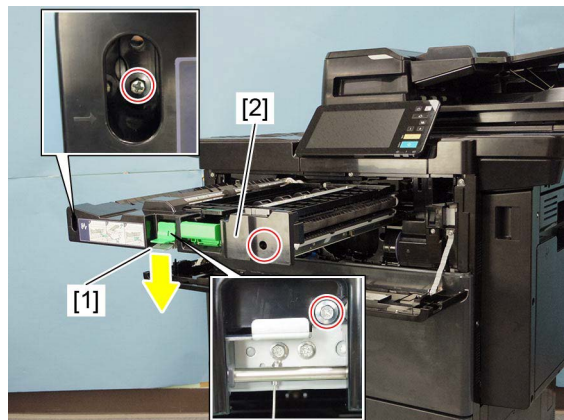

Fig. 4-681

- (3) Open the bridge unit upper cover [3] and take off the bridge unit front cover [2] while keeping the lever [4] of the bridge unit lowered.

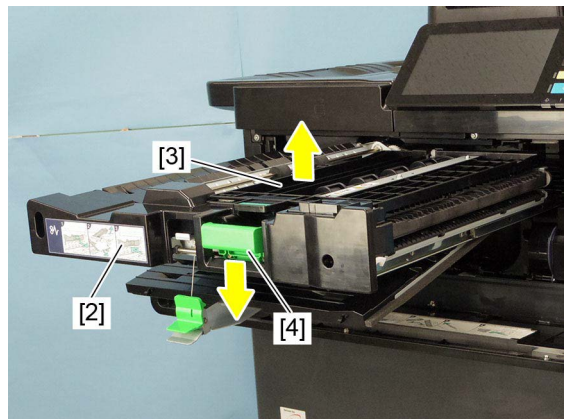

Fig. 4-682

4.10.13 Bridge unit lower cover

- (1) Open the front cover and pull out the bridge unit.
- (2) Open the bridge unit lower cover [1]. Remove 1 screw and the wire [2].

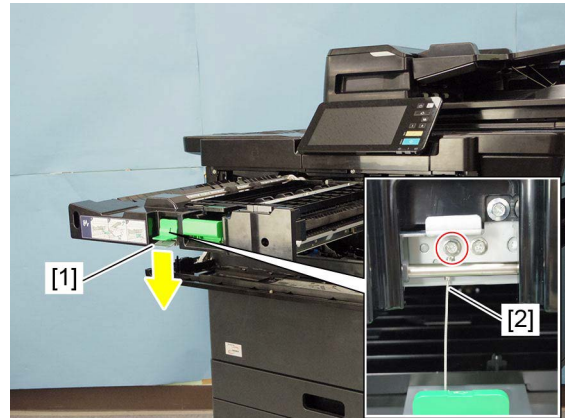

Fig. 4-683

- (3) Remove 1 clip and take off the bridge unit lower cover [1] by sliding it.

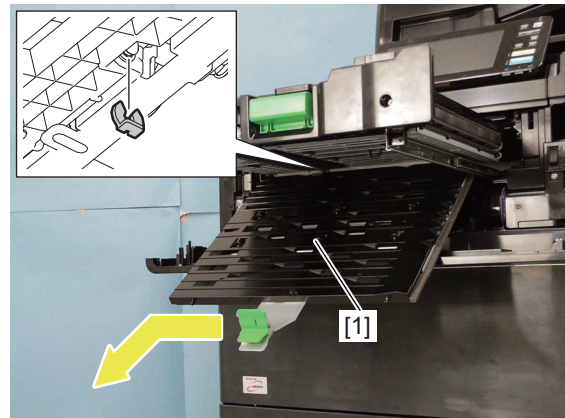

Fig. 4-684

Notes:

The leaf springs with the idling rollers are usually not needed to be disassembled; however, if they are removed and installed, fix the screws while pushing the rollers in the direction of the arrow in the figure to prevent the exit paper sideways deviation.

After the rollers are installed, check that the rollers are parallel to the installation holes.

When pressing the idling rollers, press them in the direction opposite to each other because the 2 leaf springs must be installed in that manner.

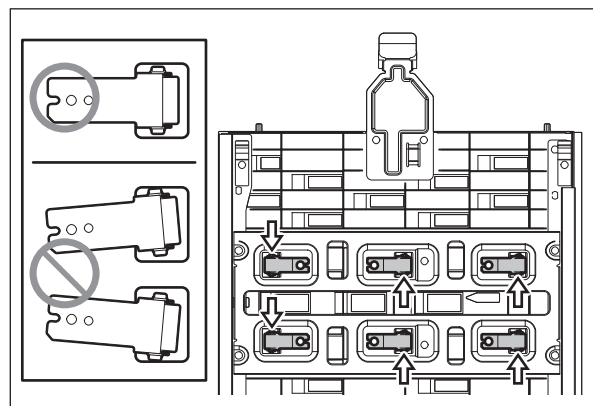

Fig. 4-685

4.10.14 Bridge unit transport entrance motor (M4), Reverse motor (M3)

- (1) Take off the bridge unit.
P. 4-271 "4.10.11 Bridge unit"
- (2) Remove 1 screw and the ground wire. Release the ground wire from 2 clamps.
- (3) Release the harness from 2 harness clamps and disconnect 2 connectors.
- (4) Disconnect the connector from the reverse motor.

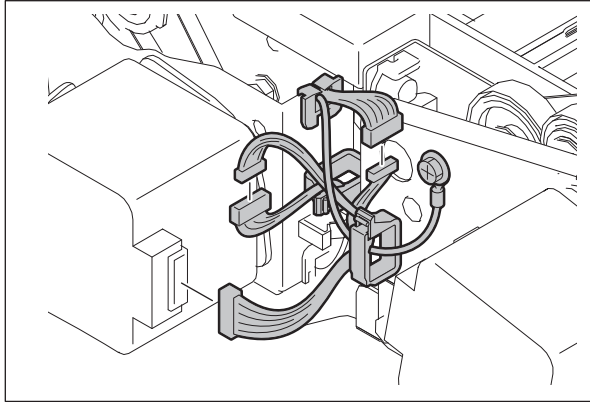

Fig. 4-686

- (5) Remove 3 screws and take off the motor bracket [1].

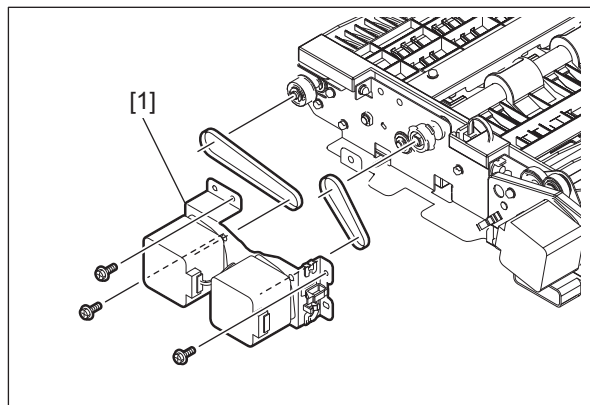

Fig. 4-687

- (6) Release the harnesses from 3 harness clamps.

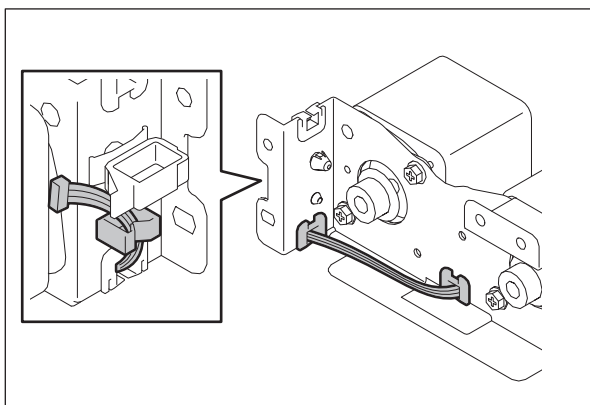

Fig. 4-688

- (7) Remove 2 screws and take off the bridge unit transport entrance motor [2].
- (8) Disconnect the connector from the bridge unit transport entrance motor.

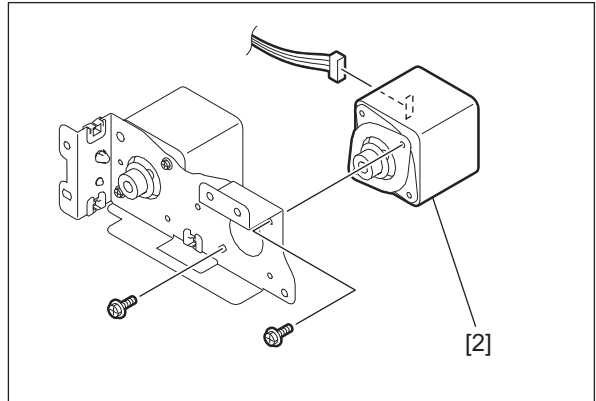

Fig. 4-689

- (9) Remove 2 screws and take off the reverse motor [3].

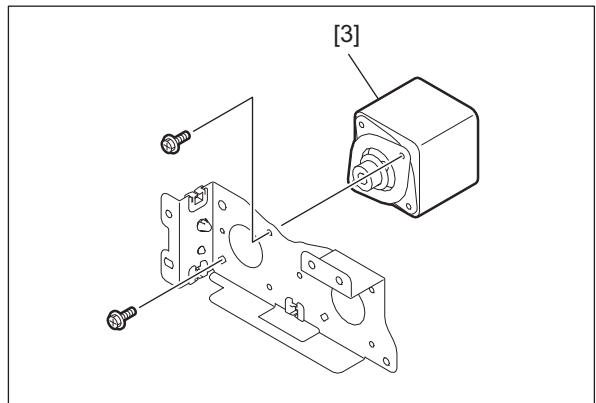

Fig. 4-690

4.10.15 Bridge unit transport exit motor (M5)

- (1) Take off the bridge unit.
 P. 4-271 "4.10.11 Bridge unit"
- (2) Take off the bridge unit transport entrance motor.
 P. 4-274 "4.10.14 Bridge unit transport entrance motor (M4), Reverse motor (M3)"
- (3) Disconnect 1 connector.

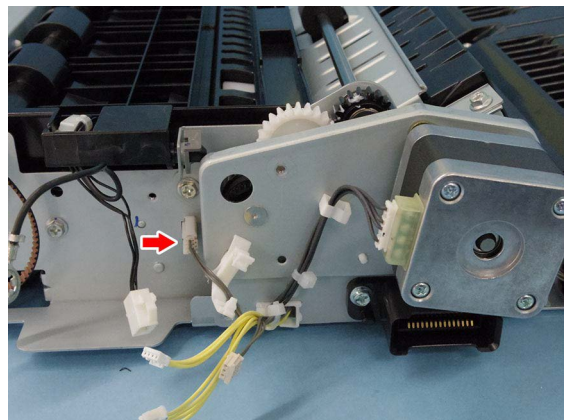

Fig. 4-691

(4) Disconnect 1 connector and release the harness from 2 harness clamps [1].

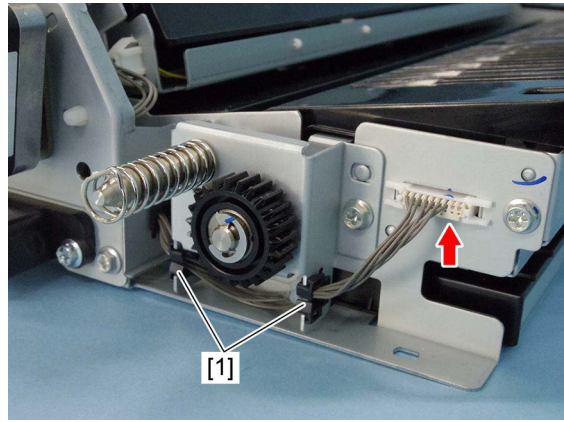

Fig. 4-692

(5) Remove 4 screws and take off the motor bracket [2].

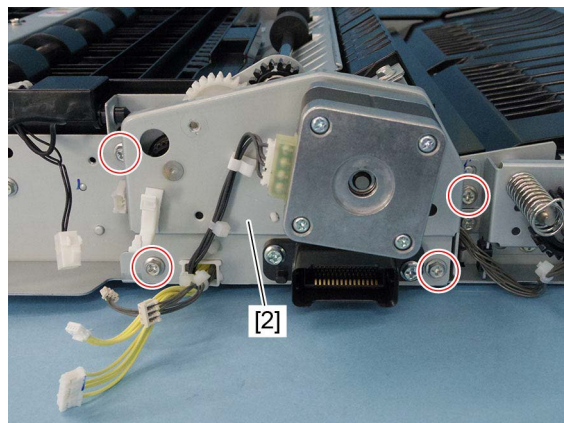

Fig. 4-693

(6) Disconnect 1 connector.

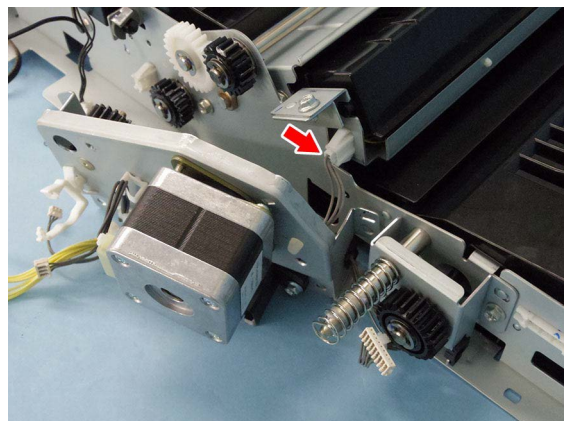

Fig. 4-694

- (7) Remove 2 screws. Take off the bridge unit transport exit motor [3] and remove the gear and belt.

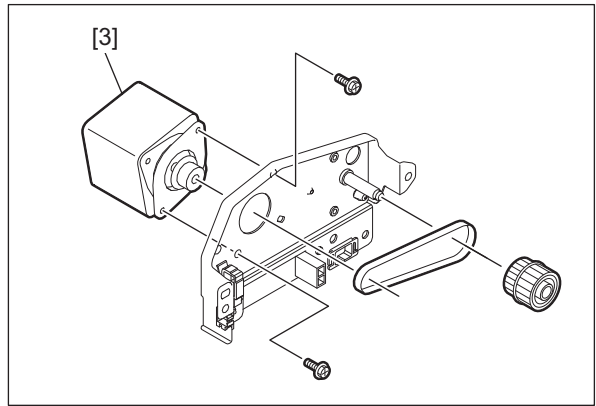

Fig. 4-695

4.10.16 Bridge unit upper cover

- (1) Take off the bridge unit.
P. 4-271 "4.10.11 Bridge unit"
- (2) Remove 1 screw and take off the ground wire.
- (3) Disconnect the connector and release the harness and ground wire from 2 harness clamps.

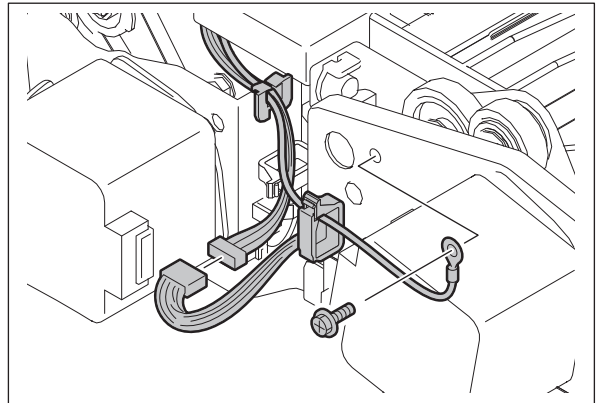

Fig. 4-696

- (4) Remove 1 screw and release the stopper.

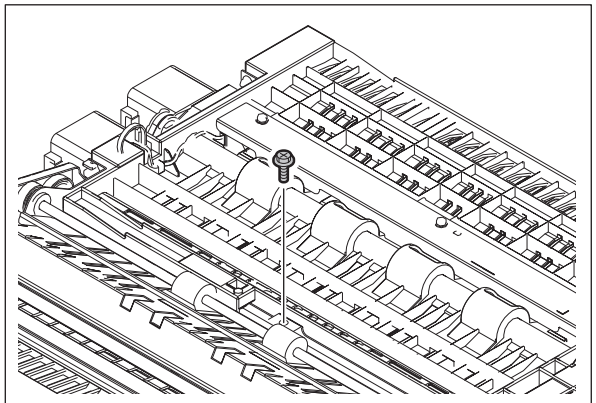

Fig. 4-697

- (5) Remove the clip and then take off the bridge unit upper cover [1] by sliding it.

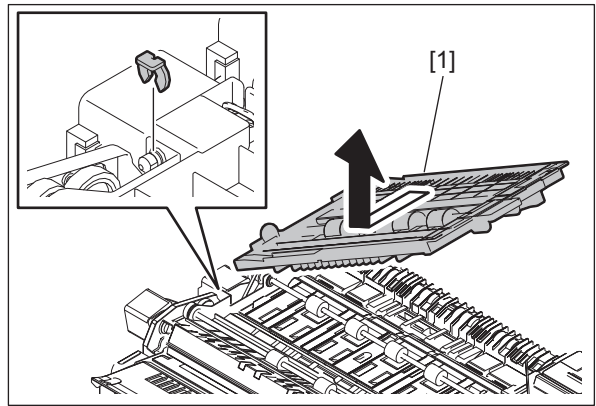

Fig. 4-698

4.10.17 Bridge unit transport roller-1

- (1) Take off the bridge unit.
📖 P. 4-271 "4.10.11 Bridge unit"
- (2) Take off the bridge unit front cover.
📖 P. 4-272 "4.10.12 Bridge unit front cover"
- (3) Take off the bridge unit upper cover.
📖 P. 4-277 "4.10.16 Bridge unit upper cover"
- (4) Remove 3 screws and take off the duct [1].

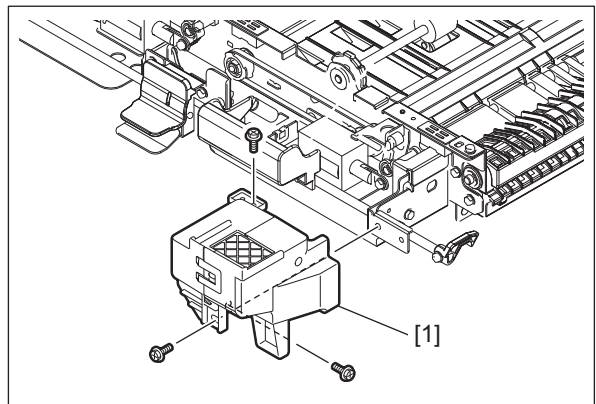

Fig. 4-699

- (5) Remove 2 screws and take off the bracket [2].

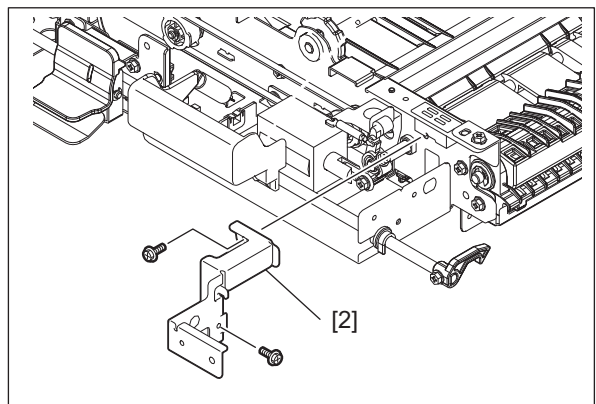

Fig. 4-700

- (6) Remove the belt from the bridge unit transport entrance motor.

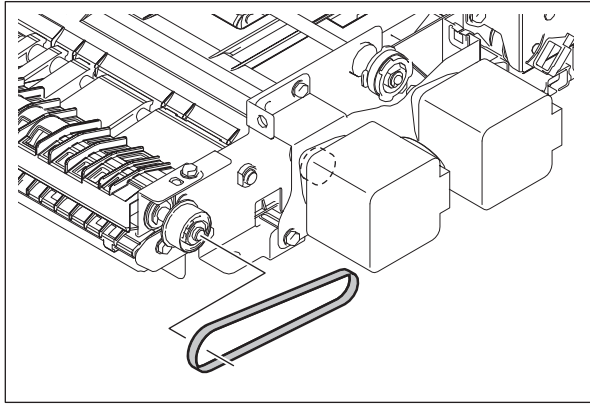

Fig. 4-701

- (7) Remove 1 screw and take off transport guide-1 [3] by sliding it toward you.
(8) Remove 4 screws and take off the transport guide-1 unit.

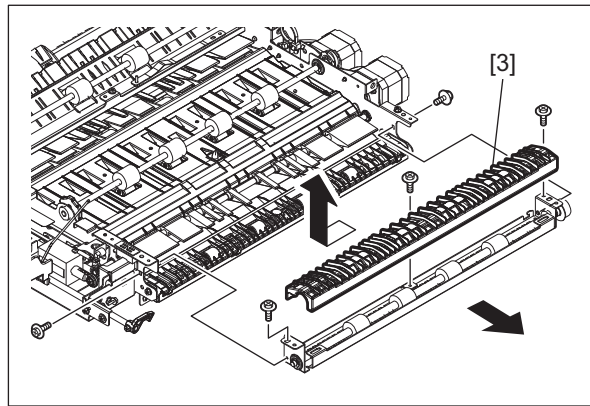

Fig. 4-702

- (9) Remove the E-ring and gear on the rear side.

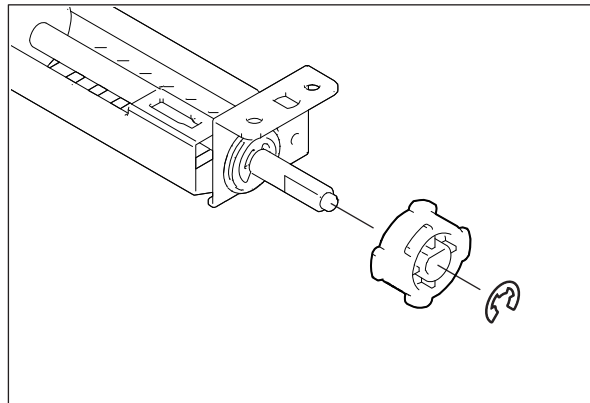

Fig. 4-703

(10) Remove 2 E-rings and 2 ball bearings [4]. Take off the bridge unit transport roller-1 [5].

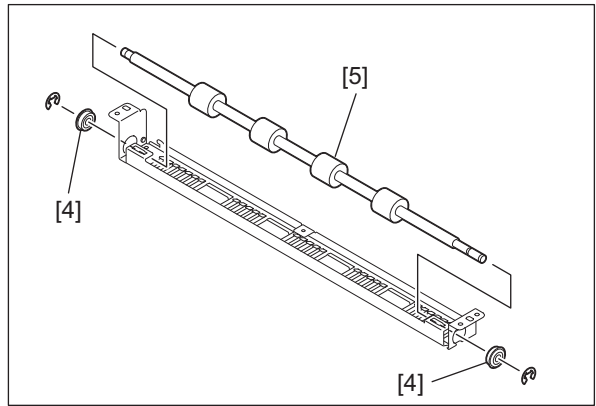

Fig. 4-704

4.10.18 Bridge unit transport roller-2

- (1) Remove the reverse roller.
P. 4-284 "4.10.20 Reverse roller"
- (2) Remove the transport path switching solenoid (bridge unit/reverse section).
P. 4-287 "4.10.23 Transport path switching solenoid (bridge unit/reverse section) (SOL1)"
- (3) Remove 5 screws and take off the transport guide-2 [1].

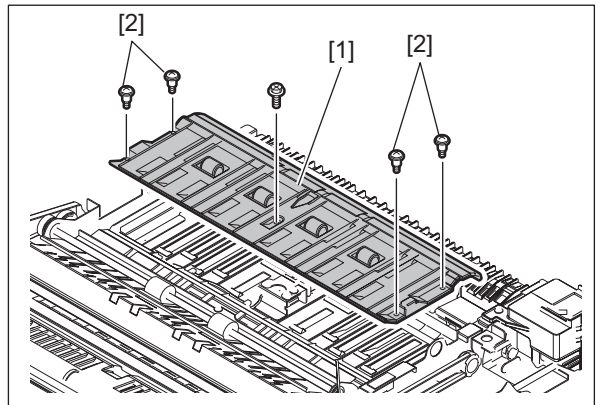

Fig. 4-705

Notes:

- The type of the screw differs depending on the installation position. The screws [2] are the shoulder ones.

- The leaf springs with the idling rollers are usually not needed to be disassembled; however, if they are removed and installed, fix the screws while pushing the rollers in the direction of the arrow in the figure to prevent the exit paper sideways deviation. After the rollers are installed, check that the rollers are parallel to the installation holes.

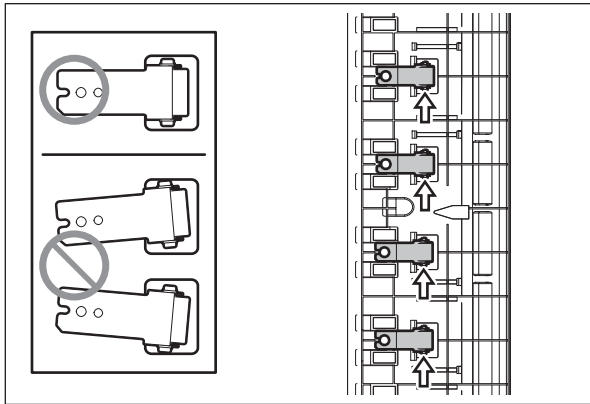

Fig. 4-706

- (4) Remove 1 E-ring, the gear and belt.

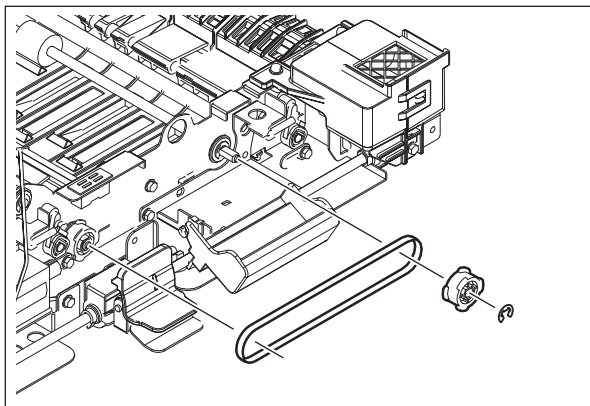

Fig. 4-707

- (5) Remove 2 E-rings and 2 ball bearings [2]. Take off the bridge unit transport roller-2 [3].

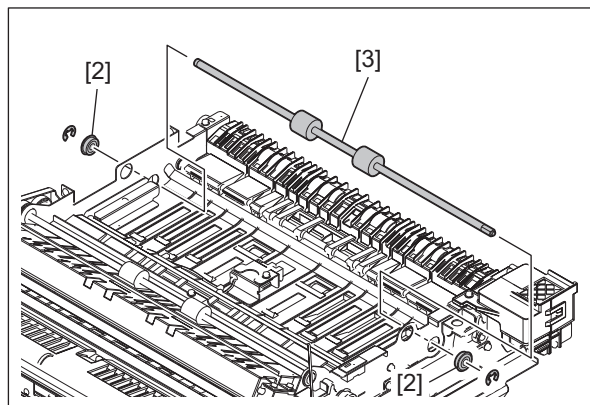





Fig. 4-708

4.10.19 Bridge unit transport roller-3

- (1) Remove the reverse roller.
 P. 4-284 "4.10.20 Reverse roller"
- (2) Take off the transport guide-2.
 P. 4-289 "4.10.25 Bridge unit path entrance sensor (S55)"
- (3) Take off the bridge unit paper exit roller-1.
 P. 4-285 "4.10.21 Bridge unit paper exit roller-1"
- (4) Remove 2 screws and disconnect the connector. Take off the transport guide unit [1].

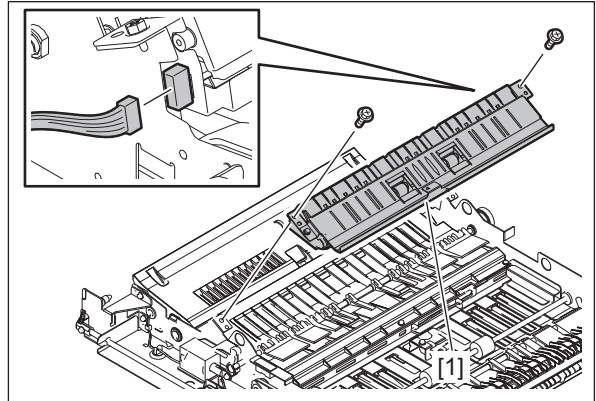

Fig. 4-709

- (5) Remove 2 screws, the spring and actuator [2].

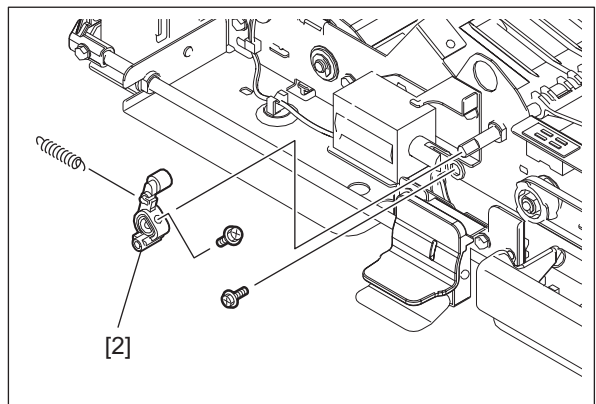

Fig. 4-710

- (6) Remove 2 E-rings, 2 bushings and the flap [3].

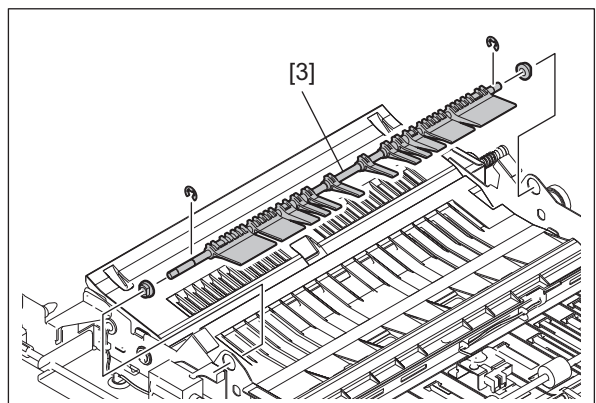

Fig. 4-711

- (7) Remove the E-ring, pulley and belt on the front side.

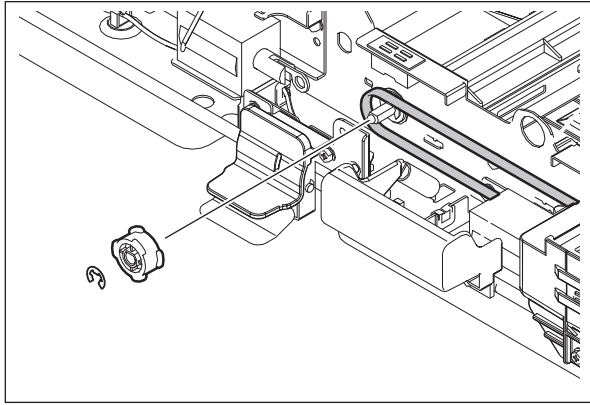

Fig. 4-712

- (8) Remove 5 screws and take off the transport guide-3 [4].

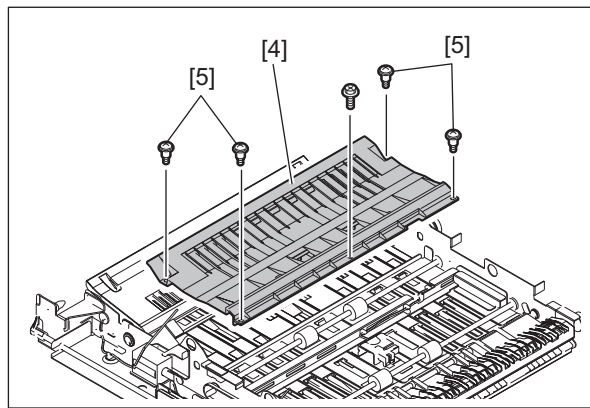

Fig. 4-713

Notes:

The type of the screw differs depending on the installation position. The screws [5] are the shoulder ones.

- (9) Remove 1 gear, 2 E-rings and 2 ball bearings [6]. Then take off the bridge unit transport roller-3 [7].

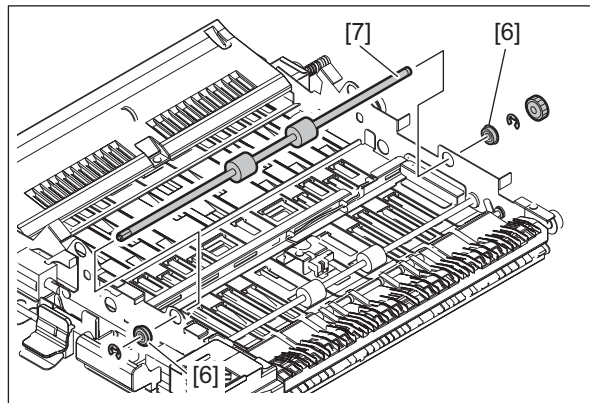

Fig. 4-714

4.10.20 Reverse roller

- (1) Take off the bridge unit.
📖 P. 4-271 “4.10.11 Bridge unit”
- (2) Take off the bridge unit front cover.
📖 P. 4-272 “4.10.12 Bridge unit front cover”
- (3) Take off the bridge unit upper cover.
📖 P. 4-277 “4.10.16 Bridge unit upper cover”
- (4) Remove each bracket of the bridge unit transport entrance motor and the reverse motor.
📖 P. 4-274 “4.10.14 Bridge unit transport entrance motor (M4), Reverse motor (M3)”
- (5) Remove 1 E-ring and the pulley.
- (6) Remove 1 E-ring and move the ball bearing [1] to the inner side.

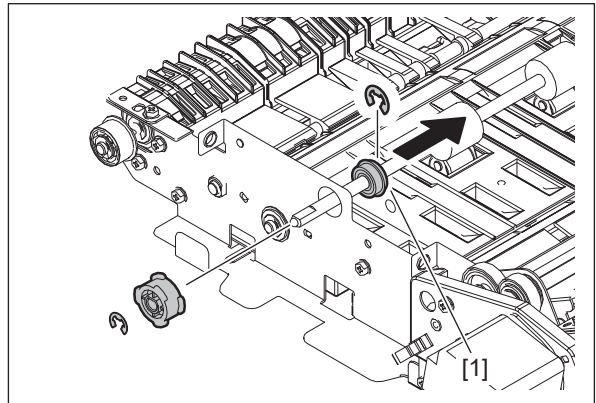

Fig. 4-715

- (7) Remove the reverse roller [3] and 2 ball bearings [2].
- (8) Remove 1 E-ring from the reverse roller [3].

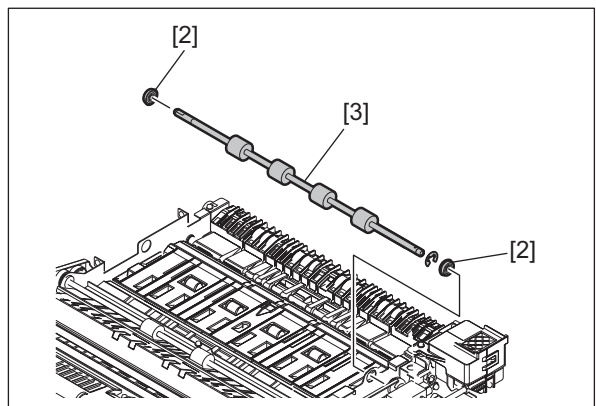

Fig. 4-716

4.10.21 Bridge unit paper exit roller-1

- (1) Take off the bridge unit.
P. 4-271 "4.10.11 Bridge unit"
- (2) Take off the bridge unit front cover.
P. 4-272 "4.10.12 Bridge unit front cover"
- (3) Take off the bridge unit upper cover.
P. 4-277 "4.10.16 Bridge unit upper cover"
- (4) Remove the motor bracket of the bridge unit transport exit motor.
P. 4-275 "4.10.15 Bridge unit transport exit motor (M5)"
- (5) Remove 1 E-ring, 1 gear and 1 ball bearing [1].

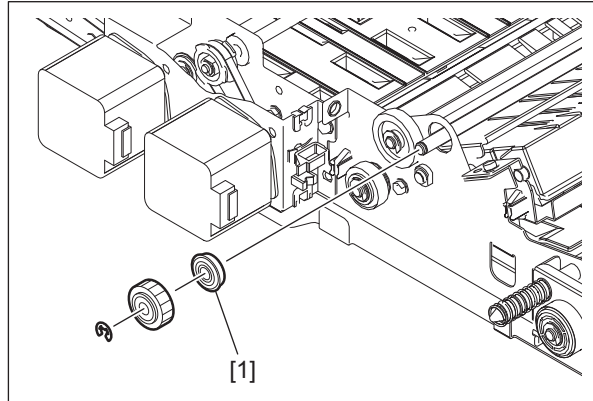

Fig. 4-717

- (6) Remove 1 E-ring and 1 ball bearing [2]. Then take off the bridge unit paper exit roller-1 [3].

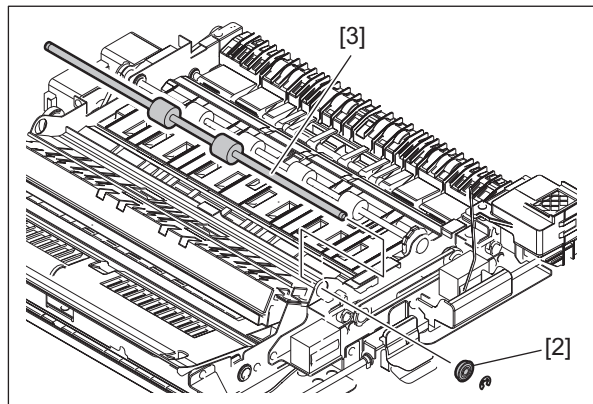

Fig. 4-718

4.10.22 Bridge unit paper exit roller-2

- (1) Take off the bridge unit.
📖 P. 4-271 “4.10.11 Bridge unit”
- (2) Take off the bridge unit front cover.
📖 P. 4-272 “4.10.12 Bridge unit front cover”
- (3) Remove 1 screw and take off the transport guide-4 [1] by sliding it toward you.

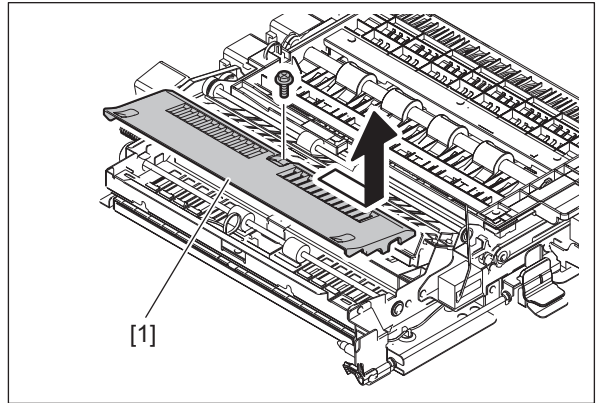

Fig. 4-719

- (4) Remove 2 E-rings, 1 gear and 2 ball bearings [2]. Then take off the bridge unit paper exit roller-2 [3].

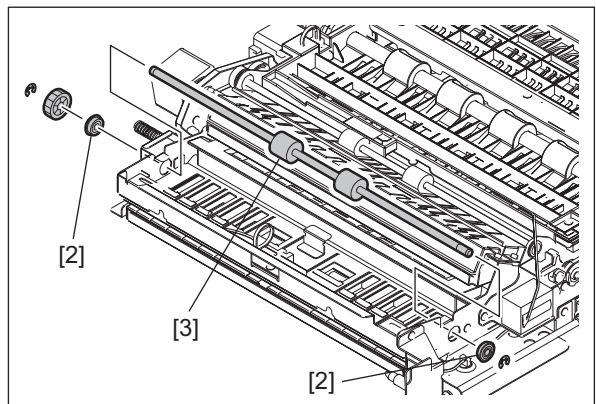

Fig. 4-720

4.10.23 Transport path switching solenoid (bridge unit/reverse section) (SOL1)

- (1) Take off the bridge unit front cover.
P. 4-272 "4.10.12 Bridge unit front cover"
- (2) Remove 1 spring [1].

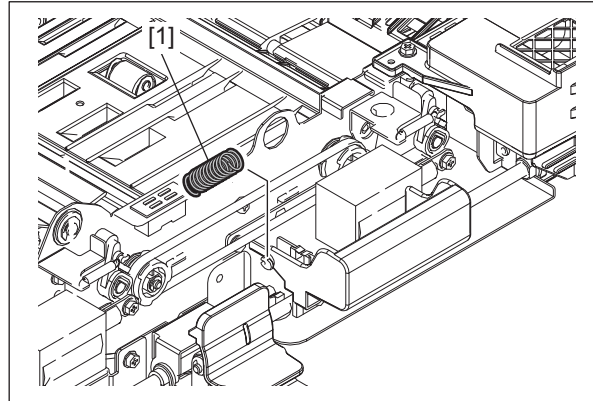

Fig. 4-721

- (3) Release the harness from the harness clamp and disconnect the connector.
- (4) Remove the screw and link.

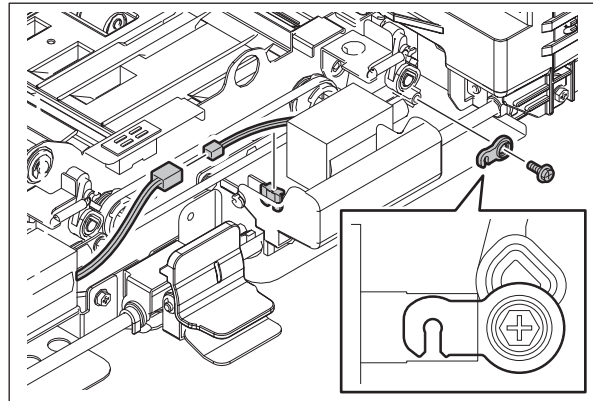

Fig. 4-722

- (5) Remove 2 screws and take off the transport path switching solenoid (bridge unit/reverse section) [2].

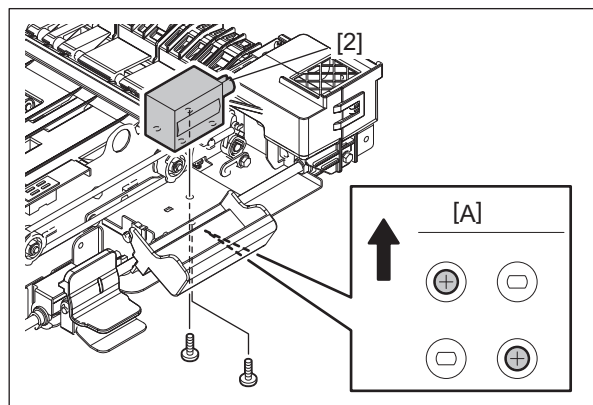

Fig. 4-723

[A] Front side

4.10.24 Transport path switching solenoid (upper/lower paper exit) (SOL2)

- (1) Take off the bridge unit front cover.
📖 P. 4-272 "4.10.12 Bridge unit front cover"
- (2) Release the harness from the harness clamp and disconnect the connector.
- (3) Remove the screw and link.

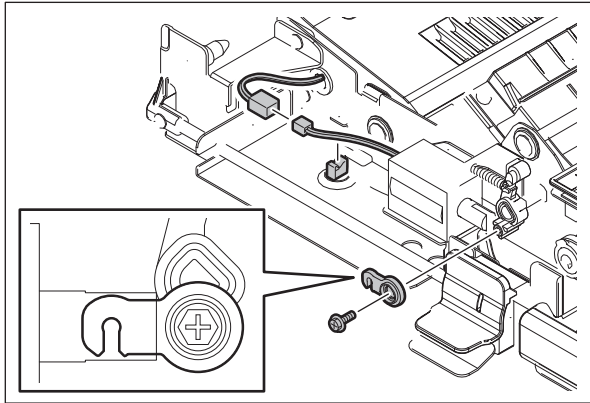

Fig. 4-724

- (4) Remove 2 screws and take off the transport path switching solenoid (upper/lower paper exit) [1].

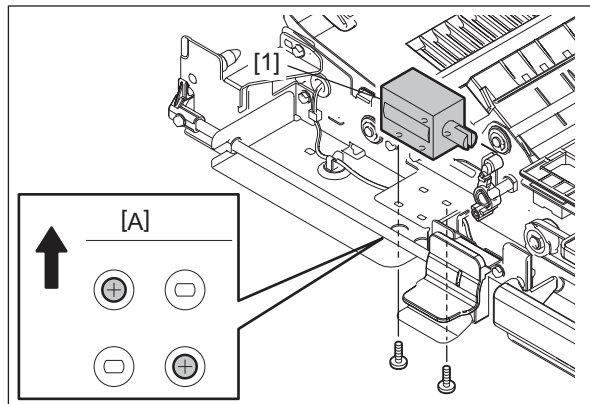



Fig. 4-725

[A] Front side

4.10.25 Bridge unit path entrance sensor (S55)

- (1) Remove the reverse roller.
 P. 4-284 "4.10.20 Reverse roller"
- (2) Remove 5 screws and take off the transport guide-2.

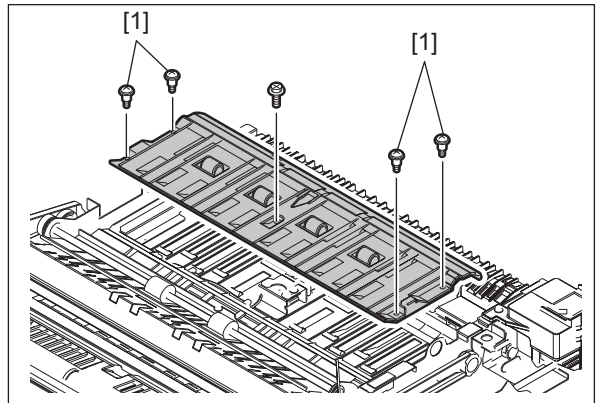

Fig. 4-726

Notes:

The type of the screw differs depending on the installation position. The screws [1] are the shoulder ones.

- (3) Remove 1 screw and take off the sensor bracket [2].
- (4) Release the harness from 1 harness clamp and disconnect the connector.

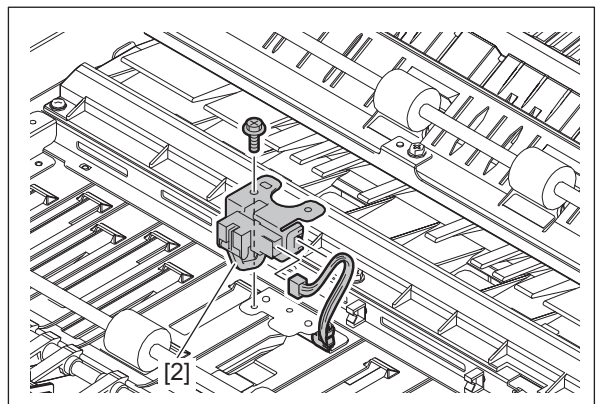

Fig. 4-727

- (5) Remove the bridge unit path entrance sensor [3] from the sensor bracket.

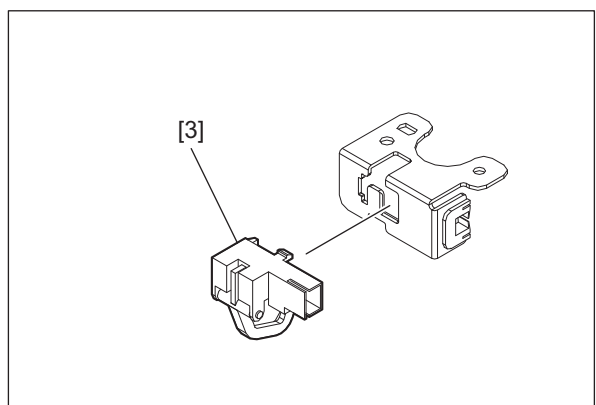

Fig. 4-728

4.10.26 Bridge unit path exit sensor (S56)

- (1) Open the front cover and pull out the bridge unit.
- (2) Remove 1 screw and take off the transport guide-4 [1] by sliding it.

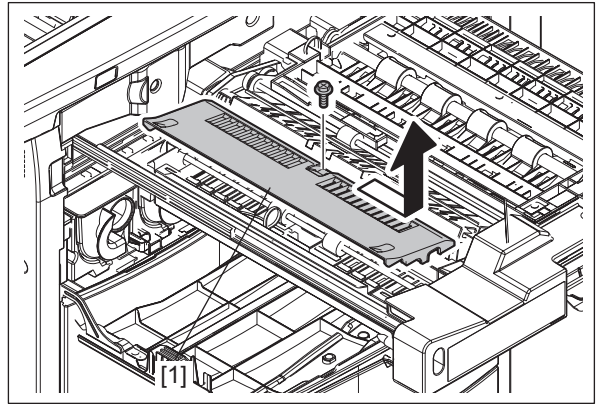

Fig. 4-729

- (3) Release the harnesses from 1 harness clamp [2]. Remove 1 harness clamp [3].

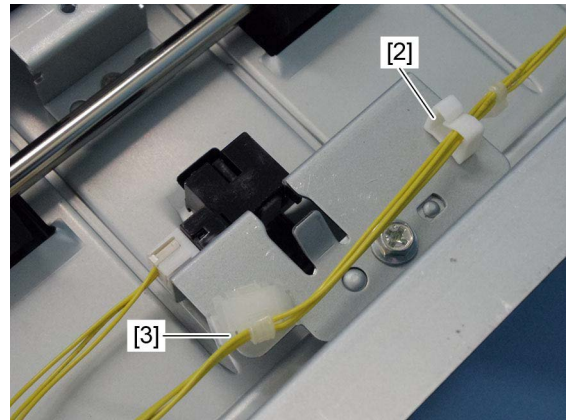

Fig. 4-730

- (4) Disconnect 1 connector. Remove 1 screw and take off the sensor bracket [4].

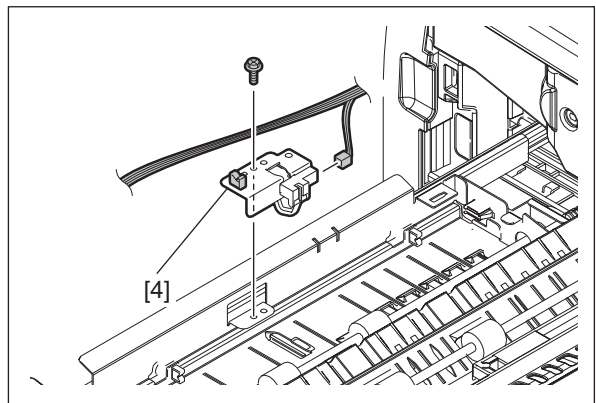

Fig. 4-731

- (5) Remove the bridge unit path exit sensor [5] from the sensor bracket.

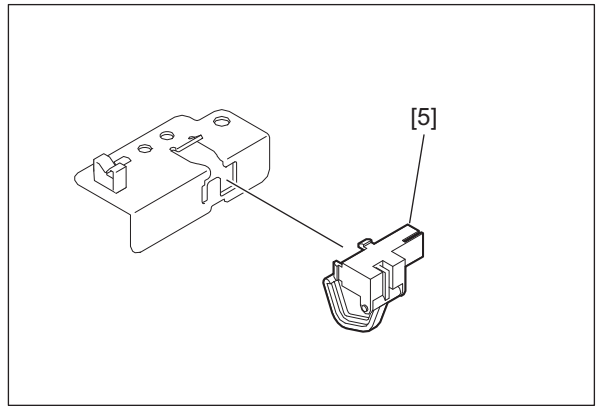

Fig. 4-732

4.10.27 Reverse sensor (S59)

- (1) Open the front cover and pull out the bridge unit.
(2) Remove 3 screws and take off the sensor stay [1].

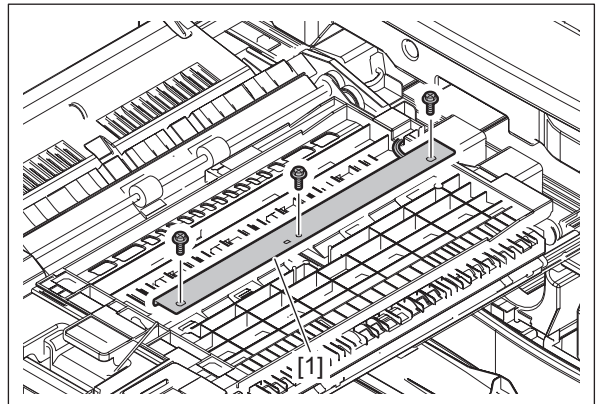

Fig. 4-733

- (3) Remove 1 screw and disconnect the connector. Take off the reverse sensor [2].

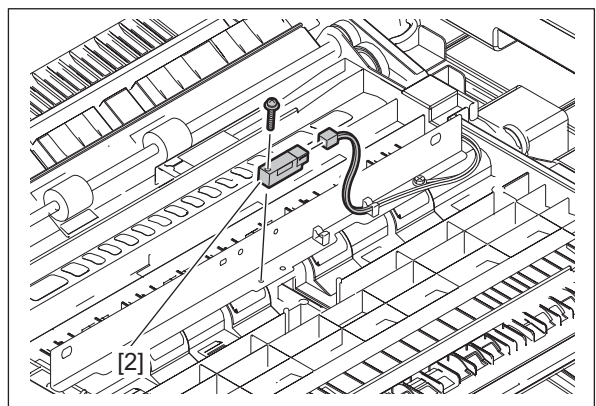



Fig. 4-734

4.10.28 Reverse section stationary jam detection sensor (S58)

- (1) Take off the bridge unit paper exit roller-1.
 P. 4-285 “4.10.21 Bridge unit paper exit roller-1”
- (2) Disconnect 1 connector, remove 2 screws and take off the transport guide unit [1].

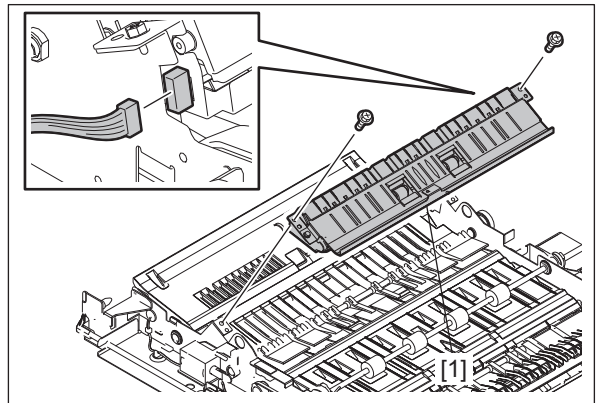

Fig. 4-735

- (3) Remove 2 screws and take off the roller guide [2].

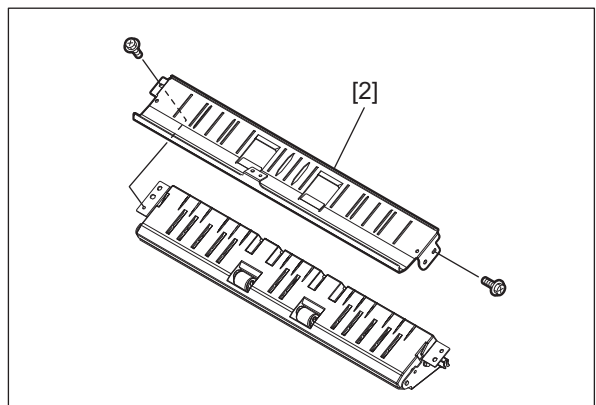

Fig. 4-736

- (4) Remove 1 screw, 1 shoulder screw [3] and take off the paper exit guide [4].

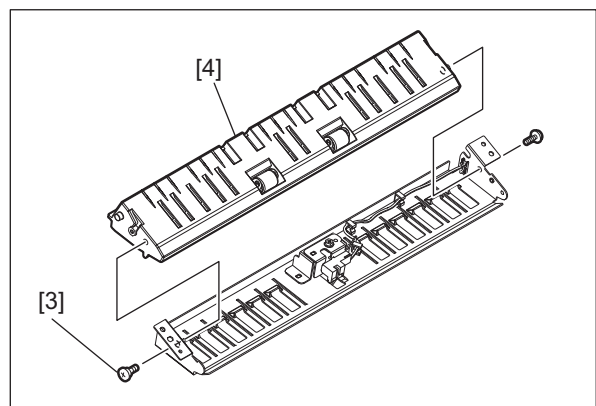

Fig. 4-737

Notes:

The type of the screw differs depending on the installation position.

- (5) Remove 1 screw and take off the sensor bracket [5].
- (6) Release the harness from the harness clamp and disconnect the connector.

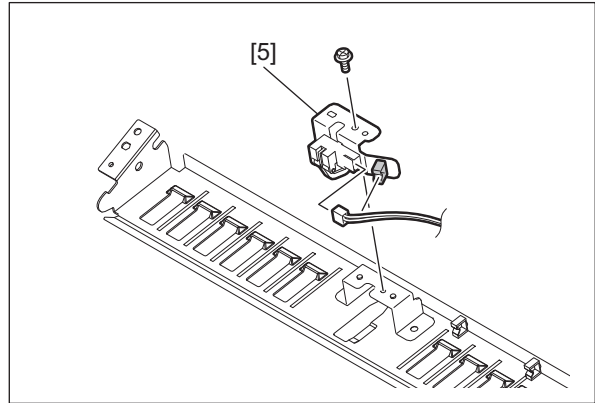

Fig. 4-738

- (7) Take off the reverse section stationary jam detection sensor [6] from the sensor bracket.

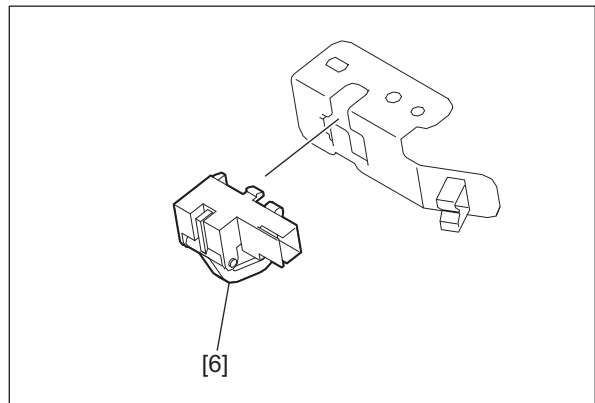

Fig. 4-739

4.10.29 Bridge unit cooling fan (F6)

- (1) Take off the top front cover.
📖 P. 4-5 "4.1.9 Top front cover"
- (2) Take off the right top cover.
📖 P. 4-3 "4.1.4 Right top cover"
- (3) Take off the front lower cover.
📖 P. 4-4 "4.1.7 Front lower cover (control panel lower cover)"
- (4) Pull out the bridge unit.
- (5) Remove 3 screws and take off the inner cover [1].

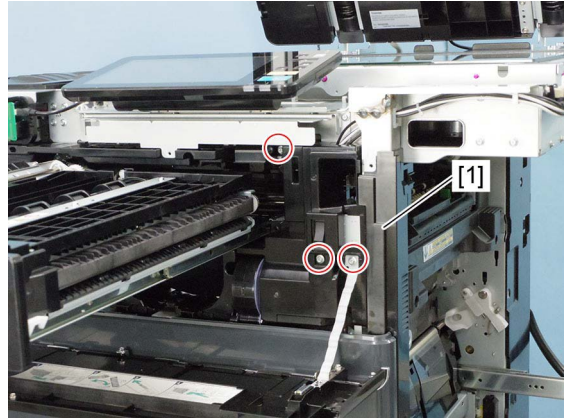

Fig. 4-740

- (6) Remove 3 screws and take off the stay [2] and cover [3].

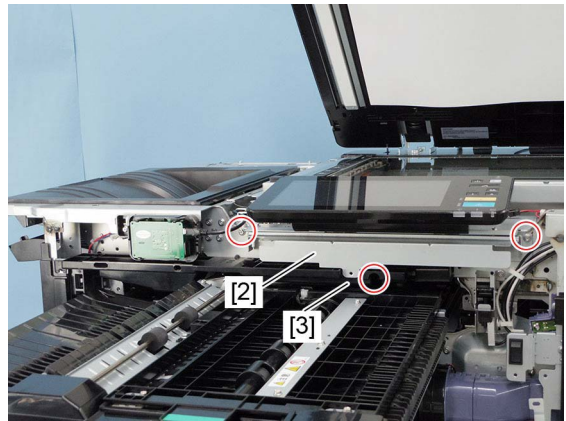

Fig. 4-741

- (7) Release the harness from 1 harness clamp and disconnect the connector [4].
- (8) Remove 1 screw.

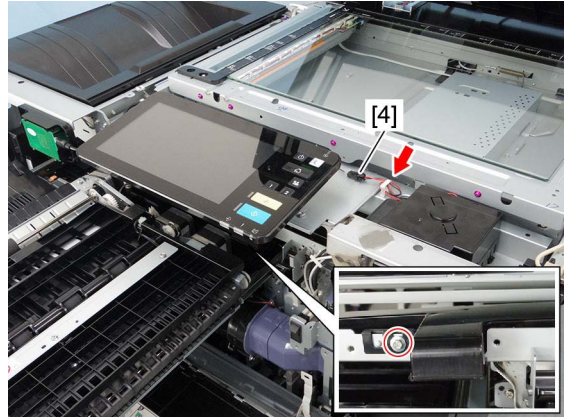

Fig. 4-742

- (9) Remove 6 screws and take off the metal plate [5].

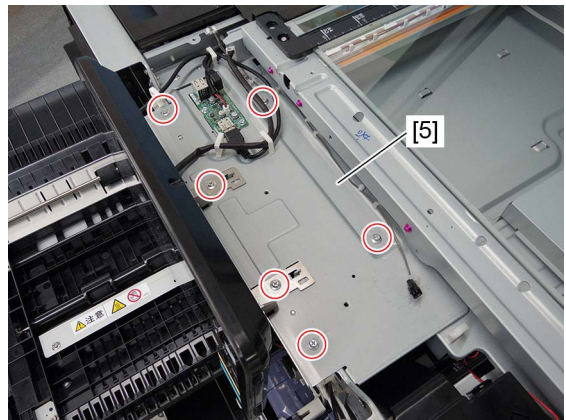

Fig. 4-743

- (10) Remove the duct [6].

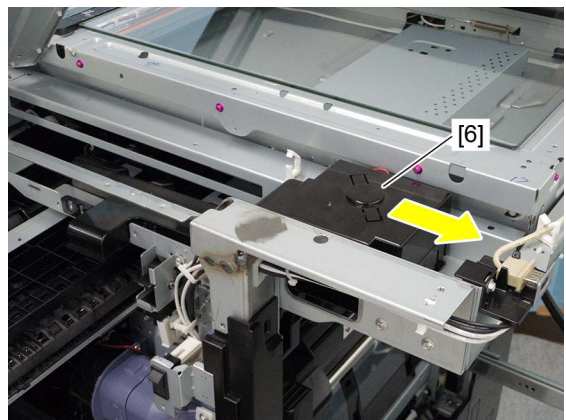

Fig. 4-744

(11) Release 9 latches and take off the duct cover [7].

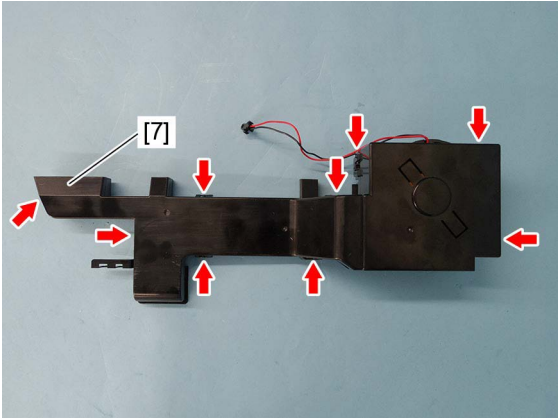

Fig. 4-745

(12) Take off the bridge unit cooling fan [8].

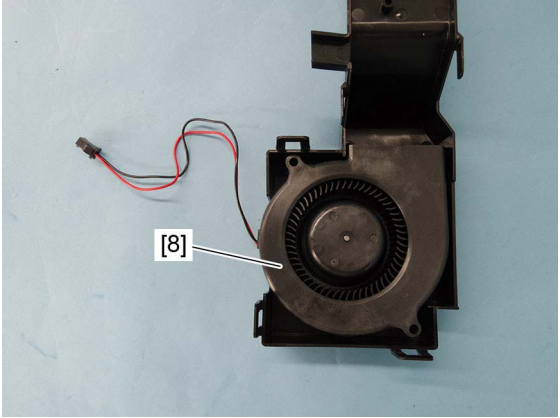

Fig. 4-746

4.10.30 Front cover opening/closing detection switch (SW9), Bridge unit connecting detection switch (SW8)

Notes:

- When the front cover opening/closing detection switch (SW9) is replaced or removed, be sure to perform the operation check with the input check (test mode 03).
- If the installation is insufficient, this switch is not performing properly. In this case, you may touch the rotating portions such as the gear in the toner motor during the drive and could be injured as a result.

- (1) Take off the switch bracket.
📖 P. 4-189 “4.6.52 Toner motor interlock switch (SW3)”
- (2) Disconnect the connector and remove the front cover opening/closing detection switch [1] from the switch bracket.
- (3) Disconnect the connector and remove the bridge unit connecting detection switch [2] from the switch bracket.

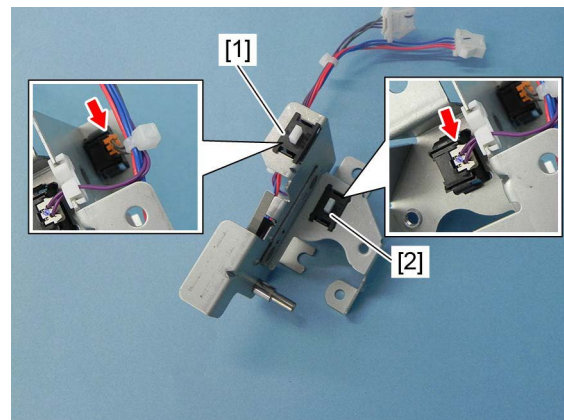

Fig. 4-747

4.10.31 Duplexing bridge unit

- (1) Take off the right top cover.
📖 P. 4-3 “4.1.4 Right top cover”
- (2) Take off the fuser unit.
📖 P. 4-221 “4.9.1 Fuser unit”
- (3) Remove 1 screw and take off the cover [1].



Fig. 4-748

- (4) Remove 2 screws and disconnect 1 connector. Take off the duplexing bridge unit [2].

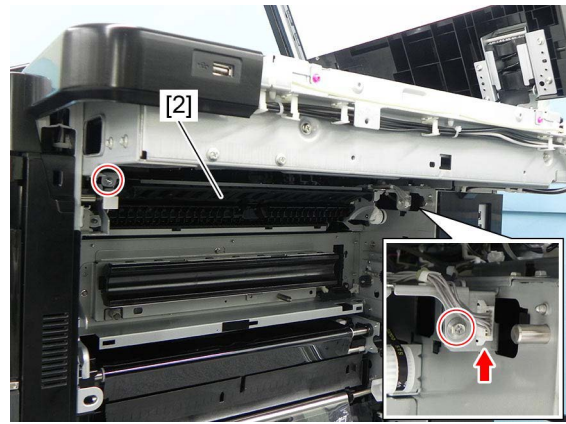

Fig. 4-749

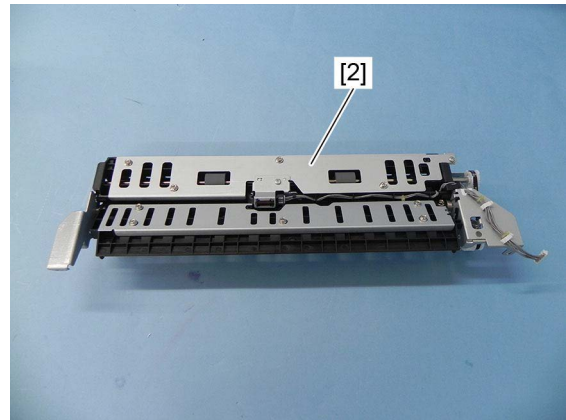

Fig. 4-750

4.10.32 Duplexing unit opening/closing detection sensor (S64)

- (1) Take off the duplexing bridge unit.
📖 P. 4-297 "4.10.31 Duplexing bridge unit"
- (2) Remove 2 E-rings, 2 pulleys [1] and 1 belt [2].

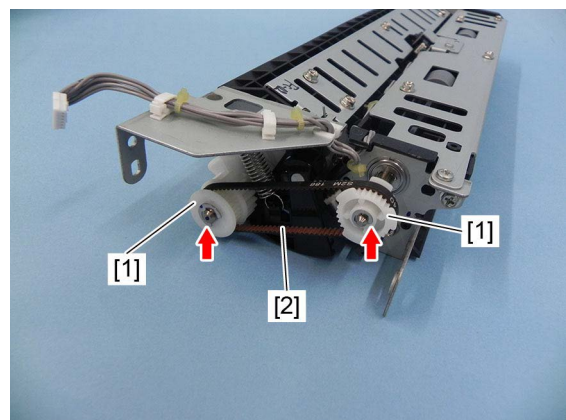

Fig. 4-751

- (3) Release 3 latches and remove the duplexing unit opening/closing detection sensor [3].

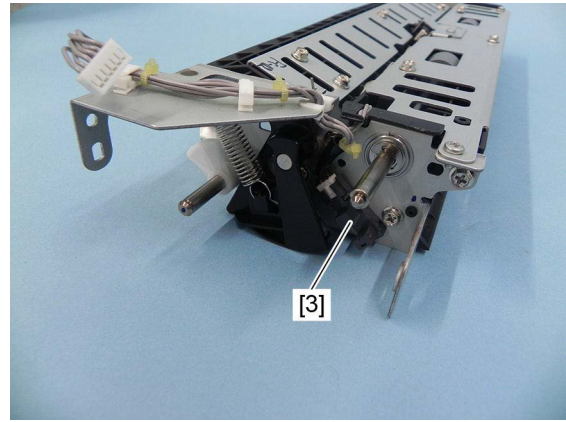

Fig. 4-752

- (4) Disconnect the connector from the duplexing unit opening/closing detection sensor [3].

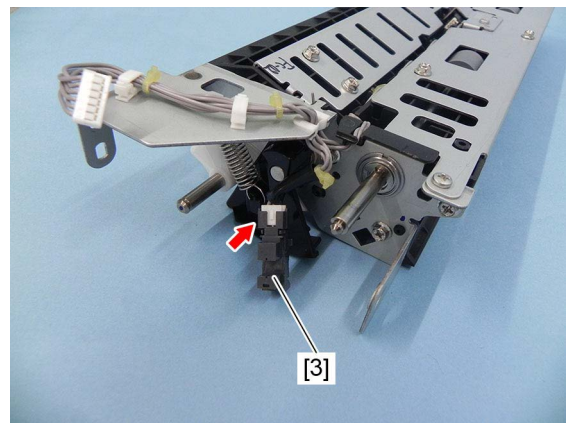

Fig. 4-753

Notes:

When installing the sensor, be careful not to bend the latches of the sensor.

4.10.33 Reverse path sensor (S57)

- (1) Take off the duplexing bridge unit.
📖 P. 4-297 “4.10.31 Duplexing bridge unit”
- (2) Remove 1 screw. Release the harnesses from 1 harness clamp [1]. Disconnect 1 connector and take off the sensor bracket [2].

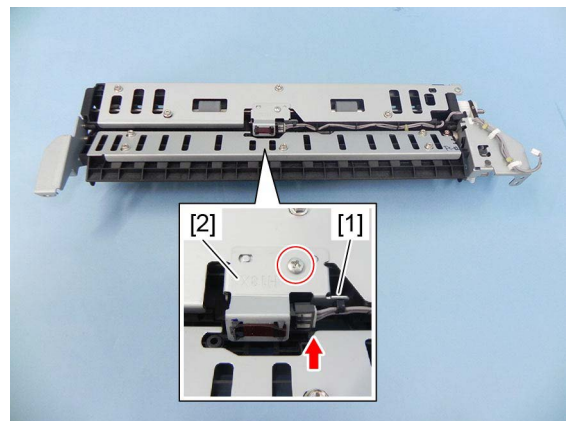

Fig. 4-754

(3) Remove 1 E-ring.

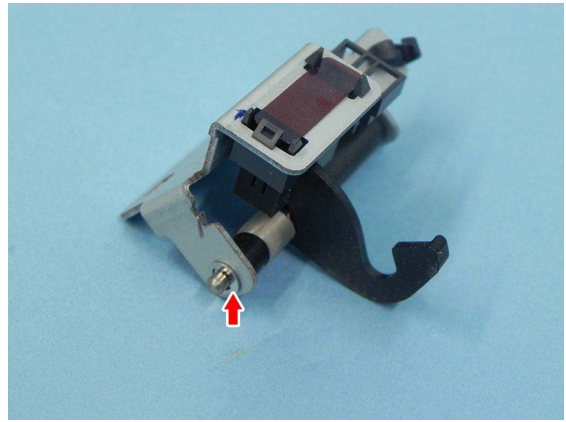

Fig. 4-755

(4) Remove the pin [3] and take off the sensor actuator [4].

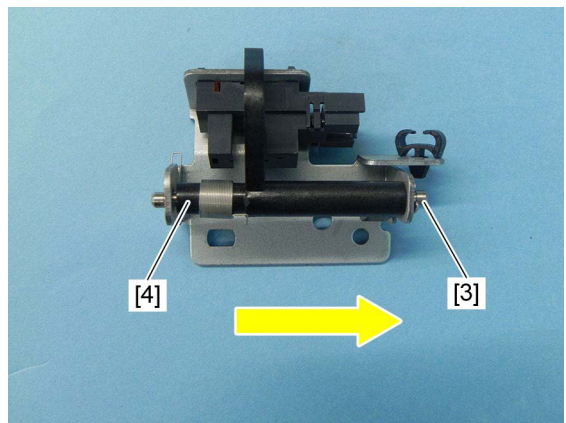

Fig. 4-756

Notes:

When installing the sensor, hook the spring securely and make sure that the actuator returned to its original position by the spring force.

(5) Remove 1 film [5] and take off the reverse path sensor [6].

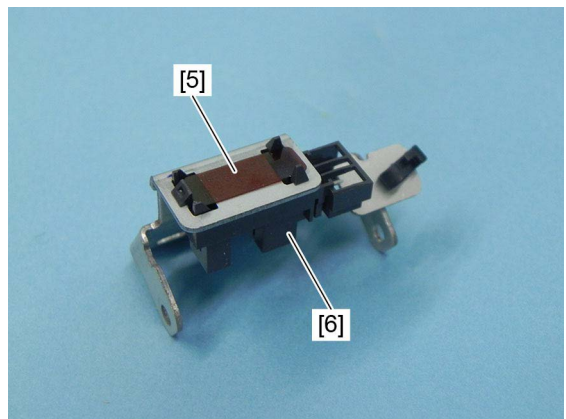

Fig. 4-757

Notes:

When installing the sensor, be careful not to bend the latches of the sensor.

4.10.34 Duplexing bridge transport roller

- (1) Take off the duplexing bridge unit.
P. 4-297 “4.10.31 Duplexing bridge unit”
- (2) Remove 2 pulleys and 1 belt.
P. 4-298 “4.10.32 Duplexing unit opening/closing detection sensor (S64)”
- (3) Remove the reverse path sensor bracket.
P. 4-299 “4.10.33 Reverse path sensor (S57)”
- (4) Remove 5 screws and take off the duplexing bridge unit upper plate [1].

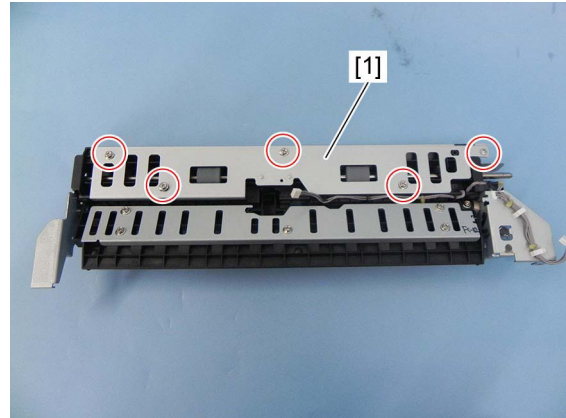

Fig. 4-758

- (5) Remove 2 E-rings, 1 bushing [2] and 1 ball bearing [3]. Take off the duplexing bridge transport roller [4].

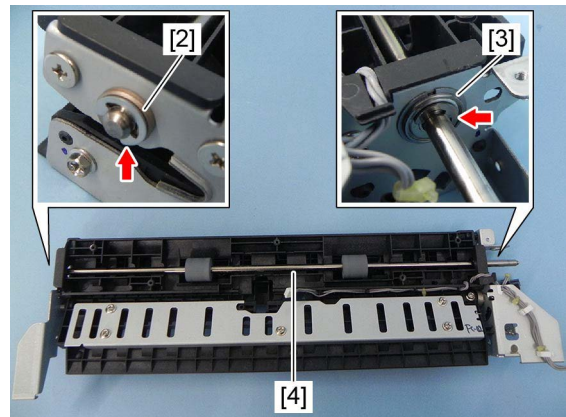

Fig. 4-759

4.10.35 Duplexing unit upper cover

- (1) Pull out the duplexing unit and open the bypass tray [1].

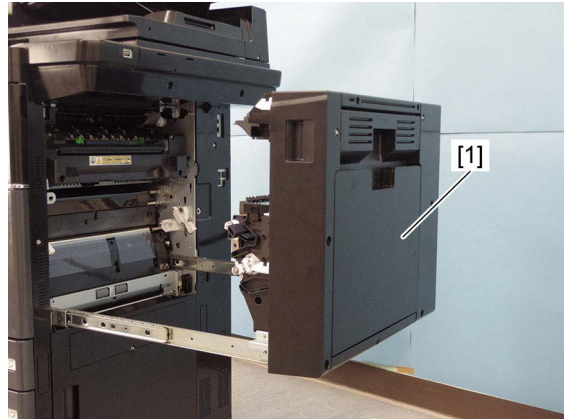

Fig. 4-760

- (2) Open the duplexing unit cover [2].

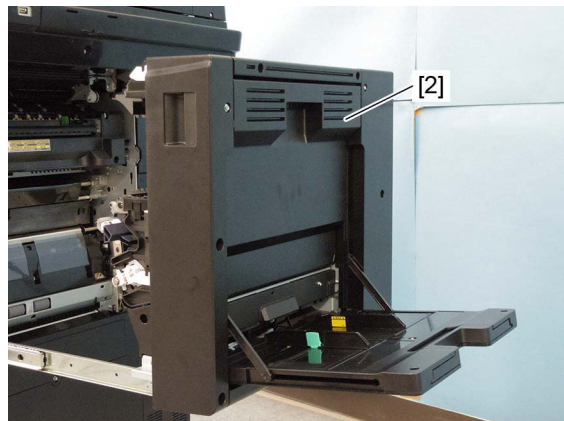

Fig. 4-761

- (3) Remove 2 screws and release 4 hooks. Take off the duplexing unit upper side cover [3].

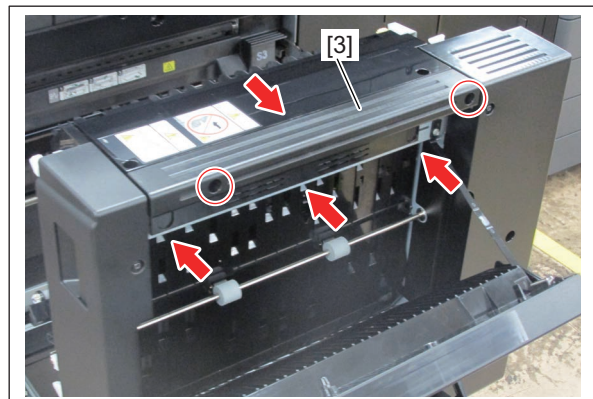

Fig. 4-762

- (4) Remove 2 screws and release 2 hooks. Take off the duplexing unit upper cover [4].

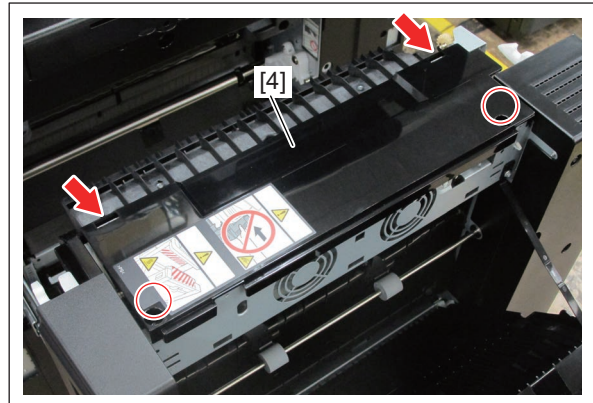

Fig. 4-763

4.10.36 Duplexing unit front side cover

- (1) Take off the duplexing unit front cover.
P. 4-10 "4.1.18 Duplexing unit front cover"
- (2) Remove 2 screws.

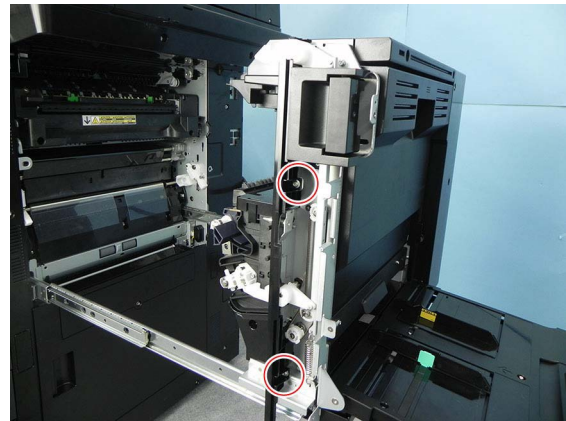

Fig. 4-764

- (3) Release the hook by pushing the upper side of the duplexing unit front side cover [1] to the rear side. Then remove the duplexing unit front side cover [1] by sliding it toward the left side.

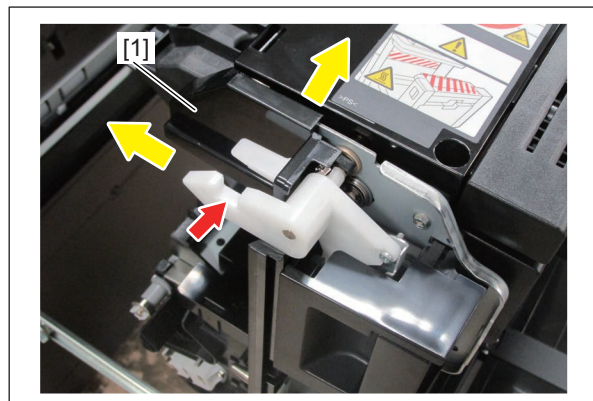

Fig. 4-765

4.10.37 Duplexing unit rear side cover

- (1) Take off the duplexing unit rear cover.
📖 P. 4-11 “4.1.19 Duplexing unit rear cover”
- (2) Remove 2 screws and take off the duplexing unit rear side cover [1] by sliding it in the direction of the arrow.

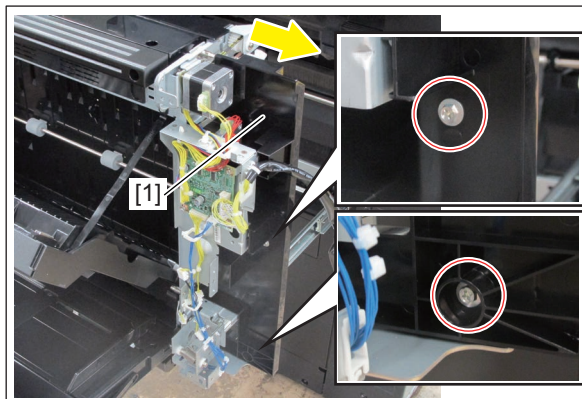

Fig. 4-766

Notes:

When installing the cover, insert the 3 hooks of the duplexing unit rear side cover into the frame.

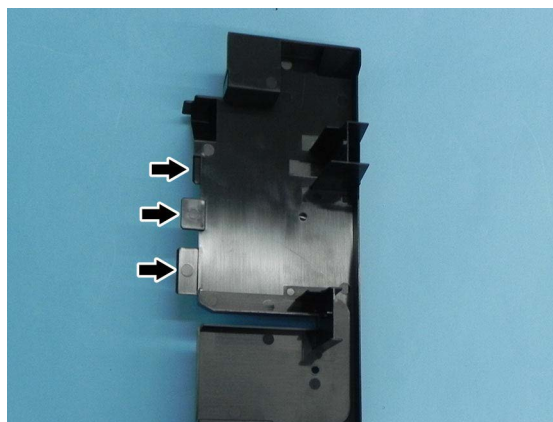

Fig. 4-767

4.10.38 Reversed paper cooling fan (F11)

- (1) Take off the duplexing unit upper cover.
📖 P. 4-302 “4.10.35 Duplexing unit upper cover”
- (2) Remove 1 screw and lift up the bracket [1].

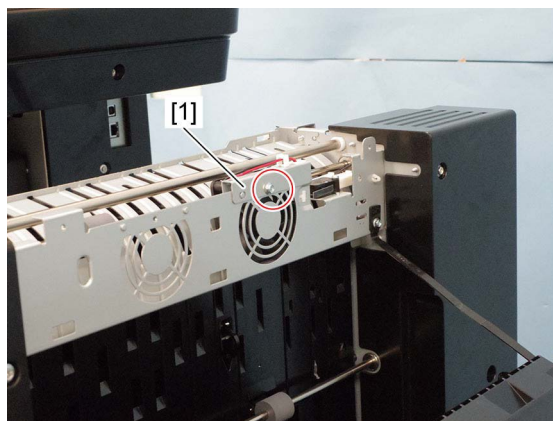

Fig. 4-768

- (3) Release the harnesses from 3 harness clamps.

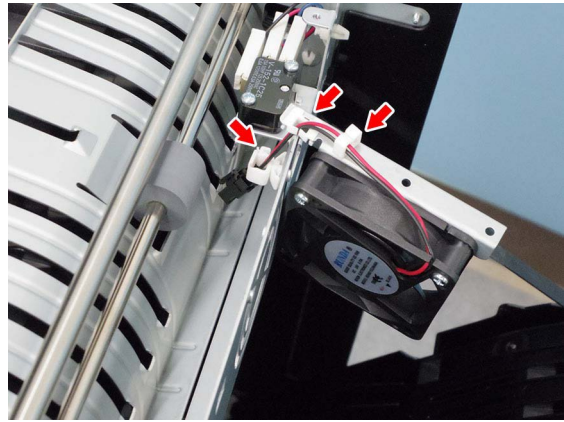

Fig. 4-769

- (4) Disconnect 1 connector.

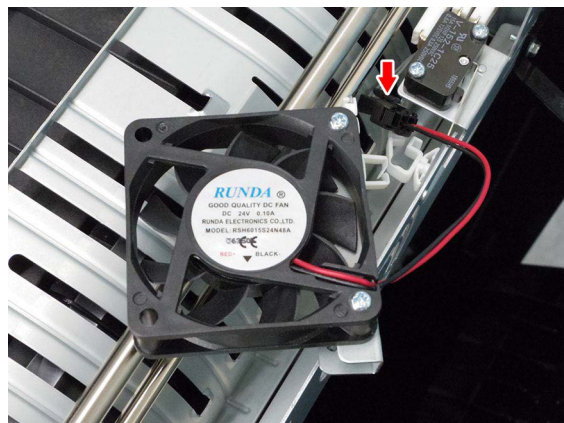

Fig. 4-770

- (5) Remove 2 screws and take off the reversed paper cooling fan [2].

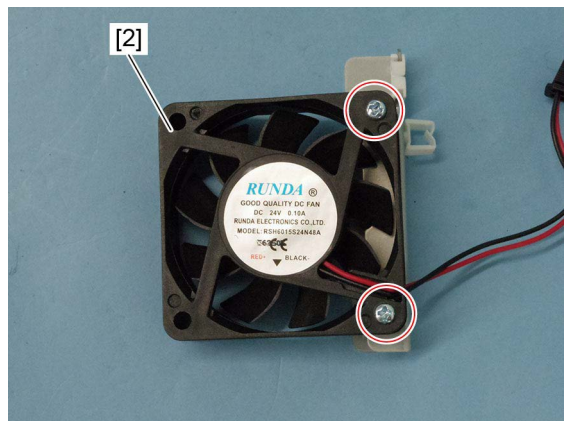

Fig. 4-771

4.10.39 ADU transport motor (M7)

- (1) Take off the duplexing unit rear side cover.
📖 P. 4-304 "4.10.37 Duplexing unit rear side cover"
- (2) Disconnect the connector from the ADU transport motor [1].
- (3) Remove 2 screws and take off the ADU transport motor [1] with the bracket [2].

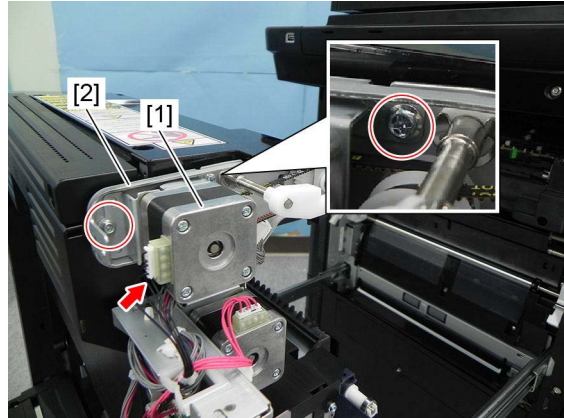

Fig. 4-772

Notes:

When installing the motor, set the belt securely to the gear and the pulley.

- (4) Remove 2 screws and take off the bracket [2] from the ADU transport motor [1].

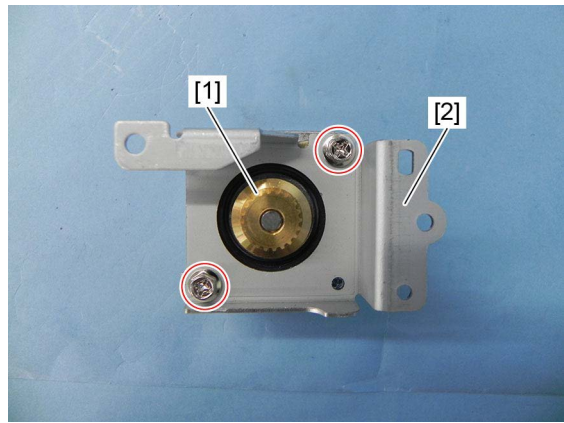

Fig. 4-773

4.10.40 ADU original feed motor (M8)

- (1) Take off the duplexing unit rear side cover.
P. 4-304 "4.10.37 Duplexing unit rear side cover"
- (2) Disconnect the connector from the ADU paper feed motor [1].
- (3) Remove 2 screws and take off the ADU paper feed motor [1] and the belt [2].

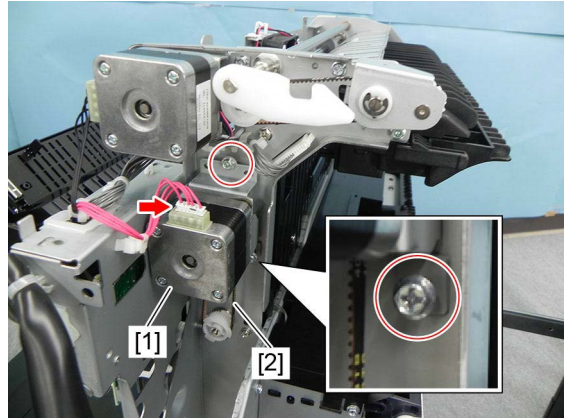

Fig. 4-774

Notes:

When installing the motor, set the belt securely to the ADU paper feed motor and the pulley.

- (4) Remove 2 screws and take off the bracket [3] from the ADU paper feed motor [1].

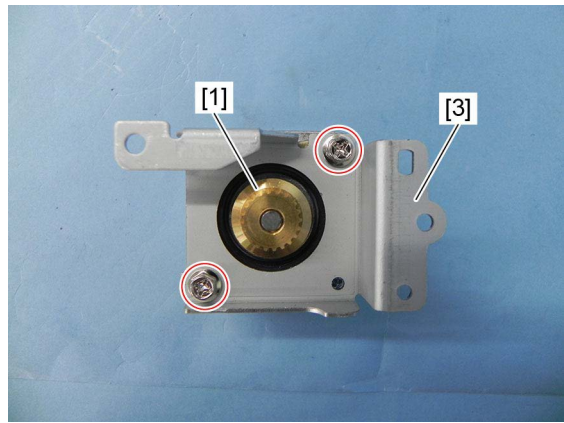

Fig. 4-775

4.10.41 ADU board (ADU)

- (1) Take off the duplexing unit rear cover.
P. 4-11 "4.1.19 Duplexing unit rear cover"
- (2) Release the harnesses from 1 harness clamp. Disconnect all connectors that are connected to the ADU board [1].

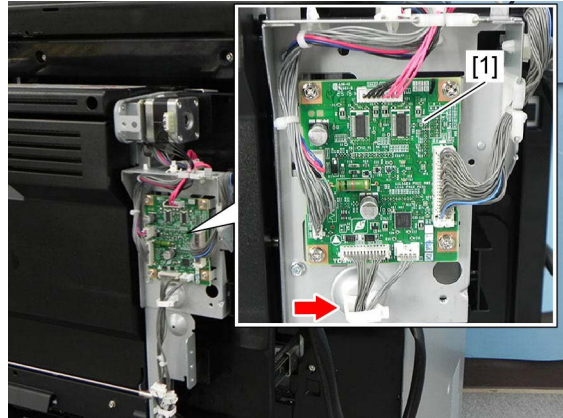

Fig. 4-776

- (3) Remove 4 screws and take off the ADU board [1].

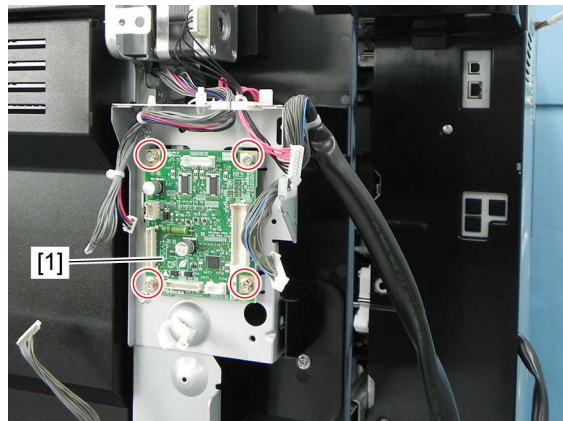

Fig. 4-777

4.10.42 ADU transport roller-1

- (1) Take off the duplexing unit front cover.
📖 P. 4-10 "4.1.18 Duplexing unit front cover"
- (2) Take off the duplexing unit upper cover.
📖 P. 4-302 "4.10.35 Duplexing unit upper cover"
- (3) Take off the duplexing unit front side cover.
📖 P. 4-303 "4.10.36 Duplexing unit front side cover"
- (4) Take off the ADU transport motor.
📖 P. 4-306 "4.10.39 ADU transport motor (M7)"
- (5) Remove 2 screws. Release 1 hook and take off the front hook cover [1].

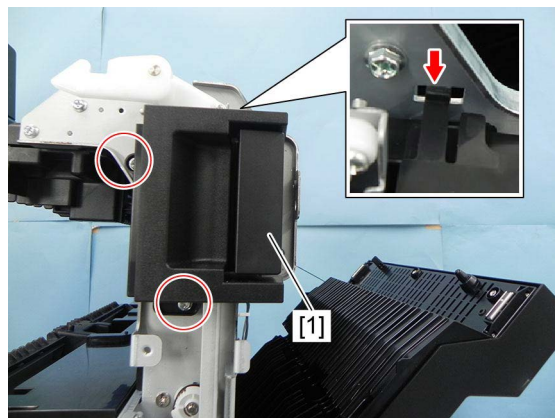

Fig. 4-778

- (6) Remove 1 spring [2].

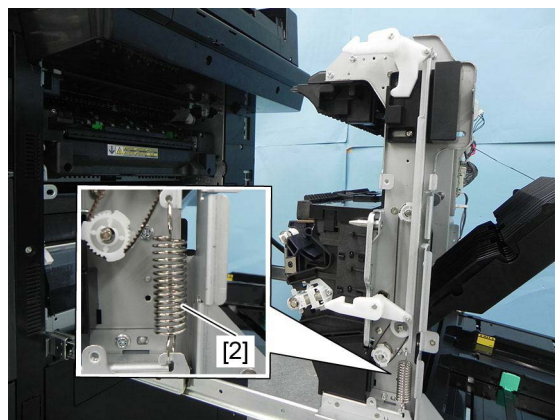

Fig. 4-779

Notes:

Be careful because the spring force is quite strong.

- (7) Remove 1 screw, 1 shoulder screw [4] and take off the front hook [3].

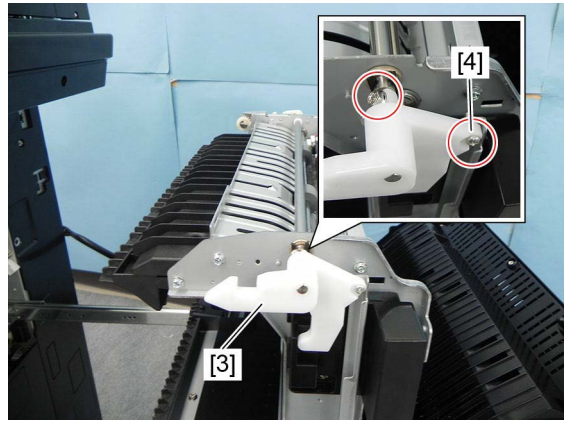

Fig. 4-780

Notes:

The type of the screw differs depending on the installation position.

- (8) Remove 2 E-rings, 2 pulleys [5], 2 belts [6], 1 bushing [7] and the bracket [8].

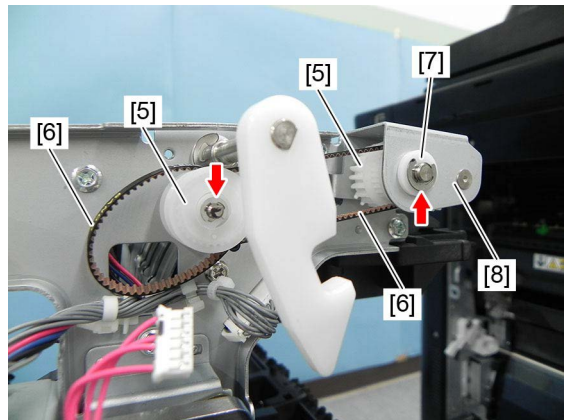

Fig. 4-781

- (9) Remove the clip and bushing [9] on the front side of the lever shaft.

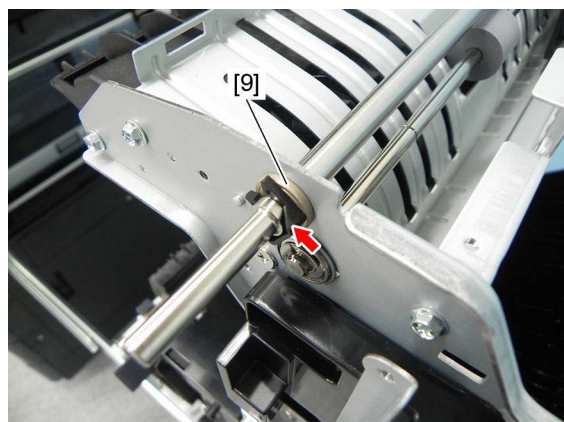

Fig. 4-782

(10) Take off the lever shaft [10] from the rear side.

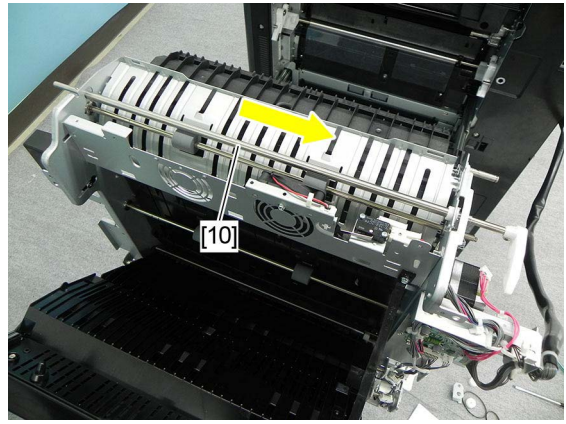

Fig. 4-783

(11) Remove 2 E-rings and 2 ball bearings [11]. Take off the ADU transport roller-1 [12].

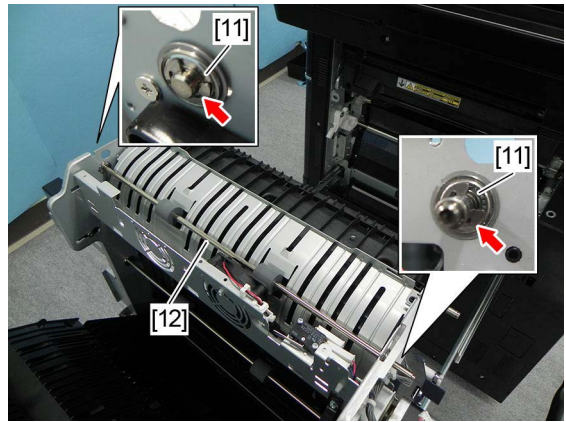

Fig. 4-784

4.10.43 ADU transport roller-2

- (1) Take off the duplexing unit rear cover.
📖 P. 4-11 “4.1.19 Duplexing unit rear cover”
- (2) Take off the duplexing unit front side cover.
📖 P. 4-303 “4.10.36 Duplexing unit front side cover”
- (3) Take off the ADU paper feed motor.
📖 P. 4-307 “4.10.40 ADU original feed motor (M8)”
- (4) Open the duplexing unit cover.
- (5) Remove 2 screws. Release 1 hook and take off the front hook cover [1].

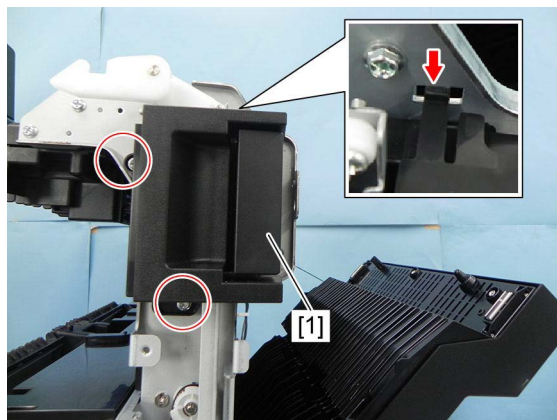

Fig. 4-785

- (6) Remove 1 spring [2].

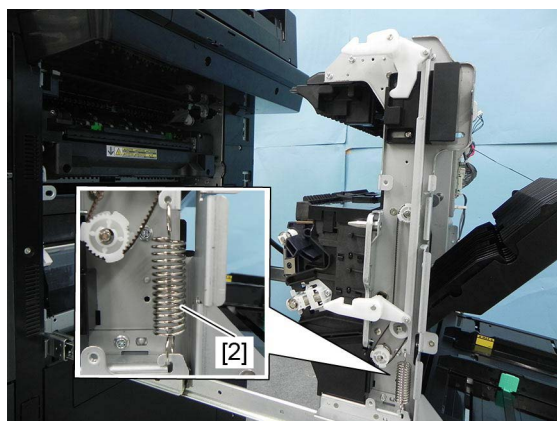

Fig. 4-786

Notes:

Be careful because the spring force is quite strong.

(7) Remove 2 screws and take off the hook stay [3].

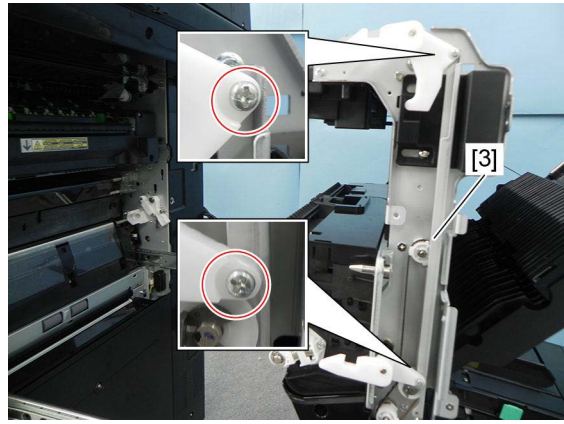

Fig. 4-787

(8) Remove 2 E-rings, 1 clip [4], 3 pulleys [5] and 2 belts [6].

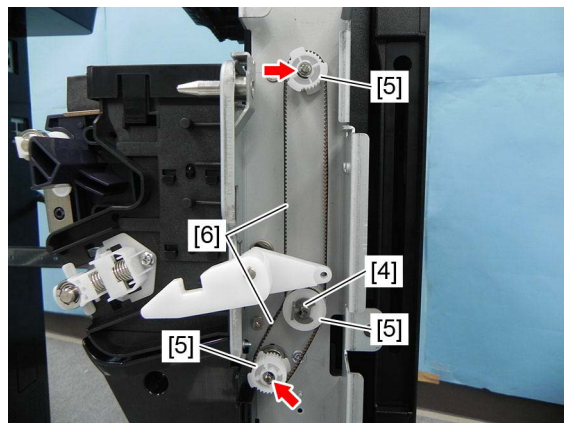

Fig. 4-788

(9) Remove 1 E-ring and 1 pulley [7].

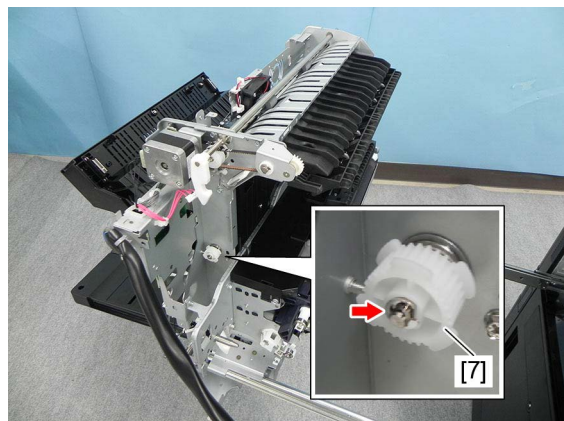

Fig. 4-789

(10) Remove 2 E-rings and 2 ball bearings [8]. Take off the ADU transport roller-2 [9].

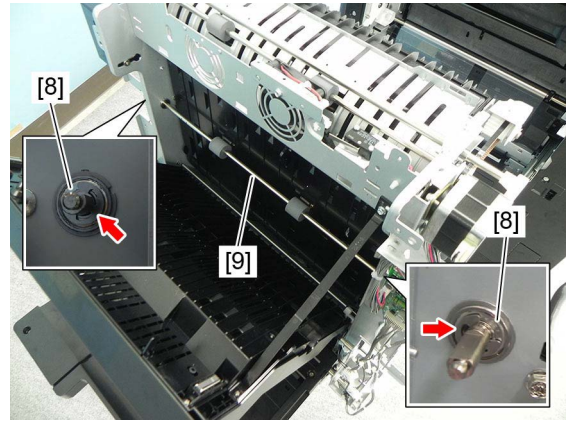

Fig. 4-790

4.10.44 ADU transport roller-3

- (1) Take off the duplexing unit front side cover.
P. 4-303 "4.10.36 Duplexing unit front side cover"
- (2) Take off the duplexing unit rear side cover.
P. 4-304 "4.10.37 Duplexing unit rear side cover"
- (3) Take off the bypass unit.
P. 4-59 "4.5.2 Bypass unit"
- (4) Remove the hook stay.
P. 4-312 "4.10.43 ADU transport roller-2"
- (5) Remove 1 E-ring, 1 clip [1], 1 pulley [2] and 1 belt [3].

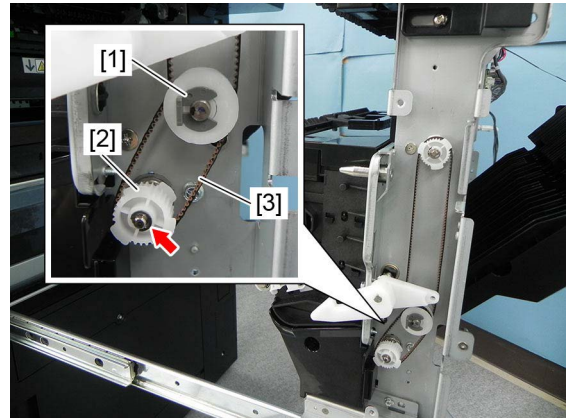

Fig. 4-791

- (6) Remove 2 E-rings and 2 ball bearings [4]. Take off the ADU transport roller-3 [5].

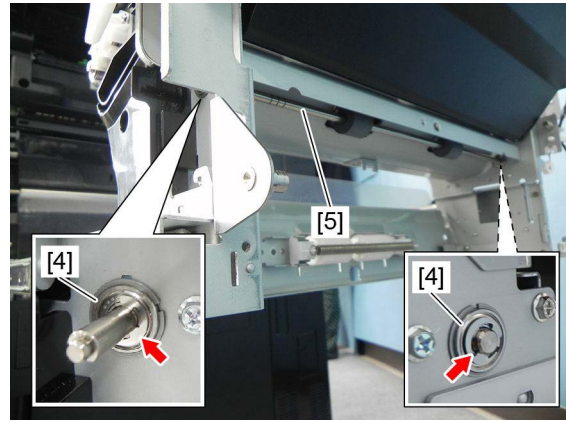

Fig. 4-792

4.10.45 Duplexing unit path exit sensor (S67)

- (1) Take off the 2nd transfer roller.
P. 4-212 "4.7.13 2nd transfer roller"
- (2) Remove 1 screw and take off the sensor bracket [1].
- (3) Release the harness from 1 harness clamp [2] and disconnect 1 connector.

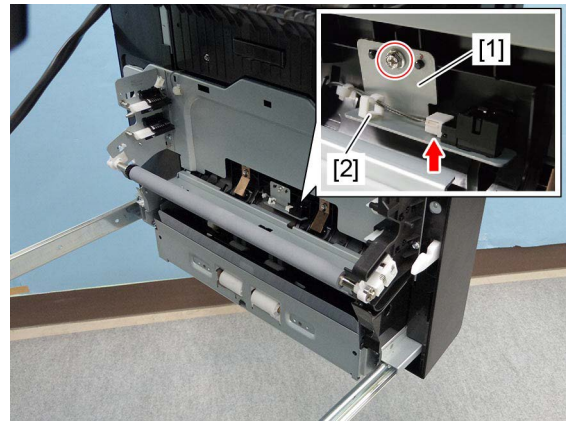

Fig. 4-793

- (4) Remove the duplexing unit path exit sensor [3] from the sensor bracket [1].

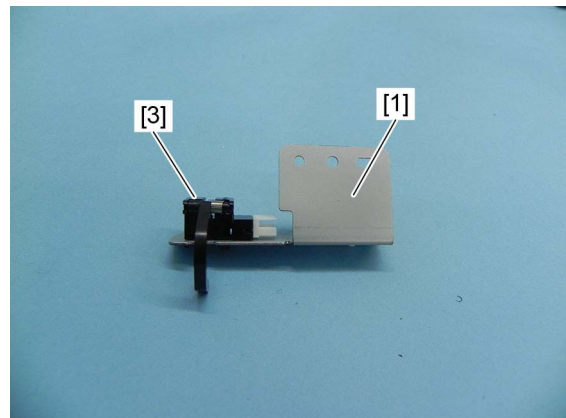

Fig. 4-794

4.10.46 Fuser transport sensor (S65)

- (1) Pull out the duplexing unit.
- (2) Remove 1 screw, 2 shoulder screws [2] and take off the transport guide [1].

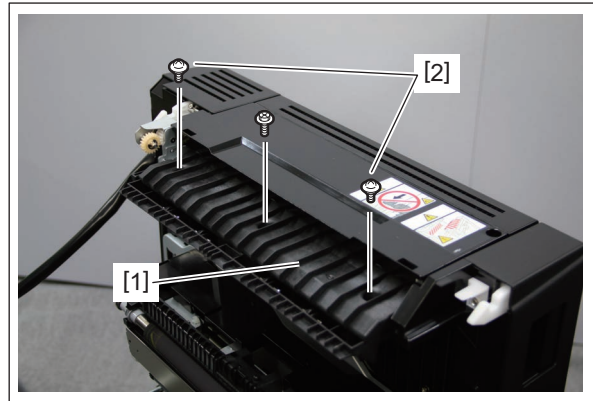

Fig. 4-795

Notes:

The shoulder screws are used on the front side and rear side. When installing, pay attention not to confuse them with other kinds of screws.

- (3) Remove 1 screw and take off the sensor bracket [3].

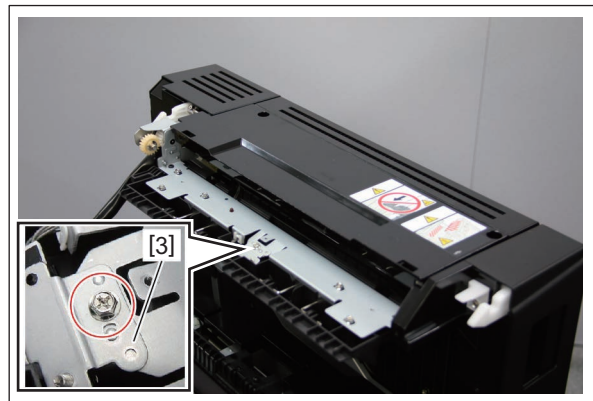

Fig. 4-796

- (4) Disconnect 1 connector from the fuser transport sensor [4].

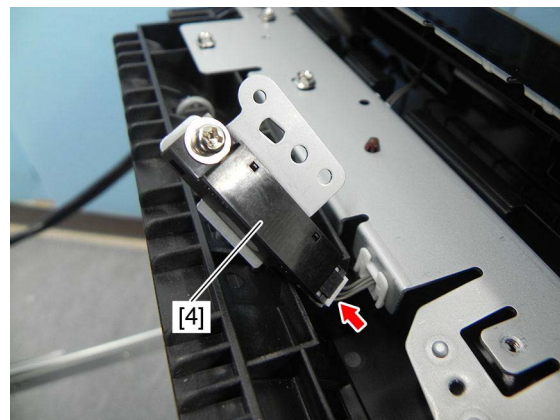

Fig. 4-797

- (5) Remove 1 screw and take off the fuser transport sensor [4] from the sensor bracket [3].

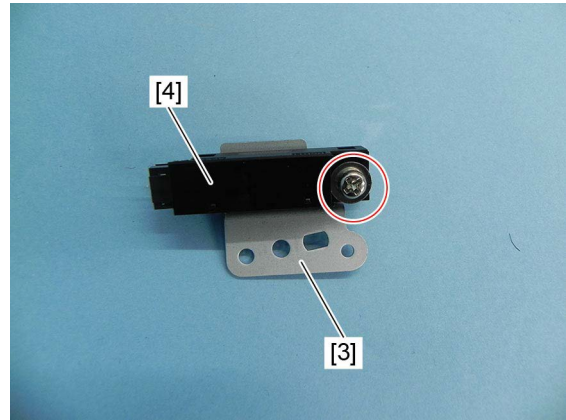

Fig. 4-798

4.10.47 Duplexing unit path exit sensor (S66)

- (1) Pull out the duplexing unit.
(2) Remove 3 screws and take off the duplexing unit left side cover [1] from the 2 hooks.

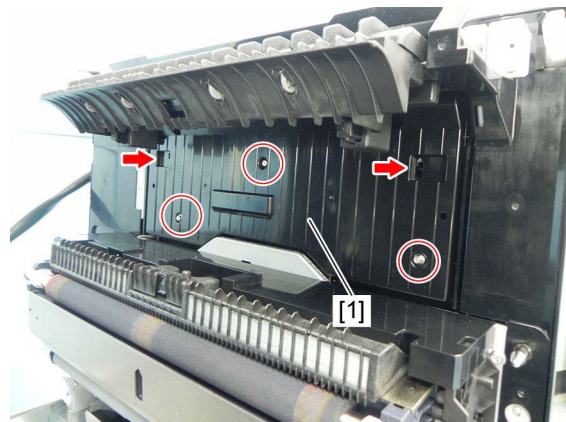

Fig. 4-799

- (3) Remove 1 screw and take off the sensor bracket [2].
(4) Disconnect 1 connector from the duplexing unit path entrance sensor [3].

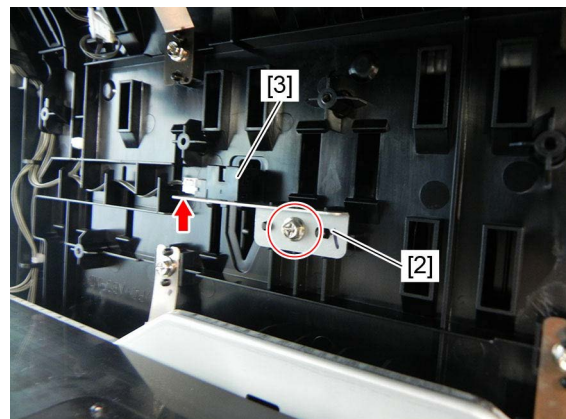

Fig. 4-800

(5) Remove the duplexing unit path entrance sensor [3] from the sensor bracket [2].

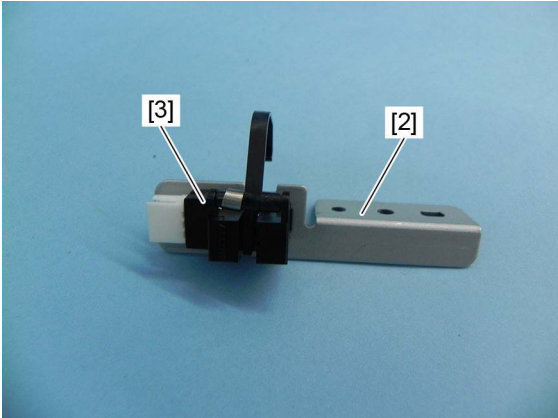

Fig. 4-801

4.10.48 Duplexing unit cover opening/closing detection switch (SW7)

- (1) Take off the duplexing unit upper cover.
📖 P. 4-302 “4.10.35 Duplexing unit upper cover”
- (2) Remove 2 screws and take off the duplexing unit cover opening/closing detection switch [1].

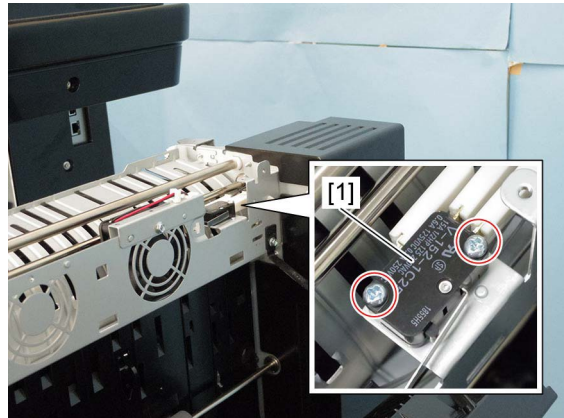

Fig. 4-802

- (3) Release 1 clamp and disconnect 3 connectors [3] from the duplexing unit cover opening/closing detection switch [2].

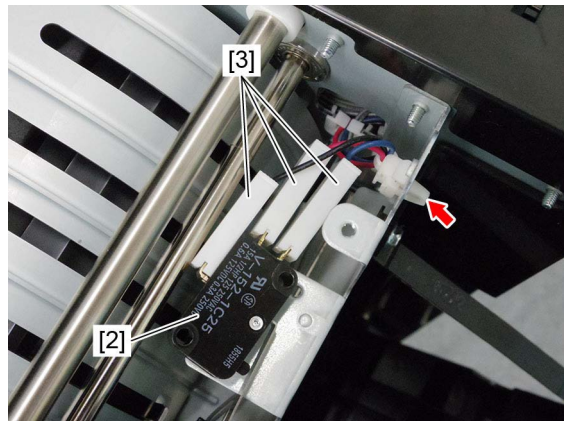

Fig. 4-803

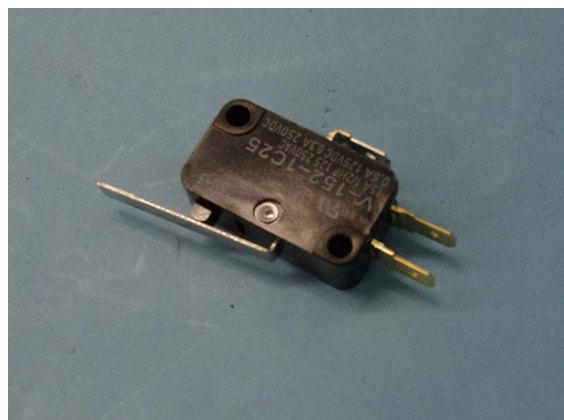

Fig. 4-804

4.10.49 IH interlock switch (SW4)

Notes:

- When the IH interlock switch is replaced or removed, be sure to perform the operation check with the input check (test mode FS-03).
- If the installation is insufficient, this could cause an electric shock, or a burn injury due to overheating of the fuser unit since power continues to be supplied to the IH coil and the IH board while the cover is open.

- (1) Take off the right rear cover.
📖 P. 4-12 “4.1.21 Right rear cover”
- (2) Remove 2 screws. Disconnect 2 connectors and take off the switch bracket [1].

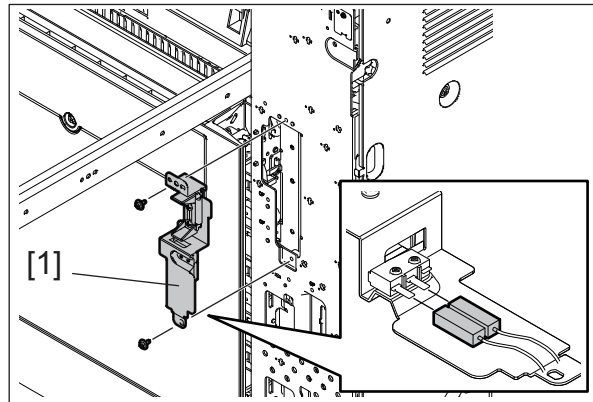

Fig. 4-805

- (3) Remove 2 screws and take off the IH interlock switch [2] from the switch bracket.

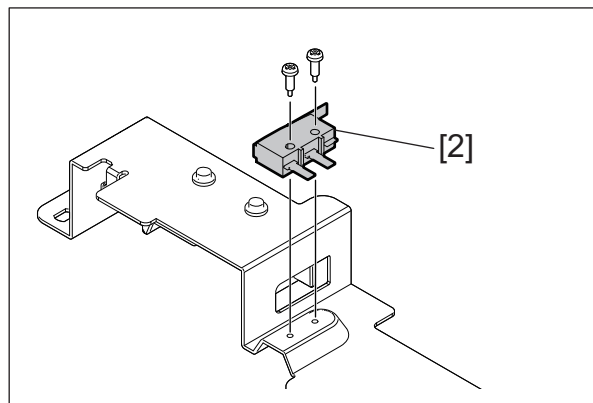

Fig. 4-806

4.10.50 Interlock switch (SW2), Duplexing unit interlock switch (SW10)

Notes:

- When the interlock switch is replaced or removed, be sure to perform the operation check with the input check (test mode FS-03).
- If the interlock switch is not installed appropriately when it is replaced or installed, it may not work normally. If you carry out the maintenance of the MFP in such a situation, you could get an electric shock by touching live sections or be injured by touching moving sections. Therefore, to avoid this, be sure to perform correct handling and installation.

- (1) Pull out the bridge unit.
📖 P. 4-271 “4.10.11 Bridge unit”
- (2) Remove 2 screws and take off the right inner cover [1].

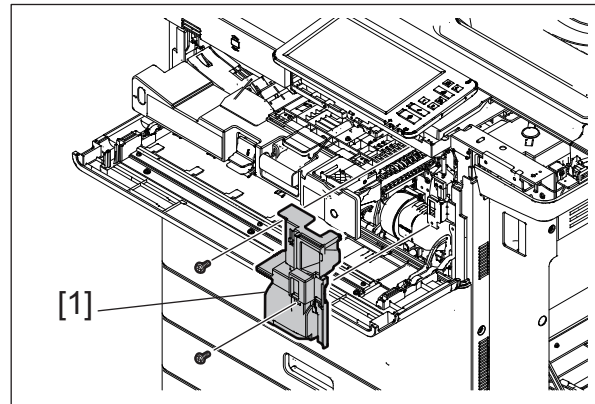

Fig. 4-807

- (3) Remove 1 screw. Disconnect 1 connector and take off the switch bracket [2].

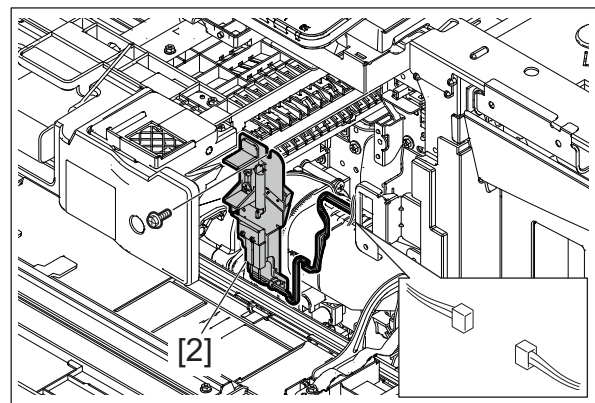

Fig. 4-808

- (4) Remove 2 screws. Disconnect 2 connectors and take off the interlock switch [3] from the switch bracket.

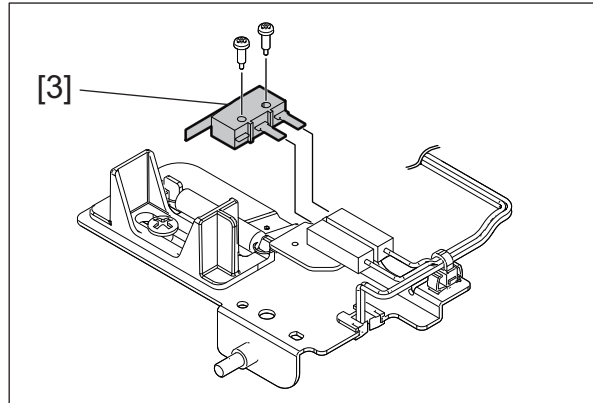

Fig. 4-809

- (5) Remove 2 screws. Disconnect 2 connectors and take off the duplexing unit interlock switch [4] from the switch bracket.

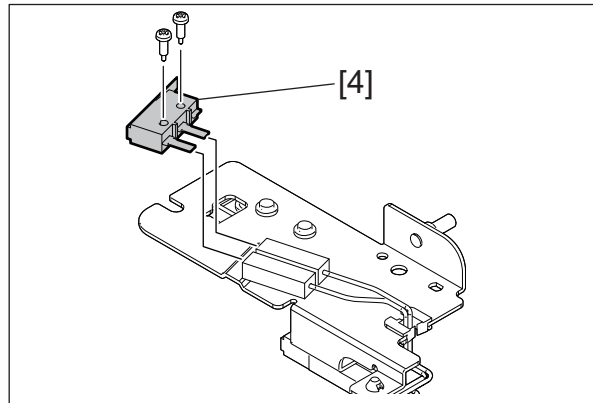

Fig. 4-810

4.10.51 Fuser unit exhaust heat fan (F2), Bridge unit exhaust heat fan (F1)

- (1) Take off the IH board cover.
P. 9-23 "9.1.20 IH board"
- (2) Remove 1 harness clamp [1]. Remove 2 screws and disconnect 4 connectors.

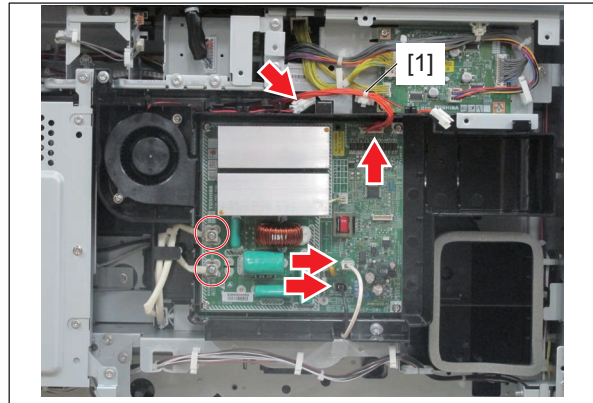

Fig. 4-811

- (3) Remove 2 screws and take off the IH board case [2].

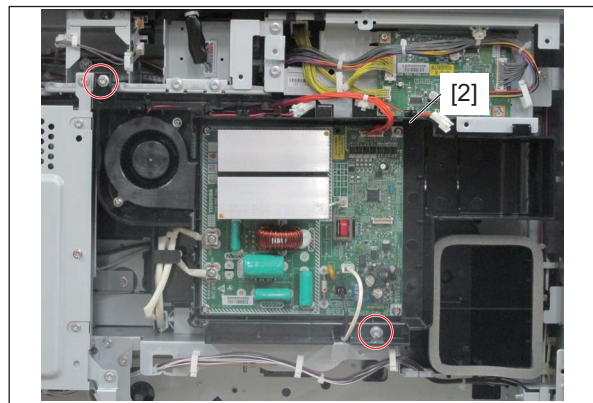

Fig. 4-812

- (4) Disconnect 2 connectors. Release 3 hooks [3] and take off the fan with its duct [4].

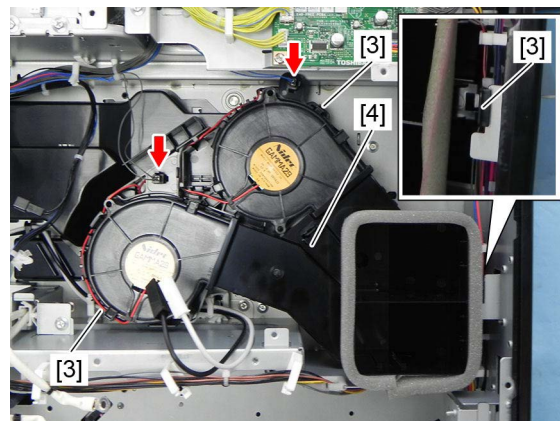

Fig. 4-813

- (5) Disconnect 1 connector [5]. Release 2 hooks [6] and take off the bridge unit exhaust heat fan [7].
- (6) Disconnect 1 connector [8]. Release 2 hooks [9] and take off the fuser unit exhaust heat fan [10].

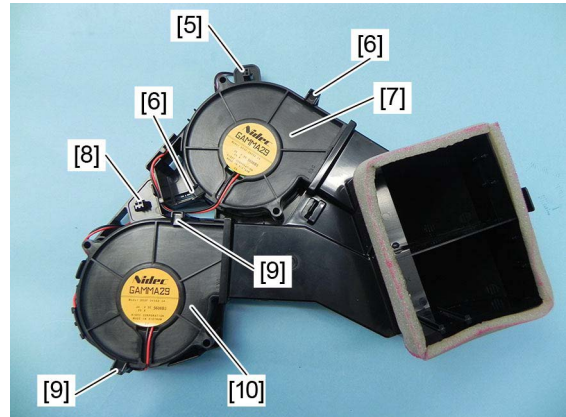

Fig. 4-814

4.10.52 Upper discharge brush

- (1) Take off the upper paper exit roller unit.
 ⓘ P. 4-264 "4.10.5 Upper paper exit sensor (S61), Upper exit tray paper full detection sensor (S62)"
- (2) Remove 4 screws and take off the 2 discharge brushes [1].

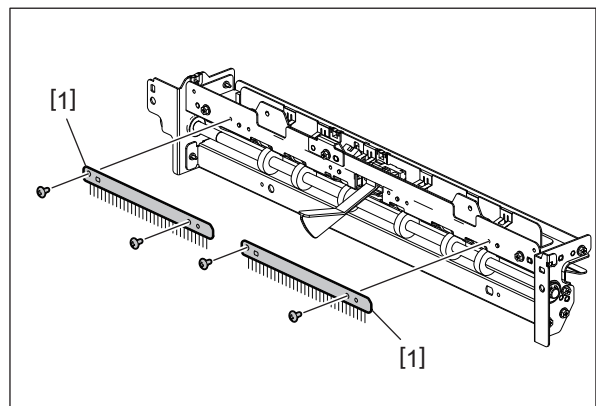

Fig. 4-815

4.10.53 Lower discharge brush

- (1) Take off the left top cover.
📖 P. 4-8 "4.1.15 Left top cover"
- (2) Lift up the reverse path cover [1]. Remove 2 screws and take off the lower discharge brush [2].

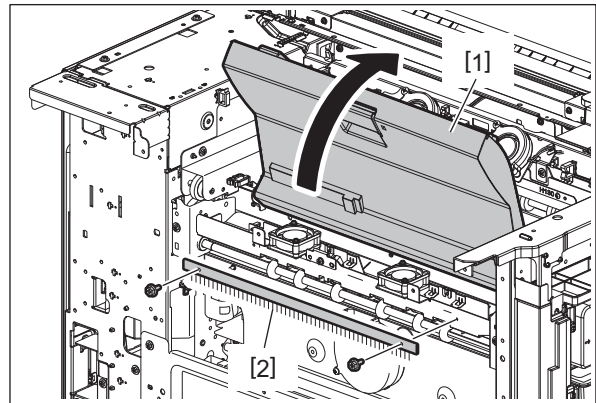

Fig. 4-816

4.11 Dual Scan Document Feeder (DSDF)

Notes:

 P. 4-366 “4.11.31 Intermediate transport unit”

Be sure to attach the stopper jig or to take off the DSDF from the MFP before starting the procedures mentioned above or later. If the unit is taken off from the DSDF while it is installed in the MFP, the DSDF will be pulled up as its weight becomes lighter, resulting in danger.

4.11.1 Removal of the DSDF

- (1) Take off the SYS board cover.
 P. 9-1 “9.1.1 SYS board cover”
- (2) Disconnect 1 HDMI connector.
Disconnect 1 communication connector of the DSDF.

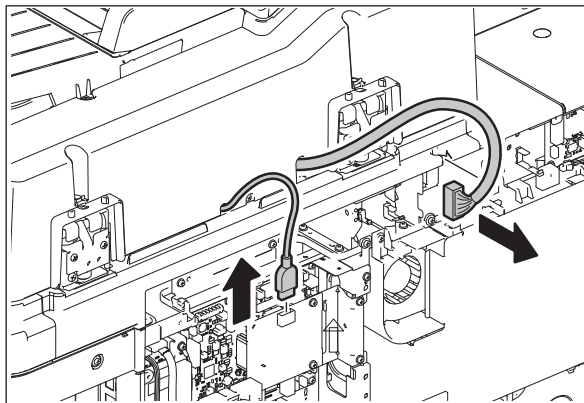

Fig. 4-817

Notes:

After the power cable is disconnected, an electric charge may remain in the boards of the MFP. Therefore, be sure to disconnect the communication connector when about 1 minute (e.g.: the time for taking off the rear cover) has passed after the power cable is disconnected.

- (3) Remove 4 screws and take off 2 brackets [1].

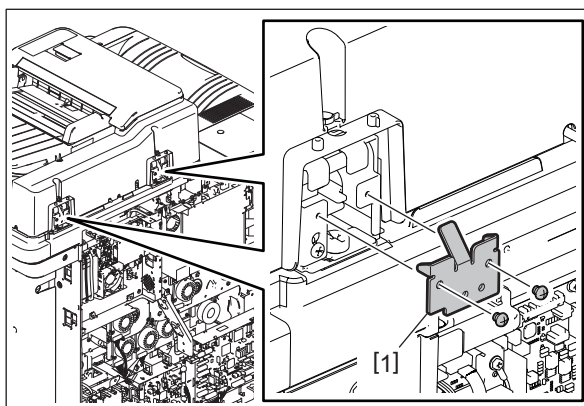

Fig. 4-818

(4) Remove 2 screws and 2 washers.

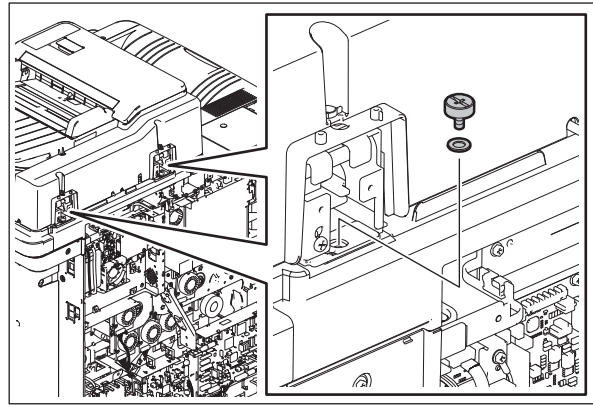

Fig. 4-819

(5) Take off 1 hinge cover.

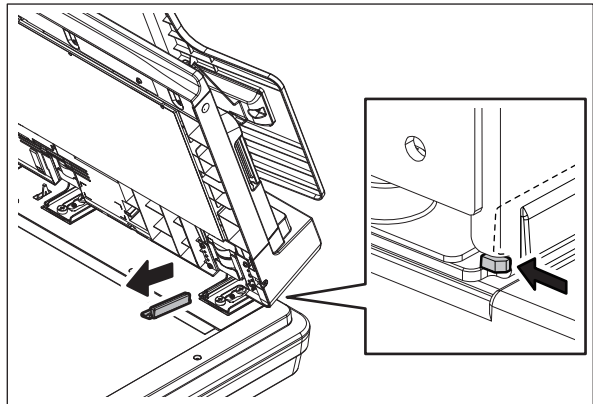

Fig. 4-820

(6) Open the DSDF [2] and remove 2 screws. Take off the DSDF [2] by sliding it to the rear side.

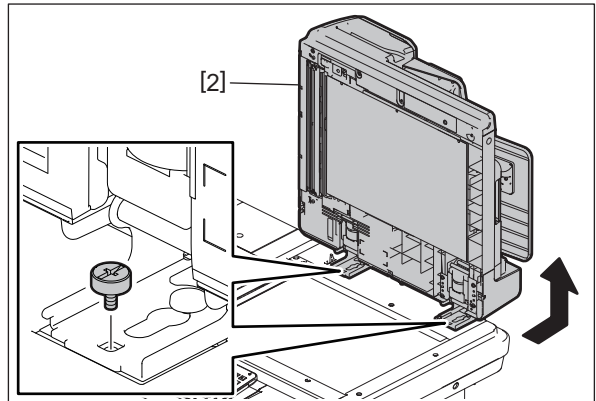

Fig. 4-821

4.11.2 Installing of the DSDF

- (1) Install the DSDF.

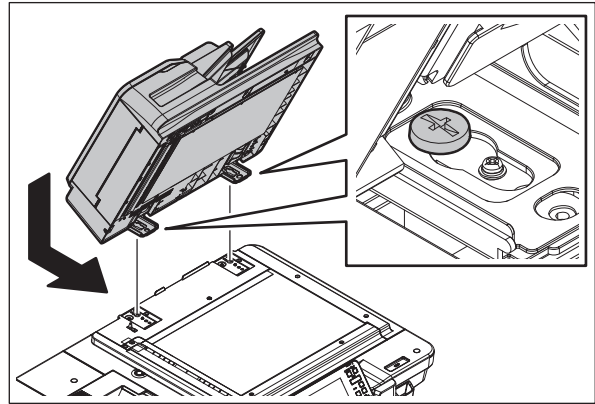

Fig. 4-822

- (2) Temporarily tighten 2 screws on the front side.

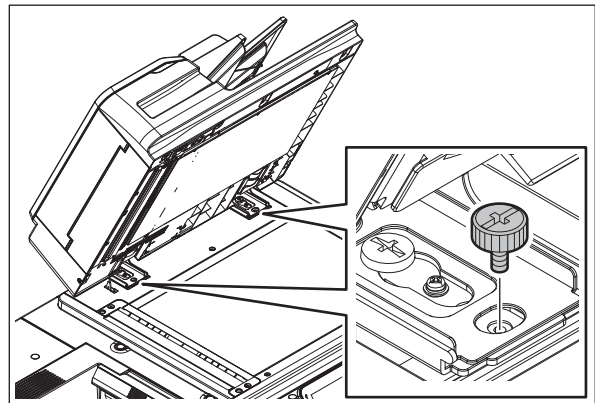

Fig. 4-823

- (3) Temporarily tighten 2 screws with 2 washers on the rear side.

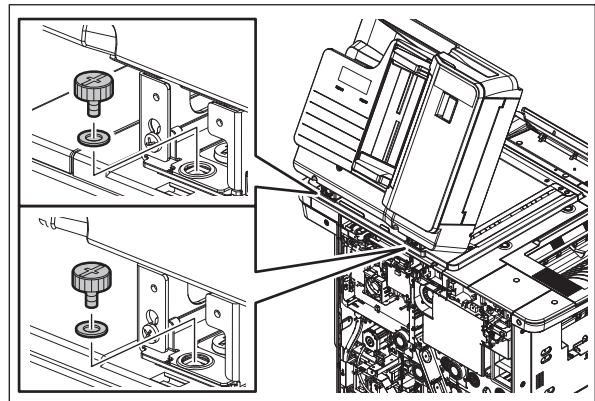

Fig. 4-824

Notes:

When the screw is tightened temporarily, make a gap by 1 mm or less between its lower surface and the upper surface of the washer so that the hinge can be slid.

- (4) Adjust the DSDF.
📖 P. 6-84 "6.13.1 Position adjustment"

Notes:

After adjusting the DSDF, tighten 2 screws on the front side and 2 screws with 2 washers on the rear side.

- (5) Install the hinge cover.

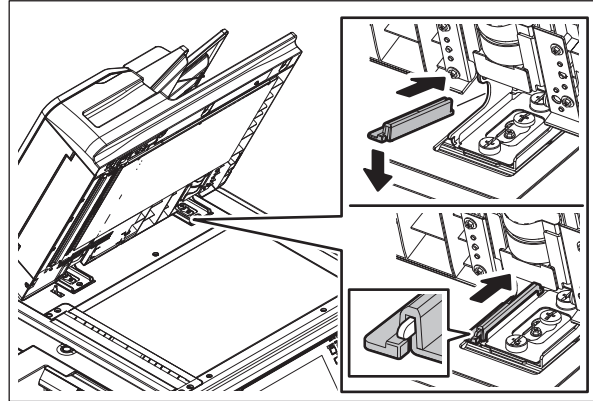

Fig. 4-825

- (6) Connect the HDMI connector.

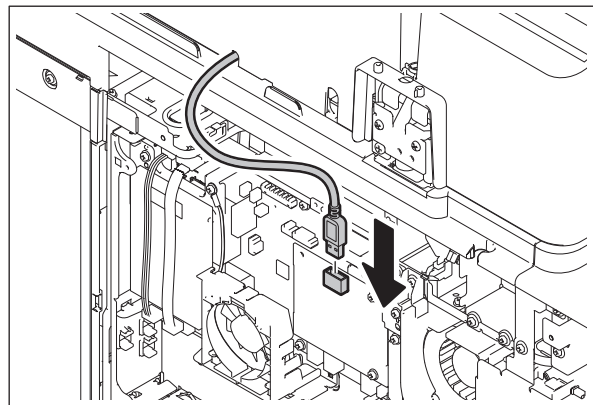

Fig. 4-826

- (7) Connect the communication connector.

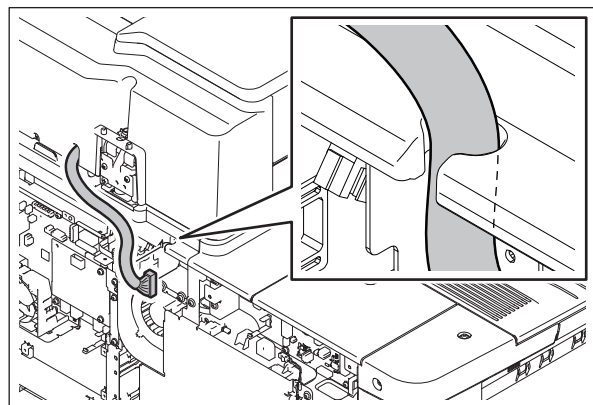

Fig. 4-827

- (8) Install the SYS board cover and rear cover.
- (9) Reset the platen sheet.
📖 P. 6-102 "6.13.8 Platen sheet"

4.11.3 DSDF pickup unit

- (1) Open the original jam access cover [1].

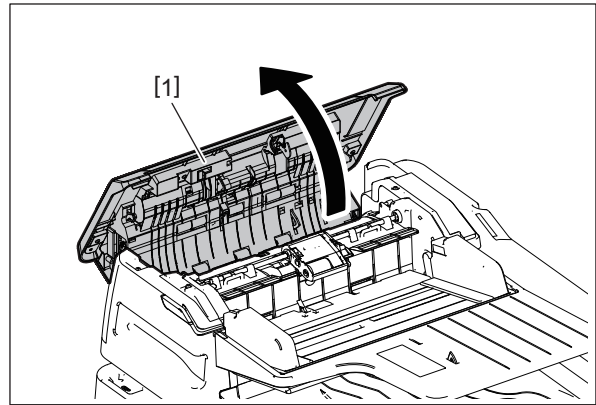

Fig. 4-828

- (2) Turn the lever [2] and take off the DSDF pickup unit [3].

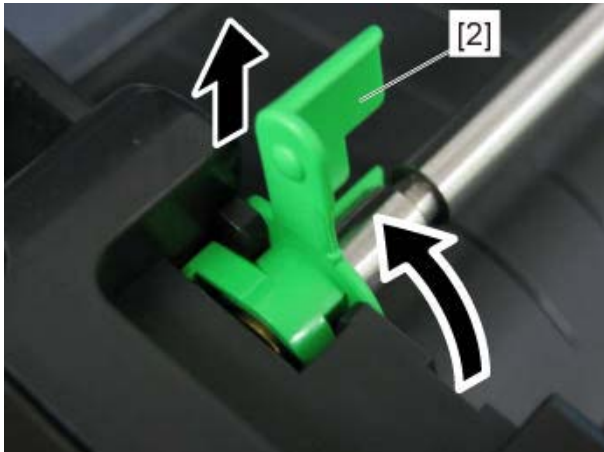

Fig. 4-829

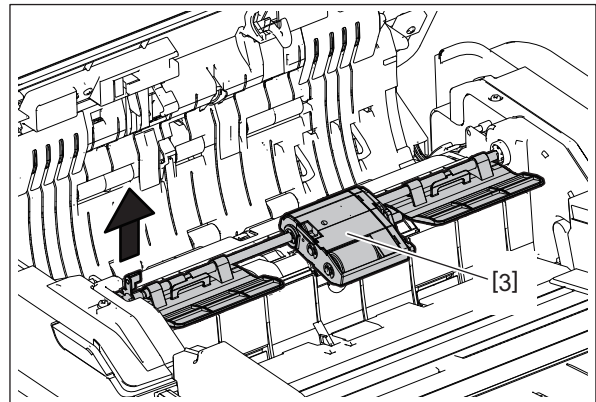

Fig. 4-830

DSDF pickup unit

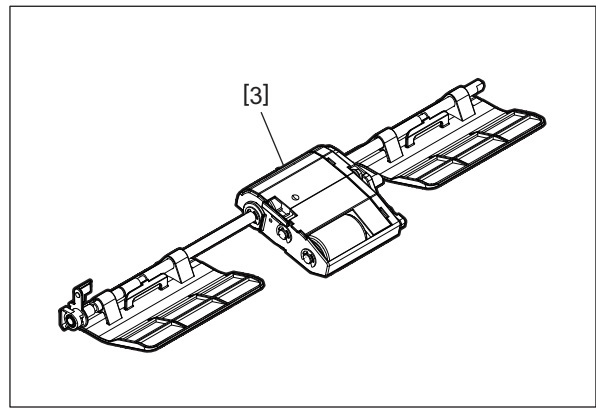

Fig. 4-831

4.11.4 DSDF separation roller

- (1) Remove the DSDF pickup unit.
 P. 4-330 “4.11.3 DSDF pickup unit”
- (2) Open the DSDF separation roller cover [4].



Fig. 4-832



Fig. 4-833

(3) Turn the arm [5] to release the lock.



Fig. 4-834

(4) Turn the lever [6] of the front side to align the protrusion to the groove.



Fig. 4-835

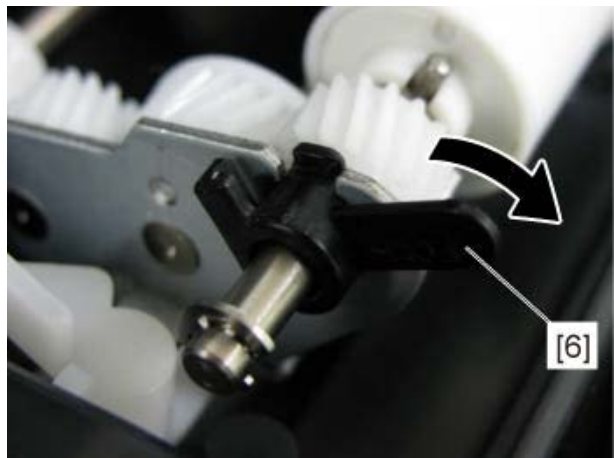

Fig. 4-836

- (5) Turn the lever [7] of the rear side to align the protrusion to the groove.

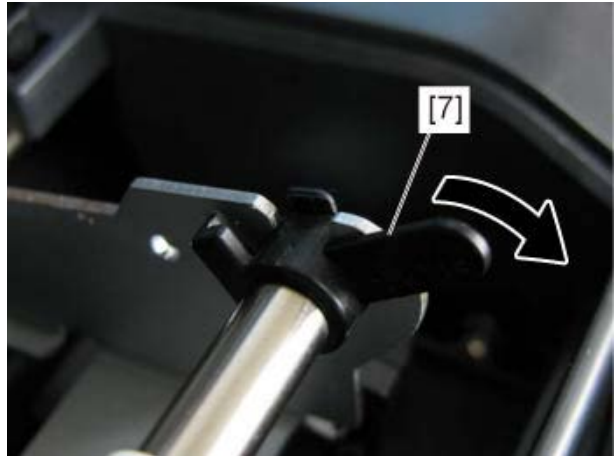

Fig. 4-837

- (6) Slide the DSDF separation roller unit [8] to the front side to take it off.

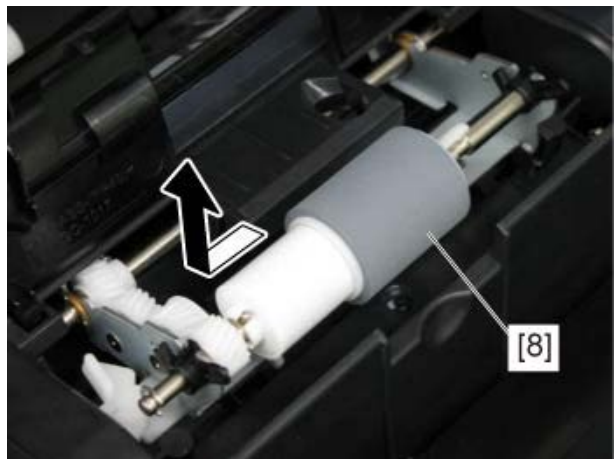

Fig. 4-838

DSDF separation roller unit



Fig. 4-839

- (7) Take off the lever [7] of the rear side from the DSDF separation roller unit [8].
- (8) Release the latch and take off the DSDF separation roller [9].

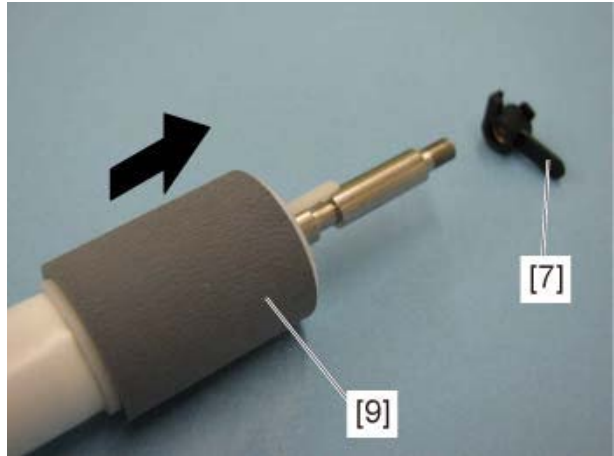

Fig. 4-840

DSDF separation roller



Fig. 4-841

4.11.5 DSDF pickup roller

- (1) Remove the DSDF pickup unit.
P. 4-330 "4.11.3 DSDF pickup unit"
- (2) Remove the paper guide [1].

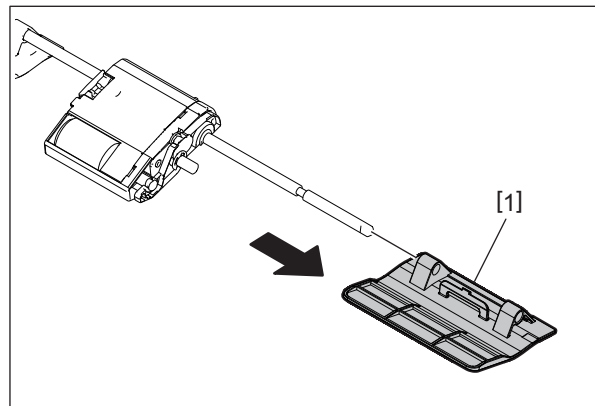

Fig. 4-842

- (3) Take off the holder cover [2].
- (4) Release the stopper [3].

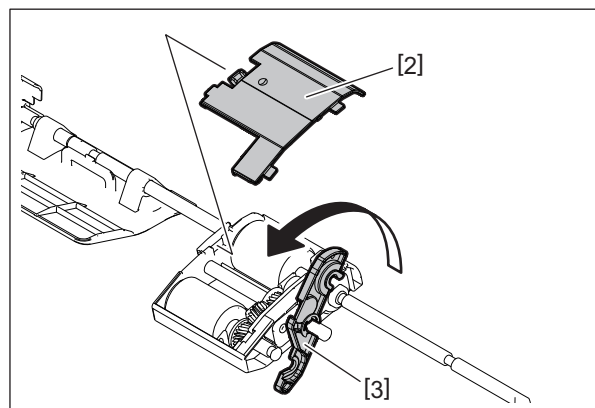

Fig. 4-843

- (5) Remove the shaft [4] and take off the DSDF pickup roller [5].

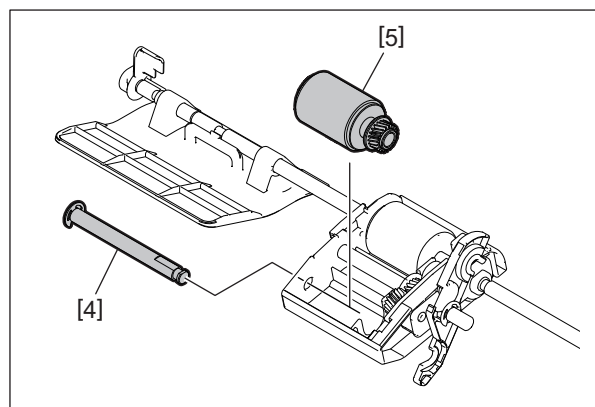

Fig. 4-844

4.11.6 DSDF original feed roller^{PM}

- (1) Remove the DSDF pickup unit.
P. 4-330 “4.11.3 DSDF pickup unit”
- (2) Remove the holder cover and release the stopper.
P. 4-335 “4.11.5 DSDF pickup roller”
- (3) Take off the shaft [1].

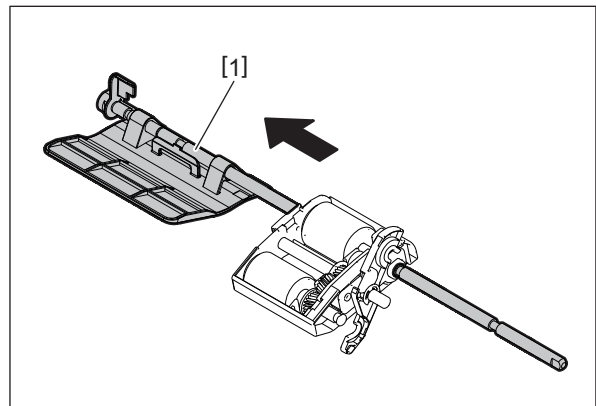

Fig. 4-845

- (4) Take off the DSDF original feed roller [2].

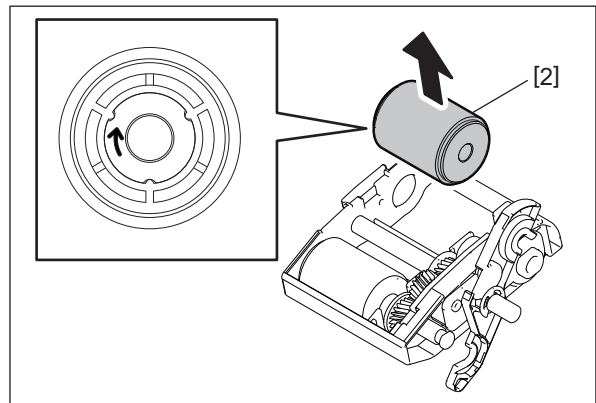

Fig. 4-846

DSDF original feed roller

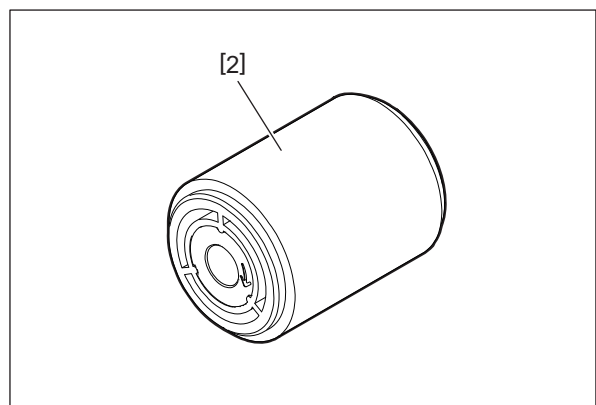

Fig. 4-847

4.11.7 DSDF rear cover

- (1) Remove 3 screws.

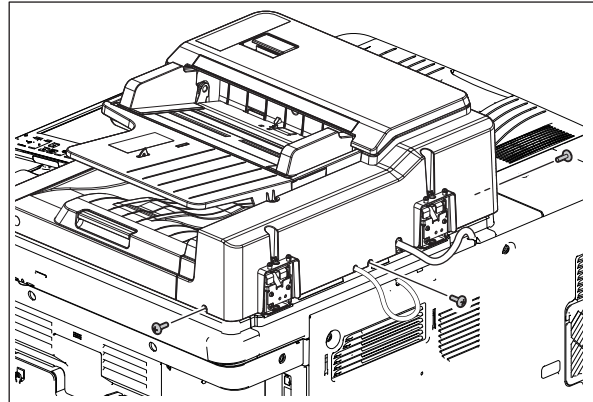

Fig. 4-848

- (2) Open the original jam access cover and remove 1 screw for the metal part [1] and another 1 screw for the plastic part [2].

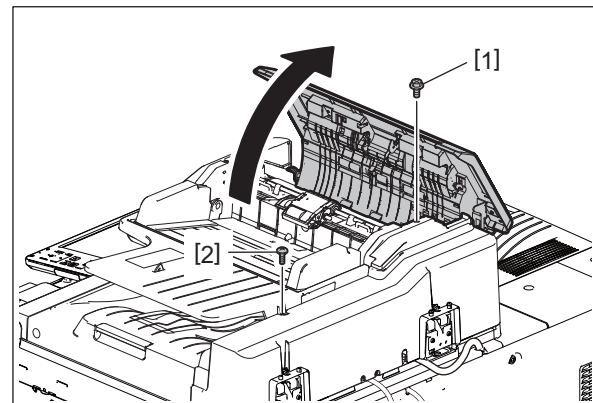

Fig. 4-849

- (3) While lifting up the original tray [3], remove the DSDF rear cover [4].

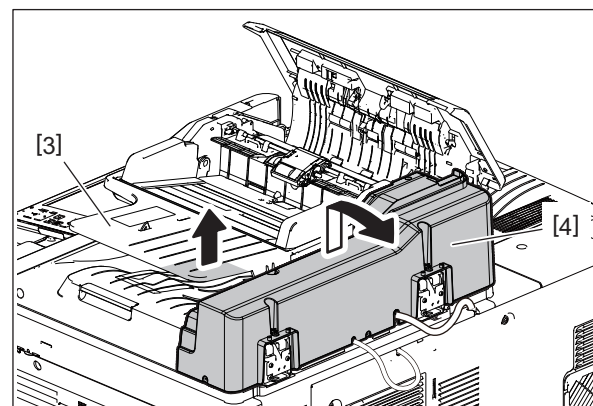

Fig. 4-850

4.11.8 DSDF front cover

- (1) Open the DSDF.
- (2) Remove 2 screws [1] for the metal part and another 2 screws [2] for the plastic part.



Fig. 4-851

- (3) Remove 1 screw and take off the DSDF front cover [5].

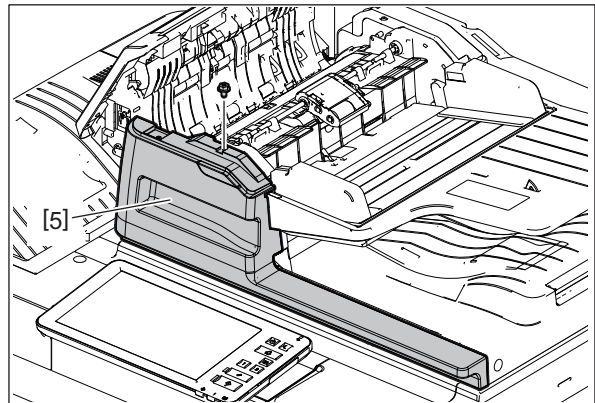

Fig. 4-852

4.11.9 Original jam access cover

- (1) Take off the DSDF rear cover.
📖 P. 4-337 “4.11.7 DSDF rear cover”
- (2) Take off the DSDF front cover.
📖 P. 4-338 “4.11.8 DSDF front cover”
- (3) Disconnect 2 connectors.

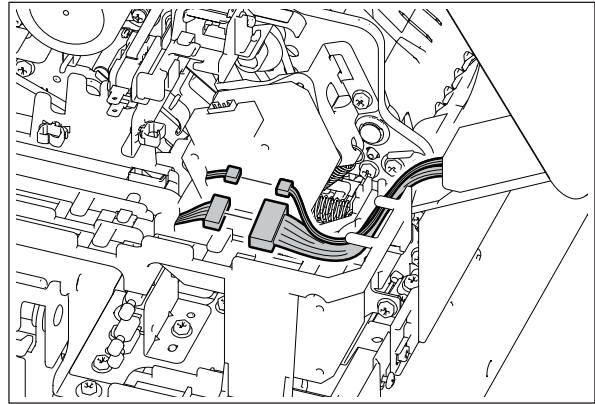

Fig. 4-853

- (4) Remove 1 screw and the hinge pin [6] of the rear side.

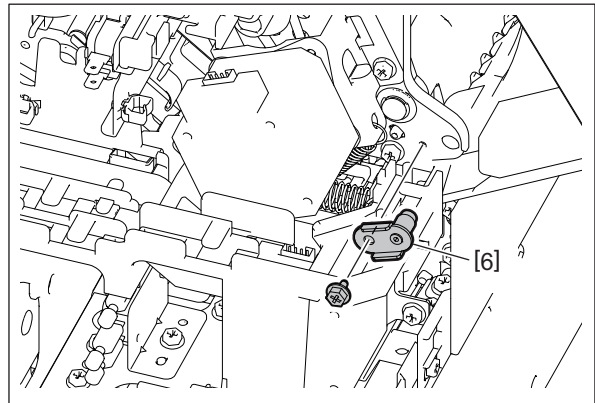

Fig. 4-854

- (5) Remove 1 screw and the hinge pin [7] of the front side.
- (6) Remove 1 screw of the original jam access cover stopper [8].

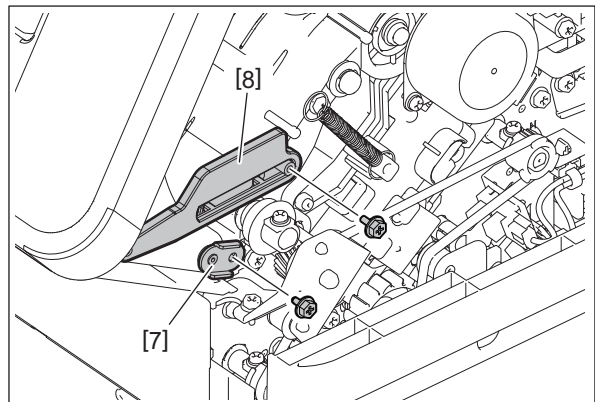

Fig. 4-855

- (7) Take off the original jam access cover [9].

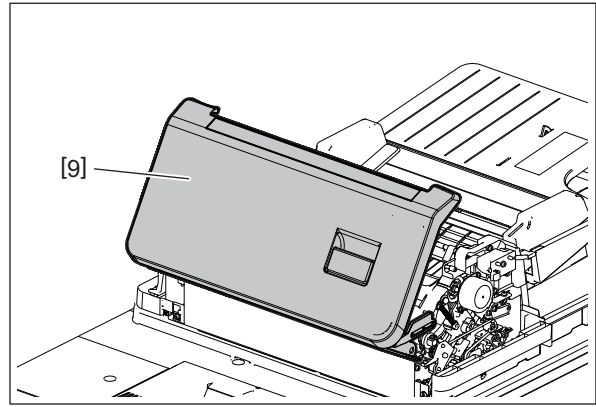



Fig. 4-856

Notes:

When installing and taking off the original jam access cover, be careful not to damage it or the transport guide of the DSDF left cover.

4.11.10 DSDF left cover

- (1) Take off the original jam access cover.
 P. 4-339 “4.11.9 Original jam access cover”
- (2) Remove 1 screw [1] for the metal part and another 1 screw [2] for the plastic part.
- (3) Take off the DSDF left cover [3] upward.

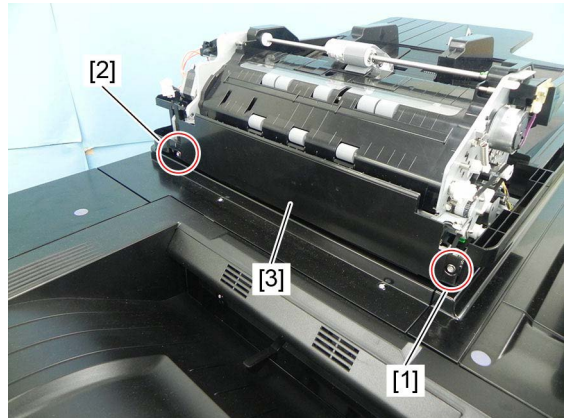

Fig. 4-857

4.11.11 DSDF-LED PC board (LEDD)

- (1) Take off the DSDF front cover.
P. 4-338 “4.11.8 DSDF front cover”
- (2) Disconnect 1 connector.
Remove 1 screw and take off the DSDF-LED PC board [12].

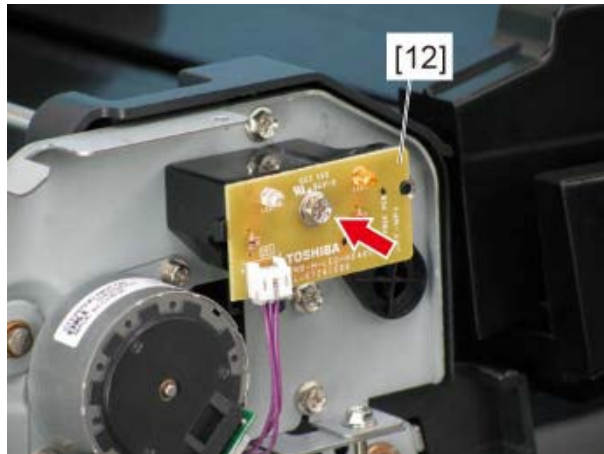

Fig. 4-858

4.11.12 DSDF control PC board (DLGD)

- (1) Take off the DSDF rear cover.
P. 4-337 “4.11.7 DSDF rear cover”
- (2) Disconnect 13 connectors.
- (3) Remove 2 screws and take off the DSDF control PC board [13].

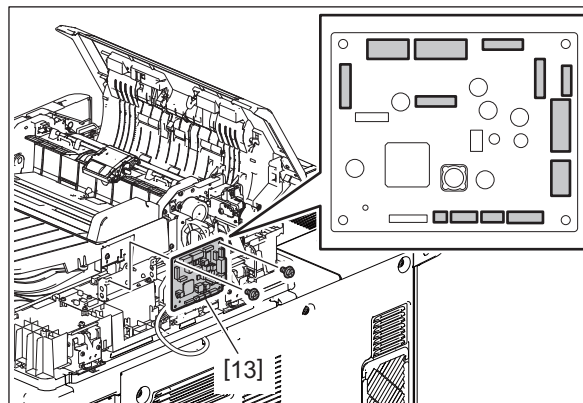

Fig. 4-859

Notes:

When the DSDF control PC board is replaced, be sure to perform this adjustment.

P. 6-100 “6.13.7 DSDF read-in sensor-1 adjustment”

4.11.13 DSDF relay PC board (DFRLY)

- (1) Take off the DSDF rear cover.
P. 4-337 “4.11.7 DSDF rear cover”
- (2) Take off the DSDF cooling fan motor.
P. 4-354 “4.11.22 DSDF cooling fan motor (FD1)”
- (3) Disconnect 1 HDMI cable. Release the lock and disconnect 1 flat cable.

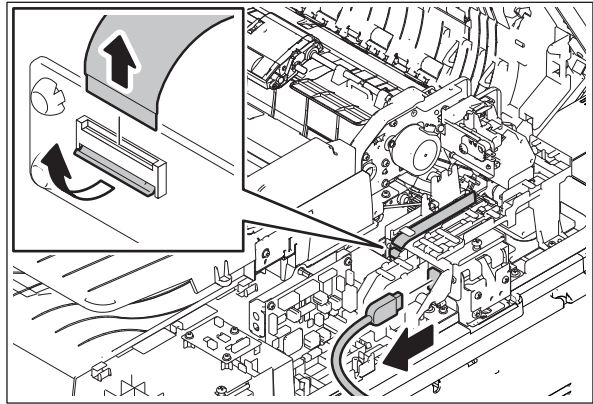

Fig. 4-860

Notes:

- When connecting the flat cable to the connector, do not push it in strongly.
 - When installing the flat cable, be careful not to insert it at an angle.
 - Do not apply pressure to or damage the edge of the flat cable.
 - When installing a flat cable, make sure that the conductor side will be the upper side.
- (4) Release the harness [6] from the harness guide [5].
Disconnect the connectors [7] for the DSDF upper cover interlock switch and the DSDF lower cover interlock switch.
Remove 2 screws and take off the harness guide [5].

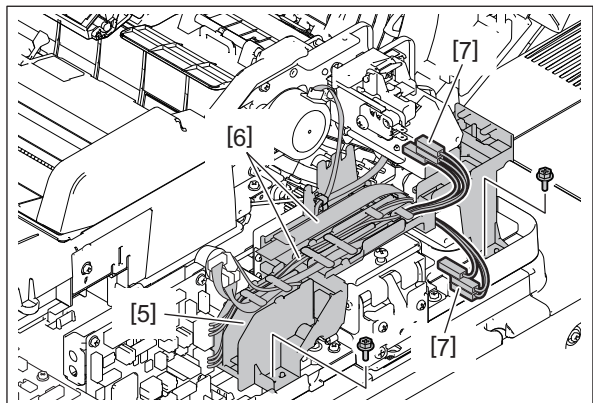

Fig. 4-861

Notes:

Release the harness from the clamp of the harness guide [5].

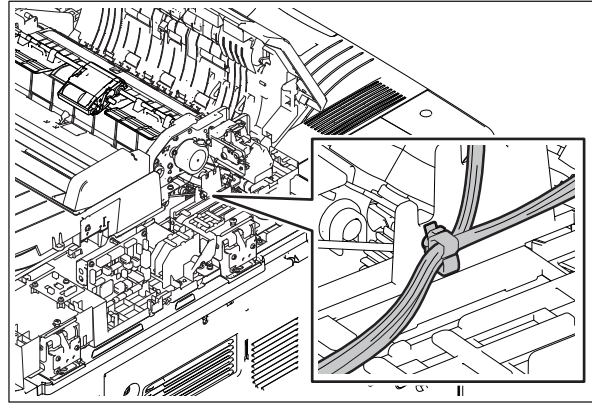

Fig. 4-862

- (5) Take off the DSDF relay PC board [14] from the harness guide.

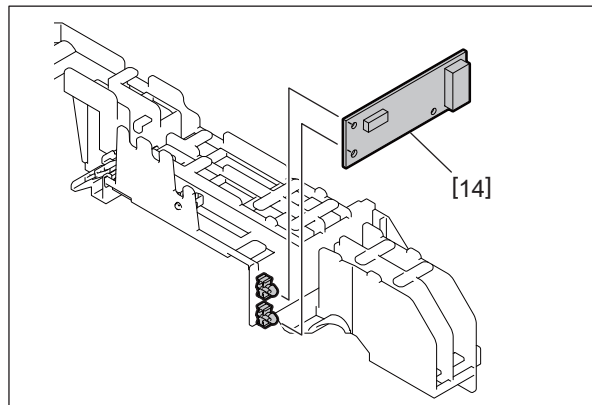

Fig. 4-863

4.11.14 DSDF multiple feeding detection relay PC board (DLGRLY)

- (1) Take off the DSDF rear cover.
P. 4-337 "4.11.7 DSDF rear cover"
- (2) Disconnect 3 connectors from the DSDF multiple feeding detection relay PC board.
- (3) Remove 3 screws [1] and take off the DSDF multiple feeding detection relay PC board [2].

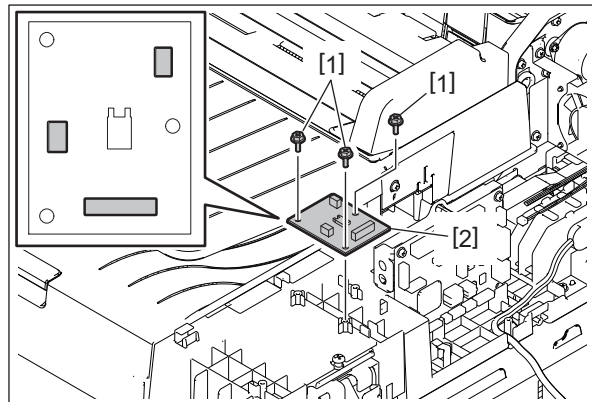



Fig. 4-864

4.11.15 Original tray

- (1) Take off the DSDf rear cover.
 P. 4-337 "4.11.7 DSDf rear cover"
- (2) Take off the DSDf front cover.
 P. 4-338 "4.11.8 DSDf front cover"
- (3) Disconnect 2 connectors from the DSDf control PC board.

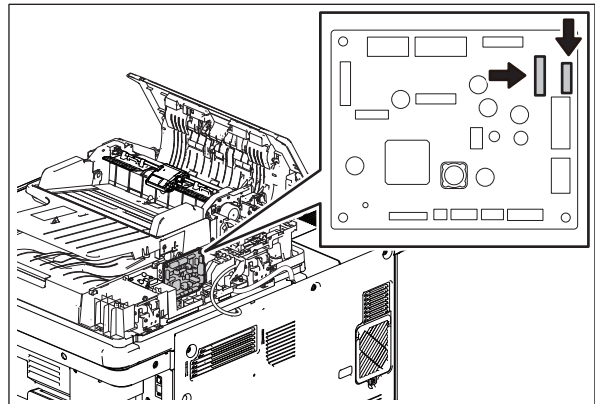

Fig. 4-865

- (4) Take off the bracket cover [1].
- (5) Remove 1 screw. Take off the original tray bracket [2] and the original tray holder [3].

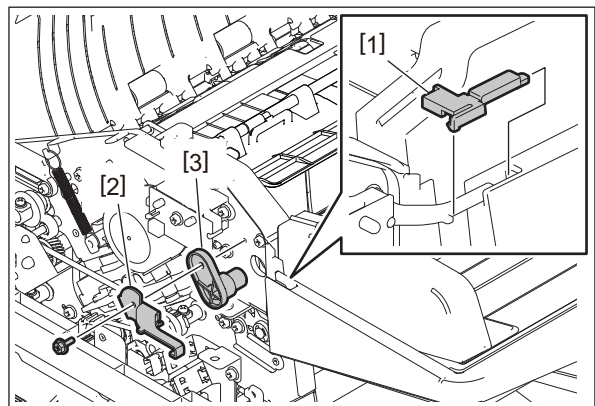

Fig. 4-866

- (6) Take off the original tray [4].

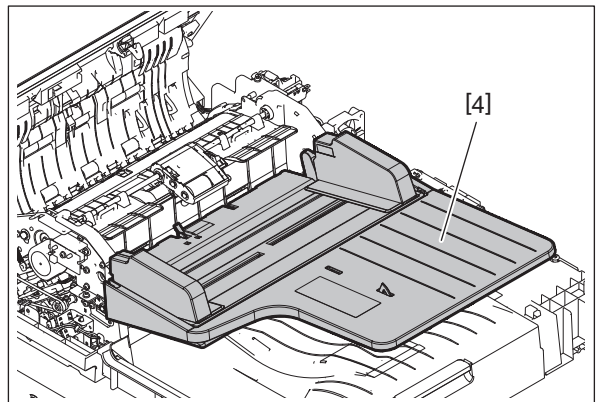

Fig. 4-867

4.11.16 DSDF tray original length sensor-1 (SD1), DSDF tray original length sensor-2 (SD2)

- (1) Take off the original tray.
📖 P. 4-344 “4.11.15 Original tray”
- (2) Remove 1 screw and take off the sensor cover [14].



Fig. 4-868

- (3) Disconnect 1 connector respectively from the DSDF tray original length sensor-1 [15] and the DSDF tray original length sensor-2 [16].
- (4) Release the latch from each sensor. Take off the DSDF tray original length sensor-1 [15] and the DSDF tray original length sensor-2 [16].

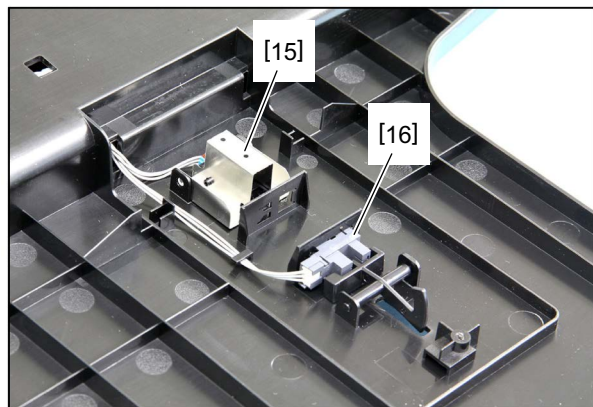

Fig. 4-869

4.11.17 DSDF tray original width sensor (SD3)

- (1) Take off the original tray.
P. 4-344 “4.11.15 Original tray”
- (2) Remove 1 screw and take off the tray holder [17].
Take off the movable tray [18].

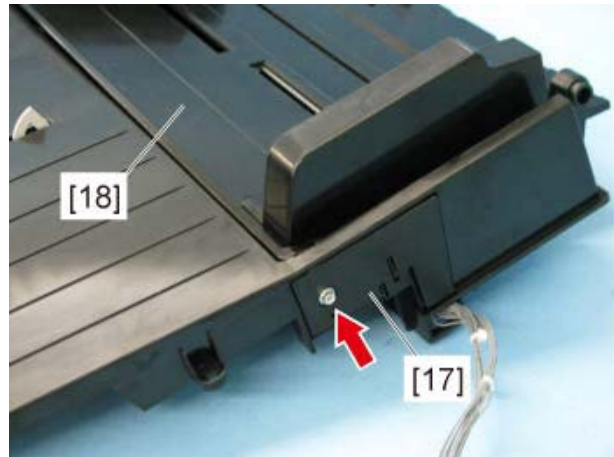

Fig. 4-870

Notes:

When installing the tray holder, be careful not to let the harness get caught in it.

- (3) Remove 1 screw and take off the original width sensor cover [19].

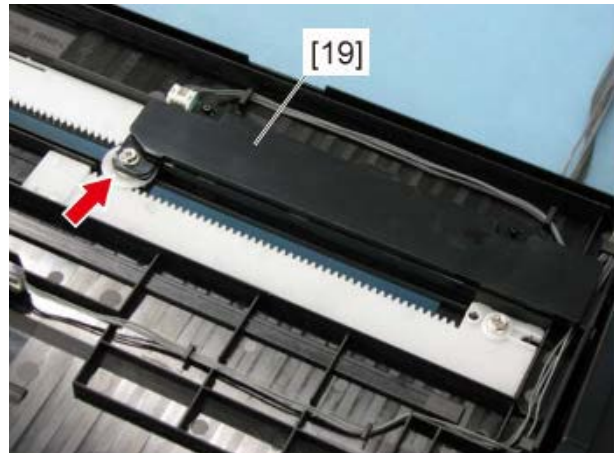

Fig. 4-871

Notes:

Pay attention not to remove the washer and the wave washer of the pinion.

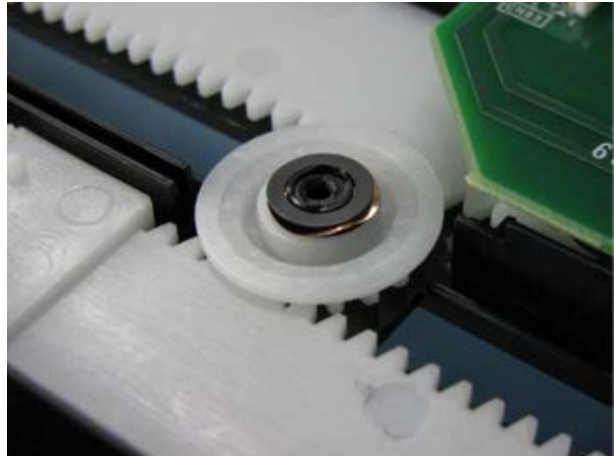

Fig. 4-872

- (4) Disconnect 1 connector and take off the DSDF tray original width sensor [20].

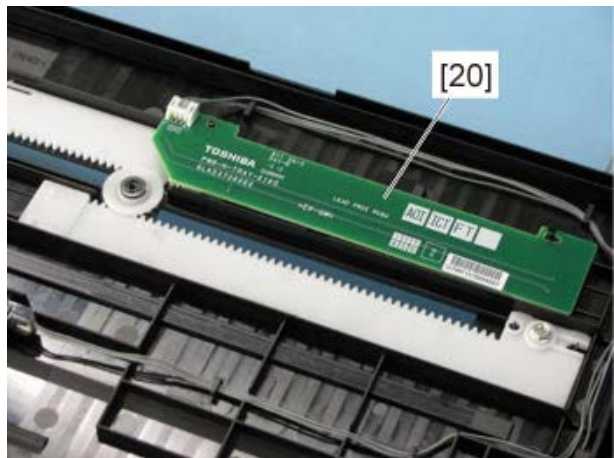

Fig. 4-873

4.11.18 DSDF original empty sensor (SD4)

- (1) Take off the original tray.
P. 4-344 "4.11.15 Original tray"
- (2) Remove 1 screw and take off the tray holder [17].
Take off the movable tray [18].

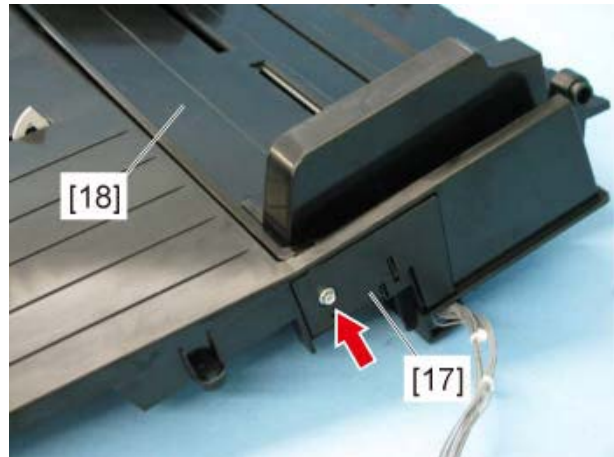

Fig. 4-874

Notes:

When installing the tray holder, be careful not to let the harness get caught in it.

- (3) Disconnect 1 connector. Release the latch and take off the DSDF original empty sensor [21].

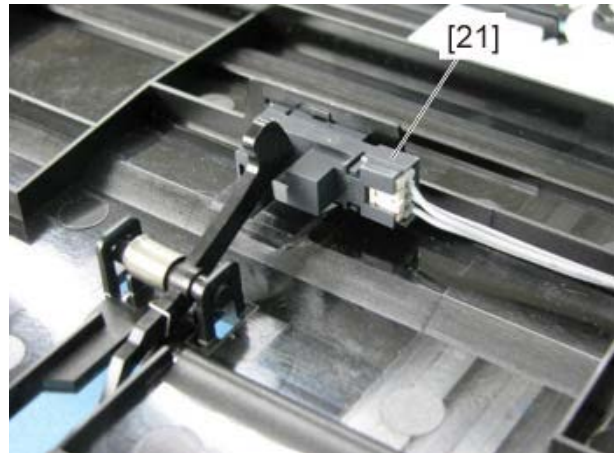



Fig. 4-875

4.11.19 DSDF original feed sensor (SD5), DSDF tray lift upper limit sensor (SD9)

- (1) Take off the original jam access cover.
 P. 4-339 "4.11.9 Original jam access cover"
- (2) Remove 4 screws.

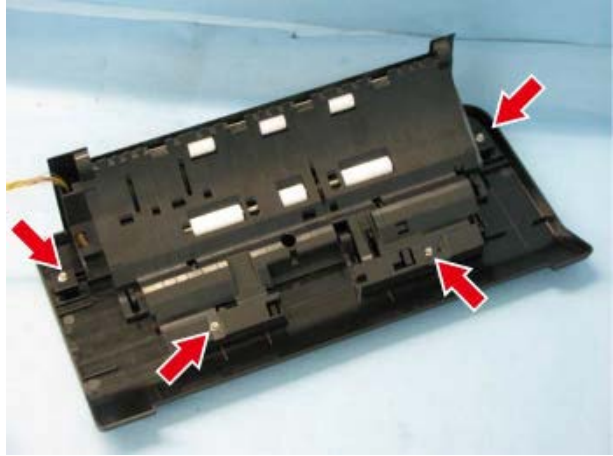

Fig. 4-876

- (3) While pulling the lever, take off the top cover [1].

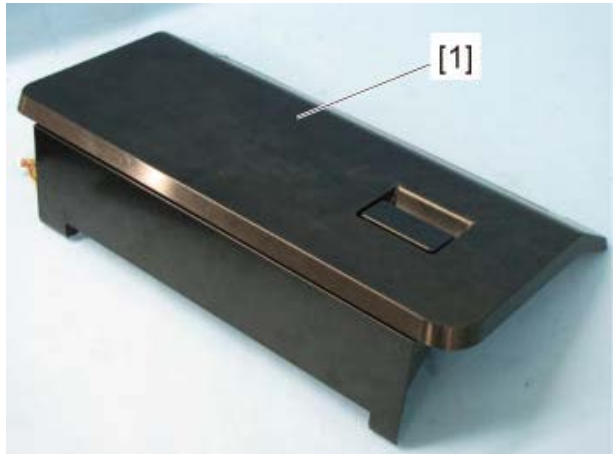

Fig. 4-877

- (4) Release the spring [2] and remove the lever [3].

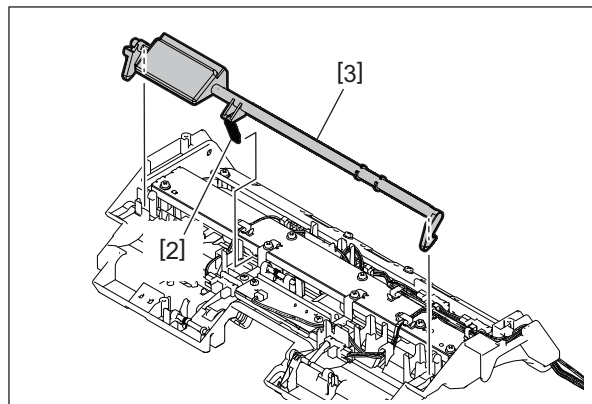

Fig. 4-878

- (5) Disconnect 1 connector [4]. Release the latch and take off the DSDF original feed sensor [5].

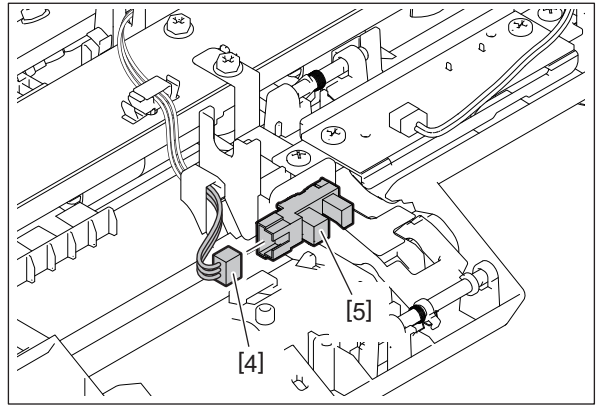

Fig. 4-879

- (6) Disconnect 1 connector [6]. Release the latch and take off the DSDF tray lift upper limit sensor [7].

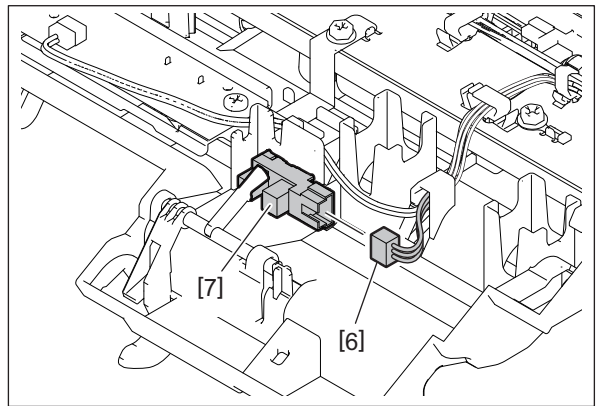

Fig. 4-880

4.11.20 DSDF tray original width detection sensor-1 (SD7), DSDF tray original width detection sensor-2 (SD8)

- (1) Take off the original jam access cover.
P. 4-339 “4.11.9 Original jam access cover”
- (2) Remove 4 screws.

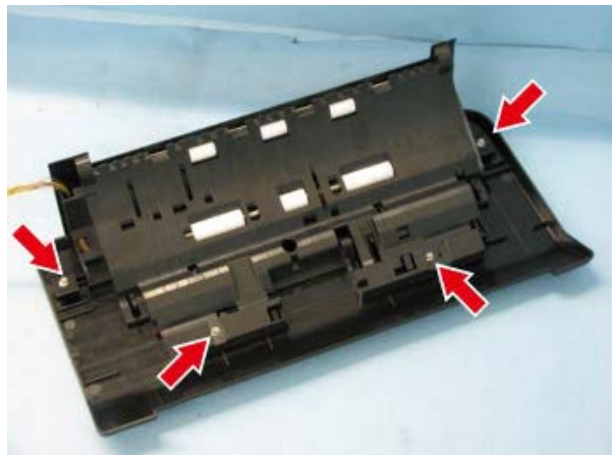

Fig. 4-881

- (3) While pulling the lever, take off the top cover [1].

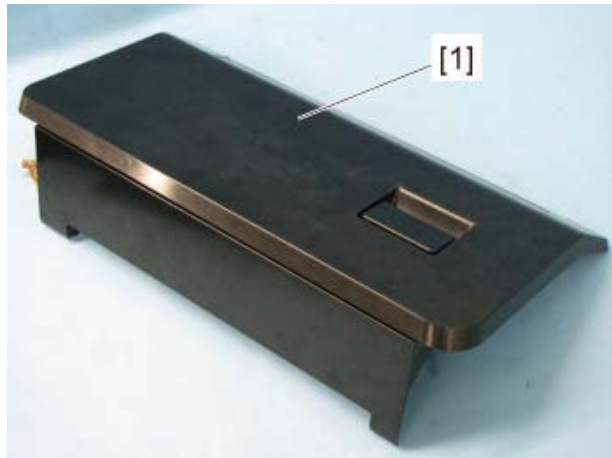

Fig. 4-882

- (4) Remove 2 screws and take off the left top cover [4].

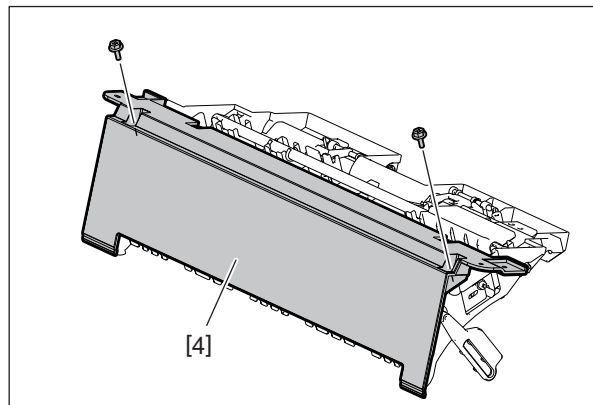

Fig. 4-883

- (5) Disconnect 1 connector. Release the latch and take off the DSDF tray original width detection sensor-1 [5].
- (6) Disconnect 1 connector. Release the latch and take off the DSDF tray original width detection sensor-2 [6].

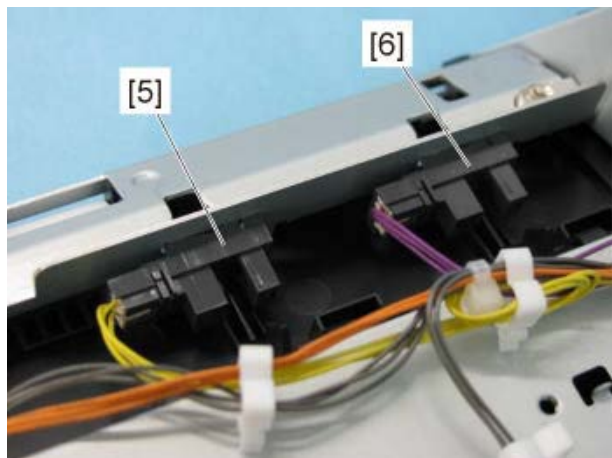

Fig. 4-884

4.11.21 DSDF registration sensor (SD6)

- (1) Take off the original jam access cover.
P. 4-339 “4.11.9 Original jam access cover”
- (2) Remove 4 screws.

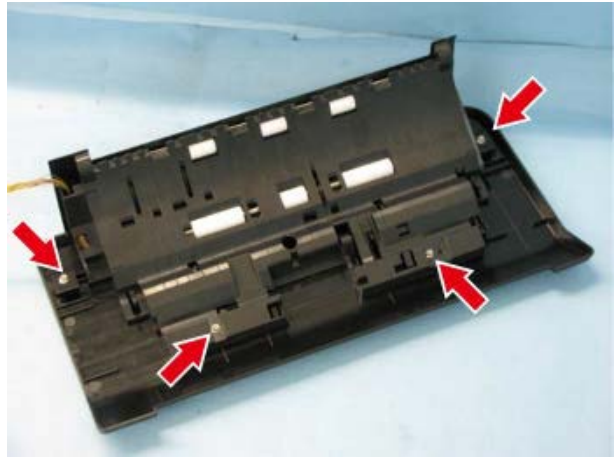

Fig. 4-885

- (3) While pulling the lever, take off the top cover [1].

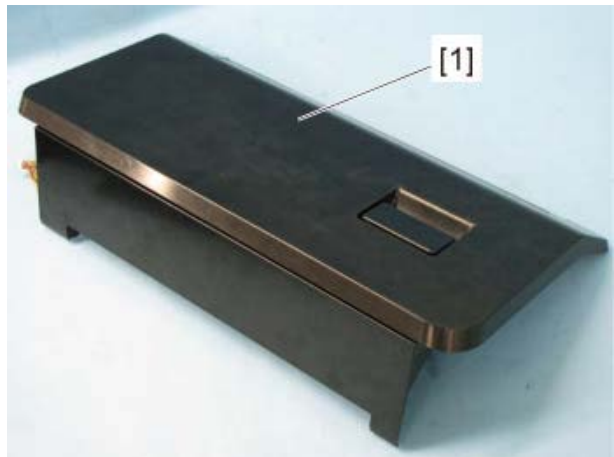

Fig. 4-886

- (4) Remove 2 screws and take off the left top cover [4].

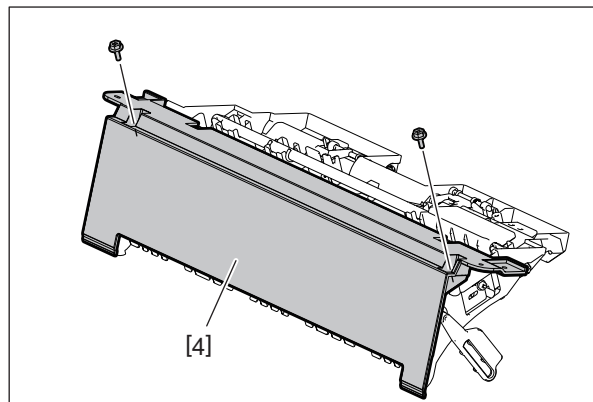

Fig. 4-887

- (5) Disconnect 2 connectors [5].
- (6) Remove 8 screws [6] and take off the stay [7].

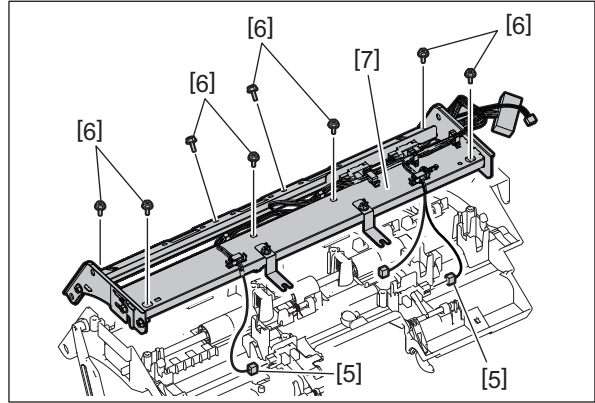

Fig. 4-888

Notes:

Be careful not to drop any of the 6 springs.

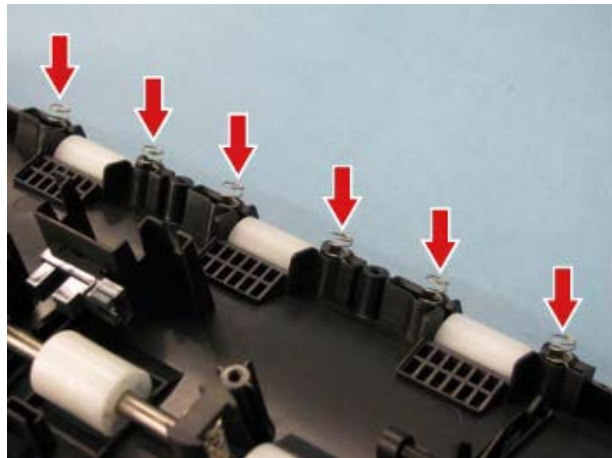

Fig. 4-889

- (7) Disconnect 1 connector [9] and take off the DSDF registration sensor [8].

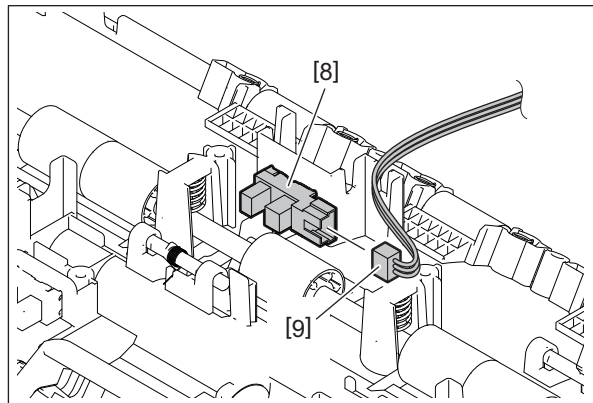



Fig. 4-890

4.11.22 DSDF cooling fan motor (FD1)

- (1) Take off the DSDF rear cover.
 P. 4-337 "4.11.7 DSDF rear cover"
- (2) Disconnect 1 connector [1]. Remove 2 screws and take off the DSDF cooling fan motor bracket [2].

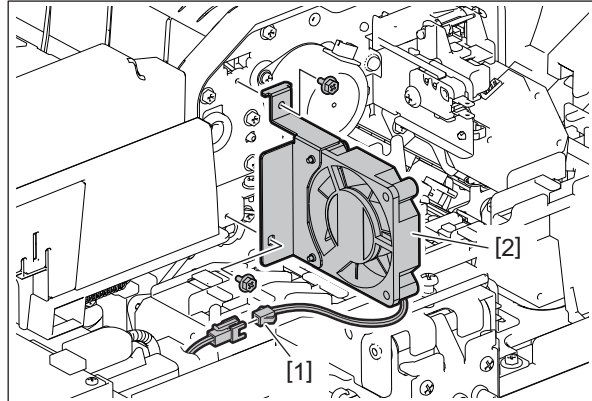

Fig. 4-891

- (3) Remove 2 screws and take off the DSDF cooling fan motor [3] from the bracket.

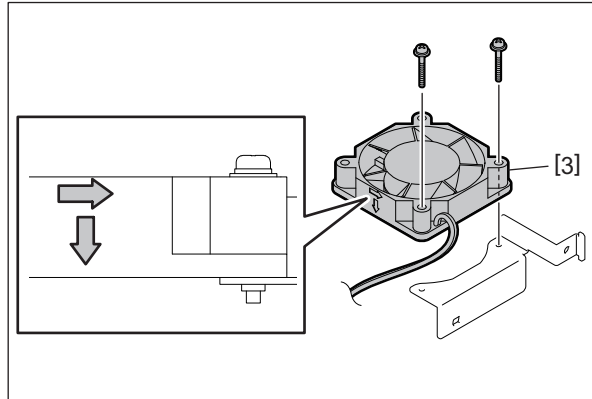

Fig. 4-892

4.11.23 DSDF upper cover interlock switch (SWD2)

Notes:

If the interlock switch is not installed appropriately when it is replaced or installed, it may not work normally. If you carry out the maintenance of the MFP in such a situation, you could get an electric shock by touching live sections or be injured by touching moving sections. Therefore, to avoid this, be sure to perform correct handling and installation.

- (1) Take off the DSDF cooling fan motor bracket.
📖 P. 4-354 “4.11.22 DSDF cooling fan motor (FD1)”
- (2) Disconnect 3 connectors. Remove 1 screw and take off the DSDF upper cover interlock switch [4].



Fig. 4-893

Notes:

The color of all 3 harnesses for the DSDF upper cover interlock switch is orange.

4.11.24 DSDF upper cover opening/closing detection sensor (SD16)

Notes:

If the interlock switch is not installed appropriately when it is replaced or installed, it may not work normally. If you carry out the maintenance of the MFP in such a situation, you could get an electric shock by touching live sections or be injured by touching moving sections. Therefore, to avoid this, be sure to perform correct handling and installation.

- (1) Take off the DSDF rear cover.
📖 P. 4-337 “4.11.7 DSDF rear cover”
- (2) Remove 2 screws and take off the sensor bracket [1].

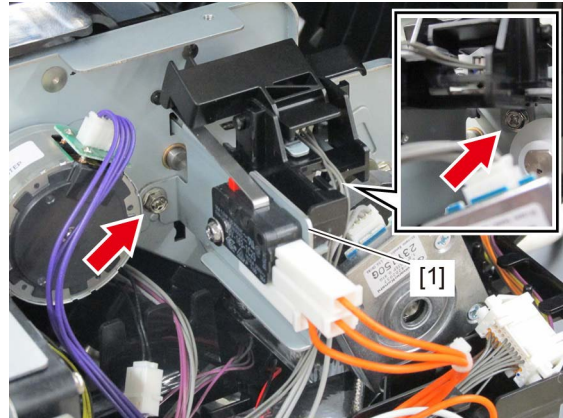

Fig. 4-894

- (3) Release the harness [4] from the harness clamp [2] and actuator [3]. Release 2 latches [5] of the actuator [3] and remove it.

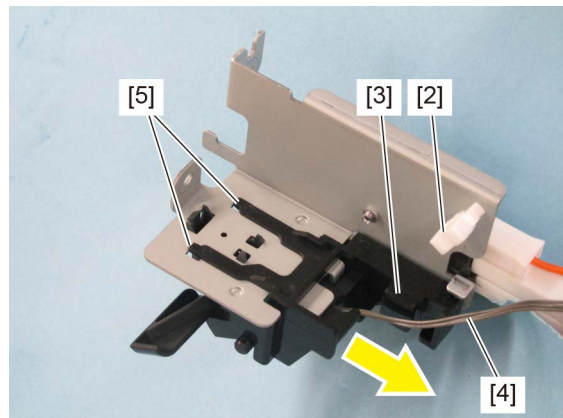

Fig. 4-895

(4) Release 3 latches [6].

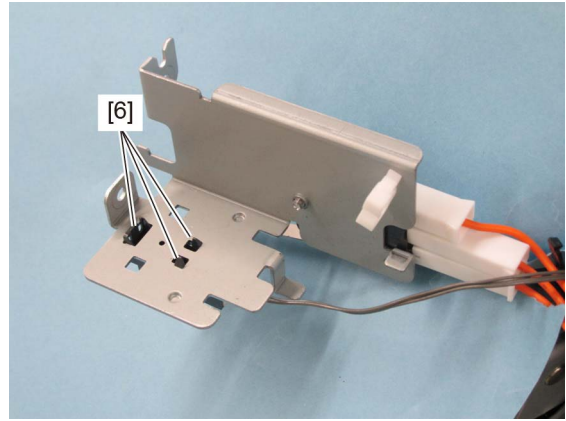

Fig. 4-896

(5) Disconnect 1 connector [7] and take off the DSDF upper cover opening/closing detection sensor [8].

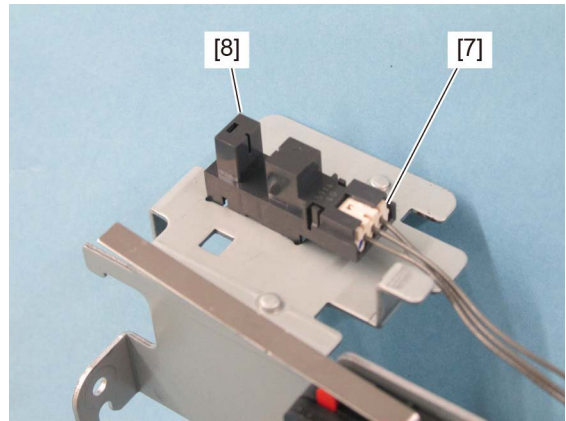

Fig. 4-897

4.11.25 DSDF registration motor (MD3)

- (1) Take off the DSDF rear cover.
📖 P. 4-337 “4.11.7 DSDF rear cover”
- (2) Take off the DSDF cooling fan motor (FD1).
📖 P. 4-354 “4.11.22 DSDF cooling fan motor (FD1)”
- (3) Disconnect 1 HDMI cable. Release the lock and disconnect 1 flat cable.

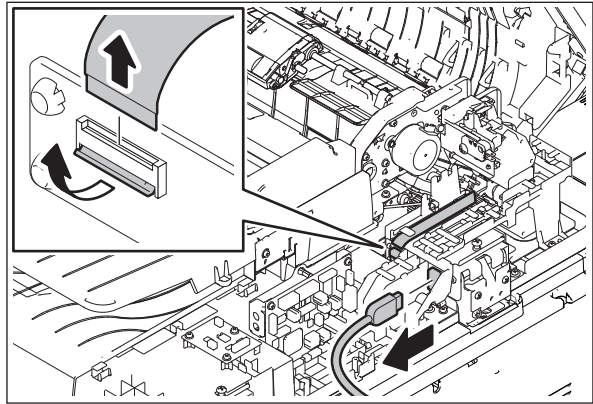

Fig. 4-898

Notes:

- When connecting the flat cable to the connector, do not push it in strongly.
 - When installing the flat cable, be careful not to insert it at an angle.
 - Do not apply pressure to or damage the edge of the flat cable.
 - When installing a flat cable, make sure that the conductor side will be the upper side.
- (4) Release the harness [6] from the harness guide [5].
Disconnect the connectors [7] for the DSDF upper cover interlock switch and the DSDF lower cover interlock switch.
Remove 2 screws and take off the harness guide [5].

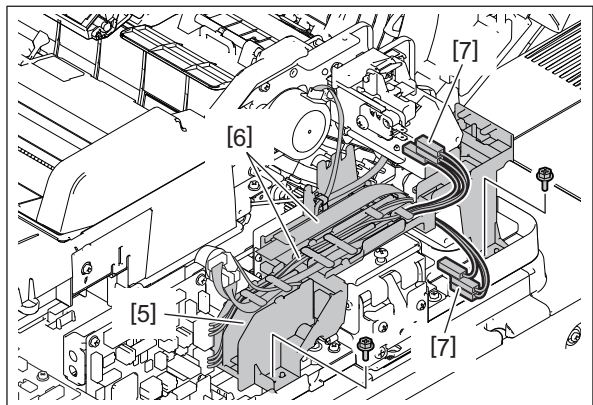

Fig. 4-899

Notes:

Release the harness from the clamp of the harness guide [5].

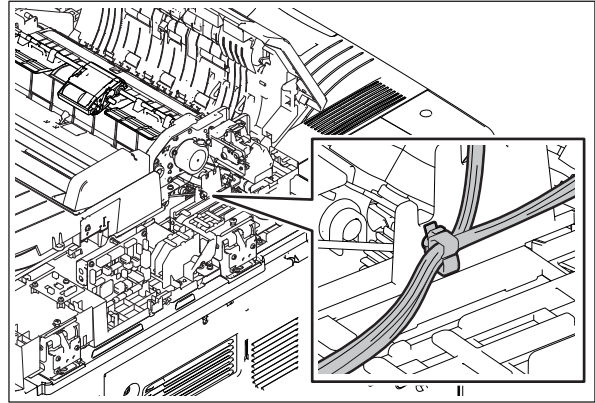

Fig. 4-900

- (5) Disconnect 1 connector [9] from the DSDF registration motor.
Remove 2 screws and take off the DSDF registration motor bracket [10].

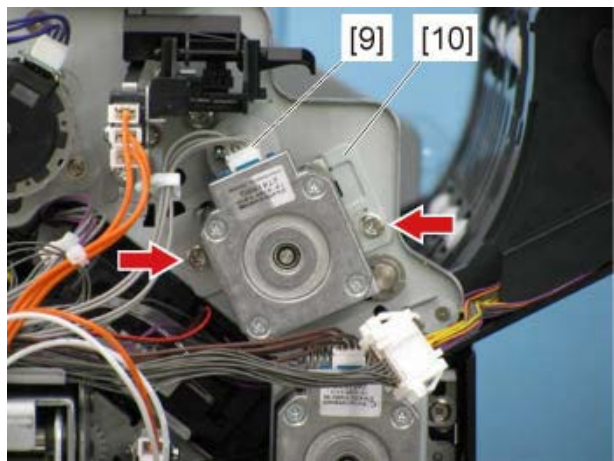

Fig. 4-901

Notes:

- When installing the DSDF registration motor bracket, be sure to hook the pulley to the timing belt.
- The harness color of the DSDF registration motor is gray. Be sure to check the harness color at installing.

- (6) Remove 2 screws and take off the DSDF registration motor [11] from the DSDF registration motor bracket [10].

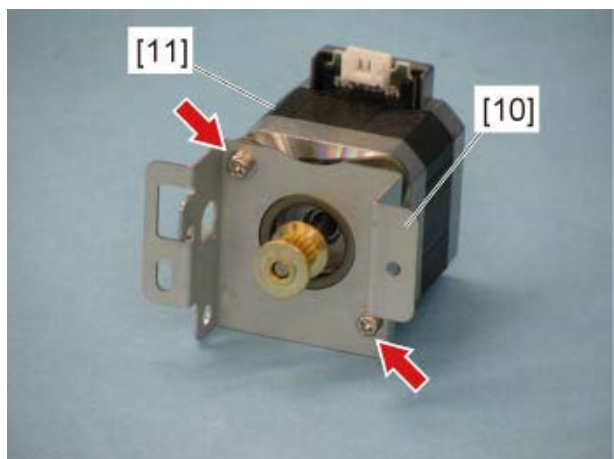

Fig. 4-902

4.11.26 DSDF read motor (MD4)

- (1) Take off the DSDF rear cover.
P. 4-337 “4.11.7 DSDF rear cover”
- (2) Take off the DSDF cooling fan motor (FD1).
P. 4-354 “4.11.22 DSDF cooling fan motor (FD1)”
- (3) Disconnect 1 HDMI cable. Release the lock and disconnect 1 flat cable.

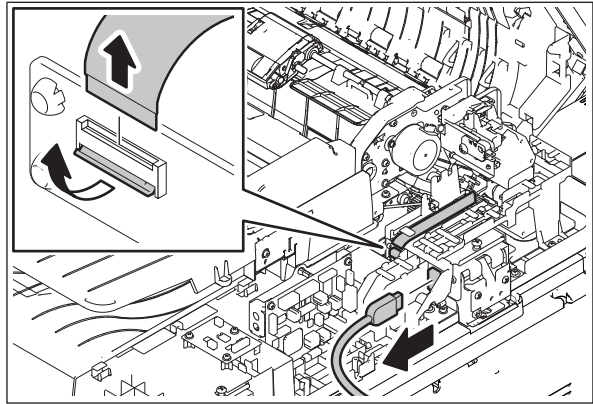

Fig. 4-903

Notes:

- When connecting the flat cable to the connector, do not push it in strongly.
 - When installing the flat cable, be careful not to insert it at an angle.
 - Do not apply pressure to or damage the edge of the flat cable.
 - When installing a flat cable, make sure that the conductor side will be the upper side.
- (4) Release the harness [6] from the harness guide [5].
Disconnect the connectors [7] for the DSDF upper cover interlock switch and the DSDF lower cover interlock switch.
Remove 2 screws and take off the harness guide [5].

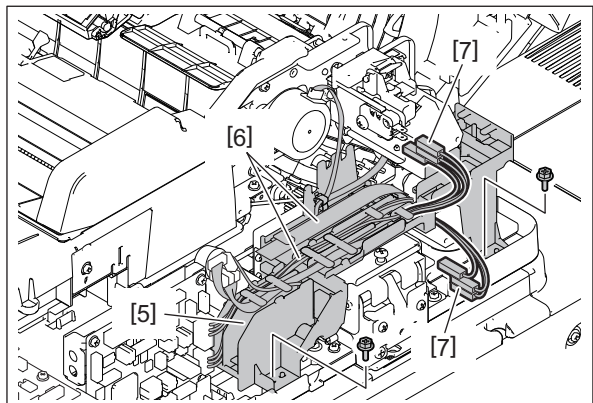

Fig. 4-904

Notes:

Release the harness from the clamp of the harness guide [5].

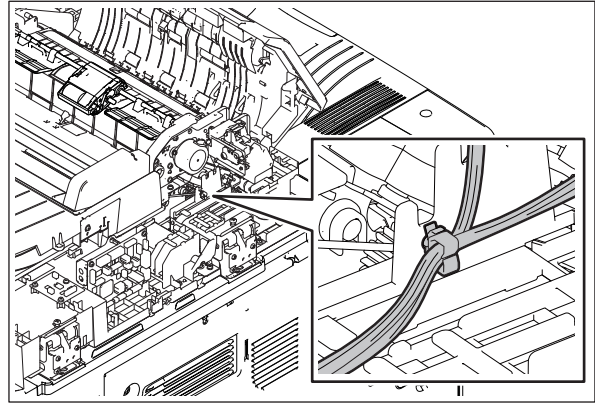

Fig. 4-905

- (5) Disconnect 1 connector [12] from the DSDF read motor.
- (6) Remove the tension spring [13].
Remove 2 screws and take off the DSDF read motor bracket [14].

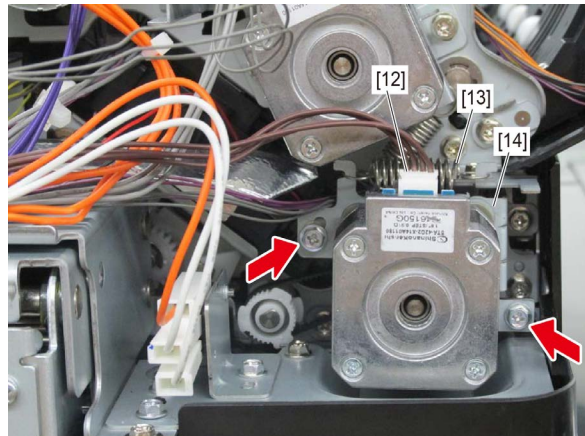

Fig. 4-906

Notes:

- When installing the DSDF read motor bracket, be sure to hook the pulley to the timing belt.
- When installing, temporarily tighten 2 screws, hook the tension spring and then securely tighten them.

- (7) Remove 2 screws and take off the DSDF read motor [25] from the DSDF read motor bracket [24].

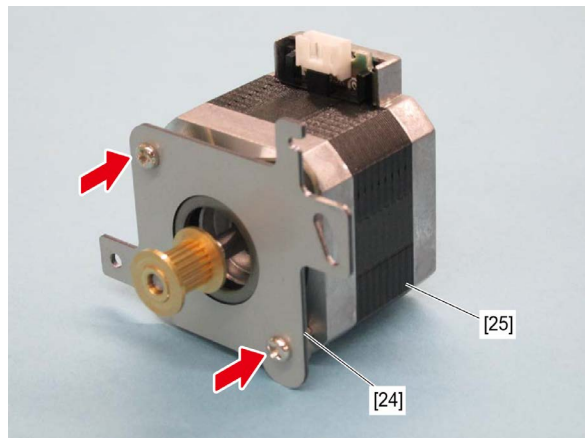

Fig. 4-907

4.11.27 Paper original exit motor (MD5)

- (1) Take off the DSDF rear cover.
P. 4-337 "4.11.7 DSDF rear cover"
- (2) Take off the DSDF cooling fan motor (FD1).
P. 4-354 "4.11.22 DSDF cooling fan motor (FD1)"
- (3) Disconnect 1 HDMI cable. Release the lock and disconnect 1 flat cable.

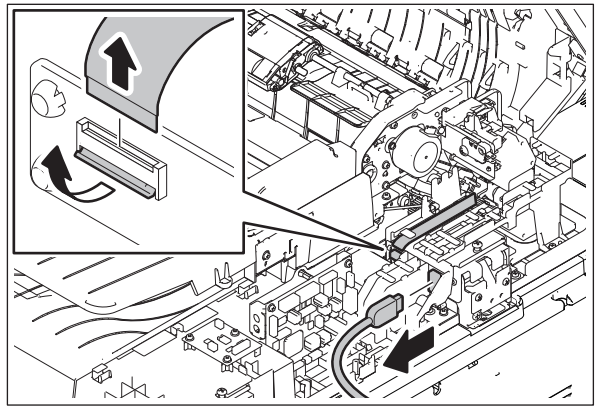

Fig. 4-908

Notes:

- When connecting the flat cable to the connector, do not push it in strongly.
 - When installing the flat cable, be careful not to insert it at an angle.
 - Do not apply pressure to or damage the edge of the flat cable.
 - When installing a flat cable, make sure that the conductor side will be the upper side.
- (4) Release the harness [6] from the harness guide [5].
Disconnect the connectors [7] for the DSDF upper cover interlock switch and the DSDF lower cover interlock switch.
Remove 2 screws and take off the harness guide [5].

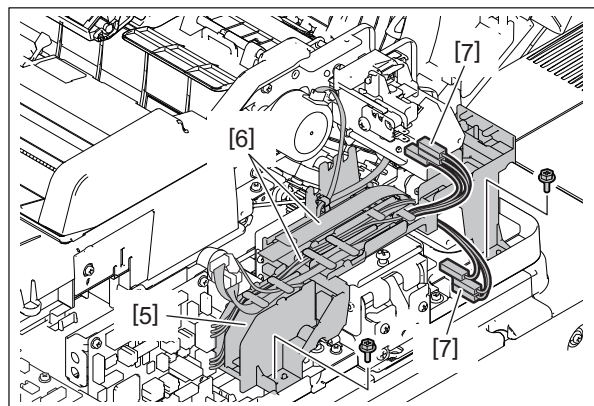

Fig. 4-909

Notes:

Release the harness from the clamp of the harness guide [5].

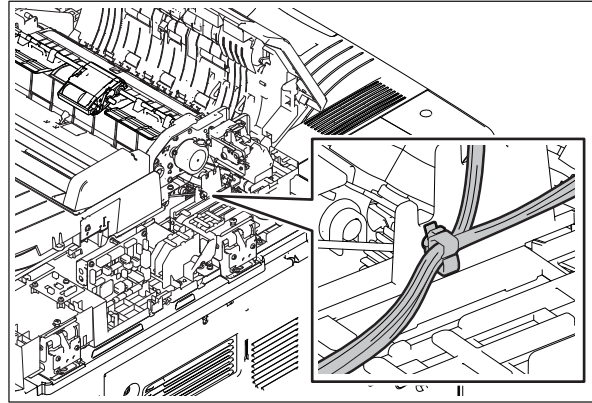

Fig. 4-910

- (5) Disconnect 1 connector [15] from the DSDF paper exit motor.
- (6) Remove the tension spring [16].
- (7) Remove 2 screws and take off the DSDF original exit motor bracket [17].

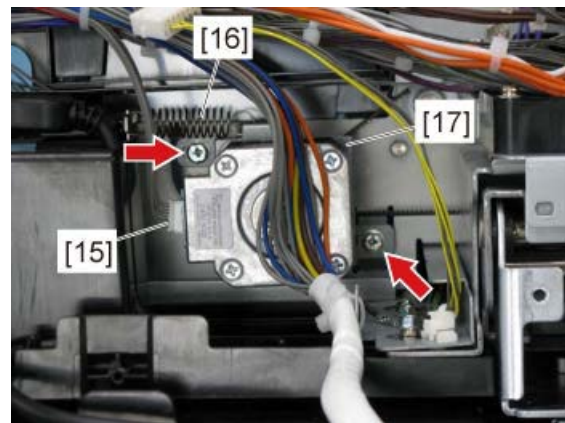

Fig. 4-911

Notes:

- When installing the DSDF original exit motor bracket, be sure to hook the pulley to the timing belt.
- When installing, temporarily tighten 2 screws, hook the tension spring and then securely tighten them.

- (8) Remove 2 screws and take off the DSDF original exit motor [18] from the DSDF original exit motor bracket [17].

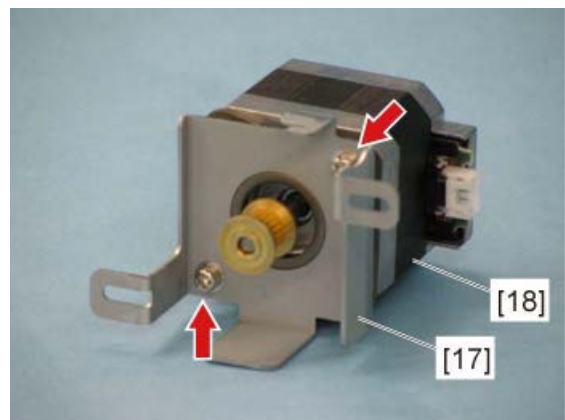

Fig. 4-912

4.11.28 DSDF lower cover interlock switch (SWD1)

Notes:

If the interlock switch is not installed appropriately when it is replaced or installed, it may not work normally. If you carry out the maintenance of the MFP in such a situation, you could get an electric shock by touching live sections or be injured by touching moving sections. Therefore, to avoid this, be sure to perform correct handling and installation.

- (1) Take off the DSDF read motor.
📖 P. 4-360 “4.11.26 DSDF read motor (MD4)”
- (2) Disconnect 3 connectors. Remove 1 screw and take off the DSDF lower cover interlock switch [19].

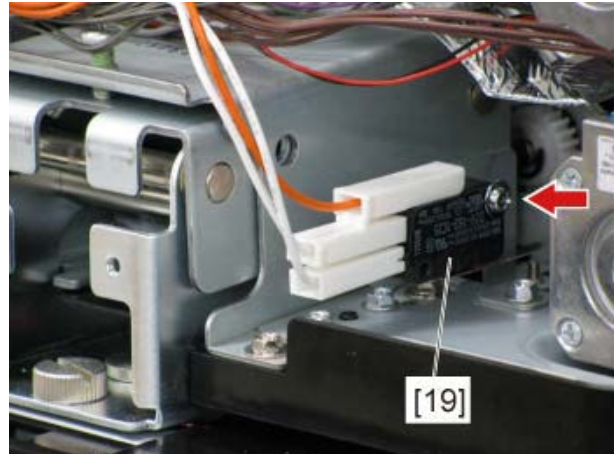

Fig. 4-913

Notes:

Color of 3 harnesses for the DSDF lower cover interlock switch: Orange (1) and white (2)

4.11.29 DSDF original feed motor (MD1)

- (1) Take off the DSDF rear cover.
P. 4-337 “4.11.7 DSDF rear cover”
- (2) Disconnect 1 connector [20]. Remove 2 screws. Take off the DSDF original feed motor [21] by sliding it to the upper left.

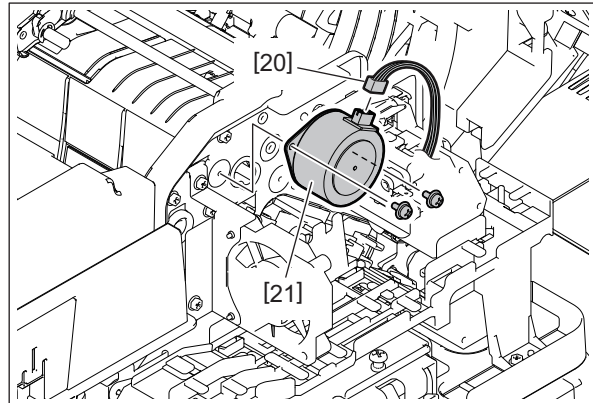

Fig. 4-914

Notes:

The harness color of the DSDF original feed motor is purple. Be sure to check the harness color at installing.

4.11.30 DSDF separation motor (MD2)

- (1) Take off the DSDF-LED board.
P. 4-341 “4.11.11 DSDF-LED PC board (LEDD)”
- (2) Disconnect 1 connector [22]. Remove 2 screws. Turn the DSDF separation motor [23] clockwise and slide it to the upper right to take it off.

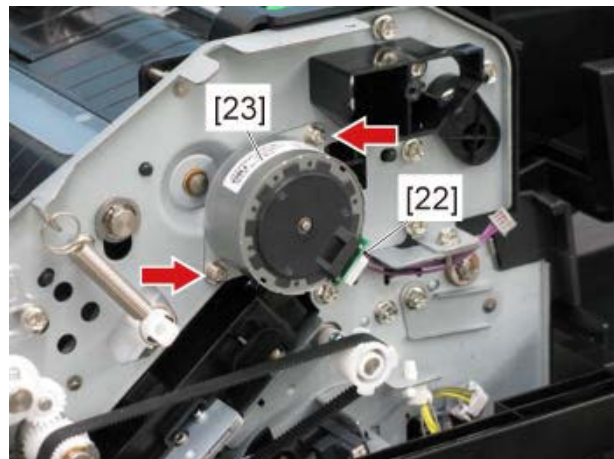

Fig. 4-915

4.11.31 Intermediate transport unit

- (1) Take off the original jam access cover.
📖 P. 4-339 “4.11.9 Original jam access cover”
- (2) Take off the original tray.
📖 P. 4-344 “4.11.15 Original tray”
- (3) Take off the DSDF cooling fan motor.
📖 P. 4-354 “4.11.22 DSDF cooling fan motor (FD1)”
- (4) Disconnect 5 connectors.

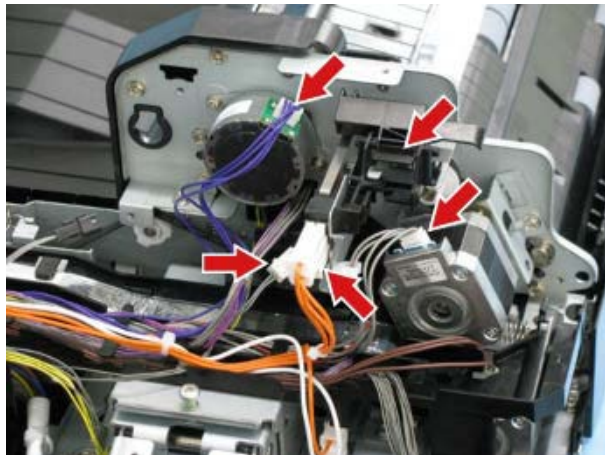

Fig. 4-916

- (5) Disconnect 3 connectors.

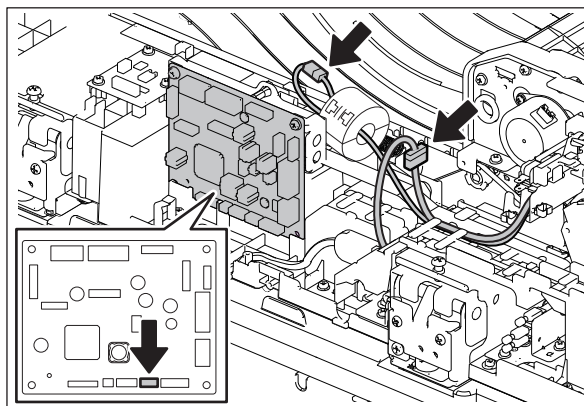

Fig. 4-917

- (6) Remove 1 screw and take off the pulley bracket [14] by sliding it toward the front side.
- (7) Remove 1 screw.

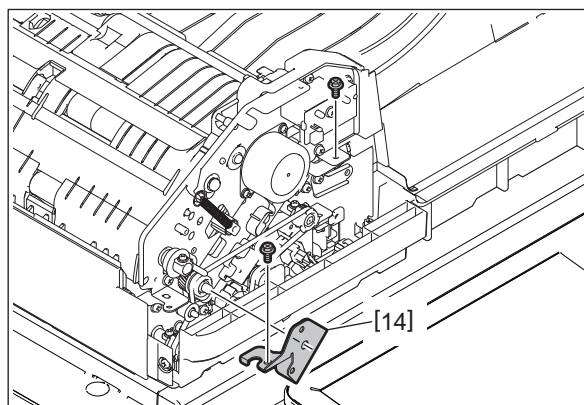

Fig. 4-918

(8) Remove 2 screws.

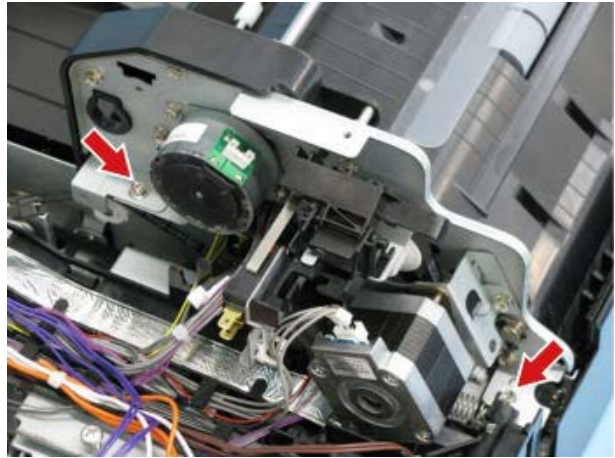

Fig. 4-919

(9) Take off the intermediate transport unit [1].

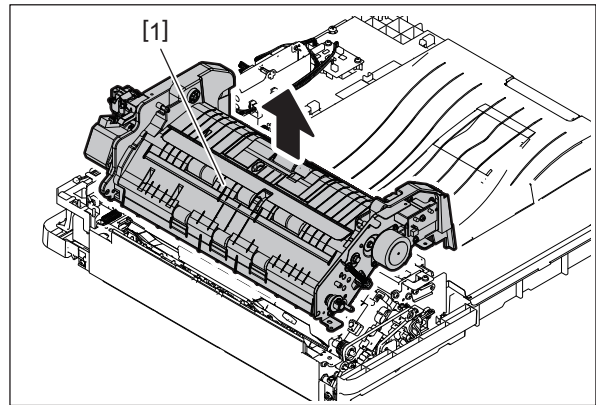



Fig. 4-920

4.11.32 DSDF read-in sensor-1 (SD11), DSDF read-in sensor-2 (SD12)

- (1) Take off the DSDF-CCD module.
 P. 4-376 “4.11.39 DSDF-CCD module (CCDD)”
- (2) Disconnect 2 connectors and remove 1 screw. Take off the sensor bracket [2].

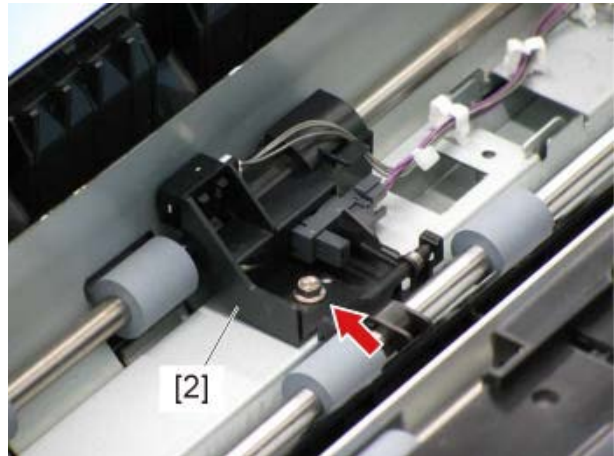

Fig. 4-921

- (3) Release the latch and take off the DSDF read-in sensor-1 [3] from the sensor bracket.
- (4) Release the latch and take off the DSDF read-in sensor-2 [4] from the sensor bracket.

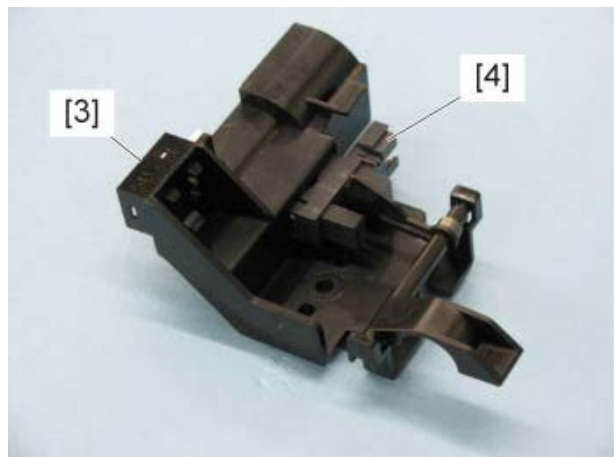



Fig. 4-922

Notes:

When the DSDF read-in sensor-1 is replaced, be sure to perform this adjustment.

 P. 6-100 “6.13.7 DSDF read-in sensor-1 adjustment”

4.11.33 DSDF original exit sensor (SD13), DSDF tray lift lower limit sensor (SD10)

- (1) Take off the intermediate transport unit.
📖 P. 4-366 "4.11.31 Intermediate transport unit"
- (2) Disconnect 1 connector [10].

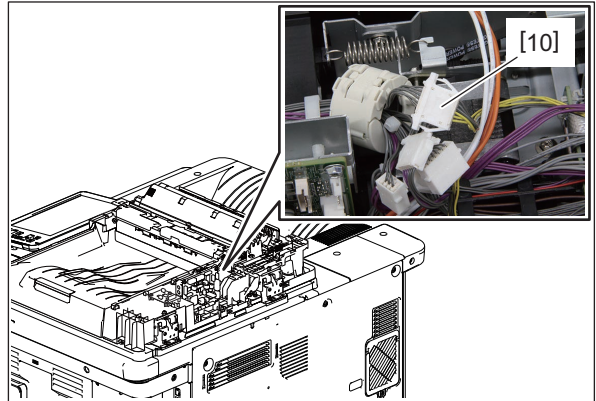

Fig. 4-923

- (3) Remove 1 screw. Remove the pin [6] at the front of the sensor stay [5] and release the latch [7] at the center. Take off the sensor stay.

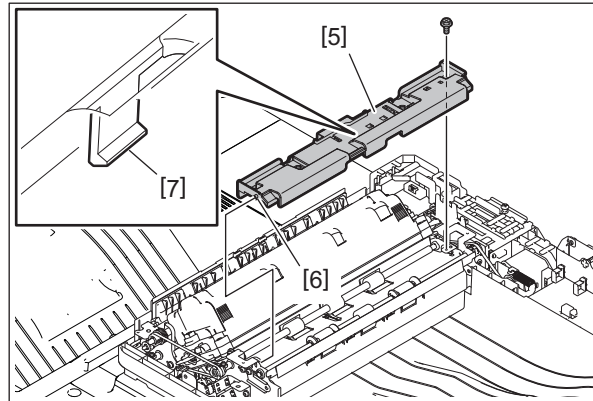

Fig. 4-924

- (4) Disconnect 1 connector. Release the latch and take off the DSDF original exit sensor [8].

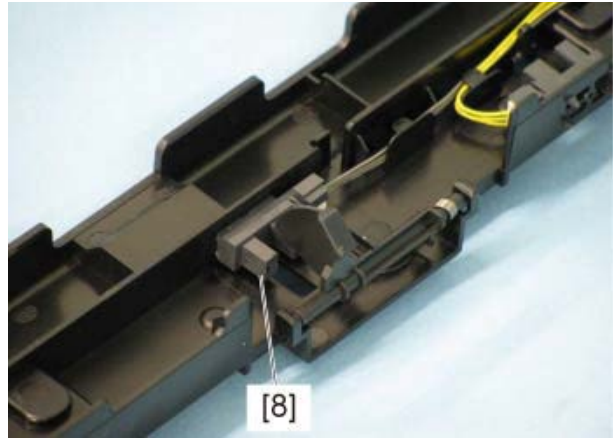

Fig. 4-925

- (5) Disconnect 1 connector. Release the latch and take off the DSDF tray lift lower limit sensor [9].

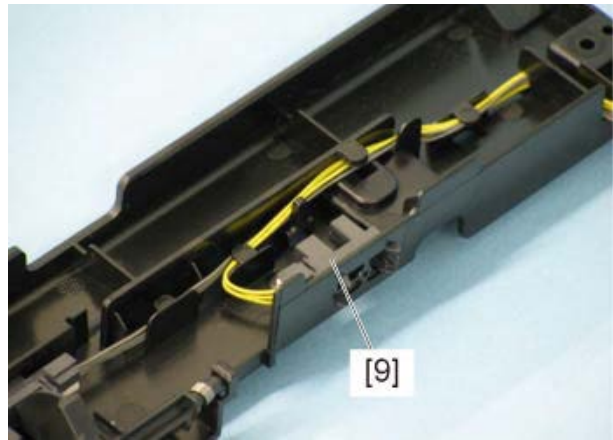

Fig. 4-926

4.11.34 Lower transport unit

- (1) Take off the DSDF-CCD module.
📖 P. 4-376 "4.11.39 DSDF-CCD module (CCDD)"
- (2) Take off the DSDF left cover.
📖 P. 4-340 "4.11.10 DSDF left cover"
- (3) Remove 8 screws and take off the lower transport unit [10].

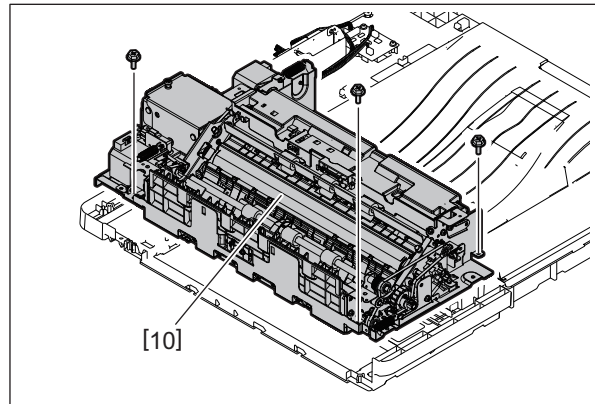

Fig. 4-927

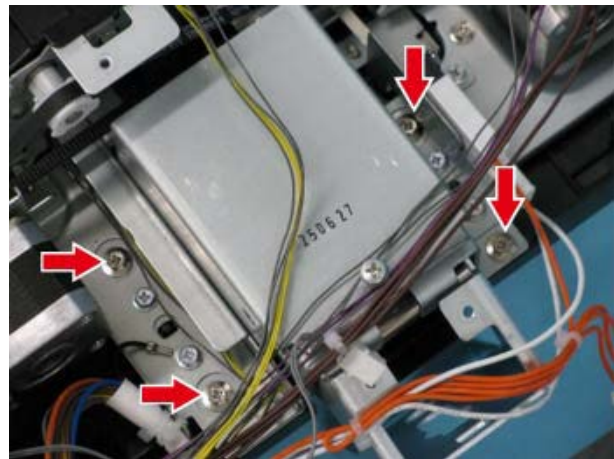

Fig. 4-928

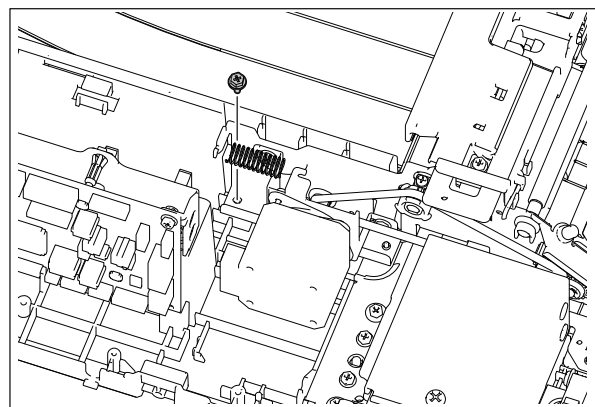

Fig. 4-929

Lower transport unit

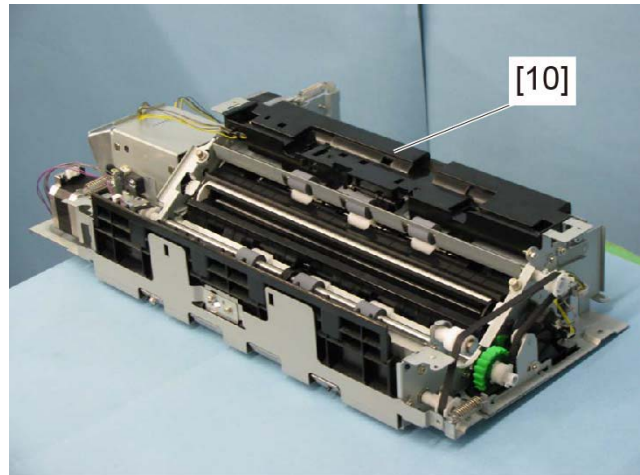

Fig. 4-930

4.11.35 DSDF shading sheet HP sensor (SD14)

- (1) Take off the lower transport unit.
📖 P. 4-371 "4.11.34 Lower transport unit"
- (2) Turn the roller [1].

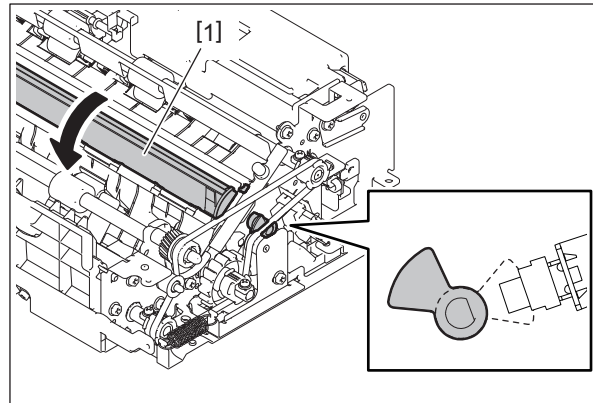

Fig. 4-931

- (3) Disconnect the connector [2] and take off the DSDF shading sheet HP sensor [3].

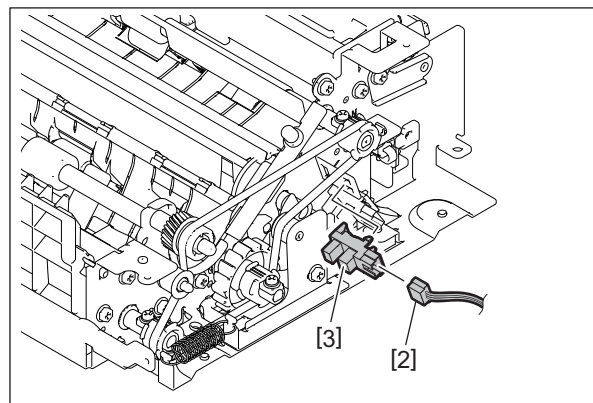

Fig. 4-932

4.11.36 DSDF lower cover opening/closing detection sensor (SD15)

- (1) Take off the lower transport unit.
P. 4-371 "4.11.34 Lower transport unit"
- (2) Remove 2 screws [1] and take off the DSDF original exit cover [2].

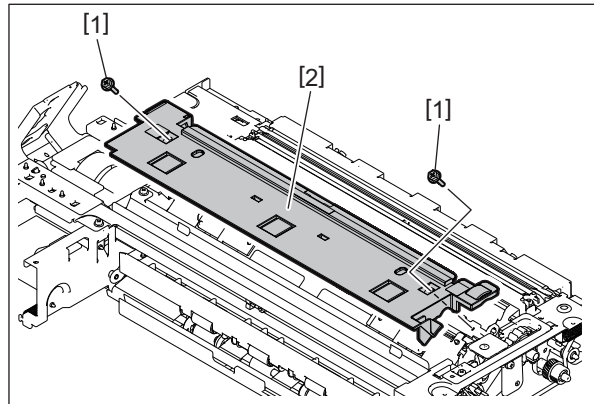

Fig. 4-933

- (3) Disconnect the connector [3] and take off the DSDF lower cover opening/closing detection sensor [4].

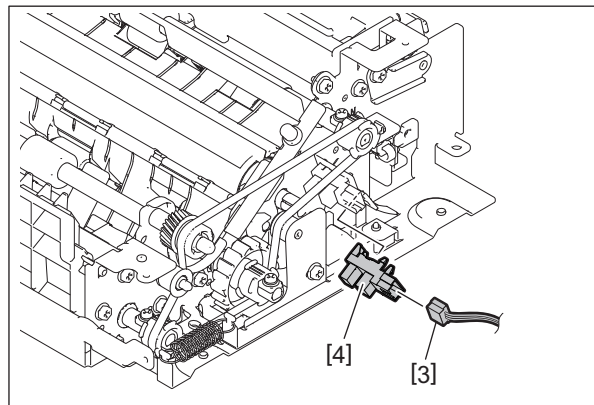



Fig. 4-934

4.11.37 Multiple feeding detection sensor (reception side) (SD18)

- (1) Remove the lever.
 P. 4-349 “4.11.19 DSDF original feed sensor (SD5), DSDF tray lift upper limit sensor (SD9)”
- (2) Disconnect 1 connector [1].
- (3) Remove 2 screws [2] and take off the multiple feeding detection sensor unit [3].

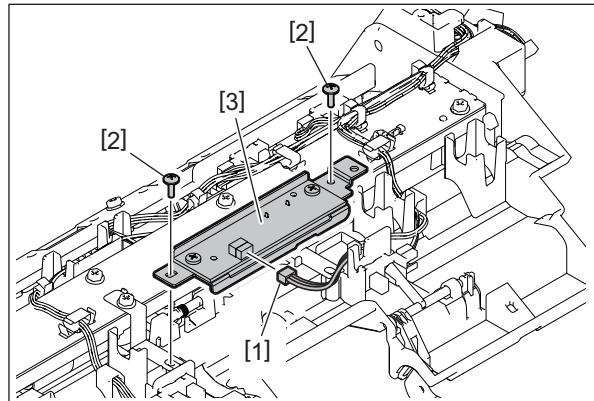

Fig. 4-935

- (4) Remove 2 screws [4] and take off the multiple feeding detection sensor (reception side) [5].

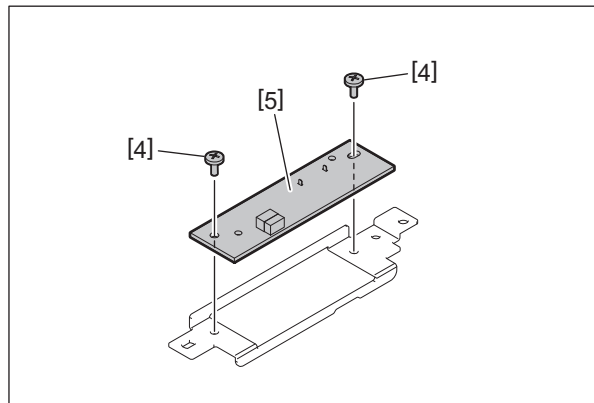

Fig. 4-936

4.11.38 Multiple feeding detection sensor (transmission side) (SD17)

- (1) Take off the original jam access cover.
📖 P. 4-339 “4.11.9 Original jam access cover”
- (2) Remove the DSDF pickup unit.
📖 P. 4-330 “4.11.3 DSDF pickup unit”
- (3) Take off the intermediate transport unit.
📖 P. 4-366 “4.11.31 Intermediate transport unit”
- (4) Remove 2 screws [1] and take off the multiple feeding detection sensor unit [2]. Disconnect the connector [3].

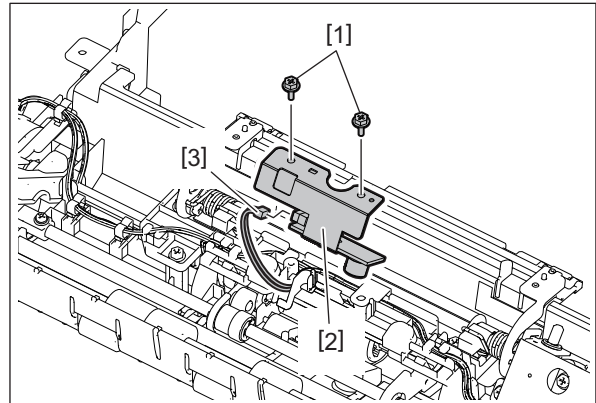

Fig. 4-937

- (5) Remove 1 screw [4] and take off the multiple feeding detection sensor (transmission side) [5].

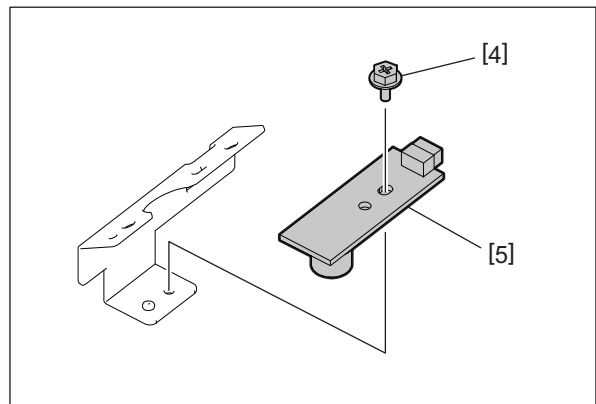

Fig. 4-938

4.11.39 DSDF-CCD module (CCDD)

Notes:

- Be sure to attach the stopper jig or to take off the DSDF from the MFP before starting the procedure. If the unit is taken off from the DSDF while it is installed in the MFP, the DSDF will be pulled up as its weight becomes lighter, resulting in danger.
 - A characteristic value for image process is embedded in this DSDF-CCD module. When the DSDF or DSDF-CCD module has been replaced, be sure to perform FS-05-3240 (Data acquisition of characteristic value of the scanner).
- (1) Take off the intermediate transport unit.
📖 P. 4-366 “4.11.31 Intermediate transport unit”
 - (2) Disconnect 1 connector and remove 1 flat harness.

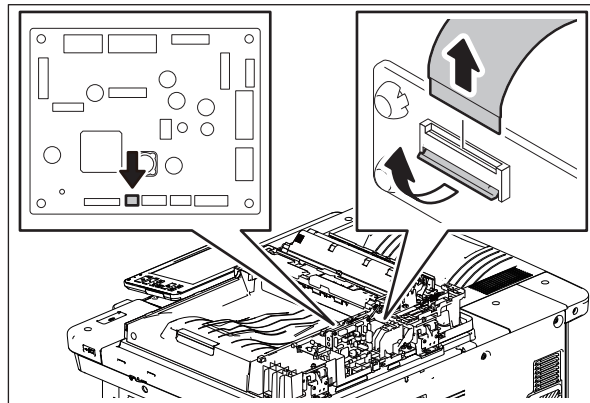

Fig. 4-939

- (3) Take off the DSDF-CCD module [1].

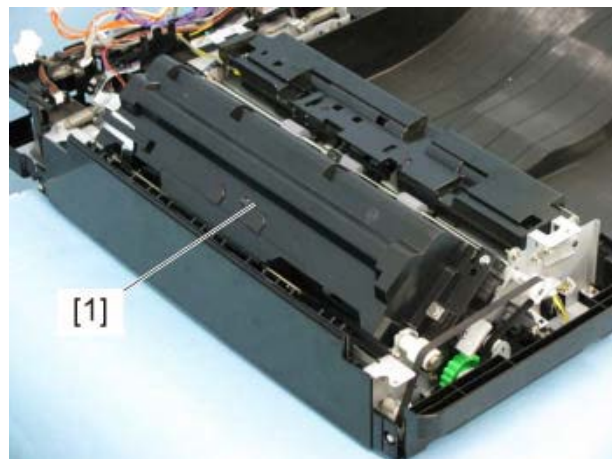

Fig. 4-940

DSDF-CCD module

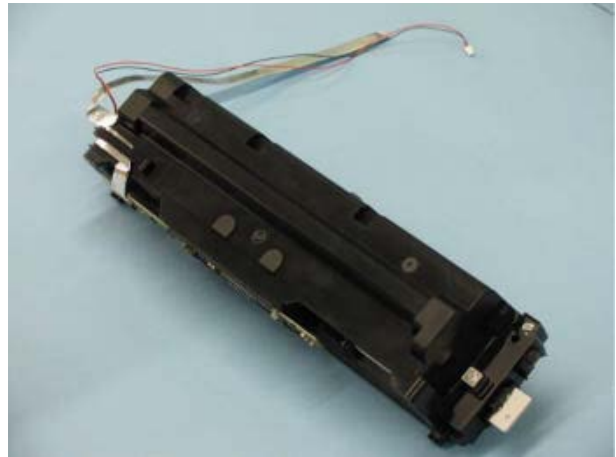

Fig. 4-941

Notes:

- Do not leave fingerprints or stains on the slit glass [2] of the DSDF-CCD module.
- Pay close attention not to cause any impact or vibration to the DSDF-CCD module because it is a precision apparatus.

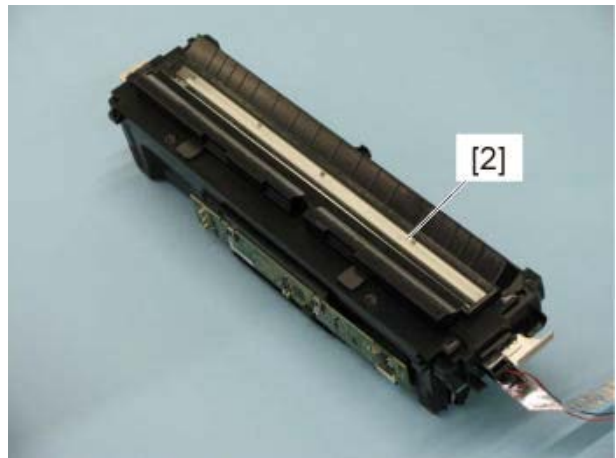

Fig. 4-942

4.11.40 Right hinge

Notes:

- Replace the right and left hinges in a set.
- Before starting the procedure, remove the platen sheet to avoid its becoming scratched or stained.
- Be sure to take off the DSDF from the MFP before starting the procedure.
- When the DSDF is taken off to reassemble it, place it on a flat table.
When the DSDF is placed on a flat table, it will be tilted due to a protrusion on the hinge. As a consequence, the parts may not be attached properly. To avoid this, do not put the hinge on the table.

- (1) Raise the DSDF [1].

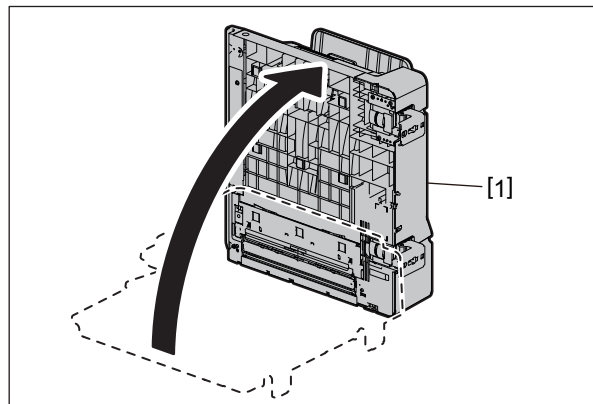

Fig. 4-943

- (2) Remove 4 screws and take off the right hinge [2].

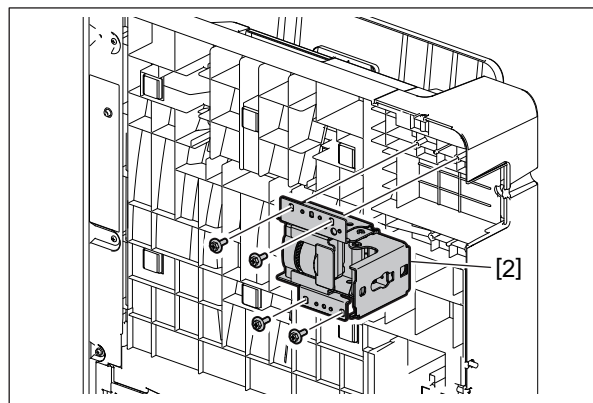

Fig. 4-944

Notes:

- Support the DSDF with your hand so that it does not fall over.

4.11.41 Left hinge

Notes:

- Replace the right and left hinges in a set.
- Before starting the procedure, remove the platen sheet to avoid its becoming scratched or stained.
- Be sure to take off the DSDF from the MFP before starting the procedure.
- When the DSDF is taken off to reassemble it, place it on a flat table.
- When the DSDF is placed on a flat table, it will be tilted due to a protrusion on the hinge. As a consequence, the parts may not be attached properly. To avoid this, do not put the hinge on the table.

- (1) Raise the DSDF.
- (2) Remove 2 screws [4] for the plastic part and another 2 screws [3] for the metal part.

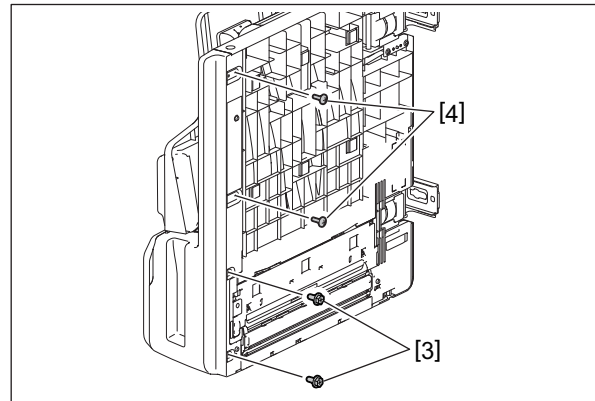

Fig. 4-945

Notes:

Support the DSDF with your hand so that it does not fall over.

- (3) Place the DSDF horizontally.
- (4) Remove 1 screw and take off the DSDF front cover [5].

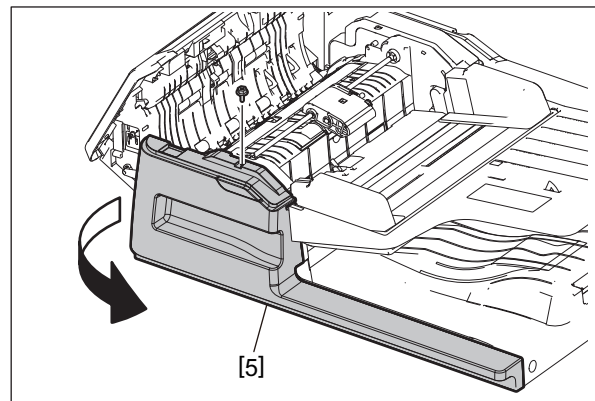

Fig. 4-946

- (5) Take off the DSDF rear cover.
📖 P. 4-337 "4.11.7 DSDF rear cover"
- (6) Take off the DSDF cooling fan motor bracket.
📖 P. 4-354 "4.11.22 DSDF cooling fan motor (FD1)"
- (7) Take off the original jam access cover.
📖 P. 4-339 "4.11.9 Original jam access cover"
- (8) Take off the original tray.
📖 P. 4-344 "4.11.15 Original tray"

- (9) Take off the intermediate transport unit.
📖 P. 4-366 “4.11.31 Intermediate transport unit”
- (10) Take off the DSDF-CCD module.
📖 P. 4-376 “4.11.39 DSDF-CCD module (CCDD)”
- (11) Take off the DSDF left cover.
📖 P. 4-340 “4.11.10 DSDF left cover”
- (12) Disconnect 2 connectors.

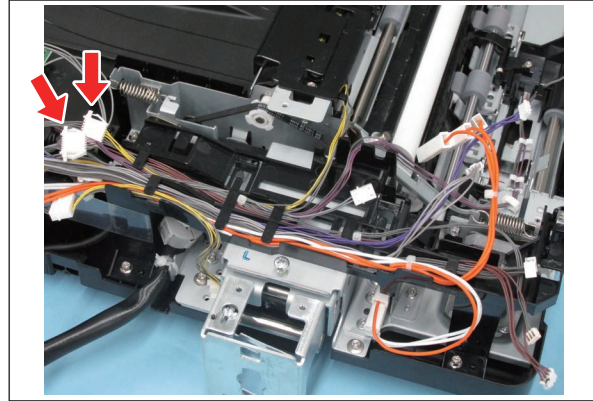

Fig. 4-947

- (13) Remove 1 screw and take off the DSDF lower cover interlock switch [6] with the bracket.

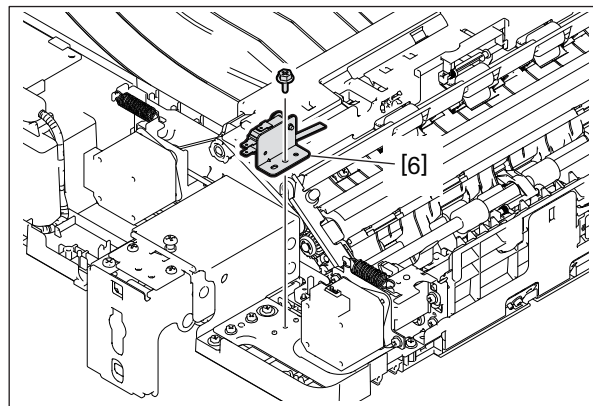

Fig. 4-948

- (14) Remove 1 screw.

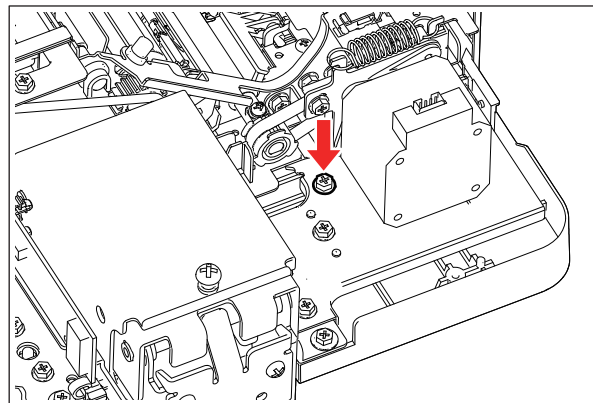

Fig. 4-949

- (15) Remove the harness guide.
📖 P. 4-342 “4.11.13 DSDF relay PC board (DFRLY)”
- (16) Take off the lower transport unit.
📖 P. 4-371 “4.11.34 Lower transport unit”

(17) Remove 5 screws and take off the left hinge [7].

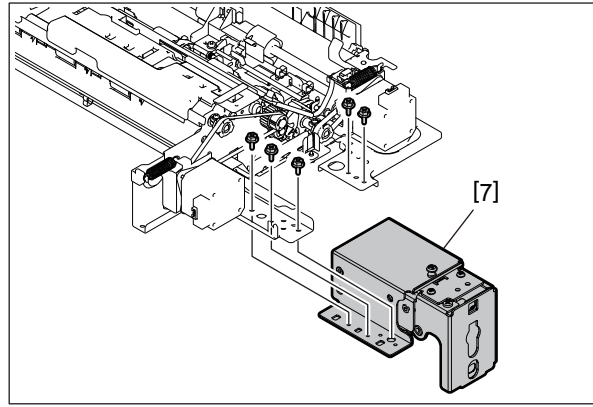

Fig. 4-950

Installation procedure of the left hinge

1. Remove 1 screw and take off the bracket [8].

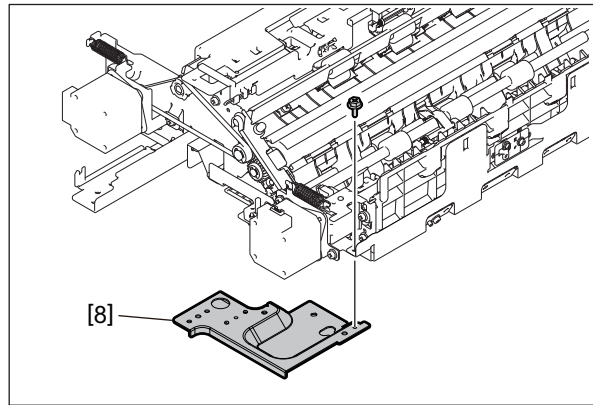

Fig. 4-951

2. Secure the left hinge [9] with 2 screws.

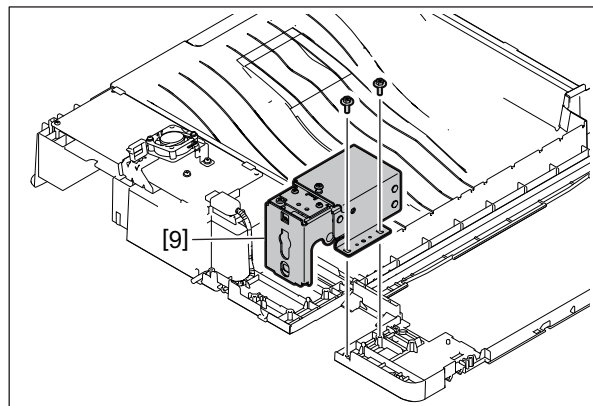

Fig. 4-952

3. Secure the bracket [8] with 4 screws.

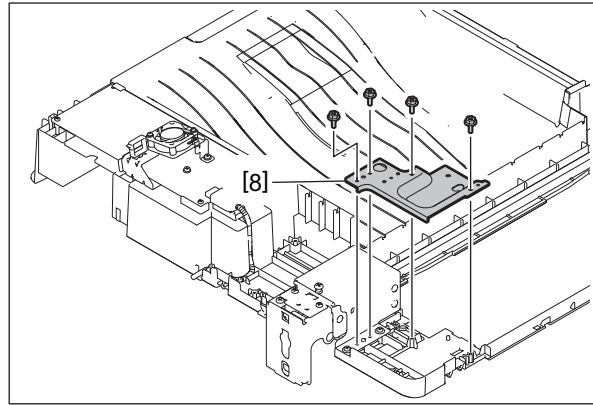

Fig. 4-953

4. Attach the lower transport unit [10] to the base and secure the left hinge with 5 screws.

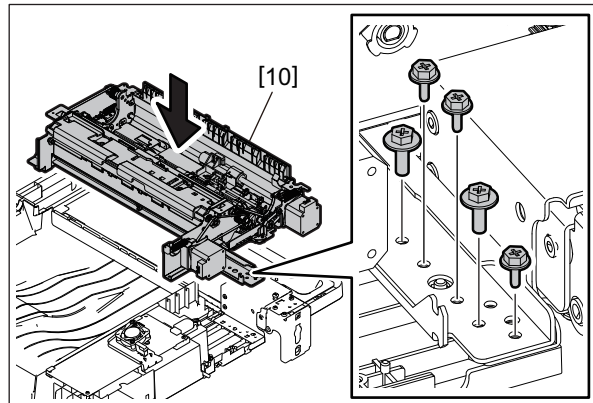

Fig. 4-954

5. Secure the lower transport unit with 4 screws.

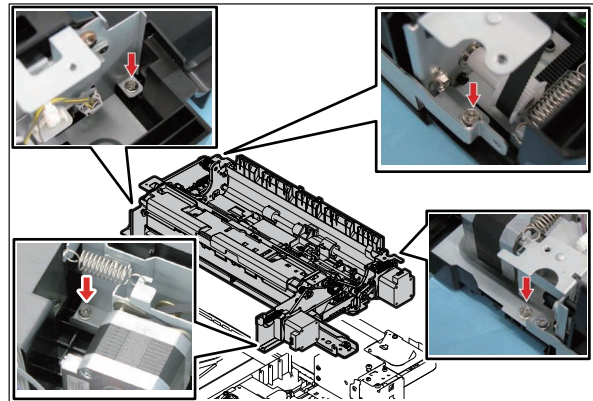

Fig. 4-955

6. After this, perform assembly in the reverse order of removal.

4.12 Film Attachment Reference

4.12.1 Registration films (F), (R)

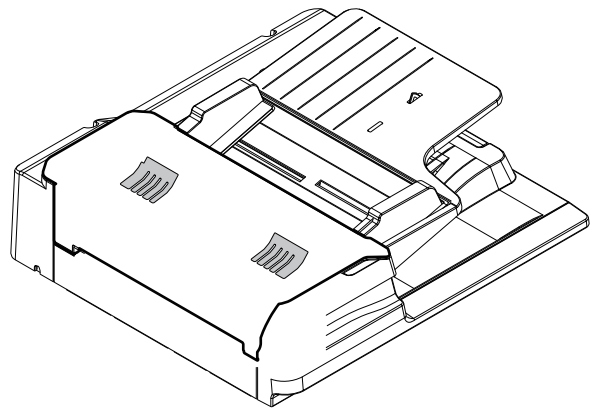

Fig. 4-956

Attach them as shown in the figure below.

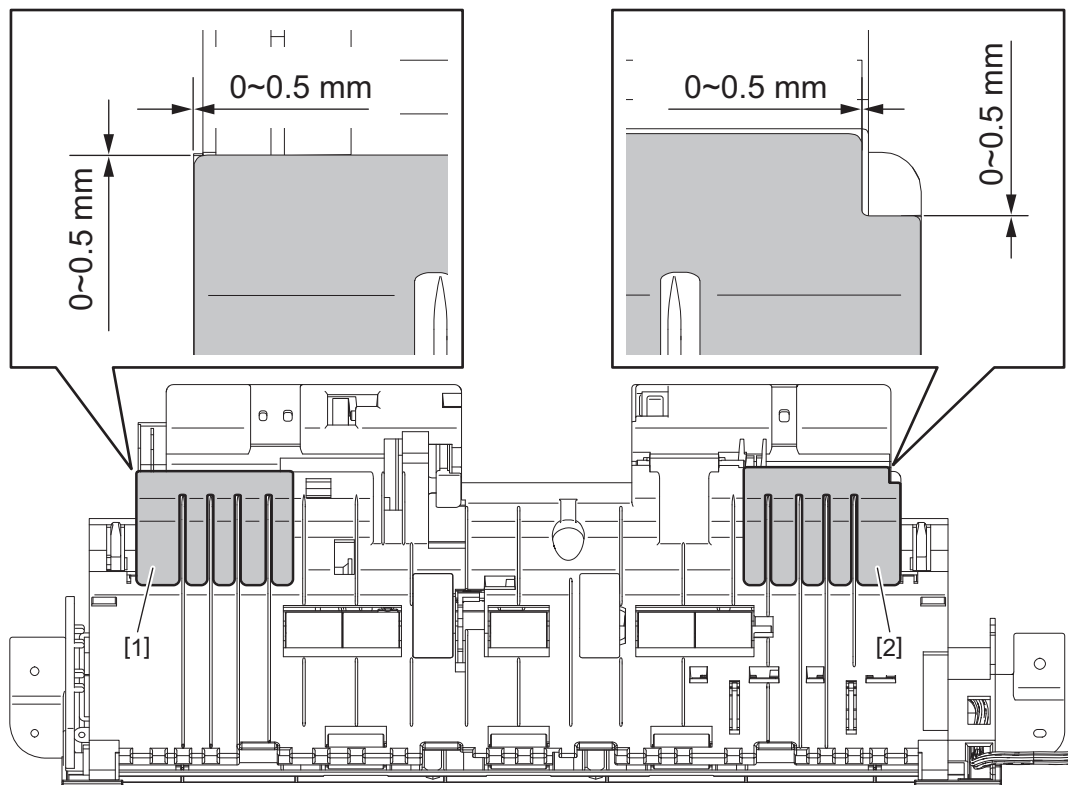

Fig. 4-957

[1] Registration film (R)

[2] Registration film (F)

4.12.2 Films with a spacer

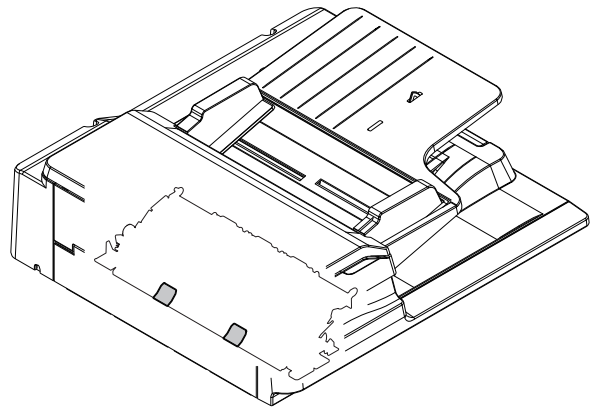

Fig. 4-958

Attach them as shown in the figure below.

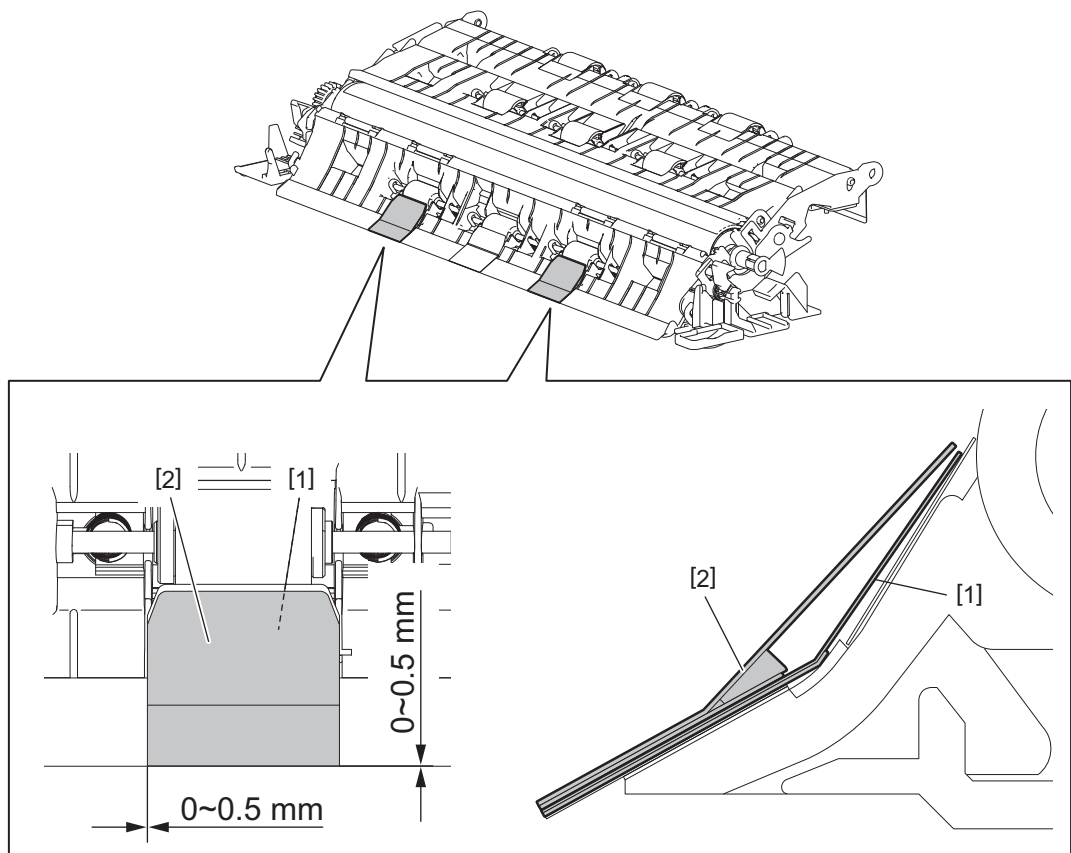

Fig. 4-959

[1] Film

[2] Films with a spacer

4.13 Removal and Installation of Options

4.13.1 External Large Capacity Feeder (2.5K) (Ex-LCF)

- (1) Press the [ON/OFF] button on the control panel to shut down the MFP.
- (2) Remove the power cable.
- (3) Press the button to separate the External Large Capacity Feeder (2.5K) (Ex-LCF) from the MFP.

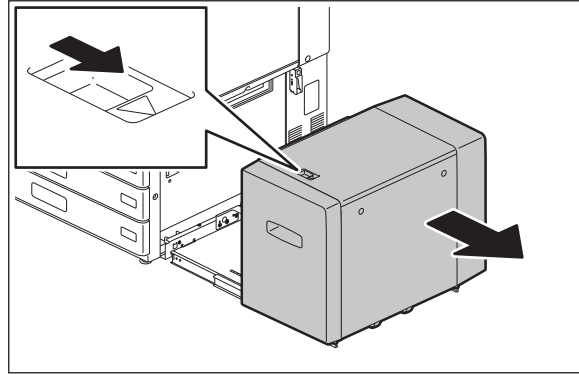

Fig. 4-960

- (4) Remove 1 screw and take off the connector cover [1].

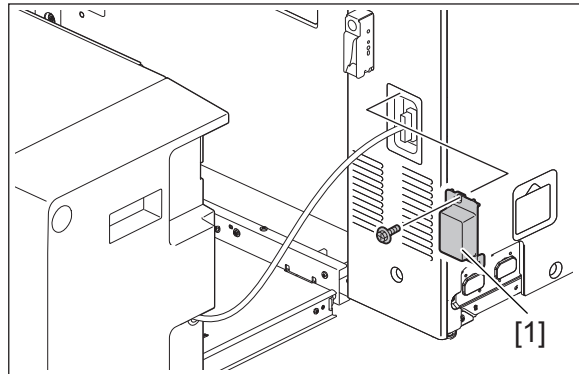

Fig. 4-961

- (5) Disconnect the communication cable [2] of the External Large Capacity Feeder (2.5K) (Ex-LCF).

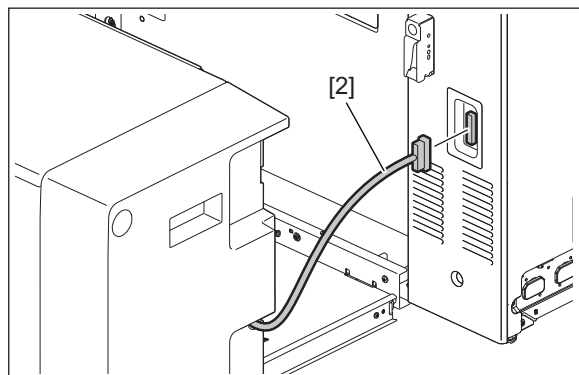

Fig. 4-962

(6) Remove 2 screws on the rear side.

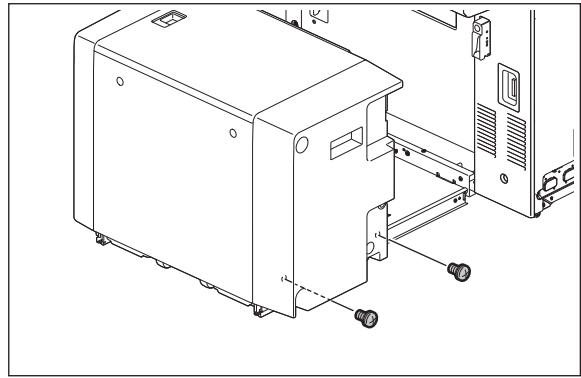

Fig. 4-963

(7) Remove 2 screws on the front side.

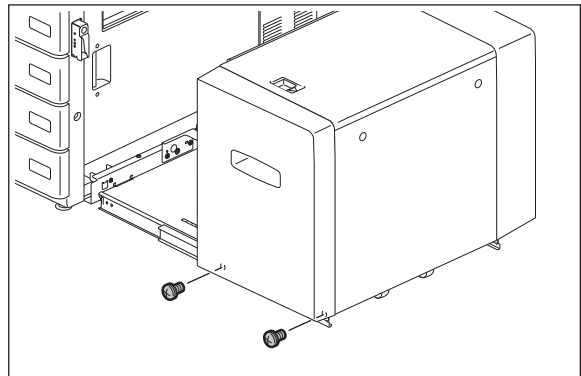

Fig. 4-964

(8) Lift up the External Large Capacity Feeder (2.5K) (Ex-LCF) and take it off from the slide rail.

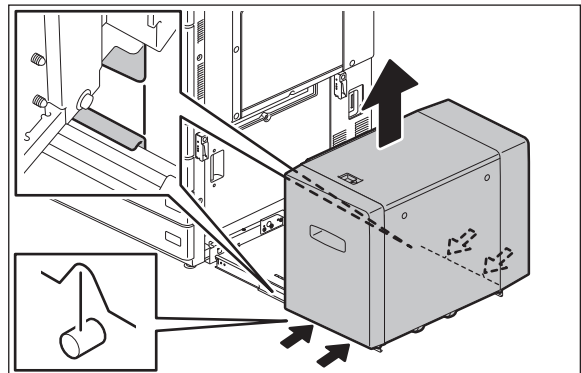

Fig. 4-965

4.13.2 LCF Connector

- (1) Press the [ON/OFF] button on the control panel to shut down the MFP.
- (2) Remove the power cable.
- (3) Press the button to separate the External Large Capacity Feeder (2.5K) (Ex-LCF) from the MFP.

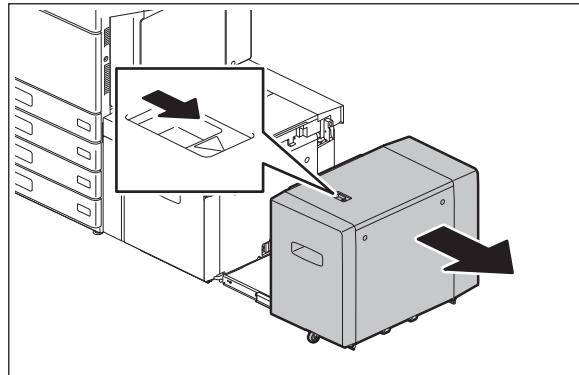

Fig. 4-966

- (4) Press the button to separate the External Large Capacity Feeder (2.0K) (Ex-LCF) with the LCF Connector attached from the MFP.

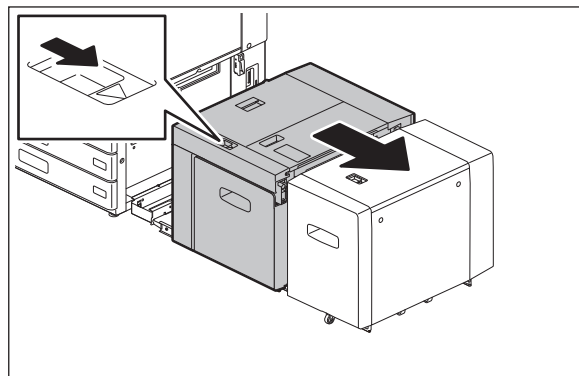

Fig. 4-967

- (5) Remove 1 screw and take off the connector cover [1].

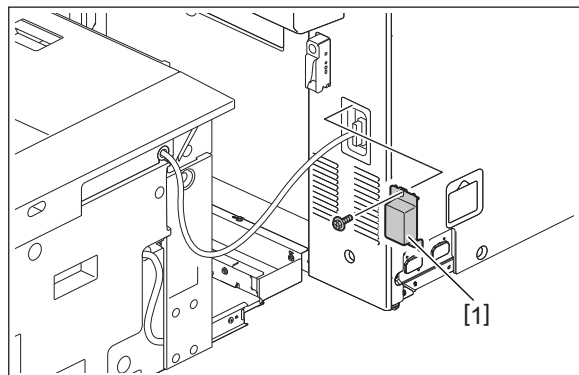

Fig. 4-968

- (6) Disconnect the communication cable [2] of the LCF Connector.

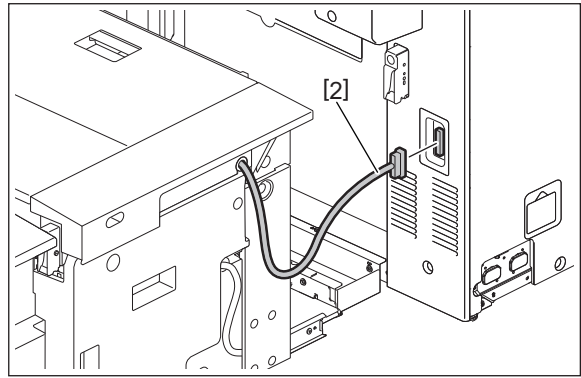

Fig. 4-969

- (7) Remove 3 screws and take off the cover [3] of the LCF Connector.

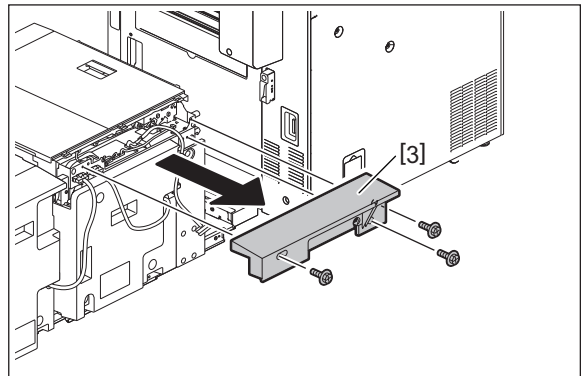

Fig. 4-970

- (8) Disconnect the communication cable [4] of the External Large Capacity Feeder (2.0K) (Ex-LCF) from the LCF Connector.

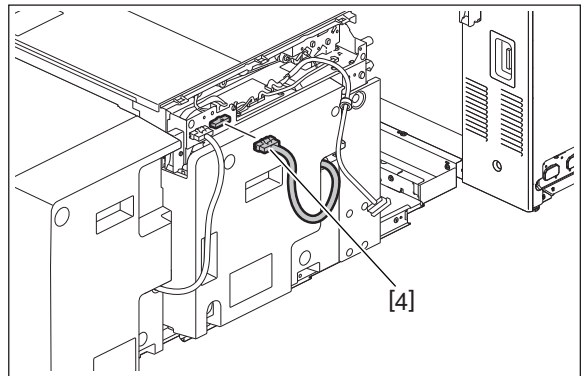

Fig. 4-971

- (9) Disconnect the communication cable [5] of the External Large Capacity Feeder (2.5K) (Ex-LCF) from the LCF Connector.

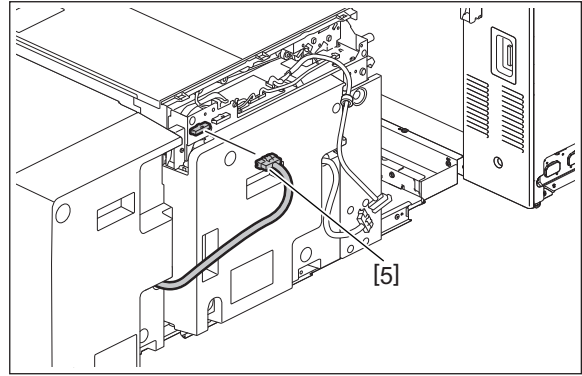

Fig. 4-972

- (10) Attach the cover [3] of the LCF Connector with 3 screws.

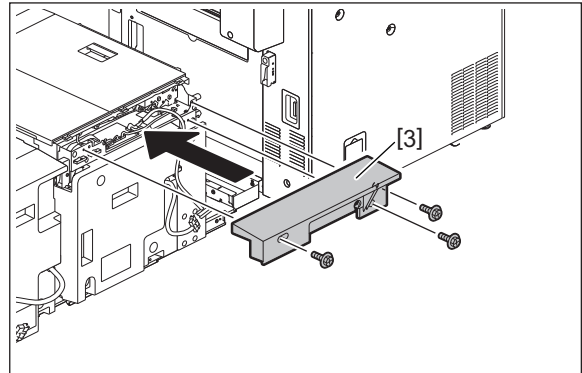

Fig. 4-973

- (11) Remove 2 screws and take off the cover [6].

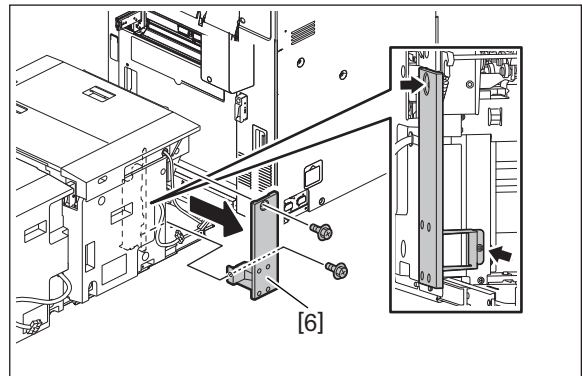

Fig. 4-974

- (12) Pull out the tray unit of the External Large Capacity Feeder (2.0K) (Ex-LCF).
- (13) Remove 2 screws and take off the cover [7].

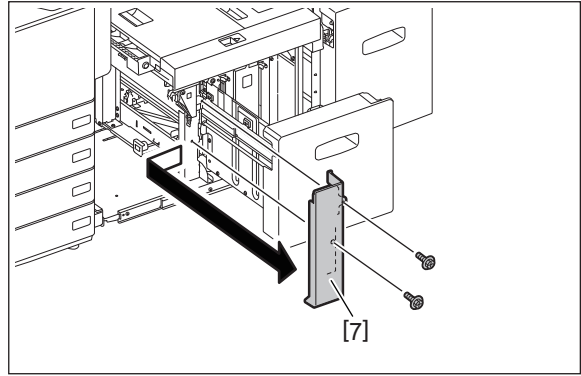

Fig. 4-975

- (14) Take off the LCF Connector.

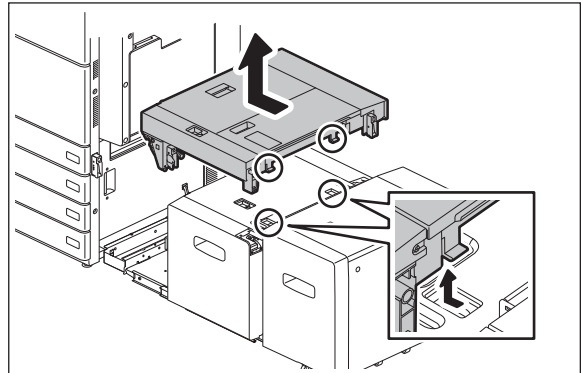

Fig. 4-976

4.13.3 When 2 External Large Capacity Feeder (2.5K) (Ex-LCF) units are installed

- (1) Take off the LCF Connector.
📖 P. 4-387 "4.13.2 LCF Connector"
- (2) Remove 2 screws on the rear side.

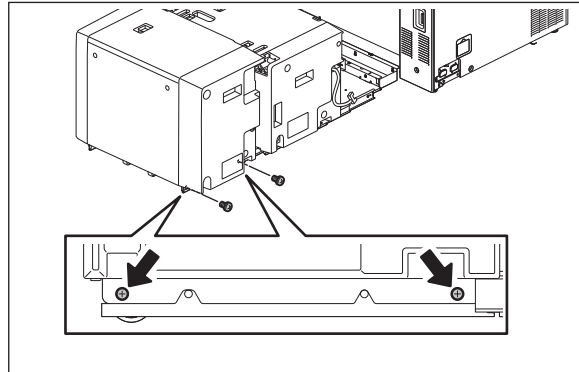

Fig. 4-977

- (3) Remove 2 screws on the front side.

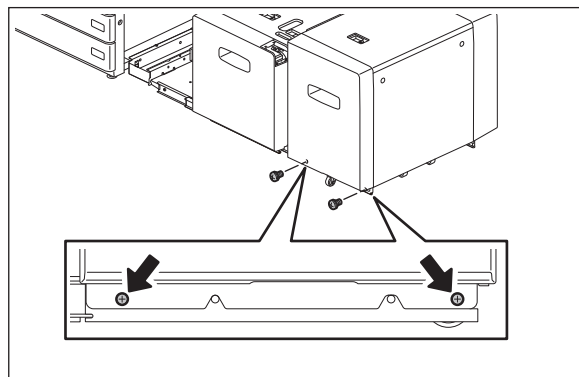

Fig. 4-978

- (4) Lift up the External Large Capacity Feeder (2.5K) (Ex-LCF) and take it off from the slide rail.

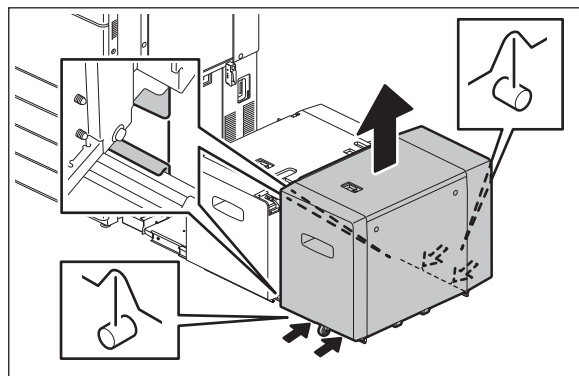



Fig. 4-979

4.13.4 External Large Capacity Feeder (2.0K) (Ex-LCF)

- (1) Take off the LCF Connector.
 P. 4-387 "4.13.2 LCF Connector"
- (2) Remove 2 screws on the rear side.

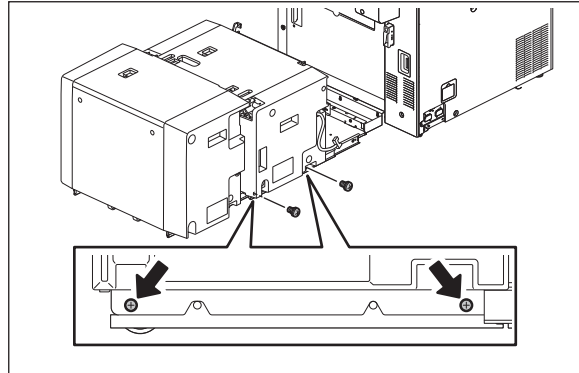

Fig. 4-980

- (3) Remove 2 screws on the front side.

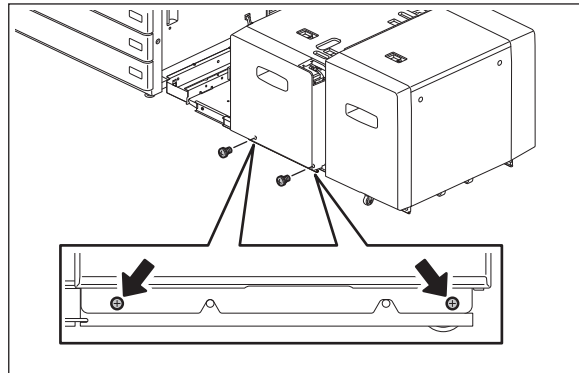

Fig. 4-981

- (4) Lift up the External Large Capacity Feeder (2.0K) (Ex-LCF) and take it off from the slide rail.

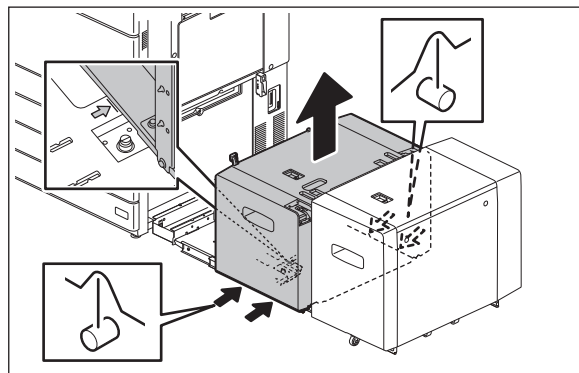

Fig. 4-982

4.13.5 Finisher, Saddle Stitch Finisher

- (1) Press the [ON/OFF] button on the control panel to shut down the MFP.
- (2) Remove the power cable.
- (3) Take off the connector cover and disconnect the communication cable [1] of the Finisher or the Saddle Stitch Finisher.

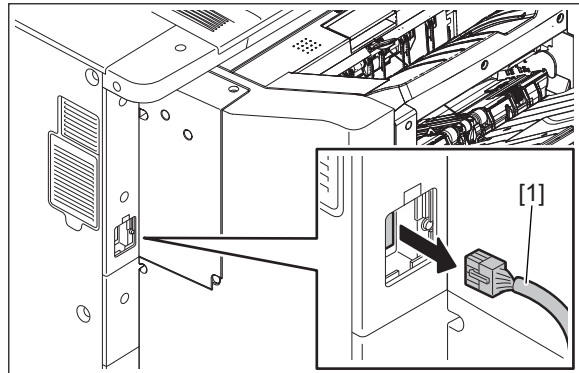

Fig. 4-983

- (4) Separate the Finisher or the Saddle Stitch Finisher from the MFP.

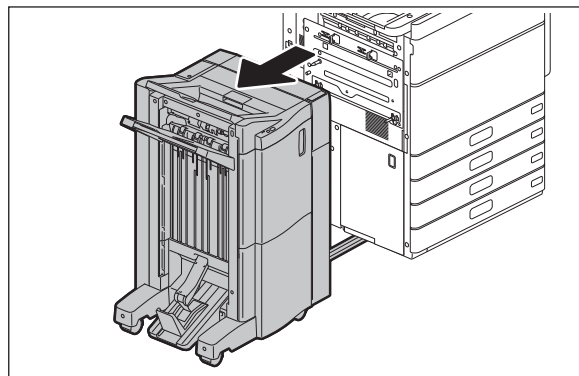

Fig. 4-984

- (5) Remove 3 screws and take off the guide rail from the Finisher or the Saddle Stitch Finisher.

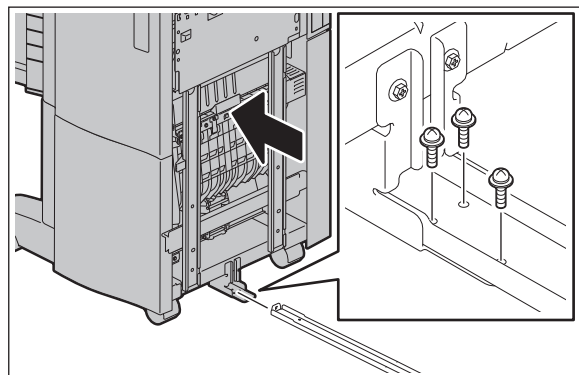

Fig. 4-985

4.13.6 Hole Punch Unit

- (1) Press the [ON/OFF] button on the control panel to shut down the MFP.
- (2) Remove the power cable.
- (3) Take off the connector cover and disconnect the communication cable [1] of the Finisher or the Saddle Stitch Finisher.

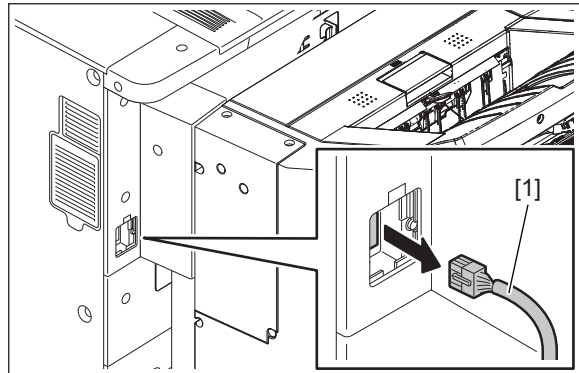

Fig. 4-986

- (4) Separate the Finisher or the Saddle Stitch Finisher from the MFP.

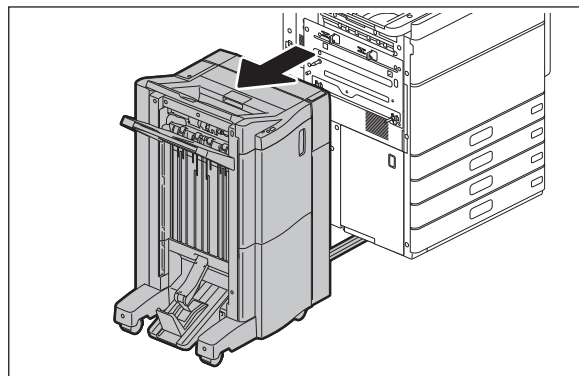

Fig. 4-987

- (5) When the Saddle Stitch Finisher is installed, take off the saddle unit.

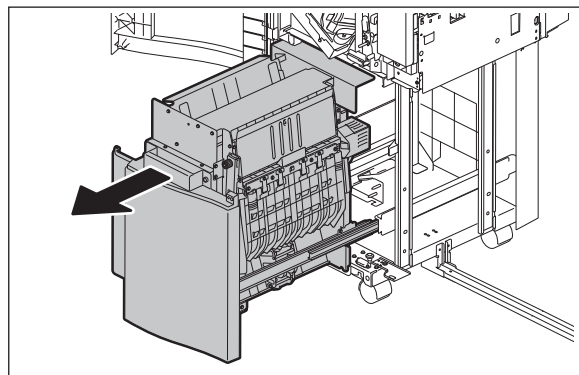

Fig. 4-988

- (6) Take off the cover.

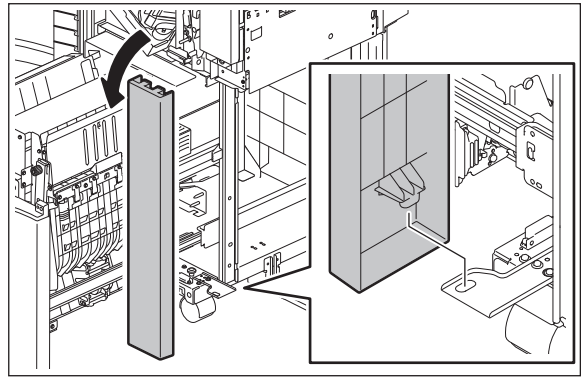

Fig. 4-989

- (7) Remove 2 screws and take off the cover.

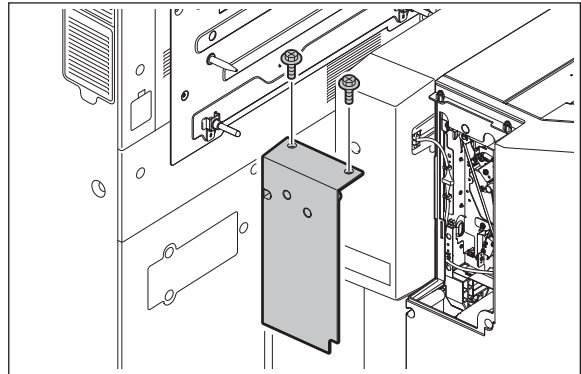

Fig. 4-990

Notes:

When installing the cover, be careful not to let the harness get caught in it.

- (8) Remove 1 harness clamp. Release the harnesses from 7 harness clamps.

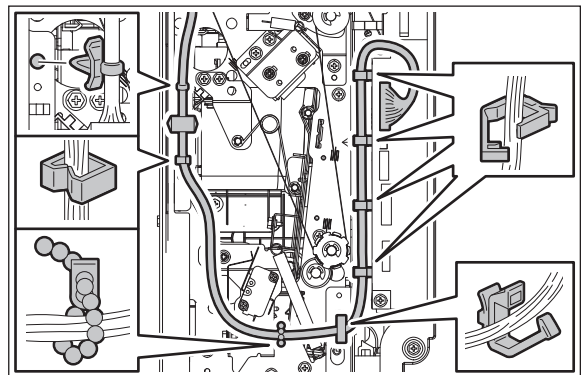

Fig. 4-991

(9) Disconnect 1 connector.

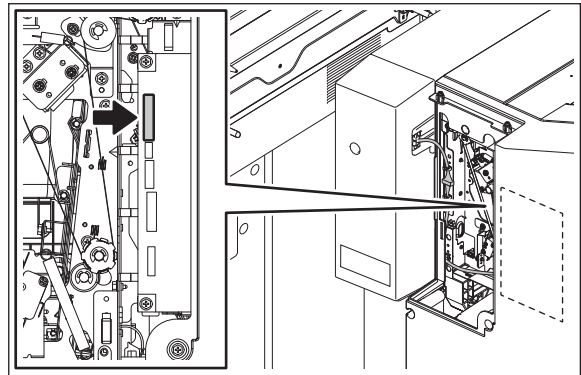

Fig. 4-992

(10) Disconnect 1 connector.

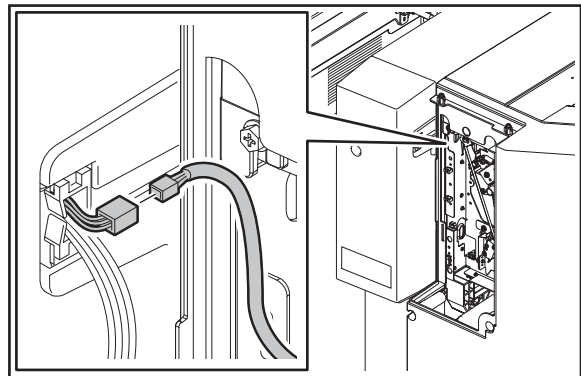

Fig. 4-993

(11) Open the cover of the Finisher.

(12) Remove 2 screws and take off the hole punch unit.

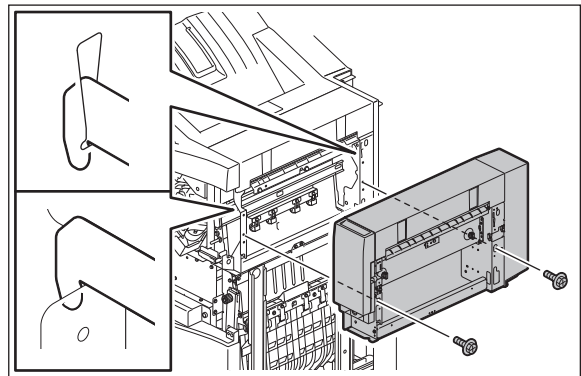

Fig. 4-994

5. SELF-DIAGNOSTIC MODE

5.1 Overview

This MFP consists of two servicing menus which have different start-up methods. Setting and adjustment can be performed by entering into a mode such as [05 ADJUSTMENT MODE] or [49 Firmware Update] from each menu.

- FS Menu

| Mode | | Contents |
|-----------------------------|------------------------|---|
| 03 TEST MODE | | Checks the status of the input/output signals. |
| 04 TEST PRINT MODE | | Outputs the test patterns. |
| 05 ADJUSTMENT MODE | | Adjusts various items. |
| 08 SETTING MODE | | Sets various items. |
| 20 PM SUPPORT MODE | | Clears each counter. |
| 30 LIST PRINT MODE | | Prints various lists or outputs them in a CSV format. |
| FAX | 11 FAX CLEAR MODE | Sets the fax unit. |
| | 12 FAX LIST PRINT MODE | The setting contents of the fax function can be output. |
| | 13 FAX FUNCTION MODE | Sets the fax function. |
| | 19 RAM EDIT MODE | Performs special adjustment and setting for the fax function. (This is not used generally.) |
| 35 DATA BACKUP/RESTORE MODE | | Backs up or restores data. |
| 36 CLONING | | Creates and installs clone files. |
| 37 LICENSE MANAGEMENT | | Manages the license of applications. |
| 38 DEACTIVATE RELEASE MODE | | Reconnects the detached device. |

- HS Menu

| Mode | | Contents |
|--------------------------|--|--|
| 01 Control Panel Check | | Checks various contents regarding the LCD, LED, hard keys and digital keys on the control panel. |
| 49 Firmware Update | | Performs firmware update with a USB storage device. |
| 59 SRAM Data Cloning | | Backs up the SRAM data to a USB storage device. |
| 73 Firmware Assist | | Supports at the time of replacing the SYS board, SRAM and normal storage device. Clears error flags or SRAM. Performs safety deletion of the normal storage device and SRAM. |
| 74 Storage Assist | | Checks the type of the storage device connected and initializes it. |
| 75 File System Recovery | | Checks and recovers the file system of the connected storage. Initializes the normal storage device. |
| 76 SRAM Maintenance | | Recovers the MFP from particular errors such as F800 or F900. |
| 77 Detach Release | | Reconnects the detached device. |
| 78 Option Storage Assist | | Formats the optional storage device and deletes its settings. |
| TPM Restore | | Restores TPM information. |

Remarks:

Only the modes which are available for this MFP are displayed on each menu.

[A] Starting each menu

| Menu | | | Mode*1 | | Operation | | | |
|--|---|--|--------|--|-----------|-----------------------------------|---|-----------------------------------|
| FS Menu [FUNCTION CLEAR] + [START] + [ON/OFF] | → | Enter a service password and press [OK]. | → | 03 TEST MODE | → | Refer to the SELF-DIAGNOSIS CODE. | | |
| | | | | 04 TEST PRINT MODE | → | Refer to the SELF-DIAGNOSIS CODE. | | |
| | | | | 05 ADJUSTMENT MODE | → | CLASSIC*2 | → | Refer to the SELF-DIAGNOSIS CODE. |
| | | | | 08 SETTING MODE | → | CLASSIC*2 | → | Refer to the SELF-DIAGNOSIS CODE. |
| | | | | 20 PM SUPPORT MODE | → | | | Ch 5.8 |
| | | | | 30 LIST PRINT MODE | → | | | Ch 5.9 |
| | | | | FAX • 11 FAX CLEAR MODE • 12 FAX LIST PRINT MODE • 13 FAX FUNCTION MODE • 19 RAM EDIT MODE*3 | → | | | Refer to the SELF-DIAGNOSIS CODE. |
| | | | | 35 DATA BACKUP/RESTORE MODE | → | | | Ch 5.11 |
| | | | | 36 CLONING | → | | | Ch 5.12 |
| | | | | 37 LICENSE MANAGEMENT | → | | | Ch 5.13 |
| | | | | 38 DEACTIVATE RELEASE MODE | → | | | Ch 5.14 |
| HS Menu [HOME] + [START] + [ON/OFF] | → | Enter a service password and press [OK]. | → | 01 Control Panel Check | → | Ch 5.15 | | |
| | | | | 49 Firmware Update | → | Ch 11.2.4 | | |
| | | | | 59 SRAM Data Cloning | → | Ch 12.1.4 | | |
| | | | | 73 Firmware Assist | → | Ch 5.16 | | |
| | | | | 74 Storage Assist | → | Ch 5.17 | | |
| | | | | 75 File System Recovery | → | Ch 5.18 | | |
| | | | | 76 SRAM Maintenance | → | Ch 5.19 | | |
| | | | | 77 Detach Release | → | Ch 5.20 | | |
| 78 Option Storage Assist | → | Ch 5.21 | | | | | | |
| TPM Restore*4 | → | Enter a service password and press [OK]. | → | | Ch 5.22 | | | |

*1 : FS Menu: Select the mode and press [Next]. HS Menu: Select the icon of the mode.

*2 : Press [Classic] displayed at the upper right of the menu.

*3 : This is not used generally.

*4 : This function is displayed and becomes operable, only after the SYS board has been replaced.

[B] Cancellation of the self-diagnostic mode

The modes, which can be entered from [FS Menu], can be canceled by the following methods.

- When [FS Menu] is displayed on the screen:
Press [FS Menu] to return to the menu screen. Press [Normal].
- The self-diagnostic mode finishes and the [HOME] screen appears. Rebooting/non-rebooting of the MFP will be performed depending on the mode worked and the code operated.
- When only [Return] is displayed on the screen:
Press [Return] for several times until [FS Menu] is displayed on the screen. When [FS Menu] appears, press it.
- When neither [Return] nor [FS Menu] is not displayed on the screen:
Press the [ON/OFF] button and perform the shut-down operation on the screen displayed.

To cancel the modes, which can be entered from [HS Menu], press the [ON/OFF] button for a few seconds to shut down the MFP.

[C] State transition diagram of self-diagnostic modes

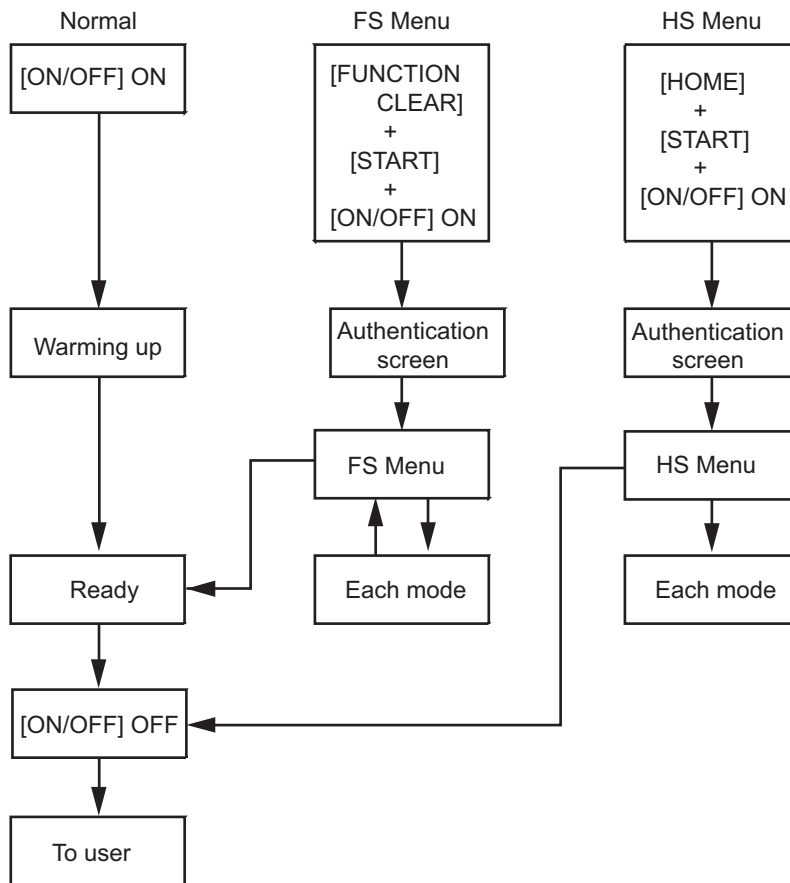

Fig.5-1

Notes:

Be sure to cancel the self-diagnostic mode before customers start using the MFP.

[D] Changing and setting of the service password

- (1) Press [Settings] on the FS Menu. The [Settings] screen appears.
- (2) Press [Service Password] to change or reset the service password.

5.2 Description Rule for Each Menu and Mode

The description of the self-diagnostic code complies with the rule below.

Example

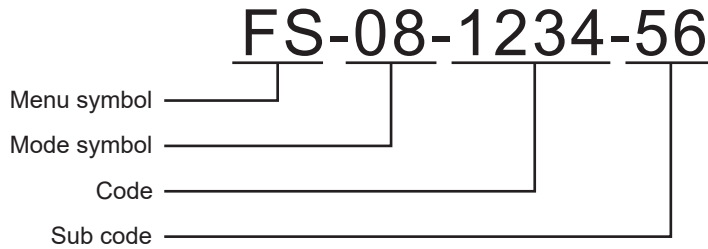

Fig.5-2

- (1) Menu symbol
FS: FS Menu (Starting by pressing the [ON/OFF] button while pushing the [FUNCTION CLEAR] and [START] buttons simultaneously.)
HS: HS Menu (Starting by pressing the [ON/OFF] button while pushing the [HOME] and [START] buttons simultaneously.)
- (2) Mode symbol
The first two digits of each mode
- (3) Code
Code number
- (4) Sub code
This will only be given when a sub code exists.

[A] FS Menu

[05 ADJUSTMENT MODE] and [08 SETTING MODE]:

“FS-05-1234-56” or “Perform FS-05-1234-56” is taken for explanation purposes.

- (1) Start the FS Menu by pressing the [ON/OFF] button while pushing the [FUNCTION CLEAR] and [START] buttons simultaneously.

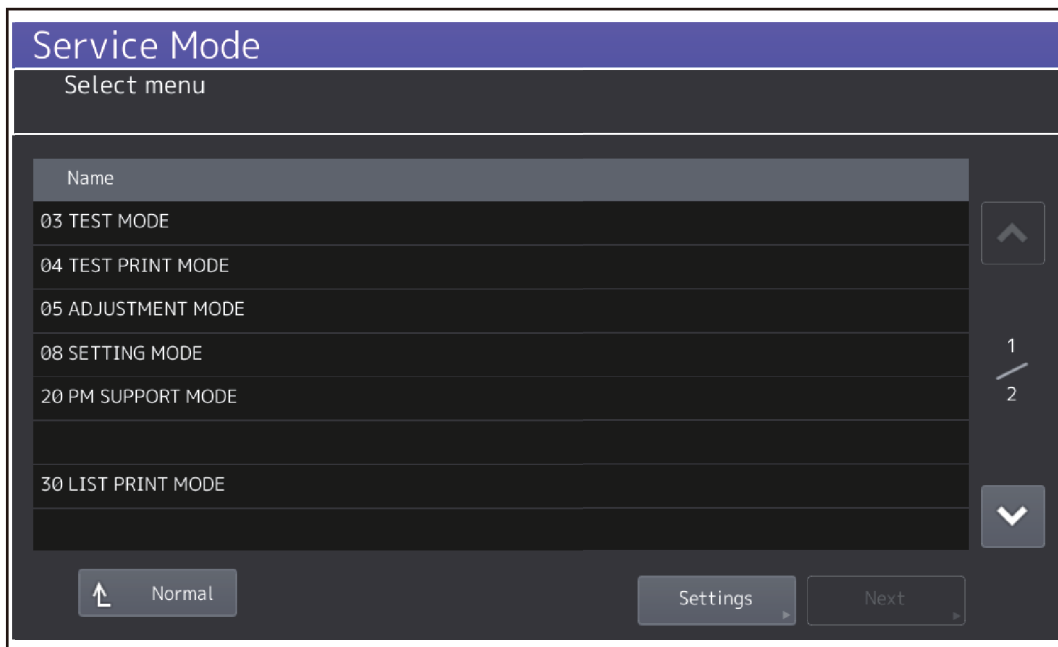

Fig.5-3

- (2) Select [05 ADJUSTMENT MODE] or [08 SETTING MODE] and press [Next].
- (3) Press [Classic] on the upper right of the menu to display the adjustment mode menu.

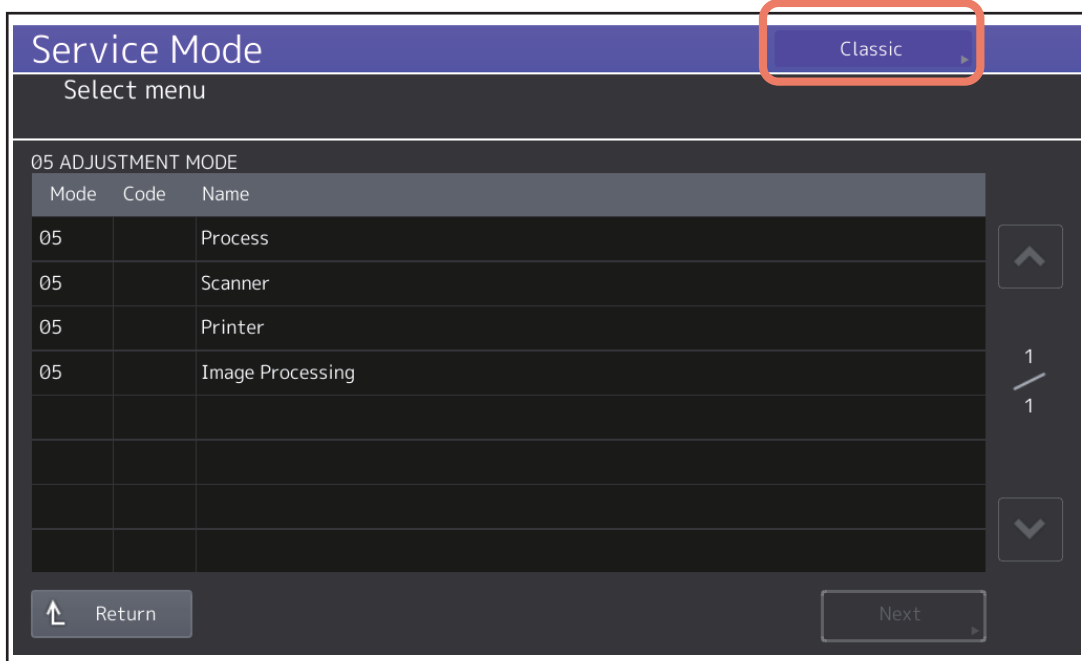

Fig.5-4

- (4) By using the digital keys displayed on the screen, enter [1], [2], [3], [4] and then press the [START] button. Enter the sub codes [5] and [6] and then press the [START] button.
- (5) Carry out the adjustment by following the instructions displayed on the screen or press the [START] button.

[03 TEST MODE]:

The key-pressing procedures for the modes, which are set by the combination of the [F1], [F2] and [F3] keys, are described as below.

[F1: ON]: Only F1 is turned ON.

[F1, 2: ON]: F1 and F2 are turned ON.

* The number of the [F] key, which is turned ON, is depicted by dividing with “,” (commas) as above.

[F1, 2, 3: ON]: All of the [F] keys are turned ON.

[F: OFF]: All of the [F] keys are turned OFF.

e.g.:

[FS-03-F:OFF-9-A]: Turn OFF all of the [F] keys in the FS-03 mode, select [9] and then [A].

[FS-03-F1:ON-9-A]: Turn ON the [F1] key in the FS-03 mode, select [9] and then [A].

[FAX]:

In case of [FS-11], [FS-12] or [FS-13] is given in the explanations, select [FAX] in the [FS Menu] and then press [Next] to choose each mode.

[B] HS Menu

- (1) Start the HS Menu by pressing the [ON/OFF] button while pushing the [HOME] and [START] buttons simultaneously.

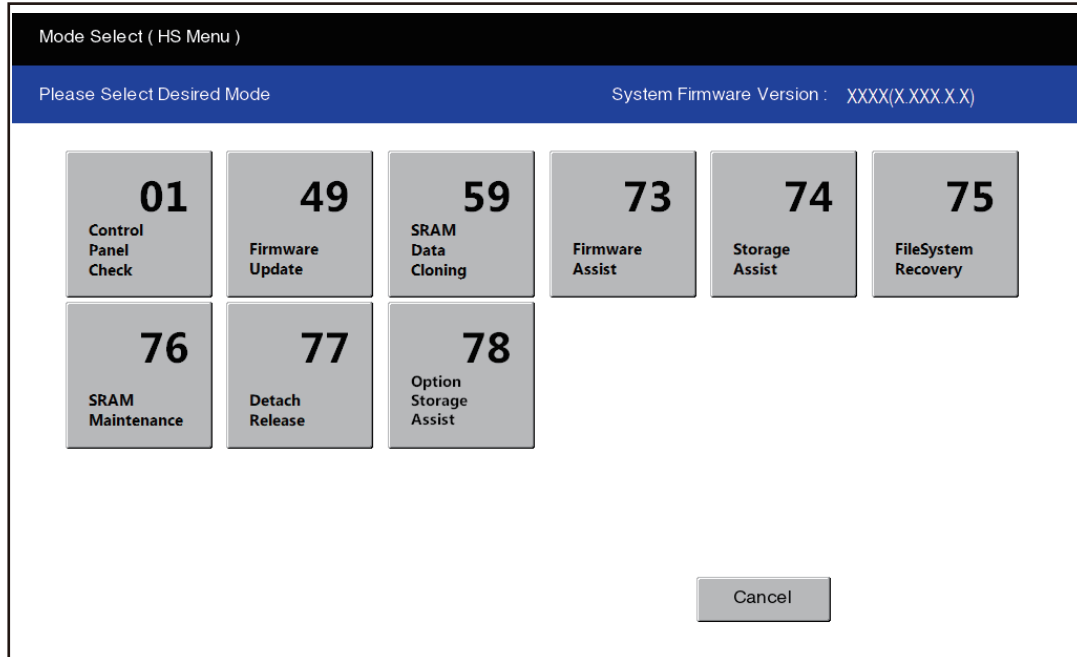

Fig.5-5

- (2) Press the icon to operate.
- (3) Follow the instructions displayed on the screen.

[C] When the setting contents of the code are applied

The setting value is given at the end of the description by dividing with “:” (colons).

Example: [FS-08-8911:3]: “3” is set for FS-08-8911.

5.3 Service UI

5.3.1 Overview

Each mode of the self-diagnostic codes can be used by selecting the keyword of the screen in the Service UI.

The codes which are used frequently can be selected in the Service UI.

The Service UI can be used in the following modes in the FS Menu.

05 ADJUSTMENT MODE

08 SETTING MODE

Notes:

Not all codes can be used in the Service UI.

For the codes available with the Service UI, refer to the "SELF-DIAGNOSIS CODE" (separate document).

5.3.2 Operation procedure

- (1) Start the FS Menu. Select the mode of the above Service UI and press [Next].
- (2) Select the item whose setting is to be changed and press [Next] until the code number is displayed.

The display shifts to the classic screen of the selected code.

5.3.3 Starting the FS Menu from the normal mode

If the gear icon is displayed on the USER FUNCTIONS menu of the normal mode, the FS Menu can be started.

- (1) Turn the power ON of the MFP.
- (2) Enter the service ID and service password if necessary.
- (3) Press [User Functions] on the HOME screen.
- (4) Press the gear icon on the upper left of the screen for at least 3 seconds.

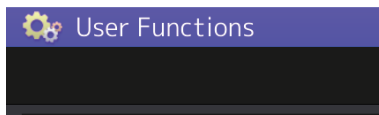

Fig.5-6

- (5) Enter the service password and press [OK].
The FS Menu appears.
In case the password has been forgotten, ask the administrator to reset the service password.

5.4 03 TEST MODE

5.4.1 Output check

The status of the output signal can be checked.

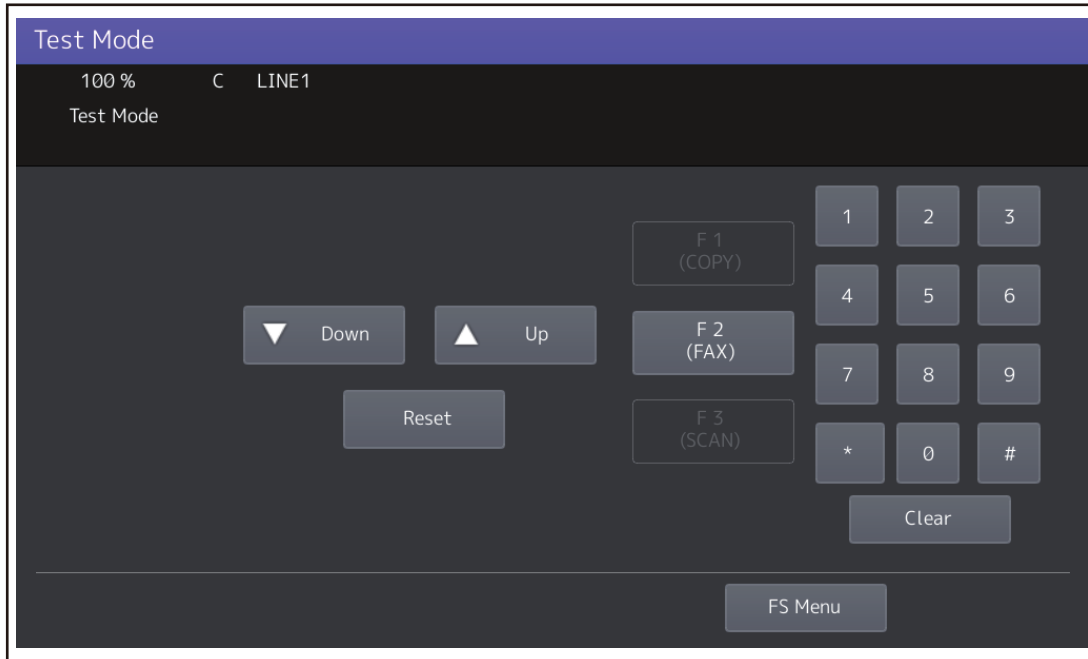

Fig.5-7

Operation procedure: Refer to the SELF-DIAGNOSIS CODE (separate document).

5.4.2 Input check

The status of each input signal can be checked by operating the [F1], [F2], [F3] and the digital keys.

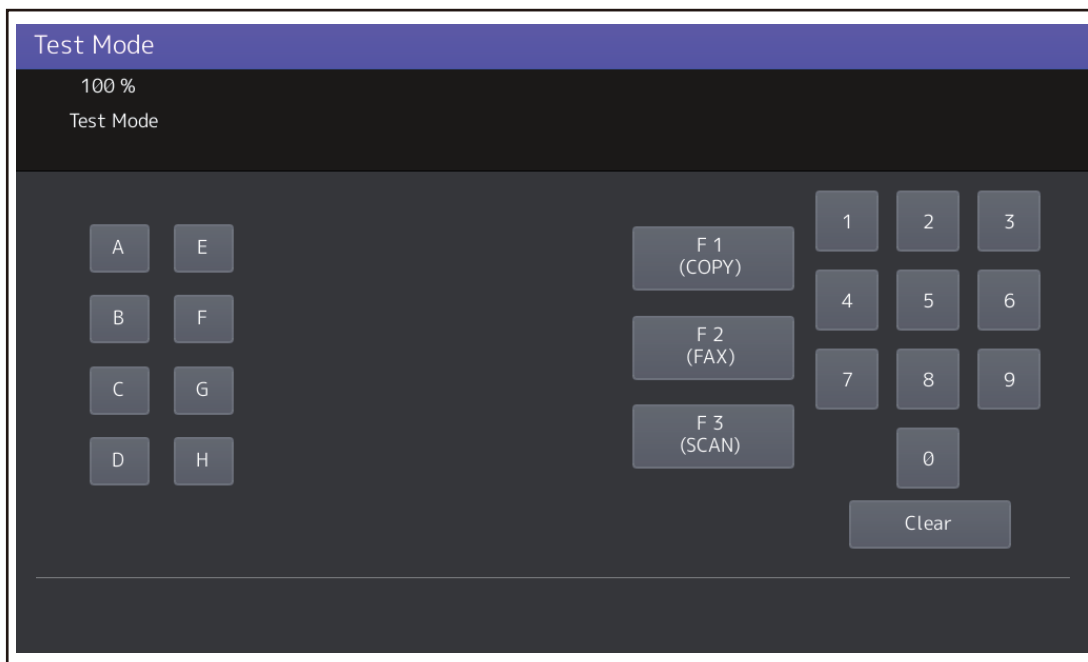

Fig.5-8

Operation procedure: Refer to the SELF-DIAGNOSIS CODE (separate document).

5.5 04 TEST PRINT MODE

The embedded test pattern can be printed out.

Operation procedure: Refer to the SELF-DIAGNOSIS CODE (separate document).

5.6 05 ADJUSTMENT MODE

Various adjustments and test printings can be performed.

Operation procedure: Refer to the SELF-DIAGNOSIS CODE (separate document).

5.6.1 TEST COPY

One set of the test copy can be printed in the [Classic] mode standby screen in the [05 ADJUSTMENT MODE].

Operation procedure:

- (1) Press [TEST COPY] in the [Classic] Mode standby screen in the [05 ADJUSTMENT MODE].
- (2) Specify the drawer, original mode and density.
Available items vary depending on the models.
- (3) Press the [START] button.

5.6.2 TEST PRINT

One sheet of the test print for various patterns can be printed out by entering a 1 to 3-digit code and pressing [TEST PRINT] in the [Classic] mode standby screen in [05 ADJUSTMENT MODE].

Operation procedure: Refer to the SELF-DIAGNOSIS CODE (separate document).

5.7 08 SETTING MODE

Various settings can be set.

Operation procedure: Refer to the SELF-DIAGNOSIS CODE (separate document).

5.8 20 PM SUPPORT MODE

 P. 7-5 “7.4 20 PM SUPPORT MODE”

Operation procedure:

[FS] → [20] → (Operation started) → Exit

5.9 30 LIST PRINT MODE

5.9.1 List output table

The following lists can be printed out in the list print mode.

Lists can be printed or saved in a USB storage device by outputting them into a CSV file format list.

| List | Code | | Output file name | Operation procedure |
|---|-------|-----|--|---------------------|
| | Print | CSV | | |
| Adjustment mode (05) data list | 101 | 201 | AJUSTMENT_LIST_sn_date.csv | 1 |
| Setting mode (08) data list | 102 | 202 | SETTING_LIST_sn_date.csv | 1 |
| PM support mode data list | 103 | 203 | PM_LIST_sn_date.csv | 2 |
| Pixel counter list (toner cartridge reference) | 104 | 204 | PIXEL_TONER_LIST_sn_date.csv | 2 |
| Pixel counter list (service technician reference) | 105 | 205 | PIXEL_SERVICE_LIST_sn_date.csv | 2 |
| Error history list (Max.: 1,000) | 106 | 206 | ERROR_LOG_sn_date.csv | 2 |
| Error history list (Latest: 80) | 107 | - | - | 2 |
| Firmware update log (Max.: 200) | 108 | 208 | FW_UPGRAE_LOG_sn_date.csv | 2 |
| Power ON/OFF log (Max.: 100) | 110 | 210 | POWER_ONOFF_LOG_sn_date.csv | 2 |
| Version list | 111 | 211 | VERSION_LIST_sn_date.csv | 2 |
| Engine firmware log ^{*1} | - | 212 | ENG_FW_LOG_sn_date.csv | 2 |
| Total counter list | 114 | 214 | TOTAL_COUNTER_LIST_sn_date.csv | 2 |
| Misfeeding transport error log | - | 217 | MISFEEDING_TRANSPORT_ERROR_LOG_sn_date.csv | 2 |
| User operation log | - | 218 | FAX_OPERATION_LOG_sn_date.csv, SIMPLE_FAX_OPERATION_LOG_sn_date.csv | 2 |
| Setting change history | - | 219 | SETTING_CHANGE_HISTORY_sn_date.csv | 2 |
| DF Paper sensor log ^{*1} | - | 220 | DF_PAPER_SENSOR_LOG_sn_date.csv | 2 |
| (05) adjustment value difference | 121 | 221 | 05DIFFERENCE_CODE_LIST_sn_date.csv | 2 |
| (08) setting value difference | 122 | 222 | 08DIFFERENCE_CODE_LIST_sn_date.csv | 2 |
| Jog log / Message log | - | 223 | JOB_LOG_sn_date ^{*2} MESSAGE_LOG_sn_date ^{*2} | 2 |
| FAX function mode (13) data list | - | 224 | FAX_FUNCTION_LIST_sn_date.csv | 2 |
| Application list (Max.: 100) | 125 | 225 | APPLICATION_LIST_sn_date.csv | 2 |
| Life counter clear log | 811 | 911 | LIFE_COUNTER_CLEAR_LOG_sn_date.csv | 2 |
| Output all CSV files | - | 300 | CSV format files other than (05) adjustment value difference and (08) setting value difference | 2 |

sn: Serial number of the MFP

date: File create date and time (YYYYMMDDHHMMSS)

*1 : Output this only when instructed.

*2 : Encryption file

5.9.2 Operation procedure

Lists can be printed by performing the code for printing. In addition, a CSV format file can be stored in a USB storage device by performing the code for csv outputting while it is inserted.

Operation procedure 1

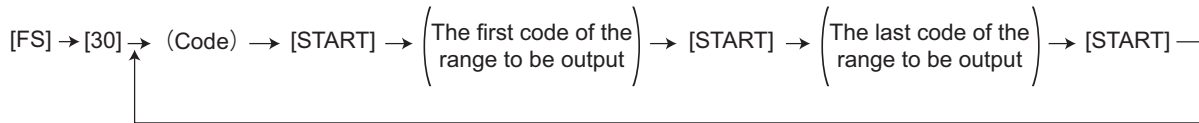

Fig.5-9

Operation procedure 2

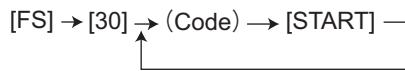

Fig.5-10

5.9.3 Samples of the output

Adjustment mode (05) data list

| 05 ADJUSTMENT MODE DATA LIST | | | | | | | |
|------------------------------|------|----------------------|------|-------------------------|------|-----------------|------|
| 20xx-xx-xx xx:xx | | S/N: Cxxxxxxx | | FIN S/N: FIN S/N-xxxxxx | | TOTAL: 99999 | |
| | | TOSHIBA e-STUDIOxxxx | | | | DF TOTAL: 99999 | |
| CODE | DATA | CODE | DATA | CODE | DATA | CODE | DATA |
| 2000 | 128 | 3860-0 | 88 | 4830 | 128 | 5920 | 128 |
| . | . | . | . | . | . | . | . |
| . | . | . | . | . | . | . | . |
| . | . | . | . | . | . | . | . |
| . | . | . | . | . | . | . | . |
| . | . | . | . | . | . | . | . |
| . | . | . | . | . | . | . | . |
| . | . | . | . | . | . | . | . |
| . | . | . | . | . | . | . | . |
| . | . | . | . | . | . | . | . |
| . | . | . | . | . | . | . | . |
| . | . | . | . | . | . | . | . |
| . | . | . | . | . | . | . | . |
| . | . | . | . | . | . | . | . |
| . | . | . | . | . | . | . | . |

Fig.5-11

| Item | Contents |
|------|---|
| CODE | A self-diagnostic code is described. "XXXX-YY" is described when a sub code exists. |
| DATA | Value of the code |

The selected setting codes and the current setting value for each code are output in a list.

Remarks:

- Only the codes available to set or check are output.
- Codes whose setting value at the time of the output is not unnecessary are not output (e.g.: setting time of the MFP).

Setting mode (08) data list

| | | | | | | | |
|---------------------------|------|----------------------|------|-------------------------|------|-----------------|------|
| 08 SETTING MODE DATA LIST | | S/N: Cxxxxxxx | | FIN S/N: FIN S/N-xxxxxx | | TOTAL: 99999 | |
| 20xx-xx-xx xx:xx | | TOSHIBA e-STUDIOxxxx | | | | DF TOTAL: 99999 | |
| CODE | DATA | CODE | DATA | CODE | DATA | CODE | DATA |
| 2010 | 2 | 2880 | 12 | 3040 | 0 | 3070-3 | 0 |
| . | . | . | . | . | . | . | . |
| . | . | . | . | . | . | . | . |
| . | . | . | . | . | . | . | . |
| . | . | . | . | . | . | . | . |
| . | . | . | . | . | . | . | . |
| . | . | . | . | . | . | . | . |
| . | . | . | . | . | . | . | . |
| . | . | . | . | . | . | . | . |
| . | . | . | . | . | . | . | . |
| . | . | . | . | . | . | . | . |
| . | . | . | . | . | . | . | . |
| . | . | . | . | . | . | . | . |
| . | . | . | . | . | . | . | . |

Fig.5-12

| Item | Contents |
|------|---|
| CODE | A self-diagnostic code is described. "XXXX-YY" is described when a sub code exists. |
| DATA | Value of the code |

The selected setting codes and the current setting value for each code are output in a list.

Remarks:

- Only the codes available to set or check are output.
- Codes whose setting value at the time of the output is not unnecessary are not output (e.g.: setting time of the MFP).

PM support mode data list

| PM SUPPORT CODE LIST | | | | |
|----------------------|--------------------------------|----------------------------------|-------------------------|------------------|
| | | S/N: Cxxxxxxx | FIN S/N: FIN S/N-xxxxxx | TOTAL : 99999 |
| 20xx-xx-xx xx:xx | | TOSHIBA e-STUDIOxxxx | | DF TOTAL : 99999 |
| UNIT | OUTPUT PAGES DEVELOP COUNTS | PM OUTPUT PAGE DEVELOP COUNTS | DRIVE COUNTS | PM DRIVE COUNTS |
| DRUM | 2516 | 70000 | 11735 | 170000 |
| DRUM BLADE | 2516 | 70000 | 11735 | 170000 |
| GRID | 2516 | 70000 | 11735 | 170000 |
| MAIN CHARGER NEEDLE | 2516 | 70000 | 11735 | 170000 |
| CHARGER CLEANING PAD | 2516 | 70000 | 11735 | 170000 |
| : | : | : | : | : |
| : | : | : | : | : |

Fig.5-13

| Item | Contents |
|--------------------------------|---|
| UNIT | Unit name |
| OUTPUT PAGES/DEVELOP COUNTS | Number of output pages |
| PM OUTPUT PAGES/DEVELOP COUNTS | Number of recommended pages for replacement |
| DRIVE COUNTS | Drive time |
| PM DRIVE COUNTS | Recommended time for replacement |

Sub unit information for 20 PM support mode is output.
Use this list for confirming the PM units to be replaced at each PM.

Remarks:

- When the recommended value has been exceeded, “*” will be added to the number of output pages or drive time.
- See the following page for PM:
 P. 7-1 “7. PREVENTIVE MAINTENANCE (PM)”

Pixel counter list (toner cartridge reference)

| PIXEL COUNTER CODE LIST | | | | | | |
|-------------------------|------------|------------------------|-------------------------|------------------|-----|-------|
| | | S/N: Cxxxxxxx | FIN S/N: FIN S/N-xxxxxx | TOTAL : 99999 | | |
| 20xx-xx-xx xx:xx | | TOSHIBA e-STUDIOxxxx | | DF TOTAL : 99999 | | |
| TONERCARTRIDGE | | | | | | |
| NO. | DATE | | PPC | PRN | FAX | TOTAL |
| 0 | 20xx-xx-xx | Print Count[LT/A4] | 181 | 45 | --- | 226 |
| 1 | 20xx-xx-xx | Average Pixel Count[%] | 2.70 | 1.74 | --- | 2.51 |
| 2 | 20xx-xx-xx | Latest Pixel Count[%] | 6.15 | 0.39 | --- | 0.39 |

Fig.5-14

| Item | Contents |
|-------|----------------------|
| No. | Consecutive number |
| DATE | Date |
| PPC | Counter for copying |
| PRN | Counter for printing |
| FAX | Counter for fax |
| TOTAL | Total counter |

Pixel counter data (toner cartridge reference) are output in a list.

Remarks:

See the following page for the pixel counter:

 P. 14-7 “14.3 Pixel Counter”

Pixel counter list (service technician reference)

| PIXEL COUNTER CODE LIST | | | | | | |
|-------------------------|------------|------------------------|-------------------------|-----------------|-----|-------|
| | | S/N: Cxxxxxxx | FIN S/N: FIN S/N-xxxxxx | TOTAL: 99999 | | |
| 20xx-xx-xx xx:xx | | TOSHIBA e-STUDIOxxxx | | DF TOTAL: 99999 | | |
| SERVICEMAN | | | | | | |
| NO. | DATE | | PPC | PRN | FAX | TOTAL |
| 0 | 20xx-xx-xx | Print Count[LT/A4] | 181 | 45 | --- | 226 |
| 1 | 20xx-xx-xx | Average Pixel Count[%] | 2.70 | 1.74 | --- | 2.51 |
| 2 | 20xx-xx-xx | Latest Pixel Count[%] | 6.15 | 0.39 | --- | 0.39 |

Fig.5-15

| Item | Contents |
|-------|----------------------|
| No. | Consecutive number |
| DATE | Date |
| PPC | Counter for copying |
| PRN | Counter for printing |
| FAX | Counter for fax |
| TOTAL | Total counter |

Pixel counter data (service technician reference) are output in a list.

Remarks:

See the following page for the pixel counter:

 P. 14-7 "14.3 Pixel Counter"

Error history list

| ERROR HISTORY LIST | | | | | | |
|--------------------|----------|----------------------|----------|-------------------------|------------------------------|-----------------|
| | | S/N: Cxxxxxxx | | FIN S/N: FIN S/N-xxxxxx | | TOTAL: 99999 |
| | | TOSHIBA e-STUDIOxxxx | | | | DF TOTAL: 99999 |
| 20xx-xx-xx xx:xx | | | | | | |
| CODE | COUNTER | DATE | TIME | ZOOM_XY | ABCD_EFHI_JLOP_QR | |
| F110 | 00000000 | xxxx-xx-xx | xx:xx:xx | 000 000 | 0000_0000_0000_00_0000000000 | |
| F110 | 00000000 | xxxx-xx-xx | xx:xx:xx | 000 000 | 0000_0000_0000_00_0000000000 | |
| F110 | 00000000 | xxxx-xx-xx | xx:xx:xx | 000 000 | 0000_0000_0000_00_0000000000 | |
| F110 | 00000000 | xxxx-xx-xx | xx:xx:xx | 000 000 | 0000_0000_0000_00_0000000000 | |
| F110 | 00000000 | xxxx-xx-xx | xx:xx:xx | 000 000 | 0000_0000_0000_00_0000000000 | |
| EAD0 | 00000000 | xxxx-xx-xx | xx:xx:xx | 000 000 | 0000_0000_0000_00_0000000000 | |
| E860 | 00000000 | xxxx-xx-xx | xx:xx:xx | 000 000 | 0000_0000_0000_00_0000000000 | |
| E731 | 00000000 | xxxx-xx-xx | xx:xx:xx | 000 000 | 0000_0000_0000_00_0000000000 | |
| E090 | 00000000 | xxxx-xx-xx | xx:xx:xx | 000 000 | 0000_0000_0000_00_0000000000 | |
| E870 | 00000000 | xxxx-xx-xx | xx:xx:xx | 000 000 | 0000_0000_0000_00_0000000000 | |
| E724 | 00000000 | xxxx-xx-xx | xx:xx:xx | 000 000 | 0000_0000_0000_00_0000000000 | |

Fig.5-16

The error history is output.

The maximum output numbers are as below.

- FS-30-106/206: 1,000
- FS-30-107: 80

Remarks:

- Only errors occurred under the normal mode and 30 list print mode are output.
- For the details of the error codes and items, refer to the following reference.
 - 📖 P. 8-6 "8.2 Error Code List"
 - 📖 P. 8-67 "8.2.11 Error history"

Firmware update log

| FW UPGRADE LOG | | | | | | | | | | | | |
|------------------|--------------|------------|----------------------|----------|-------------------------|----------|-----------------|----------|----------|----------|----------|--------|
| | | | S/N: Cxxxxxxx | | FIN S/N: FIN S/N-xxxxxx | | TOTAL: 99999 | | | | | |
| 20xx-xx-xx xx:xx | | | TOSHIBA e-STUDIOxxxx | | | | DF TOTAL: 99999 | | | | | |
| MANUFACTURE DATE | | 20xx-xx-xx | | | | | | | | | | |
| UNPACKING DATE | | 20xx-xx-xx | | | | | | | | | | |
| USER | ROM/VERSION | DATE | TOTAL | COPY(B) | COPY(2) | COPY(C) | PRINT(B) | PRINT(2) | PRINT(C) | LIST | FAX | STATUS |
| Service | Txxxxxx-xxxx | 20xx-xx-xx | 99999999 | 99999999 | 99999999 | 99999999 | 99999999 | 99999999 | 99999999 | 99999999 | 99999999 | OK |
| Service | Txxxxxx-xxxx | 20xx-xx-xx | 99999999 | 99999999 | 99999999 | 99999999 | 99999999 | 99999999 | 99999999 | 99999999 | 99999999 | OK |
| Service | Txxxxxx-xxxx | 20xx-xx-xx | 99999999 | 99999999 | 99999999 | 99999999 | 99999999 | 99999999 | 99999999 | 99999999 | 99999999 | OK |
| . | . | . | . | . | . | . | . | . | . | . | . | . |
| . | . | . | . | . | . | . | . | . | . | . | . | . |
| . | . | . | . | . | . | . | . | . | . | . | . | . |
| . | . | . | . | . | . | . | . | . | . | . | . | . |
| . | . | . | . | . | . | . | . | . | . | . | . | . |
| . | . | . | . | . | . | . | . | . | . | . | . | . |

Fig.5-17

| Item | Contents |
|-------------|--|
| USER | User who updated the firmware |
| ROM/VERSION | Firmware version |
| DATE | Firmware update date |
| TOTAL | Total counter data at firmware update |
| COPY(B) | Copy counter data (black) at firmware update |
| COPY(2) | Copy counter data (twin color) at firmware update |
| COPY(C) | Copy counter data (full color) at firmware update |
| PRINT(B) | Print counter data (black) at firmware update |
| PRINT(2) | Print counter data (twin color) at firmware update |
| PRINT(C) | Print counter data (full color) at firmware update |
| LIST | List print counter data at firmware update |
| FAX | Fax print counter data at firmware update |
| STATUS | Update result |

Firmware update logs are output.

Remarks:

- MANUFACTURE DATE: Manufacturing date, UNPACKING DATE: Unpacking date
- Lists are output only when the versions of ROMs updated with a USB storage device.

Power ON/OFF log

| POWER ON_OFF LOG | | | | S/N: Cxxxxxxx | FIN S/N: FIN S/N-xxxxxx | TOTAL: 99999 | |
|------------------|----------|----------|----------|----------------------|-------------------------|-----------------|----------|
| 20xx-xx-xx xx:xx | | | | TOSHIBA e-STUDIOxxxx | | DF TOTAL: 99999 | |
| DATE | TIME | FUNCTION | TOTAL | DATE | TIME | FUNCTION | TOTAL |
| xxxx-xx-xx | xx:xx:xx | ON | 99999999 | xxxx-xx-xx | xx:xx:xx | ON | 99999999 |
| xxxx-xx-xx | xx:xx:xx | OFF | 99999999 | xxxx-xx-xx | xx:xx:xx | OFF | 99999999 |
| xxxx-xx-xx | xx:xx:xx | ON | 99999999 | xxxx-xx-xx | xx:xx:xx | ON | 99999999 |
| xxxx-xx-xx | xx:xx:xx | OFF | 99999999 | xxxx-xx-xx | xx:xx:xx | OFF | 99999999 |
| xxxx-xx-xx | xx:xx:xx | ON | 99999999 | xxxx-xx-xx | xx:xx:xx | RMT_OFF | 99999999 |
| xxxx-xx-xx | xx:xx:xx | OFF | 99999999 | | | | |
| xxxx-xx-xx | xx:xx:xx | ON | 99999999 | | | | |
| xxxx-xx-xx | xx:xx:xx | OFF | 99999999 | | | | |
| xxxx-xx-xx | xx:xx:xx | RMT_OFF | 99999999 | | | | |
| xxxx-xx-xx | xx:xx:xx | OFF | 99999999 | | | | |
| . | . | . | . | | | | |
| . | . | . | . | | | | |
| . | . | . | . | | | | |

Fig.5-18

| Item | Contents |
|----------|---|
| DATE | Power ON/OFF date |
| TIME | Power ON/OFF time |
| FUNCTION | Power ON/OFF information (Power ON, Power OFF, Remote reset) |
| TOTAL | Total counter data at power ON/OFF |

Power ON/OFF logs are output.

Version list

```

VERSION LIST
S/N: Cxxxxxxx      FIN S/N : FIN S/N-xxxxxxx      TOTAL :      9999999
20xx-xx-xx xx:xx  TOSHIBA e-STUDIOxxxxx      DF TOTAL :  9999999

SYSTEM FIRMWARE ROM VERSION      : Txxxxxxxxxxx
SYSTEM FIRMWARE INTERNAL ROM VERSION: Vx.x.x.xx.xx
PRINTER ROM VERSION               : xxxM-xxx
SCANNER ROM VERSION               : xxxS-xxx
PFC ROM VERSION                   : xxxF-xxx
RADF/DSDF ROM VERSION             : DF-xxx
FINISHER STACKER ROM VERSION      : FIN-
FINISHER PUNCH ROM VERSION        : PUN-
FAX BOARD FIRMWARE ROM VERSION    : xxxxxxxx
SYSTEM FIRMWARE OS VERSION        : Vx.xxx.x.x
STORAGE DEVICE DATA VERSION      : Txxxxxxxxxxx
NIC FIRMWARE ROM VERSION          : XXXXXXXXXXXX
LANGUAGE VERSION
  English(US)                     : xxx.xxx  xxx xxx xx xx:xx:xx xxxx
  .                                 .
  .                                 .
  .                                 .

CAPACITY OF STORAGE DEVICE        : xx.x GB
DEVICE INFORMATION OF STORAGE DEVICE : xxx xxxxxx-xxxxxx
SERIAL NUMBER OF STORAGE DEVICE   : xx-xxxxxxxxxxxx
MEMORY SIZE                       : xxx MB / xxx MB
INSTALLED ELK NAME                : Data overwrite enabler
                                   IPsec enabler
                                   Meta scan enabler
                                   External interface enabler
                                   .
                                   .
                                   .

```

Fig.5-19

The versions of each firmware and language are output.

Notes:

Some of the characters in the fonts that are used to print the version list are not supported. As a result, the language names under LANGUAGE VERSION may not be printed correctly when the version list is printed.

Total counter list

| | | | |
|--|---------------------------------------|-------------------------|---------------------------------------|
| TOTAL COUNTER LIST 20xx-xx-xx xx:xx | S/N: Cxxxxxxxx TOSHIBA e-STUDIOxxx | FIN S/N: FIN S/N-xxxxxx | TOTAL : 9999999 DF TOTAL : 9999999 |
|--|---------------------------------------|-------------------------|---------------------------------------|

| PRINT COUNTER | | | | | |
|---------------|--------|--------|---------|--------|--------|
| | COPY | FAX | PRINTER | LIST | TOTAL |
| SMALL | xxxxxx | xxxxxx | xxxxxx | xxxxxx | xxxxxx |
| LARGE | xxxxxx | xxxxxx | xxxxxx | xxxxxx | xxxxxx |
| TOTAL | xxxxxx | xxxxxx | xxxxxx | xxxxxx | xxxxxx |

| SCAN COUNTER | | | |
|--------------|------------|--------|--------|
| TOTAL | FULL COLOR | BLACK | TOTAL |
| COPY | xxxxxx | xxxxxx | xxxxxx |
| FAX | xxxxxx | xxxxxx | xxxxxx |
| NETWORK | xxxxxx | xxxxxx | xxxxxx |
| TOTAL | xxxxxx | xxxxxx | xxxxxx |

| COPY | | | |
|-------|------------|--------|--------|
| | FULL COLOR | BLACK | TOTAL |
| SMALL | xxxxxx | xxxxxx | xxxxxx |
| LARGE | xxxxxx | xxxxxx | xxxxxx |
| TOTAL | xxxxxx | xxxxxx | xxxxxx |

| FAX | | | |
|-------|------------|--------|--------|
| | FULL COLOR | BLACK | TOTAL |
| SMALL | xxxxxx | xxxxxx | xxxxxx |
| LARGE | xxxxxx | xxxxxx | xxxxxx |
| TOTAL | xxxxxx | xxxxxx | xxxxxx |

| NETWORK | | | |
|---------|------------|--------|--------|
| | FULL COLOR | BLACK | TOTAL |
| SMALL | xxxxxx | xxxxxx | xxxxxx |
| LARGE | xxxxxx | xxxxxx | xxxxxx |
| TOTAL | xxxxxx | xxxxxx | xxxxxx |

CARIBRATION COUNTER : XX DESTINY UNEVENNESS CORRECTION COUNTER : XX
 OCR COUNTER : XX

Fig.5-20

The total counter list is output.

Remarks:

When "1" (Enable) is set for FS-08-3667, a QR code is added to the total counter list.

Misfeeding transport error log

```

MISFEEDING TRANSPORT ERROR LOG, VERSION 1.0.0
20xx-xx-xx xx:xx
TOSHIBA e-STUDIOxxxx
Cxxxxxxxx
FIN S/N-xxxxxxxx
TOTAL,42737,691,5318,DF TOTAL,700
CODE,DATE-TIME,DATA
E120,2012-8-13,22:35:27,17,0,10,0,0,0,0,0,0,0,0,0,0,0,0,0,0,0,0,100,200,0,0
.      .
.      .
.      .
    
```

Fig.5-21

| Item | Contents | Remarks |
|------|-----------------------|---|
| CODE | Error code | Code of the error which occurred |
| DATE | Occurrence date | Date that the error occurred |
| TIME | Occurrence time | Time that the error occurred |
| DATA | Self-diagnostic value | Self-diagnostic value which related to the occurred error |

Paper feed transport error logs are output.

Remarks:

- Only the CSV format file output is performed.
- Maximum output number: 1,000

User operation log

```

FAX OPERATION LOG,VERSION 3.0.0
20xx-xx-xx xx:xx
TOSHIBA e-STUDIOxxxx
Cxxxxxxxx
FIN S/N-xxxxxxxx
TOTAL,42737,691,5318,DF TOTAL,700
DATE-TIME,FUNCTION,OPERATION,TARGET,PARAMETER
04/07 17:03:40014,SYSTEM,Display Legacy UI,USERFUNCTION
04/07 17:05:04741,SYSTEM,Display Legacy UI,USERFUNCTION
04/07 17:05:14410,COMMON,Input Edit Done,UserAuthentication_ChangePassword_OldPasswordBox,*****
.
.

```

Fig.5-22

```

SIMPLE FAX USER OPERATION LOG,VERSION 3.0.0
20xx-xx-xx xx:xx
TOSHIBA e-STUDIOxxxx
Cxxxxxxxx
FIN S/N-xxxxxxxx
TOTAL,42737,691,5318,DF TOTAL,700
DATE-TIME,FUNCTION,OPERATION,TARGET,PARAMETER
04/07 17:03:40014,SYSTEM,Display Legacy UI,USERFUNCTION
04/07 17:05:04741,SYSTEM,Display Legacy UI,USERFUNCTION
04/07 17:05:14410,COMMON,Input Edit Done,UserAuthentication_ChangePassword_OldPasswordBox,*****
.
.

```

Fig.5-23

| Item | Contents | Remarks |
|-----------|-------------------------|---|
| DATE-TIME | Operation date and time | Date and time that users operated |
| FUNCTION | Function name | FAX or COMMON or SYSTEM or Simple FAX COMMON: Common popup OK, Cancel, etc. SYSTEM: Switching functions to Legacy |
| OPERATION | Operation information | Information operated by the user |
| TARGET | Operation information | Supplementary information operated by the user |
| PARAMETER | Operation information | Supplementary information operated by the user |

User operation logs related to the fax function are output.

Remarks:

- Only the CSV format file output is performed.
- Maximum output number: 1,000
- User information, such as a password, direct entry prohibited setting, mailbox, are not recorded.

Setting change history

```

SETTING CHANGE HISTORY,VERSION 3.0.0
20xx-xx-xx xx:xx
TOSHIBA e-STUDIOxxxx
Cxxxxxxxx
FIN S/N-xxxxxxxx
TOTAL,42737,691,5318,DF TOTAL,700
"Date Time","OperationApplication","userName","settingValue","settingXpath","DomainName"
"20XX-04-13T18:17:00","Other","","0","/Network/Services/IPP/enabled",""
"20XX-04-13T17:17:25","Panel","Service","8","Category-08/C-8942",""
"20XX-04-06T20:28:37","Panel","Admin","terminalIP","Controller/Settings/xxxx/IPFax/xx/xx",""
"20XX-04-06T20:26:04","TopAccess","admin","Manual","Controller/Settings/xxxx/xx/xx/xx",""
.      .
.      .
.      .

```

Fig.5-24

| Item | Contents | Remarks |
|----------------------|-------------------------|--|
| Date Time | Change date time | Date and time when the user changed the settings |
| OperationApplication | Change operation source | Where the setting change operation was performed (Panel / TopAccess / Other) |
| userName | Change username | The part where the setting change operation was performed (user name with Admin / Service / Admin authority) |
| settingValue | Value after change | Value after change operation |
| settingXpath | Setting name | Setting name of the changed operation (xpath notation) |
| DomainName | Domain name | |

Setting change logs of users are output.

Remarks:

- Only the CSV format file output is performed.
- Maximum output number: 1,000
- Settings which are automatically altered in accordance with the changes made to others are not included.
- When changes have been made by means of the remote service, the use of this service is also recorded.
- When changes have been made by batch processing with cloning, only the execution of cloning is recorded. Changes made to each setting are not recorded.
- When changes have been made by batch processing with the self-diagnostic batch setting, only changes made to each setting are recorded. The execution of the self-diagnostic batch setting is not recorded.
- User data, Home data and Template data are not included.
- Values of the user information, such as a password and IP address, are replaced with “*”.

(05) adjustment value difference

| 05 DIFFERENCE LIST | | | S/N: Cxxxxxxx FIN S/N: FIN S/N-xxxxx | | |
|--------------------|--------|---------|---|--------|---------|
| xx-xx-xx xx:xx | | | TOSHIBA e-STUDIOxxxx | | |
| | | | TOTAL: 99999 | | |
| | | | DF TOTAL: 99999 | | |
| CODE | BACKUP | CURRENT | CODE | BACKUP | CURRENT |
| * 2400 | 128 | 160 | | | |
| . | . | . | | | |
| . | . | . | | | |
| . | . | . | | | |
| . | . | . | | | |
| . | . | . | | | |
| . | . | . | | | |
| . | . | . | | | |
| . | . | . | | | |
| . | . | . | | | |
| . | . | . | | | |
| . | . | . | | | |
| . | . | . | | | |

Fig.5-25

| Item | Contents |
|---------|---|
| CODE | A self-diagnostic code is described. "XXXX-YY" is described when a sub code exists. |
| BACKUP | Backup value |
| CURRENT | Current value |

The differences of [05 ADJUSTMENT MODE] between the values at the factory shipment and the current are output.

Remarks:

- "*" is added to the left side of the code if there is a difference.
- "+" is added to the left side of the code whose BACKUP data do not exist.
- BACKUP data are created when an easy-setup is finished.
- Only the codes available to set or check are output.
- Codes whose setting value at the time of the output is not unnecessary are not output (e.g.: setting time of the MFP).

Notes:

- Back-up data of the factory default are automatically created when the automatic gamma adjustment of the easy set-up mode has been completed during the unpacking and setting up of the MFP. The back-up file will be retained even if the system firmware is upgraded. However, the file will be deleted when the standard storage device is formatted or replaced.
- When the easy set-up mode is restarted while a specified value such as 4 through 9 is set for FS-08-9022 (Production process management status for easy setup), the back-up file stored during unpacking and setting-up is deleted after the completion of the automatic gamma adjustment and a new one is created. The value as of then is stored in the created back-up file.

- When no back-up file exists
When FS-30-121 (122) is performed, the MFP returns to the ready state of the 30 LIST PRINT MODE without printing being performed. When FS-30-221 (222) is performed, the MFP returns to the ready state of the 30 LIST PRINT MODE and the error message “The file cannot be saved.” appears on the panel.

(08) setting value difference

| | | | | | |
|--------------------|--------|---------|----------------------|-------------------------|-----------------|
| 08 DIFFERENCE LIST | | | S/N: Cxxxxxxx | FIN S/N: FIN S/N-xxxxxx | TOTAL: 99999 |
| xx-xx-xx xx:xx | | | TOSHIBA e-STUDIOxxxx | | DF TOTAL: 99999 |
| CODE | BACKUP | CURRENT | CODE | BACKUP | CURRENT |
| * 2400 | 128 | 160 | | | |
| . | . | . | | | |
| . | . | . | | | |
| . | . | . | | | |
| . | . | . | | | |
| . | . | . | | | |
| . | . | . | | | |
| . | . | . | | | |
| . | . | . | | | |
| . | . | . | | | |
| . | . | . | | | |
| . | . | . | | | |

Fig.5-26

| Item | Contents |
|---------|---|
| CODE | A self-diagnostic code is described. "XXXX-YY" is described when a sub code exists. |
| BACKUP | Backup value |
| CURRENT | Current value |

The differences of [08 SETTING MODE] between the values at the factory shipment and the current are output.

Remarks:

- "*" is added to the left side of the code if there is a difference.
- "+" is added to the left side of the code whose BACKUP data do not exist.
- BACKUP data are created when an easy-setup is finished.
- Only the codes available to set or check are output.
- Codes whose setting value at the time of the output is not unnecessary are not output (e.g.: setting time of the MFP).

Notes:

- Back-up data of the factory default are automatically created when the automatic gamma adjustment of the easy set-up mode has been completed during the unpacking and setting up of the MFP. The back-up file will be retained even if the system firmware is upgraded. However, the file will be deleted when the standard storage device is formatted or replaced.
- When the easy set-up mode is restarted while a specified value such as 4 through 9 is set for FS-08-9022 (Production process management status for easy setup), the back-up file stored during unpacking and setting-up is deleted after the completion of the automatic gamma adjustment and a new one is created. The value as of then is stored in the created back-up file.

- When no back-up file exists
When FS-30-121 (122) is performed, the MFP returns to the ready state of the 30 LIST PRINT MODE without printing being performed. When FS-30-221 (222) is performed, the MFP returns to the ready state of the 30 LIST PRINT MODE and the error message “The file cannot be saved.” appears on the panel.

FAX function mode (13) data list

```

13 FAX FUNCTION LIST FOR MAINTENANCE,VERSION x.x.x
20xx/xx/xx xx:xx:xx
TOSHIBA e-STUDIOxxxx
Cxxxxxxxx

TOTAL, 9999999, 9999999, 9999999, DF TOTAL, 9999999
CODE, SUB, DATA,
100, , 0
101, , 1
102, , 2
103, , 3
104, , 4
105, , 5
106, , 6
107, , 7
108, , 8
109, , 9
110, , 0
111, , 1
112, , 2

. .
. .
. .
. .
. .
. .

```

Fig.5-27

| Item | Contents |
|------|---|
| CODE | Self-diagnostic code |
| SUB | Sub code (This will be blank if a sub code does not exist.) |
| DATA | Value of the code |

The codes and the current setting value are output in a list.

Remarks:

Only the codes available to set or check are output.

Application list

| APPLICATION LIST | S/N : Cxxxxxxx | FIN S/N : FIN S/N-xxxxxxx | TOTAL | : 2146 |
|--|-------------------------------|---------------------------|----------|--------------|
| 20xx-xx-xx xx:xx | TOSHIBA e-STUDIOxxxx | | DF TOTAL | : 1213 |
| APPLICATION | | | | |
| NAME | APP ID/LOCALE | VERSION | | |
| e-Bridge Plus for xxxx | xxxxxxx-xxxx-xxxx-xxxxxxxxxxx | 1.0.0 | | |
| | English(US) | 1.2.1 | | |
| e-Bridge Plus for xxxxxxxxxxxxxxxxxxxxxxxx xx xxxxxxxx | xxxxxxx-xxxx-xxxx-xxxxxxxxxxx | 1.0.0 | | |
| | English(US) | 1.2.2 | | |
| | English(GB) | 1.1.1 | | |
| | Japanese | 1.3.1 | | |
| . | | | | |
| . | | | | |
| APPLICATION LICENSE | | | | |
| NAME | APP ID | INSTALL DATE | | |
| e-Bridge Plus for xxxx | xxxxxxx-xxxx-xxxx-xxxxxxxxxxx | 20xx-xx-xxTxx:xx:xx | | |
| e-Bridge Plus for xxxxxxxxxxxxxxxxxxxxxxxx xx xxxxxxxx | xxxxxxx-xxxx-xxxx-xxxxxxxxxxx | 20xx-xx-xxTxx:xx:xx | | |
| . | | | | |
| . | | | | |
| UNIFIED LICENSE | | | | |
| NAME | CERTIFICATE NUMBER | STATUS | DAYS | INSTALL DATE |
| e-Bridge Plus for xxxx | XXXXXXXXXX | ENABLE | xxxx | 20xx-xx-xx |
| e-Bridge Plus for xxxxxxxxxxxxxxxxxxxxxxxx xx xxxxxxxx | XXXXXXXXXX | DISABLE | - | 20xx-xx-xx |
| . | | | | |
| . | | | | |

Fig.5-28

Applications

| Item | Contents |
|---------------|--|
| NAME | Application name |
| APP ID/LOCALE | Application ID or language |
| VERSION | Version of the application or language |

Application license

| Item | Contents |
|--------------|----------------------------------|
| NAME | Application name |
| APP ID | Application ID |
| INSTALL DATE | Installation date of the license |

UNIFIED license

| Item | Contents |
|--------------------|------------------------------------|
| NAME | License name |
| CERTIFICATE NUMBER | License certificate ID |
| STATUS | License status (Enable or Disable) |
| DAYS | Valid period of the license |
| INSTALL DATE | Installation date of the license |

Installed application and license information are output.

Remarks:

The maximum output numbers are as below.

Application: 30 (Up to 100 applications can be output by changing the setting value of FS-08-3798.)

Application license: 100

UNIFIED license: 100

Life counter clear log

| UNIT | DATE | TOTAL | OUTPUT PAGES | DRIVE COUNTS |
|--------------------------|------------|--------|--------------|--------------|
| Drum(K) | 20xx-06-01 | xxxxxx | xxxxxx | xxxxxxxx |
| | 20xx-07-01 | xxxxxx | xxxxxx | xxxxxxxx |
| | 20xx-08-01 | xxxxxx | xxxxxx | xxxxxxxx |
| | 20xx-09-01 | xxxxxx | xxxxxx | xxxxxxxx |
| | 20xx-10-01 | xxxxxx | xxxxxx | xxxxxxxx |
| Drum Blade (K) | 20xx-06-01 | xxxxxx | xxxxxx | xxxxxxxx |
| | 20xx-07-01 | xxxxxx | xxxxxx | xxxxxxxx |
| | 20xx-08-01 | xxxxxx | xxxxxx | xxxxxxxx |
| | 20xx-09-01 | xxxxxx | xxxxxx | xxxxxxxx |
| | 20xx-10-01 | xxxxxx | xxxxxx | xxxxxxxx |
| Grid (K) | 20xx-06-01 | xxxxxx | xxxxxx | xxxxxxxx |
| | 20xx-07-01 | xxxxxx | xxxxxx | xxxxxxxx |
| | 20xx-08-01 | xxxxxx | xxxxxx | xxxxxxxx |
| | 20xx-09-01 | xxxxxx | xxxxxx | xxxxxxxx |
| | 20xx-10-01 | xxxxxx | xxxxxx | xxxxxxxx |
| Main Charger Needle (K) | 20xx-06-01 | xxxxxx | xxxxxx | xxxxxxxx |
| | 20xx-07-01 | xxxxxx | xxxxxx | xxxxxxxx |
| | 20xx-08-01 | xxxxxx | xxxxxx | xxxxxxxx |
| | 20xx-09-01 | xxxxxx | xxxxxx | xxxxxxxx |
| | 20xx-10-01 | xxxxxx | xxxxxx | xxxxxxxx |
| Charger Cleaning Pad (K) | 20xx-06-01 | xxxxxx | xxxxxx | xxxxxxxx |
| | 20xx-07-01 | xxxxxx | xxxxxx | xxxxxxxx |
| | 20xx-08-01 | xxxxxx | xxxxxx | xxxxxxxx |
| | 20xx-09-01 | xxxxxx | xxxxxx | xxxxxxxx |
| | 20xx-10-01 | xxxxxx | xxxxxx | xxxxxxxx |
| Drum Gap Spacer (K) | 20xx-06-01 | xxxxxx | xxxxxx | xxxxxxxx |
| | 20xx-07-01 | xxxxxx | xxxxxx | xxxxxxxx |
| | 20xx-08-01 | xxxxxx | xxxxxx | xxxxxxxx |
| | 20xx-09-01 | xxxxxx | xxxxxx | xxxxxxxx |
| | 20xx-10-01 | xxxxxx | xxxxxx | xxxxxxxx |
| Pick Up Roller(1st CST.) | 20xx-06-01 | xxxxxx | xxxxxx | xxxxxxxx |
| | 20xx-07-01 | xxxxxx | xxxxxx | xxxxxxxx |
| | 20xx-08-01 | xxxxxx | xxxxxx | xxxxxxxx |
| | 20xx-09-01 | xxxxxx | xxxxxx | xxxxxxxx |
| | 20xx-10-01 | xxxxxx | xxxxxx | xxxxxxxx |
| Feed Roller(1st CST.) | 20xx-06-01 | xxxxxx | xxxxxx | xxxxxxxx |
| | 20xx-07-01 | xxxxxx | xxxxxx | xxxxxxxx |
| | 20xx-08-01 | xxxxxx | xxxxxx | xxxxxxxx |
| | 20xx-09-01 | xxxxxx | xxxxxx | xxxxxxxx |
| | 20xx-10-01 | xxxxxx | xxxxxx | xxxxxxxx |
| Sep Roller(1st CST.) | 20xx-06-01 | xxxxxx | xxxxxx | xxxxxxxx |
| | 20xx-07-01 | xxxxxx | xxxxxx | xxxxxxxx |
| | 20xx-08-01 | xxxxxx | xxxxxx | xxxxxxxx |
| | 20xx-09-01 | xxxxxx | xxxxxx | xxxxxxxx |
| | 20xx-10-01 | xxxxxx | xxxxxx | xxxxxxxx |
| Pick Up Roller(2nd CST.) | 20xx-06-01 | xxxxxx | xxxxxx | xxxxxxxx |
| | 20xx-07-01 | xxxxxx | xxxxxx | xxxxxxxx |
| | 20xx-08-01 | xxxxxx | xxxxxx | xxxxxxxx |
| | 20xx-09-01 | xxxxxx | xxxxxx | xxxxxxxx |
| | 20xx-10-01 | xxxxxx | xxxxxx | xxxxxxxx |
| Feed Roller(2nd CST.) | 20xx-06-01 | xxxxxx | xxxxxx | xxxxxxxx |
| | 20xx-07-01 | xxxxxx | xxxxxx | xxxxxxxx |
| | 20xx-08-01 | xxxxxx | xxxxxx | xxxxxxxx |
| | 20xx-09-01 | xxxxxx | xxxxxx | xxxxxxxx |
| | 20xx-10-01 | xxxxxx | xxxxxx | xxxxxxxx |
| Sep Roller(2nd CST.) | 20xx-06-01 | xxxxxx | xxxxxx | xxxxxxxx |
| | 20xx-07-01 | xxxxxx | xxxxxx | xxxxxxxx |
| | 20xx-08-01 | xxxxxx | xxxxxx | xxxxxxxx |
| | 20xx-09-01 | xxxxxx | xxxxxx | xxxxxxxx |
| | 20xx-10-01 | xxxxxx | xxxxxx | xxxxxxxx |
| . | | | | |
| . | | | | |

Fig.5-29

| Item | Contents |
|--------------|---|
| UNIT | Cleared unit name |
| DATE | Cleared date |
| TOTAL | Total counter at the time of clear |
| OUTPUT PAGES | Number of output pages of the unit at the time of clear |
| DRIVE COUNTS | Drive time of the unit at the time of clear |

The clear history of the PM part counter is output.

Remarks:

Up to 5 logs remain per 1 part.

5.10 FAX

Adjustment [Setup Fax] and setting of the fax function can be carried out.

Select [FAX] in the FS Menu and press [Next]. The following modes are displayed.

- 11 FAX CLEAR MODE
- 12 FAX LIST PRINT MODE
- 13 FAX FUNCTION MODE
- 19 RAM EDIT MODE

Notes:

The data automatically received during the self-diagnostic mode are sometimes not printed.

Therefore, be sure to disconnect the modular cord from the line connector (LINE1, LINE2) of the MFP before starting the self-diagnostic mode. After the MFP is released from the self-diagnostic mode, reconnect the modular cord.

5.10.1 11 FAX CLEAR MODE

Select [FAX] in the FS Menu and press [Next]. Select [11 FAX CLEAR MODE] and press [Next]. [Setup Fax] and [Custom Initialize] are displayed.

[A] [Setup Fax]

The region of the fax can be set.

- (1) Press [Setup Fax].
- (2) Select the region and press [OK].

[B] [Custom Initialize]

Various fax memories can be initialized.

- Memory areas
 - User registration area (SRAM)
 - ID registration area
 - Home position
 - Image data area (storage device, SRAM)
 - Transmission file
 - Reception file
 - Image data file management area
 - Mailbox information
 - System setting area (NVRAM)
 - Settings in the [13 FAX FUNCTION MODE] areas 100 - 999
- Operation
 - (1) Press [Custom Initialize].
 - (2) Select the mode.
 - [Init Memory (Fax)], [Init Memory (IP Fax)]: Initializes the user registration area (SRAM) so that there are no data stored. Initializes the system setting area (NVRAM) so that its value is reset to the default setting.
 - [Clear Data]: Initializes the image data area (storage device, SRAM) so that there are no data stored.
 - [System Setup (Fax)], [System Setup (IP Fax)]: Initializes the system setting area (NVRAM) so that its value is reset to the default setting.

5.10.2 12 FAX LIST PRINT MODE

The setting contents of the fax function can be output.

- (1) Select [FAX] in the FS Menu and press [Next]. Select [12 FAX LIST PRINT MODE] and press [Next].
- (2) Select the list to output and press [Print].

The names of the lists in [12 FAX LIST PRINT MODE] are shown below.

Protocol trace list (Line 1)
Protocol trace list (Line 2)
Protocol trace list (IP Fax)
Error count list (transmis./recept.) (Line 1)
Error count list (transmis./recept.) (Line 2)
Error count list (transmis./recept.) (IP Fax)
ERROR COUNT LIST (IFAX)
ERROR COUNT LIST (SCAN)
Function List for Maintenance
Memory dump list (system)
Memory dump list (FAX/LINE1)
Memory dump list (FAX/LINE2)
SUPPLY ORDER LIST

5.10.3 13 FAX FUNCTION MODE

Various fax functions can be set.

Operation procedure: Refer to the SELF-DIAGNOSIS CODE (separate document).

5.10.4 19 RAM EDIT MODE

This is the mode for the special adjustments and settings. (This is not used generally.)

5.11 35 DATA BACKUP/RESTORE MODE

Backup files of the storage in the MFP can be saved (backed up) in a USB storage device or an external server and those saved backup files can be restored in the storage of the MFP.

- (1) Select [35 DATA BACKUP/RESTORE MODE] in the FS Menu and press [Next].
[Data Backup] and [Data Restore] are displayed.
- (2) Select [Data Backup] or [Data Restore] and press [Next]. Press [USB Media].
- (3) Insert a USB storage device into the MFP and press [OK]. Backing up or restoring of the data starts.

Remarks:

For details, see below.

 P. 12-7 “12.3 Backing Up and Restoring Data”

5.12 36 CLONING

A clone file including the setting information of this MFP and the user information can be created and clone files can be installed in this MFP.

For details, see below.

 P. 12-4 “12.2 Cloning (FS Menu)”

5.13 37 LICENSE MANAGEMENT

The application license can be registered or deleted.

For details, refer to the “License Management MANUAL” (separate document).

5.14 38 DEACTIVATE RELEASE MODE

Detached devices can be reconnected.

- (1) Press [Select] of the device to be reconnected.
- (2) Press [Execute].
- (3) Reboot the MFP.

Notes:

This operation must be carried out after the repairing of the detached device has been finished.

Remarks:

The same operation can be carried out with “77 Detach Release” of the HS Menu.

5.15 01 Control Panel Check

The following items can be checked.

- LCD back light illumination and brightness
- LCD display
- Hard keys performance
- LEDs illumination
- Digital keys performance
- LCD touch sensor
- USB storage device connection

Notes:

To check the performance of the digital keys, connect the ten key option before starting this mode.

5.15.1 Screen transition

Notes:

It is not possible to return to the HS Menu from [01 Control Panel Check]. To quit [01 Control Panel Check], display the LCD back light check screen A and then press the [ON/OFF] button for a few seconds to shut down.

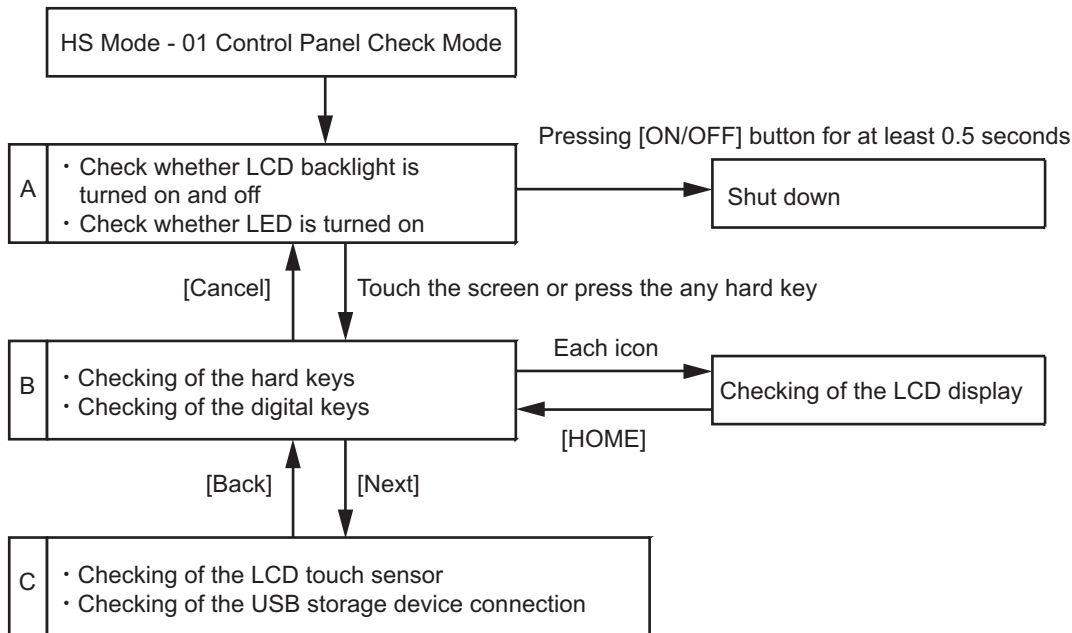

Fig.5-30

5.15.2 Checking of the LCD back light and LEDs

By pressing [01 Control Panel Check], the LCD back light blinks in 3-second intervals. Moreover, all LEDs are lit.

Remarks:

By touching the screen or pressing any hard key, the screen is shifted to the hard key confirmation screen.

5.15.3 Checking of the LCD display, hard keys and digital keys

[A] Checking of the LCD display

By pressing the icon on the touch panel, the LCD display (pictures 1 to 15) confirmation screen is displayed.

Remarks:

The screen is returned to this one when the [HOME] button is pressed on each screen.

[B] Checking of the hard keys

By pressing each hard key, a particular text is displayed and the lighting condition of the LED is changed. The following table shows each text and performance when the hard key is pressed.

| Hard key | Text | Performance |
|---|----------------|--|
| POWER (pressing for at least 0.5 seconds) | MAIN POWER | The [MEMORY RX] LED is turned OFF. |
| ENERGY SAVER | ENERGY SAVER | The [ENERGY SAVER] LED is turned OFF. |
| ACCESS | ACCESS | The [PRINT DATA] LED is turned OFF. |
| HOME | HOME | The [!] LED is turned OFF. |
| Programmable key 1 | P-1 | The LCD back light is made darker by each pressing. (10 levels) |
| Programmable key 2 | P-2 | The LCD back light is made lighter by each pressing. (10 levels) |
| FUNCTION CLEAR | FUNCTION CLEAR | The [FUNCTION CLEAR] LED is turned OFF. |
| START | START | The [START] LED is turned OFF. |

The text is displayed only while the key is being pressed. Each LED is turned OFF only while the key is being pressed.

[C] Checking of the digital keys for the Ten Key option

By pressing each digital key, a particular text is displayed. The following table shows each text when the digital key is pressed.

| Digital key | Text |
|-------------|----------|
| 1 | OP-1 |
| 2 | OP-2 |
| 3 | OP-3 |
| 4 | OP-4 |
| 5 | OP-5 |
| 6 | OP-6 |
| 7 | OP-7 |
| 8 | OP-8 |
| 9 | OP-9 |
| 0 | OP-0 |
| * | OP-* |
| # | OP-# |
| C | OP-CLEAR |

Remarks:

- By pressing the icon on the screen, the LCD display confirmation screen is displayed.
- By pressing [Next] in the LCD display, the screen is shifted to the LCD touch sensor and USB storage device confirmation screen.

5.15.4 Checking of the LCD touch sensor and USB storage device connection

The screen is shifted to the LCD touch sensor and USB storage device confirmation screen by pressing [Next].

[A] Checking of the LCD touch sensor

It can be checked whether the operations of swipe, pinch-out (enlargement) and pinch-in (reduction) are correctly detected on the screen. When the above operation is performed on the screen, an arrow which indicates the one detected by the touch sensor and a message are displayed.

Moreover, when any of [LH], [LL], [RH] or [RL] located on each corner of the screen is pressed, the calibration condition of the touched position can be checked.

[B] Checking of the USB storage device connection

It can be checked whether a USB storage device inserted into the USB port is connected properly. Install a USB storage device in the USB port and press the [START] button.

When a USB storage device is connected properly, [USB Connection Success] is displayed. If not, [USB Connection Failed] is displayed.

Remarks:

It is not possible to return to the HS Menu from [01 Control Panel Check]. To quit [01 Control Panel Check], display the LCD back light check screen and then press the [ON/OFF] button for a few seconds to shut down.

5.16 73 Firmware Assist

5.16.1 Overview

The following operations can be carried out; standard storage device partition, SRAM data initialization, standard storage device and SRAM data deletion, encryption key and license backing up and restoration.

The following table shows the functions in this mode.

| Function | Contents |
|---------------------------------------|---|
| Clear Software Update Error Flag | Clears an update error flag. |
| Format Root Partition | Initializes data storage partition of the standard storage device. |
| Format Storage | Creates a partition in a standard storage device. |
| Key Backup/Restore | Backs up or restores the encryption key and license. |
| Erase Storage Securely | Erases data in a normal HDD securely. |
| Clear Service Tech Password | Initializes the service password. |
| Clear SRAM | Initializes SRAM data. |
| Erase SRAM Securely | Erases data in the SRAM securely. |
| Format Storage Without Key Generation | Creates a partition in a standard storage device without having to upgrade the key. |
| Storage Data Restore | Performs initializing, backup data restoring and firmware upgrading in a series. |

5.16.2 Operation procedure

- (1) Press [73 Firmware Assist].
- (2) Press the icon to operate.

5.16.3 Functions

[A] Clear Software Update Error Flag

Even if the firmware downloading has been completed normally, the recovery mode may accidentally start up and an F600 error (service call) occurs when the power is turned ON again. In this case, clear the Update Error flags used in the download process with this function. (Normally, the flags are automatically cleared in the download process.)

Moreover, in the case of the recovery mode accidentally starting up after the replacement of the SRAM, the flags are cleared with this function.

[B] Format Root Partition

When a defect occurs on the UI data, etc. which are stored in the standard storage device, the partition with the stored UI data, etc. is initialized with this function.

Do not use this function since it is not normally necessary.

The system firmware must be installed after performing this function.

[C] Format Storage

After the standard storage device is replaced, when UI data are downloaded using a USB storage device, it is necessary to create a partition in the standard storage device of this MFP before downloading.

Notes:

- When this operation has been done, all data in the current standard storage device are erased. Therefore, perform this only when a new standard storage device is installed.
- When this operation has been done, do not perform SRAM data initialization (Clear SRAM) before the normal startup.

[D] Key Backup/Restore

When the SRAM or the SYS board is replaced or initialized, the encryption key and license are erased. Therefore, they need to be backed up or restored with this function.

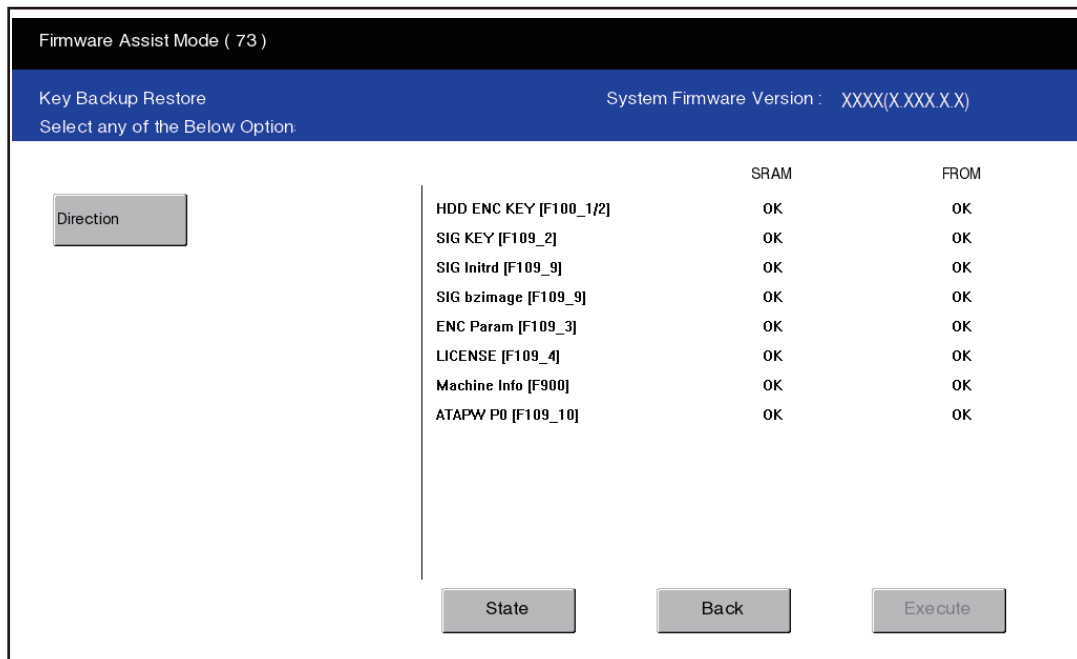

Fig.5-31

- (1) When “KeyBroken” or “KeyNull” is displayed on the FROM row, press [Direction] once and then [Execute].

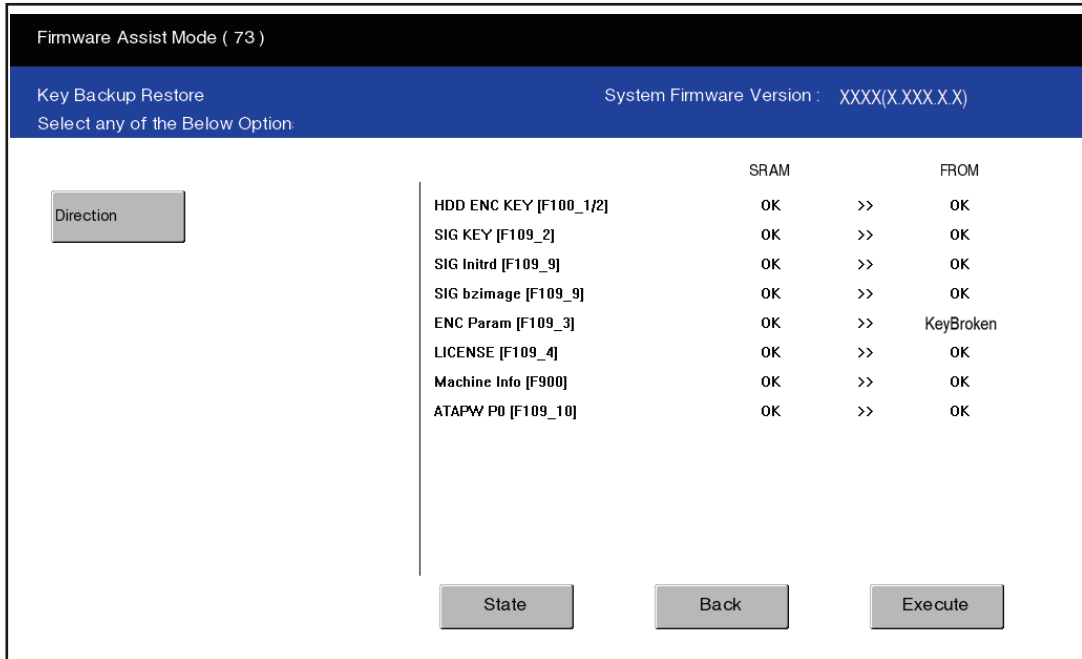

Fig.5-32

The encryption key and license of the SRAM are recovered in the FROM.

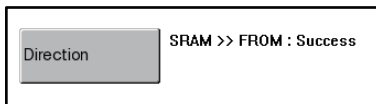

Fig.5-33

- (2) When “KeyBroken” or “KeyNull” is displayed on the SRAM row, press [Direction] twice and then [Execute].

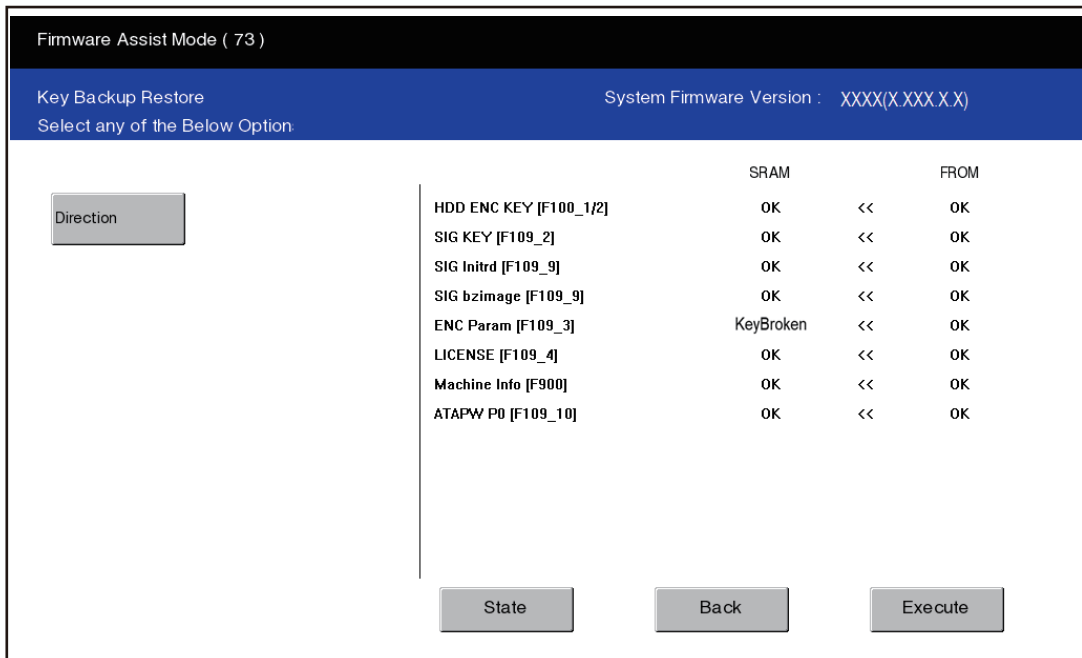

Fig.5-34

The encryption key and license of the FROM are backed up in the SRAM.

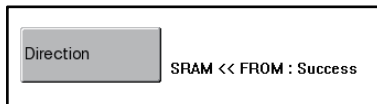

Fig.5-35

[E] Erase Storage Securely

This function is used before a normal HDD is disposed of. This overwrites all the used areas on the HDD with the selected data and makes it unusable. After selecting this function, specify the level below to be overwritten. This setting is the overwriting method complying with DoD 5220.22-M.

LOW (Normally use this setting.)

This is the standard overwriting method.

“00-FF-Random-Verify” Once

MEDIUM

This overwriting method is more secure than LOW.

The erasing time is between LOW and HIGH.

“00-FF-Random” three times repeatedly -Verify

HIGH

This is the most secure overwriting method.

It takes the longest time to erase data.

“00-FF-Random” five times repeatedly -Verify

SIMPLE

This is the simple overwriting method.

It takes the shortest time to erase data.

Overwrite the Random data once

The reconfirmation screen is displayed when the icon is pressed. Press [OK]: Processing starts.
Press [Back]: The screen returns to the previous one.

Notes:

When this operation has been done, do not perform SRAM data initialization (Clear SRAM) before the normal startup.

[F] Clear SRAM

When the SRAM is replaced with a new one, abnormal values may be written in the new SRAM. In this case, SRAM data must be initialized with this function.

Notes:

- This function is required only when a new SRAM is installed.
- When this operation has been done, all data in the SRAM are erased. Therefore, perform this only when a new SRAM is installed.
- After this operation has been done, do not perform the initialization and formatting of the standard storage device before starting the MFP in the normal mode.

[G] Erase SRAM Securely

This function is used before discarding the SRAM.

This overwrites all the used areas on the SRAM with the selected data and makes it unusable.

Immediately after selecting this function, the processing starts.

[H] Clear Service Tech Password

This function is necessary after the standard storage device is replaced.

When the standard storage device is replaced, the service password is set as a blank in the new one.

Therefore, the service password does not match the one saved in the SRAM. In this function, the service password is copied from the SRAM to a new standard storage device so that both service passwords become the same. The setting is reflected when the MFP is started up in the normal mode.

[I] Storage Data Restore

Performs initializing, backup data restoring and firmware upgrading of a standard storage device in a series.

Notes:

- Perform this function only after the standard storage device is replaced or when there will be no problem even if all the information in it is erased.
- Perform this function only when a USB storage device (*), in which the backup data and the firmware standard package are stored, is prepared.
 - * It is available even if these 2 files are stored in different USB storage devices separately.

(1) Install the USB storage device with the back-up data stored in the MFP.

(2) Perform this function.

- Initialize the standard storage device and restore the back-up data.
- If the firmware standard package is stored in this USB storage device, continuously upgrade the firmware.
- If the firmware standard package is not stored in this USB storage device, an error appears. In such a case, install the USB storage device with the firmware standard package stored in the MFP and press [OK]. Firmware upgrading will start.
- After upgrading is completed, reboot the MFP.

5.17 74 Storage Assist Mode

5.17.1 Overview

The type of the standard storage device and optional storage device can be checked and the condition of those devices can be returned to the one at the time of factory shipment.

74 Storage Assist function

- Checks the type of the storage device connected.
- Disposes of the connected storage device safely without any data leakage.
- Deletes image data when reusing a used storage device.

5.17.2 Operation procedure

- (1) Press [74 Storage Assist].
The type of the storage connected is displayed.
When a Secure HDD is mounted: Secure HDD
When a Normal HDD is mounted: Normal HDD
When an SSD is mounted: SSD
- (2) Press the icon to operate.

Notes:

- When “Normal HDD” is displayed, this function cannot be performed. In such a case, the following error message appears.
“Operation Failed. Press SoftPower Key to Switch Off.”
- If the type of the storage device cannot be identified, “Unknown HDD” may appear.
 P. 8-245 “ [F106_1] Optional storage device error”

5.17.3 Functions

[A] Revert Factory Initial Status Storage

This function is used to dispose of the connected storage device as well as the MFP.

When this function is executed, all data in the storage device are deleted and it is reverted to its initial status at the factory shipment.

Data deletion requires only a few seconds. In order to make it usable again, the creation of the partition is necessary.

- (1) Press [Revert Factory Initial Status Storage].
- (2) Press [OK] to carry out the operation.
When the operation is finished, the result appears on the screen.

Notes:

- If the MFP is started up in the normal mode under this condition, a service call (storage device mount error) will occur.
- After this has been performed, clearing of the storage device and reinstallation of applications are necessary.

5.18 75 File System Recovery

5.18.1 Overview

This is a mode to check if there is any damage to the file system and recover it if necessary. Use this mode only in the following cases.

- There is a possibility of damage to the file system.
- There is apparent damage to the file system, requiring recovery or initialization.

The following table shows the functions in this mode.

| Function | Contents |
|--------------------|---|
| Check F/S | Checks the file system. |
| Recovery F/S | Recovers the file system. |
| Initialize Storage | Initializes a partition in standard and optional storage devices. |
| Initialize DB | Initializes database (LDAP DB, log DB, language DB, AppMgmt DB, HomeScreen DB, JobHistory DB, AppLicense DB). |
| SMART Info | Displays the various information in standard and optional storage devices. |
| DISK Info | Displays the usage rate of each partition. |
| Storage Utility | Initializes log files. |

5.18.2 Operation procedure

- (1) Press [75 File System Recovery].
- (2) Press the icon to operate.

Notes:

- Do not turn the power OFF after the processing has started (while the processing is being performed).
- After the processing is completed, a beep sounds 4 times and either “Completed” or “Failed” appears on the screen.

5.18.3 Functions

[A] Check F/S

In case that particular service calls occur or there is a possibility of damage to the file system, the status of each partition can be checked.

Explanation for each item

ALL: Checks all partitions.

/: Checks all root partition only.

Others: Checks each partition shown above.

Remarks:

More than one partition can be selected. (A check mark is displayed at the selected item.)

Notes:

If damage is found, recover or initialize the file system.

[B] Recovery F/S

In case that an error occurs during the file system check, each partition can be recovered.

Explanation for each item

ALL: Recovers all partitions.

/: Recovers root partition only.

Others: Recovers displayed each partition.

Remarks:

More than one partition can be selected. (A check mark is displayed at the selected item.)

Notes:

If an error occurs during recovery, initialize the file system.

[C] Initialize Storage

In case that an error occurs during the file system checking and the partition cannot be recovered with the recovery, each partition can be initialized.

It is recommended to export the user information such as the address book before performing this function.

Explanation for each item

ALL: Initializes partitions other than root one and creates initial files.

Others: Initializes each partition.

Remarks:

More than one partition can be selected. (A check mark is displayed at the selected item.)

Notes:

- Install the system software by performing HS-49 after initialization.
- If initialization is carried out by selecting [ALL], the log database is also initialized. Back up the data before initializing if necessary.
- If [ALL] is selected, do not perform SRAM data formatting (Clear SRAM) before the normal startup.

[D] Initialize DB

In case that particular service calls occur or there is a possibility of damage to the database, each one can be initialized.

Explanation for each item

LDAP DB: Initializes address book data and the user information database.

Log DB(Log,Msg): Initializes the job log database and the message database.

Language DB: Initializes the language database.

AppMgmt DB: Initializes the application database.

HomeScreen DB: Initializes the home screen database.

JobHistory DB: Initializes the job history database.

AppLicense DB: Initializes the application license database.

ULM DB: Initializes the license manager database.

FingerPrint DB: Initializes the fingerprint database.

[E] SMART Info

This function is used to display the various types of information of the storage connected. The various types of information of the storage connected are displayed once this function is carried out. “---” is displayed for the items not supported.

Remarks:

- NAV (Normalized Attribute Value): Indicates the value of the specified storage device condition as compared to the manufacturer’s optimum value.
- Worst (Worst Ever Normalized Attribute Value): Indicates the worst value of NAV permitted by the manufacturer.

Notes:

The values of NAV and Worst should be treated as a rough reference since their basis may differ depending on the specification of the storage device.

[F] DISK Info

The usage rate of each partition can be checked. When this function is executed, the usage rate of each partition is displayed.

[G] Storage Utility

Log files for researching can be deleted. Since only a certain amount of log files for researching is usually stored in the work area of a storage device, the use of this mode is not necessary. In case the performance level of the MFP is lowered (e.g.: the response of the control panel becomes extremely slow), make use of this mode. This phenomenon may be resolved.

5.19 76 SRAM Maintenance

5.19.1 Overview

This is a mode in which you can clear particular errors such as F800 or F900.
The processing contents of this mode are the same as those for [Clear SRAM] in [HS-73].

Functions of 76 SRAM Maintenance

- The serial number of this MFP can be set.
- An F800 error can be cleared.
- An F900 error can be cleared.

5.19.2 Operation procedure

- (1) Press [76 SRAM Maintenance].
- (2) Press the icon to operate.

Remarks:

- [Turn Line Mode ON] or [Turn Line Mode OFF] starts once each icon is pressed.
- When [Set Serial Number], [Reset Date and Time], [SRAM Re-Initialize] or [Clear SRAM] is pressed, the confirmation screen appears.

5.19.3 Functions

[A] Turn Line Mode ON

The MFP enters into the manufacturing mode.

[B] Turn Line Mode OFF

The MFP returns from the manufacturing mode.

[C] Set Serial Number

When replacing the SYS-SRAM, select this mode since it is necessary to set the serial number of the MFP in order to perform recovery by using SRAM backup data. Key in the serial number and press [OK]. Then the serial number is set in the SYS-SRAM.

- Clear SRAM first and then set the serial number in this mode.
- After setting, perform recovery by using SRAM backup data.
 P. 12-2 “12.1.4 Cloning procedure”

[D] Reset Date and Time

Select this to clear an F800 error which occurred when the date and time were set as after the end of the year 2037 or when the actual end of the year 2037 has come.

- After executing this, start the MFP in the normal mode to reset the date and time.

[E] SRAM Re-Initialize

Clear an F900 error with this item, since it cannot be cleared if the SRAM and the SYS board are replaced together or when the SRAM is initialized with incorrect model information when it is replaced.

- After performing [Clear SRAM], carry out this function.
- Then perform initialization by following the replacement procedure of the SRAM.
 P. 9-39 “9.2.5 Precautions and procedure when replacing the SRAM”

[F] Clear SRAM

Select this to clear all SRAM data when replacing the SRAM.

- After replacing the SRAM, clear the SRAM data with this function.
- Then perform initialization by following the replacement procedure of the SRAM.
 P. 9-39 “9.2.5 Precautions and procedure when replacing the SRAM”

Notes:

After this operation has been done, do not perform the initialization and formatting of the standard storage device before starting the MFP in the normal mode.

5.20 77 Detach Release

Detached devices can be reconnected.

- (1) Press [Select] of the device to be reconnected.
- (2) Press [Execute].
- (3) Reboot the MFP.

Notes:

This operation must be carried out after the repairing of the detached device has been finished.

Remarks:

The same operation can be carried out with “38 DEACTIVATE RELEASE MODE” of the FS Menu.

5.21 78 Option Storage Assist

Formatting and removal setting of the optional storage device can be done.

[A] Format Option Storage

When an optional storage device has been replaced, format a new one by means of this function.

[B] Disable Option Storage

When an optional storage device has been removed, disable its setting by means of this function.

Notes:

The setting can be disabled only when the optional storage device is as below.

- SSD and normal HDD
- Security HDD to which “0” is set for 08-9717-1

5.22 TPM Restore

Restores TPM information.

Notes:

- This function is displayed and becomes operable, only after the SYS board has been replaced in an MFP in which TPM is enabled.
- TPM information is important for users. Therefore, request users to enter a part of the information.

- (1) Install the USB storage device. (Operation by a user)
- (2) Start the HS Menu.
- (3) Press [TPM].

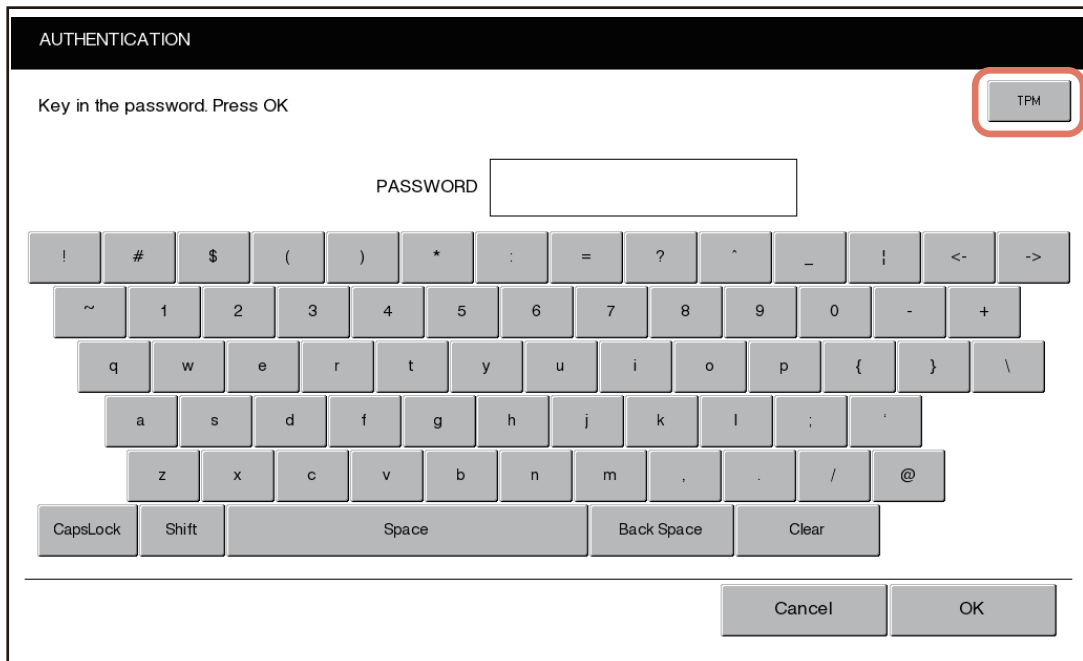

Fig.5-36

- (4) Enter the service password and press [OK].
- (5) Enter the password used when the TPM information has been backed up. (Operation by a user)
- (6) Press [Restore].
- (7) When "Operation Completed" appears, remove the USB storage device. (Operation by a user)
- (8) Turn the power OFF.

5.23 Batch Setting for Self-Diagnostic Codes

5.23.1 Overview

The encrypted setting files in which each setting value has been written can be stored in a USB storage device. Installing this USB storage device in the MFP and reading a setting file enables the batch setting for the self-diagnostic codes.

- After the batch setting is performed, a result file is stored in the USB storage device.

Notes:

This function is not available if an automatic execution script such as a log collection is stored in a USB storage device.

5.23.2 Setting files

An encrypted file in which the setting values for each code to be changed is written

File name: Apply a name by employing the usable characters for a FAT32 format (extension: diag).

Notes:

- A setting file has to be located in the 1st or 2nd layer of the root folder of a USB storage device.
- No other automatic execution script has to be located in the same layer in which a setting file is stored.
- Even if writing of the setting values has failed, the processing will not stop and writing into the setting file will continue to its end. After the processing has been completed, the result of the writing of all codes is stored in a result file and then a message indicating partial success will be displayed.

5.23.3 Result files

[1] Result files

A file in which success or failure of the replacement of the setting values for each code included in the setting files is written. A result file is stored in a USB storage device after this code is performed.

File name: DIG_RESULT_XXXX_yymmddhhmmss.xml (XXXX: Serial No.)

File format: xml format

[2] Example

```
<Policy>
  <Data>
    <Category-05/>
    <Category-08>
      <Code>
        <MainCode>8724</MainCode>
        <RESULT>SUCCESS</RESULT>
      </Code>
      <Code>
        <MainCode>9240</MainCode>
        <RESULT>FAILED</RESULT>
      </Code>
      <Code>
        <MainCode>9264</MainCode>
        <SubCode>1</SubCode>
        <RESULT>UNSPECIFIED</RESULT>
      </Code>
    </Category-08>
```

```

    <Category-13/>
  </Data>
</Policy>
* SUCCESS: Update of values has succeeded.
* FAILED: Update of values has failed.
* UNSPECIFIED: No codes written has existed. A value to be set is outside the assignable
  range.

```

Notes:

- The result files are saved in the root directory of the USB storage device.
- As for the codes whose values have been altered caused by the batch setting of another one, their items, such as the code number, the value changed and the success/failure of the change, are not described in a result file.
- In case an unavailable code for writing is included in the setting file, the processing will continue and then a message indicating partial success will be displayed after the setting of all codes has been completed. Unavailable codes for writing are displayed in the list by pressing [View]. [OK] is pressed on the screen of the message indicating partial success or the list screen, the display is returned to the BASIC screen.

5.23.4 Operation procedure

- (1) Enter into the Classic mode with [FS-08].
- (2) Install a USB storage device with setting files are stored in the MFP.
- (3) Key in [3673] and then press the [START] button.
- (4) Select a setting file.

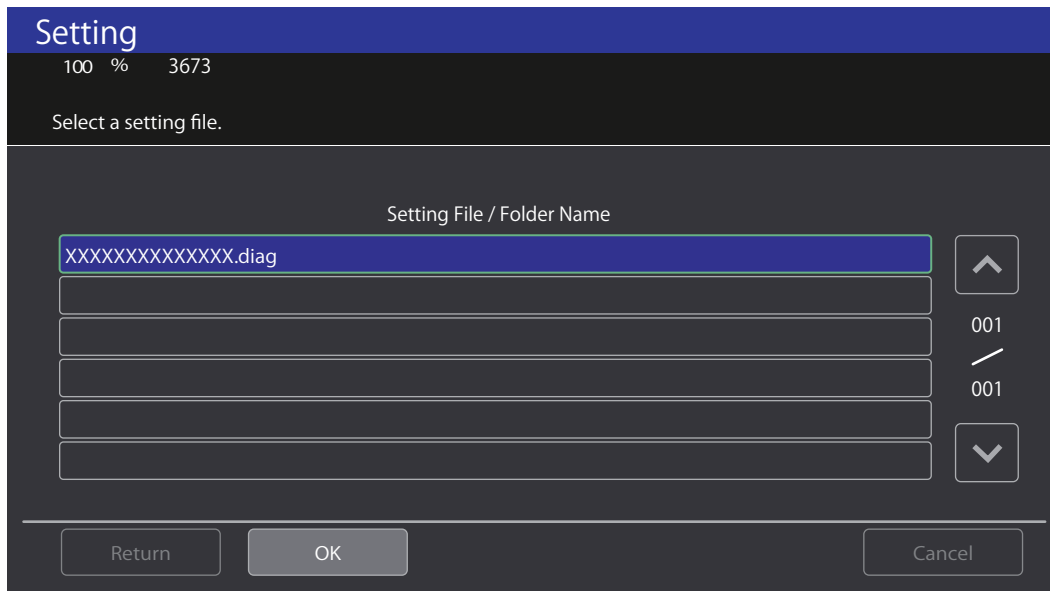

Fig.5-37

- (5) Press [OK].
- (6) Setting for all codes included in the setting file is completed, the BASIC screen of the 08 mode appears.
- (7) Remove the USB storage device.

Remarks:

When the screen is shifted to the FS Menu using the gear icon on the [User Functions] screen, the status is moved to the normal mode after the USB batch setting is finished.

- If a code which requires rebooting is included in the setting file, a reboot promotion screen appears.

6. SETTING AND ADJUSTMENT

6.1 Image Related Adjustment

6.1.1 Adjustment order

Perform image related adjustment in accordance with the following order.

Notes:

- When replacing components which have other specified instructions for adjustment, these are to be given priority.
- The adjustments connected with the dotted lines are not mandatory. However, if an adjustment is required, keep to the given the order.

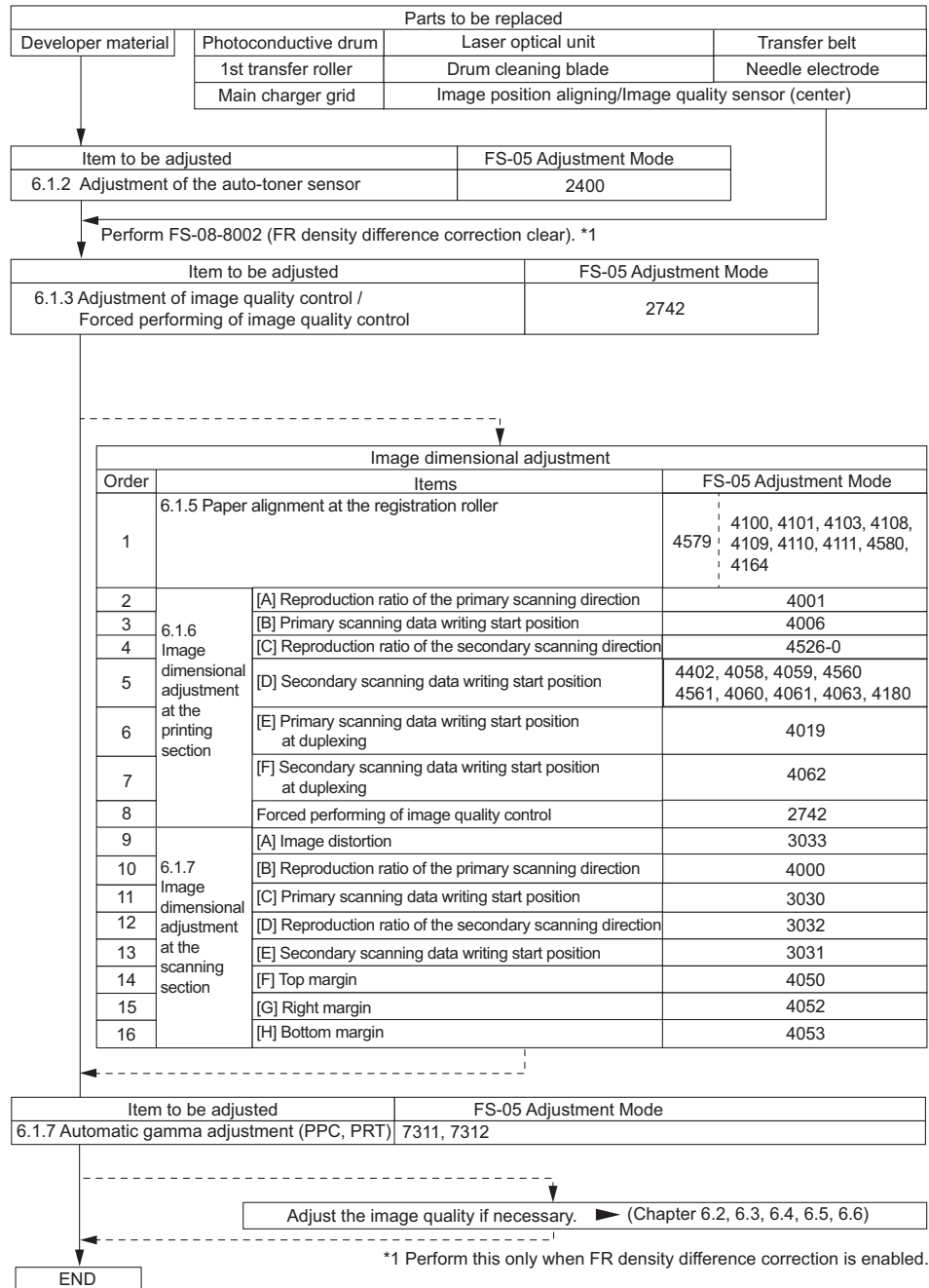

Fig.6-1

6.1.2 Auto-toner sensor adjustment

- When the following parts have been replaced, adjust the auto-toner sensor.
 - Developer material
- If the value of FS-08-2707-3 (Toner density ratio manual offset control) has been changed from “0”, return the sub code value of the corresponding color to “0”.

- (1) Install the drum cleaner unit.
- (2) Install a developer unit with no developer material in it.
- (3) Remove the sub-hopper.
- (4) Install the developer material cartridge in the place where the sub-hopper was attached.

Notes:

Do not install the toner cartridge.

- (5) Perform FS-05. The following message will be displayed.

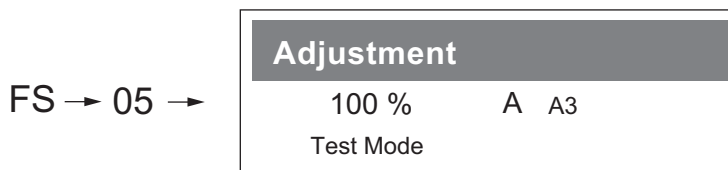

Fig.6-2

- (6) Key in the code and press the [START] button.
Code: 2400

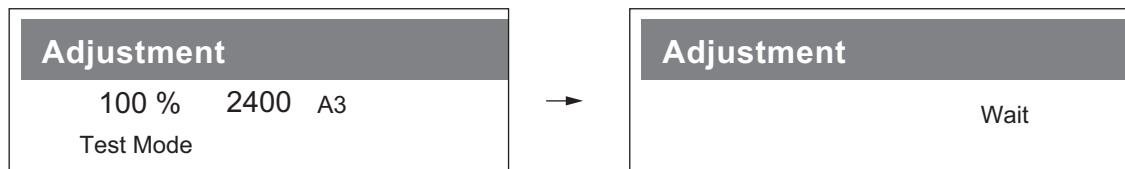

Fig.6-3

- (7) The following screen is displayed after approx. 2 minutes have passed.

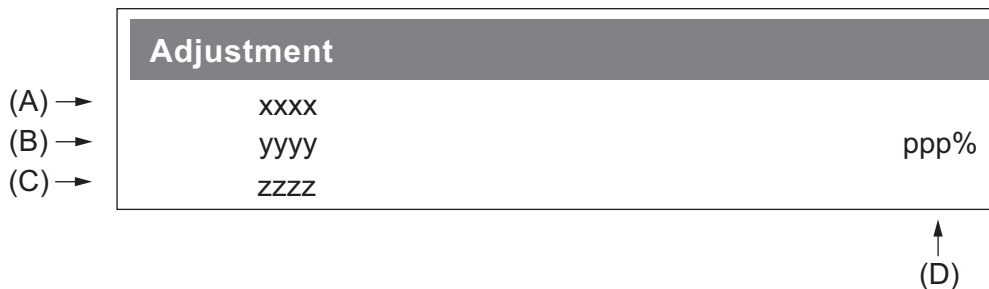

Fig.6-4

- (A): Current sensor output value (bit)
- (B): Sensor output control value (bit)
- (C): Target value of the adjustment reference voltage (V)
- (D): Humidity (%)

- (8) After approx. 15 seconds have passed, the values on the screen are changed and [OK] is displayed.
- (9) Press [OK] to store the adjustment result in the memory.

(10) Turn the power OFF and install the toner cartridge.

Notes:

When “Waste toner box replacement” is displayed at adjustment, follow the steps below.

1. Replace the waste toner box with a new one and close the front cover.
2. Key in [4833] (Recovery from toner empty/waste toner full).
3. Check that “WAIT” is displayed.

6.1.3 Image quality control adjustment

When any of the following parts is replaced, be sure to perform FS-05-2742 (Enforced performing of image quality control (closed-loop)).

- Photoconductive drum
- Developer material
- Laser optical unit
- Transfer belt
- 1st transfer roller
- Drum cleaning blade
- Needle electrode
- Main charger grid
- Image position aligning/image quality sensor (center)

| Code | Item to be adjusted | Contents |
|------------|--|--|
| FS-05-2742 | Enforced performing of image quality control (closed-loop) | <p><Procedure></p> <ol style="list-style-type: none"> 1. Perform FS-05-2742. 2. "WAIT" is displayed. 3. When the adjustment finishes normally, the MFP returns to the initial state of the Adjustment Mode. <p>When an error has occurred</p> <p><When "Waste toner box replacement" is displayed></p> <ol style="list-style-type: none"> 1. Replace the waste toner box with a new one and close the front cover. 2. Key in [4833] (Recovery from toner empty/waste toner full). 3. Check that "WAIT" is displayed. <p><When toner empty is displayed></p> <ol style="list-style-type: none"> 1. Replace the empty toner cartridge with a new one and close the front cover. 2. Key in [4833] (Recovery from toner empty/waste toner full). 3. Check that "WAIT" is displayed. <p><Other abnormalities></p> <p>Take the appropriate action described in Troubleshooting.  P. 8-1 "8. ERROR CODE AND TROUBLESHOOTING"</p> |

6.1.4 Alignment position adjustment

[A] Adjustment from the setup screen

Paper alignment at the registration roller can be adjusted in the following procedure by performing FS-05-4579.

- (1) Select the drawer.

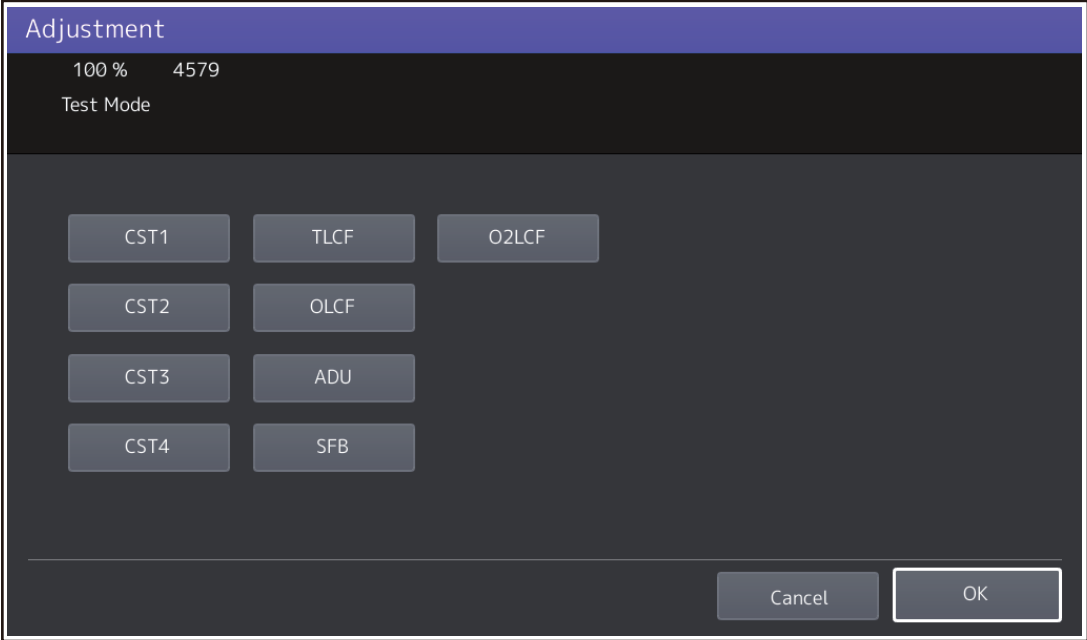

Fig.6-5

- (2) Select the paper size.

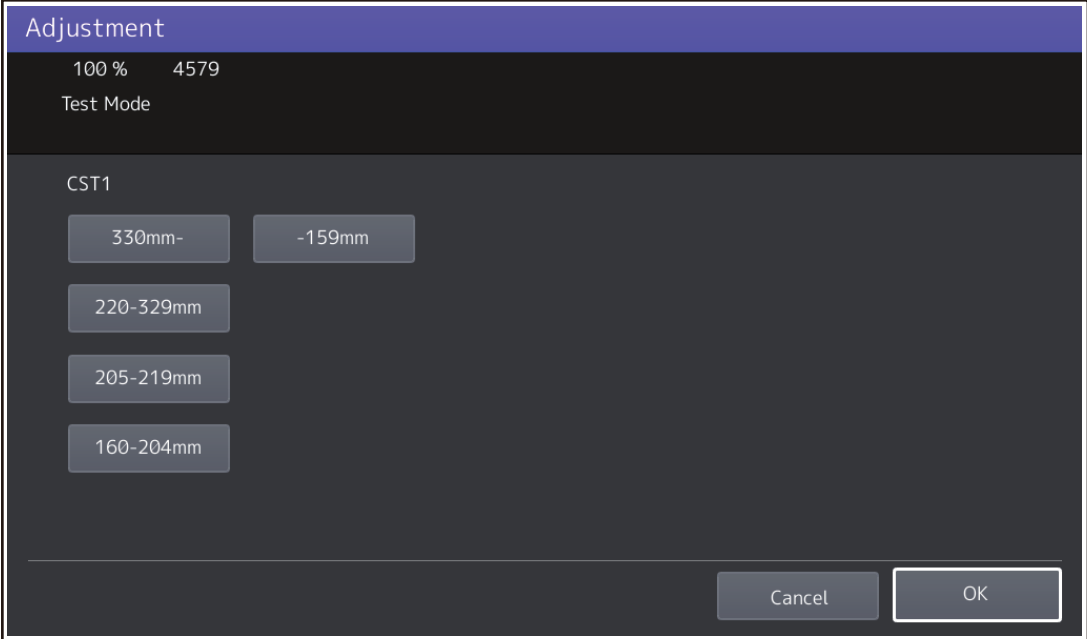

Fig.6-6

- (3) Select the paper type.

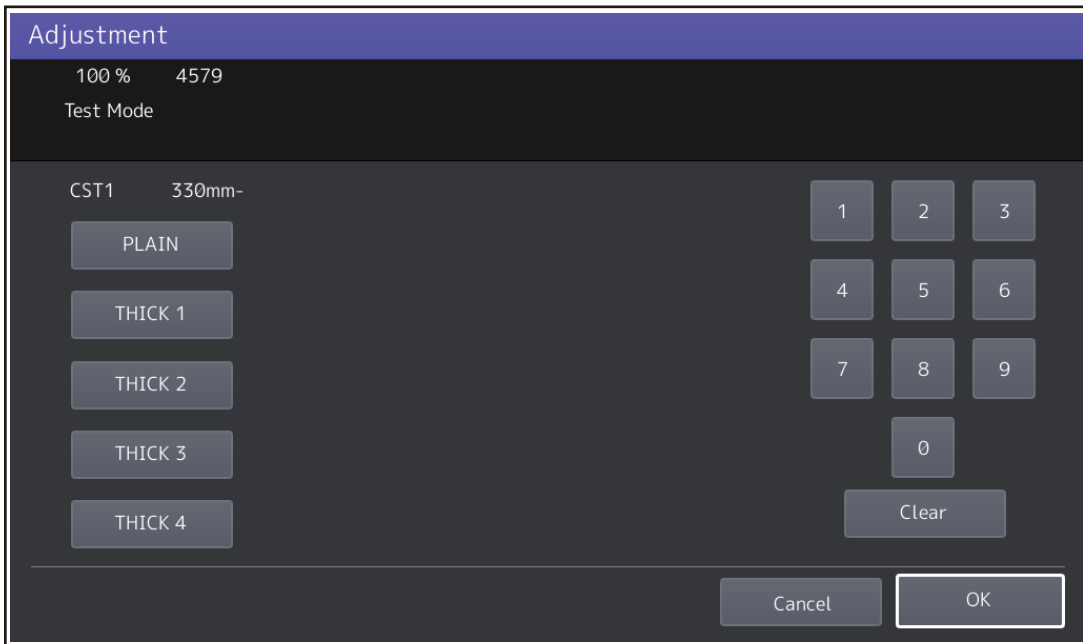

Fig.6-7

- (4) Key in the adjustment value.

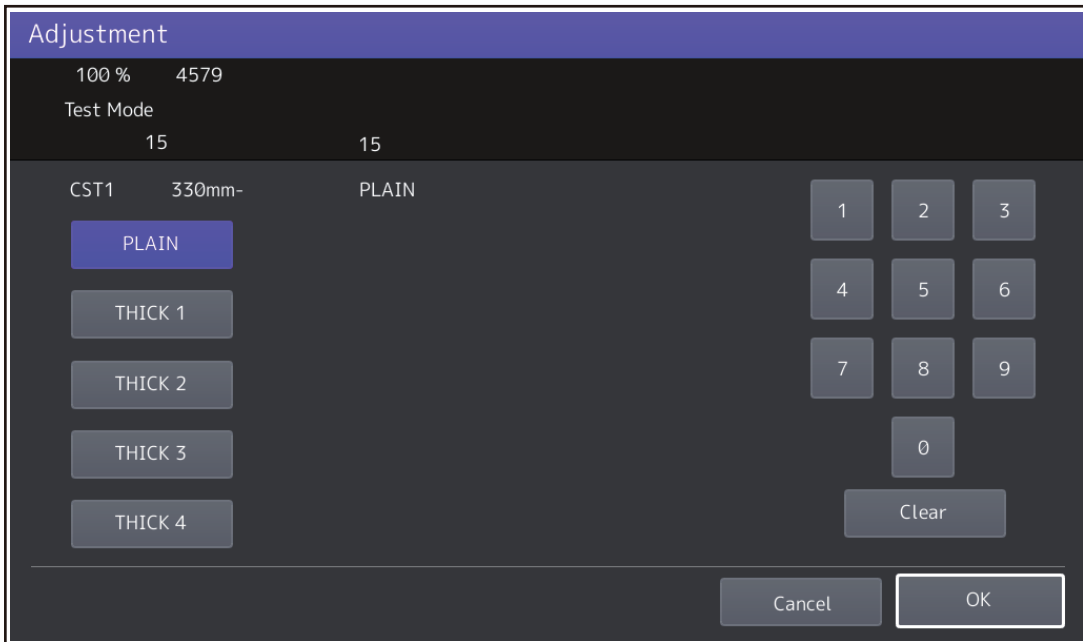

Fig.6-8

- (5) Press [OK] to finish the adjustment.
Press the [FUNCTION CLEAR] button to return to the previous menu.

[B] Adjustment by direct code entry

The alignment position can be adjusted by using the following codes in the 05 Adjustment Mode.

Drawer, Bypass tray, Automatic Duplexing Unit (ADU), Large Capacity Feeder (T-LCF)

| Drawer | Code | Sub code | Change amount per 1 step | Paper type*2 | |
|--------------------------------|------|--------------------|---|------------------------|---------|
| 1st drawer (CST1) | 4100 | 0, 1, 2, 3, 4*1 | This may vary depending on the paper source, paper type and paper size. Refer to the SELF-DIAGNOSIS CODE (separate document). | Plain, Recycled, Thick | |
| | 4115 | | | Thick 1 | |
| | 4582 | | | Thick 2 | |
| | 4588 | | | Thick 3 | |
| | 4133 | | | Thick 4 | |
| 2nd drawer (CST2) | 4101 | 0, 1, 2, 3, 4*1 | This may vary depending on the paper source, paper type and paper size. Refer to the SELF-DIAGNOSIS CODE (separate document). | Plain, Recycled, Thick | |
| | 4116 | | | Thick 1 | |
| | 4583 | | | Thick 2 | |
| | 4589 | | | Thick 3 | |
| | 4136 | | | Thick 4 | |
| 3rd drawer (CST3) | 4108 | 0, 1, 2, 3, 4*1 | This may vary depending on the paper source, paper type and paper size. Refer to the SELF-DIAGNOSIS CODE (separate document). | Plain, Recycled, Thick | |
| | 4117 | | | Thick 1 | |
| | 4584 | | | Thick 2 | |
| | 4590 | | | Thick 3 | |
| | 4140 | | | Thick 4 | |
| 4th drawer (CST4) | 4109 | 0, 1, 2, 3, 4*1 | This may vary depending on the paper source, paper type and paper size. Refer to the SELF-DIAGNOSIS CODE (separate document). | Plain, Recycled, Thick | |
| | 4118 | | | Thick 1 | |
| | 4585 | | | Thick 2 | |
| | 4591 | | | Thick 3 | |
| | 4144 | | | Thick 4 | |
| Bypass tray (SFB) | 4103 | 0, 1, 2, 3, 4*1 | This may vary depending on the paper source, paper type and paper size. Refer to the SELF-DIAGNOSIS CODE (separate document). | Plain, Recycled, Thick | |
| | 4104 | | | Thick 1 | |
| | 4105 | | | Thick 2 | |
| | 4106 | | | Thick 3 | |
| | 4601 | | | Thick 4 | |
| | 4107 | | | Transparency | |
| | 4128 | | | Special 1 | |
| | 4129 | | | Special 2 | |
| Automatic Duplexing Unit (ADU) | 4110 | - | - | Plain, Recycled, Thick | |
| | 4120 | | | Thick 1 | |
| | 4615 | | | Thick 2 | |
| | 4593 | | | Thick 3 | |
| | 4602 | | | Thick 4 | |
| | 4603 | | | Special 1 | |
| | 4604 | | | Special 2 | |
| Large Capacity Feeder (T-LCF) | 4111 | - | - | Plain, Recycled, Thick | |
| | 4119 | | | 0 | Thick 1 |
| | | | | 1 | Thick 2 |
| | | | | 2 | Thick 3 |
| | | | | 5 | Thick 4 |

*1 See the correspondence table for the paper size and the sub code.

*2 See the correspondence table for the paper type and the paper weight.

External Large Capacity Feeder

| Drawer | Code | Sub code | Change amount per 1 step | Paper type*2 |
|--|------|-----------------|---|------------------------|
| External Large Capacity Feeder (Ex-LCF (2.5K)) | 4580 | 0, 1, 2, 3, 4*1 | This may vary depending on the paper source, paper type and paper size. Refer to the SELF-DIAGNOSIS CODE (separate document). | Plain, Recycled, Thick |
| | 4581 | | | Thick 1 |
| | 4586 | | | Thick 2 |
| | 4592 | | | Thick 3 |
| | 4168 | | | Thick 4 |
| External Large Capacity Feeder (Ex-LCF (2.0K)) | 4164 | | | Plain, Recycled, Thick |
| | 4165 | | | Thick 1 |
| | 4166 | | | Thick 2 |
| | 4167 | | | Thick 3 |
| | 4171 | | | Thick 4 |

*1 See the correspondence table for the paper size and the sub code.

*2 See the correspondence table for the paper type and the paper weight.

Correspondence table for the paper size and the sub code

| Length in the secondary scanning direction | Sub code |
|--|----------|
| 330 mm or longer | 0 |
| 220 mm to 329 mm | 1 |
| 205 mm to 219 mm | 2 |
| 160 mm to 204 mm | 3 |
| 159 mm or shorter | 4 |

Correspondence table for the paper type and the paper weight

| Paper type | Paper weight (g/m ²) |
|------------|----------------------------------|
| Plain | 60 to 80 |
| Thick | 81 to 105 |
| Thick 1 | 106 to 163 |
| Thick 2 | 164 to 209 |
| Thick 3 | 210 to 256 |
| Thick 4 | 257 to 300 |

<Procedure>

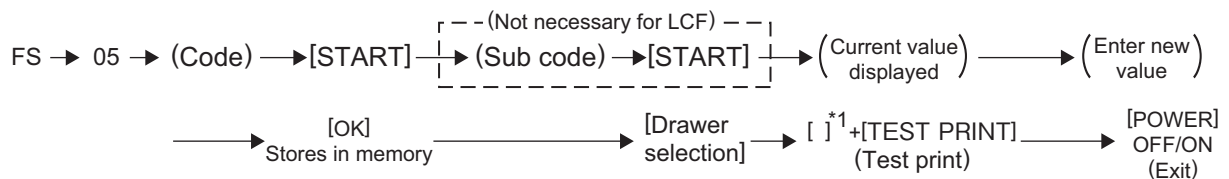

Fig.6-9

- *1 1: Simplex black grid pattern
3: Duplex black grid pattern

Notes:

If paper alignment is too large, abnormal noise (paper-folding noise) or actual paper folding may occur during paper feeding. If the paper alignment is too small, on the other hand, a skew, an image dislocation in the feeding direction, E010 (Paper not reaching the paper exit sensor jam) or E011 (Transfer belt paper-clinging jam) may occur. Pay attention to the above and select the appropriate value.

6.1.5 Image dimensional adjustment at the printing section

This adjustment is performed by using the chart output from the MFP. There are two ways of the image dimensional adjustment: Type 1 and Type 2.

- Type 1: Actual dimension adjustment method (Adjusts the image position and the ratio by measuring and checking the actual dimension of the images. The reference position of the image is the leading edge at the front.)

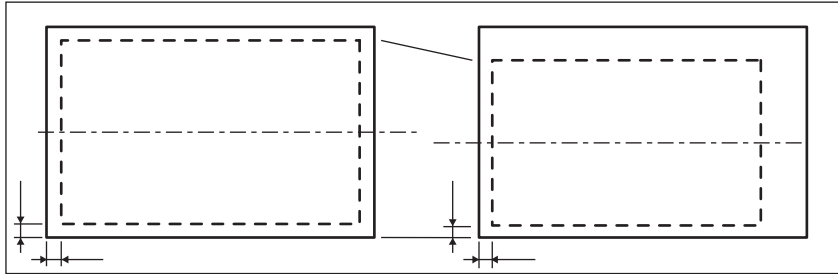

Fig.6-10

- Adjustment with a high degree of accuracy can be made.
 - The reference is given to the front side of the leading edge. Therefore, when the paper size is changed, the void around the paper tends to be altered accordingly.
- Type 2: Void even adjustment method (Adjusts the image position and the ratio by measuring and checking the void. The reference position of the image is the center of the paper.)

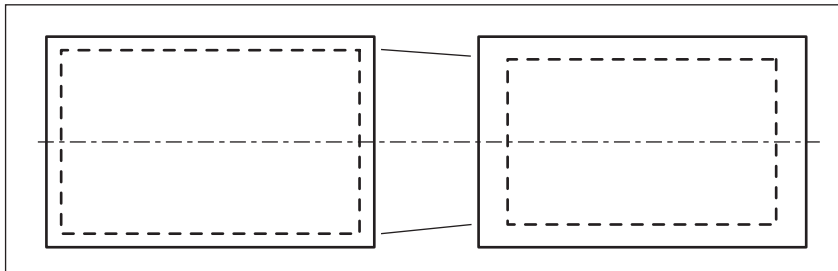

Fig.6-11

- The image position at the front and the back sides can make to be aligned easily.
- The void around the paper can make to be evenly aligned easily.

Remarks:

The void correction of paper frequently used can be made easily by entering its actual dimension into FS-05-4922 and then performing FS-05-4920.

Use the appropriate chart corresponding to the adjustment instruction. After the image dimensional adjustment, perform FS-05-2742 (Enforced performing of image quality control (closed-loop)).

In addition, check that no gap has occurred in the following adjustments.

Scanning Section:  P. 6-18 “6.1.6 Image dimensional adjustment at the scanning section”

Type 1: Actual dimension adjustment method

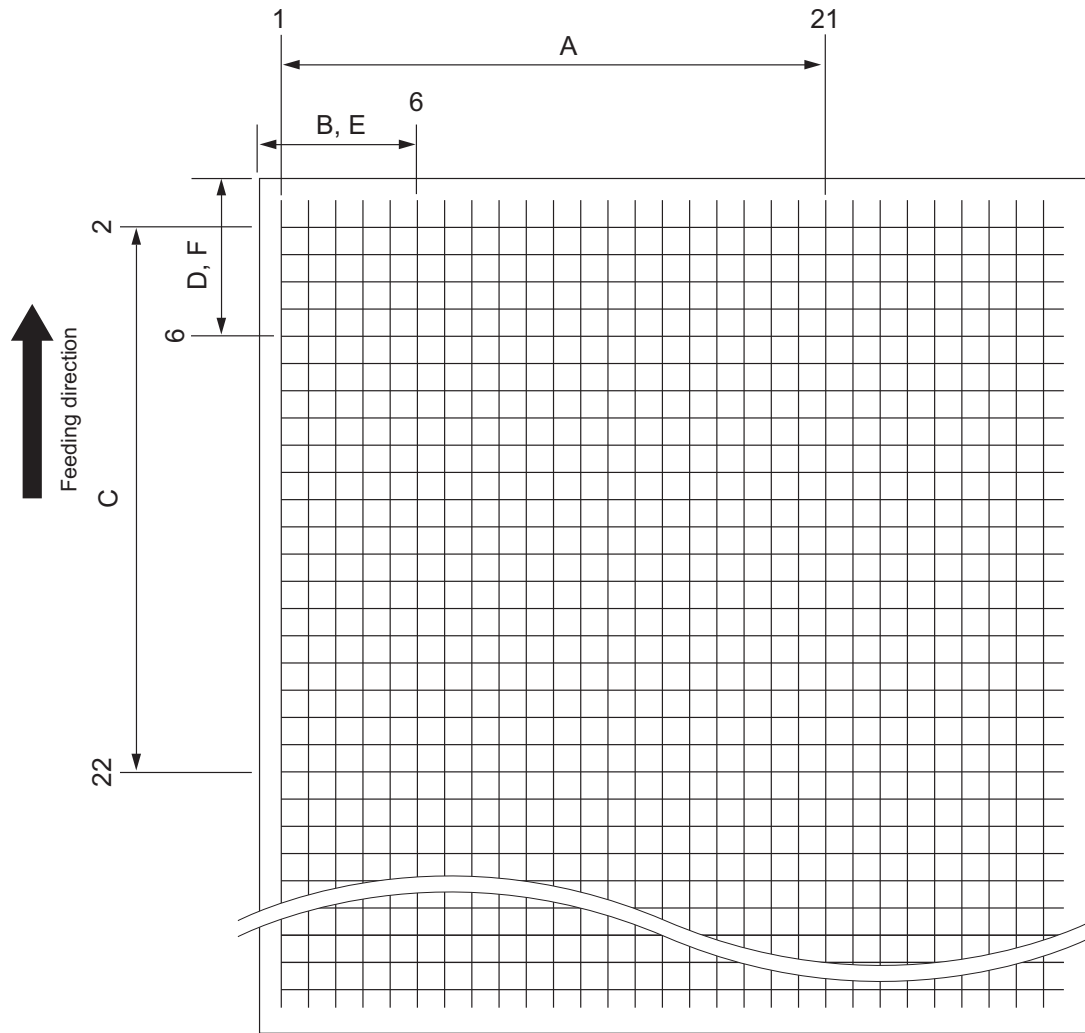

* E, F : Measure on the top side of the chart.

Fig.6-12

| | Adjustment acceptable range | Detail of adjustment | Chart |
|---|-----------------------------|---|-------|
| A | 200 mm ± 0.5 mm | 📖 P. 6-12 "[A] Reproduction ratio of the primary scanning direction" | 05-1 |
| B | 52 mm ± 0.5 mm | 📖 P. 6-12 "[B] Primary scanning direction data writing start position" | |
| C | 200 mm ± 0.5 mm | 📖 P. 6-13 "[C] Reproduction ratio of the secondary scanning direction" | |
| D | 52 mm ± 0.5 mm | 📖 P. 6-14 "[D] Secondary scanning direction data writing start position" | |
| E | 52 mm ± 0.5 mm | 📖 P. 6-14 "[E] Primary scanning direction data writing start position at duplexing" | 05-3 |
| F | 52 mm ± 0.5 mm | 📖 P. 6-15 "[F] Secondary scanning direction data writing start position at duplexing" | |

Notes:

As for C, D and F, the measurement should be carried out by considering that there is a 1st line even if it is not actually printed.

Type 2: Void even adjustment method
Simplex

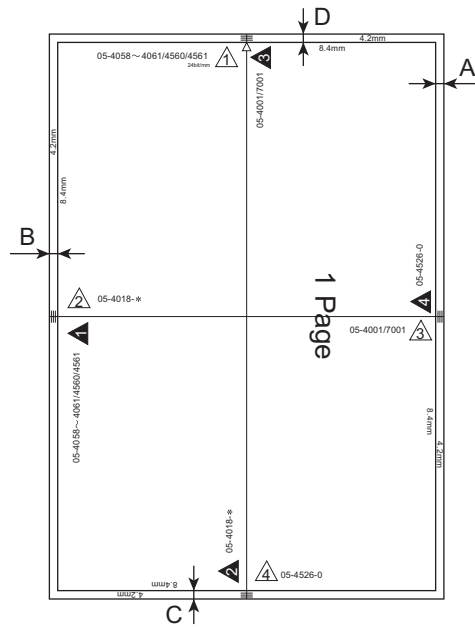

Duplex

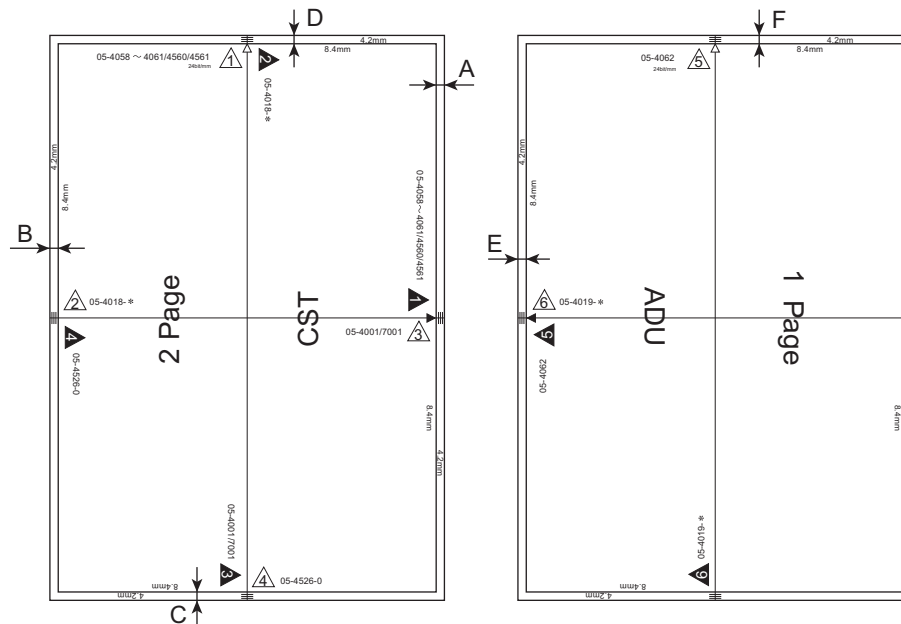

Fig.6-13

| Measurement position | Adjustment acceptable range | Detail of adjustment | Chart |
|----------------------|-----------------------------|---|--------|
| A | 4.2 mm ± 0.5 mm | P. 6-12 "[A] Reproduction ratio of the primary scanning direction" | 05-315 |
| B | 4.2 mm ± 0.5 mm | P. 6-12 "[B] Primary scanning direction data writing start position" | |
| C | 4.2 mm ± 0.5 mm | P. 6-13 "[C] Reproduction ratio of the secondary scanning direction" | |
| D | 4.2 mm ± 0.5 mm | P. 6-14 "[D] Secondary scanning direction data writing start position" | |
| E | 4.2 mm ± 0.5 mm | P. 6-14 "[E] Primary scanning direction data writing start position at duplexing" | 05-316 |
| F | 4.2 mm ± 0.5 mm | P. 6-15 "[F] Secondary scanning direction data writing start position at duplexing" | |

[A] Reproduction ratio of the primary scanning direction

| Paper source | Code | Acceptable value | Change amount per 1 step | Paper size | Chart |
|--------------|---------|------------------|--------------------------|------------|----------------|
| 2nd drawer | 05-4001 | 0 to 255 | Approx. 0.10 mm | A3, LD | 05-1 or 05-315 |

- (1) Print out the chart in the ready state of the Classic mode of FS-05.
Perform FS-05-1 or FS-05-315 and then press [TEST PRINT].
- (2) Check that the distance A of the chart is within the acceptable range.
FS-05-1: 200 mm \pm 0.5 mm (Recommendation: 200 mm +0/-5 mm)
FS-05-315: 4.2 mm \pm 0.5 mm
- (3) If not, change the value of the code.
The larger the adjustment value is, the longer the distance A becomes.
- (4) Output the chart again and measure the distance A.

[B] Primary scanning direction data writing start position

Use the following code to adjust all paper sources at once.

| Paper source | Code | Acceptable value | Change amount per 1 step | Paper size | Chart |
|--------------|---------|------------------|--------------------------|------------|----------------|
| 2nd drawer | 05-4006 | 0 to 255 | Approx. 0.04 mm | A3, LD | 05-1 or 05-315 |

Use the following code to adjust the paper sources individually.

| Adjustment order | Paper source | Code | Sub code | Acceptable value | Change amount per 1 step | Paper size | Chart |
|------------------|---------------|---------|----------|------------------|--------------------------|------------|----------------|
| 1 | 1st drawer | 05-4018 | 0 | 0 to 255 | Approx. 0.04 mm | A3, LD | 05-1 or 05-315 |
| 2 | Bypass tray | | 5 | | | | |
| 3 | 2nd drawer | | 1 | | | | |
| 4 | 3rd drawer | | 2 | | | | |
| 5 | 4th drawer | | 3 | | | | |
| 6 | T-LCF * | | 4 | | | A4, LT | |
| 7 | Ex-LCF (2.5K) | | 6 | | | | |
| 8 | Ex-LCF (2.0K) | | 7 | | | | |

* When the T-LCF is installed, adjustment of the 3rd and 4th drawers is unnecessary.

- (1) Print out the chart in the ready state of the Classic mode of FS-05.
Perform FS-05-1 or FS-05-315 and then press [TEST PRINT].
- (2) Check that the distance B of the chart is within the acceptable range.
FS-05-1: 52 mm \pm 0.5 mm
FS-05-315: 4.2 mm \pm 0.5 mm
- (3) If not, change the value of the corresponding code.
The larger the adjustment value is, the longer the distance B becomes.
- (4) Output the chart again and measure the distance B.

Notes:

- The adjustment result of FS-05-4006 is reflected to the control of each paper source. Therefore, perform adjustment for each paper source after FS-05-4006 has been carried out.
- If the setting value for each paper source has been changed, perform printing by selecting one whose value has been changed and check the images.

[C] Reproduction ratio of the secondary scanning direction

| Paper source | Code | Sub code* | Acceptable value | Change amount per 1 step | Paper size | Chart |
|--------------|---------|-----------|------------------|---|------------|-------------------|
| 2nd drawer | 05-4526 | 0 | 0 to 255 | 0.04% (6529A) 0.05% (7529A) 0.06% (9029A) | A3, LD | 05-1 or 05-315 |
| | | 1 | | 0.04% | | |
| | | 2 | | 0.04% | | |
| | | 4 | | 0.04% (9029A) | | |

The meaning of the sub code is as below.

| Sub code | Explanation |
|----------|--|
| 0 | Plain, Recycled, Thick |
| 1 | Thick 1, Thick 2, Thick 3, Thick 4 |
| 2 | Thick 3, Thick 4 |
| 4 | Plain, Recycled, Thick (Low temperature) |

- (1) Print out the chart in the ready state of the Classic mode of FS-05.
Perform FS-05-1 or FS-05-315 and then press [TEST PRINT].
- (2) Check that the distance C of the chart is within the acceptable range.
FS-05-1: 200 mm ± 0.5 mm (Recommendation: 200 mm +0/-5 mm)
FS-05-315: 4.2 mm ± 0.5 mm
- (3) If not, change the value of the corresponding code.
 - The larger the adjustment value is, the longer the distance C becomes.
 - If the value has been changed, an image at the trailing edge may run off from the paper length or its density may become lighter. Therefore, perform adjustment while the image is being checked.
- (4) Output the chart again and measure the distance C.

Notes:

- The adjustment result of FS-05-4526-0 is reflected to the control of FS-05-4526-1, 2, 4. Therefore, do not change the values of FS-05-4526-1, 2, 4 unless otherwise required.
- The setting value of FS-05-4526-0 is reflected to the charts 05-1, 05-3, 05-315 and 05-316. Therefore, the adjustment result of FS-05-4526-1, 2, 4 cannot be checked with these charts.
- An image at the trailing edge may run off from the paper length or its density may become lighter. Therefore, perform adjustment while the image is being checked.

[D] Secondary scanning direction data writing start position

Use the following code to adjust all paper sources at once.

| Paper source | Code | Acceptable value | Change amount per 1 step | Paper size | Chart |
|--------------|---------|------------------|--------------------------|------------|----------------|
| 2nd drawer | 05-4402 | 0 to 200 | Approx. 0.10 mm | A3, LD | 05-1 or 05-315 |

Use the following code to adjust the paper sources individually.

| Adjustment order | Paper source | Code | Acceptable value | Change amount per 1 step | Paper size | Chart |
|------------------|---------------|---------|------------------|--------------------------|------------|----------------|
| 1 | 1st drawer | 05-4058 | 0 to 100 | Approx. 0.10 mm | A3, LD | 05-1 or 05-315 |
| 2 | 2nd drawer | 05-4059 | | | | |
| 3 | T-LCF * | 05-4561 | | | | |
| 4 | 3rd drawer | 05-4060 | | | | |
| 5 | 4th drawer | 05-4560 | | | | |
| 6 | Bypass tray | 05-4061 | | | | |
| 7 | Ex-LCF (2.5K) | 05-4063 | | | | |
| 8 | Ex-LCF (2.0K) | 05-4180 | | | | |

* When the T-LCF is installed, adjustment of the 3rd and 4th drawers is unnecessary.

- (1) Print out the chart in the ready state of the Classic mode of FS-05.
Perform FS-05-1 or FS-05-315 and then press [TEST PRINT].
- (2) Check that the distance D of the chart is within the acceptable range.
FS-05-1: 52 mm \pm 0.5 mm
FS-05-315: 4.2 mm \pm 0.5 mm
- (3) If not, change the value of the corresponding code.
The larger the adjustment value is, the longer the distance D becomes.
- (4) Output the chart again and measure the distance D.

Notes:

- The adjustment result of FS-05-4402 is reflected to the control of each paper source. Therefore, perform adjustment for each paper source after FS-05-4402 has been carried out.
- If the setting value for each paper source has been changed, perform printing by selecting one whose value has been changed and check the images.

[E] Primary scanning direction data writing start position at duplexing

| Adjustment order | Paper source | Code | Sub code | Acceptable value | Change amount per 1 step | Paper size | Chart |
|------------------|--------------|---------|----------|------------------|--------------------------|----------------------------------|----------------|
| 1 | 2nd drawer | 05-4019 | 0 | 0 to 255 | Approx. 0.04 mm | Long size (330 mm or longer) | 05-3 or 05-316 |
| 2 | | | 1 | | | Short size (A4 or LT or shorter) | |
| | | | 2 | | | Middle size | |

- (1) Print out the chart in the ready state of the Classic mode of FS-05.
Perform FS-05-3 or FS-05-316 and then press [TEST PRINT].
- (2) Check that the distance E of the chart is within the acceptable range.
FS-05-3: 52 mm \pm 0.5 mm
FS-05-316: 4.2 mm \pm 0.5 mm
- (3) If not, change the value of the corresponding code.
The larger the adjustment value is, the longer the distance E becomes.

- (4) Output the chart again and measure the distance E.

Notes:

- The adjustment result of FS-05-4006 has been reflected in FS-05-4019-0.
- The adjustment results of FS-05-4019-0 and FS-05-4006 are reflected to the control of each paper source. Therefore, perform adjustment for each paper size after FS-05-4006 and FS-05-4019-0 have been carried out.
- If the setting value for each paper size has been changed, perform printing by selecting one whose value has been changed and check the images.

[F] Secondary scanning direction data writing start position at duplexing

| Paper source | Code | Acceptable value | Change amount per 1 step | Paper size | Chart |
|--------------|---------|------------------|--------------------------|------------|----------------|
| 2nd drawer | 05-4062 | 0 to 100 | Approx. 0.10 mm | A3, LD | 05-3 or 05-316 |

- (1) Print out the chart in the ready state of the Classic mode of FS-05.
Perform FS-05-3 or FS-05-316 and then press [TEST PRINT].
- (2) Check that the distance F of the chart is within the acceptable range.
FS-05-3: 52 mm \pm 0.5 mm
FS-05-316: 4.2 mm \pm 0.5 mm
- (3) If not, change the value of the code.
The larger the adjustment value is, the longer the distance F becomes.
- (4) Output the chart again and measure the distance F.

<Adjustment order summarize from A to F>

| Measurement position | Code | Sub code | Paper source | Paper size | Type 1 | | Type 2 | | Change amount per 1 step |
|----------------------|---------------|----------|---------------|-------------|--------|-----------------------|--------|-----------------------|--|
| | | | | | Chart | Acceptable range (mm) | Chart | Acceptable range (mm) | |
| A | 05-4001 | - | 2nd drawer | A3, LD | 05-1 | 200 ± 0.5 | 05-315 | 4.2 ± 0.5 | 0.10 mm |
| B | 05-4006 | - | 2nd drawer | A3, LD | 05-1 | 52 ± 0.5 | 05-315 | 4.2 ± 0.5 | 0.04 mm |
| | 05-4018 | 0 | 1st drawer | A3, LD | 05-1 | 52 ± 0.5 | 05-315 | 4.2 ± 0.5 | 0.04 mm |
| | | 5 | Bypass tray | | | | | | |
| | | 1 | 2nd drawer | | | | | | |
| | | 2 | 3rd drawer | | | | | | |
| | | 3 | 4th drawer | | | | | | |
| | | 4 | T-LCF | A4, LT | | | | | |
| | | 6 | Ex-LCF (2.5K) | | | | | | |
| 7 | Ex-LCF (2.0K) | | | | | | | | |
| C | 05-4526 | 0 | 2nd drawer | A3, LD | 05-1 | 200 ± 0.5 | 05-315 | 4.2 ± 0.5 | 0.04%/0.05%/0.06%, 0.04%, 0.04%, 0.04% |
| | | 1 | | | | | | | |
| | | 2 | | | | | | | |
| | | 4 | | | | | | | |
| D | 05-4402 | - | 2nd drawer | A3, LD | 05-1 | 52 ± 0.5 | 05-315 | 4.2 ± 0.5 | 0.10 mm |
| | 05-4058 | | 1st drawer | | | | | | |
| | 05-4059 | | 2nd drawer | | | | | | |
| | 05-4561 | | T-LCF | A4, LT | | | | | |
| | 05-4060 | | 3rd drawer | A3, LD | | | | | |
| | 05-4560 | | 4th drawer | | | | | | |
| | 05-4061 | | Bypass tray | A4, LT | | | | | |
| | 05-4063 | | Ex-LCF (2.5K) | | | | | | |
| | 05-4180 | | Ex-LCF (2.0K) | | | | | | |
| E | 05-4019 | 0 | 2nd drawer | Long size | 05-3 | 52 ± 0.5 | 05-316 | 4.2 ± 0.5 | 0.04 mm |
| | | 1 | | Short size | | | | | |
| | | 2 | | Middle size | | | | | |
| F | 05-4062 | - | 2nd drawer | A3, LD | 05-3 | 52 ± 0.5 | 05-316 | 4.2 ± 0.5 | 0.10 mm |

[G] Print position adjustment (user)

A user can adjust the following items from the [User Functions] screen - [Admin] - [General] - [Print Position Adjustment].

| Item to be adjusted | Drawer | Code | Sub code | Recommended value | Acceptable value | Default value | Operation procedure |
|------------------------------|--|---------|----------|---|------------------|---------------|---------------------|
| Primary scanning direction | 1st drawer (CST1) | 05-4883 | 0 | To move the image to the front side: Set a larger value. To move the image to the rear side: Set a smaller value. Approx. 0.5 mm per 1 step | 122 to 134 | 128 | 05 Procedure 4 |
| | 2nd drawer (CST2) | | 1 | | | | |
| | 3rd drawer (CST3) | | 2 | | | | |
| | 4th drawer (CST4) | | 3 | | | | |
| | Large Capacity Feeder (T-LCF) | | 4 | | | | |
| | Bypass tray (SFB) | | 5 | | | | |
| | External Large Capacity Feeder (Ex-LCF (2.5K)) | | 6 | | | | |
| | External Large Capacity Feeder (Ex-LCF (2.0K)) | | 7 | | | | |
| | Automatic Duplexing Unit (ADU) | | 8 | | | | |
| Secondary scanning direction | 1st drawer (CST1) | 05-4884 | 0 | To move the image to the trailing edge side: Set a larger value. To move the image to the leading edge side: Set a smaller value. Approx. 0.5 mm per 1 step | 128 to 134 | | |
| | 2nd drawer (CST2) | | 1 | | | | |
| | 3rd drawer (CST3) | | 2 | | | | |
| | 4th drawer (CST4) | | 3 | | | | |
| | Large Capacity Feeder (T-LCF) | | 4 | | | | |
| | Bypass tray (SFB) | | 5 | | | | |
| | External Large Capacity Feeder (Ex-LCF (2.5K)) | | 6 | | | | |
| | External Large Capacity Feeder (Ex-LCF (2.0K)) | | 7 | | | | |
| | Automatic Duplexing Unit (ADU) | | 8 | | | | |

Notes:

This adjustment is added to that for [A] to [F].

6.1.6 Image dimensional adjustment at the scanning section

[A] Image distortion

Notes:

- The specification of the distortion is 1 mm to 200 mm when the 1st drawer or 2nd drawer is used, and is 3 mm to 200 mm when the 3rd drawer, 4th drawer, or T-LCF.
- Do not perform this adjustment when the distortion is within the above value. If the adjustment has failed, fogging or a C260 error will occur.
- This adjustment is for the distortion in the scanning section. Therefore, do not use this to correct paper skew at paper feeding.
- When performing the adjustment, marginally rotate the screw by approximately one quarter while checking the image.

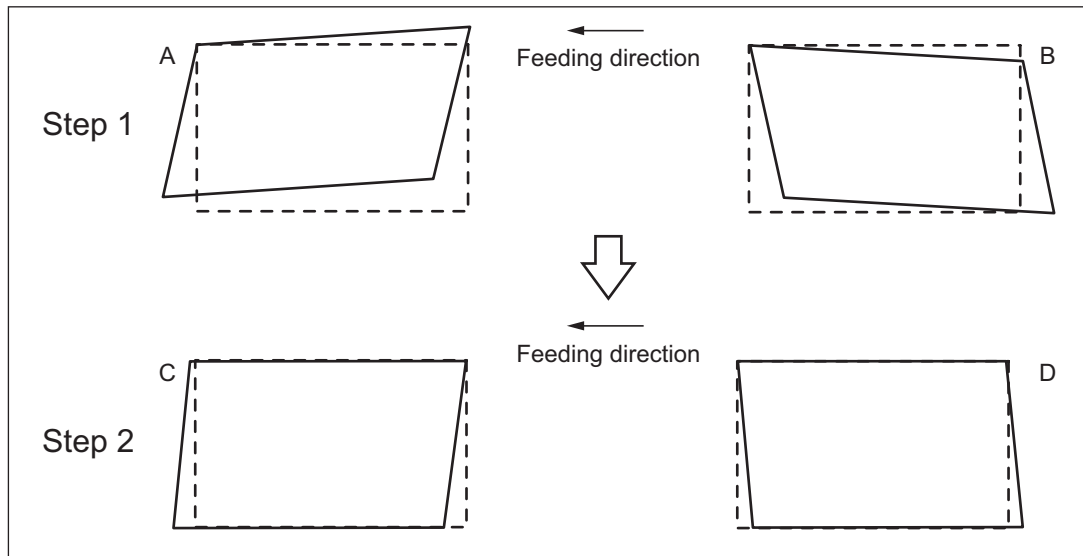

Fig.6-14

- (1) Perform FS-05.
- (2) Press [TEST COPY] → [START] button to make a copy of any image on a sheet of A3 or LD paper.
- (3) Key in [3033] and press the [START] to move the carriage to the adjustment position.

- (4) Make an adjustment in the order of step 1 and 2.
Step 1
In case of A:
Tighten the mirror-1 adjustment screw (Rear) [1]. (CW)
In case of B:
Loosen the mirror-1 adjustment screw (Rear) [1]. (CCW)

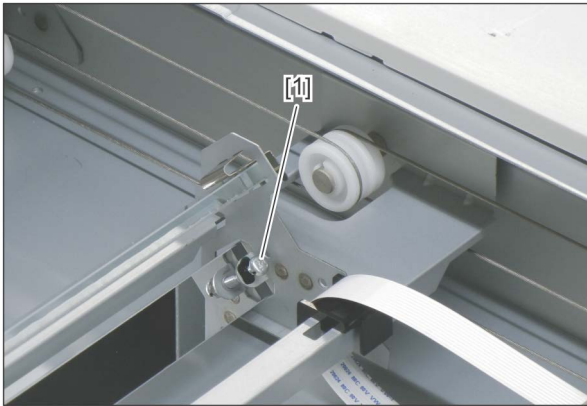

Fig.6-15

- Step 2
In case of C:
Tighten the mirror-1 adjustment screw (Rear) [1]. (CW)
In case of D:
Loosen the mirror-1 adjustment screw (Rear) [1]. (CCW)

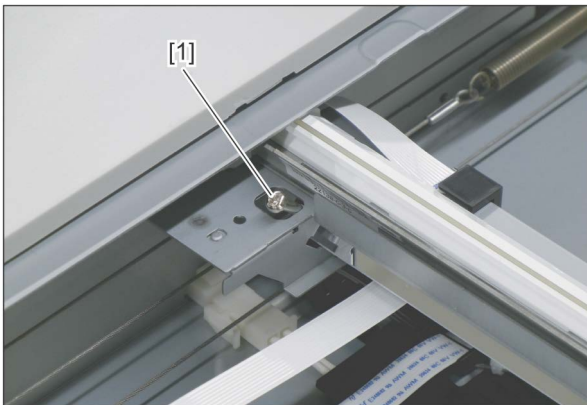

Fig.6-16

- (5) Apply the screw locking agents to the adjustment screws. (2 areas)
Recommended screw lock agent
Manufacturer: Three Bond
Product name: 1401E

[B] Reproduction ratio of the primary scanning direction

| Paper source | Code | Acceptable value | Change amount per 1 step | Paper size | Original | Original mode | Ratio |
|--------------|---------|------------------|--------------------------|------------|----------|---------------|-------|
| 2nd drawer | 05-4000 | 0 to 255 | Approx. 0.10 mm | A3, LD | Scale | Text/Photo | 100% |

- (1) During the ready state of the Classic mode of FS-05, place the scale on the original glass and perform copying.
 - The scale should be placed on the rear to front direction.
 - Press [TEST COPY] and the [START] button.
- (2) Measure the distance B between 10 mm and 270 mm of the copied image by a scale and check that it is within the acceptable range.
Acceptable range: $260 \text{ mm} \pm 0.5 \text{ mm}$
- (3) If not, change the value of the code.
The larger the adjustment value is, the longer the distance B becomes.
- (4) Output the test copy again and measure the distance B.

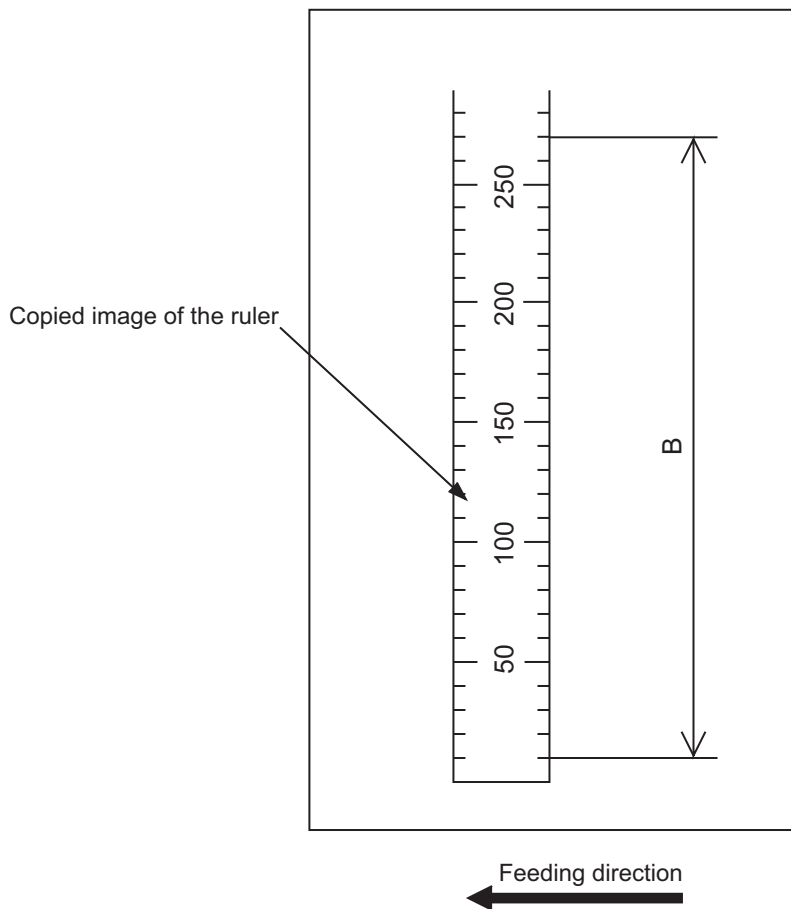

Fig.6-17

[C] Primary scanning direction data image position

| Paper source | Code | Acceptable value | Change amount per 1 step | Paper size | Original | Original mode | Ratio |
|--------------|---------|------------------|--------------------------|------------|----------|---------------|-------|
| 2nd drawer | 05-3030 | 0 to 255 | Approx. 0.04 mm | A3, LD | Scale | Text/Photo | 100% |

- (1) During the ready state of the Classic mode of FS-05, place the scale on the original glass and perform copying.
 - The scale should be placed while its front edge is aligned to the rear side and its side edge to the original scale at the paper exiting side.
 - Press [TEST COPY] and the [START] button.
- (2) Measure the distance C between the front side end of the copied image and the 10 mm line by a scale and check that it is within the acceptable range.
Acceptable range: 10 mm \pm 0.5 mm
- (3) If not, change the value of the code.
The larger the adjustment value is, the longer the distance C becomes.
- (4) Output the test copy again and measure the distance C.

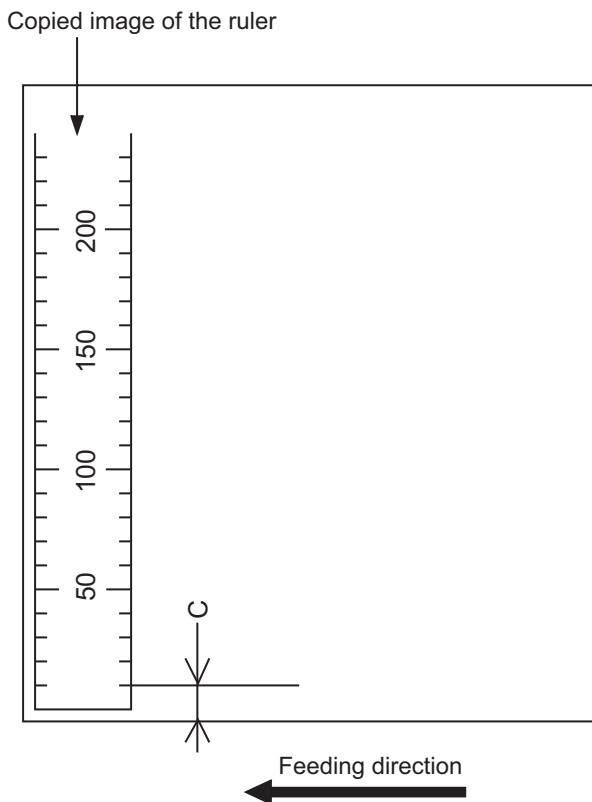

Fig.6-18

[D] Reproduction ratio of the secondary scanning direction

| Paper source | Code | Acceptable value | Change amount per 1 step | Paper size | Original | Original mode | Ratio |
|--------------|---------|------------------|--------------------------|------------|----------|---------------|-------|
| 2nd drawer | 05-3032 | 63 to 193 | Approx. 0.018 % | A3, LD | Scale | Text/Photo | 100% |

- (1) During the ready state of the Classic mode of FS-05, place the scale on the original glass and perform copying.
 - The scale should be placed while its front edge is aligned to the original scale at the paper exiting side in the paper feeding to the paper exiting direction.
 - Press [TEST COPY] and the [START] button.
- (2) Measure the distance D between 200 mm and 400 mm of the copied image by a scale and check that it is within the acceptable range.
Acceptable range: 200 mm \pm 0.5 mm
- (3) If not, change the value of the code.
The larger the adjustment value is, the longer the distance D becomes.
- (4) Output the test copy again and measure the distance D.

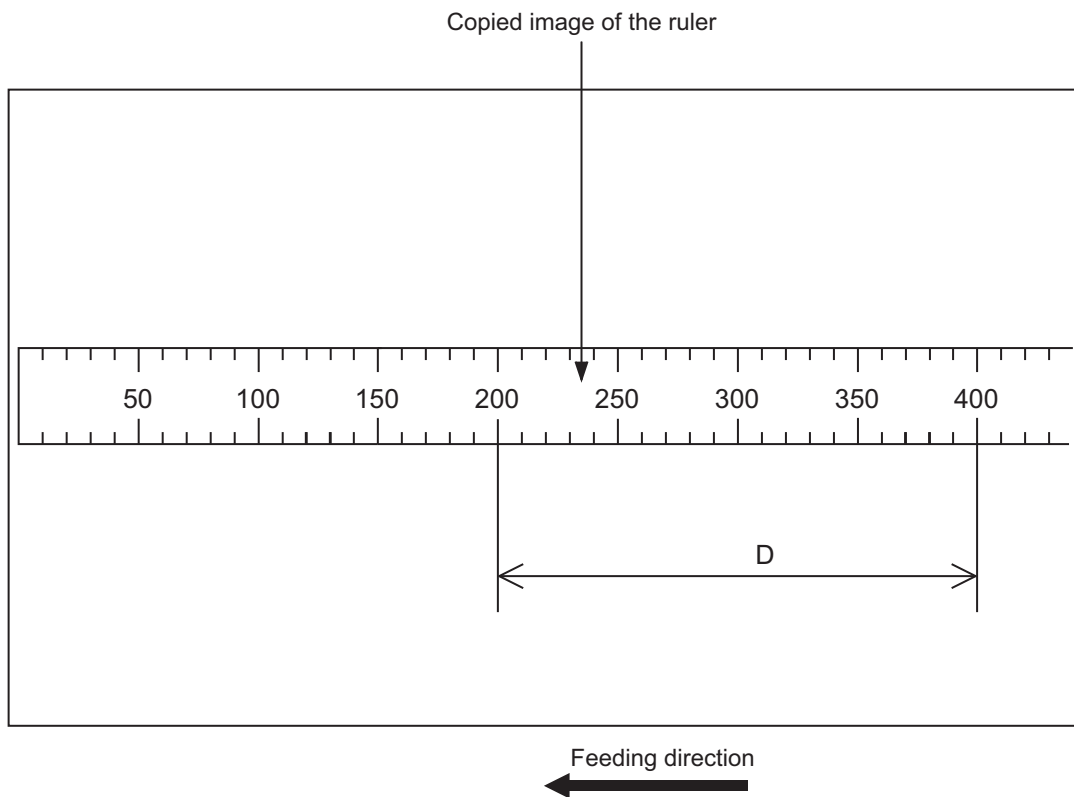

Fig.6-19

[E] Secondary scanning direction data image position

| Paper source | Code | Acceptable value | Change amount per 1 step | Paper size | Original | Original mode | Ratio |
|--------------|---------|------------------|--------------------------|------------|----------|---------------|-------|
| 2nd drawer | 05-3031 | 90 to 148 | Approx. 0.08 mm | A3, LD | Scale | Text/Photo | 100% |

- (1) During the ready state of the Classic mode of FS-05, place the scale on the original glass and perform copying.
 - The scale should be placed while its front edge is aligned to the original scale at the paper exiting side in the paper feeding to paper exiting direction.
 - Press [TEST COPY] and the [START] button.
- (2) Measure the distance E between the leading edge of the copied image and the 10 mm line by a scale and check that it is within the acceptable range.
Acceptable range: 10 mm \pm 0.5 mm
- (3) If not, change the value of the code.
The larger the adjustment value is, the longer the distance E becomes.
- (4) Output the test copy again and measure the distance E.

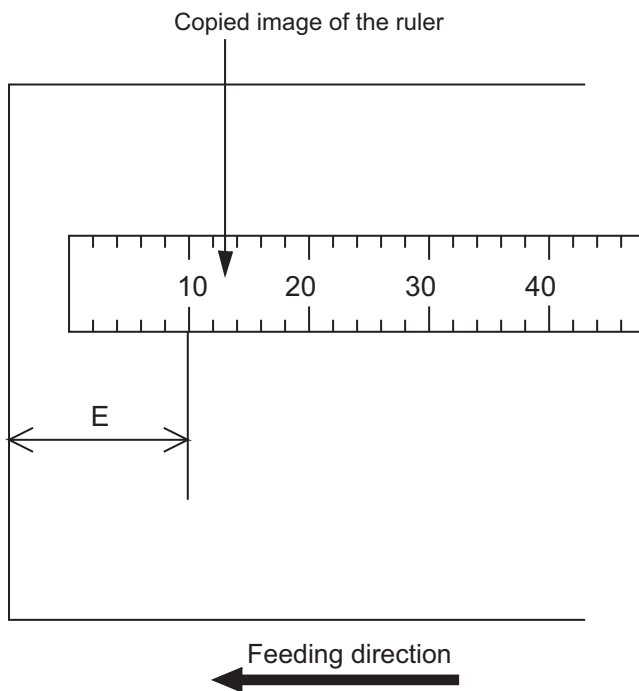

Fig.6-20

[F] Top margin

| Paper source | Code | Acceptable value | Change amount per 1 step | Paper size | Original | Original mode | Ratio |
|--------------|---------|------------------|--------------------------|------------|----------|---------------|-------|
| 2nd drawer | 05-4050 | 0 to 255 | Approx. 0.04 mm | A3, LD | DF: Open | Text/Photo | 100% |

- (1) During the ready state of the Classic mode of FS-05, perform copying while the DF is kept open. Press [TEST COPY] and the [START] button.
- (2) Measure the margin F at the leading edge of the copied image by a scale and check that it is within the acceptable range.
Acceptable range: 4.2 mm \pm 0.5 mm
- (3) If not, change the value of the code.
The larger the adjustment value is, the wider the margin F becomes.
- (4) Output the test copy again and measure the margin F.

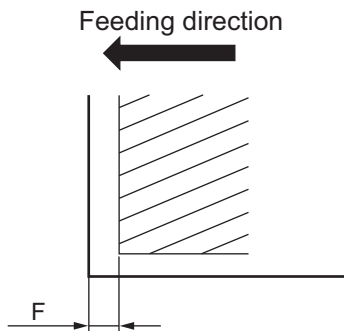

Fig.6-21

[G] Right margin

| Paper source | Code | Acceptable value | Change amount per 1 step | Paper size | Original | Original mode | Ratio |
|--------------|---------|------------------|--------------------------|------------|----------|---------------|-------|
| 2nd drawer | 05-4052 | 0 to 255 | Approx. 0.04 mm | A3, LD | DF: Open | Text/Photo | 100% |

- (1) During the ready state of the Classic mode of FS-05, perform copying while the DF is kept open. Press [TEST COPY] and the [START] button.
- (2) Measure the margin G at the leading edge of the copied image by a scale and check that it is within the acceptable range.
Acceptable range: 4.2 mm \pm 0.5 mm
- (3) If not, change the value of the code.
The larger the adjustment value is, the wider the margin G becomes.
- (4) Output the test copy again and measure the margin G.

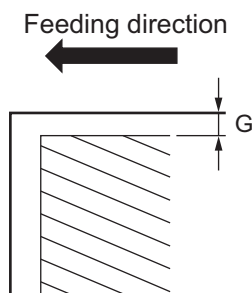

Fig.6-22

[H] Bottom margin

| Paper source | Code | Acceptable value | Change amount per 1 step | Paper size | Original | Original mode | Ratio |
|--------------|---------|------------------|--------------------------|------------|----------|---------------|-------|
| 2nd drawer | 05-4053 | 0 to 255 | Approx. 0.04 mm | A3, LD | DF: Open | Text/Photo | 100% |

- (1) During the ready state of the Classic mode of FS-05, perform copying while the DF is kept open. Press [TEST COPY] and the [START] button.
- (2) Measure the margin H at the leading edge of the copied image by a scale and check that it is within the acceptable range.
Acceptable range: $4.2 \text{ mm} \pm 0.5 \text{ mm}$
- (3) If not, change the value of the code.
The larger the adjustment value is, the wider the margin H becomes.
- (4) Output the test copy again and measure the margin H.

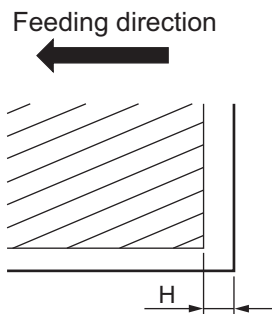

Fig.6-23

6.1.7 Automatic gamma adjustment

The density and gradation reproduction can be optimized. When parts are replaced or the gradation reproduction in the images is improper, perform this adjustment.

Notes:

- When any of the following parts has been replaced, be sure to carry out this adjustment.
 - Photoconductive drum
 - Developer material
 - Laser optical unit
 - Transfer belt
 - 1st transfer roller
 - Drum cleaning blade
 - Needle electrode
 - Main charger grid
 - Image position aligning/image quality sensor (center)
 - SRAM
 - Sub EEPROM (for the LGC board)
 - Standard storage device
- When any of the following parts has been replaced, check images and carry out this adjustment if required.
 - 2nd transfer roller

<Procedure>

- (1) Key in the code for chart printing in the ready state of the Classic mode of FS-05 to print out the chart for automatic gamma adjustment.
 - Use A4 or LT size paper.
 - When printing out the chart, use the paper frequently used and set the code corresponding to the paper.
- (2) Place the chart printed out in step (1) on the original glass.
When placing the chart, put its printed side down and align its side with 2 black squares to the reference at the left rear corner.
- (3) Key in the adjustment code and press the [START] button.

| Function | Test print code | Adjustment code |
|-----------------------------|-----------------|-----------------|
| Copying, Printing (600 dpi) | 05-93 | 05-7311 |
| Printing (1,200 dpi) | 05-253 | 05-7312 |

- (4) Press [OK] to reflect the adjustment result.

Remarks:

- To cancel the reflection of the adjustment result, press [Cancel].
- When "ADJUSTMENT ERROR" is shown, press [Cancel] to clear the error display and then perform the adjustment from step (2) again.

6.1.8 Density Unevenness Correction

The density difference at the front and rear can be corrected. Correction can be made automatically or manually.

Remarks:

The automatic correction can be carried out through the [Home] screen - [Image Recovery] - [Density Unevenness Correction].

Notes:

- When the automatic correction is carried out, the manual correction value is returned to the default one.
- When the manual correction is performed after the automatic correction, its result is added to the manual correction.
- For a printing job, this is effective only when “1” (Enabled) is set for FS-08-8124.
- This is effective for printing (600 dpi) only.
- When this correction is performed, the density sometimes becomes lighter. To make the density darker, adjust it in accordance with the following reference.
 P. 6-29 “[4] Density adjustment”

[1] Automatic correction

- (1) Print a chart for the density difference correction at the front and rear with FS-05TP-291.
- (2) Place the chart printed out in step (1) on the original glass.
When placing the chart, put its printed side down and align its side with 2 black squares to the reference at the left rear corner.
- (3) Perform FS-05-7329.

Remarks:

- When “ADJUSTMENT ERROR” is shown, press [Cancel] to clear the error display. Then replace the chart correctly and perform the adjustment from step (2) again.
- The efficiency of the density unevenness correction can be adjusted by means of FS-05-8548. When a larger value is set, correction tends to be made.

[2] Manual correction

| Function | Item to be adjusted | Code | Sub code | Recommended value | Acceptable value | Default value | Operation procedure | |
|---------------------|---------------------|--------|----------|-------------------|--|---------------|---------------------|----------------------|
| Printing (600 dpi)* | K (Black) | Area 1 | 8544 | 0, 1, 2 | To make the density darker: Set a larger value. To make the density lighter: Set a smaller value. | 0 to 255 | 128 | 05 Procedure 4 |
| | | Area 2 | 8545 | | | | | |
| | | Area 3 | 8546 | | | | | |
| | | Area 4 | 8547 | | | | | |

* For a printing job, this is effective only when “1” (Enabled) is set for 08-8124.

The meaning of the sub code is as below.

| Sub code | Density area to be adjusted |
|----------|-----------------------------|
| 0 | Low density |
| 1 | Medium density |
| 2 | High density |

The details about the chart and area are shown as below.

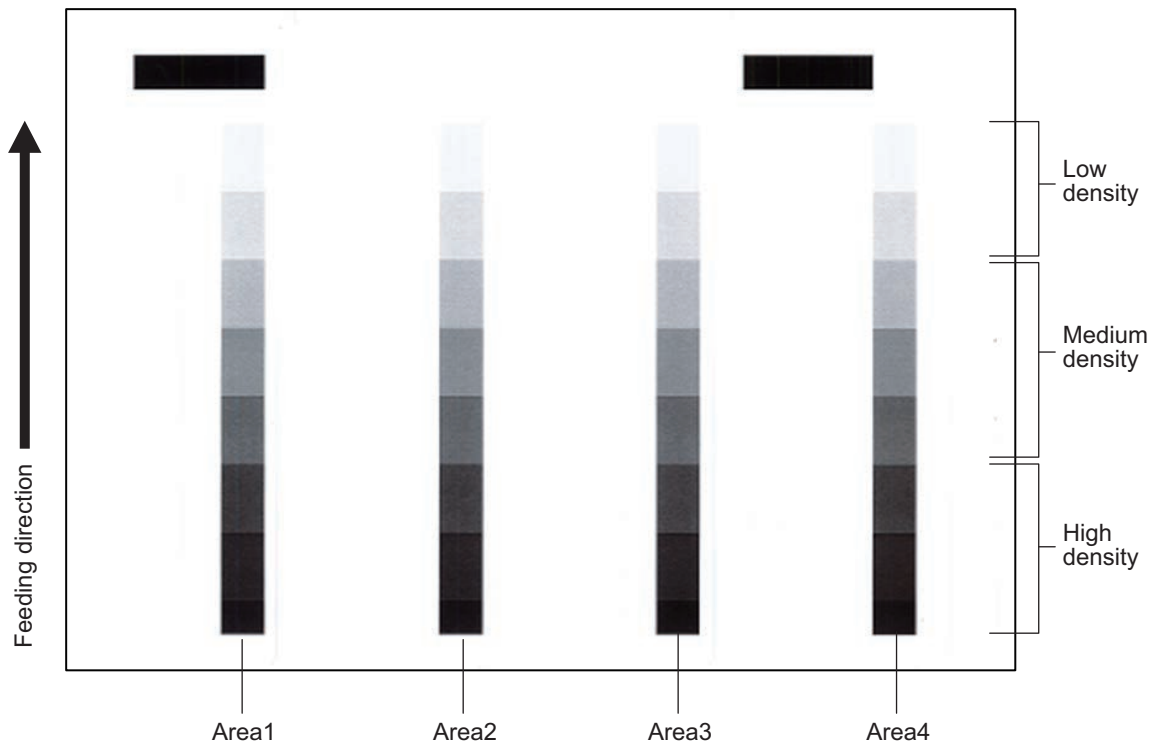

[3] Correction screen

When FS-08-8002 is performed, the values for automatic and manual correction are returned to the default ones.

Remarks:

The gradation level reproducibility of gradation images can be switched by the following codes.

| Color mode | Code | Sub code | Recommended value | Acceptable value | Default value | Operation procedure |
|-------------------|---------|----------|--------------------------------------|------------------|---------------|----------------------|
| Printer (600 dpi) | 05-8092 | 0 | 0: Standard 1: Gradation priority | 0 to 1 | 0 | 05 Procedure 4 |
| | | 1 | | | 1 | |

The meaning of the sub code is as below.

| Sub code | Explanation |
|----------|---|
| 0 | When the FR density difference correction is disabled |
| 1 | When the FR density difference correction is enabled |

Notes:

- When the value for FS-05-2662 has been changed, return it to the default one after FS-08-8002 (FR density difference correction clear) has been performed.
- When any parts in the following units are replaced while FR density difference correction is enabled, perform FS-08-8002 (FR density difference correction clear).
 - Data writing section
 - Process unit (developer unit, cleaner)
 - Transfer unit (TBU, TRU)
 - Image quality control section
 - Fusing section

[4] Density adjustment

The target value of the image quality control can be corrected.

| Code | Sub code | Meaning of the sub code | Recommended value | Acceptable value | Default value | Operation procedure |
|---------|----------|-------------------------|--|------------------|---------------|----------------------|
| 05-2662 | 3 | K (Black) | To make the density darker: Set a larger value. To make the density lighter: Set a smaller value. | 0 to 999 | 340 | 05 Procedure 4 |

Notes:

- Set the value within 0 to +50 to the default one.
- Use “+20” as the target value for the adjustment at the first time. After then, perform this adjustment by increasing the value in small steps while checking the images. (FS-05-293)
- Make sure to perform FS-05-2742 after the density has been adjusted. After FS-05-2742 is performed, the density will change.

6.1.9 Scanning and paper feeding direction instruction patterns superposition function

Patterns to indicate the scanning direction during original scanning and the paper feeding direction during printing are synthesized on images of copying, printing, scanning and fax. This will be used to collect images for investigating the problems of an MFP.



| Code | Recommended value | Acceptable value | Default value |
|---------|-------------------|------------------|---------------|
| 05-7030 | 0: OFF 1: ON | 0 to 1 | 0 |

Notes:

Be sure to return the value to "0" (default) when the investigation is finished.

The patterns and colors to be synthesized as information for original scanning are as below.

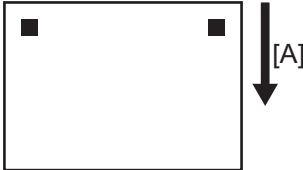
| MFP performance | Pattern color |
|------------------------------------|---------------|
| Black copying, black scanning, fax | Black |
| Gray Scale scanning | Gray |

| | | |
|--|---|---------------------------------|
| Scanned by placing an original on the original glass |  | [A] Carriage scanning direction |
| DSDF: Front side |  | [B] DSDF feeding direction |
| DSDF: Back side |  | [C] DSDF feeding direction |

The patterns and colors to be synthesized as information for the paper feeding direction are as below.

| MFP performance | Pattern color |
|------------------------------------|---------------|
| Black copying, black printing, fax | Black |

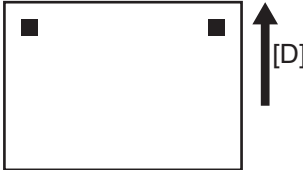
| | | |
|-----------------|---|-----------------------------|
| Outputted paper |  | [D] Paper feeding direction |
|-----------------|---|-----------------------------|

6.2 Image Related Adjustment (Overview)

6.2.1 List

The following adjustment is applied to the image quality for various functions.

Notes:

When the adjustment has been carried out, check the image quality for all the functions to which the adjustment is applied.

| Adjustment | Functions which can be adjusted | | | |
|---|---------------------------------|----------|----------|-----|
| | Copying | Printing | Scanning | Fax |
| 6.3.4Blank page judgment threshold adjustment | Yes | | Yes | |
| 6.3.5Void amount adjustment for blank page judgment | Yes | | Yes | |
| 6.3.10Background offset adjustment (DF) | Yes | | Yes* | Yes |
| 6.3.11Background offset adjustment on the back side of paper (DSDF) | Yes | | Yes* | Yes |

* Color adjustment is also possible.

6.2.2 Operation procedure

The operation procedure of the image quality adjustment is as follows.

[1] Operation procedure of the 05 Adjustment Mode

Procedure 1

- (1) Press [FS-05] > [Classic] to move to the code entry screen.
- (2) Key in the code and press the [START] button.
- (3) Key in the adjustment value and press [OK].
- (4) Perform test copy or test print if required.
If the desired image density has not been attained, repeat steps (2) to (4).

Procedure 4

- (1) Press [FS-05] > [Classic] to move to the code entry screen.
- (2) Key in the code and press the [START] button.
- (3) Key in the sub code and press the [START] button.
- (4) Key in the adjustment value and press [OK].
- (5) Perform test copy or test print if required.
If the desired image density has not been attained, repeat steps (2) to (5).

6.3 Image Quality Adjustment (Copying Function)

6.3.1 Density adjustment

The center value of the density can be adjusted.

If the setting value of the manual adjustment is changed, the density of the step of all indicators including the center value will be altered when an attempt is made to change the density manually on the [Basic] tab of the screen.

| Item to be adjusted | Mode | Code | Recommended value | Acceptable value | Default value | Operation procedure |
|---------------------|----------------|---------|--|------------------|---------------|---------------------|
| Automatic density | Text/Photo | 05-7123 | To make the density darker: Set a larger value. To make the density lighter: Set a smaller value. | 0 to 255 | 128 | 05 Procedure 1 |
| | Text | 05-7124 | | | | |
| | Photo | 05-7125 | | | | |
| | Custom | 05-7137 | | | | |
| Manual density | Text/Photo | 05-7114 | | | | |
| | Text | 05-7115 | | | | |
| | Photo | 05-7116 | | | | |
| | Custom | 05-7134 | | | | |
| | Drop out color | 05-7160 | | | | |

Notes:

- Be sure to carry out this adjustment after performing the following one.
 P. 6-26 “6.1.7 Automatic gamma adjustment”
- To check an image of Custom and Drop out color, use the one copied in the normal startup.
- The change of the setting value of the self-diagnostic code by 20 steps equivalents to that for 1 scale of the indicator.

6.3.2 Gamma balance adjustment

The density can be adjusted. The adjustment can be performed by selecting its density area from the following: low density, medium density and high density.

| Mode | Code | Sub code | Recommended value | Acceptable value | Default value | Operation procedure |
|----------------|---------|----------|--|------------------|---------------|---------------------|
| Text/Photo | 05-7190 | 0, 1, 2 | To make the density darker: Set a larger value. To make the density lighter: Set a smaller value. | 0 to 255 | 128 | 05 Procedure 4 |
| Text | 05-7191 | | | | | |
| Photo | 05-7192 | | | | | |
| Custom | 05-7189 | | | | | |
| Drop out color | 05-7187 | | | | | |

The meaning of the sub code is as below.

| Sub code | Density area to be adjusted |
|----------|-----------------------------|
| 0 | Low density |
| 1 | Medium density |
| 2 | High density |

Notes:

- Be sure to carry out this adjustment after performing the following one.
 P. 6-26 “6.1.7 Automatic gamma adjustment”
- To check an image of Custom and Drop out color, use the one copied in the normal startup.
- Change the setting value by 20 steps while checking the image to set the most appropriate value.
- The density may be reversed with that for the adjoining density area depending on the setting value.

6.3.3 Background adjustment

The density of the background can be adjusted.

| Mode | Code | Recommended value | Acceptable value | Default value | Operation procedure |
|----------------|---------------------|--|------------------|---------------|----------------------|
| Text/Photo | 05-7100 05-7086* | To make the background darker: Set a larger value. To make the background lighter: Set a smaller value. | 0 to 255 | 128 | 05 Procedure 1 |
| Text | 05-7101 | | | | |
| Photo | 05-7102 | | | | |
| Custom | 05-7106 | | | | |
| Drop out color | 05-7107 | | | | |

* Manual density only

Notes:

- To check an image of Custom and Drop out color, use the one copied in the normal startup.
- The change of the setting value of the self-diagnostic code by 25 steps equivalents to that for 1 scale of the indicator.
- The setting value is the center value of [Background Adjustment] of the screen. Therefore, when the setting value is changed, all scales of the indicator are shifted by the value set in this setting accordingly.
- Change the setting value by 10 steps while checking the image to set the most appropriate value.

6.3.4 Blank page judgment threshold adjustment

The threshold is adjusted for identification of whether the original set is a blank page or not.

| Code | Recommended value | Acceptable value | Default value | Operation procedure |
|---------|--|------------------|---------------|---------------------|
| 05-7618 | To make the original tend to be judged as a blank page: Set a larger value. To make the original does not tend to be judged as a blank page: Set a smaller value. | 0 to 255 | 128 | 05 Procedure 1 |

Notes:

Change the setting value by 15 steps while checking whether the original to be judged as blank is properly removed to set the most appropriate value.

6.3.5 Void amount adjustment for blank page judgment

The range of the image area to use blank page judgment of the original can be adjusted.

| Code | Sub code | Recommended value | Acceptable value | Default value | Operation procedure |
|---------|----------|---|------------------|---------------|---------------------|
| 05-7616 | 0 | To make the image area wider: Set a smaller value. To make the image area narrower: Set a larger value. | 0 to 255 | 200 | 05 Procedure 4 |

Notes:

- 24 steps of the setting value are equivalent to approx. 1 mm image area.
- If too a smaller value is set, stains at the edges of an original may be judged as images. Due to this, the desired judgment may not be obtained.

6.3.6 Sharpness adjustment

The sharpness of images can be adjusted to make it softer or sharper.
The adjustment can be made for each original mode.

| Mode | Code | Recommended value | Acceptable value | Default value | Operation procedure |
|----------------|---------|---|------------------|---------------|----------------------|
| Text/Photo | 05-7056 | To make the image softer or to make moiré inconspicuous: Set a smaller value. To make the image sharper or to make thin lines clearer: Set a larger value. | 0 to 255 | 128 | 05 Procedure 1 |
| Text | 05-7057 | | | | |
| Photo | 05-7058 | | | | |
| Custom | 05-7249 | | | | |
| Drop out color | 05-7062 | | | | |

Notes:

- To check an image of Custom and Drop out color, use the one copied in the normal startup.
- The change of the setting value of the self-diagnostic code by 25 steps equivalents to that for 1 scale of the indicator.
- The setting value is the center value of [Sharpness] of the screen. Therefore, when the setting value is changed, all scales of the indicator is shifted by the value set in this setting accordingly.
- The larger the value is, the more moiré tends to occur.

6.3.7 Range correction adjustment

The background peak value used for the range correction can be set to fixing or varying.

| Item to be adjusted | Original mode | Code | Recommended value | Acceptable value | Default value | Operation procedure |
|---------------------|---------------|---------|-------------------|-----------------------------|---------------|----------------------|
| Manual density | Text/Photo | 05-7286 | - | 0 to 1 | 0 | 05 Procedure 1 |
| | Text | 05-7287 | | 0: Background peak - Fixed | 1 | |
| | Custom | 05-7237 | | 1: Background peak - Varied | 0 | |

Notes:

- To check an image of Custom, use the one copied in the normal startup.
- When “0” (Background peak - Fixed) is set: A certain level of the density can be removed regardless of the background of the original Uneven density in images will not occur.
- When “1” (Background peak - Varied) is set: The background will be removed corresponding to the background level of the original. The removal level of the background may not become even depending on the design of the original.

6.3.8 Smudged/faint text adjustment

The smudged or faint text can be adjusted.

| Original mode | Code | Recommended value | Acceptable value | Default value | Operation procedure |
|---------------|---------|---|------------------|---------------|----------------------|
| Text/Photo | 05-7097 | To make the text and thin lines thicker: Set a smaller value. To make the text and thin lines thinner: Set a larger value. | 0 to 4 | 2 | 05 Procedure 1 |
| Text | 05-7098 | | | | |
| Custom | 05-7252 | | | | |

Remarks:

- To check an image of Custom, use the one copied in the normal startup.
- Change the setting value by 1 step while checking the image to set the most appropriate value.

6.3.9 Emission level adjustment

The emission level can be set. The density can be adjusted by changing the dot size.

| Original mode | Code | Sub code | Recommended value | Acceptable value | Default value | Operation procedure | | | | | | |
|---------------|---------|----------|--|------------------|--|----------------------|----------|--|----------------------|----------|-----|----------------------|
| Text/Photo | 05-7218 | 0 | To make the density darker: Set a larger value. To make the density lighter: Set a smaller value. | 0 to 255 | 0 | 05 Procedure 4 | | | | | | |
| | | 1 | | | 63 | | | | | | | |
| | | 2 | | | 127 | | | | | | | |
| | | 3 | | | 191 | | | | | | | |
| | | 4 | | | 255 | | | | | | | |
| Text | 05-7219 | 0 | | | To make the density darker: Set a larger value. To make the density lighter: Set a smaller value. | | 0 to 255 | 0 | 05 Procedure 4 | | | |
| | | 1 | | | | | | 63 | | | | |
| | | 2 | | | | | | 127 | | | | |
| | | 3 | | | | | | 191 | | | | |
| | | 4 | | | | | | 255 | | | | |
| Photo | 05-7220 | 0 | | | | | | To make the density darker: Set a larger value. To make the density lighter: Set a smaller value. | | 0 to 255 | 0 | 05 Procedure 4 |
| | | 1 | | | | | | | | | 63 | |
| | | 2 | | | | | | | | | 127 | |
| | | 3 | | | | | | | | | 191 | |
| | | 4 | | | | | | | | | 255 | |

Notes:

- The setting of the sub code 4 is the most influential one to the density.
- Change the setting value by 8 steps while checking the image to set the most appropriate value.
- The value of the sub code should be entered so that the value of the order becomes $0 < 1 < 2 < 3 < 4$.

6.3.10 Background offset adjustment (DF)

The reproduction ratio of the background in DF scanning can be adjusted. The adjustment value is applied to both the front and back sides.

| Color mode | Code | Recommended value | Acceptable value | Default value | Operation procedure |
|------------|---------|--|------------------|---------------|----------------------|
| Full color | 05-7026 | To make the background darker: Set a larger value. | 0 to 255 | 128 | 05 Procedure 1 |
| Black | 05-7025 | To make the background lighter: Set a smaller value. | | | |

Notes:

- Change the setting value by 20 steps while checking the image to set the most appropriate value.
- The adjustment results for the Black mode is applied to the image quality for copying, scanning (Black, Gray scale) and fax.
- The adjustment results for the Full Color mode is applied to the image quality only for scanning (Full color).

6.3.11 Background offset adjustment on the back side of paper (DSDF)

The reproduction ratio of the background on the back side of paper in DSDF scanning can be adjusted. The adjustment value is applied to the back side only.

| Color mode | Code | Recommended value | Acceptable value | Default value | Operation procedure |
|------------|---------|--|------------------|---------------|----------------------|
| Full color | 05-7024 | To make the background darker: Set a larger value. To make the background lighter: Set a smaller value. | 0 to 255 | 128 | 05 Procedure 1 |
| Black | 05-7023 | | | | |

Notes:

- Change the setting value by 20 steps while checking the image to set the most appropriate value.
- The adjustment results for the Black mode is applied to the image quality for copying, scanning (Black, Gray scale) and fax.
- The adjustment results for the Full Color mode is applied to the image quality only for scanning (Full color).

6.3.12 Drop out color adjustment

The drop out level of a gray-like color during the drop out color mode can be adjusted.

| Code | Recommended value | Acceptable value | Default value | Operation procedure |
|---------|--|------------------|---------------|----------------------|
| 05-7066 | To make the gray-like color tend to be dropped out: Set a larger value. To make the gray-like color does not tend to be dropped out: Set a smaller value. | 20 to 80 | 50 | 05 Procedure 1 |

Notes:

- Be sure to carry out this adjustment after performing the following one.
 P. 6-26 “6.1.7 Automatic gamma adjustment”
- Changing by “10” of the setting value is equivalent to 1 step of the slide bar on the LCD.
- To check an image of Drop out color, use the one copied in the normal startup.

6.3.13 Scanning streak reduction

Streaks generated on images during the scanning of an original can be reduced. The reduction level can be set for using the DF or the original glass, respectively.

When the DF is used for scanning, detection is performed for every scanned page to reduce streaks. When the original glass is used for scanning, refer to the result of the automatic streak detection on it to reduce streaks.

| Code | Item to be adjusted | Recommended value | Acceptable value | Default value | Operation procedure |
|---------|---|--|------------------|---------------|----------------------|
| 08-7103 | Streak correction enable/disable setting | 0: Disabled 1: Enabled | 0 to 1 | 0 | 05 Procedure 1 |
| 08-7104 | Streak correction level setting (scanning by placing an original on the original glass) | Correction level 0: Low 1: Medium 2: High | 0 to 2 | | |
| 08-7105 | Streak correction level setting (DF scanning) | Correction level 0: Low 1: Medium 2: High | 0 to 2 | | |

| Code | Item to be adjusted | Operation procedure |
|---------|----------------------------|---------------------|
| 08-7103 | Streak detection execution | 05 Procedure 1* |

* Perform this by placing an A4 or LT blank sheet of paper on the original glass.

Notes:

- To reduce streaks when the original glass is used for scanning, be sure to perform FS-05-7619.
- When streaks have not appeared on images due to the original glass being cleaned, perform FS-08-7108 and clear the detection result of FS-05-7619.

The correction level intensity of the scanning streak reduction level setting can be adjusted.

| Item to be adjusted | Code | Sub code | Recommended value | Acceptable value | Default value | Operation procedure |
|--|---------|----------|--|------------------|---------------|----------------------|
| When scanning by placing an original on the original glass | 05-7623 | 0 | To make the streak correction intensity higher: Set a larger value. To make the streak correction intensity lower: Set a smaller value. | 0 to 255 | 0 | 05 Procedure 4 |
| When using the DF for scanning (front side) | | 1 | | | | |
| When using the DF for scanning (back side) | | 2 | | | | |

Notes:

- When a larger value is set, the images around the streaks may be corrupted.
- This is effective only when “0” is set for FS-08-7102.
- When “1” is set for FS-08-7102, streak correction will be executed when only the DF is used for scanning.

6.3.14 Background removal level adjustment

The effectiveness of the removal can be adjusted for each original mode in the black mode and auto density.

| Color mode | Original mode | Code | Recommended value | Acceptable value | Default value | Operation procedure |
|------------|---------------|---------|---|------------------|---------------|----------------------|
| Black | Text/Photo | 05-7032 | To decrease the effectiveness of background removal: Set a larger value. To increase the effectiveness of background removal: Set a smaller value. | 0 to 255 | 128 | 05 Procedure 1 |
| | Text | 05-7033 | | | | |
| | Photo | 05-7034 | | | | |
| | Custom | 05-7036 | | | | |

Notes:

Do not apply this adjustment to a certain original and paper since this setting is reflected to all types of originals.

6.3.15 Low density text reproduction adjustment

The way of removing the background can be switched to a more effective one in order to reproduce a low density text for each original mode in the black mode and auto density.

| Color mode | Original mode | Code | Recommended value | Acceptable value | Default value | Operation procedure |
|------------|---------------|---------|---|------------------|---------------|----------------------|
| Black | Text/Photo | 05-7238 | 0: Factory setting value (Default) 1: Disabled 2: Enabled | 0 to 2 | 0 | 05 Procedure 1 |
| | Text | 05-7239 | | | | |
| | Photo | 05-7240 | | | | |
| | Custom | 05-7242 | | | | |

Notes:

When the value is set to “1”, the density of the images may become lighter in its entirety. In such a case, increase the setting value of the density adjustment by approx. 20.

 P. 6-32 “6.3.1 Density adjustment”

6.4 Image Quality Adjustment (Printing Function)

6.4.1 Gamma balance adjustment

The density of the printing can be adjusted. The adjustment can be performed for each printer driver and resolution by selecting its density area from the following: low density, medium density and high density.

| PDL, Resolution | Halftone | Item to be adjusted | Code | Sub code | Recommended value | Acceptable value | Default value | Operation procedure |
|-----------------|----------|---------------------|---------|----------|--|------------------|---------------|----------------------|
| PS 600 dpi | Smooth | All | 05-7315 | 0, 1, 2 | To make the density darker: Set a larger value. To make the density lighter: Set a smaller value. | 0 to 255 | 128 | 05 Procedure 4 |
| | Detail | All | 05-7316 | | | | | |
| | Auto | Text | 05-7360 | | | | | |
| | | Graphic | 05-7361 | | | | | |
| | | Image | 05-7362 | | | | | |
| PS 1200 dpi | Smooth | All | 05-7309 | | | | | |
| | Detail | All | 05-7310 | | | | | |
| | Auto | Text | 05-7357 | | | | | |
| | | Graphic | 05-7358 | | | | | |
| | | Image | 05-7359 | | | | | |
| PCL 600 dpi | Smooth | All | 05-7317 | | | | | |
| | Detail | All | 05-7318 | | | | | |
| | Auto | Text | 05-7363 | | | | | |
| | | Graphic | 05-7364 | | | | | |
| | | Image | 05-7365 | | | | | |

The meaning of the sub code is as below.

| Sub code | Density area to be adjusted |
|----------|-----------------------------|
| 0 | Low density |
| 1 | Medium density |
| 2 | High density |

Notes:

- Be sure to carry out this adjustment after performing the following one.
 P. 6-26 “6.1.7 Automatic gamma adjustment”
- The range of the effectiveness varies depending on the halftone setting.
- Change the setting value by 10 steps while checking the image to set the most appropriate value.
- For Mac, adjust the PS drivers.
- The density may be reversed with that for the adjoining density area depending on the setting value.

<Density area range (lower, medium and high density)>

The color from the 1st to the 7th stage (low density), from the 8th to the 11th stage (medium density) and from the 12th to the 13th stage (high density) in “Patch chart for gamma adjustment ([94] [TEST PRINT])” can be used as a guide for the range of the density area (low density, medium density, high density) influenced by the change of the adjustment value.

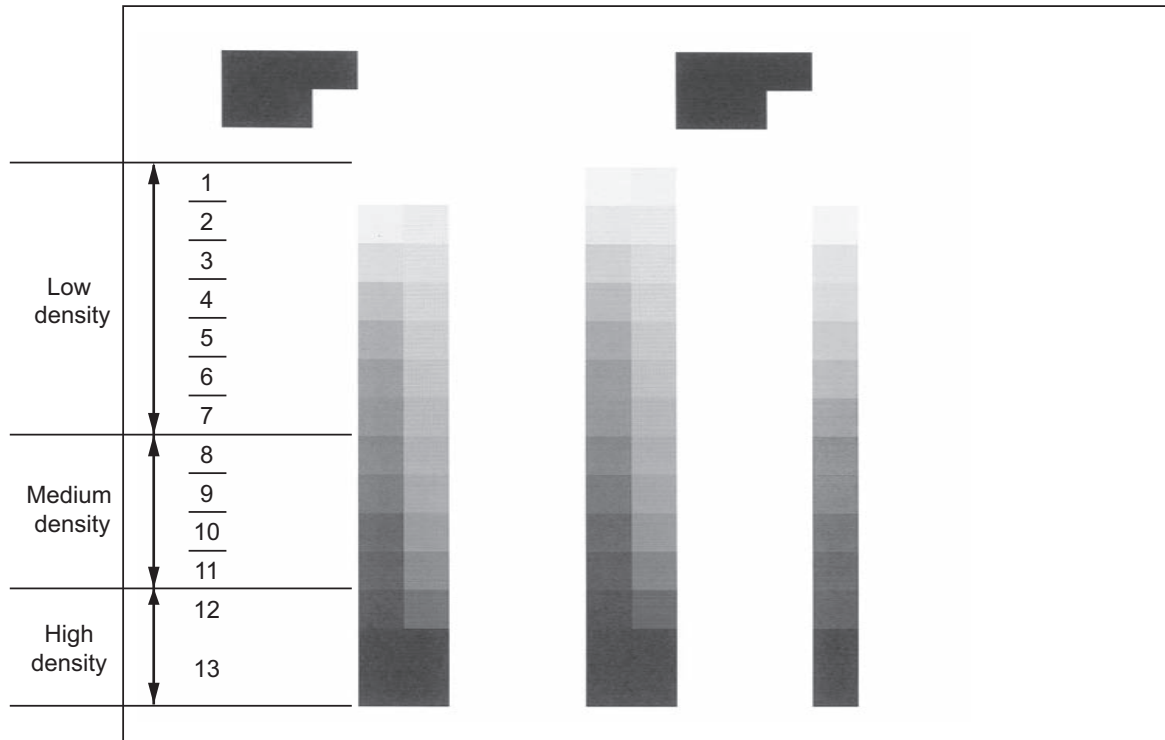

Fig.6-24

6.4.2 Text density adjustment

The density of characters can be adjusted.

| Color mode | PDL | Code | Sub code | Recommended value | Acceptable value | Default value | Operation procedure |
|------------|-----|---------|----------|--|------------------|---------------|---------------------|
| Black | PS | 05-7340 | - | To make the characters darker: Set a larger value. To make the characters lighter: Set a smaller value. | 0 to 8 | 0 | 05 Procedure 1 |
| | PCL | 05-7341 | | | | | |

* 600 dpi only

6.4.3 Density upper limit value adjustment in toner saving mode

The upper limit value of the density when “Toner Saving Mode” is selected in the [Custom] tab of the printer driver can be adjusted.

| Resolution | PDL | Code | Sub code | Recommended value | Acceptable value | Default value | Operation procedure |
|------------|-----|---------|----------|--|------------------|---------------|---------------------|
| 600 dpi | PS | 05-7307 | 0 | To make the density darker: Set a larger value. To make the density lighter: Set a smaller value. | 0 to 255 | 176 | 05 Procedure 4 |
| | PCL | | 1 | | | | 05 Procedure 1 |
| 1200 dpi | PS | 05-7302 | - | | | | 05 Procedure 1 |

6.4.4 Fine line enhancement switching

The range to enhance thin lines and small characters can be switched.

| Color mode | Code | Sub code | Recommended value | Acceptable value | Default value | Operation procedure |
|------------|---------|----------|-------------------|---|---------------|----------------------|
| Black | 05-7322 | 0, 1 | - | 0 to 1 0: Applied to all the contents for Image and Graphic 1: Applied to all the contents for Image, the small text for Text and a thin line for Graphic | 1 | 05 Procedure 4 |

The meaning of the sub code is as below.

| Sub code | Item to be adjusted |
|----------|---------------------|
| 0 | PS |
| 1 | PCL |

Notes:

When "0" is set, white spots will be enhanced in the boundary of colors and they will become conspicuous.

6.4.5 Sharpness adjustment

The sharpness of the boundary of text and lines can be adjusted.

[1] Sharpness adjustment

| Color mode | Original type | Code | Sub code | Recommended value | Acceptable value | Default value | Operation procedure |
|------------------|---------------|---------|----------|---|------------------|---------------|---------------------|
| Black*1 | - | 05-8118 | 0, 1, 2 | To make the image softer or to make moiré inconspicuous: Set a smaller value. To make the image sharper or to make thin lines clearer: Set a larger value. | 0 to 255 | 128, 128, 128 | 05 Procedure 4 |
| e-Filing (Black) | - | 05-8120 | - | | | 128 | 05 Procedure 1 |

The meaning of the sub code is as below.

| Sub code | Item to be adjusted |
|----------|---------------------|
| 0 | Text |
| 1 | Graphic |
| 2 | Image |

*1: The meaning of the sub code when “1” is set in FS-05-7322 is as below.

| Sub code | Item to be adjusted |
|----------|---------------------|
| 0 | Text |
| 1 | Graphic / Thin text |
| 2 | Image |

Notes:

- 25 steps of the setting value are equivalent to 1 step of the sharpness adjustment on the printer driver.
- Change the setting value by 10 steps while checking the image to set the most appropriate value.
- When “0” is set, the image quality will not be changed even if the sharpness is adjusted on the printer driver.

[2] Prevention setting of white voids resulting from the sharpness adjustment

| Color mode | Code | Sub code | Recommended value | Acceptable value | Default value | Operation procedure |
|------------|---------|----------|--|------------------|---------------|---------------------|
| Black | 05-8114 | 0, 1, 2 | Prevents white voids resulting from the sharpness adjustment. 0: Disabled 1: Enabled | 0 to 1 | 0 | 05 Procedure 4 |

The meaning of the sub code is as below.

| Sub code | Item to be adjusted |
|----------|---------------------|
| 0 | Text |
| 1 | Graphics |
| 2 | Image |

6.4.6 Thin line width lower limit adjustment

The thickness of the thin lines can be adjusted.

| Resolution | Code | Recommended value | Acceptable value | Default value | Operation procedure |
|------------|---------|---|------------------|---------------|----------------------|
| 600 dpi | 05-8240 | To make the thin lines thicker: Set a larger value. To make the thin lines thinner: Set a smaller value. | 1 to 9 | 2 | 05 Procedure 1 |
| 1200 dpi | 05-8241 | | | | |

Notes:

This adjustment will be effective when the [Distinguish Thin Lines] check box is selected.

6.4.7 Background adjustment

The density of the background can be adjusted.

| Resolution | Halftone | Code | Sub code | Recommended value | Acceptable value | Default value | Operation procedure |
|------------|---------------|---------|----------|---|------------------|---------------|----------------------|
| 600 dpi | Auto / Smooth | 05-8012 | 0, 1 | To make the background darker: Set a larger value. | 0 to 255 | 128 | 05 Procedure 4 |
| | Detail | 05-8015 | | | | | |
| 1200 dpi | Auto / Smooth | 05-8018 | - | To make the background lighter: Set a smaller value. | 0 to 255 | 128 | 05 Procedure 1 |
| | Detail | 05-8019 | | | | | |

Notes:

The change of the setting value of the self-diagnostic code by 25 steps equivalents to that for 1 scale of the indicator.

The meaning of the sub code is as below.

| Sub code | Item to be adjusted |
|----------|---------------------|
| 0 | PS |
| 1 | PCL |

6.4.8 Emission level adjustment

The emission level when the following jobs are printed can be set.

- e-Filing

The density can be adjusted by changing the dot size.

| Original mode | Code | Sub code | Recommended value | Acceptable value | Default value | Operation procedure |
|---------------|---------|----------|---|------------------|---------------|----------------------|
| e-Filing | 05-7356 | 0 | To make the density darker: Set a larger value. | 0 to 255 | 0 | 05 Procedure 4 |
| | | 1 | | | 63 | |
| | | 2 | To make the density lighter: Set a smaller value. | | 127 | |
| | | 3 | | | 191 | |
| | | 4 | | | 255 | |

Notes:

- The setting of the sub code 4 is the most influential one to the density.
- Change the setting value by 8 steps while checking the image to set the most appropriate value.
- The value of the sub code should be entered so that the value of the order becomes $0 < 1 < 2 < 3 < 4$.
- This will not be applied to the images printed by the printer driver.

6.4.9 Graphic line density adjustment (1200 dpi)

The density of fine lines and small characters can be adjusted. Moreover, the range to which the density adjustment is applied can be arranged.

[1] Adjusting the density

| Resolution | Code | Sub code | Recommended value | Acceptable value | Default value | Operation procedure |
|------------|---------|----------|--|------------------|---------------|----------------------|
| 1200 dpi | 05-8242 | 0 | To make the density darker: Set a larger value. To make the density lighter: Set a smaller value. | 0 to 5 | 3 | 05 Procedure 4 |

[2] Arranging the application range of the density adjustment

| Resolution | Item to be adjusted | Code | Sub code | Recommended value | Acceptable value | Default value | Operation procedure |
|------------|---------------------|---------|----------|--|------------------|---------------|----------------------|
| 1200 dpi | Lower limit value | 05-8243 | 0 | When a lower limit is decreased, lines with lighter colors will be adjusted. When an upper limit is increased, lines with darker colors will be adjusted. | 0 to 255 | 1 | 05 Procedure 4 |
| | Upper limit value | | 1 | | | 200 | |

Notes:

Set the values of the upper and lower limit properly making sure that they are not set in reverse.

6.4.10 Gradation reproduction switching for Text

The gradation reproduction method of Text can be switched.

| Resolution | PDL | Code | Sub code | Recommended value | Acceptable value | Default value | Operation procedure |
|------------|-----|---------|----------|-------------------|--|---------------|----------------------|
| 600 dpi | PS | 05-7386 | 0 | | 0 to 1 0: Text reproduction priority (Text with medium density will be darker.) 1: Gradation reproduction priority (Text with medium density will be lighter.) | 0 | 05 Procedure 4 |
| | PCL | | 1 | | | | |
| 1200 dpi | PS | 05-7387 | - | | | | 05 Procedure 1 |

6.4.11 Smudged text in black adjustment

Smudged black text and thin lines can be adjusted.

| Resolution | PDL | Code | Recommended value | Acceptable value | Default value | Operation procedure |
|------------|-----|---------|---|------------------|---------------|----------------------|
| 600 dpi | PS | 05-7325 | To make the black text and thin lines thicker: Set a smaller value. To make the black text and thin lines thinner: Set a larger value. | 0 to 9 | 2 | 05 Procedure 1 |
| | PCL | 05-7326 | | | 5 | |
| 1200 dpi | PS | 05-7305 | | 0 to 9 | 5 | |

6.4.12 Halftone setting

When [Auto] is selected in [Halftone] of the printer driver, the type of the halftone to be applied to each object can be changed.

| Resolution | Item to be adjusted | Code | Sub code | Recommended value | Acceptable value | Default value | Operation procedure |
|------------|---------------------|---------|----------|-------------------|---|---------------|----------------------|
| 600 dpi | Text | 05-7382 | 0 | - | 1 to 2 1: Detail 2: High definition | 1 | 05 Procedure 4 |
| | Graphic | | 1 | | 0 to 1 0: Smooth 1: Detail | 1 | |
| | Image | | 2 | | 0 | | |
| 1200 dpi | Text | 05-7383 | 0 | - | 0 to 1 0: Smooth 1: Detail | 1 | 05 Procedure 4 |
| | Graphic | | 1 | | | 0 | |
| | Image | | 2 | | | 0 | |

Notes:

When this adjustment is carried out, perform the following adjustment.

 P. 6-26 “6.1.7 Automatic gamma adjustment”

6.4.13 White void correction around the text

White voids around the text whose color is the same as that for the background can be corrected.

| Color mode | Resolution | PDL | Code | Sub code | Meaning of the sub code | Recommended value | Acceptable value | Default value | Operation procedure |
|------------|------------|-----|---------|----------|-------------------------|--|------------------|---------------|----------------------|
| Black | 600 dpi | PS | 05-8204 | 0 | - | 0: OFF When a larger value is set, white voids around the text can be suppressed. | 0 to 5 | 0 | 05 Procedure 4 |
| | | PCL | | 1 | - | | | | |
| | 1200 dpi | PS | 05-7378 | - | - | | | | 05 Procedure 1 |

Notes:

When a larger value is set, the area around the text will be darker. Therefore, set the appropriate value while checking the images.

When the white void correction is performed for images formed by K toner only, the object to be applied can be selected.

| Color mode | Resolution | PDL | Code | Sub code | Recommended value | Acceptable value | Default value | Operation procedure |
|------------|------------|-----|---------|----------|--|------------------|---------------|----------------------|
| Black | 600 dpi | PS | 05-8206 | 0 | 0: Graphic only 1: Image only 2: Applied to both Graphic and Image | 0 to 2 | 0 | 05 Procedure 4 |
| | | PCL | | 1 | | | | |

6.5 Image Quality Adjustment (Scanning Function)

6.5.1 Gamma balance adjustment

The density of the Black and Gray scale can be adjusted. The adjustment can be performed by selecting its density area from the following: low density, medium density and high density.

| Color mode | Original mode | Code | Sub code | Recommended value | Acceptable value | Default value | Operation procedure |
|------------|---------------|---------|----------|--|------------------|---------------|----------------------|
| Black | Text/Photo | 05-7485 | 0, 1, 2 | To make the density darker: Set a larger value. To make the density lighter: Set a smaller value. | 0 to 255 | 128 | 05 Procedure 4 |
| | Photo | 05-7487 | | | | | |
| | Custom | 05-7480 | | | | | |
| Gray scale | - | 05-7488 | | | | | |

The meaning of the sub code is as below.

| Sub code | Item to be adjusted |
|----------|---------------------|
| 0 | Low density |
| 1 | Medium density |
| 2 | High density |

Notes:

Change the setting value by 20 steps while checking the image to set the most appropriate value.

6.5.2 RGB color balance adjustment

The color balance of the color scanning can be adjusted.

| Color mode | Original mode | Code | Sub code | Recommended value | Acceptable value | Default value | Operation procedure |
|------------|---------------|---------|----------|--|------------------|---------------|----------------------|
| Full color | Text/Photo | 05-8425 | 0, 1, 2 | To make the applicable color a higher level: Set a larger value. To make the applicable color a lower level: Set a smaller value. | 0 to 255 | 128 | 05 Procedure 4 |
| | Text | 05-8426 | | | | | |
| | Photo | 05-8427 | | | | | |
| | Custom | 05-8428 | | | | | |

The meaning of the sub code is as below.

| Sub code | Item to be adjusted |
|----------|---------------------|
| 0 | Red |
| 1 | Green |
| 2 | Blue |

Notes:

The change of the setting value of the self-diagnostic code by 25 steps equivalents to that for 1 scale of the indicator.

6.5.3 Density adjustment

The center value of the density can be adjusted.

If the setting value of the manual adjustment is changed, the density of the step of all indicators including the center value will be altered when [Auto] is selected in Exposure on the [Scan Setting] screen.

| Color mode | Item to be adjusted | Original mode | Code | Recommended value | Acceptable value | Default value | Operation procedure |
|----------------|---------------------|---------------|---------|--|------------------|---------------|----------------------|
| Full color | Manual density | Text/Photo | 05-8339 | To make the density darker: Set a larger value. To make the density lighter: Set a smaller value. | 0 to 255 | 128 | 05 Procedure 1 |
| | | Text | 05-8340 | | | | |
| | | Photo | 05-8341 | | | | |
| | | Custom | 05-8380 | | | | |
| | Automatic density | Text/Photo | 05-8342 | | | | |
| | | Text | 05-8343 | | | | |
| | | Photo | 05-8344 | | | | |
| | | Custom | 05-8381 | | | | |
| Gray scale | Manual density | - | 05-7447 | | | | |
| | Automatic density | | 05-7459 | | | | |
| Black | Manual density | Text/Photo | 05-7444 | | | | |
| | | Text | 05-7445 | | | | |
| | | Photo | 05-7446 | | | | |
| | | Custom | 05-7475 | | | | |
| | Automatic density | Text/Photo | 05-7456 | | | | |
| | | Text | 05-7457 | | | | |
| | | Photo | 05-7458 | | | | |
| | | Custom | 05-7478 | | | | |
| Drop out color | | | 05-7443 | | | | |

Notes:

The change of the setting value of the self-diagnostic code by 20 steps equivalents to that for 1 scale of the indicator.

6.5.4 Background adjustment

The density of the background can be adjusted.

| Color mode | Original mode | Code | Recommended value | Acceptable value | Default value | Operation procedure |
|----------------|---------------|---------|--|------------------|---------------|----------------------|
| Full color | Text/Photo | 05-8309 | To make the background darker: Set a larger value. To make the background lighter: Set a smaller value. | 0 to 255 | 128 | 05 Procedure 1 |
| | Text | 05-8310 | | | | |
| | Photo | 05-8311 | | | | |
| | Custom | 05-8370 | | | | |
| Gray scale | - | 05-7439 | | | | |
| Black | Text/Photo | 05-7436 | | | | |
| | Text | 05-7437 | | | | |
| | Photo | 05-7438 | | | | |
| | Custom | 05-7441 | | | | |
| Drop out color | | 05-7442 | | | | |

Notes:

- The change of the setting value of the self-diagnostic code by 25 steps equivalents to that for 1 scale of the indicator.
- The setting value is the center value of [Background Adjustment] of the [Scan Setting] screen. Therefore, when the setting value is changed, all scales of the indicator is shifted by the value set in this setting accordingly.
- Change the setting value by 10 steps while checking the image to set the most appropriate value.

6.5.5 ACS judgment threshold

The threshold to judge whether the original is color or black can be adjusted when Auto Color is selected.

| Item to be adjusted | Code | Recommended value | Acceptable value | Default value | Operation procedure |
|---------------------|---------|--|------------------|---------------|----------------------|
| Auto Color | 05-7630 | To make the image area wider: Set a smaller value. To make the image area narrower: Set a larger value. | 0 to 255 | 70 | 05 Procedure 4 |

Notes:

Change the setting value by 20 steps while checking the image to set the most appropriate value.

6.5.6 Void amount adjustment for ACS judgment

The range of the image area to use the color or black judgment of the original can be adjusted when Auto Color is selected.

| Item to be adjusted | Code | Sub code | Recommended value | Acceptable value | Default value | Operation procedure |
|---------------------|---------|----------|--|------------------|---------------|----------------------|
| Auto Color | 05-7616 | 1 | To make the image area wider: Set a smaller value. To make the image area narrower: Set a larger value. | 0 to 255 | 200 | 05 Procedure 4 |

Notes:

- 24 steps of the setting value are equivalent to approx. 1 mm image area.
- If too a smaller value is set, stains at the edges of an original may be judged as images. Due to this, the desired judgment may not be obtained.

6.5.7 Blank page judgment threshold adjustment

The threshold is adjusted for identification of whether the original set is a blank page or not. For the adjustment method, see the following reference.

📖 P. 6-33 “6.3.4 Blank page judgment threshold adjustment”

6.5.8 Void amount adjustment for blank page judgment

The range of the image area to use blank page judgment of the original can be adjusted. For the adjustment method, see the following reference.

📖 P. 6-33 “6.3.5 Void amount adjustment for blank page judgment”

6.5.9 Sharpness adjustment

The sharpness of the boundary of text and lines can be adjusted.

| Color mode | Original mode | Code | Recommended value | Acceptable value | Default value | Operation procedure |
|------------|---------------|---------|---|------------------|---------------|---------------------|
| Black | Text/Photo | 05-7430 | To make the image softer or to make moiré inconspicuous: Set a smaller value. To make the image sharper or to make thin lines clearer: Set a larger value. | 0 to 255 | 200 | 05 Procedure 4 |
| | Text | 05-7431 | | | | |
| | Photo | 05-7432 | | | | |
| | Custom | 05-7470 | | | | |
| Full color | Text/Photo | 05-8354 | | | | |
| | Text | 05-8335 | | | | |
| | Photo | 05-8336 | | | | |
| | Custom | 05-8375 | | | | |
| Gray scale | - | 05-7433 | | | | |

Notes:

- The change of the setting value of the self-diagnostic code by 25 steps equivalents to that for 1 scale of the indicator.
- The setting value is the center value of [Sharpness] of the [Scan Setting] screen. Therefore, when the setting value is changed, all scales of the indicator is shifted by the value set in this setting accordingly.
- Change the setting value by 10 steps while checking the image to set the most appropriate value.

6.5.10 Contrast adjustment

The contrast in color scanning can be adjusted.

| Color mode | Original mode | Code | Recommended value | Acceptable value | Default value | Operation procedure |
|------------|---------------|---------|--|------------------|---------------|---------------------|
| Full color | Text/Photo | 05-8419 | To make the contrast higher: Set a larger value. To make the contrast lower: Set a smaller value. | 0 to 255 | 128 | 05 Procedure 1 |
| | Text | 05-8420 | | | | |
| | Photo | 05-8421 | | | | |
| | Custom | 05-8422 | | | | |

Notes:

The change of the setting value of the self-diagnostic code by 25 steps equivalents to that for 1 scale of the indicator.

6.5.11 Black density fine adjustment

Black in color scanning can be adjusted so that it will be close to the color of an original.

| Color mode | Original mode | Code | Recommended value | Acceptable value | Default value | Operation procedure |
|------------|---------------|---------|--|------------------|---------------|----------------------|
| Full color | Text/Photo | 05-8314 | To make black darker: Set a larger value. To make black lighter: Set a smaller value. | 0 to 4 | 1 | 05 Procedure 1 |
| | Text | 05-8315 | | | 0 | |
| | Photo | 05-8316 | | | | |
| | Custom | 05-8371 | | | | |

Notes:

Be careful not to let the value be too large since the gradation is reproduced worse in the darker side.

6.5.12 RGB conversion method selection

The color space conversion method in color scanning can be adjusted.

| Color mode | Original mode | Code | Recommended value | Acceptable value | Default value | Operation procedure |
|------------|---------------|---------|-------------------|---|---------------|----------------------|
| Full color | Text/Photo | 05-8319 | - | 0: sRGB 1: AppleRGB 2: ROMMRGB 3: AdobeRGB | 0 | 05 Procedure 1 |
| | Text | 05-8320 | | | | |
| | Photo | 05-8321 | | | | |
| | Custom | 05-8372 | | | | |

6.5.13 Saturation adjustment

The saturation in color scanning can be adjusted.

| Color mode | Original mode | Code | Recommended value | Acceptable value | Default value | Operation procedure |
|------------|---------------|---------|--|------------------|---------------|----------------------|
| Full color | Text/Photo | 05-8324 | To make the saturation higher: Set a larger value. To make the saturation lower: Set a smaller value. | 0 to 255 | 128 | 05 Procedure 1 |
| | Text | 05-8325 | | | | |
| | Photo | 05-8326 | | | | |
| | Custom | 05-8373 | | | | |

6.5.14 SlimPDF capacity and image quality adjustment

The file size and the image quality can be adjusted by changing the compression ratio and resolution for areas other than text (such as a background) in SlimPDF.

The sharpness of the background can also be adjusted.

| Item to be adjusted | Code | Recommended value | Acceptable value | Default value | Operation procedure |
|---------------------|---------|---|------------------|---------------|----------------------|
| Compression ratio | 05-9104 | To improve the image quality: Set a larger value. (The file size will become larger.) To reduce the file size: Set a smaller value. (The image quality will become worse. (Noise will be increased in outlines and the boundary of white and other colors.)) | 0 to 10 | 5 | 05 Procedure 1 |
| Sharpness | 05-9105 | To make the outline and boundary clearer: Set a larger value. (Noise will be enhanced or moiré may occur.) To make the outline and boundary softer: Set a smaller value. (Images may be blurred.) | | | |
| Resolution | 05-9107 | 0: 75 dpi, 1: 100 dpi, 2: 150 dpi, 3: 200 dpi To improve the image quality: Set a larger value. (The file size will become larger.) To reduce the file size: Set a smaller value. (The image quality will become worse. (Some characters will become hard to read and the boundary of photos will be blurred.)) | 0 to 3 | 1 | |

Notes:

- Change the setting value of FS-05-9104 and FS-05-9105 by 2 steps while checking the image in order to set the most appropriate value.
- When “5” is set in FS-05-9105, the sharpness will not be adjusted.
- Performing the adjustment by combining FS-05-9104 and FS-05-9107 can obtain good balance in the image quality and file size.
e.g.: Set 2 or a larger value in FS-05-9107 to improve the image quality and set 4 or a smaller value in FS-05-9104 to reduce the file size.

6.5.15 Surrounding void amount adjustment

The void amount around the scanned image during selecting [Auto Detected] can be adjusted. Perform this adjustment to remove shadows of the original generated around images.

| Paper size | Size detection | Code | Recommended value | Acceptable value | Default value | Operation procedure |
|-------------|----------------|---------|---|------------------|---------------|----------------------|
| Standard | - | 05-7489 | To increase the void amount: Set a larger value. To decrease the void amount: Set a smaller value. | 0 to 255 | 0 | 05 Procedure 1 |
| Custom size | Size selection | 05-7490 | | | | |
| | Auto | 05-7491 | | | | |

Notes:

When the setting value of the self-diagnostic code is changed by 24 steps, the void amount will be altered by approx. 1 mm accordingly.

6.5.16 JPEG compression level adjustment

The compression ratio for saving the scanned images in the JPEG format can be adjusted.

| Color mode | Code | Sub code | Meaning of the sub code | Recommended value | Acceptable value | Default value | Operation procedure |
|------------|---------|----------|-------------------------|---|------------------|---------------|----------------------|
| Full color | 05-8304 | 0 | High | To increase the compression ratio: Set a smaller value. To decrease the compression ratio: Set a larger value. | 0 to 255 | 128 | 05 Procedure 4 |
| | | 1 | Mid | | | | |
| | | 2 | Low | | | | |

Notes:

The larger the value is, the greater the file size but the higher the image quality becomes.

6.5.17 Scanning streak reduction

Streaks generated on images during the scanning of an original can be reduced. The reduction level can be set for using the DF or the original glass, respectively.

When the DF is used for scanning, detection is performed for every scanned page to reduce streaks.

When the original glass is used for scanning, refer to the result of the automatic streak detection on it to reduce streaks.

For the adjustment method, see the following reference.

 P. 6-36 “6.3.13 Scanning streak reduction”

6.5.18 Background offset adjustment (DF)

The reproduction ratio of the background in DF scanning can be adjusted. The adjustment value is applied to both the front and back sides.

For the adjustment method, see the following reference.

 P. 6-35 “6.3.10 Background offset adjustment (DF)”

6.5.19 Background offset adjustment on the back side of paper (DSDF)

The reproduction ratio of the background on the back side of paper in DSDF scanning can be adjusted. The adjustment value is applied to the back side only.

For the adjustment method, see the following reference.

 P. 6-36 “6.3.11 Background offset adjustment on the back side of paper (DSDF)”

6.5.20 Low density text reproduction process adjustment

The way of removing the background to create a priority for reducing a low density text can be set in the black mode and auto density.

This setting can be made for each original mode.

| Color mode | Original mode | Code | Recommended value | Acceptable value | Default value | Operation procedure |
|------------|---------------|---------|---|------------------|---------------|----------------------|
| Black | Text/Photo | 05-7408 | 0: Factory setting value 1: Disabled 2: Enabled | 0 to 2 | 0 | 05 Procedure 1 |
| | Text | 05-7409 | | | | |
| | Photo | 05-7410 | | | | |
| | Gray Scale | 05-7411 | | | | |
| | Custom | 05-7412 | | | | |

Notes:

When the value is set to “2”, the density of the images may become darker in its entirety. In such a case, decrease the setting value of the density adjustment by approx. 20.

 P. 6-32 “6.3.1 Density adjustment”

6.6 Image Quality Adjustment (Fax Function)

6.6.1 Density adjustment

The center value of the density can be adjusted.

If the setting value of the manual adjustment is changed, the density of the step of all indicators including the center value will be altered when [Auto] is selected in Exposure on the [Option] screen.

| Item to be adjusted | Original mode | Code | Recommended value | Acceptable value | Default value | Operation procedure |
|---------------------|---------------|---------|--|------------------|---------------|----------------------|
| Manual density | Text/Photo | 05-7533 | To make the density darker: Set a larger value. To make the density lighter: Set a smaller value. | 0 to 255 | 128 | 05 Procedure 1 |
| | Text | 05-7534 | | | | |
| | Photo | 05-7535 | | | | |
| Automatic density | Text/Photo | 05-7542 | | | | |
| | Photo | 05-7543 | | | | |

Notes:

The change of the setting value of the self-diagnostic code by 20 steps equivalents to that for 1 scale of the indicator.

6.6.2 Emission level adjustment

The emission level in the fax function can be set. The density can be adjusted by changing the dot size.

| Code | Sub code | Recommended value | Acceptable value | Default value | Operation procedure |
|---------|----------|--|------------------|---------------|----------------------|
| 05-7595 | 0 | To make the density darker: Set a larger value. To make the density lighter: Set a smaller value. | 0 to 255 | 0 | 05 Procedure 4 |
| | 1 | | | 63 | |
| | 2 | | | 127 | |
| | 3 | | | 191 | |
| | 4 | | | 255 | |

Notes:

- The setting of the sub code 4 is the most influential one to the density.
- Change the setting value by 8 steps while checking the image to set the most appropriate value.
- The value of the sub code should be entered so that the value of the order becomes $0 < 1 < 2 < 3 < 4$.

6.6.3 Background offset adjustment (DF)

The reproduction ratio of the background in DF scanning can be adjusted. The adjustment value is applied to both the front and back sides.

For the adjustment method, see the following reference.

📖 P. 6-35 “6.3.10 Background offset adjustment (DF)”

6.6.4 Background offset adjustment on the back side of paper (DSDF)

The reproduction ratio of the background on the back side of paper in DSDF scanning can be adjusted. The adjustment value is applied to the back side only.

For the adjustment method, see the following reference.

📖 P. 6-36 “6.3.11 Background offset adjustment on the back side of paper (DSDF)”

6.7 Scanning Section

6.7.1 Carriage-1 position adjustment

- (1) Take off the DSDF.
📖 P. 4-326 “4.11.1 Removal of the DSDF”
- (2) Take off the top right cover.
📖 P. 4-2 “4.1.3 Top right cover”
- (3) Take off the original glass.
📖 P. 4-23 “4.3.1 Original glass”
- (4) Take off the top left cover.
📖 P. 4-6 “4.1.10 Top left cover”
- (5) Move the carriage-1 [1] toward the paper exiting side.

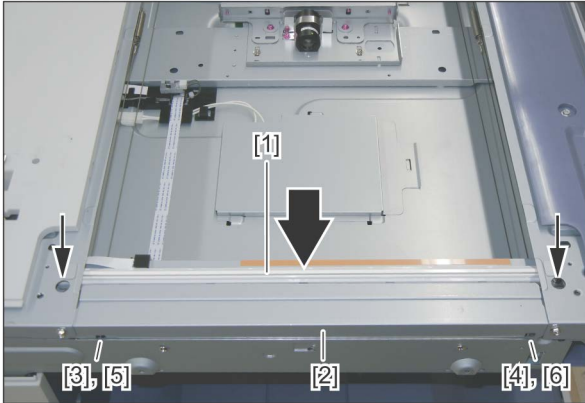

Fig.6-25

Notes:

Rotate the drive pulley to move the carriage.

- (6) Loosen the 2 fixing screws of the wire. Tighten the screws by aligning the sections [5] and [6] of the carriage-1 with the inside of the exit side frame [2].

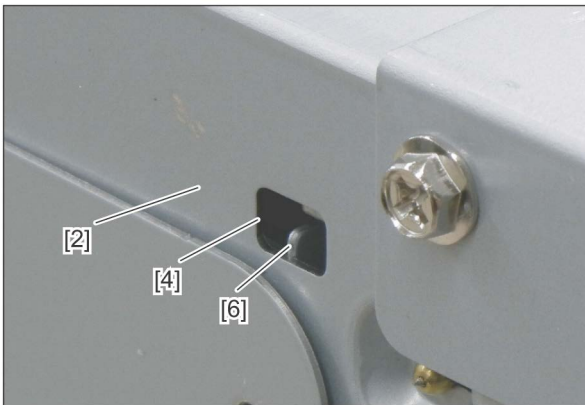

Fig.6-26

Notes:

Confirm that they are aligned properly through the windows [3] and [4] of the paper exiting side frame [2].

6.7.2 Lens unit position adjustment

Count the number of lines and write it down for later reference before removing the lens unit. When installing the lens unit, the same number of lines needs to be visible.

📖 P. 4-30 “4.3.5 Lens unit (CCD driving PC board)”

6.7.3 Belt tension adjustment of the scan motor

- (1) Take off the DSDF.
📖 P. 4-326 “4.11.1 Removal of the DSDF”
- (2) Take off the top left cover.
📖 P. 4-6 “4.1.10 Top left cover”
- (3) Take off the rear cover.
📖 P. 4-12 “4.1.22 Rear cover”
- (4) Take off the top rear cover.
📖 P. 4-13 “4.1.23 Top rear cover”
- (5) Hook the belt tension jig [1] to the motor bracket [2] and hook section of the frame [3].
- (6) Loosen the screws [4], [5].
- (7) The scan motor [6] is pulled by the belt tension jig [1]. When it is stopped, tighten the screws in order of [4] and [5].
- (8) Remove the belt tension jig [1].

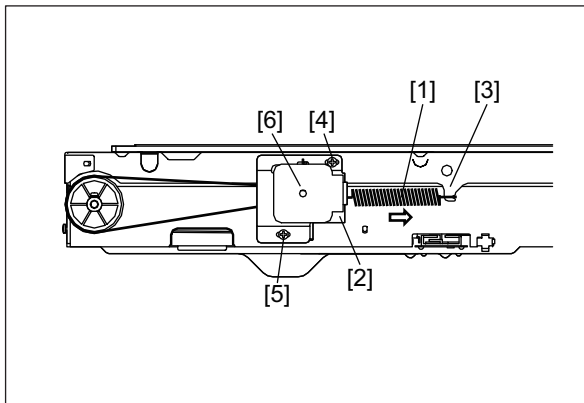

Fig.6-27

6.8 Paper feeding section

6.8.1 Adjustment of the clearance of the paper and side guide

If the clearance between the paper and the side guide is too wide, it can be adjusted to between 0 and 1 mm using the following procedure.

- (1) Take off the drawer from the MFP.
- (2) Move the side guide [1] and loosen 1 screw.

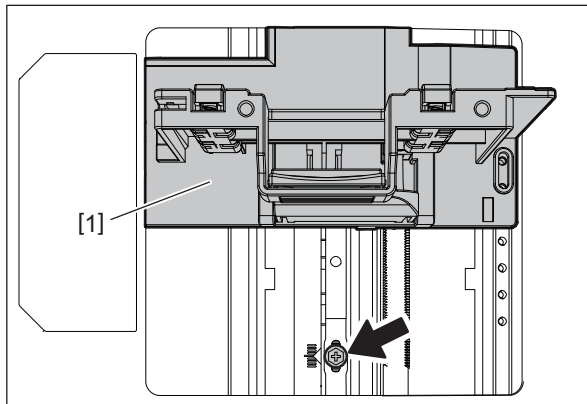

Fig.6-28

- (3) Move the side guide lock adjustment piece [2] to the front and tighten the screw.

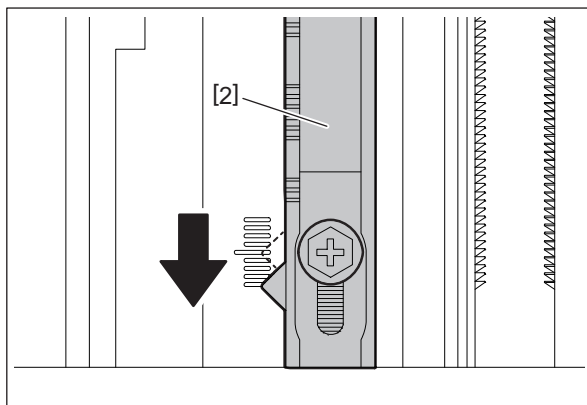

Fig.6-29

6.8.2 Separation roller pressure force adjustment (drawer)

If abnormal paper feeding or multiple paper feeding has occurred frequently before the preventive maintenance time of the separation roller, this may be improved by adjusting the pressure force of the separation roller.

Notes:

- Before performing this adjustment, take a memo of the pre-adjustment setting position.
- By performing the adjustment, the occurrence of abnormal paper feeding or multiple paper feeding will increase. If necessary, give sufficient explanation to the users.
- Perform the adjustment carefully depending on the paper.

- (1) Remove the paper feed unit.
📖 P. 4-72 "4.5.13 Paper feed unit"
- (2) Remove 1 screw and then attach it temporarily in the oblong hole next to it.

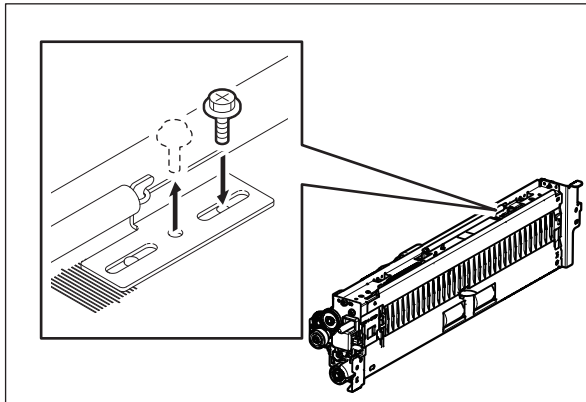

Fig.6-30

Notes:

Make a mark for the installation position of the bracket in advance.

- (3) Move the bracket and perform the adjustment as below.
 - To solve abnormal paper feeding: Move the bracket in the direction A. (Multiple feeding tends to occur.)
 - To solve multiple paper feeding: Move the bracket in the direction B. (Abnormal paper feeding tends to occur.)

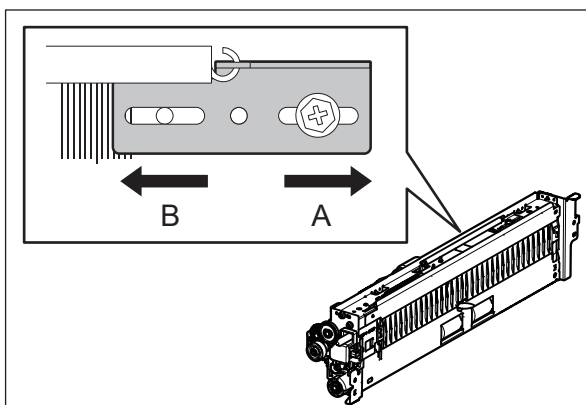

Fig.6-31

Notes:

The recommended moving distance of the bracket is within 2 or 3 scale marks.

- (4) Securely tighten the temporarily attached screw.

Notes:

- If the film attached to the front of the separation roller is worn and shortened, its life tends to be decreased. Therefore, check the length of the film.
Reference value of C (distance between the edges of the metal plate and the film): 7.0 mm \pm 0.2 mm
- If the distance C is 6.5 mm or shorter, replace the film.

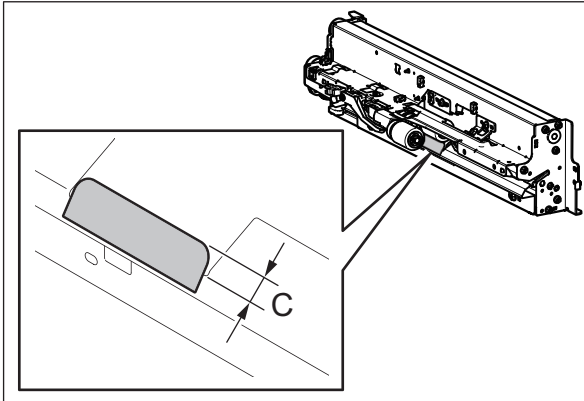

Fig.6-32

6.8.3 Separation roller pressure force adjustment (bypass unit)

If abnormal paper feeding or multiple paper feeding has occurred frequently before the preventive maintenance time of the separation roller, this may be improved by adjusting the pressure force of the separation roller.

Notes:

- Before performing this adjustment, take a memo of the pre-adjustment setting position.
- By performing the adjustment, the occurrence of abnormal paper feeding or multiple paper feeding will increase. If necessary, give sufficient explanation to the users.
- Perform the adjustment carefully depending on the paper.

(1) Take off the bypass unit.

 P. 4-59 "4.5.2 Bypass unit"

(2) Remove 1 screw and take off the bracket [1].

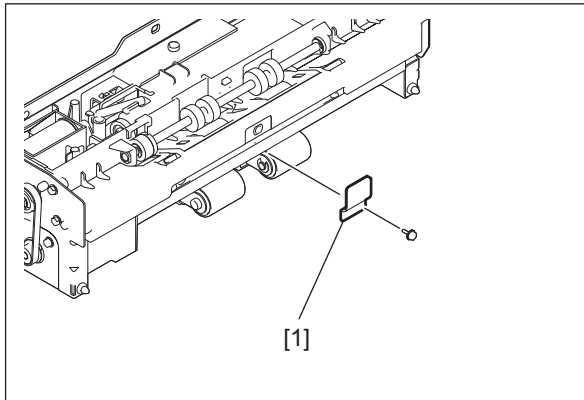

Fig.6-33

(3) Remove 4 screws and take off the SFB lower unit [2].

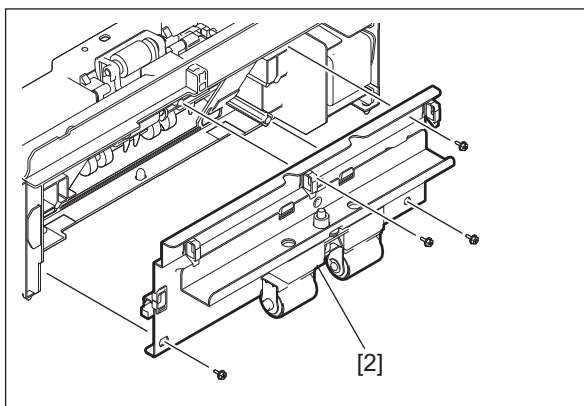

Fig.6-34

- (4) Disconnect 1 connector, remove 2 screws and take off the SFB lower guide [3].

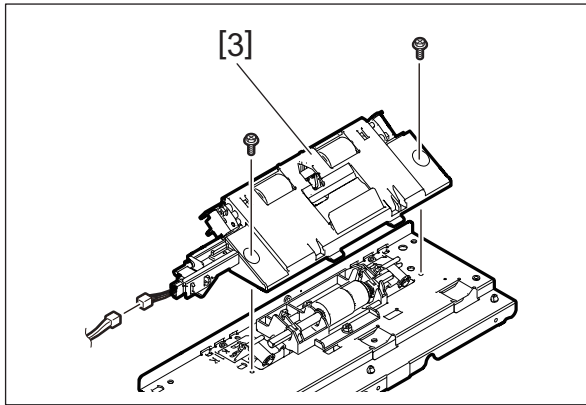

Fig.6-35

- (5) Remove 1 screw from the round hole on the front side bracket [4] and then attach it temporarily in the oblong hole.

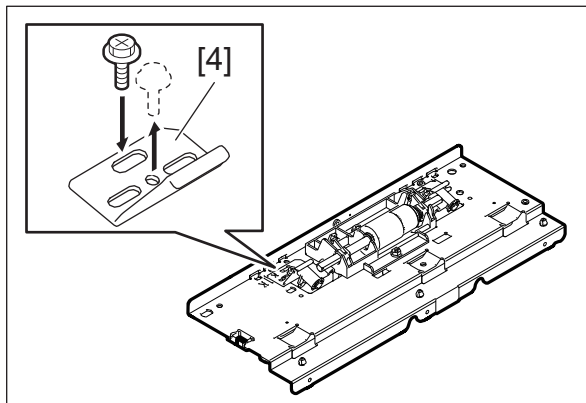

Fig.6-36

- (6) Move the front side bracket [4] and perform the adjustment as below.
- To solve abnormal paper feeding: Move the bracket in the direction A. (Multiple feeding tends to occur.)
 - To solve multiple paper feeding: Move the bracket in the direction B. (Abnormal paper feeding tends to occur.)

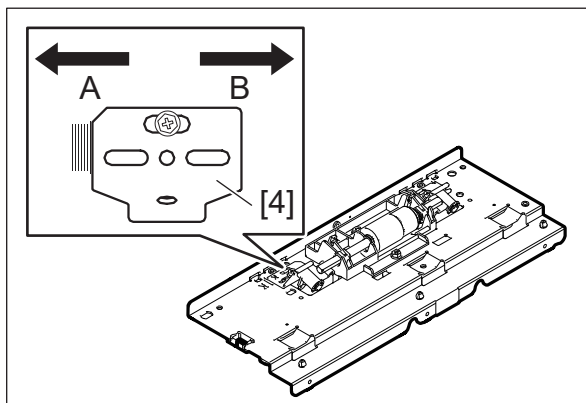

Fig.6-37

Notes:

The recommended moving distance of the bracket is within 1 or 2 scale marks.

- (7) Securely tighten the temporarily attached screw.

Notes:

If abnormal paper feeding or multiple paper feeding is not solved even if steps 1 through 7 have been carried out, perform the following steps 8 through 10.

- (8) Remove 1 screw from the round hole on the rear side bracket [5] and then attach it temporarily in the oblong hole.

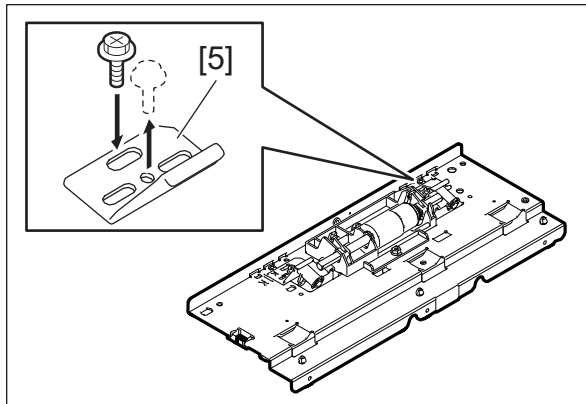

Fig.6-38

- (9) Move the rear side bracket [5] and perform the adjustment as below.

- To solve abnormal paper feeding: Move the bracket in the direction A. (Multiple feeding tends to occur.)
- To solve multiple paper feeding: Move the bracket in the direction B. (Abnormal paper feeding tends to occur.)

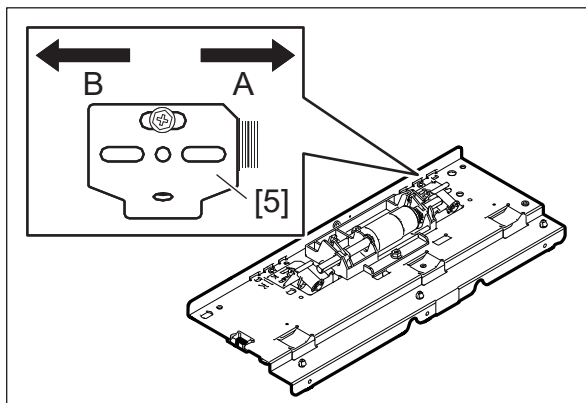

Fig.6-39

Notes:

The recommended moving distance of the bracket is within 1 or 2 scale marks.

- (10) Securely tighten the temporarily attached screw.

6.8.4 Paper transport sideways deviation adjustment (drawer)

Perform this adjustment if paper folding on the leading edge of the paper or paper misfeeding has occurred due to sideways deviation during paper transporting.

Notes:

- If streak images appear on the side of the 300-mm width paper, perform the adjustment in the direction with no streak images appearing.
- After this adjustment, be sure to carry out primary scanning direction data writing start position.
📖 P. 6-12 “[B] Primary scanning direction data writing start position”
- To adjust the sideways deviation of the images and paper, carry out the primary scanning direction data writing start position, but not this adjustment.
📖 P. 6-12 “[B] Primary scanning direction data writing start position”

- (1) Take off the drawer from the MFP.
- (2) Move the side guides [1] to the inside.

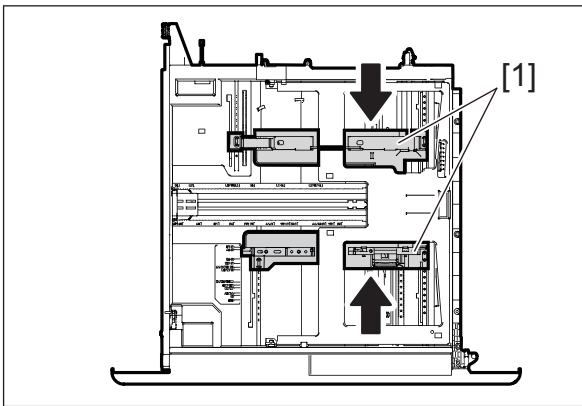

Fig.6-40

- (3) While keeping away from the stopper [2], remove the tray metal plate [3].

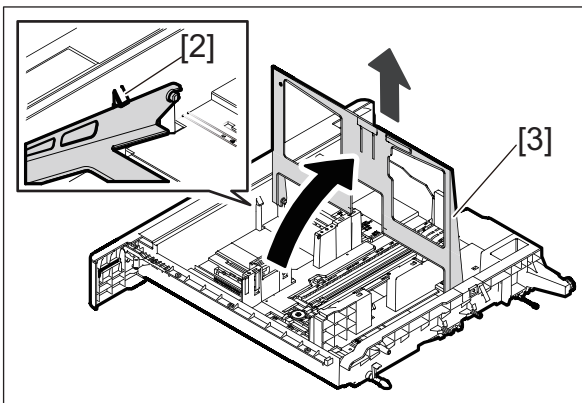

Fig.6-41

- (4) Loosen 1 screw [4].

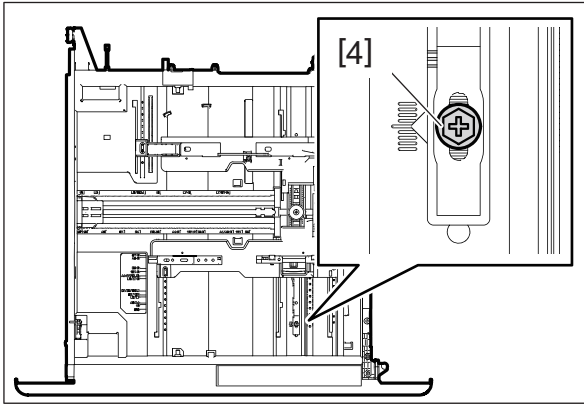

Fig.6-42

- (5) Move the side guide lock adjustment piece [5] and tighten the screw [4].

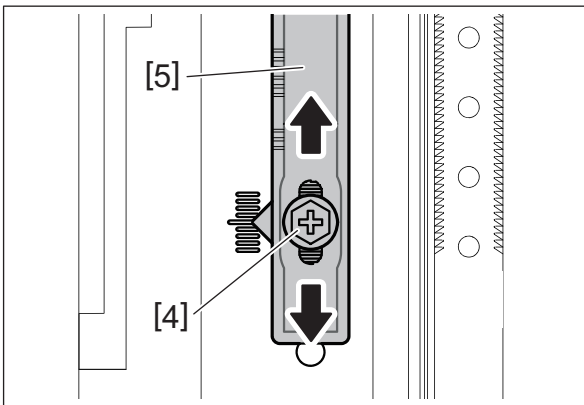

Fig.6-43

Remarks:

- To move the side guides to the rear side, shift the adjustment piece in that direction.
 - To move the side guides to the front side, shift the adjustment piece in that direction.
 - The movement amount for 1 scale mark is approx. 1 mm.
 - The recommended adjustment amount is within ± 3 scale marks.
- (6) Remove 1 screw [6] and the end pusher [7].

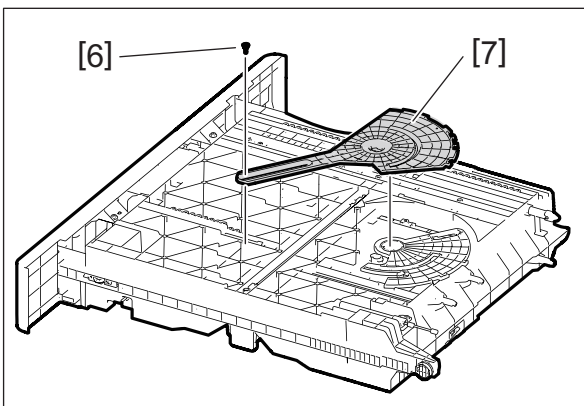

Fig.6-44

- (7) Remove the side pusher [8].

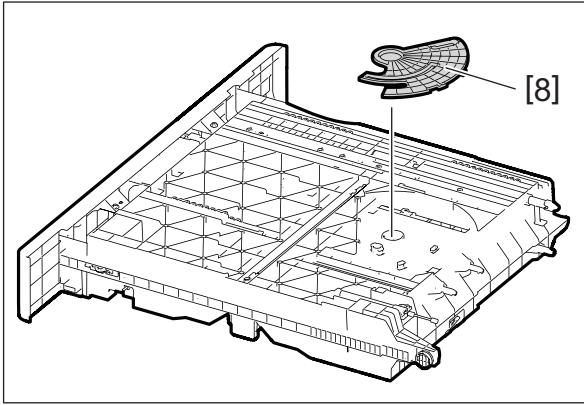

Fig.6-45

- (8) Loosen 1 screw [9].

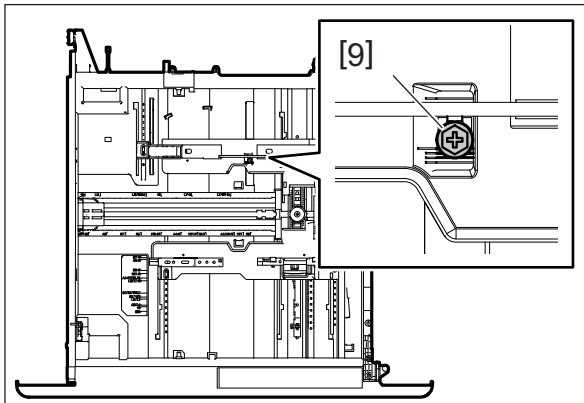

Fig.6-46

- (9) Move the pusher fixing piece [10] at the rear of the screw [9] by the same movement amount as the side guide lock adjustment piece [5] has been shifted, but in the opposite direction.

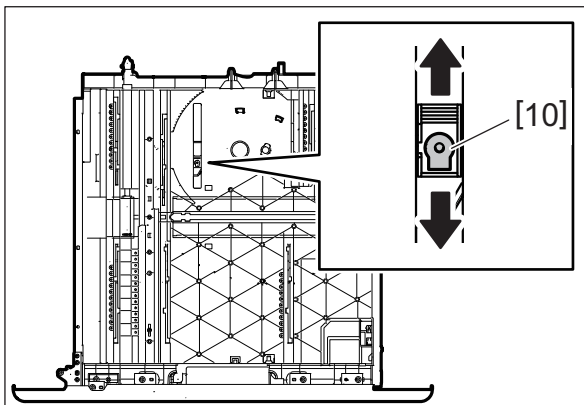

Fig.6-47

(10) Tighten 1 screw [9].

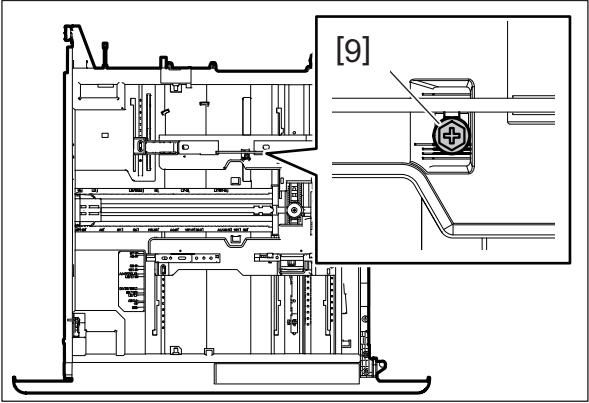

Fig.6-48

6.8.5 Bypass unit paper transport sideways deviation adjustment

Perform this adjustment if paper folding on the leading edge of the paper or paper misfeeding has occurred due to sideways deviation during paper transporting.

Notes:

- If streak images appear on the side of the 300-mm width paper, perform the adjustment in the direction with no streak images appearing.
- After this adjustment, be sure to carry out primary scanning direction data writing start position.
📖 P. 6-12 “[B] Primary scanning direction data writing start position”
- To adjust the sideways deviation of the images and paper, carry out the primary scanning direction data writing start position, but not this adjustment.
📖 P. 6-12 “[B] Primary scanning direction data writing start position”

- (1) Move the side guides halfway to the center.
- (2) Loosen 1 screw.
- (3) Move the side guide at the rear to the front or rear side.
- (4) Tighten 1 screw.

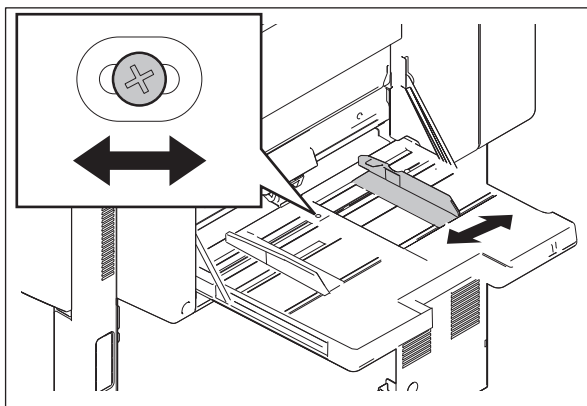

Fig.6-49

Notes:

The paper transport position is moved according to the amount and direction in which the side guide is moved.

6.8.6 Paper transport sideways deviation adjustment (T-LCF)

Perform this adjustment if paper folding on the leading edge of the paper or paper misfeeding has occurred due to sideways deviation during paper transporting.

Notes:

- After this adjustment, be sure to carry out primary scanning direction data writing start position.
📖 P. 6-12 “[B] Primary scanning direction data writing start position”
 - To adjust the sideways deviation of the images and paper, carry out the primary scanning direction data writing start position, but not this adjustment.
📖 P. 6-12 “[B] Primary scanning direction data writing start position”
- (1) Take out the Tandem LCF paper feed unit.
📖 P. 4-109 “4.5.47 Tandem LCF paper feed unit”
 - (2) Loosen 4 screws.

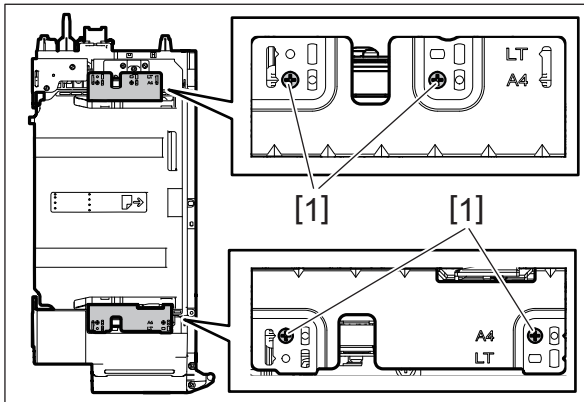

Fig.6-50

- (3) Move the side guides [2] to the front or rear side.

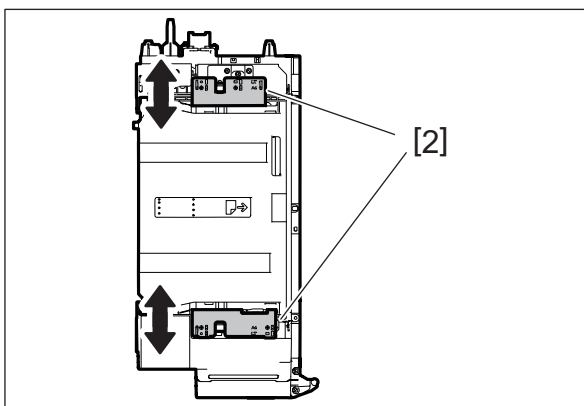

Fig.6-51

Notes:

The front and rear side guides should be moved by the same amount and in the same direction.

- (4) Tighten 4 screws.

6.9 Process Unit Related Section

6.9.1 Auto-toner sensor adjustment

When the developer material is replaced, adjust the auto-toner sensor.

📖 P. 6-2 “6.1.2 Auto-toner sensor adjustment”

6.9.2 Doctor-to-sleeve gap adjustment (developer unit)

Jig to be used: Doctor sleeve jig

<Adjustment procedure>

- (1) Take off the developer unit from the MFP and discharge the developer material.
- (2) Loosen 2 screws fixing the doctor blade [1]. Insert the gauge with the thickness “0.65” of the doctor sleeve jigs [2] into 3 places of the gap between the developer sleeve and doctor blade. Adjust the gap and tighten the screws.

Adjustment reference: 0.65 ± 0.05 mm

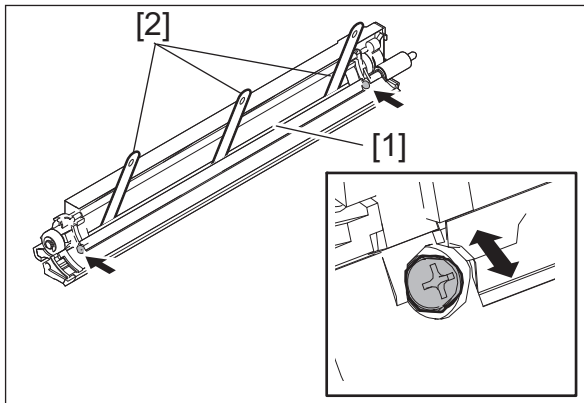

Fig.6-52

Notes:

- Peel the protection sheet [3] of the doctor blade in advance to perform the adjustment. At that time, be careful not to damage the protection sheet [3].

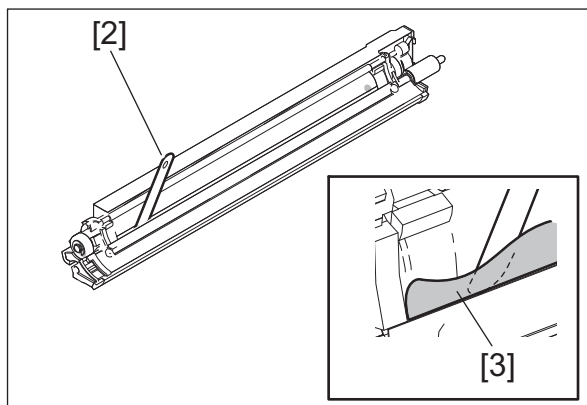

Fig.6-53

- When confirming and adjusting the gap between the developer sleeve and the doctor blade [1], insert the gauge into the gap after rotating the developer sleeve so that its marking [4] faces the doctor blade [1].

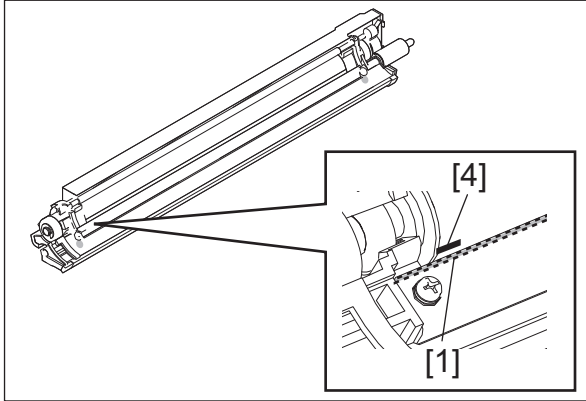

Fig.6-54

- (3) Confirm that the gauge “0.60” of the doctor sleeve jig [2] is smoothly inserted into the gap between the developer sleeve and doctor blade [1] and the gauge “0.70” cannot be inserted into the gap.

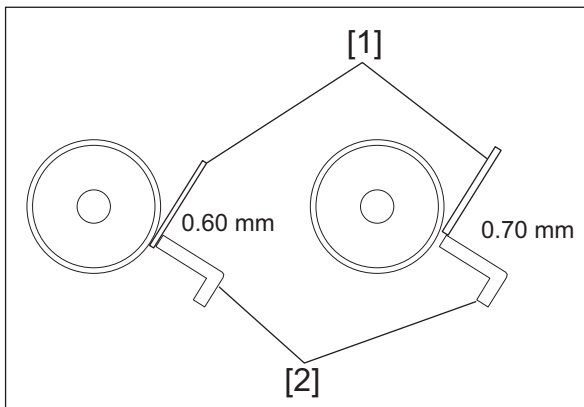



Fig.6-55

6.10 Image Quality Control Section

6.10.1 Image quality control related adjustment

When the image position aligning/image quality sensor (center) is replaced, perform the adjustment in the following order.

- (1) Set "0" in FS-08-2588.
 - (2) Perform FS-05-2742 (Enforced performing of image quality control).
 - (3) Perform Automatic gamma adjustment.
-  P. 6-4 "6.1.3 Image quality control adjustment"
-  P. 6-26 "6.1.7 Automatic gamma adjustment"

6.11 Fusing Section

6.11.1 Separation plate gap adjustment

Perform this adjustment when the following parts are replaced or disassembled.

- Separation plate

Confirm the gap when the following parts are replaced.

- Fuser belt
- Fuser belt lubricating sheet
- Fuser belt pad
- Pressure roller

Notes:

- Wait until the fuser unit is completely cooled down, and then start the adjustment.
- Place the fuser unit on a flat surface.
- Be sure not to damage the fuser belt with the gap adjustment jig.
- Adjust the gap while the pressure roller is contacted to the fuser belt.
- If the fuser unit is not installed in the MFP after the replacement or adjustment but must be kept as a unit for a long time, be sure to leave the pressure roller released from the fuser belt.

<Gap to be confirmed>

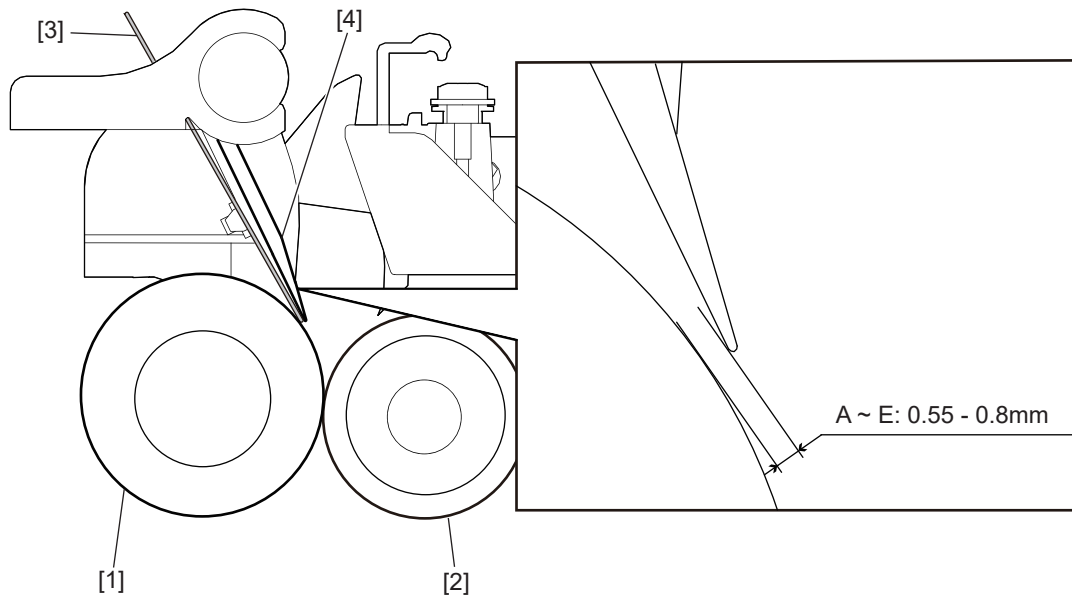

Fig.6-56

- [1] Fuser belt
- [2] Pressure roller
- [3] Separation plate gap adjustment jig
- [4] Separation plate

<Jig to be used>

Separation plate gap adjustment jig

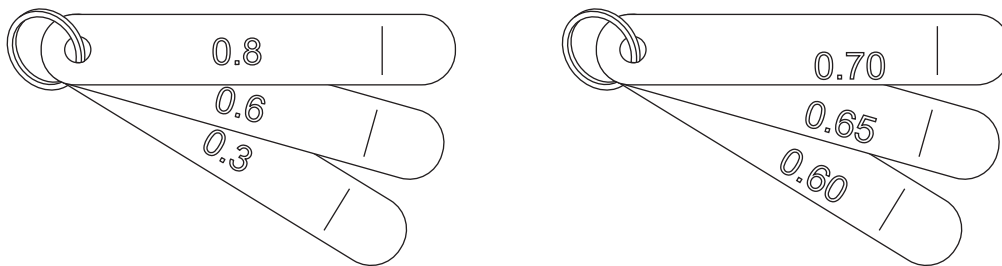

Fig.6-57

<Adjustment procedure>

- (1) Take off the fuser unit transport guide.
📖 P. 4-222 "4.9.3 Fuser unit transport guide"
- (2) Rotate the contacting/releasing cam [1] in the direction of the arrow with a flathead screwdriver. Fix the pressure roller and the fuser belt so that they contact each other.

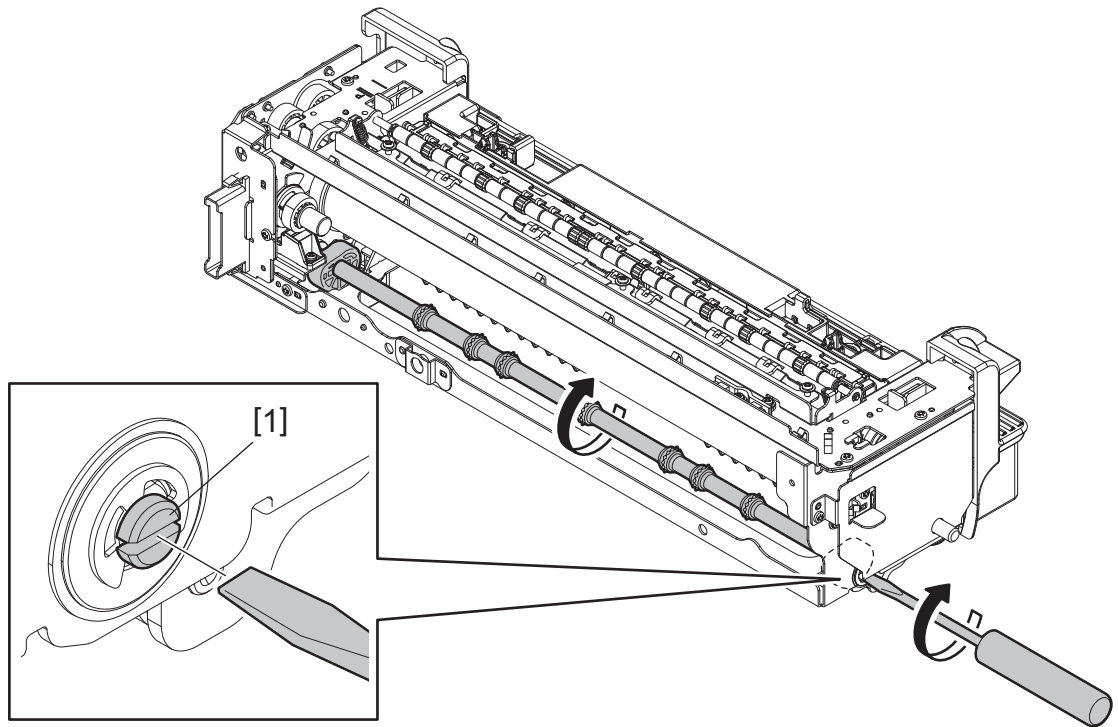

Fig.6-58

Notes:

Confirm that the position of the plate [2] indicates "Contact".

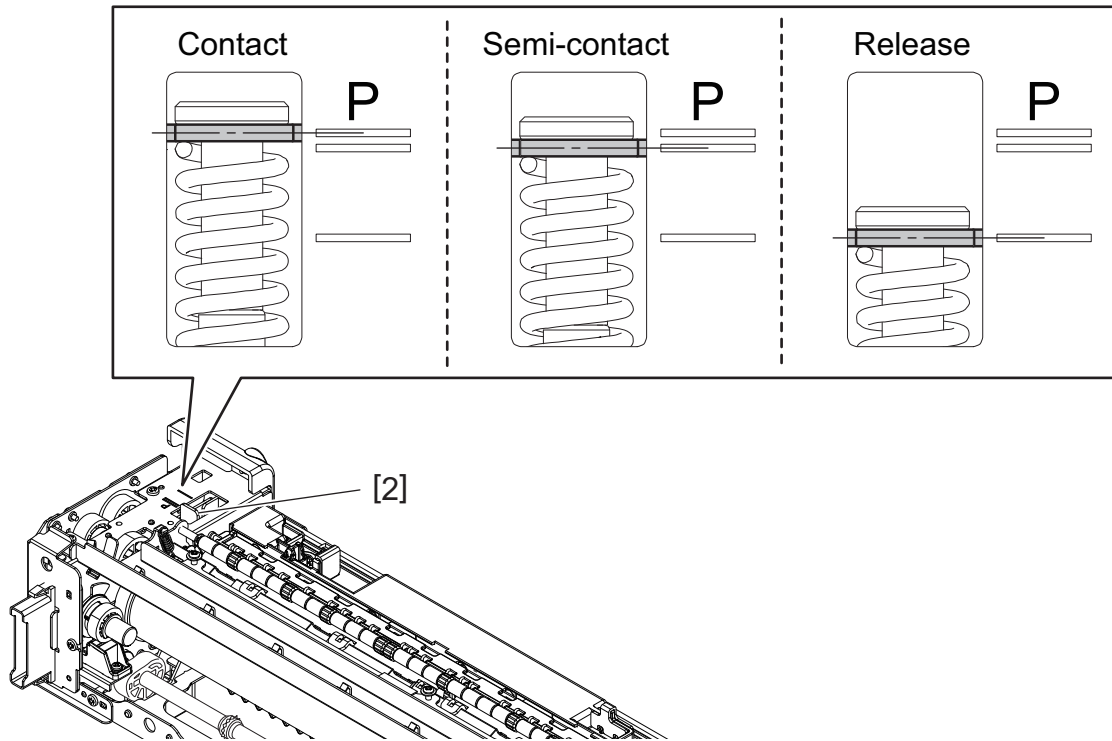

Fig.6-59

- (3) Adapt the fuser belt to the roller by rotating the gear [3] a few times in the direction of the arrow.

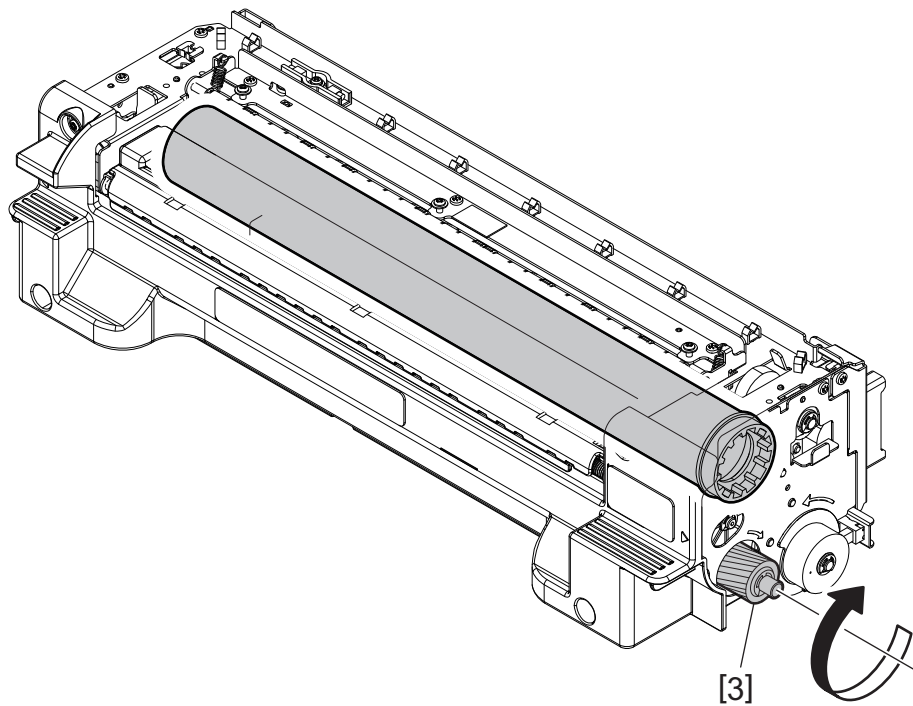

Fig.6-60

- (4) Insert the jig into the windows [A] and [E] and then adjust the gap to 0.55 to 0.8 mm.
- (5) Confirm the gaps of the window [B], [C] and [D]. When the gap is 0.55 to 0.8 mm, adjustment is completed.
- (6) If the gaps [B], [C] and [D] are narrower than 0.55 mm, adjust with center screw fasten.
If the gaps [B], [C] and [D] are wider than 0.8 mm, loosen the front, center and rear screw, and then readjust from step (4).

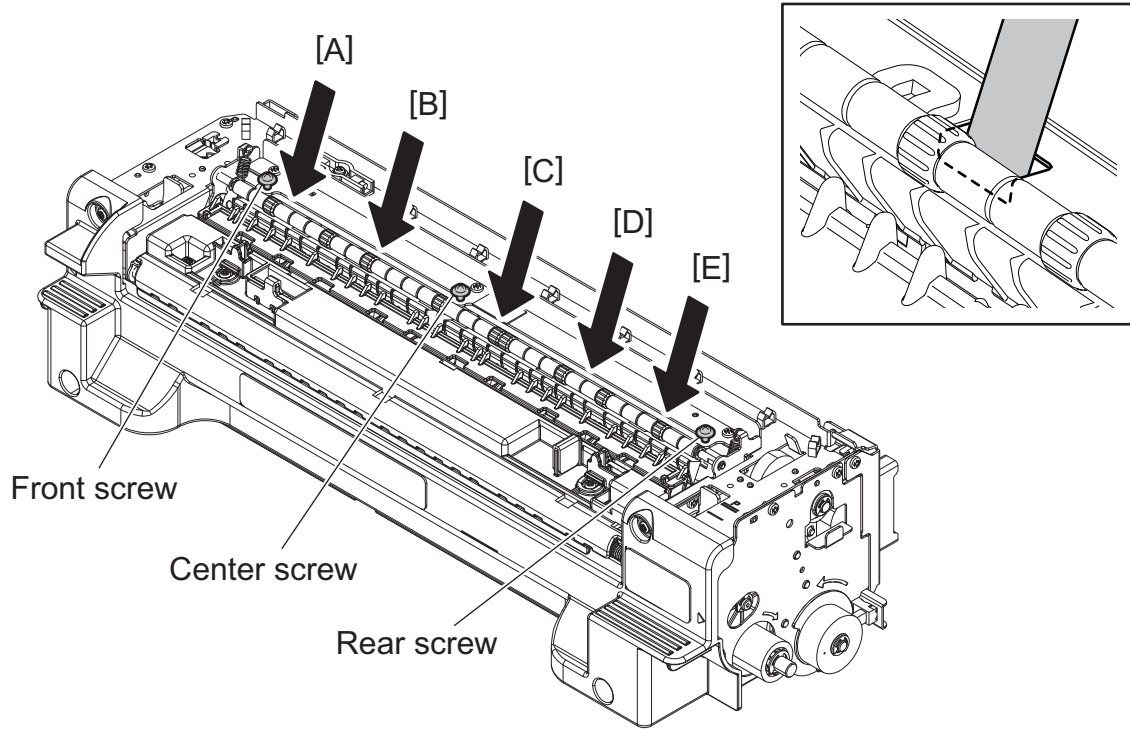

Fig.6-61

6.11.2 Separation guide gap adjustment

Perform this adjustment when the following parts are replaced or disassembled.

- Separation guide
- Separation guide fixing plate

Confirm the gap when the following parts are replaced.

- Fuser belt
- Fuser belt lubricating sheet
- Fuser belt pad
- Pressure roller

Notes:

- Wait until the fuser unit is completely cooled down, and then start the adjustment.
- Place the fuser unit on a flat surface.
- Be sure not to damage the fuser belt with the gap adjustment jig.
- Adjust the gap while the pressure roller is contacted to the fuser belt.
- If the fuser unit is not installed in the MFP after the replacement or adjustment but must be kept as a unit for a long time, be sure to leave the pressure roller released from the fuser belt.

<Gap to be confirmed>

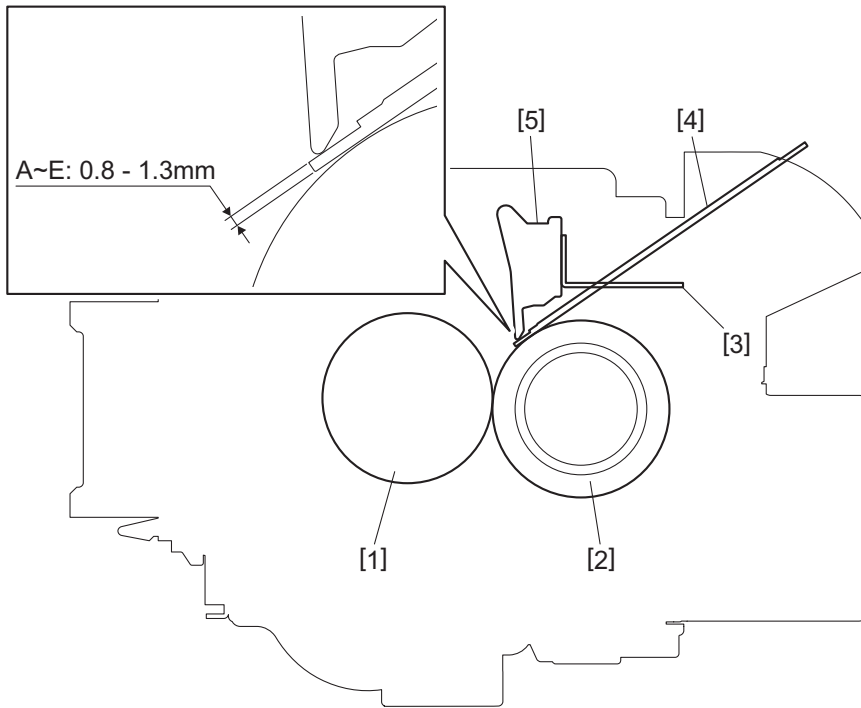

Fig.6-62

- [1] Fuser belt
- [2] Pressure roller
- [3] Separation guide fixing plate
- [4] Separation guide gap adjustment jig
- [5] Separation guide

<Jig to be used>

Separation guide gap adjustment jig

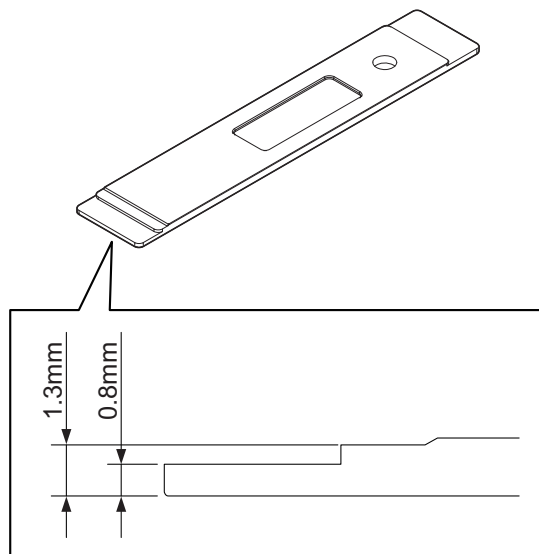

Fig.6-63

<Adjustment procedure>

- (1) Take off the fuser unit transport guide.
📖 P. 4-222 "4.9.3 Fuser unit transport guide"
- (2) Rotate the contacting/releasing cam [1] in the direction of the arrow with a flathead screwdriver. Fix the pressure roller and the fuser belt to a contacted state.

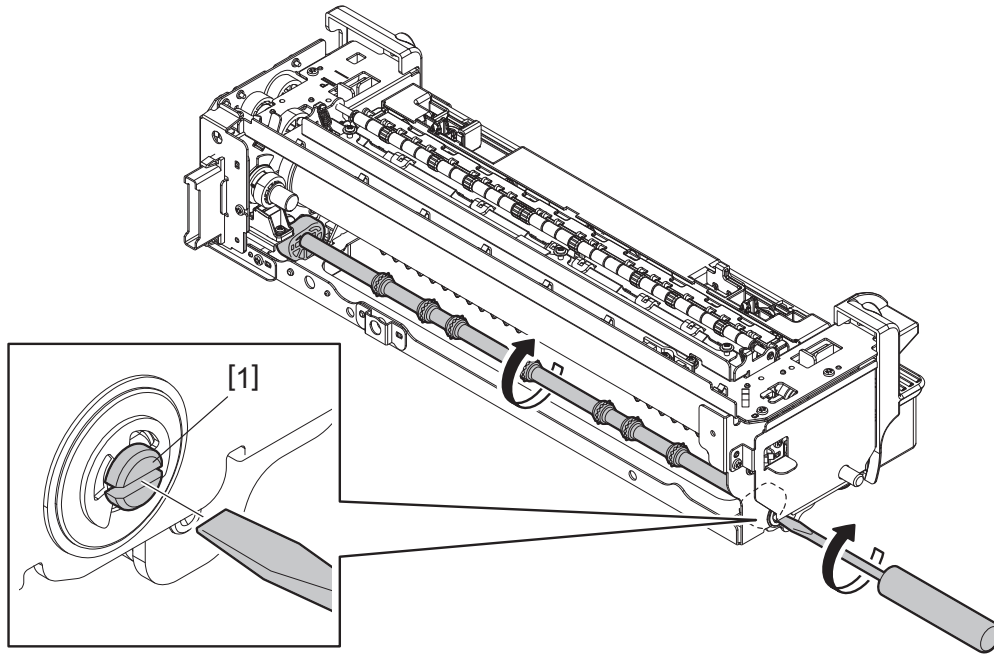

Fig.6-64

Notes:

Confirm that the position of the plate [2] indicates "Contact".

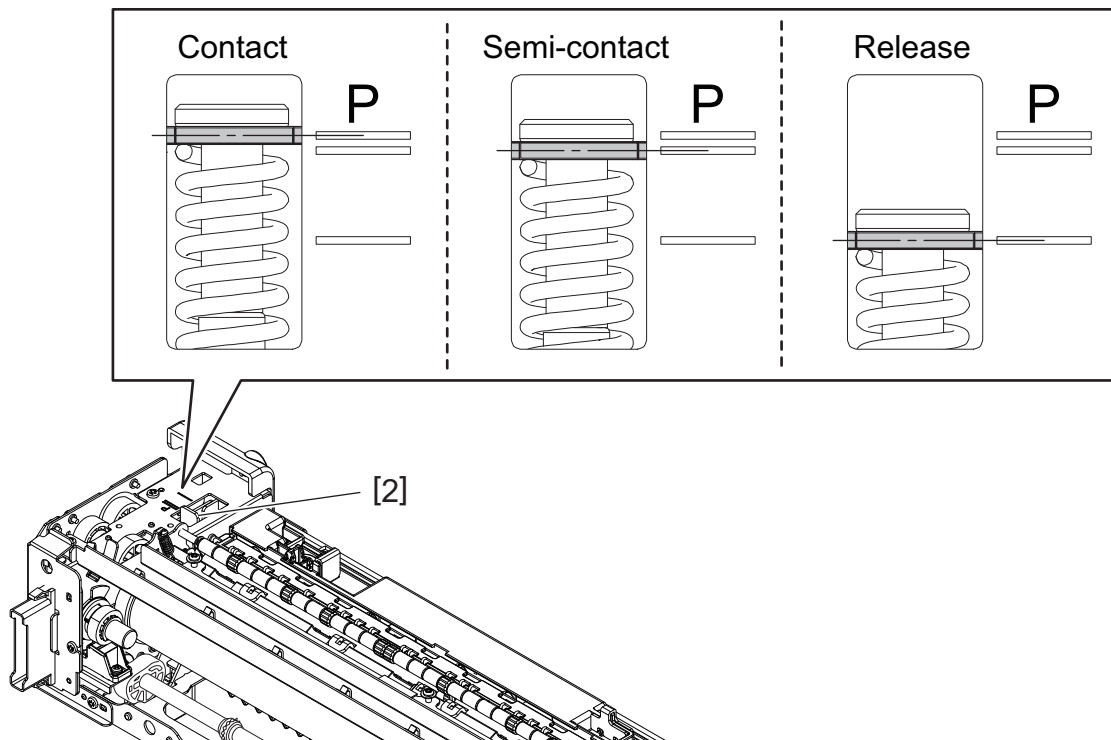

Fig.6-65

- (3) Adapt the fuser belt to the roller by rotating the gear [3] a few times in the direction of the arrow.

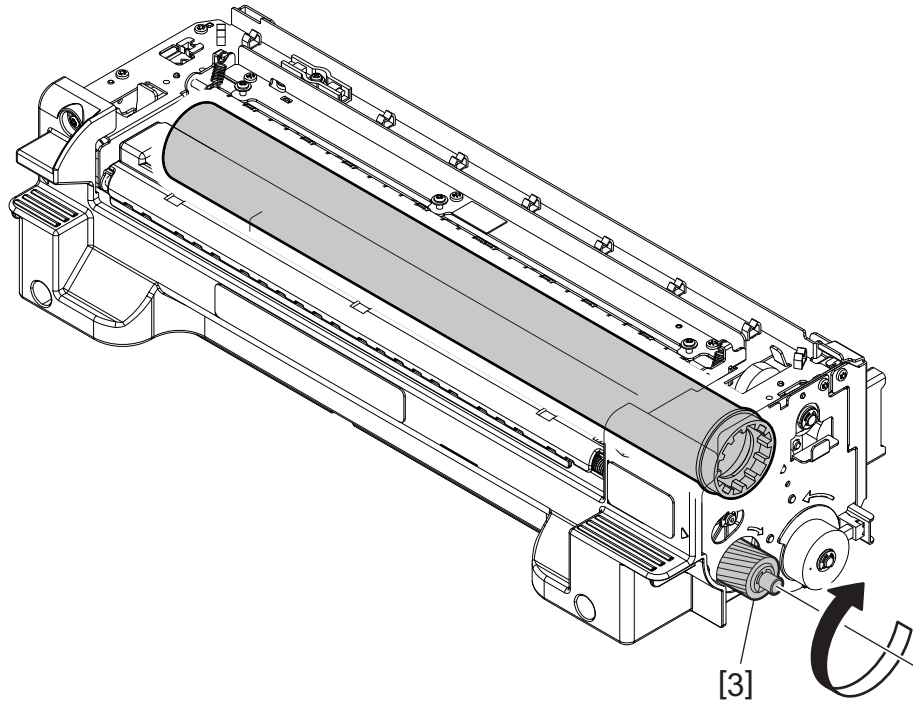

Fig.6-66

- (4) Remove 1 screws and take off the separation guide cover [4].

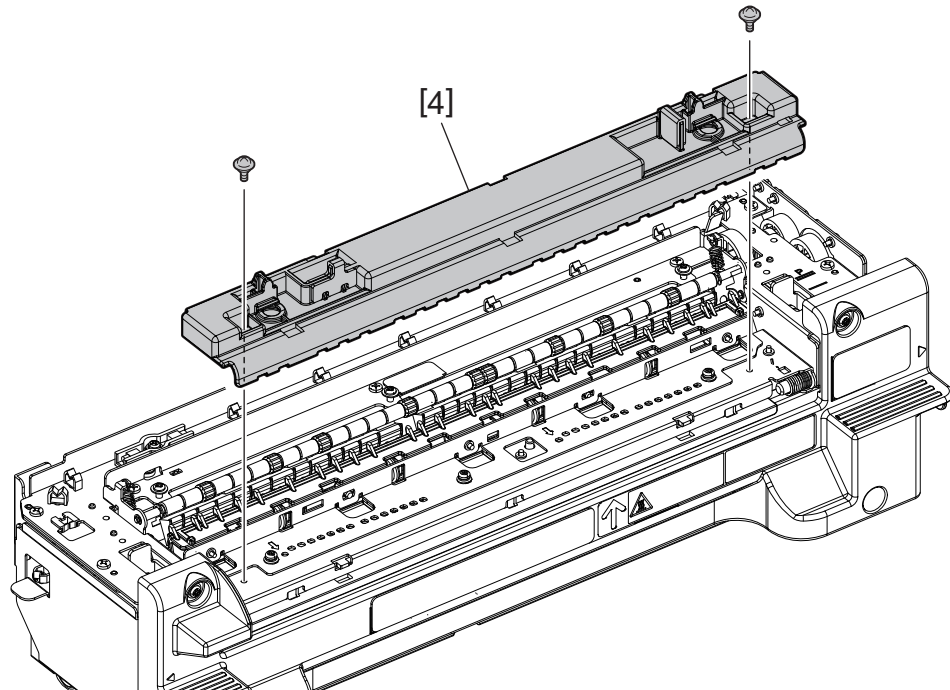

Fig.6-67

- (5) Loosen 3 screws of the separation guide fixing plate.

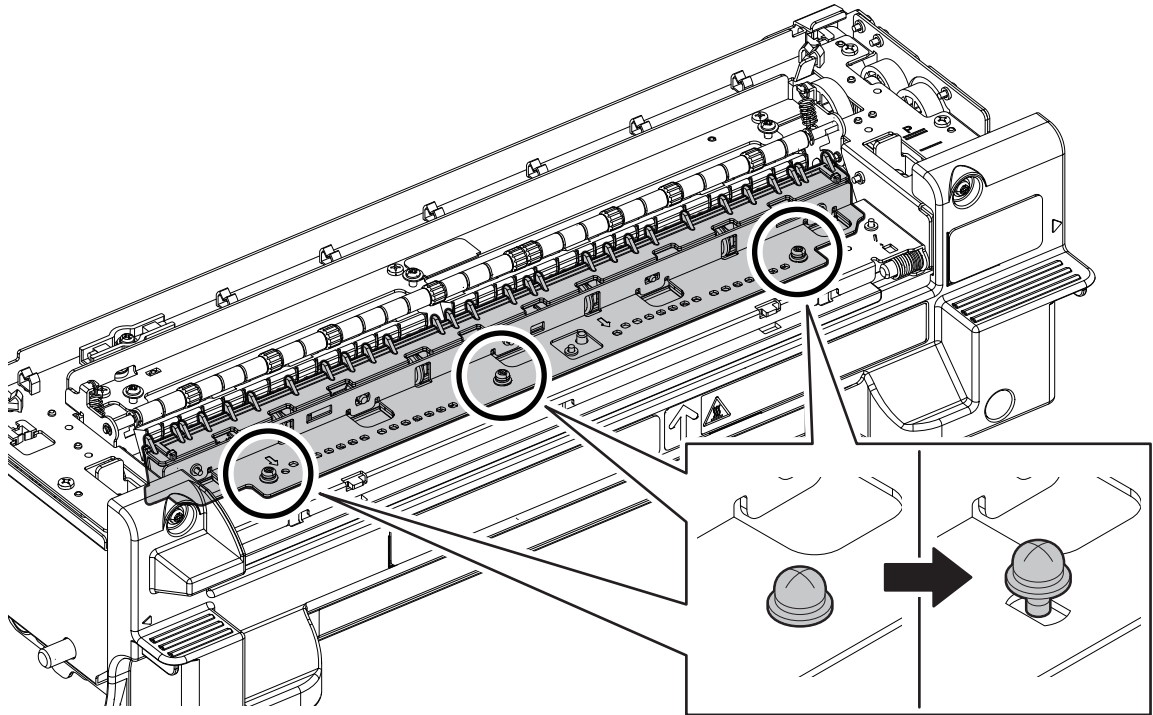

Fig.6-68

- (6) Insert the jig into the windows [A] and [E]. Adjust the gap between the pressure roller and the fixing plate of the separation guide by moving it so that the jig thickness 0.8 mm level can be put in smoothly, but that for the 1.3 mm one cannot. After the adjustment, tighten the screws of the separation guide fixing plate.

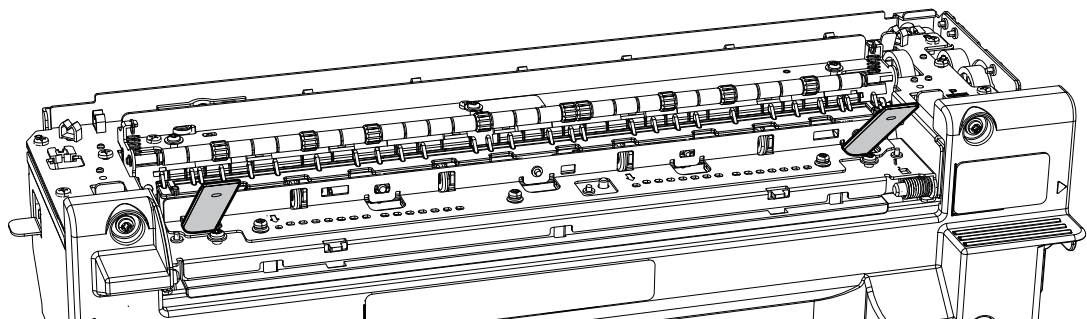
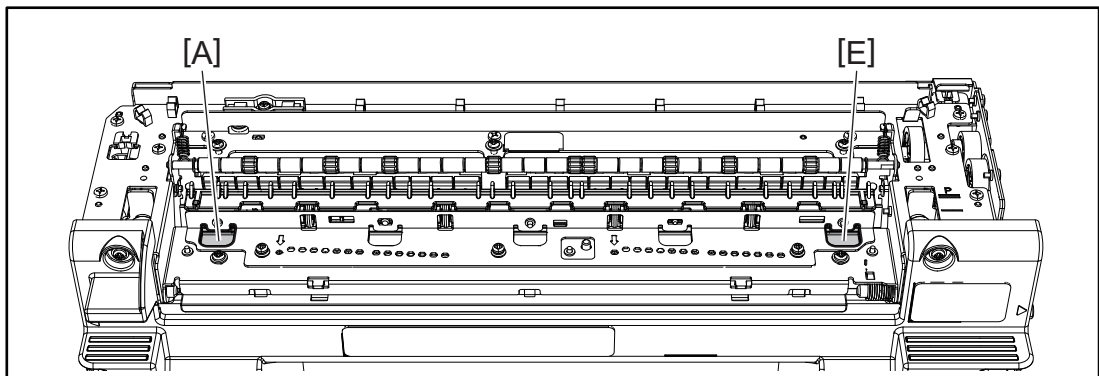

Fig.6-69

- (7) Insert the jig into the windows [B], [C] and [D], so that the jig thickness 0.8 mm level can be put in smoothly but that for the 1.3 mm one cannot. When this can be confirmed for all windows, the adjustment is completed. If any of the gaps does not meet this condition, return to step 5.

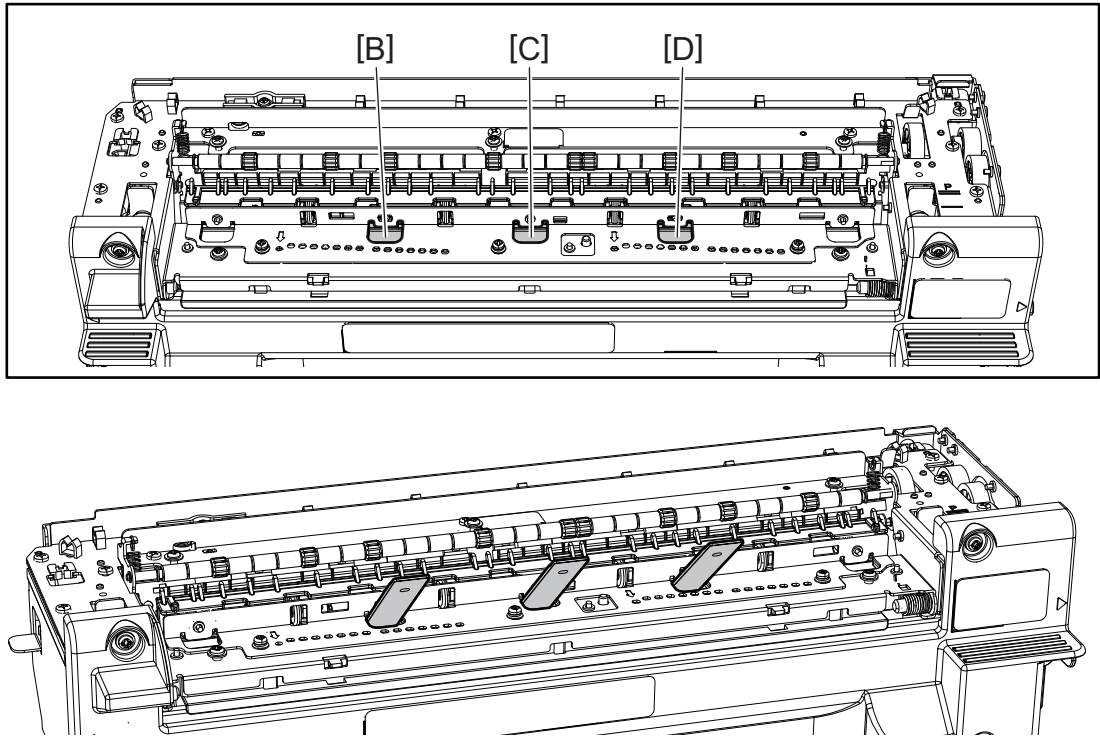

Fig.6-70

6.12 Control Panel Calibration

6.12.1 Overview

Perform this adjustment when the touched position on the touch panel sometimes cannot be detected properly, such as a touch-and-response position mismatch or a slow response.

Remarks:

- A defect in the touch panel may have resulted due to disassembling and replacing of the control panel or its temporary change.
- If the control panel is replaced in a unit base, performing this function is not necessary.

6.12.2 Operation procedure

- (1) Perform FS-08-9050.
The calibration screen appears and a plus mark is displayed on the upper left of the screen.
- (2) Touch the center of the plus mark in the following order.
The plus mark is displayed in the order of [2] > [3] > [4], when it is touched and recognized.

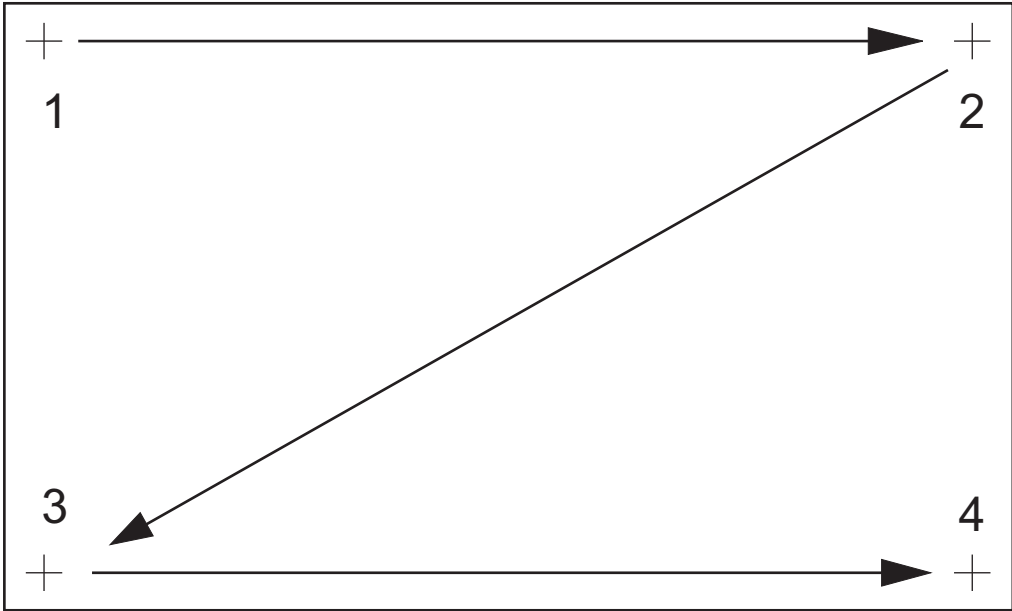

Fig.6-71

Notes:

- It is recommended to touch the plus mark using a touch pen with a fine tip.
- Calibration is performed at the touched position. Therefore, touch the mark properly.

- (3) When circle marks are displayed, keep touching the center of the marks with your fingers in the following order.
After a few seconds have passed, the next circle marks are displayed.

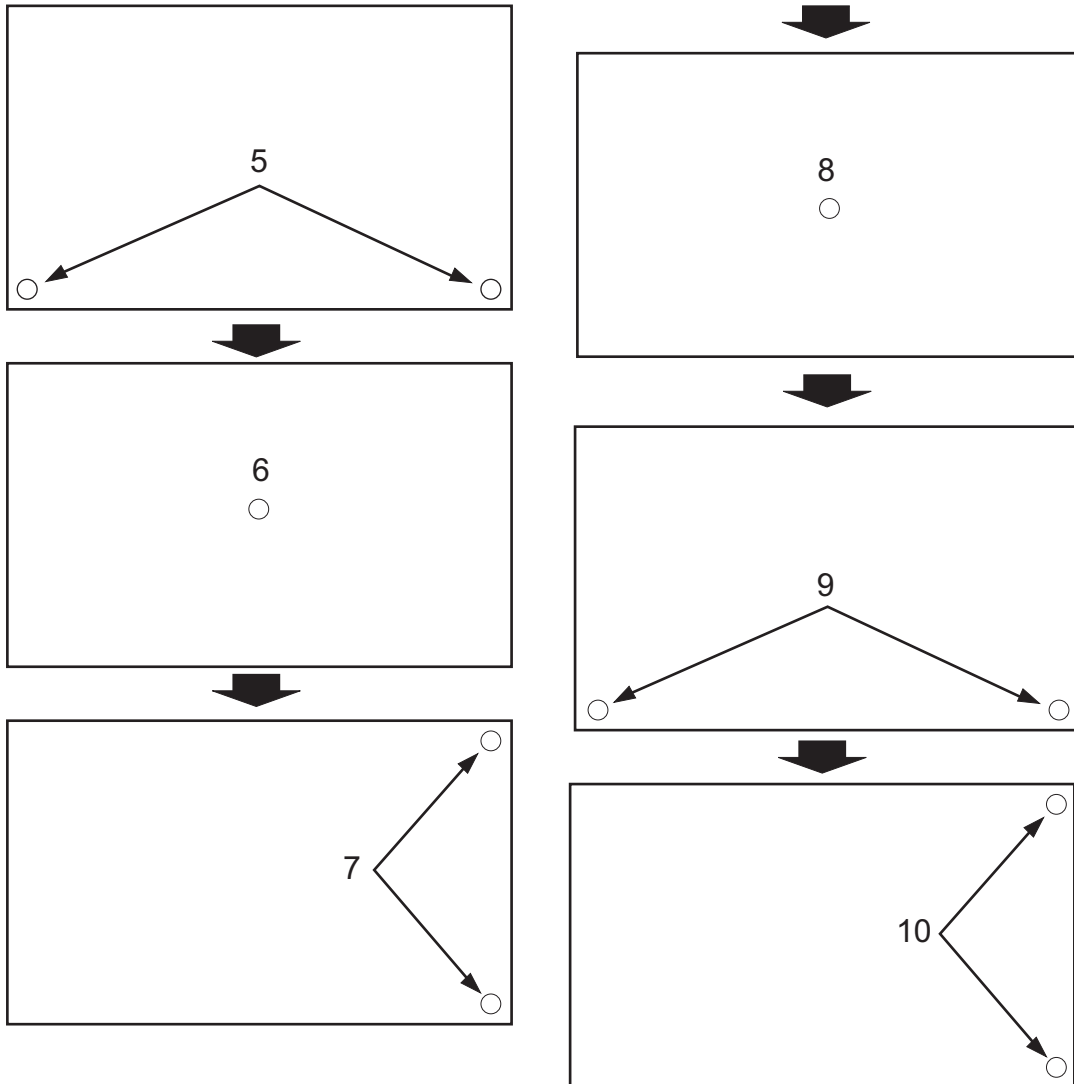

Fig.6-72

Notes:

- When two circle marks are displayed, touch them simultaneously.
- Calibration is performed at the touched position. Therefore, touch the mark properly.

(4) After all the marks are touched, the following screen appears and then calibration is completed.

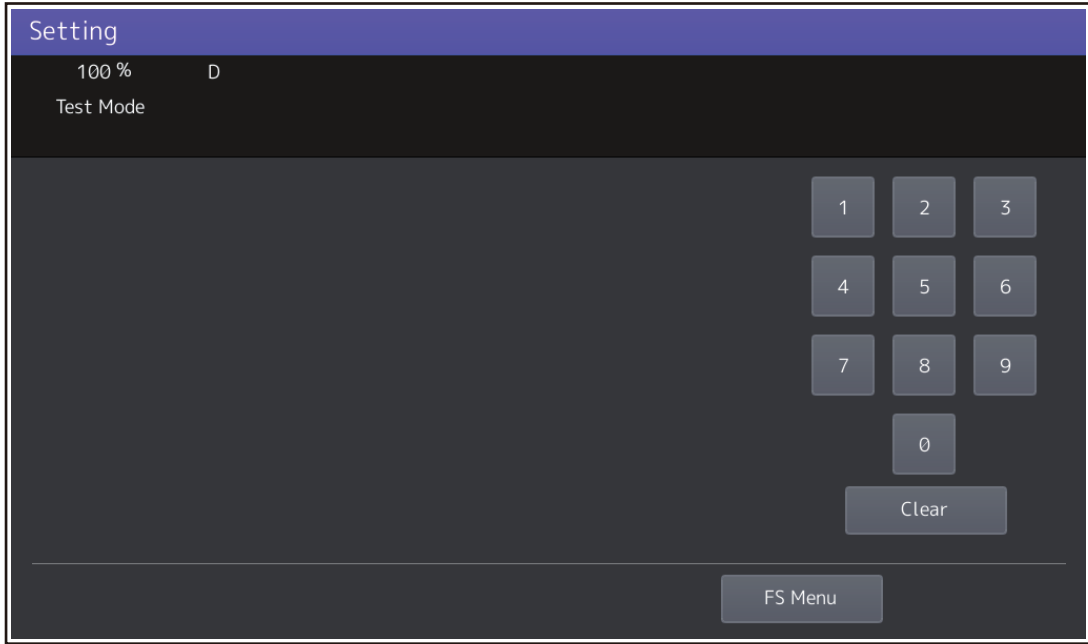

Fig.6-73

6.13 Dual Scan Document Feeder (DSDF)

6.13.1 Position adjustment

Perform this adjustment when the DSDF is not installed in the correct position.

Notes:

Check if the image adjustment for the MFP is performed properly before this adjustment of the DSDF.

[1] Checking procedure

- (1) Open the DSDF and install 2 positioning pins.

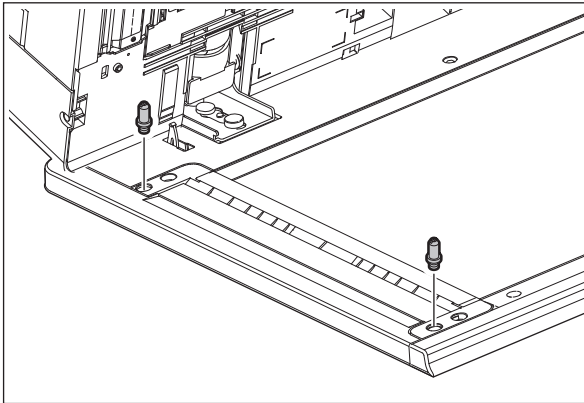

Fig.6-74

- (2) Remove the platen sheet.

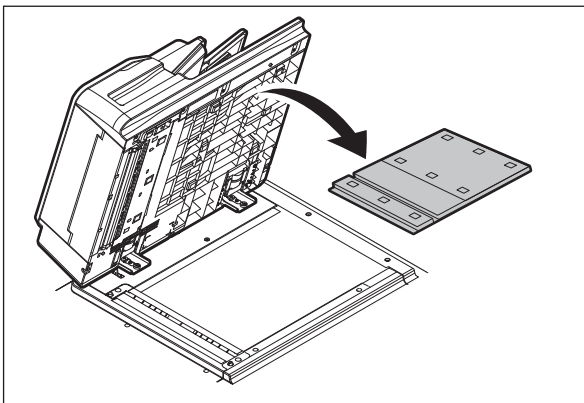

Fig.6-75

- (3) Close the DSDF and check if the positioning pins fit the holes on the DSDF.

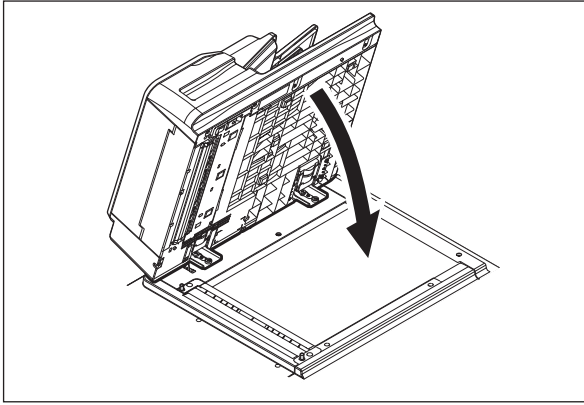

Fig.6-76

Notes:

If the positioning pins cannot be fitted into the holes on the DSDF properly, go to P. 6-85 “[2] Adjustment procedure” to adjust the position of the DSDF and then install it.

- (4) Place the platen sheet on the original glass and align it to the top left corner. Close the DSDF gently and check if the platen sheet is attached properly.

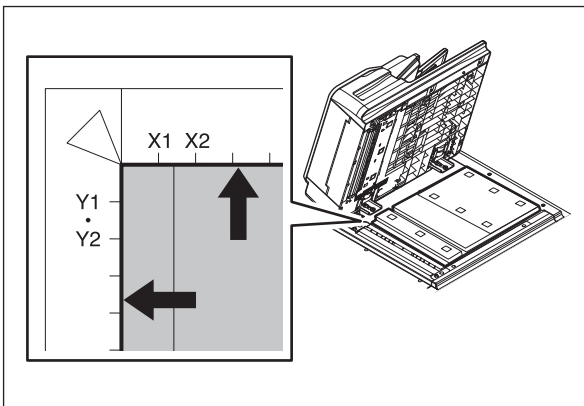

Fig.6-77

[2] Adjustment procedure

If the pins cannot be fitted into the holes, perform the adjustment according to the following procedure.

- (1) Remove the brackets on the hinges.

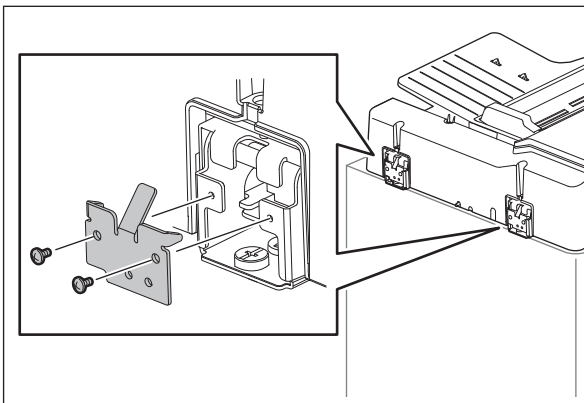

Fig.6-78

- (2) Loosen the fixing screws.

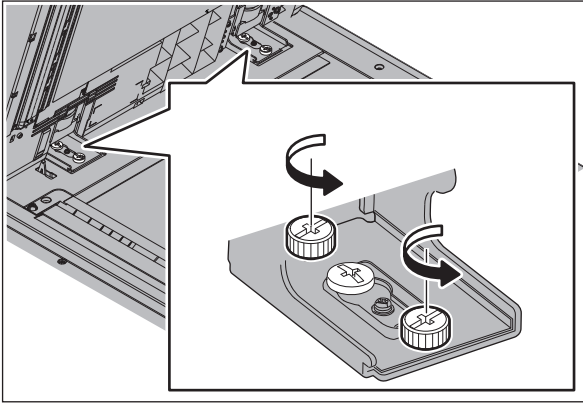

Fig.6-79

- (3) Position the pins with the holes on the DSDF by moving it so that the pins fit into the holes when the DSDF is closed.

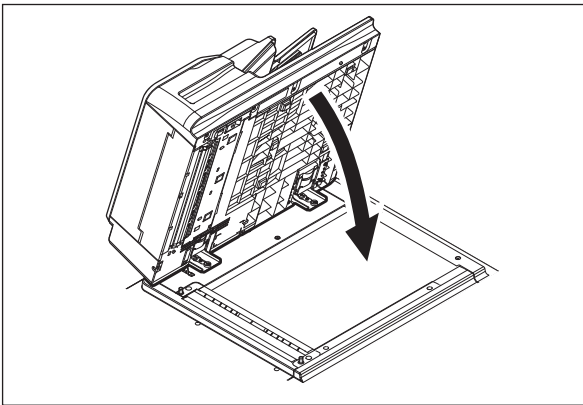

Fig.6-80

- (4) Tighten the fixing screws of the rear side.

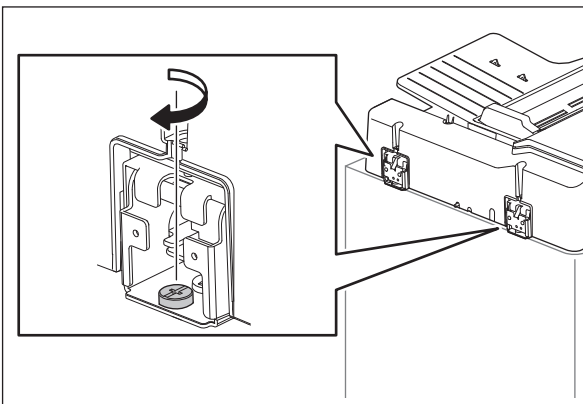

Fig.6-81

- (5) Tighten the fixing screws of the front side.

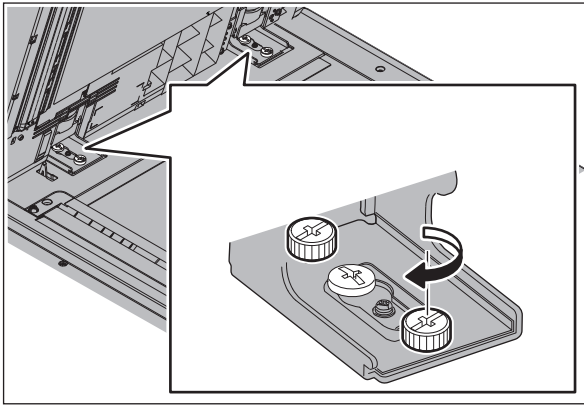

Fig.6-82

- (6) Install the brackets on the hinges.

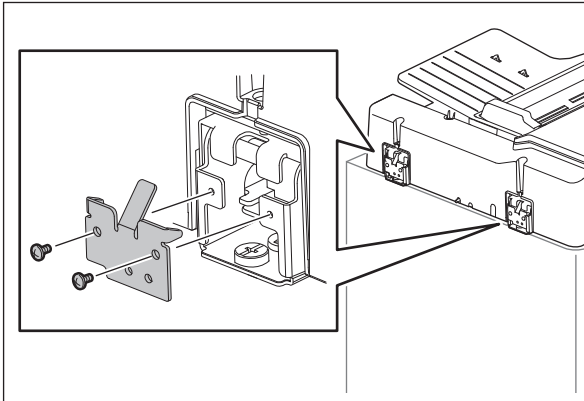

Fig.6-83

- (7) Place the platen sheet on the original glass and align it to the top left corner. Close the DSDF gently and check if the platen sheet is attached properly.

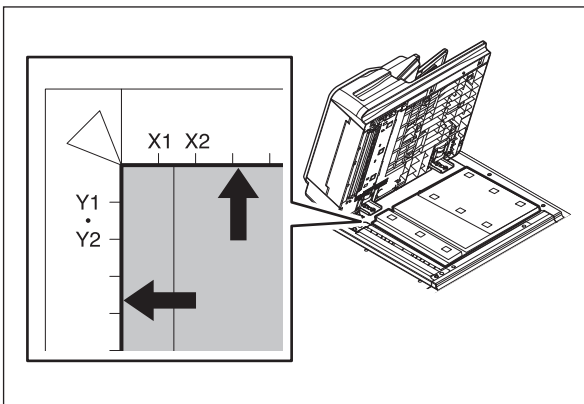

Fig.6-84

6.13.2 Height adjustment

Notes:

Check if the image adjustment for the MFP is performed properly before this adjustment of the DSDF.

[1] Checking procedure

- (1) Close the DSDF.
- (2) Light the exposure lamp.
 - Perform FS-03-267.
- (3) Visually check the gap between the protrusion "A" and the cover "B" from the left hand side of the MFP. If the value is not within the tolerance, perform the adjustment according to the following procedure.

[Tolerance of the gap]

Rear side: 0 to 0.5 mm

Front side: 0 mm

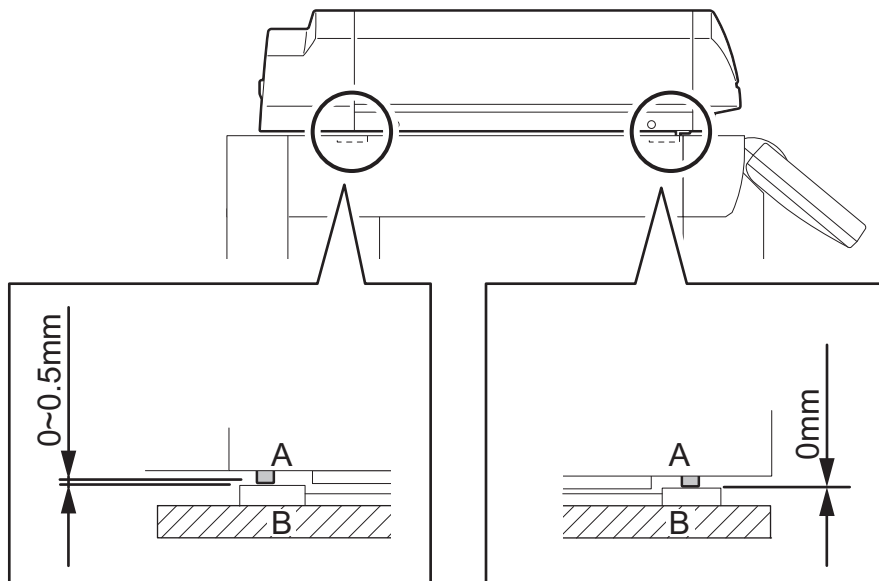

Fig.6-85

[2] Adjustment procedure

- (1) Close the DSDF.
- (2) Adjust it by turning the adjustment screws on the hinges.
 - Adjust the height on the rear side by means of the screw on the hinge on the paper feeding side of the DSDF.
Turn it clockwise: Heightened
Turn it counterclockwise: Lowered

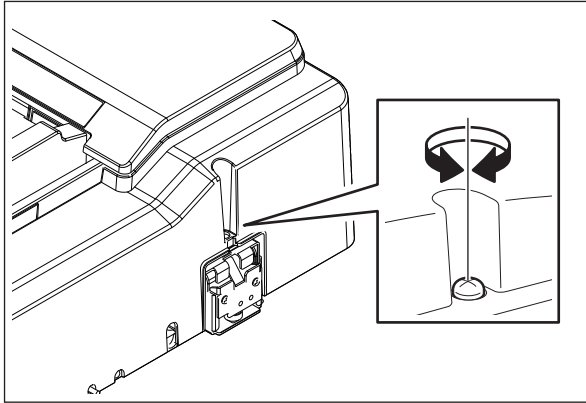

Fig.6-86

- Adjust the gap on the front side by means of the screw on the hinge on the paper exiting side of the DSDF.
Turn it clockwise: Lowered
Turn it counterclockwise: Heightened

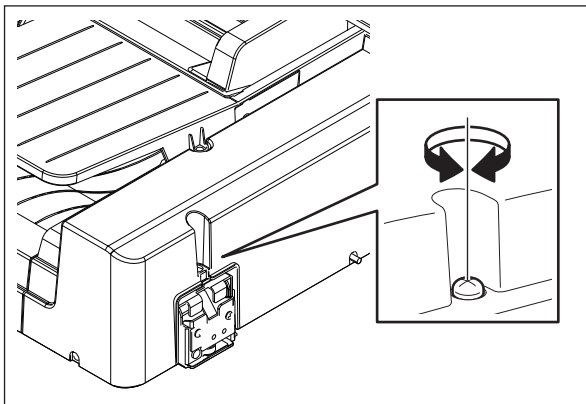

Fig.6-87

6.13.3 Skew adjustment

Notes:

- Check if the image adjustment for the MFP is performed properly before this adjustment of the DSDF.
- The DSDF position adjustment shall be adjusted properly.

[1] Checking procedure

Check the image using the chart (original) with vertical and horizontal lines in the following procedure.

[1-1] Simplex (front side) copying:

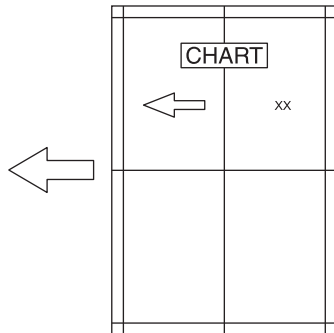

Fig.6-88

- (1) Place the chart provided as an original with its face up on the original tray of the DSDF, select [Sort mode] and [1 Sided → 1 Sided] and then press the [START] button.
- (2) Superimpose the chart on the copy and check the inclination of the copy image.

[1-2] Duplex (back side) copying:

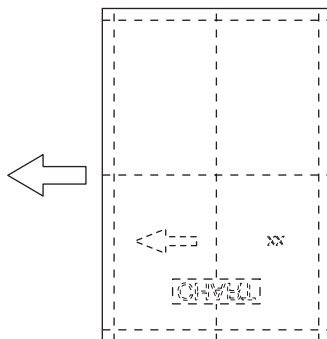

Fig.6-89

- (1) Place the chart provided as an original with its face down on the original tray of the DSDF, select [Sort mode] and [2 Sided → 2 Sided] and then press the [START] button.
- (2) Superimpose the chart on the copy and check the inclination of the copy image.

[2] Adjustment procedure

[2-1] Simplex (front side) copying:

- (1) Change the fixing screws of the front side to the shoulder head screw (service parts).

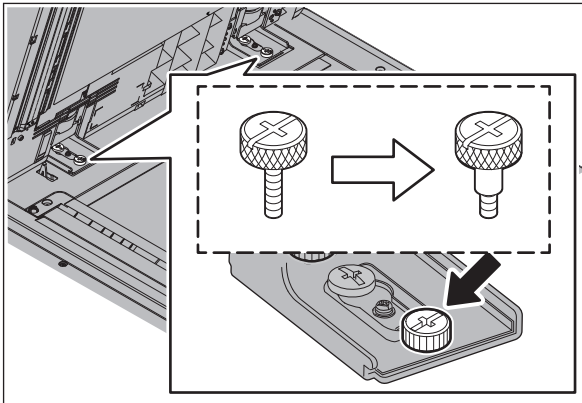

Fig.6-90

- (2) Turn the adjustment screw while checking the scale of the hinge.

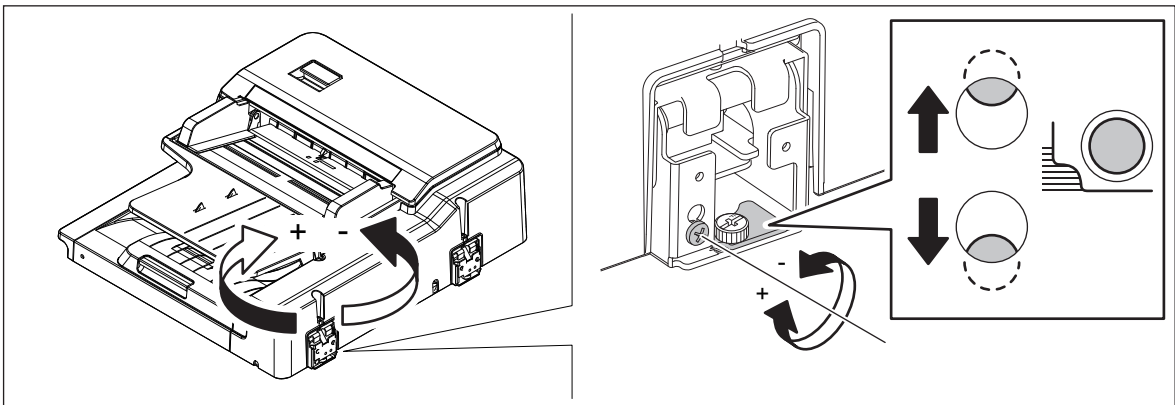

Fig.6-91

- (3) If the image skew is "C" as shown in the figure below, shift the aligning plate in the direction of "-", and if "D", shift it to "+".

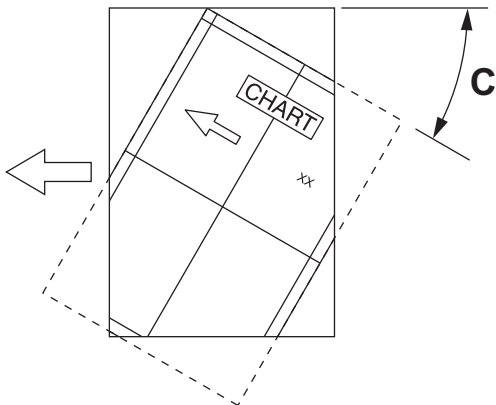

Fig.6-92

Shift the aligning plate in the direction of "-".

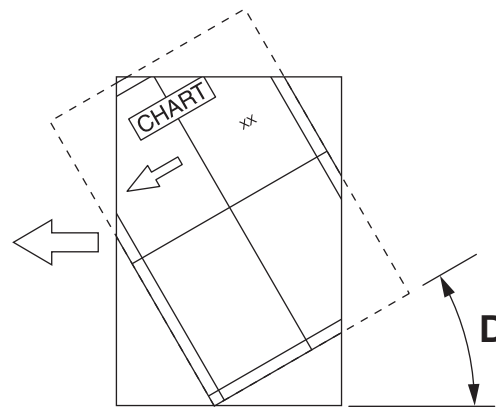

Fig.6-93

Shift the aligning plate in the direction of "+".

- (4) Check the skew of the copy image by using a chart.

[2-2] Duplex (back side) copying:

- (1) Take off the DSDF front cover.
☞ P. 4-338 “4.11.8 DSDF front cover”
- (2) Clarify the attachment position of the plate by drawing a marking-off line.

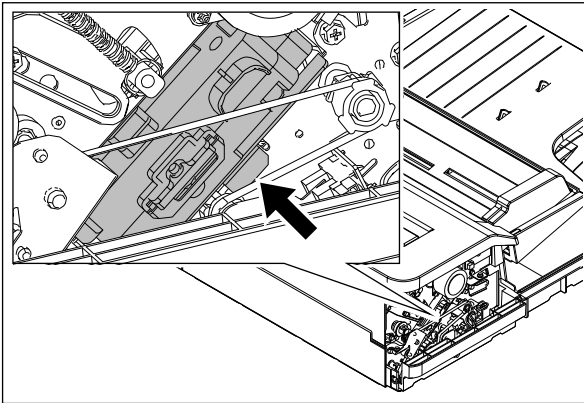

Fig.6-94

- (3) Loosen the screw.

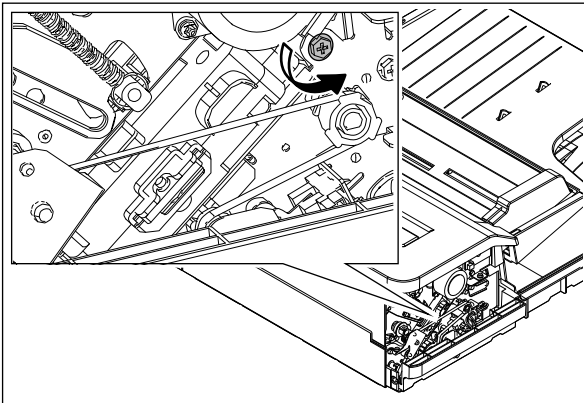

Fig.6-95

- (4) If the image skew is "C" as shown in the figure below, shift the aligning plate in the direction of "-", and if "D", shift it to "+".

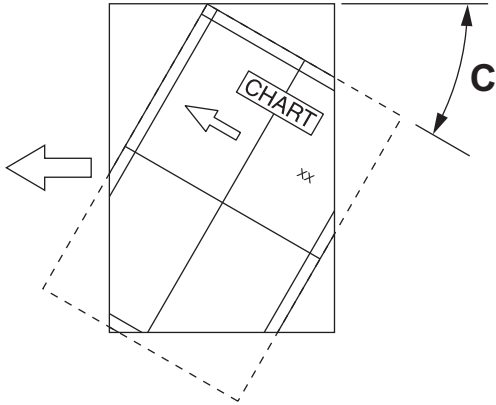

Fig.6-96
Shift the aligning plate in the direction of "-".

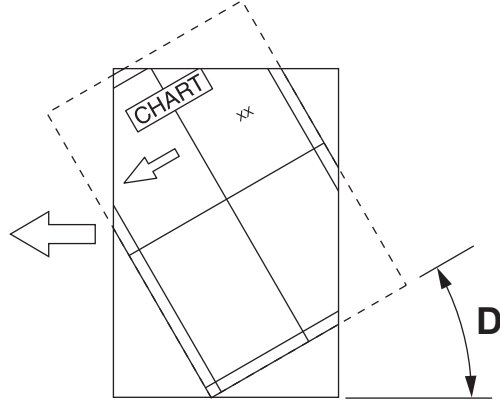

Fig.6-97
Shift the aligning plate in the direction of "+".

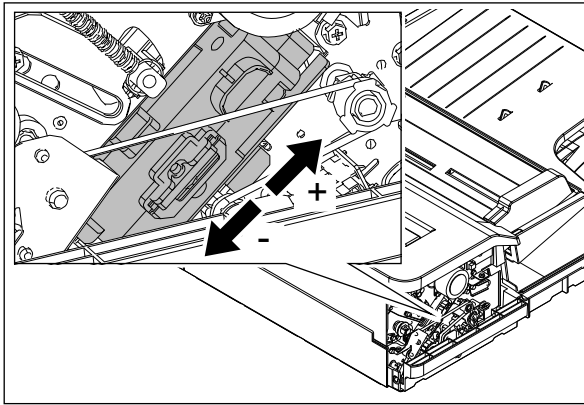

Fig.6-98

- (5) Tighten the screw loosened in step 3. Check the skew of the copy image by using a chart.
 (6) Install the DSDF front cover.

6.13.4 Leading edge position adjustment

Notes:

Check if the image adjustment for the MFP is performed properly before this adjustment of the DSDF.

Also, the DSDF position and height shall be adjusted properly.

[1] Checking procedure

Check the image using the chart (original) with vertical and horizontal lines in the following procedure.

[1-1] Simplex (front side) copying:

- (1) Place the chart provided as an original with its face up on the original tray of the DSDF, select [Sort mode] and [1 Sided → 1 Sided] and then press the [START] button.
- (2) Superimpose the chart on the copy and check the leading edge E of the chart and F of the copy.

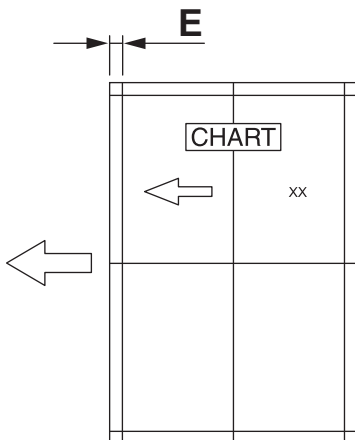

Fig.6-99Chart (original)

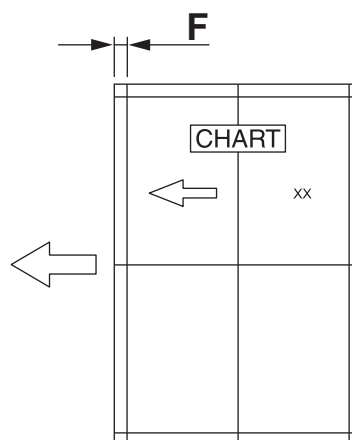

Fig.6-100Copy

[1-2] Duplex (back side) copying:

- (1) Place the chart provided as an original with its face down on the original tray of the DSDF, select [Sort mode] and [2 Sided → 2 Sided] and then press the [START] button.
- (2) Superimpose the chart on the copy and check the leading edge E of the chart and F of the copy.

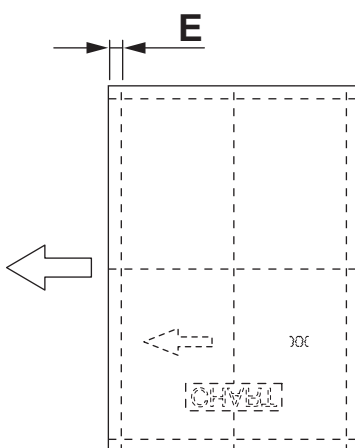

Fig.6-101Chart (original)

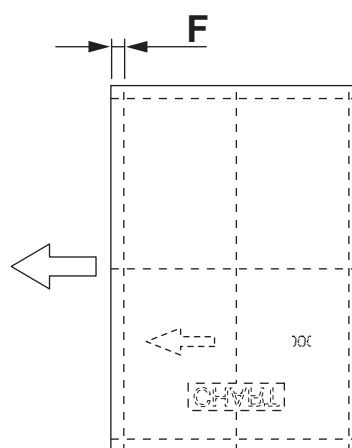

Fig.6-102Copy

[2] Adjustment procedure

[2-1] Simplex (front side) copying:

- (1) Perform FS-05-3044.
- (2) Enter the value.
 - If the leading edge F margin of the copy image is larger than the E margin of the chart, enter a value smaller than the current one.
 - If the leading edge F margin of the copy image is smaller than the E margin of the chart, enter a value larger than the current one.

Notes:

Changing one value shifts the copy image by 0.1 mm.

- (3) Press [OK].

[2-2] Duplex (back side) copying:

- (1) Perform FS-05-3045.
- (2) Enter the value.
 - If the leading edge F margin of the copy image is larger than the E margin of the chart, enter a value smaller than the current one.
 - If the leading edge F margin of the copy image is smaller than the E margin of the chart, enter a value larger than the current one.

Notes:

Changing one value shifts the copy image by 0.1 mm.

- (3) Press [OK].

6.13.5 Sideways deviation adjustment

Notes:

Check if the image adjustment for the MFP is performed properly before this adjustment of the DSDF.

Also, the DSDF position and height shall be adjusted properly.

[1] Checking procedure

[1-1] Simplex (front side) copying:

Check the image using the chart (original) with a center line in the following procedure.

- (1) Place the chart provided as an original with its face up on the original tray of the DSDF.
- (2) Select [Sort mode] and press the [START] button.
- (3) Fold the copy in half and check if the center line is misaligned.

[1-2] Duplex (back side) copying:

Check the image using the chart (original) with a center line in the following procedure.

- (1) Place the chart provided as an original with its face down on the original tray of the DSDF.

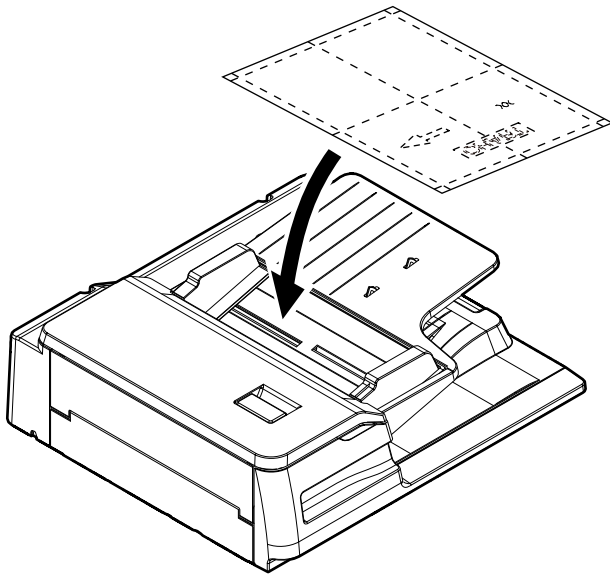

Fig.6-103

- (2) Select [2 Sided -> 1 Sided] and press the [START] button.
- (3) Fold the copy in half and check if the center line is misaligned.

[2] Adjustment procedure

[2-1] Simplex (front side) copying:

- (1) Perform FS-05-3043.
 - If the center line of the copy image is shifted to the front side
Enter a larger value than the current one.

Notes:

Changing one value shifts the copy image by 0.0423 mm.

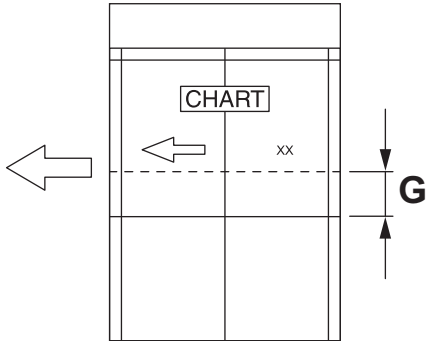

Fig.6-104

- If the center line of the copy image is shifted to the rear side
Enter a smaller value than the current one.

Notes:

Changing one value shifts the copy image by 0.0423 mm.

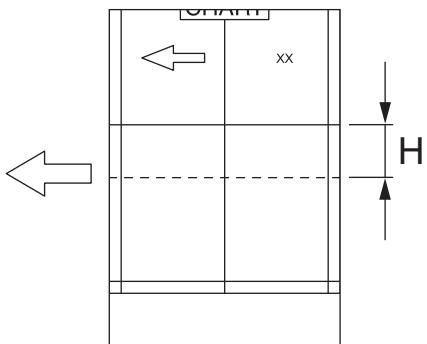

Fig.6-105

- (2) Press [OK].

[2-2] Duplex (back side) copying:

(1) Perform FS-05-3049.

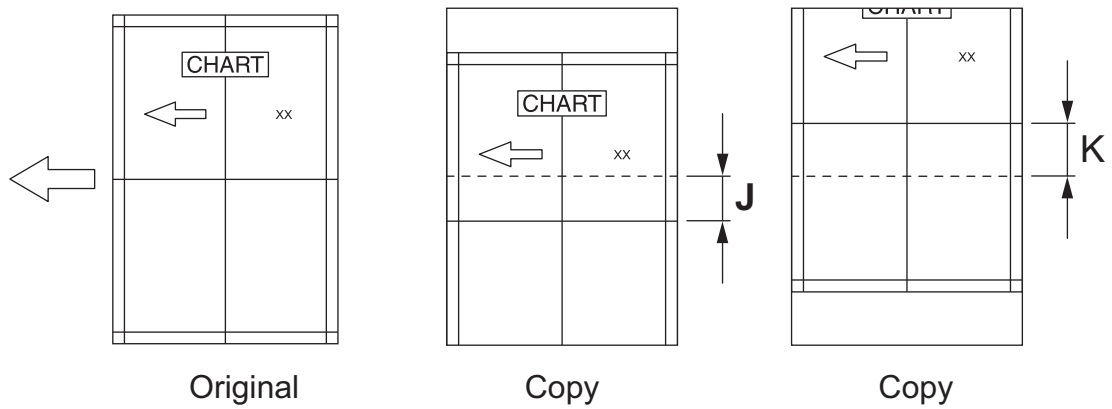

Fig.6-106

- If the center line of the copy image is shifted to the right side to the feeding direction (J)
Enter a larger value than the current one.
- If the center line of the copy image is shifted to the left side to the feeding direction (K)
Enter a smaller value than the current one.

Notes:

Changing one value shifts the copy image by 0.0423 mm.

(2) Press [OK].

6.13.6 Reproduction ratio adjustment

Notes:

Check if the image adjustment for the MFP is performed properly before this adjustment of the DSDF.

Also, the DSDF position and height shall be adjusted properly.

[1] Checking procedure

Check the image using the chart (original) with vertical and horizontal lines in the following procedure.

- (1) Place the chart provided as an original with its face up on the original tray of the DSDF.
- (2) Select [Sort mode] and press the [START] button.
- (3) Superimpose the chart on the copy and check the image dimension "l".

[2] Adjustment procedure

- (1) Perform FS-05-3042.
 - If the copy image dimension "l" is larger than the chart dimension, enter a value smaller than the current one.
 - If the copy image dimension "l" is smaller than the chart dimension, enter a value larger than the current one.

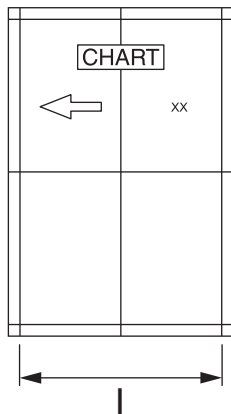

Fig.6-107

- (2) Press [OK].

6.13.7 DSDF read-in sensor-1 adjustment

[1] DSDF read-in sensor-1 automatic adjustment

Notes:

When the DSDF control PC board or the DSDF read-in sensor-1 is replaced, be sure to perform this adjustment.

- (1) Perform FS-05-3210.

Notes:

- Be sure to close all of the DSDF covers before the adjustment is performed.
- Check that there is no paper on the DSDF read-in sensor-1 so that the light is not shielded.

[2] DSDF read-in sensor-1 manual adjustment

Notes:

When the DSDF read-in sensor-1 is replaced or re-installed, perform this manual adjustment.

- (1) Take off the DSDF left cover.
📖 P. 4-340 “4.11.10 DSDF left cover”
- (2) Install the original jam access cover.
- (3) Close the original jam access cover and the DSDF.
- (4) Perform FS-05-3221.

Notes:

Be sure not to open the original jam access cover and the DSDF until step 7 is finished. If you do so, the adjustment value will be reset. In this case, repeat the adjustment from step 3.

- (5) Loosen 1 prism adjustment screw.

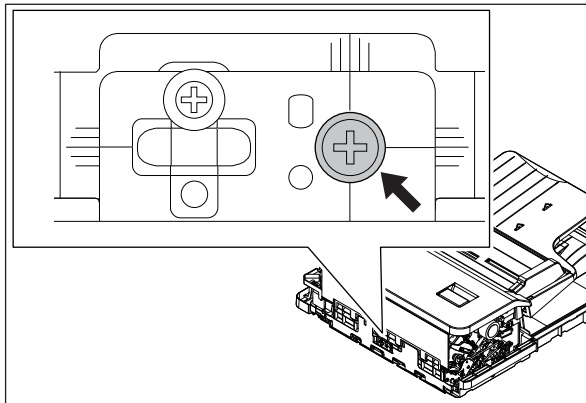

Fig.6-108

- (6) Slide the prism vertically. When the prism comes to the proper adjustment position, LED1 on the DSDF control PC board lights. At this position, tighten 1 prism adjustment screw.

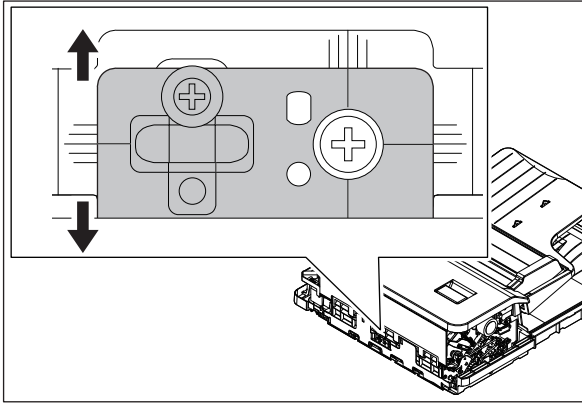

Fig.6-109

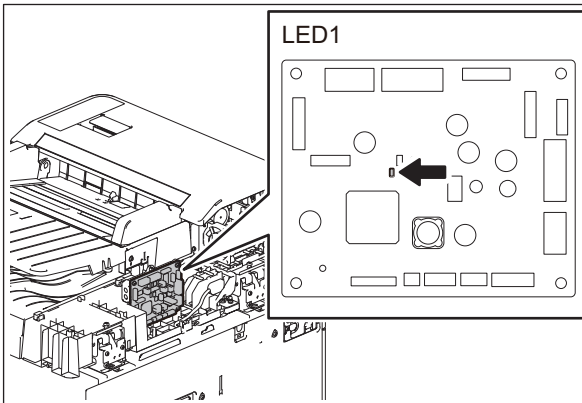

Fig.6-110

- (7) Perform FS-05-3210 (Automatic adjustment).

Notes:

After the manual adjustment is performed, be sure to do the automatic one.

- (8) Turn the power OFF and install the cover.

6.13.8 Platen sheet

If a shadow-like dark area appears on the edge of the image, reset the platen sheet.

- (1) Remove the platen sheet.

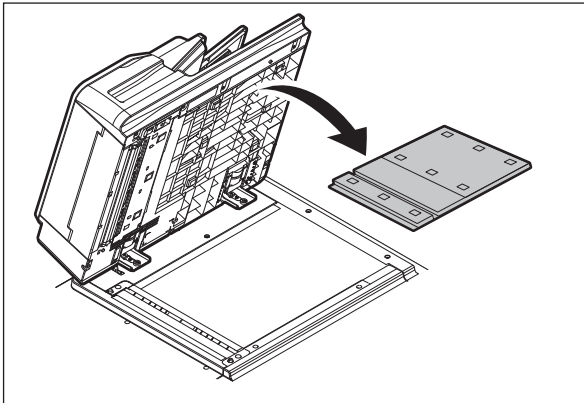

Fig.6-111

- (2) Place the platen sheet on the original glass and align it to the top left corner. Close the DSDF gently and check if the platen sheet is attached properly.

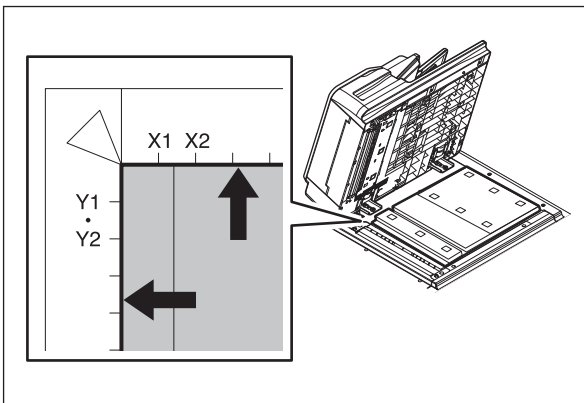

Fig.6-112

6.13.9 DSDF separation roller pressure force adjustment

In cases, the life of the separation roller may be shortened or paper misfeeding (E712, E721) and multiple feeding (E724) may occur regardless of the operation frequency of the Dual Scan Document Feeder (DSDF). This comes from the weight or edge status of paper used and the amount of paper dust.

Generally, paper misfeeding and multiple feeding often occur around the life end of the roller. However, if they often occur even though its life has not yet reached its replacement timing, or if the life end comes much earlier than the scheduled replacement timing, paper jams and multiple feeding can be suppressed by adjusting the pressure force of the separation roller.

In this method; however, when the roller life becomes longer, paper misfeeding and multiple feeding may occur frequently and when they are suppressed, the roller life may become shorter. Therefore, perform this adjustment while checking the status carefully, and if necessary, give a sufficient explanation to the users. If necessary, give sufficient explanation to the users.

- (1) Remove the DSDF pickup unit.
📖 P. 4-330 "4.11.3 DSDF pickup unit"

- (2) Open the DSDF separation roller cover [1].

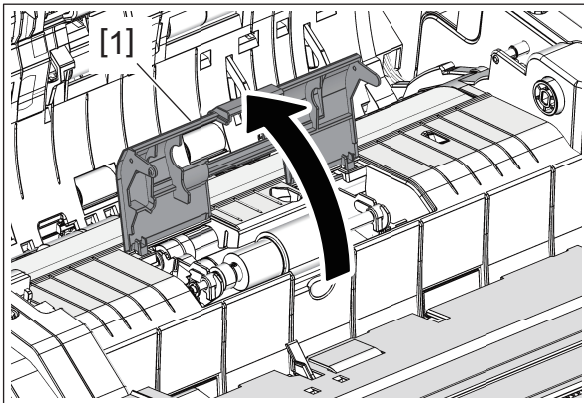

Fig.6-113

- (3) Turn the arm [2] to release the lock.

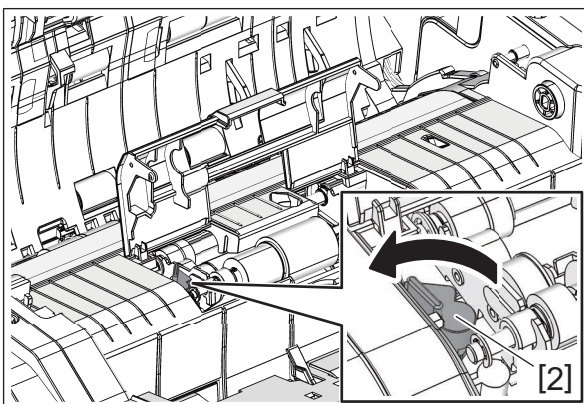

Fig.6-114

- (4) Lift up the DSDF separation roller unit [3].

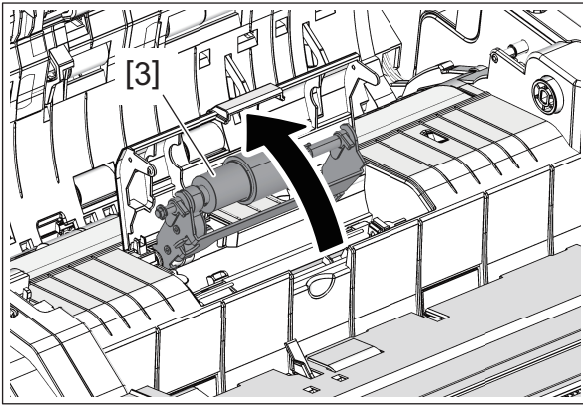

Fig.6-115

- (5) Move the adjustment plate [4] in the direction of F or R by 1 scale.
- Move to the direction F: Paper misfeeding (E712, E721) will be suppressed. The roller life will become longer (but multiple feeding may occur frequently).
 - Move to the direction R: Multiple feeding will be suppressed (but the roller life may become shorter).

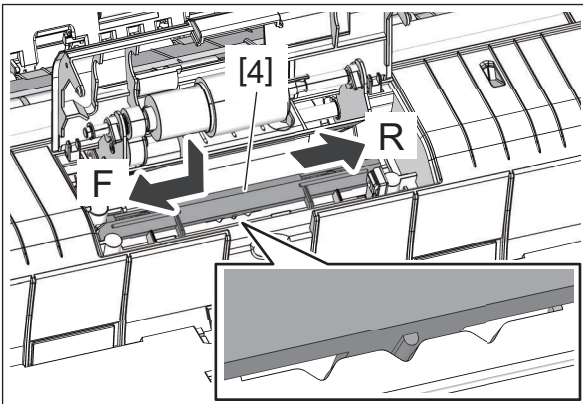

Fig.6-116

7. PREVENTIVE MAINTENANCE (PM)

7.1 Overview

The purpose of preventive maintenance (PM) is to maintain the quality level of this MFP by periodically inspecting, cleaning and replacing the parts whose replacement timing has come. There are PM kits packaged for each unit or a group of parts with the same replacement number of output pages, allowing you to carry out efficient parts replacement.

7.2 PM Display

7.2.1 Overview

The maintenance timing for the PM parts of the process unit, such as the drum, and those for other units, such as the 2nd transfer roller, varies depending on the use conditions by users. Therefore, this MFP shows the appropriate maintenance timing of each part on the LCD of the control panel.

7.2.2 PM display condition

The conditions of the PM display consist of the codes of the 08 SETTING MODE for the “setting value treated as a threshold of the PM display”, “counter indicating the current number of prints and driving time” and “setting value which determines the display conditions”.

The PM timing is displayed when the counter exceeds the setting value according to the display condition based on the “setting value which determines the display conditions”.

- Setting value treated as a threshold of the PM display
FS-08-6190: PM counter setting value [Process unit (K)]
FS-08-6191: PM time counter setting value [Process unit (K)]
FS-08-5562: PM counter setting value [PM parts other the process unit]
FS-08-5563: PM time counter setting value [PM parts other the process unit]

Notes:

When “0” is set as the setting value, the PM timing is not displayed.

- Counter indicating the current number of the prints and driving time
FS-08-6194: PM counter current value [Process unit (K)]
FS-08-6195: PM time counter current value [Process unit (K)]
FS-08-5576: PM counter current value [PM parts other the process unit]
FS-08-5577: PM time counter current value [PM parts other the process unit]
- Setting value which determines the display conditions
FS-08-6198: PM switching of output pages/driving counts [Process unit (K)]
FS-08-5585: PM switching of output pages/driving counts [PM parts other the process unit]

7.2.3 PM display content

When the counter value exceeds the setting value, the MFP notifies you that the maintenance time has arrived by displaying the message "Time for periodic maintenance ****" on the LCD screen. "****" in the message is a 4-digit hexadecimal number code. This number is allocated in the following manner, therefore the parts needing maintenance can be identified.

PM parts for the process unit (K): 0008

Developer material (K): 0080

PM parts other than the process unit: 0100

If multiple parts have reached the maintenance time, the sum of the corresponding code values listed above is displayed in hexadecimal numbers.

For example, if the PM parts other than the process unit (K), developer material (K) and process unit reach the maintenance time, the 4-digit hexadecimal number code will be "0188" in hexadecimal numbers: $0008+0080+0100=0188$.

7.2.4 Counter clearing

The counter indicating “current number of prints and driving time” used for the PM display function is cleared by entering “0” in it or resetting it in the 20 PM SUPPORT MODE.

Notes:

Even if “0” is entered in the PM management setting value of the 08 SETTING MODE, the corresponding counter for the PM display is not reset. Be sure to clear the counter in the 20 PM SUPPORT MODE when the maintenance is finished.

The reset condition of each counter is as follows:

- FS-08-6194: PM counter current value [Process unit (K)]
- FS-08-6195: PM time counter current value [Process unit (K)]
When the current value of “Cleaner/Drum/Charger (K)” on the main screen or “Drum (K)” on the sub-screen in the 20 PM support mode is cleared, the counter is reset.
- FS-08-5576: PM counter current value [PM parts other the process unit]
- FS-08-5577: PM time counter current value [PM parts other the process unit]
When the current value of “2nd Transfer” on the main screen or “2nd Transfer Roller” on the sub-screen in the 20 PM support mode is cleared, the counter is reset.

7.3 PM Procedure

(1) Preparation

Ask the user about the current conditions of the MFP and note them down.

Before starting maintenance, make some sample copies and store them.

See the replacement record and check the parts to be replaced in the 20 PM SUPPORT MODE or 30 LIST PRINT MODE.

- 20 PM SUPPORT MODE (FS-20)
- 30 LIST PRINT MODE (FS-30-103)

| UNIT | OUTPUT PAGES DEVELOP COUNTS | PM OUTPUT PAGES DEVELOP COUNTS | DRIVE COUNTS | PM DRIVE COUNTS |
|-------------------------|--------------------------------|-----------------------------------|--------------|-----------------|
| DRUM(K) | 1957 | 1957 | 3940 | 170000 |
| DRUM BLADE(K) | 1957 | 1957 | 10870 | 170000 |
| GRID(K) | 1957 | 1957 | 10870 | 170000 |
| MAIN CHARGER NEEDLE(K) | 1957 | 1957 | 10870 | 170000 |
| CHARGER CLEANING PAD(K) | 1957 | 1957 | 10870 | 170000 |
| OZONE FILTER 1 | 1077 | 1077 | 3766 | 170000 |
| TONER FILTER | 1077 | 1077 | 3766 | 170000 |
| OZONE FILTER 2 | 1077 | 1077 | 3766 | 170000 |
| BLACK DEVELOOER | 1077 | 1077 | 3766 | 170000 |
| BELT BLADE | 1077 | 1077 | 9547 | 170000 |
| CLEANING PAD | 1077 | 1077 | 9547 | 170000 |
| 2nd TRANSFER ROLLER | 1077 | 1077 | 9547 | 170000 |
| FUSER BELT | 1077 | 1077 | 9547 | 170000 |
| PRESS ROLLER | 1077 | 1077 | 9547 | 170000 |
| FUSER PAD | 1077 | 1077 | 9547 | 170000 |
| SLIDE SHEET | 1077 | 1077 | 9547 | 170000 |
| GRID(C) | 1077 | 1077 | 9547 | 170000 |
| OIL RECOVERY SHEET | 1077 | 1077 | 9547 | 170000 |

Fig. 7-1

Be sure to turn OFF the power and unplug the power cable from the outlet.

(2) Maintenance

Perform cleaning, lubrication and part replacement in accordance with the preventive maintenance checklist.

(3) Confirmation

After finishing the maintenance, make some copies to confirm that the MFP works properly.

7.4 20 PM SUPPORT MODE

7.4.1 Overview

This MFP has the 20 PM SUPPORT MODE which enables you to confirm the use status of each part (the number of output pages or developed pages, and drive counts) requiring periodic replacement and also the replacement record, as well as clearing counter values efficiently. This record can also be printed out in the 30 LIST PRINT MODE.

7.4.2 Operation flow

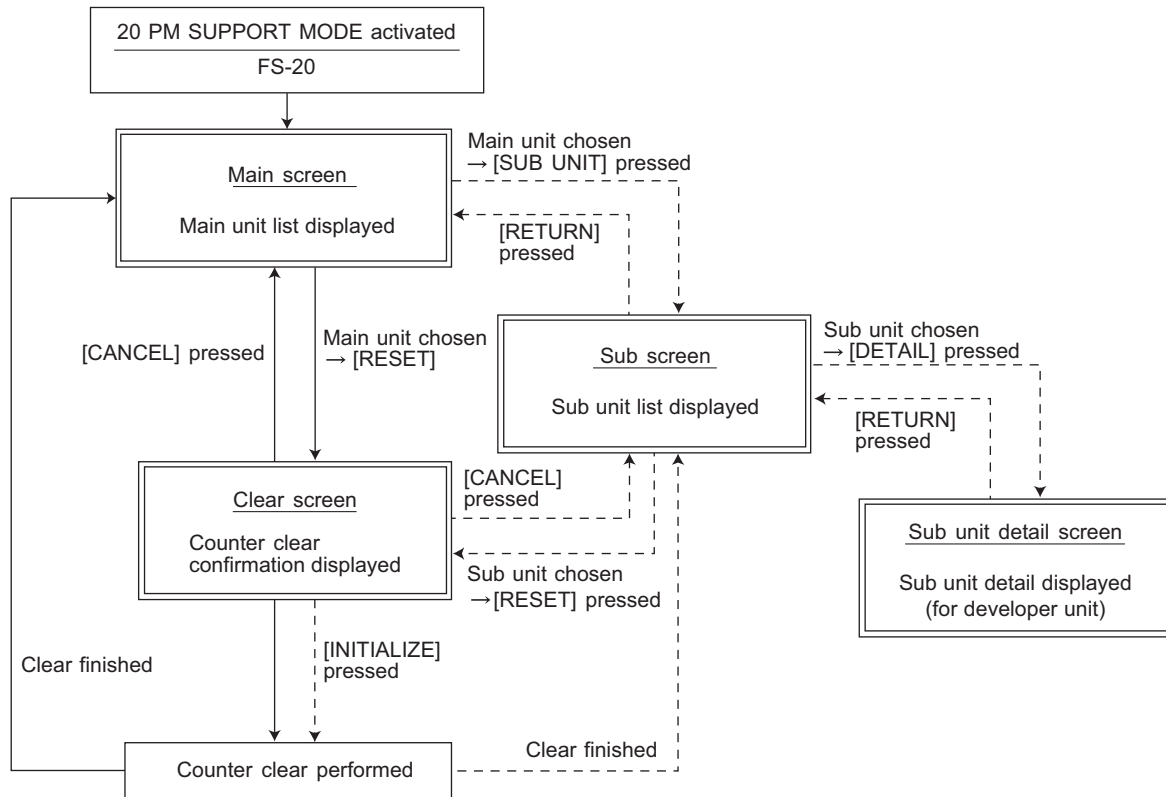

Fig. 7-2

- The authentication screen appears. Press [OK]. (Enter the password, if one has been set.)
- The screen goes back to the main screen when the counter clear is performed after moving from the main screen. The screen goes back to the sub screen when the counter clear is performed after moving from the sub screen. The screen goes back in the same manner when [Cancel] is pressed.

7.4.3 Operation screen

The description of the display (including the function of each button) on the LCD screen is shown below.

[1] Main screen

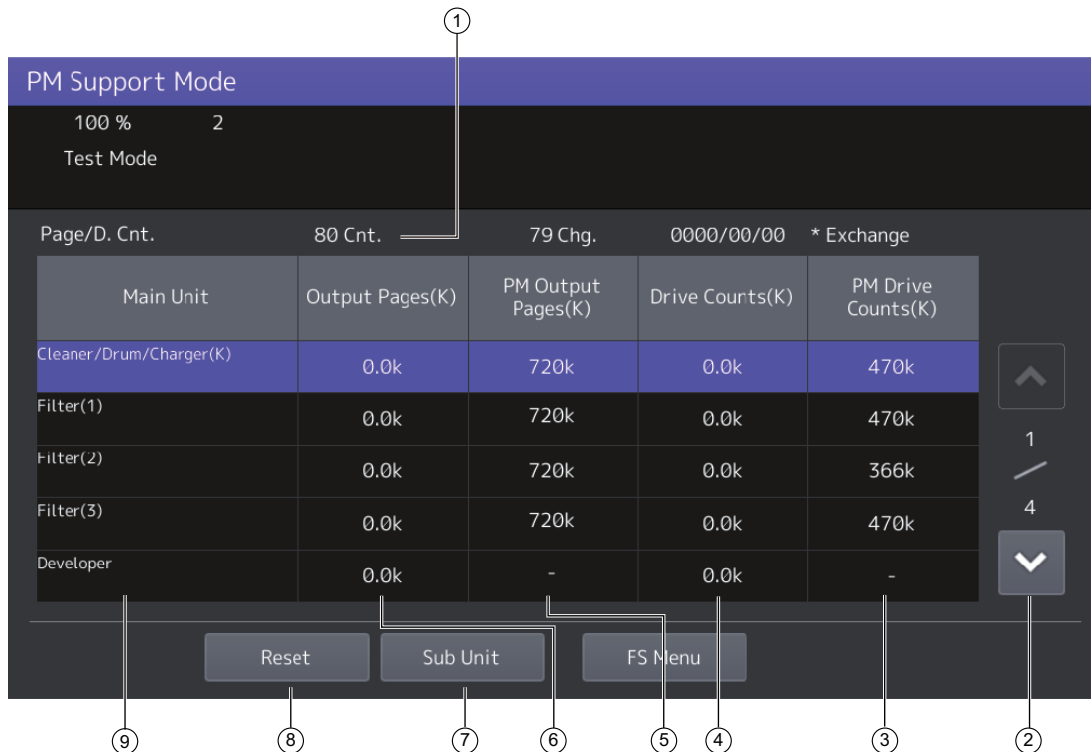

Fig. 7-3

1. The number of printed/developed pages (Page/D.cnt), drive counts (Cnt.) and previous replacement date (Chg.) for a selected unit are displayed. If the replacement date for the sub unit is different, information is not displayed. Therefore, press [Sub Unit] to move to the sub screen to see each information.
2. Select this to move to the next or previous page.
3. The standard value of the drive counts to replace the units (parts) is displayed.
4. The current value of the drive counts is displayed.
“*” is displayed next to the current value when the number of the drive counts has exceeded its PM standard value.
5. The standard value of the printed/developed pages to replace the units (parts) is displayed.
6. The current value of the printed/developed pages is displayed.
When there are differences among the sub units (parts), “_” is displayed and “Check Sub Unit” is displayed at the top.
“*” is displayed next to the current value when the number of the printed/developed pages has exceeded its PM standard value.
7. Select this to move to the sub screen of the selected unit.
8. Select this to move to the clear screen to clear the selected unit counters 4 and 6.
All sub unit (part) counters belonging to that unit are also included.
When the unit is not selected, all counters are cleared.
9. The main unit name is displayed.

Notes:

- “-” is always displayed at the drive counts section for the DF and paper feeding system.
- “-” is displayed at the value field for the paper source which is not installed since it differs depending on the structure of options.

[2] Sub screen (for other than the developer unit)

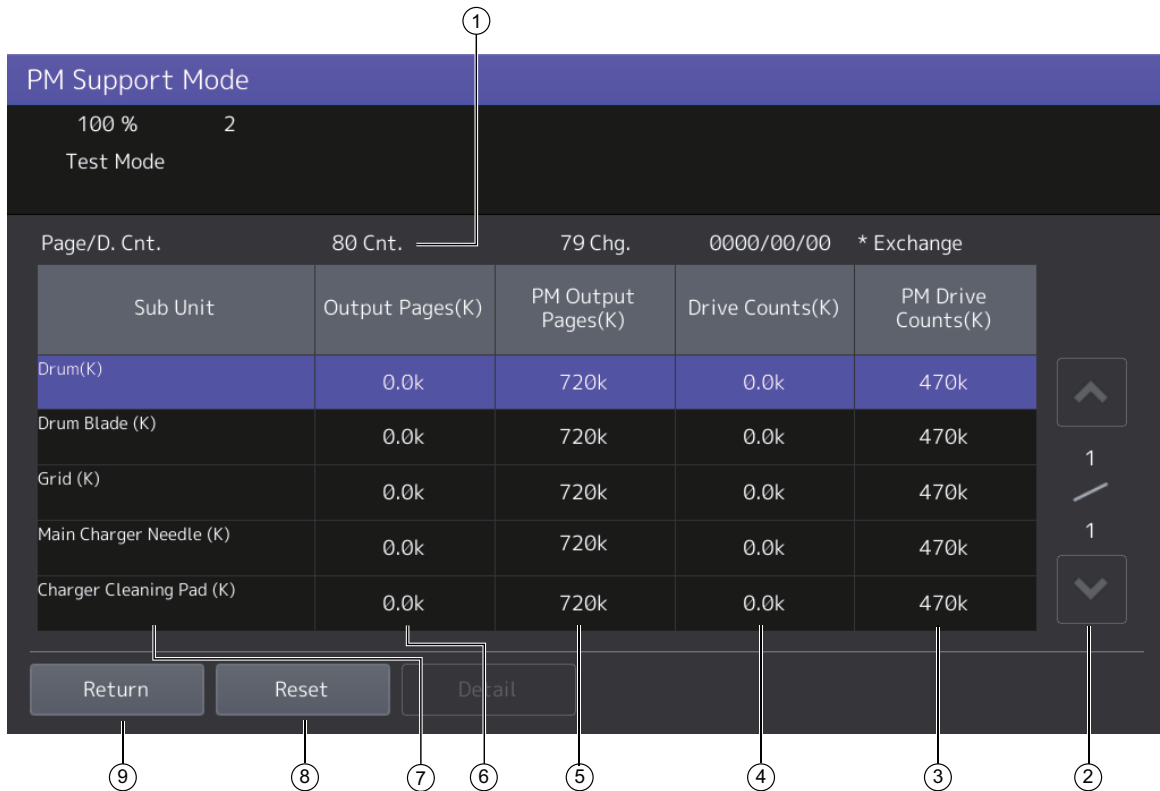

Fig. 7-4

1. The number of printed/developed pages, drive counts and previous replacement date for a selected sub units (parts) are displayed.
2. Select this to move to the next or previous page.
3. The standard value of the drive counts to replace the sub units (parts) is displayed.
4. The current value of the drive counts is displayed.
 "*" is displayed next to the current value when the number of the drive counts has exceeded its PM standard value.
5. The standard value of the printed/developed pages to replace the sub units (parts) is displayed.
6. The current value of the printed/developed pages is displayed.
 "*" is displayed next to the current value when the number of the printed/developed pages has exceeded its PM standard value.
7. The sub unit name is displayed.
8. Select this to move to the clear screen to clear the selected sub unit counters.
9. Select this to return to the main screen.

[3] Sub screen (for the developer unit)



Fig. 7-5

1. The number of printed/developed pages, drive counts and previous replacement date for a selected sub units (parts) are displayed.
2. Select this to move to the next or previous page.
3. The current value of the drive counts is displayed.
4. The current value of the printed page counts is displayed.
5. The sub unit name is displayed.
6. Select this to move to the sub unit detail screen.
7. Select this to move to the clear screen to clear the selected sub unit counters.
Be sure to perform counter clearing immediately after the selected sub unit (developer material) is replaced with a new one.
8. Select this to return to the main screen.

Notes:

"-" is displayed since there is no reference value in the number of printed/developed pages and drive count.

[4] Sub unit detail screen (for the developer material)

PM Support Mode

100 % 2

Test Mode

* Exchange

| Sub Unit | SUPPLY RATIO | DRIVE RATIO | PERFORMANCE INDEX | THRESHOLD |
|-----------------|--------------|-------------|-------------------|-----------|
| Black Developer | 118 | 107 | 0 | 100 |
| | | | | |
| | | | | |
| | | | | |

Return

1

1

7 6 5 4 3 2 1

Fig. 7-6

1. Select this to move to the next or previous page.
2. The threshold value of the performance index of the developer material is displayed.
3. The current value of the performance index of the developer material is displayed.
“*” is displayed next to the current value when it has exceeded the threshold value of the performance index of the developer material.
4. The current value of the drive ratio is displayed.
5. The current value of the supply ratio is displayed.
6. The sub unit name is displayed.
7. Select this to return to the sub screen.

[5] Clear screen

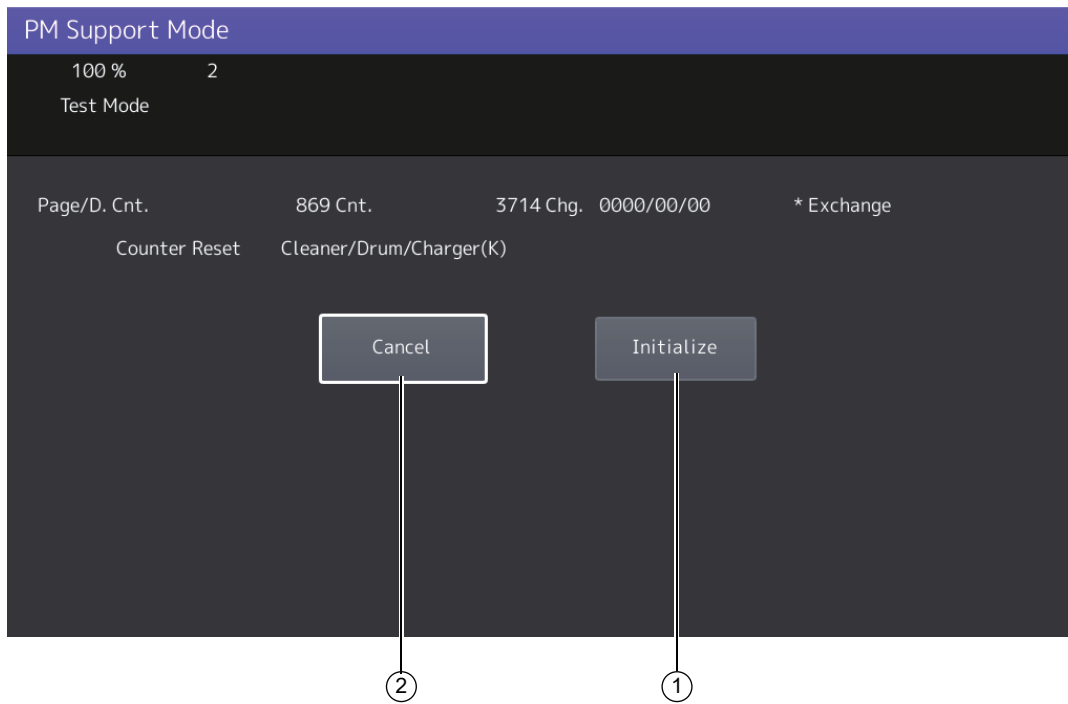

Fig. 7-7

1. Select this to clear the number of printed/developed pages and drive counts and to update the previous replacement date.
2. Select this to return to the main or sub screen without having clear the counter.

7.4.4 Access tree

The relationship between the main unit and the sub unit is as below.

Notes:

Some parts in this manual are described with different names on the LCD. In this case, the name in this manual is indicated in square brackets [].

| Main screen | Sub screen |
|--|---|
| Cleaner/Drum/Charger (K) [Process unit (K) (Black)] | Drum (K) Drum Blade (K) [Drum cleaning blade (K)] Grid (K) [Main charger grid] Main Charger Needle (K) [Needle electrode] Charger Cleaning Pad (K) [Main charger cleaner] |
| Filter (1) | Ozone filter-1 |
| Filter (2) | Toner filter Ozone filter-2 |
| Developer Unit | Black Developer [Developer material (K)] |
| Transfer belt cleaner | Transfer belt cleaning blade Transfer Belt Facing Roller Cleaner [2nd transfer facing roller cleaning pad] |
| 2nd Transfer Unit | 2nd Transfer Roller |
| Fuser Unit | Fuser Belt Press Roller [Pressure roller] Fuser Pad [Fuser belt pad] Slide Sheet [Fuser belt lubricating sheet] Oil Recovery Sheet |
| 1st CST. | Pickup Roller (1st. CST) [Pickup roller] Feed Roller (1st CST.) [Paper feed roller] Sep Roller (1st CST.) [Separation roller] |
| 2nd CST. | Pickup Roller (2nd. CST) [Pickup roller] Feed Roller (2nd CST.) [Paper feed roller] Sep Roller (2nd CST.) [Separation roller] |
| 3rd CST. | Pickup Roller (3rd. CST) [Pickup roller] Feed Roller (3rd CST.) [Paper feed roller] Sep Roller (3rd CST.) [Separation roller] |
| 4th CST. | Pickup Roller (4th. CST) [Pickup roller] Feed Roller (4th CST.) [Paper feed roller] Sep Roller (4th CST.) [Separation roller] |
| SFB | Pickup Roller (SFB) [Pickup roller (Bypass unit)] Feed roller (SFB) Sep Roller (SFB) |
| T-LCF | Pickup Roller (T-LCF) [Pickup roller (T-LCF)] Feed roller (T-LCF) Sep Roller (T-LCF) |
| O-LCF [Ex-LCF (2.5K)] | Pickup Roller (O-LCF) [Pickup roller (Ex-LCF (2.5K))] Feed roller (O-LCF) Sep Roller (O-LCF) |
| O2-LCF [Ex-LCF (2.0K)] | Pickup Roller (O2-LCF) [Pickup roller (Ex-LCF (2.0K))] Feed roller (O2-LCF) Sep Roller (O2-LCF) |
| DSDF | Pickup Roller (DSDF) [Pickup roller (DSDF)] Feed roller (DSDF) Sep Roller (DSDF) |

Notes:

- When the counter value of any of the pickup roller, paper feed roller and separation roller in each unit is cleared, the value of the feeding retry counter is also reset simultaneously.
- When [Clear] is pressed after selecting the paper feed unit in the main screen, the value of the feeding retry counter is also reset simultaneously.

Feeding retry counter:

- 1st drawer: Reset the feeding retry counter (FS-08-6230)
- 2nd drawer: Reset the feeding retry counter (FS-08-6231)
- 3rd drawer: Reset the feeding retry counter (FS-08-6232)
- 4th drawer: Reset the feeding retry counter (FS-08-6233)
- Bypass unit: Reset the feeding retry counter (FS-08-6234)
- T-LCF: Reset the feeding retry counter (FS-08-6235)
- Ex-LCF (2.5K): Reset the feeding retry counter (FS-08-6242)
- Ex-LCF (2.0K): Reset the feeding retry counter (FS-08-5655)

7.5 Part Replacement Workflow

The replacement timing of parts differs depending on the user's conditions of use. Therefore, it is necessary to consider not only the number of printed/developed pages but also the drive time counts when deciding the timing for parts replacement. Even if the number of printed/developed pages has reached the level of replacement, for instance, the part may still be usable if its drive time counts do not reach the specified amount. On the other hand, the part may need replacement even if the number of printed/developed pages has not reached the level of replacement if its driving time exceeds the specified drive time counts. The replacement timing of some parts, such as the paper feed roller, is greatly dependent on the number of output pages rather than the drive time counts. The following workflow diagram shows how to judge the timing of replacement with the number of printed/developed pages.

E.g.: When the number of printed/developed pages has reached the specified one

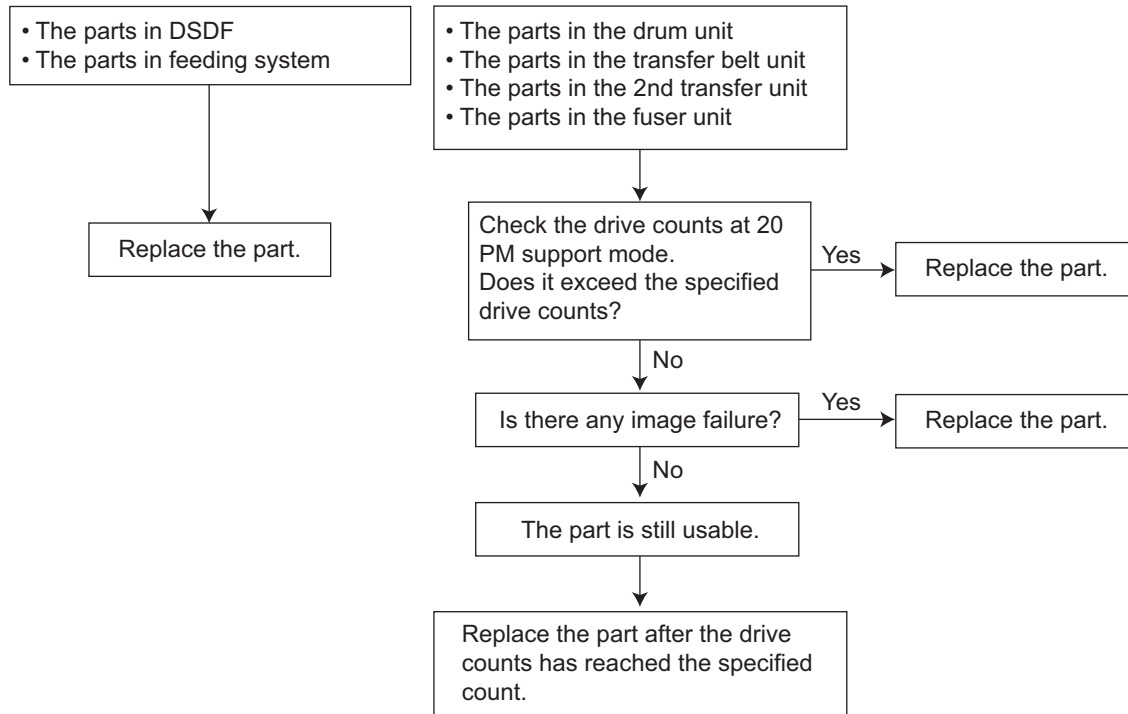

Fig. 7-8

E.g.: When an image failure occurred before the number of printed/developed pages has reached the specified one

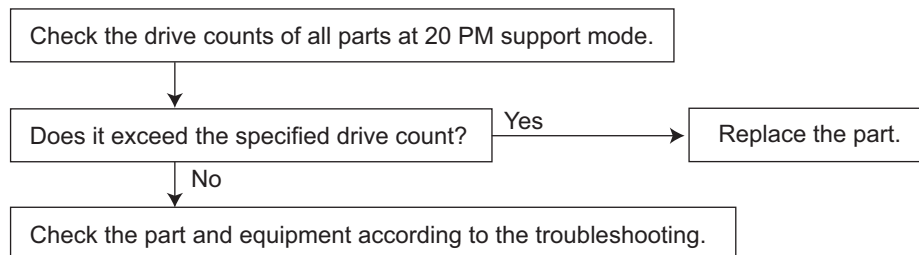

Fig. 7-9

E.g.: When the performance index of the developer material has exceeded its threshold value

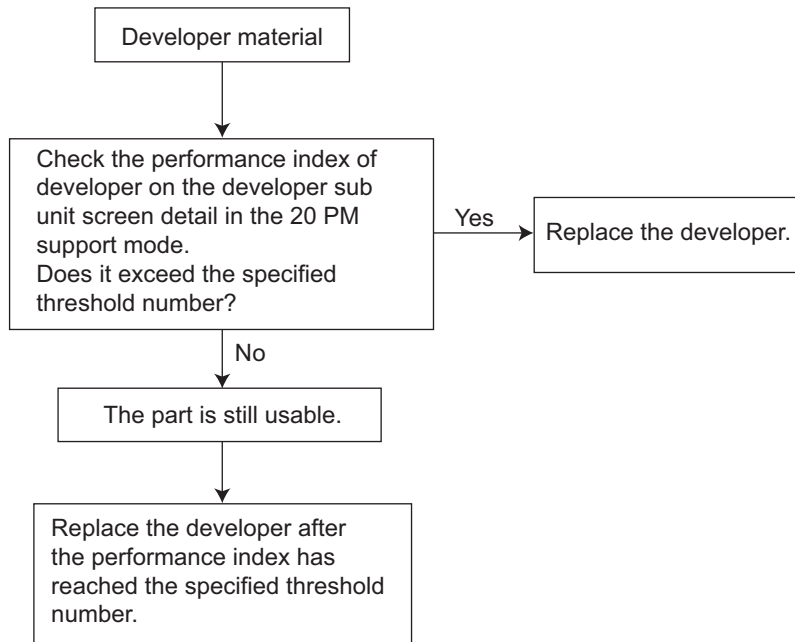

Fig. 7-10

E.g.: When an image failure occurred even though the performance index of the developer material has not exceeded its threshold value

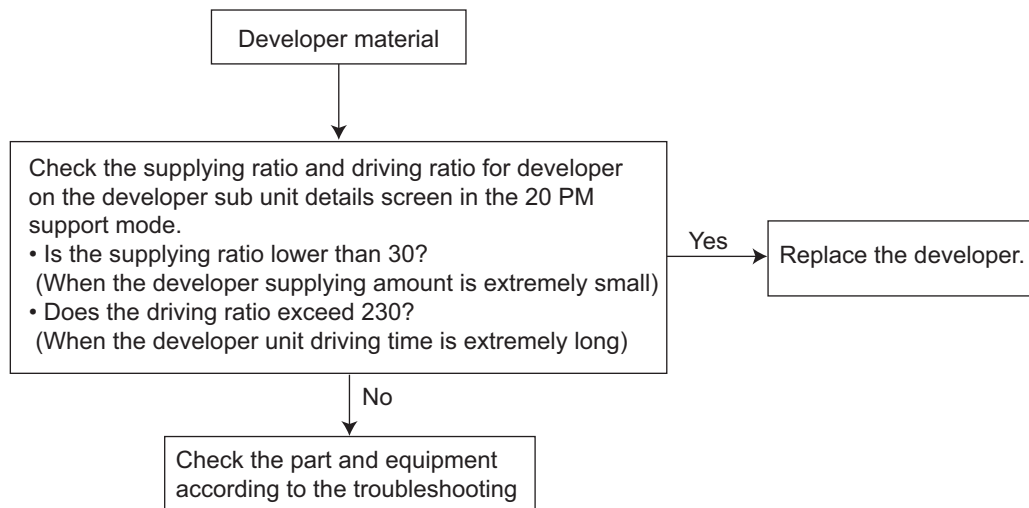

Fig. 7-11

7.6 Preventive Maintenance Checklist

The following shows the items to be checked for each unit during the preventive maintenance.

Symbols and values used in the checklist

| Item | Explanation |
|---------------------|---|
| Cleaning | A: Clean with alcohol B: Clean with a soft pad, cloth or vacuum cleaner |
| Lubrication/Coating | L: Launa 40 SI: Silicon oil W1: White grease (Molykote EM-30L) W2: White grease (Molykote HP-300) AV: Alvania No. 2 FL: FLOIL (GE-334C) C: Coating material (SANKOL CFD-409M) |
| Replacement | Value: Replacement cycle R1: Replacement R3: Replace if deformed or damaged |
| Operation check | Yes: After cleaning or replacement, confirm there is no problem. |

Notes:

- Perform cleaning and lubricating in the following timing. Lubricate the replacement parts according to the replacement cycle.

| Model name | Print |
|------------|----------------------|
| 6529A | Every 590,000 sheets |
| 7529A | Every 660,000 sheets |
| 9029A | Every 740,000 sheets |

- If the replacement cycle differs according to the models, the value is indicated in the order of that for 6529A, 7529A and 9029A.
- The replacement cycle of the parts in the feeding section equals to the number of sheets fed from each paper source.
- Be careful not to put oil on the rollers, belts and belt pulleys when lubricating.
- “<P-I>” represents the page item in “e-STUDIO6529A/7529A/9029A Service Parts List”.
- Check if the toner supply opening of each sub-hopper, the shutter of the waste toner box and the entrance of the waste toner transport path are dirty every time you pull out the process unit or take off the drum cleaner unit or the developer unit. Clean them if required.

7.6.1 Scanner

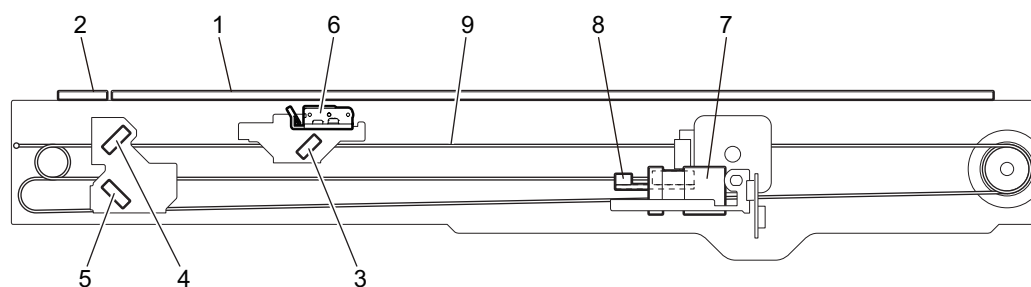

Fig. 7-12

PM timing

| Model name | (x 1,000 sheets) |
|------------|------------------|
| 6529A | 590 |
| 7529A | 660 |
| 9029A | 740 |

| Item | | Cleaning, etc. | | Replacement (x 1,000) | | Operation check | <P-I> |
|------|-------------------------------------|----------------|---------------------|-----------------------|--------------|-----------------|-------|
| | | Cleaning | Lubrication/Coating | Sheets | Drive counts | | |
| 1 | Original glass | B or A | | | | | 54-2 |
| 2 | DF original glass | B | | | | | 54-3 |
| 3 | Mirror-1 | B | | | | | - |
| 4 | Mirror-2 | B | | | | | - |
| 5 | Mirror-3 | B | | | | | - |
| 6 | Reflector | B | | | | | - |
| 7 | Lens | B | | | | | 50-9 |
| 8 | Automatic original detection sensor | B | | | | | 50-12 |
| 9 | Slide sheet (front, rear) | B | | | | | - |

1: Original glass, 2: DF original glass

Clean both sides of the original glass and DF original glass. Also clean the film attached to the DF original glass in order to wipe off any dirt or paper dust.

Make sure that there is no dust on the mirrors-1, -2, -3 and lens after cleaning. Then install the original glass and DF original glass.

Notes:

- Make sure that there is no fingerprints or oil staining on the glass surface underneath the original scale since it is the reading part of the shading correction plate.
- Moreover, when cleaning the original glass with alcohol, do so only for the stained areas because fog may appear.

7.6.2 Paper feeding section

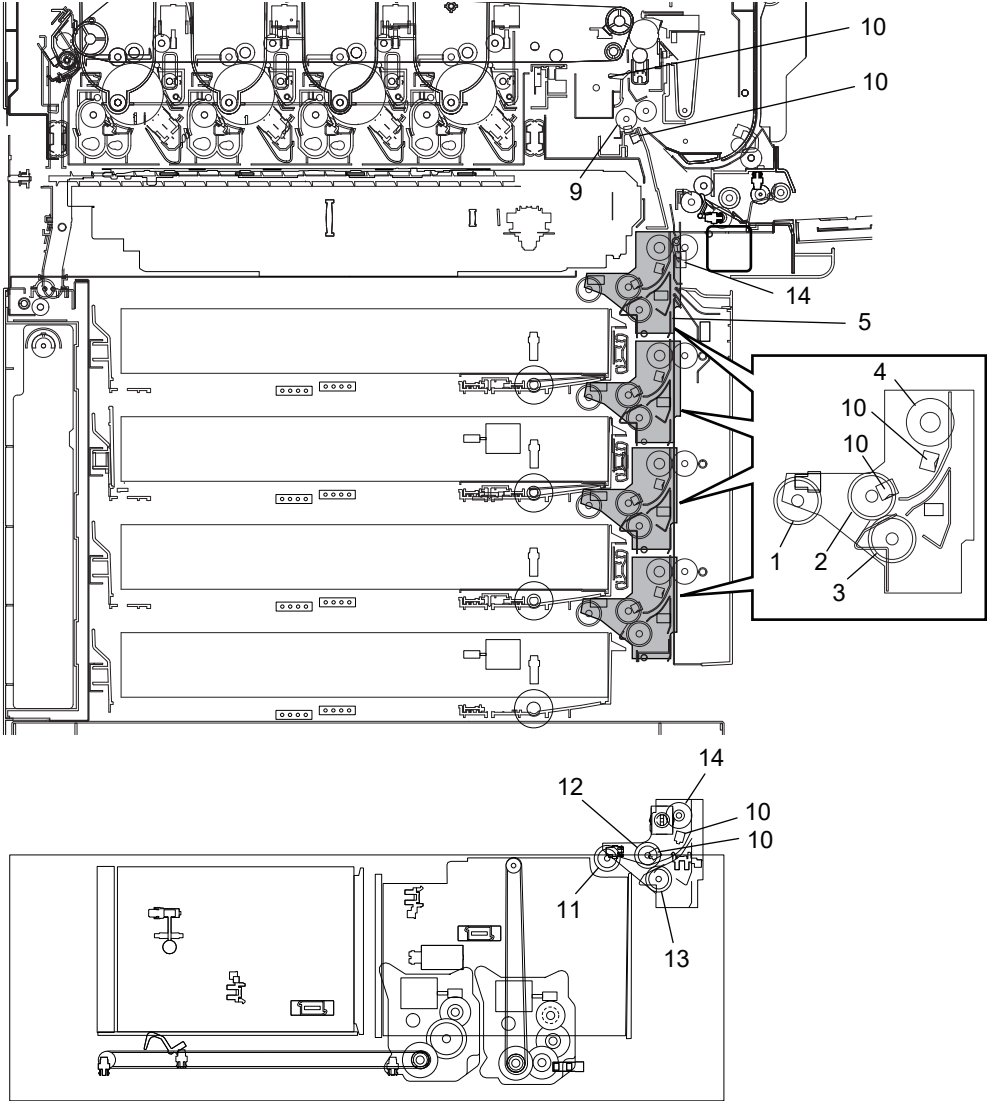

7

Fig. 7-13

PM timing

| Model name | (x 1,000 sheets) |
|------------|------------------|
| 6529A | 590 |
| 7529A | 660 |
| 9029A | 740 |

| Item | | Cleaning, etc. | | Replacement (x 1,000) | | Operation check | <P-I> |
|------|-----------------------------------|----------------|---------------------|-----------------------|--------------|-----------------|-------|
| | | Cleaning | Lubrication/Coating | Sheets | Drive counts | | |
| 1 | Pickup roller | | | 200 | | | 11-36 |
| 2 | Paper feed roller | | | 200 | | | 11-36 |
| 3 | Separation roller | | | 200 | | | 11-35 |
| 4 | Transport roller | A | | R3 | | | 11-22 |
| 5 | Paper guide | B | | | | | 11-28 |
| 6 | Drive gear (tooth face and shaft) | | W1 | | | | - |
| 7 | GCB bushing bearing | | L | | | | - |
| 8 | Plastic bushing bearing | | W1 | | | | - |
| 9 | Registration roller (metal) | A | | R3 | | | 10-1 |
| 10 | Sensor section | A | | | | | 11-45 |
| 11 | Pickup roller (T-LCF) | | | 400/400/500 | | | 11-36 |
| 12 | Paper feed roller (T-LCF) | | | 400/400/500 | | | 11-36 |
| 13 | Separation roller (T-LCF) | | | 400/400/500 | | | 11-35 |
| 14 | Transport roller (T-LCF) | A | | R3 | | | 11-22 |

6: Drive gear

Apply some white grease (Molykote EM-30L) to the teeth of gears and shafts of the drive gears.

Notes:

Make sure that oil is not running over or scattered around as the gear is rotated coming into the clutch after lubricating to the gear which is located near the clutch. The quantity of oil should be smaller than that to be applied to the other parts.

7.6.3 Bypass unit

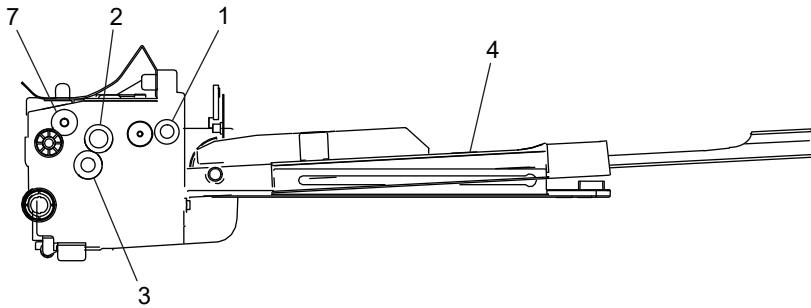

Fig. 7-14

PM timing

| Model name | (x 1,000 sheets) |
|------------|------------------|
| 6529A | 590 |
| 7529A | 660 |
| 9029A | 740 |

| Item | | Cleaning, etc. | | Replacement (x 1,000) | | Operation check | <P-> |
|------|---------------------|----------------|---------------------|-----------------------|--------------|-----------------|-------|
| | | Cleaning | Lubrication/Coating | Sheets | Drive counts | | |
| 1 | Pickup roller | | | 120 | | | 15-15 |
| 2 | Paper feed roller | | | 120 | | | 15-10 |
| 3 | Separation roller | | W2 | 120 | | | 16-43 |
| 4 | Bypass tray | B | | | | | 17-5 |
| 5 | Drive gear (Shaft) | | W1 | | | | - |
| 6 | GCB bushing bearing | | L | | | | - |
| 7 | Transport roller | A | | R3 | | | 15-8 |

3: Separation roller

When replacing the separation roller, apply 1 rice-sized grain of white grease (Molykote HP-300) on the places of the holder shown in the figure (8 places).

Notes:

Make sure that the grease does not adhere to the roller surface. Wipe it off with alcohol if it does adhered.

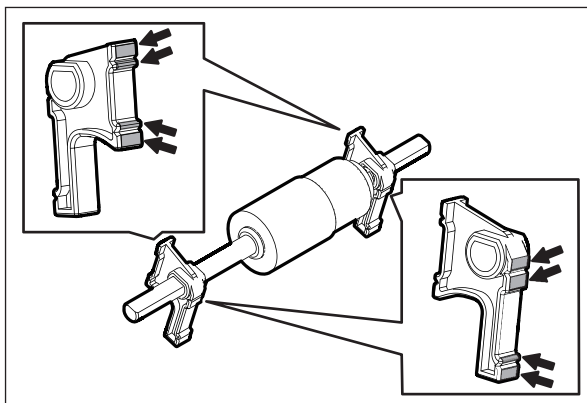

Fig. 7-15

7.6.4 Main charger

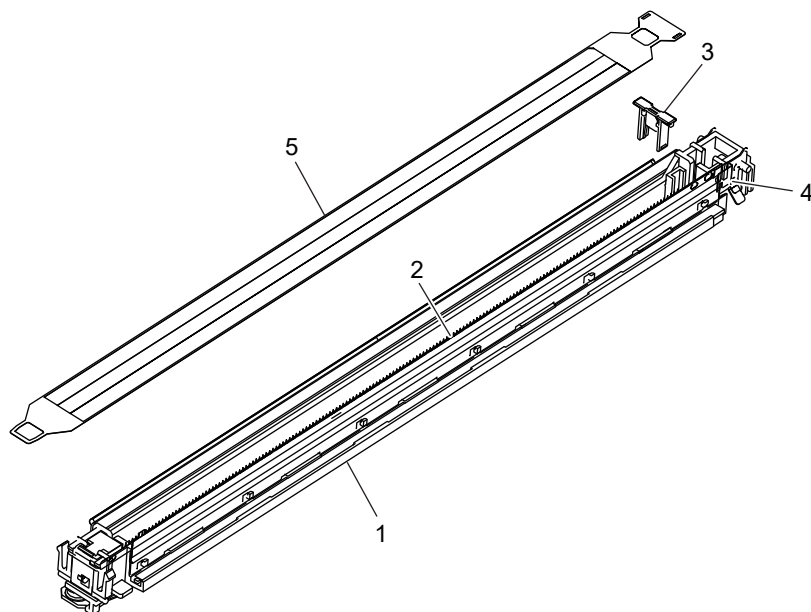

Fig. 7-16

PM timing

| Model name | (x 1,000 sheets) | (x 1,000 drive counts) |
|------------|------------------|------------------------|
| 6529A | 590 | 638 |
| 7529A | 660 | 572 |
| 9029A | 740 | 470 |

| Item | | Cleaning, etc. | | Replacement (x 1,000) | | Operation check | P-I |
|------|--------------------------|----------------|---------------------|-----------------------|--------------|-----------------|-------|
| | | Cleaning | Lubrication/Coating | Sheets | Drive counts | | |
| 1 | Main charger case | B | | | - | | 64-1 |
| 2 | Needle electrode | | | R1 | R1 | Yes | 64-13 |
| 3 | Needle electrode cleaner | | | R1 | R1 | Yes | 64-16 |
| 4 | Terminal point | B | | | | | 64-2 |
| 5 | Main charger grid | | | R1 | R1 | Yes | 64-17 |

1: Main charger case

Clean the main charger case with a cloth soaked in water and squeezed tightly, and then wipe them with a dry cloth.

7.6.5 Drum, cleaner unit, filter

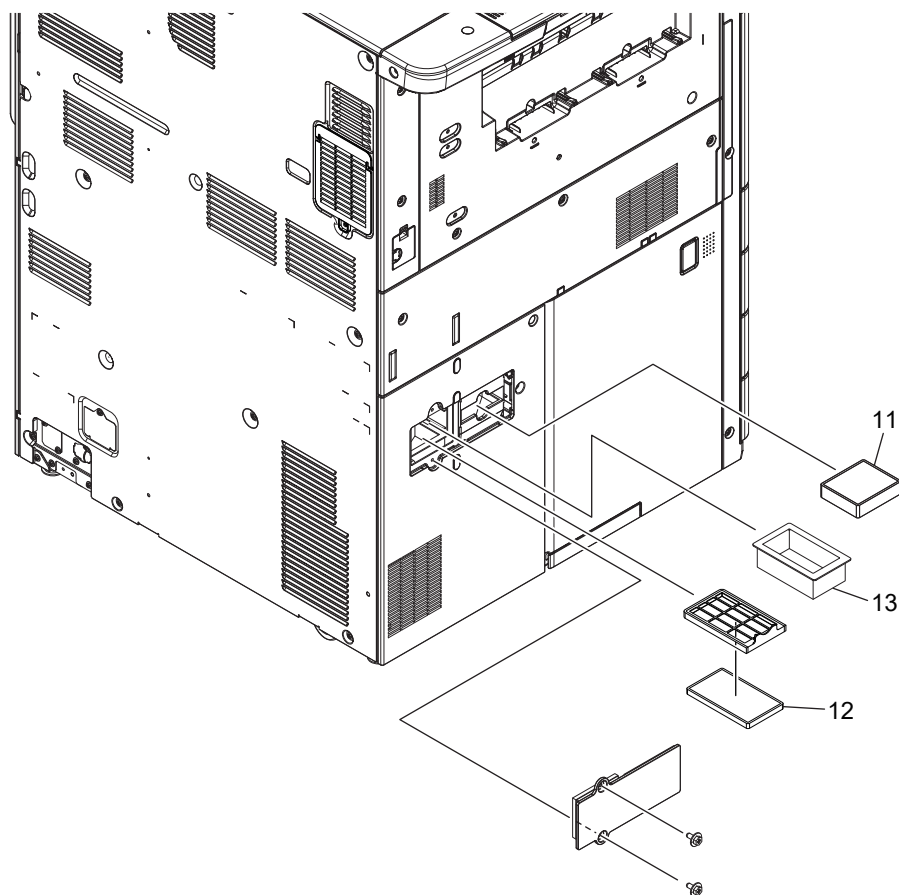
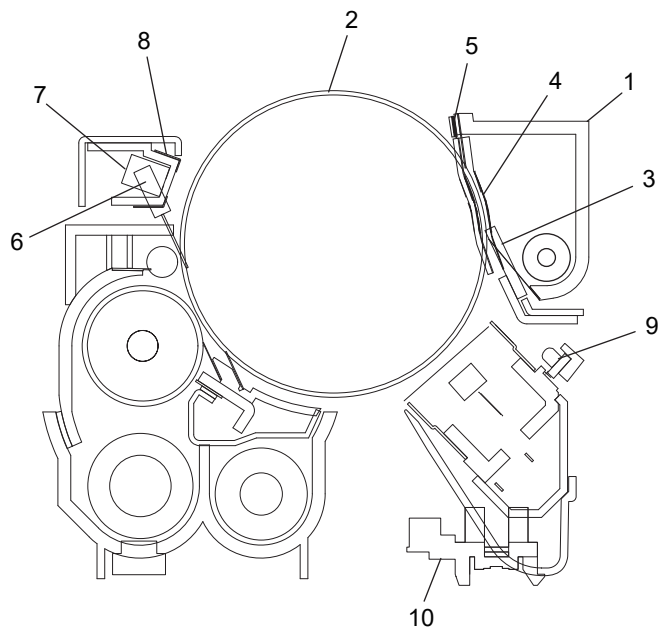

Fig. 7-17

PM timing

| Model name | (x 1,000 sheets) | (x 1,000 drive counts) |
|------------|------------------|------------------------|
| 6529A | 590 | 638 |
| 7529A | 660 | 572 |
| 9029A | 740 | 470 |

| Item | | Cleaning, etc. | | Replacement (x 1,000) | | Operation check | <P-I> |
|------|--|----------------|---------------------|-----------------------|--------------|-----------------|--------------|
| | | Cleaning | Lubrication/Coating | Sheets | Drive counts | | |
| 1 | Cleaner unit (whole) | B | | | | | - |
| 2 | Drum | | | R1 | R1 | | 202-1 |
| 3 | Drum cleaning blade | | | R1 | R1 | | 63-21 |
| 4 | Blade side seal | | | R3 | R3 | | 63-23, 63-24 |
| 5 | Recovery blade | B | | R3 | R3 | | 63-25 |
| 6 | Drum thermistor | B | | | | | 59-27 |
| 7 | Drum surface potential (V0) sensor | B | | | | | 59-22 |
| 8 | Drum surface potential (V0) sensor shutter | B | | | | | 59-24 |
| 9 | Discharge LED | B | | | | | 64-20 |
| 10 | Needle electrode cleaner detection sensor | B | | | | | 59-4 |
| 11 | Ozone filter-1 | | | R1 | R1 | | 49-34 |
| 12 | Ozone filter-2 | | | R1 | 500/445/366 | | 49-3 |
| 13 | Toner filter | | | R1 | 500/445/366 | | 49-25 |

1: Cleaner unit (whole)

Remove any toner on the waste toner section of the drum cleaner unit and the upper section of the EPU tray toner duct.

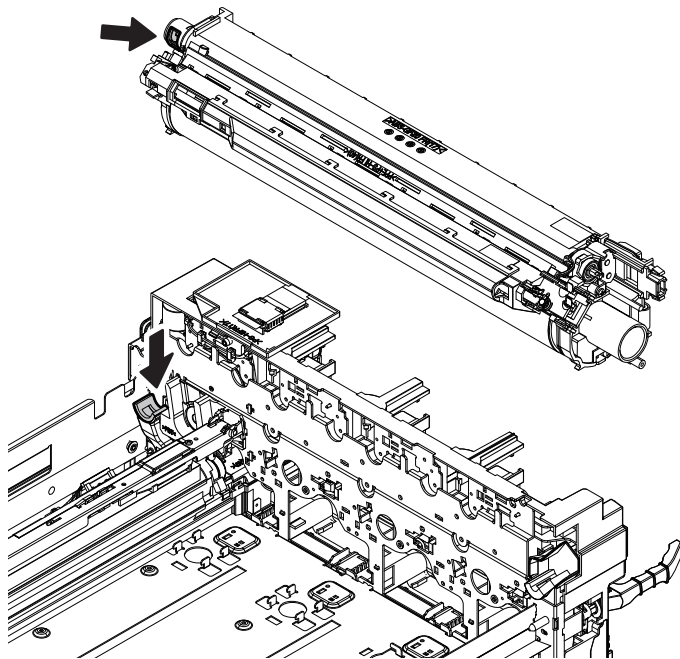

Fig. 7-18

2: Drum

- Handling precautions

If fingerprints or oil adhere to the surface of the drum, its properties may degrade, affecting the quality of the copy image. So, wear gloves to avoid touching the drum surface with your bare hands. Be sure to handle the drum carefully when installing and removing it so as not to damage the drum surface.

After the process unit is installed in the MFP, there may be grease at the inner side of the drum flange (shown as "B" in the figure below) that was transferred from the drum coupling. So hold the lever (shown as "A" in the figure below) when you hold the drum or the drum cleaner unit. Do not hook your finger on the flange hole on the rear side.

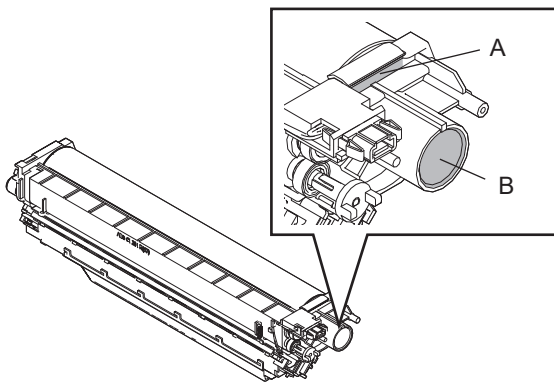

Fig. 7-19

- Clearing the drum counter

When the drum has been replaced with a new one, the drum counter for the new drum (K) must be cleared to 0 (zero). This clearing can be performed in 20 PM SUPPORT MODE.
Drum (K): FS-08-6250-0, 3, 6, 7

- Storage location of drums

The drum should be stored in a dark place where the ambient temperature is between 10°C to 35°C (no condensation). Be sure to avoid places where drums may be subjected to high humidity, chemicals and/or their fumes.

Do not place the drum in a location where it is exposed to direct sunlight or high intensity light such as near a window. Otherwise the drum will fatigue, and will not produce sufficient image density immediately after being installed in the MFP.

- Cleaning

At periodic maintenance calls, wipe the entire surface of the drum clean using the designated cleaning cotton. Note that there is no need to clean the surface of the new drum unless there is a problem. Use sufficiently thick cleaning cotton (dry soft pad) so as not to scratch the drum surface inadvertently with your fingertips or nails. Also, remove your rings and wristwatch before starting cleaning work to prevent accidental damage to the drum.

Do not use alcohol, selenium refresher and other organic solvents or silicon oil as they will have an adverse effect on the drum.

Also clean the doctor blade when the drum is being replaced.

- Scratches on drum surface

If the surface is scratched in such a way that the aluminum substrate is exposed, no copy image will be produced on this area. In addition, the cleaning blade will be damaged so replacement with a new drum will be necessary.

- Collecting used drums

Regarding the recovery and disposal of used drums, follow the relevant local regulations or rules.

3: Drum cleaning blade

- Handling precautions

Pay attention to the following points as the cleaning blade life is determined by the condition of its edge. Replace the cleaning blade with new ones if poor images are copied due to the damaged blade regardless of the number of output pages which have been made.

- Do not allow hard objects to hit or rub against blade edge.
- Do not rub the edge with a cloth or soft pad.
- Do not leave oil (or fingerprints, etc.) on the edges.
- Do not apply solvents such as paint thinner to the blade.
- Do not allow paper fibers or dirt to contact the edge.
- Do not place near a heat source.

- Cleaning

Clean the blade edge with a cloth moistened with water and squeezed lightly.

Since the edge of the blade is vulnerable and can be easily damaged by factors such as the adherence of paper dust.

4: Blade side seal

- Be sure to attach the blade side seals according to the attachment reference in the figure below.
 - Move the blade [2] toward the front side and secure it with 2 screws.
 - By following the attachment reference in the figure below, attach the blade side seal [1].

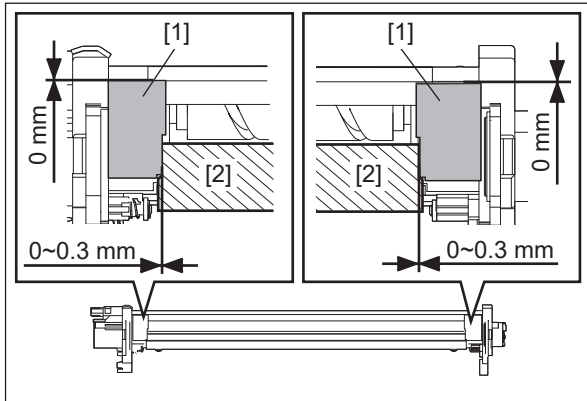

Fig. 7-20

- After the blade side seals [1] are attached, move the blade retaining bracket and check that it is neither caught by the blade [2] nor does it come up on to the blade side seal.

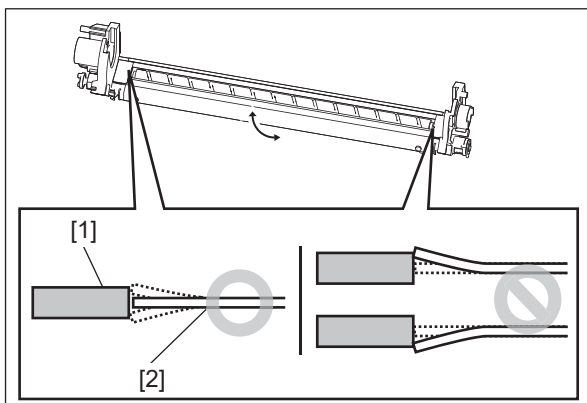

Fig. 7-21

5: Recovery blade

Clean the surface of the recovery blade with a soft pad or cloth, if dirt cannot be removed with a vacuum cleaner. If the edge of recovery blade is damaged, replace the blade regardless of the number of output pages.

Notes:

Never use water or alcohol for cleaning the recovery blade.

7: Drum surface potential (V0) sensor, 8: Drum surface potential (V0) sensor shutter

Clean them with a vacuum cleaner.

Notes:

When cleaning them, be careful not to let any toner or developer material enter into the detecting section of each drum surface potential (V0) sensor.

13: Toner filter

If the toner filter is not replaced at the specified replacement timing, the suction efficiency against the scattered toner decreases, and thus it may cause suction failure and the amount of scattered toner in the MFP may increase. So be sure to replace it periodically.

7.6.6 Developer unit

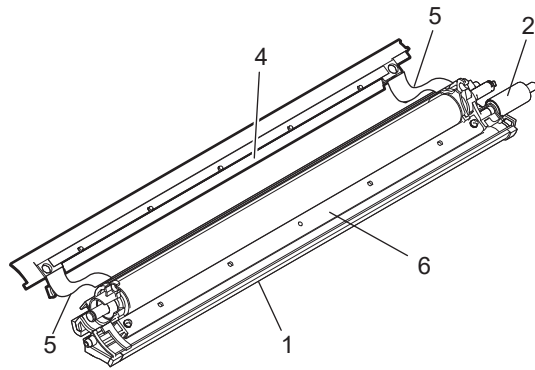

Fig. 7-22

PM timing

| Model name | (x 1,000 sheets) | (x 1,000 drive counts) |
|------------|------------------|------------------------|
| 6529A | 590 | 638 |
| 7529A | 660 | 572 |
| 9029A | 740 | 470 |

| Item | | Cleaning, etc. | | Replacement (x 1,000) | | Operation check | <P-I> |
|------|---------------------------|----------------|---------------------|-----------------------|--------------|-----------------|-------|
| | | Cleaning | Lubrication/Coating | Sheets | Drive counts | | |
| 1 | Developer unit (whole) | B | | | | | 203-6 |
| 2 | Developer unit drive gear | | W1 | | | | 62-14 |
| 3 | Developer material | | | R3 | R3 | | 202-2 |
| 4 | Front seal | B | | R3 | R3 | | 62-32 |
| 5 | Side seal | B | | R3 | R3 | | 62-16 |
| 6 | Doctor blade | B | | R3 | R3 | | 62-18 |

1. Developer unit (whole), 6: Doctor blade

- Cleaning

Clean the doctor blade so as to prevent developer material from adhering to it when the drum is being replaced.

Space the front seal from the developer sleeve and then insert a doctor blade cleaning jig into the doctor sleeve gap. Then clean the doctor blade by running the jig from one end to the other 3 times along with the edge of the blade.

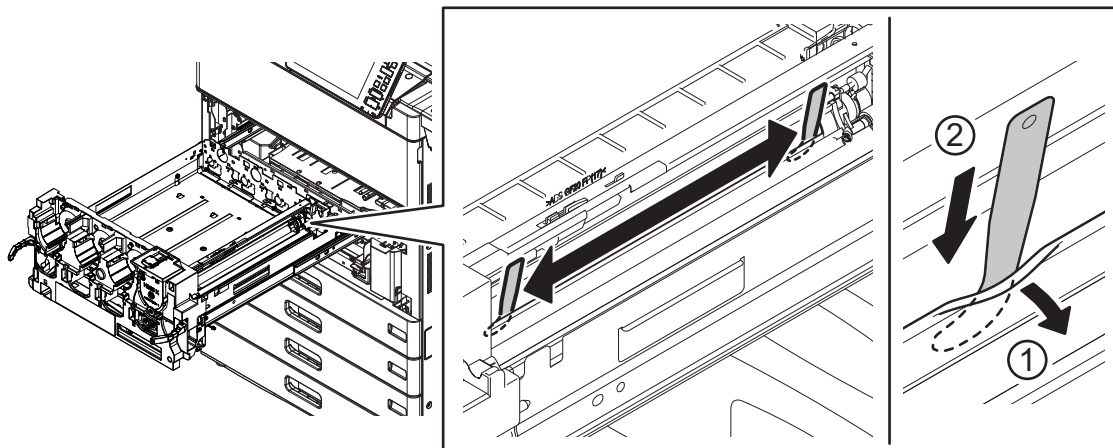

Fig. 7-23

- Removal of foreign matter in the developer unit
 - (1) Pull out the process unit (EPU).
 - (2) Lift up the urethane sheet.
 - (3) Insert the cleaning jig all the way in the developer unit at a position approx. 30 mm away from the white streak.

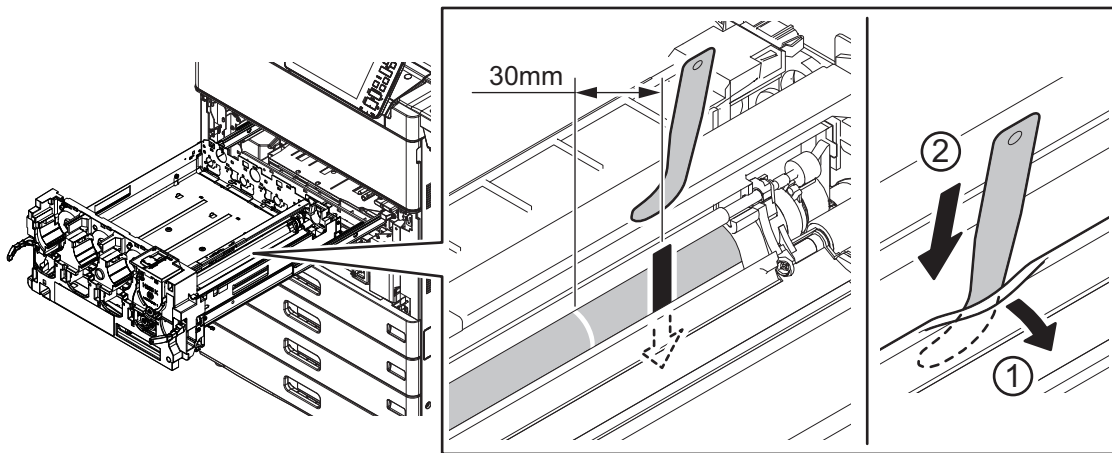

Fig. 7-24

- (4) Slide the cleaning jig to where the white streak appears.
- (5) Pull out the cleaning jig while manually turning the gear [1] to rotate the developer sleeve.

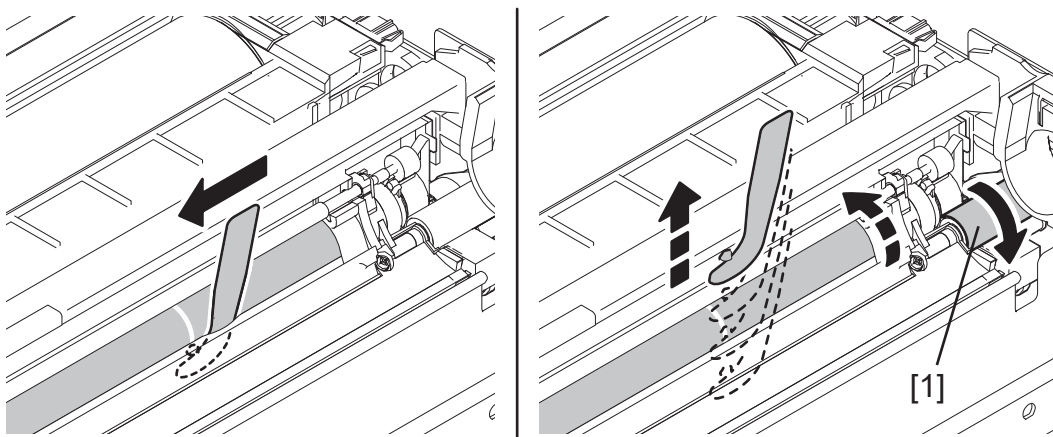

Fig. 7-25

Remarks:

If foreign matter is not removed by the above procedure, take off the developer unit, discharge the developer material on to a sheet of clean paper and then remove any foreign matter found. If you cannot find any foreign matter, exchange the developer material.

- Removal of foreign matter on the developer sleeve
 - (1) Apply a sheet of paper to the developer sleeve.
 - (2) Scrape off foreign matter and developer material on the developer sleeve using the jig.

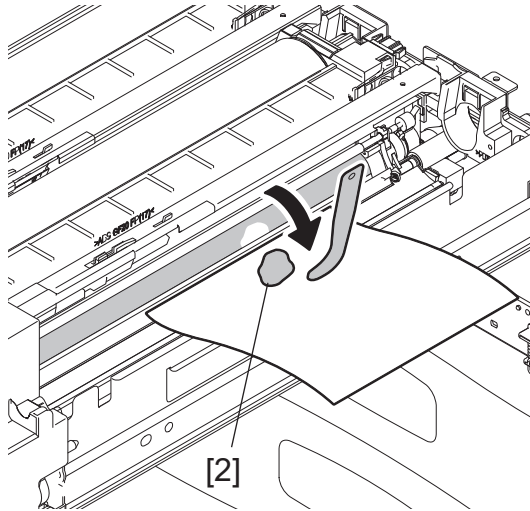

Fig. 7-26

- Scattered toner
If toner is scattered in the developer unit or has accumulated in the developer unit duct, check whether the toner filter has been periodically replaced. If not, it may increase the amount of toner scattered around the developer unit.

Notes:

After the toner filter was replaced, check if the following parts are stained with toner and clean them if required.

1. Developer unit, 2: Developer unit drive gear, 4: Front seal, 5: Side seal

3: Developer material

After replacing the developer material, be sure to perform the auto-toner sensor adjustment and then image quality control initialization.

- 📖 P. 6-2 “6.1.2 Auto-toner sensor adjustment”
- 📖 P. 6-4 “6.1.3 Image quality control adjustment”

7.6.7 Waste toner box

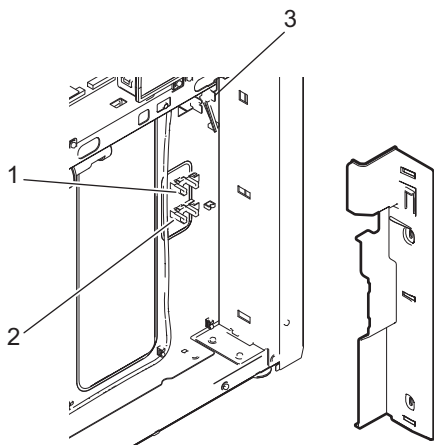

Fig. 7-27

PM timing

| Model name | (x 1,000 sheets) |
|------------|------------------|
| 6529A | 590 |
| 7529A | 660 |
| 9029A | 740 |

| Item | | Cleaning, etc. | | Replacement (x 1,000) | | Operation check | <P-I> |
|------|--|----------------|---------------------|-----------------------|--------------|-----------------|-------|
| | | Cleaning | Lubrication/Coating | Sheets | Drive counts | | |
| 1 | Waste toner box full detection sensor | B | | | | | 65-45 |
| 2 | Waste toner box nearly full detection sensor | B | | | | | 65-45 |
| 3 | Waste toner box detection sensor | B | | | | | 5-17 |

7.6.8 Transfer belt unit, Transfer belt cleaning unit

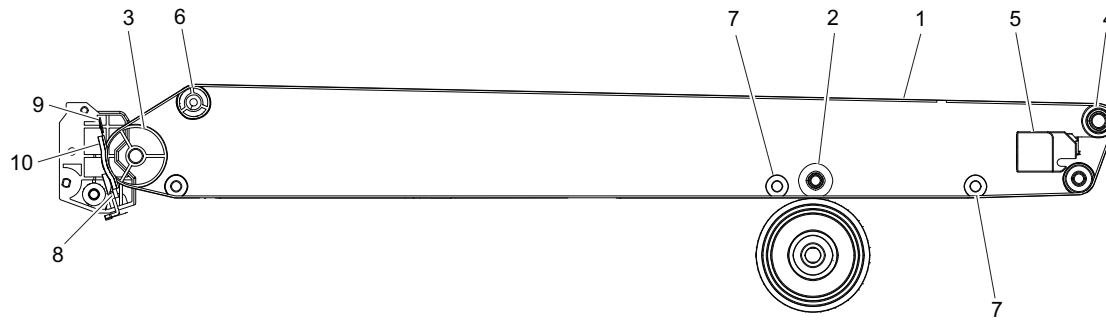

Fig. 7-28

PM timing

| Model name | (x 1,000 sheets) | (x 1,000 drive counts) |
|------------|------------------|------------------------|
| 6529A | 590 | 638 |
| 7529A | 660 | 572 |
| 9029A | 740 | 470 |

| Item | Cleaning, etc. | | Replacement (x 1,000) | | Operation check | <P-I> |
|------|---|---------------------|-----------------------|--------------|-----------------|--------------|
| | Cleaning | Lubrication/Coating | Sheets | Drive counts | | |
| 1 | Transfer belt | | R3 | R3 | | 31-33 |
| 2 | 1st transfer roller | | R3 | R3 | | 30-58 |
| 3 | Cleaning facing roller | A | R3 | R3 | | 31-16 |
| 4 | 2nd transfer facing roller | A | R3 | R3 | | 30-34 |
| 5 | 2nd transfer facing roller cleaning pad | | R1 | R1 | | 30-51 |
| 6 | Tension roller | A | R3 | R3 | | 33-11 |
| 7 | Idling roller | A | R3 | R3 | | 30-55 |
| 8 | Transfer belt cleaning blade | | R1 | R1 | | 34-1 |
| 9 | Recovery blade | B | R3 | R3 | | 34-17 |
| 10 | Transfer belt cleaner side seal (front, rear) | | R1 | R1 | | 34-18, 34-22 |

1: Transfer belt

- Handling precautions
 - Do not touch the front and back surfaces of the transfer belt directly with your bare hands.
 - Do not get any oil or foreign matter on the front and back surfaces of the transfer belt.
 - Do not apply pressure to the transfer belt in order to avoid making any scratches on it.
 - When replacing the transfer belt and transfer belt cleaning unit, apply enough patting powder evenly. Otherwise this could result in poor belt cleaning.
 - When replacing the transfer belt, clean the cleaning facing roller, 2nd transfer facing roller and tension roller with alcohol. Then make sure that there is no foreign matter on the 1st transfer roller surface and then install a new transfer belt.
 - After replacing the transfer belt, be sure to perform the image quality control initialization.
 📖 P. 6-69 "6.10.1 Image quality control related adjustment"
- Cleaning

When cleaning, use alcohol to wipe off any dirt, such as toner adhering to the roller. Then wipe it completely clean with a dry cloth until no marks remain. At this time, make absolutely sure that you leave no scratches or dents on the transfer belt surface. If there is a crack or a large scratch on the transfer belt, replace it regardless of the number of printed sheets.

- Resetting the counter at the replacement
Counter resetting is not possible in the PM support mode because the transfer belt is not a PM part. Therefore reset the counter in the PM management setting (FS-08-6328-0) after the transfer belt has been replaced.

2: 1st transfer roller

- When the 1st transfer roller is replaced, apply FLOIL (GE-334C) all around the shaft on the rear edge of the roller contacting with the bearing inside the roller holder.
- Counter resetting is not possible in the PM support mode because the 1st transfer roller is not a PM part. Therefore reset the counter in the following PM management settings after the 1st transfer roller was replaced.
 - FS-08-6314-0: 1st transfer roller (K)

3: Cleaning facing roller, 4: 2nd transfer facing roller, 6: Tension roller, 7: Idling roller

Fully clean up the toner and any other such matter adhering to the roller with alcohol. If any dirt remains, this may be the cause of defective images. In addition, remove any dust or toner adhering to the inside of the transfer belt unit so that the roller will remain clean.

8: Transfer belt cleaning blade

- Handling precautions
 - Do not allow hard objects to hit or rub against blade edge.
 - Do not rub the edge with a cloth or soft pad.
 - Do not leave oil (or fingerprints, etc.) on the edges.
 - Do not apply solvents such as paint thinner to the blade.
 - Do not allow paper fibers or dirt to contact the edge.
 - Do not place near a heat source.

10: Transfer belt cleaner side seal

Be sure to attach the transfer belt cleaner side seals according to the attachment reference in the figure below.

Part A: Pay attention to the following. If the blade is caught by the side seal or comes up on to it, the blade may turn up. If the gap between the blade and the side seal is too wide, this will cause toner scattering.

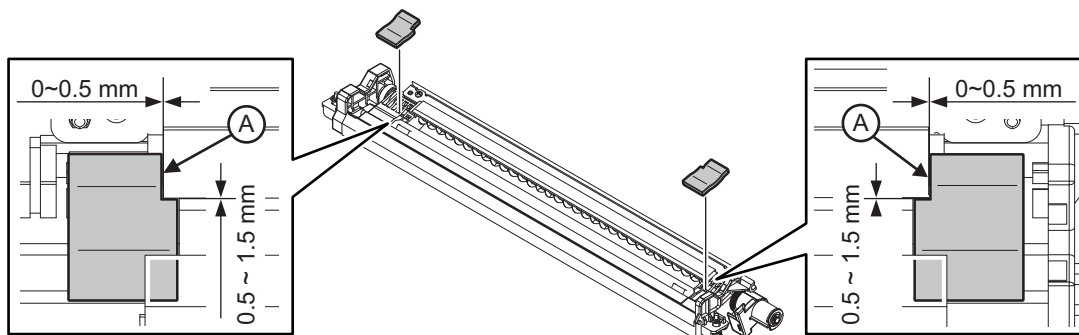

Fig. 7-29

7.6.9 Image quality control unit

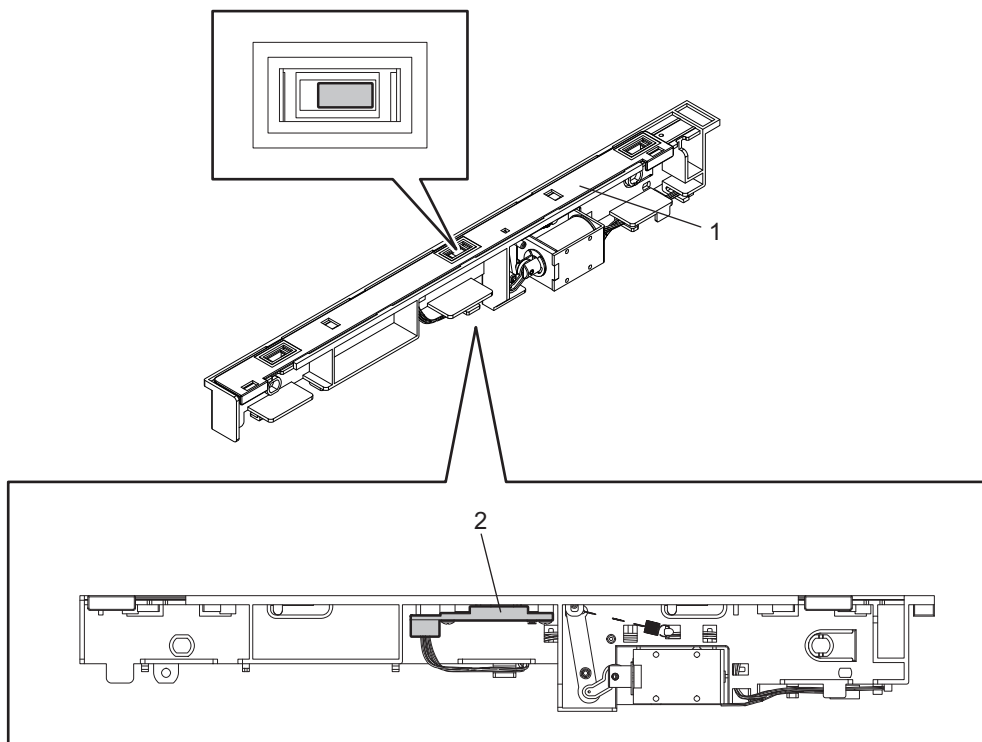

Fig. 7-30

PM timing

| Model name | (x 1,000 sheets) | (x 1,000 drive counts) |
|------------|------------------|------------------------|
| 6529A | 590 | 638 |
| 7529A | 660 | 572 |
| 9029A | 740 | 470 |

| Item | | Cleaning, etc. | | Replacement (x 1,000) | | Operation check | <P-I> |
|------|---|----------------|---------------------|-----------------------|--------------|-----------------|-------|
| | | Cleaning | Lubrication/Coating | Sheets | Drive counts | | |
| 1 | Sensor shutter | B | | R3 | R3 | | 6-28 |
| 2 | Image position aligning/image quality sensor (center) | A | | R3 | R3 | | 6-5 |

7.6.10 2nd Transfer Unit

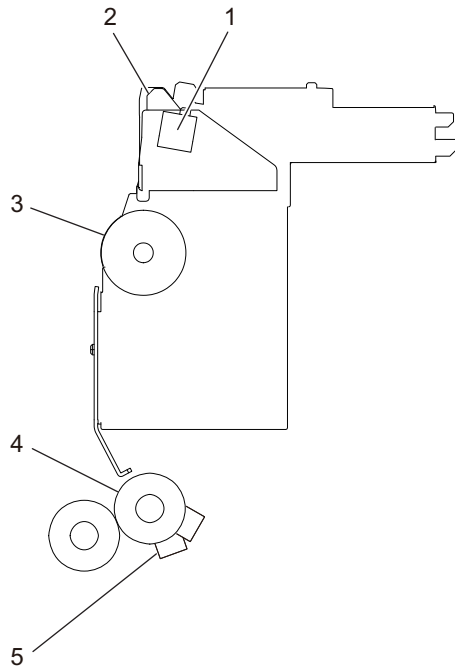

Fig. 7-31

PM timing

| Model name | (x 1,000 sheets) | (x 1,000 drive counts) |
|------------|------------------|------------------------|
| 6529A | 590 | 638 |
| 7529A | 660 | 572 |
| 9029A | 740 | 470 |

| Item | | Cleaning, etc. | | Replacement (x 1,000) | | Operation check | <P-I> |
|------|---|----------------|---------------------|-----------------------|--------------|-----------------|-------|
| | | Cleaning | Lubrication/Coating | Sheets | Drive counts | | |
| 1 | 2nd transfer side paper clinging detection sensor | B | | | | | 29-4 |
| 2 | 2nd transfer paper guide | A | | | | | 29-11 |
| 3 | 2nd transfer roller | | | R1 | R1 | | 29-6 |
| 4 | Registration roller (rubber) | A | | R3 | R3 | | 21-28 |
| 5 | Registration roller paper dust cleaning brush | B | | | | | 22-45 |

1: 2nd transfer side paper clinging detection sensor

A black film [1] is affixed to the sheet metal of the IH coil in order to prevent the erroneous detection of the sensor.

If any toner adheres to this film [1], erroneous detection may result. To prevent this, take off the fuser and wipe off the toner on the film [1] with a cloth.

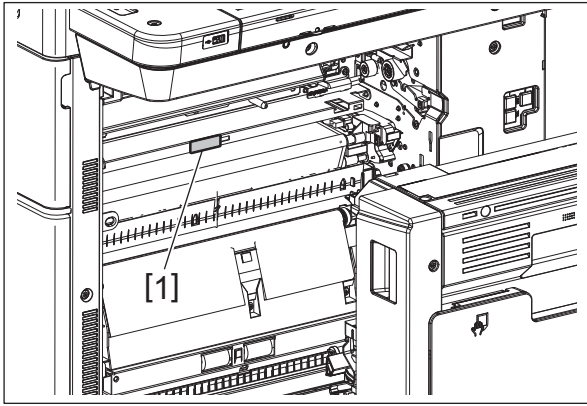

Fig. 7-32

3: 2nd transfer roller

Since the bearings [3] are press-fitted in the bushings [1] and [2], be sure to remove them in a straight direction, so that the bearings do not fall off.

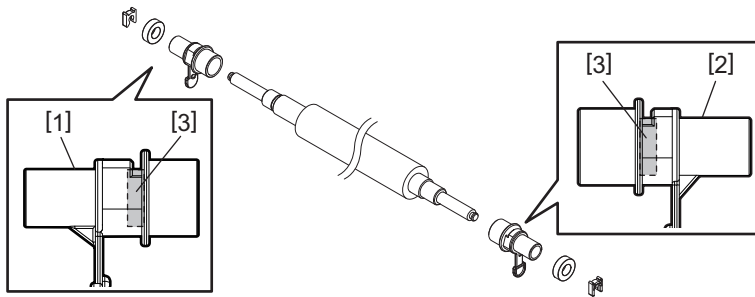

Fig. 7-33

5: Registration roller paper dust cleaning brush

Take off the registration roller paper dust cleaning brush from the 2nd transfer unit. Then remove the paper dust on the brush with a vacuum cleaner.

7.6.11 Fuser unit

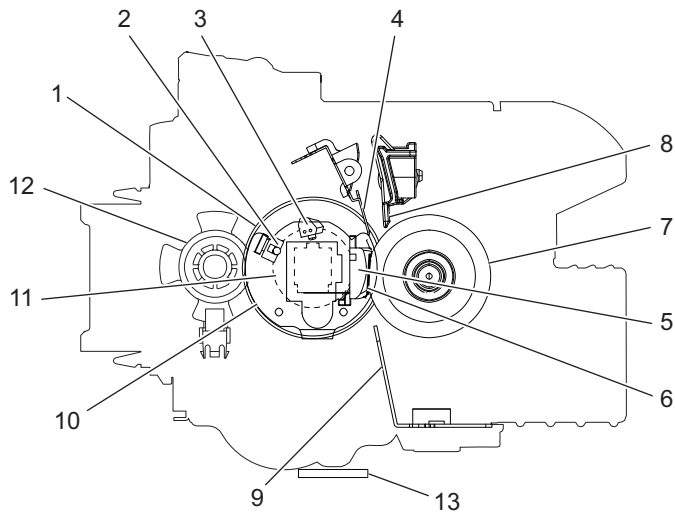

Fig. 7-34

PM timing

| Model name | (x 1,000 sheets) | (x 1,000 drive counts) |
|------------|------------------|------------------------|
| 6529A | 590 | 632 |
| 7529A | 660 | 626 |
| 9029A | 740 | 531 |

| Item | | Cleaning, etc. | | Replacement (x 1,000) | | Operation check | <P-I> |
|------|--------------------------------------|----------------|---------------------|-----------------------|--------------|-----------------|-------------------------|
| | | Cleaning | Lubrication/Coating | Sheets | Drive counts | | |
| 1 | Fuser Belt | | | R1 | R1 | | 42-22 |
| 2 | Fuser belt thermostat | | | R3 | R3 | | 42-21, 42-52 |
| 3 | Fuser belt thermistor (center, edge) | | | R3 | R3 | | 42-21, 42-55 |
| 4 | Separation plate | A | | R3 | R3 | | 41-14 |
| 5 | Fuser belt pad | | | R1 | R1 | | 42-44 |
| 6 | Fuser belt lubricating sheet | | | R1 | R1 | | 42-22 |
| 7 | Pressure roller | | | R1 | R1 | | 42-17 |
| 8 | Separation guide | A | | R3 | R3 | | 41-25 |
| 9 | Fuser unit entrance guide | A | | R3 | R3 | | 43-34 |
| 10 | Front fuser belt oil recovery sheet | | | R1 | R1 | | 42-22 |
| 11 | Rear fuser belt oil recovery sheet | | | R1 | R1 | | 42-22 |
| 12 | Rear fuser gear oil recovery sheet | | | R1 | R1 | | 42-22 |
| 13 | Rear fuser cover oil recovery sheet | | | R1 | R1 | | 42-22 |
| 14 | Fuser gear shaft | | W2 | | | | 42-2, 42-17, 43-4 |
| 15 | Fuser gear | | W2 | R3 | R3 | | 42-1, 42-18, 43-1, 43-2 |
| 16 | Fuser drive gear (MFP side) | | | R3 | R3 | | 39-21 |
| 17 | Pressure roller contact/release cam | | W2 | R3 | R3 | | 43-11 |

1: Fuser belt

When replacing the fuser belt, apply the silicon oil to the inside of the fuser belt.

P. 4-226 “4.9.7 Fuser belt”

2: Fuser belt thermostat, 3: Fuser belt thermistor (center, edge)

Replace the fuser belt unit in its entirety with a new one if a fuser belt thermostat or a fuser belt thermistor has been damaged or deformed.

4: Separation plate, 8: Separation guide

If toner adheres to the separation plate or separation guide, wipe it off with a dry cloth. Do not take off the separation guide unless otherwise required.

9: Fuser unit entrance guide

If toner has adhered, wipe it off with alcohol.

14: Fuser gear shaft

When performing preventive maintenance, apply an appropriate amount of white grease (HP-300) to the 6 shafts.

Notes:

Do not apply white grease to the shaft [1].

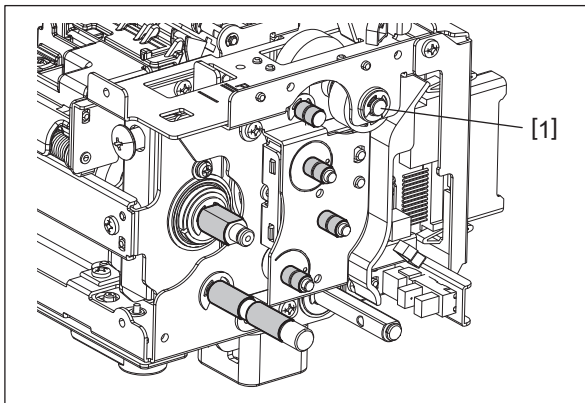

Fig. 7-35

15: Fuser gear

When performing preventive maintenance, apply an appropriate amount of white grease (HP-300) to the 6 gears. Moreover, apply grease in the same manner as well as when replacing them with new ones.

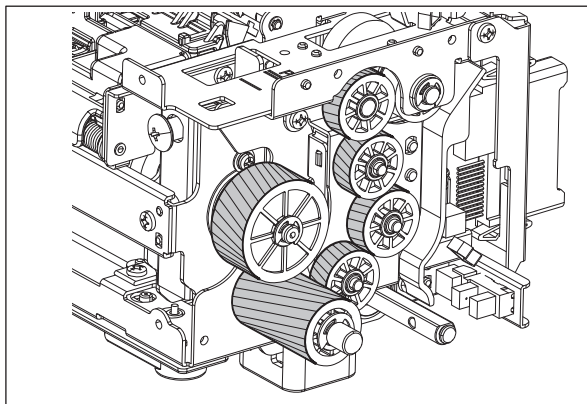

Fig. 7-36

16: Fuser drive gear (MFP side)

Pay attention not to drop the pin [1] when removing the gear.

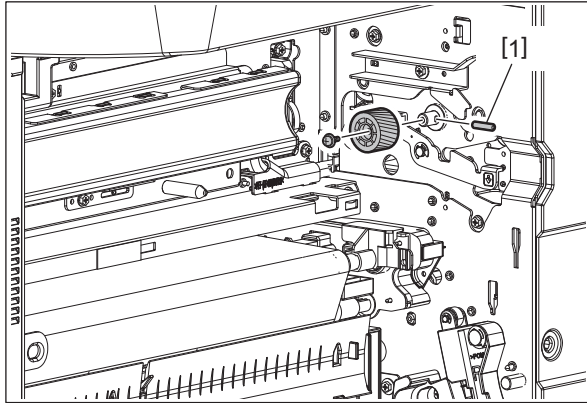

Fig. 7-37

17: Pressure roller contact/release cam

When performing preventive maintenance, apply an appropriate amount of white grease (HP-300) to the 2 cams. Moreover, apply grease in the same manner as well as when replacing them with new ones.

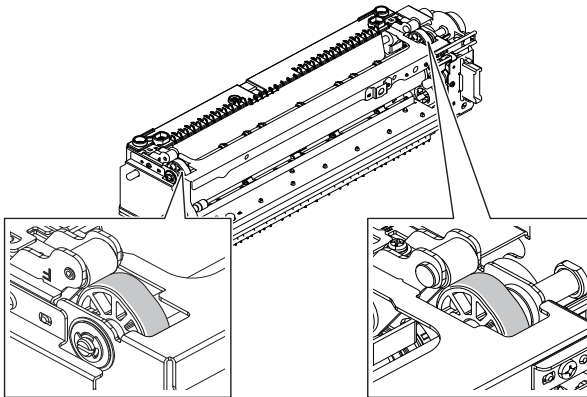

Fig. 7-38

7.6.12 Duplexing unit

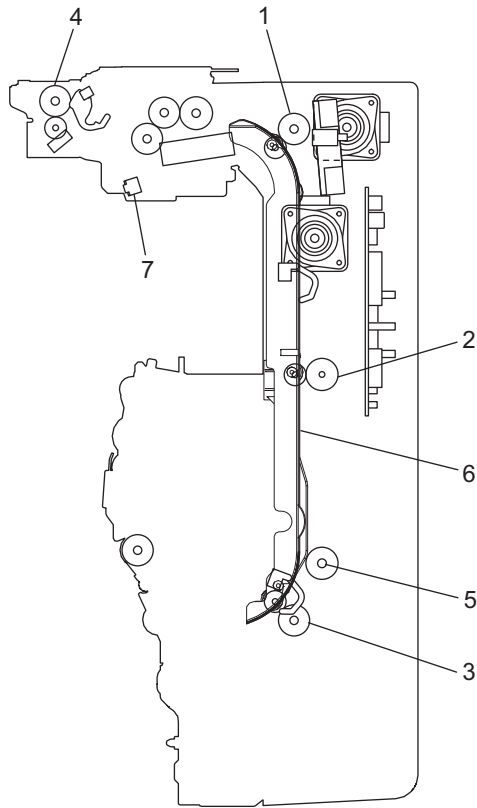

Fig. 7-39

PM timing

| Model name | (x 1,000 sheets) |
|------------|------------------|
| 6529A | 590 |
| 7529A | 660 |
| 9029A | 740 |

| Item | | Cleaning, etc. | | Replacement (x 1,000) | | Operation check | <P-I> |
|------|-----------------------------------|----------------|---------------------|-----------------------|--------------|-----------------|-------|
| | | Cleaning | Lubrication/Coating | Sheets | Drive counts | | |
| 1 | ADU transport roller-1 | A | | R3 | R3 | | 18-6 |
| 2 | ADU transport roller-2 | A | | R3 | R3 | | 18-5 |
| 3 | ADU transport roller-3 | A | | R3 | R3 | | 18-7 |
| 4 | Duplexing bridge transport roller | A | | R3 | R3 | | 20-12 |
| 5 | Pulley stud | | W1 | | | | - |
| 6 | Paper guide | B | | | | | 19-2 |
| 7 | Fuser transport sensor | B | | | | | 22-19 |

7: Fuser transport sensor

Clean the detection portion shown in the figure.

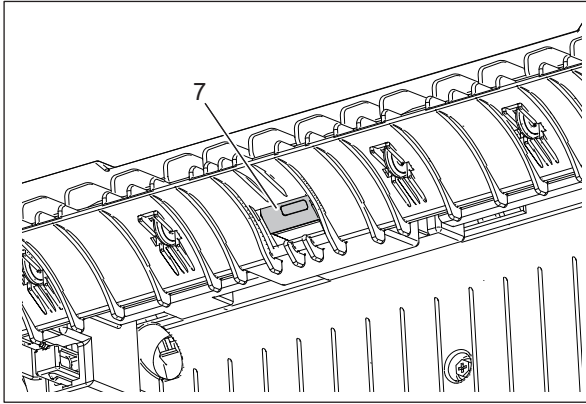

Fig. 7-40

7.6.13 Bridge Unit

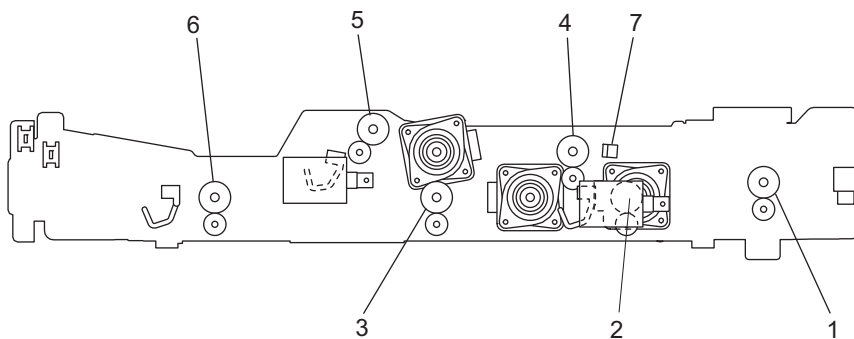

Fig. 7-40

PM timing

| Model name | (x 1,000 sheets) |
|------------|------------------|
| 6529A | 590 |
| 7529A | 660 |
| 9029A | 740 |

| Item | | Cleaning, etc. | | Replacement (x 1,000) | | Operation check | <P-I> |
|------|---------------------------------|----------------|---------------------|-----------------------|--------------|-----------------|-------|
| | | Cleaning | Lubrication/Coating | Sheets | Drive counts | | |
| 1 | Bridge unit transport roller-1 | A | | | | | 24-17 |
| 2 | Bridge unit transport roller-2 | A | | | | | 23-3 |
| 3 | Bridge unit transport roller-3 | A | | | | | 23-4 |
| 4 | Reverse roller | A | | | | | 24-25 |
| 5 | Bridge unit paper exit roller-1 | A | | | | | 24-26 |
| 6 | Bridge unit paper exit roller-2 | A | | | | | 23-5 |
| 7 | Reverse sensor | A | | | | | 26-25 |

7.6.14 Paper exit unit

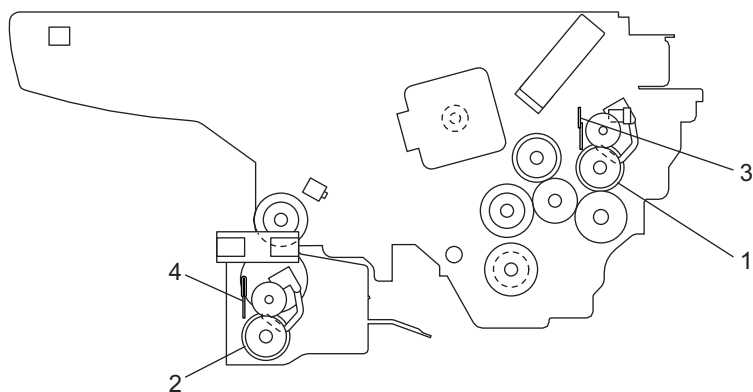

Fig. 7-41

PM timing

| Model name | (x 1,000 sheets) |
|------------|------------------|
| 6529A | 590 |
| 7529A | 660 |
| 9029A | 740 |

| Item | | Cleaning, etc. | | Replacement (x 1,000) | | Operation check | <P-I> |
|------|-------------------------|----------------|---------------------|-----------------------|--------------|-----------------|-------|
| | | Cleaning | Lubrication/Coating | Sheets | Drive counts | | |
| 1 | Upper paper exit roller | A | | | | | 36-6 |
| 2 | Lower paper exit roller | A | | | | | 35-27 |
| 3 | Upper discharge brush | A | | R3 | | | 36-17 |
| 4 | Lower discharge brush | A | | R3 | | | 35-29 |

3: Upper discharge brush, 4: Lower discharge brush

Replace the discharge brush with a new one if its bristles do not touch the output paper.

7.6.15 DSDF

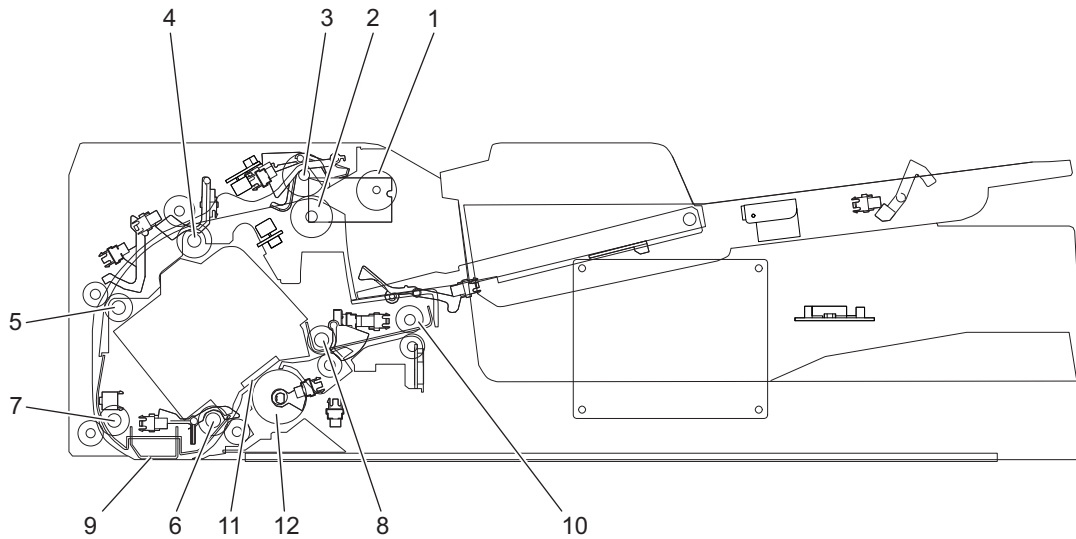

Fig. 7-42

PM timing

| Model name | (x 1,000 sheets) |
|------------|------------------|
| 6529A | 590 |
| 7529A | 660 |
| 9029A | 740 |

| Item | Cleaning, etc. | | Replacement (x 1,000) | | Operatio n check | <P-I> |
|------|-------------------------------|-------------------------|-----------------------|--------------|---------------------|-------|
| | Cleaning | Lubricatio n/Coating | Sheets | Drive counts | | |
| 1 | DSDF pickup roller | | 120 | | | 81-18 |
| 2 | DSDF separation roller | | 120 | | | 85-21 |
| 3 | DSDF original feed roller | | 120 | | | 81-14 |
| 4 | DSDF registration roller | A | | | | 87-14 |
| 5 | Pre-read roller-1 | A | | | | 87-13 |
| 6 | Pre-read roller-2 | A | | | | 94-21 |
| 7 | Post-read roller-1 | A | | | | 94-12 |
| 8 | Post-read roller-2 | A | | | | 91-15 |
| 9 | Scanning guide | A | | | | 95-3 |
| 10 | DSDF original exit roller | A | | | | 91-12 |
| 11 | DSDF-CCD original glass | B | | | | 85-22 |
| 12 | DSDF shading correction plate | B | | | | 92-24 |

1: DSDF pickup roller

- When the DSDF pickup roller is replaced, clean its shaft holes in the DSDF pickup unit.

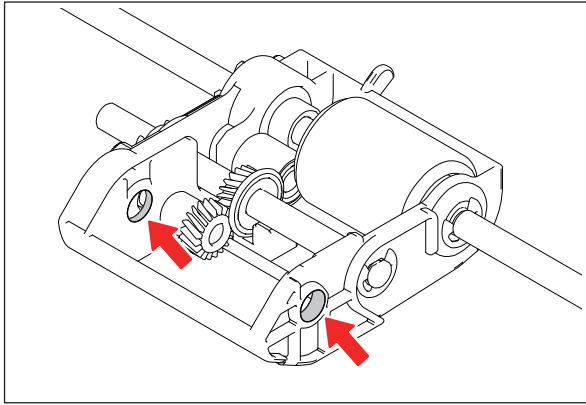

Fig. 7-43

- Remove the DSDF pickup unit. Release the hook. Remove the lever from the DSDF pickup unit. Apply grease (Molykote EM-30L) by 0.01 cc to the edge of the shaft.

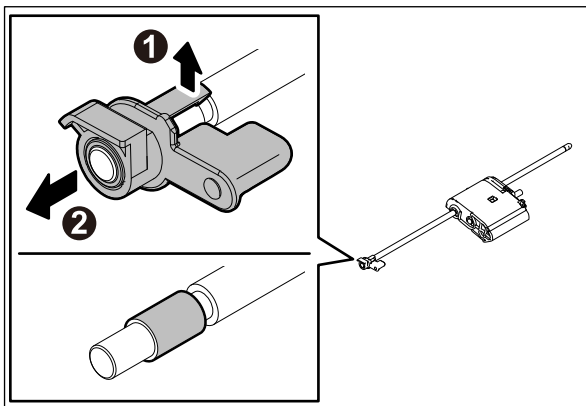

Fig. 7-44

7.7 Machine Refreshing Checklist

The check items for each unit at the machine refreshment are shown below.

Symbols and values used in the checklist

| Item | Explanation |
|---------------------|---|
| Cleaning | A: Clean with alcohol B: Clean with a soft pad, cloth or vacuum cleaner |
| Lubrication/Coating | W1: White grease (Molykote EM-30L) W2: White grease (Molykote HP-300) R4: Lubrication recommended. If the parts are not lubricated at the machine refreshing interval, inspect their lubrication status at the subsequent PM. |
| Replacement | R1: Replacement R2: For preventive maintenance, check if the parts are damaged and replace them as required. If the parts are not replaced at the machine refreshing interval, inspect them at the subsequent PM. R3: Replace if deformed or damaged If the parts are not replaced at the machine refreshing interval, inspect them at the subsequent PM. |
| Operation check | O: After cleaning or replacement, confirm there is no problem. |

Notes:

- When performing machine refreshment, check the items in the preventive maintenance checklist in addition to the items in the machine refreshing checklist.
- Perform cleaning and lubricating in the following timing. Lubricate the replacement parts according to the replacement cycle.

| Model name | Print count |
|------------|------------------|
| 6529A | 1,180,000 sheets |
| 7529A | 1,320,000 sheets |
| 9029A | 1,480,000 sheets |

- Be careful not to put oil on the rollers, belts and belt pulleys when lubricating.
- “<P-I>” represents the page item in “e-STUDIO6529A/7529A/9029A Service Parts List”.

| Item | Cleaning | Lubrication/Coating | Replacement | <P-I> |
|-----------------------------------|----------|---------------------|-------------|-------|
| 1 Drum (K) developer drive unit | | W1 (R4) | | |
| 2 Drum (YMC) developer drive unit | | W1 (R4) | | |
| 3 Transfer belt drive unit | | W1 (R4) | | |
| 4 Fuser drive unit | | W1 (R4) | | |
| 5 Felt (fuser unit) | | | R3 | 41-3 |

4: Fuser drive unit

For lubrication, see the following reference.

 P. 4-255 “4.9.19 Pressure roller contact/release motor (M48)”

7.8 Storage of Supplies and Replacement Parts

Precautions for storing supplies and replacement parts are shown below.

1. Toner, Developer material
Toner and developer should be stored in a place where the ambient temperature is between 10°C to 35°C (no condensation), and should also be protected against direct sunlight during transportation.
2. Photoconductive drum
Photoconductive drum should be stored in a dark place where the ambient temperature is between 10°C to 35°C (no condensation) Avoid places where the rollers and belts may be subjected to high humidity, chemicals and/or their fumes.
Do not place the drum in a location where it is exposed to direct sunlight or high intensity light such as near a window. Otherwise the drum will fatigue, and will not produce sufficient image density immediately after being installed in the MFP.
3. Cleaning blade (Drum, Transfer belt, 2nd transfer roller)
Cleaning blade should be stored in a flat place where the ambient temperature is between 10°C to 35°C, putting it in horizontal. Avoid places where the rollers and belts may be subjected to high humidity, chemicals and/or their fumes.
4. Transfer belt, Transfer roller, Fuser belt, Pressure roller
Avoid places where the rollers and belts may be subjected to high humidity, chemicals and/or their fumes.
5. Fuser belt
Oil co-packed with the fuser belt and PM kit should be stored in a stable condition. Therefore, keep it in an exclusive container and do not change this to another one.
6. Fuser unit
The oil inside the fuser unit may leak if it is tilted. Therefore, keep the fuser unit in a horizontal position when it is being stored or during transportation.
7. Paper, Envelope
Avoid storing copy paper in places where it may be subjected to high humidity. After a package is opened, be sure to place and store it in a storage bag.

7.9 PM Kit

A PM kit is a package for each unit of replacement parts requiring PM.

| Kit name | Component | Q'ty | <P-I>* |
|-----------------------------------|---|------|--------|
| EPU-KIT-FC556-G (6529A/7529A) | Needle electrode | 1 | 64-13 |
| | Main charger grid | 1 | 64-17A |
| | Needle electrode cleaner | 1 | 64-16 |
| | Drum cleaning blade | 1 | 63-21 |
| EPU-KIT-FC556-S (9029A) | Needle electrode | 1 | 64-13 |
| | Main charger grid | 1 | 64-17B |
| | Needle electrode cleaner | 1 | 64-16 |
| | Drum cleaning blade | 1 | 63-21 |
| TBU-KIT-FC556 | 2nd transfer facing roller cleaning pad | 1 | 30-51 |
| | Transfer belt cleaning blade | 1 | 34-1 |
| | Transfer belt cleaner side seal (front) | 1 | 34-18 |
| | Transfer belt cleaner side seal (rear) | 1 | 34-22 |
| FLTR-KIT-DP55 | Toner filter | 1 | 49-25 |
| | Ozone filter-1 | 1 | 49-34 |
| | Ozone filter-2 | 1 | 49-3 |
| FR-KIT-FC556-FU | Fuser belt | 1 | 42-22 |
| | Pressure roller | 1 | 42-17 |
| | Fuser belt pad | 1 | 42-44 |
| | Fuser belt lubricating sheet | 1 | 42-22 |
| | Front fuser belt oil recovery sheet | 1 | 42-22 |
| | Rear fuser belt oil recovery sheet | 1 | 42-22 |
| | Rear fuser gear oil recovery sheet | 1 | 42-22 |
| | Rear fuser cover oil recovery sheet | 1 | 42-22 |
| | Silicon oil | 1 | 42-63 |
| ROL-KIT-FC75 | Pickup roller | 1 | 11-36A |
| | Paper feed roller | 1 | 11-36A |
| | Separation roller | 1 | 11-35A |
| ROL-KIT-FC75-U (for T-LCF) | Pickup roller | 1 | 11-36B |
| | Paper feed roller | 1 | 11-36C |
| | Separation roller | 1 | 11-35B |
| KIT-ROL-MR-4010 | Pickup roller | 1 | 81-18 |
| | Paper feed roller | 1 | 81-14 |
| | Separation roller | 1 | 85-21 |
| ROL-KIT-MP2502-U (for MP-2503) | Pickup roller | 2 | 5-46 |
| | Paper feed roller | 1 | 4-2 |
| | Separation roller | 1 | 4-3 |
| ROL-KIT-MP-2002 (for MP-2002) | Pickup roller | 2 | 4-18 |
| | Paper feed roller | 1 | 4-9 |
| | Separation roller | 1 | 4-37 |

* "<P-I>" represents the page item in "e-STUDIO6529A/7529A/9029A Service Parts List".

7.10 Maintenance Parts

The parts used for the maintenance of this MFP are as follows.

| No. | Name | Purpose | <P-I>* |
|-----|-------------------------------------|---|--------|
| 1 | Cleaning brush | Cleaning inside of the MFP | 201-1 |
| 2 | Doctor blade cleaning jig | Cleaning the doctor blade | 201-2 |
| 3 | Wire holder jig | Fixing the wire at the assembly of the carriage wire | 201-3 |
| 4 | DSDF positioning pin | Determining the position of the DSDF | 201-4 |
| 5 | Doctor sleeve jig | Measuring the gap between the developer sleeve and the doctor blade | 201-5 |
| 6 | Belt tension jig | Adjusting the belt tension at the installation of the scan motor | 201-6 |
| 7 | Separation plate gap adjustment jig | Adjusting the gap between the fuser belt and separation guide (step 0.50, 0.55, 0.60) | 201-7 |
| 8 | Separation plate gap adjustment jig | Adjusting the gap between the fuser belt and separation guide (step 0.30, 0.60, 0.80) | 201-8 |
| 9 | Drum bag | Storing the drum | 201-9 |
| 11 | Patting powder | For the transfer belt | 201-11 |
| 12 | Color test chart (TCC-2) | Test chart for A4/LD | 201-12 |
| 13 | Color test chart | Test chart for A3/LD | 201-13 |
| 14 | DSDF stopper jig | Pressing the DSDF to prevent it from becoming open | 201-14 |
| 15 | Separation guide gap adjustment jig | Adjusting the gap between the pressure roller and separation guide | 201-15 |

* "<P-I>" represents the page item in "e-STUDIO6529A/7529A/9029A Service Parts List".

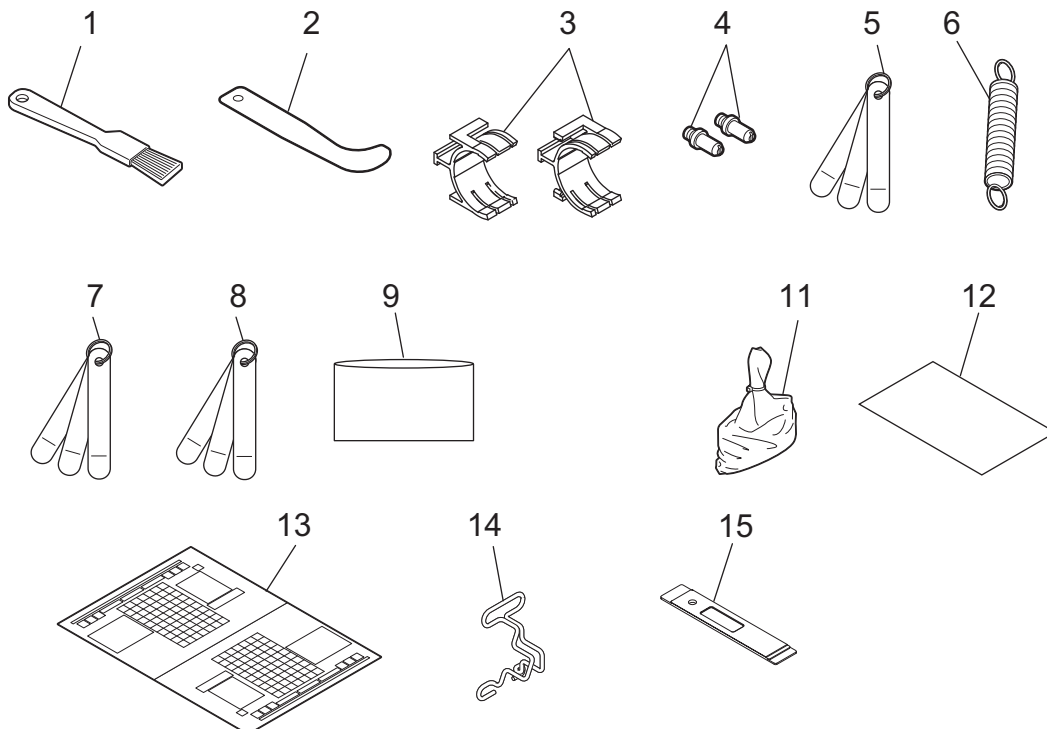

Fig. 7-45

7.10.1 How to attach the DSDF stopper jig

- (1) Take off the DSDF front cover.
📖 P. 4-338 “4.11.8 DSDF front cover”
- (2) Take off the cover of the scanner section in the MFP.
📖 P. 4-4 “4.1.6 Front top cover (control panel top cover)”
- (3) Attach the DSDF stopper jig.

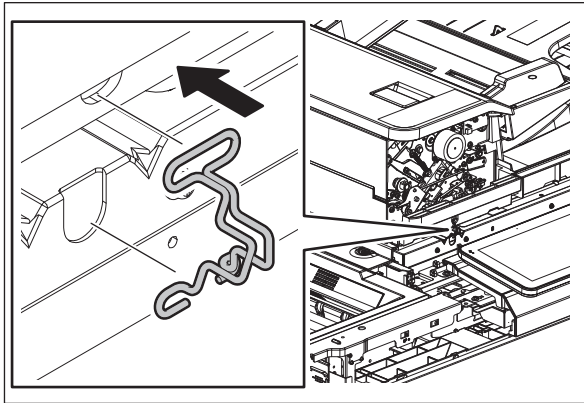

Fig. 7-46

Remarks:

- Insert the upper side of the stopper jig into the hole of the DSDF.

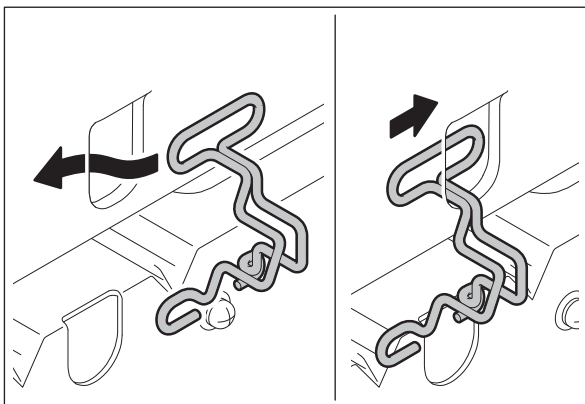

Fig. 7-47

- Hold the stopper jig and insert its lower side into the hole on the frame of the MFP.

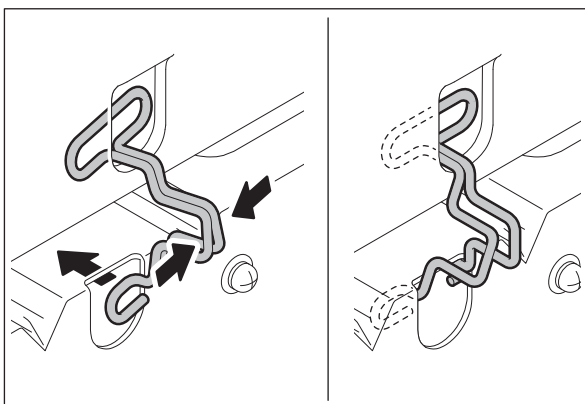

Fig. 7-48

7.11 Grease List

The grease used for the maintenance of this MFP is as follows.

| Symbol | Name | Type | Color | Volume | Container | <P-I>* |
|--------|------------------------------------|-----------------------|-----------------------|--------|-----------|---------|
| L | Launa 40 | Lubricating oil | Yellow or transparent | 100 cc | Oiler | 201-101 |
| W1 | White grease (Molykote EM-30L) | Grease | White | 100 g | Tube | 201-102 |
| W2 | White grease (Molykote HP-300) | Heat-resisting grease | White | 10 g | Bottle | 201-103 |
| AV | Alvania No. 2 | Grease | Amber | 100 g | Tube | 201-104 |
| FL | FLOIL (GE-334C) | Conductive grease | Black | 20 g | Bottle | 201-105 |
| FL2 | Transparent grease (FLOIL G-347CA) | Contact grease | Transparent | 10 g | Bottle | 201-106 |

* "<P-I>" represents the page item in "e-STUDIO6529A/7529A/9029A Service Parts List".

8. ERROR CODE AND TROUBLESHOOTING

8.1 Overview

This chapter explains the procedures for solving troubles occurring in the MFP.

When a trouble occurs, check if an error code is displayed on the LCD screen of the control panel first. If displayed, refer to “8.2Error Code List” to figure out the classification and contents of the error, and then refer to “8.3Analysis from Error Codes” to remove its cause.

When no error is displayed but the MFP does not operate properly or images are not printed properly, refer to “8.4Other Errors” or “8.5Troubleshooting for the Image” to remove its cause.

When troubles have occurred in the MFP, various causes can be considered. Check the items below first.

- Is there any problem with the power cable or an outlet?
Check that the power cable is inserted securely. If it is almost removed or not inserted securely, power voltage may become unstable, causing a trouble in the MFP.
- Are the connectors connected securely?
Reconnect them securely. Even if they are apparently inserted, there may be a contact failure. Carefully check if the connection is secured especially after the disassembly or replacement of parts.
- Are there any abnormalities in the setting value of the self-diagnostic code?
If an abnormal value has been entered in the self-diagnostic code related to the problem, an operation failure may occur. If an abnormal value has been entered in the self-diagnostic code related to the image quality adjustment, defective images may occur. Therefore, check that the proper value has been entered in the self-diagnostic code.
- Are there any similar cases?
Check if there have been any similar problems in the troubleshooting in the Service Manual. If there are similar cases, refer to their troubleshooting.

Notes:

If an unusual odor is detected or if smoke or fire comes out of the MFP, immediately unplug the power cable.

Even in the cases other than the above, fully observe safety precautions.

If any PC board or HDD shall be replaced, refer to the following reference.

 P. 9-27 “9.2 Precautions, Procedures and Settings for Replacing PC Boards and Storage Device”

8.1.1 If a problem continues even after performing all troubleshooting

If a problem continues even after performing all troubleshooting and technical tips, report the problem to the appropriate Toshiba service center along with the following information. This information will help the service center understand your problem and take quick action to find the solution.

1. Serial number
 2. List Print (Refer to the appropriate Service Manual for the detailed procedure to obtain a List Print.)
 - A. Enter the value given below to obtain a List Print by CSV file.
FS-30-300: All CSV files
 - B. Enter the value given below to obtain a List Print by printing it out.
FS-30-101: 05 ADJUSTMENT MODE
FS-30-102: 08 SETTING MODE
FS-30-104: Pixel counter data (Toner cartridge standard)
FS-30-106: Error history (Max.: 1,000 cases)
FS-30-108: Firmware update log (Max.: 200 cases)
FS-30-110: Power on/off log (Max.: 100 cases)
 3. For image-related problems, refer to the reference below.
 - 📖 P. 8-474 “8.5.38 If an image-related problem continues after performing all troubleshooting”
If a problem nevertheless continues to persist, collect image samples with the problem areas and the feeding direction marked first. Then provide information about the type, size, and weight of the paper along with a copy of the print data and spool file causing the problem.
A marking for the feeding direction can be added by the operation of the reference below.
 - 📖 P. 6-30 “6.1.9 Scanning and paper feeding direction instruction patterns superposition function”
 4. For abnormal acoustic noise, describe the situation in as much detail as possible.
 5. For hardware-related problems, provide photos of any broken parts, misfed paper, etc. In case of paper misfeeding, include the type of paper and its manufacturer.
 6. For software-related problems, provide list prints, TopAccess Logs and the detailed procedure needed to duplicate the problem.
- * This is the minimum information required to report a complaint. Any further information will be a help to find out the cause of the problem.
- * Follow the directions of the service center if they request additional information as each issue is unique to some degree.

8.1.2 Collection of debug logs with a USB storage device

[1] Overview

The purpose of collecting the debug logs is to acquire the necessary information to analyze problems which have occurred while the MFP is being operated, by following the procedure below. (Only the problems whose investigation seem to be required)

In such a case, you can collect the debug logs by inserting a USB storage device containing the dedicated script file into the MFP. Even if the power has to be turned OFF and then back ON after a problem occurs, the debug logs will be saved in the MFP (up to 3 logs). If the debug logs have already been saved in the MFP, they also can be collected.

The following information is included in the USB debug logs.

Internal operation, Job history, storage device and memory usage status, etc. Personal/Corporate information (address book) not included

When the debug logs are collected, also do so for the following information since it may be difficult to investigate only using the debug log.

- List print mode [FS-30-300: All CSV files]
 - Job logs below in TopAccess > [Logs] > [Export Logs]
 - Print Job Log Export
 - Fax Transmission Journal Export
 - Fax Reception Journal Export
 - Scan Log Export
 - Message Log Export
 - Problem occurrence timeAlternatively, the time when the user called if it is difficult to work out when it occurred
 - Status of when you collected the debug log
- As in the example below, check the status to know if the problem occurred at the debug log collection or how the user recovered it.
- E.g.: You checked the problem and connected a USB storage device to the MFP.
- E.g.: No problem occurred when an attempt to collect the debug log was made; however, the log may have been collected since the user did turn OFF the power when the problem occurred.

[2] Collection procedure

1. Precautions
 - When collecting a log, be sure to obtain consent from the user in advance.
 - Be sure to get the dedicated script file from the service center.
2. About USB storage devices

Be sure to format the USB storage device with FAT32 beforehand. (Recommend size: 2 GB or more)
3. Advance preparation of collection

Store the dedicated script file to the root directory of the USB storage device.
4. Collection procedure
 - (1) Insert the USB storage device with the dedicated script file stored into the MFP while the power is ON.
 - After the USB storage device is inserted into the MFP, the screen will change.
 - (2) Select [Basic Debug Logs], [All Debug Logs] or [9S-300CSV Print Job List] and then press the [START] button.
 - [9S-300CSV Print Job List] can be selected together with [Basic Debug Logs]. In addition, [9S-300CSV Print Job List] can also be selected together with [All Debug Logs].
 - The log collection of [All Debug Logs] will start automatically if no operation is made for 30 seconds after the screen has been changed.
 - The LED of the MFP starts blinking when the log collection has begun.
 - The panel display will be changed during the log collection depending on the conditions of the MFP. However, the log collection will continue as long as the LED is blinking.

- (3) When the log collection is finished, the beeping sound is heard. After the beeping sound has stopped, remove the USB storage device.
- The MFP will reboot automatically in 10 seconds after a beeping sound.
 - If this has not been done automatically after 30 seconds have passed, reboot the MFP manually.

Notes:

Do not remove the USB storage device while the LED in the MFP is blinking.
 If the LED does not start blinking after the USB storage device is inserted and a few minutes have passed, attempt the procedure from step (1) again.
 If there is no beeping sound after the LED starts blinking (about 20 minutes), attempt the procedure from step (1) again.
 If the USB storage device is inserted when the MFP is not ready, the debug logs cannot be collected.

5. Collected debug logs

- When the collection of the debug logs is completed, the compressed file of the collected logs is stored in the root directory of the USB storage device.

File name:

| | |
|------------------------------|--|
| XXXX.YYYYMMDDHHmmSS | (for [Basic Debug Logs], [All Debug Logs]) |
| XXXX.YYYYMMDDHHmmSS.Defunct | (for [All Debug Logs]) |
| XXXX.YYYYMMDDHHmmSS.PowerOff | (for [All Debug Logs]) |
| XXXX.YYYYMMDDHHmmSS_9S300 | (for [9S-300CSV Print Job List]) |
| XXXX.YYYYMMDDHHmmSS_JobList | (for [9S-300CSV Print Job List]) |
| XXXX.YYYYMMDDHHmmSS.USBLog | (for [Basic Debug Logs], [All Debug Logs], [9S-300CSV Print Job List]) |
| md5sum.txt | (for [Basic Debug Logs], [All Debug Logs], [9S-300CSV Print Job List]) |

(XXXX= Serial number of the MFP, YYYY= year, MM= month, DD= day, HH= hour, mm= minute, SS= second)

- After the debug logs have been collected, be sure to send them to the service center together with a report.

8.1.3 Traceability label

A traceability label with a management No. at the manufacturing printed is attached to some units. If a problem occurs in a unit, report it to the appropriate service center along with the traceability label information to help them to understand it.

[1] Management No.

A management number consists of 13 digits with letters of the alphabet and numbers. The following shows the meaning of each block.

- From the 1st to 4th digits: Classification
- From the 5th to 10th digits: Production date
- From the 11th to 13th digits: Sequential numbers

| Classification | | | | Production date | | | | | | Sequential numbers | | | |
|----------------|---|---|---|-----------------|---|---|---|---|----|--------------------|----|----|----------|
| 1 | 2 | 3 | 4 | 5 | 6 | 7 | 8 | 9 | 10 | 11 | 12 | 13 | (digits) |
| 1 | 2 | 3 | 4 | 1 | 2 | 3 | 4 | 5 | 6 | 1 | 2 | 3 | |

[2] Applicable units

A traceability label is attached to the following units.

| No. | Unit | Remarks |
|-----|--------------------|---------|
| 1 | Scanner | |
| 2 | Fuser | |
| 3 | Duplexing unit | |
| 4 | Laser optical unit | |
| 5 | Developer unit | |
| 6 | Drum cleaner unit | |
| 7 | Main charger | |
| 8 | LGC/PFC board case | |
| 9 | DRV PC board | |
| 10 | CTIF board | |

8.1.4 Detach function

When the ADF or finishers break down, a service call will occur and the MFP goes into an inoperable condition.

In such a case, you can make the MFP operable by electrically detaching the broken-down ADF or finishers. This function is called “detach”.

This function is carried out by having a user press [Detach] when a service call has occurred.

This function is released by setting the following self-diagnostic code after the broken-down ADF or finishers are repaired.

FS-08-9722: Deactivate Cancel

8.2 Error Code List

The following error codes are displayed at the upper right of the screen when the “CLEAR PAPER” or “CALL SERVICE” symbol is blinking.

Remarks:

Elision character of the “Error code display media”

Panl: Control panel

JLog: JobLog (TopAccess Print Log - Scan Log)

ML: Message Log (TopAccess Message Log)

Noti: Notification

CSV: CSV output (List print)

Y: Yes

2nd: An error status has been detected twice (= error code has been determined)

5th: An error status has been detected five times (= error code has been determined)

8.2.1 Paper misfeeding

| Code | Message | Error code display media | | | | |
|---|---|--------------------------|----|----|------|-----|
| | | Panl | JL | ML | Noti | CSV |
| [E010] Paper not reaching the paper exit sensor jam | Paper Ejection Misfeed - Please Clear Paper Path. | - | - | Y | Y | Y |
| [E011] Transfer belt paper-clinging jam | Paper Misfeed in Printer - Please Clear Paper Path. | - | - | Y | Y | Y |
| [E020] Paper stopping at the paper exit sensor jam | Paper Ejection Misfeed - Please Clear Paper Path. | - | - | Y | Y | Y |
| [E030] Power-ON jam | Paper Misfeed in Printer - Please Clear Paper Path. | - | - | Y | Y | Y |
| [E061] Incorrect paper size setting for the 1st drawer jam | Paper Misfeed in Printer - Please Clear Paper Path. | - | - | Y | Y | Y |
| [E062] Incorrect paper size setting for the 2nd drawer jam | Paper Misfeed in Printer - Please Clear Paper Path. | - | - | Y | Y | Y |
| [E063] Incorrect paper size setting for the 3rd drawer jam | Paper Misfeed in Printer - Please Clear Paper Path. | - | - | Y | Y | Y |
| [E064] Incorrect paper size setting for the 4th drawer jam | Paper Misfeed in Printer - Please Clear Paper Path. | - | - | Y | Y | Y |
| [E065] Incorrect paper size setting for the bypass tray jam | Paper Misfeed in Printer - Please Clear Paper Path. | - | - | Y | Y | Y |
| [E090] Image data delay jam | Paper Misfeed in Printer - Please Clear Paper Path. | - | - | Y | Y | Y |
| [E091] Motor-ON time-out jam | Paper Misfeed in Printer - Please Clear Paper Path. | - | - | Y | Y | Y |
| [E0A0] Image transport ready time-out jam | Paper Misfeed in Printer - Please Clear Paper Path. | - | - | Y | Y | Y |
| [E110] ADU paper misfeed jam | Paper Insertion Misfeed - Please Clear Paper Path. | - | - | Y | Y | Y |
| [E120] Bypass tray paper misfeed jam | Paper Insertion Misfeed - Please Clear Paper Path. | - | - | Y | Y | Y |
| [E130] 1st drawer paper misfeed jam | Paper Insertion Misfeed - Please Clear Paper Path. | - | - | Y | Y | Y |
| [E140] 2nd drawer paper misfeed jam | Paper Insertion Misfeed - Please Clear Paper Path. | - | - | Y | Y | Y |
| [E150] 3rd drawer paper misfeed jam | Paper Insertion Misfeed - Please Clear Paper Path. | - | - | Y | Y | Y |
| [E160] 4th drawer paper misfeed jam | Paper Insertion Misfeed - Please Clear Paper Path. | - | - | Y | Y | Y |
| [E180] Ex-LCF 2.5K paper misfeed jam | Paper Insertion Misfeed - Please Clear Paper Path. | - | - | Y | Y | Y |

| Code | Message | Error code display media | | | | |
|--|---|--------------------------|----|----|------|-----|
| | | Panl | JL | ML | Noti | CSV |
| [E190] T-LCF paper misfeed jam | Paper Insertion Misfeed - Please Clear Paper Path. | - | - | Y | Y | Y |
| [E1A0] Ex-LCF 2.0K paper misfeed jam | Paper Insertion Misfeed - Please Clear Paper Path. | - | - | Y | Y | Y |
| [E1B0] Ex-LCF 2.0K paper transport jam | Paper Insertion Misfeed - Please Clear Paper Path. | - | - | Y | Y | Y |
| [E1C0] Ex-LCF 2.0K paper transport jam | Paper Insertion Misfeed - Please Clear Paper Path. | - | - | Y | Y | Y |
| [E1C1] Ex-LCF 2.0K paper transport jam | Paper Insertion Misfeed - Please Clear Paper Path. | - | - | Y | Y | Y |
| [E200] 1st drawer paper transport jam | Paper Misfeed in Printer - Please Clear Paper Path. | - | - | Y | Y | Y |
| [E210] 2nd drawer paper transport jam | Paper Misfeed in Printer - Please Clear Paper Path. | - | - | Y | Y | Y |
| [E220] 2nd drawer paper transport jam | Paper Misfeed in Printer - Please Clear Paper Path. | - | - | Y | Y | Y |
| [E230] 1st drawer paper transport jam | Paper Misfeed in Printer - Please Clear Paper Path. | - | - | Y | Y | Y |
| [E240] 2nd drawer paper transport jam | Paper Misfeed in Printer - Please Clear Paper Path. | - | - | Y | Y | Y |
| [E250] Ex-LCF 2.5K paper transport jam | Paper Misfeed in Printer - Please Clear Paper Path. | - | - | Y | Y | Y |
| [E260] Ex-LCF paper transport jam | Paper Misfeed in Printer - Please Clear Paper Path. | - | - | Y | Y | Y |
| [E261] Ex-LCF 2.5K paper transport jam | Paper Misfeed in Printer - Please Clear Paper Path. | - | - | Y | Y | Y |
| [E270] Bypass tray paper transport jam | Paper Insertion Misfeed - Please Clear Paper Path. | - | - | Y | Y | Y |
| [E290] Ex-LCF paper transport jam | Paper Insertion Misfeed - Please Clear Paper Path. | - | - | Y | Y | Y |
| [E2B0] 1st drawer paper stopping at the registration sensor jam | Paper Insertion Misfeed - Please Clear Paper Path. | - | - | Y | Y | Y |
| [E2B1] 2nd drawer paper stopping at the registration sensor jam | Paper Insertion Misfeed - Please Clear Paper Path. | - | - | Y | Y | Y |
| [E2B2] 3rd drawer paper stopping at the registration sensor jam | Paper Insertion Misfeed - Please Clear Paper Path. | - | - | Y | Y | Y |
| [E2B3] 4th drawer paper stopping at the registration sensor jam | Paper Insertion Misfeed - Please Clear Paper Path. | - | - | Y | Y | Y |
| [E2B4] Bypass tray paper stopping at the registration sensor jam | Paper Insertion Misfeed - Please Clear Paper Path. | - | - | Y | Y | Y |
| [E2B5] T-LCF paper stopping at the registration sensor jam | Paper Insertion Misfeed - Please Clear Paper Path. | - | - | Y | Y | Y |
| [E2B6] ADU paper stopping at the registration sensor jam | Paper Insertion Misfeed - Please Clear Paper Path. | - | - | Y | Y | Y |
| [E2B7] Ex-LCF paper stopping at the registration sensor jam | Paper Insertion Misfeed - Please Clear Paper Path. | - | - | Y | Y | Y |
| [E2B8] Ex-LCF paper stopping at the registration sensor jam | Paper Insertion Misfeed - Please Clear Paper Path. | - | - | Y | Y | Y |
| [E300] 3rd drawer paper transport jam | Paper Misfeed in Printer - Please Clear Paper Path. | - | - | Y | Y | Y |
| [E310] 3rd drawer paper transport jam | Paper Misfeed in Printer - Please Clear Paper Path. | - | - | Y | Y | Y |
| [E320] 3rd drawer paper transport jam | Paper Misfeed in Printer - Please Clear Paper Path. | - | - | Y | Y | Y |
| [E330] 4th drawer paper transport jam | Paper Misfeed in Printer - Please Clear Paper Path. | - | - | Y | Y | Y |

| Code | Message | Error code display media | | | | |
|--|--|--------------------------|----|----|------|-----|
| | | Panl | JL | ML | Noti | CSV |
| [E340] 4th drawer paper transport jam | Paper Misfeed in Printer - Please Clear Paper Path. | - | - | Y | Y | Y |
| [E350] 4th drawer paper transport jam | Paper Misfeed in Printer - Please Clear Paper Path. | - | - | Y | Y | Y |
| [E360] 4th drawer paper transport jam | Paper Misfeed in Printer - Please Clear Paper Path. | - | - | Y | Y | Y |
| [E370] 3rd drawer paper transport jam | Paper Misfeed in Printer - Please Clear Paper Path. | - | - | Y | Y | Y |
| [E380] 4th drawer paper transport jam | Paper Misfeed in Printer - Please Clear Paper Path. | - | - | Y | Y | Y |
| [E3C0] T-LCF paper transport jam | Paper Misfeed in Printer - Please Clear Paper Path. | - | - | Y | Y | Y |
| [E3D0] T-LCF paper transport jam | Paper Misfeed in Printer - Please Clear Paper Path. | - | - | Y | Y | Y |
| [E3E0] T-LCF paper transport jam | Paper Misfeed in Printer - Please Clear Paper Path. | - | - | Y | Y | Y |
| [E3F0] T-LCF paper transport jam | Paper Misfeed in Printer - Please Clear Paper Path. | - | - | Y | Y | Y |
| [E400] Duplexing unit open jam | Paper Misfeed in Printer - Please Clear Paper Path. | - | - | Y | Y | Y |
| [E430] Duplexing unit cover open jam | Paper Misfeed in Printer - Please Clear Paper Path. | - | - | Y | Y | Y |
| [E440] Paper feed cover open jam | Paper Misfeed in Printer - Please Clear Paper Path. | - | - | Y | Y | Y |
| [E450] Ex-LCF open jam | Paper Misfeed in Printer - Please Clear Paper Path. | - | - | Y | Y | Y |
| [E480] Bridge unit open jam | Paper Misfeed in Printer - Please Clear Paper Path. | - | - | Y | Y | Y |
| [E4A0] Waste toner cover open jam | Paper Misfeed in Printer - Please Clear Paper Path. | - | - | Y | Y | Y |
| [E4B0] Reverse path cover open jam | Paper Misfeed in Printer - Please Clear Paper Path. | - | - | Y | Y | Y |
| [E4C1] Ex-LCF 2.0K open jam | Paper Misfeed in Printer - Please Clear Paper Path. | - | - | Y | Y | Y |
| [E4C2] LCF Connector cover open jam | Paper Misfeed in Printer - Please Clear Paper Path. | - | - | Y | Y | Y |
| [E510] ADU paper transport jam | Paper Misfeed in Automatic Duplexing Unit - Please Clear Paper Path. | - | - | Y | Y | Y |
| [E511] ADU paper transport jam | Paper Misfeed in Automatic Duplexing Unit - Please Clear Paper Path. | - | - | Y | Y | Y |
| [E540] ADU paper transport jam | Paper Misfeed in Automatic Duplexing Unit - Please Clear Paper Path. | - | - | Y | Y | Y |
| [E550] Paper remaining jam on the transport path | Paper Misfeed in Printer - Please Clear Paper Path. | - | - | Y | Y | Y |
| [E551] Paper remaining jam on the transport path (after a service call has occurred) | [Error] Paper Misfeed in the engine. Please clear paper path | - | - | Y | Y | Y |
| [E552] Paper remaining jam on the transport path (when the cover is closed) | [Error] Paper Misfeed in the engine. Please clear paper path | - | - | Y | Y | Y |
| [E570] Paper not reaching the bridge unit jam | Paper Misfeed in Printer - Please Clear Paper Path. | - | - | Y | Y | Y |
| [E580] Paper stopping at the bridge unit jam | Paper Misfeed in Printer - Please Clear Paper Path. | - | - | Y | Y | Y |
| [E590] Paper stopping at the upper paper exit sensor jam | Paper Misfeed in Printer - Please Clear Paper Path. | - | - | Y | Y | Y |

| Code | Message | Error code display media | | | | |
|---|---|--------------------------|----|----|------|-----|
| | | Panl | JL | ML | Noti | CSV |
| [E5A0] Paper not reaching the upper paper exit sensor jam | Paper Misfeed in Printer - Please Clear Paper Path. | - | - | Y | Y | Y |
| [E703] DSDf multiple feeding jam | Paper Misfeed in Automatic Document Feeder - Please Clear Paper Path. | - | - | Y | - | Y |
| [E712] Original not reaching the DSDf registration sensor jam | Paper Misfeed in Automatic Document Feeder - Please Clear Paper Path. | - | - | Y | - | Y |
| [E714] Paper feed signal reception jam in DSDf | Paper Misfeed in Automatic Document Feeder - Please Clear Paper Path. | - | - | Y | - | Y |
| [E717] Original not reaching the DSDf original feed sensor jam | Paper Misfeed in Automatic Document Feeder - Please Clear Paper Path. | - | - | Y | - | Y |
| [E718] Original setting jam, original tray lift abnormality | Paper Misfeed in Automatic Document Feeder - Please Clear Paper Path. | - | - | Y | - | Y |
| [E721] Original not reaching the DSDf read-in sensor-1 jam | Paper Misfeed in Automatic Document Feeder - Please Clear Paper Path. | - | - | Y | - | Y |
| [E722] Original not reaching the DSDf original exit sensor jam | Paper Misfeed in Automatic Document Feeder - Please Clear Paper Path. | - | - | Y | - | Y |
| [E724] Original stopping at the DSDf registration sensor jam | Paper Misfeed in Automatic Document Feeder - Please Clear Paper Path. | - | - | Y | - | Y |
| [E725] Original stopping at the DSDf read-in sensor-1 jam | Paper Misfeed in Automatic Document Feeder - Please Clear Paper Path. | - | - | Y | - | Y |
| [E726] DSDf transport or paper exit signal reception jam | Paper Misfeed in Automatic Document Feeder - Please Clear Paper Path. | - | - | Y | - | Y |
| [E727] Original not reaching the DSDf read-in sensor-2 jam | Paper Misfeed in Automatic Document Feeder - Please Clear Paper Path. | - | - | Y | - | Y |
| [E729] Original stopping at the DSDf read-in sensor-2 jam | Paper Misfeed in Automatic Document Feeder - Please Clear Paper Path. | - | - | Y | - | Y |
| [E731] Original stopping at the DSDf original exit sensor jam | Paper Misfeed in Automatic Document Feeder - Please Clear Paper Path. | - | - | Y | - | Y |
| [E762] Original remaining at the DSDf registration sensor jam | Paper Misfeed in Automatic Document Feeder - Please Clear Paper Path. | - | - | Y | - | Y |
| [E769] Original remaining at the DSDf original feed sensor jam | Paper Misfeed in Automatic Document Feeder - Please Clear Paper Path. | - | - | Y | - | Y |
| [E770] Original remaining at the DSDf original width detection sensor-1 jam | Paper Misfeed in Automatic Document Feeder - Please Clear Paper Path. | - | - | Y | - | Y |
| [E771] Original remaining at the DSDf original width detection sensor-2 jam | Paper Misfeed in Automatic Document Feeder - Please Clear Paper Path. | - | - | Y | - | Y |
| [E774] Original remaining at the DSDf read-in sensor-1 jam | Paper Misfeed in Automatic Document Feeder - Please Clear Paper Path. | - | - | Y | - | Y |
| [E775] Original remaining at the DSDf read-in sensor-2 jam | Paper Misfeed in Automatic Document Feeder - Please Clear Paper Path. | - | - | Y | - | Y |

| Code | Message | Error code display media | | | | |
|---|---|--------------------------|----|----|------|-----|
| | | Panl | JL | ML | Noti | CSV |
| [E777] Original remaining at the DSDF original exit sensor jam | Paper Misfeed in Automatic Document Feeder - Please Clear Paper Path. | - | - | Y | - | Y |
| [E860] DSDF original jam access cover open jam, DSDF shading sheet HP sensor abnormality | Paper Misfeed in Automatic Document Feeder - Please Clear Paper Path. | - | - | Y | - | Y |
| [E870] DSDF open jam | Paper Misfeed in Automatic Document Feeder - Please Clear Paper Path. | - | - | Y | - | Y |
| [E910] Paper not reaching the bridge unit path entrance sensor jam | Paper Misfeed in Printer - Please Clear Paper Path. | Y | - | Y | Y | Y |
| [E920] Paper stopping at the bridge unit path entrance sensor jam | Paper Misfeed in Printer - Please Clear Paper Path. | Y | - | Y | Y | Y |
| [E930] Paper not reaching the bridge unit path exit sensor jam | Paper Misfeed in Printer - Please Clear Paper Path. | Y | - | Y | Y | Y |
| [E940] Paper stopping at the bridge unit path exit sensor jam | Paper Misfeed in Printer - Please Clear Paper Path. | Y | - | Y | Y | Y |
| [E970] Paper not reaching the lower paper exit sensor jam | Paper Misfeed in Printer - Please Clear Paper Path. | Y | - | Y | Y | Y |
| [E980] Paper stopping at the lower paper exit sensor jam | Paper Misfeed in Printer - Please Clear Paper Path. | Y | - | Y | Y | Y |
| [E9F0] Punching jam (Finisher, Saddle Stitch Finisher) | Hole Punch Unit Misfeed in Finisher - Please Clear Hole Punch. | Y | - | Y | Y | Y |
| [EA10] Paper transport delay jam (Finisher, Saddle Stitch Finisher) | Paper Misfeed in Finisher - Please Clear Paper Path. | Y | - | Y | Y | Y |
| [EA20] Paper transport stop jam (Finisher, Saddle Stitch Finisher) | Paper Misfeed in Finisher - Please Clear Paper Path. | Y | - | Y | Y | Y |
| [EA21] Paper size error jam (Finisher, Saddle Stitch Finisher) | Paper Misfeed in Finisher - Please Clear Paper Path. | Y | - | Y | Y | Y |
| [EA22] Hole punch unit paper size error jam (Finisher, Saddle Stitch Finisher) | Paper Misfeed in Finisher - Please Clear Paper Path. | - | - | Y | Y | Y |
| [EA23] Paper transport stop jam (Finisher, Saddle Stitch Finisher) | Paper Misfeed in Finisher - Please Clear Paper Path. | - | - | Y | Y | Y |
| [EA24] Paper transport delay jam (Finisher, Saddle Stitch Finisher) | Paper Misfeed in Finisher - Please Clear Paper Path. | - | - | Y | Y | Y |
| [EA25] Paper transport delay jam after the paper stack has exited (Finisher, Saddle Stitch Finisher) | Paper Misfeed in Finisher - Please Clear Paper Path. | - | - | Y | Y | Y |
| [EA26] Paper transport stop jam due to a stop signal from the MFP (Finisher, Saddle Stitch Finisher) | Paper Misfeed in Finisher - Please Clear Paper Path. | - | - | Y | Y | Y |
| [EA27] Paper transport stop jam (Finisher, Saddle Stitch Finisher) | Paper Misfeed in Finisher - Please Clear Paper Path. | - | - | Y | Y | Y |
| [EA28] Paper transport stop jam due to an assist guide plate operation delay (Finisher, Saddle Stitch Finisher) | Paper Misfeed in Finisher - Please Clear Paper Path. | - | - | Y | Y | Y |
| [EA29] Paper transport stop jam due to a stack transport operation delay (Finisher, Saddle Stitch Finisher) | Paper Misfeed in Finisher - Please Clear Paper Path. | - | - | Y | Y | Y |
| [EA31] Transport path paper remaining jam (Finisher, Saddle Stitch Finisher) | Paper Misfeed in Finisher - Please Clear Paper Path. | - | - | Y | Y | Y |
| [EA32] Exit paper remaining jam (Finisher, Saddle Stitch Finisher) | Paper Misfeed in Finisher - Please Clear Paper Path. | Y | - | Y | Y | Y |
| [EA40] Stationary tray open jam (Finisher, Saddle Stitch Finisher) | Paper Misfeed in Finisher - Please Clear Paper Path. | Y | - | Y | Y | Y |
| [EA41] Front upper cover open jam (Finisher, Saddle Stitch Finisher) | Paper Misfeed in Finisher - Please Clear Paper Path. | Y | - | Y | Y | Y |

| Code | Message | Error code display media | | | | |
|---|--|--------------------------|----|----|------|-----|
| | | Panl | JL | ML | Noti | CSV |
| [EA42] Hole punch: Front cover open jam (Finisher, Saddle Stitch Finisher) | Paper Misfeed in Finisher - Please Clear Paper Path. | Y | - | Y | Y | Y |
| [EA50] Stapling jam (Finisher, Saddle Stitch Finisher) | Staple Jam in Finisher - Please Clear Staple. | Y | - | Y | Y | Y |
| [EA60] Paper early arrival jam (Finisher, Saddle Stitch Finisher) | Paper Misfeed in Finisher - Please Clear Paper Path. | Y | - | Y | Y | Y |
| [EA70] Stack exit belt home position error (Finisher, Saddle Stitch Finisher) | Paper Misfeed in Finisher - Please Clear Paper Path. | Y | - | Y | Y | Y |
| [EA90] Front lower open jam (Saddle Stitch Finisher) | Paper Misfeed in Finisher - Please Clear Paper Path. | Y | - | Y | Y | Y |
| [EAA0] Paper remaining jam in the saddle stitch unit (Saddle Stitch Finisher) | Paper Misfeed in Finisher - Please Clear Paper Path. | Y | - | Y | Y | Y |
| [EAB0] Paper transport jam in the saddle stitch unit (Saddle Stitch Finisher) | Paper Misfeed in Finisher - Please Clear Paper Path. | Y | - | Y | Y | Y |
| [EAB1] Paper size error jam (Saddle Stitch Finisher) | Paper Misfeed in Finisher - Please Clear Paper Path. | Y | - | Y | Y | Y |
| [EAD0] Print end command time-out error | Paper Misfeed in Printer - Please Clear Paper Path. | - | - | Y | Y | Y |
| [EAE0] Finisher receiving time-out jam | Paper Misfeed in Printer - Please Clear Paper Path. | - | - | Y | Y | Y |
| [EAE1] Finisher receiving time-out jam (1) | Paper Misfeed in Printer - Please Clear Paper Path. | - | - | Y | Y | Y |
| [EAE2] Finisher receiving time-out jam (2) | Paper Misfeed in Printer - Please Clear Paper Path. | - | - | Y | Y | Y |
| [EAE3] Finisher receiving time-out jam (3) | Paper Misfeed in Printer - Please Clear Paper Path. | - | - | Y | Y | Y |
| [EAE4] Finisher receiving time-out jam (4) | Paper Misfeed in Printer - Please Clear Paper Path. | - | - | Y | Y | Y |
| [EAE5] Finisher receiving time-out jam (5) | Paper Misfeed in Printer - Please Clear Paper Path. | - | - | Y | Y | Y |
| [EAE6] Finisher receiving time-out jam (6) | Paper Misfeed in Printer - Please Clear Paper Path. | - | - | Y | Y | Y |
| [EAE7] Finisher receiving time-out jam (7) | Paper Misfeed in Printer - Please Clear Paper Path. | - | - | Y | Y | Y |
| [EAE8] Finisher receiving time-out jam (8) | Paper Misfeed in Printer - Please Clear Paper Path. | - | - | Y | Y | Y |
| [EAE9] Finisher receiving time-out jam (9) | Paper Misfeed in Printer - Please Clear Paper Path. | - | - | Y | Y | Y |
| [EAEA] Finisher receiving time-out jam (10) | Paper Misfeed in Printer - Please Clear Paper Path. | - | - | Y | Y | Y |
| [EAEB] Finisher receiving time-out jam (11) | Paper Misfeed in Finisher - Please Clear Paper Path. | - | - | Y | Y | Y |
| [EAEC] Finisher receiving time-out jam (12) | Paper Misfeed in Printer - Please Clear Paper Path. | - | - | Y | Y | Y |
| [EAED] Finisher receiving time-out jam (13) | Paper Misfeed in Printer - Please Clear Paper Path. | - | - | Y | Y | Y |
| [EAEF] Finisher receiving time-out jam (15) | Paper Misfeed in Printer - Please Clear Paper Path. | - | - | Y | Y | Y |
| [EAFA] Catching motor home position sensor detection abnormality | Paper Misfeed in Finisher - Please Clear Paper Path. | Y | - | Y | Y | Y |
| [EAFB] Stapler movement abnormality (Finisher, Saddle Stitch Finisher) | Paper Misfeed in Finisher - Please Clear Paper Path. | Y | - | Y | Y | Y |
| [EAFD] Movable tray height abnormality (Finisher, Saddle Stitch Finisher) | Paper Misfeed in Finisher - Please Clear Paper Path. | Y | - | Y | Y | Y |
| [EAFD] Movable tray movement abnormality (Finisher, Saddle Stitch Finisher) | Paper Misfeed in Finisher - Please Clear Paper Path. | Y | - | Y | Y | Y |

| Code | Message | Error code display media | | | | |
|---|--|--------------------------|----|----|------|-----|
| | | Panl | JL | ML | Noti | CSV |
| [EAFE] Assist guide cam position abnormality (Finisher, Saddle Stitch Finisher) | Paper Misfeed in Finisher - Please Clear Paper Path. | Y | - | Y | Y | Y |
| [EB30] Ready time-out jam | Paper Misfeed in Printer - Please Clear Paper Path. | - | - | Y | Y | Y |
| [EB50] Paper remaining on the transport path jam due to multiple feeding | Paper Misfeed in Printer - Please Clear Paper Path. | - | - | Y | Y | Y |
| [EB60] Paper remaining on the transport path jam due to multiple feeding | Paper Misfeed in Printer - Please Clear Paper Path. | - | - | Y | Y | Y |
| [ED10] Hole punch: Skew adjustment motor home position detection abnormality (Finisher, Saddle Stitch Finisher) | Paper Misfeed in Finisher - Please Clear Paper Path. | Y | - | Y | Y | Y |
| [ED11] Hole punch: Sideways deviation adjustment motor home position detection abnormality (Finisher, Saddle Stitch Finisher) | Paper Misfeed in Finisher - Please Clear Paper Path. | Y | - | Y | Y | Y |
| [ED13] Front alignment plate home position abnormality (Finisher, Saddle Stitch Finisher) | Paper Misfeed in Finisher - Please Clear Paper Path. | Y | - | Y | Y | Y |
| [ED14] Rear alignment plate home position abnormality (Finisher, Saddle Stitch Finisher) | Paper Misfeed in Finisher - Please Clear Paper Path. | Y | - | Y | Y | Y |
| [ED15] Paddle home position abnormality (Finisher, Saddle Stitch Finisher) | Paper Misfeed in Finisher - Please Clear Paper Path. | Y | - | Y | Y | Y |
| [ED16] Buffer tray home position abnormality (Finisher, Saddle Stitch Finisher) | Paper Misfeed in Finisher - Please Clear Paper Path. | Y | - | Y | Y | Y |
| [EF10] Saddle stitch setting of unsupported paper (Saddle Stitch Finisher) | Paper Misfeed in Finisher - Please Clear Paper Path. | Y | - | Y | Y | Y |
| [EF11] Front saddle stitch stapling jam (Saddle Stitch Finisher) | Paper Misfeed in Finisher - Please Clear Paper Path. | Y | - | Y | Y | Y |
| [EF12] Rear saddle stitch stapling jam (Saddle Stitch Finisher) | Paper Misfeed in Finisher - Please Clear Paper Path. | Y | - | Y | Y | Y |
| [EF13] Saddle stitch paper holding home position abnormality (Saddle Stitch Finisher) | Paper Misfeed in Finisher - Please Clear Paper Path. | Y | - | Y | Y | Y |
| [EF14] Saddle stitch paper ejection jam (Saddle Stitch Finisher) | Paper Misfeed in Finisher - Please Clear Paper Path. | Y | - | Y | Y | Y |
| [EF15] Saddle stitch side alignment plate home position sensor abnormality (Saddle Stitch Finisher) | Paper Misfeed in Finisher - Please Clear Paper Path. | Y | - | Y | Y | Y |
| [EF16] Saddle stitch stacker motor home position abnormality (Saddle Stitch Finisher) | Paper Misfeed in Finisher - Please Clear Paper Path. | Y | - | Y | Y | Y |
| [EF17] Saddle stitch folding blade home position abnormality (Saddle Stitch Finisher) | Paper Misfeed in Finisher - Please Clear Paper Path. | Y | - | Y | Y | Y |
| [EF18] Saddle stitch additional folding roller home position abnormality (Saddle Stitch Finisher) | Paper Misfeed in Finisher - Please Clear Paper Path. | Y | - | Y | Y | Y |
| [EF19] Saddle stitch paper folding jam (Saddle Stitch Finisher) | Paper Misfeed in Finisher - Please Clear Paper Path. | Y | - | Y | Y | Y |
| [EF20] Saddle stitch stacker jam (Saddle Stitch Finisher) | Paper Misfeed in Finisher - Please Clear Paper Path. | - | - | Y | Y | Y |
| [EF21] Hole punch: Paper leading edge skew detection abnormality (Finisher, Saddle Stitch Finisher) | Paper Misfeed in Finisher - Please Clear Paper Path. | - | - | Y | Y | Y |

| Code | Message | Error code display media | | | | |
|--|--|--------------------------|----|----|------|-----|
| | | PanI | JL | ML | Noti | CSV |
| [EF22] Hole punch: Paper leading edge detection abnormality (Finisher, Saddle Stitch Finisher) | Paper Misfeed in Finisher - Please Clear Paper Path. | - | - | Y | Y | Y |
| [EF23] Hole punch: Paper position alignment abnormality (Finisher, Saddle Stitch Finisher) | Paper Misfeed in Finisher - Please Clear Paper Path. | - | - | Y | Y | Y |
| [EF24] Hole punch: Paper trailing edge skew detection abnormality (Finisher, Saddle Stitch Finisher) | Paper Misfeed in Finisher - Please Clear Paper Path. | - | - | Y | Y | Y |
| [EF25] Hole punch: Paper trailing edge detection abnormality (Finisher, Saddle Stitch Finisher) | Paper Misfeed in Finisher - Please Clear Paper Path. | - | - | Y | Y | Y |
| [EF27] Hole punch: Paper edge detection abnormality 1 (Finisher, Saddle Stitch Finisher) | Paper Misfeed in Finisher - Please Clear Paper Path. | - | - | Y | Y | Y |
| [EF28] Hole punch: Paper edge detection abnormality 2 (Finisher, Saddle Stitch Finisher) | Paper Misfeed in Finisher - Please Clear Paper Path. | - | - | Y | Y | Y |
| [EF29] Hole punch: Required performance abnormality (Finisher, Saddle Stitch Finisher) | Paper Misfeed in Finisher - Please Clear Paper Path. | - | - | Y | Y | Y |

8.2.2 Service call

| Code | Message | Error code display media | | | | |
|--|--|--------------------------|----|----|------|-----|
| | | Panl | JL | ML | Noti | CSV |
| [C010] Drum motor locking error | Fatal Error - Please Contact Service Technician. | 2nd | - | Y | Y | Y |
| [C023] Developer unit motor (K) locking error | Fatal Error - Please Contact Service Technician. | Y | - | Y | Y | Y |
| [C024] Developer unit mixer motor (K) locking error | Fatal Error - Please Contact Service Technician. | Y | - | Y | Y | Y |
| [C130] 1st drawer tray abnormality | Printer Input Error. | Y | - | Y | Y | Y |
| [C140] 2nd drawer tray abnormality | Printer Input Error. | Y | - | Y | Y | Y |
| [C150] 3rd drawer tray abnormality | Printer Input Error. | Y | - | Y | Y | Y |
| [C160] 4th drawer tray abnormality | Printer Input Error. | Y | - | Y | Y | Y |
| [C180] T-LCF tray abnormality | Printer Input Error. | Y | - | Y | Y | Y |
| [C1A0] T-LCF end fence abnormality | Printer Input Error. | Y | - | Y | Y | Y |
| [C1C0] Ex-LCF 2.5K tray motor abnormality | Printer Input Error. | Y | - | Y | Y | Y |
| [C1E0] Ex-LCF 2.0K tray motor abnormality | Printer Input Error. | Y | - | Y | Y | Y |
| [C252] EEPROM communication error | Fatal Error - Please Contact Service Technician. | 2nd | - | Y | Y | Y |
| [C253] EEPROM reading error | Fatal Error - Please Contact Service Technician. | 2nd | - | Y | Y | Y |
| [C254] ASIC communication error | Fatal Error - Please Contact Service Technician. | 2nd | - | Y | Y | Y |
| [C260] Peak detection error | Fatal Error - Please Contact Service Technician. | 2nd | - | Y | Y | Y |
| [C262] Communication error | Fatal Error - Please Contact Service Technician. | 2nd | - | Y | Y | Y |
| [C270] Carriage home position sensor not turning OFF within a specified period of time, Downloading firmware with an incorrect model | Fatal Error - Please Contact Service Technician. | Y | - | Y | Y | Y |
| [C280] Carriage home position sensor not turned ON within a specified period of time | Fatal Error - Please Contact Service Technician. | Y | - | Y | Y | Y |
| [C290] Scanner power supply abnormality | Fatal Error - Please Contact Service Technician. | 2nd | - | Y | Y | Y |
| [C360] Needle electrode cleaner abnormality | Fatal Error - Please Contact Service Technician. | 2nd | - | Y | Y | Y |
| [C380] Developer material (K) toner density lower limit abnormality | Fatal Error - Please Contact Service Technician. | 2nd | - | Y | Y | Y |
| [C381] Developer material (K) toner density upper limit abnormality | Fatal Error - Please Contact Service Technician. | 2nd | - | Y | Y | Y |
| [C382] Auto-toner sensor (K) connection abnormality | Fatal Error - Please Contact Service Technician. | 2nd | - | Y | Y | Y |
| [C3C0] Process unit (EPU tray) connection abnormality | Fatal Error - Please Contact Service Technician. | 2nd | - | Y | Y | Y |
| [C440] Fusing temperature abnormality (low temperature WAIT control abnormality at printing status) | Fatal Error - Please Contact Service Technician. | Y | - | Y | Y | Y |
| [C445] Fusing temperature abnormality (pre-running end temperature abnormality) | Fatal Error - Please Contact Service Technician. | Y | - | Y | Y | Y |
| [C446] Fusing temperature abnormality (pre-running end temperature abnormality) | Fatal Error - Please Contact Service Technician. | Y | - | Y | Y | Y |
| [C447] Fusing temperature abnormality (temperature abnormality at ready status and during printing) | Fatal Error - Please Contact Service Technician. | Y | - | Y | Y | Y |

| Code | Message | Error code display media | | | | |
|--|--|--------------------------|----|----|------|-----|
| | | Panl | JL | ML | Noti | CSV |
| [C449] Fusing temperature abnormality (high temperature abnormality) | Fatal Error - Please Contact Service Technician. | Y | - | Y | Y | Y |
| [C471] IH board initialization abnormality | Fatal Error - Please Contact Service Technician. | 2nd | - | Y | Y | Y |
| [C472] No power supply | Fatal Error - Please Contact Service Technician. | Y | - | Y | Y | Y |
| [C473] Power voltage upper limit abnormality | Fatal Error - Please Contact Service Technician. | 2nd | - | Y | Y | Y |
| [C474] Power voltage lower limit abnormality | Fatal Error - Please Contact Service Technician. | 2nd | - | Y | Y | Y |
| [C480] IGBT high temperature abnormality | Fatal Error - Please Contact Service Technician. | 2nd | - | Y | Y | Y |
| [C4B0] Status counter abnormality | Fatal Error - Please Contact Service Technician. | Y | - | Y | Y | Y |
| [C4B1] Fuser unit power voltage identification abnormality | Fatal Error - Please Contact Service Technician. | 2nd | - | Y | Y | Y |
| [C4B2] IH firmware combination error | Fatal Error - Please Contact Service Technician. | 2nd | - | Y | Y | Y |
| [C4E0] Pressure roller release abnormality | Fatal Error - Please Contact Service Technician. | 2nd | - | Y | Y | Y |
| [C4E1] Pressure roller contact and semi-contact abnormality | Fatal Error - Please Contact Service Technician. | 2nd | - | Y | Y | Y |
| [C4E2] Fuser belt rotation detection sensor abnormality | Fatal Error - Please Contact Service Technician. | 2nd | - | Y | Y | Y |
| [C550] Communication error between the scanner and the DF | Fatal Error - Please Contact Service Technician. | 5th | - | Y | Y | Y |
| [C551] DF model detection abnormality | Fatal Error - Please Contact Service Technician. | Y | - | Y | Y | Y |
| [C552] DF abnormality | Fatal Error - Please Contact Service Technician. | 5th | - | Y | Y | Y |
| [C553] DSDf-CCD module peak detection abnormality | Fatal Error - Please Contact Service Technician. | 5th | - | Y | Y | Y |
| [C554] AFE communication error | Fatal Error - Please Contact Service Technician. | 5th | - | Y | Y | Y |
| [C55A] Multiple feeding detection sensor connection abnormality | Fatal Error - Please Contact Service Technician. | 5th | - | Y | Y | Y |
| [C55B] Multiple feeding detection sensor abnormality | Fatal Error - Please Contact Service Technician. | 5th | - | Y | Y | Y |
| [C560] Communication error between engine-CPU and PFC board | Fatal Error - Please Contact Service Technician. | 5th | - | Y | Y | Y |
| [C580] Communication error between the LGC board and the Finisher | Printer Output Error. | 5th | - | Y | Y | Y |
| [C5A0] EEPROM communication abnormality (LGC board) | Fatal Error - Please Contact Service Technician. | Y | - | Y | Y | Y |
| [C5A1] EEPROM data abnormality (LGC board) | Fatal Error - Please Contact Service Technician. | Y | - | Y | Y | Y |
| [C5A8] Sub EEPROM communication abnormality | Fatal Error - Please Contact Service Technician. | Y | - | Y | Y | Y |
| [C5A9] Sub EEPROM data abnormality | Fatal Error - Please Contact Service Technician. | Y | - | Y | Y | Y |
| [C730] DSDf EEPROM writing abnormality | Automatic Document Feeder Error - Please Contact Service Technician. | 2nd | - | Y | Y | Y |
| [C7B0] Initialization performance abnormality | Automatic Document Feeder Error - Please Contact Service Technician. | 5th | - | Y | Y | Y |

| Code | Message | Error code display media | | | | |
|--|--|--------------------------|----|----|------|-----|
| | | Panl | JL | ML | Noti | CSV |
| [C8C0] DSDF read-in sensor-1 automatic adjustment abnormality | Automatic Document Feeder Error - Please Contact Service Technician. | 2nd | - | Y | Y | Y |
| [C8E0] DF communication protocol abnormality | Automatic Document Feeder Error - Please Contact Service Technician. | 5th | - | Y | Y | Y |
| [C911] CTIF board access abnormality (K) | Failed to access to the toner IC chip | - | - | Y | Y | Y |
| [C916] Sub-CPU abnormality | Fatal Error - Please Contact Service Technician. | 2nd | - | Y | Y | Y |
| [C940] Engine-CPU abnormality | Fatal Error - Please Contact Service Technician. | 2nd | - | Y | Y | Y |
| [C963] Connection detection abnormality between the SYS board and the LGC board | [Error] Printer Needs Attention: Call for service | 2nd | - | Y | Y | Y |
| [C970] High-voltage transformer leakage abnormality | Fatal Error - Please Contact Service Technician. | 2nd | - | Y | Y | Y |
| [CA10] Polygonal motor abnormality | Fatal Error - Please Contact Service Technician. | 2nd | - | Y | Y | Y |
| [CA20] H-Sync detection error | Fatal Error - Please Contact Service Technician. | 2nd | - | Y | Y | Y |
| [CB00] Finisher communication error (Finisher, Saddle Stitch Finisher) | Printer Output Error. | 2nd | - | Y | Y | Y |
| [CB10] Entrance motor abnormality (Finisher, Saddle Stitch Finisher) | Printer Output Error. | 2nd | - | Y | Y | Y |
| [CB11] Buffer tray guide motor abnormality (Finisher, Saddle Stitch Finisher) | Fatal Error - Please Contact Service Technician. | 5th | - | Y | Y | Y |
| [CB14] Assist guide motor abnormality (Finisher, Saddle Stitch Finisher) | Fatal Error - Please Contact Service Technician. | 5th | - | Y | Y | Y |
| [CB15] Catching motor abnormality (Finisher, Saddle Stitch Finisher) | Fatal Error - Please Contact Service Technician. | 5th | - | Y | Y | Y |
| [CB30] Movable tray shift motor abnormality (Finisher, Saddle Stitch Finisher) | Printer Output Error. | 2nd | - | Y | Y | Y |
| [CB31] Movable tray movement abnormality (Finisher, Saddle Stitch Finisher) | Fatal Error - Please Contact Service Technician. | 5th | - | Y | Y | Y |
| [CB40] Front alignment motor abnormality (Finisher, Saddle Stitch Finisher) | Printer Output Error. | 5th | - | Y | Y | Y |
| [CB50] Stapler home position abnormality (Finisher, Saddle Stitch Finisher) | Printer Output Error. | 5th | - | Y | Y | Y |
| [CB51] Stapler movement home position abnormality (Finisher, Saddle Stitch Finisher) | Fatal Error - Please Contact Service Technician. | 5th | - | Y | Y | Y |
| [CB60] Stapler unit shift motor abnormality (Finisher, Saddle Stitch Finisher) | Printer Output Error. | 5th | - | Y | Y | Y |
| [CB80] Finisher backup RAM data abnormality (Finisher, Saddle Stitch Finisher) | Printer Output Error. | 2nd | - | Y | Y | Y |
| [CB81] Finisher Flash ROM data abnormality (Finisher, Saddle Stitch Finisher) | Fatal Error - Please Contact Service Technician. | 2nd | - | Y | Y | Y |
| [CB82] Finisher main program error (Finisher, Saddle Stitch Finisher) | Fatal Error - Please Contact Service Technician. | 2nd | - | Y | Y | Y |
| [CB84] Hole punch: Punch main program error (Finisher, Saddle Stitch Finisher) | Fatal Error - Please Contact Service Technician. | 2nd | - | Y | Y | Y |
| [CB93] Saddle additional folding motor abnormality (Saddle Stitch Finisher) | Fatal Error - Please Contact Service Technician. | 5th | - | Y | Y | Y |

| Code | Message | Error code display media | | | | |
|---|--|--------------------------|----|----|------|-----|
| | | Panel | JL | ML | Noti | CSV |
| [CB94] Saddle transport motor abnormality (Saddle Stitch Finisher) | Fatal Error - Please Contact Service Technician. | 5th | - | Y | Y | Y |
| [CB95] Stacker motor abnormality (Saddle Stitch Finisher) | Fatal Error - Please Contact Service Technician. | 5th | - | Y | Y | Y |
| [CBA0] Front saddle stapler home position abnormality (Saddle Stitch Finisher) | Fatal Error - Please Contact Service Technician. | 5th | - | Y | Y | Y |
| [CBB0] Rear saddle stapler home position abnormality (Saddle Stitch Finisher) | Fatal Error - Please Contact Service Technician. | 5th | - | Y | Y | Y |
| [CBC0] Saddle stitch side alignment motor abnormality (Saddle Stitch Finisher) | Fatal Error - Please Contact Service Technician. | 5th | - | Y | Y | Y |
| [CBE0] Saddle stitch folding motor abnormality (Saddle Stitch Finisher) | Fatal Error - Please Contact Service Technician. | 5th | - | Y | Y | Y |
| [CC20] Communication error between the finisher control PC board and the saddle control PC board | Fatal Error - Please Contact Service Technician. | 2nd | - | Y | Y | Y |
| [CC30] Stack transport motor abnormality (Finisher, Saddle Stitch Finisher) | Fatal Error - Please Contact Service Technician. | 5th | - | Y | Y | Y |
| [CC31] Transport motor abnormality (Finisher, Saddle Stitch Finisher) | Fatal Error - Please Contact Service Technician. | 2nd | - | Y | Y | Y |
| [CC41] Assist guide cam home position abnormality (Finisher, Saddle Stitch Finisher) | Fatal Error - Please Contact Service Technician. | 2nd | - | Y | Y | Y |
| [CC51] Hole punch: Transport motor abnormality (Finisher, Saddle Stitch Finisher) | Fatal Error - Please Contact Service Technician. | 2nd | - | Y | Y | Y |
| [CC52] Hole punch: Skew adjustment motor abnormality (Finisher, Saddle Stitch Finisher) | Fatal Error - Please Contact Service Technician. | 5th | - | Y | Y | Y |
| [CC60] Hole punch: Punch motor abnormality (Finisher, Saddle Stitch Finisher) | Fatal Error - Please Contact Service Technician. | 2nd | - | Y | Y | Y |
| [CC61] Hole punch: Punch motor home position detection abnormality (Finisher, Saddle Stitch Finisher) | Fatal Error - Please Contact Service Technician. | 5th | - | Y | Y | Y |
| [CC71] Hole punch: Punch ROM abnormality (Finisher, Saddle Stitch Finisher) | Fatal Error - Please Contact Service Technician. | Y | - | Y | Y | Y |
| [CC72] Hole punch: Punch RAM data abnormality (Finisher, Saddle Stitch Finisher) | Fatal Error - Please Contact Service Technician. | Y | - | Y | Y | Y |
| [CC73] Hole punch: Punch device power supply abnormality (Finisher, Saddle Stitch Finisher) | Fatal Error - Please Contact Service Technician. | Y | - | Y | Y | Y |
| [CC74] Hole punch: Punch transport pulse abnormality (Finisher, Saddle Stitch Finisher) | Fatal Error - Please Contact Service Technician. | Y | - | Y | Y | Y |
| [CC80] Rear alignment motor abnormality (Finisher, Saddle Stitch Finisher) | Fatal Error - Please Contact Service Technician. | 2nd | - | Y | Y | Y |
| [CD60] Sub-hopper toner sensor abnormality | Fatal Error - Please Contact Service Technician. | - | - | Y | Y | Y |
| [CD64] Sub-hopper toner motor (K) abnormality | Fatal Error - Please Contact Service Technician. | - | - | Y | Y | Y |
| [CD71] Waste toner transport motor locking error | Fatal Error - Please Contact Service Technician. | - | - | Y | Y | Y |
| [CDE0] Paddle home position abnormality (Finisher, Saddle Stitch Finisher) | Printer Output Error. | 5th | - | Y | Y | Y |

| Code | Message | Error code display media | | | | |
|---|--|--------------------------|----|----|------|-----|
| | | Panl | JL | ML | Noti | CSV |
| [CE00] Communication error between the finisher control PC board and the hole punch control PC board (Finisher, Saddle Stitch Finisher) | Fatal Error - Please Contact Service Technician. | 5th | - | Y | Y | Y |
| [CE10] Image quality sensor abnormality | Fatal Error - Please Contact Service Technician. | 2nd | - | Y | Y | Y |
| [CE20] Image quality sensor abnormality (no pattern level) | Fatal Error - Please Contact Service Technician. | 2nd | - | Y | Y | Y |
| [CE40] Image quality control test pattern abnormality | Fatal Error - Please Contact Service Technician. | 2nd | - | Y | Y | Y |
| [CE41] Image quality TRC control test pattern abnormality | Fatal Error - Please Contact Service Technician. | 2nd | - | Y | Y | Y |
| [CE50] Temperature/humidity sensor abnormality | Fatal Error - Please Contact Service Technician. | 2nd | - | Y | Y | Y |
| [CE60] Drum thermistor (Y) abnormality | Fatal Error - Please Contact Service Technician. | 2nd | - | Y | Y | Y |
| [CE90] Drum thermistor (K) abnormality | Fatal Error - Please Contact Service Technician. | 2nd | - | Y | Y | Y |
| [CF10] Communication module writing abnormality (Finisher, Saddle Stitch Finisher) | Printer Output Error. | 2nd | - | Y | Y | Y |
| [CF90] Laser optical unit shutter abnormality | Fatal Error - Please Contact Service Technician. | 2nd | - | Y | Y | Y |
| [F070] Communication error between the system-CPU and the engine-CPU | Fatal Error - Please Contact Service Technician. | 5th | - | Y | Y | Y |
| [F071] Communication initialization error between the system-CPU and the engine-CPU | Fatal Error - Please Contact Service Technician. | 2nd | - | Y | Y | Y |
| [F074] Communication error between the system-CPU and the engine-CPU | Fatal Error - Please Contact Service Technician. | 2nd | - | Y | Y | - |
| [F090] SRAM error on the SYS board | Fatal Error - Please Contact Service Technician. | Y | - | Y | Y | - |
| [F100_0] Storage device initialization error | Fatal Error - Please Contact Service Technician. | Y | - | Y | Y | - |
| [F100_1] Storage device initialization error | Fatal Error - Please Contact Service Technician. | Y | - | Y | Y | - |
| [F100_2] Storage device initialization error | Fatal Error - Please Contact Service Technician. | Y | - | Y | Y | - |
| [F100_3] Serial number value error | Fatal Error - Please Contact Service Technician. | Y | - | Y | Y | - |
| [F100_4] Hash check error of encryption partition key | Fatal Error - Please Contact Service Technician. | Y | - | Y | Y | - |
| [F101_0] Optional storage device installation error | Fatal Error - Please Contact Service Technician. | Y | - | Y | Y | - |
| [F101_1] Optional storage device root partition mount error (formatting failure) | Fatal Error - Please Contact Service Technician. | Y | - | Y | Y | - |
| [F101_2] Optional storage device partition mount error | Fatal Error - Please Contact Service Technician. | Y | - | Y | Y | - |
| [F101_3] Optional storage device partition mount error | Fatal Error - Please Contact Service Technician. | Y | - | Y | Y | - |
| [F101_4] Optional storage device partition mount error | Fatal Error - Please Contact Service Technician. | - | - | - | - | - |
| [F101_5] Partition mount error | Fatal Error - Please Contact Service Technician. | - | - | - | - | - |
| [F101_6] Partition mount error | Fatal Error - Please Contact Service Technician. | - | - | - | - | - |
| [F101_7] Partition mount error | Fatal Error - Please Contact Service Technician. | - | - | - | - | - |

| Code | Message | Error code display media | | | | |
|---|--|--------------------------|----|----|------|-----|
| | | Panl | JL | ML | Noti | CSV |
| [F101_8] Partition mount error | Fatal Error - Please Contact Service Technician. | - | - | - | - | - |
| [F101_9] Partition mount error | Fatal Error - Please Contact Service Technician. | - | - | - | - | - |
| [F101_10] Partition mount error | Fatal Error - Please Contact Service Technician. | - | - | - | - | - |
| [F101_11] Partition mount error | Fatal Error - Please Contact Service Technician. | - | - | - | - | - |
| [F101_12] Optional storage device mount error | Fatal Error - Please Contact Service Technician. | - | - | - | - | - |
| [F101_13] Error due to damage to file | Fatal Error - Please Contact Service Technician. | - | - | - | - | - |
| [F101_14] Partition mount error | Fatal Error - Please Contact Service Technician. | - | - | - | - | - |
| [F102] Storage device start error | Fatal Error - Please Contact Service Technician. | Y | - | Y | Y | - |
| [F103] Storage device transfer time-out error | Fatal Error - Please Contact Service Technician. | 5th | - | Y | Y | - |
| [F104] Storage device data error | Fatal Error - Please Contact Service Technician. | 5th | - | Y | Y | - |
| [F105] Other errors for the storage device | Fatal Error - Please Contact Service Technician. | 5th | - | Y | Y | - |
| [F106_0] Optional storage device error | - | 2nd | - | - | - | - |
| [F106_1] Optional storage device error | - | 2nd | - | - | - | - |
| [F106_2] Optional storage device error | - | 2nd | - | - | - | - |
| [F106_3] Optional storage device error | - | 2nd | - | - | - | - |
| [F106_4] Optional storage device error | - | 2nd | - | - | - | - |
| [F109_5] Key consistency error | - | 2nd | - | - | - | - |
| [F106_6] Optional storage device error | - | 2nd | - | - | - | - |
| [F106_7] Optional storage device error | - | 2nd | - | - | - | - |
| [F106_8] Optional storage device error | - | 2nd | - | - | - | - |
| [F106_10] Optional storage device error | - | 2nd | - | - | - | - |
| [F106_11] License damage | - | 2nd | - | - | - | - |
| [F106_12] License damage | - | 2nd | - | - | - | - |
| [F106_UNDEF] Optional storage device error | - | 2nd | - | - | - | - |
| [F107] File system error | - | 2nd | - | - | - | - |
| [F109_0] Key consistency error | - | Y | - | - | - | - |
| [F109_1] Key consistency error | - | Y | - | - | - | - |
| [F109_2] Key consistency error | - | Y | - | - | - | - |
| [F109_3] Key consistency error | - | Y | - | - | - | - |
| [F109_4] Key consistency error | - | Y | - | - | - | - |
| [F109_5] Key consistency error | - | Y | - | - | - | - |
| [F109_6] Key consistency error | - | Y | - | - | - | - |
| [F109_7] Key consistency error | - | Y | - | - | - | - |
| [F109_8] Key consistency error | - | Y | - | - | - | - |
| [F109_9] Key consistency error | - | Y | - | - | - | - |
| [F109_10] Key consistency error | - | Y | - | - | - | - |
| [F109_11] Key consistency error | - | Y | - | - | - | - |
| [F109_12] Key consistency error | - | Y | - | - | - | - |

| Code | Message | Error code display media | | | | |
|---|--|--------------------------|----|----|------|-----|
| | | Panl | JL | ML | Noti | CSV |
| [F110] Communication error between the system-CPU and the scanner-CPU | Fatal Error - Please Contact Service Technician. | 5th | - | Y | Y | Y |
| [F111] Scanner-CPU response error | Fatal Error - Please Contact Service Technician. | 5th | - | Y | Y | Y |
| [F115] S-VDEN ON signal time-out error | Fatal Error - Please Contact Service Technician. | 2nd | - | Y | Y | Y |
| [F116] S-VDEN OFF signal time-out error | Fatal Error - Please Contact Service Technician. | 2nd | - | Y | Y | Y |
| [F117] S-VDEN ON (back side) signal time-out error | Fatal Error - Please Contact Service Technician. | 2nd | - | Y | Y | Y |

| Code | Message | Error code display media | | | | |
|--|--|--------------------------|----|----|------|-----|
| | | Panl | JL | ML | Noti | CSV |
| [F118] S-VDEN OFF (back side) signal time-out error | Fatal Error - Please Contact Service Technician. | 2nd | - | Y | Y | Y |
| [F119] Scanner abnormality detection | Fatal Error - Please Contact Service Technician. | 5th | - | Y | Y | Y |
| [F11A] Scanner communication error | Fatal Error - Please Contact Service Technician. | 2nd | - | Y | Y | Y |
| [F11B] Communication error between the DSDF-CCD module and the SYS board | Fatal Error - Please Contact Service Technician. | 2nd | - | Y | Y | Y |
| [F120] Database error | Fatal Error - Please Contact Service Technician. | Y | - | Y | Y | - |
| [F121] User Information management database error | User Management DB corrupted. | 2nd | - | Y | Y | - |
| [F122] Message/job log management database error | Log Management DB corrupted. | Y | - | Y | Y | - |
| [F124] Application management database error | AppManagement DB corrupted. | Y | - | Y | Y | - |
| [F125] Home screen database error | HomeScreen DB corrupted. | Y | - | Y | Y | - |
| [F126] Job history database error | JobHistory DB corrupted. | Y | - | Y | Y | - |
| [F127] Application license management database error | AppLicense DB corrupted. | Y | - | Y | Y | - |
| [F128] License manager database error | LMDB ERROR | - | - | Y | Y | - |
| [F130] Invalid MAC address | - | 2nd | - | - | - | - |
| [F131] Filtering setting file damage error | Fatal Error - Please Contact Service Technician. | Y | - | Y | Y | - |
| [F141_0] Standard storage device installation error | - | 2nd | - | Y | Y | Y |
| [F141_1] Standard storage device root partition mount error (formatting failure) | - | 2nd | - | Y | Y | Y |
| [F141_2] Standard storage device partition mount error | - | 2nd | - | Y | Y | Y |
| [F141_3] Standard storage device partition mount error | - | 2nd | - | Y | Y | Y |
| [F141_4] Standard storage device partition mount error | - | 2nd | - | Y | Y | Y |
| [F141_5] Partition mount error | - | 2nd | - | Y | Y | Y |
| [F141_6] Partition mount error | - | 2nd | - | Y | Y | Y |
| [F141_7] Partition mount error | - | 2nd | - | Y | Y | Y |
| [F141_8] Partition mount error | - | 2nd | - | Y | Y | Y |
| [F141_9] Partition mount error | - | 2nd | - | Y | Y | Y |
| [F141_10] Partition mount error | - | 2nd | - | Y | Y | Y |
| [F141_11] Partition mount error | - | 2nd | - | Y | Y | Y |
| [F141_12] Standard storage device mount error | - | 2nd | - | Y | Y | Y |
| [F141_13] Error due to damage to file | - | 2nd | - | Y | Y | Y |
| [F141_14] Partition mount error | - | 2nd | - | Y | Y | Y |
| [F150] Power failure during the manufacturing mode | - | Y | - | Y | Y | - |
| [F200] Data Overwrite Enabler disabled | Fatal Error - Please Contact Service Technician. | Y | - | Y | Y | - |
| [F350] SYS board abnormality | Fatal Error - Please Contact Service Technician. | Y | - | Y | Y | Y |
| [F351] SYS board abnormality | Fatal Error - Please Contact Service Technician. | Y | - | Y | Y | Y |
| [F400] SYS board cooling fan abnormality | Fatal Error - Please Contact Service Technician. | Y | - | Y | Y | - |

| Code | Message | Error code display media | | | | |
|--|--|--------------------------|----|----|------|-----|
| | | Panl | JL | ML | Noti | CSV |
| [F410] Power abnormality | Fatal Error - Please Contact Service Technician. | 2nd | - | Y | Y | Y |
| [F510] Application start error | - | 5th | - | - | - | - |
| [F520] Operating system start error | - | Y | - | - | - | - |
| [F521] Integrity check error | - | Y | - | - | - | - |
| [F523] Security check error at the startup | - | Y | - | - | - | - |
| [F525] Invalid file execution error | - | Y | - | - | - | - |
| [F526] Anti-malware function error | - | Y | - | - | - | - |
| [F550] Encryption partition error | Fatal Error - Please Contact Service Technician. | Y | - | | | - |
| [F600] Firmware update error | - | Y | - | | | - |
| [F700] Overwrite error | Fatal Error - Please Contact Service Technician. | - | - | Y | Y | - |
| [F800] Date error | - | Y | - | | | - |
| [F900] MFP information consistency error | - | Y | - | - | - | - |
| [F901] Communication error | - | Y | - | - | - | - |

8.2.3 Error in Internet fax and scanning functions

1. Internet fax related error

| Code | Message | Error code display media | | | | |
|--|---|--------------------------|----|----|------|-----|
| | | Panl | JL | ML | Noti | CSV |
| [1C10] System access abnormality | Illegal Job status | - | Y | - | Y | - |
| [1C11] Insufficient memory | Not enough memory | - | Y | - | Y | - |
| [1C12] Message reception error | Illegal Job status | - | Y | - | Y | - |
| [1C13] Message transmission error | Illegal Job status | - | Y | - | Y | - |
| [1C14] Invalid parameter | Invalid parameter specified | - | Y | - | Y | - |
| [1C15] Exceeding file capacity | Message size exceeded limit or maximum size | - | Y | - | Y | - |
| [1C30] Directory creation failure | Failed to create directory | - | Y | - | Y | - |
| [1C31] File creation failure | Failed to create file | - | Y | - | Y | - |
| [1C32] File deletion failure | Failed to delete file | - | Y | - | Y | - |
| [1C33] File access failure | Failed to create file | - | Y | - | Y | - |
| [1C40] Image conversion abnormality | Failed to convert image file format | - | Y | - | Y | - |
| [1C60] Storage device full during processing | Failed To Process your Job. Insufficient Storage space. | - | Y | - | Y | - |
| [1C61] Address book reading failure | Failed to read AddressBook | - | Y | - | Y | - |
| [1C63] Terminal IP address unset | Invalid Domain Address | - | Y | - | Y | - |
| [1C64] Terminal mail address unset | Invalid Domain Address | - | Y | - | Y | - |
| [1C65] SMTP mail address unset | Failed to connect to SMTP server | - | Y | - | Y | - |
| [1C66] Server time-out error | Failed to connect to SMTP server | - | Y | - | Y | - |
| [1C69] SMTP server connection error | Failed to connect to SMTP server | - | Y | - | Y | - |
| [1C6B] Terminal mail address error | Invalid address specified in To: field | - | Y | - | Y | - |
| [1C6C] Destination mail address error | Invalid address specified in To: field | - | Y | - | Y | - |
| [1C6D] System error | NIC system error | - | Y | - | Y | - |
| [1C70] SMTP client OFF | SMTP service is not available | - | Y | - | Y | - |
| [1C71] SMTP authentication error | Failed SMTP Authentication | - | Y | - | Y | - |
| [1C72] POP before SMTP error | POP Before SMTP Authentication Failed | - | Y | - | Y | - |
| [1CC0] Job canceling | Job canceled | - | Y | - | Y | - |
| [1CC1] Power failure | Power failure occurred | - | Y | - | Y | - |

2. RFC related error

| Code | Message | Error code display media | | | | |
|--|---|--------------------------|----|----|------|-----|
| | | Panl | JL | ML | Noti | CSV |
| [2500] HOST NAME error (RFC: 500), Destination mail address error (RFC: 500), Terminal mail address error (RFC: 500) | Syntax error, command unrecognized | - | Y | - | Y | - |
| [2501] HOST NAME error (RFC: 501), Destination mail address error (RFC: 501), Terminal mail address error (RFC: 501) | Syntax error in parameters or arguments | - | Y | - | Y | - |
| [2503] Destination mail address error (RFC: 503) | Bad sequence of commands | - | Y | - | Y | - |
| [2504] HOST NAME error (RFC: 504) | Command parameter not implemented | - | Y | - | Y | - |
| [2550] Destination mail address error (RFC: 550) | Mailbox unavailable | - | Y | - | Y | - |
| [2551] Destination mail address error (RFC: 551) | User not local | - | Y | - | Y | - |
| [2552] Terminal/destination mail address error (RFC: 552) | Insufficient system storage | - | Y | - | Y | - |
| [2553] Destination mail address error (RFC: 553) | Mailbox name not allowed | - | Y | - | Y | - |

3. Remote scanning related error

| Code | Message | Error code display media | | | | |
|--|--|--------------------------|----|----|------|-----|
| | | Panl | JL | ML | Noti | CSV |
| [2A00] Successful completion (BoxInTA) | Successfully stored document | - | Y | - | - | - |
| [2A20] System management module resource acquiring failure | Failed to acquire resource | - | Y | - | - | - |
| [2A31] WS Scan disabled | WS Scan function is not available | - | Y | - | - | - |
| [2A40] System error | NIC system error | - | Y | - | - | - |
| [2A50] Job canceling | Job canceled | - | Y | - | - | - |
| [2A51] Power failure | Power failure occurred | - | Y | - | - | - |
| [2A60] WS Scan user authentication failure | Authentication for WS Scan failed | - | Y | - | - | - |
| [2A70] RemoteScan privilege check error | Insufficient permission to execute RemoteScan | - | - | Y | - | - |
| [2A71] WS Scan privilege check error | Insufficient permission to execute WS Scan | - | Y | - | - | - |
| [2A72] e-Filing data access privilege check error (Scan Utility) | Insufficient permission to access e-Filing box using scan utility | - | - | Y | - | - |
| [2A73] Address book operation privilege check error | Insufficient permission to execute Addressbook Export/Import operation | - | - | Y | - | - |
| [2AD0] e-Filing data backing up | Backup operation of e-Filing data from Backup/Restore Utility is done | - | - | Y | - | - |
| [2AD1] e-Filing data restoring | Restore operation of e-Filing data from Backup/Restore Utility is done | - | - | Y | - | - |
| [2AD2] e-Filing data archiving | Archive operation of e-Filing data is done | - | - | Y | - | - |
| [2AD3] e-Filing data restoring | Restore operation of e-Filing data is done | - | - | Y | - | - |
| [2AD4] e-Filing data downloading (Scan Utility) | Download e-Filing data by scan utility | - | - | Y | - | - |

4. e-Filing related error

| Code | Message | Error code display media | | | | |
|--|---|--------------------------|----|----|------|-----|
| | | Panl | JL | ML | Noti | CSV |
| [2B00] Doc saving successful (BoxIn) | Successfully stored document | - | Y | - | Y | - |
| [2B01] Successful completion (BoxPrnTA) | Successfully sent document to print queue | - | - | - | - | - |
| [2B11] Job status abnormality | Job status failed | - | Y | - | Y | - |
| [2B20] File library function error | Failed to access file | - | Y | - | Y | - |
| [2B30] Insufficient storage device space in BOX partition | Insufficient Storage Device space. | - | Y | - | Y | - |
| [2B31] Status of the specified e-Filing or folder is undefined or being created or deleted | Failed to access Electronic Filing | - | Y | - | Y | - |
| [2B50] Image library error | Failed to process image | - | Y | - | Y | - |
| [2B51] List library error | Failed to print images from the document box | - | Y | - | Y | - |
| [2B71] There are documents which will expire in a few days | Document(s) expire(s) in a few days | - | - | Y | Y | - |
| [2B80] Storage device space in /BOX partition is nearly full (90%) | Storage Device space for Electronic Filing nearly full. | - | - | Y | Y | - |
| [2B90] Insufficient memory capacity | Insufficient Memory | - | Y | - | Y | - |
| [2BA0] Invalid Box password | Invalid Box password specified | - | Y | - | Y | - |
| [2BA1] The specified paper size, color mode or resolution is not available. | Failed to process image. | - | Y | - | Y | - |
| [2BB0] Job canceling | Job canceled | - | Y | - | Y | - |
| [2BB1] Power failure | Power failure occurred | - | Y | - | Y | - |
| [2BC0] Fatal failure occurred | NIC system error | - | Y | - | Y | - |
| [2BD0] Power failure during restoring of e-Filing | Power failure occurred during e-Filing restore. | - | - | Y | Y | - |
| [2BD1] e-Filing is initialized. | e-Filing Box Storage is initialized. | - | - | Y | Y | - |
| [2BE0] Machine parameter reading error | Failed to get machine parameter | - | Y | - | Y | - |
| [2BF0] Exceeding the maximum number of pages | Maximum number of pages has been exceeded (list Maximum) | - | Y | - | Y | - |
| [2BF1] Exceeding the maximum number of documents | Maximum number of documents has been exceeded (list Maximum) | - | Y | - | Y | - |
| [2BF2] Exceeding the maximum number of folders | Maximum number of folders has been exceeded (list Maximum) | - | Y | - | Y | - |

5. E-mail related error

| Code | Message | Error code display media | | | | |
|--|--|--------------------------|----|----|------|-----|
| | | Panl | JL | ML | Noti | CSV |
| [2C00] Communication successful completion | Sent scanned image(s) by email | - | Y | - | Y | - |
| [2C01] Notification transmission successful completion | Sent scanned image(s) by email | - | Y | - | Y | - |
| [2C02] Transferring completion (E-mail reception) | Sent scanned image(s) by email | - | Y | - | Y | - |
| [2C04] Notification transmission successful completion | Service information was sent by E-mail | - | Y | - | Y | - |
| [2C10] System access abnormality | Illegal Job status | - | Y | - | Y | - |
| [2C11] Insufficient memory | Not enough memory | - | Y | - | Y | - |
| [2C12] Message reception error | Illegal Job status | - | Y | - | Y | - |
| [2C13] Message transmission error | Illegal Job status | - | Y | - | Y | - |
| [2C14] Invalid parameter | Invalid parameter specified | - | Y | - | Y | - |
| [2C15] Exceeding file capacity | Message size exceeded limit or maximum size | - | Y | - | Y | - |
| [2C20] System management module access abnormality | Illegal Job status | - | Y | - | Y | - |
| [2C21] Job control module access abnormality | Illegal Job status | - | Y | - | Y | - |
| [2C22] Job control module access abnormality | Illegal Job status | - | Y | - | Y | - |
| [2C30] Directory creation failure | Failed to create directory | - | Y | - | Y | - |
| [2C31] File creation failure | Failed to create file | - | Y | - | Y | - |
| [2C32] File deletion failure | Failed to delete file | - | Y | - | Y | - |
| [2C33] File access failure | Failed to create file | - | Y | - | Y | - |
| [2C40] Image conversion abnormality | Failed to convert image file format | - | Y | - | Y | - |
| [2C43] Encryption error | Encryption error. Failed to create file | - | Y | - | Y | - |
| [2C44] Encryption PDF enforced mode error | Creating the image file was not permitted | - | Y | - | Y | - |
| [2C45] Meta data creation error (ScanToEmail) | Failed in making meta data | - | Y | - | Y | - |
| [2C46] Creation of a signed PDF has failed. (An error due to the expiration date of a certificate): ScanToEmail | Creation of a signed PDF has failed since the certificate expired. | - | Y | - | Y | - |
| [2C47] Creation of a signed PDF has failed. (Version consistency between the signed PDF and certificates PDF): ScanToEmail | Version consistency between the signed PDF and certificates PDF | - | Y | - | Y | - |
| [2C50] Authentication failure at job execution | Insufficient permission to execute Scan job | - | Y | - | Y | - |
| [2C60] Storage device full during processing | Failed To Process your Job. Insufficient Storage space. | - | Y | - | Y | - |
| [2C61] Address book reading failure | Failed to read AddressBook | - | Y | - | Y | - |
| [2C62] Memory acquiring failure | Not enough memory | - | Y | - | Y | - |
| [2C63] Terminal IP address unset | Invalid Domain Address | - | Y | - | Y | - |
| [2C64] Terminal mail address unset | Invalid Domain Address | - | Y | - | Y | - |
| [2C65] SMTP mail address unset | Failed to connect to SMTP server | - | Y | - | Y | - |
| [2C66] Server time-out error | Failed to connect to SMTP server | - | Y | - | Y | - |
| [2C69] SMTP server connection error | Failed to connect to SMTP server | - | Y | - | Y | - |

| Code | Message | Error code display media | | | | |
|--|--|--------------------------|----|----|------|-----|
| | | PanI | JL | ML | Noti | CSV |
| [2C6A] HOST NAME error (no RFC error) | Failed to send E-mail message | - | Y | - | Y | - |
| [2C6B] Terminal mail address error | Invalid address specified in From: field | - | Y | - | Y | - |
| [2C6C] Destination mail address error (no RFC error) | Invalid address specified in To: field | - | Y | - | Y | - |
| [2C70] SMTP client OFF | SMTP service is not available | - | Y | - | Y | - |
| [2C71] SMTP authentication error | Failed SMTP Authentication | - | Y | - | Y | - |
| [2C72] POP before SMTP error | POP Before SMTP Authentication Failed | - | Y | - | Y | - |
| [2CC0] Job canceling | Job canceled | - | Y | - | Y | - |
| [2CC1] Power failure | Power failure occurred | - | Y | - | Y | - |

6. File sharing related error

| Code | Message | Error code display media | | | | |
|---|--|--------------------------|----|----|------|-----|
| | | PanI | JL | ML | Noti | CSV |
| [2D00] Successful completion (saving in a local directory) | Stored document in controller shared folder | - | Y | - | Y | - |
| [2D01] Successful completion (saving in Remote) | Stored document in network folder | - | Y | - | Y | - |
| [2D02] Successful completion (saving of a received FaxtoFile/&File in a local directory) | Stored document in controller shared folder | - | Y | - | Y | - |
| [2D03] Successful completion (saving of a received FaxtoFile/&File in Remote) | Stored document in network folder | - | Y | - | Y | - |
| [2D04] Successful completion (saving of a received EmailtoFile/&File in a local directory) | Stored document in controller shared folder | - | Y | - | Y | - |
| [2D05] Successful completion (saving of a received EmailtoFile/&File in Remote) | Stored document in network folder | - | Y | - | Y | - |
| [2D10] System access abnormality | Illegal Job status | - | Y | - | Y | - |
| [2D11] Insufficient memory | Not enough memory | - | Y | - | Y | - |
| [2D12] Message reception error | Illegal Job status | - | Y | - | Y | - |
| [2D13] Message transmission error | Illegal Job status | - | Y | - | Y | - |
| [2D14] Invalid parameter | Invalid parameter specified | - | Y | - | Y | - |
| [2D15] Exceeding the maximum size for file sharing | Document size exceeded limit or maximum size | - | Y | - | Y | - |
| [2D30] Directory creation failure | Failed to create directory | - | Y | - | Y | - |
| [2D31] File creation failure | Failed to create file | - | Y | - | Y | - |
| [2D32] File deletion failure | Failed to delete file | - | Y | - | Y | - |
| [2D33] File access failure | Failed to create file | - | Y | - | Y | - |
| [2D40] Image conversion abnormality | Failed to convert image file format | - | Y | - | Y | - |
| [2D43] Encryption error | Encryption error. Failed to create file | - | Y | - | Y | - |
| [2D44] Encryption PDF enforced mode error | Creating the image file was not permitted | - | - | - | Y | - |
| [2D45] Meta data creation error (ScanToFile) | Failed in making meta data | - | Y | - | Y | - |
| [2D46] Creation of a signed PDF has failed. (An error due to the expiration date of a certificate): ScanToFile | Creation of a signed PDF has failed since the certificate expired. | - | Y | - | Y | - |
| [2D47] Creation of a signed PDF has failed. (Version consistency between the signed PDF and certificates PDF): ScanToFile | Version consistency between the signed PDF and certificates PDF | - | Y | - | Y | - |

| Code | Message | Error code display media | | | | |
|--|---|--------------------------|----|----|------|-----|
| | | Panl | JL | ML | Noti | CSV |
| [2D50] Authentication failure at job execution (A ScanToFile job is carried out while user authentication or department authentication has not been done.) | Insufficient permission to execute Scan job | - | Y | - | Y | - |
| [2D62] File server connection failure | Failed to connect to network destination. Check destination path | - | Y | - | Y | - |
| [2D63] Invalid network path | Specified network path is invalid. Check destination path | - | Y | - | Y | - |
| [2D64] Login failure | Logon to file server failed. Check username and password | - | Y | - | Y | - |
| [2D65] New document creation failure caused by an excess of documents in a folder | There are too many documents in folder. Failed in creating new document | - | Y | - | Y | - |
| [2D66] Storage capacity full failure during processing | Failed To Process your Job. Insufficient Storage space. | - | Y | - | Y | - |
| [2D67] FTP service not available | FTP service is not available | - | Y | - | Y | - |
| [2D68] File sharing service not available | File Sharing service is not available | - | Y | - | Y | - |
| [2D69] NetWare service not available | NetWare service is not available | - | Y | - | Y | - |
| [2DA0] Periodical deletion of scanned documents has been completed properly | Expired scan documents deleted from share folder. | - | - | Y | Y | - |
| [2DA1] Periodical deletion of transmitted fax documents has been completed properly. | Expired Sent Fax documents deleted from shared folder | - | - | Y | Y | - |
| [2DA2] Periodical deletion of received fax documents has been completed properly. | Expired Received Fax documents deleted from shared folder | - | - | Y | Y | - |
| [2DA3] Manual deletion of scanned documents has been completed properly. | Scanned documents in shared folder deleted upon user's request | - | - | Y | Y | - |
| [2DA4] Manual deletion of transmitted fax documents has been completed properly. | Sent Fax Documents in shared folder deleted upon user's request. | - | - | Y | Y | - |
| [2DA5] Manual deletion of received fax documents has been completed properly. | Received Fax Documents in shared folder deleted upon user's request. | - | - | Y | Y | - |
| [2DA6] File deletion failure | Failed to delete file | - | - | Y | Y | - |
| [2DA7] Resource acquiring failure | Failed to acquire resource | - | - | Y | Y | - |
| [2DC0] Job canceling | Job canceled | - | Y | - | Y | - |
| [2DC1] Power failure | Power failure occurred | - | Y | - | Y | - |
| [2E00] Successful completion (saving in a USB storage device) | Stored document in controller USB Media | - | Y | - | Y | - |
| [2E01] Successful completion (saving of a received FaxtoFile/&File in a USB storage device) | Stored document in controller USB Media | - | Y | - | Y | - |
| [2E02] Successful completion (saving of a received EmailtoFile/&File in a USB storage device) | Stored document in controller USB Media | - | Y | - | Y | - |
| [2E10] System access abnormality in ScanToUSB | Illegal Job status | - | Y | - | Y | - |
| [2E11] Insufficient memory capacity in ScanToUSB | Not enough memory | - | Y | - | Y | - |
| [2E12] Message reception error in ScanToUSB | Illegal Job status | - | Y | - | Y | - |
| [2E13] Message transmission error in ScanToUSB | Illegal Job status | - | Y | - | Y | - |
| [2E14] Parameter error in ScanToUSB | Invalid parameter specified | - | Y | - | Y | - |

| Code | Message | Error code display media | | | | |
|--|---|--------------------------|----|----|------|-----|
| | | PanI | JL | ML | Noti | CSV |
| [2E15] Exceeding the maximum size for file sharing | Document size exceeded limit or maximum size | - | Y | - | Y | - |
| [2E30] Directory creation failure in ScanToUSB | Failed to create directory | - | Y | - | Y | - |
| [2E31] File creation failure in ScanToUSB | Failed to create file | - | Y | - | Y | - |
| [2E32] File deletion failure in ScanToUSB | Failed to delete file | - | Y | - | Y | - |
| [2E33] File access failure in ScanToUSB | Failed to create file | - | Y | - | Y | - |
| [2E40] Image conversion abnormality in ScanToUSB | Failed to convert image file format | - | Y | - | Y | - |
| [2E43] Encryption failure in ScanToUSB | Encryption error. Failed to create file | - | Y | - | Y | - |
| [2E44] Encryption PDF enforced mode error in ScanToUSB | Creating the image file was not permitted | - | - | - | Y | - |
| [2E45] Meta data creation error in USB storage device (ScanToFile) | Failed in making meta data | - | Y | - | Y | - |
| [2E46] Creation of a signed PDF has failed. (An error due to the expiration date of a certificate): ScanToUSB | Creation of a signed PDF has failed since the certificate expired. | - | Y | - | Y | - |
| [2E47] Creation of a signed PDF has failed. (Version consistency between the signed PDF and certificates PDF): ScanToUSB | Version consistency between the signed PDF and certificates PDF | - | Y | - | Y | - |
| [2E50] Authentication failure at job execution | Insufficient permission to execute Scan job | - | Y | - | Y | - |
| [2E65] File creation error due to insufficient USB folder capacity in ScanToUSB | There are too many documents in folder. Failed in creating new document | - | Y | - | Y | - |
| [2E66] Storage device full failure during ScanToUSB | Failed To Process your Job. Insufficient Storage space. | - | Y | - | Y | - |
| [2EC0] Job canceling | Job canceled | - | Y | - | Y | - |
| [2EC1] Power failure in ScanToUSB | Power failure occurred | - | Y | - | Y | - |

7. E-mail reception related error

| Code | Message | Error code display media | | | | |
|--|--|--------------------------|----|----|------|-----|
| | | Panl | JL | ML | Noti | CSV |
| [3000] E-mail reception is completed properly | Received E-mail Job was successfully completed. | - | Y | - | Y | - |
| [3A10] E-mail MIME error | MIME Error has been detected in the received mail. | - | Y | - | Y | - |
| [3A20] E-mail analysis error | Analyze Error has been detected in the received mail. | - | Y | - | Y | - |
| [3A30] Partial mail time-out error | Whole partial mails were not reached by timeout. | - | Y | - | Y | - |
| [3A40] Partial mail related error | Partial Mail Error has been detected in the received mail. | - | Y | - | Y | - |
| [3A50] Insufficient storage device capacity error | Storage Device Full Error has occurred with this mail. | - | Y | - | Y | - |
| [3A70] Partial mail interruption error | Receiving partial mail was aborted since the partial mail setting has been changed to Disable. | - | Y | - | Y | - |
| [3A80] Partial mail reception setting OFF | Partial mail was received during the partial mail setting is disabled. | - | Y | - | Y | - |
| [3B10] E-mail format error | Format Error has been detected in the received mail. | - | Y | - | Y | - |
| [3B20] Content-Type error | Content-Type Error has been detected in the received mail. | - | Y | - | Y | - |
| [3B40] E-mail decode error | Decode Error has been detected in the received mail. | - | Y | - | Y | - |
| [3B50] Received mail data deletion | Received Email data was broken. It was deleted from mail server. | - | - | Y | Y | - |
| [3C10] TIFF analysis error | Tiff Analyze Error has been detected in the received mail. | - | Y | - | Y | - |
| [3C13] TIFF analysis error | Tiff Analyze Error has been detected in the received mail. | - | Y | - | Y | - |
| [3C20] TIFF compression error | Tiff Compression Error has been detected in the received mail. | - | Y | - | Y | - |
| [3C30] TIFF resolution error | Tiff Resolution Error has been detected in the received mail. | - | Y | - | Y | - |
| [3C40] TIFF paper size error | Tiff Paper Size Error has been detected in the received mail. | - | Y | - | Y | - |
| [3C50] Offramp destination error | Offramp Destination Error has been detected in the received mail. | - | Y | - | Y | - |
| [3C60] Offramp security error | Offramp Security Error has been detected in the received mail. | - | Y | - | Y | - |
| [3C70] Power failure | Power Failure has been occurred in E-mail receiving. | - | Y | - | Y | - |
| [3C90] Offramp fax transmission disable error | OffRamp Fax transmission disable error has been detected in the received mail. | - | Y | - | Y | - |
| [3D10] Destination address error | SMTP Destination Error has been detected in the received mail. This mail was deleted. | - | - | Y | Y | - |
| [3D20] Maximum number of offramp destination error | OffRamp Destination limitation Error has been detected in the received mail. | - | - | Y | Y | - |

| Code | Message | Error code display media | | | | |
|--|--|--------------------------|----|----|------|-----|
| | | Panl | JL | ML | Noti | CSV |
| [3D30] No Fax Unit error | Fax unit Error has occurred because the OffRamp mail was received but it has no Fax unit. | - | - | Y | Y | - |
| [3E10] POP3 server connection error | POP3 Connection Error has occurred in the received mail. | - | - | Y | Y | - |
| [3E20] POP3 server connection time-out error | POP3 Connection Timeout Error has occurred in the received mail. | - | - | Y | Y | - |
| [3E30] POP3 login error | POP3 Login Error has occurred in the received mail. | - | - | Y | Y | - |
| [3E40] POP3 login type error | POP3 Login Error occurred in the received mail. | - | - | Y | Y | - |
| [3F10] File I/O error | File I/O Error has occurred in this mail. The mail cannot be received until File I/O is recovered. | - | - | Y | Y | - |
| [3F20] File I/O error | File I/O Error has occurred in this mail. The mail cannot be received until File I/O is recovered. | - | Y | - | Y | - |

8.2.4 Printer function error

Following codes are displayed at the end of the user name on the print job log screen.

| Code | Message | Error code display media | | | | |
|--|---|--------------------------|----|----|------|-----|
| | | Panl | JL | ML | Noti | CSV |
| [4000] Successful completion | - | - | - | - | - | - |
| [4011] Print job cancellation | - | - | - | - | - | - |
| [4012] Automatic deletion of expired print jobs | - | - | - | - | - | - |
| [4021] Power failure at print job processing | - | - | - | - | - | - |
| [4031] Storage device full during print | - | - | - | - | - | - |
| [4032] Exceeding the upper limit of the registration number for the sharing jobs | - | - | - | - | - | - |
| [4033] Network setting error | - | - | - | - | - | - |
| [4041] User authentication error | - | - | - | - | - | - |
| [4042] Department authentication error | - | - | - | - | - | - |
| [4043] Project authentication error | - | - | - | - | - | - |
| [4045] Problem in LDAP server connection or LDAP server authorization settings | - | - | - | - | - | - |
| [4111] Quota over error (no quota in a department and user) | - | - | - | - | - | - |
| [4112] Quota over error (no quota in a user) | - | - | - | - | - | - |
| [4113] Quota over error (no quota in a department) | - | - | - | - | - | - |
| [4121] Job canceling due to external counter error | - | - | - | - | - | - |
| [4211] Printing data storing limitation error | - | - | - | - | - | - |
| [4212] e-Filing storing limitation error | - | - | - | - | - | - |
| [4213] File storing limitation error | - | - | - | - | - | - |
| [4214] Fax and internet fax transmission limitation error | - | - | - | - | - | - |
| [4221] Private-print-only error | - | - | - | - | - | - |
| [4222] Hold-print-only error | - | - | - | - | - | - |
| [4223] Private-print-only and Hold-print-only error | - | - | - | - | - | - |
| [4231] Hardcopy security printing error | - | - | - | - | - | - |
| [4243] Sharing job - An error caused by not having a license | - | - | - | - | - | - |
| [4244] Sharing job - An error caused by function disabled | - | - | - | - | - | - |
| [4245] OCR functions not available | OCR function is not available. | - | - | - | Y | - |
| [4311] No privilege to perform a job | - | - | - | - | - | - |
| [4312] No privilege to store a file | - | - | - | - | - | - |
| [4313] No privilege for StoreToFile | - | - | - | - | - | - |
| [4314] No privilege for SendToFax and SendToIFax | - | - | - | - | - | - |
| [4321] No privilege for the print settings | - | - | - | - | - | - |
| [4411] Image data creation failure | - | - | - | - | - | - |
| [4412] Decoding error | - | - | - | - | - | - |
| [4511] Connection timeout | Print failure due to connection timeout | Y | - | Y | - | - |
| [4521] Reaching the maximum number of connections | Cannot print due to connection limit | Y | - | Y | - | - |

| Code | Message | Error code display media | | | | |
|---|--|--------------------------|----|----|------|-----|
| | | PanI | JL | ML | Noti | CSV |
| [4522] Exceeding the upper limit of the registration number of jobs during data reception | Registered print job number reached to limit during printing | Y | - | Y | - | - |
| [4523] Storage device full during data reception | Storage Device full occurred during printing | Y | - | Y | - | - |
| [4611] Font download failure (exceeding the maximum number of registrations) | - | - | - | - | - | - |
| [4612] Font download failure (storage device full) | - | - | - | - | - | - |
| [4613] Font download failure (others) | - | - | - | - | - | - |
| [4621] Downloaded font deletion failure | - | - | - | - | - | - |
| [4721] Connection error of multi station print (Unavailable combination of the version) | Cannot connect MFP due to unexpected combination of Multi Station Print | - | - | Y | - | - |
| [4731] Multi Station print jobs have been removed. (An error has occurred in the job list.) | Multi Station Print job(s) have been deleted because an error occurred in the Job List | - | - | Y | - | - |
| [4F10] System abnormality | - | - | - | - | - | - |
| [4F11] RIP process error | - | - | - | - | - | - |

8.2.5 TopAccess related error, Communication error with external application

| Code | Message | Error code display media | | | | |
|---|---|--------------------------|----|----|------|-----|
| | | PanI | JL | ML | Noti | CSV |
| [5110] Toner cartridge detection error | Toner not recognized. Please confirm it. | - | - | - | - | - |
| [5211] PM counter excess | - | - | - | Y | Y | - |
| [5212] Time for cleaning of the main charger | Open the front cover, and clean the slit glass and main charger. | - | - | Y | Y | - |
| [5310] Toner (K) empty | - | - | - | - | - | - |
| [5400] MFP registration success | Succeeded in MFP registration | - | - | Y | Y | - |
| [5401] Immediate connection execution to an eCC server | Immediate connection to Remote Maintenance Service has been executed. | - | - | Y | Y | - |
| [5410] MFP registration error | Remote maintenance service error | - | - | Y | Y | - |
| [5411] MFP registration lock error | Remote maintenance service error | - | - | Y | Y | - |
| [5412] Server busy error | Remote maintenance service error | - | - | Y | Y | - |
| [5413] Server error | Remote maintenance service error | - | - | Y | Y | - |
| [5414] Invalid device file error | Remote maintenance service error | - | - | Y | Y | - |
| [5415] Communication error | Remote maintenance service error | - | - | Y | Y | - |
| [5416] Update failure of MFP setting file and system software | Remote maintenance service error | - | - | Y | Y | - |
| [5417] MFP setting file or system software is invalid. | Remote maintenance service error | - | - | Y | Y | - |
| [5419] File transmission to an eCC server failure | Remote maintenance service error | - | - | Y | Y | - |
| [5501] Communication data size exceeding error between the mobile and embedded applications | Request data or response data are too large. | - | - | Y | Y | - |
| [5502] Timeout error during the communication between the mobile and embedded applications | Timeout has occurred at the time of the communication between the mobile and embedded applications. | - | - | Y | Y | - |
| [5601] Proxy authentication failure | Failed to proxy authentication. | - | - | Y | Y | - |
| [5A10] End of trial day | Trial Day will expire in a few days | - | - | Y | Y | - |
| [5BD0] Power failure during the database restoration | Power failure occurred during restore | - | - | Y | Y | - |
| [5C10] Fax Unit installation error | FAX Unit is not attached. | - | - | Y | Y | - |
| [5C11] Network fax transmission error | Security error on Address Book. | - | - | Y | Y | - |

8.2.6 MFP access error

| Code | Message | Error code display media | | | | |
|---|---|--------------------------|----|----|------|-----|
| | | Panl | JL | ML | Noti | CSV |
| [6000] User login success to an MFP | Successful user login | - | - | Y | Y | - |
| [6001] User login failure to an MFP | Failed user login | - | - | Y | Y | - |
| [6002] User logout success from an MFP: Manual logout | Successful user logout | - | - | Y | Y | - |
| [6003] User logout success from an MFP: Automatic logout | Successful user logout (Session Time Out) | - | - | Y | Y | - |
| [6004] Authentication success of a user box password | Successful User Box Authentication | - | - | Y | Y | - |
| [6005] Authentication failure of a user box password | Failed User Box Authentication | - | - | Y | Y | - |
| [6006] UserToken binding failure | User login information was broken | - | - | Y | Y | - |
| [6007] User login failure to an MFP | Failed user login | - | - | Y | Y | - |
| [6008] Connection failure to an external Role Base Access Control (LDAP) server | Failed to connect on External LDAP server for Role Base Access Control | - | - | Y | Y | - |
| [6009] User login failure to an MFP (during NIC initialization) | Failed user login (Authentication server connection error) | - | - | Y | Y | - |
| [600A] Department code not assigned to a user | Department code has not been assigned to the user | - | - | Y | Y | - |
| [600B] Password authentication of the Public Box has succeeded. | Successful Public Box Authentication | - | - | Y | Y | - |
| [600C] Password authentication of the Public Box has failed. | Failed Public Box Authentication | - | - | Y | Y | - |
| [6010] Home directory not found | Cannot find the Home Directory. | - | - | Y | Y | - |
| [6011] User automatic registration failure (due to an upper limit of the user registration number) | Failed to register the user by automatically (Maximum number of registered users) | - | - | Y | Y | - |
| [6013] Connection failure to an authentication server | Failed to connect on the authentication server | - | - | Y | Y | - |
| [6014] Inaccessible authentication server detection | Server is not responding. Authentication is conducted skipping the server for a certain period of time. | - | - | Y | Y | - |
| [6031] Setting error: CL code error | Illegal CL code. | - | - | Y | Y | - |
| [6032] Card abnormality: Validity date error | Illegal period. | - | - | Y | Y | - |
| [6033] Card abnormality: Flag information error (no room-entry data) | No entering record. | - | - | Y | Y | - |
| [6034] Card abnormality: Flag information error (card information error) | Illegal entering record. | - | - | Y | Y | - |
| [6035] Setting error: Flag information error (card information unset) | Illegal SSFC settings of MFP. | - | - | Y | Y | - |
| [6036] Setting error: Flag information error (information between an MFP and a card does not match) | Unmatched settings and card info. | - | - | Y | Y | - |
| [6037] Permission flag for use not available | You cannot be used. | - | - | Y | Y | - |
| [6040] Card authentication: Read error | Failed to read the card | - | - | Y | Y | - |
| [6041] Card authentication: Card related error | Card Authentication Failed because of Card Reading Error | - | - | Y | Y | - |
| [6042] Card authentication: Card setting error | Card Authentication Failed because of Setting Error | - | - | Y | Y | - |
| [6043] Card authentication failure (duplication of card information) | Card Authentication Failed because the card information was duplicated on the card server. | - | - | Y | Y | - |

| Code | Message | Error code display media | | | | |
|---|--|--------------------------|----|----|------|-----|
| | | Panl | JL | ML | Noti | CSV |
| [6044] Card notification failure (Stage2) | Card Notification Communication Error | - | - | Y | Y | - |
| [6066] PIN authentication failure (duplication of a PIN code) | PIN Authentication Failed because the PIN code was duplicated on the PIN server. | - | - | Y | Y | - |
| [6070] Fingerprint authentication (User login success to an MFP) | Successful user login | - | - | Y | Y | - |
| [6071] Fingerprint authentication (User logout success from an MFP: manual logout) | Successful user logout | - | - | Y | Y | - |
| [6072] Fingerprint authentication (User logout success from an MFP: automatic logout) | Successful user logout (Session Time Out) | - | - | Y | Y | - |
| [6073] Fingerprint authentication (failure) | Failed Fingerprint Authentication | - | - | Y | Y | - |
| [6100] User account locking out | User account is locked | - | - | Y | Y | - |
| [6101] e-Filing locking out | Box is locked | - | - | Y | Y | - |
| [6102] User account is being locked out. | Failed to login because the user account had been locked out. | - | - | Y | Y | - |
| [6103] e-Filing is being locked out. | Failed to access Box because the Box had been locked out. | - | - | Y | Y | - |
| [6121] Automatic secure erase failure | Failed to Secure Erase | - | - | Y | Y | - |
| [6130] Synchronization with a time server has succeeded. | Successfully verified clock with Time Server | - | - | Y | Y | - |
| [6131] Synchronization failure with a time server | MFP fail to verify clock with Time Server | - | - | Y | Y | - |
| [6150] Print log database full | Print Log full (100% Used) Log OverWrite will be start Log OverWrite will be start | - | - | Y | Y | - |
| [6151] Print log database nearly full (95%) | Print Log near full (95% Used) | - | - | Y | Y | - |
| [6152] Print log database nearly full (90%) | Print Log near full (90% Used) | - | - | Y | Y | - |
| [6153] Print log database nearly full (80%) | Print Log near full (80% Used) | - | - | Y | Y | - |
| [6154] Print log database nearly full (70%) | Print Log near full (70% Used) | - | - | Y | Y | - |
| [6160] Scan log database full | Scan Log full (100% Used) Log OverWrite will be start | - | - | Y | Y | - |
| [6161] Scan log database nearly full (95%) | Scan Log near full (95% Used) | - | - | Y | Y | - |
| [6162] Scan log database nearly full (90%) | Scan Log near full (90% Used) | - | - | Y | Y | - |
| [6163] Scan log database nearly full (80%) | Scan Log near full (80% Used) | - | - | Y | Y | - |
| [6164] Scan log database nearly full (70%) | Scan Log near full (70% Used) | - | - | Y | Y | - |
| [6170] Fax transmission database full | FAX_Transmission Log full (100% Used) Log OverWrite will be start | - | - | Y | Y | - |
| [6171] Fax transmission database nearly full (95%) | FAX_Transmission Log near full (95% Used) | - | - | Y | Y | - |
| [6172] Fax transmission database nearly full (90%) | FAX_Transmission Log near full (90% Used) | - | - | Y | Y | - |
| [6173] Fax transmission database nearly full (80%) | FAX_Transmission Log near full (80% Used) | - | - | Y | Y | - |
| [6174] Fax transmission database nearly full (70%) | FAX_Transmission Log near full (70% Used) | - | - | Y | Y | - |
| [6180] Fax reception database full | FAX_Receive Log full (100% Used) Log OverWrite will be start | - | - | Y | Y | - |
| [6181] Fax reception database nearly full (95%) | FAX_Receive Log near full (95% Used) | - | - | Y | Y | - |
| [6182] Fax reception database nearly full (90%) | FAX_Receive Log near full (90% Used) | - | - | Y | Y | - |

| Code | Message | Error code display media | | | | |
|---|---|--------------------------|----|----|------|-----|
| | | Panl | JL | ML | Noti | CSV |
| [6183] Fax reception database nearly full (80%) | FAX_Receive Log near full (80% Used) | - | - | Y | Y | - |
| [6184] Fax reception database nearly full (70%) | FAX_Receive Log near full (70% Used) | - | - | Y | Y | - |
| [6190] Message log database full | Message Log full (100% Used) Log OverWrite will be start | - | - | Y | Y | - |
| [6191] Message log database nearly full (95%) | Message Log near full (95% Used) | - | - | Y | Y | - |
| [6192] Message log database nearly full (90%) | Message Log near full (90% Used) | - | - | Y | Y | - |
| [6193] Message log database nearly full (80%) | Message Log near full (80% Used) | - | - | Y | Y | - |
| [6194] Message log database nearly full (70%) | Message Log near full (70% Used) | - | - | Y | Y | - |
| [61A0] Secure Receive ON mode | Secure Receive was enabled | - | - | Y | - | - |
| [61A1] Secure Receive OFF mode | Secure Receive was disabled | - | - | Y | - | - |
| [61C0] Application log database full | Application Log full (100% Used) Log OverWrite will be start | - | - | Y | Y | - |
| [61C1] Application log database nearly full (95%) | Application Log near full (95% Used) | - | - | Y | Y | - |
| [61C2] Application log database nearly full (90%) | Application Log near full (90% Used) | - | - | Y | Y | - |
| [61C3] Application log database nearly full (80%) | Application Log near full (80% Used) | - | - | Y | Y | - |
| [61C4] Application log database nearly full (70%) | Application Log near full (70% Used) | - | - | Y | Y | - |
| [61D0] Instruction to back up the storage device (SATA Port 0) (Backing up is required since the storage device may be malfunctioning.) | Please make a backup of Storage Device data. | Y | - | Y | Y | - |
| [61D1] Instruction to replace the storage device (SATA Port 0) (Replacing is required since the storage is on the verge of malfunctioning.) | Exchange of the Storage Device is required. Please contact service. | Y | - | Y | Y | - |
| [61D2] Instruction to back up the storage device (SATA Port 1) (Backing up is required since the storage device may be malfunctioning.) | Back up the storage device data | Y | - | Y | Y | - |
| [61D3] Instruction to replace the storage device (SATA Port 1) (Replacing is required since the storage is on the verge of malfunctioning.) | Replace the storage device (SATA Port 1) | Y | - | Y | Y | - |
| [6200] Security level change of an MFP by a service technician | Service Technician changed Security Level | - | - | Y | Y | - |
| [6220] Execution of the administrator setting wizard | - | - | - | - | - | - |
| [6221] Security settings change by an administrator | - | - | - | - | - | - |
| [6240] A user password is outside the security policy. | - | - | - | - | - | - |
| [6241] An e-Filing password is outside the security policy. | - | - | - | - | - | - |
| [6260] User information change | - | - | - | - | - | - |
| [6261] Role information change | - | - | - | - | - | - |
| [6262] Group role information change | - | - | - | - | - | - |
| [6280] Self-signed certification generation | - | - | - | - | - | - |

| Code | Message | Error code display media | | | | |
|--|---------|--------------------------|----|----|------|-----|
| | | PanI | JL | ML | Noti | CSV |
| [6281] Server certification generation | - | - | - | - | - | - |
| [6282] Certification addition failure | - | - | - | - | - | - |
| [6283] Encryption key generation | - | - | - | - | - | - |

8.2.7 Maintenance error

| Code | Message | Error code display media | | | | |
|--|---|--------------------------|----|----|------|-----|
| | | Panl | JL | ML | Noti | CSV |
| [7100] System firmware installation success | Successfully updated Copier Firmware | - | - | Y | Y | - |
| [7101] System firmware installation failure | Failed to update Copier Firmware | - | - | Y | Y | - |
| [7102] Engine firmware installation success | Successfully updated Main ROM | - | - | Y | Y | - |
| [7103] Engine firmware installation failure | Failed to update Main ROM | - | - | Y | Y | - |
| [7104] Scanner firmware installation success | Successfully updated Scan ROM | - | - | Y | Y | - |
| [7105] Scanner firmware installation failure | Failed to update Scan ROM | - | - | Y | Y | - |
| [7108] Printer driver installation success | Successfully updated printer driver. | - | - | Y | Y | - |
| [7109] Printer driver installation failure | Failed to update printer driver. | - | - | Y | Y | - |
| [710A] Point and Print data installation success | Successfully updated printer driver. | - | - | Y | Y | - |
| [710B] Point and Print data installation failure | Failed to update printer driver. | - | - | Y | Y | - |
| [710E] Language pack installation success | Successfully installed language package | - | - | Y | Y | - |
| [710F] Language Pack installation failure | Failed to install language package | - | - | Y | Y | - |
| [7110] Patch installation success | Successfully installed patch | - | - | Y | Y | - |
| [7111] Patch installation failure | Failed to install patch | - | - | Y | Y | - |
| [7112] Plugin installation success | Successfully installed plugin | - | - | Y | Y | - |
| [7113] Plugin installation failure | Failed to install plugin | - | - | Y | Y | - |
| [7114] Storage device data installation success | Successfully updated Storage Device | - | - | Y | Y | - |
| [7115] Storage device data installation failure | Failed to update Storage Device | - | - | Y | Y | - |
| [7116] DF firmware installation success | Successfully updated DF ROM | - | - | Y | Y | - |
| [7117] DF firmware installation failure | Failed to update DF ROM | - | - | Y | Y | - |
| [7118] PFC firmware installation success | Successfully updated PFC ROM | - | - | Y | Y | - |
| [7119] PFC firmware installation failure | Failed to update PFC ROM | - | - | Y | Y | - |
| [711A] Electronic key clear | Cleared License Key | - | - | Y | Y | - |
| [711C] Electronic key returning success | Successfully removed License Key | - | - | Y | Y | - |
| [711D] License key returning failure | Failed to remove License Key | - | - | Y | Y | - |
| [711E] Electronic key installation success | Successfully installed License Key | - | - | Y | Y | - |
| [711F] License key installation failure | Failed to install License Key | - | - | Y | Y | - |
| [7120] Address Book data import success | Successfully imported address book data | - | - | Y | Y | - |
| [7121] Address Book data import failure | Failed to import address book data | - | - | Y | Y | - |
| [7124] MailBox data import success | Successfully imported Mailbox data | - | - | Y | Y | - |
| [7125] MailBox data import failure | Failed to import Mailbox data | - | - | Y | Y | - |
| [7126] Format file for meta scan import success | Successfully imported XML format file | - | - | Y | Y | - |
| [7127] Format file for meta scan import failure | Failed to import XML format file | - | - | Y | Y | - |

| Code | Message | Error code display media | | | | |
|---|--|--------------------------|----|----|------|-----|
| | | PanI | JL | ML | Noti | CSV |
| [7128] User Information import success | Successfully imported user information | - | - | Y | Y | - |
| [7129] User Information import failure | Failed to import user information | - | - | Y | Y | - |
| [712A] Role information import success | Successfully imported role information | - | - | Y | Y | - |
| [712B] Role information import failure | Failed to import role information | - | - | Y | Y | - |
| [712C] Department data import success | Successfully imported department code | - | - | Y | Y | - |
| [712D] Role information import failure | Failed to import department code | - | - | Y | Y | - |
| [7130] Print Data Converter import success | Successfully imported print data converter | - | - | Y | Y | - |
| [7131] Print Data Converter import failure | Failed to import print data converter | - | - | Y | Y | - |
| [7132] Some user information import failure | Failed to import some user information | - | - | Y | Y | - |
| [7133] Some user information, role and group import failure | Failed to import some user information, roles and groups | - | - | Y | Y | - |
| [7134] Some department data import failure | Failed to import some department codes | - | - | Y | Y | - |
| [7136] EWB error screen file importing success | Successfully imported EWB error screen file | - | - | Y | Y | - |
| [7137] EWB error screen file importing failure | Failed to imported EWB error screen file | - | - | Y | Y | - |
| [7138] Certificate collection success from SCEP server | Successfully collected certificates from an SCEP server | - | - | Y | Y | - |
| [7139] Certificate collection failure from SCEP server | Failed to collect certificates from an SCEP server | - | - | Y | Y | - |
| [713A] Certificate import success | Successfully imported certificates | - | - | Y | Y | - |
| [713B] Certificates import failure | Failed to import certificates | - | - | Y | Y | - |
| [713C] User Combined data import success | Successfully imported user information, role and group | - | - | Y | Y | - |
| [713D] User Combined data import failure | Failed to import user information, role and group | - | - | Y | Y | - |
| [713E] Address book and mailbox data import success | Successfully imported address book and mailbox data | - | - | Y | Y | - |
| [713F] Address book and mailbox import failure | Failed to import address book and mailbox data | - | - | Y | Y | - |
| [7140] Address Book data export success | Successfully exported address book data | - | - | Y | Y | - |
| [7141] Address Book data export failure | Failed to export address book data | - | - | Y | Y | - |
| [7144] MailBox data export success | Successfully exported Mailbox data | - | - | Y | Y | - |
| [7145] MailBox data export failure | Failed to export Mailbox data | - | - | Y | Y | - |
| [7148] User Information export success | Successfully exported user information | - | - | Y | Y | - |
| [7149] User Information export failure | Failed to export user information | - | - | Y | Y | - |
| [714A] Role information export success | Successfully exported role information | - | - | Y | Y | - |
| [714B] Role information export failure | Failed to export role information | - | - | Y | Y | - |
| [714C] Department information export success | Successfully exported department code | - | - | Y | Y | - |

| Code | Message | Error code display media | | | | |
|--|--|--------------------------|----|----|------|-----|
| | | PanI | JL | ML | Noti | CSV |
| [714D] Department information export failure | Failed to export department code | - | - | Y | Y | - |
| [714E] ICC Profile export success | Successfully exported ICC profile | - | - | Y | Y | - |
| [714F] ICC Profile export failure | Failed to export ICC profile | - | - | Y | Y | - |
| [7150] Log data export success | Successfully exported log data | - | - | Y | Y | - |
| [7151] Log data export failure | Failed to export log data | - | - | Y | Y | - |
| [7152] Log clear | Executed log clear | - | - | Y | Y | - |
| [7154] Log DB has been rebuilt automatically since it was damaged. | Rebuilt the Log DB by Log DB corruption | - | - | Y | Y | - |
| [7156] AppManagement DB has been rebuilt automatically since it was damaged. | Rebuilt the AppManagement DB due to AppManagement DB corruption. | - | - | Y | Y | - |
| [7157] HomeScreen DB has been rebuilt automatically since it was damaged. | Rebuilt the HomeScreen DB due to HomeScreen DB corruption. | - | - | Y | Y | - |
| [7158] JobHistory DB has been rebuilt automatically since it was damaged. | Rebuilt the JobHistory DB due to JobHistory DB corruption. | - | - | Y | Y | - |
| [7159] AppLicense DB has been rebuilt automatically since it was damaged. | Rebuilt the AppLicense DB by AppLicense DB corruption | - | - | Y | Y | - |
| [715A] Print Data Converter export success | Successfully exported print data converter | - | - | Y | Y | - |
| [715B] Print Data Converter export failure | Failed to export print data converter | - | - | Y | Y | - |
| [715C] User Combined data export success | Successfully exported user information, role and group | - | - | Y | Y | - |
| [715D] User Combined data export failure | Failed to export user information, role and group | - | - | Y | Y | - |
| [715E] Address book and mailbox data export success | Successfully exported address book and mailbox data | - | - | Y | Y | - |
| [715F] Address book and mailbox export failure | Failed to export address book and mailbox data | - | - | Y | Y | - |
| [7160] Addition in the address book | Added new destinations | - | - | Y | Y | - |
| [7162] Addition in e-Filing | Added new user boxes | - | - | Y | Y | - |
| [7163] Addition of department code | Added new department codes | - | - | Y | Y | - |
| [7165] Department counter clearing | Cleared Department Counter | - | - | Y | Y | - |
| [7166] Change in the address book | Edited address book | - | - | Y | Y | - |
| [7168] Change in e-Filing | Edit e-Filing | - | - | Y | Y | - |
| [7169] Change in the department code | Edited department code | - | - | Y | Y | - |
| [716C] Consistency processing of user department counter | Edited department code | - | - | Y | - | - |
| [7170] Deletion of destination | Deleted unnecessary destinations | - | - | Y | Y | - |
| [7172] Deletion of user box | Deleted unnecessary user boxes | - | - | Y | Y | - |
| [7173] Deletion of the department code | Deleted unnecessary department codes | - | - | Y | Y | - |
| [7174] Addition of new users | Added new users | - | - | Y | Y | - |
| [7175] Change in user information | Changed user information | - | - | Y | Y | - |
| [7176] Deletion of user | Deleted unnecessary users | - | - | Y | Y | - |
| [7177] Addition of new roles | Added new roles | - | - | Y | Y | - |
| [7178] Change in role information | Changed role information | - | - | Y | Y | - |
| [7179] Deletion of role | Deleted unnecessary roles | - | - | Y | Y | - |
| [717A] Addition of new groups | Added new groups | - | - | Y | Y | - |

| Code | Message | Error code display media | | | | |
|---|--|--------------------------|----|----|------|-----|
| | | Panl | JL | ML | Noti | CSV |
| [717B] Change in group information | Changed group information | - | - | Y | Y | - |
| [717C] Deletion of group information | Deleted group information | - | - | Y | Y | - |
| [717D] Update of role/group assignment of users | Role/group assignment of users has been updated. | - | - | Y | Y | - |
| [717E] User's EWB information has been removed. | User's EWB information has been removed. | - | - | Y | Y | - |
| [7182] Change in device setting | Changed device settings | - | - | Y | Y | - |
| [7183] Change in network setting | Changed network settings | - | - | Y | Y | - |
| [7184] Change in security setting | Changed security settings | - | - | Y | Y | - |
| [7185] Change in authentication setting | Changed authentication settings | - | - | Y | Y | - |
| [7188] A user password is outside the security policy. | Failed to change the password due to the security policy | - | - | Y | Y | - |
| [7189] An e-Filing password is outside the security policy. | e-Filing Box password is not pursuant to Security Policy | - | - | Y | Y | - |
| [718A] The time set in the MFP has been changed. | Edited Date & Time Setting | - | - | Y | Y | - |
| [718B] Summer time has started. | Started the Daylight Savings Time | - | - | Y | Y | - |
| [718C] End of summer time | Ended the Daylight Savings Time | - | - | Y | Y | - |
| [7190] DDNS public key file upload success | Successfully uploaded DDNS public key | - | - | Y | Y | - |
| [7191] DDNS public key file upload failure | Failed to upload DDNS public key | - | - | Y | Y | - |
| [7192] DDNS secret key file upload success | Successfully uploaded DDNS secret key | - | - | Y | Y | - |
| [7193] DDNS secret key file upload failure | Failed to upload DDNS secret key | - | - | Y | Y | - |
| [71A0] Self-signed certification generation | Generated Self signed Certificate | - | - | Y | Y | - |
| [71A1] CA certification addition success | Success to add CA certificate | - | - | Y | Y | - |
| [71A2] CA certificates addition failure | Failed to add CA certificates | - | - | Y | Y | - |
| [71A3] Encryption key generation | Cryptographic key generated | - | - | Y | Y | - |
| [71A4] Encryption key consistency check failure | Failed to consistency check for encryption key | - | - | Y | Y | - |
| [71A5] Device certification deletion success | Successfully deleted device certificates | - | - | Y | Y | - |
| [71A6] Device certificates deletion failure | Failed to delete device certificates | - | - | Y | Y | - |
| [71A7] CA certification deletion success | Successfully deleted CA certificates | - | - | Y | Y | - |
| [71A8] CA certificates deletion failure | Failed to delete CA certificates | - | - | Y | Y | - |
| [71A9] The validated date of the device certificates has expired. | The validated date of the device certificates has expired. | - | - | Y | Y | - |
| [71AA] Unknown error occurred during collection of certificates from an SCEP server | Unknown error occurred during collection of certificates from an SCEP server | - | - | Y | Y | - |
| [71AB] Timeout error occurred during collection of certificates from an SCEP server | Timeout error occurred during collection of certificates from an SCEP server | - | - | Y | Y | - |
| [71AC] File saving error occurred during collection of certificates from an SCEP server | File saving error occurred during collection of certificates from an SCEP server | - | - | Y | Y | - |
| [71AD] SCEP certificate collection error | Failed SCEP operation | - | - | Y | Y | - |
| [71B0] Software package file decryption failure | Failed to decrypt Software Package | - | - | Y | Y | - |

| Code | Message | Error code display media | | | | |
|--|--|--------------------------|----|----|------|-----|
| | | Panl | JL | ML | Noti | CSV |
| [71B2] Laser firmware installation success | Successfully updated Laser ROM | - | - | Y | Y | - |
| [71B3] Laser firmware installation failure | Failed to update Laser ROM | - | - | Y | Y | - |
| [71B4] Finisher firmware installation success | Successfully updated Finisher ROM | - | - | Y | Y | - |
| [71B5] Finisher firmware installation failure | Failed to update Finisher ROM | - | - | Y | Y | - |
| [71B6] Saddle firmware installation success | Successfully updated Saddle ROM | - | - | Y | Y | - |
| [71B7] Saddle firmware installation failure | Failed to update Saddle ROM | - | - | Y | Y | - |
| [71B8] Punch firmware installation success | Successfully updated Punch ROM | - | - | Y | Y | - |
| [71B9] Punch firmware installation failure | Failed to update Punch ROM | - | - | Y | Y | - |
| [71BA] UI data installation success | Successfully updated UI Data | - | - | Y | - | - |
| [71BB] UI data installation failure | Failed to update UI Data | - | - | Y | - | - |
| [71BC] UI data recovery success | UI Data successfully rolled back | - | - | Y | - | - |
| [71BD] UI data recovery failure | Failed to rollback UI Data | - | - | Y | - | - |
| [71BE] UI data installation failure | Failed to update UI Data (non-permitted machine) | - | - | Y | - | - |
| [71BF] UI data installation failure | Failed to update UI Data (non-permitted model) | - | - | Y | - | - |
| [71C0] Integrity check by user request start | Integrity check by user request started | - | - | Y | Y | - |
| [71C0] Integrity check by user request end | No problems found in the integrity check by user request | - | - | Y | Y | - |
| [71C2] Integrity check by user request cancel | Integrity check cancelled by a user | - | - | Y | Y | - |
| [71C3] Integrity check at startup end | No problems found in the integrity check at startup | - | - | Y | Y | - |
| [71D0] Factory Default failure | Failed to restore Factory Default settings | - | - | Y | Y | - |
| [71E0] License abnormality due to damage on the license manager database | LMDB Recovery | - | - | Y | Y | - |
| [71F0] Clone file creation success | Successfully created clone file | - | - | Y | Y | - |
| [71F1] Clone file creation failure | Failed to create clone file | - | - | Y | Y | - |
| [71F2] Clone file import success | Successfully imported clone file | - | - | Y | Y | - |
| [71F3] Clone file import failure | Failed to import clone file | - | - | Y | Y | - |
| [71F4] Clone file decryption failure | Failed to decrypt clone file | - | - | Y | Y | - |
| [71F5] Clone file encryption failure | Failed to encrypt clone file | - | - | Y | Y | - |
| [7200] Image log saving success to an external server | Successful transfer of Image Log to the external server | - | - | Y | Y | - |
| [7201] Image log saving failure to an external server | Failed to transfer of Image Log to the external server | - | - | Y | Y | - |
| [7210] User management information synchronization success | Successful synchronization of User Management information | - | - | Y | Y | - |
| [7211] User management information synchronization failure | Failed to synchronize User Management information | - | - | Y | Y | - |
| [7212] User management information synchronization failure (incorrect setting) | Failed to synchronize User Management information (setting mistake) | - | - | Y | Y | - |
| [7213] Some user management information synchronization failure | Failed to synchronize User Management information for some secondary MFP | - | - | Y | Y | - |
| [7220] AddressBook delivery success | Successful synchronization of AddressBook | - | - | Y | Y | - |

| Code | Message | Error code display media | | | | |
|--|--|--------------------------|----|----|------|-----|
| | | Panl | JL | ML | Noti | CSV |
| [7221] AddressBook delivery failure | Failed to synchronize Address Book | - | - | Y | Y | - |
| [7222] Some AddressBook delivery failure | Failed to synchronize AddressBook for some secondary MFP | - | - | Y | Y | - |
| [7230] Project creation | Added new Project Code | - | - | Y | Y | - |
| [7231] Project edition | Edited Project Code | - | - | Y | Y | - |
| [7232] Project deletion | Removed a Project Code | - | - | Y | Y | - |
| [7233] Project export success | Successfully exported Project Code | - | - | Y | Y | - |
| [7234] Project export failure | Failed to export Project Code | - | - | Y | Y | - |
| [7235] Exported project downloading | Download Project Code. | - | - | Y | Y | - |
| [7236] Project import success | Successfully imported Project Code | - | - | Y | Y | - |
| [7237] Project import failure | Failed to import Project Code | - | - | Y | Y | - |
| [7238] A part of projects import failure | Failed to import some Project Codes | - | - | Y | Y | - |
| [7240] Address book download | The address book has been downloaded. | - | - | Y | Y | - |
| [7242] Mailbox download operation | The mailbox has been downloaded. | - | - | Y | Y | - |
| [7244] User information download operation | The user information has been downloaded. | - | - | Y | Y | - |
| [7245] Role information download operation | The role information has been downloaded. | - | - | Y | Y | - |
| [7246] Department code download operation | The department code has been downloaded. | - | - | Y | Y | - |
| [7247] ICC profile download operation | The ICC profile has been downloaded. | - | - | Y | Y | - |
| [7248] Log download operation | The log has been downloaded. | - | - | Y | Y | - |
| [7249] User information, role and group download operation | The user information, role and group have been downloaded. | - | - | Y | Y | - |
| [724A] The address book and mailbox have been downloaded. | The address book and mailbox have been downloaded. | - | - | Y | Y | - |
| [7248] Clone file download operation | The clone file has been downloaded. | - | - | Y | Y | - |
| [724C] Print data converter download operation | The print data converter has been downloaded. | - | - | Y | Y | - |
| [7272] Fax firmware1 installation success | Successfully updated FAX FIRMWARE1 | - | - | Y | Y | - |
| [7273] Fax firmware1 installation failure | Failed to update FAX FIRMWARE1 | - | - | Y | Y | - |
| [7274] Fax firmware2 installation success | Successfully updated FAX FIRMWARE2 | - | - | Y | Y | - |
| [7275] Fax firmware2 installation failure | Failed to update FAX FIRMWARE2 | - | - | Y | Y | - |
| [7276] NIC firmware installation success | Successfully updated NIC FIRMWARE | - | - | Y | Y | - |
| [7277] NIC firmware installation failure | Failed to update NIC FIRMWARE | - | - | Y | Y | - |
| [7278] Monotype RIP Font installation success | Successfully installed Monotype RIP Font | - | - | Y | Y | - |
| [7279] Monotype RIP Font installation failure | Failed to install Monotype RIP Font | - | - | Y | Y | - |
| [7280] Data backup file storing success | Data Backup file storage was completed successfully | Y | - | Y | Y | - |

| Code | Message | Error code display media | | | | |
|--|---|--------------------------|----|----|------|-----|
| | | PanI | JL | ML | Noti | CSV |
| [7281] Data backup file storing cancel | Data Backup file storage was cancelled | Y | - | Y | Y | - |
| [7282] Periodical data backing up has not been executed. | Regular Data Backup was not performed | Y | - | Y | Y | - |
| [7283] Data backup file storing failure (A USB storage device has not been inserted) | Data Backup file storage failed (USB media was not inserted) | Y | - | Y | Y | - |
| [7284] Data backup file storing failure (Storing of a file into a USB storage device has failed) | Data Backup file storage failed (Failed to save the file to USB media) | Y | - | Y | Y | - |
| [7285] Data backup file storing failure (Connection to an external server is not possible) | Data Backup file storage failed (Failed to connect to the external server) | Y | - | Y | Y | - |
| [7286] Data backup file storing failure (Storing of a file into an external server has failed) | Data Backup file storage failed (Failed to save the file to the external server) | Y | - | Y | Y | - |
| [7287] Data backup file storing failure | Data Backup file storage failed | Y | - | Y | Y | - |
| [7288] Data back-up file saving failure (Cloud storage certificates error) | Saving of the data back-up file has failed. (Cloud storage certificate error) | Y | - | Y | Y | - |
| [7289] Data back-up file saving failure (Cloud storage full) | Saving of the data back-up file has failed. (Cloud storage full error) | Y | - | Y | Y | - |
| [728A] Data back-up file saving failure (Server error) | Saving of the data back-up file has failed. (Server error) | Y | - | Y | Y | - |
| [728B] Data back-up file failure (Connection error: Invalid URL) | Saving of the data back-up file has failed. (Connection error: Invalid URL) | Y | - | Y | Y | - |
| [728C] Data back-up file saving failure (Connection error: Connection impossible) | Saving of the data back-up file has failed. (Connection error: Connection impossible) | Y | - | Y | Y | - |
| [728D] Data back-up file saving failure (Connection error: Invalid certificates) | Saving of the data back-up file has failed. (Connection error: Invalid certificate) | Y | - | Y | Y | - |
| [728E] Data back-up file saving failure (Connection error) | Saving of the data back-up file has failed. (Connection error) | Y | - | Y | Y | - |
| [7290] Data restoring success | Data Restore process was completed successfully | Y | - | Y | Y | - |
| [7291] Job cancel of data restore processing | Data Restore from USB media or the external server was cancelled | Y | - | Y | Y | - |
| [7292] Data restore processing failure (A USB storage device is not inserted) | Data Restore process failed (USB media was not inserted) | Y | - | Y | Y | - |
| [7293] Data restore processing failure (Connection to an external server is not possible) | Data Restore process failed (Failed to connect to the external server) | Y | - | Y | Y | - |
| [7294] Data restore processing failure (Obtaining a file from a USB storage device has failed) | Data Restore process failed (Failed to get the Data Backup file from USB media) | Y | - | Y | Y | - |
| [7295] Data restore processing failure (Obtaining a file from an external server has failed) | Data Restore process failed (Failed to get the Data Backup file from external server) | Y | - | Y | Y | - |
| [7296] Data restore processing failure (Data backup file is corrupted.) | Data Restore process failed (Data Backup file is corrupted) | Y | - | Y | Y | - |
| [7297] Data restore processing failure | Data Restore process failed | Y | - | Y | Y | - |
| [7298] Data restoration failure (Cloud server certificates error) | Data restoration has failed. (Cloud server certificates error) | Y | - | Y | Y | - |
| [7299] Data restoration failure (Back-up files do not exist in the cloud server.) | Data restoration has failed. (Back-up files not found in the cloud server.) | Y | - | Y | Y | - |

| Code | Message | Error code display media | | | | |
|--|--|--------------------------|----|----|------|-----|
| | | Panl | JL | ML | Noti | CSV |
| [729A] Data restoration failure (Server error) | Data restoration has failed. (Server error) | Y | - | Y | Y | - |
| [729B] Data restoration failure (Connection error: Invalid URL) | Data restoration has failed. (Connection error: Invalid URL) | Y | - | Y | Y | - |
| [729C] Data restoration failure (Connection error: Connection impossible) | Data restoration has failed. (Connection error: Connection impossible) | Y | - | Y | Y | - |
| [729D] Data restoration failure (Connection error: Invalid certificates) | Data restoration has failed. (Connection error: Invalid certificates) | Y | - | Y | Y | - |
| [729E] Data restoration failure (Connection error) | Data restoration has failed. (Connection error) | Y | - | Y | Y | - |
| [729F] Data restoration failure (Inconsistency in the settings of the optional storage device) | Storage Device Restore process failed (Optional storage setting inconsistency) | Y | - | Y | Y | - |
| [72A0] Deletion of event notification destination information registered from an application | Notification events that were registered from an application were deleted. | - | - | Y | Y | - |
| [72B0] Enabling of TPM by means of the control panel or the self-diagnostic code has succeeded. | Succeeded to enable TPM | - | - | Y | Y | - |
| [72B1] Enabling of TPM by means of the control panel or the self-diagnostic code has failed. | Failed to enable TPM | - | - | Y | Y | - |
| [72B2] Disabling of TPM by means of the control panel or the self-diagnostic code has succeeded. | Succeeded to disable TPM | - | - | Y | Y | - |
| [72B3] Disabling of TPM by means of the control panel or the self-diagnostic code has failed. | Failed to disable TPM | - | - | Y | Y | - |
| [72B4] Backup of the TPM key has succeeded. | Succeeded to backup TPM key | - | - | Y | Y | - |
| [72B5] TPM key backup failure | Failed to backup TPM key | - | - | Y | Y | - |
| [72B6] Restoration of the TPM key has succeeded. | Succeeded to restore TPM key | - | - | Y | Y | - |
| [72B7] TPM key restoration failure | Failed to restore TPM key | - | - | Y | Y | - |
| [72B8] Consistency confirmation of the public key has succeeded. (At the startup of the MFP when TPM and secure startup are enabled) | Succeeded to consistency check for public key | - | - | Y | Y | - |
| [72C0] Fingerprint registration has succeeded. | Succeeded fingerprint registration | - | - | Y | Y | - |
| [72C1] Fingerprint registration failure | Failed fingerprint registration | - | - | Y | Y | - |
| [72C2] Fingerprint registration failure (fingerprint duplication) | This has failed since the same fingerprint has already been registered. | - | - | Y | Y | - |
| [72C3] Fingerprint deletion has succeeded. | Succeeded fingerprint deletion | - | - | Y | Y | - |
| [72C4] The deletion of a fingerprint has failed due to an internal error (standard storage device malfunction, database damage or hardware error). | Failed fingerprint deletion | - | - | Y | Y | - |
| [72C5] Deletion of all fingerprints has succeeded. | Succeeded all fingerprints deletion | - | - | Y | Y | - |
| [72C6] The deletion of all the registered fingerprints has failed due to an internal error (standard storage device malfunction, database damage or hardware error). | Failed all fingerprints deletion | - | - | Y | Y | - |
| [72C7] Connection of the fingerprint reader has been completed. | A fingerprint reader connected | - | - | Y | Y | - |

| Code | Message | Error code display media | | | | |
|--|---|--------------------------|----|----|------|-----|
| | | Panl | JL | ML | Noti | CSV |
| [72C8] Connection of the fingerprint reader has been disconnected. | A fingerprint reader disconnected | - | - | Y | Y | - |
| [72C9] Fingerprint DB has been damaged. | Fingerprint DB has been damaged. | - | - | Y | Y | - |
| [72CA] Recovery of the fingerprint DB has been completed. | Fingerprint DB has been recovered. | - | - | Y | Y | - |
| [72CB] Fingerprint template has been damaged. | Fingerprint template has been damaged. | - | - | Y | Y | - |
| [72CC] Fingerprint reading has failed. | Fingerprint reading has failed. | - | - | Y | Y | - |
| [72D0] UI data installation failure | Failed to update UI Data (compatibility check error) | - | - | Y | - | - |
| [72D1] System firmware installation failure | Failed to update Copier Firmware (compatibility check error) | - | - | Y | Y | - |
| [72D2] Upgrading of the plug-in for printer drivers has succeeded. | Successfully updated plugin of printer driver. | - | - | Y | Y | - |
| [72D3] Upgrading of the plug-in for printer drivers has failed. | Failed to update plugin of printer driver. | - | - | Y | Y | - |
| [72D4] Deletion of the plug-in for printer drivers has succeeded. | Successfully deleted plugin of printer driver. | - | - | Y | Y | - |
| [72D5] Deletion of the plug-in for printer drivers has failed. | Failed to delete plugin of printer driver. | - | - | Y | Y | - |
| [72D6] UI data installation failure | Failed to update UI Data (License check error) | - | - | Y | - | - |
| [72E0] Transition of template data to the home screen has succeeded. | Successfully transited template data to the home screen | - | - | Y | Y | - |
| [72E1] Template data to the home screen transition failure | Failed to transit template data to the home screen | - | - | Y | Y | - |
| [72E2] A part of the template data has not been transferred to the home screen. | Failed to transit some template data to the home screen | - | - | Y | Y | - |
| [72F0] Execution of the remote command has succeeded. | Execution of the remote command has succeeded. | - | - | Y | - | - |
| [72F1] Execution permission of the remote command has not been assigned to an administrator. | Execution permission of the remote command has not been assigned to an administrator. | - | - | Y | - | - |
| [72F2] Remote command execution is not available since jobs or another service are being operated. | Remote command execution is not available since jobs or another service are being operated. | - | - | Y | - | - |
| [72F3] Remote command file decryption failure | Decryption of the remote command file has failed. | - | - | Y | - | - |
| [72F4] Remote command verification failure | Verification of the remote command file has failed. | - | - | Y | - | - |
| [72F5] Compatibility error of the file format of the remote command | No compatibility in the file format of the remote command | - | - | Y | - | - |
| [72F6] Remote command execution failure | Failed to execute the remote command | - | - | Y | - | - |
| [72F7] Execution of a part of remote command has failed. | Failed to execute a part of the remote command | - | - | Y | - | - |
| [72F8] The power of the MFP has been turned OFF while the remote command was being operated. | The power of the MFP has been turned OFF while the remote command was being operated. | - | - | Y | - | - |
| [7300] An application has been installed. | Successfully installed Application | - | - | Y | Y | - |
| [7301] Application installation failure | Failed to install Application | - | - | Y | Y | - |
| [7302] An application has been uninstalled. | Successfully uninstalled Application | - | - | Y | Y | - |

| Code | Message | Error code display media | | | | |
|---|---|--------------------------|----|----|------|-----|
| | | PanI | JL | ML | Noti | CSV |
| [7303] Uninstallation of an application has failed. | Failed to uninstall Application | - | - | Y | Y | - |
| [7304] An application has been updated. | An application has been updated. | - | - | Y | Y | - |
| [7305] Updating of an application has failed. | Failed to update Application | - | - | Y | Y | - |
| [7306] Deletion of all the applications has succeeded. | Application removal completed | - | - | Y | Y | - |
| [7307] Deletion of all the applications has failed. | Failed to completely delete application. | - | - | Y | Y | - |
| [7308] Applications have automatically stopped. | Automatically stopped the application. | - | - | Y | Y | - |
| [7309] Applications have automatically started. | Automatically started the application. | - | - | Y | Y | - |
| [7311] Start of an application has failed. | Failed to start Application | - | - | Y | Y | - |
| [7313] An application has ended abnormally. | Application was terminated abnormally | - | - | Y | Y | - |
| [7315] App start duplicated error | App start duplicated error. Please retry later. | - | - | Y | Y | - |
| [7316] Invalid application license | Application license is invalid. | - | - | Y | Y | - |
| [7320] The license of an application is enabled | Application license was activated. | - | - | Y | Y | - |
| [7321] Enabling of the license for an application has failed. | Failed to activation of application license | - | - | Y | Y | - |
| [7322] The license of an application has been disabled. | Application license was inactivated. | - | - | Y | Y | - |
| [7323] Disabling of the license for an application has failed. | Failed to inactivation of application license | - | - | Y | Y | - |
| [7324] Installation of the application license has succeeded. | Installed the application license. | - | - | Y | Y | - |
| [7325] Installation of the application license has failed. | Failed to install the application license. | - | - | Y | Y | - |
| [7326] Application license has been uninstalled. | Application license uninstalled. | - | - | Y | Y | - |
| [7327] Uninstallation of the application license has failed. | Failed to uninstall the application license. | - | - | Y | Y | - |
| [7328] Deletion of all the application licenses has succeeded. | Application license removal completed | - | - | Y | Y | - |
| [7329] Deletion of all the application licenses has failed. | Failed to completely delete application license. | - | - | Y | Y | - |
| [7330] The validated date of the license for an application will nearly have expired. | The expiration date of the license of the application approaches. | - | - | Y | Y | - |
| [7331] The validity date of the license for an application has expired. | The time limit of the application license expired. | - | - | Y | Y | - |
| [7332] Application installation error | Failed to install Application. Please update the Application. | - | - | Y | Y | - |
| [7333] Application start error | Failed to start Application. Please update the Application. | - | - | Y | Y | - |
| [7334] Installation of the application localization data has succeeded. | Successfully installed Application Localization. | - | - | Y | Y | - |
| [7335] Installation of the application localization data has failed. | Failed to install Application Localization. | - | - | Y | Y | - |
| [7336] Application install error | Application install error. The application is not supported for this MFP. | - | - | Y | Y | - |

| Code | Message | Error code display media | | | | |
|--|---|--------------------------|----|----|------|-----|
| | | Panl | JL | ML | Noti | CSV |
| [7337] Automatic addition of application icons has failed since the Home screen to which they are automatically added had already become full | Failed to add application button automatically. | - | - | Y | Y | - |
| [7338] Application installation error (The application does not exist or is being operated.) | Failed to install Application. The application does not exist or is being operated | - | - | Y | Y | - |
| [7339] Application installation error (The use of the embedded application is not allowed.) | Failed to install Application. The use of the embedded application is not allowed. | - | - | Y | Y | - |
| [7340] Application installation error (The framework version of the MFP is old.) | Failed to install Application. The framework version of the MFP is old. | - | - | Y | Y | - |
| [7341] Application installation error (The version of the application is old.) | Failed to install Application. The version of the application is old. | - | - | Y | Y | - |
| [7342] Application installation error (Other jobs exist.) | Failed to install Application. Other jobs exist. | - | - | Y | Y | - |
| [7343] Application installation error (The control panel is being used or another service is being operated.) | Failed to install Application. The panel is being operated or other jobs are being running. | - | - | Y | Y | - |
| [7344] Installation or updating of the application has failed since files or folders could not be created. | Failed to install Application. Access to a file or folder failed. | - | - | Y | Y | - |
| [7345] Installation or updating of the application has failed since not enough space is remaining in a file storage device. | Failed to install Application. Not enough space has remained in a file storage. | - | - | Y | Y | - |
| [7346] Installation or updating of the application has failed since no execution privilege has been assigned (while the user authentication is enabled). | Failed to install Application. No execution privilege | - | - | Y | Y | - |
| [7347] Installation or updating of the application has failed since the file does not exist. | Failed to install Application. No files exist | - | - | Y | Y | - |
| [7348] Installation or updating of the application has failed since the application package is invalid. | Failed to install Application. Application package is invalid. | - | - | Y | Y | - |
| [7349] Installation or updating of the application has failed since the signature of the application package is invalid. | Failed to install Application. Application package signature is invalid. | - | - | Y | Y | - |
| [7350] Installation or updating of the application has failed since the application package to be installed is not supported by the MFP. | Failed to install Application. Application does not operate in this MFP. | - | - | Y | Y | - |
| [7351] Application installation error (The registration number has exceeded the maximum.) | Failed to install Application. The registration numbers exceeded the upper limit. | - | - | Y | Y | - |
| [7352] Installation or updating of the application has failed since the required operation is not supported. | Failed to install Application. The required operation is not supported. | - | - | Y | Y | - |
| [7353] Application uninstallation error (The application does not exist or is being operated.) | Application uninstall error. The application does not exist or is being operated | - | - | Y | Y | - |
| [7354] Application uninstallation error (Other jobs exist.) | Application uninstall error. Other jobs exist. | - | - | Y | Y | - |
| [7355] Application uninstallation error (The control panel is being used or another service is being operated.) | Application uninstall error. The panel is being operated or other jobs are being running. | - | - | Y | Y | - |

| Code | Message | Error code display media | | | | |
|--|---|--------------------------|----|----|------|-----|
| | | Panl | JL | ML | Noti | CSV |
| [7356] Uninstallation of the application has failed since no execution privilege has been assigned (while the user authentication is enabled). | Application uninstal error. No execution privilege | - | - | Y | Y | - |
| [7357] Application rollback has succeeded. | Succeeded to rollback applications | - | - | Y | Y | - |
| [7358] Application rollback has failed. | Failed to rollback applications | - | - | Y | Y | - |
| [7359] Application rollback error (The application does not exist or is being operated) | Application rollback error The application does not exist or is being operated | - | - | Y | Y | - |
| [7360] Application rollback error (Other jobs exist.) | Application rollback error Other jobs exist. | - | - | Y | Y | - |
| [7361] Application rollback error (The control panel is being used or another service is being operated.) | Application rollback error The panel is being operated or other jobs are being running. | - | - | Y | Y | - |
| [7362] Application rollback has failed since no execution privilege has been assigned. | Application rollback error No execution privilege | - | - | Y | Y | - |
| [7400] License activation success (Online) | License Activation Success(Online) | - | - | Y | Y | - |
| [7401] License activation success (Offline) | License Activation Success(Offline) | - | - | Y | Y | - |
| [7402] License activation failure (Online) | License Activation failed | - | - | Y | Y | - |
| [7403] License activation failure (network timeout) | License Activation failed, NW timeout | - | - | Y | Y | - |
| [7404] License activation failure (network error) | License Activation failed, NW error | - | - | Y | Y | - |
| [7410] License deactivation success (Online) | License Deactivate Success(Online) | - | - | Y | Y | - |
| [7411] License deletion success (Offline) | License Deactivate Success(Offline) | - | - | Y | Y | - |
| [7412] License deactivation failure (Online) | License Deactivation failed | - | - | Y | Y | - |
| [7423] License deactivation failure (network timeout) | License Deactivation failed, NW timeout | - | - | Y | Y | - |
| [7424] License deactivation failure (network error) | License Deactivation failed, NW error | - | - | Y | Y | - |
| [7430] Serial number mismatching | License Activation failed, Invalid serial number | - | - | Y | Y | - |
| [7431] Subnet mismatching | License Activation failed, Invalid subnet | - | - | Y | Y | - |
| [7432] Domain mismatching | License Activation failed, Invalid Domain | - | - | Y | Y | - |
| [7433] Invalid license certificates ID | License Activation failed (Invalid input) | - | - | Y | Y | Y |
| [7434] License duplicating installation | License Activation failed (Same license) | - | - | Y | Y | Y |
| [7435] Unsupported license activation | License Activation failed (unsupported license) | - | - | Y | Y | Y |
| [7440] Signature mismatching | License file Signature mismatch error | - | - | Y | Y | - |
| [7441] End of the trial period | Trial License expired | - | - | Y | Y | - |
| [7442] End of the valid period | License period expired | - | - | Y | Y | - |
| [7444] No license exists | License Not Found | - | - | Y | Y | - |
| [7445] Full of the license | License Full | - | - | Y | Y | - |
| [7470] Creation of the debug log has succeeded. | Succeeded to create debug log | - | - | Y | - | - |
| [7471] Debug log creation failure | Failed to create debug log | - | - | Y | - | - |

| Code | Message | Error code display media | | | | |
|---|---|--------------------------|----|----|------|-----|
| | | Panl | JL | ML | Noti | CSV |
| [7472] Transmission of the debug log to the remote maintenance service has succeeded. | Succeeded to transmit the debug log to the remote maintenance service | - | - | Y | - | - |
| [7473] Debug log to the remote maintenance service transmission failure | Failed to transmit the debug log to the remote maintenance service | - | - | Y | - | - |
| [7474] Transmission of the debug log by an e-mail has succeeded. | Succeeded to transmit the debug log by an e-mail | - | - | Y | - | - |
| [7475] Debug log by an e-mail transmission failure | Failed to transmit the debug log by an e-mail | - | - | Y | - | - |
| [7476] Obtaining of the print data has succeeded. | Succeeded to obtain print data | - | - | Y | - | - |
| [7477] Print data collection failure | Failed to obtain print data | - | - | Y | - | - |
| [7478] Transmission of the print data to the remote maintenance service has succeeded. | Succeeded to transmit the print data to the remote maintenance service | - | - | Y | - | - |
| [7479] Print data to the remote maintenance service transmission failure | Failed to transmit the print data to the remote maintenance service | - | - | Y | - | - |
| [747A] Transmission of the print data by an e-mail has succeeded. | Succeeded to transmit the print data by an e-mail | - | - | Y | - | - |
| [747B] Print data by an e-mail transmission failure | Failed to transmit the print data by an e-mail | - | - | Y | - | - |
| [747C] Print data by an e-mail transmission failure (Data size exceeding error) | Failed to transmit the print data by an e-mail (exceeding the maximum size) | - | - | Y | - | - |
| [747D] Obtaining of the network capture has succeeded. | Succeeded to obtain the network capture | - | - | Y | - | - |
| [747E] Network capture collection failure | Failed to obtain the network capture | - | - | Y | - | - |
| [747F] Transmission of the network capture to the remote maintenance service has succeeded. | Succeeded to transmit the network capture to the remote maintenance service | - | - | Y | - | - |
| [7480] Network capture to the remote maintenance service transmission failure | Failed to transmit the network capture to the remote maintenance service | - | - | Y | - | - |
| [7481] Transmission of the network capture by an e-mail has succeeded. | Succeeded to transmit the network capture by an e-mail | - | - | Y | - | - |
| [7482] Network capture by an e-mail transmission failure | Failed to transmit the network capture to the remote maintenance service | - | - | Y | - | - |
| [7483] Network capture by an e-mail transmission failure (Data size exceeding error) | Failed to transmit the network capture to the remote maintenance service (exceeding the maximum size) | - | - | Y | - | - |
| [7484] Deletion of the log data has succeeded. | Succeeded to delete the log data | - | - | Y | - | - |
| [7485] Log data deletion failure | Failed to delete the log data | - | - | Y | - | - |
| [7486] The log level has been changed. | Log level changed | - | - | Y | - | - |
| [7487] The log level has been set to the default. | The log level set to the default | - | - | Y | - | - |
| [7488] Debug logs have been properly saved in a USB storage device. | Debug log was stored to USB. | - | - | Y | - | - |
| [7489] Debug logs saving failure | Failed to store the debug log to USB. | - | - | Y | - | - |
| [7490] Remote Panel Operation (Cloud hub) connection start | Remote panel connection started | - | - | Y | - | - |

| Code | Message | Error code display media | | | | |
|--|---|--------------------------|----|----|------|-----|
| | | Panl | JL | ML | Noti | CSV |
| [7491] Remote Panel Operation (Cloud hub) connection error: authentication error | Remote panel connection failed (authentication error) | - | - | Y | - | - |
| [7492] Remote Panel Operation (Cloud hub) connection error: network error | Remote panel connection failed (network error) | - | - | Y | - | - |
| [7493] Remote Panel Operation (Cloud hub) connection end | Remote panel connection ended | - | - | Y | - | - |
| [74A0] Anti-malware setting change | Edited Antimalware setting. | - | - | Y | - | - |
| [74A1] Updating of the firmware of the card reader has succeeded. | Successfully updated Firmware | - | - | Y | - | - |
| [74A2] Updating of the firmware of the card reader has failed. | Failed to update Firmware | - | - | Y | - | - |
| [74A3] The card reader has not been installed. Alternatively, the firmware of the installed card reader cannot be updated. | Card reader is not connected, or Card reader used cannot be updated with firmware | - | - | Y | - | - |
| [74A4] The specified file cannot be used for updating the firmware. | File is not a firmware update. | - | - | Y | - | - |
| [74A5] There are no files in the specified folder. | No firmware update file | - | - | Y | - | - |

8.2.8 Network error

| Code | Message | Error code display media | | | | |
|--|--|--------------------------|----|----|------|-----|
| | | Panl | JL | ML | Noti | CSV |
| [8000] IPv4 address conflict | Static address of IPv4 was duplicated. | - | - | Y | Y | - |
| [8011] IPv6 link local address conflict | Link Local address of IPv6 was duplicated. | - | - | Y | Y | - |
| [8012] IPv6 manual address conflict | Manual address of IPv6 was duplicated. | - | - | Y | Y | - |
| [8013] IPv6 stateless address conflict | Stateless address of IPv6 was duplicated. | - | - | Y | Y | - |
| [8014] IPv6 stateful address conflict | Stateful address of IPv6 was duplicated. | - | - | Y | Y | - |
| [8021] Authentication success | - | - | - | - | - | - |
| [8022] 802.1X authentication failure | Authentication Failure | - | - | Y | - | - |
| [8023] Connection failure to an authentication server and a switch | Can not contact Authentication Server/Switch | - | - | Y | - | - |
| [8024] Certificates verification failure | Certificate verification Failure | - | - | Y | - | - |
| [8031] IPsec error for IKEv1 certification failure | No IKE proposal chosen | - | - | Y | Y | - |
| [8032] IPsec error for wrong proposal selection | IKE Certificate Authentication failed | - | - | Y | Y | - |
| [8033] IPsec error for shared key authentication failure | IKE Pre-shared key Authentication failed | - | - | Y | Y | - |
| [8034] IPsec error for invalid certificates upload | Invalid Certificate | - | - | Y | Y | - |
| [8035] IPsec error for non-supported certificates | Certificate Type unsupported | - | - | Y | Y | - |
| [8036] IPsec error for invalid certificates of authentication | Invalid Certificate | - | - | Y | Y | - |
| [8037] IPsec error for certificates disable | Certificate unavailable | - | - | Y | Y | - |
| [8038] IPsec error for SA non-existing | No ISAKMP SA established | - | - | Y | Y | - |
| [8039] IPsec error for invalid signature for certification | Invalid Signature | - | - | Y | Y | - |
| [803A] IPsec error for wrong selection of proposal | No IKEv2 proposal chosen | - | - | Y | Y | - |
| [803B] IPsec error for IKEv2 certification failure | IKEv2 Certificate Authentication failed | - | - | Y | Y | - |
| [803C] IKEv2 error for IKEv2 if secret key authentication failed | IKEv2 Secret key Authentication failed | - | - | Y | Y | - |
| [803D] IPsec error if peer does not support IKEv2 and falling back to IKEv1 | Falling Back to IKEv1 | - | - | Y | Y | - |
| [803E] IPsec error if ISAKMP SA is uncreated or destroyed due to some uncertain conditions | ISAKMP SA unusable (deleted) | - | - | Y | Y | - |
| [803F] IPsec error for IKEv2 if crypto operation failed | Crypto operation failed | - | - | Y | Y | - |
| [8040] IPsec error for IKEv2 if key info is invalid | Invalid key information | - | - | Y | Y | - |
| [8041] IPsec error for IKEv2 if CA is not trusted | CA not trusted | - | - | Y | Y | - |
| [8042] IPsec error for authentication method inconsistency | Authentication Method mismatch | - | - | Y | Y | - |
| [8043] IPsec error for version inconsistency | IKE Version mismatch | - | - | Y | Y | - |
| [8044] IPsec error for encapsulation inconsistency | Encapsulation mode mismatch | - | - | Y | Y | - |

| Code | Message | Error code display media | | | | |
|--|---|--------------------------|----|----|------|-----|
| | | Panl | JL | ML | Noti | CSV |
| [8045] IPsec error for peer IP inconsistency | Peer IP Address mismatch | - | - | Y | Y | - |
| [8046] IPsec error for local IP inconsistency | Local IP Address mismatch | - | - | Y | Y | - |
| [8047] IPsec error for local ID inconsistency | Local ID mismatch | - | - | Y | Y | - |
| [8048] IPsec error for remote ID inconsistency | Remote ID mismatch | - | - | Y | Y | - |
| [8049] IPsec error for remote IP inconsistency | IPsec Remote IP mismatch | - | - | Y | Y | - |
| [804A] IPsec error for IKEv2 timeout | IKEv1/IKEv2 Timed out | - | - | Y | Y | - |
| [804B] IPsec error for invalid of ID manual key | Invalid manual key data | - | - | Y | Y | - |
| [8061] Update error for secure primary DDNS | Secure Update to Primary DDNS failed. | - | - | Y | Y | - |
| [8062] Update error for secure secondary DDNS | Secure Update to Secondary DDNS failed. | - | - | Y | Y | - |
| [8063] Update error for IPv6 secure primary DDNS | Secure update to primary IPv6 server failed | - | - | Y | Y | - |
| [8064] Update error for IPv6 secure secondary DDNS | Secure Update to Secondary IPv6 DDNS failed | - | - | Y | Y | - |
| [8065] Update error for IPv6 primary DDNS | IPv6 Update to Primary DDNS failed. | - | - | Y | Y | - |
| [8066] Update error for IPv6 secondary DDNS | IPv6 Update to Secondary DDNS failed. | - | - | Y | Y | - |
| [8067] Update error for IPv4 primary DDNS | IPv4 Update to Primary DDNS failed. | - | - | Y | Y | - |
| [8068] Update error for IPv4 secondary DDNS | IPv4 Update to Secondary DDNS failed. | - | - | Y | Y | - |
| [8069] Message displayed when the key file for SIG(0) or TSIG is invalid | Invalid TSIG/SIG(0) Key file uploaded | - | - | Y | Y | - |
| [80B1] Bluetooth connection failure | Bluetooth Disconnected | - | - | Y | Y | - |
| [80B2] Bluetooth print error | Bluetooth Print error | - | - | Y | Y | - |
| [80B3] Bluetooth fatal error | Bluetooth Fatal error | - | - | Y | Y | - |
| [80B4] Bluetooth storage nearly full | Bluetooth Storage Near Full | - | - | Y | Y | - |
| [80B5] Bluetooth storage full | Bluetooth Storage Full | - | - | Y | Y | - |
| [80C0] TLS session establishment failure (invalid message) | Failed to establish the TLS session (unexpected message) | - | - | Y | Y | - |
| [80C1] TLS session establishment failure (invalid MAC data) | Failed to establish the TLS session (bad record mac) | - | - | Y | Y | - |
| [80C2] TLS session establishment failure (decoding failure) | Failed to establish the TLS session (decryption failed) | - | - | Y | Y | - |
| [80C3] TLS session establishment failure (recording length abnormality) | Failed to establish the TLS session (record overflow) | - | - | Y | Y | - |
| [80C4] TLS session establishment failure (data decompression failure) | Failed to establish the TLS session (decompression failure) | - | - | Y | Y | - |
| [80C5] TLS session establishment failure (handshake failure) | Failed to establish the TLS session (handshake failure) | - | - | Y | Y | - |
| [80C6] TLS session establishment failure (certificate abnormality) | Failed to establish the TLS session (bad certificate) | - | - | Y | Y | - |
| [80C7] TLS session establishment failure (non-support certificate) | Failed to establish the TLS session (unsupported certificate) | - | - | Y | Y | - |
| [80C8] TLS session establishment failure (invalid certificate) | Failed to establish the TLS session (certificate revoked) | - | - | Y | Y | - |

| Code | Message | Error code display media | | | | |
|---|---|--------------------------|----|----|------|-----|
| | | Panl | JL | ML | Noti | CSV |
| [80C9] TLS session establishment failure (certificate with validity date expired) | Failed to establish the TLS session (certificate expired) | - | - | Y | Y | - |
| [80CA] TLS session establishment failure (certificate process error) | Failed to establish the TLS session (certificate unknown) | - | - | Y | Y | - |
| [80CB] TLS session establishment failure (invalid parameter) | Failed to establish the TLS session (illegal parameter) | - | - | Y | Y | - |
| [80CC] TLS session establishment failure (unknown CA certificate) | Failed to establish the TLS session (unknown ca) | - | - | Y | Y | - |
| [80CD] TLS session establishment failure (access rejection) | Failed to establish the TLS session (access denied) | - | - | Y | Y | - |
| [80CE] TLS session establishment failure (decoding error) | Failed to establish the TLS session (decode error) | - | - | Y | Y | - |
| [80CF] TLS session establishment failure (decryption error) | Failed to establish the TLS session (decrypt error) | - | - | Y | Y | - |
| [80D0] TLS session establishment failure (export restrictions) | Failed to establish the TLS session (export restriction) | - | - | Y | Y | - |
| [80D1] TLS session establishment failure (non-support protocol version) | Failed to establish the TLS session (protocol version) | - | - | Y | Y | - |
| [80D2] TLS session establishment failure (internal error) | Failed to establish the TLS session (internal error) | - | - | Y | Y | - |
| [80D3] TLS session establishment failure (cancellation by a user) | Failed to establish the TLS session (user canceled) | - | - | Y | Y | - |
| [80D4] TLS session establishment failure (invalid renegotiation) | Failed to establish the TLS session (no renegotiation) | - | - | Y | Y | - |
| [80F0] LDAP DB damage detection | LDAP DB damage detected | - | - | Y | - | - |
| [8101] Wireless connection in the Access point failure | Wireless association with Access point failure | - | - | Y | - | - |
| [8102] Connection failure of MFP to the Access point with a specified SSID | MFP not able to contact the Access point with the specified SSID | - | - | Y | - | - |
| [8103] Wireless certificate verification failure | Wireless Certificate verification failure | - | - | Y | - | - |
| [8104] Wireless LAN / Bluetooth module hardware error | Wireless module Error | - | - | Y | - | - |
| [8106] The number of connection sessions of Wi-Fi Direct has reached the maximum. | Wi-Fi Direct Session MAX | - | - | Y | - | - |
| [8121] Domain: Authentication failure | Domain - General Failure during Authentication | - | - | Y | Y | - |
| [8122] Domain: Invalid user name or password | Domain - Invalid Username or Password | - | - | Y | Y | - |
| [8123] Domain: Invalid server | Domain - Server not present in Network | - | - | Y | Y | - |
| [8124] Domain: Invalid user account | Domain - User account is disabled on Server | - | - | Y | Y | - |
| [8125] Domain: Expired user account | Domain - User account has expired and cannot be used for logon | - | - | Y | Y | - |
| [8126] Domain: Locked user account | Domain - User account is locked and cannot be used for logon | - | - | Y | Y | - |
| [8127] Domain: Invalid log-in time | Domain - Invalid logon hours for the User | - | - | Y | Y | - |
| [8128] Active directory domain: Clock skew error | Active Directory Domain - Clock Skew error due to difference in Time between Server and MFP | - | - | Y | Y | - |

| Code | Message | Error code display media | | | | |
|--|---|--------------------------|----|----|------|-----|
| | | Panl | JL | ML | Noti | CSV |
| [8129] Active directory domain: Expired Kerberos ticket | Active Directory Domain - Kerberos Ticket has expired and cannot be used for Authentication | - | - | Y | Y | - |
| [812A] Active directory domain: Kerberos ticket authentication failure | Active Directory Domain - Verification of the Ticket has failed | - | - | Y | Y | - |
| [812B] Active directory domain: Invalid realm name | Active Directory Domain-The Domain specified could not be found | - | - | Y | Y | - |
| [8200] The IPv4 address has conflicted. (Secondary interface) | Static address of IPv4 was duplicated. (secondary) | - | - | Y | Y | - |
| [8211] The IPv6 link local address has conflicted. (Secondary interface) | Link Local address of IPv6 was duplicated. (secondary) | - | - | Y | Y | - |
| [8212] The IPv6 manual address has conflicted. (Secondary interface) | Manual address of IPv6 was duplicated. (secondary) | - | - | Y | Y | - |
| [8213] The IPv6 stateless address has conflicted. (Secondary interface) | Stateless address of IPv6 was duplicated. (secondary) | - | - | Y | Y | - |
| [8214] The IPv6 stateful address has conflicted. (Secondary interface) | Stateful address of IPv6 was duplicated. (secondary) | - | - | Y | Y | - |

8.2.9 Notification

| Code | Message | Error code display media | | | | |
|---|---|--------------------------|----|----|------|-----|
| | | Panl | JL | ML | Noti | CSV |
| [D101] Paper presence/absence in the LCF | Paper Empty in Large Capacity Feeder - Please Add Paper. | - | - | Y | Y | - |
| [D102] Paper presence/absence in the SFB | - | - | - | - | - | - |
| [D103] Paper presence/absence in the 1st drawer | Paper Empty in Drawer 1 - Please Add Paper. | - | - | Y | Y | - |
| [D104] Paper presence/absence in the 2nd drawer | Paper Empty in Tray 2 - Please Add Paper. | - | - | Y | Y | - |
| [D105] Paper presence/absence in the PFP1 | Paper Empty in Drawer 3 - Please Add Paper. | - | - | Y | Y | - |
| [D106] Paper presence/absence in the PFP2 | Paper Empty in Drawer 4 - Please Add Paper. | - | - | Y | Y | - |
| [D201] Front cover | Front Cover Open - Please Close Cover. | - | - | Y | Y | - |
| [D202] Paper feed cover of the MFP | Paper Feeding Cover Open - Please Close Cover. | - | - | Y | Y | - |
| [D204] T-LCF cover (taking off of the LCF (large capacitor feeder)) | Lower Side Cover Open - Please Close Cover. | - | - | Y | Y | - |
| [D205] Paper feed cover of the PFP (side cover) | Lower Side Cover Open - Please Close Cover. | - | - | Y | Y | - |
| [D206] ADU cover / unit | Automatic Duplexing Unit Cover Open - Please Close Cover. | - | - | Y | Y | - |
| [D207] Bridge kit transport cover | Relay Unit Cover Open - Please Close Cover. | - | - | Y | Y | - |
| [D209] Finisher joint has come off | Finisher Joint Cover Open - Please Close Cover. | - | - | Y | Y | - |
| [D20A] Finisher door | Finisher Door Open - Please Close Door. | - | - | Y | Y | - |
| [D20E] Saddle stitch stapler connection | Lower Tray Delivery Cover Open - Please Close Cover | - | - | Y | Y | - |
| [D20F] Front cover of the punch unit | Punch Unit Front Cover Open - Please Close Cover. | - | - | Y | Y | - |
| [D211] Job separator cover | Job Separator Cover Open - Please Close Cover. | - | - | Y | Y | - |
| [D217] Top cover of the Finisher | Finisher Door Open - Please Close Door. | - | - | Y | Y | - |
| [D301] Toner (K) empty | Black Toner Empty - Please Refill. | - | - | Y | Y | - |
| [D302] Toner (C) empty | Cyan Toner Empty - Please Refill. | - | - | Y | Y | - |
| [D303] Toner (M) empty | Magenta Toner Empty - Please Refill. | - | - | Y | Y | - |
| [D304] Toner (Y) empty | Yellow Toner Empty - Please Refill. | - | - | Y | Y | - |
| [D30F] Waste toner box full | Waste Toner Box Full - Please Replace. | - | - | Y | Y | - |
| [D311] Non-genuine toner (K) | - | - | - | - | - | - |
| [D312] Non-genuine toner (C) | - | - | - | - | - | - |
| [D313] Non-genuine toner (M) | - | - | - | - | - | - |
| [D314] Non-genuine toner (Y) | - | - | - | - | - | - |
| [D321] Toner (K) nearly empty | - | Y | - | - | - | - |
| [D322] Toner (C) nearly empty | - | Y | - | - | - | - |
| [D323] Toner (M) nearly empty | - | Y | - | - | - | - |
| [D324] Toner (Y) nearly empty | - | Y | - | - | - | - |

| Code | Message | Error code display media | | | | |
|--|--------------------------------------|--------------------------|----|----|------|-----|
| | | Panl | JL | ML | Noti | CSV |
| [D32E] Waste toner box nearly full | - | - | - | - | Y | - |
| [D341] Cartridge (K) empty | Black Toner Empty - Please Refill. | - | - | Y | - | - |
| [D342] Cartridge (C) empty | Cyan Toner Empty - Please Refill. | - | - | Y | - | - |
| [D343] Cartridge (M) empty | Magenta Toner Empty - Please Refill. | - | - | Y | - | - |
| [D344] Cartridge (Y) empty | Yellow Toner Empty - Please Refill. | - | - | Y | - | - |
| [D361] Fuser unit replacement completion | New unit was installed | - | - | Y | - | - |
| [D362] EPU (K) replacement completion | New unit was installed | - | - | Y | - | - |
| [D363] EPU (C) replacement completion | New unit was installed | - | - | Y | - | - |
| [D364] EPU (M) replacement completion | New unit was installed | - | - | Y | - | - |
| [D365] EPU (Y) replacement completion | New unit was installed | - | - | Y | - | - |
| [D366] EPU2 (K) replacement completion | New unit was installed | - | - | Y | - | - |
| [D367] EPU2 (C) replacement completion | New unit was installed | - | - | Y | - | - |
| [D368] EPU2 (M) replacement completion | New unit was installed | - | - | Y | - | - |
| [D369] EPU2 (Y) replacement completion | New unit was installed | - | - | Y | - | - |
| [D401] 1st drawer | Close Drawer 1 | - | - | Y | Y | - |
| [D402] 2nd drawer | Close Drawer 2 | - | - | Y | Y | - |
| [D403] 3rd drawer | Close Drawer 3 | - | - | Y | Y | - |
| [D404] 4th drawer | Close Drawer 4 | - | - | Y | Y | - |
| [D405] Paper supply door of the T-LCF | Close large capacity feeder (LCF) | - | - | Y | Y | - |
| [D407] Paper supply door of the T-LCF (left side) | Close large capacity feeder (LCF) | - | - | Y | Y | - |
| [D711] 2nd drawer installation and removal | Add/Remove Drawer 2 | - | - | Y | Y | - |
| [D712] 3rd drawer installation and removal | Add/Remove Drawer 3 | - | - | Y | Y | - |
| [D713] 4th drawer installation and removal | Add/Remove Drawer 4 | - | - | Y | Y | - |
| [D718] LCF installation and removal | Add/Remove Large Capacity Feeder | - | - | Y | Y | - |
| [D730] Finisher installation and removal | Add/Remove Finisher | - | - | Y | Y | - |
| [D731] Saddle stitch unit installation and removal | Add/Remove Saddle Finisher | - | - | Y | Y | - |
| [D732] Hole punch unit installation and removal | Add/Remove Hole Punch Unit | - | - | Y | Y | - |
| [D750] ADU installation and removal | Add/Remove Automatic Duplexing Unit | - | - | Y | Y | - |
| [D751] Bridge kit installation and removal | Add/Remove Relay Unit | - | - | Y | Y | - |
| [D770] ADF installation and removal | Add/Remove Automatic Document Feeder | - | - | Y | Y | - |
| [D7B0] FAX Unit line 1 installation and removal | Add/Remove Fax Unit(Line1) | - | - | Y | Y | - |
| [D7B1] FAX Unit line 2 installation and removal | Add/Remove Fax Unit(Line2) | - | - | Y | Y | - |
| [D7E0] Coin controller installation and removal | Add/Remove Coin Controller | - | - | Y | Y | - |
| [D7E1] Key copy counter installation and removal | Add/Remove Key Copy Counter | - | - | Y | Y | - |
| [D800] Shutdown | The machine was shut down | - | - | Y | Y | - |
| [D801] Power ON | Turned on the power | - | - | Y | Y | - |
| [D802] Shifting into the energy saving mode | Gone into the power save mode | - | - | Y | Y | - |
| [D803] Shifting into the sleep mode | Gone into the sleep mode | - | - | Y | - | - |

| Code | Message | Error code display media | | | | |
|---|--------------------------------------|--------------------------|----|----|------|-----|
| | | PanI | JL | ML | Noti | CSV |
| [D804] Reboot execution | The machine was rebooted | - | - | Y | Y | - |
| [D805] Silent reboot | - | - | - | - | - | - |
| [D806] Rebooting for recovering from an internal error (service call) | Rebooted to address internal errors. | Y | - | Y | - | - |

8.2.10 FAX error

| Code | Message | Error code display media | | | | |
|---|--|--------------------------|----|----|------|-----|
| | | Panl | JL | ML | Noti | CSV |
| [0000] • Fax - The fax transmission has succeeded. - The fax reception has succeeded. • IP Fax - The IP Fax transmission has succeeded. - The IP Fax reception has succeeded. | <ul style="list-style-type: none"> Your Send Fax job is successfully completed Your Received Fax job is successfully completed Your Send IP Fax job is successfully completed Your Received IP Fax job is successfully completed | - | - | - | Y | - |
| [0012] Original jam | <ul style="list-style-type: none"> Failed to process your send Fax job Failed to process your received Fax job | - | - | - | Y | - |
| [0013] Cover is open | <ul style="list-style-type: none"> Failed to process your send Fax job Failed to process your received Fax job | - | - | - | Y | - |
| [0020] Power failure | <ul style="list-style-type: none"> Failed to process your send Fax job Failed to process your received Fax job Failed to process your send IP Fax job Failed to process your received IP Fax job | - | - | - | Y | - |
| [0030] Recording paper jam | <ul style="list-style-type: none"> Your Fax job is canceled Your received Fax job is canceled | - | - | - | Y | - |
| [0033] Polling error | <ul style="list-style-type: none"> Failed to process your send Fax job Failed to process your received Fax job | - | - | - | Y | - |
| [0040] Modem communication error | <ul style="list-style-type: none"> Failed to process your send Fax job Failed to process your received Fax job | - | - | - | Y | - |
| [0042] Memory full | <ul style="list-style-type: none"> Failed to process your received Fax job Failed to process your received IP Fax job | - | - | - | Y | - |
| [0050] Line is busy | <ul style="list-style-type: none"> Failed to process your send Fax job Failed to process your send IP Fax job | - | - | - | Y | - |
| [0051] No cable connected for fax line | Failed to process your send Fax job | Y | - | - | Y | - |
| [0052] T1 time-out | <ul style="list-style-type: none"> Failed to process your send Fax job Failed to process your received Fax job Failed to process your send IP Fax job Failed to process your received IP Fax job | - | - | - | Y | - |
| [00B0] Initial signal not detected | <ul style="list-style-type: none"> Failed to process your send Fax job Failed to process your received Fax job | - | - | - | Y | - |

| Code | Message | Error code display media | | | | |
|--|--|--------------------------|----|----|------|-----|
| | | PanI | JL | ML | Noti | CSV |
| [00B1] Terminal constants not compatible | <ul style="list-style-type: none"> Failed to process your send Fax job Failed to process your received Fax job Failed to process your send IP Fax job Failed to process your received IP Fax job | - | - | - | Y | - |
| [00B2] DCN reception (Phase B) | <ul style="list-style-type: none"> Failed to process your send Fax job Failed to process your received Fax job Failed to process your send IP Fax job Failed to process your received IP Fax job | - | - | - | Y | - |
| [00B3] DCS / DTC not detected | <ul style="list-style-type: none"> Failed to process your send Fax job Failed to process your received Fax job Failed to process your send IP Fax job Failed to process your received IP Fax job | - | - | - | Y | - |
| [00B4] Training error | <ul style="list-style-type: none"> Failed to process your send Fax job Failed to process your received Fax job Failed to process your send IP Fax job Failed to process your received IP Fax job | - | - | - | Y | - |
| [00B5] CFR not detected | <ul style="list-style-type: none"> Failed to process your send Fax job Failed to process your received Fax job Failed to process your send IP Fax job Failed to process your received IP Fax job | - | - | - | Y | - |
| [00B6] No response made to CTC | <ul style="list-style-type: none"> Failed to process your send Fax job Failed to process your received Fax job Failed to process your send IP Fax job Failed to process your received IP Fax job | - | - | - | Y | - |
| [00B7] Phase B cannot be completed | <ul style="list-style-type: none"> Failed to process your send Fax job Failed to process your received Fax job Failed to process your send IP Fax job Failed to process your received IP Fax job | - | - | - | Y | - |
| [00C0] Image signal carrier not detected | <ul style="list-style-type: none"> Failed to process your send Fax job Failed to process your received Fax job Failed to process your send IP Fax job Failed to process your received IP Fax job | - | - | - | Y | - |

| Code | Message | Error code display media | | | | |
|---|--|--------------------------|----|----|------|-----|
| | | PanI | JL | ML | Noti | CSV |
| [00C1] High-speed signal not detected | <ul style="list-style-type: none"> Failed to process your send Fax job Failed to process your received Fax job Failed to process your send IP Fax job Failed to process your received IP Fax job | - | - | - | Y | - |
| [00C2] Image signal carrier disconnected | <ul style="list-style-type: none"> Failed to process your send Fax job Failed to process your received Fax job Failed to process your send IP Fax job Failed to process your received IP Fax job | - | - | - | Y | - |
| [00C4] EOL time-out | <ul style="list-style-type: none"> Failed to process your send Fax job Failed to process your received Fax job Failed to process your send IP Fax job Failed to process your received IP Fax job | - | - | - | Y | - |
| [00C5] Excess length of data received | <ul style="list-style-type: none"> Failed to process your send Fax job Failed to process your received Fax job Failed to process your send IP Fax job Failed to process your received IP Fax job | - | - | - | Y | - |
| [00C6] Image code conversion error | <ul style="list-style-type: none"> Failed to process your send Fax job Failed to process your received Fax job Failed to process your send IP Fax job Failed to process your received IP Fax job | - | - | - | Y | - |
| [00C7] Phase C cannot be completed | <ul style="list-style-type: none"> Failed to process your send Fax job Failed to process your received Fax job Failed to process your send IP Fax job Failed to process your received IP Fax job | - | - | - | Y | - |
| [00C8] Transmitted image was not made in time | Failed to process your send IP Fax job | - | - | - | Y | - |
| [00D0] Post message not detected | <ul style="list-style-type: none"> Failed to process your send Fax job Failed to process your received Fax job Failed to process your send IP Fax job Failed to process your received IP Fax job | - | - | - | Y | - |

| Code | Message | Error code display media | | | | |
|---|--|--------------------------|----|----|------|-----|
| | | PanI | JL | ML | Noti | CSV |
| [00D1] DCN reception | <ul style="list-style-type: none"> Failed to process your send Fax job Failed to process your received Fax job Failed to process your send IP Fax job Failed to process your received IP Fax job | - | - | - | Y | - |
| [00D2] Poor image quality | <ul style="list-style-type: none"> Failed to process your send Fax job Failed to process your received Fax job Failed to process your send IP Fax job Failed to process your received IP Fax job | - | - | - | Y | - |
| [00D3] No response made to EOR | <ul style="list-style-type: none"> Failed to process your send Fax job Failed to process your received Fax job Failed to process your send IP Fax job Failed to process your received IP Fax job | - | - | - | Y | - |
| [00D4] No response made to RR | <ul style="list-style-type: none"> Failed to process your send Fax job Failed to process your received Fax job Failed to process your send IP Fax job Failed to process your received IP Fax job | - | - | - | Y | - |
| [00D5] T5 time-out | <ul style="list-style-type: none"> Failed to process your send Fax job Failed to process your received Fax job Failed to process your send IP Fax job Failed to process your received IP Fax job | - | - | - | Y | - |
| [00D6] ERR returned to EOR | <ul style="list-style-type: none"> Failed to process your send Fax job Failed to process your received Fax job Failed to process your send IP Fax job Failed to process your received IP Fax job | - | - | - | Y | - |
| [00D7] Line disconnected by transmission of EOR | <ul style="list-style-type: none"> Failed to process your send Fax job Failed to process your received Fax job Failed to process your send IP Fax job Failed to process your received IP Fax job | - | - | - | Y | - |
| [00D8] Time-out between FCD frame | <ul style="list-style-type: none"> Failed to process your send Fax job Failed to process your received Fax job Failed to process your send IP Fax job Failed to process your received IP Fax job | - | - | - | Y | - |

| Code | Message | Error code display media | | | | |
|--|--|--------------------------|----|----|------|-----|
| | | Panl | JL | ML | Noti | CSV |
| [00DA] MCF not returned | <ul style="list-style-type: none"> Failed to process your send Fax job Failed to process your received Fax job Failed to process your send IP Fax job Failed to process your received IP Fax job | - | - | - | Y | - |
| [00E8] Storage device error | <ul style="list-style-type: none"> Failed to process your send Fax job Failed to process your received Fax job Failed to process your send IP Fax job Failed to process your received IP Fax job | - | - | - | Y | - |
| [00F0] Software trouble | <ul style="list-style-type: none"> Failed to process your send Fax job Failed to process your received Fax job Failed to process your send IP Fax job Failed to process your received IP Fax job | - | - | - | Y | - |
| [00F1] Hardware noise | <ul style="list-style-type: none"> Failed to process your send Fax job Failed to process your received Fax job | - | - | - | Y | - |
| [00F4] Software trouble (Fax Unit) | <ul style="list-style-type: none"> Failed to process your send Fax job Failed to process your received Fax job | - | - | - | Y | - |
| [0100] Registration success | Registration to SIP server Success. | - | - | Y | Y | - |
| [0101] Response Time-out (Registration) | Registration to SIP server failed. | - | - | Y | Y | - |
| [0102] Response Time-out (Invite) | IP Fax response timeout error | - | - | - | Y | - |
| [0103] "Multiple Choices" reception | Registration to SIP server failed. | Y | - | Y | Y | - |
| [0104] "Moved Permanently" reception | Registration to SIP server failed. | Y | - | Y | Y | - |
| [0105] "Moved Temporarily" reception | Registration to SIP server failed. | Y | - | Y | Y | - |
| [0106] "Use Proxy" reception | Registration to SIP server failed. | Y | - | Y | Y | - |
| [0107] "Alternative Service" reception | Registration to SIP server failed. | Y | - | Y | Y | - |
| [0109] "Bad Request" reception | Registration to SIP server failed. | Y | - | Y | Y | - |
| [010A] "Unauthorized" reception | Registration to SIP server failed. | Y | - | Y | Y | - |
| [010B] "Payment Required" reception | Registration to SIP server failed. | Y | - | Y | Y | - |
| [010C] "Forbidden" reception | Registration to SIP server failed. | Y | - | Y | Y | - |
| [010D] "Not Found" reception | Registration to SIP server failed. | Y | - | Y | Y | - |
| [010E] "Method Not Allowed" reception | Registration to SIP server failed. | Y | - | Y | Y | - |
| [010F] "Not Acceptable" reception | Registration to SIP server failed. | Y | - | Y | Y | - |
| [0110] "Proxy Authentication Required" reception | Registration to SIP server failed. | Y | - | Y | Y | - |
| [0111] "Request Timeout" reception | Registration to SIP server failed. | Y | - | Y | Y | - |
| [0113] "Gone" reception | Registration to SIP server failed. | Y | - | Y | Y | - |
| [0115] "Precondition Failed" reception | Registration to SIP server failed. | Y | - | Y | Y | - |
| [0116] "Request Entity Too Large" reception | Registration to SIP server failed. | Y | - | Y | Y | - |
| [0117] "Request-URI Too Long" reception | Registration to SIP server failed. | Y | - | Y | Y | - |
| [0118] "Unsupported Media Type" reception | Registration to SIP server failed. | Y | - | Y | Y | - |

| Code | Message | Error code display media | | | | |
|--|---|--------------------------|----|----|------|-----|
| | | Panl | JL | ML | Noti | CSV |
| [0119] "Unsupported URI Scheme" reception | Registration to SIP server failed. | Y | - | Y | Y | - |
| [011A] "Unknown Resource-Priority" reception | Registration to SIP server failed. | Y | - | Y | Y | - |
| [011B] "Bad Extension" reception | Registration to SIP server failed. | Y | - | Y | Y | - |
| [011C] "Extension Required" reception | Registration to SIP server failed. | Y | - | Y | Y | - |
| [011D] "Session Timer Too Small" reception | Registration to SIP server failed. | Y | - | Y | Y | - |
| [011E] "Interval Too Brief" reception | Registration to SIP server failed. | Y | - | Y | Y | - |
| [011F] "Anonymity disallowed" reception | Registration to SIP server failed. | Y | - | Y | Y | - |
| [0120] "Temporarily Unavailable" reception | Registration to SIP server failed. | Y | - | Y | Y | - |
| [0121] "Call/Transaction Does Not Exist" reception | Registration to SIP server failed. | Y | - | Y | Y | - |
| [0122] "Loop Detected" reception | Registration to SIP server failed. | Y | - | Y | Y | - |
| [0123] "Too Many Hops" reception | Registration to SIP server failed. | Y | - | Y | Y | - |
| [0124] "Address Incomplete" reception | Registration to SIP server failed. | Y | - | Y | Y | - |
| [0125] "Ambiguous" reception | Registration to SIP server failed. | Y | - | Y | Y | - |
| [0126] "Busy Here" reception | Registration to SIP server failed. | Y | - | Y | Y | - |
| [0127] "Request Terminated" reception | Registration to SIP server failed. | Y | - | Y | Y | - |
| [0128] "Not acceptable here" reception | Registration to SIP server failed. | Y | - | Y | Y | - |
| [0129] "Bad Event" reception | Registration to SIP server failed. | Y | - | Y | Y | - |
| [012A] "Request Updated" reception | Registration to SIP server failed. | Y | - | Y | Y | - |
| [012B] "Request Pending" reception | Registration to SIP server failed. | Y | - | Y | Y | - |
| [012C] "Undecipherable" reception | Registration to SIP server failed. | Y | - | Y | Y | - |
| [012D] "Security Agreement Required" reception | Registration to SIP server failed. | Y | - | Y | Y | - |
| [012E] "Internal Server Error" reception | Registration to SIP server failed. | Y | - | Y | Y | - |
| [012F] "Not Implemented" reception | Registration to SIP server failed. | Y | - | Y | Y | - |
| [0130] "Bad Gateway" reception | Registration to SIP server failed. | Y | - | Y | Y | - |
| [0131] "Service Unavailable" reception | (Panl) Due to IP line traffic,It may take time to send. (ML) Transmission takes time because IP line is crowded. | Y | - | Y | Y | - |
| [0132] "Gateway Time-out" reception | Registration to SIP server failed. | Y | - | Y | Y | - |
| [0133] "Version Not Supported" reception | Registration to SIP server failed. | Y | - | Y | Y | - |
| [0134] "Message Too Large" reception | Registration to SIP server failed. | Y | - | Y | Y | - |
| [0135] "Precondition Failure" reception | Registration to SIP server failed. | Y | - | Y | Y | - |
| [0136] "Busy Everywhere" reception | Registration to SIP server failed. | Y | - | Y | Y | - |
| [0137] "Decline" reception | Registration to SIP server failed. | Y | - | Y | Y | - |
| [0138] "Does Not Exist Anywhere" reception | Registration to SIP server failed. | Y | - | Y | Y | - |
| [0139] "Not Acceptable" reception | Registration to SIP server failed. | Y | - | Y | Y | - |
| [013D] Other errors | Registration to SIP server failed. | Y | - | Y | Y | - |
| [013E] Other errors | IP Fax communication error | - | - | - | Y | - |
| [0140] Startup failure | (Panl) Reboot machine due to IP Fax initializing error. (ML) Failed to start IP Fax. | Y | - | Y | Y | - |
| [0141] Job interruption due to setting change | JOB interruption due to setting change occurred | - | - | - | Y | - |
| [0142] Recipient entry error | IP Fax communication error | - | - | - | Y | - |
| [0143] SIP server is unavailable | IP Fax communication error | - | - | - | Y | - |
| [0144] Under congestion | IP Fax communication error | - | - | - | Y | - |
| [0150] Disconnected by other side's device | IP Fax communication error | - | - | - | Y | - |

| Code | Message | Error code display media | | | | |
|--|--|--------------------------|----|----|------|-----|
| | | Panl | JL | ML | Noti | CSV |
| [0200] The IP Fax transmission has been completed. | Your Send IP Fax job is successfully completed | - | - | - | Y | - |
| [0300] "Multiple Choices" reception | IP Fax communication error | - | - | - | Y | - |
| [0301] "Moved Permanently" reception | IP Fax communication error | - | - | - | Y | - |
| [0302] "Moved Temporarily" reception | IP Fax communication error | - | - | - | Y | - |
| [0305] "Use Proxy" reception | IP Fax communication error | - | - | - | Y | - |
| [0380] "Alternative Service" reception | IP Fax communication error | - | - | - | Y | - |
| [0400] "Bad Request" reception | IP Fax communication error | - | - | - | Y | - |
| [0401] "Unauthorized" reception | IP Fax communication error | - | - | - | Y | - |
| [0402] "Payment Required" reception | IP Fax communication error | - | - | - | Y | - |
| [0403] "Forbidden" reception | IP Fax communication error | - | - | - | Y | - |
| [0404] "Not Found" reception | IP Fax communication error | - | - | - | Y | - |
| [0405] "Method Not Allowed" reception | IP Fax communication error | - | - | - | Y | - |
| [0406] "Not Acceptable" reception | IP Fax communication error | - | - | - | Y | - |
| [0407] "Proxy Authentication Required" reception | IP Fax communication error | - | - | - | Y | - |
| [0408] "Request Timeout" reception | IP Fax communication error | - | - | - | Y | - |
| [0410] "Gone" reception | IP Fax communication error | - | - | - | Y | - |
| [0412] "Precondition Failed" reception | IP Fax communication error | - | - | - | Y | - |
| [0413] "Request Entity Too Large" reception | IP Fax communication error | - | - | - | Y | - |
| [0414] "Request-URI Too Long" reception | IP Fax communication error | - | - | - | Y | - |
| [0415] "Unsupported Media Type" reception | IP Fax communication error | - | - | - | Y | - |
| [0416] "Unsupported URI Scheme" reception | IP Fax communication error | - | - | - | Y | - |
| [0417] "Unknown Resource-Priority" reception | IP Fax communication error | - | - | - | Y | - |
| [0420] "Bad Extension" reception | IP Fax communication error | - | - | - | Y | - |
| [0421] "Extension Required" reception | IP Fax communication error | - | - | - | Y | - |
| [0422] "Session Timer Too Small" reception | IP Fax communication error | - | - | - | Y | - |
| [0423] "Interval Too Brief" reception | IP Fax communication error | - | - | - | Y | - |
| [0433] "Anonymity disallowed" reception | IP Fax communication error | - | - | - | Y | - |
| [0480] "Temporarily Unavailable" reception | IP Fax communication error | - | - | - | Y | - |
| [0481] "Call/Transaction Does Not Exist" reception | IP Fax communication error | - | - | - | Y | - |
| [0482] "Loop Detected" reception | IP Fax communication error | - | - | - | Y | - |
| [0483] "Too Many Hops" reception | IP Fax communication error | - | - | - | Y | - |
| [0484] "Address Incomplete" reception | IP Fax communication error | - | - | - | Y | - |
| [0485] "Ambiguous" reception | IP Fax communication error | - | - | - | Y | - |
| [0486] "Busy Here" reception | IP Fax communication error | - | - | - | Y | - |
| [0487] "Request Terminated" reception | IP Fax communication error | - | - | - | Y | - |
| [0488] "Not acceptable here" reception | IP Fax communication error | - | - | - | Y | - |
| [0489] "Bad Event" reception | IP Fax communication error | - | - | - | Y | - |
| [0490] "Request Updated" reception | IP Fax communication error | - | - | - | Y | - |
| [0491] "Request Pending" reception | IP Fax communication error | - | - | - | Y | - |
| [0493] "Undecipherable" reception | IP Fax communication error | - | - | - | Y | - |
| [0494] "Security Agreement Required" reception | IP Fax communication error | - | - | - | Y | - |
| [0500] "Internal Server Error" reception | IP Fax communication error | - | - | - | Y | - |
| [0501] "Not Implemented" reception | IP Fax communication error | - | - | - | Y | - |

| Code | Message | Error code display media | | | | |
|--|--|--------------------------|----|----|------|-----|
| | | Panl | JL | ML | Noti | CSV |
| [0502] "Bad Gateway" reception | IP Fax communication error | - | - | - | Y | - |
| [0503] "Service Unavailable" reception | (Panl) Due to IP line traffic,It may take time to send. (ML) Transmission takes time because IP line is crowded. | Y | - | - | Y | - |
| [0504] "Gateway Time-out" reception | IP Fax communication error | - | - | - | Y | - |
| [0505] "Version Not Supported" reception | IP Fax communication error | - | - | - | Y | - |
| [0513] "Message Too Large" reception | IP Fax communication error | - | - | - | Y | - |
| [0580] "Precondition Failure" reception | IP Fax communication error | - | - | - | Y | - |
| [0600] "Busy Everywhere" reception | IP Fax communication error | - | - | - | Y | - |
| [0603] "Decline" reception | IP Fax communication error | - | - | - | Y | - |
| [0604] "Does Not Exist Anywhere" reception | IP Fax communication error | - | - | - | Y | - |
| [0606] "Not Acceptable" reception | IP Fax communication error | - | - | - | Y | - |
| [4246] IP Fax license is not installed | IP Fax license is not installed | - | - | Y | - | - |
| [DA01] Fax Unit line 1 malfunction | (Panl) Fax line1 is out of order. Reboot the machine. (ML) FAX Unit Line1 is broken. Please Contact Service Technician. | Y | - | Y | - | - |
| [DA02] Fax Unit line 2 malfunction | (Panl) Fax line2 is out of order. Reboot the machine. (ML) FAX Unit Line2 is broken. Please Contact Service Technician. | Y | - | Y | - | - |

8.2.11 Error history

In the setting mode (FS-08-9703), the latest twenty groups of error data will be displayed.

Display
example

| | | | | | |
|------------|------------------|---------------------|-------------|-------------|---------------------------------|
| EA10 | 01234567 | 2021-07-11 17:05:32 | 064 | 064 | 2362_1000_0000_0 _XXXXXXXXXX |
| Error code | Total counter | YYYY-MM-DD HH:MM:SS | MMM | NNN | ABCD_EFHI_JLOP_Q_R |
| 4 digits | 8 digits | 14 digits | 3 digits | 3 digits | 23 digits |

| | |
|-----|--|
| A | Paper source (*1) |
| | 0: Not selected, 1: Bypass tray, 2: LCF, 3: 1st drawer, 4: 2nd drawer, 5: 3rd drawer, 6: 4th drawer, 7: Ex-LCF01(*1), 8: Unused, 9: Ex-LCF02(*2) |
| B | Paper size code |
| | 0: A5/ST, 1: A5-R, 2: ST-R, 3: LT, 4: A4, 5: B5-R, 6: LT-R, 7: A4-R, 8: OTHER/UNIV, 9: B5, A: FOLIO/COMP, B: LG, C: B4, D: LD, E: A3, F: 13"LG, G: Unused, H: A6-R, I: Postcard, J: 8.5"SQ, K: A3-wide/LD-wide, L: Unused, M: 8K, N: 16K-R, O: 16K, P: COM10, Q: DL, R: Monarch, S: CHO-3, T: YOU-4, U: SRA3 (320 x 450), V: SRA3 (320 x 460), W: 13" x 19" (330 x 483), Z: Unused, a: Envelope Kaku-2 |
| C | Sort mode, staple mode |
| | 0: Non-sort/Non-staple, 1: Group, 2: Sort, 7: Front staple 8: Double staple, 9: Rear staple, A: Saddle stitch, B: Center fold, C: Top Left, D: Top Right, E: Top Center, F: Left Center |
| D | ADF mode |
| | 0: Not used, 1: Single (SADF), 2: Continuous |
| E | APS/AMS mode |
| | 0: Not selected, 1: APS, 2: AMS |
| F | Duplex mode |
| | Copying: 0: Not selected, 1: Book, 2: Double-sided/Single-sided, 4: Double-sided/Duplex copying, 8: Single-sided/Duplex copying Printing: 0: Single-sided, 8: Double-sided Fax: 0: Single-sided, 8: Double-sided e-Filing: 0: Single-sided, 8: Double-sided List printing: 0: Single-sided - |
| H | Image shift |
| | 0: Unused, 1: Book, 2: Left, 3: Right, 4: Top, 5: Bottom, 6: Book + Top, 7: Book + Bottom, 8: Left + Top, 9: Left + Bottom, A: Right + Top, B: Right + Bottom |
| I | Editing |
| | 0: Unused, 1: Masking, 2: Trimming, 3: Mirror image, 4: Unused, 5: NEG/POS |
| J | Edge erase, Dual-page |
| | 0: Unused, 1: Edge erase, 2: Dual-page, 3: Edge erase & Dual-page |
| K | Not used |
| L | Function |
| | 0: Unused, 1: Copying, 2: Fax/Internet fax transmission, 3: Fax/Internet fax/E-mail reception printing, 4: Not used, 5: Printing/List print, 6: Scan/E-mail transmission |
| MMM | Primary scanning reproduction ratio (display in hexadecimal) |
| | (M x 256) + (M x 16)+M |

| | |
|-----|---|
| NNN | Secondary scanning reproduction ratio (display in hexadecimal) |
| | $(N \times 256) + (N \times 16) + N$ |
| O | Color mode |
| | 0: Auto color, 1: Full color, 2: Black, 3: Unused, 4: Twin color copy, 5: Gray scale (Scan), 6: Unused, 7: Gray scale (Copy) |
| P | Media type |
| | 0: Plain paper, 1: Thick 1, 2: Thick 2, 3: Thick 3, 4: Thick 4, 5: Special paper 1, 6: Special paper 2, 7: Recycled paper, 8: Unused, 9: Unused, A: Thin paper, B: OHP film, C: Thick 1/ reverse, D: Thick 2/ reverse, E: Thick 3/ reverse, F: Thick 4/ reverse, G: Special paper 1/ reverse, H: Special paper 2/ reverse, I: Envelope, J: Tab paper, K: Plain paper/ reverse, L: Recycled paper/ reverse, M: Thin paper/ reverse, N: Unused, O: Unused, P: Envelope/ reverse, Q: Thick, R: Thick/ reverse, S to Z: Unused, a: User type 1, b: User type 2, c: User type 3, d: User type 4, e: User type 5, f: User type 6, g: User type 7, h: User type 8, i: User type 9, j: User type 10 |
| Q | RADF size mixed |
| | 0: Not used, 1: Mixed, 2: Not mixed |
| R | Workflow ID: 10-digit ID |

*1: "EX-LCF01" means the "MP-2503".

*2: "EX-LCF02" means the "MP-2002".

8.3 Analysis from Error Codes

8.3.1 Check item

| Check item | Description |
|-----------------|---|
| Sensor check | <ul style="list-style-type: none"> Check the motors in the test mode. Check that there is no dust on the sensors. Check that the actuator is correctly operated. |
| Connector check | <ul style="list-style-type: none"> Check if the connectors are disconnected. Check if the pins are deformed and do come off. Even if the connectors are not apparently disconnected, they may be connected too loosely. Therefore, check carefully and connect them securely. |
| Harness check | <ul style="list-style-type: none"> Check if the harnesses are scratched or open circuited. Check if the harnesses are caught. Check all harnesses used to connect the PC boards and electric parts. |
| Motor check | <ul style="list-style-type: none"> Check the motors in the test mode. Check if there is any abnormality, such as loosening of screws, in the installation. Check if there is any abnormality in the gears, timing belts and rollers to which the motor driving is transmitted. Perform the items in "Connector check". Perform the items in "Harness check". |
| PC board check | <ul style="list-style-type: none"> Check if the board is short circuited or open circuited. Check if the mounted parts on the PC boards are damaged. Check that the PC boards are installed properly. Perform the items in "Connector check". |

8.3.2 Connector number, input check, output check

| Number | Name | Connector | Connectors | Input check | Output check |
|--------|--------------------------------------|--------------|------------|------------------------|------------------------------------|
| MD1 | DSDF original feed motor | DLG board | CN77 | - | FS-03-281 |
| MD2 | DSDF separation motor | DLG board | CN80 | - | FS-03-291 FS-03-292 |
| MD3 | DSDF registration motor | DLG board | CN79 | - | FS-03-282 |
| MD4 | DSDF read motor | DLG board | CN79 | - | FS-03-283 |
| MD5 | DSDF original exit motor | DLG board | CN77 | - | FS03-274 FS-03-284 FS-03-285 |
| M1 | Scan motor | SYS board | CN124 | - | FS-03-261 |
| M2 | Exit motor | DRV PC board | CN540 | - | FS-03-140/190 FS-03-142/192 |
| M3 | Reverse motor | DRV PC board | CN539 | - | FS-03-132/182 FS-03-134/184 |
| M4 | Bridge unit transport entrance motor | DRV PC board | CN539 | - | FS-03-130/180 |
| M5 | Bridge unit transport exit motor | DRV PC board | CN539 | - | FS-03-136/186 FS-03-138/188 |
| M6 | Fuser motor | LGC board | CN309 | FS-03-[F2]ON/[3]/[F] | FS-03-129/179 |
| M7 | ADU transport motor | ADU board | CN495 | - | FS-03-144/194 |
| M8 | ADU paper feed motor | ADU board | CN495 | - | FS-03-146/196 |
| M12 | Bypass tray motor | ADU board | CN496 | - | FS-03-126/176 |
| M13 | Transfer belt motor | LGC board | CN309 | - | FS-03-116/166 |
| M15 | Toner motor (K) | LGC board | CN310 | - | FS-03-219 |
| M19 | Sub-hopper toner motor (K) | EPU board | CN560 | FS-03-[ALL]OFF/[4]/[E] | FS-03-223 FS-03-227 |
| M23 | Needle electrode cleaner motor (K) | EPU board | CN560 | FS-03-[ALL]OFF/[4]/[A] | FS-03-207 |

| Number | Name | Connector | Connectors | Input check | Output check |
|--------|--|-----------|-----------------|--|---------------|
| M27 | Drum motor (K) | LGC board | CN303 | - | FS-03-110/160 |
| M29 | Developer unit mixer motor (K) | LGC board | CN301 | FS-03-[ALL]OFF/[5]/[C] FS-03-[ALL]OFF/[5]/[E] | FS-03-114/164 |
| M30 | Developer unit motor (K) | LGC board | CN301 | FS-03-[ALL]OFF/[5]/[E] | FS-03-112/162 |
| M33 | Waste toner transport motor | LGC board | CN318 | - | FS-03-234 |
| M34 | Polygonal motor | LGC board | CN337, CN320 | FS-03-[ALL]OFF/[5]/[H] | FS-03-103/153 |
| M37 | Mirror motor (K) | LGC board | CN337, CN320 | - | - |
| M38 | Shutter motor | LGC board | CN322 | - | FS-03-201 |
| M39 | Registration motor | PFC board | CN364 | - | FS-03-128/178 |
| M40 | Transport motor-1 | PFC board | CN362 | - | FS-03-124/174 |
| M41 | Transport motor-2 | PFC board | CN364 | - | FS-03-125/175 |
| M42 | 1st/2nd drawer paper feed motor | PFC board | CN362 | - | FS-03-120/170 |
| | | | | - | FS-03-121/171 |
| M43 | 3rd/4th drawer/T-LCF paper feed motor | PFC board | CN352 | - | FS-03-122/172 |
| | | | | - | FS-03-123/173 |
| M44 | 1st drawer tray-up motor | PFC board | CN358 | - | FS-03-246 |
| M45 | 3rd drawer/LCF tray-up motor | PFC board | CN357 | - | FS-03-248 |
| M46 | T-LCF tray-up motor | PFC board | CN356 | - | FS-03-257 |
| M47 | T-LCF end fence motor | PFC board | CN356 | - | FS-03-256 |
| M48 | Pressure roller contact/release motor | LGC board | CN309 | - | FS-03-272 |
| M49 | 2nd drawer tray-up motor | PFC board | CN358 | - | FS-03-247 |
| M50 | 4th drawer/LCF tray-up motor | PFC board | CN357 | - | FS-03-249 |
| FD1 | DSDL cooling fan motor | DLG board | CN85 | - | FS-03-296 |
| F1 | Bridge unit heat exhausting fan | PFC board | CN363 | - | FS-03-463 |
| | | | | - | FS-03-464 |
| F2 | Fuser unit heat exhausting fan | PFC board | CN363 | - | FS-03-461 |
| | | | | - | FS-03-462 |
| F6 | Bridge unit cooling fan | PFC board | CN365 | - | FS-03-459 |
| F8 | IH board cooling fan (suction) | LGC board | CN309 | - | FS-03-446 |
| | | | | - | FS-03-453 |
| F9 | IH board cooling fan (exhaust) | LGC board | CN309 | - | FS-03-454 |
| F11 | Reversed paper cooling fan | ADU board | CN497 | - | FS-03-455 |
| F14 | Developer unit cooling fan | LGC board | CN322 | - | FS-03-441 |
| | | | | - | FS-03-442 |
| F17 | Ozone mixing fan (K) | EPU board | CN560 | - | FS-03-445 |
| F21 | Fuser insulation fan | LGC board | CN307 | - | FS-03-451 |
| F22 | Laser optical unit cooling fan (front) | LGC board | CN307 | - | FS-03-437 |
| | | | | - | FS-03-438 |
| F23 | Laser optical unit cooling fan (rear) | LGC board | CN309 | - | FS-03-439 |
| | | | | - | FS-03-440 |
| F24 | Ozone suctioning fan | LGC board | CN318 | - | FS-03-447 |
| | | | | - | FS-03-448 |
| F25 | Scattered toner suctioning fan | LGC board | CN318 | - | FS-03-449 |
| F27 | SYS board cooling fan | SYS board | CN117 | - | - |
| F32 | Upper paper exit section cooling fan (rear) | PFC board | CN365 | - | FS-03-466 |
| F34 | Lower paper exit section cooling fan (rear) | PFC board | CN365 | - | FS-03-467 |
| F35 | Lower paper exit section cooling fan (front) | PFC board | CN365 | - | |

| Number | Name | Connector | Connectors | Input check | Output check |
|--------|---|-----------|------------|--|---------------|
| F36 | Lower paper exit section cooling fan (bottom) | LGC board | CN322 | - | FS-03-468 |
| F37 | Power supply unit cooling fan | LGC board | CN315 | - | FS-03-433 |
| SD1 | DSDF tray original length sensor-1 | DLG board | CN76 | FS-03-[F2]ON/[7]/[A] | - |
| SD2 | DSDF tray original length sensor-2 | DLG board | CN76 | FS-03-[F2]ON/[8]/[D] | - |
| SD3 | DSDF tray original width sensor | DLG board | CN73 | FS-03-[F2]ON/[8]/[A] FS-03-[F2]ON/[8]/[B] FS-03-[F2]ON/[8]/[C] | - |
| SD4 | DSDF original empty sensor | DLG board | CN73 | FS-03-[F2]ON/[7]/[B] | - |
| SD5 | DSDF original feed sensor | DLG board | CN74 | FS-03-[F2]ON/[8]/[E] | - |
| SD6 | DSDF registration sensor | DLG board | CN74 | FS-03-[F2]ON/[7]/[H] | - |
| SD7 | DSDF original width detection sensor-1 | DLG board | CN74 | FS-03-[F2]ON/[8]/[F] | - |
| SD8 | DSDF original width detection sensor-2 | DLG board | CN74 | FS-03-[F2]ON/[8]/[G] | - |
| SD9 | DSDF tray lift upper limit sensor | DLG board | CN74 | FS-03-[F2]ON/[6]/[E] | - |
| SD10 | DSDF tray lift lower limit sensor | DLG board | CN75 | FS-03-[F2]ON/[6]/[F] | - |
| SD11 | DSDF read-in sensor-1 | DLG board | CN75 | FS-03-[F2]ON/[7]/[G] | - |
| SD12 | DSDF read-in sensor-2 | DLG board | CN75 | FS-03-[F2]ON/[6]/[D] | - |
| SD13 | DSDF original exit sensor | DLG board | CN75 | FS-03-[F2]ON/[7]/[E] | - |
| SD14 | DSDF shading sheet HP sensor | DLG board | CN75 | FS-03-[F2]ON/[6]/[A] | - |
| SD15 | DSDF lower cover opening/closing detection sensor | DLG board | CN75 | FS-03-[F2]ON/[6]/[C] | - |
| SD16 | DSDF upper cover opening/closing detection sensor | DLG board | CN80 | FS-03-[F2]ON/[7]/[C] | - |
| SD17 | Multiple feeding detection sensor (transmission side) | DLG board | CN87 | FS-03-[F2]ON/[6]/[H] | - |
| SD18 | Multiple feeding detection sensor (reception side) | DLG board | CN87 | | - |
| S1 | Automatic original detection sensor-1 | SYS board | CN121 | FS-03-[F2]ON/[5]/[D] | - |
| S2 | Automatic original detection sensor-2 | SYS board | CN121 | FS-03-[F2]ON/[5]/[E] | - |
| S3 | Carriage home position sensor | SYS board | CN121 | FS-03-[F2]ON/[5]/[H] | - |
| S4 | Platen sensor-1 | SYS board | CN121 | FS-03-[F2]ON/[5]/[C] | - |
| S5 | Platen sensor-2 | SYS board | CN121 | FS-03-[F2]ON/[5]/[G] | - |
| S12 | Temperature/humidity sensor | LGC board | CN318 | FS-03-[F1]ON/[1] FS-03-[F1]ON/[2] | - |
| S13 | Waste toner box nearly full detection sensor | LGC board | CN318 | FS-03-[ALL]OFF/[2]/[A] | - |
| S14 | Waste toner box full detection sensor | LGC board | CN318 | FS-03-[ALL]OFF/[3]/[B] | - |
| S16 | Waste toner box detection sensor | LGC board | CN318 | FS-03-[ALL]OFF/[3]/[C] | - |
| S21 | Image position aligning/image quality sensor (center) | LGC board | CN311 | FS-03-[ALL]OFF/[6]/[B] | FS-03-117/167 |
| S24 | Shutter sensor (home position) | LGC board | CN322 | FS-03-[ALL]OFF/[6]/[F] | - |
| S25 | Shutter sensor (end position) | LGC board | CN322 | FS-03-[ALL]OFF/[6]/[G] | - |
| S26 | Auto-toner sensor (K) | EPU board | CN560 | - | - |
| S30 | Needle electrode cleaner detection sensor (K) | EPU board | CN560 | FS-03-[ALL]OFF/[4]/[A] | - |

| Number | Name | Connector | Connectors | Input check | Output check |
|--------|---|--------------|------------|--|--------------|
| S34 | Drum surface potential (V0) sensor (K) | EPU board | CN561 | - | - |
| S38 | Sub-hopper toner sensor (K) | EPU board | CN558 | FS-03-[ALL]OFF/[1]/[E] | - |
| S42 | Auger lock detection sensor | EPU board | CN557 | FS-03-[ALL]OFF/[3]/[D] | - |
| S47 | Transfer belt paper clinging detection sensor | LGC board | CN311 | FS-03-[ALL]OFF/[7]/[B] | - |
| S48 | Pressure roller contact/release detection sensor | LGC board | CN312 | FS-03-[F2]ON/[3]/[H] | - |
| S49 | Fuser belt rotation detection sensor | LGC board | CN312 | FS-03-[F2]ON/[3]/[E] | - |
| S51 | 2nd transfer side paper clinging detection sensor | ADU board | CN497 | FS-03-[ALL]OFF/[7]/[A] | - |
| S52 | Registration sensor | PFC board | CN363 | FS-03-[ALL]OFF/[7]/[C] FS-03-[F3]ON/[2]/[A] | - |
| S55 | Bridge unit path entrance sensor | DRV PC board | CN539 | FS-03-[ALL]OFF/[7]/[D] FS-03-[F3]ON/[2]/[D] | - |
| S56 | Bridge unit path exit sensor | DRV PC board | CN539 | FS-03-[ALL]OFF/[7]/[E] FS-03-[F3]ON/[2]/[C] | - |
| S57 | Reverse path sensor | DRV PC board | CN539 | FS-03-[ALL]OFF/[7]/[G] | - |
| S58 | Reverse section stationary jam detection sensor | DRV PC board | CN539 | FS-03-[ALL]OFF/[7]/[H] FS-03-[F3]ON/[2]/[F] | - |
| S59 | Reverse sensor | PFC board | CN363 | FS-03-[ALL]OFF/[7]/[F] FS-03-[ALL]OFF/[8]/[A] | - |
| S60 | Reverse section paper transport detection sensor | PFC board | CN365 | FS-03-[ALL]OFF/[8]/[B] | - |
| S61 | Upper paper exit sensor | PFC board | CN365 | FS-03-[ALL]OFF/[8]/[C] FS-03-[ALL]OFF/[8]/[D] | - |
| S62 | Upper exit tray paper full detection sensor | PFC board | CN365 | FS-03-[ALL]OFF/[8]/[E] | - |
| S63 | Lower paper exit sensor | PFC board | CN365 | FS-03-[ALL]OFF/[9]/[A] FS-03-[ALL]OFF/[9]/[B] | - |
| S64 | Duplexing unit opening/closing detection sensor | PFC board | CN363 | FS-03-[F1]ON/[5]/[C] FS-03-[F1]ON/[5]/[D] | - |
| S65 | Fuser transport sensor | ADU board | CN497 | FS-03-[ALL]OFF/[6]/[H] FS-03-[ALL]OFF/[8]/[F] | - |
| S66 | Duplexing unit path entrance sensor | ADU board | CN497 | FS-03-[ALL]OFF/[8]/[G] | - |
| S67 | Duplexing unit path exit sensor | ADU board | CN497 | FS-03-[ALL]OFF/[8]/[H] | - |
| S71 | Bypass tray paper sensor | ADU board | CN498 | FS-03-[ALL]OFF/[9]/[C] | - |
| S72 | Bypass tray paper feed sensor | ADU board | CN498 | FS-03-[ALL]OFF/[9]/[D] | - |
| S73 | 1st drawer detection sensor | PFC board | CN360 | FS-03-[F3]ON/[7]/[A] | - |
| S74 | 1st drawer bottom sensor | PFC board | CN358 | FS-03-[F3]ON/[7]/[B] | - |
| S75 | 1st drawer paper empty sensor | PFC board | CN360 | FS-03-[F3]ON/[7]/[C] | - |
| S76 | 1st drawer tray-up sensor | PFC board | CN360 | FS-03-[F3]ON/[7]/[D] | - |
| S77 | 1st drawer transport sensor | PFC board | CN360 | FS-03-[F3]ON/[7]/[E] | - |
| S78 | 1st drawer paper feed sensor | PFC board | CN360 | FS-03-[F3]ON/[7]/[F] | - |
| S79 | 1st drawer paper width detection sensor | PFC board | CN358 | FS-03-[F3]ON/[3]/[A] FS-03-[F3]ON/[3]/[B] FS-03-[F3]ON/[3]/[C] FS-03-[F3]ON/[3]/[D] | - |
| S80 | 1st drawer paper length detection sensor | PFC board | CN358 | FS-03-[F3]ON/[3]/[E] FS-03-[F3]ON/[3]/[F] FS-03-[F3]ON/[3]/[G] FS-03-[F3]ON/[3]/[H] | - |
| S81 | 2nd drawer detection sensor | PFC board | CN360 | FS-03-[F3]ON/[8]/[A] | - |

| Number | Name | Connector | Connectors | Input check | Output check |
|--------|--|-----------|------------|--|--------------|
| S82 | 2nd drawer bottom sensor | PFC board | CN359 | FS-03-[F3]ON/[8]/[B] | - |
| S83 | 2nd drawer paper empty sensor | PFC board | CN360 | FS-03-[F3]ON/[8]/[C] | - |
| S84 | 2nd drawer tray-up sensor | PFC board | CN360 | FS-03-[F3]ON/[8]/[D] | - |
| S85 | 2nd drawer transport sensor | PFC board | CN360 | FS-03-[F3]ON/[8]/[E] | - |
| S86 | 2nd drawer paper feed sensor | PFC board | CN360 | FS-03-[F3]ON/[8]/[F] | - |
| S87 | 2nd drawer paper width detection sensor | PFC board | CN359 | FS-03-[F3]ON/[4]/[A] FS-03-[F3]ON/[4]/[B] FS-03-[F3]ON/[4]/[C] FS-03-[F3]ON/[4]/[D] | - |
| S88 | 2nd drawer paper length detection sensor | PFC board | CN359 | FS-03-[F3]ON/[4]/[E] FS-03-[F3]ON/[4]/[F] FS-03-[F3]ON/[4]/[G] FS-03-[F3]ON/[4]/[H] | - |
| S89 | 3rd drawer/T-LCF detection sensor | PFC board | CN354 | FS-03-[F3]ON/[9]/[A] | - |
| S90 | 3rd drawer bottom sensor | PFC board | CN357 | FS-03-[F3]ON/[9]/[B] | - |
| S91 | 3rd drawer/T-LCF paper empty sensor | PFC board | CN354 | FS-03-[F3]ON/[9]/[C] | - |
| S92 | 3rd drawer/T-LCF tray-up sensor | PFC board | CN354 | FS-03-[F3]ON/[9]/[D] | - |
| S93 | 3rd drawer/T-LCF transport sensor | PFC board | CN354 | FS-03-[F3]ON/[9]/[E] | - |
| S94 | 3rd drawer/T-LCF paper feed sensor | PFC board | CN354 | FS-03-[F3]ON/[9]/[F] | - |
| S95 | 3rd drawer paper width detection sensor | PFC board | CN357 | FS-03-[F3]ON/[5]/[A] FS-03-[F3]ON/[5]/[B] FS-03-[F3]ON/[5]/[C] FS-03-[F3]ON/[5]/[D] | - |
| S96 | 3rd drawer paper length detection sensor | PFC board | CN357 | FS-03-[F3]ON/[5]/[E] FS-03-[F3]ON/[5]/[F] FS-03-[F3]ON/[5]/[G] FS-03-[F3]ON/[5]/[H] | - |
| S97 | 4th drawer detection sensor | PFC board | CN355 | FS-03-[F3]ON/[0]/[A] | - |
| S98 | 4th drawer bottom sensor | PFC board | CN357 | FS-03-[F3]ON/[0]/[B] | - |
| S99 | 4th drawer paper empty sensor | PFC board | CN355 | FS-03-[F3]ON/[0]/[C] | - |
| S100 | 4th drawer tray-up sensor | PFC board | CN355 | FS-03-[F3]ON/[0]/[D] | - |
| S101 | 4th drawer transport sensor | PFC board | CN355 | FS-03-[F3]ON/[0]/[E] | - |
| S102 | 4th drawer paper feed sensor | PFC board | CN355 | FS-03-[F3]ON/[0]/[F] | - |
| S103 | 4th drawer paper width detection sensor | PFC board | CN357 | FS-03-[F3]ON/[6]/[A] FS-03-[F3]ON/[6]/[B] FS-03-[F3]ON/[6]/[C] FS-03-[F3]ON/[6]/[D] | - |
| S104 | 4th drawer paper length detection sensor | PFC board | CN357 | FS-03-[F3]ON/[6]/[E] FS-03-[F3]ON/[6]/[F] FS-03-[F3]ON/[6]/[G] FS-03-[F3]ON/[6]/[H] | - |
| S106 | T-LCF standby side tray paper amount detection sensor | PFC board | CN356 | FS-03-[ALL]OFF/[0]/[A] | - |
| S107 | T-LCF bottom sensor | PFC board | CN356 | FS-03-[ALL]OFF/[0]/[B] | - |
| S108 | T-LCF standby side tray detection sensor | PFC board | CN356 | FS-03-[ALL]OFF/[0]/[C] | - |
| S109 | T-LCF standby side paper empty sensor | PFC board | CN356 | FS-03-[ALL]OFF/[0]/[D] | - |
| S110 | T-LCF stopper opening/closing detection sensor (front) | PFC board | CN356 | FS-03-[ALL]OFF/[0]/[E] | - |

| Number | Name | Connector | Connectors | Input check | Output check |
|----------|---|---------------------|-----------------|--|------------------------|
| S111 | T-LCF stopper opening/closing detection sensor (rear) | PFC board | CN356 | FS-03-[ALL]OFF/[0]/[F] | - |
| S112 | T-LCF end fence home position sensor | PFC board | CN356 | FS-03-[ALL]OFF/[0]/[G] | - |
| S113 | T-LCF end fence stop position sensor | PFC board | CN356 | FS-03-[ALL]OFF/[0]/[H] | - |
| S114 | Paper feed cover sensor | LGC board | CN307 | FS-03-[F2]ON/[1]/[A] | - |
| SWD1 | DSDF lower cover interlock switch | DLG board | CN72 | - | - |
| SWD2 | DSDF upper cover interlock switch | DLG board | CN72 | - | - |
| SW2 | Interlock switch | LVPS | CN532/ CN513 | FS-03-[F2]ON/[2]/[F] FS-03-[F1]ON/[5]/[B] | |
| SW3 | Toner motor interlock switch | LGC board | CN310 | - | - |
| SW4 | IH interlock switch | PS | CN532 | - | - |
| SW5 | Reverse path cover switch | PFC board | CN365 | FS-03-[F2]ON/[3]/[A] | - |
| SW7 | Duplexing unit cover opening/closing detection switch | ADU board | CN494 | FS-03-[F2]ON/[3]/[B] | - |
| SW8 | Bridge unit connecting detection switch | PFC board | CN365 | FS-03-[F2]ON/[3]/[C] | - |
| | | | | FS-03-[F3]ON/[2]/[G] | - |
| SW9 | Front cover opening/closing detection switch | PFC board | CN365 | FS-03-[ALL]OFF/[3]/[F] | - |
| SW10 | Duplexing unit interlock switch | PS | CN513 | - | - |
| CLD | DSDF tray-up clutch | DLG board | CN85 | - | - |
| CLT4 | 3rd drawer transport clutch | PFC board | CN352 | - | FS-03-252 |
| CLT5 | 3rd drawer paper feed clutch | PFC board | CN352 | - | FS-03-250 |
| CLT6 | 4th drawer transport clutch | PFC board | CN352 | - | FS-03-253 |
| CLT7 | 4th drawer paper feed clutch | PFC board | CN352 | - | FS-03-251 |
| SOL1 | Transport path switching solenoid (bridge unit/reverse section) | DRV PC board | CN539 | - | FS-03-275 |
| SOL2 | Transport path switching solenoid (upper/lower paper exit) | DRV PC board | CN539 | - | FS-03-276/168 |
| SOL3 | Image quality shutter solenoid | LGC board | CN311 | - | FS-03-118 |
| SOL4 | V0 sensor shutter solenoid (K) | EPU board | CN560 | - | FS-03-212 |
| SOL8 | Bypass pickup solenoid | ADU board | CN498 | - | FS-03-254 |
| SOL9 | T-LCF pickup solenoid | PFC board | CN354 | - | FS-03-255 |
| SOL10 | T-LCF stopper opening/closing solenoid (front) | PFC board | CN356 | - | FS-03-258 |
| SOL11 | T-LCF stopper opening/closing solenoid (rear) | PFC board | CN356 | - | FS-03-259 |
| SOL12 | Toner cover solenoid (K) | LGC board | CN313 | - | FS-03-481 |
| DLGD | DSDF control PC board | SYS board | CN122 | - | - |
| LEDD | DSDF-LED PC board | DLG board | CN80 | - | FS-03-262 FS-03-263 |
| DFRLY | DSDF Relay PC board | DSDF Relay PC board | CN90 | - | - |
| DLGR LY | DSDF multiple feeding detection relay PC board | DLG board | CN87 | - | - |
| DSDF-I/F | DSDF I/F PC board | SYS board | CN89 | - | - |
| CCD | CCD driving PC board | SYS board | CN120 | - | - |
| DSP | Display PC board | SYS board | CN116 | - | - |

| Number | Name | Connector | Connectors | Input check | Output check |
|---------|--|---------------------|-----------------|--|---------------|
| KEY | Key PC board | SYS board | CN116 | - | - |
| CTIF | Toner cartridge interface PC board | LGC board | CN328 | - | - |
| CTRG | Toner cartridge PC board | - | - | - | - |
| SYS | System control PC board | - | - | - | - |
| LGC | Logic PC board | - | - | - | - |
| LDR-K | Laser driving PC board (K) | LGC board | CN326 | - | - |
| V0S | Drum surface potential sensor control PC board | EPU board | CN561 | - | - |
| PFC | Paper feeding control PC board | - | - | - | - |
| ADU | ADU control PC board | PFC board | CN361 | - | - |
| DRV | DRV PC board | PFC board | CN366, CN367 | - | - |
| IH | Heater control PC board | LGC board | CN309 | - | - |
| DAMP | DAMP PC board | - | - | - | - |
| FIL-AC | Filter PC board (AC) | - | - | - | - |
| FIL-IH | Filter PC board (IH) | - | - | - | - |
| SFBB | Paper width detection PC board | ADU board | CN498 | FS-03-[ALL]OFF/[9]/[E] FS-03-[ALL]OFF/[9]/[F] FS-03-[ALL]OFF/[9]/[G] FS-03-[ALL]OFF/[9]/[H] | - |
| EXP | Exposure lamp | SYS board | CN123 | - | FS-03-267 |
| ERS-K | Discharge LED (K) | LGC board | CN310 | - | FS-03-214 |
| IH-COIL | IH coil | - | - | - | - |
| DH1 | Scanner damp heater | - | - | - | - |
| DH3 | Drum damp heater | - | - | - | - |
| THM1 | Drum thermistor (K) | EPU board | CN560 | FS-03-[F1]ON/[3] | - |
| THM5 | Fuser belt center thermistor | LGC board | CN312 | - | - |
| THM6 | Fuser belt edge thermistor | LGC board | CN312 | - | - |
| THMO 1 | Scanner damp heater thermostat | - | - | - | - |
| THMO 4 | Fuser belt thermostat | PS | CN408 | - | - |
| | | IH board | CN563 | - | - |
| CCDD | DSDF-CCD module | DSDF Relay PC board | CN91 | - | - |
| TCP | Touch panel | SYS board | CN116 | - | - |
| PS | Switching regulator | - | - | - | - |
| HVT | High-voltage transformer | - | - | - | - |
| WLAN/BT | Wireless LAN / Bluetooth Module | SYS board | CN114 | FS-03-[F1]ON/[0]/[B] | - |
| M1 | 2.5K Ex-LCF transport motor | 2.5K Ex-LCF | CN854 | - | FS-03-127/177 |
| M2 | 2.5K Ex-LCF tray motor | 2.5K Ex-LCF | CN855 | - | FS-03-270 |
| S1 | 2.5K Ex-LCF paper empty sensor | 2.5K Ex-LCF | CN856 | FS-03-[F2]ON/[1]/[G] | - |
| S2 | 2.5K Ex-LCF tray-up sensor | 2.5K Ex-LCF | CN856 | FS-03-[F2]ON/[2]/[A] | - |
| S3 | 2.5K Ex-LCF paper feed sensor | 2.5K Ex-LCF | CN856 | FS-03-[F2]ON/[1]/[F] | - |
| S4 | 2.5K Ex-LCF set sensor | 2.5K Ex-LCF | CN852 | FS-03-[F2]ON/[1]/[D] | - |
| S5 | 2.5K Ex-LCF tray sensor | 2.5K Ex-LCF | CN852 | FS-03-[F2]ON/[1]/[E] | - |
| S6 | 2.5K Ex-LCF tray bottom sensor | 2.5K Ex-LCF | CN852 | FS-03-[F2]ON/[1]/[H] | - |
| CLT1 | 2.5K Ex-LCF transport clutch | 2.5K Ex-LCF | CN856 | - | FS-03-269 |

| Number | Name | Connector | Connectors | Input check | Output check |
|--------|---|-------------|------------|----------------------|---------------|
| CLT2 | 2.5K Ex-LCF paper feed clutch | 2.5K Ex-LCF | CN856 | - | FS-03-268 |
| M1 | 2.0K Ex-LCF transport motor | 2.0K Ex-LCF | CN854 | - | FS-03-148/198 |
| M2 | 2.0K Ex-LCF tray motor | 2.0K Ex-LCF | CN855 | - | FS-03-473 |
| S1 | 2.0K Ex-LCF paper empty sensor | 2.0K Ex-LCF | CN856 | FS-03-[F1]ON/[6]/[G] | - |
| S2 | 2.0K Ex-LCF tray-up sensor | 2.0K Ex-LCF | CN856 | FS-03-[F1]ON/[6]/[A] | - |
| S3 | 2.0K Ex-LCF paper feed sensor | 2.0K Ex-LCF | CN856 | FS-03-[F1]ON/[6]/[F] | - |
| S4 | 2.0K Ex-LCF set sensor | 2.0K Ex-LCF | CN852 | FS-03-[F1]ON/[6]/[D] | - |
| S5 | 2.0K Ex-LCF tray sensor | 2.0K Ex-LCF | CN852 | FS-03-[F1]ON/[6]/[E] | - |
| S6 | 2.0K Ex-LCF tray bottom sensor | 2.0K Ex-LCF | CN852 | FS-03-[F1]ON/[6]/[H] | - |
| CLT1 | 2.0K Ex-LCF transport clutch | 2.0K Ex-LCF | CN856 | - | FS-03-472 |
| CLT2 | 2.0K Ex-LCF paper feed clutch | 2.0K Ex-LCF | CN856 | - | FS-03-471 |
| SLC1 | LCF Connector entrance transport sensor | LCB | CN1033 | FS-03-[F1]ON/[7]/[D] | - |
| SLC2 | LCF Connector intermediate transport sensor | LCB | CN1033 | FS-03-[F1]ON/[7]/[E] | - |
| SLC3 | LCF Connector paper exit sensor | LCB | CN1032 | FS-03-[F1]ON/[7]/[F] | - |
| SWLC1 | LCF Connector cover switch | LCB | CN1032 | FS-03-[F1]ON/[7]/[B] | - |
| CLC1 | LCF Connector transport clutch | LCB | CN1032 | - | FS-03-474 |
| CLC2 | LCF Connector paper exit clutch | LCB | CN1032 | - | FS-03-475 |

8.3.3 Paper misfeeding (E series errors)

[E010] Paper not reaching the paper exit sensor jam

| Classification | Error content |
|----------------|---|
| Paper exit jam | The paper which has passed through the fuser unit does not reach the paper exit sensor. |

| Check item | Measures |
|----------------------------------|---|
| Paper | <ul style="list-style-type: none"> • Check if the paper is damaged or if it has been folded. • Check the side guide in the drawer to confirm whether there is a reason for paper skewing in it. |
| Fuser transport sensor | <ul style="list-style-type: none"> • Sensor check (Input check) • Actuator check • Connector check • Harness check • Replace the sensor. |
| ADU board | <ul style="list-style-type: none"> • PC board check • Connector check • Harness check • Replace the PC board. |
| Fuser unit | <ul style="list-style-type: none"> • Check if toner has adhered to the fuser entrance guide. If needed, clean it. • Check if the separation plate is dirty. If so, clean it. • Check if the gap between the separation plate and the fuser belt is abnormal. If there is any abnormality, correct it. • Replace the separation plate. |
| PFC board | <ul style="list-style-type: none"> • PC board check • Connector check • Harness check • Replace the PC board. |
| LGC board | <ul style="list-style-type: none"> • PC board check • Connector check • Harness check • Replace the PC board. |
| Registration roller | Check the condition of the roller. If it has deteriorated, replace it. |
| Leading edge margin | <ul style="list-style-type: none"> • Check that the image position and margin are adjusted properly. • Widen the margin if needed. |
| 2nd transfer belt paper clinging | Paper misfeeding has occurred caused by paper clinging in the 2nd transfer section, perform the troubleshooting for an E011 error. |

| Parts to be replaced | Remarks |
|------------------------|---------|
| Fuser transport sensor | |
| ADU board | |
| Fuser unit | |
| Paper exit sensor | |
| PFC board | |
| LGC board | |
| Registration roller | |

[E011] Transfer belt paper-clinging jam

| Classification | Error content |
|---------------------|---|
| Paper transport jam | <ul style="list-style-type: none"> • Paper after the 2nd transfer has adhered and clung to the transfer belt. • A transport jam has occurred between the registration sensor and the paper clinging detection sensor. |

| Check item | Measures |
|--------------------|--|
| Paper | Use the paper which meets the specification. |
| Transfer belt unit | <ul style="list-style-type: none"> • Check that the transfer belt unit is installed properly. • Replace the transfer belt or transfer belt unit. |

| Check item | Measures |
|---|---|
| Transfer belt motor | <ul style="list-style-type: none"> • Check that the motor is working. (Output check) • Connector check • Harness check • Replace the motor. |
| Registration motor | <ul style="list-style-type: none"> • Check that the motor is working. (Output check) • Connector check • Harness check • Replace the motor. |
| Transfer belt paper clinging detection sensor | <ul style="list-style-type: none"> • Sensor check (Input check) • Connector check • Harness check • Replace the sensor. |
| 2nd transfer side paper clinging detection sensor | <ul style="list-style-type: none"> • Sensor check (Input check) • Connector check • Harness check • Replace the sensor. |
| PFC board | <ul style="list-style-type: none"> • PC board check • Connector check • Harness check • Replace the PC board. |
| LGC board | <ul style="list-style-type: none"> • PC board check • Connector check • Harness check • Replace the PC board. |
| Registration roller | Check the condition of the roller. If it has deteriorated, replace it. |
| Transfer belt cleaner unit | <ul style="list-style-type: none"> • Check if there is any abnormality in the transfer belt cleaning blade. • Check if the waste toner auger is overloaded. |
| 2nd transfer bias offset | Change the setting value of the following codes to 6 or 7 and check that the problem is solved. FS-05-2936-0, FS-05-2936-7 FS-05-2937-0, FS-05-2937-7 |
| Change of the 2nd transfer bias | <p>If the leading edge of the paper clings to the 2nd transfer roller and causes paper misfeeding, change the value of FS-05-5402 and FS-05-5403 (2nd transfer roller bias correction factor of the leading/trailing edge of the paper). The larger the value, the smaller the transfer voltage of the leading/trailing edge of the paper.</p> <p>Black mode print (front side): FS-05-2940-*</p> <p>Black mode print (back side): FS-05-2941-*</p> <p>Notes: After these codes are changed, perform solid duplex-printing and check that there is no faint or void image on the leading/trailing edge of the paper.</p> |

| Parts to be replaced | Remarks |
|---|---------|
| Transfer belt unit | |
| Transfer belt motor | |
| Registration motor | |
| Transfer belt paper clinging detection sensor | |
| 2nd transfer side paper clinging detection sensor | |
| PFC board | |
| LGC board | |
| Registration roller | |
| Transfer belt cleaner unit | |

[E020] Paper stopping at the paper exit sensor jam

| Classification | Error content |
|----------------|---|
| Paper exit jam | The trailing edge of the paper does not pass through the fuser transport sensor after its leading edge has reached this sensor. |

| Check item | Measures |
|------------------------|---|
| Paper | <ul style="list-style-type: none"> • Check if the paper is damaged or if it has been folded. • Check the side guide in the drawer to confirm whether there is a reason for paper skewing in it. |
| Fuser transport sensor | <ul style="list-style-type: none"> • Sensor check (Input check) • Actuator check • Connector check • Harness check • Replace the sensor. |
| ADU board | <ul style="list-style-type: none"> • PC board check • Connector check • Harness check • Replace the PC board. |
| Fuser unit | <ul style="list-style-type: none"> • Check if toner has adhered to the fuser entrance guide. If needed, clean it. • Check if the separation plate is dirty. If so, clean it. • Check if the gap between the separation plate and the fuser belt is abnormal. If there is any abnormality, correct it. • Replace the separation plate. |
| PFC board | <ul style="list-style-type: none"> • PC board check • Connector check • Harness check • Replace the PC board. |
| LGC board | <ul style="list-style-type: none"> • PC board check • Connector check • Harness check • Replace the PC board. |
| Registration motor | <ul style="list-style-type: none"> • Check that the motor is working. (Output check) • Connector check • Harness check • Replace the motor. |
| Leading edge margin | <ul style="list-style-type: none"> • Check that the image position and margin are adjusted properly. • Widen the margin if needed. |
| Self-diagnostic code | Change the setting value of FS-08-4542 (Switching for incorrect size jam detection) from "1" (Disabled) to "0" (Enabled). |

| Parts to be replaced | Remarks |
|------------------------|---------|
| Fuser transport sensor | |
| ADU board | |
| Fuser unit | |
| PFC board | |
| Registration motor | |

[E030] Power-ON jam

| Classification | Error content |
|---|---|
| Other paper jam | There is paper on the paper transport path when the power is turned ON. |
| Check item | Measures |
| Paper | Check that there is paper where the paper misfeed sign is indicating on the screen. |
| Sensors in the paper misfeed area | <ul style="list-style-type: none"> • Sensor check (Input check) • Actuator check • Connector check • Harness check • Replace the sensor. <p>Remarks: For the sensors in the paper misfeed area, see the next section.</p> <p>Transport section</p> <ul style="list-style-type: none"> • Registration sensor • Transfer belt paper clinging detection sensor • 2nd transfer side paper clinging detection sensor • 1st drawer transport sensor <p>Fusing section</p> <ul style="list-style-type: none"> • Fuser transport sensor • Reverse path sensor <p>ADU section</p> <ul style="list-style-type: none"> • Duplexing unit path entrance sensor • Duplexing unit path exit sensor <p>Bypass unit section</p> <ul style="list-style-type: none"> • Bypass tray paper feed sensor <p>Paper feeding section</p> <ul style="list-style-type: none"> • 2nd drawer transport sensor • 3rd drawer/T-LCF transport sensor • 4th drawer transport sensor <p>Bridge kit section</p> <ul style="list-style-type: none"> • Bridge unit path entrance sensor • Bridge unit path exit sensor • Reverse sensor • Reverse section stationary jam detection sensor <p>Upper paper exit section</p> <ul style="list-style-type: none"> • Upper paper exit sensor <p>Lower paper exit section</p> <ul style="list-style-type: none"> • Lower paper exit sensor <p>Reverse section</p> <ul style="list-style-type: none"> • Reverse section paper transport detection sensor <p>Ex-LCF section</p> <ul style="list-style-type: none"> • Ex-LCF paper feed sensor <p>LCF Connector section</p> <ul style="list-style-type: none"> • LCF Connector intermediate transport sensor <p>Finisher section</p> <ul style="list-style-type: none"> • Sensor (Finisher) |
| LGC board | <ul style="list-style-type: none"> • PC board check • Connector check • Harness check • Replace the PC board. |
| ADU board | <ul style="list-style-type: none"> • PC board check • Connector check • Harness check • Replace the PC board. |
| PFC board | <ul style="list-style-type: none"> • PC board check • Connector check • Harness check • Replace the PC board. |
| Parts to be replaced | Remarks |
| Registration sensor | |
| Transfer belt paper clinging detection sensor | |

| Parts to be replaced | Remarks |
|---|---------|
| 2nd transfer side paper clinging detection sensor | |
| 1st drawer transport sensor | |
| Fuser transport sensor | |
| Reverse path sensor | |
| Duplexing unit path entrance sensor | |
| Duplexing unit path exit sensor | |
| Bypass tray paper feed sensor | |
| 2nd drawer transport sensor | |
| 3rd drawer/T-LCF transport sensor | |
| 4th drawer transport sensor | |
| Bridge unit path entrance sensor | |
| Bridge unit path exit sensor | |
| Reverse sensor | |
| Reverse section stationary jam detection sensor | |
| Upper paper exit sensor | |
| Lower paper exit sensor | |
| Reverse section paper transport detection sensor | |
| Ex-LCF paper feed sensor | |
| LCF Connector intermediate transport sensor | |
| Sensor (Finisher) | |
| LGC board | |
| ADU board | |
| PFC board | |

[E061] Incorrect paper size setting for the 1st drawer jam

[E062] Incorrect paper size setting for the 2nd drawer jam

[E063] Incorrect paper size setting for the 3rd drawer jam

[E064] Incorrect paper size setting for the 4th drawer jam

[E065] Incorrect paper size setting for the bypass tray jam

| Classification | Error content |
|-----------------|---|
| Other paper jam | <ul style="list-style-type: none"> The size of the paper in the drawer differs from the size setting of the MFP. The size of the paper in the bypass tray differs from the size setting of the MFP. |

| Check item | Measures |
|--|---|
| Setting | <ul style="list-style-type: none"> If any paper remains in the MFP, drawer or bypass tray, remove it. Match the paper size of the setting and the one in the drawer or the bypass tray. |
| 1st drawer paper width detection sensor | <ul style="list-style-type: none"> Sensor check (Input check) Actuator check Connector check Harness check Replace the sensor. |
| 1st drawer paper length detection sensor | <ul style="list-style-type: none"> Sensor check (Input check) Actuator check Connector check Harness check Replace the sensor. |

| Check item | Measures |
|--|---|
| 2nd drawer paper width detection sensor | <ul style="list-style-type: none"> • Sensor check (Input check) • Actuator check • Connector check • Harness check • Replace the sensor. |
| 2nd drawer paper length detection sensor | <ul style="list-style-type: none"> • Sensor check (Input check) • Actuator check • Connector check • Harness check • Replace the sensor. |
| 3rd drawer paper width detection sensor | <ul style="list-style-type: none"> • Sensor check (Input check) • Actuator check • Connector check • Harness check • Replace the sensor. |
| 3rd drawer paper length detection sensor | <ul style="list-style-type: none"> • Sensor check (Input check) • Actuator check • Connector check • Harness check • Replace the sensor. |
| 4th drawer paper width detection sensor | <ul style="list-style-type: none"> • Sensor check (Input check) • Actuator check • Connector check • Harness check • Replace the sensor. |
| 4th drawer paper length detection sensor | <ul style="list-style-type: none"> • Sensor check (Input check) • Actuator check • Connector check • Harness check • Replace the sensor. |
| PFC board | <ul style="list-style-type: none"> • PC board check • Connector check • Harness check • Replace the PC board. |

| Parts to be replaced | Remarks |
|--|---------|
| 1st drawer paper width detection sensor | |
| 1st drawer paper length detection sensor | |
| 2nd drawer paper width detection sensor | |
| 2nd drawer paper length detection sensor | |
| 3rd drawer paper width detection sensor | |
| 3rd drawer paper length detection sensor | |
| 4th drawer paper width detection sensor | |
| 4th drawer paper length detection sensor | |
| PFC board | |

[E090] Image data delay jam

| Classification | Error content |
|-----------------|--|
| Other paper jam | The image data to be printed cannot be prepared. |

| Check item | Measures |
|----------------|---|
| Transport path | Remove any paper remaining in front of the registration sensor. |
| Power source | Check if the error is cleared by turning the power OFF and then back ON. |
| SYS board | <ul style="list-style-type: none"> • PC board check • Connector check (SYS board - LGC board) • Harness check (SYS board - LGC board) • Replace the PC board. |
| LGC board | <ul style="list-style-type: none"> • PC board check • Connector check (SYS board - LGC board) • Harness check (SYS board - LGC board) • Replace the PC board. |
| Storage device | Check the connector of the HDD or the SSD. |

| Parts to be replaced | Remarks |
|----------------------|--|
| SYS board | |
| LGC board | |
| Storage device | |
| Harness | Connecting for the SYS board and LGC board |

[E091] Motor-ON time-out jam

| Classification | Error content |
|-----------------|--|
| Other paper jam | The MFP does not operate properly because an abnormality has occurred on an interface between the SYS board and the LGC board. |

| Check item | Measures |
|----------------|---|
| Transport path | Open the cover and remove any paper. |
| Power source | Check if the error is cleared by turning the power OFF and then back ON. |
| SYS board | <ul style="list-style-type: none"> • PC board check • Connector check (SYS board - LGC board) • Harness check (SYS board - LGC board) • Replace the PC board. |
| LGC board | <ul style="list-style-type: none"> • PC board check • Connector check (SYS board - LGC board) • Harness check (SYS board - LGC board) • Replace the PC board. |
| Storage device | Check the connector of the HDD or the SSD. |

| Parts to be replaced | Remarks |
|----------------------|--|
| SYS board | |
| LGC board | |
| Storage device | |
| Harness | Connecting for the SYS board and LGC board |

[E0A0] Image transport ready time-out jam

| Classification | Error content |
|----------------------|---|
| Other paper jam | The image data to be printed cannot be sent. |
| Check item | Measures |
| LGC board | <ul style="list-style-type: none"> PC board check Connector check (SYS board - LGC board) Harness check (SYS board - LGC board) Replace the PC board. |
| SYS board | <ul style="list-style-type: none"> PC board check Connector check (SYS board - LGC board) Harness check (SYS board - LGC board) Replace the PC board. |
| Parts to be replaced | Remarks |
| LGC board | |
| SYS board | |
| Harness | Connecting for the SYS board and LGC board |

[E110] ADU paper misfeed jam

| Classification | Error content |
|-------------------------|---|
| Paper misfeeding | Paper which has passed through the ADU does not reach the registration sensor during duplex printing. |
| Check item | Measures |
| Registration guide | Check the registration guide. If there is an abnormality, replace it. |
| Registration sensor | <ul style="list-style-type: none"> Sensor check (Input check) Actuator check Connector check Harness check Replace the sensor. |
| PFC board | <ul style="list-style-type: none"> PC board check Connector check Harness check Replace the PC board. |
| ADU original feed motor | <ul style="list-style-type: none"> Check that the motor is working. (Output check) Connector check Harness check Replace the motor. |
| ADU board | <ul style="list-style-type: none"> PC board check Connector check Harness check Replace the PC board. |
| ADU transport roller | Check the condition of the roller. If it has deteriorated, replace it. |
| Registration roller | Check the condition of the roller. If it has deteriorated, replace it. |
| Registration motor | <ul style="list-style-type: none"> Check that the motor is working. (Output check) Connector check Harness check Replace the motor. |
| LGC board | <ul style="list-style-type: none"> PC board check Connector check Harness check Replace the PC board. |
| Parts to be replaced | Remarks |
| Registration sensor | |
| PFC board | |
| ADU original feed motor | |
| ADU board | |
| ADU transport roller | |

| Parts to be replaced | Remarks |
|----------------------|---------|
| Registration roller | |
| Registration motor | |
| LGC board | |

[E120] Bypass tray paper misfeed jam

| Classification | Error content |
|------------------|--|
| Paper misfeeding | Paper fed from the bypass tray does not reach the bypass tray paper feed sensor. |

| Check item | Measures |
|-------------------------------|---|
| Bypass tray | <ul style="list-style-type: none"> • Check if the paper is damaged or if it has been folded. • Check the side guide in the bypass tray to confirm whether there is a cause of paper skewing in it. |
| Roller (bypass tray) | Check the condition of the paper feed roller, separation roller and pickup roller. If they have deteriorated, replace them. |
| Bypass tray paper feed sensor | <ul style="list-style-type: none"> • Sensor check (Input check) • Actuator check • Connector check • Harness check • Replace the sensor. |
| Bypass tray motor | <ul style="list-style-type: none"> • Check that the motor is working. (Output check) • Connector check • Harness check • Replace the motor. |
| Bypass pickup solenoid | <ul style="list-style-type: none"> • Solenoid check (Output check) • Connector check • Harness check |
| Bypass unit driving section | <ul style="list-style-type: none"> • Check if the parts are installed properly. • Check if the parts are damaged or deformed. • Check if a load is applied to the parts or if there is an abnormality in their performance. • Check if there is any abnormality in the timing belt. |
| ADU board | <ul style="list-style-type: none"> • PC board check • Connector check • Harness check • Replace the PC board. |
| PFC board | <ul style="list-style-type: none"> • PC board check • Connector check • Harness check • Replace the PC board. |

| Parts to be replaced | Remarks |
|-------------------------------|---|
| Roller (bypass tray) | Paper feed roller, Separation roller, Pickup roller |
| Bypass tray paper feed sensor | |
| Bypass tray motor | |
| Bypass pickup solenoid | |
| ADU board | |
| PFC board | |

[E130] 1st drawer paper misfeed jam

| Classification | Error content |
|------------------|--|
| Paper misfeeding | Paper fed from the 1st drawer does not reach the 1st drawer paper feed sensor. |

| Check item | Measures |
|---------------------------------|---|
| Paper | <ul style="list-style-type: none"> • Check if the paper is damaged or if it has been folded. • Check the side guide in the drawer to confirm whether there is a reason for paper skewing in it. • Check that the paper stack height is within the specified range. |
| Roller (1st drawer) | Check the condition of the paper feed roller, separation roller and pickup roller. If they have deteriorated, replace them. |
| 1st drawer paper feed sensor | <ul style="list-style-type: none"> • Sensor check (Input check) • Actuator check • Connector check • Harness check • Replace the sensor. |
| 1st/2nd drawer paper feed motor | <ul style="list-style-type: none"> • Check that the motor is working. (Output check) • Connector check • Harness check • Replace the motor. |
| PFC board | <ul style="list-style-type: none"> • PC board check • Connector check • Harness check • Replace the PC board. |
| Paper feeding driving section | <ul style="list-style-type: none"> • Check if the parts are installed properly. • Check if the parts are damaged or deformed. • Check if a load is applied to the parts or if there is an abnormality in their performance. • Check if there is any abnormality in the timing belt. |

| Parts to be replaced | Remarks |
|---------------------------------|---|
| Roller (1st drawer) | Paper feed roller, Separation roller, Pickup roller |
| 1st drawer paper feed sensor | |
| 1st/2nd drawer paper feed motor | |
| PFC board | |

[E140] 2nd drawer paper misfeed jam

| Classification | Error content |
|------------------|--|
| Paper misfeeding | Paper fed from the 2nd drawer does not reach the 2nd drawer paper feed sensor. |

| Check item | Measures |
|---------------------------------|---|
| Paper | <ul style="list-style-type: none"> • Check if the paper is damaged or if it has been folded. • Check the side guide in the drawer to confirm whether there is a reason for paper skewing in it. • Check that the paper stack height is within the specified range. |
| Roller (2nd drawer) | Check the condition of the paper feed roller, separation roller and pickup roller. If they have deteriorated, replace them. |
| 2nd drawer paper feed sensor | <ul style="list-style-type: none"> • Sensor check (Input check) • Actuator check • Connector check • Harness check • Replace the sensor. |
| 1st/2nd drawer paper feed motor | <ul style="list-style-type: none"> • Check that the motor is working. (Output check) • Connector check • Harness check • Replace the motor. |
| PFC board | <ul style="list-style-type: none"> • PC board check • Connector check • Harness check • Replace the PC board. |

| Check item | Measures |
|-------------------------------|---|
| Paper feeding driving section | <ul style="list-style-type: none"> • Check if the parts are installed properly. • Check if the parts are damaged or deformed. • Check if a load is applied to the parts or if there is an abnormality in their performance. • Check if there is any abnormality in the timing belt. |

| Parts to be replaced | Remarks |
|---------------------------------|---|
| Roller (2nd drawer) | Paper feed roller, Separation roller, Pickup roller |
| 2nd drawer paper feed sensor | |
| 1st/2nd drawer paper feed motor | |
| PFC board | |

[E150] 3rd drawer paper misfeed jam

| Classification | Error content |
|------------------|--|
| Paper misfeeding | Paper fed from the 3rd drawer does not reach the 3rd drawer/T-LCF paper feed sensor. |

| Check item | Measures |
|---------------------------------------|---|
| Paper | <ul style="list-style-type: none"> • Check if the paper is damaged or if it has been folded. • Check the side guide in the drawer to confirm whether there is a reason for paper skewing in it. • Check that the paper stack height is within the specified range. |
| Roller (3rd drawer) | Check the condition of the paper feed roller, separation roller and pickup roller. If they have deteriorated, replace them. |
| 3rd drawer/T-LCF detection sensor | <ul style="list-style-type: none"> • Sensor check (Input check) • Actuator check • Connector check • Harness check • Replace the sensor. |
| 3rd/4th drawer/T-LCF paper feed motor | <ul style="list-style-type: none"> • Check that the motor is working. (Output check) • Connector check • Harness check • Replace the motor. |
| 3rd drawer paper feed clutch | <ul style="list-style-type: none"> • Check that the clutch is working. (Output check) • Connector check • Harness check • Replace the clutch. |
| PFC board | <ul style="list-style-type: none"> • PC board check • Connector check • Harness check • Replace the PC board. |
| Paper feeding driving section | <ul style="list-style-type: none"> • Check if the parts are installed properly. • Check if the parts are damaged or deformed. • Check if a load is applied to the parts or if there is an abnormality in their performance. • Check if there is any abnormality in the timing belt. |

| Parts to be replaced | Remarks |
|---------------------------------------|---|
| Roller (3rd drawer) | Paper feed roller, Separation roller, Pickup roller |
| 3rd drawer/T-LCF detection sensor | |
| 3rd/4th drawer/T-LCF paper feed motor | |
| 3rd drawer paper feed clutch | |
| PFC board | |

[E160] 4th drawer paper misfeed jam

| Classification | Error content |
|------------------|--|
| Paper misfeeding | Paper fed from the 4th drawer does not reach the 4th drawer paper feed sensor. |

| Check item | Measures |
|---------------------------------------|---|
| Paper | <ul style="list-style-type: none"> • Check if the paper is damaged or if it has been folded. • Check the side guide in the drawer to confirm whether there is a reason for paper skewing in it. • Check that the paper stack height is within the specified range. |
| Roller (4th drawer) | Check the condition of the paper feed roller, separation roller and pickup roller. If they have deteriorated, replace them. |
| 4th drawer paper feed sensor | <ul style="list-style-type: none"> • Sensor check (Input check) • Actuator check • Connector check • Harness check • Replace the sensor. |
| 3rd/4th drawer/T-LCF paper feed motor | <ul style="list-style-type: none"> • Check that the motor is working. (Output check) • Connector check • Harness check • Replace the motor. |
| 4th drawer paper feed clutch | <ul style="list-style-type: none"> • Check that the clutch is working. (Output check) • Connector check • Harness check • Replace the clutch. |
| PFC board | <ul style="list-style-type: none"> • PC board check • Connector check • Harness check • Replace the PC board. |
| Paper feeding driving section | <ul style="list-style-type: none"> • Check if the parts are installed properly. • Check if the parts are damaged or deformed. • Check if a load is applied to the parts or if there is an abnormality in their performance. • Check if there is any abnormality in the timing belt. |

| Parts to be replaced | Remarks |
|---------------------------------------|---|
| Roller (4th drawer) | Paper feed roller, Separation roller, Pickup roller |
| 4th drawer paper feed sensor | |
| 3rd/4th drawer/T-LCF paper feed motor | |
| 4th drawer paper feed clutch | |
| PFC board | |

[E180] Ex-LCF 2.5K paper misfeed jam

| Classification | Error content |
|------------------|---|
| Paper misfeeding | Paper fed from the Ex-LCF 2.5K does not reach the Ex-LCF paper feed sensor. |

| Check item | Measures |
|--------------------------|---|
| Paper | <ul style="list-style-type: none"> • Check if the paper is damaged or if it has been folded. • Check the side guide in the drawer to confirm whether there is a reason for paper skewing in it. • Check that the paper stack height is within the specified range. |
| Roller (Ex-LCF) | Check the condition of the paper feed roller, separation roller and pickup roller. If they have deteriorated, replace them. |
| Ex-LCF paper feed sensor | <ul style="list-style-type: none"> • Sensor check (Input check) • Actuator check • Connector check • Harness check • Replace the sensor. |

| Check item | Measures |
|--------------------------------------|---|
| Ex-LCF transport motor | <ul style="list-style-type: none"> • Check that the motor is working. (Output check) • Connector check • Harness check • Replace the motor. |
| Ex-LCF paper feed clutch | <ul style="list-style-type: none"> • Check that the clutch is working. (Output check) • Connector check • Harness check • Replace the clutch. |
| Ex-LCF board | <ul style="list-style-type: none"> • PC board check • Connector check • Harness check • Replace the PC board. |
| PFC board | <ul style="list-style-type: none"> • PC board check • Connector check • Harness check • Replace the PC board. |
| LGC board | <ul style="list-style-type: none"> • PC board check • Connector check • Harness check • Replace the PC board. |
| Ex-LCF paper feeding driving section | <ul style="list-style-type: none"> • Check if the parts are installed properly. • Check if the parts are damaged or deformed. • Check if a load is applied to the parts or if there is an abnormality in their performance. • Check if there is any abnormality in the timing belt. |

| Parts to be replaced | Remarks |
|--------------------------|---|
| Roller (Ex-LCF) | Paper feed roller, Separation roller, Pickup roller |
| Ex-LCF paper feed sensor | |
| Ex-LCF transport motor | |
| Ex-LCF paper feed clutch | |
| Ex-LCF board | |
| PFC board | |
| LGC board | |

[E190] T-LCF paper misfeed jam

| Classification | Error content |
|------------------|--|
| Paper misfeeding | Paper fed from the T-LCF does not reach the T-LCF paper feed sensor. |

| Check item | Measures |
|-------------------------|---|
| Paper | <ul style="list-style-type: none"> • Check if the paper is damaged or if it has been folded. • Check the side guide in the drawer to confirm whether there is a reason for paper skewing in it. • Check that the paper stack height is within the specified range. |
| Roller (T-LCF) | Check the condition of the paper feed roller, separation roller and pickup roller. If they have deteriorated, replace them. |
| T-LCF paper feed sensor | <ul style="list-style-type: none"> • Sensor check (Input check) • Actuator check • Connector check • Harness check • Replace the sensor. |
| T-LCF paper feed clutch | <ul style="list-style-type: none"> • Check that the clutch is working. (Output check) • Connector check • Harness check • Replace the clutch. |
| PFC board | <ul style="list-style-type: none"> • PC board check • Connector check • Harness check • Replace the PC board. |

| Check item | Measures |
|------------|---|
| LGC board | <ul style="list-style-type: none"> • PC board check • Connector check • Harness check • Replace the PC board. |

| Parts to be replaced | Remarks |
|-------------------------|---|
| Roller (T-LCF) | Paper feed roller, Separation roller, Pickup roller |
| T-LCF paper feed sensor | |
| T-LCF paper feed clutch | |
| PFC board | |
| LGC board | |

[E1A0] Ex-LCF 2.0K paper misfeed jam

| Classification | Error content |
|------------------|---|
| Paper misfeeding | Paper fed from the Ex-LCF 2.0K does not reach the Ex-LCF paper feed sensor. |

| Check item | Measures |
|--------------------------------------|---|
| Paper | <ul style="list-style-type: none"> • Check if the paper is damaged or if it has been folded. • Check the side guide in the drawer to confirm whether there is a reason for paper skewing in it. • Check that the paper stack height is within the specified range. |
| Roller (Ex-LCF) | Check the condition of the paper feed roller, separation roller and pickup roller. If they have deteriorated, replace them. |
| Ex-LCF paper feed sensor | <ul style="list-style-type: none"> • Sensor check (Input check) • Actuator check • Connector check • Harness check • Replace the sensor. |
| Ex-LCF transport motor | <ul style="list-style-type: none"> • Check that the motor is working. (Output check) • Connector check • Harness check • Replace the motor. |
| Ex-LCF paper feed clutch | <ul style="list-style-type: none"> • Check that the clutch is working. (Output check) • Connector check • Harness check • Replace the clutch. |
| Ex-LCF board | <ul style="list-style-type: none"> • PC board check • Connector check • Harness check • Replace the PC board. |
| PFC board | <ul style="list-style-type: none"> • PC board check • Connector check • Harness check • Replace the PC board. |
| LGC board | <ul style="list-style-type: none"> • PC board check • Connector check • Harness check • Replace the PC board. |
| Ex-LCF paper feeding driving section | <ul style="list-style-type: none"> • Check if the parts are installed properly. • Check if the parts are damaged or deformed. • Check if a load is applied to the parts or if there is an abnormality in their performance. • Check if there is any abnormality in the timing belt. |

| Parts to be replaced | Remarks |
|--------------------------|---|
| Roller (Ex-LCF) | Paper feed roller, Separation roller, Pickup roller |
| Ex-LCF paper feed sensor | |
| Ex-LCF transport motor | |
| Ex-LCF paper feed clutch | |

| Parts to be replaced | Remarks |
|----------------------|---------|
| Ex-LCF board | |
| PFC board | |
| LGC board | |

[E1B0] Ex-LCF 2.0K paper transport jam

| Classification | Error content |
|---------------------|--|
| Paper transport jam | Paper fed from the Ex-LCF 2.0K does not reach the 1st drawer transport sensor. |

| Check item | Measures |
|---------------------------------|---|
| Paper | <ul style="list-style-type: none"> • Check if the paper is damaged or if it has been folded. • Check the side guide in the drawer to confirm whether there is a reason for paper skewing in it. • Check that the paper stack height is within the specified range. |
| Roller (Ex-LCF) | Check the condition of the paper feed roller, separation roller and pickup roller. If they have deteriorated, replace them. |
| 1st drawer transport sensor | <ul style="list-style-type: none"> • Sensor check (Input check) • Actuator check • Connector check • Harness check • Replace the sensor. |
| Ex-LCF transport motor | <ul style="list-style-type: none"> • Check that the motor is working. (Output check) • Connector check • Harness check • Replace the motor. |
| LCF Connector paper exit clutch | <ul style="list-style-type: none"> • Check that the clutch is working. (Output check) • Connector check • Harness check • Replace the clutch. |
| Ex-LCF board | <ul style="list-style-type: none"> • PC board check • Connector check • Harness check • Replace the PC board. |
| PFC board | <ul style="list-style-type: none"> • PC board check • Connector check • Harness check • Replace the PC board. |

| Parts to be replaced | Remarks |
|---------------------------------|---|
| Roller (Ex-LCF) | Paper feed roller, Separation roller, Pickup roller |
| 1st drawer transport sensor | |
| Ex-LCF transport motor | |
| LCF Connector paper exit clutch | |
| Ex-LCF board | |
| PFC board | |

[E1C0] Ex-LCF 2.0K paper transport jam

| Classification | Error content |
|---------------------|--|
| Paper transport jam | Paper fed from the Ex-LCF 2.0K does not reach the registration sensor. |

| Check item | Measures |
|---------------------------------|---|
| Paper | <ul style="list-style-type: none"> • Check if the paper is damaged or if it has been folded. • Check the side guide in the drawer to confirm whether there is a reason for paper skewing in it. • Check that the paper stack height is within the specified range. |
| Registration sensor | <ul style="list-style-type: none"> • Sensor check (Input check) • Actuator check • Connector check • Harness check • Replace the sensor. |
| Transport motor-1 | <ul style="list-style-type: none"> • Check that the motor is working. (Output check) • Connector check • Harness check • Replace the motor. |
| Roller (Ex-LCF) | Check the condition of the paper feed roller, separation roller and pickup roller. If they have deteriorated, replace them. |
| Ex-LCF transport motor | <ul style="list-style-type: none"> • Check that the motor is working. (Output check) • Connector check • Harness check • Replace the motor. |
| LCF Connector paper exit clutch | <ul style="list-style-type: none"> • Check that the clutch is working. (Output check) • Connector check • Harness check • Replace the clutch. |
| Ex-LCF board | <ul style="list-style-type: none"> • PC board check • Connector check • Harness check • Replace the PC board. |
| PFC board | <ul style="list-style-type: none"> • PC board check • Connector check • Harness check • Replace the PC board. |
| LGC board | <ul style="list-style-type: none"> • PC board check • Connector check • Harness check • Replace the PC board. |

| Parts to be replaced | Remarks |
|---------------------------------|---|
| Roller (Ex-LCF) | Paper feed roller, Separation roller, Pickup roller |
| Registration sensor | |
| Transport motor-1 | |
| Ex-LCF transport motor | |
| LCF Connector paper exit clutch | |
| Ex-LCF board | |
| PFC board | |
| LGC board | |

[E1C1] Ex-LCF 2.0K paper transport jam

| Classification | Error content |
|---------------------|--|
| Paper transport jam | Paper fed from the Ex-LCF 2.0K does not reach the LCF Connector paper exit sensor. |

| Check item | Measures |
|---------------------------------|---|
| Paper | <ul style="list-style-type: none"> • Check if the paper is damaged or if it has been folded. • Check the side guide in the drawer to confirm whether there is a reason for paper skewing in it. • Check that the paper stack height is within the specified range. |
| Roller (Ex-LCF) | Check the condition of the paper feed roller, separation roller and pickup roller. If they have deteriorated, replace them. |
| LCF Connector paper exit sensor | <ul style="list-style-type: none"> • Sensor check (Input check) • Actuator check • Connector check • Harness check • Replace the sensor. |
| Ex-LCF transport motor | <ul style="list-style-type: none"> • Check that the motor is working. (Output check) • Connector check • Harness check • Replace the motor. |
| Ex-LCF transport clutch | <ul style="list-style-type: none"> • Check that the clutch is working. (Output check) • Connector check • Harness check • Replace the clutch. |
| Ex-LCF paper feed clutch | <ul style="list-style-type: none"> • Check that the clutch is working. (Output check) • Connector check • Harness check • Replace the clutch. |
| Ex-LCF board | <ul style="list-style-type: none"> • PC board check • Connector check • Harness check • Replace the PC board. |
| LCF Connector board | <ul style="list-style-type: none"> • PC board check • Connector check • Harness check • Replace the PC board. |
| PFC board | <ul style="list-style-type: none"> • PC board check • Connector check • Harness check • Replace the PC board. |

| Parts to be replaced | Remarks |
|---------------------------------|---|
| Roller (Ex-LCF) | Paper feed roller, Separation roller, Pickup roller |
| LCF Connector paper exit sensor | |
| Ex-LCF transport motor | |
| Ex-LCF transport clutch | |
| Ex-LCF paper feed clutch | |
| Ex-LCF board | |
| LCF Connector board | |
| PFC board | |

[E200] 1st drawer paper transport jam
[E210] 2nd drawer paper transport jam
[E270] Bypass tray paper transport jam
[E300] 3rd drawer paper transport jam
[E330] 4th drawer paper transport jam
[E3C0] T-LCF paper transport jam

| Classification | Error content |
|---------------------|---|
| Paper transport jam | Paper does not reach the registration sensor. |

| Check item | Measures |
|----------------------------|---|
| Paper | <ul style="list-style-type: none"> • Check if the paper is damaged or if it has been folded. • Check the side guide in the drawer to confirm whether there is a reason for paper skewing in it. • Check that the paper stack height is within the specified range. |
| Registration sensor | <ul style="list-style-type: none"> • Sensor check (Input check) • Actuator check • Connector check • Harness check • Replace the sensor. |
| Transport motor-1 | <ul style="list-style-type: none"> • Check that the motor is working. (Output check) • Connector check • Harness check • Replace the motor. |
| Roller (each paper source) | Check the condition of the paper feed roller, separation roller and pickup roller. If they have deteriorated, replace them. |
| PFC board | <ul style="list-style-type: none"> • PC board check • Connector check • Harness check • Replace the PC board. |
| LGC board | <ul style="list-style-type: none"> • PC board check • Connector check • Harness check • Replace the PC board. |

| Parts to be replaced | Remarks |
|----------------------------|---|
| Roller (each paper source) | Paper feed roller, Separation roller, Pickup roller |
| Registration sensor | |
| Transport motor-1 | |
| PFC board | |
| LGC board | |

[E220] 2nd drawer paper transport jam
[E310] 3rd drawer paper transport jam
[E340] 4th drawer paper transport jam
[E3D0] T-LCF paper transport jam

| Classification | Error content |
|---------------------|---|
| Paper transport jam | Paper does not reach the 1st drawer transport sensor. |

| Check item | Measures |
|-----------------------------|---|
| Paper | <ul style="list-style-type: none"> • Check if the paper is damaged or if it has been folded. • Check the side guide in the drawer to confirm whether there is a reason for paper skewing in it. • Check that the paper stack height is within the specified range. |
| 1st drawer transport sensor | <ul style="list-style-type: none"> • Sensor check (Input check) • Actuator check • Connector check • Harness check • Replace the sensor. |

| Check item | Measures |
|----------------------------|---|
| Transport motor-2 | <ul style="list-style-type: none"> • Check that the motor is working. (Output check) • Connector check • Harness check • Replace the motor. |
| Transport motor-1 | <ul style="list-style-type: none"> • Check that the motor is working. (Output check) • Connector check • Harness check • Replace the motor. |
| Roller (each paper source) | Check the condition of the paper feed roller, separation roller and pickup roller. If they have deteriorated, replace them. |
| PFC board | <ul style="list-style-type: none"> • PC board check • Connector check • Harness check • Replace the PC board. |
| LGC board | <ul style="list-style-type: none"> • PC board check • Connector check • Harness check • Replace the PC board. |

| Parts to be replaced | Remarks |
|-----------------------------|---|
| Roller (each paper source) | Paper feed roller, Separation roller, Pickup roller |
| 1st drawer transport sensor | |
| Transport motor-2 | |
| Transport motor-1 | |
| PFC board | |
| LGC board | |

[E230] 1st drawer paper transport jam

| Classification | Error content |
|---------------------|---|
| Paper transport jam | Paper does not reach the 1st drawer transport sensor. |

| Check item | Measures |
|---------------------------------|---|
| 1st drawer transport sensor | <ul style="list-style-type: none"> • Sensor check (Input check) • Actuator check • Connector check • Harness check • Replace the sensor. |
| Transport motor-1 | <ul style="list-style-type: none"> • Check that the motor is working. (Output check) • Connector check • Harness check • Replace the motor. |
| 1st/2nd drawer paper feed motor | <ul style="list-style-type: none"> • Check that the motor is working. (Output check) • Connector check • Harness check • Replace the motor. |
| Roller (1st drawer) | Check the condition of the paper feed roller, separation roller and pickup roller. If they have deteriorated, replace them. |
| PFC board | <ul style="list-style-type: none"> • PC board check • Connector check • Harness check • Replace the PC board. |
| LGC board | <ul style="list-style-type: none"> • PC board check • Connector check • Harness check • Replace the PC board. |

| Parts to be replaced | Remarks |
|-----------------------------|---|
| Roller (1st drawer) | Paper feed roller, Separation roller, Pickup roller |
| 1st drawer transport sensor | |
| Transport motor-1 | |

| Parts to be replaced | Remarks |
|---------------------------------|---------|
| 1st/2nd drawer paper feed motor | |
| PFC board | |
| LGC board | |

[E240] 2nd drawer paper transport jam

| Classification | Error content |
|---------------------|---|
| Paper transport jam | Paper does not reach the 2nd drawer transport sensor. |

| Check item | Measures |
|---------------------------------|---|
| 2nd drawer transport sensor | <ul style="list-style-type: none"> • Sensor check (Input check) • Actuator check • Connector check • Harness check • Replace the sensor. |
| Transport motor-1 | <ul style="list-style-type: none"> • Check that the motor is working. (Output check) • Connector check • Harness check • Replace the motor. |
| 1st/2nd drawer paper feed motor | <ul style="list-style-type: none"> • Check that the motor is working. (Output check) • Connector check • Harness check • Replace the motor. |
| Roller (2nd drawer) | Check the condition of the paper feed roller, separation roller and pickup roller. If they have deteriorated, replace them. |
| PFC board | <ul style="list-style-type: none"> • PC board check • Connector check • Harness check • Replace the PC board. |
| LGC board | <ul style="list-style-type: none"> • PC board check • Connector check • Harness check • Replace the PC board. |

| Parts to be replaced | Remarks |
|---------------------------------|---|
| Roller (2nd drawer) | Paper feed roller, Separation roller, Pickup roller |
| 2nd drawer transport sensor | |
| Transport motor-1 | |
| 1st/2nd drawer paper feed motor | |
| PFC board | |
| LGC board | |

[E250] Ex-LCF 2.5K paper transport jam

| Classification | Error content |
|---------------------|--|
| Paper transport jam | Paper fed from the Ex-LCF 2.5K does not reach the LCF Connector intermediate transport sensor. |

| Check item | Measures |
|---|---|
| Paper | <ul style="list-style-type: none"> • Check if the paper is damaged or if it has been folded. • Check the side guide in the drawer to confirm whether there is a reason for paper skewing in it. • Check that the paper stack height is within the specified range. |
| Roller (Ex-LCF) | Check the condition of the paper feed roller, separation roller and pickup roller. If they have deteriorated, replace them. |
| LCF Connector intermediate transport sensor | <ul style="list-style-type: none"> • Sensor check (Input check) • Actuator check • Connector check • Harness check • Replace the sensor. |

| Check item | Measures |
|--------------------------|---|
| Ex-LCF transport motor | <ul style="list-style-type: none"> • Check that the motor is working. (Output check) • Connector check • Harness check • Replace the motor. |
| Ex-LCF transport clutch | <ul style="list-style-type: none"> • Check that the clutch is working. (Output check) • Connector check • Harness check • Replace the clutch. |
| Ex-LCF paper feed clutch | <ul style="list-style-type: none"> • Check that the clutch is working. (Output check) • Connector check • Harness check • Replace the clutch. |
| Ex-LCF board | <ul style="list-style-type: none"> • PC board check • Connector check • Harness check • Replace the PC board. |
| LCF Connector board | <ul style="list-style-type: none"> • PC board check • Connector check • Harness check • Replace the PC board. |
| PFC board | <ul style="list-style-type: none"> • PC board check • Connector check • Harness check • Replace the PC board. |

| Parts to be replaced | Remarks |
|---|---|
| Roller (Ex-LCF) | Paper feed roller, Separation roller, Pickup roller |
| LCF Connector intermediate transport sensor | |
| Ex-LCF transport motor | |
| Ex-LCF transport clutch | |
| Ex-LCF paper feed clutch | |
| Ex-LCF board | |
| LCF Connector board | |
| PFC board | |

[E260] Ex-LCF paper transport jam

| Classification | Error content |
|---------------------|---|
| Paper transport jam | Paper fed from the Ex-LCF does not reach the registration sensor. |

| Check item | Measures |
|---------------------|---|
| Registration sensor | <ul style="list-style-type: none"> • Sensor check (Input check) • Actuator check • Connector check • Harness check • Replace the sensor. |
| Transport motor-1 | <ul style="list-style-type: none"> • Check that the motor is working. (Output check) • Connector check • Harness check • Replace the motor. |
| Roller (Ex-LCF) | Check the condition of the paper feed roller, separation roller and pickup roller. If they have deteriorated, replace them. |
| PFC board | <ul style="list-style-type: none"> • PC board check • Connector check • Harness check • Replace the PC board. |
| LGC board | <ul style="list-style-type: none"> • PC board check • Connector check • Harness check • Replace the PC board. |

| Parts to be replaced | Remarks |
|----------------------|---|
| Roller (Ex-LCF) | Paper feed roller, Separation roller, Pickup roller |
| Registration sensor | |
| Transport motor-1 | |
| PFC board | |
| LGC board | |

[E261] Ex-LCF 2.5K paper transport jam

| Classification | Error content |
|---------------------|--|
| Paper transport jam | Paper fed from the Ex-LCF 2.5K does not reach the LCF Connector paper exit sensor. |

| Check item | Measures |
|---------------------------------|---|
| Paper | <ul style="list-style-type: none"> Check if the paper is damaged or if it has been folded. Check the side guide in the drawer to confirm whether there is a reason for paper skewing in it. Check that the paper stack height is within the specified range. |
| Roller (Ex-LCF) | Check the condition of the paper feed roller, separation roller and pickup roller. If they have deteriorated, replace them. |
| LCF Connector paper exit sensor | <ul style="list-style-type: none"> Sensor check (Input check) Actuator check Connector check Harness check Replace the sensor. |
| Ex-LCF transport motor | <ul style="list-style-type: none"> Check that the motor is working. (Output check) Connector check Harness check Replace the motor. |
| LCF Connector transport clutch | <ul style="list-style-type: none"> Check that the clutch is working. (Output check) Connector check Harness check Replace the clutch. |
| LCF Connector board | <ul style="list-style-type: none"> PC board check Connector check Harness check Replace the PC board. |
| PFC board | <ul style="list-style-type: none"> PC board check Connector check Harness check Replace the PC board. |

| Parts to be replaced | Remarks |
|---------------------------------|---|
| Roller (Ex-LCF) | Paper feed roller, Separation roller, Pickup roller |
| LCF Connector paper exit sensor | |
| Ex-LCF transport motor | |
| LCF Connector transport clutch | |
| LCF Connector board | |
| PFC board | |

[E290] Ex-LCF paper transport jam

| Classification | Error content |
|---------------------|---|
| Paper transport jam | Paper fed from the Ex-LCF does not reach the 1st drawer transport sensor. |

| Check item | Measures |
|-----------------------------|---|
| 1st drawer transport sensor | <ul style="list-style-type: none"> Sensor check (Input check) Actuator check Connector check Harness check Replace the sensor. |

| Check item | Measures |
|-------------------------|---|
| Transport motor-1 | <ul style="list-style-type: none"> • Check that the motor is working. (Output check) • Connector check • Harness check • Replace the motor. |
| Roller (Ex-LCF) | Check the condition of the paper feed roller, separation roller and pickup roller. If they have deteriorated, replace them. |
| Ex-LCF transport motor | <ul style="list-style-type: none"> • Check that the motor is working. (Output check) • Connector check • Harness check • Replace the motor. |
| Ex-LCF transport clutch | <ul style="list-style-type: none"> • Check that the clutch is working. (Output check) • Connector check • Harness check • Replace the clutch. |
| PFC board | <ul style="list-style-type: none"> • PC board check • Connector check • Harness check • Replace the PC board. |
| LGC board | <ul style="list-style-type: none"> • PC board check • Connector check • Harness check • Replace the PC board. |

| Parts to be replaced | Remarks |
|-----------------------------|---|
| Roller (Ex-LCF) | Paper feed roller, Separation roller, Pickup roller |
| 1st drawer transport sensor | |
| Transport motor-1 | |
| Ex-LCF transport motor | |
| Ex-LCF transport clutch | |
| PFC board | |
| LGC board | |

[E2B0] 1st drawer paper stopping at the registration sensor jam

[E2B1] 2nd drawer paper stopping at the registration sensor jam

[E2B2] 3rd drawer paper stopping at the registration sensor jam

[E2B3] 4th drawer paper stopping at the registration sensor jam

[E2B4] Bypass tray paper stopping at the registration sensor jam

[E2B5] T-LCF paper stopping at the registration sensor jam

[E2B6] ADU paper stopping at the registration sensor jam

[E2B7] Ex-LCF paper stopping at the registration sensor jam

[E2B8] Ex-LCF paper stopping at the registration sensor jam

| Classification | Error content |
|---------------------|---|
| Paper transport jam | The trailing edge of the paper does not pass through the registration sensor. |

| Check item | Measures |
|-----------------------------|---|
| 2nd drawer transport sensor | <ul style="list-style-type: none"> • Sensor check (Input check) • Actuator check • Connector check • Harness check • Replace the sensor. |
| Registration motor | <ul style="list-style-type: none"> • Check that the motor is working. (Output check) • Connector check • Harness check • Replace the motor. |
| Roller (each paper source) | Check the condition of the paper feed roller, separation roller and pickup roller. If they have deteriorated, replace them. |

| Check item | Measures |
|------------|---|
| PFC board | <ul style="list-style-type: none"> • PC board check • Connector check • Harness check • Replace the PC board. |
| LGC board | <ul style="list-style-type: none"> • PC board check • Connector check • Harness check • Replace the PC board. |

| Parts to be replaced | Remarks |
|-----------------------------|---|
| Roller (each paper source) | Paper feed roller, Separation roller, Pickup roller |
| 2nd drawer transport sensor | |
| Registration motor | |
| PFC board | |
| LGC board | |

[E320] 3rd drawer paper transport jam

[E350] 4th drawer paper transport jam

[E3E0] T-LCF paper transport jam

| Classification | Error content |
|---------------------|--|
| Paper transport jam | Paper does not reach the 2nd drawer paper feed sensor. |

| Check item | Measures |
|---------------------------------|---|
| 2nd drawer transport sensor | <ul style="list-style-type: none"> • Sensor check (Input check) • Actuator check • Connector check • Harness check • Replace the sensor. |
| 1st/2nd drawer paper feed motor | <ul style="list-style-type: none"> • Check that the motor is working. (Output check) • Connector check • Harness check • Replace the motor. |
| 3rd drawer transport clutch | <ul style="list-style-type: none"> • Check that the clutch is working. (Output check) • Connector check • Harness check • Replace the clutch. |
| Roller (each paper source) | Check the condition of the paper feed roller, separation roller and pickup roller. If they have deteriorated, replace them. |
| PFC board | <ul style="list-style-type: none"> • PC board check • Connector check • Harness check • Replace the PC board. |
| LGC board | <ul style="list-style-type: none"> • PC board check • Connector check • Harness check • Replace the PC board. |

| Parts to be replaced | Remarks |
|---------------------------------|---|
| Roller (each paper source) | Paper feed roller, Separation roller, Pickup roller |
| 2nd drawer transport sensor | |
| 1st/2nd drawer paper feed motor | |
| 3rd drawer transport clutch | |
| PFC board | |
| LGC board | |

[E360] 4th drawer paper transport jam

| Classification | Error content |
|---------------------|---|
| Paper transport jam | Paper does not reach the 3rd drawer/T-LCF transport sensor. |

| Check item | Measures |
|---------------------------------------|---|
| 3rd drawer/T-LCF transport sensor | <ul style="list-style-type: none"> • Sensor check (Input check) • Actuator check • Connector check • Harness check • Replace the sensor. |
| 3rd/4th drawer/T-LCF paper feed motor | <ul style="list-style-type: none"> • Check that the motor is working. (Output check) • Connector check • Harness check • Replace the motor. |
| 3rd drawer transport clutch | <ul style="list-style-type: none"> • Check that the clutch is working. (Output check) • Connector check • Harness check • Replace the clutch. |
| 4th drawer transport clutch | <ul style="list-style-type: none"> • Check that the clutch is working. (Output check) • Connector check • Harness check • Replace the clutch. |
| Roller (4th drawer) | Check the condition of the paper feed roller, separation roller and pickup roller. If they have deteriorated, replace them. |
| PFC board | <ul style="list-style-type: none"> • PC board check • Connector check • Harness check • Replace the PC board. |
| LGC board | <ul style="list-style-type: none"> • PC board check • Connector check • Harness check • Replace the PC board. |

| Parts to be replaced | Remarks |
|---------------------------------------|---|
| Roller (4th drawer) | Paper feed roller, Separation roller, Pickup roller |
| 3rd drawer/T-LCF transport sensor | |
| 3rd/4th drawer/T-LCF paper feed motor | |
| 3rd drawer transport clutch | |
| 4th drawer transport clutch | |
| PFC board | |
| LGC board | |

[E370] 3rd drawer paper transport jam

| Classification | Error content |
|---------------------|---|
| Paper transport jam | Paper does not reach the 3rd drawer/T-LCF transport sensor. |

| Check item | Measures |
|---------------------------------------|---|
| 3rd drawer/T-LCF transport sensor | <ul style="list-style-type: none"> • Sensor check (Input check) • Actuator check • Connector check • Harness check • Replace the sensor. |
| 3rd/4th drawer/T-LCF paper feed motor | <ul style="list-style-type: none"> • Check that the motor is working. (Output check) • Connector check • Harness check • Replace the motor. |
| 3rd drawer paper feed clutch | <ul style="list-style-type: none"> • Check that the clutch is working. (Output check) • Connector check • Harness check • Replace the clutch. |
| 3rd drawer transport clutch | <ul style="list-style-type: none"> • Check that the clutch is working. (Output check) • Connector check • Harness check • Replace the clutch. |
| Roller (3rd drawer) | Check the condition of the paper feed roller, separation roller and pickup roller. If they have deteriorated, replace them. |
| PFC board | <ul style="list-style-type: none"> • PC board check • Connector check • Harness check • Replace the PC board. |
| LGC board | <ul style="list-style-type: none"> • PC board check • Connector check • Harness check • Replace the PC board. |

| Parts to be replaced | Remarks |
|---------------------------------------|---|
| Roller (3rd drawer) | Paper feed roller, Separation roller, Pickup roller |
| 3rd drawer/T-LCF transport sensor | |
| 3rd/4th drawer/T-LCF paper feed motor | |
| 3rd drawer paper feed clutch | |
| 3rd drawer transport clutch | |
| PFC board | |
| LGC board | |

[E380] 4th drawer paper transport jam

| Classification | Error content |
|---------------------|---|
| Paper transport jam | Paper does not reach the 4th drawer transport sensor. |

| Check item | Measures |
|---------------------------------------|---|
| 4th drawer transport sensor | <ul style="list-style-type: none"> • Sensor check (Input check) • Actuator check • Connector check • Harness check • Replace the sensor. |
| 3rd/4th drawer/T-LCF paper feed motor | <ul style="list-style-type: none"> • Check that the motor is working. (Output check) • Connector check • Harness check • Replace the motor. |
| 4th drawer paper feed clutch | <ul style="list-style-type: none"> • Check that the clutch is working. (Output check) • Connector check • Harness check • Replace the clutch. |
| 4th drawer transport clutch | <ul style="list-style-type: none"> • Check that the clutch is working. (Output check) • Connector check • Harness check • Replace the clutch. |
| Roller (4th drawer) | Check the condition of the paper feed roller, separation roller and pickup roller. If they have deteriorated, replace them. |
| PFC board | <ul style="list-style-type: none"> • PC board check • Connector check • Harness check • Replace the PC board. |
| LGC board | <ul style="list-style-type: none"> • PC board check • Connector check • Harness check • Replace the PC board. |

| Parts to be replaced | Remarks |
|---------------------------------------|---|
| Roller (4th drawer) | Paper feed roller, Separation roller, Pickup roller |
| 4th drawer transport sensor | |
| 3rd/4th drawer/T-LCF paper feed motor | |
| 4th drawer paper feed clutch | |
| 4th drawer transport clutch | |
| PFC board | |
| LGC board | |

[E3F0] T-LCF paper transport jam

| Classification | Error content |
|---------------------|---|
| Paper transport jam | Paper does not reach the 3rd drawer/T-LCF transport sensor. |

| Check item | Measures |
|---------------------------------------|---|
| 3rd drawer/T-LCF transport sensor | <ul style="list-style-type: none"> • Sensor check (Input check) • Actuator check • Connector check • Harness check • Replace the sensor. |
| 3rd/4th drawer/T-LCF paper feed motor | <ul style="list-style-type: none"> • Check that the motor is working. (Output check) • Connector check • Harness check • Replace the motor. |
| 3rd drawer paper feed clutch | <ul style="list-style-type: none"> • Check that the clutch is working. (Output check) • Connector check • Harness check • Replace the clutch. |
| 3rd drawer transport clutch | <ul style="list-style-type: none"> • Check that the clutch is working. (Output check) • Connector check • Harness check • Replace the clutch. |
| Roller (T-LCF) | Check the condition of the paper feed roller, separation roller and pickup roller. If they have deteriorated, replace them. |
| PFC board | <ul style="list-style-type: none"> • PC board check • Connector check • Harness check • Replace the PC board. |
| LGC board | <ul style="list-style-type: none"> • PC board check • Connector check • Harness check • Replace the PC board. |

| Parts to be replaced | Remarks |
|---------------------------------------|---|
| Roller (T-LCF) | Paper feed roller, Separation roller, Pickup roller |
| 3rd drawer/T-LCF transport sensor | |
| 3rd/4th drawer/T-LCF paper feed motor | |
| 3rd drawer paper feed clutch | |
| 3rd drawer transport clutch | |
| PFC board | |
| LGC board | |

[E400] Duplexing unit open jam

| Classification | Error content |
|----------------|---|
| Cover open jam | The duplexing unit has become open during printing. |

| Check item | Measures |
|---|---|
| Duplexing unit opening/closing detection sensor | <ul style="list-style-type: none"> • Sensor check (Input check) • Actuator check • Connector check • Harness check • Replace the sensor. |
| Interlock switch | <ul style="list-style-type: none"> • Switch check (Input check) • Connector check • Harness check • Replace the switch. |
| Switching regulator | <ul style="list-style-type: none"> • PC board check • Connector check • Harness check • Fuse check • Replace the PC board. |
| PFC board | <ul style="list-style-type: none"> • PC board check • Connector check • Harness check • Replace the PC board. |
| LGC board | <ul style="list-style-type: none"> • PC board check • Connector check • Harness check • Replace the PC board. |

| Parts to be replaced | Remarks |
|---|---------|
| Duplexing unit opening/closing detection sensor | |
| Interlock switch | |
| Switching regulator | |
| PFC board | |
| LGC board | |

[E430] Duplexing unit cover open jam

| Classification | Error content |
|----------------|--|
| Cover open jam | The cover of the duplexing unit has become open during printing. |

| Check item | Measures |
|--|---|
| Duplexing unit interlock switch, Duplexing unit cover opening/closing detection switch | <ul style="list-style-type: none"> • Switch check (Input check) • Connector check • Harness check • Replace the switch. |
| ADU board | <ul style="list-style-type: none"> • PC board check • Connector check • Harness check • Replace the PC board. |
| PFC board | <ul style="list-style-type: none"> • PC board check • Connector check • Harness check • Replace the PC board. |

| Parts to be replaced | Remarks |
|--|---------|
| Duplexing unit interlock switch, Duplexing unit cover opening/closing detection switch | |
| ADU board | |
| PFC board | |

[E440] Paper feed cover open jam

| Classification | Error content |
|-------------------------|---|
| Cover open jam | The paper feed cover has become open during printing. |
| Check item | Measures |
| Paper feed cover sensor | <ul style="list-style-type: none"> • Sensor check (Input check) • Actuator check • Connector check • Harness check • Replace the sensor. |
| PFC board | <ul style="list-style-type: none"> • PC board check • Connector check • Harness check • Replace the PC board. |
| LGC board | <ul style="list-style-type: none"> • PC board check • Connector check • Harness check • Replace the PC board. |
| Parts to be replaced | Remarks |
| Paper feed cover sensor | |
| PFC board | |
| LGC board | |

[E450] Ex-LCF open jam

| Classification | Error content |
|---|---|
| Cover open jam | The Ex-LCF has been disconnected from the MFP during printing. |
| Check item | Measures |
| Bridge unit connecting detection switch | <ul style="list-style-type: none"> • Switch check (Input check) • Connector check • Harness check • Replace the switch. |
| ADU board | <ul style="list-style-type: none"> • PC board check • Connector check • Harness check • Replace the PC board. |
| Ex-LCF set sensor | <ul style="list-style-type: none"> • Sensor check (Input check) • Actuator check • Connector check • Harness check • Replace the sensor. |
| Ex-LCF board | <ul style="list-style-type: none"> • PC board check • Connector check • Harness check • Replace the PC board. |
| PFC board | <ul style="list-style-type: none"> • PC board check • Connector check • Harness check • Replace the PC board. |
| Parts to be replaced | Remarks |
| Ex-LCF set sensor | |
| Ex-LCF board | |
| PFC board | |

[E480] Bridge unit open jam

| Classification | Error content |
|---|---|
| Cover open jam | The bridge unit has been pulled out during printing. |
| Check item | Measures |
| Bridge unit connecting detection switch | <ul style="list-style-type: none"> Switch check (Input check) Connector check Harness check Replace the switch. |
| Bridge unit drawer connector | <ul style="list-style-type: none"> Connector check (Input check) Harness check |
| ADU board | <ul style="list-style-type: none"> PC board check Connector check Harness check Replace the PC board. |
| Parts to be replaced | Remarks |
| Bridge unit connecting detection switch | |
| Bridge unit drawer connector | |
| ADU board | |

[E4A0] Waste toner cover open jam

| Classification | Error content |
|----------------------------------|---|
| Cover open jam | The waste toner cover has become open during printing. |
| Check item | Measures |
| Waste toner box detection sensor | <ul style="list-style-type: none"> Sensor check (Input check) Actuator check Connector check Harness check Replace the sensor. |
| LGC board | <ul style="list-style-type: none"> PC board check Connector check Harness check Replace the PC board. |
| Parts to be replaced | Remarks |
| Waste toner box detection sensor | |
| LGC board | |

[E4B0] Reverse path cover open jam

| Classification | Error content |
|----------------------------------|---|
| Cover open jam | The reverse path cover has become open during printing. |
| Check item | Measures |
| Reverse path cover switch | <ul style="list-style-type: none"> Switch check (Input check) Connector check Harness check Replace the switch. |
| PFC board | <ul style="list-style-type: none"> PC board check Connector check Harness check Replace the PC board. |
| Parts to be replaced | Remarks |
| Waste toner box detection sensor | |
| PFC board | |

[E4C1] Ex-LCF 2.0K open jam

| Classification | Error content |
|----------------|---|
| Cover open jam | The Ex-LCF 2.0K has been disconnected from the MFP during printing. |

| Check item | Measures |
|---------------------|---|
| Ex-LCF set sensor | <ul style="list-style-type: none"> • Sensor check (Input check) • Actuator check • Connector check • Harness check • Replace the sensor. |
| Ex-LCF board | <ul style="list-style-type: none"> • PC board check • Connector check • Harness check • Replace the PC board. |
| LCF Connector board | <ul style="list-style-type: none"> • PC board check • Connector check • Harness check • Replace the PC board. |
| PFC board | <ul style="list-style-type: none"> • PC board check • Connector check • Harness check • Replace the PC board. |

| Parts to be replaced | Remarks |
|----------------------|---------|
| Ex-LCF set sensor | |
| Ex-LCF board | |
| LCF Connector board | |
| PFC board | |

[E4C2] LCF Connector cover open jam

| Classification | Error content |
|----------------|--|
| Cover open jam | The LCF Connector cover has become open during printing. |

| Check item | Measures |
|----------------------------|---|
| LCF Connector cover switch | <ul style="list-style-type: none"> • Switch check (Input check) • Actuator check • Connector check • Harness check • Replace the switch. |
| LCF Connector board | <ul style="list-style-type: none"> • PC board check • Connector check • Harness check • Replace the PC board. |
| PFC board | <ul style="list-style-type: none"> • PC board check • Connector check • Harness check • Replace the PC board. |

| Parts to be replaced | Remarks |
|----------------------------|---------|
| LCF Connector cover switch | |
| LCF Connector board | |
| PFC board | |

[E510] ADU paper transport jam

| Classification | Error content |
|----------------|---|
| Cover open jam | Paper does not reach the reverse path sensor after it has been switchbacked in the reverse section. |

| Check item | Measures |
|-------------------------|---|
| Reverse path sensor | <ul style="list-style-type: none"> • Sensor check (Input check) • Actuator check • Connector check • Harness check • Replace the sensor. |
| Reverse motor | <ul style="list-style-type: none"> • Check that the motor is working. (Output check) • Connector check • Harness check • Replace the motor. |
| ADU original feed motor | <ul style="list-style-type: none"> • Check that the motor is working. (Output check) • Connector check • Harness check • Replace the motor. |
| Rollers | Check the condition of the roller. If it has deteriorated, replace it. |
| DRV board | <ul style="list-style-type: none"> • PC board check • Connector check • Harness check • Replace the PC board. |
| PFC board | <ul style="list-style-type: none"> • PC board check • Connector check • Harness check • Replace the PC board. |

| Parts to be replaced | Remarks |
|-------------------------|---------|
| Reverse path sensor | |
| Reverse motor | |
| ADU original feed motor | |
| Rollers | |
| DRV board | |
| PFC board | |

[E511] ADU paper transport jam

| Classification | Error content |
|----------------|--|
| Cover open jam | Paper which has passed through the reverse path sensor does not reach the duplexing unit path entrance sensor. |

| Check item | Measures |
|-------------------------------------|---|
| Duplexing unit path entrance sensor | <ul style="list-style-type: none"> • Sensor check (Input check) • Actuator check • Connector check • Harness check • Replace the sensor. |
| Reverse motor | <ul style="list-style-type: none"> • Check that the motor is working. (Output check) • Connector check • Harness check • Replace the motor. |
| ADU original feed motor | <ul style="list-style-type: none"> • Check that the motor is working. (Output check) • Connector check • Harness check • Replace the motor. |
| Rollers | Check the condition of the roller. If it has deteriorated, replace it. |
| DRV board | <ul style="list-style-type: none"> • PC board check • Connector check • Harness check • Replace the PC board. |

| Check item | Measures |
|------------|---|
| PFC board | <ul style="list-style-type: none"> • PC board check • Connector check • Harness check • Replace the PC board. |

| Parts to be replaced | Remarks |
|-------------------------------------|---------|
| Duplexing unit path entrance sensor | |
| Reverse motor | |
| ADU original feed motor | |
| Rollers | |
| DRV board | |
| PFC board | |

[E540] ADU paper transport jam

| Classification | Error content |
|----------------|--|
| Cover open jam | Paper which has passed through the duplexing unit path entrance sensor does not reach the duplexing unit path exit sensor. |

| Check item | Measures |
|---------------------------------|---|
| Duplexing unit path exit sensor | <ul style="list-style-type: none"> • Sensor check (Input check) • Actuator check • Connector check • Harness check • Replace the sensor. |
| ADU original feed motor | <ul style="list-style-type: none"> • Check that the motor is working. (Output check) • Connector check • Harness check • Replace the motor. |
| ADU transport motor | <ul style="list-style-type: none"> • Check that the motor is working. (Output check) • Connector check • Harness check • Replace the motor. |
| Rollers | Check the condition of the roller. If it has deteriorated, replace it. |
| ADU board | <ul style="list-style-type: none"> • PC board check • Connector check • Harness check • Replace the PC board. |

| Parts to be replaced | Remarks |
|---------------------------------|---------|
| Duplexing unit path exit sensor | |
| ADU original feed motor | |
| ADU transport motor | |
| Rollers | |
| ADU board | |

[E550] Paper remaining jam on the transport path

[E551] Paper remaining jam on the transport path (after a service call has occurred)

[E552] Paper remaining jam on the transport path (when the cover is closed)

| Classification | Error content |
|-----------------|--|
| Other paper jam | <ul style="list-style-type: none"> • Paper is detected on the transport path when printing has been finished. • Paper is detected on the transport path after a service call has occurred. • Paper is detected on the transport path after the cover has been closed. |

| Check item | Measures |
|-----------------------------------|---|
| Paper | Check that there is paper where the paper misfeed sign is indicating on the screen. |
| Roller (each paper source) | Check the condition of the paper feed roller, separation roller and pickup roller. If they have deteriorated, replace them. |
| Sensors in the paper misfeed area | <p>Check the sensors mounted in the location in question.</p> <p>Transport section</p> <ul style="list-style-type: none"> • Registration sensor • Transfer belt paper clinging detection sensor • 2nd transfer side paper clinging detection sensor • 1st drawer transport sensor <p>Fusing section</p> <ul style="list-style-type: none"> • Fuser transport sensor • Reverse path sensor <p>ADU section</p> <ul style="list-style-type: none"> • Duplexing unit path entrance sensor • Duplexing unit path exit sensor <p>Bypass unit section</p> <ul style="list-style-type: none"> • Bypass tray paper feed sensor <p>Paper feeding section</p> <ul style="list-style-type: none"> • 4th drawer paper feed sensor • 3rd drawer/T-LCF transport sensor • 2nd drawer transport sensor <p>Bridge kit section</p> <ul style="list-style-type: none"> • Bridge unit path entrance sensor • Bridge unit path exit sensor • Reverse sensor • Reverse section stationary jam detection sensor <p>Upper paper exit section</p> <ul style="list-style-type: none"> • Upper paper exit sensor <p>Lower paper exit section</p> <ul style="list-style-type: none"> • Lower paper exit sensor <p>Reverse section</p> <ul style="list-style-type: none"> • Reverse section paper transport detection sensor <p>Ex-LCF section</p> <ul style="list-style-type: none"> • Ex-LCF paper feed sensor <p>LCF Connector section</p> <ul style="list-style-type: none"> • LCF Connector entrance transport sensor • LCF Connector intermediate transport sensor <p>Finisher section</p> <ul style="list-style-type: none"> • Sensor (Finisher) <ul style="list-style-type: none"> • Sensor check (Input check) • Actuator check • Connector check • Harness check • Replace the sensor. |
| ADU board | <ul style="list-style-type: none"> • PC board check • Connector check • Harness check • Replace the PC board. |
| DRV board | <ul style="list-style-type: none"> • PC board check • Connector check • Harness check • Replace the PC board. |
| PFC board | <ul style="list-style-type: none"> • PC board check • Connector check • Harness check • Replace the PC board. |

| Parts to be replaced | Remarks |
|-----------------------------------|---------|
| Sensors in the paper misfeed area | |
| ADU board | |
| DRV board | |
| PFC board | |

[E570] Paper not reaching the bridge unit jam

| Classification | Error content |
|---------------------|--|
| Paper transport jam | Paper does not reach the reverse sensor. |

| Check item | Measures |
|--------------------------------------|---|
| Reverse sensor | <ul style="list-style-type: none"> • Sensor check (Input check) • Actuator check • Connector check • Harness check • Replace the sensor. |
| Bridge unit transport entrance motor | <ul style="list-style-type: none"> • Check that the motor is working. (Output check) • Connector check • Harness check • Replace the motor. |
| Fuser motor | <ul style="list-style-type: none"> • Check that the motor is working. (Output check) • Connector check • Harness check • Replace the motor. |
| Rollers | Check the condition of the roller. If it has deteriorated, replace it. |
| DRV board | <ul style="list-style-type: none"> • PC board check • Connector check • Harness check • Replace the PC board. |
| PFC board | <ul style="list-style-type: none"> • PC board check • Connector check • Harness check • Replace the PC board. |
| LGC board | <ul style="list-style-type: none"> • PC board check • Connector check • Harness check • Replace the PC board. |

| Parts to be replaced | Remarks |
|--------------------------------------|---------|
| Reverse sensor | |
| Bridge unit transport entrance motor | |
| Fuser motor | |
| Rollers | |
| DRV board | |
| PFC board | |
| LGC board | |

[E580] Paper stopping at the bridge unit jam

| Classification | Error content |
|---------------------|--|
| Paper transport jam | Paper does not reach the reverse sensor. |

| Check item | Measures |
|----------------|---|
| Reverse sensor | <ul style="list-style-type: none"> • Sensor check (Input check) • Actuator check • Connector check • Harness check • Replace the sensor. |

| Check item | Measures |
|----------------------------------|---|
| Reverse motor | <ul style="list-style-type: none"> • Check that the motor is working. (Output check) • Connector check • Harness check • Replace the motor. |
| Bridge unit transport exit motor | <ul style="list-style-type: none"> • Check that the motor is working. (Output check) • Connector check • Harness check • Replace the motor. |
| Rollers | Check the condition of the roller. If it has deteriorated, replace it. |
| PFC board | <ul style="list-style-type: none"> • PC board check • Connector check • Harness check • Replace the PC board. |
| DRV board | <ul style="list-style-type: none"> • PC board check • Connector check • Harness check • Replace the PC board. |

| Parts to be replaced | Remarks |
|----------------------------------|---------|
| Reverse sensor | |
| Reverse motor | |
| Bridge unit transport exit motor | |
| Rollers | |
| PFC board | |
| DRV board | |

[E590] Paper stopping at the upper paper exit sensor jam

| Classification | Error content |
|---------------------|---|
| Paper transport jam | The trailing edge of the paper does not pass through the upper paper exit sensor. |

| Check item | Measures |
|-------------------------|---|
| Upper paper exit sensor | <ul style="list-style-type: none"> • Sensor check (Input check) • Actuator check • Connector check • Harness check • Replace the sensor. |
| Paper exit motor | <ul style="list-style-type: none"> • Check that the motor is working. (Output check) • Connector check • Harness check • Replace the motor. |
| Rollers | Check the condition of the roller. If it has deteriorated, replace it. |
| PFC board | <ul style="list-style-type: none"> • PC board check • Connector check • Harness check • Replace the PC board. |
| DRV board | <ul style="list-style-type: none"> • PC board check • Connector check • Harness check • Replace the PC board. |
| LGC board | <ul style="list-style-type: none"> • PC board check • Connector check • Harness check • Replace the PC board. |

| Parts to be replaced | Remarks |
|-------------------------|---------|
| Upper paper exit sensor | |
| Paper exit motor | |
| Rollers | |

| Parts to be replaced | Remarks |
|----------------------|---------|
| PFC board | |
| DRV board | |
| LGC board | |

[E5A0] Paper not reaching the upper paper exit sensor jam

| Classification | Error content |
|---------------------|---|
| Paper transport jam | Paper does not reach the upper paper exit sensor. |

| Check item | Measures |
|----------------------------------|---|
| Upper paper exit sensor | <ul style="list-style-type: none"> • Sensor check (Input check) • Actuator check • Connector check • Harness check • Replace the sensor. |
| Bridge unit transport exit motor | <ul style="list-style-type: none"> • Check that the motor is working. (Output check) • Connector check • Harness check • Replace the motor. |
| Rollers | Check the condition of the roller. If it has deteriorated, replace it. |
| PFC board | <ul style="list-style-type: none"> • PC board check • Connector check • Harness check • Replace the PC board. |
| DRV board | <ul style="list-style-type: none"> • PC board check • Connector check • Harness check • Replace the PC board. |
| LGC board | <ul style="list-style-type: none"> • PC board check • Connector check • Harness check • Replace the PC board. |

| Parts to be replaced | Remarks |
|----------------------------------|---------|
| Upper paper exit sensor | |
| Bridge unit transport exit motor | |
| Rollers | |
| PFC board | |
| DRV board | |
| LGC board | |

[E703] DSDf multiple feeding jam

| Classification | Error content |
|----------------|---|
| DSDf jam | Multiple feeding of originals has occurred. |

| Check item | Measures |
|---|---|
| Multiple feeding detection sensor (transmission side) | <ul style="list-style-type: none"> • Sensor check (Input check) • Actuator check • Connector check • Harness check • Replace the sensor. |
| Multiple feeding detection sensor (reception side) | <ul style="list-style-type: none"> • Sensor check (Input check) • Actuator check • Connector check • Harness check • Replace the sensor. |
| DSDf multiple feeding relay board | <ul style="list-style-type: none"> • PC board check • Connector check • Harness check • Replace the PC board. |

| Check item | Measures |
|-----------------------|---|
| DSDF control PC board | <ul style="list-style-type: none"> • PC board check • Connector check • Harness check • Replace the PC board. |

| Parts to be replaced | Remarks |
|---|---------|
| Multiple feeding detection sensor (transmission side) | |
| Multiple feeding detection sensor (reception side) | |
| DSDF multiple feeding relay board | |
| DSDF control PC board | |

[E712] Original not reaching the DSDF registration sensor jam

| Classification | Error content |
|----------------|--|
| DSDF jam | The original fed from the original tray does not reach the DSDF registration sensor. |

| Check item | Measures |
|---|---|
| Original | Flatten and reload an original if it is abnormally curled or is folded. |
| DSDF pickup roller DSDF original feed roller DSDF separation roller | Check the condition of the roller. If it has been stained, clean it. If it has deteriorated, replace it. |
| DSDF registration sensor | <ul style="list-style-type: none"> • Sensor check (Input check) • Actuator check • Connector check • Harness check • Replace the sensor. |
| DSDF control PC board | <ul style="list-style-type: none"> • PC board check • Connector check • Harness check • Replace the PC board. |

| Parts to be replaced | Remarks |
|--------------------------|---|
| Roller (DSDF) | DSDF pickup roller, DSDF original feed roller, DSDF separation roller |
| DSDF registration sensor | |
| DSDF control PC board | |

[E714] Paper feed signal reception jam in DSDF

| Classification | Error content |
|----------------|---|
| DSDF jam | The DSDF has received the paper feed signal from the MFP even though there is no original on the original tray. |

| Check item | Measures |
|----------------------------|---|
| Reproducibility | Release the misfeeding and reattempt copying or scanning. |
| DSDF original empty sensor | <ul style="list-style-type: none"> • Sensor check (Input check) • Actuator check • Connector check • Harness check • Replace the sensor. |
| DSDF control PC board | <ul style="list-style-type: none"> • PC board check • Connector check • Harness check • Replace the PC board. |

| Parts to be replaced | Remarks |
|----------------------------|---------|
| DSDF original empty sensor | |
| DSDF control PC board | |

[E717] Original not reaching the DSDF original feed sensor jam

| Classification | Error content |
|----------------|---|
| DSDF jam | The original does not reach the DSDF original feed sensor even though original feeding has started. |

| Check item | Measures |
|---------------------------|---|
| DSDF original feed sensor | <ul style="list-style-type: none"> • Sensor check (Input check) • Actuator check • Connector check • Harness check • Replace the sensor. |
| DSDF original feed motor | <ul style="list-style-type: none"> • Check that the motor is working. (Output check) • Connector check • Harness check • Replace the motor. |
| DSDF control PC board | <ul style="list-style-type: none"> • PC board check • Connector check • Harness check • Replace the PC board. |

| Parts to be replaced | Remarks |
|---------------------------|---------|
| DSDF original feed sensor | |
| DSDF original feed motor | |
| DSDF control PC board | |

[E718] Original setting jam, original tray lift abnormality

| Classification | Error content |
|----------------|--|
| DSDF jam | <ul style="list-style-type: none"> • The original tray lift has been driven to raise itself and the DSDF tray lift upper limit sensor has not been turned ON within a specified time. • The original tray lift has been driven to lower itself and the DSDF tray lift lower limit sensor has not been turned ON within a specified time. |

| Check item | Measures |
|--|--|
| During original feeding or the initial operation, when an original is pulled out after being placed | |
| Malfunction | <p>Check whether an operation to apply a load to the original tray has been performed while it is being raised or lowered.</p> <p>Check that there is no foreign matter in the original tray lifting section.</p> <p>If the cause of this problem is any of the above, take an appropriate measure, open and then close the cover to release the problem.</p> <p>If the cause of this problem is other than the above, take the following measure.</p> |
| When the original tray lift is being rising (When this problem has occurred after the original placing or during original transporting) | |
| DSDF tray lift upper limit sensor | <p>There will be an abnormality in the DSDF tray lift upper limit sensor when an error occurs while the tray is being raised.</p> <ul style="list-style-type: none"> • Sensor check (Input check) • Actuator check • Connector check • Harness check • Replace the sensor. |
| When the original tray lift is being lowering (When this problem has occurred if an original is pulled out during the initial operation or the operation itself) | |
| DSDF tray lift lower limit sensor | <p>There will be an abnormality in the DSDF tray lift lower limit sensor when an error occurs while the tray is being lowered.</p> <ul style="list-style-type: none"> • Sensor check (Input check) • Actuator check • Connector check • Harness check • Replace the sensor. |
| When the original tray lift does not work (not being raised and lowered) | |

| Check item | Measures |
|-----------------------|---|
| DSDF tray-up clutch | There will be an abnormality in the DSDF tray-up clutch if it does not work. <ul style="list-style-type: none"> • Check that the clutch is working. • Connector check • Harness check • Replace the clutch. |
| DSDF separation motor | There will be an abnormality in the DSDF separation motor if it does not work. <ul style="list-style-type: none"> • Check that the motor is working. (Output check) • Connector check • Harness check • Replace the motor. |
| All | |
| DSDF control PC board | Check that there is no abnormality on the DSDF control PC board when operation failure has occurred in the DSDF tray lift upper limit sensor, DSDF tray lift lower limit sensor, DSDF tray-up clutch or DSDF separation motor. If there is any abnormality, replace it. |

| Parts to be replaced | Remarks |
|-----------------------------------|---------|
| DSDF tray lift upper limit sensor | |
| DSDF tray lift lower limit sensor | |
| DSDF tray-up clutch | |
| DSDF separation motor | |
| DSDF control PC board | |

[E721] Original not reaching the DSDF read-in sensor-1 jam

| Classification | Error content |
|----------------|--|
| DSDF jam | The original passed through the DSDF registration sensor does not reach the DSDF read-in sensor-1. |

| Check item | Measures |
|---|--|
| DSDF registration roller Pre-read roller | Check the condition of the roller. If it has been stained, clean it. If it has deteriorated, replace it. |
| DSDF read-in sensor-1 | <ul style="list-style-type: none"> • Sensor check (Input check) • Perform DSDF read-in sensor-1 automatic adjustment. • Connector check • Harness check • Replace the sensor. |
| Aligning amount | Perform FS-05-3040 (Alignment position adjustment). |
| DSDF read motor | <ul style="list-style-type: none"> • Check that the motor is working. (Output check) • Connector check • Harness check • Replace the motor. |
| DSDF registration motor | <ul style="list-style-type: none"> • Check that the motor is working. (Output check) • Connector check • Harness check • Replace the motor. |
| DSDF control PC board | <ul style="list-style-type: none"> • PC board check • Connector check • Harness check • Replace the PC board. |

| Parts to be replaced | Remarks |
|--------------------------|---------|
| DSDF registration roller | |
| Pre-read roller | |
| DSDF read-in sensor-1 | |
| DSDF read motor | |
| DSDF registration motor | |
| DSDF control PC board | |

[E722] Original not reaching the DSDF original exit sensor jam

| Classification | Error content |
|----------------|---|
| DSDF jam | The original passed through the DSDF read-in sensor-2 does not reach the DSDF original exit sensor. |

| Check item | Measures |
|---------------------------|---|
| Post-read roller-2 | Check the condition of the roller. If it has been stained, clean it. If it has deteriorated, replace it. |
| DSDF original exit sensor | <ul style="list-style-type: none"> • Sensor check (Input check) • Actuator check • Connector check • Harness check • Replace the sensor. |
| DSDF control PC board | <ul style="list-style-type: none"> • PC board check • Connector check • Harness check • Replace the PC board. |

| Parts to be replaced | Remarks |
|---------------------------|---------|
| Post-read roller-2 | |
| DSDF original exit sensor | |
| DSDF control PC board | |

[E724] Original stopping at the DSDF registration sensor jam

| Classification | Error content |
|----------------|---|
| DSDF jam | The trailing edge of the original does not pass through the DSDF registration sensor after its leading edge has passed through this sensor. |

| Check item | Measures |
|---|---|
| DSDF registration roller | Check the condition of the roller. If it has been stained, clean it. If it has deteriorated, replace it. |
| DSDF registration sensor | <ul style="list-style-type: none"> • Sensor check (Input check) • Actuator check • Connector check • Harness check • Replace the sensor. |
| DSDF tray original length sensor-1 DSDF tray original length sensor-2 DSDF tray original width sensor | <ul style="list-style-type: none"> • Sensor check (Input check) • Actuator check • Connector check • Harness check • Replace the sensor. |
| DSDF control PC board | <ul style="list-style-type: none"> • PC board check • Connector check • Harness check • Replace the PC board. |

| Parts to be replaced | Remarks |
|------------------------------------|---------|
| DSDF registration roller | |
| DSDF registration sensor | |
| DSDF tray original length sensor-1 | |
| DSDF tray original length sensor-2 | |
| DSDF tray original width sensor | |
| DSDF control PC board | |

[E725] Original stopping at the DSDF read-in sensor-1 jam

| Classification | Error content |
|----------------|--|
| DSDF jam | The trailing edge of the original does not pass through the DSDF read-in sensor-2 after its leading edge has passed through this sensor. |

| Check item | Measures |
|-----------------------|--|
| Post-read roller-1 | Check the condition of the roller. If it has been stained, clean it. If it has deteriorated, replace it. |
| DSDF read-in sensor-1 | <ul style="list-style-type: none"> • Sensor check (Input check) • Perform DSDF read-in sensor-1 automatic adjustment. • Connector check • Harness check • Replace the sensor. |
| DSDF control PC board | <ul style="list-style-type: none"> • PC board check • Connector check • Harness check • Replace the PC board. |

| Parts to be replaced | Remarks |
|-----------------------|---------|
| Post-read roller-1 | |
| DSDF read-in sensor-1 | |
| DSDF control PC board | |

[E726] DSDF transport or paper exit signal reception jam

| Classification | Error content |
|----------------|--|
| DSDF jam | A transport or paper exit signal has been received even if no original is in the DSDF. |

| Check item | Measures |
|-----------------------|---|
| Reproducibility | Turn the power OFF and then back ON to check the occurrence. |
| DSDF control PC board | <ul style="list-style-type: none"> • PC board check • Connector check • Harness check • Replace the PC board. |
| SYS board | <ul style="list-style-type: none"> • PC board check • Connector check • Harness check • Replace the PC board. |
| Switching regulator | <ul style="list-style-type: none"> • Check that the 24 V power supply is working. • Check that the 5 V power supply is working. • PC board check • Connector check • Harness check • Fuse check • Replace the switching regulator. |

| Parts to be replaced | Remarks |
|-----------------------|---------|
| DSDF control PC board | |
| SYS board | |
| Switching regulator | |

[E727] Original not reaching the DSDF read-in sensor-2 jam

| Classification | Error content |
|----------------|---|
| DSDF jam | The original passed through the DSDF read-in sensor-1 does not reach the DSDF read-in sensor-2. |

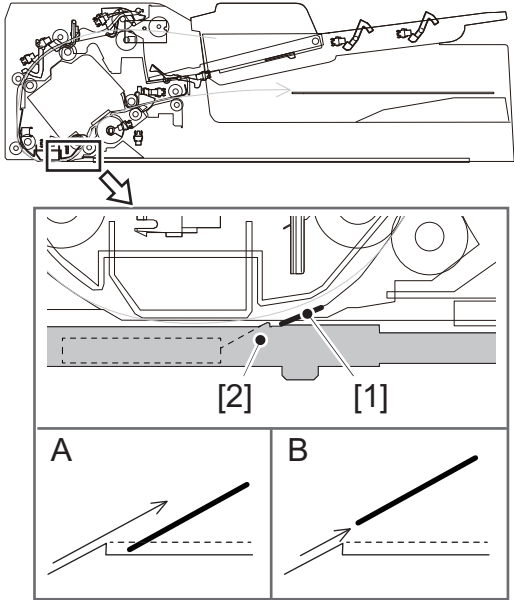
| Check item | Measures |
|-----------------------|---|
| Film [1] | <p>If an original has stopped at the transparent film [1], turn on the exposure lamp (output check: FS-03-267) and confirm the position between the film [1] and the upper edge of the slope [2].</p>  <p>Fig.8-1</p> <p>State A (throughout the whole of the transparent film): OK (Go to the next step.) State B: Perform the height adjustment. Replace the film if the position between it and the upper edge of the slope cannot be adjusted as shown above [A].</p> |
| Post-read roller-1 | Check the condition of the roller. If it has been stained, clean it. If it has deteriorated, replace it. |
| Installation | Check that the DSDF is installed properly. |
| DSDF read-in sensor-2 | <ul style="list-style-type: none"> • Sensor check (Input check) • Actuator check • Connector check • Harness check • Replace the sensor. |
| DSDF control PC board | <ul style="list-style-type: none"> • PC board check • Connector check • Harness check • Replace the PC board. |

| Parts to be replaced | Remarks |
|-----------------------|---------|
| Post-read roller-1 | |
| DSDF read-in sensor-2 | |
| DSDF control PC board | |

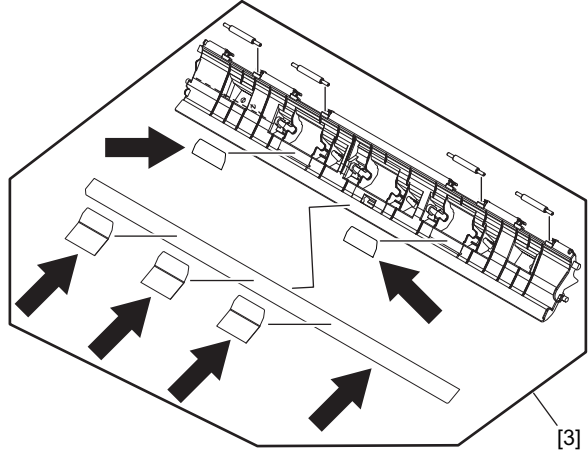
| Parts to be replaced | Remarks |
|----------------------|--|
| Film | Replace all the films or the guide [3].  Fig.8-2 |

[E729] Original stopping at the DSDF read-in sensor-2 jam

| Classification | Error content |
|----------------|--|
| DSDF jam | The trailing edge of the original does not pass through the DSDF read-in sensor-2 after its leading edge has passed through this sensor. |

| Check item | Measures |
|--------------------------|---|
| DSDF pre-read roller-2 | Check the condition of the roller. If it has been stained, clean it. If it has deteriorated, replace it. |
| DSDF read-in sensor-2 | <ul style="list-style-type: none"> • Sensor check (Input check) • Actuator check • Connector check • Harness check • Replace the sensor. |
| DSDF original exit motor | <ul style="list-style-type: none"> • Check that the motor is working. (Output check) • Connector check • Harness check • Replace the motor. |
| DSDF control PC board | <ul style="list-style-type: none"> • PC board check • Connector check • Harness check • Replace the PC board. |

| Parts to be replaced | Remarks |
|--------------------------|---------|
| DSDF pre-read roller-2 | |
| DSDF read-in sensor-2 | |
| DSDF original exit motor | |
| DSDF control PC board | |

[E731] Original stopping at the DSDF original exit sensor jam

| Classification | Error content |
|----------------|--|
| DSDF jam | The trailing edge of the original does not pass through the DSDF original exit sensor after its leading edge has passed through this sensor. |

| Check item | Measures |
|---------------------------|--|
| DSDF original exit roller | Check the condition of the roller. If it has been stained, clean it. If it has deteriorated, replace it. |
| Original exit section | Check that there is no original or foreign matter in the transport path. If there is any, remove it. |

| Check item | Measures |
|---------------------------|---|
| DSDF original exit sensor | <ul style="list-style-type: none"> • Sensor check (Input check) • Actuator check • Connector check • Harness check • Replace the sensor. |
| DSDF control PC board | <ul style="list-style-type: none"> • PC board check • Connector check • Harness check • Replace the PC board. |

| Parts to be replaced | Remarks |
|---------------------------|---------|
| DSDF original exit roller | |
| DSDF original exit sensor | |
| DSDF control PC board | |

[E762] Original remaining at the DSDF registration sensor jam

| Classification | Error content |
|----------------|---|
| DSDF jam | The DSDF registration sensor remains turned ON. |

| Check item | Measures |
|--------------------------|---|
| Original exit section | Check that there is no original or foreign matter in the transport path. If there is any, remove it. |
| DSDF registration sensor | <ul style="list-style-type: none"> • Sensor check (Input check) • Actuator check • Connector check • Harness check • Replace the sensor. |
| DSDF control PC board | <ul style="list-style-type: none"> • PC board check • Connector check • Harness check • Replace the PC board. |

| Parts to be replaced | Remarks |
|--------------------------|---------|
| DSDF registration sensor | |
| DSDF control PC board | |

[E769] Original remaining at the DSDF original feed sensor jam

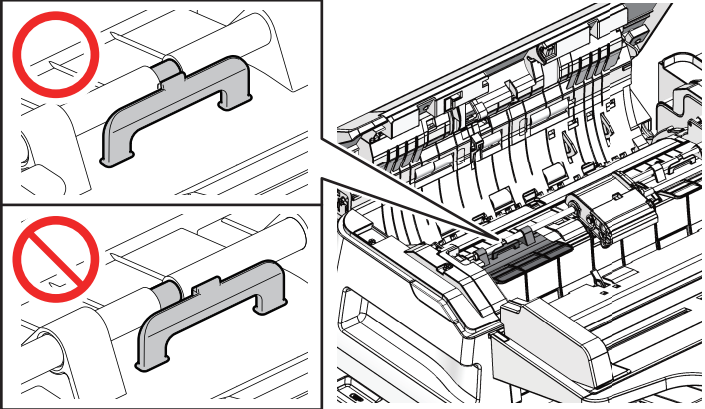
| Classification | Error content |
|---------------------------------|--|
| DSDF jam | The DSDF original feed sensor remains turned ON. |
| Check item | Measures |
| Corner folding prevention guide | <ul style="list-style-type: none"> • Check if the guide is installed properly. • If its latch has come off from the shaft groove, slide the guide to reinstall it. • Replace the corner folding protective guide if it is damaged.  <p>Fig.8-3</p> |
| DSDF original feed sensor | <ul style="list-style-type: none"> • Sensor check (Input check) • Actuator check • Connector check • Harness check • Replace the sensor. |
| DSDF control PC board | <ul style="list-style-type: none"> • PC board check • Connector check • Harness check • Replace the PC board. |

| Parts to be replaced | Remarks |
|---------------------------------|---------|
| Corner folding prevention guide | |
| DSDF original feed sensor | |
| DSDF control PC board | |

[E770] Original remaining at the DSDF original width detection sensor-1 jam

| Classification | Error content |
|--|---|
| DSDF jam | The DSDF original width detection sensor-1 remains turned ON. |
| Check item | Measures |
| DSDF original width detection sensor-1 | <ul style="list-style-type: none"> • Sensor check (Input check) • Actuator check • Connector check • Harness check • Replace the sensor. |
| DSDF control PC board | <ul style="list-style-type: none"> • PC board check • Connector check • Harness check • Replace the PC board. |
| Parts to be replaced | Remarks |
| DSDF original width detection sensor-1 | |
| DSDF control PC board | |

[E771] Original remaining at the DSDF original width detection sensor-2 jam

| Classification | Error content |
|----------------|---|
| DSDF jam | The DSDF original width detection sensor-2 remains turned ON. |

| Check item | Measures |
|--|---|
| DSDF original width detection sensor-2 | <ul style="list-style-type: none"> • Sensor check (Input check) • Actuator check • Connector check • Harness check • Replace the sensor. |
| DSDF control PC board | <ul style="list-style-type: none"> • PC board check • Connector check • Harness check • Replace the PC board. |

| Parts to be replaced | Remarks |
|--|---------|
| DSDF original width detection sensor-2 | |
| DSDF control PC board | |

[E774] Original remaining at the DSDF read-in sensor-1 jam

| Classification | Error content |
|----------------|--|
| DSDF jam | The DSDF read-in sensor-1 remains turned ON. |

| Check item | Measures |
|-----------------------|--|
| DSDF read-in sensor-1 | <ul style="list-style-type: none"> • Sensor check (Input check) • Perform DSDF read-in sensor-1 automatic adjustment. • Connector check • Harness check • Replace the sensor. |
| DSDF control PC board | <ul style="list-style-type: none"> • PC board check • Connector check • Harness check • Replace the PC board. |

| Parts to be replaced | Remarks |
|-----------------------|---------|
| DSDF read-in sensor-1 | |
| DSDF control PC board | |

[E775] Original remaining at the DSDF read-in sensor-2 jam

| Classification | Error content |
|----------------|--|
| DSDF jam | The DSDF read-in sensor-2 remains turned ON. |

| Check item | Measures |
|-----------------------|---|
| Pre-read roller-2 | Check the condition of the roller. If it has been stained, clean it. If it has deteriorated, replace it. |
| DSDF read-in sensor-2 | <ul style="list-style-type: none"> • Sensor check (Input check) • Actuator check • Connector check • Harness check • Replace the sensor. |
| DSDF control PC board | <ul style="list-style-type: none"> • PC board check • Connector check • Harness check • Replace the PC board. |

| Parts to be replaced | Remarks |
|-----------------------|---------|
| Pre-read roller-2 | |
| DSDF read-in sensor-2 | |

| Parts to be replaced | Remarks |
|-----------------------|---------|
| DSDF control PC board | |

[E777] Original remaining at the DSDF original exit sensor jam

| Classification | Error content |
|----------------|--|
| DSDF jam | The DSDF original exit sensor remains turned ON. |

| Check item | Measures |
|---------------------------|---|
| DSDF original exit roller | Check the condition of the roller. If it has been stained, clean it. If it has deteriorated, replace it. |
| DSDF original exit sensor | <ul style="list-style-type: none"> • Sensor check (Input check) • Actuator check • Connector check • Harness check • Replace the sensor. |
| DSDF control PC board | <ul style="list-style-type: none"> • PC board check • Connector check • Harness check • Replace the PC board. |

| Parts to be replaced | Remarks |
|---------------------------|---------|
| DSDF original exit roller | |
| DSDF original exit sensor | |
| DSDF control PC board | |

[E860] DSDF original jam access cover open jam, DSDF shading sheet HP sensor abnormality

| Classification | Error content |
|----------------|---|
| DSDF jam | <p>The DSDF original jam access cover has become open during DSDF operation.</p> <p>The paper exit motor has been driven and the DSDF shading sheet HP sensor has not been turned ON within a specified time.</p> <p>Details: If this problem has occurred at the start of a duplex copying or scanning job or at the end of a copying or scanning job, the cover may have opened as a result.</p> <p>The home position detection is carried out by the DSDF shading sheet HP sensor when the cover or the DSDF is closed, the power is turned ON, during the initial operation or at the end of a job. This home position detection checks that the DSDF shading sheet HP sensor is turned ON within a specified time after the DSDF exit motor has started driving. If the home position cannot be detected when the cover or the DSDF is closed or the power is turned ON, a cover open error will be displayed. If the home position cannot be detected during the initial operation or at the end of a job, a DSDF shading sheet HP sensor abnormality will occur and this error code will be displayed.</p> |

| Check item | Measures |
|---|---|
| When paper misfeeding has occurred at the start or end of the original transportation | |
| DSDF lower cover | Check that the cover is closed appropriately. |
| DSDF lower cover opening/closing detection sensor | <ul style="list-style-type: none"> • Sensor check (Input check) • Actuator check • Connector check • Harness check • Replace the sensor. |
| DSDF lower cover interlock switch | <ul style="list-style-type: none"> • Check that the switch is working properly. • Connector check • Harness check • Replace the switch. |

| Check item | Measures |
|---|---|
| DSDf original exit motor | <ul style="list-style-type: none"> • Check that the motor is working. If yes, check the DSDf shading sheet HP sensor. (Output check) • Connector check • Harness check • Replace the motor. |
| DSDf shading sheet HP sensor | <ul style="list-style-type: none"> • Sensor check (Input check) • Actuator check • Connector check • Harness check • Replace the sensor. |
| DSDf control PC board | <ul style="list-style-type: none"> • PC board check • Connector check • Harness check • Replace the PC board. |
| When paper misfeeding has occurred during original transportation | |
| DSDf upper cover DSDf lower cover Front cover (MFP) | Check that the cover is closed appropriately. |
| DSDf upper cover opening/ closing detection sensor | <ul style="list-style-type: none"> • Sensor check (Input check) • Actuator check • Connector check • Harness check • Replace the sensor. |
| DSDf upper cover interlock switch | <ul style="list-style-type: none"> • Check that the switch is working properly. • Connector check • Harness check • Replace the switch. |
| DSDf lower cover opening/ closing detection sensor | <ul style="list-style-type: none"> • Sensor check (Input check) • Actuator check • Connector check • Harness check • Replace the sensor. |
| DSDf lower cover interlock switch | <ul style="list-style-type: none"> • Check that the switch is working properly. • Connector check • Harness check • Replace the switch. |
| DSDf original exit motor | <ul style="list-style-type: none"> • Check that the motor is working. If yes, check the DSDf shading sheet HP sensor. (Output check) • Connector check • Harness check • Replace the motor. |
| DSDf shading sheet HP sensor | <ul style="list-style-type: none"> • Sensor check (Input check) • Actuator check • Connector check • Harness check • Replace the sensor. |
| DSDf control PC board | <ul style="list-style-type: none"> • PC board check • Connector check • Harness check • Replace the PC board. |

| Parts to be replaced | Remarks |
|---|---------|
| DSDf lower cover opening/closing detection sensor | |
| DSDf lower cover interlock switch | |
| DSDf original exit motor | |
| DSDf shading sheet HP sensor | |
| DSDf control PC board | |
| DSDf upper cover opening/ closing detection sensor | |
| DSDf upper cover interlock switch | |

[E870] DSDF open jam

| Classification | Error content |
|----------------|---|
| DSDF jam | The DSDF has become open during DSDF operation. |

| Check item | Measures |
|-----------------------|---|
| Platen sensor-1 | <ul style="list-style-type: none"> • Sensor check (Input check) • Actuator check • Connector check • Harness check • Replace the sensor. |
| Platen sensor-2 | <ul style="list-style-type: none"> • Sensor check (Input check) • Actuator check • Connector check • Harness check • Replace the sensor. |
| DSDF control PC board | <ul style="list-style-type: none"> • PC board check • Connector check • Harness check • Replace the PC board. |

| Parts to be replaced | Remarks |
|-----------------------|---------|
| Platen sensor-1 | |
| Platen sensor-2 | |
| DSDF control PC board | |

[E910] Paper not reaching the bridge unit path entrance sensor jam

[E920] Paper stopping at the bridge unit path entrance sensor jam

| Classification | Error content |
|---------------------|---|
| Paper transport jam | <ul style="list-style-type: none"> • Paper which has passed through the fuser transport sensor does not reach the bridge unit path entrance sensor. • The trailing edge of the paper does not pass through the bridge unit path entrance sensor after its leading edge has reached this sensor. |

| Check item | Measures |
|---|---|
| Bridge unit path entrance sensor | <ul style="list-style-type: none"> • Sensor check (Input check) • Actuator check • Connector check • Harness check • Replace the sensor. |
| Transport path switching solenoid (bridge unit/reverse section) | <ul style="list-style-type: none"> • Solenoid check (Output check) • Connector check • Harness check • Replace the solenoid. |
| Bridge unit transport entrance motor | <ul style="list-style-type: none"> • Check that the motor is working. (Output check) • Connector check • Harness check • Replace the motor. |
| Bridge unit transport exit motor | <ul style="list-style-type: none"> • Check that the motor is working. (Output check) • Connector check • Harness check • Replace the motor. |
| Rollers | Check the condition of the roller. If it has deteriorated, replace it. |
| DRV board | <ul style="list-style-type: none"> • PC board check • Connector check • Harness check • Replace the PC board. |

| Parts to be replaced | Remarks |
|---|---------|
| Bridge unit path entrance sensor | |
| Transport path switching solenoid (bridge unit/reverse section) | |

| Parts to be replaced | Remarks |
|--------------------------------------|---------|
| Bridge unit transport entrance motor | |
| Bridge unit transport exit motor | |
| Rollers | |
| DRV board | |

[E930] Paper not reaching the bridge unit path exit sensor jam

[E940] Paper stopping at the bridge unit path exit sensor jam

| Classification | Error content |
|----------------|---|
| Bridge kit jam | <ul style="list-style-type: none"> • The leading edge of the paper does not reach the bridge unit path exit sensor after it has reached the bridge unit path entrance sensor. • The trailing edge of the paper does not pass through the bridge unit path exit sensor after its leading edge has reached this sensor. |

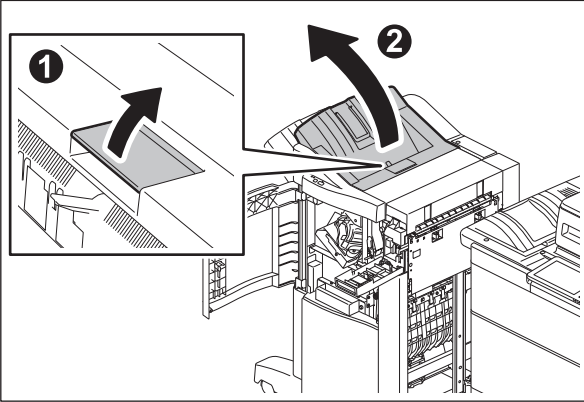
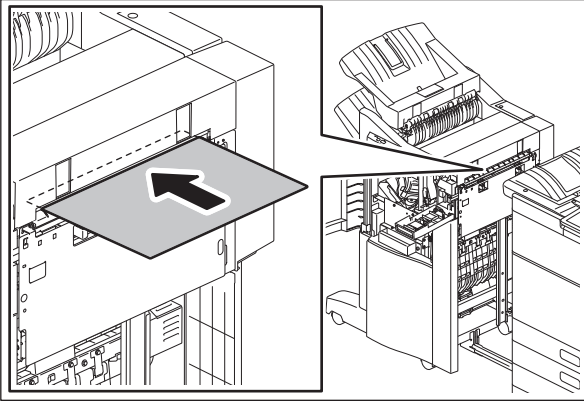
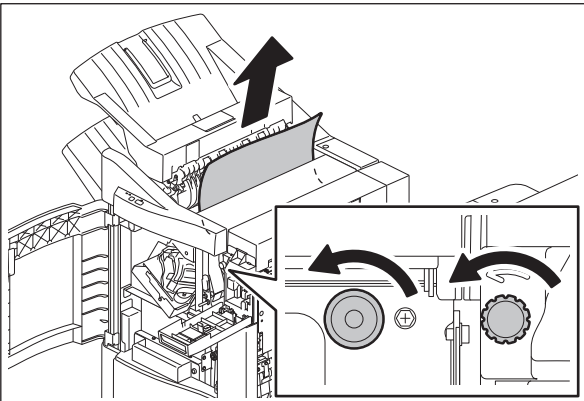
| Check item | Measures |
|-----------------|--|
| Hole Punch Unit | <p data-bbox="587 144 1390 197">If this error has occurred immediately after the unpacking and installation, a sheet in the hole punch unit may be deformed.</p> <ol data-bbox="587 200 1050 253" style="list-style-type: none"> <li data-bbox="587 200 1015 227">1. Separate the Finisher from the MFP. <li data-bbox="587 229 1050 253">2. Open the stationary tray of the Finisher.  <p data-bbox="587 672 659 697">Fig.8-4</p> <ol data-bbox="587 740 1358 793" style="list-style-type: none"> <li data-bbox="587 740 1358 793">3. Insert one sheet of A4/LT-size thick paper (216 g/m² (80 lb. Bond) or equivalent) into the paper transport inlet of the Hole Punch Unit.  <p data-bbox="587 1215 659 1240">Fig.8-5</p> <ol data-bbox="587 1283 1390 1378" style="list-style-type: none"> <li data-bbox="587 1283 1390 1378">4. Open the front cover of the Finisher. Turn the 2 knobs in the direction of the arrow simultaneously. Upon making the thick paper pass through by means of turning the knobs in the direction of the arrow, the sheet deformation will be corrected.  <p data-bbox="587 1800 659 1825">Fig.8-6</p> |

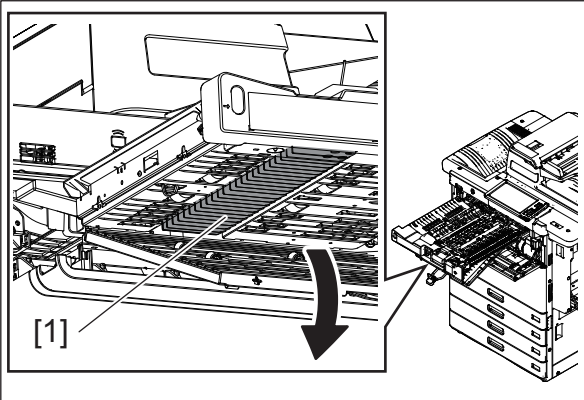
| Check item | Measures |
|--|---|
| Bridge unit transport guide | <p>Take off the bridge unit lower cover. Check if there are any scratches on the rib of the transport guide of the bridge unit.</p>  <p>Fig.8-7</p> <p>If there are scratches on it, perform sideways deviation adjustment for each drawer so that the edge of paper does not contact the rib of the transport guide of the bridge unit. <small>📖 P. 6-55 "6.8.1 Adjustment of the clearance of the paper and side guide"</small></p> |
| Bridge unit path exit sensor | <ul style="list-style-type: none"> • Sensor check (Input check) • Actuator check • Connector check • Harness check • Replace the sensor. |
| Transport path switching solenoid (upper/lower paper exit) | <ul style="list-style-type: none"> • Solenoid check (Output check) • Connector check • Harness check • Replace the solenoid. |
| Bridge unit transport exit motor | <ul style="list-style-type: none"> • Check that the motor is working. (Output check) • Connector check • Harness check • Replace the motor. |
| Roller (bridge unit) | Check the condition of the roller. If it has deteriorated, replace it. |
| DRV board | <ul style="list-style-type: none"> • PC board check • Connector check • Harness check • Replace the PC board. |

| Parts to be replaced | Remarks |
|--|---------|
| Bridge unit path exit sensor | |
| Transport path switching solenoid (upper/lower paper exit) | |
| Bridge unit transport exit motor | |
| Roller (bridge unit) | |
| DRV board | |

[E970] Paper not reaching the lower paper exit sensor jam

| Classification | Error content |
|---------------------|--|
| Paper transport jam | Paper transported from the bridge unit does not reach the lower paper exit sensor. |

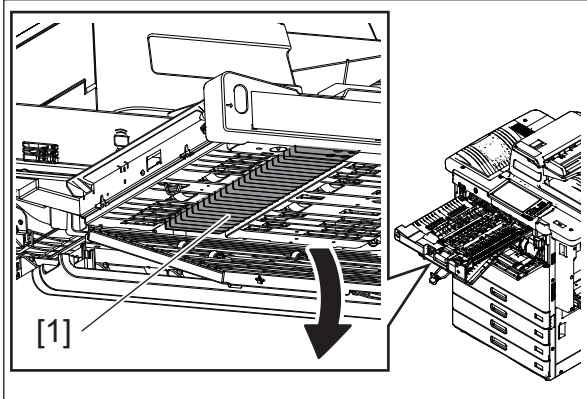
| Check item | Measures |
|----------------------------------|---|
| Bridge unit transport guide | <p>Take off the bridge unit lower cover. Check if there are any scratches on the rib of the transport guide of the bridge unit.</p>  <p>Fig.8-8</p> <p>If there are scratches on it, perform sideways deviation adjustment for each drawer so that the edge of paper does not contact the rib of the transport guide of the bridge unit. <small>☞ P. 6-55 "6.8.1 Adjustment of the clearance of the paper and side guide"</small></p> |
| Lower paper exit sensor | <ul style="list-style-type: none"> • Sensor check (Input check) • Actuator check • Connector check • Harness check • Replace the sensor. |
| Bridge unit transport exit motor | <ul style="list-style-type: none"> • Check that the motor is working. (Output check) • Connector check • Harness check • Replace the motor. |
| Roller (paper exit unit) | Check the condition of the roller. If it has deteriorated, replace it. |
| PFC board | <ul style="list-style-type: none"> • PC board check • Connector check • Harness check • Replace the PC board. |
| DRV board | <ul style="list-style-type: none"> • PC board check • Connector check • Harness check • Replace the PC board. |

| Parts to be replaced | Remarks |
|----------------------------------|---------|
| Lower paper exit sensor | |
| Bridge unit transport exit motor | |
| Roller (paper exit unit) | |
| PFC board | |
| DRV board | |

[E980] Paper stopping at the lower paper exit sensor jam

| Classification | Error content |
|---------------------|---|
| Paper transport jam | Paper transported from the bridge unit does not pass through the lower paper exit sensor. |

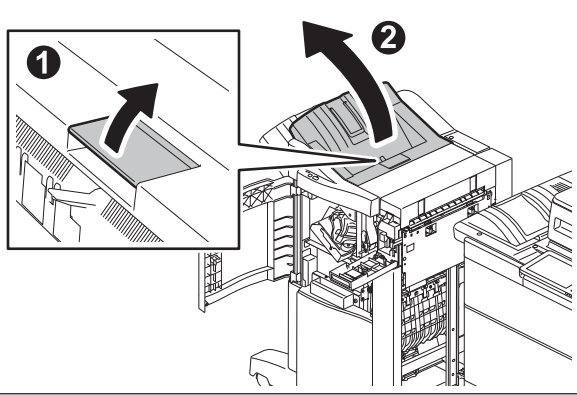
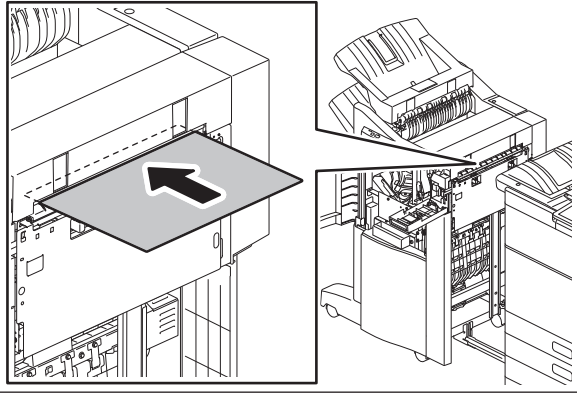
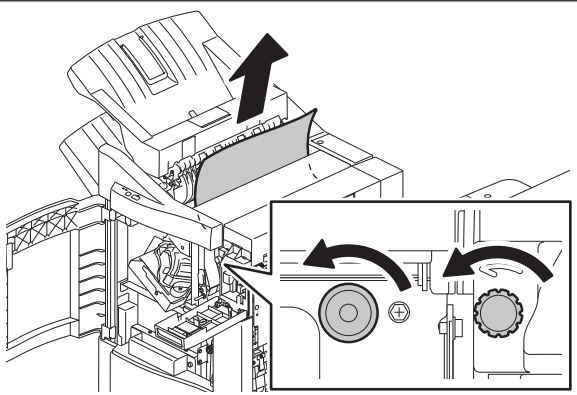
| Check item | Measures |
|-----------------|--|
| Hole Punch Unit | <p>If this error has occurred immediately after the unpacking and installation, a sheet in the hole punch unit may be deformed.</p> <ol style="list-style-type: none"> 1. Separate the Finisher from the MFP. 2. Open the stationary tray of the Finisher.  <p>Fig.8-9</p> <ol style="list-style-type: none"> 3. Insert one sheet of A4/LT-size thick paper (216 g/m² (80 lb. Bond) or equivalent) into the paper transport inlet of the Hole Punch Unit.  <p>Fig.8-10</p> <ol style="list-style-type: none"> 4. Open the front cover of the Finisher. Turn the 2 knobs in the direction of the arrow simultaneously. Upon making the thick paper pass through by means of turning the knobs in the direction of the arrow, the sheet deformation will be corrected.  <p>Fig.8-11</p> |

| Check item | Measures |
|--------------------------|---|
| Lower paper exit sensor | <ul style="list-style-type: none"> • Sensor check (Input check) • Actuator check • Connector check • Harness check • Replace the sensor. |
| Paper exit motor | <ul style="list-style-type: none"> • Check that the motor is working. (Output check) • Connector check • Harness check • Replace the motor. |
| Roller (paper exit unit) | Check the condition of the roller. If it has deteriorated, replace it. |
| PFC board | <ul style="list-style-type: none"> • PC board check • Connector check • Harness check • Replace the PC board. |
| DRV board | <ul style="list-style-type: none"> • PC board check • Connector check • Harness check • Replace the PC board. |

| Parts to be replaced | Remarks |
|--------------------------|---------|
| Lower paper exit sensor | |
| Paper exit motor | |
| Roller (paper exit unit) | |
| PFC board | |
| DRV board | |

[E9F0] Punching jam (Finisher, Saddle Stitch Finisher)

| Classification | Error content |
|--|-------------------------------------|
| Finisher jam Saddle stitch finisher jam | Punching is not performed properly. |

| Check item | Measures |
|----------------------------------|---|
| Punch motor (M3) | <ul style="list-style-type: none"> • Check that the motor is working. • Connector check • Harness check • Replace the motor. |
| Punch HP sensor (S4) | <ul style="list-style-type: none"> • Sensor check • Actuator check • Connector check • Harness check • Replace the sensor. |
| Punch sensor (S5) | <ul style="list-style-type: none"> • Sensor check • Actuator check • Connector check • Harness check • Replace the sensor. |
| Hole punch control PC board (HP) | <ul style="list-style-type: none"> • PC board check • Connector check • Harness check • Replace the PC board. |
| Finisher control PC board | <ul style="list-style-type: none"> • PC board check • Connector check • Harness check • Replace the PC board. |

| Parts to be replaced | Remarks |
|----------------------------------|---------|
| Punch motor (M3) | |
| Punch HP sensor (S4) | |
| Punch sensor (S5) | |
| Hole punch control PC board (HP) | |

| Parts to be replaced | Remarks |
|---------------------------|---------|
| Finisher control PC board | |

[EA10] Paper transport delay jam (Finisher, Saddle Stitch Finisher)

| Classification | Error content |
|--|---------------------------|
| Finisher jam Saddle stitch finisher jam | Paper transport delay jam |

| Check item | Measures |
|--|--|
| Paper feed sensor (S22) | <ul style="list-style-type: none"> • Sensor check • Actuator check • Connector check (CN1) • Harness check • Replace the sensor. |
| Transport path switching solenoid (SOL5) | <ul style="list-style-type: none"> • Solenoid check While the solenoid is turned ON or OFF, if the gap between the surface of the transport guide and the upper surface of the tip of the flap is not within the proper value (OFF: 1.5 to 2.1 mm, ON: 2.3 to 2.9 mm), adjust this. • Connector check (CN1) • Harness check |
| Entrance motor (M1) | <ul style="list-style-type: none"> • Check that the motor is working. • Connector check (CN17) • Harness check • Replace the motor. |
| Finisher control PC board (FIN) | <ul style="list-style-type: none"> • PC board check • Connector check (CN1, CN17) • Harness check • Replace the PC board. |

| Parts to be replaced | Remarks |
|---------------------------------|---------|
| Paper feed sensor (S22) | |
| Entrance motor (M1) | |
| Finisher control PC board (FIN) | |

[EA20] Paper transport stop jam (Finisher, Saddle Stitch Finisher)

| Classification | Error content |
|--|---------------------------|
| Finisher jam Saddle stitch finisher jam | Paper transport delay jam |

| Check item | Measures |
|---------------------------------|---|
| Entrance sensor (S1) | <ul style="list-style-type: none"> • Sensor check • Actuator check • Connector check • Harness check • Replace the sensor. |
| Finisher control PC board (FIN) | <ul style="list-style-type: none"> • PC board check • Connector check (CN8) • Harness check • Replace the PC board. |
| Assist guide | Check if there is any abnormality in the adjustment (height) of the guide. |

| Parts to be replaced | Remarks |
|---------------------------------|---------|
| Entrance sensor (S1) | |
| Finisher control PC board (FIN) | |

[EA21] Paper size error jam (Finisher, Saddle Stitch Finisher)

| Classification | Error content |
|--|---|
| Finisher jam Saddle stitch finisher jam | The transport sensor on the finisher transport path detects that the paper is shorter than the acceptable size. |

| Check item | Measures |
|---------------------------------|---|
| Paper | Use the paper specified in the specifications if a one shorter than the acceptable size is utilized. |
| Entrance sensor (S1) | <ul style="list-style-type: none"> • Sensor check • Actuator check • Connector check • Harness check • Replace the sensor. |
| Transport sensor (S2) | <ul style="list-style-type: none"> • Sensor check • Actuator check • Connector check • Harness check • Replace the sensor. |
| Finisher control PC board (FIN) | <ul style="list-style-type: none"> • PC board check • Connector check (CN8) • Harness check • Replace the PC board. |

| Parts to be replaced | Remarks |
|---------------------------------|---------|
| Entrance sensor (S1) | |
| Transport sensor (S2) | |
| Finisher control PC board (FIN) | |

[EA22] Hole punch unit paper size error jam (Finisher, Saddle Stitch Finisher)

| Classification | Error content |
|--|--|
| Finisher jam Saddle stitch finisher jam | The paper position sensor of the Hole Punch Unit detects that the paper is shorter than the acceptable size. |

| Check item | Measures |
|--|--|
| Paper | Use the paper specified in the specifications if a one shorter than the acceptable size is utilized. |
| Paper position sensor (S6-1, S6-2) (Hole punch unit) | <ul style="list-style-type: none"> • Clean the sensor and around it to remove the paper dust. • Sensor check • Connector check (CN1, CN2) • Harness check • Replace the sensor. |
| Finisher control PC board (FIN) | <ul style="list-style-type: none"> • PC board check • Connector check (CN8) • Harness check • Replace the PC board. |
| Hole punch control PC board (HP) | <ul style="list-style-type: none"> • PC board check • Connector check (CN1, CN2) • Harness check • Replace the PC board. |

| Parts to be replaced | Remarks |
|--|---------|
| Paper position sensor (S6-1, S6-2) (Hole punch unit) | |
| Finisher control PC board (FIN) | |
| Hole punch control PC board (HP) | |

[EA23] Paper transport stop jam (Finisher, Saddle Stitch Finisher)

| Classification | Error content |
|--|---|
| Finisher jam Saddle stitch finisher jam | The trailing edge of the paper does not pass through the transport sensor after its leading edge has passed through this sensor on the finisher transport path. |

| Check item | Measures |
|---------------------------------|---|
| Paper | Use the paper specified in the specifications if a one shorter than the acceptable size is utilized. |
| Transport sensor (S2) | <ul style="list-style-type: none"> • Sensor check • Actuator check • Connector check • Harness check • Replace the sensor. |
| Finisher control PC board (FIN) | <ul style="list-style-type: none"> • PC board check • Connector check (CN8) • Harness check • Replace the PC board. |

| Parts to be replaced | Remarks |
|---------------------------------|---------|
| Transport sensor (S2) | |
| Finisher control PC board (FIN) | |

[EA24] Paper transport delay jam (Finisher, Saddle Stitch Finisher)

| Classification | Error content |
|--|---|
| Finisher jam Saddle stitch finisher jam | The leading edge of the paper does not reach the transport sensor after it has passed through the entrance sensor on the finisher transport path. |

| Check item | Measures |
|--|--|
| Pinch roller arm | Check the position of the pinch roller arm. If it is down, correct its mechanism. |
| Transport path switching solenoid (SOL5) | <ul style="list-style-type: none"> • Solenoid check While the solenoid is turned ON or OFF, if the gap between the surface of the transport guide and the upper surface of the tip of the flap is not within the proper value (OFF: 1.5 to 2.1 mm, ON: 2.3 to 2.9 mm), adjust this. • Connector check (CN1) • Harness check |
| Entrance sensor (S1) | <ul style="list-style-type: none"> • Sensor check • Actuator check • Connector check (CN8) • Harness check • Replace the sensor. |
| Transport sensor (S2) | <ul style="list-style-type: none"> • Sensor check • Actuator check • Connector check (CN8) • Harness check • Replace the sensor. |
| Entrance motor (M1) | <ul style="list-style-type: none"> • Check that the motor is working. • Connector check (CN17) • Harness check • Replace the sensor. |
| Finisher control PC board (FIN) | <ul style="list-style-type: none"> • PC board check • Connector check (CN1, CN8, CN17) • Harness check • Replace the PC board. |

| Parts to be replaced | Remarks |
|---------------------------------|---------|
| Entrance sensor (S1) | |
| Transport sensor (S2) | |
| Entrance motor (M1) | |
| Finisher control PC board (FIN) | |

[EA25] Paper transport delay jam after the paper stack has exited (Finisher, Saddle Stitch Finisher)

| Classification | Error content |
|--|---|
| Finisher jam Saddle stitch finisher jam | The finishing tray paper detection sensor detects the paper after the exiting of a stack of the paper is completed. |

| Check item | Measures |
|---------------------------------|---|
| Transport sensor (S2) | <ul style="list-style-type: none"> • Sensor check • Actuator check • Connector check (CN8) • Harness check • Replace the sensor. |
| Finisher control PC board (FIN) | <ul style="list-style-type: none"> • PC board check • Connector check (CN25) • Harness check • Replace the PC board. |

| Parts to be replaced | Remarks |
|---------------------------------|---------|
| Transport sensor (S2) | |
| Finisher control PC board (FIN) | |

[EA26] Paper transport stop jam due to a stop signal from the MFP (Finisher, Saddle Stitch Finisher)

| Classification | Error content |
|--|---|
| Finisher jam Saddle stitch finisher jam | A command to stop the MFP operation is received while paper is being transported. |

| Check item | Measures |
|------------|---|
| Finisher | <ul style="list-style-type: none"> • Check if the harness between the MFP and the finisher controller PC board (FIN) is disconnected or open circuited. • Check if the pattern on the finisher controller PC board (FIN) is open circuited or short circuited. • Update the finisher firmware. • Replace the finisher control PC board (FIN). |
| LGC board | <ul style="list-style-type: none"> • Check if the harness between the Finisher and the LGC board is disconnected or open circuited. • Connector check (CN304) • Check if the pattern on the LGC board is open circuited or short circuited. • Replace the LGC board. |

| Parts to be replaced | Remarks |
|---------------------------------|---------|
| Finisher control PC board (FIN) | |
| LGC board | |

[EA27] Paper transport stop jam (Finisher, Saddle Stitch Finisher)

| Classification | Error content |
|--|--|
| Finisher jam Saddle stitch finisher jam | The entrance sensor is turned ON in a slower timing than that specified. |

| Check item | Measures |
|---------------------------------|---|
| Entrance sensor (S1) | <ul style="list-style-type: none"> • Sensor check • Actuator check • Connector check (CN8) • Harness check • Replace the sensor. |
| Finisher control PC board (FIN) | <ul style="list-style-type: none"> • PC board check • Connector check (CN8) • Harness check • Replace the PC board. |

| Parts to be replaced | Remarks |
|---------------------------------|---------|
| Entrance sensor (S1) | |
| Finisher control PC board (FIN) | |

[EA28] Paper transport stop jam due to an assist guide plate operation delay (Finisher, Saddle Stitch Finisher)

| Classification | Error content |
|--|---|
| Finisher jam Saddle stitch finisher jam | An attempt to start the assist guide plate operation for dropping the paper on the finishing tray is made, but the previous assist guide plate operation has not yet been finished. |

| Check item | Measures |
|---------------------------------|--|
| Assist guide | <ul style="list-style-type: none"> • Check if there is any abnormality in the installation of the guide. • Check if there is any mechanical problem. • If there is any, correct it. |
| Assist guide motor (M10) | <ul style="list-style-type: none"> • Check that the motor is working. • Connector check (CN10) • Harness check • Replace the motor. |
| Finisher control PC board (FIN) | <ul style="list-style-type: none"> • PC board check • Connector check (CN10) • Harness check • Replace the PC board. |

| Parts to be replaced | Remarks |
|---------------------------------|---------|
| Assist guide motor (M10) | |
| Finisher control PC board (FIN) | |

[EA29] Paper transport stop jam due to a stack transport operation delay (Finisher, Saddle Stitch Finisher)

| Classification | Error content |
|--|--|
| Finisher jam Saddle stitch finisher jam | An attempt to drop a stack of the paper on the finishing tray by extending the buffer tray is made, but the previous stack has not yet exited. |

| Check item | Measures |
|---------------------------------|--|
| Buffer tray guide | <ul style="list-style-type: none"> • Check if there is any abnormality in the installation of the guide. • Check if there is any mechanical problem. • If there is any, correct it. |
| Buffer tray guide motor (M2) | <ul style="list-style-type: none"> • Check that the motor is working. • Connector check (CN10) • Harness check • Replace the motor. |
| Finisher control PC board (FIN) | <ul style="list-style-type: none"> • PC board check • Connector check (CN10) • Harness check • Replace the PC board. |

| Parts to be replaced | Remarks |
|---------------------------------|---------|
| Buffer tray guide motor (M2) | |
| Finisher control PC board (FIN) | |

[EA31] Transport path paper remaining jam (Finisher, Saddle Stitch Finisher)

| Classification | Error content |
|--|--|
| Finisher jam Saddle stitch finisher jam | An attempt to drop a stack of the paper on the finishing tray by extending the buffer tray is made, but the previous stack has not yet exited. |

| Check item | Measures |
|--|--|
| Entrance sensor (S1) | <ul style="list-style-type: none"> • Sensor check • Actuator check • Connector check (CN8) • Harness check • Replace the sensor. |
| Paper feed sensor (S22) | <ul style="list-style-type: none"> • Sensor check • Actuator check • Connector check (CN1) • Harness check • Replace the sensor. |
| Paper position sensor (S6-1, S6-2) (Hole punch unit) | <ul style="list-style-type: none"> • Clean the sensor and around it to remove the paper dust. • Sensor check • Connector check (CN1, CN2) • Harness check • Replace the sensor. |
| Transport sensor (S2) | <ul style="list-style-type: none"> • Sensor check • Actuator check • Connector check (CN8) • Harness check • Replace the sensor. |
| Finisher control PC board (FIN) | <ul style="list-style-type: none"> • PC board check • Connector check (CN1, CN8) • Harness check • Replace the PC board. |
| Hole punch control PC board (HP) | <ul style="list-style-type: none"> • PC board check • Connector check (CN1, CN2) • Harness check • Replace the PC board. |

| Parts to be replaced | Remarks |
|--|---------|
| Entrance sensor (S1) | |
| Paper feed sensor (S22) | |
| Paper position sensor (S6-1, S6-2) (Hole punch unit) | |
| Transport sensor (S2) | |
| Finisher control PC board (FIN) | |
| Hole punch control PC board (HP) | |

[EA32] Exit paper remaining jam (Finisher, Saddle Stitch Finisher)

| Classification | Error content |
|--|---|
| Finisher jam Saddle stitch finisher jam | Paper is detected in the finishing tray paper sensor when the power is turned ON. |

| Check item | Measures |
|---|--|
| Finishing tray paper detection sensor (S12) | <ul style="list-style-type: none"> • Sensor check • Actuator check • Connector check (CN25) • Harness check • Replace the sensor. |
| Finisher control PC board (FIN) | <ul style="list-style-type: none"> • PC board check • Connector check (CN25) • Harness check • Replace the PC board. |

| Parts to be replaced | Remarks |
|---|---------|
| Finishing tray paper detection sensor (S12) | |
| Finisher control PC board (FIN) | |

[EA40] Stationary tray open jam (Finisher, Saddle Stitch Finisher)

| Classification | Error content |
|--|---|
| Finisher jam Saddle stitch finisher jam | <ul style="list-style-type: none"> The cover of the finisher has become open during the operation. The stationary tray of the finisher has become open during the operation. The 24 V voltage cannot be detected on the finisher control PC board. |

| Check item | Measures |
|--|--|
| Stationary tray | <ul style="list-style-type: none"> Check if there is any abnormality in the cover. Close the cover if it is opened. Replace the cover. |
| Stationary tray opening/closing switch (SW2) | <ul style="list-style-type: none"> Switch check Actuator check Connector check (CN14) Harness check Replace the switch. |
| Front cover opening/closing switch (SW1) | <ul style="list-style-type: none"> Switch check Actuator check Connector check (CN14) Harness check Replace the switch. |
| Finisher connection cable | <ul style="list-style-type: none"> Check if there is any abnormality in the cable. Connector check |
| Finisher control PC board (FIN) | <ul style="list-style-type: none"> PC board check Connector check (CN14) Harness check Replace the PC board. |
| Saddle control PC board (SDL) | <ul style="list-style-type: none"> PC board check Connector check (CN6) Harness check Replace the PC board. |
| Hole punch control PC board (HP) | <ul style="list-style-type: none"> PC board check Connector check (CN4) Harness check Replace the PC board. |

| Parts to be replaced | Remarks |
|--|---------|
| Front upper cover | |
| Stationary tray opening/closing switch (SW2) | |
| Front cover opening/closing switch (SW1) | |
| Finisher control PC board (FIN) | |
| Saddle control PC board (SDL) | |
| Hole punch control PC board (HP) | |

[EA41] Front upper cover open jam (Finisher, Saddle Stitch Finisher)

| Classification | Error content |
|--|---|
| Finisher jam Saddle stitch finisher jam | The front upper cover of the finisher has become open during the operation. |

| Check item | Measures |
|--|---|
| Front upper cover | <ul style="list-style-type: none"> • Check if there is any abnormality in the cover. • Close the cover if it is opened. • Check if the cover locking bracket is damaged. • Replace the cover locking bracket. |
| Front cover opening/closing switch (SW1) | <ul style="list-style-type: none"> • Switch check • Actuator check • Connector check (CN14) • Harness check • Replace the switch. |
| Finisher control PC board (FIN) | <ul style="list-style-type: none"> • PC board check • Connector check (CN14) • Harness check • Replace the PC board. |

| Parts to be replaced | Remarks |
|--|---------|
| Cover locking bracket | |
| Front cover opening/closing switch (SW1) | |
| Finisher control PC board (FIN) | |

[EA42] Hole punch: Front cover open jam (Finisher, Saddle Stitch Finisher)

| Classification | Error content |
|---------------------|--|
| Hole punch unit jam | The front cover of the hole punch unit has become open during the operation. |

| Check item | Measures |
|---|---|
| Front cover | <ul style="list-style-type: none"> • Check if there is any abnormality in the cover. • Close the cover if it is opened. • Replace the cover. |
| Front cover opening/closing sensor (S1) | <ul style="list-style-type: none"> • Sensor check • Actuator check • Connector check • Harness check • Replace the sensor. |
| Hole punch control PC board (HP) | <ul style="list-style-type: none"> • PC board check • Connector check (CN10) • Harness check • Replace the PC board. |

| Parts to be replaced | Remarks |
|---|---------|
| Front cover | |
| Front cover opening/closing sensor (S1) | |
| Hole punch control PC board (HP) | |

[EA50] Stapling jam (Finisher, Saddle Stitch Finisher)

| Classification | Error content |
|--|---------------------------------|
| Finisher jam Saddle stitch finisher jam | Stapling is not correctly done. |

| Check item | Measures |
|---------------------------------|--|
| Stapler | <ul style="list-style-type: none">• Take off the staple cartridge and remove the staple sheet slid from the staple case.• If the actuator of the stapler safety sensor (S11) does not move smoothly, remove its clip from the side and then reattach it.• Connector check (CN2)• Harness check• Replace the stapler. |
| Finisher control PC board (FIN) | <ul style="list-style-type: none">• PC board check• Connector check (CN2)• Harness check• Replace the PC board. |

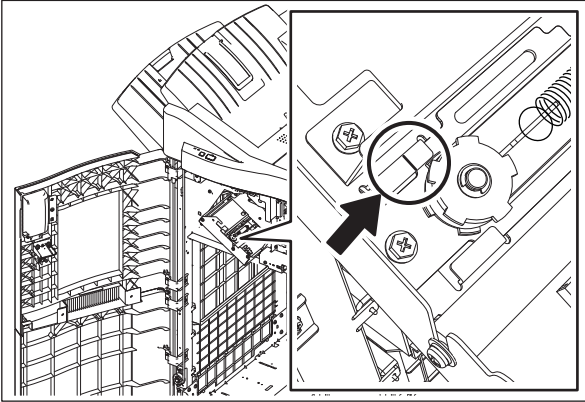
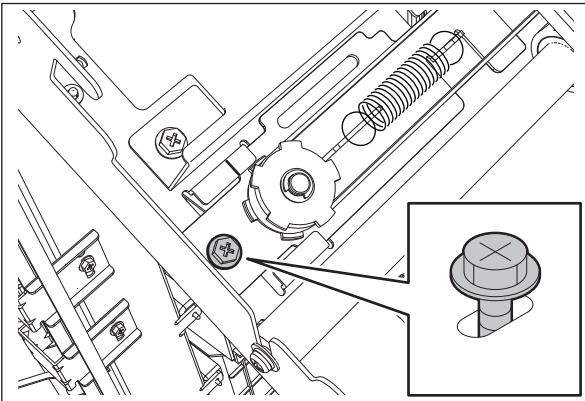
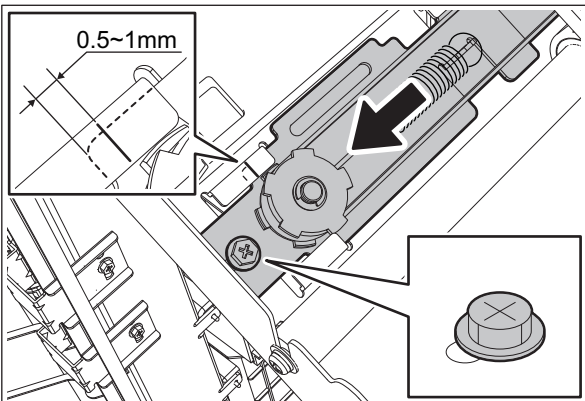
| Check item | Measures |
|---------------------------------|--|
| Belt | <p data-bbox="587 136 1350 193">Check if the belt tension of the stapler unit is loosened. If it is loosened, perform the adjustment according to the following procedure.</p> <ol data-bbox="587 193 1358 221" style="list-style-type: none"> <li data-bbox="587 193 1358 221">1. Before adjusting the belt tension, make a mark for the initial position.  <p data-bbox="587 640 671 668">Fig.8-12</p> <ol data-bbox="587 697 1126 725" style="list-style-type: none"> <li data-bbox="587 697 1126 725">2. Loosen the screw of the belt pulley metal plate.  <p data-bbox="587 1144 671 1172">Fig.8-13</p> <ol data-bbox="587 1202 1337 1259" style="list-style-type: none"> <li data-bbox="587 1202 1337 1259">3. Move the pulley to the front side by 0.5 to 1.0 mm from the marked position and then tighten the screw.  <p data-bbox="587 1678 671 1706">Fig.8-14</p> |
| Parts to be replaced | Remarks |
| Stapler | |
| Finisher control PC board (FIN) | |

[EA60] Paper early arrival jam (Finisher, Saddle Stitch Finisher)

| Classification | Error content |
|--|---|
| Finisher jam Saddle stitch finisher jam | Paper has arrived at the finisher from the MFP too early. |

| Check item | Measures |
|---------------------------------|---|
| Paper feed sensor (S22) | <ul style="list-style-type: none"> • Sensor check • Actuator check • Connector check (CN1) • Harness check • Replace the sensor. |
| Finisher control PC board (FIN) | <ul style="list-style-type: none"> • PC board check • Connector check (CN1) • Harness check • Replace the PC board. |

| Parts to be replaced | Remarks |
|---------------------------------|---------|
| Paper feed sensor (S22) | |
| Finisher control PC board (FIN) | |

[EA70] Stack exit belt home position error (Finisher, Saddle Stitch Finisher)

| Classification | Error content |
|--|--|
| Finisher jam Saddle stitch finisher jam | The stack exit belt is not at its home position. |

| Check item | Measures |
|---------------------------------|---|
| Paper feed sensor (S22) | <ul style="list-style-type: none"> • Sensor check • Actuator check • Connector check (CN1) • Harness check • Replace the sensor. |
| Finisher control PC board (FIN) | <ul style="list-style-type: none"> • PC board check • Connector check (CN1) • Harness check • Replace the PC board. |

| Parts to be replaced | Remarks |
|---------------------------------|---------|
| Paper feed sensor (S22) | |
| Finisher control PC board (FIN) | |

[EA90] Front lower open jam (Saddle Stitch Finisher)

| Classification | Error content |
|----------------------------|--|
| Saddle stitch finisher jam | The front lower cover has become open during printing. |

| Check item | Measures |
|---|--|
| Front lower cover | Close the front lower cover if it is open. |
| Saddle stitch unit opening/closing switch (SW5) | <ul style="list-style-type: none"> • Switch check • Actuator check • Connector check (CN26) • Harness check • Replace the switch. |

| Parts to be replaced | Remarks |
|---|---------|
| Saddle stitch unit opening/closing switch (SW5) | |

[EAA0] Paper remaining jam in the saddle stitch unit (Saddle Stitch Finisher)

| Classification | Error content |
|----------------------------|--|
| Saddle stitch finisher jam | Paper is detected in the saddle stitch unit when the power is turned ON. |

| Check item | Measures |
|---------------------------------|--|
| Paper | <ul style="list-style-type: none"> • Check if there is any paper in the saddle stitch section of the Finisher or the on the transport path of the MFP. Remove it if there is. • Use the paper specified in the specifications if a one shorter than the acceptable size is utilized. |
| Junction box sensor (S26) | <ul style="list-style-type: none"> • Sensor check • Actuator check • Connector check (CN1) • Harness check • Replace the sensor. |
| Transport path-2 sensor (S27) | <ul style="list-style-type: none"> • Sensor check • Actuator check • Connector check (CN3) • Harness check • Replace the sensor. |
| Transport path-3 sensor (S28) | <ul style="list-style-type: none"> • Sensor check • Actuator check • Connector check (CN3) • Harness check • Replace the sensor. |
| Eject roller sensor (S29) | <ul style="list-style-type: none"> • Sensor check • Actuator check • Connector check (CN3) • Harness check • Replace the sensor. |
| Finisher control PC board (FIN) | <ul style="list-style-type: none"> • PC board check • Connector check (CN21, CN1) • Harness check • Replace the PC board. |
| Saddle control PC board (SDL) | <ul style="list-style-type: none"> • PC board check • Connector check (CN3, CN6) • Harness check • Replace the PC board. |

| Parts to be replaced | Remarks |
|---------------------------------|---------|
| Junction box sensor (S26) | |
| Transport path-2 sensor (S27) | |
| Transport path-3 sensor (S28) | |
| Eject roller sensor (S29) | |
| Finisher control PC board (FIN) | |
| Saddle control PC board (SDL) | |

[EAB0] Paper transport jam in the saddle stitch unit (Saddle Stitch Finisher)

| Classification | Error content |
|----------------------------|--|
| Saddle stitch finisher jam | Paper is detected in the saddle stitch unit when the power is turned ON. |

| Check item | Measures |
|-------------------------|---|
| Paper | If any paper remains in the finisher, remove it. |
| Transport roller | <ul style="list-style-type: none"> • Check if there is any abnormality in the rotation of the roller. • Check if there is any mechanical problem. • If there is any, correct it. |
| Paper feed sensor (S22) | <ul style="list-style-type: none"> • Sensor check • Actuator check • Connector check (CN1) • Harness check • Replace the sensor. |

| Check item | Measures |
|--|---|
| Junction box sensor (S26) | <ul style="list-style-type: none"> • Sensor check • Actuator check • Connector check (CN1) • Harness check • Replace the sensor. |
| Transport path-2 sensor (S27) | <ul style="list-style-type: none"> • Sensor check • Actuator check • Connector check (CN3) • Harness check • Replace the sensor. |
| Transport path-3 sensor (S28) | <ul style="list-style-type: none"> • Sensor check • Actuator check • Connector check (CN3) • Harness check • Replace the sensor. |
| Eject roller sensor (S29) | <ul style="list-style-type: none"> • Sensor check • Actuator check • Connector check (CN3) • Harness check • Replace the sensor. |
| Saddle transport motor (M16) | <ul style="list-style-type: none"> • Check that the motor is working. • Connector check (CN5) • Harness check • Replace the motor. |
| Transport path switching solenoid (SOL5) | <ul style="list-style-type: none"> • Solenoid check While the solenoid is turned ON or OFF, if the gap between the surface of the transport guide and the upper surface of the tip of the flap is not within the proper value (OFF: 1.5 to 2.1 mm, ON: 2.3 to 2.9 mm), adjust this. • Connector check (CN17) • Harness check |
| Entrance motor (M1) | <ul style="list-style-type: none"> • Check that the motor is working. • Connector check (CN1) • Harness check • Replace the motor. |
| Finisher control PC board (FIN) | <ul style="list-style-type: none"> • PC board check • Connector check • Harness check • Replace the PC board. |
| Saddle control PC board (SDL) | <ul style="list-style-type: none"> • PC board check • Connector check • Harness check • Replace the PC board. |

| Parts to be replaced | Remarks |
|---------------------------------|---------|
| Paper feed sensor (S22) | |
| Junction box sensor (S26) | |
| Transport path-2 sensor (S27) | |
| Transport path-3 sensor (S28) | |
| Eject roller sensor (S29) | |
| Saddle transport motor (M16) | |
| Entrance motor (M1) | |
| Finisher control PC board (FIN) | |
| Saddle control PC board (SDL) | |

[EAB1] Paper size error jam (Saddle Stitch Finisher)

| Classification | Error content |
|----------------------------|--|
| Saddle stitch finisher jam | Paper is shorter than the acceptable paper size. |

| Check item | Measures |
|---------------------------------|---|
| Paper | Use the paper specified in the specifications if a one shorter than the acceptable size is utilized. |
| Paper feed sensor (S22) | <ul style="list-style-type: none"> • Sensor check • Actuator check • Connector check (CN1) • Harness check • Replace the sensor. |
| Junction box sensor (S26) | <ul style="list-style-type: none"> • Sensor check • Actuator check • Connector check (CN1) • Harness check • Replace the sensor. |
| Transport path-2 sensor (S27) | <ul style="list-style-type: none"> • Sensor check • Actuator check • Connector check (CN3) • Harness check • Replace the sensor. |
| Transport path-3 sensor (S28) | <ul style="list-style-type: none"> • Sensor check • Actuator check • Connector check (CN3) • Harness check • Replace the sensor. |
| Eject roller sensor (S29) | <ul style="list-style-type: none"> • Sensor check • Actuator check • Connector check (CN3) • Harness check • Replace the sensor. |
| Finisher control PC board (FIN) | <ul style="list-style-type: none"> • PC board check • Connector check • Harness check • Replace the PC board. |
| Saddle control PC board (SDL) | <ul style="list-style-type: none"> • PC board check • Connector check • Harness check • Replace the PC board. |

| Parts to be replaced | Remarks |
|---------------------------------|---------|
| Paper feed sensor (S22) | |
| Junction box sensor (S26) | |
| Transport path-2 sensor (S27) | |
| Transport path-3 sensor (S28) | |
| Eject roller sensor (S29) | |
| Finisher control PC board (FIN) | |
| Saddle control PC board (SDL) | |

[EAD0] Print end command time-out error

| Classification | Error content |
|--|--|
| Finisher jam Saddle stitch finisher jam | Printing has not been finished normally because of a communication error between the SYS board and the LGC board at the end of printing. |

| Check item | Measures |
|-----------------|--|
| Reproducibility | Turn the power OFF and then back ON to check the occurrence. |
| SYS board | <ul style="list-style-type: none"> • PC board check • Connector check (CN130, CN131, CN132) • Harness (flat cable) check • Replace the PC board. |

| Check item | Measures |
|------------|--|
| LGC board | <ul style="list-style-type: none"> PC board check Connector check (CN330, CN331, CN332) Harness (flat cable) check Replace the PC board. |

| Parts to be replaced | Remarks |
|----------------------|---------|
| SYS board | |
| LGC board | |

- [EAE0] Finisher receiving time-out jam
- [EAE1] Finisher receiving time-out jam (1)
- [EAE2] Finisher receiving time-out jam (2)
- [EAE3] Finisher receiving time-out jam (3)
- [EAE4] Finisher receiving time-out jam (4)
- [EAE5] Finisher receiving time-out jam (5)
- [EAE6] Finisher receiving time-out jam (6)
- [EAE7] Finisher receiving time-out jam (7)
- [EAE8] Finisher receiving time-out jam (8)
- [EAE9] Finisher receiving time-out jam (9)
- [EAEA] Finisher receiving time-out jam (10)
- [EAEB] Finisher receiving time-out jam (11)
- [EAEC] Finisher receiving time-out jam (12)
- [EAED] Finisher receiving time-out jam (13)
- [EAEF] Finisher receiving time-out jam (15)

| Classification | Error content |
|--|---|
| Finisher jam Saddle stitch finisher jam | <ul style="list-style-type: none"> Finisher adjustment value writing abnormality Finisher ON/OFF abnormality Stack of paper enforced exiting abnormality Stack of paper enforced exiting abnormality (Saddle stitch unit) Mechanical initialize abnormality Finisher response abnormality Stack of paper exiting status abnormality Stapling status abnormality Saddle stitch folding status abnormality Cancellation abnormality Finisher communication abnormality Finisher reception data abnormality Finisher transmission data abnormality Sensor passing notification abnormality Finisher paper exiting end abnormality |

| Check item | Measures |
|-----------------|--|
| Reproducibility | Turn the power OFF and then back ON to check the occurrence. |
| Finisher | <ul style="list-style-type: none"> PC board check Connector check Harness check Replace the PC board. |
| LGC board | <ul style="list-style-type: none"> Check if the finisher works properly. Check if the 24 V voltage is being supplied to the finisher. Check if there is any abnormality in the interface connector between the finisher and the LGC board. Check if the harness between the finisher and the LGC board is scratched or open circuited. |

[EAFA] Catching motor home position sensor detection abnormality

| Classification | Error content |
|--|---|
| Finisher jam Saddle stitch finisher jam | The detection of the home position of the catching motor ends abnormally. |

| Check item | Measures |
|---|--|
| Catching motor (M21) | <ul style="list-style-type: none"> • Check that the motor is working. • Connector check (CN17) • Harness check • Replace the motor. |
| Catching motor home position sensor (S52) | <ul style="list-style-type: none"> • Sensor check • Actuator check • Connector check (CN17) • Harness check • Replace the sensor. |
| Finisher control PC board (FIN) | <ul style="list-style-type: none"> • PC board check • Connector check (CN11) • Harness check • Replace the PC board. |

| Parts to be replaced | Remarks |
|---|---------|
| Catching motor (M21) | |
| Catching motor home position sensor (S52) | |
| Finisher control PC board (FIN) | |

[EAFB] Stapler movement abnormality (Finisher, Saddle Stitch Finisher)**[CB51] Stapler movement home position abnormality (Finisher, Saddle Stitch Finisher)**

| Classification | Error content |
|--|--|
| [EAFB] Finisher jam Saddle stitch finisher jam [CB51] Finisher service call Saddle stitch finisher service call | The stapler is not at its home position. |

| Check item | Measures |
|---|--|
| Stapler | <ul style="list-style-type: none"> • Check if there is any abnormality in the installation of the stapler. • Check if there is any mechanical problem. • If there is any, correct it. |
| Stapler unit home position sensor (S10) | <ul style="list-style-type: none"> • Sensor check • Actuator check • Connector check (CN27) • Harness check • Replace the sensor. |
| Stapler unit shift motor (M9) | <ul style="list-style-type: none"> • Check that the motor is working. • Connector check (CN15) • Harness check • Replace the motor. |

| Parts to be replaced | Remarks |
|---|---------|
| Stapler unit home position sensor (S10) | |
| Stapler unit shift motor (M9) | |

[EAFC] Movable tray height abnormality (Finisher, Saddle Stitch Finisher)**[CB30] Movable tray shift motor abnormality (Finisher, Saddle Stitch Finisher)**

| Classification | Error content |
|--|--|
| [EAFC] Finisher jam Saddle stitch finisher jam [CB30] Finisher service call Saddle stitch finisher service call | The movable tray shift motor or the movable tray does not work normally. |

| Check item | Measures |
|---|---|
| Movable tray | <ul style="list-style-type: none"> • Check if there is any abnormality in the installation of the tray. • Check if there is any mechanical problem. • If there is any, correct it. |
| Movable tray shift motor (M12) | <ul style="list-style-type: none"> • Check that the motor is working. • Connector check (CN19) • Harness check • Replace the motor. |
| Movable tray position sensors A, B, C (S13, S14, S15) | <ul style="list-style-type: none"> • Sensor check • Actuator check • Connector check (CN20) • Harness check • Replace the sensor. |

| Parts to be replaced | Remarks |
|---|---------|
| Movable tray shift motor (M12) | |
| Movable tray position sensors A, B, C (S13, S14, S15) | |

[EAFD] Movable tray movement abnormality (Finisher, Saddle Stitch Finisher)**[CB31] Movable tray movement abnormality (Finisher, Saddle Stitch Finisher)**

| Classification | Error content |
|--|--|
| [EAFD] Finisher jam Saddle stitch finisher jam [CB31] Finisher service call Saddle stitch finisher service call | The actuator of the movable tray stack height detection sensor does not move smoothly. |

| Check item | Measures |
|---|--|
| Movable tray stack height detection sensor (S16) | <ul style="list-style-type: none"> • Sensor check • Actuator check • Connector check (CN22) • Harness check • Replace the sensor. |
| Movable tray position sensors A, B, C (S13, S14, S15) | <ul style="list-style-type: none"> • Sensor check • Actuator check • Connector check (CN20) • Harness check • Replace the sensor. |

| Parts to be replaced | Remarks |
|---|---------|
| Movable tray stack height detection sensor (S16) | |
| Movable tray position sensors A, B, C (S13, S14, S15) | |

[EAFE] Assist guide cam position abnormality (Finisher, Saddle Stitch Finisher)

| Classification | Error content |
|--|--|
| Finisher jam Saddle stitch finisher jam | The assist guide cam or the assist guide motor does not work normally. |

| Check item | Measures |
|---------------------------------|---|
| Assist guide cam | <ul style="list-style-type: none"> • Check if there is any abnormality in the installation of the cam. • Check if there is any mechanical problem by rotating it. • If there is any, correct it. |
| Assist guide motor (M10) | <ul style="list-style-type: none"> • Check that the motor is working. • Connector check (CN10) • Harness check • Replace the motor. |
| Finisher control PC board (FIN) | <ul style="list-style-type: none"> • PC board check • Connector check (CN10) • Harness check • Replace the PC board. |

| Parts to be replaced | Remarks |
|---------------------------------|---------|
| Assist guide motor (M10) | |
| Finisher control PC board (FIN) | |

[EB30] Ready time-out jam

| Classification | Error content |
|--|---|
| Finisher jam Saddle stitch finisher jam | The operation could not be continued properly when the paper has been transported from the MFP to the finisher due to a communication abnormality between them. |

| Check item | Measures |
|-----------------|---|
| Reproducibility | Turn the power OFF and then back ON to check the occurrence. |
| Finisher | <ul style="list-style-type: none"> • Check if the finisher works properly. • Check if there is any abnormality in the interface connector between the finisher and the LGC board. • Check if the harness between the finisher and the LGC board is scratched or open circuited. • Update the finisher firmware to the latest one. |

[EB50] Paper remaining on the transport path jam due to multiple feeding

| Classification | Error content |
|-----------------|--|
| Other paper jam | The multiple feeding of preceding paper caused the misfeeding of upcoming paper. |

| Check item | Measures |
|-------------------------------|---|
| 1st drawer paper feed sensor | <ul style="list-style-type: none"> • Sensor check (Input check) • Actuator check • Connector check • Harness check • Replace the sensor. |
| 2nd drawer paper feed sensor | <ul style="list-style-type: none"> • Sensor check (Input check) • Actuator check • Connector check • Harness check • Replace the sensor. |
| Bypass tray paper feed sensor | <ul style="list-style-type: none"> • Sensor check (Input check) • Actuator check • Connector check • Harness check • Replace the sensor. |

| Check item | Measures |
|---------------------------------|---|
| Duplexing unit path exit sensor | <ul style="list-style-type: none"> • Sensor check (Input check) • Actuator check • Connector check • Harness check • Replace the sensor. |
| Registration sensor | <ul style="list-style-type: none"> • Sensor check (Input check) • Actuator check • Connector check • Harness check • Replace the sensor. |
| 3rd drawer paper feed clutch | <ul style="list-style-type: none"> • Clutch check (Output check) • Connector check • Harness check • Replace the clutch. |
| PFC board | <ul style="list-style-type: none"> • PC board check • Connector check • Harness check • Replace the PC board. |
| DRV board | <ul style="list-style-type: none"> • PC board check • Connector check • Harness check • Replace the PC board. |
| ADU board | <ul style="list-style-type: none"> • PC board check • Connector check • Harness check • Replace the PC board. |
| LGC board | <ul style="list-style-type: none"> • PC board check • Connector check • Harness check • Replace the PC board. |
| Rollers | Check the condition of the each transport roller. If it has deteriorated, replace it. |

| Parts to be replaced | Remarks |
|---------------------------------|---------|
| 1st drawer paper feed sensor | |
| 2nd drawer paper feed sensor | |
| Bypass tray paper feed sensor | |
| Duplexing unit path exit sensor | |
| Registration sensor | |
| 3rd drawer paper feed clutch | |
| PFC board | |
| DRV board | |
| ADU board | |
| LGC board | |
| Rollers | |

[EB60] Paper remaining on the transport path jam due to multiple feeding

| Classification | Error content |
|----------------|--|
| Paper exit jam | The multiple feeding of preceding paper caused the misfeeding of upcoming paper. |

| Check item | Measures |
|---------------------|---|
| Registration sensor | <ul style="list-style-type: none"> • Sensor check (Input check) • Actuator check • Connector check • Harness check • Replace the sensor. |

| Check item | Measures |
|------------|---|
| PFC board | <ul style="list-style-type: none"> • PC board check • Connector check • Harness check • Replace the PC board. |
| LGC board | <ul style="list-style-type: none"> • PC board check • Connector check • Harness check • Replace the PC board. |
| Rollers | Check the condition of the each transport roller. If it has deteriorated, replace it. |

| Parts to be replaced | Remarks |
|----------------------|---------|
| Registration sensor | |
| PFC board | |
| LGC board | |
| Rollers | |

[ED10] Hole punch: Skew adjustment motor home position detection abnormality (Finisher, Saddle Stitch Finisher)

| Classification | Error content |
|---------------------|--|
| Hole punch unit jam | The home position of the skew adjustment motor cannot be detected. |

| Check item | Measures |
|----------------------------------|---|
| Skew adjustment mechanism | <ul style="list-style-type: none"> • Check if there is any abnormality in the movement of the skew adjustment motor. • Check if there is any mechanical problem by moving it. • If there is any, correct it. |
| Skew adjustment motor (M1) | <ul style="list-style-type: none"> • Check that the motor is working. • Connector check (CN10) • Harness check • Replace the motor. |
| Skew HP sensor (S2) | <ul style="list-style-type: none"> • Sensor check • Actuator check • Connector check (CN10) • Harness check • Replace the sensor. |
| Hole punch control PC board (HP) | <ul style="list-style-type: none"> • PC board check • Connector check (CN10) • Harness check • Replace the PC board. |

| Parts to be replaced | Remarks |
|----------------------------------|---------|
| Skew adjustment motor (M1) | |
| Skew HP sensor (S2) | |
| Hole punch control PC board (HP) | |

[ED11] Hole punch: Sideways deviation adjustment motor home position detection abnormality (Finisher, Saddle Stitch Finisher)

| Classification | Error content |
|---------------------|--|
| Hole punch unit jam | The home position of the sideways deviation adjustment motor cannot be detected. |

| Check item | Measures |
|---|---|
| Sideways deviation adjustment mechanism | <ul style="list-style-type: none"> • Check if there is any abnormality in the movement of the sideways deviation adjustment motor. • Check if there is any mechanical problem by moving it. • If there is any, correct it. |

| Check item | Measures |
|--|---|
| Sideways deviation adjustment motor (M2) | <ul style="list-style-type: none"> • Check that the motor is working. • Connector check (CN9) • Harness check • Replace the motor. |
| Sideways deviation HP sensor (S3) | <ul style="list-style-type: none"> • Sensor check • Actuator check • Connector check (CN8) • Harness check • Replace the sensor. |
| Hole punch control PC board (HP) | <ul style="list-style-type: none"> • PC board check • Connector check (CN8, CN9) • Harness check • Replace the PC board. |

| Parts to be replaced | Remarks |
|--|---------|
| Sideways deviation adjustment motor (M2) | |
| Sideways deviation HP sensor (S3) | |
| Hole punch control PC board (HP) | |

[ED13] Front alignment plate home position abnormality (Finisher, Saddle Stitch Finisher)

| Classification | Error content |
|--|--|
| Finisher jam Saddle stitch finisher jam | The home position of the front alignment plate cannot be detected. |

| Check item | Measures |
|---|---|
| Front alignment plate | <ul style="list-style-type: none"> • Check if there is any abnormality in the movement of the front alignment plate. • Check if there is any mechanical problem by moving it. • If there is any, correct it. |
| Front alignment plate home position sensor (S7) | <ul style="list-style-type: none"> • Sensor check • Actuator check • Connector check (CN25) • Harness check • Replace the sensor. |
| Front alignment motor (M5) | <ul style="list-style-type: none"> • Check that the motor is working. • Connector check (CN18) • Harness check • Replace the motor. |
| Finisher control PC board (FIN) | <ul style="list-style-type: none"> • PC board check • Connector check (CN18, CN25) • Harness check • Replace the PC board. |

| Parts to be replaced | Remarks |
|---|---------|
| Front alignment plate home position sensor (S7) | |
| Front alignment motor (M5) | |
| Finisher control PC board (FIN) | |

[ED14] Rear alignment plate home position abnormality (Finisher, Saddle Stitch Finisher)

| Classification | Error content |
|--|---|
| Finisher jam Saddle stitch finisher jam | The home position of the rear alignment plate cannot be detected. |

| Check item | Measures |
|--|--|
| Rear alignment plate | <ul style="list-style-type: none"> Check if there is any abnormality in the movement of the rear alignment plate. Check if there is any mechanical problem by moving it. If there is any, correct it. |
| Rear alignment plate home position sensor (S8) | <ul style="list-style-type: none"> Sensor check Actuator check Connector check (CN25) Harness check Replace the sensor. |
| Rear alignment motor (M6) | <ul style="list-style-type: none"> Check that the motor is working. Connector check (CN18) Harness check Replace the motor. |
| Finisher control PC board (FIN) | <ul style="list-style-type: none"> PC board check Connector check (CN18, CN25) Harness check Replace the PC board. |

| Parts to be replaced | Remarks |
|--|---------|
| Rear alignment plate home position sensor (S8) | |
| Rear alignment motor (M6) | |
| Finisher control PC board (FIN) | |

[ED15] Paddle home position abnormality (Finisher, Saddle Stitch Finisher)

| Classification | Error content |
|--|---|
| Finisher jam Saddle stitch finisher jam | The home position of the paddle cannot be detected. |

| Check item | Measures |
|----------------------------------|--|
| Paddle | <ul style="list-style-type: none"> Check if there is any abnormality in the movement of the paddle. Check if there is any mechanical problem by rotating it. If there is any, correct it. |
| Paddle home position sensor (S3) | <ul style="list-style-type: none"> Sensor check Actuator check Connector check (CN15) Harness check Replace the sensor. |
| Paddle motor (M3) | <ul style="list-style-type: none"> Check that the motor is working. Connector check (CN16) Harness check Replace the motor. |
| Finisher control PC board (FIN) | <ul style="list-style-type: none"> PC board check Connector check (CN15, CN16) Harness check Replace the PC board. |

| Parts to be replaced | Remarks |
|----------------------------------|---------|
| Paddle home position sensor (S3) | |
| Paddle motor (M3) | |
| Finisher control PC board (FIN) | |

[ED16] Buffer tray home position abnormality (Finisher, Saddle Stitch Finisher)

| Classification | Error content |
|--|--|
| Finisher jam Saddle stitch finisher jam | The home position of the buffer tray cannot be detected. |

| Check item | Measures |
|---------------------------------------|--|
| Buffer tray guide | <ul style="list-style-type: none"> • Check if there is any abnormality in the movement of the buffer tray guide. • Check if there is any mechanical problem by opening and closing it. • If there is any, correct it. |
| Buffer tray home position sensor (S5) | <ul style="list-style-type: none"> • Sensor check • Actuator check • Connector check (CN11) • Harness check • Replace the sensor. |
| Assist guide motor (M10) | <ul style="list-style-type: none"> • Check that the motor is working. • Connector check (CN10) • Harness check • Replace the motor. |
| Buffer tray guide motor (M2) | <ul style="list-style-type: none"> • Check that the motor is working. • Connector check (CN10) • Harness check • Replace the motor. |
| Finisher control PC board (FIN) | <ul style="list-style-type: none"> • PC board check • Connector check (CN10) • Harness check • Replace the PC board. |

| Parts to be replaced | Remarks |
|---------------------------------------|---------|
| Buffer tray home position sensor (S5) | |
| Assist guide motor (M10) | |
| Buffer tray guide motor (M2) | |
| Finisher control PC board (FIN) | |

[EF10] Saddle stitch setting of unsupported paper (Saddle Stitch Finisher)

| Classification | Error content |
|----------------------------|---|
| Saddle stitch finisher jam | Unsupported paper size, type and an excess number of pages for stapling are selected. |

| Check item | Measures |
|------------|---|
| Paper | Check the paper size, type and number of pages for stapling. Change the settings to the supported ones. |

[EF11] Front saddle stitch stapling jam (Saddle Stitch Finisher)

| Classification | Error content |
|----------------------------|---------------------------------------|
| Saddle stitch finisher jam | Front stapling is not correctly done. |

| Check item | Measures |
|--|--|
| Paper | Use the paper specified in the specifications if a type outside of the range is selected. |
| Staple cartridge of the saddle stitch (front side) | Remove the staple sheet slid from the staple case. |
| Front saddle stitch stapler drive unit | <ul style="list-style-type: none"> • Check if there is any abnormality in the movement of the drive unit. • Check if there is any mechanical problem by moving it. • If there is any, correct it. • Connector check • Harness check |

| Check item | Measures |
|-------------------------------|---|
| Saddle control PC board (SDL) | <ul style="list-style-type: none"> • PC board check • Connector check (CN2) • Harness check • Replace the PC board. |

| Parts to be replaced | Remarks |
|-------------------------------|---------|
| Saddle control PC board (SDL) | |

[EF12] Rear saddle stitch stapling jam (Saddle Stitch Finisher)

| Classification | Error content |
|----------------------------|--------------------------------------|
| Saddle stitch finisher jam | Rear stapling is not correctly done. |

| Check item | Measures |
|---|--|
| Paper | Use the paper specified in the specifications if a type outside of the range is selected. |
| Staple cartridge of the saddle stitch (rear side) | Remove the staple sheet slid from the staple case. |
| Rear saddle stitch stapler drive unit | <ul style="list-style-type: none"> • Check if there is any abnormality in the movement of the drive unit. • Check if there is any mechanical problem by moving it. • If there is any, correct it. • Connector check • Harness check |
| Saddle control PC board (SDL) | <ul style="list-style-type: none"> • PC board check • Connector check (CN1) • Harness check • Replace the PC board. |

| Parts to be replaced | Remarks |
|-------------------------------|---------|
| Saddle control PC board (SDL) | |

[EF13] Saddle stitch paper holding home position abnormality (Saddle Stitch Finisher)

| Classification | Error content |
|----------------------------|--|
| Saddle stitch finisher jam | The home position of the paper holding cannot be detected. |

| Check item | Measures |
|--|---|
| Paper holding cam | <ul style="list-style-type: none"> • Check if there is any abnormality in the movement of the cam. • Check if there is any mechanical problem by rotating it. • If there is any, correct it. |
| Paper holding home position sensor (S38) | <ul style="list-style-type: none"> • Sensor check • Actuator check • Connector check (CN5) • Harness check • Replace the sensor. |
| Paper holding clutch (CLT4) | <ul style="list-style-type: none"> • Check that the clutch is working. • Connector check (CN5) • Harness check • Replace the clutch. |
| Saddle transport motor (M16) | <ul style="list-style-type: none"> • Check that the motor is working. • Connector check (CN5) • Harness check • Replace the motor. |
| Saddle control PC board (SDL) | <ul style="list-style-type: none"> • PC board check • Connector check (CN5) • Harness check • Replace the PC board. |

| Parts to be replaced | Remarks |
|--|---------|
| Paper holding home position sensor (S38) | |
| Paper holding clutch (CLT4) | |

| Parts to be replaced | Remarks |
|-------------------------------|---------|
| Saddle transport motor (M16) | |
| Saddle control PC board (SDL) | |

[EF14] Saddle stitch paper ejection jam (Saddle Stitch Finisher)

| Classification | Error content |
|----------------------------|--|
| Saddle stitch finisher jam | Paper ejection is not completed within a fixed time. |

| Check item | Measures |
|---------------------------------|---|
| Ejection sensor (S31) | <ul style="list-style-type: none"> • Sensor check • Actuator check • Connector check (CN7) • Harness check • Replace the sensor. |
| Saddle control PC board (SDL) | <ul style="list-style-type: none"> • PC board check • Connector check (CN6, CN7) • Harness check • Replace the PC board. |
| Finisher control PC board (FIN) | <ul style="list-style-type: none"> • PC board check • Connector check (CN21) • Harness check • Replace the PC board. |

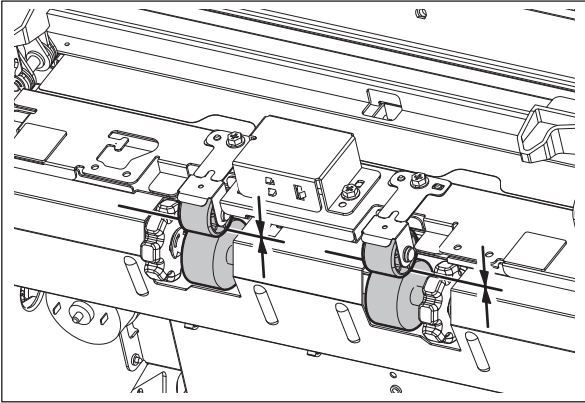
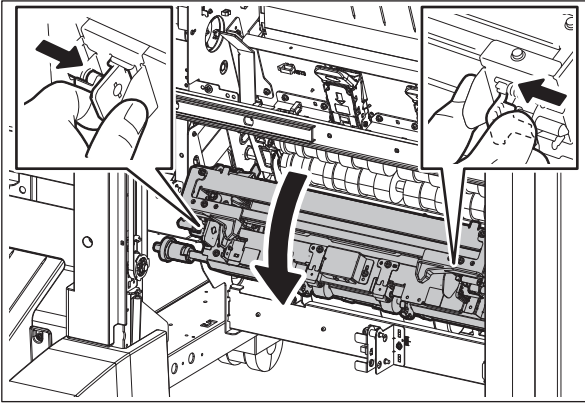
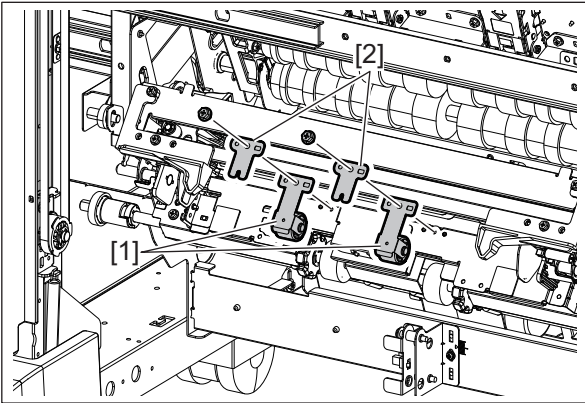
| Check item | Measures |
|--|---|
| <p>Leaf springs and the assist leaf springs of the transport pinch roller (for the saddle)</p> | <ul style="list-style-type: none"> Check if there is any gap between the ejection roller (for the saddle) and the ejection pinch roller (for the saddle). If there is, replace the leaf springs and the assist leaf springs of the ejection pinch roller (for the saddle).  |
| | <p>Fig.8-15</p> <ul style="list-style-type: none"> Check if the leaf springs [1] and the assist leaf springs [2] of the ejection pinch roller (for the saddle) are deformed. In order to confirm that there is no warpage or deformation on the leaf springs and the assist leaf springs of the ejection pinch roller (for the saddle), remove them and put them on a flat place. If they are warped or deformed, replace them. For the removal procedure of the leaf springs [1] and the assist leaf springs [2], refer to the following figures.  |
| |  <p>Fig.8-17</p> |

| Check item | Measures |
|--|--|
| <p>Leaf springs and the assist leaf springs of the transport pinch roller (for the saddle)</p> | <div data-bbox="595 140 1185 544" data-label="Image"> </div> <p data-bbox="587 555 671 580">Fig.8-18</p> <p data-bbox="627 612 703 638">Notes:</p> <p data-bbox="663 644 1390 719">In order to confirm that there is no warpage or deformation on the leaf springs and the assist leaf springs of the ejection pinch roller (for the saddle), remove them and put them on a flat place.</p> <div data-bbox="595 736 1185 1136" data-label="Image"> </div> <p data-bbox="587 1146 671 1172">Fig.8-19</p> <div data-bbox="595 1215 1185 1619" data-label="Image"> </div> <p data-bbox="587 1630 671 1655">Fig.8-20</p> |

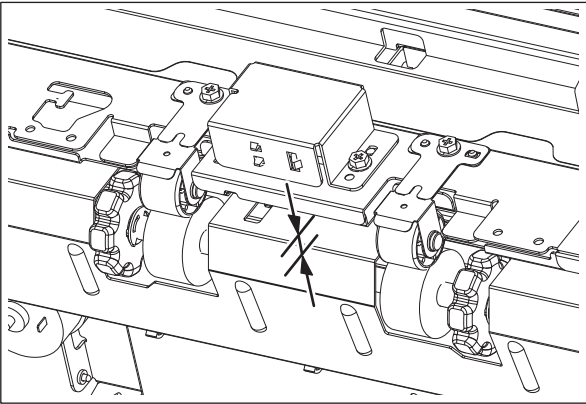
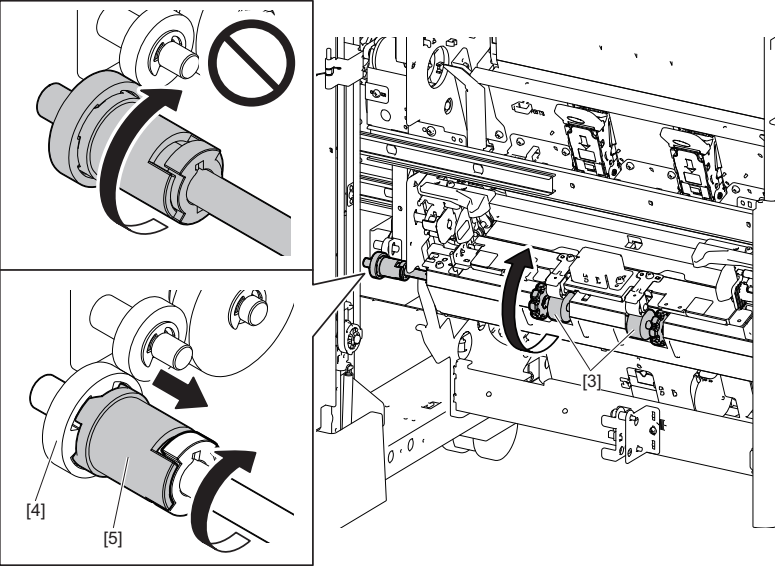
| Check item | Measures |
|----------------------------------|--|
| Lower ejection guide | <p>Check that the gap of the lower ejection guide is 15 mm or below. If the gap is larger than 15 mm, check the attachment condition or replace the lower ejection guide.</p>  <p>Fig.8-21</p> |
| Ejection roller (for the saddle) | <ul style="list-style-type: none"> Check the engagement status of the gear [4] by rotating the ejection roller [3] (for the saddle) in the direction of the arrow (opposite direction of the exiting). When not good: The gear [4] rotates without having been engaged. (The ratchet [5] does not rotate.) When OK: The ratchet [5] rotates while sliding, but the gear [4] is stopped. (The gear [4] is engaged.)  <p>Fig.8-22</p> |

| Check item | Measures |
|----------------------------------|--|
| Ejection roller (for the saddle) | <ul style="list-style-type: none"> <li data-bbox="587 136 1390 242">• In the case of “not good”, replace the bracket [7] at the idle gear [6] side. When replacing, check the position where the pre-change bracket [7] is attached and add its marking in order to install the post-change one in the same place. <p data-bbox="587 668 671 689">Fig.8-23</p> <p data-bbox="624 753 1129 774">Follow the figures below to remove the bracket.</p> <p data-bbox="587 1200 671 1221">Fig.8-24</p> <p data-bbox="587 1689 671 1710">Fig.8-25</p> |

| Check item | Measures |
|----------------------------------|--|
| Ejection roller (for the saddle) |  |

Fig.8-26

| | |
|-------------------------|--|
| Additional folding unit | <ul style="list-style-type: none"> Correct the misalignment of the shaft of the additional folding unit [8]. Move the screws in the direction of the arrow and secure them. (both the front and rear)  |
|-------------------------|--|

Fig.8-27

| | |
|--|--|
| | <ul style="list-style-type: none"> Replace the following parts. <ul style="list-style-type: none"> - BRIR-ROD-EX-F-SDL-F5330 - PLT-BURR-ROD-EX-F-SDL - ASYS-PLT3-FILM3-EFS - FILM4-EFS Check if there is a disconnection of the connector, incorrect installation or breakage of the ejection transport sensor (S41) [9]. If there is, reinstall the sensor correctly or replace it. Move the bracket [10] in the direction of the arrow and secure it with the screw.  |
|--|--|

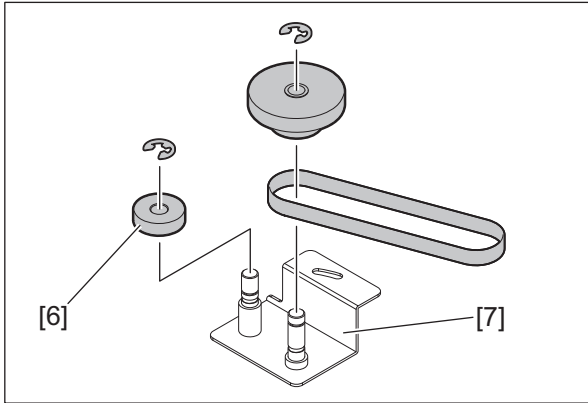
Fig.8-28

| Parts to be replaced | Remarks |
|-----------------------|---------|
| Ejection sensor (S31) | |

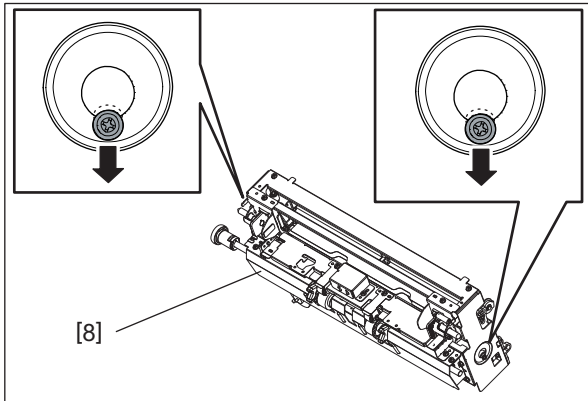
| Parts to be replaced | Remarks |
|---------------------------------|---------|
| Saddle control PC board (SDL) | |
| Finisher control PC board (FIN) | |
| Lower ejection guide | |

[EF15] Saddle stitch side alignment plate home position sensor abnormality (Saddle Stitch Finisher)

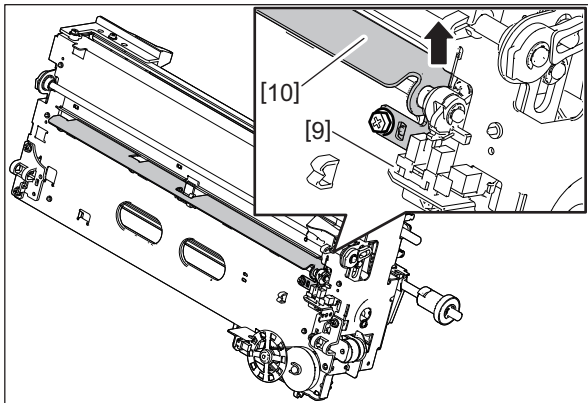
| Classification | Error content |
|----------------------------|--|
| Saddle stitch finisher jam | The home position of the jog cannot be detected. |

| Check item | Measures |
|---|---|
| Jog | <ul style="list-style-type: none"> Check if there is any abnormality in the movement of the jog. Check if there is any mechanical problem by moving it. If there is any, correct it. |
| Side alignment plate home position sensor (S36) | <ul style="list-style-type: none"> Sensor check Actuator check Connector check (CN4) Harness check Replace the sensor. |
| Side alignment motor (M15) | <ul style="list-style-type: none"> Check that the motor is working. Connector check (CN4) Harness check Replace the motor. |
| Saddle control PC board (SDL) | <ul style="list-style-type: none"> PC board check Connector check (CN4) Harness check Replace the PC board. |

| Parts to be replaced | Remarks |
|---|---------|
| Side alignment plate home position sensor (S36) | |
| Side alignment motor (M15) | |
| Saddle control PC board (SDL) | |

[EF16] Saddle stitch stacker motor home position abnormality (Saddle Stitch Finisher)

| Classification | Error content |
|----------------------------|--|
| Saddle stitch finisher jam | The home position of the stacker carrier cannot be detected. |

| Check item | Measures |
|------------------------------------|---|
| Stacker carrier | <ul style="list-style-type: none"> Check if there is any abnormality in the movement of the stacker carrier. Check if there is any mechanical problem by moving it. If there is any, correct it. |
| Stacker home position sensor (S33) | <ul style="list-style-type: none"> Sensor check Actuator check Connector check (CN8) Harness check Replace the sensor. |
| Stacker motor (M14) | <ul style="list-style-type: none"> Check that the motor is working. Connector check (CN8) Harness check Replace the motor. |
| Saddle control PC board (SDL) | <ul style="list-style-type: none"> PC board check Connector check (CN8) Harness check Replace the PC board. |

| Parts to be replaced | Remarks |
|------------------------------------|---------|
| Stacker home position sensor (S33) | |
| Stacker motor (M14) | |

| Parts to be replaced | Remarks |
|-------------------------------|---------|
| Saddle control PC board (SDL) | |

[EF17] Saddle stitch folding blade home position abnormality (Saddle Stitch Finisher)

| Classification | Error content |
|----------------------------|--|
| Saddle stitch finisher jam | The home position of the folding blade cam cannot be detected. |

| Check item | Measures |
|--|---|
| Folding blade cam | <ul style="list-style-type: none"> • Check if there is any abnormality in the movement of the folding blade cam. • Check if there is any mechanical problem by moving it. • If there is any, correct it. |
| Folding blade home position sensor (S35) | <ul style="list-style-type: none"> • Sensor check • Actuator check • Connector check (CN12) • Harness check • Replace the sensor. |
| Folding motor (M17) | <ul style="list-style-type: none"> • Check that the motor is working. • Connector check (CN9) • Harness check • Replace the motor. |
| Folding blade clutch (CLT3) | <ul style="list-style-type: none"> • Check that the clutch is working. • Connector check (CN13) • Harness check • Replace the clutch. |
| Saddle control PC board (SDL) | <ul style="list-style-type: none"> • PC board check • Connector check (CN9, CN12, CN13) • Harness check • Replace the PC board. |

| Parts to be replaced | Remarks |
|--|---------|
| Folding blade home position sensor (S35) | |
| Folding motor (M17) | |
| Folding blade clutch (CLT3) | |
| Saddle control PC board (SDL) | |

[EF18] Saddle stitch additional folding roller home position abnormality (Saddle Stitch Finisher)

| Classification | Error content |
|----------------------------|--|
| Saddle stitch finisher jam | The home position of the additional folding roller cannot be detected. |

| Check item | Measures |
|---|--|
| Additional folding carrier | <ul style="list-style-type: none"> • Check if there is any abnormality in the movement of the additional folding carrier. • Check if there is any mechanical problem by moving it. • If there is any, correct it. |
| Additional folding home position sensor (S39) | <ul style="list-style-type: none"> • Sensor check • Actuator check • Connector check (CN7) • Harness check • Replace the sensor. |
| Additional folding motor encoder sensor (S42) | <ul style="list-style-type: none"> • Sensor check • Actuator check • Connector check (CN7) • Harness check • Replace the sensor. |
| Additional folding motor (M20) | <ul style="list-style-type: none"> • Check that the motor is working. • Connector check (CN10) • Harness check • Replace the motor. |

| Check item | Measures |
|-------------------------------|---|
| Saddle control PC board (SDL) | <ul style="list-style-type: none"> • PC board check • Connector check (CN7, CN10) • Harness check • Replace the PC board. |

| Parts to be replaced | Remarks |
|---|---------|
| Additional folding home position sensor (S39) | |
| Additional folding motor encoder sensor (S42) | |
| Additional folding motor (M20) | |
| Saddle control PC board (SDL) | |

[EF19] Saddle stitch paper folding jam (Saddle Stitch Finisher)

| Classification | Error content |
|----------------------------|--|
| Saddle stitch finisher jam | Fold processed paper cannot be transported to the additional folding roller. |

| Check item | Measures |
|---------------------------------|---|
| Paper | Use the paper specified in the specifications if a type outside of the range is selected. |
| Ejection transport sensor (S41) | <ul style="list-style-type: none"> • Sensor check • Actuator check • Connector check (CN7) • Harness check • Replace the sensor. |
| Saddle control PC board (SDL) | <ul style="list-style-type: none"> • PC board check • Connector check (CN6, CN7) • Harness check • Replace the PC board. |
| Finisher control PC board (FIN) | <ul style="list-style-type: none"> • PC board check • Connector check (CN21) • Harness check • Replace the PC board. |

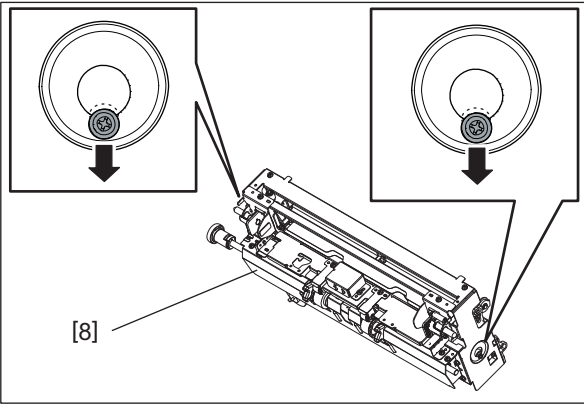
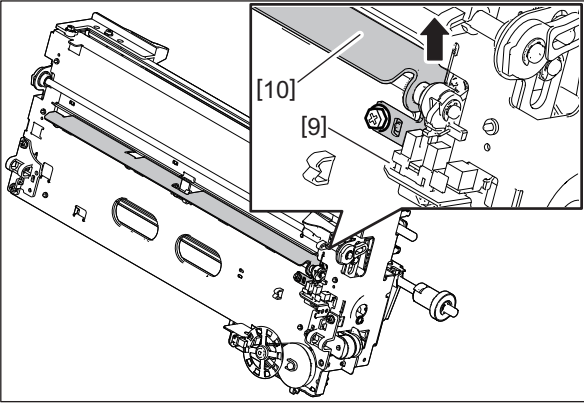
| Check item | Measures |
|-------------------------|--|
| Additional folding unit | <ul style="list-style-type: none"> • Correct the misalignment of the shaft of the additional folding unit [8]. Move the screws in the direction of the arrow and secure them. (both the front and rear)  <p>Fig.8-29</p> <ul style="list-style-type: none"> • Replace the following parts. <ul style="list-style-type: none"> - BRIR-ROD-EX-F-SDL-F5330 - PLT-BURR-ROD-EX-F-SDL - ASYS-PLT3-FILM3-EFS - FILM4-EFS • Check if there is a disconnection of the connector, incorrect installation or breakage of the ejection transport sensor (S41) [9]. If there is, reinstall the sensor correctly or replace it. Move the bracket [10] in the direction of the arrow and secure it with the screw.  <p>Fig.8-30</p> |

| Parts to be replaced | Remarks |
|---------------------------------|---------|
| Ejection transport sensor (S41) | |
| Saddle control PC board (SDL) | |
| Finisher control PC board (FIN) | |

[EF20] Saddle stitch stacker jam (Saddle Stitch Finisher)

| Classification | Error content |
|----------------------------|---|
| Saddle stitch finisher jam | Transported paper cannot be detected in the stacker paper detection sensor. |

| Check item | Measures |
|--------------------------------------|---|
| Paper | Use the paper specified in the specifications if a type outside of the range is selected. |
| Stacker paper detection sensor (S30) | <ul style="list-style-type: none"> • Sensor check • Actuator check • Connector check (CN3) • Harness check • Replace the sensor. |
| Saddle control PC board (SDL) | <ul style="list-style-type: none"> • PC board check • Connector check (CN3, CN6) • Harness check • Replace the PC board. |
| Finisher control PC board (FIN) | <ul style="list-style-type: none"> • PC board check • Connector check (CN21) • Harness check • Replace the PC board. |

| Parts to be replaced | Remarks |
|--------------------------------------|---------|
| Stacker paper detection sensor (S30) | |
| Saddle control PC board (SDL) | |
| Finisher control PC board (FIN) | |

[EF21] Hole punch: Paper leading edge skew detection abnormality (Finisher, Saddle Stitch Finisher)

| Classification | Error content |
|---------------------|--|
| Hole punch unit jam | One of the two skew sensors cannot detect paper within a specified time. |

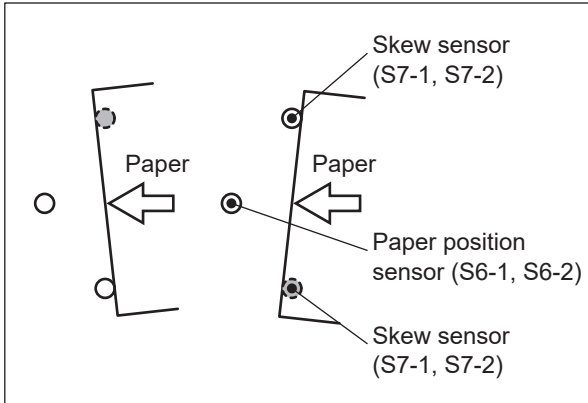
| Check item | Measures |
|----------------------------------|--|
| Paper | <p>When the paper is stopped at the position in the figure, perform troubleshooting for the paper folding.</p>  <p>Fig.8-31</p> |
| Skew sensors (S7-1, S7-2) | <ul style="list-style-type: none"> • Sensor check • Connector check (CN6, CN7) • Harness check • Replace the sensor. |
| Hole punch control PC board (HP) | <ul style="list-style-type: none"> • PC board check • Connector check (CN4, CN6, CN7) • Harness check • Replace the PC board. |

| Parts to be replaced | Remarks |
|----------------------------------|---------|
| Skew sensors (S7-1, S7-2) | |
| Hole punch control PC board (HP) | |

[EF22] Hole punch: Paper leading edge detection abnormality (Finisher, Saddle Stitch Finisher)

| Classification | Error content |
|---------------------|--|
| Hole punch unit jam | The leading edge of the paper cannot be detected within a specified time after its skewing was detected. |

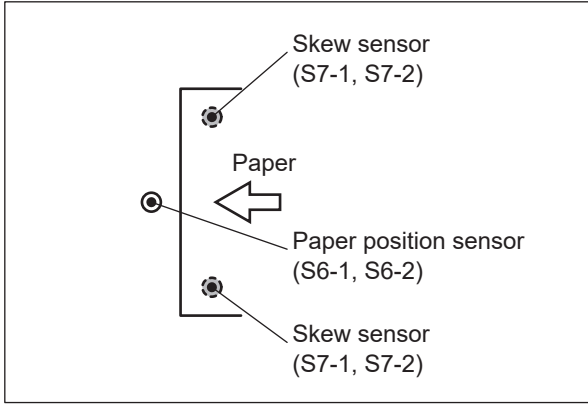
| Check item | Measures |
|-------------------------------------|--|
| Paper | <p>When the paper is stopped at the position in the figure, perform troubleshooting for the paper folding.</p>  <p>Fig.8-32</p> |
| Paper position sensors (S6-1, S6-2) | <ul style="list-style-type: none"> • Sensor check • Connector check (CN1, CN2) • Harness check • Replace the sensor. |
| Hole punch control PC board (HP) | <ul style="list-style-type: none"> • PC board check • Connector check (CN1, CN2, CN4) • Harness check • Replace the PC board. |

| Parts to be replaced | Remarks |
|-------------------------------------|---------|
| Paper position sensors (S6-1, S6-2) | |
| Hole punch control PC board (HP) | |

[EF23] Hole punch: Paper position alignment abnormality (Finisher, Saddle Stitch Finisher)

| Classification | Error content |
|---------------------|---|
| Hole punch unit jam | The position of the paper cannot be detected by the sideways deviation mechanism. |

| Check item | Measures |
|--|---|
| Sideways deviation adjustment motor (M2) | <ul style="list-style-type: none"> • Check that the motor is working. • Connector check (CN9) • Harness check • Replace the motor. |
| Sideways deviation HP sensor (S3) | <ul style="list-style-type: none"> • Sensor check • Actuator check • Connector check (CN8) • Harness check • Replace the sensor. |
| Paper position sensors (S6-1, S6-2) | <ul style="list-style-type: none"> • Sensor check • Connector check (CN1, CN2) • Harness check • Replace the sensor. |

| Check item | Measures |
|----------------------------------|---|
| Hole punch control PC board (HP) | <ul style="list-style-type: none"> • PC board check • Connector check (CN1, CN2, CN4, CN8, CN9) • Harness check • Replace the PC board. |

| Parts to be replaced | Remarks |
|--|---------|
| Sideways deviation adjustment motor (M2) | |
| Sideways deviation HP sensor (S3) | |
| Paper position sensors (S6-1, S6-2) | |
| Hole punch control PC board (HP) | |

[EF24] Hole punch: Paper trailing edge skew detection abnormality (Finisher, Saddle Stitch Finisher)

| Classification | Error content |
|---------------------|--|
| Hole punch unit jam | One of the two skew sensors cannot detect paper within a specified time. |

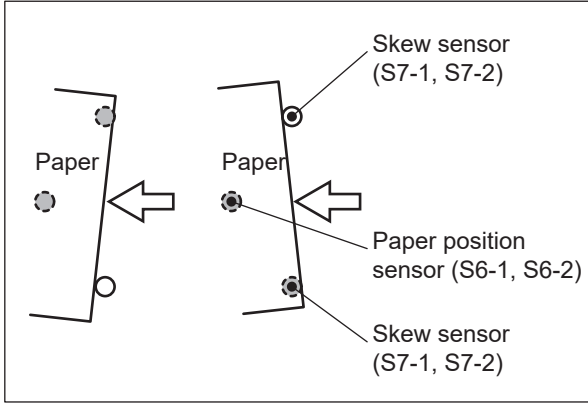
| Check item | Measures |
|----------------------------------|---|
| Paper | <p>When the paper is stopped at the position in the figure, perform troubleshooting for the paper folding.</p>  <p>Fig.8-33</p> |
| Skew sensors (S7-1, S7-2) | <ul style="list-style-type: none"> • Sensor check • Connector check (CN6, CN7) • Harness check • Replace the sensor. |
| Hole punch control PC board (HP) | <ul style="list-style-type: none"> • PC board check • Connector check (CN4, CN6, CN7) • Harness check • Replace the PC board. |

| Parts to be replaced | Remarks |
|----------------------------------|---------|
| Skew sensors (S7-1, S7-2) | |
| Hole punch control PC board (HP) | |

[EF25] Hole punch: Paper trailing edge detection abnormality (Finisher, Saddle Stitch Finisher)

| Classification | Error content |
|---------------------|---|
| Hole punch unit jam | The trailing edge of the paper cannot be detected within a specified time after its skewing was detected. |

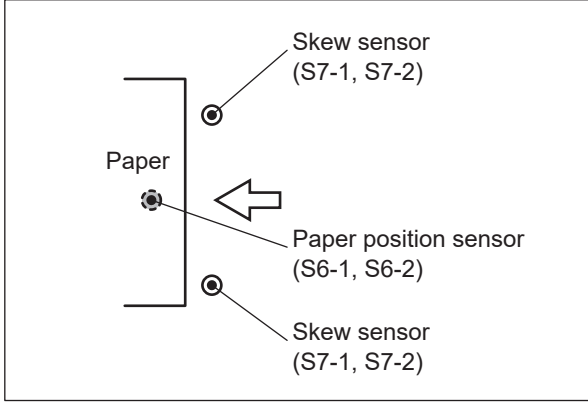
| Check item | Measures |
|-------------------------------------|--|
| Paper | <ul style="list-style-type: none"> When the paper is stopped at the position in the figure, perform troubleshooting for the paper folding.  <p>Fig.8-34</p> <ul style="list-style-type: none"> If paper dusts or punch wastes are adhering on the paper position sensors (S6-1, S6-2), remove them. |
| Paper position sensors (S6-1, S6-2) | <ul style="list-style-type: none"> Sensor check Connector check (CN1, CN2) Harness check Replace the sensor. |
| Hole punch control PC board (HP) | <ul style="list-style-type: none"> PC board check Connector check (CN1, CN2, CN4) Harness check Replace the PC board. |

| Parts to be replaced | Remarks |
|-------------------------------------|---------|
| Paper position sensors (S6-1, S6-2) | |
| Hole punch control PC board (HP) | |

[EF27] Hole punch: Paper edge detection abnormality 1 (Finisher, Saddle Stitch Finisher)

| Classification | Error content |
|---------------------|---|
| Hole punch unit jam | The leading edge of the paper is detected before the paper leading edge skew detection. |

| Check item | Measures |
|----------------------------------|---|
| Skew sensors (S7-1, S7-2) | <ul style="list-style-type: none"> Sensor check Connector check (CN6, CN7) Harness check Replace the sensor. |
| Hole punch control PC board (HP) | <ul style="list-style-type: none"> PC board check Connector check (CN4, CN6, CN7) Harness check Replace the PC board. |

| Parts to be replaced | Remarks |
|----------------------------------|---------|
| Skew sensors (S7-1, S7-2) | |
| Hole punch control PC board (HP) | |

[EF28] Hole punch: Paper edge detection abnormality 2 (Finisher, Saddle Stitch Finisher)

| Classification | Error content |
|---------------------|---|
| Hole punch unit jam | The trailing edge of the paper is detected before the paper trailing edge skew detection. |

| Check item | Measures |
|----------------------------------|---|
| Skew sensors (S7-1, S7-2) | <ul style="list-style-type: none"> • Sensor check • Connector check (CN6, CN7) • Harness check • Replace the sensor. |
| Hole punch control PC board (HP) | <ul style="list-style-type: none"> • PC board check • Connector check (CN4, CN6, CN7) • Harness check • Replace the PC board. |

| Parts to be replaced | Remarks |
|----------------------------------|---------|
| Skew sensors (S7-1, S7-2) | |
| Hole punch control PC board (HP) | |

[EF29] Hole punch: Required performance abnormality (Finisher, Saddle Stitch Finisher)

| Classification | Error content |
|---------------------|---|
| Hole punch unit jam | A performance which is required cannot be executed. |

| Check item | Measures |
|----------------------------------|---|
| Setting | Check if the conditions of the paper size, paper weight and paper type are appropriate for hole punching. If not, change the setting. |
| Hole punch control PC board (HP) | <ul style="list-style-type: none"> • PC board check • Connector check (CN6, CN14) • Harness check • Replace the PC board. |

| Parts to be replaced | Remarks |
|----------------------------------|---------|
| Hole punch control PC board (HP) | |

8.3.4 Service call (C series errors)

[C010] Drum motor locking error

| Classification | Error content |
|-------------------|---|
| Motor abnormality | The drum motor does not work normally. (The MFP will be rebooted at the first time the error occurs.) |

| Check item | Measures |
|-----------------------------|--|
| Drum motor (K) | <ul style="list-style-type: none"> • Check that the motor is working. (Output check) • Connector check • Harness check • Replace the motor. |
| K-drum/developer drive unit | <p>Check if there is any of the following abnormality in the unit. If there is any abnormality, correct it.</p> <ul style="list-style-type: none"> • Foreign matter is adhering or has entered. • Parts such as gears, shafts, bushing and bearings are damaged. • Motors and other parts are not attached correctly. |
| Drum cleaner unit | <p>Check if there is any of the following abnormality in the unit. If there is any abnormality, correct it.</p> <ul style="list-style-type: none"> • Foreign matter is adhering or has entered. • Parts such as gears, shafts, bushing and bearings are damaged. • The cleaning blade is peeled off or damaged. • The side seal is peeled off or damaged. • The E-ring attached to the tip of the nozzle comes off. <div data-bbox="651 800 1385 1357" data-label="Image"> </div> <p>Fig.8-35</p> <ul style="list-style-type: none"> • When installing the drum cleaner unit, check that the orange label attached on the shutter is clearly visible. |

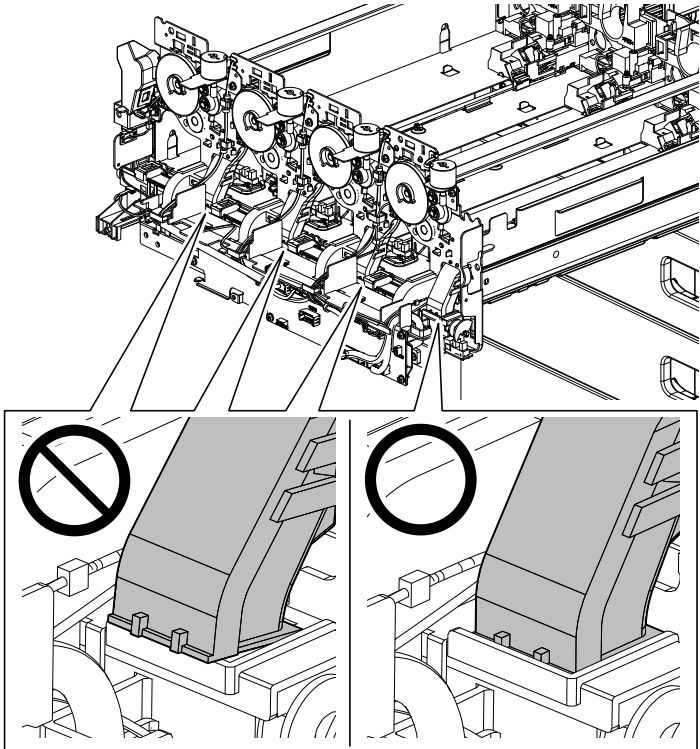
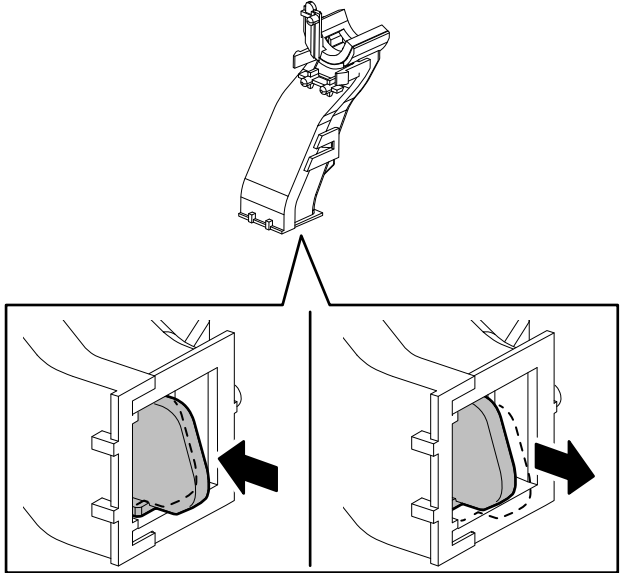
| Check item | Measures |
|------------------------------|---|
| Drum unit side vertical duct | <ul style="list-style-type: none"> • Check if waste toner is clogged. • Check that the drum unit side vertical duct is installed properly or does not run over onto the rib.  <p>Fig.8-36</p> <ul style="list-style-type: none"> • Check that the slider in the drum unit side vertical duct can move smoothly. If not, clean the inside of the drum unit side vertical duct.  <p>Fig.8-37</p> |

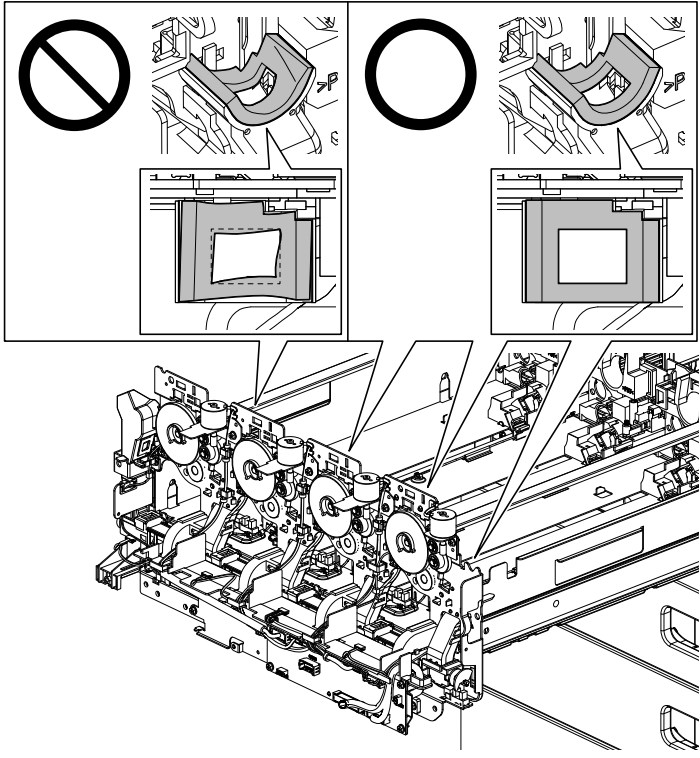
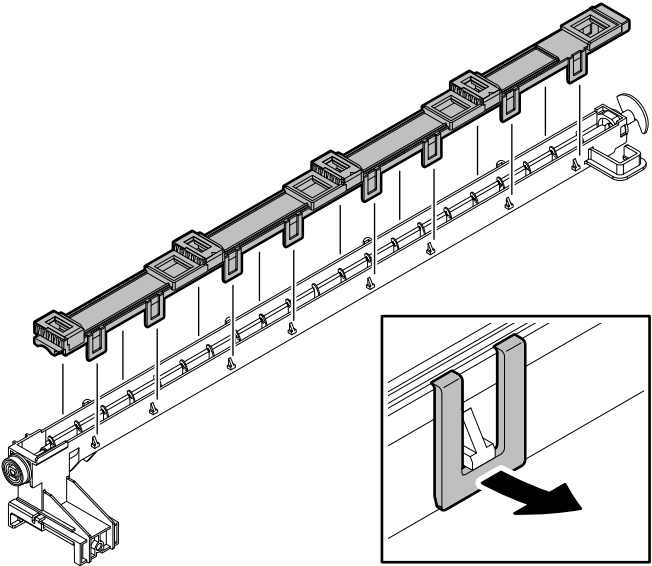
| Check item | Measures |
|--|--|
| Drum unit side vertical duct | <ul style="list-style-type: none"> Check if any of the sponge sheets at the upper part of the drum unit side vertical duct blocks the insertion slot. If yes, replace it.  <p>Fig.8-38</p> |
| EPU tray waste toner horizontal transport unit | <p>Check if there is any of the following abnormality in the unit. If there is any abnormality, correct it.</p> <ul style="list-style-type: none"> Foreign matter is adhering or has entered. Parts such as gears, shafts, bushing and bearings are damaged. Parts are not attached correctly. Waste toner is clogged.  <p>Fig.8-39</p> |
| LGC board | <ul style="list-style-type: none"> PC board check Connector check Harness check Replace the PC board. |

| Parts to be replaced | Remarks |
|--|---------|
| Drum motor (K) | |
| K-drum/developer drive unit | |
| Drum cleaner unit | |
| Drum unit side vertical duct | |
| EPU tray waste toner horizontal transport unit | |
| LGC board | |

[C023] Developer unit motor (K) locking error

| Classification | Error content |
|-------------------|---|
| Motor abnormality | The developer unit motor (Y) does not work normally. (The MFP will be rebooted at the first time the error occurs.) |

| Check item | Measures |
|------------------------------|--|
| Developer unit motor (K) | <ul style="list-style-type: none"> • Check that the motor is working. (Output check) • Connector check • Harness check • Replace the motor. |
| Developer unit | <p>Check if there is any of the following abnormality in the unit. If there is any abnormality, correct it.</p> <ul style="list-style-type: none"> • Foreign matter is adhering or has entered. • Parts such as gears, shafts, bushing and bearings are damaged. • Parts are not attached correctly. • The amount of the developer material is abnormal. |
| Waste toner transport path | <p>Check if there is any of the following abnormality in the unit. If there is any abnormality, correct it.</p> <ul style="list-style-type: none"> • Foreign matter is adhering or has entered. • Parts such as gears, shafts, bushing and bearings are damaged. • Parts are not attached correctly. • Waste toner is clogged. |
| Process unit driving section | <p>Check if there is any of the following abnormality in the unit. If there is any abnormality, correct it.</p> <ul style="list-style-type: none"> • Foreign matter is adhering or has entered. • Parts such as gears, shafts, bushing and bearings are damaged. • Motors and other parts are not attached correctly. |
| LGC board | <ul style="list-style-type: none"> • PC board check • Connector check • Harness check • Replace the PC board. |

| Parts to be replaced | Remarks |
|------------------------------|---------|
| Developer unit motor (K) | |
| Developer unit | |
| Waste toner transport path | |
| Process unit driving section | |
| LGC board | |

[C024] Developer unit mixer motor (K) locking error

| Classification | Error content |
|--------------------------------|--|
| Motor abnormality | The developer mixer motor (K) does not work normally. (The MFP will be rebooted at the first time the error occurs.) |
| Check item | Measures |
| Developer unit mixer motor (K) | <ul style="list-style-type: none"> • Check that the motor is working. (Output check) • Connector check • Harness check • Replace the motor. |
| Developer unit | <p>Check if there is any of the following abnormality in the unit. If there is any abnormality, correct it.</p> <ul style="list-style-type: none"> • Foreign matter is adhering or has entered. • Parts such as gears, shafts, bushing and bearings are damaged. • Parts are not attached correctly. • The amount of the developer material is abnormal. |
| LGC board | <ul style="list-style-type: none"> • PC board check • Connector check • Harness check • Replace the PC board. |
| Drum thermistor (K) | Check that the drum thermistor contacts the drum properly. |
| EPU tray | <ul style="list-style-type: none"> • Check if waste toner is clogged.  |

Fig.8-40

| Check item | Measures |
|--------------------------------|--|
| Drum unit side vertical duct | <ul style="list-style-type: none"> Check that the slider in the drum unit side vertical duct can move smoothly. If not, clean the inside of the drum unit side vertical duct.  <p>Fig.8-41</p> |
| Drum unit side vertical duct | <ul style="list-style-type: none"> Check if any of the sponge sheets at the upper part of the drum unit side vertical duct blocks the insertion slot. If yes, replace it.  <p>Fig.8-42</p> |
| Process unit driving section | <p>Check if there is any of the following abnormality in the unit. If there is any abnormality, correct it.</p> <ul style="list-style-type: none"> Foreign matter is adhering or has entered. Parts such as gears, shafts, bushing and bearings are damaged. Motors and other parts are not attached correctly. |
| Parts to be replaced | Remarks |
| Developer unit mixer motor (K) | |
| Developer unit | |

| Parts to be replaced | Remarks |
|------------------------------|---------|
| LGC board | |
| Drum thermistor (K) | |
| Drum unit side vertical duct | |
| Process unit driving section | |

[C130] 1st drawer tray abnormality

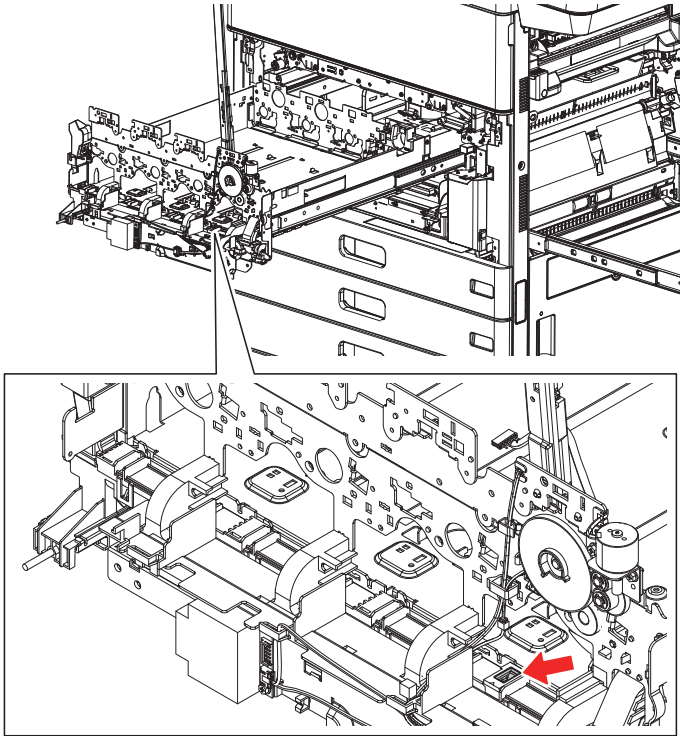
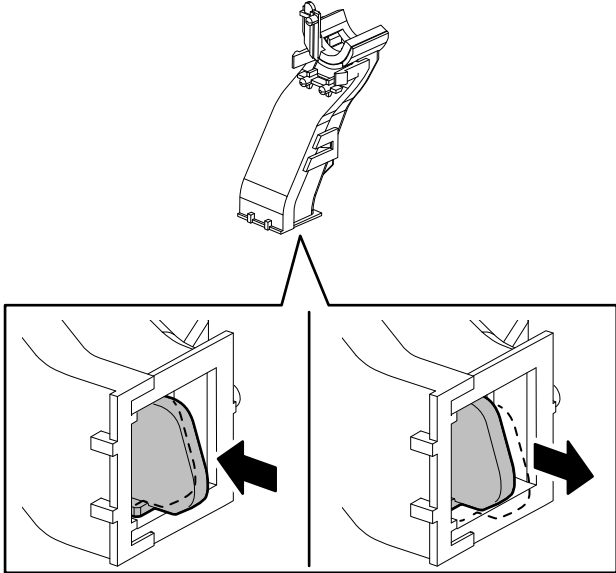
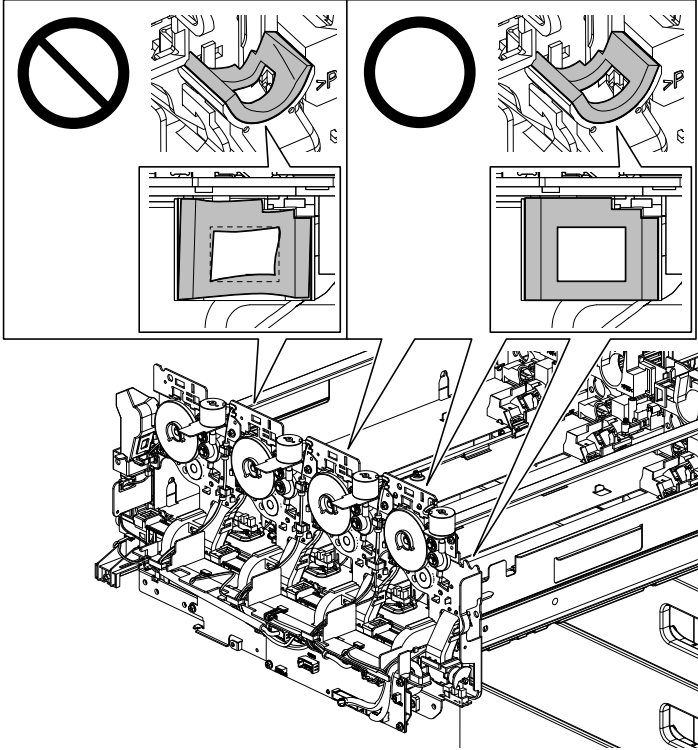
| Classification | Error content |
|-------------------|---|
| Motor abnormality | The 1st drawer tray-up motor or the 1st drawer tray does not work normally. |

| Check item | Measures |
|---------------------------|---|
| 1st drawer tray-up motor | <ul style="list-style-type: none"> • Check that the motor is working. (Output check) • Connector check • Harness check • Replace the motor. |
| 1st drawer tray-up sensor | <ul style="list-style-type: none"> • Sensor check (Input check) • Actuator check • Connector check • Harness check • Replace the sensor. |
| PFC board | <ul style="list-style-type: none"> • PC board check • Connector check • Harness check • Replace the PC board. |

| Parts to be replaced | Remarks |
|---------------------------|---------|
| 1st drawer tray-up motor | |
| 1st drawer tray-up sensor | |
| PFC board | |

[C140] 2nd drawer tray abnormality

| Classification | Error content |
|-------------------|---|
| Motor abnormality | The 2nd drawer tray-up motor or the 2nd drawer tray does not work normally. |

| Check item | Measures |
|---------------------------|---|
| 2nd drawer tray-up motor | <ul style="list-style-type: none"> • Check that the motor is working. (Output check) • Connector check • Harness check • Replace the motor. |
| 2nd drawer tray-up sensor | <ul style="list-style-type: none"> • Sensor check (Input check) • Actuator check • Connector check • Harness check • Replace the sensor. |
| PFC board | <ul style="list-style-type: none"> • PC board check • Connector check • Harness check • Replace the PC board. |

| Parts to be replaced | Remarks |
|---------------------------|---------|
| 2nd drawer tray-up motor | |
| 2nd drawer tray-up sensor | |
| PFC board | |

[C150] 3rd drawer tray abnormality

| Classification | Error content |
|-------------------|---|
| Motor abnormality | The 3rd drawer tray-up motor or the 3rd drawer tray does not work normally. |

| Check item | Measures |
|---------------------------------|---|
| 3rd drawer tray-up motor | <ul style="list-style-type: none"> • Check that the motor is working. (Output check) • Connector check • Harness check • Replace the motor. |
| 3rd drawer/T-LCF tray-up sensor | <ul style="list-style-type: none"> • Sensor check (Input check) • Actuator check • Connector check • Harness check • Replace the sensor. |
| PFC board | <ul style="list-style-type: none"> • PC board check • Connector check • Harness check • Replace the PC board. |

| Parts to be replaced | Remarks |
|---------------------------------|---------|
| 3rd drawer tray-up motor | |
| 3rd drawer/T-LCF tray-up sensor | |
| PFC board | |

[C160] 4th drawer tray abnormality

| Classification | Error content |
|-------------------|---|
| Motor abnormality | The 4th drawer tray-up motor or the 4th drawer tray does not work normally. |

| Check item | Measures |
|---------------------------|---|
| 4th drawer tray-up motor | <ul style="list-style-type: none"> • Check that the motor is working. (Output check) • Connector check • Harness check • Replace the motor. |
| 4th drawer tray-up sensor | <ul style="list-style-type: none"> • Sensor check (Input check) • Actuator check • Connector check • Harness check • Replace the sensor. |
| PFC board | <ul style="list-style-type: none"> • PC board check • Connector check • Harness check • Replace the PC board. |

| Parts to be replaced | Remarks |
|---------------------------|---------|
| 4th drawer tray-up motor | |
| 4th drawer tray-up sensor | |
| PFC board | |

[C180] T-LCF tray abnormality

| Classification | Error content |
|-------------------|---|
| Motor abnormality | The T-LCF tray-up motor or the T-LCF tray does not work normally. |

| Check item | Measures |
|---------------------|---|
| T-LCF tray-up motor | <ul style="list-style-type: none"> • Check that the motor is working. (Output check) • Connector check • Harness check • Replace the motor. |

| Check item | Measures |
|---------------------------------|---|
| 3rd drawer/T-LCF tray-up sensor | <ul style="list-style-type: none"> • Sensor check (Input check) • Actuator check • Connector check • Harness check • Replace the sensor. |
| T-LCF bottom sensor | <ul style="list-style-type: none"> • Sensor check (Input check) • Actuator check • Connector check • Harness check • Replace the sensor. |
| PFC board | <ul style="list-style-type: none"> • PC board check • Connector check • Harness check • Replace the PC board. |

| Parts to be replaced | Remarks |
|---------------------------------|---------|
| T-LCF tray-up motor | |
| 3rd drawer/T-LCF tray-up sensor | |
| T-LCF bottom sensor | |
| PFC board | |

[C1A0] T-LCF end fence abnormality

| Classification | Error content |
|-------------------|--|
| Motor abnormality | The T-LCF end fence motor or the T-LCF end fence does not work normally. |

| Check item | Measures |
|--------------------------------------|---|
| T-LCF end fence motor | <ul style="list-style-type: none"> • Check that the motor is working. (Output check) • Connector check • Harness check • Replace the motor. |
| T-LCF end fence home position sensor | <ul style="list-style-type: none"> • Sensor check (Input check) • Actuator check • Connector check • Harness check • Replace the sensor. |
| T-LCF end fence stop position sensor | <ul style="list-style-type: none"> • Sensor check (Input check) • Actuator check • Connector check • Harness check • Replace the sensor. |
| PFC board | <ul style="list-style-type: none"> • PC board check • Connector check • Harness check • Replace the PC board. |

| Parts to be replaced | Remarks |
|--------------------------------------|---------|
| T-LCF end fence motor | |
| T-LCF end fence home position sensor | |
| T-LCF end fence stop position sensor | |
| PFC board | |

[C1C0] Ex-LCF 2.5K tray motor abnormality

| Classification | Error content |
|-------------------|---|
| Motor abnormality | The Ex-LCF 2.5K motor does not work normally. |

| Check item | Measures |
|--------------|--|
| Installation | Check that the installation of the Ex-LCF is appropriate. If the hook is not secured appropriately or the gap between the MFP and Ex-LCF is not even, adjust the tilt of the Ex-LCF. |

| Check item | Measures |
|---------------------------|---|
| Ex-LCF tray motor | <ul style="list-style-type: none"> • Check that the motor is working. (Output check) • Connector check • Harness check • Replace the motor. |
| Ex-LCF tray-up sensor | <ul style="list-style-type: none"> • Sensor check (Input check) • Actuator check • Connector check • Harness check • Replace the sensor. |
| Ex-LCF tray bottom sensor | <ul style="list-style-type: none"> • Sensor check (Input check) • Actuator check • Connector check • Harness check • Replace the sensor. |
| PFC board | <ul style="list-style-type: none"> • PC board check • Connector check • Harness check • Replace the PC board. |
| Ex-LCF board | <ul style="list-style-type: none"> • PC board check • Connector check • Harness check • Replace the PC board. |

| Parts to be replaced | Remarks |
|---------------------------|---------|
| Ex-LCF tray motor | |
| Ex-LCF tray-up sensor | |
| Ex-LCF tray bottom sensor | |
| PFC board | |
| Ex-LCF board | |

[C1E0] Ex-LCF 2.0K tray motor abnormality

| Classification | Error content |
|-------------------|---|
| Motor abnormality | The Ex-LCF 2.0K motor does not work normally. |

| Check item | Measures |
|---------------------------|---|
| Installation | Check that the installation of the Ex-LCF is appropriate. If the hook is not secured appropriately or the gap between the MFP and Ex-LCF is not even, adjust the tilt of the Ex-LCF. |
| Ex-LCF tray motor | <ul style="list-style-type: none"> • Check that the motor is working. (Output check) • Connector check • Harness check • Replace the motor. |
| Ex-LCF tray-up sensor | <ul style="list-style-type: none"> • Sensor check (Input check) • Actuator check • Connector check • Harness check • Replace the sensor. |
| Ex-LCF tray bottom sensor | <ul style="list-style-type: none"> • Sensor check (Input check) • Actuator check • Connector check • Harness check • Replace the sensor. |
| PFC board | <ul style="list-style-type: none"> • PC board check • Connector check • Harness check • Replace the PC board. |
| Ex-LCF board | <ul style="list-style-type: none"> • PC board check • Connector check • Harness check • Replace the PC board. |

| Parts to be replaced | Remarks |
|---------------------------|---------|
| Ex-LCF tray motor | |
| Ex-LCF tray-up sensor | |
| Ex-LCF tray bottom sensor | |
| PFC board | |
| Ex-LCF board | |

[C252] EEPROM communication error

[C253] EEPROM reading error

| Classification | Error content |
|---------------------|--|
| Scanner abnormality | EEPROM communication error EEPROM reading error (The MFP will be rebooted at the first time the error occurs.) |

| Check item | Measures |
|-----------------|---|
| Reproducibility | Turn the power OFF and then back ON to check the occurrence. |
| Harness | <ul style="list-style-type: none"> Check if the connectors between the SYS board and the CCD board are connected properly. If there is any abnormality in the harness and connectors between the SYS board and the CCD board, replace the harness and connectors. |
| CCD board | <ul style="list-style-type: none"> PC board check Connector check Harness check Replace the PC board. |
| SYS board | <ul style="list-style-type: none"> PC board check Replace the PC board. |

| Parts to be replaced | Remarks |
|----------------------|---------|
| SYS board | |
| Harness | |
| CCD board | |

[C254] ASIC communication error

| Classification | Error content |
|---------------------|--|
| Scanner abnormality | ASIC communication error (The MFP will be rebooted at the first time the error occurs.) |

| Check item | Measures |
|-----------------|---|
| Reproducibility | Turn the power OFF and then back ON to check the occurrence. |
| SYS board | <ul style="list-style-type: none"> PC board check Replace the PC board. |

| Parts to be replaced | Remarks |
|----------------------|---------|
| SYS board | |

[C260] Peak detection error

| Classification | Error content |
|---------------------|---|
| Scanner abnormality | Lighting of the exposure lamp (white reference) is not detected when the power is turned ON. (The MFP will be rebooted at the first time the error occurs.) |

| Check item | Measures |
|---------------|--|
| Exposure lamp | <ul style="list-style-type: none"> Check if the exposure lamp lights. (Output check) Connector check Harness check Check if the wiring of the harness is proper. Replace the exposure lamp if it does not light. |
| Shading sheet | Check if there is any scratch or stain on the shading sheet. |

| Check item | Measures |
|----------------------|--|
| Carriage | <ul style="list-style-type: none"> • Move the carriage to the left stopping point to check whether it is tilted. • Check if the wire fixing screw is loosened. • Check if the carriage works normally. Check if the movement of the carriage is unstable due to disengagement of the carriage roller. |
| Mirror | <ul style="list-style-type: none"> • Check if the mirror is tilted. • Check that the lens is reflected in the mirror looking at the carriage-1 from the upper position. • Check if the mirror is secured by the leaf spring. |
| CCD board, lens unit | <ul style="list-style-type: none"> • Check if the lens unit is installed properly. (Check if the lens unit is tilted or the screw is securely tightened.) • Connector check • Harness check |
| SYS board | <ul style="list-style-type: none"> • PC board check • Connector check • Harness check • Replace the PC board. |

| Parts to be replaced | Remarks |
|------------------------|---------|
| Exposure lamp | |
| Shading sheet | |
| Carriage-1, carriage-2 | |
| CCD board, lens unit | |
| SYS board | |

[C262] Communication error

| Classification | Error content |
|---------------------|--|
| Scanner abnormality | Communication error between the CCD board and the SYS board (The MFP will be rebooted at the first time the error occurs.) |

| Check item | Measures |
|------------|---|
| Harness | <ul style="list-style-type: none"> • Check if the connectors between the SYS board and the CCD board are connected properly. • If there is any abnormality in the harness and connectors between the SYS board and the CCD board, replace the harness and connectors. |
| CCD board | <ul style="list-style-type: none"> • PC board check • Connector check • Harness check • Replace the PC board. |
| SYS board | <ul style="list-style-type: none"> • PC board check • Connector check • Harness check • Replace the PC board. |

| Parts to be replaced | Remarks |
|----------------------|---------|
| Harness | |
| CCD board | |
| SYS board | |

[C270] Carriage home position sensor not turning OFF within a specified period of time, Downloading firmware with an incorrect model

| Classification | Error content |
|---------------------|---|
| Scanner abnormality | <ul style="list-style-type: none"> The carriage does not shift from its home position within a specified time. Downloading firmware with an incorrect model |

| Check item | Measures |
|-------------------------------|--|
| Carriage locking | Check if the carriage locking screw for packaging is attached. |
| CCD board | <ul style="list-style-type: none"> PC board check Connector check Harness check Replace the PC board. |
| Firmware | If the model of the downloaded firmware is incorrect, a C270 error occurs. If the exposure lamp blinks twice, download the correct firmware. |
| Carriage home position sensor | <ul style="list-style-type: none"> Sensor check (Input check) Actuator check Connector check Harness check Replace the sensor. |
| SYS board | <ul style="list-style-type: none"> PC board check Connector check Harness check Replace the PC board. |
| Scan motor | <ul style="list-style-type: none"> Check that the motor is working. (Output check) Connector check Harness check Motor check Replace the motor. |
| Setting | Initialize the SRAM. |

| Parts to be replaced | Remarks |
|-------------------------------|---------|
| CCD board | |
| Carriage home position sensor | |
| SYS board | |
| Scan motor | |

[C280] Carriage home position sensor not turned ON within a specified period of time

| Classification | Error content |
|---------------------|---|
| Scanner abnormality | The carriage home position sensor is not turned ON within a specified period of time. |

| Check item | Measures |
|-------------------------------|---|
| Carriage locking | Check if the carriage locking screw for packaging is attached. |
| CCD board | <ul style="list-style-type: none"> PC board check Connector check Harness check Replace the PC board. |
| Carriage home position sensor | <ul style="list-style-type: none"> Sensor check (Input check) Actuator check Connector check Harness check Replace the sensor. |
| SYS board | <ul style="list-style-type: none"> PC board check Connector check Harness check Replace the PC board. |

| Check item | Measures |
|------------|---|
| Scan motor | <ul style="list-style-type: none"> • Check that the motor is working. (Output check) • Connector check • Harness check • Replace the motor. |

| Parts to be replaced | Remarks |
|-------------------------------|---------|
| CCD board | |
| Carriage home position sensor | |
| SYS board | |
| Scan motor | |

[C290] Scanner power supply abnormality

| Classification | Error content |
|---------------------|--|
| Scanner abnormality | No 24 V power supply is given to the scanner and thus the scanning system does not operate. (The MFP will be rebooted the first time this error occurs.) |

| Check item | Measures |
|------------|---|
| SYS board | <ul style="list-style-type: none"> • PC board check • Connector check • Harness check • Replace the PC board. |
| LVPS | <ul style="list-style-type: none"> • PC board check • Connector check • Harness check • Replace the PC board. |

| Parts to be replaced | Remarks |
|----------------------|---------|
| SYS board | |
| LVPS | |

[C360] Needle electrode cleaner abnormality

| Classification | Error content |
|-----------------------------|---|
| Process related abnormality | The needle electrode cleaner does not work normally. (The MFP will be rebooted at the first time the error occurs.) |

| Check item | Measures |
|---|---|
| Main charger | Perform FS-08-4606-0 to 3 to check the condition of the main charger. |
| Needle electrode cleaner detection sensor (K) | <ul style="list-style-type: none"> • Sensor check (Input check) • Actuator check • Connector check • Harness check • Replace the sensor. |
| Needle electrode cleaner motor (K) | <ul style="list-style-type: none"> • Check that the motor is working. (Output check) • Connector check • Harness check • Replace the motor. |
| EPU board | <ul style="list-style-type: none"> • PC board check • Connector check • Harness check • Replace the PC board. |
| LGC board | <ul style="list-style-type: none"> • PC board check • Connector check • Harness check • Replace the PC board. |

| Parts to be replaced | Remarks |
|---|---------|
| Needle electrode cleaner detection sensor (K) | |
| Needle electrode cleaner motor (K) | |

| Parts to be replaced | Remarks |
|----------------------|---------|
| EPU board | |
| LGC board | |

[C380] Developer material (K) toner density lower limit abnormality

[C381] Developer material (K) toner density upper limit abnormality

[C382] Auto-toner sensor (K) connection abnormality

| Classification | Error content |
|-----------------------------|--|
| Process related abnormality | An output of the auto-toner sensor cannot be detected properly. (The MFP will be rebooted at the first time the error occurs.) |

| Check item | Measures |
|-----------------------|--|
| EPU tray | <ul style="list-style-type: none"> Check if this problem is solved by removing and then reinstalling the EPU tray. Check if there is any toner or dust on the drawer connectors on the EPU and the MFP. If there is any, remove it. |
| Developer unit | <ul style="list-style-type: none"> Check if the developer unit is installed properly. Check if the developer unit and the drive coupling of the MFP side are engaged properly. Check if the mixer of the developer unit is rotating properly. Check if the amount of the developer material is too large or too small. |
| Auto-toner sensor (K) | <ul style="list-style-type: none"> Check if there is any toner or dust on the auto-toner sensor connector and the drawer connector on the EPU. If there is any, remove it. Connector check Harness check Replace the sensor. |
| EPU board | <ul style="list-style-type: none"> PC board check Connector check Harness check Replace the PC board. |
| LGC board | <ul style="list-style-type: none"> PC board check Connector check Harness check Replace the PC board. |

| Parts to be replaced | Remarks |
|-----------------------|---------|
| Auto-toner sensor (K) | |
| EPU board | |
| LGC board | |
| Developer material | |

[C3C0] Process unit (EPU tray) connection abnormality

| Classification | Error content |
|-----------------------------|--|
| Process related abnormality | The connection of the process unit (EPU tray) cannot be detected. (The MFP will be rebooted at the first time the error occurs.) |

| Check item | Measures |
|------------|---|
| EPU tray | <ul style="list-style-type: none"> Check if this problem is solved by removing and then reinstalling the EPU tray. Check if there is any toner or dust on the drawer connectors on the EPU and the MFP. If there is any, remove it. |
| EPU board | <ul style="list-style-type: none"> PC board check Connector check Harness check Replace the PC board. |
| LGC board | <ul style="list-style-type: none"> PC board check Connector check Harness check Replace the PC board. |

| Parts to be replaced | Remarks |
|----------------------|---------|
| EPU board | |
| LGC board | |

[C440] Fusing temperature abnormality (low temperature WAIT control abnormality at printing status)

[C445] Fusing temperature abnormality (pre-running end temperature abnormality)

[C446] Fusing temperature abnormality (pre-running end temperature abnormality)

[C447] Fusing temperature abnormality (temperature abnormality at ready status and during printing)

[C449] Fusing temperature abnormality (high temperature abnormality)

| Classification | Error content |
|------------------------|--|
| Fuser unit abnormality | <ul style="list-style-type: none"> An abnormality of the thermistor is detected. The temperature of the heat roller does not rise within a specified period of time. The temperature of the heat roller has exceeded the range. |

| Check item | Measures |
|--------------------------------|---|
| Power voltage | Check if the power voltage is normal. (The voltage during the operation is $\pm 10\%$ of the rated voltage.) |
| Thermistor | <ul style="list-style-type: none"> Check if each thermistor is installed properly. Harness check Connector check |
| Fuser unit | <ul style="list-style-type: none"> Check if the fuser unit is installed properly. Check if the drawer connector is damaged or there is a defect in its connection. Check if the IH coil or the heater is open circuited. Check if the terminal of the IH coil or the heater is attached securely. Check if each thermostat is blown. |
| Switching regulator | <ul style="list-style-type: none"> PC board check Connector check Harness check Replace the PC board. |
| LGC board | <ul style="list-style-type: none"> PC board check Connector check Harness check Replace the PC board. |
| IH board | <ul style="list-style-type: none"> PC board check Connector check Harness check Replace the PC board. |
| Clearing of the status counter | <p>After the measures have been taken, perform the following items.</p> <ol style="list-style-type: none"> Perform FS-08-2002. Change the displayed status counter value to "0". By turning the power OFF and then back ON, check that the MFP will enter into the ready state. |

| Parts to be replaced | Remarks |
|----------------------|---------|
| Thermistor | |
| Fuser unit | |
| Switching regulator | |
| LGC board | |
| IH board | |

[C471] IH board initialization abnormality

[C472] No power supply

| Classification | Error content |
|------------------------|---|
| Fuser unit abnormality | <ul style="list-style-type: none"> Power is not supplied to the IH board. There is any abnormality in the power supply environment of the installation location. (The MFP will be rebooted at the first time the error occurs.) |

| Check item | Measures |
|--------------------------------|---|
| Power cable | <ul style="list-style-type: none"> Check if the power cable is inserted securely. Check if there is any abnormality such as scratches in the power cable. |
| Power voltage | Check if the power voltage is normal. (The voltage during the operation is $\pm 10\%$ of the rated voltage.) |
| IH interlock switch | <ul style="list-style-type: none"> Switch check (Input check) Connector check Harness check Replace the switch. |
| Fuser unit | <ul style="list-style-type: none"> Check if the fuser unit is installed properly. Check if the drawer connector is damaged or there is a defect in its connection. Check if the IH coil is open circuited. Check if the terminal of the IH coil is attached securely. Check if each thermostat is blown. |
| Switching regulator | <ul style="list-style-type: none"> PC board check Connector check Harness check Replace the PC board. |
| FIL board | <ul style="list-style-type: none"> PC board check Connector check Harness check Replace the PC board. |
| LGC board | <ul style="list-style-type: none"> PC board check Connector check Harness check Replace the PC board. |
| IH board | <ul style="list-style-type: none"> PC board check Connector check Harness check Replace the PC board. |
| Clearing of the status counter | After the measures have been taken, perform the following items. <ol style="list-style-type: none"> Perform FS-08-2002. Change the displayed status counter value to "0". By turning the power OFF and then back ON, check that the MFP will enter into the ready state. |

| Parts to be replaced | Remarks |
|----------------------|---------|
| IH interlock switch | |
| Switching regulator | |
| FIL board | |
| LGC board | |
| IH board | |

[C473] Power voltage upper limit abnormality**[C474] Power voltage lower limit abnormality**

| Classification | Error content |
|------------------------|--|
| Fuser unit abnormality | <ul style="list-style-type: none"> The power voltage supplied to the IH board is higher than the rated voltage. The power voltage supplied to the IH board is lower than the rated voltage. (The MFP will be rebooted at the first time the error occurs.) |

| Check item | Measures |
|--------------------------------|---|
| Power cable | <ul style="list-style-type: none"> Check if the power cable is inserted securely. Check if there is any abnormality such as scratches in the power cable. |
| Power voltage | Check if the power voltage is normal. (The voltage during the operation is $\pm 10\%$ of the rated voltage.) |
| Switching regulator | <ul style="list-style-type: none"> PC board check Connector check Harness check Replace the PC board. |
| FIL board | <ul style="list-style-type: none"> PC board check Connector check Harness check Replace the PC board. |
| LGC board | <ul style="list-style-type: none"> PC board check Connector check Harness check Replace the PC board. |
| IH board | <ul style="list-style-type: none"> PC board check Connector check Harness check Replace the PC board. |
| Clearing of the status counter | After the measures have been taken, perform the following items. <ol style="list-style-type: none"> Perform FS-08-2002. Change the displayed status counter value to "0". By turning the power OFF and then back ON, check that the MFP will enter into the ready state. |

| Parts to be replaced | Remarks |
|----------------------|---------|
| Switching regulator | |
| FIL board | |
| LGC board | |
| IH board | |

[C480] IGBT high temperature abnormality

| Classification | Error content |
|------------------------|--|
| Fuser unit abnormality | The IGBT (element of the IH board) is overheated. (The MFP will be rebooted at the first time the error occurs.) |

| Check item | Measures |
|--------------------------------|---|
| IH board cooling fan (exhaust) | <ul style="list-style-type: none"> Check that the fan is working. (Output check) Connector check Harness check Replace the fan. |
| IH board cooling fan (suction) | <ul style="list-style-type: none"> Check that the fan is working. (Output check) Connector check Harness check Replace the fan. |
| LGC board | <ul style="list-style-type: none"> PC board check Connector check Harness check Replace the PC board. |

| Check item | Measures |
|--------------------------------|--|
| IH board | <ul style="list-style-type: none"> PC board check Connector check Harness check Replace the PC board. |
| Switching regulator | <ul style="list-style-type: none"> PC board check Connector check Harness check Replace the PC board. |
| Clearing of the status counter | <p>After the measures have been taken, perform the following items.</p> <ol style="list-style-type: none"> Perform FS-08-2002. Change the displayed status counter value to "0". By turning the power OFF and then back ON, check that the MFP will enter into the ready state. |

| Parts to be replaced | Remarks |
|--------------------------------|---------|
| IH board cooling fan (exhaust) | |
| IH board cooling fan (suction) | |
| LGC board | |
| IH board | |
| Switching regulator | |

[C4B0] Status counter abnormality

| Classification | Error content |
|------------------------|---|
| Fuser unit abnormality | An abnormal value is entered in the status counter. |

| Check item | Measures |
|--------------------------------|--|
| LGC board | <ul style="list-style-type: none"> PC board check Connector check Harness check Replace the PC board. |
| Sub EEPROM | Check if the Sub EEPROM is mounted properly. |
| Clearing of the status counter | <p>After the measures have been taken, perform the following items.</p> <ol style="list-style-type: none"> Perform FS-08-2002. Change the displayed status counter value to "0". By turning the power OFF and then back ON, check that the MFP will enter into the ready state. |

| Parts to be replaced | Remarks |
|----------------------|---------|
| LGC board | |

[C4B1] Fuser unit power voltage identification abnormality

| Classification | Error content |
|------------------------|---|
| Fuser unit abnormality | The destination selected in the IH board and the MFP does not match. (The MFP will be rebooted at the first time the error occurs.) |

| Check item | Measures |
|------------|---|
| Fuser unit | <ul style="list-style-type: none"> Check if the fuser unit is installed properly. Check if the drawer connector is damaged or there is a defect in its connection. Check if the IH coil is open circuited. Check if the terminal of the IH coil is attached securely. Check if each thermostat is blown. |
| LGC board | <ul style="list-style-type: none"> PC board check Connector check Harness check Replace the PC board. |
| IH board | <ul style="list-style-type: none"> PC board check Connector check Harness check Replace the PC board. |

| Parts to be replaced | Remarks |
|----------------------|---------|
| Fuser unit | |
| LGC board | |
| IH board | |

[C4B2] IH firmware combination error

| Classification | Error content |
|------------------------|---|
| Fuser unit abnormality | The destination selected in the IH board and the MFP does not match. (The MFP will be rebooted at the first time the error occurs.) |

| Check item | Measures |
|------------|--|
| Firmware | <ul style="list-style-type: none"> Check if the combination of the version for all the firmware items installed in the MFP is appropriate. Reinstall the firmware with the correct combination of the version. |
| LGC board | <ul style="list-style-type: none"> PC board check Connector check Harness check Replace the PC board. |
| IH board | <ul style="list-style-type: none"> PC board check Connector check Harness check Replace the PC board. |

| Parts to be replaced | Remarks |
|----------------------|---------|
| LGC board | |
| IH board | |

[C4E0] Pressure roller release abnormality

[C4E1] Pressure roller contact and semi-contact abnormality

| Classification | Error content |
|------------------------|--|
| Fuser unit abnormality | <ul style="list-style-type: none"> The releasing behavior of the pressure roller cannot be detected. There is an abnormality in the pressure roller contact/release detection sensor. The contacting and semi-contacting behavior of the pressure roller cannot be detected. |

| Check item | Measures |
|--|--|
| Pressure roller contact/release detection sensor | <ul style="list-style-type: none"> Sensor check (Input check) Actuator check Connector check Harness check Replace the sensor. |
| Pressure roller contact/release motor | <ul style="list-style-type: none"> Check that the motor is working. (Output check) Connector check Harness check Replace the motor. |
| Fuser unit | <ul style="list-style-type: none"> Check if the fuser unit is installed properly. Check if the drawer connector is damaged or there is a defect in its connection. Connector check Harness check |
| LGC board | <ul style="list-style-type: none"> PC board check Connector check Harness check Replace the PC board. |

| Parts to be replaced | Remarks |
|--|---------|
| Pressure roller contact/release detection sensor | |
| Pressure roller contact/release motor | |

| Parts to be replaced | Remarks |
|----------------------|---------|
| Fuser unit | |
| LGC board | |

[C4E2] Fuser belt rotation detection sensor abnormality

| Classification | Error content |
|------------------------|--|
| Fuser unit abnormality | The fuser belt does not rotate normally. |

| Check item | Measures |
|--------------------------------------|---|
| Fuser belt rotation detection sensor | <ul style="list-style-type: none"> • Sensor check (Input check) • Check the rotation detection plate (rotor). • Connector check • Harness check • Replace the sensor. |
| Fuser unit | <ul style="list-style-type: none"> • Check if the fuser unit is installed properly. • Check if the drawer connector is damaged or there is a defect in its connection. • Connector check • Harness check • Check if grease is applied to the gears (shaft and tooth surface). • Check if there is any abnormality in the fuser belt. • Check if the parts such as gears, shafts, bushing and bearings are damaged. |
| Fuser unit driving section | <ul style="list-style-type: none"> • Check if the drive unit is installed properly. • Check if the drive metal plate is broken. • Check if grease is applied to the gears (shaft and tooth surface). • Check if the parts such as gears, shafts, bushing and bearings are damaged. • Check if there is any abnormality in the one-way clutch. |
| Fuser motor | <ul style="list-style-type: none"> • Check that the motor is working. (Output check) • Connector check • Harness check • Replace the motor. |
| LGC board | <ul style="list-style-type: none"> • PC board check • Connector check • Harness check • Replace the PC board. |

| Parts to be replaced | Remarks |
|--------------------------------------|---------|
| Fuser belt rotation detection sensor | |
| Fuser unit | |
| Fuser unit driving section | |
| Fuser motor | |
| LGC board | |

[C550] Communication error between the scanner and the DF

| Classification | Error content |
|------------------|---|
| DSDF abnormality | Communication cannot be made properly between the scanner and the DF. (This error is determined when the problem is not solved even if the MFP is rebooted by the specified number of times.) |

| Check item | Measures |
|----------------|--|
| HDMI cable | Check that the HDMI cable is connected properly. |
| DSDF I/F board | <ul style="list-style-type: none"> • PC board check • Connector check (CN89) • Harness check • Replace the PC board. |

| Check item | Measures |
|------------|--|
| DSDF board | <ul style="list-style-type: none"> PC board check Connector check (CN71) Harness check Replace the PC board. |
| SYS board | <ul style="list-style-type: none"> PC board check Connector check Harness check Replace the PC board. |

| Parts to be replaced | Remarks |
|----------------------|---------|
| HDMI cable | |
| DSDF I/F board | |
| DSDF board | |
| SYS board | |

[C551] DF model detection abnormality

| Classification | Error content |
|------------------|--|
| DSDF abnormality | An incorrect DF is installed in the MFP. |

| Check item | Measures |
|----------------|---|
| DSDF | <ul style="list-style-type: none"> Check if a DSDF of the correct model is installed. Replace the DSDF with the correct one. |
| DSDF I/F board | <ul style="list-style-type: none"> PC board check Connector check (CN129) Harness check Replace the PC board. |
| SYS board | <ul style="list-style-type: none"> PC board check Connector check Harness check Replace the PC board. |

| Parts to be replaced | Remarks |
|----------------------|---------|
| DSDF | |
| DSDF I/F board | |
| SYS board | |

[C552] DF abnormality

| Classification | Error content |
|------------------|--|
| DSDF abnormality | DF abnormality (This error is determined when the problem is not solved even if the MFP is rebooted by the specified number of times.) |

| Check item | Measures |
|-----------------------|--|
| DSDF control PC board | <ul style="list-style-type: none"> PC board check Connector check (CN71) Harness check Replace the PC board. |
| Firmware | Reinstall the DSDF firmware. |

| Parts to be replaced | Remarks |
|-----------------------|---------|
| DSDF control PC board | |

[C553] DSDF-CCD module peak detection abnormality

| Classification | Error content |
|------------------|--|
| DSDF abnormality | <ul style="list-style-type: none"> The light source of the DSDF-CCD module does not light. There is a detection error of the light source. (This error is determined when the problem is not solved even if the MFP is rebooted by the specified number of times.) |

| Check item | Measures |
|--------------------------|---|
| HDMI cable | Check that the HDMI cable is connected properly. (CN129) |
| DSDF I/F board | <ul style="list-style-type: none"> PC board check Connector check (CN89) Harness check Replace the PC board. |
| DSDF control PC board | <ul style="list-style-type: none"> PC board check Connector check (CN71) Harness check Replace the PC board. |
| SYS board | <ul style="list-style-type: none"> PC board check Connector check Harness check Replace the PC board. |
| Switching regulator | <ul style="list-style-type: none"> PC board check Connector check Harness check Replace the PC board. |
| DSDF original exit motor | <ul style="list-style-type: none"> Check that the motor is working. (Output check) Connector check Harness check Replace the motor. |
| DSDF-CCD module | <ul style="list-style-type: none"> Check if the connectors of the DSDF-CCD module are connected properly. Check if there is any abnormality in the DSDF-CCD module. |

| Parts to be replaced | Remarks |
|--------------------------|---------|
| DSDF I/F board | |
| DSDF control PC board | |
| SYS board | |
| DSDF original exit motor | |
| DSDF-CCD module | |

[C554] AFE communication error

| Classification | Error content |
|------------------|---|
| DSDF abnormality | Communication error between the DSDF-CCD module and the SYS board (This error is determined when the problem is not solved even if the MFP is rebooted by the specified number of times.) |

| Check item | Measures |
|-----------------|---|
| HDMI cable | Check that the HDMI cable is connected properly. |
| DSDF I/F board | <ul style="list-style-type: none"> PC board check Connector check (CN89) Harness check Replace the PC board. |
| SYS board | <ul style="list-style-type: none"> PC board check Connector check Harness check Replace the PC board. |
| DSDF-CCD module | <ul style="list-style-type: none"> Check if the connectors of the DSDF-CCD module are connected properly. Check if there is any abnormality in the DSDF-CCD module. |

| Parts to be replaced | Remarks |
|----------------------|---------|
| DSDF I/F board | |
| DSDF-CCD module | |
| SYS board | |

[C55A] Multiple feeding detection sensor connection abnormality

| Classification | Error content |
|------------------|---|
| DSDF abnormality | A signal from the multiple feeding detection sensor cannot be detected. (This error is determined when the problem is not solved even if the MFP is rebooted by the specified number of times.) |

| Check item | Measures |
|-----------------------------------|---|
| Multiple feeding detection sensor | <ul style="list-style-type: none"> • Check if the sensor is installed properly. • Connector check • Harness check • Replace the sensor. |
| DSDF control PC board | <ul style="list-style-type: none"> • PC board check • Connector check • Harness check • Replace the PC board. |

| Parts to be replaced | Remarks |
|-----------------------------------|---------|
| Multiple feeding detection sensor | |
| DSDF control PC board | |

[C55B] Multiple feeding detection sensor abnormality

| Classification | Error content |
|------------------|---|
| DSDF abnormality | A malfunction of the sensor is detected. A signal from the multiple feeding detection sensor cannot be received properly. (This error is determined when the problem is not solved even if the MFP is rebooted by the specified number of times.) |

| Check item | Measures |
|-----------------------------------|---|
| Multiple feeding detection sensor | <ul style="list-style-type: none"> • Sensor check • Connector check • Harness check • Replace the sensor. |
| DSDF control PC board | <ul style="list-style-type: none"> • PC board check • Connector check • Harness check • Replace the PC board. |

| Parts to be replaced | Remarks |
|-----------------------------------|---------|
| Multiple feeding detection sensor | |
| DSDF control PC board | |

[C560] Communication error between engine-CPU and PFC board

| Classification | Error content |
|------------------------------|---|
| Circuit related service call | Communication cannot be made properly between the engine-CPU and PFC board. (This error is determined when the problem is not solved even if the MFP is rebooted by the specified number of times.) |

| Check item | Measures |
|------------|---|
| LGC board | <ul style="list-style-type: none"> • PC board check • Connector check • Harness check • Replace the PC board. |

| Check item | Measures |
|----------------------|---|
| PFC board | <ul style="list-style-type: none"> PC board check Connector check Harness check Replace the PC board. |
| Parts to be replaced | Remarks |
| LGC board | |
| PFC board | |

[C580] Communication error between the LGC board and the Finisher

| Classification | Error content |
|----------------------|--|
| Finisher abnormality | A communication error has occurred between the LGC board and the Finisher. (This error is determined when the problem is not solved even if the MFP is rebooted by the specified number of times.) |

| Check item | Measures |
|---------------------------|---|
| Finisher | <ul style="list-style-type: none"> Check if the installed Finisher is an option exclusively set for the model. Replace the Finisher with the one exclusively set for the model. |
| LGC board | <ul style="list-style-type: none"> PC board check Connector check Harness check Replace the PC board. |
| Finisher control PC board | <ul style="list-style-type: none"> PC board check Connector check (CN3, CN13) Harness check Replace the PC board. |

| Parts to be replaced | Remarks |
|---------------------------|---------|
| LGC board | |
| Finisher control PC board | |

[C5A0] EEPROM communication abnormality (LGC board)

| Classification | Error content |
|--------------------|---------------------------------------|
| EEPROM abnormality | There is no response from the EEPROM. |

| Check item | Measures |
|------------|---|
| EEPROM | Check the EEPROM. |
| LGC board | <ul style="list-style-type: none"> PC board check Replace the PC board. |

| Parts to be replaced | Remarks |
|----------------------|---------|
| LGC board | |

[C5A1] EEPROM data abnormality (LGC board)

| Classification | Error content |
|--------------------|---|
| EEPROM abnormality | An abnormality has occurred in the EEPROM data. |

| Check item | Measures |
|-----------------|--|
| EEPROM | Check the EEPROM. |
| LGC board | <ul style="list-style-type: none"> PC board check Replace the PC board. |
| Reproducibility | Reboot the MFP to check that the error does not occur. If it changes to another code, follow its troubleshooting procedure. |
| EEPROM data | <ol style="list-style-type: none"> Perform FS-08-4871. Reboot the MFP to check that the error does not occur. If it changes to another code, follow its troubleshooting procedure. |

| Parts to be replaced | Remarks |
|----------------------|---------|
| LGC board | |

[C5A8] Sub EEPROM communication abnormality

| Classification | Error content |
|------------------------|--|
| Sub EEPROM abnormality | There is no response from the Sub EEPROM. (The MFP will be rebooted at the first time the error occurs.) |

| Check item | Measures |
|------------|---|
| Sub EEPROM | Check the Sub EEPROM. |
| LGC board | <ul style="list-style-type: none"> • PC board check • Socket check • Replace the PC board. |

| Parts to be replaced | Remarks |
|----------------------|---------|
| Sub EEPROM | |
| LGC board | |

[C5A9] Sub EEPROM data abnormality

| Classification | Error content |
|--------------------|--|
| EEPROM abnormality | An abnormality has occurred in the Sub EEPROM data. (The MFP will be rebooted at the first time the error occurs.) |

| Check item | Measures |
|-----------------|--|
| Sub EEPROM | Check the Sub EEPROM. |
| LGC board | <ul style="list-style-type: none"> • PC board check • Socket check • Replace the PC board. |
| Reproducibility | Reboot the MFP to check that the error does not occur. If it changes to another code, follow its troubleshooting procedure. |
| Sub EEPROM data | <ol style="list-style-type: none"> 1. Perform FS-08-4870. 2. Reboot the MFP to check that the error does not occur. If it changes to another code, follow its troubleshooting procedure. |

| Parts to be replaced | Remarks |
|----------------------|---------|
| Sub EEPROM | |
| LGC board | |

[C730] DSDF EEPROM writing abnormality

| Classification | Error content |
|------------------|--|
| DSDF abnormality | An abnormality has occurred while the data are being written in the EEPROM of the DSDF. (The MFP will be rebooted at the first time the error occurs.) |

| Check item | Measures |
|-----------------------|---|
| Adjustment | Perform DSDF read-in sensor-1 automatic adjustment. |
| DSDF control PC board | <ul style="list-style-type: none"> • PC board check • Connector check (CN122) • Harness check • Replace the PC board. |

| Parts to be replaced | Remarks |
|-----------------------|---------|
| DSDF control PC board | |

[C7B0] Initialization performance abnormality

| Classification | Error content |
|------------------|--|
| DSDF abnormality | The initialization is not completed within the specified time. (This error is determined when the problem is not solved even if the MFP is rebooted by the specified number of times.) |

| Check item | Measures |
|--------------------|---|
| Reproducibility | Turn the power OFF and then back ON to check the occurrence. |
| DSDF shading sheet | Clean the DSDF shading sheet. |
| SYS board | <ul style="list-style-type: none"> • PC board check • Connector check (CN122) • Harness check • Replace the PC board. |

| Parts to be replaced | Remarks |
|----------------------|---------|
| DSDF shading sheet | |
| SYS board | |

[C8C0] DSDF read-in sensor-1 automatic adjustment abnormality

| Classification | Error content |
|------------------|---|
| DSDF abnormality | An adjustment value becomes outside the specified one during DSDF read-in sensor-1 automatic adjustment. (The MFP will be rebooted at the first time the error occurs.) |

| Check item | Measures |
|-----------------------|---|
| DSDF read-in sensor-1 | <ul style="list-style-type: none"> • Sensor check • Connector check • Harness check • Perform DSDF read-in sensor-1 adjustment manually. • Replace the sensor. |
| DSDF control PC board | <ul style="list-style-type: none"> • PC board check • Connector check • Harness check • Replace the PC board. |

| Parts to be replaced | Remarks |
|-----------------------|---------|
| DSDF read-in sensor-1 | |
| DSDF control PC board | |

[C8E0] DF communication protocol abnormality

| Classification | Error content |
|------------------|---|
| DSDF abnormality | System stop is required due to the control abnormality. (This error is determined when the problem is not solved even if the MFP is rebooted by the specified number of times.) |

| Check item | Measures |
|-----------------------|--|
| Reproducibility | Turn the power OFF and then back ON to check the occurrence. |
| DSDF control PC board | <ul style="list-style-type: none"> • PC board check • Connector check (CN71) • Harness check • Replace the PC board. |
| SYS board | <ul style="list-style-type: none"> • PC board check • Connector check • Harness check • Replace the PC board. |

| Parts to be replaced | Remarks |
|-----------------------|---------|
| DSDF control PC board | |
| SYS board | |

[C911] CTIF board access abnormality (K)

| Classification | Error content |
|------------------------------|---|
| Circuit related service call | Abnormal access to the toner cartridge IC chip |
| Check item | Measures |
| Reproducibility | Open and then close the front cover to check if "Non-genuine toner cartridge" is displayed. When this is displayed, use a genuine toner cartridge. |
| Toner cartridge | <ul style="list-style-type: none"> Check the symptom by removing and then reinstalling the toner cartridge (K). Check if the CTRG board properly contact the toner cartridge (K). Wipe the contact point with a soft cloth if it is stained. <p>Notes: Avoid directly touching the contact point with your hands.</p> |
| CTIF board | <ul style="list-style-type: none"> Check if there is any abnormality in the installation of the PC board. Connector check Harness check Check if the springs for the contact point for the toner cartridge (K) is deformed. Gently push the spring for the contact point to check that it has returned. <p>Notes: If the spring is pushed strongly, it may be deformed.</p> <ul style="list-style-type: none"> Replace the PC board. |
| LGC board | <ul style="list-style-type: none"> PC board check Connector check Harness check Replace the PC board. |
| Setting | When the error is cleared, set "0" (normal) to the following self-diagnostic codes. K: FS-08-4689-3 |

| Parts to be replaced | Remarks |
|----------------------|---------|
| Toner cartridge | |
| LGC board | |
| CTIF board | |

[C916] Sub-CPU abnormality

| Classification | Error content |
|------------------------------|--|
| Circuit related service call | An abnormality has occurred during the access to the sub-CPU. (The MFP will be rebooted at the first time the error occurs.) |
| Check item | Measures |
| Reproducibility | Turn the power OFF and then back ON to check the occurrence. |
| LGC board | <ul style="list-style-type: none"> PC board check Replace the PC board. |
| Parts to be replaced | Remarks |
| LGC board | |

[C940] Engine-CPU abnormality

| Classification | Error content |
|------------------------------|---|
| Circuit related service call | An abnormality has occurred in the engine-CPU. (The MFP will be rebooted at the first time the error occurs.) |
| Check item | Measures |
| Reproducibility | Turn the power OFF and then back ON to check the occurrence. |
| Firmware | <ul style="list-style-type: none"> Check if the combination of the version for all the firmware items installed in the MFP is appropriate. Reinstall the engine firmware. |
| LGC board | <ul style="list-style-type: none"> PC board check Replace the PC board. |
| Parts to be replaced | Remarks |
| LGC board | |

[C963] Connection detection abnormality between the SYS board and the LGC board

| Classification | Error content |
|--|--|
| Circuit related service call | The 3.3 V voltage output of the SYS board cannot be detected by the LGC board. (The MFP will be rebooted at the first time the error occurs.) |
| Check item | Measures |
| LGC board | <ul style="list-style-type: none"> PC board check Check that the LED1 on the LGC board is lit. If not, replace the LGC board.  P. 8-403 "8.4.15 Error check by the LEDs on the LGC board" Connector check Harness check Replace the PC board. |
| SYS board | <ul style="list-style-type: none"> PC board check Connector check Harness check Replace the PC board. |
| Harness between the SYS board and the LGC board | Check if there is any abnormality in it. |
| Power supply harness between the SYS board and the switching regulator | Check if there is any abnormality in it. |
| Parts to be replaced | Remarks |
| LGC board | |
| SYS board | |
| Harness | |

[C970] High-voltage transformer leakage abnormality

| Classification | Error content |
|------------------------------|--|
| Circuit related service call | Leakage from the main charger has been detected. |

| Check item | Measures |
|---|---|
| Main charger | <ul style="list-style-type: none"> • Check if the main charger is installed properly. • Check if there is any abnormality such as damage, deformation foreign matter adhering to the main charger grid. • Check if there is any abnormality such as damage, deformation foreign matter adhering to the needle electrode. |
| Spring of the high-voltage supply contact point | <ul style="list-style-type: none"> • Check if the spring of the high-voltage supply contact point is deformed. • If so, correct or replace it. |
| High-voltage transformer | <ul style="list-style-type: none"> • PC board check • Connector check • Harness check • Replace the PC board. |

| Parts to be replaced | Remarks |
|---|---------|
| Main charger | |
| Spring of the high-voltage supply contact point | |
| High-voltage transformer | |

[CA10] Polygonal motor abnormality

| Classification | Error content |
|------------------------------|---|
| Writing related service call | The polygonal motor does not work normally. |

| Check item | Measures |
|--|---|
| Polygonal motor | <ul style="list-style-type: none"> • Check that the motor is working. (Output check) • Connector check • Harness check (between the laser optical unit and LGC board) • Replace the laser optical unit. |
| LGC board | <ul style="list-style-type: none"> • PC board check • Connector check • Harness check • Replace the PC board. |
| Laser optical unit cooling fan (front) | <ul style="list-style-type: none"> • Check that the fan is working. (Output check) • Connector check • Harness check • Fan check • Replace the fan. |
| Laser optical unit cooling fan (rear) | <ul style="list-style-type: none"> • Check that the fan is working. (Output check) • Connector check • Harness check • Fan check • Replace the fan. |

| Parts to be replaced | Remarks |
|--|---------|
| Laser optical unit | |
| LGC board | |
| Laser optical unit cooling fan (front) | |
| Laser optical unit cooling fan (rear) | |

[CA20] H-Sync detection error

| Classification | Error content |
|------------------------------|---|
| Writing related service call | The laser beams cannot be detected by the H-sync detection PC board. (The MFP will be rebooted at the first time the error occurs.) |

| Check item | Measures |
|---|---|
| Laser optical unit | <ul style="list-style-type: none"> • Connector check • Harness check (between the laser optical unit and LGC board) • Replace the laser optical unit. <p>Notes: Even if the flat cable is not apparently disconnected, it may be connected too loosely. Therefore, check carefully and connect it securely.</p> |
| LGC board | <ul style="list-style-type: none"> • PC board check • Connector check • Harness check • Replace the PC board. <p>Notes: Even if the flat cable is not apparently disconnected, it may be connected too loosely. Therefore, check carefully and connect it securely.</p> |
| Grounding | Check if the grounding is applied securely. |
| EPU | Check if all the EPUs are installed properly. |
| Main charger | <ul style="list-style-type: none"> • Check if the main charger is installed properly. • Check if there is any abnormality such as damage, deformation foreign matter adhering to the main charger grid. • Check if there is any abnormality such as damage, deformation foreign matter adhering to the needle electrode. |
| Spring of the high-voltage supply contact point | <ul style="list-style-type: none"> • Check if the spring of the high-voltage supply contact point is deformed. • If so, correct or replace it. |

| Parts to be replaced | Remarks |
|---|---------|
| Laser optical unit | |
| LGC board | |
| EPU | |
| Main charger | |
| Spring of the high-voltage supply contact point | |

[CB00] Finisher communication error (Finisher, Saddle Stitch Finisher)

| Classification | Error content |
|--|--|
| Finisher service call Saddle stitch finisher service call | A communication error has occurred between the MFP and the Finisher. (This error is determined when the problem is not solved even if the MFP is rebooted by the specified number of times.) |

| Check item | Measures |
|------------|---|
| Finisher | <ul style="list-style-type: none"> • Check if the harness between the MFP and the Finisher is disconnected or open circuited. • Check if the finisher control PC board is open circuited or short circuited. • Update the finisher firmware. • Replace the finisher control PC board. |
| LGC board | <ul style="list-style-type: none"> • PC board check • Connector check • Harness check • Replace the PC board. |

| Parts to be replaced | Remarks |
|---------------------------|---------|
| Finisher control PC board | |
| LGC board | |

[CB10] Entrance motor abnormality (Finisher, Saddle Stitch Finisher)

| Classification | Error content |
|--|--|
| Finisher service call Saddle stitch finisher service call | The entrance motor or the entrance roller does not work normally. (The MFP will be rebooted at the first time the error occurs.) |

| Check item | Measures |
|---------------------------|--|
| Entrance roller | Check the condition of the roller. If it has been stained, clean it. If it has deteriorated, replace it. |
| Entrance motor | <ul style="list-style-type: none"> • Check that the motor is working. • Connector check • Harness check • Replace the motor. |
| Finisher control PC board | <ul style="list-style-type: none"> • PC board check • Connector check (CN17) • Harness check • Replace the PC board. |

| Parts to be replaced | Remarks |
|---------------------------|---------|
| Entrance roller | |
| Entrance motor | |
| Finisher control PC board | |

[CB11] Buffer tray guide motor abnormality (Finisher, Saddle Stitch Finisher)

| Classification | Error content |
|--|---|
| Finisher service call Saddle stitch finisher service call | <ul style="list-style-type: none"> • The buffer tray guide motor or the buffer tray guide does not work normally. • A CB11 error will occur if an ED16 error has occurred three times in succession or it has occurred during the initialization. (This error is determined when the problem is not solved even if the MFP is rebooted by the specified number of times.) |

| Check item | Measures |
|---------------------------|--|
| Buffer tray | While the buffer roller is being raised, open and then close the buffer tray guide. If there is any mechanical problem, correct it. |
| Buffer tray guide motor | <ul style="list-style-type: none"> • Check that the motor is working. • Connector check • Harness check • Replace the motor. |
| Finisher control PC board | <ul style="list-style-type: none"> • PC board check • Connector check (CN10) • Harness check • Replace the PC board. |

| Parts to be replaced | Remarks |
|---------------------------|---------|
| Buffer tray | |
| Buffer tray guide motor | |
| Finisher control PC board | |

[CB14] Assist guide motor abnormality (Finisher, Saddle Stitch Finisher)

| Classification | Error content |
|--|--|
| Finisher service call Saddle stitch finisher service call | The assist guide motor does not work normally. (This error is determined when the problem is not solved even if the MFP is rebooted by the specified number of times.) |

| Check item | Measures |
|--------------------|--|
| Assist guide motor | <ul style="list-style-type: none"> • Check that the motor is working. • Connector check • Harness check • Replace the motor. |

| Check item | Measures |
|---------------------------|--|
| Finisher control PC board | <ul style="list-style-type: none"> PC board check Connector check (CN10) Harness check Replace the PC board. |
| Parts to be replaced | Remarks |
| Assist guide motor | |
| Finisher control PC board | |

[CB15] Catching motor abnormality (Finisher, Saddle Stitch Finisher)

| Classification | Error content |
|--|--|
| Finisher service call Saddle stitch finisher service call | The catching motor does not work normally. (This error is determined when the problem is not solved even if the MFP is rebooted by the specified number of times.) |

| Check item | Measures |
|---------------------------|--|
| Catching motor | <ul style="list-style-type: none"> Check that the motor is working. Connector check Harness check Replace the motor. |
| Finisher control PC board | <ul style="list-style-type: none"> PC board check Connector check (CN17) Harness check Replace the PC board. |

| Parts to be replaced | Remarks |
|---------------------------|---------|
| Catching motor | |
| Finisher control PC board | |

[CB40] Front alignment motor abnormality (Finisher, Saddle Stitch Finisher)

| Classification | Error content |
|--|--|
| Finisher service call Saddle stitch finisher service call | The front alignment motor or the front alignment plate does not work normally. (This error is determined when the problem is not solved even if the MFP is rebooted by the specified number of times.) |

| Check item | Measures |
|----------------------------|---|
| Front alignment plate | <ul style="list-style-type: none"> Check if there is any abnormality in the installation of the front alignment plate. Check if there is any mechanical problem by moving it. If there is any, correct it. |
| Front alignment motor (M5) | <ul style="list-style-type: none"> Check that the motor is working. Connector check Harness check Replace the motor. |
| Finisher control PC board | <ul style="list-style-type: none"> PC board check Connector check (CN18) Harness check Replace the PC board. |

| Parts to be replaced | Remarks |
|----------------------------|---------|
| Front alignment plate | |
| Front alignment motor (M5) | |
| Finisher control PC board | |

[CB50] Stapler home position abnormality (Finisher, Saddle Stitch Finisher)

| Classification | Error content |
|--|---|
| Finisher service call Saddle stitch finisher service call | The stapler unit home position sensor does not work normally. (This error is determined when the problem is not solved even if the MFP is rebooted by the specified number of times.) |

| Check item | Measures |
|---------------------------|--|
| Stapler unit | <ul style="list-style-type: none">• Connector check• Harness check |
| Finisher control PC board | <ul style="list-style-type: none">• PC board check• Connector check• Harness check• Replace the PC board. |

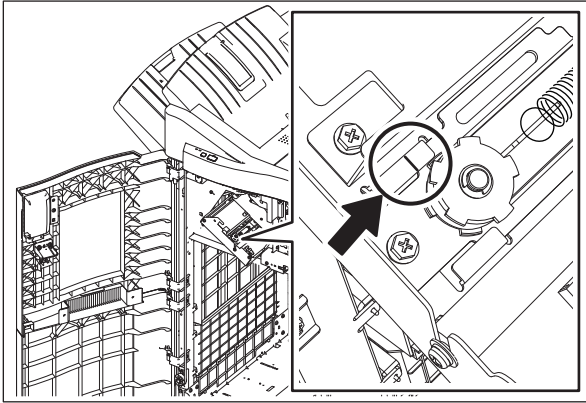
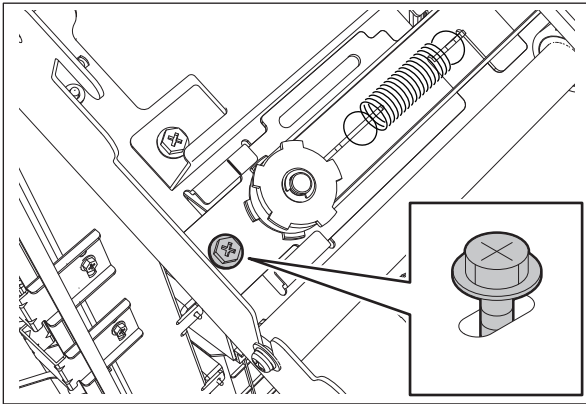
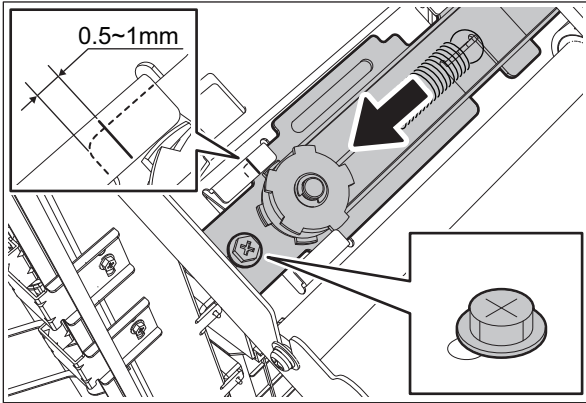
| Check item | Measures |
|-----------------------------|--|
| Belt | <p data-bbox="635 136 1382 193">Check if the belt tension of the stapler unit is loosened. If it is loosened, perform the adjustment according to the following procedure.</p> <p data-bbox="635 193 1310 246">1. Before adjusting the belt tension, make a mark for the initial position.</p>  <p data-bbox="635 668 719 693">Fig.8-43</p> <p data-bbox="635 725 1177 753">2. Loosen the screw of the belt pulley metal plate.</p>  <p data-bbox="635 1174 719 1200">Fig.8-44</p> <p data-bbox="635 1234 1382 1289">3. Move the pulley to the front side by 0.5 to 1.0 mm from the marked position and then tighten the screw.</p>  <p data-bbox="635 1710 719 1736">Fig.8-45</p> |
| Parts to be replaced | Remarks |
| Stapler unit | |
| Finisher control PC board | |

[CB60] Stapler unit shift motor abnormality (Finisher, Saddle Stitch Finisher)

| Classification | Error content |
|--|--|
| Finisher service call Saddle stitch finisher service call | The stapler unit shift motor or the stapler unit does not work normally. |

| Check item | Measures |
|-------------------------------|--|
| Stapler unit | <ul style="list-style-type: none"> • Connector check • Harness check |
| Stapler unit shift motor (M9) | <ul style="list-style-type: none"> • Check that the motor is working. • Connector check • Harness check • Replace the motor. |
| Finisher control PC board | <ul style="list-style-type: none"> • PC board check • Connector check (CN18) • Harness check • Replace the PC board. |

| Parts to be replaced | Remarks |
|-------------------------------|---------|
| Stapler unit | |
| Stapler unit shift motor (M9) | |
| Finisher control PC board | |

[CB80] Finisher backup RAM data abnormality (Finisher, Saddle Stitch Finisher)

| Classification | Error content |
|--|---|
| Finisher service call Saddle stitch finisher service call | An abnormality of the checksum value of the finisher control PC board is detected when the power is turned ON. (The MFP will be rebooted at the first time the error occurs.) |

| Check item | Measures |
|---------------------------------|---|
| Reproducibility | Turn the power OFF and then back ON to check the occurrence. |
| Finisher control PC board (FIN) | <ul style="list-style-type: none"> • PC board check • Connector check • Harness check • Replace the PC board. |

| Parts to be replaced | Remarks |
|---------------------------------|---------|
| Finisher control PC board (FIN) | |

[CB81] Finisher Flash ROM data abnormality (Finisher, Saddle Stitch Finisher)

| Classification | Error content |
|--|--|
| Finisher service call Saddle stitch finisher service call | An abnormality of the checksum value of the finisher control PC board is detected when the power is turned ON. |

| Check item | Measures |
|---------------------------------|---|
| Reproducibility | Turn the power OFF and then back ON to check the occurrence. |
| Finisher control PC board (FIN) | <ul style="list-style-type: none"> • PC board check • Connector check • Harness check • Replace the PC board. |

| Parts to be replaced | Remarks |
|---------------------------------|---------|
| Finisher control PC board (FIN) | |

[CB82] Finisher main program error (Finisher, Saddle Stitch Finisher)

| Classification | Error content |
|--|---|
| Finisher service call Saddle stitch finisher service call | Finisher main program error (The MFP will be rebooted at the first time the error occurs.) |
| Check item | Measures |
| Reproducibility | Turn the power OFF and then back ON to check the occurrence. |
| Firmware | Reinstall the finisher firmware. |
| Finisher control PC board (FIN) | <ul style="list-style-type: none"> • PC board check • Connector check • Harness check • Replace the PC board. |
| Parts to be replaced | Remarks |
| Finisher control PC board (FIN) | |

[CB84] Hole punch: Punch main program error (Finisher, Saddle Stitch Finisher)

| Classification | Error content |
|-----------------------------------|---|
| Hole punch unit service call | Punch main program error (The MFP will be rebooted at the first time the error occurs.) |
| Check item | Measures |
| Reproducibility | Turn the power OFF and then back ON to check the occurrence. |
| Firmware | Reinstall the punch firmware. |
| Hole punch control PC board (PNC) | <ul style="list-style-type: none"> • PC board check • Connector check • Harness check • Replace the PC board. |
| Parts to be replaced | Remarks |
| Hole punch control PC board (PNC) | |

[CB93] Saddle additional folding motor abnormality (Saddle Stitch Finisher)

| Classification | Error content |
|-------------------------------------|--|
| Saddle stitch finisher service call | An abnormal interruption of the encoder pulse of the additional folding motor or its operation abnormality has occurred. (This error is determined when the problem is not solved even if the MFP is rebooted by the specified number of times.) |
| Check item | Measures |
| Additional folding carrier | <ul style="list-style-type: none"> • Check if there is any abnormality in the installation of the additional folding carrier. • Check if there is any mechanical problem by moving it. • If there is any, correct it. |
| Additional folding motor (M20) | <ul style="list-style-type: none"> • Check that the motor is working. • Connector check • Harness check • Replace the motor. |
| Saddle control PC board (SDL) | <ul style="list-style-type: none"> • PC board check • Connector check (CN10) • Harness check • Replace the PC board. |
| Parts to be replaced | Remarks |
| Additional folding carrier | |
| Additional folding motor (M20) | |
| Saddle control PC board (SDL) | |

[CB94] Saddle transport motor abnormality (Saddle Stitch Finisher)

| Classification | Error content |
|-------------------------------------|---|
| Saddle stitch finisher service call | <ul style="list-style-type: none"> An abnormal interruption of the saddle transport motor or its operation abnormality has occurred. An abnormality has occurred in the paper holding mechanism or the path switching solenoid. (This error is determined when the problem is not solved even if the MFP is rebooted by the specified number of times.) |

| Check item | Measures |
|-------------------------------|---|
| Saddle transport roller | <ul style="list-style-type: none"> Check if there is any abnormality in the installation of the saddle transport roller. Check if there is any mechanical problem by moving it. If there is any, correct it. |
| Saddle transport motor (M16) | <ul style="list-style-type: none"> Check that the motor is working. Connector check Harness check Replace the motor. |
| Saddle control PC board (SDL) | <ul style="list-style-type: none"> PC board check Connector check (CN5) Harness check Replace the PC board. |

| Parts to be replaced | Remarks |
|-------------------------------|---------|
| Saddle transport roller | |
| Saddle transport motor (M16) | |
| Saddle control PC board (SDL) | |

[CB95] Stacker motor abnormality (Saddle Stitch Finisher)

| Classification | Error content |
|-------------------------------------|---|
| Saddle stitch finisher service call | An abnormal interruption of the stacker motor or its operation abnormality has occurred. (This error is determined when the problem is not solved even if the MFP is rebooted by the specified number of times.) |

| Check item | Measures |
|-------------------------------|---|
| Stacker carrier | <ul style="list-style-type: none"> Check if there is any abnormality in the installation of the stacker carrier. Check if there is any mechanical problem by moving it. If there is any, correct it. |
| Stacker motor (M14) | <ul style="list-style-type: none"> Check that the motor is working. Connector check Harness check Replace the motor. |
| Saddle control PC board (SDL) | <ul style="list-style-type: none"> PC board check Connector check (CN8) Harness check Replace the PC board. |

| Parts to be replaced | Remarks |
|-------------------------------|---------|
| Stacker carrier | |
| Stacker motor (M14) | |
| Saddle control PC board (SDL) | |

[CBA0] Front saddle stapler home position abnormality (Saddle Stitch Finisher)

| Classification | Error content |
|-------------------------------------|---|
| Saddle stitch finisher service call | The detection of the home position of the stapler ends abnormally. (This error is determined when the problem is not solved even if the MFP is rebooted by the specified number of times.) |

| Check item | Measures |
|----------------------------------|---|
| Front saddle stapler clinch unit | <ul style="list-style-type: none"> • Connector check • Harness check • Replace the unit. |
| Saddle control PC board (SDL) | <ul style="list-style-type: none"> • PC board check • Connector check (CN2) • Harness check • Replace the PC board. |

| Parts to be replaced | Remarks |
|----------------------------------|---------|
| Front saddle stapler clinch unit | |
| Saddle control PC board (SDL) | |

[CBB0] Rear saddle stapler home position abnormality (Saddle Stitch Finisher)

| Classification | Error content |
|-------------------------------------|---|
| Saddle stitch finisher service call | The detection of the home position of the stapler ends abnormally. (This error is determined when the problem is not solved even if the MFP is rebooted by the specified number of times.) |

| Check item | Measures |
|---------------------------------|---|
| Rear saddle stapler clinch unit | <ul style="list-style-type: none"> • Connector check • Harness check • Replace the unit. |
| Saddle control PC board (SDL) | <ul style="list-style-type: none"> • PC board check • Connector check (CN1) • Harness check • Replace the PC board. |

| Parts to be replaced | Remarks |
|---------------------------------|---------|
| Rear saddle stapler clinch unit | |
| Saddle control PC board (SDL) | |

[CBC0] Saddle stitch side alignment motor abnormality (Saddle Stitch Finisher)

| Classification | Error content |
|-------------------------------------|--|
| Saddle stitch finisher service call | The side alignment motor or the alignment plate jog does not work normally. (This error is determined when the problem is not solved even if the MFP is rebooted by the specified number of times.) |

| Check item | Measures |
|-------------------------------|---|
| Jog | <ul style="list-style-type: none"> • Check if there is any abnormality in the movement of the jog. • Check if there is any mechanical problem by moving it. • If there is any, correct it. |
| Side alignment motor (M15) | <ul style="list-style-type: none"> • Check that the motor is working. • Connector check (CN4) • Harness check • Replace the motor. |
| Saddle control PC board (SDL) | <ul style="list-style-type: none"> • PC board check • Connector check (CN4) • Harness check • Replace the PC board. |

| Parts to be replaced | Remarks |
|-------------------------------|---------|
| Side alignment motor (M15) | |
| Saddle control PC board (SDL) | |

[CBE0] Saddle stitch folding motor abnormality (Saddle Stitch Finisher)

| Classification | Error content |
|-------------------------------------|--|
| Saddle stitch finisher service call | An abnormal interruption of the encoder pulse of the folding motor or its operation abnormality has occurred. (This error is determined when the problem is not solved even if the MFP is rebooted by the specified number of times.) |

| Check item | Measures |
|------------------------------------|---|
| Folding motor encoder sensor (S34) | <ul style="list-style-type: none"> • Sensor check • Encoder check • Connector check (CN13) • Harness check • Replace the sensor. |
| Folding motor (M17) | <ul style="list-style-type: none"> • Check that the motor is working. • Connector check (CN9) • Harness check • Replace the motor. |
| Saddle control PC board (SDL) | <ul style="list-style-type: none"> • PC board check • Connector check (CN9, CN13) • Harness check • Replace the PC board. |

| Parts to be replaced | Remarks |
|------------------------------------|---------|
| Folding motor encoder sensor (S34) | |
| Folding motor (M17) | |
| Saddle control PC board (SDL) | |

[CC20] Communication error between the finisher control PC board and the saddle control PC board

| Classification | Error content |
|-------------------------------------|--|
| Saddle stitch finisher service call | A communication error has occurred between the finisher control PC board and the saddle control PC board. (The MFP will be rebooted at the first time the error occurs.) |

| Check item | Measures |
|---------------------------------|--|
| Finisher control PC board (FIN) | <ul style="list-style-type: none"> • PC board check • Connector check (CN21) • Harness check • Replace the PC board. |
| Saddle control PC board (SDL) | <ul style="list-style-type: none"> • PC board check • Connector check (CN6) • Harness check • Replace the PC board. |
| Firmware | Reinstall the finisher firmware. |

| Parts to be replaced | Remarks |
|---------------------------------|---------|
| Finisher control PC board (FIN) | |
| Saddle control PC board (SDL) | |

[CC30] Stack transport motor abnormality (Finisher, Saddle Stitch Finisher)

| Classification | Error content |
|--|--|
| Finisher service call Saddle stitch finisher service call | The stack transport motor or the stack transport belt does not work normally. (This error is determined when the problem is not solved even if the MFP is rebooted by the specified number of times.) |

| Check item | Measures |
|---------------------------------|---|
| Stack exit belt | <ul style="list-style-type: none"> Check if there is any abnormality in the movement of the stack exit belt. Check if there is any mechanical problem by moving it. If there is any, correct it. |
| Stack transport motor (M8) | <ul style="list-style-type: none"> Check that the motor is working. Connector check Harness check Replace the motor. |
| Finisher control PC board (FIN) | <ul style="list-style-type: none"> PC board check Connector check (CN18) Harness check Replace the PC board. |

| Parts to be replaced | Remarks |
|---------------------------------|---------|
| Stack exit belt | |
| Stack transport motor (M8) | |
| Finisher control PC board (FIN) | |

[CC31] Transport motor abnormality (Finisher, Saddle Stitch Finisher)

| Classification | Error content |
|--|--|
| Finisher service call Saddle stitch finisher service call | The transport motor, the stack transport roller-1 or -2 does not work normally. (The MFP will be rebooted at the first time the error occurs.) |

| Check item | Measures |
|--|--|
| Stack transport roller-1, stack transport roller-2 | <ul style="list-style-type: none"> Check if there is any abnormality in the rotation of the roller. Check if there is any mechanical problem by moving it. If there is any, correct it. |
| Transport motor (M7) | <ul style="list-style-type: none"> Check that the motor is working. Connector check Harness check Replace the motor. |
| Finisher control PC board (FIN) | <ul style="list-style-type: none"> PC board check Connector check (CN15) Harness check Replace the PC board. |

| Parts to be replaced | Remarks |
|--|---------|
| Stack transport roller-1, stack transport roller-2 | |
| Transport motor (M7) | |
| Finisher control PC board (FIN) | |

[CC41] Assist guide cam home position abnormality (Finisher, Saddle Stitch Finisher)

| Classification | Error content |
|--|--|
| Finisher service call Saddle stitch finisher service call | The home position of the assist guide cam cannot be detected. (The MFP will be rebooted at the first time the error occurs.) |

| Check item | Measures |
|------------------|--|
| Assist guide cam | <ul style="list-style-type: none"> Check if there is any abnormality in the movement of the assist guide cam. Check if there is any mechanical problem by moving it. If there is any, correct it. |

| Check item | Measures |
|--|---|
| Assist guide home position sensor (S6) | <ul style="list-style-type: none"> • Sensor check • Actuator check • Connector check • Harness check • Replace the sensor. |
| Finisher control PC board (FIN) | <ul style="list-style-type: none"> • PC board check • Connector check (CN11) • Harness check • Replace the PC board. |

| Parts to be replaced | Remarks |
|--|---------|
| Assist guide cam | |
| Assist guide home position sensor (S6) | |
| Finisher control PC board (FIN) | |

[CC51] Hole punch: Transport motor abnormality (Finisher, Saddle Stitch Finisher)

| Classification | Error content |
|------------------------------|---|
| Hole punch unit service call | The sideways deviation adjustment motor or the punch unit does not work normally. (The MFP will be rebooted at the first time the error occurs.) |

| Check item | Measures |
|--|---|
| Sideways deviation HP sensor (S3) | <ul style="list-style-type: none"> • Sensor check • Actuator check • Connector check (CN8) • Harness check • Replace the sensor. |
| Sideways deviation adjustment motor (M2) | <ul style="list-style-type: none"> • Check that the motor is working. • Connector check (CN9) • Harness check • Replace the motor. |
| Hole punch control PC board (HP) | <ul style="list-style-type: none"> • PC board check • Connector check (CN8, CN9) • Harness check • Replace the PC board. |

| Parts to be replaced | Remarks |
|--|---------|
| Sideways deviation HP sensor (S3) | |
| Sideways deviation adjustment motor (M2) | |
| Hole punch control PC board (HP) | |

[CC52] Hole punch: Skew adjustment motor abnormality (Finisher, Saddle Stitch Finisher)

| Classification | Error content |
|------------------------------|--|
| Hole punch unit service call | The skew adjustment motor or the punch unit does not work normally. (This error is determined when the problem is not solved even if the MFP is rebooted by the specified number of times.) |

| Check item | Measures |
|----------------------------|--|
| Skew HP sensor (S2) | <ul style="list-style-type: none"> • Sensor check • Actuator check • Connector check (CN10) • Harness check • Replace the sensor. |
| Skew adjustment motor (M1) | <ul style="list-style-type: none"> • Check that the motor is working. • Connector check (CN10) • Harness check • Replace the motor. |

| Check item | Measures |
|----------------------------------|--|
| Hole punch control PC board (HP) | <ul style="list-style-type: none"> • PC board check • Connector check (CN10) • Harness check • Replace the PC board. |

| Parts to be replaced | Remarks |
|----------------------------------|---------|
| Skew HP sensor (S2) | |
| Skew adjustment motor (M1) | |
| Hole punch control PC board (HP) | |

[CC60] Hole punch: Punch motor abnormality (Finisher, Saddle Stitch Finisher)

| Classification | Error content |
|------------------------------|--|
| Hole punch unit service call | The punch motor or the punch unit does not work normally. (The MFP will be rebooted at the first time the error occurs.) |

| Check item | Measures |
|----------------------------------|---|
| Punch motor (M3) | <ul style="list-style-type: none"> • Check that the motor is working. • Connector check • Harness check • Replace the motor. |
| Punch HP sensor (S4) | <ul style="list-style-type: none"> • Sensor check • Actuator check • Connector check • Harness check • Replace the sensor. |
| Punch sensor (S5) | <ul style="list-style-type: none"> • Sensor check • Actuator check • Connector check • Harness check • Replace the sensor. |
| Hole punch control PC board (HP) | <ul style="list-style-type: none"> • PC board check • Connector check (CN3) • Harness check • Replace the PC board. |

| Parts to be replaced | Remarks |
|----------------------------------|---------|
| Punch motor (M3) | |
| Punch HP sensor (S4) | |
| Punch sensor (S5) | |
| Hole punch control PC board (HP) | |

[CC61] Hole punch: Punch motor home position detection abnormality (Finisher, Saddle Stitch Finisher)

| Classification | Error content |
|------------------------------|---|
| Hole punch unit service call | The punch motor or the punch unit does not work normally. (This error is determined when the problem is not solved even if the MFP is rebooted by the specified number of times.) |

| Check item | Measures |
|----------------------|---|
| Punch motor (M3) | <ul style="list-style-type: none"> • Check that the motor is working. • Connector check • Harness check • Replace the motor. |
| Punch HP sensor (S4) | <ul style="list-style-type: none"> • Sensor check • Actuator check • Connector check • Harness check • Replace the sensor. |

| Check item | Measures |
|----------------------------------|---|
| Hole punch control PC board (HP) | <ul style="list-style-type: none"> PC board check Connector check (CN3, CN4, CN5) Harness check Replace the PC board. |
| Finisher control PC board | <ul style="list-style-type: none"> PC board check Connector check (CN7) Harness check Replace the PC board. |

| Parts to be replaced | Remarks |
|----------------------------------|---------|
| Punch motor (M3) | |
| Punch HP sensor (S4) | |
| Hole punch control PC board (HP) | |
| Finisher control PC board | |

[CC71] Hole punch: Punch ROM abnormality (Finisher, Saddle Stitch Finisher)

| Classification | Error content |
|------------------------------|--|
| Hole punch unit service call | An abnormality of the checksum value of the hole punch control PC board is detected when the power is turned ON. |

| Check item | Measures |
|----------------------------------|---|
| Reproducibility | Turn the power OFF and then back ON to check the occurrence. |
| Hole punch control PC board (HP) | <ul style="list-style-type: none"> PC board check Connector check Harness check Replace the PC board. |
| Finisher control PC board (FIN) | <ul style="list-style-type: none"> PC board check Connector check Harness check Replace the PC board. |

| Parts to be replaced | Remarks |
|----------------------------------|---------|
| Hole punch control PC board (HP) | |
| Finisher control PC board (FIN) | |

[CC72] Hole punch: Punch RAM data abnormality (Finisher, Saddle Stitch Finisher)

| Classification | Error content |
|------------------------------|--|
| Hole punch unit service call | An abnormality of the checksum value of the finisher control PC board is detected when the power is turned ON. |

| Check item | Measures |
|----------------------------------|---|
| Reproducibility | Turn the power OFF and then back ON to check the occurrence. |
| Hole punch control PC board (HP) | <ul style="list-style-type: none"> PC board check Connector check Harness check Replace the PC board. |
| Finisher control PC board (FIN) | <ul style="list-style-type: none"> PC board check Connector check Harness check Replace the PC board. |

| Parts to be replaced | Remarks |
|----------------------------------|---------|
| Hole punch control PC board (HP) | |
| Finisher control PC board (FIN) | |

[CC73] Hole punch: Punch device power supply abnormality (Finisher, Saddle Stitch Finisher)
[CC74] Hole punch: Punch transport pulse abnormality (Finisher, Saddle Stitch Finisher)

| Classification | Error content |
|------------------------------|--|
| Hole punch unit service call | The punch motor or the punch unit does not work normally. (This error is determined when the problem is not solved even if the MFP is rebooted by the specified number of times.) |

| Check item | Measures |
|----------------------------------|---|
| Reproducibility | Turn the power OFF and then back ON to check the occurrence. |
| Firmware | Reinstall the finisher firmware. |
| Hole punch control PC board (HP) | <ul style="list-style-type: none"> • PC board check • Connector check • Harness check • Replace the PC board. |

| Parts to be replaced | Remarks |
|----------------------------------|---------|
| Hole punch control PC board (HP) | |

[CC80] Rear alignment motor abnormality (Finisher, Saddle Stitch Finisher)

| Classification | Error content |
|--|--|
| Finisher service call Saddle stitch finisher service call | The rear alignment motor or the rear alignment plate does not work normally. (The MFP will be rebooted at the first time the error occurs.) |

| Check item | Measures |
|---------------------------------|--|
| Rear alignment plate | <ul style="list-style-type: none"> • Check if there is any abnormality in the installation of the rear alignment plate. • Check if there is any mechanical problem by moving it. • If there is any, correct it. |
| Rear alignment motor (M6) | <ul style="list-style-type: none"> • Check that the motor is working. • Connector check • Harness check • Replace the motor. |
| Finisher control PC board (FIN) | <ul style="list-style-type: none"> • PC board check • Connector check (CN18) • Harness check • Replace the PC board. |

| Parts to be replaced | Remarks |
|---------------------------------|---------|
| Rear alignment plate | |
| Rear alignment motor (M6) | |
| Finisher control PC board (FIN) | |

[CD60] Sub-hopper toner sensor abnormality

| Classification | Error content |
|-----------------------------------|---|
| Copy process related service call | An abnormality has occurred in the sub-hopper toner sensor. |

| Check item | Measures |
|-------------------------------|--|
| When unpacking and setting up | If an error has occurred after the first time the power has been turned ON, check FS-08-9022. If its value is "0", perform auto-toner adjustment. If its value is other than "0", enter "0" and then perform auto-toner adjustment. |
| Sub-hopper toner sensor | <ul style="list-style-type: none"> • Sensor check (Input check) • Connector check • Harness check • Replace the sensor. |
| EPU board | <ul style="list-style-type: none"> • PC board check • Connector check • Harness check • Replace the PC board. |

| Check item | Measures |
|-------------------------|---|
| LGC board | <ul style="list-style-type: none"> • PC board check • Connector check • Harness check • Replace the PC board. |
| Parts to be replaced | Remarks |
| Sub-hopper toner sensor | |
| EPU board | |
| LGC board | |

[CD64] Sub-hopper toner motor (K) abnormality

| Classification | Error content |
|-----------------------------------|--|
| Copy process related service call | An abnormality has occurred in the sub-hopper toner motor. |

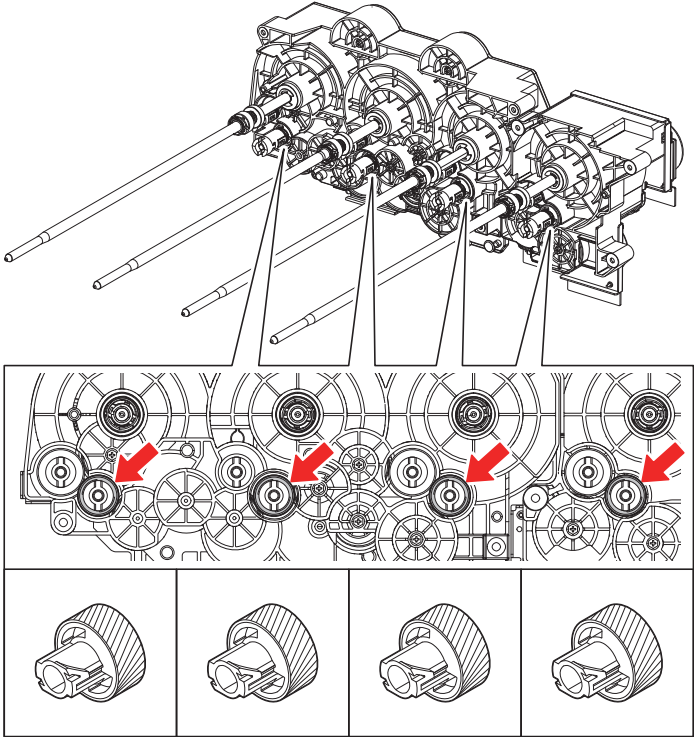
| Check item | Measures |
|-----------------------------|--|
| Sub-hopper toner motor | <ul style="list-style-type: none"> • Check that the motor is working. (Output check) • Connector check • Harness check • Replace the motor. |
| EPU board | <ul style="list-style-type: none"> • PC board check • Connector check • Harness check • Replace the PC board. |
| LGC board | <ul style="list-style-type: none"> • PC board check • Connector check • Harness check • Replace the PC board. |
| K-drum/developer drive unit | <ul style="list-style-type: none"> • Check if the mixer coupling is installed properly. • Check if grease is applied to the gears (shaft and tooth surface). • Check if the parts such as gears, shafts, bushing and bearings are damaged. <div style="text-align: center;">  </div> <p>Fig.8-46</p> |
| Developer unit | Check if the mixer coupling is installed properly. |

| Parts to be replaced | Remarks |
|-----------------------------|---------|
| Sub-hopper toner sensor | |
| EPU board | |
| LGC board | |
| K-drum/developer drive unit | |
| Developer unit | |

[CD71] Waste toner transport motor locking error

| Classification | Error content |
|-----------------------------------|--|
| Copy process related service call | The auger in the waste toner transport path does not rotate. |

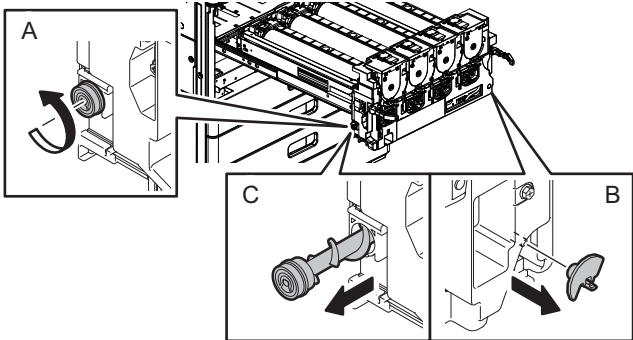
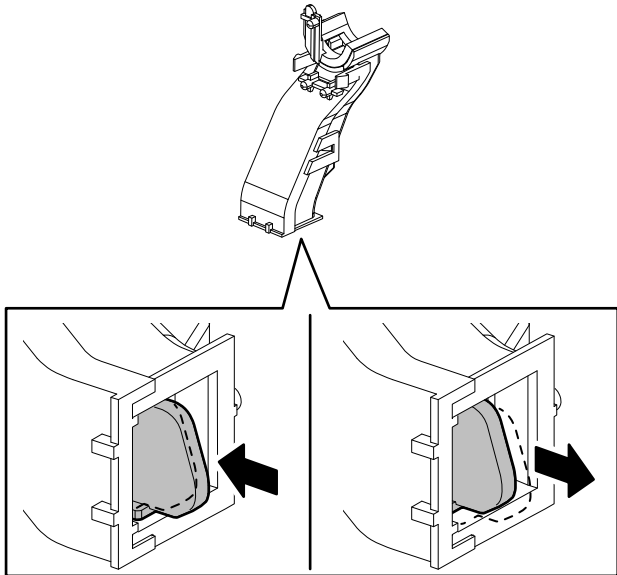
| Check item | Measures |
|------------------------------|---|
| Auger | <ul style="list-style-type: none"> Turn the gear to discharge the toner in the waste toner transport path. Check if the load is reduced. (Figure A) Remove the actuator (figure B) and pull out the auger (figure C). Clean the waste toner transport path and check if the load is reduced.  <p>Fig.8-47</p> |
| Drum unit side vertical duct | <ul style="list-style-type: none"> Check if waste toner is clogged. Check that the slider in the drum unit side vertical duct can move smoothly. If not, clean the inside of the drum unit side vertical duct.  <p>Fig.8-48</p> |

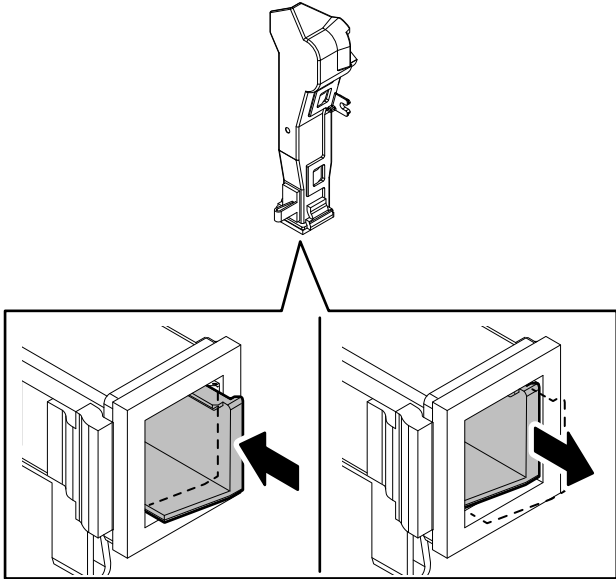
| Check item | Measures |
|--------------------------------|--|
| TBU cleaner side vertical duct | <ul style="list-style-type: none"> • Check if waste toner is clogged. • Check that the slider in the drum unit side vertical duct can move smoothly. If not, clean the inside of the drum unit side vertical duct.  <p>Fig.8-49</p> |
| Waste toner transport unit | <p>Check if there is any of the following abnormality in the unit. If there is any abnormality, correct it.</p> <ul style="list-style-type: none"> • Waste toner is clogged. • Foreign matter is adhering or has entered. • Parts such as gears, shafts, bushing and bearings are damaged. |
| Waste toner transport motor | <ul style="list-style-type: none"> • Check that the motor is working. (Output check) • Connector check • Harness check • Replace the motor. |
| Auger lock detection sensor | <ul style="list-style-type: none"> • Sensor check (Input check) • Actuator check • Connector check • Harness check • Replace the sensor. |
| EPU board | <ul style="list-style-type: none"> • PC board check • Connector check • Harness check • Replace the PC board. |
| LGC board | <ul style="list-style-type: none"> • PC board check • Connector check • Harness check • Replace the PC board. |
| Parts to be replaced | Remarks |
| Drum unit side vertical duct | |
| TBU cleaner side vertical duct | |
| Waste toner transport unit | |
| Waste toner transport motor | |
| Auger lock detection sensor | |
| EPU board | |
| LGC board | |

[CDE0] Paddle home position abnormality (Finisher, Saddle Stitch Finisher)

| Classification | Error content |
|--|---|
| Finisher service call Saddle stitch finisher service call | The paddle motor or the paddle does not work normally. (This error is determined when the problem is not solved even if the MFP is rebooted by the specified number of times.) |

| Check item | Measures |
|---------------------------------|--|
| Paddle | <ul style="list-style-type: none"> Check if there is any abnormality in the movement of the paddle. Check if there is any mechanical problem by moving it. If there is any, correct it. |
| Paddle motor (M3) | <ul style="list-style-type: none"> Check that the motor is working. Connector check (CN16) Harness check Replace the motor. |
| Finisher control PC board (FIN) | <ul style="list-style-type: none"> PC board check Connector check (CN16) Harness check Replace the PC board. |

| Parts to be replaced | Remarks |
|---------------------------------|---------|
| Paddle | |
| Paddle motor (M3) | |
| Finisher control PC board (FIN) | |

[CE00] Communication error between the finisher control PC board and the hole punch control PC board (Finisher, Saddle Stitch Finisher)

| Classification | Error content |
|--|---|
| Finisher service call Saddle stitch finisher service call | A communication error has occurred between the finisher control PC board and the hole punch control PC board. (This error is determined when the problem is not solved even if the MFP is rebooted by the specified number of times.) |

| Check item | Measures |
|----------------------------------|---|
| Finisher control PC board (FIN) | <ul style="list-style-type: none"> PC board check Connector check (CN7) Harness check Replace the PC board. |
| Hole punch control PC board (HP) | <ul style="list-style-type: none"> PC board check Connector check (CN4) Harness check Replace the PC board. |
| Firmware | <ul style="list-style-type: none"> Reinstall the finisher firmware. Reinstall the hole punch unit firmware. |

| Parts to be replaced | Remarks |
|----------------------------------|---------|
| Finisher control PC board (FIN) | |
| Hole punch control PC board (HP) | |

[CE10] Image quality sensor abnormality

| Classification | Error content |
|----------------------------|--|
| Image forming service call | The output value of the sensor is out of the specified range when the light source of the image quality sensor is OFF. |

| Check item | Measures |
|---|---|
| Image position aligning/image quality sensor (center) | <ul style="list-style-type: none"> Sensor check Connector check Harness check Replace the sensor. |

| Check item | Measures |
|------------|--|
| LGC board | <ul style="list-style-type: none"> • PC board check • Connector check • Harness check • Replace the PC board. |
| Setting | <ol style="list-style-type: none"> 1. Set "1" (Valid) in FS-08-2486 (Image quality closed-loop control / Contrast voltage). 2. Perform FS-05-2742 (Enforced performing of image quality control (closed-loop)) to check that this has finished normally. When an error has occurred, follow its troubleshooting procedure. 3. Perform the automatic gamma adjustment to check that this has finished normally. 4. Set "0" in all of the values for FS-08-2528 to FS-08-2531 (Abnormality detection count (Y/M/C/K) Display). |

| Parts to be replaced | Remarks |
|---|---------|
| Image position aligning/image quality sensor (center) | |
| LGC board | |

[CE20] Image quality sensor abnormality (no pattern level)

| Classification | Error content |
|----------------------------|---|
| Image forming service call | The output value of the sensor is out of the specified range when the image quality control test pattern is not formed. |

| Check item | Measures |
|--------------------------------------|--|
| 1. Image quality sensor output value | <p>Check the value of FS-05-2757. Check if the value of FS-05-2757-0 is "0" and that for FS-05-2757-1 is "255". If the value is other than those, go to step 2. If the values are "0" and "255", go to step 5.</p> |
| 2. Transfer belt, Transfer belt unit | <ul style="list-style-type: none"> • Check if the transfer belt unit and transfer belt are installed securely. If there is any abnormality, correct it. • Check if the drum and transfer belt work properly. When the transfer belt works properly, check its surface by making a full rotation of the transfer belt. Output check: FS-03-116, FS-03-166 • Check if there are any abnormal stains, large scratches or breakages on the transfer belt surface. If there is any abnormality, replace it. • Check if the toner images have remained on the surface of the transfer belt. If yes, check the installation status of the transfer belt cleaning unit and replace it if there is any abnormality in it. • Check if the transfer belt is loose or undulating. If there is any abnormality, replace it. • When the drum and transfer belt do not work properly, check if the drive gears are damaged or parts are contacting one another. If there is any abnormality, correct it. <p>If there is no abnormality, go to step 3.</p> |
| 3. Image quality control unit | <ul style="list-style-type: none"> • Take off the transfer belt unit so that the image quality control unit can be seen. • Check if the sensor shutter work properly. Output check: FS-03-118, FS-03-168 • Check if the sensor shutter is damaged. Check if there is any abnormality in the sensor shutter solenoid. • Check if the surface of the image quality sensor is stained with toner. If so, clean it with a cotton swab or a soft cloth. <p>If there is no abnormality, go to step 4.</p> |
| 4. Image quality shutter solenoid | <ul style="list-style-type: none"> • Solenoid check Output check: FS-03-118, FS-03-168 • Connector check • Harness check • Replace the solenoid. <p>If there is no abnormality, go to step 5.</p> |

| Check item | Measures |
|--|--|
| 5. Image position aligning/image quality sensor (center) | <ul style="list-style-type: none"> • Sensor check • Connector check • Harness check • Replace the sensor. If there is no abnormality, go to step 6. |
| 6. LGC board | <ul style="list-style-type: none"> • PC board check • Connector check • Harness check • Replace the PC board. If there is no abnormality, go to step 7. |
| 7. Confirmation | <ol style="list-style-type: none"> 1. Set "0" (Invalid) in FS-08-2486 (Image quality closed-loop control / Contrast voltage). For 7529A, set "0" (Disabled) for FS-08-2561 (Drum surface potential sensor control), too. 2. Perform FS-05-2740 (Enforced performing of image quality control (open-loop)). 3. Perform FS-30-101 (List print) and FS-04-270 (Image quality control test pattern) more than one time to check if there is any abnormality in the images. If there is any abnormality in them, perform proper measures by following the troubleshooting for images. If there is no abnormality, go to step 8. |
| 8. Setting | <ol style="list-style-type: none"> 1. Set "1" (Valid) in FS-08-2486 (Image quality closed-loop control / Contrast voltage). For 7529A, set "1" (Enabled) for FS-08-2561 (Drum surface potential sensor control), too. 2. Perform FS-05-2742 (Enforced performing of image quality control (closed-loop)) to check that this has finished normally. When an error has occurred, follow its troubleshooting procedure. 3. Perform the automatic gamma adjustment to check that this has finished normally. 4. Set "0" in all of the values for FS-08-2528 to FS-08-2531 (Abnormality detection count (Y/M/C/K) Display). |

| Parts to be replaced | Remarks |
|---|---------|
| Transfer belt, Transfer belt unit | |
| Image quality control unit | |
| Image quality shutter solenoid | |
| Image position aligning/image quality sensor (center) | |
| LGC board | |

[CE40] Image quality control test pattern abnormality

| Classification | Error content |
|----------------------------|--|
| Image forming service call | The image quality control test pattern is not formed normally. |

| Check item | Measures |
|-----------------|--|
| 1. EPU | Check if each EPU is installed properly. |
| 2. Main charger | Check if there is any abnormality such as deformation on the rods and handle of the main charger cleaner. Correct it if there is any abnormality. |
| 3. Drum drive | Check if the drum is rotated properly by manually turning the gear of the drum cleaner unit. If not, correct the auger and its surrounding hardware. |

| Check item | Measures |
|--|---|
| 4. Laser optical unit | <ul style="list-style-type: none"> • Check if there is any abnormality in the harness and connector between the laser optical unit and the LGC board. • Check if there is any abnormality such as stain or scratches on the laser optical unit. Correct it if there is any abnormality. • Check that the shutter is working properly. <ol style="list-style-type: none"> 1. Take off the process unit so that the shutter can be seen. 2. Perform FS-03-201. 3. Check if the shutter work properly. If there is an abnormality, correct it. |
| 5. Image position aligning/image quality sensor (center) | <ul style="list-style-type: none"> • Sensor check • Connector check • Harness check • If it has been stained, clean it. • Replace the sensor. |
| 6. Image quality control unit | <ol style="list-style-type: none"> 1. Arrange the image quality control unit so that it can be seen. 2. Check if the sensor shutter work properly. Output check: FS-03-118, FS-03-168 3. Check if the sensor shutter is damaged. Check if there is any abnormality in the sensor shutter solenoid. |
| 7. Transfer belt, Transfer belt unit | <ul style="list-style-type: none"> • Check if the transfer belt unit and transfer belt are installed securely. If there is any abnormality, correct it. • Check if the drum and transfer belt work properly. When the transfer belt works properly, check its surface by making a full rotation of the transfer belt. Output check: FS-03-116, FS-03-166 • Check if there are any abnormal stains, large scratches or breakages on the transfer belt surface. If there is any abnormality, replace it. • Check if the toner images have remained on the surface of the transfer belt. If yes, check the installation status of the transfer belt cleaning unit and replace it if there is any abnormality in it. • Check if the transfer belt is loose or undulating. If there is any abnormality, replace it. • When the drum and transfer belt do not work properly, check if the drive gears are damaged or parts are contacting one another. If there is any abnormality, correct it. |
| 8. Spring of the high-voltage supply contact point | <ul style="list-style-type: none"> • Check if the spring of the high-voltage supply contact point is deformed. If it is, replace it. • Check if foreign matter adheres to the spring of the high-voltage supply contact point. If it does, clean it. |
| 9. Abnormality occurrence status checking | Perform FS-08-2531 (Abnormality detection Display/0 clearing (K)) to check the abnormality occurrence status. |
| 10. Identification of the color with an abnormality | <ul style="list-style-type: none"> • Check the first pattern detection value in FS-05-2758-5 (Image quality sensor detection value) to determine whether or not a test pattern abnormality has occurred. Check if the value exceeds "600". • Check if the developer unit has been installed properly. |
| 11. Setting | <ol style="list-style-type: none"> 1. Set "0" (Invalid) in FS-08-2486 (Image quality closed-loop control / Contrast voltage). For 9029A, set "0" (Disabled) for FS-08-2561 (Drum surface potential sensor control), too. 2. Perform FS-05-2740 (Enforced performing of image quality control (open-loop)). 3. Perform FS-30-101 (List print) and FS-04-270 (Image quality control test pattern) more than one time to check if there is any abnormality in the images. If there is any abnormality in them, perform proper measures by following the troubleshooting for images. |
| 12. LGC board | <ul style="list-style-type: none"> • PC board check • Connector check • Harness check • Replace the PC board. |

| Check item | Measures |
|-------------|--|
| 13. Setting | <ol style="list-style-type: none"> Set "1" (Valid) in FS-08-2486 (Image quality closed-loop control / Contrast voltage). For 9029A, set "2" (Enabled) for FS-08-2561 (Drum surface potential sensor control), too. Perform FS-05-2742 (Enforced performing of image quality control (closed-loop)) to check that this has finished normally. When an error has occurred, follow its troubleshooting procedure. Perform the automatic gamma adjustment to check that this has finished normally. Set "0" for FS-08-2531 (Abnormality detection Display/0 clearing (K)). |

| Parts to be replaced | Remarks |
|---|---------|
| Main charger | |
| Drum cleaner unit | |
| Laser optical unit | |
| Image position aligning/image quality sensor (center) | |
| Image quality control unit | |
| Transfer belt, Transfer belt unit | |
| Spring of the high-voltage supply contact point | |
| 1st transfer contact/release clutch | |
| 1st transfer contact/release sensor | |
| LGC board | |

[CE41] Image quality TRC control test pattern abnormality

| Classification | Error content |
|----------------------------|--|
| Image forming service call | The image quality control test pattern is not formed normally. |

| Check item | Measures |
|-----------------------|--|
| Parts and units check | <p>Perform FS-05-2801-11 and check the value. If the value exceeds "600", perform steps 1 through 4 of this procedure. If not, perform the automatic gamma adjustment to check that this has finished normally. If this error has occurred again, perform steps 1 through 4 of this procedure.</p> <ol style="list-style-type: none"> Set "0" for both FS-08-2600 and FS-08-8103 to disable the image quality TRC control setting. Perform FS-30-101 (List print) and FS-04-270 (Image quality control test pattern) more than one time to check if there is any abnormality in the images. If there is any abnormality, perform the following items. <ul style="list-style-type: none"> Check if the process unit and developer unit are installed properly. Correct them if necessary. Check if the toner or developer material is adhering around the laser optical unit. If so, clean it. Check the images. If there is any abnormality, correct it. Set "1" for both FS-08-2600 and FS-08-8103 to enable the image quality TRC control setting. Perform the automatic gamma adjustment to check that this has finished normally. If a CE41 error occurs again, go to the next step. |
| SYS board | <ul style="list-style-type: none"> PC board check Connector check Harness check Replace the PC board. After replacing the PC board, perform the automatic gamma adjustment to check that this has finished normally. If a CE41 error occurs again, go to the next step. |

| Check item | Measures |
|------------|--|
| LGC board | <ul style="list-style-type: none"> • PC board check • Connector check • Harness check • Replace the PC board. • After replacing the PC board, perform the automatic gamma adjustment to check that this has finished normally. <p>Remarks: When the LGC board is installed, reinstall the removed SYS board first.</p> |

| Parts to be replaced | Remarks |
|----------------------|---------|
| LGC board | |
| SYS board | |

[CE50] Temperature/humidity sensor abnormality

| Classification | Error content |
|-----------------------------------|--|
| Copy process related service call | The output value of the temperature/humidity sensor is out of the specified range. |

| Check item | Measures |
|-----------------------------|---|
| Temperature/humidity sensor | <ul style="list-style-type: none"> • Sensor check • Connector check • Harness check • Replace the sensor. |
| LGC board | <ul style="list-style-type: none"> • PC board check • Connector check • Harness check • Replace the PC board. |

| Parts to be replaced | Remarks |
|-----------------------------|---------|
| Temperature/humidity sensor | |
| LGC board | |

[CE60] Drum thermistor (Y) abnormality

| Classification | Error content |
|-----------------------------------|--|
| Copy process related service call | The output value of the drum thermistor (Y) is out of the specified range. |

| Check item | Measures |
|---------------------|---|
| Drum thermistor (Y) | <ul style="list-style-type: none"> • Thermistor check (Input check) • Connector check • Harness check • Replace the sensor. |
| EPU board | <ul style="list-style-type: none"> • PC board check • Connector check • Harness check • Replace the PC board. |

| Parts to be replaced | Remarks |
|----------------------|---------|
| Drum thermistor (Y) | |
| EPU board | |

[CE90] Drum thermistor (K) abnormality

| Classification | Error content |
|-----------------------------------|--|
| Copy process related service call | The output value of the drum thermistor (K) is out of the specified range. |

| Check item | Measures |
|---------------------|---|
| Drum thermistor (K) | <ul style="list-style-type: none"> • Thermistor check (Input check) • Connector check • Harness check • Replace the sensor. |
| EPU board | <ul style="list-style-type: none"> • PC board check • Connector check • Harness check • Replace the PC board. |

| Parts to be replaced | Remarks |
|----------------------|---------|
| Drum thermistor (K) | |
| EPU board | |

[CF10] Communication module writing abnormality (Finisher, Saddle Stitch Finisher)

| Classification | Error content |
|--|---|
| Finisher service call Saddle stitch finisher service call | An abnormality to write into the communication module has occurred. |

| Check item | Measures |
|---------------------------------|---|
| Finisher | Check if the connector and harness between the MFP and the Finisher is disconnected or open circuited. |
| Finisher control PC board (FIN) | <ul style="list-style-type: none"> • PC board check • Connector check (CN3, CN13) • Harness check • Replace the PC board. |
| LGC board | <ul style="list-style-type: none"> • PC board check • Connector check • Harness check • Replace the PC board. |
| Firmware | Reinstall the finisher firmware. |

| Parts to be replaced | Remarks |
|---------------------------------|---------|
| Finisher control PC board (FIN) | |
| LGC board | |

[CF90] Laser optical unit shutter abnormality

| Classification | Error content |
|----------------------------|-------------------------------------|
| Image forming service call | The shutter does not work normally. |

| Check item | Measures |
|--------------------------------|---|
| Laser optical unit | <ul style="list-style-type: none"> • Check if they are installed properly. • Check if there is any abnormality in the appearance of the parts. • Connector check • Harness check • Replace the shutter or th laser optical unit. |
| Shutter motor | <ul style="list-style-type: none"> • Check that the motor is working. (Output check) • Connector check • Harness check • Replace the motor. |
| Shutter sensor (home position) | <ul style="list-style-type: none"> • Sensor check (Input check) • Connector check • Harness check • Replace the sensor. |

| Check item | Measures |
|-------------------------------|---|
| Shutter sensor (end position) | <ul style="list-style-type: none"> • Sensor check (Input check) • Connector check • Harness check • Replace the sensor. |
| LGC board | <ul style="list-style-type: none"> • PC board check • Connector check • Harness check • Replace the PC board. |

| Parts to be replaced | Remarks |
|--------------------------------|---------|
| Laser optical unit | |
| Shutter motor | |
| Shutter sensor (home position) | |
| Shutter sensor (end position) | |
| LGC board | |

8.3.5 Service call (F series errors)

[F070] Communication error between the system-CPU and the engine-CPU

| Classification | Error content |
|------------------------------------|---|
| Communication related service call | A communication error has occurred between the system-CPU and the engine-CPU. (This error is determined when the problem is not solved even if the MFP is rebooted by the specified number of times.) |

| Check item | Measures |
|---------------------|---|
| Reproducibility | Turn the power OFF and then back ON. Then check if the error code changes to another one. If it changes to another code, follow its troubleshooting procedure. |
| Firmware | <ul style="list-style-type: none"> Check the version of the system firmware on the SYS board. Check the version of the engine firmware on the LGC board. |
| SYS board | <ul style="list-style-type: none"> PC board check Connector check (SYS board - LGC board) Harness check (SYS board - LGC board) Replace the PC board. |
| LGC board | <ul style="list-style-type: none"> PC board check Check that the LED1 on the LGC board is lit. If not, replace the LGC board. P. 8-403 "8.4.15 Error check by the LEDs on the LGC board" Connector check (SYS board - LGC board) Harness check (SYS board - LGC board) Replace the PC board. |
| Switching regulator | <ul style="list-style-type: none"> PC board check Connector check (switching regulator - LGC board) Harness check (switching regulator - LGC board) Replace the PC board. |

| Parts to be replaced | Remarks |
|----------------------|---------|
| SYS board | |
| LGC board | |
| Switching regulator | |

[F071] Communication initialization error between the system-CPU and the engine-CPU

| Classification | Error content |
|------------------------------------|--|
| Communication related service call | A communication initialization error has occurred between the system-CPU and the engine-CPU. |

| Check item | Measures |
|---------------------|---|
| Firmware | <ul style="list-style-type: none"> Check the version of the system firmware on the SYS board. Check the version of the engine firmware on the LGC board. |
| SYS board | <ul style="list-style-type: none"> PC board check Connector check (SYS board - LGC board) Harness check (SYS board - LGC board) Replace the PC board. |
| LGC board | <ul style="list-style-type: none"> PC board check Check that the LED1 on the LGC board is lit. If not, replace the LGC board. P. 8-403 "8.4.15 Error check by the LEDs on the LGC board" Connector check (SYS board - LGC board) Harness check (SYS board - LGC board) Replace the PC board. |
| Switching regulator | <ul style="list-style-type: none"> PC board check Connector check (switching regulator - LGC board) Harness check (switching regulator - LGC board) Replace the PC board. |

| Parts to be replaced | Remarks |
|----------------------|---------|
| SYS board | |
| LGC board | |

| Parts to be replaced | Remarks |
|----------------------|---------|
| Switching regulator | |

[F074] Communication error between the system-CPU and the engine-CPU

| Classification | Error content |
|------------------------------------|--|
| Communication related service call | There is no response for the engine-CPU. (This error is determined when the problem is not solved even if the MFP is rebooted by the specified number of times.) |

| Check item | Measures |
|---------------------|---|
| Reproducibility | Turn the power OFF and then back ON. Then check if the error code changes to another one. If it changes to another code, follow its troubleshooting procedure. |
| Firmware | <ul style="list-style-type: none"> • Check the version of the system firmware on the SYS board. • Check the version of the engine firmware on the LGC board. |
| SYS board | <ul style="list-style-type: none"> • PC board check • Connector check (SYS board - LGC board) • Harness check (SYS board - LGC board) • Replace the PC board. |
| LGC board | <ul style="list-style-type: none"> • PC board check • Connector check (SYS board - LGC board) • Harness check (SYS board - LGC board) • Replace the PC board. |
| Switching regulator | <ul style="list-style-type: none"> • PC board check • Connector check (switching regulator - LGC board) • Harness check (switching regulator - LGC board) • Replace the PC board. |
| LGC board | Check that the LED2 on the LGC board is lit. If not, replace the LGC board. |

| Parts to be replaced | Remarks |
|----------------------|---------|
| SYS board | |
| LGC board | |
| Switching regulator | |

[F090] SRAM error on the SYS board

| Classification | Error content |
|-----------------------------|--|
| System related service call | Initialization error of the SRAM on the SYS board. |

| Check item | Measures |
|------------|--|
| SRAM | <ul style="list-style-type: none"> • Check if the SRAM is installed properly. • By following the procedure below, initialize the SRAM to check that it should be restored. <ol style="list-style-type: none"> 1. Shut down the MFP. 2. Perform FS-08. 3. Press [CLASSIC]. 4. When "SRAM REQUIRES INITIALIZATION" is displayed on the LCD screen, check the destination and then press the [START] button. If the destination is not correct, enter the correct one and then press the [START] button. 5. After the confirmation message is displayed on the LCD screen, press [INITIALIZE]. (SRAM initialization starts.) 6. Enter the serial number of the MFP correctly. (FS-08-9601) 7. Initialize the NIC information. (FS-08-9083) 8. Shut down the MFP. 9. Perform FS-05. 10. Press [CLASSIC]. 11. Perform FS-05-3203 and FS-05-3240 (Data acquisition of characteristic value of the scanner). 12. By using the [05-93] [TEST PRINT] test pattern, perform FS-05-7311(Automatic gamma adjustment (PPC)). (FS-05-7869) 13. By using the [05-253] [TEST PRINT] test pattern, perform FS-05-7869 (Automatic gamma adjustment (PRT)). (FS-05-7312) 14. Reboot the MFP. <ul style="list-style-type: none"> • If the error still persists, replace the SRAM. |
| SYS board | <ul style="list-style-type: none"> • PC board check • Connector check • Harness check • Replace the PC board. |

| Parts to be replaced | Remarks |
|----------------------|---------|
| SRAM | |
| SYS board | |

[F100_0] Storage device initialization error



| Classification | Error content |
|-----------------------------|------------------------------------|
| System related service call | The key data operation has failed. |

| Check item | Measures |
|------------|--|
| SRAM | <ul style="list-style-type: none"> • Check if the SRAM is installed properly. • By following the procedure below, initialize the SRAM to check that it should be restored. <ol style="list-style-type: none"> 1. Shut down the MFP. 2. Perform FS-08. 3. Press [CLASSIC]. 4. When "SRAM REQUIRES INITIALIZATION" is displayed on the LCD screen, check the destination and then press the [START] button. If the destination is not correct, enter the correct one and then press the [START] button. 5. After the confirmation message is displayed on the LCD screen, press [INITIALIZE]. (SRAM initialization starts.) 6. Enter the serial number of the MFP correctly. (FS-08-9601) 7. Initialize the NIC information. (FS-08-9083) 8. Shut down the MFP. 9. Perform FS-05. 10. Press [CLASSIC]. 11. Perform FS-05-3203 and FS-05-3240 (Data acquisition of characteristic value of the scanner). 12. By using the [4] [TEST PRINT] test pattern, perform FS-05-7869 (Automatic gamma adjustment (PPC)). (FS-05-7869) 13. By using the [70] [TEST PRINT] test pattern, perform FS-05-7869 (Automatic gamma adjustment (PRT)). (FS-05-8008, FS-05-8009) 14. Reboot the MFP. <ul style="list-style-type: none"> • If the error still persists, replace the SRAM. |
| SYS board | <ul style="list-style-type: none"> • PC board check • Connector check • Harness check • Replace the PC board. |

| Parts to be replaced | Remarks |
|----------------------|---------|
| SRAM | |
| SYS board | |

[F100_1] Storage device initialization error

| Classification | Error content |
|-----------------------------|--|
| System related service call | Encryption key data of either the SRAM or the SYS board are damaged. |

| Check item | Measures |
|--|---|
| Encryption key status | Perform HS-73 Firmware Assist mode > Key Backup/Restore and check the displayed message. Take the appropriate countermeasures shown below according to the error and messages displayed in the "SRAM" and "FROM" fields. |
| "SRAM" field: OK "FROM" field: AccessFailed | Replace the SYS board. |
| "SRAM" field: OK "FROM" field: KeyNull | Recover the encryption key on the SYS board.  P. 9-37 "[C] Restore Encryption Key and License" |
| "SRAM" field: OK "FROM" field: KeyBroken | |
| "SRAM" field: AccessFailed "FROM" field: OK | Replace the SRAM. (Backup data not used) |
| "SRAM" field: KeyNull "FROM" field: OK | Recover the encryption key on the SRAM by means of backup.  P. 9-41 "[G] Backup encryption key and license (FROM > SRAM)" |
| "SRAM" field: KeyBroken "FROM" field: OK | |

| Check item | Measures |
|--|---|
| “SRAM” field: Keymismatch “FROM” field: Keymismatch | <ul style="list-style-type: none"> The error occurs when the SYS board is replaced: Recover the encryption key on the SYS board. P. 9-37 “[C] Restore Encryption Key and License” The error occurs except when the SYS board is replaced: Replace the SRAM. |
| Firmware | If the error still persists, reinstall the system firmware and the system software by the HS-49 Firmware Update mode. |

| Parts to be replaced | Remarks |
|----------------------|---------|
| SRAM | |
| SYS board | |

[F100_2] Storage device initialization error

| Classification | Error content |
|-----------------------------|--|
| System related service call | Encryption key data of both the SRAM or the SYS board are damaged. |

| Check item | Measures |
|--|--|
| Encryption key status | Perform HS-73 Firmware Assist mode > Key Backup/Restore and check the displayed message. Take the appropriate countermeasures shown below according to the error and messages displayed in the “SRAM” and “FROM” fields. |
| “SRAM” field: * “FROM” field: AccessFailed | Replace the SYS board. <ul style="list-style-type: none"> When there are backup data in a USB storage device: <ol style="list-style-type: none"> Recover all the data on the SRAM by means of cloning. HS-59 SRAM Data Cloning > Restore SRAM Data from USB Recover the encryption key and the license on the SYS board by means of restoring. P. 9-37 “[C] Restore Encryption Key and License” |
| “SRAM” field: AccessFailed “FROM” field: * | Replace the SRAM. |
| “SRAM” field: KeyNull / KeyBroken “FROM” field: KeyNull / KeyBroken | <ul style="list-style-type: none"> When there are no backup data in a USB storage device: Reinstall the system software. When there are backup data in a USB storage device: <ol style="list-style-type: none"> Recover all the data on the SRAM by means of cloning. HS-59 SRAM Data Cloning > Restore SRAM Data from USB Recover the encryption key and the license on the SYS board by means of restoring. P. 9-37 “[C] Restore Encryption Key and License” |
| Firmware | If the error still persists, reinstall the system firmware and the system software by the HS-49 Firmware Update mode. |

* AccessFailed, KeyNull or KeyBroken

| Parts to be replaced | Remarks |
|----------------------|---------|
| SRAM | |
| SYS board | |

[F100_3] Serial number value error

| Classification | Error content |
|-----------------------------|--|
| System related service call | Only the first two characters of the serial number are entered. (The serial number is not completely entered.) |
| Check item | Measures |
| Serial number | <ul style="list-style-type: none"> Perform FS-08-9601 (Equipment number (serial number) display) to enter the serial number. If an F100_3 error occurs at the FS Menu startup, select HS-76 SRAM Maintenance > Set Serial Number and enter the serial number. |

[F100_4] Hash check error of encryption partition key

| Classification | Error content |
|-----------------------------|--|
| System related service call | Hash check error of encryption partition key |
| Check item | Measures |
| SYS board | Replace the SYS board. |
| Parts to be replaced | Remarks |
| SYS board | |

[F101_0] Optional storage device installation error**[F101_1] Optional storage device root partition mount error (formatting failure)****[F101_2] Optional storage device partition mount error****[F101_3] Optional storage device partition mount error**

| Classification | Error content |
|-----------------------------|---|
| System related service call | <p>Sub code 0: The installation of the storage device cannot be detected.</p> <p>Sub code 1: The storage device cannot be installed due to damage to the areas in which the program is mainly stored.</p> <p>Sub codes 2, 3: The areas other than those described in the F101_1 and F101_4 to F101_10 errors are damaged.</p> |

| Check item | Measures |
|---|---|
| 1. SRAM | Check if the SRAM was used in another MFP. |
| 2. Optional storage device | <p>Turn the power of the MFP OFF and check the installation status of the optional storage device.</p> <ul style="list-style-type: none"> Check if there is any abnormality in the connector and the harness. Check if the connector pins are bent. Check if the optional storage device was used in another MFP. |
| 3. Key | <p>If the error still persists even after step 2, perform this step.</p> <ul style="list-style-type: none"> Perform HS-73 Firmware Assist > Key Backup/Restore and check that each Key Status is "OK". If not, recover the key. (Carry out SRAM to FROM copying or FROM to SRAM copying.) |
| 4. Format | <p>If the error still persists even after step 3, perform this step.</p> <p>Perform HS-73 Firmware Assist > Format Storage, and then install "System Software (HD data)" with HS-49 Firmware Update.</p> <p>Notes:</p> <p>The following contents will be deleted with this operation.</p> <ul style="list-style-type: none"> Message Log Job Log Spool Data (Print, Email reception) Template |
| 5. Setting | <p>If an F101_1 error has occurred while a security storage device is installed or if the error still persists even after step 4, perform the following item and reattempt step 4.</p> <ul style="list-style-type: none"> HS-74 Storage Assist > Revert Factory Initial Status Storage |
| 6. Harness of the optional storage device | If the error still persists even after step 5, replace the harness of the optional storage device. |
| 7. Optional storage device | If the error still persists even after step 6, replace the optional storage device. |

| Check item | Measures |
|--------------|---|
| 8. SYS board | If the error still persists even after step 7, replace the SYS board. |

| Parts to be replaced | Remarks |
|--|---------|
| Harness of the optional storage device | |
| Optional storage device | |
| SYS board | |

[F101_4] Optional storage device partition mount error

[F101_12] Optional storage device mount error

| Classification | Error content |
|-----------------------------|---|
| System related service call | Sub code 4: The "/work" partition is damaged. Sub code 12: File link error in the "/work" partition. |

| Check item | Measures |
|---|--|
| 1. SRAM | Check if the SRAM was used in another MFP. |
| 2. Optional storage device | Turn the power of the MFP OFF and check the installation status of the optional storage device. <ul style="list-style-type: none"> • Check if there is any abnormality in the connector and the harness. • Check if the connector pins are bent. • Check if the optional storage device was used in another MFP. |
| 3. Key | If the error still persists even after step 2, perform this step. <ul style="list-style-type: none"> • Perform HS-73 Firmware Assist > Key Backup/Restore and check that each Key Status is "OK". • If not, recover the key. (Carry out SRAM to FROM copying or FROM to SRAM copying.) |
| 4. Recovery | If the error still persists even after step 3, perform HS-75 File System Recovery > Recovery F/S > /work and then reboot the MFP. |
| 5. Initialization | If the error still persists even after step 4, perform HS-75 File System Recovery > Initialize Storage > /work and then reboot the MFP. |
| 6. Format | If the error still persists even after step 5, perform this step. Perform HS-73 Firmware Assist > Format Storage, and then install "System Software (HD data)" with HS-49 Firmware Update. <p>Notes:</p> <ul style="list-style-type: none"> • The following contents will be deleted with this operation. • Message Log • Job Log • Spool Data (Print, Email reception) • Template |
| 7. Setting | If the error still persists even after step 6, perform the following and then reattempt step 6. <ul style="list-style-type: none"> • HS-74 Storage Assist > Revert Factory Initial Status Storage |
| 8. Optional storage device | If the error still persists even after step 7, replace the optional storage device. |
| 9. Harness of the optional storage device | If the error still persists even after step 8, replace the harness of the optional storage device. |
| 10. SYS board | If the error still persists even after step 9, replace the SYS board. |

| Parts to be replaced | Remarks |
|--|---------|
| Harness of the optional storage device | |
| Optional storage device | |
| SYS board | |

[F101_5] Partition mount error

| Classification | Error content |
|-----------------------------|---|
| System related service call | Sub code 5: The "/registration" partition is damaged. |

| Check item | Measures |
|---|--|
| 1. SRAM | Check if the SRAM was used in another MFP. |
| 2. Optional storage device | Turn the power of the MFP OFF and check the installation status of the optional storage device. <ul style="list-style-type: none"> • Check if there is any abnormality in the connector and the harness. • Check if the connector pins of the optional storage device are bent. • Check if the optional storage device was used in another MFP. |
| 3. Key | If the error still persists even after step 2, perform this step. <ul style="list-style-type: none"> • Perform HS-73 Firmware Assist > Key Backup/Restore and check that each Key Status is "OK". • If not, recover the key. (Carry out SRAM to FROM copying or FROM to SRAM copying.) |
| 4. Recovery | If the error still persists after step 3, perform HS-75 File System Recovery > Recovery F/S > /registration and reboot the MFP. |
| 5. Initialization | If the error still persists even after step 4, perform HS-75 File System Recovery > Initialize Storage > /registration and then reboot the MFP. |
| 6. Format | If the error still persists even after step 5, perform this step. Perform HS-73 Firmware Assist > Format Storage, and then install "System Software (HD data)" with HS-49 Firmware Update. <p>Notes:</p> <p>The following contents will be deleted with this operation.</p> <ul style="list-style-type: none"> • Message Log • Job Log • Spool Data (Print, Email reception) • Template |
| 7. Setting | If the error still persists even after step 6, perform the following and then reattempt step 6. <ul style="list-style-type: none"> • HS-74 Storage Assist > Revert Factory Initial Status Storage |
| 8. Optional storage device | If the error still persists even after step 7, replace the optional storage device. |
| 9. Harness of the optional storage device | If the error still persists even after step 8, replace the harness of the optional storage device. |
| 10. SYS board | If the error still persists even after step 9, replace the SYS board. |

| Parts to be replaced | Remarks |
|--|---------|
| Harness of the optional storage device | |
| Optional storage device | |
| SYS board | |

[F101_6] Partition mount error

| Classification | Error content |
|-----------------------------|---|
| System related service call | Sub code 6: The "/backup" partition is damaged. |

| Check item | Measures |
|---|--|
| 1. SRAM | Check if the SRAM was used in another MFP. |
| 2. Optional storage device | Turn the power of the MFP OFF and check the installation status of the optional storage device. <ul style="list-style-type: none"> • Check if there is any abnormality in the connector and the harness. • Check if the connector pins of the optional storage device are bent. • Check if the optional storage device was used in another MFP. |
| 3. Key | If the error still persists even after step 2, perform this step. <ul style="list-style-type: none"> • Perform HS-73 Firmware Assist > Key Backup/Restore and check that each Key Status is "OK". • If not, recover the key. (Carry out SRAM to FROM copying or FROM to SRAM copying.) |
| 4. Recovery | If the error still persists even after step 3, perform HS-75 File System Recovery > Recovery F/S > /backup and then reboot the MFP. |
| 5. Initialization | If the error still persists even after step 4, perform HS-75 File System Recovery > Initialize Storage > /backup and then reboot the MFP. |
| 6. Format | If the error still persists even after step 5, perform this step. Perform HS-73 Firmware Assist > Format Storage, and then install "System Software (HD data)" with HS-49 Firmware Update. <p>Notes:</p> <p>The following contents will be deleted with this operation.</p> <ul style="list-style-type: none"> • Message Log • Job Log • Spool Data (Print, Email reception) • Template |
| 7. Setting | If the error still persists even after step 6, perform the following and then reattempt step 6. <ul style="list-style-type: none"> • HS-74 Storage Assist > Revert Factory Initial Status Storage |
| 8. Optional storage device | If the error still persists even after step 7, replace the optional storage device. |
| 9. Harness of the optional storage device | If the error still persists even after step 8, replace the harness of the optional storage device. |
| 10. SYS board | If the error still persists even after step 9, replace the SYS board. |

| Parts to be replaced | Remarks |
|--|---------|
| Harness of the optional storage device | |
| Optional storage device | |
| SYS board | |

[F101_7] Partition mount error

| Classification | Error content |
|-----------------------------|--|
| System related service call | Sub code 7: The "/imagedata" partition is damaged. |

| Check item | Measures |
|---|--|
| 1. SRAM | Check if the SRAM was used in another MFP. |
| 2. Optional storage device | Turn the power of the MFP OFF and check the installation status of the optional storage device. <ul style="list-style-type: none"> • Check if there is any abnormality in the connector and the harness. • Check if the connector pins of the optional storage device are bent. • Check if the optional storage device was used in another MFP. |
| 3. Key | If the error still persists even after step 2, perform this step. <ul style="list-style-type: none"> • Perform HS-73 Firmware Assist > Key Backup/Restore and check that each Key Status is "OK". • If not, recover the key. (Carry out SRAM to FROM copying or FROM to SRAM copying.) |
| 4. Recovery | If the error still persists after step 3, perform HS-75 File System Recovery > Recovery F/S > /imagedata and reboot the MFP. |
| 5. Initialization | If the error still persists even after step 4, perform HS-75 File System Recovery > Initialize Storage > /imagedata and then reboot the MFP. |
| 6. Format | If the error still persists even after step 5, perform this step. Perform HS-73 Firmware Assist > Format Storage, and then install "System Software (HD data)" with HS-49 Firmware Update. <p>Notes:</p> <p>The following contents will be deleted with this operation.</p> <ul style="list-style-type: none"> • Message Log • Job Log • Spool Data (Print, Email reception) • Template |
| 7. Setting | If the error still persists even after step 6, perform the following and then reattempt step 6. <ul style="list-style-type: none"> • HS-74 Storage Assist > Revert Factory Initial Status Storage |
| 8. Optional storage device | If the error still persists even after step 7, replace the optional storage device. |
| 9. Harness of the optional storage device | If the error still persists even after step 8, replace the harness of the optional storage device. |
| 10. SYS board | If the error still persists even after step 9, replace the SYS board. |

| Parts to be replaced | Remarks |
|--|---------|
| Harness of the optional storage device | |
| Optional storage device | |
| SYS board | |

[F101_8] Partition mount error

| Classification | Error content |
|-----------------------------|--|
| System related service call | Sub code 8: The "/storage" partition is damaged. |

| Check item | Measures |
|---|--|
| 1. SRAM | Check if the SRAM was used in another MFP. |
| 2. Optional storage device | Turn the power of the MFP OFF and check the installation status of the optional storage device. <ul style="list-style-type: none"> • Check if there is any abnormality in the connector and the harness. • Check if the connector pins of the optional storage device are bent. • Check if the optional storage device was used in another MFP. |
| 3. Key | If the error still persists even after step 2, perform this step. <ul style="list-style-type: none"> • Perform HS-73 Firmware Assist > Key Backup/Restore and check that each Key Status is "OK". • If not, recover the key. (Carry out SRAM to FROM copying or FROM to SRAM copying.) |
| 4. Recovery | If the error still persists even after step 3, perform HS-75 File System Recovery > Recovery F/S > /storage and then reboot the MFP. |
| 5. Initialization | If the error still persists even after step 4, perform HS-75 File System Recovery > Initialize Storage > /storage and then reboot the MFP. |
| 6. Format | If the error still persists even after step 5, perform this step. Perform HS-73 Firmware Assist > Format Storage, and then install "System Software (HD data)" with HS-49 Firmware Update. <p>Notes:</p> <p>The following contents will be deleted with this operation.</p> <ul style="list-style-type: none"> • Message Log • Job Log • Spool Data (Print, Email reception) • Template |
| 7. Setting | If the error still persists even after step 6, perform the following and then reattempt step 6. <ul style="list-style-type: none"> • HS-74 Storage Assist > Revert Factory Initial Status Storage |
| 8. Optional storage device | If the error still persists even after step 7, replace the optional storage device. |
| 9. Harness of the optional storage device | If the error still persists even after step 8, replace the harness of the optional storage device. |
| 10. SYS board | If the error still persists even after step 9, replace the SYS board. |

| Parts to be replaced | Remarks |
|--|---------|
| Harness of the optional storage device | |
| Optional storage device | |
| SYS board | |

[F101_9] Partition mount error

| Classification | Error content |
|-----------------------------|---|
| System related service call | Sub code 9: The "/encryption" partition is damaged. |

| Check item | Measures |
|---|--|
| 1. SRAM | Check if the SRAM was used in another MFP. |
| 2. Optional storage device | Turn the power of the MFP OFF and check the installation status of the optional storage device. <ul style="list-style-type: none"> • Check if there is any abnormality in the connector and the harness. • Check if the connector pins of the optional storage device are bent. • Check if the optional storage device was used in another MFP. |
| 3. Key | If the error still persists even after step 2, perform this step. <ul style="list-style-type: none"> • Perform HS-73 Firmware Assist > Key Backup/Restore and check that each Key Status is "OK". • If not, recover the key. (Carry out SRAM to FROM copying or FROM to SRAM copying.) |
| 4. Recovery | If the error still persists after step 3, perform HS-75 File System Recovery > Recovery F/S > /encryption and reboot the MFP. |
| 5. Initialization | If the error still persists even after step 4, perform HS-75 File System Recovery > Initialize Storage > /encryption and then reboot the MFP. |
| 6. Format | If the error still persists even after step 5, perform this step. Perform HS-73 Firmware Assist > Format Storage, and then install "System Software (HD data)" with HS-49 Firmware Update. <p>Notes:</p> <p>The following contents will be deleted with this operation.</p> <ul style="list-style-type: none"> • Message Log • Job Log • Spool Data (Print, Email reception) • Template |
| 7. Setting | If the error still persists even after step 6, perform the following and then reattempt step 6. <ul style="list-style-type: none"> • HS-74 Storage Assist > Revert Factory Initial Status Storage |
| 8. Optional storage device | If the error still persists even after step 7, replace the optional storage device. |
| 9. Harness of the optional storage device | If the error still persists even after step 8, replace the harness of the optional storage device. |
| 10. SYS board | If the error still persists even after step 9, replace the SYS board. |

| Parts to be replaced | Remarks |
|--|---------|
| Harness of the optional storage device | |
| Optional storage device | |
| SYS board | |

[F101_10] Partition mount error

| Classification | Error content |
|-----------------------------|---|
| System related service call | Sub code 10: The “/application” partition is damaged. |

| Check item | Measures |
|---|--|
| 1. SRAM | Check if the SRAM was used in another MFP. |
| 2. Optional storage device | Turn the power of the MFP OFF and check the installation status of the optional storage device. <ul style="list-style-type: none"> • Check if there is any abnormality in the connector and the harness. • Check if the connector pins of the optional storage device are bent. • Check if the optional storage device was used in another MFP. |
| 3. Key | If the error still persists even after step 2, perform this step. <ul style="list-style-type: none"> • Perform HS-73 Firmware Assist > Key Backup/Restore and check that each Key Status is “OK”. • If not, recover the key. (Carry out SRAM to FROM copying or FROM to SRAM copying.) |
| 4. Recovery | If the error still persists after step 3, perform HS-75 File System Recovery > Recovery F/S > /application and reboot the MFP. |
| 5. Initialization | If the error still persists even after step 4, perform HS-75 File System Recovery > Initialize Storage > /application and then reboot the MFP. |
| 6. Format | If the error still persists even after step 5, perform this step. Perform HS-73 Firmware Assist > Format Storage, and then install “System Software (HD data)” with HS-49 Firmware Update. <p>Notes:</p> <p>The following contents will be deleted with this operation.</p> <ul style="list-style-type: none"> • Message Log • Job Log • Spool Data (Print, Email reception) • Template |
| 7. Setting | If the error still persists even after step 6, perform the following and then reattempt step 6. <ul style="list-style-type: none"> • HS-74 Storage Assist > Revert Factory Initial Status Storage |
| 8. Optional storage device | If the error still persists even after step 7, replace the optional storage device. |
| 9. Harness of the optional storage device | If the error still persists even after step 8, replace the harness of the optional storage device. |
| 10. SYS board | If the error still persists even after step 9, replace the SYS board. |

| Parts to be replaced | Remarks |
|--|---------|
| Harness of the optional storage device | |
| Optional storage device | |
| SYS board | |

[F101_11] Partition mount error

| Classification | Error content |
|-----------------------------|--|
| System related service call | Sub code 11: The "/platform" partition is damaged. |

| Check item | Measures |
|---|---|
| 1. SRAM | Check if the SRAM was used in another MFP. |
| 2. Optional storage device | Turn the power of the MFP OFF and check the installation status of the optional storage device. <ul style="list-style-type: none"> • Check if there is any abnormality in the connector and the harness. • Check if the connector pins of the optional storage device are bent. • Check if the optional storage device was used in another MFP. |
| 3. Format | If the error still persists even after step 2, perform this step. Perform HS-73 Firmware Assist > Format Storage, and then install "System Software (HD data)" with HS-49 Firmware Update. Notes: The following contents will be deleted with this operation. <ul style="list-style-type: none"> • Message Log • Job Log • Spool Data (Print, Email reception) • Template |
| 4. Setting | If the error still persists even after step 3, perform the following and then reattempt step 3. <ul style="list-style-type: none"> • HS-74 Storage Assist > Initialize Storage > /application |
| 5. Optional storage device | If the error still persists even after step 4, replace the optional storage device. |
| 6. Harness of the optional storage device | If the error still persists even after step 5, replace the harness of the optional storage device. |
| 7. SYS board | If the error still persists even after step 6, replace the SYS board. |

| Parts to be replaced | Remarks |
|--|---------|
| Harness of the optional storage device | |
| Optional storage device | |
| SYS board | |

[F101_13] Error due to damage to file

| Classification | Error content |
|-----------------------------|---|
| System related service call | Sub code 13: A file in the "/imagedata" partition is damaged. |

| Check item | Measures |
|----------------------------|---|
| 1. SRAM | Check if the SRAM was used in another MFP. |
| 2. Optional storage device | Turn the power of the MFP OFF and check the installation status of the optional storage device. <ul style="list-style-type: none"> • Check if there is any abnormality in the connector and the harness. • Check if the connector pins of the optional storage device are bent. • Check if the optional storage device was used in another MFP. |
| 3. Recovery | If the error still persists even after step 2, perform this step. <ul style="list-style-type: none"> • Perform HS-75 File System Recovery > Recovery F/S > /imagedata and reboot the MFP. |
| 4. Format | If the error still persists even after step 3, perform this step. Perform HS-73 Firmware Assist > Format Storage, and then install "System Software (HD data)" with HS-49 Firmware Update. Notes: The following contents will be deleted with this operation. <ul style="list-style-type: none"> • Message Log • Job Log • Spool Data (Print, Email reception) • Template |
| 5. Setting | If the error still persists even after step 4, perform the following and then reattempt step 4. <ul style="list-style-type: none"> • HS-74 Storage Assist > Revert Factory Initial Status Storage |

| Check item | Measures |
|---|--|
| 6. Optional storage device | If the error still persists even after step 5, replace the optional storage device. |
| 7. Harness of the optional storage device | If the error still persists even after step 6, replace the harness of the optional storage device. |
| 8. SYS board | If the error still persists even after step 7, replace the SYS board. |

| Parts to be replaced | Remarks |
|--|---------|
| Harness of the optional storage device | |
| Optional storage device | |
| SYS board | |

[F101_14] Partition mount error

| Classification | Error content |
|-----------------------------|---|
| System related service call | Sub code 14: The optional storage device cannot be installed due to the damage to the “//rollback” partition. |

| Check item | Measures |
|---|---|
| 1. Reproducibility | Reboot the MFP. |
| 2. SRAM | Check if the SRAM was used in another MFP. |
| 3. Optional storage device | Turn the power of the MFP OFF and check the installation status of the optional storage device. <ul style="list-style-type: none"> • Check if there is any abnormality in the connector and the harness. • Check if the connector pins of the optional storage device are bent. • Check if the optional storage device was used in another MFP. |
| 4. Format | If the error still persists even after step 3, perform this step. Perform HS-73 Firmware Assist > Format Storage, and then install “System Software (HD data)” with HS-49 Firmware Update. <p>Notes: The following contents will be deleted with this operation.</p> <ul style="list-style-type: none"> • Message Log • Job Log • Spool Data (Print, Email reception) • Template |
| 5. Setting | If the error still persists even after step 4, perform the following and then reattempt step 4. <ul style="list-style-type: none"> • HS-74 Storage Assist > Revert Factory Initial Status Storage |
| 6. Optional storage device | If the error still persists even after step 5, replace the optional storage device. |
| 7. Harness of the optional storage device | If the error still persists even after step 6, replace the harness of the optional storage device. |
| 8. SYS board | If the error still persists even after step 7, replace the SYS board. |

| Parts to be replaced | Remarks |
|--|---------|
| Harness of the optional storage device | |
| Optional storage device | |
| SYS board | |

[F102] Storage device start error

| Classification | Error content |
|--|---|
| Storage device related service call | A storage device cannot become the "Ready" state. |
| Check item | Measures |
| Standard storage device | <ul style="list-style-type: none"> Standard storage device check Connector check |
| Optional storage device | <ul style="list-style-type: none"> Optional storage device check Connector check Harness check |
| Parts to be replaced | Remarks |
| Standard storage device | |
| Harness of the optional storage device | |
| Optional storage device | |
| SYS board | |

[F103] Storage device transfer time-out error**[F104] Storage device data error****[F105] Other errors for the storage device**

| Classification | Error content |
|--|--|
| Storage device related service call | <ul style="list-style-type: none"> Reading/writing cannot be performed within the specified period of time. An abnormality is detected in data of storage device. Another error has occurred in the storage device. (This error is determined when the problem is not solved even if the MFP is rebooted by the specified number of times.) |
| Check item | Measures |
| Standard storage device | <ul style="list-style-type: none"> Standard storage device check Connector check |
| Optional storage device | <ul style="list-style-type: none"> Optional storage device check Connector check Harness check |
| Parts to be replaced | Remarks |
| Standard storage device | |
| Harness of the optional storage device | |
| Optional storage device | |
| SYS board | |

[F106_0] Optional storage device error

| Classification | Error content |
|-------------------------------------|---|
| Storage device related service call | <ul style="list-style-type: none"> The security HDD has been replaced with a normal HDD illegally. The security SSD has been replaced with a normal SSD illegally. |
| Check item | Measures |
| Storage device type | Perform HS-74 Storage Assist and check the storage device type displayed on the Current Storage Type menu. If a normal type storage device is installed, replace it with the one that was there previously or a security type storage device. When a security type storage device is installed, go to the next step. |
| | Notes: To replace with the original storage device, start the MFP in the normal mode and then reinstall the system software only if any abnormality occurs. |

| Check item | Measures |
|-------------------------|--|
| Optional storage device | <ul style="list-style-type: none"> Optional storage device check Connector check Harness check If the problem cannot be confirmed, perform the following items. <ol style="list-style-type: none"> Perform HS-74 Storage Assist > Revert Factory Initial Status Storage. Reinstall the system software. If the error still persists, replace the optional storage device. |
| SYS board | Replace the SYS board. |

| Parts to be replaced | Remarks |
|--|---------|
| Harness of the optional storage device | |
| Optional storage device | |
| SYS board | |

[F106_1] Optional storage device error

| Classification | Error content |
|-------------------------------------|---|
| Storage device related service call | Storage device type detection has failed. |

| Check item | Measures |
|-------------------------|---|
| Reproducibility | <ul style="list-style-type: none"> Reboot the MFP. Reinstall the system software. |
| Optional storage device | <ul style="list-style-type: none"> Optional storage device check Connector check Harness check Perform HS-75 File System Recovery to check the file system and restore it. If HS-75 File System Recovery cannot be performed, replace the optional storage device. Perform HS-74 Storage Assist and check the storage device type displayed on the Current Storage Type menu. If "Unknown" is displayed, reinstall the system software. If the error still persists, replace the optional storage device. |
| SYS board | Replace the SYS board. |

| Parts to be replaced | Remarks |
|--|---------|
| Harness of the optional storage device | |
| Optional storage device | |
| SYS board | |

[F106_2] Optional storage device error

| Classification | Error content |
|-------------------------------------|--|
| Storage device related service call | Downloading of or consistency check for the encryption key has failed. |

| Check item | Measures |
|-------------------------|--|
| Key | <p>Check the status of HDD ENC KEY (encryption key) displayed in HS-73 Firmware Assist > Key Backup/Restore. After confirming, shut down the MFP.</p> <ul style="list-style-type: none"> When both the SRAM and FROM status are OK, reinstall the system firmware. In case either the SRAM or FROM status is other than OK, recover the encryption key. In case both the SRAM and FROM status fail, reinstall the system software. |
| Optional storage device | <ul style="list-style-type: none"> Replace the optional storage device. Replace the harness of the optional storage device. |
| SYS board | Replace the SYS board. |

| Parts to be replaced | Remarks |
|--|---------|
| Harness of the optional storage device | |
| Optional storage device | |
| SYS board | |

[F106_3] Optional storage device error

| Classification | Error content |
|-------------------------------------|---|
| Storage device related service call | The generation of the authentication Admin Password has failed. |

| Check item | Measures |
|-------------------------|---|
| Format | <p>Perform HS-73 Firmware Assist > Format Storage and then install "System Software (HD data)" with HS-49 Firmware Update. After confirming, shut down the MFP.</p> <p>Notes: The following contents will be deleted with this operation.</p> <ul style="list-style-type: none"> • Message Log • Job Log • Spool Data (Print, Email reception) • Template |
| Optional storage device | <ul style="list-style-type: none"> • Replace the optional storage device. • Replace the harness of the optional storage device. |
| SYS board | Replace the SYS board. |

| Parts to be replaced | Remarks |
|--|---------|
| Harness of the optional storage device | |
| Optional storage device | |
| SYS board | |

[F106_4] Optional storage device error

| Classification | Error content |
|-------------------------------------|---|
| Storage device related service call | The generation of a random number for authentication data has failed. |

| Check item | Measures |
|-------------------------|---|
| Format | <p>Perform HS-73 Firmware Assist > Format Storage and then install "System Software (HD data)" with HS-49 Firmware Update. After confirming, shut down the MFP.</p> <p>Notes: The following contents will be deleted with this operation.</p> <ul style="list-style-type: none"> • Message Log • Job Log • Spool Data (Print, Email reception) • Template |
| Optional storage device | <ul style="list-style-type: none"> • Replace the optional storage device. • Replace the harness of the optional storage device. |
| SYS board | Replace the SYS board. |

| Parts to be replaced | Remarks |
|--|---------|
| Harness of the optional storage device | |
| Optional storage device | |
| SYS board | |

[F106_5] Optional storage device error

| Classification | Error content |
|-------------------------------------|---|
| Storage device related service call | The transmission of authentication data has failed. |

| Check item | Measures |
|-------------------------|---|
| Format | <p>Perform HS-73 Firmware Assist > Format Storage and then install "System Software (HD data)" with HS-49 Firmware Update. After confirming, shut down the MFP.</p> <p>Notes: The following contents will be deleted with this operation.</p> <ul style="list-style-type: none"> • Message Log • Job Log • Spool Data (Print, Email reception) • Template <p>Remarks: When this error has occurred after returning SRAM data for SRAM cloning, copy the Secure HDD key from the FROM to the SRAM.</p> <ol style="list-style-type: none"> 1. Perform HS-73 Firmware Assist > Key Backup/Restore to check the key status. 2. Press [Direction] twice. Check that the copying of the key from the FROM to the SRAM is selected. 3. Press [Execute]. When the restoring of the key is completed, "Success" appears. 4. After the operation is completed, shut down the MFP. |
| Optional storage device | <ul style="list-style-type: none"> • Replace the optional storage device. • Replace the harness of the optional storage device. |
| SYS board | Replace the SYS board. |

| Parts to be replaced | Remarks |
|--|---------|
| Harness of the optional storage device | |
| Optional storage device | |
| SYS board | |

[F106_6] Optional storage device error

[F106_7] Optional storage device error

[F106_8] Optional storage device error

[F106_10] Optional storage device error

[F106_UNDEF] Optional storage device error

| Classification | Error content |
|-------------------------------------|---|
| Storage device related service call | Error caused by reason other than F106_0 to 5 |

| Check item | Measures |
|-------------------------|---|
| Format | <p>Perform HS-73 Firmware Assist > Format Storage and then install "System Software (HD data)" with HS-49 Firmware Update. After confirming, shut down the MFP.</p> <p>Notes: The following contents will be deleted with this operation.</p> <ul style="list-style-type: none"> • Message Log • Job Log • Spool Data (Print, Email reception) • Template |
| Optional storage device | <ul style="list-style-type: none"> • Replace the optional storage device. • Replace the harness of the optional storage device. |
| SYS board | Replace the SYS board. |

| Parts to be replaced | Remarks |
|--|---------|
| Harness of the optional storage device | |

| Parts to be replaced | Remarks |
|-------------------------|---------|
| Optional storage device | |
| SYS board | |

[F106_11] License damage

| Classification | Error content |
|------------------------------|---|
| License related service call | Both licenses saved in the storage device and the SRAM are damaged. |

| Check item | Measures |
|-------------------------|---|
| Backup data restoring | Restore the backup data with the latest status, including all the activated licenses. Remarks: Applications with the trial license cannot be recovered from the backup data. If necessary, reinstall the applications. |
| License activation | If there are no backup data as above, reactivate all the licenses which have been activated in this MFP. If the functions have been activated by the export license file, import the license exported from the host unit of the MFP. |
| Optional storage device | <ul style="list-style-type: none"> Replace the optional storage device. Replace the harness of the optional storage device. |
| SRAM | Replace the SRAM. |
| SYS board | Replace the SYS board. |

| Parts to be replaced | Remarks |
|--|---------|
| SRAM | |
| Harness of the optional storage device | |
| Optional storage device | |
| SYS board | |

[F106_12] License damage

| Classification | Error content |
|------------------------------|--|
| License related service call | The license registered in the SRAM is damaged. |

| Check item | Measures |
|-----------------|--|
| Reproducibility | <ul style="list-style-type: none"> Reboot the MFP. If the problem still persists, perform FS-08-9053 and reboot the MFP again. |
| SRAM | Replace the SRAM. |
| SYS board | Replace the SYS board. |

| Parts to be replaced | Remarks |
|----------------------|---------|
| SRAM | |
| SYS board | |

[F107] File system error

| Classification | Error content |
|-----------------------------|---|
| System related service call | File system error |
| Setting | Perform HS-73 Firmware Assist > Format Storage and then install "SYSTEM SOFTWARE(SD) COMMON" with the HS-49 Firmware Update. After confirming, shut down the MFP. Note: The following contents will be deleted with this operation. <ul style="list-style-type: none">• Message Log• Job Log• Spool Data (Print, Email reception)• Template |
| Standard storage device | If the error still persists even after the above step is performed, replace the standard storage device. If the above step is cannot be performed, replace the standard storage device. |
| Optional storage device | If the error still persists even after the above step is performed, replace the optional storage device. Moreover, if the above step is cannot be performed, replace the optional storage device. |

| Parts to be replaced | Remarks |
|-----------------------------|----------------|
| Standard storage device | |
| Optional storage device | |
| SYS board | |

[F109_0] Key consistency error**[F109_1] Key consistency error****[F109_2] Key consistency error**

| Classification | Error content |
|--------------------------|---|
| Key related service call | Sub code 0: Consistency of each key data item has failed due to damage in the consistency check module. Sub code 1: key data used for the SRAM encryption are damaged. Sub code 2: key data used for the SRAM encryption are damaged. |

| Check item | Measures |
|-----------------|--|
| Reproducibility | Reboot the MFP. |
| Firmware | <ul style="list-style-type: none"> Reinstall the system firmware. Reinstall the system software. |
| SRAM | Replace the SRAM. |
| SYS board | Replace the SYS board. |

| Parts to be replaced | Remarks |
|----------------------|---------|
| SRAM | |
| SYS board | |

[F109_3] Key consistency error

| Classification | Error content |
|-----------------------------|---|
| System related service call | The parameter for storage device partition encryption is damaged. |

| Check item | Measures |
|--|--|
| Encryption key status | Perform HS-73 Firmware Assist mode > Key Backup/Restore and check the displayed message. Take the appropriate countermeasures shown below according to the error and messages displayed in the "SRAM" and "FROM" fields. |
| "SRAM" field: * "FROM" field: AccessFailed | Replace the SYS board. <ul style="list-style-type: none"> When there are backup data in a USB storage device: <ol style="list-style-type: none"> Recover all the data on the SRAM by means of cloning. HS-59 SRAM Data Cloning > Restore SRAM Data from USB Recover the encryption key and the license on the SYS board by means of restoring. 📖 P. 9-37 "[C] Restore Encryption Key and License" |
| "SRAM" field: AccessFailed "FROM" field: * | Replace the SRAM. |
| "SRAM" field: AccessFailed "FROM" field: OK | |
| "SRAM" field: OK "FROM" field: KeyNull / KeyBroken | Recover the encryption key on the SYS board. 📖 P. 9-37 "[C] Restore Encryption Key and License" |
| "SRAM" field: KeyNull / KeyBroken "FROM" field: OK | Recover the encryption key on the SRAM by means of backup. 📖 P. 9-41 "[G] Backup encryption key and license (FROM > SRAM)" |
| "SRAM" field: KeyNull / KeyBroken "FROM" field: KeyNull / KeyBroken | <ul style="list-style-type: none"> When there are no backup data in a USB storage device: Reinstall the system software. When there are backup data in a USB storage device: <ol style="list-style-type: none"> Recover all the data on the SRAM by means of cloning. HS-59 SRAM Data Cloning > Restore SRAM Data from USB Recover the encryption key and the license on the SYS board by means of restoring. 📖 P. 9-37 "[C] Restore Encryption Key and License" |
| Firmware | If the error still persists, reinstall the system firmware and the system software by the HS-49 Firmware Update mode. |

* AccessFailed or KeyMismatch

| Parts to be replaced | Remarks |
|----------------------|---------|
| SRAM | |
| SYS board | |

[F109_4] Key consistency error

| Classification | Error content |
|-----------------------------|-------------------------------|
| System related service call | The license data are damaged. |

| Check item | Measures |
|--|--|
| Encryption key status | Perform HS-73 Firmware Assist mode > Key Backup/Restore and check the displayed message. Take the appropriate countermeasures shown below according to the error and messages displayed in the "SRAM" and "FROM" fields. |
| "SRAM" field: * "FROM" field: AccessFailed | Replace the SYS board. <ul style="list-style-type: none"> When there are backup data in a USB storage device: <ol style="list-style-type: none"> Recover all the data on the SRAM by means of cloning. HS-59 SRAM Data Cloning > Restore SRAM Data from USB Recover the encryption key and the license on the SYS board by means of restoring. P. 9-37 "[C] Restore Encryption Key and License" |
| "SRAM" field: AccessFailed "FROM" field: * | Replace the SRAM. |
| "SRAM" field: Keymismatch "FROM" field: Keymismatch | <ul style="list-style-type: none"> When this error has occurred during replacing the SYS board, recover the license on it. (Restore the license from the SRAM to the FROM.) When this error has occurred except during replacement of the SYS board, recover the license of the SRAM. (Back up the license from the FROM to the SRAM.) |
| Firmware | If the error still persists, reinstall the system firmware and the system software by the HS-49 Firmware Update mode. |

* AccessFailed or KeyMismatch

| Parts to be replaced | Remarks |
|----------------------|---------|
| SRAM | |
| SYS board | |

[F109_5] Key consistency error

| Classification | Error content |
|--|--|
| Storage device related service call | The encryption key of the optional storage device is damaged. |
| Check item | Measures |
| Encryption key status | Perform HS-73 Firmware Assist mode > Key Backup/Restore and check the displayed message. Take the appropriate countermeasures shown below according to the error and messages displayed in the "SRAM" and "FROM" fields. |
| "SRAM" field: * "FROM" field: AccessFailed | Replace the SYS board. <ul style="list-style-type: none"> When there are backup data in a USB storage device: <ol style="list-style-type: none"> Recover all the data on the SRAM by means of cloning. HS-59 SRAM Data Cloning > Restore SRAM Data from USB Recover the encryption key and the license on the SYS board by means of restoring. P. 9-37 "[C] Restore Encryption Key and License" |
| "SRAM" field: AccessFailed "FROM" field: * | Replace the SRAM. |
| "SRAM" field: OK "FROM" field: KeyNull / KeyBroken | Recover the encryption key on the SYS board. P. 9-37 "[C] Restore Encryption Key and License" |
| "SRAM" field: KeyNull / KeyBroken "FROM" field: KeyNull / KeyBroken | <ul style="list-style-type: none"> When there are no backup data in a USB storage device: Reinstall the system software. When there are backup data in a USB storage device: <ol style="list-style-type: none"> Recover all the data on the SRAM by means of cloning. HS-59 SRAM Data Cloning > Restore SRAM Data from USB Recover the encryption key and the license on the SYS board by means of restoring. P. 9-37 "[C] Restore Encryption Key and License" |
| "SRAM" field: KeyMismatch "FROM" field: KeyMismatch | <ul style="list-style-type: none"> The error occurs when the SYS board is replaced: Recover the encryption key on the SYS board by means of restoring. (Transfer the key from the SRAM to the FROM.) P. 9-37 "[C] Restore Encryption Key and License" The error occurs except when the SYS board is replaced: Recover the encryption key on the SRAM by means of restoring. (Transfer the key from the FROM to the SRAM.) P. 9-41 "[G] Backup encryption key and license (FROM > SRAM)" |

* AccessFailed or KeyMismatch

| Parts to be replaced | Remarks |
|----------------------|---------|
| SRAM | |
| SYS board | |

[F109_6] Key consistency error

| Classification | Error content |
|-------------------------------------|--|
| Storage device related service call | The administrator password for the authentication of the optional storage device is damaged. |

| Check item | Measures |
|--|--|
| Encryption key status | Perform HS-73 Firmware Assist mode > Key Backup/Restore and check the displayed message. Take the appropriate countermeasures shown below according to the error and messages displayed in the "SRAM" and "FROM" fields. |
| "SRAM" field: * "FROM" field: AccessFailed | Replace the SYS board. <ul style="list-style-type: none"> When there are backup data in a USB storage device: <ol style="list-style-type: none"> Recover all the data on the SRAM by means of cloning. HS-59 SRAM Data Cloning > Restore SRAM Data from USB Recover the encryption key and the license on the SYS board by means of restoring. 📖 P. 9-37 "[C] Restore Encryption Key and License" |
| "SRAM" field: AccessFailed "FROM" field: * | Replace the SRAM. |
| "SRAM" field: OK "FROM" field: KeyNull / KeyBroken | Recover the encryption key on the SYS board. 📖 P. 9-37 "[C] Restore Encryption Key and License" |
| "SRAM" field: KeyNull / KeyBroken "FROM" field: OK | Backup the encryption key of the SRAM. 📖 P. 9-37 "[C] Restore Encryption Key and License" |
| "SRAM" field: KeyNull / KeyBroken "FROM" field: KeyNull / KeyBroken | <ul style="list-style-type: none"> When there are no backup data in a USB storage device: Reinstall the system software. When there are backup data in a USB storage device: <ol style="list-style-type: none"> Recover all the data on the SRAM by means of cloning. HS-59 SRAM Data Cloning > Restore SRAM Data from USB Recover the encryption key and the license on the SYS board by means of restoring. 📖 P. 9-37 "[C] Restore Encryption Key and License" |
| "SRAM" field: KeyMismatch "FROM" field: KeyMismatch | <ul style="list-style-type: none"> The error occurs when the SYS board is replaced: Recover the encryption key on the SYS board by means of restoring. (Transfer the key from the SRAM to the FROM.) 📖 P. 9-37 "[C] Restore Encryption Key and License" The error occurs except when the SYS board is replaced: Recover the encryption key on the SRAM by means of restoring. (Transfer the key from the FROM to the SRAM.) 📖 P. 9-41 "[G] Backup encryption key and license (FROM > SRAM)" |

* AccessFailed or KeyMismatch

| Parts to be replaced | Remarks |
|----------------------|---------|
| SRAM | |
| SYS board | |

[F109_7] Key consistency error

| Classification | Error content |
|-------------------------------------|--|
| Storage device related service call | Hash check of the optional storage device authentication key has failed. |

| Check item | Measures |
|---|---|
| Format | Perform HS-73 Firmware Assist mode > Key Backup/Restore and check the displayed message. Take the appropriate countermeasures shown below according to the error and messages displayed in the "SRAM" and "FROM" fields. |
| "SRAM" field: * "FROM" field: AccessFailed | Perform HS-73 Firmware Assist > Format Storage and then install "System Software (HD data)" with HS-49 Firmware Update. Notes: The following contents will be deleted with this operation. <ul style="list-style-type: none"> • Message Log • Job Log • Spool Data (Print, Email reception) • Template |
| SRAM | Replace the SRAM. |
| SYS board | Replace the SYS board. |

| Parts to be replaced | Remarks |
|----------------------|---------|
| SRAM | |
| SYS board | |

[F109_8] Key consistency error**[F109_9] Key consistency error**

| Classification | Error content |
|--------------------------|---|
| Key related service call | The public key data of the FROM image used in the secure startup are damaged. |

| Check item | Measures |
|-----------------|--|
| Reproducibility | Reboot the MFP. |
| Firmware | <ul style="list-style-type: none"> • Reinstall the system firmware. • Reinstall the system software. |
| SRAM | Replace the SRAM. |
| SYS board | Replace the SYS board. |

| Parts to be replaced | Remarks |
|----------------------|---------|
| SRAM | |
| SYS board | |

[F109_10] Key consistency error

| Classification | Error content |
|-------------------------------------|--|
| Storage device related service call | Hash check of the standard storage device authentication key has failed. |

| Check item | Measures |
|---|---|
| Encryption key status | Perform HS-73 Firmware Assist mode > Key Backup/Restore and check the displayed message. Take the appropriate countermeasures shown below according to the error and messages displayed in the "SRAM" and "FROM" fields. |
| "SRAM" field: * "FROM" field: AccessFailed | Replace the SYS board. When there are backup data in a USB storage device: <ol style="list-style-type: none"> 1. Recover all the data on the SRAM by means of cloning. HS-59 SRAM Data Cloning > Restore SRAM Data from USB 2. Recover the encryption key and the license on the SYS board by means of restoring.  P. 9-37"[C] Restore Encryption Key and License" |
| "SRAM" field: AccessFailed "FROM" field: * | Replace the SRAM. |

| Check item | Measures |
|--|--|
| “SRAM” field: OK “FROM” field: KeyNull /KeyBroken | Recover the encryption key on the SYS board. 📖 P. 9-37“[C] Restore Encryption Key and License” |
| “SRAM” field: KeyNull /KeyBroken “FROM” field: OK | Backup the encryption key of the SRAM. 📖 P. 9-41“[G]Backup encryption key and license (FROM > SRAM)” |
| “SRAM” field: KeyNull /KeyBroken “FROM” field: KeyNull /KeyBroken | When there are no backup data in a USB storage device: Reinstall the system software. When there are backup data in a USB storage device: 1. Recover all the data on the SRAM by means of cloning. HS-59 SRAM Data Cloning > Restore SRAM Data from USB 2. Recover the encryption key and the license on the SYS board by means of restoring. 📖 P. 9-37“[C] Restore Encryption Key and License” |
| “SRAM” field: KeyMismatch “FROM” field: KeyMismatch | The error occurs when the SYS board is replaced: Recover the encryption key on the SYS board by means of restoring. (Transfer the key from the SRAM to the FROM.) 📖 P. 9-37“[C] Restore Encryption Key and License” The error occurs except when the SYS board is replaced: Recover the encryption key on the SRAM by means of restoring. (Transfer the key from the FROM to the SRAM.) 📖 P. 9-41“[G]Backup encryption key and license (FROM > SRAM)” |

* AccessFailed or KeyMismatch

| Parts to be replaced | Remarks |
|----------------------|---------|
| SRAM | |
| SYS board | |

[F109_11] Key consistency error

| Classification | Error content |
|-------------------------------------|--|
| Storage device related service call | Hash check of the optional storage device authentication key has failed. |

| Check item | Measures |
|--|---|
| Encryption key status | Perform HS-73 Firmware Assist mode > Key Backup/Restore and check the displayed message. Take the appropriate countermeasures shown below according to the error and messages displayed in the “SRAM” and “FROM” fields. |
| “SRAM” field: * “FROM” field: AccessFailed | Replace the SYS board. When there are backup data in a USB storage device: 1. Recover all the data on the SRAM by means of cloning. HS-59 SRAM Data Cloning > Restore SRAM Data from USB 2. Recover the encryption key and the license on the SYS board by means of restoring. 📖 P. 9-37“[C] Restore Encryption Key and License” |
| “SRAM” field: AccessFailed “FROM” field: * | Replace the SRAM. |
| “SRAM” field: OK “FROM” field: KeyNull /KeyBroken | Recover the encryption key on the SYS board. 📖 P. 9-37“[C] Restore Encryption Key and License” |
| “SRAM” field: KeyNull /KeyBroken “FROM” field: OK | Backup the encryption key of the SRAM. 📖 P. 9-41“[G]Backup encryption key and license (FROM > SRAM)” |
| “SRAM” field: KeyNull /KeyBroken “FROM” field: KeyNull /KeyBroken | When there are no backup data in a USB storage device: Reinstall the system software. When there are backup data in a USB storage device: 1. Recover all the data on the SRAM by means of cloning. HS-59 SRAM Data Cloning > Restore SRAM Data from USB 2. Recover the encryption key and the license on the SYS board by means of restoring. 📖 P. 9-37“[C] Restore Encryption Key and License” |

| Check item | Measures |
|--|--|
| “SRAM” field: Keymismatch “FROM” field: Keymismatch | The error occurs when the SYS board is replaced: Recover the encryption key on the SYS board by means of restoring. (Transfer the key from the SRAM to the FROM.) 📖 P. 9-37“[C] Restore Encryption Key and License” The error occurs except when the SYS board is replaced: Recover the encryption key on the SRAM by means of restoring. (Transfer the key from the FROM to the SRAM.) 📖 P. 9-41“[G]Backup encryption key and license (FROM > SRAM)” |

* AccessFailed or KeyMismatch

| Parts to be replaced | Remarks |
|----------------------|---------|
| SRAM | |
| SYS board | |

[F109_12] Key consistency error

| Classification | Error content |
|--------------------------|---------------------------------------|
| Key related service call | TAW key consistency check has failed. |

| Check item | Measures |
|--|---|
| Encryption key status | Perform HS-73 Firmware Assist mode > Key Backup/Restore and check the displayed message. Take the appropriate countermeasures shown below according to the error and messages displayed in the “SRAM” and “FROM” fields. |
| “SRAM” field: OK “FROM” field: AccessFailed | Replace the SRAM. |
| “SRAM” field: OK “FROM” field: KeyNull /KeyBroken | The error occurs when the SYS board is replaced: Recover the TPM information on the SYS board. 📖 P. 5-50 “5.22 TPM Restore” The error occurs except when the SYS board is replaced: Recover the encryption key on the SYS board by means of restoring. (Transfer the key from the SRAM to the FROM.) 📖 P. 9-37“[C] Restore Encryption Key and License” |
| “SRAM” field: Keymismatch “FROM” field: Keymismatch | The error occurs when the SYS board is replaced: Recover the TPM information on the SYS board. 📖 P. 5-50 “5.22 TPM Restore” The error occurs except when the SYS board is replaced: Recover the encryption key on the SRAM by means of restoring. (Transfer the key from the FROM to the SRAM.) 📖 P. 9-41“[G]Backup encryption key and license (FROM > SRAM)” |

| Parts to be replaced | Remarks |
|----------------------|---------|
| SYS board | |

[F110] Communication error between the system-CPU and the scanner-CPU

[F111] Scanner-CPU response error

| Classification | Error content |
|--------------------------------------|--|
| Scanning system related service call | <ul style="list-style-type: none"> A communication error has occurred between the system-CPU and the scanner-CPU. There is no response from the scanner-CPU. (This error is determined when the problem is not solved even if the MFP is rebooted by the specified number of times.) |

| Check item | Measures |
|-----------------|--|
| Reproducibility | Turn the power OFF and then back ON to check the occurrence. |
| Setting | <ul style="list-style-type: none"> Check if the value of FS-08-9000 (Destination setting of the MFP) is set correctly. Perform FS-05--3203 (Data transfer of characteristic value of scanner). |
| Firmware | Update the scanner firmware installed in the MFP. |

[F115] S-VDEN ON signal time-out error**[F116] S-VDEN OFF signal time-out error**

| Classification | Error content |
|--------------------------------------|--|
| Scanning system related service call | The scanning job has not finished normally. (The MFP will be rebooted at the first time the error occurs.) |

| Check item | Measures |
|-----------------------|---|
| Reproducibility | Turn the power OFF and then back ON to check the occurrence. If it changes to another code, follow its troubleshooting procedure. |
| Harness, connector | <ul style="list-style-type: none"> • Check if the joint connector (J12) between the DSDF and the MFP is connected properly or there is any abnormality in it. • Check if there is any abnormality in the harnesses between the SYS board and the joint connector, and between the joint connector and the DSDF control PC board. • If there is any abnormality such as scratches, open-circuit and catching on the harness or its pin is deformed, replace them. |
| DSDF control PC board | <ul style="list-style-type: none"> • PC board check • Connector check • Harness check • Replace the PC board. |
| SYS board | <ul style="list-style-type: none"> • PC board check • Connector check • Harness check • Replace the PC board. |

| Parts to be replaced | Remarks |
|-----------------------|---------|
| Harness | |
| DSDF control PC board | |
| SYS board | |

[F117] S-VDEN ON (back side) signal time-out error**[F118] S-VDEN OFF (back side) signal time-out error**

| Classification | Error content |
|--------------------------------------|--|
| Scanning system related service call | The scanning job has not finished normally. (The MFP will be rebooted at the first time the error occurs.) |

| Check item | Measures |
|-----------------------|---|
| Reproducibility | Turn the power OFF and then back ON to check the occurrence. If it changes to another code, follow its troubleshooting procedure. |
| Harness, connector | <ul style="list-style-type: none"> • Check if the joint connector (J12) between the DSDF and the MFP is connected properly or there is any abnormality in it. • Check if there is any abnormality in the harnesses between the SYS board and the joint connector, and between the joint connector and the DSDF control PC board. • If there is any abnormality such as scratches, open-circuit and catching on the harness or its pin is deformed, replace them. |
| DSDF control PC board | <ul style="list-style-type: none"> • PC board check • Connector check (CN71) • Harness check • Replace the PC board. |
| SYS board | <ul style="list-style-type: none"> • PC board check • Connector check • Harness check • Replace the PC board. |

| Parts to be replaced | Remarks |
|-----------------------|---------|
| Harness | |
| DSDF control PC board | |
| SYS board | |

[F119] Scanner abnormality detection

| Classification | Error content |
|--------------------------------------|--|
| Scanning system related service call | There is an abnormality in the connection between the scanner-CPU and the system-CPU (This error is determined when the problem is not solved even if the MFP is rebooted by the specified number of times.) |
| Check item | Measures |
| SYS board | <ul style="list-style-type: none"> PC board check Replace the PC board. |
| Parts to be replaced | Remarks |
| SYS board | |

[F11A] Scanner communication error

| Classification | Error content |
|--------------------------------------|---|
| Scanning system related service call | Communication error between the CCD board and the SYS board (The MFP will be rebooted at the first time the error occurs.) |
| Check item | Measures |
| Reproducibility | Turn the power OFF and then back ON. Then check if the error code changes to another one. If it changes to another code, follow its troubleshooting procedure. |
| Harness | <ul style="list-style-type: none"> Check if there is an abnormality in the harness between the CCD board and the SYS board. Check if the harness is connected to the connector properly. If there is any abnormality such as scratches, open-circuit and catching on the harness or its pin is deformed, replace them. |
| CCD board | <ul style="list-style-type: none"> PC board check Connector check (CN001) Harness check Replace the PC board. |
| SYS board | <ul style="list-style-type: none"> PC board check Connector check Harness check Replace the PC board. |
| Parts to be replaced | Remarks |
| Harness | |
| CCD board | |
| SYS board | |

[F11B] Communication error between the DSDF-CCD module and the SYS board

| Classification | Error content |
|--------------------------------------|---|
| Scanning system related service call | Communication error between the DSDF-CCD module and the SYS board (The MFP will be rebooted at the first time the error occurs.) |
| Check item | Measures |
| Reproducibility | Turn the power OFF and then back ON. Then check if the error code changes to another one. If it changes to another code, follow its troubleshooting procedure. |
| SYS board | <ul style="list-style-type: none"> PC board check Connector check Harness check Replace the PC board. |

| Check item | Measures |
|-----------------------|--|
| DSDF I/F board | <ul style="list-style-type: none"> • Check if the DSDF I/F board is installed in the SYS board properly. • Check if there is any abnormality in the connector (CN89) of the DSDF I/F board. • Check if the connectors between the DSDF I/F board and the DSDF control PC board are disconnected or the harnesses are open circuited. Correct it if there is abnormality. • Check if there is any abnormality in the DSDF I/F board (IC6, IC9, IC204). • Replace the DSDF I/F board. |
| DSDF control PC board | <ul style="list-style-type: none"> • PC board check • Connector check • Harness check • Replace the PC board. |
| HDMI cable | Check if the HDMI cables (CN78, CN90) are connected properly. |
| DSDF-CCD module | <ul style="list-style-type: none"> • Check if the connectors of the DSDF-CCD module are connected properly. • Check if there is any abnormality in the DSDF-CCD module. |

| Parts to be replaced | Remarks |
|-----------------------|---------|
| Harness | |
| DSDF I/F board | |
| DSDF control PC board | |
| DSDF-CCD module | |
| SYS board | |

[F120] Database error

| Classification | Error content |
|-----------------------------|-------------------------------------|
| System related service call | Database is not operating normally. |

| Check item | Measures |
|-------------------------|--|
| Database | <p>Check that no jobs are remaining. Then perform HS-75 File System Recovery > Initialize DB > LDAP DB and Log DB(Job,Msg) to rebuild the database.</p> <p>Notes:</p> <ul style="list-style-type: none"> • If an attempt is made to rebuild the database with jobs remaining, delete them after completing. • When [Rebuilding all database] is performed, all data included in Log, User, Role, Group, Department and Address book information will be deleted. After rebuilding, data can be recovered by restoring those backed up in advance. |
| Firmware | Reinstall the system software. HS-49 Firmware Update > System Software(HD data) |
| Standard storage device | <ul style="list-style-type: none"> • Connector check • Replace the standard storage device. |
| Optional storage device | <ul style="list-style-type: none"> • Replace the optional storage device. • Replace the harness of the optional storage device. |

| Parts to be replaced | Remarks |
|-------------------------|---------|
| Standard storage device | |
| Optional storage device | |

[F121] User Information management database error

| Classification | Error content |
|-----------------------------|---|
| System related service call | Login after the startup with any mode has failed because the user management information database is damaged. |

| Check item | Measures |
|-------------------------|--|
| Database | <p>Check that no jobs are remaining. Then perform HS-75 File System Recovery > Initialize DB > LDAP DB to rebuild the database.</p> <p>Notes:</p> <ul style="list-style-type: none"> • If an attempt is made to rebuild the database with jobs remaining, delete them after completing. • When [Rebuilding all database] is performed, all data included in Log, User, Role, Group, Department and Address book information will be deleted. After rebuilding, data can be recovered by restoring those backed up in advance. |
| Firmware | Reinstall the system software. HS-49 Firmware Update > System Software(HD data) |
| Standard storage device | <ul style="list-style-type: none"> • Connector check • Replace the standard storage device. |
| Optional storage device | <ul style="list-style-type: none"> • Replace the optional storage device. • Replace the harness of the optional storage device. |

| Parts to be replaced | Remarks |
|-------------------------|---------|
| Standard storage device | |
| Optional storage device | |

[F122] Message/job log management database error

| Classification | Error content |
|-----------------------------|--|
| System related service call | Login after the startup with any mode has failed because the log management information database is damaged. |

| Check item | Measures |
|-------------------------|--|
| Database | <p>Check that no jobs are remaining. Then perform HS-75 File System Recovery > Initialize DB > Log DB(Job,Msg) to rebuild the database.</p> <p>Notes:</p> <ul style="list-style-type: none"> • If an attempt is made to rebuild the database with jobs remaining, delete them after completing. • When [Rebuilding all database] is performed, all data included in Log, User, Role, Group, Department and Address book information will be deleted. After rebuilding, data can be recovered by restoring those backed up in advance. |
| Firmware | Reinstall the system software. HS-49 Firmware Update > System Software(HD data) |
| Standard storage device | <ul style="list-style-type: none"> • Connector check • Replace the standard storage device. |
| Optional storage device | <ul style="list-style-type: none"> • Replace the optional storage device. • Replace the harness of the optional storage device. |

| Parts to be replaced | Remarks |
|-------------------------|---------|
| Standard storage device | |
| Optional storage device | |

[F124] Application management database error

| Classification | Error content |
|-----------------------------|---|
| System related service call | The application management database is damaged. |
| Check item | Measures |
| Database | Perform HS-75 File System Recovery > Initialize DB > AppMgmt DB to delete the journal file. Notes: All of the application information will be deleted. |
| Firmware | Reinstall the system software. HS-49 Firmware Update > System Software(HD data) |
| Standard storage device | <ul style="list-style-type: none"> Connector check Replace the standard storage device. |
| Optional storage device | <ul style="list-style-type: none"> Replace the optional storage device. Replace the harness of the optional storage device. |
| Parts to be replaced | Remarks |
| Standard storage device | |
| Optional storage device | |

[F125] Home screen database error

| Classification | Error content |
|-----------------------------|---|
| System related service call | The home screen database is damaged. |
| Check item | Measures |
| Database | Perform HS-75 File System Recovery > Initialize DB > HomeScreen DB to delete the journal file. |
| Firmware | Reinstall the system software. HS-49 Firmware Update > System Software(HD data) |
| Standard storage device | <ul style="list-style-type: none"> Connector check Replace the standard storage device. |
| Optional storage device | <ul style="list-style-type: none"> Replace the optional storage device. Replace the harness of the optional storage device. |
| Parts to be replaced | Remarks |
| Standard storage device | |
| Optional storage device | |

[F126] Job history database error

| Classification | Error content |
|-----------------------------|---|
| System related service call | The job history database is damaged. |
| Check item | Measures |
| Database | Perform HS-75 File System Recovery > Initialize DB > JobHistory DB to delete the journal file. |
| Firmware | Reinstall the system software. HS-49 Firmware Update > System Software(HD data) |
| Standard storage device | <ul style="list-style-type: none"> Connector check Replace the standard storage device. |
| Optional storage device | <ul style="list-style-type: none"> Replace the optional storage device. Replace the harness of the optional storage device. |
| Parts to be replaced | Remarks |
| Standard storage device | |
| Optional storage device | |

[F127] Application license management database error

| Classification | Error content |
|-----------------------------|---|
| System related service call | The application license management database is damaged. |

| Check item | Measures |
|-------------------------|---|
| Database | Perform HS-75 File System Recovery > Initialize DB > AppLicense DB to delete the journal file. |
| Firmware | Reinstall the system software. HS-49 Firmware Update > System Software(HD data) |
| Standard storage device | <ul style="list-style-type: none"> Connector check Replace the standard storage device. |
| Optional storage device | <ul style="list-style-type: none"> Replace the optional storage device. Replace the harness of the optional storage device. |

| Parts to be replaced | Remarks |
|-------------------------|---------|
| Standard storage device | |
| Optional storage device | |

[F128] License manager database error

| Classification | Error content |
|-----------------------------|--|
| System related service call | The license manager database is damaged. |

| Check item | Measures |
|-------------------------|--|
| Reproducibility | Turn the power OFF and then back ON to check the occurrence. If the error code is changed to 71E0, follow its troubleshooting procedure. |
| Database | <ol style="list-style-type: none"> Perform HS-75 File System Recovery > Initialize DB > ULM DB to delete the journal file. Reboot the MFP to check the occurrence. If the error code is changed to 71E0, follow its troubleshooting procedure. |
| SRAM | Replace the SRAM. |
| Standard storage device | <ul style="list-style-type: none"> Connector check Replace the standard storage device. |
| Optional storage device | <ul style="list-style-type: none"> Replace the optional storage device. Replace the harness of the optional storage device. |

| Parts to be replaced | Remarks |
|-------------------------|---------|
| Standard storage device | |
| Optional storage device | |

[F130] Invalid MAC address

| Classification | Error content |
|-----------------------------|--|
| System related service call | This error will occur when the first 3 bytes of the MAC address is not "00", "80", "91" or "C8", "3A", "1B". |

| Check item | Measures |
|------------|-----------------------|
| SYS board | Replace the PC board. |

| Parts to be replaced | Remarks |
|----------------------|---------|
| SYS board | |

[F131] Filtering setting file damage error

| Classification | Error content |
|-----------------------------|--|
| System related service call | The filtering function does not work properly due to the damage to the file for the filtering setting. |

| Check item | Measures |
|------------|---|
| Format | <p>Perform HS-73 Firmware Assist > Format Storage, and then install "System Software (HD data)" with HS-49 Firmware Update.</p> <p>Notes: The following contents will be deleted with this operation.</p> <ul style="list-style-type: none"> • Message Log • Job Log • Spool Data (Print, Email reception) • Template |

| Parts to be replaced | Remarks |
|-------------------------|---------|
| Standard storage device | |
| Optional storage device | |

[F141_0] Standard storage device installation error

[F141_1] Standard storage device root partition mount error (formatting failure)

[F141_2] Standard storage device partition mount error

[F141_3] Standard storage device partition mount error

| Classification | Error content |
|-----------------------------|---|
| System related service call | <p>Sub code 0: The installation of the storage device cannot be detected.</p> <p>Sub code 1: The storage device cannot be installed due to damage to the areas in which the program is mainly stored.</p> <p>Sub codes 2, 3: The areas other than those described in the F101_1 and F101_4 to F101_10 errors are damaged.</p> |

| Check item | Measures |
|----------------------------|--|
| 1. SRAM | Check if the SRAM was used in another MFP. |
| 2. Standard storage device | <p>Turn the power of the MFP OFF and check the installation status of the standard storage device.</p> <ul style="list-style-type: none"> • Check if there is any abnormality in the connector. • Check if the connector pins are bent. • Check if the standard storage device was used in another MFP. |
| 3. Key | <p>If the error still persists even after step 2, perform this step.</p> <ul style="list-style-type: none"> • Perform HS-73 Firmware Assist > Key Backup/Restore and check that each Key Status is "OK". • If not, recover the key. (Carry out SRAM to FROM copying or FROM to SRAM copying.) |
| 4. Format | <p>If the error still persists even after step 3, perform this step.</p> <p>Perform HS-73 Firmware Assist > Format Storage, and then install "System Software (HD data)" with HS-49 Firmware Update.</p> <p>Notes: The following contents will be deleted with this operation.</p> <ul style="list-style-type: none"> • Message Log • Job Log • Spool Data (Print, Email reception) • Template |
| 5. Setting | <p>If an F101_1 error has occurred while a security storage device is installed or if the error still persists even after step 4, perform the following item and reattempt step 4.</p> <ul style="list-style-type: none"> • HS-74 Storage Assist > Revert Factory Initial Status Storage |
| 6. Standard storage device | If the error still persists even after step 5, replace the standard storage device. |
| 7. SYS board | If the error still persists even after step 6, replace the SYS board. |

| Parts to be replaced | Remarks |
|-------------------------|---------|
| Standard storage device | |
| SYS board | |

[F141_4] Standard storage device partition mount error

[F141_12] Standard storage device mount error

| Classification | Error content |
|-----------------------------|---|
| System related service call | Sub code 4: The "/work" partition is damaged. Sub code 12: File link error in the "/work" partition. |

| Check item | Measures |
|----------------------------|---|
| 1. SRAM | Check if the SRAM was used in another MFP. |
| 2. Standard storage device | Turn the power of the MFP OFF and check the installation status of the standard storage device. <ul style="list-style-type: none"> Check if there is any abnormality in the connector. Check if the connector pins are bent. Check if the standard storage device was used in another MFP. |
| 3. Key | If the error still persists even after step 2, perform this step. <ul style="list-style-type: none"> Perform HS-73 Firmware Assist > Key Backup/Restore and check that each Key Status is "OK". If not, recover the key. (Carry out SRAM to FROM copying or FROM to SRAM copying.) |
| 4. Recovery | If the error still persists even after step 3, perform HS-75 File System Recovery > Recovery F/S > /work and then reboot the MFP. |
| 5. Initialization | If the error still persists even after step 4, perform HS-75 File System Recovery > Initialize Storage > /work and then reboot the MFP. |
| 6. Format | If the error still persists even after step 5, perform this step. Perform HS-73 Firmware Assist > Format Storage and then install "System Software (HD data)" with HS-49 Firmware Update. <p>Notes:</p> <p>The following contents will be deleted with this operation.</p> <ul style="list-style-type: none"> Message Log Job Log Spool Data (Print, Email reception) Template |
| 7. Setting | If the error still persists even after step 6, perform the following and then reattempt step 6. <ul style="list-style-type: none"> HS-74 Storage Assist > Revert Factory Initial Status Storage |
| 8. Standard storage device | If the error still persists even after step 7, replace the standard storage device. |
| 9. SYS board | If the error still persists even after step 8, replace the SYS board. |

| Parts to be replaced | Remarks |
|-------------------------|---------|
| Standard storage device | |
| SYS board | |

[F141_5] Partition mount error

| Classification | Error content |
|-----------------------------|---|
| System related service call | Sub code 5: The "/registration" partition is damaged. |

| Check item | Measures |
|----------------------------|--|
| 1. SRAM | Check if the SRAM was used in another MFP. |
| 2. Standard storage device | Turn the power of the MFP OFF and check the installation status of the standard storage device. <ul style="list-style-type: none"> • Check if there is any abnormality in the connector. • Check if the connector pins are bent. • Check if the standard storage device was used in another MFP. |
| 3. Key | If the error still persists even after step 2, perform this step. <ul style="list-style-type: none"> • Perform HS-73 Firmware Assist > Key Backup/Restore and check that each Key Status is "OK". • If not, recover the key. (Carry out SRAM to FROM copying or FROM to SRAM copying.) |
| 4. Recovery | If the error still persists after step 3, perform HS-75 File System Recovery > Recovery F/S > /registration and reboot the MFP. |
| 5. Initialization | If the error still persists even after step 4, perform HS-75 File System Recovery > Initialize Storage > /registration and then reboot the MFP. |
| 6. Format | If the error still persists even after step 5, perform this step. Perform HS-73 Firmware Assist > Format Storage and then install "System Software (HD data)" with HS-49 Firmware Update. <p>Notes: The following contents will be deleted with this operation.</p> <ul style="list-style-type: none"> • Message Log • Job Log • Spool Data (Print, Email reception) • Template |
| 7. Setting | If the error still persists even after step 6, perform the following and then reattempt step 6. <ul style="list-style-type: none"> • HS-74 Storage Assist > Revert Factory Initial Status Storage |
| 8. Standard storage device | If the error still persists even after step 7, replace the standard storage device. |
| 9. SYS board | If the error still persists even after step 8, replace the SYS board. |

| Parts to be replaced | Remarks |
|-------------------------|---------|
| Standard storage device | |
| SYS board | |

[F141_6] Partition mount error

| Classification | Error content |
|-----------------------------|--|
| System related service call | Sub code 6: The "/backup" partition is damaged. |
| Check item | Measures |
| 1. SRAM | Check if the SRAM was used in another MFP. |
| 2. Standard storage device | Turn the power of the MFP OFF and check the installation status of the standard storage device. <ul style="list-style-type: none"> • Check if there is any abnormality in the connector. • Check if the connector pins are bent. • Check if the standard storage device was used in another MFP. |
| 3. Key | If the error still persists even after step 2, perform this step. <ul style="list-style-type: none"> • Perform HS-73 Firmware Assist > Key Backup/Restore and check that each Key Status is "OK". • If not, recover the key. (Carry out SRAM to FROM copying or FROM to SRAM copying.) |
| 4. Recovery | If the error still persists even after step 3, perform HS-75 File System Recovery > Recovery F/S > /backup and then reboot the MFP. |
| 5. Initialization | If the error still persists even after step 4, perform HS-75 File System Recovery > Initialize Storage > /backup and then reboot the MFP. |
| 6. Format | If the error still persists even after step 5, perform this step. Perform HS-73 Firmware Assist > Format Storage and then install "System Software (HD data)" with HS-49 Firmware Update. <p>Notes: The following contents will be deleted with this operation.</p> <ul style="list-style-type: none"> • Message Log • Job Log • Spool Data (Print, Email reception) • Template |
| 7. Setting | If the error still persists even after step 6, perform the following and then reattempt step 6. <ul style="list-style-type: none"> • HS-74 Storage Assist > Revert Factory Initial Status Storage |
| 8. Standard storage device | If the error still persists even after step 7, replace the standard storage device. |
| 9. SYS board | If the error still persists even after step 8, replace the SYS board. |
| Parts to be replaced | Remarks |
| Standard storage device | |
| SYS board | |

[F141_7] Partition mount error

| Classification | Error content |
|-----------------------------|--|
| System related service call | Sub code 7: The "/imagedata" partition is damaged. |
| Check item | Measures |
| 1. SRAM | Check if the SRAM was used in another MFP. |
| 2. Standard storage device | Turn the power of the MFP OFF and check the installation status of the standard storage device. <ul style="list-style-type: none"> • Check if there is any abnormality in the connector. • Check if the connector pins are bent. • Check if the standard storage device was used in another MFP. |
| 3. Key | If the error still persists even after step 2, perform this step. <ul style="list-style-type: none"> • Perform HS-73 Firmware Assist > Key Backup/Restore and check that each Key Status is "OK". • If not, recover the key. (Carry out SRAM to FROM copying or FROM to SRAM copying.) |
| 4. Recovery | If the error still persists after step 3, perform HS-75 File System Recovery > Recovery F/S > /imagedata and reboot the MFP. |
| 5. Initialization | If the error still persists even after step 4, perform HS-75 File System Recovery > Initialize Storage > /imagedata and then reboot the MFP. |
| 6. Format | If the error still persists even after step 5, perform this step. Perform HS-73 Firmware Assist > Format Storage and then install "System Software (HD data)" with HS-49 Firmware Update. <p>Notes: The following contents will be deleted with this operation.</p> <ul style="list-style-type: none"> • Message Log • Job Log • Spool Data (Print, Email reception) • Template |
| 7. Setting | If the error still persists even after step 6, perform the following and then reattempt step 6. <ul style="list-style-type: none"> • HS-74 Storage Assist > Revert Factory Initial Status Storage |
| 8. Standard storage device | If the error still persists even after step 7, replace the standard storage device. |
| 9. SYS board | If the error still persists even after step 8, replace the SYS board. |
| Parts to be replaced | Remarks |
| Standard storage device | |
| SYS board | |

[F141_8] Partition mount error

| Classification | Error content |
|-----------------------------|--|
| System related service call | Sub code 8: The "/storage" partition is damaged. |
| Check item | Measures |
| 1. SRAM | Check if the SRAM was used in another MFP. |
| 2. Standard storage device | Turn the power of the MFP OFF and check the installation status of the standard storage device. <ul style="list-style-type: none"> • Check if there is any abnormality in the connector. • Check if the connector pins are bent. • Check if the standard storage device was used in another MFP. |
| 3. Key | If the error still persists even after step 2, perform this step. <ul style="list-style-type: none"> • Perform HS-73 Firmware Assist > Key Backup/Restore and check that each Key Status is "OK". • If not, recover the key. (Carry out SRAM to FROM copying or FROM to SRAM copying.) |
| 4. Recovery | If the error still persists even after step 3, perform HS-75 File System Recovery > Recovery F/S > /storage and then reboot the MFP. |
| 5. Initialization | If the error still persists even after step 4, perform HS-75 File System Recovery > Initialize Storage > /storage and then reboot the MFP. |
| 6. Format | If the error still persists even after step 5, perform this step. Perform HS-73 Firmware Assist > Format Storage and then install "System Software (HD data)" with HS-49 Firmware Update. <p>Notes: The following contents will be deleted with this operation.</p> <ul style="list-style-type: none"> • Message Log • Job Log • Spool Data (Print, Email reception) • Template |
| 7. Setting | If the error still persists even after step 6, perform the following and then reattempt step 6. <ul style="list-style-type: none"> • HS-74 Storage Assist > Revert Factory Initial Status Storage |
| 8. Standard storage device | If the error still persists even after step 7, replace the standard storage device. |
| 9. SYS board | If the error still persists even after step 8, replace the SYS board. |
| Parts to be replaced | Remarks |
| Standard storage device | |
| SYS board | |

[F141_9] Partition mount error

| Classification | Error content |
|-----------------------------|--|
| System related service call | Sub code 9: The "/encryption" partition is damaged. |
| Check item | Measures |
| 1. SRAM | Check if the SRAM was used in another MFP. |
| 2. Standard storage device | Turn the power of the MFP OFF and check the installation status of the standard storage device. <ul style="list-style-type: none"> • Check if there is any abnormality in the connector. • Check if the connector pins are bent. • Check if the standard storage device was used in another MFP. |
| 3. Key | If the error still persists even after step 2, perform this step. <ul style="list-style-type: none"> • Perform HS-73 Firmware Assist > Key Backup/Restore and check that each Key Status is "OK". • If not, recover the key. (Carry out SRAM to FROM copying or FROM to SRAM copying.) |
| 4. Recovery | If the error still persists after step 3, perform HS-75 File System Recovery > Recovery F/S > /encryption and reboot the MFP. |
| 5. Initialization | If the error still persists even after step 4, perform HS-75 File System Recovery > Initialize Storage > /encryption and then reboot the MFP. |
| 6. Format | If the error still persists even after step 5, perform this step. Perform HS-73 Firmware Assist > Format Storage and then install "System Software (HD data)" with HS-49 Firmware Update. <p>Notes: The following contents will be deleted with this operation.</p> <ul style="list-style-type: none"> • Message Log • Job Log • Spool Data (Print, Email reception) • Template |
| 7. Setting | If the error still persists even after step 6, perform the following and then reattempt step 6. <ul style="list-style-type: none"> • HS-74 Storage Assist > Revert Factory Initial Status Storage |
| 8. Standard storage device | If the error still persists even after step 7, replace the standard storage device. |
| 9. SYS board | If the error still persists even after step 8, replace the SYS board. |
| Parts to be replaced | Remarks |
| Standard storage device | |
| SYS board | |

[F141_10] Partition mount error

| Classification | Error content |
|-----------------------------|--|
| System related service call | Sub code 10: The "/application" partition is damaged. |
| Check item | Measures |
| 1. SRAM | Check if the SRAM was used in another MFP. |
| 2. Standard storage device | Turn the power of the MFP OFF and check the installation status of the standard storage device. <ul style="list-style-type: none"> • Check if there is any abnormality in the connector. • Check if the connector pins are bent. • Check if the standard storage device was used in another MFP. |
| 3. Key | If the error still persists even after step 2, perform this step. <ul style="list-style-type: none"> • Perform HS-73 Firmware Assist > Key Backup/Restore and check that each Key Status is "OK". • If not, recover the key. (Carry out SRAM to FROM copying or FROM to SRAM copying.) |
| 4. Recovery | If the error still persists after step 3, perform HS-75 File System Recovery > Recovery F/S > /application and reboot the MFP. |
| 5. Initialization | If the error still persists even after step 4, perform HS-75 File System Recovery > Initialize Storage > /application and then reboot the MFP. |
| 6. Format | If the error still persists even after step 5, perform this step. Perform HS-73 Firmware Assist > Format Storage and then install "System Software (HD data)" with HS-49 Firmware Update. <p>Notes: The following contents will be deleted with this operation.</p> <ul style="list-style-type: none"> • Message Log • Job Log • Spool Data (Print, Email reception) • Template |
| 7. Setting | If the error still persists even after step 6, perform the following and then reattempt step 6. <ul style="list-style-type: none"> • HS-74 Storage Assist > Revert Factory Initial Status Storage |
| 8. Standard storage device | If the error still persists even after step 7, replace the standard storage device. |
| 9. SYS board | If the error still persists even after step 8, replace the SYS board. |
| Parts to be replaced | Remarks |
| Standard storage device | |
| SYS board | |

[F141_11] Partition mount error

| Classification | Error content |
|-----------------------------|--|
| System related service call | Sub code 11: The "/platform" partition is damaged. |

| Check item | Measures |
|----------------------------|--|
| 1. SRAM | Check if the SRAM was used in another MFP. |
| 2. Standard storage device | Turn the power of the MFP OFF and check the installation status of the standard storage device. <ul style="list-style-type: none"> • Check if there is any abnormality in the connector. • Check if the connector pins are bent. • Check if the standard storage device was used in another MFP. |
| 3. Format | If the error still persists even after step 2, perform this step. Perform HS-73 Firmware Assist > Format Storage and then install "System Software (HD data)" with HS-49 Firmware Update. Notes: The following contents will be deleted with this operation. <ul style="list-style-type: none"> • Message Log • Job Log • Spool Data (Print, Email reception) • Template |
| 4. Setting | If the error still persists even after step 3, perform the following and then reattempt step 3. <ul style="list-style-type: none"> • HS-74 Storage Assist > Initialize Storage > /application |
| 5. Standard storage device | If the error still persists even after step 4, replace the standard storage device. |
| 6. SYS board | If the error still persists even after step 5, replace the SYS board. |

| Parts to be replaced | Remarks |
|-------------------------|---------|
| Standard storage device | |
| SYS board | |

[F141_13] Error due to damage to file

| Classification | Error content |
|-----------------------------|---|
| System related service call | Sub code 13: A file in the "/imagedata" partition is damaged. |

| Check item | Measures |
|----------------------------|--|
| 1. SRAM | Check if the SRAM was used in another MFP. |
| 2. Standard storage device | Turn the power of the MFP OFF and check the installation status of the standard storage device. <ul style="list-style-type: none"> • Check if there is any abnormality in the connector. • Check if the connector pins are bent. • Check if the standard storage device was used in another MFP. |
| 3. Recovery | If the error still persists even after step 2, perform this step. <ul style="list-style-type: none"> • Perform HS-75 File System Recovery > Recovery F/S > /imagedata and reboot the MFP. |
| 4. Format | If the error still persists even after step 3, perform this step. Perform HS-73 Firmware Assist > Format Storage and then install "System Software (HD data)" with HS-49 Firmware Update. Notes: The following contents will be deleted with this operation. <ul style="list-style-type: none"> • Message Log • Job Log • Spool Data (Print, Email reception) • Template |
| 5. Setting | If the error still persists even after step 4, perform the following and then reattempt step 4. <ul style="list-style-type: none"> • HS-74 Storage Assist > Revert Factory Initial Status Storage |
| 6. Standard storage device | If the error still persists even after step 5, replace the standard storage device. |

| Check item | Measures |
|-------------------------|---|
| 7. SYS board | If the error still persists even after step 6, replace the SYS board. |
| Parts to be replaced | Remarks |
| Standard storage device | |
| SYS board | |

[F141_14] Partition mount error

| Classification | Error content |
|-----------------------------|---|
| System related service call | Sub code 14: The standard storage device cannot be installed due to the damage to the “//rollback” partition. |

| Check item | Measures |
|----------------------------|---|
| 1. Reproducibility | Reboot the MFP. |
| 2. SRAM | Check if the SRAM was used in another MFP. |
| 2. Standard storage device | Turn the power of the MFP OFF and check the installation status of the standard storage device. <ul style="list-style-type: none"> • Check if there is any abnormality in the connector. • Check if the connector pins are bent. • Check if the standard storage device was used in another MFP. |
| 4. Format | If the error still persists even after step 3, perform this step. Perform HS-73 Firmware Assist > Format Storage and then install “System Software (HD data)” with HS-49 Firmware Update. <p>Notes: The following contents will be deleted with this operation.</p> <ul style="list-style-type: none"> • Message Log • Job Log • Spool Data (Print, Email reception) • Template |
| 5. Setting | If the error still persists even after step 4, perform the following and then reattempt step 4. <ul style="list-style-type: none"> • HS-74 Storage Assist > Revert Factory Initial Status Storage |
| 6. Standard storage device | If the error still persists even after step 5, replace the standard storage device. |
| 7. SYS board | If the error still persists even after step 6, replace the SYS board. |

| Parts to be replaced | Remarks |
|-------------------------|---------|
| Standard storage device | |
| SYS board | |

[F150] Power failure during the manufacturing mode

| Classification | Error content |
|-----------------------------|---|
| System related service call | When a power failure occurred during the manufacturing mode, this error code appears at the next startup. |

| Check item | Measures |
|-----------------|---|
| Reproducibility | Turn the power OFF and then back ON. Then check if the error code changes to another one. If it changes to another code, follow its troubleshooting procedure. |
| Setting | Set "0" in FS-08-9010. If it changes to another code, follow its troubleshooting procedure. |

[F200] Data Overwrite Enabler disabled

| Classification | Error content |
|-----------------------------|---|
| System related service call | The data overwrite function has become disabled. Remarks: An F200 error will not occur in an MFP in which a data overwrite enabler is installed as the standard. |

| Check item | Measures |
|------------|--|
| License | Set "1" in FS-08-9238 to enable the license. |

[F350] SYS board abnormality

| Classification | Error content |
|-----------------------------|-----------------------|
| System related service call | SYS board abnormality |

| Check item | Measures |
|------------|--|
| Firmware | <ul style="list-style-type: none"> Check if the combination of the version for all the firmware items installed in the MFP is appropriate. Reinstall the firmware with the correct combination of the version. |
| SYS board | <ul style="list-style-type: none"> PC board check Connector check Harness check Replace the PC board. |

| Parts to be replaced | Remarks |
|----------------------|---------|
| SYS board | |

[F351] SYS board abnormality

| Classification | Error content |
|-----------------------------|-----------------------|
| System related service call | SYS board abnormality |

| Check item | Measures |
|---------------------|---|
| Firmware | <ul style="list-style-type: none"> Check if the combination of the version for the system firmware, system software and scanner firmware installed in the MFP is appropriate. Reinstall the firmware with the correct combination of the version. |
| DSDf relay PC board | <ul style="list-style-type: none"> PC board check Connector check (CN129) Harness check Replace the PC board. |
| SYS board | <ul style="list-style-type: none"> PC board check Connector check Harness check Replace the PC board. |

| Parts to be replaced | Remarks |
|----------------------|---------|
| DSDf relay PC board | |
| SYS board | |

[F400] SYS board cooling fan abnormality

| Classification | Error content |
|-----------------------------|---|
| System related service call | There is an abnormality in the SYS board cooling fan. |
| Check item | Measures |
| SYS board cooling fan | Check if the SYS board cooling fan is rotating properly. Check if there is any foreign matter on the SYS board cooling fan. |
| SYS board | <ul style="list-style-type: none"> • PC board check • Connector check (CN117) • Harness check • Replace the PC board. |
| Parts to be replaced | Remarks |
| SYS board cooling fan | |
| SYS board | |

[F410] Power abnormality

| Classification | Error content |
|-----------------------------|---|
| System related service call | The status of the LSI mounted on the SYS board has become an error due to a power abnormality. The MFP will be automatically rebooted at the first-time occurrence; however, the error history will not remain when rebooting is done automatically. This error code appears if an error has occurred continuously. |
| Check item | Measures |
| Power cable | <ul style="list-style-type: none"> • Check if the power cable is inserted securely. • Check if there is any abnormality such as scratches in the power cable. |
| User's site | <ul style="list-style-type: none"> • Do not plug any cables for other devices in the outlet to which that for the MFP is connected. • The power cable co-packed with the MFP must be used. • The power cable must be used without employing any extension cables. • Be sure to use an outlet which is far from the one to which a device, such as an air conditioner or a printer, which uses a large amount of power is connected. |
| Switching regulator | <ul style="list-style-type: none"> • PC board check • Connector check • Harness check • Replace the PC board. |
| SYS board | <ul style="list-style-type: none"> • PC board check • Connector check • Harness check • Replace the PC board. |
| Parts to be replaced | Remarks |
| Switching regulator | |
| SYS board | |

[F510] Application start error

| Classification | Error content |
|-----------------------------|---|
| System related service call | Start of an application has failed. |
| Check item | Measures |
| Reproducibility | <ul style="list-style-type: none"> • Reboot the MFP. • Reinstall the system software. |

| Check item | Measures |
|------------|---|
| Format | Perform HS-73 Firmware Assist > Format Storage and then install "System Software (HD data)" with HS-49 Firmware Update. Notes: The following contents will be deleted with this operation. <ul style="list-style-type: none"> • Message Log • Job Log • Spool Data (Print, Email reception) • Template |

[F520] Operating system start error

| Classification | Error content |
|-----------------------------|-------------------------------------|
| System related service call | Start of an application has failed. |

| Check item | Measures |
|--------------------|--|
| 1. Reproducibility | <ul style="list-style-type: none"> • Reboot the MFP. • Reinstall the system software. |
| 2. Recovery | If the error still persists even after step 1, perform HS-75 File System Recovery > Check F/S. If there is a partition with an error, perform HS-75 File System Recovery > Recovery F/S and then reboot the MFP. |
| 3. Initialization | If the error still persists even after step 2, perform HS-75 File System Recovery > Initialize Storage and then reboot the MFP. |
| 4. Format | If the error still persists even after step 3, perform this step. Perform HS-73 Firmware Assist > Format Storage and then install "System Software (HD data)" with HS-49 Firmware Update. Notes: The following contents will be deleted with this operation. <ul style="list-style-type: none"> • Message Log • Job Log • Spool Data (Print, Email reception) • Template |

[F521] Integrity check error

| Classification | Error content |
|-----------------------------|---|
| System related service call | The program data authentication has failed. |

| Check item | Measures |
|-----------------|--|
| Reproducibility | Turn the power OFF and then back ON to check the occurrence. |
| Firmware | Reinstall all the firmware items and applications which are already stored in the MFP. (System firmware, system software, applications, engine firmware, scanner firmware, fax firmware) |

[F523] Security check error at the startup

| Classification | Error content |
|-----------------------------|--|
| System related service call | An abnormality has been detected during the security condition check at the startup. |

| Check item | Measures |
|-----------------|--|
| Reproducibility | Turn the power OFF and then back ON to check the occurrence. |
| Firmware | Reinstall all the firmware items and applications which are already stored in the MFP. (System firmware, system software, applications, engine firmware, scanner firmware, fax firmware) |

[F525] Invalid file execution error

| Classification | Error content |
|-----------------------------|--|
| System related service call | Execution of a possibly invalid file has been detected. |
| Check item | Measures |
| 1. Reproducibility | Turn the power OFF and then back ON to check the occurrence. |
| 2. Firmware | Reinstall all the firmware items and applications which are already stored in the MFP. (System firmware, system software, applications, engine firmware, scanner firmware, fax firmware) |
| 3. Format | If the error still persists even after step 2, perform this step and then reattempt step 2. <ul style="list-style-type: none"> HS-73 Firmware Assist > Format Storage |

[F526] Anti-malware function error

| Classification | Error content |
|-----------------------------|--|
| System related service call | A problem has occurred in the anti-malware function. <ul style="list-style-type: none"> Daemon cannot be started or is ended abnormally. The white list is broken. |
| Check item | Measures |
| 1. Reproducibility | Turn the power OFF and then back ON to check the occurrence. |
| 2. Firmware | Reinstall all the firmware items and applications which are already stored in the MFP. (System firmware, system software, applications, engine firmware, scanner firmware, fax firmware) |
| 3. Format | If the error still persists even after step 2, perform this step and then reattempt step 2. <ul style="list-style-type: none"> HS-73 Firmware Assist > Format Storage |

[F550] Encryption partition error

| Classification | Error content |
|-----------------------------|---|
| System related service call | Reading and writing of the encryption partition has failed. |
| Check item | Measures |
| Key | Perform HS-73 Firmware Assist mode > Key Backup/Restore and check the displayed message. Restore the encryption key according to the error and messages displayed in the "SRAM" and "FROM" fields. |

[F600] Firmware update error

| Classification | Error content |
|-----------------------------|---|
| System related service call | Updating of the firmware has failed. |
| Check item | Measures |
| Setting | <ol style="list-style-type: none"> Perform HS-73 Firmware Assist > Clear Software Update Error Flag. Reinstall the firmware in error on the F600 error screen. |

[F700] Overwrite error

| Classification | Error content |
|-----------------------------|---|
| System related service call | An error has occurred during overwriting. |
| Check item | Measures |
| Reproducibility | Reboot the MFP. |
| Optional storage device | Replace the optional storage device. |

[F800] Date error

| Classification | Error content |
|-----------------------------|---|
| System related service call | Year 2038 problem |
| Check item | Measures |
| Setting | <ol style="list-style-type: none"> 1. Perform HS-76 SRAM Maintenance > Reset Date and Time. 2. Ask the administrator to set the date and time. |

[F900] MFP information consistency error

| Classification | Error content |
|-----------------------------|--|
| System related service call | The MFP information is damaged. |
| Check item | Measures |
| Reproducibility | Perform HS-76 SRAM Maintenance > SRAM Re-initialize and reboot the MFP. |
| Optional storage device | <ol style="list-style-type: none"> 1. Perform HS-73 Firmware Assist > Key Backup/Restore. 2. Press [Key] twice. Check that the copying of the key from the FROM to the SRAM is selected. 3. Press [Execute]. When the restoring of the key is completed, "Success" appears. 4. After the operation is completed, shut down the MFP. |

[F901] Communication error

| Classification | Error content |
|------------------------------------|---|
| System related service call | <ul style="list-style-type: none"> • The information of the LGC board is damaged. • An LGC board for another model with a different processing speed has been installed. |
| Check item | Measures |
| Connection condition of connectors | Check if there is no problem in all the harnesses and connectors connected to the LGC board. |
| Optional storage device | <ul style="list-style-type: none"> • Check if an LGC board appropriate for the model has been installed. The model of the MFP can be confirmed by the rating label attached to it. The model matching the LGC board can be checked by looking at the label color attached to it. • If an LGC board for a different model has been installed, replace it with the appropriate one. |
| Parts to be replaced | Remarks |
| LGC board | |

8.3.6 Internet fax and scanning functions error

Notes:

When storage device initialization is performed (HS-75 File System Recovery > Initialize Storage), all data in the shared folder, e-Filing, Address Book, template, etc. are erased. Be sure to back up these data before the initialization. Note that some of data cannot be backed up.

 P. 9-31 “9.2.3 Precautions and procedures when replacing the storage device”

[1] Internet fax related error

[1C10] System access abnormality

| Classification | Error content |
|----------------------------|--|
| Internet fax related error | System access abnormality |
| Check item | Measures |
| Setting | Turn the power OFF and then back ON. Perform the job in error again. If the error still persists, check if the settings of SSL/TLS and the authentication are specified properly in the SMTP client setting. If the error nevertheless continues to persist, check if there are no jobs existing and then initialize the storage device. |

[1C11] Insufficient memory

| Classification | Error content |
|----------------------------|--|
| Internet fax related error | Insufficient memory |
| Check item | Measures |
| Setting | Perform the job in error again after the running jobs are completed if there are any. If the error still persists, turn the power OFF and then back ON and then perform the jobs again. |

[1C12] Message reception error

[1C13] Message transmission error

| Classification | Error content |
|----------------------------|--|
| Internet fax related error | [1C12] Message reception error [1C13] Message transmission error |
| Check item | Measures |
| Setting | Turn the power OFF and then back ON. Perform the job in error again. |

[1C14] Invalid parameter

| Classification | Error content |
|----------------------------|---|
| Internet fax related error | Invalid parameter |
| Check item | Measures |
| Setting | Form the template again if it is used. If the error still persists, turn the power OFF and then back ON and then perform the jobs again. |

[1C15] Exceeding file capacity

| Classification | Error content |
|----------------------------|--|
| Internet fax related error | Exceeding file capacity |
| Check item | Measures |
| Setting | Extend the “Maximum send to E-mail/IFAX size” or reduce the number of pages and perform the job again. |

[1C30] Directory creation failure**[1C31] File creation failure****[1C33] File access failure**

| Classification | Error content |
|----------------------------|---|
| Internet fax related error | [1C30] Directory creation failure [1C31] File creation failure [1C33] File access failure |
| Check item | Measures |
| Setting | Check if the access privilege to the storage directory is writable. Check if the server or local disk has sufficient space in its disk capacity. |
| Parts to be replaced | Remarks |
| SYS board | |

[1C32] File deletion failure

| Classification | Error content |
|----------------------------|---|
| Internet fax related error | File deletion failure |
| Check item | Measures |
| Setting | Turn the power OFF and then back ON. Perform the job in error again. If the error nevertheless continues to persist, check if there are no jobs existing and then initialize the storage device (HS-75 File System Recovery > Initialize Storage). |

[1C40] Image conversion abnormality

| Classification | Error content |
|----------------------------|--|
| Internet fax related error | Image conversion abnormality |
| Check item | Measures |
| Setting | Turn the power OFF and then back ON. Perform the job in error again. Replace the SYS board and perform the job again. |
| Parts to be replaced | Remarks |
| SYS board | |

[1C60] Storage device full during processing

| Classification | Error content |
|----------------------------|--|
| Internet fax related error | Storage device full failure during processing |
| Check item | Measures |
| Setting | Delete the jobs in being set, in running or in HOLD, PRIVATE, PROOF or INVALID and the perform the job again. Reduce the number of pages of the job in error and then perform it again. Check if the server or local disk has sufficient space in its disk capacity. |
| Parts to be replaced | Remarks |
| SYS board | |

[1C61] Address book reading failure

| Classification | Error content |
|----------------------------|---|
| Internet fax related error | AddressBook reading failure |
| Check item | Measures |
| Setting | Turn the power OFF and then back ON. Perform the job in error again. Reset the data in the Address Book and perform the job again. |

[1C63] Terminal IP address unset

| Classification | Error content |
|----------------------------|--|
| Internet fax related error | Terminal IP address unset |
| Check item | Measures |
| Setting | Reset the Terminal ID address. Turn the power OFF and then back ON. Perform the job in error again. |

[1C64] Terminal mail address unset

| Classification | Error content |
|----------------------------|--|
| Internet fax related error | Terminal mail address unset |
| Check item | Measures |
| Setting | Reset the Terminal mail address. Turn the power OFF and then back ON. Perform the job in error again. |

[1C65] SMTP mail address unset

| Classification | Error content |
|----------------------------|---|
| Internet fax related error | SMTP mail address unset |
| Check item | Measures |
| Setting | Reset the SMTP address and perform the job. Turn the power OFF and then back ON. Perform the job in error again. |

[1C66] Server time-out error

| Classification | Error content |
|----------------------------|--|
| Internet fax related error | Server time-out error |
| Check item | Measures |
| Setting | Check if the SMTP server works properly. |

[1C69] SMTP server connection error

| Classification | Error content |
|----------------------------|---|
| Internet fax related error | SMTP server connection error |
| Check item | Measures |
| Setting | Reset the login name and password of the SMTP server and perform the job again. Check if the SMTP server works properly. |

[1C6B] Terminal mail address error

| Classification | Error content |
|----------------------------|--|
| Internet fax related error | Terminal mail address error |
| Check item | Measures |
| Setting | Check if the SMTP authentication method is correct. Check if an invalid character is included in the Terminal mail address. Select the correct SMTP authentication method, set the appropriate Terminal mail address by removing invalid characters and perform the job again. |

[1C6C] Destination mail address error

| Classification | Error content |
|----------------------------|---|
| Internet fax related error | Destination mail address error |
| Check item | Measures |
| Setting | Check if an invalid character is included in the Destination mail address. Set the appropriate Destination mail address by removing invalid characters and perform the job again. |

[1C6D] System error

| Classification | Error content |
|----------------------------|--|
| Internet fax related error | System error |
| Check item | Measures |
| Setting | Turn the power OFF and then back ON. Perform the job in error again. If the error still persists, replace the SYS board. |
| Parts to be replaced | Remarks |
| SYS board | |

[1C70] SMTP client OFF

| Classification | Error content |
|----------------------------|--|
| Internet fax related error | SMTP client OFF |
| Check item | Measures |
| Setting | Enable the SMTP setting and perform the job again. |

[1C71] SMTP authentication error

| Classification | Error content |
|----------------------------|---|
| Internet fax related error | SMTP authentication error |
| Check item | Measures |
| Setting | Check if the SMTP authentication method, login name and password are correct. Then perform the job again. |

[1C72] POP before SMTP error

| Classification | Error content |
|----------------------------|---|
| Internet fax related error | POP before SMTP error |
| Check item | Measures |
| Setting | Check if both the settings of POP before SMTP and POP3 are correct. Then perform the job again. |

[1CC1] Power failure

| Classification | Error content |
|----------------------------|---|
| Internet fax related error | Power failure |
| Check item | Measures |
| Setting | Check if the power cable is connected properly or is inserted securely. Check if the power voltage is unstable. |

[2] RFC related error

[2500] HOST NAME error (RFC: 500), Destination mail address error (RFC: 500), Terminal mail address error (RFC: 500)

[2501] HOST NAME error (RFC: 501), Destination mail address error (RFC: 501), Terminal mail address error (RFC: 501)

| Classification | Error content |
|-------------------|--|
| RFC related error | [2500] HOST NAME error (RFC: 500), Destination mail address error (RFC: 500), Terminal mail address error (RFC: 500) [2501] HOST NAME error (RFC: 501), Destination mail address error (RFC: 501), Terminal mail address error (RFC: 501) |

| Check item | Measures |
|------------|---|
| Setting | Check if the Destination mail address and Destination mail address are correct. Check if the mail server works properly. Turn the power OFF and then back ON. Perform the job in error again. |

[2503] Destination mail address error (RFC: 503)

[2504] HOST NAME error (RFC: 504)

[2551] Destination mail address error (RFC: 551)

| Classification | Error content |
|-------------------|---|
| RFC related error | [2503] Destination mail address error (RFC: 503) [2504] HOST NAME error (RFC: 504) [2551] Destination mail address error (RFC: 551) |

| Check item | Measures |
|------------|---|
| Setting | Check if the mail server works properly. Turn the power OFF and then back ON. Perform the job in error again. If the error still persists, replace the SYS board. |

| Parts to be replaced | Remarks |
|----------------------|---------|
| SYS board | |

[2550] Destination mail address error (RFC: 550)

| Classification | Error content |
|-------------------|---|
| RFC related error | Destination mail address error (RFC: 550) |

| Check item | Measures |
|------------|---|
| Setting | Check the state of the mail box in the mail server. |

[2552] Terminal/destination mail address error (RFC: 552)

| Classification | Error content |
|-------------------|--|
| RFC related error | Terminal / Destination mail address error (RFC: 552) |

| Check item | Measures |
|------------|---|
| Setting | Confirm the capacity of the mail box in the mail server. Reattempt the transmission by selecting the text mode or selecting a lower resolution or dividing the original. Turn the power OFF and then back ON. Perform the job in error again. |

[2553] Destination mail address error (RFC: 553)

| Classification | Error content |
|-------------------|---|
| RFC related error | Destination mail address error (RFC: 553) |

| Check item | Measures |
|------------|---|
| Setting | Check if invalid characters are used in the mail box name in the mail server. |

[3] Remote scanning related error

[2A20] System management module resource acquiring failure

| Classification | Error content |
|-------------------------------|---|
| Remote scanning related error | System management module resource acquiring has failed. |

| Check item | Measures |
|------------|--|
| Setting | Perform the job in error again. If the error still persists, turn the power OFF and then back ON and then perform the jobs again. |

[2A31] WS Scan disabled

| Classification | Error content |
|-------------------------------|--|
| Remote scanning related error | A job is performed while WS Scan function is disabled. |

| Check item | Measures |
|------------|---|
| Setting | Check if WS Scan function (Web Scanning Service) is disabled on TopAccess. If it is disabled, enable it. Or, check if the forcible encryption setting of the secure PDF is enabled. |

[2A40] System error

| Classification | Error content |
|-------------------------------|------------------------------|
| Remote scanning related error | A system error has occurred. |

| Check item | Measures |
|------------|--|
| Setting | Turn the power OFF and then back ON. Perform the job in error again. |

[2A51] Power failure

| Classification | Error content |
|-------------------------------|---------------|
| Remote scanning related error | Power failure |

| Check item | Measures |
|------------|---|
| Setting | <ul style="list-style-type: none">• Check if the power cable is connected properly or is inserted securely.• Check if the power voltage is unstable. |

[2A60] WS Scan user authentication failure

| Classification | Error content |
|-------------------------------|--|
| Remote scanning related error | WS Scan for job authentication has failed. |

| Check item | Measures |
|------------|--|
| Setting | <ul style="list-style-type: none">• When "1" (TTEC's WIA driver) is set for FS-08-9749 and Windows Fax&Scan is also used: Check if the user name used to log in Windows is registered as a user.• When MFP panel or EWB Scan is used: Check if the login user name is registered as a user. |

[2A70] RemoteScan privilege check error

| Classification | Error content |
|-------------------------------|---|
| Remote scanning related error | A job is performed by a user without Remote Scan privilege. |

| Check item | Measures |
|------------|--|
| Setting | Check if the correct privilege is given to the user. |

[2A71] WS Scan privilege check error

| Classification | Error content |
|-------------------------------|---|
| Remote scanning related error | A job is performed by a user without WS Scan privilege. |
| Check item | Measures |
| Setting | Check if the correct privilege is given to the user. |

[2A72] e-Filing data access privilege check error (Scan Utility)

| Classification | Error content |
|-------------------------------|--|
| Remote scanning related error | A user without e-Filing data access privilege tried to use Scan utility. |
| Check item | Measures |
| Setting | Check if the correct privilege is given to the user. |

[2A73] Address book operation privilege check error

| Classification | Error content |
|-------------------------------|--|
| Remote scanning related error | Address book operation privilege check error |
| Check item | Measures |
| Setting | A user who does not have the AddressbookRemoteAccess privilege has performed export or import of the address book. Check if the correct privilege is given to the user. |

[4] e-Filing related error**[2B11] Job status abnormality****[2B20] File library function error****[2B30] Insufficient storage device space in BOX partition****[2BC0] Fatal failure occurred**

| Classification | Error content |
|------------------------|---|
| e-Filing related error | [2B11] Job status abnormality [2B20] File library function error [2B30] Insufficient storage device space in BOX partition [2BC0] Fatal failure occurred |

| Check item | Measures |
|------------|---|
| Setting | <ul style="list-style-type: none"> Erase some data in e-Filing or the shared folder and then perform the job in error again (in case of a 2B30 error). Ask the administrator if the e-Filing function is disabled. Turn the power OFF and then back ON. Perform the job in error again. Check if there are no other running jobs and perform the storage device formatting (HS-75 File System Recovery > Initialize Storage). If the recovery is still not completed, replace the SYS board. |

| Parts to be replaced | Remarks |
|----------------------|---------|
| SYS board | |

[2B31] Status of the specified e-Filing or folder is undefined or being created or deleted

| Classification | Error content |
|------------------------|---|
| e-Filing related error | Status of the specified e-Filing or folder is undefined or being created or deleted |

| Check item | Measures |
|------------|--|
| Setting | <ul style="list-style-type: none"> Check if the specified e-Filing or folder exists. Delete the specified e-Filing or folder. Change the name of the folder to be created. Perform the job in error again. |

[2B50] Image library error**[2B90] Insufficient memory capacity**

| Classification | Error content |
|------------------------|---|
| e-Filing related error | [2B50] Image library error [2B90] Insufficient memory capacity |

| Check item | Measures |
|------------|---|
| Setting | <ul style="list-style-type: none"> Turn the power OFF and then back ON. Perform the job in error again. If the error still persists, replace the SYS board. Delete the jobs in being set, in running or in HOLD, PRIVATE, PROOF or INVALID and then perform the job in error again. |

| Parts to be replaced | Remarks |
|----------------------|---------|
| SYS board | |

[2B51] List library error

| Classification | Error content |
|------------------------|--------------------|
| e-Filing related error | List library error |

| Check item | Measures |
|------------|--|
| Setting | <p>Check if the Function list can be printed. If printing is possible, perform the job in error again. If printing is not possible, replace the SYS board. If it still cannot be printed, initialize the storage device (HS-75 File System Recovery mode > Initialize Storage).</p> |

| Parts to be replaced | Remarks |
|----------------------|---------|
| SYS board | |

[2BA0] Invalid Box password

| Classification | Error content |
|------------------------|----------------------|
| e-Filing related error | Invalid Box password |

| Check item | Measures |
|------------|--|
| Setting | <ul style="list-style-type: none"> Check if the password is correct. Reset the password. If this error has occurred when data in e-Filing is printed, perform printing with the administrator password. |

[2BA1] The specified paper size, color mode or resolution is not available.

| Classification | Error content |
|------------------------|--|
| e-Filing related error | Invalid paper size, color mode, resolution |

| Check item | Measures |
|------------|---|
| Setting | The specified paper size, color mode or resolution is not available. Check the setting. |

[2BB1] Power failure**[2BD0] Power failure during restoring of e-Filing**

| Classification | Error content |
|------------------------|---|
| e-Filing related error | [2BB1] Power failure [2BD0] Power failure during restoring of e-Filing |

| Check item | Measures |
|------------|--|
| Setting | <ul style="list-style-type: none"> Check if the power cable is connected properly or is inserted securely. Check if the power voltage is unstable. |

[2BE0] Machine parameter reading error

| Classification | Error content |
|------------------------|--|
| e-Filing related error | Machine parameter reading error |
| Check item | Measures |
| Setting | Turn the power OFF and then back ON. Perform the job in error again. |

[2BF0] Exceeding the maximum number of pages

| Classification | Error content |
|------------------------|---|
| e-Filing related error | Exceeding the maximum number of pages |
| Check item | Measures |
| Setting | Reduce the number of pages of the job in error and then perform it again. |

[2BF1] Exceeding the maximum number of documents

| Classification | Error content |
|------------------------|---|
| e-Filing related error | Exceeding the maximum number of documents |
| Check item | Measures |
| Setting | Back up the documents in the box or folder to a client PC or delete them. |

[2BF2] Exceeding the maximum number of folders

| Classification | Error content |
|------------------------|---|
| e-Filing related error | Exceeding the maximum number of folders |
| Check item | Measures |
| Setting | Back up the folders in the box to a client PC or delete them. |

[5] E-mail related error**[2C10] System access abnormality**

| Classification | Error content |
|----------------------|--|
| E-mail related error | System access abnormality |
| Check item | Measures |
| Setting | Turn the power OFF and then back ON. Perform the job in error again. If the error still persists, check if the settings of SSL/TLS and the authentication are specified properly in the SMTP client setting. If the error nevertheless continues to persist, check if there are no jobs existing and then perform the storage device formatting. |

[2C11] Insufficient memory

| Classification | Error content |
|----------------------|--|
| E-mail related error | Insufficient memory |
| Check item | Measures |
| Setting | Perform the job in error again after the running jobs are completed if there are any. If the error still persists, turn the power OFF and then back ON and then perform the jobs again. |

[2C12] Message reception error**[2C13] Message transmission error**

| Classification | Error content |
|----------------------|---|
| E-mail related error | [2C12] Message reception error [2C13] Message transmission error |

| Check item | Measures |
|------------|--|
| Setting | Turn the power OFF and then back ON. Perform the job in error again. |

[2C14] Invalid parameter

| Classification | Error content |
|----------------------|-------------------|
| E-mail related error | Invalid parameter |

| Check item | Measures |
|------------|---|
| Setting | Form the template again if it is used. If the error still persists, turn the power OFF and then back ON and then perform the jobs again. |

[2C15] Exceeding file capacity

| Classification | Error content |
|----------------------|-------------------------|
| E-mail related error | Exceeding file capacity |

| Check item | Measures |
|------------|--|
| Setting | Extend the "Maximum send to E-mail/iFAX size" or reduce the number of pages and perform the job again. |

[2C20] System management module access abnormality**[2C21] Job control module access abnormality****[2C22] Job control module access abnormality**

| Classification | Error content |
|----------------------|---|
| E-mail related error | [2C20] System management module access abnormality [2C21], [2C22] Job control module access abnormality. |

| Check item | Measures |
|------------|---|
| Setting | Turn the power OFF and then back ON. Perform the job in error again. Check if there are no other running jobs and perform the storage device formatting (HS-75 File System Recovery > Initialize Storage). If the recovery is still not completed, replace the SYS board. |

| Parts to be replaced | Remarks |
|----------------------|---------|
| SYS board | |

[2C30] Directory creation failure**[2C31] File creation failure****[2C33] File access failure**

| Classification | Error content |
|----------------------|---|
| E-mail related error | [2C30] Directory creation failure [2C31] File creation failure [2C33] File access failure |

| Check item | Measures |
|------------|---|
| Setting | <ul style="list-style-type: none"> Check if the access privilege to the storage directory is writable. Check if the server or local disk has sufficient space in its disk capacity. |

[2C32] File deletion failure

| Classification | Error content |
|----------------------|---|
| E-mail related error | File deletion failure |
| Check item | Measures |
| Setting | Turn the power OFF and then back ON. Perform the job in error again. If the error still occurs, first, check if there are no jobs existing and then perform the storage device formatting (HS-75 File System Recovery > Initialize Storage). |

[2C40] Image conversion abnormality**[2C62] Memory acquiring failure**

| Classification | Error content |
|----------------------|--|
| E-mail related error | [2C40] Image conversion abnormality [2C62] Memory acquiring failure |
| Check item | Measures |
| Setting | <ul style="list-style-type: none"> • Turn the power OFF and then back ON. Perform the job in error again. • Replace the SYS board and perform the job again. |
| Parts to be replaced | Remarks |
| SYS board | |

[2C43] Encryption error

| Classification | Error content |
|----------------------|--|
| E-mail related error | Encryption error |
| Check item | Measures |
| Setting | Turn the power OFF and then back ON. Perform the job in error again. |

[2C44] Encryption PDF enforced mode error

| Classification | Error content |
|----------------------|--|
| E-mail related error | Encryption PDF enforced mode error |
| Check item | Measures |
| Setting | Reset the encryption setting and perform the job in error again. If an image file without being encrypted needs to be created, ask the administrator. |

[2C45] Meta data creation error (ScanToEmail)

| Classification | Error content |
|----------------------|--|
| E-mail related error | Creation of meta data failed when a user tried to perform meta scan for ScanToEmail. |
| Check item | Measures |
| Setting | Check the template settings and perform the job in error again. If the error still persists, turn the power OFF and then back ON and then perform the job in error again. |

[2C46] Creation of a signed PDF has failed. (An error due to the expiration date of a certificate): ScanToEmail

| Classification | Error content |
|----------------------|---|
| E-mail related error | Creation of a signed PDF has failed since the certificate expired. |
| Check item | Measures |
| Setting | Register the certificate again from TopAccess or the control panel. |

[2C47] Creation of a signed PDF has failed. (Version consistency between the signed PDF and certificates PDF): ScanToEmail

| Classification | Error content |
|----------------------|---|
| E-mail related error | Creation of a signed PDF has failed since the combination of the certificate data (signature algorithm, public key) and the PDF version is not supported. |
| Check item | Measures |
| Setting | <p>Perform one of the following items.</p> <ul style="list-style-type: none"> • Make the PDF version to 1.7 by setting "4" in FS-08-3817. • Make the PDF/A file format setting to PDF/A2-b by means of TopAccess or by setting "1" in FS-08-9471. • From TopAccess, set SHA1 for the signature algorithm and RSA1024 for the public key of the certificate and then register it again. |

[2C50] Authentication failure at job execution

| Classification | Error content |
|----------------------|--|
| E-mail related error | Authentication failure at job execution |
| Check item | Measures |
| Setting | <p>A ScanToEmail job is carried out while user authentication or department authentication has not been done.</p> <p>Retry the job after user authentication or department authentication has been done.</p> |

[2C60] Storage device full during processing

| Classification | Error content |
|----------------------|--|
| E-mail related error | Storage device full failure during processing |
| Check item | Measures |
| Setting | <ul style="list-style-type: none"> • Delete the jobs in being set, in running or in HOLD, PRIVATE, PROOF or INVALID and the perform the job again. • Reduce the number of pages of the job in error and then perform it again. • Check if the server or local disk has sufficient space in its disk capacity. |

[2C61] Address book reading failure

| Classification | Error content |
|----------------------|---|
| E-mail related error | AddressBook reading failure |
| Check item | Measures |
| Setting | <ul style="list-style-type: none"> • Turn the power OFF and then back ON. Perform the job in error again. • Reset the data in the Address Book and perform the job again. |

[2C63] Terminal IP address unset

| Classification | Error content |
|----------------------|--|
| E-mail related error | Terminal IP address unset |
| Check item | Measures |
| Setting | <ul style="list-style-type: none"> • Reset the Terminal ID address. • Turn the power OFF and then back ON. Perform the job in error again. |

[2C64] Terminal mail address unset

| Classification | Error content |
|----------------------|--|
| E-mail related error | Terminal mail address unset |
| Check item | Measures |
| Setting | <ul style="list-style-type: none"> Reset the Terminal mail address. Turn the power OFF and then back ON. Perform the job in error again. |

[2C65] SMTP mail address unset

| Classification | Error content |
|----------------------|---|
| E-mail related error | SMTP mail address unset |
| Check item | Measures |
| Setting | <ul style="list-style-type: none"> Reset the SMTP address and perform the job. Turn the power OFF and then back ON. Perform the job in error again. |

[2C66] Server time-out error

| Classification | Error content |
|----------------------|--|
| E-mail related error | Server time-out error |
| Check item | Measures |
| Setting | Check if the SMTP server works properly. |

[2C69] SMTP server connection error

| Classification | Error content |
|----------------------|---|
| E-mail related error | SMTP server connection error |
| Check item | Measures |
| Setting | <ul style="list-style-type: none"> Reset the login name and password of the SMTP server and perform the job again. Check if the SMTP server works properly. |

[2C6A] HOST NAME error (no RFC error)

| Classification | Error content |
|----------------------|--|
| E-mail related error | HOST NAME error (no RFC error) |
| Check item | Measures |
| Setting | Check if an invalid character is included in the device name. Delete the invalid character and set the appropriate device name. |

[2C6B] Terminal mail address error

| Classification | Error content |
|----------------------|--|
| E-mail related error | Terminal mail address error |
| Check item | Measures |
| Setting | Check if the SMTP authentication method is correct. Check if an invalid character is included in the Terminal mail address. Select the correct SMTP authentication method, set the appropriate Terminal mail address by removing invalid characters and perform the job again. |

[2C6C] Destination mail address error (no RFC error)

| Classification | Error content |
|----------------------|---|
| E-mail related error | Destination mail address error (no RFC error) |
| Check item | Measures |
| Setting | Check if an invalid character is included in the Destination mail address. Set the appropriate Destination mail address by removing invalid characters and perform the job again. |

[2C70] SMTP client OFF

| Classification | Error content |
|----------------------|--|
| E-mail related error | SMTP client OFF |
| Check item | Measures |
| Setting | Enable the SMTP setting and perform the job again. |

[2C71] SMTP authentication error

| Classification | Error content |
|----------------------|---|
| E-mail related error | SMTP authentication error |
| Check item | Measures |
| Setting | Check if the SMTP authentication method, login name and password are correct. Then perform the job again. |

[2C72] POP before SMTP error

| Classification | Error content |
|----------------------|---|
| E-mail related error | POP before SMTP error |
| Check item | Measures |
| Setting | Check if both the settings of POP before SMTP and POP3 are correct. Then perform the job again. |

[2CC1] Power failure

| Classification | Error content |
|----------------------|---|
| E-mail related error | Power failure |
| Check item | Measures |
| Setting | Check if the power cable is connected properly or is inserted securely. Check if the power voltage is unstable. |

[6] File sharing related error

[2D10] System access abnormality

[2D32] File deletion failure

[2DA6] File deletion failure

[2DA7] Resource acquiring failure

| Classification | Error content |
|----------------------------|--|
| File sharing related error | [2D10] System access abnormality [2D32] [2DA6] File deletion failure [2DA7] Resource acquiring failure |

| Check item | Measures |
|------------|---|
| Setting | <ul style="list-style-type: none">• Delete some files in the shared folder by using Explorer because of automatic/manual file deletion failure (in case of [2DA6]).• Turn the power OFF and then back ON. Perform the job in error again. If the error still occurs, first, check if there are no jobs existing and then perform the storage device formatting (HS-75 File System Recovery > Initialize Storage). |

[2D11] Insufficient memory

| Classification | Error content |
|----------------------------|---------------------|
| File sharing related error | Insufficient memory |

| Check item | Measures |
|------------|--|
| Setting | Perform the job in error again after the running jobs are completed if there are any. If the error still persists, turn the power OFF and then back ON and then perform the jobs again. |

[2D12] Message reception error

[2D13] Message transmission error

| Classification | Error content |
|----------------------------|---|
| File sharing related error | [2D12] Message reception error [2D13] Message transmission error |

| Check item | Measures |
|------------|--|
| Setting | Turn the power OFF and then back ON. Perform the job in error again. |

[2D14] Invalid parameter

| Classification | Error content |
|----------------------------|-------------------|
| File sharing related error | Invalid parameter |

| Check item | Measures |
|------------|---|
| Setting | Form the template again if it is used. If the error still persists, turn the power OFF and then back ON and then perform the jobs again. |

[2D15] Exceeding the maximum size for file sharing

| Classification | Error content |
|----------------------------|---|
| File sharing related error | Exceeding the maximum size for file sharing |

| Check item | Measures |
|------------|--|
| Setting | Delete some documents in the folder and then perform the job in error again. |

[2D30] Directory creation failure**[2D31] File creation failure****[2D33] File access failure**

| Classification | Error content |
|----------------------------|---|
| File sharing related error | [2D30] Directory creation failure [2D31] File creation failure [2D33] File access failure |
| Check item | Measures |
| Setting | <ul style="list-style-type: none"> • Check if the access privilege to the storage directory is writable. • Check if the server or local disk has sufficient space in its disk capacity. |

[2D40] Image conversion abnormality

| Classification | Error content |
|----------------------------|--|
| File sharing related error | Image conversion abnormality |
| Check item | Measures |
| Setting | <ul style="list-style-type: none"> • Turn the power OFF and then back ON. Perform the job in error again. • Replace the SYS board and perform the job again. |

[2D43] Encryption error

| Classification | Error content |
|----------------------------|--|
| File sharing related error | Encryption error |
| Check item | Measures |
| Setting | Turn the power OFF and then back ON. Perform the job in error again. |

[2D44] Encryption PDF enforced mode error

| Classification | Error content |
|----------------------------|--|
| File sharing related error | Encryption PDF enforced mode error |
| Check item | Measures |
| Setting | Reset the encryption setting and perform the job in error again. If an image file without being encrypted needs to be created, ask the administrator. |

[2D45] Meta data creation error (ScanToFile)

| Classification | Error content |
|----------------------------|--|
| File sharing related error | Creation of meta data failed when a user tried to perform meta scan for ScanToFile. |
| Check item | Measures |
| Setting | Check the template settings and perform the job in error again. If the error still persists, turn the power OFF and then back ON and then perform the job in error again. |

[2D46] Creation of a signed PDF has failed. (An error due to the expiration date of a certificate): ScanToFile

| Classification | Error content |
|----------------------|---|
| E-mail related error | Creation of a signed PDF has failed since the certificate expired. |
| Check item | Measures |
| Setting | Register the certificate again from TopAccess or the control panel. |

[2D47] Creation of a signed PDF has failed. (Version consistency between the signed PDF and certificates PDF): ScanToFile

| Classification | Error content |
|----------------------|--|
| E-mail related error | Creation of a signed PDF has failed since the combination of the certificate data (signature algorithm, public key) and the PDF version is not supported. |
| Check item | Measures |
| Setting | Perform one of the following items. <ul style="list-style-type: none"> • Make the PDF version to 1.7 by setting "4" in FS-08-3817. • Make the PDF/A file format setting to PDF/A2-b by means of TopAccess or by setting "1" in FS-08-9471. • From TopAccess, set SHA1 for the signature algorithm and RSA1024 for the public key of the certificate and then register it again. |

[2D50] Authentication failure at job execution (A ScanToFile job is carried out while user authentication or department authentication has not been done.)

| Classification | Error content |
|----------------------------|---|
| File sharing related error | Authentication failure at job execution (A ScanToFile job is carried out while user authentication or department authentication has not been done.) |
| Check item | Measures |
| Setting | Retry the job after user authentication or department authentication has been done. |

[2D62] File server connection failure

| Classification | Error content |
|----------------------------|---|
| File sharing related error | File server connection failure |
| Check item | Measures |
| Setting | <ul style="list-style-type: none"> • Check the IP address and path of the server. • Check if the server works properly. |

[2D63] Invalid network path

| Classification | Error content |
|----------------------------|---|
| File sharing related error | Invalid network path |
| Check item | Measures |
| Setting | Check the network path. If the network path is correct, turn the power OFF and then back ON and then perform the jobs again. |

[2D64] Login failure

| Classification | Error content |
|----------------------------|--|
| File sharing related error | Login failure |
| Check item | Measures |
| Setting | <ul style="list-style-type: none"> • Reset the login name and password and perform the job. • Check if the account setting of the server is correct. |

[2D65] New document creation failure caused by an excess of documents in a folder

| Classification | Error content |
|----------------------------|--|
| File sharing related error | New document creation failure caused by an excess of documents in a folder |
| Check item | Measures |
| Setting | Delete some documents in the folder. |

[2D66] Storage capacity full failure during processing

| Classification | Error content |
|----------------------------|--|
| File sharing related error | Storage capacity full failure during processing |
| Check item | Measures |
| Setting | <ul style="list-style-type: none"> Delete the jobs in being set, in running or in HOLD, PRIVATE, PROOF or INVALID and the perform the job again. Reduce the number of pages of the job in error or select a lower resolution and then perform the job again. Check if the server or local disk has sufficient space in its disk capacity. |

[2D67] FTP service not available

| Classification | Error content |
|----------------------------|---|
| File sharing related error | FTP service not available |
| Check item | Measures |
| Setting | Check if the setting of the FTP service is enabled. |

[2D68] File sharing service not available

| Classification | Error content |
|----------------------------|---|
| File sharing related error | File sharing service not available |
| Check item | Measures |
| Setting | Check if the setting of the SMB is enabled. |

[2D69] NetWare service not available

| Classification | Error content |
|----------------------------|--|
| File sharing related error | When a user tried to perform ScanToFile with NetWare protocol even though the NetWare setting is disabled, a message notifies the user that NetWare service is disabled. |
| Check item | Measures |
| Setting | Check if the setting of the NetWare is enabled. |

[2DC1] Power failure

| Classification | Error content |
|----------------------------|--|
| File sharing related error | Power failure |
| Check item | Measures |
| Setting | Check if the power cable is connected properly or is inserted securely. Check if the power voltage is unstable. |

[2E10] System access abnormality in ScanToUSB

| Classification | Error content |
|----------------------------|--|
| File sharing related error | Job status is invalid. |
| Check item | Measures |
| Setting | Turn the power OFF and then back ON. Perform the job in error again. If the error still occurs, first, check if there are no jobs existing and then perform the storage device formatting (HS-75 File System Recovery > Initialize Storage). |

[2E11] Insufficient memory capacity in ScanToUSB

| Classification | Error content |
|----------------------------|--|
| File sharing related error | Insufficient memory capacity in ScanToUSB |
| Check item | Measures |
| Setting | Perform the job in error again after the running jobs are completed if there are any. If the error still persists, turn the power OFF and then back ON and then perform the jobs again. |

[2E12] Message reception error in ScanToUSB**[2E13] Message transmission error in ScanToUSB**

| Classification | Error content |
|----------------------------|--|
| File sharing related error | Job status is invalid. |
| Check item | Measures |
| Setting | Turn the power OFF and then back ON. Perform the job in error again. |

[2E14] Parameter error in ScanToUSB

| Classification | Error content |
|----------------------------|---|
| File sharing related error | The specified parameter is invalid. |
| Check item | Measures |
| Setting | Form the template again if it is used. If the error still persists, turn the power OFF and then back ON and then perform the jobs again. |

[2E15] Exceeding the maximum size for file sharing

| Classification | Error content |
|----------------------------|--|
| File sharing related error | There are too many files in the folder. Creation of a new document has failed. |
| Check item | Measures |
| Setting | Delete some documents in the folder and then perform the job in error again. |

[2E30] Directory creation failure in ScanToUSB**[2E31] File creation failure in ScanToUSB**

| Classification | Error content |
|----------------------------|---|
| File sharing related error | [2E30] Creation of a directory has failed. [2E31] Creation of a file has failed. |
| Check item | Measures |
| Setting | <ul style="list-style-type: none"> • Check if the access privilege to the storage directory is writable. • Check if the server or local disk has sufficient space in its disk capacity. |

[2E32] File deletion failure in ScanToUSB

| Classification | Error content |
|----------------------------|---|
| File sharing related error | Deletion of a file has failed. |
| Check item | Measures |
| Setting | Turn the power OFF and then back ON. Perform the job in error again. If the error still occurs, first, check if there are no jobs existing and then perform the storage device formatting (HS-75 File System Recovery > Initialize Storage). |

[2E33] File access failure in ScanToUSB

| Classification | Error content |
|----------------------------|---|
| File sharing related error | Creation of a file has failed. |
| Check item | Measures |
| Setting | <ul style="list-style-type: none"> • Check if the access privilege to the storage directory is writable. • Check if the server or local disk has sufficient space in its disk capacity. |

[2E40] Image conversion abnormality in ScanToUSB

| Classification | Error content |
|----------------------------|--|
| File sharing related error | Conversion of image file format has failed. |
| Check item | Measures |
| Setting | <ul style="list-style-type: none"> • Turn the power OFF and then back ON. Perform the job in error again. • Replace the SYS board and perform the job again. |
| Parts to be replaced | Remarks |
| SYS board | |

[2E43] Encryption failure in ScanToUSB

| Classification | Error content |
|----------------------------|--|
| File sharing related error | Creation of a file has failed due to PDF encryption error. |
| Check item | Measures |
| Setting | Turn the power OFF and then back ON. Perform the job in error again. |

[2E44] Encryption PDF enforced mode error in ScanToUSB

| Classification | Error content |
|----------------------------|--|
| File sharing related error | Creation of an image file is not permitted. |
| Check item | Measures |
| Setting | Reset the encryption setting and perform the job in error again. To create an image file not encrypted, consult your administrator. |

[2E45] Meta data creation error in USB storage device (ScanToFile)

| Classification | Error content |
|----------------------------|--|
| File sharing related error | Creation of meta data has failed. |
| Check item | Measures |
| Setting | Check the template settings and perform the job in error again. If the error still persists, turn the power OFF and then back ON and then perform the job in error again. |

[2E46] Creation of a signed PDF has failed. (An error due to the expiration date of a certificate): ScanToUSB

| Classification | Error content |
|----------------------|---|
| E-mail related error | Creation of a signed PDF has failed since the certificate expired. |
| Check item | Measures |
| Setting | Register the certificate again from TopAccess or the control panel. |

[2E47] Creation of a signed PDF has failed. (Version consistency between the signed PDF and certificates PDF): ScanToUSB

| Classification | Error content |
|----------------------|---|
| E-mail related error | Creation of a signed PDF has failed since the combination of the certificate data (signature algorithm, public key) and the PDF version is not supported. |

| Check item | Measures |
|------------|--|
| Setting | Perform one of the following items. <ul style="list-style-type: none"> • Make the PDF version to 1.7 by setting "4" in FS-08-3817. • Make the PDF/A file format setting to PDF/A2-b by means of TopAccess or by setting "1" in FS-08-9471. • From TopAccess, set SHA1 for the signature algorithm and RSA1024 for the public key of the certificate and then register it again. |

[2E50] Authentication failure at job execution

| Classification | Error content |
|----------------------------|--|
| File sharing related error | A ScanToUSB job is carried out while user authentication or department authentication has not been done. |

| Check item | Measures |
|------------|---|
| Setting | Retry the job after user authentication or department authentication has been done. |

[2E65] File creation error due to insufficient USB folder capacity in ScanToUSB

| Classification | Error content |
|----------------------------|--|
| File sharing related error | Creation of a new file failed because there were too many files in the USB folder. |

| Check item | Measures |
|------------|--------------------------------------|
| Setting | Delete some documents in the folder. |

[2E66] Storage device full failure during ScanToUSB

| Classification | Error content |
|----------------------------|--|
| File sharing related error | Storage device has become full while storing data in the storage device. |

| Check item | Measures |
|------------|---|
| Setting | <ul style="list-style-type: none"> • Delete the jobs in being set, in running or in HOLD, PRIVATE, PROOF or INVALID and the perform the job again. • Reduce the number of pages of the job in error and then perform it again. • Check if there is enough space in the USB storage device. |

[2EC1] Power failure in ScanToUSB

| Classification | Error content |
|----------------------------|---|
| File sharing related error | A job was interrupted due to a power failure. |

| Check item | Measures |
|------------|--|
| Setting | <ul style="list-style-type: none"> • Check if the power cable is connected properly or is inserted securely. • Check if the power voltage is unstable. |

[7] E-mail reception related error

[3A10] E-mail MIME error

| Classification | Error content |
|--------------------------------|-------------------|
| E-mail reception related error | E-mail MIME error |

| Check item | Measures |
|------------|--|
| Setting | The format of the e-mail is not supported by MIME1.0. Ask the sender to retransmit the e-mail in the format supported by MIME1.0. |

[3A20] E-mail analysis error

[3B10] E-mail format error

[3B40] E-mail decode error

| Classification | Error content |
|--------------------------------|--|
| E-mail reception related error | [3A20] E-mail analysis error [3B10] E-mail format error [3B40] E-mail decode error |

| Check item | Measures |
|------------|---|
| Setting | E-mail data are damaged from the transmission to the reception. Ask the sender to retransmit the e-mail. |

[3A30] Partial mail time-out error

| Classification | Error content |
|--------------------------------|-----------------------------|
| E-mail reception related error | Partial mail time-out error |

| Check item | Measures |
|------------|--|
| Setting | A partial mail is not received in a specified period of time. Ask the sender to retransmit the e-mail. Or, set the time-out period of the partial mail longer. |

[3A40] Partial mail related error

| Classification | Error content |
|--------------------------------|----------------------------|
| E-mail reception related error | Partial mail related error |

| Check item | Measures |
|------------|--|
| Setting | The format of the partial mail is not supported by this MFP. Ask the sender to recreate and retransmit the partial mail in an RFC2046 format. |

[3A50] Insufficient storage device capacity error

| Classification | Error content |
|--------------------------------|--|
| E-mail reception related error | Insufficient storage device capacity error |

| Check item | Measures |
|------------|--|
| Setting | The storage device capacity is not sufficient for a temporary concentration of the jobs, etc. Ask the sender to retransmit after a certain period of time or divide the e-mail into more than one. Insufficient storage device capacity error also occurs when printing cannot be performed for reasons such as lack of printing paper. In this case, supply paper. |

[3A70] Partial mail interruption error

| Classification | Error content |
|--------------------------------|---------------------------------|
| E-mail reception related error | Partial mail interruption error |

| Check item | Measures |
|------------|---|
| Setting | The partial mail reception setting becomes OFF during its reception. Reset the partial mail reception setting ON and then ask the sender to retransmit the partial mail. |

[3A80] Partial mail reception setting OFF

| Classification | Error content |
|--------------------------------|------------------------------------|
| E-mail reception related error | Partial mail reception setting OFF |

| Check item | Measures |
|------------|---|
| Setting | Reset the partial mail reception setting ON and then ask the sender to retransmit the partial mail. |

[3B20] Content-Type error

| Classification | Error content |
|--------------------------------|--------------------|
| E-mail reception related error | Content-Type error |

| Check item | Measures |
|------------|--|
| Setting | The file format attached to the e-mail is not supported by this MFP (TIFF-FX/PDF/JPEG/XPS). Or the combination of the file formats attached to the e-mail is not available to be received together by this MFP. (The file format TIFF-FX cannot be received together with PDF, JPEG and XPS ones.) Request the sender to retransmit the file by modifying the file format which is supported by this MFP. Or request the sender to retransmit the e-mail by attaching only TIFF-FX format files or by attaching PDF, JPEG and XPS format files (a mixture of the formats is available). |

[3B50] Received mail data deletion

| Classification | Error content |
|--------------------------------|-----------------------------|
| E-mail reception related error | Received mail data deletion |

| Check item | Measures |
|------------|--|
| Setting | Received e-mail data have been deleted from a server as their reception process could not be carried out since they were broken. Check if the address of the e-mail sent immediately before the error is correct. Ask the sender to retransmit the deleted e-mail. |

[3C10] TIFF analysis error

[3C13] TIFF analysis error

| Classification | Error content |
|--------------------------------|---------------------|
| E-mail reception related error | TIFF analysis error |

| Check item | Measures |
|------------|---|
| Setting | E-mail data are damaged from the transmission to the reception. Alternatively, the file format attached to the e-mail is not supported by this MFP. (Supported: TIFF-FX) Ask the sender to retransmit the e-mail. |

[3C20] TIFF compression error

| Classification | Error content |
|--------------------------------|--|
| E-mail reception related error | TIFF compression error |
| Check item | Measures |
| Setting | The compression method of the TIFF file is not acceptable for this MFP. (Acceptable: MH, MR, MMR, JBIG) Ask the sender to retransmit the file in the acceptable compression method. |

[3C30] TIFF resolution error

| Classification | Error content |
|--------------------------------|--|
| E-mail reception related error | TIFF resolution error |
| Check item | Measures |
| Setting | The resolution of the TIFF file is not acceptable for this MFP. (Acceptable: 200 x 100, 200 x 200, 200 x 400, 400 x 400, 300 x 300 or equivalent) Ask the sender to retransmit the file in the acceptable resolution. |

[3C40] TIFF paper size error

| Classification | Error content |
|--------------------------------|---|
| E-mail reception related error | TIFF paper size error |
| Check item | Measures |
| Setting | The paper size of the TIFF file is not acceptable for this MFP. (Acceptable: A4, B4, A3, B5, LT, LG, LD or ST) Ask the sender to retransmit the file in the acceptable paper size. |

[3C50] Offramp destination error

| Classification | Error content |
|--------------------------------|---|
| E-mail reception related error | Offramp destination error |
| Check item | Measures |
| Setting | The fax number of the offramp destination is incorrect. Ask the sender to correct the fax number of the offramp destination and retransmit it. |

[3C60] Offramp security error

| Classification | Error content |
|--------------------------------|---|
| E-mail reception related error | Offramp security error |
| Check item | Measures |
| Setting | The fax number of the offramp destination is not registered in the address book. Check the fax number of the offramp destination and contact the sender. |

[3C70] Power failure

| Classification | Error content |
|--------------------------------|---|
| E-mail reception related error | Power failure |
| Check item | Measures |
| Setting | Check if the job is recovered after turning power OFF and then back ON. Request the sender to retransmit the e-mail if the job is not recovered. |

[3C90] Offramp fax transmission disable error

| Classification | Error content |
|--------------------------------|---|
| E-mail reception related error | Offramp fax transmission disable error |
| Check item | Measures |
| Setting | This error is displayed when a fax or internet fax transmission limitation error has occurred during offramp gateway function. Enable the fax transmission features. |

[3D10] Destination address error

| Classification | Error content |
|--------------------------------|--|
| E-mail reception related error | Destination address error |
| Check item | Measures |
| Setting | Check if the setting of the server of DNS is correct. Correct if any of the setting is incorrect. When the setting is correct, ask the sender to confirm if the destination is correct. |

[3D20] Maximum number of offramp destination error

| Classification | Error content |
|--------------------------------|---|
| E-mail reception related error | Offramp destination limitation error |
| Check item | Measures |
| Setting | Inform the sender that the transferring of fax data over 40 is not supported. |

[3D30] No Fax Unit error

| Classification | Error content |
|--------------------------------|---|
| E-mail reception related error | No Fax Unit error |
| Check item | Measures |
| Setting | The fax board is not installed or there is any abnormality in the fax board. Check if the fax board is installed properly. |

[3E10] POP3 server connection error

| Classification | Error content |
|--------------------------------|--|
| E-mail reception related error | POP3 server connection error |
| Check item | Measures |
| Setting | Check if the IP address or the domain name of the POP3 server set for this MFP is correct. Or, check if the POP3 server to be connected works properly. |

[3E20] POP3 server connection time-out error

| Classification | Error content |
|--------------------------------|---|
| E-mail reception related error | POP3 server connection time-out error |
| Check item | Measures |
| Setting | Check if the POP3 server to be connected works properly. Check that the LAN cable is connected properly. |

[3E30] POP3 login error

| Classification | Error content |
|--------------------------------|--|
| E-mail reception related error | POP3 login error |
| Check item | Measures |
| Setting | Check if the POP3 server login name and password set for this MFP are correct. |

[3E40] POP3 login type error

| Classification | Error content |
|--------------------------------|---|
| E-mail reception related error | POP3 login type error |
| Check item | Measures |
| Setting | Check if the login type (Auto, POP3, APOP) to the POP3 server is correct. |

[3F10] File I/O error**[3F20] File I/O error**

| Classification | Error content |
|--------------------------------|--|
| E-mail reception related error | File I/O error |
| Check item | Measures |
| Setting | Mail data are not transferred to the storage device properly. Ask the sender to retransmit the e-mail. If the error still persists after the retransmission, replace the storage device. |
| Parts to be replaced | Remarks |
| Storage device | |

8.3.7 Printer function error

[4011] Print job cancellation

| Classification | Error content |
|------------------------|---|
| Printer function error | A print job (copy, list print, network print) has been deleted from the print job screen. |

| Check item | Measures |
|------------|---|
| Setting | This message appears when deleting a job on the screen. |

[4012] Automatic deletion of expired print jobs

| Classification | Error content |
|------------------------|--|
| Printer function error | Print jobs which had expired since their retention time had passed, have been deleted automatically. (Print jobs such as Private, Hold, Proof, Invalid Department, Multi Station and jobs being skipped) |

| Check item | Measures |
|------------|--|
| Setting | When this has been carried out, this error code is displayed on the Print Log. |

[4021] Power failure at print job processing

| Classification | Error content |
|------------------------|--|
| Printer function error | The power of the MFP is turned OFF during a print job (copy, list print, network print) process. |

| Check item | Measures |
|------------|--|
| Setting | Check if the power cable is connected properly or is inserted securely. Check if the power voltage is unstable. |

[4031] Storage device full during print

| Classification | Error content |
|------------------------|--|
| Printer function error | A large amount of image data is saved in a storage device at private print or invalid network print. |

| Check item | Measures |
|------------|--|
| Setting | Delete unnecessary private print jobs and invalid department print jobs and then perform printing again. Check if the server or local disk has sufficient space in its disk capacity. |

[4032] Exceeding the upper limit of the registration number for the sharing jobs

| Classification | Error content |
|------------------------|--|
| Printer function error | No more sharing jobs can be registered because its registration number as a personal or functional has reached the upper limit. (A specific error for the Serverless Location Free Print function) |

| Check item | Measures |
|------------|---|
| Setting | Check that no unnecessary shared jobs yet to be printed are remaining. If there are such jobs, delete them. |

[4033] Network setting error

| Classification | Error content |
|------------------------|--|
| Printer function error | A sharing job cannot be registered since the applicable address has not been found from the list used for the Serverless Location Free Print function. (A specific error for the Serverless Location Free Print function) |

| Check item | Measures |
|------------|--|
| Setting | The address applicable to this MFP has not been registered in the cooperating machine list. Add the address applicable to this MFP. |

[4041] User authentication error

| Classification | Error content |
|------------------------|--|
| Printer function error | The user who intended to print a document is not registered as a user. |

| Check item | Measures |
|------------|--|
| Setting | Perform the authentication or register as a user, and then perform printing again. |

[4042] Department authentication error

| Classification | Error content |
|------------------------|---|
| Printer function error | The department whose code is specified for a print job is not registered. |

| Check item | Measures |
|------------|--|
| Setting | Check department information registered in this MFP. |

[4043] Project authentication error

| Classification | Error content |
|------------------------|--|
| Printer function error | The project whose code is specified for a print job is not registered. |

| Check item | Measures |
|------------|---|
| Setting | Check project information registered in this MFP. |

[4045] Problem in LDAP server connection or LDAP server authorization settings

| Classification | Error content |
|------------------------|---|
| Printer function error | Problem in LDAP server connection or LDAP server authorization settings |

| Check item | Measures |
|------------|--|
| Setting | Ask the LDAP server administrator to confirm the LDAP server connection or the LDAP server authorization settings. |

[4111] Quota over error (no quota in a department and user)

| Classification | Error content |
|------------------------|---|
| Printer function error | The number of the assigned pages set by the department and user management has reached 0. |

| Check item | Measures |
|------------|---|
| Setting | Both the numbers of the assigned pages set by the department management and user management have reached 0 at the same time. Assign the number of the pages again or perform initialization. |

[4112] Quota over error (no quota in a user)

| Classification | Error content |
|------------------------|--|
| Printer function error | The number of the assigned pages set by the user management has reached 0. |

| Check item | Measures |
|------------|---|
| Setting | The number of the assigned pages set by the user management has reached 0. Assign the number of the pages again or perform initialization. |

[4113] Quota over error (no quota in a department)

| Classification | Error content |
|------------------------|---|
| Printer function error | The number of the assigned pages set by the department management has reached 0. |
| Check item | Measures |
| Setting | The number of the assigned pages set by the department management has reached 0. Initialize the quota. |

[4121] Job canceling due to external counter error

| Classification | Error content |
|------------------------|--|
| Printer function error | Job canceling due to external counter error |
| Check item | Measures |
| Setting | <ol style="list-style-type: none"> 1. Drop a coin and perform the print job in error again. 2. Insert a key card and perform the print job in error again. Or, ask your administrator. 3. Insert a key counter and perform the print job in error again. 4. Release the Schedule Print setting and then perform the print job again. |

[4211] Printing data storing limitation error

| Classification | Error content |
|------------------------|---|
| Printer function error | Printing with its data being stored to the storage device temporarily (Proof print, Private print, Scheduled print, etc.) has been performed. |
| Check item | Measures |
| Setting | Select "Normal print", and then perform printing again. |

[4212] e-Filing storing limitation error

| Classification | Error content |
|------------------------|---|
| Printer function error | Printing with its data being stored to the storage device (print and e-Filing, print to e-Filing, etc.) has been performed. |
| Check item | Measures |
| Setting | Select "Normal print", and then perform printing again. |

[4213] File storing limitation error

| Classification | Error content |
|------------------------|---|
| Printer function error | The file storing function is disabled. |
| Check item | Measures |
| Setting | The file storing function is disabled. Check the setting of the MFP. |

[4214] Fax and internet fax transmission limitation error

| Classification | Error content |
|------------------------|--|
| Printer function error | The fax and internet fax transmission functions or the network fax and internet fax functions are set to "disabled". |
| Check item | Measures |
| Setting | The fax and internet fax transmission functions or the network fax and internet fax functions are set to "disabled". Check the setting of the MFP. |

[4221] Private-print-only error

| Classification | Error content |
|------------------------|--|
| Printer function error | Jobs other than Private print ones have been performed. |
| Check item | Measures |
| Setting | Email direct printing cannot be performed since Private printing is not selectable for it. Select "Private print", and then perform the printing again. |

[4222] Hold-print-only error

| Classification | Error content |
|------------------------|---|
| Printer function error | Hold-print-only error |
| Check item | Measures |
| Setting | Email direct printing cannot be performed since Hold printing is not selectable for it. |

[4223] Private-print-only and Hold-print-only error

| Classification | Error content |
|------------------------|---|
| Printer function error | Private-print-only and Hold-print-only error |
| Check item | Measures |
| Setting | Email direct printing cannot be performed since Private printing and Hold printing are not selectable for it. |

[4231] Hardcopy security printing error

| Classification | Error content |
|------------------------|--|
| Printer function error | A hardcopy security printing job has been performed when the function is restricted. |
| Check item | Measures |
| Setting | Hardcopy security printing cannot be performed because the function is restricted in the self-diagnostic mode. Check the settings of the MFP. |

[4243] Sharing job - An error caused by not having a license

| Classification | Error content |
|------------------------|---|
| Printer function error | Sharing job - An error caused by not having a license |
| Check item | Measures |
| Setting | Check if the license of the multi station print option is installed. If it is not, install it. |

[4244] Sharing job - An error caused by function disabled

| Classification | Error content |
|------------------------|--|
| Printer function error | Sharing job - An error caused by function disabled |
| Check item | Measures |
| Setting | Check from TopAccess if the function of the multi station print option is disabled. If it is disabled, enable it. |

[4245] OCR functions not available

| Classification | Error content |
|------------------------|--|
| Printer function error | OCR functions not available |
| Check item | Measures |
| Setting | Check if the OCR license or an extended memory is installed. |

[4311] No privilege to perform a job

| Classification | Error content |
|------------------------|--|
| Printer function error | No privilege to perform a job |
| Check item | Measures |
| Setting | Confirm the administrator for the job authorization. |

[4312] No privilege to store a file

| Classification | Error content |
|------------------------|--|
| Printer function error | No privilege to store a file |
| Check item | Measures |
| Setting | Ask the administrator about the privilege to store a file. |

[4313] No privilege for StoreToFile**[4314] No privilege for SendToFax and SendToIFax****[4321] No privilege for the print settings**

| Classification | Error content |
|------------------------|--|
| Printer function error | [4313] No privilege to StoreToFile is given. (e-Filing storage permission) [4314] No privilege for SendToFax and SendToIFax is given. (Fax / Internet Fax transmission permission) [4321] No privilege to the print with the specified settings is given. (Print setting permission) |
| Check item | Measures |
| Setting | Check the privilege given. Ask the administrator to add the necessary privilege. |

[4411] Image data creation failure

| Classification | Error content |
|------------------------|--|
| Printer function error | Image data creation failure |
| Check item | Measures |
| Setting | The data or file to be printed may be broken. <ul style="list-style-type: none"> • Network print: The print data are broken. Alternatively, they are invalid. • Direct print: The file is broken. Alternatively, the file format is not supported by this MFP. |

[4412] Decoding error

| Classification | Error content |
|------------------------|---|
| Printer function error | The PDF file is encrypted incorrectly or encrypted in a language not supported. |
| Check item | Measures |
| Setting | Printing using this function cannot be performed due to a decoding process error which occurs because the PDF file is encrypted incorrectly or encrypted in a language not supported. |

[4511] Connection timeout

| Classification | Error content |
|------------------------|---|
| Printer function error | Time-out is detected when printing has failed since the print data sending was stopped during the communication with the client PC or the connection had not been disconnected from the PC. |
| Check item | Measures |
| Setting | Check that the Ethernet setting of the MFP is the same as that for the hub to which the MFP is being connected. Check that the Ethernet cable is connected properly. |

[4521] Reaching the maximum number of connections

| Classification | Error content |
|------------------------|--|
| Printer function error | A job cannot be received since the MFP has reached the max. number of connections. |
| Check item | Measures |
| Setting | Perform printing again after a certain period of time. If this frequently occurs due to the network environment or the number of the client PCs, change the setting of the following self-diagnostic codes. • FS-08-3727, FS-08-3731, FS-08-3732, FS-08-3765, FS-08-9561 |

[4522] Exceeding the upper limit of the registration number of jobs during data reception

| Classification | Error content |
|------------------------|--|
| Printer function error | The reception of jobs is limited since the MFP has been in the nearly Workflow Full status. |
| Check item | Measures |
| Setting | Wait until the printing of the jobs which are being processed or are waiting is completed and then perform printing again. Delete unnecessary private print jobs and invalid department print jobs and then perform printing again. |

[4523] Storage device full during data reception

| Classification | Error content |
|------------------------|--|
| Printer function error | The reception of jobs is limited since the MFP has been in the nearly storage device Full status. |
| Check item | Measures |
| Setting | Delete unnecessary private print jobs and invalid department print jobs and then perform printing again. Check if the server or local disk has sufficient space in its disk capacity. |

[4611] Font download failure (exceeding the maximum number of registrations)**[4612] Font download failure (storage device full)**

| Classification | Error content |
|------------------------|--|
| Printer function error | [4611] A new font cannot be registered because the number of fonts registered in this MFP has already reached the limit. [4612] A new font cannot be registered because there is insufficient space in the font storage area of this MFP. |
| Check item | Measures |
| Setting | Delete one or more fonts already registered. |

[4613] Font download failure (others)

| Classification | Error content |
|------------------------|---|
| Printer function error | A new font cannot be registered due to other abnormalities. |
| Check item | Measures |
| Setting | Reattempt the downloading. Recreate font data and reattempt the downloading. |

[4621] Downloaded font deletion failure

| Classification | Error content |
|------------------------|---|
| Printer function error | The specified font cannot be deleted because it does not exist, it is undeletable or any another abnormality has occurred. |
| Check item | Measures |
| Setting | Check if the font to be deleted is registered in the MFP. Check if the font to be deleted is the one registered in the MFP beforehand. |



[4721] Connection error of multi station print (Unavailable combination of the version)

| Classification | Error content |
|------------------------|--|
| Printer function error | Connection failure of Multi Station Print because of an unavailable ROM version combination. |
| Check item | Measures |
| Setting | Check the version of the MFP to connect and then update the version of the unconnectable MFP to become the same as that for the connected one. |

[4731] Multi Station print jobs have been removed. (An error has occurred in the job list.)

| Classification | Error content |
|------------------------|--|
| Printer function error | Jobs have been removed since an error had occurred in the job list of Multi Station print. |
| Check item | Measures |
| Setting | Print the removed jobs again. |

[4F10] System abnormality

| Classification | Error content |
|------------------------|---|
| Printer function error | Printing was not performed successfully due to other abnormalities. |
| Check item | Measures |
| Setting | <ol style="list-style-type: none"> 1. Perform the job in error again. If the error still persists, turn the power OFF and then back ON and then perform the jobs again. 2. Collect the debug log with a USB storage device.  P. 8-3 "8.1.2 Collection of debug logs with a USB storage device" 3. Initialize the storage device. Refer to step 3 and later in  P. 9-31 "9.2.3 Precautions and procedures when replacing the storage device" in [E]Replace / Format storage device. |

[4F11] RIP process error

| Classification | Error content |
|------------------------|---|
| Printer function error | Printing was not performed successfully, since other abnormalities had occurred during RIP processing. |
| Check item | Measures |
| Reproducibility | <ul style="list-style-type: none"> • Reboot the MFP. • Reinstall the system software. |

8.3.8 TopAccess related error, Communication error with external application

[5110] Toner cartridge detection error

| Classification | Error content |
|-------------------------|--|
| TopAccess related error | Toner cartridge detection error |
| Check item | Measures |
| Toner cartridge | Refer to the troubleshooting for C911, C912, C913 and C914 errors.  P. 8-200 " [C911] CTIF board access abnormality (K)" |

[5212] Time for cleaning of the main charger

| Classification | Error content |
|-------------------------|---|
| TopAccess related error | Appears when the time for main charger cleaning comes (at the output of approx. every 10,000 sheets). |
| Check item | Measures |
| Main charger | Clean the main charger. |

[5310] Toner (K) empty

| Classification | Error content |
|-------------------------|---|
| TopAccess related error | The toner cartridge has become empty. |
| Check item | Measures |
| Toner cartridge | Replace the toner cartridges corresponding to the errors. If the error still persists after replacement, check if the toner cartridge interface PC board (CTIF board) or the toner cartridge PC board (CTRG board) is connected properly. |

[5410] MFP registration error

| Classification | Error content |
|---|--|
| Communication error with external application | <ul style="list-style-type: none"> The serial number of the MFP is not registered in the Remote maintenance service. The registration processing from the MFP to the Remote maintenance service has failed. |
| Check item | Measures |
| Remote maintenance service setting | Contact the administrator of the Remote maintenance service to confirm that the serial number and model name of the MFP have been correctly imported to the Remote maintenance service. (Be sure the serial number of the MFP is CAPITALIZED.) |

[5411] MFP registration lock error

| Classification | Error content |
|---|---|
| Communication error with external application | Data to send to the Remote maintenance service from the MFP have been damaged or incorrect authentication data have been sent. |
| Check item | Measures |
| Remote maintenance service setting | <ul style="list-style-type: none"> Check that the local date and time are correctly set in the MFP. If not, enter the correct ones. If an error continues to be recorded for several days even though the date and time have been correctly set, contact the administrator of the Remote Maintenance service. |

[5412] Server busy error

| Classification | Error content |
|---|---|
| Communication error with external application | The Remote maintenance service cannot handle the periodic communication from the MFP due to overloading. |
| Check item | Measures |
| None | <ul style="list-style-type: none"> The MFP performs the periodic communication automatically. Therefore, check that no error will occur at the next periodic communication. If an error continues to be recorded for several days, contact the administrator of the Remote Maintenance service. |

[5413] Server error

| Classification | Error content |
|---|---|
| Communication error with external application | <ul style="list-style-type: none"> The server of the Remote maintenance service cannot make response to the MFP. A temporary power failure has occurred. |
| Check item | Measures |
| Remote maintenance service setting | <ul style="list-style-type: none"> Contact the administrator of the Remote maintenance service to confirm that the serial number and model name of the MFP have been correctly imported to the Remote maintenance service. (Be sure the serial number of the MFP is CAPITALIZED.) If an error continues to be recorded for several days, contact the administrator of the Remote Maintenance service. |

[5414] Invalid device file error

| Classification | Error content |
|---|---|
| Communication error with external application | A device file to send to the Remote maintenance service from the MFP has been damaged. |
| Check item | Measures |
| Communication environment | <ul style="list-style-type: none"> The MFP performs the periodic communication automatically. Therefore, check that no error will occur at the next periodic communication. If an error continues to be recorded for several days, contact the administrator of the Remote Maintenance service. |

[5415] Communication error

| Classification | Error content |
|---|---|
| Communication error with external application | The MFP cannot communicate the Remote maintenance service. |
| Check item | Measures |
| Setting | Check that there is no problem in the wiring connection between the MFP and the Remote maintenance service as well as in the connection and setting of network devices. |

[5416] Update failure of MFP setting file and system software

| Classification | Error content |
|---|--|
| Communication error with external application | <ul style="list-style-type: none"> The setting files and the system software of the MFP cannot be updated because there is an ongoing job. There are too many printing and fax jobs which are ongoing. |
| Check item | Measures |
| Communication environment | Have the customer clear pending jobs in the MFP job queues and retry the update by the Remote maintenance service. |

[5417] MFP setting file or system software is invalid.

| Classification | Error content |
|---|--|
| Communication error with external application | Upgrading has failed since the setting files of the MFP or the system software that has been downloaded from the Remote maintenance server has been incorrect or has been damaged. |
| Check item | Measures |
| Communication environment | Contact the administrator of the Remote maintenance service to check that the setting files of the MFP or the system software that has been downloaded is applicable to the model. |

[5419] File transmission to an eCC server failure

| Classification | Error content |
|---|---|
| Communication error with external application | A file transmitting to an eCC server is destroyed since its size has exceeded 200 MB. |
| Check item | Measures |
| Communication environment | Reduce the number of selected items and then perform it again. |

[5501] Communication data size exceeding error between the mobile and embedded applications

| Classification | Error content |
|---------------------------|---|
| Communication error | The communication data size between the mobile and embedded applications has exceeded 10 MB. |
| Check item | Measures |
| Communication environment | Make the communication data size between the mobile and embedded applications 10 MB or below. |

[5502] Timeout error during the communication between the mobile and embedded applications

| Classification | Error content |
|---------------------------|---|
| Communication error | Timeout has occurred at the time of the communication between the mobile and embedded applications. |
| Check item | Measures |
| Communication environment | Check if the embedded application to be communicated is operated properly. |

[5601] Proxy authentication failure

| Classification | Error content |
|---------------------------|--|
| Communication error | During communication, authentication has failed in the proxy server used for the communication setting for the obtaining of EWB, embedded applications and screen saver. |
| Check item | Measures |
| Communication environment | Check if the ID and password settings of the proxy server are correct. |

[5BD0] Power failure during the database restoration

| Classification | Error content |
|----------------------------|--|
| TopAccess related error | Power supply has been cut off during the restoration of the database sent from TopAccess. |
| Check item | Measures |
| Power supply related items | <ul style="list-style-type: none"> • Check if the power cable is connected properly or is inserted securely. • Check if the power voltage is unstable. • Reattempt the restoration of the database (address book, templates, F-code (Mailbox), user information, etc.). |

[5C10] Fax Unit installation error

| Classification | Error content |
|-------------------------|---|
| TopAccess related error | Network Fax is disabled because no Fax Unit is installed. |

| Check item | Measures |
|-------------------|--|
| Fax Unit | <ul style="list-style-type: none">• Check if the Fax Unit is installed.• Check if there is any damage or abnormality on the fax board.• Check if the connectors of the fax board are connected properly. |

[5C11] Network fax transmission error

| Classification | Error content |
|-------------------------|--|
| TopAccess related error | A Network Fax job has failed because the specified address is not registered in the AddressBook. |

| Check item | Measures |
|-------------------|---|
| Setting | The address specified for the network fax has not been registered in the address book. Register it. |

8.3.9 MFP access error

[6007] User login failure to an MFP

| Classification | Error content |
|------------------|--|
| MFP access error | User authentication cannot be done because connection to the authentication server has failed. |

| Check item | Measures |
|------------|--|
| Setting | Check the server operating status and confirm that the connection from the MFP has been made firmly. |

[6008] Connection failure to an external Role Base Access Control (LDAP) server

| Classification | Error content |
|------------------|--|
| MFP access error | User authentication cannot be done because connection to an external RBAC server has failed. |

| Check item | Measures |
|------------|--|
| Setting | Check the server operating status and confirm that the connection from the MFP has been made firmly. |

[6009] User login failure to an MFP (during NIC initialization)

| Classification | Error content |
|------------------|--|
| MFP access error | Connection to an authentication server has failed since NIC initialization is being performed. |

| Check item | Measures |
|------------|---|
| Setting | Perform user login after NIC initialization has been completed. |

[600A] Department code not assigned to a user

| Classification | Error content |
|------------------|--|
| MFP access error | Authentication has failed since the department code has not been assigned to the user. |

| Check item | Measures |
|------------|---|
| Setting | Assign the department code to the user. |

[6011] User automatic registration failure (due to an upper limit of the user registration number)

| Classification | Error content |
|------------------|--|
| MFP access error | User automatic registration has failed since the user registration number has reached its upper limit. |

| Check item | Measures |
|------------|--------------------------------------|
| Setting | Delete unnecessary registered users. |

[6013] Connection failure to an authentication server

| Classification | Error content |
|------------------|---|
| MFP access error | Connection to the authentication server has failed. |

| Check item | Measures |
|------------|---|
| Setting | Check that the server settings registered from [TopAccess] > [Administration] > [Maintenance] > [Directory Service] are proper. When "Auto" is selected as the authentication method, this error may be output to the log depending on the environment. |

[6014] Inaccessible authentication server detection

| Classification | Error content |
|------------------|--|
| MFP access error | An inaccessible authentication server has been detected. |
| Check item | Measures |
| Setting | Check if the authentication server is down since there is an inaccessible authentication server. Access to the inaccessible server will be attempted again when the time set in FS-08-8788 has passed since the inaccessibility detection or when the MFP is turned OFF and then back ON. |

[6031] Setting error: CL code error

| Classification | Error content |
|------------------|---|
| MFP access error | A card cannot be used since its CL code does not match. |
| Check item | Measures |
| Setting | Use a valid card. |

[6032] Card abnormality: Validity date error

| Classification | Error content |
|------------------|--|
| MFP access error | A card cannot be used since its validity date has expired. |
| Check item | Measures |
| Setting | Use a card whose validity date has not expired. |

[6033] Card abnormality: Flag information error (no room-entry data)

| Classification | Error content |
|------------------|--|
| MFP access error | A card cannot be used since no room-entry data are recorded in it. |
| Check item | Measures |
| Setting | Use a valid card which has been used for entering the room. |

[6034] Card abnormality: Flag information error (card information error)

| Classification | Error content |
|------------------|--|
| MFP access error | A card cannot be used since the data required for its use are not set correctly. |
| Check item | Measures |
| Setting | Use a valid card. |

[6035] Setting error: Flag information error (card information unset)

| Classification | Error content |
|------------------|---|
| MFP access error | Necessary information in order to use a card is not set in the MFP. |
| Check item | Measures |
| Setting | Use a valid card or ask your administrator to register the information. |

[6036] Setting error: Flag information error (information between an MFP and a card does not match)

| Classification | Error content |
|------------------|--|
| MFP access error | A card cannot be used since its information and the value set in the MFP do not match. |
| Check item | Measures |
| Setting | Use a valid card or ask your administrator to register the information. |

[6037] Permission flag for use not available

| Classification | Error content |
|------------------|--|
| MFP access error | A card cannot be used since the privilege to use the device or MFP is not given. |

| Check item | Measures |
|------------|---|
| Setting | Use a valid card or ask your administrator to give the privilege. |

[6040] Card authentication: Read error

| Classification | Error content |
|------------------|---|
| MFP access error | Card information could not be obtained correctly. |

| Check item | Measures |
|------------|--|
| Setting | Reattempt card scanning. If the error persists even though the card scanning is attempted several times, the card information may be broken or the card reader may be damaged. |

[6041] Card authentication: Card related error

| Classification | Error content |
|------------------|--|
| MFP access error | Card information cannot be obtained correctly. |

| Check item | Measures |
|------------|--|
| Setting | Reattempt scanning. If the error persists even though the card scanning is attempted several times, the card information may be broken or the card reader may be damaged. |

[6042] Card authentication: Card setting error

| Classification | Error content |
|------------------|---|
| MFP access error | The self-diagnostic code required for card authentication is not set in this MFP correctly. |

| Check item | Measures |
|------------|---------------------------------------|
| Setting | Set the correct self-diagnostic code. |

[6073] Fingerprint authentication (failure)

| Classification | Error content |
|------------------|--|
| MFP access error | Authentication has failed since no fingerprint is registered or the authentication accuracy of the scanned fingerprint is low. |

| Check item | Measures |
|------------|--|
| Setting | <ul style="list-style-type: none"> • Place the finger again. • Carry out authentication using another finger already registered. <p>Remarks: In the following cases, the authentication accuracy becomes lowered and thus authentication becomes difficult.</p> <ul style="list-style-type: none"> • The finger is stained or injured. • The fingerprint reader is stained. • The fingerprint cannot be distinguished since its minutiae are significantly low. In such a case, make the authentication accuracy low in the fingerprint authentication accuracy setting in TopAccess. This error may be avoidable. |

[6101] e-Filing locking out

| Classification | Error content |
|------------------|--|
| MFP access error | The e-Filing became inaccessible because an incorrect password has been entered for the specified number of times. |
| Check item | Measures |
| Setting | Reattempt to access the e-Filing after a while. Ask the administrator. |

[6102] User account is being locked out.

| Classification | Error content |
|------------------|---|
| MFP access error | User login has failed because the user account is being locked out. |
| Check item | Measures |
| Setting | Log into TopAccess as an administrator and release the locked user account. |

[6103] e-Filing is being locked out.

| Classification | Error content |
|------------------|--|
| MFP access error | The e-Filing became inaccessible because an incorrect password has been entered for the specified number of times. |
| Check item | Measures |
| Setting | Reattempt to access the e-Filing after a while. For the locking period, as your administrator. |

[6121] Automatic secure erase failure

| Classification | Error content |
|------------------|---|
| MFP access error | Automatic secure erase has failed. |
| Check item | Measures |
| Setting | Data overwriting has failed due to some reasons. If the error still occurs after rebooting the MFP, study to reinstall the software or to replace the storage device using the following procedure: HS-73 Firmware Assist > Format Storage. |

[6131] Synchronization failure with a time server

| Classification | Error content |
|------------------|--|
| MFP access error | The MFP cannot be synchronized with the SNTP server. |
| Check item | Measures |
| Setting | Check if the SNTP server works properly. Check if the path to the SNTP server works properly. Check if the settings in TopAccess > [Administrator] > [Setup] > [General] > [SNTP Service] are correct. |

8.3.10 Maintenance error

[7101] System firmware installation failure

[7103] Engine firmware installation failure

[7105] Scanner firmware installation failure

[7111] Patch installation failure

[7113] Plugin installation failure

[7115] Storage device data installation failure

[7117] DF firmware installation failure

[7119] PFC firmware installation failure

| Classification | Error content |
|-------------------|---|
| Maintenance error | [7101] Installation of the system firmware has failed. [7103] Installation of the engine firmware has failed. [7105] Installation of the scanner firmware has failed. [7111] Installation of the patch has failed. [7113] Installation of the plugin has failed. [7115] Installation of the storage device data has failed. [7117] Installation of the DF firmware has failed. [7119] Installation of the PFC firmware has failed. |

| Check item | Measures |
|------------|--|
| Setting | The software package file may have a problem or may be corrupted. Check the software package file and then reinstall it. |

[7109] Printer driver installation failure

| Classification | Error content |
|-------------------|--|
| Maintenance error | Installation of the printer driver has failed. |

| Check item | Measures |
|------------|--|
| Setting | The printer driver file may have a problem or may be corrupted. Check the package file and then upload it. |

[710B] Point and Print data installation failure

| Classification | Error content |
|-------------------|--|
| Maintenance error | Installation of the Point and Print data has failed. |

| Check item | Measures |
|------------|--|
| Setting | The Point and Print data file may have a problem or may be corrupted. Check the package file and then upload it. |

[710F] Language Pack installation failure

| Classification | Error content |
|-------------------|---|
| Maintenance error | Installation of the Language Pack has failed. |

| Check item | Measures |
|------------|---|
| Setting | The Language Pack file may have a problem or may be corrupted. Check the package file and then upload it. |

[711D] License key returning failure

| Classification | Error content |
|-------------------|--|
| Maintenance error | Returning of the one-time dongle license to a USB storage device has failed. |

| Check item | Measures |
|------------|--|
| Setting | Return the license to the USB storage device used for installing the license. Check if the USB storage device is installed properly. Notes: The GP-1080 IPsec Enabler cannot return to the USB storage device due to a license issue. |

[711F] License key installation failure

| Classification | Error content |
|-------------------|---|
| Maintenance error | Installation of the one-time dongle license has failed. |
| Check item | Measures |
| Setting | Check if the USB storage device is installed properly. |

[7121] Address Book data import failure

| Classification | Error content |
|-------------------|--|
| Maintenance error | Importing of the Address Book data has failed. |
| Check item | Measures |
| Setting | Check if the proper files are used. |

[7125] MailBox data import failure

| Classification | Error content |
|-------------------|--|
| Maintenance error | Importing of the Template data has failed. |
| Check item | Measures |
| Setting | Check if the proper files are used. |

[7127] Format file for meta scan import failure

| Classification | Error content |
|-------------------|--|
| Maintenance error | Importing of the format file for meta scan has failed. |
| Check item | Measures |
| Setting | Check if the proper files are used. |

[7129] User Information import failure

| Classification | Error content |
|-------------------|--|
| Maintenance error | Importing of the user Information has failed |
| Check item | Measures |
| Setting | Check if the proper files are used. |

[712B] Role information import failure

| Classification | Error content |
|-------------------|---|
| Maintenance error | Importing of the Role information has failed. |
| Check item | Measures |
| Setting | Check if the proper files are used. |

[712D] Role information import failure

| Classification | Error content |
|-------------------|--|
| Maintenance error | Importing of the department data has failed. |
| Check item | Measures |
| Setting | Check if the proper files are used. |

[7131] Print Data Converter import failure

| Classification | Error content |
|-------------------|---|
| Maintenance error | Importing of the Print Data Converter has failed. |
| Check item | Measures |
| Setting | Check if the proper files are used. |

[7132] Some user information import failure

| Classification | Error content |
|-------------------|--|
| Maintenance error | Importing of some user information has failed. |
| Check item | Measures |
| Setting | The registered number has exceeded the upper limit during importing or invalid information may be included in some data. Check if the proper files are used and the registered number. |

[7133] Some user information, role and group import failure

| Classification | Error content |
|-------------------|--|
| Maintenance error | Importing of some user information, role and group has failed. |
| Check item | Measures |
| Setting | The registered number has exceeded the upper limit during importing or invalid information may be included in some data. Check if the proper files are used and the registered number. |

[7134] Some department data import failure

| Classification | Error content |
|-------------------|--|
| Maintenance error | Importing of some department data has failed. |
| Check item | Measures |
| Setting | The registered number has exceeded the upper limit during importing or invalid information may be included in some data. Check if the proper files are used and the registered number. |

[7139] Certificate collection failure from SCEP server

| Classification | Error content |
|-------------------|---|
| Maintenance error | Certificate collection from a SCEP server has failed. |
| Check item | Measures |
| Setting | Collect the settings of a SCEP server or in TopAccess Administration > Security > Certificate Management SCEP(Automatic). |

[713B] Certificates import failure

| Classification | Error content |
|-------------------|---|
| Maintenance error | Importing of the certificates has failed. |
| Check item | Measures |
| Setting | The certificates may have a problem or may be corrupted. Check the certificates and reattempt this. |

[713D] User Combined data import failure

| Classification | Error content |
|-------------------|---|
| Maintenance error | Importing of the User Combined data has failed. |
| Check item | Measures |
| Setting | Check if the proper files are used. |

[713F] Address book and mailbox import failure

| Classification | Error content |
|-------------------|--|
| Maintenance error | Importing of the address book and mailbox has failed. |
| Check item | Measures |
| Setting | Check that the proper files are target to be imported. |

[7141] Address Book data export failure

| Classification | Error content |
|-------------------|--|
| Maintenance error | Exporting of the Address Book data has failed. |
| Check item | Measures |
| Setting | Check if enough space remains in the standard storage device and then reattempt the operation. |

[7145] MailBox data export failure

| Classification | Error content |
|-------------------|--|
| Maintenance error | Exporting of the MailBox data has failed. |
| Check item | Measures |
| Setting | Check if enough space remains in the standard storage device and then reattempt the operation. |

[7149] User Information export failure

| Classification | Error content |
|-------------------|--|
| Maintenance error | Exporting of the user Information has failed |
| Check item | Measures |
| Setting | Check if enough space remains in the standard storage device and then reattempt the operation. |

[714B] Role information export failure

| Classification | Error content |
|-------------------|--|
| Maintenance error | Exporting of the Role information has failed. |
| Check item | Measures |
| Setting | Check if enough space remains in the standard storage device and then reattempt the operation. |

[714D] Department information export failure

| Classification | Error content |
|-------------------|--|
| Maintenance error | Exporting of the department information has failed. |
| Check item | Measures |
| Setting | Check if enough space remains in the standard storage device and then reattempt the operation. |

[714F] ICC Profile export failure

| Classification | Error content |
|-------------------|--|
| Maintenance error | Exporting of the ICC Profile has failed. |
| Check item | Measures |
| Setting | Check if enough space remains in the standard storage device and then reattempt the operation. |

[7151] Log data export failure

| Classification | Error content |
|-------------------|--|
| Maintenance error | Exporting of the log data has failed. |
| Check item | Measures |
| Setting | Check if enough space remains in the standard storage device and then reattempt the operation. |

[715B] Print Data Converter export failure

| Classification | Error content |
|-------------------|--|
| Maintenance error | Exporting of the Print Data Converter has failed. |
| Check item | Measures |
| Setting | Check if enough space remains in the standard storage device and then reattempt the operation. |

[715D] User Combined data export failure

| Classification | Error content |
|-------------------|--|
| Maintenance error | Exporting of the User Combined data has failed. |
| Check item | Measures |
| Setting | Check if enough space remains in the standard storage device and then reattempt the operation. |

[715F] Address book and mailbox export failure

| Classification | Error content |
|-------------------|--|
| Maintenance error | Exporting of the address book and mailbox has failed. |
| Check item | Measures |
| Setting | Check if enough space remains in the standard storage device and then reattempt the operation. |

[7191] DDNS public key file upload failure

| Classification | Error content |
|-------------------|---|
| Maintenance error | Uploading of the DDNS public key file has failed. |
| Check item | Measures |
| Setting | The DDNS public key file may have a problem or may be corrupted. Check the file and then upload it. |

[7193] DDNS secret key file upload failure

| Classification | Error content |
|-------------------|---|
| Maintenance error | Uploading of the DDNS secret key file has failed. |
| Check item | Measures |
| Setting | The DDNS secret key file may have a problem or may be corrupted. Check the file and then upload it. |

[71A2] CA certificates addition failure

| Classification | Error content |
|-------------------|---|
| Maintenance error | Addition of the CA certificates has failed. |
| Check item | Measures |
| Setting | The CA certificates may have a problem or may be corrupted. Check the CA certificates and reattempt this. |

[71A4] Encryption key consistency check failure

| Classification | Error content |
|-------------------|---|
| Maintenance error | Encryption key consistency check has failed. |
| Check item | Measures |
| Setting | Perform HS-73 Firmware Assist > Key Backup/Restore to recover the encryption key. |

[71A6] Device certificates deletion failure

| Classification | Error content |
|-------------------|---|
| Maintenance error | Deletion of the device certificates has failed. |
| Check item | Measures |
| Setting | Reboot the MFP and then reattempt this. |

[71A8] CA certificates deletion failure

| Classification | Error content |
|-------------------|---|
| Maintenance error | Deletion of the CA certificates has failed. |
| Check item | Measures |
| Setting | Reboot the MFP and then reattempt this. |

[71AA] Unknown error occurred during collection of certificates from an SCEP server

| Classification | Error content |
|-------------------|---|
| Maintenance error | Unknown error has occurred during collection of certificates from an SCEP server. |
| Check item | Measures |
| Setting | Collect the settings of a SCEP server or in TopAccess Administration > Security > Certificate Management SCEP(Automatic). |

[71AB] Timeout error occurred during collection of certificates from an SCEP server

| Classification | Error content |
|-------------------|---|
| Maintenance error | A timeout error has occurred during collection of certificates from an SCEP server. |
| Check item | Measures |
| Setting | Collect the settings of a SCEP server or in TopAccess Administration > Security > Certificate Management SCEP(Automatic). |

[71AC] File saving error occurred during collection of certificates from an SCEP server

| Classification | Error content |
|-------------------|---|
| Maintenance error | A file saving error has occurred during collection of certificates from an SCEP server. |
| Check item | Measures |
| Setting | Data overwriting has failed due to some reasons. If the error still occurs after rebooting the MFP, study to reinstall the software or to replace the storage device using the following procedure: HS-73 Firmware Assist > Format Storage. |

[71B0] Software package file decryption failure

| Classification | Error content |
|-------------------|---|
| Maintenance error | Decryption of the software package file has failed. |

| Check item | Measures |
|------------|--|
| Setting | The software package file may have a problem or may be corrupted. Check the software package file and then reinstall it. |

[71B5] Finisher firmware installation failure

| Classification | Error content |
|-------------------|---|
| Maintenance error | Installation of the finisher firmware has failed. |

| Check item | Measures |
|------------|---|
| Setting | Installation of the finisher firmware has failed. Reinstall the firmware. |

[71B7] Saddle firmware installation failure

| Classification | Error content |
|-------------------|---|
| Maintenance error | Installation of the saddle firmware has failed. |

| Check item | Measures |
|------------|---|
| Setting | Installation of the saddle firmware has failed. Reinstall the firmware. |

[71B9] Punch firmware installation failure

| Classification | Error content |
|-------------------|--|
| Maintenance error | Installation of the punch firmware has failed. |

| Check item | Measures |
|------------|--|
| Setting | Installation of the punch firmware has failed. Reinstall the firmware. |

[71D0] Factory Default failure

| Classification | Error content |
|-------------------|-----------------------------|
| Maintenance error | Factory default has failed. |

| Check item | Measures |
|------------|---|
| Setting | Reboot the MFP and then reattempt this. |

[71E0] License abnormality due to damage on the license manager database

| Classification | Error content |
|--------------------|---|
| License management | A message which notifies that the license manager database is restored and the recovery of the license becomes possible |

| Check item | Measures |
|-------------|--|
| Backup data | Restore the backup data with the latest status, including all the activated licenses, are stored. Remarks: Applications with the trial license cannot be recovered from the backup data. If necessary, reinstall the applications. |
| License | <ul style="list-style-type: none">• If there are no backup data as above, reactivate all the licenses which have been activated in this MFP.• If the functions have been activated by the export license file, import the license exported from the host unit of the MFP. |

[71F1] Clone file creation failure

| Classification | Error content |
|-------------------|--|
| Maintenance error | Creation of the clone file has failed. |
| Check item | Measures |
| Setting | Check if enough space remains in the standard storage device and then reattempt the operation. |

[71F3] Clone file import failure

| Classification | Error content |
|-------------------|---|
| Maintenance error | Importing of the clone file has failed. |
| Check item | Measures |
| Setting | The file may be broken. Check the file and password. Then reattempt this. |

[71F4] Clone file decryption failure

| Classification | Error content |
|-------------------|---|
| Maintenance error | Decryption of the clone file has failed. |
| Check item | Measures |
| Setting | The file may be broken or the an incorrect password has been entered. Check the file and password. Then reattempt this. |

[71F5] Clone file encryption failure

| Classification | Error content |
|-------------------|--|
| Maintenance error | Encryption of the clone file has failed. |
| Check item | Measures |
| Setting | Reboot the MFP and then reattempt this. |

[7288] Data back-up file saving failure (Cloud storage certificates error)

| Classification | Error content |
|-------------------------------|--|
| Backing Up and Restoring Data | Saving of the data back-up file has failed due a cloud storage certificates error. |
| Check item | Measures |
| Setting | Contact your administrator of the remote maintenance and ask if the MFP has been recorded for service or if its serial number has been registered in a cloud server. |

[7289] Data back-up file saving failure (Cloud storage full)

| Classification | Error content |
|-------------------------------|--|
| Backing Up and Restoring Data | Saving of the data back-up file has failed due to a cloud storage full. |
| Check item | Measures |
| Setting | Delete unnecessary data from the cloud server to secure enough space in the storage. |

[728A] Data back-up file saving failure (Server error)

| Classification | Error content |
|-------------------------------|---|
| Backing Up and Restoring Data | Saving of the data back-up file has failed due to a server error. |
| Check item | Measures |
| Setting | Wait for a while and then reattempt it. |

[728B] Data back-up file failure (Connection error: Invalid URL)

| Classification | Error content |
|-------------------------------|--|
| Backing Up and Restoring Data | Saving of the data back-up file has failed due to a connection error caused by an invalid URL. |

| Check item | Measures |
|------------|--|
| Setting | Check if the URL of the server is correct. |

[728C] Data back-up file saving failure (Connection error: Connection impossible)

| Classification | Error content |
|-------------------------------|---|
| Backing Up and Restoring Data | Saving of the data back-up file has failed due to an error in the connection to the cloud server. |

| Check item | Measures |
|------------|--|
| Setting | Check that all the network settings necessary for the backing up of data are proper. |

[728D] Data back-up file saving failure (Connection error: Invalid certificates)

| Classification | Error content |
|-------------------------------|---|
| Backing Up and Restoring Data | Saving of the data back-up file has failed due to connection error caused by an invalid SSL certificates. |

| Check item | Measures |
|------------|-----------------------------------|
| Setting | Install a valid SSL certificates. |

[728E] Data back-up file saving failure (Connection error)

| Classification | Error content |
|-------------------------------|--|
| Backing Up and Restoring Data | Saving of the data back-up file has failed due to a network error. |

| Check item | Measures |
|------------|---|
| Setting | Wait for a while and then reattempt it. |

[7298] Data restoration failure (Cloud server certificates error)

| Classification | Error content |
|-------------------------------|--|
| Backing Up and Restoring Data | Data restoration has failed due to a cloud server certificate error. |

| Check item | Measures |
|------------|--|
| Setting | Contact your administrator of the remote maintenance and ask if the MFP has been recorded for service or if its serial number has been registered in a cloud server. |

[7299] Data restoration failure (Back-up files do not exist in the cloud server.)

| Classification | Error content |
|-------------------------------|--|
| Backing Up and Restoring Data | Data restoration has failed since back-up files to perform the restoration operation do not exist in the cloud server. |

| Check item | Measures |
|------------|---|
| Setting | Check if there are the necessary back-up files in the cloud server. |

[729A] Data restoration failure (Server error)

| Classification | Error content |
|-------------------------------|--|
| Backing Up and Restoring Data | Data restoration has failed due to a server error. |

| Check item | Measures |
|------------|---|
| Setting | Wait for a while and then reattempt it. |

[729B] Data restoration failure (Connection error: Invalid URL)

| Classification | Error content |
|-------------------------------|---|
| Backing Up and Restoring Data | Data restoration has failed due to a connection error caused by an invalid URL. |

| Check item | Measures |
|------------|--|
| Setting | Check if the URL of the server is correct. |

[729C] Data restoration failure (Connection error: Connection impossible)

| Classification | Error content |
|-------------------------------|--|
| Backing Up and Restoring Data | Data restoration has failed due to an error in the connection to the cloud server. |

| Check item | Measures |
|------------|--|
| Setting | Check that all the network settings necessary for data restoration are proper. |

[729D] Data restoration failure (Connection error: Invalid certificates)

| Classification | Error content |
|-------------------------------|---|
| Backing Up and Restoring Data | Data restoration has failed due to connection error caused by an invalid SSL certificate. |

| Check item | Measures |
|------------|-----------------------------------|
| Setting | Install a valid SSL certificates. |

[729E] Data restoration failure (Connection error)

| Classification | Error content |
|-------------------------------|---|
| Backing Up and Restoring Data | Data restoration has failed due to a network error. |

| Check item | Measures |
|------------|---|
| Setting | Wait for a while and then reattempt it. |

[72B1] Enabling of TPM by means of the control panel or the self-diagnostic code has failed.

| Classification | Error content |
|-------------------|---|
| Maintenance error | Enabling of TPM by means of the control panel or the self-diagnostic code has failed. |

| Check item | Measures |
|------------|---|
| Setting | Enable the TPM again. If the error still persists, replace the SYS board. |

[72B3] Disabling of TPM by means of the control panel or the self-diagnostic code has failed.

| Classification | Error content |
|-------------------|--|
| Maintenance error | Disabling of TPM by means of the control panel or the self-diagnostic code has failed. |

| Check item | Measures |
|------------|--|
| Setting | Disable the TPM again. If the error still persists, replace the SYS board. |

[72B5] TPM key backup failure

| Classification | Error content |
|-------------------|---|
| Maintenance error | Backup of the TPM key into a USB storage device has failed. |

| Check item | Measures |
|------------|--|
| Setting | Check if the USB storage device is usable. |

[72B7] TPM key restoration failure

| Classification | Error content |
|-------------------|--|
| Maintenance error | Restoration of the TPM key from a USB storage device has failed. |

| Check item | Measures |
|------------|--|
| Setting | Check if a TPM key, which has been backed up correctly, is used. |

[72C1] Fingerprint registration failure

| Classification | Error content |
|-------------------|--------------------------------------|
| Maintenance error | Fingerprint registration has failed. |

| Check item | Measures |
|------------|---|
| Setting | <ul style="list-style-type: none">Place the finger again.Register the fingerprint using another finger. <p>Remarks: In the following cases, registration of the fingerprint may fail.</p> <ul style="list-style-type: none">The finger is stained or injured.The fingerprint reader is stained.If minutiae of the fingerprint of a registerer are significantly low, it cannot be distinguished and thus its registration will sometimes fail as a result. In such a case, make the authentication accuracy low in the fingerprint authentication accuracy setting in TopAccess. This error may be avoidable. |

[72C2] Fingerprint registration failure (fingerprint duplication)

| Classification | Error content |
|-------------------|--|
| Maintenance error | Fingerprint registration has failed due to the following reasons. <ul style="list-style-type: none">The same fingerprint has already been registered.A fingerprint having rarely similar characteristics has already been registered. |

| Check item | Measures |
|------------|--|
| Setting | <ul style="list-style-type: none">Delete the fingerprint and register it again.Register the fingerprint using another finger. |

[72C9] Fingerprint DB has been damaged.

| Classification | Error content |
|-------------------|--|
| Maintenance error | A fingerprint database stored in a standard storage device is corrupted. |

| Check item | Measures |
|------------|---|
| Setting | The error log is recorded into TopAccess and the recovery is attempted automatically. (Up to 3 times) |

[72CB] Fingerprint template has been damaged.

| Classification | Error content |
|-------------------|--|
| Maintenance error | A standard storage device is malfunctioning or a fingerprint template file (fingerprint registered file) is damaged. |

| Check item | Measures |
|------------|---|
| Setting | Delete fingerprints (specific ones or all) and register them again. |

[72CC] Fingerprint reading has failed.

| Classification | Error content |
|-------------------|---------------------------------|
| Maintenance error | Fingerprint reading has failed. |

| Check item | Measures |
|------------|--|
| Setting | Check that the fingerprint reader is connected properly. |

[72E1] Template data to the home screen transition failure

| Classification | Error content |
|-------------------|--|
| Maintenance error | Transition of template data to the home screen has failed. |
| Check item | Measures |
| Setting | Check if the proper files are used. |

[72E2] A part of the template data has not been transferred to the home screen.

| Classification | Error content |
|-------------------|--|
| Maintenance error | A part of the template data has not been transferred to the home screen due to the following reasons. <ul style="list-style-type: none"> The number of the registrations has reached the maximum during data transferring. Invalid information has been included in some data. |
| Check item | Measures |
| Setting | <ul style="list-style-type: none"> Delete unnecessary templates from the registered ones. Check if the proper files are used. |

[72F1] Execution permission of the remote command has not been assigned to an administrator.

| Classification | Error content |
|-------------------|---|
| Maintenance error | Execution permission of the remote command has not been assigned to an administrator. |
| Check item | Measures |
| Setting | Ask your administrator to permit the remote command execution from TopAccess. |

[72F2] Remote command execution is not available since jobs or another service are being operated.

| Classification | Error content |
|-------------------|---|
| Maintenance error | Remote command execution is not available since jobs or another service are being operated. |
| Check item | Measures |
| Setting | Execute the remote command again. |

[72F3] Remote command file decryption failure

| Classification | Error content |
|-------------------|---|
| Maintenance error | Decryption of the remote command file has failed. |
| Check item | Measures |
| Setting | Encrypt the remote command file (JSON file) by using the password which is the same as that for FS-08-3552 (password for the remote command). |

[72F4] Remote command verification failure

| Classification | Error content |
|-------------------|--|
| Maintenance error | Verification of the remote command file has failed. |
| Check item | Measures |
| Setting | Check if the format of the JSON file used when the remote command file is created. |

[72F5] Compatibility error of the file format of the remote command

| Classification | Error content |
|-------------------|---|
| Maintenance error | Compatibility error of the file format of the remote command |
| Check item | Measures |
| Setting | An old schema of the remote command may be applied to the MFP. Upgrade the version of the ROM in the MFP. |

[72F6] Remote command execution failure

| Classification | Error content |
|-------------------|--|
| Maintenance error | Execution of the remote command has failed. |
| Check item | Measures |
| Setting | Check if a non-existent value is written or obtaining is specified in the JSON file or self-diagnostic batch setting file which is used when the remote command file is created. |

[72F7] Execution of a part of remote command has failed.

| Classification | Error content |
|-------------------|--|
| Maintenance error | Execution of a part of remote command has failed. |
| Check item | Measures |
| Setting | Check if a non-existent value is written or obtaining is specified in the JSON file or self-diagnostic batch setting file which is used when the remote command file is created. |

[72F8] The power of the MFP has been turned OFF while the remote command was being operated.

| Classification | Error content |
|-------------------|---|
| Maintenance error | The power of the MFP has been turned OFF while the remote command was being operated. |
| Check item | Measures |
| Setting | Execute the remote command again. |

[7301] Application installation failure

| Classification | Error content |
|---|---|
| Maintenance error | Installation of the application has failed. |
| Check item | Measures |
| Does "The version of framework is old." appear during the application installation? | <ul style="list-style-type: none"> Update the system firmware. After updating the system firmware, reinstall the application. |

[7332] Application installation error

| Classification | Error content |
|-------------------|---|
| Maintenance error | Application installation error |
| Check item | Measures |
| Setting | Installation of the application has failed. Update the application. |

[7333] Application start error

| Classification | Error content |
|-------------------|-------------------------|
| Maintenance error | Application start error |

| Check item | Measures |
|------------|---|
| Setting | Start of the installation has failed. Update the application. |

[7338] Application installation error (The application does not exist or is being operated.)

| Classification | Error content |
|-------------------|--|
| Maintenance error | Installation or updating of the application has failed due to the following reasons. <ul style="list-style-type: none"> • The application does not exist. • The application is being operated. |

| Check item | Measures |
|------------|--|
| Setting | Check if the application is being operated. If it is, quit it. After that, reattempt the installation. |

[7339] Application installation error (The use of the embedded application is not allowed.)

| Classification | Error content |
|-------------------|--|
| Maintenance error | Installation or updating of the application has failed since the use of the embedded application is not allowed. |

| Check item | Measures |
|------------|--|
| Setting | Enable the application setting. (Set "1" in FS-08-3698.) |

[7340] Application installation error (The framework version of the MFP is old.)

| Classification | Error content |
|-------------------|---|
| Maintenance error | Installation or updating of the application has failed since the framework version of the MFP is old. |

| Check item | Measures |
|------------|---------------------------------------|
| Setting | Install a SYS ROM with a new version. |

[7341] Application installation error (The version of the application is old.)

| Classification | Error content |
|-------------------|---|
| Maintenance error | Installation or updating of the application has failed since the version of the application is old. |

| Check item | Measures |
|------------|--|
| Setting | Install an application with a new version. |

[7342] Application installation error (Other jobs exist.)

| Classification | Error content |
|-------------------|--|
| Maintenance error | Installation or updating of the application has failed since there are other jobs. |

| Check item | Measures |
|------------|--|
| Setting | Check if the jobs are being operated. If they are, close them. After that, reattempt the installation. |

[7343] Application installation error (The control panel is being used or another service is being operated.)

| Classification | Error content |
|-------------------|---|
| Maintenance error | Installation or updating of the application has failed due to the following reasons. <ul style="list-style-type: none"> • The control panel is being used. • Other jobs are being operated. |
| Check item | Measures |
| Setting | Check if another user is operating the MFP or is carrying out cloning. |

[7351] Application installation error (The registration number has exceeded the maximum.)

| Classification | Error content |
|-------------------|--|
| Maintenance error | Installation or updating of the application has failed since the number of the registrations has exceeded the maximum. |
| Check item | Measures |
| Setting | Increase the maximum number of the installation of the application by means of FS-08-3798 or uninstall unnecessary applications. |

[7353] Application uninstallation error (The application does not exist or is being operated.)

| Classification | Error content |
|-------------------|--|
| Maintenance error | Uninstallation of the application has failed due to the following reasons. <ul style="list-style-type: none"> • The application does not exist. • The application is being operated. |
| Check item | Measures |
| Setting | Check if the application is being operated. If it is, quit it. After that, reattempt the uninstallation. |

[7354] Application uninstallation error (Other jobs exist.)

| Classification | Error content |
|-------------------|--|
| Maintenance error | Uninstallation of the application has failed since there are other jobs. |
| Check item | Measures |
| Setting | Check if the jobs are being operated. If they are, close them. After that, reattempt the uninstallation. |

[7355] Application uninstallation error (The control panel is being used or another service is being operated.)

| Classification | Error content |
|-------------------|---|
| Maintenance error | Uninstallation of the application has failed due to the following reasons. <ul style="list-style-type: none"> • The control panel is being used. • Other jobs are being operated. |
| Check item | Measures |
| Setting | Check if another user is operating the MFP or is carrying out cloning. |

[7359] Application rollback error (The application does not exist or is being operated)

| Classification | Error content |
|-------------------|---|
| Maintenance error | Application rollback has failed due to the following reasons. <ul style="list-style-type: none"> • The application does not exist. • The application is being operated. |
| Check item | Measures |
| Setting | Check if the application is being operated. If it is, quit it. After that, reattempt the rollback. |

[7360] Application rollback error (Other jobs exist.)

| Classification | Error content |
|-------------------|--|
| Maintenance error | Application rollback has failed since there are other jobs. |
| Check item | Measures |
| Setting | Check if the jobs are being operated. If they are, close them. After that, reattempt the rollback. |

[7361] Application rollback error (The control panel is being used or another service is being operated.)

| Classification | Error content |
|-------------------|--|
| Maintenance error | Application rollback has failed due to the following reasons. <ul style="list-style-type: none"> The control panel is being used. Other jobs are being operated. |
| Check item | Measures |
| Setting | Check if another user is operating the MFP or is carrying out cloning. |

[7402] License activation failure (Online)

| Classification | Error content |
|--------------------|---|
| License management | License activation by means of [Online] has failed. |
| Check item | Measures |
| License | Ask the license provider whether the license is correct. If the license is not correct, ask the head office to issue the correct license authentication ID. |

[7403] License activation failure (network timeout)**[7404] License activation failure (network error)**

| Classification | Error content |
|---------------------|---|
| License management | License activation by means of [Online] has failed due to a network problem. |
| Check item | Measures |
| Network setting | <ul style="list-style-type: none"> Check that the URL for the license server has not been changed. If the URL for the license server has been changed, enter the post-change URL into FS-08-3634 and then reattempt the activation. Ask a user (a network administrator) to check that the value entered in the following code is correct. FS-08-8693 to 8696 |
| Network environment | Ask a user (a network administrator) to check whether the following settings are correct. <ul style="list-style-type: none"> The proxy is not filtered. The firewall is set properly. |
| License server | Ask the license provider that both servers are working. If they are not working, reattempt the activation after recovering. |

[7412] License deactivation failure (Online)

| Classification | Error content |
|--------------------|--|
| License management | License deactivation by means of [Online] has failed. |
| Check item | Measures |
| License server | Ask the license provider whether the license information exists in the server. |

[7423] License deactivation failure (network timeout)**[7424] License deactivation failure (network error)**

| Classification | Error content |
|--------------------|--|
| License management | License deactivation by means of [Online] has failed due to a network problem. |

| Check item | Measures |
|---------------------|---|
| Network setting | <ul style="list-style-type: none"> Check that the URL for the license server has not been changed. If the URL for the license server has been changed, enter the post-change URL into FS-08-3634 and then reattempt the activation. Ask a user (a network administrator) to check that the value entered in the following code is correct. FS-08-8693 to 8696 |
| Network environment | <p>Ask a user (a network administrator) to check whether the following settings are correct.</p> <ul style="list-style-type: none"> The proxy is not filtered. The firewall is set properly. |
| License server | <p>Ask the license provider that both servers are working. If they are not working, reattempt the deactivation after recovering.</p> |

[7430] Serial number mismatching

| Classification | Error content |
|--------------------|---|
| License management | The serial number registered in the license does not match that for the activated MFP while the license has been activated by means of [Offline]. |

| Check item | Measures |
|---------------|--|
| Serial number | <p>Check whether the serial number for the MFP matches the one included in the file name of the license file. If the serial number does not match, perform the activation in the MFP which has a serial number which is included in the file name of the license file.</p> |

[7431] Subnet mismatching

| Classification | Error content |
|--------------------|--|
| License management | The values of the 1st to 3rd octet registered in the license do not match those for the IP address of the MFP in which activation is being performed while the license has been activated by means of [Offline]. |

| Check item | Measures |
|------------|--|
| IP address | <p>If this error has occurred during the activation in the host unit of the MFP, ask the license provider to rerelease the license with the correct information. If this error has occurred during the activation by means of the export license file, check that the values of the 1st to 3rd octet for the IP address of the MFP in which activation is being performed match those for the host unit.</p> |

[7432] Domain mismatching

| Classification | Error content |
|--------------------|--|
| License management | The domain registered in the license does not match that for the MFP while the license has been activated by means of [Offline]. |

| Check item | Measures |
|------------|---|
| IP address | <p>If this error has occurred during the activation in the host unit of the MFP, ask the license provider to rerelease the license with the correct domain. If this error has occurred during the activation by means of the export license file, check that the domain of the MFP in which activation is being performed matches that for the host unit.</p> |

[7433] Invalid license certificates ID

| Classification | Error content |
|--------------------|--|
| License management | The license certificates ID format does not match. |

| Check item | Measures |
|------------|--|
| License | <ul style="list-style-type: none">• If the certificates ID was manually entered, check it. If it is incorrect, enter the correct one.• If the certificates ID was selected from the file, check which is correct, the file or the certificate ID. If the file or the certificates file is incorrect, enter the correct one. |

[7434] License duplicating installation

| Classification | Error content |
|--------------------|---|
| License management | The license to be installed has already been installed. |

| Check item | Measures |
|------------|---|
| License | <ul style="list-style-type: none">• Check that the license to be installed is correct. If not, install the correct one.• Check that the MFP in which the license is installed is correct. Check if the MFP is the one in which the license has already been installed. |

[7435] Unsupported license activation

| Classification | Error content |
|--------------------|--|
| License management | The license cannot be installed since it is not supported for the MFP. |

| Check item | Measures |
|------------|---|
| License | Check that the MFP in which the license is installed is correct. Check if the MFP is supported. |

[7440] Signature mismatching

| Classification | Error content |
|--------------------|-----------------------------|
| License management | The license file is broken. |

| Check item | Measures |
|----------------|--|
| License server | Ask the license provider to rerelease the license. |

[7444] No license exists

| Classification | Error content |
|--------------------|-------------------|
| License management | License Not Found |

| Check item | Measures |
|------------|--|
| - | Wait for a while and then reattempt the same operation. If this error has occurred repeatedly and the license is used continuously, deactivate or delete the license and then perform reactivation with the reusable license. |

[7445] Full of the license

| Classification | Error content |
|--------------------|--|
| License management | Since the number of the licenses registered in this MFP has reached the maximum, new ones cannot be activated. |

| Check item | Measures |
|------------|---|
| License | Deactivate or delete the licenses which are not being used. |

[7471] Debug log creation failure

| Classification | Error content |
|----------------------|---|
| Debug log management | Creation of the debug log has failed. |
| Check item | Measures |
| Setting | Wait for a while and then reattempt it. |

[7473] Debug log to the remote maintenance service transmission failure

| Classification | Error content |
|----------------------|---|
| Debug log management | Transmission of the debug log to the remote maintenance service has failed. |
| Check item | Measures |
| Setting | Check the setting for making the communication to the remote maintenance service and then reattempt it. |

[7475] Debug log by an e-mail transmission failure

| Classification | Error content |
|----------------------|--|
| Debug log management | Transmission of the debug log by an e-mail has failed. |
| Check item | Measures |
| Setting | Check the settings of the e-mail address and the server and then reattempt it. |

[7477] Print data collection failure

| Classification | Error content |
|----------------------|---|
| Debug log management | Obtaining of the print data has failed. |
| Check item | Measures |
| Setting | Wait for a while and then reattempt it. |

[7479] Print data to the remote maintenance service transmission failure

| Classification | Error content |
|----------------------|---|
| Debug log management | Transmission of the print data to the remote maintenance service has failed. |
| Check item | Measures |
| Setting | Check the setting for making the communication to the remote maintenance service and then reattempt it. |

[747B] Print data by an e-mail transmission failure

| Classification | Error content |
|----------------------|--|
| Debug log management | Transmission of the print data by an e-mail has failed. |
| Check item | Measures |
| Setting | Check the settings of the e-mail address and the server and then reattempt it. |

[747C] Print data by an e-mail transmission failure (Data size exceeding error)

| Classification | Error content |
|----------------------|---|
| Debug log management | Transmission of an e-mail has failed since the size of the print data has exceeded the maximum. |
| Check item | Measures |
| Setting | Decrease the size of the print data to be transmitted to less than 30 MB and then reattempt it. |

[747E] Network capture collection failure

| Classification | Error content |
|----------------------|--|
| Debug log management | Obtaining of the network capture has failed. |
| Check item | Measures |
| Setting | Wait for a while and then reattempt it. |

[7480] Network capture to the remote maintenance service transmission failure

| Classification | Error content |
|----------------------|---|
| Debug log management | Transmission of the network capture to the remote maintenance service has failed. |
| Check item | Measures |
| Setting | Check the setting for making the communication to the remote maintenance service and then reattempt it. |

[7482] Network capture by an e-mail transmission failure

| Classification | Error content |
|----------------------|--|
| Debug log management | Transmission of the network capture by an e-mail has failed. |
| Check item | Measures |
| Setting | Check the settings of the e-mail address and the server and then reattempt it. |

[7483] Network capture by an e-mail transmission failure (Data size exceeding error)

| Classification | Error content |
|----------------------|--|
| Debug log management | Transmission of an e-mail has failed since the size of the network capture has exceeded the maximum. |
| Check item | Measures |
| Setting | Specify the setting so that the obtaining of the network capture time becomes shorter and then reattempt it. |

[7485] Log data deletion failure

| Classification | Error content |
|----------------------|---|
| Debug log management | Deletion of the log data has failed. |
| Check item | Measures |
| Setting | Wait for a while and then reattempt it. |

[7489] Debug logs saving failure

| Classification | Error content |
|----------------------|--|
| Debug log management | Saving of the debug logs has failed. |
| Check item | Measures |
| Setting | <ul style="list-style-type: none"> • Check that there is enough space in the USB storage device. • Check that the USB storage device is properly connected in the MFP. |

[7491] Remote Panel Operation (Cloud hub) connection error: authentication error

| Classification | Error content |
|----------------------|---|
| Debug log management | Connection of the remote panel has failed due to an authentication error. |
| Check item | Measures |
| Setting | <ul style="list-style-type: none"> • Check that the entered authentication code is correct. • Check that the authentication code has not expired. |

[7492] Remote Panel Operation (Cloud hub) connection error: network error

| Classification | Error content |
|-----------------------|---|
| Debug log management | Connection of the remote panel has failed due to a network error. |

| Check item | Measures |
|-------------------|---|
| Setting | Check that the network configuration of the MFP is correct. When a proxy server is used, check its configuration again. |

8.3.11 Network error

[8000] IPv4 address conflict

| Classification | Error content |
|----------------|-----------------------|
| Network error | IPv4 address conflict |

| Check item | Measures |
|------------|--|
| Setting | Check if the same IP address is used by another MFP. |

[8011] IPv6 link local address conflict

| Classification | Error content |
|----------------|----------------------------------|
| Network error | IPv6 link local address conflict |

| Check item | Measures |
|------------|--|
| Setting | Check if the same IP address is used by another MFP. |

[8012] IPv6 manual address conflict

| Classification | Error content |
|----------------|------------------------------|
| Network error | IPv6 manual address conflict |

| Check item | Measures |
|------------|--|
| Setting | Check if the same IP address is used by another MFP. |

[8013] IPv6 stateless address conflict

| Classification | Error content |
|----------------|---------------------------------|
| Network error | IPv6 stateless address conflict |

| Check item | Measures |
|------------|--|
| Setting | Check if the same IP address is used by another MFP. |

[8014] IPv6 stateful address conflict

| Classification | Error content |
|----------------|--------------------------------|
| Network error | IPv6 stateful address conflict |

| Check item | Measures |
|------------|--|
| Setting | Check if the same IP address is used by another MFP. |

[8022] 802.1X authentication failure

| Classification | Error content |
|----------------|-------------------------------|
| Network error | 802.1X authentication failure |

| Check item | Measures |
|------------|---|
| Setting | Set the correct authentication information. |

[8023] Connection failure to an authentication server and a switch

| Classification | Error content |
|----------------|---|
| Network error | Connection to an authentication server and a switch has failed. |

| Check item | Measures |
|------------|--|
| Setting | Check the connectivity to the switch and server. |

[8024] Certificates verification failure

| Classification | Error content |
|----------------|---------------------------------------|
| Network error | Certificates verification has failed. |
| Check item | Measures |
| Setting | Install the correct certificates. |

[8031] IPsec error for IKEv1 certification failure

| Classification | Error content |
|----------------|--|
| Network error | IKEv1 certification has failed. |
| Check item | Measures |
| Setting | <ol style="list-style-type: none"> 1. CA and user certificate in both the MFP and remote peer - certificate timestamp and IPsec Certificate template should be valid. 2. The CRL DP server name is mapped in the MFP's host table or DNS entry. 3. Certificates against CRL |

[8032] IPsec error for wrong proposal selection

| Classification | Error content |
|----------------|---|
| Network error | No IKEv1 Phase1 proposal chosen |
| Check item | Measures |
| Setting | Check the IKEv1 IPsec proposal parameters (like encryption/ authentication algorithms, DH group, authentication methods) in the MFP and peer machine. |

[8033] IPsec error for shared key authentication failure

| Classification | Error content |
|----------------|---|
| Network error | IKEv1 shared key authentication has failed. |
| Check item | Measures |
| Setting | IKE pre-shared key does not match. Check the PSK of the MFP and remote machine. |

[8034] IPsec error for invalid certificates upload

| Classification | Error content |
|----------------|---|
| Network error | IKEv1 invalid certificate. |
| Check item | Measures |
| Setting | Check the CA and user certificates of the MFP and peer machine. |

[8035] IPsec error for non-supported certificates

| Classification | Error content |
|----------------|--------------------------------------|
| Network error | IKEv1 certificates is not supported. |
| Check item | Measures |
| Setting | Check the user certificate type. |

[8036] IPsec error for invalid certificates of authentication

| Classification | Error content |
|----------------|--|
| Network error | IKEv1 invalid certificate. |
| Check item | Measures |
| Setting | Check the CA certificates of the MFP and peer machine. |

[8037] IPsec error for certificates disable

| Classification | Error content |
|----------------|---|
| Network error | There are no available certificates. |
| Check item | Measures |
| Setting | Certificates have been deleted from the certificate store. Upload the certificates again. |

[8038] IPsec error for SA non-existing

| Classification | Error content |
|----------------|--|
| Network error | No SA is established, |
| Check item | Measures |
| Setting | <p>Check the IKEv1 IPsec proposal parameters (like encryption/ authentication algorithms, DH group, authentication methods) in the MFP and peer machine.</p> <ol style="list-style-type: none"> 1. Check the CA and certificate of the MFP and remote peer. Check the date of the certificate and IPsec certificate template. 2. The CRL DP server name is mapped in the MFP's host table or DNS entry. 3. Certificates against CRL |

[8039] IPsec error for invalid signature for certification

| Classification | Error content |
|----------------|---|
| Network error | Invalid signature |
| Check item | Measures |
| Setting | The signature payload (MAC or IV) does not match. Check the CA and user certificates of the MFP and peer machine. |

[803A] IPsec error for wrong selection of proposal

| Classification | Error content |
|----------------|---|
| Network error | No IKEv2 proposal is chosen. |
| Check item | Measures |
| Setting | Check the IKEv2 IPsec proposal parameters (like encryption/ authentication algorithms, DH group, authentication methods) in the MFP and peer machine. |

[803B] IPsec error for IKEv2 certification failure

| Classification | Error content |
|----------------|---|
| Network error | IKEv2 certification has failed. |
| Check item | Measures |
| Setting | <ol style="list-style-type: none"> 1. Check if the CA and user certificate in both the MFP and remote peer - certificate timestamp and IPsec Certificate template should be valid. 2. The CRL DP server name is mapped in the MFP's host table or DNS entry. 3. Certificates against CRL |

[803C] IKEv2 error for IKEv2 if secret key authentication failed

| Classification | Error content |
|----------------|---|
| Network error | IKEv2 secret key authentication has failed. |
| Check item | Measures |
| Setting | IKEv2 pre-shared key does not match. Check the PSK of the MFP and peer machine. |

[803D] IPsec error if peer does not support IKEv2 and falling back to IKEv1

| Classification | Error content |
|----------------|---|
| Network error | Falling Back to IKEv1 has been performed. |
| Check item | Measures |
| Setting | The remote machine does not support IKEv2. Downgrade and use IKEv1. |

[803E] IPsec error if ISAKMP SA is uncreated or destroyed due to some uncertain conditions

| Classification | Error content |
|----------------|----------------------------------|
| Network error | ISAKMP SA cannot be used. |
| Check item | Measures |
| Setting | Restart IPsec on peer and retry. |

[803F] IPsec error for IKEv2 if crypto operation failed

| Classification | Error content |
|----------------|---|
| Network error | Encryption in IKEv2 has failed. |
| Check item | Measures |
| Setting | If certificates are being used, upload the certificates again using a security service. Restart IPsec on the MFP. |

[8040] IPsec error for IKEv2 if key info is invalid

| Classification | Error content |
|----------------|--|
| Network error | Key information is invalid. |
| Check item | Measures |
| Setting | Check the IKE setting of the MFP and peer machine. |

[8041] IPsec error for IKEv2 if CA is not trusted

| Classification | Error content |
|----------------|--|
| Network error | Certificates have not been issued by a trusted authority. |
| Check item | Measures |
| Setting | Check the CA certificates of the MFP and peer machine. Check the timestamp of the CA certificates. |

[8042] IPsec error for authentication method inconsistency

| Classification | Error content |
|----------------|---|
| Network error | The authentication method does not match. |
| Check item | Measures |
| Setting | The IKE authentication type does not match. Check the certificate type of the MFP and peer machine. |

[8043] IPsec error for version inconsistency

| Classification | Error content |
|----------------|--|
| Network error | The IKE version does not match. |
| Check item | Measures |
| Setting | The IKE version does not match. Check the IKE version of the MFP and peer. |

[8044] IPsec error for encapsulation inconsistency

| Classification | Error content |
|----------------|---|
| Network error | Encapsulation does not match. |
| Check item | Measures |
| Setting | Check the IPsec mode (Transport, Tunnel) of the MFP and peer. |

[8045] IPsec error for peer IP inconsistency

| Classification | Error content |
|----------------|---|
| Network error | The IP address of the peer machine does not match. |
| Check item | Measures |
| Setting | The remote traffic selector does not match. Check the destination address and port in the IPsec filter. |

[8046] IPsec error for local IP inconsistency

| Classification | Error content |
|----------------|---|
| Network error | The OP address of the local machine does not match. |
| Check item | Measures |
| Setting | The local traffic selector does not match. Check the source address and port in the IPsec filter. |

[8047] IPsec error for local ID inconsistency

| Classification | Error content |
|----------------|---|
| Network error | The local ID does not match. |
| Check item | Measures |
| Setting | Check the user certificates of the MFP. |

[8048] IPsec error for remote ID inconsistency

| Classification | Error content |
|----------------|--|
| Network error | The remote ID does not match. |
| Check item | Measures |
| Setting | Check the user certificates of the peer machine. |

[8049] IPsec error for remote IP inconsistency

| Classification | Error content |
|----------------|--|
| Network error | The IPsec remote IP does not match. |
| Check item | Measures |
| Setting | The remote traffic selector does not match. Check the source address and port in the IPsec filter. |

[804A] IPsec error for IKEv2 timeout

| Classification | Error content |
|----------------|---|
| Network error | IKEv1 / IKEv2 timeout |
| Check item | Measures |
| Setting | Check the network connectivity between the MFP and peer machine. Select the flush connections option and retry. |

[804B] IPsec error for invalid of ID manual key

| Classification | Error content |
|----------------|--|
| Network error | The manual key is invalid. |
| Check item | Measures |
| Setting | Check the inbound and outbound keys (ESP encryption, authentication and AH authentication) of the MFP and remote PC. |

[8061] Update error for secure primary DDNS**[8062] Update error for secure secondary DDNS****[8063] Update error for IPv6 secure primary DDNS****[8064] Update error for IPv6 secure secondary DDNS****[8065] Update error for IPv6 primary DDNS****[8066] Update error for IPv6 secondary DDNS****[8067] Update error for IPv4 primary DDNS****[8068] Update error for IPv4 secondary DDNS**

| Classification | Error content |
|----------------|--|
| Network error | [8061] Update error for secure primary DDNS [8062] Update error for secure secondary DDNS [8063] Update error for IPv6 secure primary DDNS [8064] Update error for IPv6 secure secondary DDNS [8065] Update error for IPv6 primary DDNS [8066] Update error for IPv6 secondary DDNS [8067] Update error for IPv4 primary DDNS [8068] Update error for IPv4 secondary DDNS |
| Check item | Measures |
| Setting | Check if there is any problem in the DNS or DDNS settings. |

[8069] Message displayed when the key file for SIG(0) or TSIG is invalid

| Classification | Error content |
|----------------|--|
| Network error | This message is displayed when the key file for SIG(0) or TSIG is invalid. |
| Check item | Measures |
| Setting | Verify the TSIG/SIG(0) key files used. |

[80B1] Bluetooth connection failure

| Classification | Error content |
|--------------------------|---|
| Network error | Bluetooth connection has failed. |
| Check item | Measures |
| Module connection status | Check if the wireless LAN or Bluetooth module is connected. |

[80C0] TLS session establishment failure (invalid message)

| Classification | Error content |
|----------------|---|
| Network error | An invalid message has been received. |
| Check item | Measures |
| Setting | <ul style="list-style-type: none"> Check the SSL/TLS settings of a connect-to server. Check the SSL/TLS certificate installed in the MFP. |

[80C1] TLS session establishment failure (invalid MAC data)

| Classification | Error content |
|----------------|---|
| Network error | Invalid MAC data have been received. |
| Check item | Measures |
| Setting | <ul style="list-style-type: none"> • Check the SSL/TLS settings of a connect-to server. • Check the SSL/TLS certificate installed in the MFP. |

[80C2] TLS session establishment failure (decoding failure)

| Classification | Error content |
|----------------|---|
| Network error | TLSCiphertext data structure has been encoded by an invalid method. |
| Check item | Measures |
| Setting | <ul style="list-style-type: none"> • Check the SSL/TLS settings of a connect-to server. • Check the SSL/TLS certificate installed in the MFP. |

[80C3] TLS session establishment failure (recording length abnormality)

| Classification | Error content |
|----------------|---|
| Network error | A TLSCiphertext record whose size is $2^{14}+2048$ bytes or more has been received. Alternatively, decoding to a TLSCompressed record whose size is $2^{14}+2048$ bytes or more has been carried out. |
| Check item | Measures |
| Setting | <ul style="list-style-type: none"> • Check the SSL/TLS settings of a connect-to server. • Check the SSL/TLS certificate installed in the MFP. |

[80C4] TLS session establishment failure (data decompression failure)

| Classification | Error content |
|----------------|---|
| Network error | Data (output) with an invalid expansion function have been received. (E.g.: Data with length exceeded) |
| Check item | Measures |
| Setting | <ul style="list-style-type: none"> • Check the SSL/TLS settings of a connect-to server. • Check the SSL/TLS certificate installed in the MFP. |

[80C5] TLS session establishment failure (handshake failure)

| Classification | Error content |
|----------------|---|
| Network error | A handshake_failure alert message has been received. |
| Check item | Measures |
| Setting | <ul style="list-style-type: none"> • Check the SSL/TLS settings of a connect-to server. • Check the SSL/TLS certificate installed in the MFP. |

[80C6] TLS session establishment failure (certificate abnormality)

| Classification | Error content |
|----------------|--|
| Network error | A certificate has been broken. Alternatively, a signature which cannot be verified properly has been included. |
| Check item | Measures |
| Setting | Check the SSL/TLS certificate installed in the MFP. |

[80C7] TLS session establishment failure (non-support certificate)

| Classification | Error content |
|----------------|---|
| Network error | The type of the certificate has not been supported. |
| Check item | Measures |
| Setting | Check the SSL/TLS certificate installed in the MFP. |

[80C8] TLS session establishment failure (invalid certificate)

| Classification | Error content |
|----------------|---|
| Network error | The certificate has been disabled by its signer. |
| Check item | Measures |
| Setting | Check the SSL/TLS certificate installed in the MFP. |

[80C9] TLS session establishment failure (certificate with validity date expired)

| Classification | Error content |
|----------------|---|
| Network error | The validity date of the certificate has expired. |
| Check item | Measures |
| Setting | Check the SSL/TLS certificate installed in the MFP. |

[80CA] TLS session establishment failure (certificate process error)

| Classification | Error content |
|----------------|---|
| Network error | Since a non-specified problem has occurred, the certification process has failed. |
| Check item | Measures |
| Setting | Check the SSL/TLS certificate installed in the MFP. |

[80CB] TLS session establishment failure (invalid parameter)

| Classification | Error content |
|----------------|---|
| Network error | The acceptable range of the field for handshake has been exceeded. Alternatively, an inconsistency between another field has occurred. |
| Check item | Measures |
| Setting | <ul style="list-style-type: none"> • Check the SSL/TLS settings of a connect-to server. • Check the SSL/TLS certificate installed in the MFP. |

[80CC] TLS session establishment failure (unknown CA certificate)

| Classification | Error content |
|----------------|--|
| Network error | A valid certificate chain or a part of the chain has been received; however, there is no CA certificate. Alternatively, a certificate could not be received since it does not match the already-known relied CA. |
| Check item | Measures |
| Setting | Check the SSL/TLS certificate installed in the MFP. |

[80CD] TLS session establishment failure (access rejection)

| Classification | Error content |
|----------------|--|
| Network error | Although a valid certificate has been received, a connect-to server has rejected the access when access control was applied. |
| Check item | Measures |
| Setting | Check the SSL/TLS settings of a connect-to server. |

[80CE] TLS session establishment failure (decoding error)

| Classification | Error content |
|----------------|---|
| Network error | A value in the field is outside of the range. Alternatively, a message could be decoded since its length was inappropriate. |
| Check item | Measures |
| Setting | <ul style="list-style-type: none"> • Check the SSL/TLS settings of a connect-to server. • Check the SSL/TLS certificate installed in the MFP. |

[80CF] TLS session establishment failure (decryption error)

| Classification | Error content |
|----------------|---|
| Network error | A handshake encryption process has failed. |
| Check item | Measures |
| Setting | <ul style="list-style-type: none"> • Check the SSL/TLS settings of a connect-to server. • Check the SSL/TLS certificate installed in the MFP. |

[80D0] TLS session establishment failure (export restrictions)

| Classification | Error content |
|----------------|---|
| Network error | A negotiation which does not comply with the export restrictions of the regulation has been detected. |
| Check item | Measures |
| Setting | <ul style="list-style-type: none"> • Check the SSL/TLS settings of a connect-to server. • Check the SSL/TLS certificate installed in the MFP. |

[80D1] TLS session establishment failure (non-support protocol version)

| Classification | Error content |
|----------------|---|
| Network error | Unsupported versions of the TLS protocol have been recognized. |
| Check item | Measures |
| Setting | <ul style="list-style-type: none"> • Check that the communication with a client, server or external applications is made using the supported TLS protocol (only TLS1.2 available as of 2020) in the SSL/TLS settings. • Check the SSL/TLS certificate installed in the MFP. |

[80D2] TLS session establishment failure (internal error)

| Classification | Error content |
|----------------|---|
| Network error | A process cannot be continued due to an internal error. |
| Check item | Measures |
| Setting | <ul style="list-style-type: none"> • Check the SSL/TLS settings of a connect-to server. • Check the SSL/TLS certificate installed in the MFP. |

[80D3] TLS session establishment failure (cancellation by a user)

| Classification | Error content |
|----------------|---|
| Network error | A handshake has been canceled for a reason other than a protocol error. |
| Check item | Measures |
| Setting | <ul style="list-style-type: none"> • Check the SSL/TLS settings of a connect-to server. • Check the SSL/TLS certificate installed in the MFP. |

[80D4] TLS session establishment failure (invalid renegotiation)

| Classification | Error content |
|----------------|--|
| Network error | The following items are improper: A client response to a HelloRequest message. A server response to a ClientHello message received after the first handshake. Renegotiation performed later. |
| Check item | Measures |
| Setting | <ul style="list-style-type: none"> • Check the SSL/TLS settings of a connect-to server. • Check the SSL/TLS certificate installed in the MFP. |

[80F0] LDAP DB damage detection

| Classification | Error content |
|----------------|---|
| Network error | LDAP DB damage has been detected. |
| Check item | Measures |
| Setting | <ul style="list-style-type: none"> • Check the SSL/TLS settings of a connect-to server. • Check the SSL/TLS certificate installed in the MFP. |

[8101] Wireless connection in the Access point failure

| Classification | Error content |
|----------------|--|
| Network error | Wireless connection in the Access point has failed. |
| Check item | Measures |
| Setting | Verify the credentials used for association with the access point. |

[8102] Connection failure of MFP to the Access point with a specified SSID

| Classification | Error content |
|----------------|---|
| Network error | Connection failure of MFP to the Access point with a specified SSID failure |
| Check item | Measures |
| Setting | Verify the access point name setting and mechanism used for association same as the access point setting. |

[8103] Wireless certificate verification failure

| Classification | Error content |
|----------------|---|
| Network error | Wireless certificate verification has failed. |
| Check item | Measures |
| Setting | Verify the certificate settings used for association. |

[8104] Wireless LAN / Bluetooth module hardware error

| Classification | Error content |
|-------------------------------|--|
| Network error | Connection to access point has failed due to a wireless LAN or Bluetooth hardware error. |
| Check item | Measures |
| Wireless LAN/Bluetooth module | <ul style="list-style-type: none"> • Check the connection of the wireless LAN/Bluetooth module. • Replace the wireless LAN/Bluetooth module. |

[8121] Domain: Authentication failure

| Classification | Error content |
|----------------|---|
| Network error | An unknown domain authentication error has occurred when connecting to the domain controller. |
| Check item | Measures |
| Setting | Check the network settings of this MFP and connect to the domain controller again. |

[8122] Domain: Invalid user name or password

| Classification | Error content |
|----------------|--|
| Network error | The user name or password of the domain authentication is not valid and thus the user cannot log in. |
| Check item | Measures |
| Setting | Check if the user name or password of this MFP is entered correctly. Enter the user name or password by specifying the upper and lower case letters correctly. |

[8123] Domain: Invalid server

| Classification | Error content |
|----------------|--|
| Network error | The server cannot be detected at domain authentication. |
| Check item | Measures |
| Setting | Check if the server is down. Check the network settings of this MFP. If the name resolution is used, check the settings of the DNS and DDNS. |

[8124] Domain: Invalid user account

| Classification | Error content |
|----------------|---|
| Network error | The user account is invalid at domain authentication and thus the user cannot log in. |
| Check item | Measures |
| Setting | Check if the setting of the user account in [Active Directory User and Computer] is disabled. |

[8125] Domain: Expired user account

| Classification | Error content |
|----------------|---|
| Network error | The validity date of the user account has expired at domain authentication and thus the user cannot log in. |
| Check item | Measures |
| Setting | Check if the setting of the user account in [Active Directory User and Computer] has expired. |

[8126] Domain: Locked user account

| Classification | Error content |
|----------------|--|
| Network error | The user account has been locked at domain authentication and thus the user cannot log in. |
| Check item | Measures |
| Setting | Check the setting of the account lock-out on the server. |

[8127] Domain: Invalid log-in time

| Classification | Error content |
|----------------|--|
| Network error | The log-in time is invalid at domain authentication and thus the user cannot log in. |
| Check item | Measures |
| Setting | Check the log-in time setting of the user account in [Active Directory User and Computer]. |

[8128] Active directory domain: Clock skew error

| Classification | Error content |
|----------------|---|
| Network error | The difference between the time set in the MFP and that set in the server is more than five minutes at domain authentication of the Active Directory and thus the user cannot log in. |
| Check item | Measures |
| Setting | Match the time of the MFP and domain controller. The use of an SNTP server is recommended if it exists in the network environment. |

[8129] Active directory domain: Expired Kerberos ticket

| Classification | Error content |
|----------------|---|
| Network error | A Kerberos ticket has expired at domain authentication of the Active Directory and thus the user cannot log in. |
| Check item | Measures |
| Setting | Check if the validity date of the Kerberos ticket on the Kerberos server has expired. |

[812A] Active directory domain: Kerberos ticket authentication failure

| Classification | Error content |
|----------------|--|
| Network error | The user cannot log in due to Kerberos ticket authentication failure of Active Directory domain authentication. |
| Check item | Measures |
| Setting | Check if the user name or password of this MFP is entered correctly. If the error still persists, ask your Windows Server administrator. |

[812B] Active directory domain: Invalid realm name

| Classification | Error content |
|----------------|--|
| Network error | The user cannot log in due to invalid realm name at Active Directory domain authentication. |
| Check item | Measures |
| Setting | Check if the realm name of the Active Directory server of this MFP is incorrect. If the error still persists, ask your Windows Server administrator. |

[8200] The IPv4 address has conflicted. (Secondary interface)

| Classification | Error content |
|----------------|---|
| Network error | The IPv4 address of the secondary interface has conflicted. |
| Check item | Measures |
| Setting | Check that the same IP address is not used in other terminals in the secondary network. |

[8211] The IPv6 link local address has conflicted. (Secondary interface)

| Classification | Error content |
|----------------|---|
| Network error | The IPv6 address of the secondary interface has conflicted. |
| Check item | Measures |
| Setting | Check that the same IP address is not used in other terminals in the secondary network. |

[8212] The IPv6 manual address has conflicted. (Secondary interface)

| Classification | Error content |
|----------------|---|
| Network error | The IPv6 manual address of the secondary interface has conflicted. |
| Check item | Measures |
| Setting | Check that the same IP address is not used in other terminals in the secondary network. |

[8213] The IPv6 stateless address has conflicted. (Secondary interface)

| Classification | Error content |
|----------------|---|
| Network error | The IPv6 stateless address of the secondary interface has conflicted. |
| Check item | Measures |
| Setting | Check that the same IP address is not used in other terminals in the secondary network. |

[8214] The IPv6 stateful address has conflicted. (Secondary interface)

| Classification | Error content |
|----------------|---|
| Network error | The IPv6 stateful address of the secondary interface has conflicted. |
| Check item | Measures |
| Setting | Check that the same IP address is not used in other terminals in the secondary network. |

8.3.12 FAX error

[0012] Original jam

| Classification | Error content |
|----------------|--|
| Fax | The fax transmission has failed since an original was misfed in the DF while a fax job was being sent. |
| Check item | Measures |
| Setting | Remove the misfed original and reattempt the fax transmission. |

[0013] Cover is open

| Classification | Error content |
|----------------|--|
| Fax | The fax transmission has failed since the cover of the MFP or options that process paper was opened. |
| Check item | Measures |
| Setting | Close the cover and reattempt the fax transmission. |

[0020] Power failure Transmission

| Classification | Error content |
|----------------|---|
| Fax | The fax transmission has failed due to a power failure. |
| Check item | Measures |
| Setting | Reattempt the fax transmission. |

Reception

| Classification | Error content |
|----------------|--|
| Fax | The fax reception has failed due to a power failure. |
| Check item | Measures |
| Setting | Reattempt the fax reception. |

Transmission

| Classification | Error content |
|----------------|--|
| IP Fax | The IP Fax transmission has failed due to a power failure. |
| Check item | Measures |
| Setting | Reattempt the IP Fax transmission. |

Reception

| Classification | Error content |
|----------------|---|
| IP Fax | The IP Fax reception has failed due to a power failure. |
| Check item | Measures |
| Setting | Reattempt the IP Fax reception. |

[0030] Recording paper jam

| Classification | Error content |
|----------------|--|
| Fax | The fax transmission has been stopped due to the following reason. <ul style="list-style-type: none">• Paper misfeeding occurred with another job.• A Fax job was canceled. |
| Check item | Measures |
| Setting | In the case of paper misfeeding, remove it and reattempt the fax transmission. |

[0033] Polling error

| Classification | Error content |
|----------------|--|
| Fax | The polling reception has failed due to the following reason. <ul style="list-style-type: none"> • A polling original was not set on the other side's device. • The security setting between this MFP and the other side's device did not match. |

| Check item | Measures |
|------------|---|
| Setting | Take the following action and reattempt the polling reception. <ul style="list-style-type: none"> • Ask to set the polling original on the other side's device. • Make the security setting matched between this MFP and the other side's device. |

[0040] Modem communication error**Transmission**

| Classification | Error content |
|----------------|---|
| Fax | The fax transmission has failed since the modem could not send the signal properly. |

| Check item | Measures |
|------------|---------------------------------|
| Setting | Reattempt the fax transmission. |

Reception

| Classification | Error content |
|----------------|---|
| Fax | The fax reception has failed since the modem could not receive the signal properly. |

| Check item | Measures |
|------------|------------------------------|
| Setting | Reattempt the fax reception. |

[0042] Memory full

| Classification | Error content |
|----------------|---|
| Fax | The fax reception has been canceled since the capacity in a shortage device or an abnormality occurred in it while a fax job was being received. (Pages which are received successfully will be printed out.) |

| Check item | Measures |
|------------|---|
| Setting | Take the following action and reattempt the fax reception. <ul style="list-style-type: none"> • In the case of a capacity in a storage device, free up the memory space. • In the case of an abnormality, replace the storage device. |

| Classification | Error content |
|----------------|---|
| IP Fax | The IP Fax reception has been canceled since the capacity in a storage device or an abnormality occurred in it while an IP Fax job was being received. (Pages which are received successfully will be printed out.) |

| Check item | Measures |
|------------|--|
| Setting | Take the following action and reattempt the IP Fax reception. <ul style="list-style-type: none"> • In the case of a capacity in a storage device, free up the memory space. • In the case of an abnormality, replace the storage device. |

[0050] Line is busy

| Classification | Error content |
|----------------|---|
| Fax | Since the line of the other side's device was busy, the fax transmission has failed even though the redialing was carried out by the maximum number of specified times. |

| Check item | Measures |
|------------|---|
| Setting | Reattempt the fax transmission. Increase the number of redialing times if required. |

[0051] No cable connected for fax line

| Classification | Error content |
|----------------|--|
| Fax | The fax transmission has failed since no cable for the fax line was connected. |

| Check item | Measures |
|------------|--|
| Setting | Connect a cable for the fax line and reattempt the fax transmission. |

[0052] T1 time-out

| Classification | Error content |
|----------------|--|
| Fax | The fax transmission has failed since NSF/DIS could not be detected. (Memory transmission) |

| Check item | Measures |
|------------|---|
| Setting | Check that the other side's device is answering in the fax mode and reattempt the fax transmission. |

| Classification | Error content |
|----------------|---|
| IP Fax | The IP Fax transmission has failed since NSF/DIS could not be detected. (Memory transmission) |

| Check item | Measures |
|------------|---|
| Setting | Check that the other side's device is answering in the fax mode and reattempt the fax transmission. |

[00B0] Initial signal not detected

| Classification | Error content |
|----------------|--|
| Fax | The fax transmission has failed since NSF/DIS could not be detected. (Direct transmission) |

| Check item | Measures |
|------------|---|
| Setting | Check that the other side's device is answering in the fax mode and reattempt the fax transmission. |

[00B1] Terminal constants not compatible

Transmission

| Classification | Error content |
|----------------|---|
| Fax | The fax transmission has failed since the other side's device did not have the capability which was transferred by NSF/DIS on this MFP. |

| Check item | Measures |
|------------|---|
| Setting | Check the capability of the other side's device and reattempt the fax transmission by using a receivable mode for it. |

Reception

| Classification | Error content |
|----------------|--|
| Fax | The fax reception has failed since NSS/DCS, which was a capability other than the ones transferred by NSF/DIS on this MFP, was received. |

| Check item | Measures |
|------------|---|
| Setting | Check the capability of this MFP and reattempt the fax reception by using a receivable mode for it. |

Transmission

| Classification | Error content |
|----------------|--|
| IP Fax | The IP Fax transmission has failed since the other side's device did not have the capability which was transferred by NSF/DIS on this MFP. |

| Check item | Measures |
|------------|--|
| Setting | Check the capability of the other side's device and reattempt the IP Fax transmission by using a receivable mode for it. |

Reception

| Classification | Error content |
|----------------|---|
| IP Fax | The IP Fax job reception has failed since NSS/DCS, which was a capability other than the ones transferred by NSF/DIS on this MFP, was received. |

| Check item | Measures |
|------------|--|
| Setting | Check the capability of this MFP and reattempt the IP Fax reception by using a receivable mode for it. |

[00B2] DCN reception (Phase B)

Transmission

| Classification | Error content |
|----------------|--|
| Fax | The fax transmission has failed since DCN was sent in Phase B. |

| Check item | Measures |
|------------|---------------------------------|
| Setting | Reattempt the fax transmission. |

Reception

| Classification | Error content |
|----------------|---|
| Fax | The fax reception has failed since DCN was received in Phase B. |

| Check item | Measures |
|------------|------------------------------|
| Setting | Reattempt the fax reception. |

Transmission

| Classification | Error content |
|----------------|---|
| IP Fax | The IP Fax transmission has failed since DCN was sent in Phase B. |

| Check item | Measures |
|------------|------------------------------------|
| Setting | Reattempt the IP Fax transmission. |

Reception

| Classification | Error content |
|----------------|--|
| IP Fax | The IP Fax reception has failed since DCN was received in Phase B. |

| Check item | Measures |
|------------|---------------------------------|
| Setting | Reattempt the IP Fax reception. |

[00B3] DCS / DTC not detected

| Classification | Error content |
|----------------|---|
| Fax | The fax reception has failed since DCS/DTC could not be detected. |

| Check item | Measures |
|------------|------------------------------|
| Setting | Reattempt the fax reception. |

Transmission

| Classification | Error content |
|----------------|---|
| IP Fax | The IP Fax transmission has failed since DCS/DTC could not be detected. |

| Check item | Measures |
|------------|------------------------------------|
| Setting | Reattempt the IP Fax transmission. |

Reception

| Classification | Error content |
|----------------|--|
| IP Fax | The IP Fax reception has failed since DCS/DTC could not be detected. |

| Check item | Measures |
|------------|---------------------------------|
| Setting | Reattempt the IP Fax reception. |

[00B4] Training error Transmission

| Classification | Error content |
|----------------|---|
| Fax | This MFP has performed fall-back but the fax transmission has failed. |

| Check item | Measures |
|------------|--|
| Setting | Adjust the attenuator and link equalizer of this MFP and the other side's device and reattempt the fax transmission. |

Reception

| Classification | Error content |
|----------------|---|
| Fax | The fax reception has failed since after receiving FTT, the receiver has received a timeout or DCN. |

| Check item | Measures |
|------------|---|
| Setting | Adjust the attenuator and link equalizer of this MFP and the other side's device and reattempt the fax reception. |

Transmission

| Classification | Error content |
|----------------|--|
| IP Fax | This MFP has performed fall-back but the IP Fax transmission has failed. |

| Check item | Measures |
|------------|---|
| Setting | Check the following items and reattempt the IP Fax transmission. <ul style="list-style-type: none"> This MFP and the other side's device are connected to a network properly. If the other side's device is in the fax mode, its attenuator and link equalizer are adjusted properly. |

Reception

| Classification | Error content |
|----------------|--|
| IP Fax | The IP Fax reception has failed since after receiving FTT, the receiver has received a timeout or DCN. |

| Check item | Measures |
|------------|--|
| Setting | Check the following items and reattempt the IP Fax reception. <ul style="list-style-type: none"> This MFP and the other side's device are connected to a network properly. If the other side's device is in the fax mode, its attenuator and link equalizer are adjusted properly. |

[00B5] CFR not detected

| Classification | Error content |
|----------------|--|
| Fax | The fax transmission has failed since a training signal has been sent out but CFR could not be detected. |

| Check item | Measures |
|------------|--|
| Setting | Adjust the attenuator and link equalizer of this MFP and the other side's device and reattempt the fax transmission. |

| Classification | Error content |
|----------------|---|
| IP Fax | The IP Fax transmission has failed since a training signal has been sent out but CFR could not be detected. |

| Check item | Measures |
|------------|--|
| Setting | Check the following items and reattempt the IP Fax transmission. <ul style="list-style-type: none"> • The network of this MFP is functioning properly. • The IP Fax function of this MFP is set properly. • If the other side's device is in the fax mode, its attenuator and link equalizer are adjusted properly. |

[00B6] No response made to CTC

| Classification | Error content |
|----------------|--|
| Fax | The fax transmission has failed since no response was made to CTC. |

| Check item | Measures |
|------------|--|
| Setting | Adjust the attenuator and link equalizer of this MFP and the other side's device and reattempt the fax transmission. |

Transmission

| Classification | Error content |
|----------------|---|
| IP Fax | The IP Fax transmission has failed since no response was made to CTC. |

| Check item | Measures |
|------------|---|
| Setting | Check the following items and reattempt the IP Fax transmission. <ul style="list-style-type: none"> • This MFP and the other side's device are connected to a network properly. • If the other side's device is in the fax mode, its attenuator and link equalizer are adjusted properly. |

Reception

| Classification | Error content |
|----------------|---|
| IP Fax | The IP Fax reception has failed since DCN was received. |

| Check item | Measures |
|------------|--|
| Setting | Check the following items and reattempt the IP Fax reception. <ul style="list-style-type: none"> • This MFP and the other side's device are connected to a network properly. • If the other side's device is in the fax mode, its attenuator and link equalizer are adjusted properly. |

[00B7] Phase B cannot be completed

Transmission

| Classification | Error content |
|----------------|---|
| Fax | The fax transmission has failed since a modem error or a sequence error in the Fax Unit occurred. |

| Check item | Measures |
|------------|--|
| Setting | Reattempt the fax transmission. If the error persists, replace the Fax Unit. |

Reception

| Classification | Error content |
|----------------|--|
| Fax | The fax reception has failed since a modem error or a sequence error in the Fax Unit occurred. |

| Check item | Measures |
|------------|---|
| Setting | Reattempt the fax reception. If the error persists, replace the Fax Unit. |

Transmission

| Classification | Error content |
|----------------|---|
| IP Fax | The IP Fax transmission has failed since an error occurred in the system. |

| Check item | Measures |
|------------|--|
| Setting | Reboot this MFP and reattempt the IP Fax transmission. |

Reception

| Classification | Error content |
|----------------|--|
| IP Fax | The IP Fax reception has failed since an error occurred in the system. |

| Check item | Measures |
|------------|---|
| Setting | Reboot this MFP and reattempt the IP Fax reception. |

[00C0] Image signal carrier not detected

| Classification | Error content |
|----------------|---|
| Fax | The fax reception has failed since this MFP has failed to detect a carrier. |

| Check item | Measures |
|------------|---|
| Setting | Adjust the attenuator and link equalizer of this MFP and the other side's device and reattempt the fax reception. |

[00C1] High-speed signal not detected

| Classification | Error content |
|----------------|---|
| Fax | The fax reception has failed since this MFP has failed to detect a high-speed signal. |

| Check item | Measures |
|------------|---|
| Setting | Adjust the attenuator and link equalizer of this MFP and the other side's device and reattempt the fax reception. |

| Classification | Error content |
|----------------|--|
| IP Fax | The IP Fax reception has failed since this MFP has failed to detect a high-speed signal. |

| Check item | Measures |
|------------|---|
| Setting | Check the following items and reattempt the IP Fax reception. <ul style="list-style-type: none"> • The network of this MFP and the other side's device is functioning properly. • The IP Fax function of this MFP is set properly. • If the other side's device is in the fax mode, its attenuator and link equalizer are adjusted properly. |

[00C2] Image signal carrier disconnected

Transmission

| Classification | Error content |
|----------------|---|
| Fax | The fax transmission has failed since a carrier disconnection was detected after the image signal was picked up by the other side's device. |

| Check item | Measures |
|------------|---------------------------------|
| Setting | Reattempt the fax transmission. |

Reception

| Classification | Error content |
|----------------|---|
| Fax | The fax reception has failed since a carrier disconnection was detected after the image signal was picked up by this MFP. |

| Check item | Measures |
|------------|------------------------------|
| Setting | Reattempt the fax reception. |

| Classification | Error content |
|----------------|--|
| IP Fax | The IP Fax reception has failed since a carrier disconnection was detected after the image signal was picked up by this MFP. |

| Check item | Measures |
|------------|---------------------------------|
| Setting | Reattempt the IP Fax reception. |

[00C4] EOL time-out

| Classification | Error content |
|----------------|--|
| Fax | The fax reception has failed since this MFP could not detect EOL or not decode with MMR. |

| Check item | Measures |
|------------|------------------------------|
| Setting | Reattempt the fax reception. |

[00C5] Excess length of data received

| Classification | Error content |
|----------------|--|
| Fax | The fax reception has failed due to the disconnection of the communication since the length of the received original exceeded 2 m. |

| Check item | Measures |
|------------|---|
| Setting | Ask to make the length of the original 2 m or less and reattempt the fax reception. |

| Classification | Error content |
|----------------|---|
| IP Fax | The IP Fax reception has failed due to the disconnection of the communication since the length of the received original exceeded 2 m. |

| Check item | Measures |
|------------|--|
| Setting | Ask to make the length of the original 2 m or less and reattempt the IP Fax reception. |

[00C6] Image code conversion error

| Classification | Error content |
|----------------|---|
| Fax | The fax reception has failed since the conversion of the received image went wrong. |

| Check item | Measures |
|------------|------------------------------|
| Setting | Reattempt the fax reception. |

| Classification | Error content |
|----------------|--|
| IP Fax | The IP Fax reception has failed since the conversion of the received image went wrong. |

| Check item | Measures |
|------------|---------------------------------|
| Setting | Reattempt the IP Fax reception. |

[00C7] Phase C cannot be completed**Transmission**

| Classification | Error content |
|----------------|---|
| Fax | The fax transmission has failed since a modem error or a sequence error in the Fax Unit occurred. |

| Check item | Measures |
|------------|--|
| Setting | Reattempt the fax transmission. If the error persists, replace the Fax Unit. |

Reception

| Classification | Error content |
|----------------|--|
| Fax | The fax reception has failed since a modem error or a sequence error in the Fax Unit occurred. |

| Check item | Measures |
|------------|---|
| Setting | Reattempt the fax reception. If the error persists, replace the Fax Unit. |

Transmission

| Classification | Error content |
|----------------|---|
| IP Fax | The IP Fax transmission has failed since a system error or a sequence error occurred. |

| Check item | Measures |
|------------|--|
| Setting | Reboot this MFP and reattempt the IP Fax transmission. |

Reception

| Classification | Error content |
|----------------|--|
| IP Fax | The IP Fax reception has failed since a system error or a sequence error occurred. |

| Check item | Measures |
|------------|---|
| Setting | Reboot this MFP and reattempt the IP Fax reception. |

[00C8] Transmitted image was not made in time

| Classification | Error content |
|----------------|---|
| IP Fax | The IP Fax transmission has failed due to the disconnection of the communication from the other side's device since the notification of the transmitted image was not made in time. |

| Check item | Measures |
|------------|------------------------------------|
| Setting | Reattempt the IP Fax transmission. |

[00D0] Post message not detected**Transmission**

| Classification | Error content |
|----------------|---|
| Fax | The fax transmission has failed since this MFP could not detect an MCF, RTP, RTN, PIN or PIP or the other side's device could not detect MPS, EOM or EOP. |

| Check item | Measures |
|------------|---------------------------------|
| Setting | Reattempt the fax transmission. |

Reception

| Classification | Error content |
|----------------|--|
| Fax | The fax reception has failed since the other side's device could not detect an MCF, RTP, RTN, PIN or PIP or this MFP could not detect MPS, EOM or EOP. |

| Check item | Measures |
|------------|------------------------------|
| Setting | Reattempt the fax reception. |

Transmission

| Classification | Error content |
|----------------|--|
| IP Fax | The IP Fax transmission has failed since this MFP could not detect an MCF, RTP, RTN, PIN or PIP fax or the other side's device could not detect MPS, EOM or EOP. |

| Check item | Measures |
|------------|------------------------------------|
| Setting | Reattempt the IP Fax transmission. |

Reception

| Classification | Error content |
|----------------|---|
| IP Fax | The IP Fax reception has failed since the other side's device could not detect an MCF, RTP, RTN, PIN or PIP fax or this MFP could not detect MPS, EOM or EOP. |

| Check item | Measures |
|------------|---------------------------------|
| Setting | Reattempt the IP Fax reception. |

[00D1] DCN reception

| Classification | Error content |
|----------------|--|
| Fax | The fax reception has failed since DCN was received. |

| Check item | Measures |
|------------|------------------------------|
| Setting | Reattempt the fax reception. |

Transmission

| Classification | Error content |
|----------------|--|
| IP Fax | The IP Fax transmission has failed since DCN was received. |

| Check item | Measures |
|------------|------------------------------------|
| Setting | Reattempt the IP Fax transmission. |

Reception

| Classification | Error content |
|----------------|---|
| IP Fax | The IP Fax reception has failed since DCN was received. |

| Check item | Measures |
|------------|---------------------------------|
| Setting | Reattempt the IP Fax reception. |

[00D2] Poor image quality

Transmission

| Classification | Error content |
|----------------|--|
| Fax | The fax transmission has failed since the quality of the received image was poor in the other side's device. |

| Check item | Measures |
|------------|---------------------------------|
| Setting | Reattempt the fax transmission. |

Reception

| Classification | Error content |
|----------------|--|
| Fax | The fax reception has failed since the quality of the received image was poor. |

| Check item | Measures |
|------------|------------------------------|
| Setting | Reattempt the fax reception. |

Transmission

| Classification | Error content |
|----------------|---|
| IP Fax | The IP Fax transmission has failed since the quality of the received image was poor in the other side's device. |

| Check item | Measures |
|------------|--|
| Setting | Check the following items and reattempt the IP Fax transmission. <ul style="list-style-type: none">• The network of this MFP and the other side's device is functioning properly.• The IP Fax function of this MFP is set properly. |

Reception

| Classification | Error content |
|----------------|---|
| IP Fax | The IP Fax reception has failed since the quality of the received image was poor. |

| Check item | Measures |
|------------|---|
| Setting | Check the following items and reattempt the IP Fax reception. <ul style="list-style-type: none">• The network of this MFP and the other side's device is functioning properly.• The IP Fax function of this MFP is set properly. |

[00D3] No response made to EOR

| Classification | Error content |
|----------------|--|
| Fax | The fax transmission has failed since no response was made to EOR or DCN was received during ECM transmission. |

| Check item | Measures |
|------------|--|
| Setting | Ask to adjust the attenuator and link equalizer of the other side's device and reattempt the fax transmission. |

| Classification | Error content |
|----------------|--|
| IP Fax | The fax transmission has failed since no response was made to EOR or DCN was received during ECM transmission. |

| Check item | Measures |
|------------|--|
| Setting | Check the following items and reattempt the IP Fax transmission. <ul style="list-style-type: none">• The network of this MFP is functioning properly.• The IP Fax function of this MFP is set properly.• If the other side's device is in the fax mode, its attenuator and link equalizer are adjusted properly. |

[00D4] No response made to RR

| Classification | Error content |
|----------------|---|
| Fax | The fax transmission has failed since no response was made to RR or DCN was received during ECM transmission. |

| Check item | Measures |
|------------|--|
| Setting | Ask to adjust the attenuator and link equalizer of the other side's device and reattempt the fax transmission. |

| Classification | Error content |
|----------------|---|
| IP Fax | The fax transmission has failed since no response was made to RR or DCN was received during ECM transmission. |

| Check item | Measures |
|------------|--|
| Setting | Check the following items and reattempt the IP Fax transmission. <ul style="list-style-type: none"> • The network of this MFP is functioning properly. • The IP Fax function of this MFP is set properly. • If the other side's device is in the fax mode, its attenuator and link equalizer are adjusted properly. |

[00D5] T5 time-out

| Classification | Error content |
|----------------|---|
| Fax | The fax transmission has failed since RNR-RR was repeated and the line was disconnected due to timeout during ECM transmission. |

| Check item | Measures |
|------------|---|
| Setting | Reattempt the fax transmission. If the error persists, check whether the other side's device can output MCF or not. |

[00D6] ERR returned to EOR

| Classification | Error content |
|----------------|---|
| Fax | The fax reception has failed due to the bad condition of the communication. |

| Check item | Measures |
|------------|------------------------------|
| Setting | Reattempt the fax reception. |

| Classification | Error content |
|----------------|--|
| IP Fax | The IP Fax reception has failed due to the bad condition of the communication. |

| Check item | Measures |
|------------|--|
| Setting | Check the following items and reattempt the IP Fax reception. <ul style="list-style-type: none"> • The network of this MFP and the other side's device is functioning properly. • The IP Fax function of this MFP is set properly. |

[00D7] Line disconnected by transmission of EOR

| Classification | Error content |
|----------------|---|
| Fax | The fax transmission has failed since the line was disconnected after EOR was sent by this MFP during ECM transmission. |

| Check item | Measures |
|------------|--|
| Setting | Adjust the attenuator and link equalizer of this MFP and reattempt the fax transmission. |

| Classification | Error content |
|----------------|--|
| IP Fax | The IP Fax transmission has failed since the line was disconnected after EOR was sent by this MFP during ECM transmission. |

| Check item | Measures |
|------------|---|
| Setting | Check the following items and reattempt the IP Fax transmission. <ul style="list-style-type: none"> • The network of this MFP and the other side's device is functioning properly. • The IP Fax function of this MFP is set properly. |

[00D8] Time-out between FCD frame

| Classification | Error content |
|----------------|--|
| Fax | The fax reception has failed since a time-out occurred between the FCD frames. |

| Check item | Measures |
|------------|------------------------------|
| Setting | Reattempt the fax reception. |

[00DA] MCF not returned

| Classification | Error content |
|----------------|---|
| Fax | The fax reception has failed since MCF could not be returned from this MFP. |

| Check item | Measures |
|------------|------------------------------|
| Setting | Reattempt the fax reception. |

| Classification | Error content |
|----------------|--|
| IP Fax | The IP Fax reception has failed since MCF could not be returned from this MFP. |

| Check item | Measures |
|------------|---------------------------------|
| Setting | Reattempt the IP Fax reception. |

[00E8] Storage device error Transmission

| Classification | Error content |
|----------------|--|
| Fax | The fax transmission has failed due to a defective storage device. |

| Check item | Measures |
|------------|--|
| Setting | Reattempt the fax transmission. If the error persists, replace the storage device. |

Reception

| Classification | Error content |
|----------------|---|
| Fax | The fax reception has failed due to a defective storage device. |

| Check item | Measures |
|------------|---|
| Setting | Reattempt the fax reception. If the error persists, replace the storage device. |

Transmission

| Classification | Error content |
|----------------|---|
| IP Fax | The IP Fax transmission has failed due to a defective storage device. |

| Check item | Measures |
|------------|---|
| Setting | Reattempt the IP Fax transmission. If the error persists, replace the storage device. |

Reception

| Classification | Error content |
|----------------|--|
| IP Fax | The IP Fax reception has failed due to a defective storage device. |

| Check item | Measures |
|------------|--|
| Setting | Reattempt the IP Fax reception. If the error persists, replace the storage device. |

[00F0] Software trouble Transmission

| Classification | Error content |
|----------------|--|
| Fax | The fax transmission has failed due to defective software. |

| Check item | Measures |
|------------|---|
| Setting | Reinstall the fax firmware. If the error persists, replace the fax board. |

Reception

| Classification | Error content |
|----------------|---|
| Fax | The fax reception has failed due to defective software. |

| Check item | Measures |
|------------|---|
| Setting | Reinstall the fax firmware. If the error persists, replace the fax board. |

Transmission

| Classification | Error content |
|----------------|---|
| IP Fax | The IP Fax transmission has failed due to defective software. |

| Check item | Measures |
|------------|--|
| Setting | Check that the IP Fax function of this MFP is set properly. Reboot this MFP and reattempt the IP Fax transmission. |

Reception

| Classification | Error content |
|----------------|--|
| IP Fax | The IP Fax reception has failed due to defective software. |

| Check item | Measures |
|------------|---|
| Setting | Check that the IP Fax function of this MFP is set properly. Reboot this MFP and reattempt the IP Fax reception. |

[00F1] Hardware noise

Transmission

| Classification | Error content |
|----------------|--|
| Fax | The fax transmission has failed due to defective hardware. |

| Check item | Measures |
|------------|---|
| Setting | <ul style="list-style-type: none"> Reboot this MFP and reattempt the fax transmission. Reinstall the fax firmware. If the error persists, replace the fax board. |

Reception

| Classification | Error content |
|----------------|---|
| Fax | The fax reception has failed due to defective hardware. |

| Check item | Measures |
|------------|--|
| Setting | <ul style="list-style-type: none"> Reboot this MFP and reattempt the fax reception. Reinstall the fax firmware. If the error persists, replace the fax board. |

[00F4] Software trouble (Fax Unit)

Transmission

| Classification | Error content |
|----------------|--|
| Fax | The fax transmission has failed due to defective software. |

| Check item | Measures |
|------------|---|
| Setting | <ul style="list-style-type: none"> Reboot this MFP and reattempt the fax transmission. Reinstall the fax firmware. If the error persists, replace the fax board. |

Reception

| Classification | Error content |
|----------------|---|
| Fax | The fax reception has failed due to defective software. |

| Check item | Measures |
|------------|--|
| Setting | <ul style="list-style-type: none">• Reboot this MFP and reattempt the fax reception.• Reinstall the fax firmware.• If the error persists, replace the fax board. |

[0101] Response Time-out (Registration)

| Classification | Error content |
|----------------|--|
| IP Fax | A time-out has occurred since there was no response from an SIP server. (Register) |

| Check item | Measures |
|------------|---|
| Setting | Check the setting of the network or the SIP server. |

[0102] Response Time-out (Invite)

| Classification | Error content |
|----------------|---|
| IP Fax | The IP Fax transmission has failed due to a time-out since there was no response from an SIP server. (Invite) |

| Check item | Measures |
|------------|--|
| Setting | Reattempt the IP Fax transmission. If the error persists, check the network or the server setting and recipient information. |

[0103] “Multiple Choices” reception

| Classification | Error content |
|----------------|--|
| IP Fax | The registration to an SIP server has failed due to an error. (Multiple Choices) |

| Check item | Measures |
|------------|---|
| Setting | Check the setting of the network or the SIP server. |

[0104] “Moved Permanently” reception

| Classification | Error content |
|----------------|---|
| IP Fax | The registration to an SIP server has failed due to an error. (Moved Permanently) |

| Check item | Measures |
|------------|---|
| Setting | Check the setting of the network or the SIP server. |

[0105] “Moved Temporarily” reception

| Classification | Error content |
|----------------|---|
| IP Fax | The registration to an SIP server has failed due to an error. (Moved Temporarily) |

| Check item | Measures |
|------------|---|
| Setting | Check the setting of the network or the SIP server. |

[0106] “Use Proxy” reception

| Classification | Error content |
|----------------|---|
| IP Fax | The registration to an SIP server has failed due to an error. (Use Proxy) |

| Check item | Measures |
|------------|---|
| Setting | Check the setting of the network or the SIP server. |

[0107] “Alternative Service” reception

| Classification | Error content |
|----------------|--|
| IP Fax | The registration to an SIP server has failed due to an error. (Alternative Service) |

| Check item | Measures |
|------------|---|
| Setting | Check the setting of the network or the SIP server. |

[0109] “Bad Request” reception

| Classification | Error content |
|----------------|--|
| IP Fax | The registration to an SIP server has failed due to an error. (Bad Request) |

| Check item | Measures |
|------------|---|
| Setting | Check the setting of the network or the SIP server. |

[010A] “Unauthorized” reception

| Classification | Error content |
|----------------|---|
| IP Fax | The registration to an SIP server has failed due to an error. (Unauthorized) |

| Check item | Measures |
|------------|---|
| Setting | Check the setting of the network or the SIP server. |

[010B] “Payment Required” reception

| Classification | Error content |
|----------------|---|
| IP Fax | The registration to an SIP server has failed due to an error. (Payment Required) |

| Check item | Measures |
|------------|---|
| Setting | Check the setting of the network or the SIP server. |

[010C] “Forbidden” reception

| Classification | Error content |
|----------------|--|
| IP Fax | The registration to an SIP server has failed due to an error. (Forbidden) |

| Check item | Measures |
|------------|---|
| Setting | Check the setting of the network or the SIP server. |

[010D] “Not Found” reception

| Classification | Error content |
|----------------|--|
| IP Fax | The registration to an SIP server has failed due to an error. (Not Found) |

| Check item | Measures |
|------------|---|
| Setting | Check the setting of the network or the SIP server. |

[010E] “Method Not Allowed” reception

| Classification | Error content |
|----------------|---|
| IP Fax | The registration to an SIP server has failed due to an error. (Method Not Allowed) |

| Check item | Measures |
|------------|---|
| Setting | Check the setting of the network or the SIP server. |

[010F] “Not Acceptable” reception

| Classification | Error content |
|----------------|---|
| IP Fax | The registration to an SIP server has failed due to an error. (Not Acceptable) |

| Check item | Measures |
|------------|---|
| Setting | Check the setting of the network or the SIP server. |

[0110] “Proxy Authentication Required” reception

| Classification | Error content |
|----------------|--|
| IP Fax | The registration to an SIP server has failed due to an error. (Proxy Authentication Required) |

| Check item | Measures |
|------------|---|
| Setting | Check the setting of the network or the SIP server. |

[0111] “Request Timeout” reception

| Classification | Error content |
|----------------|--|
| IP Fax | The registration to an SIP server has failed due to an error. (Request Timeout) |

| Check item | Measures |
|------------|---|
| Setting | Check the setting of the network or the SIP server. |

[0113] “Gone” reception

| Classification | Error content |
|----------------|---|
| IP Fax | The registration to an SIP server has failed due to an error. (Gone) |

| Check item | Measures |
|------------|---|
| Setting | Check the setting of the network or the SIP server. |

[0115] “Precondition Failed” reception

| Classification | Error content |
|----------------|--|
| IP Fax | The registration to an SIP server has failed due to an error. (Precondition Failed) |

| Check item | Measures |
|------------|---|
| Setting | Check the setting of the network or the SIP server. |

[0116] “Request Entity Too Large” reception

| Classification | Error content |
|----------------|---|
| IP Fax | The registration to an SIP server has failed due to an error. (Request Entity Too Large) |

| Check item | Measures |
|------------|---|
| Setting | Check the setting of the network or the SIP server. |

[0117] “Request-URI Too Long” reception

| Classification | Error content |
|----------------|---|
| IP Fax | The registration to an SIP server has failed due to an error. (Request-URI Too Long) |

| Check item | Measures |
|------------|---|
| Setting | Check the setting of the network or the SIP server. |

[0118] “Unsupported Media Type” reception

| Classification | Error content |
|----------------|---|
| IP Fax | The registration to an SIP server has failed due to an error. (Unsupported Media Type) |

| Check item | Measures |
|------------|---|
| Setting | Check the setting of the network or the SIP server. |

[0119] “Unsupported URI Scheme” reception

| Classification | Error content |
|----------------|---|
| IP Fax | The registration to an SIP server has failed due to an error. (Unsupported URI Scheme) |

| Check item | Measures |
|------------|---|
| Setting | Check the setting of the network or the SIP server. |

[011A] “Unknown Resource-Priority” reception

| Classification | Error content |
|----------------|--|
| IP Fax | The registration to an SIP server has failed due to an error. (Unknown Resource-Priority) |

| Check item | Measures |
|------------|---|
| Setting | Check the setting of the network or the SIP server. |

[011B] “Bad Extension” reception

| Classification | Error content |
|----------------|--|
| IP Fax | The registration to an SIP server has failed due to an error. (Bad Extension) |

| Check item | Measures |
|------------|---|
| Setting | Check the setting of the network or the SIP server. |

[011C] “Extension Required” reception

| Classification | Error content |
|----------------|---|
| IP Fax | The registration to an SIP server has failed due to an error. (Extension Required) |

| Check item | Measures |
|------------|---|
| Setting | Check the setting of the network or the SIP server. |

[011D] “Session Timer Too Small” reception

| Classification | Error content |
|----------------|--|
| IP Fax | The registration to an SIP server has failed due to an error. (Session Timer Too Small) |

| Check item | Measures |
|------------|---|
| Setting | Check the setting of the network or the SIP server. |

[011E] “Interval Too Brief” reception

| Classification | Error content |
|----------------|---|
| IP Fax | The registration to an SIP server has failed due to an error. (Interval Too Brief) |

| Check item | Measures |
|------------|---|
| Setting | Check the setting of the network or the SIP server. |

[011F] “Anonymity disallowed” reception

| Classification | Error content |
|----------------|---|
| IP Fax | The registration to an SIP server has failed due to an error. (Anonymity disallowed) |

| Check item | Measures |
|------------|---|
| Setting | Check the setting of the network or the SIP server. |

[0120] “Temporarily Unavailable” reception

| Classification | Error content |
|----------------|--|
| IP Fax | The registration to an SIP server has failed due to an error. (Temporarily Unavailable) |

| Check item | Measures |
|------------|---|
| Setting | Check the setting of the network or the SIP server. |

[0121] “Call/Transaction Does Not Exist” reception

| Classification | Error content |
|----------------|--|
| IP Fax | The registration to an SIP server has failed due to an error. (Call/Transaction Does Not Exist) |

| Check item | Measures |
|------------|---|
| Setting | Check the setting of the network or the SIP server. |

[0122] “Loop Detected” reception

| Classification | Error content |
|----------------|--|
| IP Fax | The registration to an SIP server has failed due to an error. (Loop Detected) |

| Check item | Measures |
|------------|---|
| Setting | Check the setting of the network or the SIP server. |

[0123] “Too Many Hops” reception

| Classification | Error content |
|----------------|--|
| IP Fax | The registration to an SIP server has failed due to an error. (Too Many Hops) |

| Check item | Measures |
|------------|---|
| Setting | Check the setting of the network or the SIP server. |

[0124] “Address Incomplete” reception

| Classification | Error content |
|----------------|---|
| IP Fax | The registration to an SIP server has failed due to an error. (Address Incomplete) |

| Check item | Measures |
|------------|---|
| Setting | Check the setting of the network or the SIP server. |

[0125] “Ambiguous” reception

| Classification | Error content |
|----------------|--|
| IP Fax | The registration to an SIP server has failed due to an error. (Ambiguous) |

| Check item | Measures |
|------------|---|
| Setting | Check the setting of the network or the SIP server. |

[0126] “Busy Here” reception

| Classification | Error content |
|----------------|--|
| IP Fax | The registration to an SIP server has failed due to an error. (Busy Here) |

| Check item | Measures |
|------------|---|
| Setting | Check the setting of the network or the SIP server. |

[0127] “Request Terminated” reception

| Classification | Error content |
|----------------|---|
| IP Fax | The registration to an SIP server has failed due to an error. (Request Terminated) |

| Check item | Measures |
|------------|---|
| Setting | Check the setting of the network or the SIP server. |

[0128] “Not acceptable here” reception

| Classification | Error content |
|----------------|--|
| IP Fax | The registration to an SIP server has failed due to an error. (Not acceptable here) |

| Check item | Measures |
|------------|---|
| Setting | Check the setting of the network or the SIP server. |

[0129] “Bad Event” reception

| Classification | Error content |
|----------------|--|
| IP Fax | The registration to an SIP server has failed due to an error. (Bad Event) |

| Check item | Measures |
|------------|---|
| Setting | Check the setting of the network or the SIP server. |

[012A] “Request Updated” reception

| Classification | Error content |
|----------------|--|
| IP Fax | The registration to an SIP server has failed due to an error. (Request Updated) |

| Check item | Measures |
|------------|---|
| Setting | Check the setting of the network or the SIP server. |

[012B] “Request Pending” reception

| Classification | Error content |
|----------------|--|
| IP Fax | The registration to an SIP server has failed due to an error. (Request Pending) |

| Check item | Measures |
|------------|---|
| Setting | Check the setting of the network or the SIP server. |

[012C] “Undecipherable” reception

| Classification | Error content |
|----------------|---|
| IP Fax | The registration to an SIP server has failed due to an error. (Undecipherable) |

| Check item | Measures |
|------------|---|
| Setting | Check the setting of the network or the SIP server. |

[012D] “Security Agreement Required” reception

| Classification | Error content |
|----------------|--|
| IP Fax | The registration to an SIP server has failed due to an error. (Security Agreement Required) |

| Check item | Measures |
|------------|---|
| Setting | Check the setting of the network or the SIP server. |

[012E] “Internal Server Error” reception

| Classification | Error content |
|----------------|--|
| IP Fax | The registration to an SIP server has failed due to an error. (Internal Server Error) |

| Check item | Measures |
|------------|---|
| Setting | Check the setting of the network or the SIP server. |

[012F] “Not Implemented” reception

| Classification | Error content |
|----------------|--|
| IP Fax | The registration to an SIP server has failed due to an error. (Not Implemented) |

| Check item | Measures |
|------------|---|
| Setting | Check the setting of the network or the SIP server. |

[0130] “Bad Gateway” reception

| Classification | Error content |
|----------------|--|
| IP Fax | The registration to an SIP server has failed due to an error. (Bad Gateway) |

| Check item | Measures |
|------------|---|
| Setting | Check the setting of the network or the SIP server. |

[0131] “Service Unavailable” reception

| Classification | Error content |
|----------------|---|
| IP Fax | The IP Fax transmission took time since the IP line was busy. |

| Check item | Measures |
|------------|---|
| Setting | Wait for a while and then reattempt the IP Fax transmission. If this still persists, check the setting of the SIP server. |

[0132] “Gateway Time-out” reception

| Classification | Error content |
|----------------|---|
| IP Fax | The registration to an SIP server has failed due to an error. (Gateway Time-out) |

| Check item | Measures |
|------------|---|
| Setting | Check the setting of the network or the SIP server. |

[0133] “Version Not Supported” reception

| Classification | Error content |
|----------------|--|
| IP Fax | The registration to an SIP server has failed due to an error. (Version Not Supported) |

| Check item | Measures |
|------------|---|
| Setting | Check the setting of the network or the SIP server. |

[0134] “Message Too Large” reception

| Classification | Error content |
|----------------|--|
| IP Fax | The registration to an SIP server has failed due to an error. (Message Too Large) |

| Check item | Measures |
|------------|---|
| Setting | Check the setting of the network or the SIP server. |

[0135] “Precondition Failure” reception

| Classification | Error content |
|----------------|---|
| IP Fax | The registration to an SIP server has failed due to an error. (Precondition Failure) |

| Check item | Measures |
|------------|---|
| Setting | Check the setting of the network or the SIP server. |

[0136] “Busy Everywhere” reception

| Classification | Error content |
|----------------|--|
| IP Fax | The registration to an SIP server has failed due to an error. (Busy Everywhere) |

| Check item | Measures |
|------------|---|
| Setting | Check the setting of the network or the SIP server. |

[0137] “Decline” reception

| Classification | Error content |
|----------------|--|
| IP Fax | The registration to an SIP server has failed due to an error. (Decline) |

| Check item | Measures |
|------------|---|
| Setting | Check the setting of the network or the SIP server. |

[0138] “Does Not Exist Anywhere” reception

| Classification | Error content |
|----------------|--|
| IP Fax | The registration to an SIP server has failed due to an error. (Does Not Exist Anywhere) |

| Check item | Measures |
|------------|---|
| Setting | Check the setting of the network or the SIP server. |

[0139] “Not Acceptable” reception

| Classification | Error content |
|----------------|---|
| IP Fax | The registration to an SIP server has failed due to an error. (Not Acceptable) |

| Check item | Measures |
|------------|---|
| Setting | Check the setting of the network or the SIP server. |

[013D] Other errors

| Classification | Error content |
|----------------|---|
| IP Fax | The registration to an SIP server has failed due to an error. (Other errors) |

| Check item | Measures |
|------------|---|
| Setting | Check the setting of the network or the SIP server. |

[013E] Other errors

| Classification | Error content |
|----------------|--|
| IP Fax | The IP Fax transmission/reception has failed due to a communication error. (Other errors) |

| Check item | Measures |
|------------|---|
| Setting | Check the setting of the network or the SIP server. |

[0140] Startup failure

| Classification | Error content |
|----------------|---|
| IP Fax | The starting of the IP Fax function has failed. |

| Check item | Measures |
|------------|-----------------|
| Setting | Reboot the MFP. |

[0141] Job interruption due to setting change

| Classification | Error content |
|----------------|---|
| IP Fax | The implementation of an IP Fax job has been stopped since the settings were changed. |

| Check item | Measures |
|------------|--|
| Setting | Reattempt the IP Fax transmission/reception. |

[0142] Recipient entry error

| Classification | Error content |
|----------------|---|
| IP Fax | The IP Fax transmission has failed due to a communication error. (Recipient entry error) |

| Check item | Measures |
|------------|--|
| Setting | Correct the recipient and reattempt the IP Fax transmission. |

[0143] SIP server is unavailable

| Classification | Error content |
|----------------|--|
| IP Fax | The IP Fax transmission/reception has failed due to a communication error. (SIP server unavailable) |

| Check item | Measures |
|------------|---|
| Setting | Check the setting of the network or the SIP server. |

[0144] Under congestion

| Classification | Error content |
|----------------|--|
| IP Fax | The IP Fax transmission has failed due to a communication error. (Under congestion) |

| Check item | Measures |
|------------|--|
| Setting | Wait for a while and then reattempt the IP Fax transmission. |

[0150] Disconnected by other side's device**Internet fax transmission**

| Classification | Error content |
|----------------|--|
| IP Fax | The IP Fax transmission has failed due to a communication error. (Communication disconnection from the other side's device) |

| Check item | Measures |
|------------|--|
| Setting | Wait for a while and then reattempt the IP Fax transmission. |

Internet fax reception

| Classification | Error content |
|----------------|---|
| IP Fax | The IP Fax reception has failed due to a communication error. (Communication disconnection from the other side's device) |

| Check item | Measures |
|------------|---------------------------------|
| Setting | Reattempt the IP Fax reception. |

[0300] "Multiple Choices" reception

| Classification | Error content |
|----------------|--|
| IP Fax | The IP Fax transmission/reception has failed due to a communication error. (Multiple Choices) |

| Check item | Measures |
|------------|---|
| Setting | Check the setting of the network or the SIP server. |

[0301] "Moved Permanently" reception

| Classification | Error content |
|----------------|---|
| IP Fax | The IP Fax transmission/reception has failed due to a communication error. (Moved Permanently) |

| Check item | Measures |
|------------|---|
| Setting | Check the setting of the network or the SIP server. |

[0302] "Moved Temporarily" reception

| Classification | Error content |
|----------------|---|
| IP Fax | The IP Fax transmission/reception has failed due to a communication error. (Moved Temporarily) |

| Check item | Measures |
|------------|---|
| Setting | Check the setting of the network or the SIP server. |

[0305] "Use Proxy" reception

| Classification | Error content |
|----------------|---|
| IP Fax | The IP Fax transmission/reception has failed due to a communication error. (Use Proxy) |

| Check item | Measures |
|------------|---|
| Setting | Check the setting of the network or the SIP server. |

[0380] "Alternative Service" reception

| Classification | Error content |
|----------------|---|
| IP Fax | The IP Fax transmission/reception has failed due to a communication error. (Alternative Service) |

| Check item | Measures |
|------------|---|
| Setting | Check the setting of the network or the SIP server. |

[0400] “Bad Request” reception

| Classification | Error content |
|----------------|--|
| IP Fax | The IP Fax transmission/reception has failed due to a communication error. (Bad Request) |
| Check item | Measures |
| Setting | Wait for a while and then reattempt the IP Fax transmission. |

[0401] “Unauthorized” reception

| Classification | Error content |
|----------------|---|
| IP Fax | The IP Fax transmission/reception has failed due to a communication error. (Unauthorized) |
| Check item | Measures |
| Setting | Wait for a while and then reattempt the IP Fax transmission. |

[0402] “Payment Required” reception

| Classification | Error content |
|----------------|---|
| IP Fax | The IP Fax transmission/reception has failed due to a communication error. (Payment Required) |
| Check item | Measures |
| Setting | Wait for a while and then reattempt the IP Fax transmission. |

[0403] “Forbidden” reception

| Classification | Error content |
|----------------|--|
| IP Fax | The IP Fax transmission/reception has failed due to a communication error. (Forbidden) |
| Check item | Measures |
| Setting | Wait for a while and then reattempt the IP Fax transmission. |

[0404] “Not Found” reception

| Classification | Error content |
|----------------|--|
| IP Fax | The IP Fax transmission/reception has failed due to a communication error. (Not Found) |
| Check item | Measures |
| Setting | Wait for a while and then reattempt the IP Fax transmission. |

[0405] “Method Not Allowed” reception

| Classification | Error content |
|----------------|---|
| IP Fax | The IP Fax transmission/reception has failed due to a communication error. (Method Not Allowed) |
| Check item | Measures |
| Setting | Wait for a while and then reattempt the IP Fax transmission. |

[0406] “Not Acceptable” reception

| Classification | Error content |
|----------------|---|
| IP Fax | The IP Fax transmission/reception has failed due to a communication error. (Not Acceptable) |
| Check item | Measures |
| Setting | Wait for a while and then reattempt the IP Fax transmission. |

[0407] “Proxy Authentication Required” reception

| Classification | Error content |
|----------------|--|
| IP Fax | The IP Fax transmission/reception has failed due to a communication error. (Proxy Authentication Required) |
| Check item | Measures |
| Setting | Wait for a while and then reattempt the IP Fax transmission. |

[0408] “Request Timeout” reception

| Classification | Error content |
|----------------|--|
| IP Fax | The IP Fax transmission/reception has failed due to a communication error. (Request Timeout) |
| Check item | Measures |
| Setting | Wait for a while and then reattempt the IP Fax transmission. |

[0410] “Gone” reception

| Classification | Error content |
|----------------|---|
| IP Fax | The IP Fax transmission/reception has failed due to a communication error. (Gone) |
| Check item | Measures |
| Setting | Wait for a while and then reattempt the IP Fax transmission. |

[0412] “Precondition Failed” reception

| Classification | Error content |
|----------------|--|
| IP Fax | The IP Fax transmission/reception has failed due to a communication error. (Precondition Failed) |
| Check item | Measures |
| Setting | Wait for a while and then reattempt the IP Fax transmission. |

[0413] “Request Entity Too Large” reception

| Classification | Error content |
|----------------|---|
| IP Fax | The IP Fax transmission/reception has failed due to a communication error. (Request Entity Too Large) |
| Check item | Measures |
| Setting | Wait for a while and then reattempt the IP Fax transmission. |

[0414] “Request-URI Too Long” reception

| Classification | Error content |
|----------------|---|
| IP Fax | The IP Fax transmission/reception has failed due to a communication error. (Request-URI Too Long) |
| Check item | Measures |
| Setting | Wait for a while and then reattempt the IP Fax transmission. |

[0415] “Unsupported Media Type” reception

| Classification | Error content |
|----------------|---|
| IP Fax | The IP Fax transmission/reception has failed due to a communication error. (Unsupported Media Type) |
| Check item | Measures |
| Setting | Wait for a while and then reattempt the IP Fax transmission. |

[0416] “Unsupported URI Scheme” reception

| Classification | Error content |
|----------------|---|
| IP Fax | The IP Fax transmission/reception has failed due to a communication error. (Unsupported URI Scheme) |
| Check item | Measures |
| Setting | Wait for a while and then reattempt the IP Fax transmission. |

[0417] “Unknown Resource-Priority” reception

| Classification | Error content |
|----------------|--|
| IP Fax | The IP Fax transmission/reception has failed due to a communication error. (Unknown Resource-Priority) |
| Check item | Measures |
| Setting | Wait for a while and then reattempt the IP Fax transmission. |

[0420] “Bad Extension” reception

| Classification | Error content |
|----------------|--|
| IP Fax | The IP Fax transmission/reception has failed due to a communication error. (Bad Extension) |
| Check item | Measures |
| Setting | Wait for a while and then reattempt the IP Fax transmission. |

[0421] “Extension Required” reception

| Classification | Error content |
|----------------|---|
| IP Fax | The IP Fax transmission/reception has failed due to a communication error. (Extension Required) |
| Check item | Measures |
| Setting | Wait for a while and then reattempt the IP Fax transmission. |

[0422] “Session Timer Too Small” reception

| Classification | Error content |
|----------------|--|
| IP Fax | The IP Fax transmission/reception has failed due to a communication error. (Session Timer Too Small) |
| Check item | Measures |
| Setting | Wait for a while and then reattempt the IP Fax transmission. |

[0423] “Interval Too Brief” reception

| Classification | Error content |
|----------------|---|
| IP Fax | The IP Fax transmission/reception has failed due to a communication error. (Interval Too Brief) |
| Check item | Measures |
| Setting | Wait for a while and then reattempt the IP Fax transmission. |

[0433] “Anonymity disallowed” reception

| Classification | Error content |
|----------------|---|
| IP Fax | The IP Fax transmission/reception has failed due to a communication error. (Anonymity disallowed) |
| Check item | Measures |
| Setting | Wait for a while and then reattempt the IP Fax transmission. |

[0480] “Temporarily Unavailable” reception

| Classification | Error content |
|----------------|--|
| IP Fax | The IP Fax transmission/reception has failed due to a communication error. (Temporarily Unavailable) |
| Check item | Measures |
| Setting | Wait for a while and then reattempt the IP Fax transmission. |

[0481] “Call/Transaction Does Not Exist” reception

| Classification | Error content |
|----------------|--|
| IP Fax | The IP Fax transmission/reception has failed due to a communication error. (Call/Transaction Does Not Exist) |
| Check item | Measures |
| Setting | Wait for a while and then reattempt the IP Fax transmission. |

[0482] “Loop Detected” reception

| Classification | Error content |
|----------------|--|
| IP Fax | The IP Fax transmission/reception has failed due to a communication error. (Loop Detected) |
| Check item | Measures |
| Setting | Wait for a while and then reattempt the IP Fax transmission. |

[0483] “Too Many Hops” reception

| Classification | Error content |
|----------------|--|
| IP Fax | The IP Fax transmission/reception has failed due to a communication error. (Too Many Hops) |
| Check item | Measures |
| Setting | Wait for a while and then reattempt the IP Fax transmission. |

[0484] “Address Incomplete” reception

| Classification | Error content |
|----------------|---|
| IP Fax | The IP Fax transmission/reception has failed due to a communication error. (Address Incomplete) |
| Check item | Measures |
| Setting | Wait for a while and then reattempt the IP Fax transmission. |

[0485] “Ambiguous” reception

| Classification | Error content |
|----------------|--|
| IP Fax | The IP Fax transmission/reception has failed due to a communication error. (Ambiguous) |
| Check item | Measures |
| Setting | Wait for a while and then reattempt the IP Fax transmission. |

[0486] “Busy Here” reception

| Classification | Error content |
|----------------|--|
| IP Fax | The IP Fax transmission/reception has failed due to a communication error. (Busy Here) |
| Check item | Measures |
| Setting | Wait for a while and then reattempt the IP Fax transmission. |

[0487] “Request Terminated” reception

| Classification | Error content |
|----------------|---|
| IP Fax | The IP Fax transmission/reception has failed due to a communication error. (Request Terminated) |
| Check item | Measures |
| Setting | Wait for a while and then reattempt the IP Fax transmission. |

[0488] “Not acceptable here” reception

| Classification | Error content |
|----------------|--|
| IP Fax | The IP Fax transmission/reception has failed due to a communication error. (Not acceptable here) |
| Check item | Measures |
| Setting | Wait for a while and then reattempt the IP Fax transmission. |

[0489] “Bad Event” reception

| Classification | Error content |
|----------------|--|
| IP Fax | The IP Fax transmission/reception has failed due to a communication error. (Bad Event) |
| Check item | Measures |
| Setting | Wait for a while and then reattempt the IP Fax transmission. |

[0490] “Request Updated” reception

| Classification | Error content |
|----------------|--|
| IP Fax | The IP Fax transmission/reception has failed due to a communication error. (Request Updated) |
| Check item | Measures |
| Setting | Wait for a while and then reattempt the IP Fax transmission. |

[0491] “Request Pending” reception

| Classification | Error content |
|----------------|--|
| IP Fax | The IP Fax transmission/reception has failed due to a communication error. (Request Pending) |
| Check item | Measures |
| Setting | Wait for a while and then reattempt the IP Fax transmission. |

[0493] “Undecipherable” reception

| Classification | Error content |
|----------------|---|
| IP Fax | The IP Fax transmission/reception has failed due to a communication error. (Undecipherable) |
| Check item | Measures |
| Setting | Wait for a while and then reattempt the IP Fax transmission. |

[0494] “Security Agreement Required” reception

| Classification | Error content |
|----------------|--|
| IP Fax | The IP Fax transmission/reception has failed due to a communication error. (Security Agreement Required) |
| Check item | Measures |
| Setting | Wait for a while and then reattempt the IP Fax transmission. |

[0500] “Internal Server Error” reception

| Classification | Error content |
|----------------|--|
| IP Fax | The IP Fax transmission/reception has failed due to a communication error. (Internal Server Error) |
| Check item | Measures |
| Setting | Check the setting of the SIP server. |

[0501] “Not Implemented” reception

| Classification | Error content |
|----------------|--|
| IP Fax | The IP Fax transmission/reception has failed due to a communication error. (Not Implemented) |
| Check item | Measures |
| Setting | Check the setting of the SIP server. |

[0502] “Bad Gateway” reception

| Classification | Error content |
|----------------|--|
| IP Fax | The IP Fax transmission/reception has failed due to a communication error. (Bad Gateway) |
| Check item | Measures |
| Setting | Check the setting of the SIP server. |

[0503] “Service Unavailable” reception

| Classification | Error content |
|----------------|--|
| IP Fax | The IP Fax transmission/reception has failed due to a communication error. (Service Unavailable) |
| Check item | Measures |
| Setting | Wait for a while and then reattempt the IP Fax transmission. |

[0504] “Gateway Time-out” reception

| Classification | Error content |
|----------------|---|
| IP Fax | The IP Fax transmission/reception has failed due to a communication error. (Gateway Time-out) |
| Check item | Measures |
| Setting | Check the setting of the SIP server. |

[0505] “Version Not Supported” reception

| Classification | Error content |
|----------------|--|
| IP Fax | The IP Fax transmission/reception has failed due to a communication error. (Version Not Supported) |
| Check item | Measures |
| Setting | Check the setting of the SIP server. |

[0513] “Message Too Large” reception

| Classification | Error content |
|----------------|--|
| IP Fax | The IP Fax transmission/reception has failed due to a communication error. (Message Too Large) |
| Check item | Measures |
| Setting | Check the setting of the SIP server. |

[0580] “Precondition Failure” reception

| Classification | Error content |
|----------------|---|
| IP Fax | The IP Fax transmission/reception has failed due to a communication error. (Precondition Failure) |
| Check item | Measures |
| Setting | Check the setting of the SIP server. |

[0600] “Busy Everywhere” reception

| Classification | Error content |
|----------------|--|
| IP Fax | The IP Fax transmission/reception has failed due to a communication error. (Busy Everywhere) |
| Check item | Measures |
| Setting | Check the setting of the network or the SIP server. |

[0603] “Decline” reception

| Classification | Error content |
|----------------|--|
| IP Fax | The IP Fax transmission/reception has failed due to a communication error. (Decline) |
| Check item | Measures |
| Setting | Check the setting of the network or the SIP server. |

[0604] “Does Not Exist Anywhere” reception

| Classification | Error content |
|----------------|--|
| IP Fax | The IP Fax transmission/reception has failed due to a communication error. (Does Not Exist Anywhere) |
| Check item | Measures |
| Setting | Check the setting of the network or the SIP server. |

[0606] “Not Acceptable” reception

| Classification | Error content |
|----------------|---|
| IP Fax | The IP Fax transmission/reception has failed due to a communication error. (Not Acceptable) |
| Check item | Measures |
| Setting | Check the setting of the network or the SIP server. |

[4246] IP Fax license is not installed

| Classification | Error content |
|----------------|--|
| IP Fax | The license of the IP Fax has not been installed. |
| Check item | Measures |
| Setting | Check that the license of the IP Fax has been installed. |

[DA01] Fax Unit line 1 malfunction

| Classification | Error content |
|----------------|--|
| Fax | The Fax Unit of line 1 has been damaged or an abnormality has occurred in the interface between the systems. |
| Check item | Measures |
| Setting | Reboot the MFP. If the error still persists, replace the Fax Unit of line 1. |

[DA02] Fax Unit line 2 malfunction

| Classification | Error content |
|-----------------------|--|
| Fax | The Fax Unit of line 2 has been damaged or an abnormality has occurred in the interface between the systems. |

| Check item | Measures |
|-------------------|--|
| Setting | Reboot the MFP. If the error still persists, replace the Fax Unit of line 2. |

8.4 Other Errors

8.4.1 DSDF

[1] Misdetection of the original size in the DSDF



| Classification | Error content |
|----------------|----------------------------|
| DSDF | Original size misdetection |

| Check item | Measures |
|--|---|
| DSDF tray original length sensor-1 | <ul style="list-style-type: none"> Check that the sensor is working properly. (Input check: FS-03-[F2]ON/[7]/[A]) Check that the actuator is working properly. Connector check (CN970, CN76) Harness check Check if the sheet attached to the sensor is warped. Replace the sensor. |
| DSDF tray original length sensor-2 | <ul style="list-style-type: none"> Check that the sensor is working properly. (Input check: FS-03-[F2]ON/[8]/[D]) Check that the actuator is working properly. Connector check (CN971, CN76) Harness check Check if the sheet attached to the sensor is warped. Replace the sensor. |
| DSDF tray original width sensor | <ul style="list-style-type: none"> Check that the sensor is working properly. (Input check: FS-03-[F2]ON/[8]/[A][B][C]) Replace the sensor. |
| Contact point leaf spring of the DSDF tray original width sensor | Replace the contact point leaf spring of the DSDF tray original width sensor. |

| Parts to be replaced | Remarks |
|--|---------|
| DSDF tray original length sensor-1 | |
| DSDF tray original length sensor-2 | |
| DSDF tray original width sensor | |
| Contact point leaf spring of the DSDF tray original width sensor | |

[2] Multiple originals are transported simultaneously

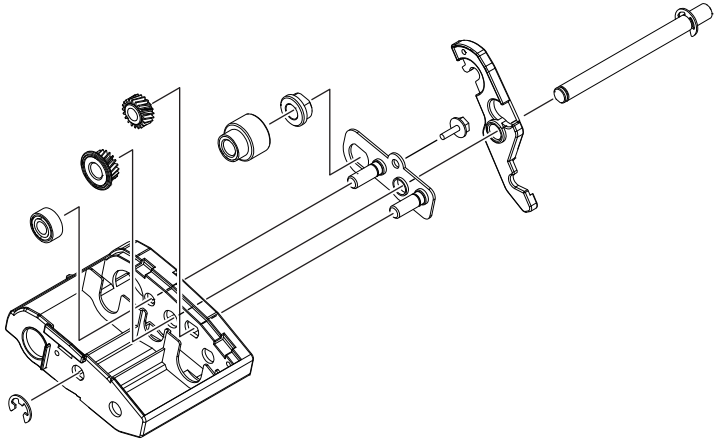
| Check item | Measures |
|------------------------|---|
| Original | <ul style="list-style-type: none"> Flatten and reload an original if it is curled abnormally or is folded. When an original beyond the specifications is copied or scanned, place it on the original glass. |
| DSDF separation roller | <ul style="list-style-type: none"> If the DSDF separation roller is dirty, clean it with alcohol. Replace the DSDF separation roller. |

| Check item | Measures |
|-------------------|--|
| Metal shaft, gear | <ul style="list-style-type: none"> • Take off the holder cover, DSDf original feed roller and DSDf pickup roller. • Remove the stopper, bracket, bushing and 4 gears.  <p>Fig.8-50</p> <ul style="list-style-type: none"> • Clean the holes in the gears and the metal shaft to remove paper dust.  <p>Fig.8-51</p> <p>Remarks: Disassembly procedure</p> <ol style="list-style-type: none"> (1) Remove the paper guide. (2) Take off the holder cover. (3) Release the stopper. Pull out the shaft and take off the pickup roller. (4) Release the stopper. Pull out the shaft and remove the bushing and one-way clutch. Take off the original feed roller. (5) Remove the screw and take off the bracket. (6) Remove 3 gears. <ul style="list-style-type: none"> • After they are cleaned, apply white grease (Molykote EM-30L) to the gear holes (indicated in the figure). <p>Notes: Pay attention not to apply grease to the tooth surface of the gears.</p>  <p>Fig.8-52</p> |

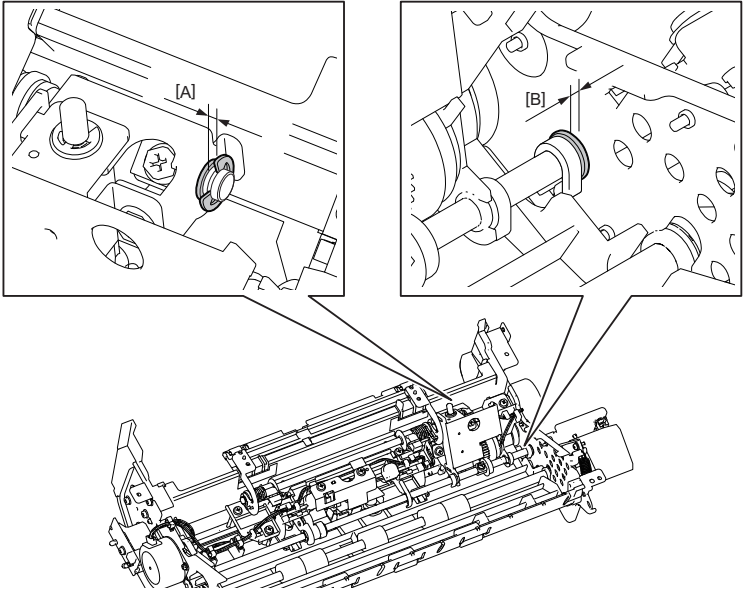
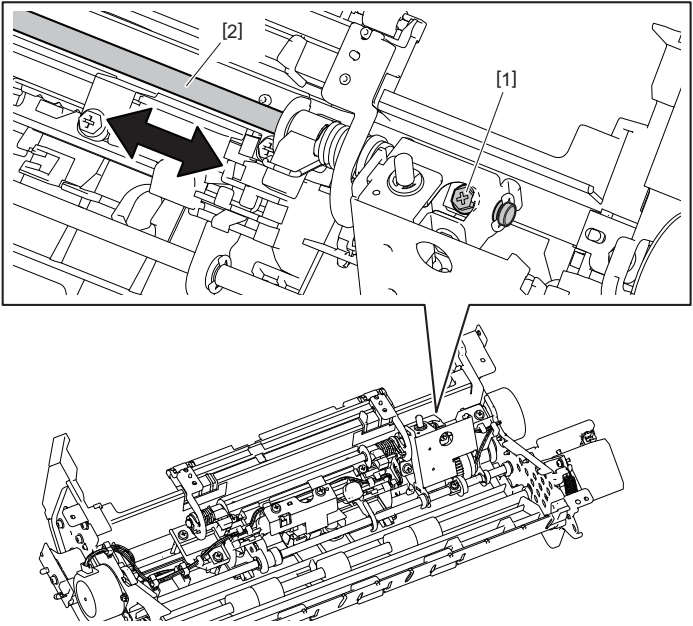
| Check item | Measures |
|--|--|
| <p>Dimension of each shaft of the intermediate transport guide</p> | <p>Take off the intermediate transport guide to check the following dimensions.</p> <ul style="list-style-type: none"> • Elevator shaft: Dimension A between the E-ring and the bushing is 1 mm or more. • DSDF separation roller drive shaft: Dimension B between the bushing and the frame is 0.3 mm or more.  <p>Fig.8-53</p> <p>If the dimensions are less than the above ones, perform the adjustment according to the following procedure.</p> <ul style="list-style-type: none"> • Arrange the dimension A between the E-ring and the bushing on the elevator shaft so that it becomes 1 mm or more. <ol style="list-style-type: none"> (1) Loosen the screw [1] and move the elevator shaft [2]. (2) Tighten the screw [1].  <p>Fig.8-54</p> |

| Check item | Measures |
|---|--|
| Dimension of each shaft of the intermediate transport guide | <ul style="list-style-type: none"> Arrange the dimension B between the bushing on the DSDF separation roller drive shaft and the frame so that it becomes 0.3 mm or more. (1) Loosen the screw [3] and move the DSDF separation roller drive shaft [4]. (2) Tighten the screw [3].  |

Fig.8-55

[3] Original is not transported to registration roller

| Check item | Measures |
|---------------------------|---|
| Original | <ul style="list-style-type: none"> Flatten and reload an original if it is curled abnormally or is folded. When an original beyond the specifications is copied or scanned, place it on the original glass. |
| DSDF pickup roller | <ul style="list-style-type: none"> If the DSDF pickup roller is dirty, clean it with alcohol. Replace the DSDF pickup roller. |
| DSDF original feed roller | <ul style="list-style-type: none"> If the DSDF original feed roller is dirty, clean it with alcohol. Replace the DSDF original feed roller. |

[4] Leading edge of original is skewed

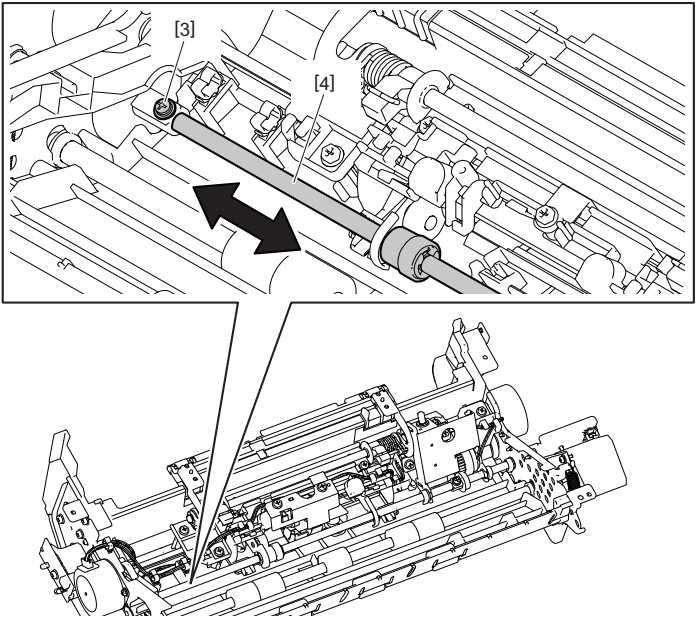
| Check item | Measures |
|------------------|--|
| Transport roller | If the DSDF transport roller is dirty, clean it with alcohol. |
| Left hinge | Check that the protrusions at the front and rear sides of the bottom face of the DSDF contact the glass surface. If not, adjust the height of the left hinge so that the protrusions at the front and rear sides contact the glass surface. |
| Right hinge | Check that the position of the right hinge is aligned properly. If not, adjust it. |

[5] Edges of original and copied image are not aligned

| Check item | Measures |
|----------------------------------|--|
| Side guides on the original tray | Set the side guides of the original tray by aligning them with the original width. |
| Scanning section | Adjust the scanning section of the MFP. |

[6] Streaks appear in copied/scanned images when using the DSDF.

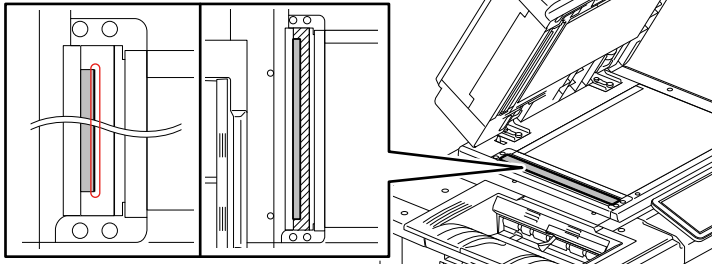
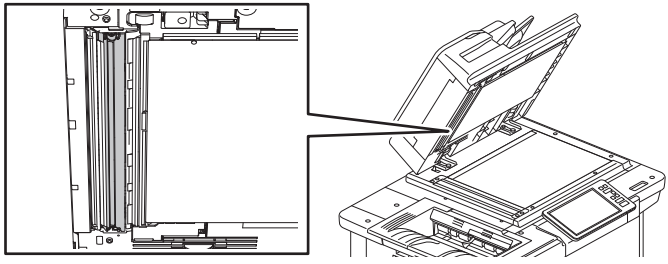
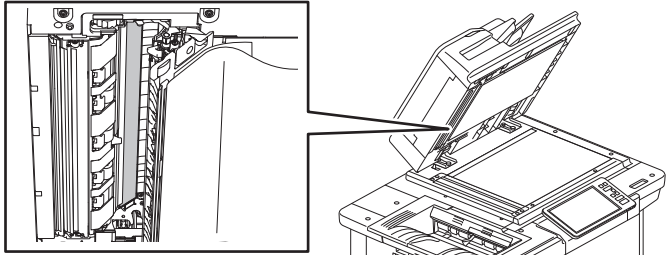
| Check item | Measures |
|--|--|
| Front side DF original glass on the MFP | <p>Wipe the ADF original glass and the edges of the black sheet of the MFP with a dry cloth. Alternatively, clean it with a well-squeezed cloth.</p>  <p>Fig.8-56</p> |
| Dual Scan Document Feeder (DSDF) | <p>Wipe the guide of the DSDF with a dry cloth. Alternatively, clean it with a well-squeezed cloth.</p>  <p>Fig.8-57</p> |
| Scanning section | <p>Check if there is any abnormality in the scanning section.</p> |
| Back side DSDF-CCD module | <ul style="list-style-type: none"> Wipe the slit glass of the DSDF-CCD module with a dry cloth or clean it with a well-squeezed cloth.  <p>Fig.8-58</p> <ul style="list-style-type: none"> Check if there is no abnormality in the DSDF-CCD module. |

Notes:

Do not use anything other than water (organic solvents, alcohol, neutral detergents).

[7] “Place Doc. Feeder in the down position“ is displayed.

When “Place Doc. Feeder in the down position” is displayed even if the DSDF or its cover is closed appropriately, take the following measures.

| Check item | Measures |
|---|--|
| DSDF lower cover | Check if the DSDF lower cover is closed appropriately. |
| DSDF original exit motor | <p>Check if the DSDF original exit motor is rotating properly. If not, check the following items.</p> <ul style="list-style-type: none"> • Check if the connector of the DSDF original exit motor is disconnected or the harnesses are open circuited. • Check if the connector of the DSDF control PC board is disconnected or the harnesses are open circuited. • Replace the DSDF original exit motor. |
| DSDF shading sheet HP sensor | <ul style="list-style-type: none"> • Check if the DSDF shading sheet HP sensor is working properly. (Input check: FS-03-[F2]ON/[6]/[A]) • Check if the connector of the DSDF shading sheet HP sensor is disconnected or the harnesses are open circuited. • Replace the DSDF shading sheet HP sensor. |
| DSDF control PC board | <ul style="list-style-type: none"> • Check if the connector of the DSDF control PC board is disconnected or the harnesses are open circuited. • Replace the DSDF control PC board. |
| DSDF lower cover opening/closing detection sensor | <ul style="list-style-type: none"> • Check if the connectors (J980, J953 and CN75) on the DSDF control PC board are disconnected from the DSDF lower cover opening/closing detection sensor or the harnesses are open circuited. Correct if any. • Check if the DSDF lower cover opening/closing detection sensor is working properly. (Input check: FS-03-[F2]ON/[6]/[C]) • Replace the DSDF lower cover opening/closing detection sensor. |
| DSDF lower cover interlock switch | <ul style="list-style-type: none"> • Check if the DSDF lower cover interlock switch is working properly. • Replace the DSDF lower cover interlock switch. |
| DSDF upper cover opening/closing detection sensor | <ul style="list-style-type: none"> • Check if the connectors (J981, J954 and CN75) on the DSDF control PC board are disconnected from the DSDF upper cover opening/closing detection sensor or the harnesses are open circuited. Correct if any. • Check if the DSDF upper cover opening/closing detection sensor is working properly. (Input check: FS-03-[F2]ON/[7]/[C]) • Replace the DSDF upper cover opening/closing detection sensor. |
| DSDF upper cover interlock switch | <ul style="list-style-type: none"> • Check if the DSDF upper cover interlock switch is working properly. • Replace the DSDF upper cover interlock switch. |
| Platen sensor-1 | <ul style="list-style-type: none"> • Check that the platen sensor-1 works properly. The platen sensor-1 works properly if the exposure lamp is lit when the DSDF is opened by 25 degrees • Replace the platen sensor-1. |
| Platen sensor-2 | <ul style="list-style-type: none"> • Check that the platen sensor-2 works properly. (Input check: FS-03-[F2]ON/[5]/[G]) • Replace the platen sensor-2. |

| Parts to be replaced | Remarks |
|---|---------|
| DSDF original exit motor | |
| DSDF shading sheet HP sensor | |
| DSDF control PC board | |
| DSDF lower cover opening/closing detection sensor | |
| DSDF lower cover interlock switch | |
| DSDF upper cover opening/closing detection sensor | |
| DSDF upper cover interlock switch | |
| Platen sensor-1 | |
| Platen sensor-2 | |

[8] White streaks appear on the back side copied image

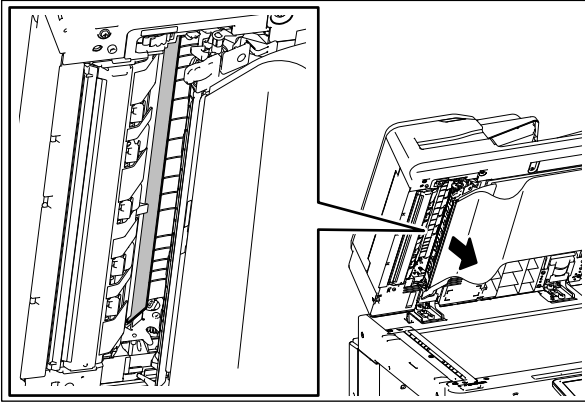
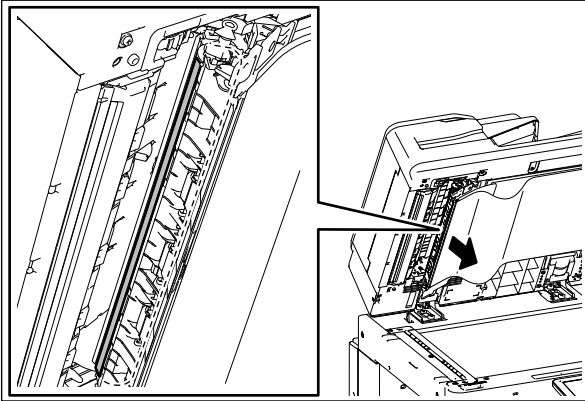
| Check item | Measures |
|-----------------------------------|---|
| Slit glass of the DSDF-CCD module | <p>Wipe the slit glass of the DSDF-CCD module with a dry cloth or clean it with a well-squeezed cloth.</p>  <p>Fig.8-59</p> |
| DSDF shading sheet | <ol style="list-style-type: none"> 1. Perform FS-03-274 in order to move the DSDF shading sheet to its cleaning position 2. Check if there are any stains on the DSDF shading sheet. If there is any foreign matter or if dust has adhered, wipe it off with a dry cloth.  <p>Fig.8-60</p> <ol style="list-style-type: none"> 3. If stains cannot be removed completely, replace the DSDF shading sheet. |
| DSDF-CCD module | Check if there is no abnormality in the DSDF-CCD module. |

8.4.2 Drum surface potential (V0) sensor (K) control related troubleshooting (9029A only)

Countermeasure when “Service Recommended for SPC” message is displayed

1. Check the control setting of Drum surface potential (V0) sensor.
Check that FS-08-2561 (Drum surface potential control setting) is set to “2”.

Remarks:

For 6529A and 7529A in which no drum surface potential (V0) sensor (K) is installed, “0” is set for FS-08-2561.

2. Check for abnormal contents (V0 sensor controlling, V0 sensor shutter closing) and abnormal stations.
 - Check the drum surface potential sensor controlling status: FS-05-2780 Sub code 3: K.
0: Normally completed
1: Control paused (due to an open cover, etc.)
2: Sensor abnormality detected
 - Check the drum surface potential (V0) sensor (K) shutter closing controlling status: FS-05-2789 Sub code 3: K
0: Normally completed
1: Control paused (due to an open cover, etc.)
2: Sensor shutter closing abnormality detected
- * When any of the drum surface potential (V0) sensor (K) controlling statuses is “2: Sensor abnormality detected” -> Go to step 3.
- * When any of the drum surface potential (V0) sensor (K) shutter closing controlling statuses is “2: Sensor shutter closing abnormality detected” -> Go to step 4.
3. Check if the connectors of the drum surface potential (V0) sensor (K) and PC boards of the troubled station are connected properly.
Reconnect the connectors and then go to the next step.
 - Connector between the drum surface potential sensor control PC board and EPU board
 - Connector between the drum surface potential (V0) sensor (K) and drum surface potential sensor control PC board
 - Connector between the solenoid of the drum surface potential (V0) sensor (K) shutter and EPU board
 - Connector of the LGC board
4. Check the status of FS-05-2782 (drum surface potential sensor output).
Check the values of the sub codes “3”, “8” and “13” in the following list.

| Sub code | Station | Grid at the measurement Bias [-V] |
|----------|---------|-----------------------------------|
| 3 | K | 300 |
| 8 | K | 900 |
| 13 | K | 500 |

- If the output of the grid bias is “0 to 30” or “1010 to 1020” in the target sensor, the drum surface potential (V0) sensor (K) shutter may become closed.

- If the drum surface potential (V0) sensor (K) or its shutter is dirty, wipe off with a soft pad or cloth.
 - If a spring or any part connecting the solenoid and the shutter has been removed, reinstall it securely.
 - Check that the drum surface potential (V0) sensor (K) shutter can be opened or closed smoothly when the movable section of its solenoid is moved by your hand, and the detection section (2 mm) of the drum surface potential (V0) sensor (K) can be seen completely when the shutter is opened.
 - Check if sounds are heard corresponding to proper solenoid operation by performing FS-03-212.
 - If not, replace the solenoid.
- If the output of the grid bias is other than “0 to 30” or “1010 to 1020” in the target sensor
 - Check that the main charger unit (K) is installed correctly. If it is dirty from dust or toner, remove it and reinstall the main charger unit (K) correctly.
 - Check that the main charger grid and needle electrode are installed correctly. If they are dirty from dust or toner, remove it and reinstall the main charger grid and needle electrode correctly.
 - Check if charging leakage has occurred in the station (K). If it is dirty from dust or toner, remove it and reinstall the station (K) correctly.
 - Check the installation of the harness of the discharge LED (K). If it is removed, reinstall it correctly.
 - Replace the drum (K).
 - Replace the drum surface potential (V0) sensor (K).
 - Replace the drum surface potential sensor control PC board.
 - Replace the EPU board.
 - Replace the LGC board.
 - Replace the high-voltage transformer.

5. Procedure of FS-05-2742 (Forced performing of image quality closed-loop control) and status confirmation

1. If the value of the drum surface potential sensor control abnormalities counter for each color is other than “0”, reset the counter.
FS-08-2560 Sub code 3: K
2. If the value of the drum surface potential sensor shutter closing control abnormalities counter for each color is other than “0”, reset the counter.
FS-08-2577 Sub code 3: K
3. Enable the drum surface potential control setting.
FS-08-2561: 0 (Disabled) → 1 (Enabled) → 2 (Enabled (perform only for the station (K)))
4. Perform FS-05-2742 (Forced performing of image quality closed-loop control).
5. If any abnormality is detected, the controlling status and “ERROR” shown below are displayed after approx. 30 to 60 seconds. Then check the content of the abnormality and the target station on the screen and then press [CANCEL] at the bottom left of the screen. The mode returns to the test mode if the drum surface potential sensor control is normally completed.

Control status

| | |
|---|--|
| Upper line: Drum surface potential (V0) sensor (K) control status | |
| | Same as that for FS-05-2780 Sub code 3: K 0: Normally completed 1: Control paused (due to an open cover, etc.) 2: Sensor abnormality detected |
| Lower line: Drum surface potential (V0) sensor (K) shutter closing control status | |
| | Same as that for FS-05-2789 Sub code 3: K 0: Normally completed 1: Control paused (due to an open cover, etc.) 2: Sensor shutter closing abnormality detected |

Message

| | |
|---|---|
| ERROR | |
| | When any of the drum surface potential (V0) sensor (K) control status (display on the upper line) is "2": Check the setting of FS-08-2561. |
| | When any of the drum surface potential (V0) sensor (K) shutter closing control status is "2": Return to step 3. |
| When "ERROR" is not displayed and the screen is returned to the test mode | |
| | 1. Output the test print. FS-04-231 (secondary scanning direction 33-gradation pattern) 2. Check if the image is normal. When the image is normal, complete the action. 3. When there is any abnormality in the image, perform the image related troubleshooting. |
| When a CE10, CE20 or CE40 error (service call) has occurred | |
| | An image quality control abnormality may have occurred. Perform the image quality control related troubleshooting. |

Notes:

- When any of the drum surface potential (V0) sensor (K) control status (display on the upper line) is "2", the drum surface potential (V0) sensor (K) shutter closing control status will not be identified. (The display on the lower line is "0".)
- If FS-05-2742 (Forced performing of image quality closed-loop control) is performed while "0" is selected for FS-08-2561 (Drum surface potential control setting), the drum surface potential control measurement will not be performed. However, if the image quality control is completed normally, the screen returns to the test mode.
- If the FS-05-2742 (Forced performing of image quality closed-loop control) is performed while "1" is selected for FS-08-2561 (Drum surface potential control setting), the following will result.
 - 9029A:
"0", "1" or "2" is displayed depending on the control status (display on the upper line). On the lower line, "0" is displayed for all stations and "ERROR" appears.
 - 6529A and 7529A:
"2" is displayed on the control status (display on the upper line), since the drum surface potential (V0) sensor (K) is not installed. On the lower line, "0" is displayed for all stations and "ERROR" appears.

8.4.3 Troubleshooting at unpacking

This section describes the procedure needed to interrupt the unpacking procedures in order to inspect or repair the MFP when any kind of trouble occurs during unpacking.

After the power of the MFP is turned on by following the unpacking instructions, the unpacking operation by means of the software will start.

This instruction prohibits any operation not described in the unpacking instructions, because the purpose is to complete the setup of the MFP properly. Therefore, if any kind of trouble has occurred during unpacking, it is necessary to forcibly quit the unpacking procedure.

When an error code or a service call is displayed, stop the unpacking procedure and clear the trouble by referring to troubleshooting.

When the MFP has been forcibly shut down, reboot it by means of FS-08-9022. The completed status before the forced shutdown can be found. For example, if "6" is displayed for FS-08-9022, this status means that the gamma adjustment has been completed.

When the error has been cleared, restart the unpacking procedure from the status in which you shut down the MFP.

To perform the gamma adjustment again, set "5" for FS-08-9022.

Moreover, to release the unpacking operation, set "99" for FS-08-9022. This enables to perform a normal startup of the MFP.

8.4.4 Drum surface potential (V0) sensor (K) control related troubleshooting at unpacking and setting up (9029A only)

[1] Confirmation

If an abnormality is detected during unpacking and setting up, after approx. 30 to 60 seconds have passed from FS-05-2742 (Forced performing of image quality closed-loop control), the controlling status and "ERROR" shown below are displayed. Check the content of the abnormality and the station with the error.

Remarks:

- After then, press [CANCEL] at the bottom of the screen.
- The mode returns to the test mode if the drum surface potential sensor control is normally completed.
- If FS-05-2742 (Forced performing of image quality closed-loop control) is performed while "0" is selected for FS-08-2561 (Drum surface potential control setting), the drum surface potential control measurement will not be performed. However, the controlling status of the last drum surface potential sensor measurement and "ERROR" are displayed. (All status values on both upper and lower lines may be "0" and also "ERROR" may be displayed.)
- When any of the drum surface potential (V0) sensor (K) control status (display on the upper line) is "2", the drum surface potential (V0) sensor (K) shutter closing control status will not be identified. (The display on the lower line is "0".)

Control status

| | |
|---|--|
| Upper line: Drum surface potential (V0) sensor (K) control status | |
| | FS-05-2780 Sub code 3 0: Normally completed 1: Control paused (due to an open cover, etc.) 2: Sensor abnormality detected |
| Lower line: Drum surface potential (V0) sensor (K) shutter closing control status | |
| | FS-05-2789 Sub code 3 0: Normally completed 1: Control paused (due to an open cover, etc.) 2: Sensor shutter closing abnormality detected |

Message

| | | |
|--------------|---|------------|
| ERROR | | |
| | When the drum surface potential (V0) sensor (K) control status (display on the upper line) is "2" | Go to [2]. |
| | When the drum surface potential (V0) sensor (K) shutter closing control status is "2" | Go to [3]. |
| Service call | | |
| | When a CE10, CE20 or CE40 error (service call) has occurred | Go to [5]. |

[2] Countermeasure to drum surface potential sensor controlling status abnormalities

Problems to measurement results when the drum surface potential (V0) sensor (K) shutter is opened
Check the following items and then go to [4].

[2-1] Checking the connector related problems

Check if the connectors of the drum surface potential sensor and PC boards of the troubled station are connected properly.

- Connector between the drum surface potential sensor control PC board and EPU board
- Connector between the drum surface potential (V0) sensor (K) and drum surface potential sensor control PC board
- Connector between the solenoid of the drum surface potential (V0) sensor (K) shutter and EPU board
- Connector of the LGC board

[2-2] Checking the main charger related problems

Check if there is any abnormality in the parts of main charger section. If the parts dirty from dust or toner, remove it and reinstall the them correctly. If the harness is removed, reinstall it correctly.

- Installation of the main charger unit
- Installation of the main charger grid and needle electrode
- Installation of the discharge LED
- Check if charging leakage has occurred.

[2-3] Checking the drum surface potential (V0) sensor (K) and drum surface potential sensor control PC board

Replace the parts around the drum surface potential (V0) sensor (K).

- Replace the drum surface potential (V0) sensor (K).
- Replace the drum surface potential sensor control PC board.

[2-4] Checking the drum surface potential (V0) sensor shutter

Check that the drum surface potential (V0) sensor (K) shutter can be opened or closed smoothly when the movable section of its solenoid is moved by your hand, and the detection section of the drum surface potential (V0) sensor (K) can be seen completely when the shutter is opened.

- If the drum surface potential (V0) sensor (K) or its shutter is dirty, wipe off with a soft pad or cloth.
- If a spring or any part connecting the solenoid and the shutter has been removed, reinstall it securely.
- Replace the shutter.
- Replace the solenoid.

[2-5] Checking the EPU board

Check the EPU board and replace it if necessary.

[2-6] Checking the photoconductive drum

Check the photoconductive drum and replace it if necessary.

[2-7] Checking the LGC board and high-voltage transformer

Check the LGC board and replace it if necessary.

Check the high-voltage transformer and replace it if necessary.

[3] Countermeasure to drum surface potential (V0) sensor (K) shutter closing control status abnormalities

Problems to measurement results when the drum surface potential (V0) sensor (K) shutter is closed
Check the following items and then go to [4].

[3-1] Checking the drum surface potential (V0) sensor shutter

Check that the drum surface potential (V0) sensor (K) shutter can be opened or closed smoothly when the movable section of its solenoid is moved by your hand, and the detection section of the drum surface potential (V0) sensor (K) can be seen completely when the shutter is opened.

- If the drum surface potential (V0) sensor (K) or its shutter is dirty, wipe off with a soft pad or cloth.
- If a spring or any part connecting the solenoid and the shutter has been removed, reinstall it securely.
- Replace the shutter.
- Replace the solenoid.

[4] Procedure of FS-05-2742 (Forced performing of image quality closed-loop control) and status confirmation

1. If the value of the drum surface potential sensor control abnormalities counter is other than "0", reset the counter.
FS-08-2560 Sub code 3
2. If the value of the drum surface potential sensor shutter closing control abnormalities counter for each color is other than "0", reset the counter.
FS-08-2577 Sub code 3
3. Enable the drum surface potential control setting.
FS-08-2561: 0 (Disabled) → 2 (Enabled (perform only for the station (K)))
4. Perform FS-05-2742 (Forced performing of image quality closed-loop control) and check the result by referring to step 1. If there is any abnormality, apply the necessary measures.

8.4.5 MFP operation disabled after the installation of option(s)

Check if the optional boards are installed properly.

8.4.6 Wireless LAN connection disabled

The connection state and settings of the Wireless LAN can be checked with [USER FUNCTIONS] > [ADMIN] > [WIRELESS LAN] > [SETTING CHECK].

For details, ask the administrator.

- "NIC INITIALIZING" does not disappear at the time of the power being turned ON and it disappears after 6 minutes with the NIC initializing time-out. In this case, the connection to the Wireless LAN does not succeed even though "NIC INITIALIZING" disappears.
- The connection to the Wireless LAN cannot be made if the access point to be connected is not found or the security settings are not correct.

8.4.7 When the duplexing unit cover open display cannot be released

1. Check if the duplexing unit opening/closing detection sensor (S64) is working normally.
2. Check if any of the fuses (F201, F202, and F203) on the switching regulator has open circuited.
3. Replace the switching regulator.
4. If the fuse is open circuited again even after the switching regulator is replaced, check if a harness connected to the connector CN512 on the switching regulator is caught or short circuited. Replace the harness if there is any abnormality.

8.4.8 Troubleshooting for one-time dongle

1. When the serial number is changed, options already installed (Meta Scan Enabler GS-1010, External Interface Enabler GS-1020, IPSec Enabler GP-1080) will be disabled.
2. For reinstallation of the options, follow the designated reinstallation procedure (the same procedure as that of board replacement).

8.4.9 Countermeasure to staining on the back side of the paper

Take off the separation guide and the separation plate at the pressure roller side. Check if toner has adhered on both the front and back sides of the guide and plate. If toner has adhered, wipe it off with a dry cloth. Use toner remover if necessary. If toner remover is used, soak it in a cloth and clean the surface of the separation plate with it.

Notes:

- After toner remover is used, wipe it off with a dry cloth.
- Be careful not to damage the surface of the separation plate and tape.
- Be careful not to deform the separation plate.

8.4.10 Countermeasure to exiting paper sideways deviation

If any problem such as corner folding on paper occurs at the receiving section of the finisher due to exiting paper sideways deviation, check the following items to correct it or replace the parts.

- Cause 1 of exiting paper sideways deviation: Bridge unit
- Cause 2 of exiting paper sideways deviation: Duplexing unit

Check that the rollers are parallel to the installation holes.

If any of them is slanted, correct or replace it.

The rollers of the lower transport guide affect the sideways deviation in the simplex and duplex mode, and the ones of the upper transport guide affect the sheet sideways deviation in the duplex modes.

The rollers in the duplexing unit affect the sideways deviation in the duplex mode.

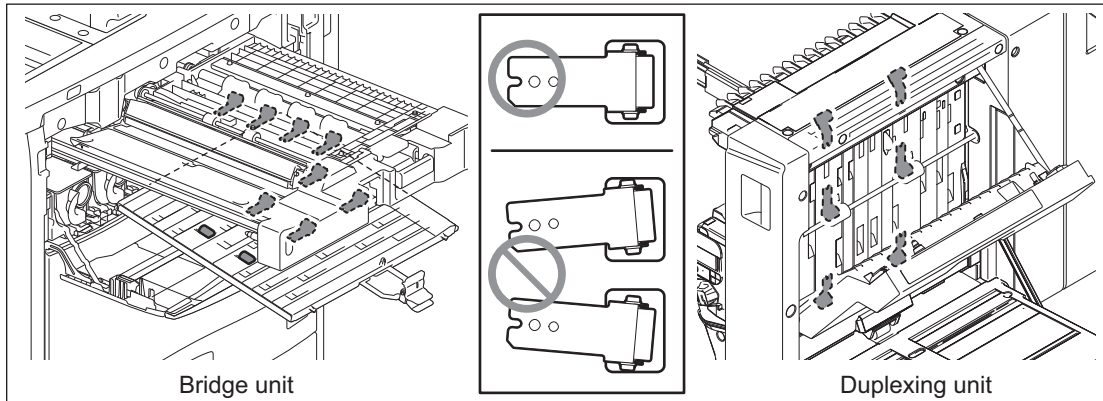

Fig.8-61

- Cause 3 of exiting paper sideways deviation: Installation status

Notes:

- Check that the MFP is installed horizontally at the installation position. (Install a level on the original glass to check.)
- Check that 4 stoppers contact the ground.

Confirmation method

1. Place A4 or LT size paper in the 1st drawer. Print 5 sheets in the simplex mode and print 5 sheets in the duplex mode using the 1st drawer, having the paper exit to the tray at the side of the MFP.
2. Check that the edges of the simplex/duplex printed sheets are located within the allowable range of the scale (B).
3. If they are not, adjust the position according to the following procedure. ((A): recommended range)

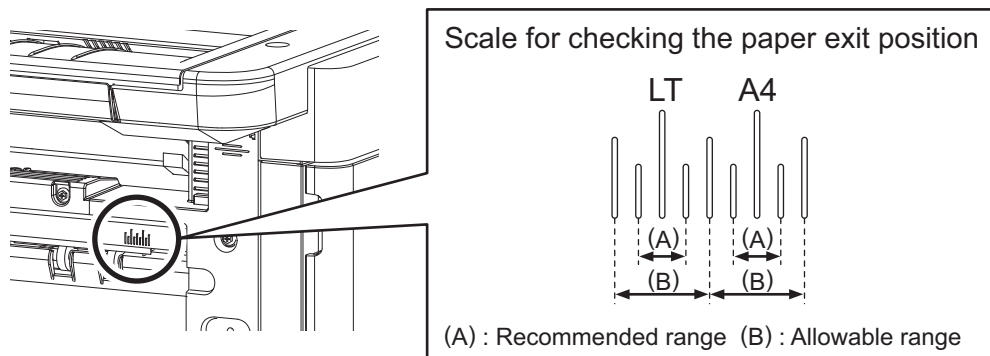

Fig.8-62

Adjustment procedure

- In case the edges are towards the front side from (B):
Turn the stopper on the right front side clockwise to lift the MFP. The paper exit position will be moved towards the rear side by approx. 0.6 to 1.0 mm for each turn.

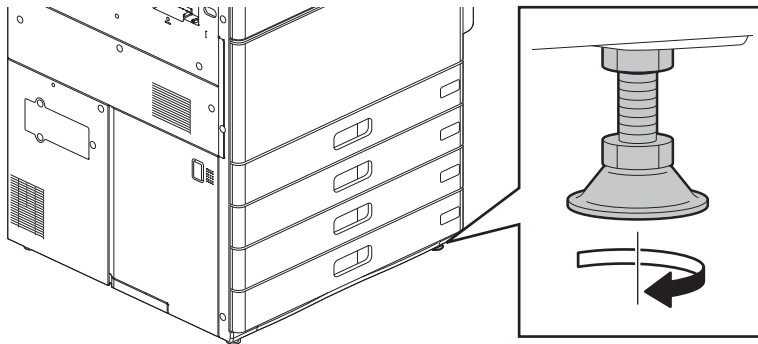

Fig.8-63

- In case the edges are towards the rear side from (B):
Turn the stopper on the left front side clockwise to lift the MFP. The paper exit position will be moved towards the front side by approx. 0.6 to 1.0 mm for each turn.

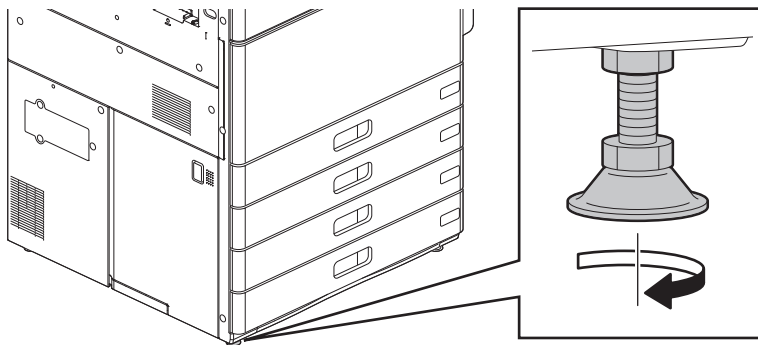

Fig.8-64

Notes:

Notes when installing the finisher

- After the above adjustment, install the finisher according to the Unpacking Instructions.
- Be sure to perform the height adjustment given in the Unpacking Instructions.

8.4.11 Problems in paper exiting

Countermeasure when the following problems occur in paper exiting to the upper or lower paper exit section, instead of the finisher being used

[1] Curling up of the exiting paper

When there is a problem during the use of small-size paper (A5-R, ST-R, etc.), such as its curling up, perform the following procedure.

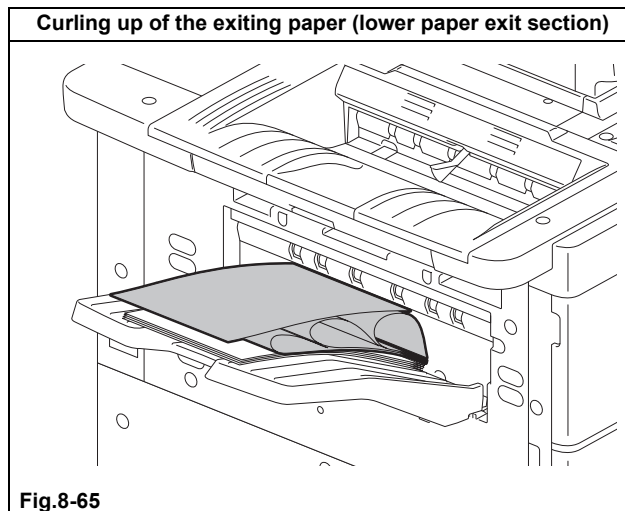

1. When this problem occurs in paper exiting to the upper paper exit section of the MFP, change the setting of the destination to the lower paper exit section.
When this problem occurs in paper exiting to the lower paper exit section of the MFP, change the setting of the destination to the upper paper exit section.
2. When this problem occurs in paper exiting to the lower paper exit section using the side exit tray (option: KA-6551-ET), use the sub tray (service part).
 - Service part: COV-SUB-TRAY-H38X (P-I: 202-25)

[2] Remaining of the trailing edge of the exiting paper (The trailing edge of the paper does not fall onto the tray.)

During the use of B5-R size paper or an OHP film, if there is a problem such as the remaining of the trailing edge of the paper at exiting, carry out the following procedure.

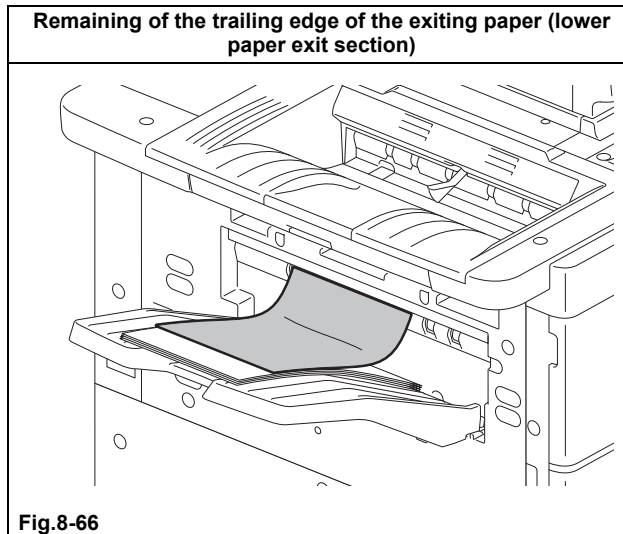

1. Add the sub tray (service part) to the side exit tray (option: KA-6551-ET).
 - Service part: COV-SUB-TRAY-H38X (P-I: 202-25)

8.4.12 Error code “M00” displayed while updating firmware

| Check item | Measures |
|---------------------|---|
| Switching regulator | <ul style="list-style-type: none"> • Connector check (CN512) • Harness check • Fuse check (F201, F202) |
| LGC board | <ul style="list-style-type: none"> • PC board check • Connector check (CN317, CN316) • Harness check |

| Parts to be replaced | Remarks |
|----------------------|---------|
| Switching regulator | |
| LGC board | |

8.4.13 “Latch the developer unit” remains displayed

After the power is turned ON, “Latch the developer unit” is displayed on the LCD screen. This display is not changed even if the developer unit is removed and then installed.

| Step | Check item | Measures |
|------|--|--|
| 1 | Installation state of the developer unit | <ul style="list-style-type: none"> Remove and install the developer unit. Close the front cover. Check if the drawer connector is connected securely or its pins are not deformed. <p>If the display is not changed even if step 1 has been carried out, perform steps 2 to 5. If the display is changed, perform steps 6 and 7.</p> |
| 2 | Change in the display | Check if the display is changed when the power is turned OFF and then back ON. If an error indication is displayed, perform its troubleshooting in accordance with its procedure. |
| 3 | SYS board | <ul style="list-style-type: none"> Connector check Harness check Open circuit or short circuit check |
| 4 | LGC board | <ul style="list-style-type: none"> Connector check Harness check Open circuit or short circuit check |
| 5 | Flat cable | Check if there is any abnormality in the terminal of the flat cable between the SYS and LGC boards. Check if the flat cable is open circuited. |
| 6 | Harness | Check if there is a short circuit or open circuit in the harness for connecting the LGC board and the developer unit. |
| 7 | Auto-toner sensor | <ul style="list-style-type: none"> Connector check Harness check Open circuit or short circuit check Replace the auto-toner sensor. |
| 8 | EPU board | <ul style="list-style-type: none"> Connector check Harness check Open circuit or short circuit check |

| Parts to be replaced | Remarks |
|----------------------|---------|
| Flat cable | |
| SYS board | |
| LGC board | |
| EPU board | |
| Developer unit | |

8.4.14 Countermeasure to stains (stripe-shaped) on the back side of the paper occurring immediately after the drum cleaner unit is removed and then reinstalled

When stains as shown below occur immediately after the drum cleaner is removed and then reinstalled, perform the following measures.

[1] Symptom

Stripe-shaped stains on the back side of the paper

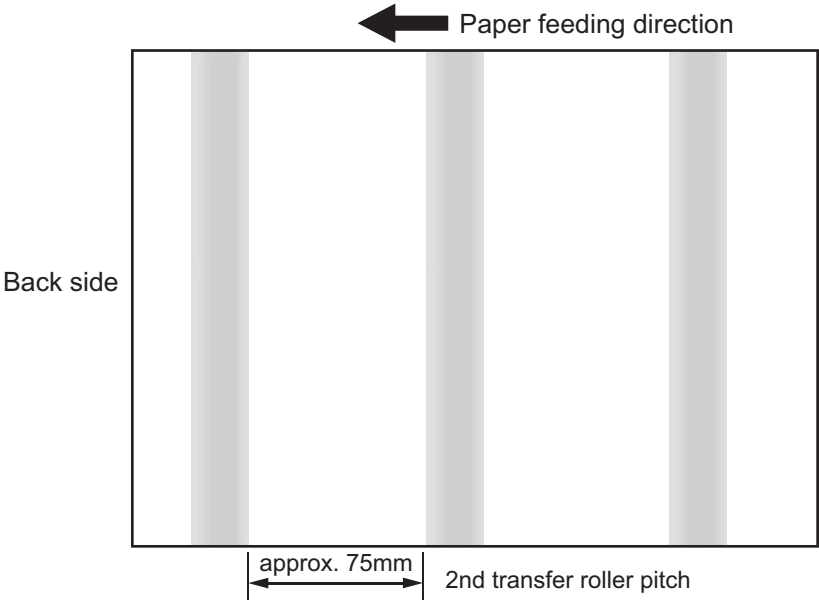

Fig.8-67

[2] Measures

Perform FS-05-2742 (Forced performing of image quality closed-loop control) or copy or print one sheet of paper.

8.4.15 Error check by the LEDs on the LGC board

2 LEDs are mounted on the LGC board. The error contents can be checked by means of their indication status.

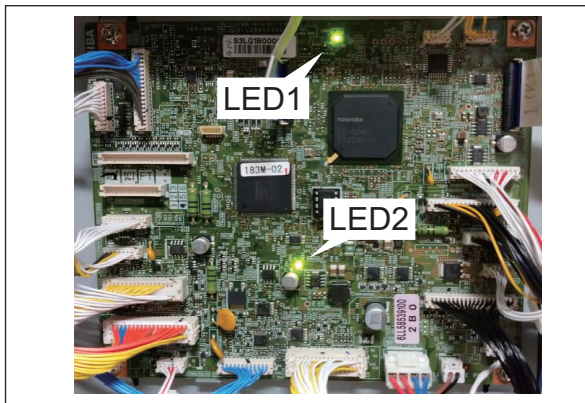

Fig.8-68

Status of the LEDs on the LGC board

| LED | Lighting condition | LGC board status | Troubleshooting |
|------|--------------------|-------------------------|--|
| LED1 | ON | Normal | - |
| | OFF | 3.3 V power abnormality | <ul style="list-style-type: none"> • Check if the harnesses are caught. • Replace the LGC board. • Replace the PFC board. |
| LED2 | ON | Normal | - |
| | OFF | 5.1 V power abnormality | <ul style="list-style-type: none"> • Check if the harnesses are caught. • Replace the LGC board. • Replace the PFC board. |
| | | Engine startup failure | <ul style="list-style-type: none"> • Check if the flat cable between the SYS board and the LGC board is not connected securely. • Reinstall the engine firmware. • Replace the LGC board. |

Remarks:

If both the LED1 and LED2 are turned OFF, a 3.3 V power abnormality may have occurred.

8.4.16 The MFP does not start after the power has been turned ON.

[1] The LCD screen does not display after the power has been turned ON.

1. Overview

When the lamps on the control panel do not light or error codes are not displayed on the screen after the power has been turned ON, perform this troubleshooting.

2. Status LED, Power LED

After the power is turned ON, the status of the MFP from the startup until the end of system device initialization (the LCD screen works) is displayed by the status LED (8-bit) on the SYS board. When the MFP does not start or the LCD screen does not display after the power is turned ON, check this status LED on the SYS board in order to judge the corresponding troubleshooting. In addition to this, the power LED is lit when 12 VA power is being supplied to the SYS board.

| | |
|---|------------|
| 1 | Status LED |
| 2 | Power LED |

3. Measures

When an error code is displayed, perform its troubleshooting.

If the LCD screen is turned OFF and an error code cannot be confirmed as a result, check the lighting condition of each LED and perform the troubleshooting according to the status below.

Main power LED and energy saver LED on the control panel

| LED | Lighting condition | SYS power LED | Troubleshooting |
|----------------|--------------------|---------------|---|
| Main Power LED | ON | ON | <p>The control panel does not operate normally.</p> <ul style="list-style-type: none"> • Check the connection of the harness (41-pin) of the control panel. Check if there is any abnormality in the harness. • Check if there is any abnormality in the parts of the control panel. • Download the system software again. • Check if there is any abnormality in the SYS board. • Replace the control panel. • Replace the SYS board. |
| | | OFF | <p>The 12 VA power is not supplied to the SYS board.</p> <ul style="list-style-type: none"> • Check the connection of the power harness of the SYS board. Check if there is any abnormality in the harness. • Check if there is any abnormality in the switching regulator. • Check if there is any abnormality in the SYS board. • Replace the power harness of the SYS board. • Replace the switching regulator. • Replace the SYS board. <p>The 12 VA power supply is stopped due to an overcurrent.</p> <ul style="list-style-type: none"> • Turn the power OFF and open the front cover. While keeping this status, press the power button to check that the SYS power LED is turned ON. <p>[If the SYS power LED is turned ON]</p> <ul style="list-style-type: none"> • Check if there is any abnormality in all the harnesses with the 24 V power supplied. • Check if there is any abnormality in all the boards with the 24 V power supplied. • Replace all boards with the 24 V power supplied. <p>[If the SYS power LED is not turned ON]</p> <ul style="list-style-type: none"> • Check if there is any abnormality in all the harnesses with the 12 VA power supplied. • Check if there is any abnormality in all the boards with the 12 VA power supplied. • Replace all boards with the 12 VA power supplied. |
| | OFF | ON | <p>The 5 VS power is not supplied to the control panel.</p> <ul style="list-style-type: none"> • Check the connection of the harness of the control panel. • Check if there is any abnormality in the parts of the control panel. |
| | | OFF | <p>The power is not supplied to the SYS board.</p> <ul style="list-style-type: none"> • Check the connection of the power supply harness of the SYS board. • Check if there is any abnormality in the switching regulator. • Check if there is no abnormality in the SYS board. |

| LED | Lighting condition | SYS power LED | Troubleshooting |
|------------------|--------------------|---------------|--|
| Energy saver LED | ON | - | - |
| | Blinking | - | When the energy saver LED is turned OFF after a certain time has passed: Initialization between the control panel and the SYS board is not completed. <ul style="list-style-type: none"> • Check the connection of the harness of the control panel. • Check if there is any abnormality in the parts of the control panel. • SYS board abnormality (Check the lighting condition of the SYS power LED and SYS status LED and perform the measures described in the next table.) |
| | | - | When the energy saver LED blinks even if some times have passed: Initialization between the control panel and the SYS board is not completed. <ul style="list-style-type: none"> • Check the connection of the harness of the control panel. • Check if there is any abnormality in the parts of the control panel. • SYS board abnormality (Check the lighting condition of the SYS power LED and SYS status LED and perform the measures described in the next table.) |
| | OFF | ON | The 12 VA power is not supplied to the control panel. <ul style="list-style-type: none"> • Check the connection of the harness of the control panel. • Check if there is any abnormality in the parts of the control panel. |

Power LED and Status LED on the SYS board

| LED | Lighting condition | SYS board status | Troubleshooting |
|-----------|--------------------|------------------------------|---|
| Power LED | OFF | Waiting for the power supply | Check the connection of the switching regulator harness and the power supply harness.  P. 8-408 "[2] The power LED on the control panel does not light after the power cable is connected." |

| LED | | Lighting condition | SYS board status | Troubleshooting |
|------------|------|---|---|---|
| Status LED | Bit0 | ON | Main memory abnormality | Replace the SYS board. |
| | Bit1 | ON | IC abnormality | Replace the SYS board. |
| | Bit2 | ON | Control panel communication error | <ul style="list-style-type: none"> Check the connection of the harness of the control panel. Check if there is any abnormality in the parts of the control panel. |
| | Bit3 | ON | ASIC detection error | Replace the SYS board. |
| | | Blinking | Initialization abnormality | Replace the SYS board. |
| | Bit4 | ON | ASIC detection error | Replace the SYS board. |
| | | Blinking | Initialization abnormality | Replace the SYS board. |
| | Bit5 | ON | Network IC communication error | <ul style="list-style-type: none"> When the error code is F130, follow its troubleshooting procedure. If the screen does not display, replace the SYS board. |
| | Bit6 | ON | OS lock | Reboot the MFP to check whether the problem is solved. If the problem reoccurs, download the system software again. |
| Bit7 | ON | During the energy saving mode, Recovery error from the energy saving mode | Reboot the MFP to check whether the problem is reproduced. If the problem reoccurs, download the system software again. | |

Remarks:

- If an error code appears, follow its troubleshooting procedure.
- When all the status LEDs are lit, replace the SYS board.

[2] The power LED on the control panel does not light after the power cable is connected.

1. Primary power supply abnormality

| Check item | Measures |
|----------------------------|--|
| Power voltage | Check if the power voltage is appropriate for the MFP. Check if the power voltage is within $\pm 10\%$ of the rated voltage. |
| Power cable | Check if the power cable is open circuited or the connectors are disconnected. |
| Inlet | Check if the inlet and its harness are open circuited or disconnected. |
| FIL board | <ul style="list-style-type: none"> • Check if the harness is inserted into the connector (CN526) properly. • Check if the harness is inserted into the connector (CN522) properly. • Check if the fuse (F1) has melted. Replace the FIL board. • If the fuse (F1) has melted again even if the FIL board has been replaced, perform the following items. <ul style="list-style-type: none"> - If the fuse (F1) cannot be blown out even when the fuser unit has been replaced and the power cable has been connected, exchange the fuser unit. - If the fuse (F1) cannot be blown out even if there is no abnormality in the fuser unit and when the connector (CN529) has been disconnected and the power cable has been connected, exchange the IH board. - If the fuse (F1) cannot be blown out even when the connector (CN577) has been disconnected and the power cable has been connected, exchange the power supply unit. - If the fuse (F1) cannot be blown out even when the damp heater switch has been turned OFF and the power cable has been connected, exchange the damp heater in question. (For the models with a damp heater installed) <p>Remarks: If the resistance value of the damp heater is as below, there will be an abnormality in the damp heater in question. Scanner damp heater: 714Ω -10% or below Drum damp heater (right): 830Ω -10% or below Drum damp heater (left): 830Ω -10% or below Drawer damp heater: $2K\Omega$ -10% or below</p> |
| Switching regulator (LVPS) | <ul style="list-style-type: none"> • Check if the fuse (F1) has melted. Replace the switching regulator. • Check if the CN511 8-pin of the switching regulator outputs $12\text{ V} \pm 5\%$. <ul style="list-style-type: none"> - Output when the connector of the control panel is disconnected: Replace the control panel. - Output when all of the connectors of the SYS board are disconnected: Replace the SYS board. - If the problem still persists even though the above steps have been carried out, replace the switching regulator [5]. |

2. Secondary power supply abnormality

| Check item | Measures |
|------------|--|
| Option | <p>Check if this problem can be solved when the connectors of the paper handling options are disconnected and then the power is turned OFF and then back ON.</p> <p>If the problem is solved, check if there is an abnormality such as catching in the harnesses of the options in question.</p> |

| Check item | Measures |
|-------------------------------|--|
| LCD screen check (LGC board) | <p>Check if this problem can be solved when the front cover or the ADU is opened. (Does the LCD screen display work?) If the problem is solved (the LCD screen displays), close all covers and check the following items.</p> <ul style="list-style-type: none"> • The LCD screen displays when CN301 is disconnected: Check or replace the reverse gate solenoid and the harness. • The LCD screen displays when CN305 is disconnected: Check or replace the fuser motor and the harness. • The LCD screen displays when CN302 is disconnected: Check or replace the IH board cooling fan-1 and the harness. Check or replace the IH board cooling fan-2 and the harness. • The LCD screen displays when CN327 is disconnected: Check or replace the drum/TBU motor and the harness. Check or replace the paper feed/developer motor and the harness. Check or replace the 1st transfer contact/release clutch and the harness. • The LCD screen displays when CN313 is disconnected: Check or replace the discharge LED (K) and the harness. • The LCD screen displays when CN325 is disconnected: Check or replace the power supply unit cooling fan and the harness. • The LCD screen displays when CN310 is disconnected: Check or replace the suctioning fan and the harness. Check or replace the paper exit section cooling fan and the harness. • The LCD screen displays when CN309 is disconnected: Check or replace the sensor shutter solenoid and the harness. • The LCD screen displays when CN320 and CN321 are disconnected: Check or replace the high-voltage transformer and the harness. • The LCD screen displays when CN322 and CN335 are disconnected: Check or replace the laser optical unit and the harness. |
| LCD screen check (PFC board) | <ul style="list-style-type: none"> • The LCD screen displays when CN461 is disconnected: Check or replace the 1st drawer paper feed clutch and the harness. Check or replace the 2nd drawer paper feed clutch and the harness. Check or replace the transport clutch (H) and the harness. Check or replace the transport clutch (L) and the harness. • The LCD screen displays when CN462 is disconnected: Check or replace the ozone exhaust fan and the harness. Check or replace the developer unit cooling fan and the harness. • The LCD screen displays when CN450 is disconnected: Check or replace the ADU board and the harness. Check or replace the bypass tray paper feed clutch. Check or replace the fuser unit cooling fan-1 and the harness. Check or replace the fuser unit cooling fan-2 and the harness. |
| PFC board | If the problem still persists even though the above items have been done, replace the PFC board. |
| LGC board | If the problem still persists even though the above items have been done, replace the LGC board. |
| SYS board | The LCD screen displays when CN125 is disconnected: Replace the SYS board. |
| Switching regulator (LVPS) | The problem is not solved (the LCD screen does not display) even if the front cover or the ADU is opened: Replace the switching regulator. |
| Power supply unit cooling fan | <p>Check if the power supply unit cooling fan rotates. If not, perform the following items.</p> <ul style="list-style-type: none"> • Check the connector of the power supply unit cooling fan. • Replace the LGC board. • Replace the switching regulator. |

8.4.17 Countermeasure to sudden power failure

| | Symptom | Check item | Measures |
|---|--|---|--|
| 1 | The [ENERGY SAVER] button is lit. The power supply is recovered by pressing the [ENERGY SAVER] button. | The mode is at the sleep mode. | Turn off the sleep mode setting. Alternatively, change the setting. |
| 2 | The power supply is recovered by pressing the [POWER] button. | The weekly timer has run. | <ul style="list-style-type: none"> Turn off the setting of the weekly timer. Alternatively, change the setting. Check if the time is set correctly. |
| 3 | The power supply is not recovered even if the [POWER] button is pressed. | The harness of the 12 V or 24 V power is short circuited. <ul style="list-style-type: none"> Check if there is any abnormality, such as scratches or being caught on the harnesses of each board, and damage on the connector pins. | <ul style="list-style-type: none"> Replace the harness. Replace the switching regulator. |
| 4 | The main power LED is not lit. | <ul style="list-style-type: none"> Check if there is any abnormality in the power cable. Check if there is any abnormality such as scratches or being caught on the harnesses for the inlet or the power button. Check if the fuse (F1) for the switching regulator are cut. Check if the harness for the switching regulator is inserted properly. | <ul style="list-style-type: none"> Replace the power cable. Replace the harnesses for the inlet, power button and the switching regulator. Replace the switching regulator. |
| 5 | The main power LED is lit. | Check the voltage of the power supply connectors (CN105, CN136) on the SYS board. <ul style="list-style-type: none"> The voltage of CN105 1-pin is lower than 8 V and that for 4-pin is lower than 8.4 V. The voltage of CN136 4-pin is 0 V, that for CN105 1-pin is 10.8 V or more and that for CN105 4-pin is 0 V. | Replace the switching regulator. |
| | | Check the voltage of the power supply connectors (CN105, CN135) on the SYS board. <ul style="list-style-type: none"> The voltage of CN105 1-pin is 8 V or more, that for CN105 4-pin is 8.4 V or more and that for CN135 4-pin is 8.4 V or more. | Replace the SYS board. |
| 6 | Power supply failed at warming up. (The main power lamp is lit.) | Check if there is any abnormality in the fuser unit. <ul style="list-style-type: none"> Check if there is any abnormality in the terminal of the connector. Check if there is any abnormality in the installation of the thermistor or no foreign matter adhering. | <ul style="list-style-type: none"> Repair the defective portions of the fuser unit. Replace the fuser unit. |
| | | Check if there is any abnormality in the LGC board. <ul style="list-style-type: none"> Check if the connector of the LGC board is disconnected, is soldered on the board firmly or its pins are damaged. | <ul style="list-style-type: none"> Replace the harness. Replace the LGC board. |
| | | Check if there is any abnormality in the switching regulator. | Replace the switching regulator. |

| | Symptom | Check item | Measures |
|----|--|--|---|
| 7 | Power supply failed when the motor rotates. Power supply failed when the cover is closed. | Check if there is any abnormality in the motor. <ul style="list-style-type: none"> Check if there is any abnormality which makes the motor disable to rotate. Check if there is any abnormality such as scratches or being caught on the harness of the motor. | Release the problems or replace the motor and harness. |
| | | Check if there is any abnormality in the options. <ul style="list-style-type: none"> Check if the problem is released when disconnecting the option. | Check if there is any abnormality in the disconnected option and release the problems. |
| 8 | Power supply failed when the ADU is opened and closed. | Check if there is any abnormality such as scratches or being caught on the harness for the ADU hinge. | Replace the harness. |
| 9 | Power supply failed when the DF is opened and closed. | <ul style="list-style-type: none"> Check if there is any abnormality such as scratches or being caught on the harness for the DF and the scanner. Check if there is any abnormality such as scratches or being caught on the harness between the SYS board and the scanner. Check if there is any abnormality in the connector pins. | Replace the harness. |
| 10 | The MFP is rebooted. | An error has occurred. (Depending on the error, the MFP will reboot at its first time and then a service call will happen at its second time.) | <ul style="list-style-type: none"> Check the error code and solve the problem. Replace the SYS board. |

| Parts to be replaced | Remarks |
|----------------------|---------|
| Power cable | |
| Switching regulator | |
| Fuser unit | |
| SYS board | |
| LGC board | |
| Harnesses | |

8.4.18 The drawer is not automatically inserted.

Perform the operation when replacing the soft-close unit for the first time.

 P. 4-121 “4.5.58 Soft-close unit (4-drawer model)”

 P. 4-122 “4.5.59 Soft-close unit (Tandem LCF model)”

8.4.19 Troubleshooting for operation abnormality

When a power failure has occurred, the storage device of the MFP will be damaged and thus a display or operation abnormality may occur. In such a case, recover the operation by performing the following items.

| Check item | Measures |
|-------------------------------|---|
| Storage device | Perform the following self-diagnostic code is to check if there is any abnormality in the storage device. If there is any abnormality, replace it. <ul style="list-style-type: none">• Standard storage device: FS-08-9008-1• Optional storage device: FS-08-9008-2 |
| Firmware updating | Update the firmware to check that the problem is solved. <ul style="list-style-type: none">• System firmware• System software• Engine firmware• Scanner firmware |
| Storage device initialization | Initialize the storage device to check that the problem is solved. Notes: <ul style="list-style-type: none">• Check the backup data in advance. Back up the data if you do not have them.• After the initialization, reattempt the necessary settings. |
| Initialize SRAM | Initialize the SRAM to check that the problem is solved. Notes: <ul style="list-style-type: none">• Check the backup data in advance. Back up the data if you do not have them.• After the initialization, reattempt the necessary settings. |

8.4.20 The waiting time for printing is too long.

If the waiting time for printing is too long, this will be shortened by changing the setting of the self-diagnostic code.

- Waiting time when a wide-size sheet is printed following the continuous printing of narrow-size ones
- Waiting time when a wide-size sheet is printed following after rotate-sort printing

Notes:

The waiting time can be improved by changing the setting; however, toner offset (shadow image) sometimes appears. Therefore, the setting should only be changed depending on the occurrence frequency or corresponding to users' requests.

[1] To make the waiting time shorter

Change the setting in accordance with the following reference.

📖 P. 8-424 "8.5.7 Toner offset (shadow image) at the edges"

[2] To remove the waiting time

Set the following values.

| Code | Setting value |
|--------------|---------------|
| FS-08-5354-0 | 1 |
| FS-08-5354-1 | 1 |
| FS-08-5354-2 | 1 |
| FS-08-5354-3 | 1 |
| FS-08-5457-0 | 0 |
| FS-08-5457-1 | 0 |

8.4.21 "Fax line1 is out of order." or "Fax line2 is out of order." displayed

1. Turn the power OFF and then back ON.
2. Replace the fax board.

8.4.22 Ethernet disabled in half-duplex communication

The Ethernet of this MFP does not support half-duplex communication.

When the port setting of the switch is fixed at half-duplex communication, use any of 10/100/1000 Mbps, full-duplex fixed communication mode or auto-negotiation function. In addition, select the setting of the MFP corresponding to that of the switch. ([ADMIN] > [NETWORK] > [ETHERNET])

Check the set communication speed as follows if required: [ADMIN] > [NETWORK] > [ETHERNET]

8.4.23 Toner cartridge unrecognized

If the toner cartridge is not recognized, check the following items.

- Check that there is no access abnormality to the toner cartridge IC chip.
- Check the setting of FS-08-4689-3 in the setting mode. If the value is "1" to "5", perform the troubleshooting in the following reference.

📖 P. 8-200 "[C911] CTIF board access abnormality (K)"

8.4.24 “Invalid Department Code” displayed

Log into TopAccess as an administrator, select [Authentication] on the [User Management] tab, and then check whether Department Setting is enabled or disabled.

Department Setting is enabled:

- Log into TopAccess as an administrator, select [Authentication] on the [User Management] tab, and then check User Management Setting.
- Check the setting of FS-08-3805 in the setting mode.

Department Setting is disabled:

- Log into TopAccess as an administrator, select [Authentication] on the [User Management] tab, and then check User Management Setting.

8.4.25 Paper cannot be fed from the Ex-LCF

No indication of the Ex-LCF is displayed on the panel even if it is actually installed.

| Step | Check item | Measures |
|------|------------|--|
| 1 | Connector | <p>Check if the connector is connected properly.</p> <ul style="list-style-type: none"> • When only the Ex-LCF 2.5K is installed Check if the connector between the MFP and the Ex-LCF 2.5K is connected properly. If it is not connected properly, reconnect it. Input check: FS-03-[COPY]7/A • When both the Ex-LCF 2.5K and Ex-LCF 2.0K are installed <ul style="list-style-type: none"> - Check if the connector between the MFP and the LCF Connector is connected properly. If it is not connected properly, reconnect it. Input check: FS-03-[COPY]7/B - Check if the connector between the LCF Connector and the Ex-LCF 2.5K is connected properly. If it is not connected properly, reconnect it. Input check: FS-03-[FAX]1/B - Check if the connector between the LCF Connector and the Ex-LCF 2.0K is connected properly. If it is not connected properly, reconnect it. Input check: FS-03-[COPY]6/B |
| 2 | Harness | <p>Check if the harness is open circuited.</p> <ul style="list-style-type: none"> • When only the Ex-LCF 2.5K is installed Check the harness between the MFP and the Ex-LCF 2.5K. Replace it if it is open circuited. • When both the Ex-LCF 2.5K and Ex-LCF 2.0K are installed <ul style="list-style-type: none"> - Check the harness between the LCF Connector and the Ex-LCF 2.5K. Replace it if it is open circuited. - Check the harness between the MFP and the LCF Connector. Replace it if it is open circuited. Replace it if it is open circuited. - Check the harness between the LCF Connector and the Ex-LCF 2.0K. |
| 3 | PC board | <p>Check if there is any abnormality in the PC board.</p> <ul style="list-style-type: none"> • When only the Ex-LCF 2.5K is installed Check if there is any abnormality in the PC board of the Ex-LCF 2.5K. If there is any abnormality, replace the PC board. • When both the Ex-LCF 2.5K and Ex-LCF 2.0K are installed <ul style="list-style-type: none"> - Check if there is any abnormality in the PC board of the Ex-LCF 2.5K. If there is any abnormality, replace it. - Check if there is any abnormality in the PC board of the Ex-LCF 2.0K. If there is any abnormality, replace the PC board. - Check if there is any abnormality in the PC board of the LCF Connector. If there is any abnormality, replace the PC board. |

| Parts to be replaced | Remarks |
|----------------------|---------|
| Harness | |
| PC board | |

8.5 Troubleshooting for the Image

8.5.1 Uneven pitch and jitter image

<Symptom>

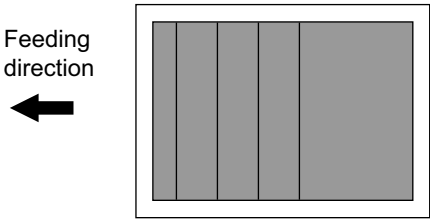
| Original mode | Location | Symptom | |
|---------------|---|--------------|---|
| All modes | At right angles to the paper feeding direction cyclically | Uneven pitch |  <p>Feeding direction</p> <p>←</p> <p>Fig.8-69</p> |

| Cause/Section | Step | Check item | Measures | Remarks |
|-------------------|--|---|---|--|
| | 1 | Test printing (A3/LD) | Output the halftone and built-in grid pattern. | For the following checks |
| | 2 | Are there uneven pitches of 188 mm? | Perform steps 5, 6 and 8. | |
| | | Are there uneven pitches of 26 mm? | Perform step 7. | |
| | 3 | This jittery image occurs in certain positions from the leading edge of the paper when the continuous printing is performed. This occurs at the position 178.277 mm from the edge of the image when printed in black. | Perform steps 9, 10, 11 and 12. | Jittering caused by the impact of the paper going into the 2nd transfer section |
| 4 | This jittery image occurs in certain positions from the leading edge of the paper on the second and subsequent pages when continuous printing is performed. The position of the jittery image varies depending on the copying speed, paper size and color. | <ul style="list-style-type: none"> Perform steps 9 and 12. When the paper size is A3 or LD, change the paper source to the bypass tray. | Jittering caused by the impact of the paper passing through the registration roller and 2nd transfer roller | |
| Drum | 5 | Are there any scratches or adhering matters on the drum surface? | Clean or replace the drum. | Replace the drum first, because in some cases, scratches cannot be visually checked. |
| Drum drive | 6 | Is there any dent, damage or deformation on the gears of the drum drive unit? | Replace the drum drive unit. | |
| | 7 | Is there any dent, damage or deformation on the motor gear section of the drum drive unit? | Replace the drum drive motor. | |
| Fuser belt | 8 | Are there any scratches or deformation on the fuser belt? | Replace the fuser belt. | |
| TBU | 9 | Is the transfer belt rotating correctly? | Install the transfer belt drive motor correctly. | |
| 2nd transfer unit | 10 | Check if there is abnormality on the surface of the 2nd transfer roller. | Replace the 2nd transfer roller. | |
| | 11 | Check if any white void in the halftone occurs at the same time. | Apply the measure in accordance with the following reference.  P. 8-457 "8.5.28 White void in halftone" | |

| Cause/Section | Step | Check item | Measures | Remarks |
|--------------------------------------|------|--|---|---------|
| Paper transportation speed | 12 | Check if an abnormal value is entered for the transportation speed. Drum motor (K): FS-05-4520 (0 to 2, 4) Registration motor: FS-05-4523 (0 to 2, 4) Heat roller: FS-05-4529 (0 to 2, 4) | Return the value to the default. | |
| Transfer belt | 13 | The density belt (stripe) which occurs once every few copies in certain positions in the primary scanning direction. (Rotation period of the belt: Approx. 1118 mm) | Replace the transfer belt. | |
| Transfer belt cleaning facing roller | 14 | Density belt pattern of 105 mm pitch | Clean or replace the transfer belt cleaning facing roller. | |
| Developer sleeve | 15 | Check if the pitch of the density fluctuation is 43.5 mm. | Replace the developer sleeve. | |
| Jittering (1.9 mm pitch) | 16 | Check if jittering has occurred in a certain position of an image after the 2nd sheet of paper. (One or two stripes in one sheet) | Replace the paper feed unit. Replace the laser optical unit. | |

8.5.2 Black spots

<Symptom>

| Original mode | Location | Symptom |
|---------------|--|---------|
| All modes | <p>Occurring cyclically in the feeding direction Pitch: 105 mm</p> <p>Perform steps 3 and 4.</p> | |
| | <p>Occurring cyclically in the feeding direction Pitch: 1118 mm (Ratio of once every 3 sheets of A3/LD paper)</p> <p>Perform steps 1, 3 and 4.</p> | |

Fig.8-70

| Cause/Section | Step | Check item | Measures | Remarks |
|---------------|------|---|--|---------|
| Transfer belt | 1 | Is there any damage or deformation on the transfer belt? | Replace the transfer belt. | |
| | 2 | Is there any foreign matter on the surface the transfer belt? | Remove the foreign matter. | |
| | 3 | Is there any foreign matter inside the transfer belt? | Remove the foreign matter. | |
| | 4 | Is there any damage, or is there adhesion of foreign matter on the 2nd transfer facing roller? | Remove the foreign matter. Replace the 2nd transfer facing roller. | |
| | 5 | Is there any damage, or is there adhesion of foreign matter on the transfer belt cleaning facing rollers? | Remove the foreign matter. Replace transfer belt cleaning facing roller. | |

8.5.3 Poor image density and gray balance

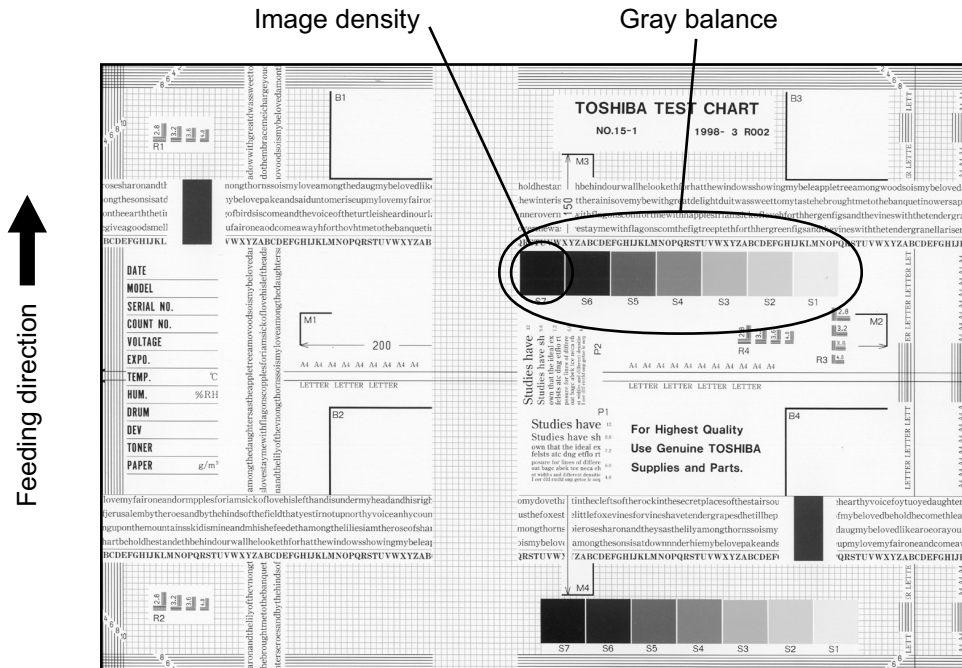

Fig.8-71

| Cause/Section | Step | Check item | Measures | Remarks |
|-----------------------------------|------|--|---|--|
| Density, gray balance | 1 | Check the image density and gray balance. | Perform FS-05-2742 (Forced performing of image quality closed-loop control) and then automatic gamma adjustment. | |
| Printing density | 2 | Check the density of printed images. | Output the test patterns and check them. Black: Use FS-04-113. Laser array breakage detection pattern: Use FS-04-286. | Go to step 6 if an abnormality occurs. |
| Scanner | 3 | Check if the original glass, mirrors or lens is dirty. | Clean it. | |
| Parameter adjustment value | 4 | Check the image processing parameters. | Perform color balance adjustment. Perform density adjustment. | |
| Image quality control abnormality | 5 | Check if the connector of the image position aligning/image quality sensor (center) is connected properly. | Reconnect the connector properly. | |
| | | Check if the harness of the image position aligning/image quality sensor (center) is open circuited. | Replace the harness. | |
| | | Does the image quality control shutter operate properly? | Correct the installation of the shutter. Replace the shutter. | |
| | | Image position aligning/image quality sensor (center) | Replace the image position aligning/image quality sensor (center). | |

| Cause/Section | Step | Check item | Measures | Remarks |
|----------------------------|------|--|--|---------|
| Printed images abnormality | 6 | Has any faded image (low density) occurred? | Perform the troubleshooting against the faded image. | |
| | | Has background fogging occurred? | Perform the troubleshooting against the background fogging. | |
| | | Has blotch image occurred? | Perform the troubleshooting against the blotch image. | |
| | | Is the transfer belt slackened? | Correct the installation of the parts around the transfer belt unit. Replace the transfer belt unit. | |
| | | Is the frame of the transfer belt unit conducted to the MFP? | Check if the grounding leaf spring contacts securely. Replace the grounding leaf spring. | |
| | | Has poor transfer occurred? | Perform the troubleshooting against the poor transfer. | |
| | | Is there any poor cleaning of the transfer belt? (Check inside the MFP.) | Correct the transfer belt area. | |
| | | Is a color band of the laser array breakage detection pattern printed out normally? Is the density level of stripes even? | If any one of stripes has not been output or density level of each stripe is different, replace the laser optical unit.) | |

* If the trouble still persists even after step 1 is performed and then steps 2 and later ones (excluding the parameter adjustment) are done, make sure to perform “Forced performing of image quality closed-loop control” and then “Automatic gamma adjustment” after taking a measure.

8.5.4 Background fogging

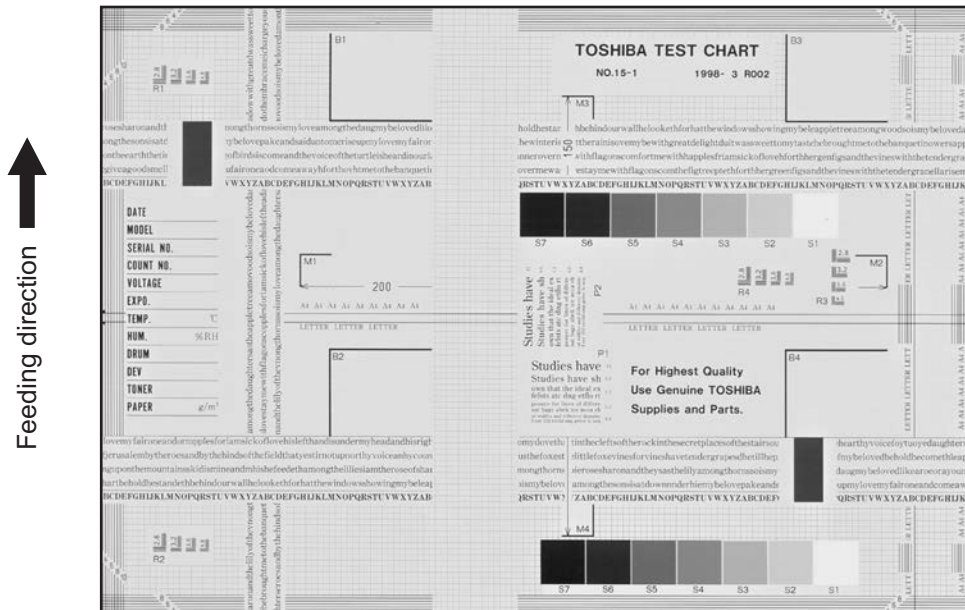

Fig.8-72

| Cause/Section | Step | Check item | Measures | Remarks |
|----------------------------|------|---|--|--|
| Adjustment | 1 | Perform the shading correction. | Perform FS-05-3218. If an error has occurred, reattempt it. If the error still persists, clean the original glass covering the shading correction plate and perform FS-05-3218 again. | |
| Density reproduction | 2 | Check the gradation reproduction. | Perform FS-05-2742 (Forced performing of image quality closed-loop control) and then automatic gamma adjustment. | |
| Printing section | 3 | Check printed images. | Output the test patterns and check them. Color: Use FS-04-231 to output each color. Black: Use FS-04-113. | Go to step 7 if an abnormality occurs. |
| Scanner | 4 | Check if the original glass, DF original glass, mirrors or lens is dirty. | Clean it. | |
| Parameter adjustment value | 5 | Check the image processing parameters. | Check the value of offsetting adjustment for background processing, background adjustment and background peak adjustment for range correction. | |
| | 6 | Adjust the image processing parameters. | While checking the above encircled image, adjust the reproduction level by the offsetting adjustment for background processing, background adjustment and background peak adjustment for range correction. | |
| Cover | 7 | Is the cover installed properly? (Is the drum exposed to the external light?) | Correct it. | |

| Cause/Section | Step | Check item | Measures | Remarks |
|--|------|--|---|---------|
| Auto-toner | 8 | Does the auto-toner sensor work properly? | Check the performance of the auto-toner sensor and readjust it if necessary. | |
| | 9 | Is the toner supply operating constantly? | Check the motor and PC board. | |
| High-voltage transformer (main charger unit output, main charger grid bias, developer unit bias) | 10 | Is the harness between the LGC board and the high-voltage transformer open circuited? Are the connectors connected securely? | Reconnect the connectors securely. Replace the harness. | |
| | 11 | Is the connector of the high-voltage harness securely connected? Is the harness open circuited? | Reconnect the connectors securely. Replace the high-voltage harness. | |
| | 12 | Does the high-voltage transformer work properly? | Replace the high-voltage transformer. | |
| Developer unit | 13 | Is the contact between the drum and developer material proper? | Check the doctor-to-sleeve gap and pole position. | |
| Developer material, toner, drum | 14 | Are the specified developer material, toner and drum used? | Use the specified developer material, toner and drum. | |
| | 15 | Have the developer material and drum reached their PM life? | Replace the developer material and drum. | |
| | 16 | Is the storage environment of the toner cartridge 35°C or less without dew? | Use the toner cartridge stored in the environment within specifications. | |
| Drum cleaning blade | 17 | Is the drum cleaned properly? | Replace the drum cleaning blade. | |
| Transfer belt cleaning blade | 18 | Is the transfer belt cleaning blade in proper contact with the transfer belt? | Take off the transfer belt and check if the transfer belt cleaning blade pressure spring is installed properly. | |
| Toner dusting | 19 | Is the toner accumulated on the seals of the developer unit? | Remove the toner and clean the seals. | |

* If the trouble still persists even after step 2 is performed and then steps 3 and later ones (excluding the parameter adjustment) are done, make sure to perform “Forced performing of image quality closed-loop control” and then “Automatic gamma adjustment” after taking a measure.

8.5.5 Moiré, lack of sharpness

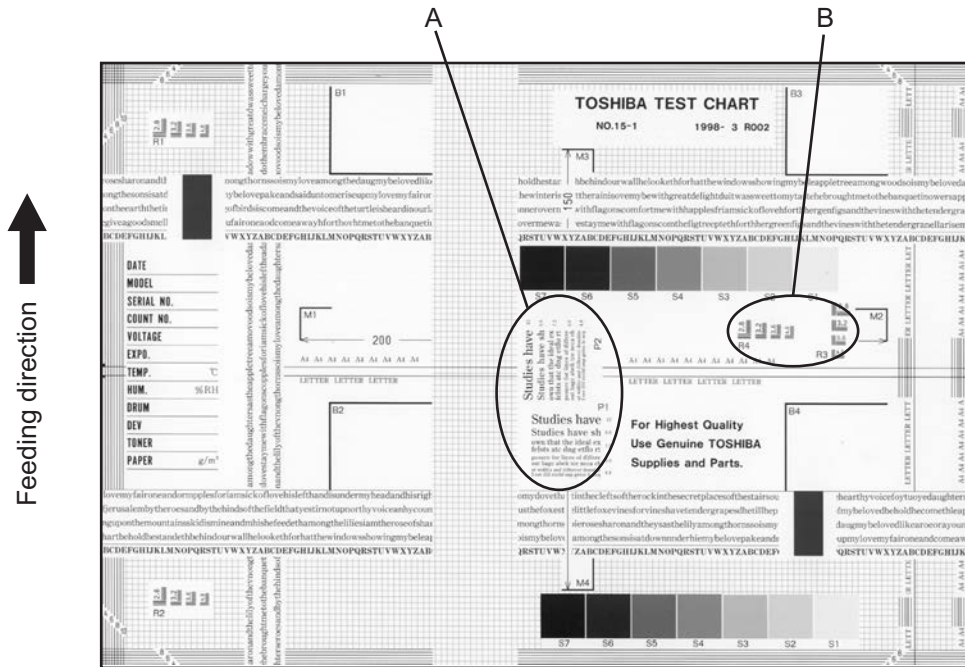

Fig.8-73

Moiré

| Cause/Section | Step | Check item | Measures | Remarks |
|----------------------------|------|---|--|---|
| Density reproduction | 1 | Check the gradation reproduction. | Perform FS-05-2742 (Forced performing of image quality closed-loop control) and then automatic gamma adjustment. | |
| Parameter adjustment value | 2 | Check the image processing parameters. | Check the sharpness adjustment value. | |
| | 3 | Adjust the image processing parameters. | While checking the encircled images A and B in the figure, decrease moiré by sharpness adjustment. | |
| Printing section | 4 | Check printed images. | Output the test patterns and check them. Use 04-FS-231 and FS-04-113 to output the test patterns. | When defects occur, perform the corresponding troubleshooting procedures. |

Lack of sharpness

| Cause/Section | Step | Check item | Measures | Remarks |
|----------------------------|------|---|--|---------|
| Density reproduction | 1 | Check the gradation reproduction. | Perform FS-05-2742 (Forced performing of image quality closed-loop control) and then automatic gamma adjustment. | |
| Parameter adjustment value | 2 | Check the image processing parameters. | Check the sharpness adjustment value. | |
| | 3 | Adjust the image processing parameters. | While checking the encircled image A in the figure, increase sharpness by sharpness adjustment. | |

* If the trouble still persists even after step 1 is performed and then steps 2 and later ones (excluding the parameter adjustment) are done, make sure to perform “Forced performing of image quality closed-loop control” and then “Automatic gamma adjustment” after taking a measure.

8.5.6 Toner offset

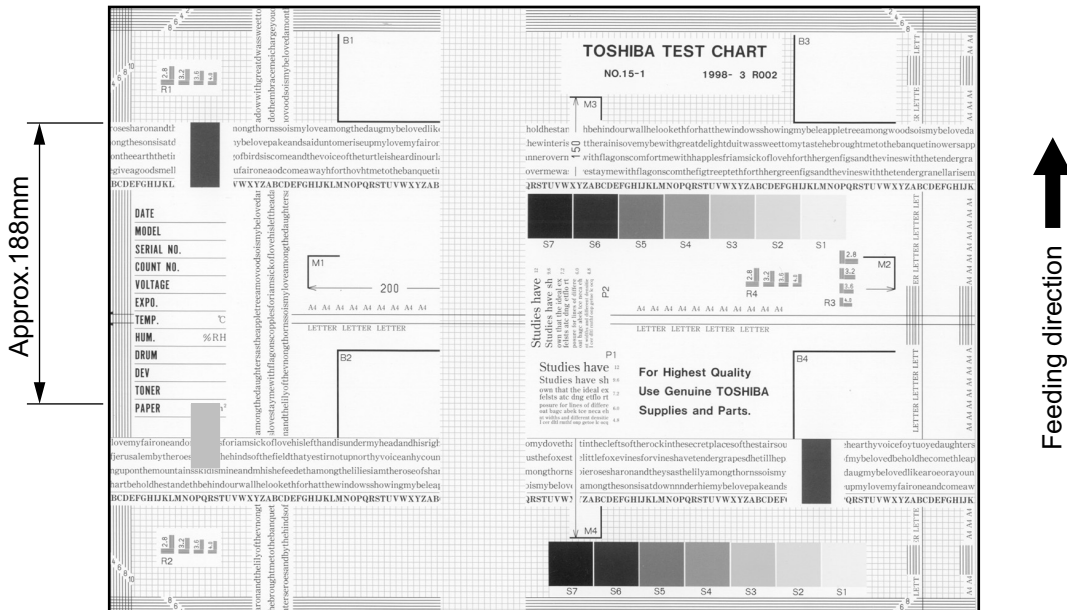

Fig.8-74

Toner offset: A shadow image appears approx. 126 mm behind the high density image.

| Cause/Section | Step | Check item | Measures | Remarks |
|-----------------------|------|--|--|---|
| Fuser unit | 1 | Is the pressure between the fuser belt and the pressure roller proper? | Check the pressure release parts and the pressure mechanism. | |
| | 2 | Are there any scratches on the fuser belt and the pressure roller surface? | Replace the fuser belt or the pressure roller. | |
| | 3 | Has the fuser belt or the pressure roller reached its PM life? | Replace the fuser belt or the pressure roller. | |
| | 4 | Is the temperature of the fuser belt proper? | Check the PC board and replace it if necessary. | |
| Paper | 5 | Is the paper type corresponding to its mode? | Use the proper type of paper or select the proper mode. | |
| | 6 | Is the non-recommended paper used? | Use the recommended paper. | |
| Developer material | 7 | Is the specified developer material used? | Use the specified developer material and toner. | |
| Scanner | 8 | Check if the original glass, mirrors or lens is dirty. | Clean it. | |
| Image quality control | 9 | Is the control activated? | Check the image quality control related codes. | |
| Density | 10 | Is the density too high? | Perform FS-05-2742 (Forced performing of image quality closed-loop control) and then automatic gamma adjustment. | |
| Printing density | 11 | Check the density of printed images. | Output the test patterns and check them. Use 04-FS-231 and FS-04-113 to output the test patterns. | When defects occur, perform the corresponding troubleshooting procedures. |

8.5.7 Toner offset (shadow image) at the edges

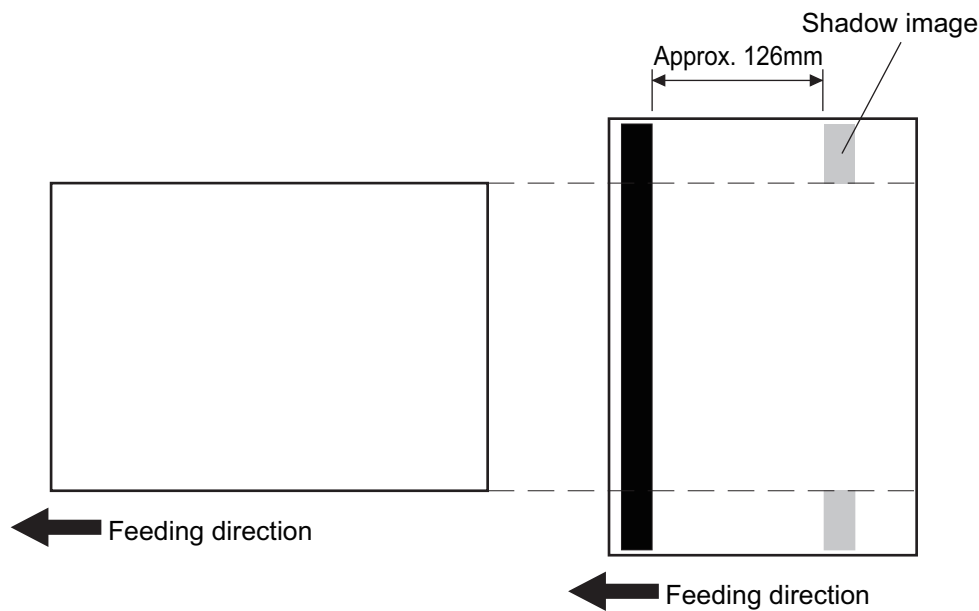

Fig.8-75

Toner offset (shadow image) sometimes appears at both edges of the paper when a wide-size sheet is printed following the continuous printing of narrow-size ones or rotate sort-printing. In such a case, change the setting of Wait between the printings of narrow-size and wide-size paper.

Notes:

- When the setting is changed, toner offset (shadow image) can be reduced; however, the performance (printing speed) will also be lowered accordingly. Therefore, the setting should only be changed depending on the occurrence frequency or corresponding to users' requests.
- The values below are the recommended ones. Therefore, adjust the values according to the situation.
- Set the number of the sheets for FS-08-5455 so that the value is within the below ones.
08-5455-0 ≤ 08-5455-1 ≤ 08-5455-2, 08-5455-3 ≤ 08-5455-4 ≤ 08-5455-5
- Set the number of the sheets for FS-08-5355 so that the value is within the below ones.
08-5355-0 ≤ 08-5355-4 ≤ 08-5355-8, 08-5355-1 ≤ 08-5355-5 ≤ 08-5355-9,
08-5355-2 ≤ 08-5355-6 ≤ 08-5355-10, 08-5355-3 ≤ 08-5355-7 ≤ 08-5355-11
08-5355-12 ≤ 08-5355-13 ≤ 08-5355-14, 08-5355-15 ≤ 08-5355-16 ≤ 08-5355-17

1. Combined job

| Code | Paper type | Recommended setting value | Remarks |
|--------------|------------|---------------------------|--|
| FS-08-5455-0 | Plain | 12 | Wait is carried out with a small number of sheets. |
| FS-08-5455-1 | | 14 | |
| FS-08-5455-2 | | 0 | |
| FS-08-5455-3 | Thick | 12 | |
| FS-08-5455-4 | | 14 | |
| FS-08-5455-5 | | 0 | |

| Code | Paper type | Recommended setting value | Remarks |
|--------------|------------|---------------------------|---------------------------|
| FS-08-5456-0 | Plain | 3 | The wait time is changed. |
| FS-08-5456-1 | | 5 | |
| FS-08-5456-2 | | 11 | |
| FS-08-5456-3 | Thick | 0 | |
| FS-08-5456-4 | | 1 | |

2. To insert the Ready state between jobs

| Code | Paper type | Recommended setting value | Remarks |
|---------------|------------|---------------------------|--|
| FS-08-5355-0 | Plain | 22 | Wait is carried out with a small number of sheets. |
| FS-08-5355-1 | Thick | 22 | |
| FS-08-5355-2 | Plain | 22 | |
| FS-08-5355-3 | Thick | 22 | |
| FS-08-5355-4 | Plain | 0 | |
| FS-08-5355-5 | Thick | 0 | |
| FS-08-5355-6 | Plain | 0 | |
| FS-08-5355-7 | Thick | 0 | |
| FS-08-5355-8 | Plain | 1 | |
| FS-08-5355-9 | Thick | 1 | |
| FS-08-5355-10 | Plain | 1 | |
| FS-08-5355-11 | Thick | 1 | |
| FS-08-5355-12 | Thick | 22 | |
| FS-08-5355-13 | | 0 | |
| FS-08-5355-14 | | 1 | |
| FS-08-5355-15 | | 22 | |
| FS-08-5355-16 | | 0 | |
| FS-08-5355-17 | | 1 | |

| Code | Paper type | Recommended setting value | Remarks | |
|---------------|------------|---------------------------|---------------------------|----|
| FS-08-5357-0 | Plain | 3 | The wait time is changed. | |
| FS-08-5357-1 | Thick | 0 | | |
| FS-08-5357-2 | Plain | 3 | | |
| FS-08-5357-3 | Thick | 1 | | |
| FS-08-5357-5 | | 1 | | |
| FS-08-5357-7 | | 2 | | |
| FS-08-5357-8 | | Plain | | 11 |
| FS-08-5357-10 | 11 | | | |
| FS-08-5357-12 | Thick | 0 | | |
| FS-08-5357-13 | | 1 | | |
| FS-08-5357-15 | | 1 | | |
| FS-08-5357-16 | | 2 | | |
| FS-08-5358-0 | | Plain | | 12 |
| FS-08-5358-1 | Thick | 12 | | |
| FS-08-5358-2 | Plain | 12 | | |
| FS-08-5358-3 | Thick | 12 | | |

8.5.8 Blurred image

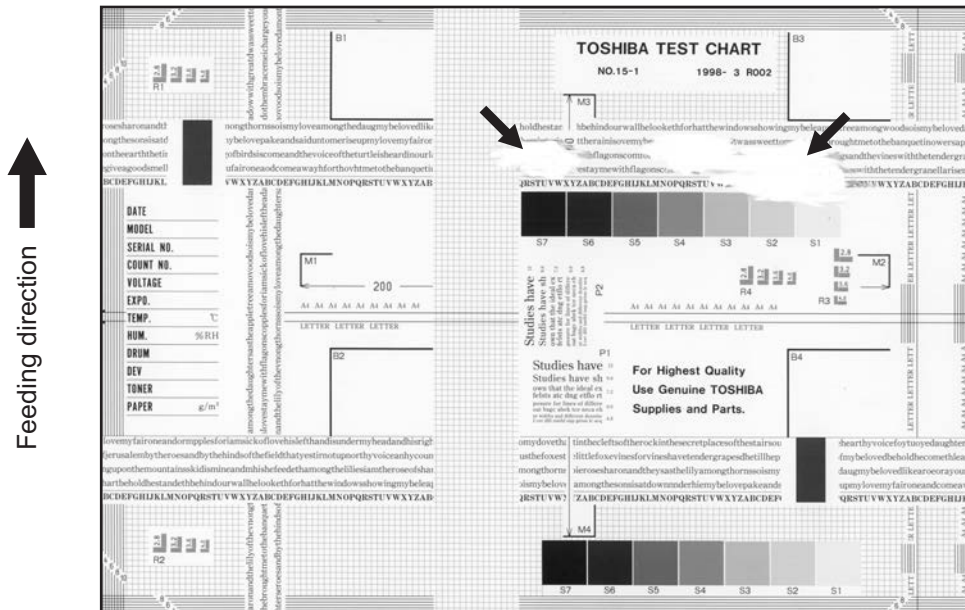

Fig.8-76

| Cause/Section | Step | Check item | Measures |
|------------------|------|--|--|
| Scanner | 1 | Is the scanner bedewed? | Clean it. |
| Drum | 2 | Is the drum bedewed or dirty? | Wipe the drum with a dry cloth. Notes: Do not use alcohol or other organic solvents or silicon oil as they will have an adverse effect on the drum. |
| Ozone suctioning | 3 | Does the ozone suctioning fan operate? | Check the connection of the connector. Replace the ozone exhaust fan. |
| | 4 | Is the ozone filter stained or damaged? | Replace it. |
| Main charger | 5 | Check if the inside wall in the case of the main charger unit is dirty or there is any fouling in the case of the main charger unit. | Clean the inside wall in the case. |
| | 6 | Check if the main charger grid is corroded, or rusted, or there is any fouling on the grid. | Replace the main charger grid. |

8.5.9 Poor fusing

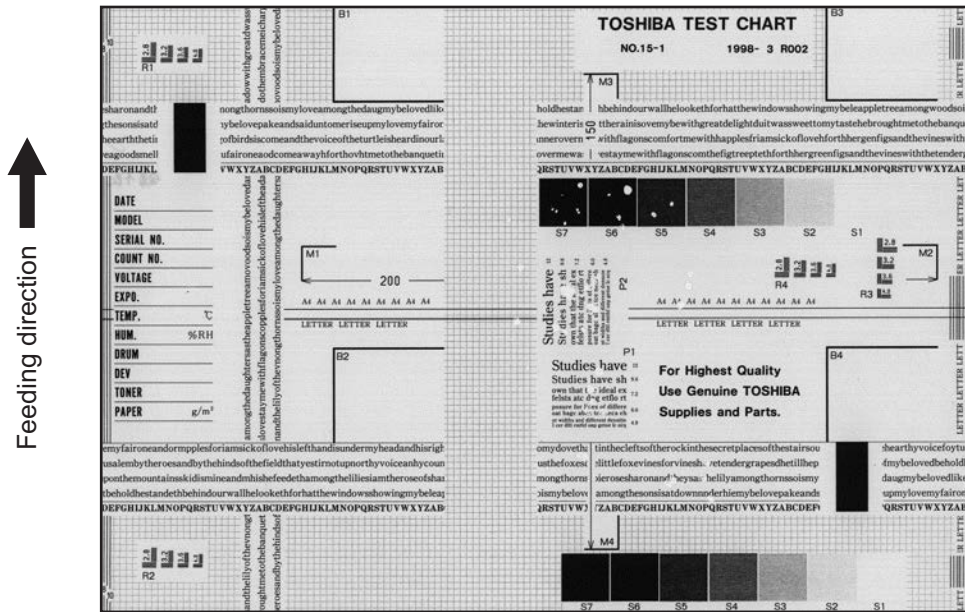

Fig.8-77

| Cause/Section | Step | Check item | Measures |
|--|------|--|--|
| Electric power abnormality, control abnormality | 1 | Is the connector in proper contact with the MFP? | Correct it. |
| | 2 | Does the IH drive circuit work properly? | Replace the IH board. |
| | 3 | Are the connectors on the LGC board and joint connectors connected properly? | Reconnect the connectors. |
| | 4 | Is there any abnormality in the LGC board? | Replace the LGC board. |
| | 5 | Is the harness connected with the LGC board short circuited or open circuited? | Replace the harness. |
| Insufficient pressure between the fuser belt and pressure roller | 6 | Is the pressure spring working properly? | Check the pressure spring and correct it. |
| Fuser belt temperature | 7 | Is the temperature of the fuser belt too low? | <ul style="list-style-type: none"> Check the setting and correct it. Clean or replace the thermistor. Check the PC board and replace it if necessary. |
| Developer material, toner | 8 | Are the specified developer material and toner used? | Use the specified developer material and toner. |
| Paper | 9 | Is the paper damp? | Change the paper. |
| | 10 | Is the paper type corresponding to its mode? | Use the proper type of paper or select the proper mode. |
| | 11 | Is the non-recommended paper used? | Use the recommended paper. |

8.5.10 Blank print

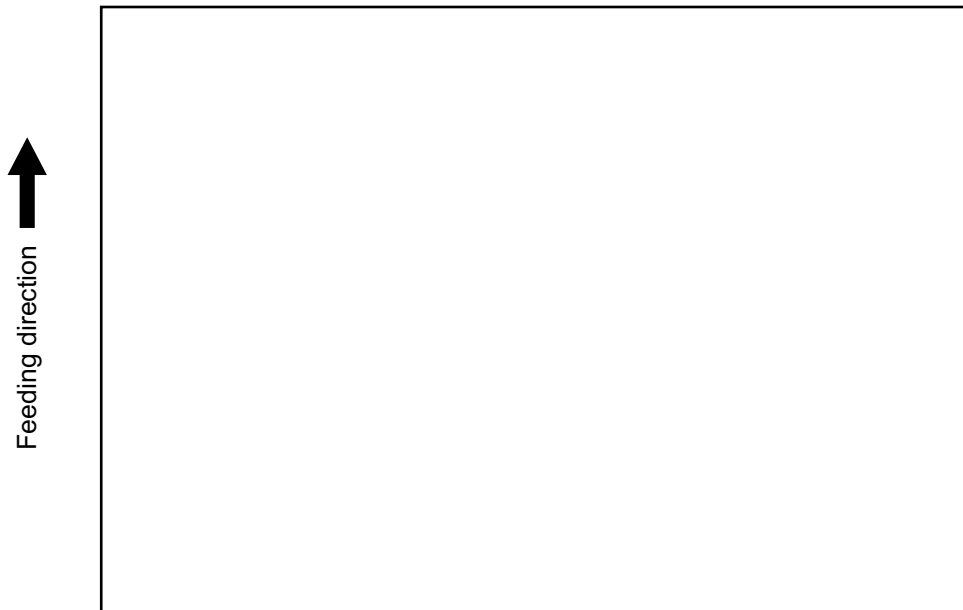

Fig.8-78

| Cause/Section | Step | Check item | Measures |
|--|------|--|---|
| High-voltage transformer (main charger unit output, 1st and 2nd transfer rollers, developer unit and main charger grid bias) | 1 | Is the harness between the LGC board and the high-voltage transformer open circuited? Are the connectors connected securely? | <ul style="list-style-type: none"> Reconnect the connectors securely. Replace the harness. |
| | 2 | Is the connector of the high-voltage harness securely connected? Is the harness open circuited? | <ul style="list-style-type: none"> Reconnect the connectors securely. Replace the high-voltage harness. |
| | 3 | Does the high-voltage transformer work properly? | Replace the high-voltage transformer. |
| Developer unit | 4 | Is the developer unit installed securely? | Check and correct the engagement of the developer sleeve coupling. |
| | 5 | Does the developer sleeve and mixer rotate? | Check and correct the developer drive system. |
| | 6 | Is the developer unit filled up with the developer material? Check that the main charger grid is not dirty. (The developer material may be reduced due to the carrier offset.) | Replace the developer material. |
| | 7 | Is the developer material transported properly? | Remove foreign matters from the developer material if there are any. |
| | 8 | Is there any magnetic brush phase error? | Check the developer pole position. |
| | 9 | Is the position of the doctor blade correct? | Adjust it with the doctor-sleeve-jig. |
| Drum | 10 | Does the drum rotate properly? | <ul style="list-style-type: none"> Check that the drum shaft is installed correctly. Check the drum drive system. |
| | 11 | Is the drum grounded? | Check the contact of the grounding plate. |

| Cause/Section | Step | Check item | Measures |
|--|------|---|---|
| Transfer unit | 12 | Does the transfer belt contact the drum properly? | <ul style="list-style-type: none"> Check if the contact release lever of the transfer belt is at the releasing position. If not, correct it. Check the installation of the transfer belt. |
| | 13 | Is the transfer belt transported properly? | Check the installation of the transfer belt and the transport mechanism. |
| | 14 | Is the contact and release operation of the transfer belt proper? | Check the connection of the connector of the 2nd transfer belt contact/release motor and open circuit of the harness. |
| SYS board, LGC board, LDR board, harnesses | 15 | Are the connectors securely connected? Is any harness between the boards open circuited? | <ul style="list-style-type: none"> Reconnect the connectors securely. Replace the harness. |
| Laser optical unit | 16 | Was the protection seal of the slit removed when replacing the unit? | Remove the protection seal. |

8.5.11 Solid print

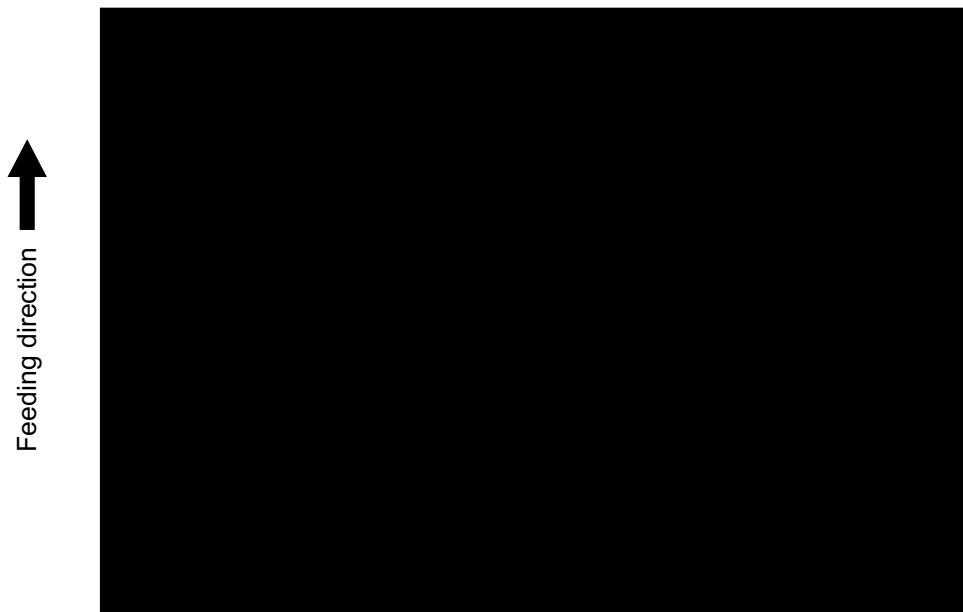

Fig.8-79

| Cause/Section | Step | Check item | Measures |
|---|------|--|---|
| Exposure lamp | 1 | Does the exposure lamp light? | <ul style="list-style-type: none"> Check the connection of the connector. If the exposure lamp does not work, replace it. |
| Main charger | 2 | Is the main charger installed securely? | Reinstall it securely. |
| | 3 | Does the needle electrode not come off? | Reinstall it securely. |
| High-voltage transformer (main charger unit output, main charger grid bias) | 4 | Is the harness between the LGC board and the high-voltage transformer open circuited? Are the connectors connected securely? | <ul style="list-style-type: none"> Reconnect the connectors securely. Replace the harness. |
| | 5 | Is the connector of the high-voltage harness securely connected? Is the harness open circuited? | <ul style="list-style-type: none"> Reconnect the connectors securely. Replace the high-voltage harness. |
| | 6 | Does the high-voltage transformer work properly? | Replace the high-voltage transformer. |
| SYS board, LGC board, harnesses | 7 | Are the connectors securely connected? Is any harness between the boards open circuited? | <ul style="list-style-type: none"> Reconnect the connectors securely. Replace the harness. |
| Scanner | 8 | Is there any foreign matter in the optical path? | Remove it. |
| Bedewing of scanner and drum | 9 | Is the scanner or drum bedewed? | <ul style="list-style-type: none"> Clean the mirrors, lens and drum. Keep the power cable plugged so that the damp heater can work. |

8.5.12 White banding and white void (in the feeding direction)

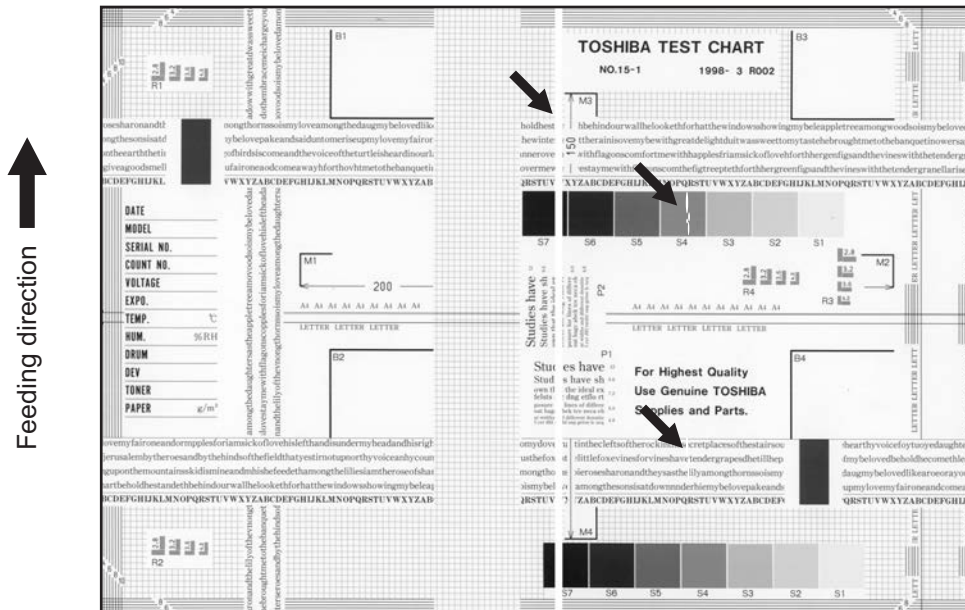

Fig.8-80

| Cause/Section | Step | Check item | Measures |
|---|------|--|--|
| Scanner | 1 | Is there any foreign matter in the optical path? | Clean the lens and mirrors. |
| Laser optical unit Main charger grid | 2 | Perform FS-05-2742 (Forced performing of image quality closed-loop control). | When FS-05-2742 (Forced performing of image quality closed-loop control) is performed, the automatic cleaning of the main charger and the LSU slit glass cleaning are performed at the same time. |
| Laser optical unit | 3 | Is there any foreign matter or dirt in the slit glass? | Remove the foreign matter or stain. (The slit glass can be cleaned even when the process unit is taken off.) |
| Developer unit | 4 | Is there foreign matter inside the developer unit or on the developer sleeve? | Check if there is a streak in the developer material on the developer sleeve. Scrape off foreign matter around the streak using a jig. If there is no streak, put the sheet of paper with a white banding to the developer sleeve and scrape off the developer material around the white band to see if there is foreign matter in it. Scrape off foreign matter and the developer material on the developer sleeve. P. 7-26 "7.6.6 Developer unit" |
| Drum | 5 | Is there foreign matter on the drum seal? | Remove the foreign matter. |
| | 6 | Do any paper fibers or dirt adhere to the developer unit and contact the drum? | Remove the paper fibers or dirt. |
| | 7 | Are there any scratches or foreign matters on the drum surface? | Replace the drum. If foreign matter is adhering to the drum surface, replace both the drum and the drum cleaning blade. |
| Main charger grid | 8 | Is there any foreign matter on the main charger grid? | Remove the foreign matter. |
| Discharge LED | 9 | Has any of the discharge LEDs gone out? | Replace the discharge LED. |

| Cause/Section | Step | Check item | Measures |
|----------------|------|---|--|
| Transfer unit | 10 | Are there any scratches or foreign matters on the transfer belt surface? | Replace the transfer belt. |
| | 11 | Does the harness or foreign matter contact with the transfer belt surface? | Correct or remove the foreign matter. |
| | 12 | Are there any scratches or holes on the 1st and 2nd transfer rollers? | Replace the 1st and 2nd transfer rollers. |
| | 13 | Is there any foreign matter on the 2nd transfer facing roller? | Remove foreign matter or clean the roller. |
| Transport path | 14 | Does the paper after transfer touch foreign matter, before entering the fuser unit? | Remove the foreign matter. |

8.5.13 White banding (at right angles to the feeding direction)

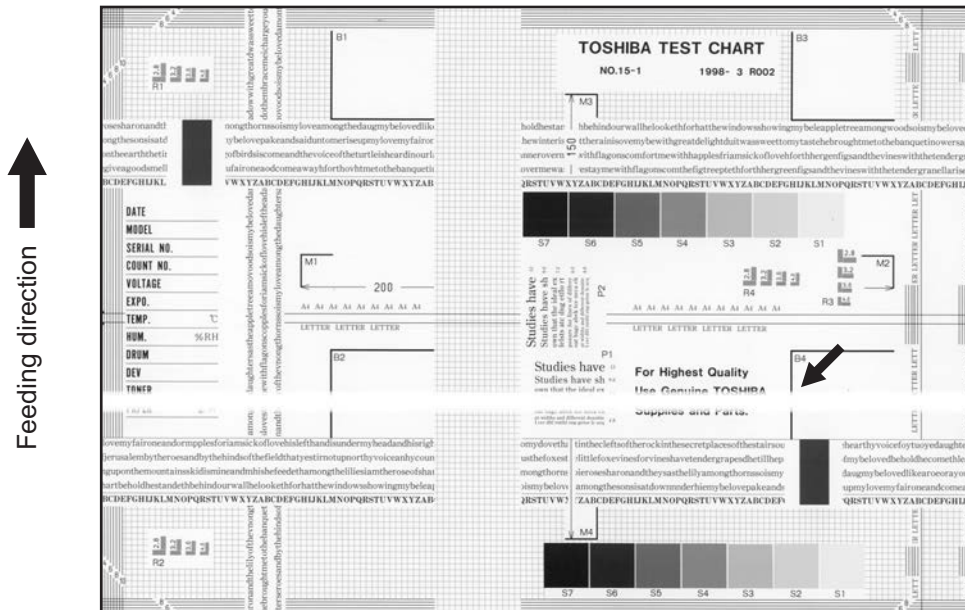

Fig.8-81

| Cause/Section | Step | Check item | Measures |
|--|------|--|---|
| Laser optical unit Main charger grid | 1 | Perform FS-05-2742 (Forced performing of image quality closed-loop control). | When FS-05-2742 (Forced performing of image quality closed-loop control) is performed, the automatic cleaning of the main charger and the LSU slit glass cleaning are performed at the same time. |
| Main charger | 2 | Is there any foreign matter on the main charger? | Remove the foreign matter. |
| | 3 | Is the terminal contact normal? | Clean or adjust the terminals. |
| | 4 | Check if the inside wall in the case of the main charger unit is dirty or there is any fouling in the case of the main charger unit. | Clean the inside wall in the case. |
| | 5 | Check if the main charger grid is corroded, or rusted, or there is any fouling on the grid. | Replace the main charger grid. |
| Drum | 6 | Are there any abnormalities on the drum surface? | Replace the drum. |
| | 7 | Is the drum grounded? | Check the contact of the grounding plate. |
| Discharge LED | 8 | Is the discharge LED lit properly? | Replace the discharge LED. |
| Developer unit | 9 | Does the developer sleeve rotate properly? Are there any abnormalities on the developer sleeve surface? | Check the developer drive system or clean the developer sleeve surface. |
| | 10 | Is the connection of the developer bias supply terminal normal? | Correct it. |
| Drive system | 11 | Does the drum, scanner or transfer belt synchronize correctly? | Check each drive system. |

| Cause/Section | Step | Check item | Measures |
|--|------|---|--|
| High-voltage transformer (main charger needle electrode/grid bias, 1st and 2nd transfer rollers, developer bias) | 12 | Is the high-voltage transformer output defective? | Check if there is any electric leakage. Check the PC board and harness. If the high-voltage transformer does not work, replace it. |

8.5.14 Skew (slantwise copying)

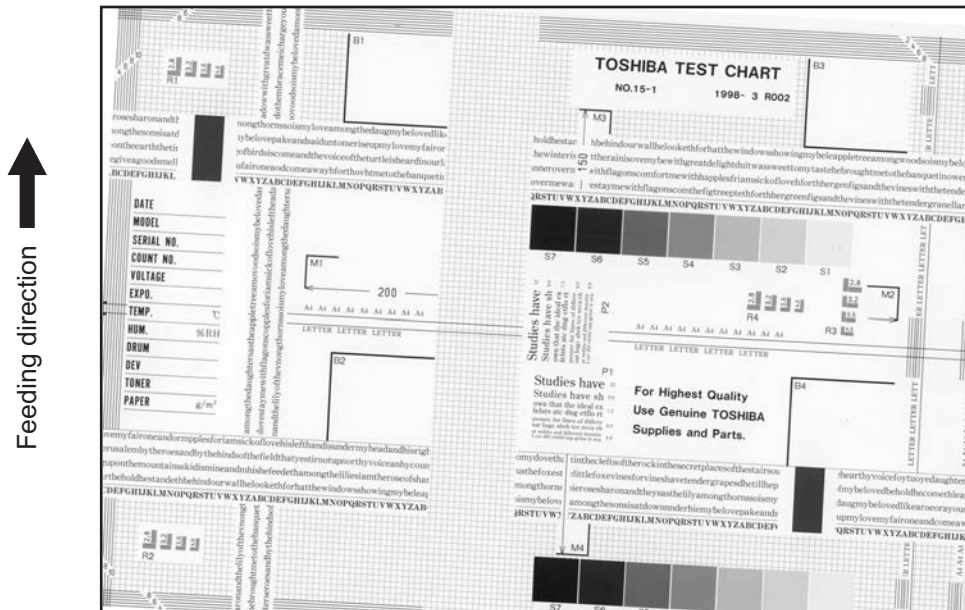

Fig.8-82

| Cause/Section | Step | Check item | Measures |
|--------------------------|------|--|---|
| Drawer, LCF | 1 | Is the drawer or T-LCF installed properly? | Reinstall the drawer or T-LCF properly. |
| | 2 | Is too much paper loaded in the drawer or T-LCF? | Reduce paper to 550 or less. (T-LCF: 1200 sheets for the paper feeding side, 1160 sheets or less for the standby side) |
| | 3 | Is the paper corner folded? | Change the paper direction and reinsert it. |
| | 4 | Are the side guides in the drawer or T-LCF set properly? | Adjust the position of the side guides. |
| Paper feed roller | 5 | Is the surface of the paper feed roller dirty? | Clean the roller surface with alcohol or replace it. |
| Rollers | 6 | Is each roller fixed to the shaft properly? | Check the E-rings, pins and clips. |
| Aligning amount | 7 | Is the paper aligning amount proper? | Increase or decrease the paper aligning amount. |
| Registration roller | 8 | Is the spring of the registration roller removed? | <ul style="list-style-type: none"> • Reattach the spring correctly. • If so, clean it. |
| Registration guide | 9 | Is the registration guide installed properly? | Correct it. |
| 2nd transfer front guide | 10 | Is the 2nd transfer front guide installed properly? | Correct it. |
| DSDF | 11 | Is the DSDF installed or adjusted properly? | Reinstall it. Readjust it. |
| Transfer belt unit | 12 | Is the transfer belt unit installed correctly? | Correct it. |

8.5.15 Black banding (in feeding direction)

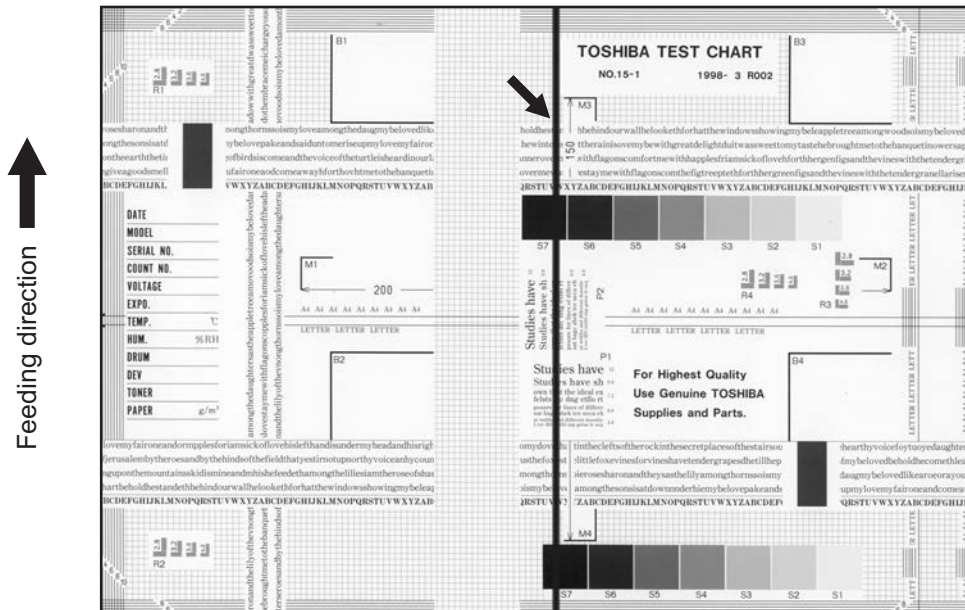

Fig.8-83

| Cause/Section | Step | Check item | Measures |
|--|------|---|---|
| Laser optical unit Main charger grid | 1 | Perform FS-05-2742 (Forced performing of image quality closed-loop control). | When FS-05-2742 (Forced performing of image quality closed-loop control) is performed, the automatic cleaning of the main charger and the LSU slit glass cleaning are performed at the same time. |
| Scanner | 2 | Is there any foreign matter in the optical path? | Clean the slit, lens and mirrors. |
| | 3 | Is there dust or stain on the shading correction plate and the DF original glass? | Clean it. |
| Main charger | 4 | Is there any foreign matter on the main charger grid? | Remove the foreign matter. |
| | 5 | Is the main charger grid dirty or deformed? | Clean or replace the main charger grid. |
| | 6 | Is there any foreign matter on the main charger? | Remove the foreign matter. |
| | 7 | Is the needle electrode dirty or deformed? | Clean or replace the needle electrode. |
| | 8 | Is the needle electrode cleaner dirty or deformed? | Clean or replace it. |
| | 9 | Is the inner surface of the main charger case dirty? | Clean the inside of the case. |
| Drum cleaner | 10 | Is there foreign matter on the tip of the drum cleaning blade? | Clean or replace the drum cleaning blade. |
| | 11 | Is toner recovery defective? | Clean the toner recovery auger section. |
| Transfer unit | 12 | Does foreign matter contact with the transfer belt surface? | Correct or remove it. |
| | 13 | Is there paper dust on the tip of the transfer belt cleaning blade? | Clean or replace the transfer belt cleaning blade. |
| | 14 | Is the transfer belt cleaning blade in proper contact with the transfer belt? | Take off the transfer belt and check if the transfer belt cleaning blade pressure spring is installed properly. |
| | 15 | Is the paper mode correct for the paper in use? | Set the correct paper mode. If streaks still appear in the correct paper mode, follow step 16. |
| | 16 | Is the bias output dependent on the 2nd transfer bias? | Perform the instruction (*1) adjustment (FS-05 mode) |

| Cause/Section | Step | Check item | Measures |
|--------------------|------|--|-------------------------------------|
| Fuser unit | 17 | Are there any scratches or stains on the fuser belt and the pressure roller surface? | Clean or replace it. |
| | | Is there any dirt on the thermistor? | Clean the thermistor. |
| Drum | 18 | Are there any scratches on the drum? | Replace it. |
| Laser optical unit | 19 | Is there any foreign matter or dirt in the slit glass? | Remove the foreign matter or stain. |

(*1): Decrease the corresponding 2nd transfer bias output as follows depending on what happened, and check if the residual image has changed and adjust the value accordingly

- Front side, black mode
Decrease the value of the code FS-05-2936-0 to 8, 10 and 28 by 1 while checking how the streaks change.
- Front side, black mode
Decrease the value of the code FS-05-2937-0 to 3, 5 to 8, 10 and 28 by 1 while checking how the streaks change.

Notes:

In case of color banding in the feeding direction caused by the 2nd transfer bias, the smaller the value is, the better the image becomes.

However, if too small a value is set, the density at the solid part will be lowered and roughness will occur due to poor transfer. Therefore, check the image carefully and set the value at the point where all the factors on the image are balanced.

8.5.16 Black banding (at right angles to feeding direction)

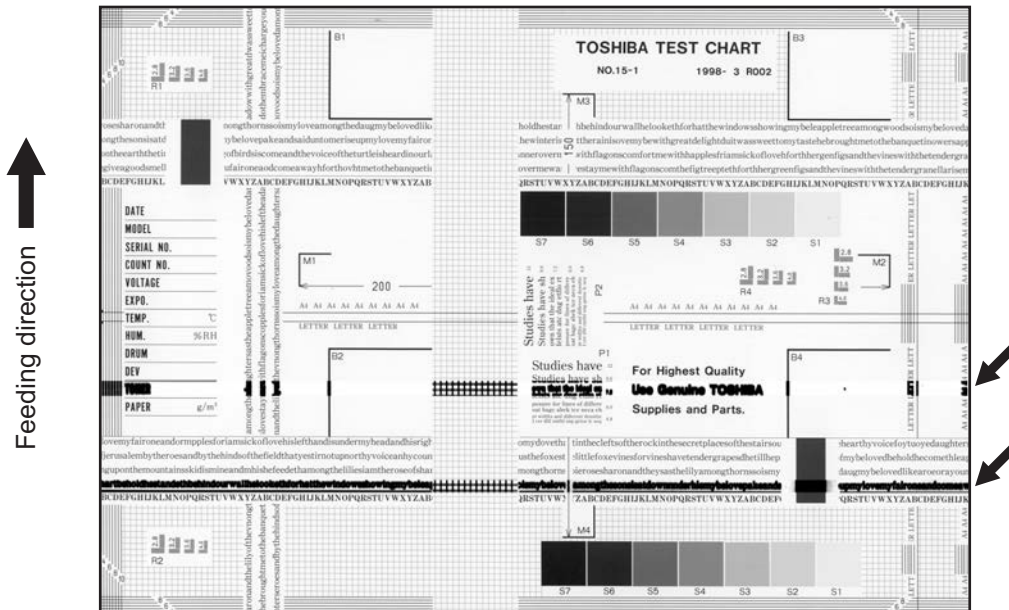

Fig.8-84

| Cause/Section | Step | Check item | Measures |
|--|------|--|---|
| Laser optical unit Main charger grid | 1 | Perform FS-05-2742 (Forced performing of image quality closed-loop control). | When FS-05-2742 (Forced performing of image quality closed-loop control) is performed, the automatic cleaning of the main charger and the LSU slit glass cleaning are performed at the same time. |
| Main charger | 2 | Is the needle electrode dirty or deformed? | Clean or replace the needle electrode. |
| Fuser unit | 3 | Replace the fuser belt or the pressure roller. | Clean it. |
| High-voltage transformer (main charger needle electrode/grid bias, 1st and 2nd transfer rollers) | 4 | Is the high-voltage transformer output defective? | Check the PC board and harness. If there is an abnormality in the high-voltage transformer, replace it. |
| | 5 | Is each joint of the high-voltage output loosened? (Check if any electric leakage is causing noise.) | Reconnect each joint. |
| Drum | 6 | Are there any deep scratches on the drum surface? | Replace the drum, especially if the scratches have reached the aluminum base. |
| | 7 | Are there any fine scratches (drum pitting) on the drum surface? | Check and correct the contact of the cleaning blade and recovery blade. |
| | 8 | Is the drum grounded? | Check the contact of the grounding plate. |
| 2nd transfer roller | 9 | Does the transfer roller rotate properly? | Clean the roller area or replace the roller. |
| Scanner | 10 | Is there any foreign matter on the rail for the carriage? | Remove the foreign matter. |

8.5.17 White spots

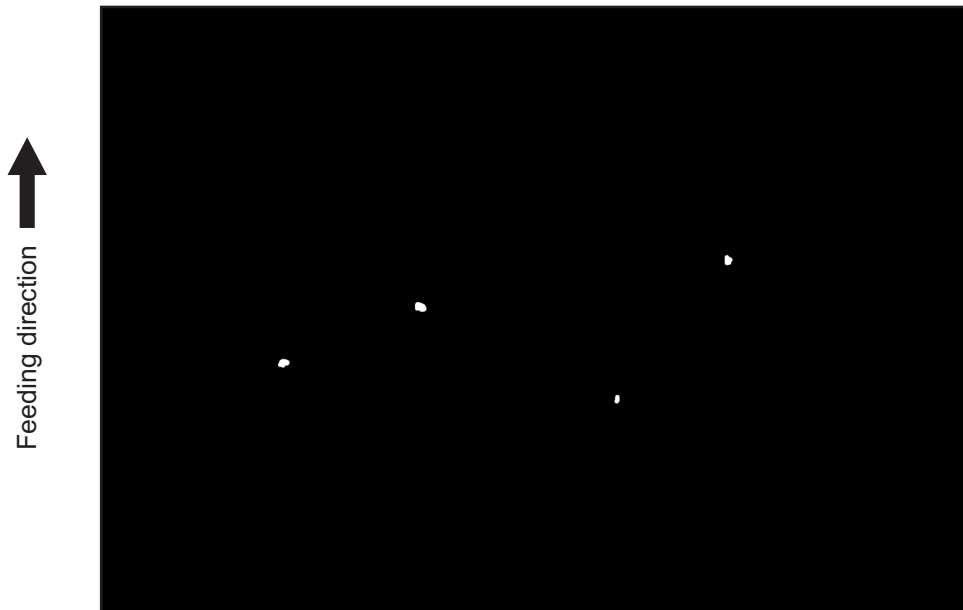

Fig.8-85

| Cause/Section | Step | Check item | Measures |
|--|---------------|--|---|
| Laser optical unit Main charger grid | 1 | Perform FS-05-2742 (Forced performing of image quality closed-loop control). | When FS-05-2742 (Forced performing of image quality closed-loop control) is performed, the automatic cleaning of the main charger and the LSU slit glass cleaning are performed at the same time. |
| Developer unit, toner cartridge | 2 | Is the toner density of the developer material proper? | <ul style="list-style-type: none"> Check and correct the auto-toner sensor and toner supply operation. Check if the amount of the toner in the toner is sufficient. |
| | 3 | Is the doctor-sleeve gap proper? | Adjust the gap. |
| Developer material, toner, drum | 4 | Are the specified developer material, toner and drum used? | Use the specified developer material, toner and drum. |
| | 5 | Have the developer material and drum reached their PM life? | Replace the developer material and drum. |
| | 6 | Is the storage environment of the toner cartridge 35°C or less without dew? | Use the toner cartridge stored in the environment within specifications. |
| | 7 | Is there any dent on the surface of the drum? | Replace the drum. |
| | 8 | Is there any film forming on the drum surface? | Clean or replace the drum. |
| | 9 | Is the drum bedewed? | Wipe the drum surface with a dry cloth. |
| | Transfer unit | 10 | Is there any foreign matter or oil on the transfer belt surface? |
| 11 | | Is there foreign matter on the transfer belt or 2nd transfer facing roller? | Clean the 2nd transfer facing roller and the inside of the transfer belt. |
| Main charger | 12 | Is there any foreign matter on the main charger? | Remove the foreign matter. |
| | 13 | Is the needle electrode dirty or deformed? | Clean or replace the needle electrode. |
| High-voltage transformer (main charger needle electrode/grid bias, developer bias, 1st and 2nd transfer rollers) | 14 | Is the high-voltage transformer output improper? | Perform the output adjustment. |

| Cause/Section | Step | Check item | Measures |
|----------------------|-------------|--|---|
| Paper | 15 | Is the paper type corresponding to its mode? | Use the proper type of paper or select the proper mode. |

8.5.18 Poor transfer

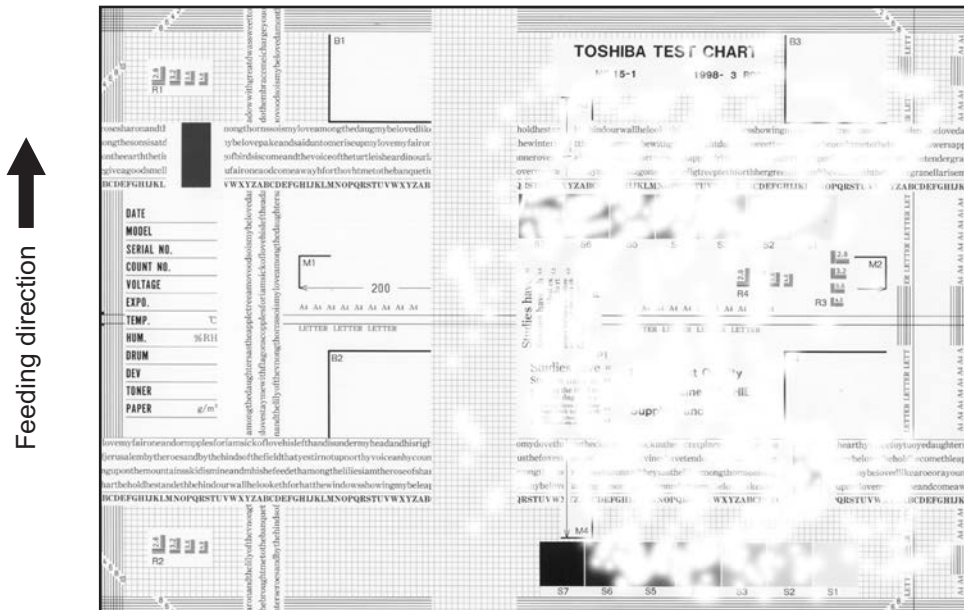

Fig.8-86

| Cause/Section | Step | Check item | Measures |
|---|------|--|--|
| Transfer unit | 1 | Is the transfer belt, 1st transfer roller or 2nd transfer roller dirty? | Clean it. |
| | 2 | Is the transfer belt in proper contact with the drum? | Correct it. |
| | 3 | Is the 2nd transfer roller in proper contact with the transfer belt? | Correct it. |
| | 4 | Is there any deformation or abnormality on the transfer belt? | Replace the transfer belt. |
| | 5 | Is there foreign matter on the 2nd transfer facing roller? | Clean the 2nd transfer facing roller and the inside of the transfer belt. Replace the cleaning pad. |
| Paper | 6 | Is the high-voltage supplied to the 2nd transfer roller correctly? | If any contact failure occurs in the feeding area (e.g.: coming off of the conductive bushing and spring), correct it. |
| | 7 | Is paper in the drawer or LCF curled? | Reinsert paper with reverse side up or change paper. |
| | 8 | Is paper in the drawer or LCF damp? | Change paper. (Avoid storing paper in a damp place.) |
| Registration roller | 9 | Is the registration roller malfunctioning? | If so, clean it. Reattach the spring if it has come off. Replace defective motor-related parts. |
| High-voltage transformer (1st and 2nd transfer rollers) | 10 | Is the harness between the LGC board and the high-voltage transformer open circuited? Are the connectors connected securely? | Reconnect the connectors securely. Replace the harness. |
| | 11 | Is the connector of the high-voltage harness securely connected? Is the harness open circuited? | Reconnect the connectors securely. Replace the high-voltage harness. |
| | 12 | Does the high-voltage transformer work properly? | Replace the high-voltage transformer. |

| Cause/Section | Step | Check item | Measures |
|--|------|---|---|
| 2nd transfer contact/release unit (Cam unit) | 13 | Is there any abnormality on the cam, pusher and actuator? | Check if the cam, pusher and actuator are installed correctly and there are no damages on them. Collect the installation or replace them if needed. |

8.5.19 Uneven image density 1

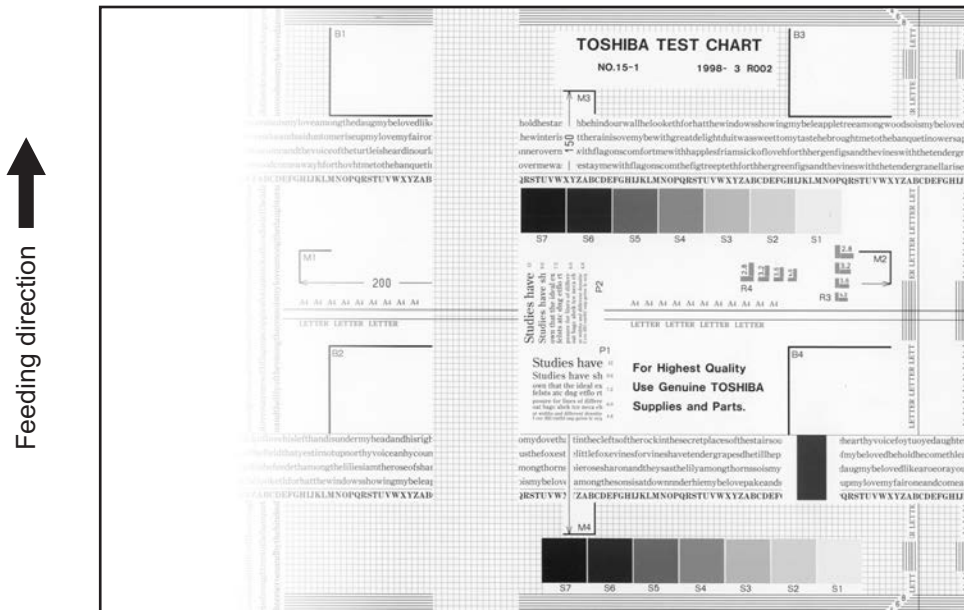

Fig.8-87

| Cause/Section | Step | Check item | Measures |
|---|------|--|---|
| Laser optical unit Main charger grid | 1 | Perform FS-05-2742 (Forced performing of image quality closed-loop control). | When FS-05-2742 (Forced performing of image quality closed-loop control) is performed, the automatic cleaning of the main charger and the LSU slit glass cleaning are performed at the same time. |
| Main charger | 2 | Is the main charger dirty? | Clean the main charger or replace the needle electrode. |
| Transfer unit | 3 | Does the transfer belt contact the drum properly? | <ul style="list-style-type: none"> Check the installation of the transfer belt. Check if the contact release lever of the transfer belt is at the releasing position. If not, correct it. |
| | 4 | Is the transfer belt, 1st transfer roller or 2nd transfer roller dirty? | Clean it. |
| | 5 | Is the 2nd transfer roller in proper contact with the transfer belt? (Is the roller tilted?) | Correct it. |
| | 6 | Is there any deformation or abnormality on the transfer belt? | Replace the transfer belt. |
| Laser optical unit | 7 | Is there any foreign matter or dirt in the slit glass? | Remove the foreign matter or stain. |
| Discharge LED | 8 | Is the discharge LED dirty? | Clean it. |
| | 9 | Has any of the discharge LEDs gone out? | Replace it. |
| Developer unit | 10 | Is the magnetic brush in proper contact with the drum? | Adjust the doctor-to-sleeve gap. |
| | 11 | Is the developer unit pressure spring applying properly? | Check the spring. |
| | 12 | Is the transport of the developer material poor? | Remove foreign matters from the developer material if there are any. |
| Scanner Section | 13 | Is the DSDF open? | Close the DSDF. |
| | | Is the original glass, mirrors or lens dirty? | Clean it. |

8.5.20 Uneven image density 2



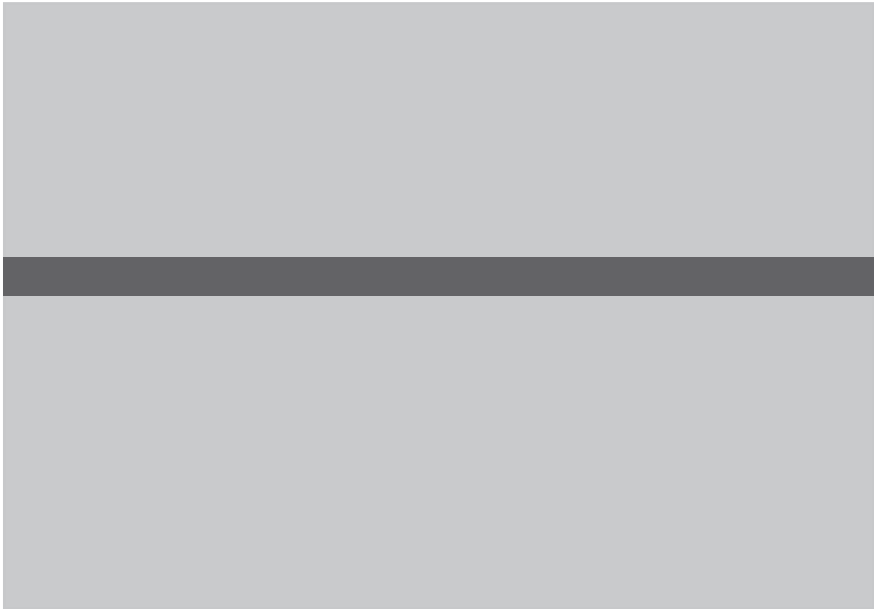

← Feeding direction

Fig.8-88



← Feeding direction

Fig.8-89

| Cause/Section | Step | Check item | Measures |
|----------------|------|---|--|
| Developer unit | 1 | Is the layer of the developer material on the developer sleeve where the density is uneven thin or lacking? | <ul style="list-style-type: none"> • Remove the foreign matter in the developer unit. • Clean the developer unit.  P. 7-26 "7.6.6 Developer unit" |
| | 2 | Does uneven image density occur again? | Adjust the doctor-sleeve gap close to the upper limit value of the adjustment reference.  P. 6-67 "6.9.2 Doctor-to-sleeve gap adjustment (developer unit)" |

8.5.21 Faded image (low density)

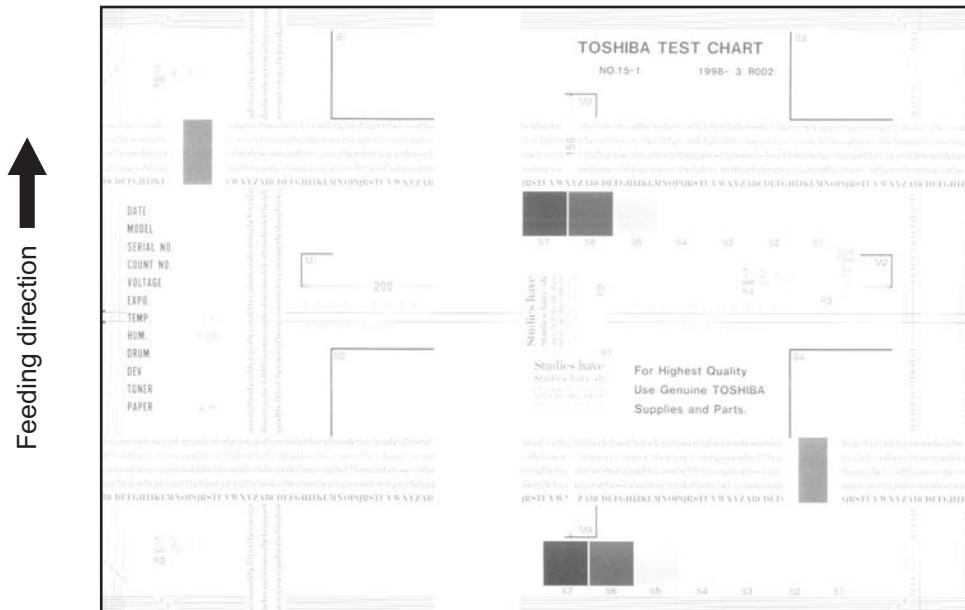

Fig.8-90

| Cause/Section | Step | Check item | Measures |
|--|------|--|---|
| Laser optical unit Main charger grid | 1 | Perform FS-05-2742 (Forced performing of image quality closed-loop control). | When FS-05-2742 (Forced performing of image quality closed-loop control) is performed, the automatic cleaning of the main charger and the LSU slit glass cleaning are performed at the same time. |
| Toner empty | 2 | Is the "ADD TONER" symbol blinking? | Replace the toner cartridge. |
| Auto-toner circuit | 3 | Is there enough toner in the toner cartridge? | Check the auto-toner adjustment performance. |
| | 4 | Is the toner density of the developer material too low? | |
| Toner motor | 5 | Does the toner motor operate properly? | Check the connector and the harness of the motor. |
| Toner cartridge | 6 | Is there any abnormality in the toner cartridge? | Replace the toner cartridge. |
| Developer material | 7 | Has the developer material reached its PM life? | Replace the developer material. |
| Developer unit | 8 | If the magnetic brush in proper contact with the drum? | <ul style="list-style-type: none"> • Check the installation of the developer unit. • Check the doctor-to-sleeve gap and pole position. |
| Main charger | 9 | Is the main charger dirty? | Clean the main charger or replace the needle electrode. |
| Drum | 10 | Is there any filming on the drum surface? | Clean or replace the drum. |
| | 11 | Has the drum reached its PM life? | Replace the drum. |
| Transfer unit | 12 | Is the transfer belt or 1st transfer roller dirty? | Clean the transfer belt and 1st transfer roller. |
| | 13 | Has the 2nd transfer roller reached its PM life? | Replace the 2nd transfer roller. |

| Cause/Section | Step | Check item | Measures |
|--|------|--|---|
| High-voltage transformer (Development) | 14 | Is the harness between the LGC board and the high-voltage transformer open circuited? Are the connectors connected securely? | <ul style="list-style-type: none"> Reconnect the connectors securely. Replace the harness. |
| | 15 | Is the connector of the high-voltage harness securely connected? Is the harness open circuited? | <ul style="list-style-type: none"> Reconnect the connectors securely. Replace the high-voltage harness. |
| | 16 | Does the high-voltage transformer work properly? | Replace the high-voltage transformer. |
| 2nd transfer contact/release unit (Cam unit) | 17 | Is there any abnormality on the cam, pusher and actuator? | Check if the cam, pusher and actuator are installed correctly and there are no damages on them. Collect the installation or replace them if needed. |
| | 18 | Is the 2nd transfer pressure reduction operating correctly when printing with thick paper? | If poor transfer still persists, perform step 16 again. |
| 2nd transfer | 19 | Is the recommended paper used? | <p>If not, change the values of FS-05-2936 to FS-05-2937 to adjust the 2nd transfer bias offset.</p> <p>Check side (front or back). Set the value for each paper type so that the density of the image quality becomes the darkest.</p> <p>Notes:</p> <ul style="list-style-type: none"> After the setting has been changed, perform automatic gamma adjustment. When the value is increased close to 10, white spots may occur. To avoid this, perform the adjustment while checking the image. When the value is increased close to 0, poor transfer may occur. To avoid this, perform the adjustment while checking the image. |

8.5.22 Image dislocation in leading edge

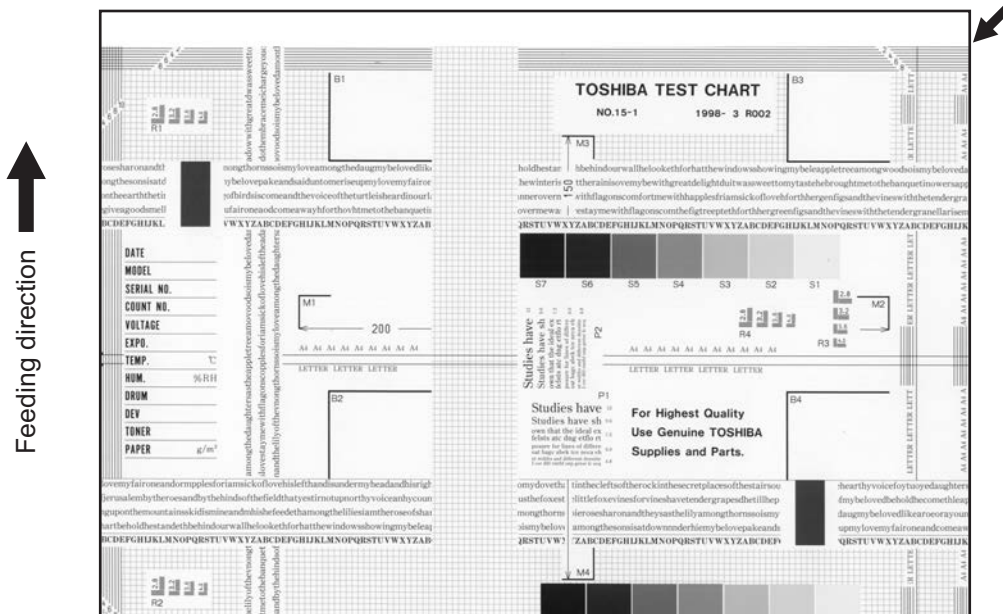

Fig.8-91

| Cause/Section | Step | Check item | Measures |
|--|------|---|--|
| Adjustment error of scanner or printer section | 1 | Is the same dislocation on every copy? | Adjust the leading edge position using the Adjustment Mode. |
| Registration roller | 2 | Is the registration roller dirty? Is the spring removed? | Clean the roller with alcohol. Reattach the spring correctly. |
| | 3 | Does the registration roller work properly? | Adjust or replace the registration roller if the gears are not engaged properly. |
| | 4 | Does the registration motor operate properly? (Is the timing of the operation delayed?) | Replace the registration motor. |
| Paper feed clutch, transport clutch | 5 | Are the paper feed clutch and transport clutch malfunctioning? | Check the harness and clutch and replace them if necessary. |
| Aligning amount | 6 | Is the paper aligning amount proper? | Decrease the paper aligning amount. |
| Rollers | 7 | Is each roller fixed to the shaft properly? | Check the E-rings, pins and clips. |
| | 8 | Is the roller surface dirty? | Clean the roller surface with alcohol or replace it. |
| Registration guide | 9 | Is the registration guide installed properly? | Correct it. |

8.5.23 Image jittering

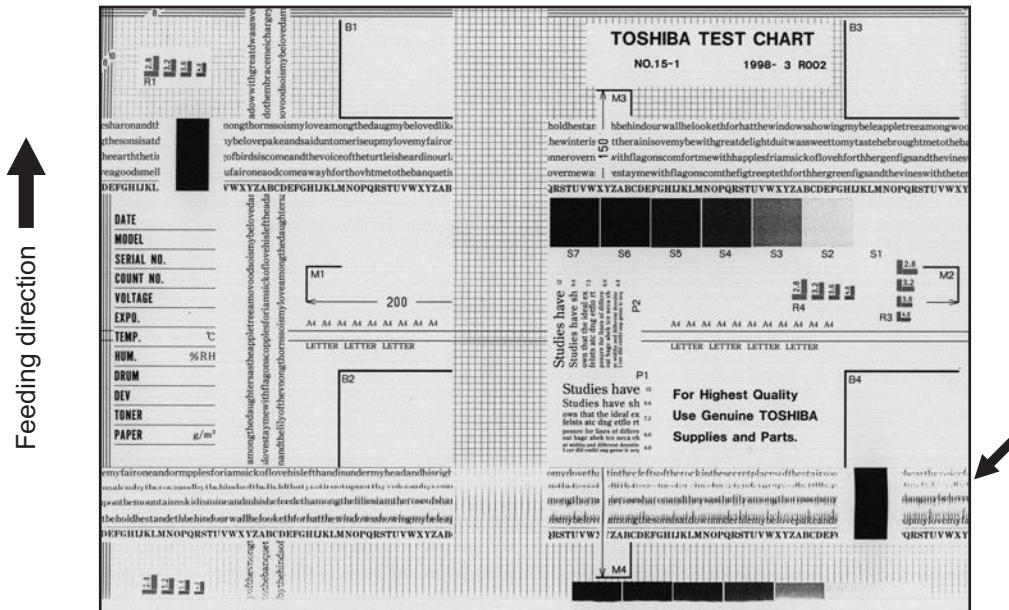

Fig.8-92

| Cause/Section | Step | Check item | Measures |
|---------------------|------|--|---|
| - | 1 | Is the toner image on the drum proper? | If proper, perform steps 1 to 3; otherwise, perform step 4 and after. |
| Registration roller | 2 | The rotation of the registration roller is normal. | Check the registration roller section and its springs. |
| Transfer unit | 3 | Does the transfer belt or 2nd transfer roller work properly? | Check the driving section. Replace the transfer belt or 2nd transfer roller if necessary. |
| Fuser unit | 4 | Does the fuser belt or pressure roller rotate properly? Does the fuser belt work properly? | Check the driving section. Replace the transfer belt or pressure roller if necessary. |
| Drum | 5 | Is there a large scratch on the drum? | Replace the drum. |
| Scanner | 6 | Is there any abnormality in the carriage feet? | Replace the carriage feet. |
| | 7 | Is the tension of the timing belt proper? | Correct the tension. |
| | 8 | Is there any abnormality in the carriage drive system? | Check the carriage drive system. |
| | 9 | Are the mirrors installed properly? | Correct it. |
| Drum drive system | 10 | Are there any abnormalities in the drum drive system? | Check the drum drive system. Clean or replace the belts, pulleys or bushings if they are dirty or there are scratches on them. |
| Developer unit | 11 | Is there any abnormality on the drive gear in the developer unit? | <ul style="list-style-type: none"> If the drive gear is worn out, replace it. Remove any developer material from the drive gear, and then reapply grease. |

8.5.24 Poor cleaning

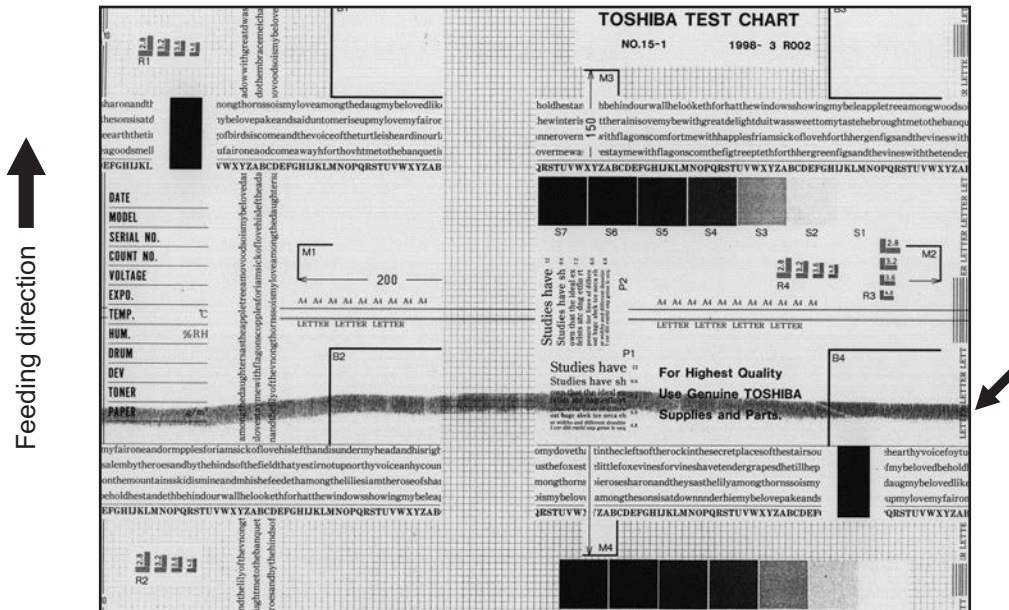

Fig.8-93

Notes:

Poor cleaning may occur in the feeding direction.

| Cause/Section | Step | Check item | Measures |
|-----------------------|------|---|---|
| Developer material | 1 | Is the specified developer material used? | Use the specified developer material and toner. |
| Drum cleaner | 2 | Is there dust on the tip of the drum cleaning blade? | Clean or replace the drum cleaning blade. |
| | 3 | Has the cleaning blade been turned up? | Replace the drum cleaning blade. |
| Transfer belt cleaner | 4 | Is there paper dust on the tip of the transfer belt cleaning blade? | Clean or replace it. |
| | 5 | Check if the transfer belt cleaning blade has been turned up? | Replace it. |
| | 6 | Is the transfer belt cleaning blade in proper contact with the transfer belt? | Take off the transfer belt and check if the transfer belt cleaning blade pressure spring is installed properly. |
| Toner recovery auger | 7 | Is toner recovery defective? | Clean the toner recovery auger. Check the pressure of the cleaning blade. |
| Fuser unit | 8 | Are there bubble-like scratches on the fuser belt surface (approx. 126mm pitch on the image)? | Replace the fuser belt. Check and correct the IH control circuit. |
| | 9 | Has the fuser belt or the pressure roller reached its PM life? | Replace it. |
| | 10 | Is the pressure between the fuser belt and the pressure roller proper? | Check and adjust the pressure mechanism. |
| | 11 | Is the temperature of the fuser belt proper? | <ul style="list-style-type: none"> • Check the setting and correct it. • Clean or replace the thermistor. • Check and correct the harness. |

8.5.25 Uneven light distribution



Fig.8-94

| Cause/Section | Step | Check item | Measures |
|--|------|--|---|
| Laser optical unit Main charger grid | 1 | Perform FS-05-2742 (Forced performing of image quality closed-loop control). | When FS-05-2742 (Forced performing of image quality closed-loop control) is performed, the automatic cleaning of the main charger and the LSU slit glass cleaning are performed at the same time. |
| Original glass | 2 | Is the original glass dirty? | Clean it. |
| Main charger | 3 | Is the needle electrode, grid or case dirty? | Clean or replace it. |
| Discharge LED | 4 | Is the discharge LED dirty? | Clean it. |
| Scanner | 5 | Is the exposure lamp, mirrors or lens dirty? | Clean it. |
| Exposure lamp | 6 | Is the exposure lamp tilted? | Adjust the installation position of the exposure lamp. |
| | 7 | Is the exposure lamp discolored or degraded? | Replace the exposure lamp. |
| Process unit | 8 | Is the laser beam interrupted by foreign matter adhering to the doctor blade area of the developer unit or the charger case of the main charger? | Remove foreign matter. |

8.5.26 Blotched image

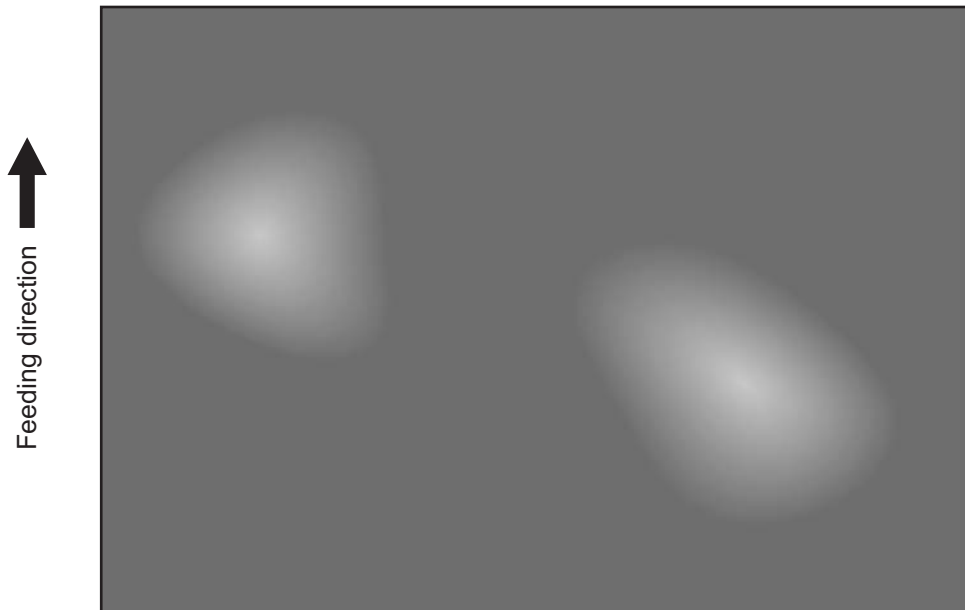

Fig.8-95

| Cause/Section | Step | Check item | Measures |
|---|------|--|---|
| Paper | 1 | Is the paper type corresponding to its mode? | Check the paper type and mode. |
| | 2 | Is paper too dry? | Change the paper. |
| Transfer unit | 3 | Is the transfer belt in proper contact with the drum? | Correct it. |
| | 4 | Is the 2nd transfer roller in proper contact with the transfer belt? | Correct it. |
| | 5 | Is there any abnormality on the transfer belt? | Clean or replace it. |
| High-voltage transformer (1st and 2nd transfer rollers) | 6 | Is the harness between the LGC board and the high-voltage transformer open circuited? Are the connectors connected securely? | <ul style="list-style-type: none"> Reconnect the connectors securely. Replace the harness. |
| | 7 | Is the connector of the high-voltage harness securely connected? Is the harness open circuited? | <ul style="list-style-type: none"> Reconnect the connectors securely. Replace the high-voltage harness. |
| | 8 | Does the high-voltage transformer work properly? | Replace the high-voltage transformer. |

8.5.27 Stain on the paper back side

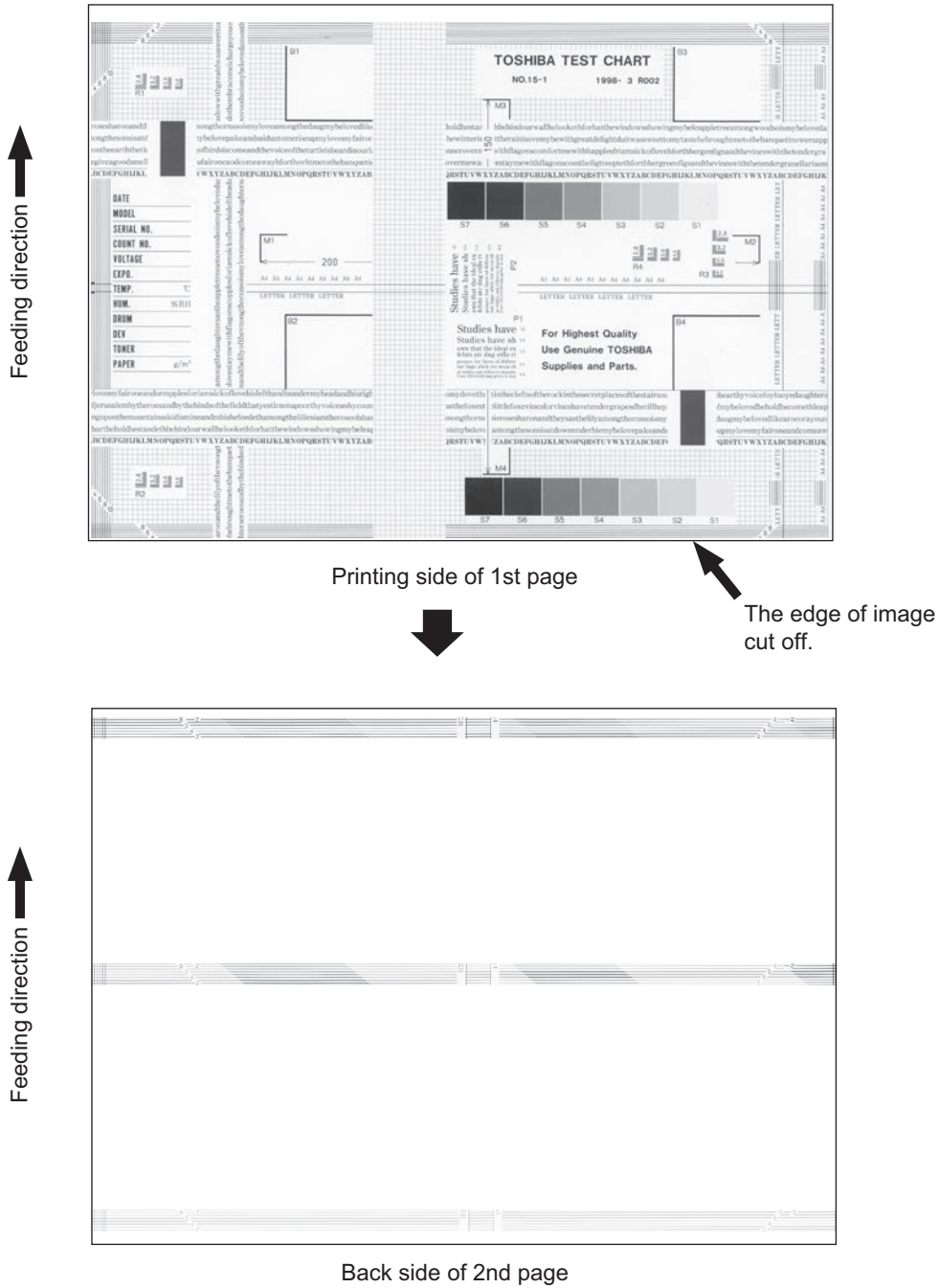

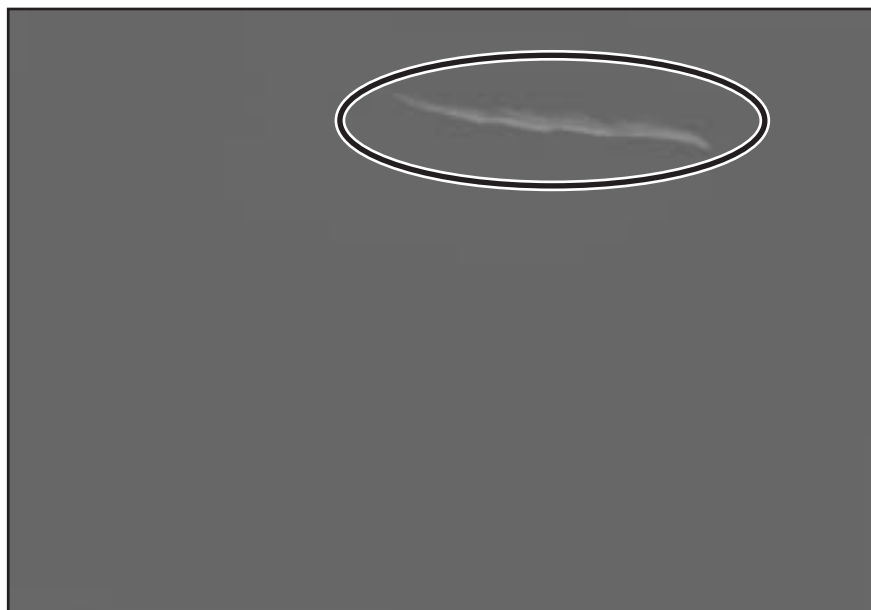

Fig.8-96

| Cause/Section | Step | Check item | Measures |
|-------------------------------|------|--|---|
| Image adjustment and setting | 1 | Is the margin of the image adjusted correctly? | Adjust the margin. |
| | 2 | Is the margin of the image adjusted correctly when the paper size is not selected in bypass feeding? | Adjust the margin. |
| | 3 | Is the margin of the image adjusted correctly in duplex printing? | Adjust the margin. (FS-05-4064 0, 1 and 4 to 5) |
| | 4 | Is the image location in the primary and secondary scanning directions correct? | Adjust the image location. |
| | 5 | Is the reproduction ratio of image in the primary and secondary scanning directions correct? | Adjust the reproduction ratio. |
| | 6 | Is the tab setting correct? | Correct the setting. |
| Paper feeding, transport area | 7 | Does the size of paper in the drawer or LCF correspond to the setting? | Use the appropriate paper size. Correct the size setting. |
| | 8 | Is the width between the slides in the drawer correct (too wide)? | Correct the position of the slides. |
| | 9 | Is the width between the slides of the bypass tray correct (too wide)? | Correct the width. |
| | 10 | Is the sideways deviation adjustment for drawers or guides of the bypass tray correct? | Adjust the sideways deviation. |
| | 11 | Is the paper aligning amount sufficient? | Adjust the aligning amount. |
| | 12 | Is the paper feed roller or transport roller dirty or worn out? | Clean or replace the roller. |
| | 13 | Is the paper type corresponding to its mode? | Use the proper type of paper or select the proper mode. |
| | 14 | Is the non-recommended paper used? | Use the recommended paper. |
| Transfer unit | 15 | Is there any stain caused by a poor cleaning, etc. on the transfer belt? | Clean the transfer belt. |
| | 16 | Is the transfer belt cleaning blade in proper contact with the transfer belt? | Take off the transfer belt and check if the transfer belt cleaning blade pressure spring is installed properly. |
| | 17 | Does the transfer roller rotate properly? | Clean the roller area. Replace the roller. |
| | 18 | Is there any foreign matter or stain on the 2nd transfer roller? | Clean or replace the roller. |
| | 19 | Has the 2nd transfer roller reached its PM life? | Replace the 2nd transfer roller. |
| 2nd transfer unit | 20 | Is there any stain caused by a poor cleaning, etc. on the 2nd transfer roller? | Clean the 2nd transfer roller. |
| | 21 | Does the 2nd transfer roller contact properly? | Check if the 2nd transfer roller is installed properly. |
| | 22 | Has the 2nd transfer roller reached its PM life? | Replace the 2nd transfer roller. |

| Cause/Section | Step | Check item | Measures |
|---------------|------|---|--|
| Fuser unit | 23 | Are the fuser belt, pressure roller, separation plate and thermistor dirty? Check the front and back sides of the separation plate by removing it. Check the gap of the separation plate. | Clean the fuser belt, pressure roller, separation plate and thermistor. When the separation plate is removed, check its gap. Adjust the gap of the separation plate.  P. 6-70 "6.11.1 Separation plate gap adjustment" |
| | 24 | Is the rib of the transport guide dirty? | Clean the rib. |
| | 25 | Check if the settings of the following self-diagnostic codes are correct. <ul style="list-style-type: none"> • Is "1" (Release) set for FS-08-5248-0 and 1 (Pressure roller contact/release setting)? • Is "0" (Invalid) set for FS-08-2179-0 to 1 (Time setting to keep temperature for print operation at print end)? | <ul style="list-style-type: none"> • Set "1" (Release) for FS-08-5248-0 and 1 (Pressure roller contact/release setting). • Set "0" (Invalid) for FS-08-2179-0 and 1 (Time setting to keep temperature for print operation at print end). |

8.5.28 White void in halftone



← Feeding direction

Fig.8-97

| Cause/Section | Step | Check item | Measures |
|-------------------|------|--|---|
| Paper | 1 | Is the appropriate paper type set? | <ul style="list-style-type: none"> • Check the paper type. • Use the recommended paper. |
| | 2 | Is the paper damaged such as curled? | Change the paper. |
| Fuser unit | 3 | Is there any stain on the metal plate of the paper guide in the fuser unit? | Clean it. |
| | 4 | Is there any deformation or scratch on the metal plate of the paper guide in the fuser unit? | Replace the paper guide. |
| | 5 | Is there any stain on the rib of the paper guide in the fuser unit? | Clean it. |
| 2nd transfer area | 6 | Are the 2nd transfer rear guide and sensor bracket installed properly? | Correct it. |

8.5.29 Paper wrinkle

There are 2 locations where the paper wrinkle occurs: before the fusing stage and in the fuser unit. See below to determine the case.

Smooth out the wrinkled paper. When there is no image in the wrinkled area: See (1) "Paper wrinkle before fusing".

Smooth out the wrinkled paper. When there is a copied image in the wrinkled area: See (2) "Paper wrinkle in the fuser unit".

(1) Paper wrinkle before fusing

Is paper set properly?

↓ NO → Set paper properly.

↓

YES

Is there any abnormality such as scratch or wear on the transport roller?

↓ YES → Replace the transport roller.

↓

NO

1. Increase the paper aligning amount.  P. 6-5 "6.1.4 Alignment position adjustment"
2. Increase the speed of the transport motor. (Adjust it at the code FS-05-4532 0 to 2 and 4.)

(2) Paper wrinkle in the fuser unit

Is paper set properly?

↓ NO → Set paper properly.

↓

YES

Has the paper absorbed moisture?

↓ YES → Use paper that has not absorbed moisture.

↓

NO

Is flexible paper such as recycled paper used?

↓ YES → Switch to the recycle paper mode. (Select "RECYCLED PAPER" in MEDIA TYPE.)

↓

If paper wrinkle still appears, proceed to NO.

NO

1. Adjust the entrance guide of the fuser unit and check if the paper wrinkle disappears. (Fig.8-98)

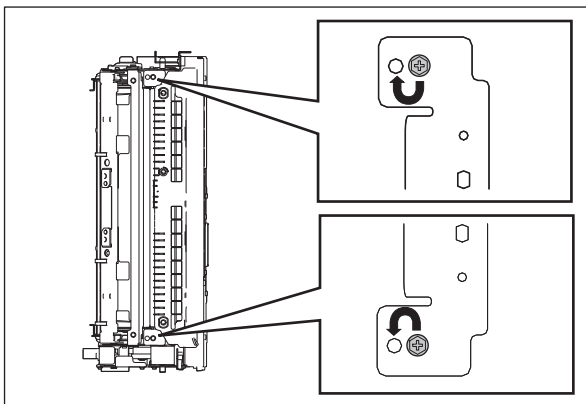

Fig.8-98

8.5.30 Toner scattering

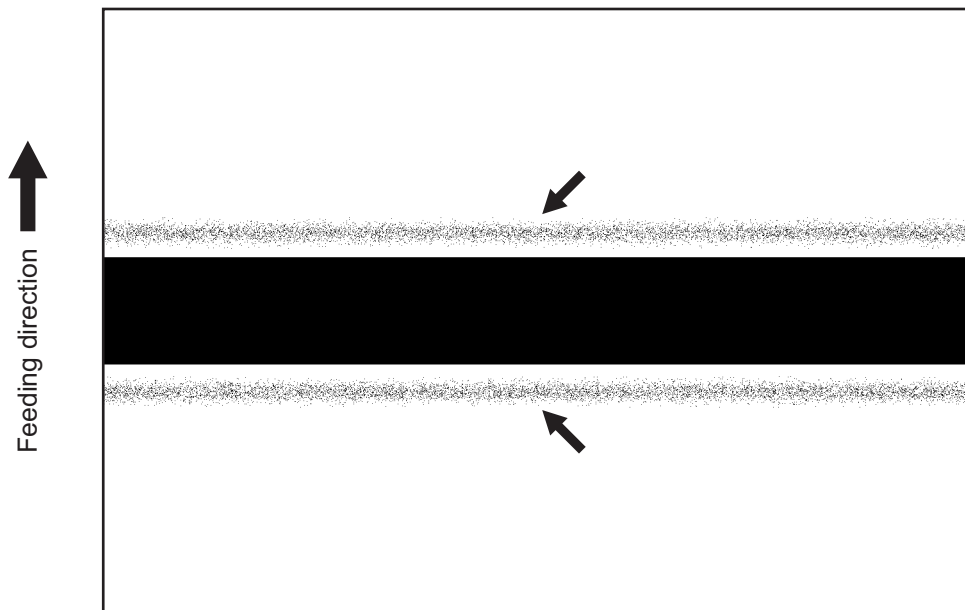

Fig.8-99

| Cause/Section | Step | Check item | Measures |
|---------------------|------|--|--|
| Paper | 1 | Is the paper type set properly? | Set the paper type to be used properly. |
| Drawer, bypass tray | 2 | Is toner scattered when printing is performed on the back side of which front side has been printed? | When printing on the back side is performed, place the paper on the bypass tray and select the paper type and [Printed] in "Back Printed". |
| 2nd transfer | 3 | Is the recommended paper used? | <p>If not, change the values of FS-05-2936 to FS-05-2937 to adjust the 2nd transfer bias offset. Check the mode (color or black) and the side (front or back). Set the value for each paper type so that the density of the image quality becomes the darkest.</p> <p>Notes:</p> <ul style="list-style-type: none"> • After the setting has been changed, perform automatic gamma adjustment. • When the value is increased close to 20, white spots may occur. To avoid this, perform the adjustment while checking the image. • When the value is increased close to 0, poor transfer may occur. To avoid this, perform the adjustment while checking the image. |

8.5.31 Residual image

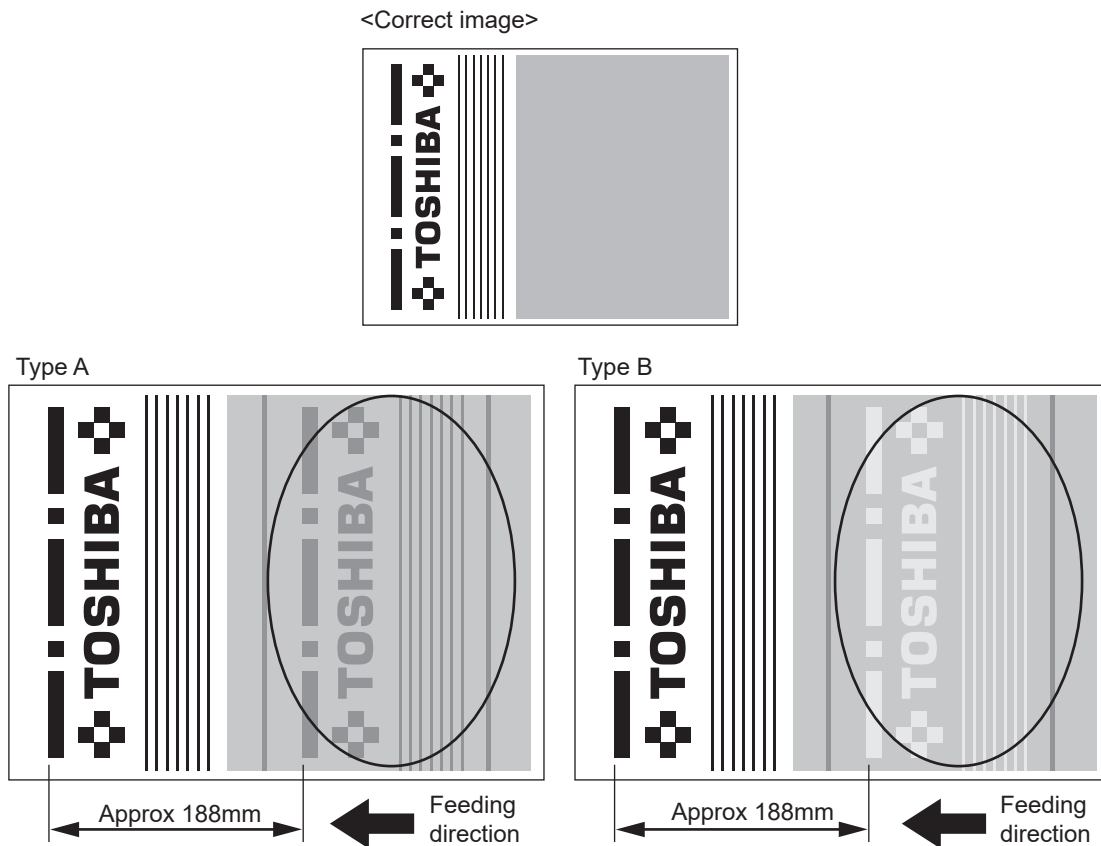

Fig.8-100

2 types (A and B) of residual images are identified. The common phenomenon is an image fused on the photoconductive drum one round before appearing faintly on the halftone part of the next image.

| Cause/Section | Step | Check item | Measures |
|---|------|---|--|
| Main charger | 1 | Is the connector of the discharge LED securely connected? | Reconnect the connector securely. |
| | 2 | Is the discharge LED dirty? | Clean it. |
| Photoconductive drum | 3 | Have the drum reached its PM life? | Replace the photoconductive drum. |
| Transfer belt unit (Mainly the cause of type B) | 4 | Is the transfer belt unit installed correctly? | Check the installation and correct it if necessary. |
| | 5 | Does the transfer belt contact the drum properly? | <ul style="list-style-type: none"> Check if the contact release lever of the transfer belt is at the releasing position. If not, correct it. Check if there is any damage to the bracket of the 1st transfer roller. |
| | 6 | Is the power supply spring on the rear side of the transfer belt unit deformed? | Correct the power supply spring. |
| | 7 | Is the bias output dependent on the 1st transfer bias? | Decrease the corresponding 1st transfer bias output as follows according to the phenomena which occurred, and check if the residual image has changed and adjust the value accordingly. See the table below. |

| Check item | Measures |
|--|---|
| Black mode, Plain paper | Decrease the value of FS-05-2905-5 by 1 while checking how the residual image has changed. |
| Black mode, Thick 1 to Thick 4 paper | Decrease the value of FS-05-2905-11 by 1 while checking how the residual image has changed. |
| Black mode, Special paper and Transparency | Decrease the value of FS-05-2905-18 by 1 while checking how the residual image has changed. |

Notes:

If the cause is the dependency on the 1st transfer bias, the residual image gradually disappears as you decrease the value of the sub-code of this code.

However, the solid part of the image may become light or an uneven grain may appear on the image if the value is too small. Check the image carefully and set the value at the point that all the factors of the image are balanced.

8.5.32 Feathered image

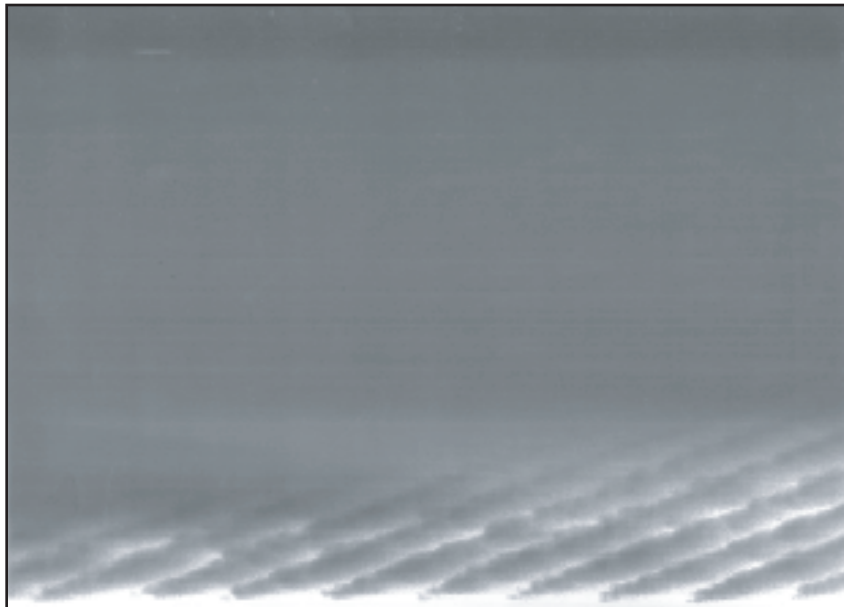

← Feeding direction

Fig.8-101

1. Overview

This problem may occur when 10 K sheets of paper with a low printing ratio (lower than 3%) are being printed continuously in the 2-sheet intermittent mode.

When the image shown above appeared, the developer material in the developer unit is probably decreasing. In this case, visually check the developer sleeve in the developer unit of the corresponding color if the layer of the developer material is formed evenly over the developer sleeve. If the layer of the developer material on the area corresponding to the feathered image is thinner than that on the other areas or totally lacking, replace the developer material.

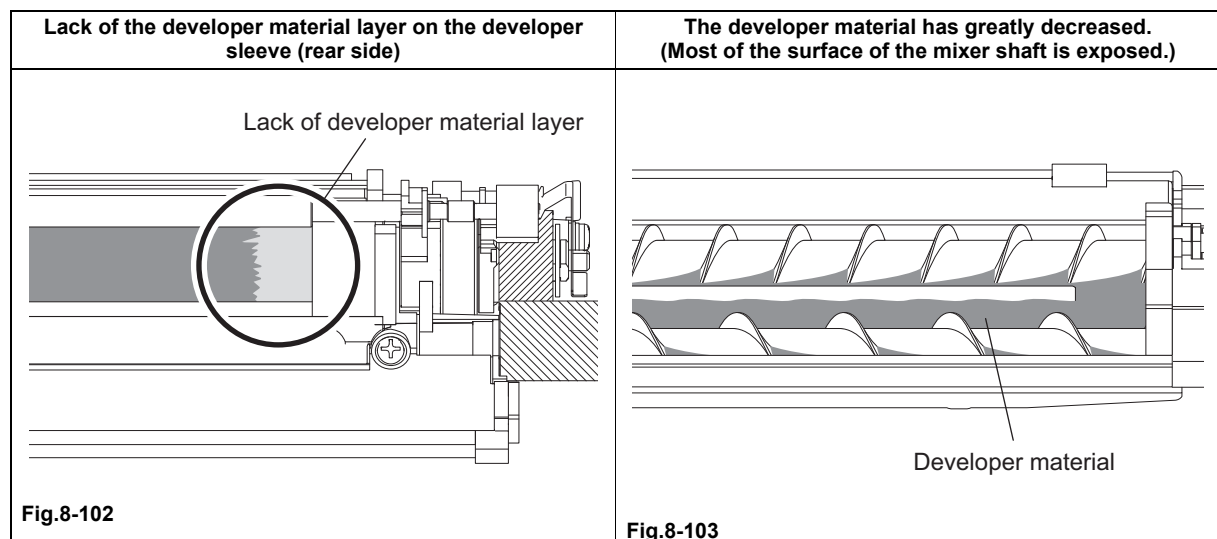

2. Investigation of cause and measures

| Cause/Section | Step | Check item | Measures |
|--------------------|------|---|---|
| MFP installation | 1 | Using a level, check if the MFP is leaning to the right side.*1 | Reinstall the MFP horizontally. |
| Main charger | 2 | Is the needle electrode, grid or case dirty? | Clean or replace it. |
| Discharge LED | 3 | Is the discharge LED lit properly? | Replace it. |
| Drum thermistor | 4 | Check the drum thermistor. (Make sure that the drum contacts the drum thermistor.) | Replace the drum thermistor. |
| Main pole position | 5 | If no abnormalities are found in the 3 items above, the main pole position may deviate from the specified range or the toner density may be controlled to be lower than the specified range. (Checking impossible) *2 | Correct the main (separation) pole position.*3 |
| Control | 6 | If the problem still persists even though steps 1 to 5 have been performed | Increase the number of the toner refreshing control times. <ul style="list-style-type: none"> Perform FS-08-2685 and change the setting value from 500 (default) to 250. Notes: The setting value of FS-08-2680 should be set to "1" (ON) in order to execute FS-08-2685. |
| Developer material | 7 | Is the layer of the developer material on the developer sleeve thin or lacking? | Replace the developer material. |

*1 : By following the description in the Unpacking Instructions, confirm that the MFP has been set in a level manner.

*2 : The toner density is reset to the normal controlling level by replacing the developer material as the last step. Therefore, the only measure to be taken in this step is the correction of the main (separation) pole position.

*3 : How to correct the main (separation) pole position of the developer sleeve

- The position of the scale has been adjusted at manufacturing. Since this will vary depending on the units, be sure to check the position before adjustment.
- Turn the pole position adjustment plate of the developer unit counterclockwise by 1 scale.
- The pole position adjustment plate has been turned counterclockwise by 2 scales at manufacturing. Turn it counterclockwise by 1 scale from that position. Do not turn it more than 1 scale.
- If the pole position adjustment plate has already been turned to around the end and thus turning by another 1 scale is not possible, rotate it counterclockwise as much as possible.
- If the pole position adjustment plate is turned counterclockwise by 2 or more scales, the image density will be lowered.
- Do not turn the pole position adjustment plate clockwise by 2 or more scales. Otherwise, the image density will be lowered, the carrier offset will occur and feathered images cannot be made better.

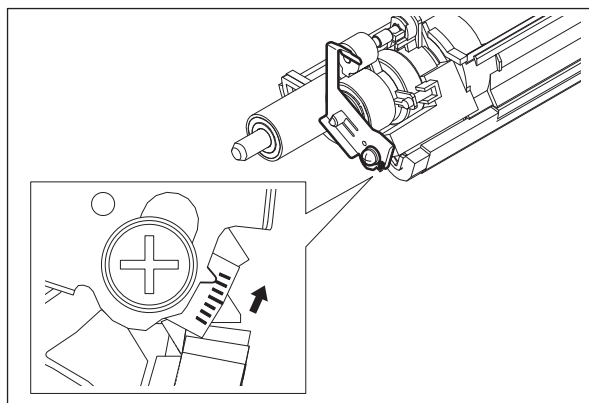
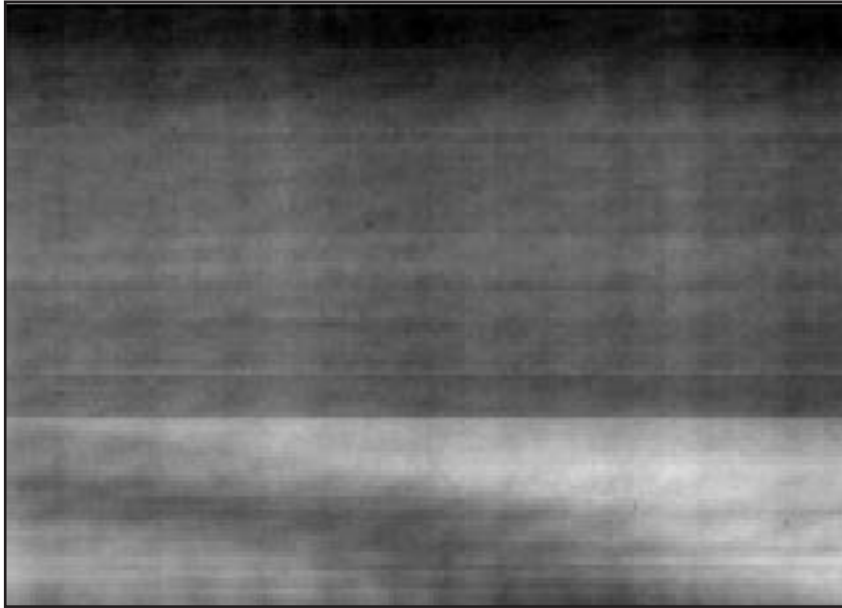

Fig.8-104

8.5.33 Low density image (rear side)



← Feeding direction

Fig.8-105

1: Developer material

This problem may occur when a large amount (10 K sheets or more) paper with a high printing ratio (85% or higher) are being printed continuously.

When the image shown above appeared (the image area approx. 5 cm from the rear end is light or light diagonal lines appear over the entire image), the developer material in the developer unit may greatly increase. In this case, take out the developer unit of the same color as the image and then take off the developer upper unit to check the amount of the developer material on the transport section under the developer sleeve. If the amount of the developer material is extremely large, scoop up the developer material with a sheet of paper or similar until the amount becomes proper.

After checking the amount, investigate the following:

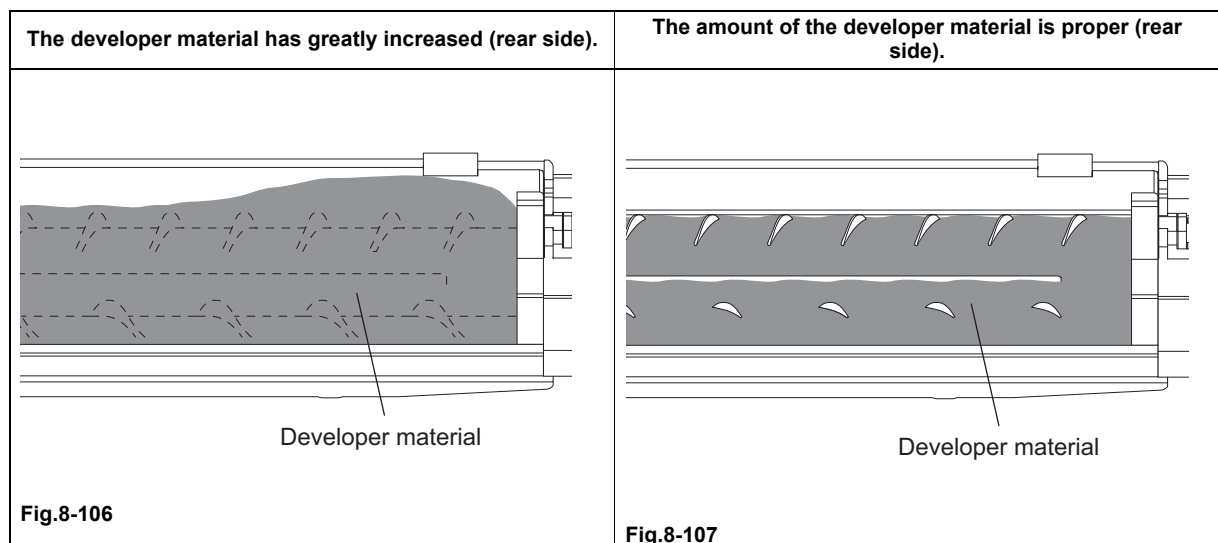

2. Investigation of cause and measures

| Cause/Section | Step | Check item | Measures |
|------------------|------|--|--|
| MFP installation | 1 | Check if the MFP is leaning to the right side using a level. *1 | Reinstall the MFP horizontally. |
| Developer unit | 2 | Check if the developer material has accumulated on the sloping section outside of the discharging outlet. Check if the scraper on it is operating properly. *2 | Reinstall the scraper properly. Replace it if it is deformed or damaged. |
| Drum thermistor | 3 | Check the drum thermistor. (Make sure that the drum contacts the drum thermistor.) | Replace the drum thermistor. |
| Toner density | 4 | If no abnormalities are found in the items above, the toner density may be controlled to be higher than the specified range. (Checking impossible) | Correct the target toner density. |

*1 : By following the description in the Unpacking Instructions, confirm that the MFP has been set in a level manner.

*2 : How to confirm the installation position or operation of the scraper

Check if the scraper is installed so that it passes through the hole as shown in the figure.

Check if the coupling of the mixer is turned in the direction of the arrow in the figure.

Notes:

Never turn the coupling in the opposite direction because the scraper will be damaged.

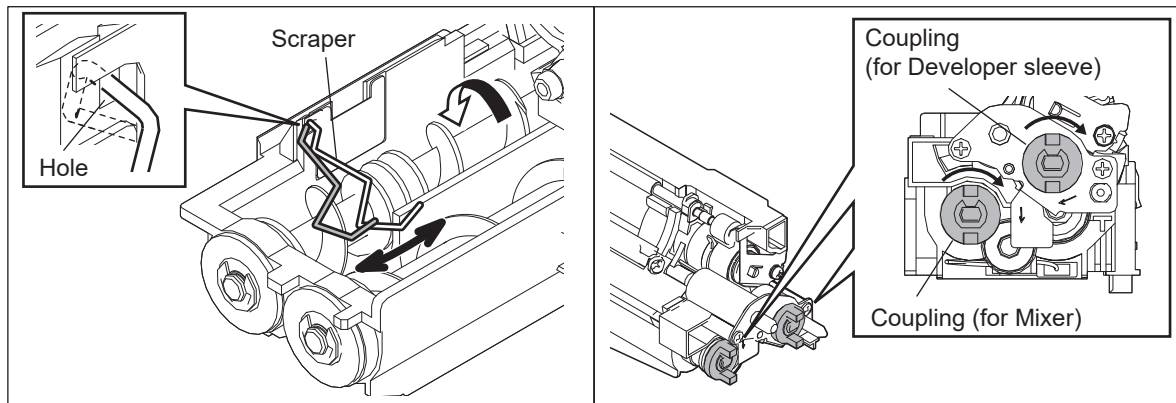

Fig.8-108

8.5.34 Image distortion (dogleg image)

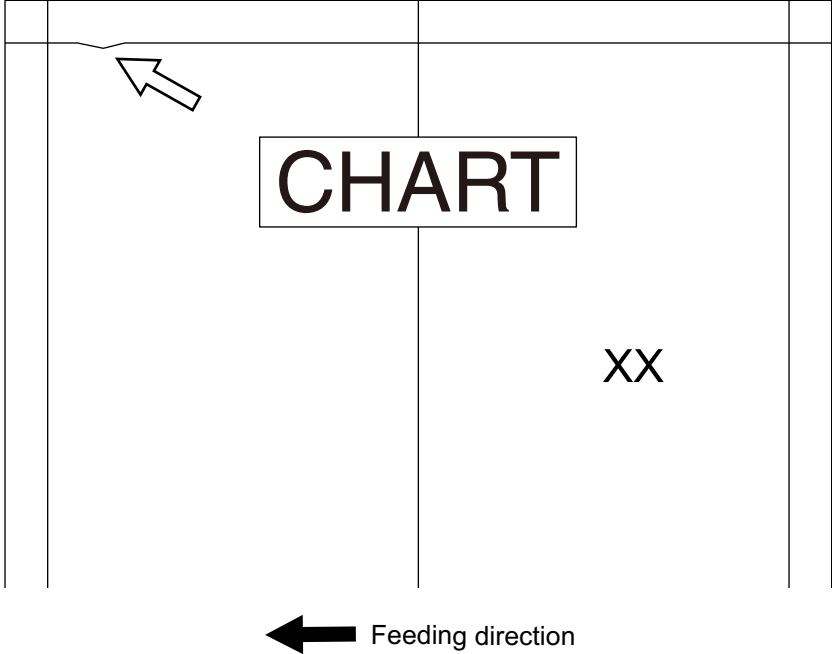

Fig.8-109

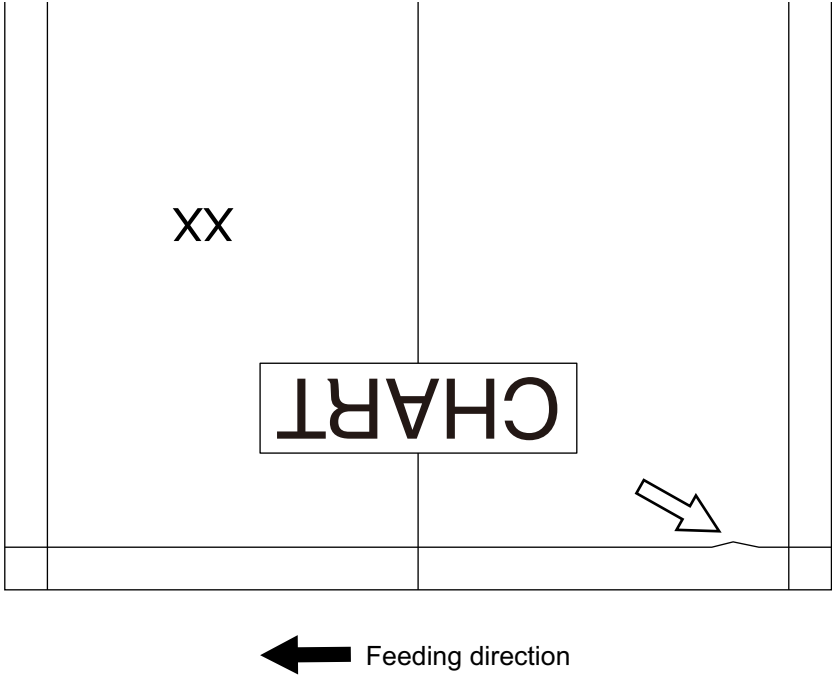

Fig.8-110

The image distortion (dogleg image) shown upper occur on the leading or trailing edge at the back side of the copied or scanned paper while the DSDF is used.

| Cause/Section | Step | Check item | Measures |
|---------------|------|--|---|
| DSDF | 1 | Position adjustment, height adjustment | <p>Check the installation condition of the DSDF and confirm that there are no abnormalities in the adjustment for its position and height.</p> <p>📖 P. 6-84 “6.13.1 Position adjustment”</p> <p>📖 P. 6-88 “6.13.2 Height adjustment”</p> |
| | 2 | Skew adjustment | <p>Perform the adjustment of image tilting at the back side.</p> <p>📖 P. 6-90 “6.13.3 Skew adjustment”</p> <p>Remarks:</p> <p>The phenomenon tends to be reduced if the CCD module is moved in the “+” direction.</p> <p>Perform the adjustment of image tilting at the front side corresponding to the tilted amount of the back side.</p> <p>Notes:</p> <ul style="list-style-type: none"> • When this adjustment is performed, the entire image may be tilted. • Even if this adjustment is performed, a dogleg image will not be resolved completely. |

8.5.35 Shadow in copied/scanned images when using the DSDF



← Feeding direction

Fig.8-111

| Cause/Section | Step | Check item | Measures | Remarks |
|--|------|---|---|---|
| Prior confirmation (MFP/DSDF adjustment condition check) | 1 | Check that the image dimensional adjustment of the MFP is performed properly. | If the adjustment is insufficient, perform the following items. 1. Image dimensional adjustment at the printing section 2. Image dimensional adjustment at the scanning section | If there is no problem in the adjustment condition, start the adjustment from step 3. |
| | 2 | Check that the image related adjustment of the DSDF is performed properly. | If the adjustment is insufficient, perform the following items. 1. Leading edge position adjustment 2. Sideways deviation adjustment 3. Reproduction ratio adjustment | |

| Cause/Section | Step | Check item | Measures | Remarks |
|--|------|---|--|---|
| Image related adjustment of the MFP and DSDF | 3 | Perform scanning from the DSDF and check whether a shadow or an image void has appeared at the leading or trailing edge in the feeding direction. | If any defects occur in images, perform the following items. <ol style="list-style-type: none"> Image dimensional adjustment at the printing section (Secondary scanning data writing start position adjustment, Reproduction ratio of the secondary scanning direction adjustment) Image dimensional adjustment at the scanning section (Secondary scanning data writing start position adjustment) Image related adjustment of the DSDF (Adjustment of the leading edge position, Adjustment of the copy ratio) | |
| | 4 | Perform scanning from the DSDF and check whether a shadow or an image void has appeared at the left or right edge in the feeding and vertical direction. | If any defects occur in images, perform the following items. <ol style="list-style-type: none"> Image dimensional adjustment at the printing section (Primary scanning data writing start position adjustment) Image dimensional adjustment at the scanning section (Primary scanning data writing start position adjustment) Adjustment of DSDF sideways deviation | |
| Copying | 5 | <ul style="list-style-type: none"> Check whether a trailing edge shadow of an original has appeared at copying only. Check whether a trailing edge shadow of an original has appeared when copying is done by selecting a larger size of paper than that for an original or by reducing the size. | If any defects occur in images, perform the following items. <ol style="list-style-type: none"> Change the value of FS- 08-3075 (Allowing of trailing edge adjustment of scanning) to "1" (Allowed). Decrease the value of FS-05-3350 (Scan trailing edge adjustment for the front side) and FS-05-3351 (Scan trailing edge adjustment for the back side) from 50 until the trailing edge shadow of an original has disappeared. <p>Remarks: When the value is decreased by "1", the image will be cut (become shorter) by 0.3 mm.</p> <p>Notes: The level of the removal of a shadow will vary depending on the conditions of the original or the sensors.</p> | This adjustment is available only for the copying function. (This adjustment cannot be performed in the scanning function.) |

8.5.36 The exit paper surface feels rough like sand is adhering to it (carrier offset)

| Cause/Section | Step | Check item | Measures |
|--------------------------|------|--|---|
| Developer material, drum | 1 | Have the developer material and drum reached their PM life? | Replace the developer material and the drum. |
| Main charger | 2 | Is there any foreign matter on the main charger? | Clean or replace the main charger. |
| Developer unit | 3 | <ul style="list-style-type: none"> Is the connector of the auto-toner sensor connected properly? Is the auto-toner sensor installed correctly? | <ul style="list-style-type: none"> Connect the connectors and perform auto-toner sensor adjustment. Install the auto-toner sensor correctly and perform auto-toner sensor adjustment. |
| Discharge LED | 4 | <p>Is the discharge LED lit? Check this by the following procedure.</p> <ol style="list-style-type: none"> Open the front lower cover. Start the MFP with 03 TEST MODE. Perform 03-214 to check that the discharge LED is lit. <p>Notes: Be sure to perform this in a short time.</p> | <ul style="list-style-type: none"> If the discharge LED is not lit, check that the connectors are connected securely. Replace the discharge LED. |
| Toner motor | 5 | Is the toner motor working properly? Perform 03-219 to check if the toner motor is working properly. | <ul style="list-style-type: none"> Check if the connectors for toner motor are connected securely. If the toner motor harness is open circuited, replace it. Replace the toner motor. Replace the CTIF board. Replace the LGC board. |
| High-voltage transformer | 6 | <ul style="list-style-type: none"> Is there any abnormality in the highvoltage connection points (CH1, CH2, CH3) of the main charger bias and the developer bias? Check if the connectors of the highvoltage transformer are connected securely. Is the harness of the high-voltage transformer open circuited? Is there any abnormality in the highvoltage transformer? | <ul style="list-style-type: none"> Connect the connectors securely. If the harness is open circuited, replace it. Replace the high-voltage transformer. |
| LGC board | 7 | <ul style="list-style-type: none"> Check if the connectors of the LGC board are connected. Is the harness of the LGC board open circuited? Is there any abnormality in the LGC board? | <ul style="list-style-type: none"> Connect the connectors securely. If the harness is open circuited, replace it. Replace the LGC board. |
| Process unit (EPU) | 8 | Is there any abnormality in the process units (EPU)? | Replace the process unit (EPU) and perform auto-toner sensor adjustment. |

Notes:

The carrier may be adhering to each transport guide, each transfer roller and the fuser belt. Therefore, perform cleaning after this troubleshooting has been carried out.

Remarks:

For the numbers of each connector, see the table below.

| | | K |
|--|-----------------------------|--------------------|
| Developer unit (Auto-toner sensor) | LGC board | CN335 |
| | Joint connector | J805, J806 J669 |
| Discharge LED | LGC board | CN310 |
| | Joint connector | J711 J896 |
| Toner motor | LGC board | CN310 |
| | Joint connector | J713 |
| High-voltage transformer | LGC board | CN319 |
| | High-voltage transformer | CN413 |

| Parts to be replaced | Remarks |
|--------------------------|-------------------------|
| Developer material | |
| Drum | |
| Main charger | |
| Discharge LED | |
| Toner motor | |
| Process unit (EPU) | Developer unit, Cleaner |
| High-voltage transformer | |
| LGC board | |
| Fuser belt | |

8.5.37 Scanned image abnormality

When the following abnormality has appeared on images in the scanning and copying functions even if there is no abnormality in the output images in the printing function, there will be an abnormality in the scanner. In such a case, perform this countermeasure.

Example of abnormal images

- (1) The entire image has become lighter or darker.
- (2) The entire image has been colored.
- (3) The color of the image does not match that of the original.

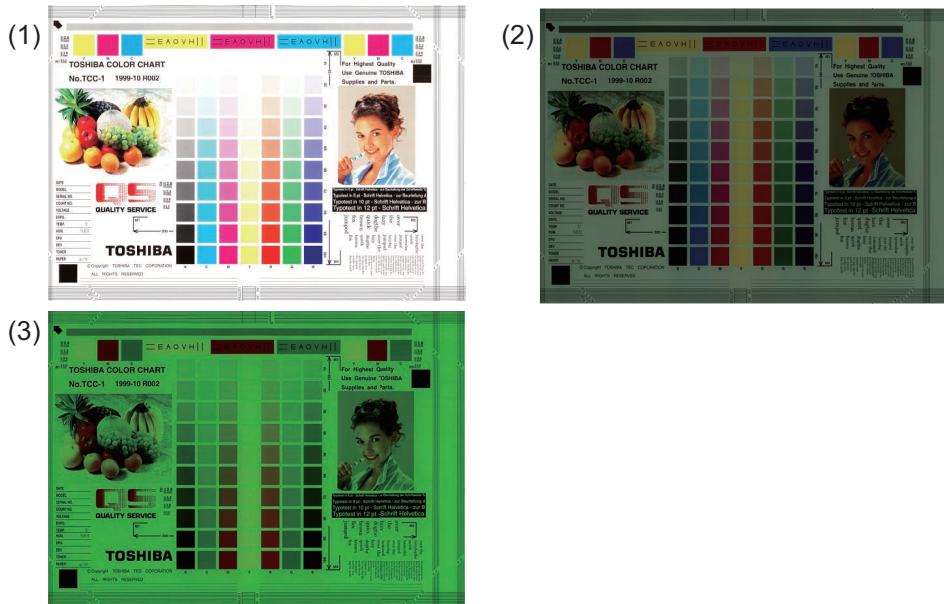

Fig.8-112

Abnormality in the scanner of the MFP

- When an abnormality in the images has occurred in scanning using the original glass
- When an abnormality in the images only on the front side has occurred in scanning using the DSDF

| Cause/Section | Step | Check item | Measures |
|---------------|------|--|--|
| Connectors | 1 | Are the connectors securely connected? | <ul style="list-style-type: none"> • Reconnect the connector of the SYS board and then check the image. • Reconnect the connector of the CCD board and then check the image. |
| SYS board | 2 | Is there any abnormality in the SYS board? | <p>If this problem still persists even after step 1 was performed, replace the SYS board and then check the image. Do not perform FS-05-3203 (Data acquisition of characteristic value of the scanner) at this time.</p> <p>If the image condition has become better, finish this troubleshooting without carrying out FS-05-3203. (It is not necessary to continue to perform the subsequent steps.)</p> |
| CCD board | 3 | Is there any abnormality in the CCD board? | <p>If this problem still persists even after step 2 was performed, replace the CCD board. Do not perform FS-05-3209 (Data transfer of characteristic value of the scanner) at this time.</p> <p>After replacing, check the image.</p> <p>If the image condition has become better, finish this troubleshooting without carrying out FS-05-3209. (It is not necessary to continue to perform the subsequent steps.)</p> |
| SRAM | 4 | Is there any abnormality in the SRAM data? | <p>If this problem still persists even after step 3 was performed, return the CCD board to a removed one. Perform FS-05-3203 (Data acquisition of characteristic value of the scanner) and check the image.</p> <p>If the image condition has become better, finish this troubleshooting.</p> |

| Cause/Section | Step | Check item | Measures |
|--------------------|------|--|--|
| CCD board, SRAM | 5 | Is there any abnormality in both the CCD board and the SRAM? | If this problem still persists even after step 4 was performed, replace the CCD board with the one used in step 3. Perform FS-05-3203 (Data acquisition of characteristic value of the scanner) and check the image. If the image condition has become better, finish this troubleshooting. |

Abnormality in the scanner (DSDF-CCD module) of the DSDF

- When an abnormality in the images only on the back side has occurred in scanning using the DSDF

| Cause/Section | Step | Check item | Measures |
|-----------------|------|--|--|
| Connectors | 1 | Are the connectors securely connected? | <ul style="list-style-type: none"> • Reinstall the DSDF I/F board and check the image. • Reconnect the HDMI cable of the DSDF I/F board and check the image. • Reconnect the connector and the HDMI cable of the DSDF control PC board and check the image. |
| DSDF I/F board | 2 | Is there any abnormality in the DSDF I/F board? | If this problem still persists even after step 1 was performed, replace the DSDF I/F board and then check the image. If the image condition has become better, finish this troubleshooting. |
| SYS board | 3 | Is there any abnormality in the SYS board? | If this problem still persists even after step 2 was performed, replace the SYS board and then check the image. Do not perform FS-05-3203 (Data acquisition of characteristic value of the scanner) at this time. If the image condition has become better, finish this troubleshooting without carrying out FS-05-3203. (It is not necessary to continue to perform the subsequent steps.) |
| DSDF-CCD module | 4 | Is there any abnormality in the DSDF-CCD module? | If this problem still persists even after step 3 was performed, replace the DSDF-CCD module. Perform FS-05-3240 (Data acquisition of characteristic value of the scanner) and check the image. If the image condition has become better, finish this troubleshooting. |

8.5.38 If an image-related problem continues after performing all troubleshooting

If an image-related problem continues even after performing all the troubleshooting, an abnormal value may have been entered in the self-diagnostic code. In such a case, attempt the initialization of the self-diagnostic code in accordance with the table below.

Notes:

- Perform the list print before the initialization.
- Initialization should be performed only for the function in which the image-related problem has occurred.
- The self-diagnostic code which will be initialized is related to the image adjustment. Therefore, only problems which have occurred during the image processing can be solved. If a cause of the problem is related to the hardware or other system issues, it will not be able to be solved even if the initialization of the self-diagnostic code is performed.

| Function | Self-diagnostic code to be initialized | Precautions |
|----------|--|---|
| Copy | FS-08-7000 | After the initialization has been carried out, perform automatic gamma adjustment. |
| Printing | FS-08-7300 | After the initialization has been carried out, perform automatic gamma adjustment (600 dpi and 1200 dpi). |
| Scanning | FS-08-7400 | None |
| Fax | FS-08-7500 | None |

9. REPLACEMENT OF PC BOARDS, SSD

9.1 Removal and Installation of PC Boards/SSD

Notes:

- When the PC board and SSD are replaced, check the notes in the following reference.
📖 P. 9-27 “9.2 Precautions, Procedures and Settings for Replacing PC Boards and Storage Device”.
- If the PC board has to be replaced due to an operational defect, this may have been caused by a contact failure of the connector. Before replacing the board, disconnect and then reconnect the connector to check if this action eliminates the operational defect.

9.1.1 SYS board cover

- (1) Remove the rear cover.
📖 P. 4-12 “4.1.22 Rear cover”
- (2) Remove 3 screws and take off the SYS board cover [1] by sliding it.

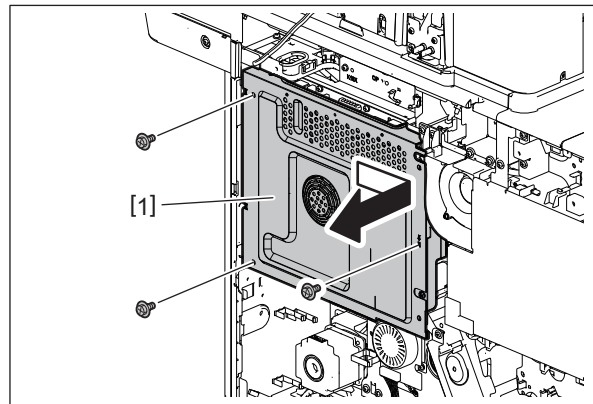

Fig. 9-1

9.1.2 SYS board (SYS)

- (1) Remove the DSDF I/F board.
📖 P. 9-23 “9.1.19 DSDF I/F board”
- (2) Remove the SYS board cooling fan.
📖 P. 9-10 “9.1.9 SYS board cooling fan (F27)”

- (3) Disconnect 11 connectors from the SYS board. Release the lock by raising the flap and remove 2 flat cables [1].

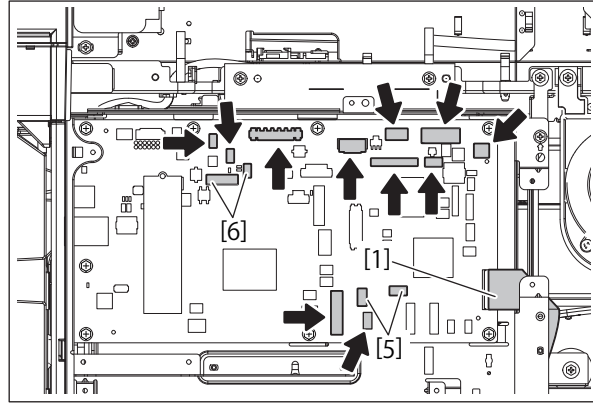

Fig. 9-2

Remarks:

- When the USB Hub Option is installed, disconnect 2 connectors [5].
The USB Hub Option is equipped as the standard for the following models.
NAD, GSA, ARD
- When the Wireless LAN / Bluetooth Module is installed, disconnect 2 connectors [6].
The Wireless LAN / Bluetooth Module is equipped as the standard for JPC models.

Notes:

- When installing the harnesses, be careful not to connect each different USB harness.
CN112: Beige USB harness
(The harness of the USB relay)
CN113: Black USB harness
(Extension cable for the card reader)
CN137: Black USB harness
(Harness for the Wireless LAN / Bluetooth Module)
- When removing the flat cable [1], release the lock by raising the flap [2] and pull out the cable.
When installing the flat cable [1], attach the cable to the connector and lock the cable by tilting the flap [2].
- When installing the flat cable [1], do not push it in strongly.
- When installing the flat cable [1], be careful not to insert it at an angle.
- Do not apply pressure to or damage the edge of the flat cable [1].

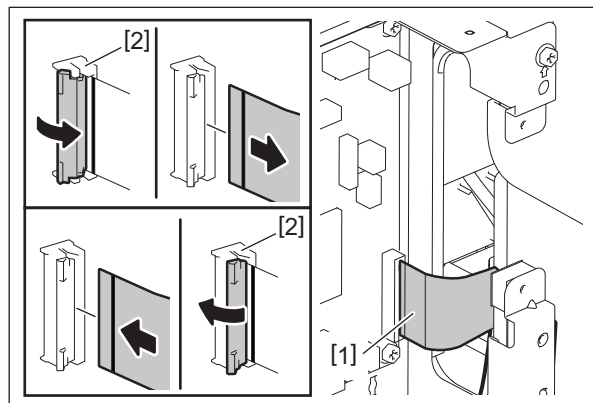

Fig. 9-3

(4) Remove 8 screws and take off the SYS board [3].

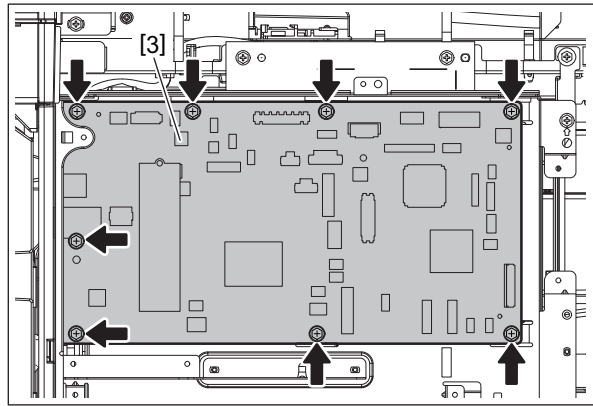

Fig. 9-4

Notes:

The SYS board to be installed differs depending on the models of the MFP. Due to this, before replacing, be sure to check the color of the identification label [4] on the SYS board to install the corresponding one in the equipment.

Label color [4]:

- 6529A/7529A/9029A (Other than GSA): Orange
- 9029A (GSA): Purple

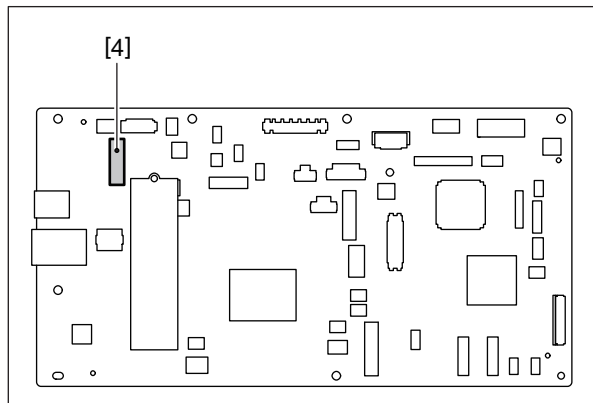



Fig. 9-5

9.1.3 SRAM

- (1) Remove the rear cover.
 P. 4-12 "4.1.22 Rear cover"
- (2) Take off the DSDF I/F board.
 P. 9-23 "9.1.19 DSDF I/F board"
- (3) Remove the SRAM [1] from the SYS board.

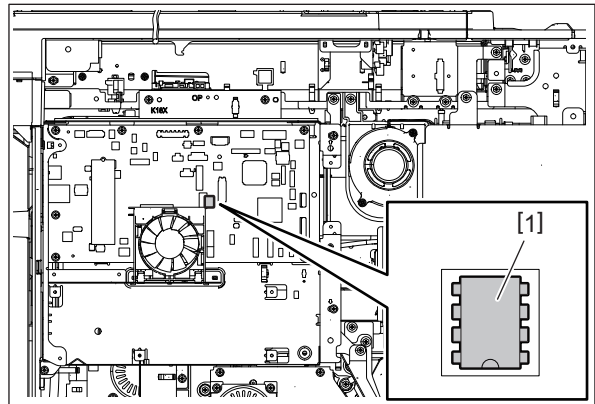



Fig. 9-6

Notes:

- Be careful not to damage the SRAM [1] when removing the SRAM [1] from the SYS board.
- When installing the SRAM [1], pay attention to the orientation. Install the SRAM [1] with its concave portion down.

9.1.4 SSD

- (1) Take off the SYS board cover.
 P. 9-1 "9.1.1 SYS board cover"
- (2) Remove 1 screw [1] and take off the SSD [2].

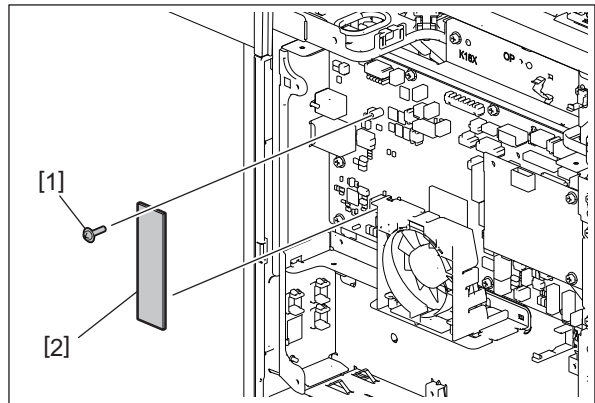

Fig. 9-7

9.1.5 Optional HDD

- (1) Take off the SYS board cover.
☞ P. 9-1 “9.1.1 SYS board cover”
- (2) Disconnect 2 connectors connected to the SYS board. Remove 4 screws and take off the optional HDD [1].

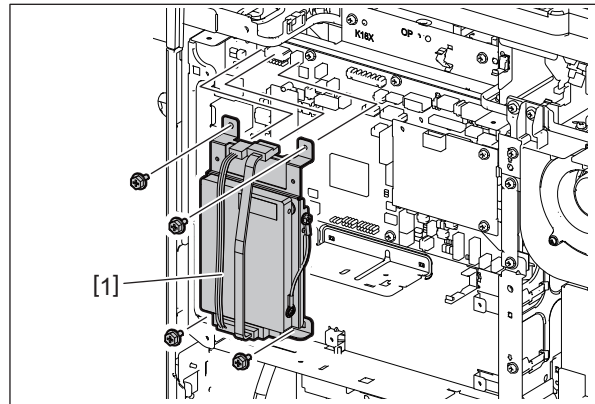

Fig. 9-8

9.1.6 Optional SSD

- (1) Take off the SYS board cover.
☞ P. 9-1 “9.1.1 SYS board cover”
- (2) Disconnect 2 connectors connected to the SYS board. Remove 4 screws and take off the optional SSD [1].

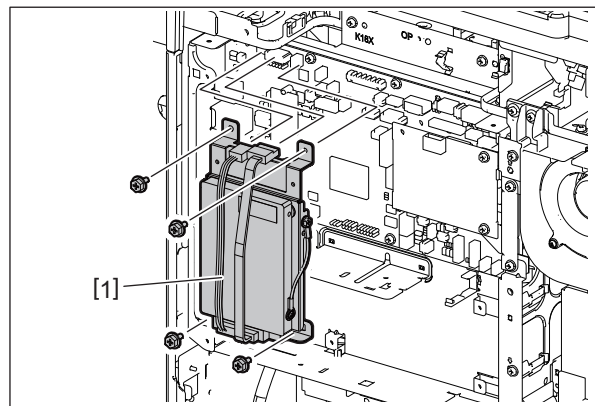

Fig. 9-9

9.1.7 SYS board case (MJD, ASD, AUD, JPC, CND)

- (1) Remove the SYS board cover.
 P. 9-1 "9.1.1 SYS board cover"
- (2) Remove the DSDF I/F board.
 P. 9-23 "9.1.19 DSDF I/F board"
- (3) Disconnect 11 connectors from the SYS board. Release the lock by raising the flap and remove 2 flat cables [1].

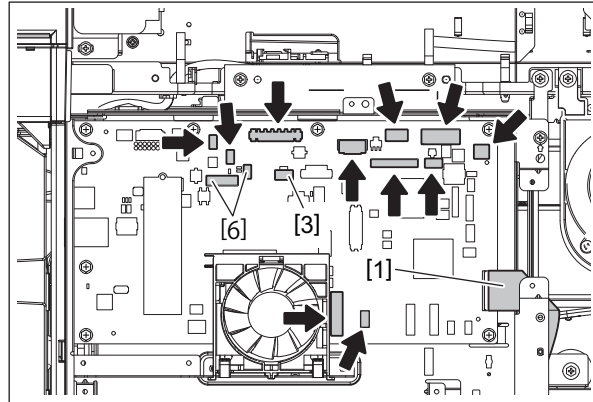

Fig. 9-10

Remarks:

When the Wireless LAN / Bluetooth Module is installed, disconnect 2 connectors [6].
The Wireless LAN / Bluetooth Module is equipped as the standard for JPC models.

Notes:

- Do not disconnect 1 connector [3] connected to the SYS board cooling fan.
- When installing the harnesses, be careful not to connect each different USB harness.
CN112: Beige USB harness
(The harness of the USB relay)
CN113: Black USB harness
(Extension cable for the card reader)
CN137: Black USB harness
(Harness for the Wireless LAN / Bluetooth Module)
- When removing the flat cable [1], release the lock by raising the flap [2] and pull out the cable.
When installing the flat cable [1], attach the cable to the connector and lock the cable by tilting the flap [2].
- When installing the flat cable [1], do not push it in strongly.
- When installing the flat cable [1], be careful not to insert it at an angle.
- Do not apply pressure to or damage the edge of the flat cable [1].

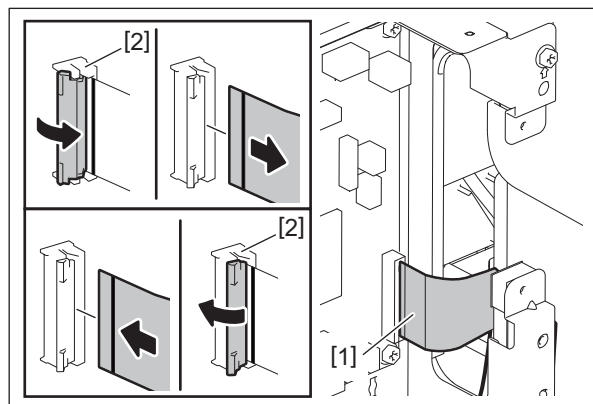

Fig. 9-11

- (4) Release the harness from the harness clamp [4]. Remove 5 screws and take off the SYS board case [5].

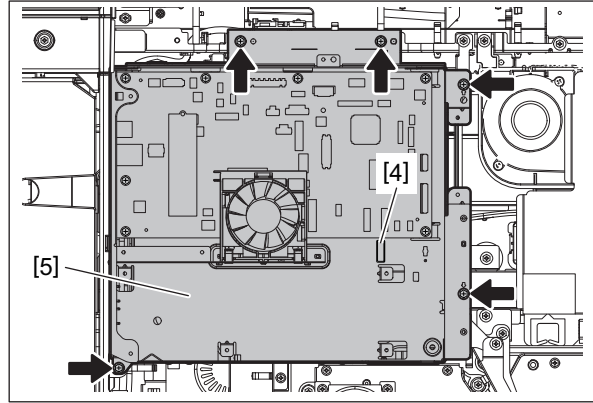

Fig. 9-12

Notes:

Hold the SYS board case to remove it.

9.1.8 SYS board case (NAD, ARD)

- (1) Remove the SYS board cover.
P. 9-1 "9.1.1 SYS board cover"
- (2) Remove the DSDF I/F board.
P. 9-23 "9.1.19 DSDF I/F board"
- (3) Disconnect 11 connectors from the SYS board. Release the lock by raising the flap and remove 2 flat cables [1].

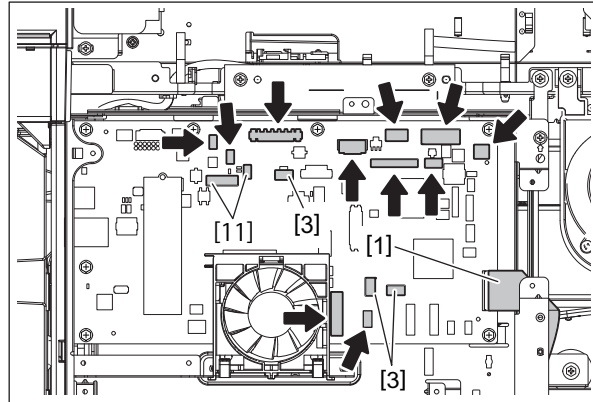

Fig. 9-13

Remarks:

When the Wireless LAN / Bluetooth Module is installed, disconnect 2 connectors [11].

Notes:

- Do not disconnect 3 connectors [3] connected to the USB Hub and the SYS board cooling fan.
- When installing the harnesses, be careful not to connect each different USB harness.
CN112: Beige USB harness
(The harness of the USB relay)
CN113: Black USB harness
(Extension cable for the card reader)
CN137: Black USB harness
(Harness for the Wireless LAN / Bluetooth Module)
- When removing the flat cable [1], release the lock by raising the flap [2] and pull out the cable.
When installing the flat cable [1], attach the cable to the connector and lock the cable by tilting the flap [2].
- When installing the flat cable [1], do not push it in strongly.
- When installing the flat cable [1], be careful not to insert it at an angle.
- Do not apply pressure to or damage the edge of the flat cable [1].

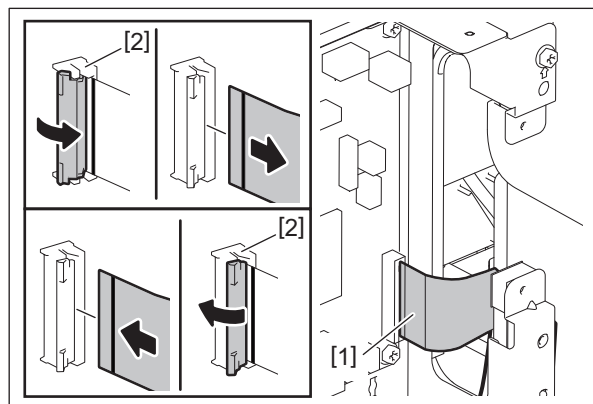

Fig. 9-14

- (4) Disconnect 2 connectors [4] from the USB Hub and release the harness from the harness clamp [5].

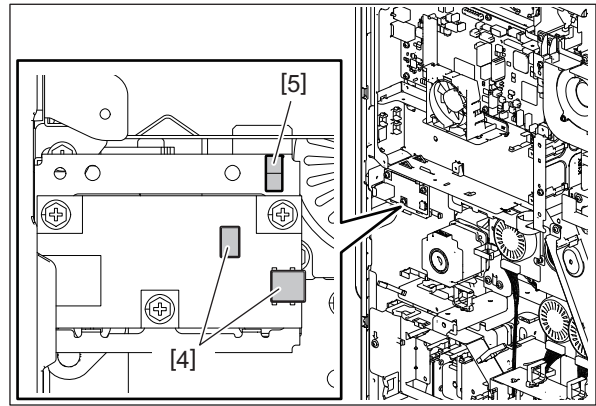

Fig. 9-15

- (5) Remove 2 screws [6]. Release the hook [7] and take off the USB Hub [8].

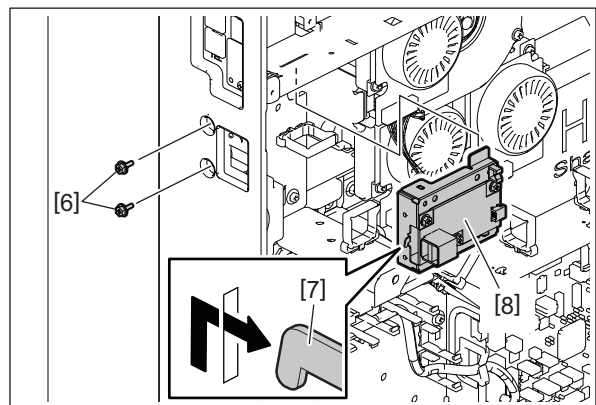

Fig. 9-16

- (6) Release the harness from the harness clamp [9]. Remove 5 screws and take off the SYS board case [10].

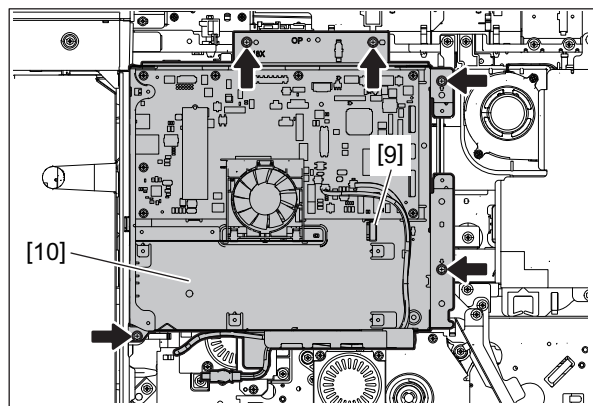



Fig. 9-17

Notes:

Hold the SYS board case to remove it.

9.1.9 SYS board cooling fan (F27)

- (1) Remove the SYS board cover.
 P. 9-1 "9.1.1 SYS board cover"
- (2) Disconnect 1 connector.
- (3) Lift 2 latches [1] and remove the SYS board cooling fan [2] by sliding it toward you.

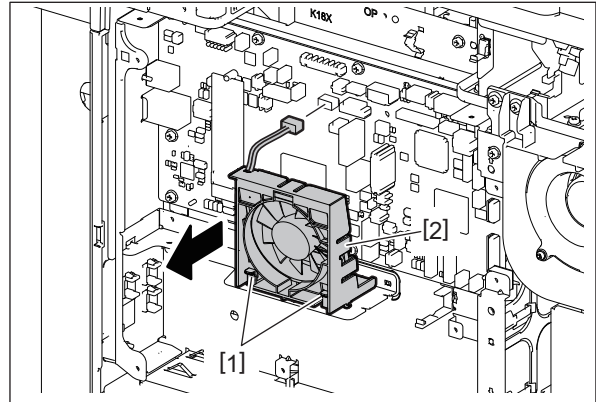



Fig. 9-18

9.1.10 LGC board (LGC)

- (1) Remove the rear cover.
 P. 4-12 "4.1.22 Rear cover"
- (2) Remove all the connectors and 1 flat cable [2] that are connected to the LGC board [1].

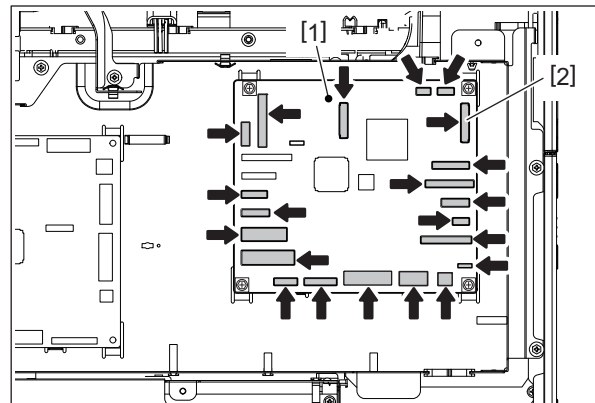

Fig. 9-19

Notes:

- When removing the flat cable [2], release the lock by raising the flap [3] and pull out the cable.
When installing the flat cable [2], attach the cable to the connector and lock the cable by tilting the flap [3].
- When installing the flat cable [2], do not push it in strongly.
- When installing the flat cable [2], be careful not to insert it at an angle.
- Do not apply pressure to or damage the edge of the flat cable [2].

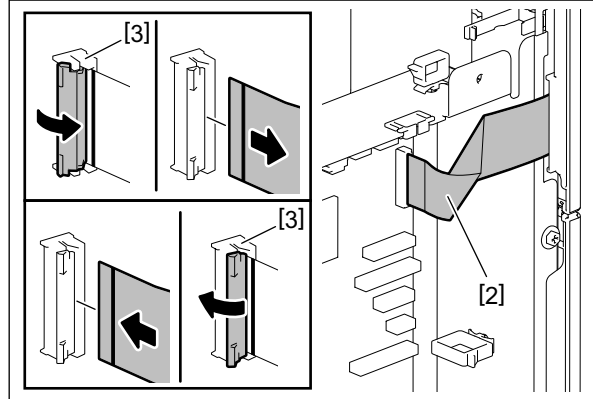

Fig. 9-20

- (3) Remove 4 screws and take off the LGC board [1].

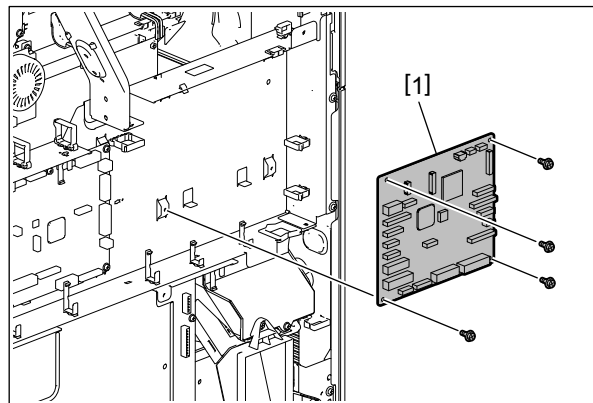

Fig. 9-21

Notes:

The LGC board to be installed differs depending on the models. Due to this, before replacing, be sure to check that the color of the identification label on the LGC board in order to install the corresponding one in the MFP.

- 6529A: Yellow
- 7529A: Pink
- 9029A: Brown

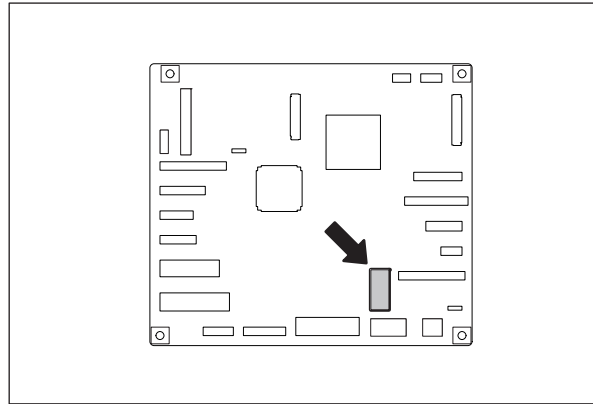

Fig. 9-22

9.1.11 Sub EEPROM

- (1) Remove the rear cover.
P. 4-12 “4.1.22 Rear cover”
- (2) Remove the Sub EEPROM [1] from the LGC board [2].

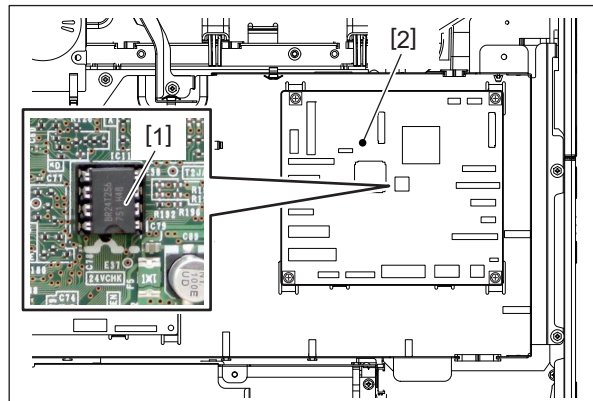



Fig. 9-23

Notes:

- Be careful not to damage the Sub EEPROM [1] when removing it from the LGC board [2].
- When installing the Sub EEPROM [1], pay attention to the orientation. Install the Sub EEPROM [1] with its concave portion down.

9.1.12 LGC/PFC board case

- (1) Remove the rear cover.
 P. 4-12 "4.1.22 Rear cover"
- (2) Disconnect all the connectors and 1 flat cable [3] that are connected to the LGC board [1] and the PFC board [2].

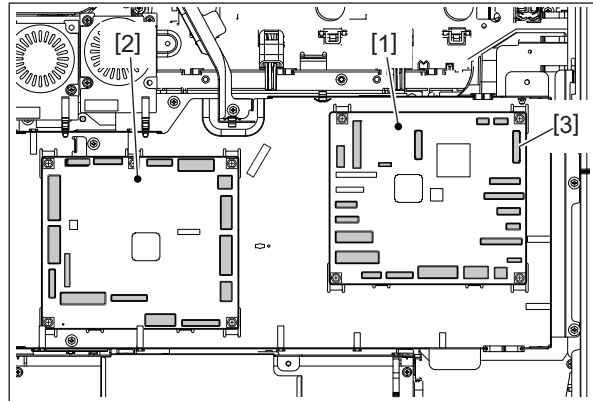

Fig. 9-24

Notes:

- When removing the flat cable [3], release the lock by raising the flap [4] and pull out the cable.
- When installing the flat cable [3], attach the cable to the connector and lock the cable by tilting the flap [4].
- When installing the flat cable [3], do not push it in strongly.
- When installing the flat cable [3], be careful not to insert it at an angle.
- Do not apply pressure to or damage the edge of the flat cable [3].

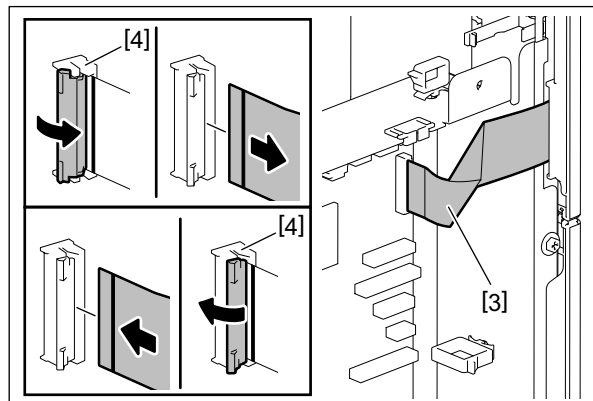

Fig. 9-25

- (3) Release the harnesses from the harness clamps shown in the figure.

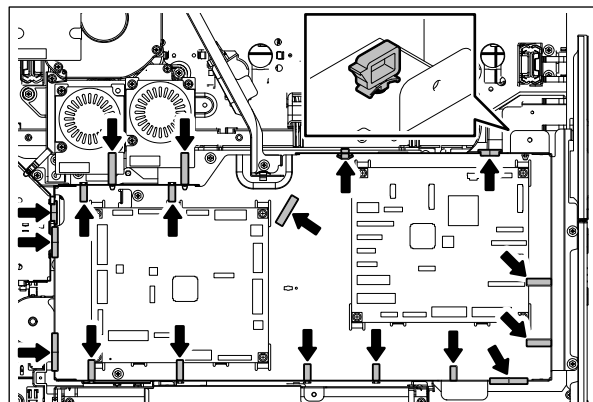

Fig. 9-26

(4) Release the flat cable from 3 flat cable clamps.

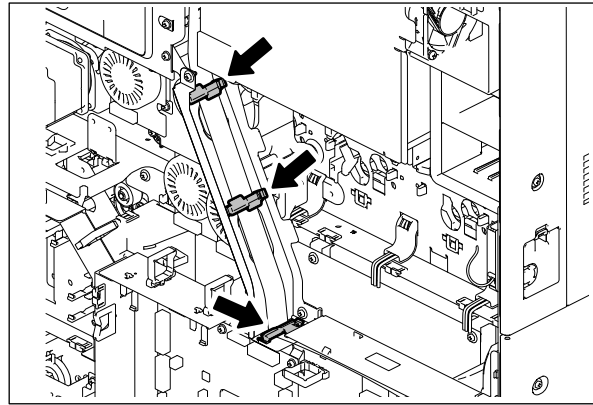

Fig. 9-27

(5) Remove 3 screws and take off the stay [4].

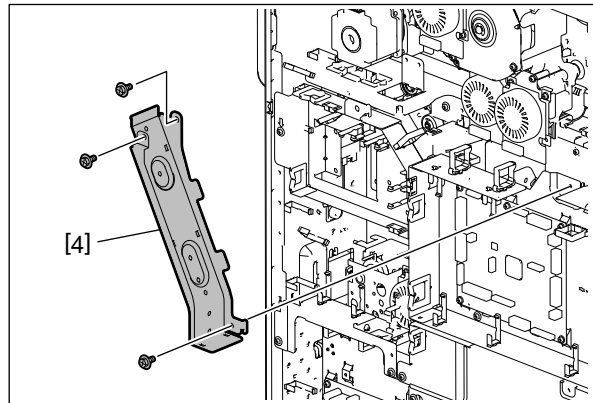

Fig. 9-28

(6) Remove 2 screws and release the bracket [5].

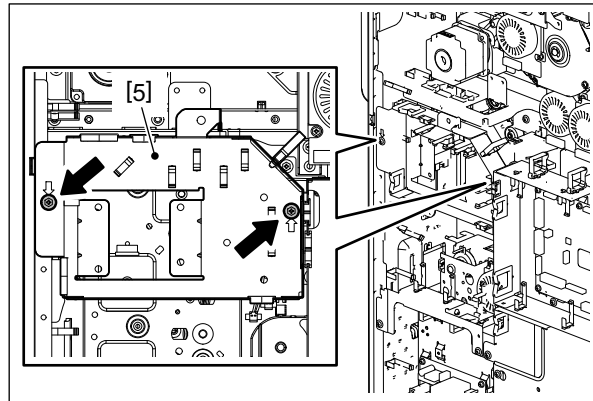

Fig. 9-29

(7) Remove 4 screws and take off the LGC/PFC board case [6].

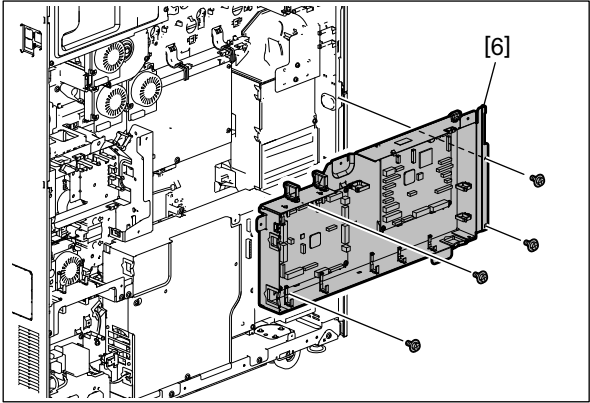



Fig. 9-30

9.1.13 PFC board (PFC)

- (1) Remove the rear cover.
 P. 4-12 "4.1.22 Rear cover"
- (2) Remove all the connectors that are connected to the PFC board [1].

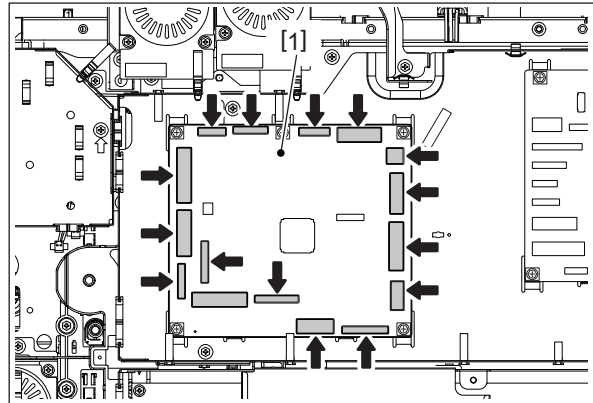

Fig. 9-31

- (3) Remove 5 screws and take off the PFC board [1].

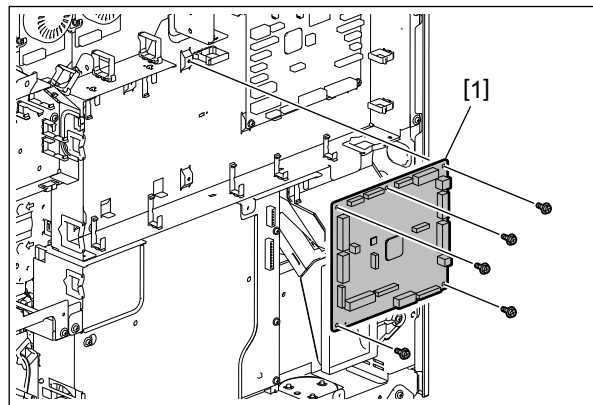

Fig. 9-32

Remarks:

The color of the identification label of the PFC board which is installed in the MFP (at the factory shipment) differs that for the one supplied as a service part.

| Model | Label color (at the factory shipment) | Label color (service part) |
|---|---------------------------------------|----------------------------|
| 6529A/7529A/9029A (4-drawer model) | Pink | Green |
| 6529A/7529A/9029A (Tandem LCF model) | Deep blue | |

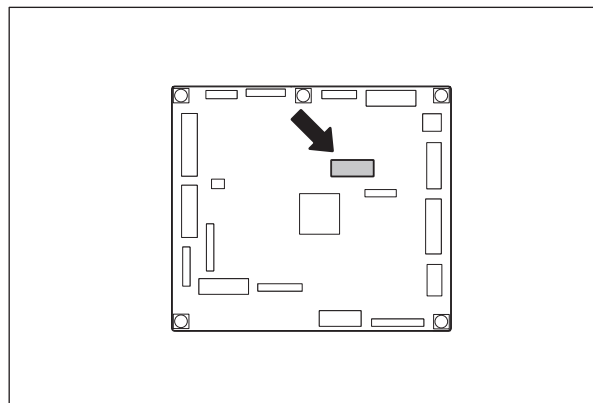



Fig. 9-33

9.1.14 Switching regulator (PS)

Notes:

- Be sure to unplug the power cable before starting this work.
- Electric charge may remain in the capacitors on the switching regulator even if the MFP is shut down and the plug is disconnected. Since there is a risk of an electric shock, pay full attention not to touch the board and mounted parts while handling the switching regulator.

(1) Remove the rear cover.

 P. 4-12 "4.1.22 Rear cover"

(2) Remove 2 screws and take off the ozone filter dummy case [4].

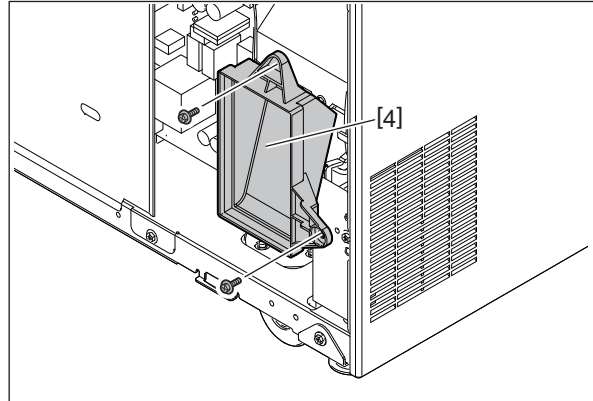

Fig. 9-34

(3) Remove 2 screws and take off the switching regulator cover [1].

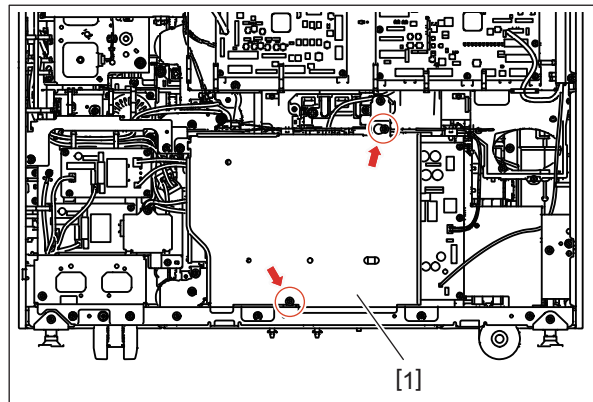

Fig. 9-35

(4) Remove all the connectors that are connected to the switching regulator [2].

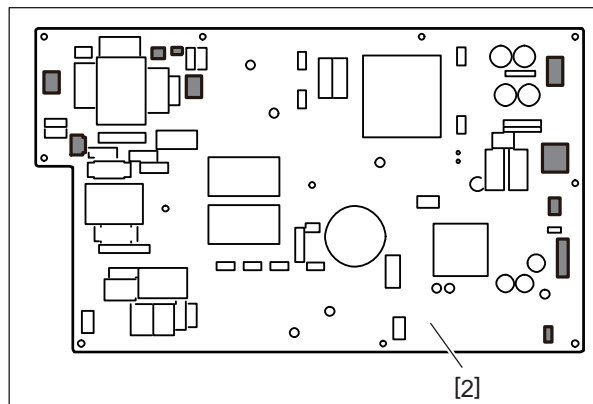

Fig. 9-36

- (5) Disconnect 1 connector and release the harness from 6 harness clamps.

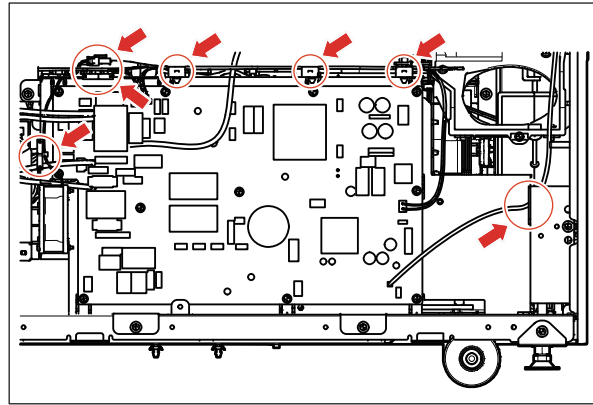

Fig. 9-37

- (6) Remove 4 screws and take off the switching regulator [3].

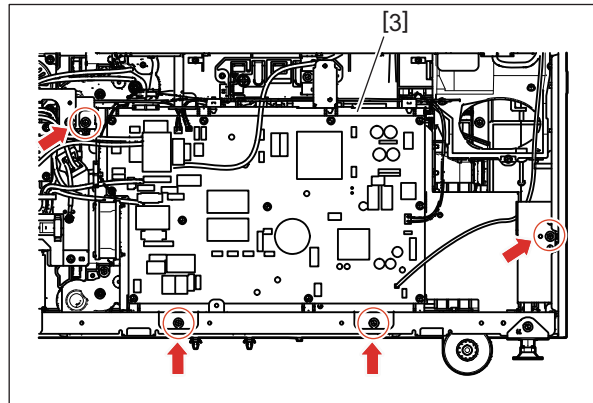

Fig. 9-38

9.1.15 High-voltage transformer (HVT)

Notes:

Be sure to unplug the power cable before starting this work.

- (1) Remove the LGC/PFC board case.
📖 P. 9-13 “9.1.12 LGC/PFC board case”
- (2) Remove the switching regulator case.
📖 P. 9-17 “9.1.14 Switching regulator (PS)”
- (3) Disconnect all the connectors that are connected to the high-voltage transformer [1].

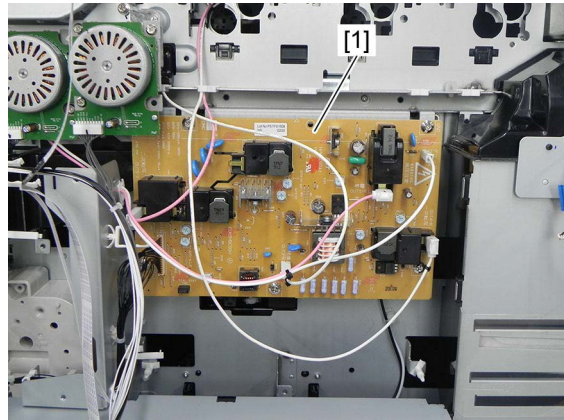

Fig. 9-39

- (4) Remove 5 screws and release 1 locking support, and then take off the high-voltage transformer [1].

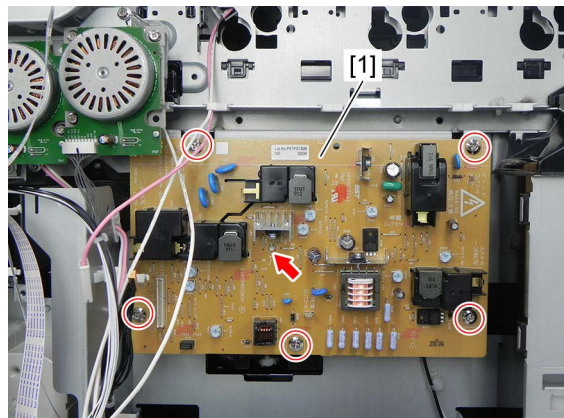

Fig. 9-40

9.1.16 FIL-AC board

Notes:

Be sure to unplug the power cable before starting this work.

- (1) Remove the rear cover.
P. 4-12 "4.1.22 Rear cover"
- (2) Disconnect 3 connectors from the FIL-AC board [1].

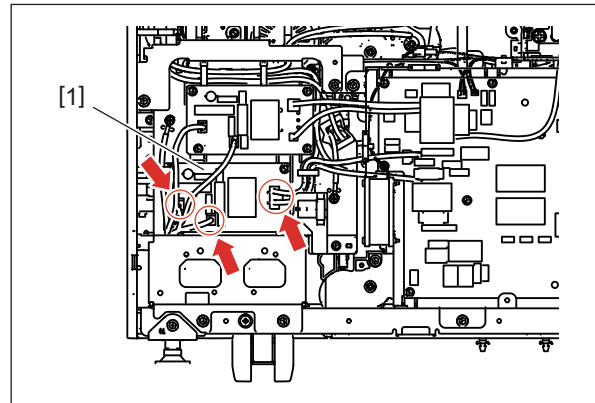

Fig. 9-41

- (3) Remove 4 screws and take off the FIL-AC board [1].

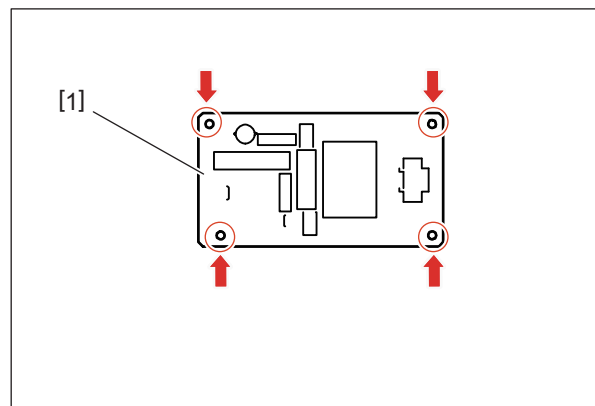

Fig. 9-42

9.1.17 FIL-IH board (9029A models of JPC only)

Notes:

Be sure to unplug the power cable before starting this work.

- (1) Remove the rear cover.
P. 4-12 "4.1.22 Rear cover"
- (2) Disconnect 4 connectors from the FIL-IH board [1].

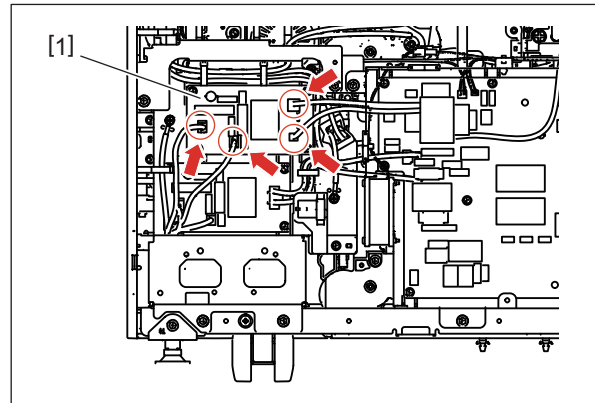

Fig. 9-43

- (3) Remove 4 screws and take off the FIL-IH board [1].

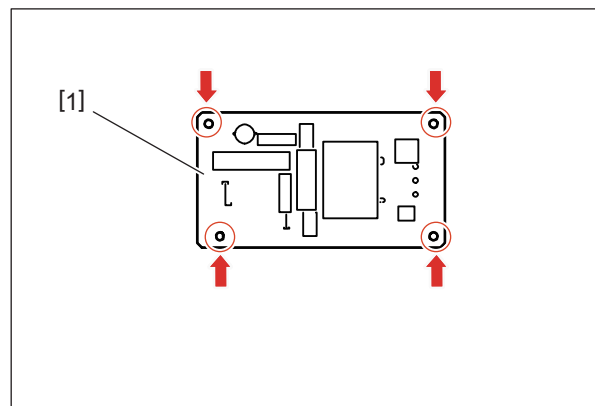

Fig. 9-44

9.1.18 DAMP PC board (ASD, AUD, ARD, JPC, CND)

Notes:

- Be sure to unplug the power cable before starting this work.
- If the DAMP PC board is not installed appropriately, a serious accident such as an electric shock may occur. Therefore, to avoid this, be sure to perform correct handling and installation.

- (1) Remove the rear cover.
P. 4-12 “4.1.22 Rear cover”
- (2) Disconnect 3 connectors from the DAMP PC board [1].

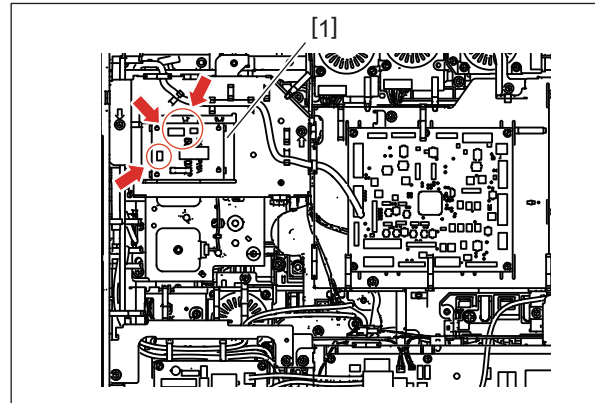

Fig. 9-45

- (3) Release 4 locking supports and remove the DAMP PC board [1].

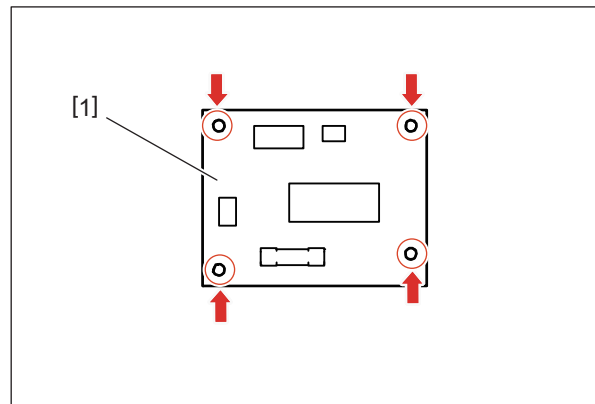



Fig. 9-46

9.1.19 DSDF I/F board

- (1) Remove the SYS board cover.
 P. 9-1 "9.1.1 SYS board cover"
- (2) Remove 2 screws [2] and disconnect 1 HDMI connector [3]. Remove 1 locking support and take off the DSDF I/F board [1].

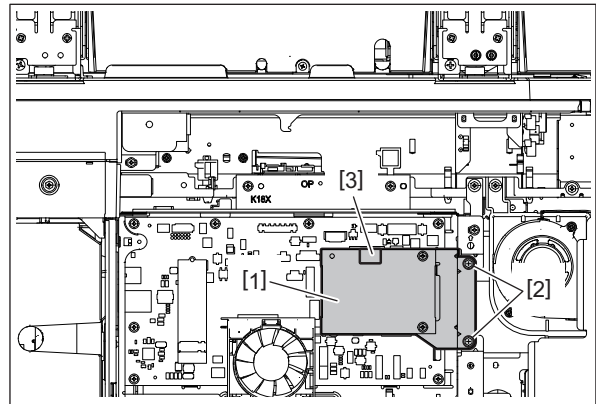

Fig. 9-47

9.1.20 IH board

Notes:

Be sure to unplug the power cable before starting this work.

- (1) Remove the rear cover.
 P. 4-12 "4.1.22 Rear cover"
- (2) Remove 4 screws and disconnect 1 connector, and then take off the IH board cover [1].

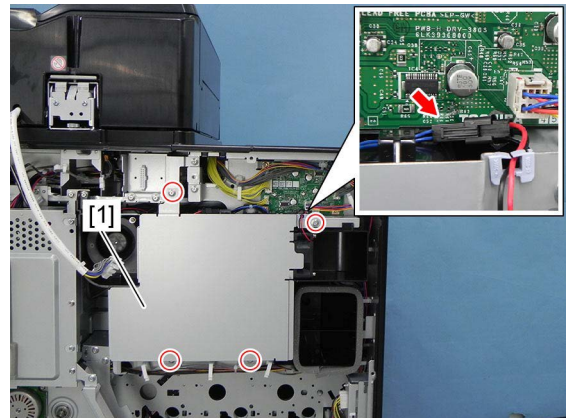

Fig. 9-48

- (3) Disconnect 3 connectors.

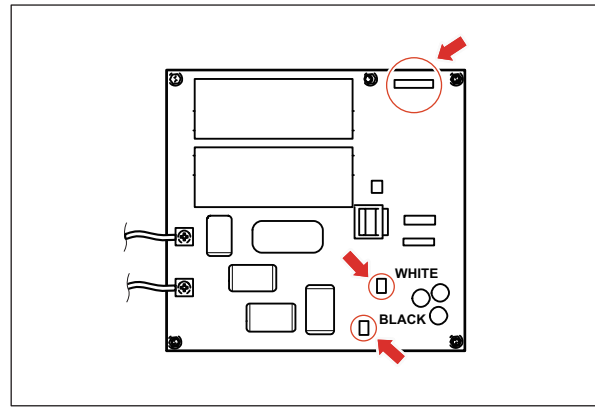

Fig. 9-49

Notes:

When connecting connectors, be careful not to confuse the white connector location with the black connector location.

- (4) Remove 1 screw for each terminal and take off 2 IH feed terminals [2].

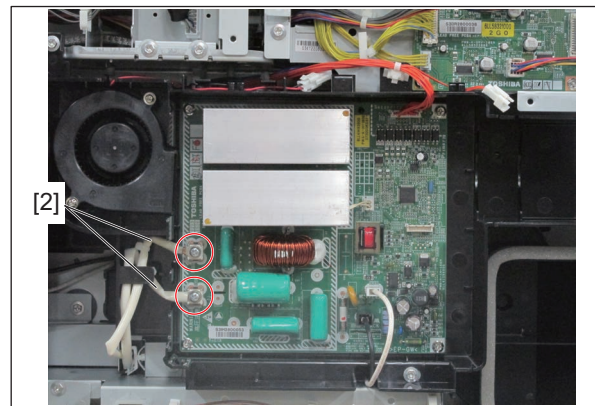

Fig. 9-50

Notes:

- Securely tighten the fixing screw of the IH feed terminals [2] so that they do not become loose.
- If the screw is not tightened securely when installing, heat will be generated due to a contact failure and this may cause a fire. To avoid this, be sure to confirm that the screw is tightened securely.

(5) Remove 4 screws and take off the IH board [3].

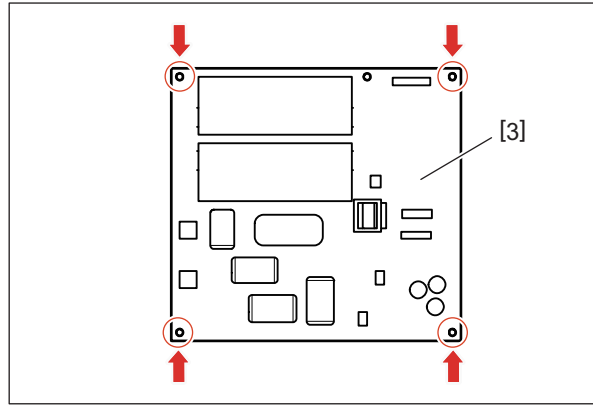

Fig. 9-51

Notes:

The IH board to be installed differs depending on the power voltage of the MFP. Due to this, before replacing, be sure to check the power voltage of the MFP and the color of the identification label on the IH board in order to install the corresponding one in the MFP.

- Power voltage 100V: Deep blue
- Power voltage 120V: White
- Power voltage 220 to 240V: Yellow

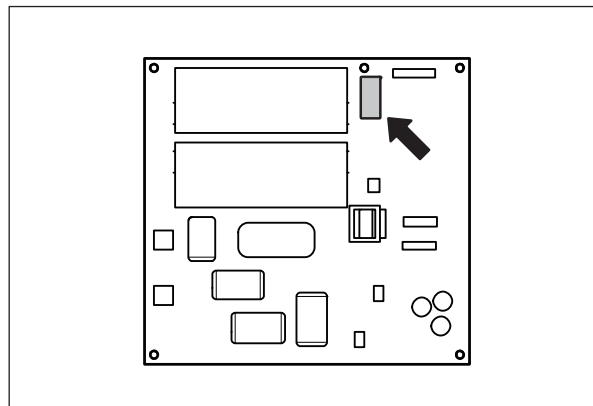



Fig. 9-52

9.1.21 DRV board

- (1) Remove the rear cover.
 P. 4-12 "4.1.22 Rear cover"
- (2) Disconnect 4 connectors from the DRV board [1].

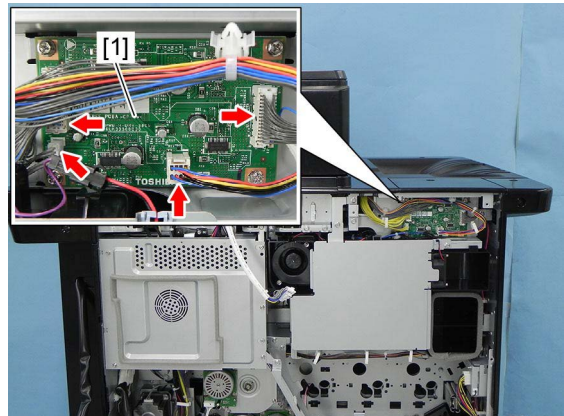

Fig. 9-53

- (3) Remove 4 screws and take off the DRV board [1].

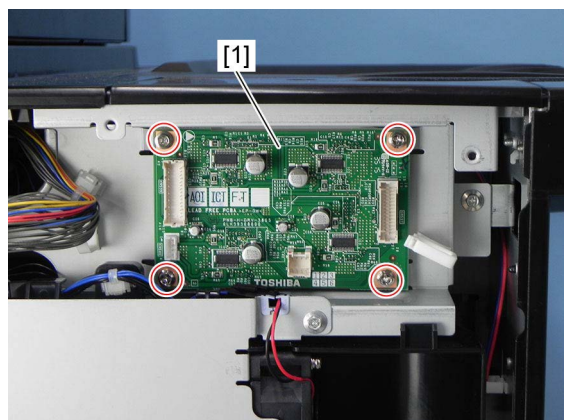



Fig. 9-54

9.1.22 CTIF board

- (1) Remove the toner motor assembly.
 P. 4-180 "4.6.46 Toner motor (K) (M15)"
- (2) Release 2 latches and remove the CTIF board [1].

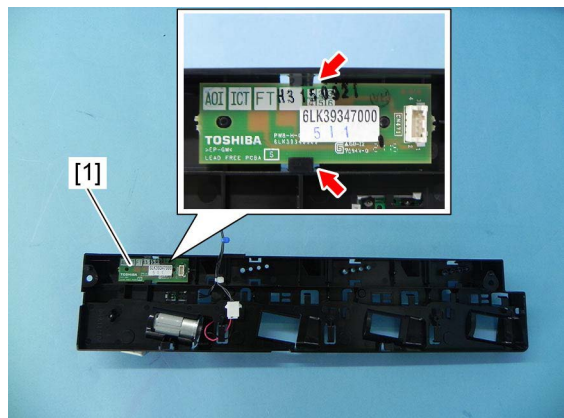







Fig. 9-55

9.2 Precautions, Procedures and Settings for Replacing PC Boards and Storage Device

9.2.1 Precautions when replacing PC boards

- The ID for each MFP is registered on the LGC board, the SYS board and Lens unit. So, if their replacement is required, be sure to replace only one board at a time. Do not replace the SYS board and the SRAM together.
- If both the LGC board and SYS board require replacement, replace them in the following procedure.
 1. First, replace one of the board to be replaced.
 2. Turn the power ON and confirm that “READY” is displayed.
 3. Turn the power OFF.
 4. Replace another board that requires replacement.
- When replacing the LGC board, remove the Sub EEPROM on the old board, and then attach it to the new board.
 P. 9-439.2.6 Procedures when replacing the LGC board”
- When the storage device requires replacement, see the following reference.
 P. 9-31 “9.2.3 Precautions and procedures when replacing the storage device”
- When the SYS board requires replacement, see the following reference.
 P. 9-36 “9.2.4 Precautions and procedures when replacing the SYS board”
- When the lens unit requires replacement, see the following reference.
 P. 9-48 “9.2.8 Procedures and settings when replacing the lens unit”
- When the SRAM requires replacement, see the following reference.
 P. 9-39 “9.2.5 Precautions and procedure when replacing the SRAM”
- When the DSP board requires replacement, see the following reference.
 P. 6-81 “6.12 Control Panel Calibration”

9.2.2 Storage device fault diagnosis

This enables the displaying of the storage device operation history, which is recorded in it, on the touch panel. Storage device failure can be diagnosed or predicted with the information displayed. The display method and items differ depending on the types of the storage device (SSD or HDD).

[1] Standard storage device (SSD)

(1) Display

Perform HS-75 File System Recovery > [SMART Info] > [Standard storage]. The following screen is displayed.

| ID | NAME | VALUE | NAV | Worst |
|----|-----------------------------|--------|-----|-------|
| 01 | Number of UNC Error | 0 | 100 | 100 |
| 09 | Power-on Hours Count | 1017 | 100 | 100 |
| 0c | Power ON/OFF Cycles Count | 287 | 100 | 100 |
| a2 | Spare Block Count(CE) | 478 | 100 | 100 |
| a8 | SATA PHY Error Count | 0 | 100 | 100 |
| aa | Bad Block Count(Later) | 0 | 100 | 100 |
| ad | Erase Count(Ave) | 15 | 100 | 100 |
| c0 | Unexpected Power Loss Count | 10 | 100 | 100 |
| c2 | Temperature | 41 | 59 | 56 |
| da | CRC Error Count | 0 | 100 | 100 |
| e7 | SSD Life Left | 99 | 100 | 100 |
| e9 | NAND Write(GB) | 1096 | 100 | 100 |
| f1 | Host Write(GB) | 611 | 100 | 100 |
| f6 | Total Erase Count | 123970 | 100 | 100 |

Model : PhisonPHSM128GFNTL-E-TE0040-S-SCRM133 ——— SSD model name
 Serial : 128210305000164 ——— SSD serial number

Fig. 9-56

- Items supported differ depending on the storage device manufacturer.
- “---” is displayed on the VALUE, NAV and Worst columns if items are not supported.

(2) Usage

The combination of the values of ID=a2 and e7 is used to diagnose whether or not the SSD has a physical failure when it is suspected.

| Result | | Description | Diagnosis |
|--------|-------|---|---------------------------------|
| ID | VALUE | | |
| a2 | 5 | The number of remaining spare blocks is small. | SSD replacement is recommended. |
| e7 | 0 | The flash memory has reached the end of its life. | SSD replacement is recommended. |

(3) ID=a2 and e7

| ID | Name | Description | Remarks |
|----|-----------------------|----------------------------------|--|
| a2 | Spare Block Count(CE) | Number of remaining spare blocks | A faulty block will be replaced with a spare one. |
| e7 | SSD Life Left | Flash memory life (%) | “100%” is indicated at the beginning of use. When it becomes “0%”, the flash memory has reached the end of its life. |

(4) Description of each ID

| ID | Name | Explanation |
|----|-----------------------------|---|
| 01 | Number of UNC Error | Uncorrectable error numbers |
| 05 | SSD Status | SSD status (0: Normal, 1: Abnormal) |
| 09 | Power-on Hours Count | Power-on hours |
| 0c | Power ON/OFF Cycles Count | Power ON/OFF times |
| a2 | Spare Block Count(CE) | Number of remaining spare blocks (A faulty block will be replaced with a spare one.) |
| a8 | SATA PHY Error Count | Error detection times in PHY (physical layer) |
| aa | Bad Block Count(Later) | Number of faulty blocks |
| ad | Erase Count(Ave) | Flash memory average erasure (P/E [*]) times per block |
| c0 | Unexpected Power Loss Count | Forcible power OFF times |
| c2 | Temperature | SSD internal temperature |
| da | CRC Error Count | CRC error occurrence times |
| e7 | SSD Life Left | Flash memory life (Unit: %) ("100%" is indicated at the beginning of use. When it becomes "0%", the flash memory has reached the end of its life.) |
| e9 | NAND Write(GB) | Writing size to a flash memory (Unit: GB) |
| f1 | Host Write(GB) | Writing size to an SSD controller (Unit: GB) |
| f2 | Host Read(GB) | Reading size from an SSD controller (Unit: GB) |
| f6 | Total Erase Count | Flash memory total erasure (P/E [*]) times |

* P/E: program/erase

[2] Optional storage device (SSD or HDD)

(1) Display

Perform HS-75 File System Recovery > [SMART Info] > [Optional storage]. The following screen is displayed.

| ID | NAME | VALUE | NAV | Worst |
|----|--------------------------------|-------|------|-------|
| 01 | Read Error Rate | 0 | 100 | 100 |
| 02 | Throughput Performance | 0 | 100 | 100 |
| 03 | Spin Up Time | 1308 | 100 | 100 |
| 04 | Spin Start /Stop Count | 92 | 100 | 100 |
| 05 | Re-allocated Sector Count | 0 | 100 | 100 |
| 06 | Read Channel Margin | ----- | ---- | ---- |
| 07 | Seek Error Rate | 0 | 100 | 100 |
| 08 | Seek Time Performance | 0 | 100 | 100 |
| 09 | Power-On Hours | 75 | 100 | 100 |
| 0a | Spin Retry Count | 0 | 101 | 100 |
| 0b | Calibration Retry Count | ----- | ---- | ---- |
| 0c | Power Cycle Count | 71 | 100 | 100 |
| bf | Shock Sense Count | 0 | 100 | 100 |
| c0 | Power-Off Retract Count | 0 | 100 | 100 |
| c1 | Load Cycle Count | 1094 | 100 | 100 |
| c2 | Temperature | 25 | 100 | 100 |
| c3 | ECC On the Fly Count | ----- | ---- | ---- |
| c4 | Re-allocation Event Count | 0 | 100 | 100 |
| c5 | Current Pending Sector Count | 0 | 100 | 100 |
| c6 | Off-Line Scan Unc Sector Count | 0 | 100 | 100 |

Model : TOSHIBA MQ01ABU032BW ——— HDD model name
 Serial : 58NBVWTST ——— HDD serial number

NextPage Back

Fig. 9-57

- Items supported differ depending on the storage device manufacturer.
- “---” is displayed on the VALUE, NAV and Worst columns if items are not supported.

(2) Usage

The combination of the values of ID=05 and c5 is used to diagnose whether or not the HDD has a physical failure when its failure is suspected (service call F100 to F109 or F120 to F124 occurred).

Refer to the following pages for details about the fault diagnosis for the SSD.

📖 P. 9-28 “[1] Standard storage device (SSD)”

| Result | | Description | Diagnosis |
|--------|--------------------------------------|---|----------------------------------|
| ID | VALUE | | |
| 05 | 0 | Low possibility of physical failure | HDD replacement is not required. |
| c5 | 0 | | |
| 05 | From 1 to 999 | Defective sector has been reassigned and the storage device is recovered. | HDD replacement is not required. |
| c5 | 0 | | |
| 05 | Any value | High possibility of defective sector existence. (There will be a possibility of physical failure depending on the use of HDD.) | HDD replacement is recommended. |
| c5 | 1 or more | | |
| 05 | Either one is at least 1000. | High possibility of physical failure | HDD replacement is recommended. |
| c5 | | | |
| 05 | All values are displayed as “-----”. | High possibility of physical failure (An HDD connector, harness or SYS board may be one of the causes.) | HDD replacement is recommended. |
| c5 | | | |

(3) ID=05 and c5

| ID | Name | Description | Remarks |
|----|------------------------------|---|--|
| 05 | Re-allocated Sector Count | Number of sectors reallocated | This value tends to increase at HDD failure. |
| c5 | Current Pending Sector Count | Number of candidate sectors to be reallocated | This value tends to increase at HDD failure. |

(4) Description of each ID

| ID | Name | Explanation |
|----|--|--|
| 01 | Read Error Rate | Read error rate |
| 02 | Throughput Performance | Throughput performance |
| 03 | Spin Up Time | Spindle motor start-up time |
| 04 | Spin Start/Stop Count | Spindle motor start and stop times |
| 05 | Re-allocated Sector Count | Number of reallocation sectors |
| 07 | Seek Error Rate | Seek error rate |
| 08 | Seek Time Performance | Seek time performance |
| 09 | Power-On Hours | Power on hours (The unit varies depending on the manufacture: Minute or Hour.) |
| 0a | Spin Retry Count | Spindle motor start-up retry times |
| 0c | Power Cycle Count | Power ON/OFF times |
| c0 | Power off Retract Count | Emergency unloading times |
| c1 | Load Cycle Count | Loading/unloading times |
| c2 | Temperature | HDD internal temperature |
| c3 | ECC On the Fly Count | ECC On the Fly count |
| c4 | Reallocation Event Count | Reallocation event times |
| c5 | Current Pending Sector Count | Number of reallocation candidate sectors |
| c6 | Off-Line Scan Uncorrectable Sector Count | Off-line scanning uncorrectable sector count |
| c7 | Ultra DMA CRC Error Count (Rate) | Ultra DMA CRC error count |
| c8 | Write Error Rate | Write error rate |

Notes:

“Over-range” is displayed if the number of digits acquired from the HDD exceeds the maximum digits which can be displayed on the control panel; however, this does not indicate an error.

9.2.3 Precautions and procedures when replacing the storage device

The following optional storage devices can be installed in this MFP.

- Security HDD (GE-1360)
- Normal HDD (GE-1270: CND only)
- Security SSD (GE-1350, GE-1280)
- Normal SSD (GE-1290: CND only)

By the setting of FS-08-9717-1 (Optional storage device security setting), data in the optional storage device are protected and operated as below.

- When “0” (Normal) is set for FS-08-9717-1: Expands the image saving area.
- When “1” (Security) is set for FS-08-9717-1: Protects major user data (scanning data, address book) and expands the image saving area.
- When “2” (High security) is set for FS-08-9717-1: Protects all user data.

Notes:

- When the storage device is replaced, it is necessary to back up the data in it before replacing and to recover them after replacing.
- To maintain the security, ask users to perform the backup or restore for users' data and information in the storage device. The service technician can perform them only when users permit it.
- Some data in the storage device cannot be backed up and can be kept only on the paper.
- Do not replace the storage device and the SRAM together.
- When the storage device is replaced, do not perform SRAM data formatting (Clear SRAM) before the normal start-up.
- When the storage device is replaced, do not restore the back-up file before the normal start-up.

A procedure for replacing the storage device is shown below.

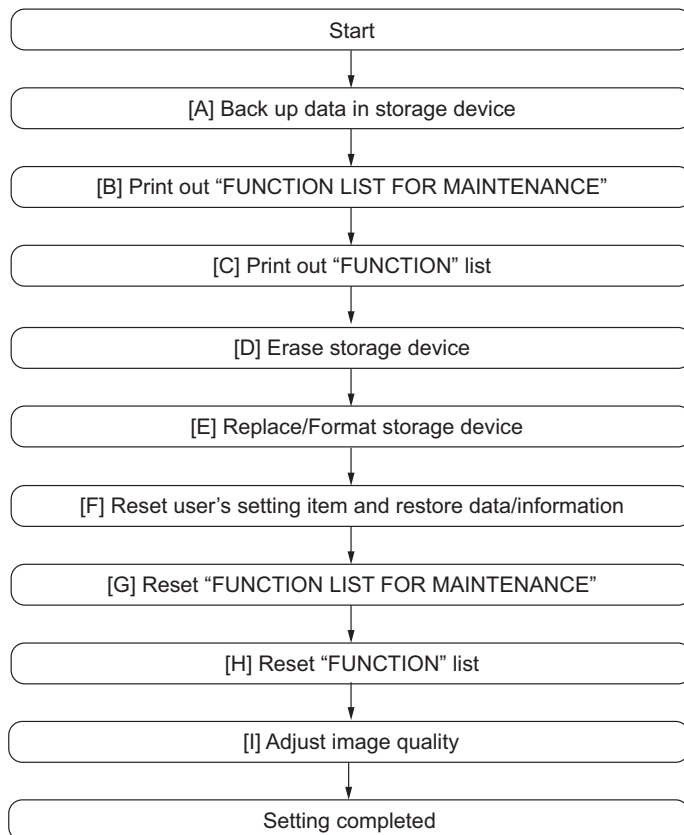

Fig. 9-58

[A] Back up data in storage devices

Ask the user (administrator) to back up the data in the storage devices. Refer to the table below for the type of data, availability and method of backup.

| Data type in storage devices | Availability | Backup method |
|--|---------------|---|
| Image data in e-Filing | Available | Archive them in "e-Filing" of TopAccess. As for the backup in Box data, all data (selectable by the box) can be backed up or restored in one go by using "e-Filing Backup/Restore Utility". |
| Mailbox information, Template registration information, Address book data, License | Available | Export them in the [Administration] tab - [Maintenance] - [Export] of TopAccess. |
| User information, Combined information (User information + Role + Group), LDAP Role, Department information, Project code | Available | Export them in the [Administration] tab - [Export/Import] - [Export] of TopAccess. |
| Log data (Print, Scan, FAX (Transmission, Reception)) | Available | Export them in the "Administrator" menu of TopAccess. (Import cannot be performed.) |
| Data in the shared folder (Scanned data, Saved data of copy and FAX transmission) | Available | Copy them to the client computer via the network. (The data which have been copied to the client computer cannot be copied to the shared folder.) |
| Print waiting data (Copying data and FAX reception data that are waiting to be printed due to the paper run-out and jam, etc.) | Not available | Finish printing them after supplying paper or releasing the jam, etc. (The data cannot be left.) |
| Print job (Private print data, Schedule print data) | Not available | If any jobs are left, print them. (The data cannot be backed up.) |
| FAX saved data (Confidential / Bulletin board data) | Not available | Print them. (The data cannot be backed up.) |
| Registration data for FAX transmission (Delayed transmission / Recovery transmission) | Not available | The data cannot be backed up. |

Notes:

If the backing up of the license has failed, reissue it and install it in the MFP again.

📖 P. 14-17 "14.6 License"

[B] Print out "FUNCTION LIST FOR MAINTENANCE"

- (1) Perform FS-12 (12 FAX LIST PRINT MODE).
- (2) Select "Function list for Maintenance" and then press [PRINT].

[C] Print out "FUNCTION" list

- (1) Press [USER FUNCTIONS] on the [HOME] screen.
- (2) Enter the password in [Administrator] tab and press [OK].

Notes:

Explain the procedure to the users (machine administrators) and ask them to enter their password.

- (3) Press [LIST/REPORT] and then [LIST].
- (4) Press [FUNCTION]. The "FUNCTION LIST" is printed out.

[D] Delete data in storage devices

- (1) Perform HS-74 Storage Assist > [Revert Factory Initial Status Storage] and then press [OK].
- (2) Turn the power OFF.

[E] Replace / Format storage device

Standard storage device

- (1) Be sure to unplug the power cable before starting this work.
- (2) Replace the standard storage device.
 P. 9-4 "9.1.4 SSD"
- (3) Creates a partition of the standard storage device.
Perform HS-73 Firmware Assist > [Format Storage] and then press [OK].
When "Operation Complete" is displayed on the LCD, creating of the partitions is completed.

Remarks:

When HS-73 Firmware Assist > [Storage Data Restore] is carried out instead of step (3), perform [Storage Data Restore] and then the following steps in [E].

(4) > (5) > (6) > (9) > (10) > (11) > (12)

In addition, skip [F] and perform the procedure from [G].

- (4) Turn the power OFF.
- (5) Initialize the service password.
Perform HS-73 Firmware Assist > [Clear Service Tech Password] and then press [OK].
When "Reset Complete" is displayed on the LCD, formatting of the service tech password is completed.
- (6) Turn the power OFF.
- (7) Update the system software using the USB storage device.
 P. 11-2 "11.2 Firmware Updating with a USB Storage Device"
- (8) Turn the power OFF.
- (9) When the Fax Board (GD-1370) is installed, perform [CUSTOM INITIALIZE] > [INIT MEMORY(FAX)] and [CLEAR DATA] in the FS-11 FAX CLEAR MODE. Then turn the power OFF.
- (10) Check the system software version (FS-08-8952).
Confirm the version displayed on the LCD, and then press [OK].
- (11) Initialize the NIC information (FS-08-9083).
- (12) Turn the power OFF.

Notes:

When replacing or formatting the standard storage device, the licenses installed in the MFP are removed. Therefore, it is necessary to restore those licenses after the replacement or formatting.

 P. 14-17 "14.6 License"

Optional storage device

- (1) Creates a partition of the standard storage device.
Perform HS-73 Firmware Assist > [Format Storage] and then press [OK].
When “Operation Complete” is displayed on the LCD, creating of the partitions is completed.
- (2) Turn the power OFF.
- (3) Update the system software using the USB storage device.
📖 P. 11-2 “11.2 Firmware Updating with a USB Storage Device”
- (4) Be sure to unplug the power cable before starting this work.
- (5) Replace the optional storage device.
📖 P. 9-5 “9.1.5 Optional HDD”
📖 P. 9-5 “9.1.6 Optional SSD”

Remarks:

Once the optional storage device is installed, its partition is created automatically.

- (6) Initialize the service password.
Perform HS-73 Firmware Assist > [Clear Service Tech Password] and then press [OK].
When “Reset Complete” is displayed on the LCD, formatting of the service tech password is completed.
- (7) Turn the power OFF.
- (8) When the Fax Board (GD-1370) is installed, perform [CUSTOM INITIALIZE] > [INIT MEMORY(FAX)] and [CLEAR DATA] in the FS-11 FAX CLEAR MODE. Then turn the power OFF.
- (9) Check the system software version (FS-08-8952).
Confirm the version displayed on the LCD and then press [OK].
- (10) Initialize the NIC information (FS-08-9083).
- (11) Turn the power OFF.

[F] Reset user’s setting items and restore data/information

Ask the user (MFP administrator) to reset the user’s setting items and to restore data or information. Refer to the following for the reset and restore.

| Items to be reset and restored | Action |
|---|--|
| Printer driver | Upload them in the “Administrator” menu of TopAccess. |
| Mailbox information, Template registration information, Address book data, License | Import them in the [Administration] tab - [Maintenance] - [Import] of TopAccess. |
| User information, Combined information (User information + Role + Group), LDAP Role, Department information, Project code | Import them in the [Administration] tab - [Export/Import] - [Import] of TopAccess. |
| Image data in e-Filing | Upload them in the “e-Filing” of TopAccess. |

Notes:

- When the SSL is enabled, perform the setting of the following items again with “Self-signed certificate” of TopAccess.
 - Country or Region Name
 - State or Province Name
 - Locality Name
 - Organization Name
 - Organizational Unit Name
 - Common Name
 - Email Address
- When the wireless LAN is used, recreate its setting. (Only when security with a certificate is used)
 - CA certificate (PEM)
 - CA certificate (DER)
- If the restoring of the licenses has failed while the storage data are backed up, reissue them and install them in the MFP again.
📖 P. 14-17 “14.6 License”

[G] Reset “FUNCTION LIST FOR MAINTENANCE”

- (1) Print out the “FUNCTION LIST FOR MAINTENANCE” list before initializing the storage device.
📖 P. 9-32 “[B] Print out “FUNCTION LIST FOR MAINTENANCE””
- (2) Perform FS-13 (13 FAX FUNCTION MODE).
- (3) Compare the lists which were printed before and after the initializing to check the setting items having the different setting values. Set the value which was set before the initializing.
- (4) Turn the power OFF.

[H] Reset “FUNCTION” list

Reset the fax function by referring to the “FUNCTION” list.

📖 P. 9-32 “[C] Print out “FUNCTION” list”.

- (1) Press [USER FUNCTIONS] on the [HOME] screen.
- (2) Enter the password in [Administrator] tab and press [OK].

Notes:

Explain the procedure to the users (MFP administrators) and ask them to enter their password.

- (3) Press [FAX] and then [TERMINAL ID] to set each item.
- (4) Press [INITIAL SETUP] to set each item.

[I] Adjust image quality

- (1) Perform Automatic gamma adjustment.
📖 P. 6-26 “6.1.7 Automatic gamma adjustment”
- (2) Turn the power OFF.

9.2.4 Precautions and procedures when replacing the SYS board

A procedure for SYS board replacement is shown below.

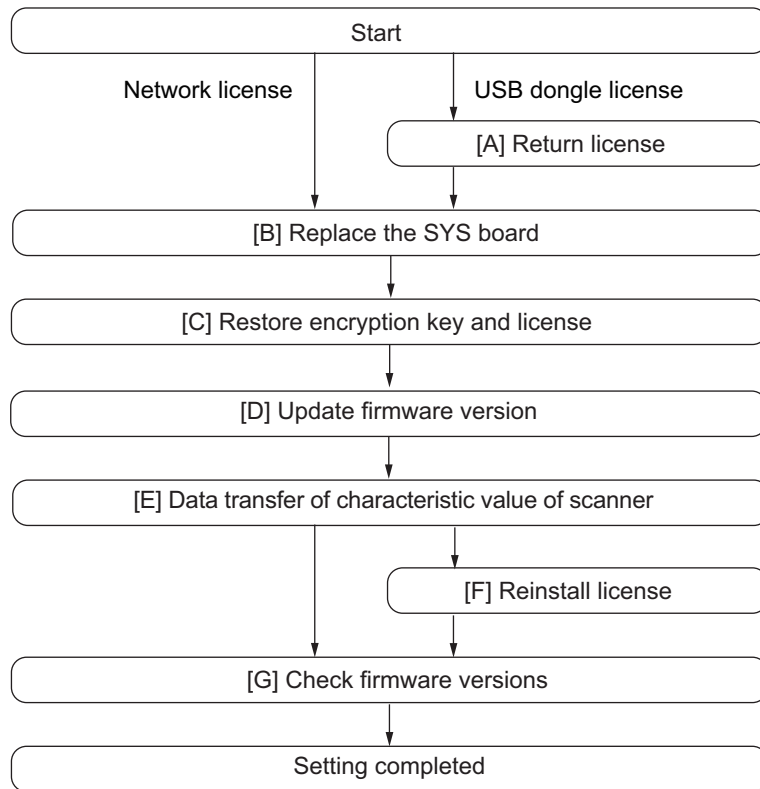

Fig. 9-59

Notes:

- When the SYS board in the MFP with TPM enabled is replaced, the restoring operation of TPM is necessary.
 - P. 5-50 “5.22 TPM Restore”
- It is required to perform storage device initialization in the MFP with the High Security Mode enabled. Therefore, perform the following items which are carried out at the storage device replacement in advance.
 - P. 9-32 “[A] Back up data in storage devices”
 - P. 9-32 “[B] Print out “FUNCTION LIST FOR MAINTENANCE””
 - P. 9-32 “[C] Print out “FUNCTION” list”

[A] Return License

Notes:

- If the 08 Setting Mode is not started up, “[A] Return License” can be omitted. In that case, reinstall the license with “[1] Re-registration when the board is replaced” if it is cleared since “[H] Reinstallation of License” cannot be performed.
- When the security mode is set to High Security, specify the security mode level to “1” (Low level) for FS-08-8911 and then reboot the MFP.

- (1) Perform FS-08-3840.
- (2) Select the license to be returned, and then press [REMOVE].
- (3) Install the one-time dongle, which you used for uploading the selected license, in the MFP and then press [OK].

- (4) The Remove screen is displayed, then press [YES].
If this screen is not displayed, check whether the one-time dongle is installed in the MFP properly.
- (5) After 10 to 40 seconds passes, the screen for notifying the success of performance is displayed. Then press [OK].
If this screen is not displayed or the screen for notifying the failure of performance is displayed, quit this operation by pressing [NO] or [CLOSE].
Then, check whether the one-time dongle, which you used for uploading the selected license, is installed in the MFP.
- (6) Check that the returned license is not displayed on the screen.

Remarks:

- If there are any other licenses to be returned, repeat from step (2).
- If there is no more licenses to be returned, press [CLOSE] and then turn the power OFF.

[B] Replace the SYS board

Notes:

Before replacing the SYS board, perform the following procedure.

 P. 9-27 "9.2.1 Precautions when replacing PC boards"

- (1) Be sure to unplug the power cable before starting this work.
- (2) Replace the SYS board.
- (3) Install the SRAM in the new SYS board (from the old SYS board).
- (4) Install the standard SSD in the new SYS board (from the old SYS board).

[C] Restore Encryption Key and License

- (1) Perform HS-73 Firmware Assist.
- (2) Press [Key Backup/Restore].
- (3) Press [Direction], and then press [Execute].
- (4) Wait until the restoring of the encryption key and license is completed. "Success" is displayed. Confirm that "OK" is indicated in all of the FROM column and then reboot the MFP.

For MFP with the High Security Mode enabled

Continue by performing the following steps.

1. Create the partitions on the storage device.
Perform HS-73 Firmware Assist > [Format Storage] and then press [OK].
When "Operation Complete" is displayed on the LCD, creating of the partitions is completed.
2. Turn the power OFF.
3. Initialize the service password.
Perform HS-73 Firmware Assist > [Clear Service Tech Password] and then press [OK].
When "Reset Complete" is displayed on the LCD, formatting of the service tech password is completed.
4. Turn the power OFF.
5. Update the system software using the USB storage device.
6. Turn the power OFF.
7. When the Fax Board (GD-1370) is installed, perform [CUSTOM INITIALIZE] > [INIT MEMORY(FAX)] and [CLEAR DATA] in the FS-11 FAX CLEAR MODE. Then turn the power OFF.

8. Check the system software version (FS-08-8952).
Confirm the version displayed on the LCD and then press [OK].
9. Initialize the NIC information (FS-08-9083).
10. Turn the power OFF.
11. Perform the following procedure.
📖 P. 12-15 “12.5.4 Procedure for entering the High Security mode”

[D] Update firmware version

- (1) Update the version of the system firmware using the USB storage device.
📖 P. 11-2 “11.2 Firmware Updating with a USB Storage Device”

[E] Data transfer of characteristic value of scanner

- (1) Perform FS-05-3203.
- (2) Turn the power OFF.

[F] Reinstall license

If the license was returned in “[A] Return License”, reinstall it with the following procedure.

- (1) Perform FS-08-3840.
- (2) Press [INSTALL].
- (3) Install the one-time dongle in the MFP (the one which you used for returning the selected license before replacing the MFP). Then press [OK].
- (4) Select the license to be installed, and then press [INSTALL].
- (5) The screen for notifying that the installation will be started is displayed. Then press [YES].
- (6) After 10 to 40 seconds passes, the screen for notifying the success of performance is displayed. Then press [OK]. If the screen for notifying a failure of the performance is displayed, quit this operation by pressing [NO].
Then check that the one-time dongle is installed properly in the MFP.
- (7) Check that the installed license is displayed on the license list.

Remarks:

- If there are any other licenses to be installed, repeat from step (2).
- If there are no other licenses to be installed, press [CLOSE] and then turn the power OFF.

[G] Check firmware versions

- System firmware version (FS-08-9930)
- Scanner firmware version (FS-08-9902)

Notes:

If the security mode is changed from High Security to Low Security in the step “[A] Return License”, set the value of FS-08-8911 to “3” (High Security).

9.2.5 Precautions and procedure when replacing the SRAM

Notes:

- Do not replace the storage device and the SRAM together.
- Be careful not to damage the board when replacing the SRAM.
- When the SRAM is replaced, do not perform the initialization of the standard storage device before starting the MFP in the normal mode.
- When disposing of the SRAM, see the following reference.
 P. 9-51 “9.3.3 Precautions when disposing of the SRAM”.

A procedure for replacing the SRAM is shown below.

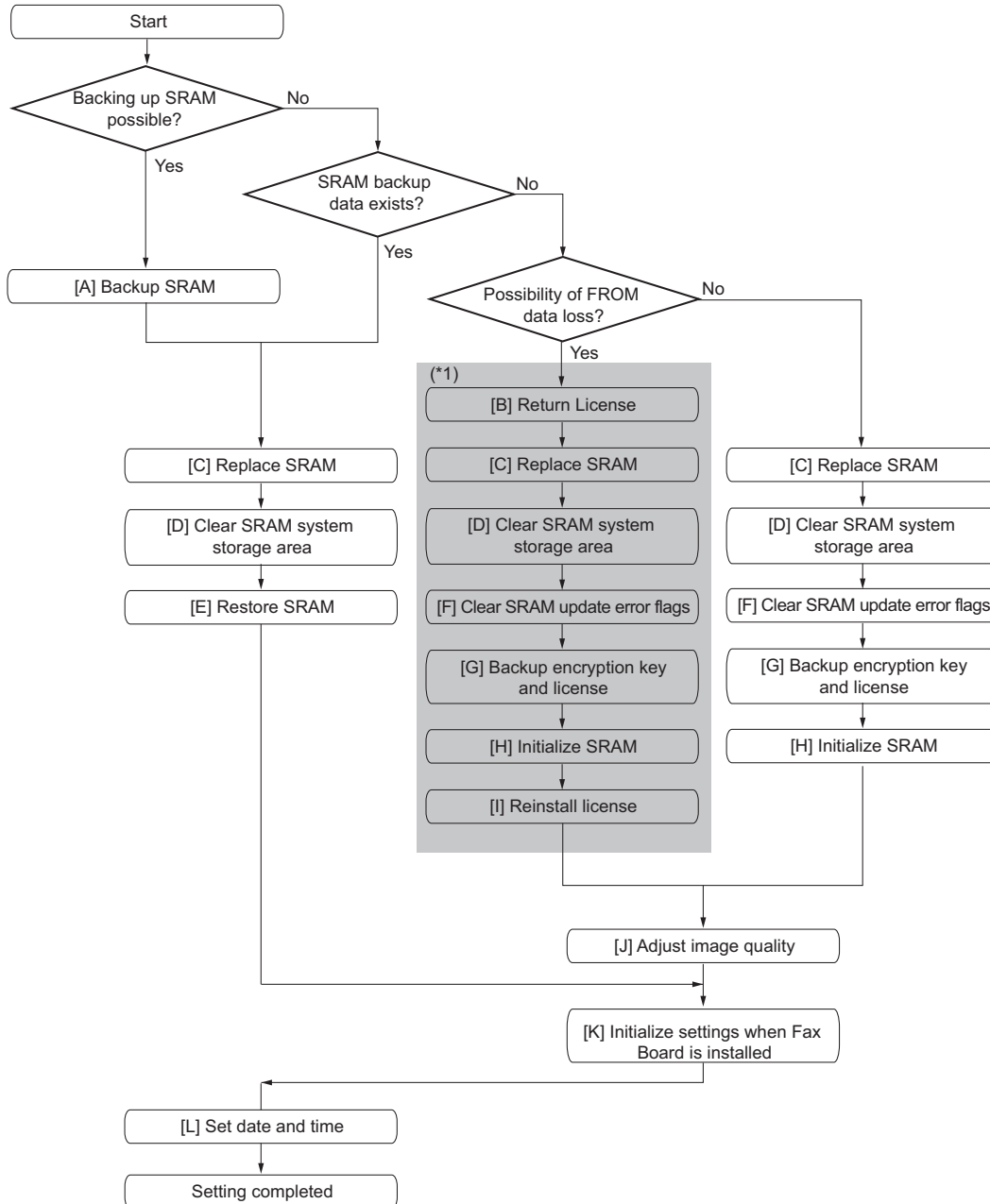

Fig. 9-60

Notes:

Use the flow (*1) when securely returning and reinstalling the license. Returning and reinstalling the license is required when it has been lost. The examples are as below.

e.g. 1: When SRAM data are overwritten on the FROM mistakenly due to an incorrect operation during the backup of the license



e.g. 2: When the SYS board (SRAM) is damaged or the license data in the FROM are broken

[A] Backup SRAM

Perform a backup before replacing the SRAM.

 P. 12-2 “[A] Backup procedure”

Notes:

- If “[A] Backup SRAM” fails, proceed to the following procedure.
 P. 9-40 “[B] Return License”
- If “[A] Backup SRAM” succeeds, proceed to the following procedure.
 P. 9-40 “[C] Replace SRAM”

[B] Return License**Notes:**

When the security mode is set to High Security, specify the security mode level to “1” (Low level) for FS-08-8911 and then reboot the MFP.

- (1) Perform FS-08-3840.
- (2) Select the license to be returned, and then press [REMOVE].
- (3) Install the one-time dongle, which you used for uploading the selected license, in the MFP and then press [OK].
- (4) The Remove screen is displayed. Press [YES].
If this screen is not displayed, check whether the one-time dongle is installed in the MFP properly.
- (5) After 10 to 40 seconds passes, the screen for notifying the success of performance is displayed. Then press [OK].
If this screen is not displayed or the screen for notifying the failure of performance is displayed, quit this operation by pressing [NO] or [CLOSE].
Then, check whether the one-time dongle, which you used for uploading the selected license, is installed in the MFP.
- (6) Check that the returned license is not displayed on the screen.

Remarks:

If there are any other licenses to be returned, repeat from step (2).

If there is no more licenses to be returned, press [CLOSE] and then turn the power OFF.

[C] Replace SRAM

- (1) Be sure to unplug the power cable before starting this work.
- (2) Replace the SRAM.
 P. 9-4 “9.1.3 SRAM”

[D] Clear SRAM system storage area

- (1) Perform HS-76 SRAM Maintenance.
The authentication screen appears. Press [OK]. (Entry of a password is unnecessary.)
- (2) When “SRAM Clear Mode” appears on the LCD, press the [Clear SRAM].
- (3) When “SRAM Format Completed” is displayed on the LCD, initializing is completed.
- (4) Turn the power OFF.

[E] Restore SRAM

- (1) Perform HS-76 SRAM Maintenance.
- (2) When “SRAM Clear Mode” appears on the LCD screen, press [Set Serial Number].
- (3) Key in the serial number printed on the label attached to the rear cover of the MFP and then press [OK].
- (4) “Set Serial Number was completed.” is displayed.
- (5) Turn the power OFF.
- (6) If there are SRAM backup data, perform restoring.
 P. 12-2 “[B] Restore procedure”
- (7) Turn the power OFF after the restoring of SRAM is completed.

Remarks:

When the restoration is completed successfully, proceed to the following procedure.  P. 9-43 “[L] Initialize settings when FAX Board (GD-1370) is installed”.

[F] Restore optional storage device setting

When an optional storage device is installed, restore the setting in accordance with the procedure below.

- (1) Perform HS-78 Restore Option Storage Settings.
- (2) When “Restore Optional Storage Settings” is displayed on the LCD, press [Restore to SRAM].
- (3) When “Confirmation Screen” is displayed on the LCD, press [OK].
- (4) When “Completed” is displayed on the LCD, restoration is completed.
- (5) Turn the power OFF.

[G] Clear SRAM Update Error Flag

- (1) Perform HS-73 Firmware Assist.
- (2) Press [Clear Software Update Error Flag].
- (3) When “Operation Complete” is displayed on the LCD, clearing the flag is completed.
- (4) Turn the power OFF.

[H] Backup encryption key and license (FROM > SRAM)

- (1) Perform HS-73 Firmware Assist.
- (2) Press [Key Backup/Restore].
- (3) Press [Direction] twice and then [Execute].
- (4) Wait until the backup of the encryption key and license is completed. "Success" is displayed. Confirm that "OK" is indicated in all of the SRAM column and then reboot the MFP.
- (5) Turn the power OFF.

[I] Initialize SRAM

- (1) Perform FS-08.
- (2) Initialize the SRAM.
When "SRAM REQUIRES INITIALIZATION" is displayed on the LCD, check the destination and then press the [START] button. If the destination is not correct, key in the correct one and then press the [START] button.
After the confirmation message is displayed, press [OK].
- (3) Perform FS-08-9030 (initialization at the software version upgrade).
- (4) Initialize the NIC information (FS-08-9083).
- (5) Enter the serial number (FS-08-9601).
Key in the serial number on the label attached to the rear cover of the MFP and then press [OK].
- (6) Turn the power OFF.

[J] Reinstall license

If the license was returned in "[B] Return License", reinstall it with the following procedure.

- (1) Perform FS-08-3840.
- (2) Press [INSTALL].
- (3) Install the one-time dongle in the MFP (the one which you used for returning the selected license before replacing the MFP). Then press [OK].
- (4) Select the license to be installed, and then press [INSTALL].
- (5) The screen for notifying that the installation will be started is displayed. Then press [YES].
- (6) After 10 to 40 seconds passes, the screen for notifying the success of performance is displayed. Then press [OK]. If the screen for notifying a failure of the performance is displayed, quit this operation by pressing [NO].
Then check that the one-time dongle is installed properly in the MFP.
- (7) Check that the installed license is displayed on the license list.

Remarks:

- If there are any other licenses to be installed, repeat from step (2).
- If there are no other licenses to be installed, press [CLOSE] and then turn the power OFF.

[K] Adjust image quality

- (1) Perform FS-05-3203 (Data transfer of characteristic value of scanner).
- (2) Perform Automatic gamma adjustment.
📖 P. 6-26 “6.1.7 Automatic gamma adjustment”
- (3) Turn the power OFF.

[L] Initialize settings when FAX Board (GD-1370) is installed

- (1) Reinstall the FAX Board (GD-1370).
- (2) Set the destination of FAX (FS-08-9001).
- (3) Turn the power OFF.
- (4) Perform FS-11 > CUSTOM INITIALIZE > INIT MEMORY(FAX).
- (5) Turn the power OFF and then back ON.
- (6) Set the dial type according to these buttons: [HOME] > [USER FUNCTIONS] > [ADMIN] > [FAX] > [INITIAL SETUP]

[M] Set date and time

Set the date and time according to these buttons. [HOME] > [USER FUNCTIONS] > [ADMIN] > [GENERAL] > [CLOCK] > [DATE/TIME]

9.2.6 Procedures when replacing the LGC board

Be sure to follow the procedure below when replacing the LGC board.

- (1) Perform FS-08-4870 to back up the data in the Main EEPROM to the Sub EEPROM.
- (2) Turn the power OFF and unplug the power cable.
- (3) Remove the LGC board.
📖 P. 9-10 “9.1.10 LGC board (LGC)”
- (4) Remove the Sub EEPROM from the LGC board.
📖 P. 9-12 “9.1.11 Sub EEPROM”
- (5) Install the removed Sub EEPROM in the new LGC board.
- (6) Attach the new LGC board to the MFP.
- (7) Perform FS-08-4871 to back up the data in the Sub EEPROM to the Main EEPROM.

Remarks:

- After the LGC board is replaced, update the version of the engine firmware to the latest one.
- Moving to FS-08 after replacing the LGC board enables the recovering of the licenses.

9.2.7 Procedures and settings when replacing the Sub EEPROM

Notes:

Be careful not to damage the Sub EEPROM when replacing it.

A procedure for replacing the Sub EEPROM is shown below.

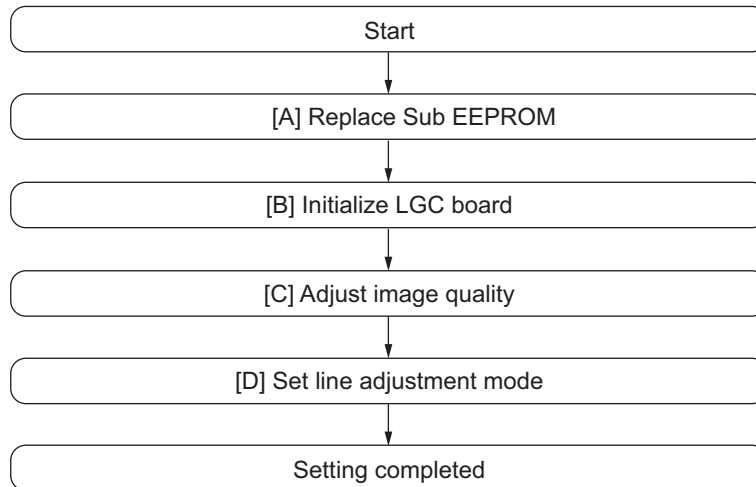

Fig. 9-61

[A] Replacing the Sub EEPROM

- (1) Turn the power OFF and unplug the power cable.
- (2) Remove the Sub EEPROM from the LGC board.
- (3) Attach the new Sub EEPROM board to the LGC board.
- (4) Perform FS-08-4870 to back up the data in the Main EEPROM to the Sub EEPROM.
- (5) If the problem still persists, replace the LGC board and perform the steps in [B].

Remarks:

After the LGC board is replaced, update the version of the engine firmware to the latest one.

[B] Initialize LGC board

- (1) Open the front cover, and check the destination printed on the white tape stuck on the MFP.
- (2) Perform FS-08-9060 (Destination display at SRAM initialization).

- (3) Check whether the displayed destination (see the below figure) of the LGC-SRAM is the same as the one in step (1).

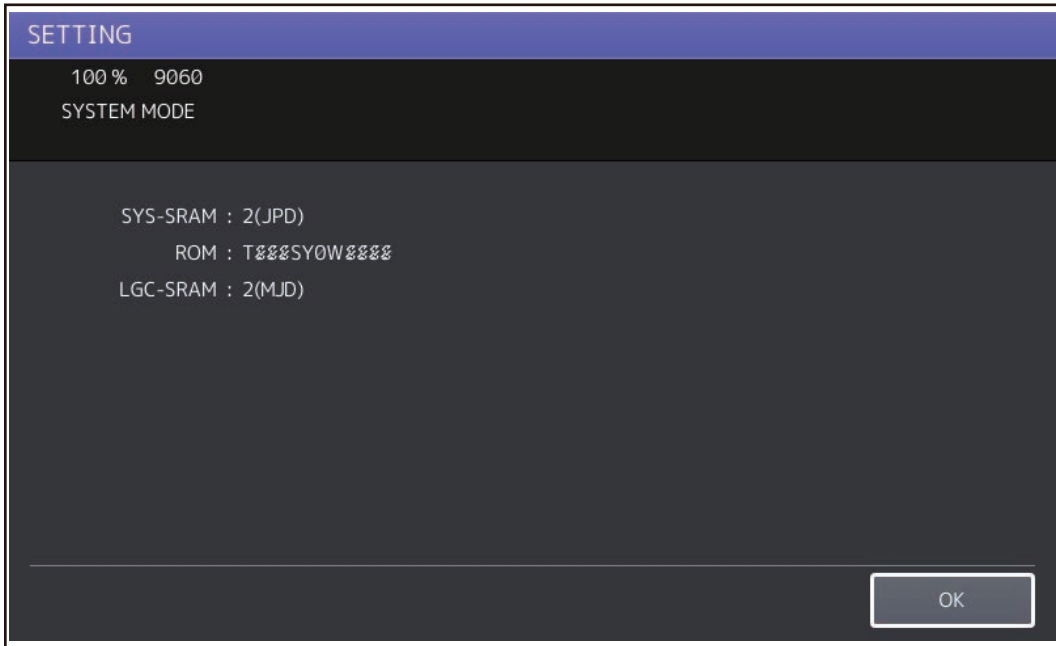

Fig. 9-62

Remarks:

If the destinations are different, initialize the LGC-SRAM with reference to the following procedure. Even if the destinations are the same, initialize the LGC-SRAM if required.

📖 P. 9-39 "9.2.5 Precautions and procedure when replacing the SRAM"

- (4) Perform FS-08-9090 (Printer all clear).
- (5) Press [INITIALIZE] to perform the initialization of the Main EEPROM.

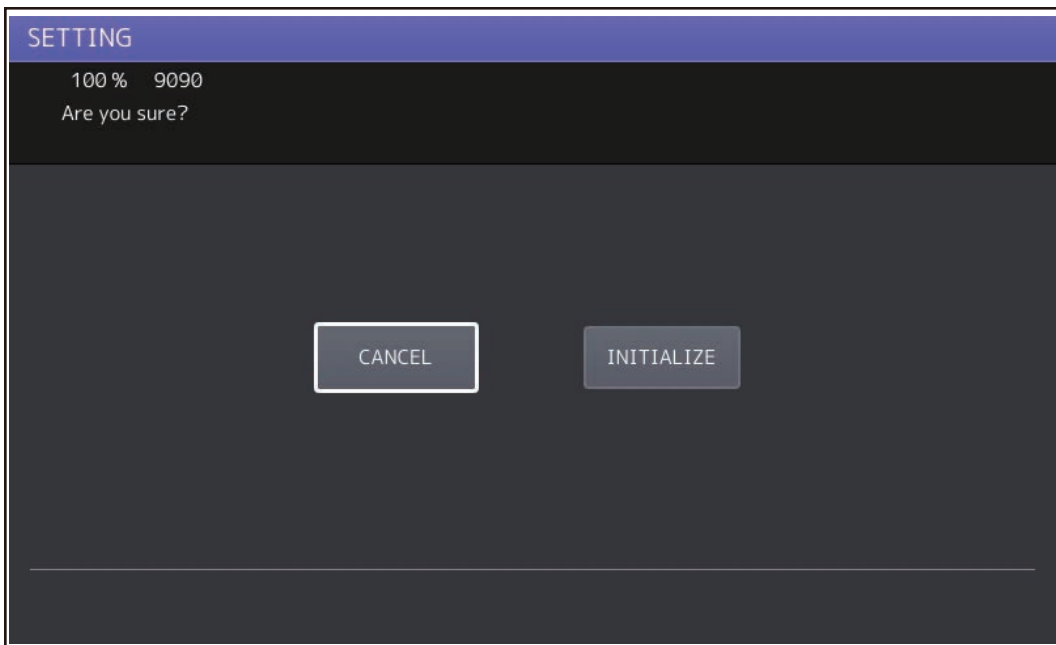

Fig. 9-63

- (6) Perform FS-08-9060 to display the destination at SRAM initialization. Check whether the destination of the one given on the attached label to the MFP and the LGC-SRAM and SYS-RAM is the same.

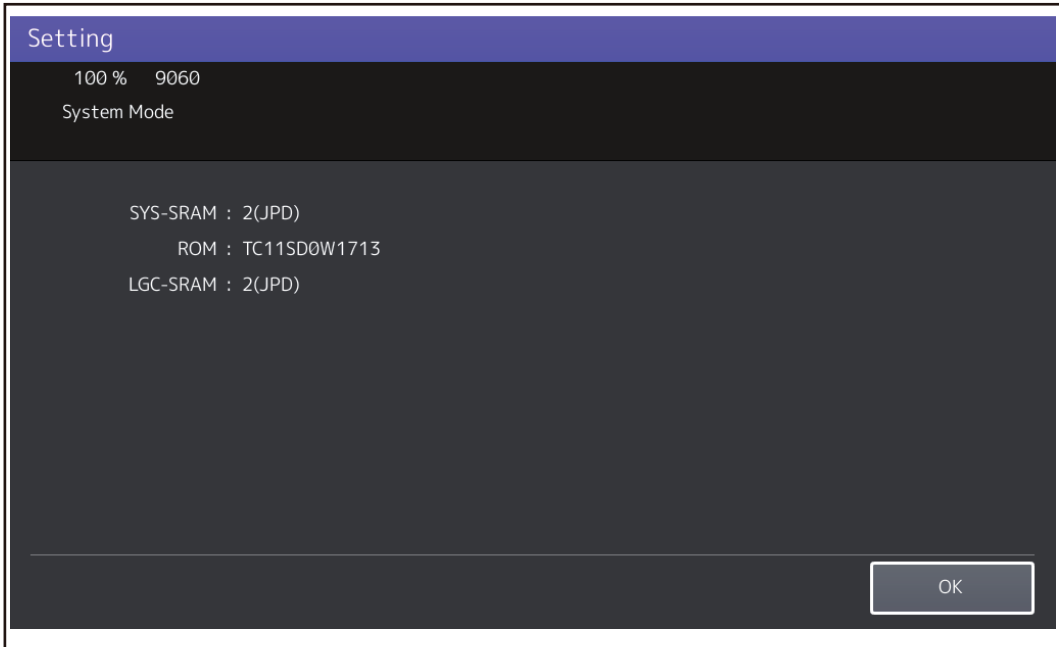

Fig. 9-64

Remarks:

If an error occurs during the initialization of the LGC board and the initialization fails, error messages are displayed on the touch panel. The error messages and the corresponding troubleshooting methods are shown below.

| Error message | Countermeasure |
|-------------------|---|
| UNDEFINED MODEL | There may be any abnormality in the LGC board. Replace the LGC board by following the reference below. 📖 P. 9-10 "9.1.10 LGC board (LGC)" |
| UNDEFINED VERSION | There may be an abnormality in the EEPROM. Recheck the destination of the LGC-SRAM. Replace the Sub EEPROM by following the reference below. 📖 P. 9-4 "9.1.3 SRAM" |
| VERIFY ERROR | Check the installation of the Sub EEPROM. |

[C] Adjust image quality

- (1) Write down the adjustment values of the following code attached to the laser optical unit cooling duct.

| | L (0) | H (1) |
|------------|-------|-------|
| FS-05-2630 | | |

- (2) Perform FS-05-2630 and then enter all the adjustment values written down in step (1).

- (3) Reset the auto toner sensor.
 1. You can complete the reset of the auto-toner sensor by directly entering the adjustment value for FS-05-2405-3 with the 05 Adjustment Mode Data List, which has been printed during the normal operation of the MFP such as when it is set up, when preventive maintenance (PM) is performed or when the developer material is replaced, etc.

Notes:

If you perform auto-toner sensor automatic adjustment without replacing the EPU, the image quality is not guaranteed.

2. If there is no list in step 1, perform the following steps 3 and 4.
3. Replace the EPU with new one.
4. Perform auto-toner sensor automatic adjustment.
📖 P. 6-2 “6.1.2 Auto-toner sensor adjustment”

Notes:

If the resetting of the auto-toner sensor is not carried out, defective images or a service call will occur.

- (4) Set “0” in FS-08-2588.
- (5) Perform FS-05-2742 (Enforced performing of image quality control (closed-loop)).
📖 P. 6-4 “6.1.3 Image quality control adjustment”
- (6) Perform the adjustment of the printing section and scanning section.
📖 P. 6-9 “6.1.5 Image dimensional adjustment at the printing section”
📖 P. 6-18 “6.1.6 Image dimensional adjustment at the scanning section” (Excluding [A])
- (7) Perform Automatic gamma adjustment.
📖 P. 6-26 “6.1.7 Automatic gamma adjustment”

[D] Set line adjustment mode

- (1) Turn the power OFF.
- (2) Perform FS-08-9010.
- (3) Set “Line adjustment mode” to “0: For factory shipment”.

Notes:

Since “1” (For line) is set for the Sub EEPROM supplied as a service part in [B] Initialize LGC board, the number of prints is not counted unless it is changed.

9.2.8 Procedures and settings when replacing the lens unit

When replacing the lens unit, follow the procedure below.

- (1) Confirm that the power is turned OFF.
- (2) Replace the lens unit.
📖 P. 4-30 “4.3.5 Lens unit (CCD driving PC board)”
- (3) Perform FS-05-3209 (Data transfer of characteristic value of scanner / SYS board > Lens unit).
- (4) Perform FS-05-3218 (Shading correction plate Automatic dust detection adjustment).
- (5) Turn the power OFF.

9.2.9 Firmware confirmation after the PC board/storage device replacement

After replacing the PC board/storage device, check the firmware version in the 08 Setting Mode and confirm if the firmware combination is correct,

| Firmware | Code |
|-----------------------------|------|
| System software | 9900 |
| System firmware | 9930 |
| Engine Firmware | 9901 |
| Scanner firmware | 9902 |
| DSDF firmware | 9903 |
| PFC firmware | 9940 |
| NIC firmware | 9990 |
| Finisher firmware | 9904 |
| Hole punch firmware | 9944 |
| Fax board firmware (Line 1) | 9905 |
| Fax board firmware (Line 2) | 9969 |

The installed ROM versions and the registered optional Electronic License Keys can be confirmed in the list print mode following the procedure below.

- (1) Perform FS-30-111 to print out VERSION LIST.
It is recommended to keep this list for future reinstallation such as the replacement of the SYS board.
- (2) Shut down the MFP.

9.2.10 License re-registration using the one-time dongle

[1] Re-registration when the board is replaced

The license registered using the one-time dongle can be re-registered only in the same MFP. When the SYS board or SRAM is replaced, follow the procedures for re-registration given below.

- (1) Perform FS-08-3840.
- (2) Press [INSTALL].
- (3) Install the one-time dongle in the MFP (the one which you used for registering the selected license) and then press [OK].
- (4) Select the license to be installed, and then press [INSTALL].
- (5) The screen for notifying that the installation will be started is displayed. Then press [YES].
- (6) After 10 to 40 seconds have passed, the screen for notifying the success of the performance is displayed. Then press [OK]. If the screen for notifying a failure of the performance is displayed, quit this operation by pressing [NO]. Then check that the one-time dongle is installed properly in the MFP.
- (7) Check that the installed license is displayed on the license list.

Remarks:

If there are any other licenses to be installed, repeat from step (2).

If there are no other licenses to be installed, press [CLOSE] and then turn the power OFF.

Notes:

This procedure is available only with the one-time dongle used for the previous registration, since the model information registered in it is utilized. Use the same one-time dongle and the MFP when registering the license.

[2] Re-registration when the MFP is replaced due to malfunction

When the MFP has to be replaced due to a malfunction, return the license registered in the MFP to the one-time dongle and register it to the new MFP following the procedure below.

Notes:

It is not possible to re-register the license for the IPsec Enabler (GP-1080) into other MFP.

- (1) Perform FS-08-3840.
- (2) Select the license to be returned, and then press [REMOVE].
- (3) Install the one-time dongle, which you used for uploading the selected license, in the MFP and then press [OK].
- (4) The Remove screen is displayed, then press [YES].
If this screen is not displayed, check whether the one-time dongle is installed in the MFP properly.
- (5) After 10 to 40 seconds have passed, the screen for notifying the success of the performance is displayed. Then press [OK].
If the screen for notifying a failure of the performance is displayed, quit this operation by pressing [NO].
Then, check whether the one-time dongle, which you used for uploading the selected license, is installed in the MFP.

(6) Check that the returned license is not displayed on the screen.

Remarks:

If there are any other licenses to be returned, repeat from step (2). If there is no more licenses to be returned, press [CLOSE] and then turn the power OFF.

(7) Replace the MFP.

(8) Perform FS-08-3840.

(9) Press [INSTALL].

(10) Install the one-time dongle in the MFP (the one which you used for returning the selected license before replacing the MFP). Then press [OK].

(11) Select the license to be installed, and then press [INSTALL].

(12) The screen for notifying that the installation will be started is displayed. Then press [YES].

(13) After 10 to 40 seconds have passed, the screen for notifying the success of the performance is displayed. Then press [OK].

If the screen for notifying a failure of the performance is displayed, quit this operation by pressing [NO].

Then check that the one-time dongle is installed properly in the MFP.

(14) Check that the installed license is displayed on the license list.

Remarks:

If there are any other licenses to be installed, repeat from step (9).

If there are no other licenses to be installed, press [CLOSE] and then turn the power OFF.

9.3 Precautions when Disposing of the Storage Devices and PC Boards

9.3.1 Precautions when disposing of the storage devices

[1] Standard storage device

When disposing of the standard storage device, perform the following operation.

HS-74 Storage Assist > [Revert Factory Initial Status Storage] > [Standard storage]

[2] Security HDD / security SSD / normal SSD (optional)

When disposing of any of the security HDD, the security SSD or the normal SSD, perform the following operation.

HS-74 Storage Assist > [Revert Factory Initial Status Storage] > [Optional storage]

[3] Optional normal HDD

When disposing of the optional normal HDD, perform the following setting

HS-73 Firmware Assist > [Erase Storage Securely]: Normal HDD securely erasing

This setting is the overwriting method complying with DoD 5220.22-M.

1. LOW: This is the normal overwriting method. (This setting is used normally.)
"00-FF-Random-Verify" Once
2. MEDIUM: This overwriting method is more secure than LOW. The erasing time is between LOW and HIGH.
"00-FF-Random" three times repeatedly -Verify
3. HIGH: This is the most secure overwriting method. It takes the longest time to erase data.
"00-FF-Random" five times repeatedly -Verify
4. SIMPLE: This is the simple overwriting method. It takes the shortest time to erase data.
Overwrite the Random data once

Remarks:

The approximate time for securely erasing a normal HDD (320GB) is as follows (referential values).

| Erase type | Erase time |
|------------|---------------------------|
| LOW | Approximately 4.25 hours |
| MEDIUM | Approximately 11 hours |
| HIGH | Approximately 17.25 hours |
| SIMPLE | Approximately 2.25 hours |

9.3.2 Precautions when disposing of the SYS board

When disposing of the SYS board, data clearing is not required since important data, such as user information, etc. are stored in the SRAM.

9.3.3 Precautions when disposing of the SRAM

When disposing of the SRAM, perform HS-73 Firmware Assist > [Erase SRAM Securely] (SRAM securely erasing) for security reasons.

Notes:

If this is performed, the MFP cannot be started up.

10. REMOTE SERVICE

This chapter explains details of the functions so that service technicians can perform service more effectively.

10.1 Auto Supply Order

10.1.1 Overview

This function automatically orders the toner cartridge and waste toner box.

(1) Order method

The following two methods are available to place an order.

- Fax
Installation of a fax board is required.
If no fax board is installed, this function is set to OFF.
- E-mail (by attaching a TIFF image)

(2) Order timing

The auto supply order is sent as indicated in the following steps.

- Toner cartridge
 1. Toner empty occurs.
 2. The toner cartridge is replaced.
 3. The toner empty counter is incremented when the total number of prints or the pixel counter value exceeds the threshold set in the following self-diagnostic code.

| Code | Setting item | Contents |
|------------|---|---|
| FS-08-6506 | Toner empty determination counter | Selects the counter to determine toner empty. 0: Output pages 1: Pixel counter |
| FS-08-6507 | Threshold setting for toner empty determination (output pages) | Sets the number of output pages to determine toner empty. This setting is valid when "0" is set for FS-08-6506. |
| FS-08-6508 | Threshold setting for toner empty determination (pixel counter) | Sets the number of the pixel counter value to determine toner empty. This setting is valid when "1" is set for FS-08-6506. |

e.g.:

When "0" is set for FS-08-6506 and "50" is set for FS-08-6507, the toner empty counter is incremented when 50 sheets are printed after the toner cartridge has been replaced.

4. When the accumulated number of toner empty times reaches the set condition, an order is placed automatically.
- Waste toner box
When the number of the waste toner full detection times reaches the set condition, an order is placed automatically.

(3) The order condition for the toner cartridge and the waste toner box can be set individually.

(4) When placing an order has failed

If some problems occur and the order cannot be placed after being registered as a job, refer to the standard countermeasure for a fax or e-mail transmission failure.

10.1.2 Setting item

To enable the Auto Supply Order function, the following settings are required.

Notes:

When selecting e-mail to place an order, it is required that the sending and the receiving of e-mails are available. Confirm the details with the administrator.

(1) Self-diagnostic setting (08 SETTING MODE)

As the default setting, the Auto Supply Order setting menu is not displayed on the HOME SCREEN.

Changing the setting is required to display the menu with FS-08-9783.

0: Valid (Fax, Internet fax)

1: Valid (Fax, Internet fax, HTTP*)

2: Invalid (Default)

When the value is changed from "2" (default) to "0", the Auto Supply Order setting menu is displayed.

* HTTP has not been supported yet.

(2) Touch panel setting

Each item is set from the Auto Supply Order menu on the HOME SCREEN.

Entering the password and customer information is required because the setting is made from the Admin menu. Setting it with the administrator is a must.

(a) Basic setting

[Admin] > [Service] > [Supply Order Setup] > [Order Information]

| | |
|--------------------|--|
| Auto Supply Order | Order method Selects from [Fax], [Mail] or [HTTP]. *1 |
| Fax Number | Fax number of a supplier *2 |
| E-mail | E-mail address of a supplier *3 |
| Customer | Customer information |
| Name | |
| Tel Number | |
| E-mail | |
| Address | |
| Supplier | Supplier information |
| Name | |
| Address | |
| Service Technician | Service technician information |
| Number | |
| Name | |
| Tel Number | |
| E-mail | |

*1 HTTP has not been supported yet.

*2 The Fax Number of the supplier must be entered when an order is made by means of a fax.

*3 The e-mail address of the supplier must be entered when an order is made by means of an e-mail.

(b) Detailed setting for the order

[Admin] > [Service] > [Supply Order Setup] > [Toner Ordering]

| | |
|-------------------|---|
| ***** TONER ORDER | Order information (Toner cartridge or waste toner box) |
| Part Number | Part number to be ordered |
| Condition | Number of conditions *1 |
| Quantity | Quantity to be ordered |
| Auto Order | ON/OFF setting of order for each part |

*1 The order is placed when the number of replacement reaches the number specified for Condition.

(c) Fax Number of this MFP (common information)

[Admin] > [Fax] > [Terminal ID]

| | |
|------------|------------------------|
| ID Name | ID name of this MFP |
| Fax Number | Fax number of this MFP |

(d) E-mail information of this MFP (common information)

[Admin] > [E-mail]

| | |
|--------------|-------------------------------|
| From Address | E-mail address of this MFP *1 |
| From Name | E-mail user name of this MFP |

*1 When sending an e-mail, the validity of the address is checked. If the address is invalid, it is not sent.

(3) Outputting of the setting list of Auto Supply Order

1. Perform FS-12 (12 FAX LIST PRINT MODE).
2. Select "SUPPLY ORDER LIST" and then press [Print].

10.1.3 Setting procedure

- (1) Perform FS-08-9783 and set the value to "0".
- (2) Turn the power OFF and then back ON.
- (3) Press [User Functions] on the HOME SCREEN.

- (4) Press the [Admin] tab.
When the administrator password has been set, the Administrator Password menu is displayed.

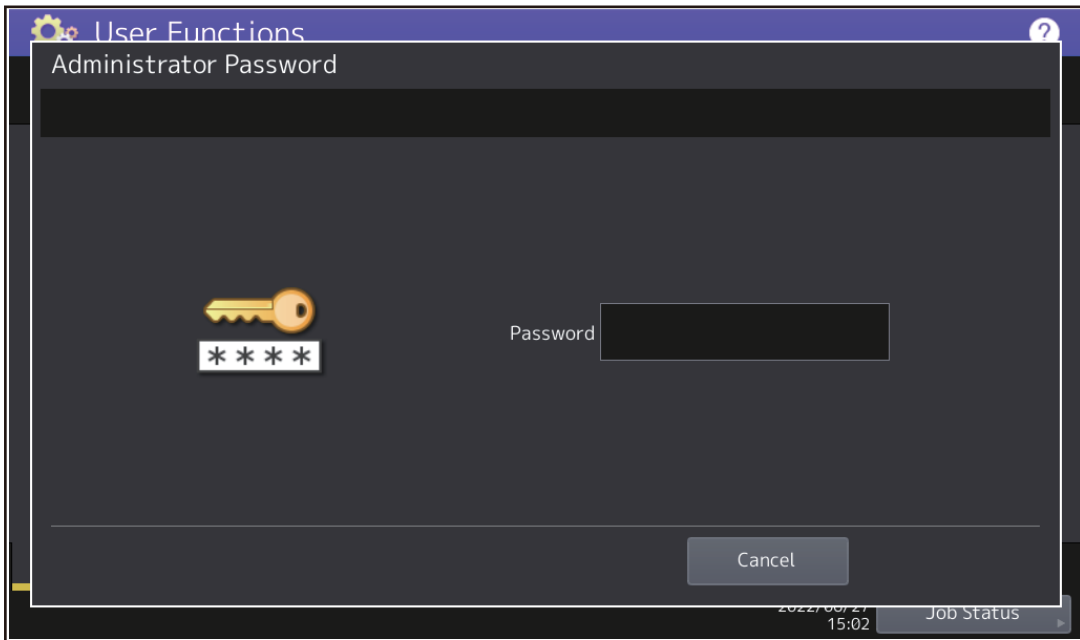

Fig.10-1

- (5) The keyboard appears upon your touching the entry box for a password. Enter the administrator password and then press [OK] or [Close].
Confirm the password with the administrator.
- (6) Press [Service] on the [Admin] tab.

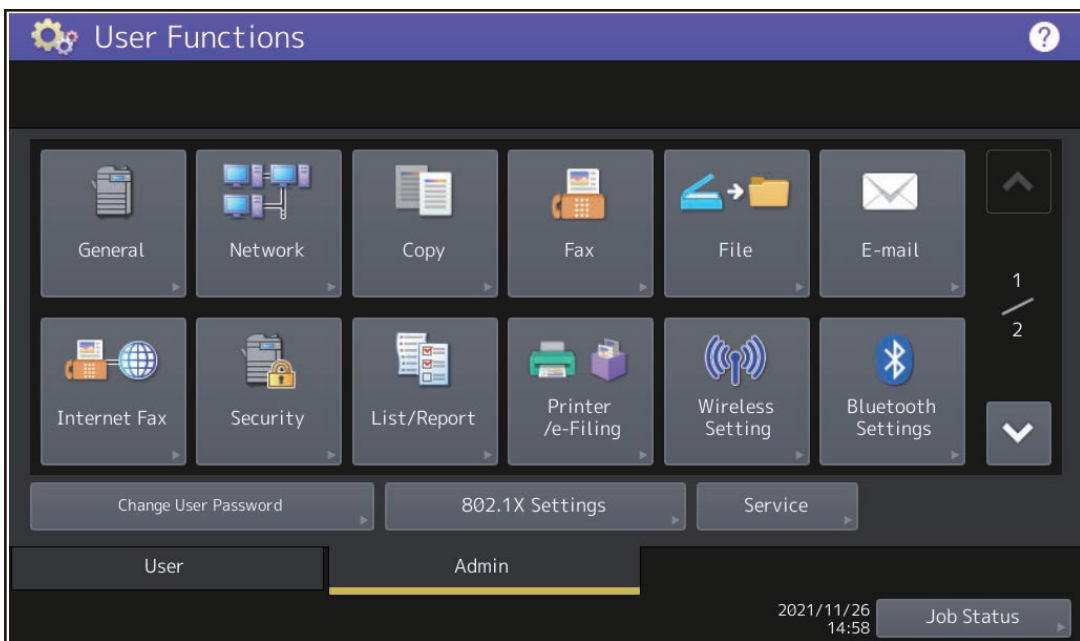

Fig.10-2

- (7) The Service menu is displayed.

(8) Press [Supply Order Setup].

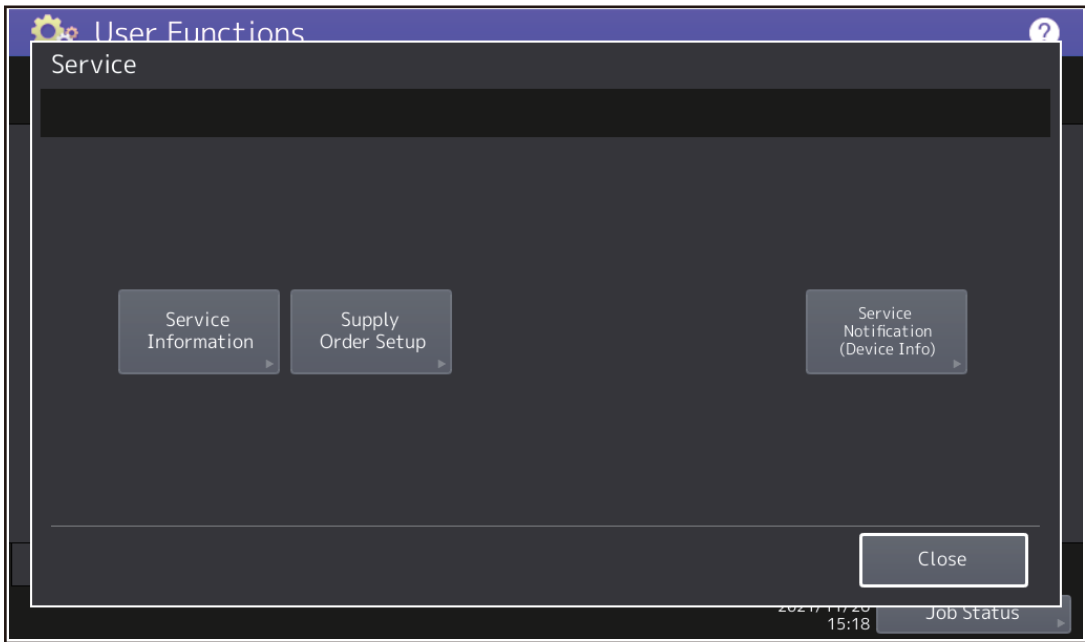

Fig.10-3

(9) Press [Order Information].

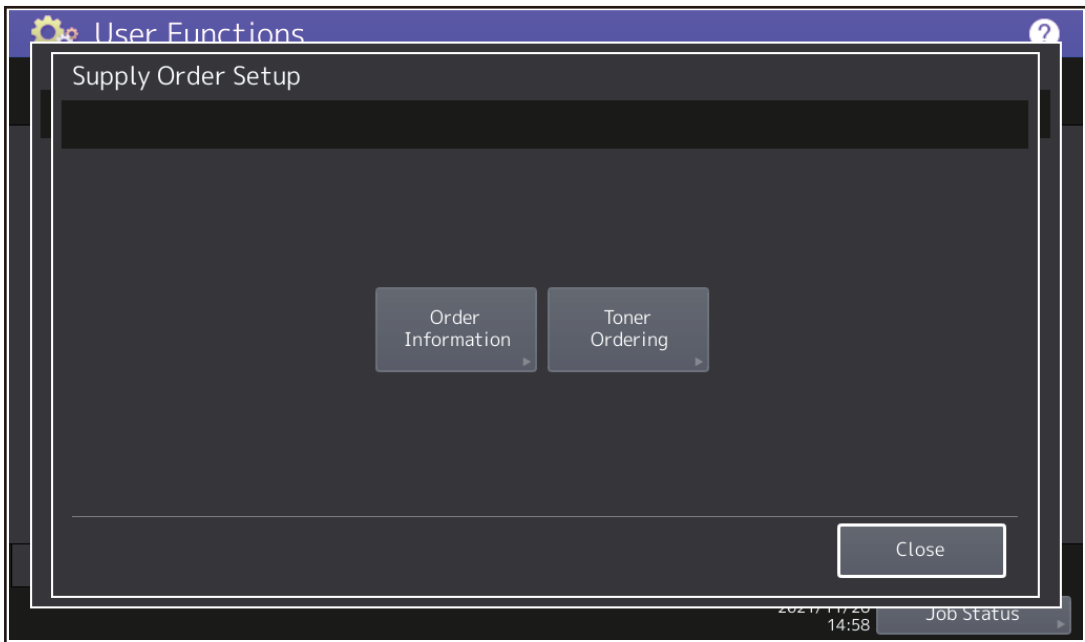

Fig.10-4

10

(10) The Order Information menu is displayed.

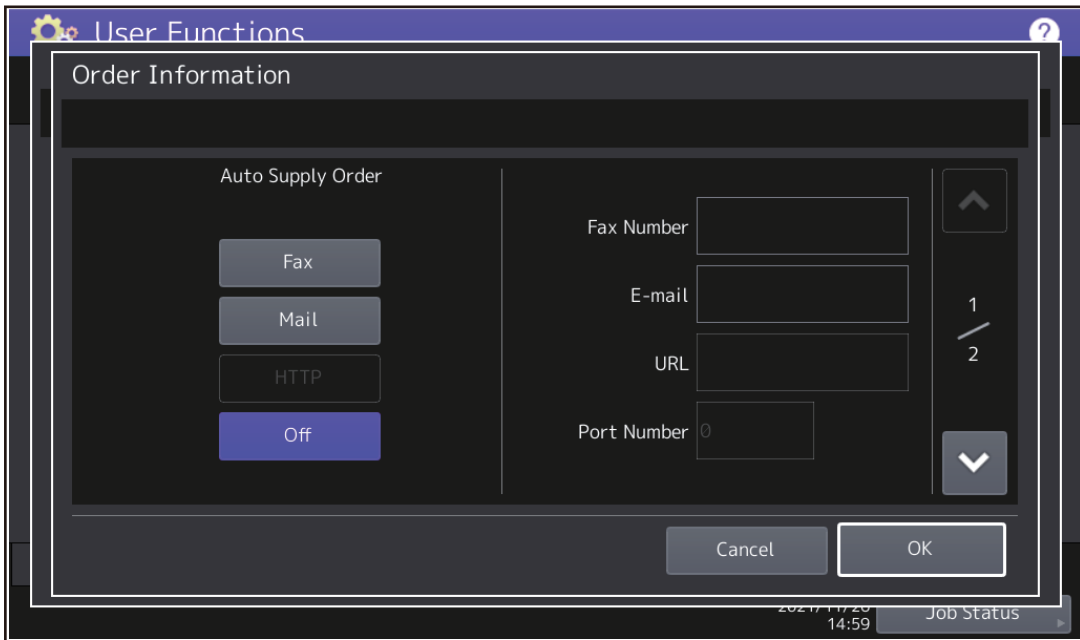

Fig.10-5

(11) Press the buttons on the Order Information menu to set the required items.

| | |
|----------------------|---|
| [Fax], [Mail], [Off] | Selects [Fax] or [Mail] for the transmitting method of the order. (HTTP has not been supported yet.) [Off]: Turns off the Auto Supply Order function. |
| [Fax Number] | Enters the Fax Number of the supplier. (This must be entered when an order is transmitted by means of a fax.) |
| [E-mail] | Enters the e-mail address of the supplier. (This must be entered when an order is transmitted by means of an e-mail.) |

(12) Press the scroll button.

(13) The Supplier menu is displayed.

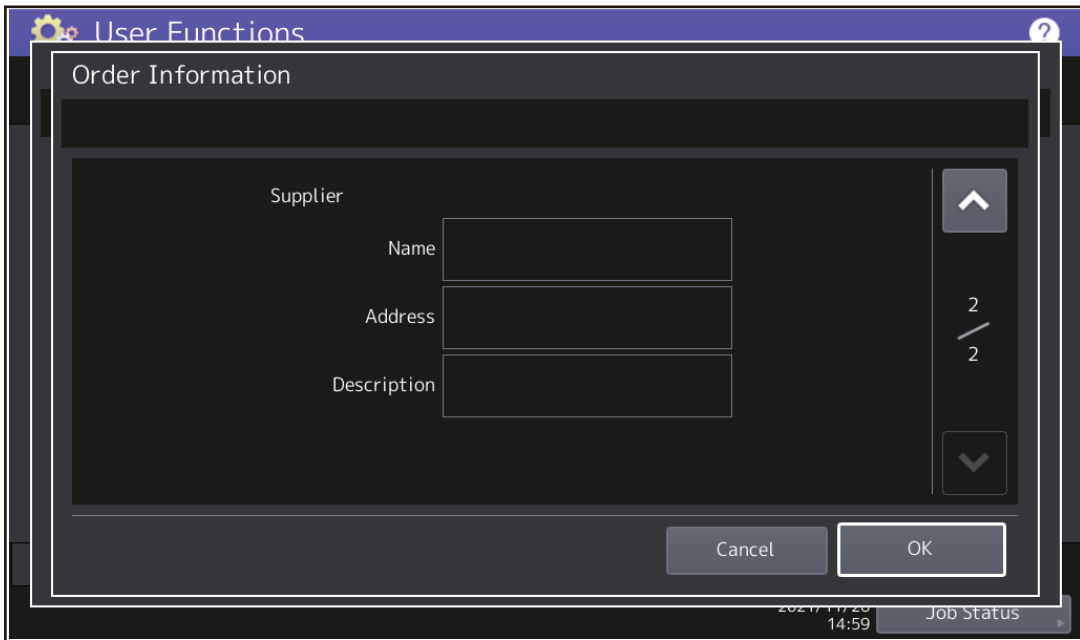

Fig.10-6

(14) Press the buttons on the Supplier menu to set the required items.

| | |
|---------------|-------------------------------------|
| [Name] | Enters the supplier name. |
| [Address] | Enters the address of the supplier. |
| [Description] | Enters the remarks if necessary. |

(15) Press [OK].

Press [OK] to register the entered information and then the screen returns to the Service menu. Press [Cancel] to cancel the entered information and then the screen returns to the Service menu.

(16) The Service menu is displayed.

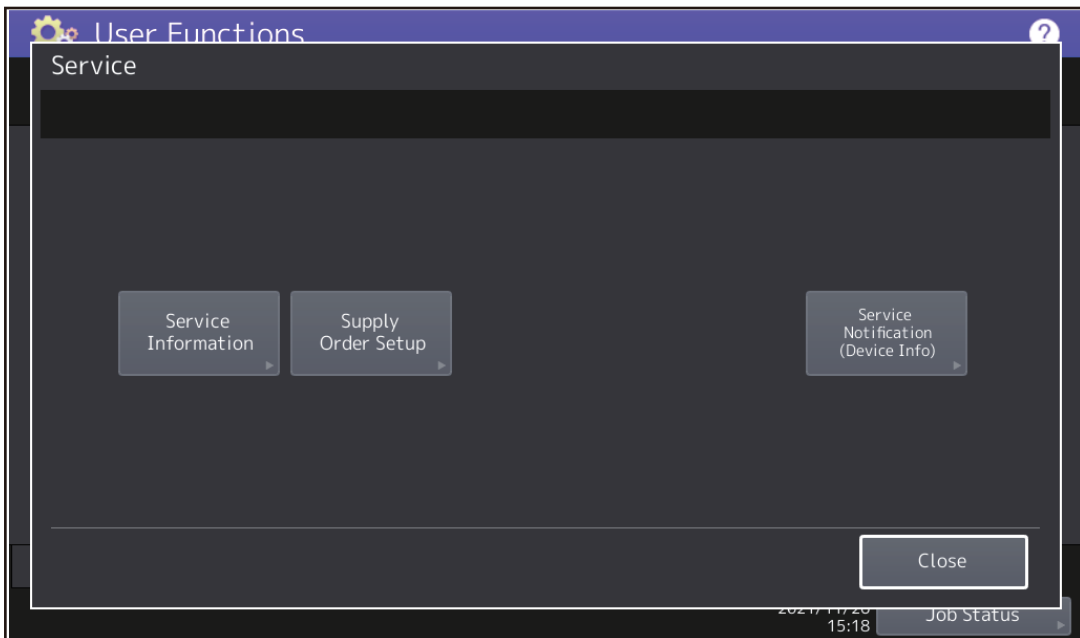

Fig.10-7

(17) Press [Service Information].

(18) The Service Information menu is displayed.

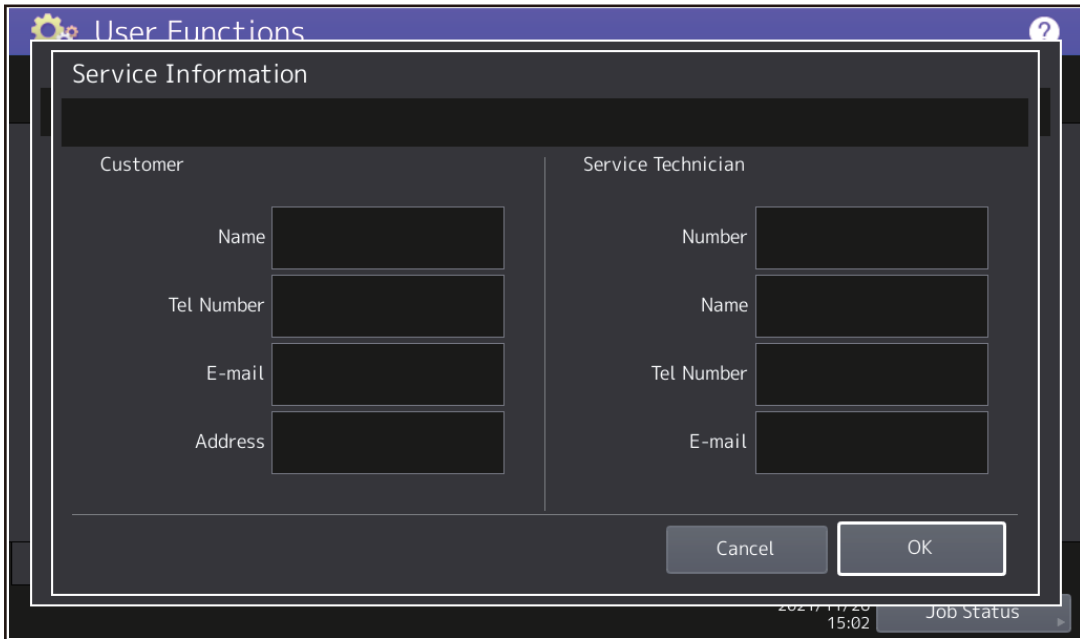

Fig.10-8

(19) Press the buttons on the Service Information menu to set the required items.

| Customer | |
|-----------------|--|
| [Name] | Enters the name of the customer. |
| [Tel Number] | Enters the telephone number of the customer. |
| [E-mail] | Enters the e-mail address of the customer. |
| [Address] | Enters the address of the customer. |

| Service Technician | |
|---------------------------|--|
| [Number] | Enters the number of the service technician. |
| [Name] | Enters the name of the service technician. |
| [Tel Number] | Enters the telephone number of the service technician. |
| [E-mail] | Enters the e-mail address of the service technician. |

(20) Press [OK] to register and complete the order information setting.

(21) The screen returns to the Service menu.

(22) Press [Supply Order Setup].

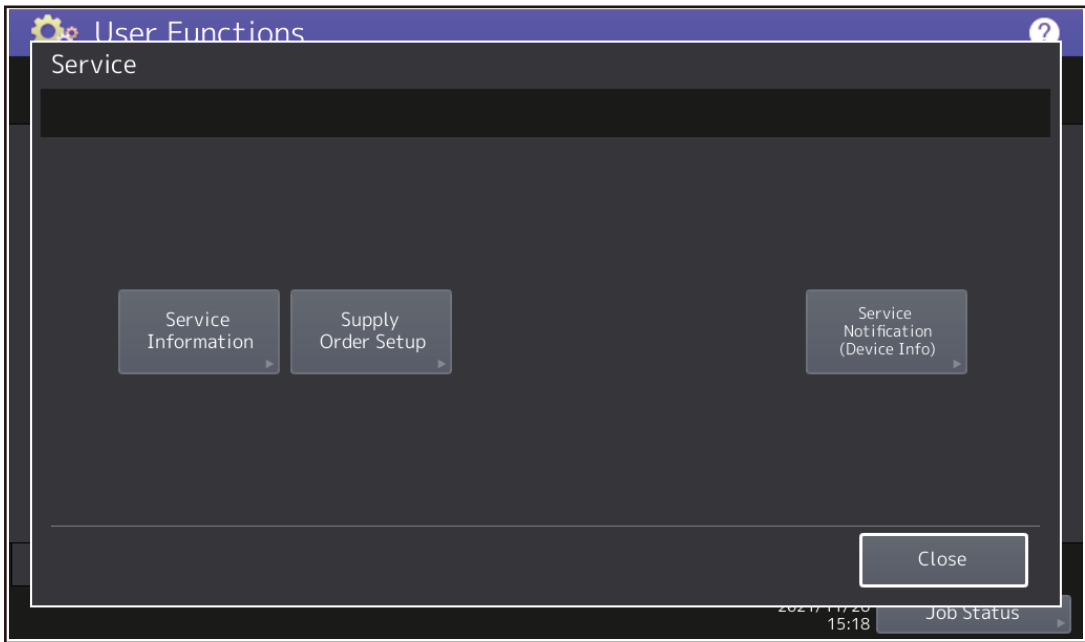

Fig.10-9

(23) Press [Toner Ordering].

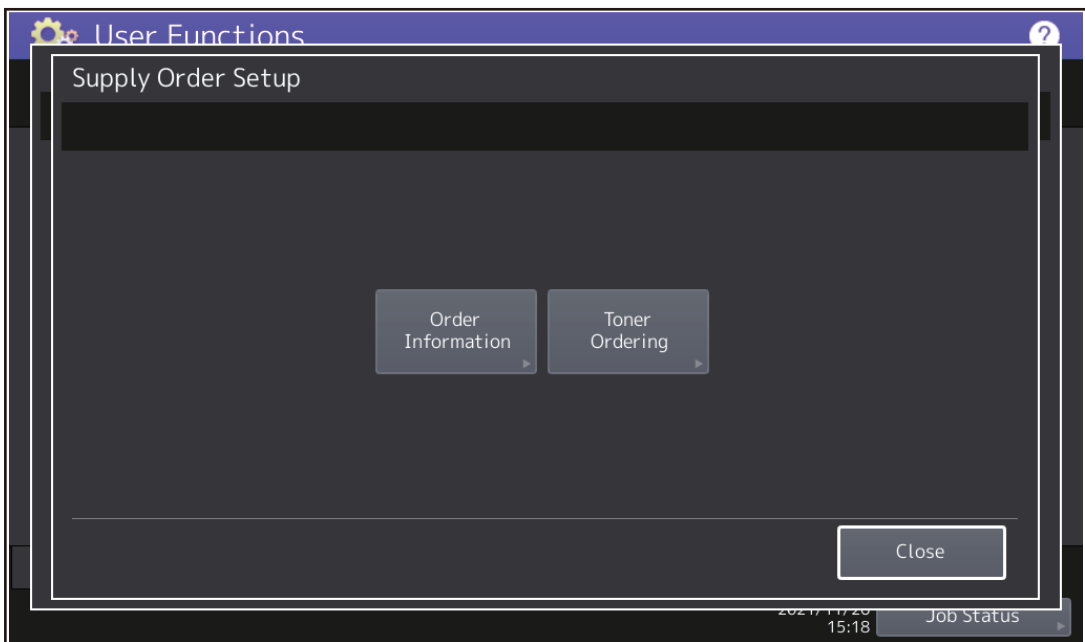

Fig.10-10

(24) The Toner Ordering menu is displayed.

- (25) Select the part to be ordered.
 (When entering the toner order information by pressing [Toner])

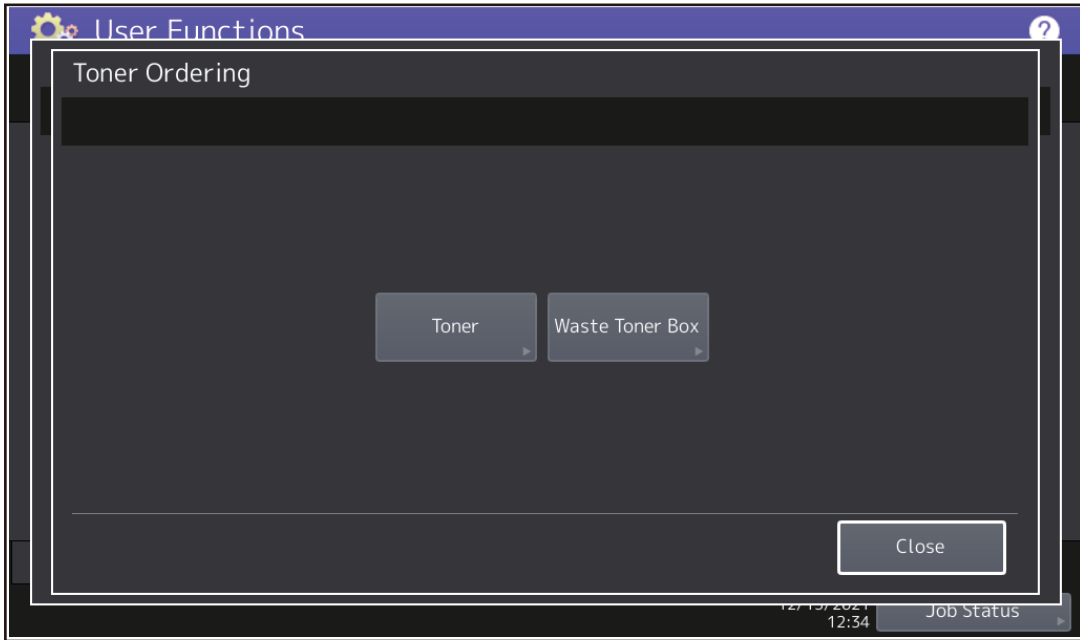

Fig.10-11

- (26) Input the order information of the toner cartridge.

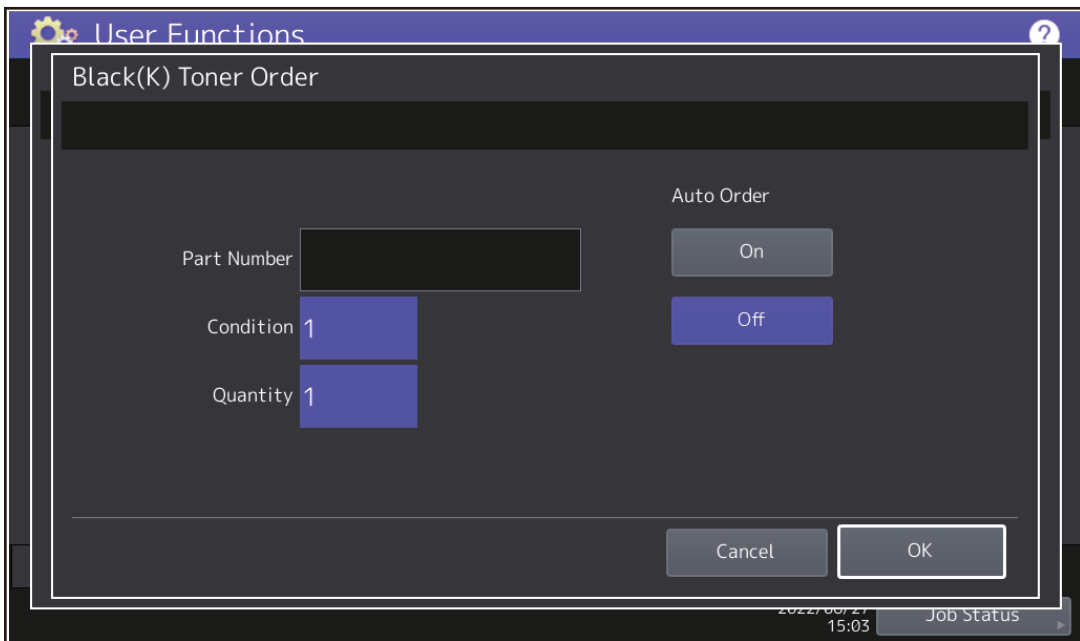

Fig.10-12

| | |
|---------------|--|
| [Part Number] | Toner cartridge number |
| [Condition] | The order is placed when the accumulated number of toner empty times reaches the value set in here. |
| [Quantity] | Quantity to be ordered |
| [Auto Order] | Selects whether each part is ordered automatically or not. [On]: Automatically ordered, [Off]: Not ordered automatically |

(27) Press [OK] to return the Toner Ordering menu.

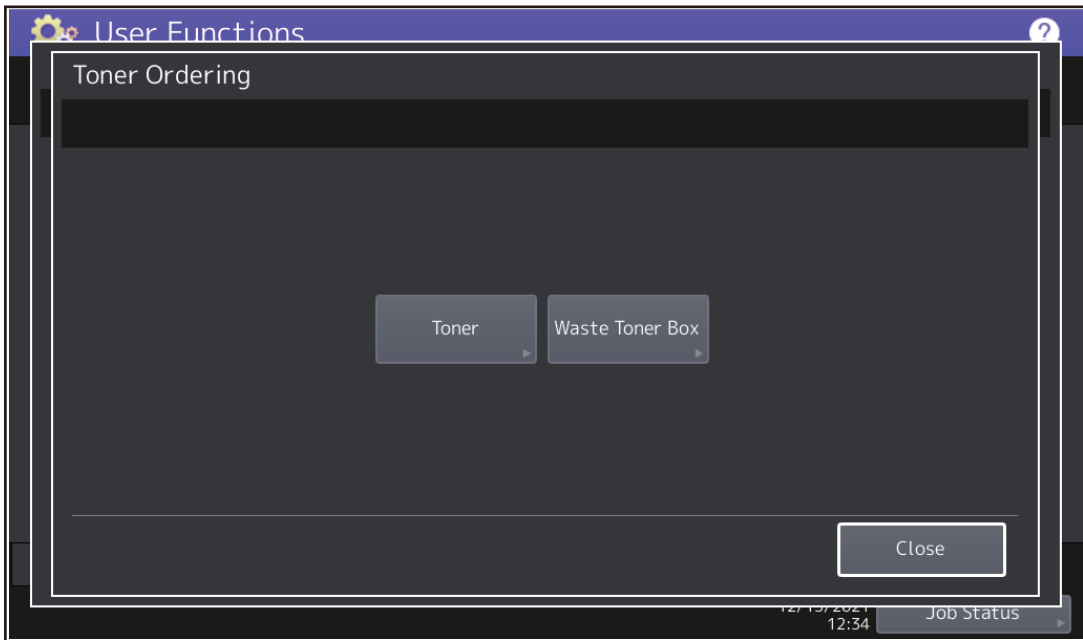

Fig.10-13

(28) Press [Waste Toner Box]. Enter the order information in the same way.

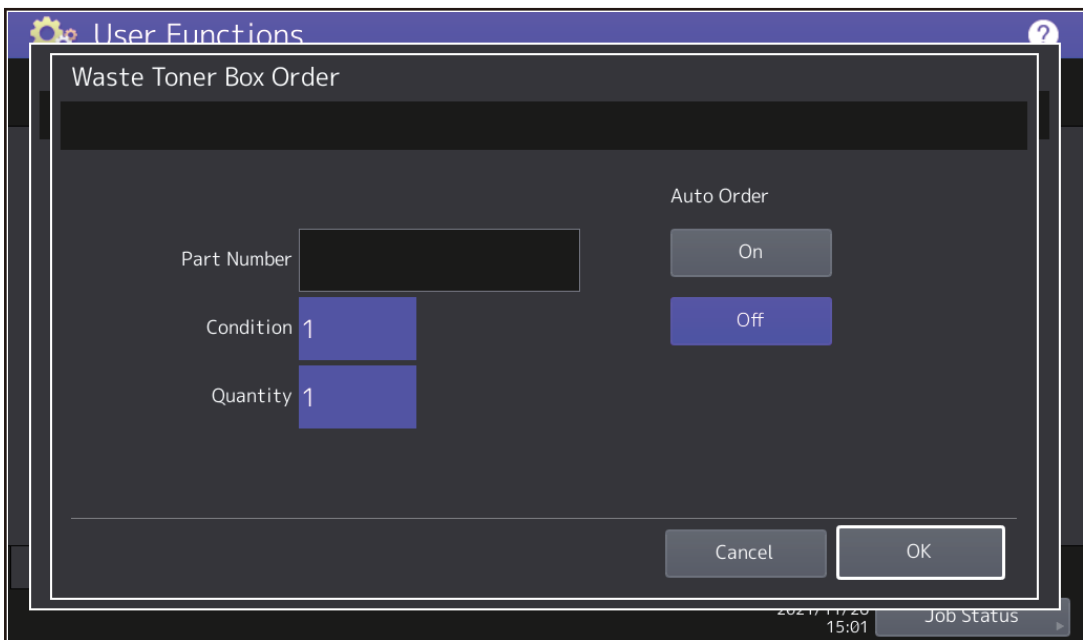

Fig.10-14

(29) Press [OK] to register the order information.

Remarks:

The Auto Supply Order setting is also available from the following 08 SETTING MODE.

| Setting item | Code | Contents |
|--|------------|--|
| Transmission method of order [Fax], [Mail], [Off] | FS-08-9750 | 0: Ordered by FAX 1: Ordered by E-mail 2: Ordered by HTTP *1 3: OFF |
| SUPPLIER [Fax Number] | FS-08-9751 | Up to 32 digits |
| SUPPLIER [E-mail] | FS-08-9752 | Up to 192 letters |
| CUSTOMER [Name] | FS-08-9756 | Up to 50 letters |
| CUSTOMER [Tel Number] | FS-08-9757 | Up to 32 digits |
| CUSTOMER [E-mail] | FS-08-9758 | Up to 192 letters |
| CUSTOMER [Address] | FS-08-9759 | Up to 100 letters |
| SERVICE TECHNICIAN [Number] | FS-08-9760 | Up to 5 digits |
| SERVICE TECHNICIAN [Name] | FS-08-9761 | Up to 50 letters |
| SERVICE TECHNICIAN [Tel Number] | FS-08-9762 | Up to 32 digits |
| SERVICE TECHNICIAN [E-mail] | FS-08-9763 | Up to 192 letters |
| SUPPLIER [Name] | FS-08-9764 | Up to 50 letters |
| SUPPLIER [Address] | FS-08-9765 | Up to 100 letters |
| Remarks [Description] | FS-08-9766 | Up to 128 letters |
| BLACK (K) TONER ORDER [Part Number] | FS-08-9776 | Up to 20 digits |
| BLACK (K) TONER ORDER [Quantity] | FS-08-9777 | 1 to 99 |
| BLACK (K) TONER ORDER [Condition] | FS-08-9778 | 1 to 99 |
| WASTE TONER BOX ORDER [Part Number] | FS-08-9779 | Up to 20 digits |
| WASTE TONER BOX ORDER [Quantity] | FS-08-9780 | 1 to 99 |
| WASTE TONER BOX ORDER [Condition] | FS-08-9781 | 1 to 99 |

*1 HTTP has not been supported yet.

10.1.4 Supply Order sheet format

The sample of order sheet is as follows.

- (1) FAX and E-mail (This format is the same as that of TIFF image attached to an E-mail.)

| SUPPLY ORDER FORM | | | |
|-------------------------------|-------------|---|------------|
| SETUP INFORMATION | | | |
| DESTINATION SETUP | : | :XX | |
| DATE & TIME | : | :19-04-'XX 13:41 | |
| CUSTOMER NAME | : | :XX | |
| CUSTOMER ADDRESS | : | :XX | |
| CUSTOMER TEL NUMBER | : | :XX | |
| CUSTOMER E-MAIL ADDRESS | : | :XX | |
| SERVICE TECHNICIAN NUMBER | : | :XX | |
| SERVICE TECHNICIAN NAME | : | :XX | |
| SERVICE TECHNICIAN TEL NUMBER | : | :XX | |
| SERVICE TECHNICIAN E-MAIL | : | :XX | |
| SUPPLIER NAME | : | :XX | |
| SUPPLIER ADDRESS | : | :XX | |
| <hr/> | | | |
| | ORDER SETUP | PART NUMBER | QUANTITY |
| TONER CARTRIDGE | : ON | XXXXXXXXXXXXX | 2 |
| WASTE TONER BOX | : ON | XXXXXXXXXXXXX | 9 |
| <hr/> | | | |
| DEVICE DESCRIPTION | : | :XXXXXXXXXXXXXXXXXXXXXXXXXXXX | |
| SERIAL NUMBER | : | :XXXXXXXXXXXXXXXXXXXXXXXXXXXX | |
| DEVICE FAX NUMBER | : | :XXXXXXXXXXXXXXXXXXXXXXXXXXXX | |
| DEVICE E-MAIL ADDRESS | : | :XXXXXXXXXXXXXXXXXXXXXXXXXXXX XXXXXXXXXXXXXXXXXXXXXXXXXXXX | |
| <hr/> | | | |
| | TOTAL | BLACK | FULL COLOR |
| PRINT COUNTER | 99999999 | 999999999 | ----- |
| SCAN COUNTER | 99999999 | 999999999 | 99999999 |
| <hr/> | | | |
| TONER INFORMATION | | | |
| BLACK REMAINING QUANTITY (%) | : | : 00000062 | |

Fig.10-15

- * Part not to be ordered is not output. (Less space between the lines)

(2) Result list

Success or failure of the supply order submission is indicated on the sheet.

| SUPPLY ORDER FORM | | | |
|-------------------------------|---|-------------------------------------|------------|
| CONFIRMATION | | ORDER SUCCESSFUL (or ORDER FAILURE) | |
| DATE & TIME | :19-04-'XX 13:41 | | |
| CUSTOMER NAME | :XXXXXXXXXXXXXXXXXXXXXXXXXXXXXXXXXXXX | | |
| CUSTOMER ADDRESS | :XXXXXXXXXXXXXXXXXXXXXXXXXXXXXXXXXXXX | | |
| CUSTOMER TEL NUMBER | :XXXXXXXXXXXXXXXXXXXXXXXXXXXXXXXXXXXX | | |
| CUSTOMER E-MAIL ADDRESS | :XXXXXXXXXXXXXXXXXXXXXXXXXXXXXXXXXXXX | | |
| SERVICE TECHNICIAN NUMBER | :XXXXXXXXXXXXXXXXXXXXXXXXXXXXXXXXXXXX | | |
| SERVICE TECHNICIAN NAME | :XXXXXXXXXXXXXXXXXXXXXXXXXXXXXXXXXXXX | | |
| SERVICE TECHNICIAN TEL NUMBER | :XXXXXXXXXXXXXXXXXXXXXXXXXXXXXXXXXXXX | | |
| SERVICE TECHNICIAN E-MAIL | :XXXXXXXXXXXXXXXXXXXXXXXXXXXXXXXXXXXX | | |
| SUPPLIER NAME | :XXXXXXXXXXXXXXXXXXXXXXXXXXXXXXXXXXXX | | |
| SUPPLIER ADDRESS | :XXXXXXXXXXXXXXXXXXXXXXXXXXXXXXXXXXXX | | |
| <hr/> | | | |
| | PART NUMBER | QUANTITY | |
| TONER CARTRIDGE | :XXXXXXXXXXXX | 2 | |
| WASTE TONER BOX | :XXXXXXXXXXXX | 9 | |
| <hr/> | | | |
| DESCRIPTION AREA | :XXXXXXXXXXXXXXXXXXXXXXXXXXXXXXXXXXXX XXXXXXXXXXXXXXXXXXXXXXXXXXXXXXXXXXXX | | |
| DEVICE DESCRIPTION | :XXXXXXXXXXXXXXXXXXXXXXXXXXXX | | |
| SERIAL NUMBER | :XXXXXXXXXXXXXXXXXXXXXXXXXXXX | | |
| DEVICE FAX NUMBER | :XXXXXXXXXXXXXXXXXXXXXXXXXXXX | | |
| DEVICE E-MAIL ADDRESS | :XXXXXXXXXXXXXXXXXXXXXXXXXXXX XXXXXXXXXXXXXXXXXXXXXXXXXXXX | | |
| | TOTAL | BLACK | FULL COLOR |
| PRINT COUNTER | 99999999 | 99999999 | ----- |
| SCAN COUNTER | 99999999 | 99999999 | 99999999 |
| TONER INFORMATION | | | |
| BLACK REMAINING QUANTITY (%) | : 0000062 | | |



Fig.10-16

* Part not to be ordered is not output. (Less space between the lines)

10.2 Service Notification

10.2.1 Overview

This function automatically notifies the status of the MFP to the service technician by an e-mail or a fax.

- Total counter transmit
When this function is effective, it notifies each counter information periodically (on the set date and time every month).
- Service call transmit (e-mail only)
When this function is effective, it notifies the corresponding error code and such at a service call error.
- PM counter transmit
When this function is effective, it notifies that the PM timing has come when the present PM count has reached to its setting value, or the present PM driving count has reached to its setting value.
- Toner near empty transmit
When this function is effective, it notifies each counter information and toner cartridge information if toner near empty occurs.
- Waste toner near full transmit
When this function is effective, it notifies each counter information and toner cartridge information if toner near empty occurs.
- Storage device alert notification
When this function is effective, it notifies an alert for backing up or replacing it.
 P. 12-11 “12.3.6 Management of the backup function”
- Deactivation notification
When this function is effective, it notifies that the deactivation has been performed (e-mail only).
 P. 8-5 “8.1.4 Detach function”

10.2.2 Setting

Notes:

When using this function, it is required that sending and receiving of an e-mail or fax are available. Confirm the details to the administrator.

[1] Preparation

If the menu display of this function is disabled (not displayed), set it to “1” (displayed) with the following code.

FS-08-9604: Display set of the [Service Notification] button

0: Not displayed

1: Displayed

[2] Setting procedure

- (1) Press [User Functions] on the HOME SCREEN and select the [Admin] tab. Enter the password and press [OK].

Confirm the password to the administrator.

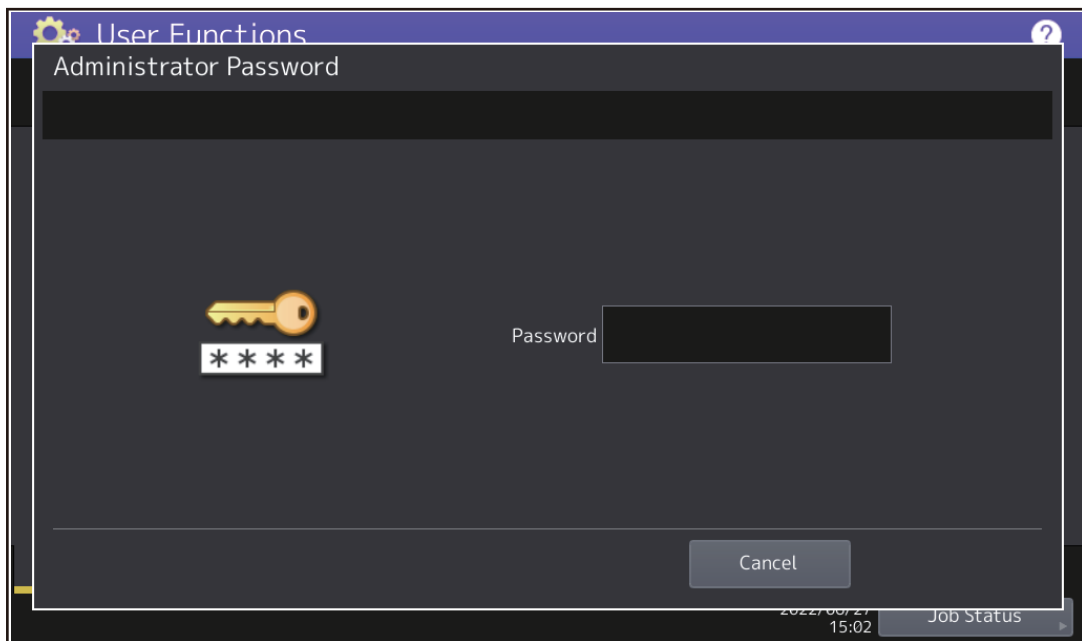

Fig.10-17

- (2) Press [Service].

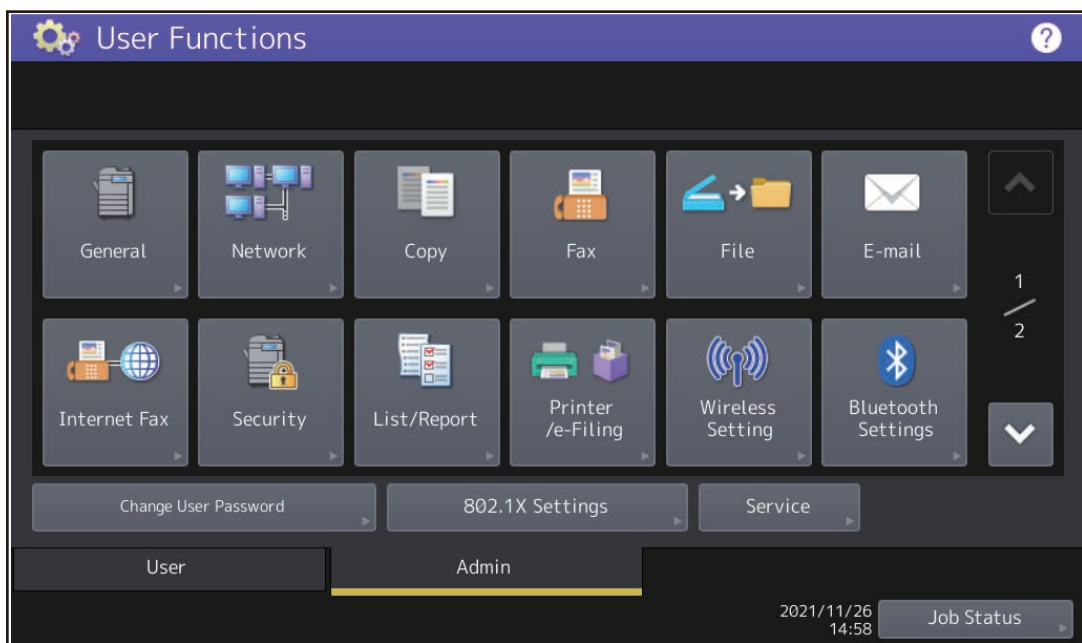

Fig.10-18

(3) Press [Service Notification].

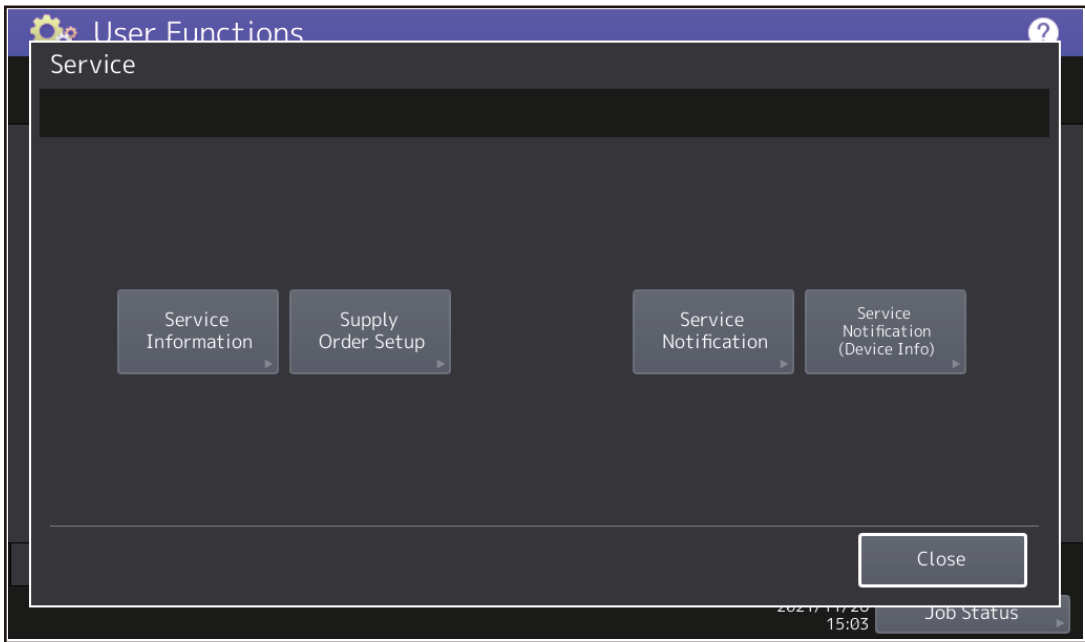

Fig.10-19

(4) Press [E-mail] or [Fax].
When [Off] is pressed, all functions related Service Notification become ineffective.

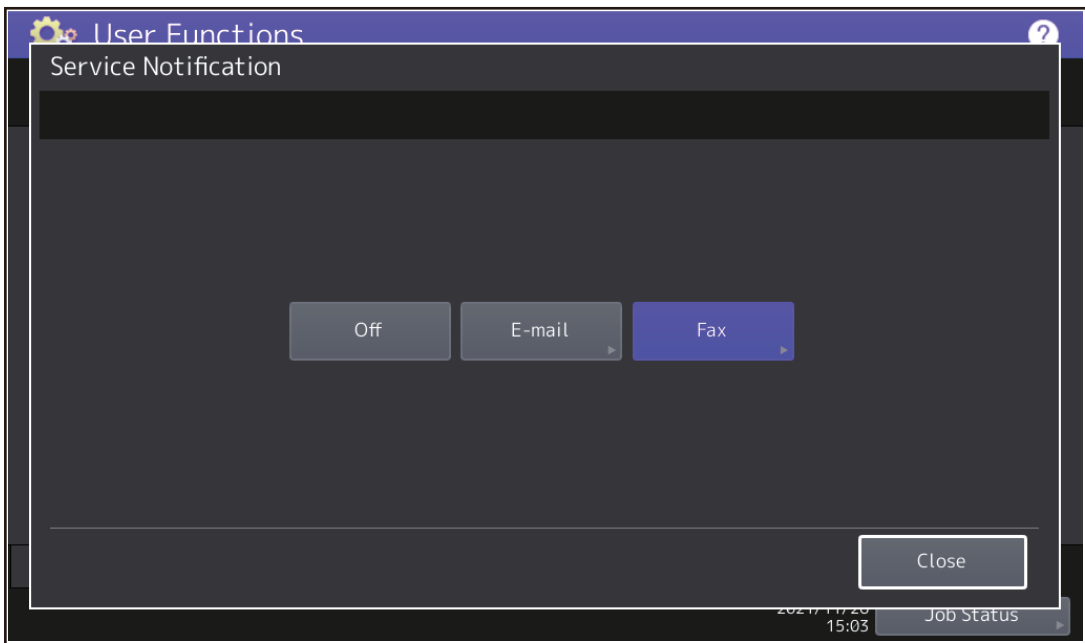

Fig.10-20

- (5) Enter the E-mail address or Fax Number of the destination and press [OK]. Up to 3 addresses can be set. (The keyboard appears upon your touching the entry box for an E-mail or a Fax Number.)

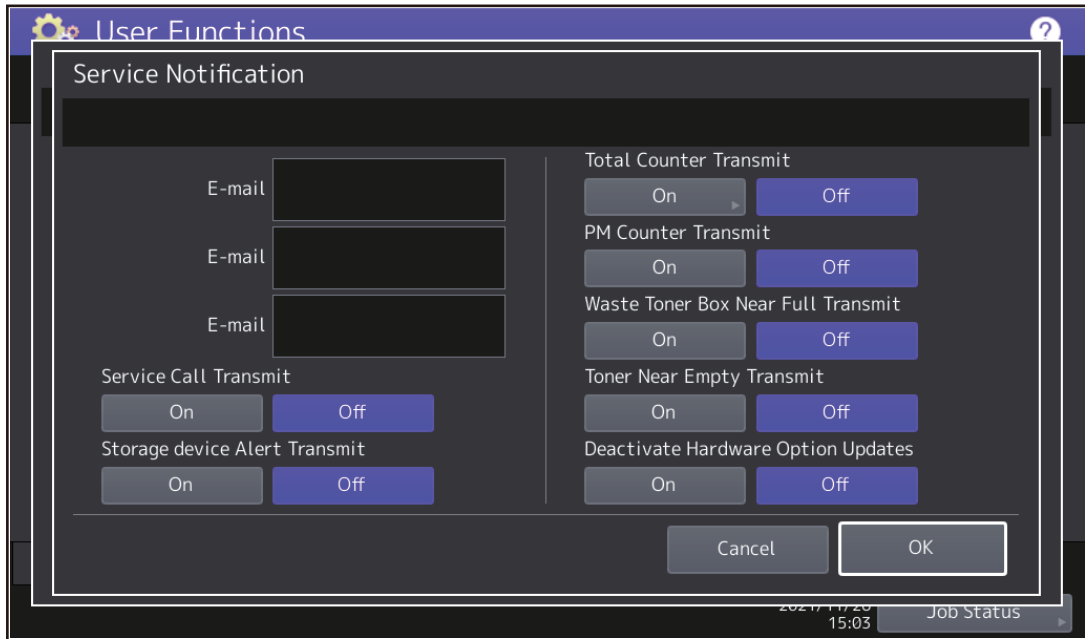

Fig.10-21

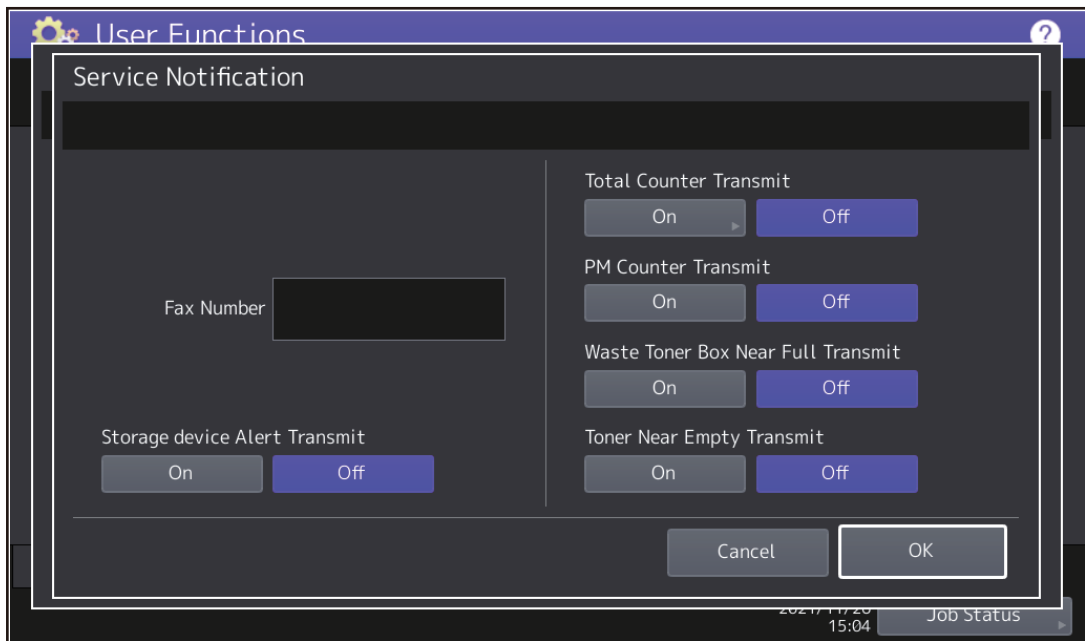

Fig.10-22

- (6) Press [On] to notify or [Off] not to notify each item for an E-mail and Fax.
 When Total Count Transmit is set to On, the screen to set the notification date is displayed. Then set the notification date with the following procedure.
 The following 3 items can be specified for the date setting.
- Day of the week (More than one day can be selected.)
 - Notify Date 1
 - Notify Date 2

Day of the week ([Sun] to [Sat])

Pressing [Sun] to [Sat] of the desired day makes transmission on every specified day. More than one day can be selected.

This does not affect the settings of Notify Date 1 and Notify Date 2.

You can send the Total Counter immediately without the above settings by pressing [Send Now].

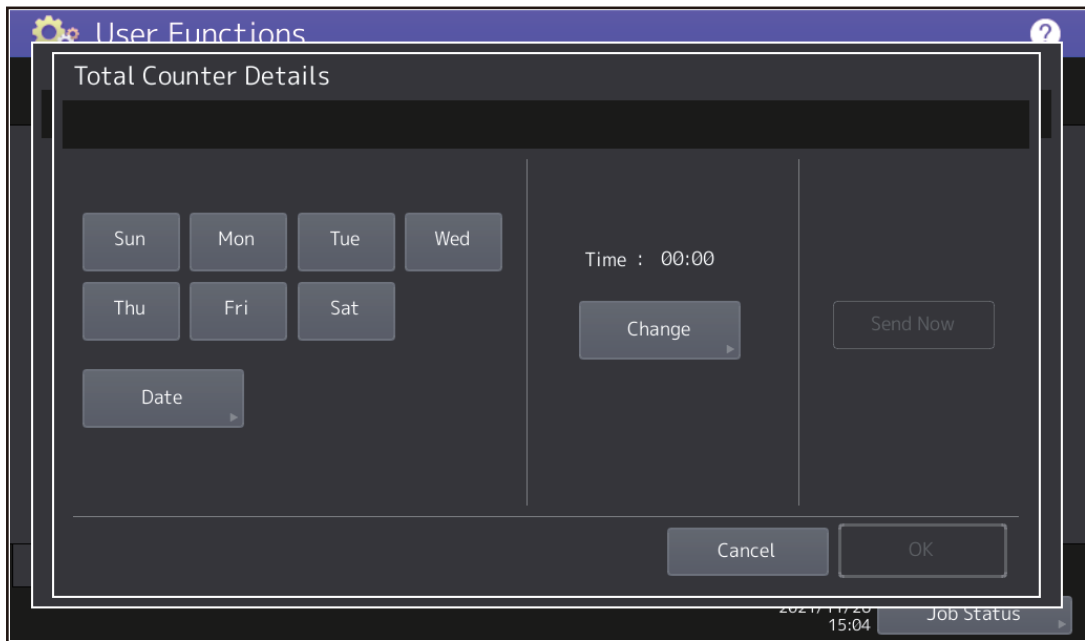

Fig.10-23

Notify Date 1 and Notify Date 2 ([Date])

Pressing [Date] sets up to 2 dates on which you want to send data.

This is not affected by the specified day of the week.

Enter the date (acceptable values: 0 to 31) in Notify Date 1 or Notify Date 2 and press [OK].

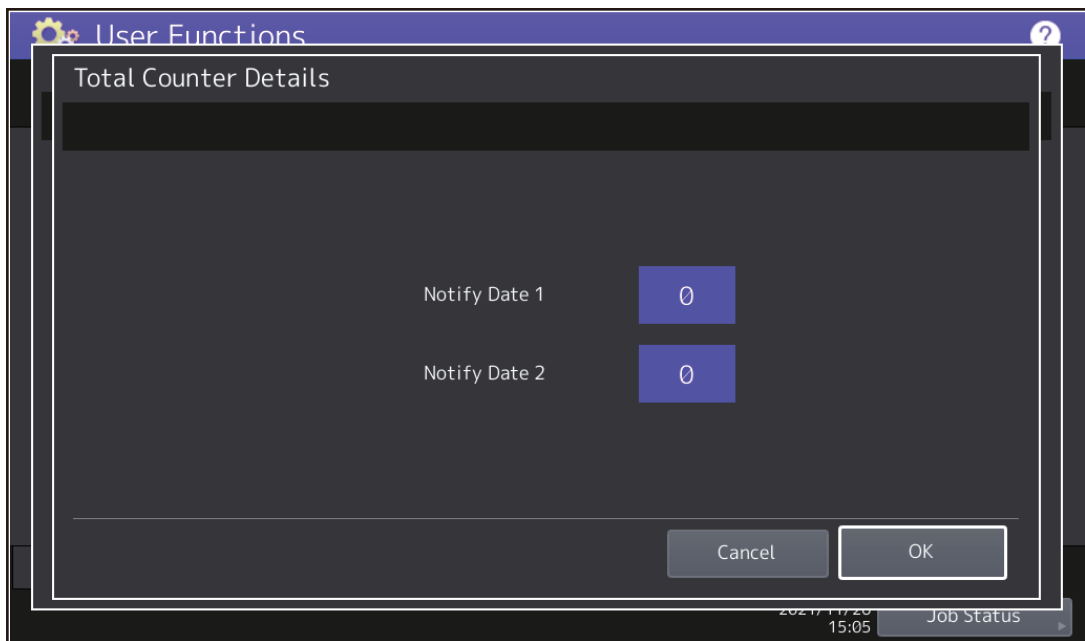

Fig.10-24

Time setting ([Change])

Pressing [Change] sets the time at which you want to send data.

This is the time when data are sent with Day of the week, Notify Date 1 and Notify Date 2.

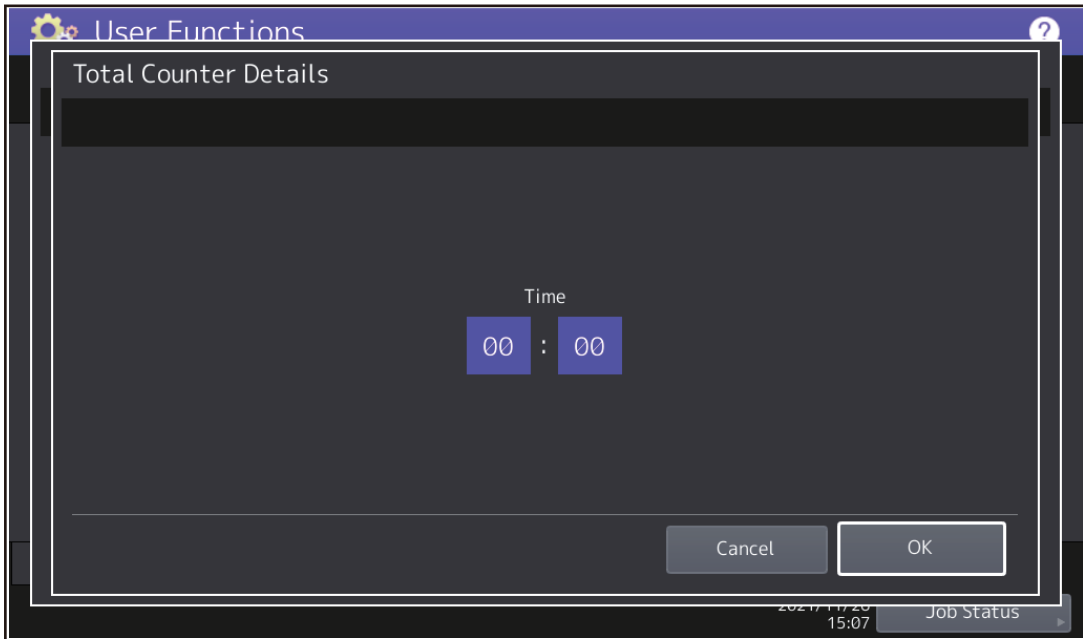

Fig.10-25

The digital keys appear by touching the value displayed in Time. Set "Time" in the left-hand column and "Minute" in the right-hand column. (Acceptable value: 00:00 to 23:59)

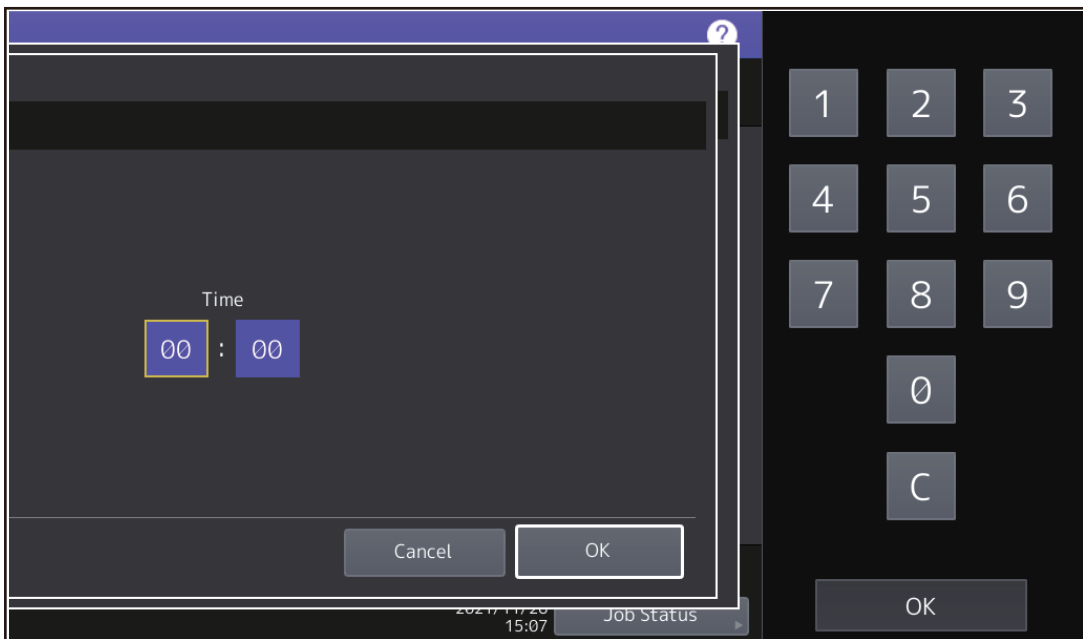

Fig.10-26

(7) After all the settings are completed, press [OK].

Notes:

- The Service Notification setting is also available from the following 08 SETTING MODE.
- Set the value "1" or "2" for FS-08-9793. Then set the items (self-diagnostic code) which you want to transmit to On.

- Register the E-mail address or Fax Number of the supplier and set the date and time for the transmission.
- Set the value “1” for the self-diagnostic code whose items should be described in the service notification.

| Setting item | Code | Contents |
|--|------------|---|
| Service notification setting | FS-08-9793 | 0: Invalid, 1: Valid (E-mail), 2: Valid (Fax) |
| E-mail address 1 | FS-08-9794 | Up to 192 letters |
| E-mail address 2 | FS-08-9607 | Up to 192 letters |
| E-mail address 3 | FS-08-9608 | Up to 192 letters |
| Fax Number | FS-08-9784 | Up to 32 digits |
| Total counter transmit setting | FS-08-9795 | 0: OFF (Invalid), 1: ON (Valid) |
| Total counter transmission date setting | FS-08-9796 | 0 to 31 |
| Total counter transmission date setting 2 | FS-08-9880 | 0 to 31 |
| Total counter transmission day setting | FS-08-9881 | 1 byte 00000000 (0) to 01111111 (127) From the 2nd bit - Sunday, Monday, Tuesday, Wednesday, Thursday, Friday, Saturday |
| Total counter transmission interval setting | FS-08-9606 | 00:00-23:59 (HHMM) |
| Service call transmission setting | FS-08-9605 | 0: OFF (Invalid), 1: ON (Valid) |
| PM counter transmit | FS-08-9797 | 0: OFF (Invalid), 1: ON (Valid) |
| Toner near empty transmit setting | FS-08-8538 | 0: OFF (Invalid), 1: ON (Valid) |
| Waste toner box nearly full transmit setting | FS-08-3699 | 0: OFF (Invalid), 1: ON (Valid) |

(8) The screen returns to the Service menu.

(9) Press [Service Notification (Device Info)].

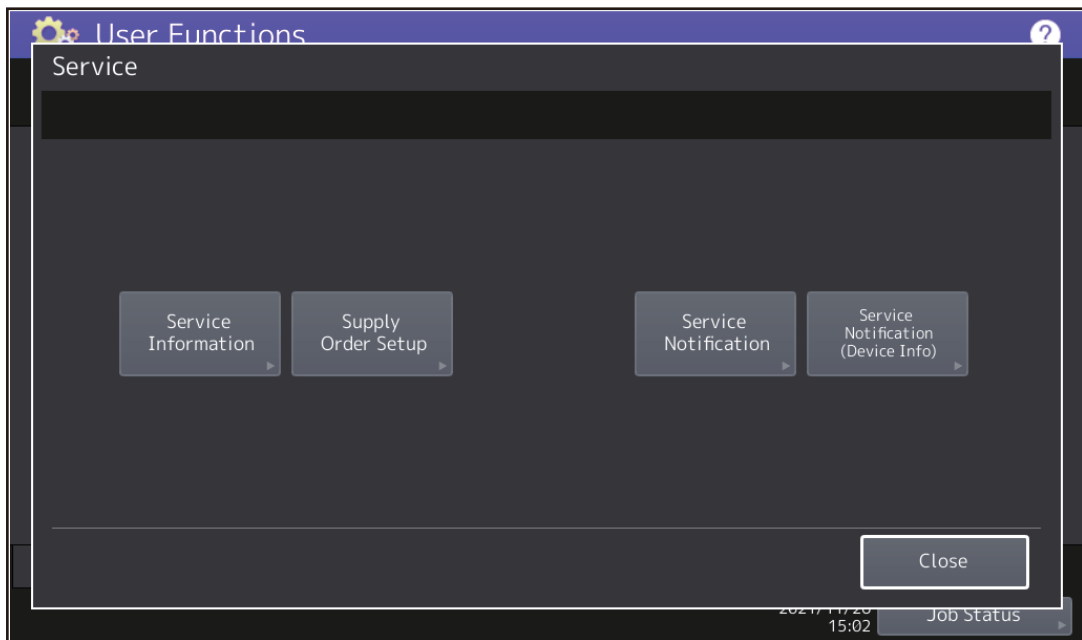

Fig.10-27

- (10) Press [On] or [Off] on the Service Notification (Device Info) menu.
When [Off] is pressed, all functions related Service Notification (Device Info) become ineffective.

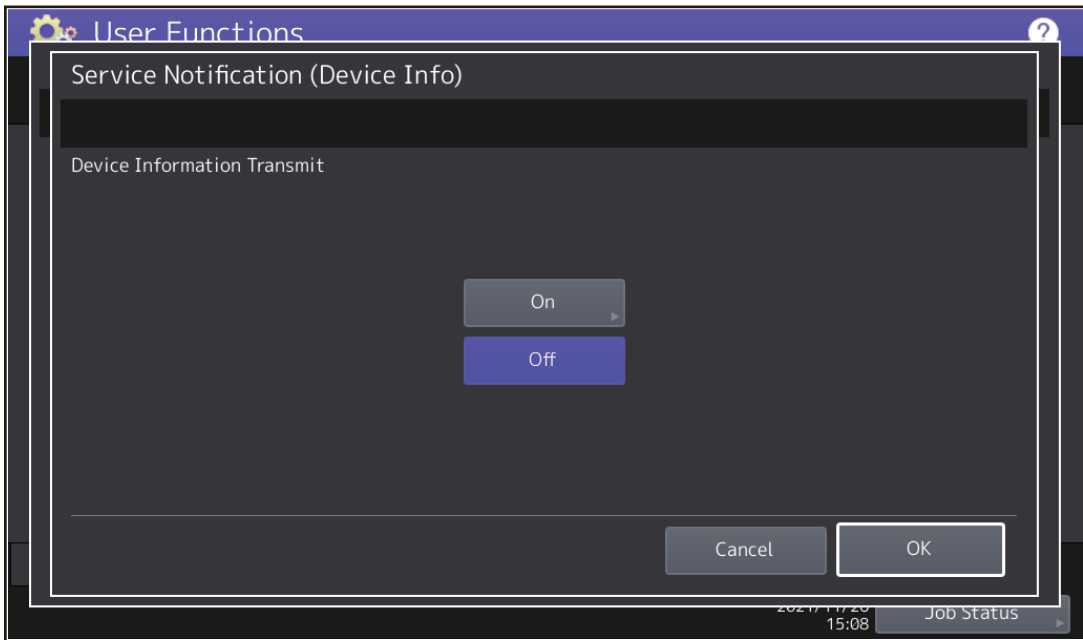

Fig.10-28

- (11) When Service Notification (Device Info) is set to On, the menu to set the notification date is displayed. Then set the notification date with the following procedure.

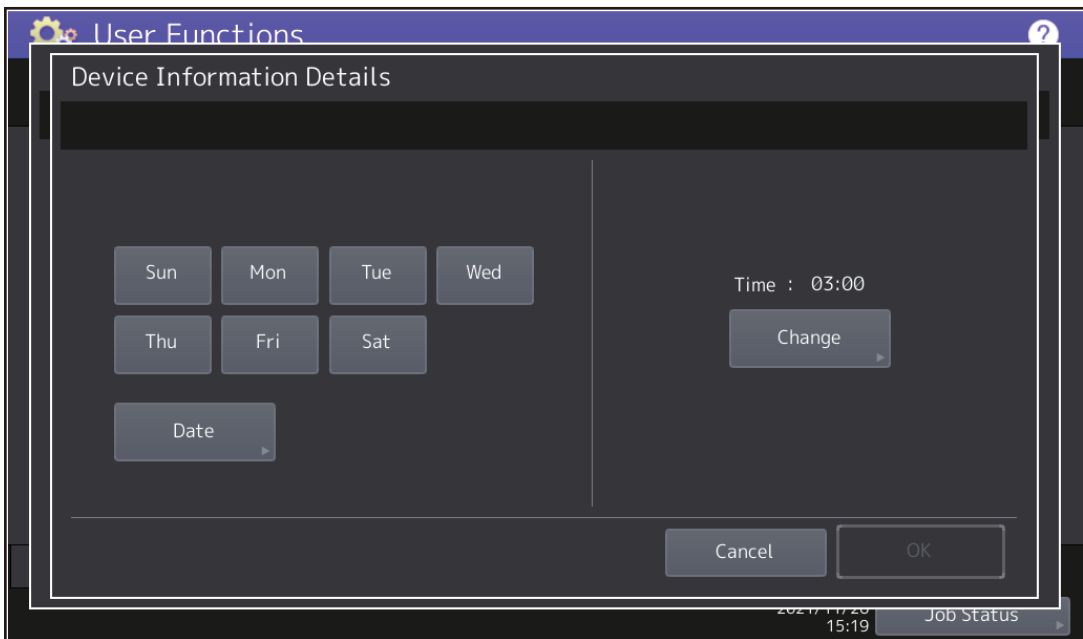

Fig.10-29

The following items for the machine information notification can be set as well as that for the total counter transmit.

- Day of the week (More than one day can be selected.)
- Notify Date 1
- Notify Date 2

After all the settings are completed, press [OK].

10.2.3 Items to be notified

The items to be notified are as follows.

[1] Total Counter Transmit / PM Counter Transmit by e-mail

Subject: COUNTER NOTIFICATION

In case of the PM Counter Transmit, the title is replaced to "PERIODICAL MAINTENANCE NOTIFICATION".

| | | |
|--------------------------------|----------------------------------|----------|
| Date | : 04/26/20XX 12:34 | |
| Machine Model | : TOSHIBA e-STUDIOXXX | |
| SerialNumber | : 1234567890 | |
| Total Counter | : 00004787 | |
| Supplier: | | |
| Name | : SUPPLIER_NAME | |
| Fax Number | : 1122334455 | |
| E-Mail | : Supplier_emailaddress@cccc.xxx | |
| Address | : SUPPLIER_ADDRESS | |
| Customer: | | |
| Name | : CUSTOMER_NAME | |
| Tel Number | : 1234567890 | |
| E-Mail | : customer_emailaddress@dddd.xxx | |
| Address | : CUSTOMER_ADDRESS | |
| Service Technician: | | |
| Number | : svc12 | |
| Name | : xxxxxxxxxxxx | |
| Tel Number | : 0987654321 | |
| E-Mail | : svc@toshibatec.co.jp | |
| ChargeCounterFormat: | | |
| LargeSizeChargeCount | 1 | |
| LargeSizeChargePaperDefinition | 1 | |
| PMCounterFormat: | | |
| LargeSizePMCount | 1 | |
| LargeSizePMPaperDefinition | 0 | |
| Charge Counter: | Large | Small |
| <Print Counter> | | |
| Black | ----- | |
| Copy | 00000000 | 00000000 |
| Print | 00000000 | 00000000 |
| List | 00000000 | 00000000 |
| FAX | 00000000 | 00000000 |
| <Scan Counter> | | |
| Full Color | ----- | |
| Net Scan | 00000000 | 00000000 |
| Black | ----- | |
| Copy Scan | 00000000 | 00000000 |
| FAX Scan | 00000000 | 00000000 |
| Net Scan | 00000000 | 00000000 |
| <FAX Counter> | | |
| Transmit | 00000000 | 00000000 |
| Receive | 00000000 | 00000000 |

(*1)

Fig.10-30

| Periodical Maintenance Counter: | | | |
|---------------------------------|------------------------|--------------|----------|
| | Pages | Drive Counts | |
| K-EPU | | | |
| Setting | 00000000 | 00000000 | |
| Current | 00000000 | 00000000 | |
| K-Dev | | | |
| Setting | 00000000 | 00000000 | |
| Current | 00000000 | 00000000 | |
| Others | | | |
| Setting | 00000000 | 00000000 | |
| Current | 00000000 | 00000000 | |
| Printer Error History: | | | |
| Date | Time | ErrorCode | Counter |
| 04/13/20XX | 16:44 | EAD0 | 00000000 |
| 04/12/20XX | 22:28 | EAD0 | 00000000 |
| 04/12/20XX | 22:23 | EAD0 | 00000000 |
| 03/15/20XX | 22:23 | EAD0 | 00000000 |
| 02/25/20XX | 11:12 | EAD0 | 00000000 |
| Toner Cartridge Information: | | | |
| Color Code | Black | | |
| Toner Near-Empty Counter | | | |
| Setting | 00000000 | | |
| Color Code | 00000000 | | |
| Toner Near-Empty Sensed | 1 | | |
| Point Of Destination | JPD | | |
| Used History | | | |
| Developer Counter | 00000056 | | |
| Developer Driving Time | 00000057 | | |
| Drum Driving Time | 00000058 | | |
| Toner | | | |
| | Remaining Quantity (%) | | |
| Black | 00000000 | | |

(*2)

Fig.10-31

*1 When "1" set for FS-08-3667, a QR code will be added.
 *2 The latest 20 errors are displayed.

[2] Total Counter Transmit / PM Counter Transmit by fax

Sheet 1

| COUNTER NOTIFICATION (*1) | SUCCESSFUL TX NOTICE (or TX FAILURE NOTICE) |
|-------------------------------|---|
| DATE | : XX/04/14 13:47 |
| MACHINE MODEL | : TOSHIBA e-STUDIOxxxx |
| SERIAL NUMBER | : 1234567890 |
| TOTAL COUNTER | : 00004787 |
| | |
| CUSTOMER NAME | : CUSTOMER_NAME |
| CUSTOMER ADDRESS | : CUSTOMER_ADDRESS |
| CUSTOMER TEL NUMBER | : 1234567890 |
| CUSTOMER E-MAIL ADDRESS | : customer_emailaddress@dddd.xxx |
| SERVICE TECHNICIAN NUMBER | : svc12 |
| SERVICE TECHNICIAN NAME | : xxxxxxxxxxxx |
| SERVICE TECHNICIAN TEL NUMBER | : 0987654321 |
| SERVICE TECHNICIAN E-MAIL | : svc@toshibatec.co.jp |
| SUPPLIER NAME | : SUPPLIER_NAME |
| SUPPLIER ADDRESS | : SUPPLIER_ADDRESS |
| SUPPLIER FAX NUMBER | : 5544332211 |
| SUPPLIER E-MAIL | : supplier_emailaddress@cccc.xxx |

Fig.10-32

| COUNTER NOTIFICATION (*1) | | | | | |
|------------------------------------|----------|--------------|--------------------------------|----------|----------|
| CHARGE COUNTER FORMAT | | | PM COUNTER FORMAT | | |
| LARGE SIZE CHARGE COUNT | | : 1 | LARGE SIZE PM COUNT | | : 1 |
| LARGE SIZE CHARGE PAPER DEFINITION | | : 1 | LARGE SIZE PM PAPER DEFINITION | | : 0 |
| CHARGE COUNTER | | | | | |
| PRINT COUNTER | | | SCAN COUNTER | | |
| BLACK | LARGE | SMALL | FULL COLOR | LARGE | SMALL |
| COPY | 00000000 | 00000000 | NET SCAN | 00000000 | 00000000 |
| PRINT | 00000000 | 00000000 | BLACK | LARGE | SMALL |
| LIST | 00000000 | 00000000 | COPY SCAN | 00000000 | 00000000 |
| FAX | 00000000 | 00000000 | FAX SCAN | 00000000 | 00000000 |
| | | | NET SCAN | 00000000 | 00000000 |
| FAX COUNTER | | | | | |
| | LARGE | SMALL | | | |
| TRANSMIT | 00000000 | 00000000 | | | |
| RECEIVE | 00000000 | 00000000 | | | |
| PERIODICAL MAINTENANCE COUNTER | | | | | |
| | PAGES | DRIVE COUNTS | | | |
| ----- | | | | | |
| K-EPU | | | | | |
| SETTING | 00000000 | 00000000 | | | |
| CURRENT | 00000000 | 00000000 | | | |
| ----- | | | | | |
| K-DEV | | | | | |
| SETTING | 00000000 | 00000000 | | | |
| CURRENT | 00000000 | 00000000 | | | |
| ----- | | | | | |
| OTHERS | | | | | |
| SETTING | 00000000 | 00000000 | | | |
| CURRENT | 00000000 | 00000000 | | | |

Fig.10-33

| COUNTER NOTIFICATION | | | | | | | |
|----------------------------------|------------|-----------|----------|----------|-------|-----------|----------|
| PRINTER ERROR HISTORY | | | | | | | |
| DATE | TIME | ERRORCODE | COUNTER | DATE | TIME | ERRORCODE | COUNTER |
| XX/04/13 | 16:44 | EAD0 | 00000000 | XX/XX/XX | XX:XX | EAD0 | 00000000 |
| XX/04/12 | 22:28 | EAD0 | 00000000 | XX/XX/XX | XX:XX | EAD0 | 00000000 |
| XX/04/12 | 22:23 | EAD0 | 00000000 | XX/XX/XX | XX:XX | EAD0 | 00000000 |
| XX/03/15 | 22:23 | EAD0 | 00000000 | XX/XX/XX | XX:XX | EAD0 | 00000000 |
| XX/02/25 | 11:12 | EAD0 | 00000000 | XX/XX/XX | XX:XX | EAD0 | 00000000 |
| Toner Cartridge Information | | | | | | | |
| Color Code | : BLACK | | | | | | |
| Toner Near-Empty Counter Setting | : 00000155 | | | | | | |
| Current | : 00000055 | | | | | | |
| Toner Near-Empty Sensed | : 1 | | | | | | |
| Point Of Destination | : JPD | | | | | | |
| Used History | | | | | | | |
| Developer Counter | : 00000056 | | | | | | |
| Developer Driving Time | : 00000057 | | | | | | |
| Drum Driving Time | : 00000055 | | | | | | |
| TONER INFORMATION | | | | | | | |
| BLACK REMAINING QUANTITY (%) | : 00000062 | | | | | | |

Fig.10-34

*1 In case of the PM Counter Transmit, the title is replaced to "PERIODICAL MAINTENANCE NOTIFICATION".

*2 The latest 20 errors are displayed.

[3] Toner near-empty notification by e-mail

Subject: Toner Near-Empty Notification

```
Date : 04/26/20XX 12:34
Machine Model : TOSHIBA e-STUDIOXXX
SerialNumber : 1234567890
Total Counter : 00004787

Supplier:
Name : SUPPLIER_NAME
Fax Number : 1122334455
E-Mail : Supplier_emailaddress@cccc.xxx
Address : SUPPLIER_ADDRESS

Customer:
Name : CUSTOMER_NAME
Tel Number : 1234567890
E-Mail : customer_emailaddress@dddd.xxx
Address : CUSTOMER_ADDRESS

Service Technician:
Number : svc12
Name : xxxxxxxxxxxx
Tel Number : 0987654321
E-Mail : svc@toshibatec.co.jp

ChargeCounterFormat:
LargeSizeChargeCount 1
LargeSizeChargePaperDefinition 1

PMCounterFormat:
LargeSizePMCount 1
LargeSizePMPaperDefinition 0

Charge Counter:
      Large      Small
<Print Counter>
Black -----
Copy      00000000  00000000
Print     00000000  00000000
List      00000000  00000000
FAX       00000000  00000000

<Scan Counter>
Full Color -----
Net Scan  00000000  00000000
Black -----
Copy Scan 00000000  00000000
FAX Scan  00000000  00000000
Net Scan  00000000  00000000

<FAX Counter>
Transmit  00000000  00000000
Receive   00000000  00000000
```

Fig.10-35

| Periodical Maintenance Counter: | | | |
|---------------------------------|------------------------|--------------|----------|
| | Pages | Drive Counts | |
| K-EPU | | | |
| Setting | 00000000 | 00000000 | |
| Current | 00000000 | 00000000 | |
| K-DEV | | | |
| Setting | 00000000 | 00000000 | |
| Current | 00000000 | 00000000 | |
| Others | | | |
| Setting | 00000000 | 00000000 | |
| Current | 00000000 | 00000000 | |
| Printer Error History: | | | |
| Date | Time | ErrorCode | Counter |
| 04/13/20XX | 16:44 | EAD0 | 00000000 |
| 04/12/20XX | 22:28 | EAD0 | 00000000 |
| 04/12/20XX | 22:23 | EAD0 | 00000000 |
| 03/15/20XX | 22:23 | EAD0 | 00000000 |
| 02/25/20XX | 11:12 | EAD0 | 00000000 |
| Toner Cartridge Information: | | | |
| Color Code | Black | | |
| Toner Near-Empty Counter | | | |
| Setting | 00000000 | | |
| Current | 00000000 | | |
| Toner Near-Empty Sensed | 1 | | |
| Point Of Destination | JPD | | |
| Used History | | | |
| Developer Counter | 00000056 | | |
| Developer Driving Time | 00000057 | | |
| Drum Driving Time | 00000058 | | |
| Toner Information | | | |
| Toner | Remaining Quantity (%) | | |
| Black | 00000000 | | |

(**1)

Fig.10-36

*1 The latest 20 errors are displayed.

[4] Toner near-empty notification by fax

Sheet 1

TONER NEAR-EMPTY NOTIFICATION

| | |
|-------------------------------|----------------------------------|
| DATE | : XX/04/14 13:47 |
| MACHINE MODEL | : TOSHIBA e-STUDIOxxxx |
| SERIAL NUMBER | : 1234567890 |
| TOTAL COUNTER | : 00004787 |
| | |
| CUSTOMER NAME | : CUSTOMER_NAME |
| CUSTOMER ADDRESS | : CUSTOMER_ADDRESS |
| CUSTOMER TEL NUMBER | : 1234567890 |
| CUSTOMER E-MAIL ADDRESS | : customer_emailaddress@dddd.xxx |
| SERVICE TECHNICIAN NUMBER | : svc12 |
| SERVICE TECHNICIAN NAME | : xxxxxxxxxxxx |
| SERVICE TECHNICIAN TEL NUMBER | : 0987654321 |
| SERVICE TECHNICIAN E-MAIL | : svc@toshibatec.co.jp |
| SUPPLIER NAME | : SUPPLIER_NAME |
| SUPPLIER ADDRESS | : SUPPLIER_ADDRESS |
| SUPPLIER FAX NUMBER | : 5544332211 |
| SUPPLIER E-MAIL ADDRESS | : supplier_emailaddress@cccc.xxx |

Fig.10-37

| TONER NEAR-EMPTY NOTIFICATION | | | | | |
|------------------------------------|----------|--------------|--------------------------------|----------|----------|
| CHARGE COUNTER FORMAT | | | PM COUNTER FORMAT | | |
| LARGE SIZE CHARGE COUNT | | : 1 | LARGE SIZE PM COUNT | | : 1 |
| LARGE SIZE CHARGE PAPER DEFINITION | | : 1 | LARGE SIZE PM PAPER DEFINITION | | : 0 |
| CHARGE COUNTER | | | | | |
| PRINT COUNTER | | | SCAN COUNTER | | |
| BLACK | LARGE | SMALL | FULL COLOR | LARGE | SMALL |
| COPY | 00000000 | 00000000 | NET SCAN | 00000000 | 00000000 |
| PRINT | 00000000 | 00000000 | BLACK | LARGE | SMALL |
| LIST | 00000000 | 00000000 | COPY SCAN | 00000000 | 00000000 |
| FAX | 00000000 | 00000000 | FAX SCAN | 00000000 | 00000000 |
| | | | NET SCAN | 00000000 | 00000000 |
| FAX COUNTER | | | | | |
| | LARGE | SMALL | | | |
| TRANSMIT | 00000000 | 00000000 | | | |
| RECEIVE | 00000000 | 00000000 | | | |
| PERIODICAL MAINTENANCE COUNTER | | | | | |
| | PAGES | DRIVE COUNTS | | | |
| ----- | | | | | |
| K-EPU | | | | | |
| SETTING | 00000000 | 00000000 | | | |
| CURRENT | 00000000 | 00000000 | | | |
| ----- | | | | | |
| K-DEV | | | | | |
| SETTING | 00000000 | 00000000 | | | |
| CURRENT | 00000000 | 00000000 | | | |
| ----- | | | | | |
| OTHERS | | | | | |
| SETTING | 00000000 | 00000000 | | | |
| CURRENT | 00000000 | 00000000 | | | |

Fig.10-38

| TONER NEAR-EMPTY NOTIFICATION | | | | | | | |
|-------------------------------|------------|-----------|----------|----------|-------|-----------|----------|
| PRINTER ERROR HISTORY | | | | | | | |
| DATE | TIME | ERRORCODE | COUNTER | DATE | TIME | ERRORCODE | COUNTER |
| XX/04/13 | 16:44 | EAD0 | 00000000 | XX/XX/XX | XX:XX | EAD0 | 00000000 |
| XX/04/12 | 22:28 | EAD0 | 00000000 | XX/XX/XX | XX:XX | EAD0 | 00000000 |
| XX/04/12 | 22:23 | EAD0 | 00000000 | XX/XX/XX | XX:XX | EAD0 | 00000000 |
| XX/03/15 | 22:23 | EAD0 | 00000000 | XX/XX/XX | XX:XX | EAD0 | 00000000 |
| XX/02/25 | 11:12 | EAD0 | 00000000 | XX/XX/XX | XX:XX | EAD0 | 00000000 |
| Toner Cartridge Information | | | | | | | |
| Color Code | : BLACK | | | | | | |
| Toner Near-Empty Counter | : 00000155 | | | | | | |
| Setting | : 00000055 | | | | | | |
| Current | : 1 | | | | | | |
| Toner Near-Empty Sensed | : JPD | | | | | | |
| Point Of Destination | : 1 | | | | | | |
| Used History | : JPD | | | | | | |
| Developer Counter | : 00000056 | | | | | | |
| Developer Driving Time | : 00000057 | | | | | | |
| Drum Driving Time | : 00000055 | | | | | | |
| TONER INFORMATION | | | | | | | |
| BLACK REMAINING QUANTITY (%) | : 00000062 | | | | | | |

(*1)

Fig.10-39

*1 The latest 20 errors are displayed.

[5] Service call transmission

Subject: Service Call Notification

Date: 04/14/20XX 13:47
Machine Name: e-STUDIOXXX SerialNumber:1234567890

Function: Print
Severity: Error
ErrorCode: XXXX
Message:
XX

Supplier:
Name : SUPPLIER_NAME
Tel Number : 1122334455
E-Mail : supplier_emailaddress@cccc.xxx
Address : SUPPLIER_ADDRESS

Customer:
Name : CUSTOMER_NAME
Tel Number : 1234567890
E-Mail : customer_emailaddress@dddd.xxx
Address : CUSTOMER_ADDRESS

Service Technician:
Number : svc12
Name : xxxxxxxxxxxx
Tel Number : 0987654321
E-Mail : svc@toshibatec.co.jp

Printer Error History:

| Date | Time | ErrorCode | Counter |
|------------|-------|-----------|---------|
| 04/13/20XX | 16:44 | F110 | |
| 04/12/20XX | 22:28 | F110 | |
| 04/12/20XX | 22:23 | F110 | |
| 03/15/20XX | 22:23 | F110 | |
| 02/25/20XX | 11:12 | F110 | |

Toner Information

| Toner | Remaining Quantity(%) |
|-------|-----------------------|
| Black | 00000000 |

(*)

(*)

Fig.10-40

*1 The values are fixed as; Function: Print, Severity: Error.

*2 The latest 20 errors are displayed.

[6] Storage device alert notification by e-mail

Subject: STORAGE DEVICE ALERT NOTIFICATION

For the SATA Port0: SSD and Port1: HDD

| | |
|--|--|
| Date | : 99-99-'99 99:99 |
| Machine Model | : TOSHIBA e-STUDIOxxxx |
| Serial Number | : 1234567890 |
| F/W Ver. | : XXXXXXXXXXXXXXXX |
| Total Counter | : 00000000 |
| Supplier: | |
| Name | : XXXXXXXXXXXXXXXXXXXXXXXXXXXXXXXXXXXX |
| Tel Number | : XXXXXXXXXXXXXXXXXXXXXXXXXXXXXXXXXXXX |
| E-Mail | : XXXXXXXXXXXXXXXXXXXXXXXXXXXXXXXXXXXX |
| Address | : XXXXXXXXXXXXXXXXXXXXXXXXXXXXXXXXXXXX |
| Customer: | |
| Name | : XXXXXXXXXXXXXXXXXXXXXXXXXXXXXXXXXXXX |
| Tel Number | : XXXXXXXXXXXXXXXXXXXXXXXXXXXXXXXXXXXX |
| E-Mail | : XXXXXXXXXXXXXXXXXXXXXXXXXXXXXXXXXXXX |
| Address | : XXXXXXXXXXXXXXXXXXXXXXXXXXXXXXXXXXXX |
| Service Technician: | |
| Number | : XXXXXXXXXXXXXXXXXXXXXXXXXXXXXXXXXXXX |
| Name | : XXXXXXXXXXXXXXXXXXXXXXXXXXXXXXXXXXXX |
| Tel Number | : XXXXXXXXXXXXXXXXXXXXXXXXXXXXXXXXXXXX |
| E-Mail | : XXXXXXXXXXXXXXXXXXXXXXXXXXXXXXXXXXXX |
| Storage Model Number (Port0) | : XXXXXXXXXXXXXXXXXXXXXXXX |
| Storage Serial Number (Port0) | : XXXXXXXXXXXXXXXXXXXXXXXX |
| SMART Information (Port0) | |
| Uncorrectable Error Count | : XXXXXXXXXXXXXXXXXXXXXXXX |
| Power-On hours Count | : XXXXXXXXXXXXXXXXXXXXXXXX |
| Drive Power Cycle Count | : XXXXXXXXXXXXXXXXXXXXXXXX |
| Spare Block Count | : XXXXXXXXXXXXXXXXXXXXXXXX |
| Later Bad Block Count | : XXXXXXXXXXXXXXXXXXXXXXXX |
| Max Erase Cunt | : XXXXXXXXXXXXXXXXXXXXXXXX |
| Avg Erase Count | : XXXXXXXXXXXXXXXXXXXXXXXX |
| Unexpected Power Loss Count | : XXXXXXXXXXXXXXXXXXXXXXXX |
| Temperature(Minimum) | : XXXXXXXXXXXXXXXXXXXXXXXX |
| Temperature(Maximum) | : XXXXXXXXXXXXXXXXXXXXXXXX |
| CRC Error Count | : XXXXXXXXXXXXXXXXXXXXXXXX |
| SSD Life Left | : XXXXXXXXXXXXXXXXXXXXXXXX |
| NAND write(GB) | : XXXXXXXXXXXXXXXXXXXXXXXX |
| Host write(GB) | : XXXXXXXXXXXXXXXXXXXXXXXX |
| Total Erase Count | : XXXXXXXXXXXXXXXXXXXXXXXX |
| Storage Model Number (Port1) | : TOSHIBAXXXXXXXXXXXXXXXXXXXXXX |
| Storage Serial Number (Port1) | : XXXXXXXXXXXXXXXXXXXXXXXX |
| SMART Information (Port1) | |
| Start/Stop Count | : 0 |
| Reallocated Sector Count | : 0 |
| Power-On hours count | : 0 |
| Drive Power Cycle Count | : 0 |
| Shock Sense Count | : 0 |
| Power-Off Retract Count | : 0 |
| Load Cycle Count | : 0 |
| Temperature(Minimum) | : 0 |
| Temperature(Maximum) | : 0 |
| Reallocated Sector Event | : 0 |
| Current Pending Sector Count | : 0 |
| CRC Error Count | : 0 |
| Loaded Hours | : 0 |
| STORAGE CHECK RESULT : Data backup and exchange of the storage device (SATA Port 1) are required. (*1) | |

Fig.10-41

Notes:

*1 Results of execution of FS-08-9008. For details, see the following reference.

 P. 12-11 “12.3.6 Management of the backup function”

[7] Storage device alert notification by fax

Sheet 1

| STORAGE DEVICE ALERT NOTIFICATION | |
|-----------------------------------|---|
| DATE | : 99-99-99 99:99 |
| MACHINE MODEL | : TOSHIBA e-STUDIOxxxx |
| SERIAL NUMBER | :1234567890 |
| TOTAL COUNTER | : 00000000 |
| CUSTOMER NAME | : XXX |
| CUSTOMER ADDRESS | : XXX |
| CUSTOMER TEL NUMBER | : XXX |
| CUSTOMER E-MAIL ADDRESS | : XXX |
| SERVICE TECHNICIAN NUMBER | : XXX |
| SERVICE TECHNICIAN NAME | : XXX |
| SERVICE TECHNICIAN TEL NUMBER | : XXX |
| SERVICE TECHNICIAN E-MAIL | : XXX |
| SUPPLIER NAME | : XXX |
| SUPPLIER ADDRESS | : XXX |
| SUPPLIER FAX NUMBER | : XXX |
| SUPPLIER E-MAIL ADDRESS | : XXX |

Fig.10-42

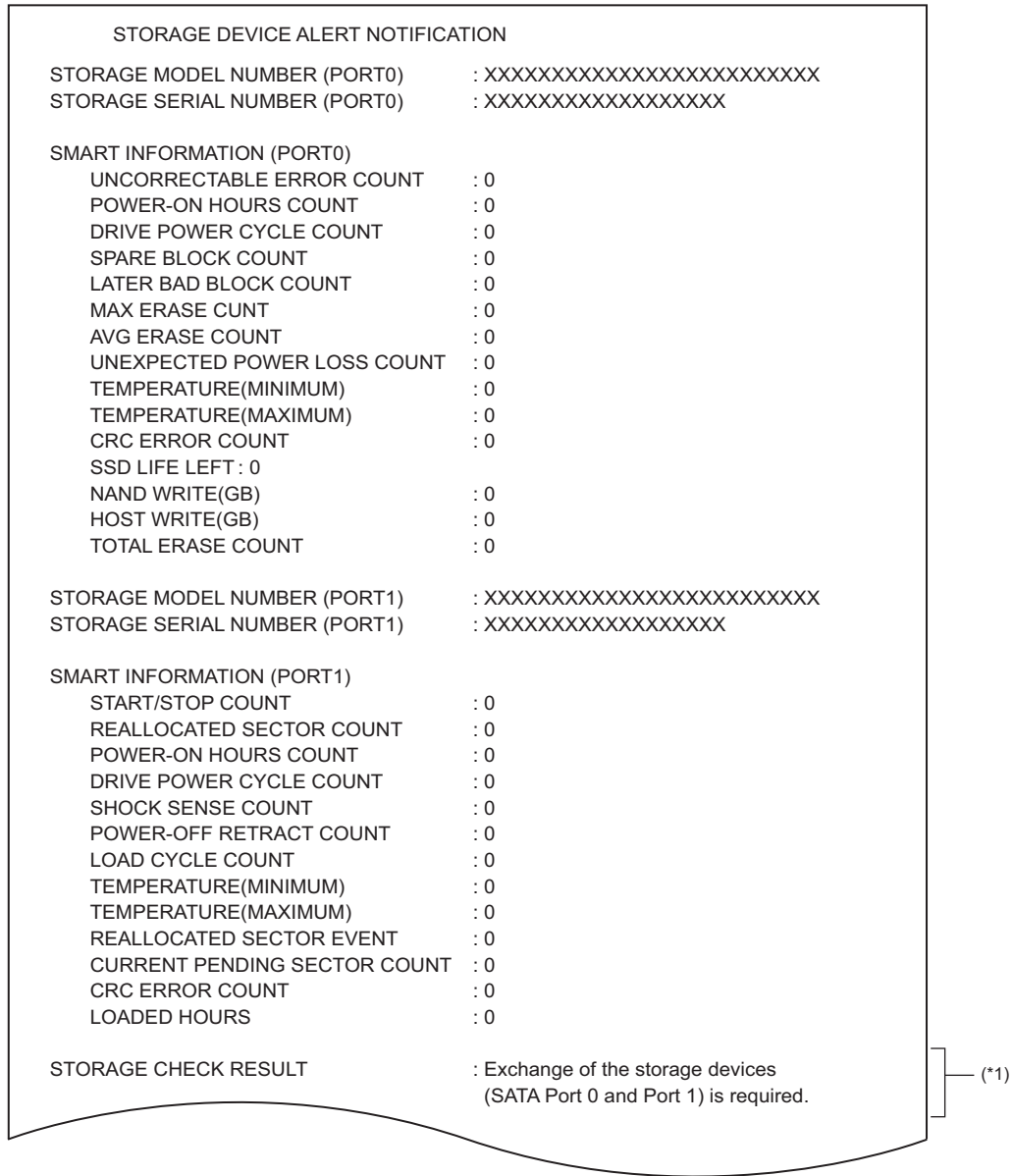



Fig.10-43

*1 Results of execution of FS-08-9008. For details, see the following reference.

 P. 12-11 “12.3.6 Management of the backup function”

[8] Deactivation notification by e-mail

Subject: DEACTIVATE NOTIFICATION

Date : 04/14/20XX 15:26
Machine Name: e-STUDIOxxxx SerialNumber:1234567890

Function : DF Deactivate
Severity : Warning
ErrorCode : DB01
Message
Document Feeder was deactivated.

Supplier:
Name : SUPPLIER_NAME
Tel Number : 1122334455
E-Mail : supplier_emailaddress@cccc.xxx
Address : SUPPLIER_ADDRESS

Customer:
Name : CUSTOMER_NAME
Tel Number : 1234567890
E-Mail : customer_emailaddress@ddd.xxx
Address : CUSTOMER_ADDRESS

Service Technician:
Number : svc12
Name : xxxxxxxxxxxx
Tel Number : 0987654321
E-Mail : svc@toshibatec.co.jp

Printer Error History:

| Date | Time | ErrorCode | Counter |
|------------|-------|-----------|----------|
| 04/13/20XX | 16:44 | EAD0 | 01234567 |
| 04/12/20XX | 22:28 | EAD0 | 01234567 |
| 04/12/20XX | 22:23 | EAD0 | 01234567 |
| 03/15/20XX | 22:23 | EAD0 | 01234567 |
| 02/25/20XX | 11:12 | EAD0 | 01234567 |

Toner Information

| Toner | Remaining Quantity(%) |
|-------|-----------------------|
| Black | 00000000 |

Fig.10-44

*1 Display example when the DF is deactivated. An error code and message are shown.

*2 The latest 20 errors are displayed.

10.3 Remote Panel (VNC)

10.3.1 Overview

By using the Remote Panel (VNC: Virtual Network Computing) function, the control panel of MFP* which is located in a remote place can be operated by a client computer or tablet.

* MFP whose IP address can be confirmed from a client computer or tablet to be operated

Notes:

- Be sure to obtain permission from the user beforehand to enable and use this function.
- If the user approval can be obtained, ask that the MFP be operated with this function enabled.
- The VNC client software needs to be installed in a client computer or tablet in order for you to perform the VNC connection with the MFP. (Recommended VNC client software: "UltraVNC")

The following items become operable in the VNC function.

- All the operations which are available on the control panel (operations of icons in the touch panel and hard keys)
- Shifting to the FS Menu from the normal mode
- Browsing and setting self-diagnostic codes in the FS Menu

Notes:

The pinch operation on the touch panel, [ON/OFF] button operation, LED lamp performance and Ten Key (option) operation are not supported.

10.3.2 Setting

[1] MFP setting

Set this function from TopAccess or [08 SETTING MODE].

[A] Setting from TopAccess

Access from TopAccess > [Administration] > [Setup] > [Network] and specify the items in VNC Setting as below.

| Item name | Setting |
|---------------------|---|
| Enable VNC Function | Select [Enable]. |
| Old Password | Enter the old password for the VNC function. |
| New Password | Enter a new password for the VNC function. |
| Retype Password | Retype the new password for the VNC function. |
| Enable SSL/TLS | Select [Disable]. |

[B] Setting from [08 SETTING MODE]

| Code | Contents | Setting |
|------------|---------------------------------|--|
| FS-08-8794 | VNC connection of control panel | Set "1" (Allowed to connect). |
| FS-08-8559 | Password at VNC connection | Enter a password for the VNC function. |
| FS-08-8699 | SSL function setting | Set "0" (Disabled). |

Notes:

- Be sure to change the default password at the time of the first setting.
- To use "UltraVNC" for the VNC client software, set [Disable] in the [Enable SSL/TLS] option.
- To perform the VNC function by selecting [Enable] for the [Enable SSL/TLS] option, use a VNC client software which supports SSL/TLS.
- Specify a password with six or more and eight or less alphanumeric letters.

- When the “Enable” is selected for Enable VNC Function (FS-08-8794: 1), the MFP cannot shift to the Super Sleep mode.

[2] Setting a client computer or tablet

Install the VNC client software.

10.3.3 Operation

[1] VNC connection between the MFP and a client computer or tablet

- (1) Start the VNC client software in the client computer or tablet.
- (2) Enter the IP address of the MFP to connect in the VNC Server field and press [Connect].

Remarks:

Select “Auto” for Quick Options.

- (3) Enter the password for the VNC connection and press [Log On].
The control panel of the connected MFP is displayed.

Notes:

Only one client computer or tablet can be connected to one MFP.

[2] Operation of the MFP on the remote panel

The MFP can be operated by mouse clicking the button or icon on the control panel displayed on the client computer or tablet.

Notes:

- The pinch operation on the touch panel, [ON/OFF] button operation, LED lamp performance and Ten Key (option) operation are not supported.
- Operation on the control panel of the MFP is possible even during the VNC connection.
- The MFP does not shift to the Energy Saving mode or Sleep mode during the VNC connection.

[3] Shifting to the FS Menu

- (1) Press the [Gear] icon with the mouse for at least 3 seconds.
- (2) Enter the service password on the login screen and press [OK].

Important:

Be sure to shift the MFP to the normal mode before quitting the VNC connection.

Notes:

- While the MFP is shifting to the FS Menu, jobs such as network printing, fax, internet fax and remote scanning are not accepted.
- If the MFP is rebooted when it is returned from the FS Menu to the normal mode, the VNC connection is disconnected. To continue the operation, perform the VNC connection again.

10.4 Remote Assistant Menu

10.4.1 Overview

By utilizing the Remote Assistant Menu, even if a service technician does not actually visit the user's site, the necessary information to solve problems can be obtained because this makes it possible to operate the screen of the MFP. The following functions are available for the Remote Assistant Menu.

- Logs Transmission
- Remote Service
- Remote Panel Operation

10.4.2 Displaying of the [Remote Assistant Menu] icon

The Remote Assistant Menu is operated by a user. Therefore, it is necessary to have the [Remote Assistant Menu] icon displayed on the HOME SCREEN in accordance with the following procedure.

- (1) Enable more than one functions contained in the Remote Assistant Menu.

Remarks:

For details, see the following reference.

📖 P. 10-40 "10.4.3 Logs Transmission"

📖 P. 10-43 "10.4.4 Remote Service"

📖 P. 10-44 "10.4.5 Remote Panel Operation"

- (2) From the HOME SCREEN, select the setting icon and then press [Button Contents] > [Register From Function List] > [Remote Assistant Menu].

10.4.3 Logs Transmission

The following functions are available for Logs Transmission.

- Investigation Logs Transmission
- Print Data Transmission
- Network Capture Transmission
- Delete All Logs

[1] Setting and functions

| Code | Contents | Setting | Investigation Logs Transmission | Print Data Transmission | Network Capture Transmission | Delete All logs |
|------------|---|---|---------------------------------|-------------------------|------------------------------|-----------------|
| FS-08-9579 | Logs transmission enable/disable setting | Set "1" (Enabled). *1 | Yes | Yes | Yes | Yes |
| FS-08-9630 | Logs transmission authentication setting | 1: Enabled(Default) Entry of the authentication code is required. 0: Disabled Entry of the authentication code is not required. Please obtain user approval before changing to this setting. | Yes | Yes | Yes | Yes |
| FS-08-9609 | Logs transmission e-mail address | Set an e-mail address. | Yes | Yes | Yes | |
| FS-08-9653 | DF Error history list Message log description setting | Set "1" (Enabled). | Yes | | | |

| Code | Contents | Setting | Investigation Logs Transmission | Print Data Transmission | Network Capture Transmission | Delete All logs |
|--------------|---|--|---------------------------------|-------------------------|------------------------------|-----------------|
| FS-08-9657 | Debug logs level change by administrator | 0: Prohibited (Default) 1: Permitted of changing the debug logs level by an administrator. Please change to this setting if necessary. | Yes | | | |
| FS-08-8942 | Debug logs level setting | This can be changed when "1" (Permitted) is set for FS-08-9657. The default value is "2" (Normal). Change the value to "0" (High) if required. *2 | Yes | | | |
| FS-08-8761-1 | Upper limit setting of print data saving number | 30: Default 0 to 100: Acceptable value If a value over 100 needs to be set, select "0" (No limitation). | | Yes | | |

*1 All functions in Logs Transmission become available.

*2 When "0" (High) is set for FS-08-8942, the performance may be lowered.

[2] Investigation Logs Transmission

[2-1] Overview

This is a function to record the information related to errors and problems of the MFP and send or save them with the specified method.

[2-2] Operation

- (1) From the HOME SCREEN, press [Remote Assistant Menu] > [Logs Transmission] > [Investigation Logs Transmission].
- (2) Select [Transmission Method].
 - [Send to Remote Maintenance Service]: Transmits via eCC (e-BRIDGE CloudConnect).
 - [Send by E-mail]: Transmits via e-mail.
 - [Store to the machine]: Stores in a storage device in the MFP.
 - [Store to USB]: Stores in the USB storage device connected to the MFP.
- (3) Press [Execute].

Remarks:

- Press the button to start creating (recording) investigation logs.
- The MFP cannot be operated during investigation logs creation and storing to the USB storage device.
- When the creation has succeeded, a pop-up menu to confirm the transmission of the data is displayed.
- After the logs are created, the MFP is automatically rebooted regardless of the succession or failure of the creation.
- The investigation logs stored in storage device in the MFP can be obtained from eBX_eBN_Service Util Tool.
- If the investigation logs have already existed in the storage device in the MFP, they will be removed before new investigation logs creation is started.
- When the size of the investigation logs to transmit to eCC exceeds 100 MB, they will be divided automatically.
- When the size of the investigation logs transmitted via e-mail exceeds 30 MB, only parts of them will be sent.

[3] Print Data Transmission

[3-1] Overview

This is a function to record the printing related information of the MFP and send or save them.

[3-2] Operation

- (1) From the HOME SCREEN, press [Remote Assistant Menu] > [Logs Transmission] > [Print Data Transmission] > [Print Data Setting]. Select [Enable] and press [Save].
- (2) Select [Transmission Method].
 - [Send to Remote Maintenance Service]: Transmits via eCC.
 - [Send by E-mail]: Transmits via e-mail.
 - [Store to the machine]: Stores in a storage device in the MFP.
 - [Store to USB]: Stores in the USB storage device connected to the MFP.
- (3) From [Print Data Setting], select [Disable] and press [Save].

Remarks:

- When [Disable] is selected in [Print Data Setting], obtaining of the print data is finished.
- When the power is turned OFF during print data obtaining, those already obtained are removed. However, they will not be removed by the shutdown operation.
- When the size of the print data to transmit to eCC exceeds 100 MB, the data will be transmitted that divided in small sizes.
- When the size of the print data transmitted by an e-mail exceeds 30 MB, a transmission error will occur.

[4] Network Capture Transmission

[4-1] Overview

This is a function to record all incoming and outgoing network activity from the MFP; and transmits the logs via selected method.

[4-2] Operation

- (1) From the HOME SCREEN, press [Remote Assistant Menu] > [Logs Transmission] > [Network Capture Transmission].
- (2) Specify [Taken time for Network Capture(Hour)].
- (3) Select [Transmission Method].
 - [Send to Remote Maintenance Service]: Transmits via eCC^{*}.
 - [Send by E-mail]: Transmits via e-mail.
 - [Store to the machine]: Stores in a storage device in the MFP.

^{*} Version R4.25 or later
- (4) Press [Start].

Remarks:

- When the size of the network capture data transmitted by an e-mail exceeds 30 MB, a transmission error may occur.
- Pressing [Start] begins the recording of the network capture.
- After the recording has been started, press [Close] so that the MFP can be used as usual.
- After the time specified in (2) has passed, the recording finishes automatically and network capture is sent by the selected transmission method.
- If the size of the network capture data reaches 2 GB, the recording finishes automatically even if it is before the specified time, and the network capture is sent.
- When the size of the network capture data to transmit to eCC exceeds 100 MB, they will be divided automatically.
- By pressing the following buttons, the network capture can also be interrupted.
 - [Break off (Don't Send)]: Interrupts the network capture and discards data at that time.
 - [Break off (Send)]: Interrupts the network capture and transmits data at that time by the selected transmission method.

[5] Delete All Logs

[5-1] Overview

This is a function to delete all files created during logs transmission.

[5-2] Operation

- (1) From the HOME SCREEN, press [Remote Assistant Menu] > [Logs Transmission] > [Delete All Logs].
- (2) After the confirmation message is displayed, press [Yes].

Remarks:

Log files are always overwritten. Therefore, it is generally not necessary to execute [Delete All Logs] function.

10.4.4 Remote Service

[1] Overview

When the remote management of the MFP is performed by means of eCC, updating of the firmware version and changing of the settings in the MFP are carried out periodically (once a day) or at the time of rebooting the MFP. Using the Remote Service function can immediately reflect any updates or setting changes to the MFP, and thus the time to solve the problem can be shortened.

[2] Setting

| Code | Description | Setting |
|------------|--|---|
| FS-08-3820 | e-BRIDGE CloudConnect enable/disable setting | Set "1" (Enabled). |
| FS-08-3821 | Remote Service authentication setting | 1: Enabled (Default) Entry of the authentication code is required. 0: Disabled Entry of the authentication code is not required. Please obtain user approval before changing to this setting. |

[3] Operation

- (1) From the HOME SCREEN, press [Remote Assistant Menu] > [Remote Service].
- (2) After the confirmation message is displayed, press [Yes].

Remarks:

- During the connecting of e-BRIDGE CloudConnect, the operation of other functions becomes impossible.
- When the connecting of eCC is finished, the MFP will reboot.
- When this operation has been completed successfully, "Communication success" is displayed on the HOME SCREEN.
- If an error has occurred, check the message log of TopAccess and take an appropriate measure.

10.4.5 Remote Panel Operation

[1] Overview

This is a function to operate the screen of the MFP in a separate location via the cloud. By utilizing this function, maintenance service can be carried out and the necessary information to solve problems can be obtained even if a service technician does not actually visit the user's site. This function can be used even if the MFP is not connected to eCC.

[2] Setting

- (1) Set the remote panel (VNC).
📖 P. 10-38 "[1] MFP setting"
- (2) Set the Remote Panel Operation function.

| Code | Description | Setting |
|--------------|---|---|
| FS-08-9467-0 | Remote Panel Operation (eRA [*]) enable/disable setting | Set "1" (Enabled). |
| FS-08-9467-1 | Remote Panel Operation (eRA [*]) authentication setting | 0: Enabled (Default) Entry of the authentication code is required. 1: Disabled Entry of the authentication code is not required. Please obtain user approval before changing to this setting. |
| FS-08-9468 | Remote Panel Operation (eRA [*]) Relay server URL | https://ap.era.toshiba-solutions.com/v1/device_connection_request Change it if needed. |

* eRA: e-Bridge Remote Assist

Notes:

- The setting in the following menu may be required. [Administration] > [Application] > [Settings] > [Proxy setting]
- This setting will also be reflected to [Host Name] and [Port No.] in [Administration] > [Application] > [Settings] > [Proxy setting].

[3] Operation

- (1) From the HOME SCREEN, press [Remote Assistant Menu] > [Remote Panel Operation].
- (2) Key in an authentication code and press [Connect].

Remarks:

The connection with the eRA server is automatically disconnected in one hour. When the connection is disconnected, perform the steps from (1) again.

11. FIRMWARE UPDATING

11.1 Overview

When you want to update the firmware to the latest one or the MFP becomes inoperable due to some defect in the firmware, updating can be performed by using a firmware package stored in the USB storage device.

Notes:

- Written firmware varies depending on the kinds of the boards provided as service parts. For updating, only the minimum firmware is installed in the system PC board, logic PC board and fax board. The latest version of the firmware at the time of delivery is written on the DSDF PC board and finisher PC board. When any of above boards is replaced with a new one in the field, check the other firmware version used and then update with a corresponding suitable version.
- “Can’t fetch Ver” is displayed in the Installed Version field when the version of the installed firmware cannot be acquired properly. For example, if [HS-49 Firmware Update] is carried out without your performing the normal startup after updating, this message will appear for some firmware.

11.2 Firmware Updating with a USB Storage Device

The software and firmware can be updated by means of a USB storage device in which an update package is stored.

For the data file for each firmware, refer to the following tables.

Notes:

When performing the update, use the latest firmware package.

11.2.1 Updating methods

There are two types of updating methods by using a USB storage device; normal update and patch update. The firmware packages are provided in a compressed file (.zip) corresponding to the updating methods.

| Updating method | Package/file name | Explanation |
|-----------------|---|---|
| Normal update | TS20ALL0Wxxxxx.zip* ¹ or TS20ALL0Wxxxx _6526AC6529A.zip* ² | Updates the version by using a package storing all files related to the firmware updating. |
| Patch update | TS20ALLPWxxxxx.zip | Updates the version by using a package storing the firmware whose correction is required. This method is applied to the system firmware and system software only. |

*1: The files for the following models have been stored.

- 2020AC/2520AC
- 2025NC/2525AC/3025AC/3525AC/4525AC/5525AC/6525AC
- 2528A/3028A/3528A/4528A/5528A/6528A
- 6526AC/6527AC/7527AC
- 6529A/7529A/9029A

*2: The files for the following models have been stored.

- 6526AC/6527AC/7527AC
- 6529A/7529A/9029A

Remarks:

- These firmware packages are provided in common for multiple models.
- "xxxxx" indicates the version.

11.2.2 File configuration of a USB storage device

Store the firmware package for updating in the root of the USB storage device. The configuration of each package is as below.

[A] Normal update

e.g.: Configuration file for TS20ALL0Wxxxx.zip

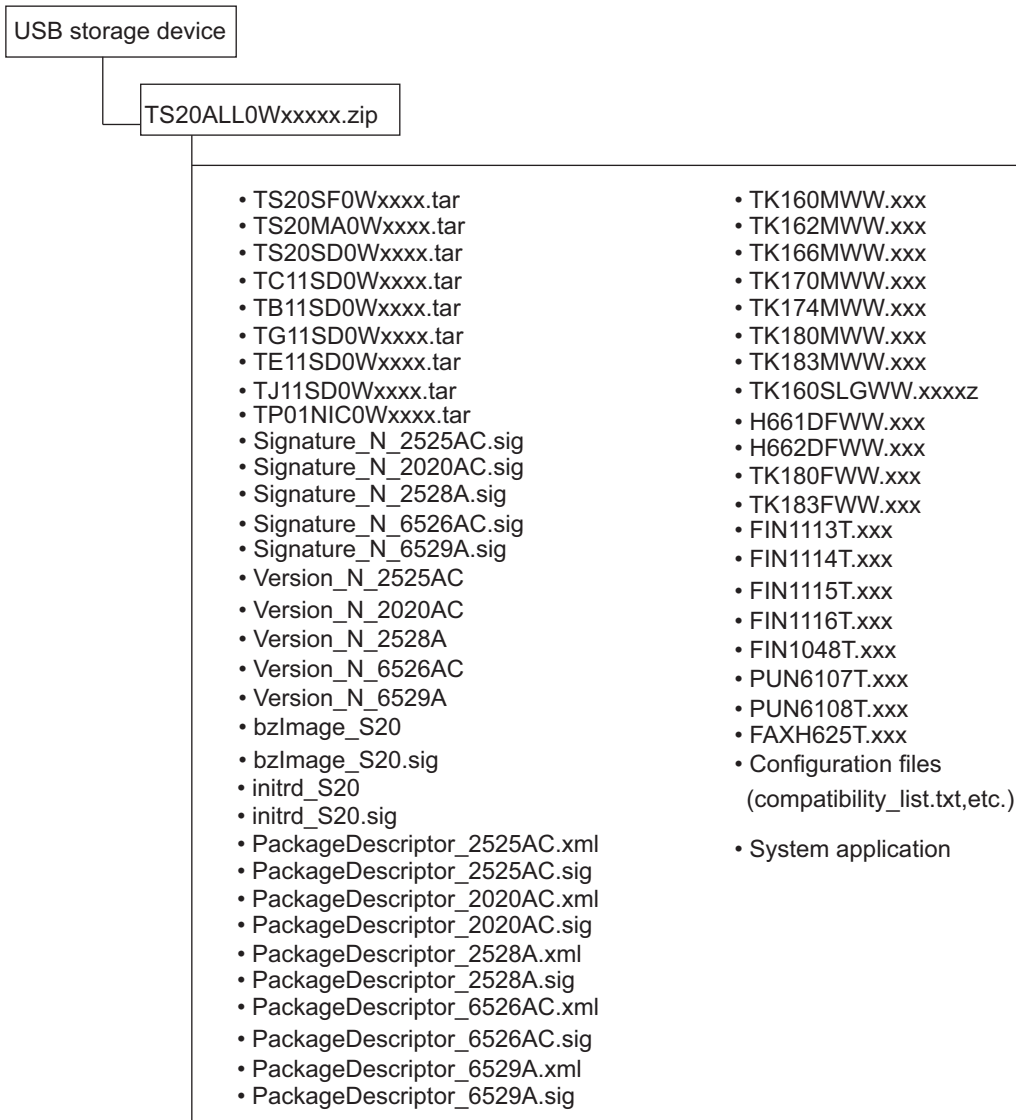

Fig.11-1

[B] Patch update

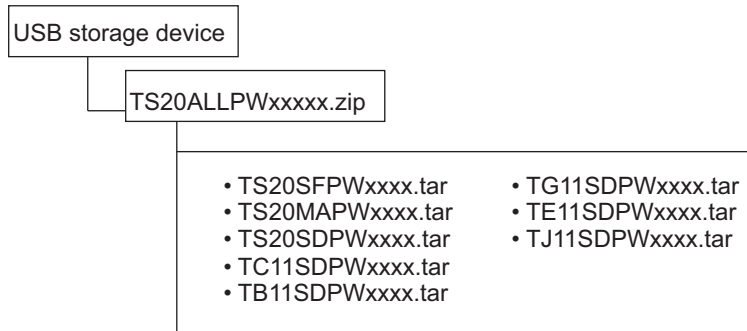

Fig.11-2

Notes:

Since the date and time set in the MFP are recorded in the firmware update log, make sure that they are correct before updating the firmware.

Important:

- For details about the specification of a USB storage device available for updating the firmware, refer to the following reference.
 📖 P. 14-16 “14.5 Usable USB storage device”
- Do not update the firmware by any storage device other than a flash memory (such as a USB connection type memory card reader, CD/DVD drive or hard disk), since it is never guaranteed.

11.2.3 Firmware type and data file for updating

During the firmware updating, the model of the MFP and the installation status of options are automatically judged and only the corresponding software is displayed.

[A] Normal update

MFP

| Firmware type | Stored | Data file name | Display |
|---|--------------------------------|-------------------|----------------------------------|
| System firmware (Common for models) | System PC board (SYS board) | TS20SF0Wxxxx.tar | SYSTEM FIRMWARE (OS) |
| System software (Common for models) | SSD | TS20MA0Wxxxx.tar | SYSTEM SOFTWARE (MA) |
| System software (Common for models) | SSD | TS20SD0Wxxxx.tar | SYSTEM SOFTWARE (SD) COMMON |
| System software (Model specific) | SSD | TJ11SD0Wxxxx.tar | SYSTEM SOFTWARE (SD) SPECIFIC |
| Engine Firmware (Model specific) | Logic PC board (LGC board) | TK183MWW.xxx | ENGINE FIRMWARE |
| Scanner firmware (Common for models) | System PC board (SYS board) | TK160SLGWW.xxx | SCANNER FIRMWARE |
| PFC firmware (Model specific) | Logic PC board (PFC board) | TK183FWW.xxx | PFC FIRMWARE |
| NIC firmware (Common for models) | System PC board (SYS board) | TP01NIC0Wxxxx.tar | NIC FIRMWARE |
| DSDf firmware (DSDf) | DLG PC board | H661DFWW.xxx | DSDf FIRMWARE |

Remarks:

“xxxx” or “xxx” indicates the version.

Options

| Firmware type | Stored | Data file name | Display |
|-------------------------------|-----------------------------|----------------|---------------------------------|
| Finisher firmware (MJ-1115) | Finisher PC board | FIN1115T.xxx | FINISHER FIRMWARE |
| Finisher firmware (MJ-1116) | Finisher PC board | FIN1116T.xxx | FINISHER FIRMWARE |
| Hole punch firmware (MJ-6108) | Hole punch PC board | PUN6108T.xxx | PUNCH FIRMWARE |
| FAX firmware (GD-1370) | System PC board (SYS board) | FAXH625T.xxx | FAX FIRMWARE1, FAX FIRMWARE2 |

Remarks:

- “xxx” indicates the version.
- Only the firmware for the options installing in the MFP is displayed.

[B] Patch update

| Firmware type | Stored | Data file name | Display |
|-------------------------------------|-----------------------------|------------------|-------------------------------|
| System firmware (Common for models) | System PC board (SYS board) | TS20SFPWxxxx.tar | SYSTEM FIRMWARE (OS) |
| System software (Common for models) | SSD | TS20MAPWxxxx.tar | SYSTEM SOFTWARE (MA) |
| System software (Common for models) | SSD | TS20SDPWxxxx.tar | SYSTEM SOFTWARE (SD) COMMON |
| System software (Model specific) | SSD | TJ11SDPWxxxx.tar | SYSTEM SOFTWARE (SD) SPECIFIC |

Remarks:

“xxxx” indicates the version.

11.2.4 Updating procedure

Important:

Never shut down the MFP during the update. Otherwise, firmware data and the following option data (if installed) could be damaged and may not be able to be operated properly.

- Meta Scan Enabler: GS-1010/1010Node
- External Interface Enabler: GS-1020/1020Node
- IPsec Enabler: GP-1080/1080Node
- OCR Enabler (GS-1110Node)
- Multi Station Print Enabler (GS-1090/1090Node)

[1] Firmware version update

- (1) Connect the USB storage device to the PC and write the data file.
Store the data file for updating in the root of the USB storage device.
- (2) Press the [ON/OFF] button to shut down the MFP.
- (3) Connect the USB storage device [1] to the USB port [2].

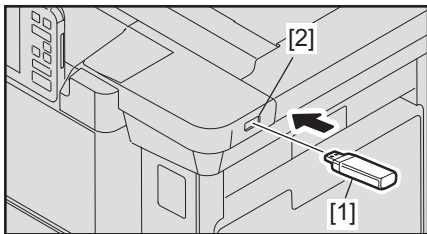

Fig.11-3

- (4) Start the HS Menu.

(5) Press [49 Firmware Update].

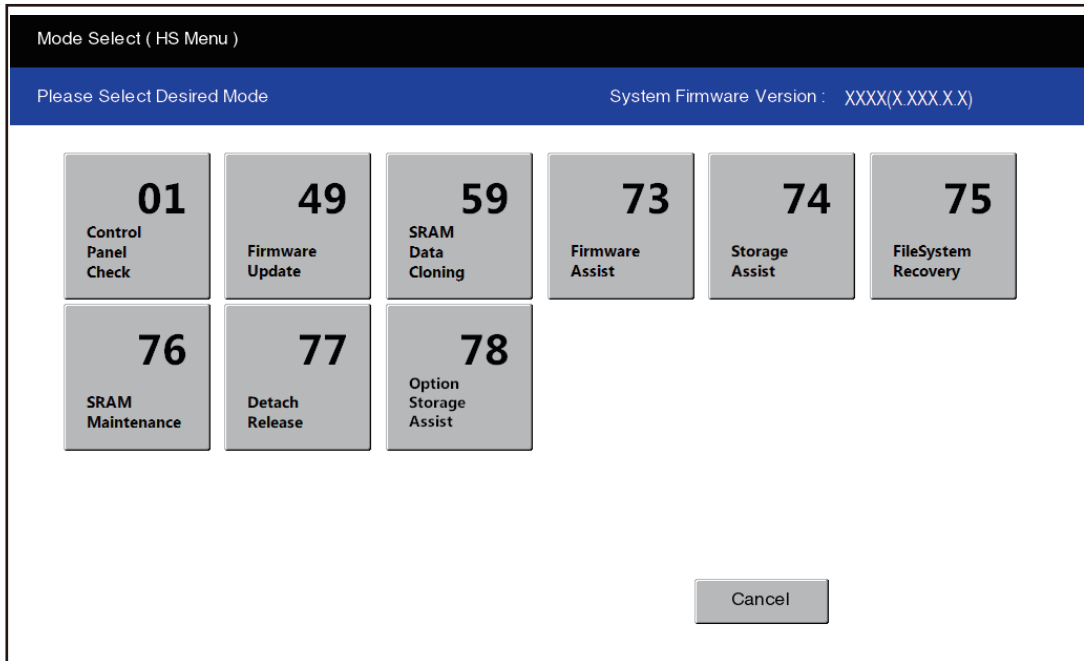

Fig.11-4

The firmware package stored in the USB storage device is displayed.

(6) Select the target firmware package and press [OK].

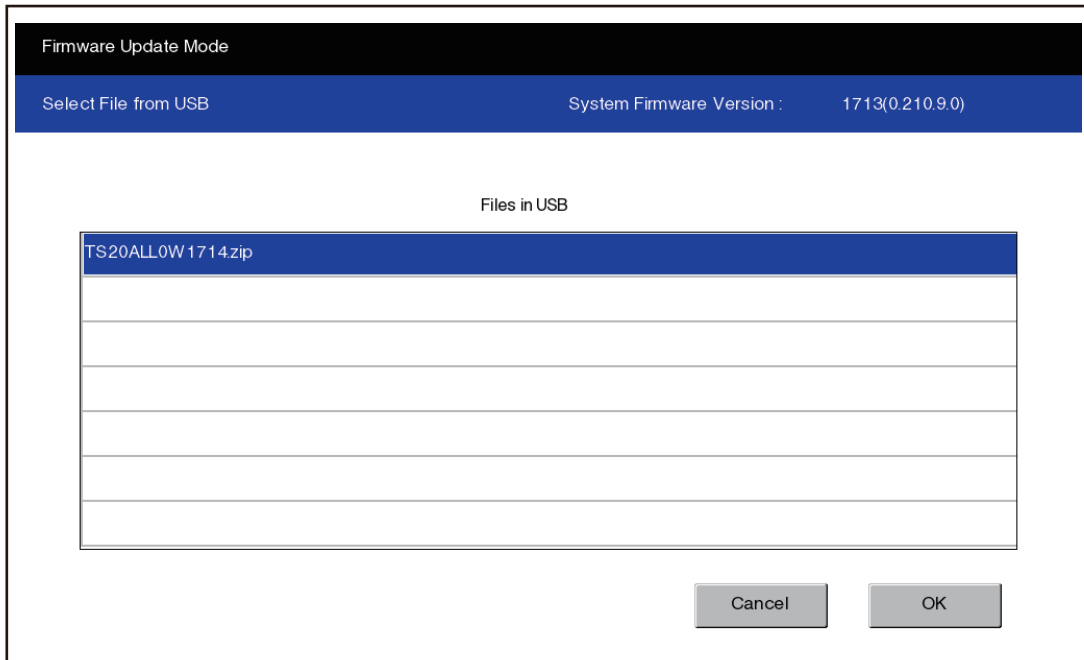

Fig.11-5

The selection screen of the update items is displayed.

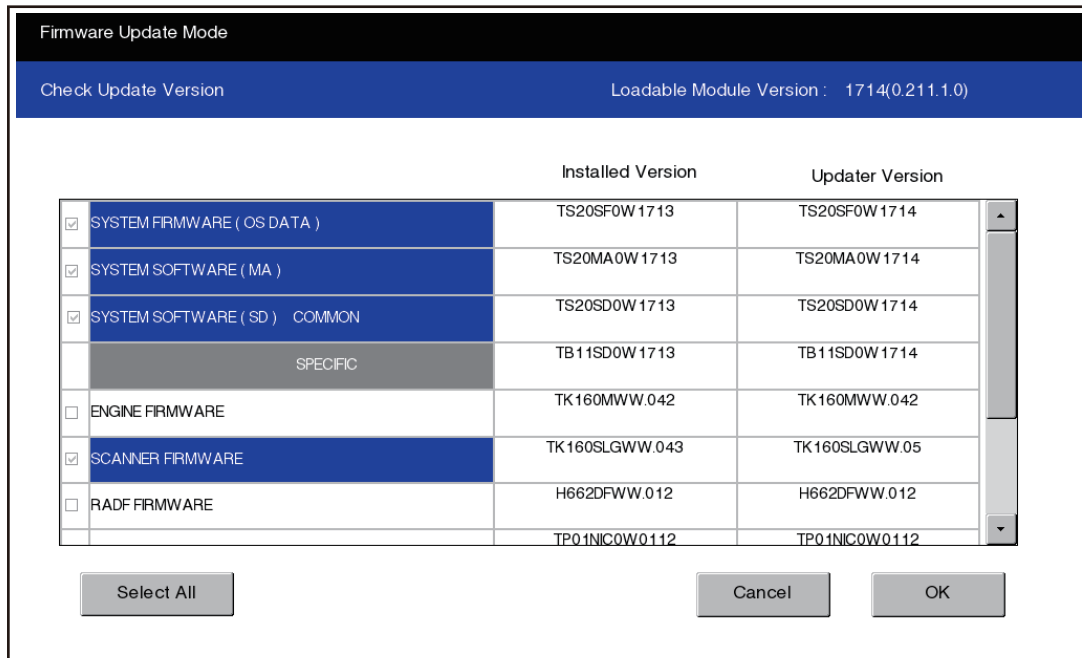

Fig.11-6

Notes:

- The model of the MFP and the installation status of options are automatically judged and only the corresponding software is displayed.
- If there is such in the update file, firmware with a later version than the current one is being selected to be updated.

[A] Normal update

| Item | File name ("xxx" or "xxxx" indicates the version.) | Remarks |
|---------------------------------|--|------------------------|
| SYSTEM FIRMWARE (OS) | TS20SF0Wxxxx.tar | Common data for models |
| SYSTEM SOFTWARE (MA) | TS20MA0Wxxxx.tar | Common data for models |
| SYSTEM SOFTWARE (SD) COMMON* | TS20SD0Wxxxx.tar | Common data for models |
| SYSTEM SOFTWARE (SD) SPECIFIC* | TJ11SD0Wxxxx.tar | Model specific data |
| ENGINE FIRMWARE | TK183MWW.xxx | Model specific data |
| SCANNER FIRMWARE | TK160SLGWW.xxx | Common data for models |
| PFC FIRMWARE | TK183FWW.xxx | Model specific data |
| NIC FIRMWARE | TP01NIC0Wxxxx.tar | Common data for models |
| DSD FIRMWARE | H661DFWW.xxx | DSD F |
| FAX FIRMWARE1, FAX FIRMWARE2 | FAXH625T.xxx | When GD-1370 installed |
| FINISHER FIRMWARE | FIN1115T.xxx | When MJ-1115 installed |
| | FIN1116T.xxx | When MJ-1116 installed |
| PUNCH FIRMWARE | PUN6108T.xxx | When MJ-6108 installed |

* SYSTEM SOFTWARE (SD) COMMON and SYSTEM SOFTWARE (SD) SPECIFIC cannot be selected separately. If updating is carried out by selecting either of them, the MFP may not be able to be operated properly.

[B] Patch update

| Item | File name ("xxxx" indicates the version.) | Remarks |
|-------------------------------|---|------------------------|
| SYSTEM FIRMWARE (OS) | TS20SFPWxxxx.tar | Common data for models |
| SYSTEM SOFTWARE (MA) | TS20MAPWxxxx.tar | Common data for models |
| SYSTEM SOFTWARE (SD) COMMON | TS20SDPWxxxx.tar | Common data for models |
| SYSTEM SOFTWARE (SD) SPECIFIC | TJ11SDPWxxxx.tar | Model specific data |

- If the USB storage device is not recognized properly, "USB device Not detected" is displayed. In this case, disconnect the USB storage device and connect it again within 3 minutes, or shut down the MFP and connect the device properly. Then repeat the procedure from step (5).
- If any of the error messages below is displayed, confirm if the data file in the USB storage device is correct. Then repeat the procedure from step (5).

| Error number | Message | Cause |
|--------------|---|--|
| 01 | Model specific update program XXXXXXXXXXXX is not stored. | No update file of this MFP exists in the USB storage device. |

(7) Select the item to be updated.

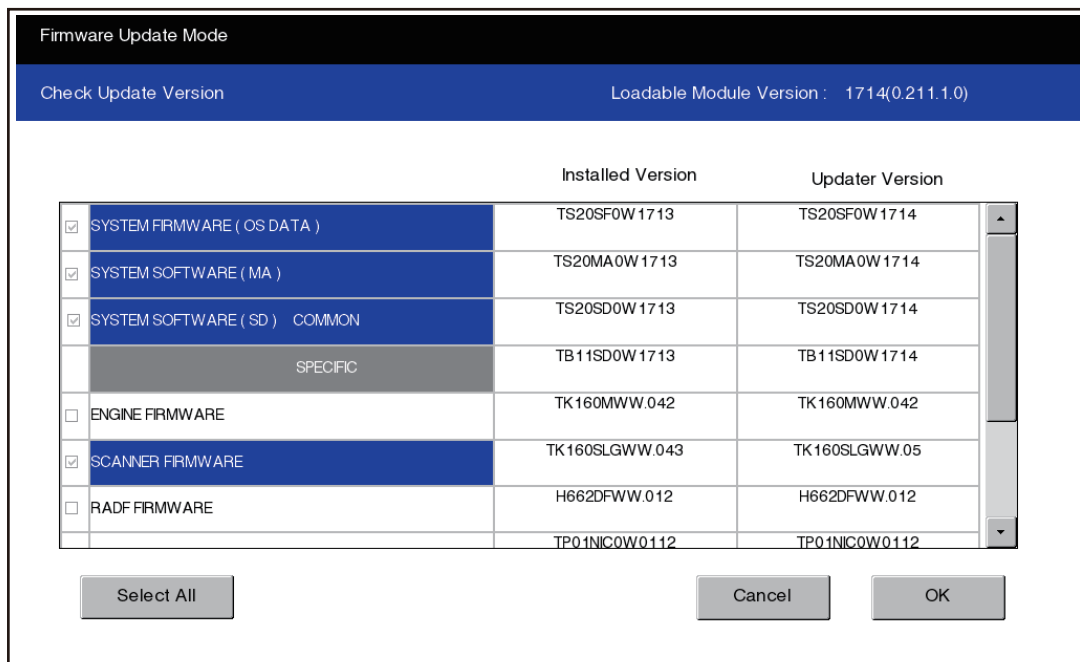

Fig.11-7

The item selected is highlighted and a check is marked at its left side. The selection is released by pressing the item once again.

| Item | Remarks |
|-------------------------------|------------------------------------|
| SYSTEM FIRMWARE (OS) | Updating the system firmware. |
| SYSTEM SOFTWARE (MA) | Updating the system firmware (MA). |
| SYSTEM SOFTWARE (SD) COMMON | Updating the system software (SD). |
| SYSTEM SOFTWARE (SD) SPECIFIC | |
| ENGINE FIRMWARE | Updating the engine firmware. |
| SCANNER FIRMWARE | Updating the scanner firmware. |
| PFC FIRMWARE | Updating the PFC firmware. |
| NIC FIRMWARE | Updating the NIC firmware. |

| Item | Remarks |
|-------------------|-----------------------------------|
| DSDF FIRMWARE | Updating the DSDF firmware. |
| FAX FIRMWARE | Updating the FAX firmware. |
| FINISHER FIRMWARE | Updating the finisher firmware. |
| PUNCH FIRMWARE | Updating the hole punch firmware. |

(8) Press [OK].

Updating starts and the processing status is displayed on the screen.

| Status display during updating | Status display when updating is completed |
|---|---|
| SYSTEM FIRMWARE (OS) update in progress | SYSTEM FIRMWARE (OS) Completed |
| SYSTEM SOFTWARE (MA) update in progress | SYSTEM SOFTWARE (MA) Completed |
| SYSTEM SOFTWARE (SD) update in progress | SYSTEM SOFTWARE (SD) Completed |
| ENGINE FIRMWARE update in progress | ENGINE FIRMWARE Completed |
| SCANNER FIRMWARE update in progress | SCANNER FIRMWARE Completed |
| PFC FIRMWARE update in progress | PFC FIRMWARE Completed |
| NIC FIRMWARE update in progress | NIC FIRMWARE Completed |
| DSDF FIRMWARE update in progress | DSDF FIRMWARE Completed |
| FAX FIRMWARE update in progress | FAX FIRMWARE Completed |
| FINISHER FIRMWARE update in progress | FINISHER FIRMWARE Completed |
| PUNCH FIRMWARE update in progress | PUNCH FIRMWARE Completed |

(9) When updating is completed properly, the following message is displayed at the bottom of the screen.

Normal update: Update successfully completed Restart the MFP

Patch update: Patch Update Successfully Restart the MFP

Notes:

- Troubleshooting when “Customized UI version is not compatible!” is displayed
In the MFP with the customized UI installed, when its version is not compatible with that for the SSD DATA to be installed, “Customized UI version is not compatible!” is displayed and the updating will fail. To continue the updating, perform FS-08-3512 (Customized UI uninstallation).
- Troubleshooting when “Update Failed” is displayed
 - Even though an update fails, do not turn the power OFF until other updates are finished.
 - “Update Failed.” is displayed at the bottom of the screen when the updating is not completed properly. “Failed” appears next to the failed item on the status display. If “Update Failed” appears at the bottom of the screen, shut down the MFP and then check the following items. After confirming and clearing the problems, restart updating from the beginning.
Does the USB storage device meet the conditions to be used for updating?
Is the data file written properly in the USB storage device?
Is the USB storage device installed properly?
Do the USB storage device and MFP operate properly?
When an H05 error occurs and it does not clear after the USB storage device is checked, replace the SYS board.
 - The integrity check system is automatically operated before firmware updating. During this operation, “Verifying Signature...” and “Progress: **%” are displayed on the screen. When the check is completed properly, no message for notifying the success will appear and the firmware updating will start. If it fails, “Invalid Signature” and “Copy Data with >valid signature in USB” will be shown. In that case, firmware updating cannot be performed, so shut down the MFP and disconnect the USB storage device. Check that there is no abnormality in the firmware data and reperform updating.
 - When a system firmware or system software update error occurs, “Update Failed” or “Failed” appears on the screen and the error number appears next to the message. For details of each error, refer to the following tables.

| System firmware update error | |
|------------------------------|-------------------------|
| Error number | Error content |
| O01 | FROM writing failed |
| O02 | FROM verification error |
| O03 | File operation error |
| O06 | Device error |
| O07 | Signature check error |
| O08 | No signature error |

| System software update error | |
|------------------------------|--|
| Error number | Error content |
| H01 | File creation error |
| H02 | File decompression error (Out of free disk space on the storage device at file extraction) |
| H03 | Partition mount error |
| H04 | Other errors |
| H05 | Signature check error |
| H06 | No signature error |
| H07 | Storage device full error |
| H08 | RIP font installation error |

- When an engine firmware, scanner firmware, DSDF firmware, hole punch firmware, finisher firmware or FAX firmware error occurs, "Update Failed" or "Failed" appears on the screen and the error number appears next to the message. For details of each error, refer to the following tables.

| Engine firmware update error | | |
|------------------------------|---|--|
| Error number | Error message | Error content |
| M01 | Request Timeout | Request timeout |
| M02 | Communication timeout (When the download is written) | Communication timeout (When the download is written.) |
| M03 | Communication timeout (When the download is finished) | Communication timeout (When the download is finished.) |
| M04 | Downloading request was denied. (When the download is requested) | Downloading request was denied. (when the download is requested.) |
| M05 | Deletion error (When the download is written) | Deletion error (When the download is written.) |
| M06 | Writing error (When the download is written) | Writing error (When the download is written.) |
| M07 | Checksum error (When the download is finished) | Checksum error (When the download is finished.) |
| M08 | Reception status code abnormality (When the download is requested) | Reception status code abnormality (when the download is requested.) |
| M09 | Reception status code abnormality (When the download is written) | Reception status code abnormality (When the download is written.) |
| M10 | Reception status code abnormality (When the download is finished) | Reception status code abnormality (When the download is finished.) |
| M11 | Version downgrade abnormality (When download request is initiated) | Version downgrade abnormality (When the download is started.) |
| M12 | File decompression error (System) | File decompression error (System) |
| M13 | File decompression error (ROM data) | File decompression error (ROM error) |
| M00 | Other error | Other errors |

| Scanner firmware update error | | |
|-------------------------------|---|--|
| Error number | Error message | Error content |
| S01 | Communication timeout (When the download is requested) | Communication timeout (when the download is requested.) |
| S02 | Communication timeout (When the download is written) | Communication timeout (When the download is written.) |
| S03 | Communication timeout (When the download is finished) | Communication timeout (When the download is finished.) |
| S05 | Deletion error (When the download is written) | Deletion error (When the download is written.) |
| S06 | Writing error (When the download is written) | Writing error (When the download is written.) |
| S08 | Reception status code abnormality (When the download is requested) | Reception status code abnormality (when the download is requested.) |
| S09 | Reception status code abnormality (When the download is written) | Reception status code abnormality (When the download is written.) |
| S10 | Reception status code abnormality (When the download is finished) | Reception status code abnormality (When the download is finished.) |
| S11 | Scanner not connected (When the download is finished) | Scanner not installed (When the download is finished.) |
| S12 | Scanner download error (When the download is requested) | Scanner download error (when the download is requested.) |
| S00 | Other error | Other errors |

| NIC firmware update error | | |
|---------------------------|---|--|
| Error number | Error message | Error content |
| N01 | Communication timeout (When the download is requested) | Communication timeout (when the download is requested.) |
| N02 | Communication timeout (When the download is written) | Communication timeout (When the download is written.) |
| N03 | Communication timeout (When the download is finished) | Communication timeout (When the download is finished.) |
| N04 | Downloading request was denied. (When the download is requested) | Downloading request was denied. (when the download is requested.) |
| N05 | Deletion error (When the download is written) | Deletion error (When the download is written.) |
| N06 | Writing error (When the download is written) | Writing error (When the download is written.) |
| N07 | Checksum error (When the download is finished) | Checksum error (When the download is finished.) |
| N08 | Reception status code abnormality (When the download is requested) | Reception status code abnormality (when the download is requested.) |
| N09 | Reception status code abnormality (When the download is written) | Reception status code abnormality (When the download is written.) |
| N10 | Reception status code abnormality (When the download is finished) | Reception status code abnormality (When the download is finished.) |
| N00 | Other error | Other errors |

| PFC firmware update error | | |
|---------------------------|---|--|
| Error number | Error message | Error content |
| P01 | Communication timeout (When the download is requested) | Communication timeout (when the download is requested.) |
| P02 | Communication timeout (When the download is written) | Communication timeout (When the download is written.) |
| P03 | Communication timeout (When the download is finished) | Communication timeout (When the download is finished.) |

| PFC firmware update error | | |
|---------------------------|---|--|
| Error number | Error message | Error content |
| P04 | Downloading request was denied. (When the download is requested) | Downloading request was denied. (when the download is requested.) |
| P05 | Deletion error (When the download is written) | Deletion error (When the download is written.) |
| P06 | Writing error (When the download is written) | Writing error (When the download is written.) |
| P07 | Checksum error (When the download is finished) | Checksum error (When the download is finished.) |
| P08 | Reception status code abnormality (When the download is requested) | Reception status code abnormality (when the download is requested.) |
| P09 | Reception status code abnormality (When the download is written) | Reception status code abnormality (When the download is written.) |
| P10 | Reception status code abnormality (When the download is finished) | Reception status code abnormality (When the download is finished.) |
| P00 | Other error | Other errors |

| DSDF firmware update error | | |
|----------------------------|---|--|
| Error number | Error message | Error content |
| R01 | Communication timeout (When the download is requested) | Communication timeout (when the download is requested.) |
| R02 | Communication timeout (When the download is written) | Communication timeout (When the download is written.) |
| R03 | Communication timeout (When the download is finished) | Communication timeout (When the download is finished.) |
| R05 | Deletion error (When the download is written) | Deletion error (When the download is written.) |
| R06 | Writing error (When the download is written) | Writing error (When the download is written.) |
| R08 | Reception status code abnormality (When the download is requested) | Reception status code abnormality (when the download is requested.) |
| R09 | Reception status code abnormality (When the download is written) | Reception status code abnormality (When the download is written.) |
| R10 | Reception status code abnormality (When the download is finished) | Reception status code abnormality (When the download is finished.) |
| R11 | ADF not connected | DSDF not installed |
| R12 | ADF download error | Invalid firmware data |
| R00 | Other error | Other errors |

| Hole punch firmware update error | | |
|----------------------------------|---|--|
| Error number | Error message | Error content |
| U01 | Communication timeout (When the download is requested) | Communication timeout (when the download is requested.) |
| U02 | Communication timeout (When the download is written) | Communication timeout (When the download is written.) |
| U03 | Communication timeout (When the download is finished) | Communication timeout (When the download is finished.) |
| U04 | Downloading request was denied. (When the download is requested) | Downloading request was denied. (when the download is requested.) |
| U05 | Deletion error (When the download is written) | Deletion error (When the download is written.) |
| U06 | Writing error (When the download is written) | Writing error (When the download is written.) |
| U07 | Checksum error (When the download is finished) | Checksum error (When the download is finished.) |

| Hole punch firmware update error | | |
|----------------------------------|---|--|
| Error number | Error message | Error content |
| U08 | Reception status code abnormality (When the download is requested) | Reception status code abnormality (when the download is requested.) |
| U09 | Reception status code abnormality (When the download is written) | Reception status code abnormality (When the download is written.) |
| U10 | Reception status code abnormality (When the download is finished) | Reception status code abnormality (When the download is finished.) |
| U00 | Other error | Other errors |

| Finisher firmware update error | | |
|--------------------------------|---|--|
| Error number | Error message | Error content |
| F01 | Time out (When the download is requested) | Communication timeout (when the download is requested.) |
| F02 | Time out (When the download is written) | Communication timeout (When the download is written.) |
| F03 | Time out (When the download is finished) | Communication timeout (When the download is finished.) |
| F04 | Reception failed (When the download is requested) | Downloading request was denied. (when the download is requested.) |
| F05 | Deletion error (When the download is written) | Deletion error (When the download is written.) |
| F06 | Writing error (When the download is written) | Writing error (When the download is written.) |
| F07 | Checksum error (When the download is finished) | Checksum error (When the download is finished.) |
| F08 | Reception status code abnormality (When the download is requested) | Reception status code abnormality (when the download is requested.) |
| F09 | Reception status code abnormality (When the download is written) | Reception status code abnormality (When the download is written.) |
| F10 | Reception status code abnormality (When the download is finished) | Reception status code abnormality (When the download is finished.) |
| F00 | Other error | Other errors |

| FAX firmware update error | | |
|---------------------------|---|--|
| Error number | Error message | Error content |
| FX01 | Communication Timeout (when the download is requested) | Communication timeout (when the download is requested.) |
| FX02 | Communication Timeout (when data is downloaded) | Communication timeout (When the download is finished.) |
| FX03 | Download request Failed | Downloading request was denied. (when the download is requested.) |
| FX04 | Received failure during download request | Reception error (when the download is requested.) |
| FX05 | Received failure during data download | Reception error (At the time of downloading) |
| FX06 | File decompression error | File decompression error |
| FX07 | Other Errors | Other errors |

(10) Check that [Automatic Initialization] is displayed and then remove the USB storage device.

(11) Press [Automatic Initialization].

The MFP is rebooted and the initialization of the updating data is carried out.

[2] Confirmation of Update Results

After updating is completed, check each data version in the 08 Setting Mode to confirm that the data have been overwritten properly.

| Firmware | Code |
|-----------------------------|------|
| System software | 9900 |
| System firmware | 9930 |
| Engine Firmware | 9901 |
| Scanner firmware | 9902 |
| DSDF firmware | 9903 |
| PFC firmware | 9940 |
| NIC firmware | 9990 |
| Finisher firmware | 9904 |
| Hole punch firmware | 9944 |
| Fax board firmware (Line 1) | 9905 |
| Fax board firmware (Line 2) | 9969 |

[3] Adjustment

Perform the adjustment of the MFP.

FS-05-2742 (Image quality control related adjustment):

 P. 6-4 "6.1.3 Image quality control adjustment"

12. MANAGEMENT OF MFP INFORMATION

12.1 Cloning (HS Menu)

12.1.1 Overview

By using [59 SRAM Data Cloning] in the HS Menu, the SRAM data can be backed up into a USB storage device and such data can be restored into the MFP.

This function backs up or restores the data of the same MFP (same serial number), and is performed when the SRAM is replaced.

Notes:

The SYS board and SRAM should never be replaced together.

12.1.2 Precautions

- When the standard storage device is initialized or replaced, back up the SRAM data afterwards.
- It is assumed that data cloning is to be performed when an MFP or any options are installed. If the address book has been registered, do not perform restoring. Otherwise, registered or set data are lost.
- For details about the specification of a USB storage device available for cloning, refer to the following reference.
 P. 14-16 “14.5 Usable USB storage device”
- Cloning (HS Menu) with any storage devices other than a flash memory (e.g.: USB-connectible memory card reader, CD/DVD drive, hard disk) will never be guaranteed. Therefore, never use them for this operation.
- Be sure to unplug the LAN cable and fax line before data are backed up / restored. Also, do not open the DSDF, cover, drawer etc. during the cloning (HS Menu).
- Data can be backed up or restored between the MFPs only with the same model and version. If the version is different, update the firmware and back up / restore data in the same version.
- Restore data to an MFP which has the same options as when the data are backed up.
- Delete the backed up files in the USB storage device after the cloning.

12.1.3 Backup files

The following files are saved in the root directory of the USB storage device by backing up.

| File name | Remarks |
|--|--|
| Modelname_MFPSerialNo_yyyy-MM-dd_hh-mm | E.g.: When backup was performed at 13:59 on October 1st, 20xx Txxx_CUK911379_20xx-10-01_13-59 |

12.1.4 Cloning procedure

[A] Backup procedure

- (1) Press the [ON/OFF] button to shut down the MFP.
- (2) Connect the USB storage device to the USB port.
- (3) Perform HS-59 -> [Backup SRAM Data to USB].

Notes:

When "Operation Failed" is displayed, turn the power OFF and then reattempt the steps from (1).

- (4) Enter the password and press [OK].

Remarks:

Maximum 15 characters

This password will be used when the backed-up clone data are restored in the MFP.

- (5) "Backup successfully done" is displayed on the LCD when the backup has been properly completed.
- (6) Turn the power OFF.

[B] Restore procedure

- (1) Press the [ON/OFF] button to shut down the MFP.
- (2) Connect the USB storage device to the USB port.
- (3) Perform HS-59 -> [Restore SRAM Data from USB].
- (4) Enter the password which has been set in (4) of [A] and press [OK].
- (5) Enter the serial number of the MFP and press [OK].

Notes:

Use the serial number given on the label attached to the rear cover for the entry.

- (6) "Restore successfully done Restart the MFP" is displayed on the LCD when the restoring has been properly completed.
- (7) Turn the power OFF.

Notes:

- When a back-up file is restored, do not perform the initialization or formatting of the standard storage device before the normal startup.
- When the back-up files, which were created before the standard storage device has been initialized or replaced, are restored, do so also for ADIKey.

 P. 9-37 "[C] Restore Encryption Key and License"

[C] Confirmation of the error

“Operation Failed” is displayed on the lower left part of the LCD when the data have not been properly backed up or restored.

Moreover, details of the error are displayed under the above message.

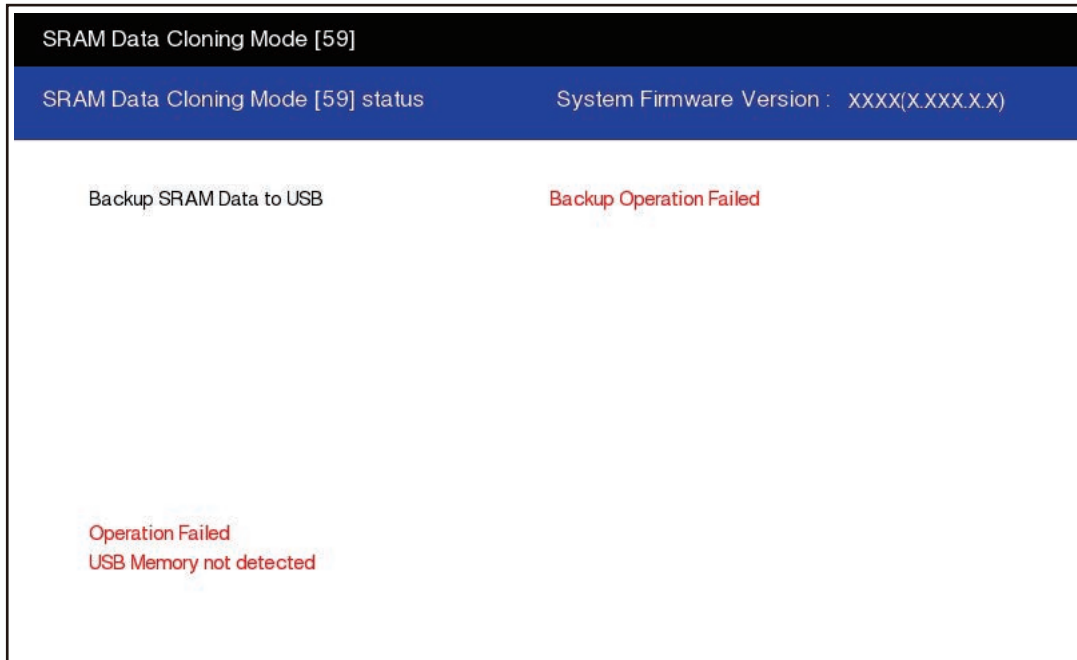

Fig.12-1

In this case, turn the power OFF and then check the following items.

After confirming and solving the problem, back up / restore the data again from the beginning.

- Does the USB storage device meet the conditions being used for this cloning?
- Is the updated program file written on the USB storage device properly?
- Is the USB storage device installed properly?
- Do the USB storage device and the MFP operate properly?

| Backup | |
|---------------------------------|--|
| Display content | Error content |
| USB device not detected | The USB storage device has not been installed. |
| SRAM Device Not Connected | The SRAM has not been installed. |
| Backup not created | Creation of the back-up file of data of the SRAM has failed. |
| Encryption Failed | An encryption of the back-up file has failed. |
| Password Not Appended to Backup | Addition of the encryption password has failed. |
| MFP Serial Number Not Set | Acquisition of the MFP serial number has failed. |

| Restore | |
|-------------------------------------|--|
| Display content | Error content |
| USB device not detected | The USB storage device has not been installed. |
| SRAM Device Not Connected | The SRAM has not been installed. |
| Invalid Backup File | The SYS board has not been recognized. |
| No Backup File Exists | No back-up file has existed in the USB storage device. |
| Invalid password | An incorrect password has been entered. |
| Decryption Failed | Decoding of the back-up file has failed. |
| Invalid MFP Serial Number: xxxxxxxx | An incorrect serial number has been entered. |
| MFP Serial Number Not Set | Acquisition of the MFP serial number has failed. |
| Backup File Corrupted | A back-up file has been damaged. |

12.2 Cloning (FS Menu)

12.2.1 Overview

By using [36 Cloning] in the FS Menu, the MFP settings or user data can be stored into a USB storage device as clone data. Also, a clone file created by another MFP can be installed to the MFP in order to make it have the same conditions as the one which created the clone file.

12.2.2 Precautions

- A clone file created by the following MFPs can be installed in this MFP.
 - e-STUDIO6526AC/6527AC/7527AC
 - e-STUDIO6529A/7529A/9029A
 - e-STUDIO2525AC/3025AC/3525AC/4525AC/5525AC/6525AC
 - e-STUDIO2020AC/2520AC
 - e-STUDIO5528A/6528A
 - e-STUDIO2528A/2528A/3528A/4528A
 - e-STUDIO330AC/400AC
 - e-STUDIO2010AC/2510AC
 - e-STUDIO2015NC/2515AC/3015AC/3515AC/4515AC/5015AC
 - e-STUDIO5516AC/6516AC/7516AC
 - e-STUDIO2018A/2518A/3018A/3518A/4518A/5018A
 - e-STUDIO5518A/6518A/7518A/8518A
 - e-STUDIO2000AC/2500AC
 - e-STUDIO2505AC/3005AC/3505AC/4505AC/5005AC
 - e-STUDIO5506AC/6506AC/7506AC
 - e-STUDIO2008A/2508A/3008A/3508A/4508A/5008A
 - e-STUDIO5508A/6508A/7508A/8508A
 - e-STUDIO3508LP/4508LP/5008LP, Loops LP35/LP45/LP50
 - e-STUDIO2050C/2550C
 - e-STUDIO2555C/3055C/3555C/4555C/5055C
 - e-STUDIO2555CSE/3055CSE/3555CSE/4555CSE/5055CSE
 - e-STUDIO5560C/6560C/6570C
 - e-STUDIO207L/257/307/357/457/507
 - e-STUDIO557/657/757/857
 - e-STUDIO307LP, Loops LP301
 - e-STUDIO287CS/347CS/407CS
 - e-STUDIO287CSL/347CSL
 - e-STUDIO477S/527S
 - e-STUDIO477SL
 - e-STUDIO2040C/2540C/3040C/3540C/4540C
 - e-STUDIO5540C/6540C/6550C
 - e-STUDIO206L/256/306/356/456/506
 - e-STUDIO256SE/306SE/356SE/456SE/506SE
 - e-STUDIO556/656/756/856
 - e-STUDIO556SE/656SE/756SE/856SE
 - e-STUDIO306LP, Loops LP30
- When a clone file created by this MFP is installed in another one, confirm the installation ability by referring to the Service Manual for the target model.
- When a clone file created by another unit of the MFP is installed in this one, settings and information about the functions which are not supported by this MFP will be disregarded.
- When cloning of user information is carried out by means of this function, ask your users to change the setting to [Enable] of [User Information Cloning] from [Administration] - [Setup] - [General settings] - [Device Information] via TopAccess.
- When cloning of the administrator password is carried out by means of this function, ask your users to change the setting to [Enable] of [Administrator's Password Cloning] from [Administration] - [Setup] - [General settings] - [Device Information] via TopAccess

- For details about the specification of a USB storage device available for cloning, refer to the following reference.
 - 📖 P. 14-16 “14.5 Usable USB storage device”
- Delete a clone file stored in the USB storage device after the cloning.
- Precautions for passwords
 - When a clone file is created through [Administration] by using TopAccess or the control panel, the service password is cloned.
For example, when cloning is performed with a clone file where the service password is blank, the cloned service password is also blank.
 - During cloning in the FS Menu, operation varies whether the setting of [User Information Cloning] from [Administration] - [Setup] - [General settings] - [Device Information] via TopAccess is [Enabled] or [Disabled].
Disabled (default): The service password is not cloned.
Enabled: The service password is cloned.

12.2.3 Clone file creation procedure

- (1) Press [36 CLONING] in the FS Menu.
- (2) Press [Create Clone File].
- (3) Select the categories to be included in the clone file.

Notes:

- If the following categories cannot be selected, ask your users to change the setting to [Enable] of [User Information Cloning] from [Administration] - [Setup] - [General settings] - [Device Information] via TopAccess.
 - User Management
 - Address Book
 - Address Book + Template + Mailboxes
- If Administrator's Password cannot be selected, ask your users to change the setting to [Enable] of [Administrator's Password Cloning] from [Administration] - [Setup] - [General settings] - [Device Information] via TopAccess.

- (4) Press [Save].
- (5) Enter a file name. Set a password if necessary.
Once a password has been set, its entry is required when this clone file is installed in the MFP.
- (6) Press [Save].
The clone file is stored by a file name with the extension ".enc" applied.

Notes:

Be sure to disconnect the USB storage device after the completion screen is displayed.

12.2.4 Clone file installation procedure

- (1) Press [36 CLONING] in the FS Menu.
- (2) Press [Install Clone File].
- (3) Connect the USB storage device with the stored clone file and press [OK].
- (4) Select the clone file to be installed.
Enter the password if one has been set.
- (5) Press [Install].

Notes:

Be sure to disconnect the USB storage device after the completion screen is displayed.

12.3 Backing Up and Restoring Data

12.3.1 Overview

By using [35 DATA BACKUP/RESTORE MODE] in the FS Menu, the MFP settings or user data stored in the storage devices and SRAM can be backed up. They also can be restored into an MFP from which the back-up files were created.

12.3.2 Applicable data

| Category name | Contents | Remarks |
|----------------------------------|--|---|
| MFP setting | Code setting values in [05 ADJUSTMENT MODE] or [08 SETTING MODE] | Codes whose [Backup] column in the self-diagnostic code list is [Yes] |
| | Gamma automatic adjustment data, LDAP roll mapping data, certificate files, language packs, client software (printer driver, univ.zip/ps3.zip/InstallClient1.exe), print data converters, ICC profiles, card reader settings, meta data XML format, print fonts, logs (jobs, messages, applications), job history data | |
| User Management | Users (including user counters), groups, roles, allocation, department codes (including department counters), templates, address books, project codes, EWB history data, home settings data | |
| Mailboxes | Mailbox data | User permission is required* |
| Application (including licenses) | Application data (including license data) | |
| e-Filing | Document data in e-Filing | User permission is required* |

* These can be backed up if they are checked in TopAccess - [Administration] - [Maintenance] - [Data Backup Function] - [Target of Data Backup].

12.3.3 Precautions

- Back-up data can be restored into an MFP from which back-up files were created.
Back-up data cannot be restored into an MFP from which the back-up files were created, if the configuration of the optional storage device differs from the one at the time of file creation.
- Although this function can be performed from the FS Menu and the User Function mode, there are restrictions on the storage location of backup files and restoration source when the FS Menu is used.

| Function | Backup file storage location/restoration source | |
|----------------------------------|---|--------------------|
| | External server | USB storage device |
| FS-[35 DATA BACKUP/RESTORE MODE] | No | Yes |
| User Function mode | Yes | Yes |

- Unique information such as the name of fax terminal or NetBIOS are not backed up.
- If periodic backup starts after backup has already been started from the control panel, or if you try to start backup when periodic backup is being performed, the latter back up will be canceled.
- When NW printer jobs or fax jobs are received during backup operation, jobs will successfully be received but not be printed out. These jobs will be printed out after the completion of backup.
- Backup files are encrypted and then stored into USB storage devices or external servers. Encryption is performed with an MFP-unique key and thus backup files cannot be restored to other MFP.
- The data backup function (FS-08-8679) cannot be enabled in the MFP with the High Security mode ON.
- For details about the specification of a USB storage device available for backup, refer to the following reference.
 P. 14-16 “14.5 Usable USB storage device”
- The approximate time for data backup/restore is as follows (referential values):
 When the backup file is 10 GB,
 Backup (USB storage device): Approximately 36 minutes + backup file creation time
 Backup (external server): Approximately 10 minutes + backup file creation time
 Restore (USB storage device): Approximately 9 minutes + time for restoring to the MFP
 Restore (external server): Approximately 24 minutes + time for restoring to the MFP
 - When applications and e-Filing are selected, backup or restore may take more 1 hour or more depending on the data volume stored in the MFP.
 - The total data volume of e-Filing and Mailbox is 30 GB or more, backup may fail.

12.3.4 Backup file creation procedure

- (1) Select [35 DATA BACKUP/RESTORE MODE] in the FS Menu.
- (2) Select [Data Backup].
- (3) Select [USB Media].
- (4) Connect the USB storage device and press [OK].

Remarks:

If backup files exist in the USB storage device, the file path, firmware version, and backup date are displayed.

- (5) Select [Backup].
- (6) Select [OK] to start backup.

Notes:

- During backup operation, you cannot move to another screen. (All hardware keys are unavailable.)
- Select [Cancel] to cancel the current process.
- When an error occurs, the error screen is displayed. For the details of the error, refer to the following.
📖 P. 8-1 “8. ERROR CODE AND TROUBLESHOOTING”
- Note the following factors, which may cause an error while storing backup files into the USB storage device.
 - No USB storage device is inserted.
 - Storing files into the USB storage device has failed due to capacity shortage or writing permission.
- Backup files are stored in a folder (serial number) in the USB storage device.
- The name of the file where backup files are stored is as follows:
(Serial number)_HddBackupData.enc
- Be sure to disconnect the USB storage device after the completion screen is displayed.

12.3.5 Restore procedure

Notes:

- Make sure that the backup file is created by the MFP you are restoring.
- Confirm that the configuration of the optional storage device of the MFP to make the restoration remains the same as when the backup was performed.

(1) Select [35 DATA BACKUP/RESTORE MODE] in the FS Menu.

(2) Press [Data Restore].

(3) Select [USB Media].

(4) Connect the USB storage device and press [OK].

Remarks:

- If backup files exist in the USB storage device, the file path, firmware version, and backup date are displayed.
- When an error occurs, the error screen is displayed.

(5) Press [Restore].

(6) Select [OK] to start backup.

Notes:

- During backup operation, you cannot move to another screen. (All hardware keys are unavailable.)
- Select [Cancel] to cancel the current process.
- When an error occurs, the error screen is displayed. For the details of the error, refer to the following.
 P. 8-1 "8. ERROR CODE AND TROUBLESHOOTING"

(7) When the progress bar reaches 100%, the MFP automatically reboots in the special mode. When processes are done in the special mode, "Complete" is displayed and the MFP reboots.

Notes:

When processes have failed, "Failed" is displayed. In that case, shut down the MFP by pressing [Shutdown] on the screen and then turn ON the MFP.

12.3.6 Management of the backup function

When the standard storage device and the optional storage device are damaged, not only the MFP stops operation, but also the data in those storages may be lost. To prevent this, the following actions are recommended.

- Periodically back up the data in the storage devices.
- Utilize the Storage device Alert function (to issue a warning when storage devices have deteriorated and replacement is required).

[1] Backup

Backup can be set or performed by the user from TopAccess or the User Function mode.

| Setting | FS Menu | User operation |
|--|---|--|
| Enabling/disabling the backup function | 08-8679 | TopAccess - [Administration] - [Maintenance] - [Data Backup Function] |
| External server setting | 08-8680, 08-8682 to 08-8687 | |
| Automatic data backup cycle | 08-8681-0 to 3 | |
| Target of Data Backup | 08-8688-0 to 1, 3 to 5 | |
| Perform data backup | [35 DATA BACKUP/RESTORE MODE] ^{*1} | User Function mode ^{*2} |
| Restore | | |

*1 : Only the USB storage device can be used.

*2 : Displayed on the screen only when 08-8679 is enabled (when the data backup function is enabled in TopAccess).

Notes:

- Periodic backup is not performed when a job is being performed. Periodic backup is automatically performed after the completion of the job.
- When the MFP is in the energy saving mode/sleep mode, periodic backup is performed after the MFP has returned from the energy saving mode/sleep mode.
- When the MFP is in the super sleep mode, periodic backup is performed after the MFP has returned from the super sleep mode. The MFP enters the super sleep mode after the completion of backup.
- When the MFP is OFF on the date specified for periodic backup, such periodic backup is skipped.
- Backup is canceled when [Cancel] is pressed during backup.

[2] Storage device Alert function

| Setting | Contents | FS Menu | Service Notification |
|------------------------------------|---|----------------|----------------------|
| S.M.A.R.T self test | Execution setting of the self-testing Remarks: The applicable storage device for this test is an HDD only. | 08-9006-0 to 3 | - |
| Judgment results | Judgment results of the storage status | 08-9008-0 to 2 | - |
| Warning indication | Settings for warnings to be displayed for the user based on the judgment results | 08-9009-0 to 1 | - |
| Equipment information notification | Settings for whether the service technician is notified with an alert when it is judged that replacement of storage devices is required | 08-9046 | Yes |

Notes:

- When the S.M.A.R.T self test is being performed, “Storage device self test is processing” is displayed.
- The S.M.A.R.T self test is performed only when the MFP is ON at the specified time and also not in the super sleep mode.
- When it is the time for fixed time reboot, the fixed time reboot is prioritized.
- The state of storage devices is checked every 6 hours. When conditions are met, a message to request data backup in storage devices or replacement of storage devices is displayed on the panel.
- When the periodic backup function is enabled, no message to request backup is displayed.
- When backup is performed with the backup function once or more, no message to request backup is displayed.
- The indication is cleared when the system firmware version up is performed.

12.4 TPM

12.4.1 Overview

This is a function to encrypt authentication information and encryption keys in the standard storage device and optional storage device and store them by means of TPM (Trusted Platform Module). The security level against property loss can be enhanced by enabling TPM.

Remarks:

- This function is disabled at the time of factory shipment.
- Users can set to enable or disable with the User Function mode and service technicians can do so by means of the self-diagnostic code.
- When this function has been enabled, a signature check is carried out at the startup.

12.4.2 Confirmation Method

Press [COUNTER] on the touch panel. If the TPM icon is displayed at the top right of the screen, TPM is in operation.



Fig.12-2

12.4.3 Precautions for MFPs with TPM enabled

When the SYS board in an MFP with TPM enabled is replaced, a USB storage device, in which a password for this function is enabled and TPM information is stored, is necessary.

12.5 High Security Mode

12.5.1 Overview

The High Security mode is a security mode complying with CC certification which is suitable for HCD-PP. When entering the High Security mode, be sure to perform preparation and follow the entering procedure.

12.5.2 Prior confirmation

- Confirm that the administrator for the MFP is authorized and ask him/her to observe the installation.
- Make sure that the security HDD (GE-1260) is installed to the MFP since it is required to enter the High Security mode complying with HCD-PP.

Notes:

When the security HDD (GE-1260) is installed, an icon of the FIPS hard disk is displayed on the counter screen.

- To avoid physical security problems, such as hardware removal or inappropriate disassembly at the installation site, take all necessary measures, such as checking who enters and leaves the site.

12.5.3 Back up data in HDD

Ask the user (administrator) to back up the data in the storage devices. Backup methods and applicable data are as follows.

| Backup method | Operation | Applicable data |
|---|---|--|
| Export information. | Export required information in TopAccess - [Administration] - [Maintenance] - [Export]. | "Address Book", "F Code", "Template" |
| Export information. | Export required information in TopAccess - [User Management] - [Export/Import] - [Export]. | "User Information", "LDAP Role", "Department Information", "Project Code" |
| Archive and download documents. | 1. Archive document by selecting them in TopAccess - [e-Filing]. 2. Download archived documents. | e-Filing data |
| Copy files. | Copy files from Share Folder to another PC. | Data stored in the share folder of the MFP such as Scan to file or Copy and file |
| Export log data. | Create export files of the target data in TopAccess - [Logs] - [Export Logs]. | All items |
| Print out the function list. | Print out [Function] in [Home] - [User Functions] - [Admin] - [List/Report] - [List]. | System related settings and user information |
| Print out Function List for Maintenance.* | Print out [Function List for Maintenance] in FS-FAX-[12 Fax List Print Mode]. | Fax related settings and user information |
| Take notes. | Take notes of information in TopAccess - [Administration]. | Information in TopAccess - [Administration] |

* Only the service technician can operate.

Notes:

- Log into the MFP or TopAccess as the Administrator.
- Print out and hand over the following data to the user since they cannot be backed up.
 - Print waiting data (Copying data and Fax reception data that are waiting to be printed due to the paper run-out and jam, etc.)
 - Print job (Private print data, Schedule print data)
 - Fax saved data (Confidential or Bulletin board data)
- Inform the user that the following data cannot be backed up.
 - Registration data for Fax transmission (Delayed transmission or Recovery transmission)
- Compatibility of cloning data is lost between the High Security mode and the normal mode; therefore, cloning data cannot be imported.
- The data backup function is not available in the MFP with the High Security mode ON.

12.5.4 Procedure for entering the High Security mode

- (1) Set "1" (Enabled) in FS-08-9717-0 (Advanced storage connection setting).
- (2) Set "2" (High security) in FS-08-9717-1 (Advanced storage security setting).
- (3) Set "3" (High level) in FS-08-8911 (Security mode (level) setting).
- (4) Reboot the MFP.
- (5) Change the administrator password.

Notes:

- Explain the procedure to the users (MFP administrators) and ask them to enter their password.
 - For the administrator password, this should comply with the high security mode password policy.
- (6) Check that the MFP is shifted to the High Security mode by means of the following display.
 - A key-shaped icon appears at the bottom of the touch panel.
 - The version name of the installed system ROM (SYS V3.0) is displayed at the top right of the counter menu.

| CPU Name | SYS Version |
|-------------------------|-------------|
| Intel Atom E3930 1.3GHz | SYS V3.0 |

- (7) Reset the user data backed up in advance.

12.5.5 Restore user information and data in HDD

Ask the user (administrator) to restore user information and data in the storage devices.

Restoration methods and applicable data are as follows.

| Restoration method | Operation | Applicable data |
|---|--|--|
| Print out the function list. | <ol style="list-style-type: none"> 1. Print out [Function] in [Home] - [User Functions] - [Admin] - [List/Report] - [List]. 2. Comparing it with the list printed out before entering the High Security mode, restore those with a different value and reenter user information. | System related settings and user information |
| Print out Function List for Maintenance.* | <ol style="list-style-type: none"> 1. Print out [Function List for Maintenance] in FS-FAX-[12 Fax List Print Mode]. 2. Comparing it with the list printed out before entering the High Security mode, restore those with a different value and reenter user information. | Fax related settings and user information |
| Reset or reenter. | Reenter the information you have taken notes of in TopAccess - [Administration]. | Information in TopAccess - [Administration] |

| Restoration method | Operation | Applicable data |
|----------------------------|--|---|
| Import information. | Import required information in TopAccess - [Administration] - [Maintenance] - [Import]. | "Address Book", "F Code", "Template" |
| Import information. | Import required information in TopAccess - [User Management] - [Export/Import] - [Import]. | "User Information", "LDAP Role", "Department Information", "Project Code" |
| Upload archived documents. | Upload archived documents in TopAccess - [e-Filing]. | e-Filing data |

* Only the service technician can operate.

Notes:

Log into the MFP or TopAccess as the Administrator.

12.5.6 Precautions

- In the High Security mode, an integrity check system is operated at every reboot. If F521 (integrity check error) is displayed, take the necessary measures following the troubleshooting procedure.
- When a self-diagnostic mode is started in the High Security mode, an authentication screen appears. Enter the default user name and password of the service.
- If a password change screen appears, reset the password according to the rules below.
 - It must not be the same as the user name or not include the user name.
 - It must be a combination of letters of the alphabet, numbers and symbols.
 - It must be 8 characters or more for the administrator password and 6 characters or more for the service password. (Maximum 64 characters)
 - The same character must not be repeated 4 times within the new password.
 - The old and the new passwords must not be the same.
- When the MFP is shifted to the High Security mode, the contents for some codes will be changed as below.
 - The default value is changed.
 - The settings cannot be changed.
 - Some setting values cannot be selected.
 For details, refer to the "Self-diagnostic code list" (separate document).
- The HDD is initialized (and the saved user data are deleted) when the MFP returns to the normal mode from the High Security mode. Be sure to back up user data before having it do so.
- In the above case, the password is not reset. The password setting can be changed with the code FS-08-8919.
- After the MFP enters the High Security mode, ask the administrator for the MFP to select [Full] and perform the Integrity check manually.

12.6 Decommissioning

12.6.1 Overview

Decommissioning is a function to perform a batch processing of deleting user data, initializing settings, etc. This function is used at the removal of the MFP.

12.6.2 Function

With decommissioning, a batch processing of deleting user data, initializing settings, etc. can be performed.

There are two ways for decommissioning; one is performed from the control panel on the MFP and the other is performed by remote operation using the remote maintenance service. In this manual, the way used for decommissioning from the control panel on the MFP is explained.

12.6.3 Precautions

- Deleted data and formatted setting values subject to decommissioning cannot be returned to the original values.
- The MFP cannot be operated after performing decommissioning.

Remarks:

- The firmware update log and the power ON/OFF log are not deleted.
- Installed licenses and system applications are not deleted.
- The data of the NIC Config List and the Function List which the remote maintenance service obtains are formatted.

12.6.4 Procedures of decommissioning

[1] Performing of decommissioning

- (1) Confirm that no paper jams and errors have occurred and the MFP is not being operated.
- (2) Perform FS-08-8615.
- (3) Press [Execution].

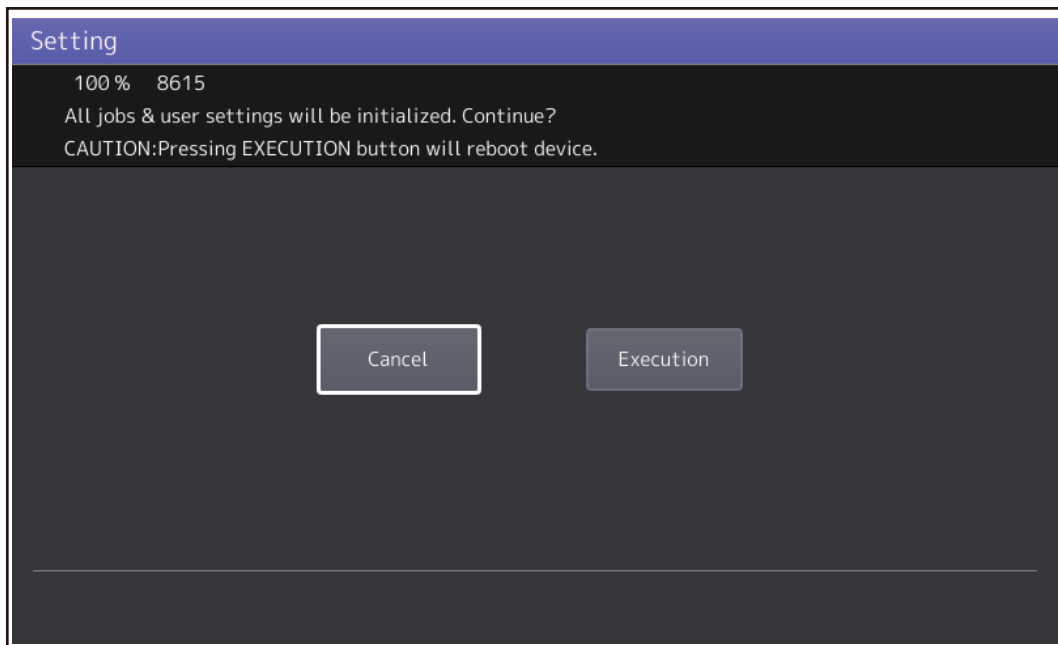

Fig.12-3

The MFP is rebooted. After rebooting, the MFP enters the decommissioning mode and starts processing.

The MFP carries out the following items while performing decommissioning.

- Stopping the network function
- Prohibiting job reception and job execution
- Deleting pending jobs
- Performing system initialization
- Deleting users information, etc.

- (4) When the processing is completed, “Success” or “Failed” is displayed.

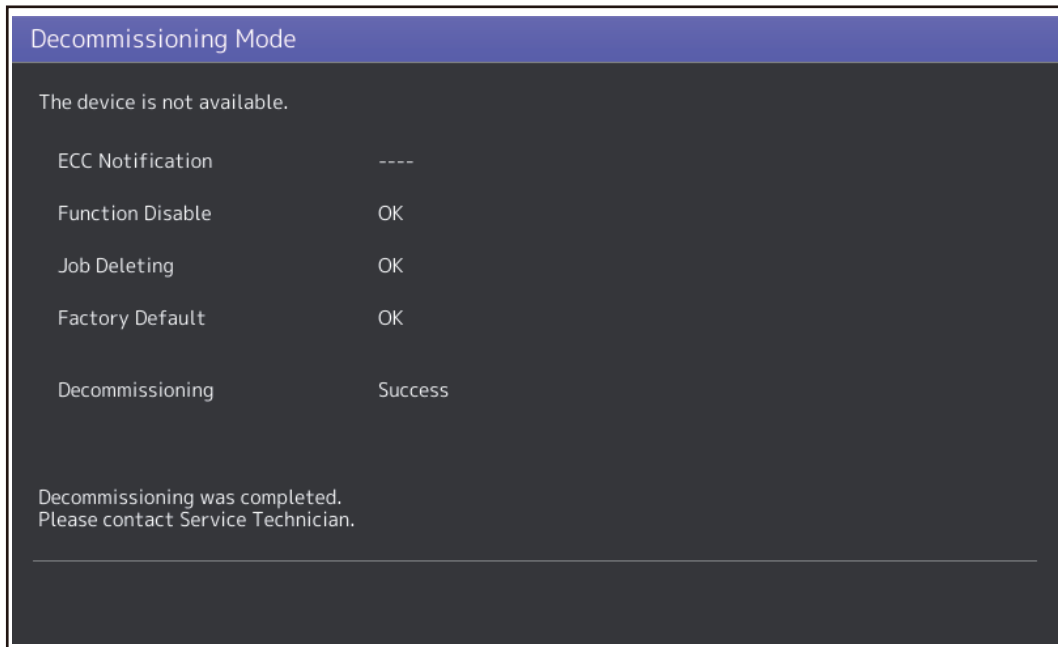

Fig.12-4

Notes:

When “Failed” is displayed, manually delete or format the data.

- (5) After the processing is completed, the MFP is kept in the decommissioning mode state.

Remarks:

The MFP will keep retaining the decommissioning mode until it is canceled.

While the decommissioning mode is retained, the processing result keeps being displayed and receiving and executing of jobs are stopped. Only the [ON/OFF] button is available.

- (6) To cancel the decommissioning mode, perform the procedure of [2].

[2] Cancellation of decommissioning

- (1) Perform FS-08-8616.

- (2) Press [Execution].

The MFP is rebooted. The MFP enters the normal mode after rebooting.

Remarks:

If the decommissioning mode cannot be canceled even though the procedure of [2] has been carried out, perform the following steps.

1. HS-49 Firmware Update.
2. Install the system software.
3. The MFP is rebooted. Confirm that the state of the MFP is changed to the normal mode.

13. WIRE HARNESS CONNECTION

13.1 AC Wire Harness

Notes:

- Toner motor interlock switch (SW3), interlock switch (SW2) and IH interlock switch (SW4) are the interlock switches with 12V DC.
- When the toner motor interlock switch (SW3) or interlock switch (SW2) or IH interlock switch (SW4) is turned OFF, 24VD output will stop.

13.1.1 100V model (6529A)

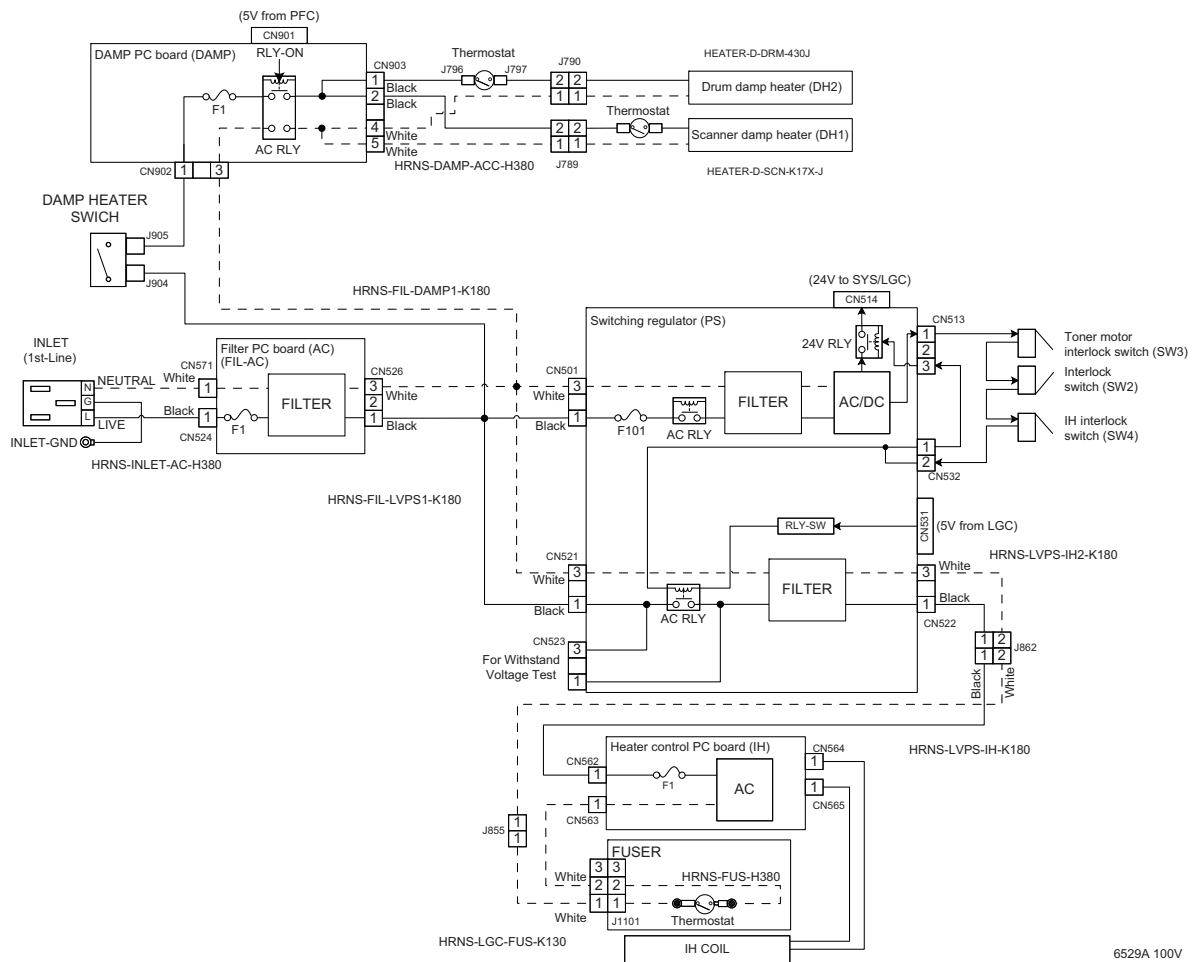

Fig.13-1

13.1.2 100V model (9029A)

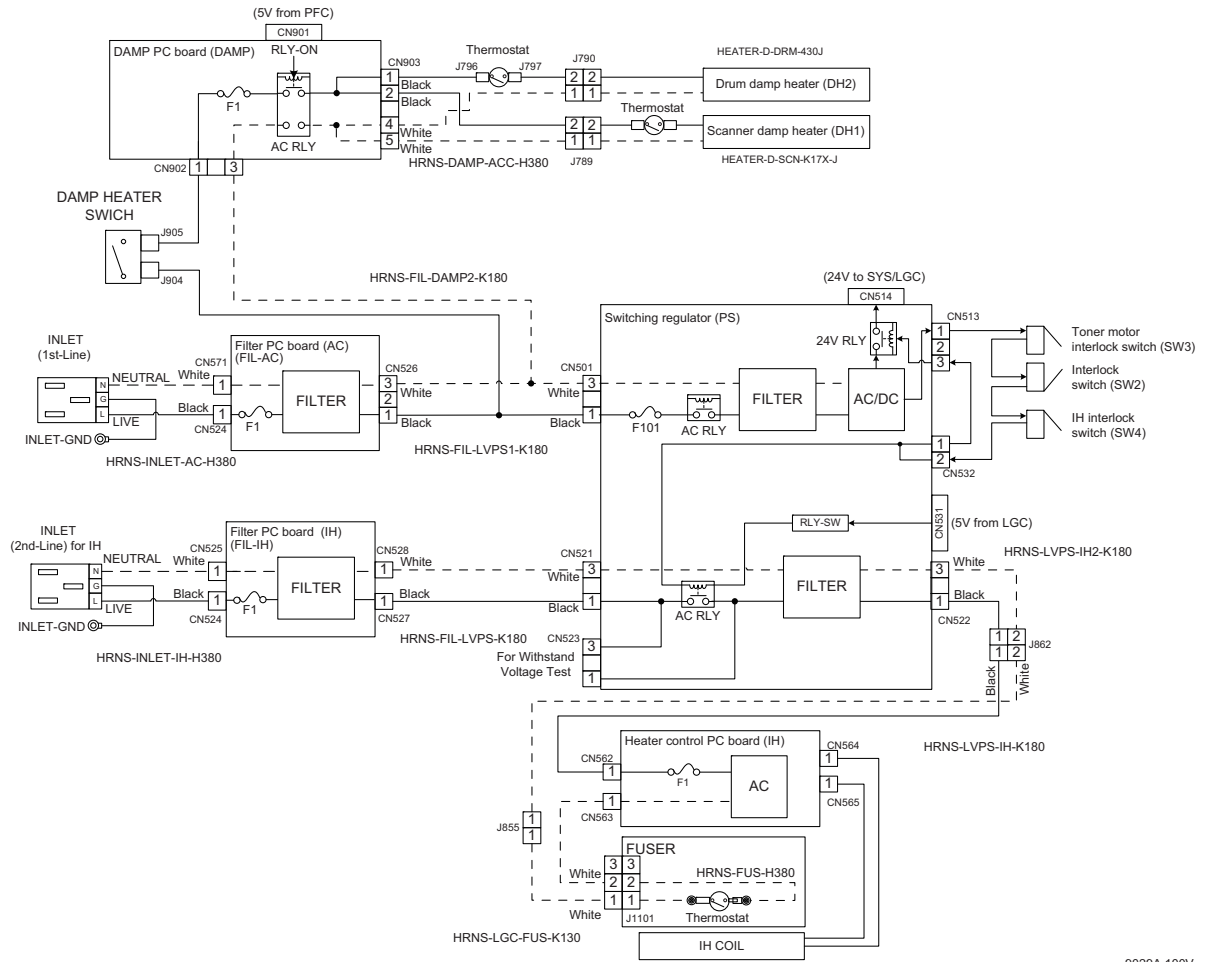

Fig.13-2

9029A 100V

13.1.3 120V model

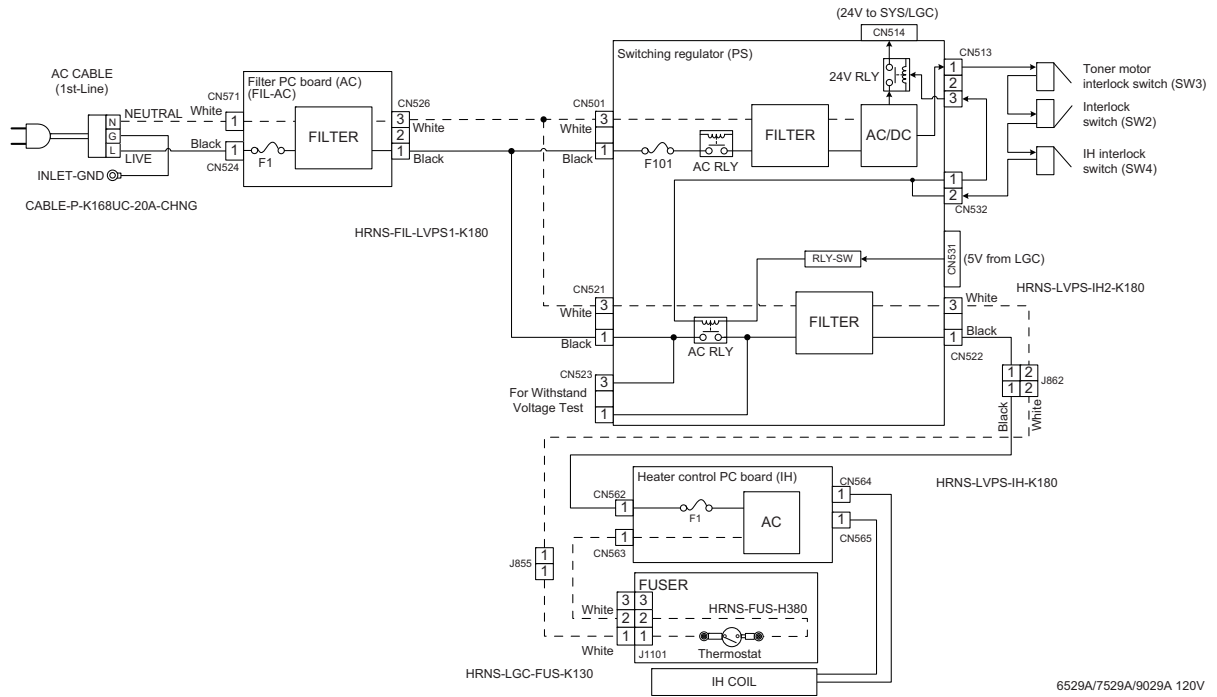

Fig.13-3

6529A/7529A/9029A 120V

13.1.4 220-240V model

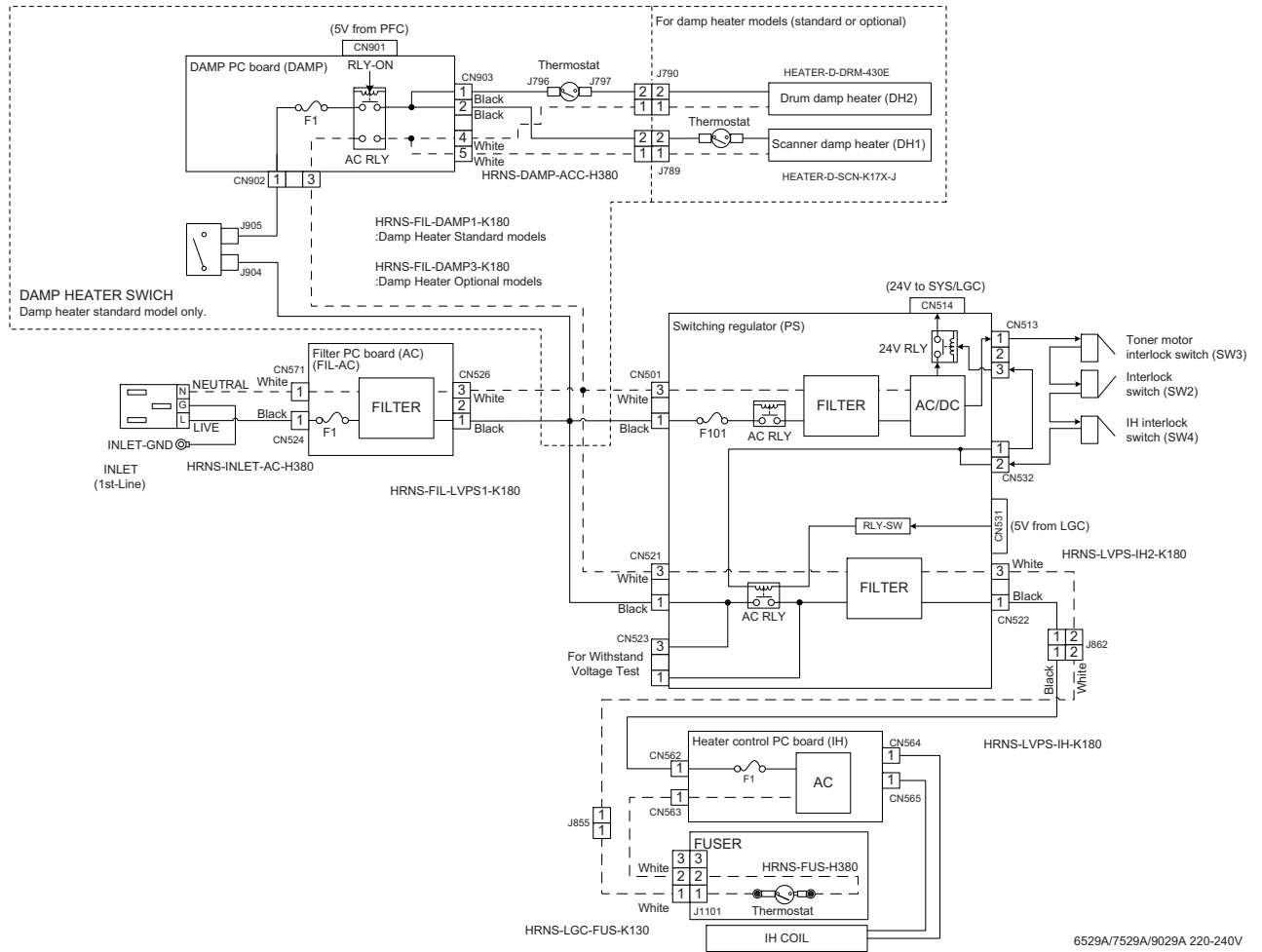
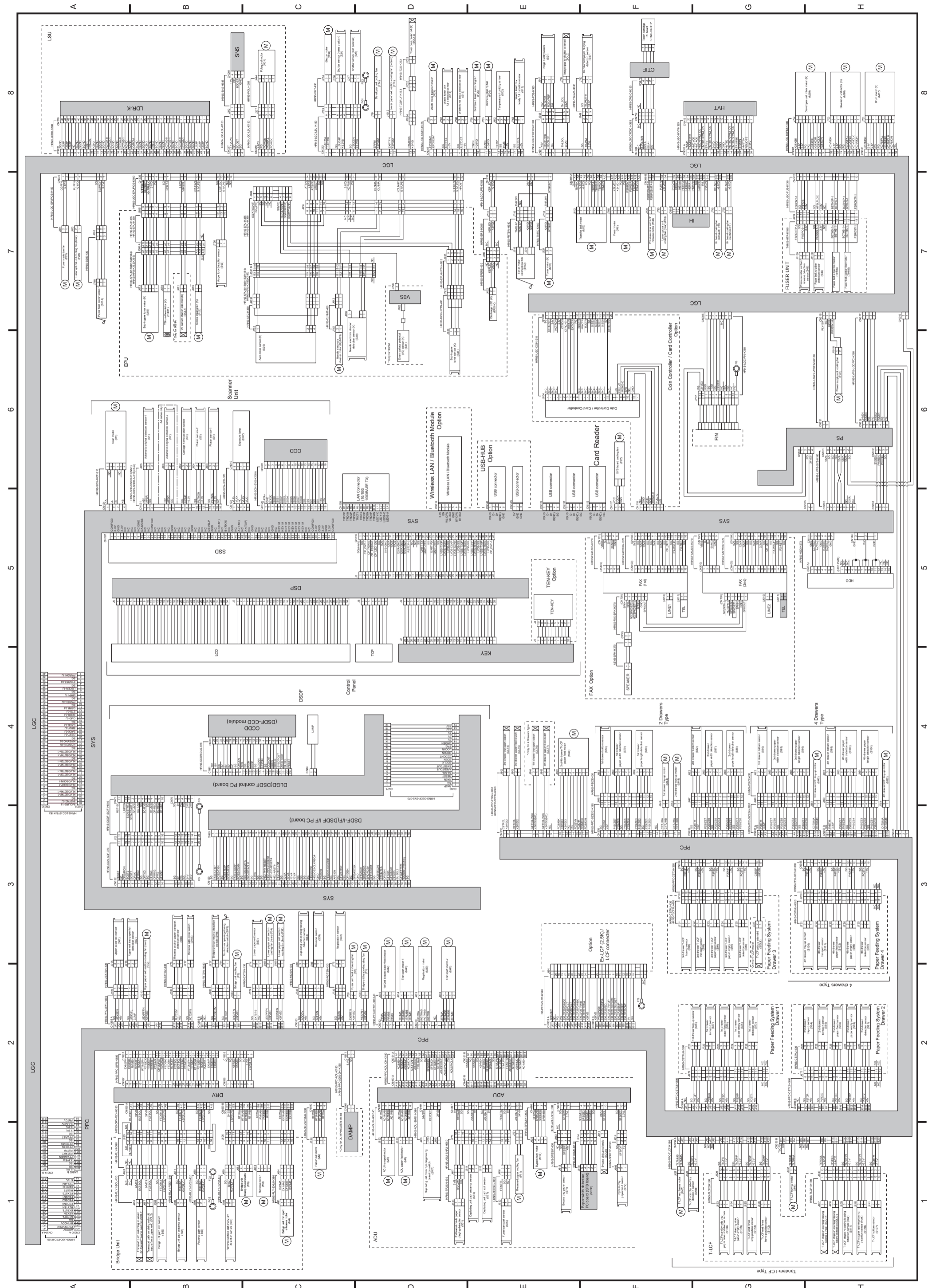
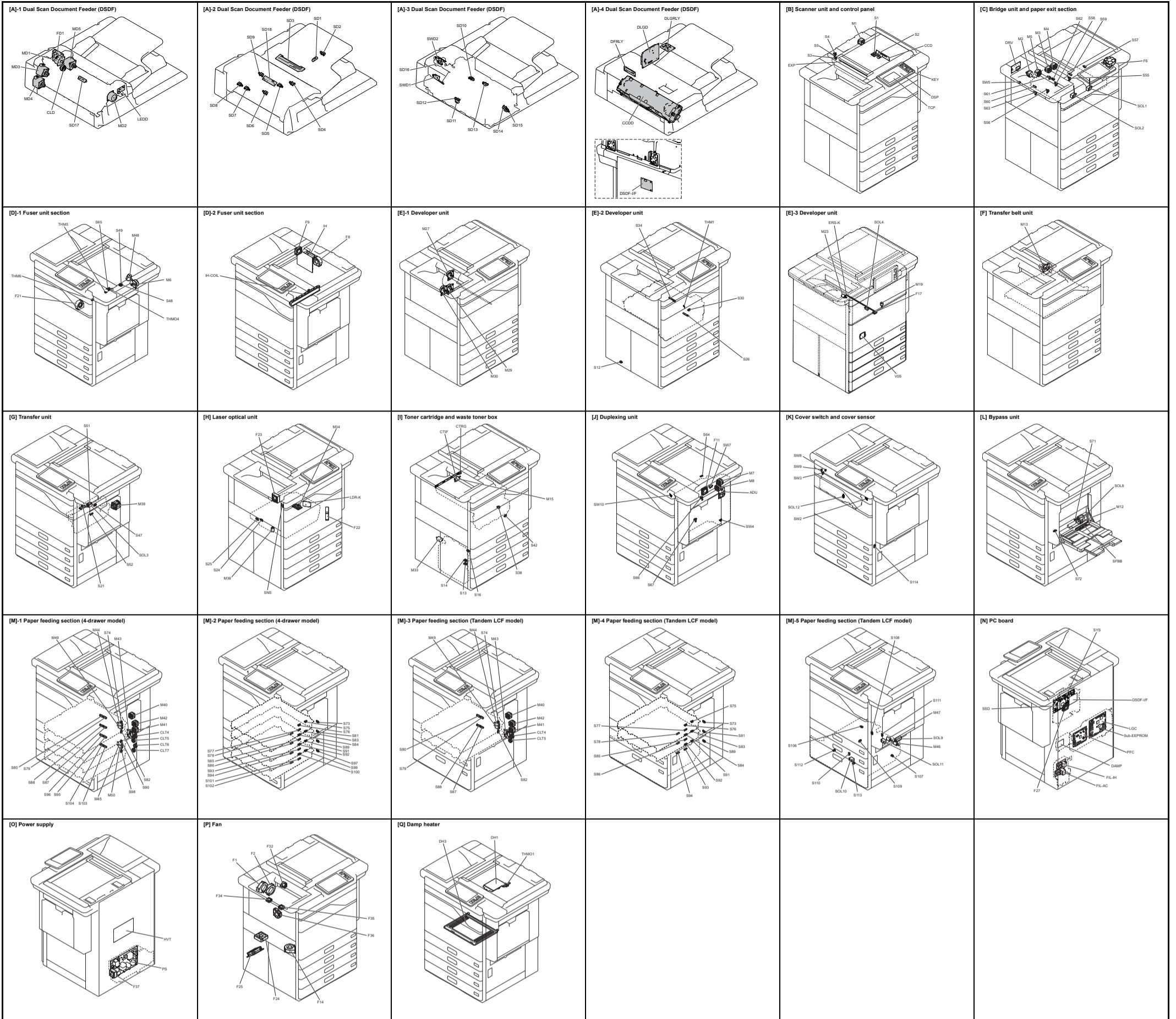

Fig.13-4

13.2.1 DC Wire Harness



13.2.2 Electric Parts Layout



| Symbol | Name | Figure | Wire harness location |
|--------|---|--------|-----------------------|
| M01 | DSDf original feed motor | [A]-1 | DSDf Harness Diagram |
| M02 | DSDf separation motor | [A]-1 | DSDf Harness Diagram |
| M03 | DSDf registration motor | [A]-1 | DSDf Harness Diagram |
| M04 | DSDf read motor | [A]-1 | DSDf Harness Diagram |
| M05 | DSDf original exit motor | [A]-1 | DSDf Harness Diagram |
| M1 | Scan motor | [B]-6A | |
| M2 | Paper exit motor | [C]-1C | |
| M3 | Reverse motor | [C]-1C | |
| M4 | Bridge unit transport entrance motor | [C]-1C | |
| M5 | Bridge unit transport exit motor | [C]-1C | |
| M6 | Fuser motor | [D]-1 | 7-F |
| M7 | ADU transport motor | [L]-1D | |
| M8 | ADU paper feed motor | [L]-1D | |
| M9 | Bypass tray motor | [I]-1E | |
| M10 | Transfer belt motor | [I]-7F | |
| M11 | Toner motor (K) | [I]-7E | |
| M12 | Sub-hopper toner motor (K) | [E]-3 | 7-B |
| M13 | Needle electrode cleaner motor (K) | [E]-3 | 6-C |
| M14 | Drum motor (K) | [E]-1 | 8-H |
| M15 | Developer unit mixer motor (K) | [E]-1 | 8-H |
| M16 | Developer unit motor (K) | [E]-1 | 8-H |
| M17 | Waste toner transport motor | [I]-8D | |
| M18 | Polygonal motor | [I]-8C | |
| M19 | Shutter motor | [I]-8C | |
| M20 | Registration motor | [C]-2D | |
| M21 | Transport motor-1 | [M]-1 | 2-D |
| M22 | Transport motor-2 | [M]-1 | 2-D |
| M23 | 1st/2nd drawer paper feed motor | [M]-1 | 2-D |
| M24 | 3rd/4th drawer/L-CF paper feed motor | [M]-1 | 4-E |
| M25 | 1st drawer tray-up motor | [M]-1 | 4-F |
| M26 | 3rd drawer/L-CF tray-up motor | [M]-1 | 4-H |
| M27 | L-CF tray-up motor | [M]-5 | 1-F |
| M28 | L-CF end fence motor | [M]-5 | 1-F |
| M29 | Pressure roller contact/release motor | [D]-1 | 7-F |
| M30 | 1st drawer tray-up motor | [M]-1 | 4-F |
| M31 | 4th drawer/L-CF tray-up motor | [M]-1 | 4-H |
| F01 | DSDf cooling fan motor | [A]-1 | DSDf Harness Diagram |
| F1 | Bridge unit heat exhausting fan | [P]-2D | |
| F2 | Fuser unit heat exhausting fan | [P]-2C | |
| F3 | Bridge unit cooling fan | [C]-2B | |
| F4 | 1st board cooling fan (exhaust) | [D]-2 | 7-G |
| F5 | 2nd board cooling fan (exhaust) | [D]-2 | 7-G |
| F6 | Reversed paper cooling fan | [L]-1E | |
| F7 | Developer unit cooling fan | [I]-8D | |
| F8 | Ozone mixing fan (K) | [E]-3 | 7-B |
| F9 | Fuser insulation fan | [D]-1 | 7-A |
| F10 | Fuser insulation fan | [D]-1 | 7-A |
| F11 | Laser optical unit cooling fan (front) | [I]-7F | |
| F12 | Laser optical unit cooling fan (rear) | [I]-7F | |
| F13 | Ozone suctioning fan | [P]-8E | |
| F14 | Scattered toner suctioning fan | [P]-8E | |
| F15 | SYS board cooling fan | [N]-6F | |
| F16 | Upper paper exit section cooling fan (rear) | [P]-2B | |
| F17 | Lower paper exit section cooling fan (rear) | [P]-3C | |
| F18 | Lower paper exit section cooling fan (front) | [P]-3C | |
| F19 | Lower paper exit section cooling fan (bottom) | [P]-3C | |
| F20 | Power supply unit cooling fan | [O]-6H | |

13.3 DSDF Harness Diagram

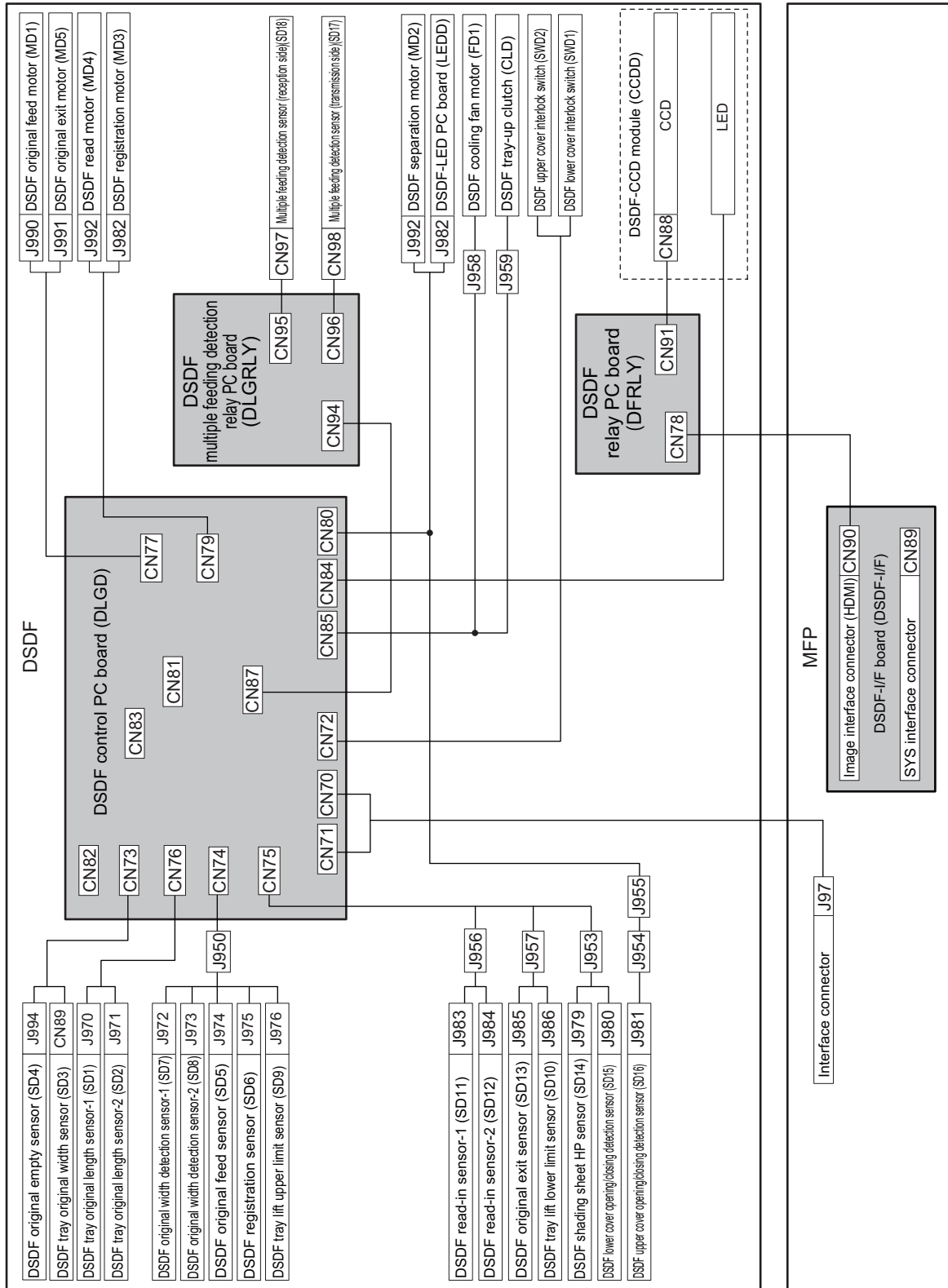

Fig.13-5

14. APPENDIX

14.1 External Counters

14.1.1 Overview

This chapter describes the interface between external counters, such as a coin controller and key copy counter.

14.1.2 Connector

- LGC board connector: CN306 (B20B-CZHK-B-1(LF)(SN)(V): manufactured by JST)
- SYS board connector: CN118 (B7B-PH-SM4): manufactured by JST)

14.1.3 Coin controller

[1] Setting

1. Set "1" or "5" in FS-08-9016.
2. Harness kit: GQ-1280-N

[2] Pin layout

Notes:

Do not connect inductive loads, such as a mechanical counter or a relay coil, to CTRON.

1. LGC board

| Pin No. | I/O | Signal name | Function | Voltage level | Remarks |
|----------|-------|-------------|-----------------------------|----------------------|---------------------------------|
| 1 to 4 | - | - | - | - | Connection prohibited |
| 5 | Power | +24V | 24 V line | DC24 V +10/-5 % | |
| 6 | Out | CTRON | Total counter On signal | Open collector | L: On IO (Max): 500 mA |
| 7 | In | CTRCNT | Copy permission signal | L = 0 V, H = DC3.3 V | L: Allowed *1 |
| 8 | Out | MCRUN | Ready to copy signal | Open collector | L: Operating IO (Max): 40 mA |
| 9 | Out | EXTCTR | Paper exit sensor On signal | Open collector | L: On IO (Max): 40 mA |
| 10 to 18 | - | - | - | - | Connection prohibited |
| 19 | Power | +5VL | 5 V line | DC5.1 V | At the sleep mode: Off |
| 20 | - | - | - | - | Connection prohibited |

*1 When the coin controller outputs the CTRCNT signal, the controller should be driven by means of an open collector or open drain to prevent the inflow of current to the MFP.

2. SYS board side

| Pin No. | I/O | Signal name | Function | Voltage level | Remarks |
|---------|-----|-----------------|-------------------|----------------|----------------------------------|
| 1 | Out | LARGE/ SMALL | Paper size signal | Open collector | L: Large size IO (Max): 20 mA |
| 2 | - | - | - | - | Connection prohibited |
| 3 | - | - | - | - | Connection prohibited |
| 4 | - | - | - | - | Connection prohibited |
| 5 | - | - | - | - | Connection prohibited |
| 6 | GND | SG | Signal Ground | 0 V | |
| 7 | - | - | - | - | Connection prohibited |

[3] Details of the signals

1. CTRON signal (output signal)

The CTRON signal is synchronized with an electronic counter of the MFP and it becomes “Low” when one sheet of paper is counted up. This signal is output from the LGC board.



Fig.14-1

2. CTCNT signal (input signal)

The CTCNT signal enables the acceptance of copies when the coin controller is connected, and copies can be accepted with “Low”. In case of “High”, “Set Key Counter” appears and copies cannot be made.

3. MCRUN signal (output signal)

The MCRUN signal is changed to “Low” during copying. It becomes “Low” at a fixed time or before the CTRON signal is turned ON, and “High” at a fixed time or after the EXTCTR signal goes OFF. However, if copying is interrupted due to forced toner supply or similar, this signal is “High” until copying is made possible again.

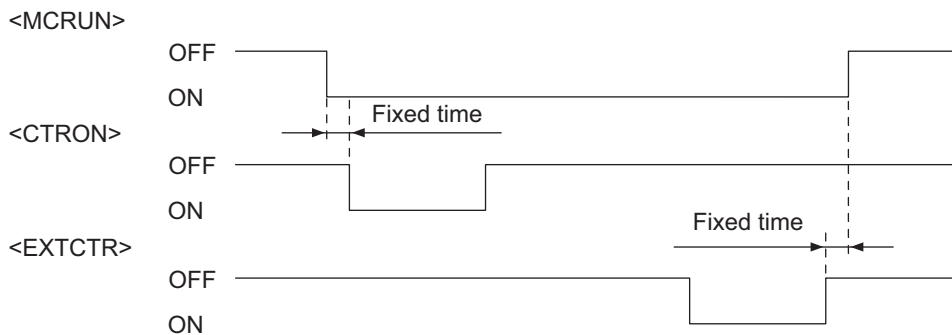

Fig.14-2

4. EXTCTR signal (output signal)

The EXTCTR signal is synchronized with “paper exit sensor ON” and becomes “Low” (ON) for a fixed time.

The coin controller counts the number of times with this signal.

This is the signal only for the coin controller.

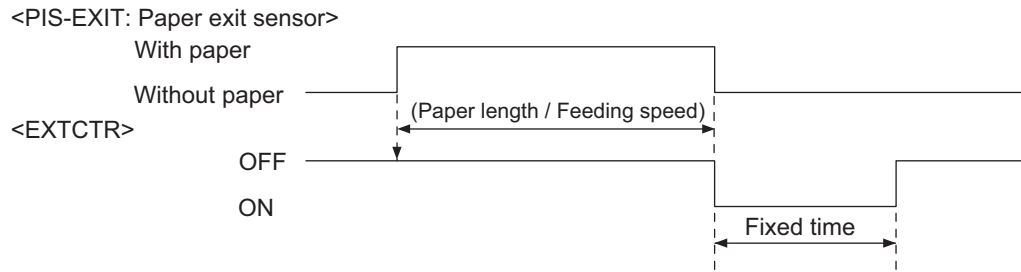

Fig.14-3

5. LARGE/SMALL signal (output signal)

When large-size paper, such as A3, A3 wide or LD, is selected for the paper size is not specified in the manual feeding, it outputs “Low” in real time. In other cases, it outputs “High”.

The setting change for large size paper is performed with F/W. This is the signal only for the coin controller.

[4] Harness (GQ-1280-N)

| PC boards | Connector | Pin No. | Signal name | Pin No. | Connector |
|----------------------|-------------|---------|-------------|---------|-------------------------------------|
| SYS board (CN118) | Connector-2 | 1 | LARGE/SMALL | 7 | Connector-3 (Coin controller) |
| | | 2 | - | 8 | |
| | | 3 | - | 9 | |
| | | 4 | - | 10 | |
| | | 5 | - | - | |
| | | 6 | SG | 12 | |
| | | 7 | - | - | |
| LGC board (CN306) | Connector-1 | 1 | - | - | |
| | | 2 | - | - | |
| | | 3 | - | - | |
| | | 4 | - | - | |
| | | 5 | +24V | 1 | |
| | | 6 | CTRON | 2 | |
| | | 7 | CTRCNT | 3 | |
| | | 8 | MCRUN | 4 | |
| | | 9 | EXTCTR | 5 | |
| | | 10 | PG | 6 | |
| | | 11 | - | - | |
| | | 12 | - | - | |
| | | 13 | - | - | |
| 14 | - | - | | | |
| 15 | - | - | | | |
| 16 | - | - | | | |
| 17 | - | - | | | |
| 18 | - | - | | | |
| 19 | +5V | 11 | | | |
| 20 | - | - | | | |

14.1.4 Key copy counter

[1] Setting

1. Set "3" in FS-08-9016.
2. Harness kit: -

[2] Pin layout

Notes:

Use 24 V supplied from the MFP as power for the output signals (KCTRON) from the transistor.

1. LGC board

| Pin No. | I/O | Signal name | Function | Voltage level | Remarks |
|---------|-------|-------------|------------------------------|----------------------|---------------------------|
| 1 | GND | SG | Signal Ground | 0 V | |
| 2 | In | CTRCNT | Copy permission signal | L = 0 V, H = DC3.3 V | L: Allowed *1 |
| 3 | Power | +24V | 24 V line | DC24 V +10/-5 % | |
| 4 | Out | KCTRON | Mechanical counter On signal | Open collector | L: On IO (Max): 500 mA |
| 5 to 20 | - | - | - | - | Connection prohibited |

*1 When the coin controller outputs the CTRCNT signal, the controller should be driven by means of an open collector or open drain to prevent the inflow of current to the MFP.

2. SYS board side

Do not connect the SYS board.

[3] Details of the signals

1. CTRCNT signal (input signal)

The CTRCNT signal enables the acceptance of copies when the key counter is connected, and copies can be accepted with "Low". In case of "High", "Set Key Counter" appears and copies cannot be made.

2. KCTRON signal (output signal)

These signals are synchronized with the electronic counter of the MFP and they become "Low" when the counter is turned ON. They are the signals for driving a mechanical counter, and output from the LGC board.

They can drive inductive loads, such as a solenoid, using 24V supplied from the MFP as power. The interval between when they are turned ON and when this happens next must be at least 100 ms. "Single count" or "Double count" can be switched according to the paper size by setting "1" or "2" for FS-08-6010.

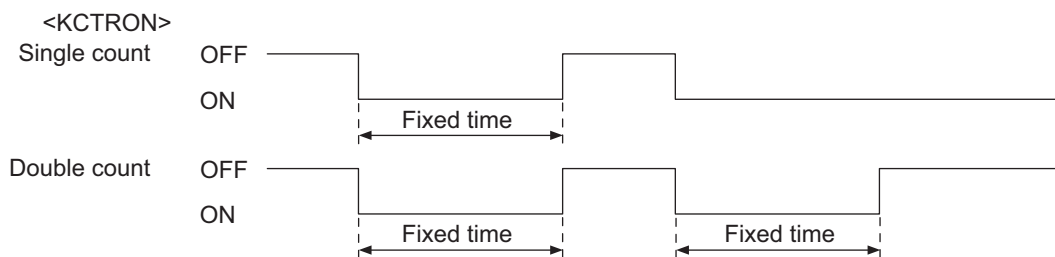

Fig.14-4

14.1.5 Precautions

[1] Setting code

Each signal will be enabled by configuring the setting code FS-08-9016 (Counter installed externally).

FS-08-9016

- 0: No external counter (default)
- 1: Coin controller
- 3: Key copy counter
- 5: Coin controller supporting mixed-size

[2] Setting value change and restrictions when using the coin controller

FS-08-9016 (Counter installed externally): Set to "1" (Coin controller) or "5" (Coin controller supporting mixed-size).

Notes:

- Mixed-size jobs will be supported by setting to "5". The switching process of the size signal is carried out for each page.
- Be sure to make the following charge settings appropriately according to the usage.
 - FS-08-9017 (Setting for counter installed externally): To charge only when copies are made, set to "1".
 - FS-08-6011 (Definition setting of large sized paper): To make only A3 and LD be specified for the large size, set to "0". To make B4, LG, FOLIO, COMP as well as A3 and LD be specified for the large size, set to "1".

[3] Installation of external counters

It is not allowed to install more than one external counter (key copy counter and coin controller) at the same time.

[4] Setting value change and restrictions when using the key counter

The key copy counter used for current models is not supported in this MFP, but the circuit for driving the counter has been mounted. The mechanical counter can be used by setting as below. However, the harness for connecting it has not been provided as an option.

Setting value

FS-08-9016 (Counter installed externally): Set to "3" (Key copy counter).

FS-08-9017 (Setting for counter installed externally): It should be charged precisely according to the usage.

E.g.: To charge only when copies are made, set to "1".

FS-08-6011 (Definition setting of large sized paper): To make only A3 and LD be specified for the large size, set to "0". To make B4, LG, FOLIO, COMP as well as A3 and LD be specified for the large size, set to "1".

[5] Restrictions when using the external counter

The Job Skip function will be disabled when an external counter is installed (when a value other than "0" is set for FS-08-9016).

Therefore, if printing is attempted while a counter or a coin controller is used, all jobs stored in the storage may be printed.

[6] Restrictions for e-Filing

When an external counter has been installed (a value other than "0" is set for FS-08-9016), documents can be saved in e-Filing and files can be saved in a shared folder. However, printing of documents saved in e-Filing is not possible.

Notes:

This will become possible by setting the value "1" (Allowed) for FS-08-8670 (e-Filing print setting when key counter/totalizer is installed) when the value "3" (Key copy counter) is set for FS-08-9016.

14.2 Optional Storage Device

14.2.1 Overview

The security setting and operation method of the optional storage device is explained.

14.2.2 Disabling setting

When the installed optional storage device is in the following condition, it can be disabled. Since the optional storage device can be disabled temporarily when it has malfunctioned, an MFP can be used without your stopping it.

[1] Condition

- SSD or normal HDD
- Security HDD to which “0” is set for FS-08-9717-1

[2] Setting procedure

Perform one of the following items.

- Set “0” for FS-08-9717-0 (Connection setting).
- Set to disable from 78 Option Storage Assist > Disable Option Storage.

Notes:

After the optional storage device has been disabled, perform HS-73 Firmware Assist > Format Storage and then install “System Software (HD data)” with HS-49 Firmware Update.

14.2.3 Security setting

FS-08-9717-1 (Security setting) is available for the security HDD.

Notes:

- Set the value suiting the MFP operation.
- When the High Security Mode is enabled, set “2” for FS-08-9717-1.
- When “1” or “2” has been set for FS-08-9717-1, the value cannot be changed to “0”.
- When “1” or “2” has been set for FS-08-9717-1, the MFP cannot be operated without having an optional storage device.
- When the value of FS-08-9717-1 is changed from “2” to “1”, perform HS-73 Firmware Assist > Format Storage and then install “System Software (HD data)” with HS-49 Firmware Update.

14.2.4 Precautions for disposal

The disposal process differs depending on the type of the optional storage device.

| Storage type | Disposal process |
|--|--|
| Security HDD, Security SSD, Normal SSD | HS-74-Revert Factory Initial Status Storage-Optional storage |
| Normal HDD | HS-73-Erase Storage Securely |

14.2.5 Data overwriting function

To enable the data overwriting function, set “1” (Enabled) in FS-08-9238.

Notes:

- This is available only when an HDD is installed.
- For some models, “1” (Enabled) is set at the time of factory shipment.

14.3 Pixel Counter

14.3.1 Overview

[1] Overview

The pixel counter is a function that counts the number of dots emitted by writing the light source and converting it into the print ratio (%) per standard paper size. This “Print ratio (%) per standard paper size” is called the Pixel count (%).

This function enables you to know how each user uses the MFP and to understand the tendency of the toner consumption (number of pages output per cartridge).

However, since some of the factors in “2” below are not taken into account by the pixel counter, its accuracy sometimes does not match the actual toner consumption.

[2] Factors affecting toner consumption

The standard number of pages output per cartridge shows the average number of pages output under the condition that the data of the print ratio 5% is printed on the standard paper size (A4 or LT) under normal temperature and humidity.

However, users do not always print under the above conditions. As for the type of original, copy/print mode and environment, each user has a different tendency, and as a result, the number of pages output per cartridge will vary.

The major factors affecting toner consumption are as follows:

- Original / Data coverage
- Original / Data density
- Original / Print mode
- Density setting
- Print pattern (Character image such as text consuming more toner than solid images even though they may have the same density.)
- Number of pages per job (More toner is required when printing in the non-continuous running mode.)
- Number of the times of image quality control
- Paper (type, size and feeding direction)
- Environmental conditions (temperature, humidity)
- Others (In addition to the above, there are other factors that may influence the toner consumption. These include variations between individual products, life of consumables, bias voltage, drum surface potential, etc.)

The general relations between the first 4 factors and toner consumption per page output in the copying function are as follows:

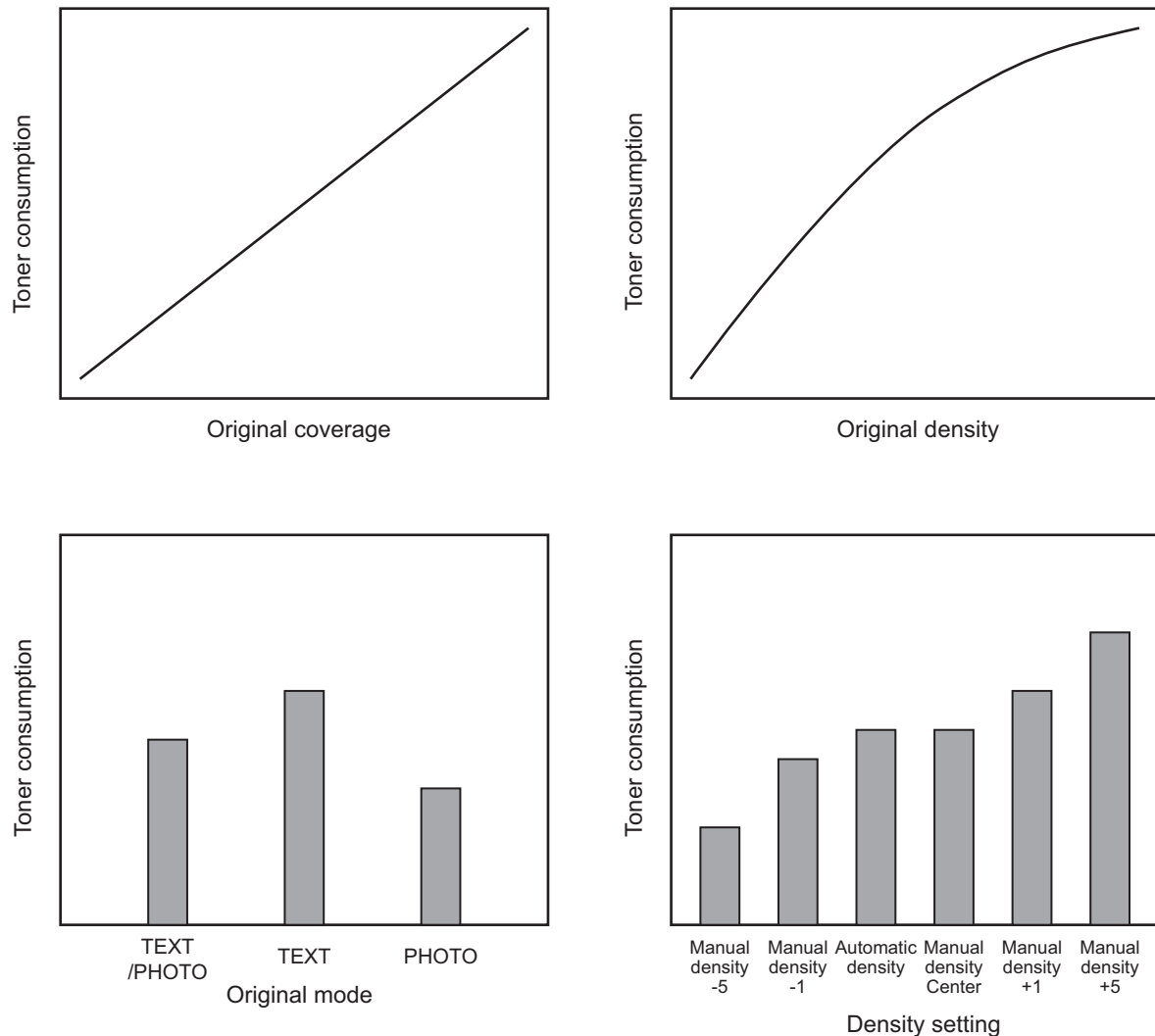

Fig.14-5 Factors affecting toner consumption and the tendency

[3] Details of the pixel counter

- Toner cartridge reference and service technician reference
The pixel counter function in this MFP has 2 references, the toner cartridge reference and the service technician reference.

Toner cartridge reference

This is a system that accumulates data between the installation of a new toner cartridge and the next installation.

The installation of a new toner cartridge is judged when the total number of the pixel count or pages output after the detection of toner cartridge empty has exceeded the threshold.

The threshold to be used is selectable in FS-08-6506 between the pixel count and pages output (0: Output pages, 1: Pixel counter). The threshold of pixel count is set in FS-08-6508 and that of pages output is set in FS-08-6507.

When a new toner cartridge is judged as installed, the data related with the previous cartridge is cleared and replaced with the data after the installation of the new cartridge.

Clearing of the counter of the toner cartridge reference is performed in FS-08-6503.

Service technician reference

This is a system that accumulates data between the service technician clearing the service technician reference counter and the subsequent clearing of the same counter. Clearing of the counter of the service technician reference is performed in FS-08-6502.

- Print count (number of output pages)
The number of pages output shown at the pixel counter is counted after all paper sizes have been converted to the standard paper size (A4/LT).
Printing on other than the standard size paper is converted by the paper area ratio.
The examples of conversion are as follows. The standard paper size is set in FS-08-6500.

E.g.:

When printing on A4/LT size: Counts the number of pages output as the print count

When printing on A3/LD size: Counts the number of pages output multiplied by 2 as the print count (Area ratio to A4/LT: 200%)

When printing on B4 size: Counts the number of pages output multiplied by 1.49 as the print count (Area ratio to A4: 149%)

When printing on LG size: Counts the number of pages output multiplied by 1.27 as the print count (Area ratio to LT: 127%)

- Pixel count (%)
The pixel count (%) shows the ratio of the emitting pixels of the writing light source to all pixels on standard-size paper.
The examples of pixel count are as follows.

Notes:

In the following examples, 'solid copy' is considered to be 100%. But since the image has 4 margins, it never actually becomes 100%.

E.g.:

Printing 5 pages on A4/LT size with solid copy (writing light source emit to all pixels)
Pixel count: 100%, Print count: 5

Printing 5 pages on A4/LT size with blank copy (writing light source never emit)
Pixel count: 0%, Print count: 5

Printing 2 pages on A4/LT size with solid copy (writing light source emit to all pixels), Printing 2 pages on A4/LT size with blank copy (writing light source never emit)
Pixel count: 50%, Print count: 4

Printing 3 pages on A4/LT size with 6% of writing light source emission, Printing 1 page on A4/LT size with 2% of writing light source emission
Pixel count: 5%, Print count: 4

Printing 2 pages on A3/LD size with solid copy (writing light source emit to all pixels)
Pixel count: 100%, Print count: 4

Printing 2 pages on A3/LD size with 6% of writing light source emission
Pixel count: 6%, Print count: 4

- Average pixel count (%) and latest pixel count (%)
There are 2 types of the value calculated as the pixel count: the average pixel count (%) and the latest pixel count (%).

Average pixel count (%)

The average value of all pixel count data after each reference data is cleared is calculated and displayed.

Latest pixel count (%)

The value is displayed for printing just before the pixel counter is confirmed.

- Type of calculated data
Since this MFP is multifunctional, the data of the pixel count are calculated for each function.

The following list is the information that can be confirmed by LCD screen. But actually, more information can be confirmed by FS-08.

📖 P. 14-14 “• Display in the FS-08 SETTING MODE”

Type of calculated data

| | Toner cartridge reference | Service technician reference |
|-------------------|---------------------------|------------------------------|
| Copying function | Yes | Yes |
| Printing function | Yes | Yes |
| Fax function | Yes | Yes |
| Total | Yes | Yes |

- Setting related with the pixel counter function

Standard paper size setting

The standard paper size (A4 or LT) to be converted into the pixel count is selected (FS-08-6500).

Pixel counter display setting

Whether or not to display the pixel counter on the LCD screen is selected (FS-08-6504).

Display reference setting

The reference when the pixel counter is displayed on the LCD screen (toner cartridge reference or service technician reference) is selected (FS-08-6505).

Toner empty determination counter

This is the counter to determine the replacement of a new toner cartridge after toner empty is detected.

After toner empty is detected by the auto-toner sensor, this counter checks whether it is detected one more time while the specified number of the pixel count or pages output is counted.

When toner empty detection fails, it can be presumed that a new toner cartridge has been installed.

Pixel counter clearing

There are 3 types for the pixel count clear as follows:

FS-08-6501: All information related to the pixel count is cleared.

FS-08-6502: All information related to the service technician reference pixel count is cleared.

FS-08-6503: All information related to the toner cartridge reference pixel count is cleared.

[4] Relationship between the pixel count and toner consumption

If a user prints out the image with large coverage or high density, this may cause the pixel count to have a large value. Moreover, the setting in which the toner consumption becomes high in the original mode or the density setting may cause it as well.

In this case, the replacement cycle of the toner cartridge is faster than for the standard number of pages output. Therefore, this trend needs to be understood as regards the service.

The relationship between the pixel count and the number of pages output per cartridge is as follows:

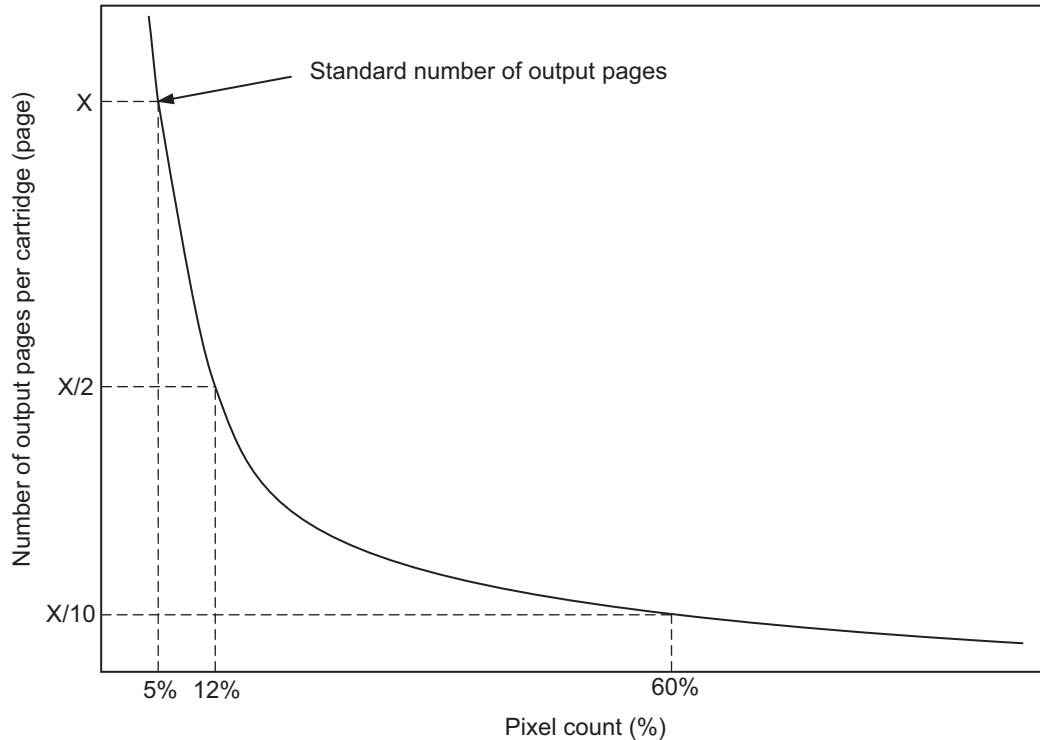

Fig.14-6 Pixel count and number of pages output per cartridge

[5] Pixel counter confirmation

- Display on the LCD screen

Whether or not to display the pixel counter on the LCD screen is selected (0: Displayed, 1: Not displayed) in the setting mode (FS-08-6504). In addition, whether or not to display it at the service technician reference or toner cartridge reference is selected (0: Service technician reference, 1: Toner cartridge reference) in FS-08-6505.

The following screen is displayed when the buttons, [Counter] and [Pixel Counter], are pressed in this order after "Displayed" is selected with the code above and the power is turned ON as usual. (The displayed buttons depend on the setting of FS-08-6505.)

The following screen is displayed when "1" (Toner cartridge reference) is selected for FS-08-6505.

| | Copy | Printer | Total |
|-------------------------|------|---------|-------|
| Print Count [LT/A4] | 0 | 352 | 352 |
| Average Pixel Count [%] | 0 | 1.96 | 1.96 |
| Latest Pixel Count [%] | 0 | 1.24 | 1.24 |

Fig.14-7 Information screen of toner cartridge reference

The following screen is displayed when "0" (Service technician reference) is selected for FS-08-6505.

| | Copy | Printer | Total |
|-------------------------|------|---------|-------|
| Print Count [LT/A4] | 0 | 352 | 352 |
| Average Pixel Count [%] | 0 | 2.40 | 2.40 |
| Latest Pixel Count [%] | 0 | 2.18 | 2.18 |

Fig.14-8 Information screen of service technician reference

- Data list printing
 The data for the pixel counter can be printed in FS-30 LIST PRINT MODE.
 FS-30-104: The data of the toner cartridge reference is printed.
 FS-30-105: The data of service technician reference is printed.

| PIXEL COUNTER CODE LIST | | S/N: Cxxxxxxx | FIN S/N: FIN S/N-xxxxxx | TOTAL : | 99999 | |
|-------------------------|------------|------------------------|-------------------------|------------|-------|-------|
| 20xx-xx-xx xx:xx | | TOSHIBA e-STUDIOxxxx | | DF TOTAL : | 99999 | |
| TONERCARTRIDGE | | | | | | |
| NO. | DATE | | PPC | PRN | FAX | TOTAL |
| 0 | 20xx-xx-xx | Print Count[LT/A4] | 181 | 45 | --- | 226 |
| 1 | 20xx-xx-xx | Average Pixel Count[%] | 2.70 | 1.74 | --- | 2.51 |
| 2 | 20xx-xx-xx | Latest Pixel Count[%] | 6.15 | 0.39 | --- | 0.39 |

Fig.14-9 Data list of toner cartridge reference

| PIXEL COUNTER CODE LIST | | S/N: Cxxxxxxx | FIN S/N: FIN S/N-xxxxxx | TOTAL : | 99999 | |
|-------------------------|------------|------------------------|-------------------------|------------|-------|-------|
| 20xx-xx-xx xx:xx | | TOSHIBA e-STUDIOxxxx | | DF TOTAL : | 99999 | |
| SERVICEMAN | | | | | | |
| NO. | DATE | | PPC | PRN | FAX | TOTAL |
| 0 | 20xx-xx-xx | Print Count[LT/A4] | 181 | 45 | --- | 226 |
| 1 | 20xx-xx-xx | Average Pixel Count[%] | 2.70 | 1.74 | --- | 2.51 |
| 2 | 20xx-xx-xx | Latest Pixel Count[%] | 6.15 | 0.39 | --- | 0.39 |

Fig.14-10 Data list of service technician reference

- Display in the FS-08 SETTING MODE
Information of the pixel count can be also checked in 08 SETTING MODE.

Print count, pixel count

Pixel count code table

| | | Toner cartridge reference | Service technician reference |
|-------------------|-------------------------|---------------------------|------------------------------|
| Copying function | Print count (page) | 6563 | 6558 |
| | Average pixel count (%) | 6623 | 6602 |
| | Latest pixel count (%) | 6724 | 6616 |
| Printing function | Print count (page) | 6565 | 6560 |
| | Average pixel count (%) | 6629 | 6603 |
| | Latest pixel count (%) | 6725 | 6617 |
| Fax function | Print count (page) | 6566 | 6561 |
| | Average pixel count (%) | 6635 | 6604 |
| | Latest pixel count (%) | 6644 | 6618 |
| Total | Average pixel count (%) | 6634 | 6605 |

Other information

Toner cartridge replacement counter

The toner cartridge replacement count is displayed.

FS-08-6576

Toner cartridge reference count started date

The toner cartridge reference count started date is displayed.

FS-08-6522

Service technician reference count cleared date

The service technician reference count cleared date is displayed.

The date when FS-08-6502 was performed is stored.

FS-08-6510

Toner cartridge reference count cleared date

The toner cartridge reference count cleared date is displayed.

The date when FS-08-6503 was performed is stored.

FS-08-6514

14.4 Notes for the installation of a card reader

- (1) The card reader to use in this equipment needs to satisfy all of the following conditions. However, the operation cannot be guaranteed even if all of these conditions are satisfied.
 1. Complying with the USB HID class and satisfying the following class codes
 - Class code: 0x03
 - Sub Class code: 0x00
 - Protocol code: 0x01
 2. An interface descriptor for the USB HID class needs to be single. (A card reader which consists of multiple HID classes, such as card reader and keyboard functions, cannot be used.)
 3. The USB VID/PID of the card reader has been registered in this equipment. For details about the registration of VID/PID, ask your service contact center.
- (2) When any problems concerning to a card reader have occurred, ask your service contact center to confirm whether the card reader satisfies the above conditions or not.

14.5 Usable USB storage device

The USB storage device for the maintenance operation of the MFP must meet the following conditions.

- A combination USB storage device with a flash memory (to be connected directly to the USB port).
- The capacity is 1 GB or more. A USB storage device with 2 GB or more is recommended.
- A USB storage device compliant with the following specifications established by USB-IF (USB Implementers Forum).
 - Class number: 8 (=08h) (Mass-storage class)
 - Sub-class number: 6 (=06h) (SCSI transfer command set)
 - Protocol number: 80 (=50h) (Bulk-only)
- A USB storage device compliant with USB2.0.
- When a USB storage device compliant with USB 3.0 is used, the MFP will be operated equivalent to USB 2.0 (HighSpeed(480Mbps)).
- The USB format type should be FAT32 or exFAT.
- A USB storage device formatted with exFAT can only be used at the time of the HS mode only.
- When a file whose size is 2 GB or larger is saved in a USB storage device, the USB format type should be exFAT.

Remarks:

A USB storage device which has been confirmed in advance to be operable in the MFP should be used.

14.6 License

14.6.1 Types and categories

There are following types and categories in the licenses.

| Type | Description | Category | Description |
|--------|---|------------|--|
| Node | This can be used only for one unit of the equipment. | Indefinite | There is no limitation in the use term. |
| | | Term | The functions can be used for a certain period of time. The time when the license has been activated becomes the start date. |
| | | Trial | The functions are activated temporarily for the trial use before purchasing the applications with the trial license. |
| Subnet | This can be used in multiple units of the equipment whose 1st to 3rd octets of the IP address are the same. | - | - |
| Domain | This can be used in multiple units of the equipment with the same domain. | - | - |

14.6.2 How to activate the license

The activation method and the operation procedure differ depending on the network environment of the equipment and the license type. Be sure to perform the operation properly in accordance with these.

| Activation method | Necessary information | Remarks |
|-------------------|---------------------------|-------------|
| [Online] | License authentication ID | * Text file |
| [Offline] | License file | zip file |

* A multiple number of license authentication IDs can be contained in one text file.

[1] [Online]

When the equipment can make an outside communication via a network, the license can be activated by selecting [Online].

Necessary information: License authentication ID

Be sure to store license authentication IDs with a text format in a USB storage device.

Remarks:

- Apply an arbitrary name to the file.
- Store the file in the root of a USB storage device.
- When a multiple number of license authentication IDs is stored in one text file, insert line feeds for each ID.

(1) In order to activate the license by [Online], perform the following network settings.

| Code | Content |
|---------------|---|
| FS-08-3634 *1 | License server URL setting |
| FS-08-8693 *2 | IP address of the license activation proxy server |
| FS-08-8694 *2 | Port number of the license activation proxy server |
| FS-08-8695 *2 | Login user name to connect to the license activation proxy server |
| FS-08-8696 *2 | Password to connect to the license activation proxy server |

*1 Obtain this information from the license provider. Use the default URL in principle.

*2 Obtain this information from the user or the network administrator.

(2) Press [Activate] on the License Management screen. The License Activation screen appears.

(3) Press [Online] on the License Activation screen.

- (4) Press [USB]. Insert a USB storage device with license authentication ID files stored into the equipment.

Remarks:

If license authentication IDs are entered by using a keyboard, press the text box without inserting a USB storage device. After the license authentication ID is entered, press [OK] and go to step (10).

- (5) Press [OK]. The Select a file screen appears and all the license authentication ID files in the USB storage device are displayed.
- (6) Select the license authentication ID file in which the license authentication ID to be activated is included. Press [OK].
- (7) The Select a License Certificate Number screen appears. All the license authentication IDs included in the selected file are displayed.
- (8) Select the license authentication ID to be activated and press [Set].
- (9) Confirm that the correct license authentication ID is entered in the text box and press [OK].
- (10) The confirmation screen appears. Press [Yes].
- (11) The screen indicating under processing appears. After a few minutes have passed, the confirmation screen indicating the success of the authentication appears. Press [OK].
- (12) Confirm that the activated license is displayed in the License Management screen.

[2] [Offline]

When the equipment cannot make an outside communication via a network, the license can be activated by selecting [Offline].

Necessary information: In case of the license file: "LIC_xxxx_yyyy.zip"

xxxx: A different value appears depending on the license.

yyyy: Serial No. of the equipment

Remarks:

- Store the license file in the root of a USB storage device.
 - Activation can be carried out only in the equipment with the same serial No. as that for the license file.
 - Check that the date and time of the equipment is correct.
 - The subnet license can be activated only in equipment in which a network connection has been made by means of the specified IP address. - The domain license can be activated only in the equipment to which a connection to the specified domain has been made.
- (1) Press [Activate] on the License Management screen. The License Activation screen appears.
 - (2) Press [Offline] on the License Activation screen.
 - (3) Insert a USB storage device with the license authentication ID files stored into the equipment.
 - (4) Press [OK]. The Select a file screen appears and all the license files in the USB storage device are displayed.
 - (5) Select the license file in which the license to be activated is included. Press [OK].
 - (6) The confirmation screen appears. Press [Yes].
 - (7) The confirmation screen indicating the success of the processing appears. Press [OK].

- (8) Confirm that the activated license is displayed in the License Management screen.

[3] Activation of the Subnet License and the Domain License in the 2nd or Later Unit of the Equipment

For the subnet license and the domain license, it is required to activate the license in several units of the equipment. The equipment in which the license has been activated by means of the license authentication ID or the license file will be the host unit. By using an export license file exported from this host unit, activate the license of other units of the equipment in which required conditions are satisfied.

- (1) On the License Management screen of the host unit, press [Details] of the license file to be exported.
- (2) Press [Export] in the License Details screen.

Remarks:

- [Export] is displayed on the screen only for the Subnet license and the Domain license.
- In case of the export license file: "LIC_xxxx_Export.zip"
xxxx: A different value appears depending on the license.

- (3) Insert a USB storage device to store the license file into the equipment and press [OK].
- (4) The confirmation screen appears. Press [Yes].
- (5) The confirmation screen indicating the success of the processing appears. Press [OK] and remove the USB storage device.
- (6) Insert the USB storage device with the export license file stored into another unit of the equipment in which the required conditions are satisfied. Activate the license.

Remarks:

- The export license file can be used in several units of the equipment.
- The activation procedure is the same as that for [Offline].

[4] Activation after Replacing or Formatting the Standard Storage Device

After the standard storage device has been replaced or formatted, the licenses will go into an incomplete status.

In such a case, after replacing or formatting the standard storage device, it is necessary to restore the backup data with the latest status, including all the activated licenses.

Normal

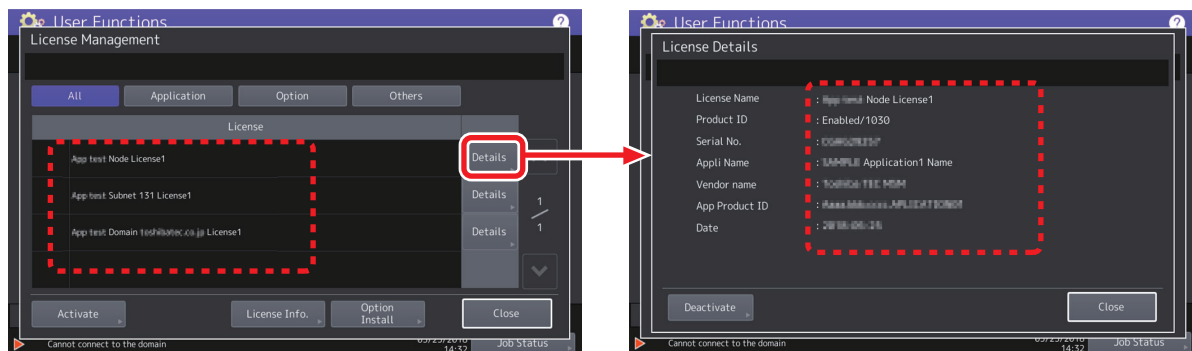

Fig.14-11

After the standard storage device replaced

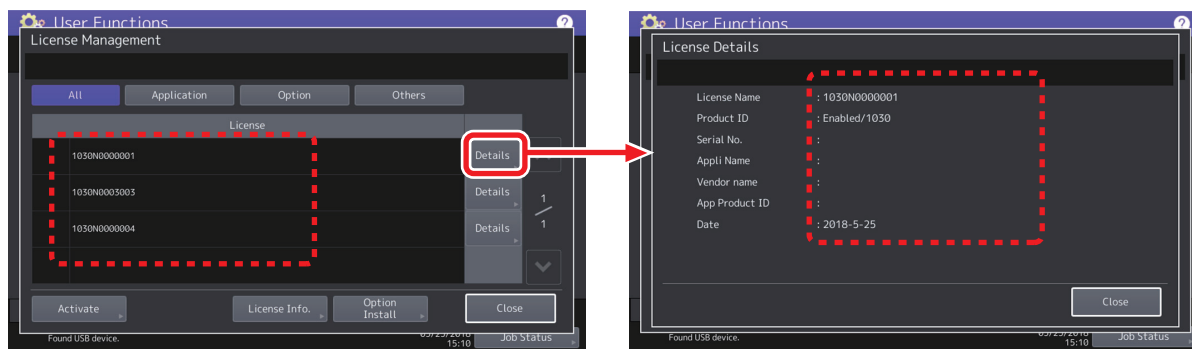

Fig.14-12

- Restore the latest backup data including all the activated licenses.
- If there are no backup data as above, reactivate all the licenses which have been activated in this equipment.
P. 14-17 “14.6.2 How to activate the license”
- If the functions have been activated by the export license file, import the license exported from the host unit of the equipment.
P. 14-19 “[3] Activation of the Subnet License and the Domain License in the 2nd or Later Unit of the Equipment”

Remarks:

- Applications with the trial license cannot be recovered from the backup data. If necessary, reinstall the applications.
- The out-of-order period caused by the breakage of the equipment is included in the day count for the term license.

14.6.3 How to deactivate the license

A license whose type is the indefinite node license can be deactivated. The deactivation method and the operation procedure differ depending on the network environment of the equipment. Be sure to perform the operation properly in accordance with this.

- (1) Press [Details] of the license to be deleted on the License Management screen.
- (2) Press [Deactivate] on the License Details screen.
- (3) Press [Online] or [Offline].

Remarks:

- For the equipment which can make an outside communication, press [Online] to deactivate the license.
- When the license is deactivated by means of the use of [Offline], send a disable certificate file (*) of the license to the license provider.
- * A file stored in a USB storage device when the license is deactivated.
“LIC_Deact_xxxx_yyyy.zip”
xxxx: A different value appears depending on the license.
yyyy: Serial No. of the equipment

- (4) The confirmation screen appears. Press [Yes].
- (5) Press [Details] of the license file which has been deactivated on the License Management screen. The License Details screen appears. Check that “Disabled” is indicated in Product ID.

14.6.4 How to delete the license

Licenses whose type are the subnet license and the domain license can be deleted. However, do not perform the deletion of these licenses in principle. If the deletion of the licenses is required for some reason, do so not only in the host unit but also in all other units in which the licenses have been activated by means of an export license file.

REVISION RECORD

Ver00e

| Ver00e <2024/04/23> | |
|------------------------|-------------------------------------|
| Page | Contents |
| 9-5 | Added GSA models for North America. |
| 5-21 | Removed E013 reference in Fig. 5-22 |
| 6-8 | Modified note |

Ver02d

| Ver02d <2024/03/15> | |
|---------------------|--|
| Page | Contents |
| 8-253 | Added content: F109_8, F109_9, F109_10 |
| 8-253a | Added content: F109_11 |
| 8-253b | Added content: F109_12 |
| 9-27 to 9-50 | Modified content in section 9.2 |
| 14-16 | Added section 14.6 License |

Ver00c

| Ver00c <2023/10/04> | |
|---------------------|---|
| Page | Contents |
| 8-183 | Modified C252 and C253 error troubleshooting |
| 8-67, 8-68 | Corrected information in Section 8.2.11 Error History |
| 7-45 | Added content to Section 7.9 PM Kit |

Ver00b

| Ver00b <2023/06/22> | |
|---------------------|--|
| Page | Contents |
| 8-279 | Added Remark to F200 Error Troubleshooting |
| 9-27 | Added item to 9.2.1 Precautions when replacing PC boards |
| 12-14 to 12-16 | Added content to 12.5 High Security Mode |

Ver00a

| Ver00a <2023/5/12> | |
|--------------------|----------------------------------|
| Page | Contents |
| 7-38 | Added Item #7 |
| 8-248a | Added F107 error troubleshooting |

Ver00

| Ver00 <2022/11/22> | |
|--------------------|-----------------|
| Page | Contents |
| | Initial release |

TOSHIBA

Toshiba Tec Corporation

1-11-1, OSAKI, SHINAGAWA-KU, TOKYO, 141-8562, JAPAN