

# SERVICE MANUAL

MULTIFUNCTIONAL DIGITAL COLOR SYSTEMS  
**e-STUDIO5530C PRO**  
**e-STUDIO7030C PRO**



© 2008, 2009 TOSHIBA TEC CORPORATION All rights reserved

Under the copyright laws, this manual cannot be reproduced in any form without prior written permission of TOSHIBA TEC CORPORATION. No patent liability is assumed, however, with respect to the use of the information contained herein.



## **Model TRC-2 a/b (e-STUDIO5530C PRO/7030C PRO)**

**Machine Code: D014/D015**

### **SERVICE MANUAL**

Read This First .....	10
Safety, Conventions, Trademarks .....	10
Conventions.....	10
Warnings, Cautions, Notes .....	11
Commonly Used Terms .....	11
General Safety Instructions .....	12
Responsibilities of the Customer Engineer .....	13
Before Installation, Maintenance .....	13
During Maintenance .....	15
After Installation, Servicing .....	17
Special Safety Instructions for Toner .....	18
Safety Instructions for this Machine .....	19
New Features of D014/D015.....	21
Responses to Requests for Improvement.....	21
Image Quality Improvement.....	29
Comparison of Changes in Basic Operation.....	32
System Configuration and New Options .....	33
More Details About Design Changes .....	38
Small Changes .....	52
Notes About Servicing .....	53
Detailed Summary of Changes.....	56

Installation.....	59
Installation Requirements.....	59
Operating Environment.....	59
Machine Level .....	60
Minimum Space Requirements.....	61
Dimensions.....	61
Power Requirements .....	62
Copier and Peripherals .....	64
System Configuration 1 .....	64
System Configuration 2 .....	65
MFP Options (Listed Alphabetically).....	66
Copier D014/D015 .....	68
Accessories .....	68
Installation .....	69
Copy Tray (B756).....	90
Accessories .....	90
Installation .....	91
A3/11" X 17" Paper Size Tray (B331).....	93
Accessories .....	93
Installation .....	93
LCT (B473), LCT Adapter (B699).....	96
Accessories .....	96
Installation .....	97
LG Unit for A4/LT LCT (B474) .....	105
Accessories .....	105
Installation .....	105
LCIT RT4000 (D350).....	109
Accessories .....	109
LCT Installation.....	110
Anti-Condensation Heater Type B: 120V .....	115
Anti-Condensation Heater Type B: 240V .....	117
2000/3000 Sheet Finishers (D373/D374).....	120
Accessories .....	120
Installation .....	121
Punch Unit (B702).....	130
Accessories .....	130

Installation .....	131
Output Jogger Unit (B703) .....	135
Accessories .....	135
Installation .....	135
Mail Box (B762).....	138
Accessories .....	138
Installation .....	138
3000-Sheet Finisher (B830), Finisher Adapter (D375) .....	141
Accessories .....	141
Finisher Adapter Kit D375 Installation.....	143
Finisher Installation.....	146
Updating the Firmware .....	151
SP Setting.....	152
Punch Unit B831 .....	153
Accessories .....	153
Installation .....	154
Cover Interposer Tray (B704).....	158
Accessories .....	158
Installation .....	159
Cover Interposer Tray CI5000 (B835) .....	165
Accessories .....	165
Installation .....	166
Docking the Cover Interposer Tray B835.....	173
Z-Folding Unit ZF4000 (B660).....	175
Accessory Check.....	175
Installation .....	176
MFP Controller Options.....	184
Overview.....	184
Enabling USB .....	185
Accessory Cards .....	186
SD Card Applications.....	187
Handling DIMMs and SD Cards.....	187
Moving Applications to One SD Card .....	189
Printer/Scanner GM-2190 (D376) and Interface Unit.....	192
Postscript3 D378 .....	194
Data Overwrite Security Unit Type H D377.....	194

Copier Connection Kit B328 .....	198
Preventive Maintenance .....	201
Overview .....	201
Required Materials .....	201
PM Counter .....	203
Displaying the PM Counter .....	203
PM Parts Screen Details .....	204
PM Tables .....	207
Main Machine .....	207
LCT B473 .....	214
LCT D350 .....	215
2000/3000-Sheet Finishers D373/D374 .....	215
Punch B702 .....	216
Cover Interposer Tray B704 .....	216
Z-Folding Unit B660 .....	217
3000-Sheet Finisher B830 .....	217
Punch B831 .....	218
Cover Interposer Tray B835 .....	218
Lubrication Points .....	219
Copier .....	219
Replacement and Adjustment .....	222
General Cautions .....	222
Drum .....	222
PCU .....	222
Transfer Belt Unit .....	223
Scanner Unit .....	223
Laser Unit .....	224
Development .....	224
Cleaning .....	225
Fusing Unit .....	225
Paper Feed .....	225
Used Toner .....	225
Common Procedures .....	226
ARDF .....	226
Operation Panel, Top Covers .....	227
Left Covers .....	227

Front Door .....	228
Right Covers.....	229
Rear Covers .....	230
Toner Hopper, Faceplate, PCU.....	230
Image Transfer Unit .....	236
Drawer Unit.....	237
Duplex Unit.....	239
Opening, Locking the Controller Box Cover.....	239
SD Card Storage .....	240
Laser Unit.....	242
Caution Decals .....	242
Polygon Motor .....	242
Laser Unit .....	244
SP Adjustments After Laser Unit Replacement.....	246
Laser Synchronization Detector.....	248
PCU .....	249
Charge Units.....	249
Separating Drum/Cleaning Unit, Removing the OPC Drum.....	251
PCU Blades and Rollers .....	253
Developer Replacement .....	258
New PCU.....	270
SP Codes After Replacements .....	272
PTR Unit.....	275
Relay Sensor .....	275
Double-Feed Detection Photosensor, Registration Sensor.....	275
PTR Unit.....	276
Paper Transfer Roller, Discharge Plate .....	278
Lubricant Bar .....	278
Cleaning Blade .....	279
Cleaning Brush Roller.....	280
Paper Transport Belt, Paper Separation Power Pack.....	280
Registration Motor .....	282
Double-Feed Detection LED.....	282
Image Transfer Unit.....	284
Emptying the Dust Collection Unit .....	284
Separating the Belt Unit and Belt Cleaning Unit .....	284

Reassembling the Belt Unit and Belt Cleaning Unit .....	286
ITB Cleaning Unit .....	289
MUSIC and ID Sensors .....	294
Image Transfer Power Pack .....	295
Belt Position Sensor .....	296
Fusing Unit .....	297
Removing the Fusing Unit .....	297
Fusing Cleaning Unit .....	298
Fusing Lamps, Dividing the Fusing Unit .....	301
Fusing Unit Rollers, Fusing Belt .....	304
Important Warning about Thermostats .....	309
Boards .....	310
PCB Layout .....	310
Controller .....	313
IPU/VBCU .....	314
HDD .....	316
PFB .....	319
HVPS .....	319
Charge Roller Power Pack .....	320
Potential Sensor Power Pack .....	320
DRB .....	321
DTMB .....	322
PSU .....	322
AC Drive Board .....	323
Memory .....	324
NVRAM .....	324
Motors .....	327
Drum Cleaning Motors .....	327
Development Motors .....	328
Drum Motor .....	328
Fusing/Exit Motor .....	330
PTR Motor .....	330
ITB Drive Motor .....	331
Air Filters and Ozone Filters .....	334
Upper Filter Box .....	335
Middle Filter Box .....	335



Lower Filter Box.....	336
Firmware Update.....	338
Before You Begin... ..	338
Firmware Update Procedure.....	338
Troubleshooting .....	341
Service Call Conditions .....	341
Service Call Table.....	341
SC Code Descriptions .....	342
Service Call Tables.....	343
SC Codes Group 1: Scanning .....	343
SC Codes Group 3: Image Development – 1 .....	354
SC Codes Group 4: Image Development - 2 .....	360
SC codes Group 5: Paper Feed .....	369
SC Codes Group 6: Device Communication.....	381
SC Codes Group 7: Peripherals .....	383
SC800: Overall System .....	400
SC900: Miscellaneous.....	407
Additional SC Codes Printed in SMC Reports .....	410
Service Tables .....	413
Service Program Mode .....	413
Group 1000 .....	414
Group 2000 .....	432
Group 3000 .....	496
Group 4000 .....	532
Group 5000 .....	550
Group 6000 .....	629
Group 7000 .....	661
Group 8000 .....	692
Details.....	741
General Overview .....	741
Main Machine .....	741
Laser Unit.....	743
Dual Beam Writing.....	743
LD Safety Switches .....	743
Boards.....	745
Overview of Important Components .....	745

IPU .....	746
Copy Process Overview .....	749
Raising and Lowering of the ITB Unit .....	749
The Copy Process .....	750
Scanner Unit .....	753
Overview .....	753
Original Size Detection .....	754
Scanner Unit Fan and Anti-Condensation Heater .....	756
Photoconductor Units (PCU) .....	757
Overview .....	757
Around The Drum .....	758
Drum Drive .....	759
Drum Charge .....	759
Drum Cleaning and Lubrication .....	761
PCU Ventilation .....	762
Development Unit .....	762
Used Toner Collection .....	766
Used Toner Path .....	766
Excess Toner Collection Coils .....	768
Process Control .....	769
Overview of Process Control .....	769
Components Used During Process Control .....	769
List of Process Control Acronyms .....	772
Important SP Codes Related to Process Control .....	773
Potential Control .....	774
MUSIC (Mirror Unit for Skew and Interval Correction) .....	781
Toner Supply Control .....	788
Image Transfer .....	791
Image Transfer Overview .....	791
ITB Drive .....	794
ITB Lift .....	795
Transfer Power Pack .....	796
ITB Cleaning .....	797
ITB Speed Control .....	798
ITB Ventilation .....	799
Paper Transfer .....	800

Fusing Unit.....	805
Overview.....	805
Thermistors, Thermostats.....	809
Fusing Unit Drive.....	810
Strippers.....	811
Fusing Belt Lubrication and Cleaning.....	811
Fusing Temperature Control.....	812
Fusing Unit Ventilation.....	813
Pressure Roller Lift Mechanism.....	814
Specifications.....	815
Specifications.....	815
Main Frame D014/D015.....	815
Optional Peripherals.....	821
Machine Configuration.....	835
Electrical Components.....	838

# Read This First







---

## Safety, Conventions, Trademarks

---

### Conventions

---

Symbol	What it means
	Core Tech Manual
	Screw
	Connector
	E-ring
	C-ring
	Harness clamp
FFC	Flexible Film Cable

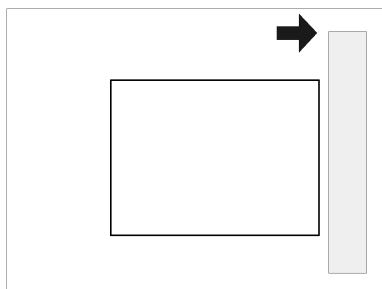

**SEF (Short Edge Feed)**

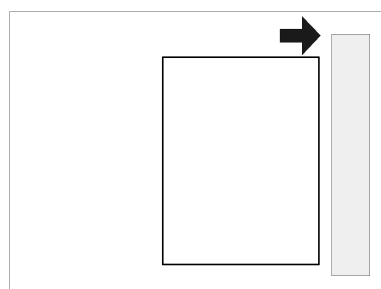

**LEF (Long Edge Feed)**

The notations "SEF" and "LEF" describe the direction of paper feed. The arrows indicate the direction of paper feed.

## Read This First

---

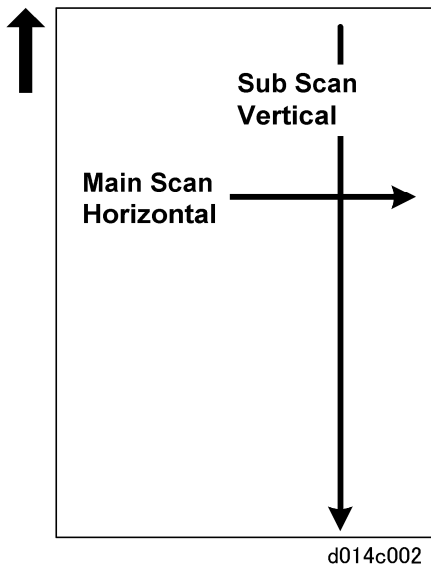

In this manual "Horizontal" means the "Main Scan Direction" and "Vertical" means the "Sub Scan Direction" relative to the paper feed direction.

---

## Warnings, Cautions, Notes

---

In this manual, the following important symbols and notations are used.

### **WARNING**

- A Warning indicates a potentially hazardous situation. Failure to obey a Warning could result in death or serious injury.

### **CAUTION**

- A Caution indicates a potentially hazardous situation. Failure to obey a Caution could result in minor or moderate injury or damage to the machine or other property.

### **Important**

- **Obey these guidelines to avoid problems such as misfeeds, damage to originals, loss of valuable data and to prevent damage to the machine**

### **Note**

- This information provides tips and advice about how to best service the machine.

---

## Commonly Used Terms

---

In the SP tables, the finishers are referred to by number (1, 2, 3), and some devices that appear in the SP tables are not supported overseas:

## Read This First

---

Finisher 1	3000/2000-Sheet Finisher B700/B701. The B700 supports corner stapling, booklet stapling and booklet folding. The B701 supports corner stapling only.
Finisher 2	3000-Sheet Finisher B706.
Finisher 3	3000-Sheet Finisher B468/B469. This finisher is not supported by models overseas. However, the SP codes for this peripheral device appear in the firmware of this machine. Please ignore references to "Finisher 3" or "Fin 3".
Z-Fold	This refers to the Z-Folding unit. The copier does not support this peripheral device at this time. Please ignore references to "Z-Fold" in the SP tables.
ITB	Image Transfer Belt
PTR	Paper Transfer Roller

---

## General Safety Instructions

---

For your safety, please read this manual carefully before you use this product. Keep this manual handy for future reference.

### **Safety Information**

Always obey the following safety precautions when using this product.

### **Safety During Operation**

In this manual, the following important symbols and notations are used.

### **Switches and Symbols**

Where symbols are used on or near switches on machines for Europe and other areas, the meaning of each symbol conforms with IEC60417.

## Read This First

---



**ON**

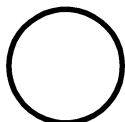

**OFF**



**Push ON/Push OFF**

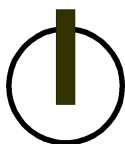

**Standby**

d014c002

---

## Responsibilities of the Customer Engineer

---

### Customer Engineer

---

Maintenance shall be done only by trained customer engineers who have completed service training for the machine and all optional devices designed for use with the machine.

### Reference Material for Maintenance

---

- Maintenance shall be done using the special tools and procedures prescribed for maintenance of the machine described in the reference materials (service manuals, technical bulletins, operating instructions, and safety guidelines for customer engineers).
- Use only consumable supplies and replacement parts designed for use of the machine.

---

## Before Installation, Maintenance

---

### Shipping and Moving the Machine

---

#### **CAUTION**

- Work carefully when lifting or moving the machine. If the machine is heavy, two or more customer engineers may be required to prevent injuries (muscle strains, spinal injuries, etc.) or damage to the machine if it is dropped or tipped over.
- Personnel moving or working around the machine should always wear proper clothing and footwear. Never wear loose fitting clothing or accessories (neckties, loose sweaters, bracelets, etc. ) or casual footwear (slippers, sandals, etc.) when

## Read This First

---

lifting or moving the machine.

- Always unplug the power cord from the power source before you move the product. Before you move the product, arrange the power cord so it will not fall under the product.

## Power

---

### **WARNING**

- Always disconnect the power plug before doing any maintenance procedure. After switching off the machine, power is still supplied to the main machine and other devices. To prevent electrical shock, switch the machine off, wait for a few seconds, then unplug the machine from the power source.
- Before you do any checks or adjustments after turning the machine off, work carefully to avoid injury. After removing covers or opening the machine to do checks or adjustments, never touch electrical components or moving parts (gears, timing belts, etc.).
- After turning the machine on with any cover removed, keep your hands away from electrical components and moving parts. Never touch the cover of the fusing unit, gears, timing belts, etc.

## Installation, Disassembly, and Adjustments

---

### **CAUTION**

- After installation, maintenance, or adjustment, always check the operation of the machine to make sure that it is operating normally. This ensures that all shipping materials, protective materials, wires and tags, metal brackets, etc., removed for installation, have been removed and that no tools remain inside the machine. This also ensures that all release interlock switches have been restored to normal operation.
- Never use your fingers to check moving parts causing spurious noise. Never use your fingers to lubricate moving parts while the machine is operating.

## Special Tools

---

### **CAUTION**

- Use only standard tools approved for machine maintenance.
- For special adjustments, use only the special tools and lubricants described in the service manual. Using tools incorrectly, or using tools that could damage parts, could damage the machine or cause injuries.



## During Maintenance

---

### General

---

#### **CAUTION**

- Before you begin a maintenance procedure: 1) Switch the machine off, 2) Disconnect the power plug from the power source, 3) Allow the machine to cool for at least 10 minutes.
- Avoid touching the components inside the machine that are labeled as hot surfaces.

### Safety Devices

---

#### **WARNING**

- Never remove any safety device unless it requires replacement. Always replace safety devices immediately.
- Never do any procedure that defeats the function of any safety device. Modification or removal of a safety device (fuse, switch, etc.) could lead to a fire and personal injury. Always test the operation of the machine to ensure that it is operating normally and safely after removal and replacement of any safety device.
- For replacements use only the correct fuses or circuit breakers rated for use with the machine. Using replacement devices not designed for use with the machine could lead to a fire and personal injuries.

### Organic Cleaners

---

#### **CAUTION**

- During preventive maintenance, never use any organic cleaners (alcohol, etc.) other than those described in the service manual.
- Make sure the room is well ventilated before using any organic cleaner. Use organic solvents in small amounts to avoid breathing the fumes and becoming nauseous.
- Switch the machine off, unplug it, and allow it to cool before doing preventive maintenance. To avoid fire or explosion, never use an organic cleaner near any part that generates heat.
- Wash your hands thoroughly after cleaning parts with an organic cleaner to contamination of food, drinks, etc. which could cause illness.
- Clean the floor completely after accidental spillage of silicone oil or other materials to prevent slippery surfaces that could cause accidents leading to hand or leg injuries. Use "My Ace" Silicone Oil Remover (or dry rags) to soak up spills. For more details, please refer to Technical Bulletin "Silicone Oil Removal" (A024-50).

## Read This First

---

### Lithium Batteries

---

#### **WARNING**

- Always replace a lithium battery on a PCB with the same type of battery prescribed for use on that board. Replacing a lithium battery with any type other than the one prescribed for use on the board could lead to an explosion or damage to the PCB.
- Never discard used batteries by mixing them with other trash. Remove them from the work site and dispose of them in accordance with local laws and regulations regarding the disposal of such items.

### Ozone Filters

---

#### **CAUTION**

- Always replace ozone filters as soon as their service life expires (as described in the service manual).
- An excessive amount of ozone can build up around machines that use ozone filters if they are not replaced at the prescribed time. Excessive ozone could cause personnel working around the machine to feel unwell.

### Power Plug and Power Cord

---

#### **WARNING**

- Before serving the machine (especially when responding to a service call), always make sure that the power plug has been inserted completely into the power source. A partially inserted plug could lead to heat generation (due to a power surge caused by high resistance) and cause a fire or other problems.
- Always check the power plug and make sure that it is free of dust and lint. Clean it if necessary. A dirty plug can generate heat which could cause a fire.
- Inspect the length of the power cord for cuts or other damage. Replace the power cord if necessary. A frayed or otherwise damaged power cord can cause a short circuit which could lead to a fire or personal injury from electrical shock.
- Check the length of the power cord between the machine and power supply. Make sure the power cord is not coiled or wrapped around any object such as a table leg. Coiling the power cord can cause excessive heat to build up and could cause a fire.
- Make sure that the area around the power source is free of obstacles so the power cord can be removed quickly in case of an emergency.
- Make sure that the power cord is grounded (earthed) at the power source with the ground wire on the plug.

## Read This First

---

- Connect the power cord directly into the power source. Never use an extension cord.
- When you disconnect the power plug from the power source, always pull on the plug, not the cable.

---

## After Installation, Servicing

---

### Disposal of Used Items

---

#### **WARNING**

- Never incinerate used toner or toner cartridges.
- Toner or toner cartridges thrown into a fire can ignite or explode and cause serious injury. At the work site always carefully wrap used toner and toner cartridges with plastic bags to avoid spillage before disposal or removal.

#### **CAUTION**

- Always dispose of used items (developer, toner, toner cartridges, OPC drums, etc.) in accordance with the local laws and regulations regarding the disposal of such items.
- To protect the environment, never dispose of this product or any kind of waste from consumables at a household waste collection point. Dispose of these items at one of our dealers or at an authorized collection site.
- Return used selenium drums to the service center for handling in accordance with company policy regarding the recycling or disposal of such items.

### Points to Confirm with Operators

---

At the end of installation or a service call, instruct the user about use of the machine.

Emphasize the following points.

- Show operators how to remove jammed paper and troubleshoot other minor problems by following the procedures described in the operating instructions.
- Point out the parts inside the machine that they should never touch or attempt to remove.
- Confirm that operators know how to store and dispose of consumables.
- Make sure that all operators have access to an operating instruction manual for the machine.
- Confirm that operators have read and understand all the safety instructions described in the operating instructions.
- Demonstrate how to turn off the power and disconnect the power plug (by pulling the

## Read This First

---

plug, not the cord) if any of the following events occur: 1) something has spilled into the product, 2) service or repair of the product is necessary, 3) the product cover has been damaged.

- Caution operators about removing paper fasteners around the machine. They should never allow paper clips, staples, or any other small metallic objects to fall into the machine.

---

## Special Safety Instructions for Toner

---

### Accidental Physical Exposure

---

#### **CAUTION**

- Work carefully when removing paper jams or replacing toner bottles or cartridges to avoid spilling toner on clothing or the hands.
- If toner is inhaled, immediately gargle with large amounts of cold water and move to a well ventilated location. If there are signs of irritation or other problems, seek medical attention.
- If toner gets on the skin, wash immediately with soap and cold running water.
- If toner gets into the eyes, flush the eyes with cold running water or eye wash. If there are signs of irritation or other problems, seek medical attention.
- If toner is swallowed, drink a large amount of cold water to dilute the ingested toner. If there are signs of any problem, seek medical attention.
- If toner spills on clothing, wash the affected area immediately with soap and cold water. Never use hot water! Hot water can cause toner to set and permanently stain fabric.

### Handling and Storing Toner

---

#### **WARNING**

- Toner, used toner, and developer are extremely flammable.
- Never store toner, developer, toner cartridges, or toner bottles (including empty toner bottles or cartridges) in a location where they will be exposed to high temperature or an open flame.

#### **CAUTION**

- Always store toner and developer supplies such as toner and developer packages, cartridges, and bottles (including used toner and empty bottles and cartridges) out of the reach of children.
- Always store fresh toner supplies or empty bottles or cartridges in a cool, dry

## Read This First

---

location that is not exposed to direct sunlight.

## Toner Disposal

---

### **WARNING**

- Never attempt to incinerate toner, used toner, or empty toner containers (bottles or cartridges). Burning toner can explode and scatter, causing serious burns.
- Always wrap used toner and empty toner bottles and cartridges in plastic bags to avoid spillage. Follow the local laws and regulations regarding the disposal of such items.
- Dispose of used toner and toner cartridges at one of our dealers or at an authorized collection site. Always dispose of used toner cartridges and toner bottles in accordance with the local laws and regulations regarding the disposal of such items.

---

## Safety Instructions for this Machine

---

### Prevention of Physical Injury

---

1. Before disassembling or assembling parts of the machine and peripherals, make sure that the machine and peripheral power cords are unplugged.
2. The plug should be near the machine and easily accessible.
3. Note that some components of the machine and the paper tray unit are supplied with electrical voltage even if the main power switch is turned off.
4. If any adjustment or operation check has to be made with exterior covers off or open while the main switch is turned on, keep hands away from electrified or mechanically driven components.
5. If the [Start] key is pressed before the machine completes the warm-up period (the [Start] key starts blinking red and green ), keep hands away from the mechanical and the electrical components as the machine starts making copies as soon as the warm-up period is completed.
6. The inside and the metal parts of the fusing unit become extremely hot while the machine is operating. Be careful to avoid touching those components with your bare hands.
7. To prevent a fire or explosion, keep the machine away from flammable liquids, gases, and aerosols.

## Read This First

---

### Health Safety Conditions

---

1. Never operate the machine without the ozone filters installed.
2. Always replace the ozone filters with the specified types at the proper intervals.
3. Toner and developer are non-toxic, but if you get either of them in your eyes by accident, it may cause temporary eye discomfort. Try to remove with eye drops or flush with water as first aid. If unsuccessful, get medical attention.

### Observance of Electrical Safety Standards

---

1. The machine and its peripherals must be installed and maintained by a customer service representative who has completed the training course on those models.
2. The NVRAM on the system control board has a lithium battery which can explode if replaced incorrectly. Replace the NVRAM only with an identical one. The manufacturer recommends replacing the entire NVRAM. Do not recharge or burn this battery. Used NVRAM must be handled in accordance with local regulations.

### Safety and Ecological Notes for Disposal

---

1. Do not incinerate toner bottles or used toner. Toner dust may ignite suddenly when exposed to an open flame.
2. Dispose of used toner, developer, and organic photoconductors in accordance with local regulations. (These are non-toxic supplies.)
3. Dispose of replaced parts in accordance with local regulations.
4. When keeping used lithium batteries in order to dispose of them later, do not put more than 100 batteries per sealed box. Storing larger numbers or not sealing them apart may lead to chemical reactions and heat build-up.

#### **CAUTION**

- The danger of explosion exists if a battery of this type is incorrectly replaced.
- Replace only with the same or an equivalent type recommended by the manufacturer. Discard used batteries in accordance with the manufacturer's instructions.

### LASER SAFETY

---

The Center for Devices and Radiological Health (CDRH) prohibits the repair of laser-based optical units in the field. The optical housing unit can only be repaired in a factory or at a location with the requisite equipment. The laser subsystem is replaceable in the field by a qualified Customer Engineer. The laser chassis is not repairable in the field. Customer

## Read This First

---

engineers are therefore directed to return all chassis and laser subsystems to the factory or service depot when replacement of the optical subsystem is required.

### **WARNING**

- Use of controls, or adjustment, or performance of procedures other than those specified in this manual may result in hazardous radiation exposure.
- Turn off the main switch before attempting any of the procedures in the Laser Unit section. Laser beams can seriously damage your eyes.

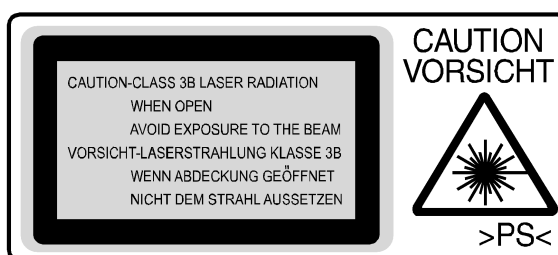

d014c-004

## Trademarks

---

- Microsoft<sup>®</sup>, Windows<sup>®</sup>, and MS-DOS<sup>®</sup> are registered trademarks of Microsoft Corporation in the United States and /or other countries.
- PostScript<sup>®</sup> is a registered trademark of Adobe Systems, Incorporated.
- PCL<sup>®</sup> is a registered trademark of Hewlett-Packard Company.
- Ethernet<sup>®</sup> is a registered trademark of Xerox Corporation.
- PowerPC<sup>®</sup> is a registered trademark of International Business Machines Corporation.
- Other product names used herein are for identification purposes only and may be trademarks of their respective companies. We disclaim any and all rights involved with those marks.

---

## New Features of D014/D015

---

### Responses to Requests for Improvement

---

This section describes changes that were implemented in response to requests for improvement in the performance of the B132/B200.

#### Improved Productivity

---

#### Copy Speed

## Read This First

---

Mode	B132/B200	D014/D015
K	B132/B200: 60 cpm	D014: 60 cpm D015: 75 cpm
FC	B132: 45 cpm	D014: 55 cpm
	B200: 55 cpm	D015: 70 cpm

Copying speed has been improved due to:

1. PxP toner with a lower melting point.
2. Better fusing control. This was achieved with a more efficient ac power supply to the fusing unit.

### Shorter Warm-up Time

B132/B200	D014/D015
300 sec.	D014 NA: 90 sec. D015 NA: 75 sec.

The shorter warm-up time was achieved by:

- Adopting a sponge hot roller for fusing; the nip is wider, so the fusing temperature is lower
- Adopting an extremely thin heating roller used at lower temperature

### Overall System

- The system timing has been overhauled based on the B132/B200 base control modules.

### Improved Reliability

---

#### Longer Service Life of Developer

Servicing has been improved by extending the service life of the developer. This was achieved by adopting a pre-mixing developer system. Toner and carrier are pre-mixed in the STC (Soft Toner Cartridge with 90 wt% toner, 10 wt% carrier). The toner and carrier are supplied together to refresh the developer already in the development units. High image quality can be maintained for a greater length of time with this system.

#### Better Stability of Image Density

Compared to the B132/B200, the consistency of the image coverage has been dramatically



## Read This First

increased. This was accomplished by the adoption of the single-direction development system.

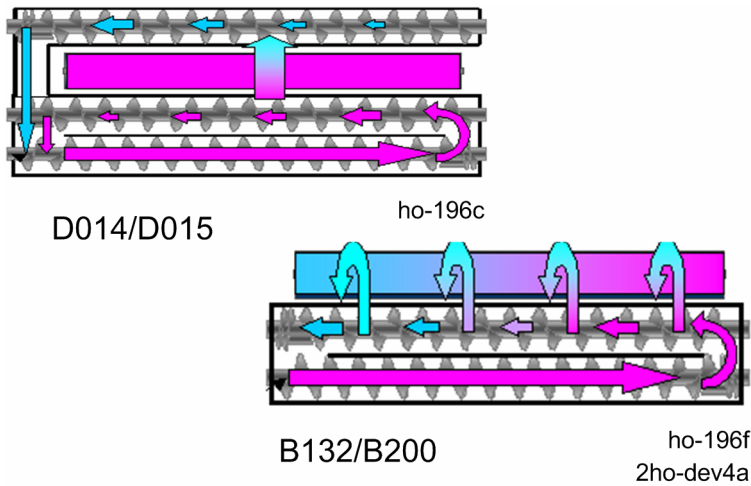

- The developer in the D014/D015 development unit is circulated in one direction. This achieves better uniformity in the application of the toner to the developer sleeve.
- Compared to the B132/B200, this means less variation in image density from left to right and from top to bottom on the output pages.

### Ventilation: More Effective Cooling

The adoption of the PxP toner with its lower melting point means that the machine must be adequately ventilated to keep the interior of the machine cooler.

#### 1. Development Unit Cooling

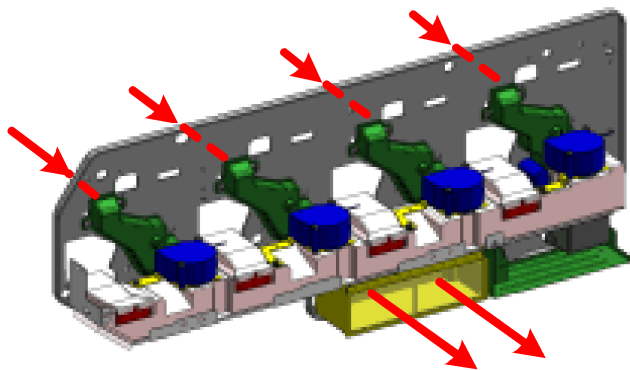

- A single fan (near the front door) draws in fresh air from outside the machine and blows it across the heat sink.
  - An exhaust fan has been added to each development unit to draw hot air away from the heat sink.
2. The heat pipe panels over the fusing unit have been overhauled.

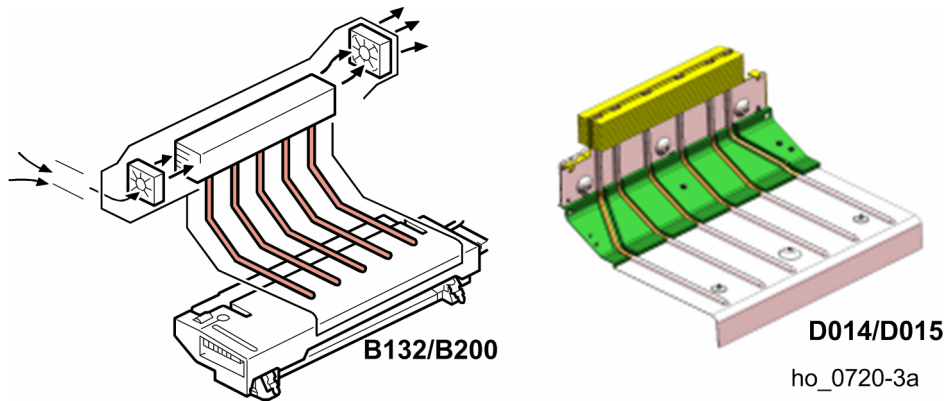

- The number of heat pipes has been increased and they have been rearranged.
- The heat sink cooling fan has been replaced with a fan with a more powerful motor that can move more air.

3. The used toner pipe path has been extended.

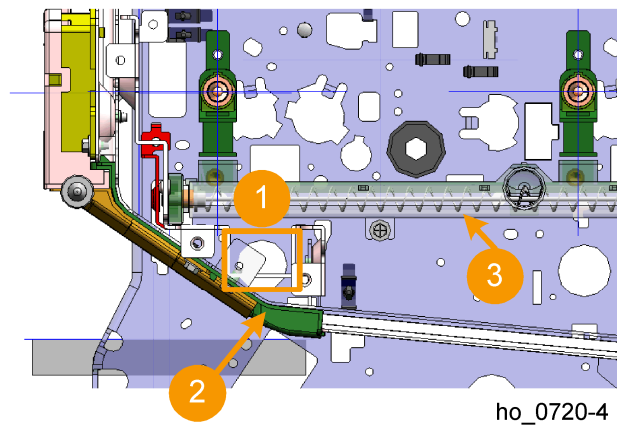

- The air vent below the Y PCU has been enlarged so that it can handle a greater volume of air. is the heat pipe, is the used toner conduit.
- Air is drawn into the vent from the fan at the front door.

4. New cooling airflow duct

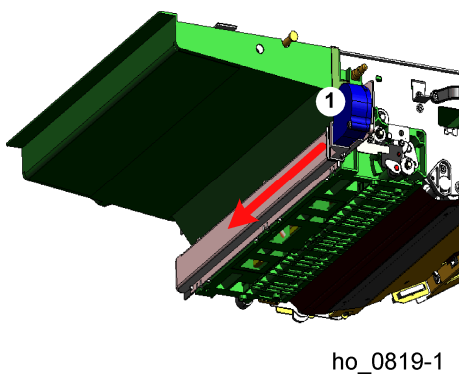

An air flow duct has been added to the ITB cleaning unit to improve ventilation.

## Read This First

### 5. New cooling fan for the paper drive unit

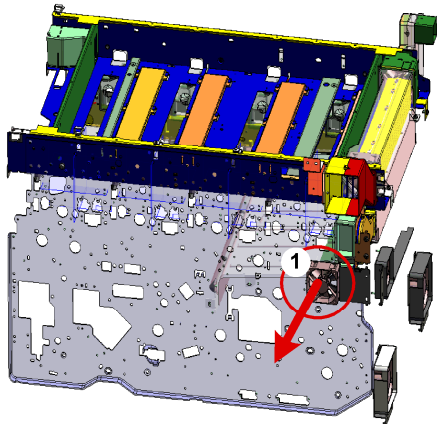

ho\_0819-2

A cooling fan has been added to the paper drive unit to improve ventilation.

### Paper Feed

#### 1. Handling Thick Paper

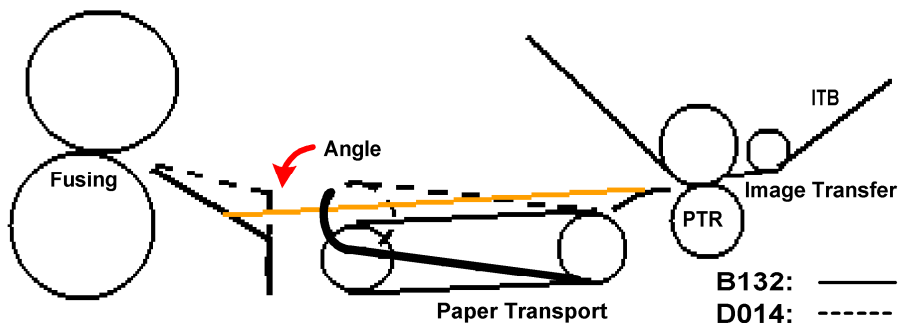

ho\_819-3

As shown in the diagram above, the paper feed path has been changed. The dotted lines show the shape of the paper feed path of the D014/D015, the solid lines the path in the B132/B200.

- The paper transport unit and the fusing unit entrance guide were both raised, so the angle is much shallower. The change in the angle allows thick paper to feed much easier. Even 300 g A4 LEF paper can now feed more efficiently.
- The area where the paper contacts the transport belt has also been enlarged.

### Paper Output

The amount of paper curl (compared with the B132/B200) has been reduced.

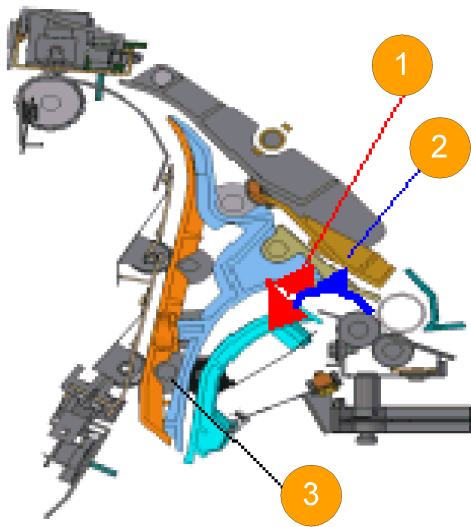

ho\_0720-6

- To reduce the amount of buckling of the paper in the paper path, the inverter relay roller feeds all paper at the same speed after it passes the de-curler. The gap between the guide plates was enlarged.
- The curvature of the turn in the paper path between the de-curler and the junction gate has been enlarged.
- Inverter relay roller has been added.

#### **Elimination of Pawl Marks on Prints**



d014n001

A new fusing belt stripper eliminates shiny stripper marks on prints.

- A new stripper plate has been designed to strip copies that occasionally stick to the fusing belt. The points of the stripper plate are flat PFA resin plates, not sharp points.
- The new PxP toner, which contains a new type of wax, separates more easily from the belt so the sheet is less likely to stick to the fusing belt.
- The new soft-sponge material of the hot roller also means that paper is less likely to stick to the fusing belt.

#### **Fusing Lamp Rearrangement in the Heating Roller**

## Read This First

The layout of the fusing lamps has been rearranged to ensure a more efficient distribution of heat.

### **D014/D015**

Heating Roller



Pressure Roller

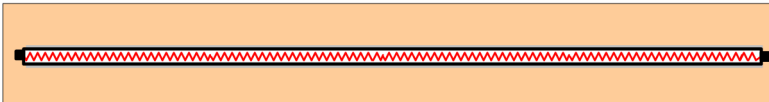

Hot Roller



### **B132/B200**

Heating Roller



Pressure Roller

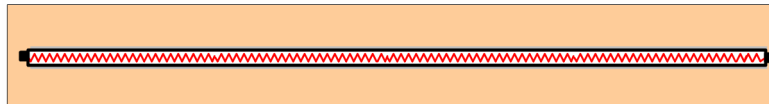

Hot Roller

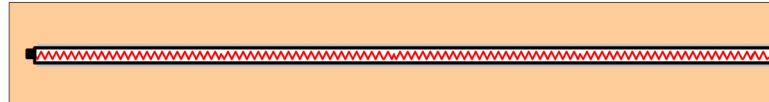

temp\_fusinglamps\_a

In the Heating Roller:

- Lamp 1 heats the entire length of the fusing belt.
- Lamp 2 heats only the ends of the fusing belt. (Used only for large paper sizes.)
- Lamp 3 heats only the center of the fusing belt. (Used for smaller, thick paper sizes; lamp 1 is not used.)

This allows better control of the heat applied to the fusing belt, based on the requirements of the paper size and paper type selected for the job.

### **Reduction of Pressure on the Hot Roller**

A new pressure roller lift mechanism has been adopted to raise the pressure roller and keep it against the hot roller only while the machine is printing.

At the end of the job, the pressure roller is lowered and separated from the hot roller.

If the pressure roller remains pressed up against the soft sponge material of the hot roller

## Read This First

---

while the machine is idle, this could permanently warp the shape of the soft hot roller and cause problems during image transfer from belt to paper.

### Handling Thicker Paper

The D014/D015 can handle paper weights up to 300 g/m<sup>2</sup> (110 lb Cover). This is a significant improvement.

The time in the nip for thick paper (Thickness 2) with the B132/B200 was 80 ms. The time in the nip for Thick 1 with the D014/D015 is 100 ms.

For thick paper:

- The nip of the D014/D015 is wider than the nip of the B132/B200.
- The line speed of the D014/D015 adjusts to slower speeds to match the thickness of the paper.

Other modifications were done to allow handling thicker paper:

- A guide mylar was added at the "turn" where the paper feeds from the paper trays, to reduce the amount of bending on the leading edge of paper as it leaves the tray.
- The paper path from the bypass tray was changed to straighten the paper path from feeding> registration> image transfer. This makes feeding thick A4 LEF much easier.
- The paper path of the duplex unit was modified slightly to reduce bending in paper at the "turn", and the junction gate solenoid has more strength to handle thicker paper.

The table below shows significant improvement in handling thicker paper.

Feed Station	B132/B200	D014/D015	UP
Paper Tray	52.3 to 127 g/m <sup>2</sup> 14 to 47 lb. Cover	52.3 to 216 g/m <sup>2</sup> 14 to 80 lb. Cover	70%
Bypass	52.3 to 256 g/m <sup>2</sup> 14 to 94 lb. Cover	52.3 to 300 g/m <sup>2</sup> 14 to 110 lb. Cover	17%
Duplexer	64 to 127.9 g/m <sup>2</sup> 17 to 47 lb. Cover	64 to 163 g/m <sup>2</sup> 17 to 90 lb. Cover	27%

## Operability

---

Some improvements have been done for the operator.

### Handling Paper Jams

The B132/B200 displayed only a message to alert the operator about a jam or double-feed.

The D014/D015 has a fully animated system to guide the operator step-by-step through jam

## Read This First

---

removal.

### **Easier Use of Paper Tray End Fence**

With the B132/B200, the operator must push and hold down a side lever while moving the end fence. With the D014/D015, the operator need only press the end fence slightly to move it to the position for a standard paper size.

### **New Arrow Indicator on Side Fence Lever**

An arrow indicator embossed on the side fence reminds the operator where to push to release and move the side fence.

---

## Image Quality Improvement

---

This section describes the changes that have been implemented to improve image quality for the D014/D015.

### **Adoption of Single-Direction Developer/Toner Supply**

---

The adoption of the single-direction developer/toner supply method has resulted in the following improvements.

- **Uniformity of Image Density**

With the B132/B200, there are minor problems with images becoming faint (front to back) because the agitator moves the toner front to back. There were variations of less than 25% with the B132/B200, but this has been reduced to less than 15% with the D014/D015. This reduction was made possible with the adoption of a one-direction development system in the development units.

- **Stabilization of Image Quality**

B132/B200 image quality shows some repeat density fluctuation (0.15), but this has been reduced with the D014/D015. The improvement was achieved by using a stable-density development system.

- **Stabilization of High Quality Images**

With the B132/B200, it was found that there was some image deterioration in high quality images created with high duty coverage during continuous paper feed. (image quality deteriorated after about 20K copies). The improvement was achieved by adoption of the developer/toner pre-mixing system.

### **Adoption of New PxP Toner**

---

The adoption of the new PxP toner has achieved the following dramatic improvements in image quality.

#### **Granularity, Reproduction of Dots**

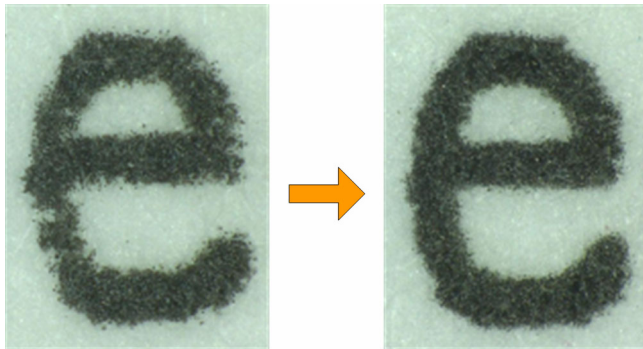

**B132/B200**

**D014/D105**

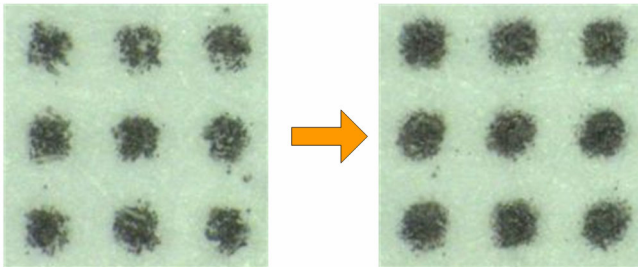

**B132/B200**

**D014/D105** ho\_0720-8.b

The difference in the granularity of B132/B200 pulverized toner (6.8  $\mu\text{m}$ ) and D014/D015 PxP toner (5  $\mu\text{m}$ ) toner has a significant effect on image quality. The D014/D015 toner with toner granules of smaller diameter reproduces a much better image with dots of 0.4, compared with 0.5 of the B132/B200.

### Sharpening Text



**B132/B200**

**D014/D105**

ho\_0720-8a\_b



## Read This First

---

There were requests from customers for sharper reproduction of text characters (reducing the "halo" effect around text characters). Better text reproduction was achieved with better control over the rotation of the development roller and drum and changing the ratio of their rotation. The drum and development roller are driven by separate motors in the D014/D015.

- **Blurring at the Trailing Edges of Images**

Many customers requested elimination of the blurring at the trailing edges of images.

This problem was solved with the development rollers and OPC drums rotating slightly slower relative to line speed.

## Elimination of Shiny Pawl Marks on Prints

---

Many customers requested elimination of the shiny streaks at the trailing edges of sheets that were caused by the strippers that removed paper from the fusing belt.

The problem of paper separation from the fusing belt was solved in two ways:

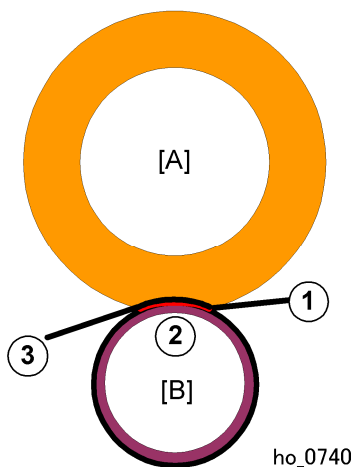

- The design of the fusing unit was changed. The hot roller [A] is composed of soft sponge. When the pressure roller [B] presses into the hot roller from below this creates a much wider nip. The paper enters the wider nip and when it exits the nip at the curvature of the nip points the paper downward. This improves separation of the paper from the fusing belt.



d014n001

- The fusing belt strippers were replaced by a new stripper plate equipped with flat soft

Read This First

plates (not points) that will not leave marks on the paper.

Comparison of Changes in Basic Operation

	D014/D015			B132/B200	
Copy Speed	D014/D015a	FC: 55 cpm, B&W: 60 cpm		B132/B200	FC: 45 cpm, B&W 60 cpm
	D014/D015b	FC: 70 cpm B&W: 75 cpm		B132/B200	FC: 55 cpm B&W: 60 cpm
Warm-up Time	EU/AP	Less than 75 sec.		< 300 sec.	
	NA	D014/D015	< 90 sec.		
	D014/D015	< 75 sec.			
First Copy	FC	D014/D015	7.5 sec.	7.5 sec.	
	D014/D015	6.4 sec.			
	B&W	D014/D015	5.7 sec.	6.5 sec.	
	D014/D015	4.9 sec.			
Power Specifications	NA	D014/D015: 120V 16A 60 Hz D014/D015: 208-240V 12A 60 Hz		120V 16A 60 Hz	
	EU/AP	220-240V 12A 50-60 Hz		220 to 240V 8.7A 50/60 Hz	
Max Power Consumption	NA	D014/D015: Less than 1920W D014/D015: Less than 2400W		< 1920 W	
	EU/AP	D014/D015: Less than 2400W			

Read This First

Line Speed		
Normal Paper	D014/D015: 282 mm/s D014/D015: 352.8 mm/s	B132/B200 282 mm/s
Thick Paper	D014/D015: Thk 1: 176.4 mm/s, Thk 2, Thk 3: 141 mm/s	B132/B200: 141 mm/s
OHP	D014/D015 141 mm/s	B132/B200 100 mm/s

**Comments**

- **Warm-up Time.** The warm-up time is much faster. This is achieved with the newly designed fusing unit and low melting-point toner.
- **First Copy.** The first copy time is much faster due to the adoption of the new fusing unit and low melting-point toner.

System Configuration and New Options

**Configuration 1 (with D373/D374 Finisher)**

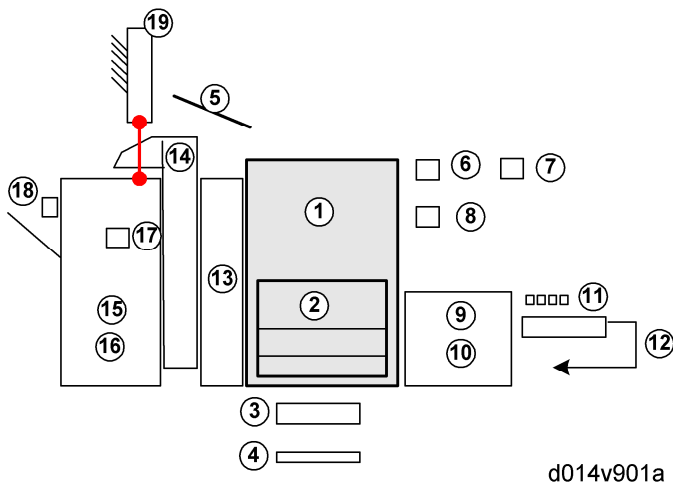

No.	Item	Comments
①	D014/D015	Main unit
②	Tandem Tray	Built into main unit
③	A3/11"x17" Tray Type (B331)	Option for tandem tray

Read This First

No.	Item	Comments
④	Tab Sheet Holder Type (B499)	Option for universal tray
⑤	Copy Tray (B756)	For no finishers
⑥	-	Not Used
⑦	-	Not Used
⑧	-	Not Used
⑨	LCT 4000 (D350) * <sup>1</sup>	Only one of these options can be installed.
⑩	A4/LT LCT (B473)	
⑪	LCT Adapter (B699)	Required for LCT B473
⑫	LG Unit for A4/LT LCT (B474)	Option for LCT B473
⑬	Z-Folding Unit ZF4000 (B660) * <sup>1</sup>	
⑭	Cover Interposer Tray (B704)	For D373 (2000-sheet), D374 (3000-sheet) finishers only. Only 1 tray. Cannot be installed with Mail Box (B762).
⑮	Finisher SR4020 (D373) * <sup>1</sup>	2000-sheet finisher, 50 staple, Booklet folding and stapling
⑯	Finisher SR4010 (D374) * <sup>1</sup>	3000-sheet finisher, 50 staple, corner stapling only
⑰	Punch Unit (B702)	For either finisher D373 or D374
⑱	Output Jogger Unit (B703)	For either finisher D373 or D374
⑲	Mail Box CS391 (B762)	For D373 (2000-sheet), D374 (3000-sheet finishers only). Cannot be installed with Cover Interposer Tray (B704)

\*<sup>1</sup> New options for this machine.

**Configuration 2 (with B830 Finisher)**

Read This First

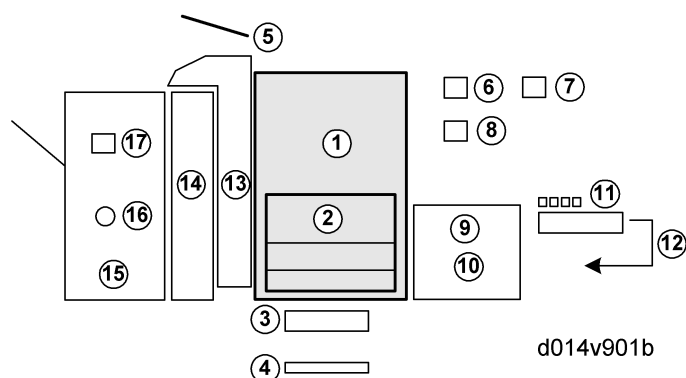

No.	Item	Comments
①	D014/D015	Main unit
②	Tandem Tray	Built into main unit
③	A3/11"x17" Tray Type (B331)	Option for tandem tray
④	Tab Sheet Holder Type (B499)	Option for universal tray
⑤	Copy Tray (B756)	For no finishers
⑥	-	Not Used
⑦	-	Not Used
⑧	-	Not Used
⑨	LCT 4000 (D350)	Only one can be installed.
⑩	A4/LT LCT (B473)	
⑪	LCT Adapter (B699)	Required for LCT B473 to adjust height.
⑫	LG Unit for A4/LT LCT (B474)	Option for LCT B473
⑬	Cover Interposer Tray CI 5000 (B835)	Two source trays. Can be installed with 3000-sheet finisher B830 only.
⑭	Z-Folding Unit ZF4000 (B660)	Can be installed with D373, D374, B830 finishers.
⑮	Finisher SR5000 (B830)	3000-Sheet finisher, 100 staples, jogger standard.

## Read This First

No.	Item	Comments
⑩	Finisher Adapter (D375)	For Finisher B830
⑪	Punch Unit PU 5000 (B831)	For 3000-sheet finisher B830 only.

## New Options for B132/B200

These are the options available for D014/D015. Only the LCIT 4000 (D350) is a new model.

### New Peripheral

- **LCT 4000 (D350).**

### Other Peripherals

- **Finisher SR4020 (D373).** 2000-sheet booklet finisher (50 staple). Capable of both corner and booklet stapling.
- **Finisher SR4010 (D374).** 3000-sheet booklet finisher (50 staple). Basically the same as the SR4020 but features corner stapling only.
- **Finisher SR5000 (B830).** Requires an adapter kit to accommodate the faster speed of the D014/D015b. A jogger unit is built-in (no installation required).
- **Z-Folding Unit ZF4000 (B660).** Can be installed with the 2000-Sheet Finisher (D373), 3000-Sheet Finisher (D374), or 3000-Sheet Finisher (B830).
- **Cover Interposer Tray CI 5000 (B835).** Equipped with two trays for feeding slip sheets. Installed on the 3000-Sheet Finisher B830 only.
- **Cover Interposer Tray (B704).** Equipped with one tray for feeding slip sheets. Installed on the 2000-Sheet Finisher (D373) or 3000-Sheet Finisher (D374). Cannot be installed with Mail Box B762.
- **Mail Box (B762).** Installed on the 2000-Sheet Finisher (D373) or 3000-Sheet Finisher (D374). Cannot be installed with Cover Interposer Tray (B704).
- **Fax Option Type C7500.** The base fax unit can accommodate both G3 and G4 boards, but only G3 will be available overseas. (The G4 option will be available only in Japan.)

### MFP Options (Listed Alphabetically)

Option	Prod. No.	Config.
Copy Connector Type 2105	B328	Board
Data Overwrite Security Unit Type H	D377	SD Card

Read This First

Option	Prod. No.	Config.
Fax Option Type C7500	D336	Board
G3 Interface Unit Type 7500	D357	Board
PostScript 3 Unit Type C7500	D378	SD Card
Printer/Scanner GM-2190	D376	SD Card

\*1: The EFI (Fiery) Controller currently under development will be connected via the Gigabit Ethernet Board.

Appearance of Actual Configurations

**Configuration Sample for General Office Customers**

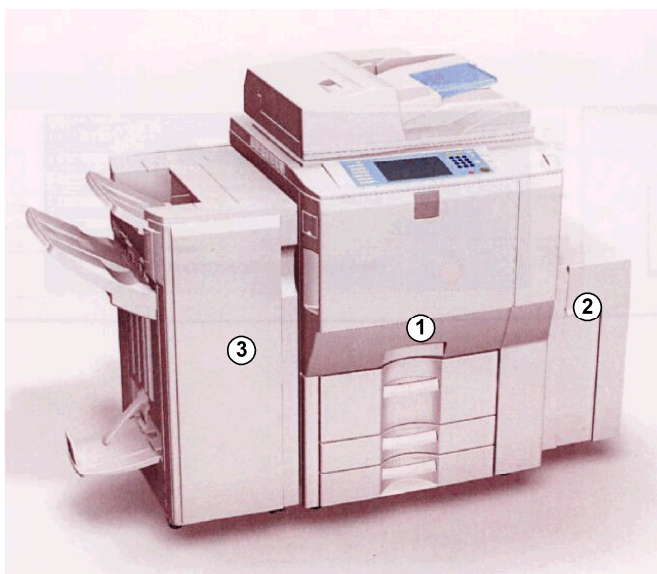

d014v901d

No.	Item	Comments
①	D014/D015	Main unit
②	RT473 LCT (B473)	Option
③	Finisher SR4020 (D373)	2000-sheet finisher, 50 staple, Booklet folding and stapling

### Configuration Sample for Light Production Customers

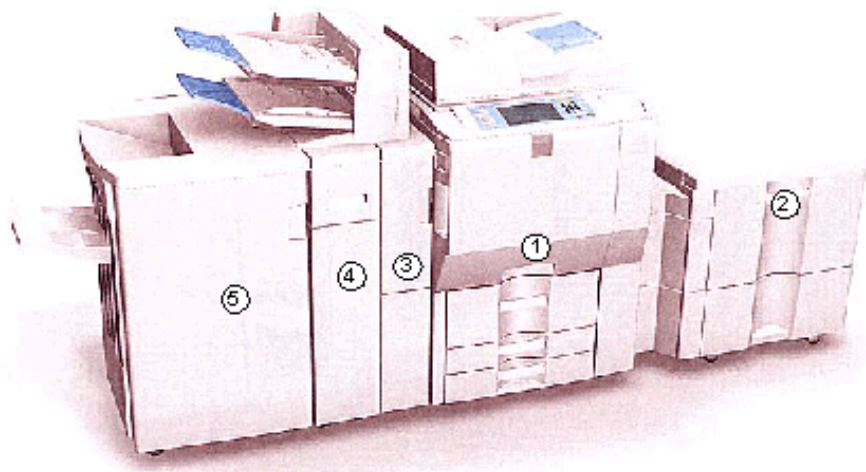

d014v901c

No.	Item	Comments
①	D014/D015	Main unit
②	LCT 4000 (D350)	New option.
③	Cover Interposer Tray CI 5000 (B835)	Two source trays.
④	Z-Folding Unit ZF4000 (B660)	
⑤	Finisher SR5000 (B830)	

---

### More Details About Design Changes

---

This is a summary of the most important design changes in the D014/D015. For more details, please refer to Section 6 of the D014/D015 manual.

#### 1. PCU (Photoconductor Unit)

---

#### Developer Filling, Replacement



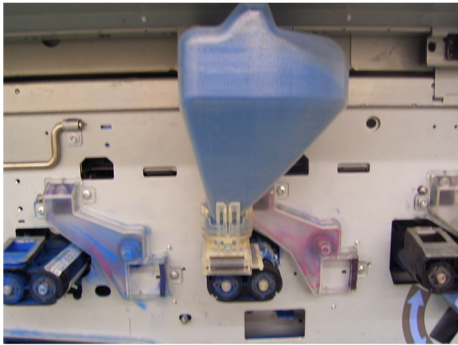

**D014/D015**

ho\_0730a

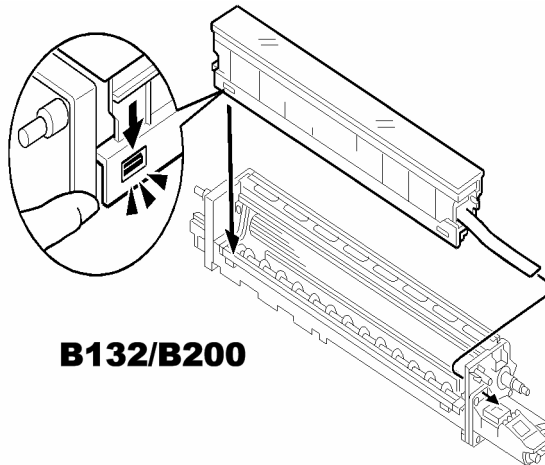

**B132/B200**

b132i106

The B132/B200 uses a plastic developer container installed inside the PCU. With the D014/D015, the developer is poured from a newly designed developer bottle attached to the front end of a PCU. After filling, the bottle is detached and discarded. With the D014/D015, it is not necessary to remove the PCUs from the machine in order to fill them with developer.

**PCU Design**

The PCU units have been redesigned. In the previous model, all the PCUs had the same structure. In this machine, the K PCU employs the charge corona wire system that is commonly used in other machines. The other PCUs (Y, C, M) use charge rollers just like the B132/B200.

**Different Designs of YCM PCU and K PCU**

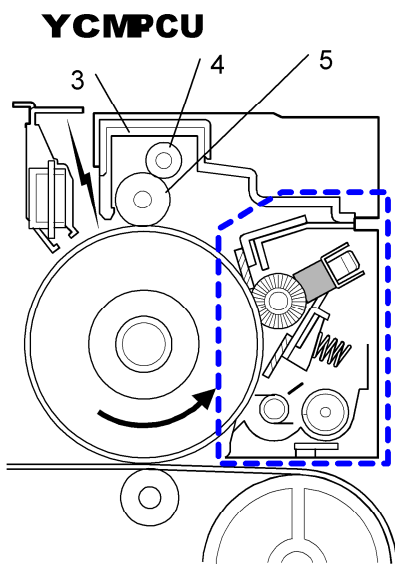

d014d977a

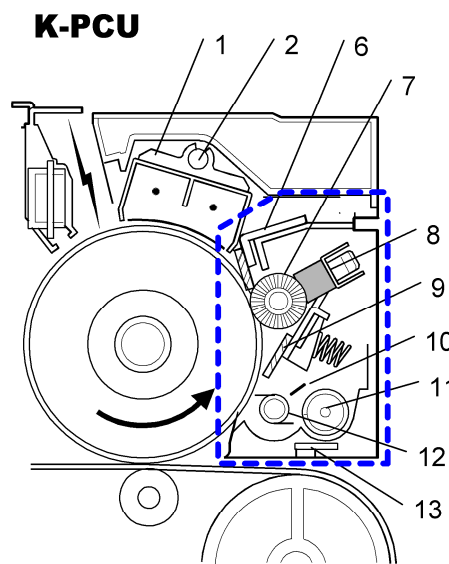

d014d977

Read This First

1	Charge Corona Unit (Scorotron type)	Only the K PCU uses a charge corona unit.
2	Charge Corona Wire Cleaner	
3	Charge Roller Unit	The Y, M, C PCUs use charge rollers.
4	Charge Roller Cleaning Roller	
5	Charge Roller	
6	Lubricant Blade	These items comprise the PCU cleaning system. The same parts and system are used in all of the four PCU units.
7	Lubricant Brush Roller	
8	Lubricant Bar	
9	Cleaning Blade	
10	Cleaning Brush Roller Flicker	
11	Toner Collection Coil	
12	Collection Coil	
13	Quenching LED	

**Note**

- The OPC drums of the B132/B200 and D014/D015 are not interchangeable.

Potential Sensors

**Potential Sensor Position**

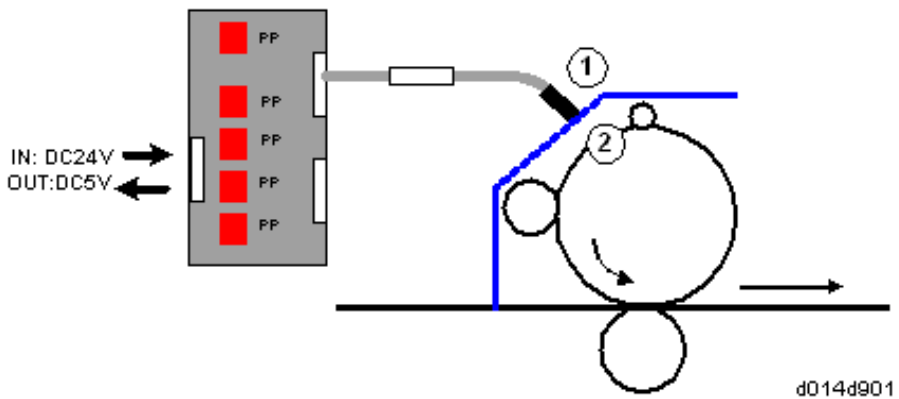

The drum potential sensors (x4) no longer reside inside the PCUs. They are attached to the

Read This First

main machine just above each PCU . This new arrangement keeps the potential sensors free of toner and dust during servicing.

2. Development Unit

**Cross-Section of Development Unit**

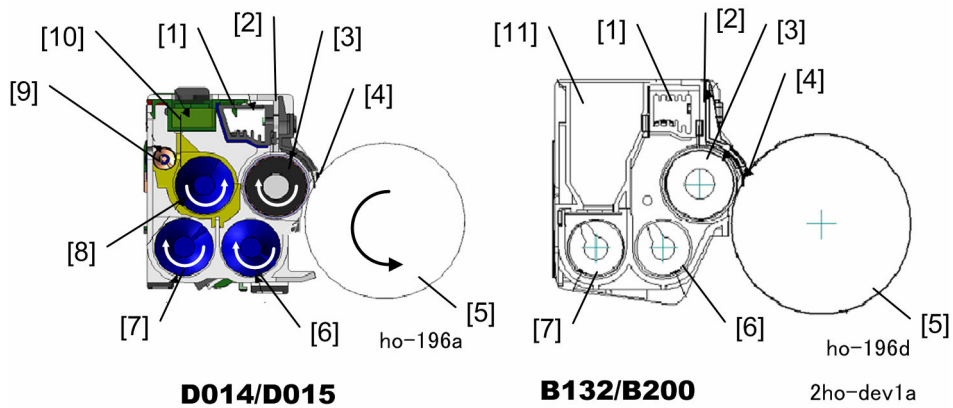

**D014/D015**

**B132/B200**

1	Heat Sink	Heat Sink
2	Doctor Blade (t=2.0)	Doctor Blade (t=2.0)
3	Development Roller	Development Roller
4	Entrance Seal	Entrance Seal
5	Drum (diameter 60)	Drum (diameter 60)
6	Toner Collection Auger (dia. 22)	Developer Auger 1 (dia. 18)
7	Mixing Auger (diameter 22)	Developer Auger 2 (dia. 18)
8	Supply Auger (dia. 22)	---
9	Used Toner Auger	---
10	Filter	---
11	---	Developer Cartridge

**Note:** The D014/D015 does not contain a developer cartridge. The PCU is filled with developer from a newly designed bottle. The PCU does not need to be removed from the

Read This First

machine in order to fill it with developer.

**External View of Development Unit**

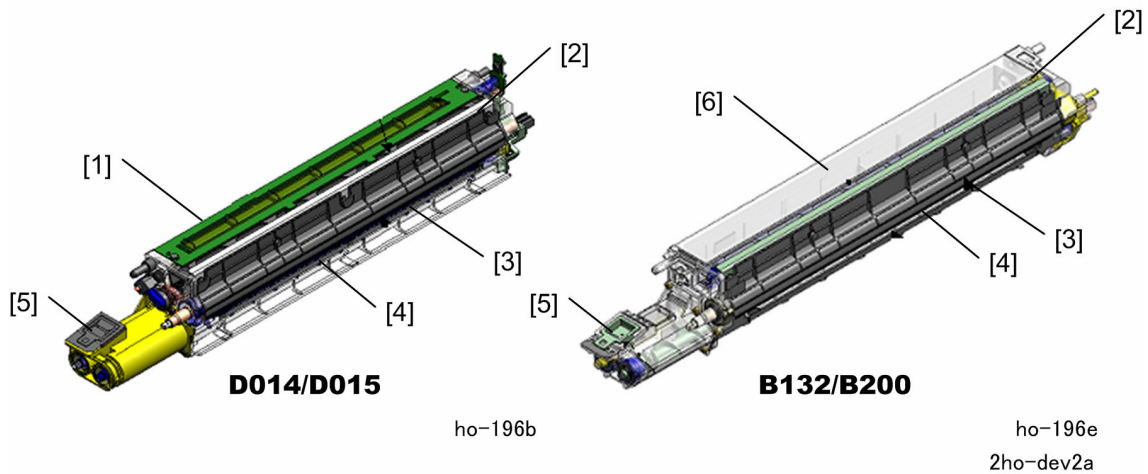

	<b>D014/D015</b>	<b>B132/B200</b>
1	Filter	---
2	Heat Sink	Heat Sink
3	Entrance Seal	Entrance Seal
4	Development Roller (diameter 25)	Development Roller (diameter 25)
5	Toner Supply Port	Toner Supply Port
6	---	Development Cartridge

**Note:** The D014/D015 does not contain a developer cartridge. The PCU is filled with developer from a newly designed bottle. The PCU does not need to be removed from the machine in order to fill it with developer.

**Toner/Developer Flow Inside the Development Unit**

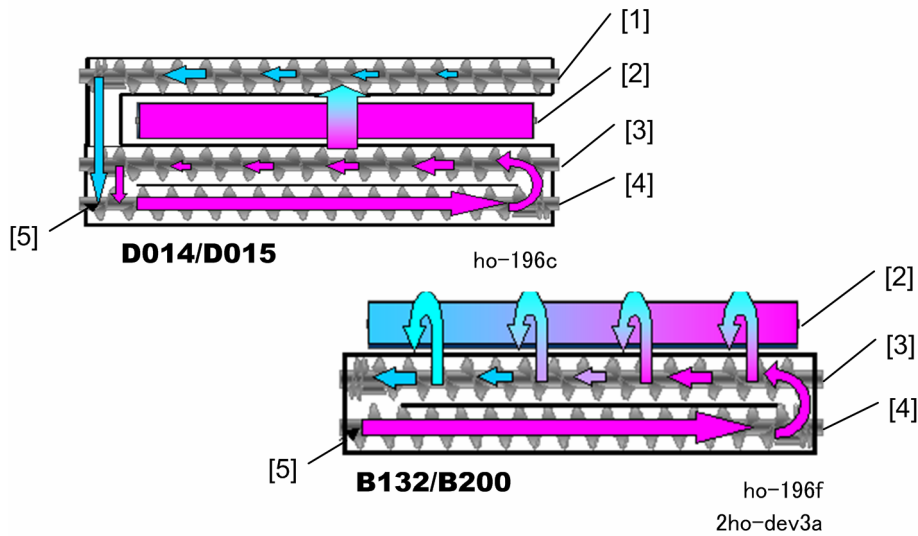

**D014/D015**

**B132/B200**

- |   |                                  |                                  |
|---|----------------------------------|----------------------------------|
| 1 | Collection Auger (dia. 22)       |                                  |
| 2 | Development Roller (diameter 25) | Development Roller (diameter 25) |
| 3 | Supply Auger (dia. 22)           | Developer Auger 1 (diameter 18)  |
| 4 | Mixing Auger (dia. 22)           | Developer Auger 2 (diameter 18)  |
| 5 | Toner Supply Port                | Toner Supply Port                |

The one-direction flow of developer in the D014/D015 development unit improves image quality.

In the D014/D015, the path for fresh developer is separate from the path that collects excess toner from the doctor blade that smooths the toner that will be applied to the drum.

Compare with the B132/B200 above where this excess toner mixes with fresh toner. The D014/D015 achieves a more even coating of toner on the drum and uses only fresh toner/developer. This means the density of the image is more uniform.

### 3. Toner Supply

---

With the exception of a few minor differences, D014/D015 uses the same toner supply system as the previous model.

#### **Toner Supply Components**

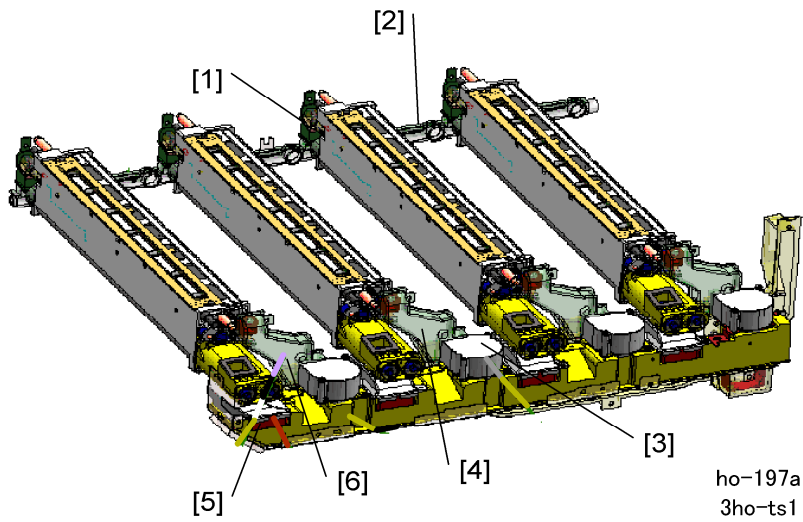

1	Waste Developer Coil* <sup>1</sup>
2	Horizontal Used Toner Transport Coil
3	Cooling Fan 2 (Doctor Blade)* <sup>1</sup>
4	Cooling Duct 2 (Development Doctor Blade)* <sup>1</sup>
5	Cooling Fan 1 (Below Development Unit)
6	Cooling Duct 1 (Below Development Unit)
	* <sup>1</sup> These are new items.

**New STC (Soft Toner Cartridge)**

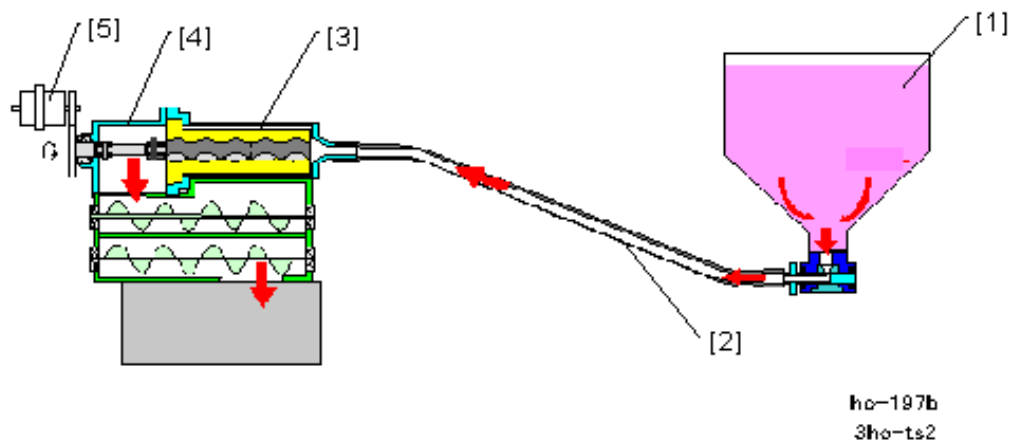

## Read This First

---

1	Toner Cartridge (STC)
2	Flexible Tubing
3	Toner Pump
4	Toner Pump Clutch
5	Sub Hopper

- Four STCs are set in the toner hopper. They are inserted left to right in this order: Y, C, M, K.
- The new PxP toner (high-resolution oil-less Polyester Polymerization toner) used in the D014/D015 has a much lower melting point. For this reason, fans and ducts have been added to the faceplate of the toner supply unit to keep the toner supply cool.
- The toner for the B132/B200 and D014/D015 is not the same, so this means that the STCs of the D014/D015 and the B132/B200 are not interchangeable. Also, the D014/D015 STC contains 90 wt% toner and 10 wt% carrier. The B132/B200 STC contains no developer.

### ★ Important

- Neither type of STC can be inserted accidentally in the wrong machine.
- The STC for the D014/D015 does not fit into the B132/B200; a B132/B200 STC does not fit in the D014/D015. However, it is possible to set the wrong type of STC and close the toner hopper even if the wrong type of STC is installed.

## 4. Transfer Unit (Image Transfer and Paper Transfer Units)

---

### ITB Unit

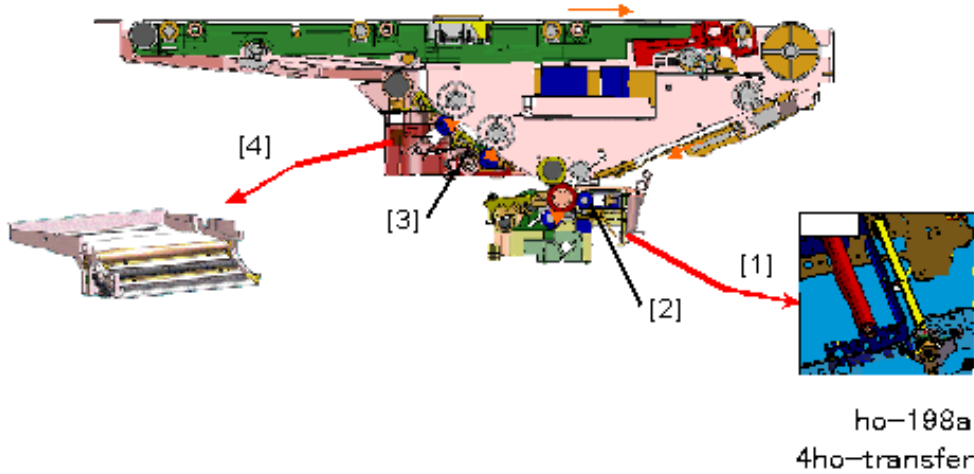

There are some changes in the transfer unit:

- The PTR lift mechanism [1] has been redesigned. This is the mechanism that keeps the PTR unit against the ITB during belt-to-paper image transfer and lowers the unit when the transfer unit is not operating.
- A lubricant brush [2] has been added to the lubricant bar assembly..
- The toner transport agitator [3] in the ITB cleaning unit [4] is new.
- The cleaning unit of the ITB (shown at the lower left in the diagram above) has also been changed. Two cleaning blades, one cleaning brush roller, and a lubricant bar (ZnSt) comprise the cleaning mechanism. These cleaning blades and roller are PM parts. For a more detailed description, see Section 3 and Section 6.

### **New PTR Lift Mechanism**

The PTR lift mechanism raises and lowers the PTR unit.

- The lift mechanism raises the PTR against the ITB for belt-to-paper image transfer.
- The lift mechanism lowers the PTR and pulls it away from the ITB when the machine is not printing.

### **PTR Lift Mechanism**



Read This First

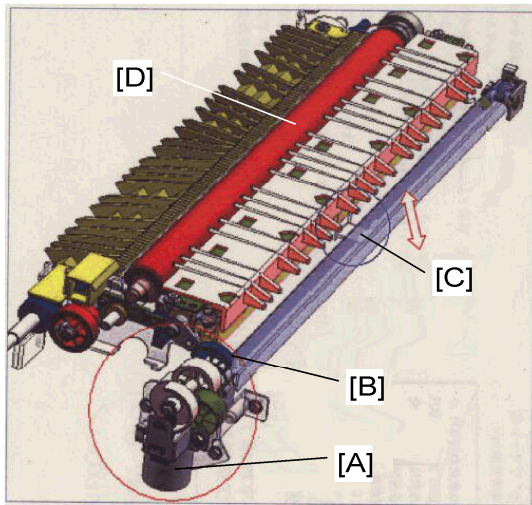

temp\_ptu2

The PTR lift motor [A] rotates cam [B]. The rotation of the cam raises and lowers the lift plate [C], which in turn raises and lowers the PTR [D].

This mechanism is necessary because the roller in the ITB unit that opposes the PTR is made of a softer material than in the B132/B200. The PTR will deform this roller if it always contacts it.

**Increased Durability of Paper Transfer Roller**

**B132/B200**

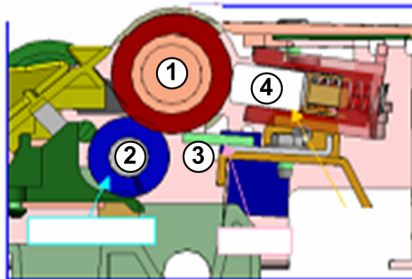

**D014/D015**

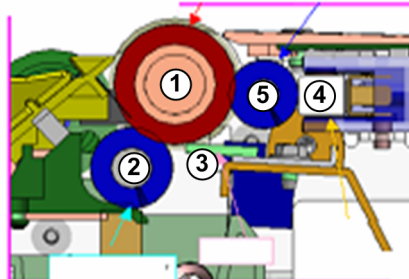

ho-0819-4a

①	PTR
②	Cleaning Brush Roller
③	Cleaning Blade
④	Lubricant Bar
⑤	Lubricant Brush Roller (D014/D015 only)

1. Reduction of Scratches on PTR

## Read This First

---

Scratches on the surface of the PTR caused by foreign particles are a problem with the B132/B200. Also, there is some scratching on the belt caused by the lubricant bar being in direct contact with the roller

In the D014/D015, the lubricant bar does not touch the roller. The lubricant brush roller picks up the lubricant (ZnSt) from the lubricant bar and applies the lubricant to the surface of the roller. This dramatically reduces the amount of scratching on the surface of the PTR and extends the life of the roller and the cleaning unit parts.

### 2. PTR layer cracking

The service life of the PTR has been extended to 600K.

Cracking between the layers of the PTR occurs in the B132/B200, resulting in its short service life: 150K. This cracking is caused by uneven pressure at the nip of the PTR and paper transfer bias roller above.

To equalize this pressure at the nip between the ITB bias roller (opposite the PTR in the ITB) and the PTR in the D014/D015, the ITB bias roller of the D014/D015 is composed of softer material. This extends the service life of the D014/D015 PTR to 300K.

## 5. Fusing Unit

---

A fusing belt and three fusing rollers comprise the new fusing unit. The rollers are the heating roller (fusing lamps x3), pressure roller (fusing lamp x1), and hot roller (no fusing lamps). The hot roller is composed of a new, soft sponge material that creates a wider nip band where a more even pressure is applied for fusing.

### General Layout of Fusing Unit

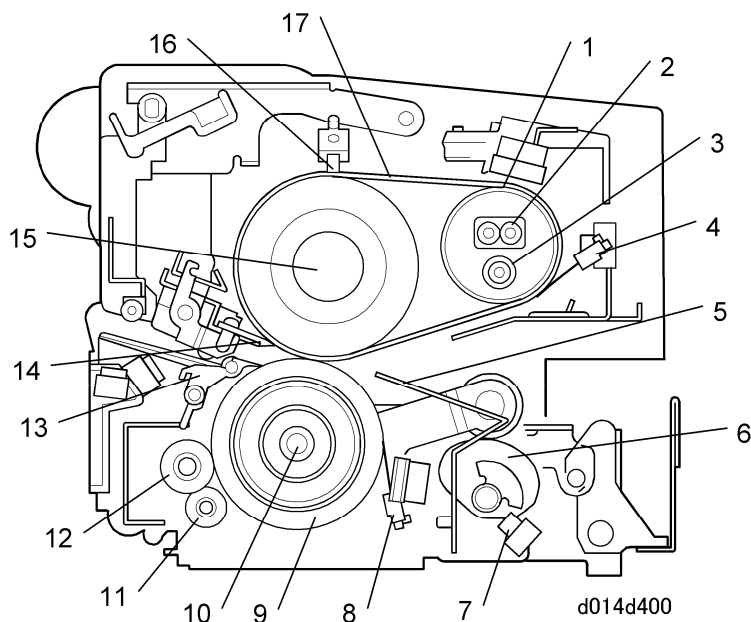

1.	Heating Roller	10.	Pressure Roller Fusing Lamp
2.	Heating Roller Fusing Lamps x2	11.	Cleaning Roller
3.	Heating Roller Fusing Lamp x1	12.	Oil Supply Roller
4.	Heating Roller Thermistor	13.	Pressure Roller Strippers
5.	Entrance Guide	14.	Fusing Belt Strippers
6.	Pressure Roller Lift Mechanism	15.	Hot Roller
7.	Pressure Roller Lift Sensor	16.	Fusing Belt Thermistor
8.	Pressure Roller Thermistor	17.	Fusing Belt
9.	Pressure Roller		

**New Pressure Roller Lift Mechanism**

A new pressure roller lift mechanism raises and lowers the pressure roller. When fusing starts, the pressure roller lift motor switches on and raises the pressure roller against the hot roller above. At the end of the job, the motor reverses and lowers the pressure roller away from the hot roller. The hot roller and pressure roller remain separated while they are idle. This prevents the pressure roller and hot roller from warping, and prolongs their service lives.

**6. Motors**

---

The following illustrations show the positions of motors around the drum, as viewed from the rear.

**Front, Rear View of Drum Cleaning, Development, Drum Motors**

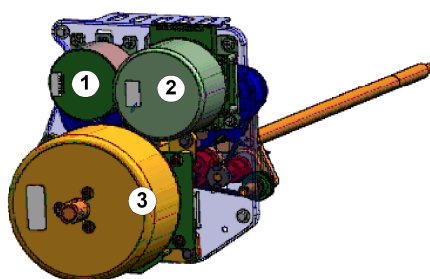

**Front**

ho-200a

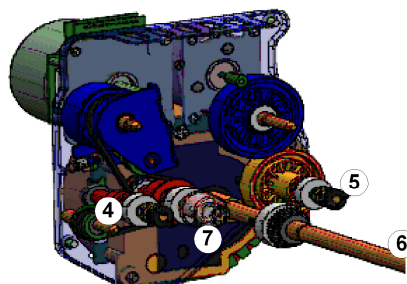

**Rear**

ho-200b  
6ho-mtr1

1.	Drum Cleaning Motors x4* <sup>1</sup>
2.	Development Motors x4* <sup>1</sup>
3.	Drum Motors x4
4.	Development Coil Shaft
5.	Drum Cleaning Motor Shaft
6.	Drum Motor Shaft
7.	Development Roller
*1: New items	

### Changes to Improve Torque Transmission Efficiency

The size of color registration errors has been reduced with changes in the design of the drum motor.

#### Drum Motor Shaft

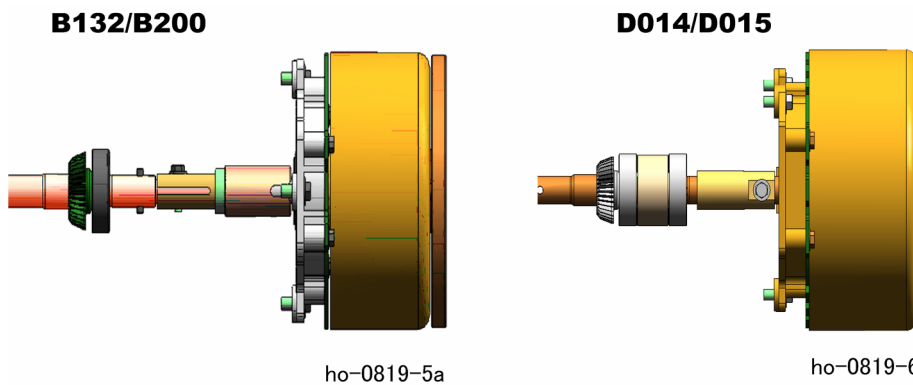

In the B132/B200, the drum motor shaft and drum motor are separate components. In the new D014/D015 drum motor, however, the shaft and motor are permanently connected. This direct-drive arrangement improves the performance of the drum motor and shaft. Also, for the D014/D015 drum motor, the rotation wave fluctuation of has been reduced by 30%.

In addition to this change in drum motor design, the FB (Feedback) control system has been improved to reduce color registration errors.

#### FB Control

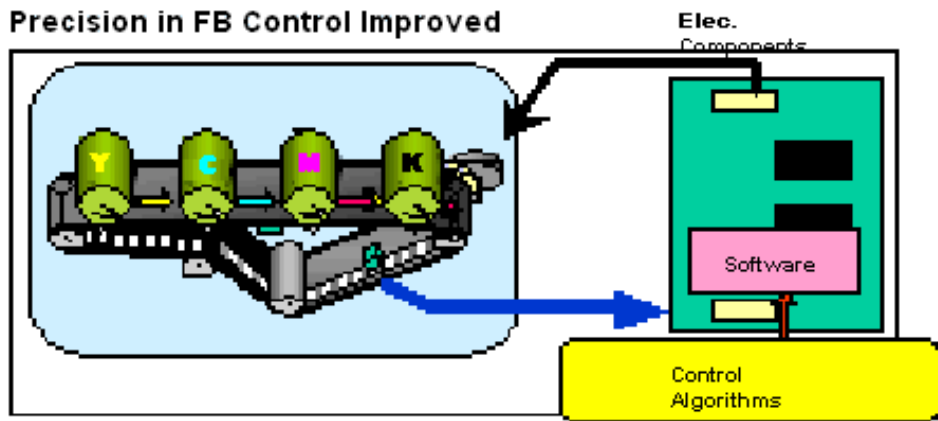

hc-0819-7

The average incidence of color registration errors on the ITB has been reduced. This has been achieved by improvement in the hardware (FB electrical components) and software (control algorithms).

**ITB Drive, PTR, Fusing/Exit Motors**



hc-200c



hc-200d

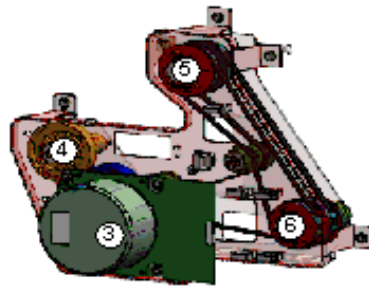

hc-200a

6hc-mtr2

①	ITB Drive Motor
②	PTR Motor
③	Fusing/Exit Motor
④	Paper Transport Belt Drive Shaft
⑤	Fusing Unit Drive Shaft
⑥	Duplex Unit Drive Shaft

## Read This First

⑦	ITB Cleaning Unit Drive Shaft
⑧	Used Toner Drive Shaft

## K/YMC Lift, Used Toner Motors

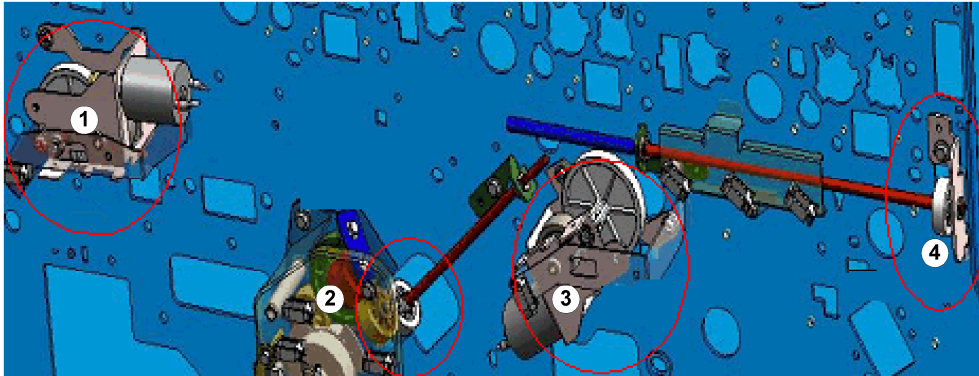

ho-200f  
6ho-mtr3

①	Black ITB Roller Lift Motor* <sup>1</sup>
②	Diagonal Used Toner Coil Motor
③	ITB Lift Motor
④	Horizontal Used Toner Coil

\*<sup>1</sup>: New item: Lowers the black image transfer roller away from the ITB and PCU drum during automatic developer installation. **Not used at this time (Oct. 2007).**

## 7. Controller Board

- The number of board slots has been reduced to three.
- The number of SD card slots has been reduced to two. (A system SD card is no longer required. The system firmware resides on the controller board.)
- A new fan has been added to the GW controller board.

## Small Changes

This is a quick summary of small changes in the D014/D015.

- **Filter Box Cover.** There are new filter boxes on the back of the machine. There are now three filter boxes.

## Read This First

---

- **Paper Tray Handles.** A new tray handle design has been adopted for the D014/D015. Also, the shape and operation of the end fence has changed.
- **Motherboard.** There is no motherboard in the D014/D015
- **Breaker Switch.** This machine does not have a breaker switch that requires testing at installation.
- **Peltier Unit.** The Peltier unit has been removed. The D014/D015 does not have a Peltier unit.
- **Paper Feed Unit.** A mylar has been added to facilitate feeding thicker paper.
- **Bypass Tray.** The operation of the side fences is much smoother.
- **Process Control.** The number of steps in process control has been reduced. Also, MUSIC processing and process control adjustment are executed at the same time at power on, so that the machine enters standby mode within a shorter length of time.
- **Fans.** Fans and ducts have been added on the faceplate that covers the toner supply unit. This new arrangement keeps the temperature lower. (The new PxP toner has a much lower melting point.)
- **Functions disabled during warm-up.** These functions have been disabled during warm-up:
  1. SP3820 (Manual Procon)
  2. Auto Color Calibration (User Tools)
  3. Color Registration (User Tools)

---

## Notes About Servicing

---

These are notes about the differences in servicing the D014/D015 machine. These changes are described in detail in Section 3.

### 1. Toner/developer and drum replacement.

The STCs of the B132/B200 and D014/D015 are not interchangeable. The D014/D015 uses the new PxP toner and the developer bottle has a new design. The B132/B200 STCs cannot be inserted in the D014/D015. The OPC drums of the B132/B200 and D014/D015 are also not interchangeable.

### 2. Scanner Unit.

The shapes and sizes of some of the scanner unit boards have changed to make them easier to service. Also, the arrangement of the APS sensors has been changed. The fan has been removed from the left side of the scanner unit.

### 3. Laser Unit.

The SP codes for the laser unit (provided on a decal attached to the laser unit) have changed. Also, the polygon motor harness connector has been modified.

#### 4. PCU

- The OPC and development unit must be separated for servicing.
- The K and YMC PCUs are not the same. The K unit uses a charge corona unit and the YMC units use charge rollers to charge the OPC drum.
- The charge roller and cleaning roller are much easier to remove.
- The PCU stand (stored under the machine) is still required for servicing. The bottom of the D014/D015 PCU stand stores only one jig (required for developer replacement).
- The PCU stand is required for servicing, because it provides two important functions: 1) It protects the drum from damage and exposure to light while the PCU is out of the machine, and 2) It keeps the OPC aligned correctly so the development unit can be reattached.
- The PCU stand must remain attached to the bottom of the main machine at the customer site.

 Note

- The shape of the D014/D015 PCU stand is not the same as the B132/B200 stand, so these stands are not interchangeable. Using the B132/B200 PCU stand with a D014/D015 PCU could damage the drum.
- The cleaning blades of the K PCU and YCM PCUs are not identical. One blade is designed for use with the K PCU and another type for the YCM PCUs. Each blade is marked "K" or "MCY" to identify the blade type.
- The cleaning blades of the K PCU and YCM PCU are identical. However, the lubricant bar units are not the same. The K PCU is marked with a "K" to distinguish it from a YMC lubricant bar unit which is not marked. (The lubricant bar itself, however, can be used in either unit.)
- A D014/D015 PCU consists of both the drum unit and the development unit. However, unlike a B132/B200 PCU unit that could be opened, with the D014/D015 the drum unit and development unit must be separated for servicing.
- Installation of a new PCU. This procedure has changed. More SP code settings are required. These SP codes are provided on a sheet with each new PCU unit.

 Important

- **When you dust the surface of a new drum, use only Lubricant Powder B1329700 (specially designed for this machine). Do not use the yellow toner from this machine because it contains developer. The developer will damage the drum and ITB.**
- Developer replacement. This is a new procedure. A jig stored on the bottom of the PCU stand is required to lock the development roller so that the old developer can be



## Read This First

---

removed from the PCU.

- The rectangular developer packs of the B132/B200 have been replaced with newly designed bottles.
- Filling and replacing developer: These are new procedures.
- TD sensor. The TD sensor is of new design and extremely sensitive (calibrated at the factory). This TD sensor cannot be replaced separately.

### 5. ITB unit

There are some minor changes in the servicing of the ITB unit. One connector has been removed, and the shapes of some parts have changed. The new ITB unit has two cleaning blades. Both blades are PM parts.

#### Important

- When you dust the surface of a new ITB, use only Lubricant Powder B1329700 (specially designed for this machine). Do not use the yellow toner from this machine, because it contains developer, and this will damage the drum and ITB.

### 6. PTR Unit

The PTR unit has a new lift mechanism and the lubrication bar is much easier to remove. Removing dust from the PTR unit is also much easier.

**7. Fusing Unit.** The fusing unit is new.

- There is a new lock arm at the back of the unit that must be released before the fusing unit can be removed. Disassembly of the fusing unit is much easier. **Important:** There are two fusing units: a 120V unit and 240 V unit.
- The fusing lamp connectors of the 120V unit are BLUE, those of the 240V unit are PINK.
- If the wrong type of fusing unit is installed in the machine, the machine will detect this and issue a warning. There is no danger of damaging either the fusing unit or main machine.
- The B132/B200 and D014/D015 fusing belts are not interchangeable. The D014/D015 belt is longer.

**8. Boards.** The layout of the main boards has changed.

- There is no motherboard.
- The AC boards of the 120V and 240V machines are different. The boards are clearly marked "100V" or "200V" in the center of the board to prevent installing the wrong type of board.
- The controller board must be removed before the IPU/VBCU boards can be removed.

### 9. HDD Removal

The HDD must be reconnected correctly. If the HDD is connected incorrectly, the machine

## Read This First

---

will issue an HDD error at power on. This will not harm the HDD or corrupt data on the disk. Just power the machine off and reconnect the HDD correctly.

### 10. Motors

- Drum motor replacement is much easier (a jig is no longer required to lock the motor shaft.)
- The development motor and drum cleaning motor can be removed separately.
- The position of the paper transfer motor has changed.
- The shape of the image transfer motor has changed.

---

## Detailed Summary of Changes

---

### External Appearance, Operation Panel

- The operation panel includes a WVGA (Wide Video Graphic Array) Color Touch-Panel
- External covers and paper trays are newly designed. Paper trays adopt a new design.

### Controller Box

- New design. Layout of internal components and PCBs has been changed.
- Also, an FCU (Fax Control Unit) is a new option.

### Main Frame Configuration, Ventilation

- New cooling fans for the development units, and a new cooling fan near the Y PCU on the left side of the machine.
- A heat sink (in the form of a pipe) has been added to the fusing unit to improve efficiency of cooling.

### Engine Drive Mechanisms

- PTR motor. A reduction gear has been added to the DD (Direct Drive) motor and transfer belt cleaning has been improved.
- The ITB encoder sensor (FB or Feedback sensors), two separate sensors on the B132/B200, have been combined into one sensor to reduce cost and improve efficiency.
- The used toner horizontal transport path has been extended.
- Along with changes in component layout around the drum, new drum cleaning motors have been added. Each drum cleaning roller is now driven by a separate motor.
- The linkage of the OPC drum motors has been improved in order to shorten warm-up time and to improve the precision of drum rotation.
- The design of the output drive shaft used in each development unit has been changed to reduce wear on the development unit gears.
- The drum potential sensors (x4) have been removed from the PCUs and mounted in the main machine, one above each PCU.

### Exposure

## Read This First

---

- Along with improvement in the line speed, the CCD, exposure lamp, scanner motor have been modified.
- In order to reduce costs, newly designed lenses and an ADF exposure glass have been adopted for this machine.

### **Laser Writing**

- In line with the improvement in the line speed, the speed of the polygon motor has been increased. (This follows similar improvement in other machines.)

### **Paper Feed**

- In response to requests for better handling of thick paper, some changes have been done within the restricted range of the present B132/B200 layout.
- Some minor changes have been done in the paper feed trays (developed based on B132/B200) to allow feeding thicker paper.
- There are no changes in paper registration.
- Some small changes have been done within the limitations of the present design of the duplex/inverter unit for better handling of thicker paper and for reduction of paper curl.

### **Development, Toner Supply**

- Adoption of high-resolution oil-less polyester polymerization toner (hereafter "PxP toner").
- A new STC (Soft Toner Cartridge) that contains toner pre-mixed with 10 wt% carrier is used to fill the development units.
- A new single-direction development method has been devised to reduce uneven image density on a single page and reduce developer deterioration.
- In order to improve the precision of heat reduction, an aluminum steel sleeve has been adopted. Also,  $V_s/V_p$  have been reduced to correct blurring at the trailing edges of solid images
- Automatic developer installation.

### **Drum Charge, Cleaning**

The following measures have been adopted to deal with the problems of blade service life and dirty OPC drums, caused by the slippage of PxP toner on the ITB:

- The K PCU uses the Scorotron Charge Method that uses a self-cleaning charge corona wire, and an auxiliary cleaning brush.
- The other PCUs (Y,M,C) use charge rollers with retractable cleaning rollers and auxiliary cleaning brushes.

### **Image Transfer**

The following measures have been adopted to deal with the problems of blade service life and dirty OPC drums, caused by the slippage of PxP toners on the ITB:

## Read This First

---

- A lubrication brush roller and lubricant counter blade (both for ZnSt) have been added downstream of the counter blade and brush system of the B132/B200 ITB cleaning system.

### **Paper Transfer**

- Reducing the amount of toner in order to deal with the problem of the short service life of the cleaning blade, caused by the slippage of PxP toners on the ITB.
- Reverse bias is applied in the intervals between sheets on the ITB.
- A new lift device has been designed to raise and lower the PTR (raise it during paper transfer and lower it away from the ITB and bias roller when the machine is idle).

### **Fusing**

- The fusing unit employs a halogen-belt design (halogen fusing lamps with fusing belt) in order to shorten the warm-up time to less than 75 to 90 sec.
- The fusing unit employs a sponge hot roller designed for a higher line speed and better grip at the nip, and also employs a new pressure roller mechanism that keeps the pressure roller separated from the hot roller when the machine is idle (this prevents warping of the soft sponge of the hot roller).
- The effect of the paper pointing downward as it exits the nip between the hot roller and pressure roller improves separation and reduces the streaking on the copies.

### **Process Control**

- The length of time to complete process control is much shorter.
- The number of ID sensor patterns has been reduced.
- The precision of the TD sensor has been improved.

### **OPC Drums**

- Adoption of the charge corona system for the K PCU improves resistance to nitrogen oxides (NOx) in the air.

### **Toner**

- The new PxP toner used in the machine has a lower melting point. This allows a shorter warm-up time, reduces the amount of heat required for fusing, and achieves more even density in images.

# Installation

---

## Installation Requirements

---

---

### Operating Environment

---

1. Temperature Range
  - Recommended Temp.: 23°C (73.4°F)
  - Allowed Temp.: 10°C to 32°C (50°F to 90°F) – See the Note below
2. Humidity Range: 15% to 80% Rh
3. Ambient Illumination: Less than 1,500 lux (do not expose to direct sunlight or strong light.)
4. Ventilation: Air must be replaced a minimum of 3 times per hour
5. Ambient Dust: Less than 0.10 mg/m<sup>3</sup>

 Note

- If the machine is installed in a location where the ambient temperature is more than 30°C (86°F): (1) Do not run full color copying longer than 2 hours, and (2) never turn the main power switch off immediately after a long copy job.
- Leave the machine on so the fans can expel the hot air from the machine and cool the electronic components.

**Recommended Temperature/Humidity Range for Operation**

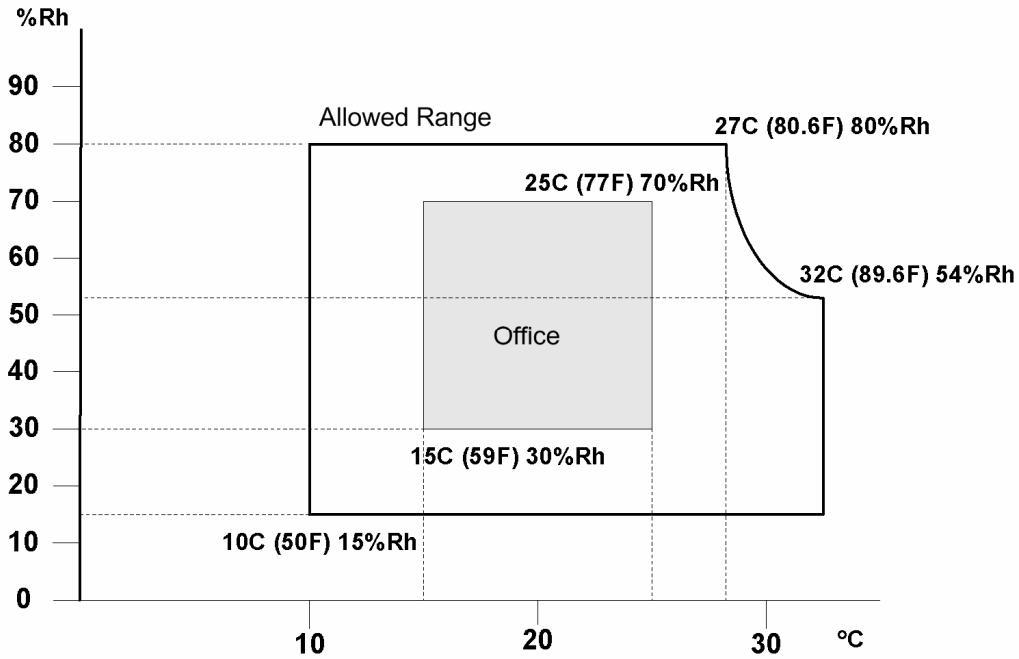

Recommended: 23C (73.4F), 50% Rh

b132i900

6. If the installation area has air-conditioners or heaters, put the machine in a location that agrees with these conditions:
  - Where there are no sudden temperature changes from low to high, or high to low.
  - Where it will not be directly exposed to cool air from an air conditioner in the summer.
  - Where it will not be directly exposed to reflected heat from a heater in the winter
7. Do not put the machine where it will be exposed to gases that can cause corrosion.
8. Put the copier on a strong and level surface. The front and rear of the machine must be less than 5 mm (0.2") away from level.
9. Do not put the machine where there could be strong vibrations.
10. Do not connect the machine to the same power source as other electrical devices.
11. The machine can make an electromagnetic field, and this can cause interference with radio or television reception.

**Machine Level**

1. Front to rear: Less than 5 mm (0.2") away from level
2. Right to left: Less than 5 mm (0.2") away from level

The machine legs can be turned to adjust them up or down, to make the machine level. Put a carpenter's level on the exposure glass.

## Installation

### Minimum Space Requirements

Put the copier near the power source. Minimum clearance must be as shown below. The same amount of clearance is necessary when optional peripheral devices are installed.

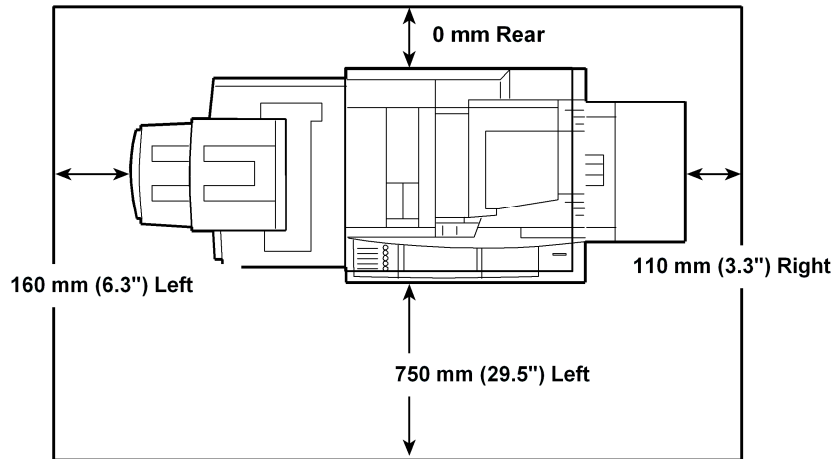

b132i111

## Dimensions

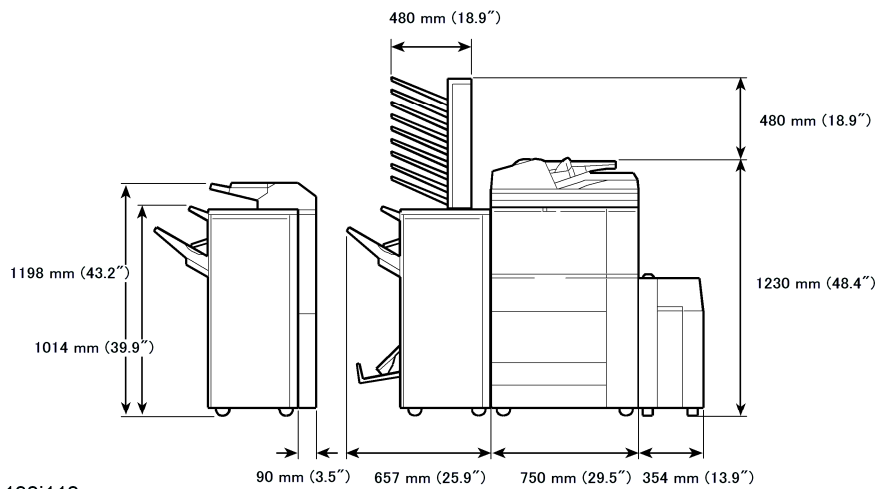

b132i112

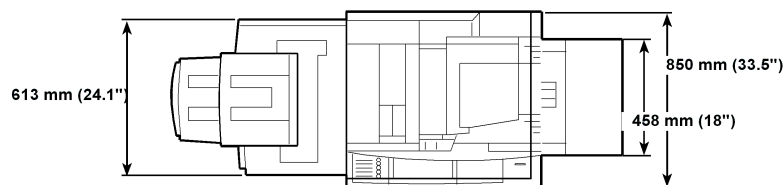

b132i113

## Power Requirements

---

### **WARNING**

- Make sure that the wall outlet is near the main machine and that you can get access to it easily. Make sure the plug is tightly connected to the outlet.
- Do not connect more than one electrical device to the same power outlet.
- Be sure to ground the machine.
- Do not put objects on the power cord.

### Input voltage level

- North America

D014	120V 60 Hz, more than 16A
D015	208 to 240V 60 Hz, more than 12A

- Europe/Asia

D014/D015	220 to 240V 50/60 Hz, more than 12A
-----------	-------------------------------------

Permissible voltage fluctuation:  $\pm 10\%$

### **Important**

- **Some electrical components are different, depending on the power supply used.**

The following components are different, depending on the power supply.

1. Power supply cord
2. AC drive board
3. Fusing unit
4. Anti-condensation heaters
  - Paper trays
  - Paper transfer section
  - Scanner heater (option)
  - LCT (B473) heater (option)
  - LCIT (D350) heater (option)

### **CAUTION**

- Do not turn off the main power switch when the power LED is lit or flashing. To prevent damage to the hard disk or memory, push the operation switch to turn the power off, then do nothing until the power LED goes off, and then turn the main



## Installation

---

power switch off.

There are two power switches on the machine:

### **Main Power Switch**

This is located on the front left corner of the machine and has a plastic cover. This switch must always be on unless a technician does work on the machine.

### **Operation Switch**

This is located on the right side of the operation panel. This is the switch that the customer uses to turn the machine on and off.

## Copier and Peripherals

This is a list of the peripheral devices that can be installed with the copier. There are two basic configurations.

### System Configuration 1

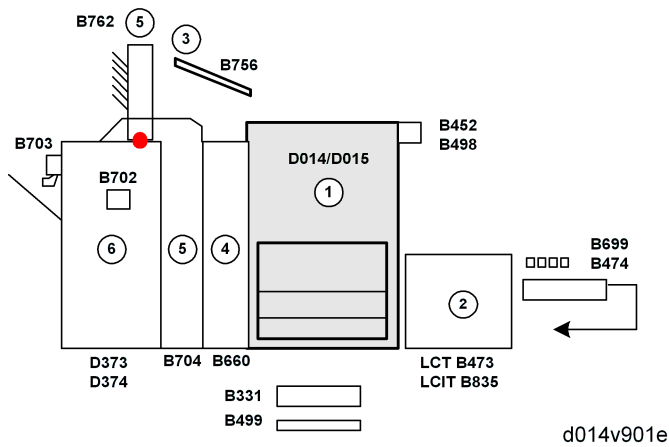

The system should be installed in the order shown above and listed below.

No.	Product No.	Item	Comments
①	D014/D015	TRC-2a/b	Main unit (e-STUDIO5530C PRO/7030C PRO)
②	D350	LCIT 4000	Only one of these options can be installed.
	B473	A4/LT LCT	
	B699	LCT Adapter	
③	B756	Copy Tray	Only if no finishers are installed
④	B660	Z-Folding Unit ZF4000	Requires either D373 or D374
⑤	B762	Mail Box CS391	For Finishers D373/D374 only. Mailbox and CIT cannot be installed together.
	B704	Cover Interposer Tray	

Installation

No.	Product No.	Item	Comments
⑥	D373	Finisher SR4020 (D373)	D373: 2000-sheet, 50 staple, Booklet folding and stapling. D374 3000-sheet, 50 staple, corner stapling only. Only one can be installed.
	D374	Finisher SR4010 (D374)	

These remaining options can be installed at any time and in any order.

Product No.	Item	Comments
B331	A3/11"x17" Tray Type	Option for tandem tray
B474	LG Unit for A4/LT LCT	Option for LCT B473
B499	Tab Sheet Holder Type	Option for tandem tray
B702	Punch Unit	For either finisher D373 or D374
B703	Output Jogger Unit	For either finisher D373 or D374

System Configuration 2

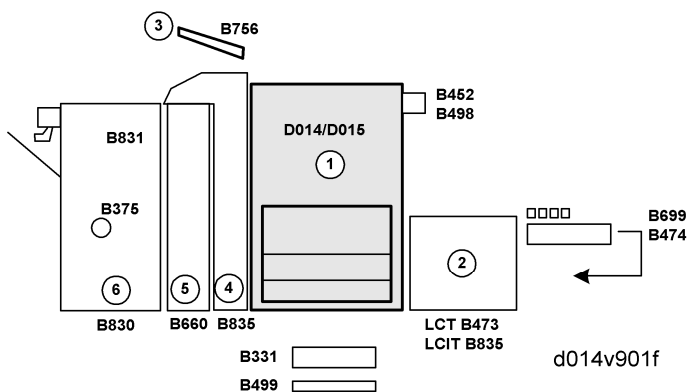

The system should be installed in the order shown above and listed below.

## Installation

No.	Product No.	Item	Comments
①	D014/D015	TRC-2a/b	Main unit (e-STUDIO5530C PRO/7030C PRO)
②	B473 B699	A4/LT LCT LCT Adapter	Only one of these optional paper banks can be installed. LCT Adapter: Required for LCT B473 to adjust the height of the paper exit.
	D350	LCIT 4000	
③	B756	Copy Tray	Only if no finishers are installed
④	B835	Cover Interposer Tray CI 5000	Two source trays. Can be installed with 3000-sheet finisher B830 only.
⑤	B660	Z-Folding Unit ZF4000	Can be installed with D373, D374, B830 finishers.
⑥	B830 B375	Finisher SR5000 Finisher Adapter	3000-Sheet finisher, 100 staples, jogger standard. Finisher Adapter: Required for TRC-2a/b

These remaining options can be installed at any time and in any order.

Product No.	Item	Comments
B331	A3/11"x17" Tray Type	Option for tandem tray
B474	LG Unit for A4/LT LCT	Option for LCT B473
B499	Tab Sheet Holder Type	Option for tandem tray
B831	Punch Unit PU 5000	For 3000-sheet finisher B830 only.

## MFP Options (Listed Alphabetically)

Here is a list of common MFP (controller) options.

## Installation

---

Option	Prod. No.	Config.
Copy Connector Type 2105	B328	Board
Data Overwrite Security Unit Type H	D377	SD Card
PostScript 3 Unit Type C7500	D378	SD Card
Printer/Scanner GM-2190	D376	SD Card

---

## Copier D014/D015

---

### Accessories

---

Check the accessories and their quantities against this list.

No.	Description	Q'ty
1.	Instructions Pocket	1
2.	Exposure glass cloth holder	1
3.	Exposure glass cloth	1
4.	Leveling Shoes	4
5.	PCU stand	1
6.	Ferrite Core	1
7.	PCU Stand Holder	1
8.	Decal: Paper Loading	1
9.	Decal: Paper Size	1

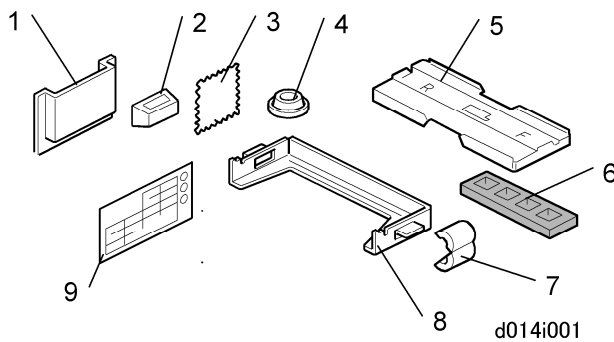

External Tapes and Packing Material

---

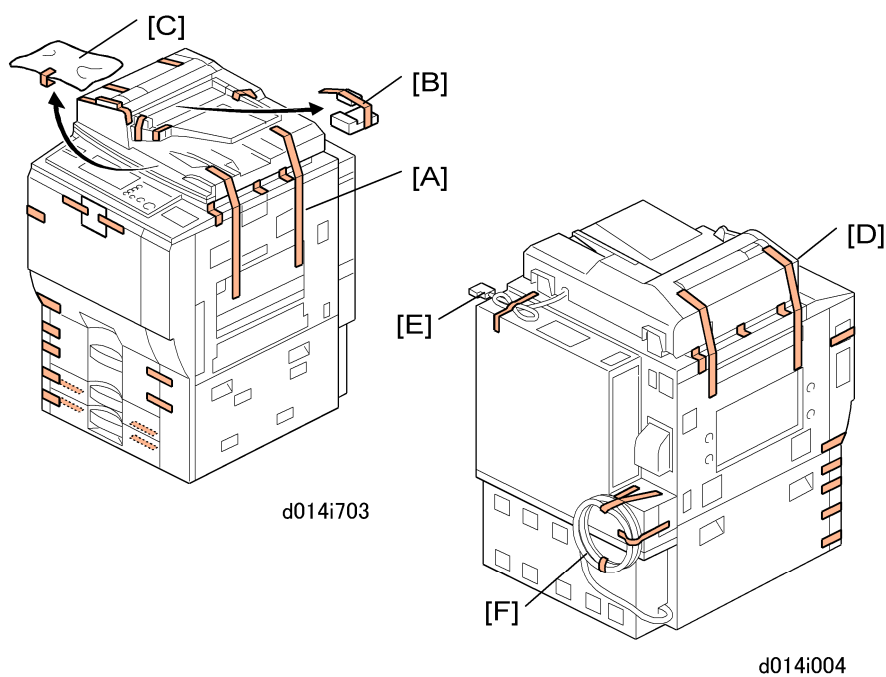

**⚠ WARNING**

- Always turn the machine off and disconnect the machine power cord before you do these procedures.

Remove all tapes and packing material from the main machine:

1. Remove:

[A]: ARDF, right side

[B]: Packing block inside ARDF

[C]: Accessories bag. Remove other accessory bags from Tray 2, Tray 3.

[D]: ARDF, left side

[E]: ARDF connector cord. Remove tape and connect the cord

[F]: Power cord

## Installation

---

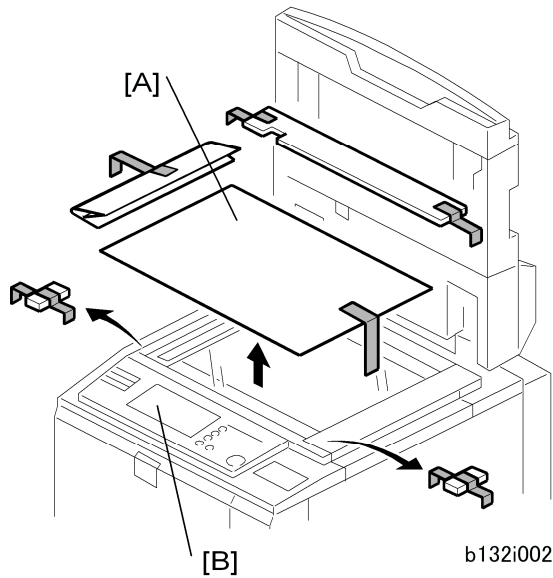

### 2. Remove:

[A]: Under ARDF

[B]: Operation panel film

## Internal Tapes and Packing Material

---

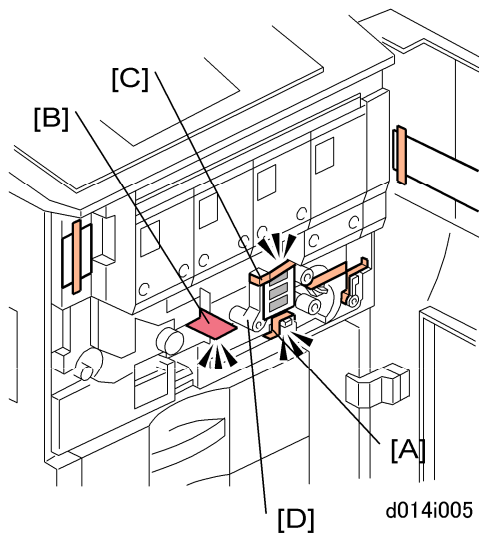

### 1. Open the front door:

2. Remove the transfer belt release lever [A] (1 tape). We will install this in the correct location later.

#### ★ Important

- Do not touch [B], [C], or [D] at this time. These items are removed after you remove the faceplate.



## Installation

- To prevent damage to the ITB, never turn down lever [D] to pull out the drawer unit until after you have removed the rod with the red tag and wire [B].
- The drawer must remain inside the machine until after the developer is installed in the developer cartridges of the PCUs.
- The rod is removed after the faceplate is removed.

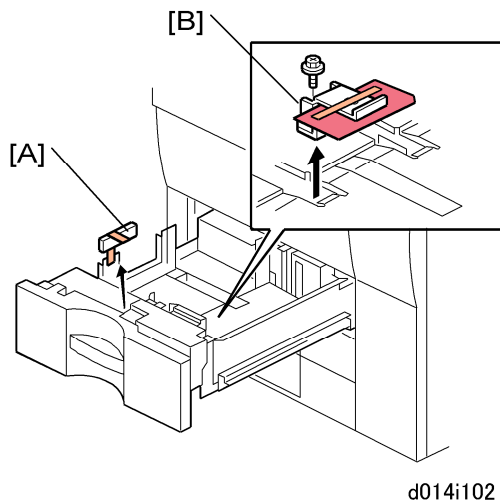

3. From Tray 1 remove:
  - [A]: Block, tape
  - [B]: Retainer, tag, wire (🔗 x 1)
4. Remove all retainers and accessories from Tray 2, Tray 3.

## Shipping Retainer Removal

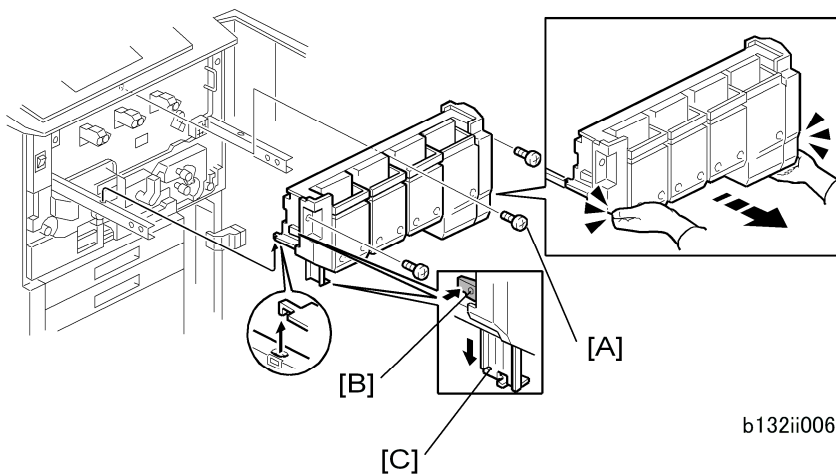

1. Prepare an open space on the floor for the hopper.
2. Remove the screws of the toner hopper cover [A] (🔩 x 3).
3. Put your hands under the left and right corners of the toner hopper, and slowly pull it out

## Installation

---

on its rails until it stops.

4. Push the lock [B] then pull down the support leg [C].
5. Make sure that the support leg is down and locked before you remove the hopper.

### CAUTION

- Always make sure that the support leg is down and locked before you remove the hopper.

6. Hold the toner hopper using the handles at the top left and right sides. Then lift the toner hopper off its rails and set it on the floor.

### CAUTION

- The hopper is heavy! Lift it carefully. Make sure that it disengages fully from the rails on the left and right, and then set it on the floor.



7. Push the hopper rails into the machine.

### Note

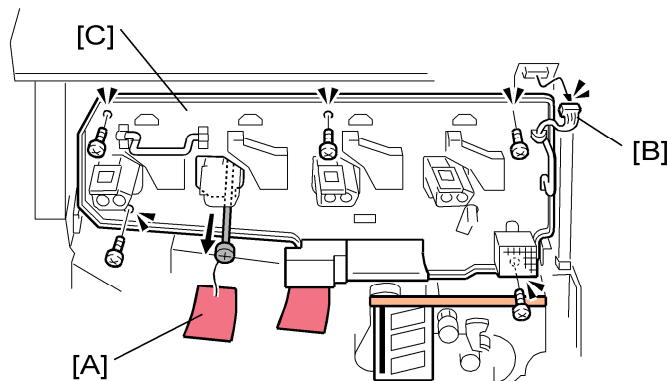
- Push in the rails until approximately an inch is out of the machine. If you push the rails in fully, you must use a pair of needle-nose (radio) pliers to pull them out again.



d014i715

8. Remove the tag, and rod [A] ( x 1).
9. Disconnect the fan connector [B].
10. Remove the faceplate [C] ( x 5).

## Installation

---

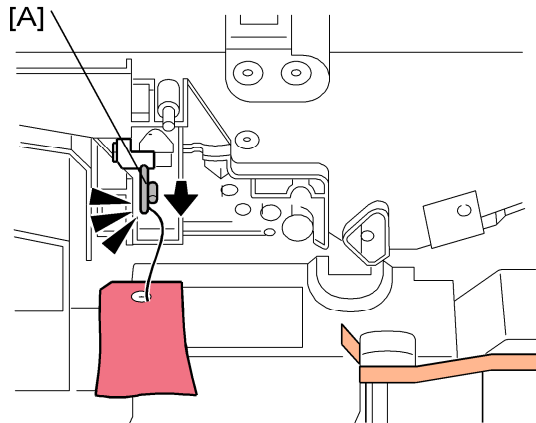

d014i723

### ★ Important

- **Do not pull out the drawer unit until after you remove the stabilizing rod and tag.**

11. Pull on the reinforced ring of the red tag to pull out the stabilizing rod [A].

## Reattach the Faceplate

---

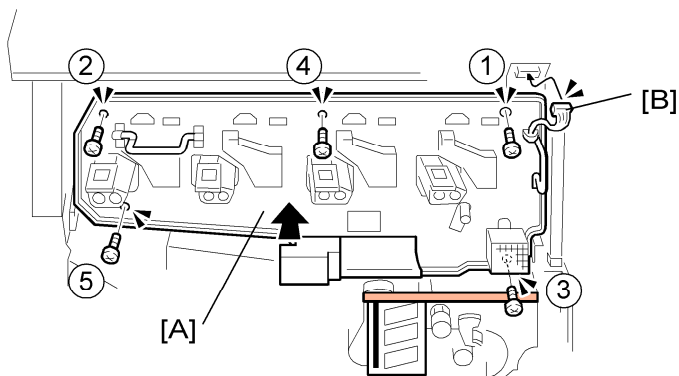

d014i716

1. Attach the faceplate [A] with the screws in the sequence shown by the numbers above (🔩 x 5).

### ★ Important

- **Do not tighten these screws too much.**

2. Reattach the fan [B].

### ★ Important

- **Make sure the fan connector is not pinched behind the faceplate.**

## Installation

### Remove Remaining Retainers and Packing Material

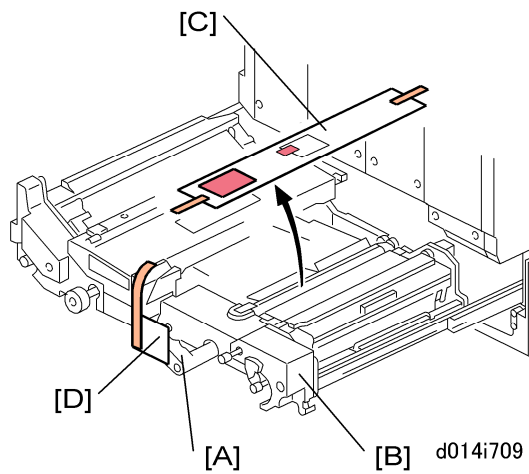

1. Turn the lever [A] down to the left, and pull the drawer unit [B] out of the machine until it stops.
2. Remove the instruction sheets [C] and [D].

#### ★ Important

- A sheet of paper protects the ITB if you accidentally pull the drawer out without first removing the rod. Do not push the drawer into the machine. Follow the procedure on the instruction sheet to remove the rod and paper.

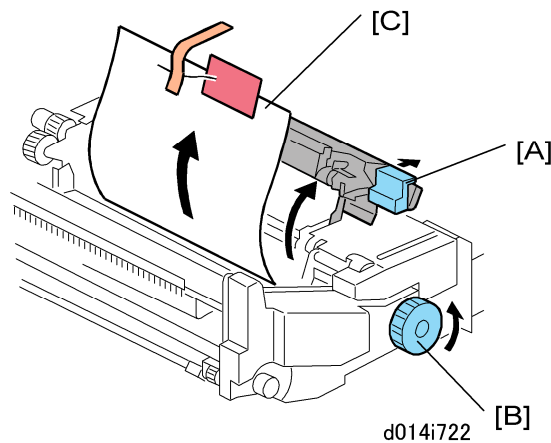

3. Raise lever **D2** [A] of the fusing unit.
4. Turn knob **D1** [B] in the direction shown by the arrow.
5. Remove protective sheet [C] with tape and red tag.
6. Lower lever **D2** [A].
7. Push the drawer into the machine until it stops.
8. Rotate handle B2 up and to the right until it stops.

## Installation

---

### Filling the PCU Units with Developer

---

#### Before You Begin...

- Follow this procedure in the order described below.
- Do not turn the machine on or off or open the front door until you are instructed to do so.

#### Developer Filling Procedure

1. If you have not already done so, remove the toner hopper unit (described above).

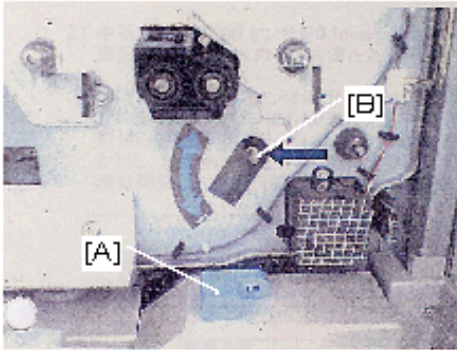

temp\_devinstall\_1

2. Attach the transfer belt release lever [A] to the tip of the shaft [B].

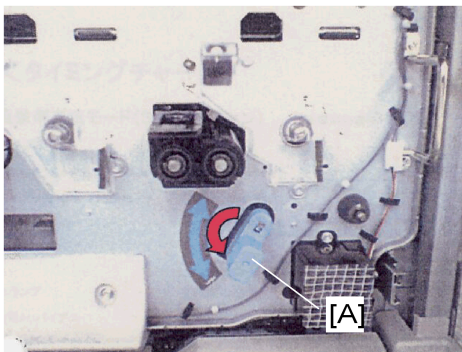

temp\_devinstall\_2

3. Rotate the lever [A] down to separate the transfer belt from the surfaces of the PCU drums.
4. Before attaching each bottle, loosen the developer to ensure that it will drain completely.



temp\_dev-shake30

- Vigorously shake the bottle up and down 10 to 15 times.

**★ Important**

- Hold the bottle as shown above, with the white component pointing up.

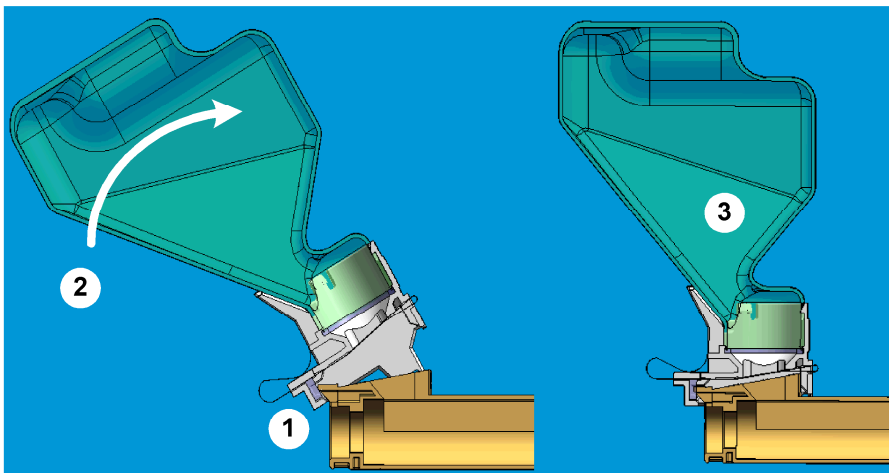

ins\_0001

5. Mount a developer bottle on each PCU.
  - Set each bottle as shown at .
  - Swing the bottle to the right until it snaps into place and is upright .
  - Install the bottles from left to right in this order: Y C M K.

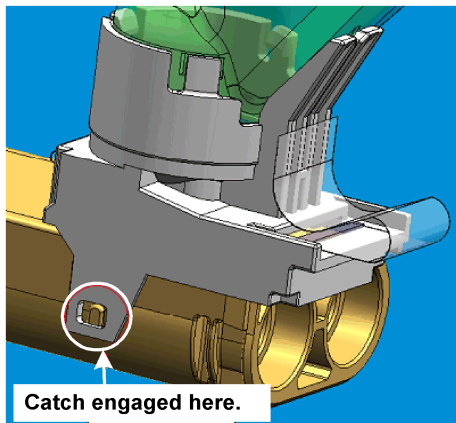

ins\_0002

6. Confirm that the neck of each bottle snaps and locks in place. Confirm that the neck of each bottle is parallel with the top of each PCU.

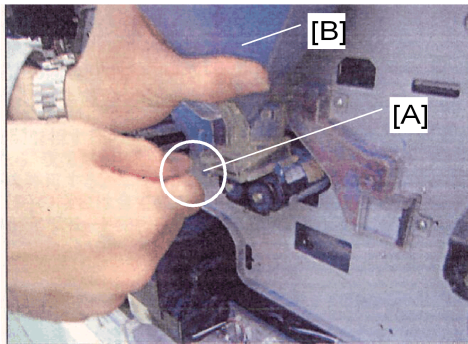

temp\_devinstall\_3

7. To prevent the bottle from falling off, hold the bottle [B] with the left hand as shown, pull the heat seal [A] out of the developer bottle and remove it.
8. Pull the seals from all of the bottles (Y, C, M, K).
9. Make sure that you have removed all the seal strips (you should have four strips, one for each bottle).
10. Gently tap the sides of each bottle to make sure that the developer flows freely.
11. **Close the front door.**

**★ Important**

- **The door must be closed before you switch the machine on.**

12. Turn the machine power on.
13. Enter the SP mode and do the following SPs:
  - **SP3814-1.** Fills all of the PCU units with developer from the attached bottles. It takes about 4 minutes. Press 'Exit' when 'Completed' appears on the display.
  - **SP3815.** Confirms that **SP3814-1** executed correctly. If **SP3814-1** executed correctly, you will see "1111" (K M C Y).

Display	What It Means
1	Succeeded
4	The PCU is already full of developer.
9	Failed
7	Developer filled before doing SP3814-1

14. Confirm that each developer bottle is completely empty.
  - Each developer bottle must be completely empty.
  - Even if SP3815 returned a "1" for each bottle to indicate successful completion of the operation, there may be toner remaining in a bottle.
  - It is very important that you check each bottle visually for remaining developer. Shine a penlight on the bottle if it is difficult to see inside the bottle.
  - If you see developer still remains in a bottle, do not disconnect the bottle. Refer to "Handling Problems with Developer Filling" under "PCU" in Section 3.
15. Switch the machine off.

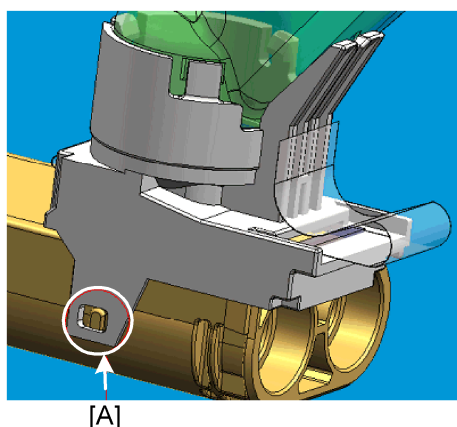

ins\_0003

16. Remove the developer bottles. Use the tip of a small screwdriver to release the bottle latch at [A].
17. Discard the empty bottles.

**★ Important**

- Obey local laws and regulations concerning the disposal of items such as the empty bottles.
- If you experience any problem with developer filling, go to Section 3 and do the procedures described under "Handling Problems with Developer Filling" in the



## Installation

### "PCU" section.

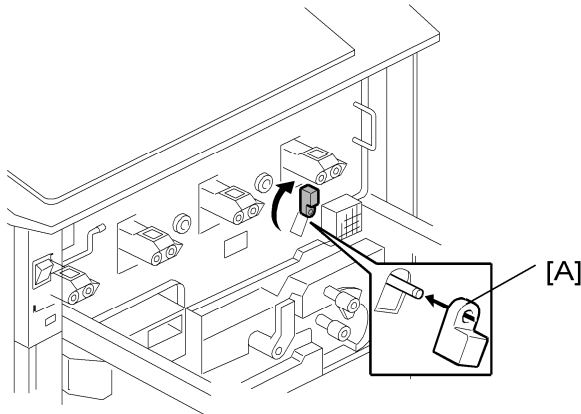

b132i707

18. Locate the transfer belt release lever [A]. (It was removed earlier with the shipping tape, and should already have been installed on the shaft in step 2.)
19. Attach the transfer belt release lever as shown above and turn it to the vertical position and make sure that it locks.

## Reinstall the Toner Hopper

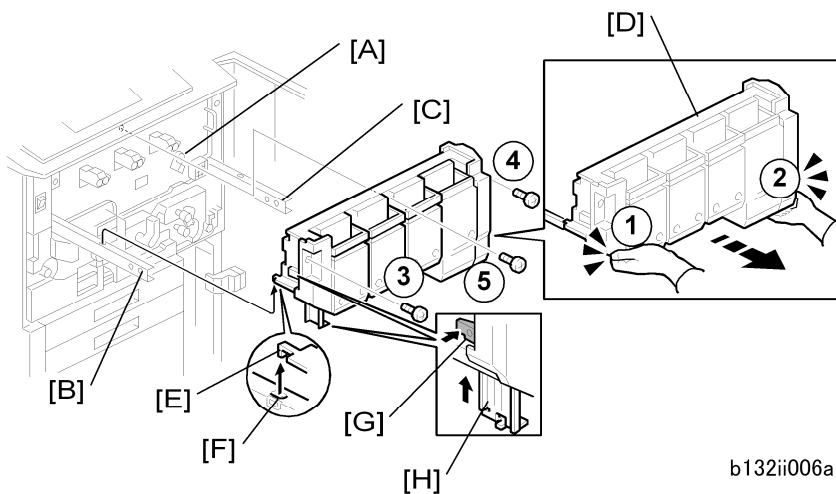

b132ii006a

1. Rotate the transfer release lever [A] up so that it locks.

### ★ Important

- The transfer belt release lever must be turned up and locked before you install the toner hopper. If you forget to attach the transfer belt release lever [A], or if it is not locked, this will cause an image transfer roller position error (SC447).
2. Pull out the toner hopper left rail [B] and right rail [C] until they are fully extended. (If the rails were pushed in fully, use a pair of needle-nose pliers to pull them out of the machine.)

## Installation

---

3. Set the toner hopper [D] on the rails.
4. Make sure the steel tabs [E] of the hopper are inserted fully into the left rail hole and the right rail hole [F].
5. Push the lock [G] and push the support leg [H].
6. Make sure that the support leg is up and locked before you push the toner hopper into the machine.
7. Put your hands at the bottom of the toner hopper at ① and ②, then push the hopper into the machine against the faceplate.

### ★ Important

- To prevent damage to the hopper, never push the top of the toner hopper.

8. Make sure that the hopper is flat against the faceplate on the right side.
9. If the toner hopper [D] is not flat against the faceplate on the right side, pull it out a short distance and make sure that the transfer belt release lever is turned up fully.
10. Attach the toner hopper (🔩 x 3). Attach the screws in this sequence: ③ ④ ⑤

## STC (Soft Toner Cartridge) Installation

---

Before you begin:

### ★ Important

- You must use the D014/D015 STCs with this machine.
- The STCs of the previous model (or any other model) cannot be used with this machine (the D014/D015 STCs contain 90% toner and 10% carrier).
- Make sure that you install each STC in the correct bin.
- The label on the toner cartridge must face the front of the machine.
- From left to right, the bins are for Y, C, M, K.
- The name of the color for each bin is on the decals that are attached to the bin release levers.

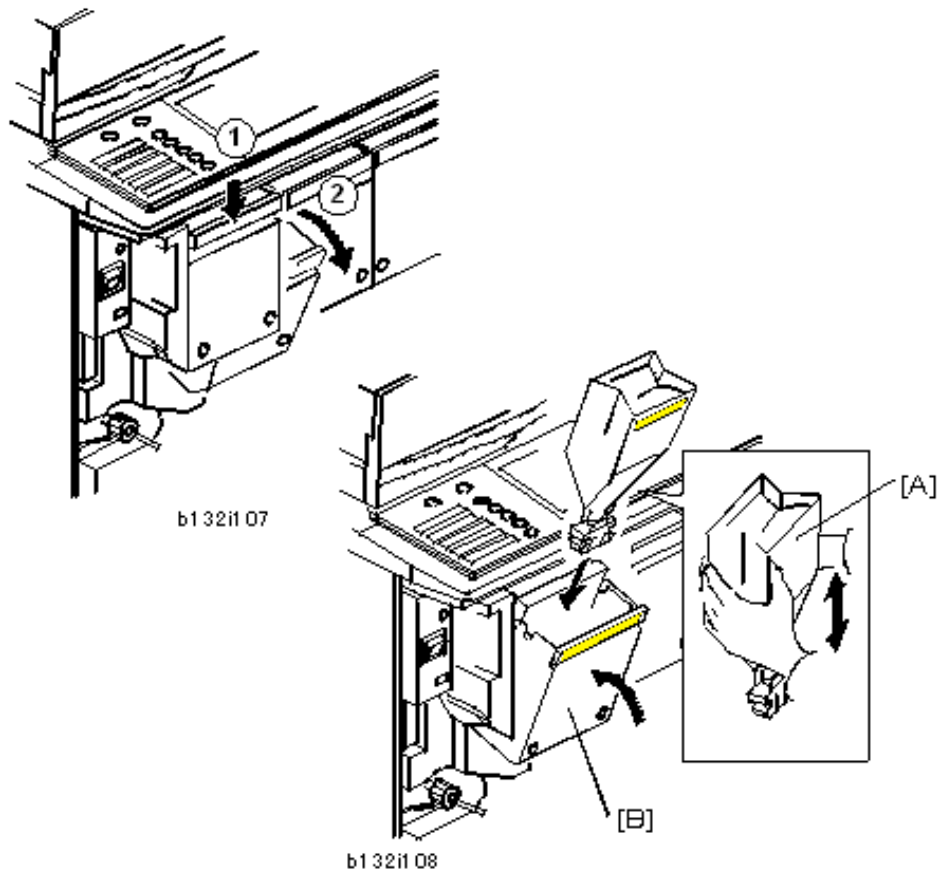

1. Push down the lock lever ① on the top edge of the Yellow bin (the bin at the far left) to release it. Then pull the bin ② in the direction of the front to open it.

**★ Important**

- To prevent damage to the bin door, do not try to pull a bin directly out. Push down on its top edge first to release it, then pull it to open it.

2. Remove the Yellow STC (Soft Toner Cartridge) from its box.
3. Shake the STC [A] up and down about 10 times. Do not squeeze or knead the toner cartridge (this will make clumps in the toner).
4. Make sure the flat bottom of the cartridge is up.
5. Set the Yellow STC in the bin [B].
6. Push the Yellow STC bin to close and lock it.
7. Repeat this procedure for the other three STCs (C, M, K)

**★ Important**

- Make sure that the color of each STC agrees with the label on the bin door before you install it.

#### Before You Begin...

- Follow this procedure in the correct order as described below.
- Do not turn on the machine until you are instructed to do so.
- To prevent damage to the drums during this procedure, **make sure that the front door is open before you switch on the machine.**

#### **CAUTION**

- If the machine is switched on during this procedure with the front door closed, processing control executes. This causes the bare drums to rotate against the counter blades before a light coat of toner has been applied to the surfaces of the drums. This could damage the drum.

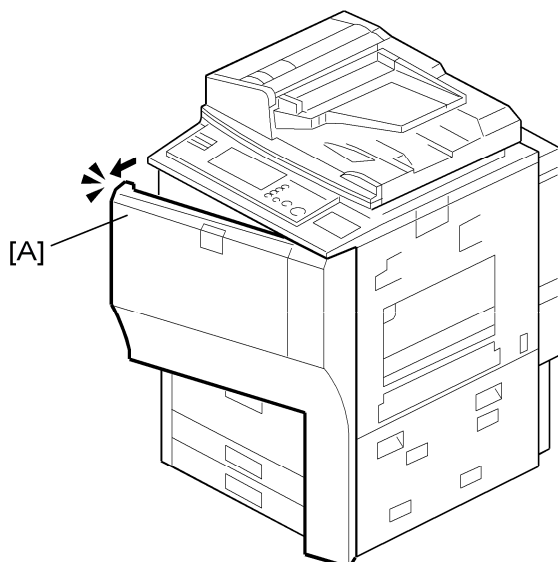

b132i721

#### 1. Open the front door [A].

##### Important

- You must open the front door.
  - Turning on the machine with the front door open prevents the machine from performing the initial process control self-check.
  - If the front door is closed, the drums will start rotating with no toner in the PCUs.
  - If the drums rotate with no toner in the PCUs, this can cause the cleaning blades to catch on a dry drum and damage the drum surface.
2. With the front door open, turn on the main power switch.
  3. Close the front door after "Open Cover" appears on the display.

##### Important

## Installation

---

- **You must close the front door.**
- 4. Wait for the machine to warm up and enter standby mode.
- 5. Enter the SP mode and do **3811-1** to send toner to the PCUs and initialize the TD sensor. This requires about 4 min.

### ★ Important

- If 'Failed' appears immediately after you start SP3811-1, the machine has not warmed up. Wait 2 minutes, and then do SP3811-1 again.
  - Do SP3811-1 only once.
  - Executing SP3811-1 more than once can cause toner spill inside the machine. SP3811-1 initializes not only the TD sensor but initializes the developer as well.
  - Never do SP3801-1 after doing SP3811. If the TD sensor is initialized twice this will cause a fatal error in toner supply control.
6. When the message tells you that the initialization is completed, touch [Close].
  7. Do **SP3812-1** to confirm that **SP3811-1** executed correctly.
    - If you see "1111" (K M C Y), this means **SP3811-1** executed correctly.
    - If you see any number other than "1111", this means an error. (See **SP3812** Errors.)

### ★ Important

- For a complete list of errors and how to solve problems related to SP3812, please refer to "4.2.3 SP3812 001 (DevSetup Execute) Errors" of the **B132/B200 Service Manual**.
8. Do SP **3821-1** to check that process control was completed successfully.
    - For each color, there is a two-digit code, in the order K,M,C,Y. '10' means that process control was completed successfully. '10101010' means that all 4 colors completed process control successfully.

## Load the Paper Trays

---

For each paper cassette tray:

1. Move the side fence and bottom fence to the correct positions for the paper.
2. Add paper to the trays.
3. Attach the paper size decals to the front of the paper cassette trays and the tandem tray.

### ↓ Note

- It is not necessary to input the paper size setting for trays 2 and 3. This is detected automatically.

## Make a Test Color Print

---

1. Make sure that A3 or DLT paper is in one of the trays.

## Installation

---



- Use the same type of paper that the customer normally uses for color outputs.
2. Put a "Color Chart C-4" on the exposure glass.
  3. Select full color mode and print one copy of the chart. You will use this in the ACC procedure, if ACC is necessary.
  4. Check the results of the copy with the customer.
    - If the quality of the color is satisfactory, ACC adjustment is not necessary.
    - If the quality of the color is not satisfactory, do the ACC adjustment described below.

## ACC (Automatic Color Calibration) Adjustment

---

Automatic color calibration is done at the factory with the procedure given below. Do this procedure only if the color quality is not satisfactory for the customer.

1. Push [User Tools] () .
2. To print a color pattern, select Maintenance> Auto Color Calibration
3. Touch "Start".  
`Machine will start self-check before  
printing test pattern  
Press [Start Printing].`
4. Touch "Start Printing".  
`Now self-checking.  
Test pattern will be printed.  
Please wait.  
The machine does process control, then it prints a test pattern.  
Place Test Pattern on the exposure glass correctly.  
Then press [Start Scanning]`
5. Remove the C-4 test chart from the exposure glass (this was put on the exposure glass during the previous procedure 'Make a Test Color Print').
6. Place the color test pattern face-down (this is the test pattern that you made in step 4). The arrow and notation ("Face down and align the arrow with the rear left corner of the exposure glass.") must be at the rear left corner.
7. Touch [Start Scanning] on the display. The machine scans the pattern one time.  
`Scanning...  
Please wait.  
If you see this error:  
Scanning failed.`

## Installation

---

Place test pattern on the exposure glass correctly.

Then press [Start Scanning].

Make sure that the arrow on the test pattern is in the upper left corner of the exposure glass.

8. Remove the pattern from the exposure glass and replace it with the C-4 Color Chart.
9. Touch "Exit" three times to return to the Copy mode screen.
10. Make a full-color copy of the test chart.
11. Compare the results of the 1st copy (made in step 3 of "Make a Test Color Print") and the 2nd copy (made in step 10 above):  
If the results of the 2nd copy are better than the results of the 1st copy, you are finished.  
-or-  
If the results of the 2nd copy are worse than the results of the 1st copy:
  - Push the [User Tools] key
  - Touch Maintenance> Auto Color Calibration> Previous Setting.
12. Remove the color chart from the exposure glass.
13. If the customer is not satisfied with the 1st copy or the 2nd copy, you must do the printer gamma adjustment (see Printer Gamma Correction in Replacement and Adjustment in the B132/B200 service manual).

## Do the Color Registration Procedure for MUSIC

---

1. Push [User Tools].
2. Touch [Maintenance]> [Color Registration].
3. Touch [OK].

This completes color registration.

## Counter Display Setting

---

The default setting for the counter is "0" (development). Do the SP setting below to set the counter for copy/print (paper count).

1. Enter the SP mode.
2. Do **SP5045-1**.
3. Select the counter to use:
  - 0: Development counter (Default)
  - 1: Page counter



- **This setting can be done only once. After it is set to "1", the counter setting cannot be changed. If the wrong setting is selected by mistake, contact your**

**technical supervisor.**

Make the Machine Level

---

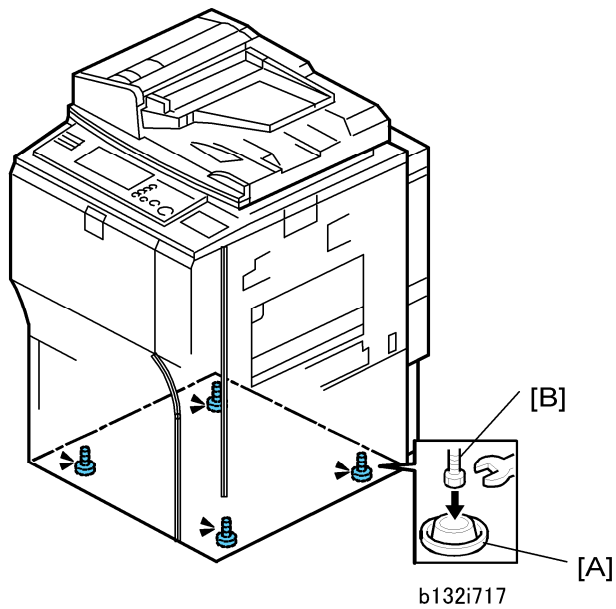

1. Place the leveling shoes [A] under the machine.
2. Place a level on the exposure glass.
3. Use a wrench to raise or lower the nuts [B] on the leveling shoes until the machine is less than 5 mm from level (measure from front-to-rear and left-to-right).

Attach the PCU Stand Rack and Store the PCU Stand

---

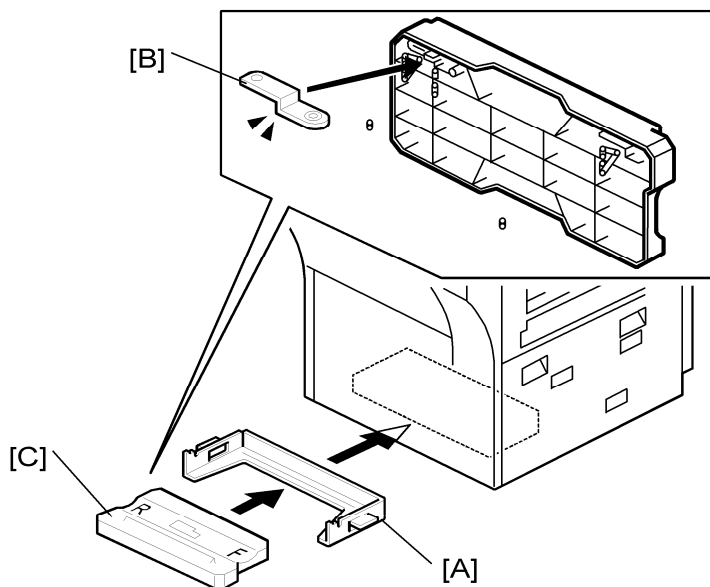

b132i718



## Installation

---

1. Hold the PCU stand rack [A] as shown, then attach it to the bottom of the machine (magnets hold it in place).
2. Make sure long lock plate [B] is inserted into the bottom of the PCU stand.
3. Slide the PCU stand [C] into the rack below the copier.

### ★ Important

- The PCU stand is required for servicing and must remain with the machine in the field.
- After a PCU is removed from the machine, it should always be placed on the PCU stand. The PCU stand (1) protects the OPC drum while the PCU is out of the machine, and (2) keeps the PCU properly aligned so the development unit can be reattached easily (after they have been separated.)
- To prevent damage to the exposed OPC drum on the bottom of the PCU, never set the PCU on the PCU stand of the previous model. Always use the PCU stand designed for the D014/D015.

## Attach Decals

---

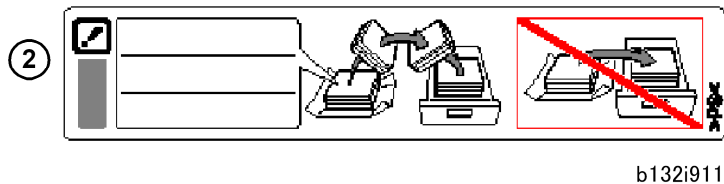
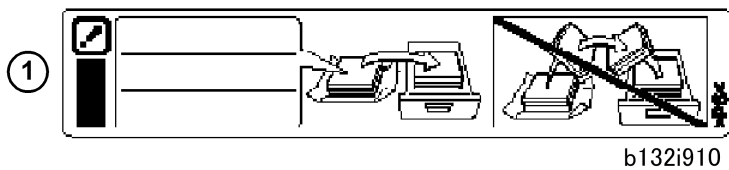

1. Attach the paper-installation decals to the trays. These tell you how to add new paper.
  - Front set decal ①: Attach this decal to the LCT if it is installed. 'Front set' means that the paper should be face up in the tray.
  - Back set decal ②: Attach these decals to the trays of the copier. 'Back set' means that the paper should be face down in the tray.

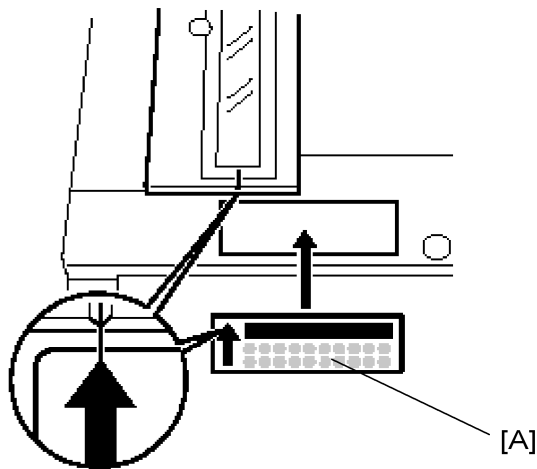

b132i912

2. Attach exposure-glass-cleaning decal [A] at the front edge of the ARDF exposure glass.

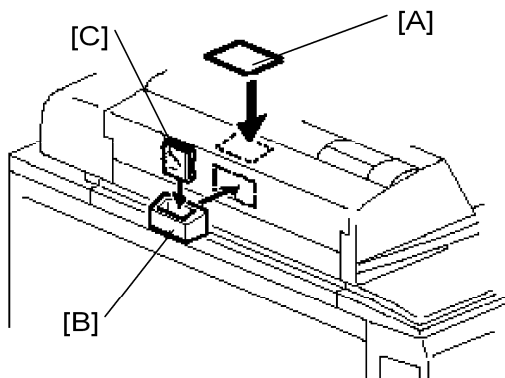

b132i913

3. Attach the original-caution decal [A], and the silicone cloth holder [B].
4. Put the silicone cloth [C] in the holder.

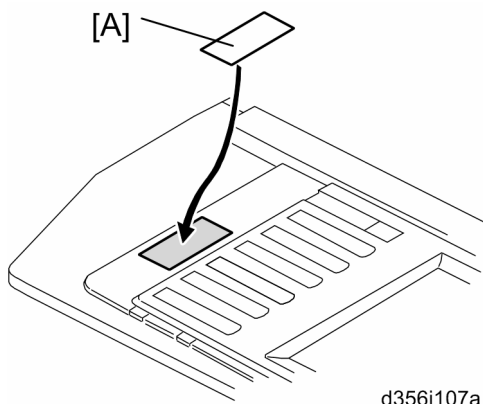

d356i107a

5. Attach the decal [A] according to the option installed.
  - If the FAX Option is NOT installed, attach the decal [A] without wording.

## Installation

---

- If the FAX option is installed, attach the decal [A] with wording “Communicating” and “Receive File”.

## Enable USB

---

Do SP5985 to enable USB.

## Print an SMC Report

---

1. Go into the SP mode.
2. Do **SP5990-1** to print a full SMC report. Keep it in a safe location, with the factory setting sheet.

## Connect the Upper and Lower Tray Heaters

---

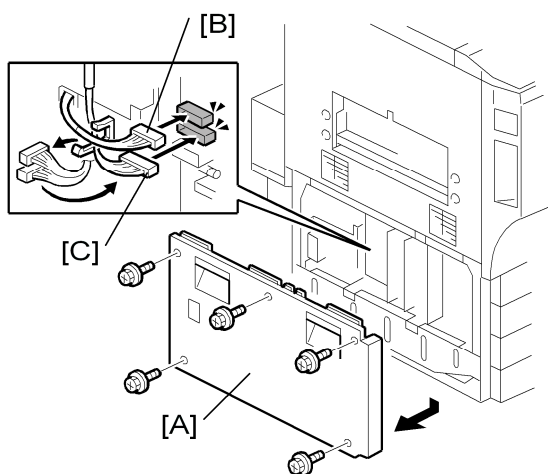

b132i009

The machine comes from the factory with the tray heaters disconnected.

### ↓ Note

- Heater connection is optional. Connect the heaters if the location is extremely humid. Speak with the customer before you connect the tray heaters.
1. Remove the left lower cover [A] (⚙️ x 5).
  2. If the paper tray unit heater (HTS) or image transfer/scanner heater are required, attach connectors HT5 [B] and HT6 [C] (🔌 x 1, 📌 x 2)

---

## Copy Tray (B756)

---

### Accessories

---

Check the accessories and their quantities against this list.

Description	Q'ty
1. Copy Tray	1
2. Actuator Arm and Bracket (not used)	1
3. Tapping Screw (not used)	2
4. Large Cap	1
5. Small Cap	4
6. Tapping Screw (M4 x 8)	1
7. Harness Clamp	1
8. Paper Height Sensor	1
9. Actuator Arm Bracket	1
10. Sensor Bracket	1
11. Actuator Arm	1

## Installation

---

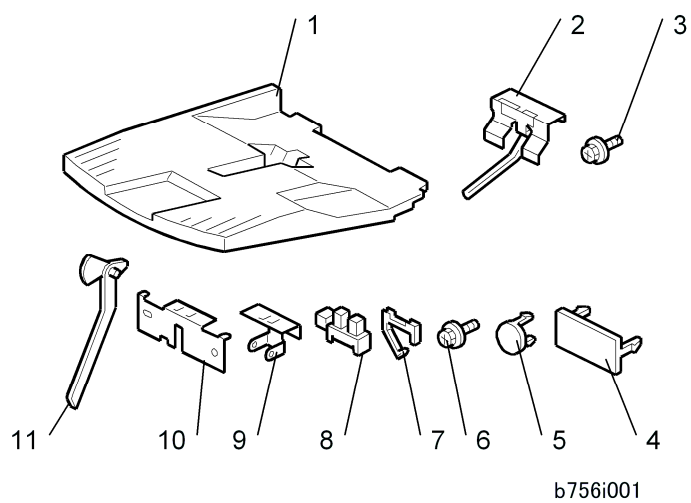

## Installation

---

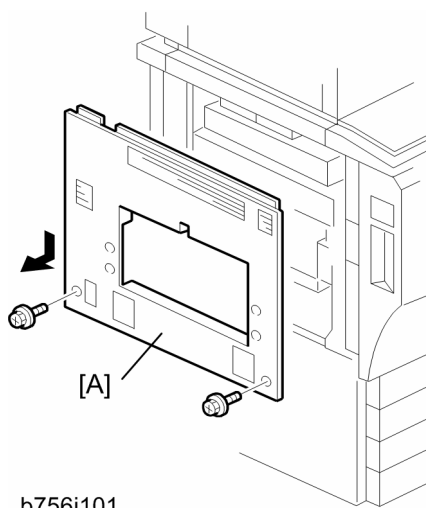

1. Remove the left upper cover [A] (⚙ x 2).

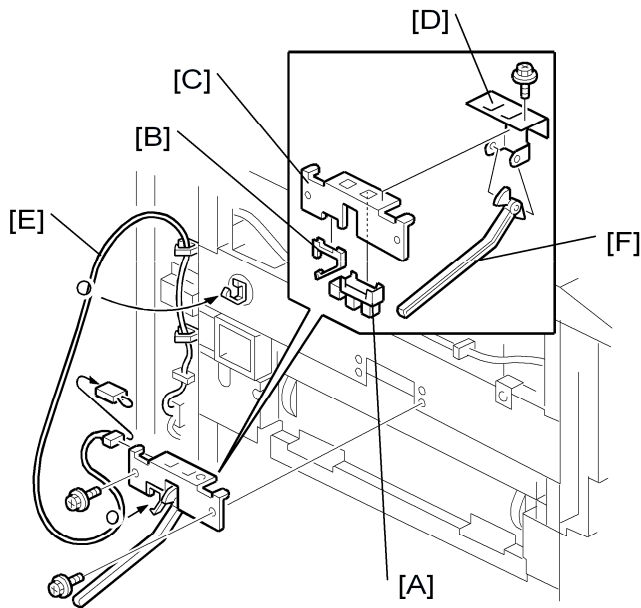

b756i003

2. Attach the paper height sensor [A] and harness clamp [B] to the sensor bracket [C].
3. Attach the sensor bracket and actuator arm bracket [D] to the copier (⚙ x 3).
4. Attach the sensor harness [E] (🔌 x 1, 🖨 x 4).

1. Attach the actuator [F] to the arms of the actuator arm bracket.

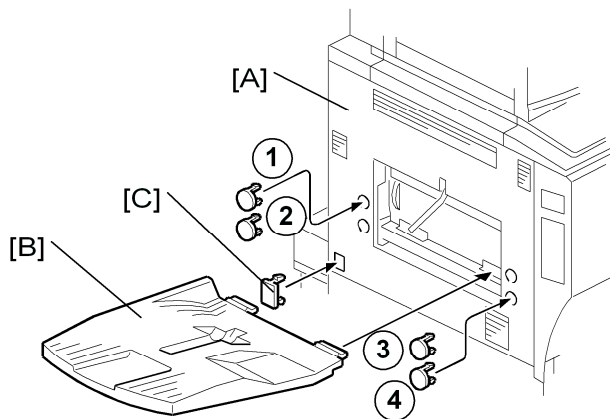

b756i002

2. Reattach the left upper cover [A] (⚙ x2).
3. Attach the tray [B].
4. Attach the small caps to the holes ①, ②, ③, ④.
5. Install the large cap [C] in the finisher power connection point.

---

## A3/11" X 17" Paper Size Tray (B331)

---

The A3/11" x 17" Paper Size Tray is installed in tray 1 of the D014/D015 copier.

---

### Accessories

---

Check the accessories and their quantities against this list.

Description	Qty
1. A3/DLT Tray	1
2. Short Connector	1
3. Paper Size Decal	1

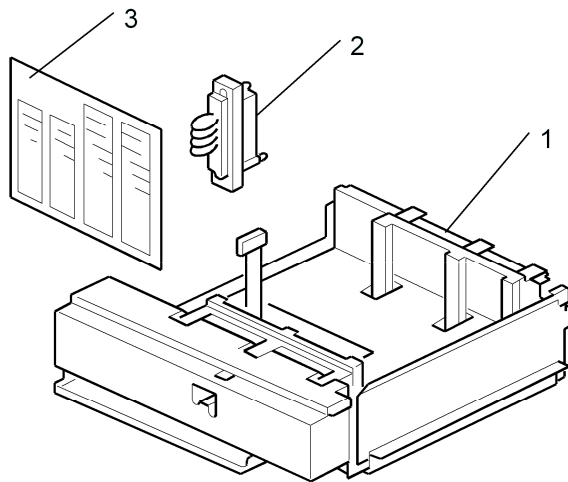

b331i001

### **WARNING**

- Always turn the machine off and disconnect the machine power cord before you do the following procedure.

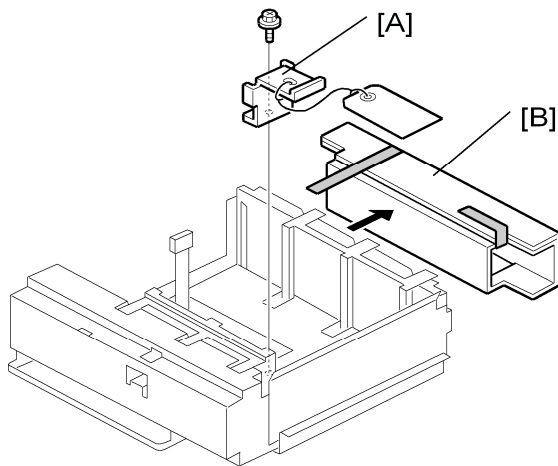

b331i011

1. Remove the metal retainer [A] and packing material [B] (1 x 1).
2. Check the position of the front and rear fences, and make sure that they are set for DLT or A3.

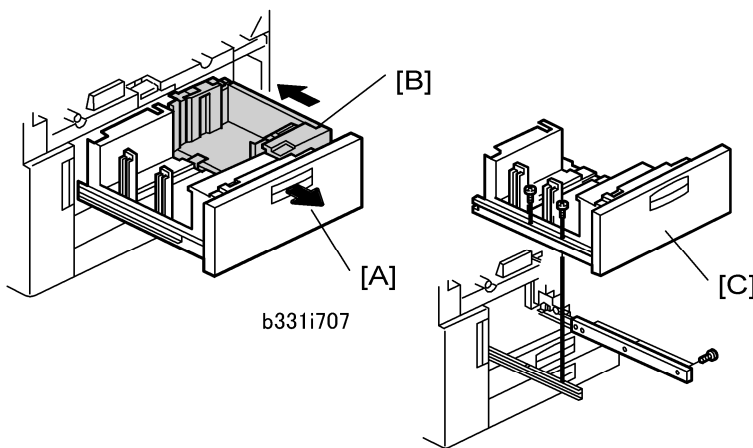

b331i708

3. Open the front doors.
4. Pull out the tandem feed tray [A] fully.
5. Push the right tandem tray [B] into the machine.
6. Remove the left tandem tray [C] (2 x left, 3 x right).



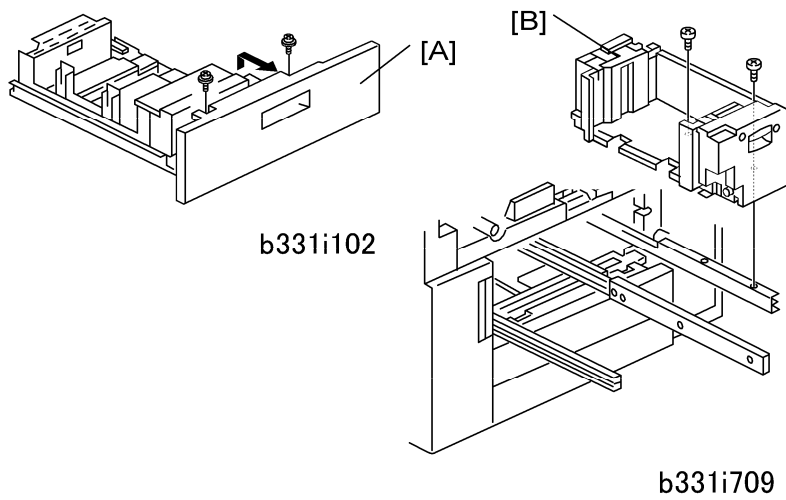

7. From the left tandem tray, remove the front cover [A] (⚙ x 2).
8. Pull out the right tandem tray [B], then remove it (⚙ x 2).

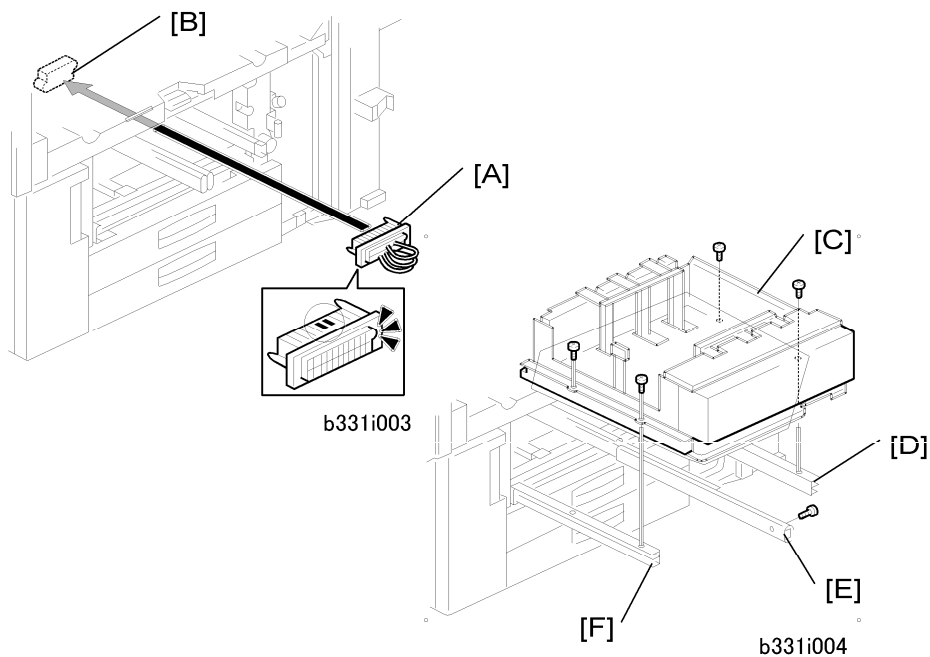

9. Put the short connector [A] into the socket in the machine [B].

↓ Note

- Hold the connector as shown in the illustration.

10. Install the A3/DLT tray [C] on the right rail [D], center rail [E], and left rail [F]. Use the screws that you removed in Steps 6 and 8.

↓ Note

- You must use the short, silver screws on the left and right rails. If you use one of the longer screws, it will stop the movement of the tray on the rails.

## Installation

---

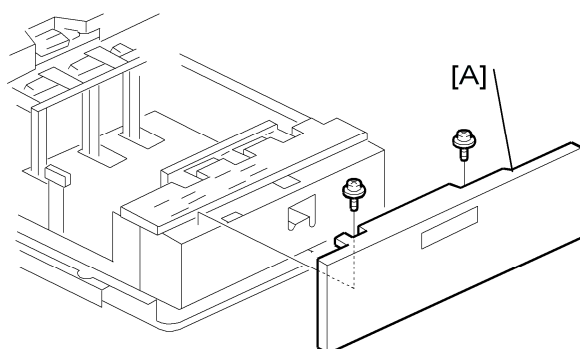

b331i105

11. Install the front cover [A] (2) that was removed from the left tandem tray.
12. Use SP5959 001 to select the paper size for Tray 1 (A3 or DLT).
13. After you select the paper size, turn the machine off and on to change the indicator on the operation panel.

---

## LCT (B473), LCT Adapter (B699)

---

### Accessories

---

Check the accessories and their quantities against this list.

#### LCT (B473)

---

Description	Qty
1. Upper docking pins (grooved)	2
2. Lower docking pin (not grooved, not for B132/B200)	1
3. Flat-head shoulder screw - M4x6	1
4. Paper Set Decal	1

## Installation

---

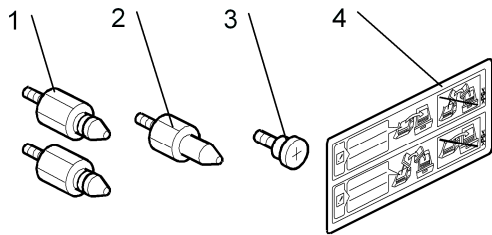

b474i101

## LCT Adapter (B699)

---

Description	Qty
1. Brackets	2
2. Supports	3
3. Machine Screws (M3x8)	3
4. Machine Screws (M4x8)	6

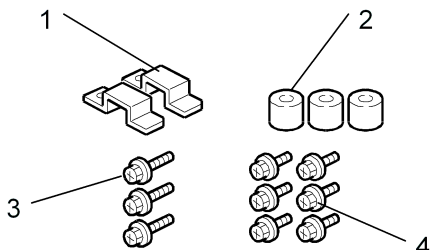

b699i101

---

## Installation

---

### Removing Tape and Accessories

---

#### **WARNING**

- Always turn the machine off and disconnect the machine power cord before you do this procedure.

## Installation

---

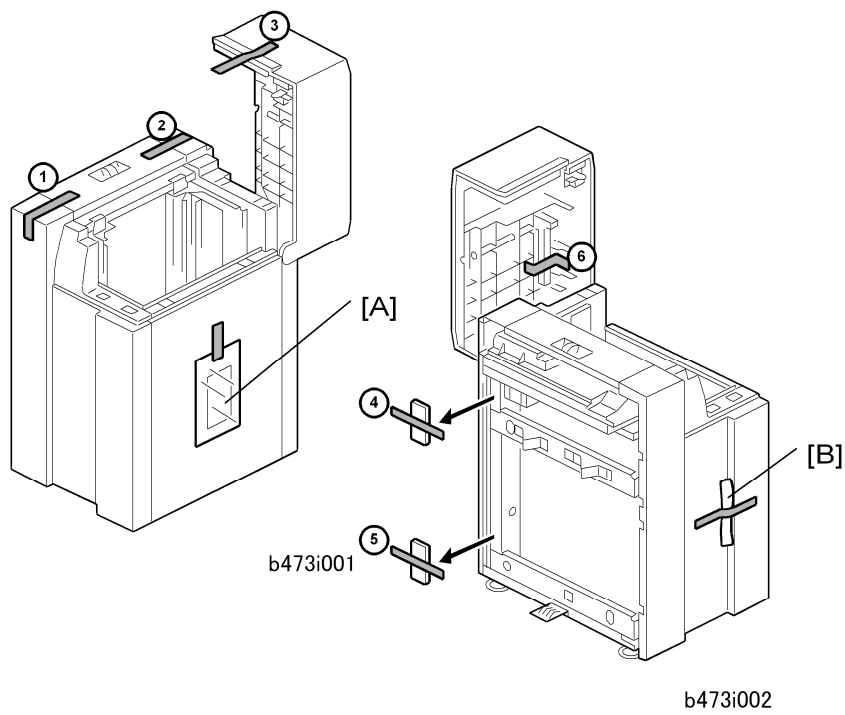

1. Remove all filament tape ① to ⑥.
2. Remove:
  - [A] Decals
  - [B] Docking pins

## LCT Adapter (B699) Installation

---

The LCT Adapter Kit B699 must be installed before you install the LCT.

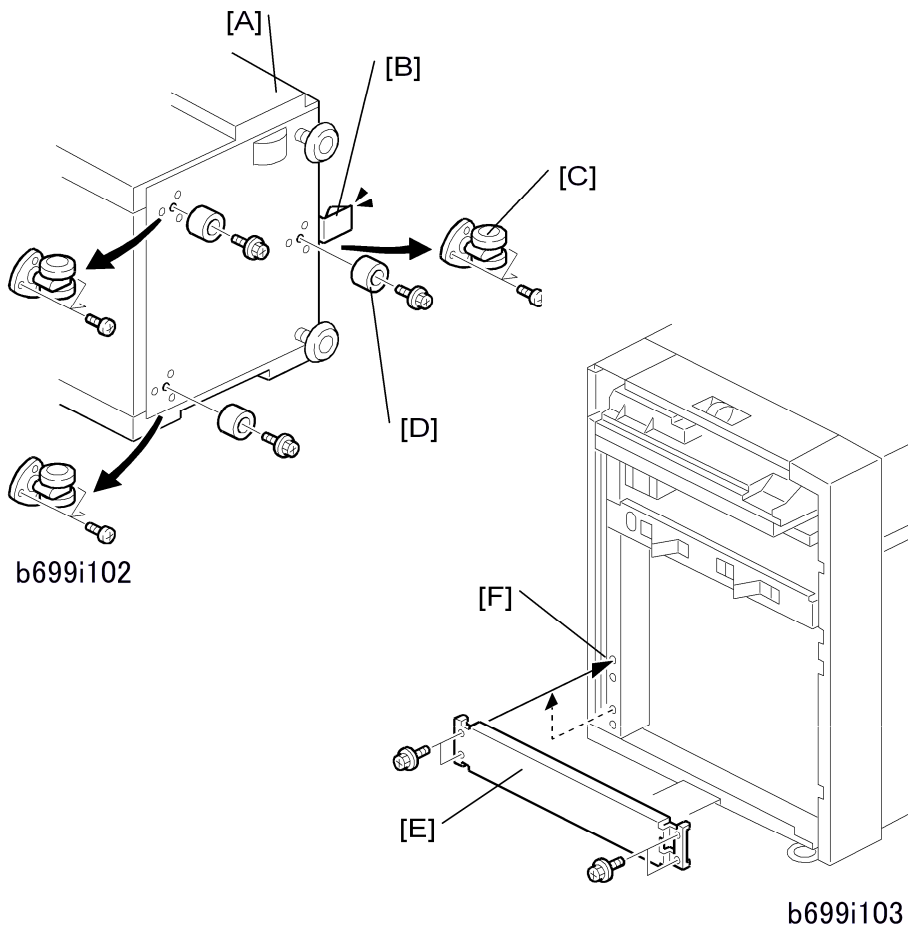

1. Put the LCT [A] on its front side.



- Do not put the LCT on its right side (the open side), or you will bend the ground plate [B].

2. Remove the 3 casters [C] (⌀ x 3 each).
3. Attach the 3 supports [D] (⌀ x 1 each – M3x8 thin screws).
4. Set the LCT in a vertical position.
5. Remove the stay [E] (⌀ x 4).
6. Attach the stay at [F] (⌀ x 4).

## Installation

### LCT Installation

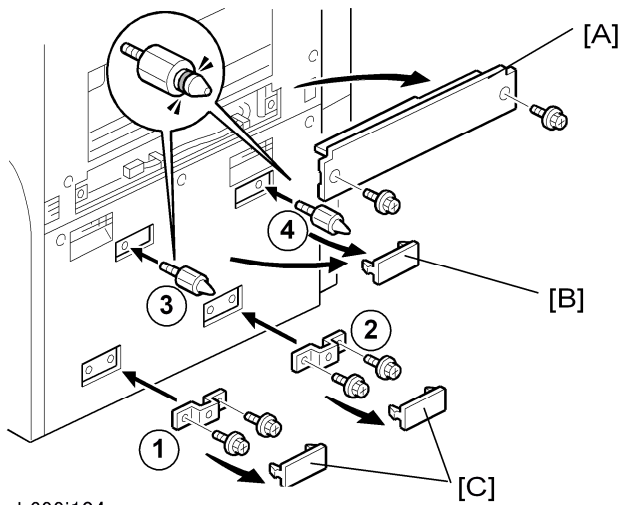

1. Remove the LCT installation cover [A] from the right side of the machine (⌀ x 2).
2. Remove the upper covers [B].
3. Remove the lower covers [C].
4. Attach the brackets ①, ② that are supplied with the LCT Adapter (B699) (⌀ x 2 each – M4 x 8).
5. Attach the two grooved docking pins ③, ④.

#### ↓ Note

- The docking pin without a groove is not necessary for this installation.

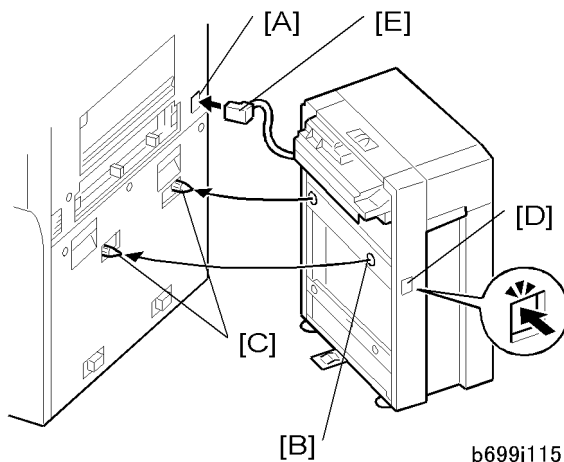

6. Remove the connector cover [A].
7. Align the holes on the side of the LCT [B] with the docking pins [C] on the side of the machine.
8. Slowly push the LCT onto the pins.

## Installation

---



- The release button [D] is used to unlock the LCT.
9. Connect the plug [E] of the LCT power connector to the side of the machine.

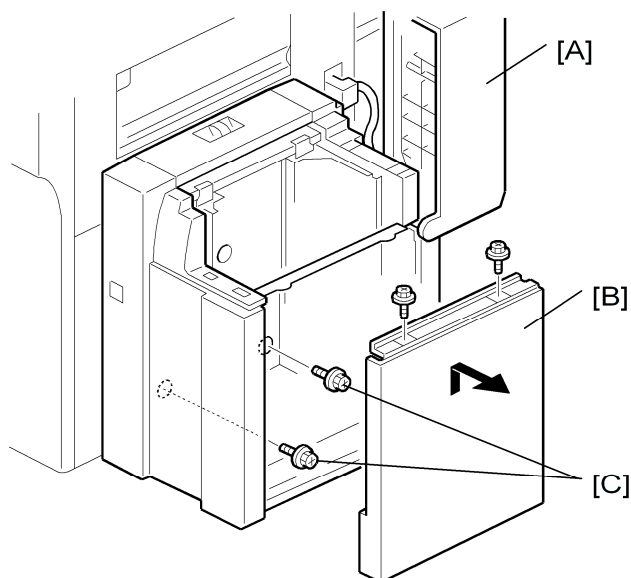

b699i107

10. Open the upper cover [A].
11. Remove the cover [B] (⌀ x 2).
12. Attach screws [C] to the brackets on the side of the machine.
13. Attach the cover [B] with the screw that you removed in Step 11.

## Adjusting Side Fences for Paper Size

---

### Before You Begin...

- The side fences must be adjusted manually for either A4 or LT. The procedure below is not required if the side fences are already set for A4.
  - Before doing this procedure, the LCT must be installed and connected to the copier and the copier must be switched on.
  - The procedure below shows how to move the side fences from the A4 to the LT positions.
1. Turn ON the copier main power switch.

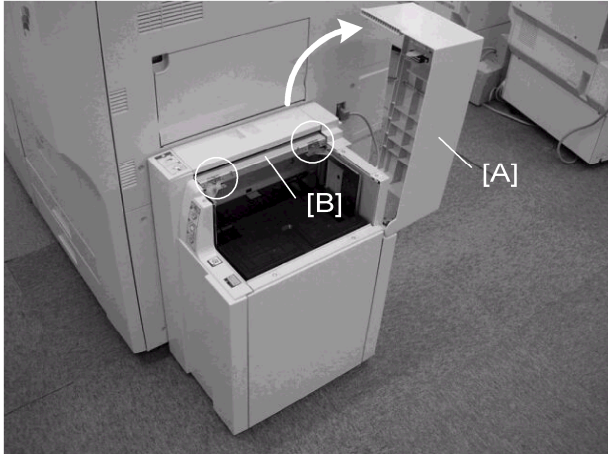

b473i200

2. Open the LCT top cover [A].
3. Check the position markers on plate [B].
  - If the fences are set for A4 and you intend to load A4, the LCT is ready and you do not need to do the following steps.
  - If the fences are set for A4 and you intend to load LT, do the steps below.

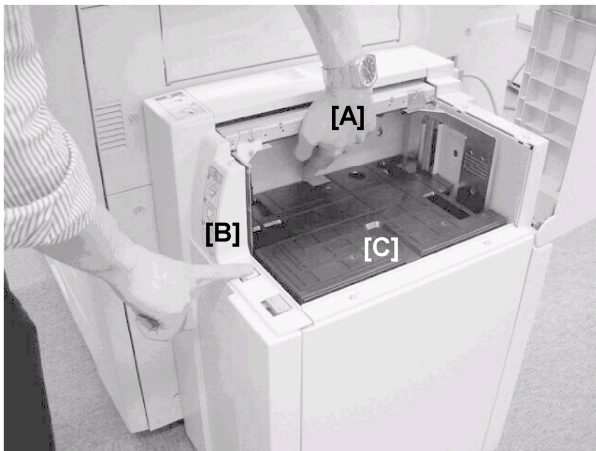

b473i201

4. Cover the photosensor [A] with your left hand.
5. Press the bottom plate operation button [B] until the bottom plate [C] is completely down, then release the button [B].



## Installation

---

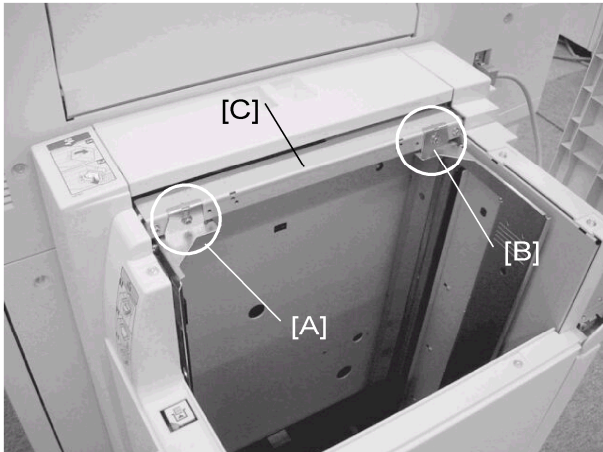

b473i203

6. Use a screw driver to remove the screws fastened to fences [A] and [B] so that the fences slide easily on plate [C].

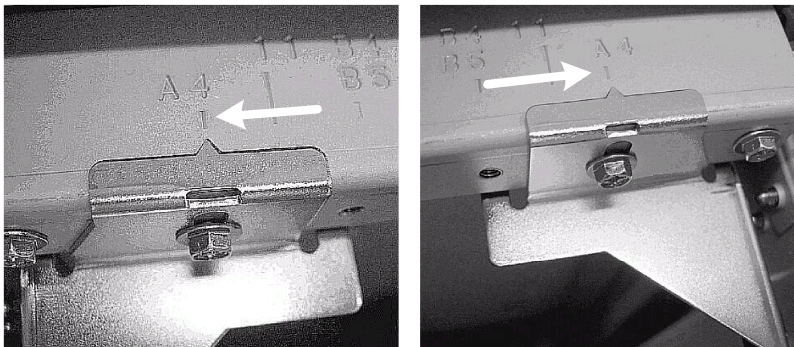

b473i203a

1. Move each side fence bracket from the A4 to the LT position, then reattach the screws.

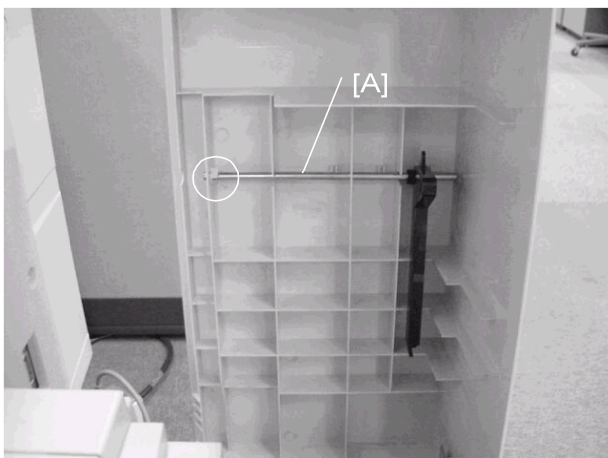

b473i204

## Installation

---

2. Remove the shaft [A] from under the LCT top cover (⌘ x1).

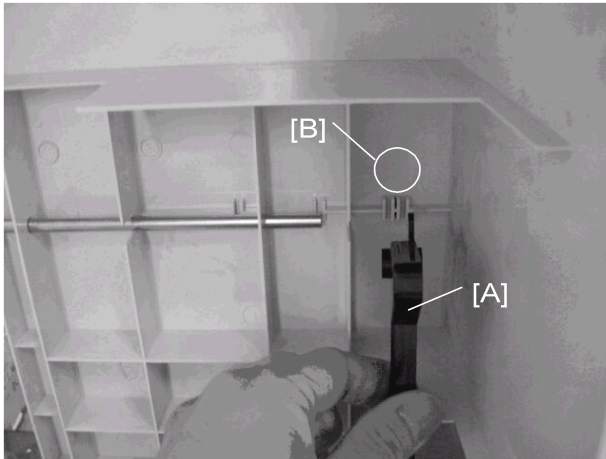

b473i205

1. Move the LCT end fence [A] from the A4 to the LT position (the position guide is written on the LCT top cover at [B]).
2. Insert the shaft [C] (⌘ x1).
3. Close the LCT top cover.
4. Do SP5959-5 and set the value to "1" (for "LT").

---

## Installation

---

---

### LG Unit for A4/LT LCT (B474)

---

The 81/2" x 14"/B4 (B474) is installed in the LCT (B473).

---

### Accessories

---

Check the accessories and their quantities against this list.

Description	Q'ty
1. Tapping screws - M4x8	4
2. Tapping hex screws - M4x8	6
3. Harness clamp	1
4. B4/LG frame	1
5. Front bracket	1
6. Rear bracket	1
7. Bottom plate extension	1
8. Cover	1

---

## Installation

---

### LCT Connected to the Machine

---

#### **WARNING**

- Turn the machine off and disconnect the machine power cord before you start this procedure.

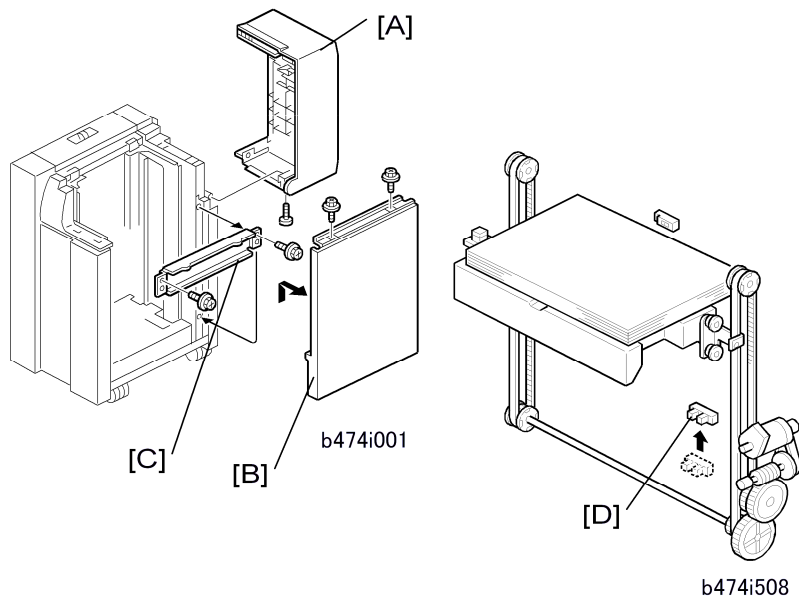

1. If the LCT is connected to the copier:
  - Open the cover and remove the paper.
  - Close the cover.
  - Turn the main power switch off.
  - Disconnect the LCT from the copier.
2. Remove the LCT cover [A] (⚙ x 1).
3. Remove the right cover [B] (⚙ x 2).
4. Remove the right stay [C] and attach it below (⚙ x 2).
5. Change the position of the lower limit sensor [D] (⚙ x 1).
6. Attach the harness clamp (not shown) to the rear of the plate. Use this clamp to hold the sensor connector wire.

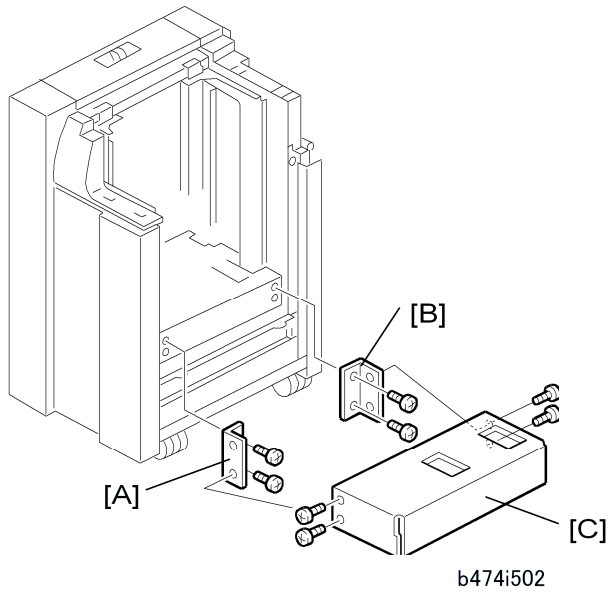

7. Attach the front bracket [A] with the beveled corner down (⚙ x 2).



- If the brackets are not easy to install, lift the bottom plate with your hand.
8. Attach the rear bracket [B] with the beveled corner down (⚙ x 2).
  9. Attach the bottom plate extension [C] with the hex screws (⚙ x 4).

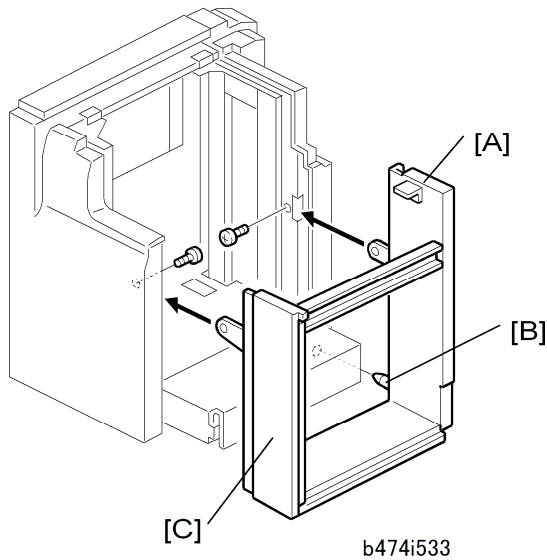

10. Remove the casters from the bottom of the B4/LG frame [A]
11. Align the positioning pin [B].
12. Attach the B4/LG frame [C] with the hex screws (⚙ x 2).

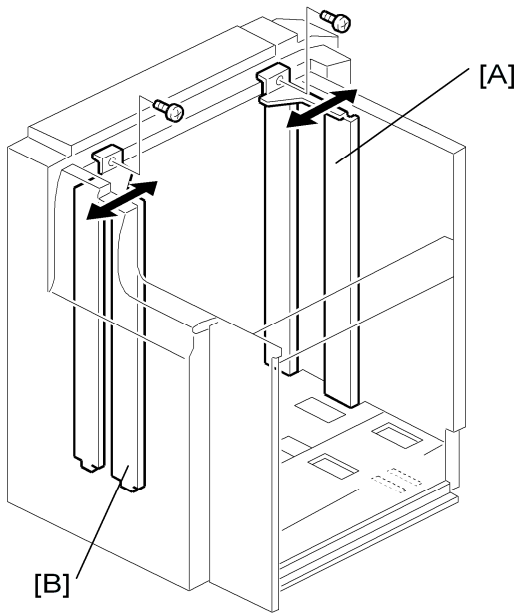

b474i555

13. Move the front side fence [A] and rear side fence [B] to the B4 or 8.5" position and attach it (⚙ x 1).

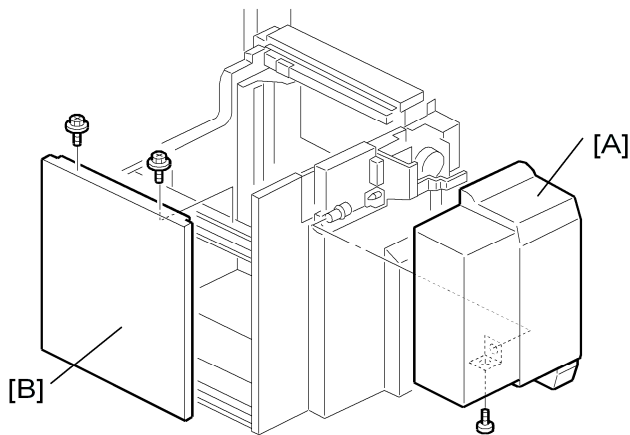

b474i506

14. Attach the cover [A] (8.5" x 14"/B4) (⚙ x 1).
15. Attach the right cover [B] (⚙ x 2).
16. Connect the LCT to the machine.
17. Turn the machine on.
18. Go into the SP mode and do **SP5959-2**.
19. Input "5" for B4 SEF or "6" for 8.5" x 14" SEF.

---

## LCIT RT4000 (D350)

---

### Accessories

---

Check the accessories and their quantities against this list.



- The accessory box is inside the LCIT (see the next page).

	Description	Qty
1.	Stay	1
2.	Relay Unit	1
3	Left Side Fence	1
4.	Right Side Fence	1
5.	Ground Wire	1
6.	Tab Sheet Holder	1
7.	Clamp	1
8.	Screws (M4x8)	2
9.	Screws (M4x8)	3
10.	Screws (Plastic Head)	1
11.	Joint Brackets	2
12.	Shoes	4
13.	Paper Size Decals (A3...)	1
14.	Paper Size Decals (A5...)	1
15.	Paper Loading Decals	1

## Installation

---

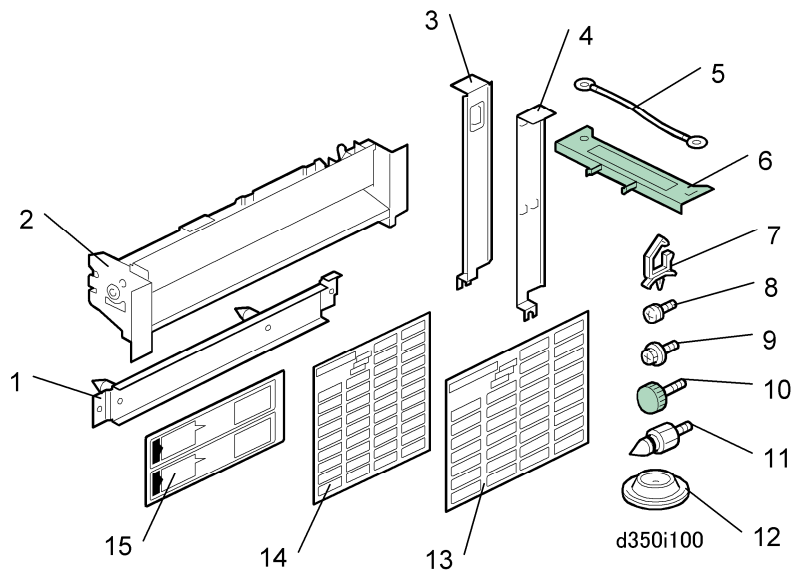

---

## LCT Installation

---

### Grounding and Preparing the LCT for Docking

---

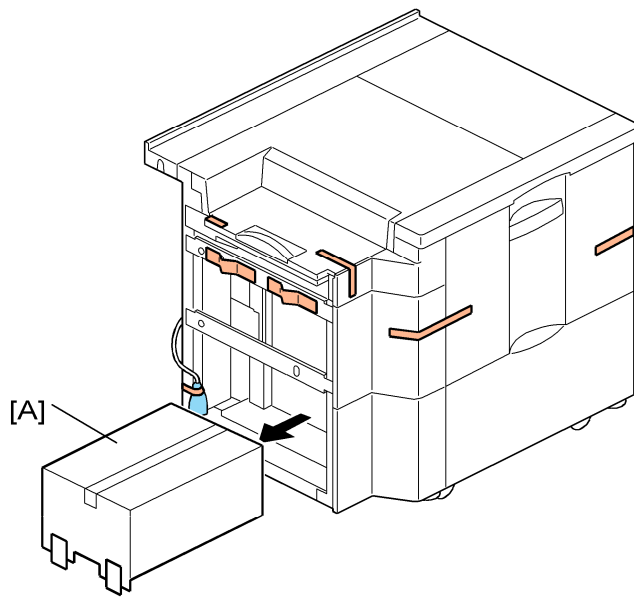

d350i101

1. Remove the accessory box [A] from inside the LCT.
2. Remove all tapes.



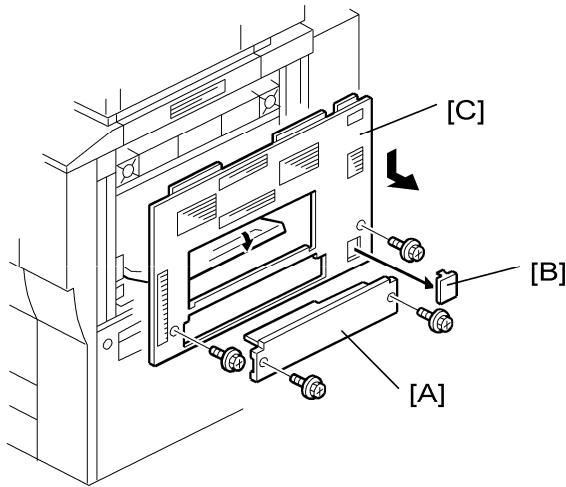

d350i102

3. Remove the paper entrance cover [A] (⚙️ x2).
4. Remove the connector cover [B].
5. Remove the right upper cover [C] (⚙️ x2).

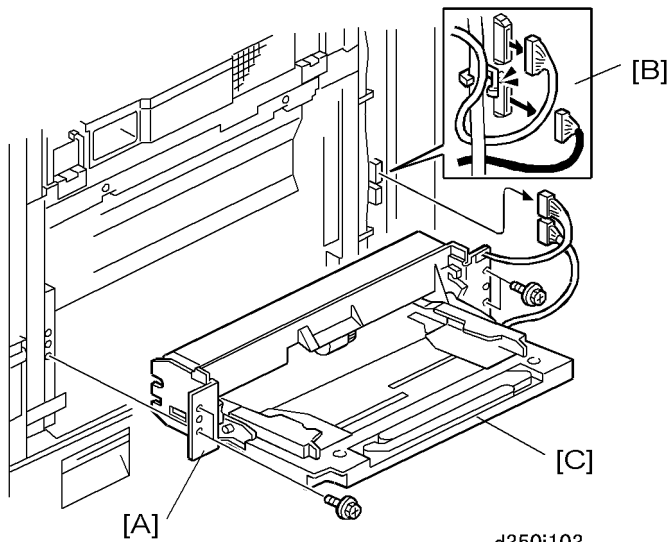

d350i103

6. Remove the plate [A] (⚙️ x2).
7. Disconnect the bypass unit connectors [B] (⚙️ x2).
8. Remove the bypass unit [C] (keep the screws) (⚙️ x4).

↓ Note

- Do not throw away the bypass tray. The customer may need it again later.

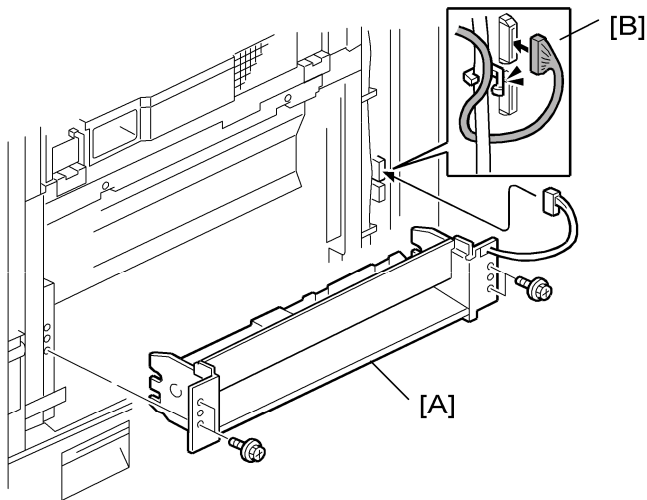

d350i104

1. Use the screws removed with the bypass tray to attach the relay unit [A] (⌀x4).
2. Connect the relay harness [B] (⌀x1).

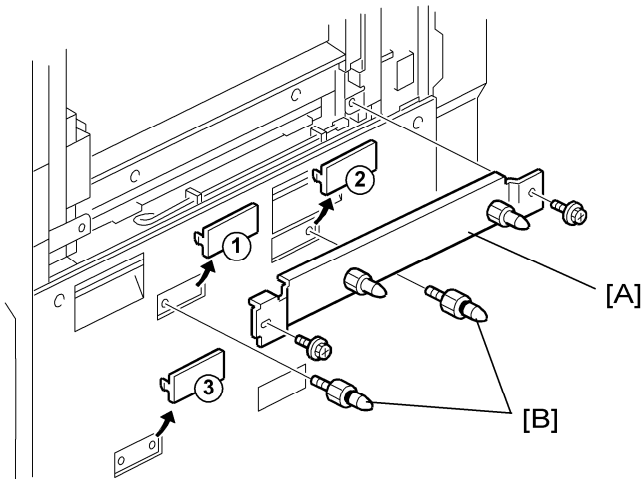

d359i105

3. Remove knockouts ①, ②, ③.
4. Attached the stay [A] with the provided screws (⌀x2).
5. Attach the joint connection pins [B] (x2).
6. Re-attach the right upper cover.

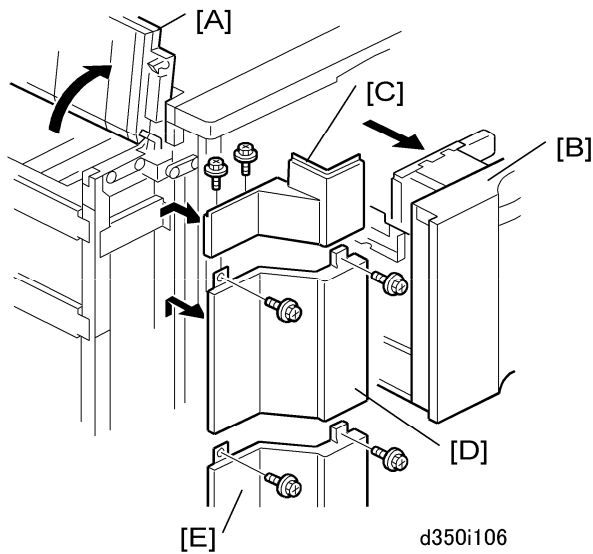

7. On the LCT, raise the paper exit cover [A].
8. Pull the paper tray [B] about halfway out of the unit.
9. Remove the left corner cover (upper) [C] (⚙ x2).
10. Remove the left corner cover (middle) [D] (⚙ x2).
11. Remove the left corner cover (lower) [E] (⚙ x2).
12. Push the paper tray [B] into the LCIT.

**★ Important**

- The paper tray [B] must be pushed in now. If the paper tray remains out, the LCIT is unstable and difficult to move.

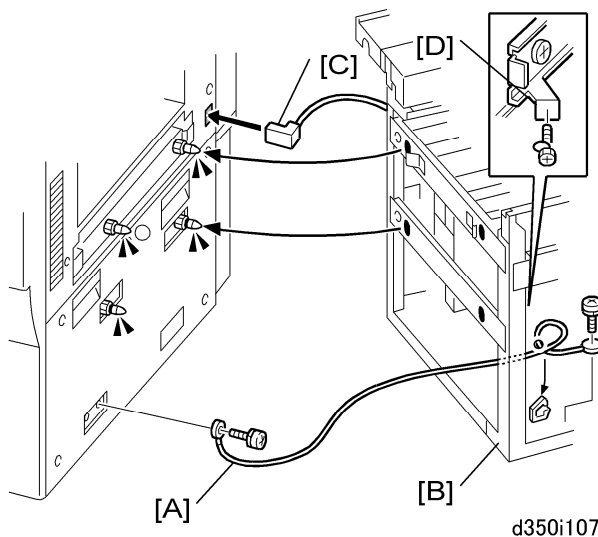

13. Attach the ground wire [A] to the main machine and LCIT (⚙ x2).

## Installation

---

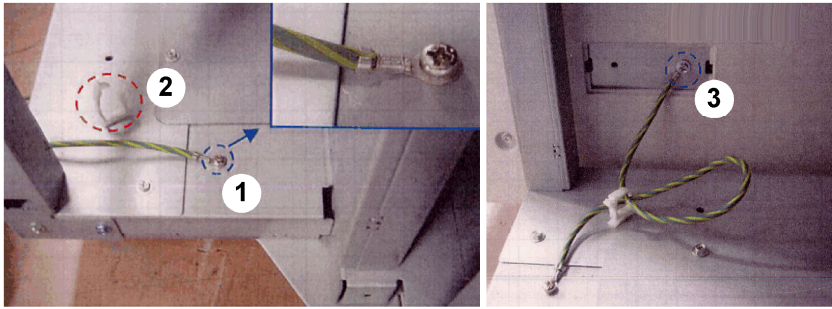

d350i107a

- On the LCIT, attach the ground wire ① and clamp it at ② (⚙️ x1, 🔌 x1).
  - Attach the other end of the ground wire to the main machine at ③ (⚙️ x1).
14. Push the LCIT [B] against the side of the main machine.
  15. Connect the LCIT I/F cable [C] to the main machine (🔌 x1).
  16. Fasten the screw to the lock plate [D] (⚙️ x1).
  17. Reattach the left corner plates (⚙️ x2 each), push the paper tray into the LCIT, and close the paper exit cover.
  18. If you are going to install the heaters, do this now. See the next section.  
-or-  
If you will not install the heaters, skip the next section.

## After Installation

---



sib79

The paper tray is large and heavy, especially when it is loaded to full capacity. Direct the customer to the warning sticker on the left side of the tray. The label is a reminder that two persons are needed to lift and handle the paper tray safely.

## Installation

### Anti-Condensation Heater Type B: 120V

#### Accessory Check

No.	Description	Qty
1	PTC Heater 100V to 240V 13W	2

#### CAUTION

- Unplug the machine power cord before starting the following procedure.
- Do the following procedure in order to prevent damage to the harnesses.
- Check that the harnesses are not damaged or pinched after installation.

The correct wire heaters must be installed for the machine.

Copier	PTC Heater	Harness Color
D014/D015 (120V)	100V to 240V 13W (D3500900)	WHITE

#### Installation Procedure for 120V

1. Confirm that the heater unit is the correct type for the machine:
  - 120V Model: Both connector harnesses are WHITE. (Use for this installation.)

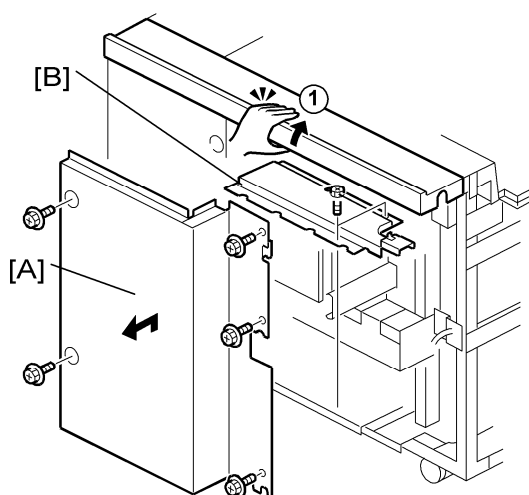

d350i151

- 208 - 240V Model: Both connector harnesses are RED. (Do not use for this installation.)

## Installation

---

2. At the back of the LCIT, remove:

[A] Rear cover (⚙️ x5). Lift cover ① to remove rear cover.

[B] Heater cover (⚙️ x2)

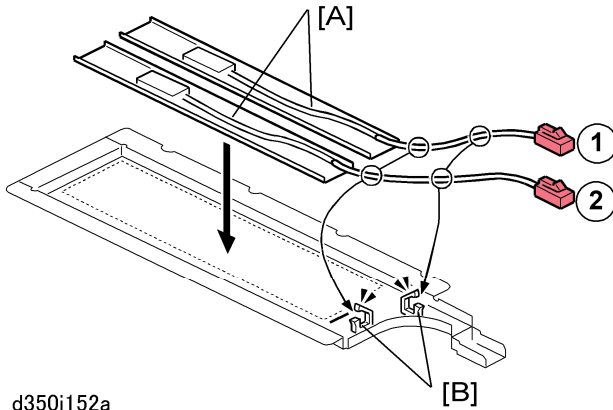

3. Remove the seals from the bottom of the heater units [A] and attach the heaters to the heater cover.
4. Confirm that the heaters are not touching or overlapping.
5. Route both harnesses through the clamps [B] and fasten the clamps.

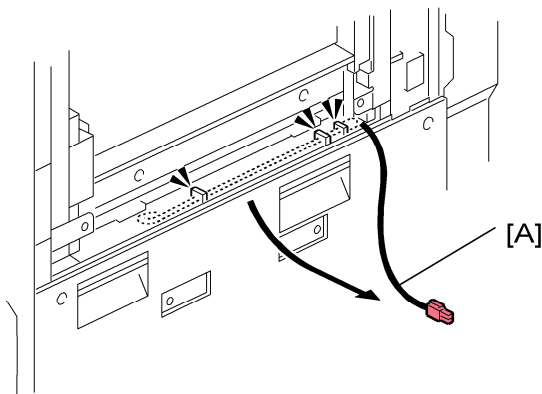

6. Pull the heater connection harness [A] away from the right side of the main machine.

## Installation

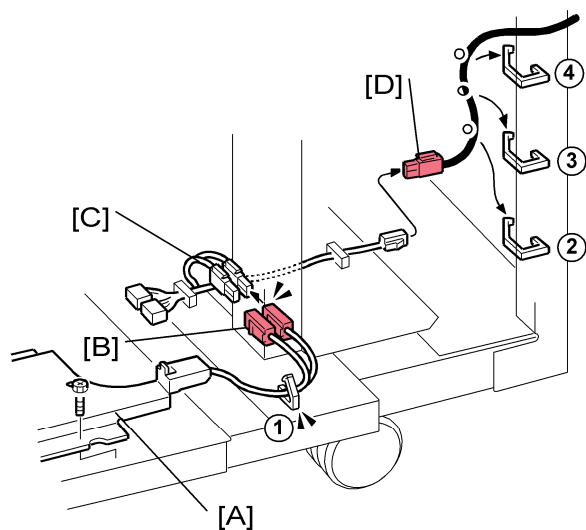

d350i154a

7. Fasten the heater cover [A] to the base plate (⚙️x2).
8. Connect the heater harnesses [B] to the relay harness [C] (🔌x2).
9. Connect the harness from the main machine [D] to the relay harness [C] (🔌x1).
10. Clamp the harnesses as shown (🔧 x4).

## Anti-Condensation Heater Type B: 240V

### Accessory Check

No.	Description	Qty
1	Nichrome Wire Heater 230V 18W	2

### **⚠️ CAUTION**

- Unplug the machine power cord before starting the following procedure.
- Do the following procedure in order to prevent damage to the harnesses.
- Check that the harnesses are not damaged or pinched after installation.

The correct wire heaters must be installed for the machine.

Copier	Nichrome Wire Heater	Harness Color
D014/D015 (208V-240V)	230V 18W (D3500901)	RED

## Installation

### Installation Procedure for 240V

1. Confirm that the heater unit is the correct type for the machine:
  - 120V Model: Both connector harnesses are WHITE. (Do not use for this installation.)
  - 208V-240V Model: Both connector harnesses are RED. (Use for this installation.)

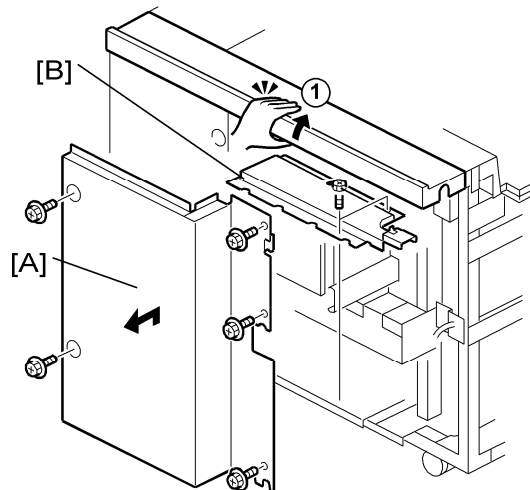

d350i151

2. At the back of the LCIT, remove:
  - [A] Rear cover (⚙ x5). Lift ① to remove rear cover.
  - [B] Heater cover (⚙ x2)

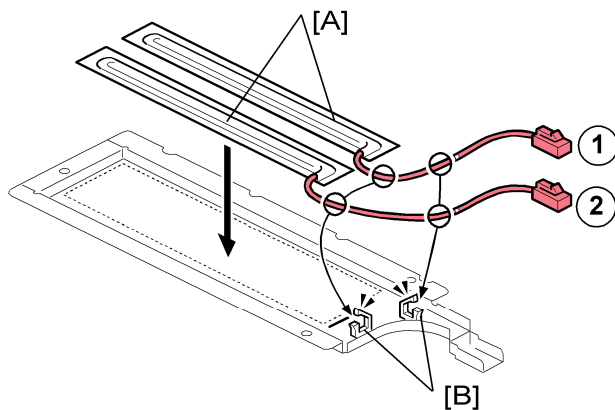

d350i152

3. Remove the seals from the bottom of the heater units [A] and attach the heaters to the heater cover.
4. Confirm that the heaters are not touching or overlapping.
5. Route both harnesses through the clamps [B] and fasten the clamps.



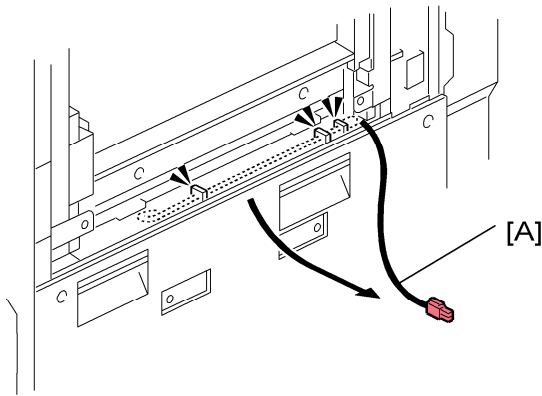

d350i153

6. Pull the heater connection harness [A] away from the right side of the main machine.

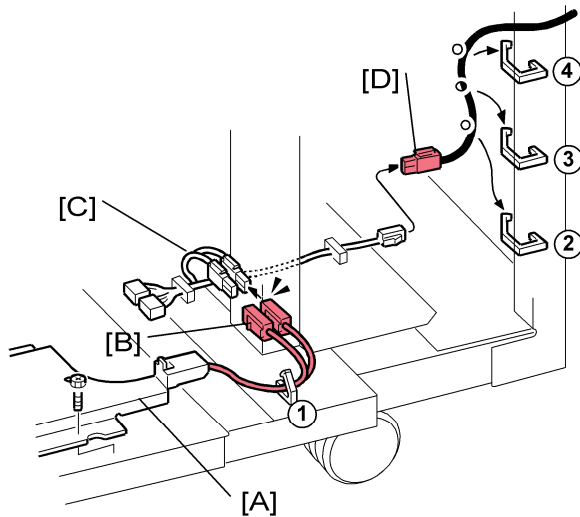

d350i154

7. Fasten the heater cover [A] to the base plate (🔩x2).
8. Connect the heater harnesses [B] to the relay harness [C] (🔌x2).
9. Connect the harness from the main machine [D] to the relay harness [C] (🔌x1).
10. Clamp the harnesses as shown (🔧 x4).

---

## 2000/3000 Sheet Finishers (D373/D374)

---

### Accessories

---

	Description	Q'ty
1.	Front joint bracket	1
2.	Rear joint bracket	1
3.	Ground (earth) plate	1
4.	Screws (M4 x 14)	4
5.	Screws (M3 x 8)	1
6.	Screws (M3 x 6)	3
7.	Screw (Plastic)	2
8.	Leveling Shoes	3
9.	Upper output tray	1
10.	Tray Holder	1
11.	Lower output tray (D373 Only)	1
12.	Support Plate for Proof Tray	1
13.	Support Plate for Shift Tray	1
14.	Cushion (with double-sided tape)	1
15.	Gasket Seal	1

## Installation

---

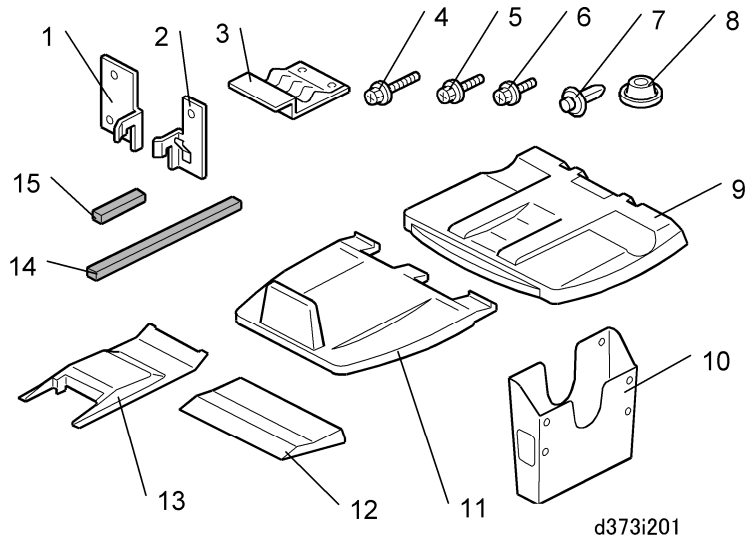

---

## Installation

---

This section shows the installation instructions for two finishers:

- D373 Booklet Finisher: This can do punching, shifting, stapling, and saddle-stitching with staples. This booklet finisher can be used with the D014 or D015.
- D374 Finisher, capable of punching, shifting, and stapling but with no saddle-stitching unit. This finisher can be used with the D014 or D015.

**Note**

- Differences in the installation procedures are shown as "D373" or "D374"

## Removing Tapes and Packing Materials

---

### **CAUTION**

- Always turn the machine off and disconnect the machine power cord before you do these procedures.

**D373/D374**

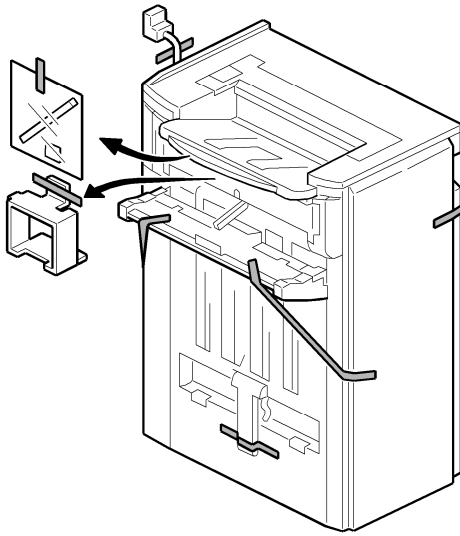

d373i102

1. Remove the machine from its box, and remove all the wrapping.
2. Remove all filament tape and packing material from the finisher.

**D373/D374**

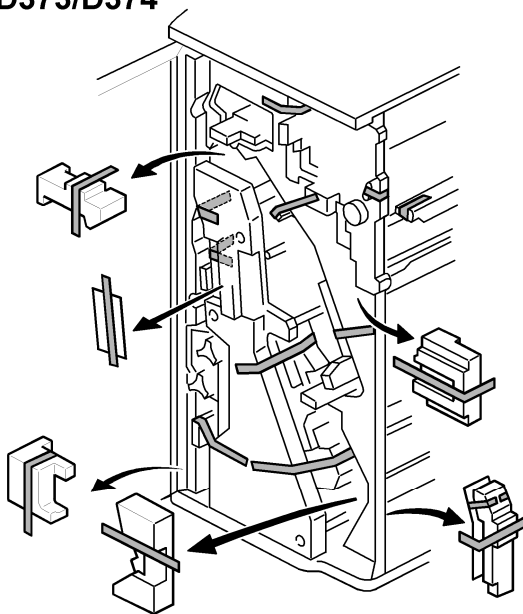

d373i202

3. Open the front door.
4. Remove all tapes and packing materials inside the finisher.

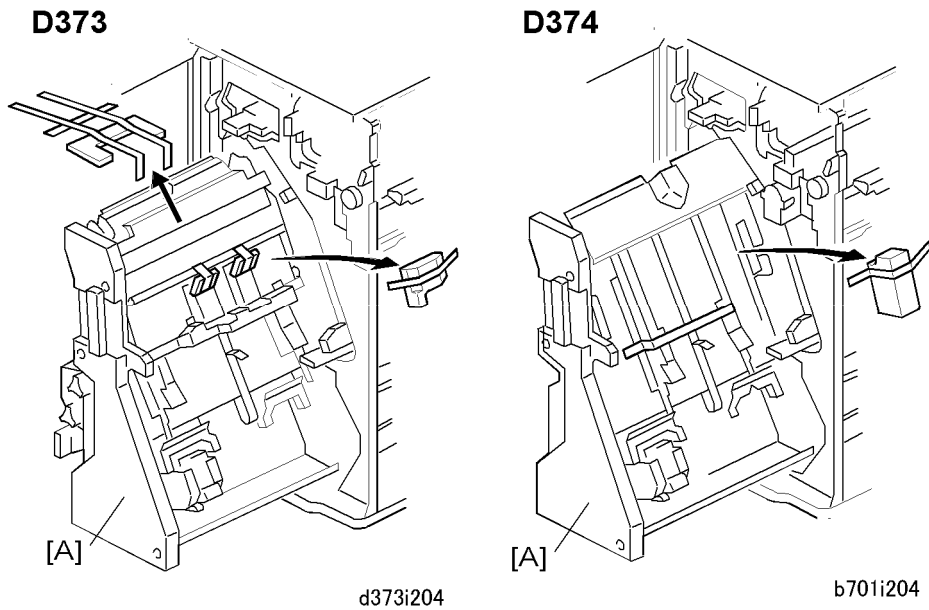

5. Pull the jogger unit [A] out of the finisher.
6. Remove the tapes and retainers.

### Docking the Finisher to the Copier

---

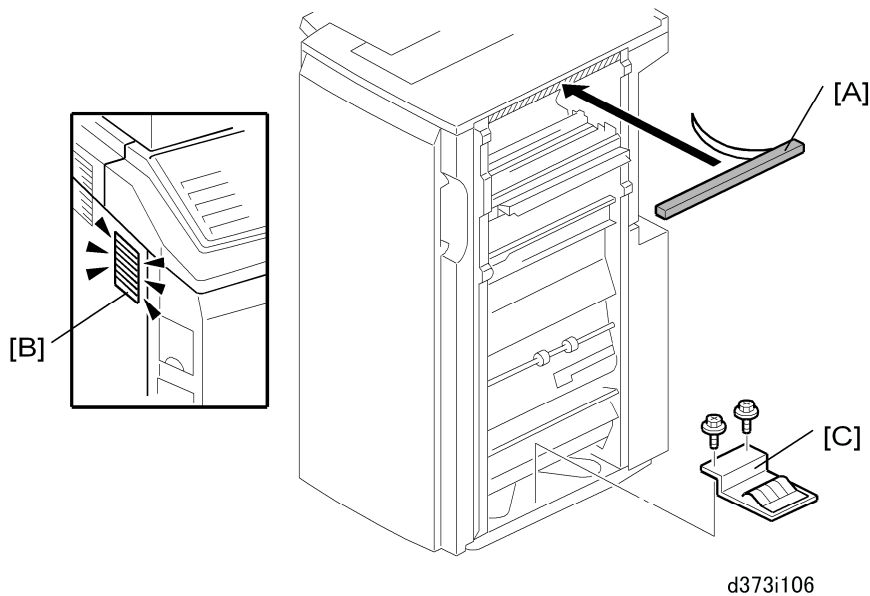

1. The first step depends on whether you will install the Cover Interposer B704.  
**If you will not install the Cover Interposer B704:**
  - Remove the strip from the sponge cushion [A] and attach it to the finisher, then go

to Step 2.

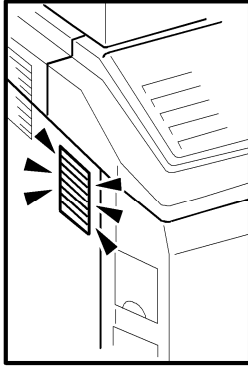

d373r734

- Do not put the sponge in a position that will prevent air flow through the air duct [B] on the copier shown above after the finisher is connected to the copier.
- Use a short screwdriver to attach the grounding plate [C] (⚙ x 2, M3 x 6).

### **If you will install the Cover Interposer B704:**

- Do not attach the sponge cushion to the finisher. It must be attached to the cover interposer.
- Do not attach the grounding plate [C] to the finisher. It must be attached to the cover interposer.
- Install the interposer on the finisher before you dock the finisher to the copier. ( Cover Interposer Tray (B704): do the complete procedure.) Then come back to the procedure for the D373/D374 finisher, and continue from 'Attaching the Trays'.

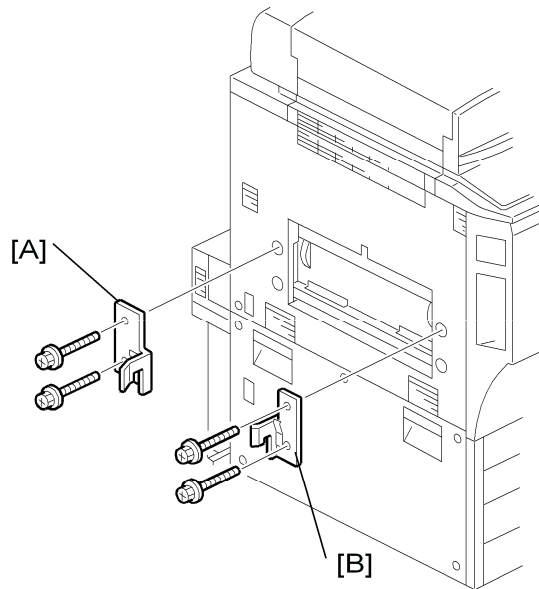

d373i105

1. Attach the rear bracket [A] (⌀ x 2, M4 x 14).
2. Attach the front bracket [B] (⌀ x 2, M4 x 14).

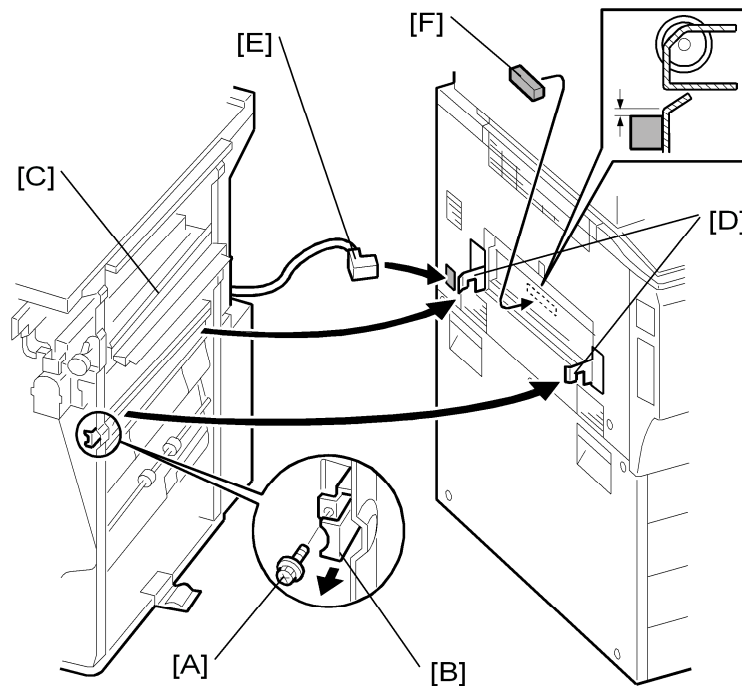

d373i107

3. Remove the screw [A] to release the lock lever [B] (⌀ x 1).
4. Slowly push the finisher against the side of the machine until the brackets [D] go into their slots. If you do this too quickly, you will bend and cause damage to the paper-entrance guide plates [C].

## Installation

---

5. Attach and tighten the screw removed in Step 4.
6. Connect finisher connector [E] to the main frame.
7. Attach the gasket seal [F] as shown.

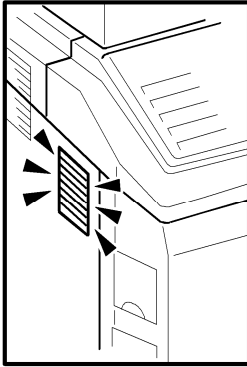

d373r734

8. Check the duct on the left side of the machine shown above. Make sure that the sponge does not block this duct.

## Attaching the Trays

---

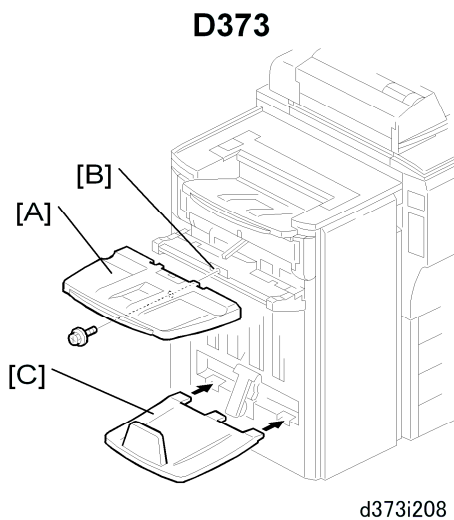

d373i208

### D373

1. Attach the upper output tray [A] (⌀ x 1, M3 x 6).
2. Make sure that the metal plate [B] is on the top of the tray.
3. Attach the lower output tray [C].

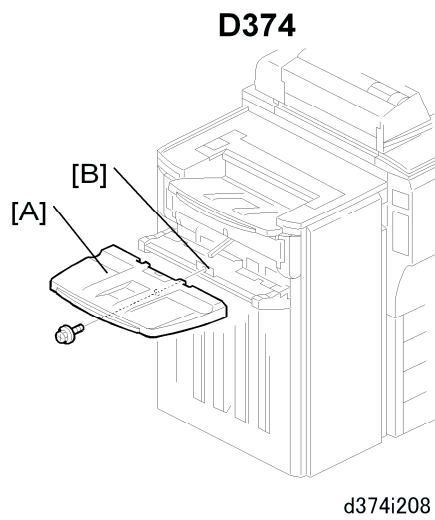

d374i208

### D374

1. Attach the output tray [A].
2. Make sure that the metal plate [B] is on the top of the tray.



## Installation

---

### Leveling the Finisher

---

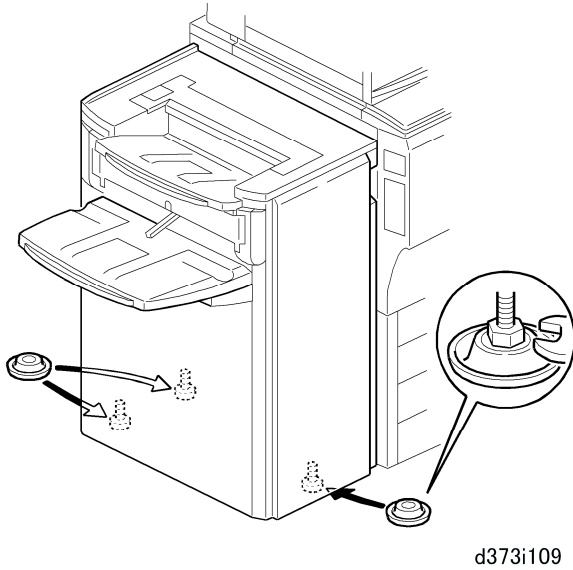

1. Put the leveling shoes (x 3) below the feet.
2. Use a wrench to adjust the height of the screws to make the machine level.

## Support Trays

---

### Tray Holder

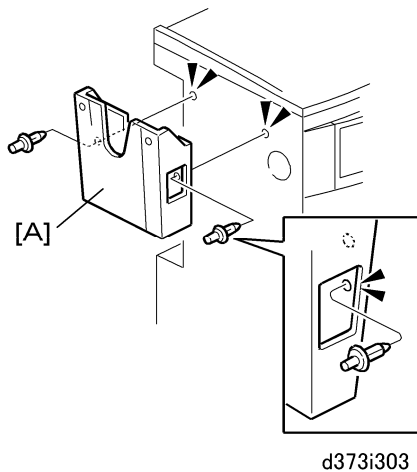

1. Attach the tray holder [A] to the side of the finisher as shown.
2. Store the support plates for this upper tray and shift tray in this holder while they are not being used.

### Support Plate for Upper Tray

Two support trays, one for the upper proof tray and one for the shift tray are provided. These support trays prevent excessively curled paper from activating the "Tray Full" message before the proof tray or shift tray is actually full.

1. Remove the paper from the paper feed tray, turn it upside down, then print.

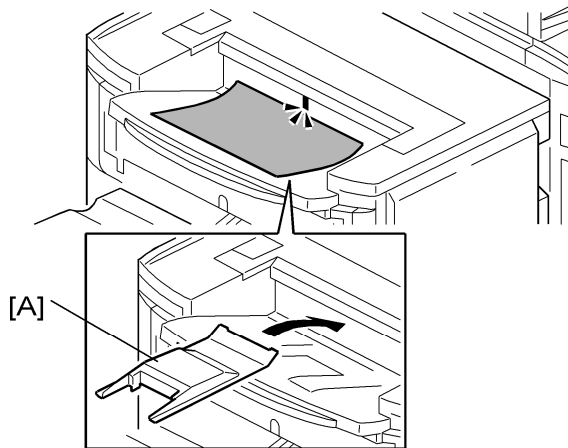

d373i301

2. If step 1 does not solve the problem, place the support tray [A] in the upper tray as shown.

### Support Plate for Shift Tray

1. Remove the paper from the paper feed tray, turn it upside down, then print.

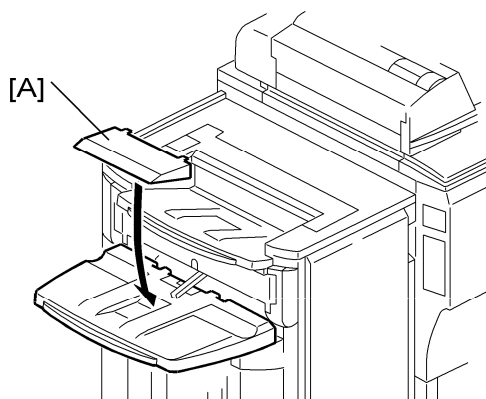

d373i302

2. If step 1 does not solve the problem, place the support tray [A] on the shift tray as shown.

## Installation

---

### Selecting the Staple Supply Name

---

Go into the SP mode and input this information.

5841	Supply Name Setting	These names show when the user prints the Inquiry List Push the Counter key, then push 'Print Inquiry List'. Push the Inquiry button on the initial User Tools screen.
013	Staple Std3	Input the name of the staples that are used for standard stapling (not booklet stapling). This setting should be done for the D373 and D374.
022	Staple Bind2	Input the name of the staples that are used for booklet stapling (saddle-stitching). This setting is necessary only for the D373.

### Enabling Booklet Binding (D373 Only)

---

To use booklet stapling, you must make sure that the center-position stapling option is displayed. If it is not, select the center-position stapling mode with a user tool.

1. Push the User Tools key.
2. Touch "Copier/Document Server Features".
3. Touch the "Input/Output" tab.
4. Select "Staple Position".
5. Touch a "Staple Position" button and touch the center (saddle-stitch) stapling symbol.
6. Go out from the User Tools mode. Set the number of copies, touch the center stapling symbol on the operation panel, then start the print job.

---

## Punch Unit (B702)

---

The Punch Unit B702 is installed in the 2000/3000 Sheet Finisher D373/D374.

---

### Accessories

---

Check the accessories and their quantities against this list.

Description	Qty
1. Punchout Waste Unit	1
2. Slide Drive Unit	1
3. Punch Waste Hopper	1
4. Screws (M3 x 6)	5
5. Side-to-Side Detection Unit	1
6. Punching Unit	1

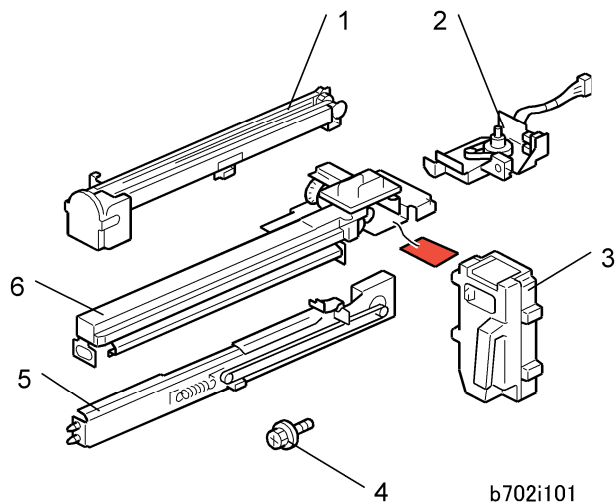

**⚠ WARNING**

- Always turn the machine off and disconnect the machine power cord before you do this procedure.

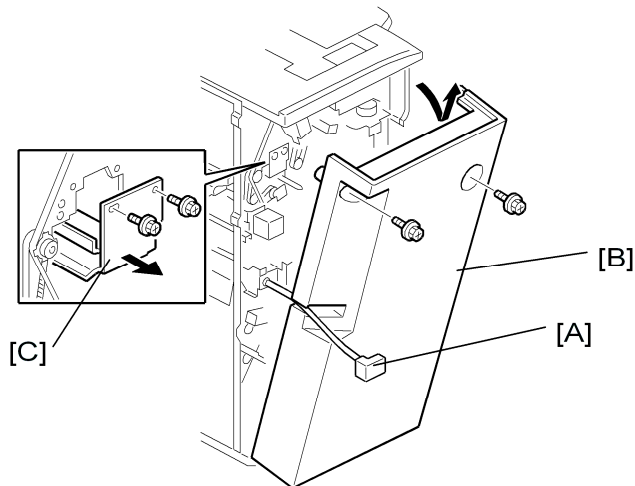

b702i102

1. If the finisher is connected to the copier, disconnect the power connector [A] and move the finisher away from the copier.
2. Remove the rear cover [B] (⚙ x 2) and open the front door.

**↓ Note**

- At the bottom of the rear cover, make sure to disconnect the tabs that attach the cover to the frame.
3. Remove the guide plate [C] (⚙ x 2).

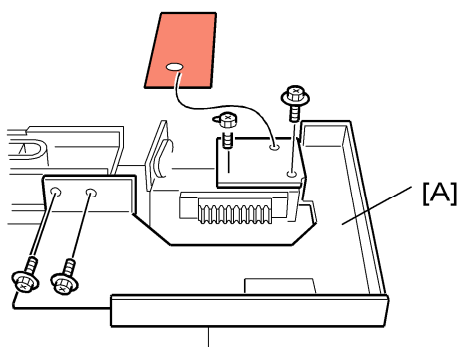

b702i201

4. Remove the shipping retainer [A] (⚙ x 4).

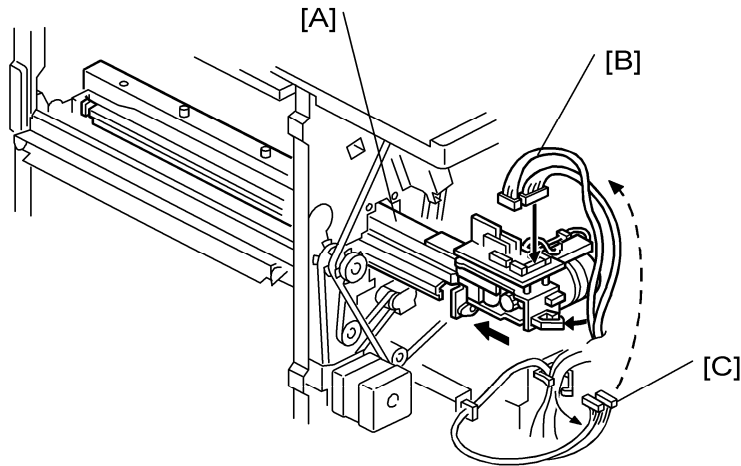

b702i103

5. Slide the punch unit [A] on its rails into the finisher. Make sure that the pins engage correctly at the front and rear.
6. Connect and attach the punch unit [B] (🔌 x 2, 📌 x 1).
  - The cables [C] are coiled and attached to the PCB.
  - Attach connectors to CN601 and CN602.

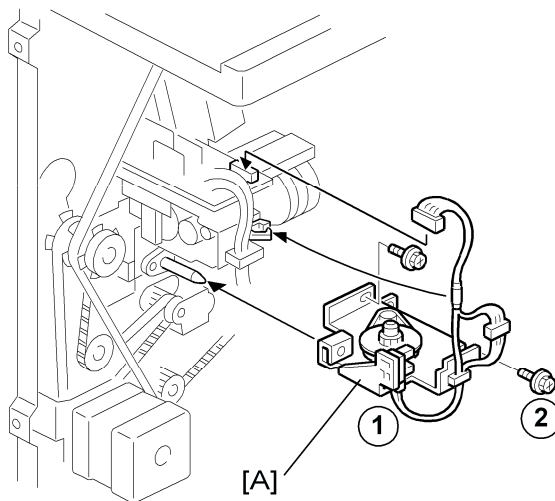

b702i104

7. Attach the slide drive unit [A] to the finisher and connect it to the punch unit (🔌 x 2, 📌 x 1). Push in the slide drive unit at ① when you attach screw ②.
8. Make sure that the punch unit moves freely and is not blocked by the screws.

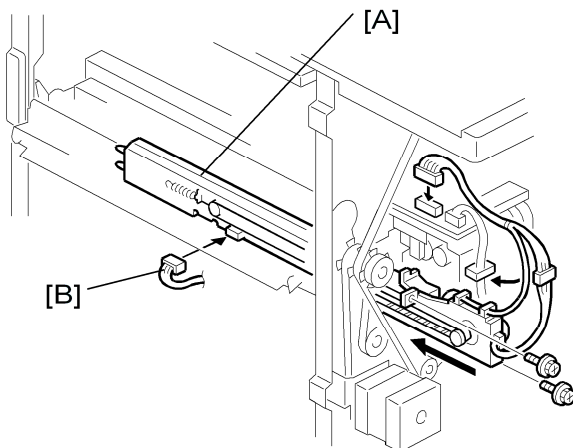

b702i105

9. Put the side-to-side detection unit [A] in the machine. Make sure that the two pins are engaged correctly at the front.
10. Make sure that the side-to-side detection unit moves smoothly on its rails. If it does not, make sure that the rails are aligned with their grooves.
11. Attach the side-to-side detection unit and connect it at the rear (⚙️ x 2, 🔌 x 1, 📏 x 1).
12. Pull the short connector out of the connector [B] then connect the cable (🔌 x 1).

↓ Note

- This is the 3-pin connector.

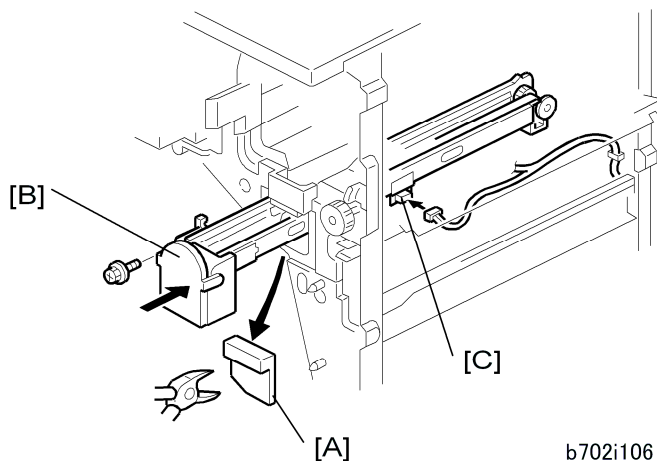

b702i106

13. At the front, use a pair of wire cutters to remove the part [A] of the cover.
14. Install the punch-waste transport unit [B] in the finisher.

↓ Note

- Make sure that the punch-waste transport unit moves smoothly on its rails. If it does not, make sure that the rails are aligned with the grooves.

15. Remove the short connector from the connector [C].

↓ Note

## Installation

---

- This is the 4-pin connector.

16. Connect the cable and attach the punch-waste transport unit (📄 x 1, 📄 x 1, 📄 x 1).

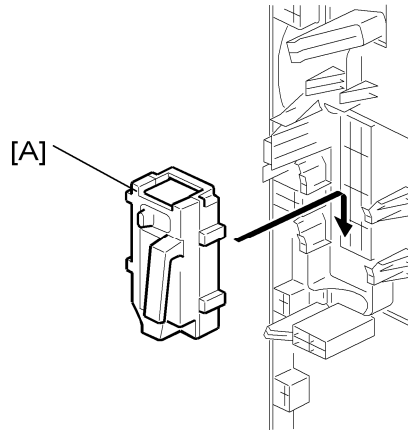

17. Set the hopper [A] in its holder.



## Installation

---

# Output Jogger Unit (B703)

---

## Accessories

---

Check the accessories and their quantities against this list.

Description	Qty
1. Jogger Unit	1
2. Tapping Screws M3x6	2

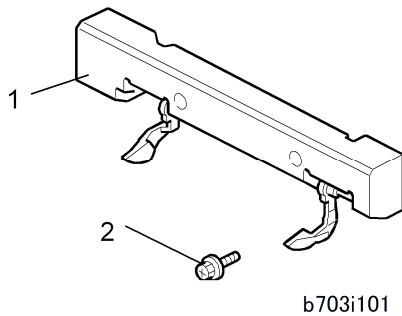

## Installation

---

The Output Jogger Unit B703 is installed only on the 2000/3000-Sheet Finisher D373/D374.

### **WARNING**

- Always switch the machine off and unplug the machine before doing any of the following procedures

## Installation

---

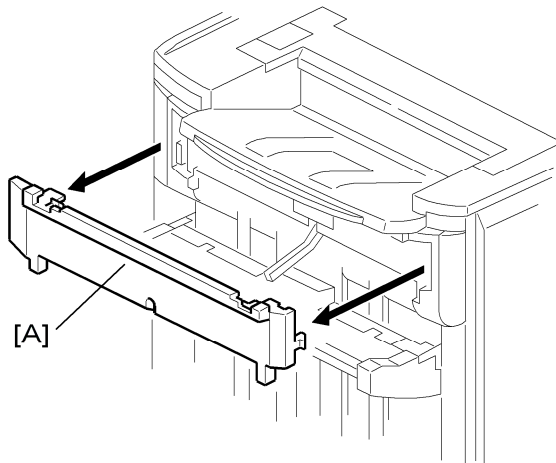

b703i103

1. Turn the main machine switch off.
2. Disconnect the finisher from the main frame.
3. Use the flat head of a screwdriver to remove the left upper cover [A].

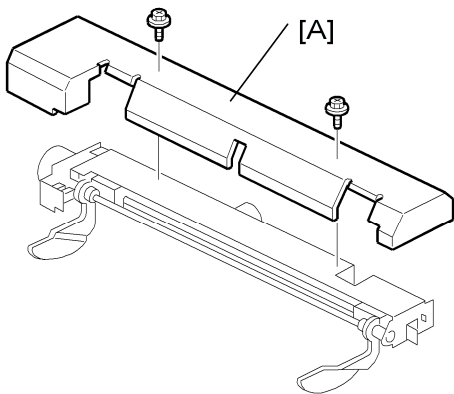

b703i102

4. Remove the cover plate [A] (⌀ x 2). Keep the screws.

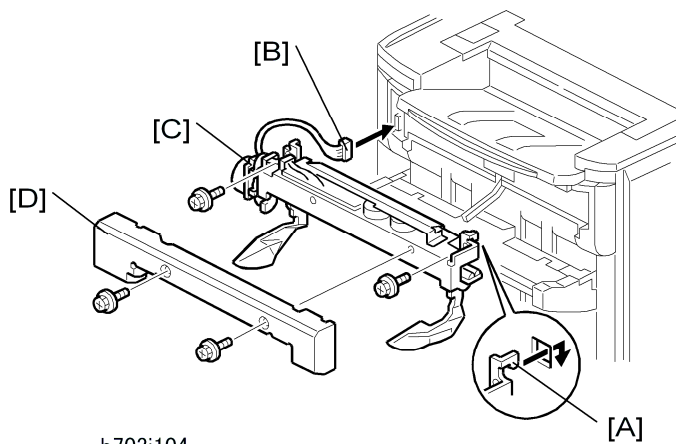



b703i104

5. While holding the jogger unit with the connector on the left, put the hooks on the frame

## Installation

---

of the jogger unit [A] into the holes in the left and right side of the finisher frame.

6. Connect connector [B] to the socket ( x 1).
7. Attach the jogger unit [C] to the finisher ( x 2).
8. Reattach the jogger unit cover [D] to the jogger unit ( x 2).

## Installation

---

### Mail Box (B762)

---

The Mail Box B762 is installed on the 2000/3000 Sheet Finisher D373/D374.

---

### Accessories

---

Check the accessories and their quantities against this list.

Description	Qty
1. Trays	9
2. Guide plate	1
3. Decals (bin display)	1
4. Tapping screws - M3x8	6

## Installation

---

### **WARNING**

- Turn the machine off and disconnect the machine power cord before you start this procedure.

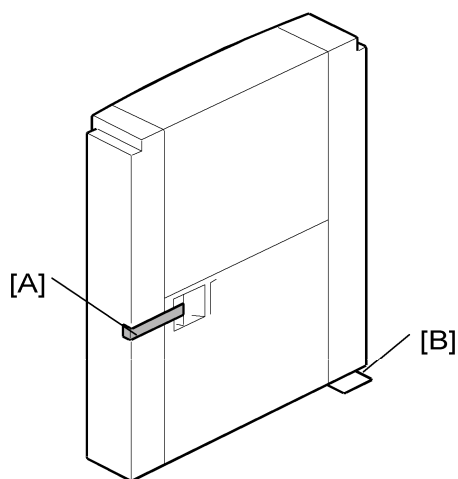

b762i101

1. Remove the filament tape [A].



## Installation

- Move the mailbox carefully. It is easy to cause damage to the corner leaf plate [B].

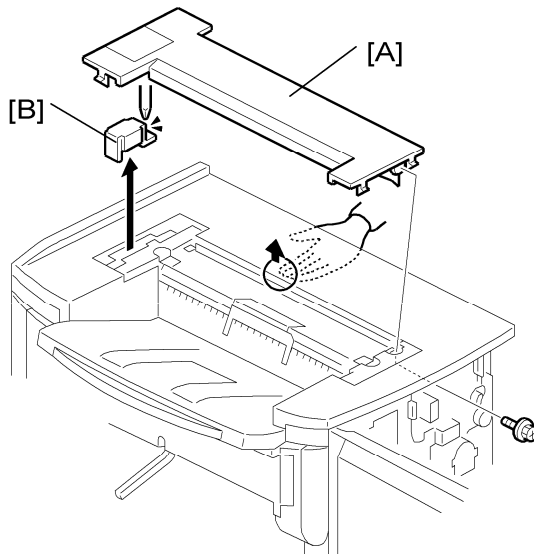

b762i102

2. If the Cover Interposer Tray B704 is installed on the D373/D374, remove it.



- The cover interposer tray and mailbox cannot be installed on the finisher at the same time.

3. Remove the top cover [A] of the finisher (⌀ x 1).
4. Remove the bracket [B] (⌀ x 1).

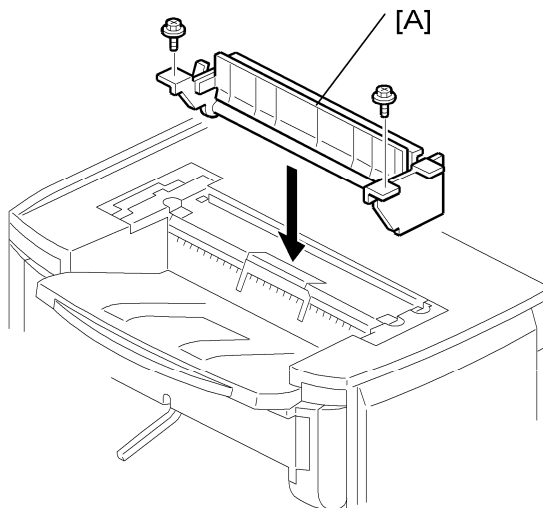

b762i103

5. Attach the guide plate [A] to the top of the finisher (⌀ x 2, M3 x 8).

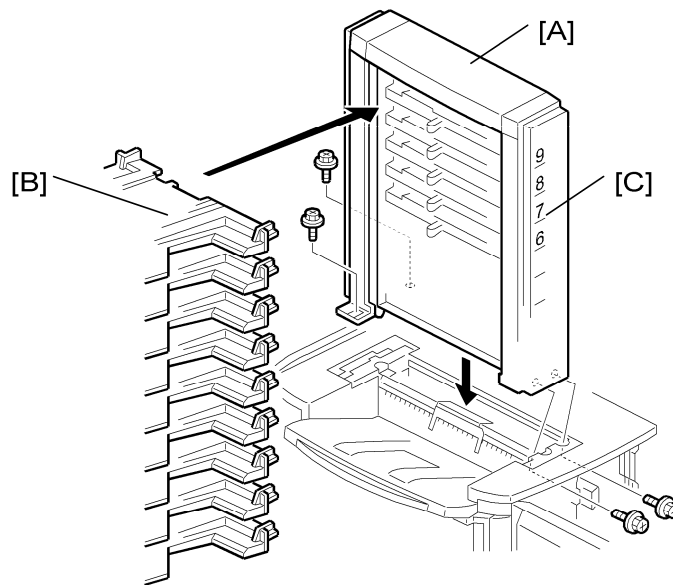

b762i104

6. Attach the mailbox [A] to the top of the finisher (4 x 4, M3 x 8).
7. Attach the 9 trays [B] to the mailbox.
8. Give the decals [C] to the customer. The customer will write on these and attach them at the correct location.

---

## 3000-Sheet Finisher (B830), Finisher Adapter (D375)

---

### Accessories

---

#### 3000-Sheet Finisher B830 Accessories

---

Check the accessories and their quantities against this list.

	Description	Q'ty
1.	Sponge Strip	1
2.	Entrance Guide Plate	1
3.	Ground Plate	1
4.	Joint Bracket	1
5.	Shift Tray	1
6.	Leveling Shoes	4
7.	Tapping Screws – M4 x 12	4
8.	Tapping Screws – M3 x 6	8
9.	Tapping Screws – M4 x 8	2
10.	Support Plate Pocket	1
11.	Support Plate	1
12.	Side Tray	1

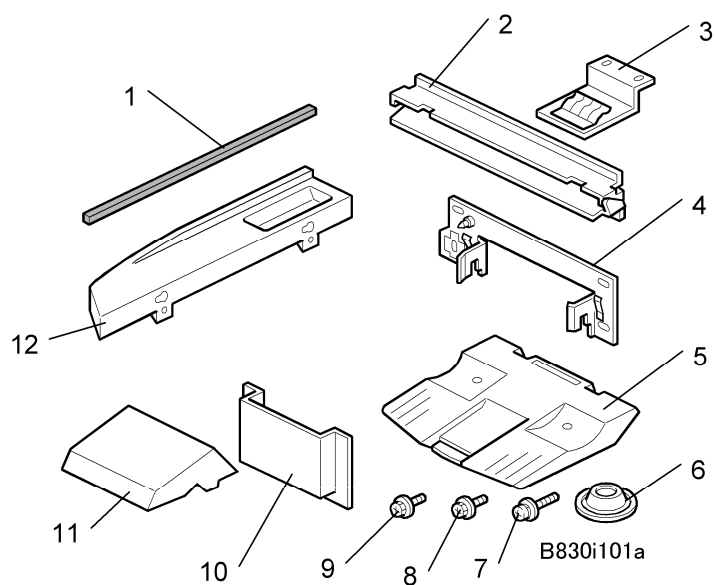

Finisher Adapter Kit D375 Accessories

Check the accessories and their quantities against this list.

**★ Important**

- This finisher adapter kit must be installed for both machines (D014/D015).

	Description	Qty
1.	Proof Auxiliary Tray	1
2.	Entrance Guide	1
3.	SD Card (for firmware update)	1
4.	Motor Harnesses	2
5.	Motor Brackets	2
6.	Serial Number Decal	1
7.	FCC: Class-A Decal	1



## Installation

---

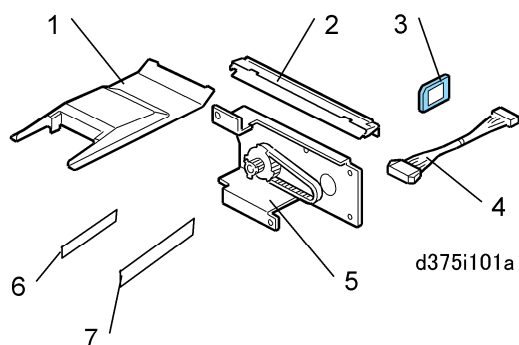

## Finisher Adapter Kit D375 Installation

---

### ★ Important

- The finisher adapter kit must be installed before the finisher and punch unit are installed.

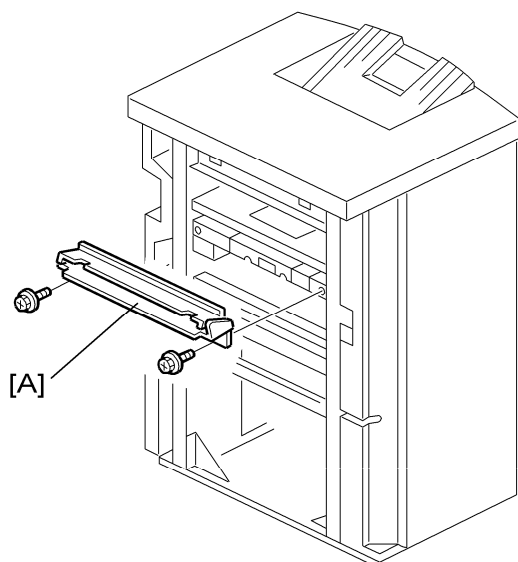

1. Attach the entrance guide [A] (2).

  - Attach the entrance guide only if the finisher will be connected directly to the main machine.
  - Do not install the entrance guide if you intend to install the Cover Interposer Tray (B835) or Z-Folding Unit (B660).

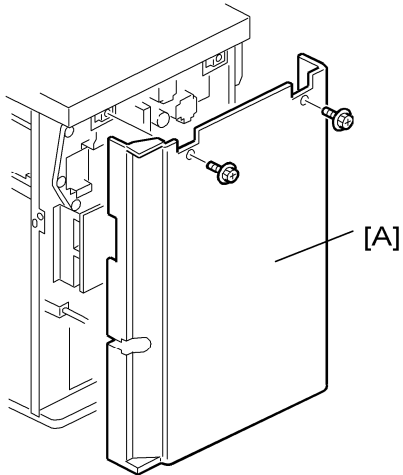

d375i103

2. Remove the finisher rear cover [A] (🔩 x 2).

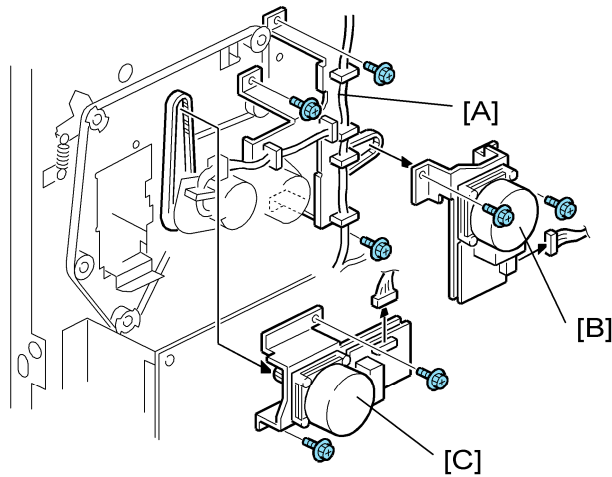

d375i104

3. Remove:

[A] Harness T-bracket screws (🔩 x3).

- Remove the screws only, not the bracket.

[B] Lower transport motor assembly (🔩 x 2, 📏 x1)

[C] Upper transport motor assembly (🔩 x 2, 📏 x1)

## Installation

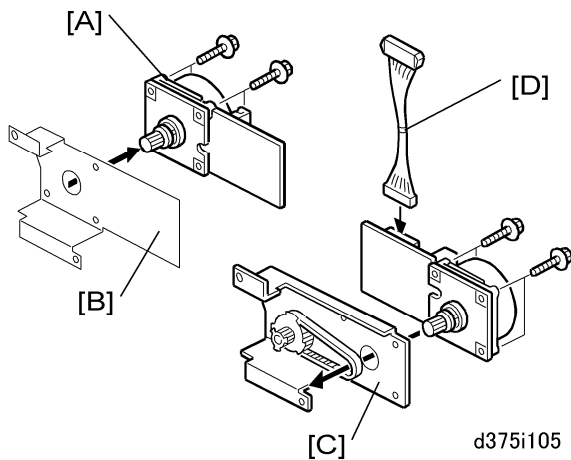

4. For both the upper and lower transport motors:
  - Remove the motor [A] from its original bracket [B] (⚙ x 2)
  - Attach the motor to the new bracket [C] (⚙ x 2).
  - Attach the new harness [D] (🔌 x 1).
5. Discard the original brackets.
  - The new brackets and harnesses are provided in the finisher adapter accessory kit.
  - The brackets are identical.

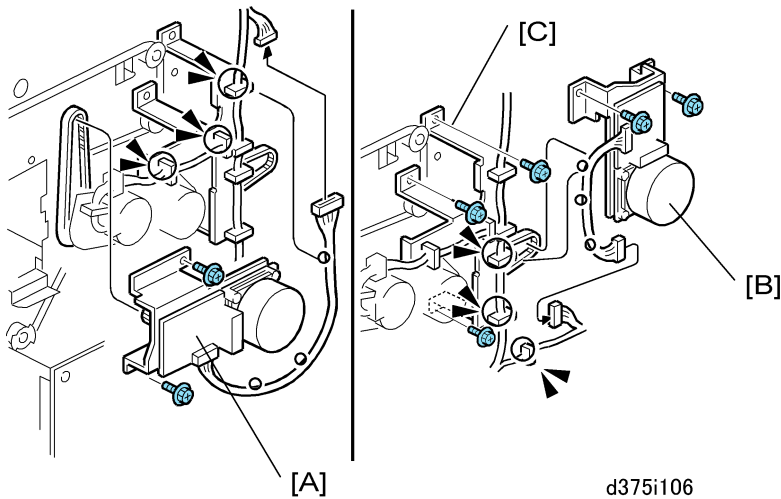

6. Attach the upper transport motor [A] assembly as shown, with the motor pointing to the right (⚙ x2, 🔌 x1, 📺 x3).
7. Attach the lower transport motor assembly as shown, with the motor pointing down [B] (⚙ x2, 🔌 x1, 📺 x3).
8. Reattach the harness T-bracket screws [C] (⚙ x3) that were removed earlier.
9. Open the front door.

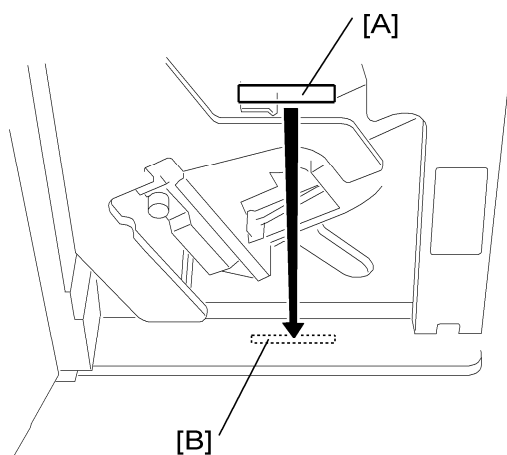

b698i107

10. Attach the serial number decal [A] below the finisher serial number decal [B] attached to the front bottom support of the frame.

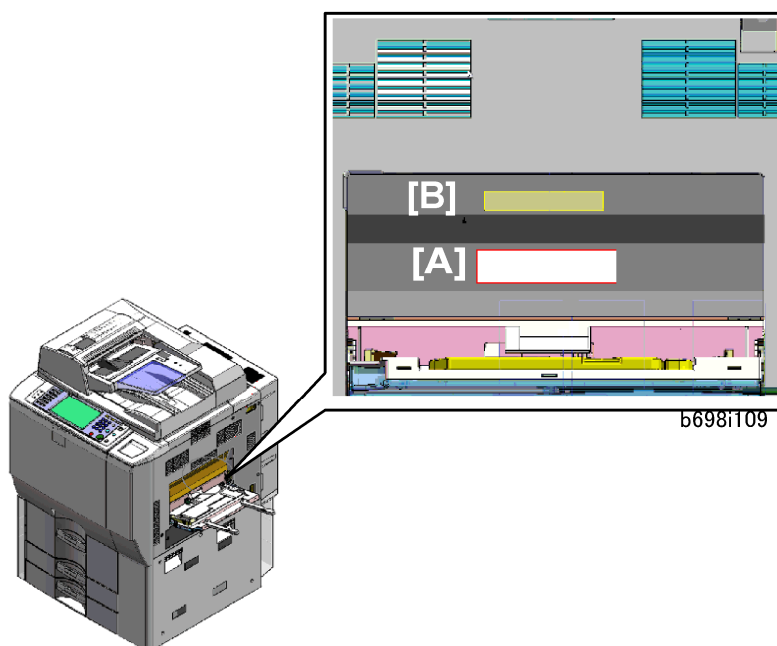

b698i109

11. On the right side of the machine, attach the FCC Class A decal [A] below the copier serial number decal [B].

---

## Finisher Installation

---

### **WARNING**

- Turn the machine off and disconnect the machine power cord before you do this procedure.
1. Unplug the machine power cord before starting the following procedure.

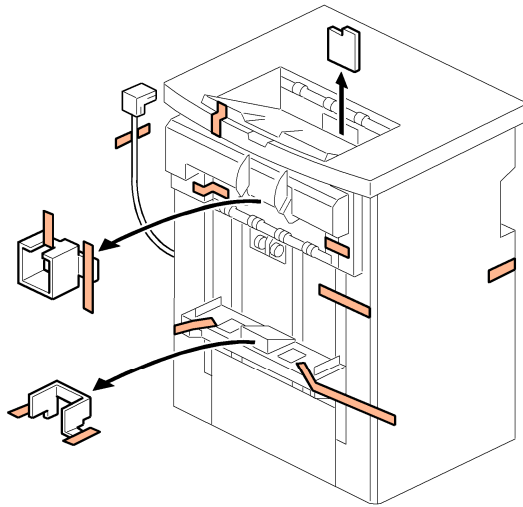

b830i102

2. Unpack the finisher and remove all tapes and shipping retainers.

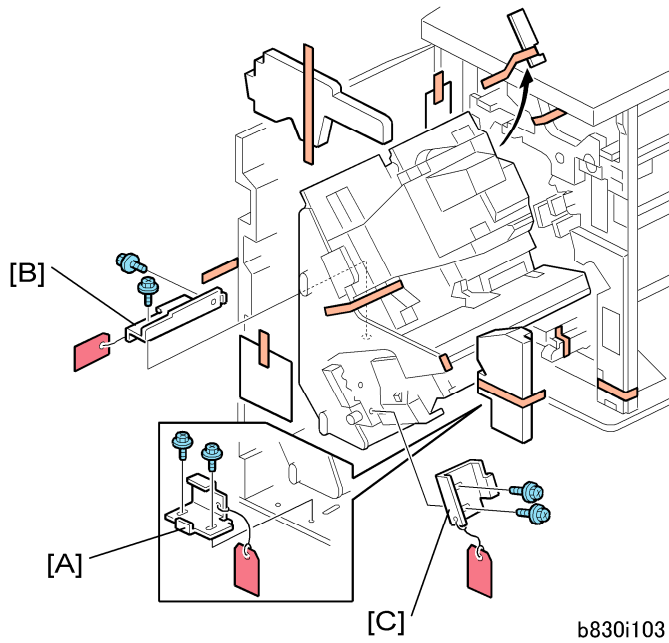

b830i103

3. Open the front door and remove the shipping retainers.
4. Remove the brackets, tags, and wires in this order: [A], [B], [C] (⌀ x 2 each).

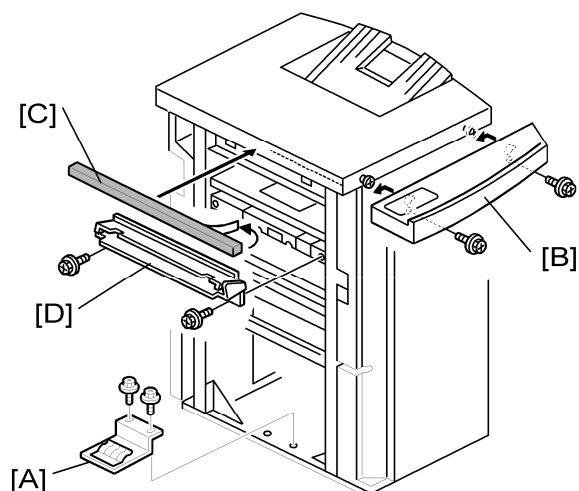

b830i105

5. Install the ground plate [A] (⌀ x 2) (M3 x 6).  
Set the ground plate so that there is no gap between the plate and the bottom frame of the finisher (as shown).
6. Install the table extension [B] (⌀ x 2) (M4 x 8).  
The edge of the table extension should be aligned with the edge of the finisher.
7. Attach the cushion [C] to the right side of the upper cover.
8. Install the entrance guide plate [D] (⌀ x 2) (M3 x 6).

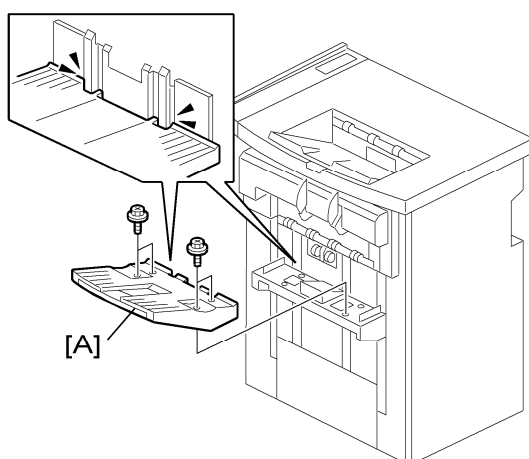

b830i109

9. Insert the shift tray [A] into the grooves and fasten it (⌀ x 4) (M3 x 6).

### Docking the Finisher B830

---

The Finisher (B830) is docked to:

- Z-folding unit (if the Booklet Finisher B836 is not installed)
- Cover Interposer tray (if Booklet Finisher B836 and Z-Folding Unit B660 are not installed)

## Installation

---

installed)

- Copier (if Z-Folding Unit B660 and Cover Interposer Tray B835 are all not installed.)

### Finisher B830 to Z-Folding Unit B660

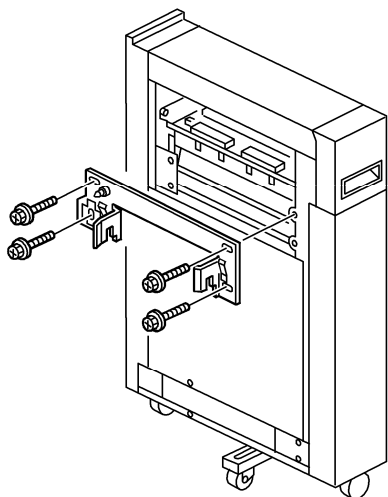

b830i204

1. Fasten the joint bracket to the Z-Folding Unit B660.
2. Dock the finisher. (Go to 'Connecting the Finisher B830'.)

### Finisher B830 to Cover Interposer Tray B835

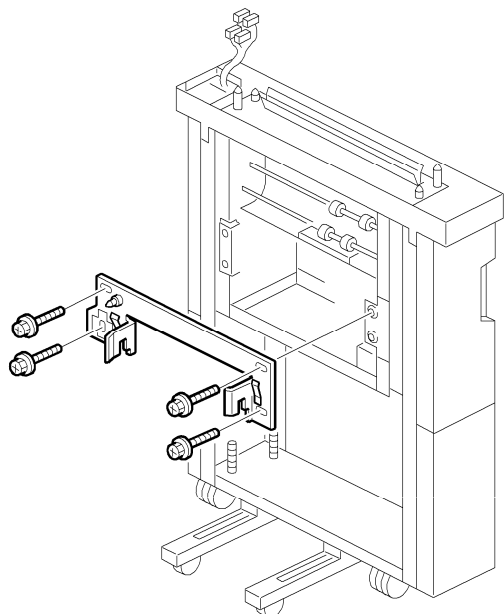

b830i203

1. Fasten the joint bracket to the Cover Interposer Tray B835.
2. Dock the finisher. (Go to 'Connecting the Finisher B830'.)

### Finisher B830 to Copier D014

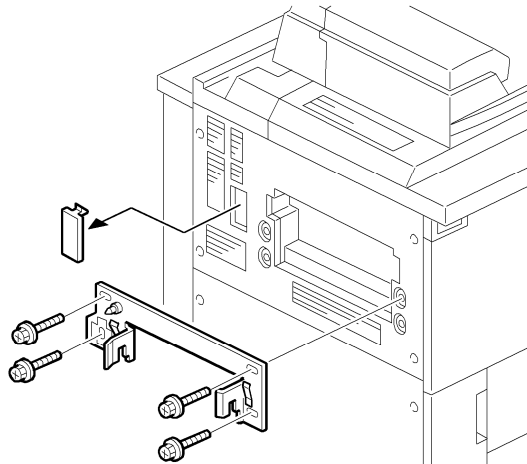

b830i201

1. Remove the connector cover
2. Fasten the joint bracket to the Copier.
3. Dock the finisher. (Go to 'Connecting the Finisher B830'.)

### Connecting the Finisher B830

---

1. Open the front door of the finisher.

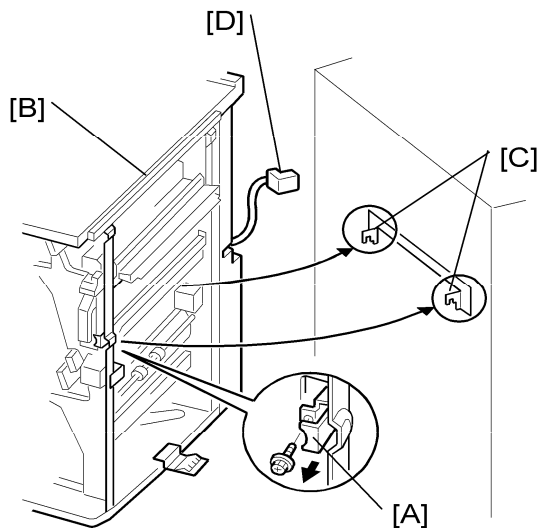

b830i202

2. Pull out the locking lever [A] (⌀ x 1).
3. Align the finisher [B] with the joint brackets [C], then slowly push the finisher onto the brackets.
4. Connect the finisher cable [D] to the copier
5. Push in the locking lever [A].



## Installation

---

6. Check that the top edges of the finisher are parallel with edges of the device (or copier) to the right.
7. Fasten the locking lever [A] (🔩 x 1)
8. Close the front door.

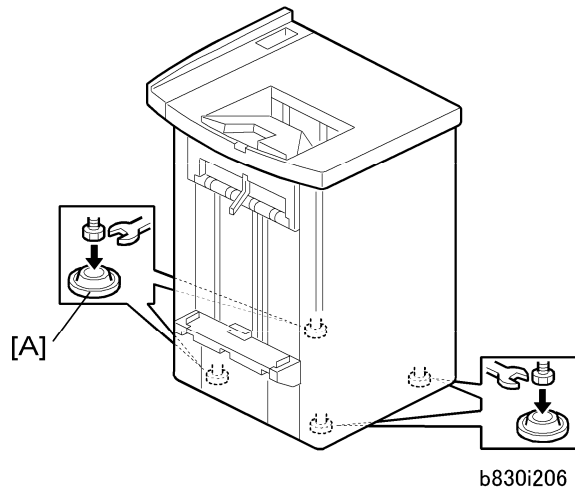

9. Set the leveling shoes [A] (x4) under the feet.
10. Turn the nuts to adjust the height of the finisher until it is level.

---

## Updating the Firmware

---

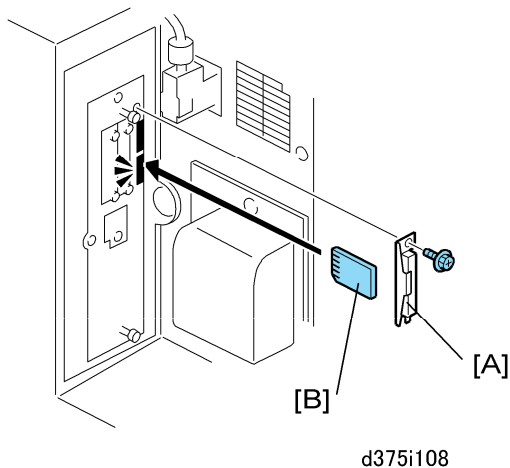

1. If the machine is on, switch it off.
2. Remove the SD card slot cover [A] from the main machine (🔩 x 1).
3. Insert an SD card [B] that contains the latest firmware for this finisher, downloaded from the web site. Insert this SD card into the service slot (lower slot).

↓ Note

- If you do not have the latest firmware, use the SD card that is provided with the

## Installation

---

finisher adapter kit. But the firmware on this card may be old.

4. Open the front door of the main machine.
5. Switch on the machine. A message prompts you to wait for the update procedure to begin, then the initial screen appears.
6. Write down the NEW version numbers. (You will need these later to confirm the success of the firmware update.)
7. Touch "Finisher" then touch "Update".
8. Wait for the update procedure to begin.
  - The update may not start for 2 or 3 minutes.
  - When the first asterisk (\*) appears in the progress bar this means the update has started.
  - The update procedure is very slow. Wait for all the hyphens (-) to be replaced by asterisks (\*) in the progress bar.



- **Never switch off the machine while the update is in progress.**
9. After asterisks have replaced all the hyphens in the progress bar, switch off the machine.
  10. Remove the SD card from the SD card slot and reattach the SD card slot cover.
  11. Close the front door.
  12. Switch on the machine.
  13. Enter the SP mode and do SP5990-5 to print the self-diagnostic report.
  14. Confirm that the finisher firmware updated successfully.
    - For "Finisher 1", you should see the numbers that you saw for the NEW column in the initial screen at Step 6.
    - If you see these numbers, the update has executed successfully.
    - If the update fails, turn the machine off and try the procedure again.
  15. Switch the machine off and remove the SD card.
  16. Switch the machine on.

This completes the firmware update procedure.

---

## SP Setting

---

1. Enter the SP mode.
2. Do **SP5841-12** and enter the name of the staples used for corner stapling.
  - This is the name that shows when the user prints the Inquiry List.
  - To print this list push User Tools> [Inquiry]> [Print Inquiry List]> [Start].

---

## Punch Unit B831

---

The Punch Unit B831 is installed in the 3000-Sheet Finisher B830.

---

### Accessories

---

Check the accessories and their quantities against this list.

	Description	Qty
1.	Punch unit	1
2.	Punch Waste Hopper	1
3.	Sensor Arm and Sensor	1
4.	Spacer (2 mm)	1
5.	Spacer (1 mm)	2
6.	Spring	1
7.	Step Screw (large) (M4 x 11)	1
8.	Tapping Screw (M4 x 10)	2
9.	Step Screw (small) (M3 x 4)	1
10.	Machine Screw, Washer (M4 x 6)	1
11.	Knob	1

## Installation

---

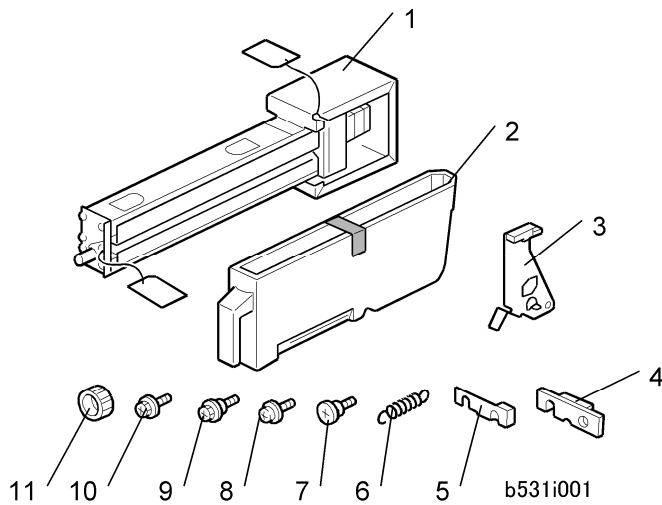

## Installation

---

### **WARNING**

- Turn the machine off and disconnect the machine power cord before you start this procedure.

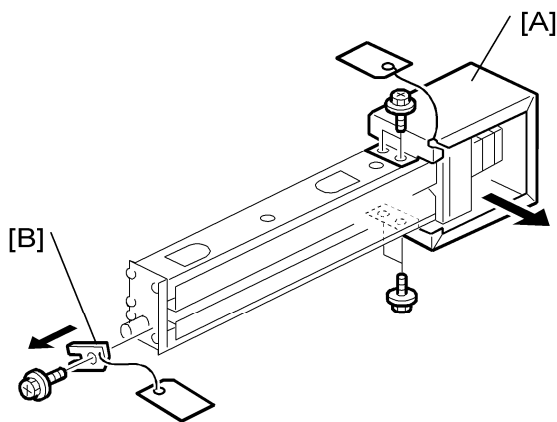

b531i109

1. If the finisher is connected to the machine, disconnect it.
2. Open the front door and remove the rear cover (⚙ x 2).
3. Remove the punch unit from its packing materials. Remove the motor protector plate [A] (⚙ x 4) and the cam lock plate [B] (⚙ x 1).

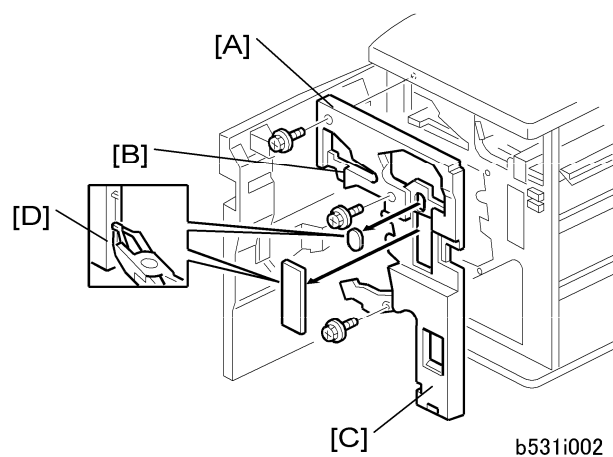

4. Remove the inner cover [A] (🔩 x 3).
5. Behind the inner cover at [B] and [C], push the lock tabs to the right to release the inner cover from the frame.
6. Remove the plastic sections [D] from the cover.

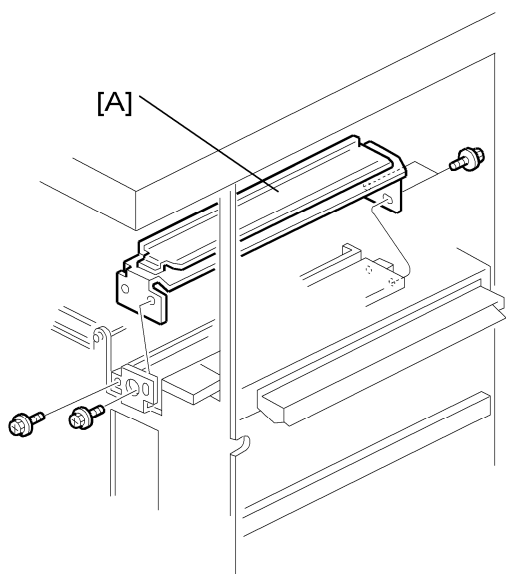

1. Remove the paper guide [A] (🔩 x 4).

## Installation

---

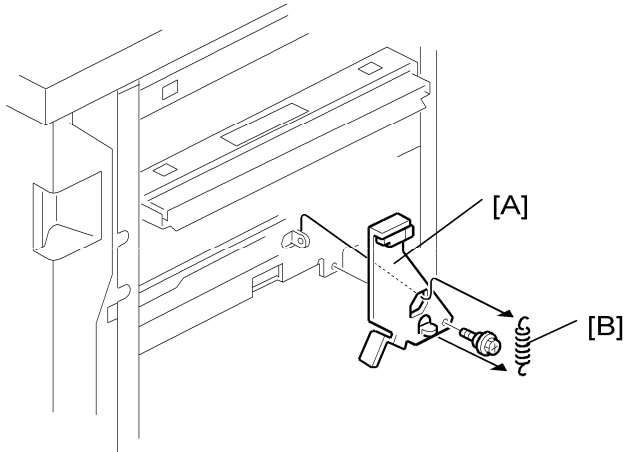

b531i004

2. Install the sensor arm [A] (1 x 1, small step screw (M3 x 4).



- Make sure that the sensor arm turns freely on the step screw.

3. Attach the spring [B].

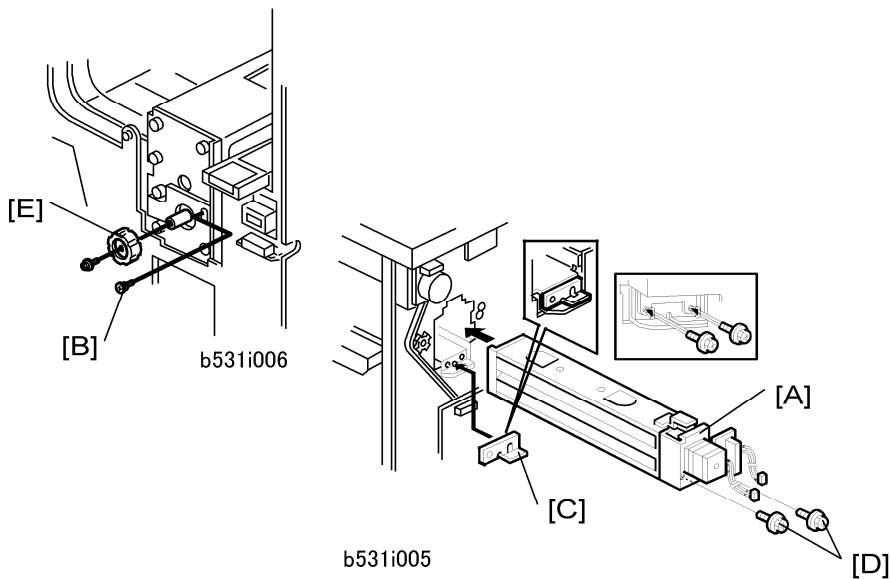

b531i005

1. At the rear of the finisher, put the punch unit [A] in the finisher.
2. At the front, attach the punch unit with the large shoulder screw [B] (1 x 1, M4 x 10).
3. At the rear, attach the 2 mm spacer [C] and attach the screws [D] to the punch unit (2 x 2, M4 x 10).



- At the hole immediately above the lock lever, use one of the screws from the

## Installation

paper guide removed above to attach the remaining two spacers to the frame. These two spacers are used to adjust the horizontal position of the punch holes.

4. At the front, attach the punch unit knob [E] (⌀ x 1).

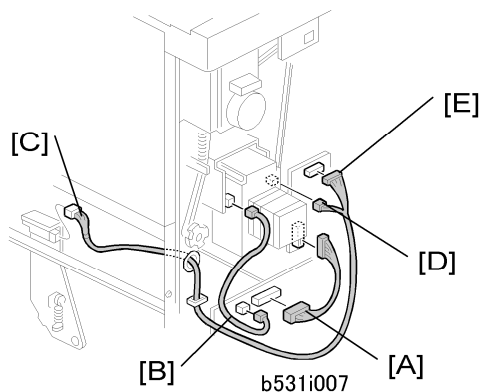

5. Connect the PCB harness connector [A] to CN129 of the finisher PCB and to CN600 of the punch unit PCB.
6. Connect the HP Sensor 2 harness connector [B] to CN130 of the finisher PCB and to HP Sensor 2.
7. Connect the end of the hopper-full-sensor cable that has one connector [C] to the hopper full sensor on the arm (⌀ x 1, clamp x 1). Then connect the other two connectors to HP Sensor 1 [D] and CN620 [E] of the punch PCB.

### Note

- No special DIP switch settings are necessary for this punch unit. The punch unit sends an identification signal to the machine. Then the machine knows the type of punch unit that is installed.

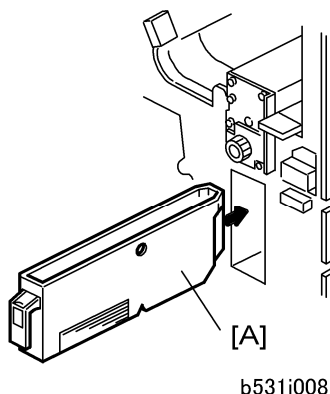

8. Put the hopper [A] in the finisher.
9. Attach the inner cover and rear cover.
10. Close the front door and connect the finisher to the machine.

## Cover Interposer Tray (B704)

---

### Accessories

---

Check the accessories and their quantities against this list. These accessories are provided for installation for several different machines. Many of the accessory items listed below are not used for this installation. For this machine:

- Cover Interposer Tray B704 is for installation on the 2000/3000-Sheet Finishers D373/D374 only and not on 3000-Sheet Finisher D830
- Cover Interposer Tray B835 is for installation on the 3000-Sheet Finisher D830 only and not on the 2000/3000-Sheet Finishers D373/D374.

	Description	Q'ty
1.	Front door extension (top)	1
2.	Rear cover extension (bottom)	1
3.	Shoulder screws	3
4.	Tapping screws – M4 x 8	9
5.	Tapping screws – M3 x 8	2
6.	Tapping screws – M3 x 6	5
7.	Adjuster plates	2
8.	Hinge Bracket	1
9.	Plate Extension (bottom)	1
10.	Gasket Seals	2
11.	Right Rear Cover Plate (B706 only)	1
12.	Spacer	1
13.	Anti-Static Brush	1
14.	Spacer (B706 only)	1



## Installation

	Description	Q'ty
15.	Spacer (Not used )	1
16.	Right front corner plate (for B706 only)	2
17.	Front door extension (bottom)	1
18,	Sponge Strip	1

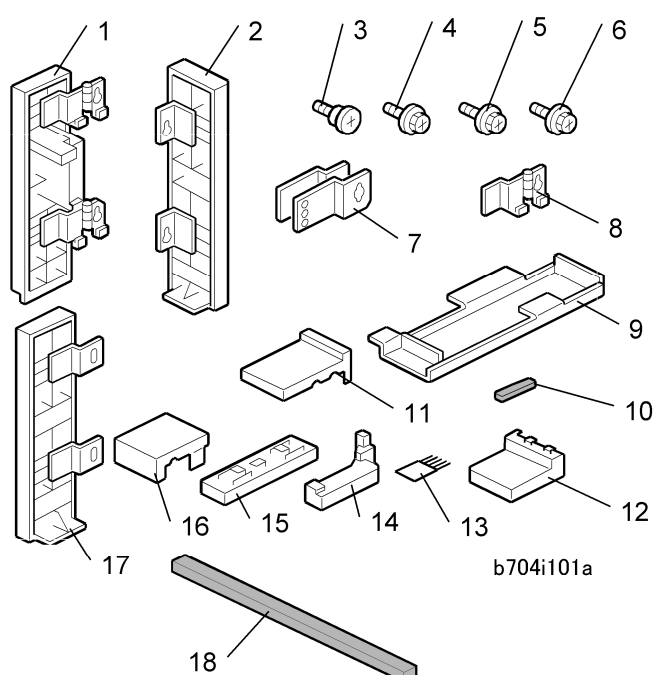

## Installation

You can install the Cover Interposer Tray B704 on these finishers only:

- 2000-Sheet Booklet Finisher D373
- 3000-Sheet Finisher D374

## Removing Tapes and Packing Materials

### **WARNING**

- Make sure that the finisher is disconnected from the main machine, and that the copier is turned off and the power cord is disconnected, before you start this procedure.

## Installation

---

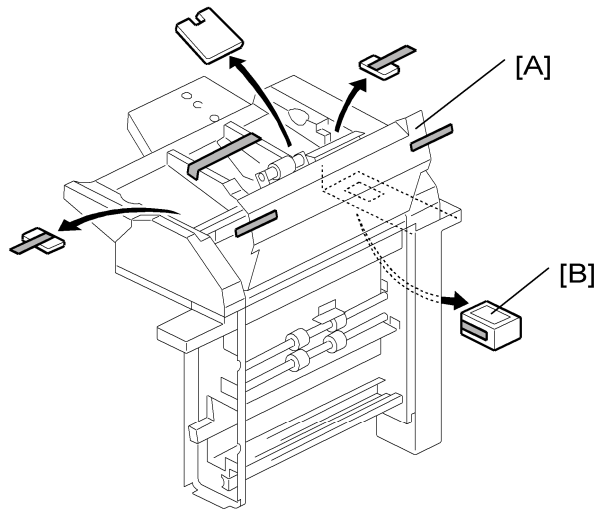

b704i102

1. If the finisher is connected to the machine, disconnect it.

### CAUTION

- After disconnecting the finisher, for safety remove the front and rear finisher connectors from the copier. Reattach them just before docking the finisher to the copier.
2. Remove all tape and retainers from the cover interposer tray [A].
  3. Remove the tape and packing material [B] from the ground connector.

## Preparing the Finisher

---

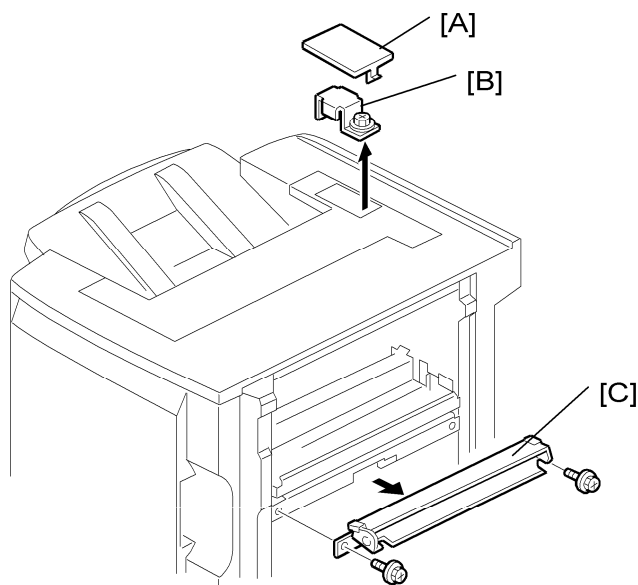

b704i103

1. Remove the cover [A] of the relay connector.

## Installation

---

2. Loosen the screw of the bracket [B] (⌀ x 1) then remove the bracket.
3. Remove the guide plate [C]. (You will attach this guide plate to the cover interposer. Do not discard it.)

### ★ Important

- If you will install the cover interposer tray on a D373/D374 finisher that was installed on the machine before this time, remove the sponge strip from the finisher. Keep this strip because you must attach it later to the interposer tray.

## Attaching the Extensions

---

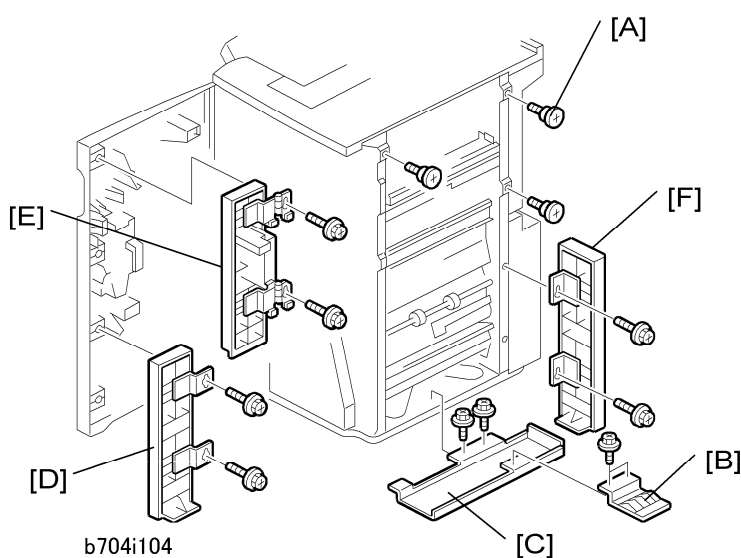

1. Attach the three shoulder screws [A] (⌀ x 3).
2. If the finisher was previously installed, remove the ground plate [B] from the finisher and keep the screws.
3. Attach the bottom plate [C] (⌀ x 2, M3 x 6) then attach the ground plate to the bottom plate (⌀ x 2).
4. Attach the bottom front cover extension [D] (⌀ x 2, M4 x 8).
5. Attach the top front cover extension [E] (⌀ x 2, M4 x 8).
6. Attach the rear cover extension [F] (⌀ x 2, M3 x 6).

## Installation

---

### Attaching the Interposer Tray

---

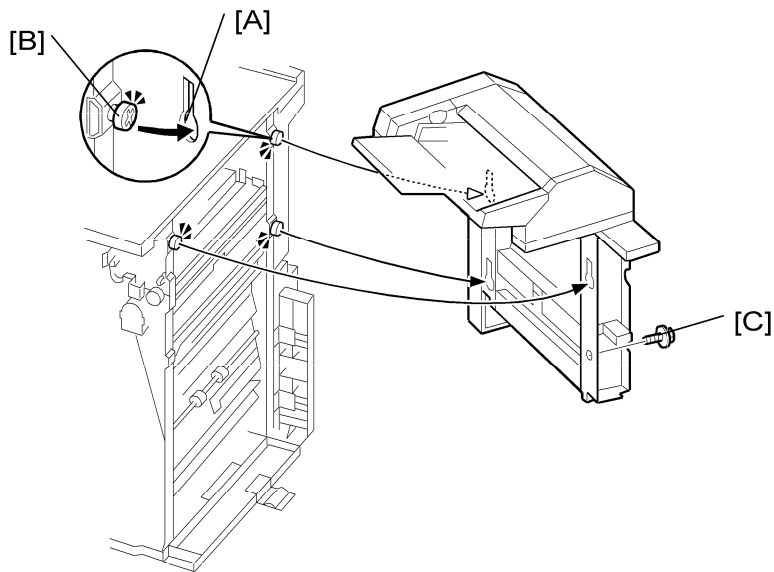

b704i105

1. Lift the cover interposer tray.
2. Align the keyholes [A] with the shoulder screws [B], and move the cover interposer down onto the screws.
3. Attach the cover interposer with the screw [C] (⌀ x 1, M3 x 6).

### Docking the Finisher/Interposer with the Machine

---

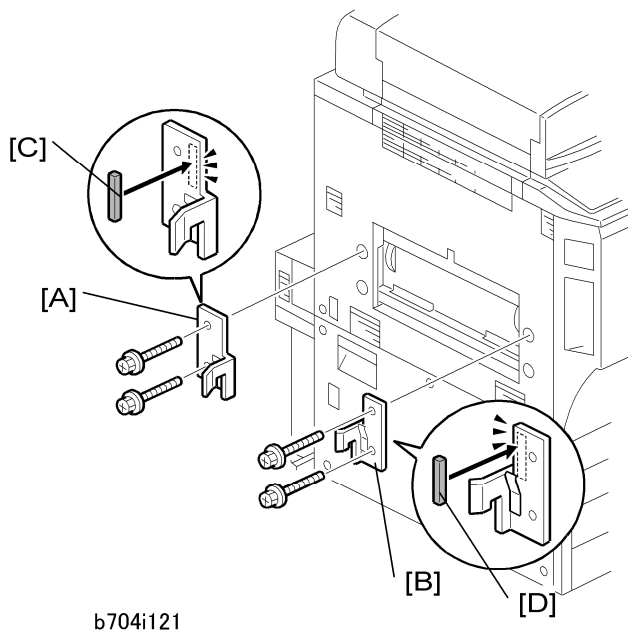

b704i121

1. Attach the rear bracket [A] (⌀ x 2, M4 x14).

## Installation

2. Attach the front bracket [B] (⌀ x 2, M4 x14).
3. Attach the gasket seals [C] and [D].

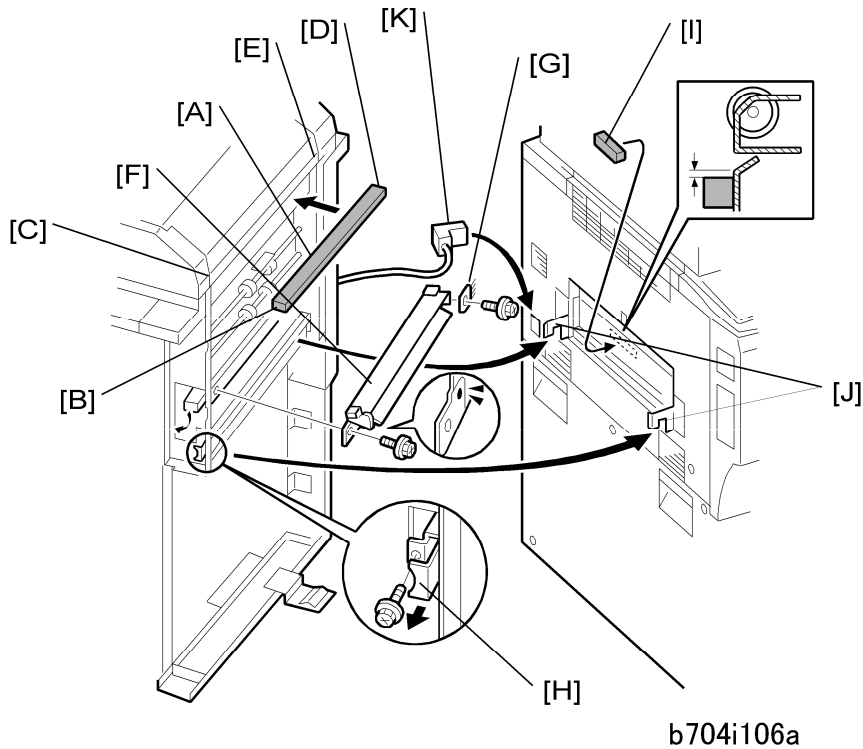

4. Attach the sponge strip [A] that is supplied with the finisher.
  - Align the sponge end [B] with the edge [C].
  - Align the sponge end [D] with the edge [E].
5. Attach the guide plate (removed from the finisher) to the cover interposer.
  - Attach the front end [F] of the plate (⌀ x 1).
  - Attach the rear end of the plate with the anti-static brush [G] (⌀ x 1).
6. Release the lock lever [H] (⌀ x 1).
7. Attach the pad [I]. This pad is provided with the finisher.
8. Slowly push the finisher against the side of the machine until the brackets [J] go into the slots.

### **WARNING**

- Move the finisher carefully to avoid bending the entrance guide plates.
9. Attach the lock lever [H] (⌀ x 1).
  10. Connect the connector [K] to the copier.

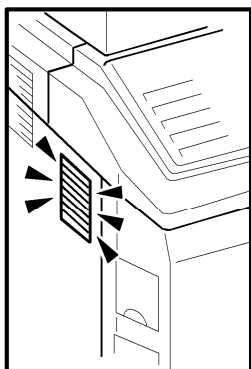

d373r734

11. Check the right side of the machine and make sure that the sponge strip does not block the air flow through the duct.

## Cover Interposer Tray CI5000 (B835)

---

### Accessories

---

Check the quantity and condition of the accessories in the box against the following list.

	Description	Q'ty
1.	Spacer	1
2.	Black Mylar	1
3.	Relay Guide Plate – Long (for B234/B235/B236)	1
4.	"L" Hinge Pins (Tray Unit Front Cover)	2
5.	Sponge Strip	1
6.	Leveling Shoes	4
7.	Rear Docking Bracket	1
8.	Front Docking Bracket	1
9.	Flat Knob Screw	1
10.	Screw (M4 x 8)	4
11.	Screw (M3 x 6)	2
12.	Screw (M4 x 12)	2
13.	Knob Screw	3
14.	Base Cover (Tray Unit)	1
15.	Rear Cover	1
16.	Screws (M4 x 14)	4
17.	Relay Guide Plate – Short (for D014/D015)	

## Installation

---

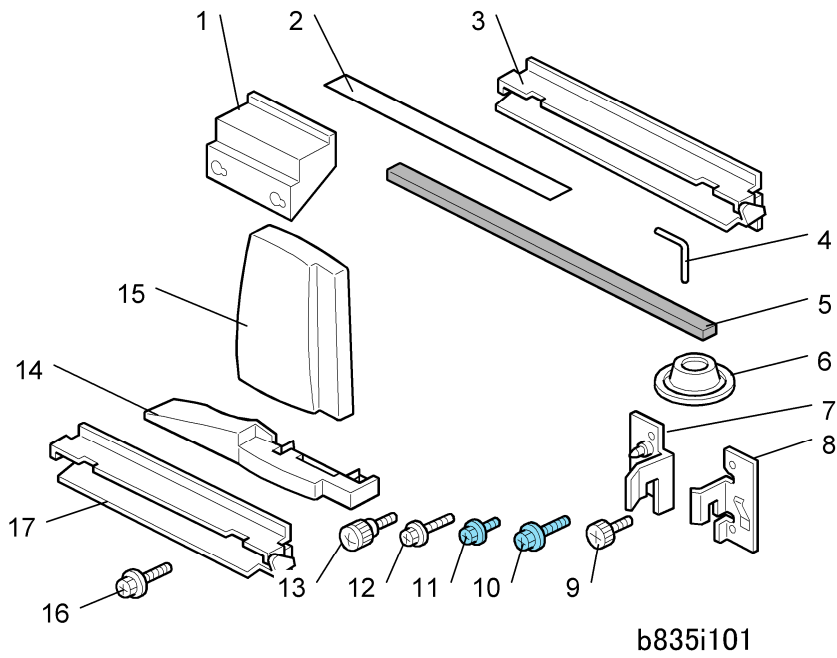

---

## Installation

---

### Setting up the Unit and Docking to the Copier

---

#### CAUTION

- Unplug the power cord before starting the following procedure.

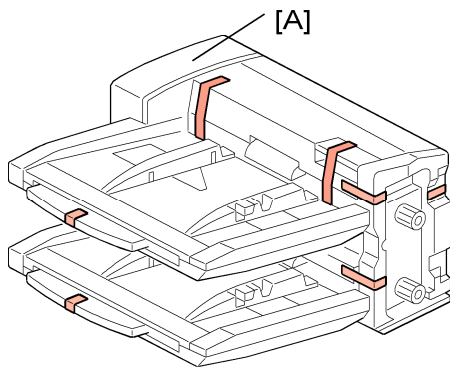

b835i102

1. Remove all the tape and shipping materials from the tray unit [A].



## Installation

---

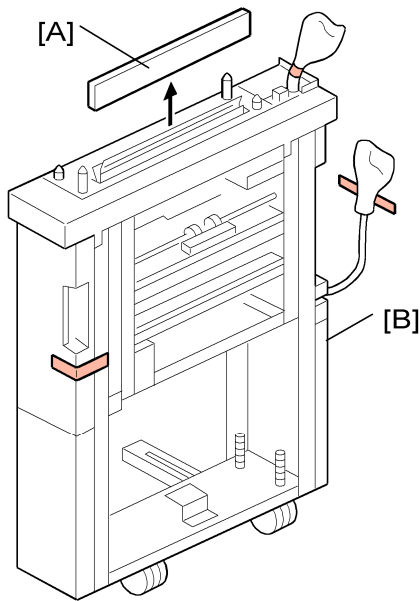

b835i103

2. Remove cover [A].
3. Remove all tape and shipping materials from the transport unit [B].

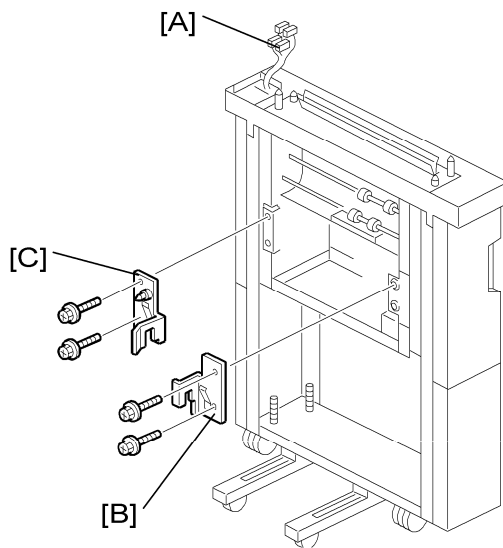

b835i105

4. Confirm that the connectors [A] are free.
5. Attach the front docking plate [B] (⚙️ x2).  
**★ Important**
  - You must use the M4 x 14 screws.
6. Attach the rear docking plate [C] (⚙️ x2). These are the docking plates for the next device to be installed in the paper feed line.

**★ Important**

## Installation

- You must use the M4 x 14 screws.

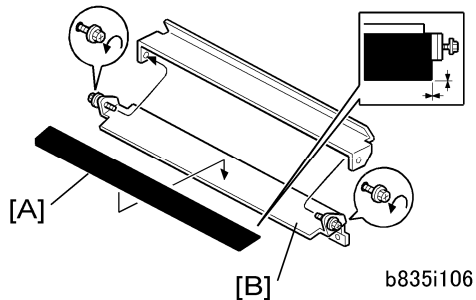

7. Attach the black mylar [A] to the relay guide plate [B] of the next finishing device to be installed to the left of the cover interposer tray (Z-folding unit or finisher).

### ★ Important

- Do not attach this mylar to either the long or short guide plates provided with the cover interposer tray accessories.

8. Peel the tape from the back of the sponge strip [A] and attach it as shown.
9. Attach the relay guide plate [B] (⌘ x2).

### ★ Important

- You must use the Relay Guide Plate – Short (12-in.)

10. Remove the ground plate [C] from the bottom cross-piece (⌘ x2).
11. Turn the ground plate over.
12. Reattach the ground plate with the same screws as shown (⌘ x2).

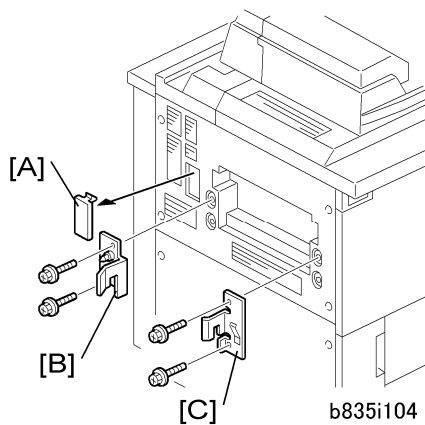

13. Remove the interface connector cover [A].
14. Attach the rear docking bracket [B] (⌘ x2).
15. Attach the front docking bracket [C] (⌘ x2).

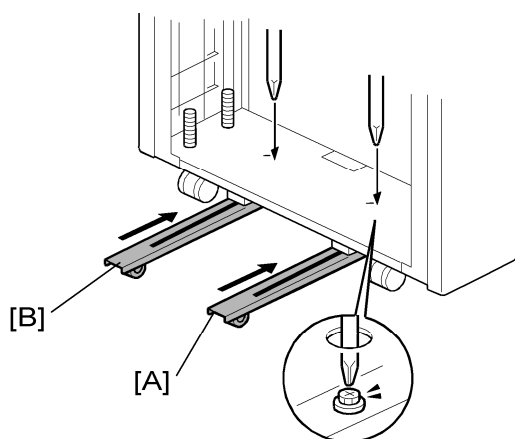

b835i109

16. If the Z-Folding Unit will be installed, loosen the screws for the rear runner [A] and front runner [B].
17. Push the runners in and re-fasten them again with the screws.

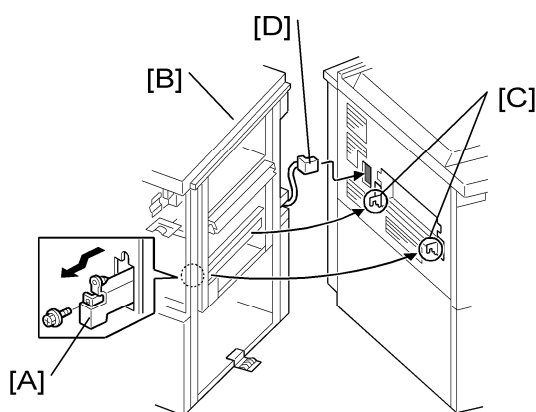

b835i108

18. Open the front door of the cover interposer tray.
19. Pull out the locking lever [A].
20. Align the finisher [B] with the joint brackets [C], then slowly push the finisher onto the brackets.
21. Connect the finisher cable [D] to the copier
22. Push in the locking lever.
23. Check that the top edges of the finisher are parallel with edges of the finisher (or copier) to the right.
24. Fasten the locking lever [A] (⌀ x 1)
25. Close the front door.

## Docking the Next Peripheral Device

---

The next peripheral device to the left of the cover interposer tray must be installed before you can mount the tray unit on top of the transport unit of the cover interposer tray.

- The tray unit of the cover interposer tray is supported by the top of the next peripheral device in line to the left, as well as the transport unit of the cover interposer.
- The next peripheral device to the left of the cover interposer must be set up and docked to the cover interposer before the transport unit of the cover interposer can be mounted.

### **Connect the next peripheral unit now.**

- Z-Folding Unit B660 (See "Z-Folding Unit B660" in this section)
- 3000-Sheet Finisher B830 (See "3000-Sheet Finisher B830" in this section)

### **CAUTION**

- Never attempt to mount the cover interposer tray unit until the next device in line (Z-Folding Unit B660, or 3000-Sheet Finisher (B830) has been docked to the transport unit (base) of the cover interposer tray.
- To prevent bending the frame of the tray unit and damaging its alignment, always remove the tray unit from the cover interposer tray transport unit at the following times:
  - 1) Before disconnecting either the cover interposer tray or the next peripheral device to the left, or
  - 2) Before doing any maintenance on either the cover interposer tray or the next peripheral device to the left.

Mounting the Tray Unit

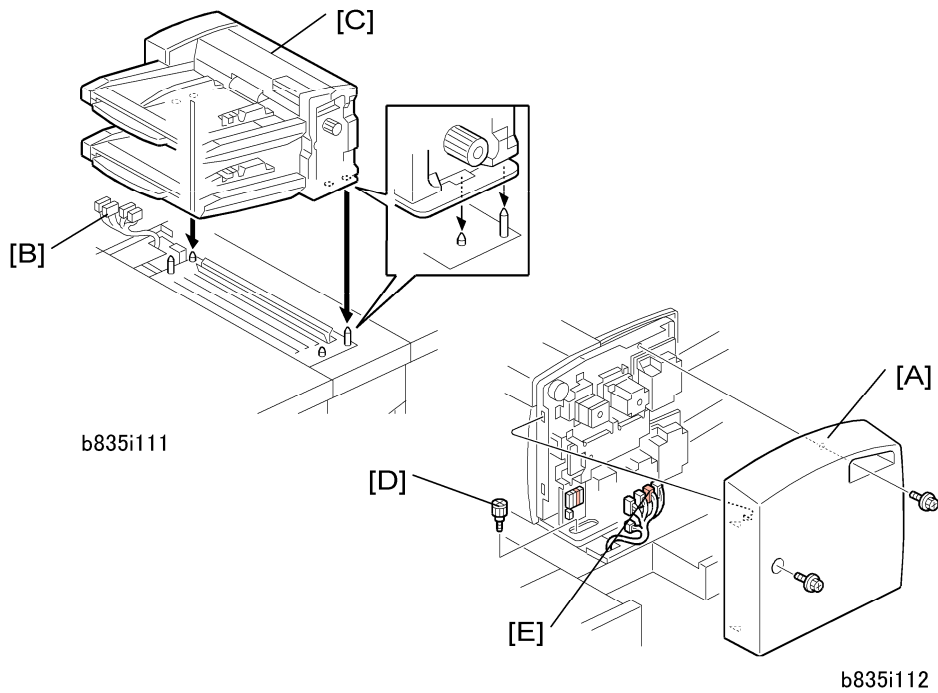

1. Remove the rear cover [A] (⚙️ x2).
2. Confirm that the connectors [B] are free.
3. Place the tray unit [C] on top of the cover interposer transport unit.
4. Attach the knob screw [D] (⚙️ x1).
5. Connect the harness connectors [E] (🔌 x5)
6. Reattach the rear cover.

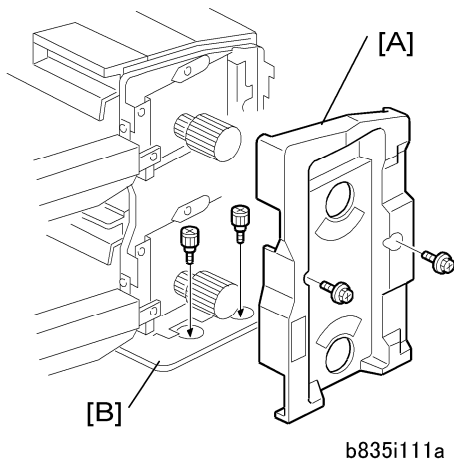

7. Remove the front inner cover [A] from the dual-tray unit (⚙️ x2).
8. Fasten the tray unit to the top of the transport unit with the knob screws [B] (⚙️ x2).

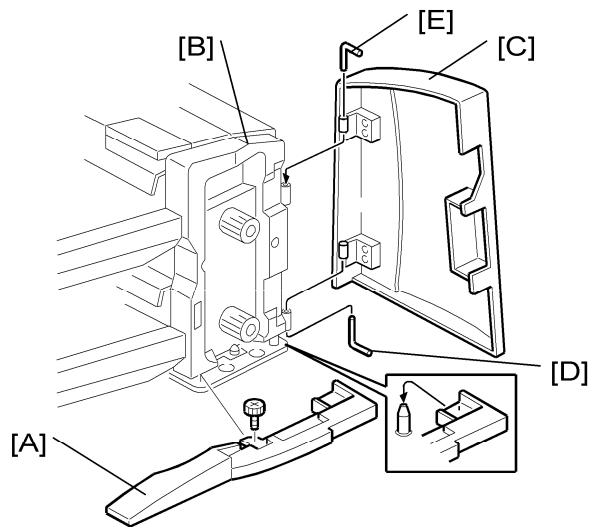

b835i113

9. Attach the base cover [A] (⚙️ x1).
10. Confirm that the holes in the cover match the positions of the reference pins.
11. Re-attach the front inner cover [B] (removed at step 7 above).
12. Position the tray unit front door [C] so that its hinges match the posts on the frame of the tray unit.
13. Hold the lower L-pin [D] as shown, insert it halfway, push it up, then rotate it into its groove.
14. Hold the upper L-pin [E] as shown, insert it halfway, push it down, then rotate it into its groove.

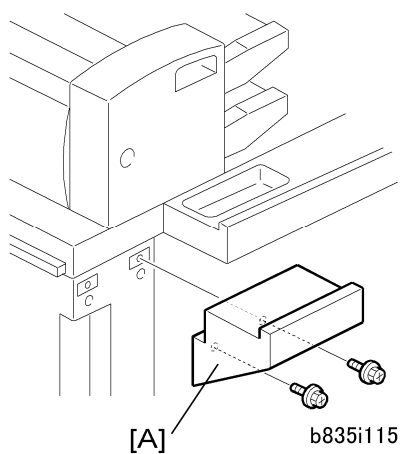

b835i115

15. Attach the spacer [A] to the rear of the transport unit (⚙️ x2).

## Installation

---

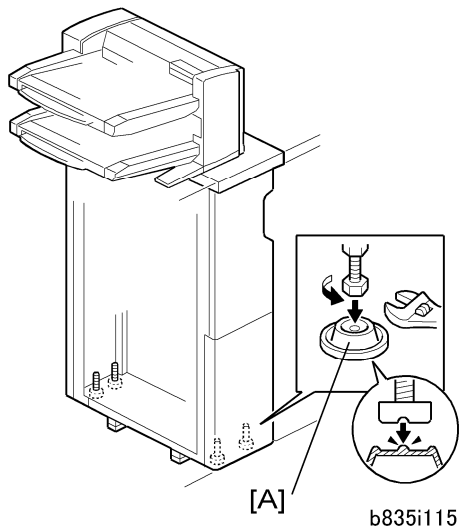

16. Set the leveling shoes [A] (x4) under the feet.
17. Turn the nuts to adjust the height of the cover interposer until it is level.

---

## Docking the Cover Interposer Tray B835

---

The following units are docked to the cover interposer tray:

- Z-Fold Unit B660
- Finisher B830

### Z-Fold Unit B660 to Cover Interposer Tray B835

---

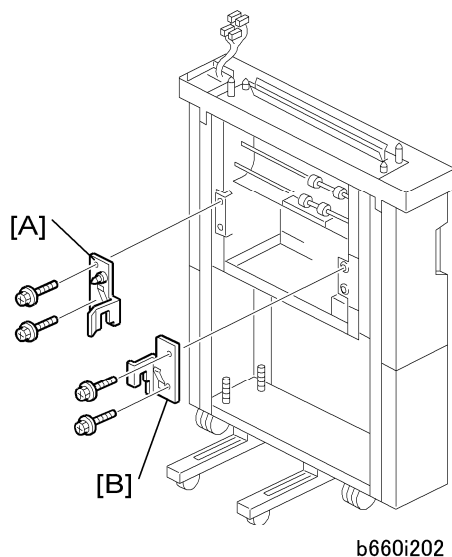

1. Attach the rear docking bracket [A].
2. Attach the front docking bracket [B].
3. Connect the Z-folding unit.

## Installation

---

### Finisher B830 to Cover Interposer Tray B835

---

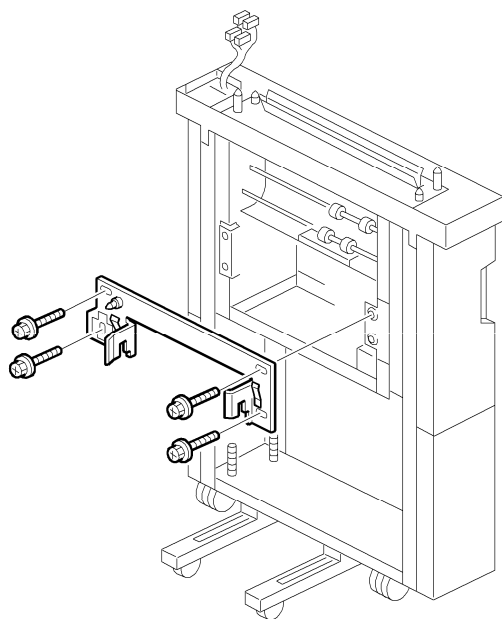

b830i203

1. Fasten the joint bracket to the Cover Interposer Tray B835.
2. Dock the finisher.

## Firmware Update

---

Install the latest version of the firmware for the cover interposer tray.

The cover interposer may not operate correctly with the D014/D015 unless the most recent version of the firmware is installed.

### **North America Only**

When the Cover Interposer Tray (B835) is installed, be sure to check the FCC Class-A decal is attached to the copier below its serial number decal.

This decal is included with the Finisher Adapter (D375) because the Cover Interposer Tray CI5000 (B835) is always installed with Finisher Adapter (D375) and the 3000-Sheet Finisher (B830).

For more details see "3000-Sheet Finisher (B830), Finisher Adapter (D375)" in section "1. Installation".



---

## Z-Folding Unit ZF4000 (B660)

---

---

### Accessory Check

---

Check the quantity and condition of the accessories in the box against the following list:

	Description	Qty
1.	Lock Bracket – Rear (Cover Interposer Tray)	1
2.	Lock Bracket – Rear	1
3.	Lock Bracket – Front (Cover Interposer Tray)*1	1
4.	Lock Bracket – Front	1
5.	Ground Plate (Cover Interposer Tray)	1
6.	Ground Plate (Z-folding unit)	1
7.	Ground Plate (Finisher or Cover Interposer Tray)	1
8.	Right Docking Bracket	1
9.	Left Docking Bracket	1
10.	Power Cord	1
11.	Front Spacer	1
12.	Rear Spacer	1
13.	Guide Plate	1
14.	Sponge Strip	1
15.	Teflon C-Clamp	2
16.	Screws M4x10	4
17.	Screws M3 x 6	8
18.	Screws M4 x 8	4

## Installation

	Description	Qty
19.	Leveling Shoes	3
20.	Drive Gear (Black – for B236 135 cpm only)	1
21.	Drive Gear Assy (Black – for B236 135 cpm only)	1

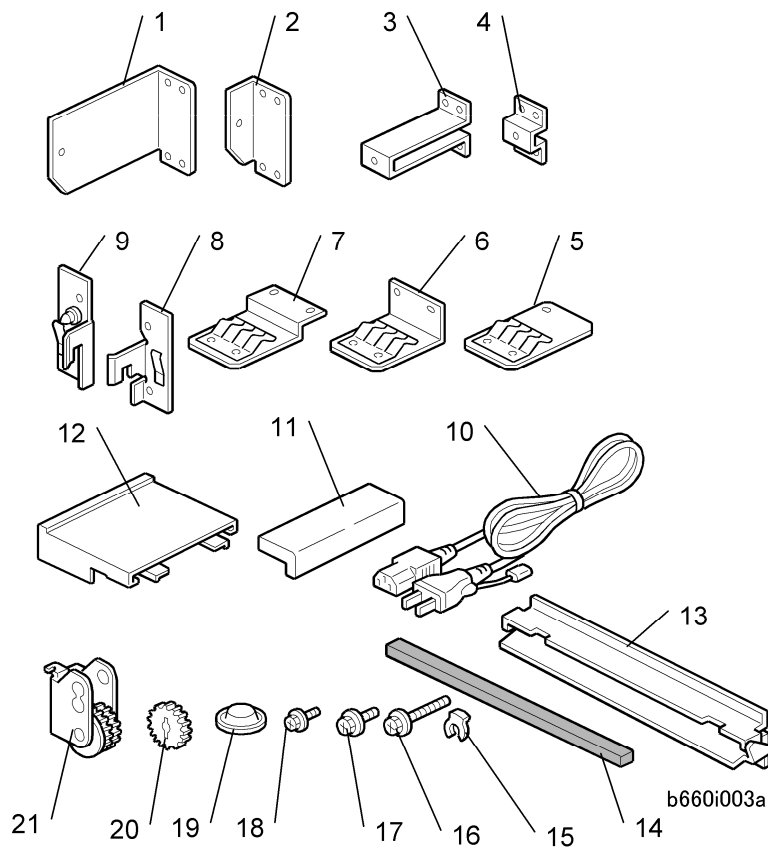

## Installation

### **⚠ CAUTION**

- Always switch the machine off and unplug the machine before doing any of the following procedures.

## Installation

### Unpacking

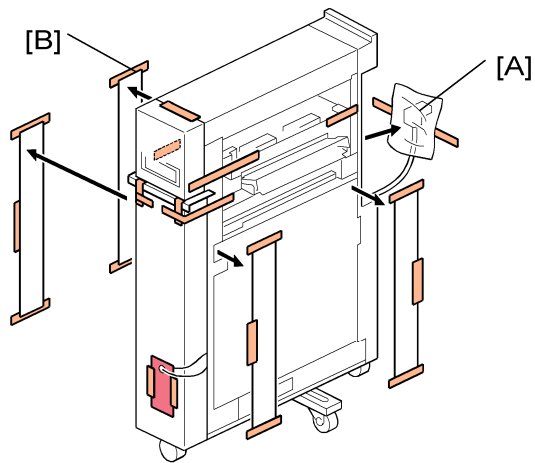

b660i001a

1. Detach the head of the I/F connector [A].
2. Remove all external tape [B] and shipping materials.

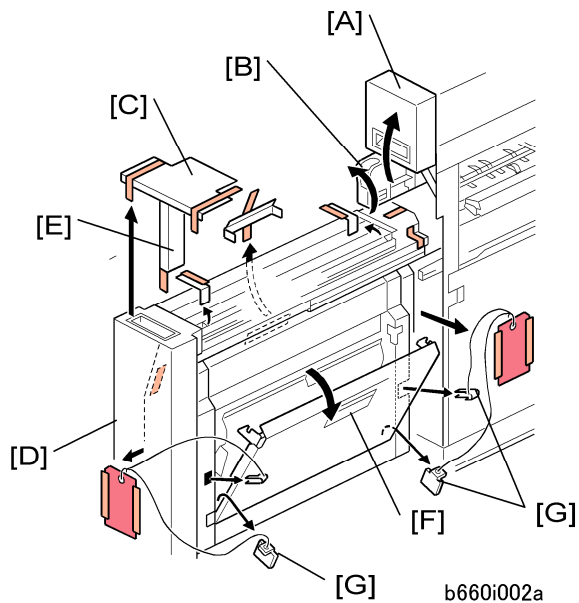

b660i002a

3. Open the front door [A].
4. Raise the horizontal transport plate [B] and remove the cushion [C].
5. Pull out the Z-folding mechanism [D] and remove the cushion [E].
6. Open the right vertical transport cover [F] completely (2 steps).
7. Remove four spacers [G] by pulling on the string.

Attaching the Brackets

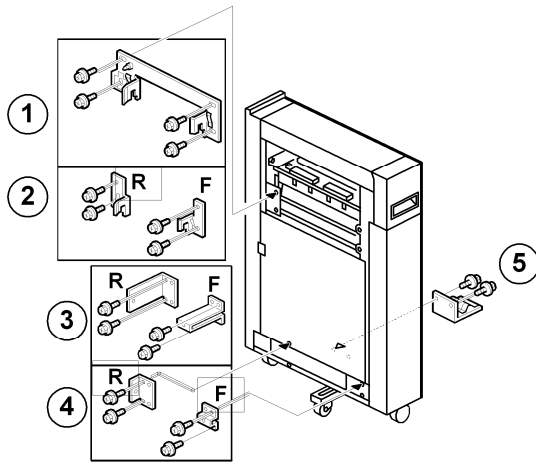

b660i004a

1. Attach the upper brackets.
    - If the Z-folder is installed with the 3000-Sheet Finisher B830, install bracket ① on the Finisher B830.
    - If the Z-folder is installed with the 2000/3000-Sheet Finisher D373/D374, install brackets ② (front and rear).
  2. Attach the lower brackets.
    - If the Z-folder is installed with the cover interposer tray, install brackets ③.
    - If the Z-folder is not installed with the cover interposer tray, install brackets ④.
- ★ Important**
- **Bracket "-F" is not required when the Z-folder is installed with the 3000-Sheet Finisher B830.**
- Attach the ground (earth) plate ⑤ to the side of the Z-folding unit that is facing the copier. Use the ground plate for the Z-folding unit. (Item 6 in the accessories list.)

## Installation

### Preparing for Docking

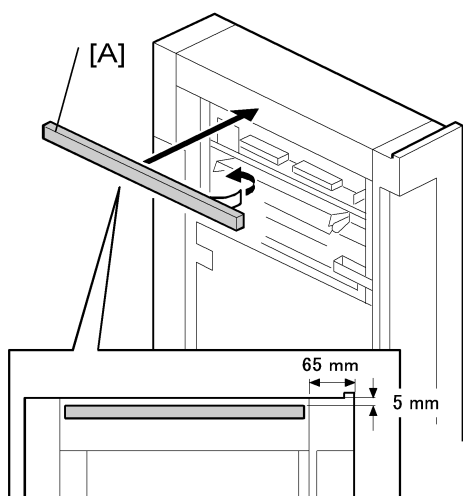

b660i005

1. Remove the tape from the sponge [A] and attach it to the Z-folding unit.

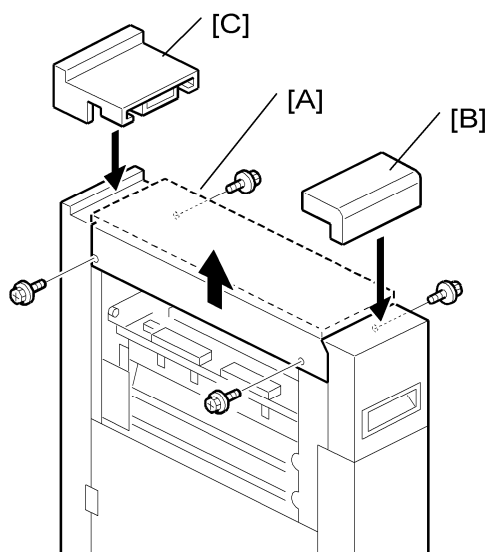

b660i010

2. Remove the top cover [A] (⚙ x 4).
3. Remove the seal from the double-sided tape on the bottom of the front spacer [B], then attach it.
4. Remove the seal from the double-sided tape on the bottom of the rear spacer [C], then attach it.
5. The spacers align the top of the Z-folding unit with the edge of the copier.
6. Reattach the top cover [A] (⚙ x 4).
7. Make sure that the top cover is level with the tops of the rear and front spacers.

## Installation

---

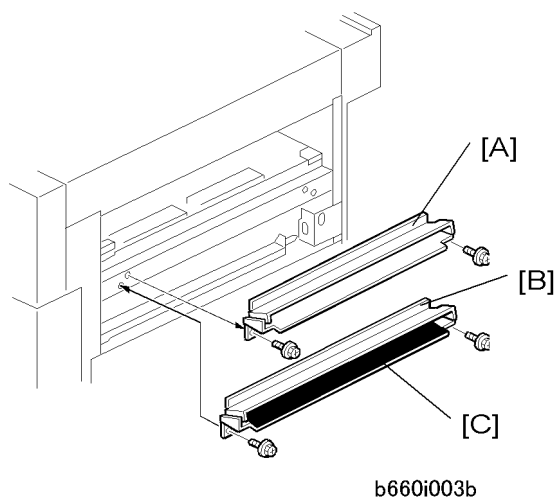

### ★ Important

- Do Steps 8 and 9 only when the Z-Folding Unit (B660) is installed with Cover Interposer Tray (B835).
8. Replace the entrance guide plate [A] with the longer guide plate [B] provided with the accessories (⚙ x 2).
  9. Attach the mylar [C] (from the accessories for the Cover Interposer B835) as shown in the illustration only to the guide plate provided with the Cover Interposer Tray B835.

## Testing the Breaker

---

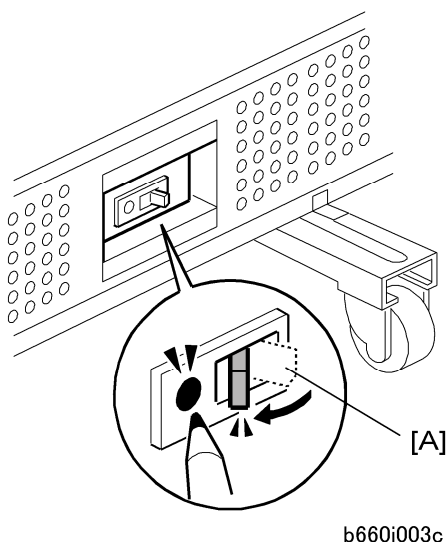

1. The breaker switch is at the lower right side of the Z-folder. Confirm that the manual breaker switch [A] is set to the right.

### ↓ Note

- When the breaker switch is set to the right (the "—" mark will be visible), the

## Installation

---

copier is ready to be turned on.

2. Connect the Z-folding unit power cord to the Z-folding unit and connect the other end of the cord to an ac power source.
3. Push in the breaker test button with the tip of a screw driver until the breaker switch snaps to the off position.
4. Confirm that the breaker switch is at the off position.
  - If the breaker switch does not move to the off position:
  - Confirm that the power cord is securely connected to the power supply.
  - Push the test button again.
  - If the breaker switch does not snap to the off position, the breaker switch must be replaced.
5. Reset the breaker switch to the on position.

## Docking the Z-Folding Unit to the Cover Interposer Tray or Copier

---

The Z-Folding Unit is docked to the Cover Interposer Tray B835, or to the Copier if the cover interposer tray is not used.

### Z-Fold Unit to Cover Interposer Tray B835

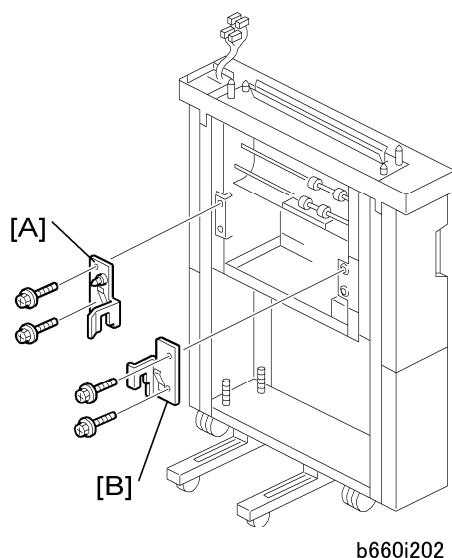

1. Attach the rear docking bracket [A].
2. Attach the front docking bracket [B].
3. Connect the Z-folding unit.

### Z-Fold B660 to Copier

## Installation

---

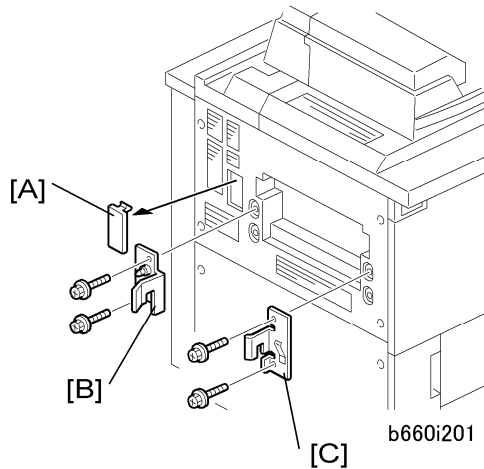

1. Remove the connector plate [A].
2. Attach the rear docking bracket [B].
3. Attach the front docking bracket [C].
4. Connect the Z-folding unit.

## Connecting the Z-Folding Unit B660

---

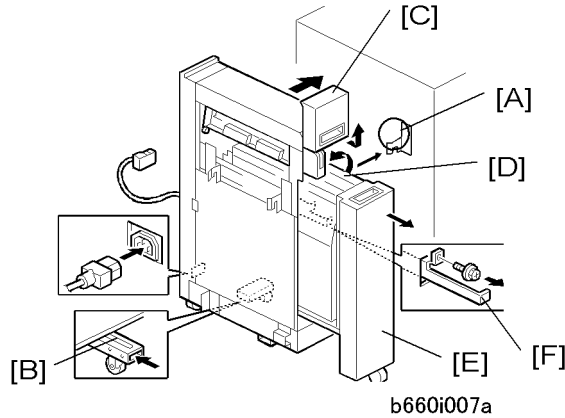

1. Fasten brackets [A] (x2) (provided accessories) to the Cover Interposer Tray B835 (or Copier) (⚙️ x 2 each).
2. Remove support screw and bracket [B], push in the support, then reattach the screw and bracket.
3. Pull the top cover [C] toward you then raise it.
4. Raise the horizontal transport plate [D] to the left.
5. Pull out the Z-folding mechanism [E].
6. Pull out the Z-folding unit lock lever [F] (⚙️ x 1).
7. At the right bottom edge of the Z-folding unit, confirm that the breaker switch is ON.



## Installation

---

**Note**

- This switch should display "—". If you see "O", set the switch to "—". The machine will not recognize the Z-folding unit if this switch is off.
8. Dock the Z-folding unit to the cover interposer tray (or Copier).
  9. Push in the lock lever [F] and fasten it (⚙ x 1).
  10. Push in the Z-folding mechanism [E], lower the horizontal transport plate [D], then close the front door [C].
  11. Connect the Z-Folding unit to the copier.
  12. Connect the Z-Folding unit power cord to the Z-folding unit and connect the other end of the cord to the power ac supply.

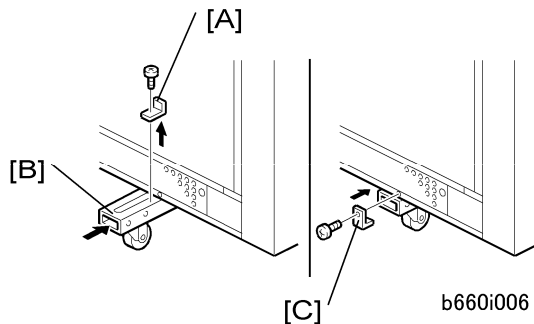

13. At the left bottom edge of the Z-folding unit, remove the bracket [A] (⚙ x 1).
14. Push in the support [B].
15. Reattach the bracket [C] (⚙ x 1).

**CAUTION**

- With the support retracted, the Z-folding unit tips easily!
16. Attach the I/F cable to the cover interposer tray (or Copier).
  17. Connect the power cord to the Z-folding unit.

## MFP Controller Options

### Overview

The machine controller box has three board slots and two SD card slots. Make sure that each board and SD card is put in the correct slot.

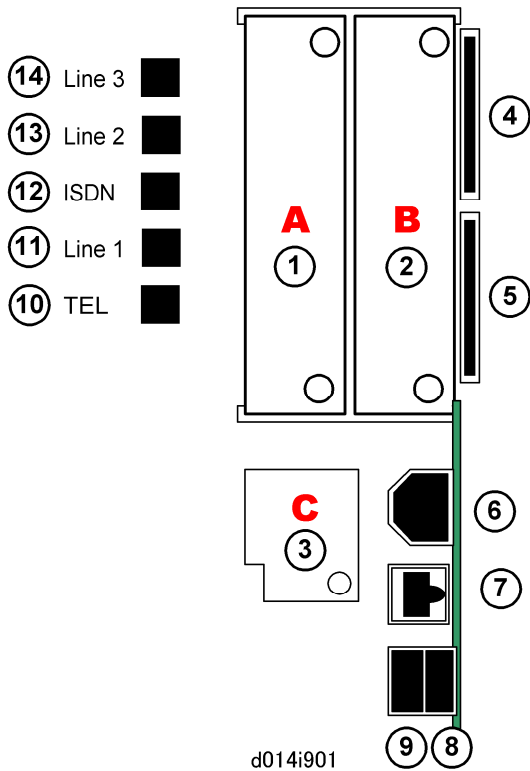

### Board Slots

No.	Name	Description
①	Slot A	Copy Connector (B328) only
②	Slot B	Not Used
③	Slot C	Gigabit Ethernet PCB for EFI Color Controller E-7100
④	Slot #2 Option Slot	<ul style="list-style-type: none"> <li>▪ Data Overwrite Security (D377)</li> <li>▪ PostScript3 (D378)</li> <li>▪ Printer/Scanner GM-2190</li> </ul>

## Installation

No.	Name	Description
⑤	Slot #1 Service Slot	The Service Slot for firmware updates, moving applications to another SD card with SP5873 (Apli Move).
⑥	USB 2.0	Built-in for connection of USB devices.
⑦	100BaseT LAN	Standard LAN connection point.
⑧	USB Ch1	Not Used
⑨	USB Ch2	
⑩	TEL	Jack for telephone connection
⑪	Line 1	Jack for main telephone line from the outside for connection to Fax Option (D356).
⑫	ISDN	Not Used
⑬	Line 2	Jack for a 2nd line connection to Fax Interface Unit (D357) (G3) when this option is installed.
⑭	Line 3	Not used. (G4 is not available for installation outside Japan at this time.)

### Important Notes

- Only two SD Card slots are available for applications.
- Other applications must be inserted in the upper slot.
- If more than one application is required in the upper slot, the applications must be moved to the same SD card with SP5873-1.
- The PostScript3 application cannot be moved to another card. However, other applications can be moved to the PostScript3 SD card.

## Enabling USB

Do SP5985 to enable USB



- **USB is built-in but it must be enabled.**

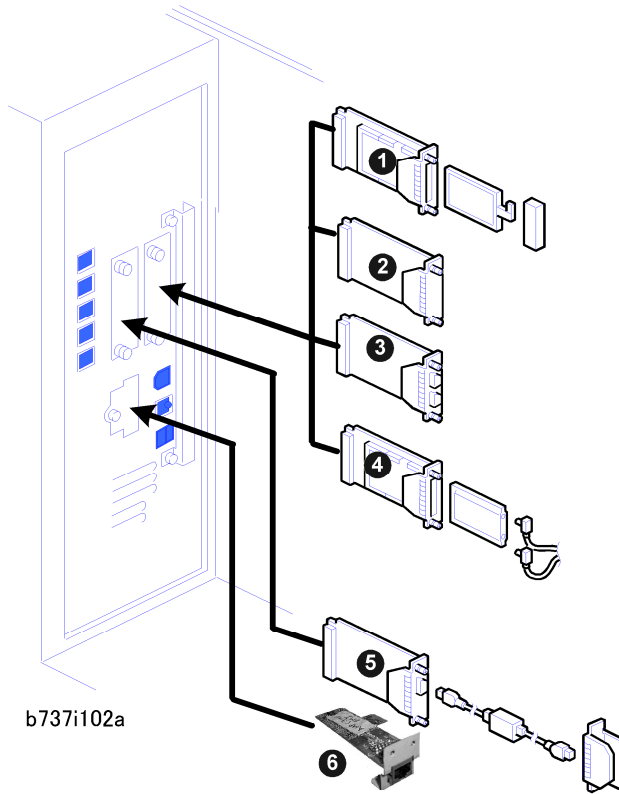

No.	Slot	Code	Option
①	Slot B	-	Not Used
②	Slot B	-	Not Used
③	Slot B	-	Not Used
④	Slot B	-	Not Used
⑤	Slot A	B328	Copy Connector
⑥	Slot C	D377	Gigabit Ethernet*1
		B828	Copy Data Security Unit Type F (not shown, is attached to the IPU inside the controller box.)

## Installation

---

\*1: The EFI (Fiery) controller is connected through Gigabit Ethernet (included in EFI controller).

---

## SD Card Applications

---

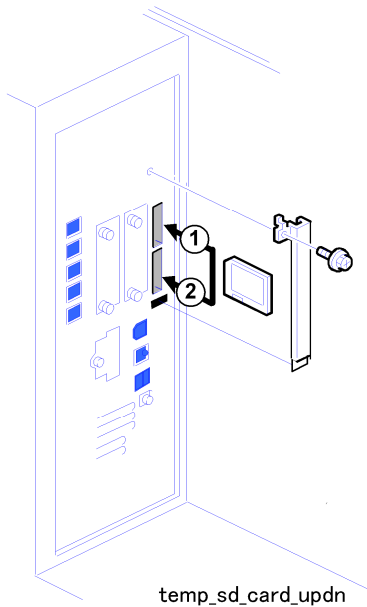

The following applications are available on SD cards.

No.	Name	SD Card Slot.
D377	Data Overwrite Security Unit Type H	1
D378	PostScript 3	1
D376	Printer/Scanner GM-2190	1

### Note:

- The VM Card must be inserted in the lower slot. This is because it requires about 22 MB of disk space, and cannot be merged onto the SD card in the upper slot if that card already contains all the other applications.
- If the customer needs more than one application in the upper slot, the applications must be moved to one SD card. (See "Moving Applications to One SD Card" in this section)

---

## Handling DIMMs and SD Cards

---

### **WARNING**

- Always turn the machine off and disconnect the machine power cord before you

## Installation

---

install a controller option.

### CAUTION

- To prevent damage to the controller box, always work carefully. Never put your hand or a tool into the box when you remove the controller box or install an option.
- To prevent damage to the circuits on the boards, always touch a metal surface to remove static charge from your hands before you handle a board..

## DIMMs

---

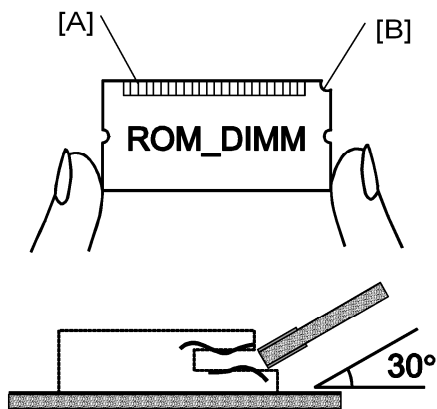

g338i901

1. Hold the ROM DIMM as shown above. The edge connector [A] points toward the slot and the notch [B] is in the top right corner.
2. Insert the edge connector [C] in the slot at a 30-degree angle from the surface of the board. If the angle is too low, the upper contact could bend.
3. Carefully move the outer edge of the ROM DIMM up and down slightly until it goes into the connector then carefully push it down until it is level with the controller board.

### Important

- If the upper contact is pushed in with force and bends, the connection will be defective and the machine will not operate.

## SD cards

---

SD cards are held in position by a small spring-lock mechanism.

1. To install an SD card, push it into the slot until it stops, then release it.
2. To remove an SD card, push the SD card in carefully to release it, and then remove it from the slot.

### Moving Applications to One SD Card

---

#### Overview

---

There are only two SD card slots:

- Upper slot. Insert the application card in this slot. If more than one application is required, the applications must be moved to one SD card with SP5873-1.

Here are some important points you should keep in mind about SD cards and their applications:

- The data necessary for authentication is transferred with the application program to the target SD card.
- Do not use an SD card if it has previously been used with a computer. Correct operation is not guaranteed if such an SD card is used.
- The SD card is the only evidence that the customer is licensed to use the application program. The service technician may occasionally need to check the SD card and its contents to solve problems. Although copied SD cards are disabled for use, they must be stored in the machine door for future use and reference. (See "Storing SD Application Cards on Site" in this section)
- A licensing agreement prohibits copying of a PostScript3 SD card. However, you can move other applications to the PS3 SD card.
- Once an SD card has been used to hold several applications, it should not be used for any other purpose.

#### Moving Applications

---

Do this procedure to put more than one application on one SD card.

1. Turn off the copier.
2. Remove the SD card slot cover ( x 2).

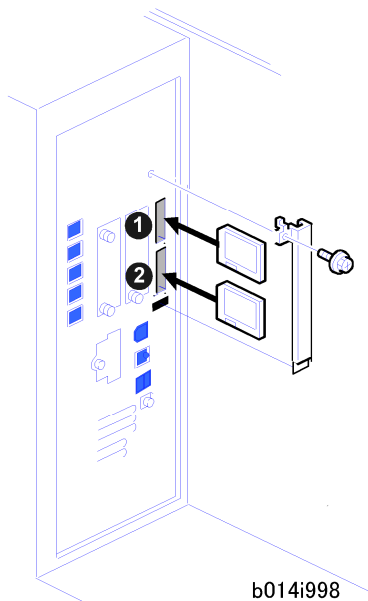

3. Insert the Source SD card in the lower slot. This card contains the application that you want to move to the other SD card.



- The PostScript3 SD card cannot be the source card because it cannot be copied.
4. Put the Target SD card in the upper slot.
  5. Open the front door.
  6. Turn the copier on.
  7. Go into the SP mode and do SP5873-1.
  8. Follow the instructions on the display and touch "Execute" to start copying.
  9. When the display tells you copying is completed, touch "Exit".
  10. Turn the copier off.
  11. Remove the Source SD card from the lower slot, and leave the target SD card in the upper slot.
  12. Turn the copier on.
  13. Go into the User Tools mode and confirm that all the applications on the SD card in the upper slot are enabled.  
User Tools> System Settings> Administrator Tools> Firmware Version> Next (5/5)
  14. Turn the copier off again, then:
    - Reattach the SD card slot cover.
    - Remove the cover from the front door, and store the SD card that was copied. (See "Storing SD Application Cards on Site" in this section)

The SD card must be stored with the machine for these reasons:



## Installation

---

- Once an SD card has been copied, it can no longer be used. But it must be stored in the front door to serve as proof of purchase by the customer.
- Also, at a later time the stored SD cards can be restored to full use with SP5873-2 (described in the next section).
- Before you put the card in the front cover, label it so that it can be easily identified.

## Undo Exec

---

1. Turn the main switch off.
2. Put the SD card with the applications in the lower slot.
3. Put the original destination SD card (the one stored in the front door) into the upper slot.

### ↓ Note

- The SD card in the upper slot must be the original SD card of the application you want to move from the lower slot to the upper slot. You cannot use any blank SD card in The upper slot. The application will be moved only to the original SD card.
4. Turn the main switch on.
  5. Go into the SP mode and do SP5873-2 (Undo Exec)
  6. Follow the messages on the operation panel to complete the procedure.
  7. Turn the main switch off.
  8. Remove the SD cards from the slots.
  9. Turn the main switch on.

## Storing SD Application Cards on Site

---

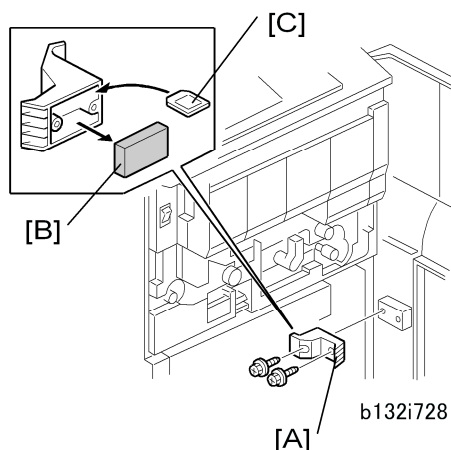

1. Open the front door.
2. Remove the cover [A] on the door (⚙ x 2).

## Installation

---

3. Remove the block [B].
4. Store the SD cards [C] inside the cover.
5. Attach the cover to the machine.

---

## Printer/Scanner GM-2190 (D376) and Interface Unit

---

### Accessories

---

Check the accessories and their quantities against this list.

	Description	Qty
1.	Printer/Scanner GM-2190 SD Card (D376)	1
2.	Key Top Assembly	1
3.	Operating Instructions – Printer	1
4.	Installation Instructions	1
5.	FCC Label	1
6.	Software CD-ROM	3

## Installation

---

### **WARNING**

- Turn the machine off and disconnect the machine power cord before you start this procedure.

## Installation

---

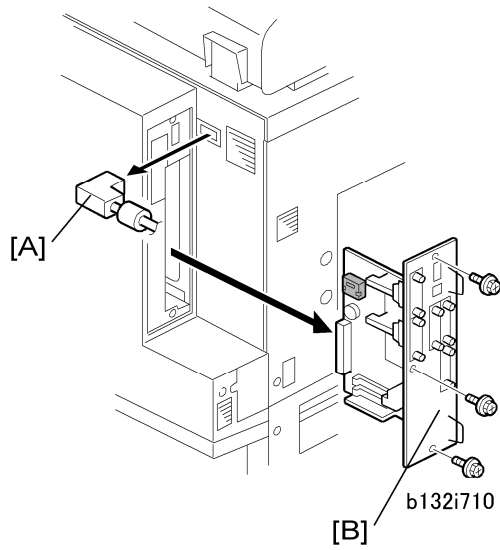

1. Disconnect the ARDF cable [A] (🔌 x 1).
2. Remove the controller board [B] (🔩 x 3).
3. Reinstall the controller board (🔩 x 3).

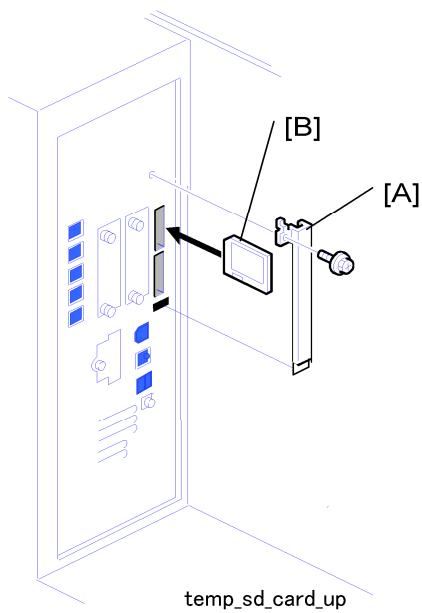

4. Remove the SD card slot cover [A] (🔩 x 1)
5. Insert the Printer/Scanner SD card in SD Card the upper slot [B].
6. Reattach the SD card slot cover (🔩 x 1).

## Installation

### Postscript3 D378

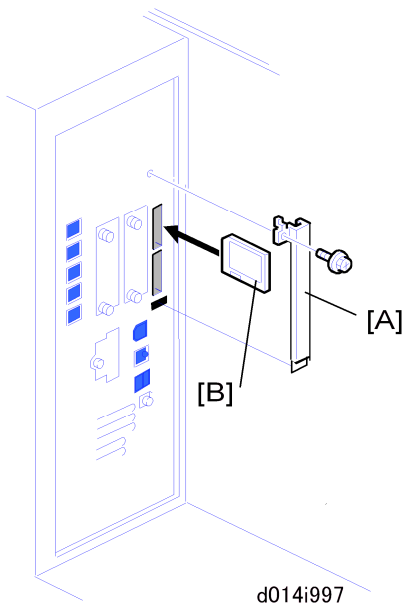

1. Remove the slot cover [A] (⚙️ x1).
2. Put the PostScript3 SD card [B] in SD card the upper slot.
  - Only one SD card slot is available for applications provided on SD cards.
  - If the customer wants to use two or more applications from SD cards, the applications must be moved to a single SD card. (See "Moving Applications to One SD Card" in this section.)
  - The PostScript3 application and fonts cannot be moved to another SD card. However, other applications can be moved onto the PostScript3 SD card.

### Data Overwrite Security Unit Type H D377

#### Accessory Check

Check the accessories and their quantities against the table below.

Description	Qt'y
1. Data Overwrite Security SD Card	1
2. Operating Instructions CD-ROM	1
3. Comments Sheet (17 languages)	2

## Installation

---

### Before You Begin...

---

1. Make sure that the Data Overwrite Security unit SD card is the correct type for this machine. **The correct type for this machine is type "H".**



- If you install any version other than type "H", you will have to replace the NVRAM and do the DOS installation procedure again.

2. Make sure that the following settings are not at the factory default settings:

- Supervisor login password
- Administrator login name
- Administrator login password

These settings must be set up by the customer before the Data Overwrite Security unit can be installed.

3. Confirm that "Admin. Authentication" is on:

- [User Tools]> "System Settings"> "Administrator Tools"> "Administrator Authentication Management"> "Admin. Authentication"> "On"
- If this setting is "Off" tell the customer that this setting must be "On" before you can do the installation procedure.

4. Confirm that "Administrator Tools" is selected and enabled:

- [User Tools]> "System Settings"> "Administrator Tools"> "Administrator Authentication Management"> "Available Settings"
- "Available Settings" is not displayed until Step 2 above is done.
- If this setting is not selected tell the customer that this setting must be selected before you can do the installation procedure.

### Seal Check and Removal

---

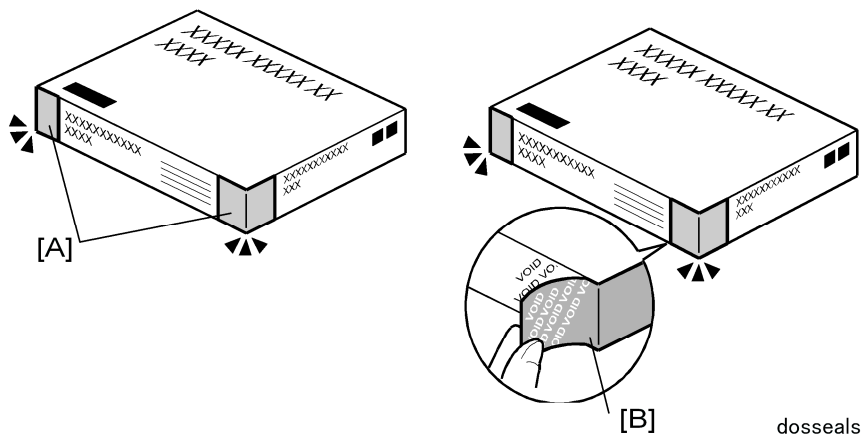

1. Check the two box seals [A] on the corners of the box and confirm that they are firmly

## Installation

---

attached.

### ★ Important

- If you see "VOID" on the tapes or on the corners of the box this means that the seals have been removed. If the "VOID" notations are visible, do not use the SD card for this installation. Contact your sales division
2. Remove the seals from both corners of the box. The silver "VOID" notations [B] become visible only after you have removed the seals. This is normal.

## Installation Procedure

---

### 🔧 Preparation

- Before doing the procedure, turn off the main power switch and unplug the machine from its power source.
1. Make sure that the machine is switched off and disconnected from its power source.
  2. Disconnect the network cable.
  3. Turn the main power switch on.
  4. Turn the operation switch and main power switch off.

### ★ Important

- Make sure that the number and "Type" are correct (**Type H, D377**). If you install the incorrect version of this application, the NVRAM must be replaced.

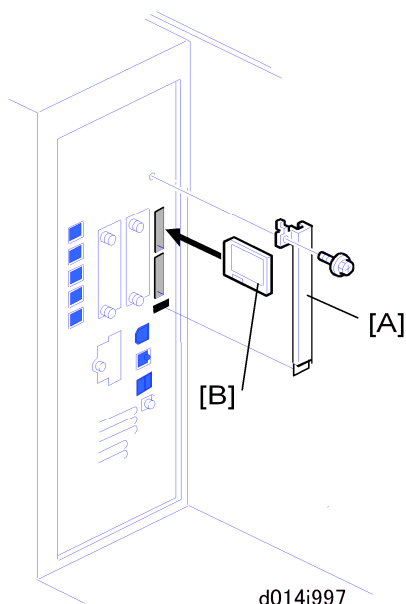

5. Remove the SD card slot cover [A] (🔧x1).
6. Remove the security tape from the SD card wrapping.

### ★ Important

- If you see "VOID" on the security tape this means that the tape has been

## Installation

---

removed.

- If the "VOID" notations are visible, do not use the SD card for this installation.

Contact your sales division

7. Insert the DOS SD card [B] into the upper slot.
8. Reconnect the network cable.
9. Turn the main power switch on.
10. Do SP5878-1 and push [Execute] to enable the DOS option.
11. Go out of the SP mode.
12. Cycle the machine off/on.
13. Do SP5990-5 to print the Self Diagnosis Test.
14. Check the diagnostic report.
  - Under [ROM No./Firmware Version] you should see the correct number for this option displayed for "HDD Format Option".
  - Under [Loading Program] you should see "GW1a\_zoffy: (number)".The numbers in the report must match. (The ROM number and firmware version number change after the firmware has been upgraded.)
  - If the ROM numbers or version numbers do not match, this means that the DOS unit type was incorrect (not "Type D"),
  - If the numbers do not match:
    - (1) Obtain the correct SD card: Data Overwrite Security D377 Type H
    - (2) Replace the NVRAM on the controller board.
    - (3) Insert the Type correct SD card in the lower slot.
    - (4) Do the DOS unit installation procedure again.

## Check Operation of the DOS Application

---

1. Turn "Auto Erase Memory Setting" on:  
[User Tools]> "System Settings"> "Administrator Tools"> "Auto Erase Memory Setting"> "On"
2. Exit User Tools.

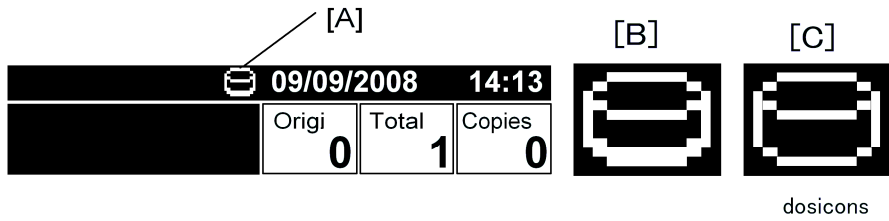

3. Check the display and make sure that the overwrite erase icon [A] is displayed.
4. Make a Sample Copy.
5. Check the overwrite erase icon.
  - The icon [B] changes to [C] when job data is stored in the hard disk.
  - The icon resumes its normal shape [B] after a data overwrite has completed.

---

### Copier Connection Kit B328

---

Check the accessories and their quantities against the table below.

Description	Qt'y
1. Connection PCB	1
2. Power Repeater Cable	1
3. Repeater Hubs	2



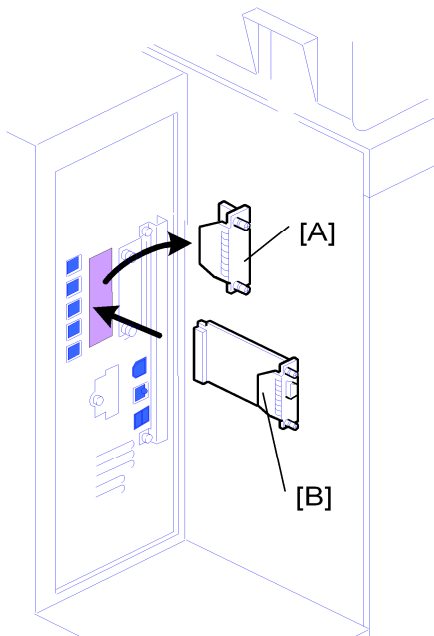

b737i904

**⚠ CAUTION**

- Turn the machine off and unplug the machine before starting the following procedure.

1. Remove the cover [A] of Slot A (⚙ x 2).
2. Install the Copier Connection Kit Board B328 [B] in Slot A and fasten it (⚙ x 2).
3. Remove the rear upper cover.

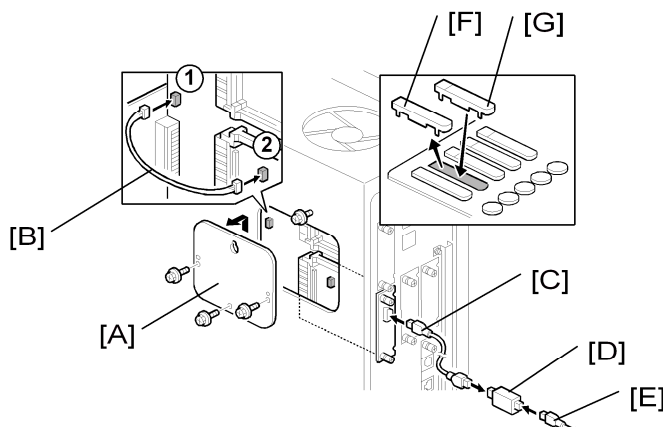

b373i112a

4. Remove the controller box cover [A] (⚙ x 3).
5. Connect the power repeater cable [B] to:
  - ① **CN594**
  - ② **CN4**

## Installation

---

6. Reattach the controller box cover and rear upper cover.
7. Repeat Steps 1 to 6 to install the connection kit on the second machine.
8. Connect the end of the interface cable [C] to the connection PCB.
9. If additional cable is required, connect the cables [E] with repeater hubs [D].
10. On the operation panel of each machine, remove the second cover [F] from the bottom ("Printer").
11. Install the appropriate key on each machine.  
Attach the "Printer/Other Function" key [G] (or its equivalent symbol for EU) if the printer/scanner option is installed.  
-or-  
Attach the "Other Function" key [G] (or its equivalent symbol for EU) if the printer/scanner option is not installed.
12. Attach the other end of the connection cable to the connection PCB installed in the other machine.

---

# Preventive Maintenance

---

---

## Overview

---

The amounts mentioned (K=1,000) as the PM interval indicate the number of prints or copies unless stated otherwise. These numbers are based on the PM counter.

---

---

## Required Materials

---

Item	Part Number
Optical Cloth	A0129111
Alcohol	None
Exposure Glass Cleaner	A1939310
Lubricant Powder	B1329700
G104 Yellow Toner* <sup>1</sup>	D0159500
Zinc Stearate	D0159501

**\*<sup>1</sup>: Do not use D014/D015 yellow toner, because it contains developer that could damage the drum and ITB.**

**★ Important**

- Lubricant Powder (B1329700) (composed of Zinc Stearate) is specially designed for this machine (D014/D015).
- Always use this lubricant powder to lubricate the drum and ITB during servicing.
- Never use the yellow toner from this machine because it contains developer, and this will damage the drum and ITB.
- Never use the previous Setting Powder (54429101) in any service procedure for the D014/D015. The composition of this Setting Powder and the Lubricant Powder is completely different.
- If you use Setting Powder (5442910) to service this machine, you will damage the drum charge roller and cause problems with image quality.

**⚠ WARNING**

- Turn off the main power switch and unplug the machine before performing any

## Preventive Maintenance

---

procedure in this section. Laser beams can seriously damage the eyes.

### ★ Important

- After you do the PM, do the forced music adjustment with SP 2111 001.

## PM Counter

---

The PM Counter main menu and submenu allows you to review the PM counts for both units and individual components.

---

### Displaying the PM Counter

---

1. Push [Clear Modes] (☒)> "107"> [Clear/Stop] (⏹).

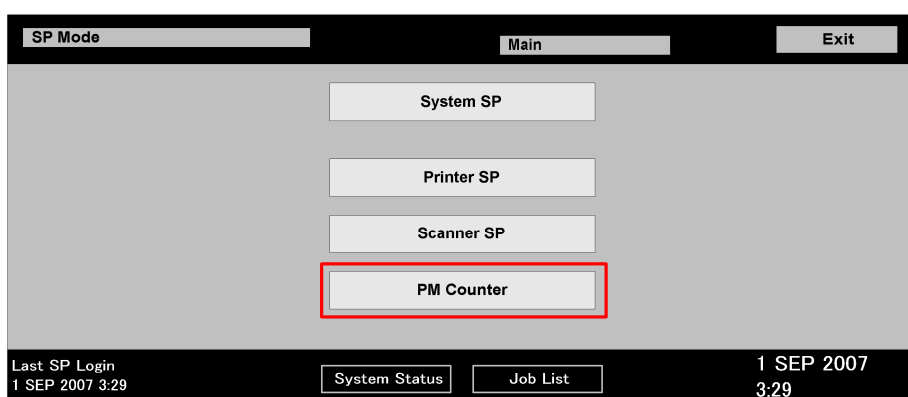

d014p901

2. Touch [PM Counter].

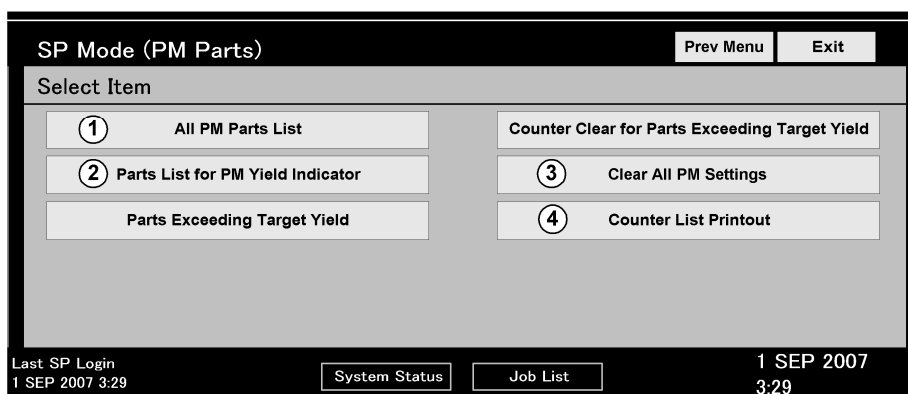

d014p902

: **All PM Parts List.** Displays all PM items (all PM items, not only PM units). Lists all PM items regardless of PM yield indicator settings.

: **Parts list for PM yield indicator.** Displays the items that have their PM yield indicator settings set to "Yes".

: **Clear all PM settings.** Resets all PM counter settings to "0" at the same time. PM items can be reset one by one with the [Clear] button.

: **Counter list print out.** Prints the PM counter on paper.

Preventive Maintenance

PM Parts Screen Details

All PM Parts list: Main Menu

The "All PM Parts list" displays all PM units and individual items. This list shows all PM items, regardless of their "PM yield indicator settings". ( Number button submenu)

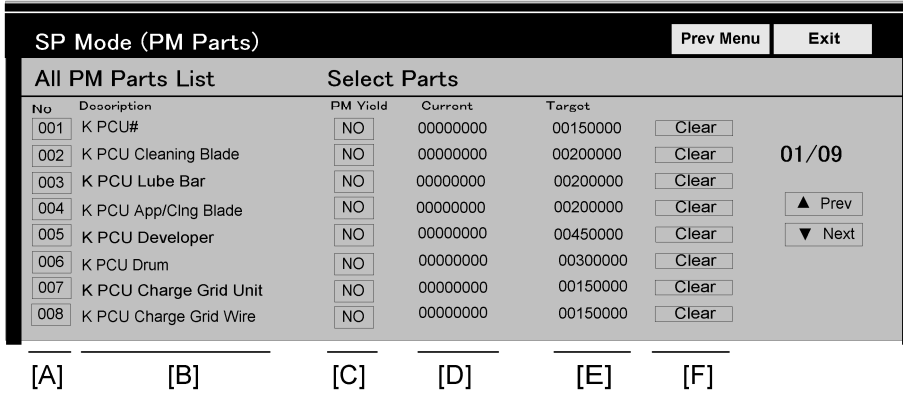

d014p903

[A]	Number buttons. Pressing a number button opens a submenu. ( Number button submenu)
[B]	Descriptions. The # mark denotes a "unit" (not individual item).
[C]	PM yield buttons. Function is the same as the "PM yield indicator settings" button.
[D]	Current PM counter value.
[E]	Target PM interval. This can be changed by pressing a number button [A].
[F]	PM counter clear button. Function is the same as the [Clear current counter] button.

Number button submenu

Press any number button to open the submenu for a part. In the example below, the number button [001] #K:PCU was pressed.

## Preventive Maintenance

---

001	#K:PCU		
Current counter	0010892	[A]	Clear current counter
Target yield	0300K	[B]	Change Target Yield
Latest1	0014846		
Latest2	[D] 0000000	[C]	PM yield indicator settings
Latest3	0000000		No Yes
Exit		▲Prev ▼Next	

d014p904

[A]: **Clear current counter.** Press to reset the selected PM counter (in this example 001 #K:PCU) to "0". You can also clear the settings by pressing the [Clear] button on the right side of the PM Counter Main Menu ([F] in the previous section).

[B]: **Change target yield.** Press to change the target PM yield. To change the setting:

- Press [Change target yield]
- Enter the number for the new target with the 10-key pad.
- Press [#] on the operation panel.

[C]: **PM yield indicator settings.** [Yes] is the default. Press [No] to remove the current item from the "Parts list for PM yield indicator".

- When set to "Yes", items marked with the # mark (# = a unit) will not have their individual items
- When set to "No", items marked with the # mark (# = a unit) only the individual components will appear in the list (the units will not appear).

[D]: **PM counter history.** This is a summary of the most recent counts

- Latest 1. The latest PM count since the unit (or part) was replaced.
- Latest 2. The previous PM count since the unit (or part) was replaced.
- Latest 3. The previous but one PM count since the unit (or part) was replaced.

### Parts list for PM yield indicator

---

This list shows the PM Parts Main Menu with only items set to "Yes" displayed.

## Preventive Maintenance

JAN 23, 2002 11:09PM

SP Mode(PM Parts) Prev. Menu Exit

Parts list for PM yield indicator Select parts

No	Description	Exceed	Current	Target	
<input type="text" value="001"/>	#K:PCU	[A]	0010892	0300K	<input type="button" value="Clear"/>
<input type="text" value="017"/>	#M:PCU		0005570	0300K	<input type="button" value="Clear"/>
<input type="text" value="033"/>	#C:PCU		0005223	0300K	<input type="button" value="Clear"/>
<input type="text" value="049"/>	#Y:PCU		0005514	0300K	<input type="button" value="Clear"/>
<input type="text" value="065"/>	ITB		0025738	0600K	<input type="button" value="Clear"/>
<input type="text" value="066"/>	#ITB Cleaning Unit		0025738	0300K	<input type="button" value="Clear"/>
<input type="text" value="070"/>	#PTR Unit		0025738	0600K	<input type="button" value="Clear"/>

01/02

b132p905

### Note::

- The # mark denotes a unit.
- Items without the # (065 ITB) denote individual components.
- An asterisk (\*) will appear in the Exceed column [A] to show items that have exceeded their target PM yields.



## PM Tables

---

### Main Machine

---

#### Symbol Key for PM Tables

I	Inspect. Clean, replace, or lubricate as needed.
C	Cleaning required.
R	Replacement required.
L	Lubrication required: <ul style="list-style-type: none"> <li>▪ Silicone Grease 501 (52039502)</li> <li>▪ Grease Barrierta – S552R (A2579300)</li> <li>▪ Grease – KS660 – SHIN-ETSU</li> <li>▪ Heat Resisting Grease MT-78</li> <li>▪ Launa Oil 40</li> </ul>

### Main Machine PM Parts

---

#### OPTICS

	150K	200K	300K	450K	600K	Note
Reflector			C			Optical cloth
1st Mirror			C			Optical cloth
2nd Mirror			C			Optical cloth
3rd Mirror			C			Optical cloth
Scanner Rails			C			Alcohol then dry cloth
Exposure Glass			C			Exposure glass cleaner
Toner Shield Glass			C			Optical cloth

## Preventive Maintenance

	150K	200K	300K	450K	600K	Note
APS Sensor			C			Dry cloth
ARDF Exposure Glass			C			Exposure glass cleaner
Dust Filters			C			Blower brush

## PCU

	150K	200K	300K	400K	450K	600K	Note
OPC Drums					R		KYMC:450K
Charge Roller Units* <sup>1</sup>	R						Replace YMC together
Charge Wire Unit* <sup>1</sup>		R					K only
Drum Cleaning Blade	R	R					YMC:150K K:200K
Drum Lubricant Blade	R	R					YMC:150K K:200K
Drum Lubricant Bar (x2)* <sup>2</sup>	R	R					YMC:150K K:200K
Lubricant Brush			R	R			YMC:300K K:400K
PCU Joint			R	R			YMC:300K K:400K
Drum Lubricant Brush Gear			R	R			YMC:300K K:400K
Idle Gear 1			R	R			YMC:300K K:400K
Idle Gear 2			R	R			YMC:300K K:400K
Used Toner			R	R			YMC:300K K:400K

## Preventive Maintenance

	150K	200K	300K	400K	450K	600K	Note
Collection Gear							
Drum Cleaning Brush Gear			R	R			
Developer K					R		
Developer Y, M, C					R		
Quenching LED	C		C			C	

\*1: The K PCU uses a charge corona system. The YMC PCUs use a charge roller system.

\*2 The lubricant bar is the same for both K and YMC PCUs when replaced as an individual part. However, the drum lubricant bar assembly which contains the springs is not the same. The K assembly is clearly marked "K" to prevent installation of the wrong type in a PCU.

### TRANSFER UNITS

	150K	300K	450K	600K	Note
<b>ITB Unit</b>					
ITB (Image Transfer Belt)				R	
ITB Unit Rollers		I		C	Wipe with dry cloth
ITB Encoder Sensor		C			Wipe with damp cloth (alcohol)
ID and MUSIC Sensors		C			
ITB Cleaning Blade		R			These items are always replaced as a set.
ITB Lubricant Bar		R			
ITB Lubricant Blade		R			
ITB Lubricant Brush Roller		R			
<b>PTR Unit</b>					

## Preventive Maintenance

	150K	300K	450K	600K	Note
PTR (Paper Transfer Roller)				R	
PTR Cleaning Blade		R			
PTR Lubrication Bar		R			
Paper Transfer Discharge Plate		R			

## FUSING UNIT

	150K	300K	450K	600K	Note
Fusing Belt				R	
Hot Roller		R, L* <sup>1</sup>			
Pressure Roller				R, L* <sup>1</sup>	
Pressure Roller Cleaning Roller		R			
Oil Supply Roller		R			
Heating Roller				C, L* <sup>1</sup>	
Heating Roller Shaft Bearings				C, L* <sup>1</sup>	
Hot Roller Shaft Bearings				C, L* <sup>1</sup>	
Pressure Roller Shaft Bearings				R, L* <sup>1</sup>	Service Life:600K
Pressure Roller Stripper Pawls		I,C			Dry cloth
Fusing Belt Stripper Plate		I,C			
Thermistors		I, C			Dry cloth
Upper Entrance Guide Plate	I	C			Damp cloth (alcohol)
Lower Entrance Guide Plate	I	C			
Gears	L* <sup>1</sup>				

## Preventive Maintenance

---

\*1: The lubrication points for the fusing unit are described in the "Lubrication Points" section.

### PAPER FEED: COPIER

	150K	300K	450K	600K	Note
Registration Rollers		C			Alcohol, dry cloth
Paper Dust Removal Unit		C			Dry cloth
Registration Sensor		C			Blower brush
Vertical Transport Roller Sensors		C			Blower brush
LCT Relay Sensor		C			Blower brush
Bypass Feed Sensor		C			Blower brush
Bypass Paper End Sensor		C			Blower brush

### PAPER FEED: Trays

	150K	300K	450K	600K	Note
Feed Guide Plate		C			Dry cloth
Grip Rollers (Drive & Idle)		C			Alcohol, dry cloth
Pick-up Rollers (Tray 1 to Tray 3)					Service Life: 1000K Replace if jams, double-feeds occur with increasing frequency.
Paper Feed Rollers (Tray 1 to Tray 3)					
Separation Rollers (Tray 1 to Tray 3)					
Grip Roller (Drive Roller)		C			Dry cloth

## Preventive Maintenance

	150K	300K	450K	600K	Note
Paper Feed Sensor		C			Blower brush
Vertical Feed Sensors		C			Blower brush
Paper-End Sensor		C			Blower brush

## DUPLEX UNIT

	150K	300K	450K	600K	Note
Duplex Entrance Sensor		C			Blower brush
Reverse Rollers (Drive & Idle)		C			Alcohol, dry cloth
Inverter Exit Roller		C			Dry cloth
Transport Rollers (x4)		C			Dry cloth
Duplex Entrance Anti-Static Brush		C			Dry cloth
Inverter Junction Gate		C			Dry cloth
Inverter Entrance Roller		C			Dry cloth

## PAPER EXIT

	150K	300K	450K	600K	Note
Heat Dissipation Roller		C			Alcohol, dry cloth
Exit Anti-Static Brush		C			Inspect, replace if deformed.
Paper Exit Rollers (Upper, Lower)		C			Alcohol, dry cloth
Paper Exit Sensor		C			Blower brush

## Preventive Maintenance

	150K	300K	450K	600K	Note
Transport Rollers		C			Blower brush

## OTHER

	150K	300K	450K	600K	Note
Upper Dust Filter		R			
Lower Dust Filters	I,C		R		
Ozone Filters					Service Life: 1200K
Development Filters			R		
Used toner bottle	I,R	I,R	I,R	I,R	Empty and clean every inspection

## ARDF PM Parts

The "K" number in the table below is the number of originals that have been fed.

	PM Visit	120K	EM	Note
External Covers	I, C			Alcohol or water, dry cloth
Feed Belt	C	R	R	Alcohol or water, dry cloth
Pick-up Roller	C	R	R	Alcohol or water, dry cloth
Separation Roller	C	R	R	Alcohol or water, dry cloth
Original Length Sensors	C		C	Blower brush
Skew Correction Sensor	C		C	Blower brush
Interval Sensor	C		C	Blower brush
Registration Sensor	C		C	Blower brush

Preventive Maintenance

	PM Visit	120K	EM	Note
Paper Exit Sensor	C		C	Blower brush
Lower Inverter Sensor	C		C	Blower brush
Separation Sensor	C		C	Blower brush
Upper Inverter Sensor	C		C	Blower brush
White Cover	C		C	Alcohol or water, dry cloth
Transport Belt	C	R	C	Alcohol or water, dry cloth
Feed Drive Gears	L			G501 Grease
Grip Roller			C	Alcohol or water, dry cloth
Transport Rollers			C	Alcohol or water, dry cloth
Scanner Rollers (Entrance/Exit)			C	Alcohol or water, dry cloth
Exit Rollers			C	Alcohol or water, dry cloth
Inverter Rollers (Lower, Exit, Upper)			C	Alcohol or water, dry cloth
Idle Rollers			C	Alcohol or water, dry cloth

LCT B473

	1000K	2000K	3000K	Expected	Note
Paper feed roller	R	R	R		
Pick-up roller	R	R	R		
Separation	R	R	R		



## Preventive Maintenance

	1000K	2000K	3000K	Expected	Note
roller					
Transport guide plate	Inspect and clean every 350K.				
Grip roller	Inspect and clean every 350K.				

## LCT D350

	500K	1000K	Note
Paper feed roller x3		R	
Pick-up rollers x3		R	
Separation rollers x3		R	
Transport guide plate	I		
Grip rollers (drive, idle rollers)	I		

## 2000/3000-Sheet Finishers D373/D374

	300K	2400K	3000K	4000K	EM	Note
Covers					I,C	Alcohol or water, dry cloth
Drive Rollers					C	Damp cloth, dry cloth
Idle Rollers					C	Damp cloth, dry cloth
Anti-Static Brush					C	Dry cloth

## Preventive Maintenance

	300K	2400K	3000K	4000K	EM	Note
Sensors					C	Blower brush
Corner Stapler				R		Print an SMC report with SP5990. Replace the unit if the staple count is 500K.
Booklet Stapler				R		Print an SMC report with SP5990. Replace the unit if the staple count is 200K.

## Punch B702

	300K	2400K	3000K	4000K	EM	
Punch Waste Hopper	I	I	I	I	I	Remove and empty
Punch Unit						Replace after 1000k punches.

## Cover Interposer Tray B704

The PM interval is for the number of sheets that have been fed.

	60K	120K	180K	EM	Note
Feed Belt	R	R	R		Replace as a set.
Pick-up Roller	R	R	R		Replace as a set.
Separation Roller	R	R	R		Replace as a set.
Driver Rollers	C	C	C		Damp clean cloth.

## Preventive Maintenance

	60K	120K	180K	EM	Note
Idle Rollers	C	C	C		Damp clean cloth.
Discharge Brush	C	C	C		Damp clean cloth.
Sensors	C	C	C		Blower brush.

## Z-Folding Unit B660

	As Needed	Note
Drive Rollers	C	Dry cloth.
Idle Rollers	C	Dry cloth.
Anti-Static Brush	C	Dry cloth.
Bushings	L	Silicone Oil
Sensors	C	Dry cloth.

## 3000-Sheet Finisher B830

	350K	700K	1050K	Note
<b>FINISHER</b>				
Driver rollers	I	I	I	Alcohol
Idle rollers	I	I	I	Alcohol
Discharge brush	I	I	I	Alcohol
Shaft Bearings	I	I	I	Lubricate with silicone oil if noisy.
Sensors	I	I	I	Blower brush.
Jogger fences	I	I	I	Make sure that the screws are tight.

## Preventive Maintenance

	350K	700K	1050K	Note
Staple waste hopper	C	C	C	Empty staple waste.

## Punch B831

	300K	450K	600K	EM	Note
Punch Waste Hopper	I	I	I		Remove and empty

## Cover Interposer Tray B835

The PM interval is for the number of sheets that have been fed.

	60 K	As Needed	Note
Drive rollers		C	Dry cloth
Idle rollers		C	Dry cloth
Feed belt	R		
Separation roller	R		
Pick-up roller	R		
Sensors		C	Blower brush.
Drive gears		I	Lubricate with a very small amount of G501.

## Lubrication Points

---

### Copier

---

#### OPC, ITB Replacement

---

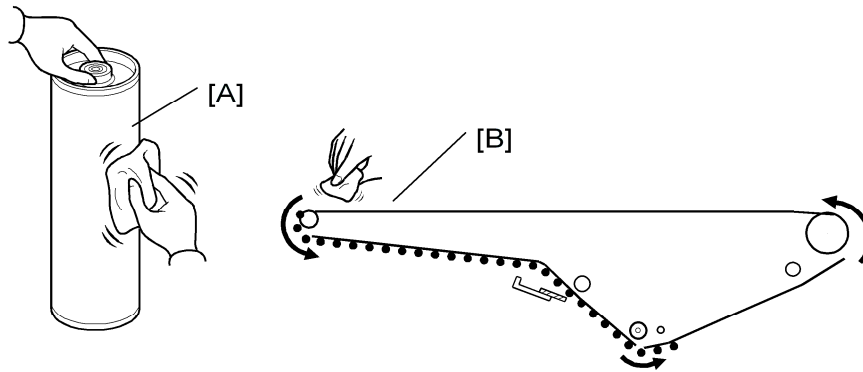

b132r319

Be sure to apply Lubricant Powder B1329700 when re-installing the drum [A] or ITB [B]. For more, please refer to "Replacement and Adjustment".

Fusing Unit

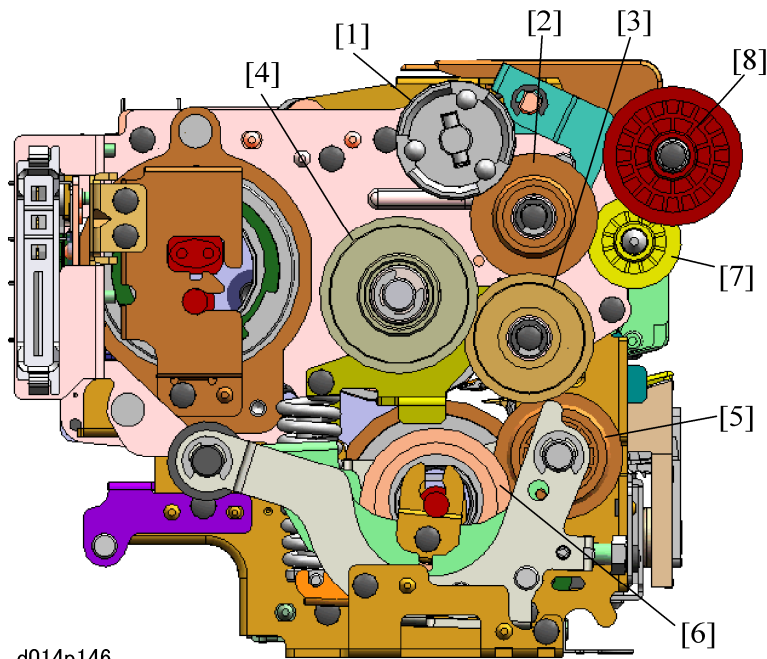

d014p146

	Part Name	Lubricant	Comment
[1]	Drive Gear	Barrierta S552R	Brush all gear teeth
[2]	Idle Gear	Barrierta S552R	Brush all gear teeth
[3]	Hot roller Idle Gear	Barrierta S552R	Brush all gear teeth
[4]	Hot roller Drive Gear	Barrierta S552R	Brush all gear teeth
[5]	Pressure roller Idle Gear	Barrierta S552R	Brush all gear teeth
[6]	Pressure roller Drive Gear	Barrierta S552R	Brush all gear teeth
[7]	Exit Idle Gear	Barrierta S552R	Brush all gear teeth
[8]	Exit Drive Gear	Barrierta S552R	Brush all gear teeth

d014p146a

Lubricate gears [2] and [5] at every 150K. Lubrication applied to these gears will lubricate the other gears during fusing unit operation.

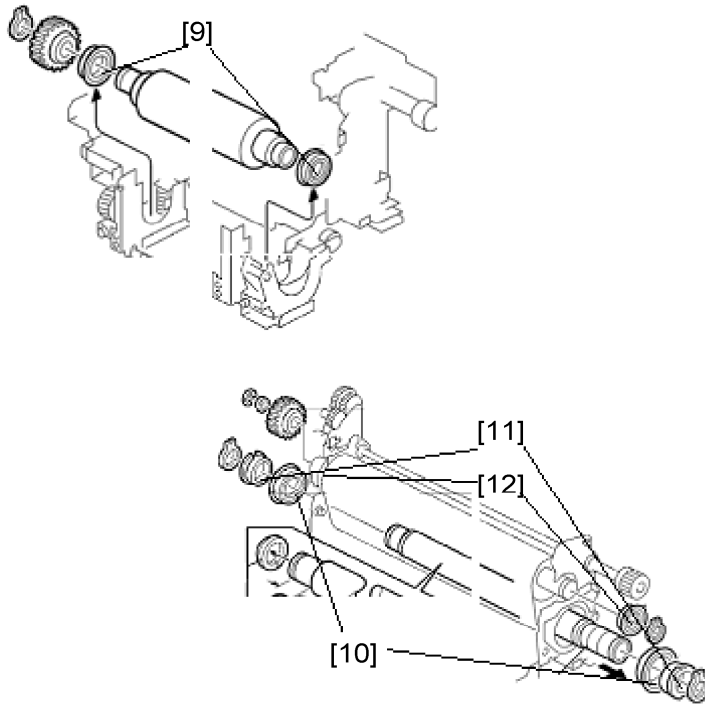

d014p145

	Part Name	Lubricant	Comment
[9]	Bearing Race $\phi 20 \times \phi 32 \times 7$	Barrierta S552R	Brush both ends
[10]	Bearing Race $\phi 35 \times \phi 47 \times 7$	Barrierta S552R	Brush both ends
[11]	Bushing Race	Barrierta S552R	Brush both ends
[12]	Bearing Race $\phi 20 \times \phi 32 \times 7$	Barrierta S552R	Brush both ends

d014p145a

Lubricate all bearings after replacement of the hot roller, pressure roller, and/or heating roller.

# Replacement and Adjustment

---

## General Cautions

---

 Important

- Never switch off either power switch while any of the electrical components are operating. Doing so might cause damage to units such as the transfer belt, drum, and development unit when they are pulled out of or put back into the copier.

---

## Drum

---

An organic photoconductor (OPC) drums are more sensitive to light and ammonia gas than a selenium drum. Follow the cautions below when handling an OPC drum.

1. When a PCU unit is removed from the machine, always place it on the PCU stand provided with the machine.
2. Never expose a drum to direct sunlight.
3. Never expose a drum to direct light of more than 1,000 Lux for more than a minute.
4. Never touch a drum surface with bare hands. If the drum surface is touched with a finger or becomes dirty, wipe it with a dry cloth or clean it with wet cotton. Wipe with a dry cloth after cleaning with wet cotton.
5. Never use alcohol to clean the drum (alcohol dissolves the drum surface).
6. Store drums in a cool, dry place away from heat.
7. Take care not to scratch the drum as the drum layer is thin and is easily damaged.
8. Never expose a drum to corrosive gases such as ammonia gas.
9. Dispose of used drums in accordance with local regulations.

---

## PCU

---

1. The PCU stand is stored in a rack attached to the bottom of the machine with strong magnets.
2. Before pulling a PCU unit out of the machine, spread some clean paper to catch spilt toner, remove the PCU stand from the bottom of the machine, clean it with a clean cloth, and then set the PCU stand on the paper to hold the PCU as soon as it is removed from the machine.
3. To prevent drum scratches, always set the PCU on the stand and leave it there as long as it is out of the machine.



## Replacement and Adjustment

---

- Remove only one PCU at a time for servicing. Only one PCU stand is provided with the machine.

### B132/B200

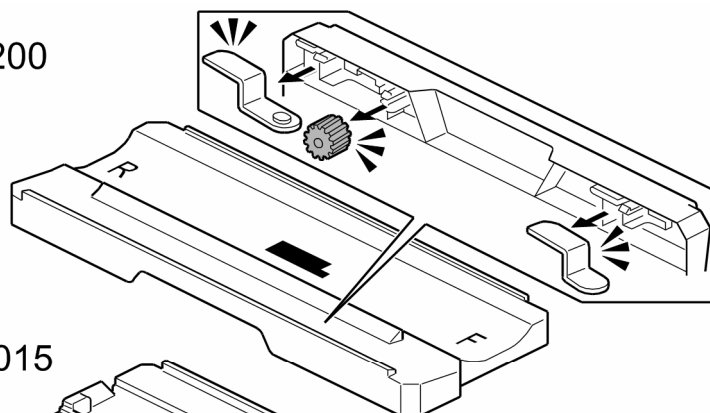

### D014/D015

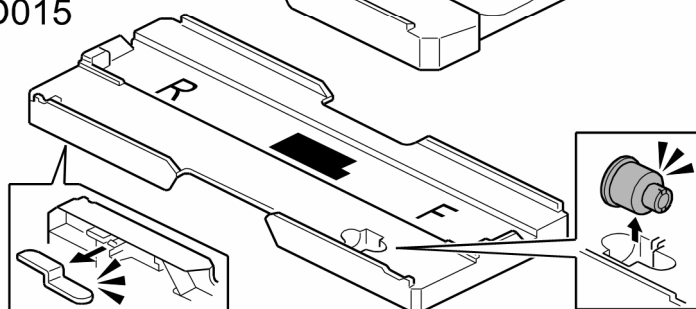

d014r420b

- The D014/D015 PCU stand is not the same as the PCU stand of the B132/B200. As shown above, the B132/B200 PCU stand holds two jigs and one gear. The D014/D015 PCU stand holds only one jig and a coupler. Also, the shapes of these PCU stands are not the same.

#### ★ Important

- Never use a B132/B200 PCU stand to service a D014/D015 PCU. The B132/B200 PCU stand could damage the exposed drum on the bottom of a D014/D015 PCU.**
- The Y, M, and C charge rollers should always be replaced together as a set.

---

## Transfer Belt Unit

---

- Never touch the transfer belt surface with bare hands.
- Take care not to scratch the transfer belt, as the surface is easily damaged.
- Before installing a new transfer belt, clean all the rollers and the inner part of the transfer belt with a dry cloth to prevent the belt from slipping.

---

## Scanner Unit

---

- When installing a new exposure glass, make sure that the white paint mark is at the rear left corner.

## Replacement and Adjustment

---

2. Clean the exposure glass with alcohol or glass cleaner to reduce the amount of static electricity on the glass surface.
3. Use a cotton pad with water or a blower brush to clean the mirrors and lenses.
4. Never bend or crease the exposure lamp cables.
5. Never disassemble the lens unit. Doing so will throw the lens and the copy image out of focus.
6. Never adjust any CCD positioning screw. Doing so will throw the CCD out of position.

---

## Laser Unit

---

1. Never loosen the screws that secure the LD drive board to the laser diode casing. Doing so would throw the LD unit out of adjustment.
2. Never adjust the variable resistors on the LD unit, as they are adjusted in the factory.
3. Never open the optical housing unit. The polygon mirror and lenses are sensitive to dust.
4. Never touch the glass surface of the polygon mirror motor unit with bare hands.

---

## Development

---

1. Avoid nicking or scratching the development roller.
2. Place a development unit on a sheet of paper after removing it from a PCU.
3. Always clean the drive gears after removing used developer.
4. Always dispose of used developer in accordance with local regulations.
5. Never load types of developer and toner into the development unit other than specified for this model. Doing so will cause poor copy quality and toner scattering.
6. Immediately after installing new developer or toner during the machine installation procedure, do the SPs as described in the Installation procedure.
7. Immediately after replacing the developer, do the SPs as described in the 'SP Codes after Replacement' section of PCU replacement.
8. Never do **SP3801** or **SP3811** with used developer.
9. When using a vacuum cleaner to clean the development unit casing, always ground the casing with your fingers to avoid damaging the toner density sensor with static electricity.
10. The TD sensor must be initialized:
  - At installation, exactly as described in the installation procedure
  - After replacing developer. (Initialize the TD sensor only for the PCU where the developer was replaced.)



## Replacement and Adjustment

---

- Never initialize the TD sensor more than once. Initializing the TD sensor more than once can cause toner scatter inside the machine.

---

## Cleaning

---

1. When servicing cleaning components, avoid nicking the edges of the cleaning blades.
2. Never handle a cleaning blade with bare hands.
3. Before disassembling a cleaning section, place a sheet of paper under it to catch any toner falling.

---

## Fusing Unit

---

1. Never handle fusing lamps and rollers with bare hands.
2. Make sure that the fusing lamps are positioned correctly and do not touch the inner surface of the rollers.

---

## Paper Feed

---

1. Do not touch the surfaces of the pick-up, feed, and separation rollers.
2. To avoid paper misfeeds, the side fences and end fence of the paper trays must be positioned correctly to align with the actual paper size.

---

## Used Toner

---

1. Check the amount of used toner at every service visit.
2. Always dispose of used toner in accordance with local regulations.
3. Never throw toner into an open flame.

---

## Common Procedures

---

---

### ARDF

---

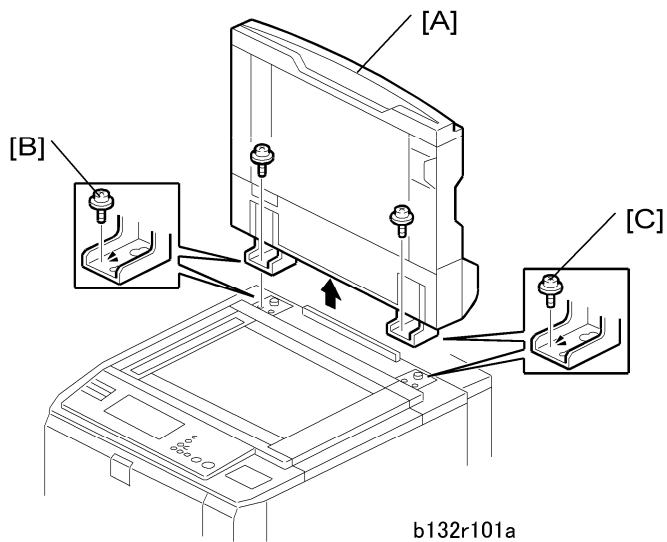

### CAUTION

- The ARDF is very heavy.
1. Raise the ARDF [A] to the vertical position.
  2. At the rear left corner of the machine, disconnect the ARDF cable.
  3. Remove the left screw [B] and right screw [C].
  4. Slide the ARDF back until the heads of the screws are in the large end of the keyholes, then lift the ARDF off the machine.

---

Operation Panel, Top Covers

---

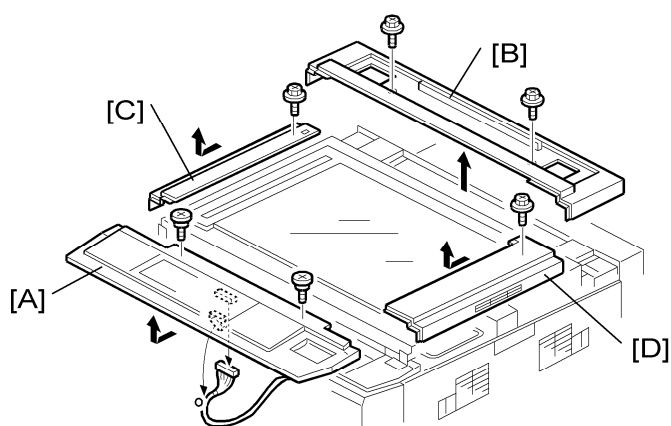

d132r701

1. Remove the ARDF (⚙️ x1, 🔩 x2).
2. Open the front door.
3. Remove:
  - [A]: Operation panel (⚙️ x1, 🔩 x2)
  - [B]: Top rear cover (🔩 x2)
  - [C]: Left top cover (🔩 x1)
  - [D]: Right top cover (🔩 x1)

---

Left Covers

---

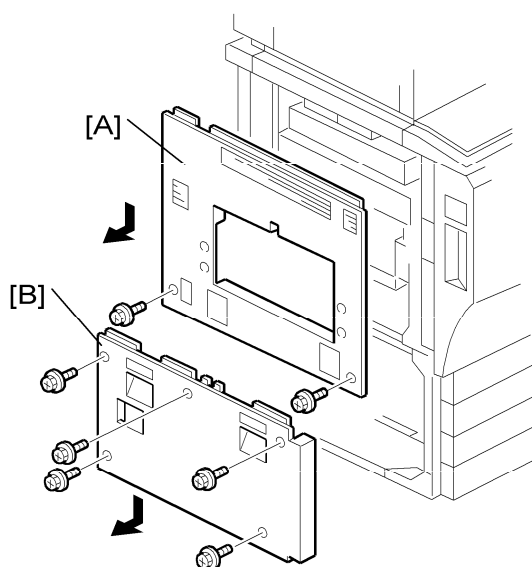

b132r702

1. If a finisher is connected:
  - Disconnect the finisher.

## Replacement and Adjustment

---

- Remove the front and back finisher connection brackets.
2. Remove:
- [A]: Left upper cover (🔩 x2)
  - [B]: Left lower cover (🔩 x5)

### Reinstallation

- Make sure all cover tabs are inserted correctly before you fasten the screws.

---

## Front Door

---

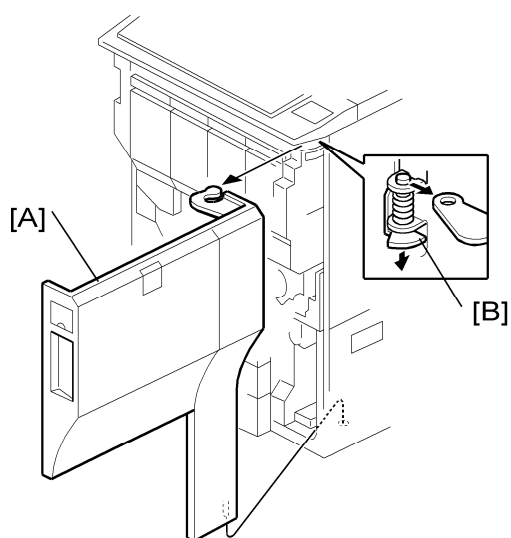

b132r703

1. Grip the front door [A] with one hand.
2. Press down the hinge bracket [B].
3. Lift the front door slightly to remove it.

### ★ Important

- If you must replace the front door, make sure that you put the SD cards from the storage location in the old front door into the storage location in the new front door.

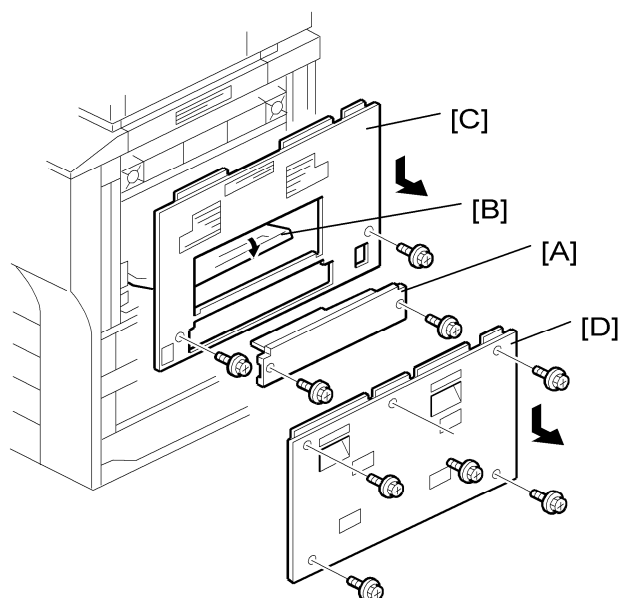

b132r704

1. Disconnect and separate the LCT if it is installed.
2. Remove:
  - [A]: Knockout (🔩 x2).  
This has been removed already if the LCT has been installed.
  - [B]: Open the bypass tray.
  - [C]: Right upper cover (🔩 x2).  
Pull the bottom of the cover down and toward you as you remove it.
  - [D]: Right lower cover (🔩 x5).  
Pull the bottom of the cover down and toward you as you remove it.

#### Reinstallation

- Make sure all the cover tabs are inserted correctly before you fasten the screws.

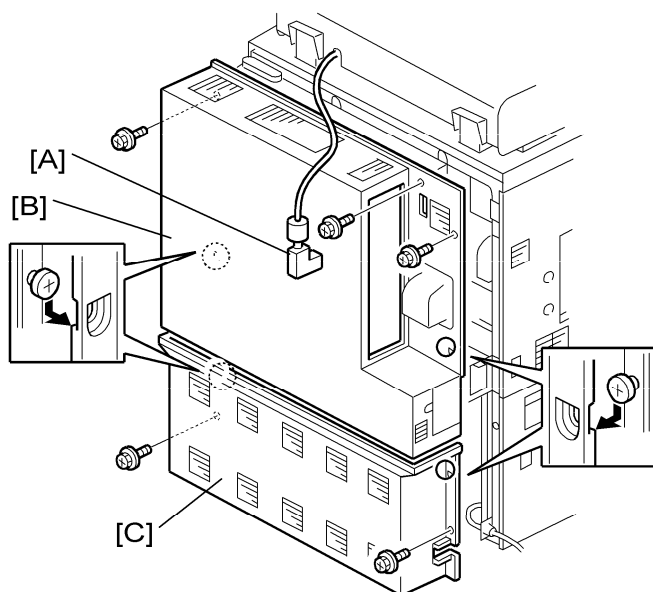

d014r705

1. Remove:

[A]: ARDF connector (🔌 x1)

[B]: Rear upper cover (🔩 x3)

[C]: Rear lower cover (🔩 x2)

- Remove the bottom screws
- Do not remove the shoulder screws.

Toner Hopper, Faceplate, PCU

Removing Hopper, Faceplate, PCU

★ Important

- To avoid damaging the toner end sensor, make sure that the main power switch is turned off and that the power cord is disconnected from the power source before you remove the hopper.



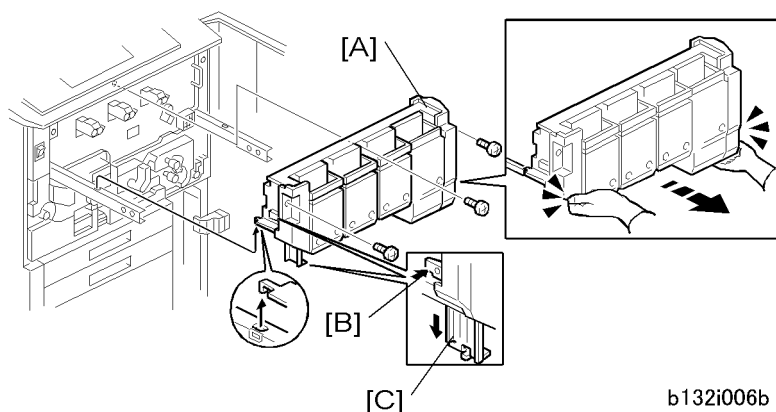

### To remove the hopper:

1. Prepare an open space on the floor for the hopper.
2. Remove the screws of the toner hopper [A] (⚙ x3).
3. Place your hands under the left and right corners of the toner hopper and slowly pull it out on its rails until it stops.

**★ Important**

- The hopper can easily slip off its rails!

4. Press the release [B] to drop the support leg [C].
5. Confirm that the support leg is down and locked.

**★ Important**

- Always make sure that the support leg is down and locked before you remove the hopper.

6. Lift the toner hopper off its rails and set it on the floor.

**⚠ CAUTION**

- The hopper is heavy, so lift it carefully. Make sure the hopper unit tabs have disengaged completely from the rails before you try to set the unit on the floor.

7. Push the hopper rails into the machine.

### To remove the faceplate

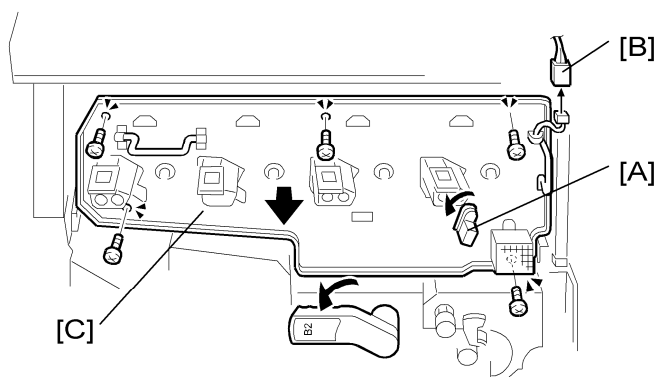

b132r201

1. Rotate the transfer belt release lever [A] counter-clockwise until it stops
2. Disconnect the fan connector [B].
3. Remove the faceplate [C] (⌀ x5).
4. Remove the PCU stand from its storage rack under the machine.

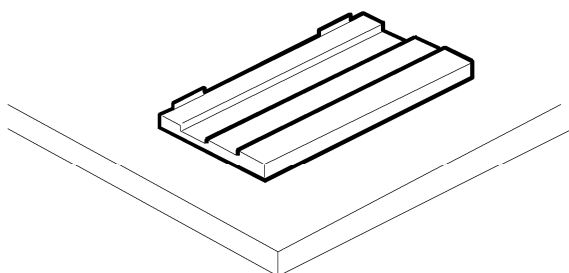

b132i902

5. Place the PCU stand on a flat surface.
6. Wipe the surface of the stand with a clean cloth to remove dust.

### To remove a PCU

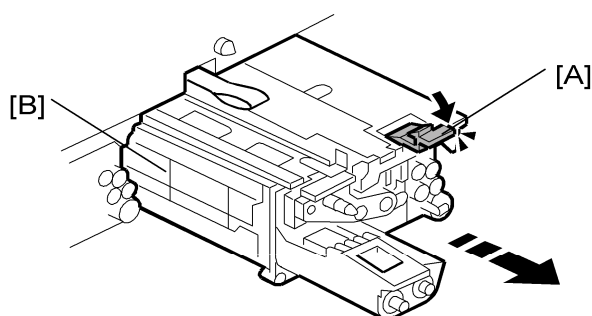

b132r202a

1. Confirm that the machine is switched off and disconnected from its power source.

**★ Important**

- To prevent damage to the drum potential sensor and its relay board, always make sure that the machine is turned off and that the power cord is

## Replacement and Adjustment

---

disconnected from the power source before you remove a PCU.

2. While pressing down the release tab [A] above the PCU, pull the PCU [B] out of the machine.

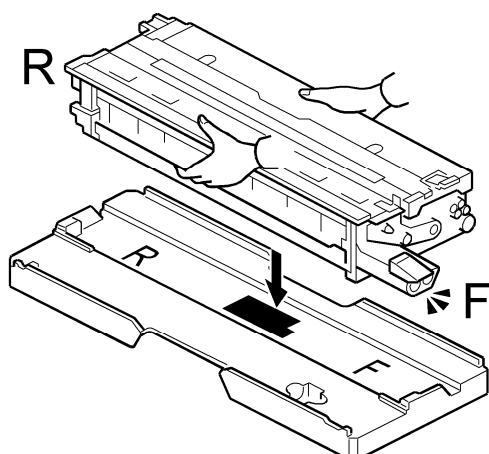

d014r214

3. With both hands on either side of the PCU [A], remove it from the machine and set it on the PCU stand [B].

### ★ Important

- This PCU stand was specially designed for the D014/D015. Do not use the PCU stand that was made for the B132 series copiers.
- The OPC drum is exposed on the bottom of the PCU, so never place your hand under the PCU.
- Never place the PCU on any surface other than the PCU stand.

## Reinstalling PCU, Faceplate, Toner Hopper

---

### To reinstall a PCU

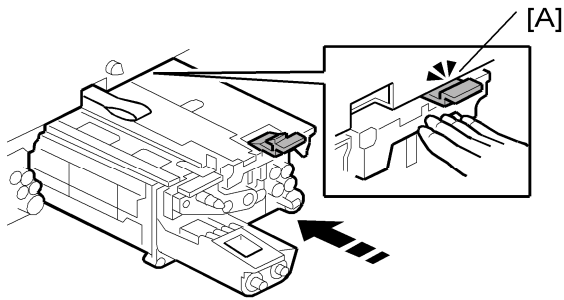

b132i114

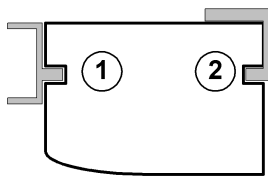

b132i905

1. Hold the PCU [A] in front of the slot where you removed it
2. Engage the slots ① and ② in the sides of the PCU with the rails. The PCU will not slide smoothly into the machine until the slots and rails are engaged properly.
3. Slowly push the PCU into the slot.
4. Make sure the release tab [A] above the PCU is locked.

### To reinstall the faceplate

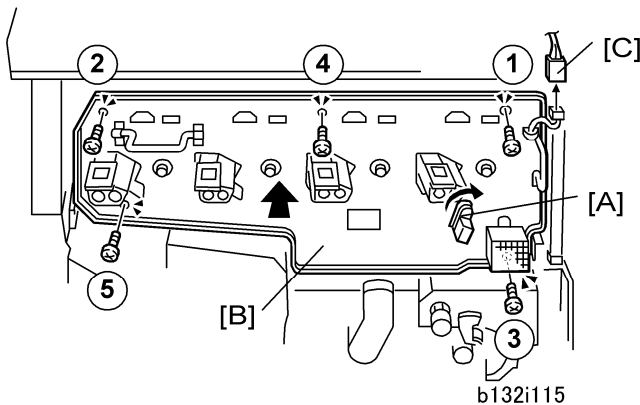

b132i115

1. Rotate the transfer belt release lever [A] clockwise to lock it.
2. Attach the faceplate [B] with the screws in order as shown above (⌀x5).
3. Reconnect the fan connector [C] (⌀x1).

### To reinstall the hopper

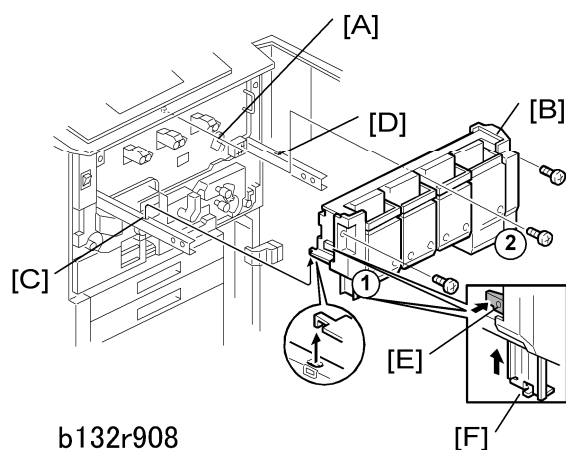

1. Confirm that the transfer belt release lever [A] is up and locked before you reattach the hopper.
2. Make sure the hopper rails are fully extended, then set the toner hopper [B] on the rails,
3. Make sure the steel tabs of the hopper are inserted into the holes in the left rail [C] and right rail [D].
4. Push up the release [E] and support leg [F].

**★ Important**

- **Make sure that the support leg is up and locked before you push the toner hopper into the machine.**

5. Place your hands at the bottom of the toner hopper at ① and ② then push the hopper against the face plate.

**★ Important**

- **To avoid damaging the hopper, never press on the top of the toner hopper.**

6. Check the right side and confirm that the hopper unit is flat against the faceplate. If the toner hopper [B] is not flat against the face plate on the right side, pull it out slightly and make sure that the transfer belt release lever is rotated up completely and locked.
7. Fasten the toner hopper to the face plate (Ⓜ x3).

Image Transfer Unit

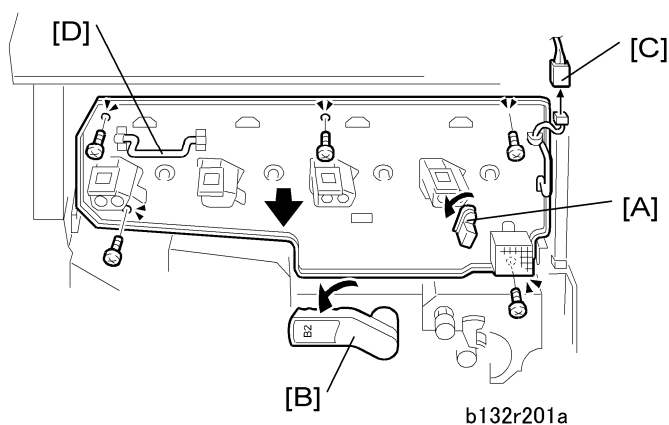

1. Cover the floor or a table with paper to prepare a place to put the image transfer unit.
2. Open the front door.
3. Remove the toner hopper, then push the hopper rails into the machine.
4. Rotate the transfer belt release lever [A] down to the left until it stops.
5. Rotate the lever **B2** [B] on the drawer unit counter-clockwise to separate the transfer roller from the ITB.
6. Disconnect [C].
7. Remove the faceplate [D] (⚙️ x1, 🔩 x5).

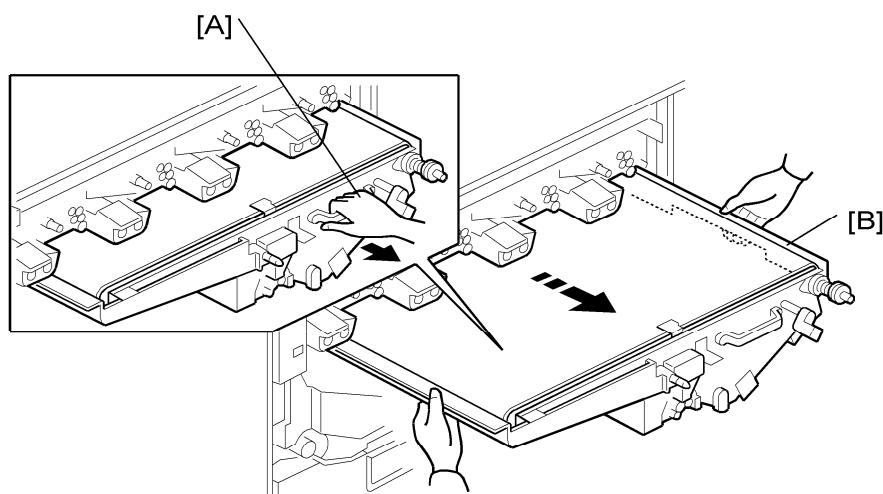

8. Use the handle [A] on the front of the transfer unit to pull the unit [B] partially out of the machine.
9. Grip both sides of the image transfer unit and pull it slowly out of the machine.

**Handling Precautions**

- Remove the image transfer unit carefully. The unit is heavy and not attached to the

## Replacement and Adjustment

---

rails with screws.

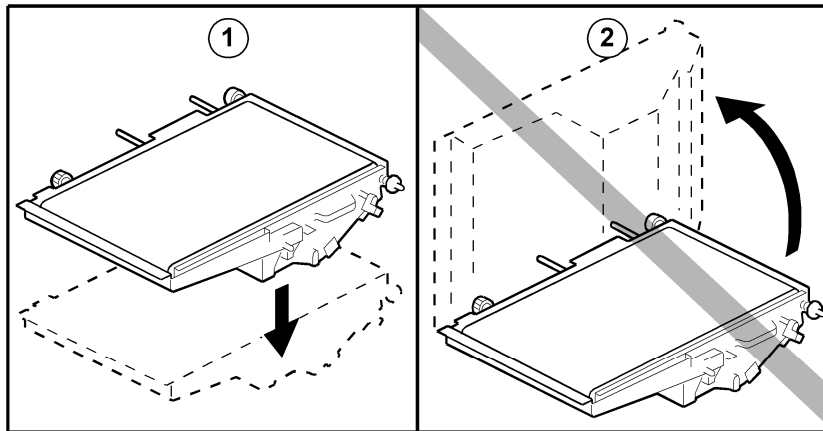

b132r309b

- To prevent toner scattering inside and outside the unit, keep the unit flat when you remove it, lift it, carry it, and put it down.
- Never stand the ITB unit on its edge before you remove the cleaning unit from the ITB.
- Never place the ITB unit on a carpet where toner can scatter or where the unit will collect dust.

### Reinstallation

- Re-insert the image transfer unit slowly and carefully to avoid snagging the belt on the frame of the machine.
- Make sure that the image transfer unit does not snag on the toner cap of the yellow PCU on the far left.

---

## Drawer Unit

---

To pull out the drawer unit:

---

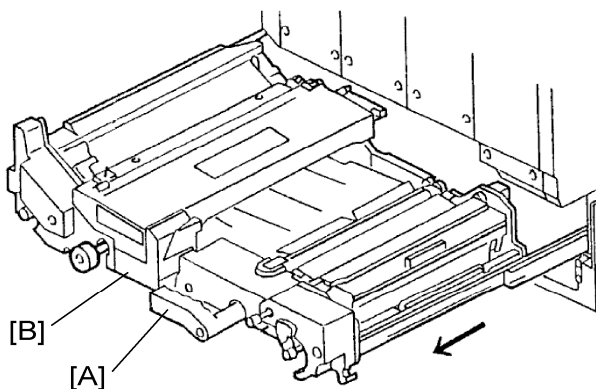

b132r900

## Replacement and Adjustment

---

1. Remove the front door.
2. Rotate the lever [A] down to left until it stops.
3. Grip the lever to pull the unit [B] out of the machine until it stops.

To remove the drawer unit:

---

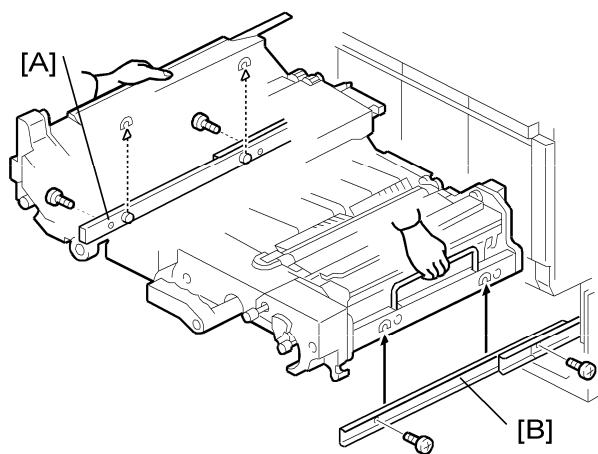

b132r301

### CAUTION

- The drawer unit is very heavy (30 kg/66lb.).

1. Disconnect the left rail [A] (⚙ x2).
2. Disconnect the right rail [B] (⚙ x2).
3. Lift the unit off the rails.
4. Push the rails into the machine.

To re-install the drawer unit

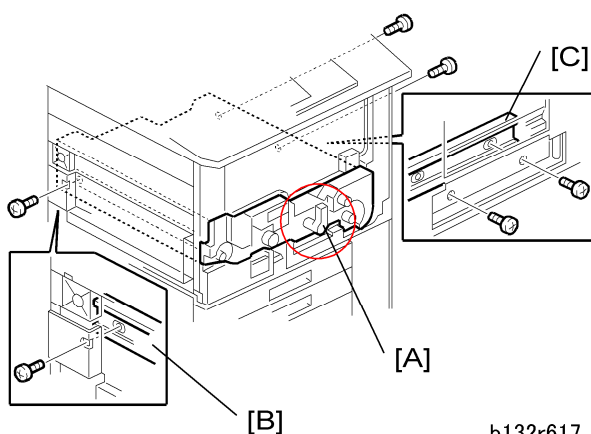

b132r617

1. Remove the right upper cover and the left upper cover.
2. Open the front door.
3. Pull out the left rail and right rail.





## Replacement and Adjustment

---

4. Set the unit on the rails.

### CAUTION



- The drawer unit is very heavy (30 kg/66 lb). Make sure that hooks are engaged with the holes in the rails.
5. Slowly push the unit into the machine until it stops.
  6. Rotate the lever [A] to the vertical position.
  7. Fasten the screws to the left rail [B] ( x2).
  8. Fasten the screws to the right rail [C] ( x2).
  9. To ensure that the unit is positioned correctly, check each screw and confirm that it is fastened tightly.

---

## Duplex Unit

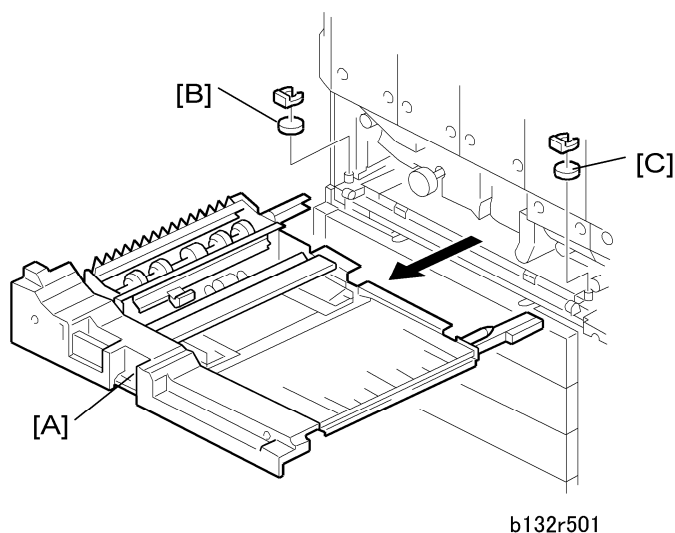
---



1. Open the front door.
2. Pull the duplex unit [A] out until it stops.
3. Remove the Teflon ring [B] from the left rear corner ( x1).
4. Remove the Teflon ring [C] from the right rear corner ( x1).
5. Lift the duplex unit from the rails and place it on a flat, level surface.

---

## Opening, Locking the Controller Box Cover

---

### CAUTION

- To prevent personal injury and damage to the controller box, when the controller box is open, it should always be locked as described below. Before doing the procedure, always switch the machine off and disconnect the power cord.

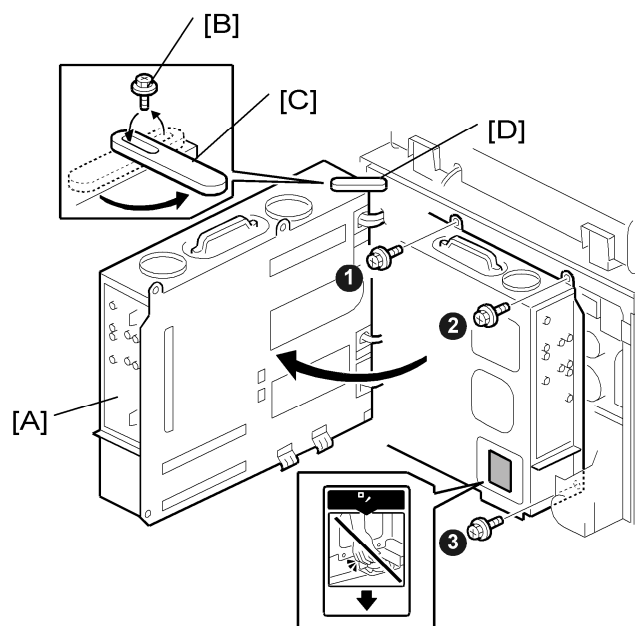

b132r715

1. Turn off the main power switch and disconnect the power cord.
2. Remove the rear covers.
3. Remove controller box screws , , .
4. Open the controller box [A] to the left until it stops.

**★ Important**

- Obey the warning on the decal to avoid touching the fan blades when you open and close the controller box.
5. Remove the left screw [B].
  6. Rotate the plastic stopper [C] counter-clockwise until it is aligned with the hole below and its tip [D] is touching the machine frame.
  7. Reattach the screw removed in Step 5 to lock the arm in position.

### Reinstallation

- Before closing the controller box, reattach the stopper arm at its original position.

---

## SD Card Storage

---

After an application has been moved from its original SD card to another SD card with SP5873-1, the empty SD card should be stored on site inside the front door of the machine.

- The original SD card is proof that the customer has purchased that application and must remain with the machine.
- If the front door is replaced, the stored SD cards must be removed and stored inside the new door.

## Replacement and Adjustment

---

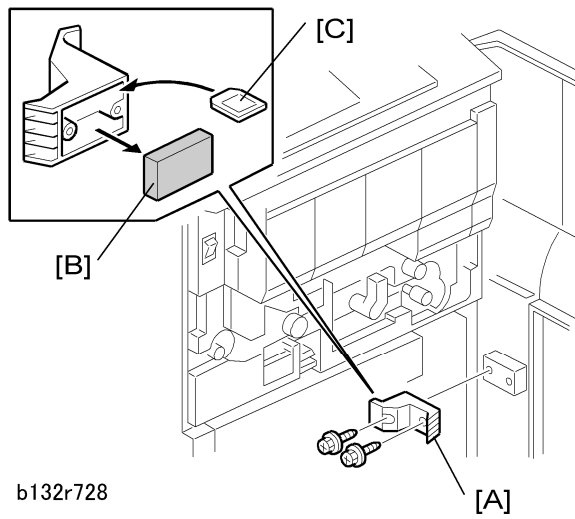

1. Open the front door.
2. Remove the cover [A] on the door (⚙️ x2).
3. Remove the block [B].
4. Store extra SD cards [C] inside the cover.
5. Reattach the cover to the door.

### Laser Unit

#### **⚠ WARNING**

- This laser unit employs two laser beams produced by a Class IIIb LD with a wavelength of 648 to 663 nm and intensity of 9 mW. Direct exposure to the eyes could cause permanent blindness.
- Before adjusting or replacing the laser unit, push the main power switch to power the machine off then unplug the machine from the power source. Allow the machine to cool for a few minutes. The polygon motor continues to rotate for approximately one to three minutes after the machine is switched off.
- Never power on the machine with any of these components removed: 1) LD unit, 2) polygon motor cover, 3) synchronization detector.

### Caution Decals

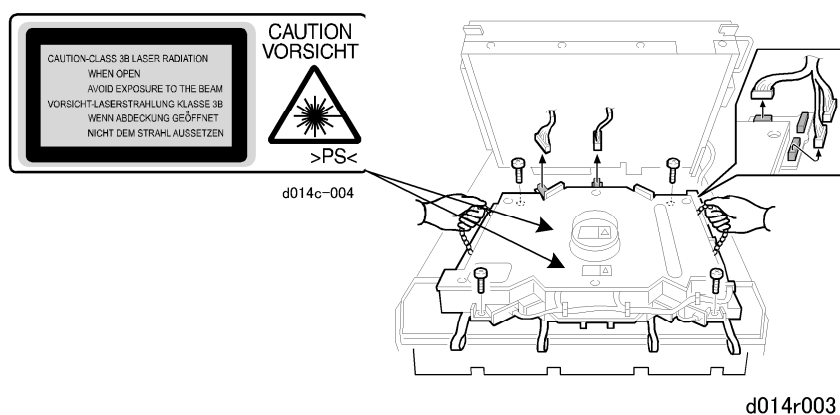

### Polygon Motor

#### **⚠ WARNING**

- Turn off the main power switch and unplug the machine before performing any procedure in this section. Laser beams can seriously damage the eyes and cause permanent blindness.

#### **★ Important**

- An accidental static discharge could damage the laser diode board attached to the lens block unit.
- Touch a metal surface to discharge any static electricity from your hands.
- The polygon motor rotates at extremely high speed and continues to rotate after you switch the machine off. To avoid damaging the motor, never remove the

## Replacement and Adjustment

polygon motor within three minutes of switching off the main power and disconnecting the power plug.

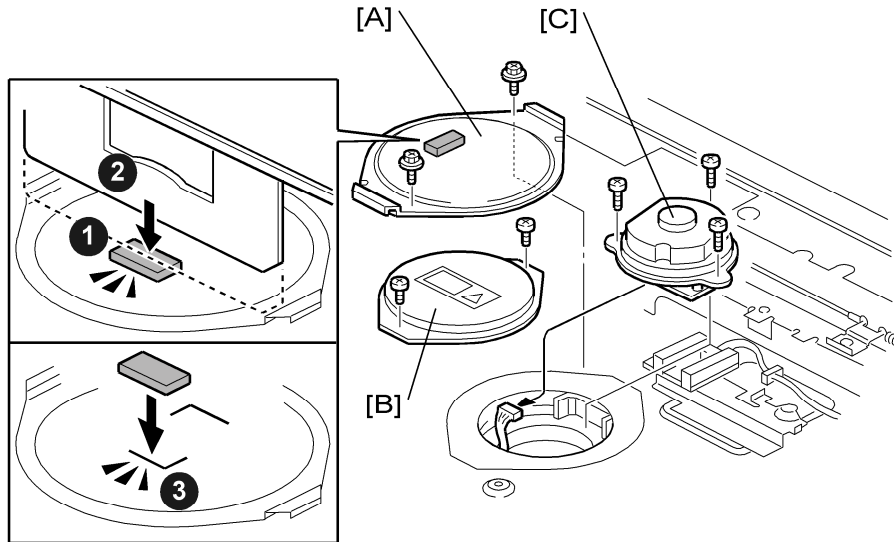

d014r131a

1. Remove:
  - Exposure glass
  - Lens block
2. Remove:
  - [A] Top cover (⚙️ x2)
  - [B] Middle cover (⚙️ x2)
  - [C] Polygon motor (⚙️ x3, 🛠️ x1, 🛠️ x1)

### ★ Important

- Never remove the paint-lock screws on top of the lens block unit.
- Never touch the glass covers of the laser ports on the sides of the polygon motor [C].

### Re-installation

The top cover [A] must be positioned correctly for reinstallation.

1. When you reinstall the top cover [A], set the top cover so that gasket touches lens bracket .

### ★ Important

- If the top cover is not positioned this way, the unit could generate electrical noise.
2. If the gasket has peeled off during removal, install a new gasket aligned with the line on the top cover. (A replacement gasket is available as a service part.)

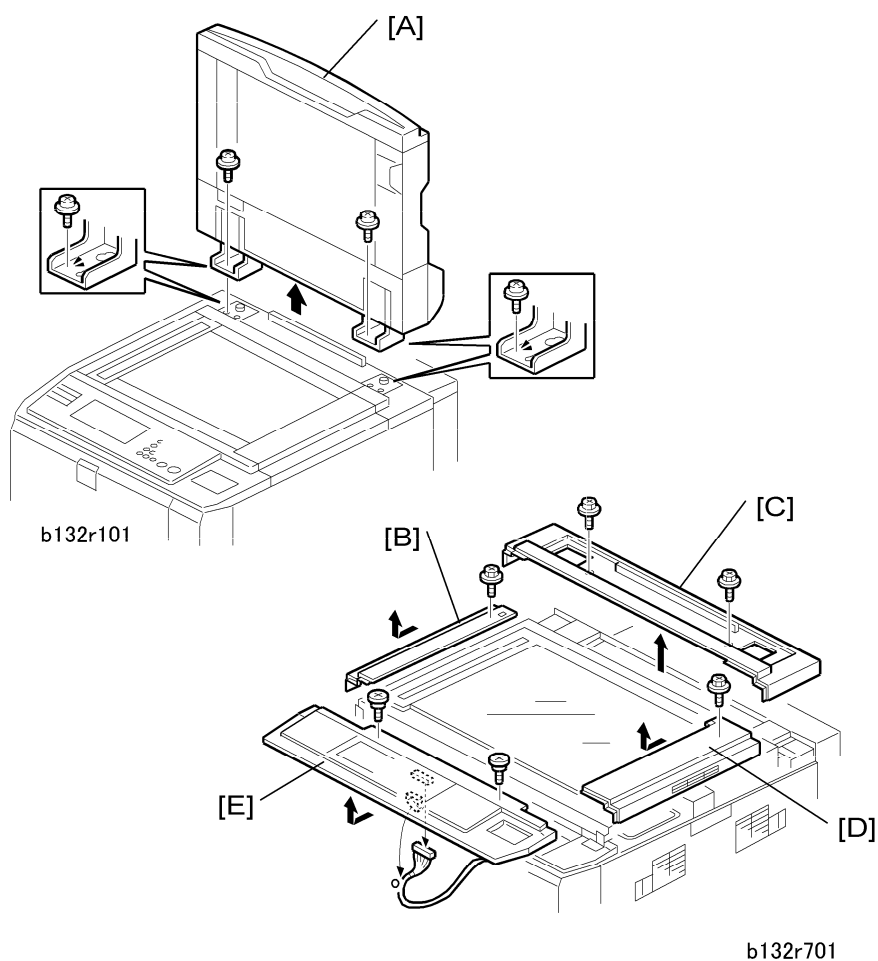

1. Remove:

[A] ARDF (⚙️ x1, 🔩 x2)

[B] Left top cover (🔩 x1)

[C] Rear top cover (🔩 x2)

[D] Right top cover (🔩 x1)

[E] Operation panel (Shoulder 🛠️ x2, ⚙️ x1)

## Replacement and Adjustment

---

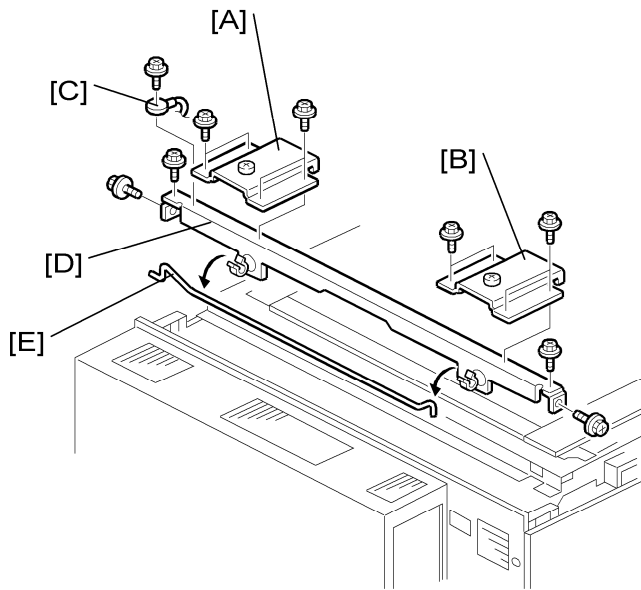

b132r001

### 2. Remove:

- [A] Left plate (⚙️ x4)
- [B] Right plate (⚙️ x4)
- [C] Ground wire (⚙️ x1)
- [D] Cross piece (⚙️ x4)
- [E] Detach the support rod from the rubber clamps.

### Reinstallation

- Be sure to reconnect ground wire [C].

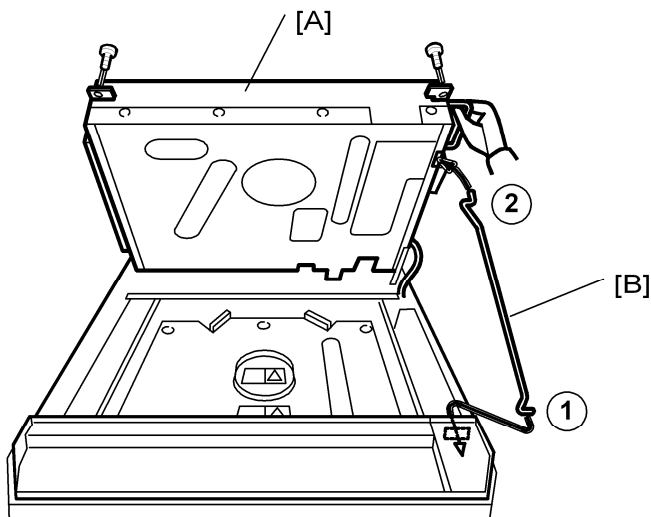

b132r002

1. Raise the scanner unit [A] (⚙️ x 2).

## Replacement and Adjustment

- Set the support rod [B] at the base ①, then under the front right corner ② of the scanner unit.

### CAUTION

- The scanner unit is very heavy. Never remove the support rod during servicing.

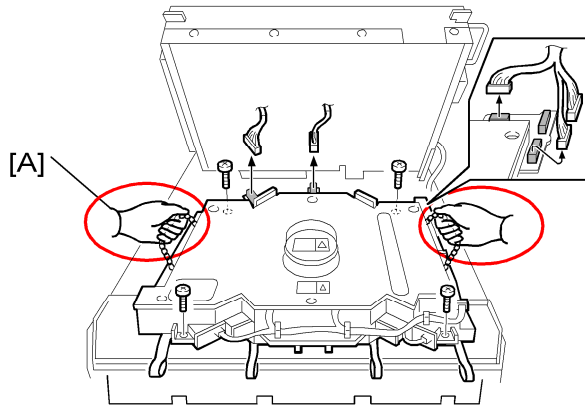

d014r003a

- Remove the laser unit [A] (⚙️ x4, 🛠️ x6)

#### Note

- The laser unit includes four LD sub units. However, the LD sub units cannot be replaced separately because factory adjustment is required.

### Reinstallation

- Be sure to reconnect the ground wire ([C] in step 2).

## SP Adjustments After Laser Unit Replacement

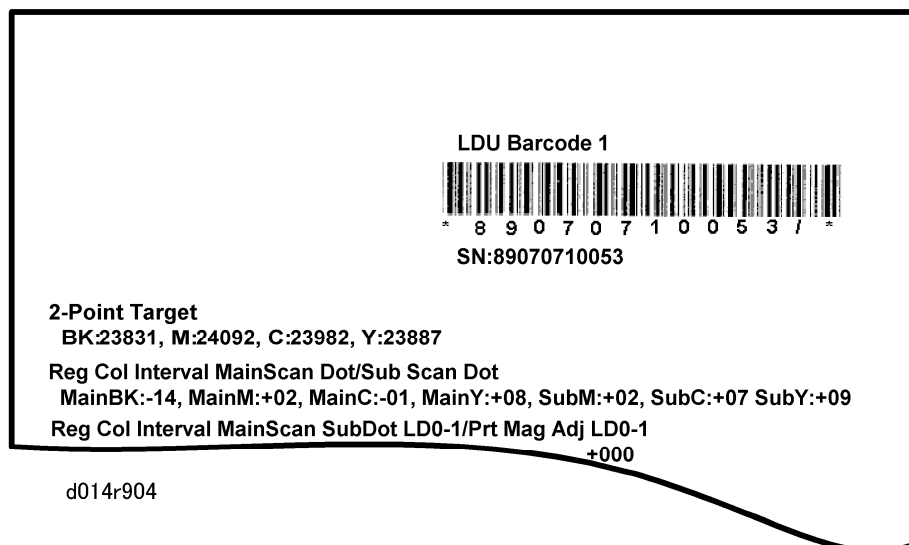

SP codes and settings are written on an A5-size sheet of paper (similar to the sample above) provided with the laser unit.



## Replacement and Adjustment

---

### ↓ Note

- Only the settings described below are required. The other information on the sheet can be ignored.
1. Enter the values on the first item in the list. These "2-Point Target" values must be entered after the LD unit has been replaced.
    - 2156-1 (K)
    - 2156-2 (M)
    - 2156-3 (C)
    - 2156-4 (Y)
  2. Next, do these SP codes and enter the values for "Prt Mag Adj LD0-1" (listed on Line 3 of the sheet).
    - 2102-5
    - 2102-6
    - 2102-7
    - 2102-8
    - The values are in the third item on the list.
    - Two values are given for each SP (for example, BK:001 -001). Enter the 2nd value for each SP code (-001 for BK for example).
  3. Next, do these SP codes and enter the values for "Spd Diff Offset: Main". These values appear as the 8th item in the list on the sheet:
    - 2101-60 (K)
    - 2101-61 (M)
    - 2101-62 (C)
    - 2101-63 (Y)
  4. Next, set the following SP codes to "0":
    - 2102-10
    - 2102-11
    - 2102-12
    - 2102-13
  5. Do SP2109-2, select Pattern 14, and print a test pattern to confirm the settings.

## Color Registration Errors

---

- In addition to the SP adjustments printed on the seal attached to the LD unit, if color registration errors occur immediately after you change the laser unit, an additional adjustment is required.
- This additional adjustment is normally not required in the field. Do it only if you see color

## Replacement and Adjustment

---

registration errors in test prints.

- See "Color Registration Test and Error Adjustment" for instructions on how to do this adjustment.

## Skew

---

If skew occurs immediately after you change the laser unit, do the skew adjustment. (See "Skew Adjustment After Laser Unit Replacement" in Section 3 of the B132/B200 Service Manual.

## Laser Synchronization Detector

---

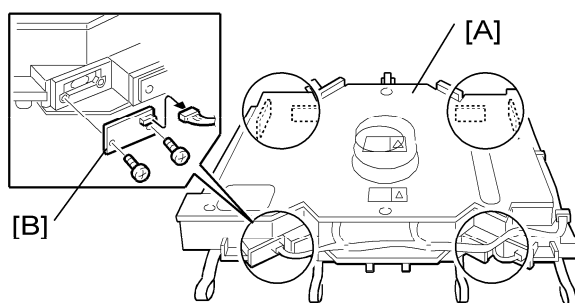

b132r004

### 1. Remove:

[A] Laser unit

[B] Laser synchronization detector (⚙️ x2, 🛠️ x1)



- The locations of the 8 laser synchronization detectors are circled in the illustration above.

---

## PCU

---

---

### Charge Units

---

The procedure for removing the drum charge components in the K PCU and YMC PCUs is different.

- The YMC PCUs use a charge roller to charge the OPC drum.
- The K PCU uses a charge wire unit to charge the OPC drum.

---

### Preparation

---

1. Remove the PCU stand from the bottom of the machine.
2. Remove the PCU from the machine.

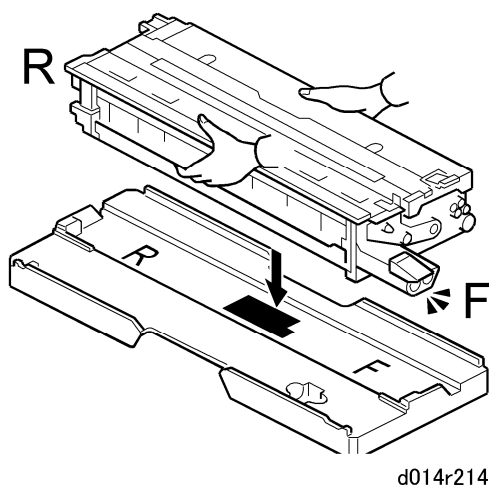

3. Set the PCU on the PCU stand.

**★ Important**

- The PCU stands for the D014/D015 and B132/B200 copiers are different. Be sure to use the PCU stand for the D014/D015. If you use the PCU stand for the B132/B200, this could damage the exposed drum on the bottom of the PCU.

## Replacement and Adjustment

---

### Charge Roller Unit: YMC PCUs

---

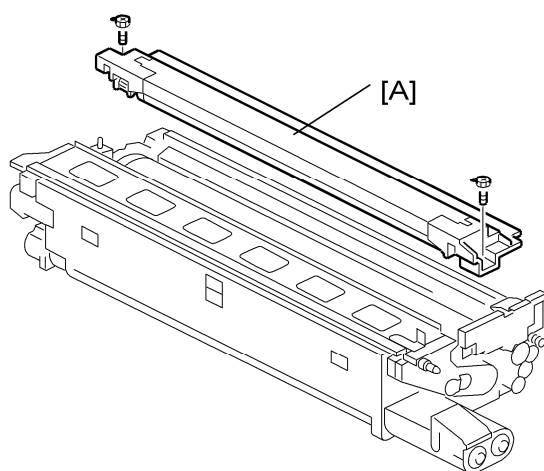

d014r452

1. Remove the charge roller unit [A] (⚙️ x2).

This unit contains the charge roller and charge roller cleaning roller.

**★ Important**

- If you need to replace a charge roller unit, be sure to replace the C, M, Y charge roller units together.

### Charge Wire Unit: K PCU

---

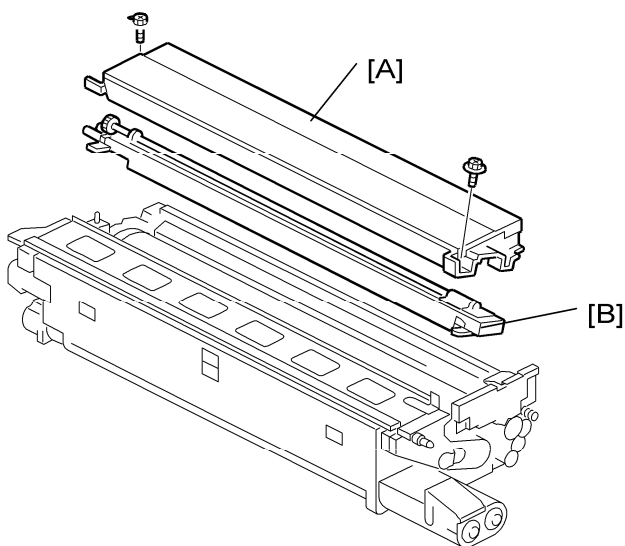

d014r451

1. Remove:

[A] Cover (⚙️ x2)

[B] Charge wire unit

The charge corona wire and charge corona wire cleaning mechanism comprise the

## Replacement and Adjustment

---

charge wire unit. The unit is replaced as you see it above (no further disassembly is required).

## Separating Drum/Cleaning Unit, Removing the OPC Drum

---

Before doing maintenance on a PCU:

- Separate the development unit and cleaning unit.
  - Remove the drum and cover it with a sheet of clean paper to protect it from light.
1. Remove:
    - PCU
    - Charge roller unit (or charge wire unit for K PCU)

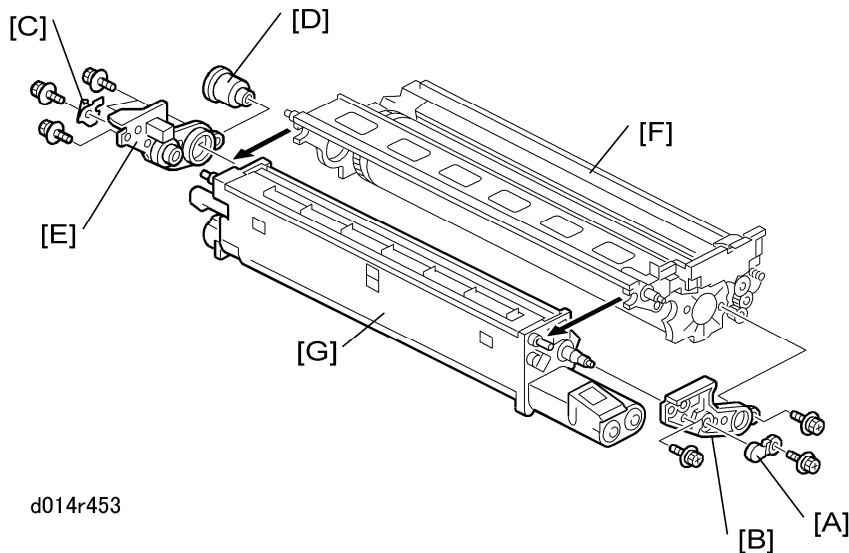

2. At the front, remove:
  - [A] Small lock plate (🔩 x1)
  - [B] Large lock plate (🔩 x2)
3. At the rear, remove:
  - [C] Small lock plate (🔩 x1)
  - [D] Brown coupling
  - [E] Large lock plate (🔩 x3)
4. Separate the drum unit [F] from the development unit [G].

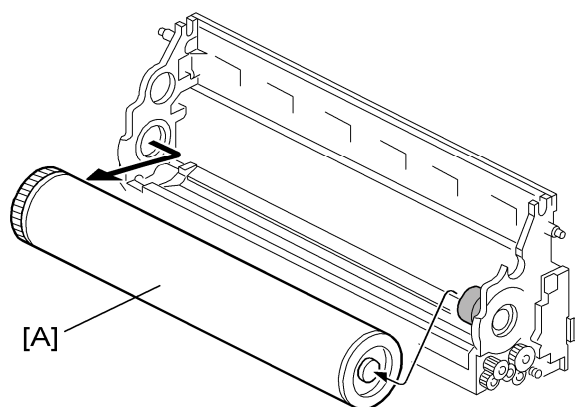

d014r454

5. Remove the drum [A] from the development unit.
6. Wrap the drum in a sheet of clean white paper to protect it from light.

### Reinstallation of the Drum

---

This procedure is the same for the YMC PCUs and the K PCU.

- Always dust the surface of a new drum before you install it.
- If you have removed the drum and intend to re-install the same drum, the surface of this drum should be dusted as well.

#### **Before you begin...**

- Make sure that you have the correct type of dusting powder for the drum. Use only Lubricant Powder B1329700 (specially designed for this machine).

#### **★ Important**

- **Never use Setting Powder 54429101. This powder can damage the drum and charge roller.**
- **Do not use the yellow toner of the D014/D015 copier because it contains developer that could damage the drum and ITB.**

#### **To dust the drum:**

1. Spread a small amount of lubricant powder on a clean sheet of paper.
2. Dip a clean, dry cloth into the lubricant powder.

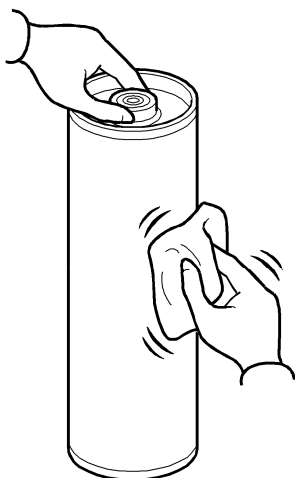

d014r960

3. Dust the surface of the drum with the cloth until the entire surface is covered.
4. When you reinstall the drum:  
Reinstall the front end of the drum first.  
Never rotate the drum manually after reinstalling it.
5. You must do the appropriate SP codes to prevent a fatal error, depending on whether you have replaced only the drum or the drum/cleaning blade. For more details, refer to the SP Codes After Replacement table.

---

## PCU Blades and Rollers

---

This section describes how to replace these parts of the drum cleaning unit:

- Lubricant bar
- Lubricant blade
- Lubricant brush roller
- Drum cleaning blade
- Collection coil

The procedures described below apply to both a YMC PCU and K PCU.

- However, the lubricant bar unit is not the same for both units. The lubricant bar unit is marked "K" for the black PCU.

## Replacement and Adjustment

---



ra\_0700

- If you replace a cleaning blade, apply lubricant powder to that cleaning blade and to the drum.

## Lubricant Bar and Lubricant Blade

---

### Preparation

- Remove the PCU
- Separate the development unit and drum unit.
- Remove the drum, cover it with a piece of clean paper, and set it aside.

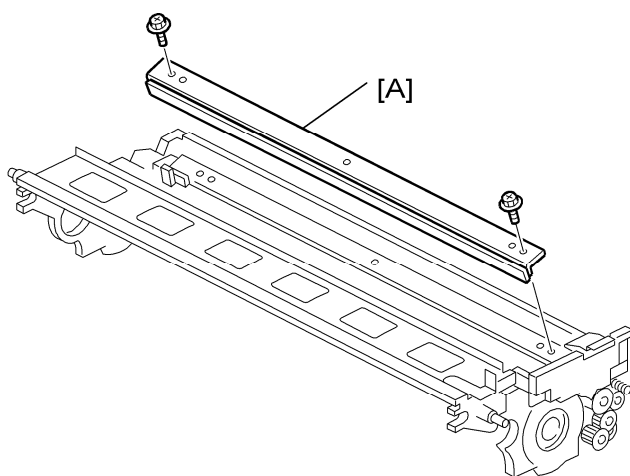

d014r455

1. Remove the lubricant blade (🔩 x2).
2. Remove the screws from the ends of the lubricant bar unit [A] (🔩 x2).



3. Remove:
  - [A] Charger roller unit holder (🔩x2)
  - [B] Bracket with sponge seal
  - [C] Lubricant bar unit cover (🔩x2)



### To remove the old lubricant bar:

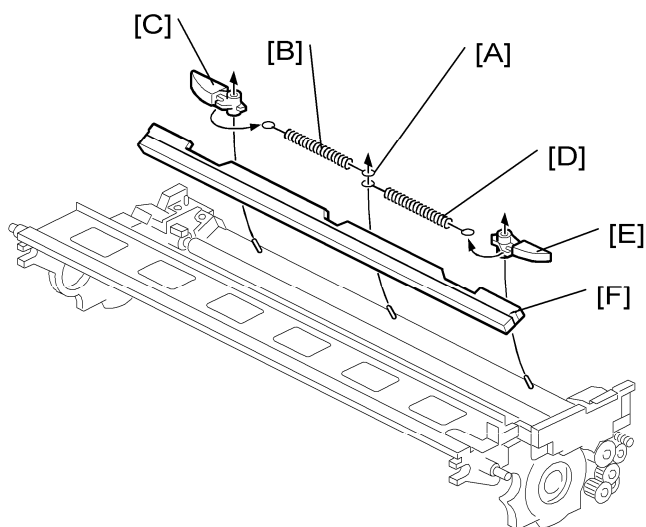

d014r457

1. At the center [A], disconnect springs from the post.
2. Disconnect the rear spring [B] from the rear bar support, then remove the support [C] from its post.
3. Disconnect the front spring [D] from the front bar supports, then remove the support [E] from its post.
4. Remove the lubricant bar [F] and replace it with a new one.

#### ↓ Note

- The lubricant bars of the K PCU and YMC PCUs are identical. The same type of lubricant bar can be installed in either type of PCU.

#### ★ Important

- The springs of the lubricant bar units are not interchangeable. The springs of the CMY lubricant bar unit are brown and stronger than the springs of the K lubricant bar unit (the K lubricant bar springs are black).

## Replacement and Adjustment

### Lubricant Brush Roller

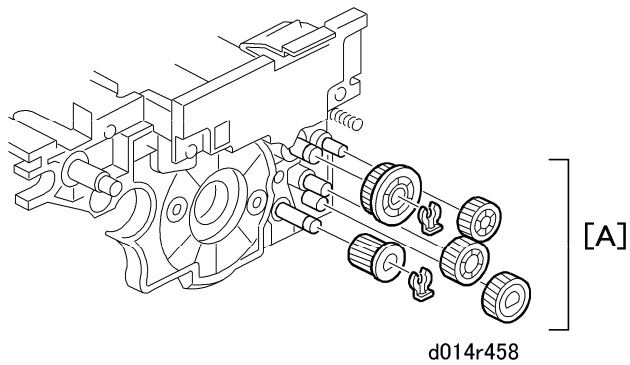

1. Remove:

[A] Gears (⊗ x2, Gears x5).

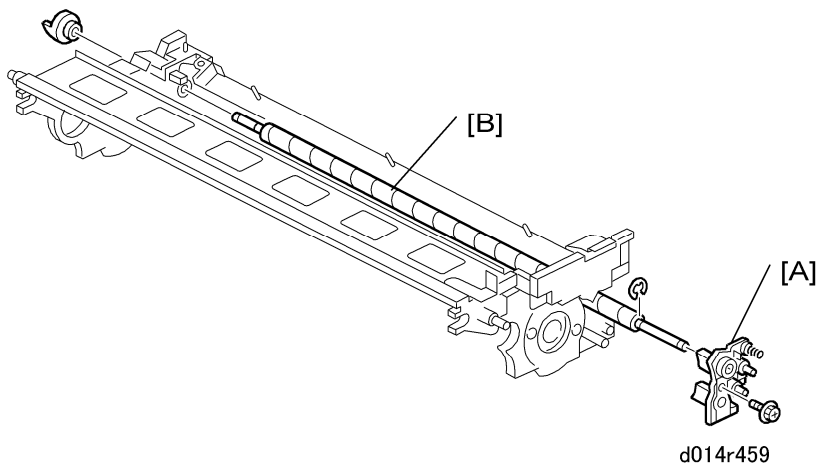

2. Remove:

[A] Shaft lock plate (⊗ x1)

[B] Lubricant brush roller (Coupling x1, ⊗ x1)

## Replacement and Adjustment

---

### Drum Cleaning Blade

---

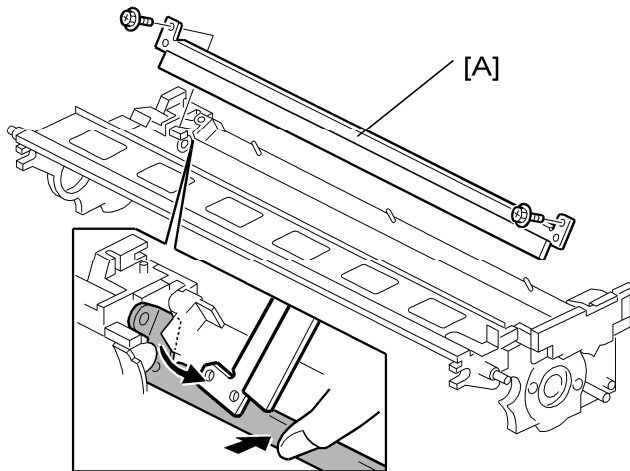

d014r460

1. Remove:  
[A] Drum cleaning blade (2).

### After Replacement

---

Do the procedure below after replacing the lubricant brush roller.

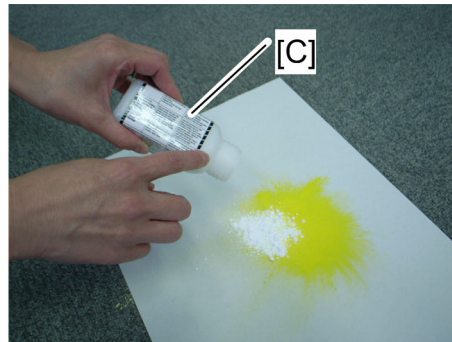
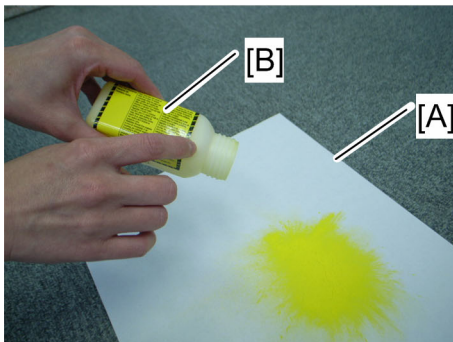

d014r465b

1. Place a sheet of clean paper [A] on a flat surface.
2. Pour a small amount of G104 Yellow Toner (D0159500) [B] from its bottle onto the paper.
3. Pour a small amount of Zinc Stearate (D0159501) [C] from its bottle.

**★ Important**

- Do not use D014/D105 yellow toner because it contains developer that could damage the drum and ITB.

## Replacement and Adjustment

---

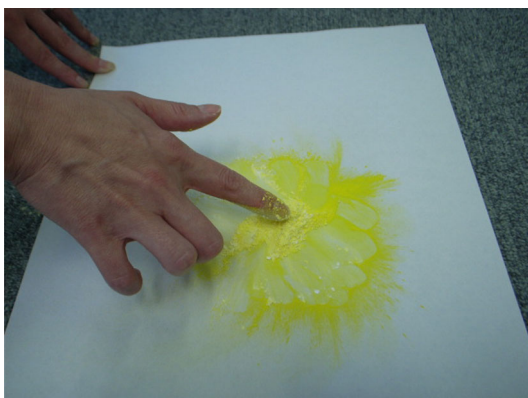

d014r465a

4. Use your finger to mix evenly the G104 Yellow Toner powder and Zinc Stearate on the paper.

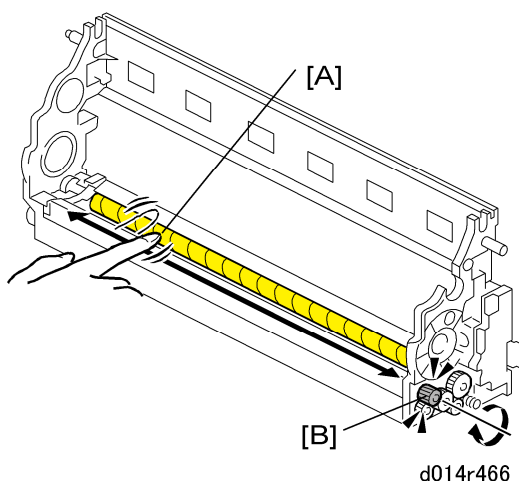

d014r466

5. Use your finger to apply the lubricant-toner mix to the cleaning brush at [A] while rotating the gear [B] in the direction shown by the arrow.

**★ Important**

- You must rotate the gear in the direction shown above.
6. After reinstalling the unit in the machine, do the forced MUSIC adjustment with SP 2111 001.

---

## Developer Replacement

---

The developer replacement procedure is the same for the YMC PCUs and the K PCU.

### Preparation

---

1. Spread some paper on a flat surface to hold developer that will be dumped from the development unit.

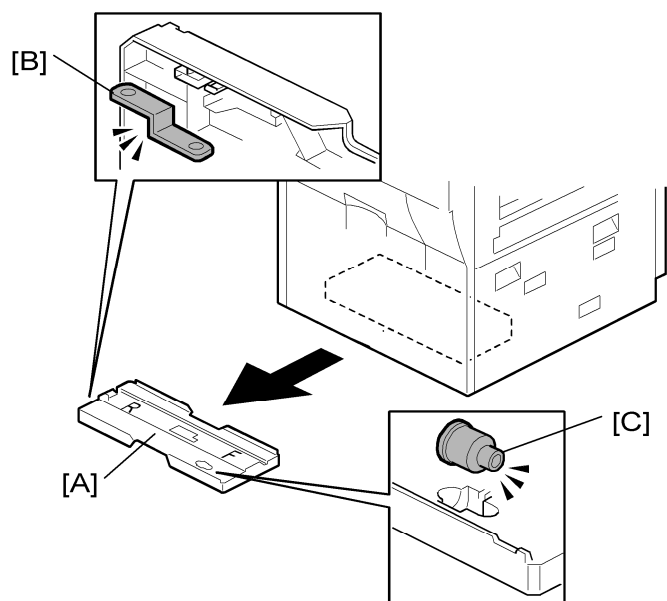

d014r718

2. Remove:

[A] PCU stand from bottom of the machine

[B] Jig

[C] Brown coupling

**★ Important**

- The PCU stands for the D014/D015 and B132/B200 copiers are different. Be sure to use the PCU stand for the D014/D015. If you use the PCU stand for the B132/B200, this could damage the exposed drum on the bottom of the PCU.

3. Remove the metal jig [B] and brown coupling [C] from the bottom of the PCU stand.

4. Set the PCU stand on a flat surface.

5. Remove:

- Toner hopper
- Faceplate
- PCU

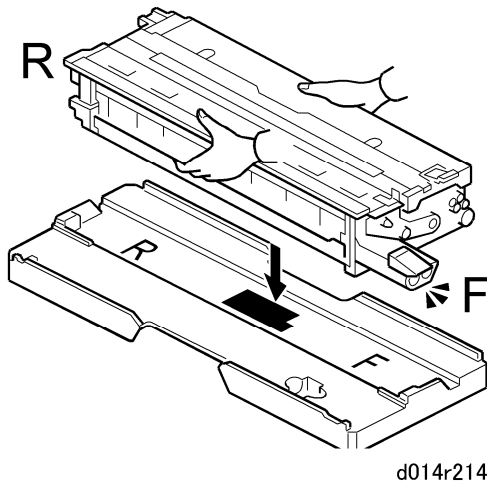

6. Position the front and rear of the PCU so that it matches the F (front) and R (rear) markings on the PCU stand.
7. Set the PCU on the stand.
  - The front-rear alignment aligns the shape of the stand with the contours of the PCU bottom.
  - This also protects the exposed drum on the bottom of the PCU during servicing.

### Removing the old developer

---

#### Preparation

- Separate the drum unit and development unit.
- Cover the drum with a sheet of clean paper and set it aside.

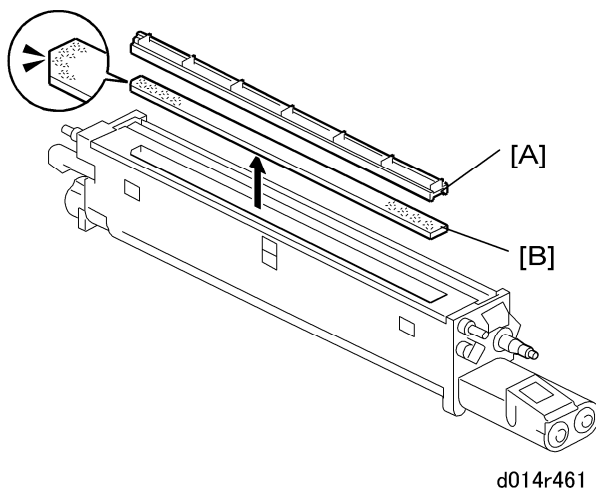

1. Remove:
  - [A] Filter frame
  - [B] Filter

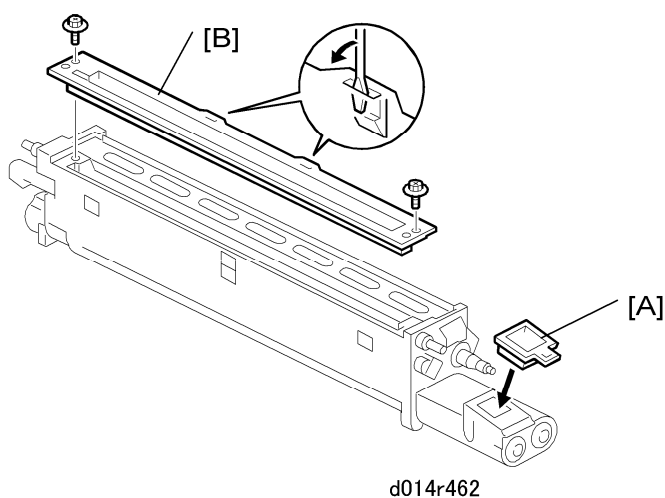

2. Insert the plug [A] into the toner port.
3. Remove the plastic cover [B] (⚙️ x2). Use the tip of a small screwdriver to dislodge the cover.

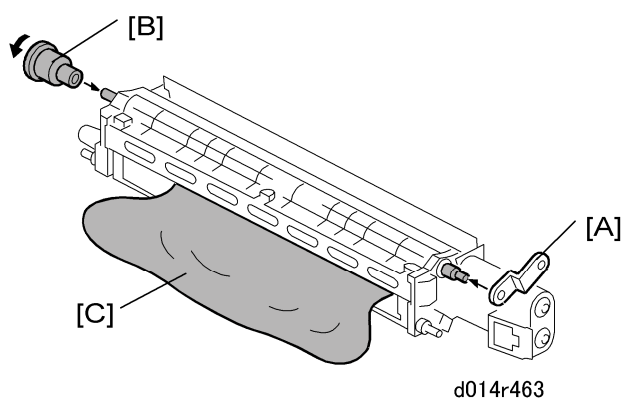

4. Attach the metal jig [A] to the end of the development roller. The jig must be set as shown.

**Note**

- The D-shaped hole of the metal jig must fit over the D-shaped shaft tip. If the hole of the metal jig is not aligned with the shaft, rotate the D-shaped shaft tip to position the shaft so the metal jig can be attached.
5. Attach the brown coupling [B] (removed from the PCU stand) to the other end of the development roller.

**Important**

- Use the brown coupling provided with the PCU stand. Using the coupling of the PCU could break it or wear it out.
6. Rotate the brown coupling in the direction shown above so the developer [C] starts to come out of the development unit.

## Replacement and Adjustment

---

↓ Note

- Turning the brown coupling in the opposite direction will not damage anything but developer will fail to come out of the development unit.

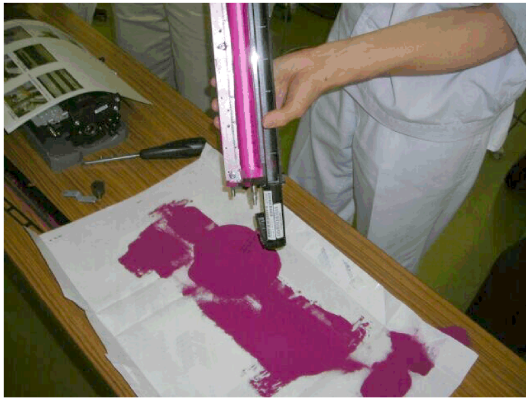

temp\_0772

7. Tip the development unit on its end to dump any remaining developer.



temp\_0774

8. Rotate the brown coupling again to push out more developer.

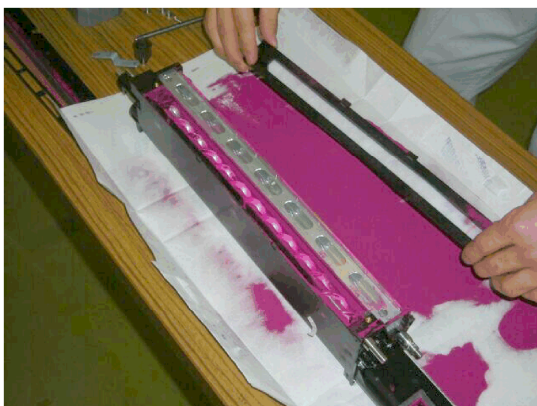

temp\_0775

9. Remove the filter unit.



## Replacement and Adjustment

---

**★ Important**

- The filter must be replaced every time the developer is replaced.



temp\_0776

10. After the filter unit has been removed, dump the last bit of developer.

**★ Important**

- Never touch or attempt to remove the doctor blade. The doctor blade is set at the factory and requires no cleaning or adjustment.

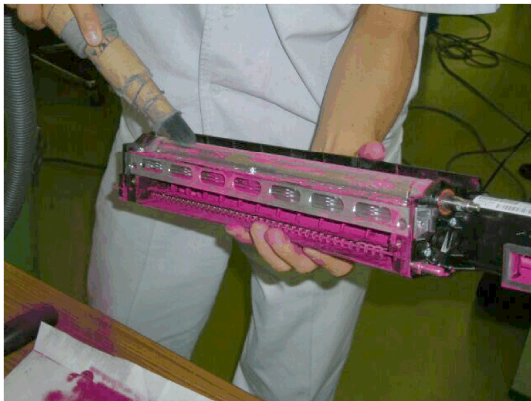

temp\_0778

11. Vacuum clean the unit, then clean it with a dry cloth.

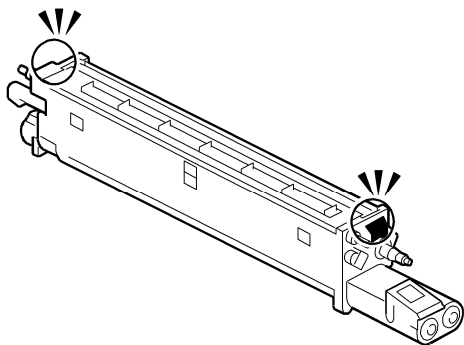

d014r464

## Replacement and Adjustment

---

12. Clean both ends of the unit. The ends must be clean and completely free of old developer.

### Reinstallation

- Always replace the filter before reinstalling the cleaned PCU. The filter must be replaced every time the developer is replaced.)

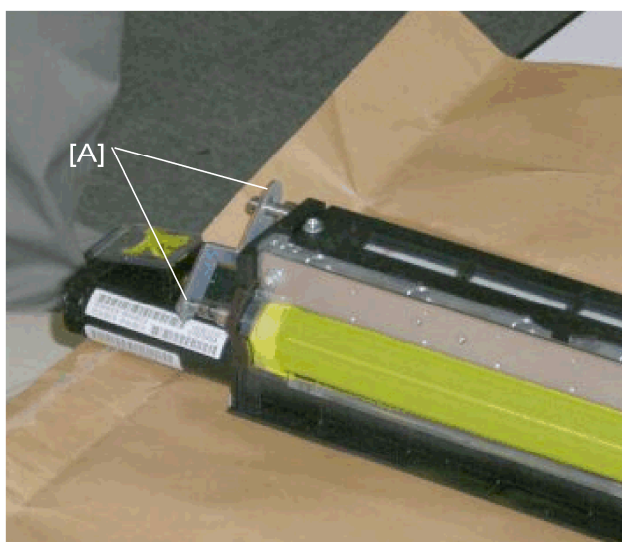

temp\_0779a

- Attach the metal jig [A] (provided with the PCU stand) to the ends of the shafts shown above. This aligns the shafts correctly for reinstallation of the PCU.
- Reinstall the PCU and faceplate.
- Do not reinstall the toner hopper yet.

## Adding New Developer

---

### Before You Begin...

- Follow this procedure in the order described below.
- Do not turn on the machine or open the front door until you are instructed to do so.

### PCU Filling Procedure

1. If you have not already done so, remove the toner hopper unit (described above).

## Replacement and Adjustment

---

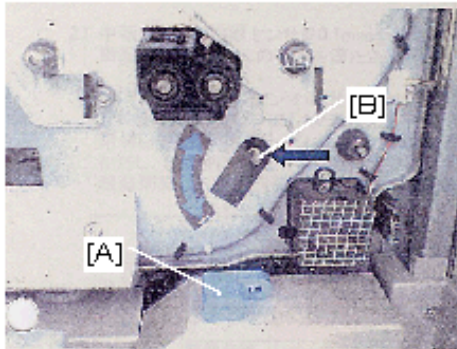

temp\_devinstall\_1

2. Attach the transfer belt release lever [A] to the tip of the shaft [B].

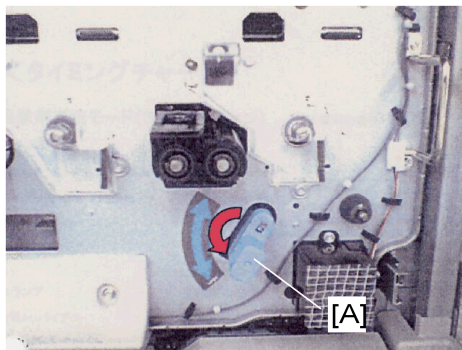

temp\_devinstall\_2

3. Rotate the lever [A] down to separate the transfer belt from the surfaces of the PCU drums.
4. Before attaching each bottle, loosen the developer to ensure that it will drain completely.



temp\_dev-shake30

- Vigorously shake the bottle up and down 10 to 15 times.

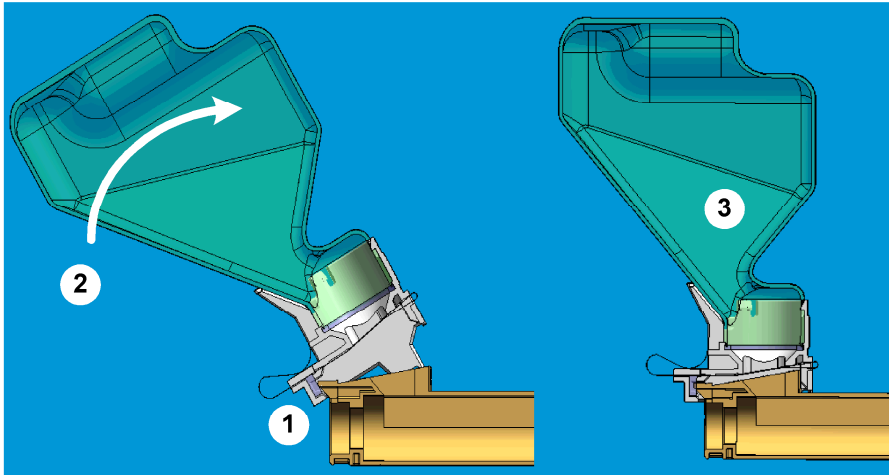

ins\_0001

5. Mount a developer bottle on each PCU.

- Set each bottle as shown at .
- Swing the bottle to the right until it snaps into place and is upright .

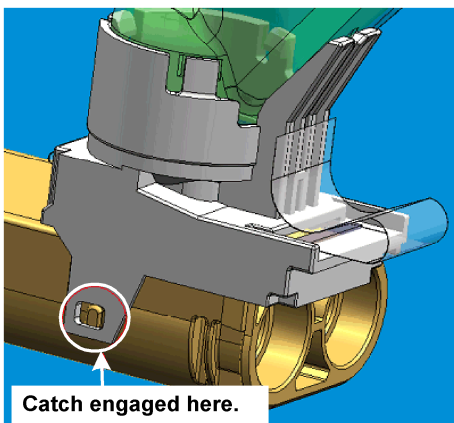

ins\_0002

6. Confirm that the neck of each bottle snaps and locks in place. Confirm that the neck of each bottle is parallel with the top of each PCU.

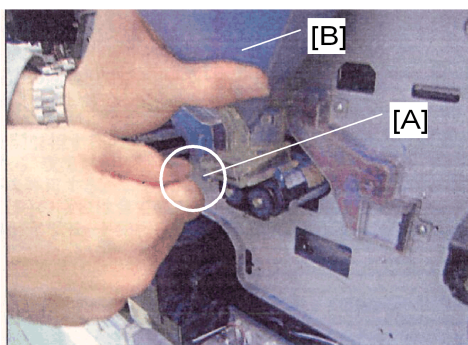

temp\_devinstall\_3

## Replacement and Adjustment

---

7. To prevent the bottle from falling off, hold the bottle [B] with the left hand as shown, pull the heat seal [A] out of the developer bottle and remove it.
8. Pull the seal from the developer bottle.
9. Make sure that you have removed the seal from the development bottle.
10. Gently tap the right side of each bottle to make sure that the developer flows freely.
11. Close the front door.



- You must close the front door.

12. Turn the machine's power on.
13. Enter the SP mode and do the appropriate SP codes:

SP	Function
3814-1	All (KMCY)
3814-2	MCY Only
3814-3	K
3814-4	M
3814-5	C
3814-6	Y
3815	Confirms that SP3814 executed correctly by displaying "1111" (KMCY). A "9" indicates an error

14. Confirm that the developer bottle is completely empty.
  - Each developer bottle must be completely empty. Even if SP3815 returned a "1" for each bottle to indicate successful completion of the operation, there may be toner remaining in a bottle. It is very important that you check each bottle visually.
  - If you see toner still remains in a bottle, do not disconnect the bottle. Refer to the next section below.
15. Switch the machine off and disconnect the power cord.

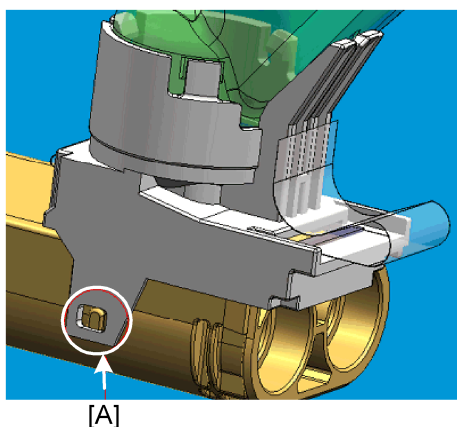

ins\_0003

16. Remove the developer bottles. Use the tip of a small screwdriver to release the bottle latch at [A].

17. Discard the empty bottles.

**★ Important**

- Obey local laws and regulations concerning the disposal of items such as the empty bottles.

18. Reattach the toner hopper.

19. Open the front door [A].

**★ Important**

- You must open the front door.
- Turning on the machine with the front door open prevents the machine from performing the initial process control self-check.
- If the front door is closed, the drums will start rotating with no toner in the PCUs.
- If the drums rotate with no toner in the PCUs, this can cause the cleaning blades to catch on a dry drum and damage the drum surface.

20. With the front door open, turn on the main power switch.

21. Do the SPs that are indicated by the table in the 'SP Codes after Replacements' section.

**↓ Note**

- If you add developer at the same time as you install a new PCU, do SP3010, 3011, 3012, or 3013 before you initialize the developer.

### Handling Problems with Developer Filling

---

#### Procedure 1

Do this procedure first.

The most common cause of an SP3815 error is failure to remove the tape from one of the

## Replacement and Adjustment

---

bottles. If you see any number other than "1" after doing SP3815:

1. Note the position of the digit where the number is displayed. For example, If the displays reads "1191" the problem occurred at the C PCU.
2. Check the attachment of the bottle at the affected PCU and make sure that the tape was removed.
3. If the tape has been removed, do Procedure 2

### Procedure 2

Do this procedure only after you have done Procedure 1 immediately above.

If all tapes have been removed but developer remains in one or more bottles, do the procedure below.

1. Do SP3814-1 to 6 for the color of whichever PCU is to be filled with developer..
2. Hold the bottle to prevent it from coming off, then tap the bottle gently a few times.
3. Open the front door then switch on the main power switch.

#### ★ Important

- The door must be open.

1. When you see the door open message on the screen, close the door.
2. Wait about 40. sec. until the SC code appears on the screen, then turn off the power switch.
3. Repeat this procedure until the bottle becomes empty.
4. After 10 attempts if the bottle is still not empty, do procedure 3 below.

### Procedure 3

The developer has probably clogged inside the bottle, so you must remove the developer bottle and the PCU. Do this procedure only after you have done Procedures 1 and 2 immediately above.



temp\_devbotoff

#### ↓ Note

- The initial process control self-check (process control after the prescribed idle

## Replacement and Adjustment

---

time and MUSIC) is disabled after SP3814 (Developer Fill) is executed and will remain disabled until after SP3801 (TD Sensor Initialization) or SP3811 (Developer Setup) are executed.

1. Cover the toner bottle with a plastic bag, and seal the mouth of the bag with your hand.
2. Remove the bottle .
3. Remove the faceplate (🔧 x5).
4. Remove the PCU from the machine.
5. Open the top of the development unit (🔧 x2).
6. Pour remaining developer from the bottle into the development unit.

---

## New PCU

---

There are two types of PCU. Before replacing a PCU, make sure that you have the correct type:

- The K PCU contains a charge wire unit, used only for black.
- The YMC PCUs use a charge roller. This PCU type can be used to replace Y, M, or C PCU.



temp\_0936

1. Remove the seal from the new PCU (the seal is similar to the permanently attached one, shown above, but you can tear it off).



## Replacement and Adjustment

---



temp\_0938

2. Stick the seal on the guide sheet provided. This reminds you which SP codes must be set for the PCU later.

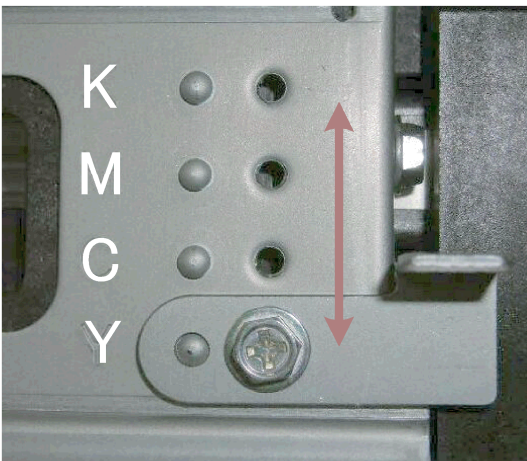

temp\_0939

3. Remove the screw and set the plate to the correct position for the PCU to be replaced. This adjustment prevents the PCU from being installed in the wrong position.
4. Install the new PCU in the machine.
5. Execute the SP codes described on the guide sheet.

## Replacement and Adjustment

		* : K=0, M=1, C=2, Y=3
□	SP3010-001 TD Sensor:K Vtcnt SP3010-002 TD Sensor:K Vt(H) SP3010-003 TD Sensor:K Vt(M) SP3010-004 TD Sensor:K Vt(L)	
□	SP3011-001 TD Sensor:M Vtcnt SP3011-002 TD Sensor:M Vt(H) SP3011-003 TD Sensor:M Vt(M) SP3011-004 TD Sensor:M Vt(L)	
□	SP3012-001 TD Sensor:C Vtcnt SP3012-002 TD Sensor:C Vt(H) SP3012-003 TD Sensor:C Vt(M) SP3012-004 TD Sensor:C Vt(L)	
□	SP3013-001 TD Sensor:Y Vtcnt SP3013-002 TD Sensor:Y Vt(H) SP3013-003 TD Sensor:Y Vt(M) SP3013-004 TD Sensor:Y Vt(L)	

d014s901

- Four SP codes must be set for the new PCU.
  - Execute only the SP codes where the sticker is attached (removed and attached to the guide sheet).
  - Do not execute any other SP codes on this sheet.
  - If you replace only the development unit, you must also do these SP modes.
6. Add developer to the new PCU.



- Do SP3010, 3011, 3012, or 3013 before you initialize the developer.

## SP Codes After Replacements

Do the following procedure after you replace the PCU, development, or any related parts. Pay attention to the combination of replaced parts in the table below (required procedures are different). Any SPs listed in this table should be performed as described below.

1. Open the front cover, then turn on the main power.
2. After the "Open Cover" message is shown on the display, close the front cover.
3. Execute the required SPs.

### Replaced Parts Table

Please refer to the notes below.

## Replacement and Adjustment

No.	Replaced Parts			Required SPs	Comments
	Drum	Developer	Drum Cleaning Blade		
1.	✓			3820-2	Before installation cover the drum completely with lubricant powder. <b>Do NOT initialize the TD sensor with:</b> - 3801-1 to 6 - 3811-1 to 6
2.	✓		✓		
4.	✓	✓		3801-1 to 6	Before installation cover the drum completely with lubricant powder. Do the SPs to initialize the TD sensor only for the color(s) that were replaced.
5.	✓	✓	✓	3811-1 to 6	
6.		✓		3801-1 to 6	Do the SPs to initialize the TD sensor only for the color(s) that were replaced.
7.		✓	✓	3811-1 to 6	

d014r900

1. Initialize the TD sensor once only.
2. If you replace the developer for two colors (C, M, Y), do the developer set up for each color, one by one. (**Never use SP3811-002.**)

### CAUTION

- Never initialize the TD sensor more than once. Initializing the TD sensor more than once can cause toner scatter inside the machine.

Initialize the TD sensor only at the following times:

- At installation, exactly as explained in the installation procedure.
- After you replace developer (only initialize the TD sensor for the color that you replaced)
- As instructed in specific troubleshooting procedures.

Here is a summary of the important difference between SP3801 001-006 (Init TD sensor) and SP3811 001-006 (Dev Setup Exe):

- SP3801 001-006 (Init TD sensor) only initializes the TD sensor.
- SP3811 001-006 (Dev Setup Exe) initializes the TD sensor and sends toner to the sub hopper of each PCU. This covers the PCU drum with a layer of toner.

Covering the drum with toner prevents the cleaning blades from scratching or bending the drums. SP3811 is necessary only when both the developer and cleaning blade are replaced together. For the other procedures, if you send toner to the PCU, that toner is

wasted.

## PTR Unit

---

### Relay Sensor

---

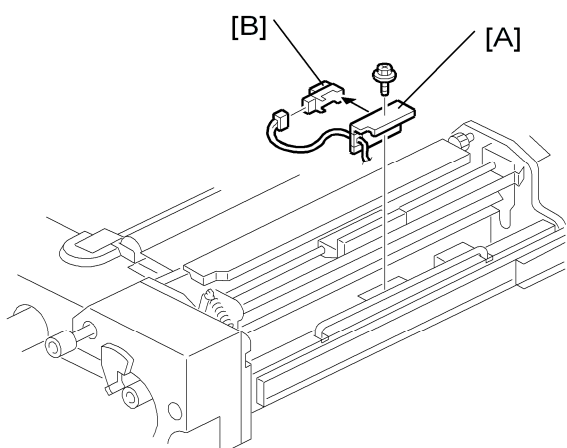

d014r615

1. Pull out the drawer unit.
2. Remove:
  - [A] Sensor bracket (🔩 x1)
  - [B] Relay sensor (🔌 x1)

### Reinstallation

- Do the forced MUSIC adjustment with SP 2111 001.

---

## Double-Feed Detection Photosensor, Registration Sensor

---

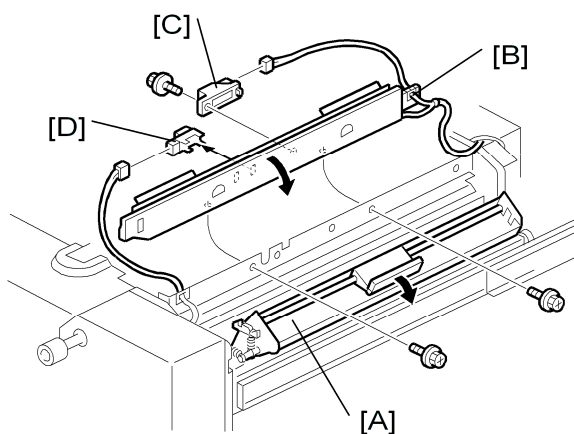

d014r616

1. Pull out the drawer unit.

## Replacement and Adjustment

---

2. Open the guide plate [A].
3. Remove:
  - [B] Sensor support plate (⚙️ x2)
  - [C] Double-feed detection photosensor (📷x1, ⚙️ x1)
  - [D] Registration sensor (📷 x1)

### Reinstallation

- Do the forced MUSIC adjustment with SP 2111 001

---

## PTR Unit

---

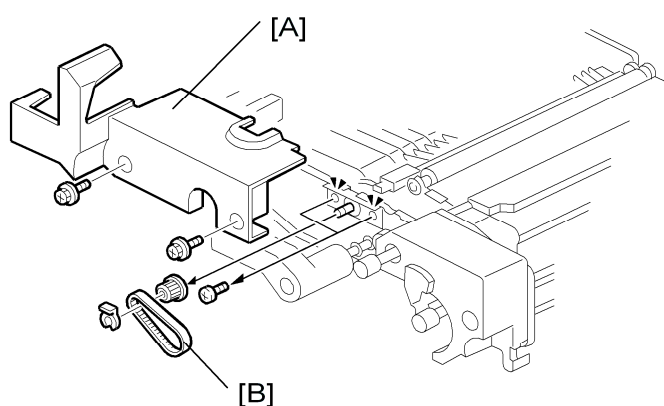

d014r302

1. Pull out the drawer unit.
2. Remove:
  - [A] Paper transport unit cover (⚙️ x2)
  - [B] Timing belt, gear (⚙️ x1)
  - Do not loosen or remove the paint-locked screws.

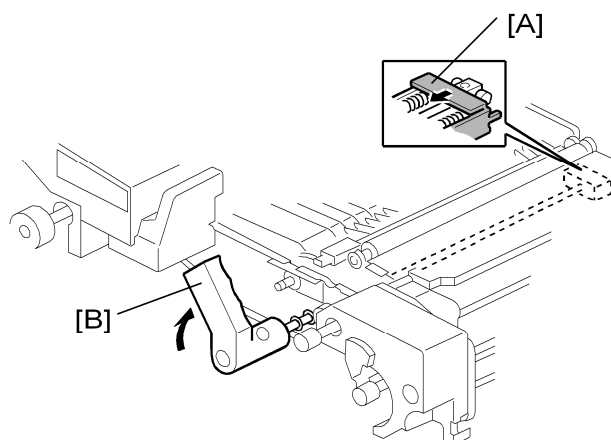

d014r302a

## Replacement and Adjustment

---

### 3. Remove:

[A] Press the release forward

[B] Raise the handle to the vertical position.

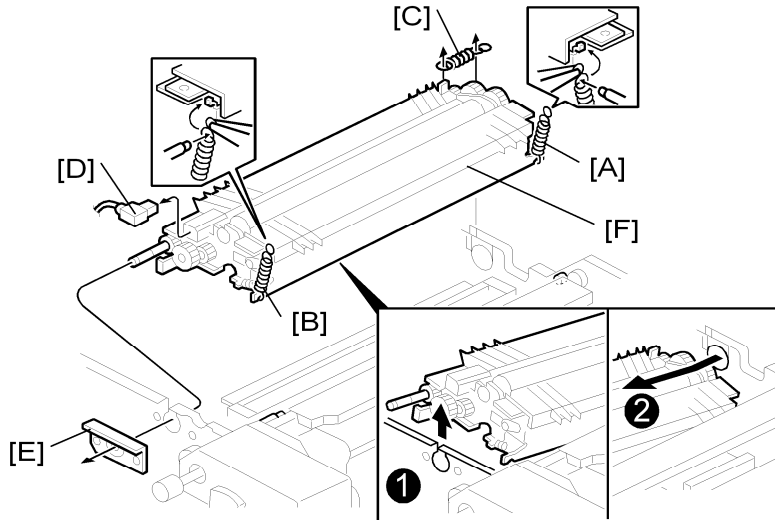

d014r303

### 4. Change the position of:

[A] Spring

[B] Spring

### 5. Remove:

[C] Spring

[D] Connector (🔗 x1) (use a pair of small pliers to remove the connector)

[E] Bracket (🔗 x2)

[F] PTR Unit

- The handle should be up.
- Raise the front .
- Pull the rear .

### Reinstallation

- Be sure to set springs [A], [B], and [C] in their original positions before you re-install the PTR Unit.
- Do the forced MUSIC adjustment with SP 2111 001.

## Replacement and Adjustment

### Paper Transfer Roller, Discharge Plate

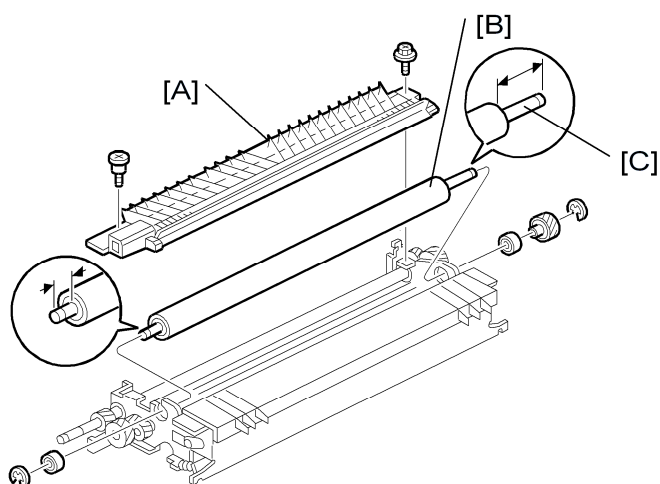

d014r304

#### 1. Remove:

- PTR Unit

[A] Paper transfer discharge plate (⌘ x2)

[B] Paper transfer roller (Ⓒ x2, Gear x1, Shaft bearings x2)

#### Reinstallation

- When you install the roller, the long end [C] is at the rear.
- Do the forced MUSIC adjustment with SP 2111 001.

### Lubricant Bar

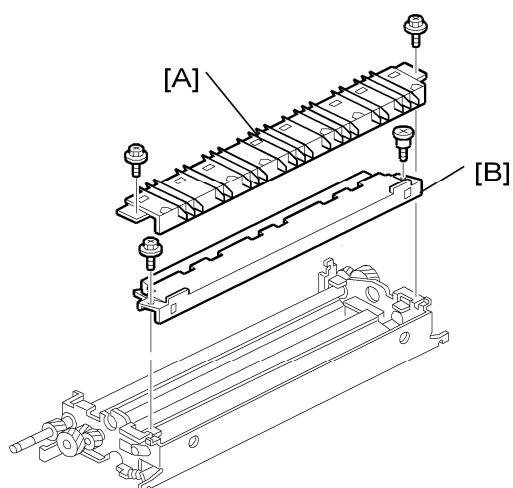

d014r305

#### ★ Important

- Work carefully to avoid scratching the paper transfer roller.



## Replacement and Adjustment

---

### 1. Remove:

- PTR Unit
- [A] Entrance guide plate (🔩 x2)
- [B] Lubrication bar (🔩 x2)

### Reinstallation

- Do the forced MUSIC adjustment with SP 2111 001

---

## Cleaning Blade

---

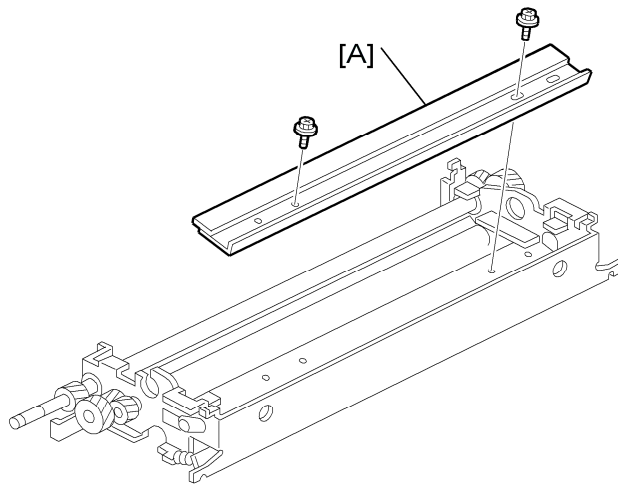

d014r306

### 1. Remove:

- PTR Unit
- Lubrication bar
- [A] Cleaning blade (🔩 x2)

### Reinstallation

- Do the forced MUSIC adjustment with SP 2111 001.

## Replacement and Adjustment

### Cleaning Brush Roller

#### Replacement

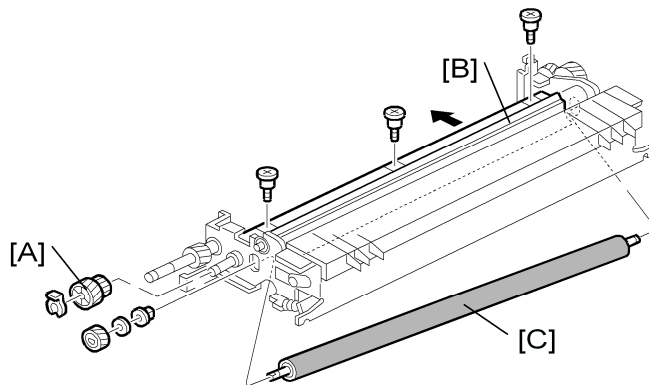

d014r307

#### 1. Remove:

- PTR Unit
- Transfer exit guide, paper transfer roller

[A] Gear (⌘ x1, Gear x1)

[B] Brush roller cover (⌘ x3)

[C] Cleaning brush roller (Gear x1, Washer x1, Shaft bearing x1)

### Paper Transport Belt, Paper Separation Power Pack

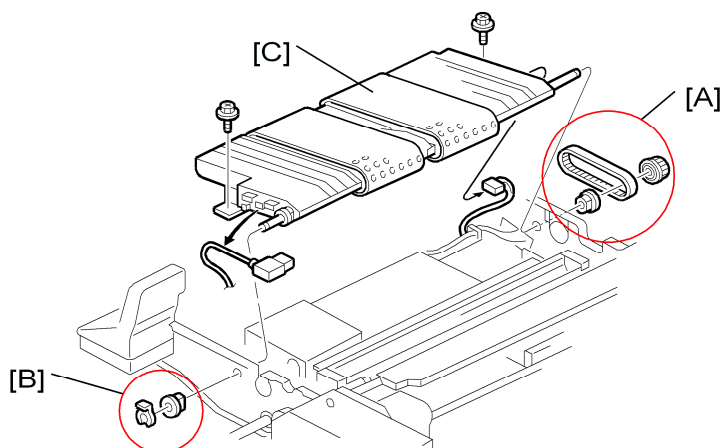

d014r308

## Replacement and Adjustment

---

1. Pull out the drawer unit
2. Remove:
  - Paper transport unit lever and cover
  - Fusing unit[A] Timing belt x1, Gear x1, Shaft bearing x1  
[B] Snap ring x1, Shaft bearing  
[C] Paper transport belt (🔧 x2, 📏 x2)

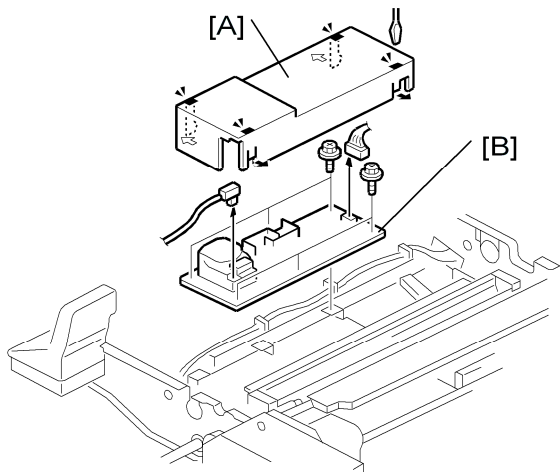

d014r308a

3. Remove:
  - [A] Cover
  - [B] Separation power pack (🔧 x6, 📏 x2)

### Reinstallation

- Do the forced MUSIC adjustment with SP 2111 001.

## Replacement and Adjustment

### Registration Motor

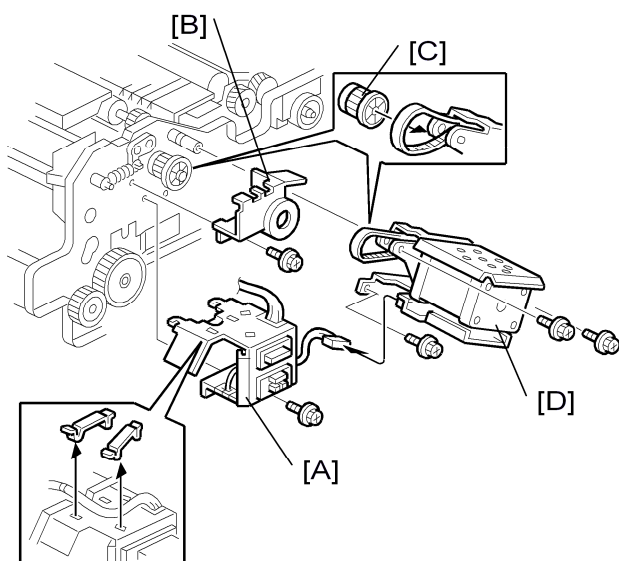

d014r618

#### 1. Remove:

- Drawer unit

[A] Drawer unit connector bracket (⚙ x1, ⚙ x3, ⚙ x2)

[B] Gear cover (⚙ x1)

[C] Registration gear (⊕ x1, Spring pin x1)

[D] Registration motor assembly (⚙ x3, ⚙ x1)

#### Reinstallation

- Do the forced MUSIC adjustment with SP 2111 001

### Double-Feed Detection LED

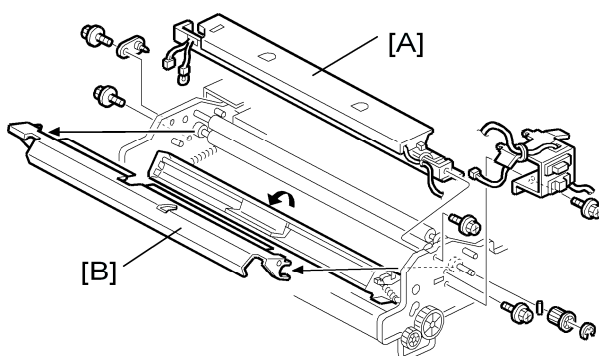

d014r619

#### 1. Remove:

- Drawer unit
- Drawer unit connector bracket

## Replacement and Adjustment

---

- Registration motor
- Sensor support plate
- Registration motor inner cover (🔩 x4)

[A] Upper stay (🔩 x2)

[B] Lower stay (🔩 x2, 📌 x1)

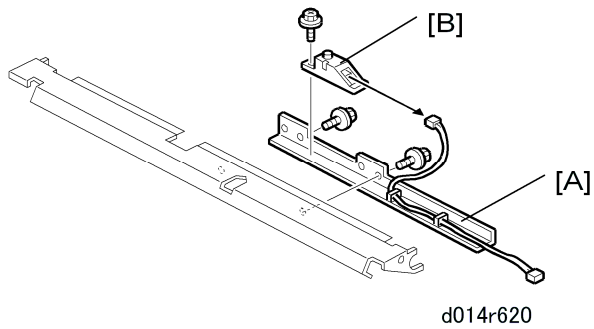

### 2. Remove:

[A] Sensor bracket (🔩 x2)

[B] Double-feed detection LED (🔩 x1, 📌 x1)

### Reinstallation

- Do the forced MUSIC adjustment with SP 2111 001.

## Image Transfer Unit

---

### Emptying the Dust Collection Unit

---

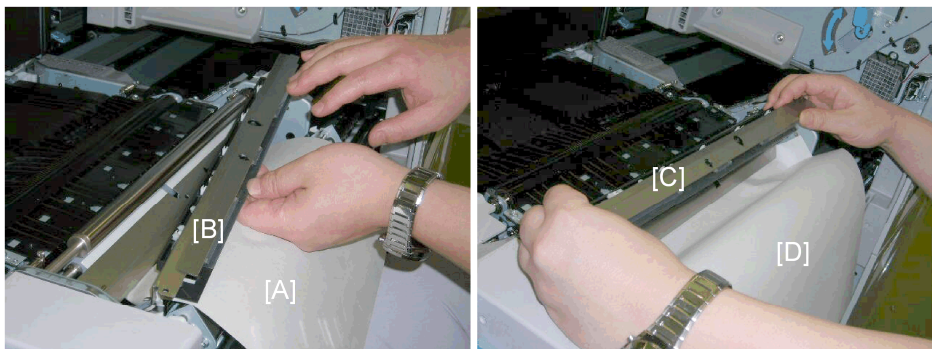

ra\_0911

1. Open the front door.
2. Pull out the drawer unit.
3. Insert a sheet of A3 paper [A] under the dust collection unit.
4. Disconnect the dust collection unit [B].
5. Dump the paper dust from the dust collection unit [C] onto the paper [D].
6. Carefully remove the paper and discard.

### Separating the Belt Unit and Belt Cleaning Unit

---

#### Disassembly and ITB Replacement

---

1. Put a clean sheet of paper on a flat surface.
2. Remove the ITB from the machine.
3. Place the ITB unit on the sheet of paper.  
To prevent spilling used toner, always hold the unit level when you remove it, lift it, carry it, or set it down.

## Replacement and Adjustment

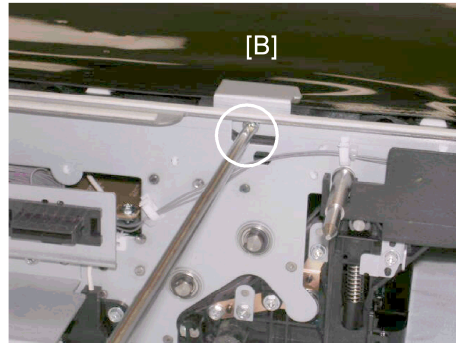
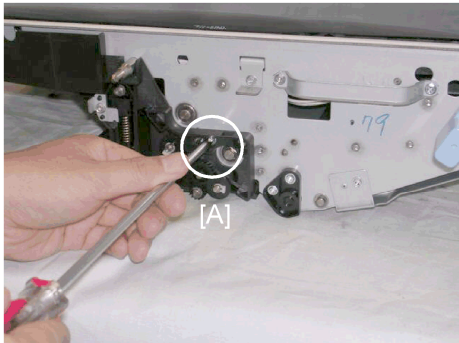

ra\_0997

4. Remove screws [A] and [B] (🔩 x2).

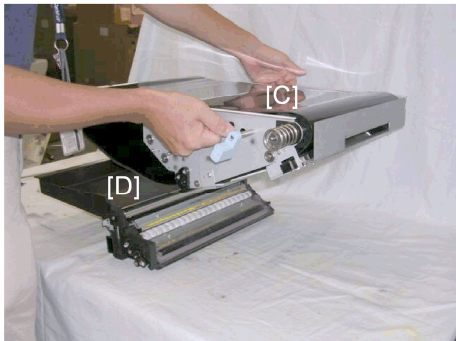
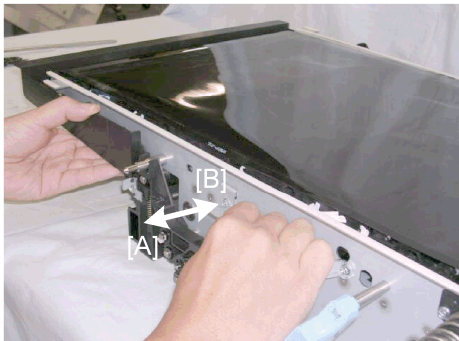

ra\_1001

5. Pull the ITB cleaning unit [A] forward while pushing the ITB belt unit backward to separate the cleaning unit from the belt unit.
6. Lift the belt unit [C] off the cleaning unit [D].

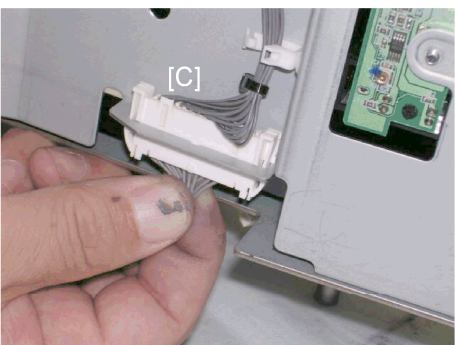
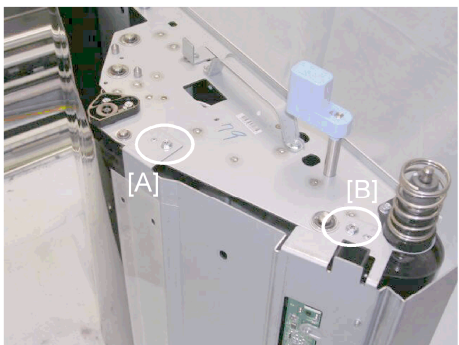

ra\_1030

7. Remove:
  - [A] Screw (🔩 x1)
  - [B] Screw (🔩 x1)
8. Disconnect [C] (🔌 x1)

Before You Begin...

---

Here are some important precautions you should obey when reassembling the ITB Unit.

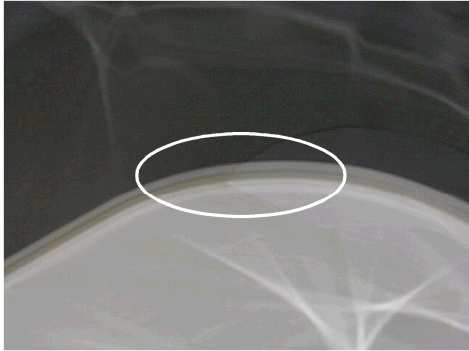

ra\_0958

- When you install the new belt, the edge of the belt with the encoder film strip must be at the back of the unit with the image position sensor. The encoder edge of the ITB is silver.

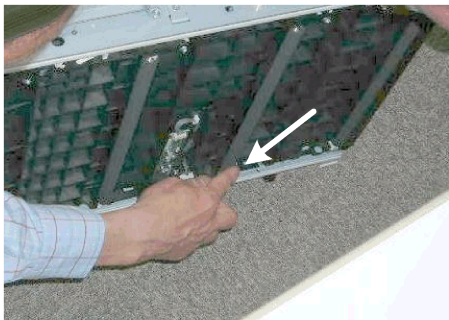

ra\_0960

- Never touch the ITB rollers when removing/installing the belt. If a roller (or the surface of the belt) is touched accidentally, moisten a clean cloth and clean the affected area.



ra\_0959

- Make sure that the belt is even with the edge of the roller as shown above.



## Replacement and Adjustment

---

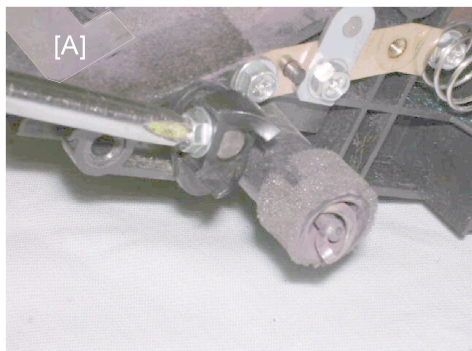

ra\_1026

- When reinstalling the ITB cleaning brush roller, confirm that the seal [A] is on top and visible.
- Always dust the ITB with lubricant powder before reinstalling the ITB unit in the machine.

## Reassembling the Belt Unit and Cleaning Unit

---



ra\_0952

1. Insert one sheet of A4/LT paper under the lubricant blade as shown to protect the corner seals of the belt cleaning unit.

**★ Important**

- The paper should be under the under the blade as shown above, not over the blade.
2. Lower the belt unit [A] onto the cleaning unit [B].

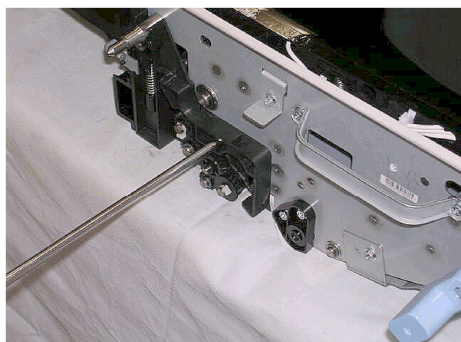

ra\_1041

3. Reassemble the belt unit and belt cleaning unit.

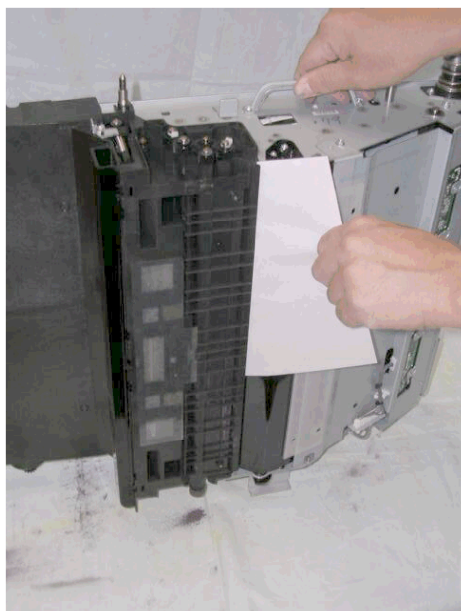

ra\_1042

4. Set the reassembled ITB unit on end as shown.
5. Pull the paper out slowly.
6. Check the paper.

If the paper is unmarked, go to the next step.

-or-

If the paper is creased or torn, separate the image transfer belt and cleaning unit.

Inspect the seal. If the seal is damaged, replace it.

### Dusting the ITB with Lubricant Powder

---

1. Get a pack of Lubricant Powder B1329700.
  - The ITB must be coated with lubricant powder B1329700 before installing a new ITB.

## Replacement and Adjustment

---

- The lubricant powder (B1329700) (composed of ZnSt) is specially designed for this machine.
- Never use setting powder (54429101) for this machine. Using this setting powder will damage the drum charge roller and cause problems with image quality.

### ★ Important

- Do not use the yellow toner from this machine, because it contains developer, and this will damage the drum and ITB.

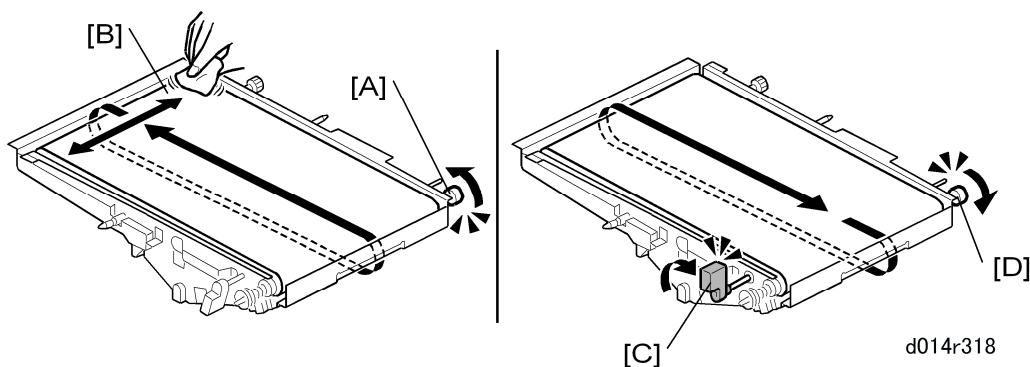

2. While rotating the knob [A] in the direction indicated by the arrow, apply Lubricant Powder B1329700 at [B] with a soft dry cloth.
3. Keep rotating the ITB at [A] while continuing to apply the powder at [B] through one full rotation until the ITB is completely covered with powder.
4. After the ITB has been completely covered with the lubricating powder, turn lever [C] to the up position.
5. After the ITB is completely covered with powder, rotate the knob [D] in the direction indicated by the arrow.
6. Keep rotating the knob at [D] until the ITB has made one full rotation. This reverse rotation covers the edge of the belt cleaning blade with lubrication powder.

### Reinstallation

- Do the forced MUSIC adjustment with SP2111-1.

---

## ITB Cleaning Unit

---

This is the ITB cleaning unit with the belt unit removed.

## Replacement and Adjustment

---

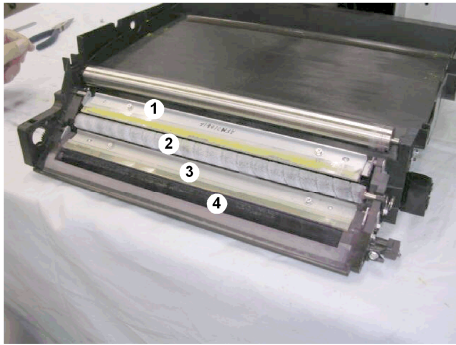

ra\_1003

①	Lubricant Blade
②	Lubricant Brush Roller* <sup>1</sup>
③	ITB Cleaning Blade
④	ITB Brush Cleaning Roller

\*<sup>1</sup> A lubricant bar is under the lubricant brush roller.

Before servicing the cleaning unit, please note:

- The lubricant blade and ITB cleaning blade are not the same, so they are not interchangeable.
- The PM interval of the lubricant blade and lubricant brush roller pair and the ITB cleaning blade and ITB brush cleaning roller pair is the same (300K). These four items are always replaced together.

### Lubricant Blade

---

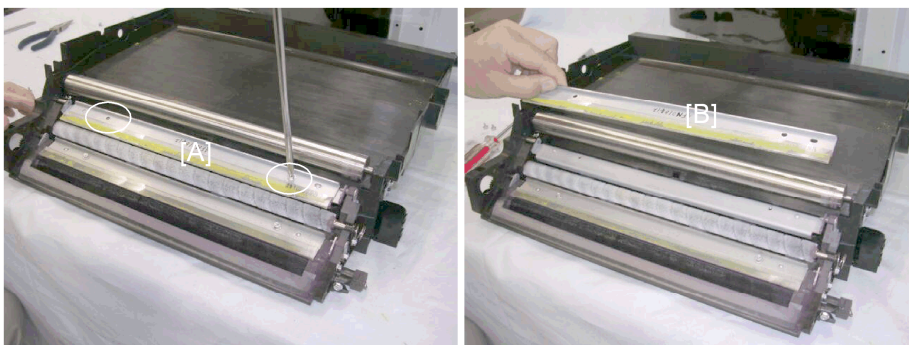

ra\_1005

1. Remove the screws of the lubricant blade [A] (⌀ x2).

## Replacement and Adjustment

---

2. Remove the lubricant blade [B].

### Lubricant Brush Roller, Lubricant Bar

---

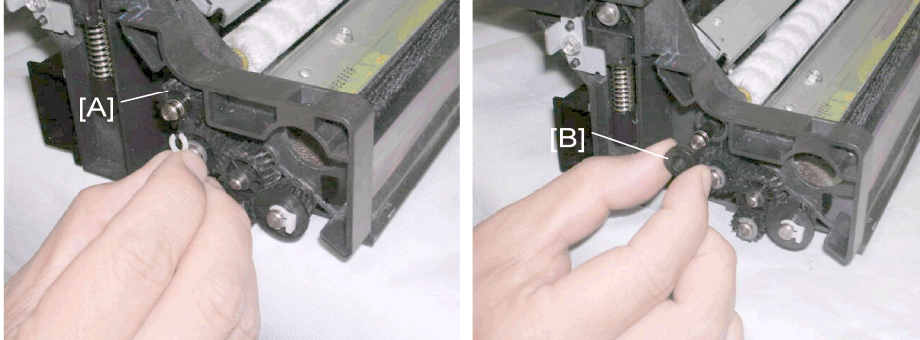

ra\_1008

1. At the back, remove:  
[A] Gear (⊗ x1)  
[B] Coupling

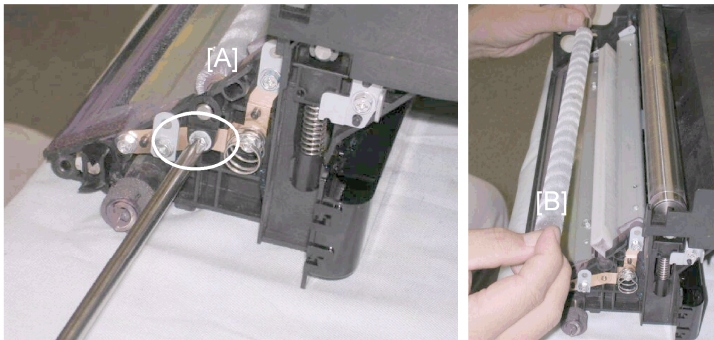

ra\_1012

2. At the front, remove screw [A] (⊗ x1).
3. Remove the lubricant brush roller [B].

## Replacement and Adjustment

---



ra\_1016

4. Remove the lubricant bar [A]

## ITB Cleaning Blade

---

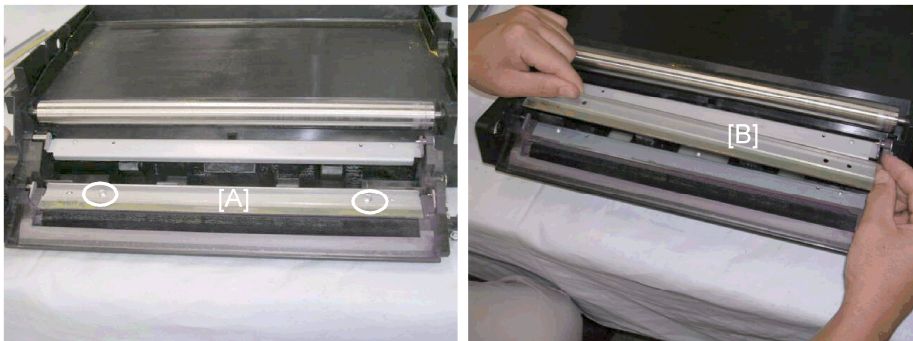

ra\_1017

1. Remove the screws of the ITB cleaning blade [A] (⚙️ x2).
2. Remove the ITB cleaning blade [B].

## Replacement and Adjustment

### ITB Brush Cleaning Roller

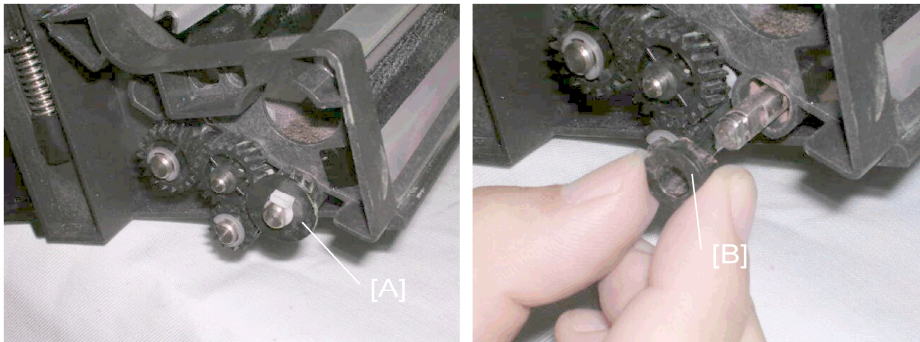

ra\_1021

1. Remove the ITB cleaning blade (🔩 x2).
2. At the rear:
  - Remove gear [A] (🔩 x1).
  - Remove coupling [B].

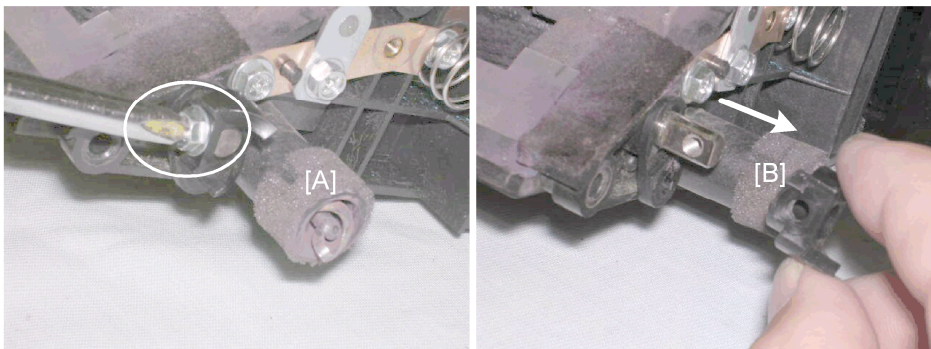

ra\_1027

3. At the front:
  - Remove screw [A] (🔩 x1)
  - Remove coupling [B].



ra\_1028

4. Remove sponge and seal casing [A].

## Replacement and Adjustment

---

5. Remove the ITB brush cleaning roller [B].

## MUSIC and ID Sensors

---

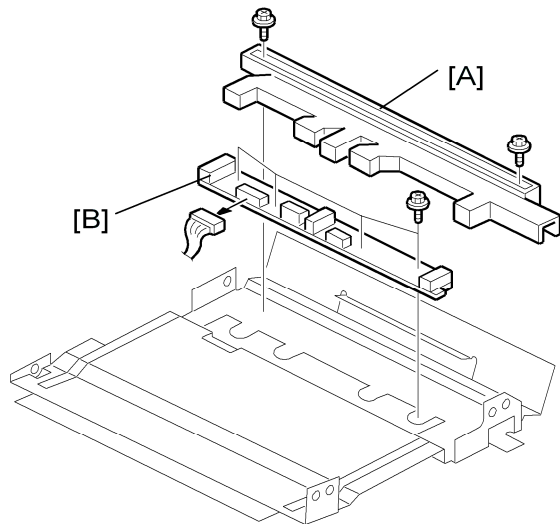

d014r332

1. Remove
    - ID sensor/MUSIC sensor plate
- [A] Cover (🔩 x2)
- [B] MUSIC and ID sensors (🔩 x4, 📏 x1)

### Reinstallation

- Do the forced MUSIC adjustment with SP2111-1.



Image Transfer Power Pack

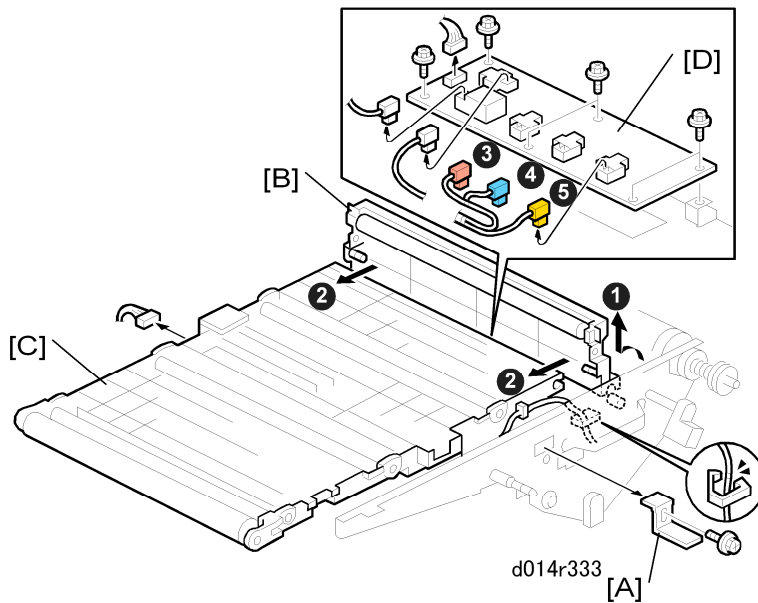

1. Remove:
  - ITB

[A] Support bracket (🔩 x1)

[B] Small idle roller plate

[C] Large idle roller plate

[D] Image transfer power pack (🔩 x6, 📡 x6)
2. Note the correct positions of the color coded connectors when you disconnect them, so that you can reconnect them correctly:
  - Red
  - Blue
  - Yellow

**Reinstallation**

## Replacement and Adjustment

---

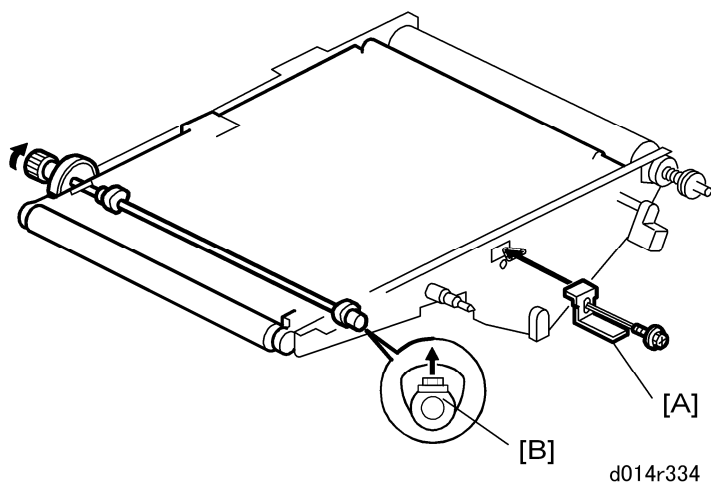

- When you reattach the support bracket [A], rotate the screw [B] up as shown, then tighten it.
- Do the forced MUSIC adjustment with SP2111-1.

---

## Belt Position Sensor

---

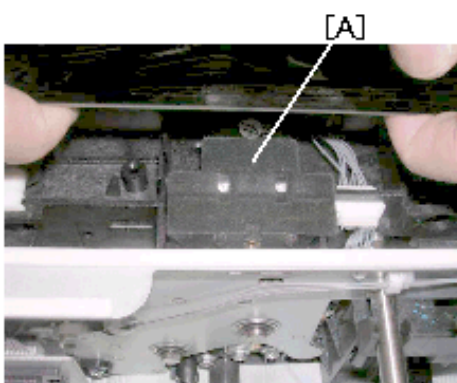

ra\_1044

### 1. Remove:

- ITB
- [A] Belt position sensor assembly (🔧 x2, 📦 x1)

### Reinstallation

After the reinstallation of the new sensor, do the following SP codes:

- SP2912-1 (Encoder Sn: Adj Light)
- SP2914-1 (Encoder Sn Get 1st Phase)
- SP2111-1 (Forced MUSIC Adjustment)

---

## Fusing Unit

---

---

### Removing the Fusing Unit

---

1. Turn off the copier and disconnect the power cord at the power source.
2. Open the front door.
3. Pull out the drawer unit.
4. Allow the machine to cool for at least 10 minutes.

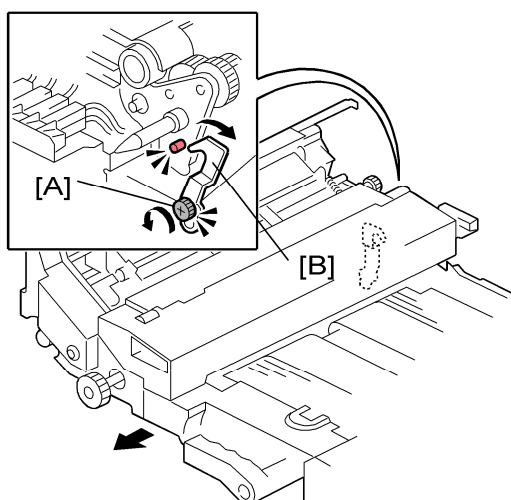

d014r401

5. At the back of the fusing unit, loosen the screw of the lock/release lever [A]. (Do not remove the screw.)
6. Rotate the lever [B] away from the pin, then tighten the screw with the lever in the open position. (Tightening the screw keeps the lever at the open position so that the fusing unit can be reinstalled easily.)

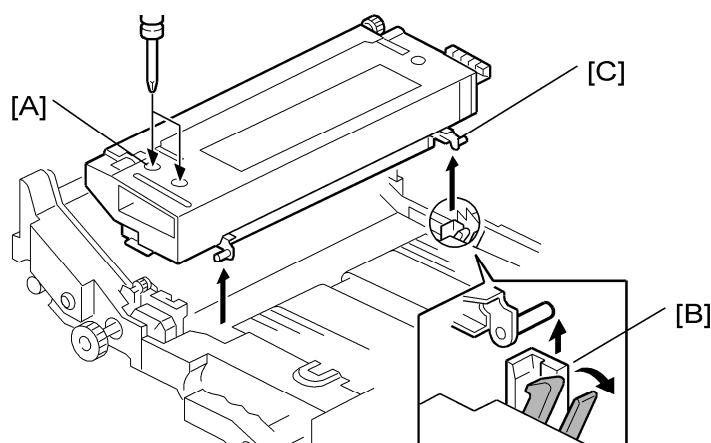

d014r402

7. Loosen both screws [A] (⌀ x2). (These screws cannot be removed.)
8. Press down both levers [B] (front and back) to unlock (to release the pins [C] at front and back).
9. Lift the fusing unit out of the drawer.
10. Set the fusing unit on a clean surface.

### Reinstallation

- Before setting the fusing unit in the drawer, make sure that the lock/release lever is in the open position.
- After reinstalling the fusing unit, make sure that the lock/release lever is in the locked position and finger tight before you close the drawer unit.
- If the lock/release lever is not locked, this could cause a problem if power is turned off accidentally during copying. If this occurs, the drawer unit can be pulled out, but the user may not be able to push it back in because the fusing unit is still pressed up by the cam. Do the following to reset the cam.
  1. Remove the fusing unit from the drawer unit.
  2. Close the drawer, then close the front door.
  3. Turn the main power on. The cam moves down.
  4. Open the drawer and put the fusing unit back in the machine.
  5. Confirm that the lock/release lever is in the locked position.
  6. Close the drawer unit and front door.

---

## Fusing Cleaning Unit

---

### Fusing Belt Strippers

---

### Preparation

## Replacement and Adjustment

- Remove the fusing unit from the machine.
- Allow the unit to cool for at least 10 minutes.
- Raise **D2** to a 45° slant.

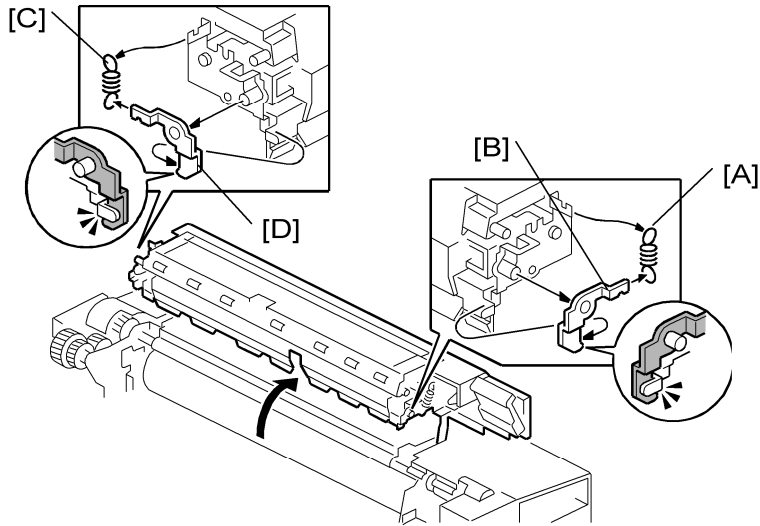

d014r405

1. Remove:
  - [A] Spring
  - [B] Plate
  - [C] Spring
  - [D] Plate

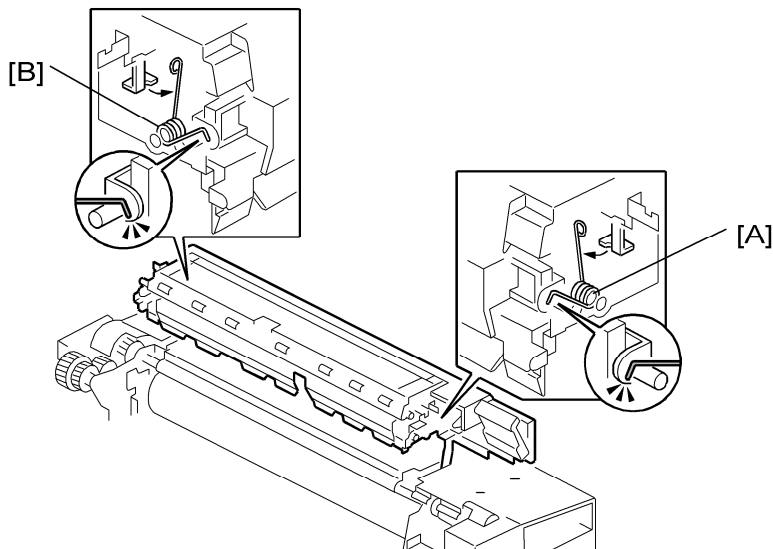

d014r406

2. Remove:
  - [A] Spring

## Replacement and Adjustment

---

[B] Spring

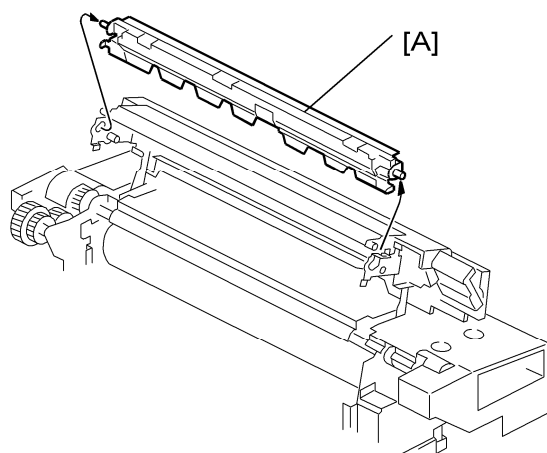

d014r407

1. Remove fusing belt stripper plate [A] with strippers attached.

## Oil Supply Roller Cleaning Roller, Oil Supply Roller

---

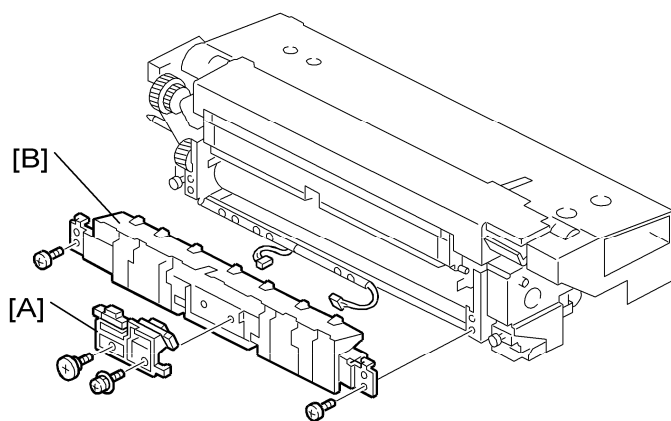

d014r403

1. Remove:  
[A] Paper exit sensor bracket (⚙️ x2, 📏 x2)  
[B] Paper exit guide (⚙️ x2)

## Replacement and Adjustment

---

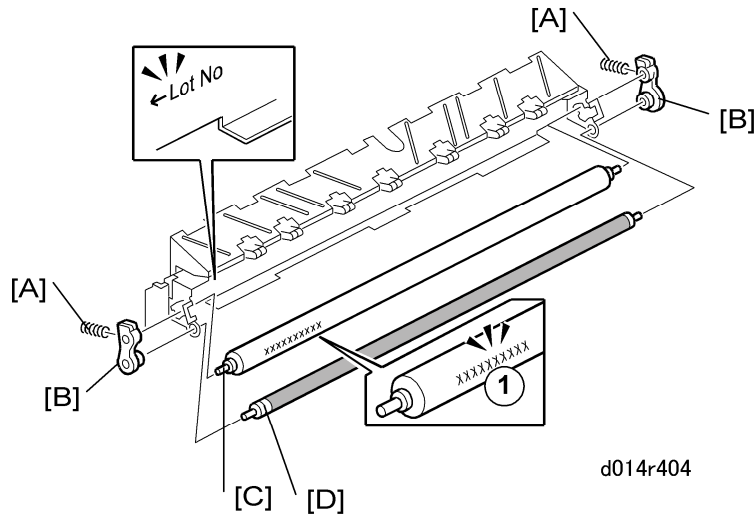

### 2. Remove:

- [A] Spring (Front x1, Back x1)
- [B] Lock plate (Front x1, Back x1)
- [C] Oil supply roller
- [D] Oil supply roller cleaning roller

### Reinstallation

- The end of the oil supply roller with the number 1 above must be installed at the front of the fusing cleaning belt unit.

---

## Fusing Lamps, Dividing the Fusing Unit

---

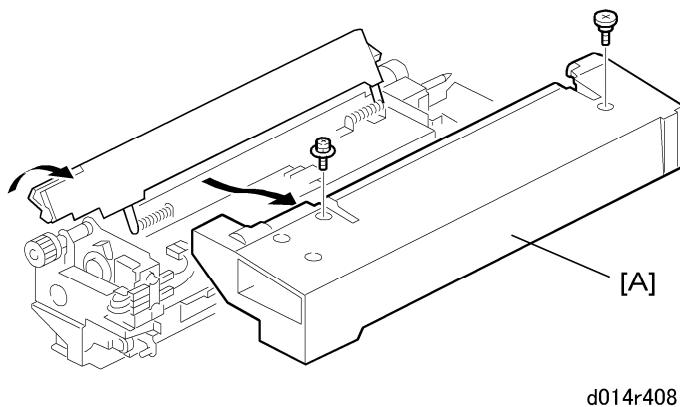

### 1. Remove:

- [A] Fusing unit cover (⌀ x2)

## Replacement and Adjustment

---

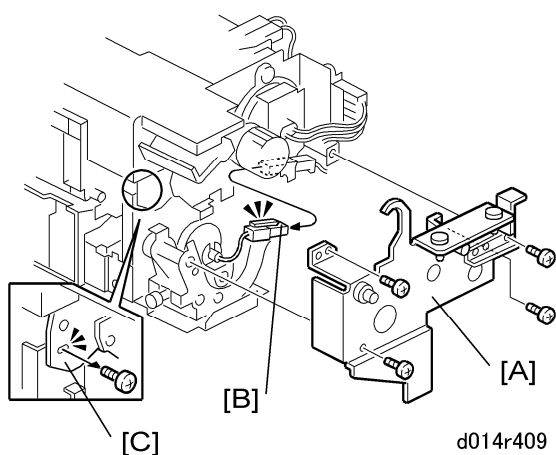

### 2. Remove:

[A] Bracket (🔩 x4)

[B] Connector (🔌 x1)

[C] Screw (🔩 x1)

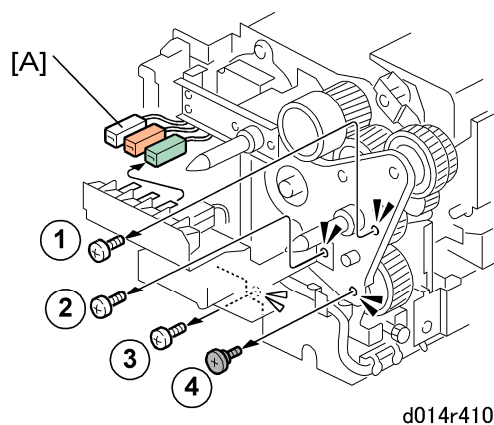

### 3. Disconnect

[A] Fusing lamps (🔌 x3)

### 4. Remove screws , , (normal screws) (step screw) (🔩 x3)



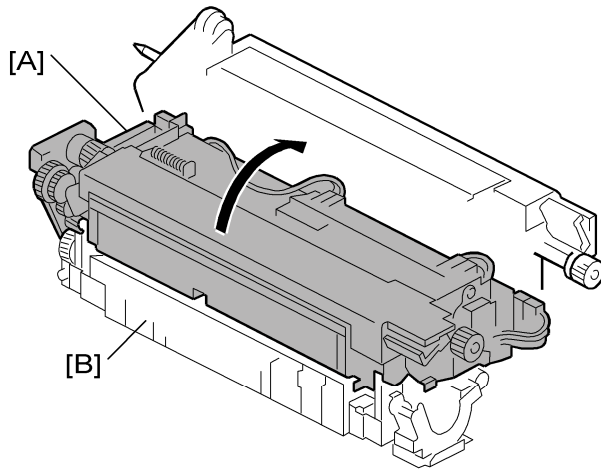

d014r411

5. Separate the two halves of the fusing unit [A] and [B].

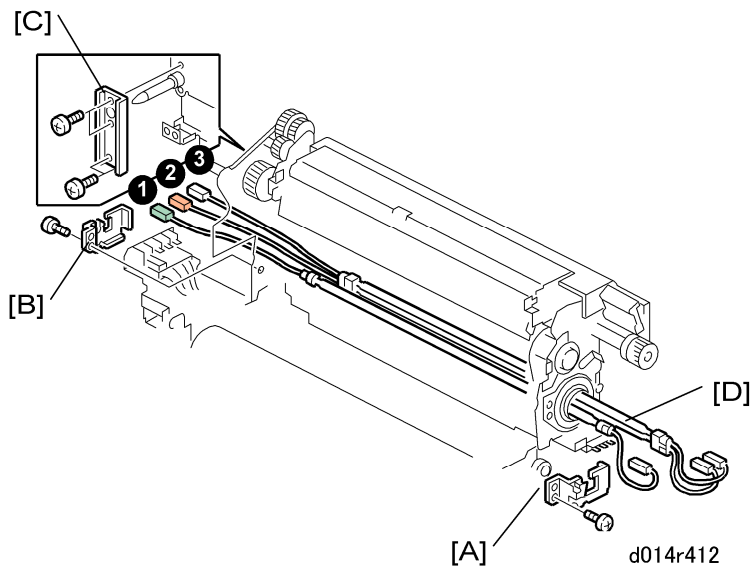

d014r412

6. Remove:
- [A] Lock plate (🔩 x1)
  - [B] Lock plate (🔩 x1)
  - [C] Bracket (🔩 x4)
  - [D] Heating roller fusing lamps (🔌 x3)

## Replacement and Adjustment

---

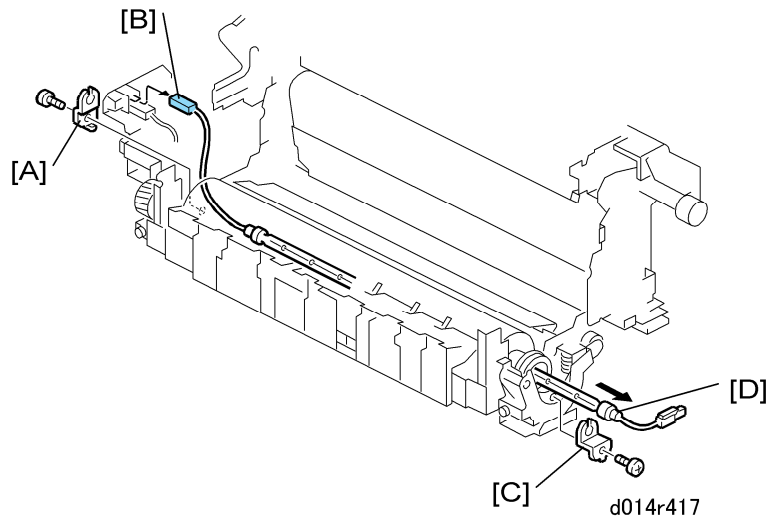

### 7. Remove:

- [A] Lock plate (🔩 x1)
- [B] Connector (🔌 x1)
- [C] Lock plate (🔩 x1)
- [D] Pressure roller fusing lamp (x1)

---

## Fusing Unit Rollers, Fusing Belt

---

### Removing the Fusing Belt, Hot Roller, Heating Roller, Pressure Roller

---

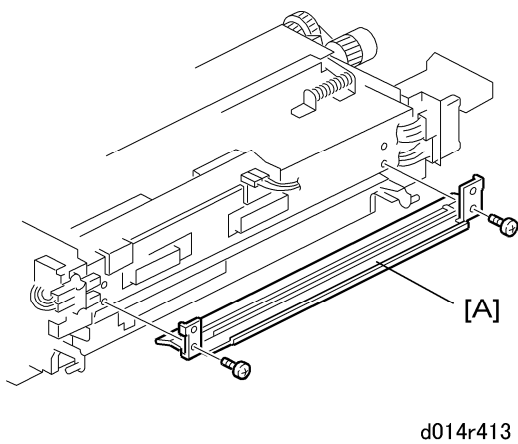

### 1. Remove:

- [A] Upper entrance guide plate (🔩 x2)

## Replacement and Adjustment

---

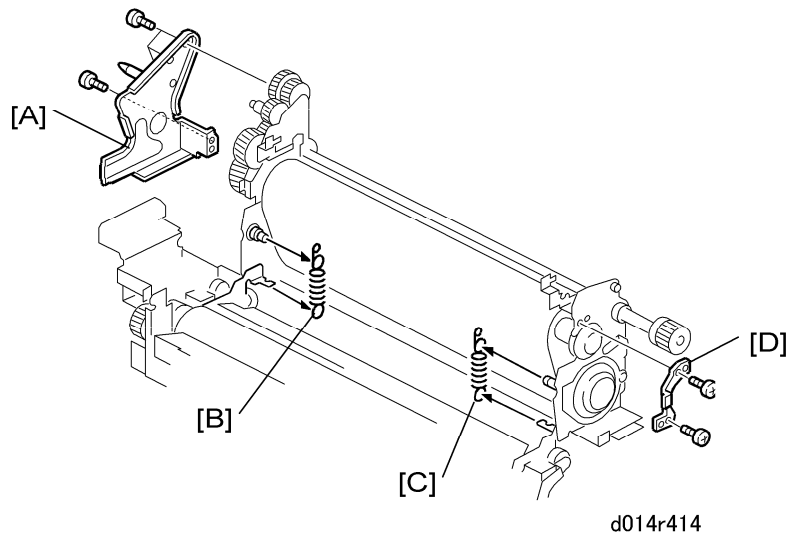

### 2. Remove:

- [A] Plate (⚙️ x4)
- [B] Spring x1
- [C] Spring x1
- [D] Bracket (⚙️ x2)

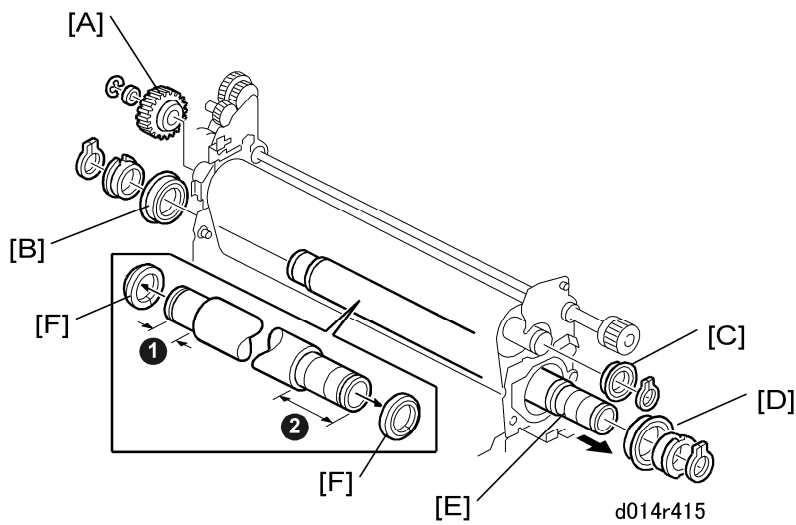

### 3. Remove:

- [A] Gear, bushing (Ⓢ x1)
- [B] Bearing, bushing (C-ring x1)  
**Note:** The flanges of the bearing and the bushing face out for reinstallation.
- [C] Bearing (C-ring x1)  
**Note:** The bearing flange faces out for reinstallation.
- [D] Bearing, bushing (C-ring x1)

## Replacement and Adjustment





**Note:** The flanges of bearing and the bushing face out for reinstallation.

[E] Heating roller

**Note:**

- Flanges [F] should be separated from the heating roller.
- Flanges [F] should be reused with the new roller if the heating roller is replaced.

### Reinstallation

- Make sure that the ends of the heating roller are arranged as shown by  and  in the illustration above. (  is shorter than  )

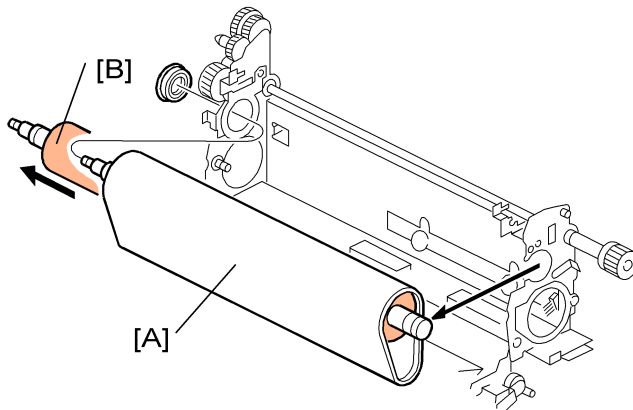

d014r416

1. Remove:

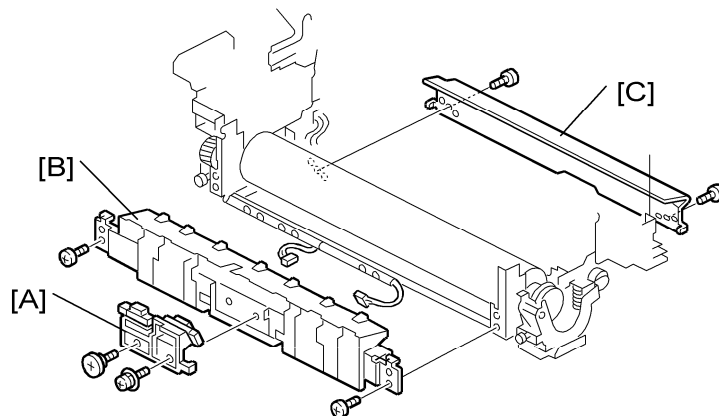

[A] Fusing belt

[B] Hot roller



d014r418

2. Remove:

[A] Paper exit sensor bracket (  x2,  x2)

[B] Paper exit guide (  x2)

[C] Lower entrance guide plate (  x2)

## Replacement and Adjustment

---

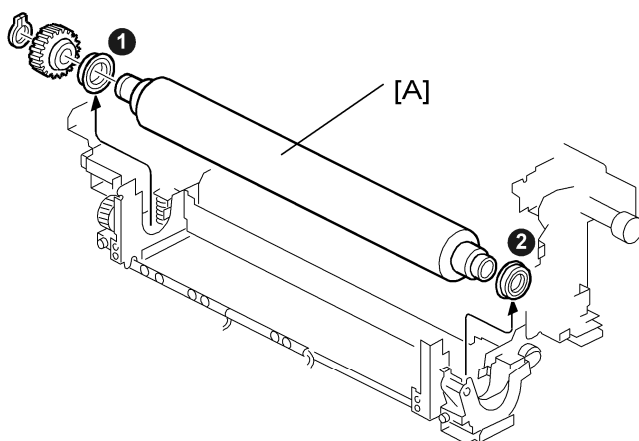

d014r419

### 3. Remove:

[A] Pressure roller (C-ring x1, gear x1, bearings x2)

**Note:** The flanges of bearings and face in for reinstallation.

## Lubrication after Replacement

---

Lubricate all bearings after replacement of the hot roller, pressure roller, and/or heating roller.

For details on the lubrication points, please refer to 'Lubrication Points' in '2. Preventive Maintenance'.

## Adjusting the Gap Between Fusing Belt Strippers and Fusing Belt

---

After replacement of the hot roller, the gap between the fusing belt strippers and the fusing belt may need to be adjusted. Normally this procedure is not required. Do this procedure only when:

- Paper has been frequently sticking to the fusing belt and jamming the fusing unit.
- Streaking caused by fusing belt stripper pawls has been occurring frequently in solid image areas.

### ★ Important

- Do this procedure to adjust the gaps only after the fusing unit has been allowed to cool. If the fusing unit is still warm when the adjustments are done, the gap adjustment may not be within specification.

### 1. Reinstall the fusing belt and hot roller.

## Replacement and Adjustment

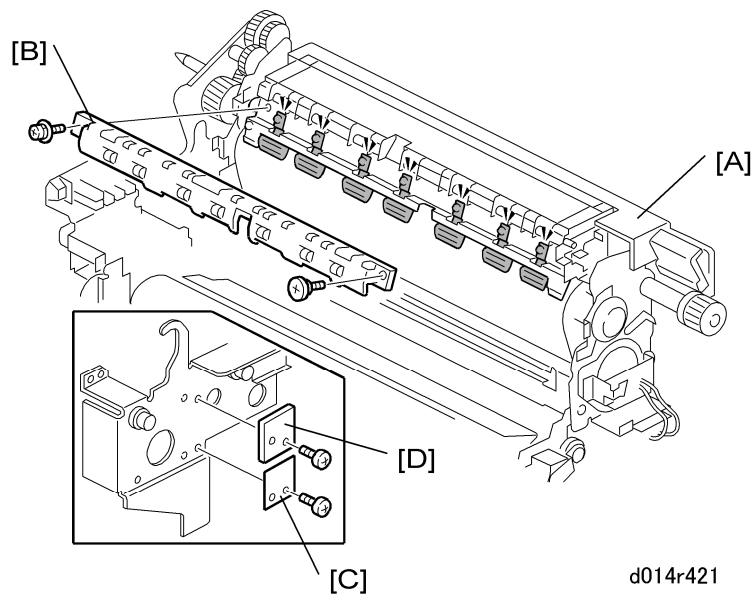

d014r421

2. Separate the two halves of the fusing unit [A].
3. Remove:
  - [B] Fusing belt separation pawl guide plate (2)
  - [C] MIN thickness plate (1)
  - [D] MAX thickness plate (1)

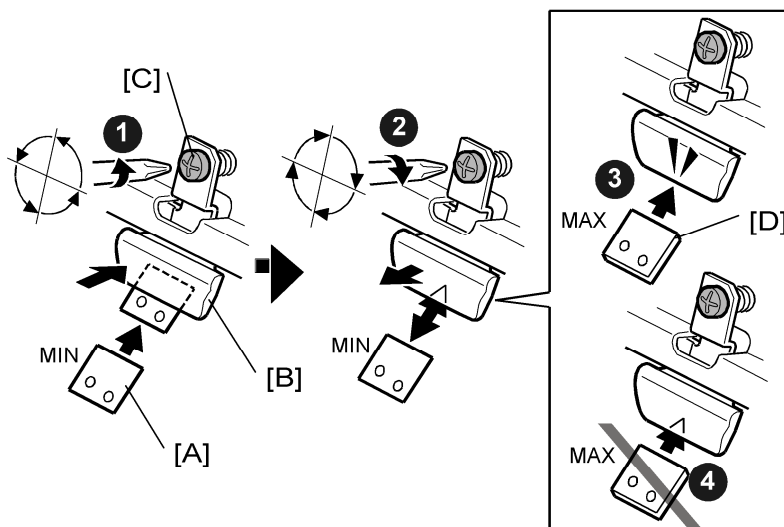

d014r422

4. Insert MIN thickness plate [A] between the separation pawl [B] and fusing belt.
5. Turn screw [C] in 90 degree steps to adjust the gap to the thickness of the MIN thickness plate inserted between the pawl and belt.
  - Turning the screw 90 degrees counter-clockwise reduces the gap.
  - Turning the screw 90 degrees clockwise increases the gap.

## Replacement and Adjustment

---

6. Remove the MIN thickness plate.
7. Confirm that the MAX thickness plate [D] cannot slip between the separation pawl and the fusing belt.
  - If the MAX thickness plate cannot slip between the separation pawl and fusing belt , no further adjustment is necessary.
  - If the MAX thickness plate can slip between the separation pawl and fusing belt , repeat from Step 5 to reduce the gap.
8. Repeat this procedure from Step 4 for every separation pawl.
9. After the gaps have been adjusted for every pawl, reinstall the MIN and MAX thickness plates.

---

## Important Warning about Thermostats

---

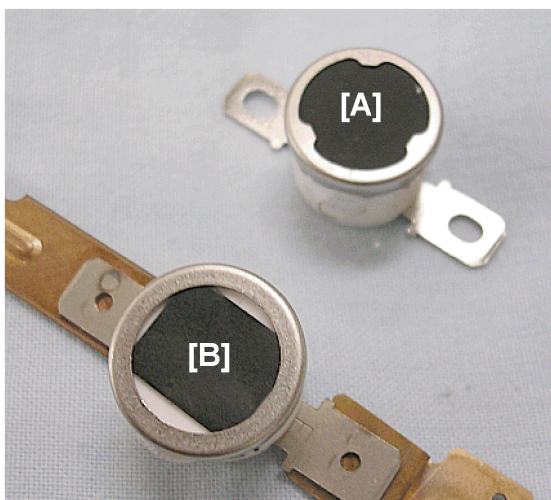

ra\_0978

The old type of thermostat [A] has been replaced with a new type of thermostat [B]. The new type has a rectangular cover with exposed edges.

### **WARNING**

- Never attempt to reset a blown thermostat by manipulating the edges of the black cover with a screw driver. Resetting a thermostat manually could cause a failure to detect overheating in the fusing unit and cause a fire hazard.

## Boards

---

### PCB Layout

---

#### Controller Box Closed

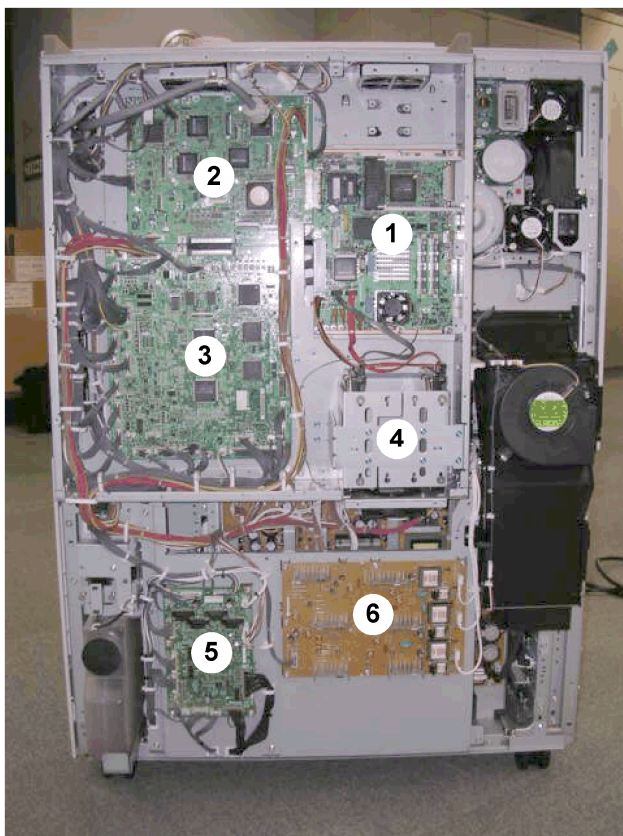

ra\_1097

①	Controller Board
②	IPU Board
③	VBCU Board
④	HDD Unit
⑤	PFB (Paper Feed Board)
⑥	HVPS (High Voltage Power Supply)



### Controller Box Open

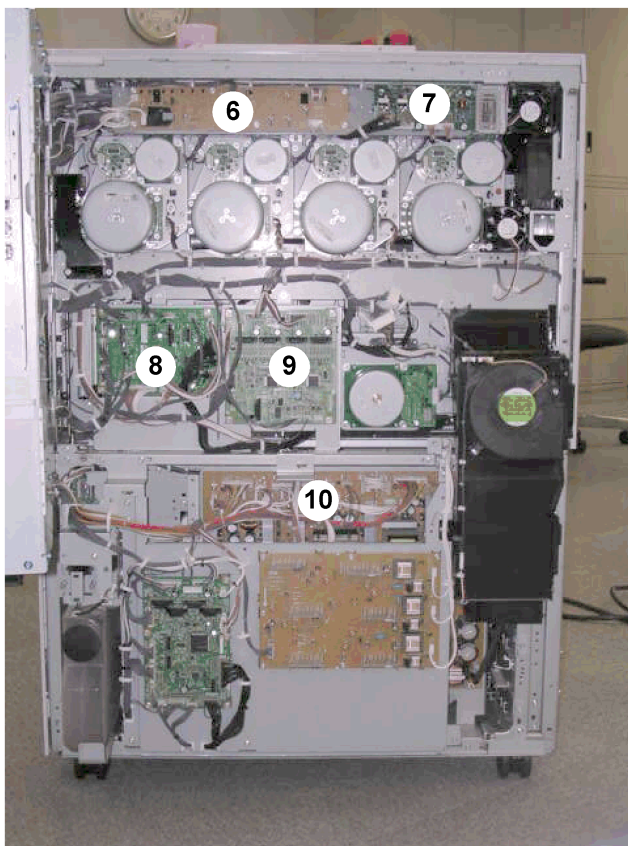

ra\_1098

⑥	Charge Roller Power Pack
⑦	Potential Sensor Power Pack
⑧	DRB (Motor Drive Board)
⑨	DTMB (Drum Transfer Motor Board)
⑩	PSU

### Left Lower Cover Removed



temp\_0875

⑪	AC Drive Board
---	----------------

### Controller

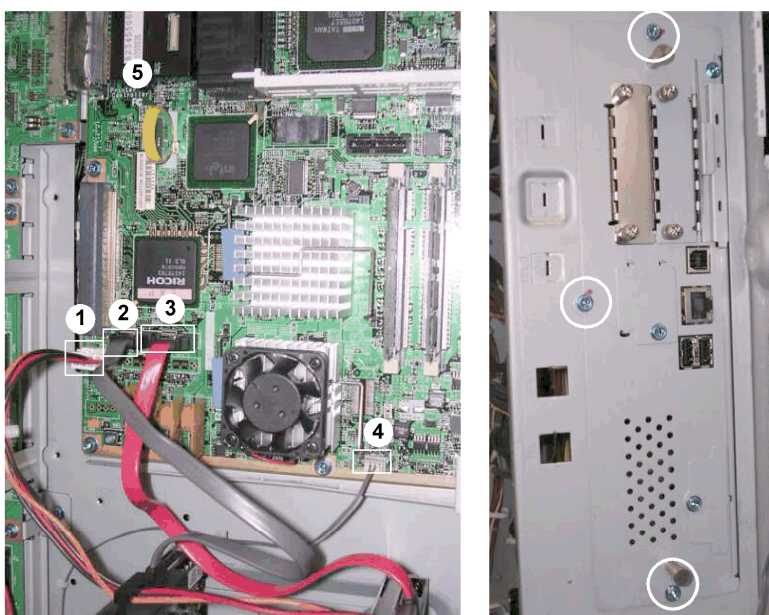

ra\_1099

#### ★ Important

- The controller box cover should always be removed so that the controller board can be disconnected before removal of the controller board.
- Never attempt to pull the controller unit out of the machine until you have removed the box cover and disconnected the controller board.
- If you attempt to pull the controller unit out of the machine without first disconnecting the board, you will break or damage the connectors.

1. Remove the controller box cover (🔧 x16)
2. Disconnect four connectors , , , (🔧 x4).
3. Remove the screws (🔧 x3).
4. Remove the controller board.

#### When installing the new controller board

#### ★ Important

- The machine will issue SC195 (Machine Serial Number Error) if you fail to do the procedure below.

1. Remove the NVRAMs from the old controller board. (See previous illustration.)
2. Install them on the new controller board after you replace the controller board.
3. Replace the NVRAMs if the NVRAM on the old controller board is defective.

#### ↓ Note

- Make sure you print out the SMC reports ("SP Mode Data" and "Logging Data")

## Replacement and Adjustment

---

before you replace the NVRAMs.

### CAUTION

- Keep NVRAMs away from any objects that can cause static electricity. Static electricity can damage NVRAM data.
- Make sure the NVRAMs are correctly installed on the controller board.
- Make sure that the DIP-switch settings on the old controller board are the same for the new controller board. Do not change the DIP switches on the controller board in the field.

## After installing the controller board

---

1. For a model without a HDD, do **SP5846-052** to copy back the address book to the flash ROM on the controller board from the SD card to which you have already copied the address book data if possible.
2. For a model in which the HDD encryption unit has been installed, restoring the encryption key is required. Refer to "Recovery from a Device Problem" in the installation procedure for the HDD Encryption Unit.
3. Turn the main power switch off/on.

## IPU/VBCU

---

### IPU/VBCU Removal

---

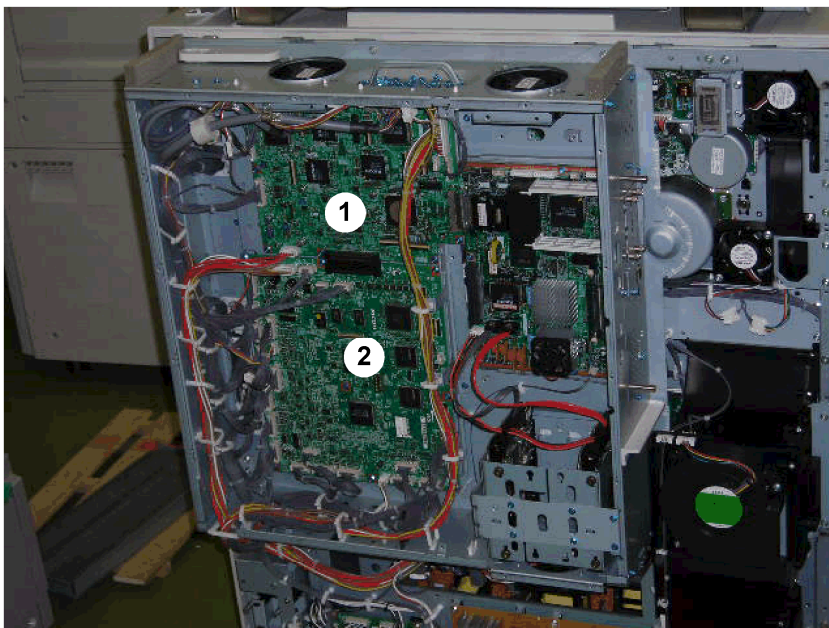

temp\_0866

### Before You Begin...

## Replacement and Adjustment

---

- The IPU and VBCU are connected and mounted on same plate. They must be removed together.
- The controller board must be removed before the IPU/VBCU can be removed.

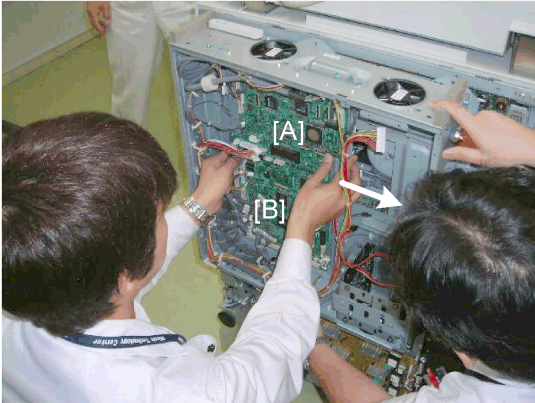

temp\_1001

1. Remove the controller board.
2. Disconnect the boards.  
[A] IPU (🔌 x8)  
[B] VBCU (🔌 x26)
3. Slide the plate with the boards attached to the right.

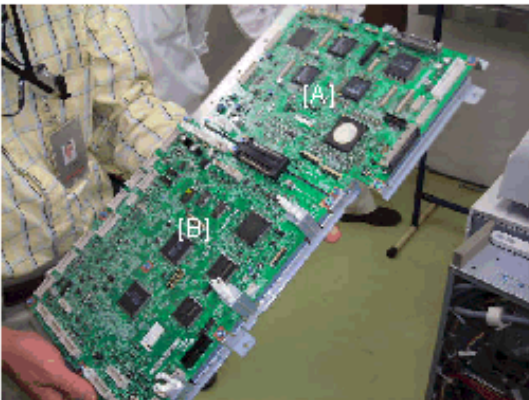

temp\_1003

4. Remove the boards from the frame.  
[A] IPU (🔑 x8)  
[B] VBCU (🔑 x9)

## Replacement and Adjustment

### VBCU Replacement

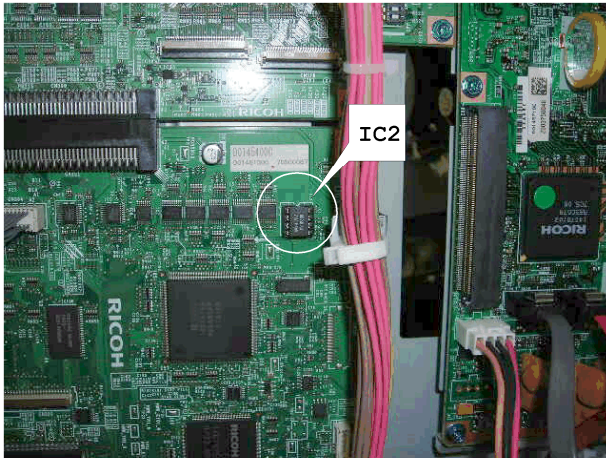

d014r501

1. Remove the EEPROM from the old VBCU. (The EEPROM shown above is marked "IC2" with a notation on the board.)
2. Install the EEPROM on the new VBCU.
3. Set the DIP SW (SW2) for the machine as shown below.

D014/D015-17      D014/D015-26, -27, -66

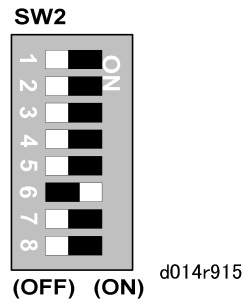
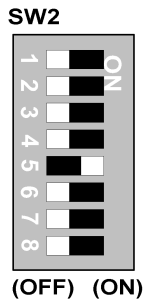

d014r915

## HDD

The HDD contains two separate hard disks (160 Gigabytes each x2 = 320 Gigabytes).

**★ Important**

- The two disks are always replaced together as a unit. Never attempt to replace a single disk.

Before replacing the HDD unit

Copy the address book data to an SD card from the HDD with **SP5846-051** if possible.

## Replacement and Adjustment

---

### Replacement Procedure

---

1. Remove:
  - Rear covers
  - Controller box cover
2. Mark the harness connectors before you disconnect them:
  - Gray: Left
  - Red: Right

**★ Important**

- The connectors fit either socket but they must be connected in the correct order as shown above: Gray: Left, Red: Right
- If the connections are reversed, the machine will issue an error at startup.
- If this occurs just reconnect the HDD correctly and start again. The HDD will not be damaged by such an incorrect startup.

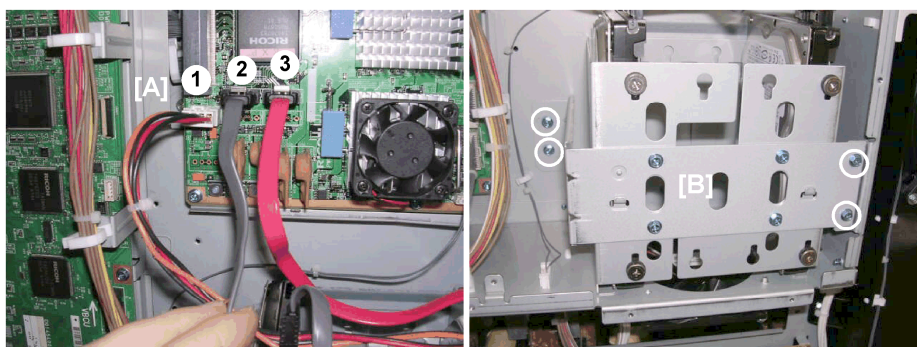

ra\_1101

1. Disconnect the HDD unit from the controller board [A] (🔧 x3).
2. Remove the HDD unit [B] (🔧 x4).

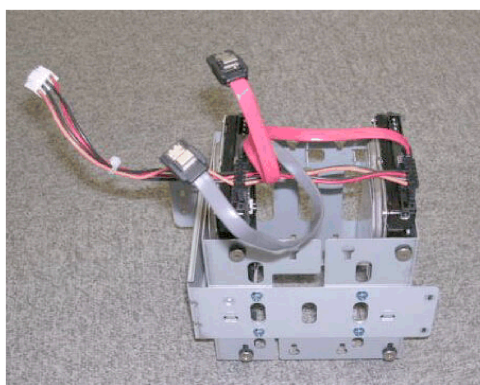

ra\_1103

3. Install the new HDD unit.
4. Reassemble the machine.
5. Enter the SP mode and do SP5832-1 to format the hard disks.



- Formatting the hard disks is recommended, even if they have already been formatted.
6. Do SP5853-1 to download the fixed stamps from the ROM to the HDD.
  7. Cycle the machine power off/on to enable the fixed stamps for use.

### After installing the new HDD unit

---

1. Do **SP5832-001** to format the hard disk.
2. Do **SP5853-001** to copy the preset stamp data from the firmware to the hard disk.
3. Do **SP5846-052** to copy back the address book to the hard disk from the SD card to which you have already copied the address book data if possible.
4. Turn the main power switch off/on.

### Disposal of HDD Units

- Never remove an HDD unit from the work site without the consent of the client.
- If the customer has any concerns about the security of any information on the HDD, the HDD must remain with the customer for disposal or safe keeping.
- The HDD may contain proprietary or classified (Confidential, Secret) information. Specifically, the HDD contains document server documents and data stored in temporary files created automatically during copy job sorting and jam recovery. Such data is stored on the HDD in a special format so it cannot normally be read but can be recovered with illegal methods.

### Reinstallation

- Explain to the customer that the following information stored on the HDD is lost when the HDD is replaced: document server documents, fixed stamps, document server address book
- The address book and document server documents (if needed) must be input again.
- If the customer is using the Data Overwrite Security or the Data Encryption feature, these applications must be installed again. For more, see Section "1. Installation".
- If the customer is using the HDD Encryption Unit, the encryption key must be restored after replacing the HDD unit. For details, see the installation procedure for the HDD Encryption Unit.



## Replacement and Adjustment

---

### PFB

---



ra\_1104

1. Remove the PFB (🔧 x14, 🛠️ x6).

### HVPS

---

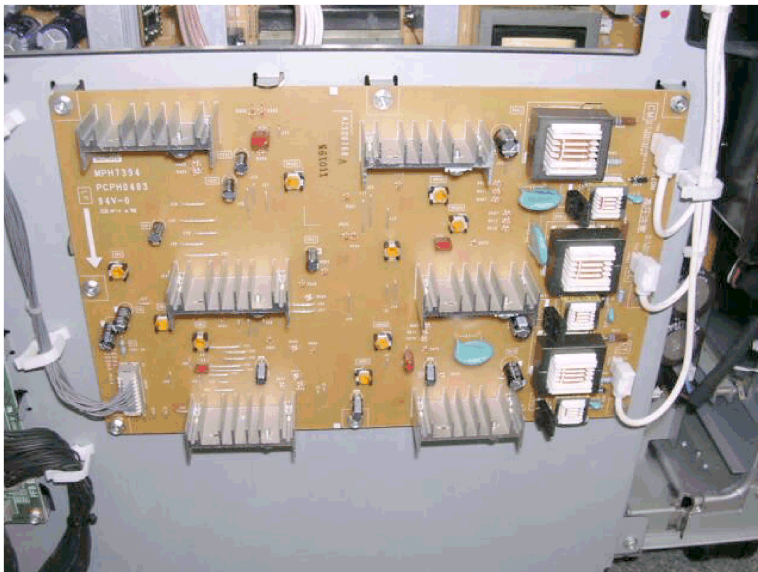

ra\_1105

1. Remove the HVPS (🔧 x4, 🛠️ x8).

## Replacement and Adjustment

### Charge Roller Power Pack

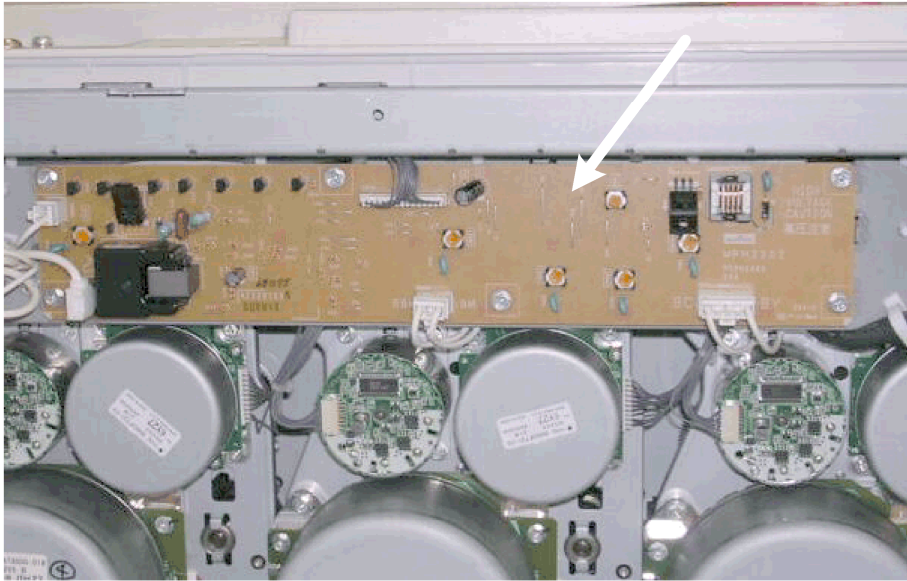

ra\_1106

1. Remove the charge roller power pack (🔧 x5, 🛠️ x6).

### Potential Sensor Power Pack

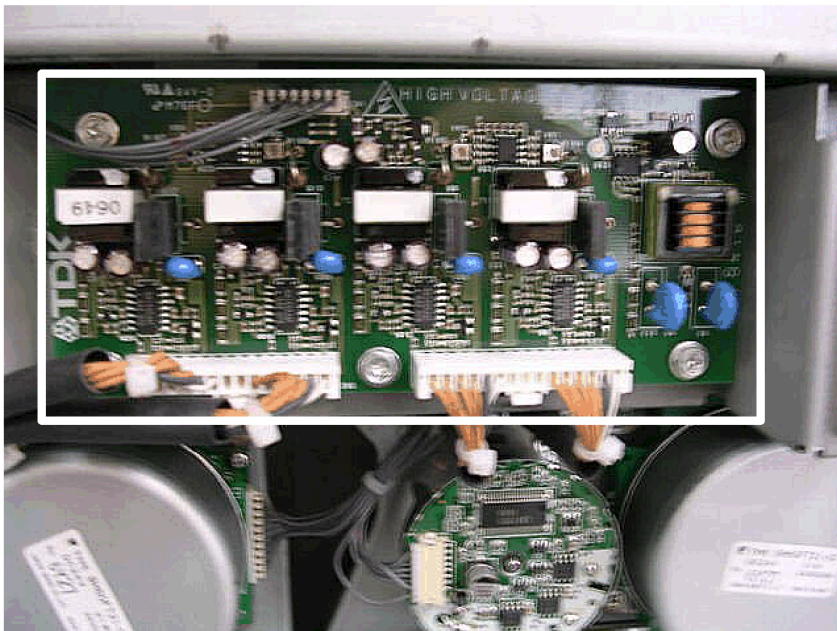

ra\_1108

1. Remove the potential sensor power pack (🔧 x3, 🛠️ x5).

DRB

---

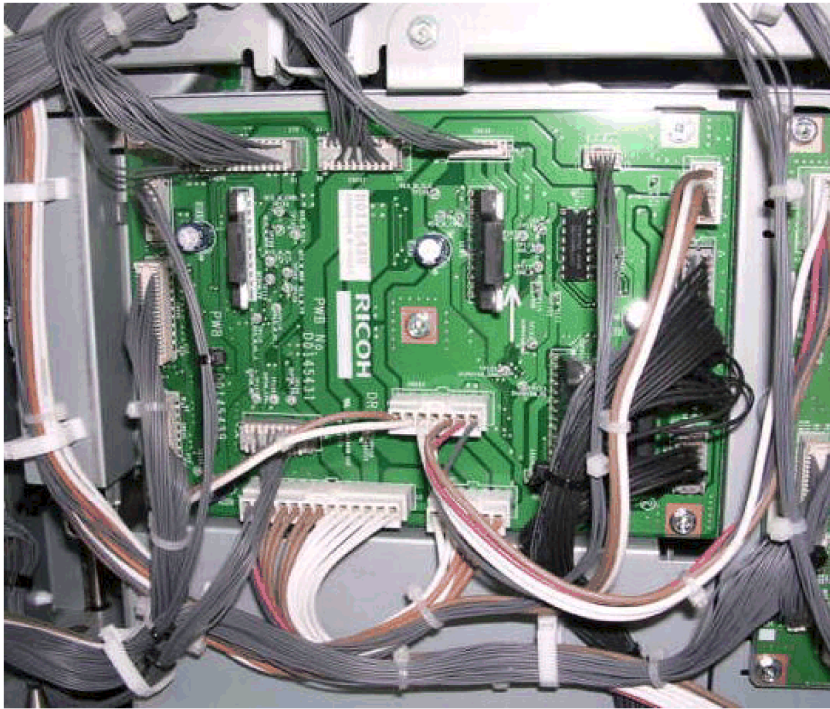

ra\_1109

1. Remove the DRB (🔧 x14, 🛠️ x5).

DTMB

---

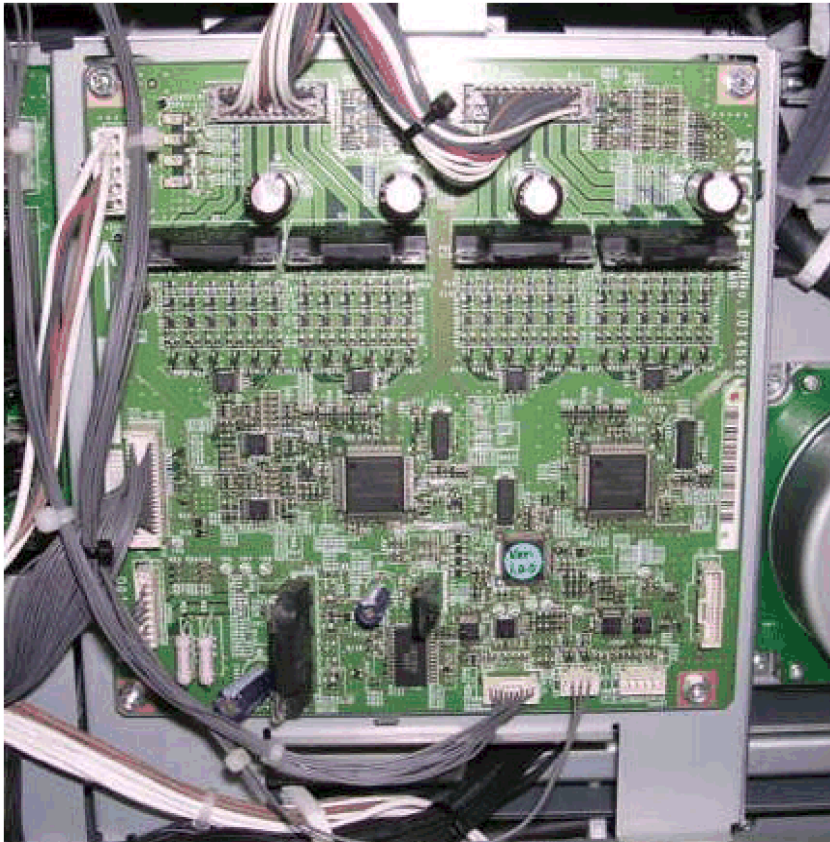

ra\_1112

1. Remove the DTMB (🔧 x7, 🛠️ x4).

---

PSU

---

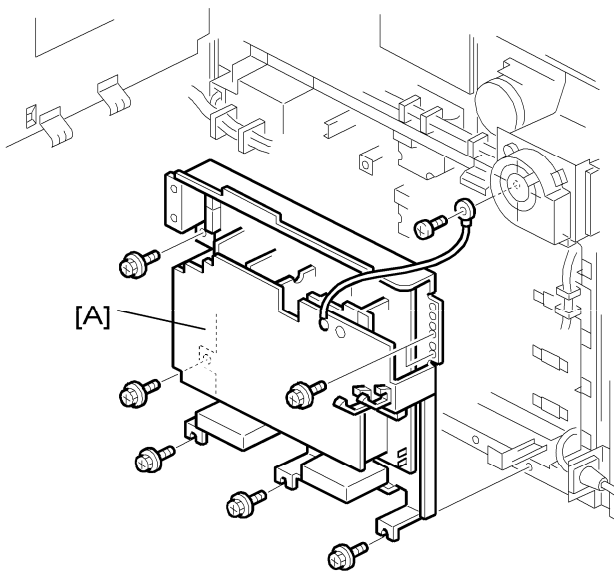

ra\_1112a

## Replacement and Adjustment

---

1. Remove the rear covers.
2. Open the controller box door.
3. Remove the PFB/HVPS board frame.
4. Remove:  
[A] PSU (🔧 x9, 🛠️ x8).

---

## AC Drive Board

---

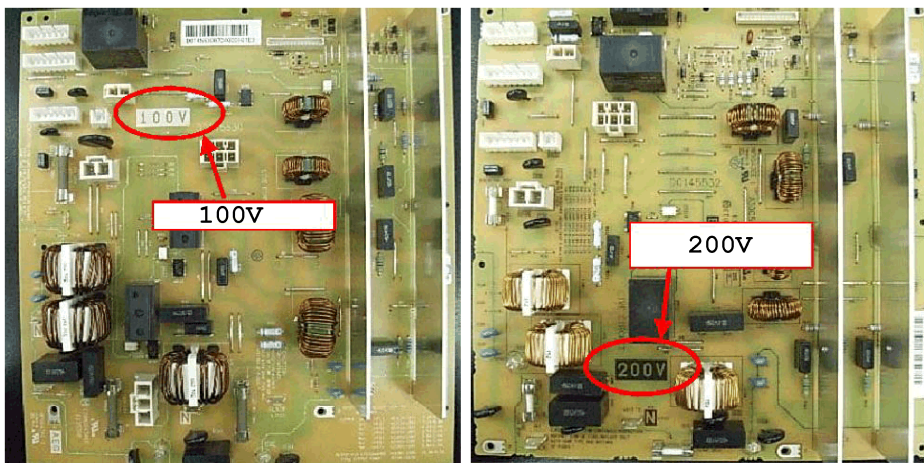

d014r505

1. Make sure that you have to correct type of board for the machine.
  - There are two types of AC drive boards: 100V and 200V.
  - The boards are clearly marked at the locations shown above.
  - Confirm the marking before installing the AC drive board.
2. Remove the AC drive board (🔧 x7, 🛠️ x8).

### Memory

---

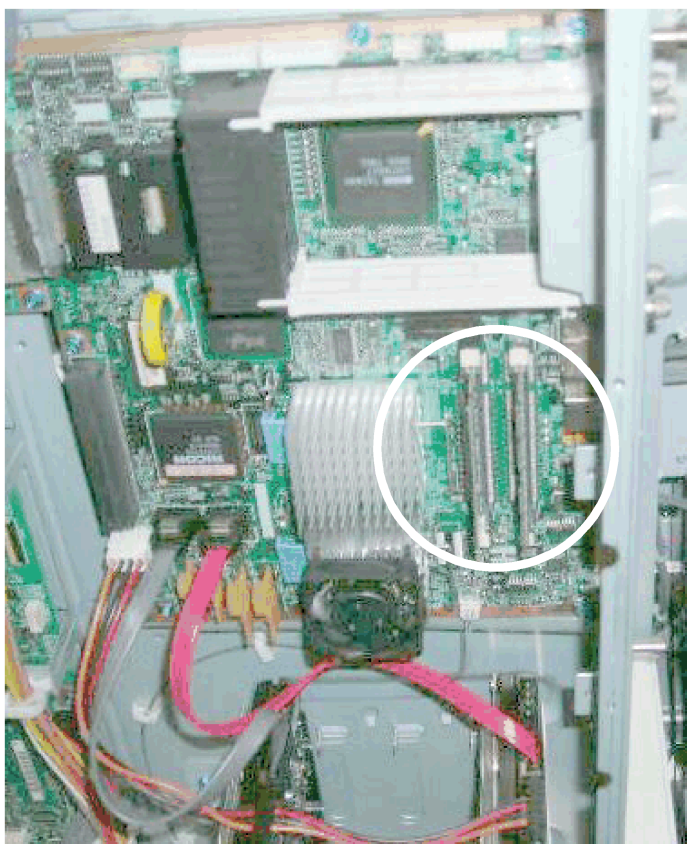

temp\_0869

1. Install memory chips.

---

### NVRAM

---

#### Before You Begin...

---

- Never remove the NVRAM until you have uploaded its contents.
- Always touch a metal surface to discharge any static on your hands before you touch the controller board.
- Work carefully when removing the NVRAM to avoid damaging other components on the controller board or short circuiting the pins of other chips.

#### Upload NVRAM Data to SD Card

---

1. Do SP5990 001 to print the SMC report.
2. Turn the copier main power switch off.
3. Insert an SD card in Slot 2
4. Execute SP5824 to upload the data to the SD card.

## Replacement and Adjustment

---

5. Switch the machine off and disconnect the power cord.

### Replace NVRAM

---

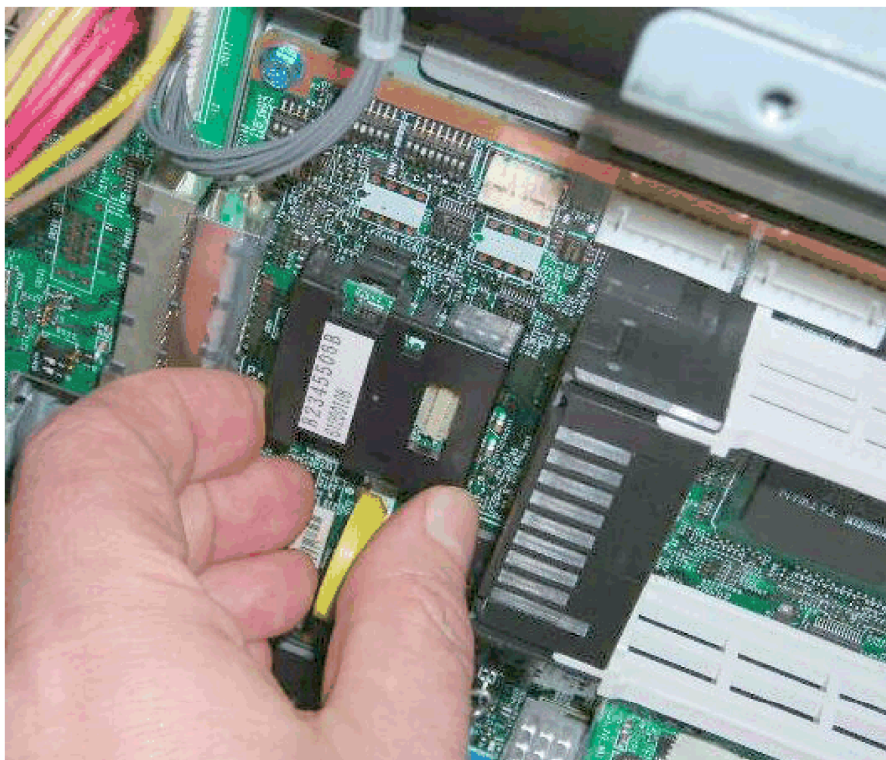

temp\_1022

1. Remove the old NVRAM.
2. Attach the new NVRAM.

### Download NVRAM Data from SD Card

---

1. Turn the copier main power switch off.
2. Put the SD card with the NVRAM data into Slot 2.
3. Open the front door of the copier.
4. Turn the copier main power switch on.

If the NVRAM is new, SC195 (Machine Serial Number Error) may appear. If this occurs:

- Enter the SP mode and do SP5801 001 to reset the memory to the defaults (All).
- Switch the machine off/on and start from Step 1.

#### **★ Important**

- **If SC195 occurs the serial number must be input. You must contact your technical supervisor.**
5. Execute SP5825 to download the data uploaded from the old NVRAM.

## Replacement and Adjustment

---

6. Switch the machine off and remove the SD card.
7. Switch the machine on, then do SP5990-1 to print another SMC report.
8. Compare this new SMC report with the report you printed in Step 1. If any of the SP settings are different, enter the SP settings of the first report.
9. Execute SP5907 and enter the brand and model name of the machine for Windows Plug & Play capability.



## Motors

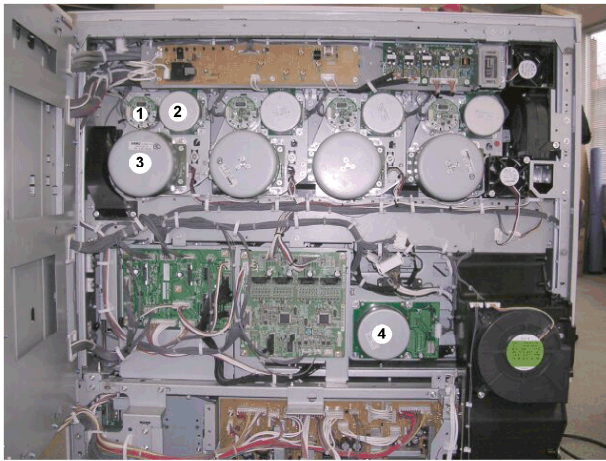

ra\_0001

①	Development Motor
②	Drum Cleaning Motor
③	Drum Motor
④	Paper Transfer Motor

1. Remove the rear covers.
2. Open and lock the controller box.

### Drum Cleaning Motors

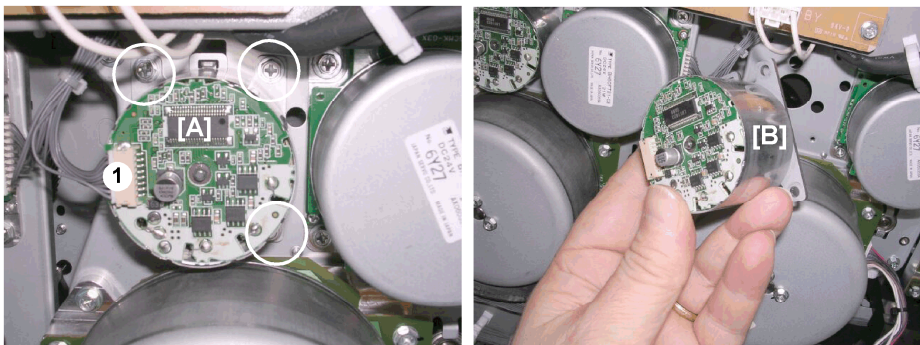

ra\_0005

1. Disconnect the drum cleaning motor [A] (⚙️ x1, 🔧 x3).

## Replacement and Adjustment

---

2. Remove the drum cleaning motor [B].

## Development Motors

---

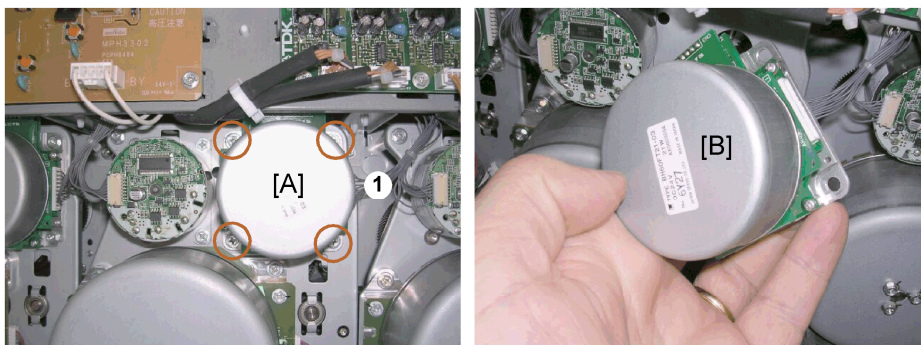

ra\_0009

1. Disconnect the development motor [A] (🔌 x1, 🛠️ x4).
2. Remove the development motor [B].

## Drum Motor

---

### Drum Motor Removal

---

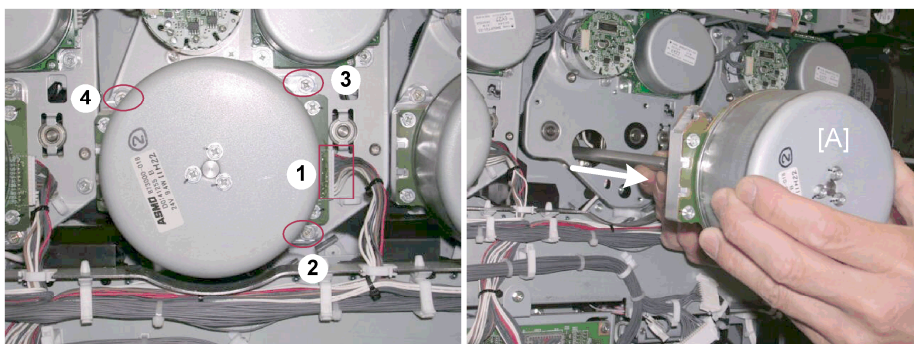

ra\_1045

1. Remove the Toner Hopper, Faceplate, PCU.
2. Disconnect the connector (🔌 x1).
3. Remove screws , , (🛠️ x3).
4. Remove the ITB unit.

#### ⬇️ Note

- Removing the ITB unit is recommended to prevent the tip of the drum motor shaft from scratching the surface of the ITB when the motor is removed or

## Replacement and Adjustment

---

reinstalled.

5. Pull out the motor [A] with its drive shaft.

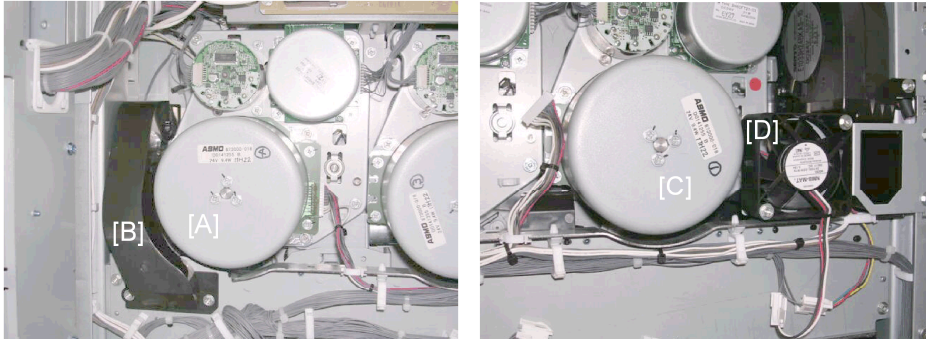

ra\_1052

### ★ Important

- In order to remove the K PCU motor [A], you must first loosen the duct [B].
- Before removing the Y PCU motor [C], you must first loosen the fan [D].

## Drum Motor Reinstallation

---

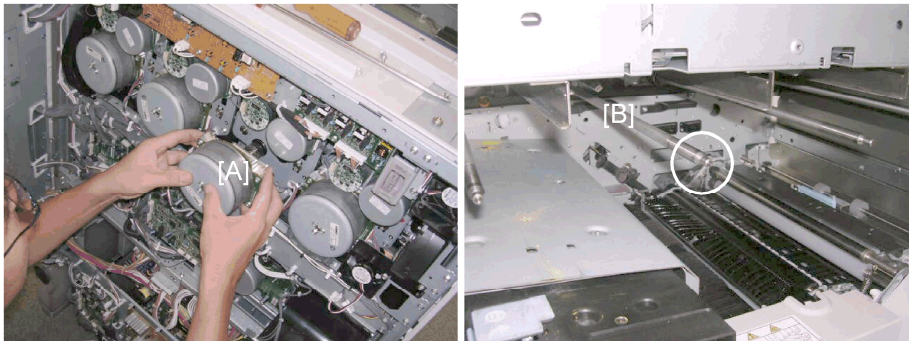

ra\_1059

1. Push the shaft into the machine and set the motor [A], so that it is straight.
2. Attach the screws and tighten them only halfway. This leaves the motor shaft loose so it can float slightly.
3. Check the front of the machine and confirm that the shaft [B] is straight.

## Replacement and Adjustment

---

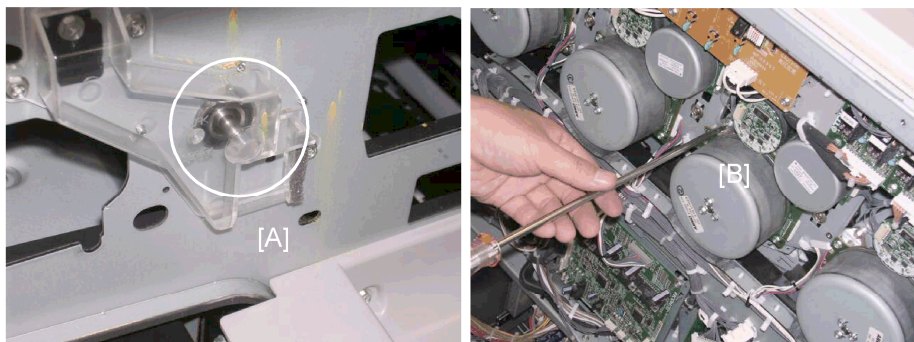

ra\_1063

4. At the front, set the faceplate set the shaft [A] as shown above.
5. Fasten the faceplate with its screws (🔩 x3).
6. At the back, tighten the screws (🔩 x3) of the drum motor [B] and attach its connector (🔌 x1).

---

## Fusing/Exit Motor

---

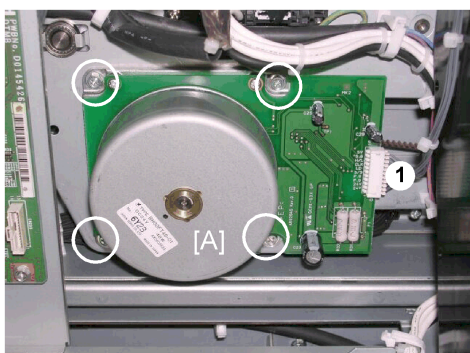

ra\_0006

1. Remove the paper transfer motor [A] (🔌 x1, 🔩 x4).

---

## PTR Motor

---

Remove the rear covers.

Open the controller box door.

## Replacement and Adjustment

---

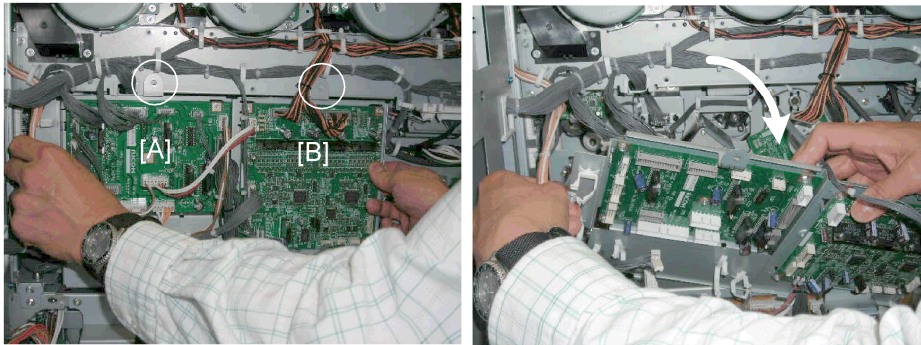

d014r510

Remove the plate that holds the DRB [A] and DTMB [B] (⚙️ x2, 🔧 x all)

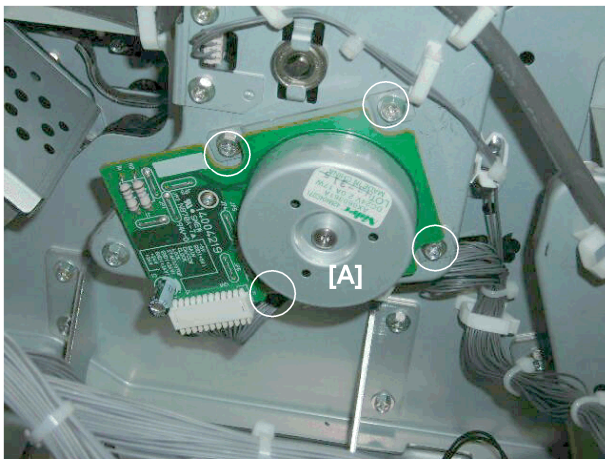

d014r511

1. Remove the PTR motor [A] (⚙️ x4, 🔧 x1).

---

## ITB Drive Motor

---

1. Remove the rear covers.  
Open the controller box door.

## Replacement and Adjustment

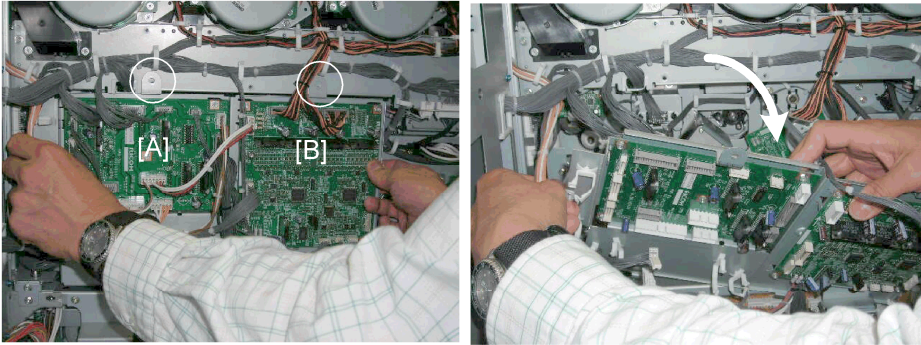

d014r510

Remove the plate that holds the DRB [A] and DTMB [B] (⚙️ x2, 🔌 x All)

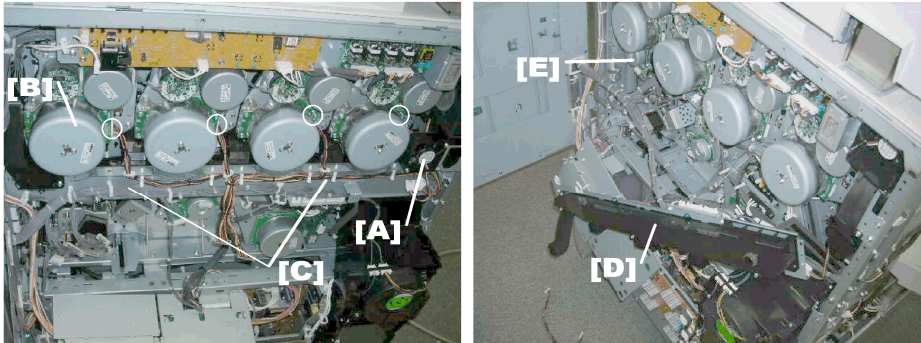

d014r520

1. Remove the fan plate with fan [A] attached (⚙️ x2).
2. Disconnect the drum motors [B] (🔌 x4).
3. Disconnect the cross-brace [C]. (There are two screws on each end of the cross-brace.)

### ★ Important

- Do not release the harnesses that are permanently locked. Release only enough harnesses so you can pull the cross-brace [D] away from the machine so that you can see the ITB motor [E].

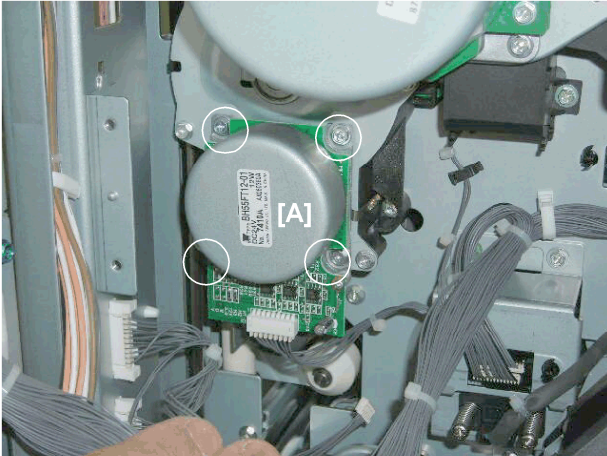

d014r521

4. Remove the ITB drive motor [A] (🔩 x4, 🛠️ x1).

## Air Filters and Ozone Filters

---

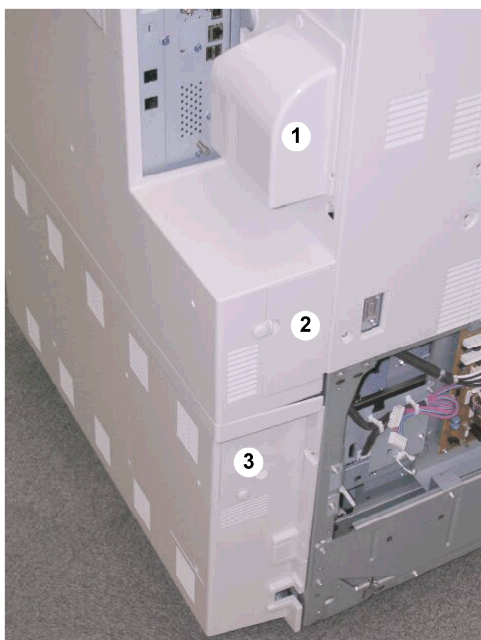

ra\_0030

①	Upper Filter Box
②	Middle Filter Box
③	Lower Filter Box

This machine has three filter boxes on the left rear corner. These boxes contain air filters and one ozone filter each.



## Replacement and Adjustment

### Upper Filter Box

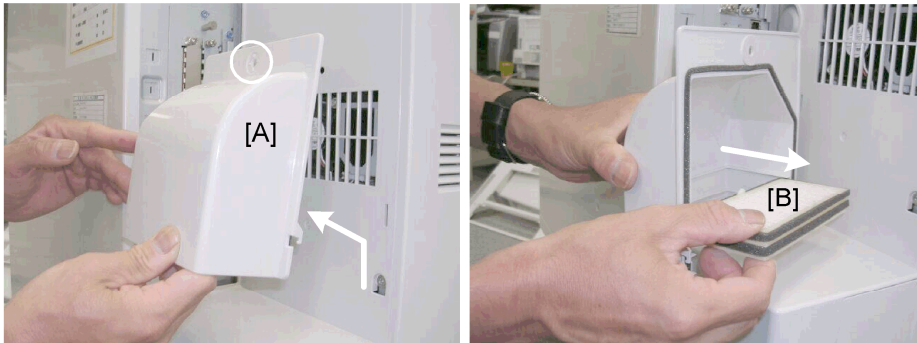

ra\_0028

1. Remove:
  - [A] Upper filter box cover (🔑 x1)
  - [B] Air filters

### Middle Filter Box

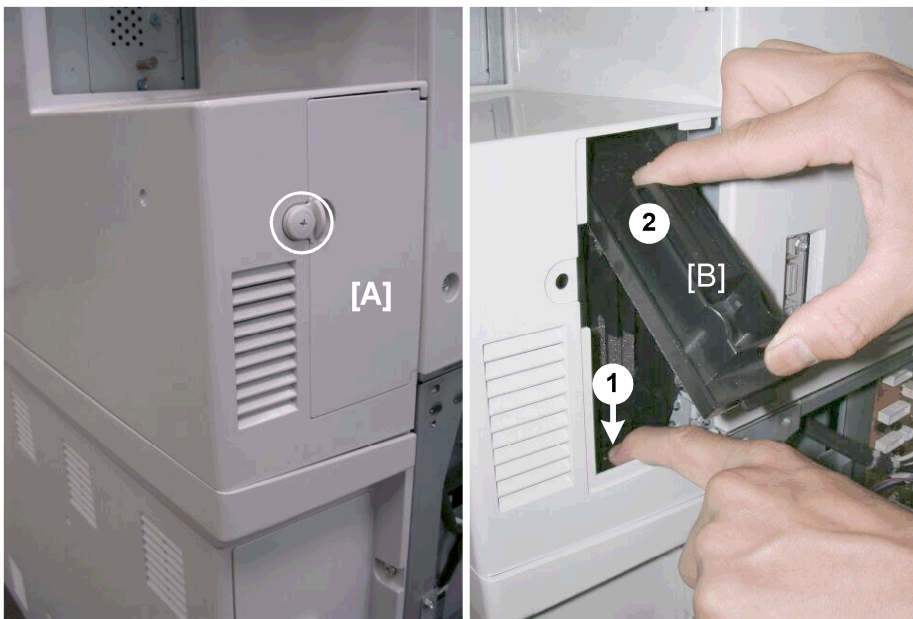

ra\_0015

1. Remove:
  - [A] Middle filter box cover (🔑 x1)
  - [B] Inner cover. Depress at 1 then pull out 2.

## Replacement and Adjustment

---

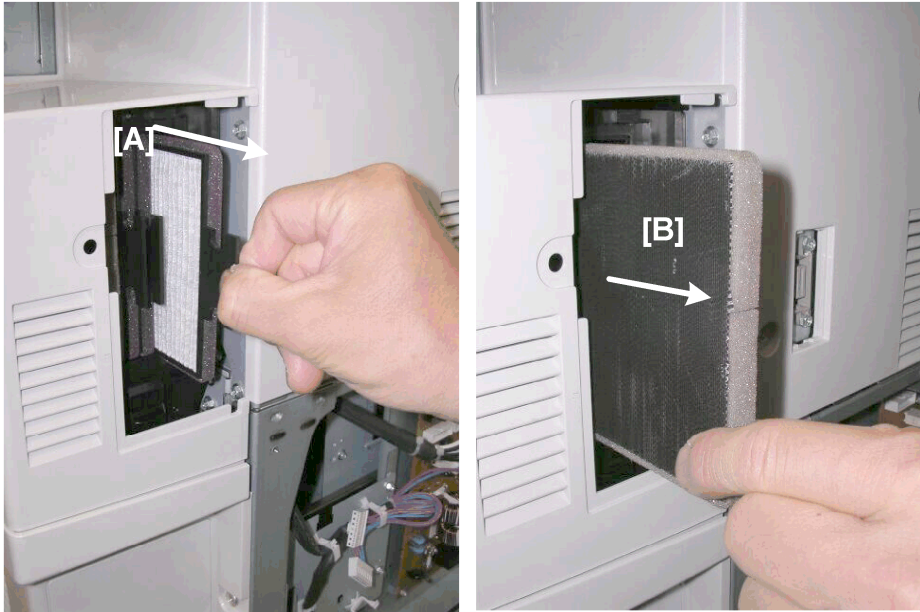

ra\_0019

2. Remove:
  - [A] Air filters
  - [B] Ozone filter

## Lower Filter Box

---

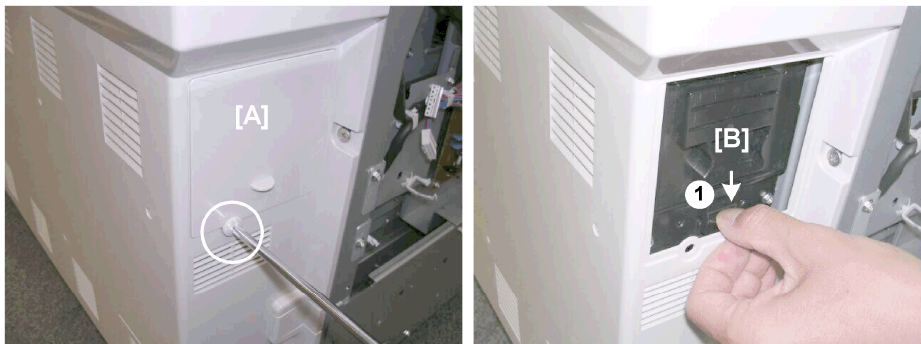

ra\_0021

1. Remove:
  - [A] Lower filter box cover (🔩 x1)
  - [B] Inner cover. Depress at **1** then remove.

## Replacement and Adjustment

---

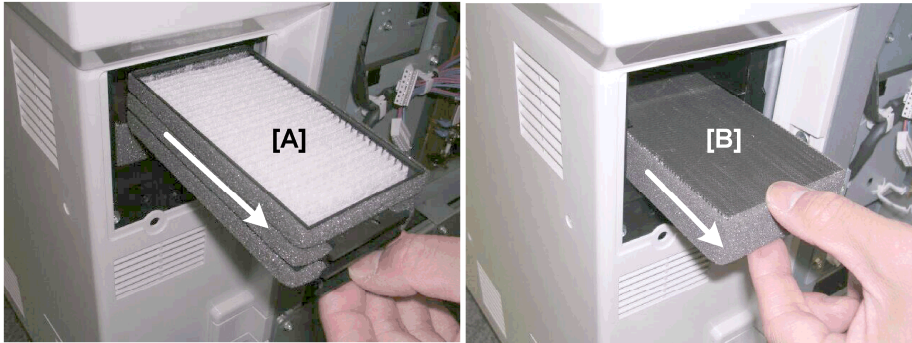

ra\_0025

2. Remove:
  - [A] Air filters
  - [B] Ozone filter

---

## Firmware Update

---

---

### Before You Begin...

---

Always obey these rules when handling and using SD cards:

- Never connect or remove an SD card with the machine on.
- Never turn the power off while the machine is downloading data from an SD card.
- The SD card is a precision item. Use it carefully. Do not keep the card in a location where there is high temperature, high humidity, or light from the sun.
- Handle SD cards carefully to avoid bending, scratching, or dropping them.
- If a power failure occurs during the firmware update, turn the machine power off/on without removing the SD card. The firmware update procedure should start again.

---

### Firmware Update Procedure

---

1. Obtain the System SD card.
2. Disconnect the network cable and other interface cables. This prevents outside interference caused by data transfers to the machine while the software is being uploaded.
3. Turn the main switch off.
4. Remove the SD card slot cover (🔑x1).
5. Insert the SD card into Slot 1 (lower slot).
6. Open the front door of the copier. This prevents generation of electrical noise from motors during the update procedure.

You will see "Please Wait" then "Preparing to start firmware update."

The first screen appears after about 90 sec.

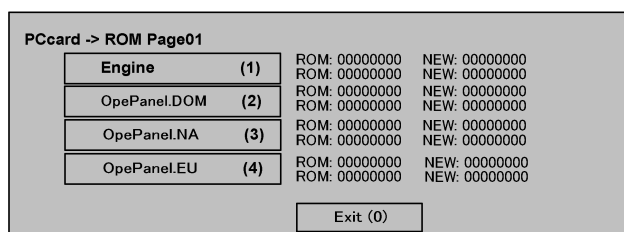

d014r912

7. Check the notations to the right.
  - "ROM" tells you the module number and version of the currently installed software.
  - "NEW" tells you the module number and version of software on the SD card in Slot 1 (lower slot).

## Replacement and Adjustment

---

8. Touch "Engine" or "OpePanel.xxx". The item that you select changes to dark gray.



- You can select "Engine" and one "OpePanel" selection if you want to update both

9. Touch [Update] or push [#] on the 10-key pad to start the update.

While the Update Is in Progress

- Remain with the machine. Do not leave it unattended.
- Never close the front door during firmware update.
- The [Start] key flashes RED during firmware update, and then lights GREEN when the update is finished.
- When the [Start] key LED starts flashing rapidly, this means the update is almost finished.
- Never switch the machine off while the [Start] key is flashing RED.
- If the machine is switched off or accidentally unplugged before the update is finished, do not remove the SD card. Just switch the machine on again. The firmware update should restart automatically. If the firmware update does not recover, obtain a new System SD card.

The following screen sequence appears after selecting one "OpePanel" selected for update.

### Operation Panel Update

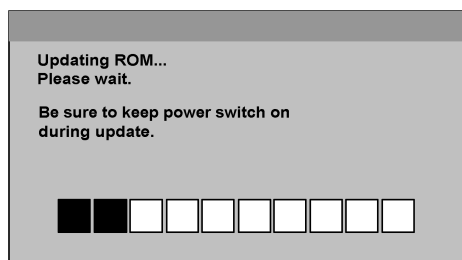

- The blocks of the progress bar fill as the update is done.
- The update requires about 9 to 10 minutes.

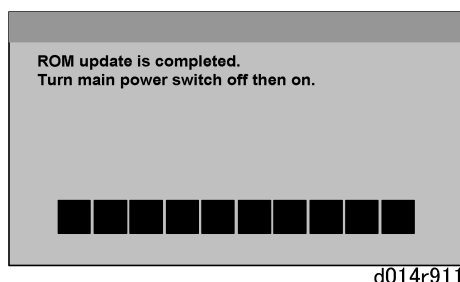

- When you see the 'update completed' message, the firmware update is complete.

### Engine Update

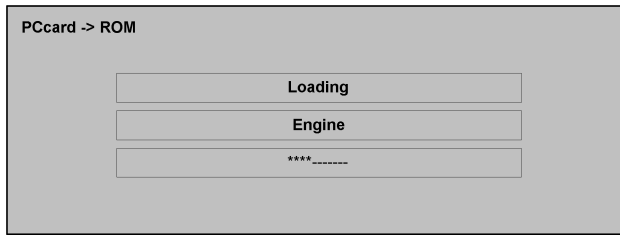

d014r913

- The middle bar tells you the name of the item that you are updating.
- The bottom bar shows the progress of the update procedure.

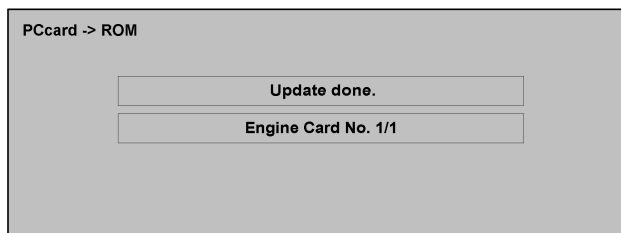

d014r914

- The update is complete when you see the "Update done" message.
  - The update requires about 2.5 minutes.
10. When you see the update completed message, turn the machine off.
  11. Remove the SD card from the SD card slot.
  12. Switch the machine on.  
This completes the update procedure.

# Troubleshooting

---

## Service Call Conditions

---

### Service Call Table

---

There are 4 levels of service call conditions.

Level	Definition	Reset Procedure
A	Fusing unit SCs are displayed on the operation panel. The machine is disabled, and operator cannot reset the SC.	Enter SP mode and do SP5810 to release the machine for servicing.
B	SCs that disable only the features that use the defective item. These SCs are not shown to the operator under normal conditions. They are displayed on the operation panel only when the defective feature is selected.	Turn the main power switch off and on.
C	SCs that are not shown on the operation panel. They are internally logged.	Logging only
D	Turning the operation switch (or main power switch) off then on resets these SCs. These SCs are displayed on the operation panel and displayed again if the error reoccurs.	Turn the operation switch (or main power switch) off and on, or the machine reboots automatically. (See below.)

#### When a Level "D" SC code occurs

When a Level D SC occurs, a screen opens on the operation panel to tell the operator:

- An error occurred
- The job in progress will be erased
- The machine will reboot automatically after approximately 30 seconds.

The operator can wait until the machine reboots automatically or touch "Reset" on the screen to reset the machine immediately and go back to the copy screen.

#### If the operator does not touch "Reset"

## Troubleshooting

---

The next message tells the operator that the machine will reset automatically and that the previous job was lost and must be started again. After reading the message, the operator touches "Confirm" on the screen. The next screen shows the number and title of the SC code, and stops until the operator turns the machine off and on.

### If the operator touches "Reset"

If the operator touches "Reset" to bypass the 30-second interval for the machine to reboot, the machine reboots immediately and the operation panel displays the copy screen.



- Do not try to use the operation panel during an automatic reboot. If the Remote Service System is in use, the SC code is sent immediately to the Service Center

---

## SC Code Descriptions

---

### Before You Begin...

- If a problem concerns a circuit board, disconnect and reconnect the connectors and then test the machine. Often a loose or disconnected harness is the cause of the problem. Always do this before you decide to replace the PCB.
- If a motor lock error occurs, check the mechanical load before you decide to replace the motor or sensors.
- When a Level "A" or "B" SC occurs while in an SP mode, the machine cannot display the SC number. If this occurs, check the SC number after leaving the SP mode.
- The machine reboots automatically when the machine issues a Level "D" SC code. This is done for Level "D" SC codes only.

### CAUTION

- Never turn off the main power switch when the power LED is lit or flashing. To avoid damaging the hard disk or memory, press the operation switch to switch the power off, wait for the power LED to go off, and then switch the main power switch off.

The main power LED () lights or flashes while the platen cover or ARDF is open, while the main machine is communicating with a facsimile or the network server, or while the machine is accessing the hard disk or memory for reading or writing data.



## Service Call Tables

### SC Codes Group 1: Scanning

SC101	D	Exposure lamp error	
		The white level peak did not reach the prescribed threshold when the white plate was scanned.	<ul style="list-style-type: none"> <li>▪ Dirty optics</li> <li>▪ Dirty white plate</li> <li>▪ Exposure lamp defective</li> <li>▪ Exposure lamp does not turn on</li> <li>▪ Lamp stabilizer defective</li> <li>▪ High voltage line leak</li> <li>▪ SIB defective</li> <li>▪ SBU defective</li> </ul>
SC120	D	Scanner home position error 1	
		The scanner home position sensor did not detect the home position (did not go OFF) after the scanner moved forward 20 mm..	<ul style="list-style-type: none"> <li>▪ Scanner motor defective</li> <li>▪ Scanner HP sensor defective</li> <li>▪ Harness between scanner motor and SIOB disconnected or broken.</li> <li>▪ SIOB defective</li> </ul>
SC121	D	Scanner home position error 2	
		The scanner home position sensor did not go ON after the scanner moved forward 6 mm and the feeler entered the HP sensor.	<ul style="list-style-type: none"> <li>▪ Scanner motor harness loose, broken, defective</li> <li>▪ Scanner motor defective</li> <li>▪ Scanner HP sensor disconnected, defective</li> <li>▪ SIOB defective</li> </ul>
SC141	D	Black level detection error	

## Troubleshooting

		During AGC the value for black level was not within $\pm 3$ of the prescribed value.	<ul style="list-style-type: none"> <li>▪ SBU defective</li> <li>▪ Harness defective</li> <li>▪ Check harnesses between SBU and IPU</li> <li>▪ IPU defective</li> <li>▪ VBCU defective</li> </ul>
SC142	D	White level detection error	
		During AGC the value for white level was not within -7 of the prescribed value.	<ul style="list-style-type: none"> <li>▪ Exposure lamp defective</li> <li>▪ Harness disconnected, damaged</li> <li>▪ Dirty exposure glass, optics</li> <li>▪ Scanner motor, drive assembly defective</li> <li>▪ SBU board defective</li> </ul>
SC143	C	SBU Auto Adjust Error	
		At power on the automatic white level adjustment failed.	<ul style="list-style-type: none"> <li>▪ Clean the white plate</li> <li>▪ Clean the optics and lenses</li> <li>▪ Check the connectors between the SBU and IPU.</li> <li>▪ Replace the SBU</li> <li>▪ Replace the IPU</li> <li>▪ Replace the VBCU</li> <li>▪ Replace the exposure lamp</li> </ul>
SC144	D	SBU communication error	
		When the machine is switched on, or when the machine returns to full operation from the energy save mode, the machine can not access the SBU register, or the SBU	<ul style="list-style-type: none"> <li>▪ SBU harness loose, disconnected, defective</li> <li>▪ SBU board defective</li> <li>▪ VBCU defective</li> </ul>

## Troubleshooting

		<p>register values are abnormal.</p> <p><b>Note:</b> The ASIC IDs read during automatic adjustment of the SBU can be displayed with SP4600.</p>	
SC161	D	IPU error	
		<p>Communication error between IPU, SBU, and VBCU.</p>	<ul style="list-style-type: none"> <li>▪ Check harness connections between SBU and IPU/VBCU</li> <li>▪ IPU defective</li> <li>▪ VBCU defective</li> </ul>
SC165	B	Illegal Copy Prevention Error	
		<p>An abnormality was detected with the ICIB board at power on.</p>	<ul style="list-style-type: none"> <li>▪ ICIB connected incorrectly</li> <li>▪ ICIB defective</li> </ul>
SC180	D	Scanner fan lock	
		<p>The fan motor next to the SIOB did not switch on within 10 sec. after the CPU issued the ON signal.</p>	<ul style="list-style-type: none"> <li>▪ Fan defective</li> <li>▪ Foreign object interfering with operation of fan</li> <li>▪ Motor harness loose, disconnected, or broken</li> <li>▪ SIOB defective</li> </ul>
SC181	B	Scanner Fan Error: Lamp Stabilizer	
		<p>The exposure lamp regulator fan is not rotating.</p>	<ul style="list-style-type: none"> <li>▪ Check the fan connections</li> <li>▪ Fan defective</li> <li>▪ Check SBU connection</li> <li>▪ Check SIOB connection</li> <li>▪ SBU defective</li> </ul>

## Troubleshooting

			<ul style="list-style-type: none"> <li>▪ SIOB defective</li> </ul>
SC182	B	Scanner Fan Error: Right Side	
		The fan located on the right side of the exposure unit is not rotating.	<ul style="list-style-type: none"> <li>▪ Check the fan connections</li> <li>▪ Fan defective</li> <li>▪ Check SBU connection</li> <li>▪ Check SIOB connection</li> <li>▪ SBU defective</li> <li>▪ SIOB defective</li> </ul>
SC195	D	Machine serial number error	
		The number registered for the machine serial number does not match.	<ul style="list-style-type: none"> <li>▪ Confirm the correct serial number of the machine in the specifications</li> </ul> <p><b>Important:</b> When SC195 occurs, the serial number must be input. Please contact your technical supervisor.</p>

## SC Codes Group 2: Exposure

SC202	D	Polygon motor error: ON timeout	
		The polygon mirror motor does not reach the targeted operating speed within the prescribed time.	<ul style="list-style-type: none"> <li>▪ Harness to polygon motor drive board disconnected, defective</li> <li>▪ Polygon motor defective</li> <li>▪ Polygon motor drive board defective</li> <li>▪ Polygon motor defective.</li> </ul>
SC203	D	Polygon motor error: OFF timeout	
		The polygon mirror motor does leave the READY status within 3 seconds after the polygon	<ul style="list-style-type: none"> <li>▪ Harness to polygon motor driver board disconnected, defective</li> <li>▪ Polygon motor defective</li> </ul>

## Troubleshooting

		motor switches off.	<ul style="list-style-type: none"> <li>▪ Polygon motor driver board defective</li> <li>▪ Polygon motor defective.</li> </ul>
--	--	---------------------	--

SC204	D	Polygon motor error: XSCRDY signal error	
		The polygon motor stopped operating while the LD unit was firing.	<ul style="list-style-type: none"> <li>▪ Harness to polygon motor driver board disconnected, defective</li> <li>▪ Polygon motor defective</li> <li>▪ Polygon motor driver board defective</li> </ul>

SC210	D	Laser beam detection error: K (Black)	
SC211	D	Laser beam detection error: Y (Yellow)	
SC212	D	Laser beam detection error: M (Magenta)	
SC213	D	Laser beam detection error: C (Cyan)	
		The laser synchronization sensor failed to detect the beginning and end of the laser beam flash for the designated color onto the polygon mirror while the mirror is rotating at the prescribed number of revolutions.	<ul style="list-style-type: none"> <li>▪ Laser synchronization detector sensor connection loose, not connected</li> <li>▪ Laser synchronization detector sensor defective</li> <li>▪ LD unit defective</li> <li>▪ IPU defective</li> <li>▪ VBCU defective</li> </ul>

SC220	D	Laser Synchronization Detector Error: K Leading Edge: LD0	
		While the polygon motor is rotating normally, no synchronizing detection signal is output for LD0 black, or leading edge, even after the laser diode has been firing for	<ul style="list-style-type: none"> <li>▪ Harness between the laser synchronizing detector and I/F unit is disconnected, defective</li> <li>▪ Check all connections between LD unit, LDB, IPU</li> <li>▪ LD unit</li> </ul>

## Troubleshooting

		2 sec.	<ul style="list-style-type: none"> <li>▪ LDB defective</li> <li>▪ IPU defective</li> </ul>
--	--	--------	--

SC221	D	Laser Synchronization Detector Error: K Leading Edge (Not LD0)	
		<p>While the polygon motor is rotating normally, no synchronizing detection signal is output for black, leading edge for any LD other than LD0.</p>	<ul style="list-style-type: none"> <li>▪ Harness between the laser synchronizing detector and I/F unit is disconnected, defective</li> <li>▪ Check all connections between LD unit, LDB, IPU</li> <li>▪ LD unit</li> <li>▪ LDB defective</li> <li>▪ IPU defective</li> </ul>

SC222	D	Laser Synchronization Detector Error: Y Leading Edge: LD0	
		<p>While the polygon motor is rotating normally, no synchronizing detection signal is output for LD0 yellow, leading edge.</p>	<ul style="list-style-type: none"> <li>▪ Harness between the laser synchronizing detector and I/F unit is disconnected, defective</li> <li>▪ Check all connections between LD unit, LDB, IPU</li> <li>▪ LD unit</li> <li>▪ LDB defective</li> <li>▪ IPU defective</li> </ul>

SC223	D	Laser Synchronization Detector Error: Y Leading Edge (Not LD0)	
		<p>While the polygon motor is rotating normally, no synchronizing detection signal is output for yellow, leading edge for any LD other than LD0.</p>	<ul style="list-style-type: none"> <li>▪ Harness between the laser synchronizing detector and I/F unit is disconnected, defective</li> <li>▪ Check all connections between LD unit, LDB, IPU</li> <li>▪ LD unit</li> <li>▪ LDB defective</li> <li>▪ IPU defective</li> </ul>

SC224	D	Laser Synchronization Detector Error: M Leading Edge: LD0	
		<p>While the polygon motor is rotating normally, no synchronizing detection signal is output for LD0 magenta, leading edge.</p>	<ul style="list-style-type: none"> <li>▪ Harness between the laser synchronizing detector and I/F unit is disconnected, defective</li> <li>▪ Check all connections between LD unit, LDB, IPU</li> <li>▪ LD unit</li> <li>▪ LDB defective</li> <li>▪ IPU defective</li> </ul>

SC225	D	Laser Synchronization Detector Error: M Leading Edge (Not LD0)	
		<p>While the polygon motor is rotating normally, no synchronizing detection signal is output for magenta, leading edge for any LD other than LD0.</p>	<ul style="list-style-type: none"> <li>▪ Harness between the laser synchronizing detector and I/F unit is disconnected, defective</li> <li>▪ Check all connections between LD unit, LDB, IPU</li> <li>▪ LD unit</li> <li>▪ LDB defective</li> <li>▪ IPU defective</li> </ul>

SC226	D	Laser Synchronization Detector Error: C Leading Edge: LD0	
		<p>While the polygon motor is rotating normally, no synchronizing detection signal is output for LD0 cyan, leading edge.</p>	<ul style="list-style-type: none"> <li>▪ Harness between the laser synchronizing detector and I/F unit is disconnected, defective</li> <li>▪ Check all connections between LD unit, LDB, IPU</li> <li>▪ LD unit</li> <li>▪ LDB defective</li> <li>▪ IPU defective</li> </ul>

SC227	D	Laser Synchronization Detector Error: C Leading Edge (Not LD0)	
-------	---	--	--

## Troubleshooting

		While the polygon motor is rotating normally, no synchronizing detection signal is output for cyan, leading edge for any LD other than LD0.	<ul style="list-style-type: none"> <li>▪ Harness between the laser synchronizing detector and I/F unit is disconnected, defective</li> <li>▪ Check all connections between LD unit, LDB, IPU</li> <li>▪ LD unit</li> <li>▪ LDB defective</li> <li>▪ IPU defective</li> </ul>
SC230	D	FGATE error: Feedback remains HIGH for K write	
		After the start of timing to create the black image, the PFGATE register of the GAVD did not assert.	<ul style="list-style-type: none"> <li>▪ Harness between the VBCU and LDB unit disconnected, loose, or defective.</li> <li>▪ LD unit defective</li> <li>▪ IPU defective</li> <li>▪ Controller board disconnected, defective</li> <li>▪ HDD defective</li> </ul>
SC231	D	FGATE error: Feedback remains LOW for K write	
		After the start of timing to create the black image, the PFGATE register of the GAVD did not assert.	<ul style="list-style-type: none"> <li>▪ Harness between the VBCU and LDB unit disconnected, loose, or defective.</li> <li>▪ LD unit defective</li> <li>▪ IPU defective</li> <li>▪ Controller board disconnected, defective</li> <li>▪ HDD defective</li> </ul>
SC232	D	FGATE error: Feedback remains HIGH for Y write	
		After the start of timing to create the yellow image, the PFGATE register of the	<ul style="list-style-type: none"> <li>▪ Harness between the VBCU and LDB unit disconnected, loose, or defective.</li> <li>▪ LD unit defective</li> </ul>



## Troubleshooting

		GAVD did not assert.	<ul style="list-style-type: none"> <li>▪ IPU defective</li> <li>▪ Controller board disconnected, defective</li> <li>▪ HDD defective</li> </ul>
--	--	----------------------	--

SC233	D	FGATE error: Feedback remains LOW for Y write	
		<p>After the start of timing to create the yellow image, the PFGATE register of the GAVD did not assert.</p>	<ul style="list-style-type: none"> <li>▪ Harness between the VBCU and LDB unit disconnected, loose, or defective.</li> <li>▪ LD unit defective</li> <li>▪ IPU defective</li> <li>▪ Controller board disconnected, defective</li> <li>▪ HDD defective</li> </ul>

SC234	D	FGATE error 1: Feedback remains HIGH for M write	
		<p>After the start of timing to create the magenta image, the PFGATE register of the GAVD did not assert.</p>	<ul style="list-style-type: none"> <li>▪ Harness between the VBCU and LDB unit disconnected, loose, or defective.</li> <li>▪ LD unit defective</li> <li>▪ IPU defective</li> <li>▪ Controller board disconnected, defective</li> <li>▪ HDD defective</li> </ul>

SC235	D	FGATE error: Feedback remains LOW for M write	
		<p>After the start of timing to create the magenta image, the PFGATE register of the GAVD does not assert.</p>	<ul style="list-style-type: none"> <li>▪ Harness between the VBCU and LDB unit disconnected, loose, or defective.</li> <li>▪ LD unit defective</li> <li>▪ IPU defective</li> <li>▪ Controller board disconnected, defective</li> <li>▪ HDD defective</li> </ul>

## Troubleshooting

SC236	D	FGATE error 1: Feedback remains HIGH for C write	
		<p>After the start of timing to create the cyan image, the PFGATE register of the GAVD did not assert.</p>	<ul style="list-style-type: none"> <li>▪ Harness between the VBCU and LDB unit disconnected, loose, or defective.</li> <li>▪ LD unit defective</li> <li>▪ IPU defective</li> <li>▪ Controller board disconnected, defective</li> <li>▪ HDD defective</li> </ul>

SC237	D	FGATE error: Feedback remains LOW for C write	
		<p>After the start of timing to create the cyan image, the PFGATE register of the GAVD does not assert.</p>	<ul style="list-style-type: none"> <li>▪ Harness between the VBCU and LDB unit disconnected, loose, or defective.</li> <li>▪ LD unit defective</li> <li>▪ IPU defective</li> <li>▪ Controller board disconnected, defective</li> <li>▪ HDD defective</li> </ul>

SC240	C	LD error: K	
SC241	C	LD error: Y	
SC242	C	LD error: M	
SC243	C	LD error: C	
		<p>An error occurred at the LD error terminal of the K, Y, M, or C LD driver after initialization of the LD because the power to the LD was higher or lower than the prescribed limit.</p>	<ul style="list-style-type: none"> <li>▪ LD defective due to wear, damage, short circuit</li> <li>▪ LDB harness disconnected, loose or defective</li> </ul>

SC268	C	Optical unit sensor error	
-------	---	---------------------------	--

## Troubleshooting

		At power on, one of the two temperature sensors in the optics unit detected a temperature lower than -10°C. -or- It detected a temperature higher than 80°C.	<ul style="list-style-type: none"> <li>▪ Thermistor disconnected (causes extremely low temperature reading)</li> <li>▪ Thermistor damaged and short circuited (causes extremely high temperature reading)</li> <li>▪ VBCU defective</li> </ul>
SC270	C	Skew Control Upper Lower Limit: Y	
		The pulse total for Yellow skew control is not within the prescribed range.	<ul style="list-style-type: none"> <li>▪ ITB not installed correctly.</li> <li>▪ ITB defective</li> <li>▪ Optical unit installed incorrectly</li> <li>▪ Optical unit defective</li> </ul>
SC271	C	Skew Control Upper Lower Limit: M	
		The pulse total for Magenta skew control is not within the prescribed range.	<ul style="list-style-type: none"> <li>▪ ITB not installed correctly.</li> <li>▪ ITB defective</li> <li>▪ Optical unit installed incorrectly</li> <li>▪ Optical unit defective</li> </ul>
SC272	C	Skew Control Upper Lower Limit: C	
		The pulse total for Cyan skew control is not within the prescribed range.	<ul style="list-style-type: none"> <li>▪ ITB not installed correctly.</li> <li>▪ ITB defective</li> <li>▪ Optical unit installed incorrectly</li> <li>▪ Optical unit defective</li> </ul>
SC285	C	MUSIC Continuous Failure	
		The MUSIC adjustment failed after four attempts.	<ul style="list-style-type: none"> <li>▪ Fusing belt installed incorrectly</li> <li>▪ Fusing belt surface scoured, scratched</li> <li>▪ MUSIC sensors dirty, defective</li> </ul>

SC Codes Group 3: Image Development – 1

SC300	D	Drum charge corona wire error: K	
		The output of the charge corona wire of the black PCU is abnormal.	<ul style="list-style-type: none"> <li>▪ CGB power pack connection loose, broken defective</li> <li>▪ Check CGB power pack connection to BCU</li> <li>▪ CGB power pack defective</li> <li>▪ BCU defective</li> <li>▪ Replace OPC drum</li> </ul>

SC301	D	AC charge output error: M	
SC302	D	AC charge output error: C	
SC303	D	AC charge output error: Y	
		An interrupt checks the status of the power pack every 10 ms. This SC is issued if the VBCU detects a short in the AC charge for M, C, Y.	
		<ul style="list-style-type: none"> <li>▪ Disconnect the high voltage cable from Terminal C of the multiple high-voltage supply board.</li> <li>▪ Attach a voltmeter to the terminal.</li> <li>▪ If there is no output from the terminal, replace the high voltage power supply.</li> </ul> <p>-or-</p> <ul style="list-style-type: none"> <li>▪ If there is output from the terminal, test the resistance between the high voltage cable and the ground. If resistance is nearly "0", check the high-voltage harness for defects and replace it if necessary.</li> <li>▪ Test the conductivity between the OPC unit and the ground. If there is no conductivity between the OPC unit and ground, replace the OPC unit.</li> <li>▪ If there is no charge PWM signal, replace the harness and/or VBCU.</li> </ul>	

## Troubleshooting

SC304	B	Charge Corona Error: Charge Leak (K PCU)	
		A abnormal detection signal (H) was detected for longer than 250 ms.	<ul style="list-style-type: none"> <li>▪ Turn the machine power off/on</li> <li>▪ CGB power pack harness connectors loose, broken, defective</li> <li>▪ Corona wire caps loose, missing</li> <li>▪ CGB power pack defective</li> <li>▪ Charge corona unit connectors loose, broken, defective</li> </ul>

SC308	C	Charge Corona Error: Wire Cleaner Error (K PCU)	
		The charge corona wire cleaner motor remained locked after the motor was switched on, or failed to switch off within the prescribed time after cleaning started.	<ul style="list-style-type: none"> <li>▪ Turn the machine power off/on</li> <li>▪ Motor overloaded due to a physical obstruction</li> <li>▪ Motor defective</li> </ul>

SC313	D	Charge, development error: M	
SC314	D	Charge, development error: C	
SC315	D	Charge, development error: Y	
		After the M, C, or Y drum started to rotate, the feedback for the charge unit of the color dropped below 0.3V.	<ul style="list-style-type: none"> <li>▪ Make sure that the settings of SP2202 are at the defaults.</li> <li>▪ Check harness connections between charge roller and transfer power pack.</li> <li>▪ Defective charge roller</li> <li>▪ Defective power pack</li> </ul>

SC316	C	Drum Charge Error: K	
SC317	C	Drum Charge Error: M	

## Troubleshooting

SC318	C	Drum Charge Error: C	
SC319	C	Drum Charge Error: Y	
		Drum charge output voltage (Vpp) exceeded 2.8 kV.	<ul style="list-style-type: none"> <li>▪ Check the connections of the charge unit of the PCU where the problem occurred.</li> <li>▪ Replace the charge unit of the PCU (CBG power pack for the K PCU, charge roller unit for YMC PCUs)</li> </ul>

SC320	D	Development power pack error: K	
SC321	D	Development power pack error: M	
SC322	D	Development power pack error: C	
SC323	D	Development power pack error: Y	
		This SC is issued if the VBCU detects a short in the development DC charge for K, M, C, Y.	<ul style="list-style-type: none"> <li>▪ Development power pack defective</li> <li>▪ High voltage power supply defective</li> <li>▪ High voltage power supply harness defective</li> <li>▪ Development unit defective</li> <li>▪ IOB harness disconnected or defective</li> <li>▪ IOB defective</li> </ul>
		<ul style="list-style-type: none"> <li>▪ Disconnect the high voltage cable from Terminal B of the high-voltage supply board.</li> <li>▪ Attach a voltmeter to the terminal.</li> <li>▪ If there is no output from the terminal, replace the high voltage power supply.</li> </ul> <p>-or-</p> <ul style="list-style-type: none"> <li>▪ If there is output from the terminal, test the resistance between the</li> </ul>	

## Troubleshooting

		<p>high voltage cable and the ground.</p> <ul style="list-style-type: none"> <li>▪ If resistance is "0" or nearly "0", check the high-voltage harness for defects and replace it if necessary.</li> <li>▪ If replacing the harness does not solve the problem,</li> <li>▪ Test the resistance between the development unit terminal and the ground. If there is no resistance (0Ω) between the development unit and the ground, replace the development unit.</li> <li>▪ If there is no development PWM signal, replace the harness and/or IOB.</li> </ul>
--	--	--

SC324	D	Development motor error: K	
SC325	D	Development motor error: M	
SC326	D	Development motor error: C	
SC327	D	Development motor error: Y	
		<p>The PLL lock signal remained HIGH or LOW for longer than the prescribed time for the K, M, C, or Y, development motor.</p>	<ul style="list-style-type: none"> <li>▪ Development motor shaft locked, blocked by obstruction</li> <li>▪ Development motor defective</li> <li>▪ DRB defective</li> </ul>

SC336	D	Developer set error: K	
SC337	D	Developer set error: M	
SC338	D	Developer set error: C	
SC339	D	Developer set error: Y	
		<p>The value of Vcnt is set at the maximum or minimum setting when the TD sensor is initialized.</p>	
		<ol style="list-style-type: none"> <li>1. Open the front door.</li> <li>2. Pull out the film seal from the black, magenta, cyan, or yellow developer bottle.</li> <li>3. Do the correct SP for the affected color:</li> </ol>	

## Troubleshooting

		<ul style="list-style-type: none"> <li>▪ SP3801 003 to initialize the TD sensor for K.</li> <li>▪ SP3801 004 to initialize the TD sensor for M.</li> <li>▪ SP3801 005 to initialize the TD sensor for C.</li> <li>▪ SP3801 006 to initialize the TD sensor for Y</li> </ul>
--	--	---

SC348	D	Toner supply motor error	
		2 sec. after the motor START signal is output, a LOCK signal cannot be detected.	<ul style="list-style-type: none"> <li>▪ Motor harness disconnected, loose, or defective</li> <li>▪ Toner pump overload</li> <li>▪ Sub hopper overload</li> <li>▪ Toner hopper motor defective</li> </ul>

SC350	B	Developer Fill Error: K
SC351	B	Developer Fill Error: M
SC352	B	Developer Fill Error: C
SC353	B	Developer Fill Error: Y
		The PCU failed to fill with developer from the developer bottle when SP3814-1 was executed.
		<ul style="list-style-type: none"> <li>▪ Developer bottle not set correctly</li> <li>▪ Developer in the bottle is clogged and not flowing</li> </ul> <p><b>Note:</b> For detailed information about how to handle problems developer filling, see "Handling Problems with Developer Filling" under "PCU" in Section 3.</p>

SC360	D	TD sensor (Vt high) error: K
SC361	D	TD sensor (Vt high) error: M
SC362	D	TD sensor (Vt high) error: C
SC363	D	TD sensor (Vt high) error: Y
		The Vt value of the black, magenta, cyan, or yellow TD sensor exceeds 0.5V for



## Troubleshooting

	10 counts.
	<ul style="list-style-type: none"> <li>▪ Black, magenta, cyan, or yellow TD sensor disconnected</li> <li>▪ Harness between TD sensor and PCU defective</li> <li>▪ Defective TD sensor, replace the PCU</li> </ul> <p><b>Note:</b> The TD sensor cannot be replaced independently. The PCU must be replaced if the TD sensor is defective.</p>

SC364	D	TD sensor (Vt low) error: K
SC365	D	TD sensor (Vt low) error: M
SC366	D	TD sensor (Vt low) error: C
SC367	D	TD sensor (Vt low) error: Y
	The Vt value of the black, magenta, cyan, or yellow TD sensor is below 0.5V for 10 counts.	
	<ul style="list-style-type: none"> <li>▪ TD sensor harness disconnected, loose, defective</li> <li>▪ A drawer connector (located on the rear of a development unit) disconnected, loose, defective</li> <li>▪ TD sensor defective, replace the PCU</li> </ul> <p><b>Note:</b> The TD sensor cannot be replaced independently. The PCU must be replaced if the TD sensor is defective.</p>	

SC372	D	TD sensor adjustment error: K
SC373	D	TD sensor adjustment error: M
SC374	D	TD sensor adjustment error: C
SC375	D	TD sensor adjustment error: Y
	During TD sensor initialization with SP3801, the output value of the black, magenta, cyan, or yellow TD sensor is not within the range of $2.5 \pm 0.2V$	
	TD harness sensor disconnected, loose or defective Harness between TD sensor and drawer disconnected, defective	

## Troubleshooting

	<ul style="list-style-type: none"> <li>▪ TD sensor defective, replace the PCU</li> </ul> <p><b>Note:</b> The TD sensor cannot be replaced independently. The PCU must be replaced if the TD sensor is defective.</p>
--	--

SC396	D	Drum motor error: K
SC397	D	Drum motor error: M
SC398	D	Drum motor error: C
SC399	D	Drum motor error: Y
	The motor is trying to rotate at power on or during normal operation but there is an excessive load on the drum shaft. The motor has no traction (due to a bent cleaning blade, for example).	
	<ul style="list-style-type: none"> <li>▪ Drum motor harness loose, broken, defective</li> <li>▪ Drum motor defective</li> <li>▪ DTMB defective</li> </ul>	

## SC Codes Group 4: Image Development - 2

		ID sensor error: Calibration
SC400	D	<p>Before adjustment <math>V_{sg\_reg} &lt; 0.5</math> but <math>V_{sg\_reg}</math> could not be adjusted to the target <math>V_{sg\_reg} = 4.0 \pm 0.2V</math> during process control.</p> <ul style="list-style-type: none"> <li>▪ ID sensor harness disconnected, loose, defective</li> <li>▪ ID sensor dirty</li> <li>▪ ID sensor defective</li> <li>▪ ITB unit drawer connector dirty</li> </ul>
		<p><b>Note:</b> <math>V_{sg\_reg}</math> is the voltage reading of the light reflected directly from the bare surface of the ITB. The additional receptor on the color sensor is not used to read the bare surface of the belt. For more, see Section "6. Details".</p>
SC410	D	ID sensor error: Development $\gamma$ K

## Troubleshooting

SC411	D	ID sensor error: Development $\gamma$ M
SC412	D	ID sensor error: Development $\gamma$ C
SC413	D	ID sensor error: Development $\gamma$ Y
Development gamma for black, magenta, cyan, or yellow is not within range (0.3 to 6.0). Process control halts when this SC is issued.		
<ul style="list-style-type: none"> <li>▪ Toner density abnormal. Refer to the image troubleshooting section in Section 4 of the B132/B200 Service Manual (Self-Check Error Codes 55 to 59, 61).</li> <li>▪ LD sensor harness loose, broken, defective</li> <li>▪ Potential sensor defective</li> <li>▪ LD unit not firing</li> <li>▪ ITB separation for CMY abnormal</li> <li>▪ Transfer power pack defective</li> </ul>		

SC414	D	ID sensor error: Development start voltage K
SC415	D	ID sensor error: Development start voltage M
SC416	D	ID sensor error: Development start voltage C
SC417	D	ID sensor error: Development start voltage Y
The development start voltage in the development of the black, magenta, cyan, or yellow PCU is not within the correct range ( $\pm 150V$ )		
<ul style="list-style-type: none"> <li>▪ Toner density abnormal. Refer to the image troubleshooting section in Section 4 of the B132/B200 Service Manual (Self-Check Error Codes 55 to 59, 61).</li> <li>▪ Potential sensor defective</li> <li>▪ LD unit not firing</li> <li>▪ ITB separation for CMY abnormal</li> <li>▪ Transfer power pack defective</li> </ul>		

SC418	C	LED error during Vsg adjustment
-------	---	---------------------------------

## Troubleshooting

		<p>PWM value: Ifsg&gt;3000</p> <p>This means the current to the LED of the ID sensor is abnormal.</p>	<ul style="list-style-type: none"> <li>▪ ID sensor dirty</li> <li>▪ ID sensor defective</li> </ul>
--	--	---	--

SC420	C	Potential sensor error: Vd Adjustment K
SC421	C	Potential sensor error: Vd Adjustment M
SC422	C	Potential sensor error: Vd Adjustment C
SC423	C	Potential sensor error: Vd Adjustment Y
		<p>The development potential of the drum before exposure (Vd) cannot be adjusted to within <math>\pm 8</math> V of the target voltage (-900V).</p>
		<ul style="list-style-type: none"> <li>▪ Drum potential sensor harness, connector is loose, broken, defective</li> <li>▪ Drum potential sensor dirty</li> <li>▪ Drum potential sensor defective</li> <li>▪ Drum connector, harness loose, broken, defective</li> <li>▪ Development power pack defective</li> <li>▪ VBCU defective</li> </ul>

SC424	C	Potential sensor error 5: VI adjustment K
SC425	C	Potential sensor error 6: VI adjustment M
SC426	C	Potential sensor error 7: VI adjustment C
SC427	C	Potential sensor error 8: VI adjustment Y
		<p>Vpl could not be adjusted to within <math>\pm 5</math>V of the target Vpl after exposure of the ID sensor patterns.</p>
		<ul style="list-style-type: none"> <li>▪ Drum worn</li> <li>▪ LD unit dirty</li> <li>▪ Poor drum ground connection</li> </ul>

SC432	C	Potential sensor error 1: Vr K
-------	---	--------------------------------

## Troubleshooting

SC433	C	Potential sensor error 2: Vr M
SC434	C	Potential sensor error 3: Vr C
SC435	C	Potential sensor error 4: Vr Y
		Vr > 200V. The residual voltage (Vr), the amount of voltage that remains on the surface of the drum after the QL fires is greater than 200V.
		<ul style="list-style-type: none"> <li>▪ Potential sensor dirty</li> <li>▪ Potential sensor defective</li> <li>▪ Charge roller defective</li> <li>▪ Charge power pack defective</li> <li>▪ OPC defective</li> </ul>

SC436	D	Potential sensor error: Vd K
SC437	D	Potential sensor error: Vd M
SC438	D	Potential sensor error: Vd C
SC439	D	Potential sensor error: Vd Y
		The VdHome reading, the first step of the process control self-check, detected that the development potential of the unexposed areas of the drum are not within the prescribed range (-500 to -800)
		<ul style="list-style-type: none"> <li>▪ Potential sensor dirty</li> <li>▪ Potential sensor defective</li> <li>▪ Charge roller defective</li> <li>▪ Charge power pack defective</li> <li>▪ OPC defective</li> </ul>

SC440	D	Image transfer power pack error: K
SC441	D	Image transfer power pack error: M
SC442	D	Image transfer power pack error: C
SC443	D	Image transfer power pack error: Y

## Troubleshooting

	An interrupt checks the status of the power pack every 10 ms. This SC is issued if the VBCU detects a short in the power pack for K, M, C, or Y.	
		<ul style="list-style-type: none"> <li>▪ Transfer belt damaged, insulation damaged</li> <li>▪ Insulation on high voltage cable damaged</li> <li>▪ Another hot point inside the machine has damaged insulation</li> <li>▪ Insulation around high-voltage power supply damaged</li> </ul>

		Image transfer motor error	
SC445	D	The control board of the ITB motor belt generated signals that indicate there is problem with the image transfer belt motor.	<ul style="list-style-type: none"> <li>▪ ITB motor defective</li> <li>▪ ITB control board defective</li> <li>▪ ITB overloaded</li> <li>▪ Encoder strip on the edge of the ITB damaged.</li> </ul>

		ITB lift motor error	
SC446	D	The state of the ITB lift sensor does not change its state (switching from off to on or vice versa), even after the ITB lift motor starts rotating.	<ul style="list-style-type: none"> <li>▪ ITB lift sensor dirty, disconnected, defective</li> <li>▪ ITB lift motor disconnected, defective</li> <li>▪ ITB sensor defective</li> <li>▪ ITB lift motor defective</li> </ul>

		Image transfer roller position error	
SC447	D	The machine checks for the presence of the K STC and the checks the status of the K image transfer roller lift sensor after the door is closed.	<ul style="list-style-type: none"> <li>▪ Transfer belt release lever down</li> <li>▪ Lift sensor connector loose, broken, dirty</li> <li>▪ Lift sensor defective</li> </ul>

SC450	D	Transfer power pack output error	
-------	---	----------------------------------	--

## Troubleshooting

		An interrupt checks the status of the power pack every 2 ms. This SC is issued if the VBCU detects a short in the power pack 250 times at T2 within 500 ms.	<ul style="list-style-type: none"> <li>▪ Damaged insulation on the high-voltage supply cable</li> <li>▪ Damaged insulation around the high-voltage power supply.</li> <li>▪ Check SIOB harness connections</li> <li>▪ SIOB defective</li> </ul>
SC452	D	PTR lift mechanism error	
		The PTR was not detected at the home position within 2 sec. after the PTR lift motor turned on.	<ul style="list-style-type: none"> <li>▪ PTR HP sensor dirty, disconnected, defective</li> <li>▪ PTR lift motor disconnected, defective</li> </ul>
SC455	D	PTR motor error	
		The lock signal from the paper transfer motor was not detected within 1 sec. after the motor switched on.	<ul style="list-style-type: none"> <li>▪ Motor disconnected</li> <li>▪ PTR shaft locked, needs cleaning, blocked by obstruction</li> <li>▪ Drive shaft of the ITB locked and overloaded, needs cleaning, or blocked by obstruction</li> <li>▪ DRB disconnected, defective</li> </ul>
SC460	D	Separation power pack output error	
		This SC is issued if the VBCU detects a short in the transfer power pack.	<ul style="list-style-type: none"> <li>▪ Damaged insulation on the high-voltage supply cable (replace cable)</li> <li>▪ Damaged insulation around the transfer power pack</li> </ul>
SC465	B	Image Transfer Roller End: K	
SC466	B	Image Transfer Roller End: M	

## Troubleshooting

SC467	B	Image Transfer Roller End: C	
SC468	B	Image Transfer Roller End: Y	
		The machine detected an abnormal reading of the resistance of the transfer roller because it is near the end of its service life.	<ul style="list-style-type: none"> <li>▪ Check the connections between the transfer roller power pack the roller</li> <li>▪ Replace image transfer roller</li> <li>▪ Image transfer power pack defective</li> </ul>

		ITB Bias Roller End	
SC472		The machine detected an abnormal reading of the resistance of the ITB bias roller because it is near the end of its service life.	<ul style="list-style-type: none"> <li>▪ Check the connections between the transfer power pack</li> <li>▪ Replace image transfer roller</li> <li>▪ Transfer power pack defective</li> </ul>

SC480	Drum cleaning motor error: K		
SC481	Drum cleaning motor error: M		
SC482	Drum cleaning motor error: C		
SC483	Drum cleaning motor error: Y		
		The drum cleaning motor failed to switch on (motor lock), or failed to reach the required speed within the prescribed time.	<ul style="list-style-type: none"> <li>▪ Motor block by physical obstruction</li> <li>▪ Motor harness loose, broken, defective</li> <li>▪ Motor defective</li> </ul>

		Used toner bottle full	
SC484	D	The toner full sensor has detected that the used toner bottle is full.	<ul style="list-style-type: none"> <li>▪ Remove the used toner bottle</li> <li>▪ Empty the used toner bottle and reinstall it</li> </ul>

SC485	D	Used toner bottle motor error	
-------	---	-------------------------------	--



## Troubleshooting

		The lock signal of the used toner bottle motor remains HIGH for more than 600 ms.	<ul style="list-style-type: none"> <li>▪ Used toner bottle harness loose, broken, defective</li> <li>▪ Used toner bottle motor defective</li> </ul>
SC487	D	Used toner bottle set error	
		The set sensor of the used toner bottle remains LOW for more than 500 ms. (The sensor goes HIGH when the bottle is installed correctly.)	<ul style="list-style-type: none"> <li>▪ Used toner bottle not installed</li> <li>▪ Remove used toner bottle and reinstall correctly</li> </ul>
SC488	D	Used toner transport lock	
		Used toner cannot be transported to the used toner bottle.	<ul style="list-style-type: none"> <li>▪ Blockage in the line to the used toner bottle</li> </ul>
SC490	D	MUSIC sensor error	
		One or more of the MUSIC sensors is not functioning normally.	<ul style="list-style-type: none"> <li>▪ MUSIC sensor harness loose, broken, defective</li> <li>▪ Sensor defective</li> </ul>
SC495		ITB encoder sensor error	
		The ITB encoder sensor that reads the encoded strip on the ITB is not functioning properly.	<ul style="list-style-type: none"> <li>▪ Sensor dirty</li> <li>▪ Sensor harness loose, broken, defective</li> <li>▪ Sensor out of position because installed incorrectly</li> </ul> ITB installed incorrectly
SC496	C	MUSIC sensor error	

## Troubleshooting

		<p>The MUSIC sensor detected an abnormal pattern on the ITB because:</p> <ul style="list-style-type: none"> <li>▪ ADC exceeded upper or lower limit.</li> <li>▪ The pattern used to calculate the amount of skew is abnormal.</li> <li>▪ The reading of the pattern exceeded the length of time the LED projected light.</li> <li>▪ LED light could not be adjusted correctly.</li> </ul>
		<ul style="list-style-type: none"> <li>▪ ITB installed incorrectly</li> <li>▪ Inspect ITB belt for damage, replace</li> <li>▪ MUSIC pattern abnormal; do a forced process control (SP3821) and check the result.</li> <li>▪ MUSIC sensor defective or disconnected</li> </ul>

		Temperature and humidity sensor error: M PCU	
SC497	C	The thermistor output of the temperature and humidity sensor above the M PCU was not within the prescribed range (0.5V to 4.2V)	<ul style="list-style-type: none"> <li>▪ Temperature and humidity sensor harness disconnected, loose, defective</li> <li>▪ Temperature and humidity sensor defective</li> </ul>

		Temperature and humidity sensor error: Toner Bottle	
SC498	C	The thermistor output of the temperature and humidity sensor below the used toner bottle was not within the prescribed range (0.5V to 4.2V)	<ul style="list-style-type: none"> <li>▪ Temperature and humidity sensor harness disconnected, loose, defective</li> <li>▪ Temperature and humidity sensor defective</li> </ul>

		ITB encoder sensor error	
SC499	C	The ITB sensor that reads the encoded film strip on the edge of the image transfer belt is sending is operating correctly.	<ul style="list-style-type: none"> <li>▪ ITB encoder sensor dirty</li> <li>▪ Sensor harness disconnected or damaged</li> <li>▪ Encoded scale on the edge of the</li> </ul>

## Troubleshooting

			<p>ITB is damaged or dirty</p> <ul style="list-style-type: none"> <li>ITB installed incorrectly</li> </ul>
--	--	--	--

## SC codes Group 5: Paper Feed

SC501	B	Tray 1 (tandem tray) feed error ( <b>Japan Only</b> )	
		<p>The tray 1 lift sensor does not switch on 10 s after the tray lift motor switches on and starts lifting the bottom plate.</p> <p>When the tray lowers, the tray lift sensor does not go off within 1.5 sec.</p> <p>The lower limit sensor of the tandem tray does not detect the lower limit within 10 sec.</p>	<ul style="list-style-type: none"> <li>Tray lift motor harness disconnected, loose, defective</li> <li>Paper or other obstacle trapped between tray and motor</li> <li>Tray lift sensor disconnected, damaged</li> <li>Lower limit sensor disconnected, damaged</li> <li>Pick-up solenoid disconnected, blocked by an obstacle</li> </ul>

SC502	B	Tray 2 (paper cassette) feed error ( <b>Japan Only</b> )	
		<p>The lift sensor is not activated within 10 seconds after the tray lift motor starts lifting the bottom plate.</p> <p>When the tray lowers, the tray lift sensor does not go off within 1.5 sec.</p> <p>The lower limit sensor of the tandem tray does not detect the lower limit within 10 sec.</p>	<ul style="list-style-type: none"> <li>Tray lift motor defective or disconnected</li> <li>Paper or other obstacle trapped between tray and motor</li> <li>Pick-up solenoid disconnected or blocked by an obstacle</li> </ul>

SC503	B	Tray 1 feed error	
		The lift sensor is not activated	<ul style="list-style-type: none"> <li>Tray lift motor defective or</li> </ul>

## Troubleshooting

		<p>within 10 seconds after the tray lift motor starts lifting the bottom plate.</p> <p>When the tray lowers, the tray lift sensor does not go off within 1.5 sec.</p>	<p>disconnected</p> <ul style="list-style-type: none"> <li>▪ Paper or other obstacle trapped between tray and motor</li> <li>▪ Pick-up solenoid disconnected or blocked by an obstacle</li> </ul>
--	--	---	---

SC504	B	Tray 2 feed error	
		<p>The lift sensor is not activated within 10 seconds after the tray lift motor starts lifting the bottom plate.</p> <p>When the tray lowers, the tray lift sensor does not go off within 1.5 sec.</p>	<ul style="list-style-type: none"> <li>▪ Tray lift motor defective or disconnected</li> <li>▪ Paper or other obstacle trapped between tray and motor</li> <li>▪ Pick-up solenoid disconnected or blocked by an obstacle</li> </ul>

SC505	C	Tandem tray rear fence motor error	
		<p>The return sensor does not switch on within 10 sec. after the rear fence motor switches on.</p> <p>The HP sensor does not switch on 10 sec. after the rear fence motor switches on.</p> <p>The HP sensor and return sensor switch on at the same time.</p>	<ul style="list-style-type: none"> <li>▪ Rear fence motor defective or poor connection</li> <li>▪ Paper or other obstacle interfering with operation of the sensors</li> <li>▪ Paper or other obstacle trapped between tray and motor</li> <li>▪ Motor mechanical overload due to obstruction</li> <li>▪ Return sensor or HP sensor defective or dirty</li> </ul>

SC510	B	LCT tray error: B473/D350	
		<p>When the bottom plate is lifted, the upper limit sensor does not come on for 30 sec.</p> <p>When the bottom plate is lowered, the lower limit sensor does not come</p>	

Troubleshooting

		<p>on for 30 sec.</p> <p>After lift begins, the upper limit sensor does not switch on before the pick-up solenoid switches on.</p> <p>The paper end sensor switches on during lift and the upper limit sensor does not switch on for 2.5 s, and a message prompts user to reset paper.</p>
		<ul style="list-style-type: none"> <li>▪ Tray lift motor harness, disconnected, loose, or defective</li> <li>▪ Tray lift motor defective</li> <li>▪ Lift sensor defective or disconnected</li> <li>▪ Pick-up solenoid defective or disconnected</li> <li>▪ Paper end sensor defective</li> </ul>

		Duplex jogger motor error 1	
SC515	C	<p>When the jogger fence moves to the home position, the jogger fence HP sensor does not switch on even after the jogger motor has moved the jogger fence 153.5 mm.</p>	<ul style="list-style-type: none"> <li>▪ Jogger fence motor defective or poor connection</li> <li>▪ Paper or other obstacle interfering with operation of the sensors or motor</li> <li>▪ Return sensor or HP sensor defective, dirty, or disconnected</li> <li>▪ Paper or other obstacle has jammed mechanism</li> <li>▪ HP sensor connector disconnected or defective</li> <li>▪ HP sensor defective</li> </ul>

		Duplex jogger motor error 2	
SC516	B	<p>When the jogger fence moves from the home position, the jogger fence HP sensor does not turn off even if the jogger motor has moved the jogger fence 153.5 mm.</p>	<ul style="list-style-type: none"> <li>▪ Jogger fence motor defective or poor connection</li> <li>▪ Paper or other obstacle interfering with operation of the sensors or motor</li> <li>▪ Return sensor or HP sensor defective, dirty, or disconnected</li> </ul>

## Troubleshooting

			<ul style="list-style-type: none"> <li>▪ Paper or other obstacle has jammed mechanism</li> <li>▪ HP sensor connector disconnected or defective</li> <li>▪ HP sensor defective</li> </ul>
--	--	--	--

SC517	D	LCIT air assist front fan error	
		The front air assist fan is not functioning properly.	<ul style="list-style-type: none"> <li>▪ Fan harness disconnected or damaged</li> <li>▪ Fan blocked by an obstruction</li> <li>▪ Fan damaged, defective</li> </ul>

SC518	D	LCIT air assist rear fan error	
		The rear air assist fan is not functioning properly.	<ul style="list-style-type: none"> <li>▪ Fan harness disconnected or damaged</li> <li>▪ Fan blocked by an obstruction</li> <li>▪ Fan damaged, defective</li> </ul>

SC530	B	Fusing cooling fan error	
		The VBCU did not receive the lock signal 5 seconds after the fusing unit fan switches on.	<ul style="list-style-type: none"> <li>▪ Fan harness disconnected or damaged</li> <li>▪ Fan blocked by an obstruction</li> <li>▪ Fan damaged</li> </ul>

SC531	B	Fusing Fan Error: Front	
		The lock signal remained HIGH for 5 sec. while the fan at the front of the fusing unit near the heat dissipation fins was operating.	<ul style="list-style-type: none"> <li>▪ Fan harness disconnected or damaged</li> <li>▪ Fan blocked by an obstruction</li> <li>▪ Fan damaged</li> </ul>

## Troubleshooting

SC532	B	Controller fan error	
		The lock signal remained HIGH for 5 sec. while the fan that cools the printed circuit boards was operating.	<ul style="list-style-type: none"> <li>▪ Fan harness disconnected or damaged</li> <li>▪ Fan blocked by an obstruction</li> <li>▪ Fan damaged</li> </ul>

SC533	B	Fusing unit suction fan error	
		The lock signal remained HIGH for 5 sec. while the fan that draws air out of the fusing unit was operating.	<ul style="list-style-type: none"> <li>▪ Fan harness disconnected or damaged</li> <li>▪ Fan blocked by an obstruction</li> <li>▪ Fan damaged</li> </ul>

SC534	B	Duplex unit fan error	
		The lock signal remained HIGH for 5 sec. while the fan that draws air out of the duplex unit was operating.	<ul style="list-style-type: none"> <li>▪ Fan harness disconnected or damaged</li> <li>▪ Fan blocked by an obstruction</li> <li>▪ Fan damaged</li> </ul>

SC535	B	Development Intake Fan Error	
		The lock signal remained HIGH for 5 sec. while the fan in the Y development unit was operating.	<ul style="list-style-type: none"> <li>▪ Fan harness disconnected or damaged</li> <li>▪ Fan blocked by an obstruction</li> <li>▪ Fan damaged</li> </ul>

SC536	B	Development Intake Fan Error: Y	
SC537	B	Development Intake Fan Error: C	
SC538	B	Development Intake Fan Error: M	
SC539	B	Development Intake Fan Error: K	
		The lock signal remained HIGH for	<ul style="list-style-type: none"> <li>▪ Fan harness disconnected or</li> </ul>

## Troubleshooting

		5 sec. while the fan in the development unit was operating.	<p>damaged</p> <ul style="list-style-type: none"> <li>▪ Fan blocked by an obstruction</li> <li>▪ Fan damaged</li> </ul>
SC540		Fusing/exit motor error	
		Motor operation was detected abnormal at power on.	<ul style="list-style-type: none"> <li>▪ Check inside the fusing unit for any obstructions</li> <li>▪ Motor harness loose, broken, defective</li> <li>▪ Motor or its driver board defective</li> </ul>
SC541	A	Heating roller thermistor (center) error 1	
		The "floating" (non-contact) thermistor at the center of the heating roller is not operating correction.	<ul style="list-style-type: none"> <li>▪ Thermistor harness connection loose, disconnected, defective</li> <li>▪ Thermistor installed incorrectly</li> <li>▪ Thermistor defective</li> </ul>
SC543	A	Heating roller thermistor (center) error 2	
		The thermistor at the center of the heating roller detected an abnormally high temperature (over 250°C)	<ul style="list-style-type: none"> <li>▪ Do SP5810 to cancel the SC fusing code.</li> <li>▪ TRIAC short, AC drive board defective</li> <li>▪ VBCU defective</li> </ul>
SC544	A	Heating roller thermistor (center) error 3	
		The thermistor detected a temperature over 260°C..	<ul style="list-style-type: none"> <li>▪ Do SP5810 to cancel the SC fusing code.</li> <li>▪ TRIAC short, AC drive board defective</li> <li>▪ VBCU defective</li> </ul>



## Troubleshooting

SC545	A	Lamp remains on	
		After hot roller reaches warm-up temperature, the center fusing lamps in the heating roller remained on at full capacity after reaching the warm-up temperature while the hot roller was not rotating.	<ul style="list-style-type: none"> <li>▪ Do SP5810 to cancel the SC fusing code.</li> <li>▪ Heating roller thermistor damaged, or out of position</li> <li>▪ Fusing lamp disconnected, broken</li> </ul>
SC546	A	Heating roller thermistor error (side)	
		The temperature measured by the heating roller thermistor does not reach 0°C after 50 sec. and remains over this temperature for 10 readings.	<ul style="list-style-type: none"> <li>▪ Loose connection of the heating roller thermistor</li> <li>▪ Defective heating roller thermistor</li> </ul>
SC547	A	Zero cross error	
		<p>When the main switch is turned on, the machine checks how many zero-cross signals are generated within 500 ms. This SC code is issued if the number of zero-cross signals detected is not within specification.</p> <p><b>Note:</b> Zero cross signals, generated from an ac power supply, are used to generate a trigger pulses to control the applied power accurately.</p>	
		<ul style="list-style-type: none"> <li>▪ Do SP5810 to cancel the SC fusing code.</li> <li>▪ Electrical noise on the power supply line</li> <li>▪ Fusing relay damaged, replace the AC drive board.</li> </ul>	
SC549	A	Heating roller thermistor (center): software error	
		The thermistor detected a temperature over 250°C 10 times within 1 sec.	<ul style="list-style-type: none"> <li>▪ Do SP5810 to cancel the SC fusing code.</li> <li>▪ TRIAC short, AC drive board defective</li> </ul>

## Troubleshooting

			<ul style="list-style-type: none"> <li>VBCU defective</li> </ul>
SC550	A	Heating roller thermistor 3 (side): hardware error	
		The thermistor detected a temperature over 260°C..	<ul style="list-style-type: none"> <li>Do SP5810 to cancel the SC fusing code.</li> <li>TRIAC short, AC drive board defective</li> <li>VBCU defective</li> </ul>
SC551	A	Pressure roller thermistor error 1	
		The temperature measured by the pressure roller thermistor did not reach 0°C after 10 attempts.	<ul style="list-style-type: none"> <li>Do SP5810 to cancel the SC fusing code.</li> <li>Loose connection of the pressure roller thermistor</li> <li>Thermistor positioned incorrectly</li> <li>Defective pressure roller thermistor</li> </ul>
SC552	A	Pressure roller thermistor error 2	
		<p>After the main switch is turned on or the cover is closed, the heating roller temperature did not reach the ready temperature (45°C) within 80 sec. after the fusing lamp switches on.</p> <p>-or-</p> <p>If the fusing unit did not reach the reload temperature after 350 sec.</p>	
		<ul style="list-style-type: none"> <li>Pressure roller thermistor harness loose, disconnected, defective</li> <li>Pressure roller thermistor defective</li> </ul>	
SC553	A	Pressure roller thermistor (software) error	
		The thermistor detected a temperature over 220°C 12 times within 1 sec.	<ul style="list-style-type: none"> <li>Do SP5810 to cancel the SC fusing code.</li> <li>TRIAC short, AC drive board</li> </ul>

## Troubleshooting

			<p>defective</p> <ul style="list-style-type: none"> <li>VBCU defective</li> </ul>
SC554	A	Pressure roller thermistor (hardware) error	
		<p>The thermistor detected a temperature over 230°C.</p>	<ul style="list-style-type: none"> <li>Do SP5810 to cancel the SC fusing code</li> <li>TRIAC short, AC drive board defective</li> <li>VBCU defective</li> </ul>
SC555	A	Pressure roller fusing lamp remains on	
		<p>After hot roller reaches warm-up temperature, the pressure roller fusing lamp remained for 300 sec. while the hot roller is not rotating.</p>	<ul style="list-style-type: none"> <li>Do SP5810 to cancel the SC fusing code.</li> <li>Thermistor damaged, or out of position</li> <li>Fusing lamp disconnected, broken</li> </ul>
SC556	A	Heating roller fusing lamp error	
		<p>After hot roller reaches warmup temperature, the heating roller fusing lamp (ends) remains for 10 sec. while the hot roller is not rotating.</p>	<ul style="list-style-type: none"> <li>Thermistor damaged, or out of position</li> <li>Fusing lamp disconnected, broken</li> </ul>
SC557	Zero Cross Over Error		
	<p>At power on the fusing relay was detected as defective.</p>	<ul style="list-style-type: none"> <li>Replace the AC drive board.</li> </ul>	
SC559	A	Three Successive Paper Jams in Fusing Unit	

## Troubleshooting

		This SC only occurs if SP1159 is on, and a jam occurred in the fusing unit for three consecutive sheets of paper. With SP1159 set to "1" the machine operation can be restored only by the service technician.	
		The paper cooling job time sensor detected paper late for 3 counts.	<ul style="list-style-type: none"> <li>▪ Remove the paper that is jammed in the fusing unit.</li> <li>▪ Make sure that the fusing unit is clean and has no obstacles in the paper feed path.</li> </ul>

		Heating roller non-contact thermistor error 1	
SC561	A	The temperature measured by the heating roller thermistor (non-contact) on the end of the heating roller did not reach the prescribed warm-up temperature within 1 sec.	<ul style="list-style-type: none"> <li>▪ Loose, broken, damaged connector</li> <li>▪ Defective thermistor</li> </ul>

		Heating roller non-contact thermistor error 2	
SC562	A	After the main switch is turned on or the cover is closed, the heating roller temperature does not reach the ready temperature within 100 sec. after the heater switches on. -or- The heating roller did not reach the ready temperature within 150 sec.	<ul style="list-style-type: none"> <li>▪ Note: Thermistor 2 stops monitoring the temperature when Thermistor 1 detects the ready temperature.</li> </ul>
		<ul style="list-style-type: none"> <li>▪ Do SP5810 to cancel the SC fusing code</li> <li>▪ Defective hot roller thermistor</li> <li>▪ Heating roller disconnected, defective</li> </ul>	

		Heating roller non-contact thermistor error 3	
SC563	A	The thermistor 2 (of the	<ul style="list-style-type: none"> <li>▪ Do SP5810 to cancel the SC fusing</li> </ul>

## Troubleshooting

		heating roller) detected a temperature over 250°C 10 times within 1 sec.	<p>code.</p> <ul style="list-style-type: none"> <li>▪ TRIAC short, AC drive board defective</li> <li>▪ VBCU defective</li> </ul>
SC564	A	Heating roller non-contact thermistor error 3	
		The thermistor detected a temperature over 260°C.	<ul style="list-style-type: none"> <li>▪ Do SP5810 to cancel the SC fusing code.</li> <li>▪ TRIAC short, AC drive board defective</li> <li>▪ VBCU defective</li> </ul>
SC565	A	Heating roller fusing lamp on error	
		After fusing belt reached warm-up temperature, the heating roller fusing lamp remained on for 20 sec. while the hot roller was not rotating.	<ul style="list-style-type: none"> <li>▪ Do SP5810 to cancel the SC fusing code.</li> <li>▪ Thermistor damaged, or out of position</li> <li>▪ Fusing lamp disconnected, broken</li> </ul>
SC568	D	Pressure roller lift error 1	
		Even after the leading edge of the paper reached the fusing exit sensor, the pressure roller lift motor did not raise the pressure roller.	<ul style="list-style-type: none"> <li>▪ Pressure roller lift sensor connection loose, broken, damaged</li> <li>▪ Clean the pressure roller lift sensor</li> <li>▪ Pressure roller lift harness loose, broken, damage</li> <li>▪ Pressure roller lift motor blocked by an obstruction</li> <li>▪ Pressure roller lift motor defective</li> </ul>
SC569	B	Pressure roller lift error 2	
		Pressure roller lift motor not	<ul style="list-style-type: none"> <li>▪ Pressure roller lift sensor</li> </ul>

## Troubleshooting

		operating correctly. (No signal to indicate completion of operation.)	<ul style="list-style-type: none"> <li>▪ connection loose, broken, damaged</li> <li>▪ Clean the pressure roller lift sensor</li> <li>▪ Pressure roller lift harness loose, broken, damage</li> <li>▪ Pressure roller lift motor blocked by an obstruction</li> <li>▪ Pressure roller lift motor defective</li> </ul>
--	--	---	--

SC570	Development intake fan error	
		<p>Fan motor not operating correctly.</p> <ul style="list-style-type: none"> <li>▪ Fan harness loose, broken, defective</li> <li>▪ Fan overload due to physical obstruction</li> <li>▪ Fan motor defective</li> </ul>

SC571	B	Ozone exhaust fan (FC) error
		<p>The fan of the middle ozone filter box not operating correctly.</p> <ul style="list-style-type: none"> <li>▪ Fan harness loose, broken, defective</li> <li>▪ Fan overload due to physical obstruction</li> <li>▪ Fan motor defective</li> </ul>

SC572	B	Ozone exhaust fan (K) error
		<p>The fan of the lower ozone filter box not operating correctly.</p> <ul style="list-style-type: none"> <li>▪ Fan harness loose, broken, defective</li> <li>▪ Fan overload due to physical obstruction</li> <li>▪ Fan motor defective</li> </ul>

SC573	B	Ozone intake fan error
		<p>The ozone filter intake fan not operating correctly.</p> <ul style="list-style-type: none"> <li>▪ Fan harness loose, broken, defective</li> </ul>

## Troubleshooting

			<ul style="list-style-type: none"> <li>▪ Fan overload due to physical obstruction</li> <li>▪ Fan motor defective</li> </ul>
--	--	--	---

SC574	Y thermistor error		<ul style="list-style-type: none"> <li>▪ Harness loose, broken, defective</li> <li>▪ Thermistor defective</li> </ul>
		The thermistor near the Y PCU has short circuited or otherwise not operating correctly.	

SC599	B	Tray 1 lift motor error	<ul style="list-style-type: none"> <li>▪ Motor harness loose, broken, defective</li> <li>▪ Motor overload due to an obstruction</li> <li>▪ Motor defective</li> </ul>
		An error was detected in the operation of the lift motor for Tray 1 (tandem tray).	

## SC Codes Group 6: Device Communication

SC620	D	ARDF communication error	<ul style="list-style-type: none"> <li>▪ ARDF disconnected</li> <li>▪ VBCU board harness disconnected, defective</li> <li>▪ VBCU board defective</li> <li>▪ Spurious noise from the power supply line</li> <li>▪ ARDF defective</li> </ul>
		A BREAK signal occurs after the machine detects the ARDF, or a communication timeout occurs.	

SC621	D	Mailbox-to-Finisher communication error	<ul style="list-style-type: none"> <li>▪ Connection cable between mailbox and finisher disconnected, defective</li> </ul>
		Communication between the mailbox and finisher is	

## Troubleshooting

		interrupted. An ACK/NCK signal was not received within 100 ms after a data frame is sent and 3 retries failed.	<ul style="list-style-type: none"> <li>▪ Finisher main board defective</li> <li>▪ VBCU defective</li> <li>▪ PSU defective</li> </ul>
SC622	D	PFB communication error	
		Communication between the VBCU and PFB was interrupted. (Communication status is monitored at 30 ms intervals.)	<ul style="list-style-type: none"> <li>▪ Connection cable between the VBCU and PFB is disconnected, defective</li> <li>▪ VBCU defective</li> <li>▪ PFB defective</li> </ul>
SC624	D	Mailbox-to-copier communication error	
		Communication between the mailbox and copier is interrupted. An ACK/NCK signal was not received within 100 ms after a data frame is sent and 3 retries failed.	<ul style="list-style-type: none"> <li>▪ Mailbox cable disconnected, defective</li> <li>▪ Mailbox main board defective</li> <li>▪ VBCU defective</li> <li>▪ PSU defective</li> </ul>
SC625	B	VBCU-DTMB (DMC1) communication error	
		Communication between the VBCU and DMC (main) was interrupted. An ACK/NAK signal was not received within 100 ms after a data frame was sent and three retries failed.	<ul style="list-style-type: none"> <li>▪ Check the DTMB harness connections at the DTMB and VBCU</li> <li>▪ DTMB defective</li> <li>▪ PSU defective</li> <li>▪ VBCU defective</li> <li>▪ 5V power supply defective</li> </ul>
SC626	B	VBCU-DTMB (DMC2) communication error	
		Communication between the	<ul style="list-style-type: none"> <li>▪ Check the DTMB harness</li> </ul>



## Troubleshooting

		VBCU and DMC (sub) was interrupted. An ACK/NAK signal was not received within 100 ms after a data frame was sent and three retries failed.	<p>connections at the DTMB and VBCU</p> <ul style="list-style-type: none"> <li>▪ DTMB defective</li> <li>▪ VBCU defective</li> <li>▪ PSU defective</li> </ul>
--	--	--	---

SC627	B	VBCU-DTMB (TMC) communication error	
		<p>Communication between the VBCU and TMC was interrupted. An ACK/NAK signal was not received within 100 ms after a data frame was sent and three retries failed.</p>	<ul style="list-style-type: none"> <li>▪ DTMB harness loose, broken, defective</li> <li>▪ DTMB defective</li> <li>▪ VBCU defective</li> <li>▪ PSU defectiv</li> </ul>

SC687	B	Memory address command error	
		<p>The VBCU does not receive a memory address command from the controller 120 seconds after paper is in the position for registration.</p>	<ul style="list-style-type: none"> <li>▪ Turn the machine power off/on</li> <li>▪ Check the controller board connections</li> <li>▪ Controller defective</li> </ul>

## SC Codes Group 7: Peripherals

SC701	D	ARDF original pickup operation error	
		<p>Even though the pickup motor is rotating clock-wise, the pickup roller home position sensor cannot detect the position of the pickup roller.</p>	
		<ul style="list-style-type: none"> <li>▪ Pickup roller HP sensor harness loose, disconnected, defective</li> <li>▪ Pickup roller HP sensor defective</li> <li>▪ Pickup motor harness loose, disconnected, defective</li> <li>▪ Pickup motor defective</li> <li>▪ ARDF control board defective</li> </ul>	

SC705	D	ARDF bottom plate lift motor	
		<p>The bottom plate HP sensor did not detect the home position of the bottom plate after the bottom plate lift motor switches on and lowers the bottom plate.</p> <p>The bottom plate position sensor does not detect the position of the plate after the lift motor switches on and raises the bottom plate.</p>	
		<ul style="list-style-type: none"> <li>▪ ARDF feed motor disconnected, defective</li> <li>▪ Bottom plate HP sensor disconnected, defective</li> <li>▪ ARDF main board defective</li> </ul>	

SC720	D	Finisher lower transport motor error	
		<p>No encoder pulse signal is detected for the transport motor within the prescribed time.</p> <p>The 1st failure causes an original jam message, and the 2nd failure causes this SC code.</p>	<ul style="list-style-type: none"> <li>▪ Lower transport motor disconnected, defective</li> <li>▪ Finisher connection to transport motor loose, defective</li> <li>▪ Lower transport motor defective</li> <li>▪ Finisher main board defective</li> </ul>

SC721	B	Finisher jogger motor error (D373/D374, B830)	
		<p>The jogger fences move out of the home position but the HP sensor output does not change within the specified number of pulses. The 1st failure causes an original jam message, and the 2nd failure causes this SC code.</p>	<ul style="list-style-type: none"> <li>▪ Jogger HP sensor disconnected, defective</li> <li>▪ Jogger motor disconnected, defective</li> <li>▪ Jogger motor overloaded due to obstruction</li> <li>▪ Finisher main board and jogger motor connection loose, defective</li> <li>▪ Finisher main board defective</li> </ul>

## Troubleshooting

SC723	B	Finisher feed-out motor (B830)	
		<p>The stack feed-out belt HP sensor does not activate within the specified time after the stack feed-out belt motor turns on. The 1st detection failure causes a jam error, and the 2nd failure causes this SC code.</p>	<ul style="list-style-type: none"> <li>▪ Stack feed-out HP sensor disconnected, defective</li> <li>▪ Feed-out motor disconnected, defective</li> <li>▪ Finisher main board connection to feed out motor disconnected, defective</li> <li>▪ Motor overload due to obstruction</li> </ul>
SC724	D	Finisher stapler hammer motor error (B830)	
		<p>Stapling does not finish within the prescribed time after the staple hammer motor turns on. The 1st detection failure causes a jam error, and the 2nd failure causes this SC code.</p>	<ul style="list-style-type: none"> <li>▪ Stapler hammer motor overloaded due to obstruction, jammed staple, number of sheets exceeds limit for stapling</li> <li>▪ Stapler hammer motor disconnected, defective</li> <li>▪ Staple hammer motor HP sensor disconnected, defective</li> </ul>
SC725	D	Finisher exit guide plate motor error (D373/D374, B830, B660)	
		<p>After moving away from the guide plate position sensor, the exit guide is not detected at the home position within the prescribed time. The 1st detection failure causes a jam error, and the 2nd failure causes this SC code.</p>	<ul style="list-style-type: none"> <li>▪ Guide plate motor disconnected, defective</li> <li>▪ Guide plate motor overloaded due to obstruction</li> <li>▪ Guide plate position sensor disconnected, defective</li> </ul>
SC726	B	Shift jogger motor 1 error (D373/D374, B830)	
		<p>The sides fences do not</p>	<ul style="list-style-type: none"> <li>▪ Shift jogger motor disconnected,</li> </ul>

## Troubleshooting

		retract within the prescribed time after the shift jogger motor switches on. The 1st detection failure causes a jam error, and the 2nd failure causes this SC code.	<ul style="list-style-type: none"> <li>defective</li> <li>▪ Shift jogger motor overloaded due to obstruction</li> <li>▪ Shift jogger HP sensor disconnected, defective</li> </ul>
SC727	B	Shift jogger motor 2 error (D373/D374)	
		The side fences do not retract within the prescribed time after the shift jogger motor switches on. The 1st detection failure causes a jam error, and the 2nd failure causes this SC code.	<ul style="list-style-type: none"> <li>▪ Motor harness disconnected, loose, defective</li> <li>▪ Motor defective</li> <li>▪ Motor overload</li> <li>▪ HP defective</li> </ul>
SC728	B	Shift jogger retraction motor error (D373/D374)	
		The side fences do not retract within the prescribed time after the retraction motor switches on. The 1st detection failure causes a jam error, and the 2nd failure causes this SC code.	<ul style="list-style-type: none"> <li>▪ Motor harness disconnected, loose, defective</li> <li>▪ Motor defective</li> <li>▪ Motor overload</li> <li>▪ HP defective</li> </ul>
SC730	B	Finisher Tray 1 shift motor error (B830)	
		The shift roller HP sensor of the upper tray does not activate within the prescribed time after the shift tray starts to move toward or away from the home position. The 1st	<ul style="list-style-type: none"> <li>▪ Shift tray HP sensor of the upper tray disconnected, defective</li> <li>▪ Shift tray motor of the upper tray is disconnected, defective</li> <li>▪ Shift tray motor of the upper tray overloaded due to obstruction</li> </ul>

## Troubleshooting

		detection failure causes a jam error, and the 2nd failure causes this SC code.	
SC731	B	Upper Transport Motor Error (Proof Tray): B830	
		No encoder pulse signal is detected for the upper transport motor within 600 ms. The 1st failure causes this SC code.	<ul style="list-style-type: none"> <li>▪ Upper transport motor disconnected, defective</li> <li>▪ Finisher connection to upper transport motor loose, defective</li> <li>▪ Upper transport motor blocked by an obstruction</li> <li>▪ Upper transport motor defective</li> <li>▪ Finisher main board defective</li> </ul>
SC732	D	Shift Tray Exit Motor: 3K Finisher B830	
		The shift tray exit motor is not operating.	<ul style="list-style-type: none"> <li>▪ Motor harness loose, broken, defective</li> <li>▪ Motor is blocked by an obstruction</li> <li>▪ Motor defective</li> <li>▪ Finisher main control board defective</li> </ul>
SC733	D	Stapler Exit Motor: B830	
		The stapler exit motor is not operating.	<ul style="list-style-type: none"> <li>▪ Motor harness loose, broken, defective</li> <li>▪ Motor is blocked by an obstruction</li> <li>▪ Motor defective</li> <li>▪ Finisher main control board defective</li> </ul>
SC734	B	Upper Tray Junction Gate Motor: 3K Finisher B830	

## Troubleshooting

		<p>The upper tray junction gate HP sensor did not detect the gate at the home position within 200 ms after two attempts.</p> <p>-or-</p> <p>The HP sensor twice detected the gate at the home position for more than 200 ms after it was supposed to open.</p>	<ul style="list-style-type: none"> <li>▪ Junction gate did not arrive at the home position within the specified time</li> <li>▪ Junction gate did not leave the home position within the specified time</li> </ul>
--	--	--	--

		Staple Junction Gate Motor Error: B830	
SC735	B	<p>The staple tray junction gate HP sensor did not detect the gate at the home position within 200 ms after two attempts.</p> <p>-or-</p> <p>The HP sensor twice detected the gate at the home position for more than 200 ms after it was supposed to open.</p>	<ul style="list-style-type: none"> <li>▪ Junction gate did not arrive at the home position within the specified time</li> <li>▪ Junction gate did not leave the home position within the specified time</li> </ul>

		Pre-Stack Junction Gate Motor Error: 3K Finisher B830	
SC736	D	<p>The pre-stack junction gate HP sensor did not detect the gate at the home position for within 200 ms after two attempts.</p> <p>-or-</p> <p>The HP sensor twice detected the gate at the home position for more than 200 ms after it</p>	<ul style="list-style-type: none"> <li>▪ Junction gate did not arrive at the home position within the specified time</li> <li>▪ Junction gate did not leave the home position within the specified time</li> </ul>

## Troubleshooting

		was supposed to open.	
SC737	D	Pre-Stack Transport Motor Error: B830	
		The pre-stack transport motor is not operating.	<ul style="list-style-type: none"> <li>▪ Motor harness loose, broken, defective</li> <li>▪ Motor is blocked by an obstruction</li> <li>▪ Motor defective</li> <li>▪ Finisher main control board defective</li> </ul>
SC738	D	Pre-Stack Junction Gate Release Motor Error: B830	
		<p>The pre-stack junction gate release HP sensor did not detect the gate at the home position within 200 ms after two attempts.</p> <p>-or-</p> <p>The HP sensor twice detected the gate at the home position for more than 200 ms after it was supposed to open.</p>	<ul style="list-style-type: none"> <li>▪ Junction gate did not arrive at the home position within the specified time</li> <li>▪ Junction gate did not leave the home position within the specified time</li> </ul>
SC740	B	Finisher corner stapler motor error (B830)	
		The stapler motor does not switch off within the prescribed time after operating. The 1st detection failure causes a jam error, and the 2nd failure causes this SC code.	<ul style="list-style-type: none"> <li>▪ Staple jam</li> <li>▪ Number of sheets in the stack exceeds the limit for stapling</li> <li>▪ Stapler motor disconnected, defective</li> </ul>
SC741	B	Finisher corner stapler rotation motor error	

## Troubleshooting

		<p>The stapler does not return to its home position within the specified time after stapling. The 1st detection failure causes a jam error, and the 2nd failure causes this SC code.</p>	<ul style="list-style-type: none"> <li>▪ Stapler rotation motor disconnected, defective</li> <li>▪ Stapler rotation motor overloaded due to obstruction</li> <li>▪ Stapler rotation HP sensor disconnected, defective</li> </ul>
--	--	--	--

		Finisher stapler movement motor error	
SC742	B	<p>The stapler HP sensor is not activated within the specified time after the stapler motor turned on. The 1st detection failure causes a jam error, and the 2nd failure causes this SC code.</p>	<ul style="list-style-type: none"> <li>▪ Stapler movement motor disconnected, defective</li> <li>▪ Stapler movement motor overloaded due to obstruction</li> <li>▪ Stapler HP sensor disconnected, defective</li> </ul>

		Booklet stapler motor error 1	
SC743	B	<p>The front stapler unit saddle-stitch motor does not start operation within the specified time. The 1st detection failure causes a jam error, and the 2nd failure causes this SC code.</p>	<ul style="list-style-type: none"> <li>▪ Front motor disconnected, defective</li> <li>▪ Front motor overloaded due to obstruction</li> </ul>

		Booklet stapler motor error 2	
SC744	B	<p>The rear stapler unit saddle-stitch motor does not start operation within the specified time. The 1st detection failure causes a jam</p>	<ul style="list-style-type: none"> <li>▪ Rear motor disconnected, defective</li> <li>▪ Rear motor overloaded due to obstruction</li> </ul>



## Troubleshooting

		error, and the 2nd failure causes this SC code.	
--	--	---	--

SC745	D	Feed-Out Belt Motor Error (D373/B830)
		The stack feed-out belt HP sensor does not activate within the specified time after the stack feed-out belt motor turns on. The 1st detection failure causes a jam error, and the 2nd failure causes this SC code.
		<p>If the motor is operating</p> <ol style="list-style-type: none"> <li>1. Stack feed-out HP sensor harness loose, broken, defective</li> <li>2. Stack feed-out HP sensor defective</li> </ol> <p>If the motor is not operating:</p> <ol style="list-style-type: none"> <li>1. Feed-out motor blocked by an obstruction</li> <li>2. Feed-out motor harness loose, broken, defective</li> <li>3. Feed-out motor defective</li> <li>4. Booklet finisher main board defective</li> </ol>

SC746	D	Stack Plate Motor Error 1: Front Motor (B830)
		The stack plate HP sensor (front) does not activate within 500 ms after the motor turns on. The 1st detection failure causes a jam error, and the 2nd failure causes this SC code.
		<p>If the motor is operating</p> <ol style="list-style-type: none"> <li>1. Front stack plate HP sensor harness loose, broken, defective</li> <li>2. Front stack plate HP sensor defective</li> </ol> <p>If the motor is not operating:</p> <ol style="list-style-type: none"> <li>1. Motor blocked by an obstruction</li> <li>2. Motor harness loose, broken, defective</li> <li>3. Motor defective</li> <li>4. Booklet finisher main board defective</li> </ol>

SC747	D	Stack Plate Motor Error 2: Center Motor (B830)
		The stack plate HP sensor (center) does not activate within 500 ms after

## Troubleshooting

		the motor turns on. The 1st detection failure causes a jam error, and the 2nd failure causes this SC code.
		<p>If the motor is operating</p> <ol style="list-style-type: none"> <li>1. Center stack plate HP sensor harness loose, broken, defective</li> <li>2. Center stack plate HP sensor defective</li> </ol> <p>If the motor is not operating:</p> <ol style="list-style-type: none"> <li>1. Motor blocked by an obstruction</li> <li>2. Motor harness loose, broken, defective</li> <li>3. Motor defective</li> <li>4. Booklet finisher main board defective</li> </ol>

SC748	D	Stack Plate Motor Error 3: Rear Motor (B830)
		The stack plate HP sensor (rear) does not activate within 500 ms after the motor turns on. The 1st detection failure causes a jam error, and the 2nd failure causes this SC code.
		<p>If the motor is operating</p> <ol style="list-style-type: none"> <li>1. Rear stack plate HP sensor harness loose, broken, defective</li> <li>2. Rear stack plate HP sensor defective</li> </ol> <p>If the motor is not operating:</p> <ol style="list-style-type: none"> <li>1. Motor blocked by an obstruction</li> <li>2. Motor harness loose, broken, defective</li> <li>3. Motor defective</li> <li>4. Booklet finisher main board defective</li> </ol>

SC750	B	Finisher tray 1 (upper tray lift) motor error
		<p>The upper tray paper height sensor does not change its status with the specified time after the tray raises or lowers. The 1st detection failure causes a jam error, and the 2nd failure causes this SC code.</p> <ul style="list-style-type: none"> <li>▪ Tray lift motor disconnected, defective</li> <li>▪ Upper tray paper height sensor disconnected, defective</li> <li>▪ Finisher main board connection to motor loose</li> <li>▪ Finisher main board defective</li> </ul>

SC753	D	Stacking Roller Motor Error (B830)	
		<p>The return drive HP sensor did not detect the stacking roller at the HP sensor within 1 sec.</p> <p>-or-</p> <p>The stacking roller did not leave the home position at the specified time.</p>	
		<p>If the motor is operating</p> <ol style="list-style-type: none"> <li>1. Return drive HP sensor harness loose, broken, defective</li> <li>2. Return drive HP sensor defective</li> </ol> <p>If the motor is not operating:</p> <ol style="list-style-type: none"> <li>1. Motor blocked by an obstruction</li> <li>2. Motor harness loose, broken, defective</li> <li>3. Motor defective</li> <li>4. Finisher main board defective</li> </ol>	

SC754	D	Stacking Roller Drag Motor Error (B830)	
		<p>The stacking roller drag motor did not turn on.</p>	<ul style="list-style-type: none"> <li>▪ Motor harness loose, broken, defective</li> <li>▪ Motor defective</li> <li>▪ Finisher control board defective</li> </ul>

SC755	D	Shift Motor Error: 3K Finisher (B830)	
		<p>The shift tray half-turn sensors:</p> <p>Failed twice to detect the shift tray at the home position at the specified time.</p> <p>-or-</p> <p>Failed twice to detect that the shift tray had left the home position.</p>	
		<p>If the motor is operating</p> <ol style="list-style-type: none"> <li>1. Half-turn sensor 1, 2 harnesses loose, broken, defective</li> <li>2. One of the half-turn sensors defective</li> </ol> <p>If the motor is not operating:</p> <ol style="list-style-type: none"> <li>1. Motor blocked by an obstruction</li> </ol>	

## Troubleshooting

		<ol style="list-style-type: none"> <li>2. Motor harness loose, broken, defective</li> <li>3. Motor defective</li> <li>4. Finisher main board defective</li> </ol>
SC760	D	Finisher punch motor error (B830)
		<p>The punch HP sensor is not activated within the specified time after the punch motor turned on. The 1st detection failure causes a jam error, and the 2nd failure causes this SC code.</p> <ul style="list-style-type: none"> <li>▪ Punch HP sensor disconnected, defective</li> <li>▪ Punch motor disconnected, defective</li> <li>▪ Punch motor overload due to obstruction</li> </ul>
SC761	B	Finisher folder plate motor error (D373)
		<p>The folder plate moves but is not detected at the home position within the specified time. The 1st detection failure causes a jam error, and the 2nd failure causes this SC code.</p> <ul style="list-style-type: none"> <li>▪ Folder plate HP sensor disconnected, defective</li> <li>▪ Folder plate motor disconnected, defective</li> <li>▪ Folder plate motor overloaded due to obstruction.</li> </ul>
SC763	D	Punch movement motor error
		<p>Occurs during operation of the punch unit. The 1st detection failure causes a jam error, and the 2nd failure causes this SC code.</p> <ul style="list-style-type: none"> <li>▪ Motor harness disconnected, loose, defective</li> <li>▪ Motor defective</li> </ul>
SC764	D	Paper position sensor slide motor error
		<p>Occurs during operation of the</p> <ul style="list-style-type: none"> <li>▪ Motor harness disconnected, loose,</li> </ul>

Troubleshooting

		punch unit. The 1st detection failure causes a jam error, and the 2nd failure causes this SC code.	<ul style="list-style-type: none"> <li>▪ defective</li> <li>▪ Motor defective</li> </ul>
--	--	--	--

SC765	D	Fold Unit Bottom Fence Lift Motor Error (D373)	
		The fold unit bottom fence did not return to the home position within the specified time.	<ul style="list-style-type: none"> <li>▪ Fold bottom fence mechanism overloaded due to an obstruction</li> <li>▪ Fold bottom fence HP sensor connector loose, broken, defective</li> <li>▪ Fold bottom fence HP sensor defective</li> <li>▪ Fold bottom fence lift motor connector loose, broken, defective</li> <li>▪ Fold bottom fence lift motor defective</li> <li>▪ Main control board defective</li> </ul>

SC766	D	Clamp Roller Retraction Motor (D373)	
		The clamp roller did not return to the home position within the specified time.	<ul style="list-style-type: none"> <li>▪ Clamp roller mechanism overloaded due to an obstruction</li> <li>▪ Clamp roller HP sensor connector loose, broken, defective</li> <li>▪ Clamp roller HP sensor defective</li> <li>▪ Clamp roller retraction motor connector loose, broken, defective</li> <li>▪ Clamp roller retraction motor defective</li> <li>▪ Main control board defective</li> </ul>

SC767	D	Stack Junction Gate Motor (D373)	
		The stack junction gate did not	<ul style="list-style-type: none"> <li>▪ Stack junction mechanism</li> </ul>

Troubleshooting

		return to the home position within the specified time.	<p>overloaded due to an obstruction</p> <ul style="list-style-type: none"> <li>▪ Stack junction gate HP sensor connector loose, broken, defective</li> <li>▪ Stack junction gate HP sensor defective</li> <li>▪ Stack junction gate motor connector loose, broken, defective</li> <li>▪ Stack junction gate motor defective</li> <li>▪ Main control board defective</li> </ul>
--	--	--	--

SC770	D	Cover Interposer Lift Motor 1 Error	
		<p>In the first tray:</p> <ul style="list-style-type: none"> <li>▪ The upper limit sensor did not detect the bottom plate within the specified time after the lift motor switched on to lift the bottom plate.</li> <li>▪ The lower limit sensor did not direct the bottom plate within the specified time after the lift motor switched on to lower the bottom plate.</li> </ul> <p><b>Note:</b> In both cases, 1 error count indicates a jam, 2 error counts cause this SC code.</p>	
		<ul style="list-style-type: none"> <li>▪ Lift motor, upper limit sensor, lower limit sensor harnesses, connectors loose, broken, defective</li> <li>▪ Lift motor defective</li> <li>▪ Upper limit sensor defective</li> <li>▪ Lower limit sensor defective</li> </ul>	

SC771	D	Cover Interposer Lift Motor 2 Error	
		<p>In the second tray:</p> <ul style="list-style-type: none"> <li>▪ The upper limit sensor did not detect the bottom plate within the specified time after the lift motor switched on to lift the bottom plate.</li> <li>▪ The lower limit sensor did not direct the bottom plate within the specified time after the lift motor switched on to lower the bottom plate.</li> </ul> <p><b>Note:</b> In both cases, 1 error count indicates a jam, 2 error counts cause</p>	

Troubleshooting

		this SC code.
		<ul style="list-style-type: none"> <li>▪ Lift motor, upper limit sensor, lower limit sensor harnesses, connectors loose, broken, defective</li> <li>▪ Lift motor defective</li> <li>▪ Upper limit sensor defective</li> <li>▪ Lower limit sensor defective</li> </ul>

SC772	D	Cover Interposer Pickup Motor 1 Error
		<p>In the first tray:</p> <ul style="list-style-type: none"> <li>▪ While the pick-up roller motor was on, the pick-up roller HP sensor did not detect the pick-up roller at the home position within the specified number of pulses.</li> <li>▪ While the pick-up roller motor was on, the pick-up roller HP sensor did not detect the pick-up roller at the home position above the specified number of pulses.</li> </ul> <p><b>Note:</b> In both cases, 1 error count indicates a jam, 2 error counts cause this SC code.</p>
		<ul style="list-style-type: none"> <li>▪ The pick-up motor, pick-up roller HP sensor harnesses, connectors were loose, broken, defective</li> <li>▪ Pick-up motor overload due to an obstruction</li> <li>▪ Pick-up motor defective</li> <li>▪ Pick-up roller HP sensor defective</li> </ul>

SC773	D	Cover Interposer Pickup Motor 2 Error
		<p>In the second tray:</p> <ul style="list-style-type: none"> <li>▪ While the pick-up roller motor was on, the pick-up roller HP sensor did not detect the pick-up roller at the home position within the specified number of pulses.</li> <li>▪ While the pick-up roller motor was on, the pick-up roller HP sensor did not detect the pick-up roller at the home position above the specified number of pulses.</li> </ul> <p><b>Note:</b> In both cases, 1 error count indicates a jam, 2 error counts cause</p>

Troubleshooting

		this SC code.
		<ul style="list-style-type: none"> <li>▪ The pick-up motor, pick-up roller HP sensor harnesses, connectors were loose, broken, defective</li> <li>▪ Pick-up motor overload due to an obstruction</li> <li>▪ Pick-up motor defective</li> <li>▪ Pick-up roller HP sensor defective</li> </ul>

SC775	D	Jogger Top Fence Motor: 3K Finisher B830
		<p>The top fence HP sensor detected that: The top fence did not arrive at the home position within the specified number of pulses.</p> <p>-or-</p> <p>The top fence failed to leave the home position within the specified number of pulses.</p>
		<p>If the jogger top fence motor is operating:</p> <ol style="list-style-type: none"> <li>1. Top fence HP sensor harness loose, broken, defective</li> <li>2. Top fence HP sensor defective</li> </ol> <p>If the jogger top fence motor is not operating:</p> <ol style="list-style-type: none"> <li>1. Motor blocked by an obstruction</li> <li>2. Motor harness loose, broken, defective</li> <li>3. Motor defective</li> <li>4. Finisher main board defective</li> </ol>

SC776	D	Jogger Bottom Fence Motor (B830)
		<p>The bottom fence HP sensor detected that: The bottom fence did not arrive at the home position at the specified time.</p> <p>-or-</p> <p>The bottom fence failed to leave the home position at the specified time.</p>
		<p>If the jogger bottom fence motor is operating:</p> <ol style="list-style-type: none"> <li>1. Bottom fence HP sensor harness loose, broken, defective</li> <li>2. Bottom fence HP sensor defective</li> </ol>



## Troubleshooting

		<p>If the jogger bottom fence motor is not operating:</p> <ol style="list-style-type: none"> <li>1. Motor blocked by an obstruction</li> <li>2. Motor harness loose, broken, defective</li> <li>3. Motor defective</li> <li>4. Finisher main board defective</li> </ol>	
SC780	D	Z-Fold Feed Motor Error	
		<p>The feed motor that drives the feed rollers and exit rollers in the Z-fold unit is not operating. The 1st alert signals a jam, the 2nd alert triggers this SC.</p>	<ul style="list-style-type: none"> <li>▪ Motor harness loose, broken, defective</li> <li>▪ Motor blocked by an obstruction</li> <li>▪ Motor defective</li> </ul>
SC781	D	Z-Fold Lower Stopper Motor Error	
		<p>The lower stopper failed to leave the home position with the specified number of motor pulses. <b>Note:</b> The 1st detection failure causes a jam error, and the 2nd failure causes this SC code.</p>	<ul style="list-style-type: none"> <li>▪ Lower stopper motor disconnected, defective</li> <li>▪ Lower stopper motor overloaded due to obstruction</li> <li>▪ Lower stopper HP sensor disconnected, defective</li> </ul>
SC782	D	Z-fold Upper Stopper Motor	
		<p>The upper stopper failed to leave the home position with the specified number of motor pulses. <b>Note:</b> The 1st detection failure causes a jam error, and the 2nd failure causes this SC code.</p>	<ul style="list-style-type: none"> <li>▪ Upper stopper motor disconnected, defective</li> <li>▪ Upper stopper motor overloaded due to obstruction</li> <li>▪ Upper stopper HP sensor disconnected, defective</li> </ul>
SC784	D	Z-Fold Timing Sensor Adjustment Error 1	
		<p>The output voltage light emitted</p>	<ul style="list-style-type: none"> <li>▪ Sensor, mirror dirty from paper</li> </ul>

## Troubleshooting

		from the sensor changed, but the return input was not sufficient to attain V0.	<ul style="list-style-type: none"> <li>▪ dust, other particles</li> <li>▪ Harness loose, broken, defective</li> <li>▪ Mirror out of position</li> </ul>
--	--	--	---

SC785	D	Z-Fold Timing Sensor Adjustment Error 2	
		The output voltage light emitted from the sensor changed, but the return input was not sufficient to attain V0.	<ul style="list-style-type: none"> <li>▪ Sensor, mirror dirty from paper dust, other particles</li> <li>▪ Harness loose, broken, defective</li> <li>▪ Mirror out of position</li> </ul>

SC786	D	Z-Fold Memory Error	
		Several attempts to write to the Z-fold memory failed.	<ul style="list-style-type: none"> <li>▪ Turn the machine power off/on</li> <li>▪ EEPROM on Z-Folder main board defective</li> </ul>

## SC800: Overall System

SC817	C	Boot loader error *GW	
		The boot loader cannot read one of the following: self-diagnostic module, kernel, or one of the files of the root file system, or the check of one of these items on the system SD card failed.	<ul style="list-style-type: none"> <li>▪ File or module on the system SD card is corrupted</li> <li>▪ File or module on the system SD card is illegal</li> <li>▪ Make sure that the system SD card is the one designed for the machine</li> <li>▪ Replace controller board.</li> </ul>

SC819	C	Fatal kernel error *GW	
-------	---	------------------------	--

## Troubleshooting

		Due to a control error, a RAM overflow occurred during system processing. One of the following messages was displayed on the operation panel.	<ul style="list-style-type: none"> <li>▪ System program defective</li> <li>▪ Controller board defective</li> <li>▪ Optional board defective</li> <li>▪ Replace controller firmware</li> </ul>
		0x696e	init died
		0x766d	vm_pageout: VM is full
		4361	Cache Error
		Other	

**Note:** For more details about this SC code error, execute SP5990 to print an SMC report so you can read the error code list. The error code is not displayed on the operation panel.

		Self-diagnostic error 1: ASIC *GW	
		The ASIC provides the central point for the control of bus arbitration for CPU access, for option bus and SDRAM access, for SDRAM refresh, and for management of the internal bus gate.	
		0B00	<p>Error code 0xffff ffff is returned when the register Write &amp; Verify check is executed on the ASIC mounted on the controller board. The ASIC controls the ROM and buses for other devices.</p> <ul style="list-style-type: none"> <li>▪ ASIC (controller board defective)</li> </ul>
		0B06	<p>ASIC not detected</p> <ul style="list-style-type: none"> <li>▪ ASIC (controller board defective)</li> <li>▪ Poor connection between North Bridge and PCI I/F: Replace controller board</li> </ul>
		0B10	<p>Failed to initialize or could not read connection bus. Data in</p> <ul style="list-style-type: none"> <li>▪ Replace controller board</li> </ul>

## Troubleshooting

			SHM register incorrect.	
--	--	--	-------------------------	--

**Note:** For more details about this SC code error, execute SP5990 to print an SMC report so you can read the error code. The error code is not displayed on the operation panel.

SC822	C	Self-diagnostic error 2: HDD *GW	
	3003	<p>Check performed when HDD is installed: HDD device busy for over 31 s. After a diagnostic command is set for the HDD, but the device remains busy for over 6 s. A diagnostic command is issued to the HDD device but the result is an error</p>	<ul style="list-style-type: none"> <li>▪ HDD defective</li> <li>▪ HDD harness disconnected, defective</li> <li>▪ Controller board defective</li> </ul>
	3004	No response to the self-diagnostic command from the ASIC to the HDDs	<ul style="list-style-type: none"> <li>▪ HDD defective</li> </ul>
	3013	Mandolin does not respond, the HDD device remains BUSY for more than 31 s, or the BUSY signal does not drop within 6 s after the diagnostic command is issued to the HDDs.	<ul style="list-style-type: none"> <li>▪ HDD defective</li> <li>▪ HDD connector loose or defective</li> <li>▪ Controller defective</li> </ul>
	3014	Error returned from HDD in response to the self-diagnostic command, Mandolin could not be located due to a read/write error at the HDD register.	<ul style="list-style-type: none"> <li>▪ HDD defective</li> </ul>

		Self-diagnostic error 3: NVRAM *GW	
SC824	C	<p>NVRAM device does not exist, NVRAM device is damaged, NVRAM socket damaged</p>	<ul style="list-style-type: none"> <li>▪ NVRAM defective</li> <li>▪ Controller board defective</li> <li>▪ NVRAM backup battery exhausted</li> </ul>

## Troubleshooting

			<ul style="list-style-type: none"> <li>▪ NVRAM socket damaged</li> </ul>
--	--	--	--

SC829		Self-diagnostic error 5: Optional RAM	
		Verify error for optional RAM.	<ul style="list-style-type: none"> <li>▪ Make sure that the resident RAM is installed in the correct slot.</li> <li>▪ Make sure the optional RAM is installed in the correct slot (Slot 0)</li> </ul>

SC833	D	Self-diagnostic error 8: Engine I/F ASIC *GW	
0F30 0F31		ASIC (Mandolin) for system control could not be detected. After the PCI configuration, the device ID for the ASIC could not be checked.	<ul style="list-style-type: none"> <li>▪ Replace the VBCU</li> </ul>
0F41		The read/write check done for resident RAM on the mother board could not be done correctly.	<ul style="list-style-type: none"> <li>▪ Replace the VBCU.</li> </ul>
50B1		Could not initialize or read the bus connection.	<ul style="list-style-type: none"> <li>▪ Check for loose connections at VBCU.</li> <li>▪ Replace VBCU</li> </ul>
50B2		Value of the SSCG register is incorrect.	<ul style="list-style-type: none"> <li>▪ Check for loose connections at VBCU.</li> <li>▪ Replace VBCU</li> </ul>

SC834	D	Self-diagnostic error 9: Optional Memory RAM DIMM	
5101		The write/verify check for the optional RAM chip on the controller board returned an error.	<ul style="list-style-type: none"> <li>▪ Controller defective</li> </ul>

## Troubleshooting

SC850	B	Net I/F error	
		Duplicate IP addresses. Illegal IP address. Driver unstable and cannot be used on the network.	<ul style="list-style-type: none"> <li>▪ IP address setting incorrect</li> <li>▪ Ethernet board defective</li> <li>▪ Controller board defective</li> </ul>

SC858	B	Data Encryption Error 1	
		These are errors of the HDD Data Encryption Option D377.	
	0	Key Acquisition	Key could be acquired. <ul style="list-style-type: none"> <li>▪ Replace the controller board</li> </ul>
	1	HDD Key Setting Error	The key was acquired but the HDD could not be set. <ul style="list-style-type: none"> <li>▪ Turn the machine power off/on several times.</li> <li>▪ Replace the controller board.</li> </ul>
	2	NVRAM Read Error	NVRAM data conversion failed (mismatch with nvram.conf) <ul style="list-style-type: none"> <li>▪ Replace the NVRAM</li> </ul>
	30	NVRAM Before Replace Error	DFU. May occur during development. <ul style="list-style-type: none"> <li>▪ Turn the machine power off/on several times.</li> <li>▪ Replace the controller board.</li> </ul>
	31	Other Error	An unexpected error occurred while data was being converted. This error is the same as SC991. See SC991 below.

SC859	B	Data Encryption Error 2	
		These are errors of the HDD Data Encryption Option D377.	
	8	HDD Check Error	Data conversion was attempted with no HDD unit present.

## Troubleshooting

			<ul style="list-style-type: none"> <li>▪ Confirm that HDD unit installed correctly</li> <li>▪ Initialize HDD with SP5832-1</li> </ul> <p><b>Note:</b> After installation, a new HDD should be formatted with SP5832-1</p>
	9	Power Loss During Data Conversion	<p>Data conversion stopped before NVRAM/HDD data was converted.</p> <ul style="list-style-type: none"> <li>▪ Format HDD with SP5832-1</li> </ul>
	10	Data Read Command Error	<p>More than two illegal DMAC communications were returned.</p> <ul style="list-style-type: none"> <li>▪ HDD defective</li> <li>▪ Format HDD with SP5832-1</li> <li>▪ Replace HDD</li> </ul>

		HDD re-try failure *GW	
SC861	D	At power on with the HDD detected, power supply to the HDD is interrupted, after the HDD is awakened from the sleep mode, the HDD is not ready within 30 s.	<p>Harness between HDD and board disconnected, defective</p> <p>HDD power connector disconnected</p> <p>HDD defective</p> <p>Controller board defective</p>

		HDD data read failure *GW	
SC863	D	The data written to the HDD cannot be read normally, due to bad sectors generated during operation.	<p>HDD defective</p> <p>Note: If the bad sectors are generated at the image partition, the bad sector information is written to NVRAM, and the next time the HDD is accessed, these bad sectors will not be accessed for read/write operation.</p>

SC864	D	HDD data CRC error *GW	
-------	---	------------------------	--

## Troubleshooting

		During HDD operation, the HDD cannot respond to an CRC error query. Data transfer did not execute normally while data was being written to the HDD.	HDD defective
SC865	D	HDD access error *GW	
		HDD responded to an error during operation for a condition other than those for SC863, 864.	HDD defective.
SC867	D	SD card error 2: SD card removed *GW	
		The SD card in the boot slot when the machine was turned on was removed while the machine was on.	Insert the SD card, then turn the machine off and on.
SC868	D	SD card error 3: SD card access *GW	
		An error occurred while an SD card was being used.	<ul style="list-style-type: none"> <li>▪ SD card not inserted correctly</li> <li>▪ SD card defective</li> <li>▪ Controller board defective</li> </ul>
SC870	B	Address book data error *GW	
		Address book data on the hard disk was detected as abnormal when it was accessed from either the operation panel or the network. The address book data cannot be read from the HDD or SD card where it is stored, or the data read from the media is	<ul style="list-style-type: none"> <li>▪ Software defective.</li> <li>▪ Cycle the machine off/on.</li> <li>▪ Replace controller firmware.</li> <li>▪ HDD defective.</li> </ul>



## Troubleshooting

		defective.	
		<p>More Details</p> <ul style="list-style-type: none"> <li>▪ Do SP5846-50 (UCS Settings – Initialize all Directory Info.) to reset all address book data.</li> <li>▪ Reset the user information with SP5832-6 (HDD Formatting– User Info).</li> <li>▪ Replace the HDDs.</li> <li>▪ Boot the machine from the SD card.</li> </ul>	

		Delete All error 1: HDD *GW	
SC874	D	<p>A data error was detected for the HDD/NVRAM after the Delete All option was used.</p> <p><b>Note:</b> The source of this error is the Data Overwrite Security Unit running from an SD card.</p>	<ul style="list-style-type: none"> <li>▪ Turn the main switch off/on and try the operation again.</li> <li>▪ Install the Data Overwrite Security Unit again..</li> <li>▪ HDD defective</li> </ul>

		Delete All error 2: Data area *GW	
SC875	D	<p>An error occurred while the machine deleted data from the HDD.</p> <p><b>Note:</b> The source of this error is the Data Overwrite Security Unit D377 running from an SD card.</p>	<ul style="list-style-type: none"> <li>▪ Cycle the machine off/on.</li> <li>▪ Try the operation again.</li> </ul>

---

## SC900: Miscellaneous

---

		Mechanical Counter 1 error	
SC901		<p>Mechanical Counter 1 was not set correctly at power on, or the operator disconnected the counter while machine was operating.</p>	<ul style="list-style-type: none"> <li>▪ Mechanical Counter 1 connection loose or defective</li> <li>▪ Mechanical Counter 1 defective</li> </ul>

## Troubleshooting

---

		Mechanical Counter 2 error	
SC902		Mechanical Counter 2 was not set correctly at power on, or the operator disconnected the counter while machine was operating.	<ul style="list-style-type: none"> <li>▪ Mechanical Counter 2 connection loose or defective</li> <li>▪ Mechanical Counter 2 defective</li> </ul>

SC910	B	External controller error 1 *GW	
SC911		External controller error 2 *GW	
SC912		External controller error 3 *GW	
SC913		External controller error 4 *GW	
		The external controller (Fiery) sends an error message.	<ul style="list-style-type: none"> <li>▪ Turn the machine power off/on</li> </ul>

SC914	B	External controller error 5 *GW	
		The external controller (Fiery) sends an error message.	<ul style="list-style-type: none"> <li>▪ Turn the machine power off/on</li> </ul>

SC919	D	External controller down *GW	
		The EAC received an interrupt signal from the FLUTE serial driver during print jobs in progress and the connection between the copier and external controller was broken. Note: The EAC is the External Api Converter.	<ul style="list-style-type: none"> <li>▪ Switch the machine off and on.</li> </ul>

SC925	B	Net File function error *GW	
-------	---	-----------------------------	--

## Troubleshooting

---

		The NetFile file management on the HDD cannot be used, or a NetFile management file is corrupted and operation cannot continue. The HDDs are defective and they cannot be debugged or partitioned, so the Scan Router functions (delivery of received faxes, document capture, etc.), Web services, and other network functions cannot be used. HDD status codes are displayed below the SC code:
		<ul style="list-style-type: none"><li>Refer to the four procedures below (Recovery from SC 925).</li></ul>

Here is a list of HDD status codes:

Display	Meaning
(-1)	HDD not connected
(-2)	HDD not ready
(-3)	No label
(-4)	Partition type incorrect
(-5)	Error returned during label read or check
(-6)	Error returned during label read or check
(-7)	“filesystem” repair failed
(-8)	“filesystem” mount failed
(-9)	Drive does not answer command
(-10)	Internal kernel error
(-11)	Size of drive is too small
(-12)	Specified partition does not exist
(-13)	Device file does not exist

### Recovery from SC 925

#### Procedure 1

If the machine shows SC codes for HDD errors (SC860 to SC865) with SC 925, do the

## Troubleshooting

---

recovery procedures for SC860 to SC865.

### Procedure 2

1. If the machine does not show one of the five HDD errors (SC860 to SC865), turn the machine power off and on.
2. If this is not the solution for the problem, then initialize the NetFile partition on the HDD with SP5832-11 (HDD Formatting – Ridoc I/F).  
NetFiles: These are jobs printed from the document server using a PC and DeskTopBinder. Before you initialize the NetFile partition on the HDD, tell the customer:
  - Received faxes on the delivery server will be erased
  - All captured documents will be erased
  - DeskTopBinder/Print Job Manager/Desk Top Editor job history will be erased
  - Documents on the document server, and scanned documents, will not be erased.
  - The first time that the network gets access to the machine, the management information must be configured again (this will use a lot of time).
3. Before you initialize the Netfile partition with SP5832-11, do these steps:
4. Go into the User Tools mode and do “Delivery Settings” to print all received fax documents that are scheduled for delivery. Then erase them.
5. In the User Tools mode, do Document Management> Batch Delete Transfer Documents.
6. Do SP5832-11, then turn the machine power off and on.

### Procedure 3

1. If “Procedure 2” is not the solution for the problem, do SP5832-1 (HDD Formatting – All)
2. Cycle the machine off/on.



- **SP5832-001 erases all document and address book data on the hard disks. Consult with the customer before you do this SP code.**

### Procedure 4

If “Procedure 3” does not solve the problem, replace the HDD.

---

## Additional SC Codes Printed in SMC Reports

---

These codes are also used in the SMC report. Codes that have the same number in this series are identified by an additional 4-digit hexadecimal number.

SC No.	Symptom	Possible Cause
853	D	IEEE802 11b card startup error

## Troubleshooting

SC No.	Symptom	Possible Cause
	Not used.	
854	D	IEEE802 11b card access error
		Not used.
855	D	IEEE802 11b card error
		Not used.
856	D	IEEE802 11b card connection board error
		Not used.
870	B	Address book data error
		<p>The address book in the hard disk is accessed. → An error is detected in the address book data; address book data is not read; or data is not written into the address book.</p> <ul style="list-style-type: none"> <li>▪ Data corruption</li> <li>▪ Defective hard disk</li> <li>▪ Defective software</li> </ul>
		<p>To recover from the error, do any of the following countermeasures:</p> <ul style="list-style-type: none"> <li>▪ Format the address book by using SP5-832-8. All data in the address book (including the user codes and counters) is initialized</li> <li>▪ Initialize the user data by using SP5-832-6 and -7 (the user codes and counters are recovered when the main switch is turned on).</li> <li>▪ Replace the hard disk (the user codes and counters are recovered when the main switch is turned on).</li> </ul>

920	D	Printer error
		<p>The printer program cannot be continued.</p> <ul style="list-style-type: none"> <li>▪ Defective hardware</li> <li>▪ Data corruption</li> <li>▪ Defective software</li> </ul>
925	D	Net file error
		<p>The management file for net files is</p> <ul style="list-style-type: none"> <li>▪ Defective hardware</li> </ul>

Troubleshooting

		<p>corrupted; net files are not normally read.</p> <p><b>Netfiles:</b> Jobs to be printed from the document server using a PC and the DeskTopBinder software</p>	<ul style="list-style-type: none"> <li>▪ Data corruption</li> <li>▪ Defective software</li> </ul>
992	C	Other system SCs	
		The controller received an unknown SC code from the engine.	<ul style="list-style-type: none"> <li>▪ Contact your product specialist.</li> </ul>
993	D	Network error	
		The ASIC program of GW controller cannot be continued.	<ul style="list-style-type: none"> <li>▪ Defective GW controller</li> </ul>

# Service Tables

---

## Service Program Mode

---

Notation	What it means
[range/step]	Example: [-9~+9/0.1 mm] The default setting can be adjusted in 0.1mm steps in the range $\pm 9$ . <b>Note:</b> The default setting for each SP mode is shown on the screen in the "Initial" box immediately below the entry box.
<b>DFU</b>	Denotes "Design or Factory Use". Do not change this value.
<b>Japan Only</b>	The feature or item is for Japan only. Do not change this value.
<b>LEF</b>	Long Edge Feed
<b>SEF</b>	Short Edge Feed
<b>Fin3, Fin4</b>	Please ignore. These notations refer to finishers not yet available for this machine at the present time (Oct 2007).

## Group 1000

---

1001	Lead Edge Reg
	<p>Adjusts the printing leading edge registration using the trimming area pattern (SP2109-2, Pattern No. 10).</p> <p>[-9 to +9/ 0.1 mm]</p> <p>Specification: 3 ±2mm</p>

1002	Fine Adj LEdge (Thick)	
	<p>Fine adjusts leading edge registration for thick paper (Thick 2, Thick 3).</p> <p>[-9 to +9/ 0.1 mm]</p>	
1	Thick 2	Thick 2: 164 to 249.9 g/m <sup>2</sup>
2	Thick 3	Thick 3: 250 to 300 g/m <sup>2</sup>

1003	Side-to-Side Reg	
	<p>Side-to-Side Registration Adjustment. Adjusts printing side-to-side registration for each feed station, using the test pattern (SP2109-2, Pattern No. 10). These SP's should be adjusted after replacing the laser synchronization detector or the laser optical unit.</p>	
1	Tray 1	[-9 to +9/ 0.1 mm]
2	Tray 2	
3	Tray 3	
4	Tray 4	<b>Japan Only</b>
5	Bypass Tray	



Service Tables

6	Dupx Tray	
7	LCT	LCT1: B473
8	WIDE LCT	LCT2: D350

1004	Reg Buckle Adj	
	Registration Buckle Adjustment. Adjusts the registration motor timing. This timing determines the amount of paper buckle at registration. (A higher setting causes more buckling.)	
1	Trays & LCT	[-9 to +9/1 mm]
2	Dupx Tray	
3	Bypass Tray	

1005	Reg Buckle Adj (Thick)	
	Registration Buckle Adjustment (Thick Paper) Adjusts the registration motor timing for thick paper only. This timing determines the amount of paper buckle at registration. (A higher setting causes more buckling.)	
1	Thick 2	Thick 2: 164 to 249.9 g/m <sup>2</sup>
2	Thick 3	Thick 3: 250 to 300 g/m <sup>2</sup>

1006	Bypass Size Disp	
	Bypass Paper Size Detection Display. Use this SP to display and confirm the size of the paper detected in the by-pass tray if paper is skewing during feeding. [0 to 255/1 mm]	

Service Tables

---

1007	Duplex Fence Adj
	Duplex Side Fence Position Adjustment. Allows fine adjustment of the distance between the edges of the sheet and the jogger fences when the fences come together to position the sheet in the duplex unit. [-3 to +3/0.1 mm]

1008	Reg Roller Adj	
	Sets the length of time the paper is force pre-fed and stopped at the registration roller for normal speed and half-speed.	
1	Normal Speed	[-3 to +3/ 0 /0.1
2	Half Speed	[-3 to +3/ -0.6 /0.1

1009	PreFeed Time Adj	
	Sets the length of time the paper is force pre-fed and stopped at the registration roller for each paper feed source.. [0 to 3/ 0 / 1]	
1	Tray 1	
2	Tray 2	
3	Tray 3	
4	Tray 4	
5	LCT 1	
6	LCT 2	
7	Bypass Tray	

1010	Fine Adj Mtr Speed <b>DFU</b>
	These SP codes are used to fine adjust the speed of the motors.

Service Tables

	[-3 to 3/-0.3/0.1	
1	Drum Motor:K	
2	Drum Motor:M	
3	Drum Motor:C	
4	Drum Motor:Y	
5	K Dev Motor: Norm2	
6	M Dev Motor: Norm2	
7	C Dev Motor: Norm2	
8	Y Dev Motor: Norm2	
9	K Drum CL Mtr: Norm2	
10	M Drum CL Mtr: Norm2	
11	C Drum CL Mtr: Norm2	
12	Y Drum CL Mtr: Norm2	
13	ITB Motor: Norm2	
14	PTR Motor: Norm2	
15	Fusing Motor: Norm2	

1011	Motor Adj.: Norm 1 <b>DFU</b>	
	These SP codes are used to adjust the speed of the motors for Normal speed 1.. [-3 to 3/0/0.1	
5	K Dev Motor	
6	M Dev Motor	
7	C Dev Motor	
8	Y Dev Motor	

Service Tables

9	K Drum CL Mtr	
10	M Drum CL Mtr	
11	C Drum CL Mtr	
12	Y Drum CL Mtr	
13	ITB Motor	
14	PTR Motor	
15	Fusing Motor	

1012	Mtr Adj.: Half 2 <b>DFU</b>	
	These SP codes are used to adjust the speed of the motors for Half speed 2. [-3 to 3/0/0.1	
5	K Dev Motor	
6	M Dev Motor	
7	C Dev Motor	
8	Y Dev Motor	
9	K Drum CL Mtr	
10	M Drum CL Mtr	
11	C Drum CL Mtr	
12	Y Drum CL Mtr	
13	ITB Motor	
14	PTR Motor	
15	Fusing Motor	

1013	Motor Adj.: Half 1 <b>DFU</b>	
------	-------------------------------	--

Service Tables

	These SP codes are used to adjust the speed of the motors for Half speed 1. [-3 to 3/0/0.1	
5	K Dev Motor	
6	M Dev Motor	
7	C Dev Motor	
8	Y Dev Motor	
9	K Drum CL Mtr	
10	M Drum CL Mtr	
11	C Drum CL Mtr	
12	Y Drum CL Mtr	
13	ITB Motor	
14	PTR Motor	
15	Fusing Motor	

1105	Hot, Htg, Press Roll Temp <b>DFU</b>	
	[140 to 200/ 170 / 1 deg.]	
1	Htg Roll Ctr:Reload	
2	Htg Roll Ctr:Idle:Reload	
3	Htg Roll Ctr:Wait:Norm	
4	Htg Roll Ctr:Wait:Low	
5	Htg Roll Ctr:Wait:High	
6	Htg Roll Ctr:1-S:Norm1:Normal	
7	Htg Roll Ctr:1-S:Norm1:high adhesion	
8	Htg Roll Ctr:1-S:Norm2:Normal	

Service Tables

9	Htg Roll Ctr:1-S:Norm2:high adhesion	
10	Htg Roll Ctr:1-S:Trace:Normal	
11	Htg Roll Ctr:1-S:Trace:high adhesion	
12	Htg Roll Ctr:1-S:Mid Thk:Normal	
13	Htg Roll Ctr:1-S:Mid Thk:high adhesion	
14	Htg Roll Ctr:1-S:Thk1:Normal	
15	Htg Roll Ctr:1-S:Thk1:high adhesion	
16	Htg Roll Ctr:Thk2:Normal	
17	Htg Roll Ctr:Thk2:high adhesion	
18	Htg Roll Ctr:Thk3:Normal	
19	Htg Roll Ctr:Thk3:high adhesion	
20	Htg Roll Ctr:OHP:Normal	
21	Htg Roll Ctr:OHP:high adhesion	
22	Htg Roll Ctr:2-S:Norm1:1C	
23	Htg Roll Ctr:2-S:Norm1:FC	
24	Htg Roll Ctr:2-S:Norm2:1C	
25	Htg Roll Ctr:2-S:Norm2:FC	
26	Htg Roll Ctr:2-S:Trace:1C	
27	Htg Roll Ctr:2-S:Trace:FC	
28	Htg Roll Ctr:2-S:Mid Thk:1C	
29	Htg Roll Ctr:2-S:Mid Thk:FC	
30	Htg Roll Ctr:2-S:Thk1:1C	
31	Htg Roll Ctr:2-S:Thk1:FC	

Service Tables

32	Htg Roll End:Reload: Adj	
33	Htg Roll End:Idle:Reload:Adj	
34	Htg Roll End:Wait:Norm:Adj	
35	Htg Roll End:Wait:Low:Adj	
36	Htg Roll End:Wait:High:Adj	
37	Htg Roll End:Feed:Adj	
38	Press Roll:Reload	
39	Press Roll:Idle:Reload	
40	Press Roll:Wait:Norm	
41	Press Roll:Wait:Low	
42	Press Roll:Wait:High	
43	Press Roll:1-S:Norm1	
44	Press Roll:1-S:Norm2	
45	Press Roll:1-S:Trace	
46	Press Roll:1-S:Mid Thk	
47	Press Roll:1-S:Thk1	
48	Press Roll:Thk2	
49	Press Roll:Thk3	
50	Press Roll:OHP	
51	Press Roll:2-S:Norm1	
52	Press Roll:2-S:Norm2	
53	Press Roll:2-S:Trace	
54	Press Roll:2-S:Mid Thk	

Service Tables

55	Press Roll:2-S:Thk1	
56	Hot Roll:Wait:Norm	
57	Hot Roll:Wait:Low	
58	Hot Roll:Wait:High	
59	Hot Roll L3:Ctr Corr Temp	
60	Hot Roll L3:End correction Temp	
61	Hot Roll:High Rot Temp	

1106	Temp Ctrl	
	These SP codes control the temperature control of the hot roller and display the temperatures of the hot roller, pressure roller, heating roller, and heating roller lamps.	
1	0:ON/OFF 1:PID	Hot roller fusing lamp control switch 0: OFF, 1: <b>PID</b>
2	Htg Roll Ctr Temp	Displays the temperature in centigrade of the fusing lamp (center) in the heating roller. Range: 0 to 230
3	Htg Roll End Temp	Displays the temperature in centigrade of the fusing lamp (ends) in the heating roller. Range: 0 to 230
4	Press Roll Temp	Displays the temperature in centigrade of the pressure roller. Range: 0 to 230
5	Hot Roll Temp	Displays the temperature in centigrade of the hot roller. Range: 0 to 230

1107	Mode Shift <b>DFU</b>	
1	Low Temp On/Off	
2	High Temp On/Off	



Service Tables

3	Low Temp:Reload	
4	High Temp:Reload	
5	Low Temp:Feed	
6	High Temp:Feed	
7	L-Limit:Htg Roll:Reload	
8	L-Limit:Press Roll:Reload	
9	H-Limit:Htg Roll:Reload	
10	H-Limit:Press Roll:Reload	
11	L-Limit:Htg Roll:Feed	
12	L-Limit:Press Roll:Feed	
13	H-Limit:Htg Roll:Feed	
15	Press Temp:Norm1	
16	Press Temp:Norm2	
17	Press Temp:Trace	
18	Press Temp:Mid Thk	
19	Press Temp:Thk1	
20	Press Temp:Thk2	
21	Press Temp:Thk3	
22	Press Temp:OHP	
25	Idle:Reload:Time	
26	Idle:Wait/Time,Low	
27	Ready:Feed:Time	
28	Press:Time	

Service Tables

29	Idle:End:Time	
35	Idle:Wait:Time,High	
36	Low Temp Reload Time Extend	
37	Extend Start Time Allowed: Line Feed	

1109	High Adhesion Mode	
1	[*0:Normal] [1: High Adhesion]	

1110	Change Temp	
1	Norm1	
2	Norm2	
3	Trace	
4	Mid Thk	
5	Thk1	
6	Thk2	
7	Thk3	
8	OHP	

1111	Measure Mode	
	Nip Width Measurement Setting Mode	
1	Nip Width:Execute	Determines whether the nip at the hot roller and pressure roller is calibrated. Touch [Execute].
2	Nip Width:Stop Time	Determines the down time of the fusing/exit motor in the fusing nip band

Service Tables

		calibration mode. [1 to 100/1 sec.]
3	Nip Width:Stop Interval	Determines the intervals between the down times of the fusing/exit motor in the nip band calibration mode. [0 to 2000/100 msec.]
4	Nip Width:Htg Roll Temp:Ctr	
5	Nip Width:Htg Roll Temp:End	
6	Nip Width:Press Roll Temp	
11	Belt:0:off 1:on	
12	Belt:Rotation Time	
13	Belt:Htg Roll Temp:Ctr	
14	Belt:Htg Roll Temp:End	
15	Belt:Press Roll Temp	

1112	Fuser Unit In/Out <b>DFU</b>
	Fusing Unit: In/Out: Start Fusing Unit Determines whether the fusing unit operates during the copy cycle for image creation and paper feed. [*1: In] [0: Out]

1113	Fusing SC Issue Time Info <b>DFU</b>
------	--------------------------------------

1159	Fusing SC Settings
	These SP codes determine whether the fusing unit SC codes are displayed.

Service Tables

1	SC On:1/Off:0 for 3 Jams	<p>This SP determines whether the machine stops and displays an SC if three consecutive jams occur in the fusing unit.</p> <p>[0 to 1/0/1]</p> <p>0: Disable. SC code is not displayed.</p> <p>1: Enable. SC code is displayed.</p>
2	SC On:0/Off:1 for No Fusing Pressure	<p>This SP determines whether an SC is displayed if the fusing pressure mechanism is not operating.</p> <p>0: Enable. SC code is displayed.</p> <p>1: Disable. SC code is not displayed.</p> <p><b>Note:</b> A jam does not necessarily occur in the fusing unit if the pressure roller lift mechanism is not operating.</p>

1201	CPM Down <b>DFU</b>	
	Adjusts the CPM down.	
1	L Temp:Judge Down Temp	Down Judgment Temp
2	L Temp:Judge Up _Temp	Up Judgment Temp
3	L Temp:1st CPM Down	CPM
4	L Temp:2nd CPM Down	
5	L Temp:3rd CPM Down	
6	Unit Low Temp:Judge Temp	Judgment Temp
7	H Temp:1st CPM Down	CPM
8	H Temp:2nd CPM Down	
9	H Temp:3rd CPM Down	
10	Down Temp: HiTemp 1: 1st CPM	Down Judgment Temp
11	Down Temp: HiTemp 1: 2nd CPM	

Service Tables

12	Down Temp: HiTemp 1: 3rd CPM	
13	Down Temp: HiTemp 2: 1st CPM	
14	Down Temp: HiTemp 2: 2nd CPM	
15	Down Temp: HiTemp 2: 3rd CPM	

1202	Htg Press Roll:Panel Off/Low Power <b>DFU</b>	
1	Htg Roll Ctr:Panel off mode	
2	Htg Roll Ctr:Low Power Mode	
3	Htg Roll End:Panel off mode	
4	Htg Roll End:Low Power Mode	
5	Press Roll:Panel off mode	
6	Press Roll:Low Power Mode	

1203	Power Control <b>DFU</b>	
	[-4 to +4/ 0 / 1]	

1301	Paper Type Detect	
	<p>These SP settings switch the on/off the paper type detection function. Two sensors, one mounted above and one below the paper at the registration rollers, detect the opacity of the first sheet and compares this reading for every subsequent sheet. If the reading is higher (thicker paper) or lower (thinner paper), the sensor triggers an error.</p> <p>[0 to 1/1] 0: Enable, 1: Disable</p>	
1	Tray 1	
2	Tray 2	

Service Tables

3	Tray 3	
4	Tray 4	<b>Japan Only</b>
5	Bypass Tray	
6	LCT	B473
7	Wide LCT	D359

1302	Double-Feed Detect	
	<p>These SP settings switch the on/off the double-feed detect function.                      [0 to 1/1]                      0: Enable, 1: Disable</p> <p>Two sensors, one mounted above and one below the paper at the registration rollers, detect the opacity of the first sheet and compares this reading for every subsequent sheet. If the reading is higher (thicker paper) or lower (thinner paper), the sensor triggers an error.</p>	
1	Tray 1	
2	Tray 2	
3	Tray 3	
4	Tray 4	<b>Japan Only</b>
5	Bypass Tray	
6	LCT	
7	Wide LCT	

1902	CPM Down Set	
1	Custom (0:Off 1:On)	
2	Pre-Punch (0:Off 1:On)	

Service Tables

1903	Thick Mode (Re-Pickup)	
1	Tray 2 (0:Off 1:On)	
2	Tray 2 (0:Off 1:On)	
3	Tray 3 (0:Off 1:On)	
4	Tray 4 (0:Off 1:On)	
5	Bypass (0:Off 1:On)	

1905	Bypass Feed Restart	
1	0:Timer 1:[Start]	
2	Timer: 0:1s 1:2s 2:3s	

1906	PType Det Light Amt	
1	Norm Paper Light Amt	
2	Trans Paper Light Amt	
3	OHP Light Amt	

1907	Ptype Det Corr Amt	
1	Normal Paper	
2	Translucent Paper	
3	OHP	

1909	Force Jam Feed	
1	0:Off 1:On	

1920	WideLCT Fan Duty	
------	------------------	--

Service Tables

1	Fan F	
2	Fan R	

1921	WideLCT Fan time – Start Time	
------	-------------------------------	--

1922	WideLCT Fan ON/OFF	
1923	Wide LCT Pickup Assist	
	[*0: Auto Select] [1: Force On] [2: Force Off]	

1924	Adj Start Timing: Paper Type Dbl Feed	
1	Line Speed 1	
2	Line Speed 2	

1925	Adj Value: Paper Type Dbl Feed	
1	Main Tray/LCT	
2	Bypass/Wide LCT	

1950	Set Fan Operation	
1	Fan Op Temp	
2	To Standby Mode Time	
3	Fan Off:LCT T/H Sensor	
4	Fan Off:Y Thermistor	
5	Fan Off Time	
11	To Standby EngA:Sn	



Service Tables

---

12	To Standby EngB:Ozone	
13	To Standby EngC:Envir	

## Group 2000

---

2101	Reg Col Interval	Color Interval Registration Adjustment.
	Use these SPs to correct problems with color registration. Color registration problems can be detected by checking the results of 2901 002 Pattern 1. Before doing these adjustments, try to solve the problem by doing SP2111. For more, see "4. Troubleshooting" in the B132/B200 Service Manual.	
1	Main Scan Dot:K	
2	Main Scan Dot:M	
3	Main Scan Dot:C	
4	Main Scan Dot:Y	
5	Main/Sub Scan:K	
6	Main/Sub Scan:M	
7	Main/Sub Scan:C	
8	Main/Sub Scan:Y	
9	Main/Sub Scan:K1-2	
10	Main/Sub Scan:M1-2	
11	Main/Sub Scan:C1-2	
12	Main/Sub Scan:Y1-2	
20	SubScan Line:K-M	
21	SubScan Line:K-C	
22	SubScan Line:K-Y	
23	SubScan M Adj:K-M	
34	SubScan M Adj:K-C	

Service Tables

25	SubScan M Adj:K-Y	
30	M Diff:Main	
31	C Diff:Main	
32	Y Diff:Main	
33	M Diff:Main/Sub	
34	C Diff:Main/Sub	
35	Y Diff:Main/Sub	
40	M Diff:Sub	
41	C Diff:Sub	
42	Y Diff:Sub	
43	M Diff:Sub D Motor	
44	C Diff:Sub D Motor	
45	Y Diff:Sub D Motor	
60	Spd Diff Offset:K Main	
61	Spd Diff Offset:M Main	
62	Spd Diff Offset:C Main	
63	Spd Diff Offset:Y Main	

2102	Prt Mag Adj	Print Magnification Adjustment
	These SP codes adjust the print magnification in the main scan direction.	
1	Main Scan Mag	
5	Mag Rate:K 1-2	
6	Mag Rate:M 1-2	
7	Mag Rate:C 1-2	

Service Tables

8	Mag Rate:Y 1-2
10	Mag Diff:K1-2
11	Mag Diff:M1-2
12	Mag Diff:C1-2
013	Mag Diff:Y1-2

2103	Prt Erase Margin	
	Adjusts the white space at the leading edge. This adjustment can be done for each paper source (Tray 1, Tray 2, etc.)	
1	LEdge:Tray 1	
2	Adj TEdge Margin	
3	Adj Left Margin	
4	Adj Right Margin	
5	TEdge Margin:Tray1	
6	TEdge Margin:Tray2	
7	TEdge Margin:Tray3	
8	TEdge Margin:Tray4	
9	LEdge Custom:Bypass	
10	LEdge Custom:LCT	
11	LEdge: Tray 2	
12	LEdge: Tray 3	
13	LEdge: Tray 4	
14	LEdge: Bypass	
15	LEdge: LCT	

Service Tables

16	LEdge: Duplex	
----	---------------	--

2104	Skew Adj	
	Use these SPs to correct skew in color registration. For more, see "4. Troubleshooting" in the B132/B200 Service Manual.	
1	Bk-M	
2	Bk-C	
3	Bk-Y	
11	Skew Corr Total M	
12	Skew Corr Total C	
13	Skew Corr Total Y	

2105	LD Syn PM Adj <b>DFU</b>	LD Pulse Modulation Synchronization Adjustment
	Raises the pulse modulation for the LD0 beam of K.	
1	Bk1	
2	M1	
3	C1	
4	Y1	
5	Bk2	
6	M2	
7	C2	
8	Y2	

Service Tables

---

2106	Poly Mtr OFF - Time Until Stop	Polygon Motor Off Setting
	The polygon mirror motor turns off if the machine receives no print job for the time specified in this SP mode after the previous job was completed. [0 to 180/1 sec]	

2107	Prt Param On/Off
	Switches enhanced shading on/off.

2108	Col Prt Stop	
	This SP determines which color to switch off for printing.	
1	Bk	[0 to 1/0] 0: Off. Color prints 1: On. Color does not print
2	M	
3	C	
4	Y	

2109	Test Pattern	
	Write Test Pattern. Some of these test patterns are used for copy image adjustments but most are used primarily for design testing. These test patterns do not use the IPU.	
1	Image Add	Select "1" to have the patterns selected with SP2109 002 print overlapped on one another. [0 to 1/1] 0: Off, 1: On
2	Select Pattern	Allows you to select the pattern to print. [0 to 20/1]

## Service Tables

	0	Off
	1	Grid Pattern
	2	Slant Grid Pattern
	3	2-Dot Horizontal Line
	4	2-Dot Vertical Line
	5	1-Dot Horizontal Line
	6	1-Dot Vertical Line
	7	1-Dot Independent
	8	2-Dot Independent
	9	4-Dot Independent
	10	Trim Area
	11	Belt Pattern
	12	100% Coverage
	13	Vertical Cross-Stitch
	14	Horizontal Cross-Stitch
	15	Crop Marks
	16	Vertical Belt
	17	Checkered Flag
	18	20 mm Grid
	19	Horizontal Grayscale
	20	Horizontal Grayscale-White Stripes
4	Col Select:YCMK	[0 to 255/1]
5	Density:K	[0 to 15/1]

Service Tables

6	Density:M	[0 to 15/1]
7	Density:C	[0 to 15/1]
8	Density:Y	[0 to 15/1]
11	Gray Density 1	[0 to 15/1]
12	Gray Density 2	[0 to 15/1]
13	Gray Density 3	[0 to 15/1]
14	Gray Density 4	[0 to 15/1]
15	Gray Density 5	[0 to 15/1]
16	Gray Density 6	[0 to 15/1]
17	Gray Density 7	[0 to 15/1]
18	Gray Density 8	[0 to 15/1]
19	Gray Density 9	[0 to 15/1]
20	Gray Density 10	[0 to 15/1]
21	Gray Density 11	[0 to 15/1]
22	Gray Density 12	[0 to 15/1]
23	Gray Density 13	[0 to 15/1]
24	Gray Density 14	[0 to 15/1]
25	Gray Density 15	[0 to 15/1]

2110	Force Tnr Cycle	
	Force Toner Supply Cycle.	
1	Do Correction	
2	Do With LD Wavelength	



Service Tables

2111	Force Tnr Pos
	<p>Force Toner Position Alignment. Touch [EXECUTE] to execute the MUSIC feature. MUSIC is the "Mirror Unit for Skew and Interval Correction".</p> <p>Three MUSIC sensors mounted above the ITB read three MUSIC sensor patterns developed on the ITB.</p> <p>The sensors read the patterns and the machine uses this feedback to adjust: 1) the positions of the 3rd scanner mirrors to correct skew (main scan), and 2) the speed of the drum motors to correct the intervals (sub scan) between the patterns.</p> <p>If the vertical alignment of the patterns or the intervals are not correct, this causes color offset. This adjustment is done for each color (Y, M, C, K).</p> <p>MUSIC executes automatically:</p> <ul style="list-style-type: none"> <li>▪ When the machine is turned on or returns from an energy save mode.</li> <li>▪ At the interval prescribed by SP2153 015 (Default: 8 min.)</li> <li>▪ After completion of the process control cycle.</li> <li>▪ When the machine receives a job after remaining idle for a long period.</li> <li>▪ After the fusing unit exceeds the prescribed temperature.</li> </ul>

2112	Mag Point Adj
	<p>Magnification Point Adjustment. Corrects the difference in magnification for each color in the left and right direction.</p> <p>[-4 to +4/0/1]</p> <p>Do SP2109 002 and print Pattern 1 on A3 size paper. Examine the pattern with a scaled loupe. For every 50 µm adjust the setting in the left or right direction. A 1 step correction corrects 50 µm. For more, see "4. Troubleshooting" in the B132/B200 Service Manual.</p>
1	M Left
2	M Right
3	C Left
4	C Right
5	Y Left
6	Y Right

Service Tables

---

2150	Prt Area Pulse <b>DFU</b>	
	Pulse Setting: Print Area Only. These SPs fine adjust magnification in the main scan direction in increments of 1/32 dots.	
1-10	K Area 1 to 10	[-120 to +120/32 sub dot]
11-20	M Area 1 to 10	
21 - 30	C Area 1 to 10	
31 - 40	Y Area 1 to 10	

2152	Shading Coeff <b>DFU</b>	
	Shading Correction Coefficient. These SPs set the shading correction coefficient for Areas 01 to 19 for each color. For a list of the ranges and default settings, print the SMC report with SP5990.	
1 - 15	K Area 1 to 15	
21 - 35	M Area 1 to 15	
41 - 55	C Area 1 to 15	
61 - 75	Y Area 1 to 15	

2153	MUSIC Settings <b>DFU</b>	
	These SPs determine how MUSIC executes. In the settings below 0: On, 1:Off.	
1	Auto Execute	Sets MUSIC to execute automatically. [0 to 1/1]
2	During ProCon	Sets MUSIC to execute after completion of the process control self-check. [0 to 1/1]

Service Tables

3	Initialization	Sets MUSIC to execute after the machine is switched on. [0 to 1/1]
4	During Data In	Sets MUSIC to execute before image data output. [0 to 1/1]
5	Writing	Sets MUSIC to execute during long print jobs. [0 to 1/1]
6	MUSIC Temp Intervals	
20	MUSIC:Temp Chg	
23	2-Point Page Interval	
24	Assign Page Interval	
29	MUSIC Density Lvl	
30	Clear Main Slip	
31	Clear Sub Slip	
32	Clear Skew Amt	
33	2-Pt Corr:Clr Offset	
39	Get Init 2-Pt Setting	
50	Add M Weight	
51	Add C Weight	
52	Add Y Weight	

2154	<b>Music Settings 2 DFU</b>	
	These SP settings switch off feedback during MUSIC for the elements listed below.	
1	Feed Back mode	

Service Tables

2	Sensor Light 1	
3	Sensor Light 2	
4	Sensor Light 3	
5	AutoLight	
6	AdjCoeff:FrontKf	
7	AdjCoeff:CtrKc	
8	AdjCoeff:RearKr	
9	MinPatchDiff:MainFine	
10	MinPatchDiff:SubFine	
11	MinPatchDiff:MainRough	
12	MinPatchDiff:SubRough	
13	ColBaseDiff:Min Value	
14	ColMidDiff:Min Value	
15	ColBaseDiff:Max Value	
16	Patch Min Gap	
17	Laser Target Adj	
18	MY Laser Max	
19	AD Upper Limit	
20	AD Lower Limit	
21	Sense Start:Norm2:Fine	
22	Sense Start:Norm2:Rough	
23	Sense Start:Norm1:Fine	
24	Sense Start:Norm1:Rough	

Service Tables

25	BeforeFilter:a1:Norm2:Fine	
26	BeforeFilter:a2:Norm2:Fine	
27	BeforeFilter:b0:Norm2:Fine	
28	BeforeFilter:b1:Norm2:Fine	
29	BeforeFilter:b2:Norm2:Fine	
30	AfterFilter:a1:Norm2:Fine	
31	AfterFilter:a2:Norm2:Fine	
32	AfterFilter:b0:Norm2:Fine	
33	AfterFilter:b1:Norm2:Fine	
34	AfterFilter:b2:Norm2:Fine	
35	BeforeFilter:a1:Norm2:Rough	
36	BeforeFilter:a2:Norm2:Rough	
37	BeforeFilter:b0:Norm2:Rough	
38	BeforeFilter:b1:Norm2:Rough	
39	BeforeFilter:b2:Norm2:Rough	
40	AfterFilter:a1:Norm2:Rough	
41	AfterFilter:a2:Norm2:Rough	
42	AfterFilter:b0:Norm2:Rough	
43	AfterFilter:b1:Norm2:Rough	
44	AfterFilter:b2:Norm2:Rough	
45	BeforeFilter:a1:Norm:1Fine	
46	BeforeFilter:a2:Norm:1Fine	
47	BeforeFilter:b0:Norm:1Fine	

Service Tables

48	BeforeFilter:b1:Norm:1Fine	
49	BeforeFilter:b2:Norm:1Fine	
50	AfterFilter:a1:Norm:1Fine	
51	AfterFilter:a2:Norm:1Fine	
52	AfterFilter:b0:Norm:1Fine	
53	AfterFilter:b1:Norm:1Fine	
54	AfterFilter:b2:Norm:1Fine	
55	BeforeFilter:a1:Norm:1Rough	
56	BeforeFilter:a2:Norm:1Rough	
57	BeforeFilter:b0:Norm:1Rough	
58	BeforeFilter:b1:Norm:1Rough	
59	BeforeFilter:b2:Norm:1Rough	
60	AfterFilter:a1:Norm:1Rough	
61	AfterFilter:a2:Norm:1Rough	
62	AfterFilter:b0:Norm:1Rough	
63	AfterFilter:b1:Norm:1Rough	
64	AfterFilter:b2:Norm:1Rough	
65	Filter QF:Norm2:Fine	
66	Filter QF:Norm2:Rough	
67	Filter QF:Norm:1Fine	
68	Filter QF:Norm:1Rough	
69	Filter Switch	
70	Adj to Target Light Amt	

Service Tables

71	Auto Adj to Target Light Amt	
----	------------------------------	--

2155	MUSIC Settings 3 <b>DFU</b>	
1	ADC Cycle:Norm2:Fine	
2	ADC Cycle:Norm2:Rough	
3	ADC Cycle:Norm:1Fine	
4	ADC Cycle:Norm:1Rough	
5	Store Point:Norm2:Fine	
6	Store Point:Norm2:Rough	
7	Store Point:Norm2:Sub	
8	Store Point:Norm:1Fine	
9	Store Point:Norm:1Rough	
10	Store Point:Norm:1Sub	
11	M Main Offset Amt1	
12	M Main Offset Amt2	
13	M Main Offset Amt3	
14	C Main Offset Amt1	
15	C Main Offset Amt2	
16	C Main Offset Amt3	
17	Y Main Offset Amt1	
18	Y Main Offset Amt2	
19	Y Main Offset Amt3	
20	M Sub Offset Amt1	
21	M Sub Offset Amt2	

Service Tables

22	M Sub Offset Amt3	
23	C Sub Offset Amt1	
24	C Sub Offset Amt2	
25	C Sub Offset Amt3	
26	Y Sub Offset Amt1	
27	Y Sub Offset Amt2	
28	Y Sub Offset Amt3	
29	Tigger V:Fine:Sub	
30	Tigger V:Fine:Main	
31	Tigger V:Roug:Sub	
32	Tigger V:Rough:Main	
33	Largest Main Offset Amt1	
34	Largest Main Offset Amt2	

2156	2-Point Measure <b>DFU</b>	
	These SP codes set the initial values for 2-point calibration.	
1	Target K	
2	Target M	
3	Target C	
4	Target Y	
21	K Differential	
22	M Differential	
23	C Differential	
24	Y Differential	



Service Tables

41	Focus Value:K	
42	Focus Value:M	
43	Focus Value:C	
44	Focus Value:Y	

2180	MUSIC Monitor	
	Displays the current and previous lens temperature readings.	
1	Lens Temp	
10	Previous Temp	

2181	Alignment Result	
	These SPs display the amount of shift correction for each color, the amount of correction done at each sensor in both the main scan and sub scan direction. [0 to 9 999 999]	
1	General	
2	M Skew Amt	
3	C Skew Amt	
4	Y Skew Amt	
10	M Main Skew 1	
11	M Main Skew 2	
12	M Main Skew 3	
13	C Main Skew 1	
14	C Main Skew 2	

Service Tables

15	C Main Skew 3	
16	Y Main Skew 1	
17	Y Main Skew 2	
18	Y Main Skew 3	
20	M Sub Skew 1	
21	M Sub Skew 2	
22	M Sub Skew 3	
23	C Sub Skew 1	
24	C Sub Skew 2	
25	C Sub Skew 3	
26	Y Sub Skew 1	
27	Y Sub Skew 2	
28	Y Sub Skew 3	

2182	MUSIC Converge Patch:Min <b>DFU</b>	
	Sets the minimum value for convergence during MUSIC for the sensors in the main and sub scan directions.	
1	M Main 1	
2	M Main 2	
3	M Main 3	
4	M Sub 1	
5	M Sub 2	
6	M Sub 3	
11	C Main 1	

Service Tables

12	C Main 2	
13	C Main 3	
14	C Sub 1	
15	C Sub 2	
16	C Sub 3	
21	Y Main 1	
22	Y Main 2	
23	Y Main 3	
24	Y Sub 1	
25	Y Sub 2	
26	Y Sub 3	

2184	Write Pulse Result <b>DFU</b>	
	Displays the pulse setting rate for main scanning in black areas (Units: 1/16th dot)	
1	K Area 0	
2	K Area 1	
3	K Area 2	
4	K Area 3	
5	K Area 4	
6	K Area 5	
7	K Area 6	
8	K Area 7	
9	K Area 8	

Service Tables

---

10	K Area 9	
11	K Area 10	
12	K Area 11	
21	M Area 0	
22	M Area 1	
23	M Area 2	
24	M Area 3	
25	M Area 4	
26	M Area 5	
27	M Area 6	
28	M Area 7	
29	M Area 8	
30	M Area 9	
31	M Area 10	
32	M Area 11	
41	C Area 0	
42	C Area 1	
43	C Area 2	
44	C Area 3	
45	C Area 4	
46	C Area 5	
47	C Area 6	
48	C Area 7	

Service Tables

49	C Area 8	
50	C Area 9	
51	C Area 10	
52	C Area 11	
61	Y Area 0	
62	Y Area 1	
63	Y Area 2	
64	Y Area 3	
65	Y Area 4	
66	Y Area 5	
67	Y Area 6	
68	Y Area 7	
69	Y Area 8	
70	Y Area 9	
71	Y Area 10	
72	Y Area 11	

2201	Set DC Charge	
	<p>These SPs set the dc bias for the standard speed and low speed mode, but take effect only when SP3501 001 is set to "1" (Fixed). The dc bias (an absolute value) is set to +200, making the default values for each color –700. The dc bias is normally adjusted by the process control self-check, but when automatic process control is switched off (by setting SP3501 001 to "1"), these values are used for the charge potential.</p>	
1	K	[-999 to –200/1V]

Service Tables

2	M	[-999 to -200/1V]
3	C	[-999 to -200/1V]
4	Y	[-999 to -200/1V]

2202	Set AC (Fixed) Charge	
	<p>These SPs set the AC bias for the standard speed mode and low speed mode, but take effect only when SP3501 001 is set to "1" (Fixed). The default ac bias for each color is 2.2 kV (220) The ac bias is normally adjusted by process control self-check, but when automatic process control is switched off (by setting SP3501 001 to "1"), these values are used for the charge potential.</p>	
1	Wire Current:K	
2	AC Bias :M	
3	AC Bias :C	
4	AC Bias :Y	

2203	Set Charge Current	
	Sets and adjusts current for charge applied to the OPC drums.	
1	Norm2:LL	
6	Norm2:ML	
11	Norm2:MM	
16	Norm2:MH	
21	Norm2:HH	
26	Norm1:LL	
31	Norm1:ML	
36	Norm1:MM	

Service Tables

41	Norm1:MH	
46	Norm1:HH	
51	Half-Speed2:LL	
56	Half-Speed2:ML	
61	Half-Speed2:MM	
66	Half-Speed2:MH	
71	Half-Speed2:HH	
76	Half-Speed1:LL	
81	Half-Speed1:ML	
86	Half-Speed1:MM	
91	Half-Speed1:MH	
96	Half-Speed1:HH	

2204	Set AC Environ Corr	
	Sets the target value for adjustment of the charge rollers of the YMC PCUs.	
2	Norm2:LL:Target:M	
3	Norm2:LL:Target:C	
4	Norm2:LL:Target:Y	
7	Norm2:ML:Target:M	
8	Norm2:ML:Target:C	
9	Norm2:ML:Target:Y	
12	Norm2:MM:Target:M	
13	Norm2:MM:Target:C	
14	Norm2:MM:Target:Y	

Service Tables

17	Norm2:MH:Target:M	
18	Norm2:MH:Target:C	
19	Norm2:MH:Target:Y	
22	Norm2:HH:Target:M	
23	Norm2:HH:Target:C	
24	Norm2:HH:Target:Y	
27	Norm1:LL:Target:M	
28	Norm1:LL:Target:C	
29	Norm1:LL:Target:Y	
32	Norm1:ML:Target:M	
33	Norm1:ML:Target:C	
34	Norm1:ML:Target:Y	
37	Norm1:MM:Target:M	
38	Norm1:MM:Target:C	
39	Norm1:MM:Target:Y	
42	Norm1:MH:Target:M	
43	Norm1:MH:Target:C	
44	Norm1:MH:Target:Y	
47	Norm1:HH:Target:M	
48	Norm1:HH:Target:C	
49	Norm1:HH:Target:Y	
52	Half-Speed2:LL:Target:M	
53	Half-Speed2:LL:Target:C	



Service Tables

54	Half-Speed2:LL:Target:Y	
57	Half-Speed2:ML:Target:M	
58	Half-Speed2:ML:Target:C	
59	Half-Speed2:ML:Target:Y	
62	Half-Speed2:MM:Target:M	
63	Half-Speed2:MM:Target:C	
64	Half-Speed2:MM:Target:Y	
67	Half-Speed2:MH:Target:M	
68	Half-Speed2:MH:Target:C	
69	Half-Speed2:MH:Target:Y	
72	Half-Speed2:HH:Target:M	
73	Half-Speed2:HH:Target:C	
74	Half-Speed2:HH:Target:Y	
77	Half-Speed1:LL:Target:M	
78	Half-Speed1:LL:Target:C	
79	Half-Speed1:LL:Target:Y	
82	Half-Speed1:ML:Target:M	
83	Half-Speed1:ML:Target:C	
84	Half-Speed1:ML:Target:Y	
87	Half-Speed1:MM:Target:M	
88	Half-Speed1:MM:Target:C	
89	Half-Speed1:MM:Target:Y	
92	Half-Speed1:MH:Target:M	

Service Tables

93	Half-Speed1:MH:Target:C	
94	Half-Speed1:MH:Target:Y	
97	Half-Speed1:HH:Target:M	
98	Half-Speed1:HH:Target:C	
99	Half-Speed1:HH:Target:Y	

2205	Adj/Display AC Charge Execution Interval	
	Sets the time intervals for the application of ac charge during printing.	
1	Execution Interval	
2	Temp Threshold 1	
3	Temp Threshold 2	
4	Previous Temp	

2207	Chg AC Reduction: Set	
	Sets the low voltage of the ac charge to be applied while an image is not being created.	

2208	Chg AC Adj:Execute <b>DFU</b>	
	Touch [EXECUTE] to manually executes an ac charge on the charge rollers of the YMC PCUs.	

2209	Chg AC Adj: Result <b>DFU</b>	
	Displays the results of the ac charge applied manually to the charge rollers of the YMC PCUs with SP2208.	

2211	Set LD Power	
------	--------------	--

Service Tables

	<p>These SPs set the power levels of the laser diodes in the exposure unit for the standard speed mode and low speed mode for each color, but take effect only when SP3501 001 is set to "1" (Fixed). With the setting at "0" the LD output is 100%. This can be adjusted in the range –117 to +127 (44% to 160%). The "0" setting is equivalent to 0.171 mW exposed on the surface of the drum. The LD power level is normally adjusted during the process control self-check. These values are used only when automatic process control is switched off (by setting SP3501 001 to "1").</p>	
1	K	[-117 to +127/1]
2	M	[-117 to +127/1]
3	C	[-117 to +127/1]
4	Y	[-117 to +127/1]

2212	Set Dev DC	
	<p>These SPs set the development dc bias for the standard speed mode and low speed mode for each color, but take effect only when SP3501 001 is set to "1" (Fixed). The dc drum charge bias (absolute value) is set to –200 V, and the default for each color is set to –500 V. These values are used only when automatic process control is switched off (by setting SP3501 001 to "1").</p>	
1	K	[-800 to 0/1 V]
2	M	[-800 to 0/1 V]
3	C	[-800 to 0/1 V]
4	Y	[-800 to 0/1 V]

2220	Chg Wire Cleaning Timing	
	<p>Selects when the charge wire of the K PCU and the charge rollers of the YMC PCUs are cleaned..</p>	

Service Tables

	<p>[0~2 / 2 / 1]                  0: OFF                  1: With process control and at intervals selected with SP2221                  2: At intervals selected with SP2221 only.</p>	
1	Execution Timing: K	
2	Execution Timing: Y,M,C	

2221	Chg Wire Cleaning Int/Dist	
	Selects the interval corona wire (K PCU) and charge roller cleaning (YMC PCUs).	
1	Execution Interval:K	[0 to 9 999 999/ 200 000/ 1 cm]
2	Execution Interval:M	
3	Execution Interval:C	
4	Execution Interval:Y	
5	Distance: K	[0 to 9 999 999/ 0/ 1 cm]
6	Distance: M	
7	Distance: C	
8	Distance: Y	
9	Delay at Power On: K	[0 to 99 999/ 5000 / 100 cm]
10	Delay at Power On: M	
11	Delay at Power On: C	
12	Delay at Power On: Y	

2222	Execute Wire Cleaning	
	These SP codes manually execute wire cleaning (K PCU) and charge roller cleaning (YMC PCUs).	

## Service Tables

1	K	
2	Y,M,C	
3	M	
4	C	
5	Y	

2223	OPC Rev After Idle Time	
	These SP codes allow you to set up how long the OPC will idle at the start of a print job after it has remained inactive.	
1	Execution Setting	Switches this SP code on/off. Default: Off (0) This SP must be set on for the other values (2 to 5 below) to take effect.
2	Execution Timing	Sets the amount of time for the OPC drum to idle before the start of the job. [0 to 360/ *1 sec.] * Default setting: D014: 75 sec. D015: 60 sec.
3	Exec Threshold:Rel Humidity	Sets the threshold of relative humidity to trigger idling of the OPCu. [0 to 99/ 65/ 1 %rH]
4	Exec Threshold:Idle Time	Sets the length of time for the OPC to idle, once the idle time has been triggered by the rH threshold. [0 to 6000/ 360/ 10 min.]
5	Exec Threshold:OPC Usage	Sets the threshold value to trigger OPC idling, depending of the number of pages printing. [0 to 400 000 / 60 000/ 10 000 sheets]
6	Chg Usage	Sets the threshold of the charge for the rotation

Service Tables

		of the OPC drum by page count after the machine has been moved to a high-humidity environment. [0 to 200,000/60,000/10,000 Sheets]
--	--	---

2225	Cleaning Speed: K <b>DFU</b>	
	These settings affect the speed of rotation of the drum cleaning brush roller for monochrome printing.	
1	Norm2	[0.1 to 3/ 0.45/ 0.01]
2	Norm1	
3	Half-Speed2	
4	Half-Speed1	
5	Period of Revs	[100 to 15 000 000/100 000/10 cm]
6	Post Switching Coefficient	[0.5 to 2/ 1 0.1]

2226	Cleaning Speed: Col	
	These settings affect the speed of rotation of the drum cleaning brush roller for color printing.	
1	Norm2	[0.1 to 3/ 0.45/ 0.01]
2	Norm1	
3	Half-Speed2	
4	Half-Speed1	
5	Period of Revs	[100 to 15 000 000/100 000/10 cm]
6	Post Switching Coefficient	[0.5 to 2/ 1 0.1]

2251	Force Tnr Supply	
------	------------------	--

Service Tables

	<p>Force Toner Supply:Execute.                  Use SPs to increase manually the supply of toner to the sub hopper of the development unit to determine if toner supply is abnormal or to recover normal operation of a color toner supply when image density becomes light. After you touch "Execute" the toner supply switches on for 0.1 sec. and then off for 0.2 sec. four times for the select color or colors.</p>	
1	Execute:K	Executes forced toner supply to the selected development unit. [0 to 1/1]
2	Execute:M	
3	Execute:C	
4	Execute:Y	
5	Execute:Col	Executes forced toner supply to the Y, M, C development units only. [0 to 1/1]
6	Execute:All Col	Executes forced toner supply to all development units (Y, M, C, K). [0 to 1/1]

2252	Set Tnr Supply	
	<p>Forced Toner Supply: Setting. Use these SPs to adjust the number of rotations done by the toner supply clutch when SP2251 001 to 006 is executed manually. The number of toner supply clutch rotations can be adjusted for each color. A high setting increases the number of rotations and increases the amount of toner supply to the development unit, resulting in a darker image for the selected color.</p>	
1	Supply Times:K	[0 to 30/1]
2	Supply Times:M	[0 to 30/1]
3	Supply Times:C	[0 to 30/1]
4	Supply Times:Y	[0 to 30/1]

2253	Manual Tnr. Fill
	<p>Fill Development Unit Sub Hoppers: Manual. Touch [EXECUTE] to start force filling of all development units with toner/developer from the STC units if toner supply is abnormal or to recover normal operation of a color toner supply when image density becomes light.</p> <p>The toner supply clutch switches on for 2 sec. and then off for 0.4 sec. to fill the sub hopper of the development unit. This on/off sequence is repeated up to 20 times or until the toner end sensor detects that toner is present in the sub hopper.</p>

2260	Pot.Sn Check
	Potential Sensor Check. Touch [EXECUTE] to execute a check of all potential sensors.

2261	Pot.Sn Chk Disp		
	Displays the results of the potential sensor check executed with SP2260.		
1	Vd:K	7	Vr:C
2	Vd:M	8	Vr:Y
3	Vd:C	9	Voffset:K
4	Vd:Y	010	Voffset:M
5	Vr:K	011	Voffset:C
6	Vr:M	012	Voffset:Y

**Notes for SP2261**



Service Tables

Reading	Definition	Abnormal Reading
Vd	Charge bias (Cdc). This is the output of the potential sensor after -700V is applied to the drum. Range: -500 to -700 V	If the reading is out of range: <ul style="list-style-type: none"> <li>▪ Potential sensor damaged</li> <li>▪ Charge unit malfunction</li> <li>▪ Charge power pack malfunction</li> </ul>
Vr	Residual voltage. This is the output of the potential sensor after the LD fires at full power. Normal: -200 V	If above -200V: <ul style="list-style-type: none"> <li>▪ Drum worn</li> <li>▪ Toner shield glass dirty</li> <li>▪ Potential sensor out of position</li> </ul>
Voffset	This is the reading of the potential sensor with no charge applied to the drum. Normal: 0 ±10V	If reading is out of range: <ul style="list-style-type: none"> <li>▪ Potential sensor dirty</li> <li>▪ Potential sensor out of position</li> </ul>

2262	TD Sn Chk
	TD Sensor Check: Execute. Touch [EXECUTE] to execute a check of all TD sensors.

2263	TD Sn Chk Disp
	Toner Density Check: Display. Displays results of 2262. Vt is the most recent output of the TD sensor.
1	Vt:K
2	Vt:M
3	Vt:C

Service Tables

4	Vt:Y	
---	------	--

2264	ID Sn Chk	
	ID Sensor Check: Touch [EXECUTE] to check the ID sensor.	

2265	ID Sn Chk Disp	
	<p>Displays the most recent ID sensor Vsg and Voffset readings.</p> <p><b>Notes:</b></p> <ul style="list-style-type: none"> <li>▪ Vsg_reg is the reading of the direct sensors in the black and color ID sensors that detect the reflectivity of the bare surface of ITB. If Vsg_reg is less than 3.8V, the ID sensor may be dirty, damaged, or disconnected</li> <li>▪ If Voffset_reg is less than 0.15, the ID sensor should be replaced. (The ID sensors are replaced as a unit.)</li> </ul>	
1	Vsg_reg	
3	Voffset_reg	

2302	Temp/Humid Disp	
	<p>This SP displays the current temperature and humidity. These readings are output by the temperature humidity display located on the bottom of the machine below the used toner bottle.</p>	
1	Temp Disp	Room temperature (°C). [0 to 100/ 0/1 deg.]
2	Rel Humidity Disp	Relative humidity (saturation point at current temperature). [0 to 100/0 /1 %rh.]

Service Tables

3	Abs Humidity Disp	Absolute humidity. [0 to 63/ 0/ 0.01 g/m <sup>3</sup> ]
4	Current Env Disp	Displays the current environment control mode. The control modes are divided into 5 levels: LL, ML, MM, MH, HH.

2303	Force Temp Corr <b>DFU</b>	
	<p>Force Ambient Temperature Correction. The temperature/humidity sensor reading is used to adjust settings during process control when this SP is set to zero (the default). The value of the absolute humidity reading displayed by SP2302 003, as well as the other readings of the conditions around the machine displayed with SP2302, are used in the process control calculations. If you touch any key (1 to 6) below, the value you select is used and the readings of the temperature/humidity sensor are ignored.</p> <p><b>Note:</b> After you press any key (1 to 6), the setting you select remains in effect only while the machine is in the SP mode. Once you leave the SP mode, this SP is reset to zero automatically.</p>	
	0: Sensor Detect 1: LLL 2: LL 3: ML	4: MM 5: MH 6: HH

2304	Set Humid Thresh	
	Ambient Humidity Threshold Setting. Sets the threshold values for the absolute humidity of the current LL and ML settings for the main machine in the present environment.	
1	Abs Humid:Thresh1	[0 to 63/ 2.5/ 0.01 g/m <sup>3</sup> ]

Service Tables

2	Abs Humid:Thresh2	[0 to 63/ 5/ 0.01 g/m <sup>3</sup>
3	Abs Humid:Thresh3	[0 to 63/ 8.4/0.01 g/m <sup>3</sup>
4	Abs Humid:Thresh4	[0 to 63/ 15/ 0.01 g/m <sup>3</sup>
5	Abs Humid:Thresh5	[0 to 64/ 24/ 0.01 g/m <sup>3</sup> ]

2307	Set Ptype Link	
	Paper Type Link Setting. For the copy mode selected, these SPs 1) switch the image transfer bias for each color and 2) switch the paper transfer and separation bias	
1	Norm	[0 to 2/1] 0: Normal Paper 1: Thick Paper 2: OHP
2	Recycled Paper	
3	Special Paper	
4	Color 1	
5	Color 2	
6	Letterhead	
7	Tab Sheet	
8	Labels	
9	Tracing Paper	
010	OHP	

2308	Set Psize Thresh	
	Set Paper Size Thresholds. Sets the correction values (Threshold 1, 2, 3, 4) for paper size.	
1	Psize:Thresh1	[0 to 350-/1 mm]

Service Tables

2	Psize:Thresh2	
3	Psize:Thresh3	
4	Psize:Thresh4	

2309	Eng d Coeff <b>DFU</b>
------	------------------------

2312	Margin K Bias	
1	ITB	Sets the value of image transfer bias for K in the areas of the image where nothing is printed. [0 to 70/0.1]
2	PTR	[0 to 1/0.01 kV]
3	SepDC	[0 to 10/0.1 µa]
4	SepAC	[8 to 12/0.1 kV]

2313	Margin FC Bias	
	This SP sets the image transfer bias for each in areas of the image where nothing is printed in the full-color mode.	
2	ITB:K	[0 to 70/ 0.1 ua]
3	ITB:M	
4	ITB:C	
5	ITB:Y	
7	PTR	
8	SepDC	
9	SepAC	

Service Tables

---

2321	Manual Vltg Meas	
	Takes a reading of the Vltg value for the ITB and PTR.	
2	FC	
3	B&W	

2322	Vltg Meas Result	
	Displays the reading of the ITB and PTR voltages.	
1	ITB:K	
2	ITB:M	
3	ITB:C	
4	ITB:Y	
5	PTR	

2323	Vltg Meas Env Disp	
1	ITB	
2	PTR	

2324	R Coeff ON/OFF	
1	ITB	
2	PTR	

2325	Current R Level Disp	
1	ITB: K	
2	ITB: M	

Service Tables

3	ITB: C	
4	ITB: Y	
5	PTR	

2326	Set Voltage Detect Interval	
1	Execution Interval	
2	Page Count:FC	
3	Page Count:BW	

2330	Set R Thresh:LLL <b>DFU</b>	
2331	Set R Thresh:LL <b>DFU</b>	
2332	Set R Thresh:ML <b>DFU</b>	
2333	Set R Thresh:MM <b>DFU</b>	
2334	Set R Thresh:MH <b>DFU</b>	
2335	Set R Thresh:HH <b>DFU</b>	
1	R Thresh1:ITB	
2	R Thresh2:ITB	
3	R Thresh3:ITB	
4	R Thresh4:ITB	
5	R Thresh5:ITB	
6	R Thresh1:PTR	
7	R Thresh2:PTR	
8	R Thresh3:PTR	
9	R Thresh4:PTR	

Service Tables

010	R Thresh5:PTR	
-----	---------------	--

2360	Resist Coeff <b>DFU</b>	
1	R Level:R-2	
2	R Level:R-1	
3	R Level:R0	
4	R Level:R+1	
5	R Level:R+2	
6	R Level:R+3	

2361	Size Coeff:R-2 <b>DFU</b>	
2362	Size Coeff:R-1 <b>DFU</b>	
2363	Size Coeff:R0 <b>DFU</b>	
2364	Size Coeff:R+1 <b>DFU</b>	
2365	Size Coeff:R+2 <b>DFU</b>	
2366	Size Coeff:R+3 <b>DFU</b>	
1	Side1:Size1	
2	Side2:Size1	
3	Side1:Size2	
4	Side2:Size2	
5	Side1:Size3	
6	Side2:Size3	
7	Side1:Size4	
8	Side2:Size4	



Service Tables

9	Side1:Size5	
10	Side2:Size5	

2380	Margin K:LLL <b>DFU</b>
2381	Margin K:LL <b>DFU</b>
2382	Margin K:ML <b>DFU</b>
2383	Margin K:MM <b>DFU</b>
2384	Margin K:MH <b>DFU</b>
2385	Margin K:HH <b>DFU</b>

2390	Margin FC:LLL <b>DFU</b>
2391	Margin FC:LL <b>DFU</b>
2392	Margin FC:ML <b>DFU</b>
2393	Margin FC:MM <b>DFU</b>
2394	Margin FC:MH <b>DFU</b>
2395	Margin FC:HH <b>DFU</b>

2401	Norm K Bias	
	Sets the standard value of bias voltages at image transfer, and paper separation in areas where black is used on plain paper during black-and-white printing.	
1	ITB	[0 to 70 / 0.1 ua]
7	Side1:PTR	[-100 to 0/ 1 ua]
8	Side1:SepDC	[0 to 10 / 0.1 ua]
9	Side1:SepAC	[8 to 12 / 0.1 ua]
12	Side2:PTR	[-100 to 0/ 0.1 ua]

## Service Tables

13	Side2:SepDC	[0 to 10/ 0.1 ua]
14	Side2:SepAC	[8 to 12/ 0.1 ua]

2406	Norm FC Bias	
	Set Bias for Plain Paper: FC. Sets the standard value of bias voltages at image transfer, and paper separation in areas the four colors are used on plain paper during full color printing.	
1	ITB:K	[0 to 70/0.1 µa]
2	ITB:M	[0 to 70/0.1 µa]
3	ITB:C	[0 to 70/0.1 µa]
4	ITM:Y	[-100 to 0/1 µa]
13	Side1:PTR	[-100 to 0/1 µa]
14	Side1:SepDC	[0 to 10/0.1 µa]
15	Side1:SepAC	[8 to 12/0.1 µa]
21	Side1:PTR	[-100 to 0/1 µa]
22	Side1:SepDC	[0 to 10/0.1 µa]
23	Side1:SepAC	[8 to 12/1 µa]

2421	LEdge Cor:Norm K	
	<p>Leading Edge Correction for Plain Paper: K. This SP sets the coefficient used to 1) correct bias at the leading edge for black image transfer (ITB) 2) bias at image to paper transfer, and 3) correct the dc and ac voltages applied at paper separation.</p> <p><b>Notes:</b> These settings apply:</p> <ul style="list-style-type: none"> <li>▪ To the distance from the leading edge set with SP2422</li> <li>▪ Only to black printing on plain paper at full speed (even when full-color is</li> </ul>	

Service Tables

	selected).	
7	Side1:PTR	[0 to 250/ 1%]
8	Side1:SepDC	
9	Side1:SepAC	
12	Side2:PTR	
13	Side2:SepDC	
14	Side2:SepAC	

2422	LEdge SWT:Norm K	
	Leading Edge Switch Timing for Plain Paper: K. Sets the switch off timing SP2421. The value selected is the number of mm from the leading edge of the paper. These settings 1) apply only to black printing on plain paper at full speed (even when full-color is selected), and 2) apply to both sides of a duplex page.	
2	PTR	[0 to 30/1 mm]
3	SepDC	
4	SepAC	

2423	TEdgeCor:Norm K	
	Trailing Edge Correction for Plain Paper: K. This SP sets the coefficient used to correct bias at image to paper transfer for each side of the paper. These settings are applied to the trailing edge for black printing on plain paper at full speed and apply to black, even when printing in full color mode.	
7	Side1:PTR	[0 to 250/1%]
12	Side2:PTR	

2424	TEdgeSWT:Norm K PTR
	<p>Trailing Edge Switch Timing for Plain Paper: K. This setting sets the start timing for application of SP2423 at the trailing edge of each sheet (Side 1, Side 2). This setting is applied to the trailing edge for black printing on plain paper at full speed and apply to black, even when printing in full color mode.</p> <p>[-100 to 0/1 mm]</p> <p>The mm distance is measured away from the trailing edge of the image.</p>

2426	LEdgeCor:Norm FC	
	<p>Leading Edge Correction for Plain Paper: FC. This SP sets the coefficient used to 1) correct bias at the leading edge for full-color image transfer (ITB) bias at image to paper transfer when using plain paper, and 3) correct the dc and ac voltages applied at paper separation.</p> <p><b>Notes:</b> These settings apply:</p> <ul style="list-style-type: none"> <li>▪ Only the distance from the leading edge set with SP2427.</li> <li>▪ Only to full color printing on plain paper at full speed.</li> </ul>	
7	Side1:PTR	[0 to 250/1%]
8	Side1:SepDC	
9	Side1:SepAC	
12	Side2:PTR	
13	Side2:SepDC	
14	Side2:SepAC	

2427	LEdgeSWT:Norm FC
	<p>Leading Edge Switch Timing for Plain Paper: FC. This SP sets switch timing that sets the distance from the leading edge where the settings of SP2426 are to apply. The value selected is the number of mm from the leading edge of the</p>

Service Tables

	paper. These settings 1) apply only full-color printing on plain paper at full speed, and 2) apply to both sides of a duplex page.	
2	PTR	[0 to 30/1 mm]
3	SepDC	[0 to 30/1 mm]
4	SepAC	[0 to 30/1 mm]

2428	TEdgeCor:Norm FC	
	Trailing Edge Correction for Plain Paper: FC. This SP sets the coefficient used to correct bias at image to paper transfer for each side of the paper. These settings are applied to the trailing edge for full-color printing on plain paper at full speed as far as where SP2429 takes effect.	
7	Side1:PTR	[0 to 250/1%]
012	Side2:PTR	

2429	TEdgeSWT:Norm FC – PTR	
	Switch Timing for Plain Paper: FC. This setting sets the start timing for application of SP2428 007, 2428 012 at the trailing edge of each sheet (Side 1, Side 2). These settings are applied to the trailing edge for black printing on plain paper at full speed and apply to black, even when printing in full color mode. [-100 to 0/1 mm] The mm distance is measured away from the trailing edge of the image.	

2430	Norm:K:LLL	Plain Paper: K Very Low
------	------------	-------------------------

Service Tables

2431	Norm:K:LL	Plain Paper: K Low
2432	Norm:K:ML	Plain Paper: K Medium Low
2433	Norm:K:MM	Plain Paper: K Medium
2434	Norm:K:MH	Plain Paper: K Medium High
2435	Norm:K:HH	Plain Paper: K High
<p>These SPs set the paper size correction coefficient for the image to paper transfer bias threshold values calculated based on the reading of the absolute humidity from the temperature/humidity sensor and the thresholds set with SP2304.</p> <p>SP2430 – Up to SP2304 001: Threshold 1          SP2431 – More than SP2304 001 Threshold 1, up to SP23204 002 Threshold 2.          SP2432 – More than SP2304 002 Threshold 2, up to SP2304 003 Threshold 3          SP2433 – More than SP2304 003 Threshold 3, up to SP2304 004 Threshold 4          SP2434 – More than SP2304 004 Threshold 4, up to SP2305 005 Threshold 3          SP2435 – More than SP2304 005 Threshold 5</p> <p>These settings apply 1) only where the image is created in black (in either black-and-white or full-color mode) on plain paper at full speed.</p>		
1	ITB	[10 to200/ 1%]
7	Side1:PTR	
8	Side1:SepDC	
9	Side1:SepAC	
12	Side2:PTR	
13	Side2:SepDC	
14	Side2:SepAC	

2440	Norm:FC:LLL	Plain Paper: FC Very Low
2441	Norm:FC:LL	Plain Paper: FC Low

Service Tables

2442	Norm:FC:ML	Plain Paper: FC Medium Low
2443	Norm:FC:MM	Plain Paper: FC Medium Medium
2444	Norm:FC:MH	Plain Paper: FC Medium High
2445	Norm:FC:HH	Plain Paper: FC High
	<p>These SPs set the paper size correction coefficient for the image to paper transfer bias threshold values calculated based on the reading of the absolute humidity from the temperature/humidity sensor and the thresholds set with SP2304.</p> <p>SP2440 – Up to SP2304 001: Threshold 1            SP2441 – More than SP2304 001 Threshold 1, up to SP23204 002 Threshold 2.            SP2442 – More than SP2304 002 Threshold 2, up to SP2304 003 Threshold 3            SP2443 – More than SP2304 003 Threshold 3, up to SP2304 004 Threshold 4            SP2444 – More than SP2304 004 Threshold 4, up to SP2305 005 Threshold 3            SP2445 – More than SP2304 005 Threshold 5</p> <p>These settings apply 1) only where the image is created in full-color on plain paper at full speed.</p>	
17	Side1:PTR	[10 to 200/ 1%]
18	Side1:SepDC	
19	Side1:SepAC	
27	Side2:PTR	
28	Side2:SepDC	
29	Side2:SepAC	

2751	Sp1 K Bias
	<p>Set Bias for Special Paper 1: K. These SPs set the standard values of the electrical charges that are applied to 1) create bias for image transfer from drum to ITB, 2) create bias for image transfer from ITB to paper (PTR), and 3) neutralize the charges on the both sides of the paper to separate the paper from the ITB (SepDC, SepAC). These settings are used when printing on Special Paper 1 in the black-and-white mode and are applied only to the image area.</p>

## Service Tables

1	ITB	[0 to 70/0.1 $\mu\text{a}$ ]
7	Side1:PTR	[-100 to 0/1 $\mu\text{a}$ ]
8	Side1:SepDC	[0 to 10/0.1 $\mu\text{a}$ ]
9	Side1:SepAC	[8 to 12/0.1 kV]
12	Side2:PTR	[-100 to 0/0.1 $\mu\text{a}$ ]
13	Side2:SepDC	[0 to 10/0.1 $\mu\text{a}$ ]
14	Side2:SepAC	[8 to 12/0.1 kV]

2756	Sp1 K Bias	
	Set Bias for Special Paper 1: K. These SPs set the standard values of the electrical charges that are applied to 1) create bias for image transfer from drum of each color (Y, M, C, K) to the ITB, 2) create bias for image transfer from ITB to paper (PTR), and 3) neutralize the charges on the both sides of the paper to separate the paper from the ITB (SepDC, SepAC). These settings are used only for Y, M, C, K when printing on Special Paper 1 in the full-color mode and are applied only to the image area.	
1	ITB:K	[0 to 70/0.1 $\mu\text{a}$ ]
2	ITB:M	[0 to 70/0.1 $\mu\text{a}$ ]
3	ITB:C	[0 to 70/0.1 $\mu\text{a}$ ]
4	ITB:Y	[0 to 70/0.1 $\mu\text{a}$ ]
13	Side1:PTR	[-100 to 0/1 $\mu\text{a}$ ]
14	Side1:SepDC	[0 to 10/0.1 $\mu\text{a}$ ]
15	Side1:SepAC	[8 to 12/0.1 kV]
21	Side2:PTR	[-100 to 0/1 $\mu\text{a}$ ]



## Service Tables

22	Side2:SepDC	[0 to 10/0.1 $\mu$ a]
23	Side1:SepAC	[8 to 12/0.1 kV]

These SPs set the paper size correction coefficients for Special Paper 1 relative to the settings done with SP2308 (Set Psize Thresh). All of these settings:

- Apply to printing on Special Paper 1 in the black-and-white mode
- Apply only to the image area

The title of each SP tells you the side and size where the setting is applied at ITB-to-paper transfer, for example: "Side1:Size1:PTR" means the setting applies to only the first side of Size 1 when the image is transferred from belt to paper.

2771	LEdge Cor:Sp1:K	
	Leading Edge Correction for Special Paper 1: K. Sets the leading edge correction coefficient when bias is applied as far as allowed by the setting of SP2772 for drum to image transfer of the image during black and white copying on Special Paper 1.	
7	Side1:PTR	[0 to 250/ 1%]
8	Side1:SepDC	
9	Side1:SepAC	
12	Side2:PTR	
13	Side2:SepDC	
14	Side2:SepAC	

2772	LEdge SWT:Sp1:K	
	Leading Edge Switch Timing for Special Paper 1: K. Sets the switch off timing of SP2771. The selected value is the number of mm from the leading edge. Applies only to printing in black-and-white mode on Special Paper 1.	
2	PTR	[0 to 30/1 mm]
3	SepDC	

Service Tables

4	SepAC	
---	-------	--

2773	TEdge Cor:Sp1 K	
	Trailing Edge Correction for Special Paper 1: K. Sets the bias applied at the trailing edge when the image is transferred from ITB to paper by setting the start timing for SP2774 at the trailing edge. Applied to the trailing edge for black-and-white mode on Special Paper 1 only.	
7	Side1:PTR	[0 to 250/1%]
12	Side2:PTR	

2774	TEdge SWT:Sp1 K	
	Trailing Edge Switch Timing for Special Paper 1: K. Sets the switch timing that determines the distance from the leading edge where the settings of SP2773 are applied during image transfer from ITB to paper. Applied only when in black-and-white mode on Special Paper 1. [-100 to 0/ 1 mm]	

2776	LEdge Cor:Sp1 FC	
	Leading Edge Correction for Special Paper 1: FC. These SPs do the following settings when printing on Special Paper 1 in the full-color mode: 1) ITB: Sets strength/timing of the correction coefficient for the application of bias when the image is transferred from the drum to the ITB. 2) PTR: Sets the strength/timing of the correction coefficient for the application of bias when the image is transferred from ITB. 3) SepDC, SepAC: Set the strength/timing of the dc and ac charges applied to neutralize the charges on the belt and paper so they will separate more easily.	

Service Tables

	<b>Note:</b> SP2776 selects the strength of the bias coefficient, and SP2777 sets the start timing of the bias application.	
7	Side1:PTR	[0 to 250/ 1%]
8	Side1:SepDC	
9	Side1:SepAC	
12	Side2:PTR	
13	Side2:SepDC	
14	Side2:SepAC	

2777	LEdge SWT:Sp1 FC	
	Leading Edge Switch Timing for Special Paper 1: FC. Sets the switch off timing of SP2776. The selected value is the number of mm from the leading edge. Applies only to printing in full-color mode on Special Paper 1.	
2	PTR	[0 to 30/1 mm]
3	SepDC	
4	SepAC	

2778	TEdge Cor:Sp1 FC (PTR)	
	Trailing Edge Correction for Special Paper 1: FC. Sets the strength of the bias coefficient for the bias applied at the trailing edge when the image is transferred from ITB to paper. Applied when printing in full-color mode on Special Paper 1.	
7	Side1:PTR	[0 to 250/1%]
12	Side2:PTR	

2779	TEdge SWT:Sp1 FC (PTR)	
------	------------------------	--

Service Tables

	<p>Switch Timing for Special Paper 1: FC. Sets the switch timing that determines the distance from the leading edge where the SP2778 settings are applied during image transfer from ITB to paper. Applied only when printing in full-color mode on Special Paper 1.</p> <p>[-100 to 0/1 mm]</p>
--	--

2780	Sp1:K:LLL	Special Paper 1: K Very Low
2781	Sp1:K:LL	Special Paper 1: K Low
2782	Sp1:K:ML	Special Paper 1: K Medium Low
2783	Sp1:K:MM	Special Paper 1: K Medium
2784	Sp1:K:MH	Special Paper 1: K Medium High
2785	Sp1:K:HH	Special Paper 1: K High
	<p>These SPs set the paper size correction coefficient for the image to paper transfer bias threshold values calculated based on the reading of the absolute humidity from the temperature/humidity sensor and the thresholds set with SP2304.</p> <p>SP2780 – Up to SP2304 001: Threshold 1            SP2781 – More than SP2304 001 Threshold 1, up to SP23204 002 Threshold 2.            SP2782 – More than SP2304 002 Threshold 2, up to SP2304 003 Threshold 3            SP2783 – More than SP2304 003 Threshold 3, up to SP2304 004 Threshold 4            SP2784 – More than SP2304 004 Threshold 4, up to SP2305 005 Threshold 3            SP2785 – More than SP2304 005 Threshold 5</p> <p>These settings apply only to the image area printed on Special Paper 1 in black-and-white mode.</p>	
1	ITB	[10 to 200/ 1%]
7	Side1:PTR	
8	Side1:SepDC	
9	Side1:SepAC	

Service Tables

12	Side2:PTR	
13	Side2:SepDC	
14	Side2:SepAC	

2790	Sp1:FC:LLL	Special Paper 1: FC Very Low
2791	Sp1:FC:LL	Special Paper 1: FC Low
2792	Sp1:FC:ML	Special Paper 1: FC Medium Low
2793	Sp1:FC:MM	Special Paper 1: FC Medium
2794	Sp1:FC:MH	Special Paper 1: FC Medium High
2795	Sp1:FC:HH	Special Paper 1: FC High

These SPs set the paper size correction coefficient for the image to paper transfer bias threshold values calculated based on the reading of the absolute humidity from the temperature/humidity sensor and the thresholds set with SP2304.

SP2790 – Up to SP2304 001: Threshold 1  
 SP2791 – More than SP2304 001 Threshold 1, up to SP23204 002 Threshold 2.  
 SP2792 – More than SP2304 002 Threshold 2, up to SP2304 003 Threshold 3  
 SP2793 – More than SP2304 003 Threshold 3, up to SP2304 004 Threshold 4  
 SP2794 – More than SP2304 004 Threshold 4, up to SP2305 005 Threshold 3  
 SP2795 – More than SP2304 005 Threshold 5

These settings apply only to the image area printed on Special Paper 1 in full-color mode.

1	ITB	[10 to 200/ 1%]
7	Side1:PTR	
8	Side1:SepDC	
9	Side1:SepAC	
12	Side2:PTR	

Service Tables

13	Side2:SepDC	
14	Side2:SepAC	

2801	Sp2 K Bias	Set Bias for Special Paper 2: K
	<p>These SPs set the standard values of the electrical charges that are applied to 1) create bias for image transfer from drum to ITB, 2) create bias for image transfer from ITB to paper (PTR), and 3) neutralize the charges on the both sides of the paper to separate the paper from the ITB (SepDC, SepAC). These settings are used when printing on Special Paper 2 in the black-and-white mode and are applied only to the image area.</p>	
1	ITB	[0 to 70/0.1 $\mu$ a]
7	Side1:PTR	[-100 to 0/1 $\mu$ a]
8	Side1:SepDC	[0 to 10/0.1 $\mu$ a]
9	Side1:SepAC	[8 to 12/0.1 kV]
12	Side2:PTR	[-100 to 0/1 $\mu$ a]
13	Side2:SepDC	[0 to 10/0.1 $\mu$ a]
14	Side2:SepAC	[8 to 12/0.1 kV]

2806	Sp2 FC Bias	
	<p>Set Bias for Special Paper 2: K. These SPs set the standard values of the electrical charges that are applied to 1) create bias for image transfer from drum of each color (Y, M, C, K) to the ITB, 2) create bias for image transfer from ITB to paper (PTR), and 3) neutralize the charges on the both sides of the paper to separate the paper from the ITB (SepDC, SepAC). These settings are used only for Y, M, C, K when printing on Special Paper 1 in the full-color mode and are applied only to the image area.</p>	

## Service Tables

1	ITB:K	[0 to 70/0.1 $\mu$ a]
2	ITB:M	[0 to 70/0.1 $\mu$ a]
3	ITB:C	[0 to 70/0.1 $\mu$ a]
4	ITB:Y	[0 to 70/0.1 $\mu$ a]
13	Side1:PTR	[-100 to 0/1 $\mu$ a]
14	Side1:SepDC	[0 to 10/0.1 $\mu$ a]
15	Side1:SepAC	[8 to 12/0.1 kV]
21	Side2:PTR	[-100 to 0/1 $\mu$ a]
22	Side2:SepDC	[0 to 10/0.1 $\mu$ a]
23	Side2:SepAC	[8 to 12/0.1 kV]

These SPs set the paper size correction coefficients for Special Paper 2 relative to the settings done with SP2308 (Set Psize Thresh). All of these settings:

- Apply to printing on Special Paper 2 in the black-and-white mode
- Apply only to the image area

The title of each SP tells you the side and size where the setting is applied at ITB-to-paper transfer, for example: "Side1:Size1:PTR" means the setting applies to only Side 1 of Size 1 when the image is transferred from belt to paper at the PTR.

2821	LEdge Cor:Sp2:K	
	Leading Edge Correction for Special Paper 2: K. Sets the leading edge correction coefficient when bias is applied as far as allowed by the setting of SP2822 for drum to image transfer of the image during black and white copying on Special Paper 2.	
7	Side1:PTR	[0 to 250/1%]
8	Side1:SepDC	
9	Side1:SepAC	

## Service Tables

12	Side2:PTR	
13	Side2:SepDC	
14	Side2:SepAC	

2822	LEdge SWT:Sp2:K	
	Leading Edge Switch Timing for Special Paper 2: K. Sets the switch off timing of SP2821. The selected value is the number of mm from the leading edge. Applies only to printing in black-and-white mode on Special Paper 2.	
2	PTR	[0 to 30/ 1mm]
3	SepDC	
4	SepAC	

2823	TEdge Cor:Sp2 K – PTR	
	Trailing Edge Correction for Special Paper 2: K. Sets the bias applied at the trailing edge when the image is transferred from ITB to paper by setting the start timing for SP2824 at the trailing edge. Applied to the trailing edge for black-and-white mode on Special Paper 2 only.	
7	Side1:PTR	[0 to 250/1%]
12	Side2:PTR	

2824	TEdge SWT:Sp2 K – PTR	
	Trailing Edge Switch Timing for Special Paper 2: K. Sets the switch timing that determines the distance from the leading edge where the settings of SP2823 is applied during image transfer from ITB to paper. Applied only when in black-and-white mode on Special Paper 2. [-100 to 0/1 mm]	



Service Tables

2826	LEdge Cor:Sp2 FC	
	<p>Leading Edge Correction for Special Paper 2: FC. These SPs do the following settings when printing on Special Paper 2 in the full-color mode:</p> <p>1) PTR: Sets the strength/timing of the correction coefficient for the application of bias when the image is transferred from ITB.</p> <p>2) SepDC, SepAC: Set the strength/timing of the dc and ac charges applied to neutralize the charges on the belt and paper so they will separate more easily.</p> <p><b>Note:</b> SP2826 selects the strength of the bias coefficient, and SP2827 sets the start timing of the bias application.</p>	
7	Side1:PTR	[0 to 250 / 1%]
8	Side1:SepDC	
9	Side1:SepAC	
12	Side2:PTR	
13	Side2:SepDC	
14	Side2:SepAC	

2827	LEdge SWT:Sp2 FC	
	<p>Leading Edge Switch Timing for Special Paper 2: FC. Sets the switch off timing of SP2826. The selected value is the number of mm from the leading edge. Applies only to printing in full-color mode on Special Paper 2.</p>	
2	PTR	[0 to 30/ 1 mm]
3	SepDC	
4	SepAC	

2828	TEdge Cor:Sp2 FC	
	Trailing Edge Correction for Special Paper 2: FC. Sets the strength of the bias	

Service Tables

	coefficient for the bias applied at the trailing edge when the image is transferred from ITB to paper. Applied when printing in full-color mode on Special Paper 2.	
7	Side1:PTR	[0 to 250/1%]
12	Side2:PTR	

2829	TEdge SWT:Sp2 FC	
	Switch Timing for Special Paper 2: FC. Sets the switch timing that determines the distance from the leading edge where the SP2828 settings are applied during image transfer from ITB to paper. Applied only when printing in full-color mode on Special Paper 2. [-100 to 0/1 mm]	

2830	Sp2:K:LLL	Special Paper 2: K Very Low
2831	Sp2:K:LL	Special Paper 2: K Low
2832	Sp2:K:ML	Special Paper 2: K Medium Low
2833	Sp2:K:MM	Special Paper 2: K Medium
2834	Sp2:K:MH	Special Paper 2: K Medium High
2835	Sp2:K:HH	Special Paper 2: K High
	<p>These SPs set the paper size correction coefficient for the image to paper transfer bias threshold values calculated based on the reading of the absolute humidity from the temperature/humidity sensor and the thresholds set with SP2304 8.</p> <p>SP2830 – Up to SP2304 001: Threshold 1            SP2831 – More than SP2304 001 Threshold 1, up to SP23204 002 Threshold 2.            SP2832 – More than SP2304 002 Threshold 2, up to SP2304 003 Threshold 3            SP2833 – More than SP2304 003 Threshold 3, up to SP2304 004 Threshold 4            SP2834 – More than SP2304 004 Threshold 4, up to SP2305 005 Threshold 3            SP2835 – More than SP2304 005 Threshold 5</p>	

Service Tables

	These settings apply only to the image area printed on Special Paper 2 in black-and-white mode.	
1	ITB	[10 to 200/ 1%
7	Side1:PTR	
8	Side1:SepDC	
9	Side1:SepAC	
12	Side2:PTR	
13	Side2:SepDC	
14	Side2:SepAC	

2840	Sp2:FC:LLL	Special Paper 2: FC Very Low
2841	Sp2:FC:LL	Special Paper 2: FC Low
2842	Sp2:FC:ML	Special Paper 2: FC Medium Low
2843	Sp2:FC:MM	Special Paper 2: FC Medium
2844	Sp2:FC:MH	Special Paper 2: FC Medium High
2845	Sp2:FC:HH	Special Paper 2: FC High
	These SPs set the standard values of the electrical charges that are applied to 1) create bias for image transfer from drum to ITB, 2) create bias for image transfer from ITB to paper (PTR), and 3) neutralize the charges on the both sides of the paper to separate the paper from the ITB (SepDC, SepAC). These settings are used when printing on Special Paper 2 in the full-color mode and are applied only to the image area.	
1	ITB	[10 to 200/ 1%
17	Side1:PTR	
18	Side1:SepDC	
19	Side1:SepAC	

Service Tables

27	Side2:PTR	
28	Side2:SepDC	
29	Side2:SepAC	

2901	Disp T/H Sn:PCU	
	<p>Temperature/Humidity Sensor: PCU. This SP displays the temperature (°C) and humidity (both relative and absolute) readings of the temperature and humidity sensor located above the M PCU on the right side of the machine. These readings are updated every 60 sec.</p> <ul style="list-style-type: none"> <li>▪ 001 to 004 display the current readings.</li> <li>▪ 005 to 008 display the previous readings.</li> </ul>	
1	Humid:Recent	[0 to 100/ 1 deg (or %rH)
2	Rel Humid:Recent	
3	Abs Humid:Recent	
4	Environ:Recent	
5	Humid:JobEnd	
6	Rel Humid:JobEnd	
7	Abd Humid:JobEnd	
8	Environ:JobEnd	

2902	Env Set:PCU	
	<p>Use these settings to turn off the temperature/humidity sensor, and raise or lower the level of detection.</p> <p>[0 to 6/1</p>	
	<p>0: Sensor Detect 1: LLL 2: LL</p>	<p>4: MM 5: MH 6: HH</p>

Service Tables

	3: ML	
--	-------	--

2903	Env Thresh: PCU	
	This SP sets the threshold value of LL and ML for the current room temperature.	
1	Abs Humid: 1	[0 to 100/0.01 g/m <sup>3</sup> ]
2	Abs Humid: 2	
3	Abs Humid: 3	
4	Abs Humid: 4	
5	Abs Humid: 5	

2904	Prevent Blade Bending	
	<p>A blade-bend prevention pattern is created with K toner on the ITB between every copy image to lubricate the ITB cleaning blade so it will not bend or scour the surface of the ITB. These SPs set 1) pattern creation interval, 2) density of the pattern, 3) whether the pattern is displayed, 4) the temperature at which the operation is done.</p> <p><b>Note:</b> This function is OFF. Changing this setting is normally not required for this machine.</p>	
1	Pattern Create Interval	Sets the number of pages between patterns. [0 to 200/1 pg.]
2	Pattern Light Intensity	Sets the density of the pattern. [0 to 63/1]
3	Op Pg Count Display	Displays the count for the number of blade prevention patterns. [0 to 200/1 pg.]
4	Set Operation Temp	Sets the threshold temperature for this SP code to start operating. [0 to 50/ 1 deg]

Service Tables

2905	Used Toner Mtr 2	Used Toner Motor 2 Control
	The used toner bottle is provided with a near-full sensor and an auger that evenly distributes the used toner inside the bottle. To extend the life of the used toner bottle near-full motor that rotates this auger, the motor and auger do not operate continuously. The motor is turned on only after a prescribed amount of toner has been consumed.	
1	Tnr Consumed	Sets the amount of toner to be consumed before the used toner bottle is switched on. [1 to 10/1 g]
2	Tnr Mtr On Time	Sets the amount of time the motor remains on. [1 to 10/1 sec.]

2906	Stop Time Reverse Ctrl	
	The K drum motor, YMC drum motor, ITB motor, and PTR motor can be set to reverse slightly immediately after they stop. This removes dust from the edges of the cleaning blades. These SP codes: <ul style="list-style-type: none"> <li>▪ Switch this feature on/off (Default: OFF)</li> <li>▪ Set the absolute intervals (distance) for execution of stop/reverse timing</li> <li>▪ Set the intervals (distance) for execution of stop/reverse timing during long print jobs.</li> </ul>	
1	Set Rev Execute:K	These SP codes switch on/off the stop/reverse feature for the K PCU drum motor, YMC PCU drum motor, ITB motor, and PTR motor. Default: Off
2	Set Rev Execute:YCM	
3	Set Rev Execute:ImgTrans	
4	Set Rev Execute:PaperTrans	
5	Set Rev Execute Interval	Sets the distance interval between motor stop/reverse executions. [1 to 500/ 1 m] Default: 30 m
6	Assign Execution	Switches on the time interval that controls motor reverse executions during continuous print jobs.

## Service Tables

7	Set Execute Interval	Sets the distance interval between motor reverse executions during continuous print jobs. [1 to 500/ 1 m] Default: 250 m
8	Op Time Setting:Bk	Sets the length of time for the K PCU drum motor to reverse. [2 to 500/30/2 msec]
9	Op Time Setting:YCM	Sets the length of time for the YMC PCU drum motors to reverse. [2 to 500/30/2 msec]
10	Op Time Setting:ImgTrans	Sets the length of time for the ITB motor to reverse. [2 to 500/30/2 msec]
11	Op Time Setting:PaperTrans	Sets the length of time for the PTR motor to reverse. [2 to 500/30/2 msec]
12	Adj Reverse Start Time	Synchronizes the timing for the K PCU drum motor, ITB motor and PTR motor to reverse simultaneously. [2 to 500/0/2 msec]

2907	PTR Lift <b>DFU</b>
	<p>This SP switches the operation of the PTR lift motor off and on. The PTR lift motor presses the PTR against the fusing belt above during belt-to-paper image transfer and lowers the PTR when it is idle. This prevents the PTR from warping.</p> <p><b>[*0: Lift Operation On]</b> [1: Lift Operation Off]</p>

2911	Environ Ctrl
	<p>These SP codes control the operation of the Peltier unit.</p> <p><b>Note:</b> The Peltier unit is not provided as a standard component of this machine. However, it is available as an option.</p>

Service Tables

1	Environ Ctrl On	Switches Peltier unit control on/off. * <b>OFF</b> /ON
4	Op Humidity	Sets the humidity level for the Peltier unit to operate. [0 to 100/60/1%]
5	Stop Humidity	Sets the humidity level for the Peltier unit to switch off. [0 to 100/35/1%]
6	Op On Time	Sets the timer for the humidity level for the Peltier unit to switch on, regardless of the humidity level control settings done with SP2911-4, -5. [1 to 60/10/1 min.]
7	Op Off Time	Sets the timer for the humidity level for the Peltier unit to switch off, regardless of the humidity level done with SP2911-4, -5. [1 to 60/5/1 min.]

2912	Encoder Sn:Adj Light	
1	Adj Light Amt	
2	Light Amt Adj:Pass/Fail	
3	Vref_Disp:Main Setting	
4	Vref_Disp:Sub Setting	
5	Analog Out:Main:After F Adj	
6	Analog Out:Sub:After F Adj	
7	Light Amt Change Flag	

2913	Encoder Sn:Output Disp	
1	Analog:Ave:Main	
2	Analog:Max:Main	



Service Tables

3	Analog:Min:Main	
4	Analog:Ave:Sub	
5	Analog:Max:Sub	
6	Analog:Min:Sub	

2914	Encoder Sn:Get 1stPhase <b>DFU</b>	
1	Get Phases:Execut All	
2	352.8 Line Speed:Execute	
3	282.0 Line Speed:Execute	
4	176.4 Line Speed:Execute	
5	141.0 Line Speed:Execute	
6	352.8 Phase Disp/Set	
7	282.0 Phase Disp/Set	
8	176.4 Phase Disp/Set	
9	141.0 Phase Disp/Set	

2915	Encoder Sn Ctrl Condition <b>DFU</b>	
1	SC499 Occurrences	
2	SC499 Causes	
3	ITB Encoder Sn Ctrl	

## Group 3000

---

3001	TD Sn:Vt Display	
	<p>Displays the current value of Vt (output voltage of the TD sensor). This is the value that the machine uses to calculate the density of the toner in each development unit. The toner density is checked after every page prints. The TD sensor output voltage is inversely proportional to the toner density:</p> <ul style="list-style-type: none"> <li>▪ If toner density is high, the voltage is low.</li> <li>▪ If toner density is low, the voltage is high.</li> </ul> <p><b>Note:</b> These readings are used to control toner supply. When the machine uses PID logic to control the machine (the default method selected with SP3301 001). The difference between Vt and Vtref is calculated and this result is used to control the on time of the sub hopper clutches that control the supply of toner to the PCUs.</p>	
1	Current Val:K	[0 to 5./0.01 V]
2	Current Val:M	
3	Current Val:C	
4	Current Val:Y	

3002	Vtcnt:Disp/Set	
	<p>Display Vtcnt (TD Sensor Control Voltage).</p> <p>Use SP 3002-001 to 004 to display and confirm the present Vtcnt setting. Vtcnt is the TD sensor control voltage. If there is a large difference between this value and the value of SP3002-005 to 008 (Initial Vtcnt), this means that over time Vtcnt will require large adjustments due to environmental conditions. The initial value of Vtcnt is determined when the developer is initialized. This value is used as a reference to adjust Vt during the auto process control self check and when the TD sensor checks the toner density between pages.</p>	

Service Tables

1	Current Val:K	[0 to 12/0.01 V]
2	Current Val:M	
3	Current Val:C	
4	Current Val:Y	
5	Initial Val:K	[0 to 12/0.01 V]
6	Initial Val:M	
7	Initial Val:C	
8	Initial Val:Y	

3003	Vtref:Disp/Set	
	<p>This SP displays the TD sensor target voltage. This target voltage is inversely proportional to the density of the toner:</p> <ul style="list-style-type: none"> <li>▪ If the target is high, toner density is lowered.</li> <li>▪ If the target is low, toner density is raised.</li> </ul> <p>The machine uses readings of the ID sensor patterns between pages to determine the amount of toner coverage and compared with the threshold values for the upper and lower limit of coverate. The result of this calculation is used to calculate Vtref.</p> <p><b>Note:</b> Vtref is the TD sensor reference voltage. It is frequently updated to stabilize the toner concentration in the development unit.</p>	
1	Current Val:K	[0 to 5/0.01 V]
2	Current Val:M	
3	Current Val:C	
4	Current Val:Y	
5	Initial Val:K	[0 to 5/0.01 V]

## Service Tables

6	Initial Val:M	
7	Initial Val:C	
8	Initial Val:Y	

3010	TD Sn: Factory Data: K	
3011	TD Sn: Factory Data: M	
3012	TD Sn: Factory Data: C	
3013	TD Sn: Factory Data: Y	
	These SP codes display the factory default settings for TD sensor initialization for the K, M, C, and Y PCUs.	
1	Vtcnt	Gain value calculated during TD sensor initialization. This is used to adjust the Vt (TD sensor output). A large gain increases Vt, and a small gain decreases it. The result of this calculation is also used to calibrate Vt during TD sensor initialization.
2	Vt(H)	"x" is K, M, C, or Y. The Vt readings are H (High), M (Medium), L (Low).
3	Vt(M)	
4	Vt(L)	

3021	Set Vt Shift	
	Use this SP to correct Vt (TD sensor output voltage) in the low speed mode (128 to 256 g/m <sup>2</sup> ). The machine then uses this value to calculate Vt for low speed mode.	
1	Shift (Std1)	D014 [0 to 5/ 0/ 0.01 V] D015 [0 to 5/ 0.2/0.01 V]
2	Shift (Half d2)	
3	Shift (Half d1)	

3042	Set Vtref Cor	
	<p>Set Vtref Correction.</p> <p>Vtref is frequently updated in the toner supply cycle to stabilize the concentration of toner in the developer. Vtref is corrected between every printed page in the paper path using the correction amounts listed below for each color. This is the default setting (0) for SP3042 001. However, you can use this SP to switch this function off.</p> <p>Vtref (TD sensor reference voltage). It is frequently updated to stabilize the toner concentration in the development unit.</p>	
1	Vtref Corr Mode	[0 to 1/1] 0: On, 1: Off Setting this SP to 1 switches off Vtref correction between pages.
2	Corr Amt(+):K	[0 to 1/0.01 V]
3	Corr Amt(+):M	
4	Corr Amt(+):C	
5	Corr Amt(+):Y	
6	Corr Amt(-):k	
7	Corr Amt(-):M	
8	Corr Amt(-):C	
9	Corr Amt(-):Y	
10	Vtref Corr Target:K	[-0.1 to 0.1/0.001 mg/cm <sup>2</sup> ]
11	Vtref Corr Target:M	
12	Vtref Corr Target:C	
13	Vtref Corr Target:Y	
14	Corr Thresh:M	[-0.1 to 0.1/0/ mg/cm <sup>2</sup> ]
15	Corr Thresh:C	

Service Tables

16	Corr Thresh:Y	
17	Corr Thresh:K	

3044	Img Area	
	These SP codes display the percentage of coverage on printed pages.	
1	Latest:K	[0 to 9999/ 1 cm <sup>2</sup> ]
2	Latest:M	
3	Latest:C	
4	Latest:Y	
5	Ave.S:K	[0 to 100/ 0.01%]
6	Ave.S:M	
7	Ave.S:C	
8	Ave.S:Y	
9	Ave.M:K	
10	Ave.M:M	
11	Ave.M:C	
12	Ave.M:Y	
13	Ave.L:K	
14	Ave.L:M	
15	Ave.L:C	
16	Ave.L:Y	
17	Set N Pgs Ave.:S	[0 to 100/ 1 sheet]
18	Set N Pgs Ave.:M	
19	Set N Pgs Ave.:L	

Service Tables

24	DotCoverage	[0 to 100/ 0.01%]
25	DotCoverage	
26	DotCoverage	
27	DotCoverage	

3101	ID Pattern:Display	
	<p>ID Sensor Pattern Coverage Display.          Displays the amount toner to be used (coverage) to create the ID sensor patterns between pages. The ID sensors cannot accurately detect the patterns if there is too much reflectivity from the black toner. This SP changes the solid ID sensor pattern to a hatched pattern.</p> <p><b>Note:</b> SP3101-1 to 4 sets detection and update timing for the creation of the ID sensor patterns.</p>	
1	Applied:K	
2	Applied:M	
3	Applied:C	
4	Applied:Y	
5	Target Apply:K	
6	Target Apply:M	
7	Target Apply:C	
8	Target Apply:Y	

3102	ID Pattern:Int	
	<p>These SP patterns set the time interval for creation of the ID sensor pattern on the drum.</p>	
1	Create Int:K	[0 to 200/10/ 1 page]

## Service Tables

2	Create Int:M	
3	Create Int:C	
4	Create Int:Y	
5	K Page Cnt	
6	M Page Cnt	[0 to 200/0/ 1 page]
7	C Page Cnt	
8	Y Page Cnt	

3111	ID Sn:Voffset <b>DFU</b>	
	Displays the output voltage of the directly reflected light when the LED of the ID sensor is switched off.	
1	Voffset_Reg	[0 to 5/0.01 V]
2	Voffset_Dif	

3121	Adjusted Vsg <b>DFU</b>	
	This SP displays the 1) results of the most recent Vsg adjustment.	
1	Vsg_Reg:Col	[0 to 5/0.01 V]
2	Vsg_Dif:Col	

3131	Ifsg After Vsg	
	Displays as a PWM value (pulse width modulation) the level of the ID sensor LED after Vsg has been adjusted. Normal Vsg readings of the ITB bare surface reflectivity should be in the range $4.0 \pm 0.2V$ .	



## Service Tables

1	lfsg:Col	[0 to 4096/1]
3	lfsg:K	

3141	ID Sn:Vmin
	Displays the minimum values read from the graduated patterns read by the ID sensor during process control.

3194	ID Coeff Display	
	Displays the most recent and averaged readings of the sensitivity correction coefficients (K2 and K5).	
1	K2:Last	[0 to 5/0.0001]
2	K5:Last	
5	K2:Ave	
6	K5:Ave	

3251	Tnr Supply Time	
	Toner Calibration Time: Display Displays for confirmation the length of time the sub hopper clutch remained on to send toner to the sub hopper after a new toner cartridge was installed.	
1	Sub Hopper CL:K	[0 to 99 999 999/1 ms]
2	Sub Hopper CL:M	
3	Sub Hopper CL:C	

Service Tables

4	Sub Hopper CL:Y	Use these SPs to display the accumulated drive time for each powder pump clutch before installing a new one. [0 to 99 999 999/1 ms]
5	Toner Pump CL:K	
6	Toner Pump CL:M	
7	Toner Pump CL:C	
8	Toner Pump CL:Y	

3301	Tnr Supply	
	Select toner supply method	
1	K	[0 to 1/1] 0: Fixed toner supply 1: PID Toner Supply
2	M	
3	C	
4	Y	

3302	Tnr Supply	
	Sets the toner supply rate for fixed toner supply mode. The rate is set by adjusting the on time of the toner supply clutch. This setting is used only if SP3301 is set to "0".	
1	Supply Rate:K	[0 to 100/ 1%]
2	Supply Rate:M	
3	Supply Rate:C	
4	Supply Rate:Y	

3303	Tnr Supply Rate	
	<p>Displays for confirmation the toner supply rate of toner supply control using the PID method. The toner supply rate is calculated as:</p> $\text{Toner Supply Rate} = \text{Toner Supply Time} / \text{Time Allowed for Toner Supply} \times 100$ <p>where:</p> <ul style="list-style-type: none"> <li>▪ Time is measured in msec.</li> <li>▪ "Time Allowed for Toner Supply (ms)" = Length of the paper (mm) + Width of the gap between sheets (mm)/Drum speed (mm/s) x 1000.</li> </ul> <p><b>Note:</b> The toner supply control method is selected with SP3301.</p>	
1	Last Val:K	[0 to 100/1%]
2	Last Val:M	
3	Last Val:C	
4	Last Val:Y	

3304	Tnr SupplyLimits	
	<p>Set Upper/Lower Limits for Toner Supply.</p> <p>Sets the upper and lower limits for toner supply rate with the fuzzy logic (PID) used as the toner supply control method.</p> <p><b>Note:</b> This SP takes effect only if 1 is selected for SP3301 to enable fuzzy logic as the toner supply method.</p> <p>The machine reads 1) the maximum and minimum settings of this SP and 2) the toner consumption of the output image surface (pixel count data). Then it calculates the maximum and minimum amount of toner for that image. After this is done, toner supply amount will not change during the job, even if Vt or any other measurement determines that more toner is necessary.</p>	
1	Max Supply Rate:K	[0 to 150/1%]
2	Max Supply Rate:M	

Service Tables

3	Max Supply Rate:C	[0 to 255/1 ms]
4	Max Supply Rate:Y	
5	Min Supply Time:K	
6	Min Supply Time:M	
7	Min Supply Time:C	
8	Min Supply Time:Y	

3306	Tnr Supply Coeff	
	<p>Set Toner Supply Coefficient</p> <p>These SPs set the toner supply coefficients for the fuzzy logic method of toner supply control.</p> <p><b>Note:</b> These SP codes operate only when 1 is selected for SP3301.</p>	
1 – 4	Ratio Coeff1:K, M, C, Y	[0 to 4300/1]
21 – 24	P_Vt_Coeff:K, M, C, Y	[0 to 150/1%]
25 – 28	I_Vt_Coeff:K, M, C, Y	
29 – 32	Si:K, M, C, Y	[-5 to 5/0.01]
33 – 36	P_Px1_Coeff1:K, M, C, Y	[0 to 150/1%]
37 – 40	P_Px1_Coeff3:K, M, C, Y	[0 to 2.55/0.01]
41 – 44	P_Px1_Coeff3:K, M, C, Y	

3310	Next Tnr Supply	
	<p>Displays information about the next toner supply: Amount, Image Area (coverage), Wait Time</p>	
1	K Amount	[0 to 65 535 / 1 mg]
2	M Amount	

## Service Tables

3	C Amount	[0 to 65 535 / 1 cm <sup>2</sup> ]
4	Y Amount	
5	K Image Area	
6	M Image Area	
7	C Image Area	
8	Y Image Area	[0 to 65 535 / 1 mg]
9	K Wait Time	
10	M Wait Time	
11	C Wait Time	
12	Y Wait Time	

3401	TE Detect Set <b>DFU</b>
	This SP code switches operation of the toner end sensor off/on. [*0:Detect], [1: No Detect]

3410	Toner Remains	
	These SP codes display the estimated amount of toner remaining.	
1	K	These SP codes display the estimated amount of toner remaining. [0 to 10 / 1] 10 to 2: Full to sufficient toner remaining 2: Estimated near end 1: Measured near end 0: Toner end
2	M	
3	C	
4	Y	
5	K Remain	These SP codes display by weight (mg) the amount of toner remaining.
6	M Remain	

Service Tables

7	C Remain	[0 to 99 999 999/ 1 mg]
8	Y Remain	
9	K % Remain	These SP codes display the percent of toner remaining. [0 to 100/ 1%]
10	M % Remain	
11	C % Remain	
12	Y % Remain	

3411	TNE Detect Disp/Set	
	This SP sets the number of pages to print after the toner near-end alert has been issued.	
1	TNE:K Sheets	Sets toner end to be measured by the number of sheets printed (toner end sensor input is ignored). [0 to 30/ 1 Sheet]
2	TNE:YMC Sheets	
3	K Pg Count	Displays the number of continuous sheets detected for toner end while the toner end sensor input is ignored. [0 to 30/ 1 Sheet]
4	M Pg Count	
5	C Pg Count	
6	Y Pg Count	
7	Disp Timing:K	This setting displays the percentage of toner remaining for toner near end. [0 to 100/ 1%]
8	Disp Timing:M	
9	Disp Timing:C	
10	Disp Timing:Y	

3412	TE Detect:Disp/Set	
	These SP codes determine how many pages print before toner supply reaches toner end.	

## Service Tables

1	TE:Sheets:Min:K	These SPs set the minimum number of monochrome and color pages guaranteed to print after the machine has determined near end until the toner-end message is displayed. [0 to 50 / 10/ 1 Sheet]
2	TE:Sheets:Min:Col	
3	TE:Sheets:Max:K	These SPs set the maximum number of pages for monochrome and color guaranteed to print after the machine has determined near end until the toner-end message is displayed. [0 to 2000/ 600/ 1 Sheet]
4	TE:Sheets:Max:Col	
5	TE:Pixel:K	These SP codes set the number of pages for monochrome and color pages to be output based on 5% A4 coverage after the machine has determined near end until the toner-end message is displayed. [0 to 100/ 30/ 1 Sheet]
6	TE:Pixel:Col	
7	K Page Cnt	These SP codes determine for each color how many pages will be output after the machine has determined near end. [0 to 2000/ 0/ 1 Sheet]
8	M Page Cnt	
9	C Page Cnt	
10	Y Page Cnt	
11	K Pixel Cnt	These SP codes display the number of pages for monochrome and color pages to output based on the amount of toner consumed (cm <sup>2</sup> ) after the machine determined near end. [0 to 1 000 000/ 0/ 1 cm <sup>2</sup> ]
12	M Pixel Cnt	
13	C Pixel Cnt	
14	Y Pixel Cnt	
15	Page Cnt Stop:Coverage	This SP sets the number of pages to print after the machine has determined near end based on percent of A4 coverage until the toner pump is switched off. [0 to 100/ 0/ 1%]

3501	Select ProCon	
	<p>Select Process Control Method</p> <p>The settings of these SP codes modify the operation of the automatic process control self-check. Automatic process control is done at these times:</p> <ul style="list-style-type: none"> <li>▪ When the machine is turned on</li> <li>▪ At the end of the job, if the number of pages since the previous process control, exceeds the value of SP 3551</li> <li>▪ Before ACC adjustment</li> <li>▪ When the developer is initialized with SP3811.</li> </ul> <p>For more about process control, see "Process Control" in Section 6.</p>	
1	<p>Potential Ctrl</p> <p>[0 to 2/1] <b>0: Auto</b>, 1: Fixed</p> <p>When the machine starts (with the front door closed), the process control self-check begins using as reference bias voltages set with the Group 3 SP codes. The referenced voltages are different, depending on whether "Auto" or "Fixed" is set:</p>	
	<b>Referenced SPs with "Auto" Selected</b>	
	SP3575 001 to 016	Dev DC Control
	SP3576 001 to 016	Chrg DC Control
	SP3577 001 to 004	Chrg AC Control
	SP3581 001 to 008	LD Power Control
	SP3551 001, 002	Procon Int
	SP3554 001	Init ProCon Set
	SP3801 001	DevSetup Execute
	SP3811 001 to 006	DevSetup Execute
	<b>Reference SPs with "Fixed" Selected</b>	
	SP2201 001 to 004	Set DC Charge



Service Tables

	SP2202 001 to 004	Set AC Charge
	SP2211 001 to 004	Set LD Power
	SP2212 001 to 004	Set Dev DC
3	Density Adj Mode	Sets the execution timing of toner density adjustment with the automatic process control self-check. [0 to 3/1] 0: Do not execute, 1: 1st Power On, 2: 1st Power On & Job End
4	ACC Before ProCon	Determines whether process control is executed before a gradation test pattern is printed using the operation panel with: [User Tools]> Maintenance> Auto Color Calibration [0 to 3/2/1] 0:Do not execute 1:Execute Potential Control 2:Execute Potential Control and Toner Density Adjustment
5	DnstyAdjTimes	Sets the upper limit of the loop wherein density is adjusted during process control. Default: 5
6	DevGamma(EnvCorrct)	Switches correction of the development gamma adjustment with the readings of the temperature/humidity sensor off and on. Touch either the "OFF" or "ON" button to toggle the setting.
7	DevGamma(TimeCorrct)	Switches the timing of the development gamma adjustment during process control off and on. Touch either the "OFF" or "ON" button to toggle the setting.

3511	Poten Tbl:Disp	
	<p>Display Potential Table</p> <p>Displays the numbers in the Potential Table selected for process control.</p> <p>The Potential Table is the lookup table that contains the potential target values (Vd, Vb, VI) for adjustment of the development potential.</p> <ul style="list-style-type: none"> <li>▪ Vd: Initial charge applied to the drum by the charge roller.</li> <li>▪ Vb: Development bias</li> <li>▪ VI: Value used to correct the strength of the lasers.</li> </ul> <p>A 4-grade pattern is first created on the drum and then transferred to the ITB:</p> <ul style="list-style-type: none"> <li>▪ On the drum, the potential sensor uses their readings of this pattern to determine development potential.</li> <li>▪ On the ITB, the ID sensors use their readings of this pattern to determine the amount of toner coverage necessary.</li> </ul> <p>For more about process control, see "Process Control" in Section 6.</p>	
1	K Value	<p>Displays the current numbers in the Potential Table for each color.</p> <p>[1 to 99/1]</p>
2	M Value	
3	C Value	
4	Y Value	
5	Target: K	<p>Displays the target values for Vd , Vb , VI after measurements of ambient conditions and compensating for residual charge on the drum (Vr).</p> <p>If the actual development gamma is less than the target development gamma, this SP shows a smaller value than the selected pointer table value.</p> <p>If the actual development gamma is greater than the target development gamma, this SP shows a larger value than the selected pointer table value.</p> <p>[1 to 99/1]</p>
6	Target: M	
7	Target: C	
8	Target: Y	

Service Tables

3531	ProCon Target	
	<p>Set Target Amount for Process Control</p> <p>This SP sets the value for the maximum coverage to be achieved by the process control self-check. Process control then analyzes the readings of the 4-grade pattern, calculates the potentials required for development gamma and V<sub>k</sub> (starting voltage), and then determines the drum charge levels, development biases, and LD power levels necessary to achieve the target coverage.</p> <p><b>Note</b></p> <ul style="list-style-type: none"> <li>▪ This SP can be used to darken printed images.</li> </ul> <p>After this SP is changed, process control must be executed manually with SP3820.</p>	
1	Max Tnr Amt:K	[0 to 1/ 0.001 mg/cm <sup>2</sup> ]
2	Max Tnr Amt:M	
3	Max Tnr Amt:C	
4	Max Tnr Amt:Y	

3540	Image Quality Adjust: Interval	
	Adjusts the interval between image quality adjustments.	
1	During Job	<p>Sets the page interval for image quality adjustment.</p> <p>[0 to 100/30/1 Page]</p>
2	During Standby	<p>Sets the time interval for image quality adjustment while the machine is in standby mode.</p> <p>[0 to 100/10/1 Min.]</p>

3551	Set Procon:Job End	
	<p>This SP sets timing of the process control self-check for job end. The process control self-check never interrupts a job to execute, even if it is time for the</p>	

Service Tables

	next self-check.	
1	B/W Mode	This SP sets the page interval for execution of process control at job end for monochrome printing. [0 to 5000/250/1]
2	Color Mode	This SP sets the page interval for execution of process control at job end for color printing. [0 to 5000/250/1]
3	Pg Cnt:B&W Mode	Displays the current page interval counts for the execution of process control execution for both monochrome and color printing. [0 to 5000/0/1]
4	Pg CntColor Mode	

3552	Set Procon:Interrupt	
	These SP codes settings determine whether a long print job is interrupted temporarily in order to execute process control. (Normally long print jobs are not interrupted for process control unless these settings are changed.)	
1	B/W Mode	Sets the page interval to trigger process control during a long monochrome print job. [0 to 2000/0/ 1 sheet]
2	Color Mode	Sets the page interval to trigger process control during a long color print job. [0 to 1000/0/ 1 sheet]
3	Pg Cnt:B&W Mode	Displays the current page counts that will interrupt long monochrome or color print jobs in order to execute process control. [0 to 5000/ 0/ 1 sheet]
4	Pg Cnt:Color Mode	

Service Tables

3554	Init ProCon Set	
	<p>The machine determines the amount of time elapsed since the drum motors stopped (print end, process control end, etc.) and the amount of change in the temperature and humidity since the last cold start.</p> <p>In order to determine if initial processing control self-check executes, the machine compares:</p> <ul style="list-style-type: none"> <li>▪ The time the drum stop last stopped (SP3556-1 to 5: Last Print Date/Time)</li> <li>▪ The temperature and humidity when the drum last stopped (SP2901-5 to 8)</li> </ul> <p>If the difference between temperature and humidity is higher than the temperature/humidity threshold for a cold start, then initial process control self-check executes again.</p>	
1	Non-use Time Setting	<p>Sets the amount of time to elapse for the K drum motor to remain idle after power on.</p> <p>[0 to 1440/360/1 min.]</p>
2	Temperature Range	<p>Sets the temperature for the K drum motor idle time at power on.</p> <p>[0 to 99/ 10/ 1 degC]</p>
3	Relative Humidity Range	<p>Sets the relative humidity for the K drum motor idle time at power on.</p> <p>[0 to 99/ 50/ 1 % rh]</p>
4	Absolute Humidity Range	<p>Sets the absolute humidity for the K drum motor idle time at power on.</p> <p>[0 to 99/ 6 1 g/m<sup>3</sup>]</p>

3555	Non-use Time Procon Set	
	<p>After the time set with SP3540-2 has elapsed the current temperature and humidity are compared with the temperature and humidity the last time the drum stopped. If the difference is greater than the threshold values set with this</p>	

Service Tables

	SP, initial process control executes.	
1	Non-use Time Setting	Sets the amount of time to elapse from the last time the K drum motor stopped. The reading is updated every 10 minutes. [0 to 1440/360/1 min.]
2	Temperature Range	Sets the temperature to be compared with the temperature from the last time the K drum motor stopped. The reading is updated every 10 minutes. [0 to 99/ 10/ 1 degC]
3	Relative Humidity Range	Sets the relative humidity to be compared with the relative humidity from the last time the K drum motor stopped. The reading is updated every 10 minutes. [0 to 99/ 50/ 1 % rh]
4	Absolute Humidity Range	Sets the absolute humidity to be compared with the relative humidity from the last time the K drum motor stopped. The reading is updated every 10 minutes. [0 to 99/ 6 1 g/m3]
5	Max Times	Sets the maximum number of times for these SP codes to execute while the machine remains in standby mode. [0 to 99/ 10/ 1 times]

3556	Latest Print Date Time	
	These SP settings display the date of the most recent print job.	
1	Year	[1 to 12/1/1 year]
2	Month	[1 to 31/1/1 month]
3	Day	[1 to 23/1/1 day]
4	Hour	[1 to 23/1/1 hour]
5	Min.	[1 to 59/1/1 min.]

Service Tables

3561	Dev gamma:Disp/Set	
	<p>Displays the value of development gamma, an indicator of development capacity. In order for the machine to determine the development potential to obtain the target coverage. During processing control the graduated patterns are created first on the drums and then on the ITB. The potential sensors read the development potential, and the ID sensors read the amount of coverage on the ITB.</p> <p>Plotting the development potential on the X axis against coverage on the Y-axis results in the development gamma curve. For more, see "Process Control" in Section 6.</p>	
1-4	Actual Val:K,M,C,Y	
5-8	Target Val:K,M,C,y	
9-012	Initial Val:K,M,C,Y	
013	Environ Corr:Bk	
014	Environ Corr:Col	
15-18	Time Lapse Corr:K,M,C,Y	
19-22	Tnr Density Corr:K,M,C,Y	
23-26	Toner Use Count:K,M,C,Y	
27-30	TnrDensity:K,M,C,Y	
31-38	Environ Corr 1-8:K	
39-46	Environ Corr 1-8:Col	
47-56	Time Lapse Corr 1-10:K	
57-71	Time Lapse Corr 1-15:Col	

3562	Display Vk
------	------------

Service Tables

	<p>Display V<sub>k</sub> (Development Start Voltage)</p> <p>Displays V<sub>k</sub>, the development start voltage. This development start voltage is used to indicate whether the developer has deteriorated. However, this is only a rough measurement due to other factors:</p> <ul style="list-style-type: none"> <li>▪ A low threshold setting for the target development gamma.</li> <li>▪ Operational variations between machines</li> <li>▪ Precision of the ID sensor measurements</li> </ul> <p>Normal range for V<sub>k</sub>: -150V to +150V</p>	
1	K	[-300 to +300/1 V]
2	M	
3	C	
4	Y	

3563	Display V <sub>r</sub>	
	<p>Display V<sub>r</sub> (Residual Potential)</p> <p>V<sub>r</sub> is the potential that remains on the surface of the drum after full exposure to the laser. The existence of this residual voltage is used as an indicator to determine the level of deterioration of the drum. V<sub>r</sub> becomes larger as the drum deteriorates.</p> <p>Normal range for V<sub>r</sub>: -200V to 0V</p>	
1	K	[-300 to +300/1 V]
2	M	
3	C	
4	Y	

3571	Display V <sub>0</sub>	
	Display V <sub>d</sub> (Value for Control of Charge Potential)	



Service Tables

	Displays the value for V0, the measure of drum potential on dark areas of the drum before laser exposure. Normal range: -700 V to -500 V	
1	K	[-999 to 0/1 V]
2	M	
3	C	
4	Y	

3572	Display Vdhome	
	Display Vd (Value for Control of Charge Potential) Displays the value for Vdhome, the electrical potential of the drum after a fixed dc bias (dc -700V) is applied by the drum charge roller. Normal range: -700V to -500V	
1	K	[-999 to 0/1 V]
2	M	
3	C	
4	Y	

3573	Target Poten:Vd	
	Display Target Potential (VdDisplay) Vd (read by the potential sensor) is the potential of dark areas of a drum before full laser exposure. This SP displays the value of Vd used by processing control to determine the target potential (Vd). The machine performs a calculation using development gamma, Vk and the maximum coverage, and then uses the result to lookup and retrieve the correct voltage from the	

Service Tables

	Potential Table. This retrieved value is used to raise the charge of the charge roller that charges the drums.	
1	K	[-999 to 0/1 V]
2	M	
3	C	
4	Y	

3574	Target Poten:VI	
	<p>Display Target Potential (VIDisplay)</p> <p>VI (read by the potential sensor) is the potential of the exposed areas after full laser exposure. This SP displays the value of VI used by processing control to determine the target potential (VI). The machine performs a calculation using development gamma, Vk and the maximum coverage, and then uses the result to lookup and retrieve the correct voltage from the Potential Table. This retrieved value is used to raise the input current of the laser diode.</p>	
1	K	[-999 to 0/1 V]
2	M	
3	C	
4	Y	

3575	Dev DC Control	
	<p>Display Value for Control of Development DC</p> <p>Displays the development bias that was referenced during processing control and used in the previous jobs (Used if process control is set for Auto with SP3501 001.)</p>	
1	Std Spd2:K	[-999 to -200/ 1V]

Service Tables

2	Std Spd2:M	
3	Std Spd2:C	
4	Std Spd2:Y	
5	Std Spd1:K	[-999 to -200/ 1V]
6	Std Spd1:M	
7	Std Spd1:C	
8	Std Spd1:Y	
9	Low Spd2:K	[-999 to -200/ 1V]
10	Low Spd2:M	
11	Low Spd2:C	
12	Low Spd2:Y	
13	Low Spd1:K	[-999 to -200/ 1V]
14	Low Spd1:M	
15	Low Spd1:C	
16	Low Spd1:Y	

3576	Chrg DC Control	
	Displays the value for control of development dc. (Used if process control is set for Auto with SP3501 001.)	
1	Std d2:K	
2	Std d2:M	
3	Std d2:C	
4	Std d2:Y	

Service Tables

5	Std d1:K	
6	Std d1:M	
7	Std d1:C	
8	Std d1:Y	
9	Low d2:K	
10	Low d2:M	
11	Low d2:C	
12	Low d2:Y	
13	Low d1:K	
14	Low d1:M	
15	Low d1:C	
16	16Y	

3577	Chrg AC Control	
	Displays the ac bias that was referenced during processing control and used in the previous jobs. Used if process control is set for Auto with SP3501 001.	
1	K	[0.5 to 1.5/ 1/ 0.01 mA]
2	M	[1.6 to 3/ 2.2/ 0.01 kV]
3	C	
4	Y	

3581	LD Power Control
------	------------------

## Service Tables

	Displays the LD power that was referenced during processing control and used in the previous jobs. Used if process control is set for Auto with SP3501 001.	
1	NorM2&Low2:K	
2	NorM2&Low2:M	
3	NorM2&Low2:C	
4	NorM2&Low2:Y	
5	Norm1&Low1:K	
6	Norm1&Low1:M	
7	Norm1&Low1:C	
8	Norm1&Low1:Y	

3701	Tnr Refresh Mode	
	These SP settings determine how the toner refresh mode is activated.	
5	Image Area Thresh:K	Sets the threshold (percentage of coverage) to trigger toner refresh mode. [0 to 25.5/5/0.1%]
6	Image Area Thresh:M	
7	Image Area Thresh:C	
8	Image Area Thresh:Y	
9	Max Pattern Length	Sets the threshold (number of sheets) to trigger toner refresh mode. [0 to 25/25/1 mm]
10	Need Ref Length:K	Displays the amount of fresh toner required. [0 to 65 535/ 0/1 mm]
11	Need Ref Length:M	
12	Need Ref Length:C	
13	Need Ref Length:Y	
14	Interrupt Thresh:K	Sets the threshold for the amount of toner

Service Tables

15	Interrupt Thresh:M	consumption to trigger toner refresh mode. [0 to 65 535/ 300/1 mm]
16	Interrupt Thresh:C	
17	Interrupt Thresh:Y	

3702	Set Expel Dev Mode	
1	Set Expel Dev Mode	Switches toner purging off/on. Default: ON
2	Required Expel Time:K	Displays the length of time required to purge K, M, C, Y toner. [0 to 655.35/ 0/0.01 sec.]
3	Required Expel Time:M	
4	Required Expel Time:C	
5	Required Expel Time:Y	
6	Execution Threshold Value	Sets the time threshold for toner purging. [2 to 255/15/ 1 sec.]
7	Calculated Value:Half-Speed	Sets the time needed to calculate filling toner for half-speed (thick paper). [0 to 655.35/ 31/ 0.01 sec.]

3710	Tnr Density Adj <b>DFU</b>	
1	K SuppTime Coeff	
2	M SuppTime Coeff	
3	C SuppTime Coeff	
4	Y SuppTime Coeff	
5	K UseTime Coeff	
6	M UseTime Coeff	
7	C UseTime Coeff	
8	Y UseTime Coeff	

Service Tables

---

3801	Init TD Sensor	
	<p>Execute Developer Setup</p> <p>Do this SP after replacing the developer in one or more of the PCUs when servicing the machine. This SP:</p> <ul style="list-style-type: none"> <li>▪ Checks for the presence of developer in the development unit. This ensures that the development unit has been filled.</li> <li>▪ Initializes TD sensor. (Calibrates Vtcnt).</li> <li>▪ Calibrates development gamma and calibrates toner density. Also does the MUSIC check and correction.</li> </ul> <p><b>Note:</b> Do SP3811 after drum and cleaning blade replacement. SP3811 should always be done:</p> <ul style="list-style-type: none"> <li>▪ During the machine installation procedure after the developer and toner have been installed, and</li> <li>▪ During machine maintenance after a drum and cleaning blade have been replaced.</li> </ul> <p>In both cases, SP3811 prevents the blade from scouring a dry drum.</p>	
1	All Colors	
2	Col	
3	K	
4	M	
5	C	
6	Y	
7	Dev Auger Time	

3802	TD Sn Init OK?	
	<p>This SP displays the results of the TD sensor initialization with SP3801 001 to 006. The machine returns the status of the previous initialization with numbers,</p>	

Service Tables

	<p>1 digit for each PCU. The numbers are read in order as "K, M, C, Y".</p> <p>Four numbers are used to indicate the status of the execution.</p> <p>1: OK (success)</p> <p>2: Cancelled (door opened, etc.)</p> <p>4: Not executed (not selected for execution; this is not an error)</p> <p>9: Vtcnt abnormal. Vtcnt (TD sensor control voltage) could not be adjusted to within 2.5 ±0.2V. The machine issued a TD sensor error for the PCU where there is a problem (SC372 to SC375).</p> <p><b>Note!</b>: The "1111" display is read from left to right: KMCY.</p>
--	---

3810	CIngInitSetExe	
	These SPs should be executed after replacement of the drum cleaning roller or drum cleaning blade.	
1	All Colors	Y, M, C, K
2	Col	Excludes Black (Y, M, C only)
3	K	
4	M	
5	C	
6	Y	
7	A3 Page Cover	Sets the number of sheets for A3 coverage to prevent scouring of the OPC drum. [0 to 100/ 3/ 1 sheet]

3811	DevSetup Execute	
	Execute Developer Setup Do this SP during the installation procedure after the developer and toner	



Service Tables

	<p>cartridges have been installed in the machine, or after the drum and cleaning blade have been replaced. This SP:</p> <ul style="list-style-type: none"> <li>▪ Checks and confirms each PCU is installed and filled with developer.</li> <li>▪ Switches on toner supply and sends toner to the sub hopper of each PCU.</li> <li>▪ Sends toner to the PCU to coat the drum with toner. This prevents the cleaning blades from bending and scouring the drums.</li> <li>▪ Initializes the TD sensors.</li> <li>▪ Starts the process control self-check to set the target for development gamma and adjusts toner density.</li> <li>▪ Starts the MUSIC sequence to check and correct color image offset.</li> </ul> <p><b>Note:</b></p> <ul style="list-style-type: none"> <li>▪ After doing SP3811, always do SP3812 to confirm that SP3811 executed correctly.</li> <li>▪ SP3811 001 is done only at machine installation, or after a drum and cleaning blade has been replaced in the PCU.</li> <li>▪ SP3801 001 to 006 is done after developer replacement for one or more PCUs.</li> </ul>	
1	Devr Setup:All	[0 to 1/1]
2	Devr Setup:Col	
3	K	
4	M	
5	C	
6	Y	

3812	DevSetup Execute
	<p>Display Result of Developer Setup Execution</p> <p>Do this SP to confirm that SP3811 executed correctly. After execution the machine displays a "1" to confirm that SP3811 executed correctly for each PCU. The "1111" display indicates the return value for each PCU: K, M, C, Y</p>

Service Tables

	<b>Note!</b> : The "1111" display is read from left to right: KMCY.
--	---

3813	Used Tnr Mode Exe	
	Used Toner Mode Execute When the machine is printing in full-color mode, the waste toner in the PCUs is transported to the waste toner bottle for the amount of time specified with SP3813 003 below.	
1	All Colors	[0 to 1/1] 0:Off, 1: On
2	K Only	
3	Set Op. Time	[10 to 240/1 sec.]

3814	Execute Developer Fill	
	These SP codes fill the PCUs with developer from the developer bottle. After doing one or more of these SP codes, always do SP3815 to confirm that the PCUs filled successfully.	
1	All (KMCY)	
2	M CY Only	
3	K	
4	M	
5	C	
6	Y	

3815	Developer Fill:Disp Result
------	----------------------------

## Service Tables

	<p>Always execute this SP code to confirm successful execution of SP3814.</p> <p><b>Note!</b>: The "1111" display is read from left to right: KMCY.</p>
--	---

3816	Developer Fill:Set <b>DFU</b>	
1	Belt Form Start Time:A	
2	Developer Fill Time:B	
3	Belt Length:C	

3817	Developer Filling: Admission	
	<p>When SP3814 (Execute Developer Fill) is executed, the process control self-check, but the MUSIC adjustment are disabled until after one of the SP codes has been executed after developer filling:</p> <ul style="list-style-type: none"> <li>▪ SP3811 (Developer Setup)</li> <li>▪ SP3801 (TD Sensor Initialization)</li> </ul> <p>This is the condition normally in effect. (SP codes 1 to 4 will display "1").</p>	
1	K	<p>Display the permission status of each PCU for developer filling after SP3814 was executed.</p> <p>1: Developer filling enabled. No process control self-check, no MUSIC adjustment until SP3811 or SP3801 have been execute.</p> <p>0: Developer filling disabled</p>
2	M	
3	C	
4	Y	
5	Reset Status: All Colors	Forcibly resets the status to "0".

3820	Manual ProCon	
	<p>Use these SP codes to execute process control manually.</p> <p>You must do SP3820 to enable any values you change with SP3531 (Procon Target). Use SP3561 to display the results of SP3820 execution.</p> <p><b>Note:</b></p> <ul style="list-style-type: none"> <li>▪ Process control is disabled during machine warm-up.</li> </ul>	

Service Tables

	<ul style="list-style-type: none"> <li>If you execute this SP code during machine warm-up, "Completed" is displayed immediately. However, the manual process control setting was not actually done.</li> </ul>	
1	Normal ProCon	Does potential control only.
2	Exe Density Adj	Does potential control and toner density adjustment.
3	ACC RunTime ProCon	Executes process control again just before ACC executes.

3821	ProCon OK?		
	Use this SP to display the history of process control executions. These SP codes are used to troubleshoot processing control. [0 to 99999999/1]		
1	History:Last	6	History:Last 6
2	History:Last 2	7	History:Last 7
3	History:Last 3	8	History:Last 8
4	History:Last 4	9	History:Last 9
5	History:Last 5	10	History:Last 10

3900	RsetProConSP		
	Reset All Process Control SP Codes Press [EXECUTE] to reset all process control related SP codes to their default values.		

## Service Tables

---

3910	Forbid LD Write <b>DFU</b>
------	----------------------------

3920	Recovery Operation Request <b>DFU</b>
------	---------------------------------------

3930	Sheet Threshold Display
	<p>This setting determines sets the threshold to determine when the machine switches from FC to BW printing during a long print job.</p> <p>[0 to 99/0/1]</p> <p>0: No switching from FC to BW</p> <p>1: Switches according to print job (FC/BW)</p> <p>2 to 99: Switches FC to BW based on the number of pages.</p>

## Group 4000

---

4008	Sub Scan Magnification Adj
	Adjusts the sub-scan magnification by changing the scanner motor speed. [-10 to +10/0.1%]

4010	Sub Scan Registration Adj
	Adjusts the leading edge registration by changing the scanning start timing in the sub-scan direction. [-30 to +30/0.1 mm]

4011	Main Scan Reg
	Adjusts the side-to-side registration by changing the scanning start timing in the main scan direction. <b>Note:</b> This adjustment is done for the ADF with SP6006 (ADF Reg. Adj.). [-25 to +25/0.1 mm]

4012	Set Scale Mask
	Sets the blank margin at each side for erasing the original shadow caused by the gap between the original and the scale. This can be done for both scanning on the exposure glass (book mode) and the ADF (ADF) for the leading and trailing edges.
1	Book:Sub LEdge [0 to 30/0.1 mm]

## Service Tables

2	Book:Sub TEdge	
3	Book:Main:LEdge	
4	Book:Main:TEdge	
5	ADF:Sub:LEdge	
7	ADF:Main:LEdge	
8	ADF:Main:TEdge	

4013	Scanner Free Run	
	Free Run: Scanner Performs the scanner free run with the exposure lamp on or off for full-color, full size (A3 or DLT).	
1	Lamp:Off	[0 to 1/1] 0: Off, 1: On
2	Lamp:On	

4014	Scan <b>DFU</b>
	Touch [Execute] to execute one scanning operation with the scanner at the home position.

4020	Dust Check
	These SP codes adjust the dust check operation at the ADF scanning glass and the white scanning belt. <b>Note:</b> Dust that triggers a warning could be removed from the glass by the

## Service Tables

	originals in the feed path. If the dust is removed by passing originals, this is not detected and the warning remains on.
1	Dust Detect:On/Off
	Switches the dust warning on and off. When this SP is on, a warning is issued if the check detects dust on the ADF scan glass or the white plate above the scanning glass. Always clean the ADF scanning glass and white plate before turning this SP on. [0 to 1/1] 0: Off, 1: On
2	Dust Detect:Lvl
	Adjusts the sensitivity of the check. If you see black streaks in copies when no warning has been issued, raise the setting to increase the level of sensitivity. If warnings are issued when you see no black streaks in copies, lower the setting. [0 to 8/1]
3	Dust Reject:Lvl
	Sets the level for vertical line correction caused by dust. A high setting can eliminate unwanted vertical lines caused by dust but it can also thin vertical lines of the original. [0 to 4/1]

4301	Operation Check APS Sensor
	<p>This SP confirms that the APS sensors are operating correctly. Place a sheet of paper on the exposure glass, then execute this SP code. For example, and A3 sheets returns the display <b>1111 1111</b> to indicate that all sensors are activated and operating normally.</p> <p><b>Note:</b> Only the first 5 bits are used:</p> <ul style="list-style-type: none"> <li>Bit 0: APS Sensor 1</li> <li>Bit 1: APS Sensor 2</li> <li>Bit 2: APS Sensor 3</li> <li>Bit 3, APS Sensor 4</li> <li>Bit 4: APS Sensor 5</li> </ul>



Service Tables

---

4303	Min Size for APS
	<p>Sets the minimum size that the will be detected by APS</p> <p>[0 to 2/1]</p> <p>[*0: Unknown Document Size]</p> <p>[1 A5-Lengthwise (HLT Lengthwise)]</p> <p>[2 A5 Sideways HLT Sideways]</p>

4305	8K/16K Detection
	<p>This SP enables the machine to recognize 8K/16K size paper automatically.</p> <p>[*0: Normal]</p> <p>[1: A4-Sideways LT-Lengthwise]</p> <p>[2: A4-Lengthwise LT-Sideways]</p> <p>[3: 8KAI, 16 KAI]</p>

4400	Org Edge Mask	
	This SP sets the area to be masked during platen (book) mode scanning.	
1	Book:Sub:LEdge	[0 to 30/0.1 mm]
2	Book:Sub:TEdge	
3	Book:Main:LEdge	
4	Book:Main:Tedge	
5	ADF:Sub:LEdge	
7	ADF:Main:TEdge	
8	ADF:Main:TEdge	

Service Tables

4417	IPU Test Pattern			
	Use this SP to select the IPU test pattern to print.			
		Test Pattern [0 to 24/1]		
	0	Scanned Image	13	Grid Pattern CMYK
	1	Gradation Main Scan A	14	Color Patch CMYK
	2	Gradation Main Scan B	15	Gray Pattern (1)
	3	Gradation Main Scan C	16	Gray Pattern (2)
	4	Gradation Main Scan D	17	Gray Pattern (3)
	5	Gradation Sub Scan 1	18	Shading Pattern
	6	Grid Pattern	19	Thin Line Pattern
	7	Slant Grid Pattern	20	Scanned + Grid Pattern
	8	Gradation RGBCMYK	21	Scanned + Grayscale
	9	UCR Pattern	22	Scanned + Color Patch
	10	Color Patch 16 (1)	23	Scanned + Slant Grid C
	11	Color Patch 16 (2)	24	Scanned + Slant Grid D
	12	Color Patch 16 64		

4429	Select Copy Data Security	
	xxx [0 to 3/3/1] 0: 1: 2: 3:	
1	Copying	

Service Tables

2	Scanning	
3	Fax Operation	

4440	Saturation Adj	
	Adjust Color Saturation This SP adjusts the saturation level for copying. [0 to 5/1] 0: High 1: Lowest 2: Lower 3: Default 4: Higher 5: Highest	

4460	Digital AE <b>DFU</b>	
	These SP codes set parameters for the AE function.	
1	Low Limit Value	This setting determines the lower limit for level of background to be skipped for the AE function. The higher the setting, the more background will be ignored. [0 to 1023/ 392/ 1]
2	Background Level	This setting determines the level of background to be output for the AE function. [0 to 1023/888/1]

4501	ACC Target Den(sity)	
	This SP sets the target density for the ACC adjustment for machines connected with the Copier Connection Kit. For more, see "Troubleshooting – Special Procedures – Color Adjustment for Connected Copiers" in the B132/B200 Service Manual.	

Service Tables

1	Copy:K:Text	[0 to 50/1]
2	Copy:C:Text	
3	Copy:M:Text	
4	Copy:Y:Text	
5	Copy:K:Photo	
6	Copy:C:Photo	
7	Copy:M:Photo	
8	Copy:Y:Photo	

4505	ACC Cor:Bright	
	Sets correction for bright areas for ACC correction.	
1 – 4	Master:K, M, C, Y	[-128 to +128/1]
5 – 8	Slave:K, M, C, Y	

4506	ACC Cor:Dark	
	Sets correction for dark areas for ACC correction.	
1 – 4	Master:K, M, C, Y	[-128 to +128/1]
5 – 8	Slave:K, M, C, Y	

4540	Print Coverage	
	This SP corrects printer coverage of 12 hues (RY, YR, YG, etc. x 4 Colors (K, C, M, Y) for a total of 48 parameters.	
1	RY Phase: Option	[-128 to +128/1]

Service Tables

2-4	RY Phase: R, G, B	
5	YR Phase: Option	
6-8	YR Phase: R, G, B	
9	YR Phase: G	
10-12	YR Phase: R, G, B	
13	GY Phase: Option	
14-16	GY Phase: R, G, B	
17	GC Phase: Option	
18-120	GC Phase: R, G, B	
21	CG Phase: Option	
22-24	CG Phase: R, G, B	
25	CB Phase: Option	
26-28	CB Phase: R, G, B	
29	BC Phase: Option	
30-32	BC Phase: R, G, B	
33	BM Phase: Option	
34-36	BM Phase: R, G, B	
37	MB Phase: Option	
38-40	MB Phase: R, G, B	
41	MR Phase: Option	
42-44	MR Phase: R, G, B	
45	RM Phase: Option	
46-48	RM Phase: R, G, B	

Service Tables

4550	Scan Apli:Txt/Print	
4551	Scan Apli:Txt	
4552	Scan Apli:Txt Dropout	
4553	Scan Apli:Txt-Photo	
4554	Scan Apli:Photo	
4565	Scan Apli:GrayScale	
4570	Scan Apli:Col Txt-Photo	
4571	Scan Apli:Col Gloss Photo	
4572	Scan Apli:AutoCol	
4580	Fax Apli:Txt-Chart	
4581	Fax Apli:Txt	
4582	Fax Apli:Txt-Photo	
4583	Fax Apli:Photo	
4584	Fax Apli:Original 1	
4585	Fax Apli:Original 2	
5	MTF: 0(Off) 1-15 (Weak-Strong)	<p>Sets the MTF level (Modulation Transfer Function) designed to improve image contrast. Set higher for stronger effect, lower for weaker effect.</p> <p>[0 to 15/1]</p>
6	Smoothing: 0(x1) 1-7 (Weak-Strong)	<p>Use to remove "jaggies" if they appear. Set higher for smoother.</p> <p>[0 to 7/1]</p>
7	Brightness: 1-255	<p>Set higher for darker, set lower for lighter.</p> <p>[1 to 255/1]</p>

Service Tables

8	Contrast: 1-255	Set higher for more contrast, set lower for less contrast. [1 to 255/1]
9	Ind Dot Erase: 0(Off) 1-7 (Strong)	Use to remove individual dots in the background if they appear. Set higher for removal of more background. [0 to 7/1]

4600	Display the ID of ASIC <b>DFU</b>	
	These SP codes display the readings of IDs read during automatic adjustment of the SBU. If one of these IDs is incorrect, this triggers SC144.	
1	VSBCNT	Displays the value read for VSBCNT during automatic SBU adjustment.
2	DAGL_L	Displays the value read for DAGL_L_ID during automatic SBU adjustment.
3	DAGL_F	Displays the value read for DAGL_F_ID during automatic SBU adjustment.

4603	AGC Operation <b>DFU</b>
	Touch [EXECUTE] to execute automatic gain control (AGC) for HP detection.

4609	Gray Balance Adj Value R <b>DFU</b>
4610	Gray Balance Adj Value G <b>DFU</b>
4611	Gray Balance Adj Value B <b>DFU</b>
4615	Gray Balance Adj Value R <b>DFU</b>
4616	Gray Balance Adj Value G <b>DFU</b>
4617	Gray Balance Adj Value B <b>DFU</b>

## Service Tables

	<p>These SP codes display the reference voltages stored in NVRAM at the factory for Red, Green, and Blue before the machine was shipped. The SBU acquires these settings every time the machine is switched on.</p> <p>[-256 to +255/1]</p>
--	---

4628	Gain Adj Range:R <b>DFU</b>	
4629	Gain Adj Range:G <b>DFU</b>	
4630	Gain Adj Range:B <b>DFU</b>	
	When switched on, these SP display the current range for the gain of RED, GREEN, and BLUE in the ASCII on the SBU after white level adjustment every time the machine is switched on.	
1	FC:F:R (G, B)	
3	FC:L:R (G, B)	
5	BK:F:R (G, B)	
7	BK:L:R (G, B)	

4631	Gain Adj Value:R <b>DFU</b>	
	When switched on, this SP displays the current range for the E (EVEN) or O (ODD) in the ASCII on the SBU after white level adjustment every time the machine is switched on.	
1	FC:F:RE	
2	FC:F:RO	
3	FC:L:RE	
4	FC:L:RO	
5	BK:F:RE	
6	BK:F:RO	



Service Tables

7	BK:L:RE	
8	BK:L:RO	

4632	Gain Adj Value:G <b>DFU</b>	
	When switched on, this SP displays the current range for E (EVEN) or O (ODD) gain of GREEN or B/W in the ASCI on the SBU after white level adjustment every time the machine is switched on.	
1	FC:F:GE	
2	FC:F:GO	
3	FC:L:GE	
4	FC:L:GO	
5	BK:F:GE	
6	BK:F:GO	
7	BK:L:GE	
8	BK:L:GO	

4633	Gain Adj Value:B <b>DFU</b>	
	When switched on, this SP displays the current range for E (EVEN) or O (ODD) gain of GREEN or B/W in the ASCI on the SBU after white level adjustment every time the machine is switched on.	
1	FC:F:BE	
2	FC:F:BO	
3	FC:L:BE	

Service Tables

4	FC:L:BO	
5	BK:F:BE	
6	BK:F:BO	
7	BK:L:BE	
8	BK:L:BO	

4641	LoopNumber:WhiteLevel <b>DFU</b>	
	Displays the number of loops done color correction for AGC (Automatic Gain Correction) during white level adjustment.	
1	FC	[0 to 1023/1]
2	BK	

4646	ErrorFlag:Auto-Adj Scanner <b>DFU</b>	
	This SP sets the error flag to display as the SBU is updated automatically when the machine is switched on.	
1	Gain1:First	
2	Gain1:Last	
3	Gain2:First	
4	Gain2:Last	
5	Black Level :first :FC	
6	Black Level :Last :FC	
7	Black Level :first :BK	

Service Tables

8	Black Level :Last :BK	
---	-----------------------	--

4647	ErrorFlag:Scanner Hardware <b>DFU</b>
------	---------------------------------------

4677	Gain Range Adj Value:R <b>DFU</b>
4678	Gain Range Adj Value:G <b>DFU</b>
4679	Gain Range Adj Value:B <b>DFU</b>

4680	Gain Adj Value: R <b>DFU</b>
4681	Gain Adj Value: G <b>DFU</b>
4682	Gain Adj Value: B <b>DFU</b>
	When switched on, these SP codes display the settings done at the factory for Red (Green, Blue) O (ODD) and E (EVEN) gain in the ASIC on the SBU after white level adjustment every time the machine is switched on.

4690	White Level Peak Data:R <b>DFU</b>
4691	White Level Peak Data:G <b>DFU</b>
4692	White Level Peak Data:G <b>DFU</b>
	When switched on, these SP codes display E (EVEN) or O (ODD) for the white level peak Red (Green, Blue) data after white level detection (AGC) after the machine is switched on.

4693	Black Level Data:R <b>DFU</b>
4694	Black Level Data:G <b>DFU</b>

Service Tables

4695	Black Level Data:G <b>DFU</b>
	When switched on, these SP codes display E (EVEN) or O (ODD) for the black level check done in the SBU for RED after the machine is switched on.

4800	DF Density Adj Value <b>DFU</b>
	This SP adjusts the white shading parameter for scanning an image with the ADF. Adjusts the density level if the ID of outputs from the DF and Platen mode are different.
1	RED [1 to 200/1]
2	GREEN [1 to 200/1]
3	BLUE [1 to 200/1]

4802	Scanner Free Run
	This SP sets the scanner in the free run mode for testing. The free run can be set with the exposure lamp off or on.
1	DF mode :Lamp Off
2	DF mode :Lamp On
	Touch [OFF] or [ON]

4804	Home Position Operation
	Touch [Execute] to do the home position operation once.

4806	FL Correction On/Off <b>DFU</b>
------	---------------------------------

4808	Result FL Detection <b>DFU</b>
------	--------------------------------

4809	Result FL Correction <b>DFU</b>
------	---------------------------------

Service Tables

4902	Disp ACC Data		
	This SP outputs the final data read at the end of ACC execution. A zero is returned if there was an error reading the data.		
1	R_DATA1	Photo C Patch Level 1 (8-bit)	[0 to 255/1]
2	G_DATA1	Photo M Patch Level 1 (8-bit)	
3	B_DATA1	Photo Y Patch Level 1 (8-bit)	
4	R_DATA2	Photo C Patch Level 17 (8-bit)	
5	G_DATA2	Photo M Patch Level 17 (8-bit)	
6	B_DATA2	Photo Y Patch Level 17 (8-bit)	

4904	Test Scan IPU		
	<p>Test Scanner IPU Board</p> <p>This SP tests the components of the BICU:</p> <ul style="list-style-type: none"> <li>Test 1 performs write and read tests the CPU by conducting a compare check that reads and writes to each register of the ASIC.</li> </ul> <p>Test 2 performs a check of the image paths and connections and displays the location of a defect of an error is detected.</p>		
1	Test 1	[0 to 65535/1]	
2	Test 2		

4905	Select Gradation Level		
	<p>This SP changes the threshold parameters of error diffusion.</p> <p>[0 to 255/1]</p>		

Service Tables

---

4907	Set SBU Test Pattern
	This SP selects the pattern generated by the SBU.
	[*0: Normal Scanner Output] [1: Fixed Value Output] [2: Main Scan Grayscale Output] [3: Sub Scan Grayscale Output] [4: Grid Output]

4918	Man Gamma Adj <b>DFU</b>
------	--------------------------

4948	ACC Execute Time:Present	
1	yy/mm/dd	
2	hh/mm/ss	

4949	ACC Execute Time:Previous <b>DFU</b>
------	--------------------------------------

4954	Read/Restore Std	
	Use this SP to calibrate the scanner gamma on each machine connected with the Copier Connection Kit.	
1	Read New Chart	Reads the "Standard Color Test Chart" to calibrate the scanner gamma curve for two machines connected with the Copier Connection Kit. Do this SP with the test chart on each connected machine.
2	Recall Prev Chart	Restores the scanner gamma to the previous value (not the factory setting).
3	Read Std. Chart	
4	Set Std Chart	

Service Tables

4991	Image Path Selection	
	Use this SP to use the 10-key pad to enter the number to determine the image path.	
	IPU	[0 to 14/1]
	0	DFID input RGB images (upper 8 bits)
	1	Synchronous RGB images in DFID
	2	Data with shading correction on
	3	Data with shading correction off
	4	Data before black offset correction
	5	Data after black offset correction
	6	Shading data
	7	Test pattern data (grayscale)
	8	RGB image after line interval correction
	9	RGB image after dot correction and pre-gamma
	10	RGB image after vertical line correction
	11	RGB image after scanner gamma correction
	12	RTB image after filtering with MTF
	13	RTB image after ADS
	14	RGB image after color processing

4993	High Light Correction <b>DFU</b>
------	----------------------------------

4994	Adj Txt/Photo Recognition Level <b>DFU</b>
------	--

## Group 5000

---

5024	mm/inch Display Selection
	<p>Selects the unit of measurement.</p> <p>After selection, turn the main power switch off and on.</p> <p>[0 to 1/1]</p> <p>0: mm</p> <p>1: inch</p>

5040	Custom Size: Main Scan
	<p>This SP adjusts the width (main scan direction) for custom size paper used with the LCIT D350.</p> <p>[100 to 330.2/<b>297</b>/0.1 mm]</p>

5041	Custom Size: Sub Scan
	<p>This SP adjusts the length (sub scan direction) for custom size paper used with the LCIT D350.</p> <p>[139.7 to 482.6/<b>210</b>/0.1 mm]</p>

5045	Accounting Counter
	<p>Selects the counting method if the meter charge mode is enabled.</p> <p><b>Note:</b> You can change the setting only one time.</p> <p>[0 to 1/ 1]</p>
	<p>0: Development counter. Shows the total counts for color (Y,M,C) and black (K).</p> <p>1: Paper counter. Shows the total page counts for: Color Total, Black Total, Color Copies, Black Copies, Color Prints, Black Prints.</p>



5047	Reverse Paper Display
	Determines whether the tray loaded with paper printed on one side is displayed. [0 to 1/1]
	0: Not displayed 1: Displayed

5051	Toner Refill Detection Display <b>Japan Only</b>
------	--

5055	Display IP Address
	Switches the IP address display on the operation panel on/off. OFF: IP address not displayed on operation panel ON: IP address displayed on operation panel.

5056	Coverage Counter Display
	Display or does not display the coverage counter on the LCD. [0 to 1 / 0 / 1] 0: Not displayed, 1: Displayed

5061	Toner Remaining Icon Display
	This SP switches the toner remaining icon on/off. Default: Off

5062	Parts PM Display Setting
	This SP switches the PM parts banner display. Default: OFF Touch [ON] then [OK] to enable the PM parts display.

5112	Non-Std. Paper Sel.
------	---------------------

Service Tables

	<p>Determines whether a non-standard paper size can be input for the universal cassette trays (Tray 2, Tray 3)</p> <p>[0 to 1/1]</p> <p>0: No</p> <p>1: Yes. If "1" is selected, the customer will be able to input a non-standard paper size using the UP mode.</p>
--	--

5113	Optional Counter Type
1	Default Optional Counter Type
	<p>Selects the type of counter:</p> <p>0: None</p> <p>1: Key card (RK3, 4) Japan only</p> <p>2: Key card down</p> <p>3: Pre-paid card</p> <p>4: Coin Lock</p> <p>5: MF key card</p> <p>11: Exp Key Card (Add)</p> <p>12: Exp Key Card (Deduct)</p>
2	External Optional Counter Type
	<p>Enables the SDK application. This lets you select a number for the external device for user access control.</p> <p>Note: "SDK" refers to software on an SD card.</p> <p>[0 to 3/1]</p> <p>0: None</p> <p>1: Expansion Device 1</p> <p>2: Expansion Device 2</p> <p>3: Expansion Device 3</p>

5114	Optional Counter I/F
	This SP sets the machine for use with the optional counter.

Service Tables

---

	Default: Off
--	--------------

5118	Disable Copying
	Temporarily denies access to the machine. <b>Japan Only</b> [0 to 1/1] 0: Release for normal operation 1: Prohibit access to machine

5120	Mode Clear Opt. Counter Removal
	Do not change. <b>Japan Only</b> [0 to 2/1] 0: Yes. Normal reset 1: Standby. Resets before job start/after completion 2: No. Normally no reset

5121	Counter Up Timing
	Determines whether the optional key counter counts up at paper feed-in or at paper exit. <b>Japan Only</b> [0 to 1/1] 0: Feed count 1: No feed count

5126	Set F-Size Document
	Set F Original Size Selection Sets the original size that the machine detects for F sizes.

## Service Tables

	[*0: 8½ x 13] [1: Folio 8¼ x 13] [2: F 8 x 13]
--	--

5127	APS Mode
	This SP can be used to switch APS (Auto Paper Select) off when a coin lock or pre-paid key card device is connected to the machine. [0 to 1/1] 0: On 1: Off

5128	Code Mode With Key/Card Option <b>Japan Only</b>
------	--

5131	Paper Size/Type Selection
	Selects the paper size type (for originals and copy paper). (Only needs to be adjusted if the optional printer controller is installed) [0 to 2/1] 0: JP (Japan) 1: NA (North America) 2: EU (Europe) After changing the value, turn the main power switch off and on.

5150	Bypass Length Setting
	Sets up the by-pass tray for long paper.

Service Tables

	<p>[0 to 1/1]                  0: Off                  1: On. Sets the tray for feeding paper up to 600 mm long.                  With this SP selected on, paper jams are not detected in the paper path.</p>
--	--

5162	App. Switch Method
	<p>Controls if the application screen is changed with a hardware switch or a software switch.                  [0 to 1/1]                  0: Soft Key Set                  1: Hard Key Set</p>

5167	Fax Printing Mode Optional Counter OFF
	<p>Enables or disables automatic print out without an accounting device. This SP is used when the receiving fax is control by an external accounting device.  <b>0:</b> Automatic printing                  1: No automatic printing</p>

5165	Z-Fold Position																
	<p>Adjusts the Z-fold position for different paper sizes.                  Note: In the table below "T" means "SEF"</p>																
	<table border="1"> <tr> <td>1</td> <td>A3T</td> <td>5</td> <td>LGT</td> </tr> <tr> <td>2</td> <td>B4T</td> <td>6</td> <td>LTT</td> </tr> <tr> <td>3</td> <td>A4T</td> <td>7</td> <td>12x18</td> </tr> <tr> <td>4</td> <td>DLTT</td> <td>8</td> <td>Other</td> </tr> </table>	1	A3T	5	LGT	2	B4T	6	LTT	3	A4T	7	12x18	4	DLTT	8	Other
1	A3T	5	LGT														
2	B4T	6	LTT														
3	A4T	7	12x18														
4	DLTT	8	Other														

5169	CE Login
	<p>If you will change the printer bit switches, you must 'log in' to service mode with this SP before you go into the printer SP mode.</p>

## Service Tables

	<p>[0 to 1/1]</p> <p>0: Off. Printer bit switches cannot be adjusted.</p> <p>1: On. Printer bit switches can be adjusted.</p>	
5187	PM Counter Print Out in UP	
	<p>This setting determines whether the PM parts counter list is printed with or without the standard values.</p> <p>[0 to 1/0/1]</p> <p>0: Does not print standard values</p> <p>1: Prints standard values</p>	
5188	Copy NV Version	
	Displays the version number of the NVRAM on the controller board.	
5191	Mode Set <b>DFU</b>	
5193	External Controller Info. Settings <b>DFU</b>	
5195	Limitless SW DFU <b>DFU</b>	
5212	Page Numbering	
3	Duplex Printout Left/Right Position	<p>Horizontally positions the page numbers printed on both sides during duplexing.</p> <p>[-10 to +10/1 mm]</p> <p>0 is center, minus is left, + is right.</p>
4	Duplex Printout High/Low Position	<p>Vertically positions the page numbers printed on both sides during duplexing.</p> <p>[-10 to +10/1 mm]</p> <p>0 is center, minus is down, + is up.</p>

5302	<b>Set Time DFU</b>
	<p>Sets the time clock for the local time. This setting is done at the factory before delivery. The setting is GMT expressed in minutes.</p> <p>[–1440 to 1440/1 min.]</p> <p>JA: +540 (Tokyo)</p> <p>NA: -300 (NY)</p> <p>EU: +6- (Paris)</p> <p>CH: +480 (Peking)</p> <p>TW: +480 (Taipei)</p> <p>AS: +480 (Hong Kong)</p>

5307	<b>Summer Time</b>	
	<p>Lets you set the machine to adjust its date and time automatically with the change to Daylight Savings time in the spring and back to normal time in the fall. This SP lets you set these items:</p> <ul style="list-style-type: none"> <li>▪ Day and time to go forward automatically in April.</li> <li>▪ Day and time to go back automatically in October.</li> <li>▪ Set the length of time to go forward and back automatically.</li> </ul> <p>The settings for 002 and 003 are done with 8-digit numbers:</p>	
	<b>Digits</b>	<b>Meaning</b>
	1st, 2nd	Month. 4: April, 10: October (for months 1 to 9, the first digit of 0 cannot be input, so the eight-digit setting for 002 or 003 becomes a seven-digit setting)
	3rd	Day of the week. 0: Sunday, 1: Monday
	4th	The number of the week for the day selected at the 3rd digit. If "0" is selected for "Sunday", for example, and the selected Sunday is the start of the 2nd week, then input a "2" for this digit.

Service Tables

	5th, 6th	The time when the change occurs (24-hour as hex code). Example: 00:00 (Midnight) = 00, 01:00 (1 a.m.) = 01, and so on
	7th	The number of hours to change the time. 1 hour: 1
	8th	If the time change is not a whole number (1.5 hours for example), digit 8 should be 3 (30 minutes).
1	Setting	Enables/disables the settings for 002 and 003. [0 to 1/1] 0: Disable 1: Enable
2	Rule Set (Start)	The start of summer time
3	Rule Set (End)	The end of summer time

5401*	Access Control ( <b>DFU</b> )	
	This SP stores the settings that limit uses access to SDK application data.	
103	Default Document ACL	
	Whenever a new login user is added to the address book in external certification mode (for Windows, LDAP, RDH), the default document ACL is updated according to this SP setting. [0 to 3 / 0 / 1] 0: View 1: Edit 2: Edit/Delete 3: Full control Note: This SP setting is ignored on a machine that is not using document server.	
200	SDK1 Unique ID	"SDK" is the "Software Development Kit". This data can be converted from SAS (VAS) when installed or uninstalled.
201	SDK1 Certification Method	
210	SDK2 Unique ID	



Service Tables

211	SDK2 Certification Method	<b>(DFU)</b>
220	SDK3 Unique ID	
221	SDK3 Certification Method	
230	SDK certification device	

5404	User Code Count Clear
	Touch [EXECUTE] to clear all user code counters.

5411	LDAP Certification
4	<p>Easy Certification Determines whether easy LDAP certification is done.</p> <p>[0 to 1/1/1] 1: On 0: Off</p>
5	<p>Password Null Not Permit This SP is referenced only when SP5411-4 is set to "1" (On).</p> <p>[0 to 1/0/1] 0: Password NULL not permitted. 1: Password NULL permitted.</p>

5413	Lockout Setting
1	<p>Lockout On/Off Switches on/off the lock on the local address book account.</p> <p>[0 to 1/0/1] 0: Off 1: On</p>
2	<p>Lockout Threshold Sets a limit on the frequency of lockouts for account lockouts.</p> <p>[1 to 10/5/1]</p>

Service Tables

3	<p>Cancellation On/Off</p> <p>Determines whether the system waits the prescribed time for input of a correct user ID and password after an account lockout has occurred.</p> <p>[0 to 1/0/1]</p> <p>0: Off (no wait time, lockout not cancelled)</p> <p>1: On (system waits, cancels lockout if correct user ID and password are entered).</p>
4	<p>Cancellation Time</p> <p>Determines the length of time that the system waits for correct input of the user ID and password after a lockout has occurred. This setting is used only if SP5413-3 is set to "1" (on).</p> <p>[1 to 999/60/1 min.]</p>

5414	Access Mitigation
1	<p>Mitigation On/Off</p> <p>Switches on/off masking of continuously used IDs and passwords that are identical.</p> <p>[0 to 1/0/1]</p> <p>0: Off</p> <p>1: On</p>
2	<p>Mitigation Time</p> <p>Sets the length of time for excluding continuous access for identical user IDs and passwords.</p> <p>[0 to 60/15/1 min.]</p>

5415	Password Attack
1	<p>Permissible Number</p> <p>Sets the number of attempts to attack the system with random passwords to gain illegal access to the system.</p> <p>[0 to 100/30/1 attempt]</p>
2	<p>Detect Time</p> <p>Sets the time limit to stop a password attack once such an attack has been</p>

Service Tables

	detected. [1 to 10/5/1 sec.]
--	---------------------------------

5416	Access Information
1	Access User Max Number Limits the number of users used by the access exclusion and password attack detection functions. [50 to 200/200/1 users]
2	Access Password Max Number Limits the number of passwords used by the access exclusion and password attack detection functions. [50 to 200/200/1 passwords]
3	Monitor Interval Sets the processing time interval for referencing user ID and password information. [1 to 10/3/1 sec.]

5417	Access Attack
1	Access Permissible Number Sets a limit on access attempts when an excessive number of attempts are detected for MFP features. [0 to 500/100/1]
2	Attack Detect Time Sets the length of time for monitoring the frequency of access to MFP features. [10 to 30/10/1 sec.]
3	Productivity Fall Waite Sets the wait time to slow down the speed of certification when an excessive number of access attempts have been detected. [0 to 9/3/1 sec.]
4	Attack Max Number

## Service Tables

	<p>Sets a limit on the number of requests received for certification in order to slow down the certification speed when an excessive number of access attempts have been detected.</p> <p>[50 to 200/200/1 attempt]</p>
5420	User Authentication
	<p>These settings should be done with the System Administrator.</p> <p><b>Note:</b> These functions are enabled only after the user access feature has been enabled.</p>
1	Copy
	<p>Determines whether certification is required before a user can use the copy applications.</p> <p>[0 to 1/0/1]</p> <p>0: On</p> <p>1: Off</p> <p>2: Color Security Setting</p>
11	<p>Document Server</p> <p>Determines whether certification is required before a user can use the document server.</p> <p>[0 to 1/0/1]</p> <p>0: On</p> <p>1: Off</p>
21	<p>Fax</p> <p>Determines whether certification is required before a user can use the fax application.</p> <p>[0 to 1/0/1]</p> <p>0: On</p> <p>1: Off</p>
31	<p>Scanner</p> <p>Determines whether certification is required before a user can use the scan applications.</p> <p>[0 to 1/0/1]</p>

Service Tables

	0: On 1: Off	
41	Printer Determines whether certification is required before a user can use the printer applications. [0 to 1/0/1] 0: On 1: Off	
51	SDK1	[0 or 1/ <b>0</b> / 1] 0: ON. 1: OFF Determines whether certification is required before a user can use the SDK application.
61	SDK2	
71	SDK3	

5481	Authentication Error Code	
	These SP codes determine how the authentication failures are displayed.	
1	System Log Disp Determines whether an error code appears in the system log after a user authentication failure occurs. [0 to 1/0/1] 0: Off 1: On	
2	Panel Disp Determines whether an error code appears on the operation panel after a user authentication failure occurs. [0 to 1/1/1] 1: On 0: Off	

5490	MF Keycard <b>Japan Only</b>	
	Sets up operation of the machine with a keycard. [0 to 1/0/1]	

Service Tables

	<p>0: Disabled. Cancels operation if no code is input.</p> <p>1: Enabled. Allows operation if another code is input and decrements the counter once for use of the entered code.</p>
--	--

5501	PM Alarm
	<p>Sets the count level for the PM alarm.</p> <p>[0 to 9999/1]</p> <p>0: Alarm disabled</p> <p>The PM alarm goes off when the print count reaches this value multiplied by 1,000.</p>

5504	Jam Alarm <b>Japan Only</b>
5505	Error Alarm <b>Japan Only</b>
5507	Supply Alarm <b>Japan Only</b>

5508	CC Call Japan Only	
1	Jam Remains	Enables/disables initiating a call.
2	Continuous Jams	
3	Continuous Door Open	<p>[0 to 1/1]</p> <p>0: Disable</p> <p>1: Enable</p>
4	Low Call Mode	<p>Enables/disables the new call specifications designed to reduce the number of calls.</p> <p>[0 to 1/1]</p> <p>0: Normal mode</p> <p>1: Reduced mode</p>

Service Tables

011	Jam Detection: Time Length	<p>Sets the length of time to determine the length of an unattended paper jam.</p> <p>[03 to 30/1]</p> <p>This setting is enabled only when SP5508-004 is enabled (set to 1).</p>
012	Jam Detection Continuous Count	<p>Sets the number of continuous paper jams required to initiate a call.</p> <p>[02 to 10/1]</p> <p>This setting is enabled only when SP5508-004 is enabled (set to 1).</p>
013	Door Open: Time Length	<p>Sets the length of time the remains opens to determine when to initiate a call.</p> <p>[03 to 30/1]</p> <p>This setting is enabled only when SP5508-004 is enabled (set to 1).</p>

5513	Parts Alarm Level Count Japan Only	
1	Normal	<p>Sets the parts replacement alarm counter to sound for the number of copies.</p> <p>[1 to 999/1 K]</p>
2	DF	<p>Sets the parts replacement alarm counter to sound for the number of scanned originals.</p> <p>[1 to 999/1 K]</p>

5514	Parts Alarm Level	Japan Only
1	Normal	
2	DF	

Service Tables

---

5610	Base Gamma Ctrl Pt:Execute <b>DFU</b>	
4	Get Factory Default	
5	Set Factory Default	
6	Restore Orginal Value	

5611	Toner Color in 2C <b>DFU</b>	
	Adjusts the toner ratio between color pairs: Black, Cyan, Magenta, Green, and Yellow.	
1	B-C	
2	B-M	
3	G-C	
4	G-Y	
5	R-M	
6	R-Y	

5618	Color Mode Display Selection	
	This SP switches the color display for the operation panel LCD. [0 to 1/1/1] 0: Domestic Japan 1: Overseas (Outside Japan)	

5792	MCS Debug SW <b>DFU</b>	
------	-------------------------	--

5793	ECS Debug SW <b>DFU</b>	
------	-------------------------	--



5801	Memory Clear	
	Resets NVRAM data to the default settings. Before executing this SP, print an SMC Report.	
1	All Clear	Initializes items 2 to 15 below.
2	Engine	Initializes all registration settings for the engine and copy process settings.
3	SCS	Initializes default system settings, SCS (System Control Service) settings, operation display coordinates, and ROM update information.
4	IMH Memory Clear	Initializes the image file system. (IMH: Image Memory Handler)
5	MCS	Initializes the automatic delete time setting for stored documents. (MCS: Memory Control Service)
6	Copier application	Initializes all copier application settings.
7	Fax application	Not used.
8	Printer application	Initializes the printer defaults, programs registered, the printer SP bit switches, and the printer CSS counter.
9	Scanner application	Initializes the defaults for the scanner and all the scanner SP modes.
10	Web Service/ Network application	Deletes the Netfile (NFA) management files and thumbnails, and initializes the Job login ID. Netfiles: Jobs to be printed from the document server using a PC and the DeskTopBinder software
11	NCS	Initializes the system defaults and interface settings (IP addresses also), the SmartNetMonitor for Admin settings, WebStatusMonitor settings, and the TELNET settings. (NCS: Network Control Service)

## Service Tables

14	Clear DCS Setting	Initializes the DCS (Delivery Control Service) settings.
15	Clear UCS Setting	Initializes the UCS (User Information Control Service) settings.
16	MIRS Setting	Initializes the MIRS (Machine Information Report Service) settings.
17	CCS	Initializes the CCS (Certification and Charge-control Service) settings.
18	SRM Memory Check	Initializes the SRM (System Resource Manager) settings.
19	LCS	Initializes the LCS (Log Count Service) settings.
20	Web Uapli	Initializes the web user application settings.
21	ECS	Initializes the ECS settings.

5803	Input Check
	Use these SPs to do the input check for the electrical components of the main machine.
1	Paper Feed 1
2	Paper Feed 2
3	Paper Feed 3
4	Paper Feed 4
5	Paper Feed 5
6	Paper Feed 6
7	Paper Feed 7
8	Paper Trans 1
9	Paper Trans 2

## Service Tables

---

010	Paper Trans 3
011	Paper Trans 4
012	Paper Trans 5
013	Paper Trans 6
014	Drum Mtr Lock
015	Development Mtr Lock
016	OPC Cleaning Mtr Lock
017	Other Motor Lock
018	Fan System 1
019	Fan System 1
020	Fan System 1
021	Fan System 1
022	Hi Volt SC 1
023	Hi Volt SC 2
024	Paper Transfer
025	Toner Supply
026	Set Detection
027	Fusing Temp Detect
028	Door
029	Used Toner Trans
030	Peltier Unit
200	HP Sensor
202	Scan Fan Lock Signal

Service Tables

5804	Output Check
	Use these SPs to do the output check for the electrical components of the main machine.
1	Fuse Fan: Front NS
2	Fuse Fan: Front HS
3	Fuse Fan: Back NS
4	Fuse Fan: Back HS
5	Opt. Fan: Front NS
7	Opt. Fan: Back NS
9	Exit Pipe Fan
10	Sub Fuse Fan: NS
11	Sub Fuse Fan: HS
14	Dupx Fan: NS
15	Dupx Fan: Front: NS
16	Dupx Fan: Front: HS
17	Dupx Fan: Back: NS
18	Dupx Fan: Back: HS
19	Exit Fan: NS
20	Exit Fan: HS
21	PCB Box Fan1:NS
23	PCB Box Fan2:NS
25	PSU Fan 1:NS
26	PSU Fan 1:HS
27	PSU Fan 2:NS

Service Tables

28	PSU Fan 2:HS
29	PT Fan 1:NS
30	PT Fan 2:NS
31	Pelt. Cool Fan:NS
32	Pelt. Cool Fan:HS
33	Potential Sn Fan
34	Ozone Fan
35	PCU Fan:Y
36	PCU Fan:C
37	PCU Fan:M
38	PCU Fan:K
39	PCU Fan:Y:HS
40	Pelt. Cir. Fan
41	Sub Hopper CL:Y
42	Sub Hopper CL:C
43	Sub Hopper CL:M
44	Sub Hopper CL:K
45	Hopper Mtr:Fwd
46	P.Pump Drv CL:Y
47	P.Pump Drv CL:C
48	P.Pump Drv CL:M
49	P.Pump Drv CL:K
50	Used Toner Mtr 1

## Service Tables

---

51	Used Toner Mtr 2
52	Chage dc:Y
53	Chage dc:C
54	Chage dc:M
55	Charge Grid K
56	Chage ac:Y
57	Chage ac:C
58	Chage ac:M
59	Charge Wire Current K
60	Dev dc:Y
61	Dev dc:C
62	Dev dc:M
63	Dev dc:K
64	Image Transfer:Y
65	Image Transfer:C
66	Image Transfer:M
67	Image Transfer:K
68	Paper Transfer:-
69	Paper Transfer:+
70	Paper Separate dc
71	Paper Separate ac
72	ID Sensor
73	Potential Sn LED:Front

Service Tables

74	Potential Sn LED:Center
75	Potential Sn LED:Rear
76	QL:Y
77	QL:C
78	QL:M
79	QL:K
80	LD:Y
81	LD:C
82	LD:M
83	LD:K
84	Polygon Mtr
85	ITB Lift M
86	ITB Lift Motor FC
95	Drum Mtr:K
96	Drum Mtr:M
97	Drum Mtr:C
98	Drum Mtr:Y
99	K Development Mtr
100	M Development Mtr
101	C Development Mtr
102	Y Development Mtr
103	K Drum Cleaning Mtr
104	M Drum Cleaning Mtr

## Service Tables

---

105	C Drum Cleaning Mtr
106	Y Drum Cleaning Mtr
107	ITB Motor
108	PRT Motor
109	Fusing/Exit M
110	Feed Mtr 1 Fwd:Rev2
111	Feed Mtr 1 Fwd:Haf2
112	Feed Mtr 1 Fwd:Hi2
113	Feed Mtr 1 Fwd:Hi2:Haf
114	Feed Mtr 1 Rev:Nor2
115	Feed Mtr 1 Rev:Haf2
116	Feed Mtr 2 Fwd:Rev2
117	Feed Mtr 2 Fwd:Haf2
118	Feed Mtr 2 Fwd:Hi2
119	Feed Mtr 2 Fwd:Hi2:Haf
120	Feed Mtr 2 Rev:Nor2
121	Feed Mtr 2 Rev:Haf2
122	Feed Mtr 3 Fwd:Rev2
123	Feed Mtr 3 Fwd:Haf2
124	Feed Mtr 3 Fwd:Hi2
125	Feed Mtr 3 Fwd:Hi2:Haf
126	Feed Mtr 3 Rev:Nor2
127	Feed Mtr 3 Rev:Haf2



## Service Tables

---

128	Feed Mtr 4 Fwd:Rev2
129	Feed Mtr 4 Fwd:Haf2
130	Feed Mtr 4 Fwd:Hi2
131	Feed Mtr 4 Fwd:Hi2:Haf
132	Feed Mtr 4 Rev:Nor2
133	Feed Mtr 4 Rev:Haf2
134	Bypass Feed CL
135	Pickup SOL:Tray 1
136	Pickup SOL:Tray 2
137	Pickup SOL:Tray 3
138	Pickup SOL:Tray 4
139	Bypass Pickup SOL
142	Rev SOL:Tray 1
143	Rev SOL:Tray 2
144	Rev SOL:Tray 3
145	Rev SOL:Tray 4
146	Tan Conn Rel SOL
147	Tan Lock SOL
149	Tandem Back Fence SOL: F
150	Tandem Back Fence SOL: R
151	Relay Mtr:Fwd:Nor2
152	Relay Mtr:Fwd:Haf2
153	Relay Mtr:Fwd:Hi1

Service Tables

154	Relay Mtr:Fwd:Hi1:Haf
155	Relay Mtr:Rev: Nor2
156	Relay Mtr:Rev: Haf2
157	Registration Mtr:Nor2
158	Registration Mtr:Haf2
159	Guide Rel SOL
160	Exit JG SOL
161	Dup/Inv Mtr:Fwd:Nor2
162	Dup/Inv Mtr:Fwd:Haf2
163	Dup/Inv Mtr:Fwd:Hi2
164	Dup/Inv Mtr:Fwd:Hi2:Haf
165	Dup/Inv Mtr:Rev:Nor2: Tab Shts
166	Dup/Inv Mtr:Rev:Haf2: Tab Shts
167	DupTrans Mtr:Fwd:Nor2
168	DupTrans Mtr:Fwd:Haf2
169	DupTrans Mtr:Fwd:Hi2
170	DupTrans Mtr:Fwd:Hi2: Haf
171	Dup JG SOL
172	Inv Pos SOL
174	Dup Jog M:HP Sn
180	Fan K:Nor
181	Ozone Fan K:Nor
182	Ozone Fan K:Haf

Service Tables

183	Main Fan:Nor
184	Main Fan:Haf
185	Dev Fan Y:Nor
186	Dev Fan C:Nor
187	Dev Fan M:Nor
188	Dev Fan K:Nor
189	ITB CIng Fan:Nor
190	ITB CIng Fan:Haf
195	Jam LED:Fusing
196	Jam LED:Exit
200	Scananer fanmotor
202	Scananer Lamp
203	Scanner Motor
205	Bk Drum Motor: High Speed 1
206	M Drum Motor: High Speed 1
207	C Drum Motor: High Speed 1
208	Y Drum Motor: High Speed 1
209	Bk Development Motor: High Speed 1
210	M Development Motor: High Speed 1
211	C Development Motor: High Speed 1
212	Y Development Motor: High Speed 1
213	Bk Cleaning Motor: High Speed 1
214	M Cleaning Motor: High Speed 1

Service Tables

215	C Cleaning Motor: High Speed 1
216	Y Cleaning Motor: High Speed 1
217	ITB Motor: High Speed 1
218	PTR Motor: High Speed 1
219	Fusing/Exit Motor: High Speed 1
220	Bk Drum Motor: Half Speed 2
221	M Drum Motor: Half Speed 2
222	C Drum Motor: Half Speed 2
223	Y Drum Motor: Half Speed 2
224	Bk Development Motor: Half Speed 2
225	M Development Motor: Half Speed 2
226	C Development Motor: Half Speed 2
227	Y Development Motor: Half Speed 2
228	Bk Cleaning Motor: Half Speed 2
229	M Cleaning Motor: Half Speed 2
230	C Cleaning Motor: Half Speed 2
231	Y Cleaning Motor: Half Speed 2
232	ITB Motor: Half Speed 2
233	PTR Motor: Half Speed 2
234	Fusing/Exit Motor: Half Speed 2
235	Bk Drum Motor: Half Speed 2
236	M Drum Motor: Half Speed 1
237	C Drum Motor: Half Speed 1

Service Tables

238	Y Drum Motor: Half Speed 1
239	Bk Development Motor: Half Speed 1
240	M Development Motor: Half Speed 1
241	C Development Motor: Half Speed 1
242	Y Development Motor: Half Speed 1
243	Bk Cleaning Motor: Half Speed 1
244	M Cleaning Motor: Half Speed 1
245	C Cleaning Motor: Half Speed 1
246	Y Cleaning Motor: Half Speed 1
247	ITB Motor: Half Speed 1
248	PTR Motor: Half Speed 1
249	Fusing/Exit Motor: Half Speed 1

5810	Cancel Fusing SC
	<p>When the machine issues one of the "Level A" SC codes shown below, this indicates a serious problem in the fusing unit. The machine is disabled and the operator cannot reset the SC. The machine requires servicing immediately. Touch [EXECUTE] release the machine for servicing.</p> <ul style="list-style-type: none"> <li>▪ SC542 – SC545 Heating roller thermistor 1</li> <li>▪ SC547 – Zero Cross</li> <li>▪ SC548 – SC550 Heating roller thermistor 2</li> <li>▪ SC551 – Pressure roller thermistor</li> <li>▪ SC553 – SC555 Pressure roller thermistor</li> <li>▪ SC662 – SC565 Hot roller thermistor</li> </ul>

5811	Machine Serial
	This SP displays the machine serial number.

## Service Tables

5812	Service Tel. No. Setting	
1	Service	Inputs the telephone number of the CE (displayed when a service call condition occurs.)
2	Facsimile	Use this to input the fax number of the CE printed on the Counter Report (UP mode). <b>Not Used</b>
3	Supply	Displayed on the initial SP screen.
4	Operation	Allows the service center contact telephone number to be displayed on the initial screen.

5816	Remote Service	
1	I/F Setting	Turns the remote diagnostics off and on. [0 to 2/1] 0: Remote diagnostics off. 1: Serial (CSS or NRS) remote diagnostics on. 2: Network remote diagnostics.
2	CE Call	Lets the customer engineer start or end the remote machine check with CSS or NRS; to do this, push the center report key.
3	Function Flag	Enables and disables remote diagnosis over the NRS network. [0 to 1/1] 0: Disables remote diagnosis over the network. 1: Enables remote diagnosis over the network.
6	Device Information Call Display	Controls if the item for initial setting of the screen for the NRS device-information notification-call is shown. [0 to 1/1] 0: Enabled. Item initial setting not shown. 1: Disable. Item for initial setting shown.

Service Tables

7	SSL Disable	Controls if RCG (Remote Communication Gate) confirmation is done by SSL during an RCG send for the NRS over a network interface. [0 to 1/1] 0: Yes. SSL not used. 1: No. SSL used.
8	RCG Connect Timeout	Sets the length of time (seconds) for the time-out when the RCG (Remote Communication Gate) connects during a call via the NRS network. [1 to 90/1 sec.]
9	RCG Write to Timeout	Sets the length of time (seconds) for the time-out when sent data is written to the RCG during a call over the NRS network. [0 to 100/1 sec.]
010	RCG Read Timeout	Sets the length of time (seconds) for the timeout when sent data is written from the RCG during a call over the NRS network. [0 to 100/1 sec.]
011	Port 80 Enable	Controls if permission is given to get access to the SOAP method over Port 80 on the NRS network. [0 to 1/1] 0: No. Access denied 1: Yes. Access granted.

021	RCG – C Registered
	This SP displays the embedded RCG-N installation end flag. 1: Installation completed 2: Installation not completed
022	RCG – C Registered Detail
	This SP displays the RCG device installation status. 0: RCG device not registered

Service Tables

	<p>1: RCG device registered</p> <p>2: Device registered</p>
023	Connect Type (N/M)
	<p>This SP displays and selects the embedded RCG-N connection method.</p> <p>0: Internet connection</p> <p>1: Dial-up connection</p>
061	Cert. Expire Timing ( <b>DFU</b> )
	Proximity of the expiration of the certification.
062	Use Proxy
	This SP setting determines if the proxy server is used when the machine communicates with the service center.
063	Proxy Host
	<p>This SP sets the address of the proxy server used for communication between the RCG device and the gateway. Use this SP to set up or display the customer proxy server address. The address is necessary to set up the embedded RCG-N.</p> <p><b>Note:</b> The address display is limited to 128 characters. Characters beyond the 128 character are ignored.</p> <p>This address is customer information and is not printed in the SMC report.</p>
064	proxy Port Number
	<p>This SP sets the port number of the proxy server used for communication between the embedded RCG-N and the gateway. This setting is necessary to set up the embedded RCG-N.</p> <p><b>Note:</b> This port number is customer information and is not printed in the SMC report.</p>
065	Proxy User Name
	<p>This SP sets the HTTP proxy certification user name.</p> <p><b>Note:</b> The length of the name is limited to 31 characters. Any character beyond the 31st character is ignored. This name is customer information and is not</p>



Service Tables

	printed in the SMC report.	
066	Proxy Password	
	<p>This SP sets the HTTP proxy certification password.</p> <p><b>Note:</b> The length of the password is limited to 31 characters. Any character beyond the 31st character is ignored. This name is customer information and is not printed in the SMC report.</p>	
067	CERT: Up State	
	Displays the status of the certification update.	
	0	The certification used by the embedded RCG-N is set correctly.
	1	The certification request (setAuthKey) for update has been received from the GW URL and certification is presently being updated.
	2	The certification update is completed and the GW URL is being notified of the successful update.
	3	The certification update failed, and the GW URL is being notified of the failed update.
	4	The period of the certification has expired and new request for an update is being sent to the GW URL.
	11	A rescue update for certification has been issued and a rescue certification setting is in progress for the rescue GW connection.
	12	The rescue certification setting is completed and the GW URL is being notified of the certification update request.
	13	The notification of the request for certification update has completed successfully, and the system is waiting for the certification update request from the rescue GW URL.
	14	The notification of the certification request has been received from the rescue GW controller, and the certification is being stored.
15	The certification has been stored, and the GW URL is being notified of the successful completion of this event.	

Service Tables

	16	The storing of the certification has failed, and the GW URL is being notified of the failure of this event.
	17	The certification update request has been received from the GW URL, the GW URL was notified of the results of the update after it was completed, but an certification error has been received, and the rescue certification is being recorded.
	18	The rescue certification of No. 17 has been recorded, and the GW URL is being notified of the failure of the certification update.
068	CERT: Error	
	Displays a number code that describes the reason for the request for update of the certification.	
	0	Normal. There is no request for certification update in progress.
	1	Request for certification update in progress. The current certification has expired.
	2	An SSL error notification has been issued. Issued after the certification has expired.
	3	Notification of shift from a common authentication to an individual certification.
	4	Notification of a common certification without ID2.
	5	Notification that no certification was issued.
	6	Notification that GW URL does not exist.
069	CERT: Up ID	
	The ID of the request for certification.	
083	Firmware Up Status	
	Displays the status of the firmware update.	
084	Non-HDD Firm Up	

## Service Tables

	This setting determines if the firmware can be updated, even without the HDD installed.
085	Firm Up User Check
	This SP setting determines if the operator can confirm the previous version of the firmware before the firmware update execution. If the option to confirm the previous version is selected, a notification is sent to the system manager and the firmware update is done with the firmware files from the URL.
086	Firmware Size
	Allows the service technician to confirm the size of the firmware data files during the firmware update execution.
087	CERT: Macro
	Displays the macro version of the @Remote certification
088	CERT: PAC
	Displays the PAC version of the @Remote certification.
089	CERT: ID2 Code
	Displays ID2 for the @Remote certification. Spaces are displayed as underscores (_). Asterisks (****) indicate that no NRS certification exists.
090	CERT: Subject
	Displays the common name of the @Remote certification subject. CN = the following 17 bytes. Spaces are displayed as underscores (_). Asterisks (****) indicate that no DESS exists.
091	CERT: Serial No.
	Displays serial number for the @Remote certification. Asterisks (****) indicate that no DESS exists.
092	CERT: Issuer
	Displays the common name of the issuer of the @Remote certification. CN = the following 30 bytes. Asterisks (****) indicate that no DESS exists.

Service Tables

093	CERT: Valid Start
	Displays the start time of the period for which the current @Remote certification is enabled.
094	CERT: Valid End
	Displays the end time of the period for which the current @Remote certification is enabled.
150	Selection Country
	<p>Select the country where embedded RCG-M is installed in the machine. After selecting the country, you must also set the following SP codes for embedded RCG-M:</p> <ul style="list-style-type: none"> <li>▪ SP5816-153</li> <li>▪ SP5816-154</li> <li>▪ SP5816-161</li> </ul> <p>0: Japan, 1: USA, 2: Canada, 3: UK, 4: Germany, 5: France 6: Italy, 7: Netherlands, 8: Belgium, 9: Luxembourg, 10: Spain</p>
151	Line type Automatic Judgment
	<p>Press [Execute].</p> <p>Setting this SP classifies the telephone line where embedded RCG-M is connected as either dial-up (pulse dial) or push (DTMF tone) type, so embedded RCG-M can automatically distinguish the number that connects to the outside line.</p> <ul style="list-style-type: none"> <li>▪ The current progress, success, or failure of this execution can be displayed with SP5816-152.</li> <li>▪ If the execution succeeded, SP5816-153 will display the result for confirmation and SP5816-154 will display the telephone number for the connection to the outside line.</li> </ul>
152	Line type Judgment Result
	<p>Displays a number to show the result of the execution of SP5816-151. Here is a list of what the numbers mean.</p> <p>0: Success</p> <p>1: In progress (no result yet). Please wait.</p>

Service Tables

	<p>2: Line abnormal</p> <p>3: Cannot detect dial tone automatically</p> <p>4: Line is disconnected</p> <p>5: Insufficient electrical power supply</p> <p>6: Line classification not supported</p> <p>7: Error because fax transmission in progress – ioctl() occurred.</p> <p>8: Other error occurred</p> <p>9: Line classification still in progress. Please wait.</p>
153	<p>Selection Dial/push</p> <p>This SP displays the classification (tone or pulse) of the telephone line to the access point for embedded RCG-M. The number displayed (0 or 1) is the result of the execution of SP5816-151. However, this setting can also be changed manually.</p> <p>[0 to 1 / 0 / 1 /step]</p> <p>0: Tone Dialing Phone</p> <p>1: Pulse Dialing Phone</p>
154	<p>Outside Line Outgoing Number</p> <p>The SP sets the number that switches to PSTN for the outside connection for embedded RCG-M in a system that employs a PBX (internal line).</p> <ul style="list-style-type: none"> <li>▪ If the execution of SP5816-151 has succeeded and embedded RCG-M has connected to the external line, this SP display is completely blank.</li> <li>▪ If embedded RCG-M has connected to an internal line, then the number of the connection to the external line is displayed.</li> <li>▪ If embedded RCG-M has connected to an external line, a comma is displayed with the number. The comma is inserted for a 2 sec. pause.</li> <li>▪ The number setting for the external line can be entered manually (including commas).</li> </ul>
155	<p>Remove Service: PPP Certification Timeout (<b>SSP</b>)</p> <p>Sets the length of the timeout for the embedded RCG-M connection to its access point. The timeout is the time from when the modem sends the ATD to when it</p>

Service Tables

	<p>receives the result code. [1 to 65536 / <b>60</b> / 1 /step]</p>
156	Dial Up User Name
	<p>Use this SP to set a user name for access to remote dial up. Follow these rules when setting a user name:</p> <ul style="list-style-type: none"> <li>▪ Name length: Up to 32 characters</li> <li>▪ Spaces and # allowed but the entire entry must be enclosed by double quotation marks (").</li> </ul>
157	Dial Up Password
	<p>Use this SP to set a password for access to remote dial up. Follow these rules when setting a user name:</p> <ul style="list-style-type: none"> <li>▪ Name length: Up to 32 characters</li> <li>▪ Spaces and # allowed but the entire entry must be enclosed by double quotation marks (").</li> </ul>
161	Local Phone Number
	<p>Use this SP to set the telephone number of the line where embedded RCG-M is connected. This number is transmitted to and used by the Call Center to return calls. Limit: 24 numbers (numbers only)</p>
162	Connection Timing Adjustment Incoming
	<p>When the Call Center calls out to an embedded RCG-M modem, it sends a repeating ID tone (*#1#). This SP sets the time the line remains open to send these ID tones after the number of the embedded RCG-M modem is dialed up and connected. [0 to 24 / <b>1</b> / 1 /step] The actual amount of time is this setting + 2 sec. For example, if you set "2", the line will remain open for 4 sec.</p>
163	Access Point
	<p>This is the telephone number of the dial-up access point for embedded RCG-M. If no setting is done for this SP code, then a preset value (determined by the</p>

Service Tables

	<p>country selected) is used.</p> <p>Default: 0</p> <p>Allowed: Up to 16 numeral characters</p>
164	<p>Line Connecting</p> <p>This SP sets the connection conditions for the customer. This setting dedicates the line to embedded RCG-M only, or sets the line for sharing between embedded RCG-M and a fax unit.</p> <p>[0 or 1 / 0 / - ]</p> <p>0: Line shared by embedded RCG-M/Fax</p> <p>1: Line dedicated to embedded RCG-M only</p> <ul style="list-style-type: none"> <li>▪ If this setting is changed, the copier must be cycled off and on.</li> <li>▪ SP5816-187 determines whether the off-hook button can be used to interrupt an embedded RCG-M transmission in progress to open the line for fax transaction.</li> </ul>
173	<p>Modem serial No.</p> <p>This SP displays the serial number registered for the embedded RCG-M.</p>
174	<p>Retransmission Limit</p> <p>Normally, it is best to allow unlimited time for certification and ID2 update requests, and for the notification that the certification has been completed. However, embedded RCGM generates charges based on transmission time for the customer, so a limit is placed upon the time allowed for these transactions. If these transactions cannot be completed within the allowed time, do this SP to cancel the time restriction.</p>
186	<p>RCG - C M Debug Bit SW</p>
187	<p>FAX TX Priority</p> <p>This SP determines whether pushing the off-hook button will interrupt an embedded RCGM transmission in progress to open the line for fax transaction. This SP can be used only if SP5816-164 is set to "0".</p> <p>[0 or 1 / 0 / - ]</p>

Service Tables

	<p>0: Disable. Setting the fax unit off-hook does not interrupt a fax transaction in progress. If the off-hook button is pushed during a embedded RCG-M transmission, the button must be pushed again to set the fax unit on-hook after the embedded RCG-M transmission has completed.</p> <p>1: Enable. When embedded RCG-M shares a line with a fax unit, setting the fax unit off-hook will interrupt a embedded RCG-M transmission in progress and open the line for a fax transaction.</p>	
200	Manual Polling	
	No information is available at this time.	
201	Regist: Status	
	Displays a number that indicates the status of the @Remote service device.	
	0	Neither the registered device by the external nor embedded RCG device is set.
	1	The embedded RCG device is being set. Only Box registration is completed. In this status, this unit cannot answer a polling request from the external RCG.
	2	The embedded RCG device is set. In this status, the external RCG unit cannot answer a polling request.
	3	The registered device by the external RCG is being set. In this status the embedded RCG device cannot be set.
4	The registered module by the external RCG has not started.	
202	Letter Number	
	Allows entry of the number of the request needed for the embedded RCG.	
203	Confirm Execute	
	Executes the inquiry request to the @Remote Gate Way URL.	
204	Confirm Result	
	Displays a number that indicates the result of the inquiry executed with SP5816-203.	



Service Tables

	0	Succeeded
	1	Inquiry number error
	2	Registration in progress
	3	Proxy error (proxy enabled)
	4	Proxy error (proxy disabled)
	5	Proxy error (Illegal user name or password)
	6	Communication error
	7	Certification update error
	8	Other error
	9	Inquiry executing
205	Confirm Place	
	Displays the result of the notification sent to the device from the GW URL in answer to the inquiry request. Displayed only when the result is registered at the GW URL.	
206	Register Execute	
	Executes "Embedded RCG Registration".	
207	Register Result	
	Displays a number that indicates the registration result.	
	0	Succeeded
	2	Registration in progress
	3	Proxy error (proxy enabled)
	4	Proxy error (proxy disabled)
	5	Proxy error (Illegal user name or password)
	6	Communication error

Service Tables

	7	Certification update error	
	8	Other error	
	9	Registration executing	
208	Error Code		
	Displays a number that describes the error code that was issued when either SP5816 204 or SP5816 207 was executed.		
	<b>Cause</b>	<b>Code</b>	<b>Meaning</b>
	Illegal Modem Parameter	-11001	Chat parameter error
		-11002	Chat execution error
		-11003	Unexpected error
	Operation Error, Incorrect Setting	-12002	Inquiry, registration attempted without acquiring device status.
		-12003	Attempted registration without execution of an inquiry and no previous registration.
		-12004	Attempted setting with illegal entries for certification and ID2.
		-12005	@Remove communication prohibited
		-12006	Confirmation requested again after confirmation completed.
-12007		Different numbers were used for registration and confirmation.	
-12008		Update certification failed because device was in use.	
Error Caused by Response from GW URL	-2385	Attempted dial up overseas without the correct international prefix for the telephone number.	

Service Tables

		-2387	Not supported at the Service Center
		-2389	Database out of service
		-2390	Program out of service
		-2391	Two registrations for same device
		-2392	Parameter error
		-2393	External RCG not managed
		-2394	Device not managed
		-2395	Box ID for external RCG is illegal
		-2396	Device ID for external RCG is illegal
		-2397	Incorrect ID2 format
		-2398	Incorrect request number format
209	Inst Clear		
	Releases the machine from its embedded RCG setup.		
250	CommLog Print		
	Prints the communication log.		

5824	NVRAM Data Upload
	Set the SD card in the lower slot then touch [EXECUTE] to upload the NVRAM data to an SD card. <b>Note:</b> When uploading in this SP mode data, the front door must be open.

5825	NVRAM Data Download
	Set the SD card in the lower slot then touch [EXECUTE] to download data from the card to the NVRAM in the machine. After downloading is completed,

## Service Tables

	remove the card and turn the machine power off and on.
5828	Network Setting
1	IPv4 Address (Ethernet/IEEE 802.11)
	This SP allows you to confirm and reset the IPv4 address for Ethernet and wireless LAN (802.11): aaa.bbb.ccc.ddd
2	IPv4 Subnet Mask (Ethernet/IEEE 802.11)
	This SP allows you to confirm and reset the IPv4 subnet mask for Ethernet and wireless LAN (802.11): aaa.bbb.ccc.ddd
3	IPv4 default Gateway (Ethernet/IEEE 802.11)
	This SP allows you to confirm and reset the IPv4 default gateway used by the network for Ethernet and wireless LAN (802.11): aaa.bbb.ccc.ddd
6	DHCP (Ethernet/IEEE 802.11)
	This SP code allows you confirm and change the setting that determines whether the IP address is used with DHCP on an Ethernet or wireless (802.11) LAN network. [0 to 1 / 1 / 1] 0: Not used (manual setting) 1: Used
021	Active IPv4 Address
	This SP allows you to confirm the IPv4 address that was used when the machine started up with DHCP.
022	Active IPv4 Subnet Mask
	This SP allows you to confirm the IPv4 subnet mask setting that was used when the machine started up with DHCP.
023	Active IPv4 Gateway Address

Service Tables

	This SP allows you to confirm the IPv4 default gateway setting that was used when the machine started up with DHCP.		
050	1284 Compatibility (Centro)	Enables and disables bi-directional communication on the parallel connection between the machine and a computer. [0 to 1 / <b>1</b> / 1] 0:Off, 1: On	
052	ECP (Centro)	Disables and enables the ECP feature (1284 Mode) for data transfer. [0 to 1 / <b>1</b> / 1] 0: Disabled, 1: Enabled	
065	Job Spooling	Switches the job spooling on and off. [0 to 1 / <b>0</b> / 1] 0: No spooling, 1: Spooling enabled	
066	Job Spooling Clear: Start Time	This SP determines whether the job interrupted at power off is resumed at the next power on. This SP operates only when SP5828-065 is set to "1". [0 to 1 / <b>1</b> / 1] 1: Resumes printing spooled jog. 0: Clears spooled job.	
069	Job Spooling (Protocol)		This SP determines whether job spooling is enabled or disabled for each protocol. This is a 8-bit setting. [0 to 1 / <b>1</b> / 1] 0: No spooling, 1: Spooling enabled
	0	LPR	4 BMLinks (Japan Only)
	1	FTP (Not Used)	5 DIPRINT
	2	IPP	6 Reserved (Not Used)
	3	SMB	7 Reserved (Not Used)

Service Tables

090	TELNET (0:OFF 1:ON)	Disables or enables Telnet operation. If this SP is disabled, the Telnet port is closed. [0 to 1 / 1 / 1] 0: Disable, 1: Enable
091	Web (0:OFF 1:ON)	Disables or enables the Web operation. [0 to 1 / 1 / 1] 0: Disable, 1: Enable
145	Active IPv6 Link Local Address	This is the IPv6 local address referenced on the Ethernet or wireless LAN (802.11) in the format: "Link-Local address" + "Prefix Length" The IPv6 address consists of a total 128 bits configured in 8 blocks of 16 bits each. These notations can be abbreviated. See "Note: IPV6 Addresses " below this table.
147	Active IPv6 Stateless Address 1	These SPs are the IPv6 stateless addresses (1 to 5) referenced on the Ethernet or wireless LAN (802.11b) in the format: "Stateless Address" + "Prefix Length" The IPv6 address consists of a total 128 bits configured in 8 blocks of 16 bits each.
149	Active IPv6 Stateless Address 2	
151	Active IPv6 Stateless Address 3	
153	Active IPv6 Stateless Address 4	
155	Active IPv6 Stateless Address 5	
156	IPv6 Manual Address	This SP is the IPv6 manually set address referenced on the Ethernet or wireless LAN (802.11) in the format: "Manual Set Address" + "Prefix Length" The IPv6 address consists of a total 128 bits configured in 8 blocks of 16 bits each. These notations can be abbreviated. See "Note: IPV6 Addresses" below this table.

158	IPv6 Gateway
	This SP is the IPv6 gateway address referenced on the Ethernet or wireless LAN (802.11). The IPv6 address consists of a total 128 bits configured in 8 blocks of 16 bits each. These notations can be abbreviated. See "Note: IPV6 Addresses" below this table.

**Note: IPV6 Addresses**

Ethernet and the Wireless LAN (802.11) reference the IPV6 "Link-Local address + Prefix Length". The IPV6 address consists of 128 bits divided into 8 blocks of 16 bits:  
 aaaa:bbbb:cccc:dddd:eeee:ffff:gggg:hhhh:

The prefix length is inserted at the 17th byte (Prefix Range: 0x0 to 0x80). The initial setting is 0x40 (64).

For example, the data: "2001123456789012abcdef012345678940h" is expressed:  
 "2001:1234:5678:9012:abcd:ef01:2345:6789": prefixlen 64

However, the actual IPV6 address display is abbreviated according to the following rules.

**Rules for Abbreviating IPV6 Addresses**

The IPV6 address is expressed in hexadecimal delimited by colons (:) with the following characters:  
 0123456789abcdefABCDEF

1. A colon is inserted as a delimiter every 4th hexadecimal character.  
 fe80:0000:0000:0000:0207:40ff:0000:340e
2. The notations can be abbreviated by eliminating zeros where the MSB and digits following the MSB are zero. The example in "2" above, then, becomes  
 fe80:0:0:0207:40ff:0:340e
3. Sections where only zeros exist can be abbreviated with double colons (::). This abbreviation can be done also where succeeding sections contain only zeros (but this can be done only at one point in the address). The example in "2" and "3" above then becomes:  
 fe80::207:40ff:0:340e (only the first null sets zero digits are abbreviated as "::")  
 -or-  
 fe80:0:0:0:207:40ff::340e (only the last null set before "340e" is abbreviated as "::")

161	IPv6 Stateless Auto Setting	Enable or disables the automatic setting for IPv6 stateless.
-----	-----------------------------	--

Service Tables

236	Web Item visible	
	Displays or does not display the Web system items. [0 x 0000 to 0 x ffff / 0 x ffff] 0: Not displayed, 1: Displayed bit0: Not Used bit1: Consumable Supplier bit2-15: Reserved (all)	
237	Web shopping link visible	
	Not Used	
238	Web supplies Link visible	
	Displays or does not display the link to Consumable Supplier on the top page and link page of the web system. [0 to 1 / 1 / 1] 0: Not display, 1:Display	
239	Web Link1 Name	
	This SP confirms or changes the URL1 name on the link page of the web system. The maximum characters for the URL name are 31 characters.	
240	Web URL	
	This SP confirms or changes the link to URL1 on the link page of the web system. The maximum characters for the URL are 127 characters.	
241	Web visible	
	Displays or does not display the link to URL1 on the top page of the web system. [0 to 1 / 1 / 1] 0: Not display, 1:Display	
242	Web Link2 Name	Same as "-239"
243	Web Link2 URL	Same as "-240"
244	Web Link2 visible	Same as "-241"



Service Tables

5832	HDD	HDD Formatting
	Enter the SP number for the partition to initialize, then press #. When the execution ends, cycle the machine off and on.	
1	HDD Formatting (All)	
2	HDD Formatting (IMH)	
3	HDD Formatting (Thumbnail)	
4	HDD Formatting (Job Log)	
5	HDD Formatting (Printer Fonts)	
6	HDD Formatting (User Info.)	
7	Mail RX Data	
8	Mail TX Data	
9	HDD Formatting (Log)	
10	HDD Formatting (Log)	
11	HDD Formatting (Ridoc I/F DeskTopBinder)	

5833	e-Cabinet Enable	
	Enables the e-Cabinet function. Then, the user names in the cabinet are enabled for use with the POP server. [0 to 1/1] 0: Disabled 1: Enabled	

5836	Capture Setting	
------	-----------------	--

Service Tables

	Capture Function (0:Off 1:On)	
1	<p>With this function disabled, the settings related to the capture feature cannot be initialized, displayed, or selected.</p> <p>[0 to 1/1] 0: Disable 1: Enable</p>	
2	Panel Setting	
	<p>Determines whether each capture related setting can be selected or updated from the initial system screen.</p> <p>[0 to 1/1] 0: Disable 1: Enable The setting for SP5836-001 has priority.</p>	
	Print Backup Function (0:Off 1:On)	
3	<p>Turns the print backup feature on and off. Default: 0 (Off)</p> <p>When this feature is on, the print backup features are shown in the initial system settings. Enabled only when optional File Format Converter (MLB:Media Link Board) is installed.</p> <p>[0 to 1/1] 0: Disable 1: Enable</p>	
071	Reduction for Copy Color	[0 to 3/1] 0:1, 1:1/2, 2:1/3, 3:1/4 <b>DFU</b>
072	Reduction for Copy B&W Text	[0 to 6/1] 0:1, 1:1/2, 2:1/3, 3:1/4, 6:2/3
073	Reduction for Copy B&W Other	[0 to 6/1] 0:1, 1:1/2, 2:1/3, 3:1/4, 6:2/3
074	Reduction for Printer Color	[0 to 3/1] 0:1, 1:1/2, 2:1/3, 3:1/4, <b>DFU</b>

Service Tables

075	Reduction for Printer B&W	[0 to 6/1] 0:1, 1:1/2, 2:1/3, 3:1/4, 6:2/3
076	Reduction for Printer B&W HQ	[1 to 5/1] 1:1/2, 3:1/4, 4:1/6, 5:1/8
077	Reduction for Printer Col 1200 dpi	
078	Reduction for Printer B&W 1200 dpi	
081	Format for Copy Color	[0 to 3/1] 0: JFIF/JPEG, 1: TIFF/MMR, 2: TIFF/MH, 3: TIFF/MR <b>DFU</b>
082	Format for Copy B&W Text	[0 to 3/1] 0: JFIF/JPEG, 1: TIFF/MMR, 2: TIFF/MH, 3: TIFF/MR
083	Format Copy B&W Other	[0 to 3/1] 0: JFIF/JPEG, 1: TIFF/MMR, 2: TIFF/MH, 3: TIFF/MR
084	Format for Printer Color	[0 to 3/1] 0: JFIF/JPEG, 1: TIFF/MMR, 2: TIFF/MH, 3: TIFF/MR <b>DFU</b>
085	Format for Printer B&W	[0 to 3/1] 0: JFIF/JPEG, 1: TIFF/MMR, 2: TIFF/MH, 3: TIFF/MR
086	Format for Printer B&W HQ	[0 to 3/1] 0: JFIF/JPEG, 1: TIFF/MMR, 2: TIFF/MH, 3: TIFF/MR
091	Default for JPEG	[5 to 95/1]
	Sets the JPEG format default for documents sent to the document management server with the MLB, with JPEG selected as the format. Enabled only when optional File Format Converter (MLB: Media Link Board) is installed.	

Service Tables

092	High Quality for JPEG	Sets the quality level of JPEG images for high quality sent to the Document Server with the MLB (Media Link Board). [5 to 95/1]
093	Low Quality for JPEG	Sets the quality level of JPEG images for low quality sent to the Document Server with the MLB (Media Link Board). [5 to 95/1]
094	Default Format for Backup Files	
	Sets the format of the backup files. [0 to 2/1] 0: TIFF 1: JPEG 2: For printing This feature can be selected only if SP5836-3 is set to "1".	
095	Default Resolution for Backup Files	Sets the resolution conversion ratio for the backup files. [0 to 3/1] 0: 1x 1: 1/2x 2: 1/3 x 3: 1/4x
097	Default Compression for Backup Files	Sets the rate of compression for the backup files. [0 to 2/1] 0: Standard 1: Low 2: High
098	Back Projection Removal	
	Removes the ghost images that are copied from the back sides of two-sided originals. [0 to 1/1] 0: Disable 1: Enable	
5840	IEEE 802.11	
6	Channel MAX	

Service Tables

	Sets the maximum range of the bandwidth for the wireless LAN. This bandwidth setting varies for different countries. [1 to 14/1]	
7	Channel MIN Sets the minimum range of the bandwidth for operation of the wireless LAN. This bandwidth setting varies for different countries. [1 to 14/1]	
8	Transmission Speed	[0 x 00 to 0 x FF / <b>0 x FF to Auto</b> / -]
	<b>0 x FF to Auto</b> [Default] 0 x 11 – 55M Fix 0 x 10 – 48M Fix 0 x 0F – 36M Fix 0 x 0E – 18M Fix 0 x 0D – 12M Fix 0 x 0B – 9M Fix 0 x 0A – 6M Fix	0 x 07 – 11M Fix 0 x 05 – 5.5M Fix 0 x 08 – 1M Fix 0 x 13 – 0 x FE (reserved) 0 x 12 – 72M (reserved) 0 x 09 – 22M (reserved)
11	WEP Key Select  Determines how the initiator (SBP-2) handles subsequent login requests. [0 to 1/1] 0: If the initiator receives another login request while logging in, the request is refused. 1: If the initiator receives another login request while logging in, the request is refused and the initiator logs out. <b>Note:</b> Displayed only when the wireless LAN card is installed.	
42	Fragment Thresh  Adjusts the fragment threshold for the IEEE802.11 card. [256 to 2346 / <b>2346</b> / 1] This SP is displayed only when the IEEE802.11 card is installed.	
43	11g CTS to Self  Determines whether the CTS self function is turned on or off.	

Service Tables

	[0 to 1 / <b>1</b> / 1] 0: Off, 1: On This SP is displayed only when the IEEE802.11 card is installed.
44	11g Slot Time Selects the slot time for IEEE802.11. [0 to 1 / <b>0</b> / 1] 0: 20 μm, 1: 9 μm This SP is displayed only when the IEEE802.11 card is installed.
45	WPA Debug Lvl Selects the debug level for WPA authentication application. [1 to 3 / <b>3</b> / 1] 1: Info, 2: warning, 3: error This SP is displayed only when the IEEE802.11 card is installed.

5841	Supply Name Setting	
	Press the User Tools key. These names appear when the user presses the Inquiry button on the User Tools screen.	
1	Toner Name Setting: Black	
2	Toner Name Setting: Cyan	
3	Toner Name Setting: Yellow	
4	Toner Name Setting: Magenta	
011	StapleStd1	
012	StapleStd2	
013	StapleStd3	Standard Staples for D373/D374
014	StapleStd4	
021	StapleBind1	
022	StapleBind2	Booklet Staples for D374

Service Tables

023	StapleBind3	
-----	-------------	--

5842	GWWS Analysis <b>DFU</b>		
		Bit	Groups
0	<p>This is a debugging tool. It sets the debugging output mode of each Net File process.</p> <p>Bit SW 0011 1111</p>	System & other groups (LSB)	
1		Capture related	
2		Authentication related	
3		Address book related	
4		Machine management related	
5		Output related (printing, delivery)	
6		Repository related	

5844	USB	
1	Transfer Rate	
	Sets the speed for USB data transmission.	

## Service Tables

	[Full Speed] [Auto Change]
2	Vendor ID Sets the vendor ID: [0x0000 to 0xFFFF/1] <b>DFU</b>
3	Product ID Sets the product ID. [0x0000 to 0xFFFF/1] <b>DFU</b>
4	Device Release Number Sets the device release number of the BCD (binary coded decimal) display. [0000 to 9999/1] <b>DFU</b> Enter as a decimal number. NCS converts the number to hexadecimal number recognized as BCD.

5845	Delivery Server Setting
	These are delivery server settings.
1	FTP Port No. [0 to 65535/1]
2	IP Address Use this SP to set the Scan Router Server address. The IP address under the transfer tab can be used with the initial system setting. [0 to FFFFFFFF/1]
6	Delivery Error Display Time Use this setting to set the length of time that the message is shown when a test error occurs during document transfer with the NetFile application and an external device.



Service Tables

	[0 to 999/1]	
	IP Address (Secondary)	
8	Sets the IP address that is given to the computer that is the secondary delivery server for Scan Router. This SP lets you set only the IP address, and does not refer to the DNS setting.	
	Delivery Server Model	
	Lets you change the model of the delivery server that is registered by the I/O device.	
9	[0 to 4/1] 0: Unknown 1: SG1 Provided 2: SG1 Package 3: SG2 Provided 4: SG2 Package	
	Delivery Svr. Capability	
	Changes the functions that the registered I/O device can do.	
010	[0 to 255/1] Bit7 = 1 Comment information exists Bit6 = 1 Direct specification of mail address possible Bit5 = 1 Mail RX confirmation setting possible Bit4 = 1 Address book automatic update function exists Bit3 = 1 Fax RX delivery function exists Bit2 = 1 Sender password function exists Bit1 = 1 Function to link MK-1 user and Sender exists Bit0 = 1 Sender specification required (if set to 1, Bit6 is set to "0")	
	Delivery Svr.Capability (Ext)	
011	These settings are for future use. They will let you increase the number of registered devices (in addition to those registered for SP5845 010). There are eight bits (Bit 0 to Bit 7). All are unused at this time.	
013	Server Scheme (Primary)	

## Service Tables

014	Server port Number (Primary)	[1 to 65535 / <b>80</b> / 1]
015	Server URL Path (Primary)	
016	Server Scheme (secondary)	
017	Server Port (Secondary)	[1 to 65535 / <b>80</b> / 1]
018	Server URL Path (Secondary)	
019	Capture Server Port Number	
020	Capture Server URL Path	[1 to 65535 / <b>80</b> / 1]
021	Capture Server URL Path	
	These SPs (5845-013/014/015/016/017/018/019/020/021) listed above are used for the scan router program.	
022	Rapid Sending Control	[0 to 1 / <b>0</b> / -] 0: Disable, 1: Enable
	Enables or disables the prevention function for the continuous data sending error.	

5846*	UCS Setting	
1	Machine ID (for Delivery Server)	
	Displays the unique device ID in use by the delivery server directory. <ul style="list-style-type: none"> <li>▪ The value is only displayed and cannot be changed.</li> <li>▪ This ID is created from the NIC MAC or IEEE 1394 EUI.</li> <li>▪ The ID is displayed as either 6-byte or 8-byte binary.</li> </ul>	
2	Machine ID Clear (for Delivery Server)	
	Clears the unique ID of the device used as the name in the file transfer directory. Execute this SP if the connection of the device to the delivery server is unstable. After clearing the ID, the ID will be established again automatically by cycling the machine off and on.	
3	Maximum Entries	

## Service Tables

	<p>Changes the maximum number of entries that UCS can handle. [2000 to 20000 / <b>2000</b> / 1 step]</p> <p>If a value smaller than the present value is set, the UCS managed data is cleared, and the data (excluding user code information) is displayed.</p>
6	<p>Delivery Server Retry Timer</p>
	<p>Sets the interval for retry attempts when the delivery server fails to acquire the delivery server address book. [0 to 255 / <b>0</b> / 1 step]</p> <p>0: No retries</p>
7	<p>Delivery Server Retry Times</p>
	<p>Sets the number of retry attempts when the delivery server fails to acquire the delivery server address book. [0 to 255 / <b>0</b> / 1step]</p>
8	<p>Delivery Server Maximum Entries</p>
	<p>Lets you set the maximum number of account entries and information about the users of the delivery server controlled by UCS. [20000 to 20000 / <b>2000</b> / 1 step]</p>
010	<p>LDAP Search Timeout</p>
	<p>Sets the length of the time-out for the search of the LDAP server. [1 to 255 / <b>60</b> /1 step]</p>
040	<p>Addr Book Migration (USB -&gt; HDD)</p>
	<p>This SP moves the address book data from the SD card or flash ROM on the controller board to the HDD. You must cycle the machine off and on after executing this SP.</p> <ol style="list-style-type: none"> <li>1. Turn the machine off.</li> <li>2. Install the HDD.</li> <li>3. Turn the machine on.</li> <li>4. Do SP5846 040.</li> <li>5. Turn the machine off/on.</li> </ol> <p><b>Note:</b> Executing this SP overwrites any address book data already on the</p>

Service Tables

	<p>HDD with the data from the flash ROM on the controller board.</p> <p>We recommend that you back up all directory information to an SD card with SP5846-051 before you execute this SP.</p> <p>After the address book data is copied to HDD, all the address book data is deleted from the flash ROM. If the operation fails, the data is not erased from the flash ROM.</p>								
041	Fill Addr Acl Info.								
	<p>This SP must be executed immediately after installation of an HDD unit in a basic machine that previously had no HDD. The first time the machine is powered on with the new HDD installed, the system automatically takes the address book from the NVRAM and writes it onto the new HDD. However, the new address book on the HDD can be accessed only by the system administrator at this stage. Executing this SP by the service technician immediately after power on grants full address book access to all users.</p> <p><b>Procedure</b></p> <ol style="list-style-type: none"> <li>1. Turn the machine off.</li> <li>2. Install the new HDD.</li> <li>3. Turn the machine on.</li> <li>4. The address book and its initial data are created on the HDD automatically. However, at this point the address book can be accessed by only the system administrator or key operator.</li> <li>5. Enter the SP mode and do SP5846 041. After this SP executes successfully, any user can access the address book.</li> </ol>								
043	Addr Book Media								
	<p>Displays the slot number where an address book data is in. [0 to 30 / - /1]</p> <table border="1"> <tr> <td>0: Unconfirmed</td> <td>20: HDD</td> </tr> <tr> <td>1: SD Slot 1</td> <td>30: Nothing</td> </tr> <tr> <td>2: SD Slot 2</td> <td></td> </tr> <tr> <td>4: USB Flash ROM</td> <td></td> </tr> </table>		0: Unconfirmed	20: HDD	1: SD Slot 1	30: Nothing	2: SD Slot 2		4: USB Flash ROM
0: Unconfirmed	20: HDD								
1: SD Slot 1	30: Nothing								
2: SD Slot 2									
4: USB Flash ROM									
047	Initialize Local Address Book								
	Clears all of the address information from the local address book of a								

## Service Tables

	machine managed with UCS.
048	Initialize Delivery Addr Book
	Push [Execute] to delete all items (this does not include user codes) in the delivery address book that is controlled by UCS.
049	Initialize LDAP Addr Book
	Push [Execute] to delete all items (this does not include user codes) in the LDAP address book that is controlled by UCS.
050	Initialize All Addr Book
	Clears everything (including users codes) in the directory information managed by UCS. However, the accounts and passwords of the system administrators are not deleted.
051	Backup All Addr Book
	Copies all directory information to the SD card. Do this SP before replacing the controller board or HDD. The operation may not succeed if the controller board or HDD is damaged.
052	Restore All Addr Book
	Copies back all directory information from the SD card to the flash ROM or HDD. Upload the address book from the old flash ROM or HDD with SP5846-51 before removing it. Do SP5846 52 after installing the new HDD.
053	Clear Backup Info.
	Deletes the address book uploaded from the SD card in the slot 2. Deletes only the files uploaded for that machine. This feature does not work if the card is write-protected. Note: After you do this SP, go out of the SP mode, turn the power off. Do not remove the SD card until the Power LED stops flashing.
060	Search Option
	This SP uses bit switches to set up the fuzzy search options for the UCS local address book.

Service Tables

	Bit	Meaning
	0	Checks both upper/lower case characters
	1	<b>Japan Only</b>
	2	
	3	
	4	--- Not Used ---
	5	--- Not Used ---
	6	--- Not Used ---
	7	--- Not Used ---
062	Complexity Option 1	
	<p>Use this SP to set the conditions for password entry to access the local address book. Specifically, this SP limits the password entry to upper case and sets the length of the password.</p> <p>[0 to 32 / 0 / 1step]</p> <p><b>Note:</b></p> <ul style="list-style-type: none"> <li>▪ This SP does not normally require adjustment.</li> <li>▪ This SP is enabled only after the system administrator has set up a group password policy to control access to the address book.</li> </ul>	
063	Complexity Option 2	
	<p>Use this SP to set the conditions for password entry to access the local address book. Specifically, this SP limits the password entry to lower case and defines the length of the password.</p> <p>[0 to 32 / 0 / 1step]</p> <p><b>Note:</b></p> <ul style="list-style-type: none"> <li>▪ This SP does not normally require adjustment.</li> <li>▪ This SP is enabled only after the system administrator has set up a group password policy to control access to the address book.</li> </ul>	
064	Complexity Option 3	

Service Tables

	<p>Use this SP to set the conditions for password entry to access the local address book. Specifically, this SP limits the password entry to numbers and defines the length of the password.</p> <p>[0 to 32 / <b>0</b> / 1step]</p> <p><b>Note:</b></p> <ul style="list-style-type: none"> <li>▪ This SP does not normally require adjustment.</li> <li>▪ This SP is enabled only after the system administrator has set up a group password policy to control access to the address book.</li> </ul>
065	Complexity Option 4
	<p>Use this SP to set the conditions for password entry to access the local address book. Specifically, this SP limits the password entry to symbols and defines the length of the password.</p> <p>[0 to 32 / <b>0</b> / 1step]</p> <p><b>Note:</b></p> <ul style="list-style-type: none"> <li>▪ This SP does not normally require adjustment.</li> <li>▪ This SP is enabled only after the system administrator has set up a group password policy to control access to the address book.</li> </ul>
091	FTP Auth Port Setting
	<p>Sets the FTP port to get the delivery server address book that is used in the individual authorization mode.</p> <p>[0 to 65535 / <b>3671</b> / 1step]</p>
094	Encryption Start
	<p>Shows the status of the encryption function of the address book on the LDAP server.</p> <p>[0 to 255 / 1 ] No default</p>

5847	Rep Resolution Reduction
	<ul style="list-style-type: none"> <li>▪ 5847 1 through 5847 6 changes the default settings of image data sent externally by the Net File page reference function.</li> <li>▪ [0 to 2/1]</li> <li>▪ 5847 21 sets the default for JPEG image quality of image files controlled by</li> </ul>

Service Tables

	<p>NetFile.</p> <ul style="list-style-type: none"> <li>"NetFile" refers to jobs to be printed from the document server with a PC and the DeskTopBinder software.</li> </ul>		
1	Rate After Copy Col	[0 to 5/1]	0: 1x 1: 1/2x 2: 1/3x 3: 1/4x 4: 1/6x 5: 1/8x 6: 2/3x1 1: "6: 2/3x" applies to 003, 005, 006 only.
2	Rate for Copy B&W Text	[0 to 6/1]	
3	Rate for Copy B&W Other	[0 to 6/1]	
4	Rate for Printer Color	[0 to 5/1]	
5	Rate for Printer B&W	[0 to 6/1]	
	Network Quality Default for JPEG		
021	<p>Sets the default value for the quality of JPEG images sent as NetFile pages. This function is available only with the MLB (Media Link Board) option installed.</p> <p>[5 to 95/1]</p>		

	Web Service	
5848*	<p>5848-2 sets the 4-bit switch assignment for the access control setting. Setting of 0001 has no effect on access and delivery from Scan Router.</p> <p>5848-100 sets the maximum size of images that can be downloaded. The default is equal to 1 gigabyte.</p>	
	Access Control.: NetFile (Lower 4 Bits Only)	
1	<p>Bit switch settings.</p> <p>0000: No access control</p> <p>0001: Denies access to Desk Top Binder. Access and deliveries from Scan Router have no effect on capture.</p>	
2	Acc. Ctrl.: Repository (only Lower 4 Bits)	<p>0000: No access control</p> <p>0001: Denies access to DeskTop Binder.</p>
3	Acc. Ctrl.: Doc. Svr. Print (Lower 4 Bits)	Switches access control



Service Tables

4	Acc. Ctrl.: User Directory (Lower 4 Bits)	on and off. 0000: OFF, 0001: ON
5	Acc. Ctrl.: Delivery Input (Lower 4 Bits)	
7	Acc. Ctrl Comm. Log Fax (Lower 4 Bits)	
9	Acc. Ctrl.: Job Control (Lower 4 Bits)	
011	Acc. Ctrl: Device Management (Lower 4 Bits)	
013	Acc. Ctrl: Fax (Lower 4 Bits)	
021	Acc. Ctrl: Delivery (Lower 4 Bits)	
022	Acc. Ctrl: User Administration (Lower 4 Bits)	
041	Acc. Ctrl: Security Setting (Lower 4 Bits only)	
100	Repository: Download Image Max. Size	Specified the max size of the image data that the machine can download/ [1 to 1024 / <b>1024</b> / 1 K]
201	Access Ctrl: Regular Trans	No information is available at this time. 0: Not allowed 1: Allowed
210	Setting: Log Type: Job 1	No information is available at this time.
211	Setting: Log Type: Job 2	No information is available at this time.
212	Setting: Log Type: Access	No information is available at this time.
213	Setting: Primary Srv	No information is available at this time.

## Service Tables

214	Setting: Secondary Srv
	No information is available at this time.
215	Setting: Start Time
	No information is available at this time.
216	Setting: Interval Time
	No information is available at this time.
217	Setting: Timing
	No information is available at this time.

5849	Installation Date
	Displays or prints the installation date of the machine.
1	Display
	The "Counter Clear Day" has been changed to "Installation Date" or "Inst. Date".
2	Switch to Print
	Determines whether the installation date is printed on the printout for the total counter. [0 to 1/1] 0: No Print 1: Print
3	Total Counter

5850*	Address Book Function <b>Japan Only</b>
	The machine is sold ready to use with a G3 line. Touch [Replacement] to switch all at once to convert to G4 after you add a G4 line. Conversely, if for some reason the G4 line becomes unusable, you can easily switch back to G3.

## Service Tables

5851*	Bluetooth
	Sets the operation mode for the Bluetooth Unit. Press either key. <b>[0: Public] / [1: Private]</b>

5853	Stamp Data Download
	Touch [EXECUTE] to download the fixed stamp data from the machine ROM onto the hard disk. Then these stamps can be used by the system. If this is not done, the user will not have access to the fixed stamps ("Confidential", "Secret", etc.). You must always execute this SP after replacing the HDD or after formatting the HDD. Always switch the machine off and on after executing this SP.

5856	Remote ROM Update
	When set to "1" allows reception of firmware data via the local port (IEEE 1284) during a remote ROM update. This setting is reset to zero after the machine is cycled off and on. Allows the technician to upgrade the firmware using a parallel cable [0 to 1/1] 0: Not allowed 1: Allowed

5857	Save Debug Log
1	On/Off (1:ON 0:OFF)
	Switches on the debug log feature. The debug log cannot be captured until this feature is switched on. [0 to 1/1] 0: OFF

Service Tables

	1: ON
	Target (2: HDD 3: SD Card)
2	Selects the destination where the debugging information generated by the event selected by SP5858 will be stored if an error is generated [2 to 3 /1] 2: HDD 3: SD Card
5	Save to HDD
	Specifies the decimal key number of the log to be written to the hard disk.
6	Save to SD Card
	Specifies the decimal key number of the log to be written to the SD Card.
9	Copy HDD to SD Card (Latest 4 MB)
	Takes the most recent 4 MB of the log written to the hard disk and copies them to the SD Card. A unique file name is generated to avoid overwriting existing file names on the SD Card. Up to 4MB can be copied to an SD Card. 4 MB segments can be copied one by one to each SD Card.
010	Copy HDD to SD Card Latest 4 MB (Any Key)
	Takes the log of the specified key from the log on the hard disk and copies it to the SD Card. A unique file name is generated to avoid overwriting existing file names on the SD Card. Up to 4 MB can be copied to an SD Card. 4 MB segments can be copied one by one to each SD Card. This SP does not execute if there is no log on the HDD with no key specified.
011	Erase HDD Debug Data
	Erases all debug logs on the HDD
012	Erase SD Card Debug Data
	Erases all debug logs on the SD Card. If the card contains only debugging files

Service Tables

	<p>generated by an event specified by SP5858, the files are erased when SP5857 010 or 011 is executed.</p> <p>To enable this SP, the machine must be cycled off and on.</p>
013	Free Space on SD Card
	Displays the amount of space available on the SD card.
014	Copy SD to SD (Latest 4MB)
	Copies the last 4MB of the log (written directly to the card from shared memory) onto an SD card.
015	Copy SD to SD (Latest 4MB Any Key)
	This SP copies the log on an SD card (the file that contains the information written directly from shared memory) to a log specified by key number.
016	Make HDD Debug
	This SP creates a 32 MB file to store a log on the HDD.
017	Make SD Debug
	This SP creates a 4 MB file to store a log on an SD card.

5858	Debug Save When	
	<p>These SPs select the content of the debugging information to be saved to the destination selected by SP5857 002.</p> <p>SP5858 3 stores one SC specified by number. Refer to Section 4 for a list of SC error codes.</p>	
1	Engine SC Error (0:OFF 1:ON)	<p>Stores SC codes generated by copier engine errors.</p> <p>[0 to 1/1]</p> <p>0: OFF</p> <p>1: ON</p>

Service Tables

2	Controller SC Error (0:OFF 1:ON)	Stores SC codes generated by GW controller errors. [0 to 1/1] 0: OFF 1: ON
3	Any SC Error	[0 to 65535/1]
4	Jam (0:OFF 1:ON)	Stores jam errors. [0 to 1/1] 0: OFF 1: ON

5859	Debug Save Key No.	
1	Key 1	<p>These SPs allow you to set up to 10 keys for log files for functions that use common memory on the controller board.</p> <p>[-9999999 to 9999999/1]</p>
2	Key 2	
3	Key 3	
4	Key 4	
5	Key 5	
6	Key 6	
7	Key 7	
8	Key 8	
9	Key 9	
010	Key 10	

5860*	SMTP/POP3/IMAP4
20	Partial Mail Receive Timeout

Service Tables

	<p>[1 to 168 / <b>72</b> / 1]</p> <p>Sets the amount of time to wait before saving a mail that breaks up during reception. The received mail is discarded if the remaining portion of the mail is not received during this prescribed time.</p>
21	MDN Response RFC2298 Compliance
	<p>Determines whether RFC2298 compliance is switched on for MDN reply mail.</p> <p>[0 to 1 / <b>1</b> / 1]</p> <p>0: No, 1: Yes</p>
22	SMTP Auth. From Field Replacement
	<p>Determines whether the FROM item of the mail header is switched to the validated account after the SMTP server is validated.</p> <p>[0 to 1 / <b>0</b> / 1]</p> <p>0: No. "From" item not switched. 1: Yes. "From" item switched.</p>
25	SMTP Auth Direct Sending
	<p>Select the authentication method for SMPT.</p> <p>Bit 0: LOGIN Bit 1: PLAIN Bit 2: CRAM_MD5 Bit 3: DIGEST_MD5 Bit 4 to Bit 7: Not Used</p> <p><b>Note:</b> This SP is activated only when SMTP authentication is enabled by UP mode.</p>
26	S/MIME: MIME Header Setting
	<p>Selects the MIME header type of an E-mail sent by S/MIME.</p> <p>[0 to 2 / <b>0</b> / 1]</p> <p>0: Microsoft Outlook Express standard 1: Internet Draft standard 2: RFC standard</p>

## Service Tables

5866	E-Mail Report	
1	Report Validity	Enables or disables the email alert function. [0 or 1 / 0 / – ] 0: Enabled, 1: Disabled
5	Add Date Field	Adds or does not add the date field to the header of the alert mail. [0 or 1 / 0 / – ] 0: Not added, 1: Added

5870	Common Key Info Writing	
	Writes to flash ROM the common proof for validating the device for NRS specifications.	
1	Writing	Note: These SPs are for future use and currently are not used.
3	Initialize	

5873	SD Card Apli Move	
	Allows you to move applications from one SD card another. For more, see "Moving Applications to One SD Card" in Section 1.	
1	Move Exec	Executes the move from one SD card to another.
2	Undo Exec	This is an undo function. It cancels the previous execution.

5875	SC Auto Reboot	
	This SP determines whether the machine reboots automatically when an SC error occurs. <b>Note:</b> The machine does not rebut for Type A (fatal) SC code errors.	
1	Reboot Setting	
	[0 to 1 / 0 / 1] 0: The machine reboots automatically when the machine issues an SC error and logs the SC error code. If the same SC occurs again, the machine does not	



Service Tables

	reboot. 1: The machine does not reboot when an SC error occurs.
2	Reboot Type
	[0 to 1 / 0 / 1] 0: Manual reboot, 1: Automatic reboot

5878	Option Setup
	Select the option to enable then touch [EXECUTE].
1	Data Overwrite Security
2	HDD Encryption

5881	Fixed Phase Block Erasing <b>DFU</b>
	Detects fixed phase.

5885*	Set WIM Function	
20	DocSvr Acc Ctrl	<p>Allows or disallows the functions of web image monitor.</p> <p><b>0</b>: OFF, <b>1</b>: ON</p> <p>Bit:</p> <p>0: Forbid all document server access</p> <p>1: Forbid user mode access</p> <p>2: Forbid print function</p> <p>3: Forbid Fax</p> <p>4: Forbid scan sending</p> <p>5: Forbid download</p> <p>6: Forbid delete</p> <p>7: Forbid guest user</p>
20	DocSvr Acc Ctrl	

Service Tables

	DocSvr Format
50	Selects the display type for the document box list. [0 to 2 / <b>0</b> / 1] 0: Thumbnail, 1: Icon, 2: Details
	DocSvr Trans
51	Sets the number of documents to be displayed in the document box list. [5 to 20 / <b>10</b> / 1]
100	Set Signature
	Set Encryption
101	Determines whether the scanned documents with the WIM are encrypted when they are transmitted by an e-mail. [0 to 1 / <b>0</b> / 1] 0: Not encrypted, 1:Encryption
200	Detect Mem Leak
201	DocSvr Timeout

5887	SD Get Counter
	<p>This SP sends a text file to an SD card inserted in SD card Slot 2 (lower slot). The operation stores. The file is stored in a folder created in the root directory of the SD card called SD_COUNTER. The file is saved as a text file (*.txt) prefixed with the number of the machine.</p> <ol style="list-style-type: none"> <li>1. Insert the SD card in SD card Slot 2 (lower slot).</li> <li>2. Select SP5887 then touch [EXECUTE].</li> <li>3. Touch [Execute] in the message when you are prompted.</li> </ol>

5888*	Personal Information Protect
	Selects the protection level for logs.

Service Tables

	<p>[0 to 1 / 0 / 1}</p> <p>0: No authentication, No protection for logs</p> <p>1: No authentication, Protected logs (only an administrator can see the logs)</p>
--	--

5907	Plug & Play Maker/Model Name
	<p>Selects the brand name and the production name for Windows Plug &amp; Play. This information is stored in the NVRAM. If the NVRAM is defective, these names should be registered again.</p> <p>After selecting, press the "Original Type" key and "#" key at the same time. When the setting is completed, the beeper sounds five times.</p>

5913	Switchover Permission Time
	Print Application Timer
2	<p>Sets the length of time to elapse before allowing another application to take control of the display when the application currently controlling the display is not operating because a key has not been pressed.</p> <p>[3 to 30/1 s]</p>
102	Print Application Set
	<p>No information is available at this time.</p> <p>[0 to 1/1/1]</p>

5959	Paper Size
	<p>Tray 1 (tandem tray) and the LCT do not have automatic paper size detection. Use these SP codes to set the paper size for Tray 1 and the optional LCT.</p>
1	Tray 1

## Service Tables

	The following paper sizes can be set. If the A3 DLT kit is not installed, you can only use settings 0 and 1	
	0: A4	6: 8.5 x 14 SEF
	1: 8.5 x 11	7: 8.5 x 11 SEF
	2: A3 SEF	8: B5
	3: B4 SEF	9: B5 SEF
	4: A4 SEF	10: Custom
	5: 11 x 17	
	LCT	
	The LCT accepts three paper sizes. Enter the correct number of the size of the paper loaded in the LCT:	
2	0: A4	4: 8.5 x 11 SEF
	1: 8.5 x 11	5: B4 SEF
	2: B5	6: 8.5 x 14 SEF
	3: A4 SEF	7: Custom Size

	Copy Server: Set Function
5967	<p>Enables and disables the document server. This is a security measure that prevents image data from being left in the temporary area of the HDD. After changing this setting, you must switch the main switch off and on to enable the new setting.</p> <p>[0 to 1/1]</p> <p>0: ON</p> <p>1: OFF</p>

	Cherry Server
5974	<p>Selects which version of the Scan Router application program, "Light" or "Full (Professional)", is installed.</p> <p>[0 to 1 / 0 / 1 /step]</p> <p>0: Light version (supplied with this machine)</p> <p>1: Full version (optional)</p>

	Device Setting
5985	<p>The NIC and USB support features are built into the GW controller. Use this SP to enable and disable these features. In order to use the NIC and USB functions built into the controller board, these SP codes must be set to "1".</p>
1	On Board NIC
	<p>[0 to 2 / 1 / 1 /step]</p> <p>0: Disable, 1: Enable, 2: Function limitation</p> <p>When the "Function limitation" is set, "On board NIC" is limited for use with only NRS or LDAP/NT authentication.</p> <p>Note:</p> <ul style="list-style-type: none"> <li>▪ Other network applications than @Remote or LDAP/NT authentication are not available when this SP is set to "2".</li> <li>▪ Even if you can change the initial settings of those network applications, the settings will not work</li> </ul>
2	On Board USB
	<p>[0 or 1 / 0 / 1/step]</p> <p>0: Disable, 1: Enable</p>

5990	SP Print Mode (SMC Print)
	<p>In the SP mode, press Copy Window to move to the copy screen, select the paper size, then press Start. Select A4/LT (Sideways) or larger to ensure that all the information prints. Press SP Window to return to the SP mode, select the desired print, and press Execute.</p>

## Service Tables

---

1	All (Data List)
2	SP (Mode Data List)
3	User Program Data
4	Logging Data
5	Diagnostic Report
6	Non-Default (Prints only SPs set to values other than defaults.)
7	NIB Summary
8	Capture Log
021	Copier User Program
022	Scanner SP
023	Scanner User Program

## Group 6000

6006	ADF Reg Adj	
	ADF Registration Adjustment	
1	ADF Main Reg Ad: Front	Adjusts the side-to-side registration for the front/back in ADF mode. [-3 to +3/0.1 mm]
2	ADF Main Reg Ad: Back	
3	ADF Sub Reg Adj	Adjusts the vertical registration for the front/back in ADF mode. [-29 to +29/0.17 mm] -29 = -4.93 mm +29 = +4.93 mm
5	ADF Buck Adj:Front	Adjusts the roller timing at the skew correction sensor/entrance roller. A higher setting causes more buckling. [-10.0 to +20/0.25 mm] -20 = -5.0 mm +20 = +5.0 mm
6	ADF Buck Adj:Back	Adjusts the roller timing at the interval sensor/scanning roller. A higher setting causes more buckling. [-16.0 to +23/0.13 mm] -16 = -2 mm +23 = +3 mm
7	ADF TEdge EMargin	These settings adjust the erase margin for the trailing edges for the front/back. [-20 to +20/0.5 mm] -20 = -10 mm +20 = +10 mm

6007	ADF Input Chk	
	<p>Displays signals received from sensors and switches in the ADF. The signals are reflected in an 8-bit array:                      (7) 0000 0000 (0)                      where 0 and 1 are used to define the state of each sensor</p> <ul style="list-style-type: none"> <li>▪ 0: No detect</li> <li>▪ 1: Detect</li> </ul>	
1	ADF Group 1	
	<b>Bit</b>	<b>Sensor</b>
	7	Registration Sensor
	6	Interval Sensor
	5	Skew Correction Sensor
	4	Separation Sensor
	3	Original Set Sensor
	2	B5 Detection Sensor
	1	A4 Detection Sensor
	0	LG Detection Sensor
2	ADF Group 2	
	<b>Bit</b>	<b>Sensor</b>
	7	APS Start Sensor
	6	ARDF Position Sensor
	5	Exit Sensor
	4	Paper Width Sensor 5



Service Tables

	3	Paper Width Sensor 4
	2	Paper Width Sensor 3
	1	Paper Width Sensor 2
	0	Paper Width Sensor 1
3	ADF Group 3	
	<b>Bit</b>	<b>Sensor</b>
	7	Not used
	6	Not used
	5	Lower Inverter Sensor
	4	Inverter Switchback Sensor
	3	Bottom Plate Position Sensor
	2 to 0	Not used

6008	ADF Output Chk	
	Turns on the ADF electrical components individually for testing.	
1	ADF Feed M:Fwd	
2	ADF Feed M:Rev	
3	ADF Trans M:Fwd	
4	ADF Ext M:Fwd	
5	ADF Top Inv M:Fwd	
6	ADF Top Inv M:Rev	
7	ADF Bot Inv M:Fwd	
8	ADF Bot Inv M:Rev	
9	ADF Pickup M:Fwd	

Service Tables

10	ADF BotPlt M:Rev	
11	ADF Top Inv SOL	
12	ADF Bot Inv SOL	

6009	ADF Free Run	
	This SP does an ADF free run in duplex original mode.	
1	Simplex	
2	Duplex	

6016	ADF OrgSizePrior	
	ADF Original Size Detection Priority. Allows selection of alternate settings for automatic original size detection. (7) 0000 0000 (1)	

6017	ADF Mag Adj	
	ADF Magnification Adjustment	
	This changes the magnification by adjusting the speed of scanning. [-50(-5%) to +50(+5%)/0.1%]	

6020	Buckle Operation	
------	------------------	--

Service Tables

	This SP switches on stopping the scanning entrance roller for all paper sizes. Normally, the scanning entrance roller stops briefly to correct skew of small paper sizes in the ADF paper path and for the 2nd side scanning of originals during duplexing. Setting this SP to "1" sets the ADF to stop the scanning entrance roller for all paper sizes to correct for skew a second time.	
1	ADF Buckle Op Set	[0 to 1/1]

6090	LCT Output Chk	A4/LT LCT (MAUI) B473
	Use these SPs to do the output check for the optional LCT.	
1	LCT Feed M	
2	LCT Pickup SOL	

6091	LCT Input Chk	LCIT RT4000 D350
	Use these SPs to do the input check for the optional LCIT.	
1	Wide LCT Feed Sn	
2	Wide LCT Trans Sn	
3	Wide LCT Exit Sn	
4	Wide LCT Door Switch	

6092	LCT Output Chk	LCIT RT4000 D350
	Use these SPs to do the output check for the optional LCIT.	
1	Wide LCT Feed M Lo1	
2	Wide LCT Feed M Lo2	
3	Wide LCT Feed M Hi1	

Service Tables

4	Wide LCT Feed M Hi2	
5	Wide LCT Trans M Lo1	
6	Wide LCT Trans M Lo2	
7	Wide LCT Trans M Hi1	
8	Wide LCT Trans M Hi2	
9	Wide LCT Exit M Lo1	
10	Wide LCT Exit M Lo2	
11	Wide LCT Exit M Hi1	
12	Wide LCT Exit M Hi2	
13	Wide LCT Pickup SOL	
14	Wide LCT Fan F	
15	Wide LCT Fan R	

6101	Adj Punch Pos 2	Punch B702 for Finishers D373/D374
	<p>Punch Position Adjustment            Adjusts the punch hole positions in the direction of paper feed.</p> <ul style="list-style-type: none"> <li>▪ NA: North America</li> <li>▪ DOM: Japan</li> <li>▪ EU: Europe</li> <li>▪ SCAN: Scandinavia</li> </ul>	
1	2-Hole:DOM	<p>[-75 to +75/0.5 mm]            + Value: Shifts punch unit in the direction of feed.            - Value: Shifts punch unit against direction of feed.</p>
2	3-Hole:NA	
3	4-Hole:EU	
4	4-Hole:SCAN	
5	2-Hole:NA	

Service Tables

---

6102	Punch Hole Reg 1	Punch B702 for Finishers D373/D374
	This SP corrects punch hole alignment by correcting the skew of each by adjusting the amount of time the finisher entrance roller remains off while the exit roller of the machine remains on. This buckles the leading edge of the sheet slightly against the finisher entrance roller while it remains off.	
1	A3 SEF	<p>[-5~+5/0.25 mm]</p> <ul style="list-style-type: none"> <li>▪ + Value: Increases time finisher entrance roller remains off.</li> <li>▪ - Value: Decreases time finisher entrance roller remains off.</li> </ul>
2	B4 SEF	
3	A4 SEF	
4	A4 LEF	
5	B5 SEF	
6	B5 LEF	
7	DLT SEF	
8	LG SEF	
9	LT SEF	
10	LT LEF	
11	12"x18"	
12	Custom	

6103	Punch Hole Reg 2	Punch B702 for Finishers D373/D374
	This SP determines whether the finisher entrance roller stops to correct skew when paper enters the finisher.	
1	A3 SEF	<p>[0 to 1/1/1]</p> <p>0: Paper stops for skew correction</p> <p>1: Paper does not stop</p>
2	B4 SEF	
3	A4 SEF	

Service Tables

4	A4 LEF	
5	B5 SEF	
6	B5 LEF	
7	DLT SEF	
8	LG SEF	
9	LT SEF	
10	LT LEF	
11	12"x18"	
12	Custom	

6104	Fine Adj Staple:Fin1	2000/3000-Sheet Finishers D373/D374
	This SP corrects the distance between the jogger fences and the sides of the stack on the finisher stapling tray.	
1	A3 SEF	<p>[-15~+1.5/0.5 mm]</p> <ul style="list-style-type: none"> <li>▪ + Value: ncreases distance between jogger fences and the sides of the stack.</li> <li>▪ - Value: Decreases the distance between the jogger fences and the sides of the stack.</li> </ul>
2	B4 SEF	
3	A4 SEF	
4	A4 LEF	
5	B5 SEF	
6	B5 LEF	
7	DLT SEF	
8	LG SEF	
9	LT SEF	
10	LT LEF	

## Service Tables

11	12"x18"	
12	Custom	

6105	Adj Staple Pos:Fin1	2000/3000-Sheet Finishers D373/D374
	This SP corrects the stapling position of the corner stapler.	
1	A3 SEF	<p>[-3.5~+3.5/0.5 mm]</p> <ul style="list-style-type: none"> <li>▪ - Value: Moves stapling position toward the rear of the machine.</li> <li>▪ + Value: Shifts the stapling position toward the front of the machine.</li> </ul>
2	B4 SEF	
3	A4 SEF	
4	A4 LEF	
5	B5 SEF	
6	B5 LEF	
7	DLT SEF	
8	LG SEF	
9	LT SEF	
10	LT LEF	
11	12"x18"	
12	Custom	

6107	Fine Adj Jog Fences:Fin1	2000/3000-Sheet Finishers D373/D374
	This SP corrects the distance between the output jogger fences and the sides of the stack when the output jogger unit attached to the side of the machine jogs sheets as they exit the finisher.	
1	A3 SEF	<p>[-15. to +1.5/0/0.5 mm]</p> <ul style="list-style-type: none"> <li>▪ + Value: Increases distance between jogger fences and the sides of the stack.</li> <li>▪ - Value: Decreases the distance between the</li> </ul>
2	B4 SEF	
3	A4 SEF	

Service Tables

4	A4 LEF	jogger fences and the sides of the stack.
5	B5 LEF	
6	A5 LEF	
7	DLT SEF	
8	LG SEF	
9	LT SEF	
10	LT LEF	
11	HLT LEF	
12	Other	

6108	Adj Prestack Shts:Fin1	
	<p>This SP sets the number of sheets sent to the pre-stack tray. With this SP set to the default (3):</p> <ul style="list-style-type: none"> <li>▪ 3 sheets are sent to the pre-stack tray.</li> <li>▪ When the 4th sheet feeds, the 4th sheet and 3 sheets from the pre-stack tray are sent to the stapling tray together.</li> </ul> <p><b>Note:</b> You may need to adjust this setting or switch it off when feeding thick or slick paper.</p>	
1	A4 LEF	[0 to 4/3/1 sheet]
2	LT LEF	0: None
3	B5 LEF	1: 1 sheet
4	10.5"x7.25" LEF	2: 2 sheets
5	A4 SEF	3: 3 sheets
6	LT SEF	4: 4 sheets
7	B5 SEF	
8	10.5"x7.25" SEF	



Service Tables

9	Other	
---	-------	--

6111	Booklet Fold Repeat	2000-Sheet Finisher D373
	<p>This SP sets the number of times the folding rollers are driven forward and reverse to sharpen the crease of a folded booklet before it exits the folding unit. When set at the default (0):</p> <ul style="list-style-type: none"> <li>▪ The folding blade pushes the center of the stack into the nip of the folding roller.</li> <li>▪ The folding rollers rotated ccw to crease the booklet, reverse cw, then rotate ccw again crease the booklet fold twice before feeding to the folding unit exit rollers.</li> </ul>	
1	A3 SEF	<p>[0 to 6/0/1]                      0: No repeated fold                      1: 2                      2: 5                      3: 10                      4: 15                      5: 25                      6: 30</p>
2	B4 SEF	
3	A4 SEF	
4	B5 SEF	
5	DLT SEF	
6	LG SEF	
7	LT SEF	
8	12"x18"	
9	Other	

6114	Free Run <b>DFU</b>	3000-Sheet Finisher B830
	<p>These SPs set the switch the following free run modes for Finisher 2 (B830). Touch [ON] to switch on, [OFF] to switch off.</p>	
1	Free Run 1	System Free Run
2	Free Run 1	Free Run (Endurance Testing)
3	Free Run 3	Free Run

Service Tables

4	Free Run 4	Shift, Free Run
---	------------	-----------------

6115	Input Check:Fin1	2000/3000-Sheet Finishers D373/D374
	<p>Use these SP codes to perform the input checks for either the 2000-Sheet Finisher D373 or 3000-Sheet Finisher D374.</p> <p>The following abbreviations are used below:</p> <ul style="list-style-type: none"> <li>▪ Sn: Sensor</li> <li>▪ HP: Home Position</li> <li>▪ Stp: Staple</li> <li>▪ BStapler: Booklet Stapler (D373 only)</li> </ul>	
1	Entrance Sn	
2	Proof Exit Sn	
3	Proof Full Sn	
4	Up Tray Exit Sn	
5	Staple Exit Sn	
6	Shift Roll HP Sn	
7	Exit Sn	
8	Exit Guide HP Sn	
9	Low Tray Hgt Sn	
10	Up Tray Hgt Sn	
11	Up Tray Full Sn	
12	Stack Roll HP Sn	
13	Jogger HP Sn	
14	Feed Out HP Sn	
15	Stp Tray Ppr Sn	
16	Stp Tray HP Sn	

Service Tables

17	Stp Rotate HP Sn	
18	Up Tray LimitSW	
19	Door Switch	
20	Corner Stp Oper	
21	Corner Stp In	
22	Corner Staples	
23	Punch HP Sn	
24	Punch Unit Hp Sn	
25	Punch Ppr HP Sn	
26	Punch Full Sn	
27	Punch HP Sn	
28	Punch DIP SW1	
29	Punch DIP SW2	
30	Stack Junc HP Sn	
31	Stack Present Sn	
32	Clamp Roll HP Sn	
33	Fold Entrance Sn	
34	Bot Fence HP Sn	
35	Fold Cam HP Sn	
36	Fold Plate HP Sn	
37	Fold Exit Sn	
38	Book Full Sn 1	
39	Book Full Sn 2	

Service Tables

40	BStapler 1 Op	
41	BStapler 1 In	
42	BStaples 1 In	
43	BStapler 2 Op	
44	BStapler 2 In	
45	BStaples 2 In	
46	Up TrayFull:3000	
47	Out Jog HP Sn 1	
48	Out Jog HP Sn 2	
49	OutJog RetractSn	

6116	Output Check:Fin1	2000/3000-Sheet Finishers D373/D374
	<p>Use these SP codes to perform the output checks for either the 2000-Sheet Finisher D373 or 3000-Sheet Finisher D374.</p> <p>The following abbreviations are used below:</p> <ul style="list-style-type: none"> <li>▪ M: Motor</li> <li>▪ JG: Junction Gate</li> <li>▪ SOL: Solenoid</li> <li>▪ Stp: Staple</li> <li>▪ Bot: Bottom</li> </ul>	
1	Entrance M	
2	Up Trans M	
3	Low Trans M	
4	Exit M	
5	Pos Roll M	
6	Shift M	

---

Service Tables

---

7	Exit Guide M	
8	Tray Lift M	
9	Stack Roller M	
10	Jogger M	
11	Feed Out M	
12	Stp Shift M	
13	Stp Rot M	
14	Corner Stp M	
15	Up JG SOL	
16	Dn JG SOL	
17	Pos Roll SOL	
18	Stp Edge Plate SOL	
19	Book Press SOL	
20	Stack JG M	
21	Fold Bot Fence M	
22	Book Stp M:Front	
23	Book Stp M:Back	
24	Fold Plate M	
25	Fold Roll M	
26	Clamp Roll M	
27	Punch M	
28	Punch Move M	
29	Punch Reg M	

Service Tables

30	OutJog M:Front	
31	OutJog M:Rear	
32	OutJog Retract M	

6150	Fine Adj Staple:Fin2	3000-Sheet Finisher B830
	This SP corrects the distance between the jogger fences and the sides of the stack on the finisher stapling tray.	
1	A3 SEF	<p>[-15~+1.5/-2/0.5 mm]</p> <ul style="list-style-type: none"> <li>▪ + Value: ncreases distance between jogger fences and the sides of the stack.</li> <li>▪ - Value: Decreases the distance between the jogger fences and the sides of the stack.</li> </ul>
2	B4 SEF	
3	A4 SEF	
4	A4 LEF	
5	B5 SEF	
6	B5 LEF	
7	DLT SEF	
8	LG SEF	
9	LT SEF	
10	LT LEF	
11	Custom	

6151	Adj Staple Pos:Fin2	3000-Sheet Finisher B830
	This SP corrects the stapling position of the corner stapler.	
1	A3 SEF	<p>[-2~+2/0/0.5 mm]</p> <ul style="list-style-type: none"> <li>▪ - Value: Moves stapling position toward the rear of the machine.</li> <li>▪ + Value: Shifts the stapling position toward the</li> </ul>
2	B4 SEF	
3	A4 SEF	

Service Tables

4	A4 LEF	front of the machine.
5	B5 SEF	
6	B5 LEF	
7	DLT SEF	
8	LG SEF	
9	LT SEF	
10	LT LEF	
11	Other	

6152	Fine Adj Out Jog:Fin2	3000-Sheet Finisher B830
	This SP corrects the distance between the output jogger fences and the sides of the stack when the output jogger unit attached to the side of the machine jogs sheets as they exit the finisher.	
1	A3 SEF	<p>[-3 to +3/0/0.01 mm]</p> <ul style="list-style-type: none"> <li>▪ + Value: Increases distance between jogger fences and the sides of the stack.</li> <li>▪ - Value: Decreases the distance between the jogger fences and the sides of the stack.</li> </ul>
2	B4 SEF	
3	A4 SEF	
4	A4 LEF	
5	B5 SEF	
6	B5 LEF	
7	A5 SEF	
8	A5 LEF	
9	DLT SEF	
10	LG SEF	
11	LT SEF	

Service Tables

12	LT LEF	
13	HLT SEF	
14	HLT LEF	
15	Custom	

6153	Adj Prestack Shts:Fin2	3000-Sheet Finisher B830
	<p>This SP sets the number of sheets sent to the pre-stack tray. With this SP set to the default (3):</p> <ul style="list-style-type: none"> <li>▪ 3 sheets are sent to the pre-stack tray.</li> <li>▪ When the 4th sheet feeds, the 4th sheet and 3 sheets from the pre-stack tray are sent to the stapling tray together.</li> </ul> <p><b>Note:</b> You may need to adjust this setting or switch it off when feeding thick or slick paper.</p>	
1	A4 LEF	<p>[0 to 2/2/1 sheet]</p> <p>0: None</p> <p>1: 1 sheet</p> <p>2: 2 sheets</p>
2	B5 LEF	
3	LT LEF	
4	Other	

6154	Adj Top Fence Pos	3000-Sheet Finisher B830
	<p>Use this SP to adjust the timing of the top fence motor that positions the top fence.</p> <p><b>Note:</b> After all the pages of a stack have been fed onto the stapling tray, the top fence jogs the stack vertically to align the leading edge of the stack for stapling.</p>	
1	A4 LEF	[-5 to 10/0/0.1 mm]
2	B5 LEF	[-5 to 2/0/0.1 mm]
3	LT LEF	[-5 to 10/0/0.1 mm]
4	Other	



Service Tables

6155	Staple Stack Jogging
	Touch [1:+1 Time] to have the jogger fences press against the sides of the stack on the staple tray one more time to align the stack for corner stapling. [*0:Default] [1:+1 Time]

6156	Input Check:Fin2	3000-Sheet Finisher B830
	Use these SP codes to perform the input checks for either the 3000-Sheet Finisher B830. The following abbreviations are used below:	
	<ul style="list-style-type: none"> <li>▪ Sn: Sensor</li> <li>▪ Hgt: Height</li> <li>▪ HP: Home Position</li> <li>▪ Stp: Staple</li> <li>▪ BStapler: Booklet Stapler (D373 only)</li> </ul>	
1	Entrance Sn	
2	Proof Exit Sn	
3	Shift Exit Sn 1	
4	Stp Exit Sn	
5	Tray Bot Plt Sn	
6	Tray Near Bot Sn	
7	Release HP Sn	
8	Jogger HP Sn	
9	Shift HP Sn 1	
10	Stapler Side HP Sn	
11	Stapler HP Sn	
12	Stapler Sn	
13	Stapler Tray Sn	

Service Tables

14	Door Open Sn	
15	Punch Sn	
16	Punch HP Sn 1	
17	Punchout Full Sn	
18	Paper Hgt Sn:Stp	
19	Paper Hgt Sn:Shift	
20	Paper Jam Sensor	
21	Proof Full Sn	
22	Stapler Rotation Sn 1	
23	S Hopper Full Sn	
24	Prestack Sn	
25	Stack Plate HP Sn	
26	Exit Guide HP Sn	
27	Stapler Rotation Sn 2	
28	Stapler Ready Sn	
29	StackPlate HP Sn 1	
30	StackPlate HP Sn 2	
31	Stp Hammer HP Sn	
32	Return Drv HP Sn	
33	Paper Hgh Sn	
34	Tray Limit SW	
35	Punch HP Sn 2	
36	Shift Jog Sn	

Service Tables

37	Shift Jog HP Sn	
38	OutJog RetractSn	
39	Emergency Stop SW	
40	Top Fence HP Sensor	
41	Bottom Fence HP Sensor	
42	Shift Tray Full Sn:Z-Fold	
43	Shift Tray Exit Sensor 2	
44	Upper Tray JG HP Sensor	
45	Stapler JG HP Sensor	
46	Prestack JG HP Sensor	
47	Stop Prestack Sensor	
48	Prestack Stopper HP Sensor	
49	Shift Tray HP Sensor 2	
50	Staple Trim Hopper Set Sn	

6157	Output Check:Fin2	3000-Sheet Finisher B830
	<p>Use these SP codes to perform the output checks for either the 3000-Sheet Finisher B830. The following abbreviations are used below:</p> <ul style="list-style-type: none"> <li>▪ Mtr: Motor</li> <li>▪ M: Motor</li> <li>▪ JG: Junction Gate</li> <li>▪ SOL: Solenoid</li> <li>▪ Stp: Staple</li> <li>▪ Bot: Bottom</li> </ul>	
1	Upper Transport Motor	
2	Shift Exit M:Cont	

Service Tables

3	Upper Tray JG Mtr:Cont	
4	Tray Lift M:1 Op	
5	Jogger M:1 Op	
6	Stp M:1 Op Horiz	
7	Stp M:1 Op	
8	Punch M:1 Op	
9	Stapler JG Mtr:Cont	
10	Stp Hammer M:1 Op	
11	Feed Out M:1 Op	
12	Shift M:1 Op	
13	Stapler Rot Mtr:Cont	
14	Stp Exit M:Cont	
15	Open Exit M:1 Op	
16	Fold Plate M:1 Op	
17	Prestack JG Mtr:1 Op	
18	Prestack Stop Mtr:1 Op	
19	Fold M:Front:1 Op	
20	Fold M:Back:1 Op	
21	Return Drv M:1 Op	
22	Return TransM:Cont	
23	Shift Jog M:1 Op	
24	ShiftJogShuntM:1 Op	
25	Top Fence Motor:1 Op	

Service Tables

26	Bottom Fence Motor:1 Op	
27	Lower Transport Mtr:Cont	
28	Upper Tray Exit Mtr:Cont	
29	Positioning Roller Mtr:Cont	
30	Prestack Trans Mtr:Cont	
31	Staple Trim Chute SOL:1 Op	

6250	Input Check:Fin3	
	For future use. (Oct. 2007)	

6251	Output Check:Fin3	
	For future use. (Oct. 2007)	

6301	Fine Adj 1st, 2nd Z-Fold	
	Use these SP codes to adjust the positions of the Z-folds done with the Z-Fold Unit B660. The 1st and 2nd folds can be adjusted separately.	

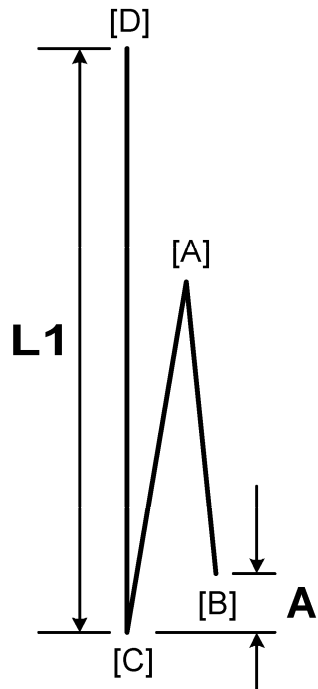

d014s902

1	1st Fold:A3 SEF	[-4 ~ +4/0/ 0.2 mm] Refer to the illustration above. Adjusts the position of the first fold [A] to decrease or increase the distance <b>A</b> between the leading edge [B] and the crease of the 2nd fold [C].
2	1st Fold:B4 SEF	
3	1st Fold:A4 SEF	
4	1st Fold:DLT SEF	
5	1st Fold:LG SEF	
6	1st Fold:LT SEF	
7	1st Fold:12"x18"	
8	1st Fold:Other	
9	2nd Fold:A3 SEF	[-4 ~ +4/0/ 0.2 mm] Refer to the illustration above. Adjusts the position of the 2nd fold [C] to decrease or increase the length <b>L1</b> of the sheet between the trailing edge [D] and the
10	2nd Fold:B4 SEF	
11	2nd Fold:A4 SEF	
12	2nd Fold:DLT SEF	

Service Tables

13	2nd Fold:LG SEF	2nd fold.
14	2nd Fold:LT SEF	
15	2nd Fold:12"x18"	
16	2nd Fold:Other	

6350	Input Check:Mail Box	9-Bin Mailbox B762
	Use these SP codes to perform the input checks for sensors and switches in the mailbox.	
1	Paper Detect Sn 1	
2	Vert Transport Sn:Bin1	
3	Paper Overflow Sn 1	
4	Paper Detect Sn 2	
5	Vert Transport Sn2:Bin3	
6	Paper Overflow Sn 2	
7	Paper Detect Sn 3	
8	Paper Overflow Sn 3	
9	Paper Detect Sn 4	
10	Vert Transport Sn3:Bin5	
11	Paper Overflow Sn 4	
12	Paper Detect Sn 5	
13	Paper Overflow Sn 5	
14	Paper Detect Sn 6	
15	Vert Transport Sn4:Bin7	
16	Paper Overflow Sn 6	

Service Tables

17	Paper Detect Sn 7	
18	Paper Overflow Sn 7	
19	Paper Detect Sn 8	
20	Vert Transport Sn 5:Bin9	
21	Paper Overflow Sn 8	
22	Paper Detect Sn 9	
23	Paper Overflow Sn 9	
24	Door Open Switch	

6351	Output Check:Mail Box	9-Bin Mailbox B762
	Use these SP codes to perform the output checks of the motor and solenoids in the mailbox.	
1	Vert Transport Motor	
2	Junction Gate SOL1	
3	Turn Gate SOL1	
4	Turn Gate SOL2	
5	Turn Gate SOL3	
6	Turn Gate SOL4	
7	Turn Gate SOL5	
8	Turn Gate SOL6	
9	Turn Gate SOL7	
10	Turn Gate SOL8	

6352	Free Run:Mail Box	
------	-------------------	--



Service Tables

	Press [ON] and [OFF] to switch on/off the mailbox for free run testing.
--	---

6400	Input Check: 2-Tray CIT	Cover Interposer Tray B835
	Use these SP codes to perform the sensor and switch input checks for the Cover Interposer Tray B835.	
1	Feed Sn1	
2	Feed Sn2	
3	Pullout Sn1	
4	Pullout Sn2	
5	Trans Sn1	
6	Trans Sn2	
7	Trans Exit Sn	
8	Entrance Sn	
9	Exit Sn	
10	Pickup HP Sn1	
11	Pickup HP Sn2	
12	Limit Sn1	
13	Limit Sn2	
14	Bot Sn1	
15	Bot Sn2	
16	Near End Sn1	
17	Near End Sn2	
18	Paper End Sn1	
19	Paper End Sn2	

Service Tables

20	Length Sn1	
21	Length Sn2	
22	Tray1 Size Sn1	
23	Tray1 Size Sn2	
24	Tray1 Size Sn3	
25	Tray1 Size Sn4	
26	Tray1 Size Sn5	
27	Tray2 Size Sn1	
28	Tray2 Size Sn2	
29	Tray2 Size Sn3	
30	Tray2 Size Sn4	
31	Tray2 Size Sn5	
32	Feed Door Sn1	
33	Feed Door Sn2	
34	Trans Door SW	
35	Front Door SW	

6401	Output Check:2-Tray CIT	Cover Interposer Tray B835
	Use these SP codes to perform the output checks for the motors of the Cover Interposer Tray B835.	
1	Stop	
2	Pickup M1	
3	Pickup M2	
4	Feed M1	

Service Tables

5	Feed M2	
6	Pullout M1	
7	Pullout M2	
8	Trans M	
9	Horizontal Trans M	

6450	Interposer Size	
	Controls the paper size for the cover interposer tray. Select a paper size and push [Execute]	
1	A3SEF/12"*18"	[0~1/1] 0: A3 SEF, 1: 12" x 18"
2	EU/China	[0~2/1] 0: 8½" x 13", 1: 8" x 13", 2: 8¼" x 13"
3	NA 1	[0~1/1] 0: 8½" x 14", 1: 8½" x 13"
4	NA 2	[0~1/1] 0: LT LEF, 1: 10½" x 7¼"
5	NA 3	[0~1/1] 0: LT SEF, 1: 8" x 10"
6	EU/Taiwan 1	[0~1/1] 0: 8-Kai, 1: DLT
7	EU/Taiwan 2	[0~1/1] 0: 16-Kai SEF, 1: LT
8	EU/Taiwan 3	[0~1/1] 0: 16-Kai SEF, 1: LT SEF

6451	Input Check:1-Tray CIT	Cover Interposer B704
------	------------------------	-----------------------

Service Tables

	Use these SP codes to perform the input checks for the sensors of the Cover Interposer Tray B704.	
1	Paper Feed Cover Sensor	
2	Bottom Plate HP Sensor	
3	Paper Near End Sensor	
4	Paper Set Sensor	
5	Bottom Plate HP Sensor	
6	Grip Sensor	
7	Guide Plate Set Sensor	
8	Exit Sensor	
9	Paper Set Sensor	
10	Width Sensor 1	
11	Width Sensor 2	
12	Width Sensor 3	
13	Length Sensor 1	
14	Length Sensor 2	
15	Length Sensor 3	

6500	Punch Adjustment
	For future use. (Oct. 2007)

6501	Paddle Pos Adjustment
	For future use. (Oct. 2007)

6502	Adj Binding Position 1
------	------------------------

## Service Tables

---

	For future use. (Oct. 2007)
6503	Adj Binding Position 2
	For future use. (Oct. 2007)
6504	Adj Punch Jog:Punching
	For future use. (Oct. 2007)
6505	Adj Punch Jog Value
	For future use. (Oct. 2007)
6506	Adj Jog:Binding 1
	For future use. (Oct. 2007)
6508	Input Check:Fin4
	For future use. (Oct. 2007)
6509	Output Check:Fin4
	For future use. (Oct. 2007)
6800	Sheet Conversion (Thick Paper)
	Permits punching, including tab sheets. Note: Do not change this setting. [1 to 3/3/1 sheet] 1: 1 Sheet 2: 2 Sheets 3: 3 Sheets

## Service Tables

---

6890	Punch Function Enabled (Z-Fold)
	Switch Z-folding off and on. Default: 0 (Off) 0:No 1:Yes

6900	ADF Bottom Lift
	<p>This SP setting determines whether the bottom plate lift motor of the of the ARDF switches on:</p> <ul style="list-style-type: none"><li>▪ When the original is set in the ARDF original tray</li></ul> <p>-or-</p> <ul style="list-style-type: none"><li>▪ When the [Start] key is pressed.</li></ul> <p>The ARDF bottom plate lift motor raises the bottom plate that pushes up the original tray and raises it to the optimum feed position.</p> <p>[0~1/1]</p> <p>0: Bottom plate lifts immediately after originals are set (Default)</p> <p>1: Bottom plate does not lift until [Start] key is pushed.</p>

---

## Group 7000

---

7401	Total SC Counter
	Displays the total number of SCs logged.

7403	SC History	
	Displays the latest 10 SC codes.	
1	Latest	
---	---	
010	Latest 9th	

7502	Total Paper Jam Counter
	Displays the total number of copy jams.

7503	Total Original Jam Counter
	Displays the total number of copy jams.

7504	Paper Jam Loc	D014/D015 Copier
	Displays the list of possible locations where a jam could have occurred in the	

Service Tables

	copier. Press the appropriate key to display the jam count for that location. These jams are caused by the failure of a sensor to activate.	
	<b>Operation Panel</b>	<b>Actual Component Name</b>
1	At Power On	
3	Tray 1: No Feed	
4	Tray 2: No Feed	
5	Tray 3: No Feed	
6	Tray 4: No Feed	
7	LCT: No Feed	
8	Trans 1 Sn:Late	1st Vertical Transport Sensor
9	Trans 2 Sn:Late	2nd Vertical Transport Sensor
10	Trans 3 Sn:Late	3rd Vertical Transport Sensor
11	Trans 4 Sn:Late	4th Vertical Transport Sensor
12	Relay Sn: Late	Relay Sensor
13	Reg Sn:Late	Registration Sensor
14	Fusing Ex Sn:Late	Fusing Exit Sensor
16	Main Ex Sn:Late	Paper Exit Sensor
19	Dup Ent Sn:Late	Duplex Entrance Sensor
20	Dup Trans Sn1:Late	Duplex Transport Sensor 1
21	Dup Trans Sn2:Late	Duplex Transport Sensor 2
22	Dup Trans Sn3:Late	Duplex Transport Sensor 3
23	Dup Ent Sn:Late	Duplex Entrance Sensor
24	LCT Relay	LCT Relay Sensor:Late
25	LCT Exit Sensor	



Service Tables

34	Bypass PE Sn:Off	Bypass Paper End Sensor
53	1st Feed Sn:Lag	1st Paper Feed Sensor:Lag
54	2nd Feed Sn:Lag	2nd Paper Feed Sensor:Lag
55	3rd Feed Sn:Lag	3rd Paper Feed Sensor:Lag
56	4th Feed Sn:Lag	4th Paper Feed Sensor:Lag
57	LCT Feed Sn:Lag	LCT Paper Feed Sensor
58	Trans 1 Sn:Lag	1st Vertical Transport Sensor:Lag
59	Trans 2 Sn:Lag	2nd Vertical Transport Sensor:Lag
60	Trans 3 Sn:Lag	3rd Vertical Transport Sensor:Lag
61	Trans 4 Sn:Lag	4th Vertical Transport Sensor:Lag
62	Relay Sn:Lag	Relay Sensor:Lag
63	Reg Sn:Lag	Registration Sensor
64	Fusing Ex Sn:Lag	Fusing Exit Sensor:Lag
66	Main Ex Sn:Lag	Main Exit Sensor
69	Dup Ent Sn:Lag	Duplex Entrance Sensor
71	Dup Trans Sn2:Lag	Duplex Transport Sensor 1
72	Dup Trans Sn3:Lag	Duplex Transport Sensor 2
74	LCT Relay Sn:Lag	LCT Relay Sensor:Lag
75	LCT Exit Sn	
84	Bypass Feed Sn	Bypass Paper Feed Sensor
98	Paper Type	Paper Type
99	Bypass Paper Feed Sn	Bypass Paper Feed Sensor

Service Tables

7504	Paper Jam Loc	2000-Sheet Finishers D373
	Displays the list of possible locations where a jam could have occurred. Press the appropriate key to display the jam count for that location. These jams are caused by the failure of a sensor to activate.	
	<b>On Operation Panel</b>	<b>Actual Component Name</b>
121	Entrance Jam	Entrance Sensor
122	Proof Tray Exit	Proof Tray Exit Sensor
123	Shift Tray Exit	Shift Tray Exit Sensor
124	Stapler Exit	Stapler Exit Sensor
125	Exit After Jogging	Exit Sensor After Jogging
126	Corner Stapling	Corner Stapling: Stapler Unit 1
127	Saddle Stapling	Saddle-Stitch Stapler Unit
128	Paper Folding	Paper Folding
129	Shift Tray Motor	Shift Tray Motor
130	Jog Fence Motor	Jogger Fence Motor
131	Shift Roller Motor	Shift Roller Motor
132	Stapler Shift M	Stapler Shift Motor
133	Stapler M	Stapler Motor: Unit 2
134	Folder Plate M	Folder Plate Motor
135	Feed Out Belt M	Feed Out Belt Motor
136	Paper Punch Motor	Paper Punch Motor
137	Z-Folding	Z-Fold Jam

Service Tables

7504	Paper Jam Loc (Fin2)	3000-Sheet Feeder B830
	Displays the list of possible locations where a jam could have occurred. Press the appropriate key to display the jam count for that location. These jams are caused by the failure of a sensor to activate.	
	<b>On Operation Panel</b>	<b>Actual Component Name</b>
141	Entrance Sn	Entrance Sensor
142	Proof Tray Exit Sn	Proof Tray Exit Sn
143	Shift Exit Sn	Shift Exit Sn
144	Stapler Exit	Stapler Exit Sensor
145	Feed Out	Feed Out
148	Upper Trans M	Upper Transport Motor
149	Shift Tray Motor	Shift Tray Motor
150	Jogger Fence Motor	Jogger Fence Motor
151	Shift Roller Motor	Shift Roller Motor
153	Stapling Motor	Stapling Motor
154	Pre-Stack Jam	
155	Feed Out Belt Motor	Feed Out Belt Motor
156	Paper Punch Motor	Paper Punch Motor
157	Z-Fold Motor Jam	

7504	Paper Jam Loc	9-Bin Mailbox B762
	Displays the list of possible locations where a jam could have occurred. Press the appropriate key to display the jam count for that location. These jams are caused by the failure of a sensor to activate.	

Service Tables

	<b>On Operation Panel</b>	<b>Actual Component Name</b>
161	Vert Trans Sn 1	Vertical Transport Sensor 1
162	Vert Trans Sn 2	Vertical Transport Sensor 2
163	Vert Trans Sn 3	Vertical Transport Sensor 3
164	Vert Trans Sn 4	Vertical Transport Sensor 4
165	Vert Trans Sn 5	Vertical Transport Sensor 5

7504	Paper Jam Loc	Cover Interposer Tray B704
	Displays the list of possible locations where a jam could have occurred. Press the appropriate key to display the jam count for that location. These jams are caused by the failure of a sensor to activate.	
	<b>On Operation Panel</b>	<b>Actual Component Name</b>
166	Paper Feed Sn	Paper Feed Sensor
167	Vert Transport Path	Vertical Transport Path
168	BotPlt Pos Sn	Bottom Plate Position Sensor

7504	Paper Jam Loc	3000-Sheet Finisher D374
	Displays the list of possible locations where a jam could have occurred. Press the appropriate key to display the jam count for that location. These jams are caused by the failure of a sensor to activate.	
	<b>On Operation Panel</b>	<b>Actual Component Name</b>
171	Entrance Trans	Entrance Sensor
172	Proof Tray Exit Sn	Proof Tray Exit Sn

Service Tables

173	Shift Exit Sn	Shift Exit Sensor
174	Stapler Exit Sn	Stapler Exit Sensor
175	Belt Feed Out	Belt Feed Out
179	Shift Tray Motor	Shift Tray Motor
180	Jogger Fence Motor	Jogger Fence Motor
181	Shift Roller Motor	Shift Roller Motor
182	Stapler Shift M	Stapler Shift Motor
183	Stapling Motor	Stapling Motor
185	Feed Out Belt Motor	Feed Out Belt Motor
186	Paper Punch Motor	Paper Punch Motor
187	Insufficient Data	

7504	Paper Jam Loc	3000-Sheet Finisher D374
	Displays the list of possible locations where a jam could have occurred. Press the appropriate key to display the jam count for that location. These jams are caused by the failure of a sensor to activate.	
	<b>On Operation Panel</b>	<b>Actual Component Name</b>
191	Entrance Sn	Entrance Sensor
192	Stapler Exit	Stapler Exit Sensor
193	Shift Exit Sn	Shift Exit Sensor
194	Stapler Exit	Stapler Exit Sensor
195	Belt Feed Out	Belt Feed Out
198	Paper Folding	Paper Folding

Service Tables

199	Shift Tray Motor	Shift Tray Motor
200	Jogger Fence Motor	Jogger Fence Motor
201	Shift Roller Motor	Shift Roller Motor
202	Stapler Shift M	Stapler Shift Motor
203	Stapling Motor	Stapling Motor
204	Paper Folding	Paper Folding
205	Feed Out Belt Motor	Feed Out Belt Motor
206	Paper Punch Motor	Paper Punch Motor
207	Insufficient Data	

7504	Paper Jam Loc (Z-Folder)	Z-Folding Unit B660
	Displays the list of possible locations where a jam could have occurred. Press the appropriate key to display the jam count for that location. These jams are caused by the failure of a sensor to activate.	
	<b>On Operation Panel</b>	<b>Actual Component Name</b>
211	Paper Feed:Late	Paper Feed Sensor: Late
212	Paper Feed:Lag	Paper Feed Sensor: Lag
213	Fold Timing Sn:Late	Fold Timing Sensor: Late
214	Fold Timing Sn:Lag	Fold Timing Sensor: Lag
215	Lead Edge Sn:Late	Leading Edge Sensor:Late
216	Lead Edge Sn:Lag	Leading Edge Sensor:Lag
217	Up Stopper Sn:Late	Upper Stopper Path Sensor:Late
218	Up Stopper Sn:Lag	Upper Stopper Path Sensor:Lag

## Service Tables

219	Lower Ex Sn:Late	Lower Exit Sensor:Late
220	Lower Ex Sn1:Lag	Lower Exit Sensor:Lag
223	Up Ex Sn:Late	Upper Exit Sensor:Late
224	Up Ex Sn:Lag	Upper Exit Sensor:Lag
225	Paper Fold M	Paper Fold Motor
226	Lower Stopper M	Lower Stopper Motor Lock
227	Upper Stopper M	Upper Stopper Motor Lock

7504	Paper Jam Loc	Cover Interposer Tray B835
	Displays the list of possible locations where a jam could have occurred. Press the appropriate key to display the jam count for that location. These jams are caused by the failure of a sensor to activate.	
	<b>On Operation Panel</b>	<b>Actual Component Name</b>
230	Tray 1: No Feed	
231	Tray 2: No Feed	
232	Tray 1: Grip Sn	
233	Tray 2: Grip Sn	
234	Tray 1: Trans Jam	
235	Tray 2: Trans Jam	
236	Exit Jam	
237	Entrance Sn Jam	
238	Exit Sn Jam	
239	Tray 1: Lift Motor	

## Service Tables

240	Tray 2: Lift Motor	
241	Tray 1: Pickup Motor	
242	Tray 2: Pickup Motor	

7505	Original Jam Det (ARDF)	
	Displays the list of possible locations where a jam could have occurred. Press the appropriate key to display the jam count for that location. These jams are caused by the failure of a sensor to activate.	
	<b>On Operation Panel</b>	<b>Actual Component Name</b>
1	At Power On	At Power On
3	Separation Sn:Late	Separation Sensor:Late
4	Skew Cor Sn:Late	Skew Correction Sensor:Late
5	Interval Sn:Late	Interval Sensor:Late
6	Reg Sn:Late	Registration Sensor:Late
7	Exit Sn:Late	Exit Sensor:Late
8	Inv Switch Sn:Late	Inverter Switchback Sensor:Late
9	Low Inv Sn:Late	Lower Inverter Sensor:Late
53	Separation Sn:Lag	SeparationsSensor:Lag
54	Skew Cor Sn:Lag	Skew Correction Sensor:Lag
55	Interval Sn:Lag	Interval Sensor:Lag
56	Reg Sn:Lag	Registration Sensor:Lag
57	Exit Sn:Lag	Exit Sensor:Lag
58	Inv Switch Sn:Lag	Inverter Switchback Sensor:Lag



Service Tables

59	Low Inv Sn:Lag	Lower Inverter Sensor:Lag
----	----------------	---------------------------

7506	Jam Count by Paper Size	
	Displays the total number of jams by paper size.	
5	A4 LEF	Displays the total number of jams by paper size.
6	A5 LEF	
14	B5 LEF	
38	LT LEF	
44	HLT LEF	
132	A3	
133	A4 SEF	
134	A5 SEF	
141	B4 SEF	
142	B5 SEF	
160	DLT SEF	
164	LG SEF	
166	LT SEF	
172	HLT SEF	
255	Others	

7507	Plotter Jam History
------	---------------------

Service Tables

1	Latest	<p>Displays the following items for the last 10 copy paper jams:            1) Jam code, 2) Paper size, 3) Total count when jam occurred, 4) Date of jam.            The "jam codes" are listed in the SMC report under SP7504.</p>
2	Latest 1	
3	Latest 2	
4	Latest 3	
5	Latest 4	
6	Latest 5	
7	Latest 6	
8	Latest 7	
9	Latest 8	
10	Latest 9	

7508	Original Jam History	
1	Original Latest	<p>Displays the following items for the Latest 10 original jams:            1) Jam code, 2) Paper size, 3) Total count when jam occurred, 4) Date of jam.            The "jam codes" are listed in the SMC report under SP7504.</p>
2	Latest 1	
3	Latest 2	
4	Latest 3	
5	Latest 4	
6	Latest 5	
7	Latest 6	
8	Latest 7	
9	Latest 8	
10	Latest 9	

Service Tables

7617	Parts PM Counter Display	
1	Normal	<b>Japan Only</b>
2	DF	<b>Japan Only</b>

7618	PM Parts Counter Reset (Japan Only)	
1	Normal	Push [Execute] to clear the parts replacement alarm counter for the main machine.
2	DF	Push [Execute] to clear the parts replacement alarm counter for the ADF.

7621	Current Value	
7622	Reset	
7623	Standard Value	
7624	Operational Value	
1	K PCU#	
2	K PCU Cleaning Blade	
3	K PCU Lube Bar	
4	K PCU Lube App/Cling Blade	
5	K PCU Developer	
6	K PCU Drum	
7	K PCU Charge Grid Unit	
8	K PCU Charge Grid Wire	
9	K PCU Idle Gear	
10	K PCU Lube App/Cling Brush	
11	K PCU Toner Cleaning Brush	<b>Not Used</b>

Service Tables

12	K PCU Joint	
13	M PCU#	
14	M PCU Cleaning Blade	
15	M PCU Lube Bar	
16	M PCU Lube App/Cing Blade	
17	M PCU Developer	
18	M PCU Drum	
19	M PCU Charge Roller Unit	
20	M PCU Idle Gear	
21	M PCU Lube App/Cing Brush	
22	M PCU Toner Cleaning Brush	<b>Not Used</b>
23	M PCU Joint	
24	C PCU#	
25	C PCU Cleaning Blade	
26	C PCU Lube Bar	
27	C PCU Lube App/Cing Blade	
28	C PCU Developer	
29	C PCU Drum	
30	C PCU Charge Roller Unit	
31	C PCU Idle Gear	
32	C PCU Lube App/Cing Brush	
33	C PCU Toner Cleaning Brush	<b>Not Used</b>
34	C PCU Joint	

Service Tables

35	Y PCU#	
36	Y PCU Cleaning Blade	
37	Y PCU Lube Bar	
38	Y PCU Lube App/Cing Blade	
39	Y PCU Developer	
40	Y PCU Drum	
41	Y PCU Charge Roller Unit	
42	Y PCU Idle Gear	
43	Y PCU Lube App/Cing Brush	
44	Y PCU Toner Cleaning Brush	<b>Not Used</b>
45	Y PCU Joint	
46	ITB #	
47	ITB Cleaning Unit #	
48	ITB Cleaning Blade	
49	ITB Lube Bar	
50	Lube Application Blade	
51	PTR Unit #	
52	PTR Blade	
53	PTR	
54	Discharge Roller	
55	PTR Lube Bar	
56	Fusing Unit #	
57	Fusing Belt	

Service Tables

58	Hot Roller	
59	Pressure Roller	
60	Lube Roller:Press Roller	
61	CIng Roller:Press Roller	
62	Shaft Bearings:Press Roll	
63	Used Toner Bottle #	
64	ADF Pickup Roller #	
65	ADF Feed Belt #	
66	ADF Reverse Roller #	
67	ADF Transport Belt	
68	ADF Dust Filter #	

7625	Pg Count History:Latest 1	
7626	Pg Count History:Latest 2	
7627	Pg Count History:Latest 3	
1	K PCU#	
2	K PCU Cleaning Blade	
3	K PCU Lube Bar	
4	K PCU Lube App/CIng Blade	
5	K PCU Developer	
6	K PCU Drum	
7	K PCU Charge Grid Unit	
8	K PCU Charge Grid Wire	
9	K PCU Idle Gear	

Service Tables

10	K PCU Lube App/Cling Brush	
11	K PCU Toner Cleaning Brush	
12	K PCU Joint	
13	M PCU#	
14	M PCU Cleaning Blade	
15	M PCU Lube Bar	
16	M PCU Lube App/Cling Blade	
17	M PCU Developer	
18	M PCU Drum	
19	M PCU Charge Roller Unit	
20	M PCU Idle Gear	
21	M PCU Lube App/Cling Brush	
22	M PCU Toner Cleaning Brush	
23	M PCU Joint	
24	C PCU#	
25	C PCU Cleaning Blade	
26	C PCU Lube Bar	
27	C PCU Lube App/Cling Blade	
28	C PCU Developer	
29	C PCU Drum	
30	C PCU Charge Roller Unit	
31	C PCU Idle Gear	
32	C PCU Lube App/Cling Brush	

Service Tables

33	C PCU Toner Cleaning Brush	
34	C PCU Joint	
35	Y PCU#	
36	Y PCU Cleaning Blade	
37	Y PCU Lube Bar	
38	Y PCU Lube App/Cing Blade	
39	Y PCU Developer	
40	Y PCU Drum	
41	Y PCU Charge Roller Unit	
42	Y PCU Idle Gear	
43	Y PCU Lube App/Cing Brush	
44	Y PCU Toner Cleaning Brush	
45	Y PCU Joint	
46	ITB #	
47	ITB Cleaning Unit #	
48	ITB Cleaning Blade	
49	ITB Lube Bar	
50	Lube Application Blade	
51	PTR Unit #	
52	PTR Blade	
53	PTR	
54	Discharge Roller	
55	PTR Lube Bar	



Service Tables

56	Fusing Unit #	
57	Fusing Belt	
58	Hot Roller	
59	Pressure Roller	
60	Lube Roller:Press Roller	
61	Cing Roller:Press Roller	
62	Shaft Bearings:Press Roll	
63	Used Toner Bottle #	
64	ADF Pickup Roller #	
65	ADF Feed Belt #	
66	ADF Reverse Roller #	
67	ADF Transport Belt	
68	ADF Dust Filter #	

7628	Clear PM Counter	
1	Clear Exceeded Counts	Do this SP to clear all PM counts that have exceeded their limits.
2	Reset All Counts	Do this SP to clear all PM counts, including those that have not exceeded their limits.

7801	No./Firmware Version (ROM)	
	Displays the ROM version numbers of the main machine and connected peripheral devices.	

7803	PM Counter Display	
------	--------------------	--

## Service Tables

---

	Displays the PM count since the last PM.
--	--

7804	PM Counter Reset
	Resets the PM count.

7807	SC/Jam Counter Reset
	Push [Start] to reset the SC and jam counters.

7826	MF Error Counter ( <b>Japan Only</b> )	
	Displays the number of counts requested of the card/key counter.	
1	Error Total	A request for the count total failed at power on. This error will occur if the device is installed but disconnected.
2	Error Staple	The request for a staple count failed at power on. This error will occur if the device is installed but disconnected.

7827	MF Error Counter Clear ( <b>Japan Only</b> )
	Press Execute to reset to 0 the values of SP7826.

7832	Self-Diagnostic Result Display
------	--------------------------------

Service Tables

	Push [#] to display a list of error codes. Nothing is displayed if no errors have occurred.
--	---

7835	ACC Counter
	No information is available at this time.
1	Copy ACC
2	Printer ACC

7836	Total Memory Size
	Displays the contents of the memory on the controller board.

7852	ADF Scan Glass
	Displays the count for the number of times the machine has detected dust on the ARDF scanning glass at the beginning of copy jobs. This SP operates only after SP4020 001 has been turned on.
1	Dust Counter
2	Clear Counter

7901	Assert Info. <b>DFU</b>	
1	Filename	Used for debugging.
2	Line No.	
3	Value	

Service Tables

---

7931	Toner Bottle Bk	Toner Information: Black
7932	Toner Bottle M	Toner Information: Magenta
7933	Toner Bottle C	Toner Information: Cyan
7934	Toner Bottle Y	Toner Information: Yellow
	Displays detailed information about the toner used in the machine.	
1	Model ID	
2	Cartridge Ver	
3	Brand ID	
4	Area ID	
5	Production ID	
6	Color ID	
7	Maintenance ID	
8	New	
9	Recycle Count	
10	Product Date	
11	Serial No	
12	EDP Code	
13	Toner Remaining	
14	Toner End	
15	Toner Refill	
16	Total Count Start	

Service Tables

17	Color Count:Start	
18	Total Count End	
19	Color Count:End	
20	Set Date	
21	End Date	

7935	Toner Bottle Log 1: Bk	
7936	Toner Bottle Log 1: M	
7937	Toner Bottle Log 1: C	
7938	Toner Bottle Log 1: Y	
1	Serial No	
2	Set Date	
3	Total Count Start	
4	Serial No	
5	Set Date	
6	Total Count Start	
7	Serial No	
8	Set Date	
9	Total Count Start	
10	Serial No	
11	Set Date	
12	Total Count Start	
13	Serial No	
14	Set Date	

Service Tables

15	Total Count Start	
----	-------------------	--

7940	PM MotdrvdistanceDisp	
7942	Motdrvdistance%Disp	
7944	Motor Drv Distance	
1	PCU:K	
2	PCU:M	
3	PCU:C	
4	PCU:Y	

7945	Pg Count	
7951	Pg Count: End Std Value	
2	K PCU Cleaning Blade	
3	K PCU Lube Bar	
4	K PCU Lube App/Cling Blade	
5	K PCU Developer	
6	K PCU Drum	
7	K PCU Charge Grid Unit	
8	K PCU Charge Grid Wire	
9	K PCU Idle Gear	
10	K PCU Lube App/Cling Brush	
11	K PCU Toner Cleaning Brush	<b>Not Used</b>
12	K PCU Joint	
13	M PCU#	

Service Tables

14	M PCU Cleaning Blade	
15	M PCU Lube Bar	
16	M PCU Lube App/Cing Blade	
17	M PCU Developer	
18	M PCU Drum	
19	M PCU Charge Roller Unit	
20	M PCU Idle Gear	
21	M PCU Lube App/Cing Brush	
22	M PCU Toner Cleaning Brush	<b>Not Used</b>
23	M PCU Joint	
24	C PCU#	
25	C PCU Cleaning Blade	
26	C PCU Lube Bar	
27	C PCU Lube App/Cing Blade	
28	C PCU Developer	
29	C PCU Drum	
30	C PCU Charge Roller Unit	
31	C PCU Idle Gear	
32	C PCU Lube App/Cing Brush	
33	C PCU Toner Cleaning Brush	<b>Not Used</b>
34	C PCU Joint	
35	Y PCU#	
36	Y PCU Cleaning Blade	

Service Tables

37	Y PCU Lube Bar	
38	Y PCU Lube App/Cing Blade	
39	Y PCU Developer	
40	Y PCU Drum	
41	Y PCU Charge Roller Unit	
42	Y PCU Idle Gear	
43	Y PCU Lube App/Cing Brush	
44	Y PCU Toner Cleaning Brush	<b>Not Used</b>
45	Y PCU Joint	
46	ITB #	
47	ITB Cleaning Unit #	
48	ITB Cleaning Blade	
49	ITB Lube Bar	
50	Lube Application Blade	
51	PTR Unit #	
52	PTR Blade	
53	PTR	
54	Discharge Roller	
55	PTR Lube Bar	
56	Fusing Unit #	
57	Fusing Belt	
58	Hot Roller	
59	Pressure Roller	



Service Tables

60	Lube Roller:Press Roller	
61	Cing Roller:Press Roller	
62	Shaft Bearings:Press Roll	
63	Used Toner Bottle #	
64	ADF Pickup Roller #	
65	ADF Feed Belt #	
66	ADF Reverse Roller #	
67	ADF Transport Belt	
68	ADF Dust Filter #	

7954	Pg Count %Display	
	This SP displays the current usage (listed as percent of usage) of the components listed below: Current Usage/Standard Usage Service Life x 100	
1	K PCU#	
2	K PCU Cleaning Blade	
3	K PCU Lube Bar	
4	K PCU App/Cing Blade	
5	K PCU Developer	
6	K PCU Drum	
7	K PCU Charge Grid Unit	
8	K PCU Charge Grid Wire	
9	K PCU Idle Gear	
10	K PCU Lube App/Cing Brush	

Service Tables

11	K PCU Toner Cleaning Brush	
12	K PCU Joint	
13	M PCU#	
14	M PCU Cleaning Blade	
15	M PCU Lube Bar	
16	M PCU Lube App/Clng Blade	
17	M PCU Developer	
18	M PCU Drum	
19	M PCU Charge Roller Unit	
20	M PCU Idle Gear	
21	M PCU Lube App/Clng Brush	
22	M PCU Toner Cleaning Brush	
23	M PCU Joint	
24	C PCU#	
25	C PCU Cleaning Blade	
26	C PCU Lube Bar	
27	C PCU Lube App/Clng Blade	
28	C PCU Developer	
29	C PCU Drum	
30	C PCU Charge Roller Unit	
31	C PCU Idle Gear	
32	C PCU Lube App/Clng Brush	
33	C PCU Toner Cleaning Brush	

Service Tables

34	C PCU Joint	
35	Y PCU#	
36	Y PCU Cleaning Blade	
37	Y PCU Lube Bar	
38	Y PCU Lube App/Cing Blade	
39	Y PCU Developer	
40	Y PCU Drum	
41	Y PCU Charge Roller Unit	
42	Y PCU Idle Gear	
43	Y PCU Lube App/Cing Brush	
44	Y PCU Toner Cleaning Brush	
45	Y PCU Joint	
46	ITB#	
47	ITB Cleaning Unit	
48	ITB Cleaning Blade	
49	ITB Lube Bar	
50	Lube Application Blade	
51	PTR Unit#	
52	PTR Blade	
53	PTR Roller	
54	Discharge Roller	
55	PTR Lube Bar	
56	Fusing Unit #	

Service Tables

57	Fusing Belt	
58	Hot Roller	
59	Pressure Roller	
60	Lube Roller: Press Roller	
61	Press Roller	
62	Shaft Bearings: Press Roll	
63	Used Toner Bottle#	
64	ADF Pickup Roller#	
65	ADF Feed Belt#	
66	ADF Reverse Roller#	
67	ADF Transport Belt	
68	Dust Filter#	

7958	Display Mtr Drv Distance	
1	Drum Motor:K	
2	Drum Motor:M	
3	Drum Motor:C	
4	Drum Motor:Y	
5	Cleaning Motor:K	
6	Cleaning Motor:M	
7	Cleaning Motor:C	
8	Cleaning Motor:Y	
9	Development Motor:K	
10	Development Motor:M	

Service Tables

11	Development Motor:C	
12	Development Motor:Y	
13	ITB Drive Motor	
14	PTR Motor	
15	Fusing Motor	

7959	Motor Drv Total	
------	-----------------	--

7960	Motor Drv Distance Reset	
1	Drum Motor:K	
2	Drum Motor:M	
3	Drum Motor:C	
4	Drum Motor:Y	
5	Cleaning Motor:K	
6	Cleaning Motor:M	
7	Cleaning Motor:C	
8	Cleaning Motor:Y	
9	Development Motor:K	
10	Development Motor:M	
11	Development Motor:C	
12	Development Motor:Y	
13	ITB Drive Motor	
14	PTR Motor	
15	Fusing Motor	

---

## Group 8000

---

These new SP counters are provided for MFP, LP, and Wide Format machines that employ GW Architecture. These SP codes have been created in response to requests by customers, sales personnel and customer engineers, and R&D staff for a standardized set of counters that can be used to log more detailed information about machine operation.

These SPs are absolutely essential to provide more detailed counters and job logs to match similar features that are being developed by competitors.

### Current Status of the SP8xxx Counters

Many of these counters are provided for features that are currently not available, such as sending color faxes, and so on. However, here are some Group 8 codes that when used in combination with others, can provide useful information.

SP Numbers	What They Do
SP8211~SP8216	The number of pages scanned to the document server.
SP8401~SP8406	The number of pages printed from the document server
SP8691~SP8696	The number of pages sent from the document server

Specifically, the following questions can be answered:

- How is the document server actually being used?
- What application is using the document server most frequently?
- What data in the document server is being reused?

### Group 8 Service Table Keys

Many of the SPs in this group are prefixed with a letter that indicates the mode of operation (the mode of operation is referred to as an 'application'). Before reading the Group 8 Service Table, make sure that you understand what these prefixes mean.

Prefixes	Meaning	
T:	Total: (Grand Total).	Grand total of items counted for all applications (C, F, P, etc.).

Service Tables

Prefixes	Meaning	
C:	Copy application.	Totals (pages, jobs, etc.) executed for each application when the job was not stored on the document server.
F:	Fax application	
P:	Print application.	
S:	Scan application.	
L:	Local storage (document server)	Totals (jobs, pages, etc.) for the document server. The L: counters work differently case by case. Sometimes, they count jobs/pages stored on the document server; this can be in document server mode (from the document server window), or from another mode, such as from a printer driver or by pressing the Store File button in the Copy mode window. Sometimes, they include occasions when the user uses a file that is already on the document server. Each counter will be discussed case by case.
O:	Other applications (external network applications, for example)	Refers to network applications such as Web Image Monitor. Utilities developed with the SDK (Software Development Kit) will also be counted with this group in the future.

The Group 8 SP codes are limited to 17 characters, forced by the necessity of displaying them on the small LCDs of printers and faxes that also use these SPs. Read over the list of abbreviations below and refer to it again if you see the name of an SP that you do not understand.

Abbreviation	What It Means
/	"By", e.g. "T:Jobs/Apl" = Total Jobs "by" Application
>	More (2> "2 or more", 4> "4 or more")
AddBook	Address Book

Service Tables

Abbreviation	What It Means
Apl	Application
B/W	Black & White
Bk	Black
C	Cyan
ColCr	Color Create
ColMode	Color Mode
Comb	Combine
Comp	Compression
Deliv	Delivery
DesApl	Designated Application. The application (Copy, Fax, Scan, Print) used to store the job on the document server, for example.
Dev Counter	Development Count, no. of pages developed.
Dup, Duplex	Duplex, printing on both sides
Emul	Emulation
FC	Full Color
FIN	Post-print processing, i.e. finishing (punching, stapling, etc.)
Full Bleed	No Margins
GenCopy	Generation Copy Mode
GPC	Get Print Counter. For jobs 10 pages or less, this counter does not count up. For jobs larger than 10 pages, this counter counts up by the number that is in excess of 10 (e.g., for an 11-page job, the counter counts up 11-10 =1)
IFax	Internet Fax
ImgEdt	Image Edit performed on the original with the copier GUI, e.g.



Service Tables

Abbreviation	What It Means
	border removal, adding stamps, page numbers, etc.
K	Black (YMCK)
LS	Local Storage. Refers to the document server.
LSize	Large (paper) Size
Mag	Magnification
MC	One color (monochrome)
NRS	New Remote Service, which allows a service center to monitor machines remotely. "NRS" is used overseas, "CSS" is used in Japan.
Org	Original for scanning
OrgJam	Original Jam
Palm 2	Print Job Manager/Desk Top Editor: A pair of utilities that allows print jobs to be distributed evenly among the printers on the network, and allows files to moved around, combined, and converted to different formats.
PC	Personal Computer
PGS	Pages. A page is the total scanned surface of the original. Duplex pages count as two pages, and A3 simplex count as two pages if the A3/DLT counter SP is switched ON.
PJob	Print Jobs
Ppr	Paper
PrtJam	Printer (plotter) Jam
PrtPGS	Print Pages
R	Red (Toner Remaining). Applies to the wide format model A2 only. This machine is under development and currently not available.

## Service Tables

Abbreviation	What It Means
Rez	Resolution
SC	Service Code (Error SC code displayed)
Scn	Scan
Sim, Simplex	Simplex, printing on 1 side.
S-to-Email	Scan-to-E-mail
SMC	SMC report printed with SP5990. All of the Group 8 counters are recorded in the SMC report.
Svr	Server
TonEnd	Toner End
TonSave	Toner Save
TXJob	Send, Transmission
YMC	Yellow, Magenta, Cyan
YMCK	Yellow, Magenta, Cyan, Black

**Note:** All of the Group 8 SPs are reset with SP5801 1 Memory All Clear, or the Counter Reset SP7808.

8001	T:Total Jobs	<p>These SPs count the number of times each application is used to do a job.</p> <p>[0~9999999/ 1]</p> <p>Note: The L: counter is the total number of times the other applications are used to send a job to the document server, plus the number of times a file already on the document server is used.</p>
8002	C:Total Jobs	
8003	F: Total Jobs	
8004	P:Total Jobs	
8005	S:Total Jobs	
8006	L:Total Jobs	

These SPs reveal the number of times an application is used, not the number of pages

## Service Tables

---

processed.

- When an application is opened for image input or output, this counts as one job.
- Interrupted jobs (paper jams, etc.) are counted, even though they do not finish.
- Only jobs executed by the customer are counted. Jobs executed by the customer engineer using the SP modes are not counted.
- When using secure printing (when a password is required to start the print job), the job is counted at the time when either "Delete Data" or "Specify Output" is specified.
- A job is counted as a fax job when the job is stored for sending.
- When a fax is received to fax memory, the F: counter increments but the L: counter does not (the document server is not used).
- A fax broadcast counts as one job for the F: counter (the fax destinations in the broadcast are not counted separately).
- A fax broadcast is counted only after all the faxes have been sent to their destinations. If one transmission generates an error, then the broadcast will not be counted until the transmission has been completed.
- A printed fax report counts as one job for the F: counter.
- The F: counter does not distinguish between fax sending or receiving.
- When a copy job on the document server is printed, SP8022 also increments, and when a print job stored on the document server is printed, SP8024 also increments.
- When an original is both copied and stored on the document server, the C: and L: counters both increment.
- When a print job is stored on the document server, only the L: counter increments.
- When the user presses the Document Server button to store the job on the document server, only the L: counter increments.
- When the user enters document server mode and prints data stored on the document server, only the L: counter increments.
- When an image received from Palm 2 is received and stored, the L: counter increments.

8011	T:Jobs/LS	These SPs count the number of jobs stored to the document server by each application, to reveal how local storage is being used for input. [0~9999999/ 1] The L: counter counts the number of jobs stored from within the document server mode screen at the operation panel.
8012	C:Jobs/LS	
8013	F:Jobs/LS	
8014	P:Jobs/LS	
8015	S:Jobs/LS	

## Service Tables

8016	L:Jobs/LS	
8017	O:Jobs/LS	

- When a scan job is sent to the document server, the S: counter increments. When you enter document server mode and then scan an original, the L: counter increments.
- When a print job is sent to the document server, the P: counter increments.
- When a network application sends data to the document server, the O: counter increments.
- When an image from Palm 2 is stored on the document server, the O: counter increments.
- When a fax is sent to the document server, the F: counter increments.

8021	T:Pjob/LS	<p>These SPs reveal how files printed from the document server were stored on the document server originally.</p> <p>[0~99999999/ 1]</p> <p>The L: counter counts the number of jobs stored from within the document server mode screen at the operation panel.</p>
8022	C:Pjob/LS	
8023	F:Pjob/LS	
8024	P:Pjob/LS	
8025	S:Pjob/LS	
8026	L:Pjob/LS	
8027	O:Pjob/LS	

- When a copy job stored on the document server is printed with another application, the C: counter increments.
- When an application like DeskTopBinder merges a copy job that was stored on the document server with a print job that was stored on the document server, the C: and P: counters both increment.
- When a job already on the document server is printed with another application, the L: counter increments.
- When a scanner job stored on the document server is printed with another application, the S: counter increments. If the original was scanned from within document server mode, then the L: counter increments.
- When images stored on the document server by a network application (including Palm

## Service Tables

---

2), are printed with another application, the O: counter increments.

- When a copy job stored on the document server is printed with a network application (Web Image Monitor, for example), the C: counter increments.
- When a fax on the document server is printed, the F: counter increments.

8031	T:Pjob/DesApl	<p>These SPs reveal what applications were used to output documents from the document server.</p> <p>[0~9999999/ 1]</p> <p>The L: counter counts the number of jobs printed from within the document server mode screen at the operation panel.</p>
8032	C:Pjob/DesApl	
8033	F:Pjob/DesApl	
8034	P:Pjob/DesApl	
8035	S:Pjob/DesApl	
8036	L:Pjob/DesApl	
8037	O:Pjob/DesApl	

- When documents already stored on the document server are printed, the count for the application that started the print job is incremented.
- When the print job is started from a network application (Desk Top Binder, Web Image Monitor, etc.) the L: counter increments.

8041	T:TX Jobs/LS	<p>These SPs count the applications that stored files on the document server that were later accessed for transmission over the telephone line or over a network (attached to an e-mail, or as a fax image by I-Fax).</p> <p>[0~9999999/ 1]</p> <p>Note: Jobs merged for sending are counted separately.</p> <p>The L: counter counts the number of jobs scanned from within the document server mode screen at the operation panel.</p>
8042	C:TX Jobs/LS	
8043	C:TX Jobs/LS	
8044	P:TX Jobs/LS	
8045	S:TX Jobs/LS	
8046	L:TX Jobs/LS	
8047	O:TX Jobs/LS	

- When a stored copy job is sent from the document server, the C: counter increments.
- When images stored on the document server by a network application or Palm2 are sent as an e-mail, the O: counter increments.

## Service Tables

---

8051	T:TX Jobs/DesApl	<p>These SPs count the applications used to send files from the document server over the telephone line or over a network (attached to an e-mail, or as a fax image by I-Fax). Jobs merged for sending are counted separately.</p> <p>[0~9999999/ 1]</p> <p>The L: counter counts the number of jobs sent from within the document server mode screen at the operation panel.</p>
8052	C:TX Jobs/DesApl	
8053	F:TX Jobs/DesApl	
8054	P:TX Jobs/DesApl	
8055	S:TX Jobs/DesApl	
8056	L:TX Jobs/DesApl	
8057	O:TX Jobs/DesApl	

- If the send is started from Desk Top Binder or Web Image Monitor, for example, then the O: counter increments.

8061	T:FIN Jobs	[0~9999999/ 1]
	These SPs total the finishing methods. The finishing method is specified by the application.	
8062	C:FIN Jobs	[0~9999999/ 1]
	These SPs total finishing methods for copy jobs only. The finishing method is specified by the application.	
8063	F:FIN Jobs	[0~9999999/ 1]
	These SPs total finishing methods for fax jobs only. The finishing method is specified by the application.	
8064	P:FIN Jobs	[0~9999999/ 1]
	These SPs total finishing methods for print jobs only. The finishing method is specified by the application.	
8065	S:FIN Jobs	[0~9999999/ 1]
	These SPs total finishing methods for scan jobs only. The finishing method is specified by the application.	

Service Tables

	Note: Finishing features for scan jobs are not available at this time.	
8066	L:FIN Jobs	[0~99999999/ 1]
	These SPs total finishing methods for jobs output from within the document server mode screen at the operation panel. The finishing method is specified from the print window within document server mode.	
8067	O:FIN Jobs	[0~99999999/ 1]
	These SPs total finishing methods for jobs executed by an external application, over the network. The finishing method is specified by the application.	
806x 1	Sort	Number of jobs started in Sort mode. When a stored copy job is set for Sort and then stored on the document server, the L: counter increments. (See SP8066 1)
806x 2	Stack	Number of jobs started out of Sort mode.
806x 3	Staple	Number of jobs started in Staple mode.
806x 4	Booklet	Number of jobs started in Booklet mode. If the machine is in staple mode, the Staple counter also increments.
806x 5	Z-Fold	Number of jobs started In any mode other than the Booklet mode and set for folding (Z-fold).
806x 6	Punch	Number of jobs started in Punch mode. When Punch is set for a print job, the P: counter increments. (See SP8064 6.)
806x 7	Other	Reserved. Not used.

8071	T:Jobs/PGS	[0~99999999/ 1]
	These SPs count the number of jobs broken down by the number of pages in the job, regardless of which application was used.	
8072	C:Jobs/PGS	[0~99999999/ 1]
	These SPs count and calculate the number of copy jobs by size based on the	

Service Tables

	number of pages in the job.		
8073	F:Jobs/PGS	[0~9999999/ 1]	
	These SPs count and calculate the number of copy jobs by size based on the number of pages in the job.		
8074	P:Jobs/PGS	[0~9999999/ 1]	
	These SPs count and calculate the number of print jobs by size based on the number of pages in the job.		
8075	S:Jobs/PGS	[0~9999999/ 1]	
	These SPs count and calculate the number of scan jobs by size based on the number of pages in the job.		
8076	L:Jobs/PGS	[0~9999999/ 1]	
	These SPs count and calculate the number of jobs printed from within the document server mode window at the operation panel, by the number of pages in the job.		
8077	O:Jobs/PGS	[0~9999999/ 1]	
	These SPs count and calculate the number of "Other" application jobs (Web Image Monitor, Palm 2, etc.) by size based on the number of pages in the job.		
807x 1	1 Page	807x 8	21~50 Pages
807x 2	2 Pages	807x 9	51~100 Pages
807x 3	3 Pages	807x 10	101~300 Pages
807x 4	4 Pages	807x 11	301~500 Pages
807x 5	5 Pages	807x 12	501~700 Pages
807x 6	6~10 Pages	807x 13	701~1000 Pages
807x 7	11~20 Pages	807x 14	1001~ Pages

- For example: When a copy job stored on the document server is printed in document server mode, the appropriate L: counter (SP8076 0xx) increments.



## Service Tables

---

- Printing a fax report counts as a job and increments the F: counter (SP 8073).
- Interrupted jobs (paper jam, etc.) are counted, even though they do not finish.
- If a job is paused and re-started, it counts as one job.
- If the finisher runs out of staples during a print and staple job, then the job is counted at the time the error occurs.
- For copy jobs (SP 8072) and scan jobs (SP 8075), the total is calculated by multiplying the number of sets of copies by the number of pages scanned. (One duplex page counts as 2.)
- The first test print and subsequent test prints to adjust settings are added to the number of pages of the copy job (SP 8072).
- When printing the first page of a job from within the document server screen, the page is counted.

8111	T:FAX TX Jobs	[0~9999999/ 0 / 1]
	<p>These SPs count the total number of jobs (color or black-and-white) sent by fax, either directly or using a file stored on the document server, on a telephone line.</p> <p>Note: Color fax sending is not available at this time.</p>	
8113	F:FAX TX Jobs	[0~9999999/ 0 / 1]
	<p>These SPs count the total number of jobs (color or black-and-white) sent by fax directly on a telephone line.</p> <p>Note: Color fax sending is not available at this time.</p>	

- These counters count jobs, not pages.
- This SP counts fax jobs sent over a telephone line with a fax application, including documents stored on the document server.
- If the mode is changed during the job, the job will count with the mode set when the job started.
- If the same document is faxed to both a public fax line and an I-Fax at a destination where both are available, then this counter increments, and the I-Fax counter (812x) also increments.
- The fax job is counted when the job is scanned for sending, not when the job is sent.

Service Tables

8121	T:IFAX TX Jobs	[0~9999999/ 0 / 1]
	<p>These SPs count the total number of jobs (color or black-and-white) sent, either directly or using a file stored on the document server, as fax images using I-Fax.</p> <p>Note: Color fax sending is not available at this time.</p>	
8123	F:IFAX TX Jobs	[0~9999999/ 0 / 1]
	<p>These SPs count the number of jobs (color or black-and-white) sent (not stored on the document server), as fax images using I-Fax.</p> <p>Note: Color fax sending is not available at this time.</p>	

- These counters count jobs, not pages.
- The counters for color are provided for future use; the color fax feature is not available at this time.
- The fax job is counted when the job is scanned for sending, not when the job is sent.

8131	T:S-to-Email Jobs	[0~9999999/ 1]
	<p>These SPs count the total number of jobs scanned and attached to an e-mail, regardless of whether the document server was used or not.</p>	
1	B/W	Count for the number of jobs with black-and-white.
2	Color	Count for the number of jobs with color.
3	ACS	Count for the number of jobs using ACS mode.
8135	S:S-to-Email Jobs	
	<p>These SPs count the number of jobs scanned and attached to an e-mail, without storing the original on the document server.</p>	
1	B/W	Count for the number of jobs with black-and-white.
2	Color	Count for the number of jobs with color.
3	ACS	Count for the number of jobs using ACS mode.

- These counters count jobs, not pages.

Service Tables

---

- If the job is stored on the document server, after the job is stored it is determined to be color or black-and-white then counted.
- If the job is cancelled during scanning, or if the job is cancelled while the document is waiting to be sent, the job is not counted.
- If the job is cancelled during sending, it may or may not be counted, depending on what stage of the process had been reached when the job was cancelled.
- If several jobs are combined for sending to the Scan Router, Scan-to-Email, or Scan-to-PC, or if one job is sent to more than one destination. each send is counted separately. For example, if the same document is sent by Scan-to-Email as well as Scan-to-PC, then it is counted twice (once for Scan-to-Email and once for Scan-to-PC).

8141	T:Deliv Jobs/Svr		[0~9999999/ 1]
	These SPs count the total number of jobs scanned and sent to a Scan Router server.		
1	B/W	Count for the number of jobs with black-and-white.	
2	Color	Count for the number of jobs with color.	
3	ACS	Count for the number of jobs using ACS mode.	
3	ACS	Count for the number of jobs using ACS mode.	
8145	S:Deliv Jobs/Svr		
	These SPs count the number of jobs scanned in scanner mode and sent to a Scan Router server.		
1	B/W	Count for the number of jobs with black-and-white.	
2	Color	Count for the number of jobs with color.	
3	ACS	Count for the number of jobs using ACS mode.	

- These counters count jobs, not pages.
- The jobs are counted even though the arrival and reception of the jobs at the Scan Router server cannot be confirmed.
- If even one color image is mixed with black-and-white images, then the job is counted as a "Color" job.

## Service Tables

---

- If the job is cancelled during scanning, or if the job is cancelled while the document is waiting to be delivered, the job is not counted.
- If the job is cancelled during sending, it may or may not be counted, depending on what stage of the process had been reached when the job was cancelled.
- Even if several files are combined for sending, the transmission counts as one job.

8151	T:Deliv Jobs/PC		[0~9999999/ 1]
	These SPs count the total number of jobs scanned and sent to a folder on a PC (Scan-to-PC). Note: At the present time, 8151 and 8155 perform identical counts.		
1	B/W	Count for the number of jobs with black-and-white.	
2	Color	Count for the number of jobs with color.	
3	ACS	Count for the number of jobs using ACS mode.	
8155	S:Deliv Jobs/PC		
	These SPs count the total number of jobs scanned and sent with Scan-to-PC.		
1	B/W	Count for the number of jobs with black-and-white.	
2	Color	Count for the number of jobs with color.	
3	ACS	Count for the number of jobs using ACS mode.	

- These counters count jobs, not pages.
- If the job is cancelled during scanning, it is not counted.
- If the job is cancelled while it is waiting to be sent, the job is not counted.
- If the job is cancelled during sending, it may or may not be counted, depending on what stage of the process had been reached when the job was cancelled.
- Even if several files are combined for sending, the transmission counts as one job.

8191	T:Total Scan PGS	These SPs count the pages scanned by each application that uses the scanner to
8192	C:Total Scan PGS	

## Service Tables

8193	F:Total Scan PGS	scan images. [0~9999999/ 1]
8195	S:Total Scan PGS	
8196	L:Total Scan PGS	

- SP 8191 to 8196 count the number of scanned sides of pages, not the number of physical pages.
- These counters do not count reading user stamp data, or reading color charts to adjust color.
- Previews done with a scanner driver are not counted.
- A count is done only after all images of a job have been scanned.
- Scans made in SP mode are not counted.

### Examples

- If 3 B5 pages and 1 A3 page are scanned with the scanner application but not stored, the S: count is 4.
- If both sides of 3 A4 sheets are copied and stored to the document server using the Store File button in the Copy mode window, the C: count is 6 and the L: count is 6.
- If both sides of 3 A4 sheets are copied but not stored, the C: count is 6.
- If you enter document server mode then scan 6 pages, the L: count is 6.

8201	T:LSize Scan PGS	[0~9999999/ 1]
	This SP counts the total number of large pages input with the scanner for scan and copy jobs. Note: These counters are displayed in the SMC Report, and in the User Tools display.	
8203	F:LSize Scan PGS	[0~9999999/ 1]
	This SP counts the total number of large pages input with the scanner for fax jobs only. Note: These counters are displayed in the SMC Report, and in the User Tools display.	
8205	S:LSize Scan PGS	[0~9999999/ 1]
	This SP counts the total number of large pages input with the scanner for	

## Service Tables

	scan jobs only Note: These counters are displayed in the SMC Report, and in the User Tools display..	
820x 1	A3/DLT, Larger	Counts A3/DLT and larger pages.
820x 2	A2, Larger	Counts A2 and larger pages.

8211	T:Scan PGS/LS	These SPs count the number of pages scanned into the document server . [0~9999999/ 1] The L: counter counts the number of pages stored from within the document server mode screen at the operation panel, and with the Store File button from within the Copy mode screen
8212	C:Scan PGS/LS	
8213	F:Scan PGS/LS	
8215	S:Scan PGS/LS	
8216	L:Scan PGS/LS	

- Reading user stamp data is not counted.
- If a job is cancelled, the pages output as far as the cancellation are counted.
- If the scanner application scans and stores 3 B5 sheets and 1 A4 sheet, the S: count is 4.
- If pages are copied but not stored on the document server, these counters do not change.
- If both sides of 3 A4 sheets are copied and stored to the document server, the C: count is 6 and the L: count is 6.
- If you enter document server mode then scan 6 pages, the L: count is 6.

8221	ADF Org Feeds	[0~9999999/ 1]
	These SPs count the number of pages fed through the ADF for front and back side scanning.	
1	Front	Number of front sides fed for scanning: With an ADF that can scan both sides simultaneously, the Front side count is the same as the number of pages fed for either simplex or duplex scanning. With an ADF that cannot scan both sides simultaneously, the Front side count is the same as the

## Service Tables

		number of pages fed for duplex front side scanning. (The front side is determined by which side the user loads face up.)
2	Back	Number of rear sides fed for scanning. With an ADF that can scan both sides simultaneously, the Back count is the same as the number of pages fed for duplex scanning. With an ADF that cannot scan both sides simultaneously, the Back count is the same as the number of pages fed for duplex rear-side scanning.

- When 1 sheet is fed for duplex scanning the Front count is 1 and the Back count is 1.
- If a jam occurs during the job, recovery processing is not counted to avoid double counting. Also, the pages are not counted if the jam occurs before the first sheet is output.

8231	Scan PGS/Mode	[0~9999999/ 1]
	These SPs count the number of pages scanned by each ADF mode to determine the work load on the ADF.	
1	Large Volume	Selectable. Large copy jobs that cannot be loaded in the ADF at one time.
2	SADF	Selectable. Feeding pages one by one through the ADF.
3	Mixed Size	Selectable. Select "Mixed Sizes" on the operation panel.
4	Custom Size	Selectable. Originals of non-standard size.
5	Platen	Book mode. Raising the ADF and placing the original directly on the platen.

- If the scan mode is changed during the job, for example, if the user switches from ADF to Platen mode, the count is done for the last selected mode.
- The user cannot select mixed sizes or non-standard sizes with the fax application so if the original's page sizes are mixed or non-standard, these are not counted.
- If the user selects "Mixed Sizes" for copying in the platen mode, the Mixed Size count is

## Service Tables

enabled.

- In the SADF mode if the user copies 1 page in platen mode and then copies 2 pages with SADF, the Platen count is 1 and the SADF count is 3.

8241	T:Scan PGS/Org	[0~9999999/ 1]			
	These SPs count the total number of scanned pages by original type for all jobs, regardless of which application was used.				
8242	C:Scan PGS/Org	[0~9999999/ 1]			
	These SPs count the number of pages scanned by original type for Copy jobs.				
8243	F:Scan PGS/Org	[0~9999999/ 0 / 1]			
	These SPs count the number of pages scanned by original type for Fax jobs.				
8245	S:Scan PGS/Org	[0~9999999/ 1]			
	These SPs count the number of pages scanned by original type for Scan jobs.				
8246	L:Scan PGS/Org	[0~9999999/ 1]			
	These SPs count the number of pages scanned and stored from within the document server mode screen at the operation panel, and with the Store File button from within the Copy mode screen				
	8241		8242	8245	8246
824x 1: Text	Yes	Yes	Yes	Yes	Yes
824x 2: Text/Photo	Yes	Yes	Yes	Yes	Yes
824x 3: Photo	Yes	Yes	Yes	Yes	Yes
824x 4: GenCopy, Pale	Yes	Yes	Yes	Yes	Yes
824x 5: Map	Yes	Yes	Yes	Yes	Yes
824x 6: Normal/Detail	Yes	No	No	No	No
824x 7: Fine/Super Fine	Yes	No	No	No	No
824x 8: Binary	Yes	No	Yes	No	No



Service Tables

824x 9: Grayscale	Yes	No	Yes	No
824x 10: Color	Yes	No	Yes	No

- If the scan mode is changed during the job, for example, if the user switches from ADF to Platen mode, the count is done for the last selected mode.

8251	T:Scan PGS/ImgEdt	<p>These SPs show how many times Image Edit features have been selected at the operation panel for each application. Some examples of these editing features are:</p> <p>Erase&gt; Border</p> <p>Erase&gt; Center</p> <p>Image Repeat</p> <p>Centering</p> <p>Positive/Negative</p> <p>[0~9999999/ 1]</p> <p>Note: The count totals the number of times the edit features have been used. A detailed breakdown of exactly which features have been used is not given.</p>
8252	C:Scan PGS/ImgEdt	
8255	P:Scan PGS/ImgEdt	
8256	L:Scan PGS/ImgEdt	
8257	O:Scan PGS/ImgEdt	

- The L: counter counts the number of pages stored from within the document server mode screen at the operation panel, and with the Store File button from within the Copy mode screen.

8261	T:Scn PGS/ColCr	[0~9999999/ 1]
	These SPs count the total number of scanned pages by the color processing mode used.	
8261 1	Color Conversion	
8261 2	Color Erase	
8261 3	Background	

Service Tables

8261 4	Other	
8262	C:Scn PGS/ColCr	[0~9999999/ 1]
	These SPs count the number of pages by the color processing mode used for Copy jobs only.	
8262 1	Color Conversion	
8262 2	Color Erase	
8262 3	Background	
8262 4	Other	

- These counters are enabled only for MFP machines that support color. The wide format machines do not support the "Background" or "Other" counters.

8265	S: Scn PGS/ColCr	
8266	L: Scn PGS/TWAIN	

8281	T:Scan PGS/TWAIN	These SPs count the number of pages scanned using a TWAIN driver. These counters reveal how the TWAIN driver is used for delivery functions. [0~9999999/ 1] Note: At the present time, these counters perform identical counts.
8285	S:Scan PGS/TWAIN	

8291	T:Scan PGS/Stamp	These SPs count the number of pages stamped with the stamp in the ADF unit. [0~9999999/ 1]
8293	F:Scan PGS/Stamp	
8295	S:Scan PGS/Stamp	The L: counter counts the number of pages stored from within the document server mode screen at the operation panel, and with the Store File button from within the Copy mode screen
8296	L:Scan PGS/Stamp	

Service Tables

8301	T:Scan PGS/Size	[0~9999999/ 1]
	These SPs count by size the total number of pages scanned by all applications. Use these totals to compare original page size (scanning) and output (printing) page size [SP 8-441].	
8302	C:Scan PGS/Size	[0~9999999/ 1]
	These SPs count by size the total number of pages scanned by the Copy application. Use these totals to compare original page size (scanning) and output (printing) page size [SP 8-442].	
8303	F:Scan PGS/Size	[0~9999999/ 0 / 1]
	These SPs count by size the total number of pages scanned by the Fax application. Use these totals to compare original page size (scanning) and output page size [SP 8-443].	
8305	S:Scan PGS/Size	[0~9999999/ 1]
	These SPs count by size the total number of pages scanned by the Scan application. Use these totals to compare original page size (scanning) and output page size [SP 8-445].	
8306	L:Scan PGS/Size	[0~9999999/ 1]
	These SPs count by size the total number of pages scanned and stored from within the document server mode screen at the operation panel, and with the Store File button from within the Copy mode screen. Use these totals to compare original page size (scanning) and output page size [SP 8-446].	
830x 1	A3	
830x 2	A4	
830x 3	A5	
830x 4	B4	
830x 5	B5	
830x 6	DLT	

## Service Tables

830x 7	LG	
830x 8	LT	
830x 9	HLT	
830x 10	Full Bleed	
830x 100	A2	Not supported.
830x 101	B3	Not supported.
830x 254	Other (Standard)	
830x 255	Other (Custom)	

8311	T:Scan PGS/Rez	[0~9999999/ 1]
	These SPs count by resolution setting the total number of pages scanned by applications that can specify resolution settings.	
8315	S:Scan PGS/Rez	[0~9999999/ 1]
	These SPs count by resolution setting the total number of pages scanned by applications that can specify resolution settings. Note: At the present time, 8311 and 8315 perform identical counts.	
831x 1	1200dpi ~	
831x 2	600dpi~1199dpi	
831x 3	400dpi~599dpi	
831x 4	200dpi~399dpi	
831x 5	~199dpi	

- Copy resolution settings are fixed so they are not counted.
- The Fax application does not allow finely-adjusted resolution settings so no count is done for the Fax application.

## Service Tables

8381	T:Total PrtPGS	<p>These SPs count the number of pages printed by the customer. The counter for the application used for storing the pages increments.</p> <p>[0~9999999/ 1]</p> <p>The L: counter counts the number of pages stored from within the document server mode screen at the operation panel. Pages stored with the Store File button from within the Copy mode screen go to the C: counter.</p>
8382	C:Total PrtPGS	
8383	F:Total PrtPGS	
8384	P:Total PrtPGS	
8385	S:Total PrtPGS	
8386	L:Total PrtPGS	
8387	O:Total PrtPGS	

- When the A3/DLT double count function is switched on with SP5104, 1 A3/DLT page is counted as 2.
- When several documents are merged for a print job, the number of pages stored are counted for the application that stored them.
- These counters are used primarily to calculate charges on use of the machine, so the following pages are not counted as printed pages:
  - Blank pages in a duplex printing job.
  - Blank pages inserted as document covers, chapter title sheets, and slip sheets.
  - Reports printed to confirm counts.
  - All reports done in the service mode (service summaries, engine maintenance reports, etc.)
  - Test prints for machine image adjustment.
  - Error notification reports.
  - Partially printed pages as the result of a copier jam.

8391	LSize PrtPGS	[0~9999999/ 1]
	<p>These SPs count pages printed on paper sizes A3/DLT and larger.</p> <p>Note: In addition to being displayed in the SMC Report, these counters are also displayed in the User Tools display on the copy machine.</p>	
8391 1	A3/DLT, Larger	
8391 2	A2, Larger	Not supported with this printer.

Service Tables

---

8401	T:PrtPGS/LS	<p>These SPs count the number of pages printed from the document server. The counter for the application used to print the pages is incremented.</p> <p>The L: counter counts the number of jobs stored from within the document server mode screen at the operation panel.</p> <p>[0~9999999/ 1]</p>
8402	C:PrtPGS/LS	
8403	F:PrtPGS/LS	
8404	P:PrtPGS/LS	
8405	S:PrtPGS/LS	
8406	L:PrtPGS/LS	

- Print jobs done with Web Image Monitor and Desk Top Binder are added to the L: count.
- Fax jobs done with Web Image Monitor and Desk Top Binder are added to the F: count.

8411	Prints/Duplex	<p>This SP counts the amount of paper (front/back counted as 1 page) used for duplex printing. Last pages printed only on one side are not counted.</p> <p>[0~9999999/ 1]</p>
------	---------------	---

8421	T:PrtPGS/Dup Comb	[0~9999999/ 1]
	<p>These SPs count by binding and combine, and n-Up settings the number of pages processed for printing. This is the total for all applications.</p>	
8422	C:PrtPGS/Dup Comb	[0~9999999/ 1]
	<p>These SPs count by binding and combine, and n-Up settings the number of pages processed for printing by the copier application.</p>	
8423	F:PrtPGS/Dup Comb	[0~9999999/ 0 / 1]
	<p>These SPs count by binding and combine, and n-Up settings the number of pages processed for printing by the fax application.</p>	
8424	P:PrtPGS/Dup Comb	[0~9999999/ 1]
	<p>These SPs count by binding and combine, and n-Up settings the number of pages processed for printing by the printer application.</p>	

Service Tables

8425	S:PrtPGS/Dup Comb	[0~9999999/ 1]
	These SPs count by binding and combine, and n-Up settings the number of pages processed for printing by the scanner application.	
8426	L:PrtPGS/Dup Comb	[0~9999999/ 1]
	These SPs count by binding and combine, and n-Up settings the number of pages processed for printing from within the document server mode window at the operation panel.	
8427	O:PrtPGS/Dup Comb	[0~9999999/ 1]
	These SPs count by binding and combine, and n-Up settings the number of pages processed for printing by Other applications	
842x 1	Simplex> Duplex	
842x 2	Duplex> Duplex	
842x 3	Book> Duplex	
842x 4	Simplex Combine	
842x 5	Duplex Combine	
842x 6	2>	2 pages on 1 side (2-Up)
842x 7	4>	4 pages on 1 side (4-Up)
842x 8	6>	6 pages on 1 side (6-Up)
842x 9	8>	8 pages on 1 side (8-Up)
842x 10	9>	9 pages on 1 side (9-Up)
842x 11	16>	16 pages on 1 side (16-Up)
842x 12	Booklet	
842x 13	Magazine	

- These counts (SP8421 to SP8427) are especially useful for customers who need to improve their compliance with ISO standards for the reduction of paper consumption.

## Service Tables

- Pages that are only partially printed with the n-Up functions are counted as 1 page.
- Here is a summary of how the counters work for Booklet and Magazine modes:

Booklet		Magazine	
Original Pages	Count	Original Pages	Count
1	1	1	1
2	2	2	2
3	2	3	2
4	2	4	2
5	3	5	4
6	4	6	4
7	4	7	4
8	4	8	4

8431	T:PrtPGS/ImgEdt	[0~9999999/ 1]
	These SPs count the total number of pages output with the three features below, regardless of which application was used.	
8432	C:PrtPGS/ImgEdt	[0~9999999/ 1]
	These SPs count the total number of pages output with the three features below with the copy application.	
8434	P:PrtPGS/ImgEdt	[0~9999999/ 1]
	These SPs count the total number of pages output with the three features below with the print application.	
8436	L:PrtPGS/ImgEdt	[0~9999999/ 1]
	These SPs count the total number of pages output from within the document	



Service Tables

	server mode window t the operation panel with the three features below.	
8437	O:PrtPGS/ImgEdt	[0~9999999/ 1]
	These SPs count the total number of pages output with the three features below with Other applications.	
843x 1	Cover/Slip Sheet	Total number of covers or slip sheets inserted. The count for a cover printed on both sides counts 2.
843x 2	Series/Book	The number of pages printed in series (one side) or printed as a book with booklet right/left pagination.
843x 3	User Stamp	The number of pages printed where stamps were applied, including page numbering and date stamping.

8441	T:PrtPGS/Ppr Size	[0~9999999/ 1]
	These SPs count by print paper size the number of pages printed by all applications.	
8442	C:PrtPGS/Ppr Size	[0~9999999/ 1]
	These SPs count by print paper size the number of pages printed by the copy application.	
8443	F:PrtPGS/Ppr Size	[0~9999999/ 0 / 1]
	These SPs count by print paper size the number of pages printed by the fax application.	
8444	P:PrtPGS/Ppr Size	[0~9999999/ 1]
	These SPs count by print paper size the number of pages printed by the printer application.	
8445	S:PrtPGS/Ppr Size	[0~9999999/ 1]

## Service Tables

	These SPs count by print paper size the number of pages printed by the scanner application.	
8446	L:PrtPGS/Ppr Size	[0~9999999/ 1]
	These SPs count by print paper size the number of pages printed from within the document server mode window at the operation panel.	
8447	O:PrtPGS/Ppr Size	[0~9999999/ 1]
	These SPs count by print paper size the number of pages printed by Other applications.	
844x 1	A3	
844x 2	A4	
844x 3	A5	
844x 4	B4	
844x 5	B5	
844x 6	DLT	
844x 7	LG	
844x 8	LT	
844x 9	HLT	
844x 10	Full Bleed	
844x 100	A2	Not supported with this printer.
844x 101	B3	Not supported with this printer.
844x 254	Other (Standard)	
844x 255	Other (Custom)	

- These counters do not distinguish between LEF and SEF.

Service Tables

8451	PrtPGS/Ppr Tray	[0~9999999/ 1]
	These SPs count the number of sheets fed from each paper feed station.	
1	Bypass	Bypass Tray
2	Tray 1	Copier
3	Tray 2	Copier
4	Tray 3	Paper Tray Unit (Option)
5	Tray 4	Paper Tray Unit (Option)
6	Tray 5	LCT (Option)
7	Tray 6	Currently not used.
8	Tray 7	Currently not used.
9	Tray 8	Currently not used.
10	Tray 9	Currently not used.

8461	T:PrtPGS/Ppr Type	[0~9999999/ 1]
	<p>These SPs count by paper type the number pages printed by all applications.</p> <p>These counters are not the same as the PM counter. The PM counter is based on feed timing to accurately measure the service life of the feed rollers. However, these counts are based on output timing.</p> <p>Blank sheets (covers, chapter covers, slip sheets) are also counted.</p> <p>During duplex printing, pages printed on both sides count as 1, and a page printed on one side counts as 1.</p>	
8462	C:PrtPGS/Ppr Type	[0~9999999/ 1]
	These SPs count by paper type the number pages printed by the copy application.	
8463	F:PrtPGS/Ppr Type	[0~9999999/ 0 / 1]

Service Tables

	These SPs count by paper type the number pages printed by the fax application.	
8464	P:PrtPGS/Ppr Type	[0~9999999/ 1]
	These SPs count by paper type the number pages printed by the printer application.	
8466	L:PrtPGS/Ppr Type	[0~9999999/ 1]
	These SPs count by paper type the number pages printed from within the document server mode window at the operation panel.	
846x 1	Normal	
846x 2	Recycled	
846x 3	Special	
846x 4	Thick	
846x 5	Normal (Back)	
846x 6	Thick (Back)	
846x 7	OHP	
846x 8	Other	

8471	PrtPGS/Mag	[0~9999999/ 1]
	These SPs count by magnification rate the number of pages printed.	
1	~49%	
2	50%~99%	
3	100%	
4	101%~200%	
5	201% ~	

- Counts are done for magnification adjusted for pages, not only on the operation panel

Service Tables

but performed remotely with an external network application capable of performing magnification adjustment as well.

- Magnification adjustments done with printer drivers with PC applications such as Excel are also counted.
- Magnification adjustments done for adjustments after they have been stored on the document server are not counted.
- Magnification adjustments performed automatically during Auto Reduce/Enlarge copying are counted.
- The magnification rates of blank cover sheets, slip sheets, etc. are automatically assigned a rate of 100%.

8481	T:PrtPGS/TonSave	<p>These SPs count the number of pages printed with the Toner Save feature switched on.</p> <p>Note: These SPs return the same results as this SP is limited to the Print application.</p> <p>[0~9999999/ 1]</p>
8484	P:PrtPGS/TonSave	

8491	T:PrtPGS/Col Mode	[0~9999999/ 1]
	These SPs count by color mode the total number of pages output by the Copy, document server, and Fax applications.	
8492	C:PrtPGS/Col Mode	[0~9999999/ 1]
	These SPs count by color mode the total output by the Copy application only	
8492	C:PrtPGS/Col Mode	[0~9999999/ 1]
	These SPs count by color mode the total output by the Copy application only	
8493	F:PrtPGS/Col Mode	[0~9999999/ 1]
	These SPs count by color mode the total output by the Fax application only	
8496	L:PrtPGS/Col Mode	[0~9999999/ 1]
	These SPs count by color mode the total output from within the document server mode window at the operation panel.	
849x 1	B/W	

## Service Tables

849x 2	Single Color	Color MFP/2-color MFP machines only.
849x 3	Two Color	Color MFP/2-color MFP machines only.
849x 4	Full Color	Color MFP machines only

### Notes for SP8491 to SP8496

- These SPs apply to the Copy, document server, and Fax applications only. They do not apply to the Print application.
- When the ACS feature is used to select the color settings automatically, the results of the ACS execute is used to increment the appropriate counter.
- If a color stamp is selected for printing on a monochrome document, the count is for B/W.
- If the output is black and white even if color print mode was selected, the pages count as Full Color.
- The color mode selected for a document stored on the document server is counted. (The color selection cannot be changed once the document is stored on the document server.)

8501	T:PrtPGS/Col Mode		[0~9999999/ 1]
	These SPs count by color mode the total number of pages printed.		
1	B/W		
2	Single Color	Color MFP and 2-Color MFP machines only.	
3	Full Color	Color MFP and Color LP machines only.	
8504	P:PrtPGS/Col Mode		[0~9999999/ 1]
	These SPs count by color mode the number of pages printed with the Print application.		
1	B/W		
2	Single Color	Color MFP and 2-Color MFP machines only.	
3	Full Color	Color MFP and Color LP machines only.	
8507	O:PrtPGS/Col Mode		[0~9999999/ 1]

## Service Tables

	These SPs count by color mode the number of pages printed with the other applications.	
1	B/W	
2	Single Color	Color MFP and 2-Color MFP machines only.
3	Full Color	Color MFP and Color LP machines only.

- At the present time, 8501 and 8504 perform identical counts, because they are both limited to the Print application.

8511	T:PrtPGS/Emul	[0~9999999/ 1]
	These SPs count by printer emulation mode the total number of pages printed.	
8514	P:PrtPGS/Emul	[0~9999999/ 1]
	These SPs count by printer emulation mode the total number of pages printed.	
851x 1	RPCS	
851x 2	RPDL	
851x 3	PS3	
851x 4	R98	
851x 5	R16	
851x 6	GL/GL2	
851x 7	R55	
851x 8	RTIFF	
851x 9	PDF	
851x 10	PCL5e/5c	
851x 11	PCL XL	

## Service Tables

851x 12	IPDL-C	
851x 13	BM-Links	Japan Only
851x 14	Other	

- SP8511 and SP8514 return the same results as they are both limited to the Print application.
- Print jobs output to the document server are not counted.

8521	T:PrtPGS/FIN	[0~9999999/ 1]
	These SPs count by finishing mode the total number of pages printed by all applications.	
8522	C:PrtPGS/FIN	[0~9999999/ 1]
	These SPs count by finishing mode the total number of pages printed by the Copy application.	
8523	F:PrtPGS/FIN	[0~9999999/ 1]
	These SPs count by finishing mode the total number of pages printed by the Fax application.	
8524	P:PrtPGS/FIN	[0~9999999/ 1]
	These SPs count by finishing mode the total number of pages printed by the Print application.	
8525	S:PrtPGS/FIN	[0~9999999/ 1]
	These SPs count by finishing mode the total number of pages printed by the Scanner application.	
8526	L:PrtPGS/FIN	[0~9999999/ 1]
	These SPs count by finishing mode the total number of pages printed from within the document server mode window at the operation panel.	
852x 1	Sort	



## Service Tables

852x 2	Stack
852x 3	Staple
852x 4	Booklet
852x 5	Z-Fold
852x 6	Punch
852x 7	Other

### Note:

- If stapling is selected for finishing and the stack is too large for stapling, the unstapled pages are still counted.
- The counts for staple finishing are based on output to the staple tray, so jam recoveries are counted.

8531	Staples	This SP counts the amount of staples used by the machine. [0~9999999/ 1]
------	---------	---

8581	T:Counter	[0~9999999/ 1]		
	<p>These SPs count the total output broken down by color output, regardless of the application used. In addition to being displayed in the SMC Report, these counters are also displayed in the User Tools display on the copy machine.</p> <p>Note: These SPs are supported by color MFP and LP machines only.</p>			
		<b>MFP Color</b>	<b>LP Color</b>	<b>Replaced:</b>
1	Total	Yes	Yes	SP73 1
2	Total: Full Color	Yes	Yes	SP7003 020
3	B&W/Single Color	Yes	Yes	SP7003 021
4	Development: CMY	Yes	Yes	SP7003 10
5	Development: K	Yes	Yes	SP7003 11

Service Tables

6	Copy: Color	Yes	No	SP7003 026
7	Copy: B/W	Yes	No	SP7003 027
8	Print: Color	Yes	Yes	SP7003 028
9	Print: B/W	Yes	Yes	SP7003 029
10	Total: Color	Yes	Yes	SP7003 030
11	Total: B/W	Yes	Yes	SP7003 023

8582	C:Counter	[0~9999999/ 1]		
	<p>These SPs count the total output broken down by color output for the Copy application only.</p> <p>Note: These SPs are supported by color copy MFP machines only.</p> <p>These counters are displayed in the SMC Report, and in the User Tools display on the copy machine.</p>			
1	B/W			
2	Single Color			
3	Two Color			
4	Full Color			

8583	F:Counter	[0~9999999/ 1]		
	<p>These SPs count the total output broken down by color output for the Fax application only.</p> <p>These SPs is supported by color copy MFP machines only.</p> <p>These counters are displayed in the SMC Report, and in the User Tools display on the copy machine.</p>			
1	B/W			

Service Tables

2	Single Color		
3	Two Color		
4	Full Color		

8584	P:Counter		[0~9999999/ 1]
	<p>These SPs count the total output broken down by color output for the Print application only. These counters are displayed in the SMC Report, and in the User Tools display on the copy machine.</p> <p>Note: These SPs are supported by color MFP and LP machines only.</p>		
	1	B/W	
	2	Single Color	
3	Full Color		

8586	L:Counter		[0~9999999/ 1]	
	<p>These SPs count the total output broken down by color for output from within the document server mode window at the operation panel. These counters are displayed in the SMC Report, and in the User Tools display on the copy machine.</p> <p>Note: These SPs are supported only by color copy MFP machines only with the fax application installed.</p>			
			<b>MFP Color</b>	<b>Replaced:</b>
	1	B/W	Yes	---
	2	Single Color	Yes	---
3	Two Color	Yes	---	
4	Single Color	Yes	---	

8591	O:Counter	[0~9999999/ 1]
------	-----------	----------------

Service Tables

	These SPs count the totals for A3/DLT paper use, number of duplex pages printed, and the number of staples used. These totals are for Other (O:) applications only.	
1	A3/DLT	
2	Duplex	
3	Staple	

8601	Coverage Counter	
1	B/W	
2	B/W Printing Pages	

8631	T:FAX TX PGS	[0 to 9999999/ 0 / 1]
	These SPs count by color mode the number of pages sent by fax to a telephone number.	
8633	F:FAX TX PGS	[0 to 9999999/ 0 / 1]
	These SPs count by color mode the number of pages sent by fax to a telephone number.	

- If a document has color and black-and-white pages mixed, the pages are counted separately as B/W or Color.
- At the present time, this feature is provided for the Fax application only so SP8631 and SP8633 are the same.
- The counts include error pages.
- If a document is sent to more than one destination with a Group transmission, the count is done for each destination.
- Polling transmissions are counted but polling RX are not.
- Relay, memory, and confidential mailbox transmissions and are counted for each destination.

Service Tables

8641	T:FAX TX PGS	[0 to 9999999/ 0 / 1]
	These SPs count by color mode the number of pages sent by fax to as fax images using I-Fax.	
8643	F:FAX TX PGS	[0 to 9999999/ 0 / 1]
	These SPs count by color mode the number of pages sent by Fax as fax images using I-Fax.	

- If a document has color and black-and-white pages mixed, the pages are counted separately as B/W or Color.
- At the present time, this feature is provided for the Fax application only so SP8641 and SP8643 are the same.
- The counts include error pages.
- If a document is sent to more than one destination with a Group transmission, the count is done for each destination.
- Polling transmissions are counted but polling RX are not.
- Relay, memory, and confidential mailbox transmissions and are counted for each destination.

8651	T:S-to-Email PGS	[0~9999999/ 1]
	These SPs count by color mode the total number of pages attached to an e-mail for both the Scan and document server applications.	
1	B/W	
2	Color	Supported by Color MFP machines only.
8655	S:S-to-Email PGS	[0~9999999/ 1]
	These SPs count by color mode the total number of pages attached to an e-mail for the Scan application only.	
1	B/W	
2	Color	Supported by Color MFP machines only.

Notes

## Service Tables

- The count for B/W and Color pages is done after the document is stored on the HDD. If the job is cancelled before it is stored, the pages are not counted.
- If Scan-to-Email is used to send a 10-page document to 5 addresses, the count is 10 (the pages are sent to the same SMTP server together).
- If Scan-to-PC is used to send a 10-page document to 5 folders, the count is 50 (the document is sent to each destination of the SMB/FTP server).
- Due to restrictions on some devices, if Scan-to-Email is used to send a 10-page document to a large number of destinations, the count may be divided and counted separately. For example, if a 10-page document is sent to 200 addresses, the count is 10 for the first 100 destinations and the count is also 10 for the second 100 destinations, for a total of 20.).

8661	T:Deliv PGS/Svr		[0~9999999/ 1]
	These SPs count by color mode the total number of pages sent to a Scan Router server by both Scan and LS applications.		
1	B/W		
2	Color	Supported by Color MFP machines only.	
8665	S:Deliv PGS/Svr		[0~9999999/ 1]
	These SPs count by color mode the total number of pages sent to a Scan Router server by the Scan application.		
1	B/W		
2	Color	Supported by Color MFP machines only.	

### Notes

- The B/W and Color counts are done after the document is stored on the HDD of the Scan Router server.
- If the job is canceled before storage on the Scan Router server finishes, the counts are not done.
- The count is executed even if regardless of confirmation of the arrival at the Scan Router server.

Service Tables

8671	T:Deliv PGS/PC	[0~9999999/ 1]
	These SPs count by color mode the total number of pages sent to a folder on a PC (Scan-to-PC) with the Scan and LS applications.	
1	B/W	
2	Color	Supported by Color MFP machines only.
8675	S:Deliv PGS/PC	[0~9999999/ 1]
	These SPs count by color mode the total number of pages sent with Scan-to-PC with the Scan application.	
1	B/W	
2	Color	Supported by Color MFP machines only.

8681	T:PCFAX TXPGS	These SPs count the number of pages sent by PC Fax. These SPs are provided for the Fax application only, so the counts for SP8681 and SP8683 are the same. [0 to 9999999/ 0 / 1]
8683	F:PCFAX TXPGS	

- This counts pages sent from a PC using a PC fax application, from the PC through the copier to the destination.
- When sending the same message to more than one place using broadcasting, the pages are only counted once. (For example, a 10-page fax is sent to location A and location B. The counter goes up by 10, not 20.)

8691	T:TX PGS/LS	These SPs count the number of pages sent from the document server. The counter for the application that was used to store the pages is incremented. [0~9999999/ 1] The L: counter counts the number of pages stored from within the document server mode screen at the operation panel. Pages stored with the Store File
8692	C:TX PGS/LS	
8693	F:TX PGS/LS	
8694	P:TX PGS/LS	
8695	S:TX PGS/LS	

## Service Tables

8696	L:TX PGS/LS	button from within the Copy mode screen go to the C: counter.
------	-------------	---

### Notes

- Print jobs done with Web Image Monitor and Desk Top Binder are added to the count.
- If several documents are merged for sending, the number of pages stored are counted for the application that stored them
- When several documents are sent by a Fax broadcast, the F: count is done for the number of pages sent to each destination.

8701	TX PGS/Port	[0~9999999/ 1]
	These SPs count the number of pages sent by the physical port used to send them. For example, if a 3-page original is sent to 4 destinations via ISDN G4, the count for ISDN (G3, G4) is 12.	
1	PSTN-1	
2	PSTN-2	
3	PSTN-3	
4	ISDN (G3,G4)	
5	Network	

8711	T:Scan PGS/Comp	[0~9999999/ 1]
	These SPs count the number of compressed pages scanned into the document server, counted by the formats listed below.	
1	JPEG/JPEG2000	
2	TIFF (Multi/Single)	
3	PDF	
4	Other	



Service Tables

8715	S:Scan PGS/Comp		[0~9999999/ 1]
	These SPs count the number of compressed pages scanned by the scan application, counted by the formats slisted below.		
1	JPEG/JPEG2000		
2	TIFF (Multi/Single)		
3	PDF		
4	Other		

8741	RX PGS/Port		[0~9999999/ 1]
	These SPs count the number of pages received by the physical port used to receive them.		
1	PSTN-1		
2	PSTN-2		
3	PSTN-3		
4	ISDN (G3,G4)		
5	Network		

8771	Dev Counter		[0~9999999/ 1]
	These SPs count the frequency of use (number of rotations of the development rollers) for black and other color toners. <b>Note:</b> For machines that do not support color, the Black toner count is the same as the Total count.		
1	Total	All toners (YMCK)	
2	K	Black toner	
3	Y	Yellow toner	
4	M	Magenta toner	

Service Tables

5	C	Cyan toner
6	R	Red toner (Wide Format A2 machines only)

8781	Toner Use Count: Color		[0~65 535]
	These SPs count the frequency of use (number of rotations of the development rollers) for black and other color toners.		
1	K	Black toner	
2	M	Magenta toner	
3	C	Cyan toner	
4	Y	Yellow toner	

8791 1	LS Memory Remain	This SP displays the percent of space available on the document server for storing documents. [0~100/ 1]
--------	------------------	---

8801	Toner Remain		[0~100/ 1]
	This SP displays the percent of toner remaining for each color. This SP allows the user to check the toner supply at any time. Note: This precise method of measuring remaining toner supply (1% steps) is better than other machines in the market that can only measure in increments of 10 (10% steps).		
1	K	Black.	Supported by B/W, Color, Wide Format A2, Wide Format Roll machines.
2	Y	Yellow	Color machines only.
3	M	Magenta	
4	C	Cyan	
5	R	R	Wide Format A2 machines only.

Service Tables

8851	Toner Coverage 0-10%		[0~65 535]
	These SPs count the percentage of dot coverage for black other color toners.		
1	K	Black toner	
2	M	Magenta toner	
3	C	Cyan toner	
4	Y	Yellow toner	

8861	Toner Coverage 11-20%		[0~65 535]
	These SPs count the percentage of dot coverage for black other color toners.		
1	K	Black toner	
2	M	Magenta toner	
3	C	Cyan toner	
4	Y	Yellow toner	

8871	Toner Coverage 21-30%		[0~65 535]
	These SPs count the percentage of dot coverage for black other color toners.		
1	K	Black toner	
2	M	Magenta toner	
3	C	Cyan toner	
4	Y	Yellow toner	

8881	Toner Coverage 31 -%		[0~65 535]
------	----------------------	--	------------

Service Tables

	These SPs count the percentage of dot coverage for black other color toners.	
1	K	Black toner
2	M	Magenta toner
3	C	Cyan toner
4	Y	Yellow toner

8891	Pages: Current Toner		[0~65 535]
	These SPs count the number of pages for the current set toner.		
1	K	Black toner	
2	M	Magenta toner	
3	C	Cyan toner	
4	Y	Yellow toner	

8901	Page/Toner_Prev1 <b>DFU</b>
8911	Page/Toner_Prev2 <b>DFU</b>

8921	Cvr Cnt/Total		
1	Coverage (%) BK		
11	Cover/Page (%): BK		

8941	Machine Status		[0~9999999/ 1]
	These SPs count the amount of time the machine spends in each operation mode. These SPs are useful for customers who need to investigate machine operation for improvement in their compliance with		

Service Tables

		ISO Standards.
1	Operation Time	Engine operation time. Does not include time while controller is saving data to HDD (while engine is not operating).
2	Standby Time	Engine not operating. Includes time while controller saves data to HDD. Does not include time spent in Energy Save, Low Power, or Off modes.
3	Energy Save Time	Includes time while the machine is performing background printing.
4	Low Power Time	Includes time in Energy Save mode with Engine on. Includes time while machine is performing background printing.
5	Off Mode Time	Includes time while machine is performing background printing. Does not include time machine remains powered off with the power switches.
6	Down Time/SC	Total down time due to SC errors.
7	Down Time/PrtJam	Total down time due to paper jams during printing.
8	Down Time/OrgJam	Total down time due to original jams during scanning.
9	Down Time/TonEnd	Total down time due to toner end.

8951	AddBook Register		
	These SPs count the number of events when the machine manages data registration.		
1	User Code	User code registrations.	[0~9999999/ 1]
2	Mail Address	Mail address registrations.	
3	Fax Destination	Fax destination registrations.	

Service Tables

4	Group	Group destination registrations.	
5	Transfer Request	Fax relay destination registrations for relay TX.	
6	F-Code	F-Code box registrations.	
7	Copy Program	Copy application registrations with the Program (job settings) feature.	[0~255 / 255]
8	Fax Program	Fax application registrations with the Program (job settings) feature.	
9	Printer Program	Printer application registrations with the Program (job settings) feature.	
10	Scanner Program	Scanner application registrations with the Program (job settings) feature.	

# Details

## General Overview

## Main Machine

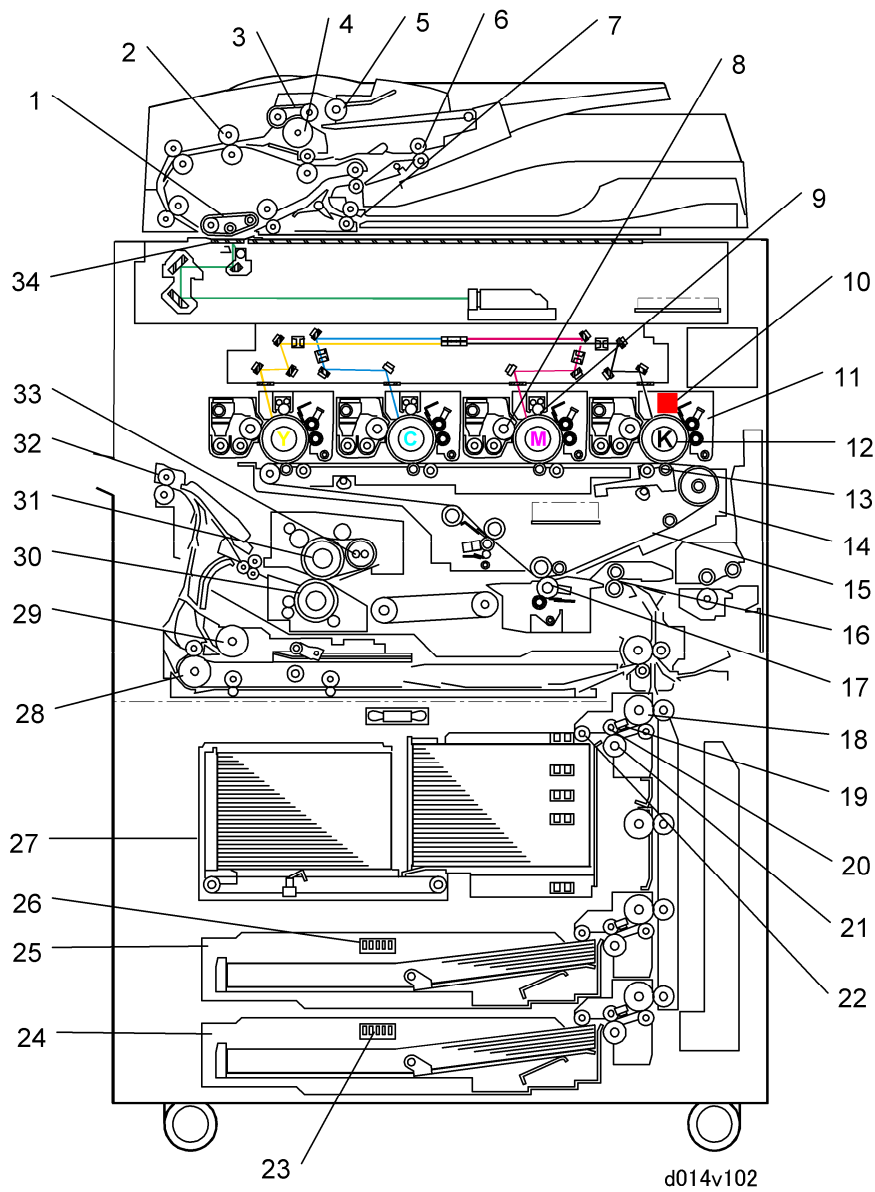

1. Transport Belt (ARDF)

18. Grip Roller

## Details

---

- |                                 |                                    |
|---------------------------------|------------------------------------|
| 2. Grip Roller (ARDF)           | 19. Feed Sensor (Paper Tray)       |
| 3. Feed Belt (ARDF)             | 20. Feed Roller (Paper Tray)       |
| 4. Separation Roller (ARDF)     | 21. Separation Roller (Paper Tray) |
| 5. Pick-up Roller (ARDF)        | 22. Pick-up Roller (Paper Tray)    |
| 6. Upper Inverter Roller (ARDF) | 23. Paper Size Switch (Tray 3)     |
| 7. Lower Inverter Roller (ARDF) | 24. Universal Tray (Tray 3)        |
| 8. Development Roller           | 25. Universal Tray (Tray 2)        |
| 9. Charge Roller                | 26. Paper Size Switch (Tray 2)     |
| 10. Charge Corona Unit          | 27. Tandem Tray (Tray 1)           |
| 11. PCU                         | 28. Inverter Exit Roller           |
| 12. OPC Drum                    | 29. Inverter Entrance Roller       |
| 13. Image Transfer Roller       | 30. Pressure Roller                |
| 14. ITB Unit                    | 31. Hot Roller                     |
| 15. Transfer Belt               | 32. Exit Roller                    |
| 16. Registration Roller         | 33. Heating Roller                 |
| 17. PTR Roller                  | 34. Exposure Glass (ARDF)          |

The color PCU units (Y,M,C) use a charge roller to charge the surface of the OPC drum. The K PCU uses a charge corona unit (Scorotron type) to charge the surface of the drum.



---

## Laser Unit

---

There is an LD unit for each color, and each LD unit uses a two-beam system. A photodiode (PD) in each LD unit detects the light emitted from the LD unit. The output of the PD is fed back to the LD control board. The LD control board uses this information to control the amount of light to make sure that it remains at the correct level.

---

## Dual Beam Writing

---

In each LD unit, two beams move across the drum in the main scan direction.

The use of two beams:

- Makes the machine print faster.
- Reduces the number of turns of the polygon mirror for a page to prolong the service life of the motor.
- Reduces the amount motor noise.

The beam pitch is fixed at 600 dpi and is not adjustable.

---

## LD Safety Switches

---

To ensure the safety of customers and customer engineers, two switches inside the cover prevent the laser beams from switching on accidentally. When the front cover is open, the +5V line connecting each LD driver on the LD control board is disconnected.

Details

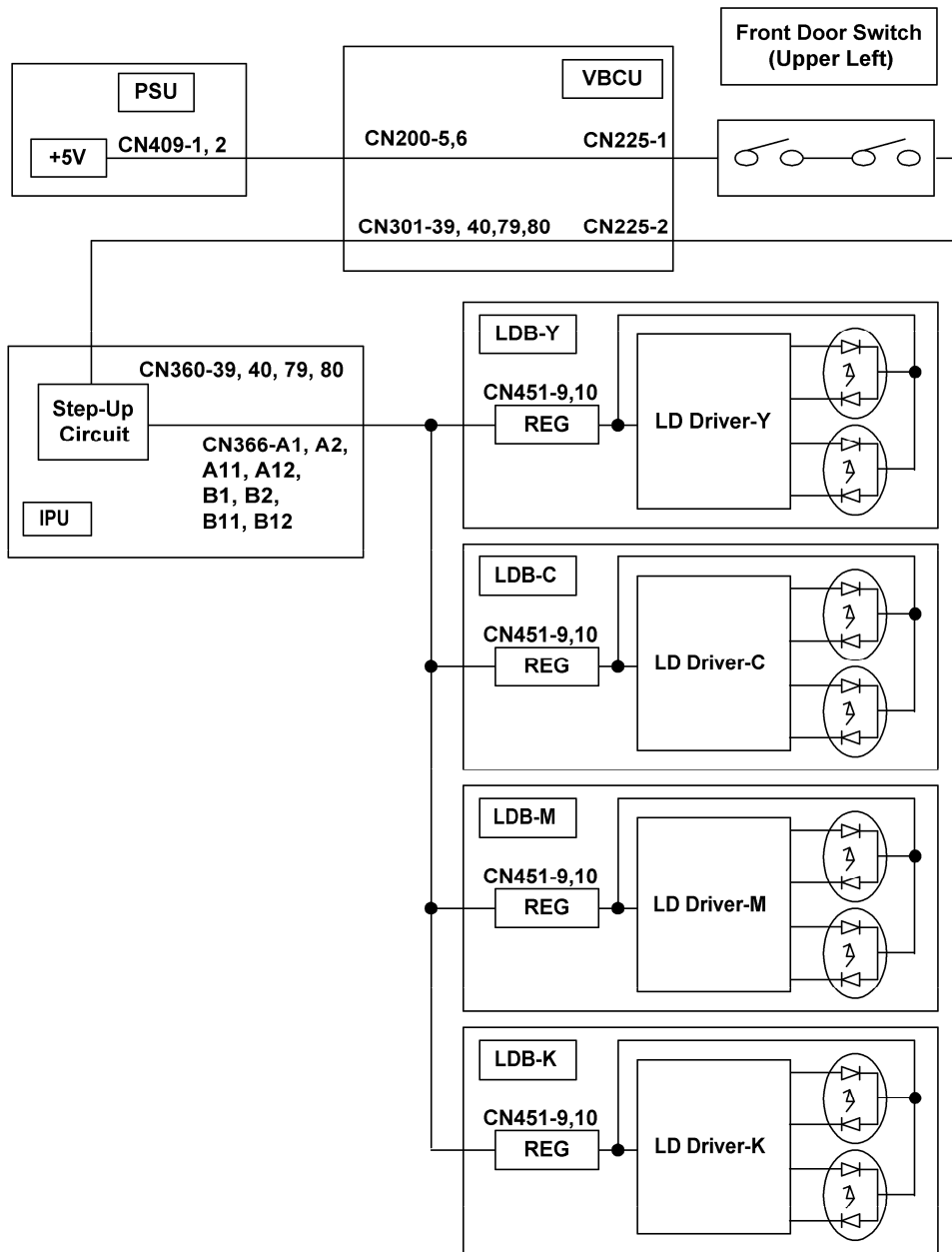

d014d900

---

## Boards

---

---

### Overview of Important Components

---

#### **VBCU (Base Engine and Image Control Unit)**

The VBCU is the main control board. It combines the functions of the BCU and IOB.

The VBCU controls these BCU (Base Control Unit) functions:

- Engine sequence control (all sensors, motors, fusing temperature control circuits)
- Image processing control (on the IPU)
- Scanning control
- GW controller interface
- Peripheral timing control

The VBCU also controls these IOB (I/O Control Board) functions:

- Input and output ports for all sensors, motors, solenoids
- All drivers
- High voltage power supply
- Analog input signals. Converts analog data to 10-bit digital data. The CPU on the VBCU reads this data.

#### **Controller**

The GW controller board controls all the optional applications. It contains the GW architecture ASICs, and connects to the VBCU and PCI interface. The controller board also has two SD card sockets. The SD card slots are use for:

- Installing holding optional applications (Printer/Scanner, PostScript3 and other options)
- Engine and operational panel firmware updates
- Moving an application from one SD card to another with SP5873-1.

#### **SBU (Sensor Board Unit)**

The SBU:

- Receives analog signals from the CCD and converts them to digital signals.
- Sends serial data to the VBCU.
- Sends signals from the main CPU to the SIOB, to control the scanner components.
- Sends digital data to the IPU.

#### **SIOB (Scanner I/O Board)**

This board controls the scanner motor and all the sensors in the scanner unit. The CPU controls this board.

#### **LDB (Laser Diode Drive Board)**



## Details

---

The signals from the 3-line CCD, one line for each color (R, G, B) and 4 analog signals per line (F\_ODD, F\_EVEN, L\_ODD, L\_EVEN), are sampled by the ASIC and converted to digital signals in the 10-bit A/D converter. This is the first phase of processing the data scanned from the original.

### Lens Block Replacement

The controller stores the SBU settings. These values must be restored after the lens block is replaced:

SP4008	Sub Scan Mag	Sub Scan Magnification Adjustment
SP4010	Sub Scan Reg	Sub Scan Registration Adjustment
SP4011	Main Scan Reg	Main Scan Registration Adjustment

- Before lens block replacement, enter the SP mode and note the settings of SP4800 001 to 003 (ARDF density adjustments for R, G, B).
- After lens block replacement, do some copy samples with the ARDF, then check the copies.
- If the copies have background, change SP4800 001 to 003 to their previous settings, or adjust until the background is acceptable.

These SP codes are also used to adjust the ARDF scanning density, if the scanning densities of the ARDF and the platen mode are not the same.

### SBU Test Mode

1. Use SP4907 (Set SBU Test Pattern) to select the pattern to print.
2. Touch "Copy Window" then press the Start key twice.

## IPU (Image Processing Unit)

---

The IPU does the following:

- Controls the scanner
- Processes the image signals from the SBU and sends them over the PCI bus to the controller memory
- Receives the image processing signals sent over the PCI bus from the controller memory, processes them, then outputs them to the VGAVD.
- Outputs the control signals for the ARDF
- Controls the relay of power and signals

## Details

---

Image processing, ADS correction, and line width correction are done on the VBCU board for all the digital data sent from the SBU. Finally, the processed data is sent to the printer as digital signals (2 bits/pixel).

---

## Copy Process Overview

---

### Raising and Lowering of the ITB Unit

---

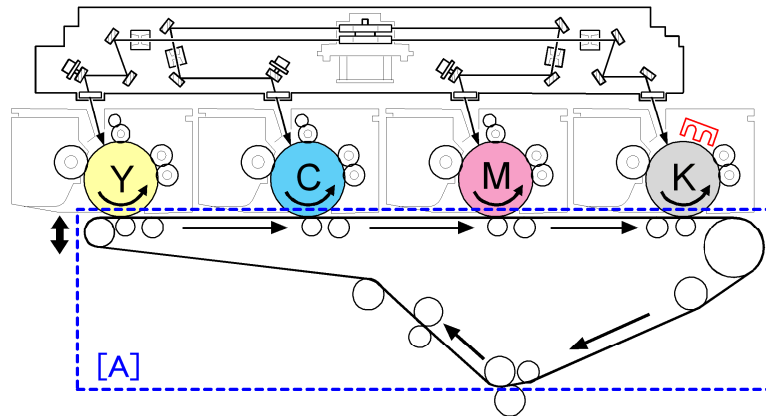

d014d001

This machine has four PCUs arranged in a straight line: Y, C, M, K above the ITB (Image Transfer Belt) unit [A]:

- The ITB lift motor raises and lowers the ITB unit.
- The ITB lift motor raises ITB unit for full-color copying. The drum of every PCU contacts the image transfer belt below.
- The ITB lift motor lowers the ITB for black-and-white copying. Only the black PCU (K) contacts the image transfer belt below.
- To reduce wear on moving parts of the color PCUs, the drums of the color PCUs (Y, M, C) do not rotate while they are separated from the image transfer belt during black-and-white copying.
- If a job contains black-and-white pages and full-color pages, the action of the ITB is controlled by SP3930-1.

The Copy Process

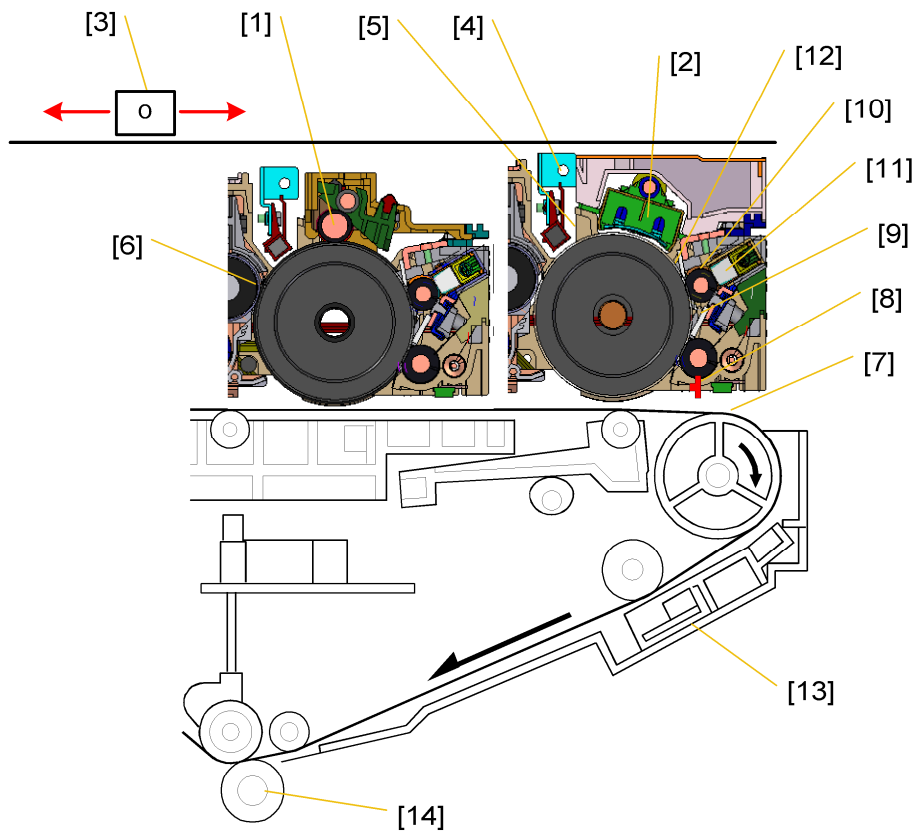

d014d984

Here is a general description of the copy process.

**Drum Charge**

In darkness a charge roller [1] in the color PCUs (Y,C,M) and a charge corona unit in the black PCU (K) [2] give a negative charge to each drum. The charge stays on the surface of the drum because the OPC layer has a high electrical resistance in the dark.

**Exposure**

A xenon lamp [3] exposes the original as it scans over the exposure glass above. Light reflected from the original passes to the CCD, where it is converted into an analog data signal. This data is converted to a digital signal, processed, and stored in the memory. At the time of printing, the data is taken from the memory and sent to the laser diode. For multi-copy runs, the original is scanned once and stored in a temporary file on the hard disk.

**Laser Exposure**

The processed image data from the scanned original is taken from the hard disk and two laser beams [4] fire and write it as an electrostatic latent image on the drum surface. The amount of charge used to create the latent image on the drum depends on the intensity and duration electrical pulse that fires the laser beam pulse.



### **Drum Potential Sensor**

There are four drum potential sensors [5], one mounted on the main machine above each PCU. These sensors detect and measure the electrical potential on the surface of each drum. This is necessary because frequent and temporary changes in temperature and humidity, as well as the changes in the surface of the drum as it ages, affect drum potential. The machine uses the readings of these sensors to set the voltage levels that are frequently adjusted during auto process control. This ensures optimum performance of copying and printing.

### **Development**

The magnetic developer brush of the development roller [6] brushes over the latent image on the rotating drum surface. Toner particles are electrostatically pulled from the magnetic developer brush onto the drum surface where the laser reduced the negative charge on the drum. The attracted toner is applied over the latent image.

### **Image Transfer**

The developed toner images are transferred from the drums to the image transfer belt (ITB) [7]. Rollers under the ITB apply a high positive charge to the reverse side of the ITB. This positive charge pulls the toner particles from the surface of the drum to the ITB. The toner pulled from the drum creates a duplicate of the image pattern on the surface of the belt.

### **Quenching**

The light from the quenching lamp [8] neutralizes the charge that formed the image on the drum surface. After cleaning and quenching, the drum surface is ready for the next cycle.

### **Drum Cleaning**

The opposing cleaning blade [9] removes toner remaining on the drum after transfer of the image. The soft lubricant brush roller [10] applies lubricant (ZnSt from the lubricant bar [11]) to the area cleaned by the cleaning blade. Finally, the lubricant blade [12] smoothes and levels the lubricant applied to the OPC.

### **ID Sensors, Music Sensors**

An ID sensor and three MUSIC sensors [13] are mounted over the surface of the image transfer belt. The laser in each PCU writes an ID sensor pattern on each drum surface (Y, M, C, K) at prescribed intervals then these patterns are transferred to the image transfer belt. The ID sensor above the patterns on the ITB measures the light reflected from each of the four patterns and sends this data (Vsp) to the CPU. These Vsp readings are used for toner supply control. The MUSIC sensors read a different set of patterns. These readings are used to 1) adjust the start timing for laser firing, 2) adjust the angle of the 3rd mirror, and 3) set the drum rotation speeds. The MUSIC sensor readings are used to ensure that the alignment of the images on the ITB is always correct.

**Paper Transfer and Separation**

A strong negative charge applied to the PTR idle roller [14] repels and pushes the image from the image transfer belt onto the paper. Immediately after this is done, a paper discharge plate neutralizes the charge on the paper and image transfer belt. The curvature of the feed path makes the paper to separate from the image transfer belt.

---

## Scanner Unit

---

---

### Overview

---

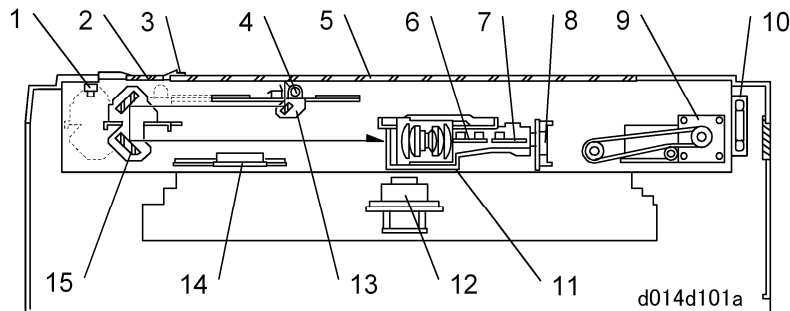

- |                                    |                                    |
|------------------------------------|------------------------------------|
| 1. Scanner HP Sensor               | 9. Scanner Motor                   |
| 2. ARDF Exposure Glass             | 10. Scanner Fan Motor              |
| 3. White Plate                     | 11. Lens Block                     |
| 4. Exposure Lamp (Xenon)           | 12. Polygon Mirror Motor           |
| 5. Exposure Glass                  | 13. 1st Scanner                    |
| 6. APS2 (Org. Length Sensors 1, 2) | 14. APS1 (Org. Width Sensors 1, 2) |
| 7. APS3 (Org. Length Sensor 3)     | 15. 2nd Scanner                    |
| 8. SBU (CCD: 600 dpi)              |                                    |

The light reflected from the original is sent to the CCD:

1st Mirror> 2nd Mirror> 3rd Mirror> Lens Block> CCD

The lens block consists of the scanner lens and SBU (CCD). The CCD converts the light that was reflected from the original and converts it to three color analog signals (R, G, B). The SBU converts the analog signals to digital signals, then sends the digital signals to the IPU.

**★ Important**

- The lens block is always replaced as a unit and requires no adjustment in the field.

Original Size Detection

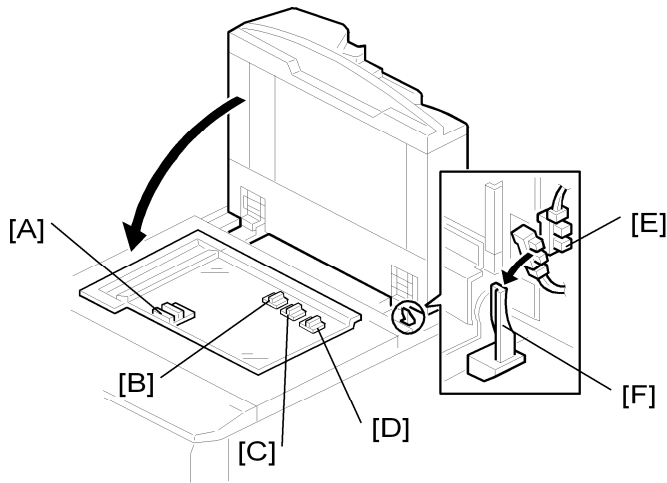

d014d102

The machine uses five sensors on three APS boards to detect the size of the original on the exposure glass.

[A]: APS1. (W1 and W2) detects original width

[B]: APS2. (L1) detects original length

[C]: APS3 (L2) detects original length

[D]: APS4. (L3) detects original length

[E]: ARDF position sensor. Detects whether the ARDF is open or closed.

[F]: APS start sensor. Triggers automatic paper size detection.

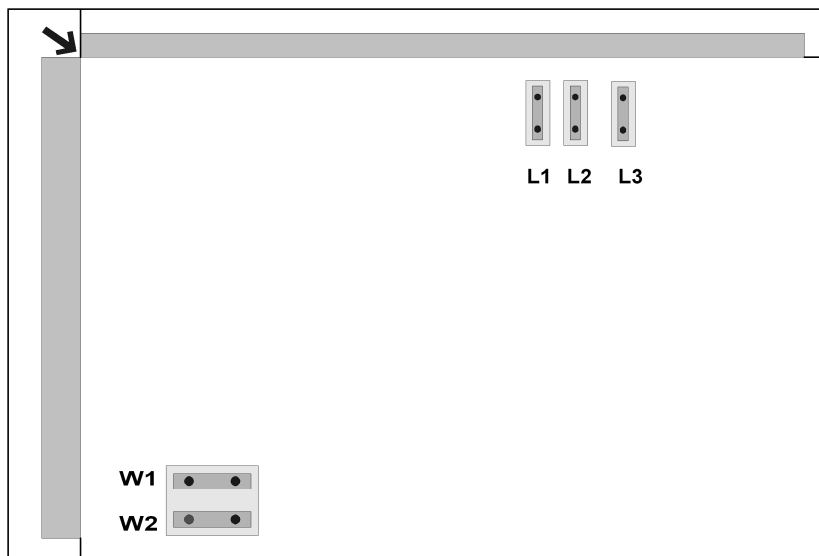

d014d973

The table shows the sensor output for each paper size.

If an original is on the exposure glass, you can check the sensor output with SP4301 (APS

Confirm).

A4/A3	LT/DLT	L3	L2	L1	W1	W2	SP4301 Display
A3	11" x 17"	1	1	1	1	1	000 11111
B4	—	1	1	1	1	0	000 11110
A4 SEF	8½" x 11"	0	1	1	0	0	000 01100
	8½" x 14"	1	1	1	0	0	000 11100
A4 LEF	11" x 8½"	0	0	0	1	1	000 00011
B5 SEF	—	0	0	1	0	0	000 00100
B5 LEF	—	0	0	0	1	0	000 00010
A5 SEF	5½" x 8½"	0	0	0	0	0	000 00000
A5 LEF	8½" x 5½"	0	0	0	0	0	000 00000

1: On (Paper Detected), 0: Off (Paper Not Detected)

**Note:** If the original is small (such as A5-LEF), all sensors are off and the machine shows that the original size cannot be detected. However, you can force the machine to detect A5/HLT in this case if you adjust SP4303 (there are settings for A5/HLT SEF and A5/HLT LEF).

**Detection Timing**

The APS sensors are always active when the machine is powered on, but the CPU checks their signals only after the platen has been lowered.

**Book Mode**

When the ARDF is open in the Book mode, the CPU checks the APS sensors and determines the original size after the [Start] key has been pressed.

**ARDF Mode**

The CPU checks the APS sensors after the platen has been lowered.

**By-pass Mode**

The APS sensors are ignored when copy paper is fed from the by-pass tray, but the by-pass tray can handle a variety of sizes and orientations. To accomplish this:

- The machine always assumes short-edge feed for paper on the by-pass tray.

## Details

---

- Width is measured by a sensor inside the by-pass tray.
- The bypass tray cannot measure length, so the registration sensor determines the length of the paper using clock pulses.

---

## Scanner Unit Fan and Anti-Condensation Heater

---

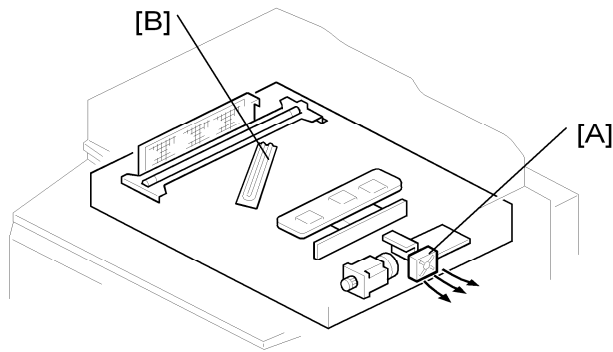

d014d104

Condensation on the mirrors can cause:

- Running, smearing and image borders
- Printing completely black or gray pages

The scanner unit is provided with a cooling fan [A] and anti-condensation heater [B] to keep the unit cool and dry. The fan pulls the heater air from around the PCBs and blows it out of the scanner unit.

The anti-condensation heater turns on when:

- The main power switch is turned off.
- The operation switch is turned off.
- The machine enters the auto off mode.

---

## Photoconductor Units (PCU)

---

### Overview

---

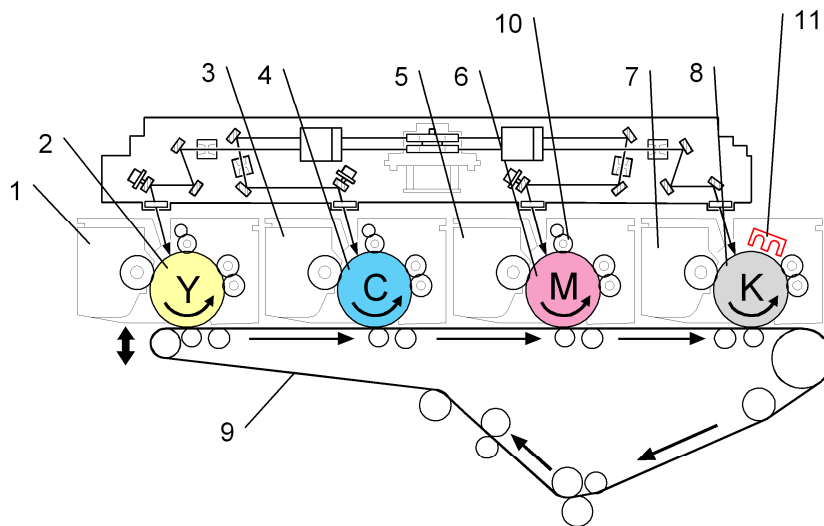

d014d001b

- |                         |                              |
|-------------------------|------------------------------|
| 1. Development Unit (Y) | 7. Development Unit (K)      |
| 2. Drum (Y)             | 8. Drum (K)                  |
| 3. Development Unit (C) | 9. Image Transfer Belt (ITB) |
| 4. Drum (C)             | 10. Charge Roller            |
| 5. Development Unit (M) | 11. Charge Corona Unit       |
| 6. Drum (M)             |                              |

Four PCU units (Y, C, M, K) are arranged in tandem from left to right. There is one PCU for each color. Each PCU consists of a development unit and drum unit pair (1)(2), (3)(4), (5)(6), (7)(8). The image that is developed on each drum transfers to the image transfer belt (9). Each color transfers onto the image transfer belt, one after the other (Y,C,M,K) during one pass of the ITB under the PCUs.

- The Y, C, and M PCUs all use a charge roller, for example (10) in the M\_PCU, to charge the drum surface.
- The K\_PCU, however, uses a charge corona unit to charge its drum.

## Details

- Also, only the K\_PCU has a temperature sensor that is used to correct process control parameters (charge voltage, for example) during process control.

All other parts of the PCU units (cleaning and development components) are identical. Only the methods of charge differ.

## Around The Drum

In this machine, the K PCU employs a charge corona unit and the other PCUs (Y, C, M) use charge rollers.

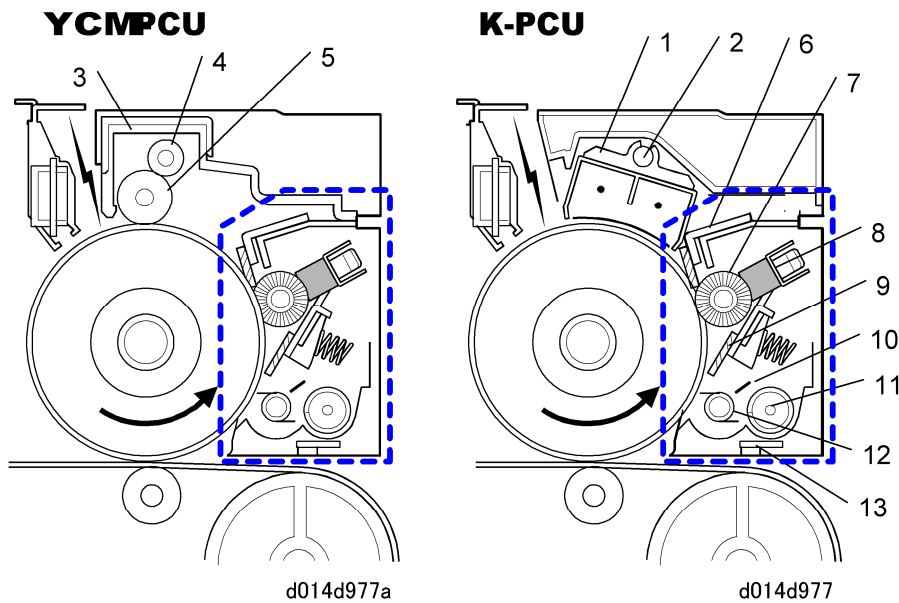

1	Charge Corona Unit (Scorotron type)	Only the K PCU uses a charge corona unit.
2	Charge Corona Wire Cleaner	
3	Charge Roller Unit	The Y, M, C PCUs use charge rollers.
4	Charge Roller Cleaning Roller	
5	Charge Roller	
6	Lubricant Blade	These items comprise the PCU cleaning system. The same parts and system are used in all of the four PCU units.
7	Lubricant Brush Roller	
8	Lubricant Bar	
9	Cleaning Blade	



## Details

10	Cleaning Brush Roller Flicker	
11	Toner Collection Coil	
12	Collection Coil	
13	Quenching LED	

## Drum Drive

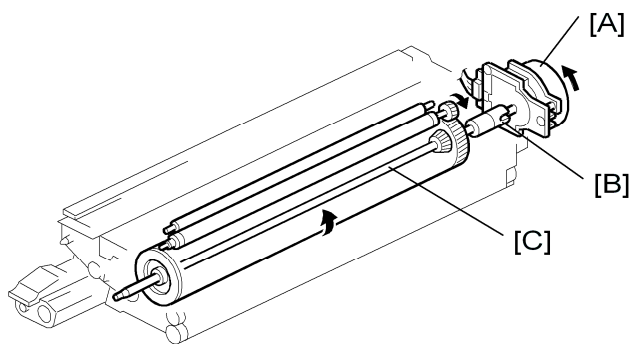

d014d204

[A]: Drum motor

[B]: Drum motor coupling

[C]: Drum shaft

Each PCU (Y, C, M, K) has an independent drum motor.

The drum motor [A] turns the drum motor coupling [B] that rotates the drum motor shaft [C].

During black-and-white copying and printing, only the black drum (K) rotates. The other color drums (Y, M, C) do not rotate.

## Drum Charge

The Y,C,M PCU units employ a charge roller to charge the drum. The K\_PCU uses a charge corona wire.

YCM PCUs

---

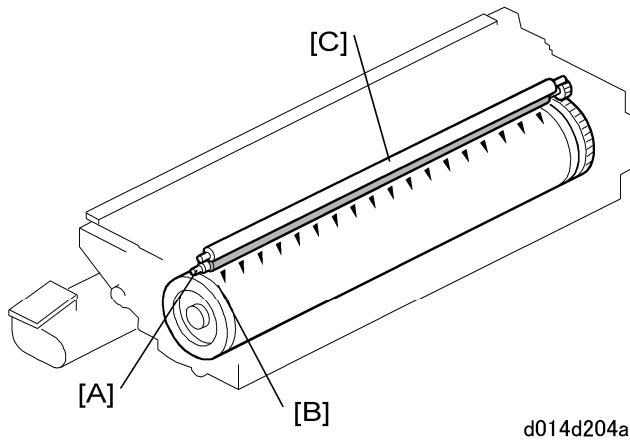

d014d204a

[A]: Charge roller

[B]: Drum

[C]: Charge roller cleaning roller

The charge roller [A] above the drum [B] charges the drum.

The charge roller cleaning roller [C] touches the charge roller and cleans it as the charge roller and cleaning roller rotate in opposite directions. The gap between drum and charge roller is 0.05 mm.

- The charge roller is the same length as the drum to ensure an even charge along the entire length of the drum.
- The charge roller receives its charge from the charge roller power pack. The power pack is connected at a terminal attached to the end of the charge roller shaft.

K PCU

---

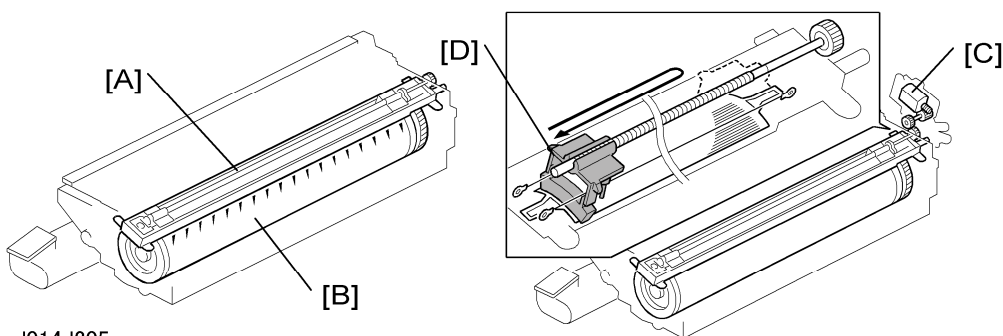

d014d205

The CGB power pack (a constant dc power pack) applies a high electrostatic charge to a pair of corona wires [A] suspended above the OPC drum [B]. The corona of this wire charges the surface of the drum below.

The amount of ozone generated during drum charging is much more than the amount

## Details

---

generated with the charge roller system used in the YMC PCUs. For this reason, the ozone filter of this machine has been enlarged and more fans have been installed around the ozone filter.

The charge wire cleaning motor [C] switches on at the time set with SP2220-1 to move the charge wire cleaning pad [D] one stroke forward and one stroke back to clean the wires. This keeps the wires free of dirt and ensures a uniform charge corona.

---

## Drum Cleaning and Lubrication

---

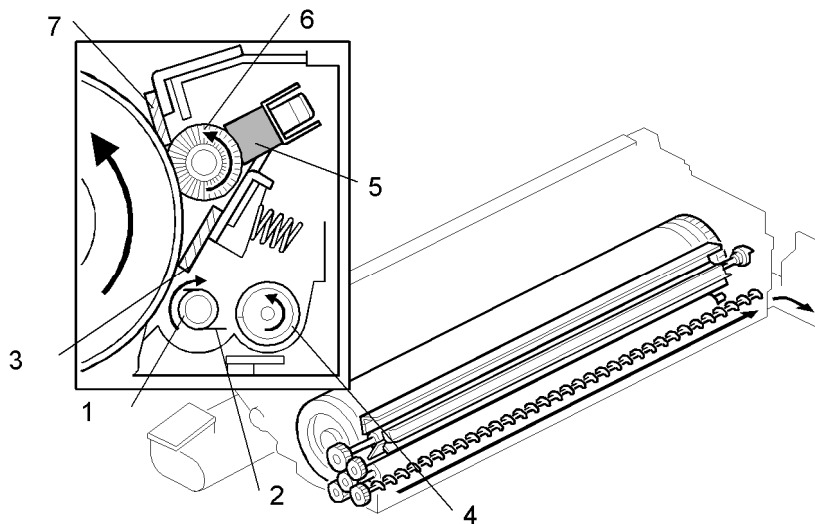

d014d203

To improve the efficiency of cleaning, the drum is lubricated with ZnSt (Zinc Stearate).

This cleaning sequence is the same in each PCU:

- The cleaning brush roller [1] brushes residual toner and other matter from the surface of the drum.
- The cleaning roller flicker [2] combs the cleaning brush roller to remove toner from the brush.
- The cleaning blade [3] (a counter blade) scrapes toner from the drum.
- All collected toner falls down into the toner collection coil [4]. This revolving coil moves the used toner to the used toner port at the back of the PCU.
- The lubricant bar [5] supplies lubricant (ZnSt) to the lubricant brush roller [6], and the lubricant brush roller applies the lubricant to the drum.
- Finally, the lubricant blade [7] smoothes the powder lubricant applied to the surface of the drum by the lubricant brush roller.

---

## Details

---

### PCU Ventilation

---

### Ozone Ventilation

---

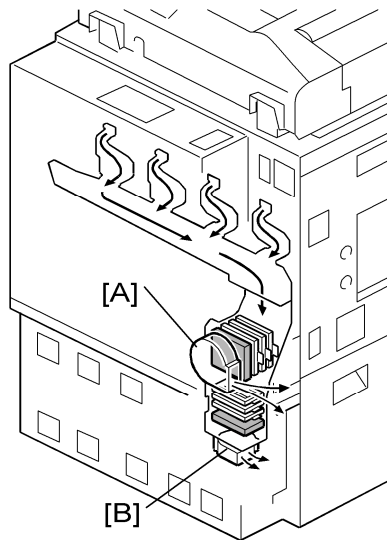

d014d962

Ozone exhaust fan [A] pulls air from the machine through the first air filter/ozone filter unit and expels it from the machine.

Ozone exhaust fan [B] pulls air through the second air filter/ozone filter unit and expels it from the machine.

---

## Development Unit

---

### Overview

---

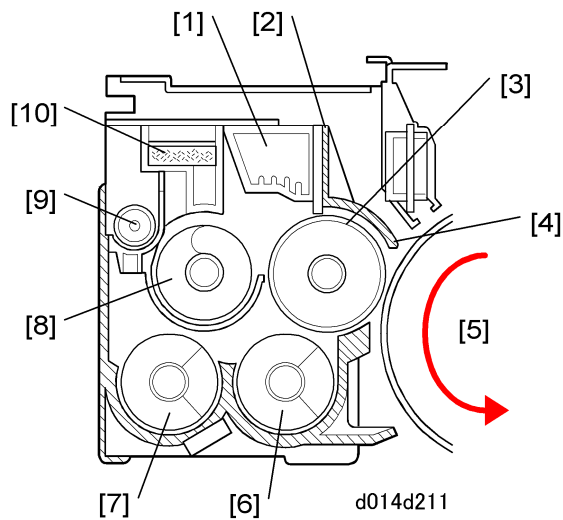

d014d211

## Details

---

1.	Heat Sink
2.	Doctor Blade (t=2.0)
3.	Development Roller
4.	Entrance Seal
5.	Drum (dia. 60)
6.	Toner Collection Auger (dia. 25)
7.	Development Auger (dia. 22)
8.	Supply Auger (dia. 22)
9.	Excess Toner Auger
10.	Filter

Development method:	Dual-component development
Agitation:	Two augers
Development unit drive:	Development motor, one for each development unit (Y, C, M, K)
Development bias:	Development bias power pack

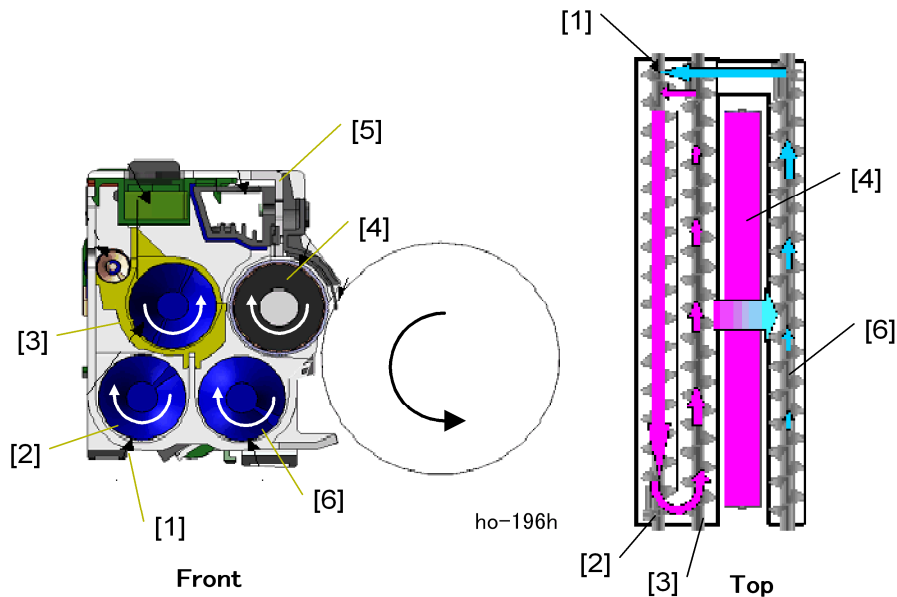

When the development unit is filled with new developer from the developer bottle, all the developer falls into the unit across its full length. Toner is supplied through a small port at the front of the development unit.

The toner enters the toner supply port [1].

The development auger [2] cross-mixes the developer and toner sent from the STC, and then sends this mixture to the supply auger [3] next to the development roller [4]. The magnetic development roller pulls the developer-toner mixture onto its surface as it rotates. Near the top of the development unit, the doctor blade [5] cuts and smoothes the developer/toner mixture to the correct thickness. The development bias power pack (not shown) applies the bias to the development bias terminal that is attached to the shaft of the development roller. Excess toner removed by the doctor blade drops into the toner collection auger [6].

## Details

### Development, PCU Unit Drive

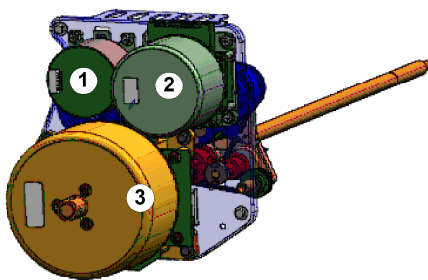

**Front**

ho-200a

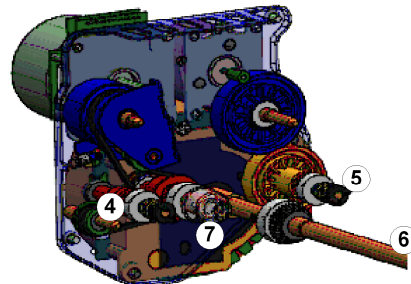

**Rear**

ho-200b

6ho-mtr1

1.	Drum Cleaning Motors x4
2.	Development Motors x4
3.	Drum Motors x4
4.	Development Auger Shaft
5.	Drum Cleaning Motor Shaft
6.	Drum Motor Shaft
7.	Development Roller Shaft

## Used Toner Collection

### Used Toner Path

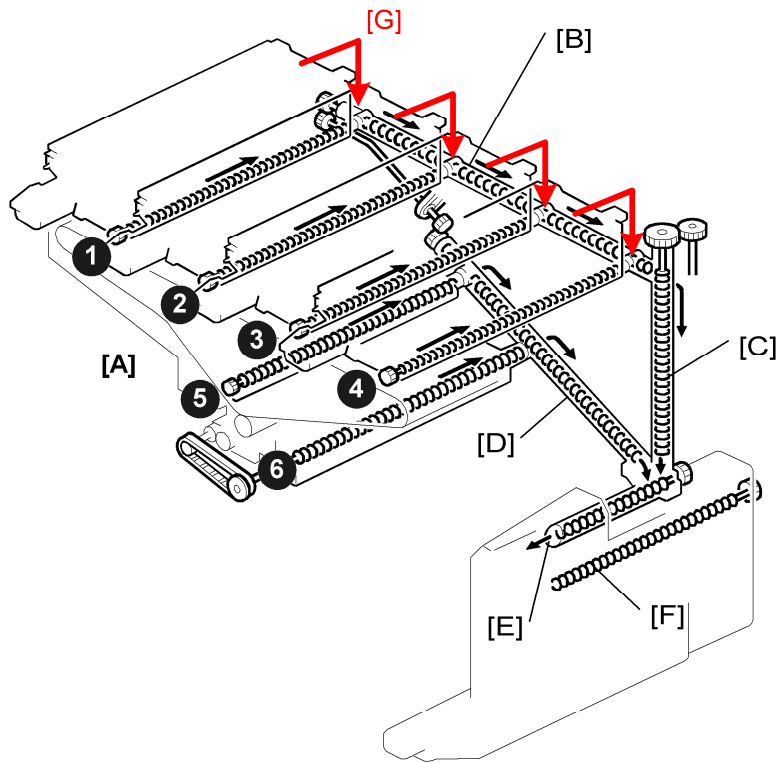

d014d215

[A]	Used Toner Collection Coils	[B]	Horizontal Used Toner Transport Coil
	① PCU (Y)	[C]	Vertical Used Toner Transport Coil
	② PCU (C)	[D]	Diagonal Used Toner Transport Coil
	③ PCU (M)	[E]	Used Toner Bottle Transport Coil
	④ PCU (K)	[F]	Used Toner Distribution Coil
	⑤ ITB Unit	[G]	Excess Toner Ports
	⑥ PTR Unit		

Excess toner from the OPC drums drops from the new excess toner collection coils onto the



horizontal used toner transport coil. (Please refer to the next section below.)

**[A]: Used Toner Collection Coils**

Six used toner collection coils (1 for each PCU and 1 each for the ITB and transfer roller) transport used toner away from these components after cleaning. The PCU motors drive coils 1 to 4. The PTR motor drives coils 5 and 6.

①	PCU (Y)
②	PCU (C)
③	PCU (M)
④	PCU (K)
⑤	ITB Unit
⑥	PTR Unit

**[B]: Horizontal Used Toner Transport Coil**

Driven by the PTR motor, this transports used toner from the PCU used toner collection coils to the vertical used toner transport coil.

**[C]: Vertical Used Toner Transport Coil**

Driven by a parallel vertical shaft connected to the used toner bottle transport motor, this transports used toner from the horizontal used toner collection coil to the central collection point above the used toner bottle.

**[D]: Diagonal Used Toner Transport Coil**

Driven by the PTR motor, this transports used toner from the ITB unit and PTR unit used toner collection coils to the central collection point above the used toner bottle.

**[E]: Used Toner Bottle Transport Coil**

Driven by the used toner bottle transport motor, this transports used toner from the central collection point to entrance of the used toner bottle.

**[F]: Used Toner Bottle Distribution Coil**

This coil at the top of the used toner bottle is driven by the used toner bottle near full motor. The coil distributes the used toner evenly across the length of the used toner bottle.

Excess Toner Collection Coils

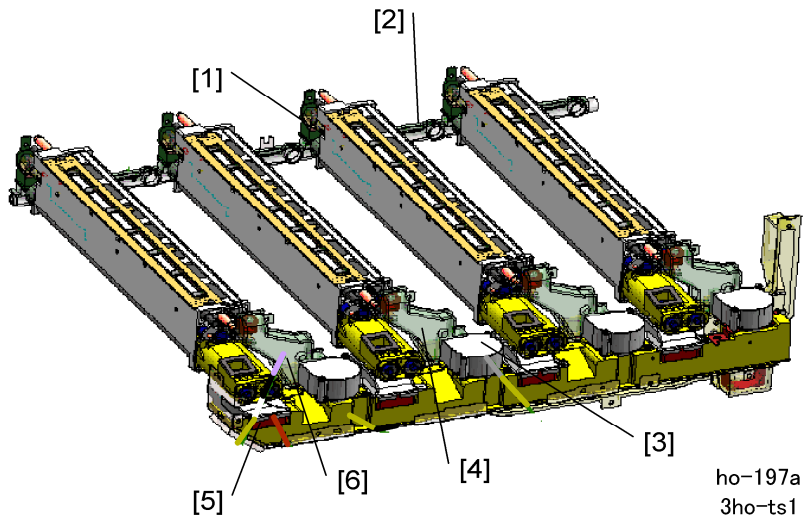

1	Excess Developer Coil* <sup>1</sup>
2	Horizontal Used Toner Transport Coil
3	Cooling Fan 2 (Doctor Blade)* <sup>1</sup>
4	Cooling Duct 2 (Development Doctor Blade)* <sup>1</sup>
5	Cooling Fan 1 (Below Development Unit)
6	Cooling Duct 1 (Below Development Unit)
* <sup>1</sup> These are new items.	

An excess developer coil has been added to each PCU in order to transport excess toner from the development unit.

## Process Control

### Overview of Process Control

In this machine, there are three phases in process control:

- **Potential control.** Adjusts the image creation process (charge, development bias, and LD power) to achieve the target toner coverage. During potential control, several series of patterns are created at prescribed times. The potential sensor and ID sensor read these patterns. The readings of these sensors are used to determine the development capacity (development gamma), and then adjust the conditions around the drum to reproduce the best possible images. Potential control also puts the machine in the best possible condition to begin toner supply control.
- **MUSIC.** MUSIC (Mirror Unit Skew Interval Correction) corrects the horizontal and vertical skewing of the print images on the ITB
- **Toner supply control.** Detects the amount of toner applied to ID sensor patterns between pages and adjusts the amount of toner supplied to the development unit to maintain consistency in the amount of toner.

### Components Used During Process Control

#### Potential Sensor

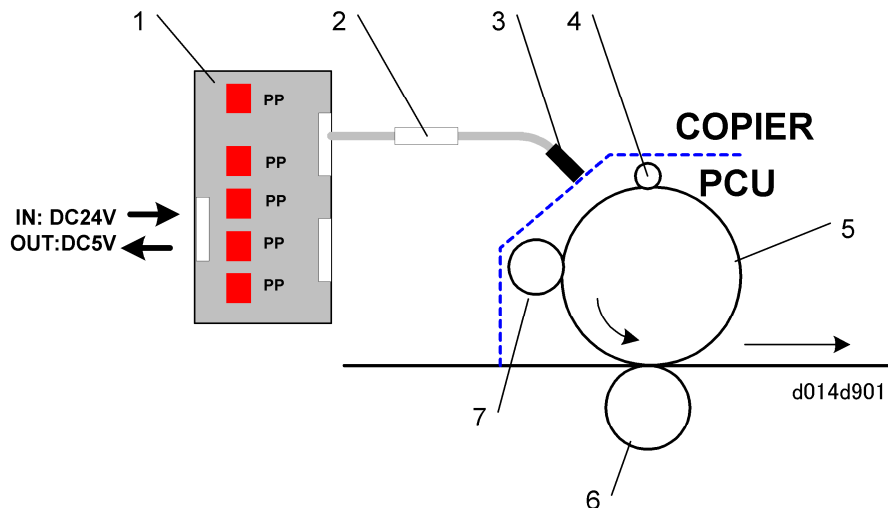

1	Potential Sensor PP	Max. output: -1000V
---	---------------------	---------------------

## Details

2	Drawer Connector	Connection point for PCU
3	Potential Sensor Probe	Mounted in the copier (not in PCU)
4	Charge Roller	Y,M,C PCU. K PCU has a corona unit.
5	OPC Drum	Surface potential: -900V max.
6	Transfer Roller	1.5kV (normal use), 5kV (transfer)
7	Development Roller	Range: -350 to -800V dc

There is a potential sensor mounted in the copier above the surface of the drum in each PCU. Each potential sensor consists of a probe and small power pack. A drawer connector connects the probe and the power pack as shown above.

The potential sensor measures the potential of the drum immediately after it is charged by the charge rollers in the Y,M,C PCUs and charge corona unit in the K PCU. It also measures a series of patterns (undeveloped latent images) exposed on the drum by the laser diodes:

- A detector in the center of a very small window measures the strength of the electrostatic charge on the drum surface. The strengths of the charges vary, depending on the surface potential of the drum.
- A feedback circuit applies voltage to the probe until the strength of this charge equals (offsets) the strength of the charge on the drum.

## ID Sensor

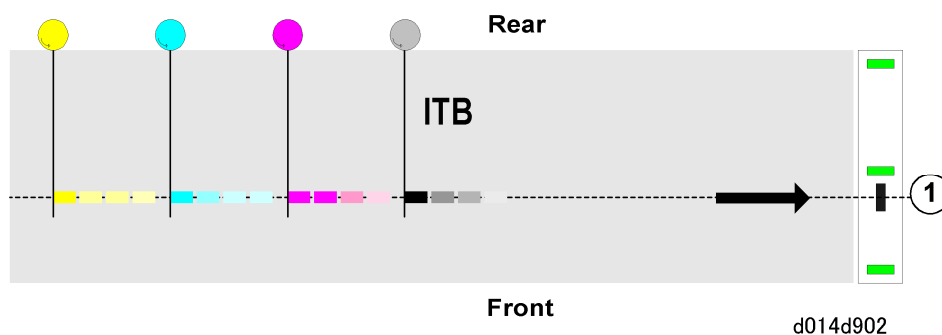

One ID sensor above the image transfer belt reads the K, M, C, and Y patterns on the belt.

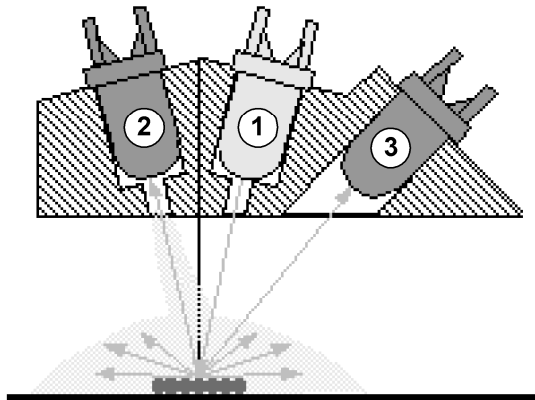

d014d904

Three diodes comprise the ID sensor:

- **(1) Emitter.** Emits light on the patterns.
- **(2) Direct reflector sensor.** Gathers light reflected directly from the patterns.
- **(3) Diffused reflector.** Gathers diffuse light from the sides of the patterns to achieve more accurate readings especially for Y, M, C.

During process control, the creation of the patterns is timed so the Magenta, Cyan and Yellow patterns are transferred to the ITB at approximately the same time. The ID sensor reads the patterns in the order K, M, C, Y.

#### TD Sensor

---

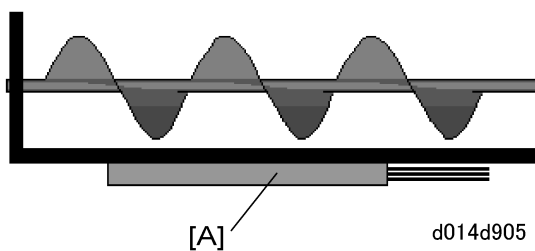

d014d905

A TD sensor [A] is attached to the bottom of the development unit in each PCU.

The TD sensor directly measures the amount of toner in the developer/toner mixture. Unlike previous machines, this TD sensor is not in direct contact with the developer/toner mixture.

$V_t$  is the output voltage of the TD sensor. When  $V_t$  goes high, toner is added to the developer to bring  $V_t$  back to the  $V_{tref}$  value.

## Details

---

### Temperature/Humidity Sensors

---

Two temperature/humidity sensors are used for process control. One is near the drum potential sensor above the M PCU, and one is below the used toner bottle.

#### **K PCU Temperature/Humidity Sensor**

The output of this sensor is used to:

- Set the level of the ac charge applied to each PCU
- Set the length of time the agitator in the development unit rotates to mix the developer and toner.

#### **Used Toner Bottle Temperature/humidity sensor**

The output of this sensor is used to control the amount of current applied to the image transfer belt and paper transfer roller. It is also used to correct fusing idling temperature during fusing temperature control.

---

### List of Process Control Acronyms

---

The potential control phase of process control involves many adjustments. Here is list of acronyms used in the descriptions of process control adjustments.

Acronym	Description
Cdc	Charge dc bias
Vb	Development charge bias
Vb*1	Development charge bias after Vr (residual potential) adjustment
Vd	Drum potential after the drum is charged by the charge roller.
Vd*1	Drum potential after Vr (residual potential) adjustment
Vdhome	The electrical potential of the drum after a fixed dc bias (dc -700V) is applied by the drum charge roller.
Vdp	Development potential ( $V_b - V_{pl}$ ). This is the ability to attract toner to the drum.
Vk	Development start voltage (checks the developer at the beginning of process control to determine whether it has deteriorated)
VI	Light potential. Development potential of areas on the drum exposed by the

## Details

Acronym	Description
	laser diodes. Maximum laser power has been applied to the diodes.
Vpl	Electrical potential after laser exposure, with 24/63 of maximum laser power (power is controlled with PWM).
Vpl* <sup>1</sup>	Electrical potential (Vpl) after Vr (residual potential) adjustment
Vpp	Charge ac bias.
Vr	Residual potential
Vsg_dif	Vsg after checking the bare surface of the ITB by the diffused reflection sensor.
Vsg	ID sensor output after reading bare surface of the ITB
Vsg_reg	Vsg after checking the bare surface of the ITB by the direct reflection ID sensor.
Vsp	ID sensor output from the most recent ID sensor pattern.
Vt	TD sensor output at the present time.
Vtcnt	Gain value calculated during TD sensor initialization. This is used to adjust the Vt (TD sensor output). A large gain increases Vt, and a small gain decreases it. The result of this calculation is also used to calibrate Vt during TD sensor initialization.
Vtref	Target output of the TD sensor. The machine always tries to adjust the toner WT% in the developer to bring Vt closer to Vtref.

\*<sup>1</sup> Adjustment done for each color Y, M, C, K

## Important SP Codes Related to Process Control

This table lists the SP codes that are associated with the most important elements of process control. For more, please refer to "Service Tables".

## Details

		SP3501 001 Potential Control Type Selection		Target Effect in Process Control
		0: Auto	1: Fixed	
<b>Charge</b>				
Charge dc bias	Cdc	SP3576	SP2201	Potential control
Charge ac bias	Vpp	SP3577	SP2202	Prevention of abnormal images
<b>Exposure</b>				
PM (LD power)	Ldp	SP3581	SP2211	Potential control
<b>Development</b>				
Development bias	Vb	SP3575	SP2212	Potential control

## Potential Control

When is Potential Control Done?

### 1. Initial Process Control Self-Check

The process control self-check is always done automatically after the machine is turned on. If one or more of the following conditions existed before the machine is switched off, this will also trigger the process control self-check:

- The machine remained idle longer than the time specified with SP3554-1.
- The temperature change since the previous time that the machine power was cycled off/on was greater than the setting specified with SP3554-2.
- The change in the relative humidity since the previous time that the machine power was cycled off/on was greater than the value specified for SP3554-3.
- The change in the absolute humidity since the previous time that the machine power was cycled off/on was greater than the value specified for SP3554-4.

**Note:** The initial process control self-check is not done when the machine is turned on with the front door open.

### 2. During a Job.

SP3552 determines when a process control self-check is done while the machine is printing,



## Details

---

receiving data for the next job, or while jobs are queued for printing. This occurs when:

- The current page count for black-and white (SP3552-3) > SP3552-1
- The current page count for color (SP3552-4) > SP3552-2

If SP3552-1, -2 are set to "0", the self-check is done at the following intervals, which depend on the development gamma from the most recent process control self-check.

- If the development gamma reading is much larger than the target value of development gamma, the process control self-check is done every 250 pages.
- If the development gamma reading is only slightly different from the target value of development gamma, the process control self-check is done every 500 pages.

### 3. At Job End

There are separate counters for black-and-white and color pages. SP3551 sets the number of pages that will trigger a process control self-check at the end of a job. SP3552 sets the number of pages that will trigger a process control self-check during a job and not wait for job end.

- Black and White: If the current page count (SP3551-3) > SP3551-1, process control will be done at the end of the job, if end-of-job process control has not been done for 250 pages
- Color: If the current page count (SP3551-4) > SP3551-2, process control will be done at the end of the job, if end-of-job process control has not been done for 250 pages

SP3551-3 or SP3551-4 can be set to "0" to disable this feature.

### 4. After a Specified Idle Time.

The machine will execute the process control self-check if the machine remains idle for the length of time specified by SP3555. After the time set with SP3540-2 has elapsed, the current temperature and humidity are compared with the temperature and humidity the last time the drum stopped. If the difference is greater than the threshold values set with this SP3555, initial process control executes. Specifically, this means this SP will trigger the self-check under the following conditions:

- The machine has not been used within a specified length of time since the last process control self-check (SP3555-1).
- Change in ambient temperature (SP3555-2).
- Change in relative humidity (SP3555-3)
- Change in absolute humidity (SP3555-4)

### 5. Before ACC (Automatic Color Calibration)

The process control self-check is done after touching [Execute] on the operation panel to start ACC and just before the ACC pattern prints. However, this operation can be changed with SP3501 004:

0	Process control self-check is not done before the ACC pattern prints.
1	A partial self-check (only potential control) is done before the ACC pattern prints. This takes about 10 seconds.
2	The full process control self-check (potential control and toner density control) is done before the ACC pattern prints (default). This takes between 10 seconds and 180 seconds.

**6. Immediately after TD sensor Initialization.**

The process control self-check is done automatically every time a TD sensor is initialized.

- Done after SP3801 001-006 is executed (after replacing the developer).
- Done after SP3811 is executed (at machine installation, or after replacing developer).

**7. Potential control process control self-check**

This is done manually by the service technician or designer with SP3820-1.

**8. Potential control/toner density adjustment process control self-check.**

This is done with SP3820-2. This SP must be done manually when only the drum is replaced (but not developer).

What is Done During Potential Control?

---

The process described below is done in each of the four PCUs. For simplicity, however, the discussions are limited to what occurs in one PCU. The illustration below shows the sequence of events during process control and MUSIC adjustment.

Note that the sensor readings used by both potential control and MUSIC adjustments are always checked at Step 1 and 2 before MUSIC executes. For example, if only MUSIC is to be updated:

- The readings are checked at Step 2.
- If the process control readings are within range, MUSIC executes.
- If the process control readings are not within range, Steps 3, 5, 6 are done then the process loops back to Step 1.
- After the new readings are done at Step 2, then MUSIC is done.

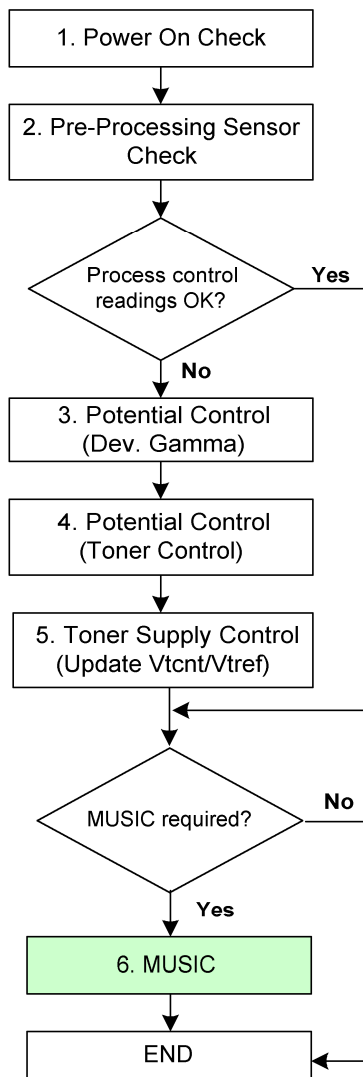

d014d988

**1. Check after Power On**

This check is performed only after the machine is powered on.

- AC Current Adjustment.  
The machine selects the current for optimum AC charge (Vpp). The optimum charge depends on the ambient temperature and humidity. The optimum charge for each temperature and humidity range is set with SP2204 (ACC Charge Correction). Insufficient charge can cause white spotting, and too much charge can cause toner film on the surface of the drum. This check ensures that the average value of Vpp after 20 samplings is  $V_{pp} > 2.8 \text{ kV}$ .
- Toner Agitation
- Vsg detection. The ID sensor detects Vsg (reflectivity of the bare drum surface)
- Transfer current adjustment.

## 2. Check Sensor Readings

The processes and analyzes the results of the sensor readings in the previous step.

- Detect Vdhome

A charge of  $-700V$  is applied to the drum. The potential sensor detects the potential of the drum and checks if the potential sensor, drum, and charge roller/corona unit are functioning normally. If the charge is within the range  $-800V$  to  $-500V$ , the drum is functioning normally.

### Possible Errors at Potential Sensor Calibration

SC Codes	For More Details:
SC436~SC439	See "Process Control Troubleshooting" in "4. Troubleshooting" in the B132/B200 Service Manual.
SP3821	15, 16, 17

- Vsg adjustment

Before the gradated patterns are read, the strength of the ID sensor output (LED PWM) is adjusted to bring the value of Vsg\_reg to the specified value.

An abnormal condition is detected when:

- Before Vsg adjustment begins,  $Vsg\_reg < 0.5V$
- After Vsg adjustment,  $Vsg\_reg$  cannot be adjusted to  $4.0 \pm 0.2V$

### Possible Errors at Vsg Adjustment

SC Codes	For More Details:
SC400, SC418	See "Process Control Troubleshooting" in "4. Troubleshooting" in the B132/B200 Service Manual.
SP3821	21, 22, 23

- Transfer current adjustment error

### Possible Errors with Transfer Current Adjustment

SC Codes	For More Details:
SC465 to SC472	See "Process Control Troubleshooting" in "4.

SC Codes	For More Details:
	Troubleshooting" in the B132/B200 Service Manual.

### 3. Potential Control (Development Gamma Measurement)

The laser diodes write the 4-grade potential sensor patterns on each drum. To make the different densities, the machine changes the PWM duty of the laser diodes.

- Potential sensor reads the 4-grade patterns on the image transfer belt. The required potentials are calculated.
- ID sensor reads the patterns 4-grade patterns on the image transfer belt to calculate the amount of toner coverage required.
- The combined readings of the potential sensor and ID sensor are used to retrieve from a lookup table the optimum values for:
  - 1) Vd (charge potential)
  - 2) Vb (development bias)
  - 3) Vpl (drum potential after exposure)

The development gamma must be in the range 0.3 to 6.0 V. Development start voltage (Vk) must be in the range -150 to 150 V. This development start voltage is used to indicate whether the developer has deteriorated. However, this is only a rough measurement that can be affected by ambient conditions and the condition of other electrical components.

#### Possible Errors at ID Sensor Pattern Detection

SC Codes	For More Details:
SC410~SC413	See "Process Control Troubleshooting" in "4. Troubleshooting" in the B132/B200 Service Manual.
SC414~SC417	
SP3821	55, 56, 57, 58, 59, 60

### 4. MUSIC

The MUSIC adjustments are done only if the process control readings are within the prescribed ranges.

### 5. Potential Control (Toner Application Control)

- Adjustment is done for residual potential. The laser unit fires at full power to compensate for a possible high residual potential on the drum. Next, the amount of

## Details

---

residual potential is detected, and the charge is adjusted to achieve the target potential. The detected  $V_r$  must be less than  $-200V$ .

- Using the values retrieved from the lookup table in Step 3 above,  $V_d$ ,  $V_b$ , and  $V_{pl}$  are updated to  $V_d^*$ ,  $V_b^*$ , and  $V_{pl}^*$ 
  - 1)  $V_b^*$ : Targeted development Bias after  $V_r$  correction
  - 2)  $V_d^*$ : Target drum potential after  $V_r$  correction
  - 3)  $V_{pl}^*$ : Target electrical potential after  $V_r$  correction

### Possible Errors at $V_r$ (Residual Potential) Adjustment

SC Codes	For More Details:
SC432~SC435	See "Process Control Troubleshooting" in "4. Troubleshooting" in the B132/B200 Service Manual.
SP3821	62

### Possible Errors at $V_d$ (Development Bias) Adjustment

SC Codes	For More Details:
SC420~SC423	See "Process Control Troubleshooting" in "4. Troubleshooting" in the B132/B200 Service Manual.
SP3821	63

### Possible Errors at $V_{pl}$ (LD Power) Adjustment

SC Codes	For More Details:
SC424~SC427	See "Process Control Troubleshooting" in "4. Troubleshooting" in the B132/B200 Service Manual.
SP3821	64

## 6. Toner Supply Control (Update $V_{tcnt}/V_{tref}$ )

Now the machine can use the values calculated during process control to calibrate  $V_{tref}$  and  $V_{tcnt}$  in order to supply the correct amount of toner. There are no checks for abnormal

Details

conditions at this step.

MUSIC (Mirror Unit for Skew and Interval Correction)

The Optical Path

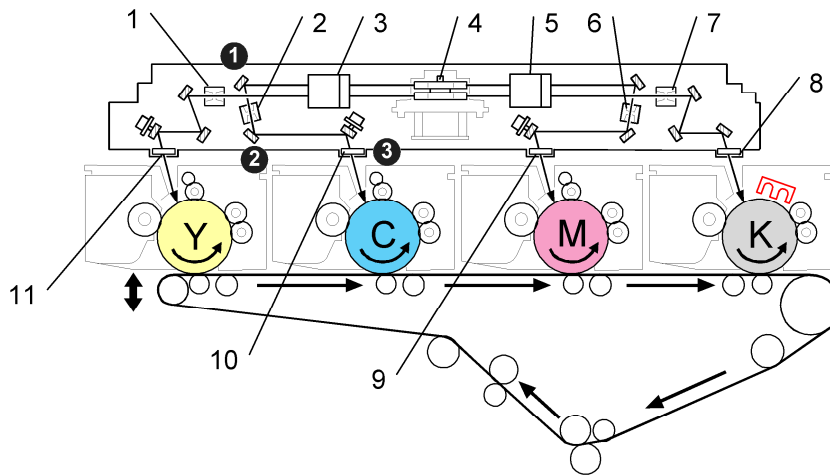

- 1. WTL Lens (Y)
- 2. WTL Lens (C)
- 3. Dual-layer f-theta Lens (C, Y)
- 4. Polygon Mirror Motor
- 5. Dual-layer f-theta Lens (M, K)
- 6. WTL Lens (M)
- 7. WTL Lens (K)
- 8. Dust-shield Glass
- 9. Dust-shield Glass
- 10. Dust-shield Glass
- 11. Dust-shield Glass

**Optical Path**

All four latent images (C, M, Y, K) are written at approximately the same time. The laser diode turn-on times for each color are timed with drum rotation and paper feed. Refer to the illustration on the previous page. The optical path for each color is as follows:

Cylindrical lens (laser beam correction in each LD unit)	(Not shown)
↓	

## Details

Polygon mirror (main scanning line)	4
↓	
F $\theta$ lens (dot position correction)	3
↓	
1st Mirror	1
↓	
WTL lens (surface distortion correction)	2
↓	
2nd Mirror	2
↓	
3rd Mirror	3
↓	
Dust-shield Glass	10
↓	
Drum	

Each f-theta lens has two layers. Because of this, it can correct both beams from the LD units. Each WTL lens corrects for image distortion.

The polygon mirror turns at high speed. The laser beams are reflected from the polygon mirror to a pair of mirrors (upper and lower), then to one more mirror and out to the drum through the dust-shield glass. The polygon mirror has six faces.

The polygon mirror motor rotates at 33,307 (D014) or 41,669 (D015) rpm for full-color and for black-and-white copying.

### ★ Important

- Because of its high rotation speed, the mirror continues to turn for about 3 minutes after the machine is turned off. Allow enough time for the mirror to stop before you start to remove the polygon motor.



## Details

---

### What does MUSIC do?

---

MUSIC is the Mirror Unit for Skew and Interval Correction. Three MUSIC sensors above the ITB read three MUSIC sensor patterns made by the machine on the ITB.

The machine uses the results to adjust:

- The machine adjusts the start timing for the laser at the start of the main scan. This adjusts the main scan. If skew is detected in the main scan direction, the machine adjusts the laser timing and the angles of the 3rd mirrors (Y, M, and C only).
- The speed of the drum motors to correct the intervals between the patterns. This adjusts the sub scan.

If the vertical alignment of the patterns is not correct, or if the intervals are not correct, this causes color registration errors.

The MUSIC adjustment is done for each color (Y, M, C, K).

### When is MUSIC done?

---

Normally, MUSIC executes automatically:

- Immediately after the machine is turned on or returns from an energy save mode.
- At the start of a job, if the temperature in the laser exposure unit changed since the end of the job by the amount set with SP2153 020 (Default: 1.5°C)
- After process control (enable/disable with SP2153 002).
- Every 100 pages during a long color job (you can change the interval with SP2153 024) if the temperature in the laser exposure unit has changed since the end of the most recent MUSIC adjustment by the amount set with SP2153 020 (Default: 1.5°C)
- Forced MUSIC (manually by the user or a technician)
  - 1) User Tools> Maintenance> Color Registration
  - 2) SP 2111 001

Here are some important points to remember about MUSIC:

- Immediately after the machine is turned on, MUSIC requires time to complete processing. But you can do a black-and-white job immediately.
- If a job is started before the MUSIC process has completed, a message ("Now Self Checking") will appear on the operation panel display.
- The job will not be done until the MUSIC process is finished. Wait for MUSIC to complete.

## Details

### Location of the MUSIC Sensors

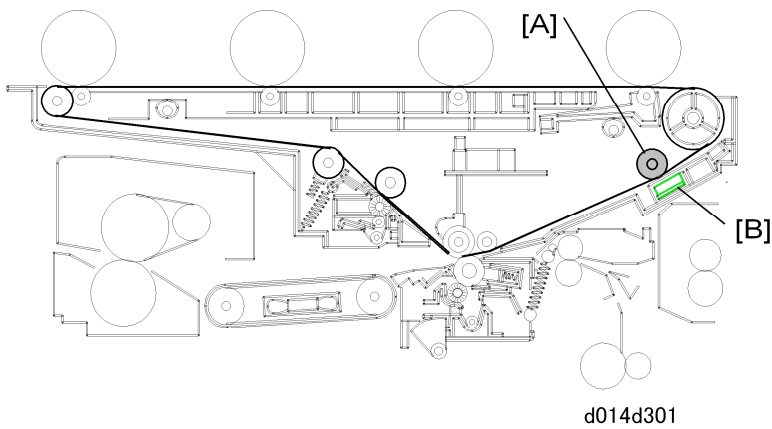

The three MUSIC sensors [A] are arranged in a straight line below the ITB.

A roller [B] opposite the sensors pushes the transfer belt against these sensors. This ensures that the sensors read the patterns accurately.

### How is MUSIC Done?

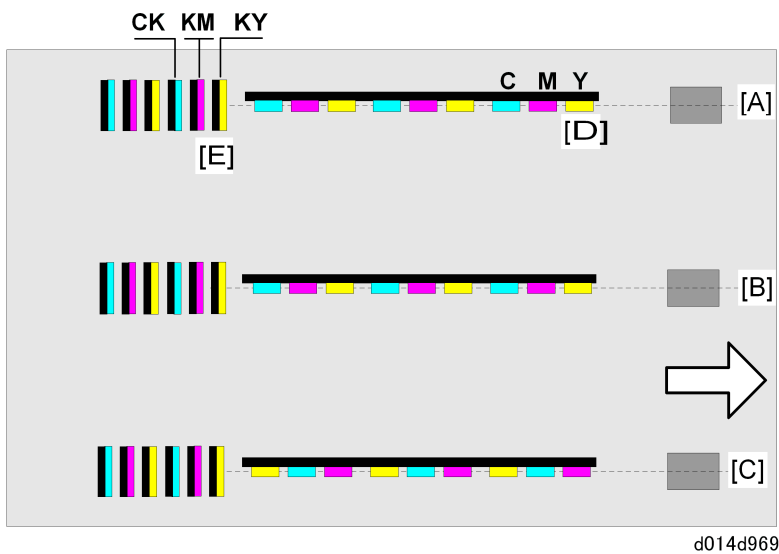

[A]: Rear MUSIC sensor

[B]: Center MUSIC sensor

[C]: Front MUSIC sensor

[D]: Main scan MUSIC patterns

[E]: Sub scan MUSIC patterns

The MUSIC sensors [A], [B], and [C] read the MUSIC patterns from the ITB.

The main scan MUSIC sensor pattern [D] consists of patches for each color (M, C, Y) beside the black (K) color patch. The sub scan MUSIC sensor pattern [E] consists of patches for

## Details

---

each color (M, C, Y) above a black (K) patch.

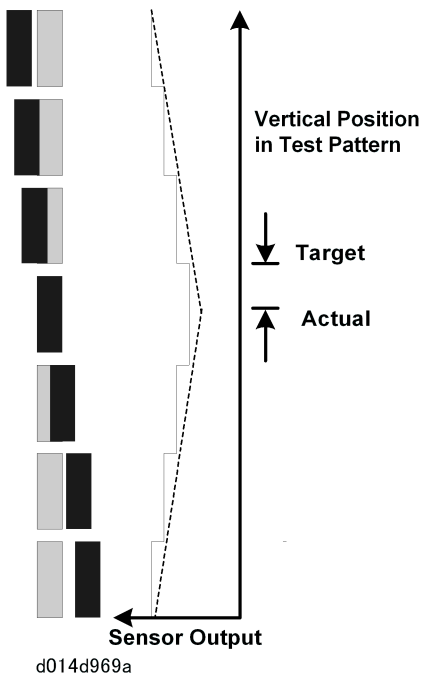

This diagram shows a close-up view of the main-scan test pattern.

K is the reference, and the positions of CMY are adjusted with reference to the K pattern.

The CMY patterns are vertical (shown in grey in the diagram), but the K pattern overlaps the CMY patterns as shown.

The MUSIC sensor response is measured. The output is the lowest when the K pattern fully overlaps the color pattern (the dotted lines in the diagram cross at this point). This is the "Actual" position as shown in the diagram. But there is a "Target" value in the machine software (an example is shown in the diagram; this is not the real target, it is just an example to explain the process). The machine compares the "Actual" and "Target" values, and adjusts the laser timing in response to the results of this comparison.

Skew is also measured in the main scan direction using the patterns at the left and right of the ITB. If skew is detected, the machine adjusts the angle of the 3rd mirrors.

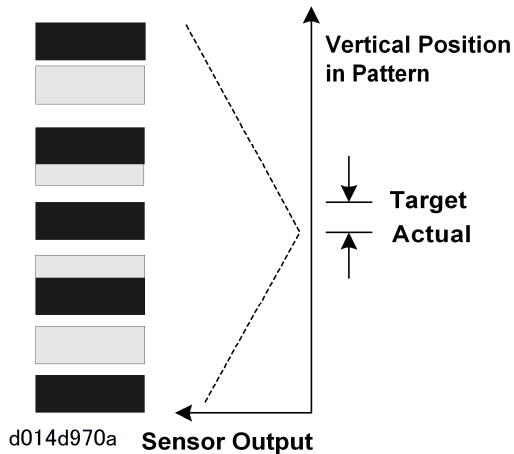

This diagram shows a close-up view of the sub-scan test pattern.

K is the reference, and the positions of CMY are adjusted with reference to the K pattern.

The CMY patterns are at constant intervals, but the K pattern overlaps the CMY patterns as shown.

The MUSIC sensor response is measured.

The output is lowest when the K pattern fully overlaps the color pattern (the dotted lines in the diagram cross at this point). This is the "Actual" position as shown in the diagram. But there is a "Target" value in the machine software (an example is shown on the diagram; this is not the real target, it is just an example to explain the process). The machine compares the "Actual" and "Target" values, and adjusts the speeds of the drum motors (Y, M, C) according to the results of this comparison.

3rd Mirror Position Adjustment

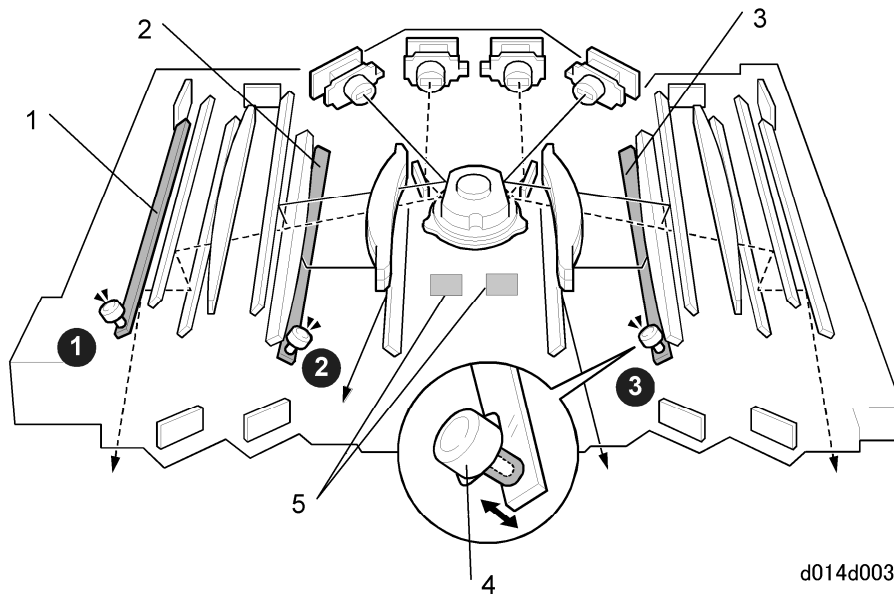

d014d003

1. 3rd Mirror (Y)
2. 3rd Mirror (C)
3. 3rd Mirror (M)
4. Mirror Adjustment Motors ①②③
5. Temperature Sensors

Each color Yellow [1], Cyan [2], Magenta [3] has a mirror. The machine uses the mirror motors (①②③) to adjust the position of each mirror to correct color registration errors on the ITB in the main scan direction. Color registration errors occur if all four color-toner images do not cover each other exactly on the ITB.

The 3rd mirror for black (K) does not have an adjustment motor. (The position of black toner on the ITB is used as a reference point to adjust the positions of the other colors.)

Exposure Unit Temperature Sensors

There are temperature sensors [5] near the f-theta lenses to monitor the temperature inside the exposure unit.

The f-theta lenses are made of plastic. The magnification ratio of plastic lenses may vary

## Details

---

slightly with temperature. The CPU uses the feedback from these temperature sensors to adjust the mirror positions during MUSIC calibration. This corrects color registration errors on the ITB.

---

## Toner Supply Control

---

### Overview

---

The toner supply method can be selected with SP3301-1 to 4.

- 0: Fixed supply mode (used for testing only; do not use this mode except during some troubleshooting procedures as described in section 4)
- 1: PID (Proportional Integral Differentiation) control mode (default)

This section describes only PID control because only PID control is used in the field. PID control uses inputs from pixel count, and from the TD and ID sensors. If the TD or ID sensor is broken, the machine uses PID control with inputs from pixel count only.

The following three functions comprise toner supply control for this machine.

#### **1. At the end of every job (at the same time as potential control)**

This is done if the number of pages since the previous toner supply control is more than the number that is set with SP 3551.

Black-and-white	After 250 pages (adjustable with SP3551 001)
Full color	After 250 pages (adjustable with SP3551 002)

Using the development gamma that was calculated during potential control, the machine determines the target amount of toner (M/A):

- Low development gamma: Raises the target image density of the sensor pattern and increases the toner concentration.
- High development gamma: Lowers the target image density of the sensor pattern and decreases the toner concentration.

#### **2. Page interval process control (Vsp detection between pages)**

This function operates only when SP3042 001 (Vtref correction) is set to "ON" (default). The Vsp ID sensor pattern is created between the page images on the ITB (Default: Every 10 pages). This interval can be adjusted with SP3102.

## Details

---

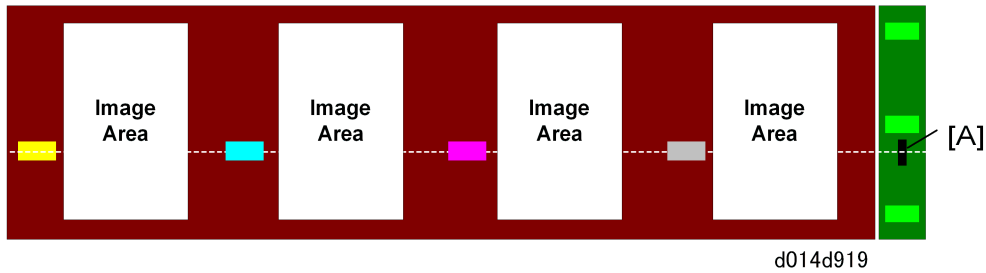

The toner M/A is calculated from readings of the ID sensor patterns by the ID sensor after every 10th page. The maximum coverage (Target M/A) that can be achieved by the process control self-check is controlled by SP3531-1, 2, 3, 4.

Toner supply is based on  $V_t - V_{tref}$

- If the pattern is too dark (too much toner):
  - >  $V_{tref}$  is increased > Toner supply amount decreases
- If the pattern is too light (not enough toner):
  - >  $V_{tref}$  is reduced > Toner supply amount increases
- TD sensor detection is also done for every page:
  - If  $V_t < V_{tref}$ , the toner supply amount is lowered.
  - If  $V_t > V_{tref}$ , the toner supply amount is raised.

Toner Supply Operation Flow

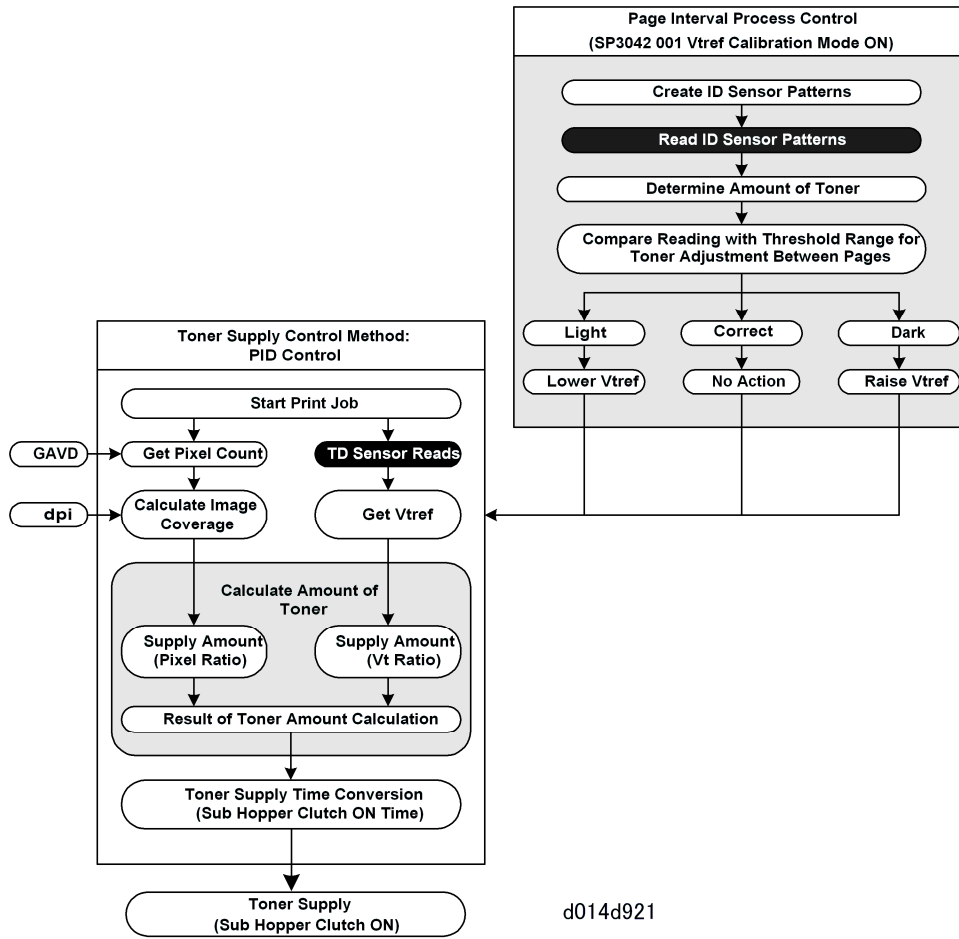



---

## Image Transfer

---

---

### Image Transfer Overview

---

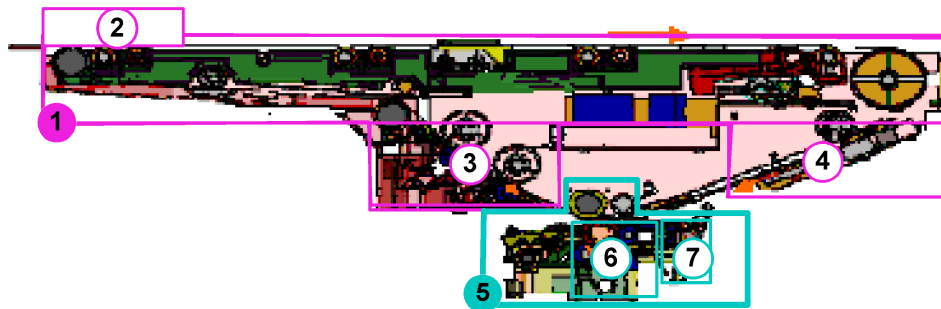

temp\_itu

The image transfer unit performs two important functions: transferring the image from the OPC drum to the ITB (Image Transfer Belt) and transferring the image from the ITB to paper. The image drum-to-belt transfer is done in the ITB unit at the top. The belt-to-paper transfer is done in the PTR (Paper Transfer Roller) unit at the bottom.

The ITB unit contains a lift mechanism, a cleaning unit, and a MUSIC sensor unit. The ITB lift mechanism raises the ITB against the bottoms of the color drums above during full-color printing and lowers the ITB for black printing and when the machine is idle. The cleaning unit cleans the ITB. The MUSIC unit contains sensors that read the MUSIC and ID sensor patterns on the belt.

The PTR unit contains a cleaning mechanism and a lift mechanism. The cleaning mechanism cleans the PTR. The lift mechanism raises the PTR against the belt, paper, and the opposing roller above when the image is transferred from belt to paper and lowers the roller when the machine is idle.

These mechanisms are described in more detail below.

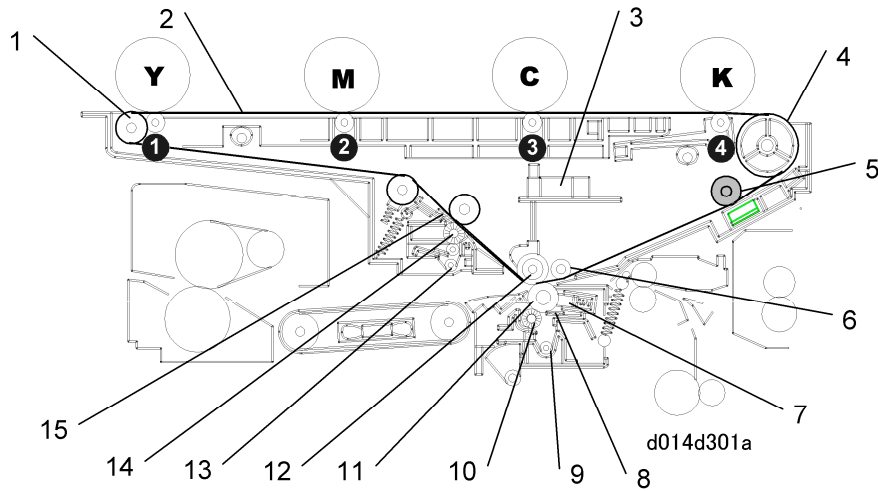

- |                                     |                                 |
|-------------------------------------|---------------------------------|
| 1. Image Transfer Rollers ( , , , ) | 9. PTR Toner Collection Coil    |
| 2. Image Transfer Belt (ITB)        | 10. PTR Cleaning Brush          |
| 3. Transfer Power Pack              | 11. PTR (Paper Transfer Roller) |
| 4. ITB Drive Roller                 | 12. ITB Bias Roller             |
| 5. ID/MUSIC Sensor Roller           | 13. ITB Toner Collection Coil   |
| 6. Belt Pressure Roller             | 14. ITB Cleaning Brush Roller   |
| 7. PTR Lubricant Bar                | 15. ITB Cleaning Blade          |
| 8. PTR Cleaning Blade               |                                 |

**1. Image Transfer Rollers ( , , , )**

The positive charge applied by the transfer power pack to these sponge rollers (one for each PCU) pulls the developed images from the drums down onto the ITB.

**2. ITB**

Receives the toner images from the four drums and holds them until they are transferred to paper. During a full-color job, all the drums (Y, C, M, K) are in contact with the ITB. During a black-and-white job where only black is used, the ITB is lowered and the Y, C, M drums separate from the ITB, and only the black (K) drum contacts the ITB.

**3. Transfer Power Pack**

Applies the positive bias to the image transfer rollers that pull the developed toner images

off the OPC drums and onto the ITB. This power pack also applies to the ITB bias roller the negative bias that pushes the images off the ITB and onto the paper.

**4. ITB Drive Roller**

Driven by the ITB drive motor, the ITB drive roller turns the ITB belt.

**5. ID/MUSIC Sensor Roller**

This idle roller opposes the ID sensor and three MUSIC sensors. It ensures that the belt is positioned close enough to the sensors for accurate readings of the ID sensor patterns and MUSIC patterns on the ITB.

**6. Belt Pressure Roller**

Presses down on the ITB and paper to hold them in place as the belt and paper enter the nip between the PTR and PTR idle roller where the images are transferred from the ITB to paper.

**7. PTR Lubricant Bar**

Lubricates the PTR to facilitate cleaning.

**8. PTR Cleaning Blade**

Removes any residual toner from the PTR after the PTR cleaning brush roller has cleaned the PTR.

**9. PTR Toner Collection Coil**

Used toner removed from the PTR by the PTR cleaning brush roller and PTR cleaning blade falls into the rotating coils. This toner is then moved to the transverse used toner collection coil and finally to the used toner bottle.

**10. PTR Cleaning Brush**

Removes residual toner from the PTR after the image is transferred from the ITB to paper.

**11. PTR (Paper Transfer Roller)**

Located below the ITB bias roller, the PTR applies pressure to the belt and paper when the image is transferred from belt to paper.

**12. ITB Bias Roller**

The transfer power pack applies a negative charge to ITB bias roller to push the negatively-charged toner image off the ITB onto the paper.

**13. ITB Toner Collection Coil**

Used toner removed from the ITB by the cleaning brush roller and ITB cleaning blade falls into the rotating coils. It is then moved to the transverse used toner collection coil and finally to the used toner bottle.

**14. ITB Cleaning Brush Roller**

## Details

---

Removes residual toner from the ITB after the image is transferred from the ITB to paper.

### 15. ITB Cleaning Blade

Removes residual toner from the belt after the ITB cleaning brush roller cleans the belt.

---

## ITB Drive

---

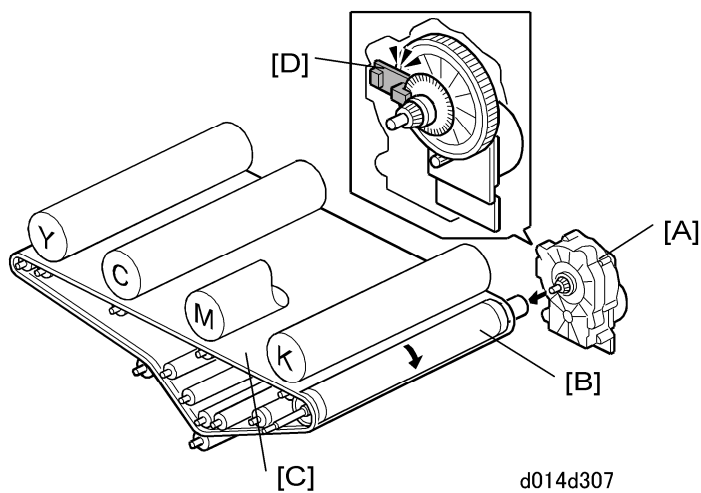

[A]: ITB drive motor
[B]: ITB drive roller
[C]: ITB
[D]: ITB Motor Encoder

The ITB drive motor [A] drives the ITB drive roller [B]. The ITB drive roller rotates the ITB [C]. Other rollers inside the ITB are idle rollers.

The ITB motor encoder [D] (inside the ITB motor unit) controls the operation of the ITB motor.

ITB Lift

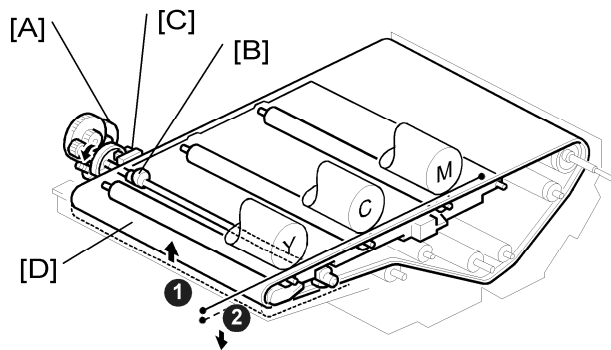

d014d310

[A]	ITB lift motor
[B]	ITB lift cam
[C]	ITB lift sensor
[D]	ITB
	FC (Full Color) position (up)
	K (Black only) position (down)

The ITB lift motor [A] (a stepper motor) turns the ITB lift cam [B]. This cam lifts and lowers the ITB [C]. The operation of the ITB lift motor is controlled by the ITB lift sensor [D]. When the machine is turned on, the ITB stays at position [E]. The Y, C, M drums are separated from the ITB.

When Full Color Mode is Selected:

- The motor turns the cam until the actuator goes into the ITB lift sensor.
- The motor stops.
- The raised cam holds the ITB at position [F]. All drums (Y, C, M, K) contact the ITB.
- The machine automatically adjusts the paper feed timing for full color copying with all the drums.
- While the Y, M, C drums are separated from the ITB, they do not turn. This reduces wear on these drums while they are not being used.

When Black-and-White Mode is Selected:

- The motor turns the cam until the actuator goes out of the ITB lift sensor.
- The motor stops.

## Details

- With the left side of the ITB down, only the black (K) drum contacts the ITB.
- The machine automatically adjusts paper feed timing for black-and-white copying with only one drum.
- The ITB stays down until the next full-color job starts

When ACS Mode is Selected:

- If the job has color pages and black-and-white pages, the ITB operation is controlled by SP 5880-1.
- The default is 0 (low productivity). In this mode, the ITB changes position each time the page type changes. This makes printing slower, but decreases wear on the color PCUs.
- If you set the SP to 1, then the machine will not move away from the color PCUs if a black-and-white page is next. This makes printing faster, but increases wear on the color PCUs.

## Transfer Power Pack

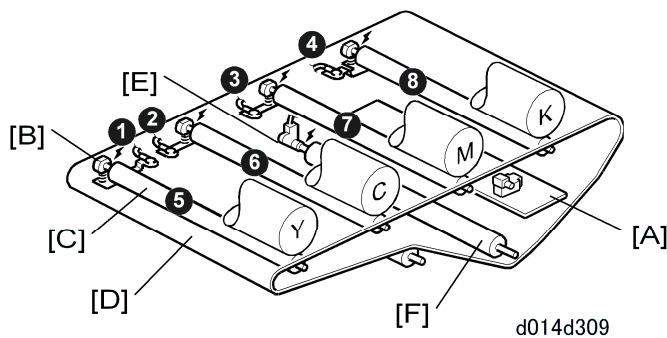

[A]	Transfer power pack
[B]	ITB transfer roller terminals , , ,
[C]	Image transfer rollers , , ,
[D]	ITB
[E]	ITB bias roller terminal
[F]	ITB bias roller

To transfer the images from drum to ITB:

## Details

---

- The transfer power pack [A] supplies a positive charge (1 kV 24 to 30  $\mu$ A) to the image transfer roller terminals [B] , , ,
- The four terminals charge the image transfer rollers [C] , , , which transfer the charge to the back of the ITB [D].
- The positively charged ITB pulls the negatively charged toner off the drums and onto the ITB.

To transfer the images from ITB to paper:

- The transfer power pack [A] supplies a negative charge to the ITB bias roller terminal [E].
- The terminal applies the negative charge to the ITB bias roller [F].
- The high negative charge of the ITB bias roller is applied to the back of the ITB. This repulses the low negative charge of the toner, forcing the images onto the paper.

The transfer power pack supplies the positive charge for image transfer to the ITB and the negative charge for image transfer from the ITB to paper. A temperature/humidity sensor under the used toner bottle motor controls the amount of the charge applied to the image transfer and ITB bias rollers.

---

## ITB Cleaning

---

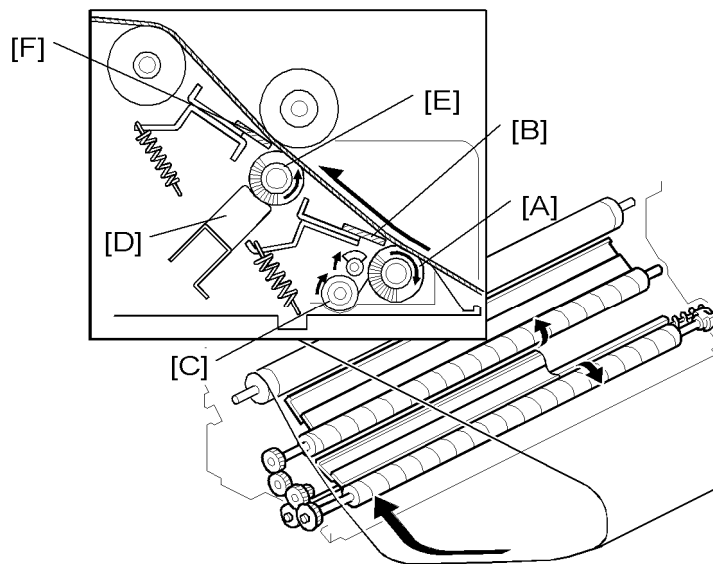

d014d306

[A]	ITB brush cleaning roller
[B]	ITB cleaning blade

## Details

[C]	Toner collection coil
[D]	Lubrication Bar
[E]	Lubricant Brush Roller
[F]	Lubricant Blade

The PTR motor rotates the ITB brush cleaning roller [A] against the bottom of the ITB as it passes above. The ITB cleaning blade [B] scrapes off any toner remaining on the belt after brush roller cleaning.

Toner removed by the brush cleaning roller and cleaning blade falls into the toner collection coil [C] that sends the used toner to the transverse toner collection coil at the back of the machine.

The lubrication bar [D] (ZnSt) lubricates the brush roller [E]. The lubricant brush roller lubricates the ITB to prevent scratching or scouring of the belt surface.

Finally, the lubricant blade [F] (ZnSt) removes any toner remaining on the lubricant brush roller.

## ITB Speed Control

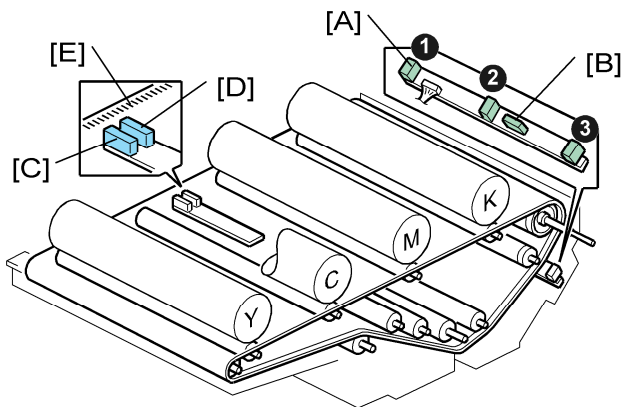

d014d308

[A]	MUSIC sensors , ,
[B]	ID Sensor
[C]	ITB position sensor 2 (Sub)
[D]	ITB position sensor 1 (Main)



## Details

[E]	ITB encoder strip
-----	-------------------

The feedback of three MUSIC sensors [A] control the speed of the drum motor to prevent color registration errors during full color printing.

There are two ITB position sensors Sensor 1 [C] and Sensor 2 [D] above the encoder strip scale [E] on the rear edge of the ITB.

- ITB position sensor 1 monitors the belt speed. The CPU uses this information to adjust the speed of the belt to account for eccentricity of the image transfer roller, differences in the thickness of the belt, belt slippage, and the load placed on the ITB by friction between the rollers at paper transfer.
- ITB position sensor 2, located a short distance from sensor 1, ensures that the number of gradations on the edge of the ITB in the gap between the sensors remains constant. This detects stretching or shrinking of the belt, and the ITB drive motor speed is adjusted to compensate for this occurrence.

## ITB Ventilation

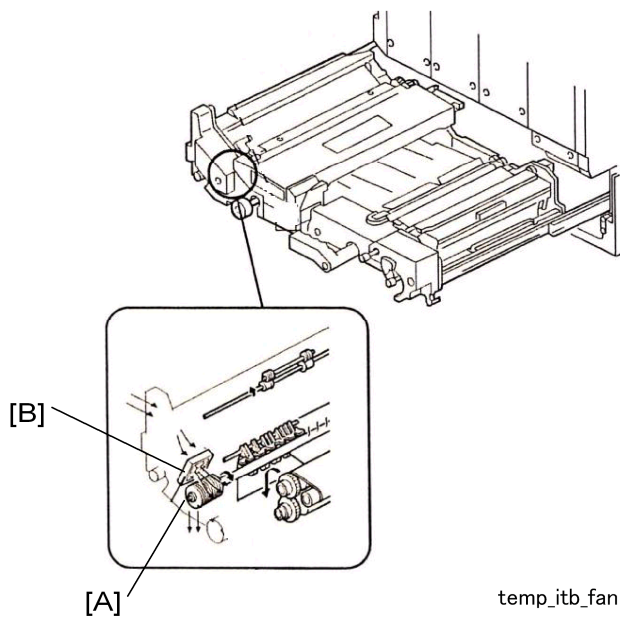

Baffled fins [A] collect heat conducted from inside the ITB unit by the heat sink. The image transfer fan [B] draws in cool air and blows air through the fins to dissipate the heat and send it out of the ITB unit.

Paper Transfer Unit Overview

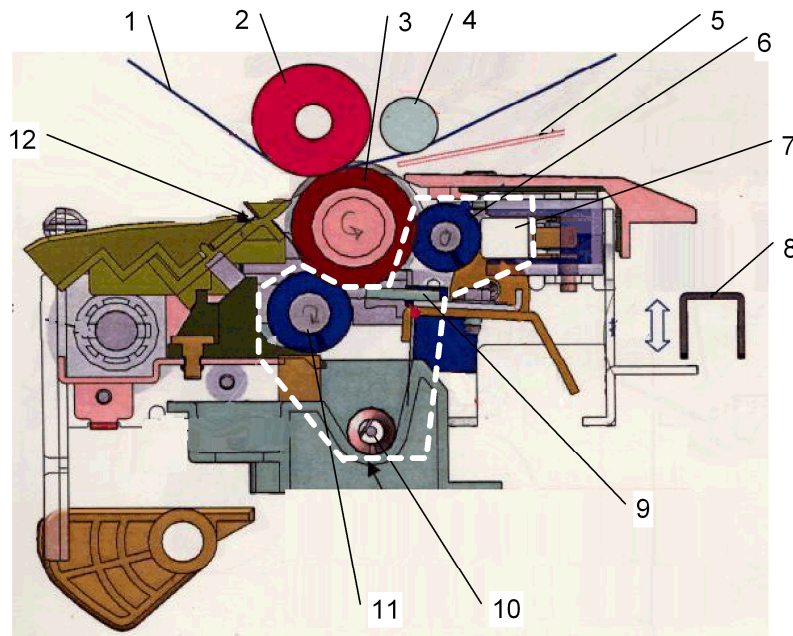

temp\_ptu1

- |                                |                           |
|--------------------------------|---------------------------|
| 1. ITB (Image Transfer Belt)   | 7. Lubrication Bar        |
| 2. ITB Bias Roller             | 8. Lift Bracket           |
| 3. PTR (Paper Transfer Roller) | 9. Cleaning Blade         |
| 4. Tension Roller              | 10. Toner Collection Coil |
| 5. Entrance Guide              | 11. Paper Dust Brush      |
| 6. Lubrication Brush Roller    | 12. Paper Discharge Plate |

**Note:** Items 6, 7, 9, 10, 11 comprise the PTR cleaning unit.

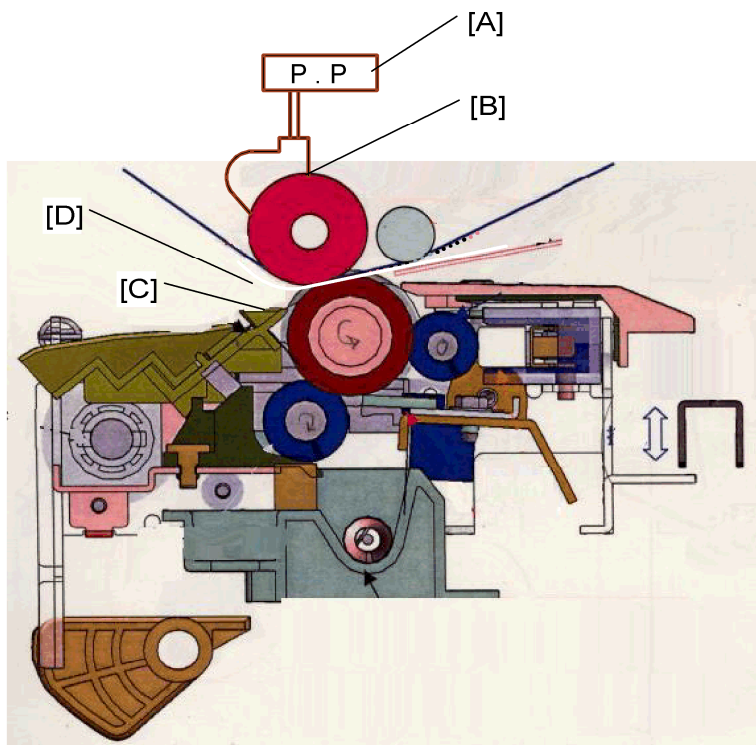

temp\_ptu1b

This machine employs a repulsion-force bias system for belt-to-paper image transfer. The transfer power pack [A] applies a negative bias to the ITB bias roller [B]. The negative bias applied to the back side of the ITB forces the toner from the surface of the belt onto the paper.

This system has two advantages:

- The negative bias has no effect on the moisture in the paper.
- Because the bias is applied from the front side of the paper, the bias can be applied more effectively, regardless of the level of humidity around the paper.

After the image has been transferred to the paper:

- The paper discharge plate [C] (connected to the separation power pack) applies an ac charge to neutralize the charges on the paper and the ITB.
- Next, curvature separation at [D] separates the paper from the belt when the ITB makes its abrupt turn toward the top of the machine for the next copy cycle.

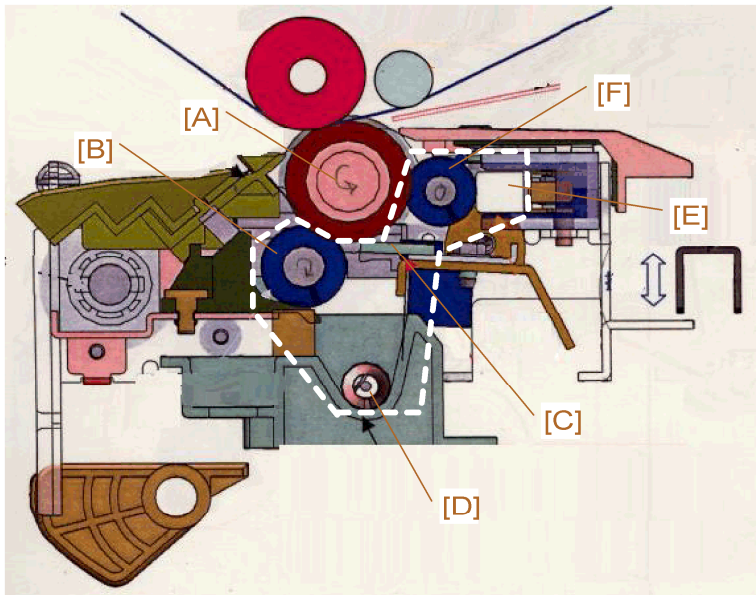

temp\_ptu1a

[A]	PTR
[B]	PTR brush cleaning roller
[C]	PTR cleaning blade
[D]	PTR toner collection coil
[E]	Lubricant bar (ZnSt)
[F]	PTR lubricant brush roller

The PTR [A] turns counter-clockwise.

The brush cleaning roller [B] (driven by the PTR motor), removes toner from the PTR. The PTR cleaning blade [C] removes any toner remaining on the surface of the PTR after brush cleaning. Toner removed by the brush cleaning roller and cleaning blade falls into the PTR toner collection coil [D]. This rotating coil moves the toner to the transverse used toner collection coil at the back of the machine where it is sent to the used toner bottle.

The PTR lubrication bar [E] lubricates the PTR lubricated brush roller [F]. This lubricated roller lubricates the surface of the PTR to prevent scratching or scouring of the roller surface.

### PTR Lift

---

The PTR lift mechanism raises and lowers the PTR unit.

- The lift mechanism raises the PTR against the ITB for belt-to-paper image transfer.
- The lift mechanism lowers the PTR and pulls it away from the ITB when the machine is not printing.

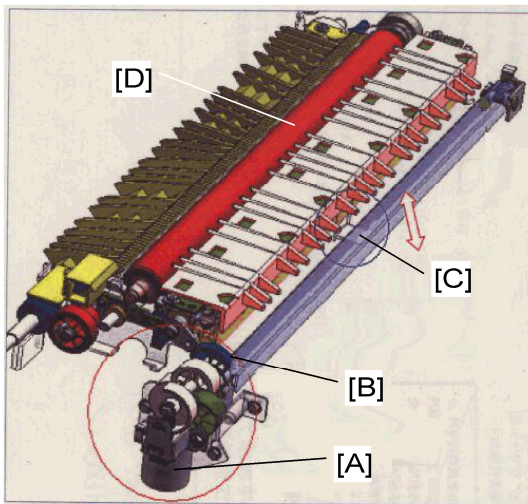

temp\_ptu2

The PTR lift motor [A] rotates cam [B]. The rotation of the cam raises and lowers the lift plate [C] which in turn raises and lowers the PTR [D].

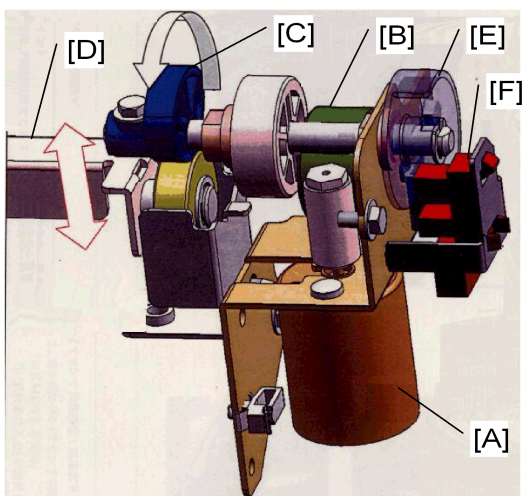

temp\_ptu3

The PTR lift motor [A] operates the drive train [B] that rotates the cam [C]. The rotation of the

## Details

---

cam raises and lowers the lift plate [D].

A circular actuator [E] attached to the shaft of the cam shaft passes through the gap in the PTR lift sensor [F]. The interaction of this actuator and sensor tells the machine when to stop raising and lowering the PTR.

## Fusing Unit

### Overview

#### Fusing Unit Components

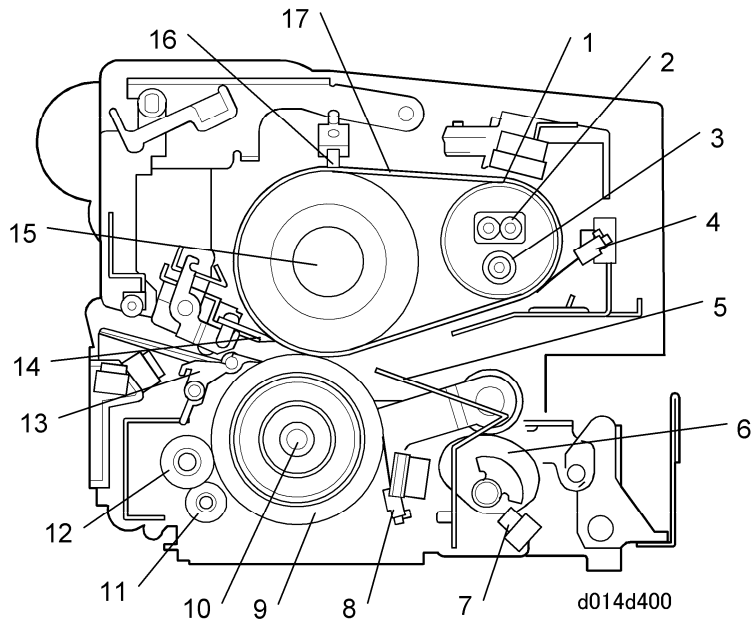

1.	Heating Roller	10.	Pressure Roller Fusing Lamp
2.	Heating Roller Fusing Lamps x2	11.	Cleaning Roller
3.	Heating Roller Fusing Lamp x1	12.	Oil Supply Roller
4.	Heating Roller Thermistor	13.	Pressure Roller Strippers
5.	Entrance Guide	14.	Fusing Belt Strippers
6.	Pressure Roller Lift Mechanism	15.	Hot Roller
7.	Pressure Roller Lift Sensor	16.	Fusing Belt Thermistor
8.	Pressure Roller Thermistor	17.	Fusing Belt
9.	Pressure Roller		

## Details

---

A fusing belt and three rollers comprise the fusing unit. The rollers are:

- Heating roller (fusing lamps x3)
- Pressure roller (fusing lamp x1)
- Hot roller (no fusing lamps).

The hot roller is composed of a new, softer sponge material that applies more even pressure during fusing. Because the hot roller is very soft, a mechanism is provided to retract the pressure roller from the hot roller and fusing belt when the machine is not operating.

## Fusing Unit Specifications

---

Fusing Method	Fusing Belt System		
Fusing Lamps	Heating Roller (3 halogen fusing lamps)		
	Pressure Roller (1 halogen fusing lamp)		
Roller Diameters	Heating Roller: 35 mm Hot Roller: 52 mm Pressure Roller: 50 mm		
Roller Thickness	Heating Roller: 0.6 mm Hot Roller: 10 mm Pressure Roller: 1.5 mm		
Heat Detection	Thermostats x3	Heating Roller Center x1 Heating Roller End x1 Pressure Roller x1	
	Thermistors x5	Heating Roller x3 Pressure Roller x1 Hot Roller x1	
Fusing Unit Drive	Fusing/Exit Motor (Paper Transport) Pressure Roller Lift Motor (Raises/lowers pressure roller)		

Warm-up Time	EU/AP	Less than 75 s		< 300 s
	NA	D014	Less than 90 s	



## Details

	D015	Less than 75 s		
First Copy	FC	D014	7.5 s	7.5 s
	D015	6.4 s		
	B&W	D014	5.7 s	6.5 s
	D015	4.9 s		

## Fusing Lamp Ratings

Heating Roller

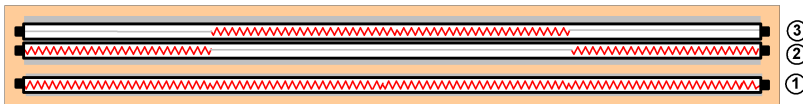

Pressure Roller

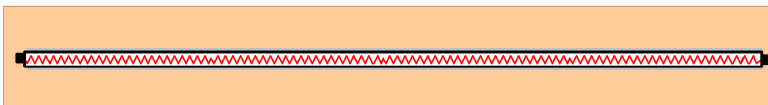

Hot Roller



temp\_fusingvc2

	NA	EU	
Heating Roller	①	117V 250W	227V 400W
	②	117V 700W	227V 700W
	③	117V 700W	227V 700W
Pressure Roller		117V 400W	227V 600W

The fusing belt system applies heat to the belt at two points: the heating roller and the pressure roller. This conserves space and allows these rollers to be smaller (less pressure is required for fusing so less torque is required).

## Details

---

- The fusing belt applies heat directly to fuse the toner to the paper.
- The heating roller has three fusing lamps. It applies heat to the fusing belt after the fusing belt passes the hot roller. The heating roller also keeps the fusing belt hot while the machine is in standby mode.
- The pressure roller has a metal core to provide rigidity, and is covered with Teflon to prevent toner from adhering to its surface. It applies heat with one fusing lamp to maintain the temperature of the fusing belt while the machine is in standby mode.
- The fusing exit sensor detects jams at the fusing exit by confirming that paper arrives at the fusing exit at the correct time.
- The hot roller is a sponge roller designed for a higher line speed and better grip at the nip. A pressure roller lift mechanism keeps the pressure roller separated from the hot roller while the machine is idle, to protect the hot roller from warping.

The fusing/exit motor speed depends on the type of paper selected for the job. Refer to the table below.

### D014

Paper Thickness Mode	Paper Wgt (g/m <sup>2</sup> )	Speed (mm/s)
Normal	52.3 to 65 (including 58 W)	282
Normal 1	66 to 100	282
Normal 2	81 to 100	282
Medium	101 to 127	282
Thick 1	128 to 163	176.4
Thick 2	164 to 249	176.4
Thick 3/OHP	250 to 300	141

### D015

Paper Thickness Mode	Paper Wgt (g/m <sup>2</sup> )	Speed (mm/s)
Normal	52.3 to 65 (including 58 W)	352.8

## Details

Paper Thickness Mode	Paper Wgt (g/m2)	Speed (mm/s)
Normal 1	66 to 100	352.8
Normal 2	81 to 100	352.8
Medium	101 to 127	282
Thick 1	128 to 163	176.4
Thick 2	164 to 249	176.4
Thick 3/OHP	250 to 300	141

## Thermistors, Thermostats

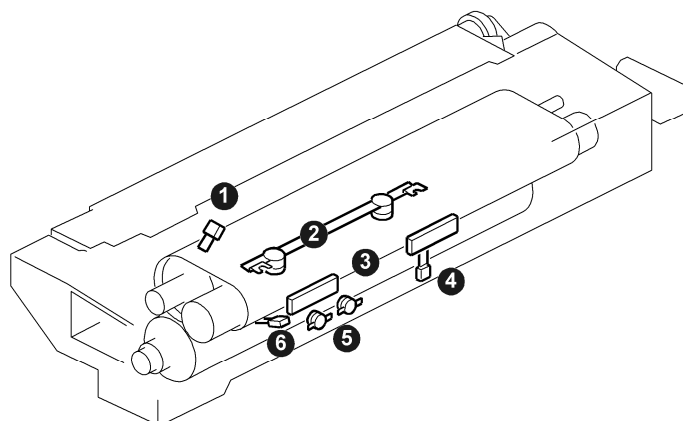

d014d401

1. Hot Roller Thermistor
2. Heating Roller Thermostats
3. Heating Roller Thermistors
4. Pressure Roller Thermistor
5. Pressure Roller Thermostats
6. Heating Roller Thermistors

The heating roller has one thermistor and two thermostats. An additional two thermistors (non-contact) are provided at the center and ends of the heating roller.

- Thermistors take heat readings that the machine uses for fusing temperature control.
- Thermostats are trip devices with hysteresis elements that will trip if a component overheats in their vicinity. When the thermostat trips, this shuts down the fusing unit.

---

Fusing Unit Drive

---

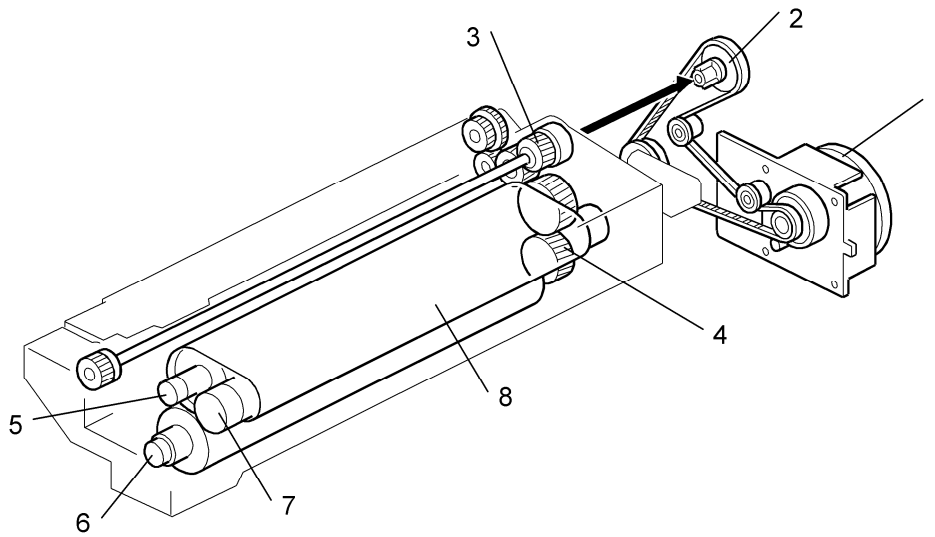

d014d402

1. Fusing/exit motor
2. Coupling, Timing Belt
3. Drive Roller
4. Idle Rollers
5. Hot Roller
6. Pressure Roller
7. Heating Roller
8. Fusing Belt

The fusing/exit motor [1] drives the coupling [2] and main drive shaft [3] via a timing belt. The idle rollers [4] rotated by the main drive shaft, turn the hot roller [5], pressure roller [6], and heating roller [7]. These rollers drive the fusing belt [8] tightly wrapped around these rollers.

---

Strippers

---

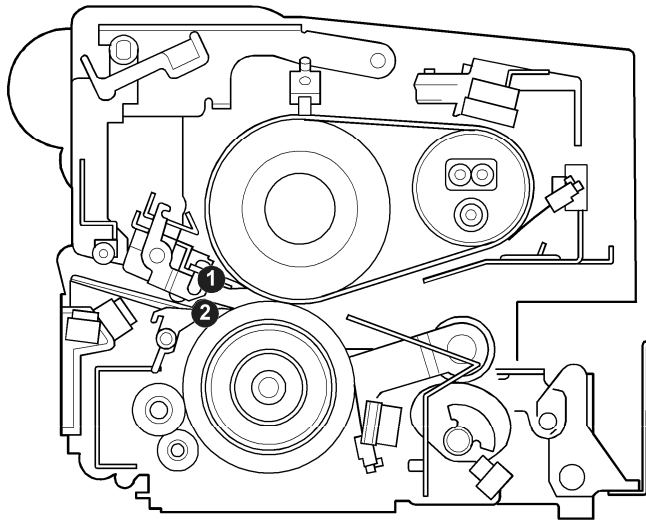

d014d400a

Stripper plates ① touching the fusing belt remove any paper that may accidentally stick to the belt after fusing. These are smooth plates, not sharp pointed pawls.

Unlike the fusing belt stripper plate mechanism, the pressure roller strippers ② are sharply pointed. They touch the fusing belt above the pressure roller to remove any paper that may accidentally stick to the belt after fusing.

---

Fusing Belt Lubrication and Cleaning

---

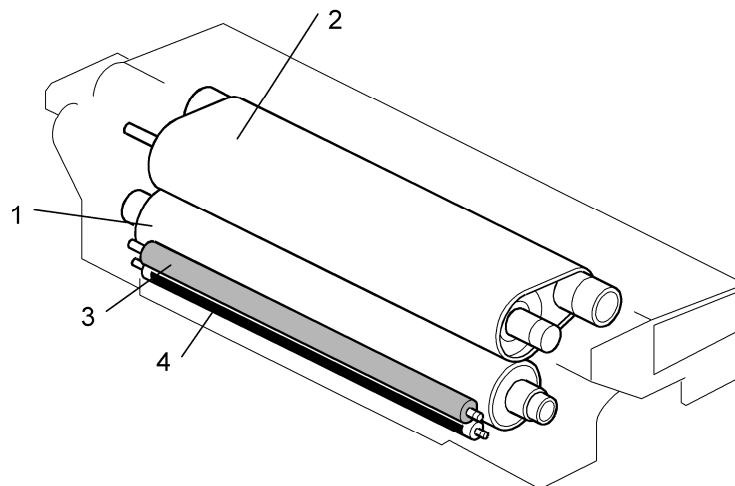

d014rd403

1. Pressure Roller
2. Fusing Belt
3. Oil Supply Roller
4. Oil Supply Roller Cleaning Roller

## Details

---

The pressure roller [1] pushes up against the fusing belt [2] and hot roller.

The oil supply roller [3] applies lubricant to the pressure roller.

The oil supply roller cleaning roller [4] cleans the oil supply roller.

---

## Fusing Temperature Control

---

### Basic Temperature Control

---

The fusing unit has four fusing lamps:

- Three in the heating roller
- One in the pressure roller
- The heating roller with its three lamps is the main source of heat for fusing.
- The hot roller has no fusing lamp so it applies no heat.
- The pressure roller maintains the temperature of the fusing belt while the machine is in standby mode.

Feedback from the thermistors assigned to each roller is used by the machine CPU to control fusing temperature.

### Temperature Adjustments

---

The temperature inside the machine is measured with the temperature sensor located near the used toner bottle. These temperature readings are used to make adjustments based on the internal temperature of the machine:

- If the temperature inside the machine is less than 20°C, all target fusing temperatures are increased by 5°C.
- If the temperature inside the machine is more than 20°C, the standby temperature is decreased by 5°C.

---

Fusing Unit Ventilation

---

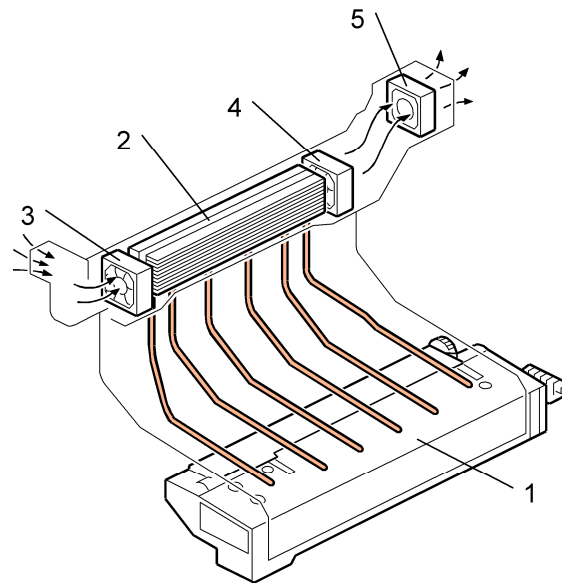

d014d404

1. Fusing Unit
2. Heat Sink
3. Intake Fan
4. Exhaust Fan 1
5. Exhaust Fan 2

Heat from the fusing unit [1] is drawn off by the pipes and collects in the heat sink [2]. The fusing unit intake fan [3] draws in cool air and blows it through the laminations of the heat sink. The first exhaust fan [4] draws the heated air out of the heat sink. The second exhaust fan [5] takes the hot air and blows it out of the machine.

---

## Pressure Roller Lift Mechanism

---

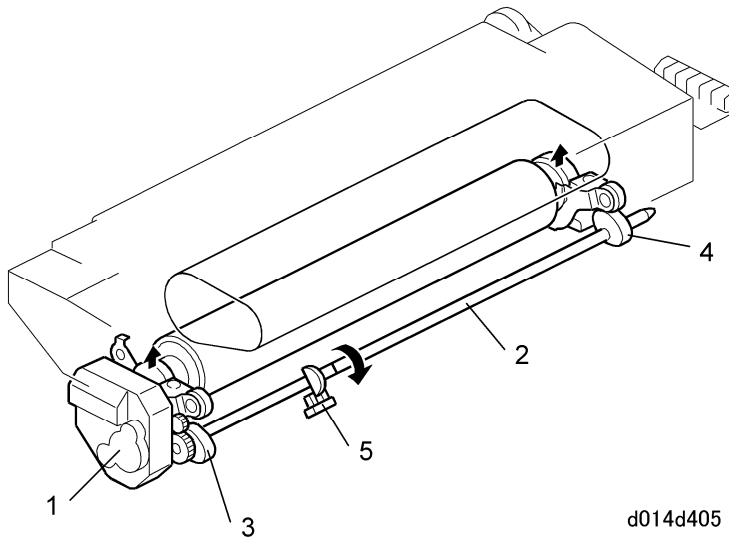

A pressure roller lift mechanism raises the pressure roller against the hot roller and fusing unit above and then lowers at the end of the job.

- When a job starts, the pressure roller lift motor [1] switches on rotates the cam shaft [2].
- The cams [3] and [4] raise the pressure roller against the hot roller and fusing belt.
- The motor (a stepper motor) stops when the actuator activates the pressure roller lift sensor [5] and the pressure roller remains up.
- At the end of the job, the motor reverses and lowers the pressure roller away from the hot roller.

The hot roller and pressure roller remain separated while the machine is idle. This prevents the pressure roller and hot roller from warping and thus prolongs their service lives.



# Specifications

---

## Specifications

---

### Main Frame D014/D015

---

#### Copying

---

Configuration	Console	
Dimensions (w x d x h)		
No ARDF	750 x 850 x 1050 mm (29.5 x 33.5 x 41.3 in.)	
With ARDF	750 x 850 x 1230 mm (29.5 x 33.5 x 48.4 in.)	
Weight (with ARDF)	Less than 298 kg (655.6 lb)	
Original Scanning	Flatbed with moving 3-line CCD array, image scanning	
Copy Process	4-drum dry electrostatic transfer system with internal transfer belt	
ARDF	Standard	
Development	Dry dual-component magnetic brush development	
Fusing	Oil-less belt fusing system	
Engine speed	D014	FC 55 cpm, BK 60 cpm
	D015	FC 70 cpm BK 75 cpm
Warm-up time	NA	D014: Less than 90 sec. D015: Less than 75 sec.
First copy time	FC	D014/D015: Less than 7.5/6.4 sec.
	BK	D014/D015: Less than 5.7/4.9 sec.

## Specifications

Original types	Sheet, book, object	
Max. original size	A3, 11" x 17"	
Resolution	Copy	600 dpi 4-bit
	Print	600 dpi 4-bit
	Scan (Send)	600 dpi 8-bit
Image Size	Default	297 (+4) x 457 mm (Note 1)
	Max.	297 (+4) x 600 mm (Note 2)

**Note 1:** Size depends on the D014/D015 application "+4" not guaranteed.

**Note 2:**

- Size depends on the D014/D015 application "+4" not guaranteed.
- Setting with SP mode is required.
- The max. setting cannot be selected if the SR5000 is installed.

Magnification	NA	7 Reduction, 5 Enlargement: 93%, 85%, 78%, 73%, 65%, 50%, 25%, 121%, 129%, 155%, 200%, 400%	
	EU/AP	7 Reduction, 5 Enlargement: 93%, 82%, 75%, 71%, 65%, 50%, 25%, 115%, 122%, 141%, 200%, 400%	
Zoom	25% to 400%		
Paper capacity (Number of sheets calculated with 80 g/m <sup>2</sup> 20 lb bond paper)	Tray 1	1,100 x2	2,200
	Tray 2	550	550
	Tray 3	550	550
	Bypass	100	100
	Copier Capacity		<b>3,400</b>

## Specifications

	With LCIT	4,000	<b>7,400</b>
Original size detection: exposure glass	NA	11" x 17", 8½" x 14" SEF, 8½" x 11" LEF/SEF	
Original size detection (ARDF)	NA	11" x 17", 10" x 14", 8½" x 14" SEF 8½" x 11", 5½" x 8½" SEF/LEF 7¼" x 10½", A3 SEF A4 SEF/LEF	
Paper weight	Tray 1	52.3 – 216 g/m <sup>2</sup> 14 Bond– 80 lb Cover	
	Tray 2	52.3 – 216 g/m <sup>2</sup> 14 Bond– 80 lb Cover	
	Tray 3	52.3 – 216 g/m <sup>2</sup> 14 Bond– 80 lb Cover	
	Bypass	52.3 – 300 g/m <sup>2</sup> 14 lb Bond– 110 lb Cover	
	Duplex mode	64 – 163 g/m <sup>2</sup> 17 lb Bond – 90 lb Index	
Output capacity	500 sheet (A4, 8½" x 11") (with copy tray)		
Power	NA	D014: 120V 60 Hz 20A D015: 208 to 240V 50 60 Hz 10A	
Max. power consumption	D014	Less than 1920 W	
	D015	Less than 2400 W	
Counter	NA	Electric counter, mechanical counter x2	
Counterfeit prevention	Bill recognition, invisible marking function		

## Specifications

---

### Printing

---

CPU	Intel Celeron LV 733 MHz	
RAM	1384 MB (shared with copying, scanning)	
HDD	320 GB (80 GB x 4)	
PDL	RPCS, PCL5c, PCL6	
Print Resolution (max.)	600 x 600 dpi (4-bit)	
Fonts	Standard	48 PCL fonts
	Option	With PS3, 136 Adobe PostScript Type 1 fonts
Connectivity		
Host interface	Standard	Ethernet RJ-45, 10-BaseT, 100BaseTX, USB 2.0
	Options*1	IEEE1284 ECP, IEEE1394 (FireWire), IEEE802.11b (Wireless LAN), Bluetooth
Network Protocol	TCP/IP, IPX/SPX, SMB (NetBEUI*2, NetBIOS over TCP/IP), AppleTalk (auto switching)	
MIB support	Private MIB	Not Used
	Standard MIB	MIB-II (RFC1213), HostResource (RFC1514), PrinterMib (RFC1759)
Network, operating systems	Windows 95, 98SE, NT 4.0, 2000, Me, XP, Server 2003 NetWare 3.12, 3.2, 4.1, 4.11, 5.0, 5.1, 6 Unix, Sun Solaris, HP-UX, SCO Open Server, Red Hat Linux, IBM AIX, Mac OS 8.6 to 9.2x, OS X 10.1 or later	

\*1: Only 1 option can be installed at a time.

\*2: Smart Device Monitor for Client is necessary for NetBEUI.

## Specifications

### Scanning

Optical resolution	100, 150, 200 (default), 300, 400, 600 dpi		
Scanning speed	TBA		
Max. scan area	297 x 432 mm (11.7" x 17")		
Auto scan size detection	Exposure glass	Supported (conforms with copier specifications)	
	ARDF	Supported (conforms with copier specifications)	
Original size	Standard	A3, A4 SEF, A4 LEF, A5 SEF/LEF, B4, B5 SEF, B5 LEF, 11" x 17" SEF, 8½" x 14" SEF, 8½" x 13" SEF, 8½" x 11" SEF/LEF, 5½" x 8½" SEF/LEF	
	Customized	Min.	10 x 10 mm (0.04" x 0.04")
		Max.	297 x 432 mm (11.7" x 17")
Compression Method	BW Binary: TIFF MH, MR, MMR Grayscale/Full Color: JPEG		
Interface support	10/100BaseTX, IEEE802.11b (Wireless LAN), IEEE1394 (FireWire)		
Scan mod	Default	BW Text	
	Supported	BW OCR, BW Text-Photo, BW Photo, Grayscale, FC Photo, FC Text Photo	
	Options*1	Auto Color Selection, sRGB Photo, sRGB Text Photo	
Image Density	Auto Density Selection, Manual Setting (7 levels)		
Image Rotation	TBA		
SADF/Batch mode	Supported		

## Specifications

Mixed size originals	Supported
----------------------	-----------

\*1: File Format Converter D377 is necessary.

Original Feed: ARDF B652

Dimensions (w x d x h)	680 x 560 x 180 mm (26.8 x 22 x 7.1 in.)	
Weight	Less than 19.5 kg (42.9 lb)	
Power consumption	Less than 59 W	
Noise	Less than 71 db	
Stack capacity	100 sheets	
Original size	Simplex	A3, A4, A5, B5, B6 5½" x 8½", 8½" x 11", 8½" x 14", 11" x 17"
	Duplex	A3, A4, A5, B4, B5 5½" x 8½", 8½" x 11", 8½" x 14", 11" x 17"
Original weight	Simplex	40 – 128 g/m <sup>2</sup> 11 – 34 lb bond
	Duplex	52 – 128 g/m <sup>2</sup> 14 – 34 lb bond
Auto Original Size Detection	NA	11" x 17", 10" x 14", 8½" x 14" SEF 8½" x 11", 5½" x 8½" SEF/LEF 7¼" x 10½", A3 SEF A4 SEF/LEF
	EU, Asia	A3, B4 SEF A4, B5, A5, B6 SEF/LEF 8½" x 13", 8K SEF 16K SEF
Original set position	Face-up, left-rear corner	

## Specifications

Special original setting	Batch, mixed sizes	
Feeding speed	Full color	60 cpm
	Black	75 cpm
Power source	From copier	

## Optional Peripherals

### LCT B473

Installation of the LCT Adapter B699 is required to adjust the height of LCT B473.

Dimension (w x d x h)	Stand-alone	314 x 458 x 659 mm (12.4 x 18 x 25.9 in.)
	With LG/B4 Option	462 x 458 x 659 mm (18.2 x 18 x 25.9 in.)
Weight	Standalone	Less than 20 kg (44 lb)
	With LG/B4 Option	Less than 27 kg (59.4 lb)
Power Consumption	Less than 50 W	
Noise	Less than 74dB	
Paper Size	A4, B5, 11"x 8½" LEF	
Paper Weight	52 - 128g/m <sup>2</sup> 14 lb – 34 lb Bond	
Paper Capacity (80 g/m <sup>2</sup> or 20 lb bond)	4,000 sheets** 2,500 sheets*	

### LCT 4000 D350

Expected Service Life	5 Years or 9,000K
Paper Feed System:	FRR-CF

## Specifications

Paper Capacity	2,000 sheets (Paper thickness: 0.11 mm)
Remaining Paper Detection (Accuracy: $\pm 30$ sheets)	5-Step including Near-End
Paper Weight	52 to 300 g/m <sup>2</sup>
Paper Size	A5 to A3, HLT to 12 x 19.2 in. Postcards (100 mm wide) Custom Size: Length: 139.7 to 482.7 mm Custom Size: Width: 100 mm to 330.2 mm (Small Size: 100 to 139.2 mm)
Paper Size Switching	Side fence, end fence adjustment.
Paper Size Detection	Automatic
Anti-Condensation Heater	Available as option
Dimensions (w x d h)	865 x 730 x 746 mm (34 x 28.7 x 29.4 in.)
Weight	Less than 86 kg (190 lb)
Power Source	DC 24 V $\pm 10\%$ (from copier)
Power Consumption:	Less than 120 W
I/F	Serial
Tab Sheet:	Requires installation of tab sheet fence. <b>Note:</b> Only A4 LEF, 8½" x 11" LEF tab sheets can be fed.

## 8½ x 14" Paper Size Tray B474

This option converts LCT B473 so it can hold and feed LG size paper.

Paper Size	8½"x14", 8½"x11", A4, B4 SEF
Paper Weight	52 - 128g/m <sup>2</sup> 14 lb – 34 lb Bond



## Specifications

---

### 9-Bin Mailbox B762

---

- The mailbox can be installed on top of the 2000-Sheet Finisher D373 or the 3000-Sheet Finisher D374 (not 3000-Sheet Finisher B830).
- The mail box must be removed to install Cover Interposer Tray B704. The mail box and cover interposer tray cannot be installed at the same time.

Dimension (w x d x h)	540 x 600 x 660 mm (21.3 x 23.6 x 26 in.)
Weight	Less than 15 kg (33 lb)
Power Consumption	Less than 48 W
Noise	Less than 74 dB
Number of Bins	9 bins
Stack Capacity of each Bin	100 sheets*
Paper Size	A5, A4, A3 5½" x 8½", 8½" x 11", 8½" x 14", 11"x17"
Paper Weight	52 - 128g/m <sup>2</sup> 14 lb – 34 lb Bond

### Cover Interposer Tray B704

---

- Cover Interposer Tray B704 can be used with the 2000-Sheet Finisher D373 or 3000-Sheet Finisher D374 between the mainframe and finisher. The interposer tray and the Mailbox B762 cannot be installed together.
- This tray cannot be installed on the 3000-Sheet Finisher B830.

Dimension (w x d x h)	500 x 600 x 600 mm (19.7 x 23.6 x 23.6 in.)
Weight	Less than 12 Kg (26.4 lb)
Power Consumption	Less than 43 W
Noise	Less than 65 db

## Specifications

Stack Capability*	200 Sheets	
Paper Size	A5-A3, 5½" x 8½" - 11" x 17"	
Paper Weight	64 g/m <sup>2</sup> -216 g/m <sup>2</sup> 17 lb Bond- 58 lb Index, 80 lb Cover	
Original Set Position	Center	
Original Set	Normal Feed	Face-up
	Booklet Feed	Face-down

## Cover Interposer Tray B835

Cover Interposer Tray B835 can be used only with the 3000-Sheet Finisher B830. It cannot be installed on the 2000/3000-Sheet Finishers D373/D374.

Speed	D014 (FC 55 cpm / BK 60cpm)	146.2 mm/s / 182.6 mm/s
	D015 (FC 70 cpm / BK 75cpm)	292.5 mm/s / 365.2 mm/s
Paper Separation	FRR System with Feed Belt	
Paper Sizes	Width: A5 SEF/5½"x8½" SEF - 13" Length: A5 LEF/5½"x8½" LEF - 19"	
Paper Weight	64 - 216 g/m <sup>2</sup>	
Capacity	400 sheets (80 g/m <sup>2</sup> ) (2 trays 200 sheets each)	
Paper Size Detection	Yes	
Paper Size Switching	Operator adjustable side fences	
Side Registration	Yes	
Power Supply	24 V ± 5% (from mainframe)	
Power Consumption	Less than 50 W	
Dimensions (w x d x h)	Less than 540 x 730 x 1200 mm	

## Specifications

	21.2" x 28.7" x 47.2"
Weight	Less than 45 kg (99 lb)

## 3000-Sheet Finisher B830

This machine requires installation of the Finisher Adapter D375 in this finisher.

Finisher			
Dimension (w x d x h)		800 x 730 x 980 mm (31.5 x 28.7 x 38.6 in.)	
Weight		Less than 65 kg (143 lb)	
Power Consumption		Less than 100W	
Noise		Less than 75 dB	
Configuration		Console type attached base-unit with Finisher Adapter	
Power Source		From base-unit	
Proof Tray	Stack Capacity*	500 sheets	A4, 8½" x 11" or smaller
		250 sheets	B4, 8½" x 14" or larger
	Paper Size	A6 SEF-A3 SEF 5½" x 8½" - 11"x17"	
	Paper Weight	52 g/m <sup>2</sup> -216 g/m <sup>2</sup> 14 lb Bond- 68 lb Bond / 140 lb Index / 90 lb Cover	
Shift Tray	Stack Capacity*	3000 sheets	A4 LEF, B5 LEF, 8½"x11" LEF
		1500 sheets	A3, A4, B4, B5 SEF 11"x17", 8½"x14", 8½" x 11" SEF

## Specifications

		500 sheets	A5 LEF, 5½"x8½" LEF	
		100 sheets	A5 SEF, 5½"x8½" SEF	
	Paper Size	A5 - A3 SEF 5½"x8½", 11"x17", 12"x18", 13"x19"		
	Paper Weight	52 g/m <sup>2</sup> -300 g/m <sup>2</sup> 14 lb Bond- 68 lb Bond / 140 lb Index / 90 lb Cover		
Staples				
Paper Size	B5-A3, 8½"x11"-11"x17"			
Paper Weight	64 g/m <sup>2</sup> -84 g/m <sup>2</sup> , 17 lb Bond-20 lb Bond			
Staple Position	Top, Bottom, 2 Staple, Top-slant			
Staple Replenishment	Cartridge exchange / 5000 pins per cartridge			
Stack Capacity with Stapler				
	Paper Size	Pages/Set	Sets	
	A4, B5	10-100 pages	200-30 sets	
	8½"x11"	2-9 pages	150 sets	
	A3, B4, 11" x 17",	10-50 pages	150-30 sets	
	8½" x 14"	2-9 pages	150 sets	

## Punch Unit B831

This punch unit is for the 3000-Sheet Finisher B830.

Punch Unit Types	NA	2/3 holes
	EU	2/4 holes
	Scandinavia	4 holes
Punch Waste Hopper Capacity	NA 2/3 hole	10,000 sheets

## Specifications

		EU 2/4 hole	15,000 sheets
Paper Weight		52 g/m <sup>2</sup> -127.9 g/m <sup>2</sup> 14 lb Bond –34 lb Bond	
Paper Size	NA 2-holes	SEF	A6 - A3, 5½" x 8½" - 8½"x11"
		LEF	A5 - A4, 5½" x 8½", 8½"x11"
	NA 3-holes	SEF	A3, B4, 11"x17"
		LEF	A4, B5, 8½"x 11"
	EU 2-holes	SEF	A6 - A3, 5½"x8½" - 11"x17"
		LEF	A5 - A4, 5½" x 8½", 8½" x 11"
	EU 4-holes	SEF	A3, B4, 11" x 17"
		LEF	A4, B5, 8½" x 11"
	Scandinavia 4-holes	SEF	B6 - A3, 5½" x 8½" - 11" x 17"
		LEF	A5 - A4, 5½" x 8½", 8½" x 11"

## 2000-Sheet Finisher D373

This finisher provides booklet as well as corner stapling. Equipped with two trays, the upper tray holds stapled and shifted copies, and the lower tray holds booklet stapled and folded copies.

Dimensions w x d x h	657 x 613 x 960 mm (25.9 x 24.1 x 37.8")
Weight	Less than 63 kg (138.6 lb) (no punch unit) Less than 65 kg (143 lb) (with punch unit)
Power Consumption	Less than 96 W
Noise	Less than 75 db
Configuration	Console type attached base-unit

Specifications

Power Source		From base-unit	
Proof Tray	Stack Capacity*	250 sheets A4, 8½"x11" or smaller 50 sheets B4, 8½"x14 or larger	
	Paper Size	A5-A3 SEF, A6 SEF, A6 LEF 5½" x8½" to 11" x 17" SEF, 12"x18" SEF	
	Paper Weight	52 g/m <sup>2</sup> -163 g/m <sup>2</sup> 14 lb Bond- 43 lb Bond / 90 lb Index / 60 lb Cover	
Shift Tray	Stack Capacity*	2,000 sheets	A4 LEF, 8½"x11" LEF
		1,000 sheets	A3 SEF, A4 SEF, B4 SEF, B5 11"x17" SEF, 8½" x14" SEF, 8½" x 11" SEF, 12"x18" SEF
		500 sheets	A5 LEF
		100 sheets	A5 SEF, B6 SEF, A6 SEF, 5½" x8½" SEF
	Paper Size	A5 - A3 SEF, A6 SEF, B6 SEF 5½" x8½" to 11" x 17" SEF, 12" x 18" SEF	
	Paper Weight	52 g/m <sup>2</sup> -256 g/m <sup>2</sup> 14 lb Bond- 68 lb Bond / 140 lb Index / 90 lb Cover	
Staple			
Paper Size		B5-A3, 8½"x11"-11"x17", 12"x18"	
Paper Weight		64 g/m <sup>2</sup> -90 g/m <sup>2</sup> , 17 lb Bond-28 lb Bond	
Staple Position		Top, Bottom, 2 Staple, Top-slant	
Staples Capacity*	Same Paper Size	50 sheets	A4, 8½" x 11" or smaller
		30 sheets	B4, 8½" x 14" or larger

## Specifications

	Mixed Paper Size	30 sheets	A4 LEF & A3 SEF, B5 LEF & B4 SEF, 8½"x11" LEF & 11" x17" SEF
	Booklet Stapling	15 sheets	A4 SEF, A3 SEF, B5 SEF, B4 SEF, 8½"x11" SEF, 8½"x14" SEF, 11"x17" SEF, 12"x18" SEF
Staple Replenishment		Corner staple	5,000 staples per cartridge
		Booklet staple	2,000 staples per cartridge
Corner Staple Capacity	Same Size	A4 LEF, 8½"x11" LEF	13-50 pages
			2-12 pages
		A4 SEF, B5, 8½"x11" SEF	10-50 pages
	2-9 pages		
	Others	10-30 pages	
		2-9 pages	
Mixed Size	A4 LEF + A3 SEF B5 LEF + B4 SEF 8½"x11" LEF + 11" x17" SEF	2-30 pages	
Booklet Staple Capacity	A4 SEF, A3 SEF, B5 SEF, B4 SEF 8½"x11" SEF, 8½"x14" SEF, 11"x17" SEF 12"x18" SEF		2-5 pages
			6-10 pages
			11-15 pages

### D373/D374 Paper Specifications

Paper Size	Plain Paper			Paper Type	
	Copier PPC	Used Paper	Recycled Paper	Colored Paper	Translucent Blueprint
A3 SEF		—			

Specifications

---

B4 SEF					
A4 SEF					
A4 LEF					
B5 SEF					
B5 LEF					
A5 SEF		—	—	—	—
A5 LEF		—	—	—	—
B6 SEF		—	—	—	—
B6 LEF		—	—	—	—
12" x 18" SEF		—			—
11" x 17" SEF		—			
8½" x 14"		—			
8½" x 11" SEF		—			
8½" x 11" LEF		—			
5½" x 8½"		—	—		—
5½" x 8½"		—	—		—

	Corner stapling, Shift, YES
	Booklet stapling/folding, Shift, YES
	Shift ONLY
	Shift NO
—	Not available



## Specifications

### 3000-Sheet Finisher D374

This finisher provides corner stapling only.

Finisher			
Dimension (w x d x h)		657 x 613 x 960 mm	
Weight		Less than 54 kg Less than 56 kg with Punch Unit	
Power Consumption		Less than 96 W	
Noise		Less than 75 db	
Configuration		Console type attached base-unit	
Power Source		From base-unit	
Proof Tray	Stack Capacity*	250 sheets A4, 8½"x11" or smaller 50 sheets B4, 8½"x14 or larger	
	Paper Size	A5-A3 SEF, A6 SEF, A6 SEF 5½"x8½"-11"x17"SEF, 12"x18" SEF	
	Paper Weight	52 g/m <sup>2</sup> -163 g/m <sup>2</sup> 14 lb Bond- 43 lb Bond / 90 lb Index / 60 lb Cover	
Shift Tray	Stack Capacity*	3,000 sheets	A4 LEF, ½" x11" LEF "
		1,500 sheets	A3 SEF, A4 SEF, B4 SEF, B5, 11"x17" SEF, 8½" x14" SEF, 8½" x 11" SEF, 12"x18" SEF
		500 sheets	A5 LEF**
		100 sheets	A5 SEF, B6 SEF, A6 SEF, 5½" x 8½",SEF
	Paper Size	A5 - A3 SEF, A6 SEF, B6 SEF, 5½" x 8½"- 11"x17" SEF, 12" x 18" SEF	
	Paper Weight	52 g/m <sup>2</sup> -256 g/m <sup>2</sup>	

## Specifications

		14 lb Bond- 68 lb Bond / 140 lb Index / 90 lb Cover		
Staples				
Paper Size		B5-A3 8½"x11"-11"x17", 12"x18"		
Paper Weight		64 g/m <sup>2</sup> -90 g/m <sup>2</sup> 17 lb Bond - 28 lb Bond		
Staple Position		Top, Bottom, 2 Staple, Top-slant		
Stapling Capacity	Same Paper Size	50 sheets	A4, 8½" x11" or smaller	
		30 sheets	B4, 8½" x14" or larger	
	Mixed Paper Size	30 sheets	A4 LEF + A3 SEF, B5 LEF + B4 SEF, 8½" x11" LEF + 11" x17" SEF	
Staple Replenishment		Cartridge exchange / 5000 pins per cartridge		
Stapled Stack Capacity (same size)	Paper Size		Pages/Set	Sets
	A4 LEF, 8½"x11" LEF		20-50 pages	150-60 sets
			2-19 pages	150 sets
	A4 SEF, B5, 8½"x11" SEF		15-50 pages	100-30 sets
			2-14 pages	100 sets
	Others		15-30 pages	100-33 sets
2-14 pages			100 sets	
Stapled Stack Capacity (mixed sizes)	A4 LEF & A3 SEF, B5 LEF & B4 SEF, 8½"x11" LEF & 11" x17" SEF		2-30 pages	50 set

## Punch Unit B702

This punch unit is designed for use with the 2000-Sheet Stapler D373 (both corner and

## Specifications

booklet stapling) and 3000-Sheet Stapler D374 (corner stapling only).

Available Punch Units		NA	2/3 hole switchable
		EU	2/4 holes switchable
		Scandinavia	4 holes
Punch Waste Replenishment		NA 2-hole	Up to 5,000 sheets
		NA 3-hole	Up to 5,000 sheets
		EU 2-hole	Up to 14,000 sheets
		EU 4-hole	Up to 7,000 sheets
		Scandinavia 4-hole	Up to 7,000 sheets
Paper Weight		52 g/m <sup>2</sup> -163 g/m <sup>2</sup> , 14 lb Bond –43 lb Bond / 90 lb Index / 60 lb Cover	
Paper Sizes	NA 2-hole	SEF	A5 to A3, 5½" x 8½" to 11"x17"
		LEF	A5 - A4, 5½" x 8½", 8½" x 11"
	NA 3-hole	SEF	A3, B4, 11"x17"
		LEF	A4, B5, 8½" x 11"
	EU 2-hole	SEF	A5 - A3, 5½" x 8½" to 11" x 17"
		LEF	A5 to A4, 5½" x 8½", 8½" x 11"
	EU 4-hole	SEF	A3, B4, 11"x17"
		LEF	A4, B5, 8½" x 11"
	Scandinavia 4-hole	SEF	A5 to A3, 5½" x 8½" to 11" x 17"
		LEF	A5 - A4, 5½" x 8½", 8½" x 11"

## Specifications

---

### Z-Folding Unit ZF4000 B660

---

Paper Size		
No Folding (52-300 g/m <sup>2</sup> )	A3, A4, A5, A6 SEF, B4, B5, B6 SEF 11" x 17", 8½"x14", 8½"x11" SEF, 5½"x8½", 12" x 18"	
Folding (64-80 g/m <sup>2</sup> )	A3, B4, A4 SEF 11" x 17", 8½"x14", 8½"x11" SEF, 12" x 18"	
Dimensions (w x d x h)	177 x 620 x 960 mm 7 x 24.5 x 37.8 in.	
Weight	Less than 55 kg (121 lb)	
Power Consumption	100 W max.	
Power Supply	North America	120 V, 60 Hz, 1A
	Europe/Asia	220-240 V, 50/60 Hz, 0.5A

### A3/11" x 17" Tray B331

---

This option is installed in Tray 1 (tandem tray) of the copier so that Tray 1 can feed larger paper. Tray 1 normally feeds LT or A4 only.

Dimension (w x d x h)	495 x 215 x 535 mm (19.5 x 8.5 x 21.1 in.)
Weight	11 kg (24.2 lb)
Paper Size	A3 SEF, B4 SEF, A4 11"x17" SEF, 8½" x 14" SEF, 8½" x 11"
Paper Capacity	1,000 Sheets

### Copy Tray Type2075 B756

---

The copy tray is installed receive copies when the copier is used without a finisher.

## Specifications

Dimension (w x d x h)	400 x 335 x 70 mm (15.8 x 13.2 x 2.8 in.)	
Weight	640 g (1.4 lb)	
Paper Capacity	500 Sheets	A4, 8½" x 11"
	250 Sheets	A3, 11" x 17"

## Machine Configuration

### Configuration 1 (with D373/D374 Finisher)

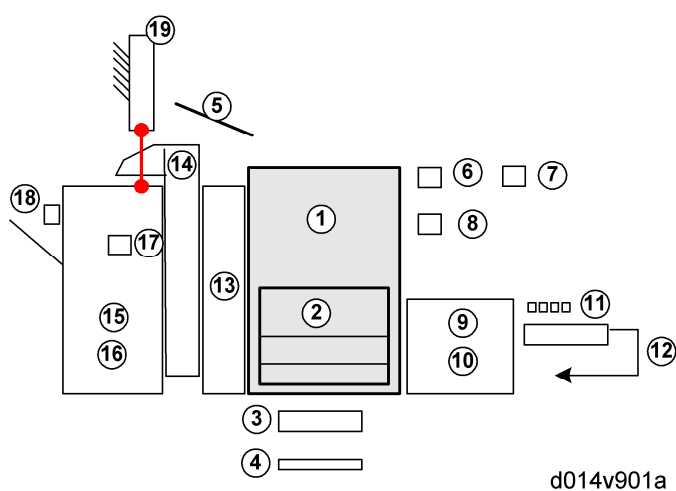

No.	Item	Comments
①	D014/D015a/b	Main unit
②	Tandem Tray	Built into main unit
③	A3/11"x17" Tray Type (B331)	Option for tandem tray
④	Tab Sheet Holder Type (B499)	Option for tandem tray
⑤	Copy Tray (B756)	For no finishers
⑥	Not Used	
⑦	Not Used	

## Specifications

No.	Item	Comments
⑧	Not Used	
⑨	LCT 4000 (D350) * <sup>1</sup>	Only one of these options can be installed.
⑩	A4/LT LCT (B473)	
⑪	LCT Adapter (B699)	Required for LCT B473
⑫	LG Unit for A4/LT LCT (B474)	Option for LCT B473
⑬	Z-Folding Unit ZF4000 (B660) * <sup>1</sup>	
⑭	Cover Interposer Tray (B704)	For D373 (2000-sheet), D374 (3000-sheet) finishers only. Only 1 tray. Cannot be installed with Mail Box (B762).
⑮	Finisher SR4020 (D373) * <sup>1</sup>	2000-sheet finisher, 50 staple, Booklet folding and stapling
⑯	Finisher SR4010 (D374) * <sup>1</sup>	3000-sheet finisher, 50 staple, corner stapling only
⑰	Punch Unit (B702)	For either finisher D373 or D374
⑱	Output Jogger Unit (B703)	For either finisher D373 or D374
⑲	Mail Box CS391 (B762)	For D373 (2000-sheet), D374 (3000-sheet finishers only). Cannot be installed with Cover Interposer Tray (B704)

\*<sup>1</sup> New options for this machine.

## Specifications

### Configuration 2 (with B830 Finisher)

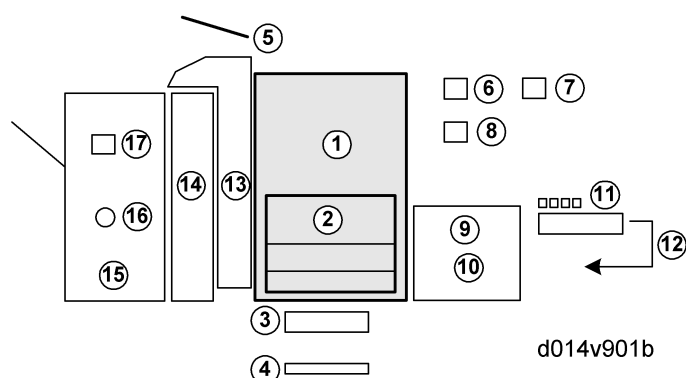

No.	Item	Comments
①	D014/D015a/b	Main unit
②	Tandem Tray	Built into main unit
③	A3/11"x17" Tray Type (B331)	Option for tandem tray
④	Tab Sheet Holder Type (B499)	Option for tandem tray
⑤	Copy Tray (B756)	For no finishers
⑥	Not Used	
⑦	Not Used	
⑧	Not Used	
⑨	LCT 4000 (D350)	Only one can be installed.
⑩	A4/LT LCT (B473)	
⑪	LCT Adapter (B699)	Required for LCT B473 to adjust height.
⑫	LG Unit for A4/LT LCT (B474)	Option for LCT B473
⑬	Cover Interposer Tray CI 5000 (B835)	Two source trays. Can be installed with 3000-sheet finisher B830 only.
⑭	Z-Folding Unit ZF4000 (B660)	Can be installed with D373, D374, B830 finishers.

## Specifications

No.	Item	Comments
⑮	Finisher SR5000 (B830)	3000-Sheet finisher, 100 staples, jogger standard.
⑯	Finisher Adapter (D375)	For Finisher B830
⑰	Punch Unit PU 5000 (B831)	For 3000-sheet finisher B830 only.

## Electrical Components

### Copier

No.	Component	Function
<b>COUNTERS</b>		
TC1	Total Counter: FC	The mechanical counter for full color printing.
TC2	Total Counter: K	The mechanical counter for black-and-white printing.
<b>HEATERS</b>		
H1	Lower Tray Heater	Keeps paper dry. Provided with machine, connection is optional.
H2	Anti-condensation Heater – Scanner (Option)	Prevents the formation of condensation in the scanner unit.
H3	Anti-condensation Heater – Transfer	This options removes moisture from the air around the paper transfer unit.
H4	Upper Tray Heater	Keeps paper dry. Provided with machine, connection is optional.
<b>HARD DISKS</b>		
HDD1	Hard Disk Drives	The HDDs hold temporary files spooled for processing and also store permanent files for the



## Specifications

No.	Component	Function
		document server application.
HDD2		2nd HDD in a set of 4.
HDD3		3rd HDD in a set of 4.
HDD4		4th HDD in a set of 4.
<b>LAMPS</b>		
L1	Exposure Lamp	Projects high intensity light on the original for exposure.
L2	Heating Roller Fusing Lamp 1	590W fusing lamp in the heating roller.
L3	Heating Roller Fusing Lamp 2	590W fusing lamp in the heating roller.
L4	Hot Roller Fusing Lamp	350W fusing lamp inside the hot roller.
L5	Pressure Roller Fusing Lamp	350W fusing lamp inside the pressure roller.
<b>MOTORS</b>		
M1	Scanner Motor	Drives the scanner unit
M2	Lower Relay Motor	Drives the lower relay roller of the relay unit at the vertical transport section.
M3	Paper Feed Motor: Tray 1	Drives the paper feed roller and grip roller of tray 1 (tandem tray).
M4	Paper Feed Motor: Tray 3	Drives the paper feed roller and grip roller of tray 3 (bottom tray).
M5	Paper Feed Motor: Tray 2	Drives the paper feed roller and grip roller of tray 2 (middle tray).
M6	Waste Toner	Drives the coil that spans the top of the waste toner

## Specifications

No.	Component	Function
	Distribution Motor	bottle.
M7	Lift Motor - Tray 2	Switches on and drives a shaft and coupling that raises a lift arm against the bottom plate under the paper stack in tray 2
M8	Lift Motor: Tray 3	Drives a shaft and coupling that raises a lift arm against the bottom plate under the paper stack in tray 3.
M9	Lift Motor: Tray 1	Drives pulleys and cables that lift the bottom plate of tray 1 (tandem tray) until the top of the paper stack reaches the correct height for feeding.
M10	Rear Fence Motor - Tray 1	Switches on when the right paper tray sensor of the tandem paper tray unit detects paper out and the left paper tray sensor detects paper present.
M11	ITB Lift Motor	Rotates the cam that raises and lowers the ITB belt.
M12	Ozone Fan Motor	Draws air from around the drums and through the ozone filter.
M13	Fusing Fan Motor	Cools the fusing unit.
M14	Fusing Cooling Fan Motor	Draws cool air into the fusing unit through a vent and past a heat sink mounted above the fusing unit.
M15	Fusing Exhaust Fan Motor	Draws the hot air away from the heat sink mounted above the fusing unit and expels the hot air through a vent
M16	Fusing/Exit Motor	Drives the fusing unit and paper exit.
M17	PTR Motor	Drives the paper transfer roller (PTR).
M18	Bypass Feed Motor	Drives the upper relay roller that feeds each sheet to the registration roller.
M19	Duplex Jogger Motor	Moves the jogger fences in the duplex unit.

## Specifications

No.	Component	Function
M20	Duplex Unit Fan Motor	Cools the duplex unit.
M21	Duplex Transport Motor	Drives transport rollers 3, 4 in the duplex unit.
M22	Duplex Inverter Motor	Feeds paper to the jogger section.
M23	Registration Motor	Rotates the registration roller.
M24	Image Transfer Fan Motor	Cools the upper area of the transfer unit where the PCUs contact the ITB.
M25	Pipe Cooling Fan Motor	Pulls in air draws it over the fins attached to the front end of the heat pipe roller.
M26	Paper Transport Fan Motor - Rear	1 of 2 vacuum fans that produce suction to keep paper on the transport belt.
M27	Paper Transport Fan Motor - Front	1 of 2 vacuum fans that produce suction to keep paper on the transport belt.
M28	Paper Exit Fan Motor	Draws hot air from around the paper exit area and expels it from the left side of the machine.
M29	Front Duplex Fan Motor	Draws hot air out of the duplex unit.
M30	Rear Duplex Fan Motor	Draws hot air out of the duplex unit.
M31	ID Sensor Dust Fan Motor	Blows air around the ID sensors to prevent dust from collecting.
M32	Cooling Fan Motor	Draws air and sends it through a duct to the four PCU cooling fans.
M33	Circulation Fan Motor	Circulates air.
M34	Laser Unit Cooling Fan Motor - Front	Draws cool air into the machine.
M35	Laser Unit Cooling Fan Motor - Rear	Expels hot air from the machine on the left side.

## Specifications

No.	Component	Function
M36	PCU Motor : M	Drives all the rollers in the Magenta PCU.
M37	PCU Motor: K	Drives all the rollers in the Black PCU.
M38	PCU Motor: Y	Drives all the rollers in the Yellow PCU.
M39	PCU Motor: C	Drives all the rollers in the Cyan PCU.
M40	Controller Box Exhaust Fan Motor 2	1 of 2 fans that cool the printed circuit boards at the back of the machine.
M41	Controller Box Exhaust Fan Motor 1	1 of 2 fans that cool the printed circuit boards at the back of the machine.
M42	Drum Motor: Y	Drives the drum in the Yellow PCU.
M43	Drum Motor: C	Drives the drum in the Cyan PCU.
M44	Drum Motor: M	Drives the drum in the Magenta PCU.
M45	Drum Motor: K	Drives the drum in the Black PCU.
M46	ITB Drive Motor	Rotates the image transfer roller that drives the ITB.
M47	3rd Mirror Motor - M	Fine adjusts the position of the 3rd mirror of the optics for M (magenta) during MUSIC adjustment.
M48	Polygon Mirror Motor	Rotates the polygon mirror in the laser optics unit
M49	3rd Mirror Motor - Y	Fine adjusts the position of the 3rd mirror of the optics for Y (Yellow) during MUSIC adjustment.
M50	3rd Mirror Motor - C	Fine adjusts the position of the 3rd mirror of the optics for C (Cyan) during MUSIC adjustment.
M51	Toner Hopper Motor	Drives the toner pump clutch and sub hopper clutch of each PCU.
M52	PCU Fan Motor: Y	Cools the Yellow PCU.
M53	PCU Fan Motor: C	Cools the Cyan PCU.

## Specifications

No.	Component	Function
M54	PCU Fan Motor: M	Cools the Magenta PCU
M55	Scanner Unit Fan Motor - Rear Left	Cools the left, rear corner of the SIOB.
M56	Scanner Unit Fan Motor - Rear Center	Cools the rear, center area of the SIOB.
M57	Scanner Unit Fan Motor - Right	Exhausts warm air from the SIOB area.
M58	Waste Toner Collection Bottle Motor	Drives the waste toner bottle transport coil that moves the toner from the central collection point into the waste toner bottle.
<b>MECHANICAL CLUTCHES</b>		
MC1	Bypass Feed Clutch	Engages and operates the pick-up roller at the bypass feed tray.
MC2	Toner Pump Clutch: M	Engages the and drives the Magenta toner pump to pull toner from the Magenta STC.
MC3	Toner Supply Clutch: M	Engages the toner supply coils in the sub hopper of the Magenta PCU to send toner to the development unit below.
MC4	Toner Pump Clutch : K	Engages the and drives the Black toner pump to pull toner from the Black STC.
MC5	Toner Supply Clutch : K	Engages the toner supply coils in the sub hopper of the Black PCU to send toner to the development unit below.
MC6	Toner Pump Clutch: Y	Engages the drive shaft and rotor of the Yellow toner pump to pull toner from the Yellow STC when more toner is needed.
MC7	Toner Supply Clutch: Y	Engages the toner supply coils in the sub hopper of the Yellow PCU to send toner to the development unit

## Specifications

No.	Component	Function
		below.
MC8	Toner Pump Clutch: C	Engages the and drives the Cyan toner pump to pull toner from the Cyan STC.
MC9	Toner Supply Clutch: C	Engages the toner supply coils in the sub hopper of the Cyan PCU to send toner to the development unit below.
<b>PCBs</b>		
PCB1	PFB (Paper Feed Board)	Controls paper trays and paper feed.
PCB2	AC Drive Board	Controls the power supply to the fusing lamps, heaters, and PSU.
PCB3	PSU (Power Supply Unit)	Supplies DC current to the machine and contains the AC drive that controls the fusing lamp power supply.
PCB4	DRB (Drive Board)	Contains the circuits for the stepping motors that drive the printer engine, and distributes electrical power to all other PCBs.
PCB5	Power Pack: Development Bias	Supplies the voltage for the bias applied to the developer in the PCUs by the development rollers.
PCB6	Power Pack: Charge	Supplies the voltage for the charge applied to the OPC drums by the charge roller.
PCB7	Power Pack: Transfer	Supplies charge to 1) the four image transfer rollers that pull the toner images from the four from the four drums (Y, M, C, K), and 2) to the paper transfer roller that pulls the image off the ITB onto paper.
PCB8	Power Pack - Separation	Supplies the dc/ac charges for paper separation.
PCB9	DTMB (Drum/Transfer Motor Board)	Controls the motors that drive the OPC drums and ITB.

## Specifications

No.	Component	Function
PCB10	IPU	Performs: 1) Image processing control, 2) GW controller interface, 3) peripheral timing control.
PCB11	Potential Sensor Board	Processes data from the Y, M, C, K, potential sensors.
PCB12	CNB (Connector Board)	Sorts and routes signals to electrical components.
PCB13	IDCB: C1	One of two ID control boards at the base of the Cyan STC. The CPU reads the board to confirm that the correct STC is inserted into the correct bin.
PCB14	IDCB: M1	One of two ID control boards at the base of the Magenta STC. The CPU reads the board to confirm that the correct STC is inserted into the correct bin.
PCB15	IDCB: K1	One of two ID control boards at the base of the Black STC. The CPU reads the board to confirm that the correct STC is inserted into the correct bin.
PCB16	IDCB: Y1	One of two ID control boards at the base of the Yellow STC. The CPU reads the board to confirm that the correct STC is inserted into the correct bin.
PCB17	SBU (Sensor Board Unit)	Contains the CCD. Converts CCD analog signals to digital signals.
PCB18	SIOB (Scanner Interface Board)	Controls all the sensors in the scanner unit and controls the carriage drive stepping motors.
PCB19	Lamp Regulator	Converts the dc power input to a stable, high frequency ac output to the exposure lamp.
PCB20	VBCU	VBCU: 1) Engine sequence control (all sensors, motors, fusing temperature monitoring circuits), 2) Scanning control, 3) Exposure control, 3) Image processing control, 4) GW controller I/F, 5) Peripheral timing control.

## Specifications

No.	Component	Function
		The I/O control board controls 1) Input/output ports for all sensors, motor, solenoids, 2) drivers, 3) high voltage power supply for PWM, and 4) analog input signals.
PCB21	LD 1 (2/2)	Laser Diode 1, 2nd of a pair, 1 of 8.
	LD 1 (1/2)	Laser Diode 1, 1st of a pair, 1 of 8.
PCB22	LD 2 (2/2)	Laser Diode 2, 2nd of a pair, 1 of 8.
	LD 2 (1/2)	Laser Diode 2, 1st of a pair, 1 of 8.
PCB23	LD 3 (2/2)	Laser Diode 3, 2nd of a pair, 1 of 8.
	LD 3 (1/2)	Laser Diode 3, 1st of a pair, 1 of 8.
PCB24	LD 4 (2/2)	Laser Diode 4, 2nd of a pair, 1 of 8.
	LD 4 (1/2)	Laser Diode 4, 1st of a pair, 1 of 8.
PCB25	LSDB: K Front	Front Laser Synchronization Detector Board for Laser Diode 4.
PCB26	LSDB: M Front	Front Laser Synchronization Detector Board for Laser Diode 3.
PCB27	LSDB: C Front	Front Laser Synchronization Detector Board for Laser Diode 2.
PCB28	LSDB: Y Front	Front Laser Synchronization Detector Board for Laser Diode 1.
PCB29	LSDB: Y Rear	Rear Laser Synchronization Detector Board for Laser Diode 1.
PCB30	LSDB: C Rear	Rear Laser Synchronization Detector Board for Laser Diode 2.
PCB31	LSDB: M Rear	Rear Laser Synchronization Detector Board for Laser Diode 3.



## Specifications

No.	Component	Function
PCB32	LSDB: K Rear	Rear Laser Synchronization Detector Board for Laser Diode 4.
PCB33	Controller Board	Incorporates the GW architecture, and connects to the BICU and PCI I/F. All the options for the printer are controlled by this board.
PCB34	Mother Board	Interfaces the controller and the BICU.
PCB35	RAPI EXT Board	Interface the copy connector and EFI controller.
PCB36	OPU (Operation Panel Unit)	Controls the operation panel.
PCB37	PI Board	Interfaces the IPU and RDS.
<b>QUENCHING LAMPS</b>		
QL1	Quenching Lamp : K	Eliminates electrical charge and neutralizes the surface of the drum in the Black PCU.
QL2	Quenching Lamp: C	Eliminates electrical charge and neutralizes the surface of the drum in the Cyan PCU.
QL3	Quenching Lamp: M	Eliminates electrical charge and neutralizes the surface of the drum in the Magenta PCU.
QL4	Quenching Lamp: Y	Eliminates electrical charge and neutralizes the surface of the drum in the Yellow PCU.
<b>SENSORS</b>		
S1	ID Sensor: Black	Reads 1) light reflected from the bare surface of the ITB, and 2) reads light reflected from the black ID sensor patterns on the ITB.
S2	ID Sensor: Color	Reads 1) light reflected from the bare surface of the ITB, and 2) reads light reflected from the color ID sensor patterns on the ITB. This sensor has one additional receptor to collect diffuse light reflected

## Specifications

No.	Component	Function
		from color toner to improve calculation of the toner density.
S3	ITB Lift Sensor	This sensor switches the ITB lift motor off when the ITB comes into contact the drums of the four PCUs.
S4	MUSIC Sensor: Center	Reads the center MUSIC pattern. This feedback is used to control the MUSIC process to correct color registration errors.
S5	MUSIC Sensor: Front	Reads the front MUSIC pattern. This feedback is used to control the MUSIC process to correct color registration errors.
S6	MUSIC Sensor: Rear	Reads the Rear MUSIC pattern. This feedback is used to control the MUSIC process to correct color registration errors.
S7	Paper Feed Sensor: Tray 2	Detects the leading edge of each sheet of paper from the pick-up roller of tray (middle tray) and switches off the pick-up roller solenoid so the pick-up roller lifts.
S8	Vertical Transport Sensor: Tray 2	Detects the leading edge and trailing edge of each sheet fed from tray 2 and signals a jam if the edges do not pass at the prescribed time.
S9	Paper End Sensor: Tray 2	Receives light reflected from the paper until the last sheet is fed from tray 2 (middle tray), then signals paper end.
S10	Lift Sensor: Tray 2	Detects when the pick-up roller (pushed up by the top of the paper stack in the right side of the tandem tray) has reached the correct height for paper feed and then switches off the tray 2 (middle tray) lift motor.
S11	Paper Feed Sensor:	Detects the leading edge of each sheet of paper

## Specifications

No.	Component	Function
	Tray 3	from the pick-up roller of tray 3 (bottom tray) and switches off the pick-up roller solenoid so the pick-up roller lifts.
S12	Vertical Transport Sensor: Tray 3	Detects the leading edge and trailing edge of each sheet fed from tray 3 and signals a jam if the edges do not pass at the prescribed time.
S13	Paper End Sensor: Tray 3	Receives light reflected from the paper until the last sheet is fed from tray 3 (bottom tray), then signals paper end.
S14	Lift Sensor: Tray 3	Detects when the pick-up roller (pushed up by the top of the paper stack in the right side of the tandem tray) has reached the correct height for paper feed and then switches off the tray 3 (bottom tray) lift motor.
S15	Bottom Temperature/Humidity Sensor	Near the waste toner bottle. Detects ambient temperature and humidity and then this output is used to control the amount of current applied to the paper transfer roller and ITB when the image is transferred to paper. Also used to correct the fusing temperature, and to extend the fusing unit idle time at low room temperatures.
S16	Waste Toner Bottle Set Sensor	Detects the position of the waste toner bottle and confirms whether it is set correctly.
S17	Waste Toner Bottle Near-Full Sensor	When the level of the waste toner rises high enough to move the actuator of this sensor out of its normal position, the sensor signals the machine that the waste toner bottle is nearly full.
S18	Waste Toner Bottle Full Sensor	Signals an alert when the waste toner bottle is full.
S19	Paper Feed Sensor -	Detects the leading edge of each sheet of paper from

## Specifications

No.	Component	Function
	Tray 1	the pick-up roller of tray 1 (tandem tray) and switches off the pick-up roller solenoid so the pick-up roller lifts.
S20	Vertical Transport Sensor - Tray 1	Detects the leading edge and trailing edge of each sheet fed from tray 1, 2, and 3 and signals a jam if the edges do not pass at the prescribed time.
S21	Paper End Sensor - Tray 1	Detects when the last sheet is fed from tray 1.
S22	Lift Sensor - Tray 1	Detects when the pick-up roller (pushed up by the top of the paper stack in the right side of the tandem tray) has reached the correct height for paper feed and then switches off the tray 1 (tandem tray) lift motor.
S23	Paper Near End Sensor - Tray 2	Detects the near end condition for tray 2 (middle tray, a universal cassette).
S24	Paper Near End Sensor: Tray 3	Detects the near end condition for tray 3 (middle tray, a universal cassette).
S25	Front Side Fence Open Sensor	Detects the actuator on the front side fence after it has reached the open position in the tandem tray.
S26	Front Side Fence Closed Sensor	Detects the actuator on the front side fence after it has reached the closed position in the tandem tray.
S27	Rear Side Fence Open Sensor	Detects the actuator on the rear side fence after it has reached the open position in the tandem tray.
S28	Rear Side Fence Closed Sensor	Detects the actuator on the rear side fence after it has reached the closed position in the tandem tray.
S29	Right Tray Down Sensor	Detects the bottom plate of the right tray and switches off the tray 1 lift motor and stops the bottom plate.

## Specifications

No.	Component	Function
S30	Paper Near End Sensor - Tray 1	Signals 10% paper remaining when the actuator on the right rail of the right tray in the tandem tray passes.
S31	Paper Height Sensor	Signals 100% paper remaining until activated. Signals 50% paper remaining when the actuator on the left rail of the right tray in the tandem tray passes.
S32	Paper Height Sensor	Signals 30% paper remaining when the actuator on the left rail of the right tray in the tandem tray passes.
S33	Paper Height Sensor	When near end sensor 1 on right rail of the right tray of the tandem tray is actuated, and paper height sensor 3 has detected the passing of the actuator on the left rail, then the near end sensor signals 10% paper remaining.
S34	Right Tray Paper Sensor	Detects paper in the right side of the tandem paper tray.
S35	Rear Fence HP Sensor	Detects the actuator on the rear fence in the tandem tray and switches off the rear fence motor.
S36	Rear Fence Return Sensor	Detects the actuator on the rear fence in the tandem tray and reverses the rear fence motor.
S37	Left Tray Paper Sensor	Detects the presence of paper in the left tray of the tandem tray.
S38	Heating Roller Temperature Sensor	Monitors the surface temperature of the heating roller and breaks the circuits to the fusing lamps if the heating roller overheats.
S39	Waste Toner Lock Sensor	Signals an alert if the waste toner collection coil locks and stops rotating.
S40	Duplex Transport Sensor 1	The feeler of this sensor detects the leading edge and trailing edge of each sheet as it passes from the jogger unit above and into the horizontal feed path of

## Specifications

No.	Component	Function
		the duplex unit below. Signals a jam if the paper does not arrive at or reach the sensor location at the prescribed time.
S41	Duplex Inverter Sensor	Detects the leading edge of the paper at the inverter exit roller and signals to switch off the reverse trigger roller solenoid to signal a jam if the paper does not arrive at the prescribed time.
S42	Duplex Entrance Sensor	Detects paper jams at the entrance of the duplex unit.
S43	Duplex Transport Sensor 3	Detects the leading edge and trailing edge of each sheet as it passes from the jogger unit above through the horizontal feed path of the duplex unit below. Signals a jam if the paper does not arrive at or reach the sensor location at the prescribed time.
S44	Duplex Transport Sensor 2	Detects the leading edge and trailing edge of each sheet as it passes from the jogger unit above and into the horizontal feed path of the duplex unit below. Signals a jam if the paper does not arrive at or reach the sensor location at the prescribed time.
S45	Duplex Jogger HP Sensor	At power on, detects the actuators on the jogger fences of the duplex unit, switches off the jogger motor and stops the fences at their home positions.
S46	Double-Feed Detection Sensor	Receives the light emitted from the double-feed detection LED and reflected from the surface of each sheet in the paper path. Signals an error if the thickness of the paper is not the same as the previous sheet.
S47	Guide Plate Position Sensor	
S48	Relay Sensor	Detects jams at the top of the vertical paper path.

## Specifications

No.	Component	Function
S49	Registration Sensor	Detects the leading edge of the paper and switches off the registration motor and stops the registration roller briefly but long enough to correct buckle the paper.
S50	Paper Exit Sensor	Detects the leading and trailing edge of each sheet at the paper exit slot to check timing and detect jams.
S51	Bypass Paper Sensor	Detects the presence of paper in the bypass tray.
S52	Bypass Paper End Sensor	Signals paper out when the last sheet feeds from the bypass tray.
S53	Bypass Paper Size Sensor	Reads the positions of the side fences (manually adjusted) to detect the width of the paper in the bypass tray. (Paper length is read with pulse counts from the registration sensor.)
S54	Paper Exit Relay Sensor	Detects paper jams at the paper exit if the paper does not arrive or leave the machine at the prescribed time.
S55	Copy Tray Full Sensor (Option)	Detects when the Copy Paper Tray B75 is full and temporarily pauses printing so the operator can remove the stack from the tray and continue.
S56	TD Sensor: M	Monitors the amount of toner in the developer/toner mixture in the development unit of the Magenta PCU.
S57	TD Sensor : K	Monitors the amount of toner in the developer/toner mixture in the development unit of the Black PCU.
S58	Temperature/Humidity Sensor : PCU K	The temperature and humidity readings of this sensor are referenced to a lookup table stored in the ROM to 1) Correct the charge roller voltage , and 2) Set the length of time the agitators in the development unit rotate to mix the toner and developer.

## Specifications

No.	Component	Function
S59	TD Sensor: Y	Monitors the amount of toner in the developer/toner mixture in the development unit of the Yellow PCU.
S60	TD Sensor: C	Monitors the amount of toner in the developer/toner mixture in the development unit of the Cyan PCU.
S61	ITB Position Sensor 2	Reads the encoder film strip on the front edge of the ITB and sends the sub scan scale signal to the CPU.
S62	ITB Position Sensor 1	Reads the encoder film strip on the front edge of the ITB and sends the main scan scale signal to the CPU.
S63	Potential Sensor : K	Reads the potential sensor pattern from the surface of the drum in the black PCU.
S64	Potential Sensor: M	Reads the potential sensor pattern from the surface of the drum in the magenta PCU.
S65	Potential Sensor: C	Reads the potential sensor pattern from the surface of the drum in the cyan PCU.
S66	Potential Sensor: Y	Reads the potential sensor pattern from the surface of the drum in the yellow PCU.
S67	Temperature Sensor: Optics 1	1 of 2 sensors (located near the left f-theta lens) that monitors the temperature in the optics unit. The results are used in the MUSIC process.
S68	Temperature Sensor: Optics 2	1 of 2 sensors (located near the right f-theta lens) that monitors the temperature in the optics unit. The results are used in the MUSIC process.
S69	Toner End Sensor: M	Detects toner end for magenta toner.
S70	Toner End Sensor : K	Detects toner end for black toner.
S71	Toner End Sensor: Y	Detects toner end for yellow toner.
S72	Toner End Sensor: C	Detects toner end for cyan toner.



## Specifications

No.	Component	Function
S73	Scanner HP Sensor	Detects the home position of the scanner.
S74	Original Width Sensors	APS1 (a board) holds two original width sensors under the exposure glass. The detection combinations of these sensors determine the width of the original on the exposure glass positioned for LEF.
S75	Original Length Sensors - 1	APS2 (a board) holds two original length sensors under the exposure glass. The detection combinations of these sensors determine the length of the original on the exposure glass positioned for SEF.
S76	Original Length Sensor -2	APS3 (a board) holds one original length sensor under the exposure glass. The detection combination of this sensor and other sensors determine the length of the original on the exposure glass positioned for SEF.
S77	Accordion Jam Sensor	Detects jams at the fusing exit by confirming that paper arrives at the prescribed time.
S78	Fusing Exit Sensor	Detects jams at the fusing exit by confirming that paper leaves at the prescribed time.
S79	LCT Relay Sensor	Confirms whether the LCT is set correctly.
<b>LEDs</b>		
LED1	Double-Feed Detection LED	Emits light which is reflected from the paper to the double-feed detection sensor to test the translucence of each sheet for double-feed detection.
LED2	Accordion Jam Sensor (LED)	Flashes to show the user which lever to release to remove a paper jam from the fusing rollers.
LED3	Fusing Exit Sensor (LED)	Flashes to show the user which lever to release to remove a paper jam from the fusing unit.

Specifications

No.	Component	Function
<b>SOLENOIDS</b>		
SOL1	Pick-up Solenoid: Tray 2	Switches on when the tray 2 (middle tray) lift motor switches on. This solenoid lowers the pick-up roller of tray 3.
SOL2	Separation Roller Solenoid: Tray 2	When tray 2 (middle tray) is selected as the paper source, this solenoid energizes and brings the separation roller in contact with the feed roller until the leading edge of the sheet feeds to the paper feed sensor.
SOL3	Pick-up Solenoid: Tray 3	Switches on when the tray 3 (bottom tray) lift motor switches on. This solenoid lowers the pick-up roller of tray 3.
SOL4	Separation Roller Solenoid: Tray 3	When tray 3 (bottom tray) is selected as the paper source, this solenoid energizes and brings the separation roller in contact with the feed roller until the leading edge of the sheet feeds to the paper feed sensor.
SOL5	Pick-up Solenoid - Tray 1	Switches on when the tray 1 (tandem tray) lift motor switches on. This solenoid lowers the pick-up roller of tray 1.
SOL6	Separation Roller Solenoid - Tray 1	When tray 1 (tandem tray) is selected as the paper source, this solenoid energizes and brings the separation roller in contact with the feed roller until the leading edge of the sheet feeds to the paper feed sensor.
SOL7	Front Side Fence Solenoid -Tray 1	When the right tray paper sensor in the tandem tray signals paper out, and the left tray paper sensor signals paper present, this energizes this solenoid which pulls open the front side fence until the front side fence open sensor detects the actuator of the

## Specifications

No.	Component	Function
		front side fence and switches off the solenoid, leaving it locked in the open position, to allow the rear fence to push the paper stack from the left tray into the right tray.
SOL8	Rear Side Fence Solenoid - Tray 1	When the right tray paper sensor in the tandem tray signals paper out, and the left tray paper sensor signals paper present, this energizes this solenoid which pulls open the rear side fence until the rear side fence open sensor detects the actuator of the rear side fence and switches off the solenoid, leaving it locked in the open position, to allow rear fence to push the paper stack from the left tray into the right tray.
SOL9	Right Tray Lock Solenoid - Tray 1	Releases the lock lever when the left tray paper sensor in the tandem tray signals that there is no paper in the left tray.
SOL10	Left Tray Lock Solenoid - Tray 1	When the rear fence motor in the tandem tray switches on, this energizes the left tray lock solenoid. This locks the left tray so it does not move while the rear fence pushes the stack from the left tray to the right tray.
SOL11	Duplex Junction Gate Solenoid	Controls the opening and closing of the duplex junction gate at the mouth of the inverter unit.
SOL12	Reverse Trigger Roller Solenoid	After a sheet is detected by the duplex entrance sensor, this solenoid energizes and pushes down the reverse trigger roller.
SOL13	Guide Plate Solenoid	Energizes when a jam occurs between the vertical transport rollers and registration roller to force the guide plate open and divert paper fed from below into the duplex tray.

## Specifications

No.	Component	Function
SOL14	Inverter Junction Gate Solenoid	Operates the inverter junction gate. The inverter junction gate turns paper into the path to the inverter unit below where it is 1) inverted for face-down output or 2) inverted for 2nd side printing.
SOL15	Bypass Pick-up Solenoid	Switches on and lowers the pick-up roller to the top of the stack in the bypass tray
<b>SWITCHES</b>		
SW1	Lower Front Door Switch	Detects whether the front door is open or closed.
SW2	Main Power Switch	Switches the machine off and on.
SW3	Upper Front Door Switches (x5)	Detect whether the front door is open or closed.
SW4	Paper Size Switch: Tray 2	The switch detects the position of the dial (set manually), and signals the paper size with a simple 5-digit binary code.
SW5	Paper Size Switch: Tray 3	The switch detects the position of the dial (set manually), and signals the paper size with a simple 5-digit binary code.
<b>THERMISTORS</b>		
TH1	Heating Roller Thermistor	Monitors the end of the heating roller and breaks the circuit to the heating lamps if a lamp overheats.
TH2	Hot Roller Thermistor	Detects and monitors the temperature of the hot roller for fusing temperature control.
TH3	Pressure Roller Thermistor	Detects the temperature of the hot roller for fusing temperature control.
<b>THERMOSTATS</b>		
TS1	Pressure Roller	Monitors the temperature of the pressure roller and

## Specifications

No.	Component	Function
	Thermostat 1	cuts the circuit if the pressure roller fusing lamp overheats.
TS2	Pressure Roller Thermostat 2	Monitors the temperature of the pressure roller and cuts the circuit if the pressure roller fusing lamp overheats.
TS3	Thermostat 1	Monitors the temperature of the fusing belt and cuts the circuit if the fusing unit overheats.
TS4	Thermostat 2	Monitors the temperature of the fusing belt and cuts the circuit if the fusing unit overheats.
TS5	Thermostat 3	Monitors the temperature of the fusing belt and cuts the circuit if the fusing unit overheats.
TS6	Thermostat 4	Monitors the temperature of the fusing belt and cuts the circuit if the fusing unit overheats.

## ARDF

No.	Component	Function
<b>MOTORS</b>		
M1	Feed Motor	Drives the feed belt, and the separation, pick-up, and transport as far as the 1st transport roller.
M2	Transport Motor	Controls the original scanning speed.
M3	Exit Motor	Feeds paper out of the ARDF and onto the original exit table.
M4	Upper Inverter Motor	Controls the rotation of the upper inverter roller that feeds the original in and out of the upper inverter path.
M5	Lower Inverter Motor	Controls the rotation of the lower inverter roller that

## Specifications

No.	Component	Function
		feeds the original in and out of the lower inverter path.
M6	Pick-up Motor	Raises and lowers the pick-up roller.
M7	Bottom Plate Lift Motor	Raises and lowers the bottom under the original stack.
<b>PCB</b>		
PCB1	ARDF Main Board	Controls the ARDF and communicates with the main copier boards.
<b>SENSORS</b>		
S1	Original Width Sensor 2	Detects paper wider than 191.5 mm (7.5 in.) measured from the reference point.
S2	Original Width Sensor 3	Detects paper wider than 230 mm (9.1 in.) measured from the reference point.
S3	Original Width Sensor 4	Detects paper wider than 263.5 mm (10.4 in.) measured from the reference point.
S4	Original Width Sensor 5	Detects paper wider than 288 mm (11.3 in.) measured from the reference point.
S5	Original Width Sensor 1	Detects paper wider than 138 mm (5.4 in.) measured from the reference point.
S6	Original Set Sensor	Detects whether an original is on the table.
S7	Bottom Plate HP Sensor	Detects whether the bottom plate is in the down position or not.
S8	Feed Cover Sensor	Detects whether the feed cover is open or not.
S9	Bottom Plate Position Sensor	Detects when the original is at the correct position for feeding.
S10	Upper Inverter Sensor	Detects leading and trailing edge of the paper as it enters and leaves the upper path of the inverter.

## Specifications

No.	Component	Function
S11	LG Detection Sensor	Detects paper longer than 318 mm (12.5 in.) on the original table.
S12	A4 Detection Sensor	Detects paper longer than 291 mm (11.5 in.) on the original table.
S13	B5 Detection Sensor	Detects paper longer than 240 mm (9.5 in.) on the original table.
S14	Interval Sensor	Adjusts the timing of the original transport speed to the original scanning speed after the original feeds. During duplex scanning, or if original is small (B6, A5, or HLT) the interval sensor detects the leading edge of the original and delays the pre-scanning motor for the prescribed number of pulses to buckle the original and correct skew.
S15	Skew Correction Sensor	After pick-up and separation, the skew correction sensor detects the leading edge of the original. This signal slows the rotation of the entrance roller for a prescribed number of pulses to buckle the original and correct skew.
S16	Separation Sensor	Detects the separation of the original.
S17	Exit Sensor	Detects the leading and trailing edges of paper feed out to the original table and detects misfeeds. Also signals when to stop the scanning belt.
S18	Registration Sensor	Detects the leading edge and trailing edges of the original to detects jams and stops the original at the ADF exposure glass to correct buckle.
S19	Pick-up Roller HP Sensor	Detects whether the pick-up roller is up or not.
S20	Lower inverter sensor	Detects the original in the path of the lower inverter before it feeds to the inverter rollers for 2nd side

## Specifications

No.	Component	Function
		scanning, or feeds to the exit rollers for exit.
S21	ARDF Position Sensor	Detects whether the ARDF unit is up or down for scanning on the main exposure glass (book mode).
S22	APS Start Sensor	Signals the CPU when the DF is opened and closed (for platen mode) so that the original size sensors in the copier can check the original size.
<b>SOLENOIDS</b>		
SOL1	Upper Inverter Solenoid	Opens and closes the upper junction gate at the entrance of the upper inverter path. During simplex scanning, closes the upper inverter path so the original exits straight to the exit tray. During duplex scanning, opens to allow the original to enter the upper inverter path and closes to direct it once again into the feed path for 2nd side scanning.
SOL2	Lower Inverter Solenoid	Opens and closes the lower junction gate. During duplex scanning opens after the 2nd side is scanned to direct the original into the lower inverter path while the next sheet is fed to the upper inverter path above, then closes to direct the original out onto the original exit tray.



Model: D014/D015	Date: 24-Oct-08	No.: TRD014018
------------------	-----------------	----------------

Subject: Halo effect in GW controller			
Classification:	<input checked="" type="checkbox"/> Troubleshooting	<input type="checkbox"/> Part information	<input type="checkbox"/> Action required
	<input type="checkbox"/> Mechanical	<input type="checkbox"/> Electrical	<input type="checkbox"/> Service manual revision
	<input type="checkbox"/> Paper path	<input type="checkbox"/> Transmit/receive	<input type="checkbox"/> Retrofit information
	<input type="checkbox"/> Product Safety	<input type="checkbox"/> Other (     )	

## SYMPTOM

Images printed by GW controller show the "halo" effect in 2-bit mode (1800x600dpi) and in 4-bit mode (9600x600dpi).

### Note:

- This symptom is most visible when text is overlaid onto halftone areas in the abovementioned modes. The greater the difference in image density between this text and halftone area, the more noticeable the halo effect is.
- This symptom is also noticeable to the user when the mode is changed to 2-bit mode. This is because the default dithering pattern for 2-bit mode is designed to improve gradation, but makes the halo effect more visible.

## SOLUTION

**Note:** The following solution is only effective when using the GW controller.

There are two ways to reduce the halo effect:

- 1) Print out the image using 1-bit mode (600x600dpi) instead, or
- 2) Change the dither pattern used in 2-bit mode (1800x600dpi).

**Note:** As mentioned above, the default dither pattern for 2-bit mode is for improving gradation. However, there is one more dither pattern that can be selected, which reduces the halo effect ("Low halo effect dither").

**See procedure below.**

Model: D014/D015

Date: 24-Oct-08

No.: TRD014018

## Procedure for changing the dither pattern used in 2-bit mode

Do the following to manually change the dither pattern used in 2-bit mode to the “Low halo effect dither”.

1. Execute **SP5801-008** (Memory Clear Printer Application).

**Note:** When you execute this SP, the following will be reset to factory settings:

- The gamma curve, which was adjusted at the last Printer ACC
- All SP-1xxx settings in Printer SP mode, which includes SP1104 (Gamma Adjustment) and SP1106 (Toner Limit).

2. When “Completed. You have to reboot.” is displayed, turn the machine power switch OFF and ON.

3. Access **Printer SP1001-002**.

4. Press the “6” key, and then the “#” key on the operation panel.

**Note:** The LCD display will change as follows:

Before (default): 00000000 (0) [00H]

**After (low halo effect dither):** 01000000 (0) [40H]

5. Exit Printer SP mode, and then turn the main power switch OFF and ON.

6. Execute Printer ACC using Test Pattern 2 (1800X600dpi).

### Note:

- As a result of this procedure, when the user selects 2-bit mode (1800x600dpi) in the printer driver, the low halo effect dither will be automatically applied.
- To change the dither pattern for 2-bit mode back to the default pattern, execute SP5801-008 (Memory Clear Printer Application). Then, turn the main power switch OFF and ON.

### Dither pattern example:

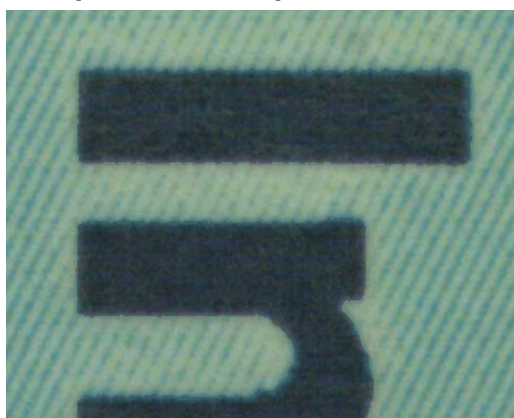

Factory default dither pattern

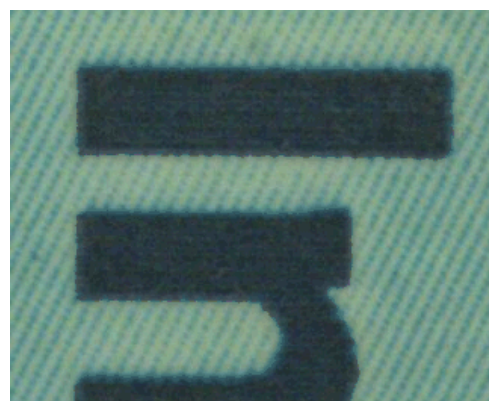

Low halo effect type dither pattern

Model: D014/D015	Date: 24-Oct-08	No.: TRD014019
------------------	-----------------	----------------

Subject: Service Manual Correction		
Classification:	<input type="checkbox"/> Troubleshooting <input type="checkbox"/> Mechanical <input type="checkbox"/> Paper path <input type="checkbox"/> Product Safety	<input type="checkbox"/> Part information <input type="checkbox"/> Electrical <input type="checkbox"/> Transmit/receive <input type="checkbox"/> Other (     )
		<input type="checkbox"/> Action required <input checked="" type="checkbox"/> Service manual revision <input type="checkbox"/> Retrofit information

The Service Manual of installation section for the **Data Overwrite Security Unit Type H [D377-06]** was corrected as follows:

Check the accessories and their quantities against the table below.

1. Service Manual: Section1. Installation / MFP Controller Options / Data Overwrite Security Unit Type H D377

**Change the following descriptions:**

Accessory Check

Check the accessories and their quantities against the table below.

Description	Q'ty
1. Data Overwrite Security SD Card	1
2. Operating Instructions CD-ROM	1
3. Comments Sheet (17 languages)	2

Item number description: "3," has been corrected to "3."

2. "Before You Begin..." the Procedure

**DELETE the following descriptions:**

- If you install any version other than "Type H", you will have to replace the NVRAM and do this installation procedure again.

3. "Seal Check and Removal"

**The illustration of package has been corrected.**

**Incorrect:**

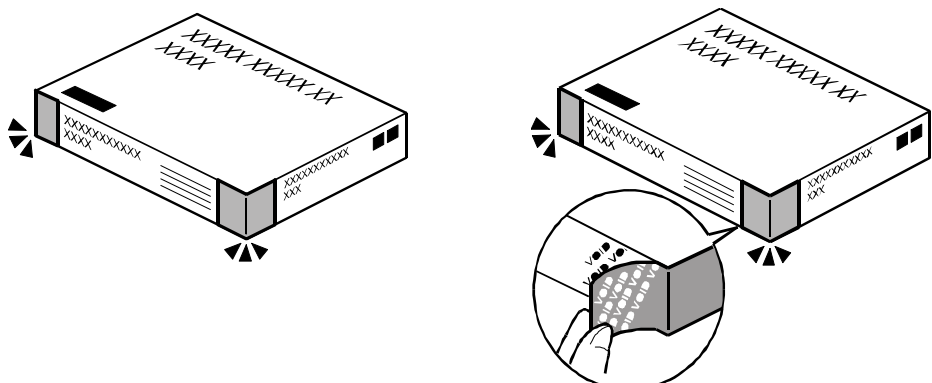

Model: D014/D015	Date: 24-Oct-08	No.: TRD014019
------------------	-----------------	----------------

**Correct:**

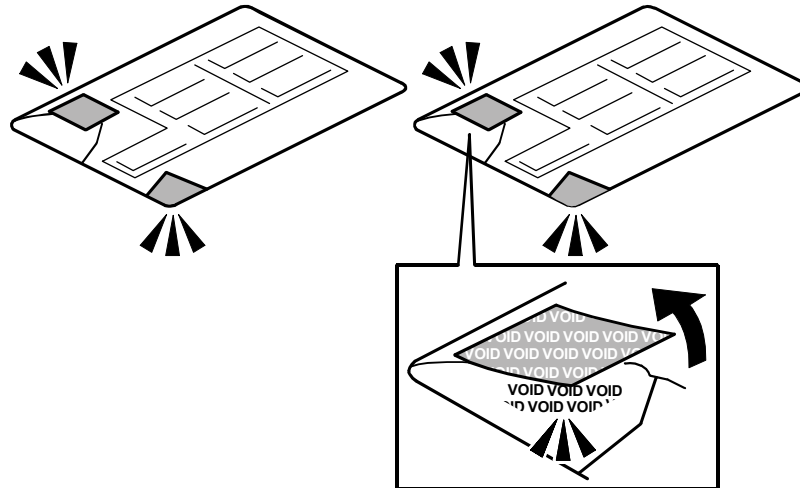

**DELETE the following descriptions:**

- Make sure that the number and "Type" are correct [Type H, D377]. If you install the incorrect version of this application, the NVRAM must be replaced.

#### 4. "Installation Procedure"

**Incorrect:**

14. Check the diagnostic report.

- Under [ROM NO./Firmware Version] you should see the correct number for this option displayed "HDD Format Option".
- Under [Loading Program] you should see "GW1a\_zoffyx:(number)".

The number in the report must be match. (The ROM number and firmware version number change after the firmware has been upgraded).

**Correct:**

14. Make sure the ROM number and firmware version in area [a] of the diagnostic report are the same as those in area [b].

- Area [a]: "ROM Number/Firmware Version" – "HDD Format Option"
- Area [b]: "Loading Program" - "GW4a\_zoffyx"

Diagnostic Report:	"ROM No. / Firmware Version" [a]	"Loading Program" [b]
DataOverwriteSecurity Unit	HDD Format Option: <b>D3775902A / 1.01x</b>	<b>GW4a_zoffyx:</b> <b>D3775902A / 1.01x</b>

Model: D014/D015	Date: 24-Oct-08	No.: TRD014019
------------------	-----------------	----------------

5.

**DELETE the following description:**

- If the ROM numbers or version numbers do not match, this means that the DOS unit type was incorrect (not "Type D").
- If the numbers do not match:
  - (1) Obtain the correct SD card: Data Overwrite Security D377 Type H
  - (2) Replace the NVRAM on the controller board.
  - (3) Insert the Type correct SD card in the lower slot.
  - (4) Do the DOS unit installation procedure again.

**Check Operation of the DOS Application**

**Replace the illustration and explanations.**

**Incorrect:**

2. Exit User Tools.
3. Check the display and make sure that the overwrite erase icon [A] is displayed.

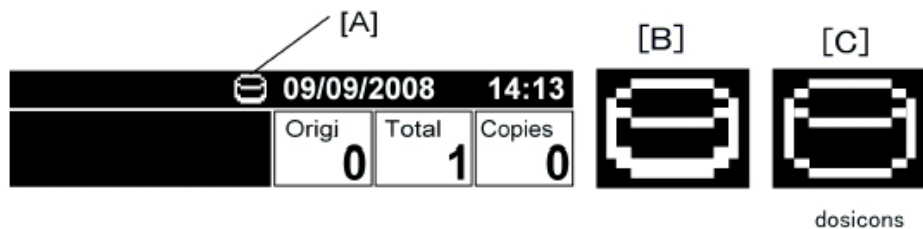

5. Check the overwrite erase icon.
  - The icon [B] changes to [C] when job data is stored in the hard disk.
  - The icon resumes its normal shape [B] after a data overwrite has completed.

**Correct:**

2. Exit User Tools.
3. Check the display and make sure that the overwrite erase icon [1] is displayed.

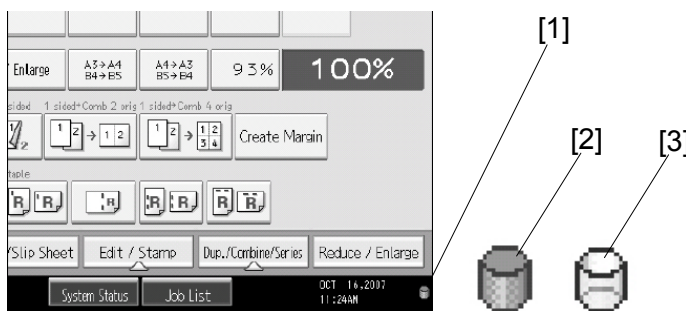

5. Check the overwrite erase icon.
  - The icon [2]: This icon is lit when there is temporary data to be overwritten, and blinks during overwriting.
  - The icon [3]: This icon is lit when there is no temporary data to be overwritten.

Model: D014/D015	Date: 24-Oct-08	No.: TRD014022
------------------	-----------------	----------------

Subject: Developer Bottle Setting			
Classification:	<input type="checkbox"/> Troubleshooting	<input type="checkbox"/> Part information	<input type="checkbox"/> Action required
	<input type="checkbox"/> Mechanical	<input type="checkbox"/> Electrical	<input checked="" type="checkbox"/> Service manual revision
	<input type="checkbox"/> Paper path	<input type="checkbox"/> Transmit/receive	<input type="checkbox"/> Retrofit information
	<input type="checkbox"/> Product Safety	<input type="checkbox"/> Other (      )	

**This is supplementary information concerning the developer bottle setting procedure.**

## SYMPTOM

The developer spills out of the developer bottle when the “Filling the PCU Units with Developer” procedure is performed.

**Note:** This procedure is on Service Manual: Section1. Installation / Copier D014/D015 / Installation / Filling the PCU Units with Developer”.

## CAUSE

The developer bottle is not locked into place when it is attached. This creates a gap between the developer bottle and PCU.

## SOLUTION

Before pulling the heat seal form the developer bottle (procedure #7) and filling the PCU units with developer, set completely the developer bottle to PCU units.

### Important:

- Be sure that there is no gap between the developer bottle and PCU unit.
- **See the IMPORTANT POINTS and PROCEDURE below.**

## Important Points for Mounting the Developer Bottle on the PCU

- Attach the bottle in the order shown (1-2-3).
- Make sure to attach [A] securely to [B].

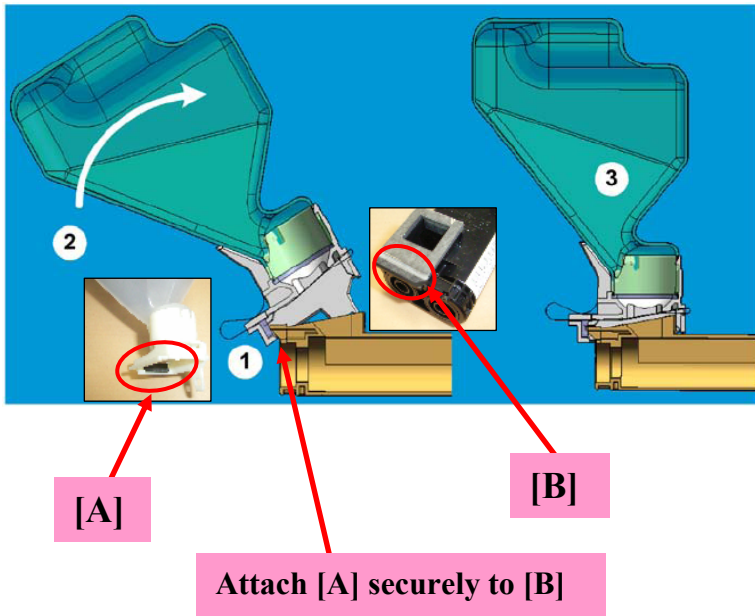

- Check the two items described below.

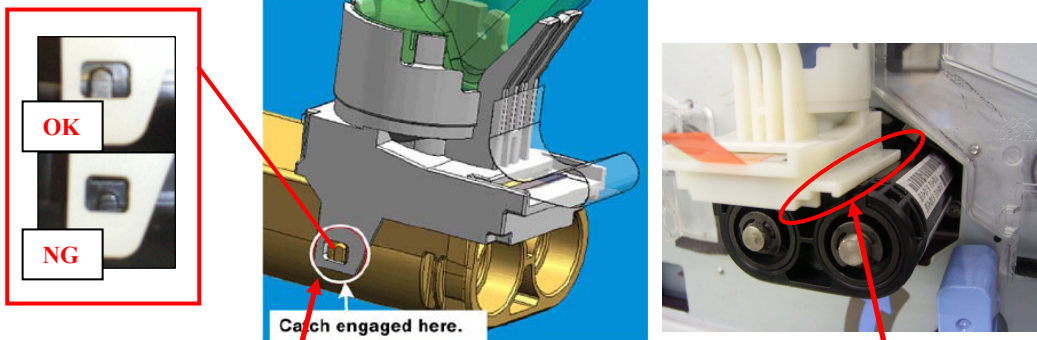

1) Make sure the neck of each bottle snaps and locks into place

2) Make sure there is no gap between the developer bottle and PCU.

## Procedure for Mounting the Developer Bottle on the PCU

1. Rest the neck of the developer bottle on the PCU, as shown in the photo.

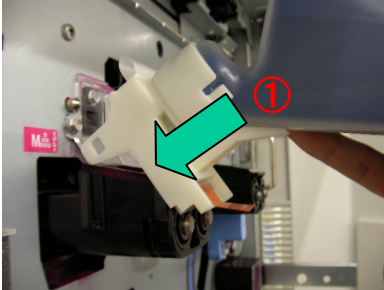

2. While maintaining the contact between the neck of the developer bottle and PCU, slide the neck upward in the direction of the arrow marked "2".

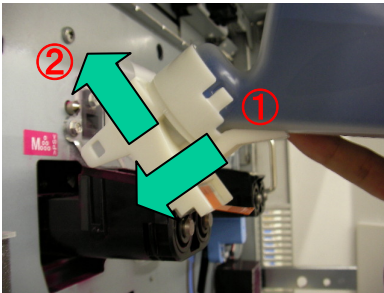

3. Rotate the developer bottle up, in the direction of the arrow marked "3", and lock the neck of the bottle into the PCU.

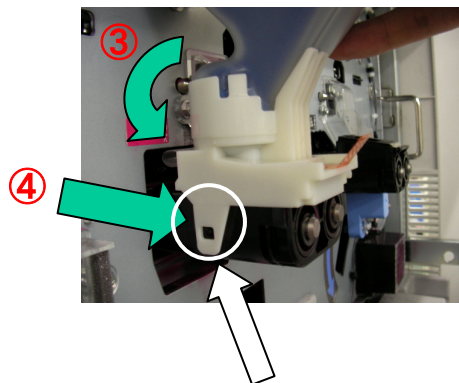
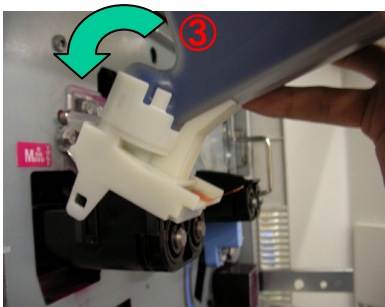

### Important:

Check this tab and make sure the bottle is locked in place. If it is not locked in place, push the neck of the bottle in the direction of the arrow marked "4" until it locks.



Model: D014/D015

Date: 24-Oct-08

No.: TRD014022

4. Hold the developer bottle with one hand, as shown. Then, remove the heat seal by pulling it out of the developer bottle.



5. Do **Sp3814-\*\*\*** and **Sp3815**.  
**Important:** Do not touch the developer bottle while the machine is performing these SPs.
6. After the developer bottle is completely empty, remove it.

Model: D014/D015	Date: 24-Oct-08	No.: TRD014023
------------------	-----------------	----------------

Subject: Requirements for installing peripherals			
Classification:	<input type="checkbox"/> Troubleshooting	<input type="checkbox"/> Part information	<input type="checkbox"/> Action required
	<input type="checkbox"/> Mechanical	<input type="checkbox"/> Electrical	<input type="checkbox"/> Service manual revision
	<input type="checkbox"/> Paper path	<input type="checkbox"/> Transmit/receive	<input type="checkbox"/> Retrofit information
	<input type="checkbox"/> Product Safety	<input checked="" type="checkbox"/> Other ( )	

## Requirements for Attaching the LCT and Cover Interposer to the D014/D015 Copier

### 1. LCT (B473-17)

Use the **PROM: Printed Circuit Board: MAUI** marked with P/N **B4735153** or newer.  
(B473 Parts Catalog, pg. 17, #1)

Cut-in S/N:

**B473-17: J4475300394** (May 2007 production)

### 2. Cover Interposer CI5000 (B835-17)

- 1) Use cover interposer firmware **ver02.030:26** (P/N B8355510A) or newer.
  - Cut-in S/N (B835-17): **L6271100001** (November 2007 production)
- 2) 12" guide plates (guide plates and screws) for D014/D015 should be included.
  - Cut-in S/N (B835-17): **L6270400094** (April 2007 production)

**NOTE:** 12" guide plates (guide plates and screws) for D014/D015 are available as service parts.

- B4682196 (Guide Plate Upper) 1pc
- B8352191 (Guide Plate Lower) 1pc
- 04513006N (M3X6 screw) 2pcs

### Important:

According to the configurations, attach the black Mylar [A] (included with the CI5000) to the 13" guide plate [B]:

Configuration 1: Mainframe + CI5000 + ZF4000 + SR4020 or SR5000

Use the 13" guide plate [B] included with the Z-Folding Unit ZF4000.

Configuration 2: Mainframe + CI5000 + SR5000

Use the 13" guide plate [B] included with the Finisher SR5000.

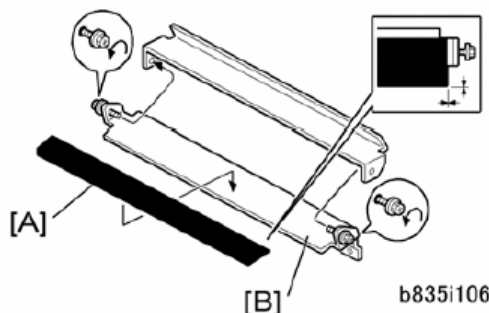

Model: D014/D015	Date: 24-Oct-08	No.: TRD014025
------------------	-----------------	----------------

Subject: Requirements for installing peripherals			
Classification:	<input type="checkbox"/> Troubleshooting	<input type="checkbox"/> Part information	<input type="checkbox"/> Action required
	<input type="checkbox"/> Mechanical	<input type="checkbox"/> Electrical	<input type="checkbox"/> Service manual revision
	<input type="checkbox"/> Paper path	<input type="checkbox"/> Transmit/receive	<input type="checkbox"/> Retrofit information
	<input type="checkbox"/> Product Safety	<input checked="" type="checkbox"/> Other (      )	

## Important Information about the Grease for the Development Unit Sleeve Shaft

- 1) To improve the image quality on the D014/D015, use the following new grease when you lubricate the development unit sleeve shaft:

Grease-KS660B      P/N: **D0149800**

**Note:** This new grease is conductive, and is completely different from any of the existing types (e.g. Grease-KS660, Silicone Grease 501, Grease Barierta-S552R). The existing types are not conductive.

- 2) This new grease, Grease-KS660B, is specially designed for use on the **D014/D015**. NEVER use this new grease on the B132/B181/B200.
- 3) In accordance with this change, the Service Manual was changed as follows:

- **Add** new grease to the table as follows (Service Manual: Section 2. Preventive Maintenance / PM Tables / Main Machine / Symbol Key for Tables):

L	Lubrication required:
	● <b>Grease-KS660B (D0149800)</b>

- **Add** the new item to the PM table as follows (Service Manual: Section 2. Preventive Maintenance / PM Table):

**PCU**

	150K	200K	300K	400K	450K	600K	Note
Development Unit	L						Lubricate the development sleeve shaft with <b>Grease-KS660B</b> .

"L": "Lubrication required" (see symbol key for PM table).

Model: D014/D015

Date: 24-Oct-08

No.: TRD014025

- **Add** the new illustration as follows (Service Manual: Section 2. Preventive Maintenance / Lubrication Points / Copier):

## Development Unit

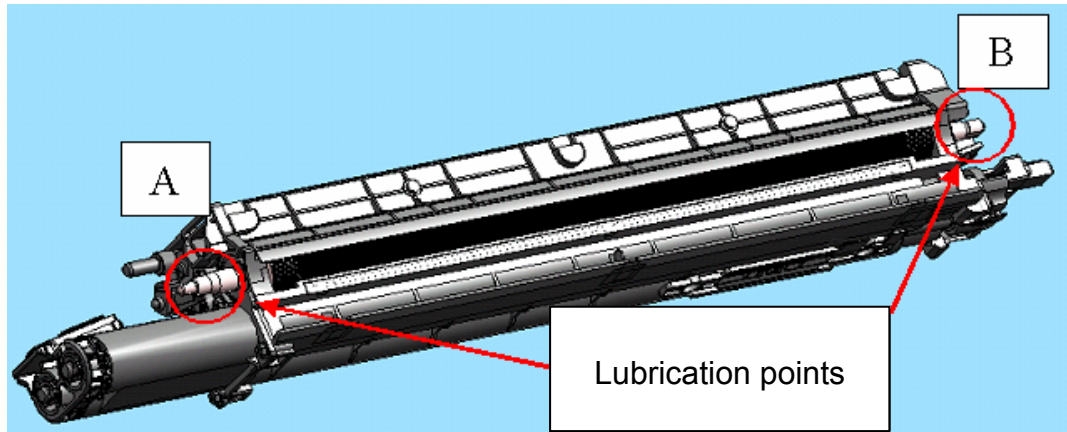

## Enlarged view of lubrication point [A]

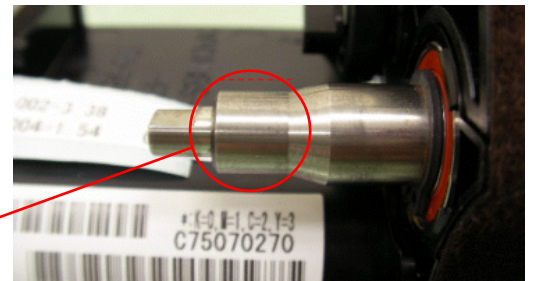
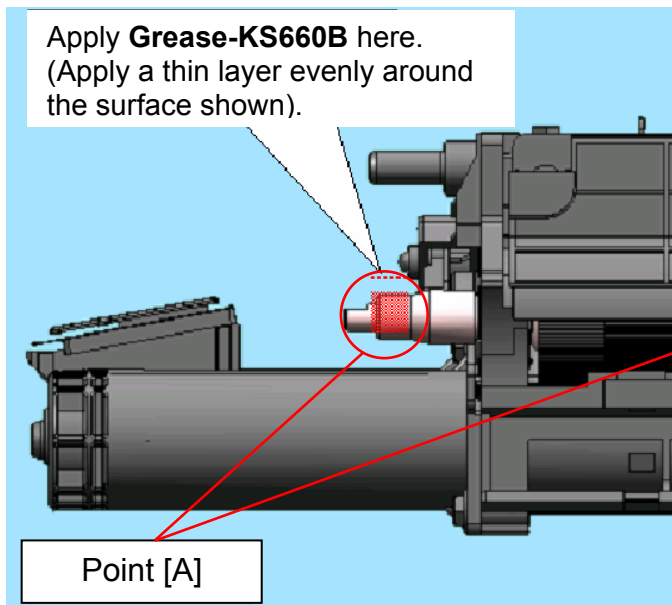

## Enlarged view of lubrication point [B]

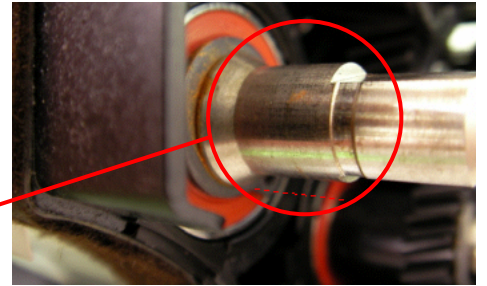
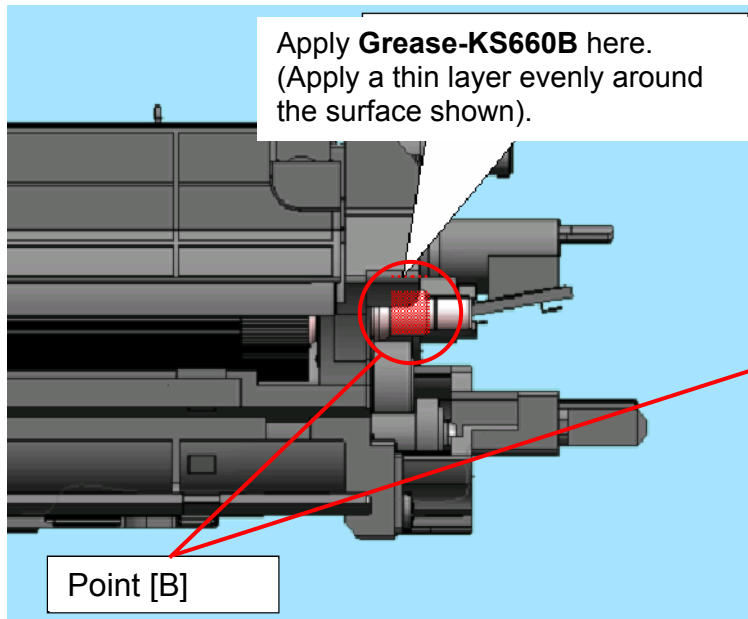

# Technical Bulletin

PAGE: 1/6

Model: D014/D015	Date: 24-Oct-08	No.: TRD014026
------------------	-----------------	----------------

Subject: PUNCH UNIT PU5000(B831) installation procedure			
Classification:	<input type="checkbox"/> Troubleshooting	<input type="checkbox"/> Part information	<input type="checkbox"/> Action required
	<input type="checkbox"/> Mechanical	<input type="checkbox"/> Electrical	<input checked="" type="checkbox"/> Service manual revision
	<input type="checkbox"/> Paper path	<input type="checkbox"/> Transmit/receive	<input type="checkbox"/> Retrofit information
	<input type="checkbox"/> Product Safety	<input type="checkbox"/> Other (     )	

D014/D015 Service Manual correction:

Replace the Installation Procedure for the **B831 Punch Unit** (Service Manual: Section1. Installation / Punch Unit B831) with the procedure in this TB.

Model: D014/D015	Date: 24-Oct-08	No.: TRD014026
------------------	-----------------	----------------

## Punch UNIT PU5000 (B831)

### Accessories

Check the quantity and condition of the accessories in the box against the following list:

Description	Q'ty
1. Punch Unit.....	1
2. Punch Waste Collection Hopper.....	1
3. Spacer (1 mm).....	2
4. Spacer (2 mm).....	1
5. Knob.....	1
6. Step Screw.....	1
7. Screw (M4 x 6) Black.....	1
8. Screw (M3 x 10).....	2
9. Spring.....	1
10. Sensor Arm and Sensor.....	1

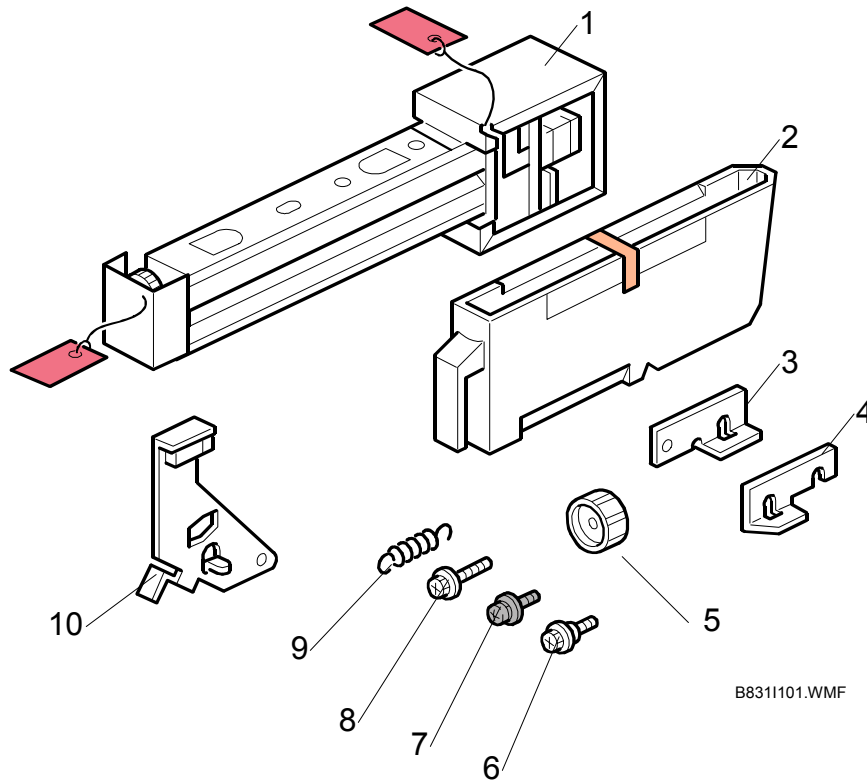

## Installation

### Important!

1. This punch unit is for the B830 (SR5000) finisher only.

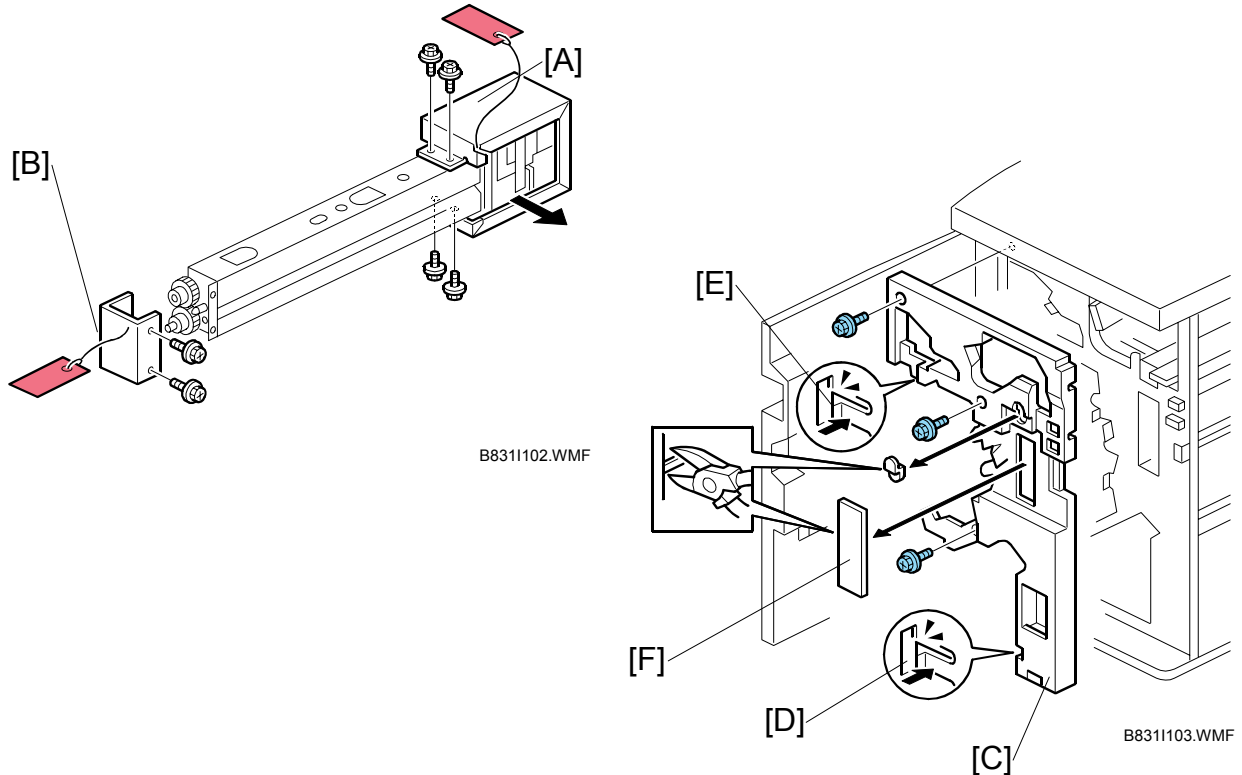

### CAUTION

Switch the machine off and unplug the machine before starting the following procedure.

1. If the finisher is connected to the machine, disconnect it.
2. Open the front door and remove the rear cover (Screw x 2 screws).
3. Unpack the punch unit and remove the motor protector plate [A] (Screw x 4, Step screw x1).
4. Remove the cam lock plate [B] (Screw x 1).
5. Remove the inner cover [C] (Screw x 3).
6. Behind the inner cover at [D] and [E], press the lock tab to the right to release the inner cover from the frame.
7. Remove the plastic knockouts [F].



Model: D014/D015

Date: 24-Oct-08

No.: TRD014026

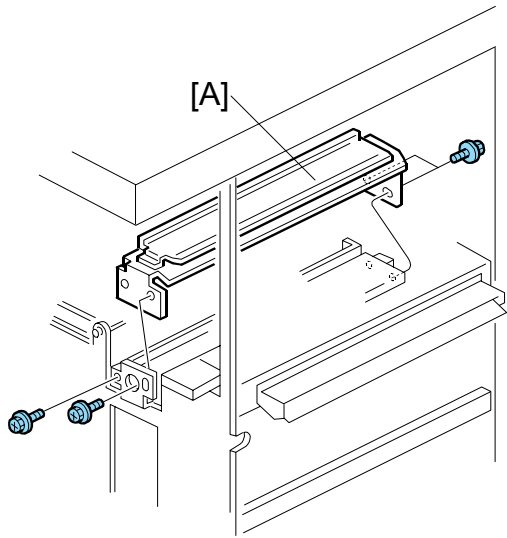

B8311104.WMF

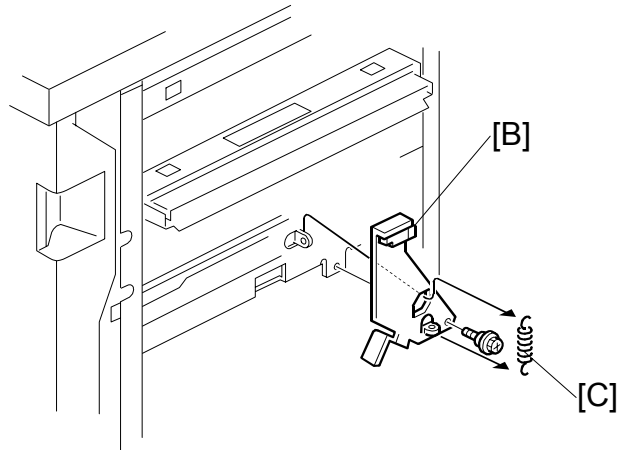

B8311106.WMF

8. Remove the paper guide [A] (Screw x 4).
9. Install the sensor arm [B] (Screw x 1, small step screw (M3 x 4)).  
**NOTE:** Make sure that the sensor arm swings freely on the step screw.
10. Attach the spring [C].

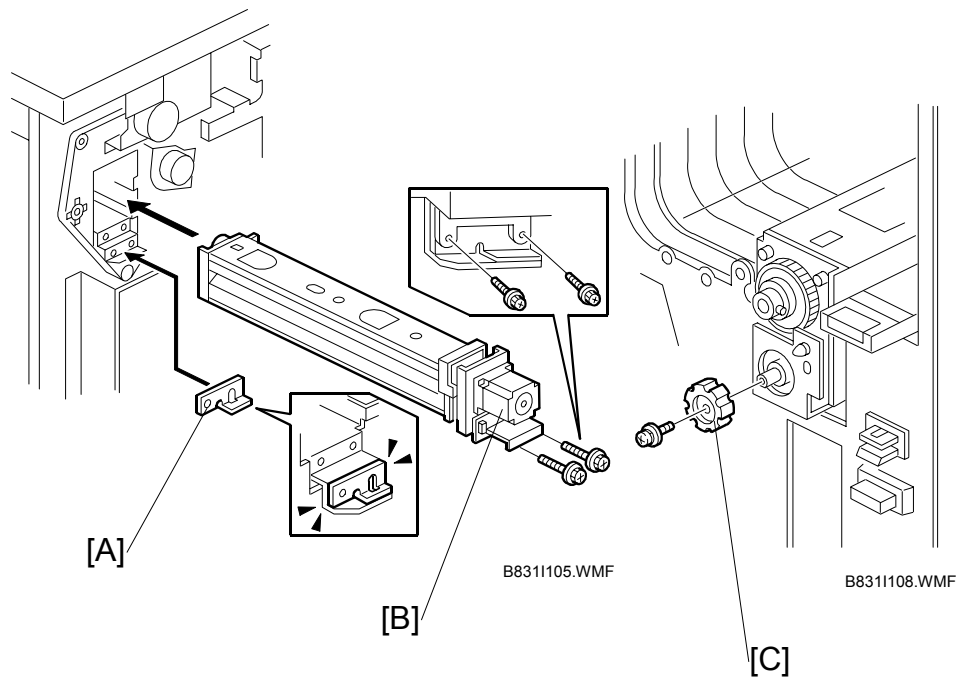

11. Position the 2 mm spacer [A] and attach the punch unit [B] (Screw x 2, M3 x 10).
12. Use one of the screws removed from the motor protector plate to fasten the remaining two spacers to the frame as shown.  
**NOTE:** These extra spacers can be used to adjust the position of the punch holes (front to rear, across the page).
13. At the front, fasten the punch unit knob [C] (Screw x 1).

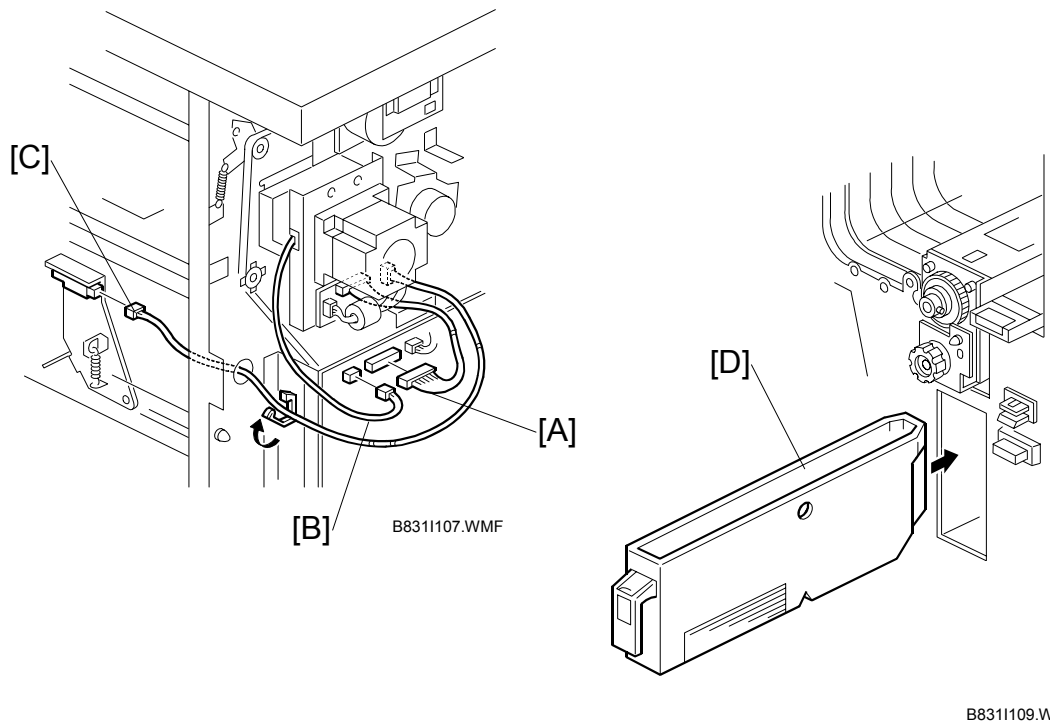

14. Connect the PCB harness connector [A] to **CN135** of the finisher PCB and to **CN600** of the punch unit PCB.
15. Connect the harness [B] to **CN136** of the finisher PCB.
16. Connect the single end of the hopper full sensor connector cable [C] to the hopper full sensor on the arm (Connector x 1, Clumpx 2).  
**NOTE:** No special DIP switch settings are required for this punch unit. A signal from the punch identifies itself by sending a signal to the copier.
17. Slide the punch waste collection hopper [D] into the finisher.
18. Re-attach the inner cover and rear cover.
19. Close the front door and re-connect the finisher to the machine.

Model: D014/D015	Date: 24-Oct-08	No.: TRD014028
------------------	-----------------	----------------

Subject: Service Manual Revision			
Classification:	<input type="checkbox"/> Troubleshooting	<input type="checkbox"/> Part information	<input type="checkbox"/> Action required
	<input type="checkbox"/> Mechanical	<input type="checkbox"/> Electrical	<input checked="" type="checkbox"/> Service manual revision
	<input type="checkbox"/> Paper path	<input type="checkbox"/> Transmit/receive	<input type="checkbox"/> Retrofit information
	<input type="checkbox"/> Product Safety	<input type="checkbox"/> Other (     )	

**Change:** The Service Manual was changed as follows:  
**Reason:** Service manual correction.

## Service Manual

### 7. Specifications

#### Electrical Components

#### Copier

HARD DISKS		
HDD1	Hard Disk Drives	The HDDs hold temporary files spooled for processing and also store permanent files for the document server application.
HDD2		2nd HDD in a set of 2

**Notes:** Deleted HDD3 and HDD4.

LAMPS		
L2	Heating Roller Fusing Lamp 3 (Center)	Heats only the center of heating roller. (NA: 700W)
L3	Heating Roller Fusing Lamp 2 (Ends)	Heats only the ends of heating roller. (NA: 700W)
L4	Heating Roller Fusing Lamp 1 (Main)	Heats the entire heating roller end to end. (NA D014: 250W) (NA D015: 600W)
L5	Pressure Roller Fusing Lamp	Heats the pressure roller. (NA: 400W)

Model: D014/D015	Date: 24-Oct-08	No.: TRD014028
------------------	-----------------	----------------

MOTORS		
M13	Fusing Unit Fan Motor: <b>Lower</b>	Cools the fusing unit.
M24	<b>Belt Cleaning Fan</b>	Cools the upper area of the transfer unit where the PCUs contact the ITB.
M31	<b>Potential Sensor Fan</b>	<b>Circulates air around the potential sensors inside the copier to keep them cool.</b>
M36	<b>Development Motor: Y</b>	<b>Drives the Y development unit.</b>
M37	<b>Development Motor: C</b>	<b>Drives the C development unit.</b>
M38	<b>Development Motor: M</b>	<b>Drives the M development unit.</b>
M39	<b>Development Motor: K</b>	<b>Drives the K development unit.</b>
<b>M59</b>	<b>Development Intake Fan – K</b>	<b>Cools the K development unit.</b>
<b>M60</b>	<b>Development Intake Fan – M</b>	<b>Cools the M development unit.</b>
<b>M61</b>	<b>Development Intake Fan – C</b>	<b>Cools the C development unit.</b>
<b>M62</b>	<b>Development Intake Fan – Y</b>	<b>Cools the Y development unit.</b>
<b>M63</b>	<b>Drum Cleaning Motor (Y)</b>	<b>Drives the Y drum cleaning rollers</b>
<b>M64</b>	<b>Drum Cleaning Motor (C)</b>	<b>Drives the C drum cleaning rollers</b>
<b>M65</b>	<b>Drum Cleaning Motor (M)</b>	<b>Drives the M drum cleaning rollers</b>
<b>M66</b>	<b>Drum Cleaning Motor (K)</b>	<b>Drives the K drum cleaning rollers.</b>

Model: D014/D015	Date: 24-Oct-08	No.: TRD014028
------------------	-----------------	----------------

<b>M67</b>	<b>Charge Wire Cleaner Motor</b>	<b>Drives the corona wire cleaning pad to the front and back to clean the charge corona wire of the K_PCU. The wire cleaner motor switches on at power on and at the end of every job.</b>
<b>M68</b>	<b>Ozone Removal Fan</b>	<b>Draws in air containing ozone.</b>
<b>M69</b>	<b>Drive Ventilation Fan</b>	<b>Cools the drive area near the fusing unit.</b>
<b>M70</b>	<b>Ozone Exhaust Fan</b>	<b>Draws air from around the drums and blows it through the ozone filter.</b>
<b>M71</b>	<b>PTR Lift Motor</b>	<b>Raises the PTR so it is pressing against the bias roller above only during paper transfer and separation, and lowers the PTR when the machine is not operating.</b>
<b>M72</b>	<b>Fusing Pressure Release Motor</b>	<b>Pulls and pushes the pressure roller to separate it from and press it against the hot roller. The pressure roller is a soft sponge roller that would warp out of shape if it were allowed to press against the hot roller while the machine is idle.</b>
<b>M73</b>	<b>HDD Cooling Fan Motor</b>	<b>Cools the HDDs.</b>
<b>M74</b>	<b>CPU Fan</b>	<b>Cools the CPU on the Controller Board.</b>

**Notes:** Added M59–M74.

<b>PCBS</b>		
<b>PCB34</b>	<b>SCNB</b>	<b>Scanner Connector Board. Harnesses from the SBU run into and out of the SCNB, reducing the number of harnesses from 2 to 1</b>
<b>PCB35</b>	<b>OPU (Operation Panel)</b>	<b>Controls the operation panel.</b>

**Notes:** Deleted PCB36 and PCB37.

Model: D014/D015	Date: 24-Oct-08	No.: TRD014028
------------------	-----------------	----------------

SENSORS		
S3	ITB Lift Sensor <b>(Full Color)</b>	This sensor switches the ITB lift motor off when the ITB comes into contact the drums of the <b>color</b> PCUs.
S38	<b>Internal</b> Temperature Sensor	<b>Located near the Y_PCU, this thermistor monitors the internal temperature of the machine.</b>
S61	<b>ITB Lift Sensor</b> <b>(BW)</b>	<b>This sensor switches the ITB lift motor off when the ITB comes into contact the drum of black PCU.</b>
S62	<b>Fusing Pressure</b> <b>Release Sensor</b>	<b>Pulls and pushes the pressure roller to separate it from and press it against the hot roller. The pressure roller is a soft sponge roller that would warp out of shape if it were allowed to press against the hot roller while the machine is idle.</b>
S67/S68	<b>Laser Unit</b> <b>Temperature</b> <b>Sensor</b>	<b>Reads the temperature in the optics unit. The results are used in the MUSIC process.</b>
S80	<b>Original Length</b> <b>Sensor -3</b>	<b>APS4 holds one original length sensor under the exposure glass. The detection combination of this sensor and other sensors determines the length of the original on the exposure glass positioned for SEF.</b>
S81	<b>Encoder</b>	<b>Monitors the encoder wheel in the ITB drive motor unit.</b>
S82	<b>PTR Contact</b> <b>Sensor</b>	<b>Detects when the PTR is lifted or lowered.</b>
S83	<b>ITB Position</b> <b>Sensor</b>	<b>Monitors the speed of the ITB.</b>

**Notes:** Added S80–S83.

Model: D014/D015	Date: 24-Oct-08	No.: TRD014028
------------------	-----------------	----------------

SOLENOIDS		
<b>SOL16</b>	<b>Charge Cleaning Solenoid: Y</b>	<b>Raises and lowers the Y charge roller cleaning roller.</b>
<b>SOL17</b>	<b>Charge Cleaning Solenoid: C</b>	<b>Raises and lowers the C charge roller cleaning roller.</b>
<b>SOL18</b>	<b>Charge Cleaning Solenoid: M</b>	<b>Raises and lowers the M charge roller cleaning roller.</b>
<b>SOL19</b>	<b>Duplex Inverter Solenoid</b>	<b>Operates the duplex inverter junction gate.</b>

**Notes:** Added SOL16–SOL19. Delete SOL12.

SWITCHES		
<b>SW6</b>	<b>Interlock SWs</b>	<b>Front door upper left.</b>

**Notes:** Added SW6.

THERMISTORS		
<b>TH4</b>	<b>Heating Roller Center Thermistor</b>	<b>Monitors the surface temperature of the heating roller center and breaks the circuits to the fusing lamps if the heating roller overheats. This is a non-contact themistor.</b>
<b>TH5</b>	<b>Heating Roller End Thermistor</b>	<b>Monitors the surface temperature of the heating roller end and breaks the circuits to the fusing lamps if the heating roller overheats. This is a non-contact themistor.</b>

**Notes:** Added TH4 and TH5.

THERMOSTATS		
<b>TS1/TS2</b>	<b>Thermostats (Pressure Roller)</b>	<b>Monitors the temperature of the pressure roller and cuts the circuit if the pressure roller fusing lamp overheats.</b>
<b>TS3/TS4</b>	<b>Thermostats (Fusing Belt)</b>	<b>Monitors the temperature of the fusing belt and cuts the circuit if the heating roller fusing lamp overheats.</b>

**Notes:** Deleted TS5.



Model: D014/D015	Date: 24-Oct-08	No.: TRD014028
------------------	-----------------	----------------

## POINT-to-POINT Diagram D014/D015 Electrical Component Layout (3/3)

Symbol	Name	Index No.	P to P	Page
<b>Sensors</b>				
<b>S67/S68</b>	<b>Laser Unit Temperature Sensor</b>	<b>18</b>	<b>D9</b>	<b>2/4</b>
<b>S69</b>	<b>Toner End Sensor: M</b>	<b>66</b>	<b>C1</b>	<b>2/4</b>
<b>S70</b>	<b>Toner End Sensor: K</b>	<b>62</b>	<b>C1</b>	<b>2/4</b>
<b>S71</b>	<b>Toner End Sensor - Y</b>	<b>74</b>	<b>B1</b>	<b>2/4</b>
<b>S72</b>	<b>Toner End Sensor - C</b>	<b>71</b>	<b>B1</b>	<b>2/4</b>
<b>S73</b>	<b>Scanner HP Sensor</b>	<b>2</b>	<b>B5</b>	<b>2/4</b>
<b>S74</b>	<b>Original Width Sensors</b>	<b>14</b>	<b>A5</b>	<b>2/4</b>
<b>S75</b>	<b>Original Length Sensor - 1</b>	<b>12</b>	<b>A5</b>	<b>2/4</b>
<b>S76</b>	<b>Original Length Sensor -2</b>	<b>11</b>	<b>B5</b>	<b>2/4</b>
<b>S77</b>	<b>Accordion Jam Sensor</b>	<b>197</b>	<b>C8</b>	<b>1/4</b>
<b>S78</b>	<b>Fusing Exit Sensor</b>	<b>198</b>	<b>C8</b>	<b>1/4</b>
<b>S79</b>	<b>LCT Relay Sensor</b>	<b>75</b>	<b>F2</b>	<b>2/4</b>
<b>S80</b>	<b>Original Length Sensor -3</b>	<b>5</b>	<b>B5</b>	<b>2/4</b>
<b>S81</b>	<b>Encoder</b>	<b>138</b>	<b>C3</b>	<b>2/4</b>
<b>S82</b>	<b>PTR Contact Sensor</b>	<b>172</b>	<b>C4</b>	<b>3/4</b>
<b>S83</b>	<b>ITB Position Sensor</b>	<b>45</b>	<b>D9</b>	<b>3/4</b>
<b>S84</b>	<b>Toner End Sensor: M</b>	<b>66</b>	<b>C1</b>	<b>2/4</b>

**Notes:** Added S67/S68–S83.

# Technical Bulletin

PAGE: 7/7

Model: D014/D015	Date: 24-Oct-08	No.: TRD014028
------------------	-----------------	----------------

Symbol	Name	Index No.	P to P	Page
Lamps				
L2	Heating Roller Fusing Lamp <b>3 (Center)</b>	195	B8	1/4
L3	Heating Roller Fusing Lamp <b>2 (Ends)</b>	195	B8	1/4

Motors				
M32	<b>Cooling Fan Motor</b>	148	D6	2/4
M33	<b>Circulation Fan Motor</b>	147	D6	2/4
<b>M70</b>	<b>Ozone Exhaust Fan</b>	<b>150</b>	<b>C6</b>	<b>3/4</b>
<b>M71</b>	<b>PTR Lift Motor</b>	<b>171</b>	<b>D4</b>	<b>3/4</b>
<b>M72</b>	<b>Fusing Pressure Release Motor</b>	<b>174</b>	<b>D5</b>	<b>3/4</b>
<b>M73</b>	<b>HDD Cooling Fan Motor</b>	<b>225</b>	<b>A4</b>	<b>4/4</b>
<b>M74</b>	<b>CPU Fan</b>	<b>226</b>	<b>A4</b>	<b>4/4</b>

**Notes:** Added M70–S74.

HDDs				
<b>HDD1</b>	<b>HDD1</b>	223	B4	4/4
<b>HDD2</b>	<b>HDD2</b>	224	B4	4/4

Model: D014/D015	Date: 24-Oct-08	No.: TRD014029
------------------	-----------------	----------------

<b>Subject:</b> Requirements for using USB			
<b>Classification:</b>	<input type="checkbox"/> Troubleshooting	<input type="checkbox"/> Part information	<input type="checkbox"/> Action required
	<input checked="" type="checkbox"/> Mechanical	<input type="checkbox"/> Electrical	<input type="checkbox"/> Service manual revision
	<input type="checkbox"/> Paper path	<input type="checkbox"/> Transmit/receive	<input type="checkbox"/> Retrofit information
	<input type="checkbox"/> Product Safety	<input type="checkbox"/> Other (      )	

## Requirements for the USB I/F on the D014/D015 Copier

### Overview

- The USB I/F on the rear face of the machine is covered by a small bracket ([A] in the photo below).
- Use the procedure below to uncover the I/F and enable the USB device.

### Procedure

1. Loosen the screw and turn the bracket [A] 180 degrees, so that the USB I/F [B] is uncovered. Then, fasten the bracket in this position.
2. Connect the USB cable.
3. Fix the cable in place using a nylon clamp [C] (1 screw), as shown.  
**Note:** The nylon clamp is available as a service part (P/N 11050323).
4. Set **SP5985-002** (On board USB Device Setting) to a value of "1" to enable the USB device. Then, turn the main power OFF/ON.

### SP5985-002: On board USB Device Setting

Model Type:	Default setting:	Setting to Enable the USB device:
D014-15	0 (disabled)	1
D015-15		

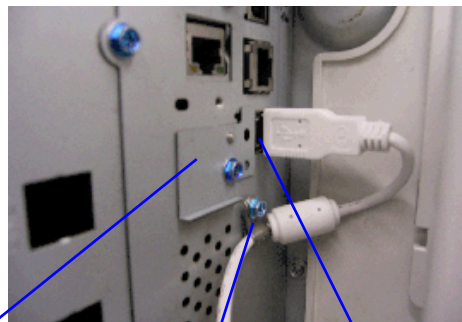

[A]

[C]

[B]

Model: D014/D015	Date: 24-Oct-08	No.: TRD014031
Subject: SC816		
Classification:	<input type="checkbox"/> Troubleshooting <input type="checkbox"/> Part information <input type="checkbox"/> Mechanical <input type="checkbox"/> Electrical <input type="checkbox"/> Paper path <input type="checkbox"/> Transmit/receive <input type="checkbox"/> Product Safety <input type="checkbox"/> Other (      )	<input type="checkbox"/> Action required <input checked="" type="checkbox"/> Service manual revision <input type="checkbox"/> Retrofit information

Please add the following to your Service Manuals:

Section 4. Troubleshooting

Service Code Tables

		Error in STR (Suspend To RAM) control ASIC *GW	
SC816	B	Error is detected in the signal from the ASIC, which controls the STR (Suspend To RAM) function.	ASIC (controller board ) defective.  Turn the main switch OFF/ON. If SC still appears, replace the controller board.

**Note:** STR is a newly-added feature of the D014/D015 copier, which further minimizes energy consumption while the machine is in Energy Saver mode.

Model: D014/D015	Date: 24-Oct-08	No.: TRD014034
Subject: Missing SC8xx Information		
Classification:	<input type="checkbox"/> Troubleshooting <input type="checkbox"/> Part information <input type="checkbox"/> Action required <input type="checkbox"/> Mechanical <input type="checkbox"/> Electrical <input checked="" type="checkbox"/> Service manual revision <input type="checkbox"/> Paper path <input type="checkbox"/> Transmit/receive <input type="checkbox"/> Retrofit information <input type="checkbox"/> Product Safety <input type="checkbox"/> Other (      )	

Please add the following to your Service Manuals:

## Section 4. Troubleshooting

### Service Code Tables

816	B	Error in STR (Suspend To RAM) control ASIC *GW Error is detected in the signal from the ASIC, which controls the STR (Suspend To RAM) function.	ASIC (controller board ) defective.  Turn the main switch OFF/ON. If SC still appears, replace the controller board.
-----	---	--	--

**Note:** STR is a newly-added feature of the D014/D015 copier, which further minimizes energy consumption while the machine is in Energy Saver mode.

851	B	IEEE 1394 I/F error Driver setting incorrect and cannot be used by the 1394 I/F. <b>Not supported by this machine</b> <ul style="list-style-type: none"> <li>● NIB (PHY), LINK module defective; change the Interface Board</li> <li>● Controller board defective</li> </ul>	
-----	---	--	--

853	B	Wireless LAN Error 1 During machine start-up, the machine can get access to the board that holds the wireless LAN, but not to the wireless LAN card (Bluetooth).	<ul style="list-style-type: none"> <li>● Wireless LAN card missing (was removed)</li> </ul>
-----	---	---	---

854	B	Wireless LAN Error 2 During machine operation, the machine can get access to the board that holds the wireless LAN, but not to the wireless LAN card (Bluetooth).	<ul style="list-style-type: none"> <li>● Wireless LAN card missing (was removed)</li> </ul>
-----	---	--	---

Model: D014/D015	Date: 24-Oct-08	No.: TRD014034
------------------	-----------------	----------------

855	B	Wireless LAN error 3
		An error is detected on the wireless LAN card (802.11a/g, g or Bluetooth).
		<ul style="list-style-type: none"> <li>● Wireless LAN card defective</li> <li>● Wireless LAN card connection incorrect</li> </ul>
856	B	Wireless LAN error 4
		An error was detected on the wireless LAN card (Bluetooth).
		<ul style="list-style-type: none"> <li>● Wireless LAN card defective</li> <li>● PCI connector (to the mother board) loose</li> </ul>
857	B	USB I/F Error
		The USB driver is not stable and caused an error.
		<ul style="list-style-type: none"> <li>● Bad USB card connection</li> </ul> Replace the controller board
860	B	HDD startup error at main power on
		<ul style="list-style-type: none"> <li>● HDD is connected but a driver error is detected.</li> <li>● The driver does not respond with the HDD within 30 s.</li> </ul>
		<ul style="list-style-type: none"> <li>● HDD is not initialized</li> <li>● Label data is corrupted</li> <li>● Defective HDD</li> </ul> Initialize the HDD with SP5832-001.
866	B	SD card error 1: Confirmation
		The machine detects an electronic license error in the application on the SD card in the controller slot immediately after the machine is turned on. The program on the SD card contains electronic confirmation license data. If the program does not contain this license data, or if the result of the check shows that the license data in the program on the SD card is incorrect, then the checked program cannot execute and this SC code is displayed.
		<ul style="list-style-type: none"> <li>● Program missing from the SD card</li> <li>● Download the correct program for the machine to the SD card</li> </ul>
867	D	SD card error 2: SD card removed
		The SD card in the slot is removed while the machine is on.
		Insert the SD card, then turn the machine off and on.

Model: D014/D015	Date: 24-Oct-08	No.: TRD014034
------------------	-----------------	----------------

868	D	<p>SD card error 3: SC card access</p> <p>An error occurs while an SD card is used.</p> <ul style="list-style-type: none"> <li>● SD card not inserted correctly</li> <li>● SD card defective</li> <li>● Controller board defective</li> </ul> <p><b>Note:</b> If you want to try to reformat the SC card, use SD Formatter Ver 1.1.</p>
-----	---	---

870	B	<p>Address book data error</p> <p>The address book data cannot be read from the HDD, SD card or flash ROM on the controller where it is stored, or the data read from the media is defective.</p> <ul style="list-style-type: none"> <li>● Software defective: Turn the machine off/on. If this is not the solution for the problem, then replace the controller firmware.</li> <li>● HDD defective.</li> </ul> <p><b>More Details</b></p> <ul style="list-style-type: none"> <li>● Do SP5846-046 (Initialize All Setting &amp; Addr Book) to reset all address book data.</li> <li>● Reset the user information with SP5832-006 (HDD Formatting– User Information).</li> <li>● Replace the HDDs.</li> </ul>
-----	---	--

872	B	<p>HDD mail receive data error</p> <ul style="list-style-type: none"> <li>● The machine detects that the HDD is not operating correctly at power on.</li> <li>● The machine detects that the HDD is not operating correctly (can neither read nor write) while processing incoming email.</li> </ul> <ul style="list-style-type: none"> <li>● HDD defective</li> <li>● The machine is turned off while the HDD is being accessed.</li> </ul> <p>Do SP5832-007 to format the mail RX data on the HDD.</p>
-----	---	--

873	B	<p>HDD mail send data error</p> <p>An error is detected on the HDD immediately after the machine has been turned on, or power has been turned off while the machine has used the HDD.</p> <ol style="list-style-type: none"> <li>1. Do SP5832-008 (Format HDD – Mail TX Data) to initialize the HDD.</li> <li>2. Replace the HDD</li> </ol>
-----	---	---

Model: D014/D015	Date: 24-Oct-08	No.: TRD014034
------------------	-----------------	----------------

876	CTL D	Log Data Error  An error is detected in the handling of the log data at power on or during machine operation. This can be caused by switching the machine off while it is operating.
-001		Log Data Error 1 <ul style="list-style-type: none"> <li>● Damaged log data file in the HDD</li> </ul> Initialize the HDD with SP5832-004.
-002		Log Data Error 2 <ul style="list-style-type: none"> <li>● HDD encryption unit not installed</li> </ul> 3. Ask the customer's administrator to disable the HDD encryption setting with a user tool. Install the HDD encryption unit.
-003		Log Data Error 3 <ul style="list-style-type: none"> <li>● Invalid log encryption key due to defective NVRAM data</li> </ul> 4. Initialize the HDD with SP5832-004. 5. Ask the customer's administrator to disable the HDD encryption setting with a user tool.
-004		Log Data Error 4 <ul style="list-style-type: none"> <li>● Unusual HDD encryption function due to defective NVRAM data</li> </ul> Initialize the HDD with SP5832-004.
-005		Log Data Error 5 <ul style="list-style-type: none"> <li>● Installed a NVRAM or HDD which was used in another machine</li> </ul> 6. Reinstall the previous NVRAM or HDD. Initialize the HDD with SP5832-004.
-099		Log Data Error 99 <ul style="list-style-type: none"> <li>● Other than the above causes</li> </ul> Ask your supervisor.

877	B	HDD DataOverwriteSecurity SD card error  The 'all delete' function cannot be executed but the DataOverwriteSecurity Unit is installed and activated. <ul style="list-style-type: none"> <li>● Defective SD card</li> <li>● SD card not installed</li> </ul> 1. Replace the NVRAM and then install the new SD card. 2. Check and reinstall the SD card.
-----	---	--



Model: D014/D015	Date: 24-Oct-08	No.: TRD014034
------------------	-----------------	----------------

878	D	TPM system authentication error
		The system firmware is not authenticated by TPM (security chip).
		<ul style="list-style-type: none"><li>● Incorrect updating for the system firmware</li><li>● Defective flash ROM on the controller board</li></ul> Replace the controller board.

880	B	File Format Converter (MLB) error
		A request to get access to the MLB is not answered within the specified time.
		<ul style="list-style-type: none"><li>● MLB defective, replace the MLB</li></ul>

Model: D014/D015	Date: 24-Oct-08	No.: TRD014035
Subject: Missing SC9xx Information		
Classification:	<input type="checkbox"/> Troubleshooting <input type="checkbox"/> Part information <input type="checkbox"/> Action required <input type="checkbox"/> Mechanical <input type="checkbox"/> Electrical <input checked="" type="checkbox"/> Service manual revision <input type="checkbox"/> Paper path <input type="checkbox"/> Transmit/receive <input type="checkbox"/> Retrofit information <input type="checkbox"/> Product Safety <input type="checkbox"/> Other (        )	

Please add the following to your Service Manuals:

Section 4. Troubleshooting

Service Code Tables

900	D	Electrical total counter error
		The total counter contains something that is not a number.
		NVRAM incorrect type NVRAM defective NVRAM data scrambled Unexpected error from external source

920	B	Printer error 1
		An internal application error was detected and operation cannot continue.
		Software defective; turn the machine off/on, or change the controller firmware Insufficient memory

921	D	Printer font error
		A necessary font is not found in the SD card.
		A necessary font is not found in the SD card. The SD card data is corrupted.

990	D	Software error 1
		The software performs an unexpected function and the program cannot continue.
		Software defective, re-boot

Model: D014/D015	Date: 24-Oct-08	No.: TRD014035
------------------	-----------------	----------------

991	C	Software error 2
		The software performs an unexpected function. However, unlike SC990, recovery processing allows the program to continue.
		Software defective, re-boot

In order to get more details about SC990 and SC991:

- 1) Execute SP7403 or print an SMC Report (SP5990) to read the history of the 10 most recent logged errors.
- 2) If you press the zero key on the operation panel with the SP selection menu displayed, you will see detailed information about the recently logged SC990 or SC991, including the software file name, line number, and so on.

**NOTE:**

1) is the recommended method, because another SC could write over the information for the previous SC.

997	B	Software Error 3: Cannot select application function
		An application does not start after the user pushed the correct key on the operation panel.
		Software bug A RAM or DIMM option necessary for the application is not installed or not installed correctly.

998	D	Software Error 4: Application cannot start
		Register processing does not operate for an application within 60 s after the machine power is turned on. No applications start correctly, and all end abnormally.
		Software bug A RAM or DIMM option necessary for the application is not installed or not installed correctly.

Model: D014/D015		Date: 24-Oct-08	No.: TRD014036
Subject: ID sensor cleaning			
Classification:	<input checked="" type="checkbox"/> Troubleshooting	<input type="checkbox"/> Part information	<input type="checkbox"/> Action required
	<input type="checkbox"/> Mechanical	<input type="checkbox"/> Electrical	<input type="checkbox"/> Service manual revision
	<input type="checkbox"/> Paper path	<input type="checkbox"/> Transmit/receive	<input type="checkbox"/> Retrofit information
	<input type="checkbox"/> Product Safety	<input type="checkbox"/> Other (     )	

## SYMPTOM

1. Light image density.
2. SC418 (LED error during Vsg adjustment) is logged many times.
3. The result of the Process Control Self-check is "22222222".

## CAUSE

The ID sensor or MUSIC sensor is wiped with a dry cloth during machine maintenance in the field. As a result, static electricity builds up on the sensor and attracts toner particles.

MUSIC and ID Sensors

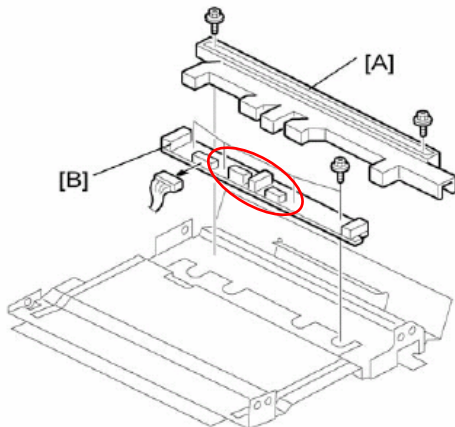

d014r332

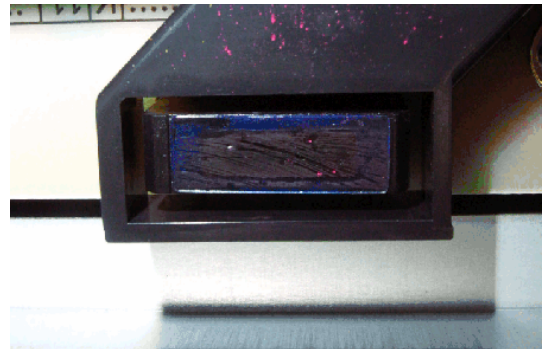

Service Manual: Section 3. Replacement and Adjustment/  
Image Transfer Unit / Music and ID Sensors

Model: D014/D015	Date: 24-Oct-08	No.: TRD014036
------------------	-----------------	----------------

## SOLUTION

Wipe the process control ID sensor and MUSIC sensor with a **DAMP** cloth (alcohol), as described in the Service Manual.

### Important:

- **Never** wipe the ID sensor or MUSIC sensor with a **DRY** cloth. If you do, the surface of the sensor will attract toner particles, which triggers one of the above symptoms.
- **Always** make sure to wipe the sensors with a **DAMP** cloth (alcohol), as mentioned in the Service Manual.

Sensors after cleaning:

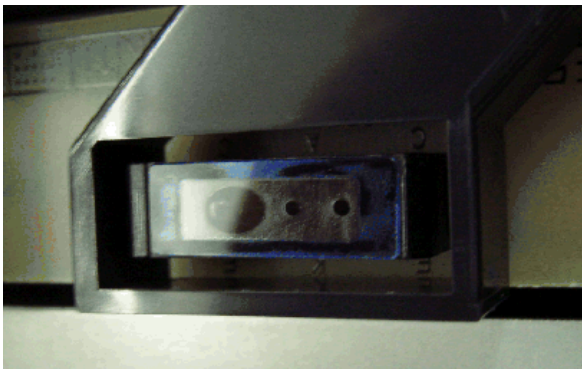

Process control ID sensor



MUSIC ID sensor

Service Manual Section 2. Preventive Maintenance  
PM Tables

### TRANSFER UNITS

	150K	300K	450K	600K	Note
ITB Unit					
ITB (Image Transfer Belt)				R	
ITB Unit Rollers		I		C	Wipe with dry cloth
ITB Encoder Sensor		C			Wipe with damp cloth (alcohol)
ID and MUSIC Sensors		C			Wipe with damp cloth (alcohol)

# Technical Bulletin

Model: D014/D015		Date: 24-Oct-08	No.: TRD014040a
Subject: Missing Booklet Adjust SP			
Classification:	<input type="checkbox"/> Troubleshooting	<input type="checkbox"/> Part information	<input type="checkbox"/> Action required
	<input type="checkbox"/> Mechanical	<input type="checkbox"/> Electrical	<input checked="" type="checkbox"/> Service manual revision
	<input type="checkbox"/> Paper path	<input type="checkbox"/> Transmit/receive	<input type="checkbox"/> Retrofit information
	<input type="checkbox"/> Product Safety	<input type="checkbox"/> Other ( )	

Please add the following information concerning SP6109 and SP6110 to your Service Manual: Section 5. Service Tables / Service Program Mode / Group 6000.

6109	Book Fold Adj	Adjust Booklet Fold Position
		This SP corrects the folding position when paper is stapled and folded.
001	A3 SEF	[-3~+3/0.2 mm] + Value: Shifts staple position toward the crease. - Value: Shifts staple position away from the crease.
002	B4 SEF	
003	A4 SEf	
004	B5 SEF	
005	DLT SEF	
006	LG SEF	
007	LT SEF	
008	12"x18"	
009	Custom Size	

B132S924.WMF

Model: D014/D015	Date: 24-Oct-08	No.: TRD014040a
------------------	-----------------	-----------------

6110	Book Staple Adj	Adjust Booklet Stapling Position
	This SP corrects the stapling position of the booklet stapler when paper is stapled and folded.	
001	A3 SEF	[-3~+3/0.2 mm ] + Value: Shifts staple position toward the crease. - Value: Shifts staple position away from the crease.
002	B4 SEF	
003	A4 SEF	
004	B5 SEF	
005	DLT SEF	
006	LG SEF	
007	LT SEF	
008	12" x 18"	
009	Custom	
B132S923.WMF		

Model: D014/D015		Date: 24-Oct-08	No.: TRD014041
Subject: SP1-008-xxx			
Classification:	<input checked="" type="checkbox"/> Troubleshooting	<input type="checkbox"/> Part information	<input type="checkbox"/> Action required
	<input type="checkbox"/> Mechanical	<input type="checkbox"/> Electrical	<input type="checkbox"/> Service manual revision
	<input type="checkbox"/> Paper path	<input type="checkbox"/> Transmit/receive	<input type="checkbox"/> Retrofit information
	<input type="checkbox"/> Product Safety	<input type="checkbox"/> Other (     )	

## SYMPTOM

Banding occurs at about 100mm from the trailing edge.

**Note:** This occurs more easily with thick paper.

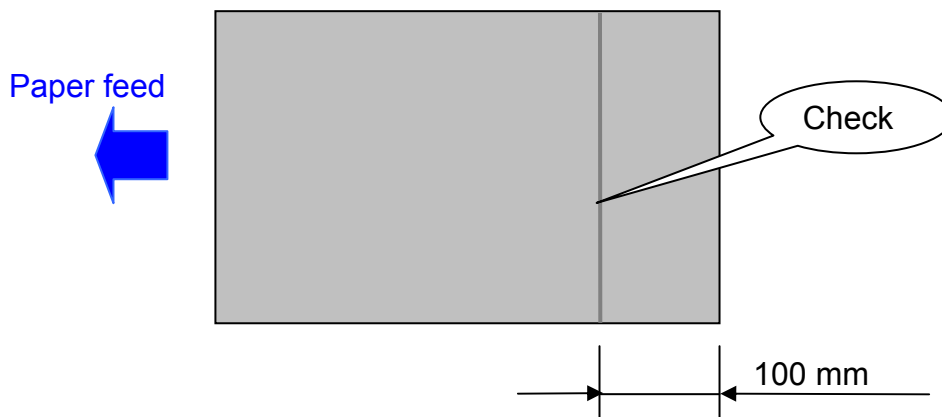

## CAUSE

The paper vibrates slightly when the trailing edge is released by the registration roller.

## SOLUTION

Adjust the value of SP1-008-001 and 002 (**see procedure below**).



Model: D014/D015

Date: 24-Oct-08

No.: TRD014041

## Procedure for Adjustment

1. Check the paper thickness setting when the banding occurs (Thick 1, Thick 2, or Thick 3).
2. Decrease the value of SP1-008-001 or -002 by 1, depending on this paper thickness setting.

	<b>D014 copier</b>	<b>D015 copier</b>
<b>SP1-008-001</b>	Thick 1	Thick 1 Thick 2
<b>SP1-008-002</b>	Thick 2 Thick 3	Thick 3

3. Print out some copy/print samples and check to see if the banding occurs.
  - If the banding still occurs, do Step 3 and Step 4 again.
  - If the width of the band increases, do Step 3 and Step 4 again, but **increase** the SP value.

# Technical Bulletin

Model: D014/D015		Date: 24-Oct-08	No.: TRD014042a
Subject: SC566			
Classification:	<input type="checkbox"/> Troubleshooting	<input type="checkbox"/> Part information	<input type="checkbox"/> Action required
	<input type="checkbox"/> Mechanical	<input type="checkbox"/> Electrical	<input checked="" type="checkbox"/> Service manual revision
	<input type="checkbox"/> Paper path	<input type="checkbox"/> Transmit/receive	<input type="checkbox"/> Retrofit information
	<input type="checkbox"/> Product Safety	<input type="checkbox"/> Other (     )	

Please add the following to your Service Manuals: Section 4. Troubleshooting / Service Call Tables / SC Codes Group 5: Paper Feed

SC566	A	Heating Roller non-contact thermistor 3
		Thermistor detects a temperature less than 0 degrees more than 3 times. 1. Do SP5810 to cancel the SC fusing code. 2. <b>Hot Roller Thermistor (Service manual: Section6. Details /Fusing Unit / Thermistors, Thermostats, call-out#1) is disconnected, broken.</b>

Model: D014/D015		Date: 24-Oct-08	No.: TRD014043
Subject: Incorrect Toner End Message			
Classification:	<input checked="" type="checkbox"/> Troubleshooting	<input type="checkbox"/> Part information	<input type="checkbox"/> Action required
	<input type="checkbox"/> Mechanical	<input type="checkbox"/> Electrical	<input type="checkbox"/> Service manual revision
	<input type="checkbox"/> Paper path	<input type="checkbox"/> Transmit/receive	<input type="checkbox"/> Retrofit information
	<input type="checkbox"/> Product Safety	<input type="checkbox"/> Other (     )	

## SYMPTOM

"(C, M, Y, or K) toner is almost empty" or "(C, M, Y, or K) toner is empty" is displayed on the operation panel when a brand new toner cartridge is installed. Then, if you install this toner cartridge on another machine, "INDEPENDENT SUPPLIER TONER CARTRIDGE HAS BEEN SET" is displayed.

## CAUSE

Developer Fill (SP3814) or Developer Setup (SP3811) was not completed correctly.

1. "(C, M, Y, or K) toner is almost empty" or "(C, M, Y, or K) toner is empty" :

The D014/D015 copier does not perform toner supply until both SP3814 (Execute Developer Fill) and SP3811(Developer Setup) have been completed correctly. This design is intentional, to ensure that SP3811 (Developer Setup) is performed correctly. The reason for this is to avoid an incorrect Developer Setup following a failed Developer Filling (there is not enough developer inside the development unit).

If the D014/D015 copier is used under these conditions, toner will NOT be supplied to the toner hopper. In other words, no toner will go into the toner hopper during copying or printing. This triggers the toner Near End condition, even though a lot of toner remains inside the toner cartridge.

2. "INDEPENDENT SUPPLIER TONER CARTRIDGE HAS BEEN SET"

If another brand new toner cartridge is installed under the conditions explained in #1, "Toner near end" appears again. This is because the D014/D015 copier cannot perform toner supply.

Once the toner Near End condition is triggered, this information is written in the ID chip on the toner cartridge. As a result, this brand new toner cartridge is identified as "independent supplier toner" or "unknown toner". This is true even when the cartridge is then used in another machine, or a machine whose NV-RAM or VBICU board has been replaced.

Model: D014/D015

Date: 24-Oct-08

No.: TRD014043

## SOLUTION

Perform the Developer Setup according to the following procedure.

### For brand new machines:

- 1) Make sure to perform "Filling the PCU with Developer" (Service Manual: Section1. Installation / Copier D014/D015 / Installation) using SP3814-001, and also the developer bottle setting and confirmation of developer setting results using SP3815-001. These two procedures are very important. **See relating TBs #TRD014022 (Developer Bottle Setting) and #TRD014044 (Developer Fill).**
- 2) Secondly, it is also very important to perform "Initializing Developer and Toner" (See Service Manual: Section1. Installation / Copier D014/D015 / Installation) using SP3811-001.

### For machines on which this symptom has already occurred:

Please perform the Developer Setup according to the following procedure.

### Status confirmation:

1. Confirm if SP3815-001 (Developer Fill: Disp Result) displays "1111" (successful all colors).  
**Note:** "1" = successful, "4" = not done "9" = failed, "7" = developer already exists
2. Confirm if SP3817-001 to 004) displays "0".  
**Note:** This value should be "0".  
"0" = Developer filling disabled (developer filling completed successfully)  
"1" = Developer filling enabled (developer filling not completed yet)
3. Confirm if SP3812-001 (Dev. Setup execute results) displays "1111" (successful all colors).

If any of the above (1, 2, or 3) displays an unsuccessful result, **try the following procedure:**

1. Replace the toner cartridge with a brand new one.  
**Note:** Once "Toner End" or "Toner Near End" appears, the Toner End flag is written to the ID chip on the toner cartridge. So, after that, this cartridge cannot be used anymore.
2. Replace the developer for all colors with new ones. Follow the procedure on pg. 298-316 of the Service Manual.  
**Important:** Make sure to perform "Filling the PCU with Developer" (Service Manual: Section1. Installation / Copier D014/D015 / Installation) using SP3814-001, and also the developer bottle setting and confirmation of developer setting results using SP3815-001 (Service Manual: Section1. Installation / Copier D014/D015 / Installation). These two procedures are very important. **See relating TBs #TRD014022 (Developer Bottle Setting) and #TRD014044 (Developer Fill).**

Model: D014/D015	Date: 24-Oct-08	No.: TRD014043
------------------	-----------------	----------------

As mentioned in the Service Manual, make sure to do the following SPs:

1) SP3811-001 (Developer Setup:All).

**Note:** It is very important to perform the "Initializing Developer and Toner" (Service Manual: Section1. Installation / Copier D014/D015 / Installation) correctly using SP3811-001.

2) SP3812-001 (Developer Setup result)

**Note:** If "1111"(KMCY) is displayed, this means SP3811-001 was executed correctly.

3) SP3821-001 (Process Control result)

**Note:** For each color, there is two-digit code, in the order of K, M, C, Y. A display of "10" means that process control was completed correctly. If "10101010" is displayed, it means that process control was completed successfully for all four colors.

Model: D014/D015		Date: 24-Oct-08	No.: TRD014044
Subject: Failed Developer Fill (SP3814)			
Classification:	<input checked="" type="checkbox"/> Troubleshooting	<input type="checkbox"/> Part information	<input type="checkbox"/> Action required
	<input type="checkbox"/> Mechanical	<input type="checkbox"/> Electrical	<input type="checkbox"/> Service manual revision
	<input type="checkbox"/> Paper path	<input type="checkbox"/> Transmit/receive	<input type="checkbox"/> Retrofit information
	<input type="checkbox"/> Product Safety	<input type="checkbox"/> Other (     )	

## SYMPTOM

"FAILED" is displayed immediately after hitting the execute button when you try to perform SP3814 (developer fill).

## CAUSE

1. The fusing unit has not been warmed up to the Ready condition yet, OR
2. The ITB release lever is set to the upper position.

### Note:

1. The engine cannot start rotating when the fusing temperature is still low.
2. If SP3814 is executed while this lever is set to the upper position, the machine will refuse the execution and display "FAILED". This is because the ITB contacts the OPC drums when this lever is set to the upper position. If SP3814 is executed under these conditions, the OPC drums will be damaged (there is no developer inside the development unit yet).

## SOLUTION

1. Execute SP3814 **after the machine beeps twice**. (This means that the fusing temperature has reached Ready condition level).
2. Make sure that the ITB release level [A] is at the **lower position** when you execute SP3814.

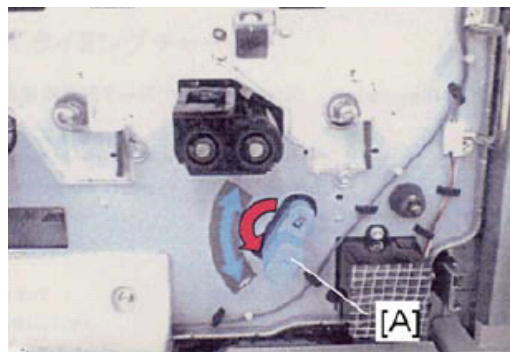

**Important:** After you execute SP3814, set the ITB release lever to the upper position. This is necessary in order to execute SP3811 (developer set up). See the Service Manual:Section1. Installation / Copier D014\_D015 / Installation / Filling the PCU Units with Developer, Step 18.

Model: D014/D015	Date: 24-Oct-08	No.: TRD014045
Subject: "G104 Yellow Toner" and "Zinc Stearate"		
Classification:	<input type="checkbox"/> Troubleshooting <input type="checkbox"/> Part information <input type="checkbox"/> Action required <input type="checkbox"/> Mechanical <input type="checkbox"/> Electrical <input checked="" type="checkbox"/> Service manual revision <input type="checkbox"/> Paper path <input type="checkbox"/> Transmit/receive <input type="checkbox"/> Retrofit information <input type="checkbox"/> Product Safety <input type="checkbox"/> Other (        )	

## G104 YELLOW TONER (D0159500) and ZINC STEARATE (D0159501)

- These are service parts consists of G104 Yellow Toner and Zinc Stearate. Use it for the PCU lubricant brush roller of the D014/D015 copier.
- Change the Service Manual as shown below.

1. Add the following to the table (**Service Manual: Section2. Preventive Maintenance / PM Tables / Main Machine / Symbol Key for Tables**):

L	Lubrication required: <ul style="list-style-type: none"> <li>● G104 YELLOW TONER (D0159500)</li> <li>● ZINC STEARATE (D0159501)</li> </ul>
---	--

2. Add the Note in the table (in bold) and description below (**Service Manual: Section2. Preventive Maintenance / PM Tables**):

**PCU**

	150K	200K	300K	400K	450K	600K	Note
Lubricant Brush			R (Y,C,M)	R (K)			<b>After replacement, apply the "G104 Yellow Toner" and "Zinc Stearate".</b>

"R": Replacement required

1. Place a sheet of clean paper on the flat surface.
2. Pour a small amount of G104 Yellow Toner (D0159500) from its bottle onto the paper.
3. Pour a small amount of Zinc Stearate (D0159501) from its bottle onto the paper.
4. Mix G104 Yellow Toner and Zinc Stearate together evenly.

**NOTE:**

DO not use the D014/D015 yellow toner instead of G104 yellow toner, because it contains developer that could damage the drum and ITB.

Model: D014/D015

Date: 24-Oct-08

No.: TRD014045

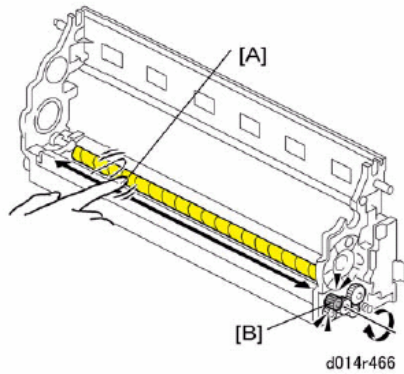

While rotating the gear [B] in the direction of the arrow shown, use your finger to apply **the Mixed Powder of G104 Yellow Toner and Zinc Stearate** across the surface of the PCU lubricant brush roller [A].

**IMPORTANT:**

1. Use a brush to apply the powder if one is available.
2. Only use this mixed powder for the **PCU lubricant brush roller** of the **D014/D015** copier. Never apply this powder to another part or another model.



# Technical Bulletin

Model: D014/D015		Date: 24-Oct-08	No.: TRD014046
Subject: SC670			
Classification:	<input checked="" type="checkbox"/> Troubleshooting	<input type="checkbox"/> Part information	<input type="checkbox"/> Action required
	<input type="checkbox"/> Mechanical	<input type="checkbox"/> Electrical	<input checked="" type="checkbox"/> Service manual revision
	<input type="checkbox"/> Paper path	<input type="checkbox"/> Transmit/receive	<input type="checkbox"/> Retrofit information
	<input type="checkbox"/> Product Safety	<input type="checkbox"/> Other (     )	

Please add the following to your Service Manuals: Section 4. Troubleshooting / Service Call Tables / SC Codes Group 6: Device Communication.

SC670	D	Engine startup error	
		1. Engine does not respond within 30s after power on. 2. Engine down detected suddenly during power on and warm up.	1. VBCU installation incorrect. 2. VBCU defective. 3. Sudden communication reset occurred between the VBCU and the controller.

Model: D014/D015		Date: 24-Oct-08	No.: TRD014048
Subject: SD card slot number			
Classification:	<input type="checkbox"/> Troubleshooting	<input type="checkbox"/> Part information	<input type="checkbox"/> Action required
	<input type="checkbox"/> Mechanical	<input type="checkbox"/> Electrical	<input checked="" type="checkbox"/> Service manual revision
	<input type="checkbox"/> Paper path	<input type="checkbox"/> Transmit/receive	<input type="checkbox"/> Retrofit information
	<input type="checkbox"/> Product Safety	<input type="checkbox"/> Other ( )	

**Service Manual Correction:**

All pages and explanations concerning the SD card slot numbers were corrected as follows:

- Slot #2 (upper slot) is the "Option Slot".
- Slot #1 (lower slot) is the "Service Slot".

Service Manual: Section 1. Installation / MFP Controller Options / Overview /Board Slots / (slot number and option type):

No.	Name	Description
4	Upper Slot Slot#2 Option Slot	<ul style="list-style-type: none"> <li>• Data Overwrite Security Unit Type H (D377)</li> <li>• PostScript3 (D378)</li> <li>• Printer Scanner GM-2190 (D376)</li> </ul>
5	Lower Slot Slot#1 Service Slot	Service Slot for firmware updates, moving applications to another SD card with SP5873 (Apli Move)

**Note:** The decal and numbers engraved in the controller box are correct (see below):

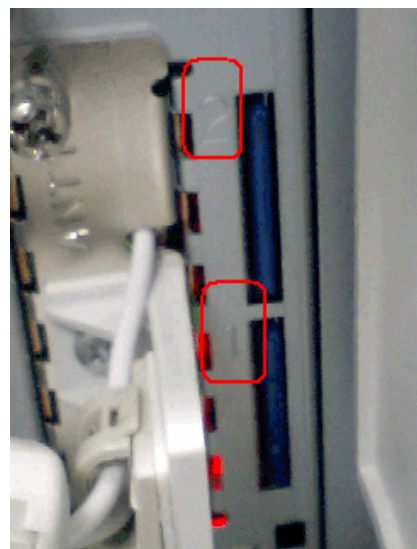

Model: D014/D015		Date: 27-Nov-08	No.:TRD014053
Subject: Undo Procedure of SD Card			
Classification:	<input type="checkbox"/> Troubleshooting	<input type="checkbox"/> Part information	<input type="checkbox"/> Action required
	<input type="checkbox"/> Mechanical	<input type="checkbox"/> Electrical	<input checked="" type="checkbox"/> Service manual revision
	<input type="checkbox"/> Paper path	<input type="checkbox"/> Transmit/receive	<input type="checkbox"/> Retrofit information
	<input type="checkbox"/> Product Safety	<input type="checkbox"/> Other (     )	

The Service Manual was corrected as follows.

**Note:** Words **in bold** were corrected.

Undo Procedure for the SD Card (pg. 191)

## UNDO EXEC

1. Turn the main switch off.
2. Put the SD card with the applications in the **upper slot**.
3. Put the original destination SD card (the one stored in the front door) into the **lower slot**.

### NOTE

• The SD card in the **lower slot** must be the original SD card of the application you want to move from the **upper slot** to the **lower slot**. You cannot use any blank SD card in the **lower slot**. The application will be moved only to the original SD card.

4. Turn the main switch on.
5. Go into the SP mode and do SP5873-2 (Undo Exec)
6. Follow the messages on the operation panel to complete the procedure.
7. Turn the main switch off.
8. Remove the SD cards from the slots.
9. Turn the main switch on.

Reissued: 2-Mar-09

Model: D014/D015		Date: 16-Feb-09	No.: TRD014062a
Subject: Description for Board Slots			
Classification:	<input type="checkbox"/> Troubleshooting	<input type="checkbox"/> Part information	<input type="checkbox"/> Action required
	<input type="checkbox"/> Mechanical	<input type="checkbox"/> Electrical	<input checked="" type="checkbox"/> Service manual revision
	<input type="checkbox"/> Paper path	<input type="checkbox"/> Transmit/receive	<input type="checkbox"/> Retrofit information
	<input type="checkbox"/> Product Safety	<input type="checkbox"/> Other (     )	

**TB Reissue.**

The items in ***bold italics*** were corrected or added.

**Service Manual Correction:**

Please correct your service manual as follows.

Page 184-185

Description for board slot #13 and #14.

**Incorrect:**

No.	Name	Description
13	Line 2	Jack for a 2nd line connection to Fax Interface Unit (D357) (G3) when this option is installed.
14	Line 3	Not used. (G4 is not available for installation outside Japan at this time.)

**Correct:**

No.	Name	Description
13	Line 2	Jack for a <b><i>2nd</i></b> line connection to G3 Interface Unit Type C7500 (D357) when this option is installed.
14	Line 3	Jack for a <b><i>3rd</i></b> line connection to G3 Interface Unit Type C7500 (D357) when this option is installed.

**Reissued 08-Apr-09**

Model: D014/D015	Date: 09-Mar-09	No.: TRD014063a
------------------	-----------------	-----------------

**RTB Reissue**

The items in ***bold italics*** were corrected or added.

Subject: Printer Service Mode			
Classification:	<input type="checkbox"/> Troubleshooting	<input type="checkbox"/> Part information	<input type="checkbox"/> Action required
	<input type="checkbox"/> Mechanical	<input type="checkbox"/> Electrical	<input checked="" type="checkbox"/> Service manual revision
	<input type="checkbox"/> Paper path	<input type="checkbox"/> Transmit/receive	<input type="checkbox"/> Retrofit information
	<input type="checkbox"/> Product Safety	<input type="checkbox"/> Other (     )	

**Service Manual Correction:**

Please add the following information to the Section.5 “Service Tables” of D014/D015 Service Manual (pg.748).

---

## Printer Service Mode

---



---

### SP1-XXX (Service Mode)

---

<b>1001</b>	[Bit Switch]	
1001 1	Bit Switch 1 Settings	Adjusts the bit switch settings. <b>DFU</b>
1001 2	Bit Switch 2 Settings	
1001 3	Bit Switch 3 Settings	
1001 4	Bit Switch 4 Settings	
1001 5	Bit Switch 5 Settings	
1001 6	Bit Switch 6 Settings	
1001 7	Bit Switch 7 Settings	
1001 8	Bit Switch 8 Settings	

<b>1003</b>	[Clear Setting]	
1003 1	Initialize Printer System	
	Initializes settings in the “System” menu of the user mode.	
1003 3	Delete Program	
	<b><i>*This SP does not function for North American model.</i></b>	

Reissued 08-Apr-09

Model: D014/D015	Date: 09-Mar-09	No.: TRD014063a
------------------	-----------------	-----------------

<b>1004</b>	[Print Summary]
1004 1	Print Summary Prints the service summary sheet (a summary of all the controller settings).

<b>1005</b>	[Display Version]
1005 1	Disp. Version Displays the version of the printer application.

<b>1006</b>	[Sample/Locked Print]	<b>0:</b> Linked, <b>1:</b> On
1006 1	Enables and disables the document server. When you select "0," the document server is enabled or disabled in accordance with Copy Service Mode SP5-967. When you select "1," the document server is enabled regardless of Copy Service Mode SP5-967.	

<b>1101</b>	[Data Recall]
	Recalls a set of gamma settings. This can be either a) the factory setting, b) the previous setting, or c) the current setting.
1101 1	Factory
1101 2	Previous
1101 3	Current
1101 4	ACC

<b>1102</b>	[Resolution Setting]
	Selects the printing mode (resolution) for the printer gamma adjustment.
1102 1	<b>2400x600 Photo</b> , 1800x600 Photo, 600 x 600 Photo, 2400x600 Text, 1800x600, Text, 600x600 Text

<b>1103</b>	[Test Page]
	Prints the test page to check the color balance before and after the gamma adjustment.
1103 1	Color Gray Scale
1103 2	Color Pattern

Reissued 08-Apr-09

Model: D014/D015	Date: 09-Mar-09	No.: TRD014063a
------------------	-----------------	-----------------

<b>1104</b>	[Gamma Adjustment]	
	Adjusts the printer gamma for the mode selected in the "Mode Selection" menu.	
1104 1	Black: Highlight	[0 to 30 / <b>15</b> / 1/step ]
1104 2	Black: Shadow	
1104 3	Black: Middle	
1104 4	Black: IDmax	
1104 21	Cyan: Highlight	
1104 22	Cyan: Shadow	
1104 23	Cyan: Middle	
1104 24	Cyan: IDmax	
1104 41	Magenta: Highlight	
1104 42	Magenta: Shadow	
1104 43	Magenta: Middle	
1104 44	Magenta: IDmax	
1104 61	Yellow: Highlight	
1104 62	Yellow: Shadow	
1104 63	Yellow: Middle	
1104 64	Yellow: IDmax	

<b>1105</b>	[Save Tone Control Value]	
	Stores the print gamma adjusted with the "Gamma Adj." menu item as the current setting. Before the machine stores the new "current setting", it moves the data currently stored as the "current setting" to the "previous setting" memory storage location.	
1105 1	Save Tone Control Value	

<b>1106</b>	[Toner Limit]	
	Adjusts the maximum toner amount for image development.	
1106 1	Toner Limit Value	[100 to 400 / <b>260</b> / 1 %/step ]
	<b>*This SP is DFU, so please don't change the default setting.</b>	

# Technical Bulletin

PAGE: 1/10

Model: D014/D015		Date: 17-Mar-09	No.: TRD014065
Subject: Description for Board Slots			
Classification:	<input type="checkbox"/> Troubleshooting	<input type="checkbox"/> Part information	<input type="checkbox"/> Action required
	<input type="checkbox"/> Mechanical	<input type="checkbox"/> Electrical	<input checked="" type="checkbox"/> Service manual revision
	<input type="checkbox"/> Paper path	<input type="checkbox"/> Transmit/receive	<input type="checkbox"/> Retrofit information
	<input type="checkbox"/> Product Safety	<input type="checkbox"/> Other (     )	

## D014/D015 Service Manual Revision

Please replace pages 187, 190-191, 324-325, 593-594, 611, and 624 with the following.

**Note:** The SD card slot numbers were corrected. These areas appear below in ***bold and italic***.



Model: D014/D015	Date: 17-Mar-09	No.: TRD014065
------------------	-----------------	----------------

## Pg. 187

\*1: The EFI (Fiery) controller is connected through Gigabit Ethernet (included in EFI controller).

### SD Card Applications

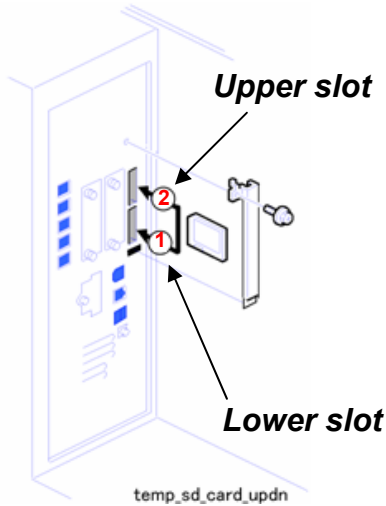

**Note:** The decal and numbers engraved in the controller box (see below).

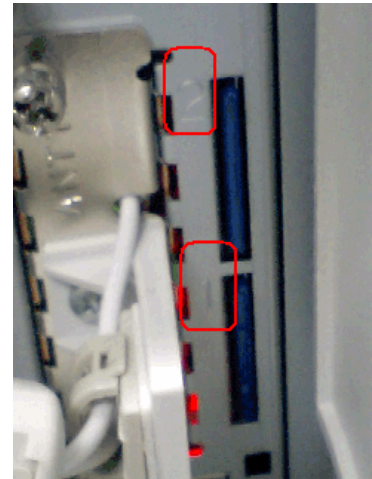
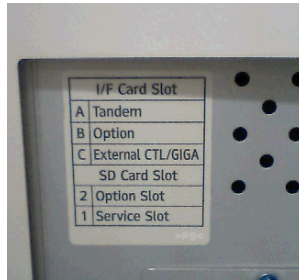

The following applications are available on SD cards.

No.	Name	SD Card Slot.
D377	Data Overwrite Security Unit Type H	<b>Slot 2 (upper slot)</b>
D378	PostScript 3	<b>Slot 2 (upper slot)</b>
D376	Printer/Scanner GM-2190	<b>Slot 2 (upper slot)</b>

**Note:**

- The VM Card must be inserted in the **Slot 1 (lower slot)**. This is because it requires about 22 MB of disk space, and cannot be merged onto the SD card in the upper slot if that card already contains all the other applications.
- If the customer needs more than one application in the upper slot, the applications must be moved to one SD card. (See "Moving Applications to One SD Card" in this section)

### Handling DIMMs and SD Cards

#### **WARNING**

Always turn the machine off and disconnect the machine power cord before you

## Pg. 190-191

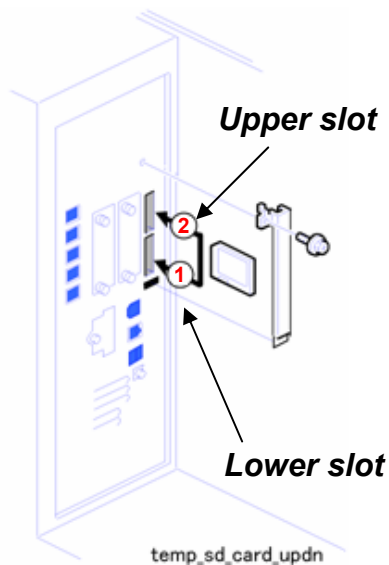

3. Insert the Source SD card in **Slot 1 (lower slot)**. This card contains the application that you want to move to the other SD card.

**Note**

- The PostScript3 SD card cannot be the source card because it cannot be copied.

4. Put the Target SD card in **Slot 2 (upper slot)**.

5. Open the front door.

6. Turn the copier on.

7. Go into the SP mode and do SP5873-1.

8. Follow the instructions on the display and touch "Execute" to start copying.

9. When the display tells you copying is completed, touch "Exit".

10. Turn the copier off.

11. Remove the Source SD card from the **Slot 1 (lower slot)**, and leave the target SD card in the **Slot 2 (upper slot)**.

12. Turn the copier on.

13. Go into the User Tools mode and confirm that all the applications on the SD card in the **Slot 2 (upper slot)** are enabled.

User Tools> System Settings> Administrator Tools> Firmware Version> Next (5/5)

14. Turn the copier off again, then:

- Reattach the SD card slot cover.
- Remove the cover from the front door, and store the SD card that was copied. (See "Storing SD Application Cards on Site" in this section)

The SD card must be stored with the machine for these reasons:

Model: D014/D015

Date: 17-Mar-09

No.: TRD014065

- Once an SD card has been copied, it can no longer be used. But it must be stored in the front door to serve as proof of purchase by the customer.
- Also, at a later time the stored SD cards can be restored to full use with SP5873-2 (described in the next section).
- Before you put the card in the front cover, label it so that it can be easily identified.

## Undo Exec

---

1. Turn the main switch off.
2. Put the SD card with the applications in the **Slot 2 (upper slot)**.
3. Put the original destination SD card (the one stored in the front door) into the **Slot 1 (lower slot)**.

### Note

- The SD card in the upper slot must be the original SD card of the application you want to move from **Slot 2 (upper slot)** to **Slot 1 (lower slot)**. You cannot use any blank SD card in **Slot 1 (lower slot)**. The application will be moved only to the original SD card.
4. Turn the main switch on.
  5. Go into the SP mode and do SP5873-2 (Undo Exec)
  6. Follow the messages on the operation panel to complete the procedure.
  7. Turn the main switch off.
  8. Remove the SD cards from the slots.
  9. Turn the main switch on.

## Storing SD Application Cards on Site

---

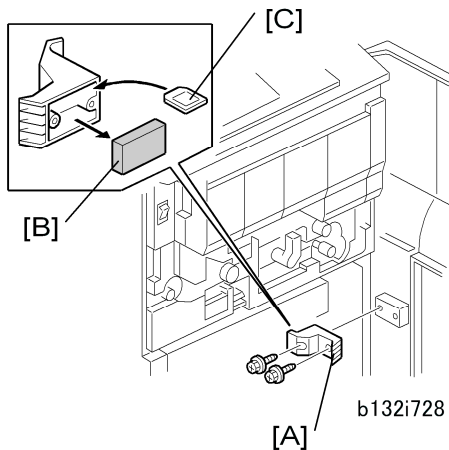

1. Open the front door.
2. Remove the cover [A] on the door (Two Screws).

## Pg. 324–325

### Memory

---

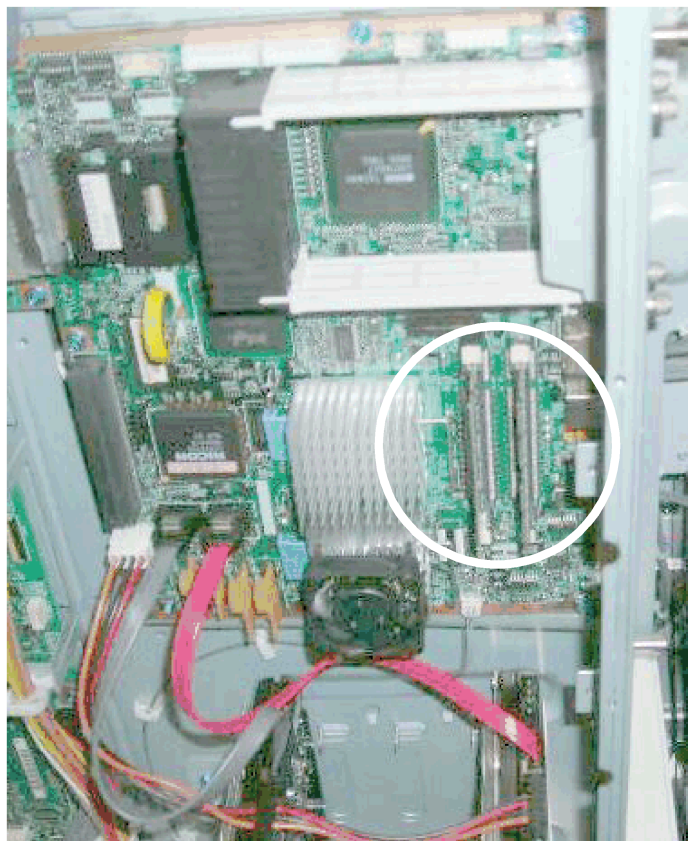

temp\_0869

1. Install memory chips.

---

### NVRAM

---

#### Before You Begin...

---

- Never remove the NVRAM until you have uploaded its contents.
- Always touch a metal surface to discharge any static on your hands before you touch the controller board.
- Work carefully when removing the NVRAM to avoid damaging other components on the controller board or short circuiting the pins of other chips.

#### Upload NVRAM Data to SD Card

---

1. Do SP5990 001 to print the SMC report.
2. Turn the copier main power switch off.
3. Insert an SD card in the **Slot1 (lower slot)**.
4. Execute SP5824 to upload the data to the SD card.

5. Switch the machine off and disconnect the power cord.

## Replace NVRAM

---

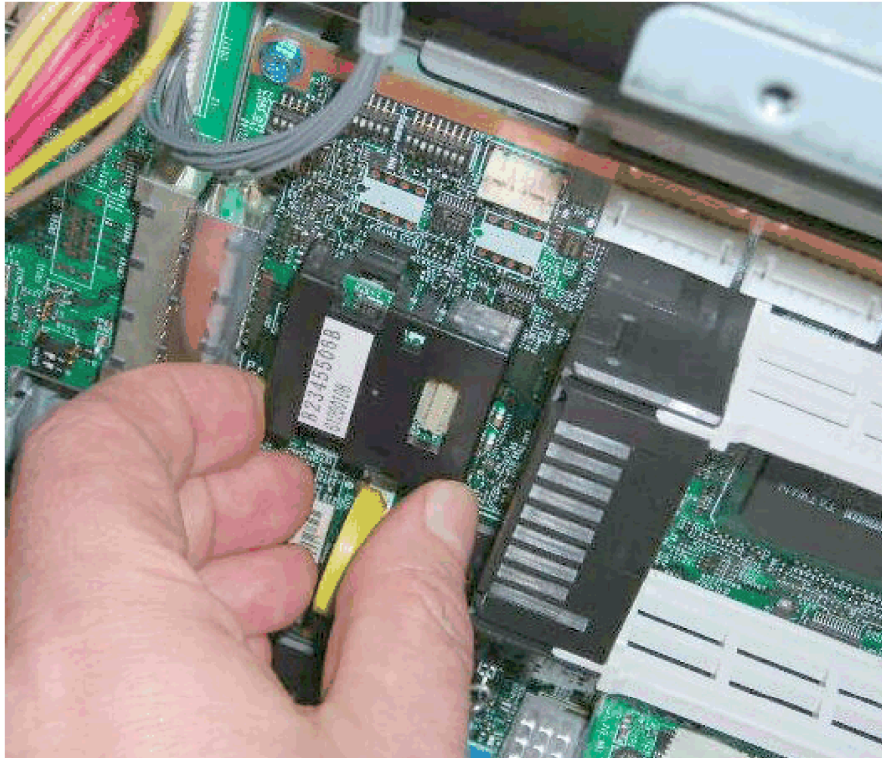

temp\_1022

1. Remove the old NVRAM.
2. Attach the new NVRAM.

## Download NVRAM Data from SD Card

---

1. Turn the copier main power switch off.
  2. Put the SD card with the NVRAM data into **Slot 1 (lower slot)**.
  3. Open the front door of the copier.
  4. Turn the copier main power switch on.  
If the NVRAM is new, SC195 (Machine Serial Number Error) may appear. If this occurs:
    - Enter the SP mode and do SP5801 001 to reset the memory to the defaults (All).
    - Switch the machine off/on and start from Step 1.
- ★ Important**
- If SC195 occurs the serial number must be input. You must contact your technical supervisor.
5. Execute SP5825 to download the data uploaded from the old NVRAM.

Model: D014/D015	Date: 17-Mar-09	No.: TRD014065
------------------	-----------------	----------------

**pg. 593–594**

	Error Caused by Response from GW URL	-12008	Update certification failed because device was in use.
		-2385	Attempted dial up overseas without the correct international prefix for the telephone number.
		-2387	Not supported at the Service Center
		-2389	Database out of service
		-2390	Program out of service
		-2391	Two registrations for same device
		-2392	Parameter error
		-2393	External RCG not managed
		-2394	Device not managed
		-2395	Box ID for external RCG is illegal
		-2396	Device ID for external RCG is illegal
		-2397	Incorrect ID2 format
-2398	Incorrect request number format		
209	Inst Clear		
	Releases the machine from its embedded RCG setup.		
250	CommLog Print		
	Prints the communication log.		

5824	NVRAM Data Upload
	<p>Set the SD card in <b>Slot 1 (lower slot)</b>, then touch [EXECUTE] to upload the NVRAM data to an SD card.</p> <p><b>Note:</b> When uploading in this SP mode data, the front door must be open.</p>

Model: D014/D015	Date: 17-Mar-09	No.: TRD014065
------------------	-----------------	----------------

5825	NVRAM Data Download
	Set the SD card in <b>Slot 1 (lower slot)</b> , then touch [EXECUTE] to download data from the card to the NVRAM in the machine. After downloading is completed, remove the card and turn the machine power off and on.

5828	Network Setting
1	IPv4 Address (Ethernet/IEEE 802.11)
	This SP allows you to confirm and reset the IPv4 address for Ethernet and wireless LAN (802.11): aaa.bbb.ccc.ddd
2	IPv4 Subnet Mask (Ethernet/IEEE 802.11)
	This SP allows you to confirm and reset the IPv4 subnet mask for Ethernet and wireless LAN (802.11): aaa.bbb.ccc.ddd
3	IPv4 default Gateway (Ethernet/IEEE 802.11)
	This SP allows you to confirm and reset the IPv4 default gateway used by the network for Ethernet and wireless LAN (802.11): aaa.bbb.ccc.ddd
6	DHCP (Ethernet/IEEE 802.11)
	This SP code allows you confirm and change the setting that determines whether the IP address is used with DHCP on an Ethernet or wireless (802.11) LAN network. [0 to 1 / 1 / 1] 0: Not used (manual setting) 1: Used
021	Active IPv4 Address
	This SP allows you to confirm the IPv4 address that was used when the machine started up with DHCP.
022	Active IPv4 Subnet Mask

Model: D014/D015	Date: 17-Mar-09	No.: TRD014065
------------------	-----------------	----------------

**pg. 611**

	Copies all directory information to the SD card. Do this SP before replacing the controller board or HDD. The operation may not succeed if the controller board or HDD is damaged.	
052	Restore All Addr Book	
	Copies back all directory information from the SD card to the flash ROM or HDD. Upload the address book from the old flash ROM or HDD with SP5846-51 before removing it. Do SP5846 52 after installing the new HDD.	
053	Clear Backup Info.	
	Deletes the address book uploaded from the SD card in the <b>Slot 1(lower slot)</b> . Deletes only the files uploaded for that machine. This feature does not work if the card is write-protected. Note: After you do this SP, go out of the SP mode, turn the power off. Do not remove the SD card until the Power LED stops flashing.	
060	Search Option	
	This SP uses bit switches to set up the fuzzy search options for the UCS local address book.	
	<b>Bit</b>	<b>Meaning</b>
	0	Checks both upper/lower case characters
	1	<b>Japan Only</b>
	2	
	3	
	4	--- Not Used ---
	5	--- Not Used ---
	6	--- Not Used ---
7	--- Not Used ---	
062	Complexity Option 1	



Model: D014/D015	Date: 17-Mar-09	No.: TRD014065
------------------	-----------------	----------------

**pg. 624**

		Selects the display type for the document box list. [0 to 2 / <b>0</b> / 1] 0: Thumbnail, 1: Icon, 2: Details		
	51	DocSvr Trans Sets the number of documents to be displayed in the document box list. [5 to 20 / <b>10</b> / 1]		
	100	Set Signature <table border="1" style="width: 100%; height: 20px; margin-top: 5px;"> <tr> <td style="width: 30%;"></td> <td style="width: 70%;"></td> </tr> </table>		
	101	Set Encryption Determines whether the scanned documents with the WIM are encrypted when they are transmitted by an e-mail. [0 to 1 / <b>0</b> / 1] 0: Not encrypted, 1:Encryption		
	200	Detect Mem Leak		
	201	DocSvr Timeout		

5887	SD Get Counter
	<p>This SP sends a text file to an SD card inserted in SD card <b>Slot 1 (lower slot)</b>. The operation stores. The file is stored in a folder created in the root directory of the SD card called SD_COUNTER. The file is saved as a text file (*.txt) prefixed with the number of the machine.</p> <ol style="list-style-type: none"> <li>1. Insert the SD card in SD card <b>Slot 1 (lower slot)</b>.</li> <li>2. Select SP5887 then touch [EXECUTE].</li> <li>3. Touch [Execute] in the message when you are prompted.</li> </ol>

5888*	Personal Information Protect
-------	------------------------------

Model: D014/D015		Date: 25-Mar-09	No.: TRD014067
Subject: Cannot Connect with DHCP Server			
Classification:	<input checked="" type="checkbox"/> Troubleshooting	<input type="checkbox"/> Part information	<input type="checkbox"/> Action required
	<input type="checkbox"/> Mechanical	<input type="checkbox"/> Electrical	<input type="checkbox"/> Service manual revision
	<input type="checkbox"/> Paper path	<input type="checkbox"/> Transmit/receive	<input type="checkbox"/> Retrofit information
	<input type="checkbox"/> Product Safety	<input type="checkbox"/> Other (     )	

**SYMPTOM:**

"Cannot Connect with DHCP (101)" is displayed in the operation panel.

**NOTE:**

"101" is the error code number, which means that DHCP server cannot be found with onboard Ethernet interface.

**CAUSE:**

LAN cable has been disconnected from the onboard Ethernet interface after " Auto-Obtain(DHCP)" was selected in the User Program mode.

**SOLUTION:**

Disable the " Auto-Obtain(DHCP)" by following procedure.

1. User Tools™System Settings™Interface Settings™Machine IPv4 Address, then select "Specify" instead of " Auto-Obtain(DHCP)".
2. Then, input the specified IP address.

Model: D014/D015	Date: 24-Jun-09	No.:TRD014084
------------------	-----------------	---------------

<b>Subject:</b> SC534		
<b>Classification:</b>	<input type="checkbox"/> Troubleshooting <input type="checkbox"/> Part information <input type="checkbox"/> Action required <input type="checkbox"/> Mechanical <input type="checkbox"/> Electrical <input checked="" type="checkbox"/> Service manual revision <input type="checkbox"/> Paper path <input type="checkbox"/> Transmit/receive <input type="checkbox"/> Retrofit information <input type="checkbox"/> Product Safety <input type="checkbox"/> Other (      )	

SC534	B	<p>Duplex unit fan Error</p> <p>The lock signal remained HIGH for 5 sec while the fan that draws air out of the duplex unit was operating.</p> <ul style="list-style-type: none"> <li>Fan harness disconnected or damaged</li> <li>Fan blocked by an obstruction</li> <li>Fan damaged</li> </ul>
-------	---	--

The fans described in SC534 on S/M (pg.373) are Front Duplex Fan Motor and Rear Duplex Fan Motor (See below figure).

Symbol	Index No.	Name
<b>M29</b>	<b>155</b>	<b>Front Duplex Fan Motor</b>
<b>M30</b>	<b>156</b>	<b>Rear Duplex Fan Motor</b>

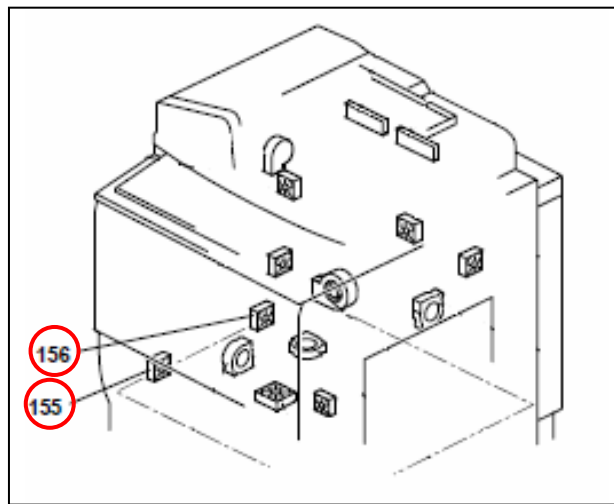

**D014/D015 ELECTRICAL COMPONENT LAYOUT (2/3)**

# Technical Bulletin

Model: D014/D015	Date: 7-Jul-09	No.: TRD014088
------------------	----------------	----------------

Subject: Service Manual Revision (LCT4000 Spec)			
Classification:	<input checked="" type="checkbox"/> Troubleshooting	<input type="checkbox"/> Part information	<input type="checkbox"/> Action required
	<input type="checkbox"/> Mechanical	<input type="checkbox"/> Electrical	<input type="checkbox"/> Service manual revision
	<input type="checkbox"/> Paper path	<input type="checkbox"/> Transmit/receive	<input type="checkbox"/> Retrofit information
	<input type="checkbox"/> Product Safety	<input type="checkbox"/> Other (      )	

Please correct the "Specifications" Section concerning LCT4000 of D014/D015 Service Manual (pg.822) as follows.

Specifications	
Paper Capacity	2,000 sheets (Paper thickness: 0.11 mm)
Remaining Paper Detection (Accuracy: ±30 sheets)	5-Step including Near-End
Paper Weight	52 to 300 g/m <sup>2</sup>
Paper Size	A5 to A3, HLT to 12 x 19.2 in. Postcards (100 mm wide) Custom Size: Length: 139.7 to <del>482.7</del> mm Custom Size: Width: 100 mm to <del>330.2</del> mm (Small Size: 100 to 139.2 mm)

	Wrong information	Correct information
Custom Size Length:	139.7 to 482.7 mm	139.7 to <b>487.6</b> mm
Custom Size Width:	100 to 330.2 mm	100 to <b>305.0</b> mm

# Technical Bulletin

Model: D014/D015	Date: 10-Jul-09	No.: TRD014089
------------------	-----------------	----------------

Subject: Service Manual Revision ( D373 Spec)			
Classification:	<input type="checkbox"/> Troubleshooting	<input type="checkbox"/> Part information	<input type="checkbox"/> Action required
	<input type="checkbox"/> Mechanical	<input type="checkbox"/> Electrical	<input checked="" type="checkbox"/> Service manual revision
	<input type="checkbox"/> Paper path	<input type="checkbox"/> Transmit/receive	<input type="checkbox"/> Retrofit information
	<input type="checkbox"/> Product Safety	<input type="checkbox"/> Other (     )	

D014/D015 Service Manual revision

Add the column shown in **bold** (regarding the capacity of the lower tray) to the following table.

7. Specifications (Optional Peripherals)

Pg. 829

	Paper size	Number of sheets/booklet	<b>Number of booklets/stack (lower tray)</b>
Booklet Staple Capacity	A4 SEF, A3 SEF, B5 SEF, B4 SEF 8.5"x11" SEF, 8.5"x14" SEF, 11"x17" SEF 12"x18" SEF	2-5 sheets	<b>30</b>
		6-10 sheets	<b>15</b>
		11-15 sheets	<b>10</b>

# D014/D015 POINT TO POINT DIAGRAM (1/4)

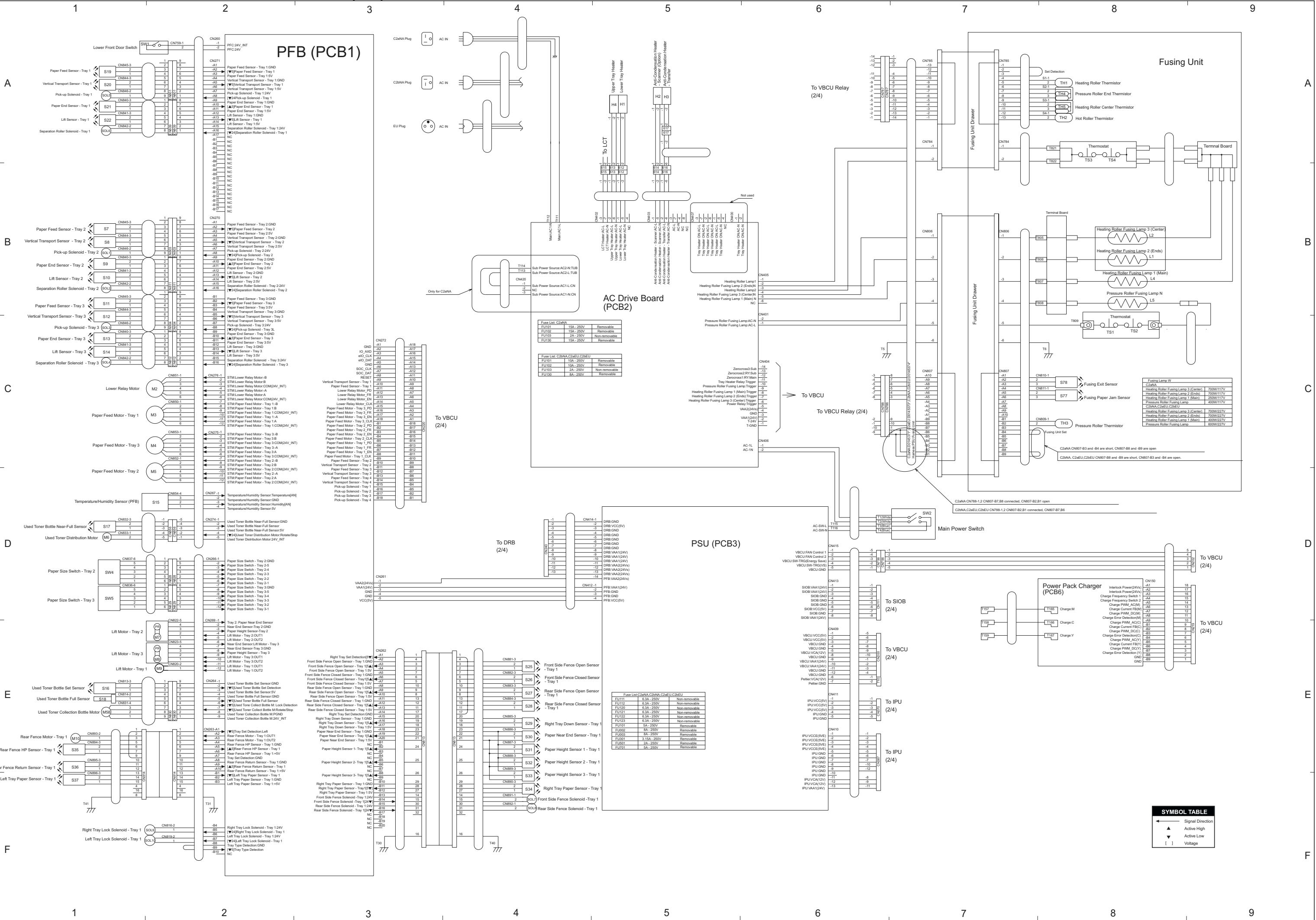

# D014/D015 POINT TO POINT DIAGRAM (2/4)

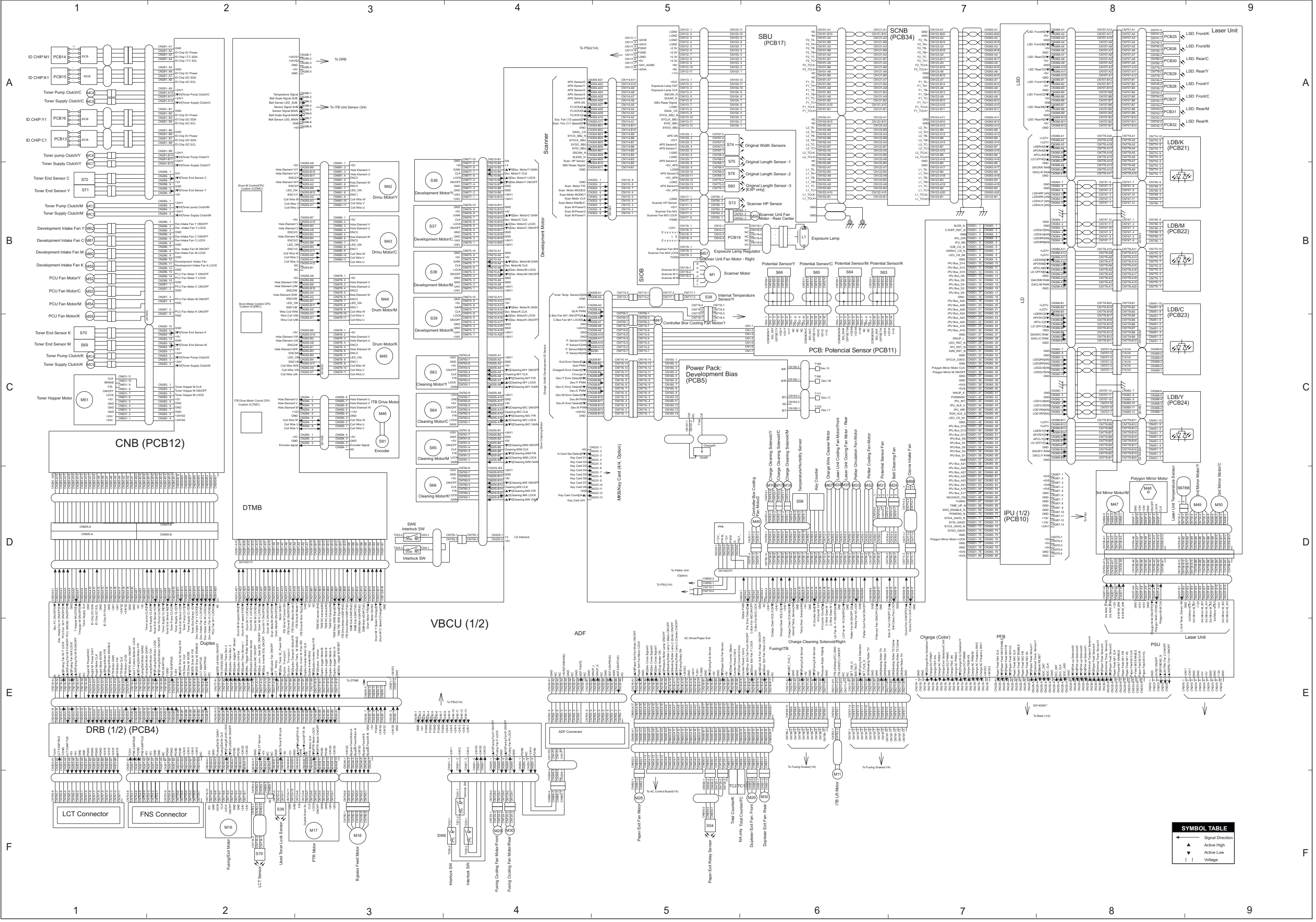

←	Signal Direction
▲	Active High
▾	Active Low
	Voltage

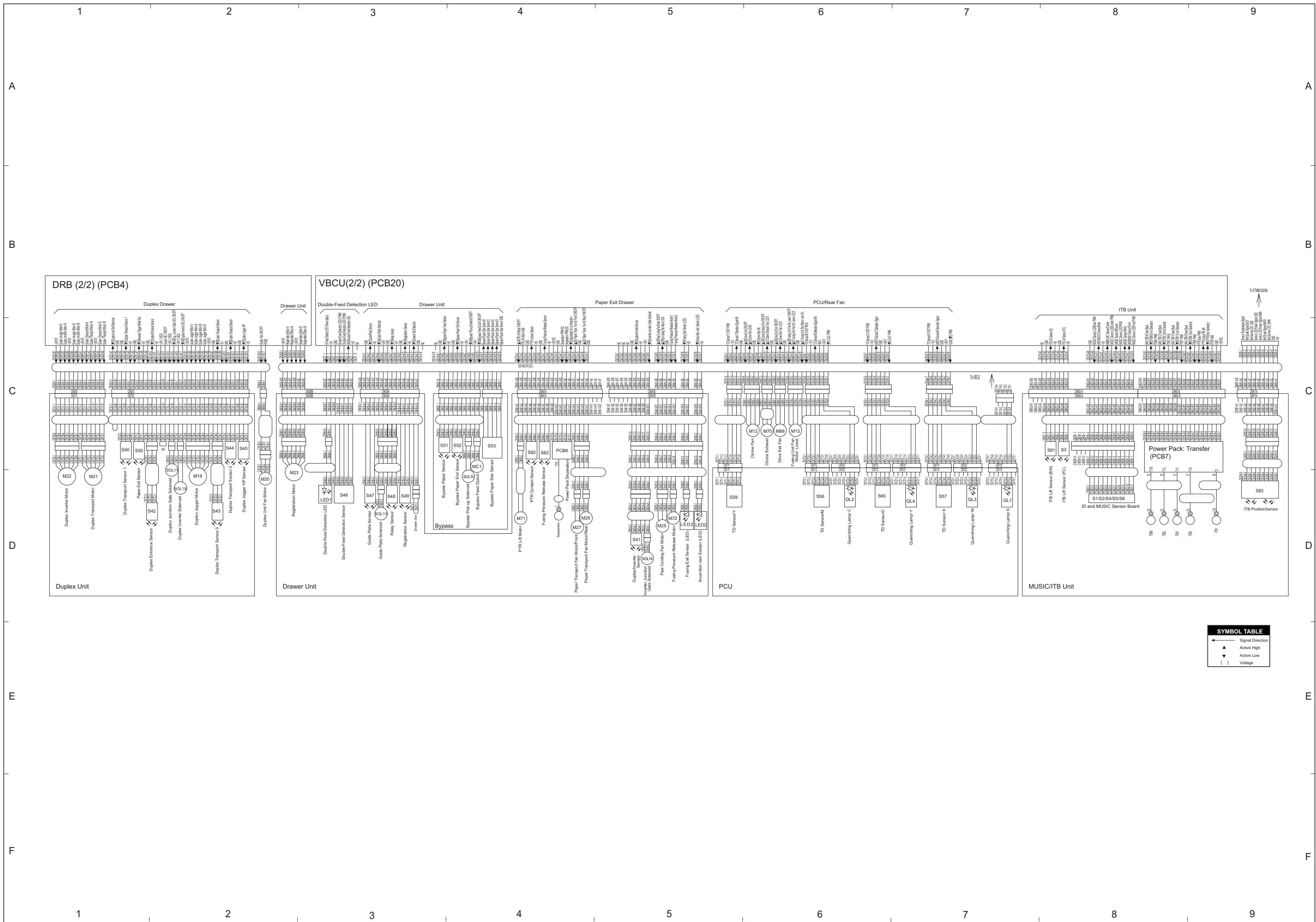



# D014/D015 POINT TO POINT DIAGRAM (4/4)

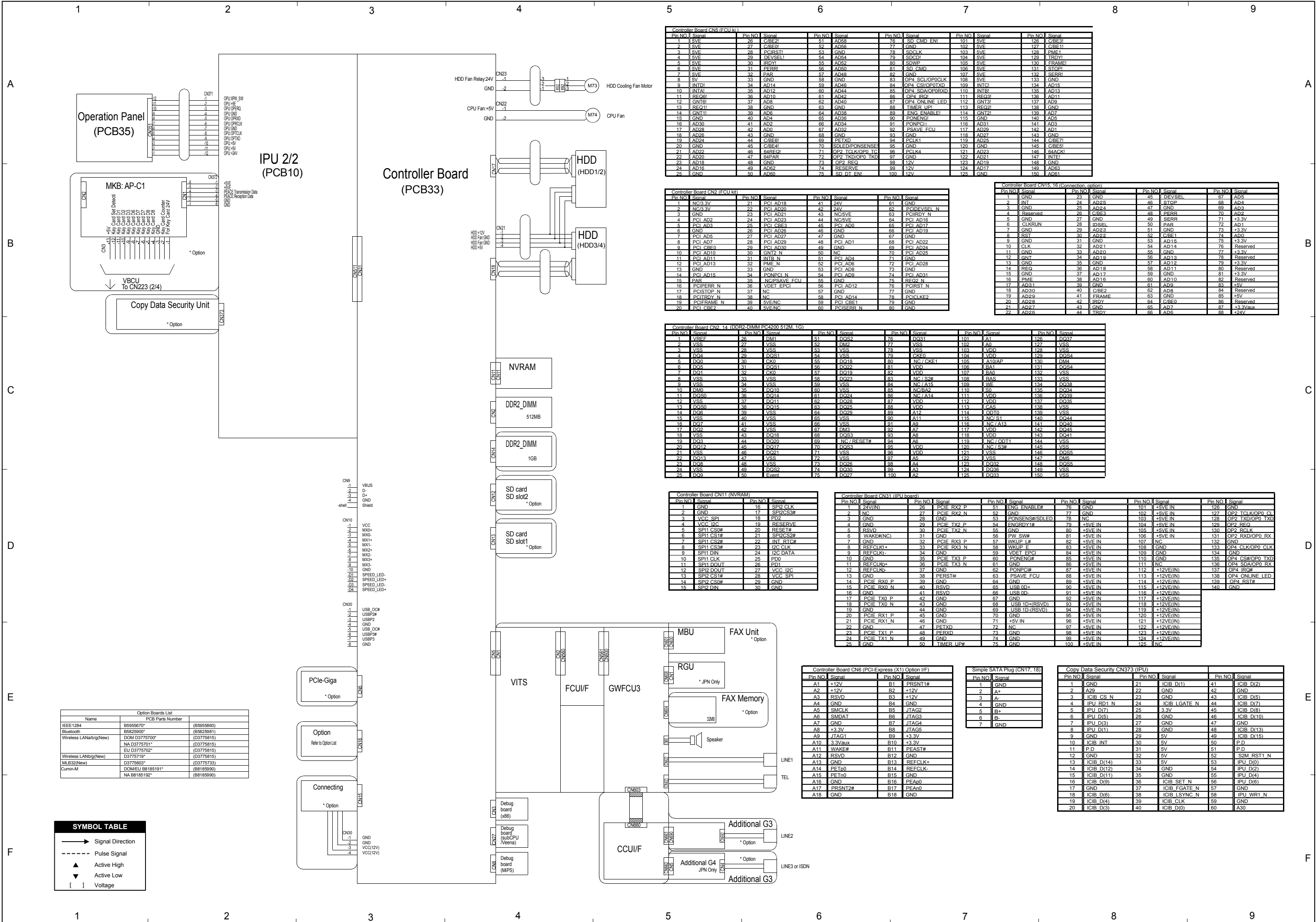

# D014/D015 ELECTRICAL COMPONENT LAYOUT (1/3)

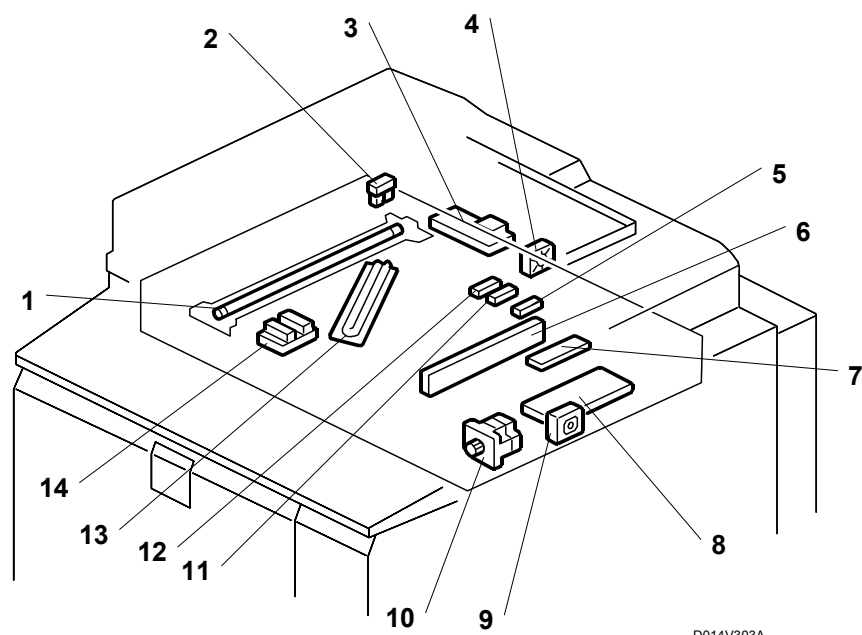

D014V303A

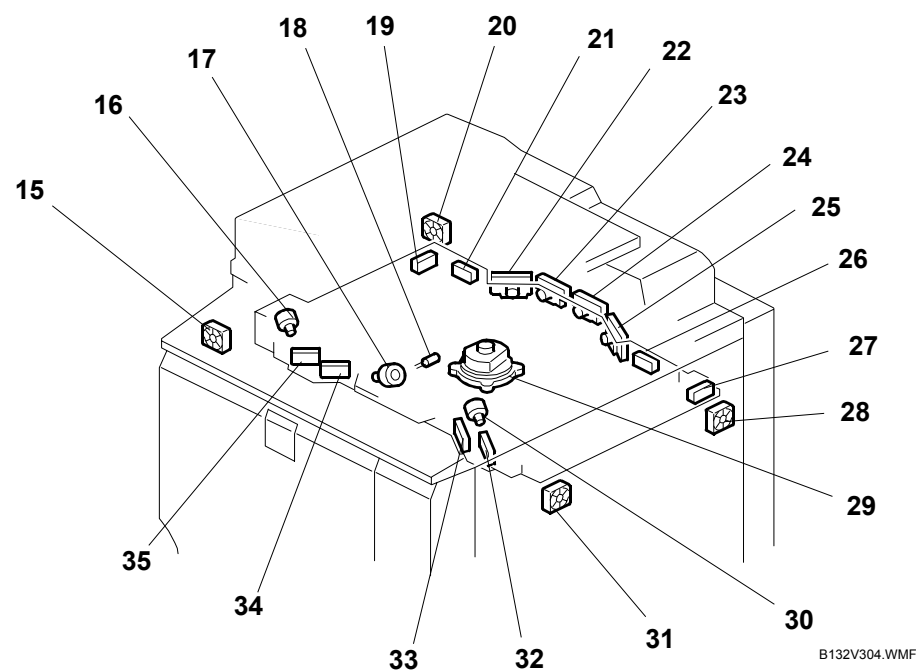

B132V304.WMF

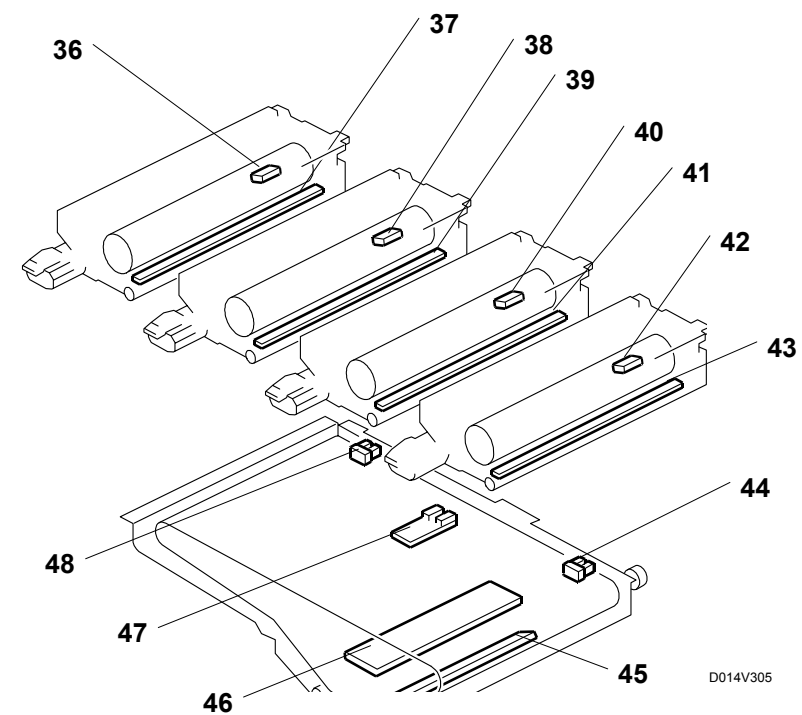

D014V305

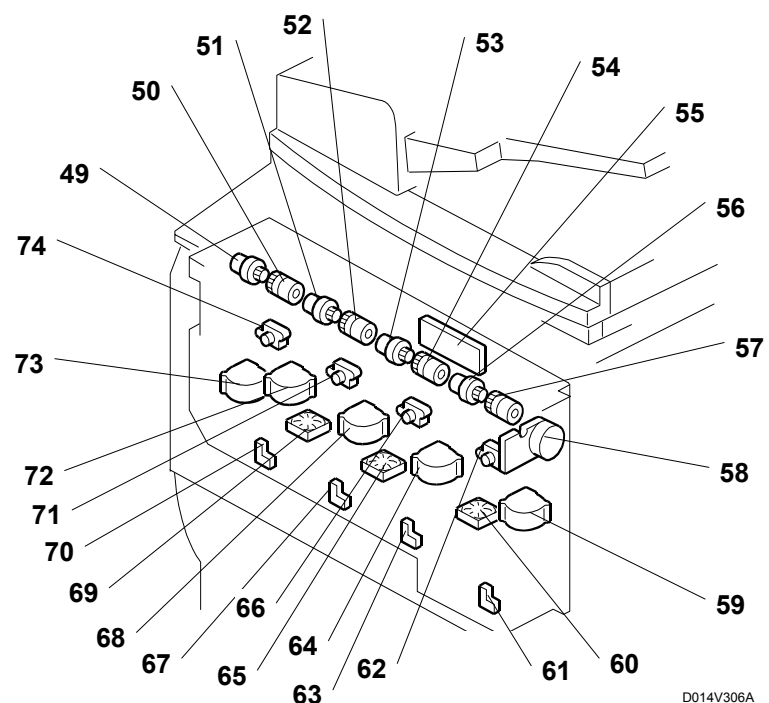

D014V306A

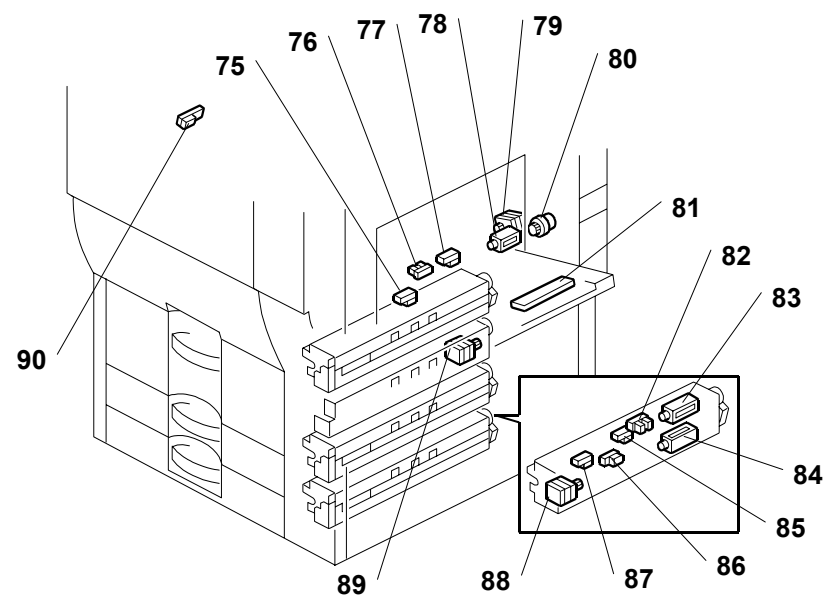

D014V310A

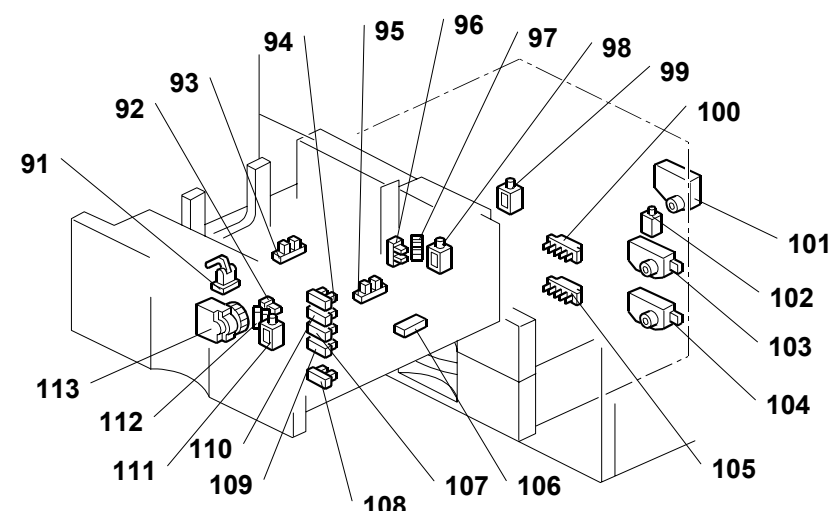

D014V311A

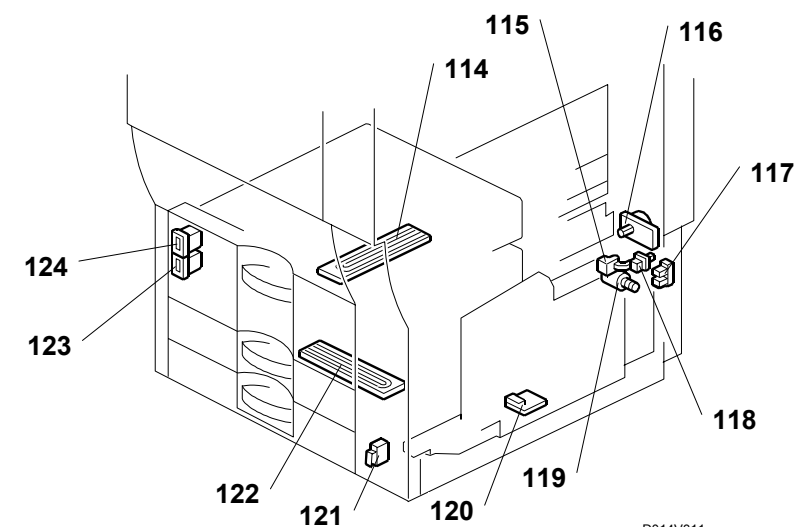

D014V311

# D014/D015 ELECTRICAL COMPONENT LAYOUT (2/3)

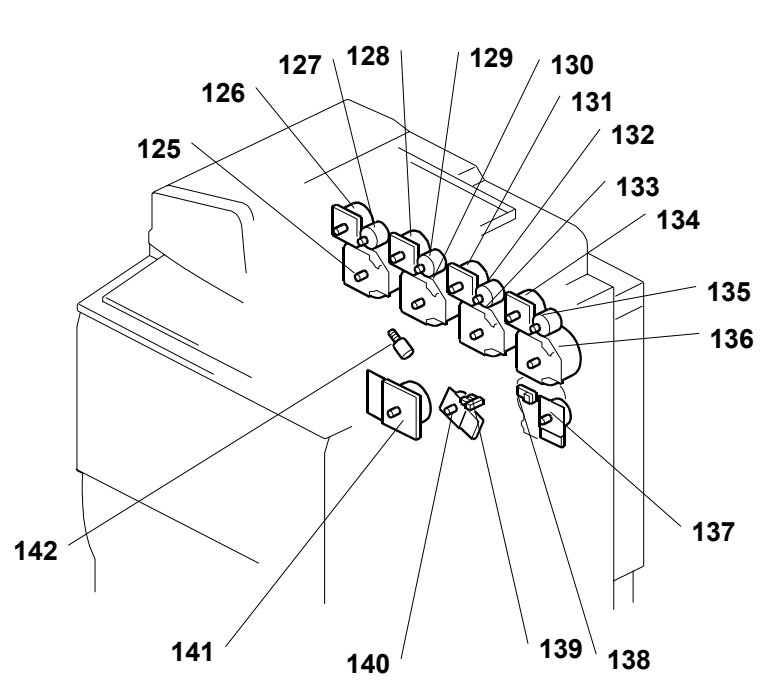

D014V309A

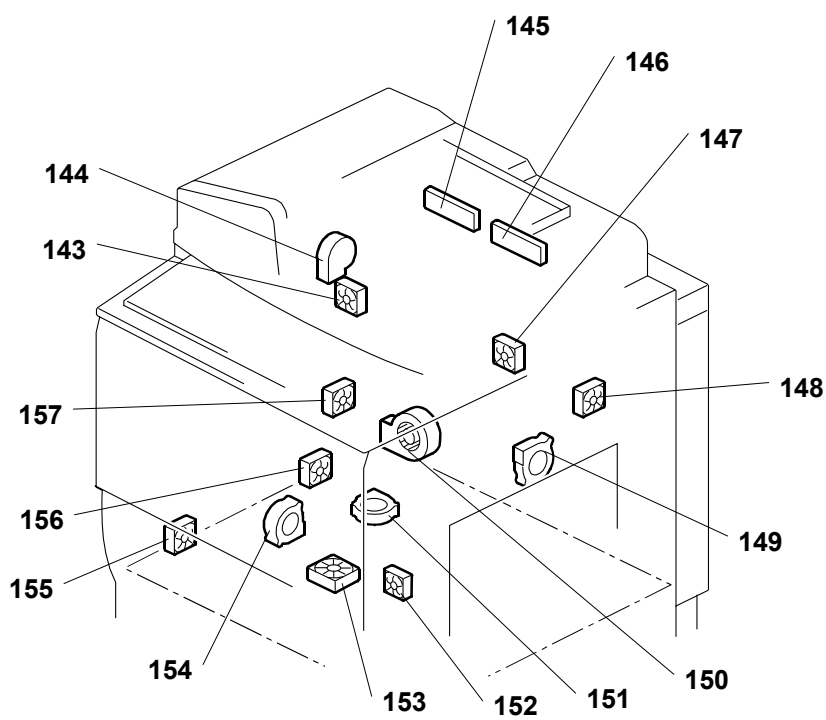

D014V309

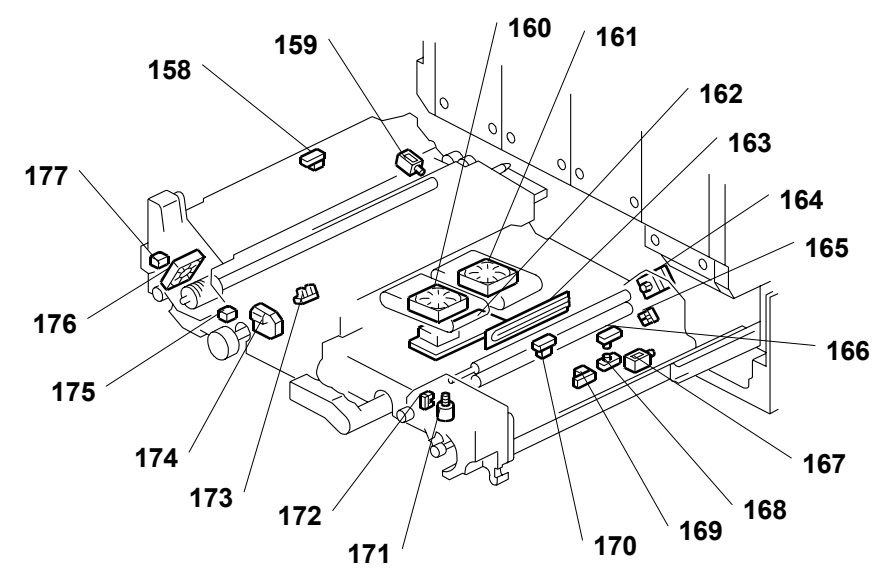

D014V308

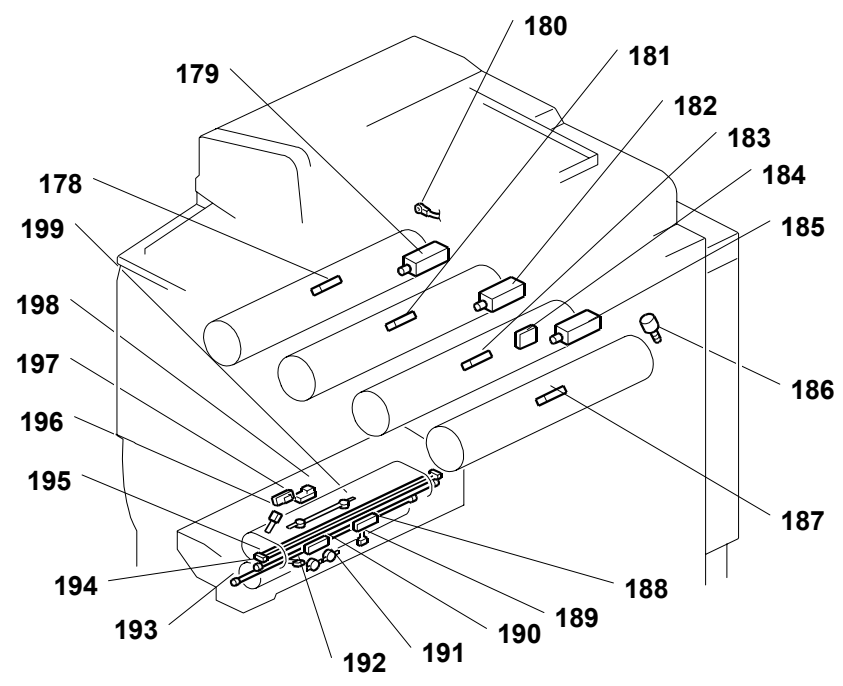

D014V351

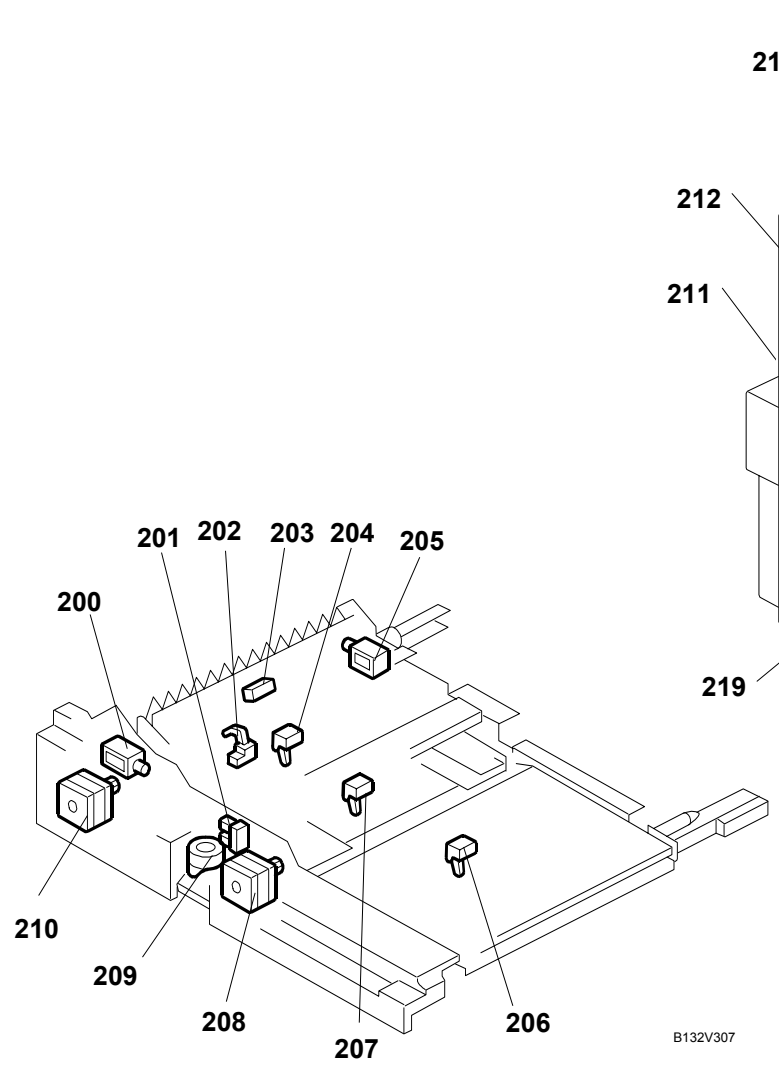

B132V307

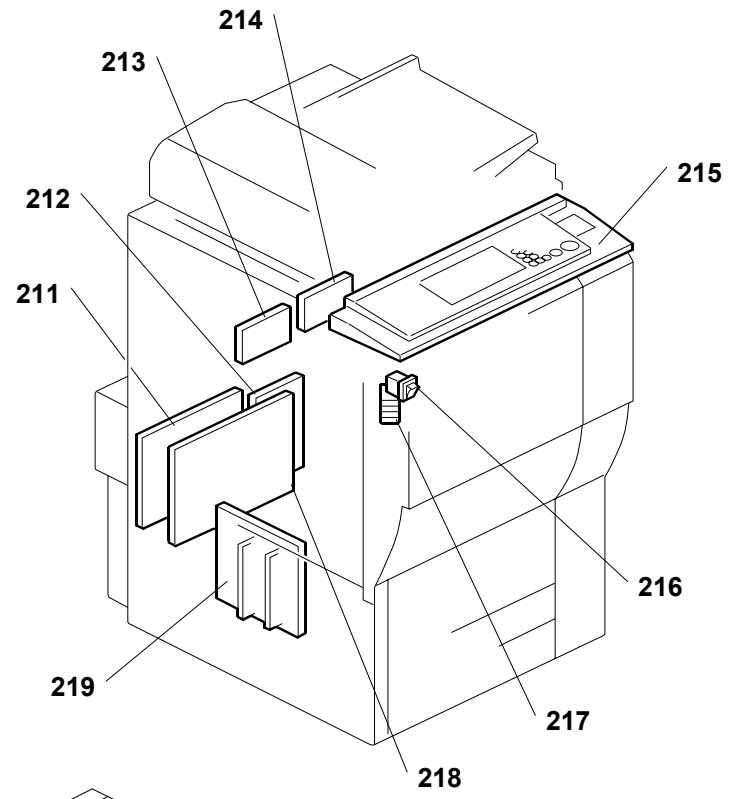

D014V301

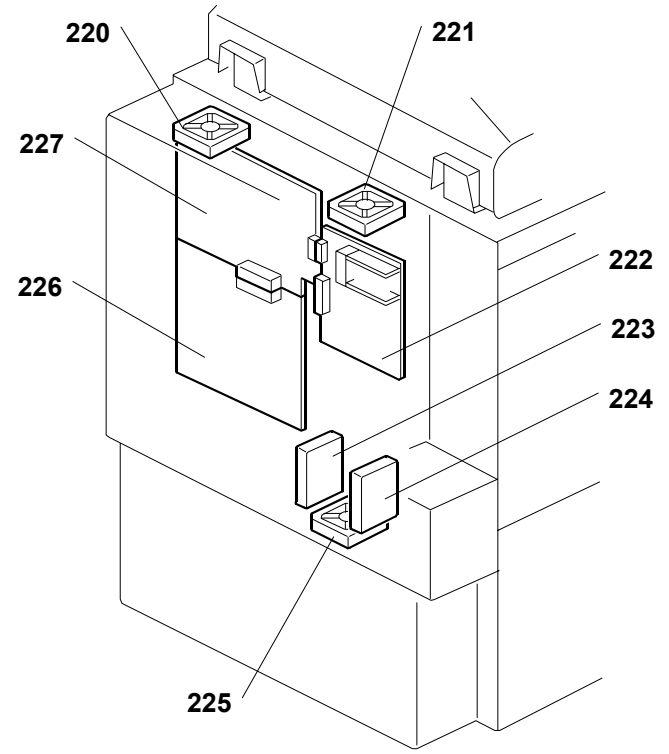

D014V302

# D014/D015 ELECTRICAL COMPONENT LAYOUT (3/3)

Symbol	Name	Index No.	P to P	Page
<b>Sensors</b>				
S1	ID Sensor: Black	45	D8	3/4
S2	ID Sensor: Color	45	D8	3/4
S3	ITB Lift Sensor (Full Color)	48	C8	3/4
S4	MUSIC Sensor: Center	45	D8	3/4
S5	MUSIC Sensor: Front	45	D8	3/4
S6	MUSIC Sensor: Rear	45	D8	3/4
S7	Paper Feed Sensor - Tray 2	87	B1	1/4
S8	Vertical Transport Sensor - Tray	86	B1	1/4
S9	Paper End Sensor - Tray 2	85	B1	1/4
S10	Lift Sensor - Tray 2	82	B1	1/4
S11	Paper Feed Sensor - Tray 3	87	B1	1/4
S12	Vertical Transport Sensor - Tray 3	86	C1	1/4
S13	Paper End Sensor - Tray 3	85	C1	1/4
S14	Lift Sensor - Tray 3	82	C1	1/4
S15	Temperature/Humidity Sensor	120	D1	1/4
S16	Used Toner Bottle Set Sensor	115	E1	1/4
S17	Used Toner Bottle Near-Full	117	D1	1/4
S18	Used Toner Bottle Full Sensor	118	E1	1/4
S19	Paper Feed Sensor - Tray 1	87	A1	1/4
S20	Vertical Transport Sensor - Tray	86	A1	1/4
S21	Paper End Sensor - Tray 1	85	A1	1/4
S22	Lift Sensor - Tray 1	82	A1	1/4
S23	Paper Near End Sensor: Tray 2	(103)	E1	1/4
S24	Paper Near End Sensor: Tray 3	(104)	E1	1/4
S25	Front Side Fence Open Sensor - Tray 1	112	E4	1/4
S26	Front Side Fence Closed Sensor - Tray 1	92	E4	1/4
S27	Rear Side Fence Open Sensor - Tray 1	97	E4	1/4
S28	Rear Side Fence Closed Sensor - Tray 1	96	E4	1/4
S29	Right Tray Down Sensor - Tray 1	108	E4	1/4
S30	Paper Near End Sensor - Tray 1	94	E4	1/4
S31	Paper Height Sensor 1- Tray 1	110	E4	1/4
S32	Paper Height Sensor 2- Tray 1	107	E4	1/4
S33	Paper Height Sensor 3- Tray 1	109	F4	1/4
S34	Right Tray Paper Sensor - Tray 1	106	F4	1/4
S35	Rear Fence HP Sensor - Tray 1	93	E1	1/4
S36	Rear Fence Return Sensor - Tray	95	E1	1/4
S37	Left Tray Paper Sensor - Tray 1	91	F1	1/4
S38	Internal Temperature Sensor	180	B5	2/4
S39	Used Toner Lock Sensor	139	F2	2/4
S40	Duplex Transport Sensor 1	204	C1	3/4
S41	Duplex/Inverter Sensor	202	D5	3/4
S42	Duplex Entrance Sensor	203	D1	3/4
S43	Duplex Transport Sensor 3	206	D2	3/4
S44	Duplex Transport Sensor 2	207	C2	3/4
S45	Duplex Jogger HP Sensor	201	C2	3/4
S46	Double-Feed Detection Sensor	166	D3	3/4
S47	Guide Plate Sensor	165	D3	3/4
S48	Relay Sensor	169	D3	3/4
S49	Registration Sensor	170	D3	3/4
S50	Paper Exit Sensor	158	C1	3/4
S51	Bypass Paper Feed Sensor	77	C3	3/4
S52	Bypass Paper End Sensor	76	C3	3/4
S53	Bypass Paper Size Sensor	81	D4	3/4
S54	Paper Exit Relay Sensor	90	F5	2/4
S56	TD Sensor - M	40	D6	3/4
S57	TD Sensor - K	42	D7	3/4
S58	Temperature/Humidity Sensor (K PCU)	184	D6	2/4
S59	TD Sensor - Y	36	D5	3/4
S60	TD Sensor - C	38	D6	3/4
S61	ITB Lift Sensor (BW)	44	C8	3/4
S62	Fusing Pressure Release Sensor	173	C4	3/4
S63	Potential Sensor - K	187	B6	2/4
S64	Potential Sensor - M	183	B6	2/4
S65	Potential Sensor - C	181	B6	2/4
S66	Potential Sensor - Y	178	B6	2/4
S67/S6	Laser Unit Temperature Sensor	18	D9	2/4
S69	Toner End Sensor - M	66	C1	2/4
S70	Toner End Sensor - K	62	C1	2/4
S71	Toner End Sensor - Y	74	B1	2/4
S72	Toner End Sensor - C	71	B1	2/4
S73	Scanner HP Sensor	2	B5	2/4
S74	Original Width Sensors	14	A5	2/4
S75	Original Length Sensor - 1	12	A5	2/4
S76	Original Length Sensor - 2	11	B5	2/4
S77	Accordion Jam Sensor	197	C8	1/4
S78	Fusing Exit Sensor	198	C8	1/4
S79	LCT Relay Sensor	75	F2	2/4
S80	Original Length Sensor - 3	5	B5	2/4
S81	Encoder	138	C3	2/4
S82	PTR Contact Sensor	172	C4	3/4
S83	ITB Position Sensor	45	D9	3/4

Symbol	Name	Index No.	P to P	Page
<b>Motors</b>				
M1	Scanner Motor	10	B5	2/4
M2	Lower Relay Motor	89	C1	1/4
M3	Paper Feed Motor - Tray 1	88	C1	1/4
M4	Paper Feed Motor - Tray 3	88	C1	1/4
M5	Paper Feed Motor - Tray 2	88	D1	1/4
M6	Used Toner Distribution Motor	119	D1	1/4
M7	Lift Motor - Tray 2	103	E1	1/4
M8	Lift Motor - Tray 3	104	E1	1/4
M9	Lift Motor - Tray 1	101	E1	1/4
M10	Rear Fence Motor - Tray 1	113	E1	1/4
M11	ITB Lift Motor	142	E6	2/4
M12	Ozone Fan	151	C6	3/4
M13	Fusing Unit Fan Motor: Lower	144	C6	3/4
M14	Fusing Cooling Fan Motor	15	F4	2/4
M15	Fusing Exhaust Fan Motor	20	F4	2/4
M16	Fusing/Exit Motor	141	F2	2/4
M17	PTR Motor	140	F3	2/4
M18	Bypass Feed Motor	79	F3	2/4
M19	Duplex Jogger Motor	209	D2	3/4
M20	Duplex Unit Fan Motor	153	D2	3/4
M21	Duplex Transport Motor	208	D1	3/4
M22	Duplex Inverter Motor	210	D1	3/4
M23	Registration Motor	164	D2	3/4
M24	Belt Cleaning Fan	154	D7	2/4
M25	Pipe Cooling Fan Motor	176	D5	3/4
M26	Paper Transport Fan Motor - Rear	161	D4	3/4
M27	Paper Transport Fan Motor -	160	D4	3/4
M28	Paper Exit Fan Motor	157	F5	2/4
M29	Front Duplex Fan Motor	155	F6	2/4
M30	Rear Duplex Fan Motor	156	F6	2/4
M31	Potential Sensor Fan	152	D6	2/4
M32	Peltier Cooling Fan Motor	148	D6	2/4
M33	Peltier Circulation Fan Motor	147	D6	2/4
M34	Laser Unit Cooling Fan Motor -	31	D6	2/4
M35	Laser Unit Cooling Fan Motor -	28	D6	2/4
M36	Development Motor: Y	126	B3	2/4
M37	Development Motor: C	128	B3	2/4
M38	Development Motor: M	131	B3	2/4
M39	Development Motor: K	134	C3	2/4
M40	Controller Box Exhaust Fan	220	D6	2/4
M41	Controller Box Exhaust Fan	221	C5	2/4
M42	Drum Motor - Y	125	B3	2/4
M43	Drum Motor - C	130	B3	2/4
M44	Drum Motor - M	133	B3	2/4
M45	Drum Motor - K	136	C3	2/4
M46	ITB Drive Motor	137	C3	2/4
M47	3rd Mirror Motor - M	30	D8	2/4
M48	Polygon Mirror Motor	29	D8	2/4
M49	3rd Mirror Motor - Y	16	D9	2/4
M50	3rd Mirror Motor - C	17	D9	2/4
M51	Toner Hopper Motor	58	C1	2/4
M52	PCU Fan Motor - Y	73	B1	2/4
M53	PCU Fan Motor - C	69	B1	2/4
M54	PCU Fan Motor - M	65	B1	2/4
M55	PCU Fan Motor - K	60	C1	2/4
M56	Scanner Unit Fan Motor - Rear	4	B6	2/4
M57	Scanner Unit Fan Motor - Right	9	B5	2/4
M58	Used Toner Collection Bottle	116	E1	1/4
M59	Development Intake Fan - K	59	B1	2/4
M60	Development Intake Fan - M	64	B1	2/4
M61	Development Intake Fan - C	68	B1	2/4
M62	Development Intake Fan - Y	72	B1	2/4
M63	Drum Cleaning Motor (Y)	127	C3	2/4
M64	Drum Cleaning Motor (C)	129	C3	2/4
M65	Drum Cleaning Motor (M)	132	C3	2/4
M66	Drum Cleaning Motor (K)	135	D3	2/4
M67	Charge Wire Cleaner Motor	186	D6	2/4
M68	Ozone Intake Fan	149	D7	2/4
M69	Drive Exit Fan	143	C6	3/4
M70	Ozone Exhaust Fan	150	C6	3/4
M71	PTR Lift Motor	171	D4	3/4
M72	Fusing Pressure Release Motor	174	D5	3/4
M73	HDD Cooling Fan Motor	225	A4	4/4
M74	CPU Fan	226	A4	4/4

Symbol	Name	Index No.	P to P	Page
<b>PCBs</b>				
PCB1	PFB	212	A3	1/4
PCB2	AC Drive Board	219	B5	1/4
PCB3	PSU	218	D5	1/4
PCB4	DRB	214	E1/B1	2/4, 3/4
PCB5	Power Pack: Development Bias	146	C5	2/4
PCB6	Charge Roller Power Pack	211	D8	1/4
PCB7	Power Pack: Transfer	46	C9	3/4
PCB8	Power Pack: Separate	162	C4	3/4
PCB9	DTMB	213	D2	2/4
PCB10	IPU	227	D7/B2	2/4, 4/4
PCB11	Potential Sensor Board	145	C6	2/4
PCB12	CNB	55	C1	2/4
PCB13	IDCB: C1	67	A1	2/4
PCB14	IDCB: M1	63	A1	2/4
PCB15	IDCB: K1	61	A1	2/4
PCB16	IDCB: Y1	70	A1	2/4
PCB17	SBU	6	A6	2/4
PCB18	SIOB	8	B5	2/4
PCB19	Lamp Regulator	3	B5	2/4
PCB20	VBCU	226	E4/B3	2/4, 3/4
PCB21	LDB (K)	25	A8	2/4
PCB22	LDB (M)	24	B8	2/4
PCB23	LDB (C)	22	C8	2/4
PCB24	LDB (Y)	23	C8	2/4
PCB25	LSD: Front: K	27	A8	2/4
PCB26	LSD: Front: M	26	A8	2/4
PCB27	LSD: Front: C	21	A8	2/4
PCB28	LSD: Front: Y	19	A8	2/4
PCB29	LSD: Rear: Y	35	A8	2/4
PCB30	LSD: Rear: C	34	A8	2/4
PCB31	LSD: Rear: M	33	A8	2/4
PCB32	LSD: Rear: K	32	A8	2/4
PCB33	Controller Board	222	B3	4/4
PCB34	SCNB	7	A7	2/4
PCB35	Operation Panel	215	A1	4/4

Symbol	Name	Index No.	P to P	Page
<b>Solenoids</b>				
SOL1	Pick-up Solenoid - Tray 2	83	B1	1/4
SOL2	Separation Roller Solenoid - Tray	84	B1	1/4
SOL3	Pick-up Solenoid - Tray 3	83	C1	1/4
SOL4	Separation Roller Solenoid - Tray	84	C1	1/4
SOL5	Pick-up Solenoid - Tray 1	83	A1	1/4
SOL6	Separation Roller Solenoid - Tray	84	A1	1/4
SOL7	Front Side Fence Solenoid - Tray 1	111	F4	1/4
SOL8	Rear Side Fence Solenoid - Tray	98	F4	1/4
SOL9	Right Tray Lock Solenoid - Tray 1	102	F1	1/4
SOL10	Left Tray Lock Solenoid - Tray 1	99	F1	1/4
SOL11	Duplex Junction Gate Solenoid	205	D2	3/4
SOL13	Guide Plate Solenoid	167	D3	3/4
SOL14	Inverter Junction Gate Solenoid	159	D5	3/4
SOL15	Bypass Pick-up Solenoid	78	D4	3/4
SOL16	Charge Cleaning Solenoid: Y	179	D6	2/4
SOL17	Charge Cleaning Solenoid: C	182	D6	2/4
SOL18	Charge Cleaning Solenoid: M	185	D6	2/4
SOL19	Duplex Inverter Solenoid	200	D2	3/4

Symbol	Name	Index No.	P to P	Page
<b>Magnetic Clutches</b>				
MC1	Bypass Feed Clutch	80	D4	3/4
MC2	Toner Pump Clutch - M	53	B1	2/4
MC3	Toner Supply Clutch - M	54	B1	2/4
MC4	Toner Pump Clutch: K	56	C1	2/4
MC5	Toner Supply Clutch: K	57	C1	2/4
MC6	Toner Pump Clutch - Y	49	B1	2/4
MC7	Toner Supply Clutch - Y	50	B1	2/4
MC8	Toner Pump Clutch - C	51	A1	2/4
MC9	Toner Supply Clutch - C	52	A1	2/4

Symbol	Name	Index No.	P to P	Page
<b>Switches</b>				
SW1	Lower Front Door Switch	121	A2	1/4
SW2	Main Power Switch	216	D7	1/4
SW4	Paper Size Switch - Tray 2	100	D1	1/4
SW5	Paper Size Switch - Tray 3	105	D1	1/4
SW6	Interlock Switches	217	D3/F4	2/4

Symbol	Name	Index No.	P to P	Page
<b>Quenching Lamps</b>				
QL1	Quenching Lamp - K	43	D7	3/4
QL2	Quenching Lamp - C	39	D6	3/4
QL3	Quenching Lamp - M	41	D7	3/4
QL4	Quenching Lamp - Y	37	D7	3/4

Symbol	Name	Index No.	P to P	Page
<b>Lamps</b>				
L1	Exposure Lamp	1	B6	2/4
L2	Heating Roller Fusing Lamp 2	195	B8	1/4
L3	Heating Roller Fusing Lamp 3 (Center)	195	B8	1/4
L4	Heating Roller Fusing Lamp 1	194	B8	1/4
L5	Pressure Roller Fusing Lamp	193	B8	1/4

Symbol	Name	Index No.	P to P	Page
<b>LEDs</b>				
LED1	Double-Feed Detection LED	168	D3	3/4
LED2	Accordion Jam Sensor (LED)	177	D5	3/4
LED3	Fusing Exit Sensor (LED)	175	D5	2/4

Symbol	Name	Index No.	P to P	Page
<b>Heaters</b>				
H1	Lower Tray Heater	122	A5	1/4
H2	Anti-Condensation Heater - Scanner (Option)	13	A5	2/4
H3	Anti-Condensation Heater -	163	A5	1/4
H4	Upper Tray Heater	114	A5	1/4

Symbol	Name	Index No.	P to P	Page
<b>Thermistors</b>				
TH1	Heating Roller Thermistor	192	A8	1/4
TH2	Hot Roller Thermistor	196	A8	1/4
TH3	Pressure Roller Thermistor	189	C8	1/4
TH4	Heating Roller Center Thermistor	188	A8	1/4
TH5	Heating Roller End Thermistor	190	A8	1/4

Symbol	Name	Index No.	P to P	Page
<b>Thermostats</b>				
TS1/2	Thermostats	191	A8/C8	1/4
TS3/4	Thermostats	199	A8/C8	1/4

Symbol	Name	Index No.	P to P	Page
<b>HDDs</b>				
HDD1/2	HDD 1/2	223	B4	4/4
HDD3/4				

# ADF (FOR D014/D015) POINT TO POINT DIAGRAM

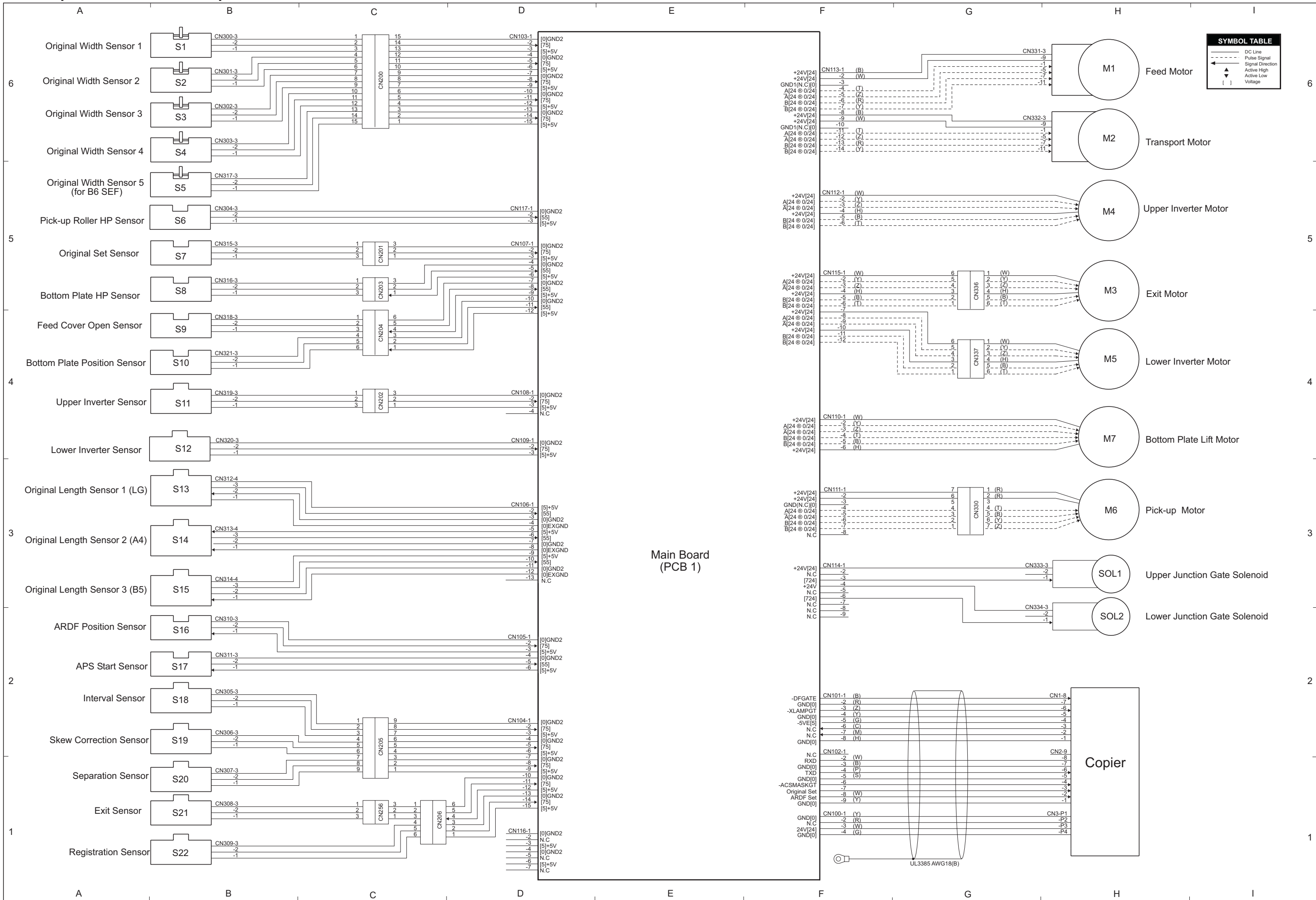

# ADF (FOR D014/D015) ELECTRICAL COMPONENT LAYOUT

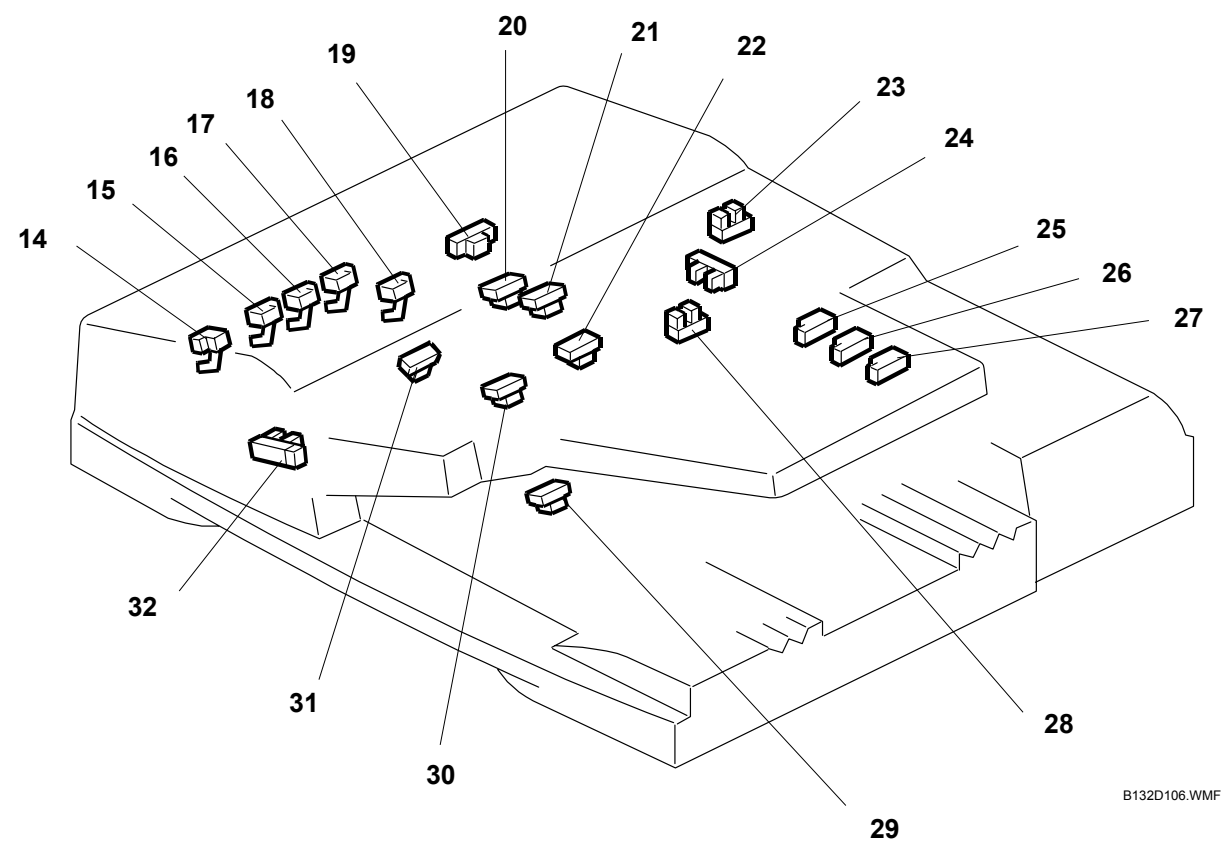
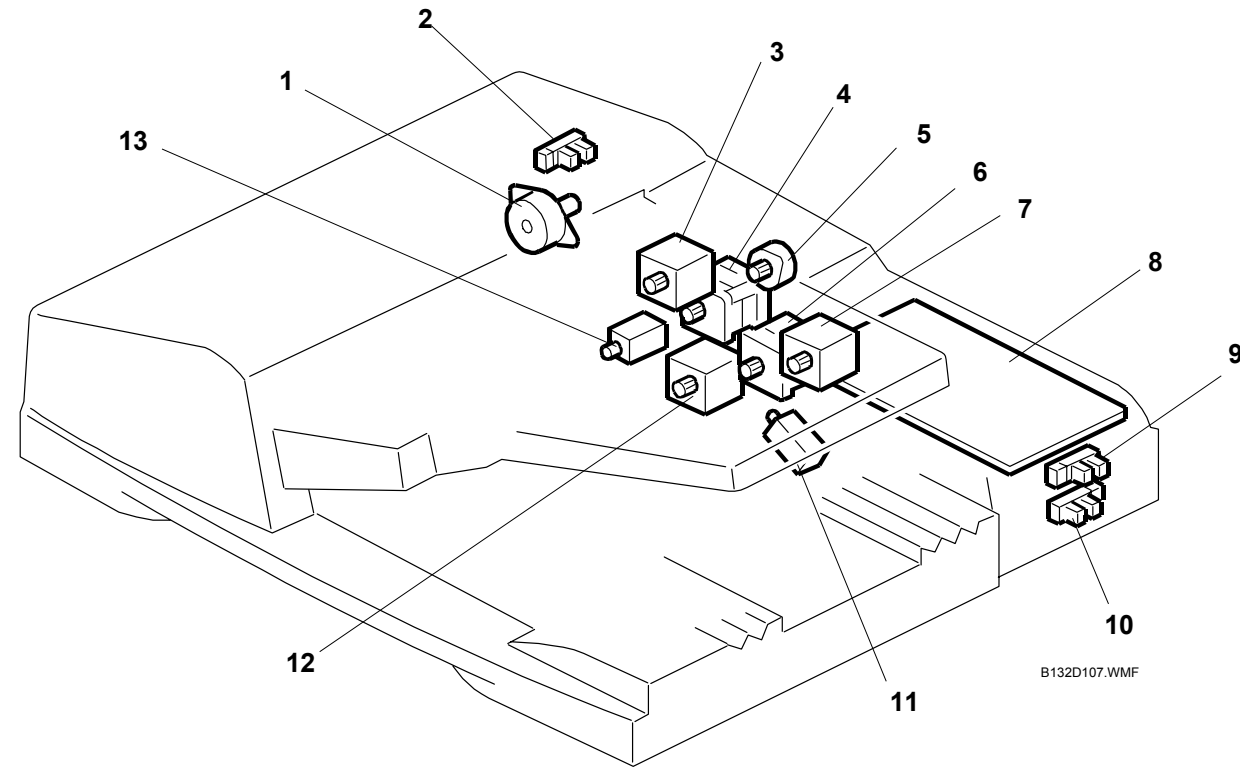

Symble	Name	Index No.	P to P
<b>Boards</b>			
PCB1	Main Board	8	E4
<b>Motors</b>			
M1	Feed Motor	4	H6
M2	Transport Motor	6	H6
M3	Upper Inverter Motor	7	H5
M4	Exit Motor	3	H5
M5	Lower Inverter Motor	12	H4
M6	Pick-up Motor	1	H4
M7	Bottom Plate Lift Motor	5	H3
<b>Sensors</b>			
S1	Original Width Sensor 1	17	B6
S2	Original Width Sensor 2	16	B6
S3	Original Width Sensor 3	15	B6
S4	Original Width Sensor 4	14	B6
S5	Original Width Sensor 5 (for B6 SEF)	18	B5
S6	Pick-up Roller HP Sensor	2	B5
S7	Original Set Sensor	28	B5
S8	Bottom Plate HP Sensor	32	B5
S9	Feed Cover Open Sensor	23	B4
S10	Bottom Plate Position Sensor	24	B4
S11	Upper Inverter Sensor	22	B4
S12	Lower Inverter Sensor	29	B4
S13	Original Length Sensor 1 (LG)	25	B3
S14	Original Length Sensor 2 (A4)	26	B3
S15	Original Length Sensor 3 (B5)	27	B3
S16	ARDF Position Sensor	9	B2
S17	APS Start Sensor	10	B2
S18	Interval Sensor	19	B2
S19	Skew Correction Sensor	20	B2
S20	Separation Sensor	21	B1
S21	Exit Sensor	30	B1
S22	Registration Sensor	31	B1
<b>Solenoids</b>			
SOL1	Upper Junction Gate Solenoid	11	H3
SOL2	Lower Junction Gate Solenoid	13	H2



**TOSHIBA**

**TOSHIBA TEC CORPORATION**

2-17-2, HIGASHIGOTANDA, SHINAGAWA-KU, TOKYO, 141-8664, JAPAN