

MULTIFUNCTIONAL DIGITAL COLOR SYSTEMS /
MULTIFUNCTIONAL DIGITAL SYSTEMS

Quick Start Guide

e-STUDIO5506AC	e-STUDIO5508A
e-STUDIO6506AC	e-STUDIO6508A
e-STUDIO7506AC	e-STUDIO7508A
	e-STUDIO8508A



Available Manuals

Some manuals are printouts and others are PDF files on the Client Utilities/User Documentation DVD. Printouts describe precautions and basic operations. Read “Safety Information” before using the equipment. PDF files describe detailed copying functions and other settings.

Printouts

Safety Information

Describes the necessary precautions for use. Read this booklet first.
PDF files on the "Client Utilities/User Documentation DVD".

Quick Start Guide (This guide)

Describes the preparations, basic usage, FAQs, maintenance and regular cleaning.
PDF files on the "Client Utilities/User Documentation DVD".

Using the Client Utilities/User Documentation DVD

Windows:

1. Set the Client Utilities/User Documentation DVD in the DVD-ROM drive on your computer.
Software Installer starts automatically.

Note

If Software Installer does not launch, use the explorer to open the [e-STUDIO] folder in the Client Utilities/User Documentation DVD and double-click “Setup.exe”.

2. Select [I agree to the terms of the License Agreement.] and click [Next].
3. Click the Open User’s Manual link in Software Installer.
The browser starts automatically and the menu is displayed.

Note

If the menu is not displayed, use the explorer to open the [Manuals] folder in the Client Utilities/User Documentation DVD and double-click “index.html”.

4. Click the title of the operator’s manual from the menu.

Mac OS:

1. Set the Client Utilities/User Documentation DVD in the DVD-ROM drive on your computer.
2. Open the [Manuals] folder in the Client Utilities/User Documentation DVD and double-click “index.html”.
3. Click the title of the operator’s manual from the menu.

Copying Guide

Describes how to use the Copy function.

Scanning Guide

Describes how to use the Scan function.

e-Filing Guide

Describes how to use the e-Filing function.

Template Guide

Describes how to use the Template function.

MFP Management Guide

Describes how to use the User Functions menu and the Counter.

Fax Guide

Describes how to use the Fax function (optional).

Paper Preparation Guide

Describes how to load paper.

Specifications Guide

Describes the specifications of this equipment and information on optional devices.

Hardware Troubleshooting Guide

Describes causes and solutions for hardware problems such as paper misfeeds and errors on the touch panel.

Software Troubleshooting Guide

Describes causes and solutions for software problems such as the printer driver.

Software Installation Guide

Describes how to install client software such as the printer driver.

Printing Guide

Describes how to use the Print function.

TopAccess Guide

Describes procedures for remote setup and management from a web-based utility, "TopAccess". "TopAccess" web utility allows you to manage the equipment from a browser.

High Security Mode Management Guide

Describes the conditions and settings for high security mode. To comply with CC Certification, see the "High Security Mode Management Guide".

Help menu for client software

See the Help menu for the following:

- AddressBook Viewer
- e-Filing Backup/Restore Utility
- TWAIN Driver / File Downloader

To read PDF files

You need to install Adobe Reader or Adobe Acrobat Reader to view and print PDF manuals. If they are not installed, you can download them from the Adobe Systems Incorporated website.

Reading This Manual

Symbols in this manual

Important items are described with the symbols shown below. Read these items before using this equipment.

⚠ WARNING Indicates a potentially hazardous situation which, if not avoided, could result in death, serious injury, serious damage, or fire in the equipment or surrounding objects.

⚠ CAUTION Indicates a potentially hazardous situation which, if not avoided, may result in minor or moderate injury, partial damage to the equipment or surrounding objects, or loss of data.

Note Indicates information to which you should pay attention when operating the equipment.

Read the following descriptions.

Tip Describes handy information for operating the equipment.



Indicates pages containing related information.

Original/paper direction

You can place paper or originals of A4 or B5 / LT size in a portrait or landscape direction. “-R” is added to these paper sizes when the paper or original is placed in a landscape direction.

Example: A4 / LT size original on the original glass

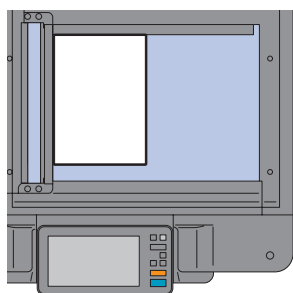

Portrait direction: A4 / LT

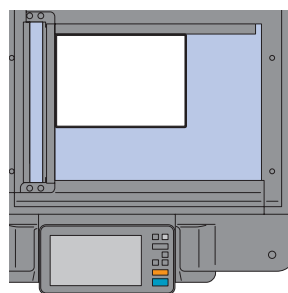

Landscape direction: A4-R / LT-R

You can only place paper or originals of A3 or B4 / LD or LG size in a landscape direction, therefore “-R” is not added to these sizes.

Screens in this manual

- Windows 10 screenshots are used to describe the procedures in Windows.
- Screens may differ depending on your model and how the equipment is used, such as the status of the installed options, the OS version, and the applications.
- Illustration screens used in this manual are for paper in the A/B format. If you use paper in the LT format, the display or the order of buttons in the illustrations may differ.

CONTENTS

Available Manuals	2
Reading This Manual	4
Recommended Toner Cartridges.....	6

Chapter 1 PREPARATIONS

Description of Components	8
Turning ON/OFF.....	16
Placing Paper and Originals	19
Installing Client Software.....	21

Chapter 2 BASIC OPERATIONS

Home Screen Operations.....	24
Copying Operations	28
Fax Operations.....	32
Scanning Operations	36
e-Filing Operations	38
Printing Operations.....	40

Chapter 3 MAINTENANCE

Replacing Toner Cartridge.....	44
Replacing Waste Toner Box.....	46
Replacing Staple Cartridge	47
Regular Cleaning.....	49

Chapter 4 TROUBLESHOOTING

Troubleshooting	52
FAQs	56

Chapter 5 INFORMATION ABOUT EQUIPMENT

Items Included with this Equipment.....	62
Client Utilities/User Documentation DVD	63
Client Software.....	64
Options	66
Logging in	69

How to back up the data	73
INDEX.....	74

Recommended Toner Cartridges

For optimal printing performance, we recommend that you use only genuine TOSHIBA toner cartridges. If you use a TOSHIBA-recommended toner cartridge, the following functions are available.

- **Cartridge detection:**

Notifies you if the toner cartridge is incorrectly installed.

- **Toner remaining check:**

Notifies you when there is little toner remaining in the cartridge, and informs your authorized service representative automatically using a remote service.

- **Image quality optimization:**

Controls image quality according to the characteristics of the toner and allows you to print images of an optimal quality.

If you are using a toner cartridge other than the one we recommend, the equipment may not be able to detect whether or not it is installed. Even if the toner cartridge is correctly installed, the error message “Toner not recognized” appears on the touch panel and printing may not be performed. You may not be able to use the image quality optimization function, the toner remaining check function, and the remote service function.

If you are using a toner cartridge other than the one we recommend, the toner will not be recognized. If this occurs, contact your service representative.

Trademarks

For trademarks, refer to the *Safety Information*.

Chapter 1

PREPARATIONS

Description of Components	8
Turning ON/OFF.	16
Placing Paper and Originals	19
Installing Client Software	21

Description of Components

This section describes the names and operations of the equipment.

Front / Right side

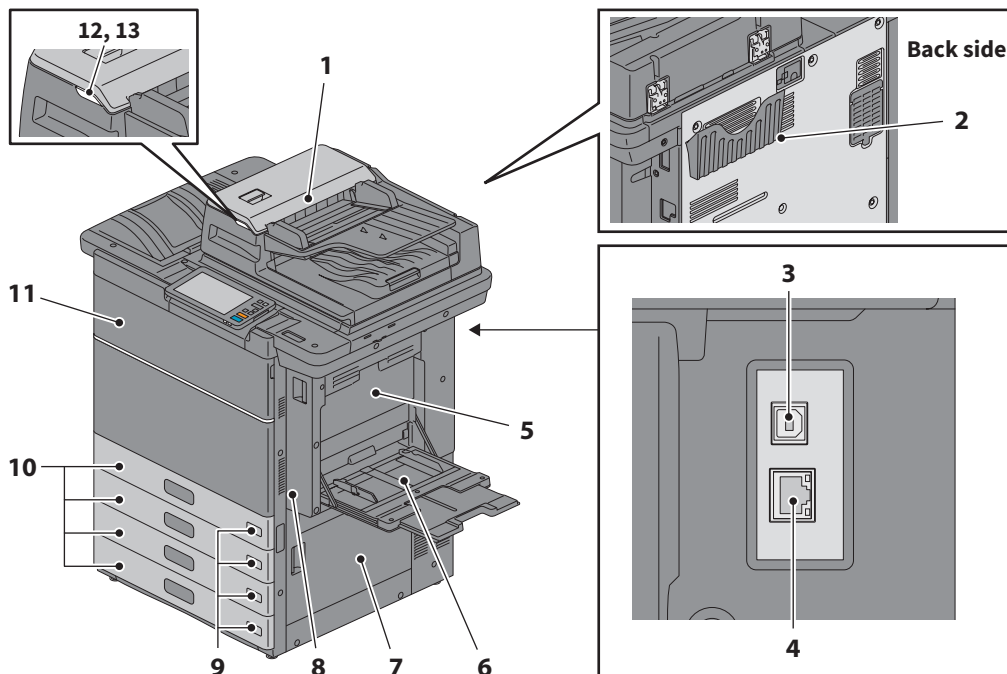

1. Dual Scan Document Feeder

Scans both sides of the original one sheet at a time.

Specifications Guide (PDF) : “Chapter 2: SPECIFICATIONS OF EQUIPMENT”

2. Operator’s Manual Pocket (back side)

Stores the manual.

3. USB terminal (4-pin)

Connects to a PC with a commercially available USB cable.

4. Network interface connector

Connects to a network.

5. Duplexing unit cover

Open when paper misfeeds occur.

6. Bypass tray

For printing on special media types such as OHP film.

P.31 “Bypass copying”

7. Paper feed cover

Open to clear misfed paper.

8. Duplexing unit

Prints on both sides of the paper. Open when paper misfeeds occur.

9. Paper size indicator

You can check the size of the paper set in the drawer.

10. Drawer

Load paper in the drawer.

P.19 “Placing Paper and Originals”

Specifications Guide (PDF) : “Chapter 1: SPECIFICATIONS OF PAPER”

11. Front cover

Open to change the toner cartridge and so on.

12. Alarm lamp (Orange)

Lights when a paper misfeed has occurred in the Dual Scan Document Feeder.

13. Document lamp (Blue)

Lights when originals are placed in the Dual Scan Document Feeder.

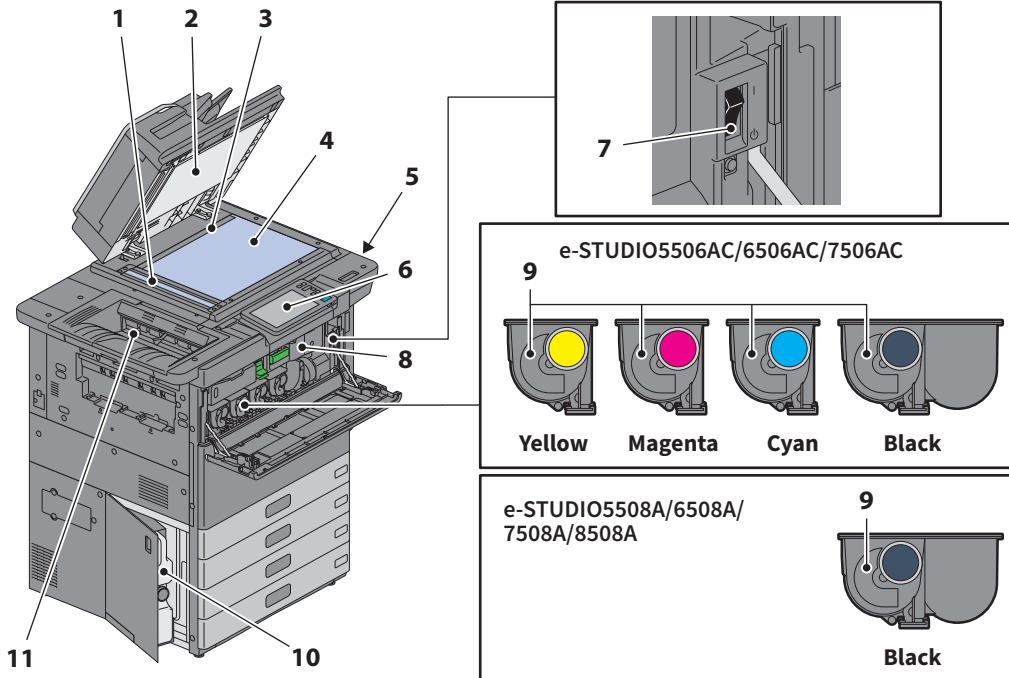
Left / Inner side**1. Scanning area**

Reads documents fed through the Dual Scan Document Feeder.

P.49 “Regular Cleaning”

2. Platen sheet

Stabilizes documents placed on the glass.

P.49 “Regular Cleaning”

3. Original scale

For checking the size of an original placed on the original glass.

4. Original glass

For copying 3D originals, book-type originals, and special paper such as OHP film, as well as plain paper.

5. USB port

For printing files stored in USB device or saving scanned data to the USB device.

6. Control panel

Sets and operates various types of functions such as copying.

P.11 “Control panel”

7. Main power switch

Turns the power ON or OFF.

P.16 “Turning ON/OFF”

8. Bridge unit

Open when paper misfeeds occur.

9. Toner cartridge

When toner runs out, a message is displayed.

Replace the cartridge.

P.44 “Replacing Toner Cartridge”

10. Waste toner box

Replace this when a message about waste toner box replacement is displayed.

P.46 “Replacing Waste Toner Box”

11. Receiving tray

Holds printouts. Extend the Tray holder when printing on large paper sizes or when printing large volume jobs.

Finisher

MJ-1111

1. Upper receiving tray
2. Stapling control section
3. Hole Punch Unit MJ-6106 Series
4. Front cover
5. Sub-tray
6. Lower receiving tray
7. Tray holder

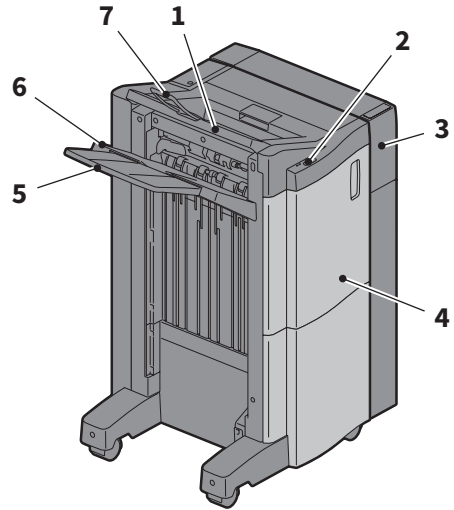

Note

- Open the tray holder when an attempt to output paper, which has a length longer than that of A3, is made or if the paper on the upper receiving tray does not align itself neatly. The output paper will be more likely to be aligned properly.
- Pull out the sub-tray when an attempt to output paper, which is longer than the lower receiving tray, is made. The output paper will be more likely to be aligned properly.

MJ-1112

1. Upper receiving tray
2. Stapling control section
3. Hole Punch Unit MJ-6106 Series
4. Front cover
5. Stopper
6. Saddle stitch tray
7. Sub-tray
8. Lower receiving tray
9. Tray holder

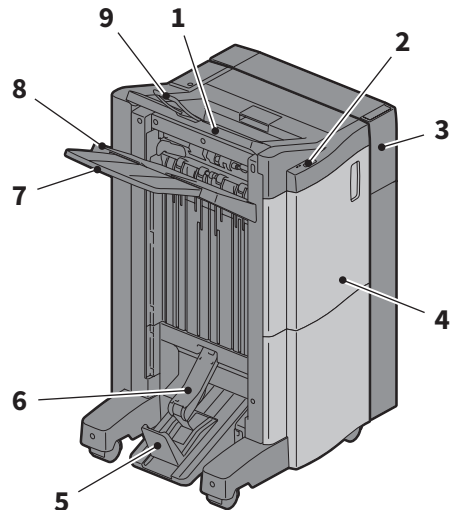

Note

- Open the tray holder when an attempt to output paper, which has a length longer than that of A3, is made or if the paper on the upper receiving tray does not align itself neatly. The output paper will be more likely to be aligned properly.
- Pull out the sub-tray when an attempt to output paper, which is longer than the lower receiving tray, is made. The output paper will be more likely to be aligned properly.

Control panel

Make for various operations and settings.

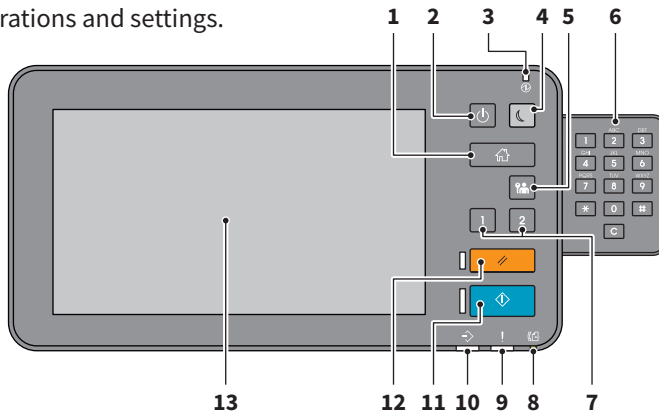

- 1. [HOME] button**
Displays the home screen.
 P.13 “Names and Functions on the Home Screen”
- 2. [POWER] button**
Turns the power on or off.
- 3. MAIN POWER lamp**
Turns on when the main power switch is ON.
- 4. [ENERGY SAVER] button**
Enter or recover from energy saving mode.
- 5. [ACCESS] button**
For when the department code or user information has been set.
 P.69 “Logging in”
- 6. Digital keys (Optional)**
Use to enter numbers.
- 7. [PROGRAMMABLE1] button / [PROGRAMMABLE2] button**
Register frequently used functions to these buttons and press them for quick access.
 MFP Management Guide (PDF) : “Chapter 2: SETTING ITEMS (Admin)”
- 8. MEMORY RX lamp**
Turns on when receiving fax data and fax communications.
- 9. Alarm lamp**
Turns on when an error occurs and action needs to be taken.
- 10. PRINT DATA lamp**
Turns on when receiving data such as print data.
- 11. [START] button**
Starts operations such as copying. The blue lamp on the left of the button turns on when the equipment is ready.
- 12. [FUNCTION CLEAR] button**
Clears all selected functions and return to the default settings.
- 13. Touch panel**
Configure various functions such as copying.
 P.14 “Using the Touch Panel”

Note

Do not touch the touch panel under the following status:

- Until the Home screen is displayed after the power is turned ON
 - While the equipment is recovering from the Super Sleep mode
- Otherwise, the touched position may not be detected properly. In such a case, reboot the equipment after the power is turned OFF or it is entered into the Super Sleep mode.

Adjusting the angle of the control panel

You can adjust the angle of the control panel between 7 and 45 degrees.



CAUTION

Be careful not to catch your hands in the gap between the equipment and the control panel.

This could cause an injury.

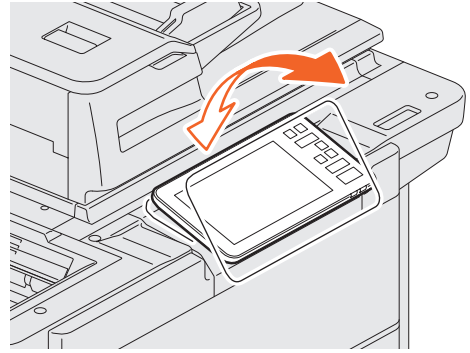

Names and Functions on the Home Screen

Displayed when you turn the equipment on or press the [HOME] button. Displays buttons for various functions.

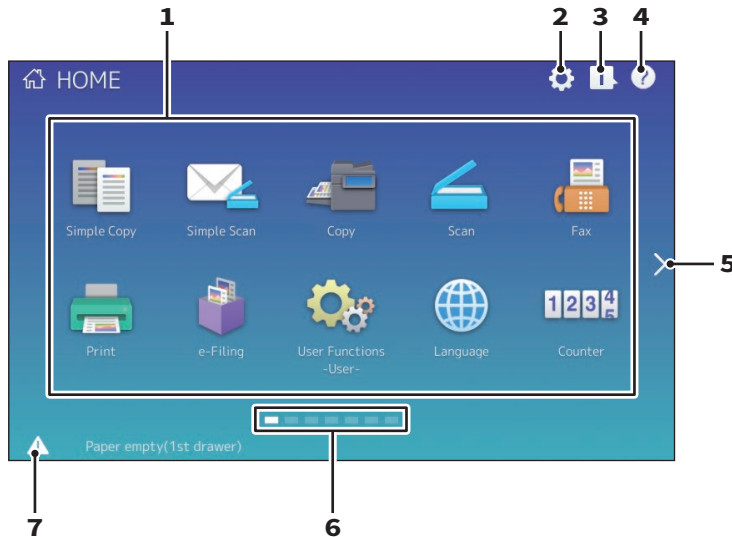

1. Recall button

Register functions, templates, URLs, etc. and recall them.

MFP Management Guide (PDF) : “Chapter 4: APPENDIX”

2. Home Setting button

Modify the home screen settings.

MFP Management Guide (PDF) : “Chapter 4: APPENDIX”

3. Job Status button

Check the progress of jobs and the process history.

Software Troubleshooting Guide (PDF) : “Chapter 1: CONFIRMING JOB STATUS ON THE TOUCH PANEL”

4. [?] (Help) button

Display information on each function.

P.55 “Using the Help”

5. Next button

Move to the next page.

6. Page Position indicator

Display the current page position.

7. Status button

Displayed when information is available.

Tip

You can change the screen displayed when the equipment is turned on to another screen, such as the Copy function screen. Contact your service technician or representative for details.

Using the Touch Panel

The touch panel supports swipe and pinch operations.

Press (Tap)

Lightly press buttons on the screen with your finger and lift it immediately.

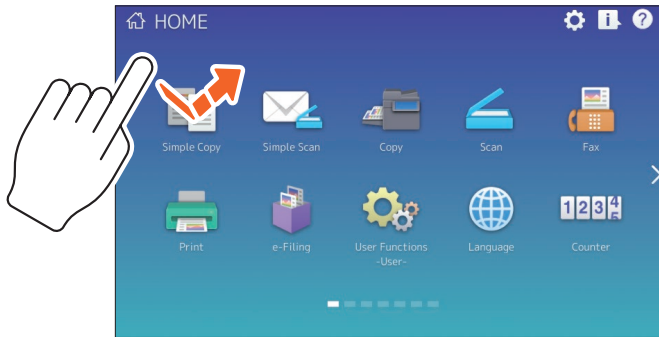

Swipe

Press the screen with your finger and slide it in one direction. Turns pages on the home screen and scrolls up and down in a list.

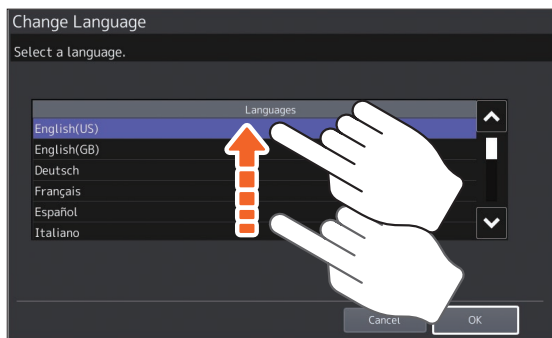

Drag & Drop

You can replace the RECALL button on the home screen. Press the button with your finger, drag it to another place, and lift your finger.

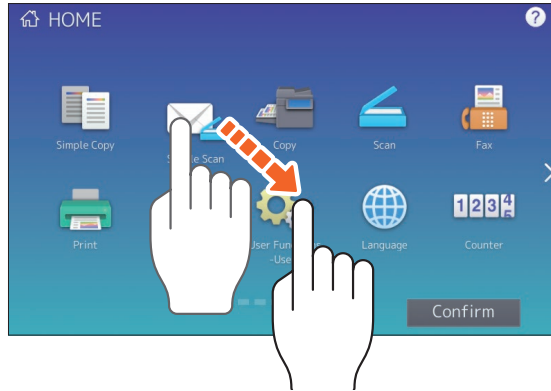

Pinch (pinch and spread)

Press the screen with two fingers, pinch them together or spread them apart on the screen. You can use this operation in previews of Easy Scan, Scan, and Fax functions.

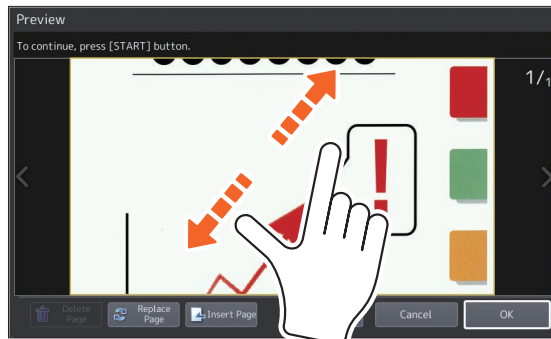

Turning ON/OFF

This section explains how to turn the power ON and OFF as well as the energy saving mode. This operation differs between when the MAIN POWER lamp (green) on the control panel is lit and when it is not.

Turning ON

When the MAIN POWER lamp (green) on the control panel is off:

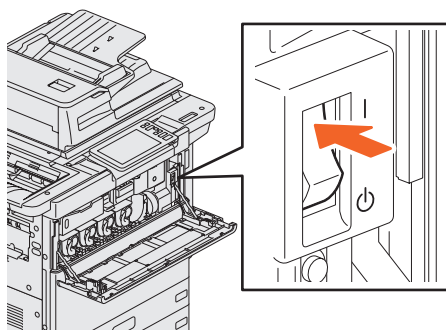
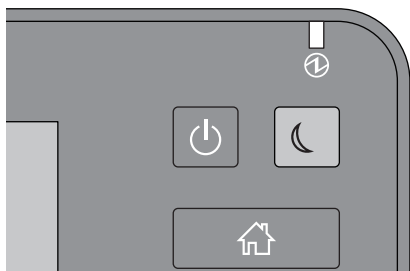

Turn ON there.

When the MAIN POWER lamp (green) on the control panel on:

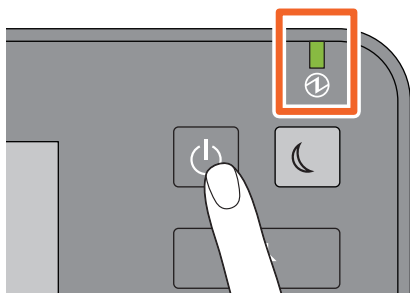

Press the [POWER] button

- The equipment starts warming up. The message is displayed to inform you that the equipment is warming up. This may take longer than normal depending on the status and condition.
- While the equipment is warming up, you can use the auto job start function. For details, see the following guide:
Copying Guide (PDF) : “Chapter 2: HOW TO MAKE COPIES” - “Basic Copying Procedure”

The home screen is displayed when ready.

When turning OFF, you also need to shut down by pressing the [POWER] button on the control panel. Do not simply turn the main power switch OFF. For details, see the following page:

P.17 “Turning OFF”

Tip

Log in to the equipment if you are managing this equipment with the Department Management function or User Management function.

P.69 “Logging in”

Turning OFF

Follow the steps below. Check the following items before turning off the equipment.

- No jobs should be left in the print job list.
- The PRINT DATA lamp (blue) or the MEMORY RX lamp (green) should not be flashing.
(If the equipment is shut down while any of the above lamps are flashing, jobs in progress such as FAX reception will be aborted.)
- No computer should access the equipment over a network, such as TopAccess.

Note

- When the [ENERGY SAVER] button (green) is on or flashing on the control panel, or the touch panel screen is still ON, do not press the main power switch to turn the power OFF. Stored data may be lost or the internal storage device may be damaged.
- If you press the [POWER] button while a job is running, a message is displayed asking if you want to delete the current job and turn off the equipment.

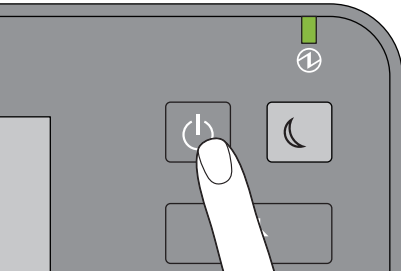

Press the [POWER] button.

You can then select how to turn the equipment off. If you press [Hibernate] or [Shutdown], the screen disappears and the equipment is turned off after a short while.

If you press [Hibernate] the memory contents are saved to the internal storage device before turning the equipment off. Select this if you want to start up the equipment faster next time it is turned on.

If you press [Shutdown] the system is restarted and the system's memory is initialized. Select this if you will not use the equipment for a long period.

Note

When turning the equipment back on after turning it off, wait for approximately 30 seconds.

When the equipment is not used for a long period of time:

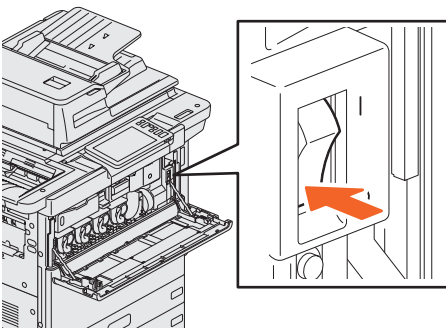

Select [Shutdown] to select a shutdown option. Check that the [ENERGY SAVER] button (green) has stopped flashing and the touch panel screen is off. Turn the power OFF with the main power switch.

The MAIN POWER lamp (green) turns off.

Saving energy when not in use – energy saving modes –

The following modes are available; Automatic Energy Save mode, Sleep mode, and Super Sleep mode. The table below shows the procedures to switch modes manually and conditions under which it enters into or recovers from each mode.

Energy saving modes	Procedure to switch modes	Conditions to enter the mode	Status of equipment	Conditions to recover from the mode
Automatic Energy Save mode	When a specified period of time ^{*1} has passed since the last use of the equipment.	—	A message is displayed to indicate the energy saving status.	When you press the [ENERGY SAVER] button, or when print data or fax data are received.
Sleep mode	When you press the [ENERGY SAVER] button ^{*2} or when a specified period of time ^{*3} has passed.	When a particular option ^{*4} is installed or when a particular protocol ^{*5} is enabled.	The touch panel display turns off and the [ENERGY SAVER] button turns green.	Same as the Automatic Energy Save mode.
Super Sleep mode	When you press the [ENERGY SAVER] button ^{*2} or when a specified period of time ^{*3} ^{*6} has passed.	When a particular option ^{*4} is not installed and also a particular protocol ^{*5} is disabled.	The touch panel display turns off and the [ENERGY SAVER] button turns green.	When you press the [ENERGY SAVER] button, when print or fax data are received through a wired LAN, or when the time set for Scheduled Print has come.

*1 The default value is 1 minute.

*2 The [ENERGY SAVER] button on the control panel.

*3 The default value is 1 minute .

*4 The Wireless LAN/Bluetooth Module.

*5 Any of IPX, AppleTalk and other protocols. When the IPsec function is enabled, the equipment enters Sleep mode. For details, see the following guide:

 [TopAccess Guide \(PDF\)](#) : “Chapter 8: [Administration] Tab Page” - “[Setup] Item List”

*6 Depending on the network environment, the time for switching to Super Sleep mode may take more than 10 minutes even if it is set to 10 minutes or less.

To change the time for entering each mode, see the following guide:

 [MFP Management Guide \(PDF\)](#) : “Chapter 2: SETTING ITEMS (Admin)” - “General”

Note

For the European version

Contact your service representative to change the default settings.

When the set time for switching to Automatic Energy Save mode is the same as Sleep mode or Super Sleep mode, the equipment enters into Sleep mode or Super Sleep mode.

Note

If an original is placed on the original glass during energy saving mode, the size is not detected even when the equipment recovers from this mode. After pressing the [START] button or the [POWER] button to recover from the mode, place it on the glass again.

Placing Paper and Originals

This section explains how to set paper and originals. Incorrect setting causes image skews or paper misfeeds. Follow the procedure below.

Placing paper

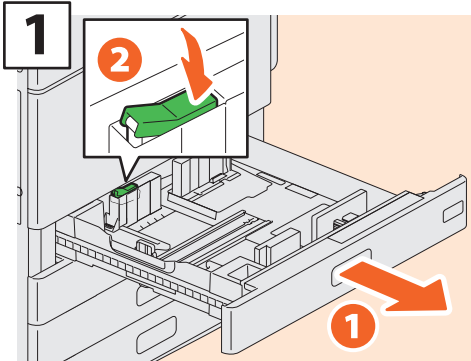

Pull out the drawer and release the side guide's lock.

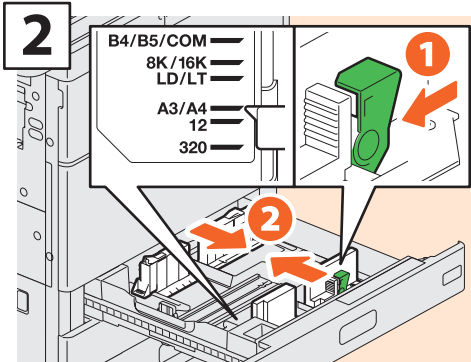

Set the side guide to match the paper width.

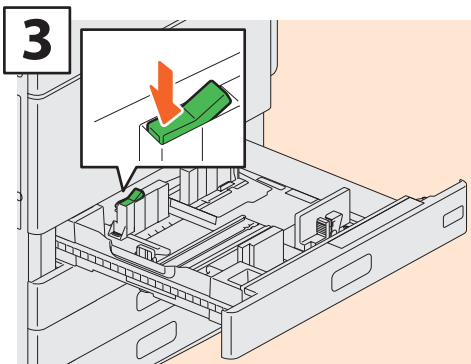

Lock the side guides.

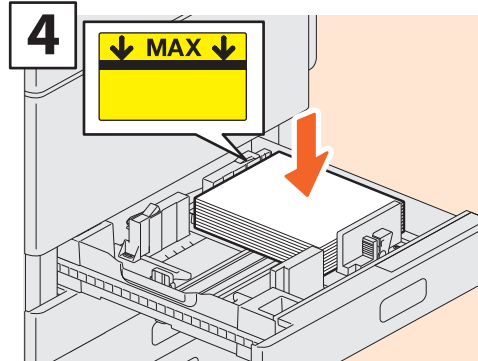

After fanning the paper, place it face up.

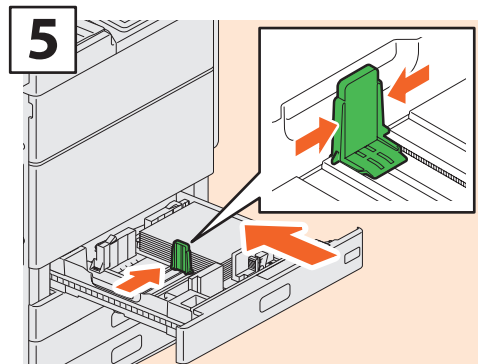

Set the end guide to match the paper size and then slowly push in the drawer.

⚠ CAUTION

Be careful not to catch your fingers when pushing the drawer back.

This could cause an injury.

Note

Check that the height of the paper does not exceed the MAX line on the side guides.

Tip

See the following page for supported paper:
 📖 *Specifications Guide* (PDF) : “Chapter 1: SPECIFICATIONS OF PAPER”

Placing originals

Original glass

1

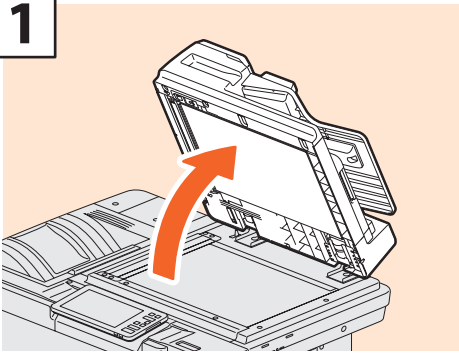

Raise the Dual Scan Document Feeder.

2

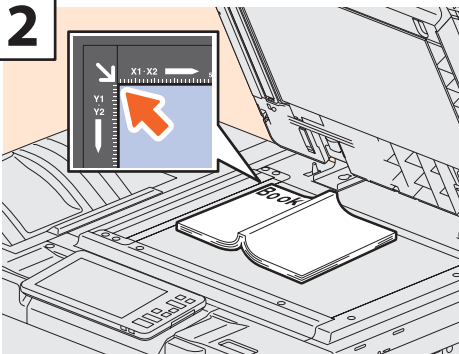

Place the original face down on the original glass and align it with the left rear corner.

3

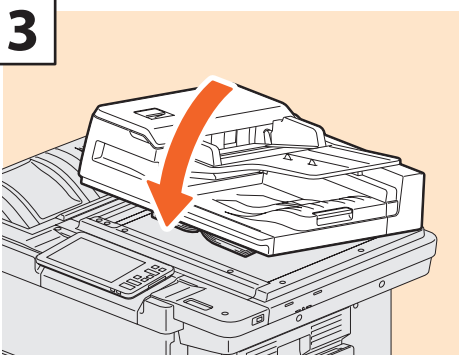

Lower the Dual Scan Document Feeder.
 📖 *Copying Guide* (PDF) : “Chapter 2: HOW TO MAKE COPIES” - “Enlarging or Reducing Images”

⚠️ CAUTION

Do not place any heavy objects (4 kg (9 lb.) or over) on the original glass and do not press on it with force.

Breaking the glass could injure you.

Dual Scan Document Feeder

1

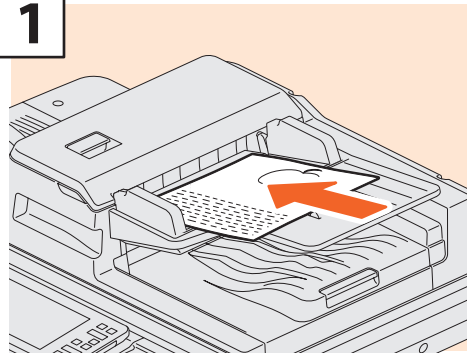

Place the originals face up on the original feeder tray.

2

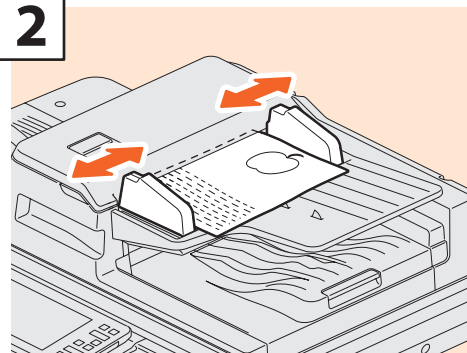

Align the side guides to the original length.

Tip

- The original size is sometimes not detected correctly. To prevent this, slowly and gently close the Dual Scan Document Feeder.
- You need to specify the size for the following originals because the size cannot be detected correctly.
 - Highly transparent originals (e.g. overhead transparencies, tracing paper)
 - Totally dark originals or originals with dark borders
 - Non-standard size originals (e.g. newspapers, magazines)
- 📖 *Copying Guide* (PDF) : “Chapter 2: HOW TO MAKE COPIES” - “Specifying the Paper Size”
- When the Dual Scan Document Feeder is closed, the scanner lamp flashes to detect the original size.
- When placing mixed-size originals on the Dual Scan Document Feeder, adjust the side guides to the widest original, and then align the originals against the guide on the front.
- 📖 P.56 “FAQs”

Installing Client Software

This section describes how to install the client software such as the printer driver from the Client Utilities/User Documentation DVD.

Recommended installation

Install recommended client software such as the printer driver all in one go.

- 1 Turn the power ON and check that the home screen is displayed on the touch panel.

 P.16 “Turning ON/OFF”

- 2 Insert the Client Utilities/User Documentation DVD in the DVD-ROM drive of a Windows computer.

Tip

Log onto Windows with a user account that allows installation such as “Administrators”.

- 3 Select [I agree to the terms of the License Agreement.] and click [Next].

- 4 Click [Recommended].

- 5 Click [Install].

- 6 A list of discovered printers is displayed. **1** Select this equipment on the list and **2** click [OK].

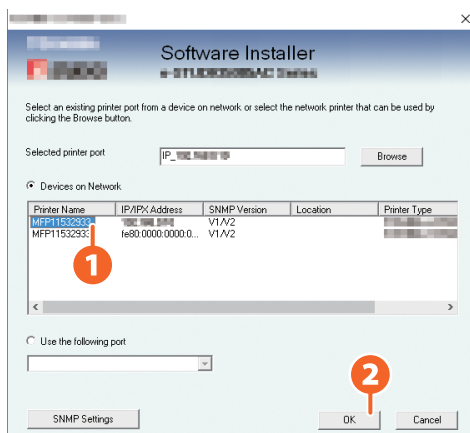

- 7** When the installation is complete, click [Finish].

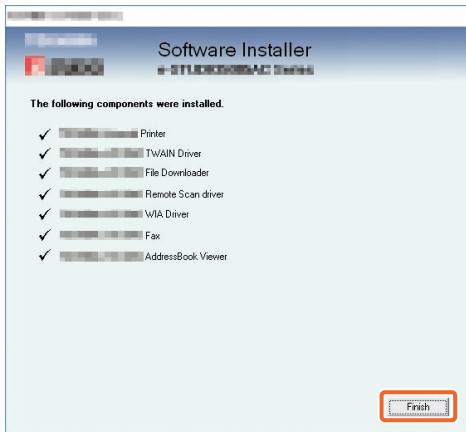

Tip

- For details of the Client Utilities/User Documentation DVD, see the following page:
 P.63 “Client Utilities/User Documentation DVD”
- For details of the recommended installation, see the following guide:
Software Installation Guide (PDF) :
 “Chapter 2: RECOMMENDED INSTALLATION”

- 8** Click [Exit] and then [Yes].

Setting the printer driver

Before using the printer driver, you must configure the options installed.

- 1** Select the [Start] menu > [Settings] > [Devices] > [Devices and printers].

- 2** Right-click on TOSHIBA Universal Printer 2, and then click [Printer properties].

- 3** Obtain configuration data of the options automatically by opening the [Device Settings] tab menu.

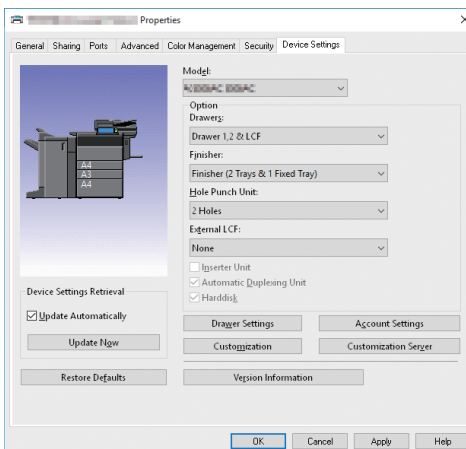

- 4** Click [OK].

Chapter 2

BASIC OPERATIONS

Home Screen Operations	24
Copying Operations	28
Fax Operations.....	32
Scanning Operations	36
e-Filing Operations	38
Printing Operations	40

Home Screen Operations

You can recall functions and register functions on the home screen.

Recalling functions

- 1 Press the [HOME] button.

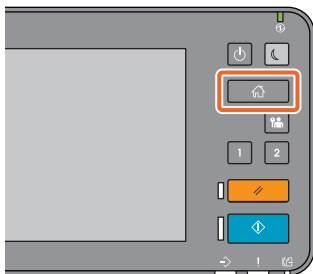

- 2 Press the function you want.

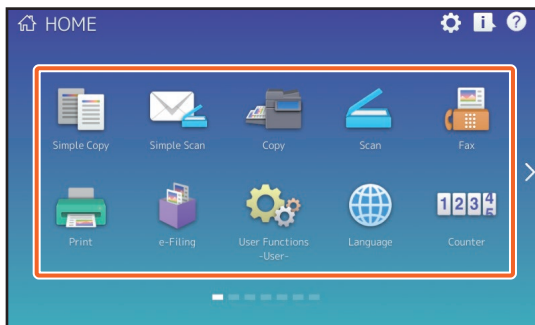

Tip

The following functions can be recalled as the default.

- Simple Copy
- Simple Scan
- Copy
- Scan
- Fax (Optional)
- Print
- e-Filing
- User Functions -User-
- Language
- Counter
- EWB (Optional)

Registering functions

1 Press the Home Setting button.

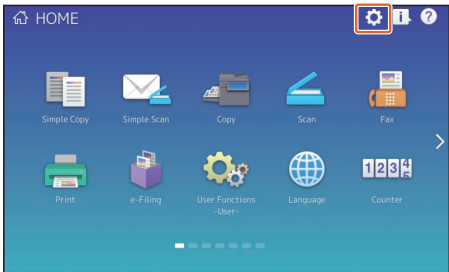

2 Enter the Administrator Password, and then press [OK].

3 Press [Button Contents].

4 Swipe the screen to display the page where you want to add the button.

5 Press a button that does not have a function assigned.

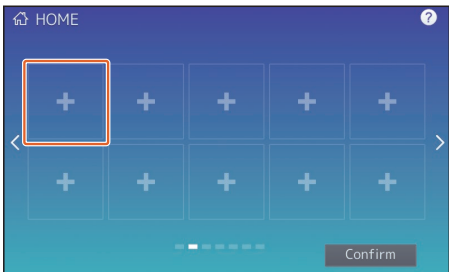

6 Select the function you want, and then press [Confirm].

7 Press [X] at the top right corner of the button registration menu screen.

Example

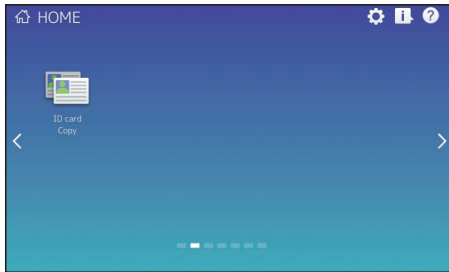

2

Tip

You can register not only the functions but also the job settings, URL and applications in the Home screen. Moreover, you can remove the registered functions and perform customization such as a change of the numbers, size and background of the buttons.

- 📖 *Template Guide* (PDF) : “Chapter 1: REGISTERING JOB SETTINGS ONTO THE HOME SCREEN”
- 📖 *MFP Management Guide* (PDF) : “Chapter 4: APPENDIX”
- 📖 *TopAccess Guide* (PDF) : “Chapter 8: [Administration] Tab Page” - “[Registration] ([Administration] tab) Item List”

Using Simple Copy

- 1 Press [Simple Copy].
- 2 Load the original document.
 P.20 "Placing originals"
- 3 Specify the **1** number of copies and **2** color mode, and press **3** [Start].

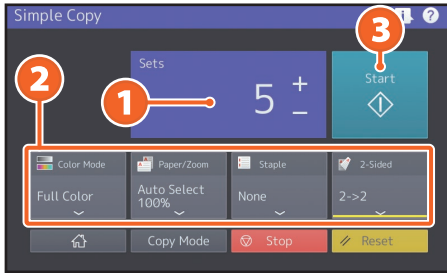

Tip

Press [Stop] if you want to cancel while copying.

- 4 If you have placed the original document on the original glass, press [Job Finish] to finish copying.

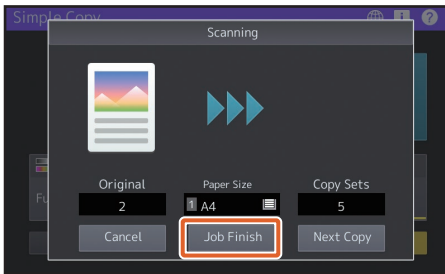

Simple Copy Settings

Sets

Specify the number of copies.

Color Mode

Specify the color mode and density.

Paper/Zoom

Specify the size of the copy paper and zoom.

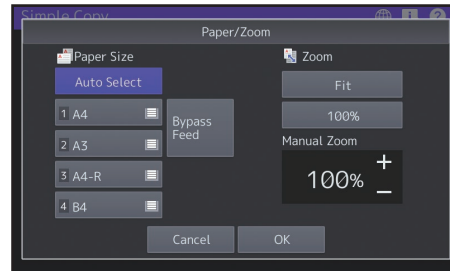

Staple

Specify how to staple.

2-Sided

Specify the duplex setting for the original and copies.

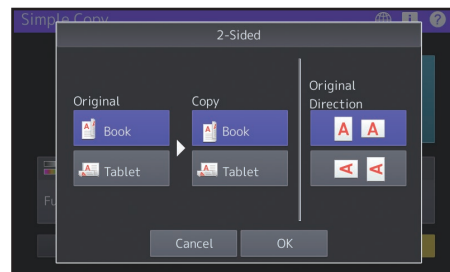
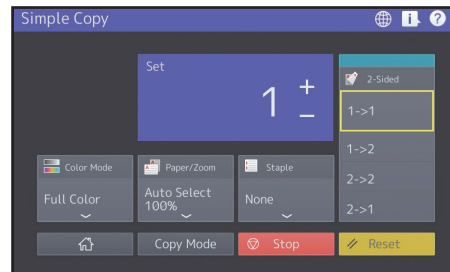

Using Simple Scan

- 1 Press [Simple Scan].
- 2 Load the original document.
 P.20 “Placing originals”
- 3 Press [Address Book] and specify the recipient E-mail address.

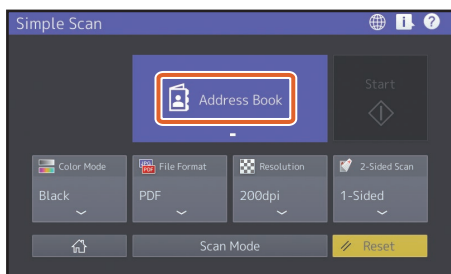

Tip

When you press [Address Book], you can select whether to use a registered E-mail address or enter an E-mail address directly.

- 4 Specify the **1** color mode or other items, and press **2** [Start].

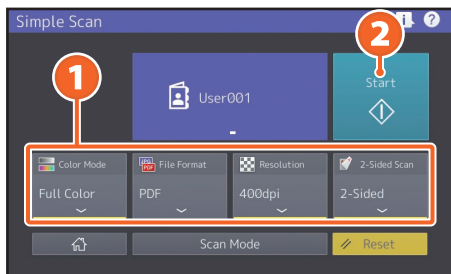

- 5 A preview is displayed. Check the image and press [OK].

Note

Simple Scan sends the scanned data to an E-mail address. An administrator needs to set up the equipment in advance.

Simple Scan Settings

Color Mode

Specify the color mode.

File Format

Specify the file format.

Resolution

Specify the resolution.

2-Sided

Specify the 2-Sided scan setting for the original.

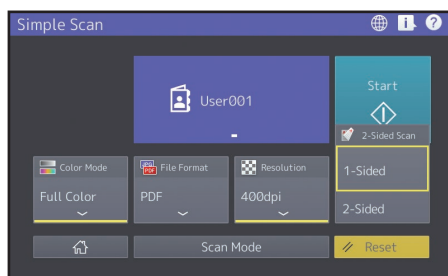

2

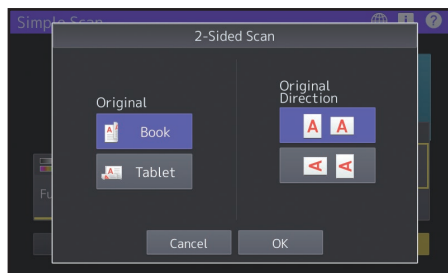

Copying Operations

This section explains procedures such as enlarging/reducing, duplex copying, and bypass copying.

Making copies

1 Press [Copy] on the home screen.

2 Place the original.
 P.20 “Placing originals”

3 Specify the **1** number of copies, **2** orientation, and **3** mode as necessary.

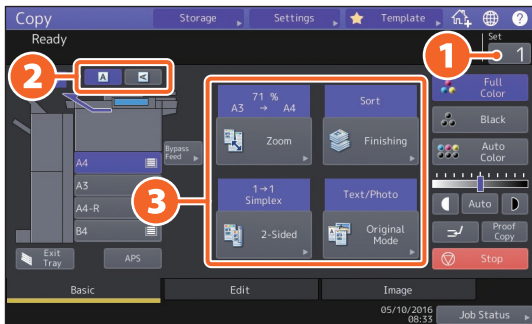

Tip

You can switch the color mode. The following modes are available.

- Full Color:** Copies in full color. (Default)
- Black:** Copies in black and white.
- Auto Color:** Automatically determines the color of the originals.

4 Press the [START] button. Copying starts.

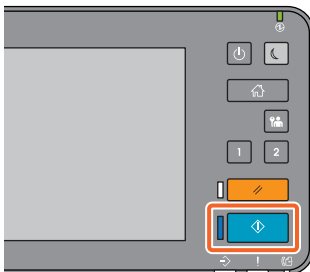

Tip

- To stop copying, press [Stop].
- Printouts are ejected to the receiving tray of the equipment or the Finisher. The tray to which the paper is ejected is indicated by the arrow on the touch panel.

Enlarging/Reducing

1 Press [Zoom].

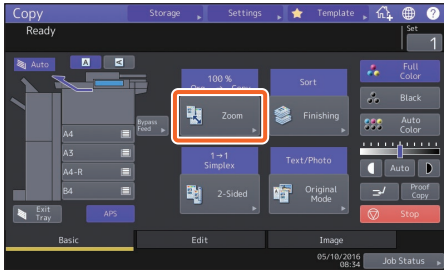

2 **1** Select the paper size, **2** press [AMS], and then **3** [OK].

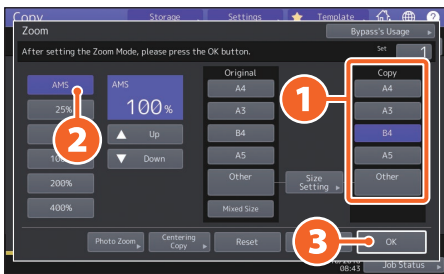

Tip

When copying a set of originals with different sizes and directions, press [Mixed Size].

Selecting finishing mode (sorting)

1 Press [Finishing].

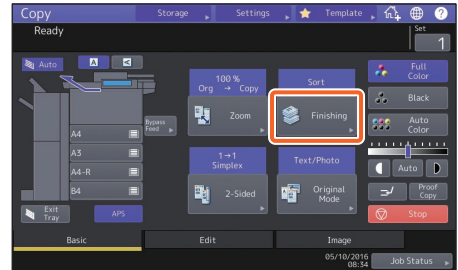

Tip

When using the Dual Scan Document Feeder, the sorting mode is automatically set.

2 **1** Press [Sort] and then **2** [OK].

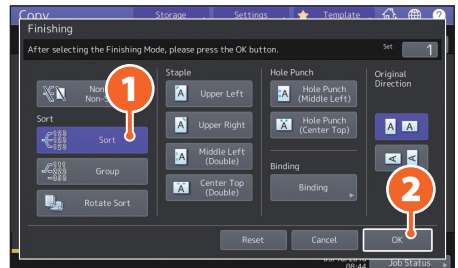

Tip

- To set the staple and hole punch mode, you need optional finishing devices.
- ☞ P.66 “Options”
- For example, when “Original 1”, “Original 2” and “Original 3” are copied in 2 sets, they can be made as follows.

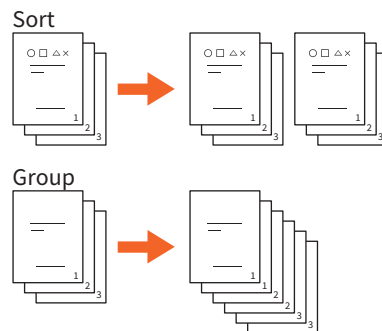

2

Setting duplex copy

1 Press [2-Sided].

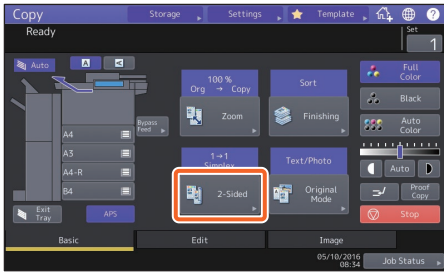

2 **1** Select the duplex mode and then **2** press [OK]. Specify the [Copy] and [Original Direction] as necessary.

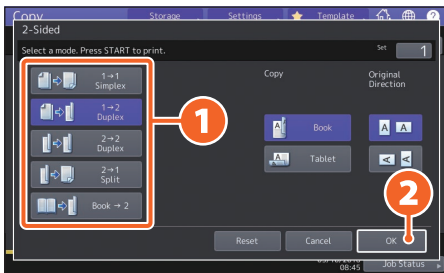

Tip

You can select from 5 types. For example, the following settings can be made.

1-sided original to 2-sided copy:



2-sided original to 2-sided copy:



Setting original mode

1 Press [Original Mode].

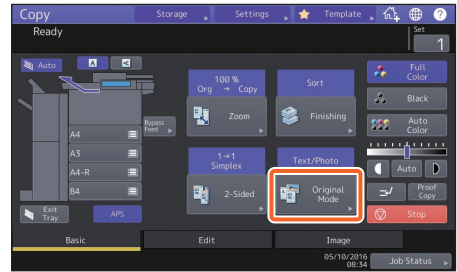

2 **1** Select the original mode and then **2** press [OK].

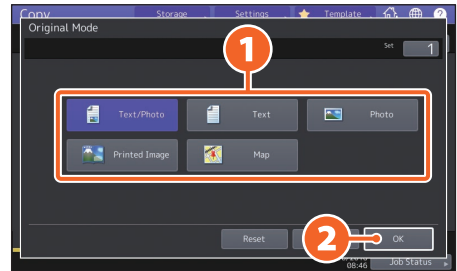

Tip

Available modes differ depending on the color mode. You can select from 5 types in full color mode. For example, the following setting can be made.

Originals with text and photographs:

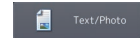

Density adjustment

Press **L** or **R** to adjust the density manually.

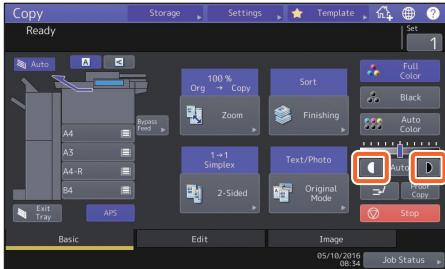

Tip

To lighten, press **L**, to darken, press **R**.

Press [Auto] to adjust the density automatically.

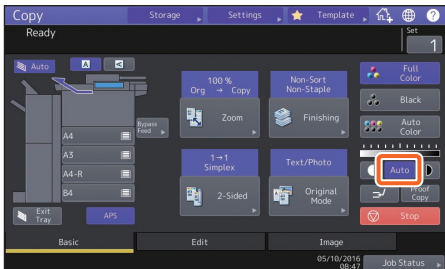

Tip

By default, density adjustment is set to [Auto] when the color mode is "Black".

Bypass copying

- 1 Move the paper holding lever to the outside, and then 2 place paper face down on the bypass tray.

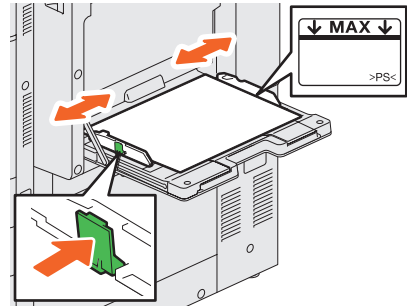

- 2 Press the button corresponding to the size of paper set on the bypass tray, and then 2 [OK].



Tip

Press [Paper Type] if the paper on the bypass tray is other than plain paper.

- 3 Press the [START] button. Bypass copying starts.

2

Fax Operations

This section explains procedures for sending a fax, such as specifying fax numbers in the address book or setting the transmission conditions.

Sending a fax

- 1 Press [Fax] on the home screen.
- 2 Place the original.
P.20 “Placing originals”
- 3
 - 1 Press () on the touch panel and enter the recipient fax number with the **2** ten key.

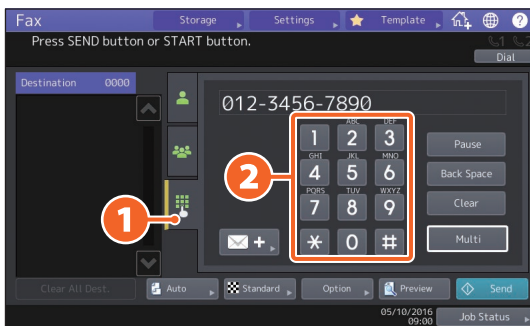

Tip

If you make a mistake when entering a fax number, press [Back Space] to delete one by one. Press [Clear] to delete all the numbers you entered.

- 4 Press [Send].



Tip

You can also press the [START] button on the control panel to send a fax.

Specifying recipients in the address book

Specifying recipients one by one

- 1 Press () and then 2 select the recipient.

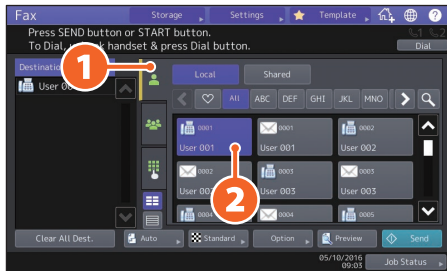

Specifying recipients in groups

- 1 Press () and then 2 select the recipient.

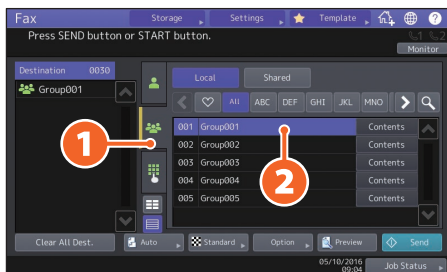

Tip

- You can specify up to 400 recipients (single and group).
- To cancel a selected recipient, press it again.

Confirming recipients

- 1 Select the recipient address you want to check from the address list.

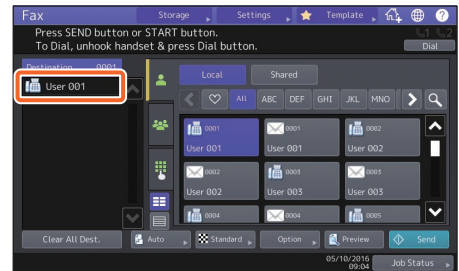

- 2 Check the recipient address on the displayed screen.

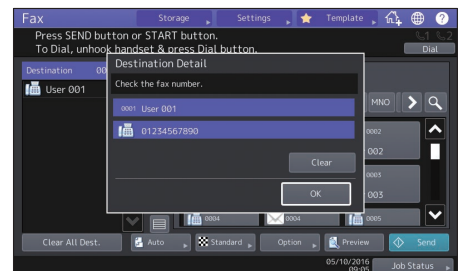

Tip

Press [Clear] to delete the recipient.

2

Setting the transmission conditions

1 Press [Option].

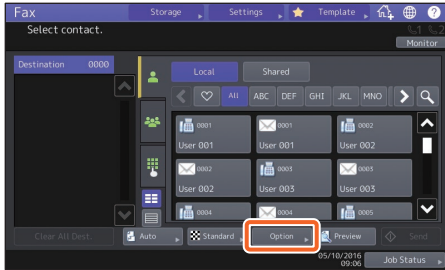

2 The transmission condition setting screen is displayed.

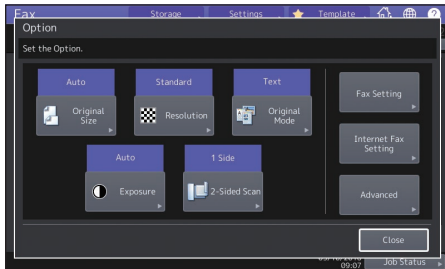

3 After each item is set, press [Close].

Canceling reserved transmissions

1 Press [Job Status].

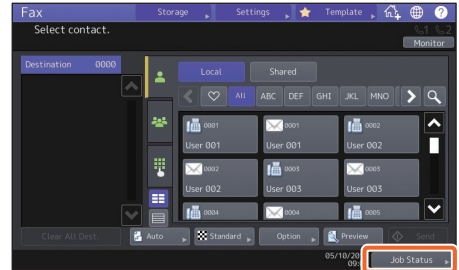

2 **1** Press [Fax], **2** select the reserved transmission you want to delete, and then **3** press [Delete].

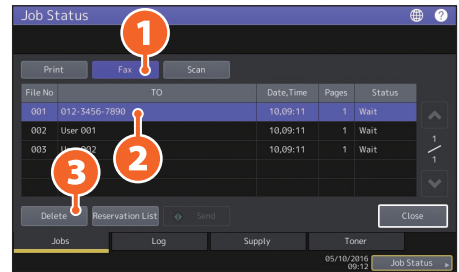

3 Press [Delete] on the confirmation screen.

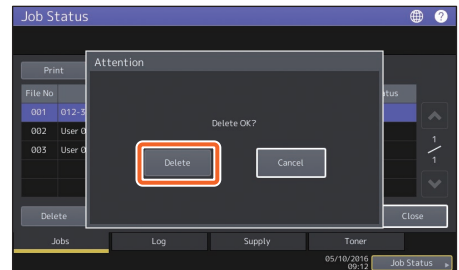

Checking communication status (log)

1 Press [Job Status].

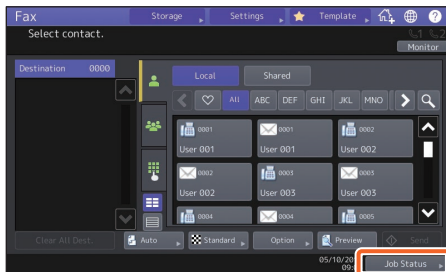

2 **1** Select the [Log] tab and then **2** press [Send].

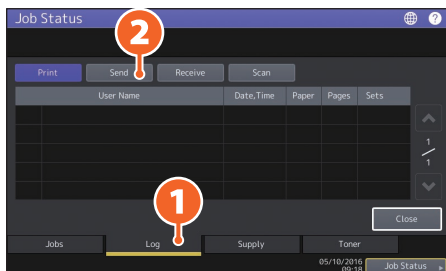

Tip

Press [Receive] to check the fax reception log.

3 If [OK] is indicated in the "Status", the transmission succeeded.

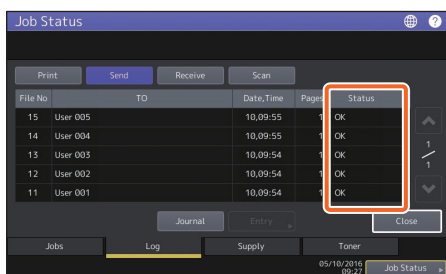

Tip

To register recipients in the address book from the send/receive log screen, select the record in the send or receive log, and then press [Entry].

Registering recipients

1 Press [User Functions-User-] on the home screen and then [Address].

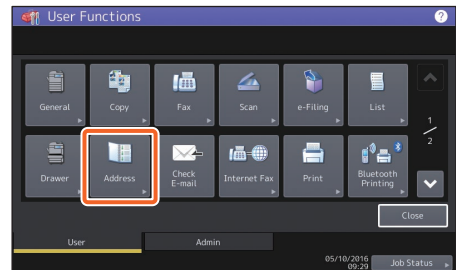

2 **1** Press an open button to create a new recipient and then **2** [Entry].

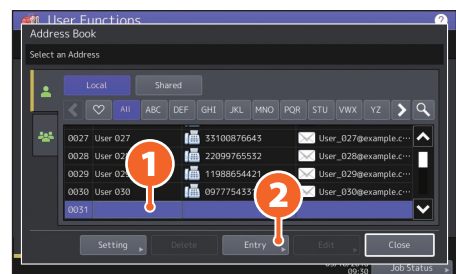

3 **1** Enter the address information, and then press **2** [OK].

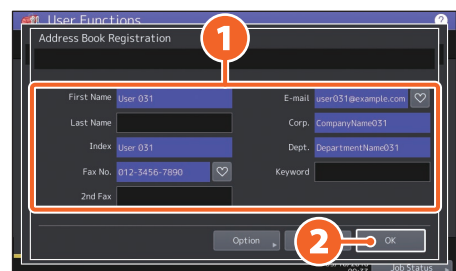

Tip

To register a group in the address book, see the following guide:

MFP Management Guide (PDF) : "Chapter 1: SETTING ITEMS (User)" - "Address"



Scanning Operations

This section explains procedures for the scanning function, such as how to store scanned data in a shared folder and store data in a Windows computer.

Storing the scanned data in a shared folder

1 Press [Scan] on the home screen.

2 Place the original.
 P.20 “Placing originals”

3 Make the scan settings.

4 Press [File].

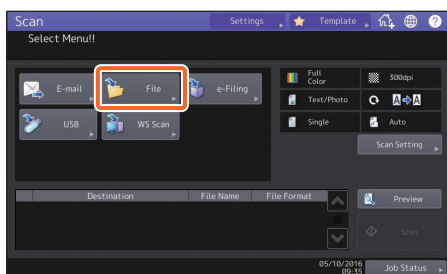

5 **1** Set [File Name], **2** File Format, etc. and then **3** press [OK].

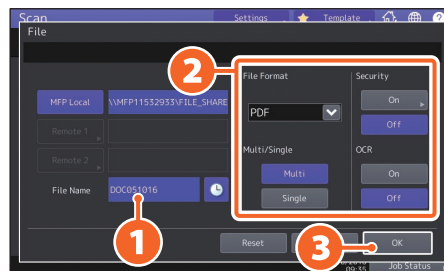

6 Press [Scan].

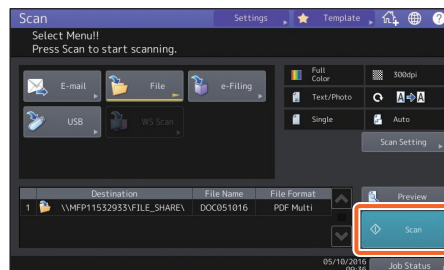

Storing scanned data of a shared folder in a Windows computer

1 Start Windows Explorer.

2 Enter the name of the shared folder in which the IP address of the equipment and the scanned data are stored in the address bar using the following format, and then press the [Enter] button.

Format: \\[IP address of the equipment] \file_share

e.g.) When the IP address of the equipment is 192.168.0.10, enter

\\192.168.0.10\file_share in the address bar of Windows Explorer.

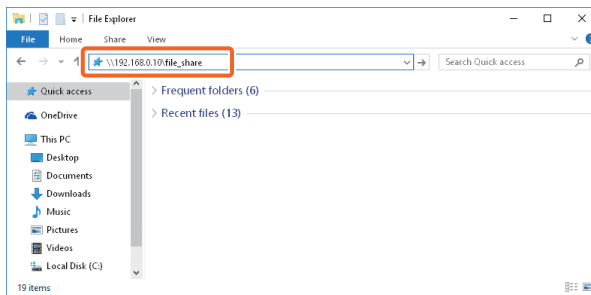

Tip

- For the IP address of the equipment, ask your network administrator.
- It is useful to make a shortcut of the “file_share” folder, as this allows you to skip step 2.

3 Store the scanned data in a Windows computer.

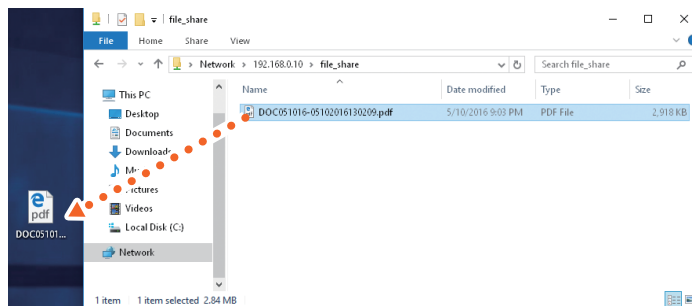

Note

Scanned data stored in the shared folder is automatically deleted in 30 days by default. Store it in a Windows computer before that.

e-Filing Operations

This function allows you to store documents in the internal storage device of the equipment and then print as required.

Storing documents

Originals are stored as e-Filing documents.

1 Press [Copy] on the home screen.

2 Place the original.
 P.20 “Placing originals”

3 **1** Press [Storage] and then **2** [Store To e-Filing].

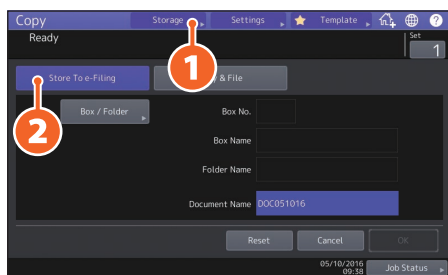

4 **1** Specify the box to be stored and the document name, and then **2** press [OK].

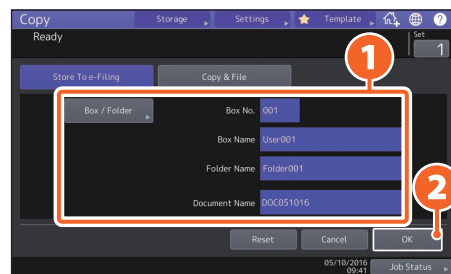

Tip

When “Print this document?” appears, press [Yes] if you want to print and store.

5 Press the [START] button to store the documents.

Tip

You can store documents by copying them, scanning them, or using the printer driver. For details, see the following guides:

Scanning Guide (PDF) : “Chapter 2: SCANNING (BASIC OPERATION)” - “Saving Data in e-Filing Boxes”

Printing Guide (PDF) : “Chapter 2: PRINTING FROM WINDOWS APPLICATIONS” - “Outputting a Job Saved to the Equipment”

Printing Documents

The following explains how to print documents stored in e-Filing.

- 1** Press [e-Filing] on the home screen.
- 2** Select the box that contains the document you want to print.
- 3** **1** Select the document you want to print, and then **2** press [Print].

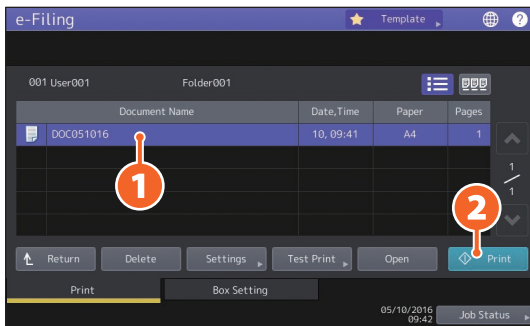

Tip



You can preview selected documents as thumbnails.



You can delete selected documents from e-Filing.



This allows you to make print settings, such as selecting the duplex printing mode or adding page numbers.



You can print specific pages for confirmation.

Printing Operations

The following explains basic operations of the printing function. This is for printing from a Windows computer with a Universal Printer 2 driver which needs to be installed in advance.

- 1 Select [Print] in the [File] menu of the application.
- 2
 - 1 Select the printer driver of the equipment, and then
 - 2 click [Preferences] ([Properties]).

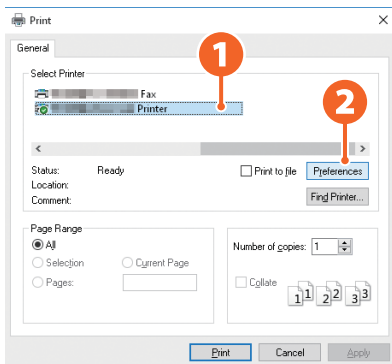

- 3 Set the print options, and click [OK].

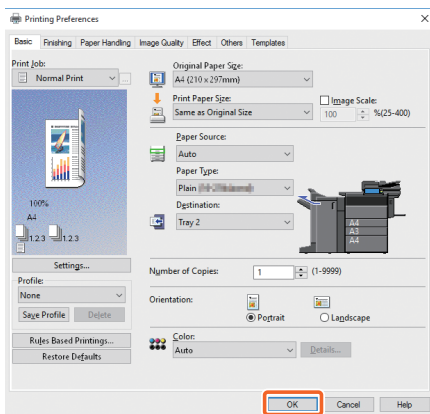

- 4 Click [Print] ([OK]).

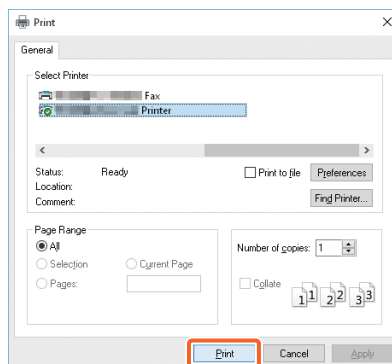

Tip

To install the printer driver in a Windows computer, see the following guide:

P.21 “Installing Client Software”

Software Installation Guide (PDF) : “Chapter 3: INSTALLING PRINTER DRIVERS FOR WINDOWS”

To install the printer driver in a Mac computer, see the following guide:

Software Installation Guide (PDF) : “Chapter 4: INSTALLING PRINTER DRIVERS FOR MAC OS”

Setting Universal Printer 2 driver

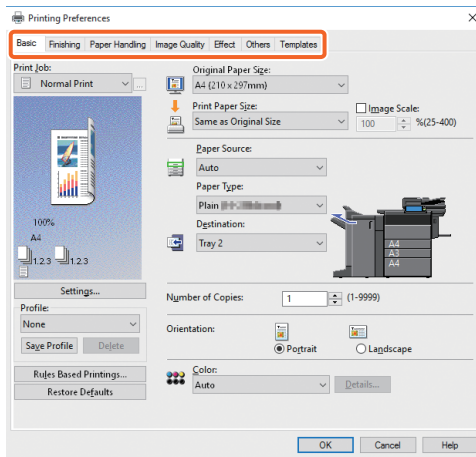

To specify paper size or number of copy sets

Click the [Basic] tab.

To specify 2-sided printing or N-up printing

Click the [Finishing] tab. If the Finisher and the Hole Punch Unit are installed, “Staple” and “Hole Punch” are available.

Tip

Select “Number of pages per Sheet” to print several pages on one sheet. Pages are reduced to fit the selected paper size and printed.

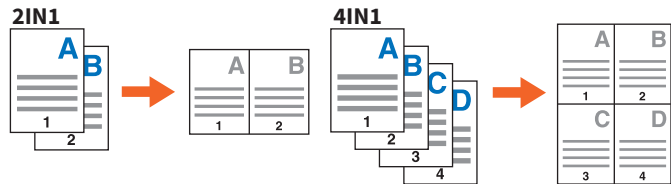

To specify Front cover printing

Click the [Paper Handling] tab.

To adjust Image quality

Click the [Image Quality] tab.

To print with character strings or graphics on the background of the paper

Click the [Effect] tab.

To skip blank pages

Click the [Others] tab.

To print with templates

Click the [Templates] tab.

MEMO

Chapter 3

MAINTENANCE

Replacing Toner Cartridge	44
Replacing Waste Toner Box	46
Replacing Staple Cartridge	47
Regular Cleaning	49

Replacing Toner Cartridge

If a message is displayed informing you that the toner cartridge needs replacing, follow the procedures below.

e-STUDIO5506AC/6506AC/7506AC

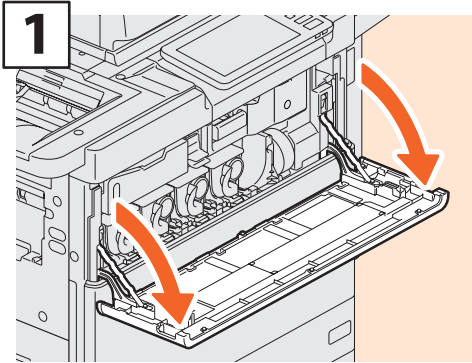

Open the front cover.

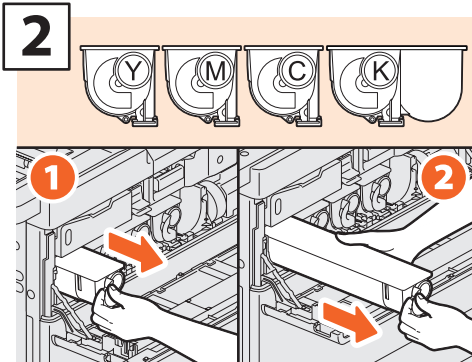

Remove the color toner cartridge.

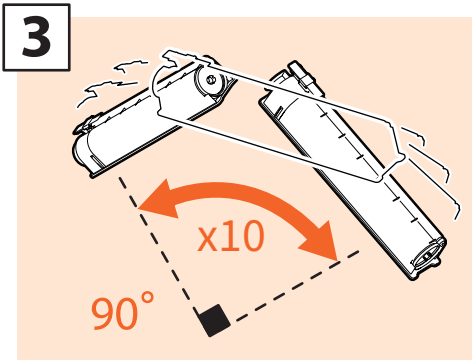

Shake the new toner cartridge well to loosen the toner inside.

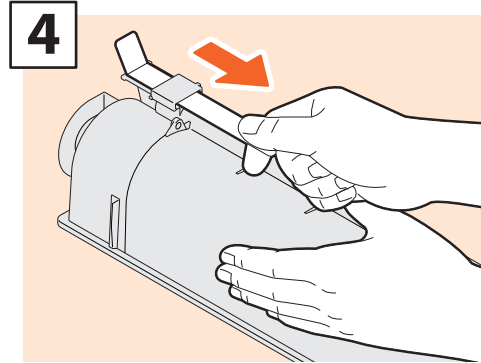

Pull off the seal.

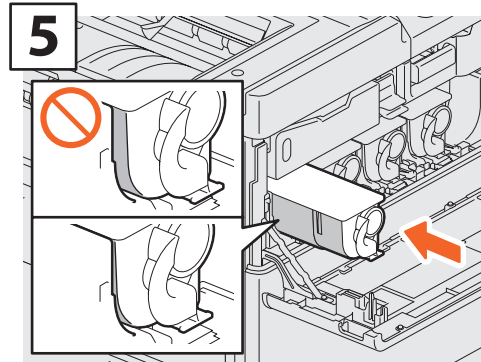

Insert the new toner cartridge until its front surface aligns to the left side wall.

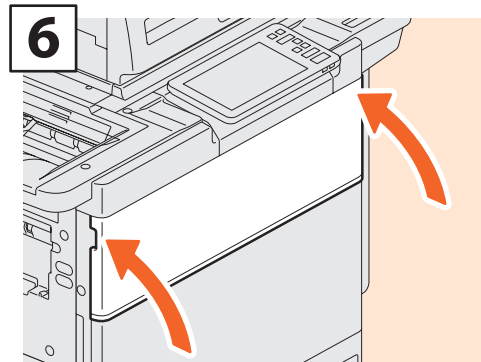

Close the front cover.

WARNING

Never attempt to incinerate toner cartridges.

Dispose of used toner cartridges and waste toner boxes in accordance with local regulations.

e-STUDIO5508A/6508A/7508A/8508A

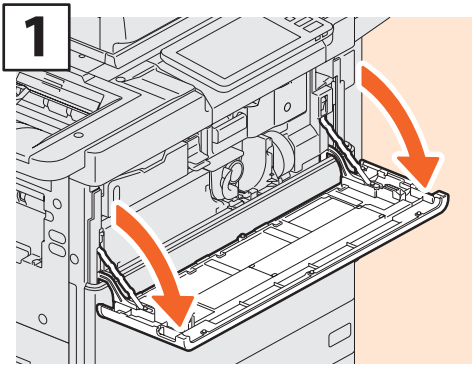

Open the front cover.

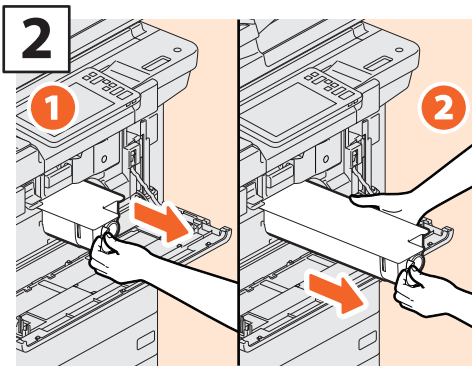

Remove the toner cartridge.

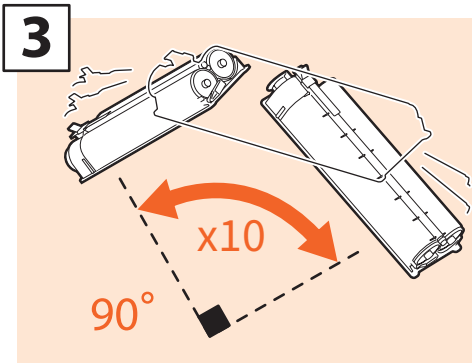

Shake the new toner cartridge well to loosen the toner inside.

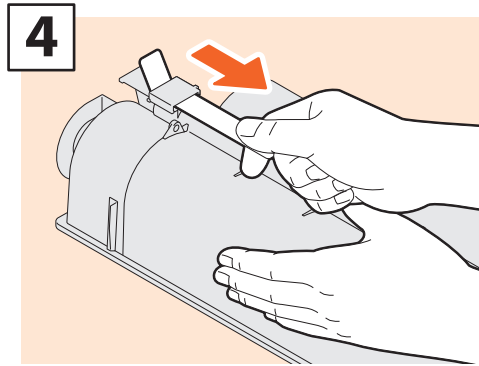

Pull off the seal.



Insert the new toner cartridge until its front surface aligns to the left side wall.

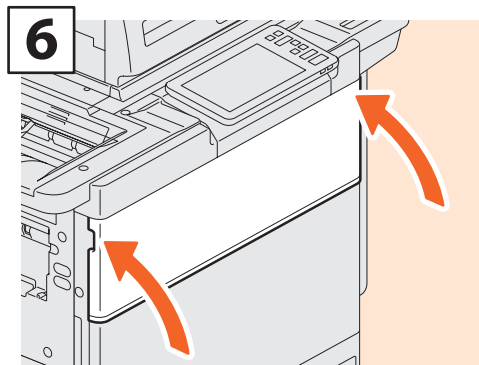

Close the front cover.

3

⚠ WARNING

Never attempt to incinerate toner cartridges.

Dispose of used toner cartridges and waste toner boxes in accordance with local regulations.

Replacing Waste Toner Box

Follow the steps below if a message is displayed on the touch panel informing you that the waste toner box needs replacing.

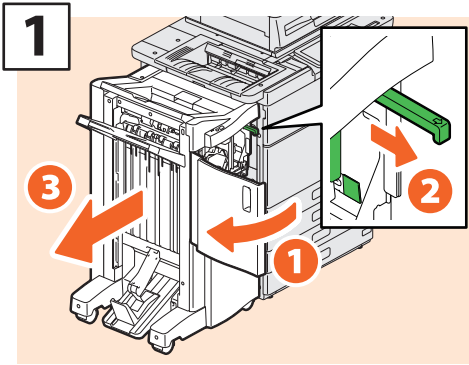

Open the front cover of the Finisher, pull the knob to unlock the Finisher, and then separate the Finisher.

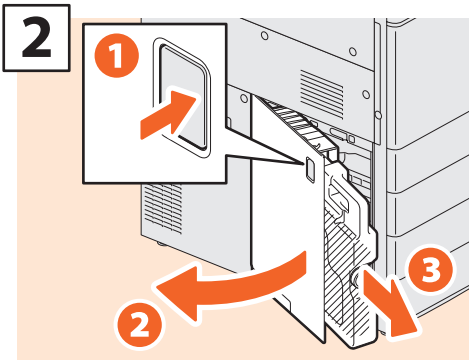

Open the waste toner box cover and remove the waste toner box.

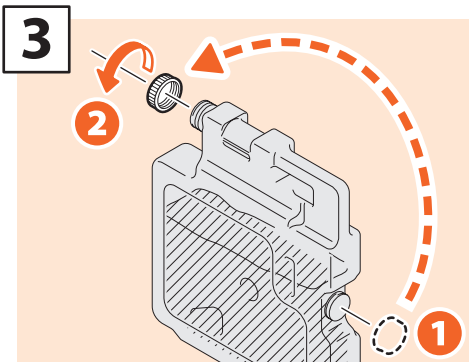

Put the lid on the waste toner box.

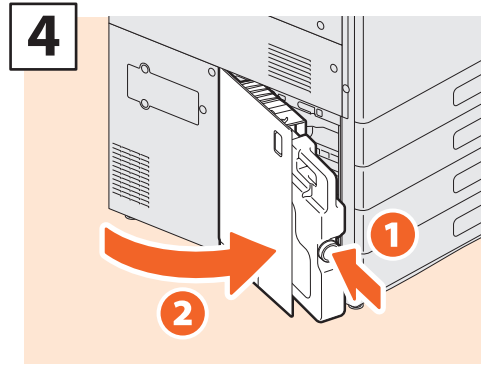

Install a new waste toner box and close the cover.

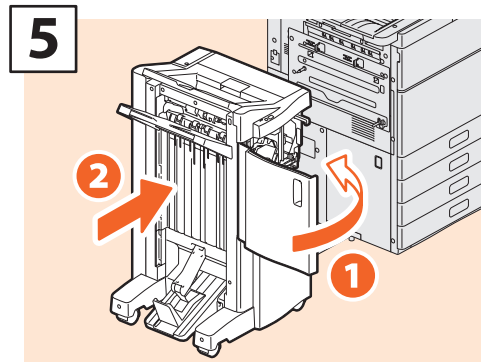

Close the front cover of the Finisher and connect the Finisher to the equipment.

Note

The knob of step 1 is inside the cover of the Hole Punch Unit when it is installed.

⚠ WARNING

Never attempt to incinerate waste toner boxes. Dispose of used toner cartridges and waste toner boxes in accordance with local regulations.

Replacing Staple Cartridge

If a message is displayed informing you that the staple cartridge needs replacing, follow the procedures below.

Stapler Unit of Finisher/Saddle Stitch Finisher

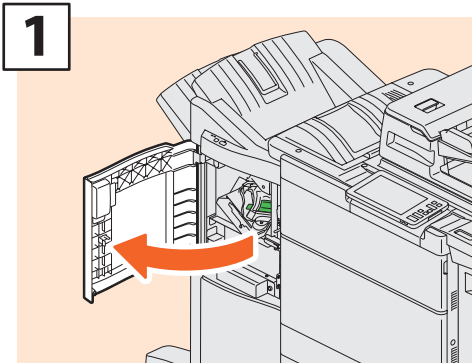

1 Open the front cover of the Finisher.

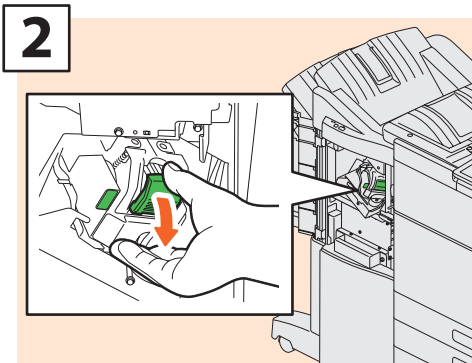

2 Remove the staple cartridge.

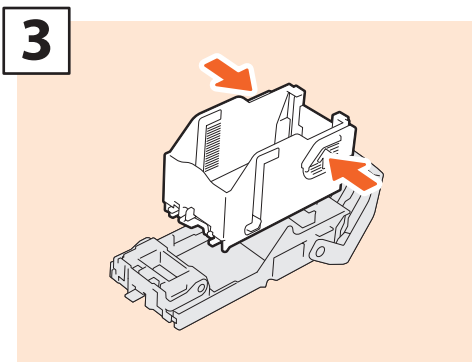

3 Take the empty staple case out of the staple cartridge.

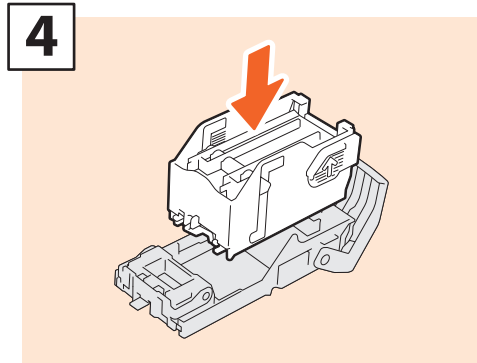

4 Install a new staple case into the staple cartridge.

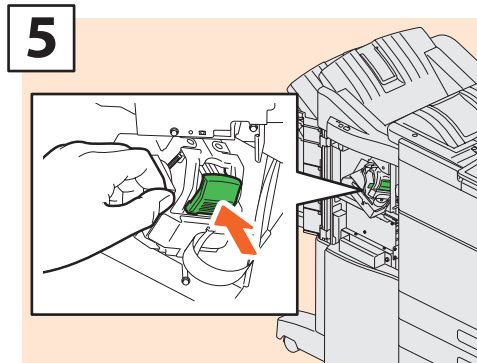

5 Install the staple cartridge.

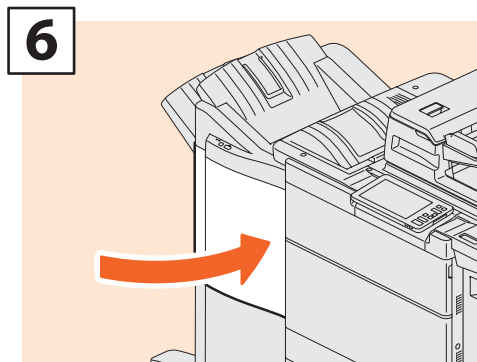

6 Close the front cover of the Finisher.

3

Saddle Stitch Unit of Saddle Stitch Finisher

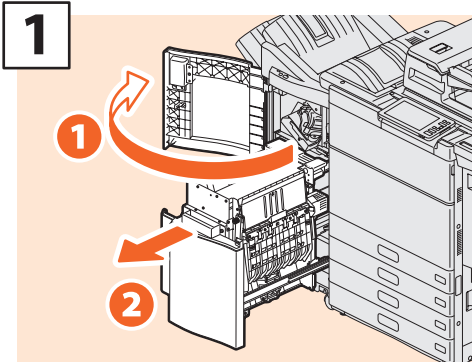

Open the front cover of the Finisher, and then pull out the saddle stitch unit.

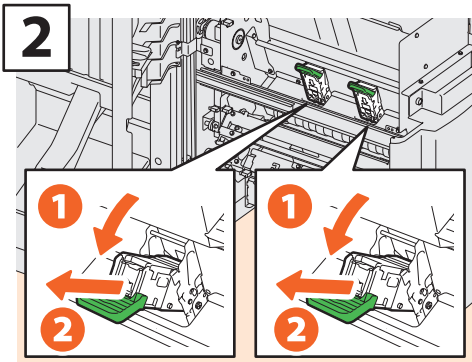

Take out the two empty staple cartridges.

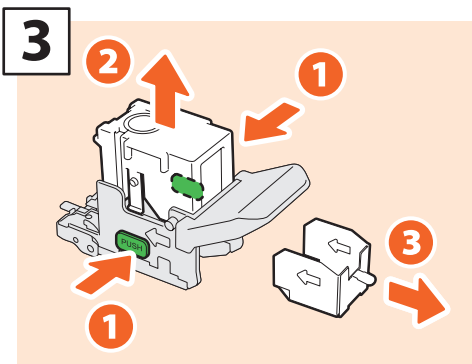

Take the empty staple case out of the staple cartridge.

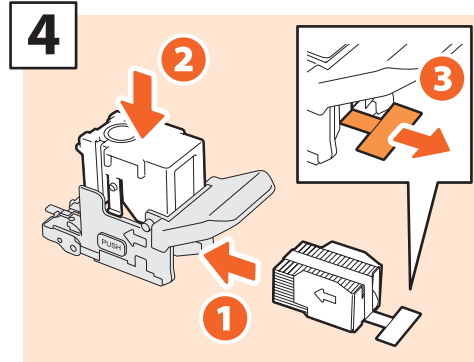

Install a new staple case into the staple cartridge and remove the seal bundling the staples.

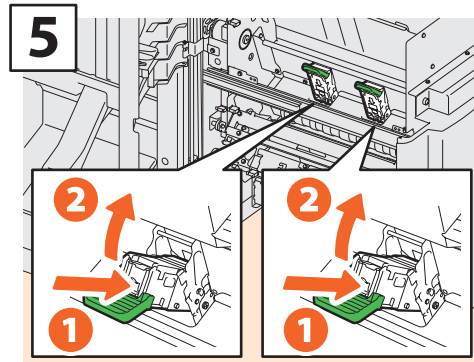

Install two new staple cartridges.

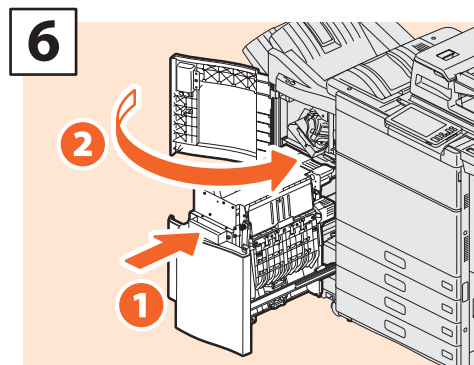

Insert the saddle stitch unit into the Finisher, and then close the front cover.

Note

Do not use the Saddle Stitch Finisher without having reattached the staple cartridges.

Regular Cleaning

Poor quality printing such as uneven and soiled images can be improved by simple cleaning. This section describes the cleaning methods.

Cleaning for the scanning area, original glass, guides, and platen sheet

We recommend cleaning the following items weekly, so that the originals can be scanned cleanly. Be careful not to scratch the parts.

Note

- Be careful not to scratch the parts.
- When cleaning the surface of the equipment, do not use such organic solvents such as thinner or benzene.
 - This could warp the shape of the surface or leave it discolored.
- When using a chemical cleaning pad, follow the instructions provided with the pad.

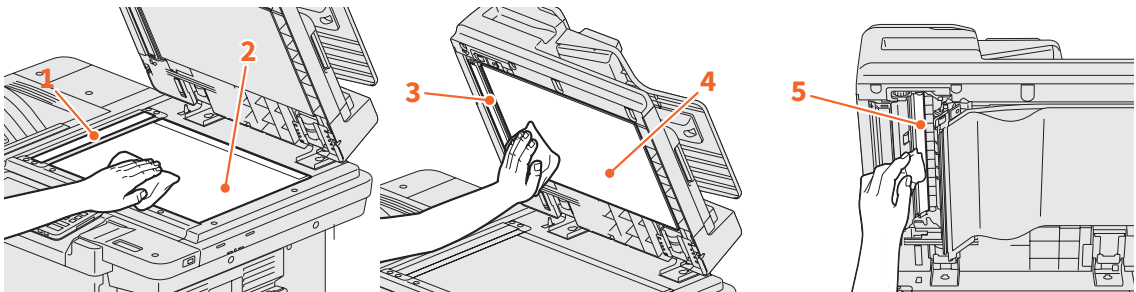

1. Scanning area (surface of the long rectangular glass) / 2. Original glass

Clean the surface with the cloth provided or a soft dry cloth. If there are still stains remaining, wipe with a piece of soft cloth which has been moistened with water and then squeezed well.

Do not use liquids other than water (such as alcohol, organic solvents or neutral detergent).

3. Guide / 4. Platen sheet

Clean the surface as follows depending on the stain.

- Clean it with a soft cloth.
- Clean it with a soft cloth lightly moistened with water.
- Clean it with a soft cloth lightly moistened with alcohol, and then wipe it with a dry cloth.
- Clean it with a soft cloth lightly moistened with watered-down neutral detergent, and then wipe it with a dry cloth.

5. Scanning area of Dual Scan Document Feeder (surface of the long rectangular glass)

Clean the surface with the cloth provided or a soft dry cloth. If there are still stains remaining, wipe with a piece of soft cloth which has been moistened with water and then squeezed well.

Do not use liquids other than water (such as alcohol, organic solvents or neutral detergent).

Cleaning for the front cover

When the front cover has got dirty, lightly wipe it clean with a soft cloth.

Note

- Be careful not to scratch the parts to be cleaned.
- Do not use a hard cloth or dirty cloth or a tissue.

MEMO

Chapter 4

TROUBLESHOOTING

Troubleshooting	52
FAQs	56

Troubleshooting

When problems such as paper misfeeds occur, see the following explanations or the guides (PDFs) on  P.54 “About the Troubleshooting Guides”.

Symbols and messages appear on the touch panel

Symbols for paper misfeeds or messages etc. occasionally appear on the touch panel. For details of the paper misfeed symbols, see the following guide:

 *Hardware Troubleshooting Guide* (PDF) : “Chapter 1: TROUBLESHOOTING FOR THE HARDWARE” - “Clearing a Paper Misfeed”

For details of the messages on the touch panel, see the following guide:

 *Hardware Troubleshooting Guide* (PDF) : “Chapter 1: TROUBLESHOOTING FOR THE HARDWARE” - “Messages Displayed on the Touch Panel”

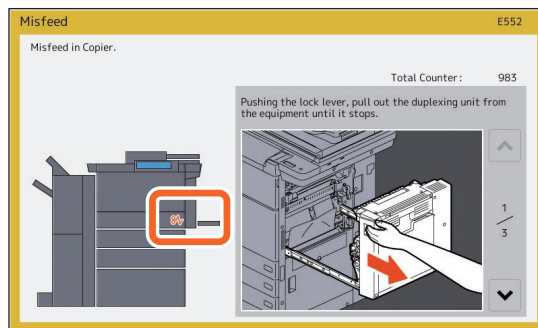

When paper misfeeds occur

When paper misfeeds occur, follow the instructions on the touch panel or see the following guide:

 *Hardware Troubleshooting Guide* (PDF) : “Chapter 1: TROUBLESHOOTING FOR THE HARDWARE” - “Clearing a Paper Misfeed”

Covers of the equipment

The covers of the equipment to be opened when paper misfeeds occur are indicated by the arrows in the following illustrations.

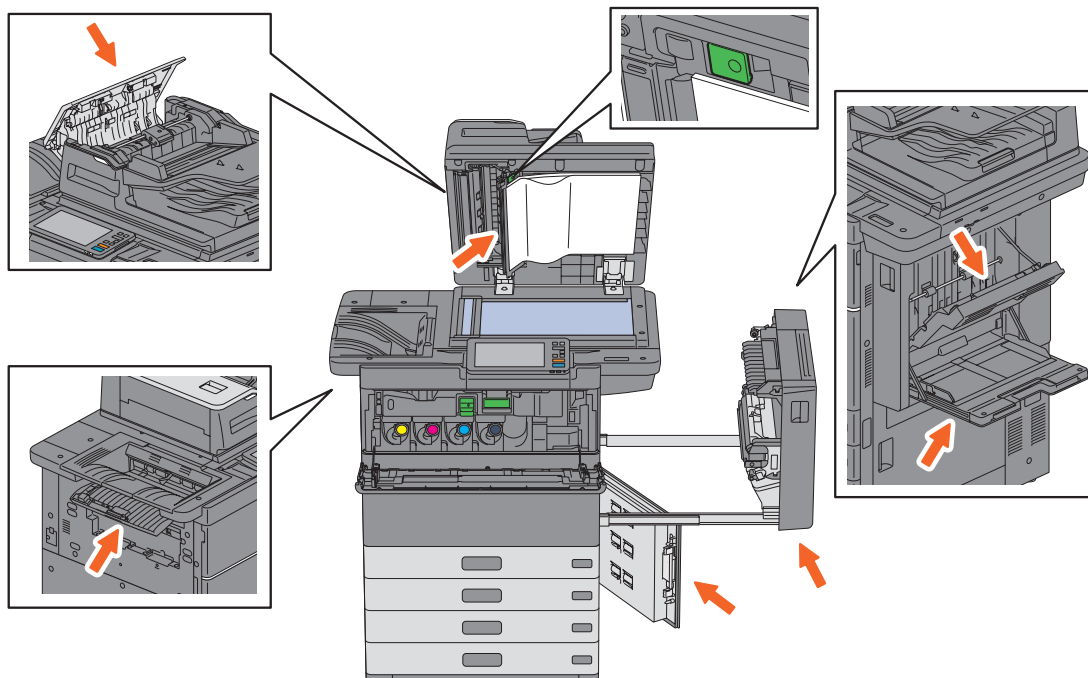

Covers of the options

The covers of the options to be opened when paper misfeeds occur are as indicated by the arrows in the following illustrations.

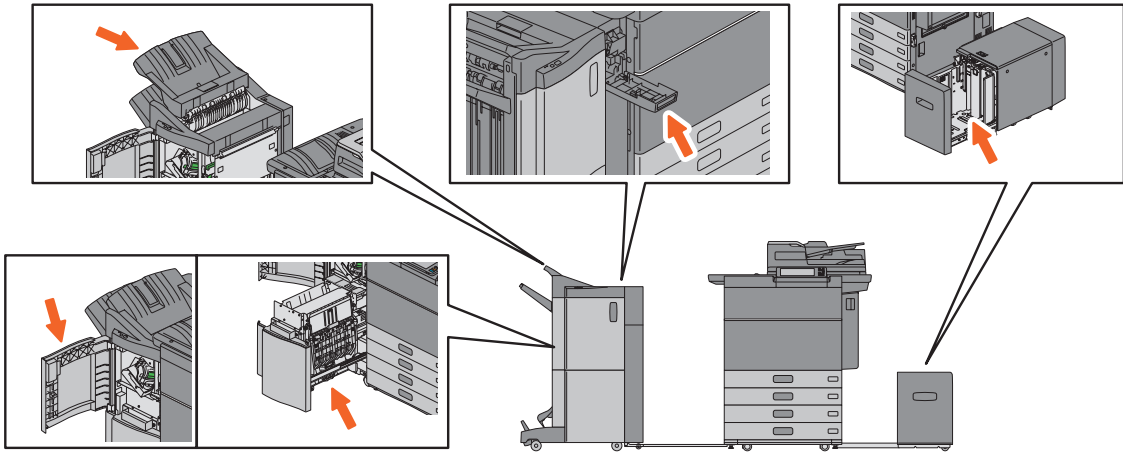

About the Troubleshooting Guides

The *Hardware Troubleshooting Guide* and the *Software Troubleshooting Guide* (PDFs) describe the causes and solutions for problems that may occur.

References to the Hardware Troubleshooting Guide

Chapter	Title	Section
Chapter 1	TROUBLESHOOTING FOR THE HARDWARE	When This Screen Is Displayed
		Messages Displayed on the Touch Panel
		Clearing a Paper Misfeed
		Clearing a Staple Jam
		Replacing a Toner Cartridge
		Replacing the Waste Toner Box
		Refilling With Staples
		Cleaning the Inside of the Equipment
		Cleaning the Hole Punch Dust Bin
Chapter 2	WHEN SOMETHING IS WRONG WITH THE EQUIPMENT	When You Think Something Is Wrong With the Equipment
		Regular Maintenance

References to the Software Troubleshooting Guide

Chapter	Title	Section
Chapter 1	CONFIRMING JOB STATUS ON THE TOUCH PANEL	Confirming Job Statuses of Printing/Copying/Scanning/Faxing
Chapter 2	TROUBLESHOOTING FOR COPYING	Copying Problems
Chapter 3	TROUBLESHOOTING FOR PRINTING	Print Job Problems
		Printer Driver Problems
		Network Connection Problems
		Client Problems
		Hardware Problems
Chapter 4	TROUBLESHOOTING FOR SCANNING	Scanning Problems
Chapter 5	TROUBLESHOOTING FOR e-Filing	e-Filing Web Utility Problems
Chapter 6	TROUBLESHOOTING FOR NETWORK CONNECTIONS	Locating the Equipment in the Network
		LDAP Search and Authentication Problems
		Printing Problems (Network Related)
		Network Fax (N/W-Fax) Driver Problems
		Client Software Authentication Problems
Chapter 7	TROUBLESHOOTING FOR FAXING	Wireless LAN Connection Problems
		Faxing Problems
Chapter 8	CHECKING THE EQUIPMENT STATUS WITH TopAccess	Hardware Status Icons on TopAccess [Device] Tab
		Error Messages
		Error Codes
Chapter 9	WHEN SOMETHING IS WRONG WITH THE EQUIPMENT	When You Think Something Is Wrong With the Equipment



Error codes

Press Job Status button on the home screen and then the [Log] tab on the touch panel. The job history and error codes are displayed in the Log menu.

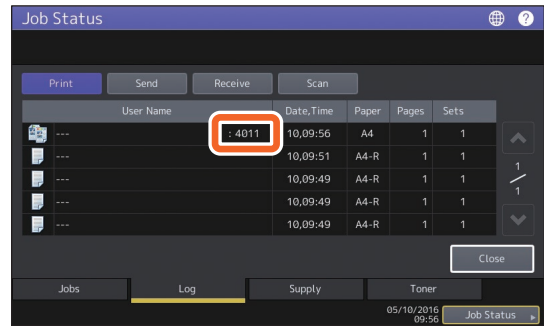
 **Software Troubleshooting Guide**(PDF) : “Chapter 8: CHECKING THE EQUIPMENT STATUS WITH TopAccess” - “Error Codes”



Using the Help

You can display the Help for this equipment by pressing  on screens that have  at the top right corner.

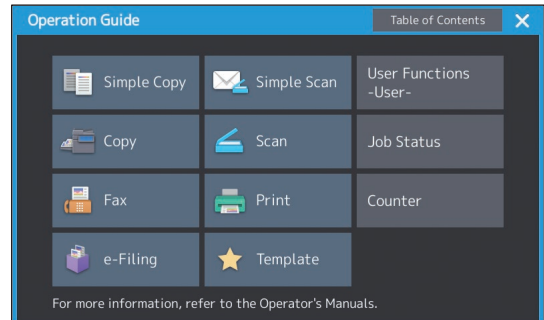

FAQs

This section introduces FAQs from our customers. If you have a problem, read this section first.

Copying

Can I copy originals in different sizes in one go?

Yes. By using the Dual Scan Document Feeder, you can copy more than one original in different sizes such as A4 or B4 in one go.

Original sizes that can be copied in one go are as follows:

North America: LD, LG, LT, LT-R, COMP

Outside North America: A3, A4, A4-R, B4, B5, FOLIO

1. Place paper in the drawer. If you want to copy on paper of the same size as the originals, place paper of the corresponding size in the different drawers.
2. Adjust the side guides to the widest original. Place the originals by aligning them against the guide on the front.

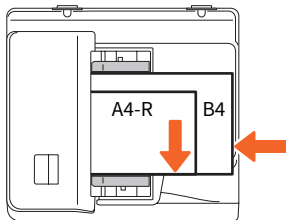

3. Press [Zoom].
4. Press [Mixed Size].
5. If you want to copy all the originals on paper of the same size, press [AMS].
6. Press [OK] to return to the basic menu for copying functions.
7. <To copy on paper of the same size>
Press an icon on the touch panel that indicates the drawer containing the paper size you want.
<To copy on paper of the same size as the original>
Press [APS].
8. Press the [START] button on the control panel.

Copying Guide (PDF) : “Chapter 2: HOW TO MAKE COPIES” - “Specifying the Paper Size” - “Copying mixed-size originals in one operation”

Can I copy an A5 original with the Dual Scan Document Feeder?

Yes. Place an A5 original on the Dual Scan Document Feeder in a landscape direction.

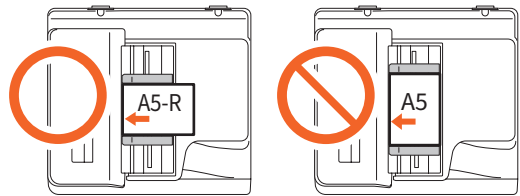

For how to place originals on the Dual Scan Document Feeder or the available types and sizes of originals see the following guide:

Paper Preparation Guide (PDF) : “Chapter 2: PLACING ORIGINALS” - “Placing Originals” - “Acceptable originals”

Black streaks appear on the copied image.

If the scanning area is dirty, black streaks may appear on the copied image or faxes made with the Dual Scan Document Feeder.

Clean the scanning area. See the following page or the following guide:

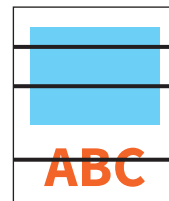

P.49 “Regular Cleaning”

Hardware Troubleshooting Guide (PDF) : “Chapter 2: WHEN SOMETHING IS WRONG WITH THE EQUIPMENT” - “Regular Maintenance”

Faxing

Can I forward a received fax?

Yes. You can forward a received fax to another facsimile as it is, or as an Internet Fax job.

To forward a fax, you need the previous settings. See the following guide:

 **GD-1370 Fax Guide** : “Chapter 3: USING THE FAX UNIT (USEFUL FUNCTIONS)” - “Using the Mailbox Function”

You can also forward to a shared folder in this equipment, an e-Filing box, or an E-mail address other than a fax number or an internet fax number, from the TopAccess menu. See the following guide:

 **TopAccess Guide** (PDF) : “Chapter 5: [Registration] Tab Page” - “[Registration] How to Set and How to Operate” - “Managing mailboxes”

How can I register or change a sender's name or fax number?

You can register or change a sender's name or fax number as follows.

User Functions-User- > Admin > Fax > Terminal ID

 **MFP Management Guide** (PDF) : “Chapter 2: SETTING ITEMS (Admin)” - “Fax” - “Registering the terminal ID”

How can I prevent mistakes in sending faxes?

To prevent mistakes, confirm that you set the correct recipient before you send a fax. See the following page:

 P.33 “Confirming recipients”

You can also prevent mistakes by following the steps below. For details, contact your service technician or representative.

- Disable the direct input of fax numbers and limit the destination setting to selections from the address book.
- Specify the destination twice and compare them. If they are the same, send the fax.

Can I send a fax from a computer?

Yes. You can send a fax or an Internet Fax from a computer in which the N/W-Fax Driver is installed. You do not need to print the original fax.

1. Select [Print] in the [File] menu of the application.
2. Select [TOSHIBA e-STUDIO Fax], and then click [Preferences] ([Properties]).
3. Specify the destination on the [Send] tab of the printer driver, and then click [OK].
4. Click [Print] ([OK]).

 **GD-1370 Fax Guide** : “Chapter 4: USING N/W-FAX DRIVER (NETWORK FAX)” - “Sending Network Faxes”

 **Software Installation Guide** (PDF) : “Chapter 2: RECOMMENDED INSTALLATION”

Scanning

How can I scan an image in the JPEG format?

Select [Full Color] or [Gray Scale] for color modes in the scan setting, and then select [JPEG] for the file format.

 **Scanning Guide** (PDF) : “Chapter 2: SCANNING (BASIC OPERATION)” - “Saving Data in the Shared Folder” or “Sending Data to an E-mail Address” or “Saving Data to a USB Storage Device”

Where is the scanned file stored?

If you have specified [File] as the storage directory, data is stored in a shared folder “file_share” in the internal storage device of this equipment. To download the data, see the following page:

 P.37 “Storing scanned data of a shared folder in a Windows computer”

I cannot forward the scanned data to a folder on the network.

Check the following:

- Is the specified folder shared? Setting the shared folder may differ depending on the equipment or OS.
- Is the network path for the folder entered correctly?
- Is the login user name or password entered correctly?
- Is your antivirus software blocking writing to the network folder?

[Remote 1] (or [Remote 2]) cannot be selected in [Save as File].

Confirm the shared folder setting on the TopAccess menu.

1. Select as follows: [Administration] tab > [Setup] > [Save as file].
2. Confirm that [Use Network Folder Destination] is selected on [Destination].
3. Confirm that [Remote 1] (or [Remote 2]) of [Remote 1 and Remote 2 Settings] is selected.

 **TopAccess Guide** (PDF) : “Chapter 8: [Administration] Tab Page” - “[Setup] Item List” - “Save as File settings”

Printing

I have installed a printer driver but cannot print.

Confirm if the port setting of the printer driver is correct.

* Log into Windows using an account that allows installation, such as for administrators.

1. Select [Devices and Printers] in the [Start] menu.
2. Right-click [TOSHIBA Universal Printer 2], and then click [Printer properties].
3. Select the port of this equipment in the [Print to the following port(s)] list on the [Ports] tab of the printer driver. Click [Configure Port].
4. Confirm if the IP address of this equipment is set correctly in the [Printer Name or IP Address] box in [Configure Standard TCP/IP Port Monitor].
5. Confirm if [Raw] is selected in [Protocol] in [Configure Standard TCP/IP Port Monitor] and “9100” is entered in the [Port Number] box of [Raw Settings].

If the problem still occurs, see the following guide or contact your administrator:

 **Software Troubleshooting Guide** (PDF) : “Chapter 3: TROUBLESHOOTING FOR PRINTING” or “Chapter 6: TROUBLESHOOTING FOR NETWORK CONNECTIONS”

Can I print on non-standard size paper?

Yes. You can print by registering a custom paper size on the printer driver.

* Log into Windows using an account that enables installation, such as for administrators.

 **Printing Guide** (PDF) : “Chapter 2: PRINTING FROM WINDOWS APPLICATIONS” - “Setting the Paper and Reproduction Ratio” - “Using various types of paper”

Client software

“Devices are not discovered in your network.” appears while installing the printer driver.

If this equipment is not discovered on the network while installing the printer driver, the following message appears. See the following guide:

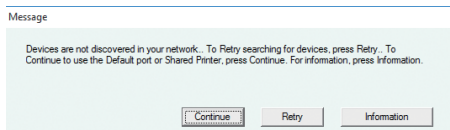

 **Software Installation Guide** (PDF) : “Chapter 3: INSTALLING PRINTER DRIVERS FOR WINDOWS” - “Installing the Printer Drivers”

I cannot install the printer driver or other software.

Try the following and then reattempt the installation.

- Uninstall any existing printer drivers.
- Quit resident software such as antivirus software.
- Log into Windows using an account that enables installation, such as for administrators.

Can I register data in CSV file to the address book?

Yes. You can register them from the AddressBook Viewer or TopAccess. See the following guide:

 Help menu of AddressBook Viewer

 **TopAccess Guide** (PDF) : “Chapter 8: [Administration] Tab Page” - “[Maintenance] How to Set and How to Operate” - “Importing and exporting”

I cannot print from my computer.

Check the following:

- Is the power turned ON?
- Is the power cable plugged in? If it is not, turn the MAIN POWER switch OFF, and then plug the power cable into an outlet.
- Is the network cable disconnected? If it is disconnected, connect it to the network interface connector.
- Has toner or paper run out?
- Does the set number of pages exceed the maximum allowed for the specific department or user?

If the problem still occurs after checking the above, see the following guide or contact your administrator:

 **Software Troubleshooting Guide** (PDF) : “Chapter 3: TROUBLESHOOTING FOR PRINTING” or “Chapter 6: TROUBLESHOOTING FOR NETWORK CONNECTIONS”

Other questions

How can I confirm or change the IP address of this equipment?

Follow the steps below on the touch panel:

User Functions-User- > Admin > Network > IPv4

 *MFP Management Guide* (PDF) : “Chapter 2: SETTING ITEMS (Admin)” - “Network”

The equipment does not recognize the inserted USB media.

Confirm that the USB media is securely inserted to the USB port.

USB media for this equipment must meet the following conditions.

- Formatted in FAT16 or FAT32
- Only one partition

* Some USB media may not be recognized even if it meets the conditions above. Try to use USB media of other manufacturers that meet the conditions above.

 *Scanning Guide* (PDF) : “Chapter 2: SCANNING (BASIC OPERATION)” - “Saving Data to a USB Storage Device”

 *Printing Guide* (PDF) : “Chapter 4: OTHER PRINTING METHODS” - “Printing files from USB media (USB Direct Printing)”

How can I check the remaining amount of toner in a toner cartridge?

Follow the steps below:

1. Press Job Status button on the home screen.
2. Press the [Toner] tab.
3. When you have finished checking, press [Close] and then press [Job Status].

When a message is displayed on the touch panel to inform you that the toner is low, prepare a new toner cartridge. The equipment can still print about 2000 pages after this message has appeared.

Replace the toner cartridge when a message is displayed on the touch panel.

 *Software Troubleshooting Guide* (PDF) : “Chapter 1: CONFIRMING JOB STATUS ON THE TOUCH PANEL” - “Confirming Job Statuses of Printing/Copying/Scanning/Faxing”

The paper misfeed symbol does not disappear even after the paper misfeed in the Dual Scan Document Feeder has been cleared.

Open the cover beneath the Dual Scan Document Feeder, and then remove the original.

 P.52 “When paper misfeeds occur”

 *Hardware Troubleshooting Guide* (PDF) : “Chapter 1: TROUBLESHOOTING FOR THE HARDWARE”

Some functions written in the Operator’s Manuals cannot be used.

This depends on the settings of this equipment or the access privilege given to the user, even though they are written in the Operator’s Manuals. For details, contact your administrator.

Chapter 5

INFORMATION ABOUT EQUIPMENT

Items Included with this Equipment.....	62
Client Utilities/User Documentation DVD	63
Client Software	64
Options	66
Logging in	69

Items Included with this Equipment

The following items are included with the equipment. Check that you have them all. Contact your service technician or representative if any are missing or damaged.

Items included with this equipment

Safety Information	Describes the necessary precautions for use. Read this booklet first.
Quick Start Guide (This guide)	Describes the preparations, basic and advanced usage, maintenance, and regular cleaning of the equipment.
Client Utilities/User Documentation DVD	Contains client software such as the printer drivers and the utility software. Contains pdf files of the Operator's Manuals such as the Copying Guide. For details, see the following page:  P.63 "Client Utilities/User Documentation DVD"



Client Utilities/User Documentation DVD

Contains pdf files of the Operator's Manuals and the following client software such as the printer drivers and the utility software.

Client software

For Windows	Client Software Installer
	Universal Printer 2 driver
	Universal PS3 printer driver
	Universal XPS printer driver
	TWAIN driver
	File downloader
	N/W-Fax driver
	AddressBook Viewer
	Remote Scan driver
	WIA driver
e-Filing Backup/Restore Utility	
For Mac OS	The PPD file and plug-ins used for the Mac OS X 10.6.8 or later
For UNIX/Linux	UNIX/Linux filter (Solaris, HP-U, AIX, Linux)
	CUPS













Tip

- To install the client software, see the following guide:
 **Software Installation Guide** (PDF) : “Chapter 1: OVERVIEW”
- For details of the client software, see the following page:
 P.64 “Client Software”



Client Software

Outlines the client software of the equipment. You need to install software except for e-Filing Web utility and TopAccess before use.





Client software for printing functions

Universal Printer 2 driver	<p>Installed during the Recommended Installation.</p> <p> <i>Software Installation Guide</i> (PDF) : “Chapter 2: RECOMMENDED INSTALLATION” or “Chapter 3: INSTALLING PRINTER DRIVERS FOR WINDOWS”</p> <p> P.40 “Printing Operations”</p> <p> <i>Printing Guide</i> (PDF) : “Chapter 2: PRINTING FROM WINDOWS APPLICATIONS”</p>
Universal PS3 printer driver	<p>Allows you to print documents in high quality mode with applications such as Adobe Systems Incorporated.</p> <p> <i>Software Installation Guide</i> (PDF) : “Chapter 2: RECOMMENDED INSTALLATION” or “Chapter 3: INSTALLING PRINTER DRIVERS FOR WINDOWS”</p> <p> <i>Printing Guide</i> (PDF) : “Chapter 2: PRINTING FROM WINDOWS APPLICATIONS”</p>
Universal XPS printer driver	<p>Allows you to print documents from WPF applications.</p> <p> <i>Software Installation Guide</i> (PDF) : “Chapter 2: RECOMMENDED INSTALLATION” or “Chapter 3: INSTALLING PRINTER DRIVERS FOR WINDOWS”</p> <p> <i>Printing Guide</i> (PDF) : “Chapter 2: PRINTING FROM WINDOWS APPLICATIONS”</p>
PPD file for Mac	<p>Allows you to print documents from Mac computers (Mac OS X 10.6.8 or later).</p> <p> <i>Software Installation Guide</i> (PDF) : “Chapter 4: INSTALLING PRINTER DRIVERS FOR MAC OS”</p> <p> <i>Printing Guide</i> (PDF) : “Chapter 3: PRINTING FROM MAC OS APPLICATIONS”</p>
UNIX/Linux filter	<p>Allows you to print documents from the UNIX/Linux workstation.</p> <p> <i>Software Installation Guide</i> (PDF) : “Chapter 5: INSTALLING PRINTER DRIVERS FOR UNIX/Linux”</p> <p> <i>Printing Guide</i> (PDF) : “Chapter 4: OTHER PRINTING METHODS” - “Printing From UNIX/Linux”</p>
CUPS	<p>Allows you to set up the CUPS print system from UNIX/Linux workstation.</p> <p> <i>Software Installation Guide</i> (PDF) : “Chapter 5: INSTALLING PRINTER DRIVERS FOR UNIX/Linux”</p>

Client software for scanning functions

Remote Scan driver	<p>Allows you to scan documents remotely and obtain scanned data as an image in TWAIN applications on Windows computers.</p> <p> <i>Software Installation Guide</i> (PDF) : “Chapter 2: RECOMMENDED INSTALLATION” or “Chapter 6: INSTALLING SCAN DRIVER AND UTILITIES (Windows)”</p>
WIA driver	<p>Allows you to scan documents remotely and obtain scanned data as an image in WIA (Windows Imaging Acquisition) applications on Windows computers.</p> <p> <i>Software Installation Guide</i> (PDF) : “Chapter 2: RECOMMENDED INSTALLATION” or “Chapter 6: INSTALLING SCAN DRIVER AND UTILITIES (Windows)”</p> <p> <i>Scanning Guide</i> (PDF) : “Chapter 4: SCANNING USING UTILITY TOOLS”</p>



Client software for e-Filing functions

TWAIN driver	Allows you to obtain documents stored in e-Filing as an image in TWAIN applications on Windows computers.  <i>Software Installation Guide</i> (PDF) : “Chapter 2: RECOMMENDED INSTALLATION” or “Chapter 6: INSTALLING SCAN DRIVER AND UTILITIES (Windows)”
File downloader	Allows you to obtain documents stored in e-Filing as an image on Windows computers.  <i>Software Installation Guide</i> (PDF) : “Chapter 2: RECOMMENDED INSTALLATION” or “Chapter 6: INSTALLING SCAN DRIVER AND UTILITIES (Windows)”
e-Filing Web utility	Allows you to operate or make settings for e-Filing using a browser. Since this utility is already installed, enter the IP address of the equipment into a browser and turn the power ON.  <i>e-Filing Guide</i> (PDF) : “Chapter 3: OPERATING WITH A CLIENT COMPUTER (e-Filing WEB UTILITY)”
e-Filing Backup/Restore Utility	Allows you to back up and restore the data stored in e-Filing.  <i>Software Installation Guide</i> (PDF) : “Chapter 8: INSTALLING e-Filing BACKUP/RESTORE UTILITIES (Windows)”

Client software for network management functions

TopAccess	Allows you to view device information, display logs, create templates and an address book, and manage the equipment using a browser. Since TopAccess is already installed, enter the IP address of the equipment into a browser and turn the power ON.  <i>TopAccess Guide</i> (PDF) : “Chapter 1: Overview”
------------------	---

Client software for network fax functions

N/W-Fax driver	Allows you to send faxes or Internet faxes from your computer. For details, see the following guides:  <i>Software Installation Guide</i> (PDF) : “Chapter 2: RECOMMENDED INSTALLATION” or “Chapter 7: INSTALLING NETWORK FAX UTILITIES (Windows)”  <i>GD-1370 Fax Guide</i> : “Chapter 4: USING N/W-FAX DRIVER (NETWORK FAX)”
AddressBook Viewer	Allows you to manage the address book (such as fax numbers and E-mail addresses) and upload the address book from your computer to the equipment.  <i>Software Installation Guide</i> (PDF) : “Chapter 2: RECOMMENDED INSTALLATION” or “Chapter 7: INSTALLING NETWORK FAX UTILITIES (Windows)”

Options

The following are sold separately, and upgrade the performance of the equipment. For details, contact your service technician or representative.

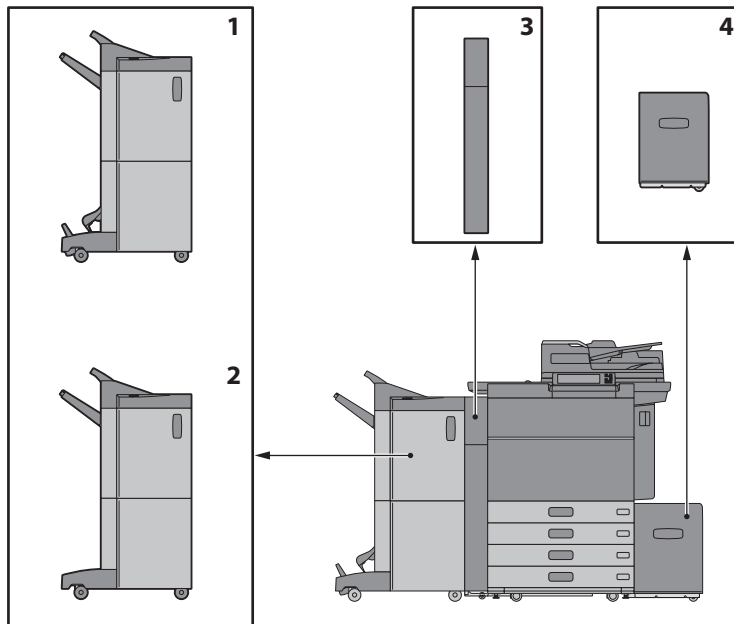

1. Saddle Stitch Finisher (MJ-1112)

Allows saddle stitching and center folding in addition to sort/group finishing and stapling. You can also install the Hole Punch Unit.

2. Finisher (MJ-1111)

Allows sort/group finishing and stapling. You can also install the Hole Punch Unit.

3. Hole Punch Unit (MJ-6106 Series)

Allows you to punch holes on printed sheets.

4. External Large Capacity Feeder (MP-2502A/L)

Allows you to feed up to 2500 sheets (80 g/m² or 20 lb. Bond) of A4 or LT paper.

Other options available are as follows. Contact your service technician or representative for details.

Accessory Tray (GR-1250)

A tray for placing accessories.

- Installed below the control panel.

Ten Key (GR-1260)

Installed on the control panel.

Accessible Arm (KK-2560)

Allows a user in a wheelchair to close the Dual Scan Document Feeder.

 P.68 “Using the Accessible Arm”

Finisher Guide Rail (KN-1103)

Used when the equipment is installed on soft surface flooring. Allows you to easily remove/install an optional finisher for the equipment.

Side Receiving Tray (KA-6551-ET)

Holds paper ejected from the equipment. The tray loading capacity is up to 500 sheets or up to 60 mm (2.36”) for 80g/m² or 20 lb. bond.

- Installed on the left side of the equipment.

Operator’s Manual Pocket (KK-5008)

Stores the manual.

FAX Unit (GD-1370)

Allows you to use the equipment as a Fax machine. You can use up to two phone lines by installing two FAX units.

- Installed inside the equipment.

Wireless LAN/Bluetooth Module (GN-4020)

Allows you to print over wireless LAN and Bluetooth.

You can also use a Bluetooth keyboard.

- Installed inside the equipment.

Data Overwrite Enabler (GP-1070)

Erases data stored temporarily when copying or executing other operation. Overwrites temporarily stored data with random data.

IPsec Enabler (GP-1080)

Allows you to use the IPsec function.

Hardcopy Security Kit (GP-1190)

Allows Hardcopy Security Printing and you can track the security pattern information.

Meta Scan Enabler (GS-1010)

Allows you to use the Meta Scan function.

External Interface Enabler (GS-1020)

Allows you to use the EWB function.

Unicode Font Enabler (GS-1007)

Allows you to print from the SAP environment using Unicode font.

OCR Enabler (GS-1080, GS-1085)

Allows you to use the OCR function.

Multi Station Print Enabler (GS-1090, GS-1095)

Allows you to use the Multi Station Print function.

FIPS Hard Disk Kit (GE-1230)

You can use hard disks that comply with the Federal Information Processing Standard (FIPS140) of the U.S.A.

Note

- Depending on the model, options may already be installed and available.
- Some options may not be available in some regions.

Using the Accessible Arm

A user in a wheelchair can close the Dual Scan Document Feeder.

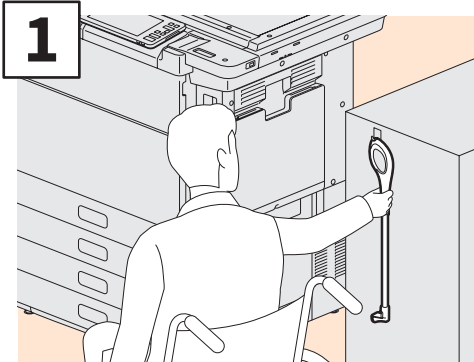

1 Hold the Accessible Arm.

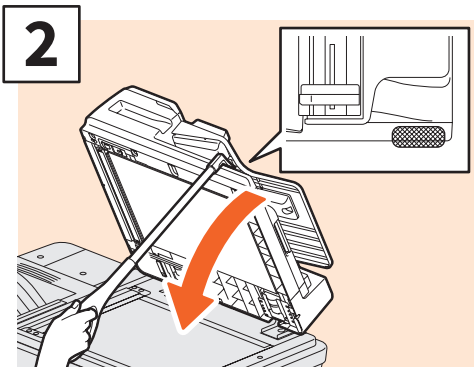

2 Hook the Accessible Arm over the top of the Dual Scan Document Feeder to close them.

Note

- Store it near the equipment. When it is stored by putting it on the equipment, choose somewhere where there is no interference with the paper supply, paper misfeeding release or toner replacement.
- Do not use this for any purposes other than closing the device.

Using the Accessory Tray

- You can use an accessory that weighs up to 3 kg (6.6 lb.) with a width of up to 236 mm (9.29"), a depth of up to 125 mm (4.92"), and a height of up to 15 mm (0.59").
- Because the temperature inside the accessory tray can become hot, make sure the accessories placed on the tray can withstand the following conditions.
Temperature: 10 to 60°C (50 to 140°F); Humidity: 20 to 85%
- Make sure accessories do not fall through the hole in the base of the Accessory Tray.
- Do not force the control panel to move on equipment on which the Accessory Tray is installed.
- Do not trap cables between the equipment's cover.
- The Extension Tray supplied is 306 mm (12.05") wide and 150 mm (5.9") high. When placing accessories on the Extension Tray, secure them using the attached hook and loop fastener. We recommend accessories that fit within the size of the Extension Tray.

Logging in

When the equipment is controlled under department or user management, you can perform copying and other functions by following the procedure below to log in.

Department management

Restricts users or manage copy volumes made by an individual group or department in your company. When the equipment is controlled under the department code, turn the power ON and enter the code.

When the power is turned ON, the following menu appears.

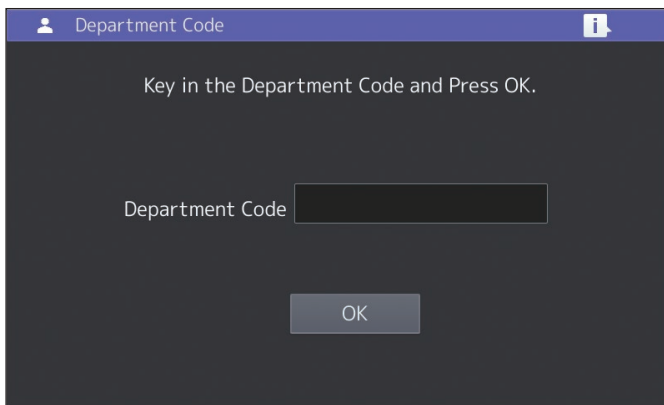

Key in a department code (max. 63 digits) previously registered and press [OK]. The menu switches and the equipment is ready for use.

If the department code keyed in is incorrect, the menu does not change.

Tip

Automatic function clear:

- Returns all settings to default without the need to press the [FUNCTION CLEAR] button on the control panel. It works when a specified period of time has passed since the last paper eject or the last use of any button. When using department or user management, the display returns to the department code or user information input menu. When they are not being used, the display returns to the home screen.
- The period is set at 45 seconds by default at the time of installation. To change the setting, see the following guide:
[📖 MFP Management Guide \(PDF\) : “Chapter 2: SETTING ITEMS \(Admin\)” - “General”](#)
- When connecting to equipment with department or user management enabled using client software, you may need to log in. For details, ask your administrator.

After the operation

To prevent unauthorized use of the equipment, return the display to the department code input menu by following either of the procedures below.

- Press the [ACCESS] button on the control panel.
- Press the [FUNCTION CLEAR] button on the control panel twice.

User management

Restricts users or manage available functions and past records for each user. When the equipment is managed under this function, turn the power ON and enter the information required (e.g. user name, password). Follow the procedure below.

Note

If you enter an invalid password several times, you cannot log in for a certain period as this is regarded as an unauthorized access.

If a message is displayed to inform you that your account is locked, or the user name or password is incorrect, and logging in cannot be performed, contact your administrator.

Tip

- If a guest user is enabled in the user management function, [Guest] is displayed on the touch panel. Press [Guest] to log in as a guest user. For the types of functions available, contact your administrator.
- Enter your PIN on the touch panel (up to 32 digits) when prompt. For details, contact your administrator.
- Enter the Project code on the touch panel (up to 63 digits) when prompt. For details, contact your administrator.
- You can check information on the user's counter by pressing the user name displayed at the top of the home screen during login. When using an internal authentication function, you can change your password.

After the operation

To prevent unauthorized use of the equipment, log out following the procedure below.

1. Perform either of the operations below.
 - Press the [ACCESS] button on the control panel.
 - Press the [FUNCTION CLEAR] button on the control panel twice.
2. On the confirmation screen, select [Yes].

1 The menu for user authentication appears.

MFP local authentication

Windows Domain authentication, LDAP authentication

The domain name is displayed in [Domain]. For LDAP authentication, the LDAP server name is displayed in [LDAP] instead of [Domain].

Tip

If the displayed domain name or LDAP server name is not yours, press  to select yours.

2 Enter the user name (up to 128 letters) and password (up to 64 letters), and then press [OK].

3 The equipment is available for use.

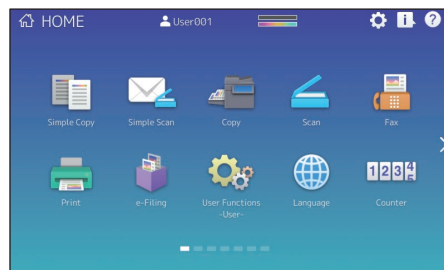

MEMO

How to back up the data

The data shown below are stored in the internal storage device in the equipment.

- MFP Setting
- User Management (User, Group, Role, Quota, Department Code, Template, Address Book, Project Code)
- MailBox
- Home Setting
- Application (Including License)
- e-Filing
- Data in a shared folder

It is recommended periodically to back up the data by yourself by referring to the following manuals as security against possible contingencies just in case. These data can be backed up into a USB storage device or an external server connected via a network. The backed-up data can be restored by means of an operation from the control panel. If any points are unclear, or you need further information, contact your service technician or representative.

	Item name	Manual	Reference to
1	Setting the data backup function	<i>TopAccess Guide</i>	“Chapter 8: [Administration] Tab Page” - “[Maintenance] Item List” - “Data Backup”
2	Backing up or restoring the data from the control panel	<i>MFP Management Guide</i>	“Chapter 2: SETTING ITEMS (Admin)” - “Setting the data backup and restore”
3	Backing up the data in a shared folder	<i>Quick Start Guide</i>	“Chapter 2: BASIC OPERATIONS” - “Scanning Operations” - “Storing scanned data of a shared folder in a Windows computer” ^{*1}

*1 The data stored in the internal storage device other than the one installed in the equipment (a storage device specified by the user) are not included.

INDEX

A, B

[ACCESS] button	11
Adjusting the angle of the control panel	12
Alarm lamp	9, 11
Bridge unit	9
Bypass tray	8

C, D

Client Software	64
Client Utilities/User Documentation DVD	63
Control panel	9, 11
Copying	28, 56
Department management	69
Description of Components	8
Digital keys (Optional)	11
Document lamp	9
Drawer	8
Dual Scan Document Feeder	8
Duplexing unit	8
Duplexing unit cover	8

E, F

e-Filing	38
[ENERGY SAVER] button	11
energy saving mode	18
Error codes	55
Faxing	32, 57
FAX Unit	67
Front cover	8
[FUNCTION CLEAR] button	11

H, I, J, L

[?] (Help) button	13
[HOME] button	11
Home Screen	13, 24
Home Setting button	13
Items Included with this Equipment	62
Job Status button	13
Large Capacity Feeder	66

M, N

MAIN POWER lamp	11
Main power switch	9
MEMORY RX lamp	11
Network interface connector	8
Next button	13

O, P

Operator's Manual Pocket	8
Options	66
Original glass	9
Original scale	9
Page Position indicator	13
Paper feed cover	8
Paper size indicator	8
Placing paper	19
Platen sheet	9
[POWER] button	11
PRINT DATA lamp	11
Printing	40, 58
[PROGRAMMABLE1] button	11
[PROGRAMMABLE2] button	11

R, S

Recall button	13
Receiving tray	9
Regular Cleaning	49
Replacing Staple Cartridge	47
Replacing Toner Cartridge	44
Replacing Waste Toner Box	46
Scanning	36, 58
Scanning area	9
[START] button	11
Status button	13
Symbols	52

T, U, W

Toner cartridge	9, 44
Touch panel	11
Turning OFF	17
Turning the power ON	16
USB port	9
USB terminal	8
User management	70
Waste toner box	9

**MULTIFUNCTIONAL DIGITAL COLOR SYSTEMS /
MULTIFUNCTIONAL DIGITAL SYSTEMS**

Quick Start Guide

e-STUDIO5506AC e-STUDIO5508A
e-STUDIO6506AC e-STUDIO6508A
e-STUDIO7506AC e-STUDIO7508A
e-STUDIO8508A

TOSHIBA TEC CORPORATION

1-11-1, OSAKI, SHINAGAWA-KU, TOKYO, 141-8562, JAPAN

