

**TOSHIBA**

**SERVICE MANUAL**

**PRINTER**

**e-STUDIO 360CP**



Edition : 8/4/05

The following paragraph does not apply to any country where such provisions are inconsistent with local law: TOSHIBA PROVIDES THIS PUBLICATION AS IS WITHOUT WARRANTY OF ANY KIND, EITHER EXPRESS OR IMPLIED, INCLUDING, BUT NOT LIMITED TO, THE IMPLIED WARRANTIES OF MERCHANTABILITY OR FITNESS FOR A PARTICULAR PURPOSE. Some states do not allow disclaimer of express or implied warranties in certain transactions; therefore, this statement may not apply to you.

This publication could include technical inaccuracies or typographical errors. Changes are periodically made to the information herein; these changes will be incorporated in later editions. Improvements or changes in the products or the programs described may be made at any time.

References in this publication to products, programs, or services do not imply that the manufacturer intends to make these available in all countries in which it operates. Any reference to a product, program, or service is not intended to state or imply that only that product, program, or service may be used. Any functionally equivalent product, program, or service that does not infringe any existing intellectual property right may be used instead. Evaluation and verification of operation in conjunction with other products, programs, or services, except those expressly designated by the manufacturer, are the user's responsibility.

Lexmark and Lexmark with diamond design are trademarks of Lexmark International, Inc.

PrintCryption is a trademark of Lexmark International, Inc.

PCLfi is a registered trademark of the Hewlett-Packard Company.

PostScriptfi is a registered trademark of Adobe Systems Incorporated.

Other trademarks are the property of their respective owners.

#### UNITED STATES GOVERNMENT RIGHTS

This software and any accompanying documentation provided under this agreement are commercial computer software and documentation developed exclusively at private expense.

## Table of contents

<b>Notices and safety information</b> .....	<b>xiii</b>
Laser notice .....	xiii
Safety information .....	xvii
<b>Preface</b> .....	<b>xx</b>
Definitions .....	xx
<b>General information</b> .....	<b>1-1</b>
<b>Overview</b> .....	<b>1-1</b>
Resolution .....	1-1
Model differences .....	1-1
<b>Options and features</b> .....	<b>1-2</b>
Compatibility .....	1-2
<b>Technical specifications</b> .....	<b>1-3</b>
Toner darkness .....	1-3
Color correction settings .....	1-3
Physical specifications and weight .....	1-3
Print speed and performance .....	1-4
Performance .....	1-5
Time to first print .....	1-5
Processor .....	1-5
Duty cycle .....	1-5
Printer memory .....	1-6
Memory configuration .....	1-6
Available memory options .....	1-6
Memory and expansion slots .....	1-6
Resident fonts .....	1-6
<b>Paper and media specifications</b> .....	<b>1-7</b>
<b>Media size supported</b> .....	<b>1-8</b>
Input .....	1-8
Output .....	1-10
<b>Input media types and weights</b> .....	<b>1-12</b>
<b>Input capacity by media and source</b> .....	<b>1-13</b>
<b>Output capacity by media and source</b> .....	<b>1-14</b>
<b>Media guidelines</b> .....	<b>1-15</b>
Paper .....	1-15
Envelopes .....	1-15
Transparencies .....	1-15
Labels .....	1-15
Glossy paper .....	1-15
<b>Print area</b> .....	<b>1-15</b>
<b>Connectivity</b> .....	<b>1-16</b>
Standard .....	1-16
<b>Network connections</b> .....	<b>1-16</b>
Internal network connections .....	1-16
<b>Data streams</b> .....	<b>1-16</b>
<b>Operating systems</b> .....	<b>1-16</b>
<b>Power and electrical specifications</b> .....	<b>1-17</b>
<b>Power requirements</b> .....	<b>1-17</b>
Electrical specifications .....	1-17
Low voltage models .....	1-17
High voltage models .....	1-17
<b>Operating clearances</b> .....	<b>1-18</b>
<b>Environment</b> .....	<b>1-18</b>
Printer temperature and humidity .....	1-18

<b>Maintenance approach</b> .....	<b>1-19</b>
<b>Standard inspection and cleaning procedure</b> .....	<b>1-19</b>
<b>Return parts</b> .....	<b>1-20</b>
<b>Service recommendations</b> .....	<b>1-20</b>
<b>Tools</b> .....	<b>1-20</b>
<b>Serial number, configuration ID, and part number</b> .....	<b>1-20</b>
<b>Acronyms</b> .....	<b>1-21</b>
<b>Diagnostic information</b> .....	<b>2-1</b>
<b>Start</b> .....	<b>2-1</b>
<b>Initial check</b> .....	<b>2-1</b>
<b>Symptom table</b> .....	<b>2-3</b>
<b>Printer messages</b> .....	<b>2-5</b>
<b>Service error message tables</b> .....	<b>2-5</b>
900 - RIP software error .....	2-5
910 - Drive Motor Error .....	2-9
911 - Paper Exit Motor Error .....	2-9
912 - High-Capacity Feed Motor Error .....	2-10
917 - RIP Fan Error .....	2-10
918 - Main Unit Fan Error .....	2-10
919 - Power Supply Fan Error .....	2-10
920 - Fuser Error Fuser Heater Trouble .....	2-11
923 - Upper Fuser Thermistor Open Error .....	2-11
924 - Lower Fuser Thermistor Open Error .....	2-11
925 - HVU Error .....	2-12
926(K), 927(C), 928(Y), 929(M) - Toner Sensor Error .....	2-12
930 - Yellow Printhead Error .....	2-13
931 - Magenta Printhead Error .....	2-13
932 - Cyan Printhead Error .....	2-14
933 - Black Printhead Error .....	2-14
934 - Color Drum Sensor Error .....	2-15
935 - Black Drum Sensor Error .....	2-15
936 - 939 Cassette Error .....	2-15
940 - High-Capacity Feed Sensor Error .....	2-16
941 - High-Capacity Feed Tray Error .....	2-16
942 - Duplex Error .....	2-16
945 - Engine Flash Error .....	2-16
946 - Printer/Printhead Controller Board Communication Error .....	2-17
947 - Finisher Communication Error .....	2-17
948 - Machine ID Error .....	2-18
949 - Tray (x) Comm .....	2-18
950 - Mirror Mismatch .....	2-19
952 - NVRAM Chip Failure .....	2-19
954 - NVRAM CRC Failure .....	2-19
955 - Code CRC .....	2-19
956 - Processor Failure .....	2-20
957 - ASIC Failure .....	2-20
958 - NAND Failure .....	2-20
960 - RAM Slot 1 Bad .....	2-20
961 - RAM Slot 2 Bad .....	2-20
964 - Emulation Error .....	2-20
970 - Standard Network Error .....	2-20
975 - Unrecognizable Network Port .....	2-20
976 - Unrecoverable Software Error in Network Port .....	2-21
978 - Bad Checksum While Programming Network Card .....	2-21
979 - Flash Parts Failed While Programming Network Port .....	2-21
980 Face Up/Down Switching Error .....	2-21
981 - Belt Up/Down Sensor Error .....	2-22
982 - Sensor Controller Error .....	2-23



983 - Black Gear Sensor Error	2-23
984 - Yellow Gear Sensor Error	2-23
985 - Transfer Belt Thermistor Error	2-24
986 - Transparency (OHP) Sensor Error	2-24
987 - Service Toner Cartridge	2-24
991 - Service Paper Option	2-25
992 - Temperature/Humidity Sensor Error	2-25
993 - CPU Error	2-25
994 - Density Sensor Error	2-26
995 - Finisher Main Feed Motor abnormal	2-27
996 - Finisher Jogging Motor Error	2-27
997 - Finisher Tractor Motor Error	2-28
998 - Tray Elevator Motor Error	2-28
999 - Stapler Motor Error	2-29
<b>Attendance messages</b>	<b>2-30</b>
Clearing finisher messages	2-42
<b>Maintenance analysis procedures (MAPS)</b>	<b>2-43</b>
Map 1 - False Side Door Open message	2-43
Map 2 - False Close Front Door message	2-43
Map 3 - False Close Tray (x) Top Cover message	2-43
Map 4 - False Tray (x) Low/Empty message	2-44
Map 5 - False 30 Oil Coating Roll Missing message	2-44
Map 6 - False <color> Print Unit Missing message	2-45
Map 7 - False 88 <color> Toner Low/Toner Empty message	2-45
Map 8 - False 40 Tray (x) Size Sensor Error message	2-46
Map 9 - False 41 Open Bin 1 Exit Tray message	2-46
Map 10 - Unrecoverable Check Tray (x) or Duplex Connection message	2-47
Map 11 - Paper size map	2-48
Map 12 - Unable to print from USB drive service check	2-49
Map 13 - False tray (x) too full	2-49
Map 14 - False 32 - replace unsupported cartridge	2-49
<b>Service checks</b>	<b>2-50</b>
<b>Drive 1 DC motor service check</b>	<b>2-50</b>
<b>Paper exit motor service check</b>	<b>2-50</b>
<b>Duplex unit service check</b>	<b>2-50</b>
<b>Paper feed unit service check</b>	<b>2-51</b>
<b>Expansion paper feed service check</b>	<b>2-52</b>
<b>Face down stacker full service check</b>	<b>2-52</b>
<b>High-capacity feeder (HCF) service check</b>	<b>2-53</b>
<b>Finisher service check</b>	<b>2-54</b>
<b>Marks on paper service check</b>	<b>2-55</b>
<b>Operator panel service check</b>	<b>2-55</b>
<b>Paper carrying service check</b>	<b>2-56</b>
<b>Paper exit, face up service check</b>	<b>2-60</b>
<b>Paper skew service check</b>	<b>2-60</b>
<b>Paper tray missing service check</b>	<b>2-60</b>
<b>Photodeveloper missing service check</b>	<b>2-61</b>
<b>Power supply service check</b>	<b>2-61</b>
<b>210 Staple jam service check</b>	<b>2-62</b>
<b>Transfer belt up/down service check</b>	<b>2-62</b>
<b>Image quality troubleshooting</b>	<b>2-63</b>
<b>Print quality problems</b>	<b>2-63</b>
No image	2-66
Black line	2-66
Black print	2-67
Missing colors	2-67
Uneven printing	2-67
Periodic dirt	2-68
White spots	2-68

<b>Options service check</b> .....	<b>2-68</b>
Serial port .....	2-68
Flash Memory Option(s) .....	2-68
DRAM Memory Option(s) .....	2-68
Hard Disk Option .....	2-68
Network Card Option .....	2-69
Error Code 976 - Network Card x .....	2-69
54 Network <x> Software Error .....	2-69
<b>Diagnostic aids</b> .....	<b>3-1</b>
<b>Power-On Self Test sequence</b> .....	<b>3-1</b>
<b>Understanding the printer operator panel</b> .....	<b>3-2</b>
<b>Printing the menu settings</b> .....	<b>3-3</b>
<b>Operator menu disabled</b> .....	<b>3-3</b>
<b>Menu overview</b> .....	<b>3-4</b>
<b>Diagnostics</b> .....	<b>3-5</b>
Navigating the Diagnostics Menu .....	3-5
Diagnostics Menu Overview .....	3-5
<b>Alignment</b> .....	<b>3-7</b>
Auto Alignment .....	3-7
Cyan, Yellow, Magenta .....	3-7
<b>Print Tests</b> .....	<b>3-8</b>
[Input Source] Print Test .....	3-8
Output Bin 1 (Print Tests) .....	3-8
Print Quality Pages .....	3-8
<b>Hardware Tests</b> .....	<b>3-8</b>
Panel Test .....	3-8
Button Test .....	3-9
Cache Test .....	3-9
DRAM Test .....	3-10
Parallel Wrap Test .....	3-10
Serial Wrap Test .....	3-12
<b>Output Bin Tests</b> .....	<b>3-13</b>
Feed Tests (Output Bin) .....	3-13
Feed To All Bins .....	3-13
Sensor Test (Output Bin) .....	3-13
<b>Finisher Tests</b> .....	<b>3-14</b>
Feed Test .....	3-14
Hole Punch Test .....	3-14
Sensor/Sw Test .....	3-14
Staple Test .....	3-15
<b>Device Tests</b> .....	<b>3-16</b>
Quick Disk Test .....	3-16
Disk Test/Clean .....	3-16
Flash Test .....	3-16
<b>Printer Setup</b> .....	<b>3-17</b>
Defaults .....	3-17
Light Quantity .....	3-17
Page Counts .....	3-17
Serial Number .....	3-18
Model Name .....	3-18
Configuration ID .....	3-18
Reset Color Calibration .....	3-19
Par [x] Strobe Adj. .....	3-19
Par S Strobe Adj. .....	3-19
Par 1 Strobe Adj. .....	3-19
Par 2 Strobe Adj. .....	3-19
Par 3 Strobe Adj. .....	3-19

<b>Event Log</b> .....	<b>3-20</b>
Display .....	3-20
Print .....	3-20
Clear .....	3-20
<b>Exit Diagnostics</b> .....	<b>3-20</b>
<b>Configuration menu</b> .....	<b>3-21</b>
<b>Black only mode</b> .....	<b>3-21</b>
<b>Print quality pages</b> .....	<b>3-21</b>
<b>Color trapping</b> .....	<b>3-21</b>
<b>Panel menus</b> .....	<b>3-21</b>
<b>PPDS emulation</b> .....	<b>3-21</b>
<b>Demo mode</b> .....	<b>3-21</b>
<b>Factory defaults</b> .....	<b>3-22</b>
<b>Energy conserve</b> .....	<b>3-22</b>
<b>Event log</b> .....	<b>3-22</b>
<b>Auto align adjust</b> .....	<b>3-22</b>
<b>Auto color adjust</b> .....	<b>3-22</b>
<b>Paper prompts</b> .....	<b>3-22</b>
<b>Envelope prompts</b> .....	<b>3-22</b>
<b>Jobs on disk</b> .....	<b>3-23</b>
<b>Disk encryption</b> .....	<b>3-23</b>
<b>Font sharpening</b> .....	<b>3-23</b>
<b>Standby disabled</b> .....	<b>3-23</b>
<b>Exit config menu</b> .....	<b>3-23</b>
<b>Theory of operation</b> .....	<b>3-24</b>
<b>Processes and configuration</b> .....	<b>3-24</b>
<b>Electrophotography process</b> .....	<b>3-24</b>
<b>Development unit</b> .....	<b>3-24</b>
<b>Transfer unit</b> .....	<b>3-25</b>
<b>Cleaning unit</b> .....	<b>3-25</b>
<b>Fusing</b> .....	<b>3-26</b>
<b>Drive system</b> .....	<b>3-28</b>
<b>Paper feeding</b> .....	<b>3-29</b>
<b>Cassette paper feeder</b> .....	<b>3-29</b>
<b>Multipurpose feeding</b> .....	<b>3-30</b>
<b>Registration unit</b> .....	<b>3-30</b>
<b>Belt unit</b> .....	<b>3-31</b>
<b>Belt up/down</b> .....	<b>3-31</b>
<b>Delivery</b> .....	<b>3-32</b>
<b>Expansion paper feeder</b> .....	<b>3-32</b>
<b>Duplex unit</b> .....	<b>3-32</b>
<b>Paper weight</b> .....	<b>3-33</b>
Purpose: .....	3-33
Values: .....	3-33
<b>Clearing paper jams</b> .....	<b>3-34</b>
200 Paper Jam .....	3-34
250 Paper Jam .....	3-36
241 244 Paper Jam .....	3-37
249 Paper Jam .....	3-37
<b>High-capacity feeder (HCF)</b> .....	<b>3-38</b>
Paper feed and separation mechanism .....	3-38
Registration operation .....	3-38
Tray up/down mechanism .....	3-39
Tray up condition .....	3-40
Tray down condition .....	3-40
Size detection mechanism .....	3-41
Residual paper detection mechanism .....	3-42
Paper end detection .....	3-42

<b>Maintenance Mode</b> .....	<b>3-43</b>
DIP switch specifications .....	3-43
<b>Finisher</b> .....	<b>3-44</b>
Finisher cross section .....	3-45
Electrical parts function .....	3-45
Paper feed mechanism .....	3-46
Straight paper path (exit paper to upper tray) .....	3-46
Path select gate .....	3-46
Inverting paper path (exit paper to lower tray through accumulator) .....	3-47
Accumulator .....	3-47
Paper registration sequence .....	3-48
Punch unit driving sequence .....	3-48
Jogging / offset mechanism .....	3-49
Jogging sequence .....	3-49
Offsetting sequence .....	3-49
Detection of fixed position .....	3-49
Stapling mechanism .....	3-50
Elevator sequence .....	3-51
<b>Finisher installation</b> .....	<b>3-52</b>
<b>Attaching the docking plate and guide rail</b> .....	<b>3-52</b>
<b>Combining the finisher and stand</b> .....	<b>3-54</b>
<b>Attaching the bins</b> .....	<b>3-58</b>
<b>Aligning the finisher and printer</b> .....	<b>3-59</b>
Lowering or raising the finisher .....	3-60
Aligning the sides of the finisher .....	3-62
Aligning the top of the finisher .....	3-63
<b>Adjusting the wheels</b> .....	<b>3-64</b>
<b>Attaching the cables</b> .....	<b>3-65</b>
Interface cable .....	3-66
Power cable .....	3-67
<b>Hole punch adjustment</b> .....	<b>3-69</b>
<b>Repair information</b> .....	<b>4-1</b>
<b>Handling ESD-sensitive parts</b> .....	<b>4-1</b>
<b>Service precautions</b> .....	<b>4-1</b>
<b>RIP board/operator panel replacement</b> .....	<b>4-2</b>
<b>Handling printed circuit boards</b> .....	<b>4-2</b>
Transportation/storage .....	4-2
Replacement: .....	4-2
Inspection: .....	4-2
<b>Check finisher alignment when moving or servicing the finisher</b> .....	<b>4-3</b>
<b>Adjustments</b> .....	<b>4-4</b>
<b>High-capacity paper feed timing belt adjustment</b> .....	<b>4-4</b>
<b>Adjustments and procedures following parts replacement</b> .....	<b>4-4</b>
<b>Removals</b> .....	<b>4-6</b>
Cover, top removal .....	4-6
Front door / operator panel removal .....	4-7
Cover, front left removal .....	4-8
Cover, rear removal .....	4-9
Cover, solenoid removal .....	4-9
Cover, left side removal .....	4-9
Cover, right side removal .....	4-10
Cover, RIP board removal .....	4-11
Tray, paper exit removal .....	4-12
Belt up/down clutch removal .....	4-12
Cassette guide removal .....	4-13
CK1 daughter board removal .....	4-13
CK2 daughter board removal .....	4-13
Connector, duplex unit removal .....	4-14

Paper tray lift motor removal	4-14
Density sensor removal/Separation fingers removal/Sensor cleaner removal	4-15
Drive gear unit sensor assembly removal	4-15
Electronic box removal	4-16
Face up paper exit assembly removal	4-17
Front cover open switch actuator removal	4-17
Fuser removal	4-18
Gear cover removal/Multipurpose feeder frame assembly	4-19
High voltage power supply board (HVPS) removal	4-20
LED printhead removal	4-20
Eraser removal	4-21
Lock handle assembly removal	4-22
Main drive unit removal	4-23
Main unit fan removal	4-25
Motor drive board removal	4-25
Multipurpose feeder paper present sensor removal	4-25
Multipurpose feeder tray removal	4-26
Paper feed unit removal	4-26
Paper-feed rollers removal	4-28
Paperpath maintenance	4-28
Paper carrying frame removal / roll removal	4-29
Registration frame	4-30
Registration clutch removal	4-30
Registration sensor removal	4-30
	4-30
Relay roller removal	4-31
Face down guide assembly removal	4-32
Face down exit roll removal	4-32
Power supply 1 removal	4-35
Power supply 2 removal	4-36
Power switch removal	4-37
Printer controller removal	4-37
Printhead controller board removal	4-38
Left slide rail removal	4-39
RIP box removal	4-39
Sensor board removal	4-40
Stay arm removal	4-40
Sub-frame removal	4-41
Sub frame F1, sub frame F2 removal	4-42
Temperature/humidity sensor removal	4-42
Top unit removal	4-43
Transfer belt removal	4-43
Turn guide cover sensor removal	4-47
Upper fan removal	4-47
Expansion feeder removals	4-49
Turn guide door removal	4-49
Expansion feeder controller board removal	4-49
Size sensor board removal	4-49
Stepper motor removal	4-50
Paper feed assembly removal	4-51
Paper tray lift motor removal	4-52
Expansion feeder turn guide door sensor assembly removal	4-52

Duplex removals	4-53
Duplex unit separation removal	4-53
Duplex unit removal	4-54
Duplex timing belt removal	4-54
Duplex pressure roller and solenoid removal	4-55
Duplex feed roller and solenoid removal	4-55
Duplex side fence motor assembly/side fence removal	4-56
Duplex paper carrying motor removal	4-57
High-capacity feeder (HCF) removals	4-58
HCF covers removal	4-58
HCF call roller, paper feed roller, reverse roller removal	4-59
HCF pickup solenoid removal	4-59
HCF paper end sensor removal	4-60
HCF paper size sensors (1, 2) removal	4-60
HCF tray motor removal	4-61
HCF paper level sensor removal	4-62
HCF power supply removal	4-62
Finisher removals	4-63
External covers removals	4-63
Finisher control board removal	4-64
Elevator motor removal	4-65
Feed motor assembly removal	4-65
Hole punch removal	4-66
Inverter paper exit discharge brush removal	4-67
Inverter paper exit roller removal	4-67
Jogging unit removal	4-68
Path select gate removal	4-69
Patting roller removal	4-70
Power supply removal	4-72
Registration roller removal	4-73
Registration roller clutch removal	4-73
Stack area discharge brush removal	4-74
Staple unit removal	4-74
Straight paper exit discharge brush removal	4-75
Straight paper exit roller removal	4-75
Timing belts 1 and 2 removal	4-77
Tractor belt removal	4-78
Tractor drive motor assembly removal	4-79

## Locations 5-1

Covers diagram	5-1
Major parts diagram	5-2
Sensor and switch locations	5-3
Component locations	5-4
Printer controller board	5-5
Printer controller board connectors	5-6
Printhead controller board	5-7
Printhead controller board connectors	5-8
CK1 board connectors	5-9
CK2 board connectors	5-10
RIP board	5-11
RIP board connectors	5-11
LVPS 1 board connectors	5-12
LVPS 2 board connectors	5-13
High voltage power supply board	5-14
Sensor board connectors	5-14
Expansion paper feeder controller board	5-15
Duplex unit controller board	5-16
Motor drive board connectors	5-16

Size sensor board .....	5-17
Paper feed actuators .....	5-18
Paper feed roller clutch .....	5-18
High-capacity feeder (HCF) .....	5-19
High-capacity paper feed configuration .....	5-19
Electrical parts layout .....	5-20
Driving parts layout .....	5-20
Finisher locations .....	5-21
<b>Preventive maintenance .....</b>	<b>6-1</b>
Maintenance kit .....	6-1
Paper path maintenance .....	6-1
Periodic maintenance .....	6-2
Lubricants and cleaners .....	6-2
<b>Parts catalog .....</b>	<b>7-1</b>
How to use this parts catalog .....	7-1
Assembly 1: Covers 1 .....	7-2
Assembly 2: Covers 2 .....	7-4
Assembly 3: Covers 3 .....	7-5
Assembly 4: Covers 4 .....	7-6
Assembly 5: Covers 5 .....	7-7
Assembly 6: Upper unit .....	7-8
Assembly 7: Paper feed .....	7-10
Assembly 8: Base 2 .....	7-12
Assembly 9: Base 3 .....	7-14
Assembly 10: Electrical A .....	7-16
Assembly 11: Electrical B .....	7-20
Assembly 12: RIP board .....	7-22
Assembly 13: Fuser unit .....	7-23
Assembly 14: Cassette .....	7-24
Assembly 15: Expansion feeder 1 .....	7-26
Assembly 16: Expansion feeder 2 .....	7-28
Assembly 17: Duplex unit 1 .....	7-30
Assembly 18: Duplex Unit 1 .....	7-31
Assembly 19: Duplex unit 2 .....	7-32
Assembly 20: High-capacity feeder 1 .....	7-34
Assembly 21: High-capacity feeder 2 .....	7-36
Assembly 22: High-capacity feeder 3 .....	7-38
Assembly 23: High-capacity feeder 4 .....	7-40
Assembly 24: High-capacity feeder 5 .....	7-42
Assembly 25: High-capacity feeder 6 .....	7-44
Assembly 26: Finisher covers .....	7-46
Assembly 27: Finisher frame .....	7-48
Assembly 28: Finisher feed 1 .....	7-50
Assembly 29: Finisher feed 2 .....	7-52
Assembly 30: Finisher elevator .....	7-53
Assembly 31: Finisher electronics .....	7-54
Assembly 32: Finisher docking 1 .....	7-55
Assembly 33: Finisher docking 2 .....	7-56
Assembly 34: Miscellaneous/options .....	7-57
Assembly 35: Parts packets .....	7-58
Assembly 36: Finisher parts packet P/N 56P9480 .....	7-63
<b>Index .....</b>	<b>I-1</b>
<b>Part number index .....</b>	<b>I-7</b>





---

## Notices and safety information

---

### Laser notice

The printer is certified in the U.S. to conform to the requirements of DHHS 21 CFR Subchapter J for Class I (1) laser products, and elsewhere is certified as a Class I laser product conforming to the requirements of IEC 60825-1.

Class I laser products are not considered to be hazardous. The printer contains internally a Class IIIb (3b) laser that is nominally a 5 milliwatt gallium arsenide laser operating in the wavelength region of 770-795 nanometers. The laser system and printer are designed so there is never any human access to laser radiation above a Class I level during normal operation, user maintenance, or prescribed service condition.

---

### Laser

Der Drucker erfüllt gemäß amtlicher Bestätigung der USA die Anforderungen der Bestimmung DHHS (Department of Health and Human Services) 21 CFR Teil J für Laserprodukte der Klasse I (1). In anderen Ländern gilt der Drucker als Laserprodukt der Klasse I, der die Anforderungen der IEC (International Electrotechnical Commission) 60825-1 gemäß amtlicher Bestätigung erfüllt.

Laserprodukte der Klasse I gelten als unschädlich. Im Inneren des Druckers befindet sich ein Laser der Klasse IIIb (3b), bei dem es sich um einen Galliumarsenlaser mit 5 Milliwatt handelt, der Wellen der Länge 770-795 Nanometer ausstrahlt. Das Lasersystem und der Drucker sind so konzipiert, dass im Normalbetrieb, bei der Wartung durch den Benutzer oder bei ordnungsgemäßer Wartung durch den Kundendienst Laserbestrahlung, die Klasse I übersteigen würde, Menschen keinesfalls erreicht.

---

### Avis relatif à l'utilisation de laser

Pour les Etats-Unis : cette imprimante est certifiée conforme aux provisions DHHS 21 CFR alinéa J concernant les produits laser de Classe I (1). Pour les autres pays : cette imprimante répond aux normes IEC 60825-1 relatives aux produits laser de Classe I.

Les produits laser de Classe I sont considérés comme des produits non dangereux. Cette imprimante est équipée d'un laser de Classe IIIb (3b) (arséniure de gallium d'une puissance nominale de 5 milliwatts) émettant sur des longueurs d'onde comprises entre 770 et 795 nanomètres. L'imprimante et son système laser sont conçus pour impossible, dans des conditions normales d'utilisation, d'entretien par l'utilisateur ou de révision, l'exposition des rayonnements laser supérieurs des rayonnements de Classe I.

---

### Avvertenze sui prodotti laser

Questa stampante è certificata negli Stati Uniti per essere conforme ai requisiti del DHHS 21 CFR Sottocapitolo J per i prodotti laser di classe 1 ed è certificata negli altri Paesi come prodotto laser di classe 1 conforme ai requisiti della norma CEI 60825-1.

I prodotti laser di classe non sono considerati pericolosi. La stampante contiene al suo interno un laser di classe IIIb (3b) all'arseniuro di gallio della potenza di 5mW che opera sulla lunghezza d'onda compresa tra 770 e 795 nanometri. Il sistema laser e la stampante sono stati progettati in modo tale che le persone a contatto con la stampante, durante il normale funzionamento, le operazioni di servizio o quelle di assistenza tecnica, non ricevano radiazioni laser superiori al livello della classe 1.

---

## Avisos sobre el láser

Se certifica que, en los EE.UU., esta impresora cumple los requisitos para los productos Láser de Clase I (1) establecidos en el subcapítulo J de la norma CFR 21 del DHHS (Departamento de Sanidad y Servicios) y, en los demás países, reúne todas las condiciones expuestas en la norma IEC 60825-1 para productos Láser de Clase I (1).

Los productos Láser de Clase I no se consideran peligrosos. La impresora contiene en su interior un Láser de Clase IIIb (3b) de arseniuro de galio de funcionamiento nominal a 5 milivatios en una longitud de onda de 770 a 795 nanómetros. El sistema Láser y la impresora están diseñados de forma que ninguna persona pueda verse afectada por ningún tipo de radiación Láser superior al nivel de la Clase I durante su uso normal, el mantenimiento realizado por el usuario o cualquier otra situación de servicio técnico.

---

## Declaração sobre Laser

A impressora está certificada nos E.U.A. em conformidade com os requisitos da regulamentação do DHHS 21 CFR Subcapítulo J para a Classe I (1) de produtos laser. Em outros locais, está certificada como um produto laser da Classe I, em conformidade com os requisitos da norma IEC 60825-1.

Os produtos laser da Classe I não são considerados perigosos. Internamente, a impressora contém um produto laser da Classe IIIb (3b), designado laser de arseneto de potássio, de 5 milliwatts, operando numa faixa de comprimento de onda entre 770 e 795 nanómetros. O sistema e a impressora laser foram concebidos de forma a nunca existir qualquer possibilidade de acesso humano a radiação laser superior a um nível de Classe I durante a operação normal, a manutenção feita pelo utilizador ou condições de assistência prescritas.

---

## Laserinformatie

De printer voldoet aan de eisen die gesteld worden aan een laserproduct van klasse I. Voor de Verenigde Staten zijn deze eisen vastgelegd in DHHS 21 CFR Subchapter J, voor andere landen in IEC 60825-1.

Laserprodukten van klasse I worden niet als ongevaarlijk aangemerkt. De printer is voorzien van een laser van klasse IIIb (3b), dat wil zeggen een gallium arsenide-laser van 5 milliwatt met een golflengte van 770-795 nanometer. Het lasergedeelte en de printer zijn zo ontworpen dat bij normaal gebruik, bij onderhoud of reparatie conform de voorschriften, nooit blootstelling mogelijk is aan laserstraling boven een niveau zoals voorgeschreven is voor klasse 1.

---

## Lasermeddelelse

Printeren er godkendt som et Klasse I-laserprodukt, i overensstemmelse med kravene i IEC 60825-1.

Klasse I-laserprodukter betragtes ikke som farlige. Printeren indeholder internt en Klasse IIIB (3b)-laser, der nominelt er en 5 milliwatt galliumarsenid laser, som arbejder på bølglængdeområdet 770-795 nanometer. Lasersystemet og printeren er udformet således, at mennesker aldrig udsættes for en laserstråling over Klasse I-niveau ved normal drift, brugervedligeholdelse eller obligatoriske servicebetingelser.

---

## Huomautus laserlaitteesta

Tämä kirjoitin on Yhdysvalloissa luokan I (1) laserlaitteiden DHHS 21 CFR Subchapter J-määrityksen mukainen ja muualla luokan I laserlaitteiden IEC 60825-1 -määrityksen mukainen.

Luokan I laserlaitteiden ei katsota olevan vaarallisia käyttäjille. Kirjoittimessa on sisäinen luokan IIIb (3b) 5 milliwatin galliumarsenidilaser, joka toimii aaltoalueella 770 - 795 nanometriä. Laserjärjestelmä ja kirjoitin on suunniteltu siten, että käyttäjä ei altistu luokan I määräyksiä voimakkaammalle säteilylle kirjoittimen normaalin toiminnan, käyttäjän tekemien huoltotoimien tai muiden huoltotoimien yhteydessä.

VARO! Avattaessa ja suojalukitus ohitettaessa olet alttiina kymmeniä milliwattien lasersäteilylle. Älä katso silmiin.

WARNING! Osynlig laserstrålning när denna del öppnas och spårren är urkopplad. Beträkta ej strålen.

---

## Laser-notis

Denna skrivare är i USA certifierad att motsvara kraven i DHHS 21 CFR, underparagraf J för laserprodukter av Klass I (1). I andra länder uppfyller skrivaren kraven för laserprodukter av Klass I enligt kraven i IEC 60825-1.

Laserprodukter i Klass I anses ej hörsovdliga. Skrivaren har en inbyggd laser av Klass IIIb (3b) som består av en laserenhet av gallium-arsenid på 5 milliwatt som arbetar i våglängdsområdet 770-795 nanometer.

Lasersystemet och skrivaren är utformade så att det aldrig finns risk för att någon person utsätts för laserstrålning över Klass I-nivån vid normal användning, underhåll som utförs av användaren eller annan fackreskriven servicepersonal.

---

## Laser-melding

Skriveren er godkjent i USA etter kravene i DHHS 21 CFR, underkapittel J, for klasse I (1) laserprodukter, og er i andre land godkjent som et Klasse I-laserprodukt i samsvar med kravene i IEC 60825-1.

Klasse I-laserprodukter er ikke betrakte som farlige. Skriveren inneholder internt en klasse IIIb (3b)-laser, som består av en gallium-arsenlaserenhet som avgir stråling i bølglengdeområdet 770-795 nanometer.

Lasersystemet og skriveren er utformet slik at personer aldri utsettes for laserstråling ut over klasse I-nivå under vanlig bruk, vedlikehold som utføres av brukeren, eller foreskrevne serviceoperasjoner.

---

## Avís sobre el Làser

Segons ha estat certificat als Estats Units, aquesta impressora compleix els requisits de DHHS 21 CFR, apartat J, pels productes I ser de classe I (1), i segons ha estat certificat en altres llocs, és un producte I ser de classe I que compleix els requisits d'IEC 60825-1.

Els productes I ser de classe I no es consideren perillosos. Aquesta impressora conté un I ser de classe IIIb (3b) d'arseni de gal·li, nominalment de 5 mil·liwatts, i funciona a la regió de longitud d'ona de 770-795 nanometres. El sistema I ser i la impressora han sigut concebuts de manera que mai hi hagi exposició a la radiació I ser per sobre d'un nivell de classe I durant una operació normal, durant les tasques de manteniment d'usuari ni durant els serveis que satisfacin les condicions prescrites.

---

#### レーザーに関するお知らせ

このプリンターは、米国ではDHHS 21 CFRサブチャプターJのクラスI (1)の基準を満たしたレーザー製品であることが証明されています。また米国以外ではIEC 825の基準を満たしたクラスIのレーザー製品であることが証明されています。

クラスIのレーザー製品には危険性はないと考えられています。このプリンターはクラスIII b (3 b)のレーザーを内蔵しています。このレーザーは、波長が770 ~ 795ナノメートルの範囲で、通常5ミリワットのガリウム砒化物を放射するレーザーです。このレーザーシステムとプリンターは、通常の操作、ユーザのメンテナンス、規定された修理においては、人体がクラスIのレベル以上のレーザー放射に晒されることのないよう設計されています。

---

#### 注意：

本打印机被美国认证合乎 DHHS 21 CFR Subchapter I 对分类 I (1) 激光产品的标准，而在其他地区则被认证合乎 IEC 825 的标准。

分类 I 激光产品一般认为不具危险性，本打印机内部含有分类 IIIb (3b) 的激光，在操作过程中会产生 5 毫瓦含镓及砷的微量激光，其波长范围在 770-795 nm 之间。本激光系统及打印机的设计，在一般操作、使用者维护或规定内的维修情况下，不会使人体接触分类 I 以上等级的辐射。

---

본프린터는 1등급 레이저 제품들에 대한 DHHS 21 CFR Subchapter 3의 규정을 준수하고 있음을 미국에서 인증받았으며, 그외의 나라에서도 IEC 825 규정을 준수하는 1등급 레이저 제품으로서 인증을 받았습니다.

1등급 레이저 제품들은 안전한 것으로 간주됩니다. 본 프린터는 5 밀리วัต 갈륨 아르세나이드 레이저로서 770-795 나노미터의 파장대에서 활동하는 Class III (3b) 레이저를 내부에 갖고 있습니다. 본 레이저 시스템과 프린터는 정상 작동 중이나 유지 보수 중 또는 규정된 서비스 상태에서 상기의 Class I 수준의 레이저 방출에 사람이 절대 접근할 수 없도록 설계되어 있습니다.

---

## Safety information

- The safety of this product is based on testing and approvals of the original design and specific components. The manufacturer is not responsible for safety in the event of use of unauthorized replacement parts.
- The maintenance information for this product has been prepared for use by a professional service person and is not intended to be used by others.
- There may be an increased risk of electric shock and personal injury during disassembly and servicing of this product. Professional service personnel should understand this and take necessary precautions.
-  **CAUTION:** When you see this symbol, there is a danger from hazardous voltage in the area of the product where you are working. Unplug the product before you begin, or use caution if the product must receive power in order to perform the task.

---

## Consignes de sécurité

- La sécurité de ce produit repose sur des tests et des agrégations portant sur sa conception d'origine et sur des composants particuliers. Le fabricant n'assume aucune responsabilité concernant la sécurité en cas d'utilisation de pièces de rechange non agréées.
- Les consignes d'entretien et de réparation de ce produit s'adressent uniquement à un personnel de maintenance qualifié.
- Le démontage et l'entretien de ce produit pouvant présenter certains risques électriques, le personnel d'entretien qualifié devra prendre toutes les précautions nécessaires.
-  **ATTENTION :** Ce symbole indique la présence d'une tension dangereuse dans la partie du produit sur laquelle vous travaillez. Débranchez le produit avant de commencer ou faites preuve de vigilance si l'exécution de la tâche exige que le produit reste sous tension.

---

## Norme di sicurezza

- La sicurezza del prodotto si basa sui test e sull'approvazione del progetto originale e dei componenti specifici. Il produttore non è responsabile per la sicurezza in caso di sostituzione non autorizzata delle parti.
- Le informazioni riguardanti la manutenzione di questo prodotto sono indirizzate soltanto al personale di assistenza autorizzato.
- Durante lo smontaggio e la manutenzione di questo prodotto, il rischio di subire scosse elettriche e danni alla persona è più elevato. Il personale di assistenza autorizzato deve, quindi, adottare le precauzioni necessarie.
-  **ATTENZIONE:** Questo simbolo indica la presenza di tensione pericolosa nell'area del prodotto. Scollegare il prodotto prima di iniziare o usare cautela se il prodotto deve essere alimentato per eseguire l'intervento.

---

## Sicherheitshinweise

- Die Sicherheit dieses Produkts basiert auf Tests und Zulassungen des ursprünglichen Modells und bestimmter Bauteile. Bei Verwendung nicht genehmigter Ersatzteile wird vom Hersteller keine Verantwortung oder Haftung für die Sicherheit übernommen.
- Die Wartungsinformationen für dieses Produkt sind ausschließlich für die Verwendung durch einen Wartungsfachmann bestimmt.
- Während des Auseinandernehmens und der Wartung des Geräts besteht ein zusätzliches Risiko eines elektrischen Schlags und körperlicher Verletzung. Das zuständige Fachpersonal sollte entsprechende Vorsichtsmaßnahmen treffen.
-  **ACHTUNG:** Dieses Symbol weist auf eine gefährliche elektrische Spannung hin, die in diesem Bereich des Produkts auftreten kann. Ziehen Sie vor den Arbeiten am Gerät den Netzstecker des Geräts, bzw. arbeiten Sie mit großer Vorsicht, wenn das Produkt für die Ausführung der Arbeiten an den Strom angeschlossen sein muss.

---

## Pautas de Seguridad

- La seguridad de este producto se basa en pruebas y aprobaciones del diseño original y componentes específicos. El fabricante no es responsable de la seguridad en caso de uso de piezas de repuesto no autorizadas.
- La información sobre el mantenimiento de este producto está dirigida exclusivamente al personal cualificado de mantenimiento.
- Existe mayor riesgo de descarga eléctrica y de daños personales durante el desmontaje y la reparación de la máquina. El personal cualificado debe ser consciente de este peligro y tomar las precauciones necesarias.
-  **PRECAUCIÓN:** este símbolo indica que el voltaje de la parte del equipo con la que está trabajando es peligroso. Antes de empezar, desenchufe el equipo o tenga cuidado si, para trabajar con Ø, debe conectarlo.

---

## Informações de Segurança

- A segurança deste produto baseia-se em testes e aprovações do modelo original e de componentes específicos. O fabricante não é responsável pela segurança, no caso de uso de peças de substituição não autorizadas.
- As informações de segurança relativas a este produto destinam-se a profissionais destes serviços e não devem ser utilizadas por outras pessoas.
- Risco de choques elétricos e ferimentos graves durante a desmontagem e manutenção deste produto. Os profissionais destes serviços devem estar avisados deste facto e tomar os cuidados necessários.
-  **CUIDADO:** Quando vir este símbolo, existe a possibilidade de uma potencial tensão perigosa na zona do produto em que está a trabalhar. Antes de começar, desligue o produto da tomada elétrica ou seja cuidadoso caso o produto tenha de estar ligado à corrente elétrica para realizar a tarefa necessária.

---

## Informació de Seguretat

- La seguretat d'aquest producte es basa en l'avaluació i aprovació del disseny original i els components específics.  
El fabricant no es fa responsable de les qüestions de seguretat si s'utilitzen peces de recanvi no autoritzades.
- La informació pel manteniment d'aquest producte està orientada exclusivament a professionals i no està destinada a ningú que no ho sigui.
- El risc de xoc elèctric i de danys personals pot augmentar durant el procés de desmuntatge i de servei d'aquest producte. El personal professional ha d'estar-ne assabentat i prendre les mesures convenients.
-  **PRECAUCIÓ:** aquest símbol indica que el voltatge de la part de l'equip amb la qual esteu treballant és perillós. Abans de començar, desendolieu l'equip o extremeu les precaucions si, per treballar amb l'equip, l'heu de connectar.

---

## 안전 사항

- 본 제품은 원래 설계 및 특정 구성품에 대한 테스트 결과로 안정성이 입증된 것입니다. 따라서 무허가 교체부품을 사용하는 경우에는 제조업체에서 안전에 대한 책임을 지지 않습니다.
- 본 제품에 관한 유지 보수 설명서는 전문 서비스 기술자용으로 작성된 것이므로, 비전문가는 사용할 수 없습니다.
- 본 제품을 해체하거나 정비할 경우, 전기적인 충격을 받거나 상처를 입을 위험이 커집니다. 전문 서비스 기술자는 이 사실을 숙지하고, 필요한 예방 조치를 취하도록 하십시오.
-  **주의:** 이 표시는 해당영역에서 고압전류가 흐른다는 위험 표시입니다. 시작전에 플러그를 뽑으시거나, 주의를 기울여 주시기 바랍니다.

---

## 安全信息

- 本产品的安全性以原来设计和特定产品的测试结果和认证为基础。万一使用未经许可的替换部件，制造商不对安全性负责。
- 本产品的维护信息仅供专业服务人员使用，并不打算让其他人使用。
- 本产品在拆卸、维修时，遭受电击或人员受伤的危险性会增高，专业服务人员对这点必须有所了解，并采取必要的预防措施。
-  **切记:** 当您看到此符号时，说明在您工作的产品区域有危险电压的存在。请在开始操作前拔掉产品的电源线，或者在产品必须使用电源来执行任务时，小心从事。

## Preface

This manual contains maintenance procedures for service personnel. It is divided into the following chapters:

1. **General information** contains a general description of the printer and the maintenance approach used to repair it. Special tools and test equipment are listed, as well as general environmental and safety instructions.
2. **Diagnostic information** contains an error indicator table, symptom tables, and service checks used to isolate failing field replaceable units (FRUs).
3. **Diagnostic aids** contains tests and checks used to locate or repeat symptoms of printer problems.
4. **Repair information** provides instructions for making printer adjustments and removing and installing FRUs.
5. **Connector locations** uses illustrations to identify the connector locations and test points on the printer.
6. **Preventive maintenance** contains the lubrication specifications and recommendations to prevent problems.
7. **Parts catalog** contains illustrations and part numbers for individual FRUs.

---

## Definitions

**Note:** A *note* provides additional information.

**Warning:** A *warning* identifies something that might damage the product hardware or software.

**CAUTION:** A *caution* identifies something that might cause a servicer harm.



**CAUTION:** When you see this symbol, there is a danger from hazardous voltage in the area of the product where you are working. Unplug the product before you begin, or use caution if the product must receive power in order to perform the task.



# 1. General information

## Overview

The 360CP is a high-speed, wide-format color LED electrophotographic printer with superior print quality for high-volume printing.

## Resolution

- 600 x 600 dpi
- 2400 image quality

## Model differences

		360CP		
32/36 ppm engine		X		
USB/parallel		X		
USB/Ethernet		X		
Memory (MB)		256		
Direct USB		X		
<b>Options available</b>				
550-sheet drawer				
Duplex				
Hard disk				
Staple and punch finisher w/ stand				
Printer cabinet				
2 X 550 + base				
High Capacity Feeder				
512 MB Memory				

All the options shown in the table are available for the 360CP.

---

## Options and features

### Compatibility

The Toshiba eST360CP color printer supports only 360CP paper-handling options. The printer's media options include:

- 550-sheet optional drawer—can be installed beneath the printer to offer an added input source which holds approximately 550 sheets of 20 lb paper. Multiple optional drawers are supported simultaneously (up to four drawers). For capacity estimates on other media types, see Media Support.
- 2 x 550-sheet drawer with printer stand supports A3, A4, JIS-B4, letter, legal, and tabloid (11x17") sizes. Only paper (16—32 lb or 60—120 g/m<sup>2</sup>) may be used from the two trays in this drawer. Includes two 550-sheet trays.
- Duplex unit— offers two-sided printing capability for the 360CP. The duplex option may be installed by the customer on the left side of the printer, or may be shipped inside the printer (dn and dtn models). Duplex does not support card stock, transparencies, labels, or envelopes. For media weights supported by the duplex unit, see Media Support.
- High-capacity feeder— provides an additional input tray (tray 3 or 5, depending on the configuration) with a total capacity of 3000 sheets, 20 lb (75 g/m<sup>2</sup>) A4/letter, plain paper). The 360CP optional high-capacity feeder is installed by the customer to the right side of the printer. The input trays support sensing for size (see supported sizes below), tray low, and tray empty.

#### Characteristics

- Capacity— 3,000 sheets, 20 lb (75 g/m<sup>2</sup>) plain paper
- Media type support—paper bond
- Sizes supported (with auto size sensing)—A4 and letter, 16—28 lb (60-105 g/m<sup>2</sup>)
- Card stock, transparency, labels, or envelopes are not supported.
- The HCF requires its own line cord
- Finisher— offers stapling, hole punching, offset stacking, and an additional output bin. Two models are available. 3- or 4-hole left-edge hole punching is available. The single staple position is the upper left corner. The finisher can support up to 1,100 sheets of unstapled, un-punched media. For stapled media, the output bin supports up to 30 stapled sets or 1,000 sheets. The stapler can staple a maximum of 30 sheets per set. Each printer can support a single finisher.

---

## Technical specifications

### ***Toner darkness***

Toner darkness settings offer five user-selectable settings to balance print darkness and toner savings. The higher the setting, the darker the print. Within the range of print darkness settings, up to 50% toner savings can be realized from the factory default setting of 4. The toner darkness setting is available through the operator panel under the Print Quality menu. Available in PostScript and PCL/XL jobs.

### ***Color correction settings***

There are three color correction settings to provide flexibility in choosing the type of color correction to be applied when printing a file.

- Auto (default) applies different color correction to each object on the printed page depending upon the type of object (text, graphics or image), and how the color for each object is specified.
- Manual allows users to customize color correction output from the operator panel. Setting selectable from the driver.
- Off no color correction is implemented.

### ***Physical specifications and weight***

Description	Height	Width	Depth	Weight
<b>Printer dimensions</b>				
360CP	20.2 in. (512 mm)	27.4 in. (695 mm)	28 in. (705 mm)	177.1 lb (80.5 kg)
<b>Paper options</b>				
Duplex option	23.8 in. (604 mm)	27.4 in. (695 mm)	13.8 in. (350 mm)	13.0 lb (5.9 kg)
550-sheet drawer <sup>1</sup>	5.1 in. (129 mm)	22 in. (559 mm)	25.8 in. (655 mm)	40.8 lb (18.5 kg)
High-capacity feeder, 3000-sheet	25.0 in. (635 mm)	14.2 in. (360 mm)	20.7 in. (525 mm)	50.0 lb (22.6 kg)
Staple Punch finisher (with stand)	41.7 in. (1060 mm)	19.5 in. (495 mm)	20.5 in. (520 mm)	56.9 lb (25.9 kg)
<b>Furniture</b>				
Printer cabinet	20.4 in. (517 mm)	26.6 in. (675 mm)	23.6 in. (598 mm)	57.5 lb (26.0 kg)
Printer base	10.2 in. (260 mm)	26.6 in. (675 mm)	21.6 in. (547 mm)	33.0 lb (15.0 kg)

<sup>1</sup> Also available in 2 x 550 + base

## Print speed and performance

Media size	Standard tray (ppm) (mono <sup>1</sup> /color)	High-capacity feeder (ppm) (mono <sup>1</sup> /color)	Multipurpose feeder (ppm) (mono <sup>1</sup> /color)
<b>Simplex printing (pages per minute)</b>			
Letter - LEF	36/32	36/32	36/32
Letter - SEF	N/S	N/S	28/25
Ledger - SEF	20/17	N/S	20/17
Legal - SEF	23/20	N/S	23/20
A3 - SEF	20/17	N/S	20/17
A4 - LEF	36/32	36/32	36/32
A4 - SEF	N/S	N/S	27/23
A5 - LEF	N/S	N/S	49/43
A5 - SEF	N/S	N/S	36/32
B4 - SEF	22/20	N/S	22/20
B5 - LEF	41/36	N/S	41/36
B5 - SEF	31/27	N/S	31/27
Transparencies - LEF	22/12	N/S	22/12
Vinyl - LEF	N/S	N/S	13
Card stock - LEF	N/S	N/S	11
Envelopes - LEF	N/S	N/S	11
Paper labels	22	N/S	22
<b>Duplex printing (sides per minute)</b>			
Letter - LEF	21/19	21/19	21/19
Letter - SEF	15/13		15/13
Ledger - SEF	12/11	N/S	12/11
Legal - SEF	14/12	N/S	14/12
A3 - SEF	12/11	N/S	12/11
A4 - LEF	21/19	21/19	21/19
A4 - SEF	15/13		15/13
A5 - SEF	21/19		21/19
A5/Exec - LEF	23/20	N/S	23/20
B4 - SEF	13/12	N/S	13/12
B5 - SEF	20/17		20/17
B5 - LEF	22/20	N/S	22/20
Transparencies - LEF	N/S	N/S	N/S
Vinyl - LEF	N/S	N/S	N/S
Card stock - LEF	N/S	N/S	N/S
Envelopes - LEF	N/S	N/S	N/S
Paper labels	N/S	N/S	N/S
<sup>1</sup> This rating assumes this printer is set to black and white mode. LEF - Long edge feed SEF - Short edge feed			

## Performance

The 360CP printer supports the speeds previously listed. Performance depends on:

- Interface to the host (USB, serial, parallel, network)
- Host system and application
- Page complexity and content
- Certain printer options installed or selected
- Printer memory
- Media size and type

## Time to first print

Simplex printing from any tray is rated at 9.5 seconds mono and 13.5 seconds color.

Mode	QuickStart	Standby <sup>1</sup>	Warm-up (seconds)
Power On	QuickStart off	N/A <sup>2</sup>	145
Power Saver	QuickStart on	Off <sup>2</sup>	120
Power Saver	QuickStart off	On	120
Power Saver	QuickStart on	On	0

## Processor

1 GHz Motorola MC7447A

## Duty cycle

- Maximum duty cycle 200,000 pages
  - True continuous duty cycle 10,000 pages
  - Lifetime maximum duty cycle 1.5 million pages
- Note:** Based on one month usage.

## Printer memory

### Memory configuration

DRAM memory	Standard	Maximum
360CP	256 MB	1024 MB

### Available memory options

- 512 MB DIMMS are available

### Memory and expansion slots

There is one slot available for memory expansion.

DDR-DRAM and Flash memory options are interchangeable within any of the memory slots available on the C920 system board. However, only one Flash memory option is recognized at a time. If multiple Flash memory options are installed, the system recognizes the largest one.

There is a USB port on the operator panel for printing PDF print jobs. The USB port only works with certain USB 1.1 thumb drives.

## Resident fonts

Emulation	Scalable Fonts	Bitmapped fonts
PCL 6	89	2
PostScript	158	0
PPDS	39	5

There are 83 symbol sets in the PCL 6 emulation to support all the languages that use these characters.

Not all symbol sets are supported by all fonts. Refer to the *Technical Reference* or use the printer operator panel to find which symbol sets are supported by each font.

Support for the euro currency character is included in all applicable fonts for both PostScript and PCL emulations. Twelve PCL symbol sets support the euro character, including all seven Windows symbol sets.

Additional fonts can be downloaded to the printer RAM, optional Flash DIMM, or hard disk. PCL emulation supports both scalable and bitmapped downloadable fonts. PostScript emulation supports only downloadable scalable fonts.

## Paper and media specifications

<b>Sources and capacities</b>		360CP		
<b>Input sources</b>				
Number of standard sources		2		
Optional input drawers		3		
High-capacity feeder		1		
Maximum number of input sources		6		
<b>Input capacities (sheets)</b>				
<b>Standard</b>				
Primary tray		550		
Second tray		N/A		
Multipurpose tray		100		
Total standard capacity		650		
<b>Optional</b>				
550-sheet drawer <sup>1</sup>		550		
High-capacity feeder		3,000		
Maximum additional drawers		3		
Maximum input capacity (without high-capacity feeder)		2,300		
Maximum input capacity with high-capacity feeder		5,300		
<b>Output destination</b>				
Number (standard)		1		
<b>Output capacities sheets</b>				
Standard output bin		550		
Face-up bin		100		
<b>Optional</b>				
Finisher		1,000		
Maximum output capacity		1,650		
<b>Other</b>				
Duplex unit				
<b>Note:</b>				
Only 1 high-capacity feeder is supported for each model.				
Only 1 finisher is supported for each model.				

<sup>1</sup> Also available in 2 x 550 + base

## Media size supported

### Input

	500-sheet input	Multipurpose feeder	High-capacity feeder	Duplex
A4 8.27 x 11.7 in. (210 x 297 mm)	X	X	X	X
A5 5.83 x 8.27 in. (148 x 210 mm)		X		X
JIS-B5 7.17 x 10.23 in. (182 x 257 mm)		X		X
JIS-B4 4.34 x 10.1 in. (364 x 252 mm)	X	X		X
Letter 8.5 x 11 in. (216 x 279 mm)	X	X	X	X
Legal 8.5 x 14 in. (216 x 256 mm)	X	X		X
Executive 7.25 x 10.5 in. (184 x 267 mm)		X		X
Tabloid 11 x 17 in. (279.4 x 431.8 mm)	X	X		X
12 x 18 in. (305 x 457 mm) C912 only	X	X		X
A3 11.69 x 16.54 in. (297 x 420 mm)	X	X		X
Universal <sup>1,2</sup> 69.85 x 127mm to 229 x 355.6mm (2.75 x 5in to 9.01 x 14 in) 148 x 182mm to 215.9 x 355.6mm (5.83 x 7.17in to 8.5 x 14in)		X X X X		X <sup>3</sup> X <sup>3</sup> X <sup>3</sup> X <sup>3</sup>
Banner 297mm x 914mm 297mm x 1219mm		X X		
7 Envelope 3.875 x 7.5 in. (98 mm x 191 mm)		X		
9 Envelope 3.875 x 8.9 in. (98 x 225.4 mm)		X		
10 Envelope 4.125 x 9.5 in. (105 x 241 mm)		X		
DL Envelope 4.33 x 8.66 in. (110 x 220 mm)		X		
C4 Envelope 9 x 12.75 in. (229 x 324 mm)		X		
C5 Envelope 6.38 x 9.01 in. (162 x 229 mm)		X		
B5 Envelope 6.93 x 9.84 in. (176 x 250 mm)		X		
Other Envelope <sup>4</sup> 11.69 x 11.69 in. (297 to 297 mm)		X		



	500-sheet input	Multipurpose feeder	High-capacity feeder	Duplex
<b>Media type</b>				
Paper	X	X	X	X
Card stock		X		
Transparencies		X <sup>5</sup>		
Envelopes		X		
Glossy paper	X	X <sup>6</sup>		X
Paper labels		X <sup>7</sup>		
Vinyl labels		X		
<p>1 When universal is selected, the page is formatted for 215.9 X 355.6mm (8.5 x 14 in).  2 Narrow media should be loaded with the length in the feed direction (portrait).  3 A5 paper(148 x 210 mm / 5.83 x 8.27 in) is the smallest paper the C920 can duplex.  4 When other envelope is selected, the page is formatted for 215.9 x 355.6 (8.5 x 14 in) unless a size is specified by the software application.</p>				

## Output

	Standard output	Bin 1	Finisher Bin 1	Finisher Bin 2
A4 8.27 x 11.7 in. (210 x 297 mm)	X	X	X	X
A5 5.83 x 8.27 in. (148 x 210 mm)	X	X	X	
JIS-B5 7.17 x 10.23 in. (182 x 257mm)		X	X	
JIS-B4 14.34 x 10.1 in. (364 x 252 mm)	X	X	X	
Letter 8.5 x 11 in. (216 x 279 mm)	X	X	X	X
Legal 8.5 x 14 in. (216 x 256 mm)	X	X	X	
Executive 7.25 x 10.5 in. (184 x 267 mm)	X	X	X	
Tabloid 11 x 17 in. (279.4 x 431.8 mm)	X	X	X	
12 x 18 in. (305 x 457 mm) C912 only	X	X	X	
A3 11.69 x 16.54 in. (297 x 420 mm)	X	X	X	
Universal 69.85 x 127mm to 229 x 355.6mm (2.75 x 5in to 9.01 x 14 in) 148 x 182mm to 215.9 x 355.6mm (5.83 x 7.17in to 8.5 x 14in)		X X X X	X X X X	
Banner 297mm x 914mm 297mm x 1219mm	X X	X X	X X	
7 Envelope 3.875 x 7.5 in. (98 x 191 mm)		X		
9 Envelope 3.875 x 8.9 in. (98 x 225.4 mm)		X		
10 Envelope 4.125 x 9.5 in. (105 x 241 mm)		X		
DL Envelope 4.33 x 8.66 in. (110 x 220 mm)		X		
C4 Envelope 9 x 12.75 in. (229 x 324 mm)		X	X	
C5 Envelope 6.38 x 9.01 in. (162 x 229 mm)		X	X	
B5 Envelope 6.93 x 9.84 in. (176 x 250 mm)		X	X	
Other Envelope <sup>4</sup> 11.69 x 11.69 in. (297 to 297 mm)		X	X	

	Standard output	Bin 1	Finisher Bin 1	Finisher Bin 2
<b>Media type</b>				
Paper	X	X	X	X
Card stock	X	X	X	
Transparencies	X	X	X	
Envelopes		X	X	
Glossy paper	X	X	X	X
Paper labels		X	X	
Vinyl labels		X		

## Input media types and weights

Media	Type	Standard tray		Multipurpose feeder		High capacity feeder	
		GSM	Lb bond	GSM	Lb bond	GSM	Lb bond
Paper	Xerographic or business	60 15	16 28	60 15	16 28	60 15	16 28
Specialty paper	Glossy laser	106 120	29 32	N/S	N/S	N/S	
Card stock	Index bristol	121 216	33 10	121 216	33 10	N/S	
Transparency	Professional color laser	175	47	175	47	N/S	
Labels	Vinyl	N/S	N/S	300	N/A	N/S	
Labels	Paper	180	48	180	48	N/S	
Envelopes	Sulfite, wood-free Up to 100% cotton	N/S		10	10	N/S	
<p>N/S = not supported N/A = Not applicable</p> <p><b>Note:</b></p> <p>The duplex option supports the same weights and types as the printer except for transparencies, envelopes, labels, and paper less than 75 GSM (20 lb bond), or greater than 105 GSM (28 lb bond).            100% cotton content maximum weight is 90 GSM (24 lb).            105 GSM (28 lb) bond envelopes are limited to 25% cotton content.            Refer to card stock + label guide for media guidelines.</p>							

## Input capacity by media and source

Media	Stack height	Capacity
<b>500-Sheet trays</b>		
Plain paper (letter, A4, legal, tabloid, A3)	2.2 in. (56 mm)	550 sheets 16 20lb (60 75g/m <sup>2</sup> )
Plain paper (letter, A4, legal, tabloid, A3)		550 sheets 20 24lb (75 90g/m <sup>2</sup> )
Plain paper (letter, A4, legal, tabloid, A3)		550 sheets 24 28lb (90 105 g/m <sup>2</sup> )
Glossy paper	1.5 in. (40 mm)	360 sheets 29 32lb (106 120 g/m <sup>2</sup> )
Card stock		200 sheets 33 44lb (121 165 g/m <sup>2</sup> )
Card stock		150 sheets 102 lb (165 216g/m <sup>2</sup> )
Transparencies (tray 1 only)	0.8 in. (20 mm)	150 sheets 47 lb (147 g/m <sup>2</sup> )
Paper labels (tray 1 only)	1.5 in. (40 mm)	200 sheets 48 lb (180 g/m <sup>2</sup> )
<b>Multipurpose feeder</b>		
Plain paper (letter, A4, legal, tabloid, A3)	0.4 in. (11 mm)	100 sheets 16 20lb (60 75g/m <sup>2</sup> )
Plain paper (letter, A4, legal, tabloid, A3)		100 sheets 20 24lb (75 90g/m <sup>2</sup> )
Plain paper (letter, A4, legal, tabloid, A3)		100 sheets 24 28lb (90 105 g/m <sup>2</sup> )
Transparencies	0.2 in. (7 mm)	50 sheets 47 lb (147 g/m <sup>2</sup> )
Card stock	0.4 in (11 mm)	50 sheets 33 44 lb (121 165 g/m <sup>2</sup> )
Card stock		45 sheets 102 lb (165 216 g/m <sup>2</sup> )
Paper labels		55 sheets 48 lb (180 g/m <sup>2</sup> )
Vinyl labels		55 sheets (300 g/m <sup>2</sup> )
Glossy paper	1.5 in. (40 mm)	360 sheets 29 32lb (106 120 g/m <sup>2</sup> )
Banner	0.4 in. (11 mm)	100 sheets 24 lb (90 g/m <sup>2</sup> )
Banner	0.2 in. (7 mm)	50 sheets 44 lb 165 g/m <sup>2</sup> )
Envelopes	0.8 in. (21 mm)	10 envelopes
<b>High-capacity feeder</b>		
Plain paper (letter, A4, legal, tabloid, A3)	12.5 in. (317 mm)	3,000 sheets 20 24 lb(75-90 g/m <sup>2</sup> )
<b>Note:</b>		
<p>Performance may vary, and is subject to media specifications and printer operating environment. At ambient environment.</p> <p>All media is letter/A4, unless otherwise noted.</p> <p>All lb weights are stated in bond, unless otherwise noted.</p> <p>All paper (including legal, tabloid, and A3) with weights less than 24 lb (90 g/m<sup>2</sup>) holds a maximum of 550 sheets.</p> <p>Refer to <i>Card Stock +Label Guide</i> for media guidelines.</p>		

### **Output capacity by media and source**

<b>Media</b>	<b>Stack heights</b>	<b>Capacity</b>
<b>Standard output bin</b>		
Plain paper	Varies	550 sheets
Glossy paper		
Card stock		300 sheets
Paper labels		
<b>Bin 1 (face-up)</b>		
Plain paper	Varies	100 sheets
Glossy paper		
Transparencies		50 sheets
Card stock		30 sheets
Vinyl labels		
Paper labels		
Banner		1 sheet
<b>Bin 2– staple punch finisher</b>		
Plain paper	6.0 in. (152 mm)	1,000 sheets 20 lb (75 g/m <sup>2</sup> )

## **Media guidelines**

### **Paper**

Following are media guidelines for successful printing:

- Rough, highly textured, limp, or pre-curved papers will result in lower print quality and more frequent paper feed failures.
- Colored papers, treated and preprinted papers, letterhead, and labels must be able to withstand 446 F (230 C) fusing temperature.
- Preprinted forms and letterhead should be selected using guidelines found in the printer *User's Guide*. The chemical process used in preprinting may render some papers unsuitable.
- Unsuitable papers include multipart forms and documents; chemically treated papers; coated, synthetic, and thermal papers; and preprinted papers requiring a high degree of registration.
- Recycled paper less than 20 lb (75 g/m<sup>2</sup>) may cause unacceptable results.

### **Envelopes**

- Envelopes should be fed long edge first, with flap trailing.
- When the finisher is attached, only long-edge fed envelopes wider than 5.8 in. (148 mm) feed direction dimension may be used. To print smaller envelopes, the finisher must be undocked during the job.
- If envelope wrinkling occurs, refer to the *User's Guide* for correct weight, type, loading, and stacking of envelopes.
- All envelopes should be new, unused, and without package damage.
- Envelopes with excessive curl or twist exceeding 0.12 in. (6 mm), stuck together, with bent corners or nicked edges, or those that interlock should not be used.
- Minimum weight: 24 lb (90 g/m<sup>2</sup>)
- The following envelopes should not be used:
  - Envelopes with windows, holes, perforations, cutouts, deep embossing or package damage.
  - Envelopes with metal clasps, string ties, or metal folding bars.
  - Envelopes with exposed flap adhesive when the flap is in the closed position.

### **Transparencies**

See Paper Media Specifications

### **Labels**

Labels should be selected using guidelines found in the *User's Guide* or the *Card Stock + Label Guide*, and tested for acceptability.

## **Print area**

Printable area for the printer is to within 0.16 in. (4.0 mm) of all edges of the media (except envelopes). Information placed outside this specified printable area will not print.

---

## **Connectivity**

### ***Standard***

Optional internal local connection.

### ***Network connections***

#### **Internal network connections**

Standard ethernet and MarkNet compatibility

### ***Data streams***

- PCL 6 Emulation
- PostScript 3 Emulation
- PPDS Migration Tool
- PDF

### ***Operating systems***

Windows 95 (OSR2), Windows 98, Windows Me, Windows NT (SP6), Windows 2000 (Professional and Server), Windows XP (Home and Professional), Windows Server 2003, Novell NetWare 3.x, 4.x, 5.x, 6x (including NDS and NPDS support), HP-UX (11.00, 11.11), Sun Solaris(7, 8, 9, 10), IBM AIX (5.1, 5.2, 5.3), SuSE Linux (8.0 and later), Red Hat Enterprise 3.0, Debian 3.0 rev 2, Linspire 4.5, Red Flag 4.0 (Simplified Chinese), Limpus 9.2 (Traditional Chinese).



---

## Power and electrical specifications

The following table specifies the nominal average power requirements for the standard printer configuration (no options installed). All power levels are shown in watts (W). Maximum current is given in amperes (A).

### Power requirements

Average nominal power requirements for the base printer configuration (110 volt). Power levels are shown in watts.

### Electrical specifications

<b>Printing states</b>		360CP			
<b>Average power while printing</b>					
Continuous mono Continuous color		400W 290W			
<b>Average power while idle</b>					
Power Saver on Power Saver off					
<b>Max current while printing</b>					
120 V 230 V		11A 6A			

### Low voltage models

- 110 to 127 V at 50 to 60 hertz (Hz) nominal
- 99 to 135 V, extreme

### High voltage models

- 220 to 240 V at 50 to 60 hertz (Hz) nominal
- 198 to 254 V, extreme

**Note:** Using a 220 to 110 power converter with the 110 V printer is not recommended.

## Operating clearances

The following clearances are recommended to ensure proper operation.

Minimum clearance requirements					
	Top	Left side	Right side	Rear	Front
Printer	9 in. 229 mm	13 in. 330 mm	6 in. 153 mm	5 in. 127 mm	27 in. 686 mm
Duplex	9 in. 229 mm	13 in. 330 mm	13 in. 330 mm	5 in. 127 mm	27 in. 686 mm
High Capacity Feeder	9 in. 229 mm.	13 in. 330 mm.	30 in. 762 mm	5 in. 127 mm	27 in. 686 mm
Finisher	9 in. 229 mm.	13 in. 330 mm.	6 in. 153 mm	5 in. 127 mm	27 in. 686 mm
<b>Note:</b> Required clearance is 13 in. (330 mm) without HCF, and 30 in. (762 mm) with HCF.					

---

## Environment

### Printer temperature and humidity

Environment	Specifications
Operating	
Air temperature - product operating	10 - 33 C (50 - 91 F)
Air relative humidity	Relative humidity 20 to 80%
Altitude	0 - 2300 meters (7,545 ft)
Ambient operating environment	3 to 27C(37-80F) and 35% to 70% RH
<b>Storage</b>	
Storage temperature printer and supplies	0 to 35C (32 to 90F)
Relative humidity	20 to 80%
<b>Shipping</b>	
Shipping temperature printer and supplies	-5 to 40C (23 to 104F) at 10 to 90% RH
Relative humidity	10 to 90%
In some cases, performance specifications (such as paper OCF, EP cartridge usage) are specified to be measured at an ambient condition	

---

## Maintenance approach

The diagnostic information in this manual leads you to the correct field replaceable unit (FRU) or part. Use the error code charts, symptom index, and service checks to determine the symptom and repair the failure. The removals in the repair information chapter may help you identify parts.

- “Printer messages” on page 2-5
- “Symptom table” on page 2-3
- “Service checks” on page 2-50
- “Repair information” on page 4-1

After you complete the repair, perform tests as needed to verify the repair. See “Diagnostic aids” on page 3-1.

### ***Standard inspection and cleaning procedure***

- Switch off printer power, and disconnect the AC power cord from the electrical outlet.
  - Remove and inspect the photodevelopers and toner cartridges, shielding them from strong light.
  - Inspect the interior of the printer, removing foreign matter such as paper clips, staples, pieces of paper or transparencies, paper dust, hair, oil, grease, or toner.
  - Clean the printer interior using a lint-free cloth. Do not use solvents or chemical cleaners to clean the printer interior.
  - Use only the specified oil or lubricant on printer parts (some service parts are lubricated at the factory).
  - Inspect and, if necessary, clean all rubber/plastic rolls with a lint-free cloth. Dry the rolls with a lint-free cloth.
  - While cleaning, inspect the interior of the printer for damaged wires, loose connections, toner leakage, loose springs, and damaged or worn parts.
  - Be sure the printer is on a single, flat, strong table or desk top.
  - Inspect all supplies (OCR, cartridges, photodevelopers/toner cartridges, belts, fuser maintenance kits and paper sources (cassettes, trays, feeders, duplex drawers, finisher, mailbox trays) for obvious damage and proper installation (paper guides not too tight). Inspect for correct media usage (paper, transparencies, labels).
  - Print demo page.
  - If additional paper sources are installed, print a demo page from each of these (if possible).
- Note:** Failure to print from an additional tray or feeder may imply one or more pins are bent in the mating connector.

## ***Return parts***

Engineering periodically analyzes returned parts for failure modes. Include a printed quality page and a menu page, before and after the repair, and tag any returnable parts with a description of the failure.

## ***Service recommendations***

Before leaving the printer, check the following:

- Be sure printer is on a flat, level, strong tabletop or level floor. This is very important for color printers that use belts. Check and set registration as necessary.
- Shake all cartridges, and be sure they are correctly installed and fully seated.
- While the cover is open, wipe any residual toner from the LEDs using a lint-free cloth.
- If you have serviced the finisher option, and in the process pulled it away from the printer during repair, ensure that it is properly aligned with the printer.

## ***Tools***

The removal and adjustment procedures require the following tools and equipment:

- Magnetic tip Phillips screwdrivers, large and small
- Flat-blade screwdrivers
- Analog volt ohmmeter (a digital volt ohmmeter may also be used)

When you make voltage readings, always use frame ground unless another ground is specified.

## ***Serial number, configuration ID, and part number***

Open the front door. The serial number, configuration ID, and part number are located as shown. The serial number is also on the menu settings page you can print from the Tests Menu.

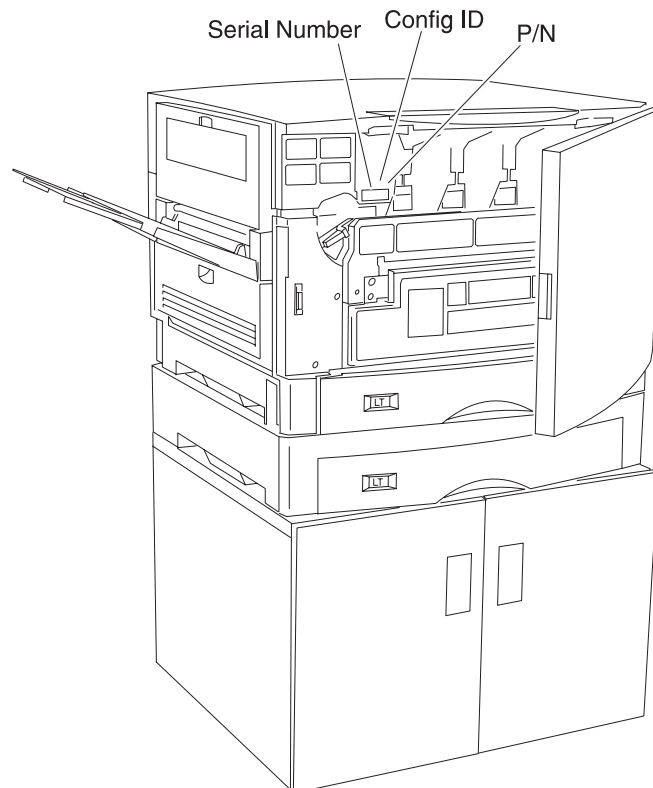

## Acronyms

ASIC	Application-specific integrated circuit
BUD	Belt up down
CMYK	Cyan yellow magenta black
CPU	Central processing unit
CRC	Cyclic redundancy check
CRU	Customer replaceable unit
CSU	Customer setup
DIMM	Dual inline memory module
DLE	Downloadable emulator
DRAM	Dynamic random access memory
EP	Electrophotographic process
EPROM	Erasable programmable read-only memory
ESD	Electrostatic discharge
FD	Face down
FRU	Field replaceable unit
FU	Face up
GHz	Gigahertz
HCF	High capacity feeder
HCPF	High capacity feeder
HTML	Hypertext markup language
HVPS	High voltage power supply
HVU	High voltage unit
Hz	Hertz
LAN	Local area network
LASER	Light amplification by stimulated emission of radiation
LCD	Liquid crystal display
LED	Light-emitting diode
LEF	Long edge feed
LVPS	Low voltage power supply
MB	Megabyte
MIF	Motor interface
MM	Millimeter
MPF	Multipurpose feeder
NVRAM	Nonvolatile random access memory
OCF	Operator correctable failure
OCR	Oil coating roll
OEM	Original equipment manufacturer
OHP	Overhead projector
PC	Photo conductor
PCB	Printed circuit board
PCL	Printer controller language
PDF	Portable Document Format
PEX	Paper exit
PICS	Problem isolation charts
PIN	Personal identification number
PIXEL	Picture element
PJL	Printer Job Language
POR	Power-on reset
POST	Power-on self test
PPM	Pages per minute
PQET	Print quality enhancement technology
RAM	Random access memory

RFID	Radio frequency identification
RH	Relative humidity
RIP	Raster image processor
ROM	Read only memory
ROS	Read-only storage
SEF	Short edge feed
SOL	Solenoid
SRAM	Static random access memory
UPR	Used parts replacement
USB	Universal serial bus
V ac	Volts alternating current
V dc	Volts direct current

## 2. Diagnostic information

---

### Start

The diagnostic information in this chapter leads you to the failing part. Before you replace an entire assembly, determine if just the defective part is available in the parts catalog. Use the error code tables, symptom table, service checks, and the diagnostic aids chapter to determine the symptom and repair the failure. The removal procedures in the Repair information chapter may help you identify parts. After you complete the repair, perform the appropriate tests to verify the repair.

If an error is displayed, locate it in the **“Service error message tables” on page 2-5**, the **“Attendance messages” on page 2-30**, or the **“Symptom table” on page 2-3**, and take the appropriate action.

If an error message appears while you are working on the printer, go to the error message table and take the indicated action.

**Warning:** Do not use a RIP board or operator panel from another C920 for diagnosing problems or errors on the printer being serviced. This can damage the machine.



**CAUTION:** Unplug power cord from the printer or electrical outlet before you connect or disconnect any cable or electronic board or assembly for personal safety and to prevent damage to the printer. Disconnect any connections between the printer and PCs peripherals. The printer requires at least two people to lift it safely. Make sure your fingers are not under the printer when you lift or set the printer down.



**CAUTION:** If the printer is kept on, never touch the conductive parts while it is not specifically required. Do not touch the LVPS cards and the motor driver board unless they are properly discharged. Never touch the live parts.

**Warning:** When operating the driving units using the diagnostics or other tools, be sure to keep them covered unless otherwise specified.

**Warning:** When operating the driving units using the diagnostics or other tools, never touch the driving units. When operating the driving units using diagnostics or other tools, be sure to follow the procedures in this manual.

**CAUTION:** Be careful to avoid burns by safely handling hot parts.

**Warning:** Servicers should wear a wrist band or the like to remove static electricity from their body, grounding their body while working. Go to **“Handling ESD-sensitive parts” on page 4-1**

### Initial check

Before you start troubleshooting, check the following:

#### Installation environment

- The power supply line voltage is plus or minus 10% of the rated line voltage.
- The machine is securely installed on a level surface in a well-ventilated place.
- The room temperature is between 10 and 32 C (50 and 90 F) and the relative humidity between 20 and 80%.
- Avoid sites generating ammonia gas, high temperature, high humidity (near water faucets, kettles, humidifiers), cold spaces, near open flames, and dusty areas.
- Avoid sites exposed to direct sunlight.

## **Print paper checks**

- Use the recommended paper for this printer.
- Paper dampness. Make a trial print with paper from a newly opened package, and check the result.



## Symptom table

Symptom	Action
You cannot print color.	Make sure the Color Correction menu item is not set to Black & White. Make sure the color print units are completely installed in the printer. Go to <b>“Transfer belt up/down service check” on page 2-62.</b>
Transparencies curl excessively.	Make sure you re using the recommended transparencies. Also be sure the paper delivery is set to the rear exit.
The printer seems slow to print.	If you set the Paper Type to Transparency or Card Stock, the printer increases the fuser temperature and slows printing to improve the print quality. After printing on these media, the printer requires additional time to cool the fuser after you select another Paper Type setting (such as Plain Paper or Letterhead).  If Printer Usage is set to Maximum Yield, the printer calibrates the print head timing. The printer performs this same calibration each time you turn the printer on and each time you open and close the top cover. Depending on the types of jobs you print, these adjustments may significantly slow print time.  If the belt is in the up position for color printing, the printer prints at 30 ppm only.  If the printer is in quick print mode, the printer prints at 17ppm until the printer is fully warmed up.
You cannot remove paper jammed in the fuser.	Open the fuser rollers by operating the fuser pressure relief lever. If you cannot remove the jam, replace the fuser. The jam access panel can also be opened. After letting the fuser cool, unscrew the two thumbscrew and open the access panel.
You cannot clear the paper jam message.	To clear the paper jam messages, you must remove all paper from the printer paper path. Check both inside the printer as well as the paper source you were using. Open and close the front cover, and press <b>Go</b> . If the message does not clear, go to <b>“Paper carrying service check” on page 2-56.</b>
Paper jam in pick-up assembly.	Go to <b>“Paper carrying service check” on page 2-56.</b>
Fuser failure.	Go to <b>“920 - Fuser Error– Fuser Heater Trouble” on page 2-11.</b>
No paper pick-up from multipurpose tray.	Go to <b>“Paper carrying service check” on page 2-56.</b>
No paper pick-up from upper or lower cassettes.	Go to <b>“Paper carrying service check” on page 2-56.</b>
Registration roller does not rotate.	Go to <b>“Paper carrying service check” on page 2-56.</b>
Operator panel does not operate properly.	Go to the Diagnostic aids chapter and run the LCD and Button tests. If the tests fail, replace the operator panel. If you still have a problem, replace the RIP controller board.  If your machine beeps 5 times and the screen is blank or all diamonds, replace the operator panel.
Foggy print Black pages Blank print White spots Poor reproduction Incorrect color image registration Dirt on back of paper Low image density White and black lines and bands	Go to <b>“Print quality problems” on page 2-63.</b>
Evenly spaced marks on the paper, or a single mark in the same place on every page.	Go to <b>“Transfer belt up/down service check” on page 2-62.</b>

Symptom	Action
Poor fusing.	Go to <b>“920 - Fuser Error– Fuser Heater Trouble” on page 2-11.</b>
Toner scatter on front or back of paper.	Check the following: Excessive toner buildup on the transfer belt. Clean off the toner, and run a test print. Transfer belt assembly Transfer belt toner waste bottle Transfer belt separation fingers Fuser separation pawl
Paper will not feed from MPF.	Be sure you have paper in the MPF. Check the paper size and type. Does it match the paper setting on the printer? Be sure the MPF paper present sensor connector (CN16) is connected to the CK1 daughter board. If the paper still does not feed, go to <b>“Paper carrying service check” on page 2-56.</b>

Symptom	Cause	Solution
Paper frequently jams in the finisher.	The finisher and printer are misaligned. The printer and finisher have been moved.  Attempting to staple, hole punch, or offset print jobs on print media other than paper.	Paper frequently jams in the finisher. Properly align the finisher with the printer. Align the top of the guide rail with the line on the holding plate by rotating the two alignment knobs closest to the holding plate. This action raises or lowers the guide rail, depending on which way the knobs are turned. The edge of the guide rail should line up with the sticker where the white and gray portions divide. Restrict use of the finisher to plain paper. You cannot hole punch transparencies, card stock, labels, or envelopes.
Printer only prints to bin 1 or bin 2.	The finisher cables are not connected properly. The printer driver and the operator panel settings are different.	Check the cable connections.  Make sure your printer driver is set to direct the output to the bin you want. Printer settings selected from a software application or driver override default settings selected from the operator panel.
You cannot clear the paper jam message.	The cover is not closed, finisher is against the printer, or there is paper somewhere in the paper path.	Open and close the top cover, and make sure the finisher is locked onto the alignment pins. Recheck the finisher and printer for additional jams.
Pages are not stapled.	Attempting to staple too many sheets.  The staple cartridge is empty. The stapler is jammed.	Reduce the number of pages in the staple job. The finisher can staple up to 30 sheets of 20 lb paper. If you attempt to staple a larger stack of paper, the finisher ejects the stack without stapling it. Install a new staple cartridge.  Check the stapler for a staple jam.

---

## Printer messages

The printer displays three types of messages: service messages, status messages, and attendance messages. *Service messages* indicate a problem that requires a service technician. *Status messages* provide information about the current state of the printer, requiring no action. *Attendance messages* alert the operator to printer problems that require operator intervention.

### ***Service error message tables***

#### **900 - RIP software error**

There may be a communication problem (Bad cable, network connection, and so on) software issue, or a hardware problem with the controller board / INA. The communication and software aspects should be checked first. Determine if the problem is constant or intermittent.

#### **Constant 900 errors**

<b>Step</b>	<b>Action and questions</b>	<b>Yes</b>	<b>No</b>
1	Disconnect the printer from any external connections. Turn the power off and remove any parallel, USB, or network connections. Turn the printer on. Does the 900 error display?	Go to step 3.	Go to step 2.
2	Run the internal test pages. Print a menu settings page from the reports menu. If the printer works properly while disconnected, have a user or the network administrator verify that there are no jobs in the queue that may be causing the error. Does the error remain?	Go to step 3.	Inform the user or network administrator of the issue.
3	Turn the printer off. Remove any options from the RIP card, such as additional memory, hard disk drives, or option cards. Does the 900 error display?	Go to step 4.	Determine which option is causing the 900 error.

4	<p>Restore factory defaults from the configuration menu.</p> <p><b>WARNING:</b> When factory defaults are restored, all menu items are returned to factory default values except:</p> <p>Display Language All settings in the Parallel Menu, Serial Menu, Network Menu, and USB Menu. All downloaded resources (fonts, macros, and symbol sets) in printer memory are deleted. Resources residing in flash memory are unaffected.</p> <p>Does the 900 error display?</p>	<p>Record the secondary error codes. With the 900 Service RIP Error displayed, press <b>Menu</b> then press ◀. The first screen of debug information appears. Press ◀ to view any additional debug information when the original message appears. Record the complete list.</p> <p>Press <b>Menu</b> to scroll. The code may be a very long string of characters and numbers, but is needed for analysis.</p> <p>Contact your next level of support.</p>	Problem solved
---	--	--	----------------

### Intermittent 900 Service RIP Error codes

Capturing the following information aids in determining the nature of the intermittent error.

1. Crash codes With the 900 Service RIP Error displayed, press **Menu** and ◀ together. Record the complete secondary codes by scrolling with Menu. The code may be a very long string of characters and numbers, but it is needed to analyze the problem.
2. Print history Print the printer history by entering Diagnostics Mode and selecting Print History in the Development menu.
3. Code level Obtain the code level for the RIP, network, and engine. All of these can be found on the Print Menus page from the Utilities menu.
4. Type of connection being used to print Record the type of connection. For example, direct USB or parallel, or network peer to peer, Ethernet, token ring, and so on.
5. Software application Does one particular application or print job sent to the printer produce this error?
6. Driver Driver or driver level loaded. With this information in hand, contact your next level of support.

### 900 Error Sub Codes

Sub Code	Error Code Meaning
.00	00 default (no match) The 900 error occurred while an unknown process was running.
.01	01 init The 900 error occurred while the init process was running.
.02	02 mpsapp The 900 error occurred while the mpsapp process was running.
.03	03 NVRAM Server The 900 error occurred while the NVRAM Server process was running.

.04	04 Objstore The 900 error occurred while the Objstore process was running.
.05	05 Nv2 The 900 error occurred while the Nv2 process was running.
.06	06 ErrorExit The 900 error occurred while the ErrorExit process was running.
.07	07 Sysmgr The 900 error occurred while the Sysmgr process was running.
.08	08 VacuumServer The 900 error occurred while the Vacuum-Server process was running.
.09	09 OS- Scheduler The 900 error occurred while the OS-Scheduler process was running.
.10	10 RIPapp The 900 error occurred while the RIPapp process was running.
.11	11 ObjStrNvSvr The 900 error occurred while the ObjStrNvSvr process was running.
.12	12 sysdebug The 900 error occurred while the sysdebug process was running.
.13	13 insmod The 900 error occurred while the insmod process was running.
.20	20 Xprot The 900 error occurred while the Xprot process was running.
.21	21 addrconf The 900 error occurred while the addrconf process was running.
.22	22 snmpd The 900 error occurred while the snmpd process was running.
.23	23 firewall_app The 900 error occurred while the firewall_app process was running.
.24	24 mdns The 900 error occurred while the mdns process was running.
.30	30 gui_app The 900 error occurred while the gui_app process was running.
.40	40 Page4 The 900 error occurred while the Page4 process was running.
.41	41 P4PQS The 900 error occurred while the P4PQS process was running.
.42	42 P4.stMain The 900 error occurred while the P4.stMain process was running.

.43	43 P4.PS The 900 error occurred while the P4.PS process was running.
.44	44 P4.Pcl The 900 error occurred while the P4.Pcl process was running.
.45	45 P4.Pjl The 900 error occurred while the P4.Pjl process was running.
.46	46 P4PageTask The 900 error occurred while the P4PageTask process was running.
.47	47 P4RenderC The 900 error occurred while the P4RenderC process was running.
.48	48 P4RenderK The 900 error occurred while the P4RenderK process was running.
.49	49 P4RenderM The 900 error occurred while the P4RenderM process was running.
.50	50 P4RenderY The 900 error occurred while the P4RenderY process was running.
.51	51 P4TimerTick The 900 error occurred while the P4TimerTick process was running.
.52	52 P4Vidlrq The 900 error occurred while the P4Vidlrq process was running.
.53	53 P4OSI_In The 900 error occurred while the P4OSI_In process was running.
.54	54 P4OSI_OutNew The 900 error occurred while the P4OSI_OutNew process was running.
.55	55 P4Notify The 900 error occurred while the P4Notify process was running.
.56	56 P4.NPAmain The 900 error occurred while the P4.NPAmain process was running.
.80	80 Scanmgr The 900 error occurred while the Scanmgr process was running.
.81	81 Hostsend The 900 error occurred while the Hostsend process was running.
.82	82 Email The 900 error occurred while the Email process was running.
.83	83 AIO_UIEvtQueue The 900 error occurred while the AIO_UIEvtQueue process was running.
.84	84 LclScanRd The 900 error occurred while the LclScanRd process was running.

.90	90 Lxkfax The 900 error occurred while the Lxkfax process was running.
.91	91 Faxcntl The 900 error occurred while the Faxcntl process was running.
.92	92 Fax_Print The 900 error occurred while the Fax_Print process was running.
.99	99 900 The 900 error occurred outside of a process context (for example, during kernel boot or other kernel operation).

### 910 - Drive Motor Error

Step	Questions/actions	Yes	No
1	Is CN18 on the printer controller board properly connected?	Go to step 2.	Connect CN18.
2	Are connectors CN1 and CN5 on the motor drive board properly connected?	Go to step 3.	Connect CN1 and CN5.
3	Is connector CN9 on the CK2 daughter board connected properly?	Replace the motor drive board and go to step 4.	Connect CN9.
4	Did replacement of the motor drive board solve the problem?	Problem solved.	Replace the CK2 daughter board, and go to step 5.
5	Did replacement of the CK2 daughter board solve the problem?	Problem solved.	Replace the printer controller board, and go to step 6.
6	Did replacement of the controller board solve the problem?	Problem solved.	Replace all supplies, and go to step 7.
7	Did replacement of all supplies solve the problem?	Problem solved.	Replace the drive motor.

### 911 - Paper Exit Motor Error

Step	Questions/actions	Yes	No
1	Is connector CN9 on the printhead controller board securely connected?	Replace the face-down unit, and go to step 2.	Plug the connector in securely.
2	Did replacement of the paper exit motor solve the problem?	Problem solved.	Replace the printhead controller board.

## 912 - High-Capacity Feed Motor Error

Step	Questions/actions	Yes	No
1	Is connector CN22 on the printer controller board securely connected?	Go to <b>“High-capacity feeder (HCF) service check” on page 2-53.</b>	Plug the connector in securely.

## 917 - RIP Fan Error

917 Service Fan Error
-----------------------

Step	Questions/actions	Yes	No
1	Is connector J5 on the RIP board connected properly?	Go to step 2.	Properly connect J5.
2	Is 24 V dc present between pins 1 and 3 of connector J5 on the RIP board?	Replace the RIP fan.	Go to step 3.
3	Is 24 V dc present between pin 80 of the RIP/printer controller and ground?	Replace the RIP board.	Replace the printer controller board.

## 918 - Main Unit Fan Error

Step	Questions/actions	Yes	No
1	Are CN14 on the printer controller board and CN03 on the printhead controller board properly connected?	Go to step 2.	Connect CN14 and CN03.
2	Is +24V present between pins and 1 and 3 on connectors CN12 (upper left fan) and CN11 (upper right fan) on the printer controller board?	Replace the failing fan.	Replace the printer controller board.

## 919 - Power Supply Fan Error

Step	Questions/actions	Yes	No
1	Is CN17 on the printer controller board properly connected?	Go to step 2.	Connect CN17.
2	Is CN6 on the CK2 daughter board properly connected?	Go to step 3.	Connect CN6.
3	Is +24 V present between pins 1 and 3 of connector CN6 on the CK2 daughter board?	Replace the power supply fan.	Replace the printer controller board.
4	Did either exchange solve the problem?	Problem solved.	Replace the CK2 daughter board.



## 920 - Fuser Error– Fuser Heater Trouble

92x Service Fuser Error
----------------------------

Step	Questions/actions	Yes	No
1	Replace the fuser. Did this fix the problem?	Problem solved.	Return the fuser, replace the power supply 2, and go to step 2.
2	Did replacing power supply 2 fix the problem?	Problem solved.	Return power supply 2, and replace the printer controller board.

## 923 - Upper Fuser Thermistor Open Error

Step	Questions/actions	Yes	No
1	Is connector CN19 on the printer controller board connected properly?	Disconnect CN19 and turn the printer on. Go to step 2.	Plug the connector in securely.
2	Is error 923 displayed?	Power off, and reconnect CN19. Go to step 3.	Replace the printer controller board.
3	Power the printer off and short-circuit pins (1 and 2) and (3 and 4) of CN19 and power on. Is error 923 displayed?	Replace the fuser.	Replace the printer controller board.

## 924 - Lower Fuser Thermistor Open Error

Step	Questions/actions	Yes	No
1	Turn off the printer and reinstall the fuser, making sure it <i>clicks</i> into place. Turn on the printer. Did this resolve the problem?	Problem solved.	Go to step 2.
2	Is connector CN19 on the printer controller board connected properly?	Disconnect CN19, and turn the printer on. Go to step 3.	Plug the connector in securely.
3	Is error 924 displayed?	Turn the printer off, and reconnect CN19. Go to step 4.	Replace the printer controller board.
4	Turn off the printer and short-circuit pins 8 and 9 of CN19. Turn on the printer. Is error 924 displayed?	Replace the fuser.	Replace the printer controller board.

## 925 - HVU Error

Step	Questions/actions	Yes	No
1	Has the high voltage power board (HVU) been removed/replaced?	Inspect the secondary card on the high voltage board (HVU) for a broken component (Q906). Replace the high voltage board (HVU) if necessary.	Go to step 2.
2	Is connector CN9 on the printer controller board connected properly?	Replace the printer controller board. Go to step 3.	Plug the connector in securely.
3	Did replacing the printer controller board fix the problem?	Problem solved.	Replace the high voltage power board (HVU).

## 926(K), 927(C), 928(Y), 929(M) - Toner Sensor Error

92x Service Toner Sensor
-----------------------------

Step	Questions/actions	Yes	No
1	Is the toner cartridge the correct type for the printer?	Go to step 2.	Recommend the customer replace the cartridge with the correct type.
2	Is the toner cartridge encoder wheel dirty?	Clean the encoder wheel and toner sensor.	Go to step 3.
3	Replace the toner cartridge for the color with the error. Did this fix the problem?	Problem solved.	Go to step 4.
4	Test the sensors. While actuating the sensor, does the voltage fluctuate between 0 V and +5 V between pins 1 and 4 and 5, 8 and 9, 12, and 13 on CN1 on the printer controller board.	Replace the printer controller board.	Replace the affected toner sensor.

## 930 - Yellow Printhead Error

930 Service Printhead Error
--------------------------------

Step	Questions/actions	Yes	No
1	Check to ensure that the cables between the LED printhead and the printhead controller board as well as the cables between the printhead controller board and the printer controller board are properly connected. Are they properly connected?	Go to step 2.	Properly connect the cables.
2	Replace the LED printhead for the affected color. Did this resolve the problem?	Problem solved.	Replace the printhead controller board, and go to step 3.
3	Did replacement of the printhead controller board resolve the problem?	Problem solved.	Replace the printer controller board.

## 931 - Magenta Printhead Error

Step	Questions/actions	Yes	No
1	Check to ensure that the cables between the LED printhead and the printhead controller board as well as the cables between the printhead controller board and the printer controller board are properly connected. Are they properly connected?	Go to step 2.	Properly connect the cables.
2	Replace the LED printhead for the affected color. Did this resolve the problem?	Problem solved.	Replace the printhead controller board, and go to step 3.
3	Did replacement of the printhead controller board resolve the problem?	Problem solved.	Replace the printer controller board.

### 932 - Cyan Printhead Error

Step	Questions/actions	Yes	No
1	Check to ensure that the cables between the LED printhead and the printhead controller board as well as the cables between the printhead controller board and the printer controller board are properly connected. Are they properly connected?	Go to step 2.	Properly connect the cables.
2	Replace the LED printhead for the affected color. Did this resolve the problem?	Problem solved.	Replace the printhead controller board, and go to step 3.
3	Did replacement of the printhead controller board resolve the problem?	Problem solved.	Replace the printer controller board.

### 933 - Black Printhead Error

Step	Questions/actions	Yes	No
1	Check to ensure that the cables between the LED printhead and the printhead controller board as well as the cables between the printhead controller board and the printer controller board are properly connected. Are they properly connected?	Go to step 2.	Properly connect the cables.
2	Replace the LED printhead for the affected color. Did this resolve the problem?	Problem solved.	Replace the printhead controller board, and go to step 3.
3	Did replacement of the printhead controller board resolve the problem?	Problem solved.	Replace the printer controller board.

### 934 - Color Drum Sensor Error

934 Service  
Drum Sensor

Step	Questions/actions	Yes	No
1	Clean the color drum sensor LED. Did this fix the problem?	Problem solved.	Go to step 2
2	Swap the yellow photo developer with a different color photo developer. Did this fix the problem?	Replace the photo developer that called the error.	Go to step 3.
3	Is connector CN2 on the printer controller board connected properly?	Replace the sub frame assembly.	Plug the connector in securely.
4	Did replacing the sub frame fix the problem?	Problem solved.	Replace the printer controller board.

### 935 - Black Drum Sensor Error

Step	Questions/actions	Yes	No
1	Clean the black drum sensor LED. Did this fix the problem?	Problem solved.	Go to step 2
2	Swap the black photo developer with a different color photo developer. Did this fix the problem?	Replace the photo developer that called the error.	Go to step 3.
3	Is connector CN2 on the printer controller board connected properly?	Replace the sub frame assembly.	Plug the connector in securely.
4	Did replacing the sub frame fix the problem?	Problem solved.	Replace the printer controller board.

### 936 - 939 Cassette Error

936 Service  
Paper Option

Step	Questions/actions	Yes	No
1	Are connectors CN8 and CN6 on the printer controller board connected properly?	Replace the printer controller board.	Plug the connector in securely.

## 940 - High-Capacity Feed Sensor Error

Step	Questions/actions	Yes	No
1	Is connector CN22 on the printer controller board connected properly?	Go to <b>“High-capacity feeder (HCF) service check” on page 2-53.</b>	Plug the connector in securely.

## 941 - High-Capacity Feed Tray Error

Step	Questions/actions	Yes	No
1	Is connector CN22 on the printer controller board connected properly?	Go to <b>“High-capacity feeder (HCF) service check” on page 2-53.</b>	Plug the connector in securely.

## 942 - Duplex Error

942 Service  
Duplex

Step	Questions/actions	Yes	No
1	Is connector CN16 on the printer controller board connected properly?	Replace the printer controller board.	Plug the connector in securely.

## 945 - Engine Flash Error

945 Service  
Engine Flash

Reflash the engine code.

## 946 - Printer/Printhead Controller Board Communication Error

946 Service Communication
------------------------------

Step	Questions/actions	Yes	No
1	Is CN03 on the printhead controller board or CN14 on the printer controller board connected properly?	Go to step 2.	Connect cables.
2	Make sure all printhead LED EPROMS are present on the printhead controller board. Are all the EPROMS present?	Go to step 3.	Install the EPROM(s) included with printhead FRU.
3	Replace the printhead controller board. Did this fix the problem?	Problem solved.	Replace the printer controller board.

## 947 - Finisher Communication Error

Step	Questions/actions	Yes	No
1	Are the finisher to printer interface cable and power cable properly connected?	Go to step 2.	Properly connect the cable.
2	Replace the interface cable. Did this resolve the problem?	Problem solved.	Replace the control finisher board. Go to step 3.
3	Did finisher control board replacement resolve the problem?	Problem solved.	Replace the printer control board.

## 948 - Machine ID Error

948 Service Machine ID
---------------------------

Step	Questions/actions	Yes	No
1	Turn the printer off, and wait 30 seconds. Turn the printer on. Did this fix the problem?	Problem solved.	Verify proper installation of the EPROMs on both the printer controller board and the printhead controller board. Go to step 2.
2	Are the EPROMs installed correctly?	Replace the printer controller board. Go to step 3.	Install the EPROMs correctly.
3	Did replacing the printer controller board fix the problem?	Problem solved.	Replace the printhead controller board.

## 949 - Tray (x) Comm

Step	Questions/actions	Yes	No
1	Replace the printer controller board. Does this fix the problem?	Problem solved.	Replace the expansion feeder control board for trays 2 - 5  If the problem is with the high-capacity paper feeder, replace the HCPF board.



## 950 - Mirror Mismatch

Step	Questions/actions	Yes	No
1	Is 950.xx(xx= 30 or greater) displayed?	Go to step 2.	Go to step 3
2	Replace the operator panel that was just installed with the original operator panel. Restart the printer. Did this fix the problem?	Problem solved. Install a new operator panel. Do not use the operator panel that generated the 950 error.	Contact your technical support center.
3	Replace the RIP card that was just installed with the original RIP card. Restart the printer. Did this fix the problem?	Problem solved. Install a new RIP card. Do not use the RIP card that generated the 950 error.	Contact your technical support center.

## 952 - NVRAM Chip Failure

952 Service NVRAM Failure
------------------------------

Step	Questions/actions	Yes	No
1	Make sure the 26-pin RIP printer controller cable is not broken or damaged. Is the cable broken or damaged?	Replace the cable.	Go to step 2.
2	Is EPROM U7 present on the printer controller board?	Replace the printer controller board.	Install EPROM U7.

## 954 - NVRAM CRC Failure

Replace the RIP board.

## 955 - Code CRC

955 Service Code CRC <loc>
-------------------------------

Replace the RIP board.

## 956 - Processor Failure

956.00 Service System Board - RIP card failure: proces- sor failure
--

956.01 Service System Board - Pro- cessor overtemp
--

Replace the RIP board.

## 957 - ASIC Failure

Replace the RIP board.

## 958 - NAND Failure

958 Service NAND Failure
-----------------------------

Replace the RIP board.

## 960 - RAM Slot 1 Bad

960 Service RAM Memory Error
---------------------------------

Replace the RAM card or the RIP board.

## 961 - RAM Slot 2 Bad

Replace the RAM card or the RIP board.

## 964 - Emulation Error

964 Service Emulation Error
--------------------------------

Replace the DLE board. If this does not fix the problem, replace the RIP board.

## 970 - Standard Network Error

970 Service Standard Network
---------------------------------

970 Service Network Card x
-------------------------------

Check the network card in slot x on the RIP card.

## 975 - Unrecognizable Network Port

Software error.

## 976 - Unrecoverable Software Error in Network Port

Software error. Go to the **“Options service check” on page 2-68**, and refer to the network card option section.

## 978 - Bad Checksum While Programming Network Card

Software error.

## 979 - Flash Parts Failed While Programming Network Port

Reflash network port.

## 980 Face Up/Down Switching Error

980 Service Switch Error
-----------------------------

Check Area B
-----------------

Step	Questions/actions	Yes	No
1	POR the machine into diagnostics mode. Perform the output bin feed test on output bin 1. Can you hear the FU/FD solenoid move during the feed test?	Check to see if linkage from the FU/FD solenoid to the FU/FD deflector is broken. Repair or replace the face-up unit.	Go to step 2.
2	Is there continuity on the FU/FD deflector solenoid between pins 1 and 2 on CN 4 on the CK2 daughter board.	Go to step 3.	Replace the face-up unit.
3	Is CN 4 on CK2 properly connected?	Go to step 4.	Properly connect the connectors.
4	Are CN 3, CN 4, CN 5 on the printer controller board properly connected?	Go to step 5.	Properly connect the connectors.
5	Is fuse 1 on the printer controller board open?	Replace the printer controller board and the drum eraser assembly.	Replace the printer controller board.

## 981 - Belt Up/Down Sensor Error

981 Service Switch Error
-----------------------------

Step	Questions/actions	Yes	No
1	Is the engine code the latest level?	Go to step 2.	Update the printer with latest code level.  If this does not resolve the problem, continue with step 2.
2	Are connectors CN409 and CN407 on the sensor board connected properly?	Go to step 3.	Plug the connectors in securely.
3	Are connectors CN11 on the CK1 daughter board, and CN15, CN3, CN4, and CN5 on the printer controller board connected properly?	Go to step 4.	Properly connect all connections.
4	Remove the transfer belt. Verify the belt up/down sensor actuator flag, on the bottom of the transfer belt unit is properly installed, not broken, and in the proper position.  Rotate the shaft attached to the belt up/down sensor actuator flag. Are there any binds other than when engaging the transfer belt?  Make sure the sensor is fully <i>snapped</i> in place, and that the sensor connector is fully seated.  Are these items correct?	Go to step 5.	If the sensor is out of position or disconnected, properly install the sensor and properly connect the sensor to the belt unit.  If the shaft attached to the belt up/down sensor actuator binds, replace the transfer belt unit.  If the sensor actuator flag is broken, replace the transfer belt unit.
5	Clean the belt up/down sensor (located on the bottom of the transfer belt unit).  Does this fix the problem?	Problem solved.	Go to step 6.
6	Disconnect the belt up/down sensor on the transfer belt unit, bypassing the density sensor and door open sensor. Power on the printer.  Does the belt up/down shaft rotate during POST?	Replace the transfer belt unit.	Go to step 7.
7	Replace the transfer belt unit.  Did this fix the problem?	Problem solved.	Replace the printer controller board.

## 982 - Sensor Controller Error

982 Service  
Sensor Control

Step	Questions/actions	Yes	No
1	Turn the printer off, and wait 30 seconds. Turn the printer on. Is error 982 displayed?	Replace the printer controller board.	Problem solved.

## 983 - Black Gear Sensor Error

983 Service  
Gear Sensor

Step	Questions/actions	Yes	No
1	Is connector CN20 on the printer controller board connected properly?	Go to step 2.	Plug the connector in securely.
2	Check the cable running to CN20 for damage. Is the cable damaged?	Replace the cable.	Go to step 3.
3	Clean the gear sensor. Does this correct the problem?	Problem solved.	Go to step 4.
4	Replace the sensor card. Did this resolve the problem?	Problem solved.	Replace the drive unit.

## 984 - Yellow Gear Sensor Error

Step	Questions/actions	Yes	No
1	Is connector CN20 on the printer controller board connected properly?	Go to step 2.	Plug the connector in securely.
2	Check the cable running to CN20 for damage. Is the cable damaged?	Replace the cable.	Go to step 3.
3	Clean the gear sensor. Does this correct the problem?	Problem solved.	Go to step 4.
4	Replace the sensor card. Did this resolve the problem?	Problem solved.	Replace the drive unit.

## 985 - Transfer Belt Thermistor Error

985 Service Thermistor Error
---------------------------------

Step	Questions/actions	Yes	No
1	Are connectors CN407 and CN411 on the sensor board connected properly?	Go to step 2.	Plug the connector in securely.
2	Is connector CN15 on the printer controller board connected properly?	Replace the transfer belt unit. If the problem remains, replace the printer controller board.	Plug the connector in securely.

## 986 - Transparency (OHP) Sensor Error

986 Service OHP Sensor
---------------------------

Step	Questions/actions	Yes	No
1	Are connectors CN4 (light emitting) and CN5 (light receiving) on the CK1 daughter board connected properly?	Go to step 2.	Plug the connector in securely.
2	Test the sensor. While actuating the sensor, does the voltage fluctuate between 0 V and +5 between pins 2 and 3 of connector CN7 of the printer controller board?	Replace the printer controller board.	Replace the MPF unit.

## 987 - Service Toner Cartridge

Step	Questions/actions	Yes	No
1	Turn the printer off and then back on. Did this fix the error?	Problem solved.	Go to step 2.
2	Try different toner cartridges. Did this fix the error?	Problem solved.	Go to step 3.
3	Check the cable connections on the RFID antenna, and CN 21 on the printer controller card. Are they properly connected?	Go to step 4.	Properly connect the connections.
4	Check the RFID cable. Is it damaged?	Replace the RFID cable.	Replace the printer controller board.

### 991 - Service Paper Option

Step	Questions/actions	Yes	No
1	POR the printer. Does the error return?	Go to step 2.	Problem solved.
2	Check connections CN3,4,5,17,18 on the printer controller board. Are they properly connected?	Go to step 3.	Properly connect the connectors.
3	Are the size sensing levers bent or damaged?	Replace the size sensing levers.	Go to step 4.
4	Replace the CK 2 daughter board. Did this solve the problem?	Problem solved.	Go to step 5.
5	Are any actuators on the paper-feed unit damaged?	Replace the paper-feed unit.	Replace the printer controller board.

### 992 - Temperature/Humidity Sensor Error

Step	Questions/actions	Yes	No
1	Is connector CN18 on the CK1 daughter card board connected properly?	Go to step 2.	Plug the connector in securely.
2	Replace the temperature and humidity sensor (a component of the paper feed gear). Did this fix the problem?	Problem solved.	Replace the printer controller board.

### 993 - CPU Error

Replace the printer controller board.

## 994 - Density Sensor Error

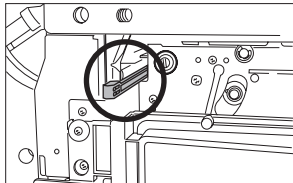
Step	Questions/actions	Yes	No
1	Is the front door fully closed?	Go to step 2.	Close the front door.
2	Is the density sensor actuator stuck in place? 	Release the density sensor actuator.	Go to step 3.
3	Are connectors CN406 and CN407 on the sensor board connected properly?	Go to step 4.	Plug the connector in securely.
4	Is connector CN15 on the printer controller board connected properly?	Replace the density sensor. Go to step 5.	Plug the connector in securely.
5	Did replacing the density sensor fix the problem?	Problem solved.	Replace the printer controller board.



## 995 - Finisher Main Feed Motor abnormal

995 Service Finisher
-------------------------

Step	Questions/actions	Yes	No
1	Is there jammed paper or other obstructions in the paper path?	Clear the paper path.	Go to step 2.
2	Check to ensure the connector PJ6 on the finisher control board and the feed motor assembly cable are properly connected. Are the cables properly connected?	Go to step 3.	Properly connect the cables.
3	Make sure the finisher set switch is activated. Measure for +24 V dc (–10%) between pins 7 and 8 and +5 V dc (–10%) between pins 7 and 6 on the feed motor assembly cable connector CN1. Is either voltage missing?	Go to step 4.	Go to step 5.
4	Disconnect the feed motor assembly cable and PJ6 on the finisher control board. Measure continuity on the cable for all positions. Is there continuity?	Go to step 6.	Replace the cable.
5	Replace the feed motor assembly. Did this resolve the problem?	Problem solved.	Replace the finisher control board.
6	Measure for +24 V dc between pins 1 and 2 on connector PJ3 on the finisher control board. Measure for +5 V dc between pins 1 and 3 on PJ2 on the finisher control board. Is either voltage missing?	Replace the power supply.	Replace the finisher control board.

## 996 - Finisher Jogging Motor Error

Step	Questions/actions	Yes	No
1	Are there foreign objects or obstructions in the jogging assembly?	Clear the objects or obstruction.	Go to step 2.
2	Are the jogging motor connectors CN2 on the finisher control board securely connected?	Go to step 3.	Securely connect the connectors.
3	Make sure the finisher set switch is activated. Measure for +24 V dc (–10%) between pin 1 on CN2 and frame ground. Is +24 V dc present?	Go to step 4.	Go to step 5.
4	Replace the jogging motor assembly. Did this resolve the problem?	Problem solved.	Replace the finisher control board.
5	Disconnect CN2 and PJ5. Perform a continuity check on the cable for all positions. Is there continuity?	Go to step 6.	Replace the cable.
6	Check for +24 V dc (–10%) between pins 1 and 2 of PJ3 on the finisher control board. Is +24 V dc present?	Replace the finisher control board.	Replace the power supply.

## 997 - Finisher Tractor Motor Error

Step	Questions/actions	Yes	No
1	Are there obstructions or foreign objects in the accumulator or face down paper path?	Remove the objects or obstructions.	Go to step 2.
2	Are the connectors CN3 at the tractor motor and PJ4 on the finisher control board securely connected?	Go to step 3.	Securely connect the connectors.
3	Make sure the finisher set switch is activated. Measure +24 V dc between pin 1 of tractor motor connector CN3 and frame ground. Is +24 V dc (–10%)?	Go to step 4.	Go to step 5.
4	Replace the tractor motor assembly. Did this resolve the problem?	Problem solved.	Replace the finisher control board.
5	Disconnect CN3 and PJ4 on the finisher control board and perform a continuity check on all positions. Is there continuity on all positions?	Go to step 6.	Replace the cable.
6	Check for +24 V dc between pins 1 and 2 of PJ3 on the finisher control board. Is +24 V dc present?	Replace the finisher control board.	Replace the power supply.

## 998 - Tray Elevator Motor Error

Step	Questions/actions	Yes	No
1	Are the connectors CN4 at the tray elevator motor and connector PJ4 on the finisher control board properly connected?	Go to step 2.	Properly connect the connectors.
2	Make sure that the finisher set switch is activated. Power the printer off. Measure for approximately +24 V dc (–10%) between pins 1 and 2 of connector CN4 at the tray elevator motor. Power the printer on and observe the voltage meter during the first 12 seconds of power up. Is +24 V dc present while the printer is powering up?	Replace the tray elevator motor.	Go to step 3.
3	Disconnect CN4 at the tray elevator motor. Disconnect PJ4 on the finisher control board. Measure for continuity between CN4 pin 1 and PJ4 pin 7. Measure for continuity between CN4 pin 2 and PJ4 pin 8. Is there continuity in both locations?	Go to step 4.	Replace the cable.
4	Measure for +24 V dc (–10%) between pins 1 and 2 on connector PJ6. Is +24 V dc present?	Replace the finisher control board.	Replace the finisher power supply.

## 999 - Stapler Motor Error

Step	Questions/actions	Yes	No
1	Are staples jammed in the stapler?	Go to step 2.	Go to step 3.
2	Clear the staple jam and run the staple test in diagnostic mode or run a staple job. Does the problem reoccur?	Replace the staple cartridge and to go step 4.	Problem solved.
3	Are the connectors CN5 on the stapler and PJ1 on the finisher control board securely connected?	Go to step 5.	Securely connect the connectors.
4	Did replacement of the stapler cartridge resolve the problem?	Problem resolved.	Replace the stapler.
5	Make sure the finisher set switch is activated. Measure for 5 V dc between pins 11 and 12 on stapler connector CN5. Is 5 V dc present?	Replace the stapler.	Replace the finisher control board.
6	Did replacement of the finisher control board correct the problem?	Problem solved.	Go to step 7.
7	Is there continuity on the stapler to finisher control board cable?	Replace the power supply.	Replace the cable.

## Attendance messages

**Note:** For more information on clearing paper jams, refer to **“Clearing paper jams” on page 3-34.**

Message	Meaning	Action
Activating Menu Changes	The printer is activating changes made to the printer settings.	Wait for the message to clear.
<b>All Photo Dev Life Warning</b>	All photodevelopers are nearing the end of life and need replacing.	-Select <b>Continue</b> to clear the message and print without replacing the photodevelopers. -Replace all photodevelopers.
<bin name> Full	The specified bin is full.	Remove the stack of paper from the specified bin to clear the message.
Black Photo Dev Life Warning	The black photodeveloper is nearing the end of life.	- Select <b>Continue</b> to clear the message and print without replacing the black photodeveloper. - Replace the black photodeveloper.
Busy	The printer is busy receiving or processing print data.	Wait for the message to clear, or cancel the print job.
Calibrating	The printer is calibrating.	Wait for the message to clear.
Cancel not available		Wait for the message to clear.
Cancelling	The printer is processing a request to cancel a job.	Wait for the message to clear.
Change <src> <Custom Type Name>	The printer is requesting a different type or size of paper.	- Select <b>Continue</b> if you have changed the media.
Change <src> <Custom String>		- Select <b>Use current</b> to print on media currently in the printer.
Change <src> <size>		- Cancel the current job.
Change <src> <type> <size>		
Check tray <x> connection	The printer cannot sense the presence of a tray.	Turn the printer off and back on. If the error recurs, turn the printer off, remove the specified tray, then reattach the tray.  If the error recurs, turn the printer off, remove the specified device, and call for service.  Select <b>Continue</b> to clear the message and print without using the device.
Clearing job accounting statistics	The printer is deleting all job statistics stored on the hard disk.	Wait for the message to clear.
Close front door	The printer's front door is open.	Close the front door to clear the message.
Close side door	The printer's side door is open.	Close the side door to clear the message.
Close door <x> Check finisher installation	A door on the finisher is open.	Close the finisher door to clear the message.
Close tray <x> top cover	The hi-cap feeder door is open.	Close the specified top cover to clear the message.
<Color> Low	The specified toner cartridge is low.	-Select <b>Continue</b> to print without replacing the toner cartridge. -Replace the specified toner cartridge.

Message	Meaning	Action
Color Photo Dev Life Warning	The color photodevelopers are nearing the end of life.	-Select <b>Continue</b> to continue printing without replacing the color photodevelopers. -Replace the color photodevelopers.
Copies		Enter the desired number of copies.
Defragmenting Flash DO NOT POWER OFF	The printer is defragmenting its flash memory.	<b>Warning:</b> Do not turn the printer off while this message is displayed. Wait for the message to clear.
Delete	Delete a print job in the printer s queue.	-Select <b>Continue</b> to delete the specified job. -Press <b>Stop</b> to cancel the operation.
Delete all	Delete all print jobs in the printer s queue.	-Select <b>Continue</b> to delete all held jobs. -Press <b>Stop</b> to cancel the operation.
Delete all confidential jobs	Delete all confidential jobs in the printer s queue.	-Select <b>Continue</b> to delete all confidential jobs. -Press <b>Stop</b> to cancel the operation.
Deleting	The printer is deleting print jobs.	Wait for the message to clear.
Disabling DLEs		Wait for the message to clear.
Disabling Menus	The printer is responding to a request to disable the menus.	Wait for the message to clear. <b>Note:</b> While the menus are disabled, you cannot change the printer settings from the operator panel.
Disk corrupted	The printer has attempted a disk recovery process, and cannot repair the disk.	-Select <b>Continue</b> to reformat the disk and delete all files currently stored on the disk. -Select <b>Do not reformat</b> to clear the message without reformatting the disk.
Disk Recovery x/5 yyy%	The printer is attempting to recover the hard disk. Disk recovery takes place in five phases; the operator panel displays the percent complete of the current phase.	Do not turn the printer off while this message is displayed. Wait for the message to clear.
Empty box M	The hole punch box on the finisher is full.	Empty the hole punch box, and if necessary, reset the hole punch counter.  Select <b>Continue</b> to clear the message and print without using the hole punch feature.
Enabling Menus	The printer is responding to a request to make the menus available to users.	Wait for the message to clear.
Encrypting Disk yyy% DO NOT POWER OFF	The printer is encrypting the hard disk. The percent complete is displayed.	<b>Warning:</b> Do not turn the printer off while this message is displayed. Wait for the message to clear.
Engine Warming	The printer is warming the fuser assembly.	Wait for the message to clear.

Message	Meaning	Action
Enter PIN		Enter the PIN you identified in the driver when you sent the confidential job to the printer.
Enter PIN to lock		Enter the correct pin number to lock the operator panel and prevent menu changes.
Error printing from USB drive	The printer is unable to process a job on a USB drive.	Wait for the message to clear.
Error reading USB drive	The printer cannot access the USB drive.	Wait for the message to clear.
Flushing buffer	The printer is flushing corrupted print data and discarding the current print job.	Wait for the message to clear.
Formatting Disk yyy% DO NOT POWER OFF	The printer is formatting the hard disk. The percent complete is displayed.	<b>Warning:</b> Do not turn the printer off while this message is displayed. Wait for the message to clear.
Formatting Flash DO NOT POWER OFF	The printer is formatting the flash memory.	<b>Warning:</b> Do not turn the printer off while this message is displayed. Wait for the message to clear.
Fuser Life Warning	The fuser is nearing the end of its life.	-Select <b>Continue</b> to clear the message and print without installing a new fuser. -Install a new fuser.
Hex Trace	The printer is in Hex Trace mode.	
Hole Punch Box Full	Self explanatory.	-Empty the hole punch box. -Select <b>Continue</b> to clear the message and print without using the hole punch feature.
Insert Staple Cartridge	Staple cartridge is empty.	-Install a staple cartridge to clear the message. -Select <b>Continue</b> to clear the message and print without using the staple feature.
Insert Tray <x>	The specified tray is missing or not fully inserted.	Insert the specified tray into the printer.
Insert hole punch box	The hole punch box is missing or not fully inserted.	-Install the hole punch box. -Select <b>Continue</b> to clear the message and print without using the hole punch feature.
Install <device> or Cancel Job	The printer is requesting a specified device be installed so it can print.	-Turn the printer off, install the specified device, and restart the printer. -Cancel the current job.
Internal System Error Reload Bookmarks		-Reload the Bookmarks. -Select <b>Continue</b> to clear the message and continue printing.
Internal System Error, Reload Security Certificates		-Reload the Security Certificates. -Select <b>Continue</b> to clear the message and continue printing.

Message	Meaning	Action
Invalid Network <x> Code		Download valid code to the printer internal print server. <b>Note:</b> You can download network code while this message is displayed.
Invalid Engine Code	The printer engine code has not been programmed or is invalid.	Download valid engine code to the printer. <b>Note:</b> You can download engine code while this message is displayed.
Invalid PIN	An incorrect PIN number has been entered.	Enter the correct PIN.
Load Manual <Custom Type>	Manually insert the specified paper into the printer.	Load the specified paper in the manual feed tray or multipurpose feeder.  Select <b>Continue</b> to ignore the manual feed request and print on paper already installed in one of the input sources.  If the printer finds a tray that has paper of the correct type and size, it feeds paper from that tray. If the printer cannot find a tray with the correct paper type and size, it prints on whatever paper is installed in the default input source.  Cancel the current job.
Load Manual <Custom String>		
Load Manual <size>		
Load Manual <size> <type>		
Load <src> with <Custom Type Name>	Self explanatory.	-Load the input source with the correct type and size media. -Cancel the current job.
Load <src> with <Custom String>		
Load <src> <size>		
Load <src> <type> <size>		
Load Staples	The finisher's staple cartridge is empty.	-Install a new staple cartridge in the stapler. -Select <b>Continue</b> to clear the message and print without stapling. -Cancel the current job.
Maintenance		Replace the maintenance items and, if necessary, reset the printer maintenance counter.

Message	Meaning	Action
Menus are Disabled	The printer menus are disabled. You cannot change the printer settings from the operator panel.	<b>Note:</b> You can still cancel a job, print a confidential job, or print a held job.
Network	See action column.	A network interface is the active communication link.
Network <x>		
Network <x>, <y>	See action column.	A network interface is the active communication link, where <x> represents the active communication link, and <y> represents the channel.
No DRAM installed	The DRAM is missing or not properly installed.	Turn the printer off, and install DRAM.
No held jobs		Wait for the message to clear.
No jobs found	The four-digit personal identification number (PIN) you entered is not associated with any confidential print job.	Select <b>Try again</b> to enter another PIN. Select <b>Cancel</b> to exit the <b>Enter PIN</b> screen.
No jobs to cancel		Wait for the message to clear.
No recognized file types		Wait for the message to clear. <b>Note:</b> The only supported file type is PDF.
Parallel	See action column.	A parallel interface is the active communication link.
Parallel <x>		
Port disabled Remove USB drive		Wait for the message to clear.
Power Saver	The printer is in Power Saver Mode. It is ready to receive a print job.	Send a job to print. Press <b>Select</b> to warm the printer to normal operating temperature and display the <b>Ready</b> message.
Printer locked, enter PIN to unlock	The operator panel has been locked.	Enter the correct PIN number to unlock the printer.
Printing		Wait for the message to clear.
Printing from USB drive DO NOT REMOVE	A job on the USB drive is being processed.	<b>Warning:</b> Do not turn the printer off or remove the USB drive while this message is displayed. Wait for the message to clear.
Printer busy Continue Quit		Select <b>Continue</b> to read the information from the USB drive. Select <b>Quit</b> to cancel the information retrieval process.
Programming System Code	New system code is being programmed into the printer.	<b>Warning:</b> Do not turn the printer off while this message is displayed. Wait for the message to clear and the printer to reset.
Programming Flash	Printer resources are being stored to the flash memory.	<b>Warning:</b> Do not turn the printer off while this message is displayed. Wait for the message to clear.
Programming Disk	Printer resources are being stored to the hard disk drive.	<b>Warning:</b> Do not turn the printer off while this message is displayed. Wait for the message to clear.
Reading USB drive DO NOT REMOVE		Wait for the message to clear.



Message	Meaning	Action
Ready	The printer is ready to receive and process print jobs.	Send a job to print.
Remote Management Active DO NOT POWER OFF		The printer settings are being configured, and the printer was taken offline to ensure it is not currently printing and processing jobs. Wait for the message to clear.
Remove all color supplies		The printer has been set to Black Only mode. Remove all color cartridges and color PC Units. Select <b>Continue</b> to clear the message and print in Black Only mode. Cancel the current job.
Remove paper from bin <x>		Remove the stack of paper from the specified bin(s).
Remove paper from all bins		Remove the paper from all output bins.
Remove paper from standard output bin		Remove the paper from the standard bin.
Replace All Photo Dev	All photo developers are nearing the end of life, and need replacing.	-Select <b>Continue</b> to clear the message and print without replacing the photodevelopers. -Replace the cyan, magenta, yellow, and black photodevelopers.
Replace <Color> Photo Dev	The specified color photodeveloper is nearing the end of life and needs replacing.	-Select <b>Continue</b> to clear the message and print without replacing the specified photodeveloper. -Replace the specified photodeveloper.
Replace All Color Photo Dev	All color photodevelopers are nearing the end of life and need replacing.	-Select <b>Continue</b> to clear the message and print without replacing the photodevelopers. -Replace the cyan, magenta, and yellow photodevelopers.
Replace Black and Oil Coating Roll	The black photodeveloper and oil coating roller are nearing the end of life and need replacing.	-Select <b>Continue</b> to clear the message and print without installing a new toner cartridge and oil coating roll. -Replace the toner cartridge and oil coating roll.
Replace oil coating roll	The oil coating roll is nearing the end of life and needs replacing.	-Select <b>Continue</b> to clear the message and print without installing a new oil coating roll. -Replace the oil coating roll.

Message	Meaning	Action
Replace Black Photo Dev	The black photodeveloper is nearing the end of life and needs replacing.	-Select <b>Continue</b> to clear the message and print without replacing the black photodeveloper. -Replace the black photodeveloper.
Replace Fuser	The fuser is nearing the end of life and needs replacing.	-Select <b>Continue</b> to clear the message and print without installing a new fuser. -Replace the fuser and, if necessary, reset the printer internal counter for the fuser.
Replace Transfer Belt	The transfer belt is nearing the end of life and needs replacing.	-Select <b>Continue</b> to clear the message and print without installing a new transfer belt. -Replace the transfer belt and, if necessary, reset the printer internal counter for the transfer belt.
Replace <Color>	Self explanatory.	Replace the specified toner cartridge.
Resetting Active Bin	Self explanatory.	Wait for the message to clear.
Resetting Fuser Count	Self explanatory.	Wait for the message to clear.
Resetting the Printer	Self explanatory.	Wait for the message to clear.
Restore Held Jobs	Restore held jobs on the hard disk?	-Select <b>Continue</b> to restore all Print and Hold jobs on the hard disk. -Select <b>Do not restore</b> to delete Print and Hold jobs.
Restoring Factory Defaults	The printer settings are being reset to the factory default state.	Wait for the message to clear. <b>Note:</b> When factory default settings are restored: -All downloaded resources (fonts, macros, symbol sets) in the printer memory are deleted. -All menu settings return to the factory default setting <i>except</i> : -The Display Language setting in the Setup Menu. -All settings in the Parallel Menu, Serial Menu, Network Menu, Infrared Menu, LocalTalk Menu, USB Menu, and Fax Menu.
Restoring held job(s) x/y	The printer has been reset or turned on, and the printer detects print and hold jobs on the hard disk.	-Wait for the message to clear. -Select <b>Quit restoring</b> to delete unrestored Print and Hold jobs. <b>Note:</b> <b>x</b> represents the number of the job being restored, and <b>y</b> represents the total number of jobs to be restored.

Message	Meaning	Action
Serial <x>	See action column.	A serial interface is the active communication link.
Some held jobs were lost	The printer frees memory by deleting the oldest held job and continues deleting held jobs until there is enough printer memory to process the job.	-Select <b>Continue</b> to clear the message and continue printing. -Cancel the current job.
Staples Empty	Staple cartridge status message	-Install a new staple cartridge.
Staples Low		-Select <b>Continue</b> to clear the message and continue printing without stapling. -Cancel the current job.
Standard Bin Full	Output bin full.	Remove the stack of paper from the bin to clear the message.
Submitting selection	The printer is processing a selection request.	Wait for the message to clear.
Transfer Belt Life Warning	The transfer belt is nearing the end of life.	-Select <b>Continue</b> to clear the message and print without installing a new transfer belt. -Replace the transfer belt and, if necessary, reset the printer internal counter for the transfer belt.
Tray <x> Empty	The specified paper tray is empty.	Load paper in the tray to clear the message.
Tray <x> Low	The specified paper tray is low.	Add paper to the tray to clear the message.
Tray <x> Missing	The specified paper tray is missing or improperly installed.	Insert the tray into the printer.
USB	See action column.	The printer is processing data through the specified USB port.
USB <x>		
USB drive removed		-Wait for the message to clear. -Insert the USB drive.
View supplies		Displays the current level of all printer supplies.
Waiting	The printer has received a page of data to print, but is waiting for an End of Job command, a Form Feed command, or additional data.	-Press <b>Select</b> to print the contents of the buffer. -Cancel the current job.
1565 Emul Error Load Emul Option	The printer automatically clears the message in 30 seconds, and then disables the download emulator on the firmware card.	Download the correct download emulator version from the appropriate Web site.
30 Coating roll missing	The coating roll in the fuser is improperly installed or missing.	Install the coating roll, and close the top cover.
30 <color> print unit missing	The specified color print unit is improperly installed or missing.	Install the specified print unit, and close the top cover.
34 Incorrect media		-Load the appropriate media in the selected source. -Select <b>Continue</b> to clear the message and print the job using a different paper source.

Message	Meaning	Action
34 Short Paper	The paper used in a print job is too short in length for the current print job.	<p>-Select <b>Continue</b> to clear the message and continue printing.</p> <p>The printer does not automatically reprint the page that prompted the message.</p> <p>-Check tray length and width guides to ensure paper is properly fitted in the tray.</p> <p>-Make sure the print job is requesting the correct size of paper.</p> <p>-Adjust the Paper Size setting for the size paper you are using.</p> <p>If MP Feeder Size is set to Universal, make sure the paper is large enough for the formatted data.</p> <p>-Cancel the current job.</p>
35 Insufficient memory to support Resource Save feature	The printer does not have enough memory to perform the specified task.	<p>-Select <b>Continue</b> to disable Resource Save and continue printing.</p> <p>-To enable Resource Save after you get this message:</p> <p>Make sure the link buffers are set to Auto, then exit the menus to activate the link buffer changes.</p> <p>When <b>Ready</b> is displayed, enable Resource Save.</p> <p>-Install additional memory.</p>
37 Insufficient memory to collate job	The printer does not have enough memory to perform the specified task.	<p>-Select <b>Continue</b> to print the portion of the job already stored and begin collating the rest of the job.</p> <p>-Cancel the current job.</p>
37 Insufficient memory for Flash Memory Defragment operation	The printer does not have enough memory to perform the specified task.	<p>-Select <b>Continue</b> to stop the defragment operation and continue printing.</p> <p>-Delete fonts, macros, and other data in printer memory.</p> <p>-Install additional printer memory.</p>
37 Insufficient memory, some held jobs were lost	The printer was unable to restore some or all of the confidential or held jobs on the hard disk.	Select <b>Continue</b> to clear the message.
38 Memory Full	Self explanatory.	<p>-Select <b>Continue</b> to clear the message and continue printing.</p> <p>The job may not print correctly.</p> <p>-Cancel the current job.</p> <p>-Install additional printer memory.</p>
39 Page is too complex to print	Self explanatory.	<p>-Select <b>Continue</b> to clear the message and continue printing.</p> <p>The job may not print correctly.</p> <p>-Cancel the current job.</p> <p>-Install additional printer memory.</p>



Message	Meaning	Action
40 Tray <x> size sense error	The hi-cap feeder detects an error in the size sensing mechanism.	-Select <b>Continue</b> to clear the message and continue printing. The job may not print correctly. -Cancel the current job. -Turn the printer off, check high capacity feeder connectors, then turn the printer on.
41 Open bin 1 exit tray	The printer wants to send a job to the bin 1 output tray, but the tray is closed.	-Open the bin 1 exit tray located on the left side of the printer. -Cancel the current job. -Select <b>Continue</b> to clear the message and print to another output bin.
51 Defective flash detected	Self explanatory.	Select <b>Continue</b> to clear the message and continue printing. You must install different flash memory before you can download any resources to flash.
52 Not enough free space in flash memory for resources	Self explanatory.	-Select <b>Continue</b> to clear the message and continue printing. Downloaded fonts and macros not previously stored in flash memory are deleted. -Delete fonts, macros, and other data stored on the flash memory. -Install a larger capacity flash memory card.
53 Unformatted flash detected	Self explanatory.	Select <b>Continue</b> to clear the message and continue printing. You must format the flash memory before you can store any resources on it. If the error message remains, the flash memory may be defective and require replacing.
54 Serial option <x> error	The printer has detected a serial interface error on a serial port.	-Make sure the serial link is set up correctly, and you are using the appropriate cable. -Make sure the serial interface parameters (protocol, baud, parity, and data bits) are set correctly on the printer and host computer. -Select <b>Continue</b> to clear the message and continue printing. The job may not print correctly. -Turn the printer off and then on to reset the printer.
54 Network <x> software error	The printer cannot establish communications with the specified network port.	-Select <b>Continue</b> to clear the message and continue printing. The job may not print correctly. -Program new firmware for the network interface. -Reset the printer.
54 Standard network software error		
55 Unsupported flash option in slot <x>		1. Turn the printer off. 2. Remove the unsupported option. 3. Turn the printer on.
55 Unsupported option in slot <x>		

Message	Meaning	Action
56 Parallel port <x> disabled 56 Std parallel port disabled	Data has been sent to the printer through a disabled parallel port.	-Select <b>Continue</b> to clear the message. The printer discards any data received through the parallel port. -Make sure the Parallel Buffer menu item is not set to <b>Disabled</b> .
56 Serial port <x> disabled	Data has been sent to the printer through a disabled serial port.	-Select <b>Continue</b> to clear the message. The printer discards any data received through the serial port. -Make sure the Serial Buffer menu item is not set to <b>Disabled</b> .
56 USB port <x> disabled	Data has been sent to the printer through a disabled USB port.	-Select <b>Continue</b> to clear the message. The printer discards any data received through the USB port. -Make sure the USB Buffer menu item is not set to <b>Disabled</b> .
57 Configuration change, some Held Jobs were lost		Select <b>Continue</b> to clear the message.
58 Input config error		One of the input trays failed, and the large capacity feeder is now configured incorrectly. The large capacity feeder must be installed as Tray 3 or Tray 5.  1. Turn off and unplug the printer. 2. Replace or remove the failed input tray. 3. Plug in the printer, and turn it on.
58 Too many disks installed	Self explanatory.	1. Turn off and unplug the printer. 2. Remove the excess hard disks. 3. Plug in the printer, and turn it on.
58 Too many flash options installed	Self explanatory.	1. Turn off and unplug the printer. 2. Remove the excess flash memory. 3. Plug in the printer, and turn it on.
58 Too many bins attached	Self explanatory.	1. Turn off and unplug the printer. 2. Remove the additional bins. 3. Plug in the printer, and turn it on.
61 Defective disk	Self explanatory.	-Select <b>Continue</b> to clear the message and continue printing. -Install a different hard disk before you perform any operations that require a hard disk.
62 Disk full	Self explanatory.	-Select <b>Continue</b> to clear the message and continue processing. Any information not previously stored on the hard disk is deleted. -Delete fonts, macros, and other data stored on the hard disk. -Install a larger hard disk.

Message	Meaning	Action
63 Unformatted disk	Self explanatory.	-Select <b>Continue</b> to clear the message and continue printing. -Format the disk. If the error message remains, the hard disk may be defective and require replacing.
64 Unsupported disk format	Self explanatory.	-Select <b>Continue</b> to clear the message and continue printing. -Format the disk. If the error message remains, the hard disk may be defective and require replacing.
80 Scheduled maintenance	A maintenance item has reached end of life and should be replaced.	-Select <b>Continue</b> to clear the message, and continue printing. -Replace the maintenance items and, if necessary, reset the printer maintenance counter.
80 Fuser life warning	The fuser is nearing or has reached end of life and should be replaced.	-Select <b>Continue</b> to clear the message and continue printing. -Replace the fuser.
80 Belt life warning	The transfer belt is nearing or has reached end of life and should be replaced.	-Select <b>Continue</b> to clear the message and continue printing. -Replace the transfer belt.
80 Replace belt	The transfer belt needs replacing.	-Select <b>Continue</b> to clear the message and continue printing. -Replace the transfer belt.
80 Replace fuser	The fuser needs replacing.	-Select <b>Continue</b> to clear the message and continue printing. -Replace the fuser.
81 Engine code CRC failure	Microcode in the engine flash code has failed a system check.	-Select <b>Continue</b> to clear the message and discard the code. -Retransmit the microcode data from the host computer.
84 Color photo developer life warning	The color photodevelopers are nearing or have reached end of life and should be replaced.	-Select <b>Continue</b> to clear the message and continue printing. -Replace all color photodevelopers.
84 Black photo developer life warning	The black photodeveloper is nearing or has reached end of life and should be replaced.	-Select <b>Continue</b> to clear the message and continue printing. -Replace the black photodeveloper.
84 Replace color photo developers	Self explanatory.	-Select <b>Continue</b> to clear the message and continue printing. -Replace all color photodevelopers.
84 Replace black photo developer	Self explanatory.	-Select <b>Continue</b> to clear the message and continue printing. -Replace the black photodeveloper.
84 Replace all photo developers	Self explanatory.	-Select <b>Continue</b> to clear the message and continue printing. -Replace all the photodevelopers.
84 <color> photo developer abnormal	The specified photodeveloper is damaged or performing abnormally.	Replace the specified photodeveloper.

Message	Meaning	Action
86 Abnormal coating roll	The coating roller is damaged, or performing abnormally.	Replace the coating roll.
88 <color> Toner is low	Self explanatory.	Replace the specified toner cartridge. Select <b>Continue</b> to clear the message and continue printing.
88 Replace <color> toner	Self explanatory.	Replace the specified toner cartridge. Select <b>Continue</b> to clear the message and continue printing.
88 OCR exhausted	The OCR has reached the end of life and needs to be replaced.	Replace the oil coating roll. Select <b>Continue</b> to clear the message and continue printing.
200.yy Paper jam		1. Clear the paper path. 2. After clearing the paper path, select <b>Continue</b> to resume printing.
24x.yy Paper jam		1. Clear the paper path. 2. After clearing the paper path, select <b>Continue</b> to resume printing.
250.yy Paper jam		1. Clear the paper path. 2. After clearing the paper path, select <b>Continue</b> to resume printing.
249.yy Paper jam		1. Clear the paper path. 2. After clearing the paper path, select <b>Continue</b> to resume printing.

### Clearing finisher messages

Message	Solution
Bin <x> Full	Remove the stack of paper from the bin to clear the message. If you assigned the bin a name, the bin name is displayed instead of the bin number. Press  to clear the message and continue printing.
Check Finisher Installation	Make sure the finisher is flush against the printer. If this does not resolve the problem, go to <b>“Finisher service check” on page 2-77</b> to check the finisher set switch.
Close Finisher Top Cover	Close the finisher top cover, and align the finisher flush against the printer to clear the message.
Empty Box	Empty the hole punch box to continue printing.
Leave Staple Job in Finisher	The printer has detected a paper jam while printing a job that must be stapled. The message <b>Leave Staple Job in Finisher</b> alternates with the <b>Paper Jam</b> message. Leave the printed pages on the stacking tray inside the finisher, and clear the paper jam in the printer. Press  to clear the message and continue printing.
Staples Empty	Replace the staple cartridge if you want to continue stapling. You can press <b>Go</b> to clear the message and continue printing without stapling.



Message	Solution
Stapler Missing	The staple holder is missing. Place the staple holder in the stapler to clear the message. Go to <b>“Finisher service check” on page 2-54</b> to check the no staple sensor.
Insert Hole Punch Box	Install the hole punch box. The printer will automatically clear the message. Go to <b>“Finisher service check” on page 2-54</b> to check the punch box detect sensor.
Insert Staple Cartridge	The staple cartridge is either missing or installed incorrectly. Correctly install the staple cartridge. Go to <b>“Finisher service check” on page 2-54</b> to check the staple cartridge set sensor.
210 Staple Jam	Open the finisher stapler door, remove the paper from the accumulator, and remove the staple jam. Go to <b>“210 Staple jam service check” on page 2-62</b> .

### **Maintenance analysis procedures (MAPS)**

#### **Map 1 - False Side Door Open message**

Step	Questions/actions	Yes	No
1	Close the side (turn guide) door. Does the message reset?	Problem solved.	Go to step 2.
2	Disconnect CN10 from the CK1 daughter card board. While activating the door switch, is there continuity at pins 1 and 2 of the connector?	Replace the printer controller board.	Replace the side door (turn guide) sensor assembly.

#### **Map 2 - False Close Front Door message**

Step	Questions/actions	Yes	No
1	Close the top unit and front cover. Does the message reset?	Problem solved.	Go to step 2.
2	Is the interlock switch actuator broken?	Replace the front door.	Go to step 3.
3	Is the actuator rod that activates the interlock switch on power supply 2 damaged or broken?	Replace the actuator rod.	Replace the power supply 2.

#### **Map 3 - False Close Tray (x) Top Cover message**

Step	Questions/actions	Yes	No
1	Remove the rear cover on the high-capacity feeder, and observe LED 9 on the HCF card while actuating the cover open micro-switch. Does the LED go on and off while opening and closing the door?	Replace the HCF card.	Replace the cover open micro-switch.

#### Map 4 - False Tray (x) Low/Empty message

Step	Questions/actions	Yes	No
1	Is the Tray (x) Low message present?	Go to step 2.	Go to step 4.
2	Is the paper level flag on the rear of the cassette jammed or binding?	Repair or replace the paper level flag.	Go to step 3.
3	Is the paper level sensor dirty?	Clean the paper level sensor.	Replace the printer control board.
4	Is the Tray (x) Empty Message present?	Go to step 5.	Problem solved.
5	Is the paper out sensor attached to its connector, but not properly attached to the paperfeed unit?	Reattach the sensor to the paper feed unit.	Go to step 6.
6	Is the paper out ball actuator broken?	Replace the paperfeed unit.	Replace printer controller board.

#### Map 5 - False 30 Oil Coating Roll Missing message

Step	Questions/actions	Yes	No
1	Is the OCR properly installed?	Go to step 2.	Properly install the OCR.
2	Is the OCR fuse missing?	Replace the OCR.	Go to step 3.
3	Is the OCR contact at the rear of the fuser damaged or broken?	Replace the fuser.	Go to step 4.
4	Is CN19 on the printer controller board properly connected?	Replace the printer controller board.	Properly connect CN19.

**Note:** Before performing map 6 or 7, remove the affected toner cartridge, shake it. Reinstall the cartridge. Restart the printer to see if the message is displayed.

### Map 6 - False <color> Print Unit Missing message

Step	Questions/actions	Yes	No
1	Are all the toner cartridges and photodevelopers installed?	Go to step 3.	Install the missing cartridge or photodeveloper.
2	Did this fix the problem?	Problem solved.	Go to step 3.
3	Are all connectors that the print unit photodeveloper contacts when the top cover is closed operating correctly and not damaged, worn, or missing?	Go to step 4.	Replace the sub frame.
4	Is CN9 on the printer controller board properly connected?	Go to step 5.	Properly connect CN9.
5	Check the connectors on the RFID antenna and CN 21 on the printer controller board. Are they properly connected?	Replace the printer controller board.	Properly connect the cables.

### Map 7 - False 88 <color> Toner Low/Toner Empty message

Step	Questions/actions	Yes	No								
1	Ensure the RIP board and the printer controller board are updated to the latest code. Are the boards at the latest code level?	Go to step 2.	Upgrade the RIP and controller board codes to the latest level.								
2	Ensure that the encoder located at the rear of the toner set is clean and free of dirt or paper dust. Is the encoder wheel clean and free of dirt or paper dust?	Go to step 3.	Clean the encoder wheel, or replace the toner set.								
3	Is the toner remaining photo interrupter sensor clean and free of obstructions?	Go to step 4.	Clean or replace the toner remaining photo interrupter.								
4	Is the connector of the problem color properly connected on the printer controller board? <table border="1" data-bbox="589 1440 831 1579"> <tbody> <tr> <td>Magenta</td> <td>CN1</td> </tr> <tr> <td>Yellow</td> <td>CN1</td> </tr> <tr> <td>Cyan</td> <td>CN1</td> </tr> <tr> <td>Black</td> <td>CN1</td> </tr> </tbody> </table>	Magenta	CN1	Yellow	CN1	Cyan	CN1	Black	CN1	Replace the printer controller board.	Properly connect the connector.
Magenta	CN1										
Yellow	CN1										
Cyan	CN1										
Black	CN1										

### Map 8 - False 40 Tray (x) Size Sensor Error message

Step	Questions/actions	Yes	No
1	On the high-capacity feeder, are the paper size adjusting screws present on the upper portion of the side fence and fully screwed into the adjusting bracket?	Go to step 2.	Replace the missing thumbscrew or screw them in all the way.
2	Observe the LEDs 1 and 2 on the HCF control board while unscrewing the paper size adjusting thumbscrews. Do the LEDs light when the screws are loosened all the way?	Replace the HCF control board.	Replace the affected sensor. Paper size sensor 1 for 11 inch or paper size sensor 2 for A4.

### Map 9 - False 41 Open Bin 1 Exit Tray message

Step	Questions/actions	Yes	No
1	Is the exit tray switch actuator broken or damaged?	Replace the paper exit tray.	Go to step 2.
2	Disconnect CN4 from the CK2 daughter board. When activating the paper exit tray switch, is there continuity between pins 1 and 2?	Replace the printer controller board.	Replace the paper exit tray switch.

## Map 10 - Unrecoverable Check Tray (x) or Duplex Connection message

Step	Questions/actions	Yes	No
1	Is the problem with a specific paper tray or the duplex unit?	Go to step 2.	Go to step 8.
2	Is the problem with tray 1?	Go to step 3.	Go to step 6.
3	Are connectors CN8 and CN6 on the printer controller board properly connected?	Go to step 4.	Properly connect the connectors.
4	Is connector CN3 on the expansion paper feed control card, for tray 1, properly connected?	Go to step 5.	Properly connect the connectors.
5	Replace the tray 1 expansion feeder control card. Does this fix the problem?	Problem solved.	Return the tray 1 expansion feeder control card, and replace the printer controller board. If the problem remains, replace the expansion feeder cable assembly.
6	Are connectors CN9, CN8, CN7 and CN3 on the expansion feeder control card (for the problem tray and the trays above and below) properly connected?	Go to step 7.	Properly connect the connectors.
7	Exchange the expansion feeder control board for the problem tray with one above or below. Does the symptom follow the exchanged card?	Replace the defective expansion feeder control card.	Replace the upper and lower expansion paper feed drawer connecting cable assemblies.
8	Are any of the pins or contacts on the duplex drawer connectors bent or damaged?	Go to step 9.	Repair or replace the connector.
9	Are connectors CN101 and CN102 on the duplex interface card properly connected?	Go to step 10.	Properly connect the connectors.
10	Replace the duplex interface card. Does this fix the problem?	Problem solved.	Return the duplex interface card and go to step 11.
11	Replace the duplex interface cable. Does this fix the problem?	Problem solved.	Go to step 12.
12	Are CN16 on the printer controller board and CN3 on the CK2 daughter board on the printer controller board properly connected?	Replace the printer controller board. If the problem remains, replace the duplex connector cable.	Properly connect the connectors.

## Map 11 - Paper size map

Step	Questions/actions	Yes	No
1	Do the paper size sensor actuators on the paper operation tray operate correctly as you slide the paper location plate?	Go to step 2.	Replace parts as necessary.
2	Do the size sensor levers operate correctly?	Go to step 3.	Replace the size sensor levers.
3	Are the following connectors properly connected? CN4 on the expansion feeder control card (trays 2 5).	Go to step 4.	Properly connect the connectors.
4	If the problem is in tray 1, replace the CK2 daughter board. If the problem is in an expansion tray, replace the size sensor card associated with the affected tray. Does this fix the problem?	Problem solved.	Replace the printer controller board (tray 1). Replace the expansion feeder control card (trays 2 5).

### Map 12 - Unable to print from USB drive service check

Step	Questions / actions	Yes	No
1	Is the file being printed, a supported format?	Go to step 2.	Try a supported file format.
2	Is the USB drive properly inserted?	Go to step 3.	Properly insert the USB drive.
3	Is the USB drive a supported drive?	Go to step 4.	Try a supported USB drive.
4	Try another drive. Did this work?	Problem solved.	Go to step 5.
5	Are the connections on the operator panel and the RIP board properly connected? Are any pins on the connectors bent or broken?	Go to step 6.	Properly connect all connections.
6	Replace the operator panel. Did this work?	Problem solved.	Go to step 7.
7	Using a voltmeter, check pin 6 for 3.3V and pin 2 for 5V on J26 on the RIP board. Are the voltages correct?	Replace the USB cable.	Replace the RIP board.

### Map 13 - False tray (x) too full

Step	Questions / actions	Yes	No
1	Is the paper cassette in the printer?	Go to step 2.	Insert the paper cassette.
2	Is the tray too full?	Take paper out of the tray until the tray full line in the cassette is visible.	Go to step 3.
3	Is the paper present sensor dirty?	Clean the sensor.	Go to step 4.
4	Is the paper feed position roll actuator broken?	Replace the paper feed unit.	Replace the printer controller board.

### Map 14 - False 32 - replace unsupported cartridge

Step	Questions / actions	Yes	No
1	Is a supported cartridge installed?	Go to step 2.	Switch to a supported cartridge.
2	Try a different cartridge. Did this work?	Problem solved.	Go to step 3.
3	Check the RFID antenna cable connections, and CN 21 on the printer controller board. Are they properly connected?	Replace the printer controller board.	Properly connect the connectors.

## Service checks

### *Drive 1 DC motor service check*

	FRU	Action
1	DC motor Drive unit 1 Printer controller board	<p>If the motor does not attempt to turn, and you receive a 910 error code, replace the driver 1 dc motor.</p> <p>Be sure the toner and photodeveloper units are not causing an overload on the dc motor.</p> <p>If the motor turns, but the paper carrying section of the machine does not rotate, check the drive 1 unit gear train for damage. Be sure the clutch on the gear train engages for color printing. Replace the drive 1 unit if necessary.</p> <p>If this does not correct the problem, replace the printer controller board.</p>

### *Paper exit motor service check*

	FRU	Action
1	Paper exit motor	<p>Check for frayed insulation on wires connecting the paper exit motor to the printhead controller board.</p> <p>Check for severed wires connecting the paper exit motor to the printhead controller board.</p> <p>Be sure connector CN09 on the printhead controller board is firmly connected. If there still is a problem, replace the face-down unit.</p>

### *Duplex unit service check*

	FRU	Action
1	Feed roller belts	Check for wear or damage to the feed roller belts. Replace as necessary.
2	Duplex stepper motor Side fence Stepper motor gears	<p>Be sure the stepper motor turns freely with no binding.</p> <p>Check for wear or damage to the associated gears.</p>
3	Feed roller solenoid assembly Paper re-feed solenoid assembly	Check for proper operation of the solenoid and linkage. Replace as necessary.
4	Photo-interrupter assembly	Ensure that the photo-interrupter actuators are operating correctly and are in the proper position.



## Paper feed unit service check

**Note:** These tests can also be performed on the expansion paper-feed units.

	FRU	Action
1	<p>Turn guide door sensor</p> <p>Paper tray level motor</p> <p>Printer controller board</p>	<p>Turn the printer on. Open the door. Check the operator panel for <b>Close Door</b> message.</p> <p>Bypass the turn guide door open sensor*. Pull out and replace the cassette. Listen for the paper tray level motor to activate. (The tray may or may not rise. The motor makes a low pitched vibrating sound.)</p> <ul style="list-style-type: none"> <li>- If the paper tray level motor operates and the <b>Close Door</b> message fails to appear, replace the turn guide door sensor.</li> <li>- If the <b>Close door</b> message appears and the paper tray level motor fails to operate, replace the paper tray level motor.</li> <li>- If the paper tray level motor fails to operate, and the <b>close Door</b> message fails to appear, check CN3, CN4, and CN5 on the printer controller board. If they are properly connected, replace the printer controller board.</li> </ul>
2	<p>Paper out sensor</p> <p>Paper feed unit</p> <p>Paper level sensor</p>	<p>Turn the printer on, and open the turn guide door. Bypass the turn guide door open sensor*.</p> <p>With the paper tray empty and the paper out sensor blocked, pull out and replace the cassette.</p> <ul style="list-style-type: none"> <li>- If the tray rises and stays in place, check for a dirty paper out sensor, and inspect the ball actuator on the paper feed unit.</li> <li>- If the ball actuator is stuck or broken, replace the paper feed unit.</li> <li>- If the ball actuator is good, replace the paper out sensor.</li> <li>- If the tray (x) empty message is displayed, check the paper out sensor to ensure it is in place.</li> </ul> <p>Turn the printer on, and open the turn guide door. Bypass the turn guide door open sensor*. Block the paper out sensor. With the tray empty, pull out and insert the cassette.</p> <ul style="list-style-type: none"> <li>- If the tray fails to rise, check for a dirty paper level sensor or broken cassette present actuator. With the turn guide door open, remove and reinsert the paper tray.</li> <li>- If the paper feed roll fails to go up when the paper tray is reinserted, replace the paper feed unit.</li> <li>- If the actuator is broken, replace the paper feed unit.</li> <li>- If the actuator is good and the sensor was clean, replace the paper level sensor.</li> <li>- If the tray too full message is displayed, clean or replace the sensor.</li> </ul>

	FRU	Action
3	Relay sensor	<p>Bypass the turn guide door open sensor*.</p> <p>Turn the printer on while holding down the paper relay sensor.</p> <ul style="list-style-type: none"> <li>- If the operator panel does not display Paper Jam , check for a dirty paper relay sensor.</li> <li>- If the paper relay sensor is clean, or the actuator for the paper relay sensor is broken, replace the sensor.</li> </ul> <p>If the sensors are replaced and problem remains, replace the printer controller board.</p>
	Paper feed clutch	<p>Check the resistance of the clutch using a multi meter. The resistance should measure 160 ohms.</p> <p>If the clutch shows a significantly higher reading, replace the clutch.</p> <p>If you replace the clutch and the problem remains, replace the printer controller board.</p>

\* The turn guide door sensor can be bypassed by pressing down the metal actuator located on the sensor. Hold it down with your finger or a piece of tape. Ensure all adhesive from the actuator is removed upon completion of service.

### ***Expansion paper feed service check***

If you have a 200 Paper Jam Tray (x) error code, check the option connection cable for proper connection to the printer or other paper feeder.

	FRU	Action
1	Feeder drive motor	If the feeder drive motor works, go to the <b>“Paper carrying service check” on page 2-56.</b>
2	Gears Paper feed clutch Expansion feeder control board	If the motor turns, but the drive gears do not, replace the gears as necessary. Check the paper feed clutch for proper operation, and replace as necessary. If this does not correct the problem, replace the expansion feeder control board.
3	Roller Roller clutch	<p>If there is a failure to pick, or if a paper jam exists in the paper feed unit, check for dirty or worn rollers.</p> <p>If there is a failure to pick but the rollers are clean, check the roller clutch. This can be done by turning the paper feed roll in both directions.</p> <p>If the shaft can be turned both directions, replace the roller clutch.</p>

### ***Face down stacker full service check***

	FRU	Action
1	Stacker full detection lever	Check the stacker full detection lever for damage.
2	Stacker full detection sensor Printer controller board	Check for a voltage fluctuation between 0 V and +5 V between pins 2 and 3 of connector CN10 on the printhead controller board while actuating the sensor.

## High-capacity feeder (HCF) service check

	FRU	Action
1	Paper size sensors 1 and 2 Residual paper sensors 1 4 Paper level sensor Lower limit switch Docking switch Upper limit Paper sensor switch Paper feed sensor	Go to <b>“Sensor/Sw Test” on page 3-14</b> , and perform the LED sensor test. You can block each sensor to verify if it is working properly. Replace the failing sensor.
2	Tray motor Paper feed motor HCPF power supply Pickup solenoid Paper feed roller Transfer roller Paper feed clutch Tray drive belt	Be sure that all rollers, gears, and belts are in good working order. Replace as necessary.
3	Paper feed clutch Pickup solenoid HCF power supply Paper feed motor Tray motor HCPF board	Go to <b>“Maintenance Mode” on page 3-43</b> , and run the tests.

## Finisher service check

	FRU	Action
1	Input path sensor Paper register sensor Upper tray exit sensor Guide stack assembly Paper full A sensor Paper detect sensor Staple home position sensor No staple sensor Punch box detect sensor Invert path sensor Lower tray exit sensor Elevator upper limit sensor Tray near full sensor Elevator lower limit sensor Jogging assembly Pap. upper level sensor Fin. set switch sensor Staple cart. set sensor	<p>Note: For frequent jams, hole punch problems, or stapling problems, first check the finisher to printer alignment. Go to <b>“Aligning the finisher and printer” on page 3-59.</b></p> <p>Run the finisher sensor test in diagnostic mode to test the sensors and switches.</p>
2	Timing belts Patting roller Path select solenoid Path select gate Guide stack assembly Jogging unit assembly Tractor drive assembly Stapler	<p>Run the staple test in diagnostic mode to test feeding and stapling function.</p>
3	Registration roller Paper exit rollers Registration sensor Registration clutch Punch clutch punch unit Timing belt	<p>Run the hole punch test in diagnostic mode to test the hole punch function.</p>
4	Elevator motor Tray wires	<p>Observe the elevator motor operation while powering the printer up.</p>

## Marks on paper service check

If you have evenly spaced marks on the paper, measure the distance between the marks, and locate the symptom in the following table. Check the assembly for dirt or damage and clean as necessary. Run a test print to verify the problem has been corrected. The indicated assemblies are replaced by the customer at prescribed intervals.

If you remove the transfer belt, do not turn it upside down. Toner will fall from the waste toner box onto the transfer sheets and roller(s) inside the belt. This causes lower transfer efficiency and washed out colors.

Distance between marks	FRU / supply item
27 mm	Absorption/charge roller (transfer roller)
31.5 mm	Photodeveloper charge roller
45.1 mm	Supply roller (toner cartridge)
46.9 mm	Upper registration roller
46.9 mm	Lower registration roller
47.5 mm	Developer roller (toner cartridge)
64.5 mm	OCR (oil coating roller)
94.2 mm	Photodeveloper drum
139.2 mm	Fuser upper roller
140 mm	Fuser lower roller
824.5 mm	Transfer belt

Fuser part locations	From paper center (mm)
Thermistor hot roll	-6
Thermistor BUR	0
TCO hot roll	66
TCO BUR	101
Detact fingers hot roll	113.5/75/37.5/0/-37.5/-75/-113.5
Detact fingers BUR	134/90/45/0/-45/-90/-134
Exit rollers	96/37.5/-37.5/-96
Star rollers	127/60/15/-15/-60/-127

## Operator panel service check

	FRU	Action
1	Operator panel Operator panel cable RIP board. Ensure code is at the latest level.	Run both the LCD Hardware Test and the Button Test in Diagnostic Mode.  Be sure the operator panel cable connections are securely connected on the RIP board and operator panel.

## Paper carrying service check

### Paper has not exited or is stopped in the high-capacity feeder (area F, 249).

	FRU	Action
1	Paper feed roller Transfer roller	Be sure the paper feed roller transfer roller, reverse roller, and call roller are free of dirt and are not damaged. Clean or replace parts as necessary.
2	Paper feed clutch Paper feed motor Sensors	Set up and run a test in Maintenance Mode, and go to <b>“High-capacity feeder (HCF) service check” on page 2-53.</b> Ensure all motors, clutches, and sensors operate correctly.
3	HCPF control card HCPF power supply	Set up and run a test in Maintenance Mode, and go to <b>“High-capacity feeder (HCF) service check” on page 2-53.</b> If no LEDs light, check the power source. Replace the HCF control card. Replace the HCF power supply.

### Paper is being picked up and carried to the registration roller (areas C, E, 250, 24x).

	FRU	Action
1	Paper feed cassette	If there are misfeeds and jams in the paper-feed unit, check to see if the corners of the paper in the cassette are curled upward. If the corners are curled, turn the entire stack of paper over. The curling could be due to humidity conditions.
2	Paper feed unit rollers  Roller clutch	Are the rollers dirty or worn? Replace as needed.  If there is a failure to pick, and the feed rollers are clean, check the roller clutch on the paperfeed unit. This check can be performed by turning the paper feed roll in both directions. If the shaft can be turned in both directions, replace the roller clutch.
3	Paper feed roller (MPF) Paper feed rolls MPF, tray 1, 2, 3, 4, 5 Carrying roller tray 1, 2, 3, 4, 5 Fanning pad (MPF)	Be sure the paper feed rollers are free of dirt and not damaged. Be sure the fanning pad is free of dirt and not damaged. Replace parts as necessary.
4	Gears	Be sure the paper feed gears are not damaged.
5	Paper feed clutch MPF clutch MPF frame assembly	Ensure the clutches are engaging properly. Check connector CN17 (tray 1), CN8 (MPF) on the CK1 daughter card, and CN18 on the expansion feeder controller card for continuity.
6	Registration sensor MPF sensor Printer controller board CK1 daughter card	If possible, check for fluctuation between 0 and +5V on the CK1 daughter card board between the following pins when actuating the sensor:  Registration sensor C N6 (pins 1 and 2) MPF sensor (C N6 pins 4 and 5) If the voltage fluctuates as stated previously, replace the printer controller board. If the voltage does not fluctuate, replace the sensor.

**Paper has stopped at the registration roller or has not reached the fuser (areas C, E, 250, 24x).**

	FRU	Action
1	Registration roller clutch Registration roller Transfer belt unit Rear paper feed guide	Check these parts for wear or damage. Replace as necessary. Be sure all guide surfaces in the paper path are free of dirt.  Check the registration roller clutch for continuity. Does the clutch engage when the printer is printing a job?  Be sure connector CN7 on the CK1 daughter board is connected properly.
2	Registration sensor Printer controller board	Check for a fluctuation of between 0 V and +5 V between pins 1 and 2 of connector CN6 on the CK1 daughter board while actuating the sensor. If the voltage fluctuates as stated above, replace the printer controller board. If the voltage does not fluctuate, replace the sensor.

**Paper has exited the registration roller and entered the fuser (areas A and B).**

	FRU	Action
1	Transfer belt unit Rear paper guide Discharge brush Fuser	Remove any buildup of toner. Replace any damaged or worn parts.  Check the paper exit flag on the fuser for damage. Replace the fuser if necessary.
2	Fuser separation pawl	Replace the fuser if paper jams cannot be removed.

**Paper has entered the fuser and exited the printer (area B).**

	FRU	Action
1	Fuser	Remove any toner buildup, and replace any worn or damaged parts.
2	Fuser exit lower roller Fuser exit upper roller Face-up exit assembly	Be sure the exit FU/FD solenoid energizes in the correct position for either face-down or face-up delivery.  Do a continuity check of the solenoid. Be sure connector CN7 is properly connected to the CK2 daughter board.
3	Face down exit assembly Face down feed roller belt	Be sure that connector CN4 is properly connected to the controller board.  Check the face-down feed roller belt.  Check for a fluctuation of between 0 V and +5 V on the printer controller board between the following pins, when actuating the sensor:  Paper exit switch CN 7 on the Ck2 daughter board (pins 4 and 5).

**Paper has entered the duplex unit (area D).**

	FRU	Action
1	Feed rollers Belts	Check for wear or damage to feed rollers and belts.
2	Duplex unit	Be sure the duplex unit is properly installed and that all connections are correct.
3	Duplex stopper motor Side fence stepper motor	Be sure the stepper motor turns freely with no binding. Check for wear or damage to the associated gears. Replace as necessary.
4	Feed roller solenoid assembly Paper re-feed solenoid assembly	Check for proper operation of the solenoid and linkage. Replace as necessary.
5	Paper tray	Check to see if the paper edge guides have shifted. If so, re-time by removing the screw and gear from the bottom of the tray and pushing the paper edge guides up against the paper lift plate. Reinstall the screw and gear.

**Paper jammed in finisher (area G).**

	FRU	Action
1	Registration roller Paper exit rollers Registration sensor Registration clutch Punch clutch punch unit	Check finisher to printer alignment. Go to <b>“Aligning the finisher and printer” on page 3-59.</b> Check all belts for wear or damage. Check the registration roller for wear or damage. Check for obstructions. Check the registration sensor by running the finisher sensor tests in diagnostic mode. Check the registration clutch by running the staple test or hole punch test in diagnostic mode. Replace parts as necessary.
2	Paper feed motor Finisher control board	Check the paper feed motors by running the staple test or hole punch test in diagnostic mode. If the paper feed motor has been replaced, replace the finisher control board.



### Paper jammed in finisher (area H).

	FRU	Action
1	<ul style="list-style-type: none"> <li>• Timing belts</li> <li>• Patting roller</li> </ul>	<p>Check finisher to printer alignment. Go to <b>“Aligning the finisher and printer” on page 3-59.</b></p> <p>Check for obstructions in the paper path. Check all belts for wear or damage.</p> <p>Check for wear or damage on the patting roller.</p>
2	<ul style="list-style-type: none"> <li>• Path select solenoid</li> <li>• Path select gate</li> <li>• Guide stack assembly</li> <li>• Jogging assembly</li> <li>• Stapler</li> </ul>	<p>Check for proper operation of the guide stack assembly and jogging assembly by running the staple test in diagnostic mode. Check the tractor belts for proper alignment.</p> <p>Replace parts as necessary.</p>
3	<ul style="list-style-type: none"> <li>• Belt home position sensor</li> <li>• Paper detecting sensor</li> <li>• Invert path sensor</li> <li>• Finisher control board</li> </ul>	<p>Ensure that all sensors are operating properly by running the sensor test in diagnostic mode.</p> <p>Replace sensors as necessary.</p>

### Paper jammed (area I).

	FRU	Action
1	Timing belts	<p>Check finisher to printer alignment. Go to <b>“Aligning the finisher and printer” on page 3-59.</b></p> <p>Check the paper path for obstructions. Check all belts for wear or damage.</p>
2	<ul style="list-style-type: none"> <li>• Invert (tray 2) exit roller</li> <li>• Exit guide (tray 2) invert assembly</li> <li>• Exit guide (tray 1) straight assembly</li> </ul>	<p>Check to ensure that all rollers are operating correctly by running the hole punch and staple tests in diagnostic mode.</p>
3	<ul style="list-style-type: none"> <li>• Paper exit sensor (tray1)</li> <li>• Paper exit sensor (tray 2)</li> <li>• Paper full sensor A (tray 2)</li> <li>• Paper upper level sensor B (tray 2)</li> </ul>	<p>Ensure that the sensors are working properly by running the sensor test in diagnostic mode.</p>
4	<ul style="list-style-type: none"> <li>• Elevator upper limit sensor</li> <li>• Elevator lower limit sensor</li> <li>• Elevator motor</li> </ul>	<p>Ensure that the elevator upper limit sensor, elevator lower limit sensor, and the elevator motor are operating correctly at power up.</p>

### ***Paper exit, face up service check***

	<b>FRU</b>	<b>Action</b>
1	Face-up exit assembly	<p>If the paper is not exiting to the back paper face-up tray or the face-down tray, check the sensor for proper operation. Look for a fluctuation of between 0 V and +5 V between pins 1 and 2 of connector CN5 of the CK2 daughter board while actuating the sensor.</p> <p>Check the FU/FD deflector that directs the paper to the proper tray.</p> <p>Check the FU/FD solenoid for continuity. Also be sure the connector is properly connected to the printer controller board.</p> <p>Check the gears and the actuating mechanism for wear or damage.</p>
2	Printer controller board	Check connectors CN18 on the printer controller board, and CN7 on the CK2 daughter board for proper connection on the printer controller board.

### ***Paper skew service check***

	<b>FRU</b>	<b>Action</b>
1	Cassette	<p>Remove the tray, and turn it upside down. The tray guides are connected at the center of the tray by a toothed gear that ensures they move in unison. If not, remove the screw at the center of the gear and, using a sheet of paper in the tray as a template, realign the guides.</p> <p>Reseat the roller at the leading edge of the transfer belt.</p> <p>Make sure the correct amount of paper is in the tray and that it is under the corner bucklers.</p> <p>The paper lift tray must be pushed down to the lock position every time the drawer is closed.</p>

### ***Paper tray missing service check***

	<b>FRU</b>	<b>Action</b>
1	<ul style="list-style-type: none"><li>• Size sensor actuators</li><li>• Cassette</li></ul>	Check to ensure that the paper size adjustment is correct for the paper being used. Ensure that the paper size sensor actuators are not bent or broken. Make sure that there are no broken parts on the cassette that would allow the cassette to move or shift from its intended position inside the printer.
2	<ul style="list-style-type: none"><li>• CK2 daughter board</li><li>• Size sensor board</li><li>• Expansion paper feeder control board</li><li>• Printer controller board</li></ul>	Be sure that connector CN18 on the printer controller board is connected properly. Also check CN4 on the expansion paper feeder control board for the associated tray.

### ***Photodeveloper missing service check***

When you replace the photodeveloper unit, all three color units must be replaced at the same time.

	<b>FRU</b>	<b>Action</b>
1	Photodeveloper	Check for dirt or damage to the sensing contacts on the rear. Clean or replace the photodeveloper drum unit if necessary.
2	Sub-frame unit	Check the sensing contacts on the sub-frame assembly. Clean or replace the affected contacts or sub-frame.
3	High voltage unit	If the problem remains, replace the high voltage unit (HVU).
4	Printer controller board	If the problem remains, replace the printer controller board.

### ***Power supply service check***

	<b>FRU</b>	<b>Action</b>
1	Voltage	Be sure the switch is on, and the power cord is firmly plugged into the printer. Be sure the correct voltage is present at the outlet.
2	Power cord	Check the power cord for continuity.
3	<ul style="list-style-type: none"><li>• Fuse</li><li>• Switch</li><li>• Power supply 1</li></ul>	The power supply fuses may be blown. Unplug the machine, and check fuse F2 on the power supply 1 for continuity. If the fuse is good, check the power switch connector for continuity.
4	Power supply 2	The power supply 2 may be defective. Check the dc power of the power supply for the following pins: CN102 pins 8 and 11 for +3.3 V CN103 pins 7 and 14 for +3.3 V CN105 pin 5 for +3.3 V CN102 pins 12 and 14 for +5 V CN103 pins 1, 3, 8, 9 for +5 V CN104 pins 1 and 2 for +5 V  CN104 pins 7 and 8 for +24 V CN105 pin 4 for +24 V CN106 pins 5 and 6 for +24 V Replace power supply 2 if necessary.

### 210 Staple jam service check



	FRU	Action
1	Stapler Staple cartridge holder	Check for jammed staples in the stapler. Clear the staple jam, go into diagnostic mode, and run a staple test. If the problem recurs, replace the staple cartridge holder. If this does not resolve the problem, replace the stapler.
2	Stapler Finisher control board Stapler cable	If the error occurs and there is no staple jam, check to ensure that connectors CN5 on the stapler and PJ1 on the finisher control board are properly connected. Make sure that the finisher set switch is activated. Measure for +5 V dc between pins 11 and 12 on stapler connector CN5. If +5 V dc is not present, check for continuity on the stapler to finisher control board cable. If there is no continuity on any pin position, replace the cable. If there is continuity, replace the finisher control board. If +5 V dc is present, replace the stapler.

### Transfer belt up/down service check

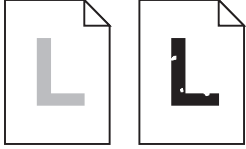
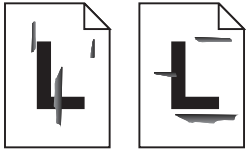

	FRU	Action
1	Belt up/down sensors Belt up/down actuator	Check the transfer belt up/down sensor. Be sure that connector CN15 is firmly connected to the printer controller board. Replace the transfer belt unit. Check for a fluctuation between 0 V and +5 V between pins 7 and 8 while actuating the sensor.
2	Belt up/down clutch	Be sure connector CN11 is firmly connected to the CK1 daughter board. Replace the belt up/down clutch if necessary.
3	Belt up/down lift cams	Check and replace the belt up/down unit if damaged.
4	Printer controller board	If there still is a problem, replace the printer controller board.

## Image quality troubleshooting

### Print quality problems

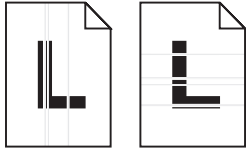
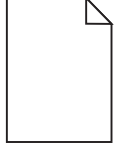
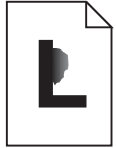
Problem	Action
<p>Print is too light, or printed images or characters have voids or dropouts.</p> 	<p>Be sure you're using recommended paper or other media. Use media from a new package.</p> <p>Be sure you have selected the correct Paper Weight setting for the media you're using.</p> <p>Be sure the affected print unit is completely installed in the printer.</p> <p>Set print darkness to 4 from the Color Menu.</p> <p>Clean the printhead LEDs.</p> <p>If you suspect a toner cartridge is low on toner, remove the appropriate toner cartridge, and gently shake it back and forth to distribute the toner evenly. Reinsert the print unit and try printing the job again.</p> <p>Replace the affected toner cartridge.</p> <p>Replace the photodevelopers. If only black print appears light, replace just the black photodeveloper. If one of the colors prints too light, replace all three of the color photodevelopers. If there is still a problem, go to <b>"Uneven printing" on page 2-67</b>.</p>
<p>Colored lines, streaks, or smudges appear on the printed page, or print appears blurred or unclear.</p> 	<p>Replace the photodevelopers. If the problem only occurs when printing black, replace just the black photodeveloper and fuser coating roll. If the problem occurs when printing one of the colors, replace all three of the color photodevelopers. If the problem remains, go to <b>"Black line" on page 2-66</b>.</p>
<p>Toner specks appear on the page.</p> 	<p>Replace the oil coating roll.</p>
<p>Toner colors the background of the page.</p> 	<p>Be sure the affected photodevelopers and toner cartridges are completely installed in the printer.</p>

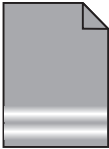
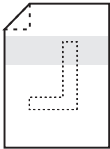
Problem	Action
<p>The page has 100% coverage of one color.</p> 	<p>Be sure the affected photodevelopers are completely installed in the printer.</p> <p>Replace the photodevelopers. If the page is black, replace just the black photodeveloper. If the page is another color, replace all three of the color photodevelopers. If this does not fix the problem, go to <b>“Black print” on page 2-67.</b></p>
<p>Light lines or streaks appear on the printed page.</p> 	<p>Clean the LEDs.</p> <p>Make sure the affected photodeveloper is completely installed in the printer.</p> <p>Remove the affected toner cartridge, and gently shake it back and forth to distribute the toner evenly. Reinsert the toner cartridge, and try printing the job again.</p> <p>Replace the affected toner cartridge.</p> <p>Replace the photodevelopers. If the problem only occurs when printing black, replace just the black photodeveloper. If the problem occurs when printing one of the colors, replace all three of the color photodevelopers and the transfer belt. If the problem remains, go to <b>“Uneven printing” on page 2-67.</b></p>
<p>The page is blank.</p> 	<p>Be sure the affected print unit is completely installed in the printer.</p> <p>Replace the affected toner cartridge. If the problem remains, go to <b>“No image” on page 2-66.</b></p>
<p>Toner smears or rubs off the page.</p> 	<p>Be sure you’re using recommended paper or media.</p> <p>Be sure you have selected the correct Paper Weight setting for the media you’re using.</p> <p>Be sure the top cover is completely closed and both sides are <i>snapped</i> shut.</p> <p>You may need to replace the fuser.</p>

Problem	Action
<p data-bbox="326 262 638 310">Color fades with fuzzy, poorly defined edges.</p> 	<p data-bbox="706 262 1446 331">Print out a Menu Settings page, and check the level of supplies. If a toner cartridge shows 10% or less, shaking the cartridge may improve the printout.</p> <p data-bbox="706 359 1458 478">Remove the cartridges and photodevelopers from the printer. Use a lint-free, dry cloth to clean the LEDs of any stray toner. Wipe one at a time and proceed from the front of the printer to the back in one gentle swipe. It may take more than one pass. Use a different spot on the cloth or a new cloth for each LED. Reinstall supplies and test.</p> <p data-bbox="706 506 1455 674">Remove the supplies from the printer. Check that the LEDs are free to move upward. With the supplies out, the metal post is visible on the LED. Push up on the post, and make sure it returns to its previous position. If the LED is binding, it is possible there is an incorrect screw holding the cover in place. If too long a screw is installed in the cover, it will bind against the LED. The correct screw length is 3.5 mm. Install the screws and test.</p> <p data-bbox="706 701 1438 770">Debris in the contact blocks may cause fading. Make sure there is nothing in the contact block to keep it from seating securely when the top cover is closed.</p> <p data-bbox="706 798 1455 896">Ensure the absorption roll/charge roll on the belt is securely seated. The black plastic T-shaped bushings should both be below the flap on the right side of the belt. A poorly seated roll can cause both skewing of the paper and problems with the magenta print.</p> <p data-bbox="706 924 1455 993">Check that the top cover is firmly closed on the printer. If the cover is not closed completely, the LED may be out of focus and allow light print on the bottom of a letter size page. Close the cover firmly and test.</p> <p data-bbox="706 1020 1455 1140">Print the quality pages in the Diagnostics Mode (under Print Test, Print Quality Pages). This often identifies the color that has a problem. If you switch the toner cartridges and the problem also changes color on the test pages, the problem is in one of the cartridges. Replace the proper color cartridge.</p>
<p data-bbox="326 1165 662 1213">Toner adheres to the back of the page.</p> 	<p data-bbox="706 1165 1455 1234">Remove the fuser oil roll, wipe it with a dry, lint-free cloth, and clean the transfer belt. If there still is a problem, go to <b>“Periodic dirt” on page 2-68.</b></p>
<p data-bbox="326 1438 638 1486">Quality of printed transparencies is inadequate.</p> 	<p data-bbox="706 1438 1295 1465">Be sure you're using the recommended transparencies.</p> <p data-bbox="706 1493 1403 1541">Be sure you have selected the correct paper weight setting for the media you are using.</p> <p data-bbox="706 1568 1338 1617">When printing transparencies, always set the Paper Type to Transparency.</p> <p data-bbox="706 1644 1328 1671">Avoid getting fingerprints on transparencies before printing.</p>

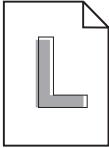
Problem	Action
Print on the page is skewed. 	Be sure the width guides in the paper tray or the multipurpose feeder fit snugly against the media you loaded. Be sure the charge roll or belt is seated properly.
A white gap is noticeable between color fills, due to poor color registration. 	Be sure all four corners of the printer are resting on a steady flat surface. Turn the printer off and back on. The printer calibrates the print head timing, which may improve registration. Be sure that Auto Registration, in diagnostic mode, is <b>On</b> .

### No image

Possible cause	Action
Moist paper	Be sure the printer is not in a damp environment and the paper is not curled or wavy due to moisture. If necessary, inform the customer about correct storage.
LED printhead	Be sure the LED printhead cable is securely connected to the printhead controller board and LED printhead assembly. If the problem remains, replace the LED printhead.
High voltage unit (HVU)	Be sure all the connectors to the high voltage unit are securely connected. If the problem remains, replace the high voltage unit.
Printer controller board	Be sure all connectors are securely connected to the printer controller board. If the problem remains, replace the printer controller board.
Printhead controller board	If the problem remains, replace the printhead controller board.

### Black line

Possible cause	Action
Photodeveloper drum	Clean any dirt from the drum surface. Replace it if it is scratched.
<ul style="list-style-type: none"> <li>• Fuser detach pawl</li> <li>• Fuser roller surface</li> <li>• Fuser thermistor surface</li> </ul>	Remove any toner buildup. Replace the fuser.
LED printhead	Clean the LED printhead. Print a blank document. Replace the LED printhead if a black line appears on the paper.



## Black print

Possible cause	Action
High voltage unit (HVU)	The printed paper has black print. Be sure the high voltage unit is properly connected. If the problem remains, replace the high voltage unit.
Sub-frame	If the problem remains, replace the right sub-frame contacts.
Photodeveloper drum set	If the problem remains after replacing the sub-frame, be sure the photodeveloper has clean contacts. If necessary, replace the photodeveloper.

## Missing colors

Possible cause	Action
<ul style="list-style-type: none"><li>• Toner cartridge unit</li><li>• Photodeveloper</li></ul>	Be sure the toner cartridge and the PC drum unit are properly seated. Be sure the contacts on the print unit are clean. Be sure the print unit is installed in the correct position. Run a print test.  If the problem remains, switch the toner cartridge with another color and run a test print. If the new color prints, replace the failing toner cartridge.
High voltage unit	If the problem remains, check the connector on the high voltage unit. Replace the high voltage unit If the problem remains. Are all the screws on the high voltage unit in place?
LED printhead unit	If the problem remains, replace the printhead and EPROM.
LED printhead controller board	If the problem remains, replace the printhead controller board.
High voltage unit (HVU)	If the problem remains, replace the high voltage unit.
Transfer belt unit	If the problem remains, replace the transfer belt unit.

## Uneven printing

Possible cause	Action
Photodeveloper	Check for condensation or dirt on the photodeveloper.
LED printhead	Clean any dirt off the exposed surface of the LED printhead. Also check the locating pins of the printhead.
Transfer belt unit	Be sure the transfer belt is clean and not damaged. Replace parts as necessary.
Top cover	Be sure the top cover is fully locked.

## Periodic dirt

Possible cause	Action
Oil coating fuser roller (OCR)	Check for dirt or damage to the fuser rolls or the oil coating roller (OCR).
Photoconductor drum	Check for scratches on the surface, and replace if necessary.
Transfer belt unit	Be sure the transfer belt is clean and not damaged. Replace parts as necessary.

## White spots

Possible cause	Action
<ul style="list-style-type: none"><li>• LED printhead</li><li>• Photodeveloper</li><li>• Toner cartridge</li></ul>	Firmly install the photodeveloper and the toner cartridge into the printer.
Belt unit	Check the transfer belt unit for scratches or nicks. Be sure there is no toner buildup on the belt. Replace the belt unit if it is damaged.

## Options service check

Service Tip: When you have a problem with any of the options installed in the options slots on the interconnect board, switch the non-operating option to one of the other option slots to isolate the failure.

### Serial port

Run the **“Serial Wrap Test”** on page 3-12.

**Note:** The Serial Wrap Test is designed to check the serial port hardware by using a wrap plug, P/N 1329048, and invoking the Serial Post Diagnostic Test. The test helps isolate the printer from the serial cable and host computer. The test provides failure information on the display for approximately three seconds. If the test indicates a problem, replace the RIP board.

### Flash Memory Option(s)

Run a copy of the test page, and check to see if the option you are checking is listed. The printer does not recognize the option being installed if the option is not listed. Be sure the memory card assembly is installed correctly and is not broken or damaged. If the Memory card assembly is correctly installed, not broken or damaged, then run the **“Flash Test”** on page 3-16. If the test fails, replace the Flash card assembly. If the problem continues, replace the RIP board.

### DRAM Memory Option(s)

This service check is the same as the flash memory option service check with the following exception:

Run the **“DRAM Test”** on page 3-10 from the menu if the DRAM Memory card assembly is correctly installed and not broken or damaged. If the test fails, replace the DRAM card assembly. If the problem continues, replace the RIP board.

### Hard Disk Option

Service Tip: The 5056-01x printers support one hard disk option. Be sure only one 3.2 GB or larger hard disk option is installed. Be sure the hard disk and the hard disk board are correctly installed. Run the **“Quick Disk**

**Test” on page 3-16** from the Device Test on the Diagnostic Menu when a problem is suspected either with the hard disk system board or with the hard disk.

**Note:** The Quick Disk Test is a non-destructive test and indicates Pass or Fail. If the test fails, replace the hard disk. If a problem still exists, replace the hard disk board.

Use the **“Disk Test/Clean” on page 3-16** to help restore the disk if it contains bad data and is unusable. This test is divided into a cleaning and a verifying or testing section.

**Warning:** This can be a very lengthy test depending on the disk size. This test leaves the hard disk unformatted. The servicer or user must reformat the disk using the Format Disk Menu operation. This is a destructive type of test. All the data on the disk is destroyed and should not be performed on a known good disk.

## **Network Card Option**

The network is installed on the system board on network model printers.

### **Error Code 976 - Network Card x**

A 976 error code indicates an unrecoverable software error in network card x. Verify that network card x is correctly installed in the socket on the interconnect board and is properly grounded. If you find no problem, contact your next level of support before replacing the network card.

### **54 Network <x> Software Error**

This error displays when the RIP software detects that a network card is installed in slot x on the interconnect board but cannot establish communications with the network card.



### **3. Diagnostic aids**

**Note:** When troubleshooting, or prior to making any adjustment to print quality, always be sure:

- The printer is installed on a level, rigid surface.
- The photodevelopers are never exchanged. Do not exchange a black photodeveloper for a color photodeveloper, as they have different surface phase counts.
- Radar Page is always used when adjusting print registration.

#### ***Power-On Self Test sequence***





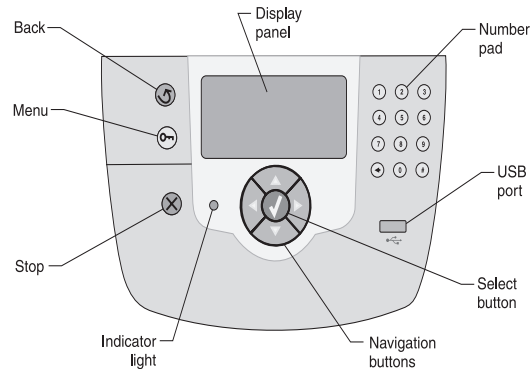

1. Power on.
2. Printer and RIP controller check:
  - ROM and RAM
  - Fuser thermistor
3. Printer hardware check:
  - Paper jam
  - Printer cartridge unit
  - Toner supply
  - Paper cassette present
4. Fuser temperature check. Temperature regulated.
5. Ready:
  - Printer controller
  - RIP controller
  - Printer condition
  - Motor/Fan
  - Heater
6. DC motor drive 1
7. Feeding paper
8. Print
9. Stepper motor drive 2
10. Paper exit
11. Stop

## Understanding the printer operator panel

The operator panel on your printer is a 4-line, back-lit, gray scale display that can show both graphics and text. The **Back**, **Menu**, and **Stop** buttons are located to the left of the display, the navigation buttons are located below the display, and the numeric pad is located to the right of the display.

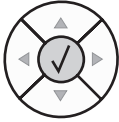



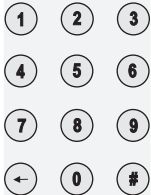

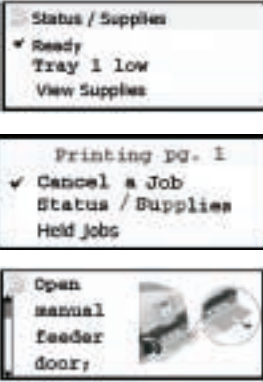
The use of the buttons and the layout of the display panel are described in the following table.

Button	Function
<b>Back</b> 	Press the <b>Back</b> button to return to the last screen you viewed. <b>Note:</b> Changes made on a screen will not be applied if you press the <b>Back</b> button.
<b>Menu</b> 	Press the <b>Menu</b> button to open the menu index. <b>Note:</b> The printer must be in the <b>Ready</b> state to access the menu index. A message indicating the menus are unavailable will appear if the printer is not ready.
<b>Stop</b> 	Press the <b>Stop</b> button to stop the mechanical operation of the printer. After pressing <b>Stop</b> , the message <b>Stopping</b> is displayed. When the printer has stopped, the status line in the operator panel will show <b>Stopped</b> , and a list of options will appear.
<b>Navigation buttons</b> 	<ul style="list-style-type: none"> <li> The <b>Up</b> or <b>Down</b> buttons are used to move up and down lists.</li> <li> When navigating through a list using the <b>Up</b> or <b>Down</b> button, the cursor moves one line at a time. Pressing the <b>Down</b> button at the bottom of the screen changes the screen to the next whole page.</li> <li> The <b>Left</b> or <b>Right</b> buttons are used to move within a screen such as moving from one menu index item to another. They are also used to scroll through text that will not fit on the screen.</li> <li> The <b>Select</b> button is used to initiate action on a selection. Press <b>Select</b> when the cursor appears next to the selection you want such as following a link, submitting a configuration item, or when you want to start or cancel a job.</li> </ul>
<b>Numeric pad</b> 	The numeric pad consists of numbers, a pound '#' sign, and a backspace button. The 5 button has a raised bump for non-visual orientation.  The numbers are used to enter numeric values for items like quantities or PINs. The backspace is used to delete the number to the left of the cursor. Pressing the backspace multiple times will delete additional entries.  The pound '#' sign is not used.

Button	Function
<p><b>Display panel</b></p> 	<p>The display panel shows messages and graphics describing the current state of the printer and indicating possible printer problems you must resolve.</p> <p>The top line of the display is the header line. If applicable, it will contain the graphic indicating the <b>Back</b> button can be used. It will also display the current status, and the Supplies (Warnings) status. If multiple warnings are present, each warning will be separated by a comma.</p> <p>The other three lines of the display are the body of the screen. This is where you view printer status, supplies messages, show-me screens, and make selections.</p>

### ***Printing the menu settings***

1. From the printer operator panel, press  to enter the menus.
2. Continue to press and release  until you see **TESTS MENU**.
3. Press the  button and scroll to **Reports**.
4. Press . **Menu Settings** is displayed on the first line.
5. Press  again to print the page. The message **Printing Menu Settings** is displayed. The printer returns to **Ready** status after the menu settings page prints.

### ***Operator menu disabled***

If the operator has disabled the menu, and you want to run operator print tests, turn the machine off, and then press **Go** and **Stop** as you turn the machine on.

## Menu overview

SUPPLIES MENU	PAPER MENU	REPORTS
Cyan Toner Magenta Toner Yellow Toner Black Toner Cyan PC Drum Magenta PC Drum Yellow PC Drum Black PC Drum Oil Coating Roll Fuser Transfer Belt Staples Hole Punch Box	Default Source Paper Size / Type Configure MP Substitute Size Paper Weight Paper Loading Custom Types Universal Setup Bin Setup	Menu Settings Printer Statistics Network Setup Page Profiles List Network Setup Page Print Fonts Print Directory

SETTINGS	SECURITY	HELP	NETWORK/PORTS
Setup Menu Finishing Menu Quality Menu Utilities Menu PDF Menu Postscript Menu PCL Emul Menu HTML Menu Image Menu	Max Invalid PIN Job Expiration	Print All Color Quality Print Quality Supplies Guide Printing Guide Media Guide Print Defects Menu Map Information Guide	TCP/IP Standard Network Network <x> Standard USB USB <x> Parallel Parallel <x> Serial Serial <x> Netware AppleTalk LexLink



## Diagnosics

Enter diagnostics mode by holding down the ▼ key and the ► key while PORing the printer. Release the keys when **Performing Self Test** displays on the screen. When the printer completes its startup, the following screen displays.

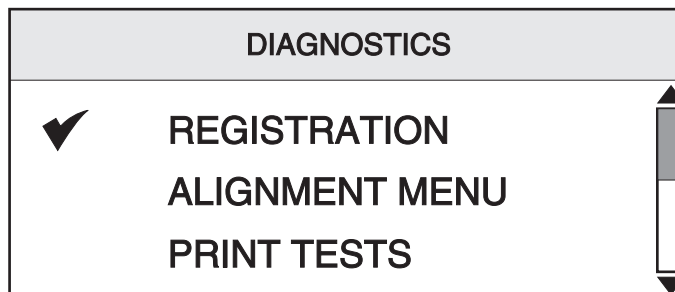

### Navigating the Diagnostics Menu

The diagnostics menu is navigated by using the ▲ and ▼ keys to scroll through the menus, and the Ⓞ key to select the items in the menu.

### Diagnosics Menu Overview

Top Level Menus	Intermediate Menu Items
Alignment Menu	Auto Align Test
	Cyan
	Yellow
Print Tests	Magenta
	Tray 1
	Tray 2
	Tray 3
	Tray 4
	Tray 5
	MP Feeder
	Standard Bin
Hardware Tests	Output Bin 1
	Prt Quality Pages
	Panel Test
	Button Test
	DRAM Test
	Cache Test
	Parallel Wrap
	Parallel Wrap 1
Parallel Wrap 2	
Serial 1 Wrap	
Serial 2 Wrap	

Top Level Menus	Intermediate Menu Items
Output Bin Tests	Feed Tests Feed To All Bins Sensor Tests
Finisher Tests	Staple Test Hole Punch Test Sensor/Sw Test Feed Tests
Device Tests	Quick Disk Test Disk Test/Clean Flash Test
Printer Setup	Defaults Light Quantity Color Page Count Mono Page Count Perm Page Count Serial Number Model Name Configuration ID Reset Calibration Par S Strobe Adj Par 1 Strobe Adj Par 2 Strobe Adj
Event Log	Display Log Print Log Clear Log
Exit Diagnostics	Press  to Exit

## Alignment

### Auto Alignment

1. Use the ▼ key to navigate to the alignment menu item.
2. Press ⓪ to select alignment.
3. Press ⓪ to select the Auto Align test.

**Note:** The printer will display **Printer Calibrating** while this test is running. Three alignment pages will print (Cyan, Magenta, Yellow).

### Cyan, Yellow, Magenta

These menu items allow you to adjust the X, Y, and Theta values for each color. Each increment of the X (Top Margin Offset) is equal to 1 / 600th of an inch. The Y and Theta values increment in 1 / 3600th of an inch.

#### Y (Cyan, Yellow, Magenta)

Modification of this setting allows users to shift right or left the position of the left margin on a per plane basis. Each increment corresponds to 1/6th of a pel at 600 dpi. A positive offset moves the margin to the right, and a negative offset moves the margin to the left.

**Note:** Modification of this setting causes the entire image to compress or expand.

#### Theta Offset (Cyan, Yellow, Magenta)

Modification of this setting allows users to shift right or left the position of the right margin on a per plane basis. The right margin adjustment is necessary to offset any vertical printhead placement error with respect to the PC drum. Each increment corresponds to an approximate shift of 1/6th of a pel at 600 dpi. A positive offset moves the margin to the left and a negative offset moves the margin to the right.

Modification of the right margin offset setting causes the entire image to move left/right on the page.

To change the value of an alignment setting in the alignment menu:

1. Use the ▼ key to scroll to the desired color (C,M,Y). Press the ⓪ key to select the color.
2. Use the ▼ key to scroll to the X, Y, or Theta setting. Press ⓪ to select the setting to adjust.
3. To change the selected setting's value, press ◀ to decrease the value, or ▶ to increase the value.
4. To save the setting's new value, press ⓪.
5. To exit the Alignment menu, press **Back**.

**Note:** You must press ⓪ to accept the setting.

## Print Tests

When “PRINT TESTS” is selected from the main Diagnostics menu, the printer’s panel displays “PRINT TESTS” in the header row. Below the header row in vertical order from top to bottom, the panel displays each installed input source on its own line. “Prt Quality Pages” appears as the very last option in the list.

### “[Input Source]” Print Test

After a user selects the input source to test, the panel displays the selected input source in the header row and, below the header row, presents two testing options: “Single” or “Continuous”. Both of these tests will generate a test page; however, a Single test prints the test page once, while the Continuous test continues printing the test page until the user presses **Stop**. During a Single test, none of the panel’s buttons are active while the test page prints. Regardless of the input source selected, the printer always generates a simplex version of the Print Test page using its default resolution. However, for either test, the media installed in the selected input source will affect the content of the test page generated by the printer.

If an input source contains:

- any size paper, then the printer will generate a page that is similar to the Registration Quick Test, except that the Print Test version of this page doesn’t contain the registration diamonds.  
**Note:** For some paper sizes (e.g. A5), the printer may require more than one sheet of paper when printing the test page.

If an input source contains:

- envelopes, then the printer will generate an Envelope Print Test pattern that consists of continuous prints of each character in the printer’s selected symbol set.  
**Note:** During a Continuous test involving an input source containing envelopes, the device will generate the Envelope Print Test pattern on the first envelope, and then leave each subsequent envelope blank. While either test prints, the panel displays “[Input Source] Printing...”. When a user presses **Stop** to end a Continuous test, the panel displays “[Input Source] Canceled”. After a Single test has printed or after a Continuous test is canceled, the panel returns to the screen described at the beginning of this section.

### Output Bin 1 (Print Tests)

This test instructs the printer to generate 2 pages and to drop them into Output Bin 1 (the face-up bin on the side of the printer). The pages printed during this test are in color and contain general information about the printer’s settings. While this test prints, the panel displays “Output Bin 1 Printing...”.

### Print Quality Pages

This setting enables a user to view the values of a broad range of the device’s settings and to test the device’s ability to generate acceptable printed output. Nine pages are printed when the Print Quality Pages test is run.

## Hardware Tests

### Panel Test

After a user chooses this setting, the printer automatically executes the Operator Panel test application which occupies the entire display panel. The test application automatically toggles each pixel in the display panel through every contrast level, beginning with the darkest (e.g. every pixel turned on and as dark as possible) and ending with the lightest (e.g. every pixel turned off). By implication, this test will show any non-functioning pixels in the panel, since these will appear as blank spaces during the test’s darker stages. The panel test application executes continuously until the user presses **Stop**. After this test is canceled, the panel will display the main “HARDWARE TESTS”.

## Button Test

The Button Test is used to verify the operation of each button on the operator panel. When this option is selected, the following is displayed:

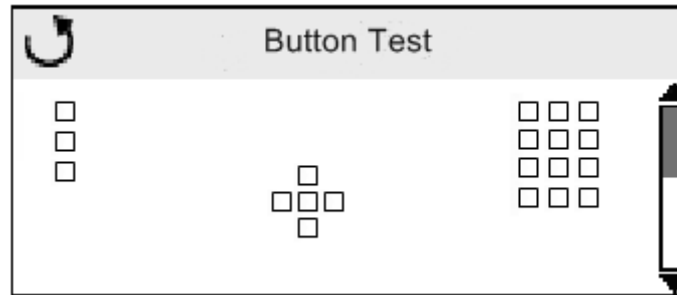

When a user presses a physical button on the panel, an "X" appears over that button's graphic on the operator panel. When the user lets the physical button go, the panel removes the "X" from the picture of the button.

To exit this test, press **Back** or **Stop**.

## Cache Test

This test is used to verify the functioning of the printer processor's cache. When a user selects this test, the panel displays "CACHE Test Testing...", then posts "Resetting the Printer" and automatically performs a POR. After the POR, the panel displays the following:

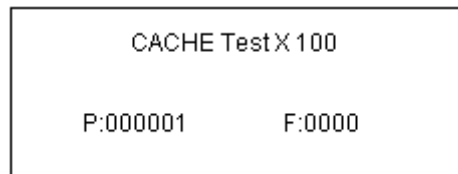

"P" represents the number of times the Cache has passed the test, and "F" represents the number of times the Cache has failed the test. The largest number that is displayable by either field is 999,999. Initially, only 4 digits appear for "F"; a fifth and sixth digit will appear if required. Each time the printer finishes a test, it increments "P" or "F" by one according to the success or failure of the Cache. The power indicator light blinks green while the Cache test executes. The only way a user can stop this test before its completion is to turn the printer off. If the test is not canceled, it automatically stops executing when all of the printer processor's Cache has been tested.

## DRAM Test

The DRAM Test is used to check the validity of both the printer's standard and optional DRAM. The test involves writing patterns of data to DRAM to verify that each bit in memory can be set and read correctly.

When a user selects this test, the panel displays "DRAM Test Testing...", then posts "Resetting the Printer" and automatically performs a POR.

After the POR, the panel displays the following:

DRAM Test 512 MB	
P:000001	F:000000

"P" represents the number of times the DRAM has passed the test, and "F" represents the number of times the DRAM has failed the test.

The largest number that is displayable by either field is 999,999. Initially, only 4 digits appear for "F"; a fifth and sixth digit will appear if required.

Each time the printer finishes a test, it increments "P" or "F" by one according to the success or failure of the DRAM.

While the DRAM test executes, the power indicator light blinks green. The only way a user can stop this test before its completion is to turn the printer off. If the test is not canceled, it automatically stops executing when all of the printer's standard and optional DRAM has been tested.

## Parallel Wrap Test

This test verifies the proper functioning of the parallel port hardware using a wrap plug. Each parallel signal is tested.

To perform this test, follow these steps:

1. Disconnect the parallel interface cable, and install the parallel wrap plug.
2. Select "HARDWARE TESTS" from the Diagnostics Menu.
3. In the HARDWARE TEST menu, select the appropriate parallel port option for testing.

When a user selects this test, the panel displays the following:

Parallel Wrap	
P:000001	F:0000

"P" represents the number of times the parallel port hardware has passed the test, and "F" represents the number of times it has failed the test. The largest number that is displayable by either field is 999,999. Initially, only 4 digits appear for "F"; a fifth and sixth digit will appear if required. Each time the printer finishes a test, it increments "P" or "F" by one according to the success or failure of the parallel port hardware. While the parallel port hardware test executes, the power indicator light blinks green. A user can cancel this test by pressing **Stop**. When a test is canceled, the panel returns to the main HARDWARE TESTS menu. Or, when the maximum number of tests has been executed, the test stops and displays the results.

If a test fails, one of the following errors will display:

- Sync Busy Error
- Byte Interrupt Request Error
- Strobe Interrupt Request Error
- Init Fall Error
- Init Busy Error
- Init Rise Error
- Host Busy Error
- RAM Data FF Error
- RAM Data AA Error
- RAM Data 00 Error
- RAM Data 55 Error
- DMA Count Error
- DMA Address Error
- DMA Interrupt Error
- DMA Memory Error
- DMA Background Error
- Clear Init Rise Error
- False Init Rise Error
- False Init Fall Error
- Autofeed Rising Interrupt Error
- Clear Autofeed Rise Error
- False Autofeed Rise Error
- Autofeed Falling Interrupt Error
- Clear Autofeed Fall Error

## Serial Wrap Test

The Serial Wrap Test is used to check the operation of the serial port hardware using a wrap plug. Each serial signal is tested.

To perform the wrap test, follow these steps:

1. Disconnect the serial interface cable, and install the serial wrap plug.
2. Select "HARDWARE TESTS" from the Diagnostics Menu.
3. In the HARDWARE TESTS menu, select the appropriate serial wrap option.

When a user selects this test, the panel displays "Serial Wrap [x] Testing..." and then transitions to a screen that shows "P:[xxxxxx] F:[xxxx]" on a separate line. "P" represents the number of times the serial port hardware has passed the test, and "F" represents the number of times it has failed the test.

The largest number that is displayable by either field is 999,999. Initially, only 4 digits appear for "F"; a fifth and sixth digit will appear if required.

Each time the printer finishes a test, it increments "P" or "F" by one according to the success or failure of the serial port hardware.

While the serial port hardware test executes, the power indicator light blinks green. A user can cancel this test by pressing **Stop**. When a test is canceled, the panel displays "Serial Wrap [x] Test Canceled". Or, once the maximum pass count or fail count is reached, the test is stopped, and the final test results are displayed.

If a test fails, one of the following errors is displayed:

- Receive Status Interrupt Error
- Status Error
- Receive Data Interrupt Error
- Transmit Data Interrupt Error
- Transmit Empty Error
- Threshold Error
- Receive Data Ready Error
- Break Interrupt Error
- Framing Error
- Parity Error
- Overrun Error
- Data Error
- Data 232 Error
- Data 422 Error
- FIFO Error
- DSR Error
- DSR PIO Error
- DSR Interrupt Error
- CTS Error
- CTS PIO Error
- CTS Interrupt Error



## Output Bin Tests

### Feed Tests (Output Bin)

This test is used to verify that media from the device's default input source can be fed to a specific output bin. No information is printed on the feed test pages.

**Note:** The feed test can be run using any of the supported paper and envelope sizes.

Each of the printer's installed bins appears as an option within this menu. For each bin, the user has two choices:

- "Single", in which the printer feeds a single sheet of media to the selected output bin; or
- "Continuous", in which the printer continuously feeds media to the selected output bin until the user presses **Stop**.

While this test runs, the power indicator blinks green, and the panel displays "[Selected Output Bin] Feeding...".

During "Single" tests, no buttons are active. However, during "Continuous" tests, Stop can be pressed to cancel the test. If a test is canceled, the printer will display "[Selected Output Bin] Canceled".

### Feed To All Bins

This test is used to verify that the printer can feed media to all installed output destinations. No information is printed on the feed test pages since the laser is not engaged during this test.

After this test is selected, the printer feeds media from the default source to each installed bin in the following order:

- Standard Bin, Bin #1, Bin #2, Bin #3, Bin #4, Bin #5, Bin #6, Bin #7, Bin #8, Bin #9, Bin #10, Bin #10, Bin #9, Bin #8, Bin #7, Bin #6, Bin #5, Bin #4, Bin #3, Bin #2, Bin #1, Standard Bin, Standard Bin, Bin #1, and so on.

While this test runs, the power indicator light blinks green and the panel displays "All Bin Test Feeding...". Because this test is always executed as a Continuous test, pressing **Stop** at any time will cancel the test.

If a test is canceled, the printer posts "All Bin Test Canceling..." and feeds any remaining media in the paper path to the appropriate output destination.

### Sensor Test (Output Bin)

Selecting this setting executes a test to verify that the selected output bin's sensors are working correctly. The sensors that appear as part of this test vary depending on which sensors are installed in the selected output bin.

When the user selects an output bin:

1. The panel displays the selected output bin's sensors.
2. The user can manipulate the printer in such a way as to actuate each of the selected bin's sensors.

The panel displays "Closed" when the sensor is closed or "Open" when the sensor is open. If the wrong message is displayed, then the sensor must be malfunctioning.

To exit the sensor test, press **Back** or **Stop**.

## ***Finisher Tests***

### **Feed Test**

This test feeds one sheet of media from the device's default input source to a finisher output bin. The device can perform this test using any paper size that is supported by the finisher. No information is printed on the test page.

**Note:** A user cannot specify the output bin to which the device will feed the test page.

The test cannot be canceled while it is running. As a result, no buttons are active during the execution of this test.

While this test executes, the power indicator light flashes green, and the panel displays "Feed Test Running".

### **Hole Punch Test**

This test is used to verify that media can be fed to a finisher output bin and then hole-punched. No information is printed on the feed test pages since the laser isn't engaged during this test. Eight sheets of paper are fed, and then the pages are hole-punched with a 3-hole or a 4-hole pattern depending on the selected punch test.

**Note:** The printer will use Letter-size paper for the 3-hole punch test and A4-size paper for the 4-hole punch test.

The Finisher Feed Test cannot be canceled or terminated when execution of the test has begun. As a result, no buttons are active during the execution of this test. While this test runs, the power indicator light flashes green, and the panel displays "Hole Punch Test Running".

### **Sensor/Sw Test**

This test is used to verify that the finisher's sensors and switches are working properly. When the **Sensor/Sw Test** item is selected, the panel displays the following options:

- Finisher Devices
- Finisher Path
- Finisher Bin

Use the key to select one of the above options. The panel will display all of the sensor names listed next, as well as each sensor's current state.

The sensor tests are divided into these three groups:

- Finisher device sensors:
  - Elev Lower Limit
  - Elev Upper Limit
  - Fin Set Switch
  - No Staple
  - Punch Box Detect
  - Staple Home Pos
  - Staple Cart Set
- Finisher path sensors:
  - Belt Home Pos
  - Input Path
  - Invert Path
  - Jogging Home Pos
  - Paper Detect
  - Paper Resist
- Finisher bin sensors:
  - Elev Lower Limit
  - Face Down Exit
  - Face Up Exit
  - Pap Upper Level
  - Paper Full A
  - Tray Near Full

To test any of the displayed sensors or switches, press ▲ or ▼ to select the appropriate item, then manually actuate the selected item. When the item is closed, the panel displays **Closed**. When the sensor is open, the panel displays **Open**.

To exit the sensor test, press **Back** or **Stop**.

## **Staple Test**

This test is used to verify the functioning of the finisher's staple mechanism. After this test is selected, the printer automatically feeds eight pieces of media from the default input source to the output bin that supports stapling. After all eight pieces of media are deposited, the device staples the packet.

While this test runs, the power indicator light blinks green, and the panel displays "Staple Test Running...". To cancel this test, the user can press **Stop**.

## Device Tests

### Quick Disk Test

This test will perform a non-destructive read/write on one block per track on the disk.

While this test runs, the power indicator light blinks green, and the panel displays “Quick Disk Test Testing...”. This test cannot be canceled.

When the test finishes, the panel posts either “Quick Disk Test Test Passed” or “Quick Disk Test Test Failed”.

### Disk Test/Clean

This test will perform a low-level format of the hard disk which will destroy all data on the disk and

which should never be performed on a good disk. In general, this test will only be used when the disk contains bad data and is therefore unusable.

**Note:** Although this test’s length will depend on the disk size, in general, this can be an extremely lengthy test.

**Note:** When this test is completed, the disk is automatically initialized with a new file system. Therefore, it is not necessary to format the disk. After this test is selected, the panel displays the message that appears in the “Contents will be lost” Priority Selection Screen in Appendix B. To exit this test and return to the DEVICE TESTS menu, the user selects “No”. This is the user’s only chance to exit this test; once the test has begun, it cannot be stopped. While this test runs, the power indicator light blinks green, and the panel displays “Formatting Disk”. Due to the nature of this test, it cannot be interrupted once it has begun. After the test finishes, the panel indicates either “Disk Test/Clean Test Passed” or “Disk Test/Clean Test Failed”.

### Flash Test

This test verifies the functioning of the flash device by writing data to it and by reading data from it. This test destroys all data on the flash device.

**Note:** This test leaves the flash unformatted. The CE or user must reformat the flash using the Format Flash operation in the Utilities Menu.

After this test is selected, the panel displays “Files will be Lost. Go/Stop?”. Press  to confirm and continue the test. To exit this test and return to the DEVICE TESTS menu, the user will select the “Stop” option on the panel. This is the only opportunity a user will have to cancel this test. While this test runs, the power indicator light blinks green, and the panel displays “Flash Test Testing...”.

At the completion of this test, the panel displays either “Flash Test Test Passed” or “Flash Test Test Failed”.

## Printer Setup

### Defaults

The value of this setting determines whether the printer uses the US or Non-US factory default value for the following printer settings:

Printer Setting	US value	Non-US value
Paper Sizes (Paper feeding sources which do not have hardware size sensing capability)	Letter	A4
Envelope Size (Envelope feeding sources which do not have hardware size sensing capability)	10 Envelope	DL Envelope
PCL Symbol Set	PC-8	PC-850
PPDS Code Page	437	850
Universal Units of Measure	Inches	Millimeters

**Note:** Changing this setting's value has the same effect as selecting "Restore Base" or "Restore Network" in the Factory Default Configuration menu setting.

### Light Quantity

- Cyan
- Magenta
- Yellow
- Black

Range = 0 to 45

**Note:** The light quantity does not need to be set when replacing a LED printhead.

### Page Counts

The values of these settings indicate the total number of mono (including blank) and color pages generated by the printer. The permanent page count can also be viewed in this sub-menu. After all manufacturing printing tests have been completed, this value is set to 0.

**Note:** Unlike in past implementations, the values of these settings cannot be changed by a user or a CE. To return to the main PRINTER SETUP menu, a user can press **Back**.





## Serial Number

This printer setting records the printer's serial number that was assigned by manufacturing.

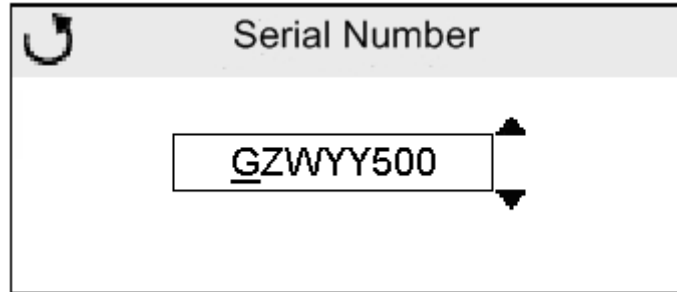
The Serial Number menu item allows you to set the Serial Number for the printer. To set the Serial Number:

1. Select the Serial Number menu item from the Printer Setup menu by pressing the  key. This screen will be displayed:



2. Move the cursor to the desired digit in the Serial Number by pressing the  or  arrow key.
3. Set the digit to the desired setting by pressing the  or  arrow key.

When you are finished setting the Serial Number, press the  key. This will save the setting.

**Note:** Do not press the **Back** key before pressing the  key. Doing this will result in the new setting not being saved.

## Model Name



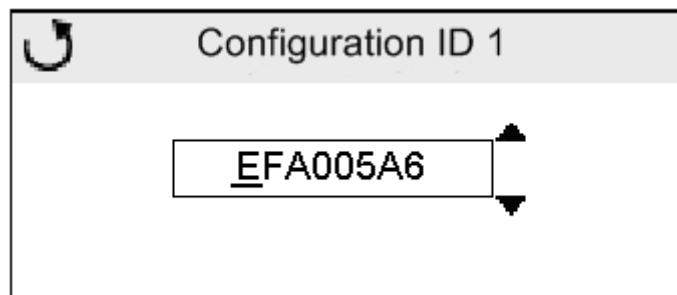

Selecting this menu item displays the printer's model name.

## Configuration ID

Use the configuration ID to communicate characteristics of the printer that cannot be determined by the hardware sensors. The configuration ID is originally set when the printer is manufactured. The C920 uses 2 Configuration IDs, each of which consists of 8 digits. When Configuration ID is selected from the PRINTER SETUP menu, the current ID is displayed:



The Configuration ID menu item allows you to set both Configuration ID settings for the printer. To set the configuration ID:

1. Select the Configuration ID menu item from the Printer Setup menu by pressing the  key.
2. Move the cursor to the desired digit in the Configuration ID by pressing the  or  arrow key.
3. Set the digit to the desired setting by pressing the  or  arrow key.

When you are finished setting the configuration ID, press the  key. This will save the setting.

**Note:** Do not press the **Back** key before pressing the  key. Doing this will result in the new setting not being saved.

After one or both configuration ID settings are saved, the printer will not POR. After saving the new configuration ID, press the **Back** key to return to the Printer Setup menu.

## Reset Color Calibration

This setting enables the printer to adjust the alignment of its color planes using pre-programmed default values. Using this setting to adjust color plane linearization may not provide as effective a calibration as would using the “Automatic Alignment Adjust”. To perform this adjustment, press the  key.

### Par [x] Strobe Adj.

This setting enables the user to adjust the amount of time the strobe is sampled in order to determine if valid data is available on the parallel port. The settings range from -4 to +6. Each time this value is incremented by 1, the strobe is sampled 50 ns longer. Each time this value is decreased by 1, the strobe is sampled 50 ns less. When the value of this setting is 0, the factory default value is used to determine the length of time the strobe is sampled.

### Par S Strobe Adj

This message displays only if the printer is configured with the standard parallel port.

### Par 1 Strobe Adj

This message displays only if a parallel port is available through the PCI slot 1.

### Par 2 Strobe Adj





This message displays only if a parallel port is available through the PCI slot 2.

### Par 3 Strobe Adj

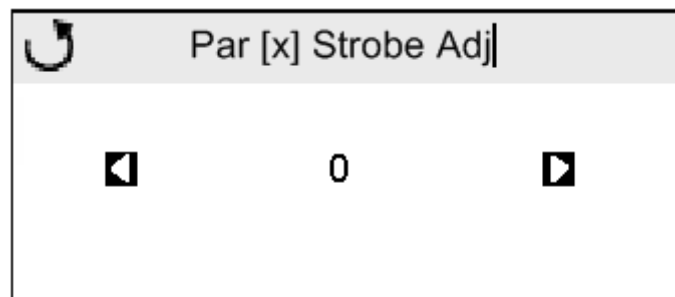
This message displays only if a parallel port is available through PCI slot 3.

To adjust one of these settings, select Par [x] Strobe Adj from the Printer Setup menu. This screen will display: (x equals the number of the strobe being adjusted)



1. Press the  or  arrow keys to increase or decrease the Strobe Adj value.
2. When the desired number is displayed, press the  key to save the value.  
**Note:** Do not press the **Back** key before pressing the  key. Doing this will result in the new setting not being saved.
3. Press the **Back** key to return to the Printer Setup menu.

## ***Event Log***

### **Display**

When “Display Log” is selected, the panel posts, “Display Log” in the header row and up to the first three log entries in the area below the header row. Each logged event is identified by the panel text that appeared when the event occurred. For instance, if the log recorded a 900 Service Error, the display version of the log would show “900 Service RIP Software”.

Log entries appear in chronological order with the topmost entry occurring most recently followed by the second to top entry and so forth down to the bottom-most entry. The events log can be scrolled up and down using the ▲ and ▼ keys. If there is more information than what can be displayed on a line, you can access that information by using the ◀ and ▶ keys to scroll left and right.

### **Print**

Selecting this item will tell the printer to print the event log. The diagnostics menu version of the event log contains information not contained in the configuration menu version of the event log.

- Date and Time Stamp
- Uptime— The amount of time from the event's occurrence and the time of the POR preceding the event.
- Debug Data
- Code Level

### **Clear**

Selecting this option clears all current events from the event log. After selecting this option, a second screen appears, asking for confirmation. The ↻ key can also be pressed to go back to the main event log screen.





## ***Exit Diagnostics***

Select this item, and press ⓧ to reset the printer.







---

## Configuration menu

To enter the configuration menu, POR the printer holding down the  key and the  key until the operator panel displays "Performing Self Test". The configuration menu can be navigated by pressing the  and  keys, and then pressing the  key to select the item.

### ***Black only mode***



Black Only mode enables a user to force the printer to always print color content in grayscale. Turning this setting "on" is equivalent to setting "Print Mode" to "Black Only"; the printer ignores any PDL or data stream commands that attempt to change the "Print Mode" setting. If this setting is "off", the printer prints color content as normal. The values for this item are on and off. Use the  or  key to navigate to the desired setting. Press the  key to activate the desired setting.

**Note:** To accept the new menu setting, you must press the  key before pressing the **Back** key.

### ***Print quality pages***



Selecting this item prints the quality pages. Pressing  initiates this operation.

### ***Color trapping***



The settings for this menu item are off and 1–5. Color trapping is an algorithm used to compensate for mechanical misregistration in the printer. In the printer's implementation, when small black text or fine black lines are being rendered, the printer checks to see if they are being rendered on top of a colored background. If so, rather than remove the color from beneath the black content, the printer leaves the color around the edge of the text or line. In this way, the "hole" in the colored region is reduced in size, which prevents the characteristic "white gap" that is caused by mis-registration. The values 1 through 5 indicate the amount of color that remains beneath the black content. Each setting is 1/600 of an inch. Therefore, the more inaccurate the registration setting, the higher this setting needs to be adjusted. To adjust the setting, press the  and  keys until the desired setting is set. Press the  key to activate the desired setting.

**Note:** To accept the new menu setting, you must press the  key before pressing the **Back** key.

### ***Panel menus***



This setting enables or disables the menus on the operator panel. The settings for this menu are "Enable" and "Disable". Use the  or  key to navigate to the desired setting. Press the  key to activate the desired setting.

### ***PPDS emulation***

The value of the PPDS emulation menu item determines if a device can recognize and use the PPDS data stream. The values for this item are activate and de-activate. To adjust the setting, press the  and  keys until the desired setting is set. Press the  key to activate the desired setting.

**Note:** To accept the new menu setting, you must press the  key before pressing the **Back** key.

### ***Demo mode***

The printer supports a demonstration mode that is used in retail environments to illustrate the features of the printer. To change the setting press the  or  key, and press the  key to save the setting. The menu settings are "Activate" and "De-activate".

**Note:** To accept the new menu setting, you must press the  key before pressing the **Back** key.

## ***Factory defaults***

Enables a user to restore all the printer's settings to either network or base printer settings.

When "Restore Base" is selected, all non-critical base printer NVRAM settings are restored.

When "Restore Network" is selected, all network NVRAM settings are restored to their factory default values.

To restore default settings, use the ▲ key or ▼ to scroll to the base or network defaults and press the ✓ key.

**Note:** The "Restore Network" option is only available on models with an integrated network adapter.

## ***Energy conserve***

Energy conserve affects the values that appear on the "Power Saver" menu in the setup menu. To activate or deactivate this item, use the ▲ or ▼ key to scroll to the desired setting, and press the ✓ key.

This setting only appears when the printer does not support "Automatic Power Saver", or the "Automatic Power Saver" feature has been deactivated.

## ***Event log***

The event log prints when the ✓ key is pressed.

## ***Auto align adjust***

This setting determines whether the printer performs an auto align adjust calibration after a certain initiating event such as a POR, close door, or new toner cartridge detection. The settings are on and off. Use the ▲ or ▼ key to scroll to the desired setting, then press the ✓ key.

**Note:** Auto align adjust should never be off during normal printer usage.

## ***Auto color adjust***

auto color adjust determines whether the printer should perform an automatic color calibration after an initiating event occurs. The settings for this option are on and off. Use the ▲ or ▼ key to scroll to the desired setting, then press the ✓ key.

**Note:** Auto color adjust should never be off during normal printer usage.

## ***Paper prompts***

Paper prompts controls the tray to which the printer directs a change paper prompt. The values for this setting are Auto, MP Feeder, and Manual Paper. Use the ▲ or ▼ key to scroll to the desired value, then press the ✓ to accept the change.

## ***Envelope prompts***

Envelope prompts controls the tray to which the printer directs an envelope change prompt. The values for this setting are Auto, MP Feeder, and Manual Paper. Use the ▲ or ▼ key to scroll to the desired value, and press the ✓ key to accept the change.

## ***Jobs on disk***

This setting only appears if there is a disk installed on the machine. Jobs on disk is used to delete buffered jobs that are on the hard disk. This option appears even if there are no buffered jobs on the disk. The values for this setting are delete and do not delete (default). Use the ▲ or ▼ key to scroll to the desired value, and press the ✓ key to accept the change.

## ***Disk encryption***

Disk encryption controls whether the printer encrypts information that is written to the disk. The setting only appears if the hard disk is installed, and the 3-2 digits of config ID 2 are set to 01 (supported) or 10 (supported with INA). The values for this setting are disable (default) or enable. Use the ▲ or ▼ key to scroll to the desired value, and press the ✓ key to accept the change.

**Note:** When disk encryption is changed, all information on the disk is destroyed. A prompt is displayed asking for confirmation of the change before executing.

## ***Font sharpening***

Font sharpening allows a user to set a text point-size value below the high frequency screens used when printing font data. For example, if the setting value is "24", all fonts sized 24 points or less use the high frequency screens. To decrease the setting value by 1, press ◀. To increase the setting value by 1, press ▶.

**Note:** The font sharpening setting affects PostScript, PCL and XL.

## ***Standby disabled***

The value of this setting determines if the Standby Mode in the setup panel menu includes a "disabled" value. If the value of this setting is "on", the "disabled" value appears in the Standby Mode menu. If the value of this setting is "off", "disabled" doesn't appear. The values for this setting are on (default) and off. Use the ▲ or ▼ key to scroll to the desired value. Press the ✓ key to accept the setting.

## ***Exit config menu***

Pressing the ✓ key while this option is selected restarts the printer into normal operating mode.

---

## Theory of operation

### *Processes and configuration*

In this printer, the toner of four colors (magenta, cyan, yellow, and black) melts and deposits dots on paper, which record color image information. This printing process is called the electrophotography process.

### *Electrophotography process*

In the electrophotography (EP) process, 6 steps take place to image toner on the page:

1. Charge
2. Expose
3. Develop
4. Transfers
5. Fuse
6. Clean / Erase

**Charge**– The heart of the EP process centers around the photoconductor (or photodeveloper). The photodeveloper unit is layered with an organic substance that makes it sensitive to light. At the beginning of EP process, the entire surface of the photodeveloper is negatively charged by a charge roller which is located within the photoconductor unit itself. This charge is directed to the photosensitive medium at a low voltage, thus reducing the generation of ozone to a very low level.

**Expose**– Once the photodeveloper is charged, the initial image is recorded by irradiating light from the LED printhead. This forms an electrostatic or “latent” image (an invisible image) on the surface of the light-sensitive photodeveloper. The area on the photodeveloper where the electrostatic image is written has been partially discharged (less negative) so that there is a charge difference between the electrostatic image and the rest of the surface area of the photodeveloper.

**Note:** Since light from the LED array varies depending on the individual LED printheads, the light emitting value (light quantity value) is stored in the EPROMs on the print head controller board (one for each color station). Given that the LED printhead and EPROM on the printhead controller board of this printer are paired, the EPROM on the printhead controller board should always be replaced whenever the LED printhead is replaced.

### *Development unit*

Toner is agitated by the cartridge hopper and then fed to the supply roll. The supply roll then transfers the toner in between the development roll and doctor blade. The doctor blade, which is made of conductive rubber, is fitted to the development roll and used to smooth the toner evenly across the surface of the development roll.

As the photodeveloper rotates, it comes into contact with toner on the development roll of the cartridge. Due to the charge differences between the electrostatic image and the rest of the surface of the photodeveloper, toner will only cling to the electrostatic image created by the light from the LED printhead.

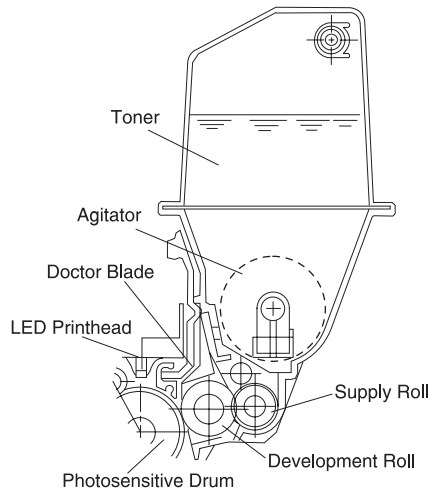

### ***Transfer unit***

Paper is fed onto the transfer belt by the registration rollers while the belt rotates at the same speed as the photodevelopers. The paper is held to the belt by an electrostatic charge from a charge roller located inside the belt.

As the paper reaches each color position, a transfer sheet located inside the belt (underneath the paper) will apply a charge to the paper. The charge difference of this electrostatic field will cause the toner image formed on the photoconductor drum to transfer to the paper.

### ***Cleaning unit***

Any toner that remains on the photodeveloper following transfer is scraped away with the cleaning blade and collected in the waste toner reservoir. Furthermore, the residual charge that remains on the photodeveloper is discharged by the erase lamp. Once this process is complete, the photodeveloper is ready to begin the EP process for the next page.

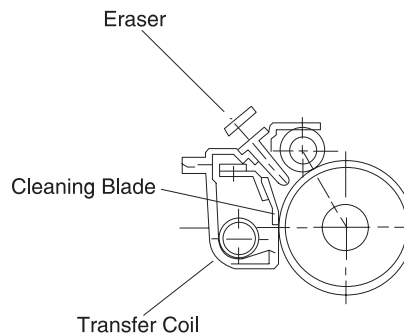

## Fusing

Once the paper has been imaged, the paper is detached from the transfer belt by the separation fingers.

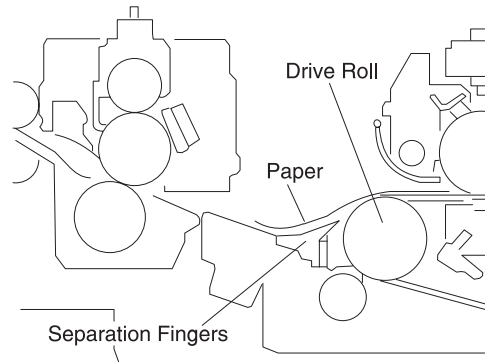

After separation, it enters the fuser where heat and pressure are applied to the paper. The toner is melted and bonded to the fibers of the paper.

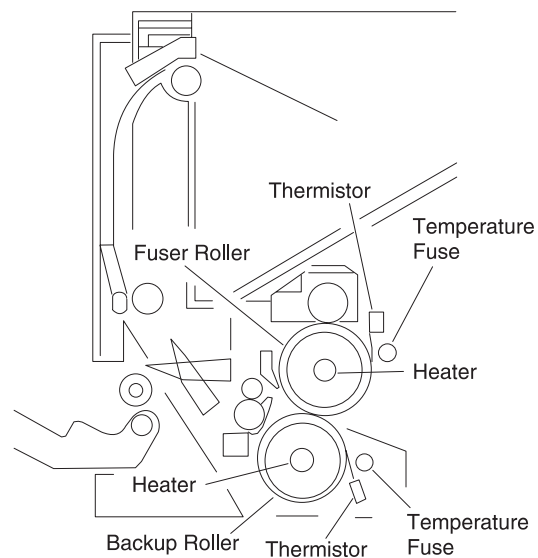

**Note:** The fuser's upper and lower fuser rollers are heated and pressure-fitted. A heater is positioned in the roller tube, and a thermistor and thermostat remain in contact with the outside of the tube. Fuser separation fingers are attached near the upper roller to separate the paper from the roller. Each thermistor sends the surface temperature of the roller to the printer controller. The printer controller turns the heater on or off according to the voltage of each thermistor. If the controller fails and the temperature of the roller exceeds specifications, the temperature fuse (TCO) connected to each heater opens, preventing overheating.

After completing the fusing process, paper is discharged from the printer. The delivery sensor detects the paper, and the FU/FD deflector switches between the face-up and face-down paper delivery.

As the paper passes through the fuser, it pulls down the sensing lever and turns on the delivery sensor. If the delivery unit remains on longer than specified, the printer controller determines that the printer is jammed.

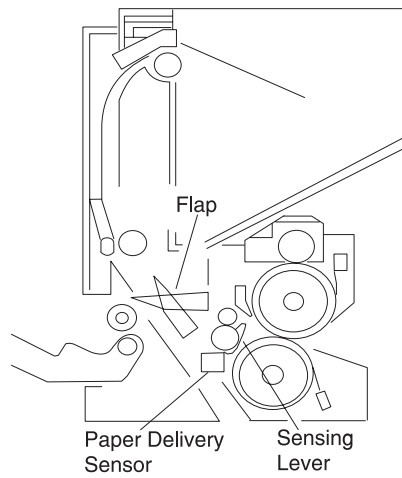

## Drive system

Drive 1, composed of a 100 V dc motor and gear unit, feeds the registration paper from the paper feeder and drives the belt unit, photodevelopers / toner cartridge, fusing unit, and face-up delivery unit. The motor rotates by the ON signal from the printer controller/motor drive unit and sends a rotation synchronization detection signal to the motor drive unit.

**Note:** The gear unit of drive 1 is adjusted in phase and should not be disassembled.

Drive 2, composed of a hybrid stepping motor and gear unit, drives the face-down delivery unit.

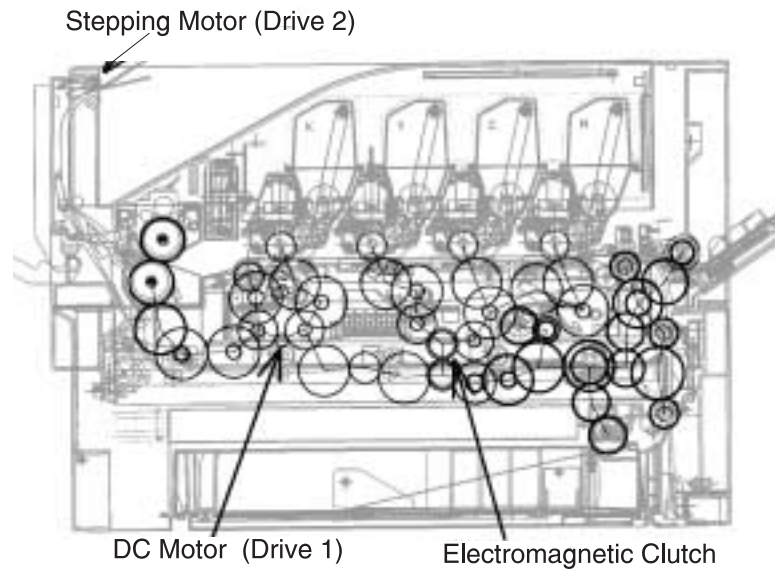



## Paper feeding

The paper feeder is a two-way system composed of the multi-paper feeder (100 sheets maximum) and an integrated 550-sheet tray. Optionally, the expansion paper feeders (550 sheets) can be increased to four layers. A high-capacity paper feeding system (3,000 sheets) may be used. Combining the multi-paper feeder, expansion paper feeders, and high-capacity paper feeding system gives the printer a maximum paper supply of up to 5,850 sheets.

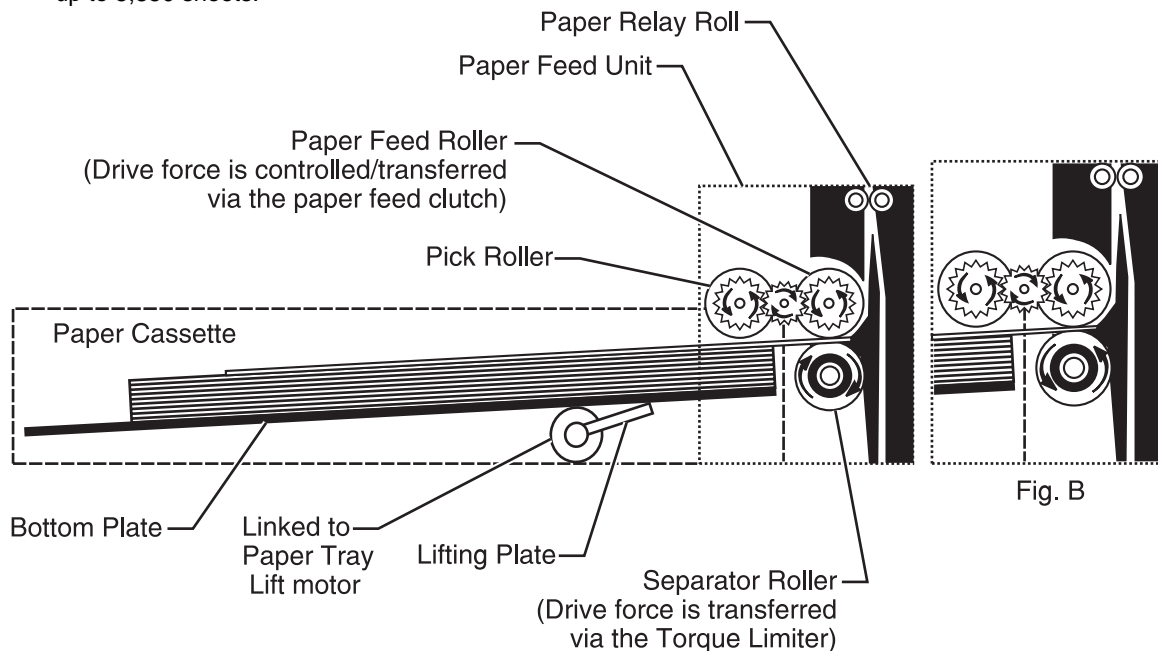

## Cassette paper feeder

The paper is raised to the proper paper-feed level by the paper tray lift motor when the cassette is replaced or when the paper present / level sensor is in the open position. If the sensor is in the open position, the printer controller board sends a signal to the paper tray lift motor to lift the tray.

The tray will continue to lift until the paper in the tray reaches the proper height and moves the paper present actuator. This will close the sensor and the paper tray lift motor will stop. In this raised position, the paper will be ready to feed to the engine.

**Note:** To prevent a jam due to paper depletion, there is a second ball actuator that places the paper out sensor in the closed position. If the paper out sensor is in the open position when the paper present / level sensor is in the closed position, the printer will signal that the tray is out of paper when a print job is sent.

Paper is fed into the printer when a signal is sent from the printer controller board to the paper feed clutch. This signal causes the paper feed roll shaft to rotate in a counterclockwise direction. The paper feed shaft also drives a gear which drives the pick roll. When the pick roll rotates, it sends the top sheet of paper in the cassette to the relay rollers inside the printer.

Double feeds are prevented by a separator roll that rotates in the opposite direction. If more than one sheet is pulled by the pick roller, the separator roller will hold back the additional sheets of paper. This theoretically will prevent a jam from occurring.

## Multipurpose feeding

The multipurpose feed clutch turns on when a signal is received by the printer controller board. The multipurpose feed roll is interconnected with drive unit 1 by a spring clutch. When the signal is received to print, the clutch engages and rotates the pick roller to feed paper.

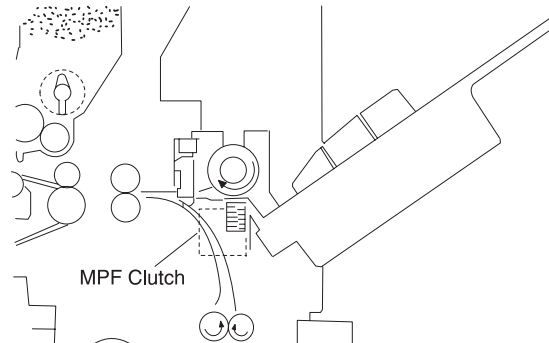

## Registration unit

Once the media is fed up the right of the printer, it temporarily stops at the registration rollers so the paper's leading edge can be adjusted so it will be parallel with the image to be printed.

The lower registration roll interfaces with the registration clutch and is responsible for feeding or stopping the paper. Once the paper is synchronized, the media passes through the registration rollers on its way to the absorption roller of the transfer belt.

**Note:** There is a registration sensor located just prior to the registration rollers. This sensor detects the presence of paper and will trigger a paper jam if the media doesn't pass by the sensor in the appropriate amount of time.

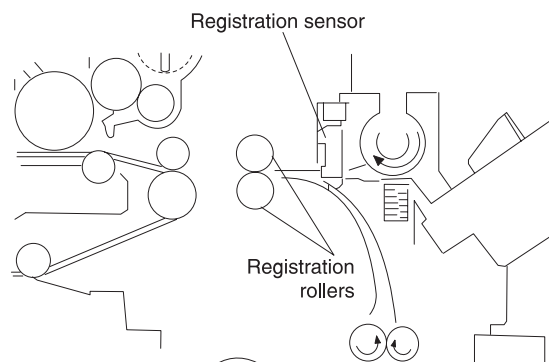

## ***Belt unit***

The transfer belt acts as a transport for the paper as it is carried from the registration rollers, underneath the photoconductor drums, and finally to the fuser.

The paper is held to the belt by an electrostatic charge that is applied by a charge roller located inside the transfer belt.

Once the image has been transferred to the paper, the transfer belt carries the paper to the separation fingers, where the paper is detached from the belt and then enters the fuser.

**Note:** Besides acting as a paper transport, the transfer belt rotates during calibration to automatically adjust the density and printer alignment. The density sensor is positioned facing the left side of the belt where the belt drive roller is located. This sensor reads small patches of toner that are laid down on the belt during calibration. To keep this sensor clean, a mechanism cleans the sensor surface when the front door is open and closed.

**Note:** Adjust the printer alignment whenever the belt unit is replaced or removed. Furthermore, if the transfer belt is damaged, toner can cling to the belt and contaminate the paper. When fingerprints or other stains appear on the belt, wipe them away with a dry cloth.

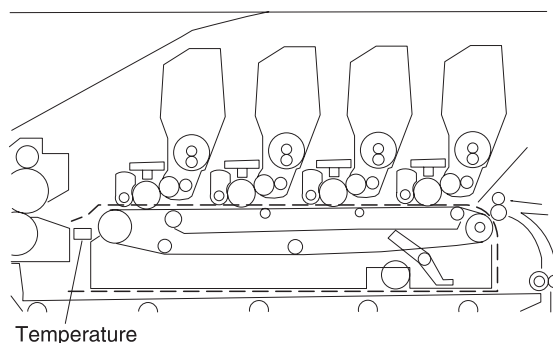

## ***Belt up/down***

In monochrome printing, switching to color printing is not required. To avoid unnecessary wear of the photosensitive drum by the cleaning blade, this operation is stopped with the electromagnetic clutch in drive 1. The transfer belt is lowered so as not to touch the photosensitive drum during color printing.

The transfer belt moves up and down with the switching shaft cam by the electromagnetic clutch in drive 1. The belt position is used to detect the cam position with the photo sensor, using the fan-shaped light-blocking plate attached to the switching shaft. Printing with the transfer belt lowered is called monochrome mode, and color printing is called color mode.

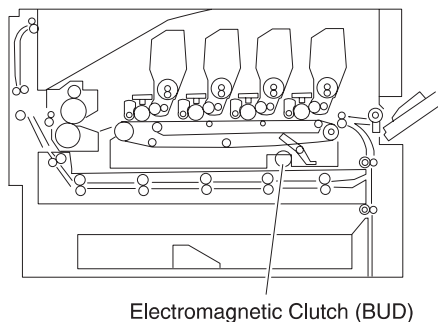

## ***Delivery***

After completing the fusing process, paper is discharged from the printer. The delivery sensor detects the paper condition, and the FU/FD deflector switches between the face-up and face-down paper delivery. The paper from the fuser pulls down the sensing lever turning on the delivery sensor (photo interrupter). If the delivery unit remains on longer than specified, the printer controller determines that the printer is jammed, and the paper delivery flap lever switches to either face down or face up.

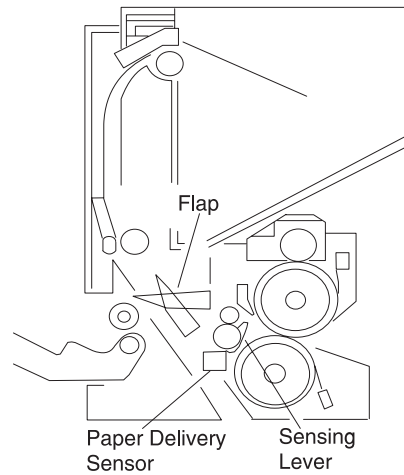

## ***Expansion paper feeder***

The optional expansion paper feeder can be installed at the lower part of the main unit. Including the main unit, up to five layers of cassettes can be used for cassette paper feeding.

## ***Duplex unit***

A duplex unit can be installed into the printer to allow two-sided printing.

Once the media has exited the fuser and is partly out of the top exit rollers, feeding is stopped and then reversed, and the media is directed into the duplex unit.

Paper fed into the duplex unit stops and synchronizes while the center position of the media is corrected by the operation of the side guide plate. Paper is then re-fed and is delivered to the normal feeding path on the right side of the printer.

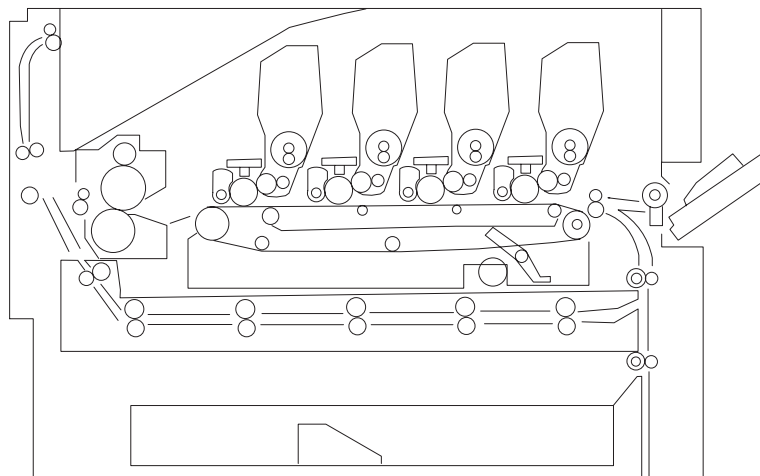

## Paper weight

### Purpose:

This menu selection is used to set the paper weight for each of the defined media types. This allows the printer to optimize the print quality for the media weight. This menu can be accessed in the Paper Menu in normal mode.

### Values:

Menu Selection	Purpose	Values
Plain Weight Transparency Weight Glossy Weight Labels Weight Vinyl Labels Bond Weight Envelope Weight Letterhead Weight Preprinted Weight Colored Weight	Identifies the relative weight of the paper loaded in a specific source, and ensures that the toner adheres properly to the printed page.	Light Normal* Heavy
Card Stock <sup>1</sup>	Identifies the relative weight of the card stock loaded in a specific source	Light Normal* Heavy
Custom <x> Weight <sup>2</sup>	Identifies the relative weight of the custom paper loaded in a specific source	Light Normal* Heavy

Light	16–20 lb
Normal*	20–24 lb
Heavy	24–28 lb

<sup>1</sup> Shown if card stock is supported in a specific source

<sup>2</sup> Shown if custom weight is supported in a specific source

\* Default value

## Clearing paper jams

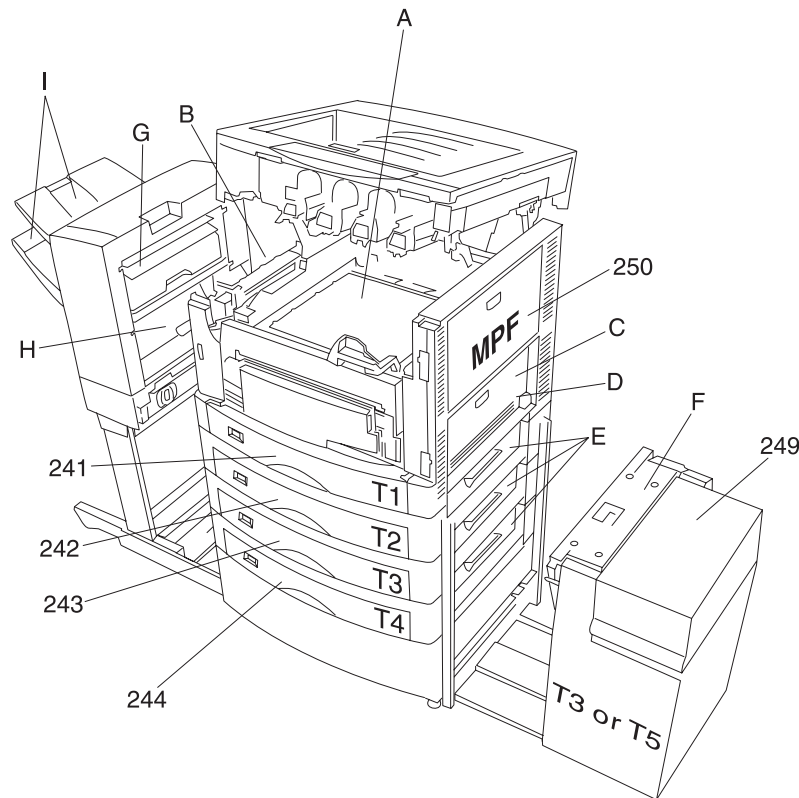

### 200 Paper Jam

This message identifies the areas (**A–F**, **MPF**, or **T1–T5**) you need to check to remove the paper or to clear the message.

#### Check Areas A, B

This message indicates a paper jam in the transfer belt, fuser, or output roller area. To clear areas A–B:

1. Open the front door.
2. Rotate the top cover locking lever to the left.
3. Place both hands on the lifting points, and squeeze the right top cover latch.
4. Lift the cover.  
**Warning:** Do not use pointed objects to remove the paper. They may damage the transfer belt.  
**Note:** The paper may be covered with unfused toner, which can stain garments.
5. Remove any paper on the transfer belt.  
If the paper source was the multipurpose feeder, check the area between the multipurpose feeder and the transfer belt.
6. Check the fuser area and top cover for additional jams.  
If there is no jammed paper in the fuser area or top cover, go to step 12. If jammed paper is present, continue with step 7.
7. Lift the fuser pressure release lever.

8. Slowly pull the paper out toward the inside of the printer. If the paper jam is difficult to remove, let the fuser cool down, and remove the fuser. Unscrew the two thumbscrews and open the jam access door on the fuser to remove the jam
9. Rotate the fuser pressure release lever down.  
The top cover will not close until the lever is in the down position.
10. Check the top cover for additional jams.  
If none, go to step 12.
11. Remove the jam.
12. Place both hands on the top cover.
13. Press down firmly until the top cover *clicks* into place.
14. Rotate the top cover locking lever to the right.  
If you cannot rotate the locking lever, the cover is not fully closed.
15. Open the jam access door on the left side of the printer.
16. Remove any paper inside the printer.
17. Close the jam access door.  
To prevent additional paper jams, make sure both sides of the door are closed.
18. Close the front door.
19. Press **Go**.  
If the paper jam message continues, check and clear all paper from the paper path.

#### **Check Area C**

This message indicates a paper jam in the duplex unit area by the access door. To clear area C:

1. Open the duplex jam access door on the right side of the printer.
2. Remove the jam.
3. Press **Go**.

If the paper jam message continues, clear any paper from the paper path.

#### **Check Area D**

This message indicates a paper jam in the duplex unit area. To clear area D:

1. Open the duplex jam access door on the right side of the printer.
2. Gently pull out the duplex unit.
3. Turn the paper forwarding dial counterclockwise.  
If the paper advances, remove the jam and go to step 7. If it does not advance, go to step 4.
4. Open the duplex unit covers.
5. Remove the jam.
6. Close the duplex unit covers.
7. Push in the duplex unit.
8. Close the duplex jam access door.
9. Press **Go**.

If the paper jam message continues, clear any paper from the paper path.

### Check Area E

This message indicates a paper jam in the top, middle, or bottom optional drawer paper path area. To clear area E:

**Note:** If you have a high-capacity feeder, pull it away from the printer.

1. Open the jam access door on the top optional drawer.
2. Remove the jam.
3. Close the jam access door.
4. Open the jam access door on the middle drawer.
5. Remove the jam.
6. Close the door.
7. Open the jam access door on the bottom drawer.
8. Remove the jam.
9. Close the door.
10. Press **Go**.  
If the paper jam message continues, clear any paper from the paper path.

### Check Area F

1. Pull the high capacity feeder away from the printer.
2. Open the jam access door on the top optional drawer.
3. Remove any jam.
4. Close the jam access door.
5. Slide the high-capacity feeder until it locks to the docking frame.  
When the feeder is in the correct position, you hear a *click*.
6. Press **Go**.  
If the paper jam message continues, check and clear all paper from the paper path.

## 250 Paper Jam

1. Slowly pull the jam out of the multipurpose feeder.  
**Note:** If you are feeding banner paper, do not pull the paper out; instead, begin with step 2.  
  
If the paper will not come out, proceed with step 2. If it does, go to step 10.
2. Open the front door.
3. Rotate the top cover locking lever to the left.
4. Place both hands on the lifting points and squeeze the right top cover latch.
5. Lift the cover.  
**Warning:** Do not use pointed objects to remove the paper. They may damage the transfer belt.
6. Remove the paper on the transfer belt.
7. Place both hands on the top cover.
8. Press down firmly until the top cover *clicks*.
9. Rotate the top cover locking lever to the right.  
If you cannot rotate the locking lever, the cover is not fully closed.
10. Close the front door.
11. Press **Go**.



## 241–244 Paper Jam

**Note:** Although tray 1 is shown, you can use the same procedure to clear any of the **241–244** or **Check Tray 1–4** messages.

Paper jam messages **241–244** and **Check Tray 1–4** indicate a jam in one of the paper trays. To remove the jam:

1. If you have a high-capacity feeder, pull it away from the printer.
2. Open the jam access door for the paper tray indicated on the display.
3. Remove the jam.
4. Close the jam access door.
5. Pull out the paper tray indicated on the display.
6. Remove any damaged paper.
7. Push down on the remaining paper in the tray until the bottom plate *clicks*.
8. Close the paper tray.
9. Press **Go**.  
If the paper jam message continues, clear any paper from the paper path.

## 249 Paper Jam

**Note:** If you have an optional printer cabinet, the high-capacity feeder will be identified as tray 3.

A **249 Paper Jam Check Tray 5** message indicates a jam in the high-capacity feeder. To remove the jam:

1. Open the high-capacity feeder top cover.
2. Remove the jam.
3. Close the cover.
4. Press **Go**.

## High-capacity feeder (HCF)

### Paper feed and separation mechanism

The high-capacity feeder consists of a tray and paper transfer mechanisms. The paper feed and separation mechanism uses a friction roller separation and paper feed system with a non-contact magnet type maintenance-free torque limiter.

When the paper feed clutch turns on, the paper feed roller shaft rotates, and the paper feed roller is driven with the one-way clutch. The call roller rotates with the relay gears to feed the top paper. The reverse roller rotates along with the paper feed roller.

During paper feed, if two sheets feed, the reverse roller rotates by the torque limiter, returning the lower sheet. When the paper feed sensor (reflection type sensor) detects the paper, the pickup solenoid turns off to raise the call roller, transferring the paper to the registration roller.

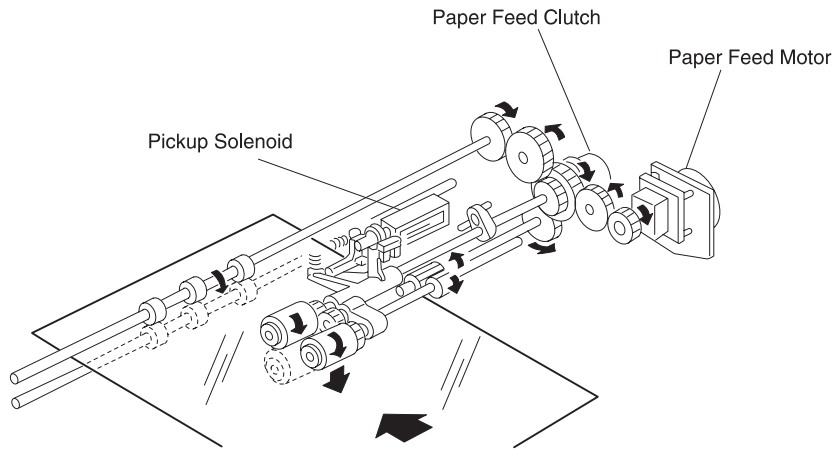

### Registration operation

When the paper feed motor rotates, the transfer roller is driven with relay gears. The reverse roller shaft rotates the gears on the paper feed clutch in the direction of the arrow and stops by the friction force of the paper feed roller.

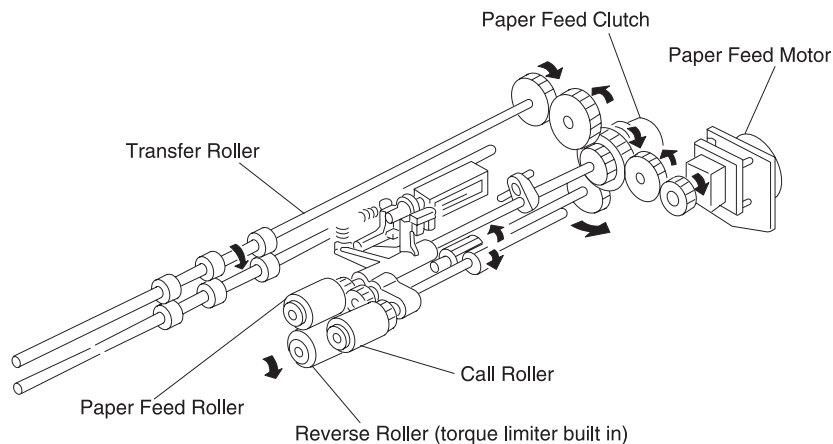

## Tray up/down mechanism

The driving force of the tray motor transmits to the tray driving pulley through the gears. Moving the tray moves up and down through the tray driving belt. After the paper loads, and the top cover is set, the pickup solenoid turns on to lower the call roller. When the tray moves up, the call roller is raised by the top surface of the paper, and the shield plate on the up sensor is released from the up sensor which turns off the tray motor.

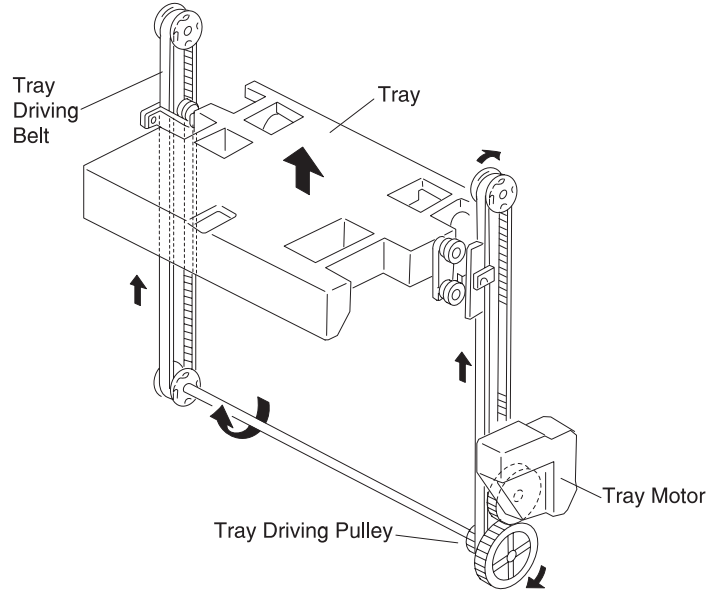

Also, when the top surface of the paper lowers during printing and the up sensor is shielded, the tray motor again rotates forward to raise the paper.

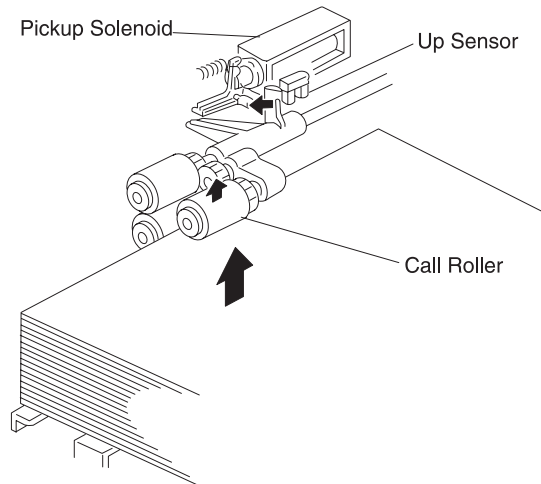

When the down button is pressed, the tray motor reverses to move the tray down. During the down motion of the tray, as the top surface of paper passes the paper level sensor, the tray motor stops. The tray moves down by about 500 sheets. The down sensor detects the tray lower limit position.

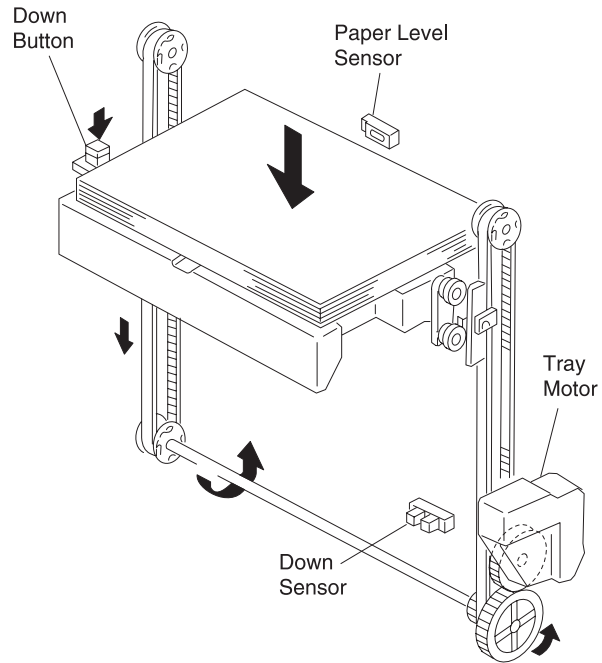

### Tray up condition

Tray up motion stops when the:

- Up sensor is OFF (not shielded)
- Power cord is connected and the joint switch is ON
- Up sensor is ON (shielded) during printing
- Top cover is closed, or when up sensor is ON

### Tray down condition

Tray down motion stops when the:

- Paper level sensor is OFF
- Down button is pressed
- Paper end is detected

**Size detection mechanism**

The paper size can be switched between A4 and letter (11 inches) by changing the side fence position.

The paper size sensor 2 detects the fixing screw 2 at the A4 position.

The paper size sensor 1 detects the fixing screw 1 at the letter position. Tray up motion stops when the up sensor is OFF, not shielded.

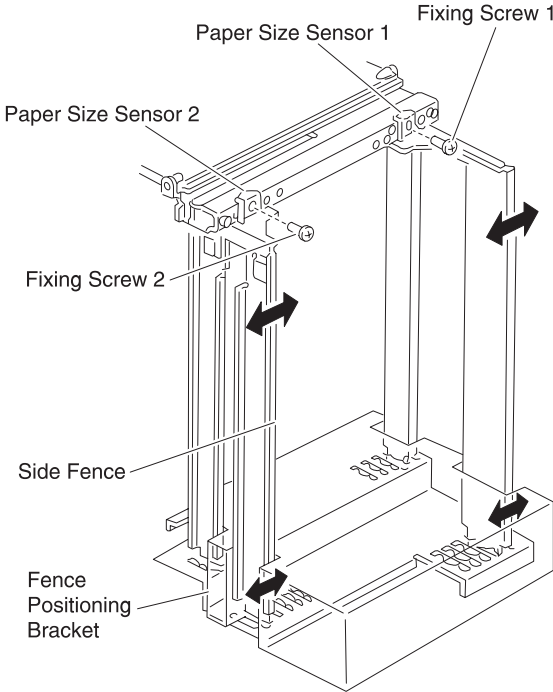

## Residual paper detection mechanism

The residual paper quantity in the tray is detected with four photo interrupters. The quantity of pages remaining in the sheet feeder displays in the following increments:

- Near end, about 80 sheets
- About 300 sheets
- About 1,000 sheets
- About 2,000 sheets

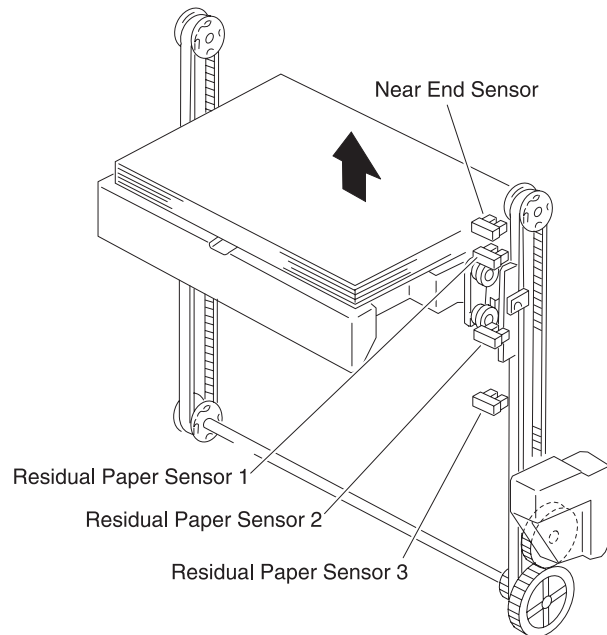

## Paper end detection

A reflection type sensor is provided on the top stay to detect the paper top surface and the paper end.

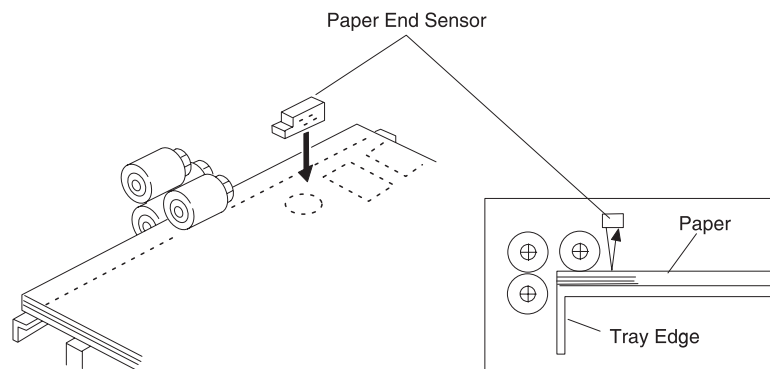

## Maintenance Mode

### DIP switch specifications

The DIP switches on the high-capacity paper feed board have the following functions:

- Function switching and initial setting of the standard machine or optional machine.

DIP switch	Function switch		Maintenance switch		Description
	4	3	2	1	
OFF					1 Standard machine initial setting
ON	X	X			
OFF	X				2 Optional machine initial setting
ON		X			

- Maintenance switch (test mode selection) is valid without connecting to the printer controller board.

DIP switch	Function switch		Maintenance switch		Test paper feed mode (standalone)
	4	3	2	1	
OFF					Test OFF mode
ON			X	X	
OFF			X		Linear velocity 101 mm/s Thick paper mode
ON				X	
OFF			X	X	Linear velocity 129 mm/s Plain paper mode
ON					
OFF				X	Linear velocity 180 mm/s
ON			X		

## Finisher

The finisher communicates with the host engine through serial interface signals and performs the following operating modes:

- **Straight**– exits paper to the upper tray.
- **Punch and straight**– stops paper at the leading edge, punches it, and exits it to the upper tray.
- **Invert**– sends paper to the accumulator, and exits it to the lower tray.
- **Punch and invert**– stops paper at the leading edge, punches it, and sends it to the accumulator where it exits to the lower tray.
- **Invert and staple**– jogs each sheet of paper in the accumulator. When the accumulated number of sheets reaches a designated number, it staples a batch of sheets, and then exits the stapled set to the lower tray.
- **Punch, invert and staple**– stops paper at the leading edge, punches it, sends it to the accumulator and jogs each sheet. When the accumulated number of sheets reaches a designated number, the batch is stapled, and exited to the lower tray.
- **Invert and offset**– jogs each sheet in the accumulator, shifts it by the offset, then exits it to the lower tray.
- **Punch, invert and offset**– stops paper at the leading edge, punches it, sends it to accumulator and jogs each page, offsets it, and then exits it to the lower tray.

**Note:** Capacity is up to 100 sheets of 20 lb paper in tray 1 (top tray), and up to 1000 sheets of 20 lb paper in tray 2 (lower tray).

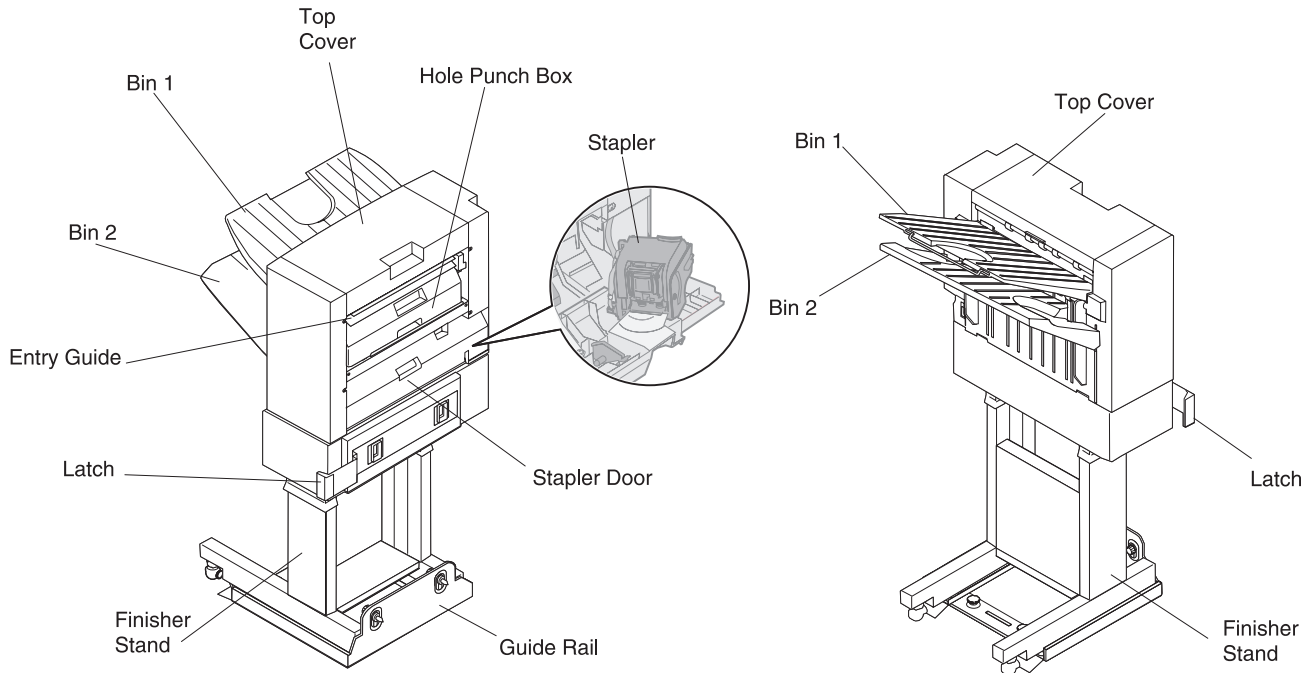



## Finisher cross section

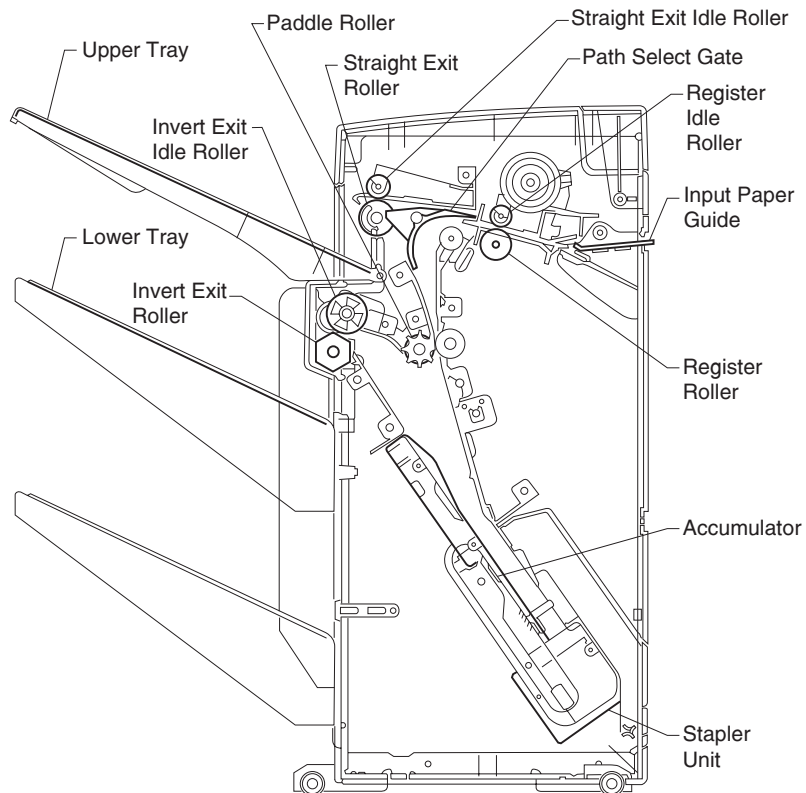

## Electrical parts function

- **Finisher Set Switch**– detects the connection with the printer.
- **Staple Cartridge Set Switch**– detects when the staple cartridge is open.
- **Staple Existence Sensor**– detects when the stapler is empty.
- **Staple Home Position Sensor**– locates home position for stapling.
- **Paper Register Sensor**– detects when paper enters into the finisher, detects paper jams and triggers the punch.
- **Paper Exit Sensor (Upper Tray) (Letter), Invert Path Sensor (A4)**– detects when paper feeds into the lower tray, the end of jogged paper and paper jams.
- **Paper Exit Sensor**– detects that paper has exited the printer.
- **Tractor Home Position Sensor**– locates home position for the drive belt.
- **Elevator Upper Limit Sensor**– detects when the lower tray is at the highest position.
- **Jogging Home Position Sensor**– locates home position for the jogging bar.
- **Paper Detecting Sensor**– detects when the paper is at the correct position for stapling.
- **Paper Full Sensor A**– detects when there is a full stack of paper on the lower tray.
- **Paper Upper Level Sensor B**– locates the top of the stacked paper on lower tray. Also detects when paper is removed from stacked papers on the lower tray while stacking.
- **Elevator Lower Limit Sensor**– detects when the lower tray is at the lowest position.

## Paper feed mechanism

Paper is transported, after it is detected at paper register sensor by drive gears and drive belts, driven by the paper feed motor or tractor drive motor and other rollers. Paper path route differs subject to the selected mode.

### Straight paper path (exit paper to upper tray)

The paper feed motor drives and rotates rollers. The path select gate is changed by the path select solenoid, and paper goes out to the upper tray by the exit rollers.

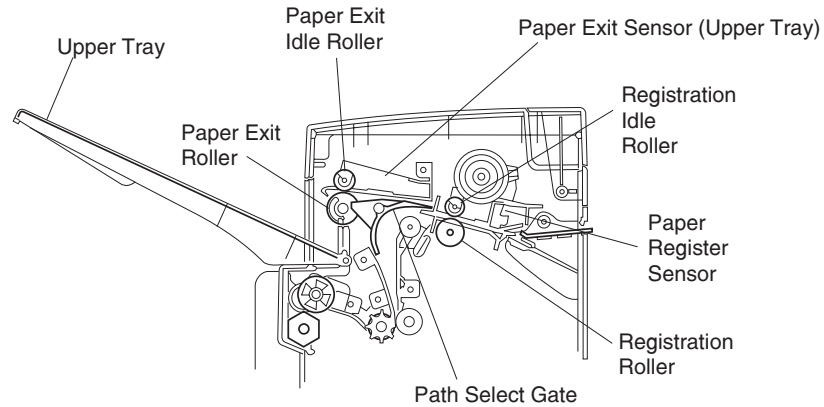

### Path select gate

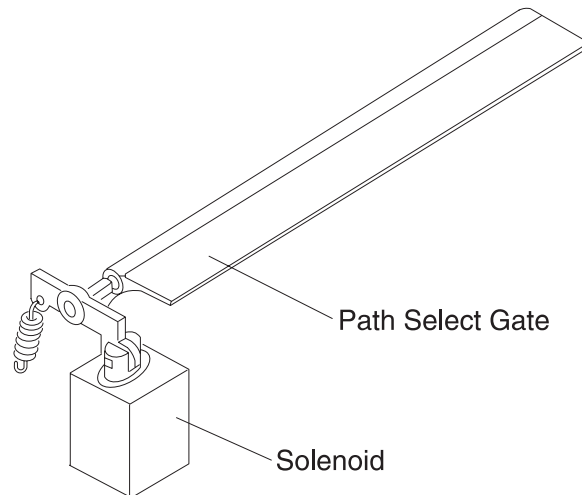

## Inverting paper path (exit paper to lower tray through accumulator)

The paper feed motor drives and rotates the rollers as paper feeds through the registration rollers, path select gate, and patting rollers. Paper is detected by the invert path sensor. Paper is then jogged by the jogging bar and driven by the belt drive motor before exiting to the lower tray (accumulator).

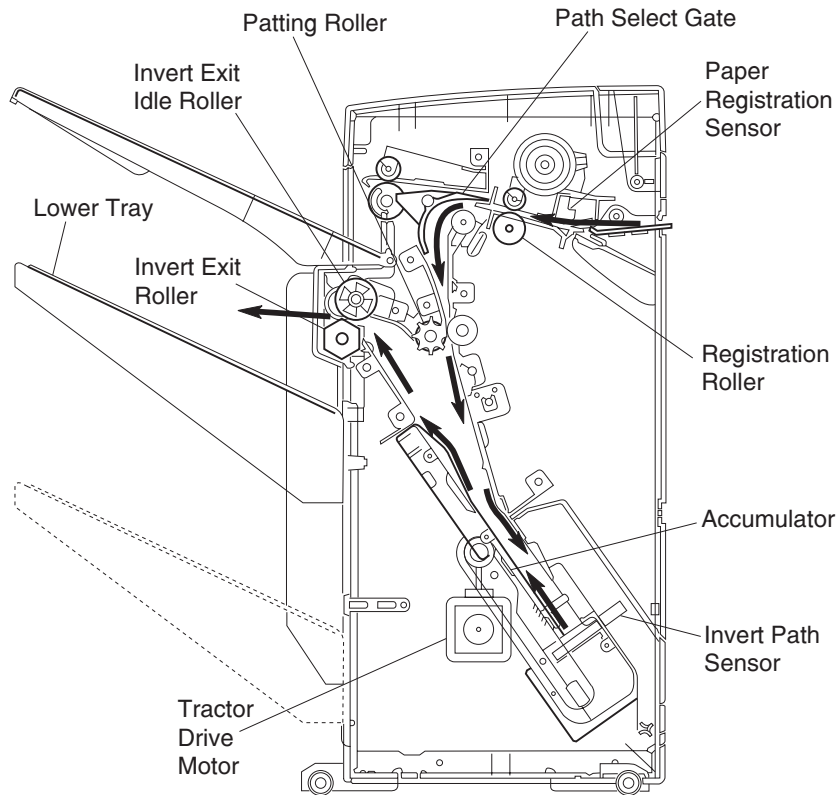

## Accumulator

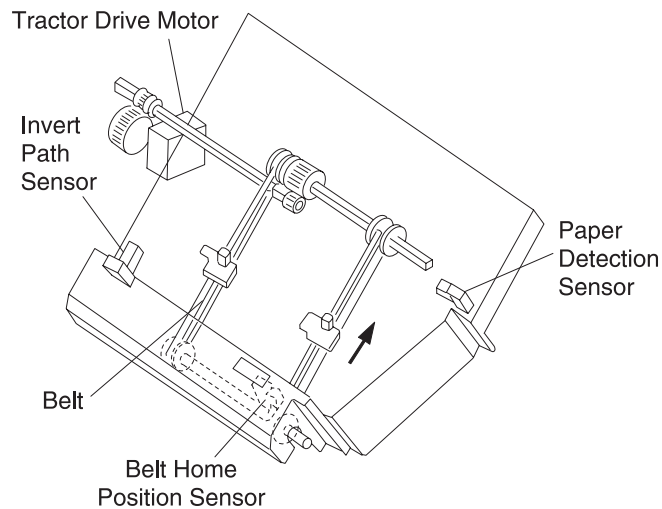

## Paper registration sequence

Paper is stopped at the hole punching position momentarily before the paper standstill clutch turns ON and changes to open. At this point, the driving force cannot be transmitted to the register rollers. The paper then stops at register rollers, and since the finisher keeps feeding the paper from the host printer, the leading edge of the paper stops at the register rollers. The paper buckles at the entrance. The paper buckle feeds downward to the lower entrance paper guide, where it is hole-punched at the leading edge. The paper standstill clutch turns OFF and changes to close as the driving force transmits to register rollers, and the paper transportation restarts.

## Punch unit driving sequence

When the paper feed motor drives, the driving force is transmitted through the punch unit drive gear to the clutch gears of the punch unit. Since the punch clutch is normally opened OFF, the driving force is not transmitted to the driving shaft. When the punch clutch turns ON, it is closed and unlocked. The driving force is then transmitted from the clutch gears to the driving shaft. As the shaft turns, the rotation of the cam causes the paper to be hole-punched. Immediately after one turn of the shaft, the punch clutch turns OFF, and the drive shaft stops.

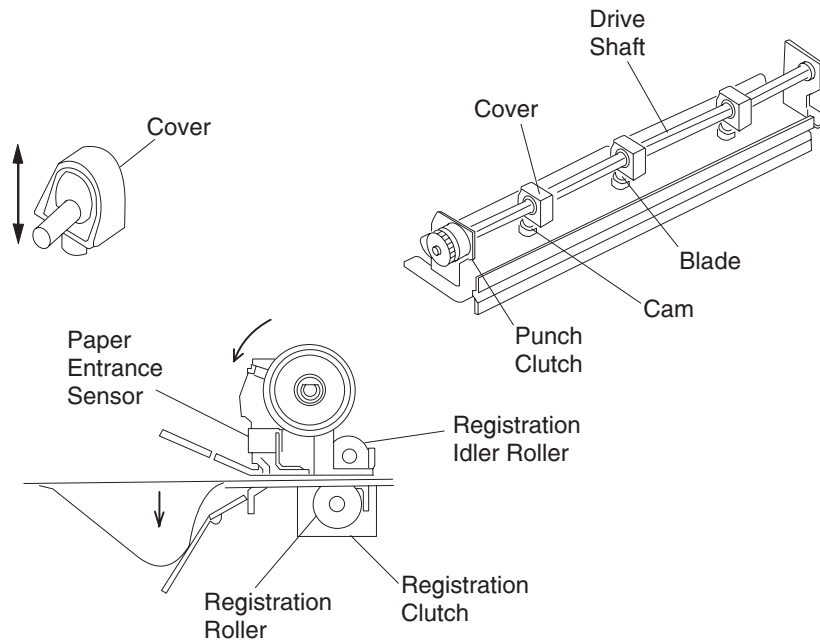

## Jogging / offset mechanism

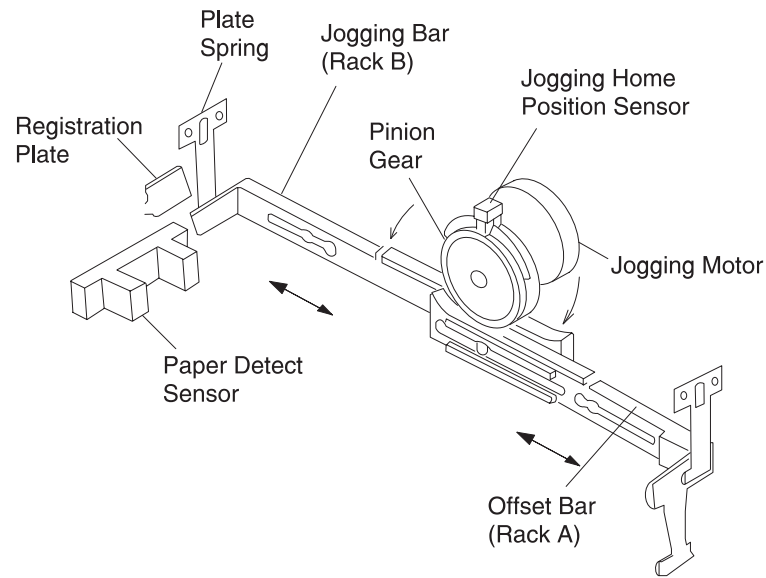

## Jogging sequence

Each sheet, upon entering the accumulator, is aligned by the jogging bar which moves the sheet horizontally until the edge of the sheet contacts the registration plate. The paper detecting sensor detects the paper position for stapling.

## Offsetting sequence

Sheets of jogged paper are offset by the horizontal movement of the jogging bar. The jogging bar is moved horizontally by the rack and pinion mechanism, while the jogging motor rotates. Each plate spring on the jogging bar pushes the rack in the direction of the pinion gear, so that the rack and pinion gears meet securely. The distance of the offset bar movement depends on paper size, A4 or letter.

## Detection of fixed position

The fixed position of the jogging bar is detected by the jogging home position sensor and a sensor flag united with the pinion. The fixed position is set when the sensor detects the sensor flag. This fixed position is used as a reference point to calculate the distance of the movement of the jogging bar and offset bar depending on paper size.

### Stapling mechanism

The stapler motor rotation drives a gear link and cam mechanism. The cam movement allows the stapler mechanism to operate.

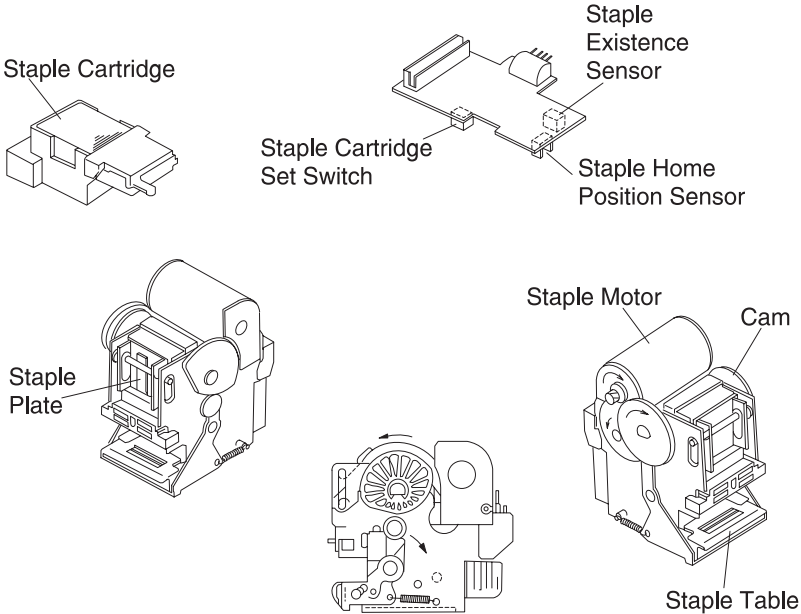

## Elevator sequence

The wire drum rotates by the elevator motor as the wire drum rolls the wire pulling the hook plate up and down. The lower tray moves up by the driving force of the elevator motor until the elevator upper limit sensor is ON, the paper feeds onto the tray, or until the paper upper level sensor B is ON if no paper feeds onto the tray. When paper feeds out to the lower tray and the paper full sensor A turns ON, the lower tray moves down until the paper full sensor A turns OFF. If paper feeds onto the lower tray when the elevator lower limit sensor turns ON, and the paper upper level sensor B turns ON, paper feeding from host printer is prohibited. When paper is removed from the lower tray and the paper upper level sensor B turns OFF, the lower tray moves up.

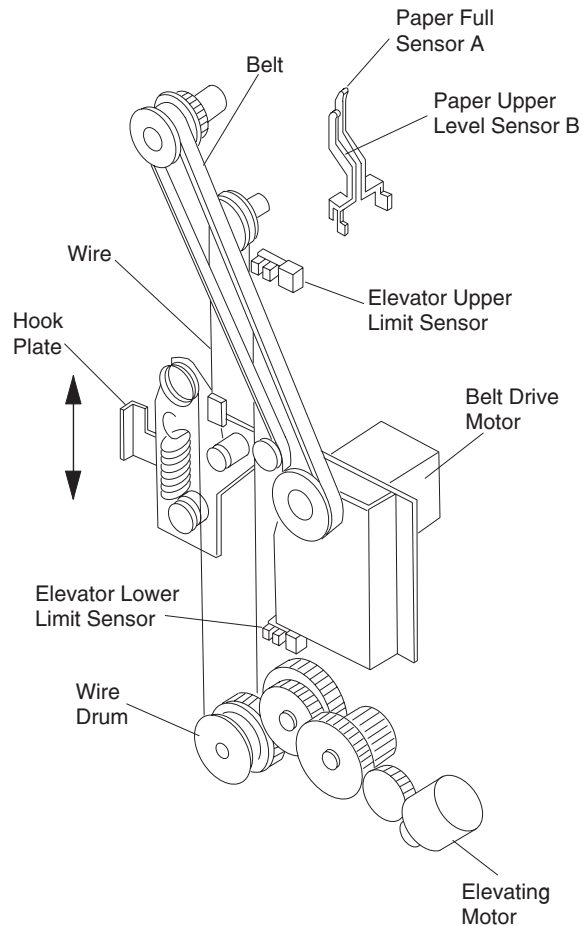

---

## Finisher installation

### *Attaching the docking plate and guide rail*

1. Lift the printer exit tray halfway and remove. You will need the tray when the finisher is attached.

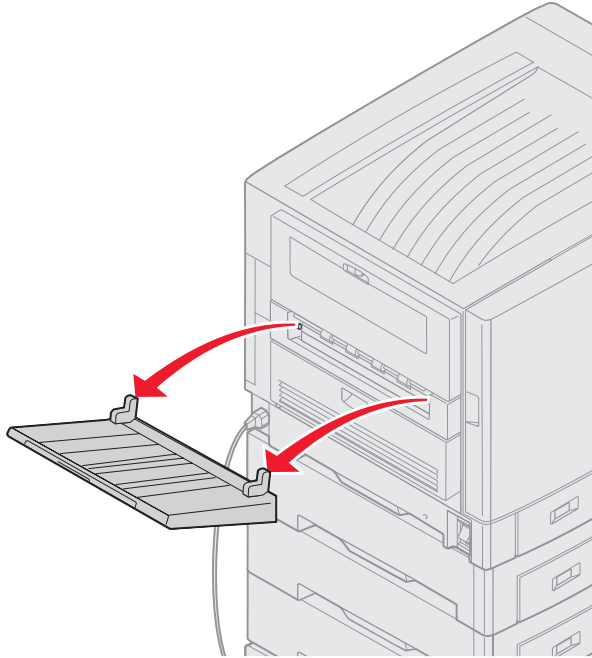

2. Insert the docking plate tabs into the printer.
3. Align the thumbscrews on the docking plate with the holes in the side of the printer.
4. Tighten the docking plate thumbscrews.
5. Align the thumbscrews on the guide rail plate with the holes in the side of the printer cabinet or stand.



6. Tighten the guide rail plate thumbscrews.

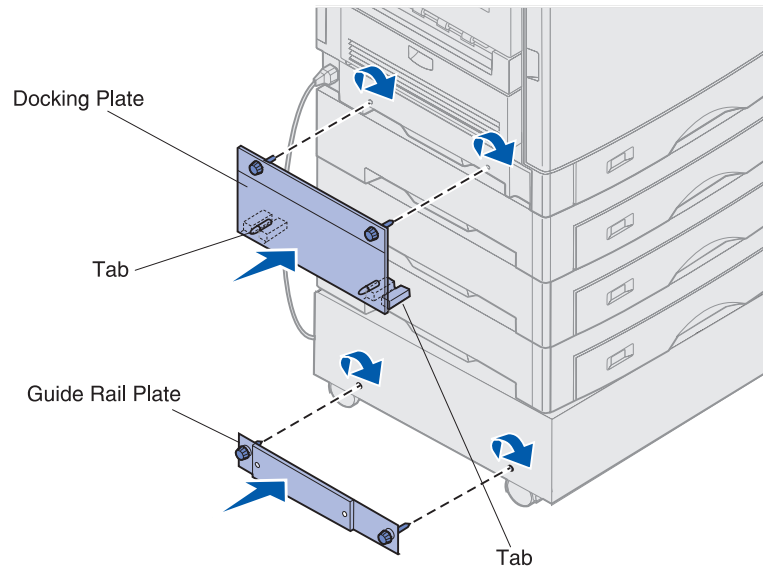

7. Align the thumbscrews on the guide rail with the holes in the guide rail plate.
8. Tighten the guide rail thumbscrews.

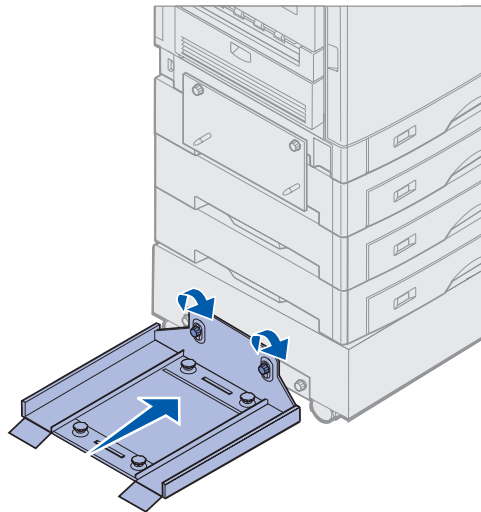

## Combining the finisher and stand

1. Roll the finisher stand onto the guide rail. Do not push the stand all the way up against the printer.

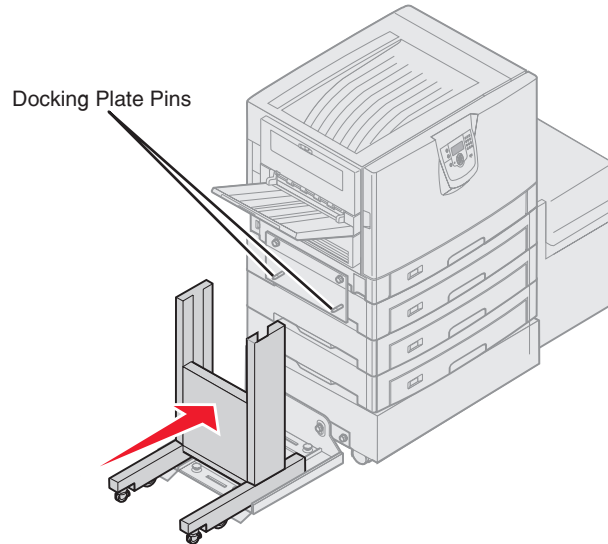

2. Remove and discard all shipping tape, packing material, and the metal shipping bracket.

**CAUTION:** When assembled, the finisher weighs 26.3 kg (56.9lb) and requires at least two people to lift it safely.).

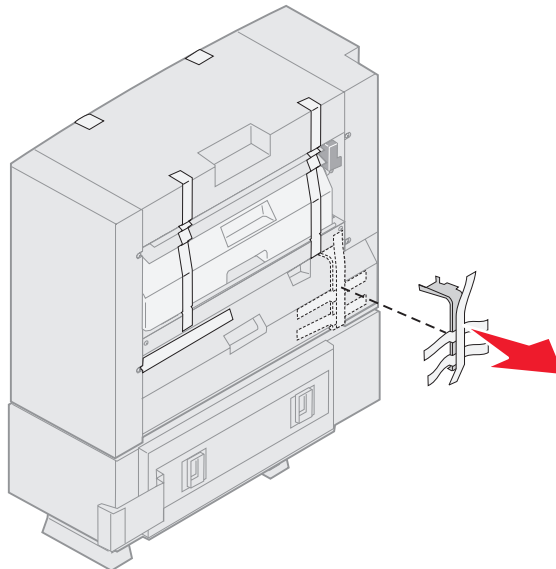

3. Open the stapler door.
4. Remove all shipping tape and packing material.

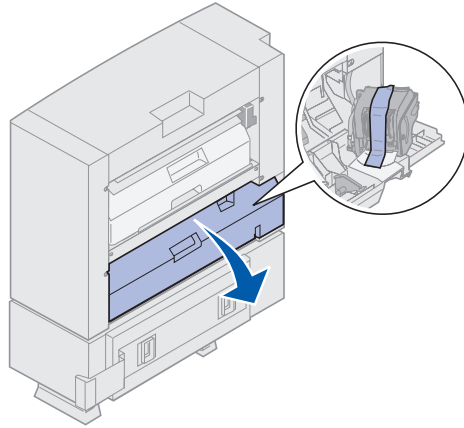

5. Lift the stapler locking lever.
6. Raise the stapler.
7. Remove all shipping tape and packing material.

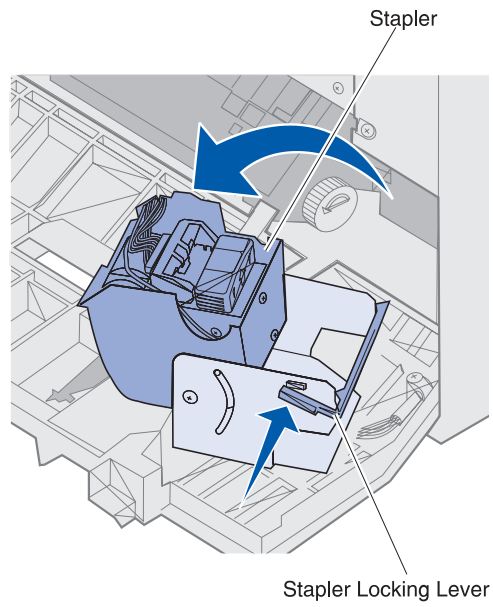

**8.** Close the stapler.

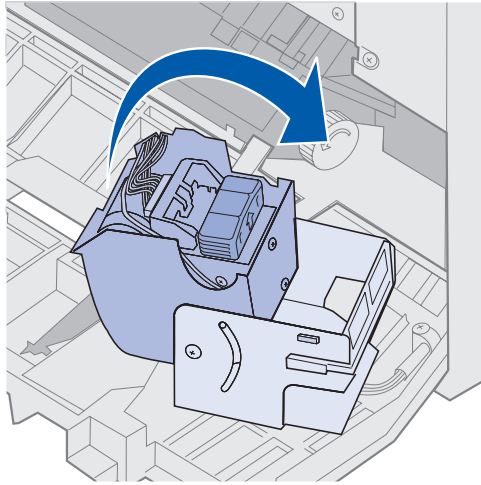

**9.** Close the stapler door.

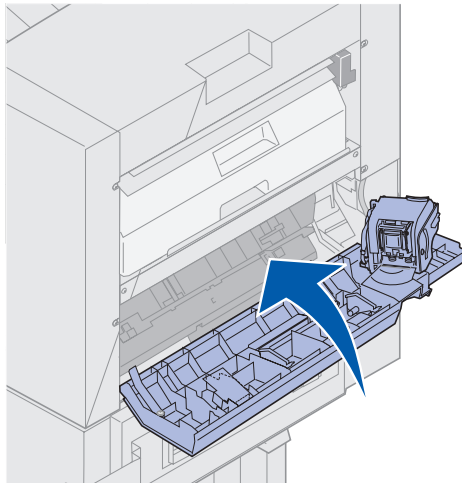

10. Align the two sockets on the bottom of the finisher with the legs of the finisher stand.
11. Lower the finisher onto the finisher stand.

**CAUTION:** When assembled, the finisher weighs 26.3 kg (56.9lb) and requires at least two people to lift it safely.

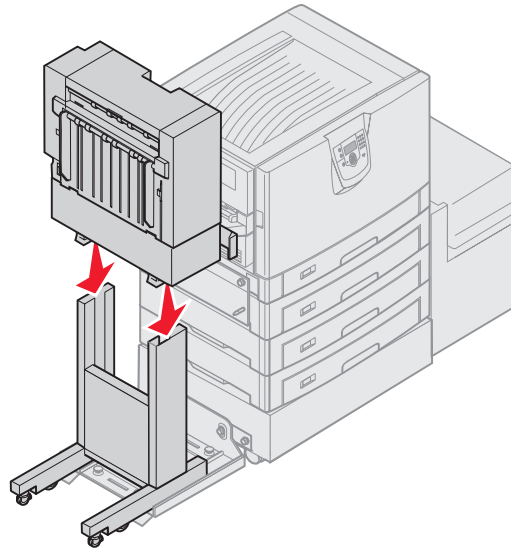

12. Remove both thumbscrew spacers.
13. Tighten the two thumbscrews.

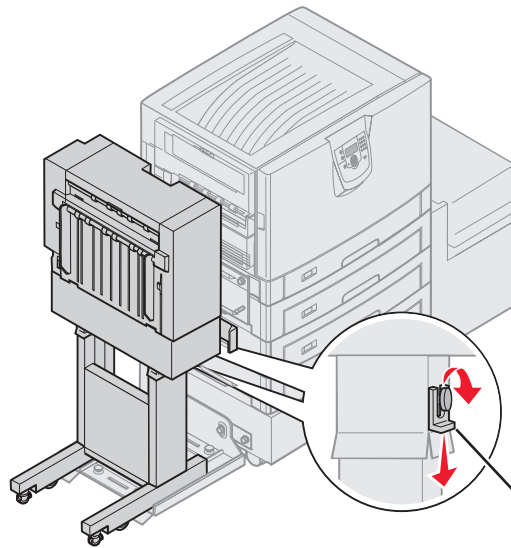

## Attaching the bins

1. Align the slots on bin 2 with the metal brackets on the rear of the finisher.
2. Slide the bin down onto the metal brackets until it is fully seated.

**Note:** When assembled, the finisher and finisher stand are referred to as the finisher.

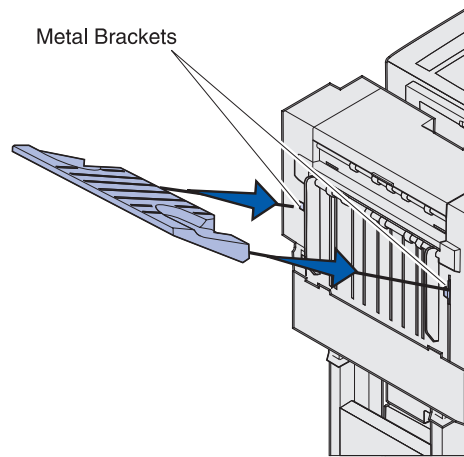

3. Align the tabs on bin 1 with the slots on the rear of the finisher.
4. Lower the bin until it is fully seated.

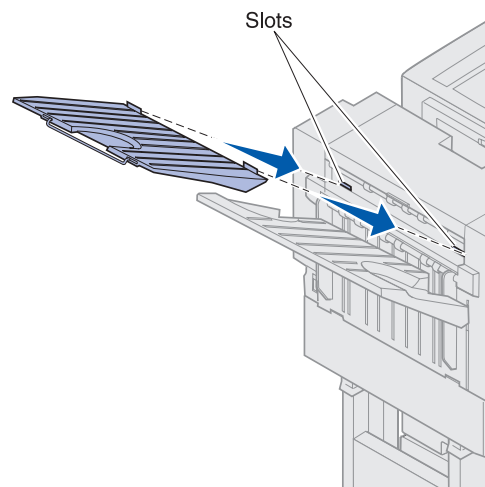

## Aligning the finisher and printer

The following three areas must align properly to prevent paper jams.

1. The docking plate pins must enter the holes in the finisher.
2. The space between the printer and finisher must be the same at the top and bottom of the finisher.
3. The alignment marks on top of the finisher must align with the edges of the cover on the side of the printer.

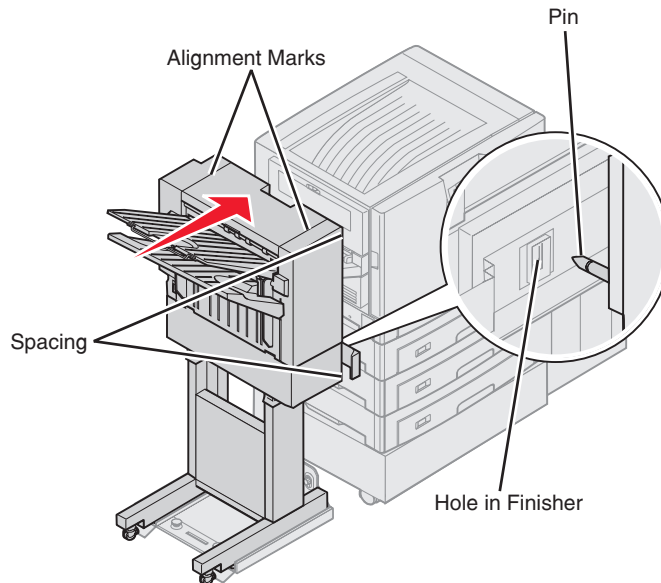

4. Roll the finisher toward the printer until the finisher locks to the docking plate pins.

You hear a *click* when the finisher locks into position.

If the pins did not go into the holes in the finisher, go to **“Lowering or raising the finisher”** on page 3-60. Otherwise, go to **“Aligning the sides of the finisher”** on page 3-62.

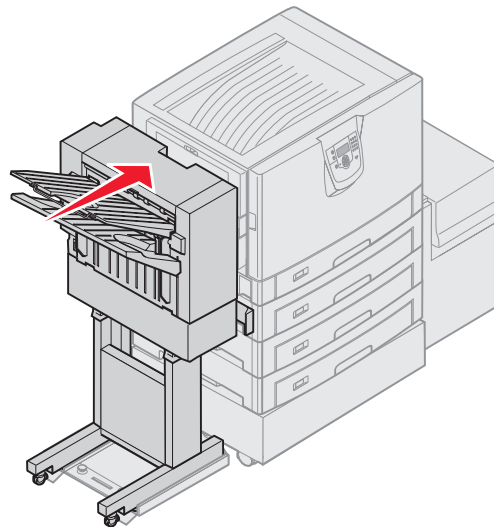

## Lowering or raising the finisher

Follow these instructions if the holes on the finisher are above or below the pins on the docking plate.

1. Determine if the pins are above or below the holes in the finisher.

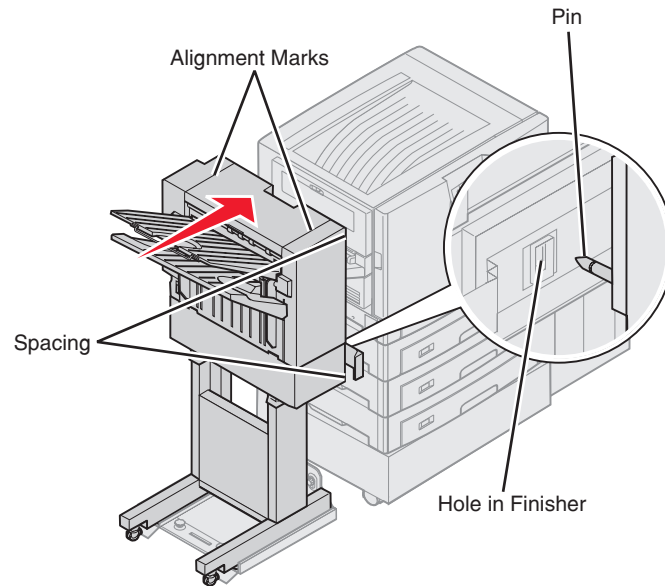

2. Loosen the guide rail thumbscrews.

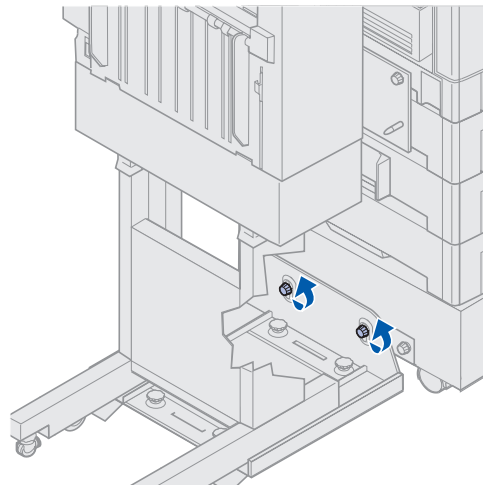

3. Rotate the adjustment knobs as needed to align the holes in the finisher with the pins.
  - To raise the finisher, rotate the adjustment knobs clockwise.
  - To lower the finisher, rotate the adjustment knobs counterclockwise.



4. Roll the finisher toward the printer until the finisher locks to the docking plate pins. You hear a *click* when the finisher locks into position. If the pins go into the holes but the finisher did not lock to the pins, go to **“Aligning the sides of the finisher” on page 3-62**. Otherwise, go to **“Aligning the top of the finisher” on page 3-63**.

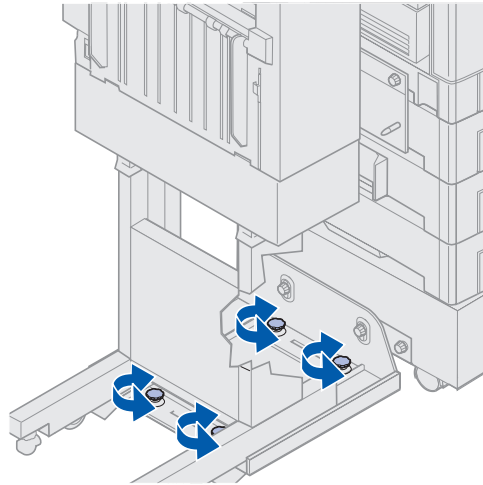

## Aligning the sides of the finisher

Follow these instructions if the distance between the finisher and printer is not the same at the top and bottom.

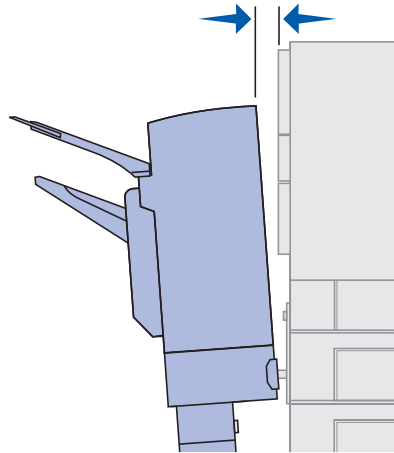

1. Loosen the guide rail thumbscrews.  
If you previously lowered or raised the guide rail plate, the thumbscrews are already loose.

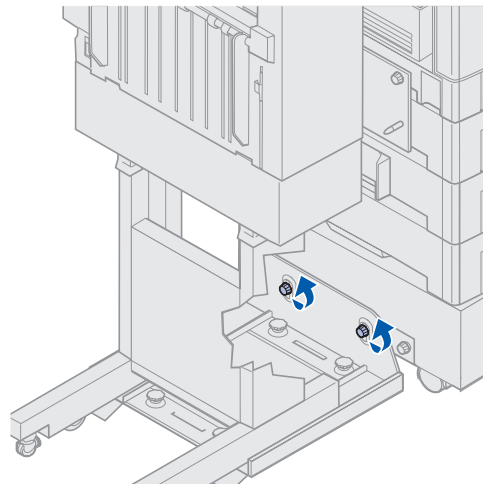

2. Rotate the rear adjustment knobs to equally align the top and bottom of the finisher with the printer.
  - To move the top of the finisher closer to the printer, rotate the adjustment knobs clockwise.
  - To move the top of the finisher away from the printer, rotate the adjustment knobs counterclockwise.

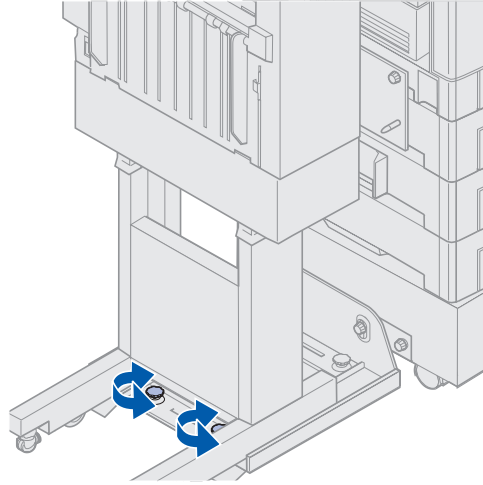

3. Roll the finisher toward the printer until the finisher locks to the docking plate pins. You hear a *click* when the finisher locks into position.

### Aligning the top of the finisher

**Note:** Anytime you move the printer or finisher, recheck the printer and finisher top alignment.

Follow these instructions if the alignment marks on top of the finisher are not aligned with the edges of the cover on the side of the printer.

1. Loosen the guide rail thumbscrews.  
If you made previous adjustments, the thumbscrews are already loose.

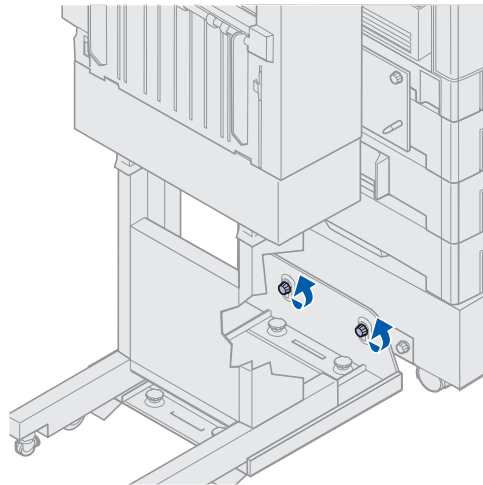

2. Rotate the adjustment knobs as needed to raise or lower the side of the finisher.
  - To raise the finisher, rotate the adjustment knobs clockwise.
  - To lower the finisher, rotate the adjustment knobs counterclockwise.
3. Tighten the guide rail thumbscrews.

4. Roll the finisher toward the printer until the finisher locks to the docking pins. You hear a *click* when the finisher locks into position.

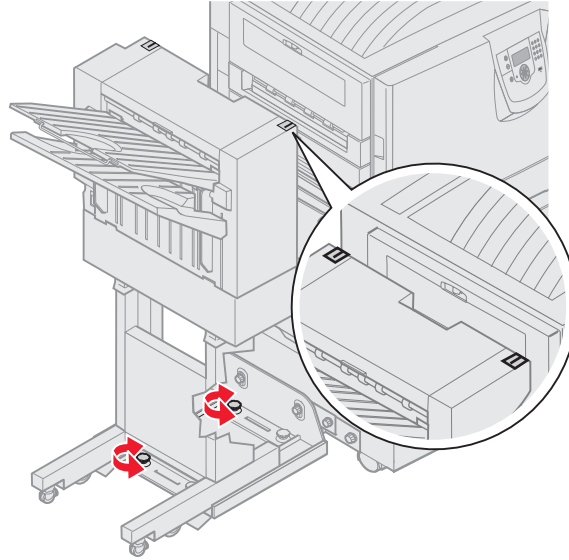

### ***Adjusting the wheels***

Adjust the wheels on the end of the finisher so the stand remains aligned when moved.

To adjust and lock the wheels:

1. Rotate the left and right upper adjustment knobs on the rear wheels until the wheels touch the floor. To lower the wheels, rotate the adjustment knobs clockwise.

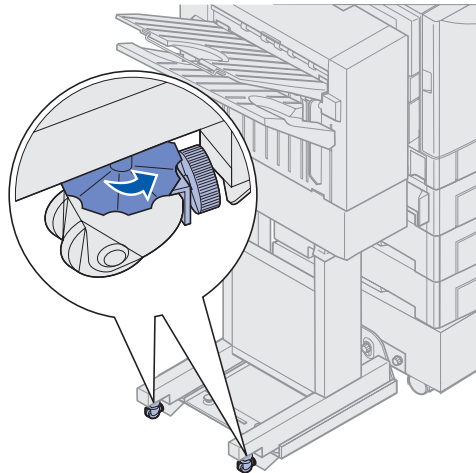

2. Turn the wheels until the locking knobs are aligned with the finisher base.

3. Rotate the locking knobs counterclockwise until they contact the finisher base.

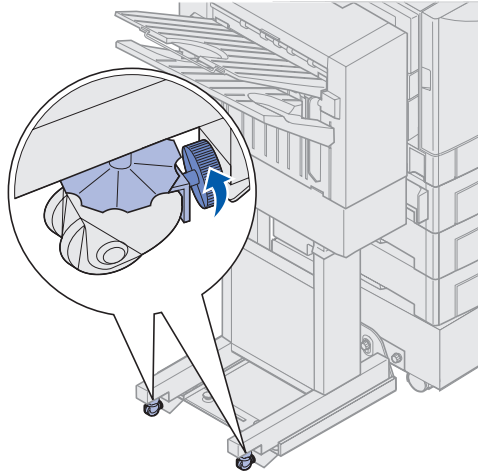

### ***Attaching the cables***

The finisher comes with an interface cable and Y-power cord. The interface cable connects the finisher to the printer, and the Y-power cord provides electrical power to the finisher and printer.

1. Turn the printer off, and unplug the power cord from the power outlet.
2. Push the latch in and hold it.
3. Roll the finisher away from the printer.
4. Release the latch.

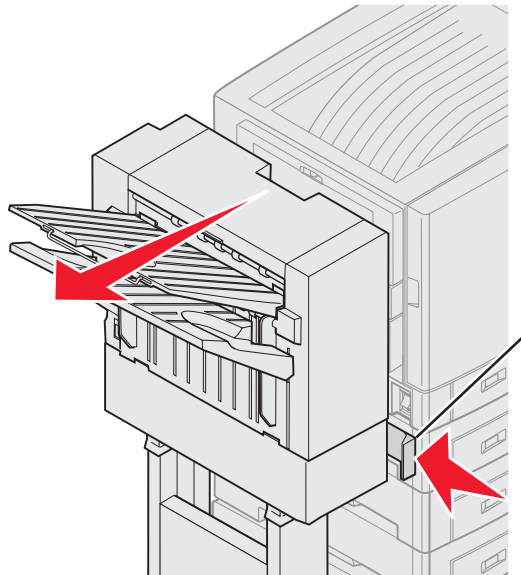

## Interface cable

**CAUTION:** Make sure the printer is turned off before continuing.

1. Plug the interface cable into the bottom connector on the back of the printer.
2. Tighten the thumbscrews.

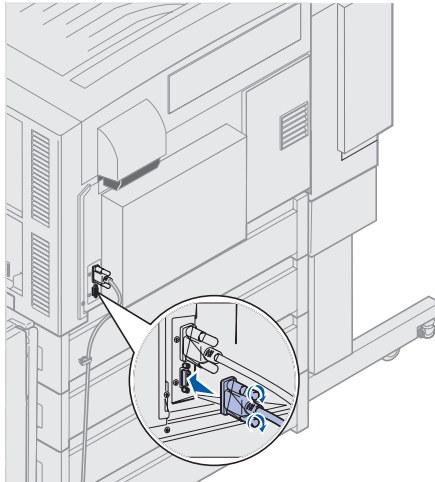

3. Plug the interface cable into the connector on the side of the finisher. The plug will be on a slight angle when connected.
4. Tighten the thumbscrews.

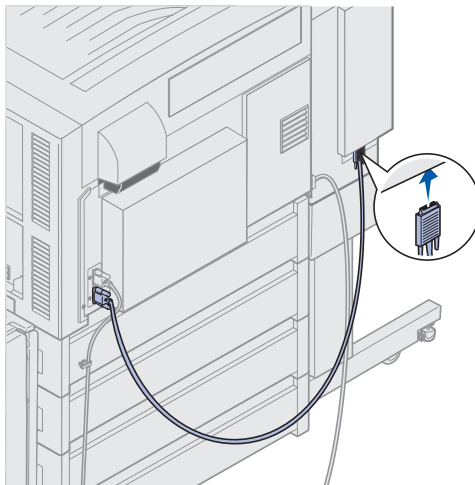

## Power cable

1. Unplug the power cord from the side of the printer.  
Set the cord aside.

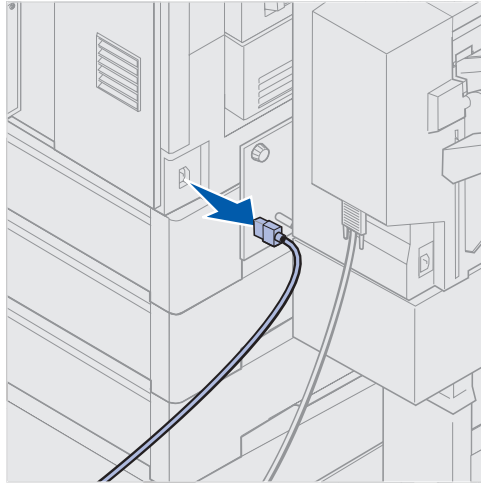

2. Plug the straight Y-power cord connector into the socket on the side of the finisher.
3. Plug the angled connector of the Y-power cord into the socket on the side of the printer.
4. Connect the previously removed printer power cord to the Y-power cord.

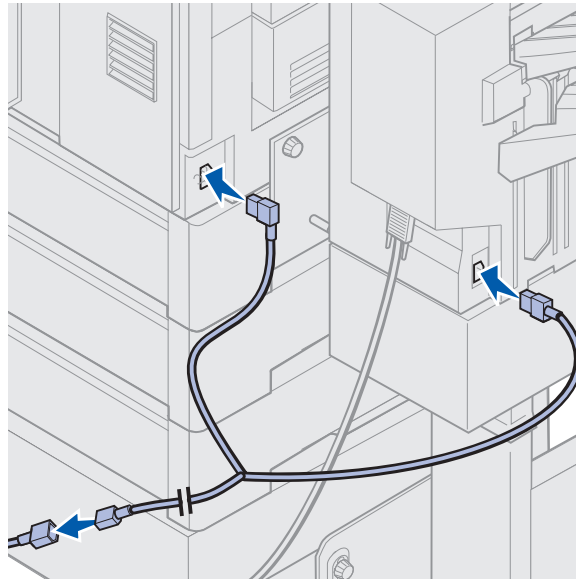

5. Remove the protective paper from the back of the cable holder.

6. Firmly press the adhesive-backed cable holder onto the back of the top optional drawer.

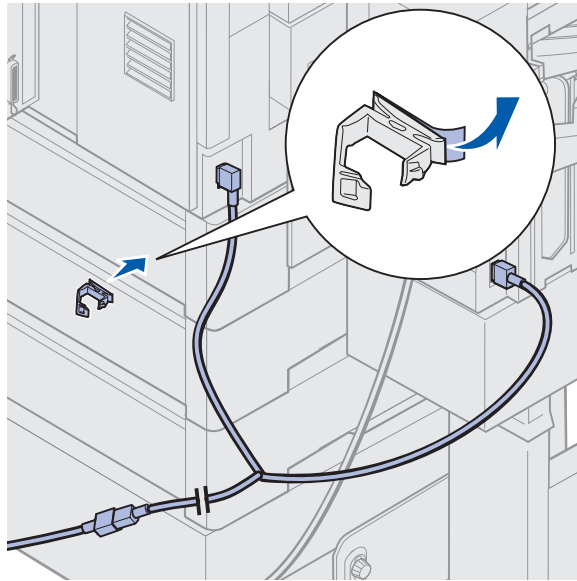

7. Place the finisher interface cable and power cord into the cable holder.
8. Close the cable holder.
9. Replug the power cord into the outlet, and turn the printer on.  
The finisher does not have a power switch. Power is controlled by the printer.

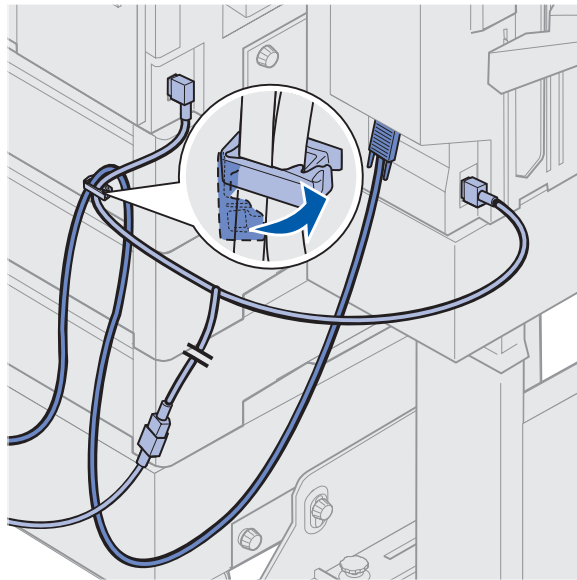



## ***Hole punch adjustment***

You can adjust the hole punch alignment by approximately 4 mm (3/16 in.). This adjustment is useful when you want to center the punched holes onto the paper or if you hole punch a printed job on different finishers.

**Note:** The following procedures are used for both three- and four-hole punch finishers.

1. Verify the alignment of the printer and finisher is correct.
  - If the alignment is not correct, go to **“Aligning the finisher and printer” on page 3-59**, print and hole punch another sheet of paper, and see if an adjustment is needed.
  - If an adjustment is needed, continue with step 2.
2. Using a sheet of paper previously punched from the finisher, fold the paper so the bottom punched hole is aligned with the top punched hole.
3. Determine if the edge of the bottom of the page is below or above the top edge of the page.
4. Loosen the guide rail thumbscrews.

**Note:** Do not move the adjustment knobs more than three complete turns from their starting position. Adjustments greater than three turns may cause paper jams.
5. Rotate both adjustment knobs the same amount to raise or lower the side of the finisher.
  - A half turn of the knob moves the position of the hole approximately one third to one half the distance of the punched hole.
  - To move the bottom of the paper down, rotate the knobs clockwise.
  - To move the bottom of the paper up, rotate the knobs counterclockwise one quarter turn.
6. Tighten the guide rail thumbscrews.
7. Print and punch another piece of paper.
8. Repeat steps 2 and 3. If the holes are not aligned, repeat steps 3 through 8.



## 4. Repair information

### *Handling ESD-sensitive parts*

Many electronic products use parts that are known to be sensitive to electrostatic discharge (ESD). To prevent damage to ESD-sensitive parts, use the following instructions in addition to all the usual precautions, such as turning off power before removing logic boards:

- Keep the ESD-sensitive part in its original shipping container (a special “ESD bag”) until you are ready to install the part into the machine.
- Make the least-possible movements with your body to prevent an increase of static electricity from clothing fibers, carpets, and furniture.
- Put the ESD wrist strap on your wrist. Connect the wrist band to the system ground point. This discharges any static electricity in your body to the machine.
- Hold the ESD-sensitive part by its edge connector shroud (cover); do not touch its pins. If you are removing a pluggable module, use the correct tool.
- Do not place the ESD-sensitive part on the machine cover or on a metal table; if you need to put down the ESD-sensitive part for any reason, first put it into its special bag.
- Machine covers and metal tables are electrical grounds. They increase the risk of damage because they make a discharge path from your body through the ESD-sensitive part. (Large metal objects can be discharge paths without being grounded.)
- Prevent ESD-sensitive parts from being accidentally touched by other personnel. Install machine covers when you are not working on the machine, and do not put unprotected ESD-sensitive parts on a table.
- If possible, keep all ESD-sensitive parts in a grounded metal cabinet (case).
- Be extra careful in working with ESD-sensitive parts when cold-weather heating is used because low humidity increases static electricity.

### *Service precautions*

Observe the following precautions whenever you service the printer:

- Be sure to unplug the printer from the outlet before attempting to service the printer.
- To reassemble the printer, reverse the order of disassembly unless otherwise specified.
- Do not operate the printer anytime during disassembly. If it is absolutely necessary to run the printer with its covers removed, do not allow your clothing to be caught in revolving parts such as the gears, rollers, and fan motor.
- Never touch the terminals of electrical parts or high-voltage parts such as the HVPS (high voltage power supply) board.
- Be sure to handle the fuser carefully, as it remains hot for a while after the printer stops running. Always unplug connectors by holding the connector housing.
- Be sure to use the fuse listed in the parts catalog.
- Do not forget to install the ground wire or ground plate to ensure positive conduction. Install the screw with a toothed washer in the correct position at reassembly.

## ***RIP board/operator panel replacement***

**Warning:** If the operator panel and the RIP board are being replaced at the same time, replace the parts in this order to avoid damage to the machine.

1. Replace the RIP card first.

**Note:** Do not replace the new operator panel and RIP card in the machine at the same time.

2. After installing the new RIP card, and before installing the new operator panel, start the printer.
3. After the printer has completed startup, turn off the printer and replace the operator panel.  
**Note:** If the operator panel display has failed, the printers' startup cycle is complete when the driver motor and fans shut down, and the machine is quiet.
4. After installing the new operator panel, start the printer, and allow the printer to go through a complete startup cycle and the display to go to Ready.
5. If the problems persist, leave the new operator panel in the machine, place the old RIP card back in the machine, and start it up. After the machine startup, shut down the machine, and install the new RIP card. After installing the new RIP card, restart the machine, and let it go through the startup cycle.

After this procedure is completed successfully, there is no need to adjust any settings.

If the above procedure fails, you must contact the technical support center for further instructions.

## ***Handling printed circuit boards***

The following precautions must be observed when handling circuit boards with metal oxide semiconductor integrated circuits.



**CAUTION:** If you are removing the motor driver board or the low voltage power supply boards, ensure they are properly discharged before handling.

### **Transportation/storage**

- During transportation or when in storage, new circuit boards must not be indiscriminately removed from their protective conductive bags.
- Do not store or place circuit boards in a location exposed to direct sunlight.
- When it becomes absolutely necessary to remove a board from its conductive bag or case, always place it on its conductive mat in an area as free as possible from static electricity.
- Do not touch pins of the integrated circuits with your bare hands.

### **Replacement:**

- Before you unplug connectors from the circuit boards, be sure the power cord has been unplugged from the power outlet.
- When you remove a board from its conductive bag or case, do not touch the pins of the integrated circuits or the printed pattern. Place it in position by holding only the edges of the board.
- Before you plug connectors into the board, be sure the power cord has been unplugged from the power outlet.

### **Inspection:**

- Avoid checking the integrated circuits directly with a multimeter; use connectors on the board.
- Never create a closed circuit across integrated circuit pins with a metal tool.
- When it is absolutely necessary to touch the integrated circuits and other electrical components on the board, be sure to ground your body.

## ***Check finisher alignment when moving or servicing the finisher***

After moving or servicing the finisher, print some test pages to the finisher to ensure the vertical and horizontal alignment is correct. If the finisher is not properly aligned, refer to **“Aligning the finisher and printer” on page 3-59** for alignment instructions.

---

## Adjustments

### ***High-capacity paper feed timing belt adjustment***

1. Secure the bracket with the screw, as shown.
2. Attach the spring and washer to the bracket with the screw.
3. Adjust the screw to 6mm  $\pm$ 1mm.
4. Tighten the screw completely.
5. Adjust the timing belt on the rear in the same manner.

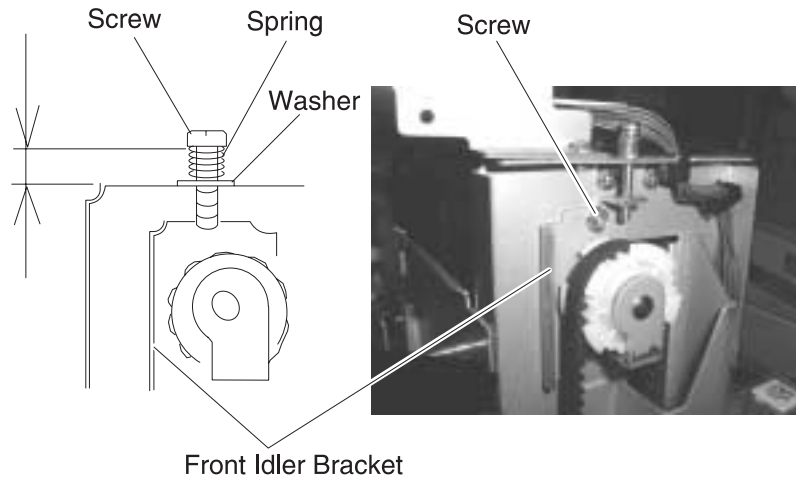

### ***Adjustments and procedures following parts replacement***

**Note:** When troubleshooting, or prior to making any adjustment to print quality, always be sure:

- The printer is installed on a level, rigid surface.
- The photodevelopers are never exchanged. Do not exchange a black photodeveloper for a color photodeveloper, as they have different surface phase counts.
- The Alignment Page is used when adjusting print registration.

Whenever you replace any of the following parts, be sure to perform the required adjustments or procedures. The adjustments are in the Repair information and Diagnostic aids chapters.

#### **Printer controller board/printer control EPROM (U7)**

If you replace the printer controller board, remove EPROM (U7), and install it on the new board. Also check the printhead alignment.

#### **Printhead controller board**

If you replace the printhead controller board, replace all the eeproms from the old printhead controller board.

#### **RIP controller board**

If you replace the RIP controller board, move the memory, and option cards from the old card to the new one.

## **Transfer belt**

If you replace the transfer belt, check the printer alignment (*X*, *Y*, and *Theta*), adjusted in diagnostic mode.

## **LED printhead controller board or LED printhead**

If you replace the LED printhead controller board or LED printhead, check and adjust the following items in diagnostic mode:

Printer Alignment (*X*, *Y*, and *Theta*)

Print the alignment pages. Make sure that you installed the EEPROMS supplied with the printhead on the printhead controller board.

---

## Removals

### *Cover, top removal*

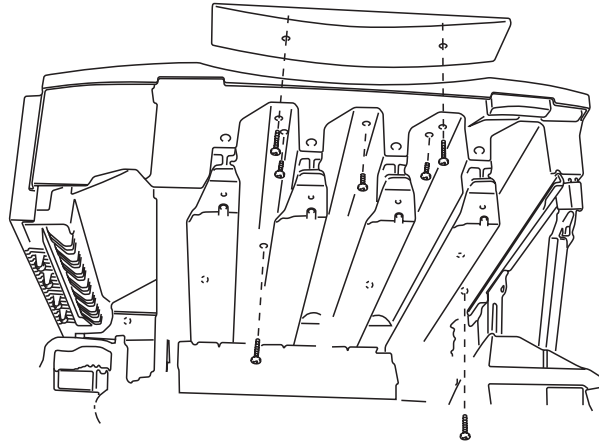

1. Open the top unit, and remove the photodevelopers and toner cartridges. Cover the photodevelopers to avoid damage from exposure to the light.
2. Remove the two silver screws, and remove the spacer.
3. Remove five black screws from the bottom and the four silver screws from the back side.
4. Remove the top cover.

**Note:** When replacing the top cover, avoid pinching or cutting wires that connect the printhead controller board to the face down unit.



## Front door / operator panel removal

**Warning:** If the operator panel and the RIP board are being replaced at the same time, replace the parts in the order described in steps a through d below to avoid damage to the machine.

- a. Replace the RIP card (this must be the first part replaced).
  - b. Restart the printer. Let the machine finish the startup cycle, which takes several minutes. The machine is silent when startup is complete.
  - c. Install the new operator panel.
  - d. Restart the printer and let the startup cycle complete.
- If the above procedure fails, contact the technical support center for further instructions.

1. Open the front door of the printer.
2. Remove the screws (A) from the stiffener bracket.

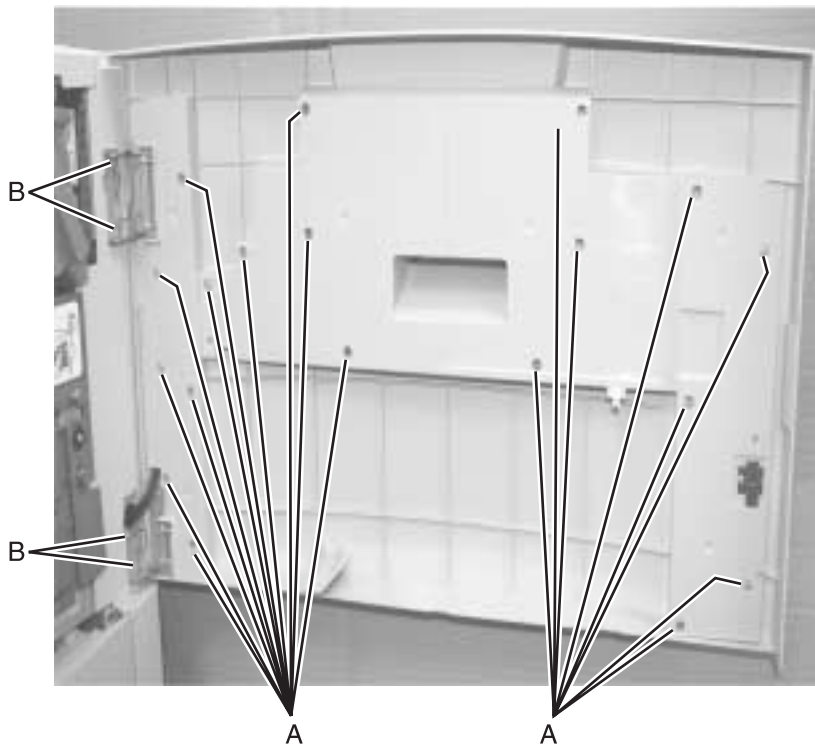

3. Remove the stiffener bracket.
  4. Clip the wire tie that holds the USB and operator panel cables to the door.  
**Note:** Refasten and properly route the cables using a wire tie to avoid pinching them with the stiffener.
  5. Unplug the two cables from the operator panel.
- Note:** To continue removing only the operator panel, skip steps 6 and 7
6. Unscrew the four screws (B) that hold the front door mounting brackets to the printer.
  7. Remove the front door from the printer.

8. Remove six screws (C) that hold the operator panel to the front door.

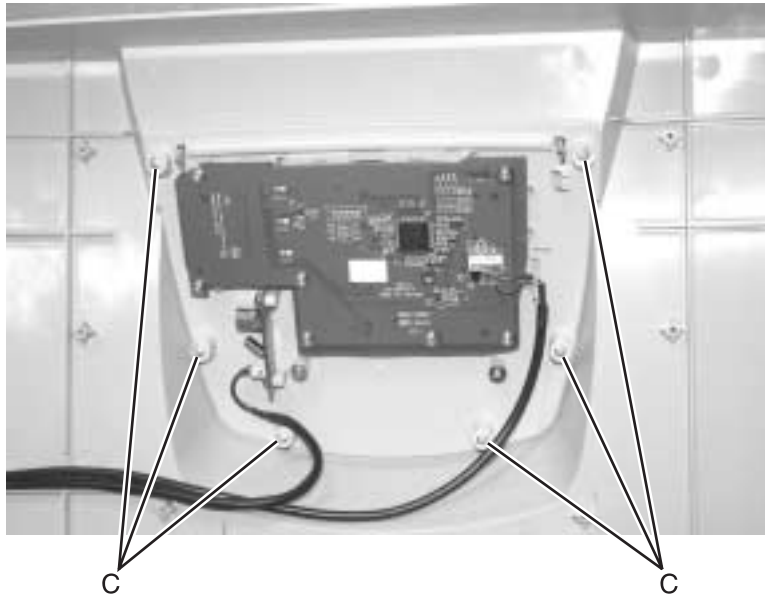

9. Remove the operator panel from the door.

**Note:** If the USB cable or the operator panel cable is being replaced, use the toroids from the old cables with the new cables.

### ***Cover, front left removal***

1. Open the front cover and remove the cassette.
2. Remove the left front cover by removing the three silver screws.

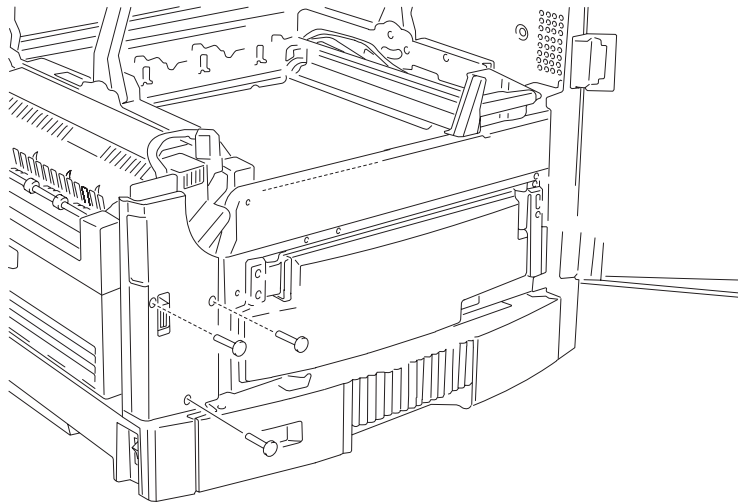

### ***Cover, rear removal***

1. Open the top unit.
2. Remove the three silver screws from the rear cover, and then remove the cover.

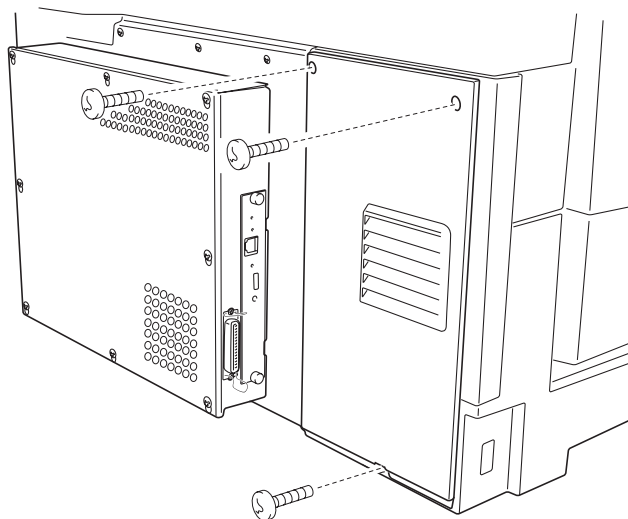

### ***Cover, solenoid removal***

1. Remove the screw from the solenoid cover.
2. Remove the solenoid cover.

### ***Cover, left side removal***

1. Remove the upper cassette, front cover, paper exit tray, and duplex unit.
2. Remove the five screws from the left side cover, and remove the cover.

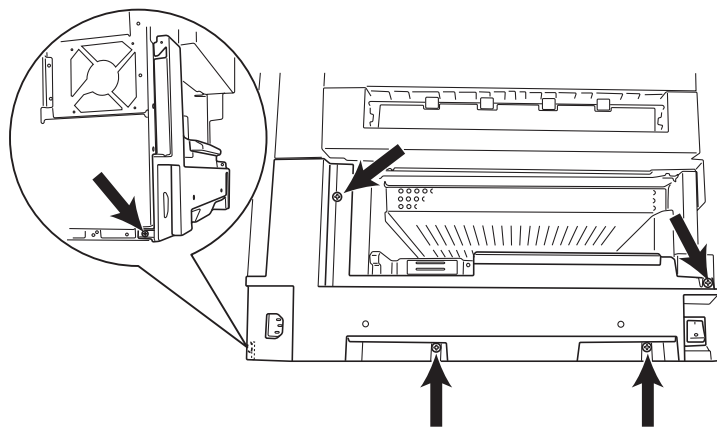

## Cover, right side removal

1. Open the top unit, and remove the front cover and upper cassette.
2. Remove the operator panel cable and the USB cable from the operator panel.  
(See “**Front door / operator panel removal**”.)
3. Remove the seven screws from the right side cover together with the turn guide, and remove the cover.

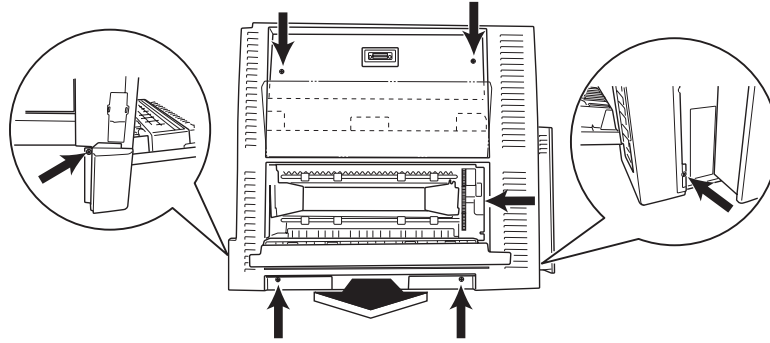

4. When installing the right side cover, insert the turn guide shaft into the bearing.

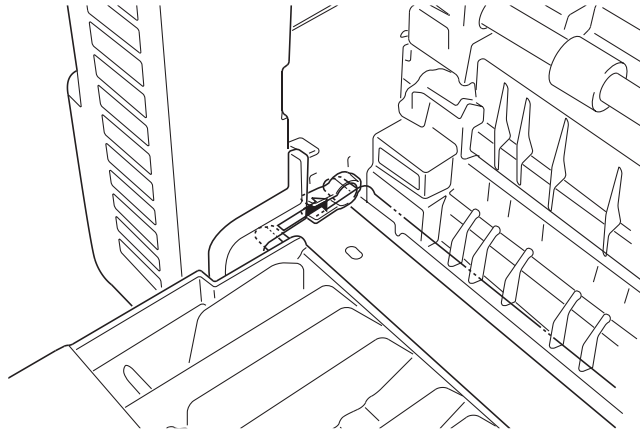

## Cover, RIP board removal

**Warning:** If the operator panel and the RIP board are being replaced at the same time, replace the parts in this order to avoid damage to the machine.

1. *Replace the RIP card first* (this must be the first part replaced).
2. Restart the printer. Let the machine finish the startup cycle. This takes a few minutes. The machine is silent when startup is complete.
3. Install the new operator panel.
4. Restart the printer, and let the startup cycle complete.

If the above procedure fails, you must contact the technical support center for further instructions.

1. Loosen the eight screws, and remove the RIP cover by sliding upward.

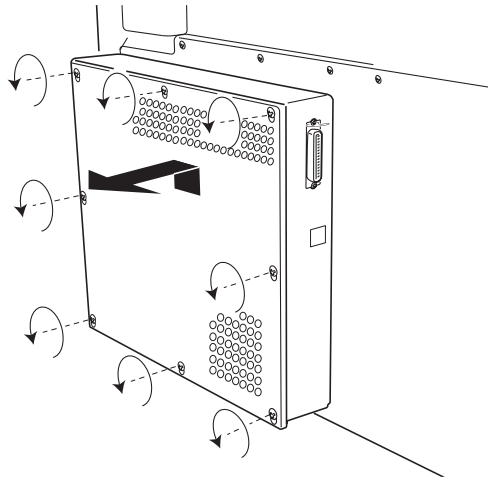

2. Disconnect all harnesses except for the processor fan (J25) from the RIP board connector.

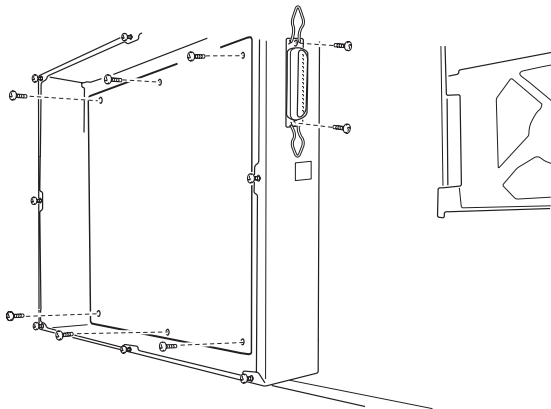

3. Remove the two screws from the parallel port connector and the screw from the USB connector.
4. Remove the eight screws from the RIP board together with the parallel connector, and remove the RIP board.

**Note:** After replacing any board on the printer, ensure all the connections are properly connected before closing the covers.

## ***Tray, paper exit removal***

1. Unlatch the hinge at the back side, then unlatch the hinge on the front side.
2. Remove the paper exit tray.

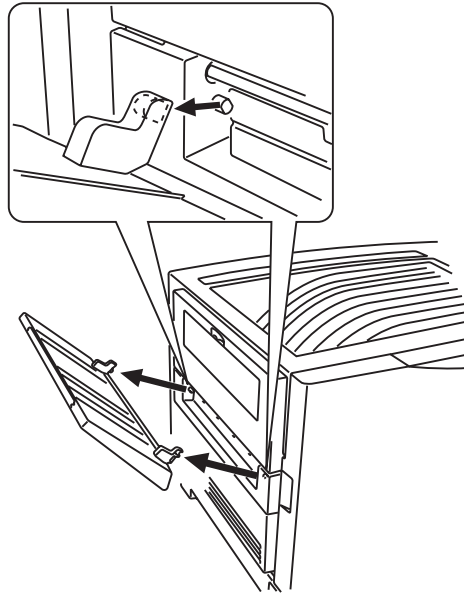

## ***Belt up/down clutch removal***

1. Remove the RIP cover, electronic box, printer controller card, and HVPS board.
2. Unplug the belt up/down clutch cable from CN1 in the CK1 daughter card board.
3. Remove the C-clip from the belt up/down clutch, and remove the clutch.

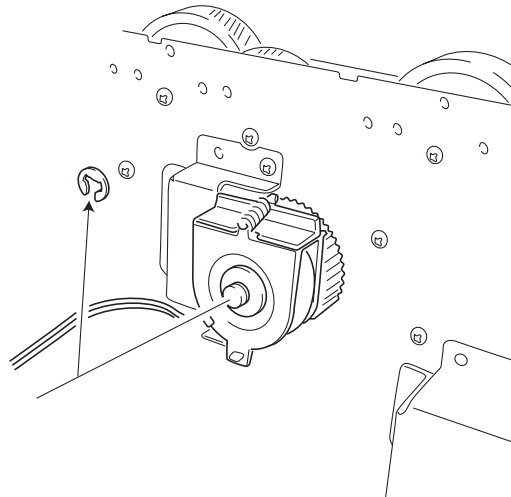

### ***Cassette guide removal***

1. Remove the paper feed frame.
2. Remove the front cover, cassette, turn guide, right side cover, and paper feed frame.
3. Remove the screws from the cassette guide, and remove the guide.

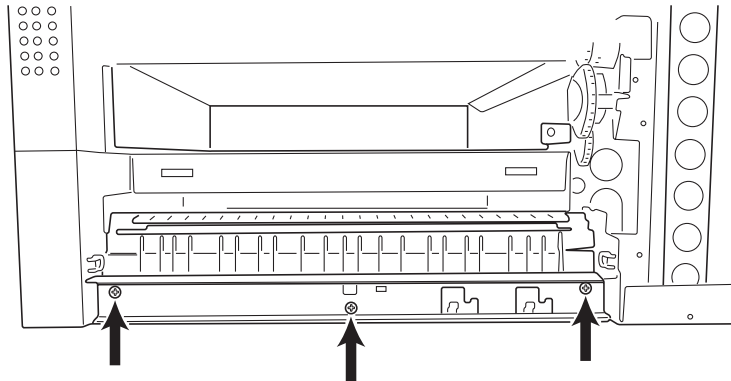

### ***CK1 daughter board removal***

1. Remove the front, right, left rear, and rear covers.
2. Remove printer controller board and HVPS board.
3. Disconnect all cables from the daughter board.
4. While pinching the nylon standoffs that attach the card to the printer frame, gently pull the CK1 daughter board away from the printer frame.

**Note:** After replacing any board on the printer, ensure all the connections are properly connected before closing the covers.

### ***CK2 daughter board removal***

1. Remove the front, right, left rear, and rear covers.
2. Remove power supply 1.
3. Unplug all cables from the daughter board.
4. Remove four screws from the daughter board, and remove the board.

**Note:** After replacing any board on the printer, ensure all the connections are properly connected before closing the covers.

### ***Connector, duplex unit removal***

1. Open the top unit and remove the upper cassette, left front cover, paper feed cover, left side cover, RIP cover, RIP board, RIP box, and the electronic box. Remove the turn guide, open the paper feed cover, and remove the duplex unit. Remove the left side cover and power supply A.
2. Disconnect the connector, and remove the two screws from the mounting plate.
3. Remove the two screws of the drawer connector from the mounting plate drawer bracket.

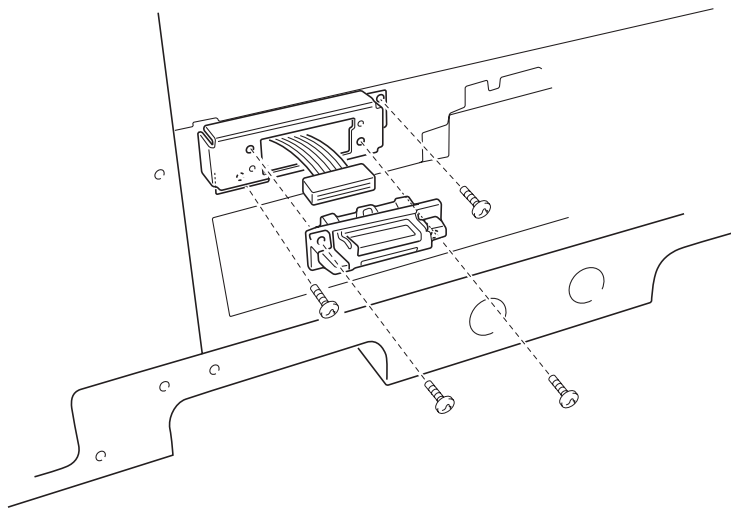

### ***Paper tray lift motor removal***

1. Remove the front, right, left rear, and rear covers.
2. Remove the cassette.
3. Disconnect the cable from the paper tray lift motor.
4. Remove the three black screws from the paper tray lift motor.
5. Remove the paper tray lift motor.



## ***Density sensor removal/Separation fingers removal/Sensor cleaner removal***

1. Open the top unit and remove the belt unit.
2. Remove the three screws from the sensor bracket.

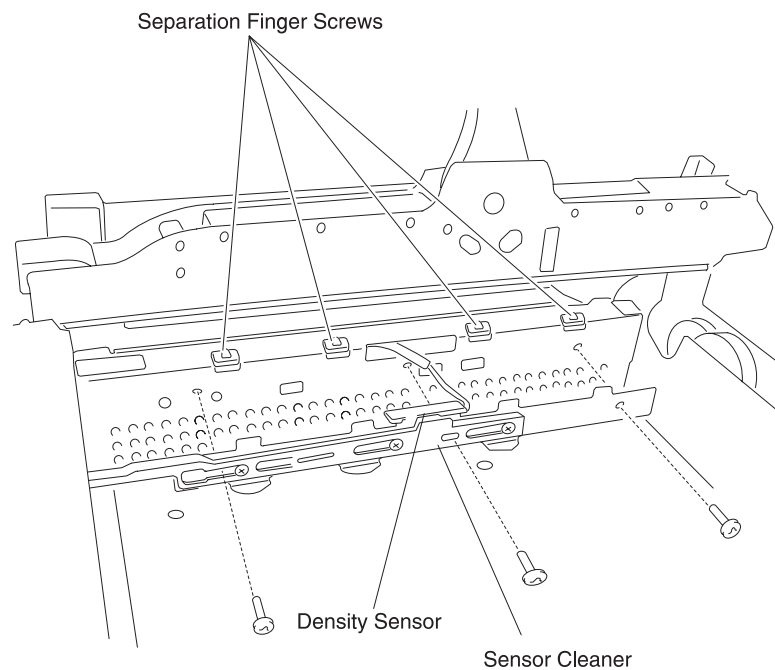

3. Remove the harness band and remove the two screws from the density sensor from the sensor bracket.
4. Remove the three set screws from the sensor cleaner assembly from the sensor bracket.
5. Remove the four separating finger screws from the fuser entrance guide.

## ***Drive gear unit sensor assembly removal***

1. Open the top unit, and remove the gear cover, RIP cover, RIP board, RIP box, electronic box, printer controller, and high voltage power supply board.
2. Remove the screw from the drive gear unit sensor assembly.

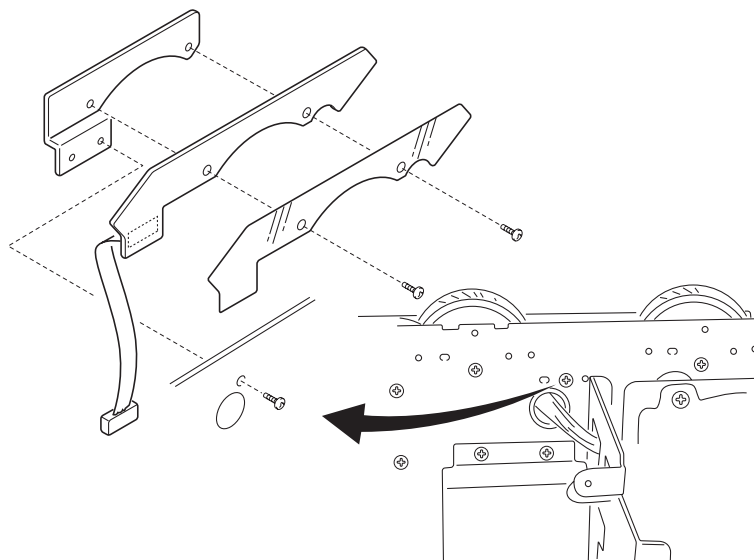

3. Remove the two screws of the drive gear unit sensor from the drum drive gear sensor assembly.

## ***Electronic box removal***

- 1.** Open the top unit, and remove the back cover.
- 2.** Remove the RIP board cover.
- 3.** Remove the RIP board.
- 4.** Remove the screws from the electronic box.

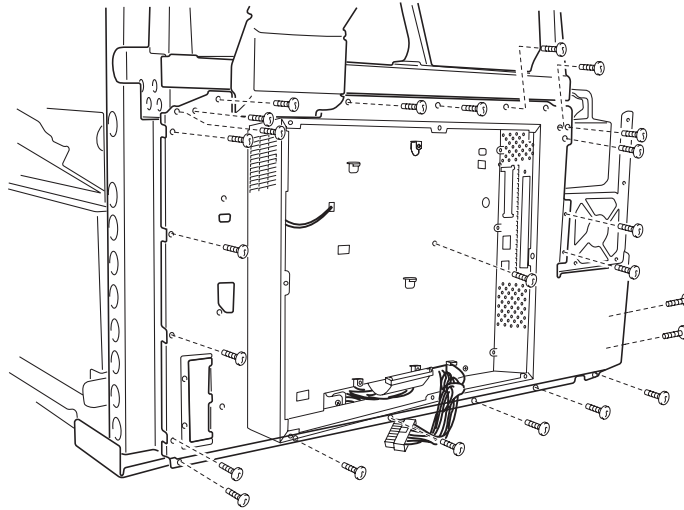

- 5.** Disconnect all cables from the rear of the electronic box, and remove the box.

### ***Face up paper exit assembly removal***

1. Open the top unit, and remove the upper cassette. Open the duplex cover, and remove the duplex unit.
2. Remove the left front cover, left side cover, and rear cover.
3. Remove the three screws from the face up delivery assembly, and remove the assembly.

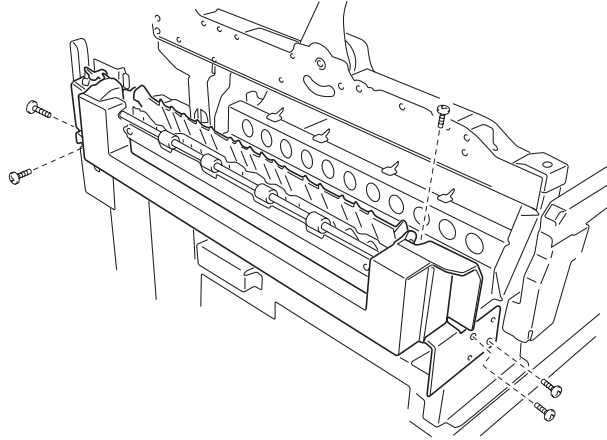

### ***Front cover open switch actuator removal***

1. Open the front cover.
2. Remove the two screws from the front cover open switch actuator.

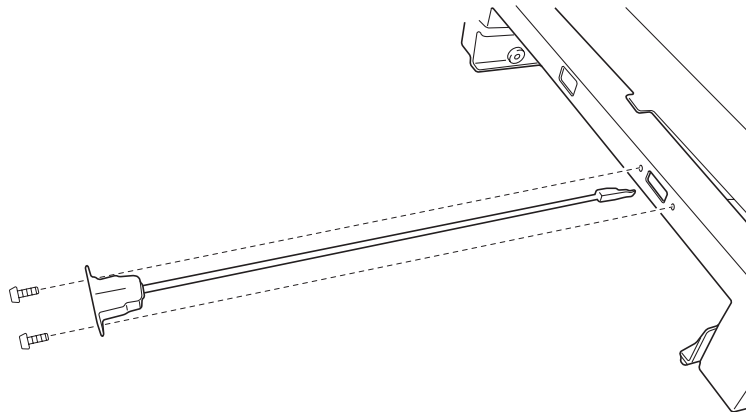

## ***Fuser removal***

1. Open the top unit.
2. Pushing the front and back lock, hold the handle, and then raise and remove the fuser.

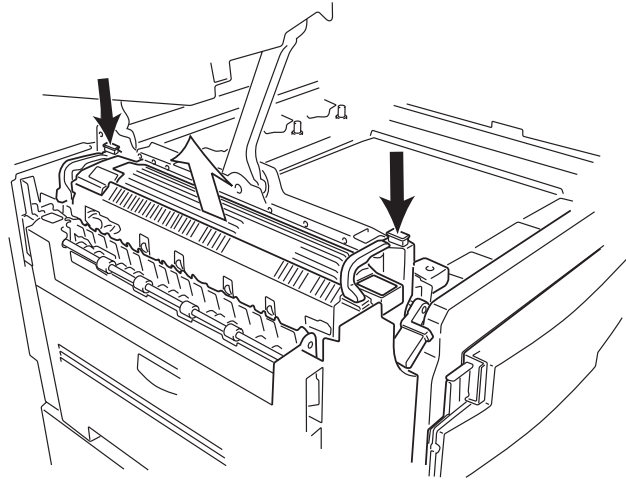

## ***Gear cover removal/Multipurpose feeder frame assembly***

1. Open the top unit, and remove the upper cassette, front cover, multipurpose feeder, right side cover, and turn guide.
2. Remove the two screws from the gear cover, and remove the cover.

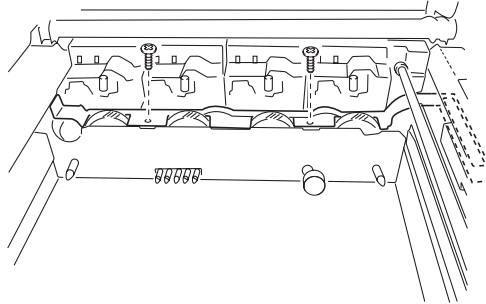

3. Remove the four screws from the multipurpose feeder frame and the ground screw.

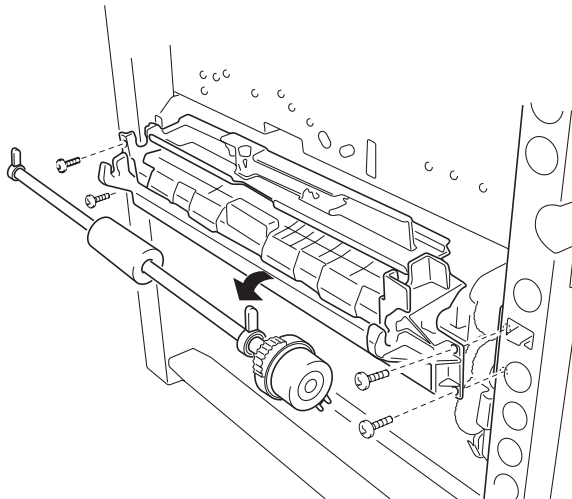

4. Disconnect the connector of the multipurpose feeder paper feed sensor.
5. Pull out the multipurpose feeder frame slightly.
6. Remove the screw from the OHP detection sensor (upper).

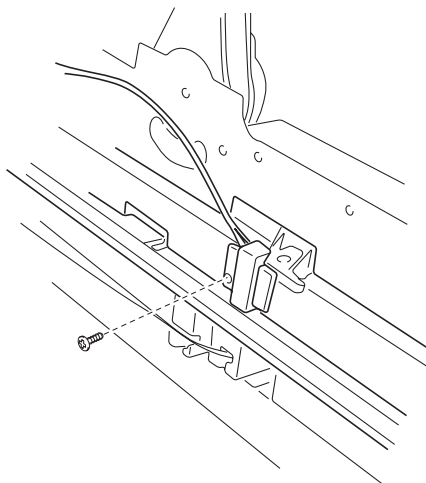

7. Turn the bearing stopper of the multipurpose feeder roll forward 1/4 turn, and remove upward.
8. Remove the multipurpose feeder frame assembly.

## High voltage power supply board (HVPS) removal

**Note:** When removing the high voltage power supply, be careful to avoid damaging the secondary daughter card (Q906). If the daughter card gets damaged, a 925 service error will result.

1. Open the top unit, and remove the RIP cover, RIP board, RIP box, electronic box, and printer controller board.
2. Remove the five screws from the printer controller board bracket.
3. Remove the connectors, and then remove the 12 screws.
4. Remove the HVPS board.

**Note:** After replacing any board on the printer, ensure all the connections are properly connected before closing the covers.

## LED printhead removal

1. Open the top unit, remove the top cover, toner cartridges, and photodeveloper drum units.

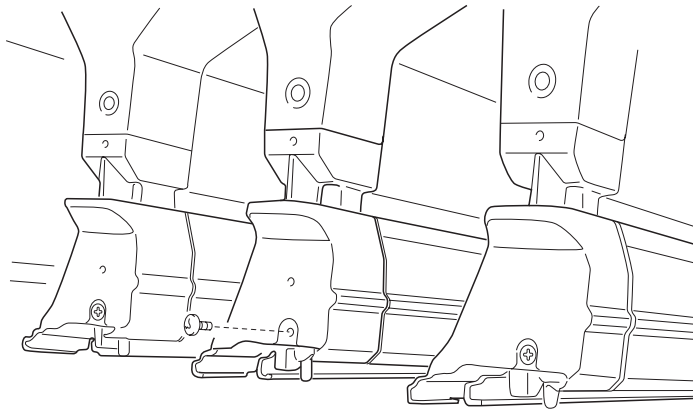

**Note:** Remove the transfer belt, or spread a cloth or paper over the transfer belt to protect it from damage.

2. Remove the short black screw from the printhead holder, and remove the holder.
3. Remove the front and rear printhead springs.
4. Remove the two screws (front and rear) from the right slide rail, and remove the rail.

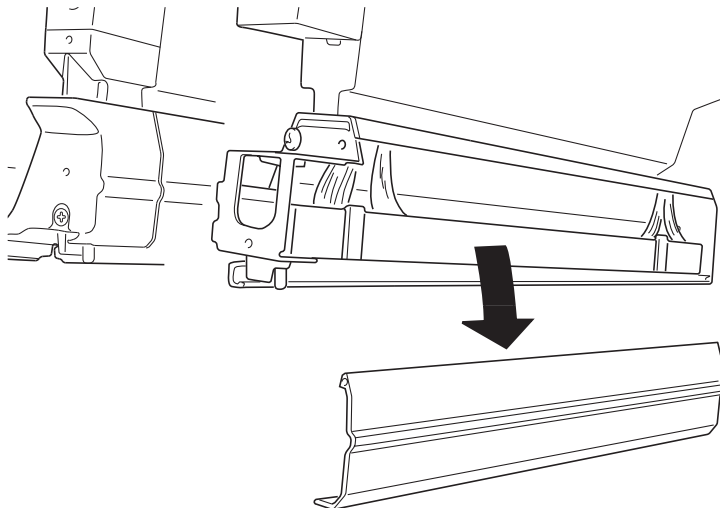

**Note:** When replacing the rail, be sure to use the short black screw. A longer screw can interfere with the LED head causing the image to be out of focus.

5. Disconnect the affected LED printhead connectors from the printhead controller board. Remove the screw from the ground wire located on the LED printhead.

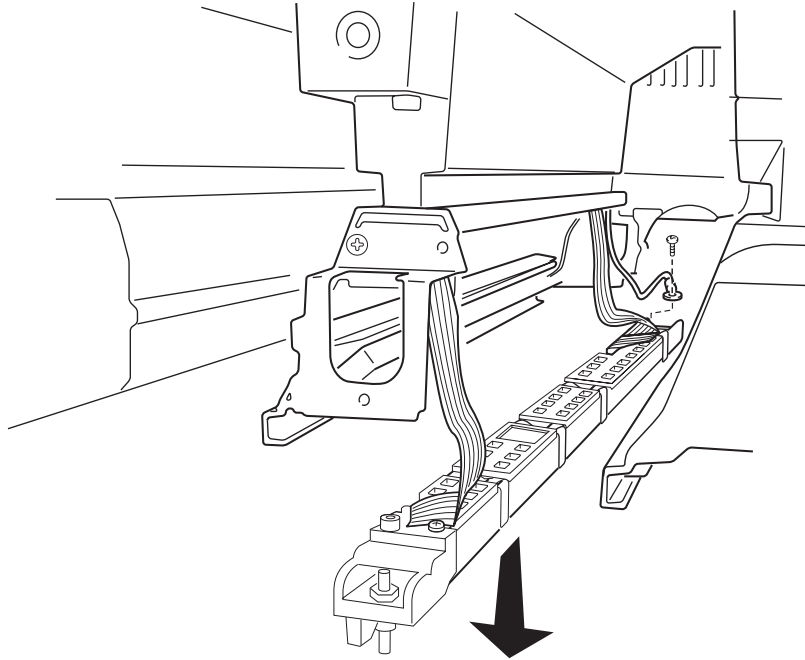

6. Remove the LED printhead and the cables from the printer.  
When replacing the LED printhead, replace the corresponding EEPROM, shipped with the printhead, on the printhead controller board.  
**Note:** The LED printhead light intensity values do not have to be entered for the printer.

### ***Eraser removal***

1. Remove the appropriate printheads (see **“LED printhead removal”** on page 4-20). Spread a cloth over the transfer belt to protect it from damage.
2. Remove the two screws from HSP holder, and remove the holder.

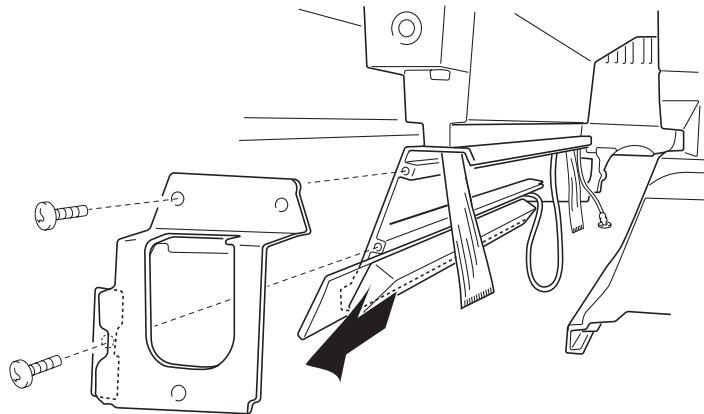

3. Remove the top cover.
4. Disconnect the eraser cable from the printhead controller board.  
C- CN06  
M- CN05  
Y- CN07  
K- CN08
5. Carefully thread the eraser cable through the upper unit and remove the eraser.

## ***Lock handle assembly removal***

1. Open the top unit.
2. Turn the plastic latch on the front and rear sides 90°.
3. Remove the spring.
4. Remove the lock handle assembly.

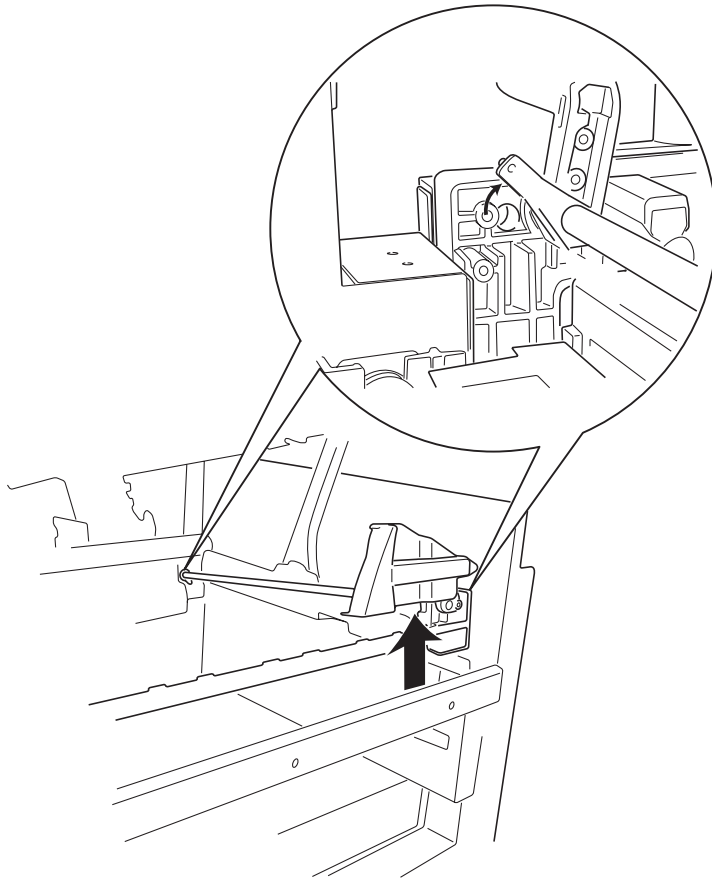



## Main drive unit removal

1. Open the top unit, and remove the gear cover, upper cassette, left front cover, paper feed cover, RIP cover, RIP board, RIP box, electronic box, and rear cover.
2. Open the turn guide and paper feed cover, and remove the duplex unit.
3. Remove the left side cover, power unit 1, and power unit 2.
4. Remove the printer controller board.
5. Remove the bracket, HVPS board, and sub frame R.
6. Remove the fuser unit, face up paper delivery unit, belt up/down clutch, and DC drive motor.
7. Remove the multipurpose feeder roll, registration roll, and paper carrying frame.
8. Remove the eight screws from the power supply 2 bracket.
9. Remove the two screws from the belt power supply 2.
10. Remove the two screws from the fan bracket.
11. Remove the three screws from the fuser connector plate.

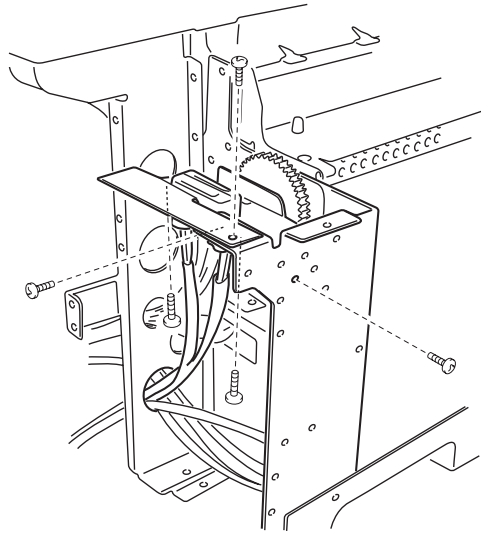

12. Remove the two screws of the fuser connector cable assembly from the fuser connector plate.

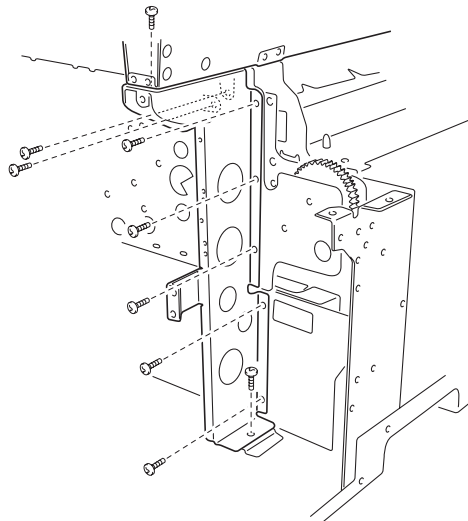

**Note:** Note the direction, when installing.

13. After removing the two screws on the bracket that attaches the rear side and paper exit side of the machine, remove the nine screws from the bracket.

- 14.** Remove the screw from the clutch stopper. The clutch stopper is attached to the ground plate with two screws.

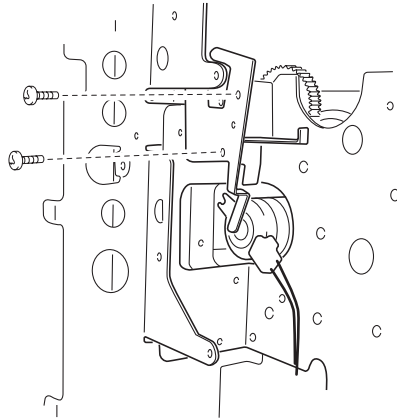

- 15.** Remove the six screws on the right side.

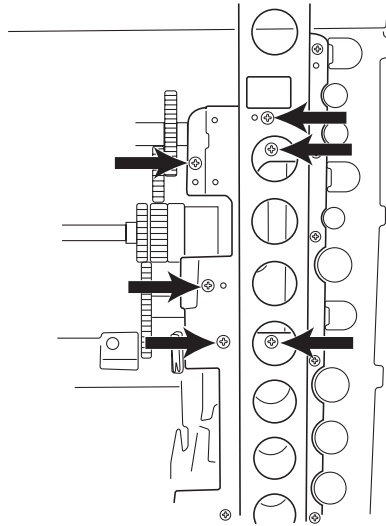

- 16.** Remove the two screws from the drive unit, and remove the unit.  
**17.** Remove the E-clip on the belt up/down clutch, and remove the changing shaft from the drive unit.  
**18.** Remove the three screws from the belt up/down clutch box, and remove the belt up/down clutch.

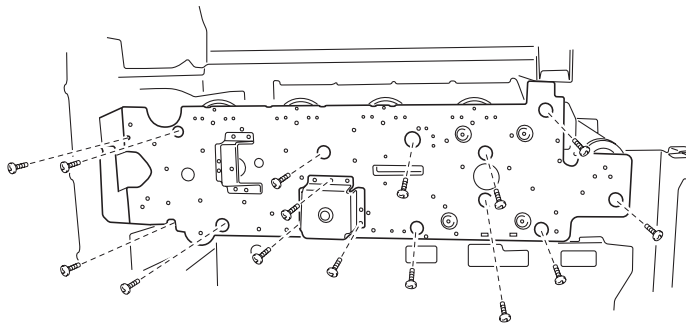

- 19.** Remove the screw from the drum gear sensor, and remove the sensor.

### **Main unit fan removal**

1. Remove the left side cover, the solenoid cover, and the rear cover.
2. Remove the LVPS (low voltage power supply) 1.
3. Remove two screws from the main unit fan bracket.

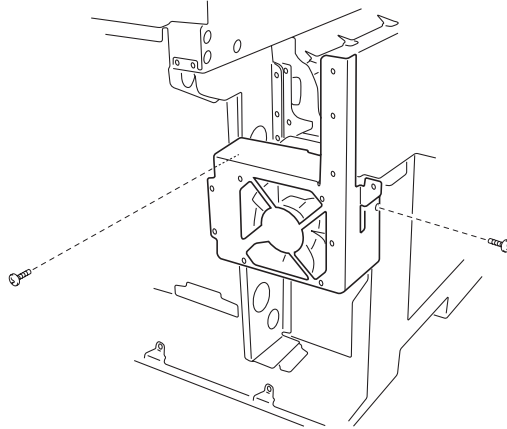

4. Disconnect the fan power cable from CN6 on the CK2 daughter card board.
5. Remove the fan.

### **Motor drive board removal**

1. Remove the upper cassette, front cover B, paper feed cover, and the left side cover.
2. Disconnect the five connectors, remove five screws, and remove two screws from the motor drive board.

### **Multipurpose feeder paper present sensor removal**

1. Open the top unit and remove the upper cassette, front cover, turn guide, multipurpose feeder, right side cover, turn guide, and multipurpose feeder frame.
2. Disconnect the connector and remove the multipurpose feeder paper present sensor.

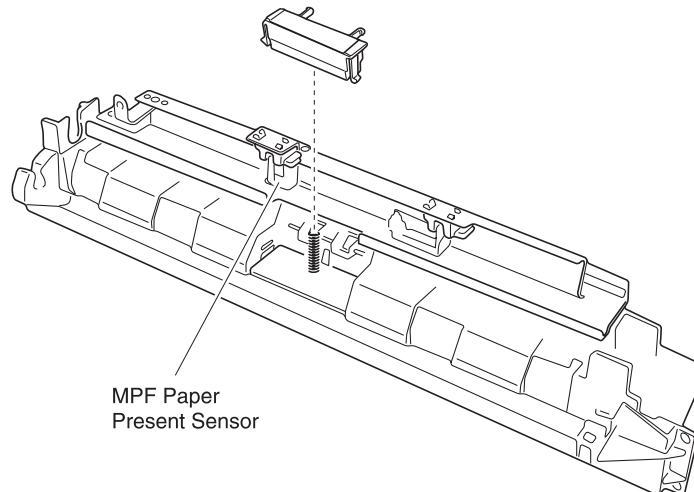

## ***Multipurpose feeder tray removal***

1. Open the top unit, and remove the front cover, cassette feeder, turn guides and right side cover.

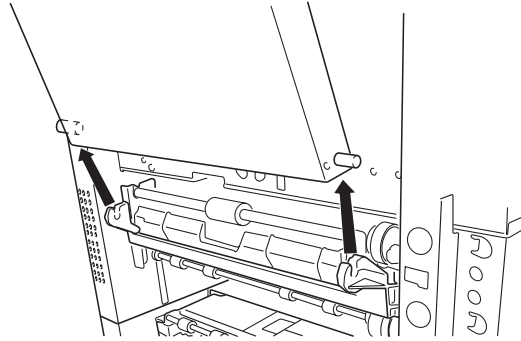

2. Open the multipurpose feeder and slide it toward the magnet in the direction of the arrow, removing it from the printer.

## ***Paper feed unit removal***

1. Remove the front, right, left rear, and rear covers.
2. Remove the printer controller board and HVPS board.
3. Unplug connectors CN23, CN16, CN10, CN20, CN12, CN15, and CN7 on the CK1 daughter card board.
4. Remove the e-clip and bushing (A) from the paper feed clutch.
5. Remove four screws (B) from the paper feed gear unit.

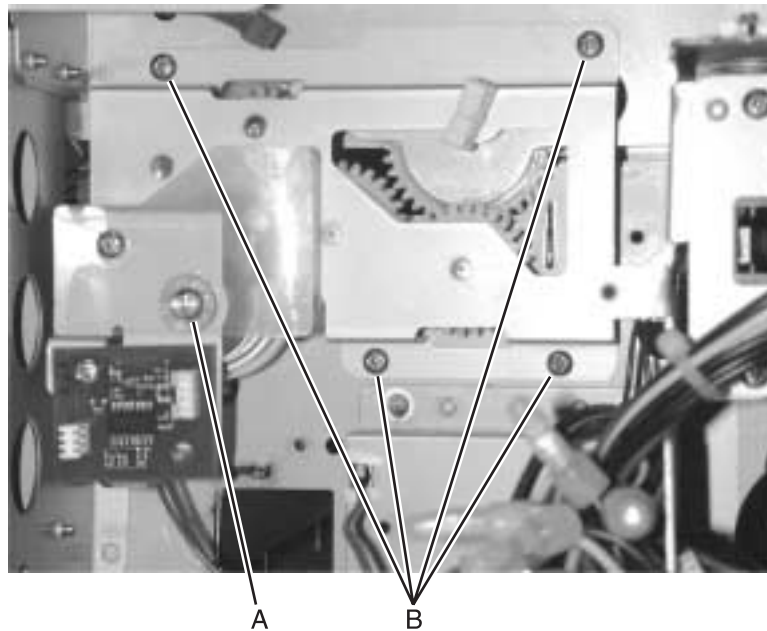

6. Remove the paper feed gear unit, paper feed clutch, and two gears (C) not held in place with an E-clip.

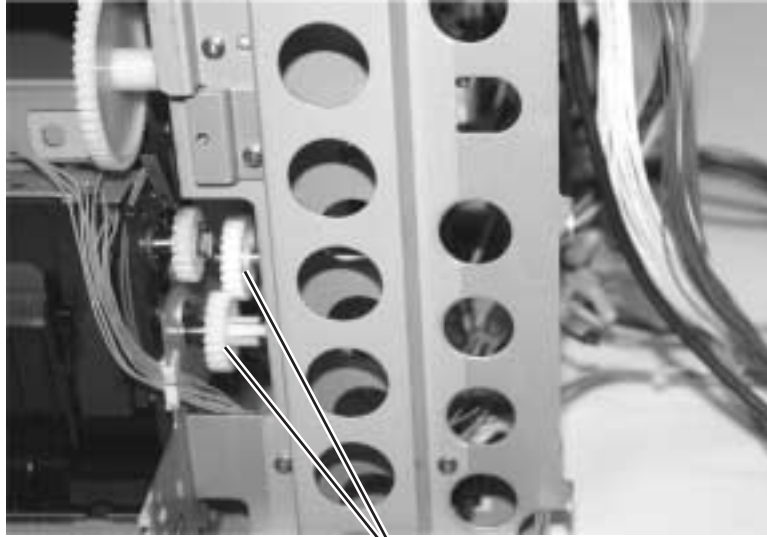

A

7. Remove the 3 screws (D), and remove the cassette guide.

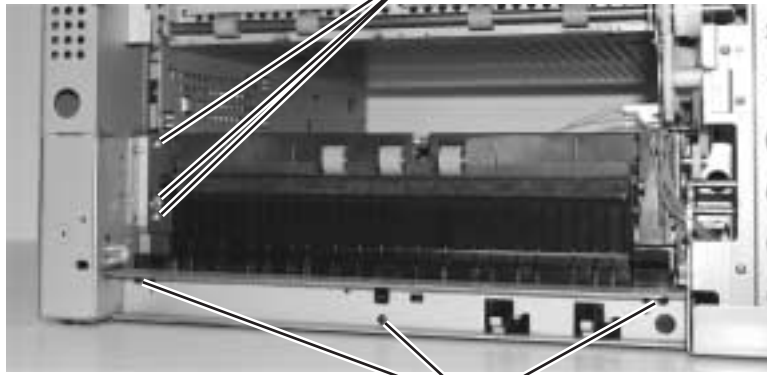

B

A

8. Remove the brass screws (E) on the left side of the paper feed unit.  
9. Remove the paper feed unit, being careful to route the sensor cabling through the wire guides.

## Paper-feed rollers removal

### Paperpath maintenance

A paper path maintenance kit can be used when a machine is experiencing misfeeds and jams after 200,000 pages. The order number for this kit is 40X1109. The kit is composed of the following parts:

56P9683	Carrying roller
40X1154	Registration frame
40X1077	Pickup roll
40X1078	Paper feed roll
40X1079	Separator roll
40X1064	FD paper exit roller

In addition to the paper-path maintenance kit, the relay roller (40X1108) and turn guide rollers (40X1072) can be ordered.

**Note:** This removal can be used for the expansion paper feed roller removal. Do not discard the white plastic retaining clips. They will be needed to attach the new rollers.

1. Turn off the printer, and unplug the power source.
2. Remove the paper cassette.
3. Pull back on the tab, and remove the pickup roller (A). **Pickup roller art here**  
**Note:** There is a small blue tab on the pickup roller.
4. Remove the white plastic retaining clip from the shaft, and slide the paperfeed roller (B) off the shaft.
5. Remove the white plastic retaining clip, and slide the separator roller (C) off the shaft. The torque limiter (D) can be removed by sliding off the shaft if it needs replacement.

## ***Paper carrying frame removal / roll removal***

1. Open the top unit, and remove the upper cassette, front cover, turn guide, multipurpose feeder, right side cover, turn guide, OHP detection sensor (upper), multipurpose feeder frame, back cover, RIP cover, RIP board, RIP box, and electronic box.
2. Remove the four screws from the paper carrying frame.

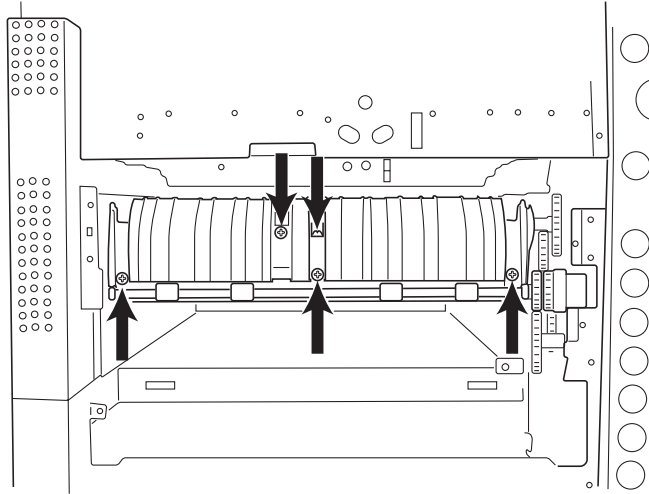

3. Remove the paper carrying frame.

**Note:** When installing, the clip of the paper carrying clutch should be securely set to the stop, and the shaft of the paper-carrying clutch and spring should be securely in contact with one another.

4. Remove the carry clutch and plastic bushing on the left side of the carrying frame.
5. Remove the E-clip and bushing on the right side of the carrying frame.
6. Remove the carrying roller.

## Registration frame

### Registration clutch removal

1. Open the top unit, open the turn guide, open the paper feed cover, and pull out the duplex unit halfway.
2. Remove the two screws from the registration frame.

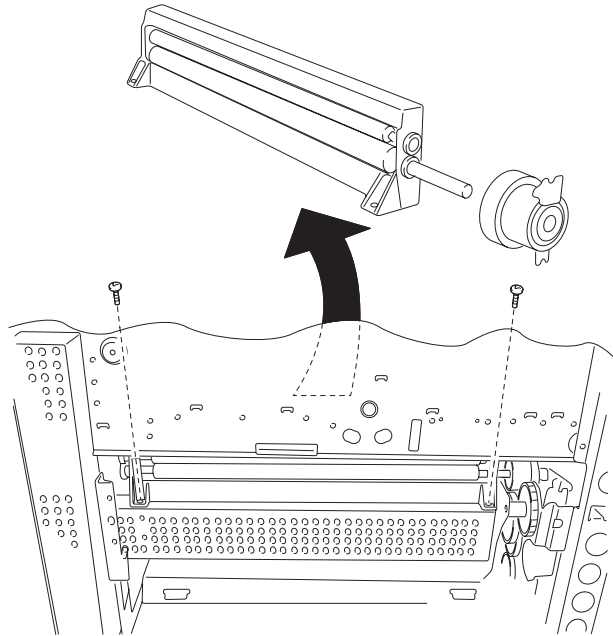

3. Remove the registration clutch.

**Note:** When installing, set the clip of the registration clutch to the stopper.

### Registration sensor removal

1. Open the top unit, and remove the upper cassette, front cover, turn guide, multipurpose feeder, right side cover, and multipurpose feeder frame.
2. Disconnect the connector of the registration sensor, and remove the sensor.

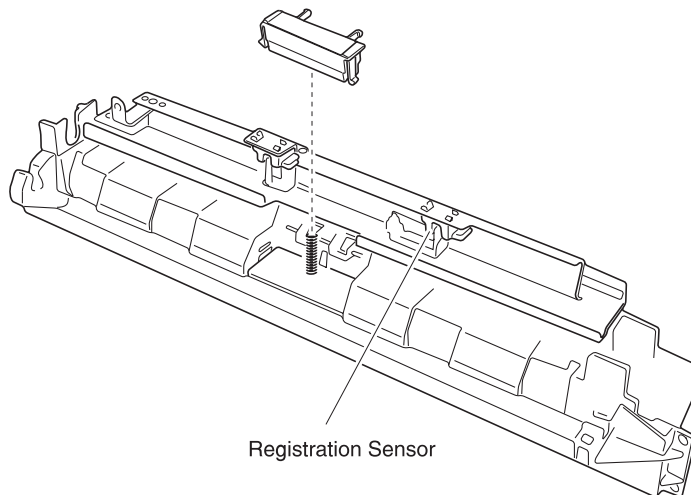



## Relay roller removal

**Note:** This removal can be used for the expansion paper-feed unit relay roller removal as well.

1. Remove the paper feed unit from the machine.
2. Remove the e-clips and bushings from each end of the relay roller shaft.
3. Remove the five screws (A) that hold the top metal plate on the unit.

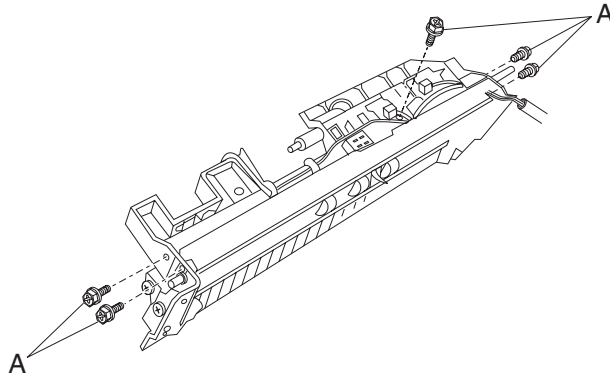

4. Remove the top plate from the paper-feed unit.
5. Slide the relay roller to the right (B), and tilt the roller up and out of the unit.

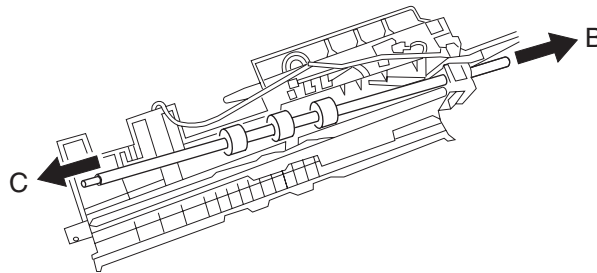

6. Pull the relay roller to the left (C), and remove the roller from the paper-feed unit.

## Face down guide assembly removal

1. Remove the top cover.
2. Disconnect the connector, and remove the five screws and two snap bands from the face down guide assembly.

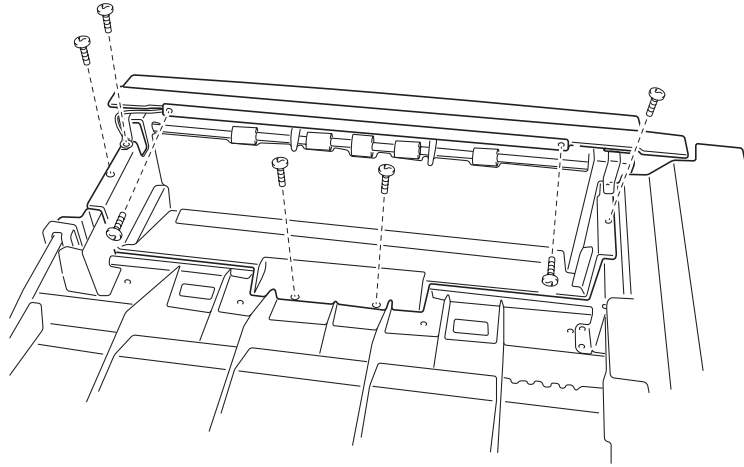

3. Remove the four screws from the face down cover and the face down guide assembly, and remove the assembly.

**Note:** When replacing the face down unit, use a tie to hold back the wiring that connects the printer controller board to the face down unit. Avoid pinching or cutting wiring that connects the face down unit to the printhead controller board.

## Face down exit roll removal

**Note:** When replacing the face down exit roller, lubricate the ends of the roller shaft with a small amount of Nyogel 744 (part number 40X0179). Open the top unit, and remove the toner cartridges, photodeveloper drum units, and upper cover.

1. Remove the face down unit from the printer.
2. Remove the three screws (A) that hold the rear cover to the face down unit.

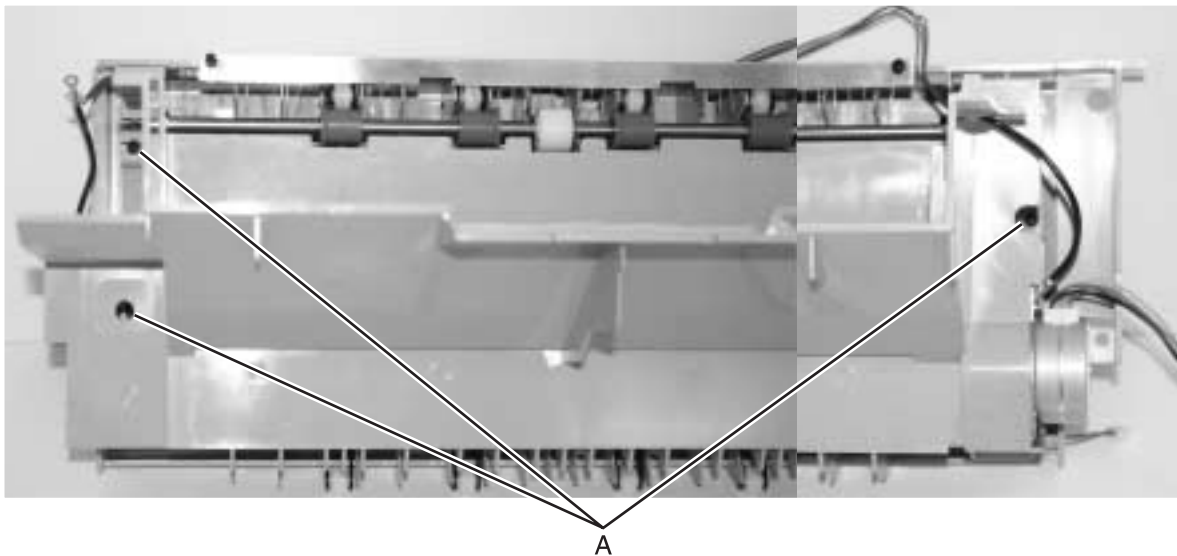

3. Remove the rear cover.



4. Remove the motor and drive belt from the exit roller shaft.
5. Remove the grounding strip (A).

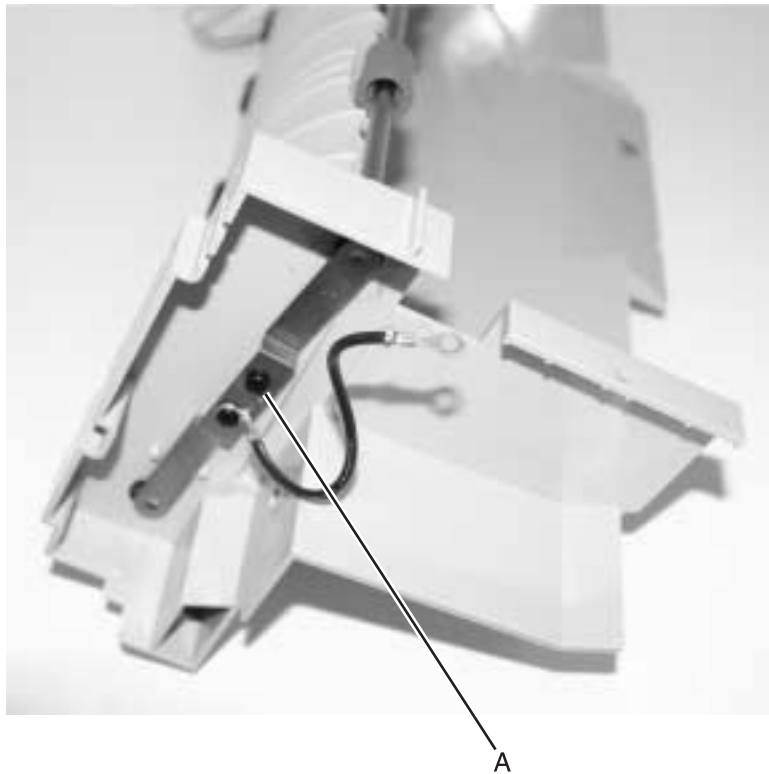

6. Remove the e-clips and bushings (A) from both ends of the exit roller shaft.

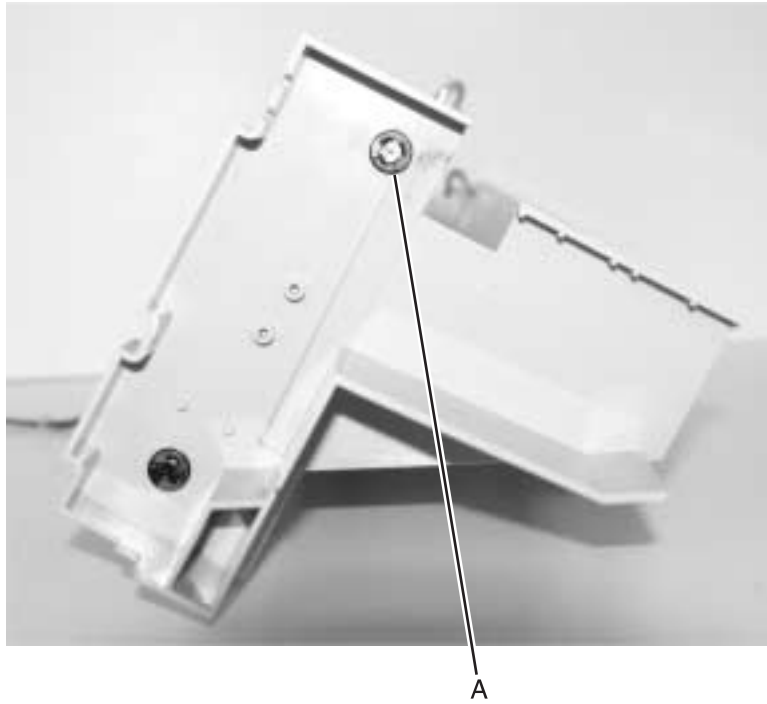

7. Pull the guide rib (A) to the left.

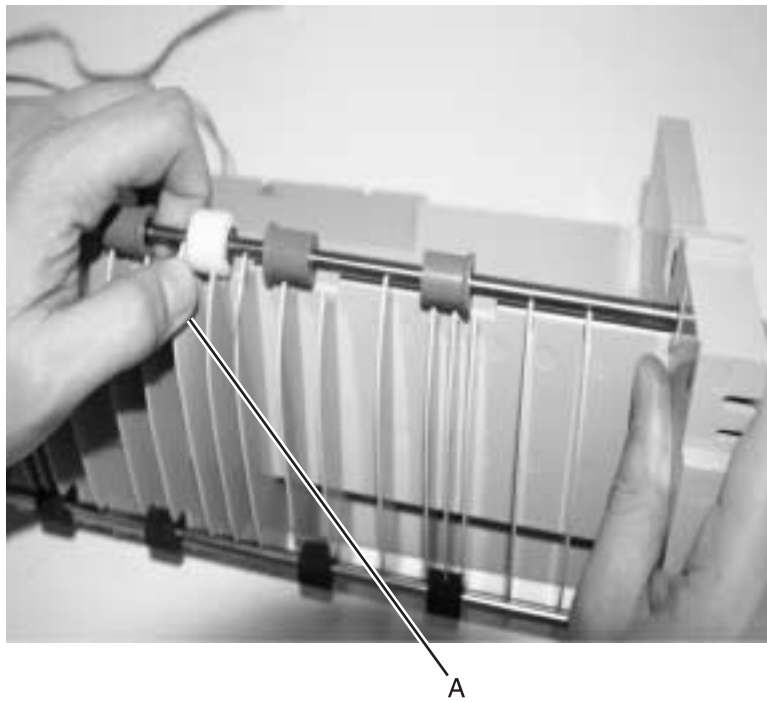

8. Remove the exit roller.

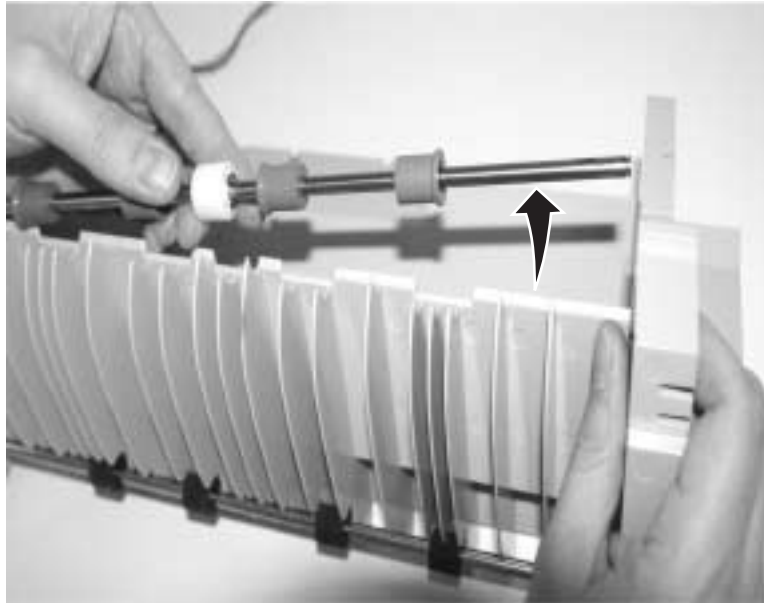

### ***Power supply 1 removal***

1. Unplug the power cord from the printer.
2. Open the top unit, and remove the RIP cover, RIP board, RIP box, and electronic box. Remove the cassette, left front cover, and back cover. Remove the left side cover.
3. Remove the insulation sheet connector, yellow ground wire, five screws, two screws with washers, and two screws with spring washers.
4. Disconnect CN106 and CN04 at power supply 2.
5. Remove the power supply.  
**Note:** When installing, incline the ground wire by 45°.

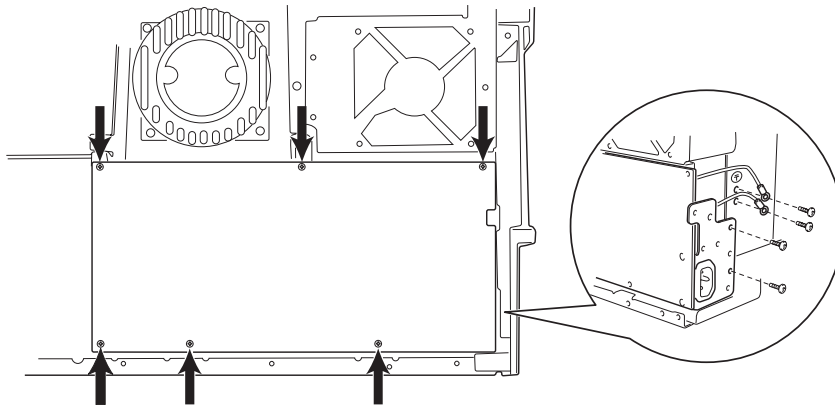

**Note:** After replacing any board on the printer, ensure all the connections are properly connected before closing the covers.

## Power supply 2 removal

1. Unplug the power cord from the printer.
2. Open the top unit, and remove the RIP cover, RIP board, RIP box, and electronic box.
3. Disconnect the connector, and remove the seven screws from power supply 2, and remove the power supply.

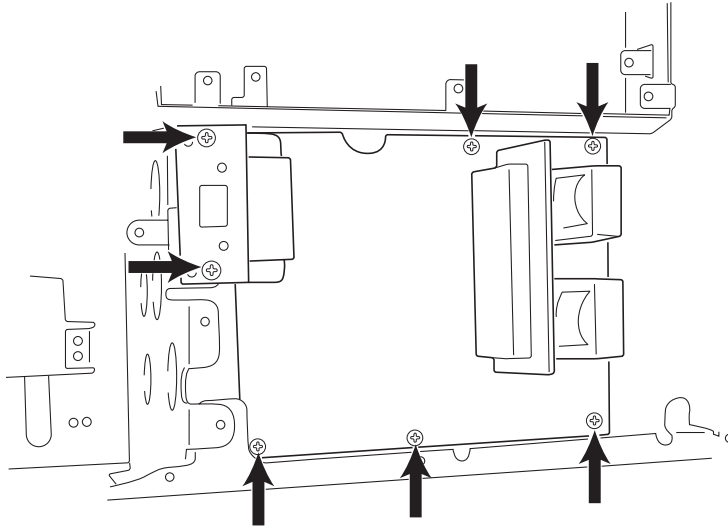

**Note:** After replacing any board on the printer, ensure all the connections are properly connected before closing the covers.

## Power switch removal

1. Remove the upper cassette, left front cover, paper feed cover, and left side cover.
2. Unlock the power switch, and pull out the power switch.

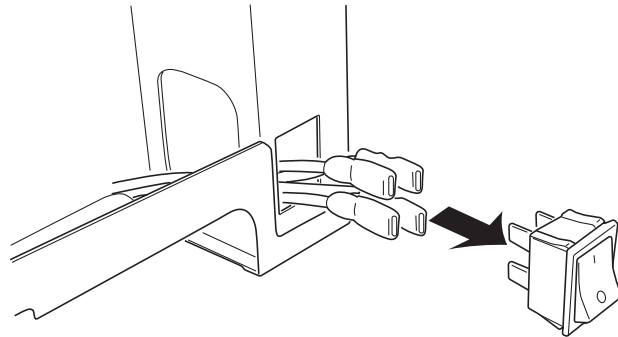

3. Remove each terminal connected to the power switch.

**Note:** When connecting, be careful to connect the connectors correctly. Insert the insulator cover, completely covering the terminal.

## Printer controller removal

1. Open the top unit, and remove the RIP cover, RIP board, RIP box, and electronic box.
2. Remove the connectors and the screws from the printer controller. Pay attention to the location, or label the two pin connectors when removing them from the board to avoid reconnection into the wrong location.

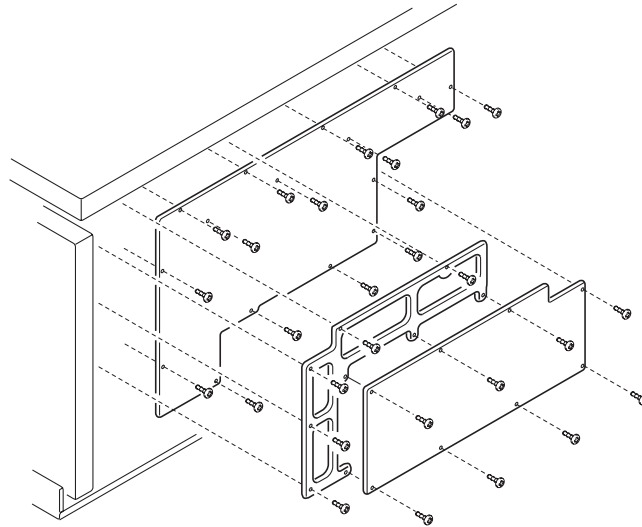

When replacing the board, install the EPROM (U7) of the former board to the new board. Also, when replacing the EPROM, set the light intensity in the diagnostic mode, and set the counter and printer alignment.

**Note:** After replacing any board on the printer, ensure all the connections are properly connected before closing the covers.

## Printhead controller board removal

1. Remove the top cover, and then remove the 20 printhead controller board connectors.
2. Remove the six screws from the printhead controller board and remove the board.

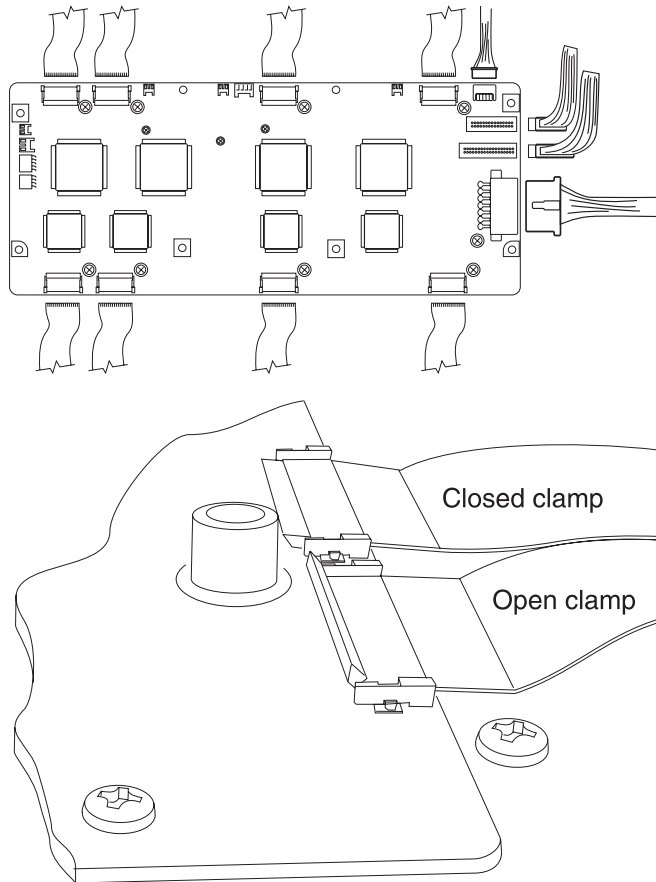

**Note:** When replacing the board, be sure to return the four EEPROMs on the former board to the same positions on the new board.

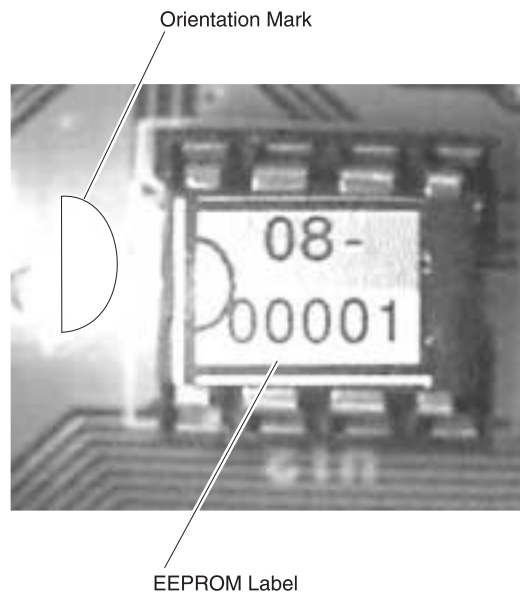



### ***Left slide rail removal***

1. Remove the upper cassette.
2. Remove the screw from both left and right slide rails.

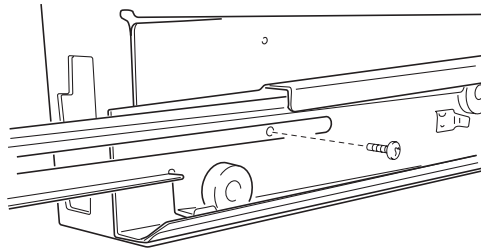

### ***RIP box removal***

1. Remove the six screws from the RIP box.

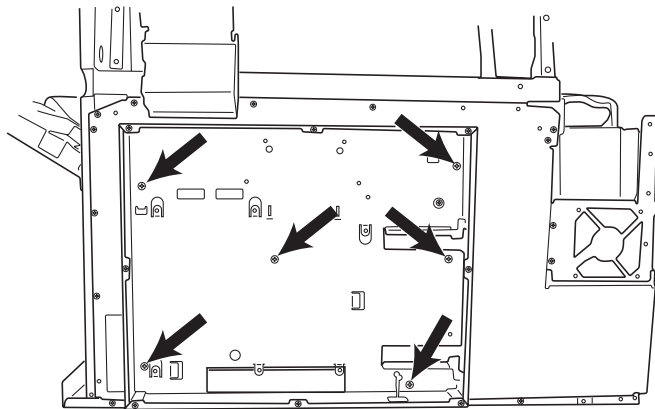

2. Slightly lift and remove the RIP box.

## **Sensor board removal**

1. Remove the transfer belt unit.
2. Remove the four connectors.
3. Remove the three screws from the waste toner full sensor board.

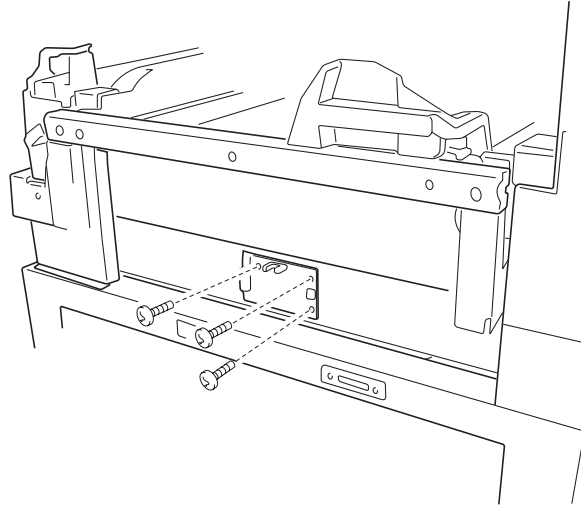

## **Stay arm removal**

1. Open the top unit, and remove the face down paper guide assembly.
2. Remove the yellow and black sub frame.
3. Remove the screw from the right stopper, and remove the stopper.

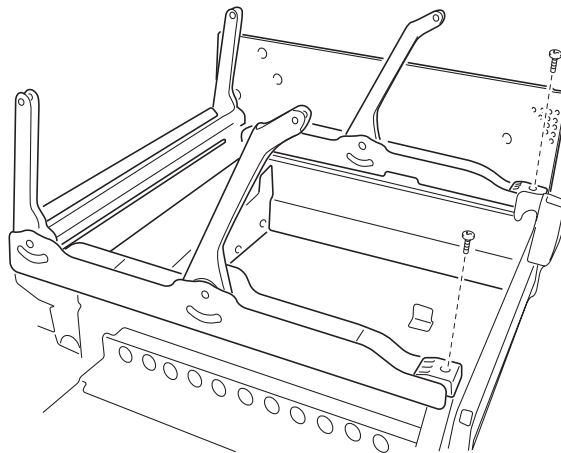

4. Remove the screw from the left stopper, and remove the stopper.
5. Remove the clip from the lock shaft.
6. Remove the 17 screws from the stay arm, and remove the arm.

## Sub-frame removal

**Important:** Read the entire procedure before removal.

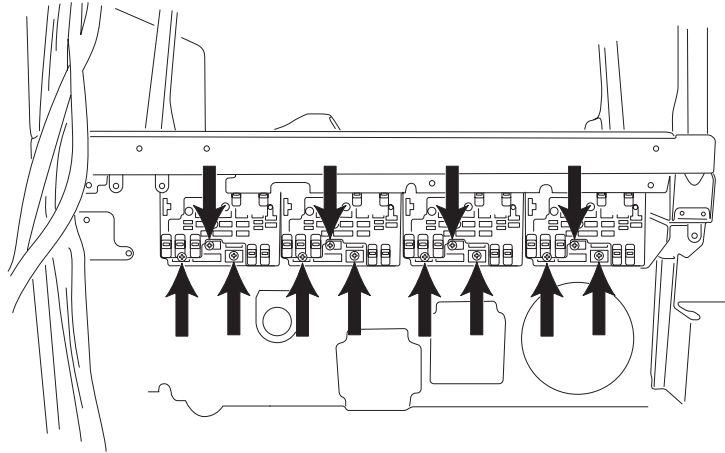

1. Open the top unit, and remove the RIP cover, RIP board, RIP box, electronic box, printer controller, printer controller bracket, and HVPS board.
2. Remove the cable ties.
3. Remove the 12 screws from the sub frame.
4. Remove sub frame.

## Sub frame F1, sub frame F2 removal

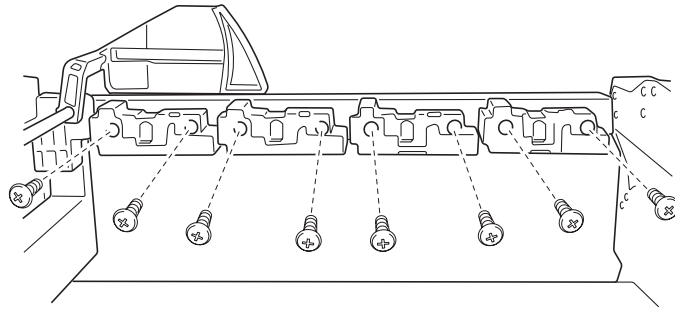

1. Open the top unit.
2. Remove the two screws from the sub frames F1 and F2.  
**Note:** Spread a paper or cloth over the belt to protect the belt. Set the sub frame F to the position of the following colors, depending on the presence of the upper detection buttons.

Magenta	Sub frame F1	Detection button available
Cyan	Sub frame F2	Detection button unavailable
Yellow	Sub frame F1	Detection button unavailable
Black	Sub frame F2	Detection button available

## Temperature/humidity sensor removal

1. Remove the rear cover, printer controller board, and HVU board.
2. Disconnect the cable from connector on the temperature humidity sensor.

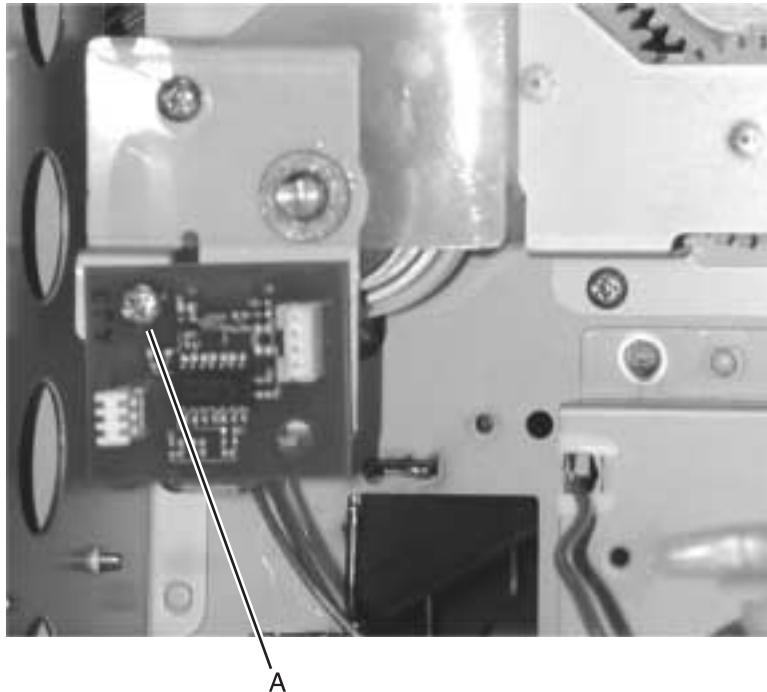

3. Remove the screw (A) holding the sensor to the paperfeed gear linkage.
4. Remove the temperature/humidity sensor.

## ***Top unit removal***

1. Open the top unit, and remove the top cover and face-down guide assembly.
2. Remove the screws, and remove the top unit.

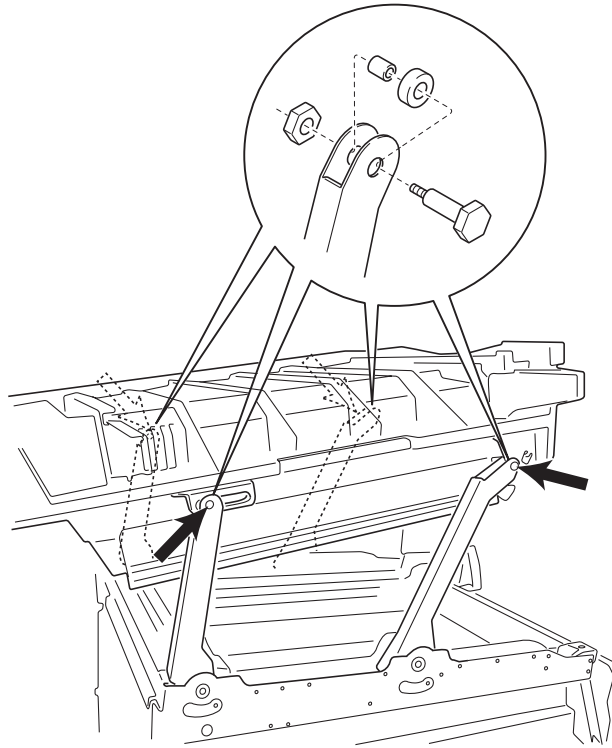

## ***Transfer belt removal***

Transfer belt removal has been simplified with a redesign of the changing shaft linkage to the belt up / down clutch. The supplies menu no longer needs to be accessed to remove the transfer belt unit.

**Note:** If the operator panel is inoperable, or if you have an unrecoverable error code, this procedure can still be used.

1. Turn the printer off, along with any optional devices connected to the printer.
2. Open the front cover and top unit.

**Warning:** Do not touch, drop, or place anything on the transfer belt. Touching the surface of the transfer belt or placing items on the belt may cause damage.

3. Loosen the thumbscrews as shown.

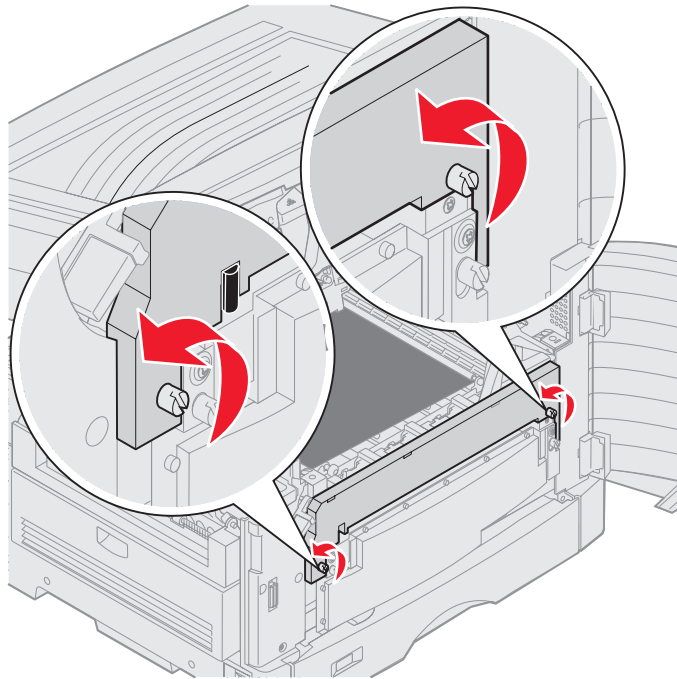

4. Lift and remove the transfer belt cover.

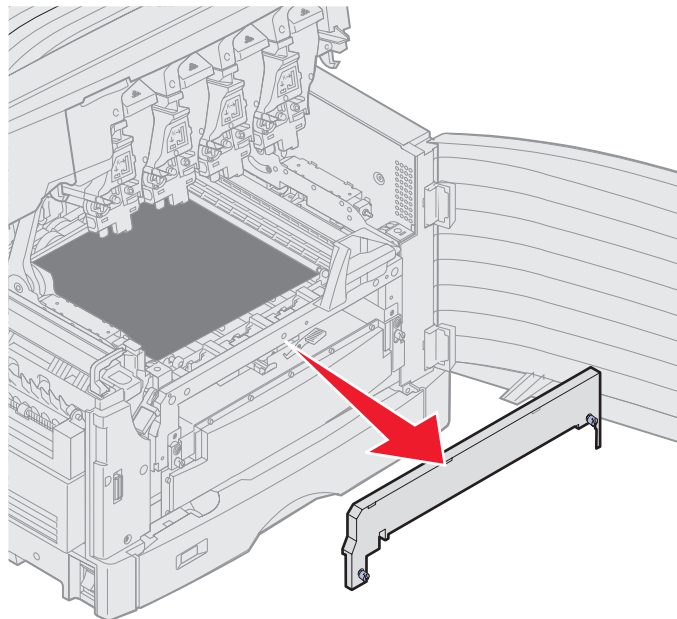

5. Loosen the thumbscrews as shown.

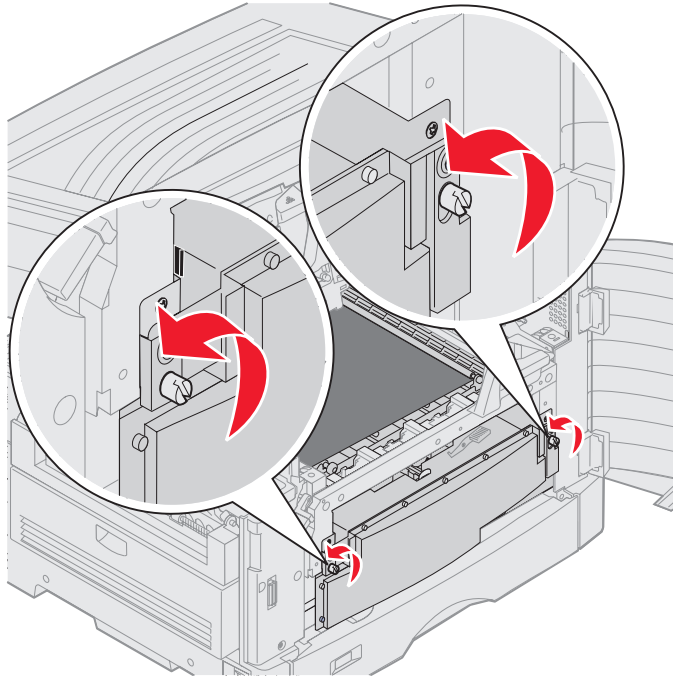

6. Press down on the transfer belt release lever as shown.

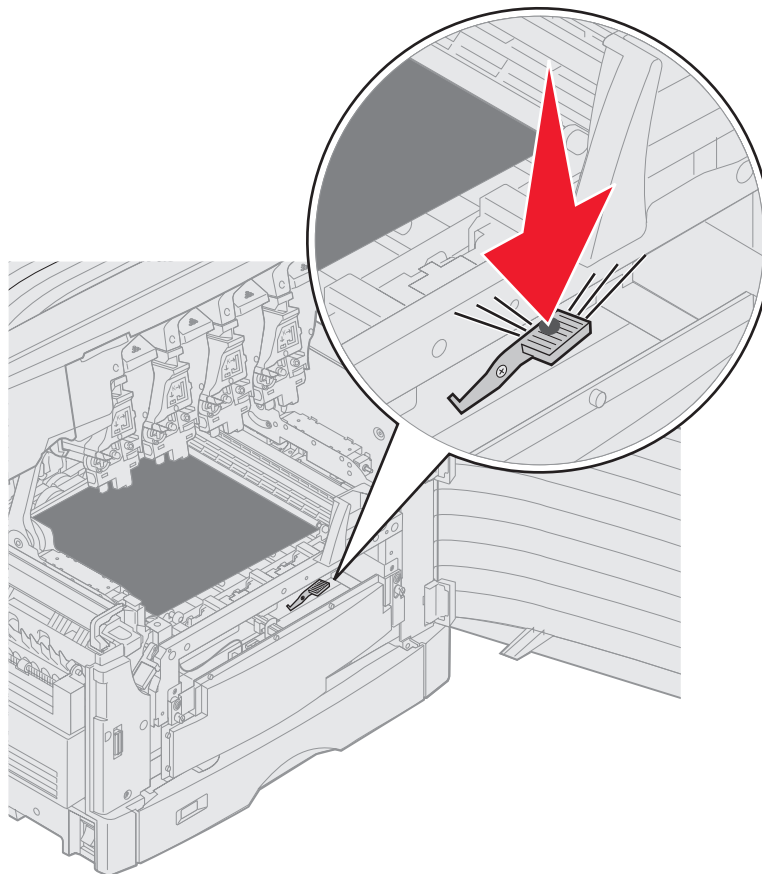

7. Pull the transfer belt out.

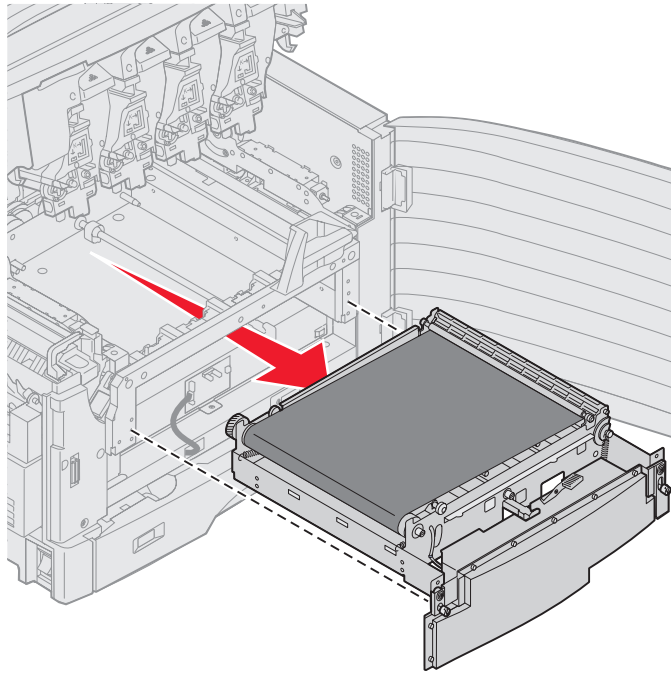

8. After replacing the transfer belt and removing the four shipping spacers, tighten the transfer belt thumbscrews, and reinstall the transfer belt cover.
9. Close the top unit, rotate the locking lever to the right, and close the front cover.
10. Turn the printer on.
11. Adjust the registration, if needed, by pressing the Menu key, scrolling to Settings, scrolling to Utilities, and selecting Alignment Info. From here, you can adjust the settings for the belt. Print an alignment page to confirm that the belt is properly adjusted. Perform further adjustments if needed.

**Note:** The belt adjustment can be adversely affected by a toner low condition.



### ***Turn guide cover sensor removal***

1. Remove the left rear, rear, and right covers.
2. Remove the print controller card and the HVPS.
3. Disconnect the sensor cable from CN10 on the CK1 daughter card board.
4. Remove two screws from the turn guide sensor assembly, and remove the sensor.

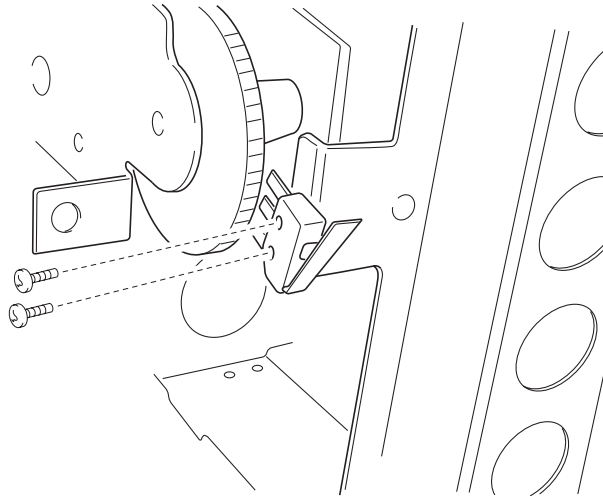

### ***Upper fan removal***

1. Open the top unit, and remove the toner cartridges and photodeveloper drum units, top cover, and face-down guide assembly.
2. Remove the four screws and the five screws from the upper bracket, and remove the bracket.

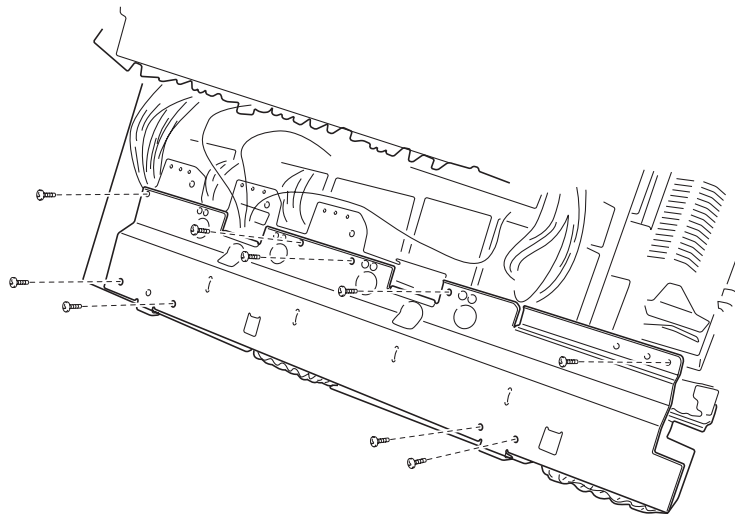

3. Remove the two screws from the left fan, and remove the fan.

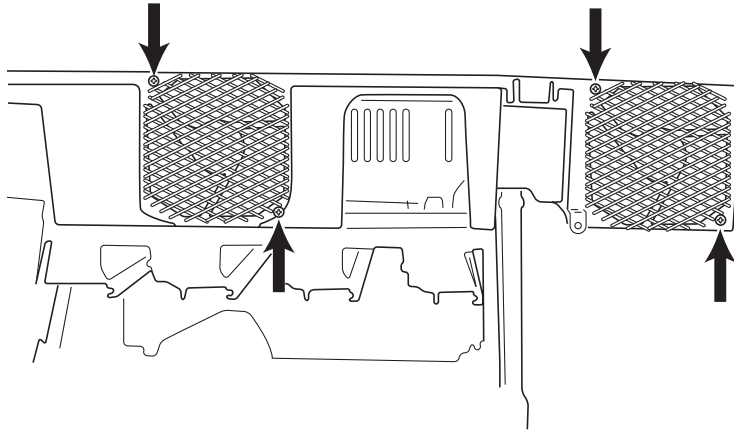

4. Remove the two screws from the right fan, and remove the fan.

---

## Expansion feeder removals

### *Turn guide door removal*

1. Open the turn guide door.
2. Pull the door hinge from the right turn guide bushing.
3. Pull the turn guide door clear of the expansion feeder.

### *Expansion feeder controller board removal*

1. Remove six screws from the expansion feeder rear cover.
2. Unplug all cables from the expansion feeder controller board.
3. Remove six screws from the controller card.

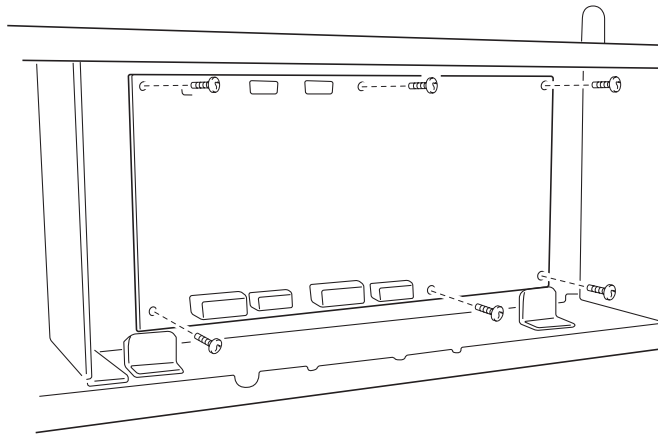

4. Remove the controller board.

**Note:** After replacing any board on the printer, ensure all the connections are properly connected before closing the covers.

### *Size sensor board removal*

1. Remove the expansion feeder controller board.
2. Remove two screws on the size sensor board.

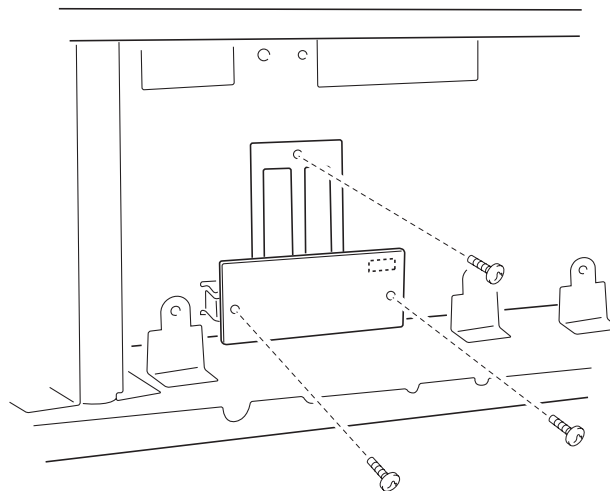

3. Remove the size sensor board.

## Stepper motor removal

1. Remove the expansion feeder rear cover.
2. Disconnect the stepper motor power cable from the expansion feeder controller board.
3. Remove three screws from the stepper motor assembly (A).

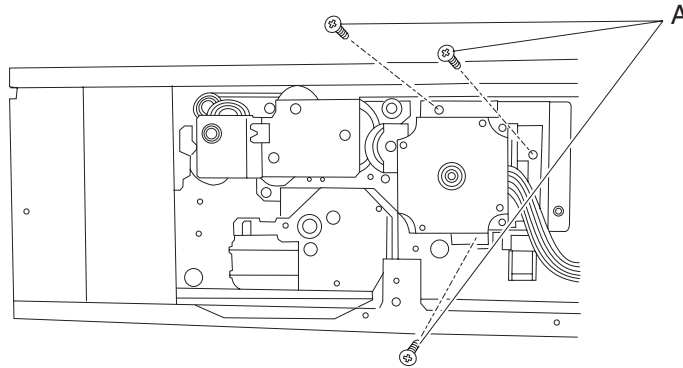

4. Remove the stepper motor assembly from the expansion feeder.

## ***Paper feed assembly removal***

1. Remove the rear cover.
2. Remove the cassette.
3. Remove the stepper motor assembly.
4. Disconnect the cables from connectors CN11, CN13, CN18 on the expansion feeder controller board.
5. Remove the screws (A) holding the paper feed gear assembly.
6. Remove the gear assembly (B) and the paper feed clutch (C).
7. Remove three gears from the paper feed unit.

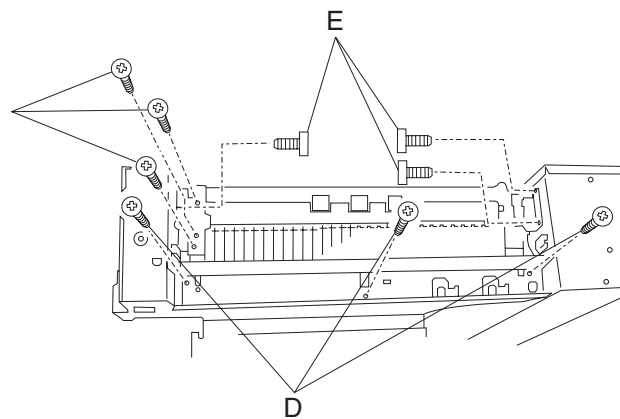
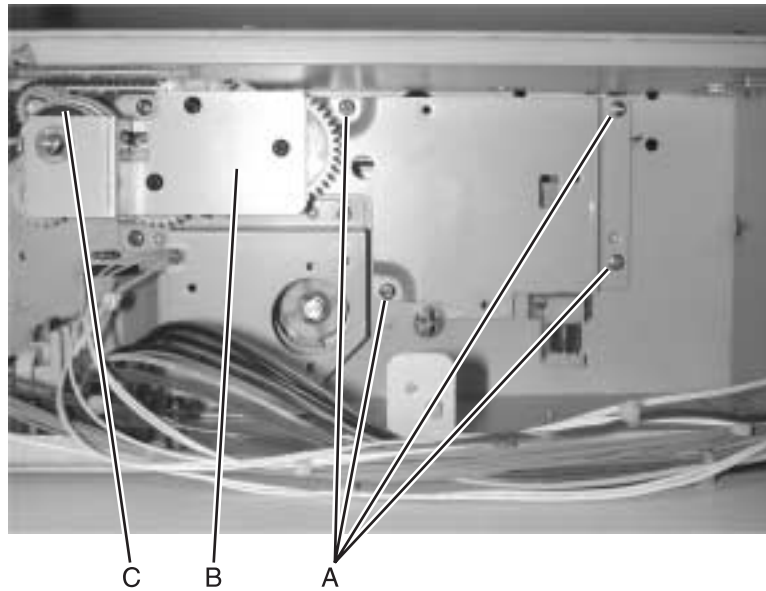

8. Remove the three cassette guide screws (D).
9. Remove three screws (E)
10. Remove three screws from the left side of the paper feed unit (F).
11. Feed the sensor cables through the side. Use care to avoid damaging the insulation.
12. Gently lift the paper feed unit out of the expansion feeder.

### ***Paper tray lift motor removal***

1. Remove the rear cover.
2. Remove the cassette.
3. Disconnect the cable from the paper tray lift motor.
4. Remove three black screws from the paper tray lift motor (A).

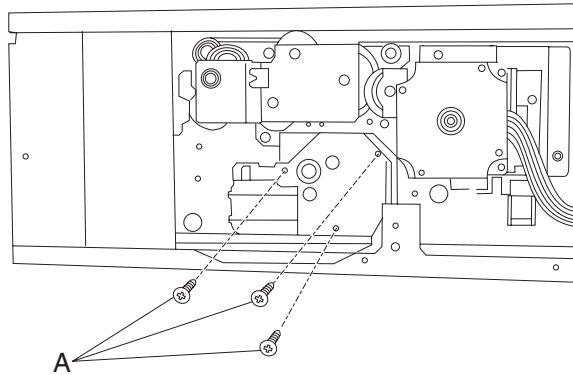

5. Remove the paper tray lift motor.

### ***Expansion feeder turn guide door sensor assembly removal***

1. Remove the rear cover.
2. Disconnect the cable from CN15 on the controller board.
3. Open the turn guide door.
4. Remove two black screws from the door sensor.
5. Thread cable, avoid fraying insulation, through side frame, and remove the sensor.

---

## Duplex removals

### *Duplex unit separation removal*

1. Remove the thumbscrews, C-clips, and screws as shown from both sides.

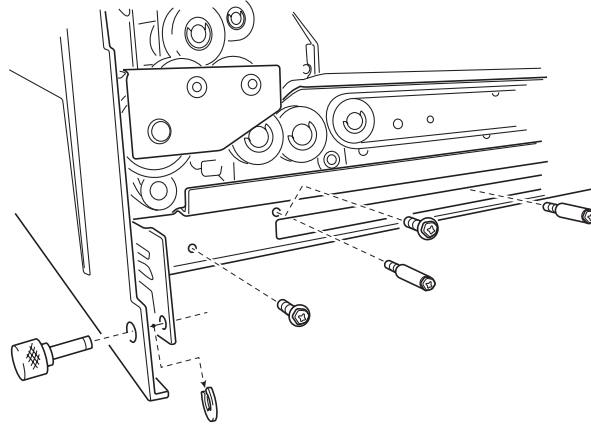

2. Remove the connectors, and separate the duplex frame from the duplex unit.

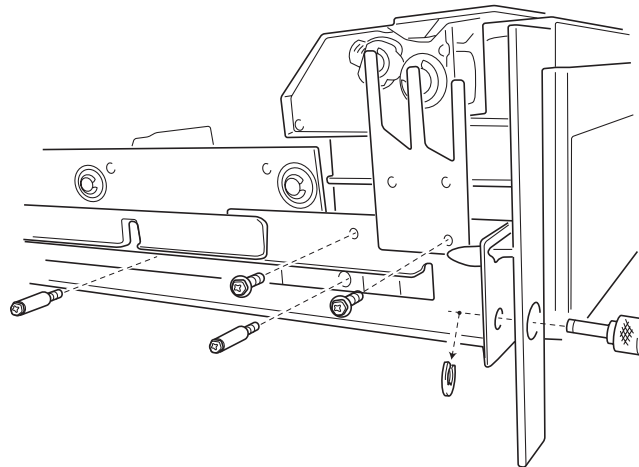

## ***Duplex unit removal***

1. Remove the four screws from the interface board, and remove the board.

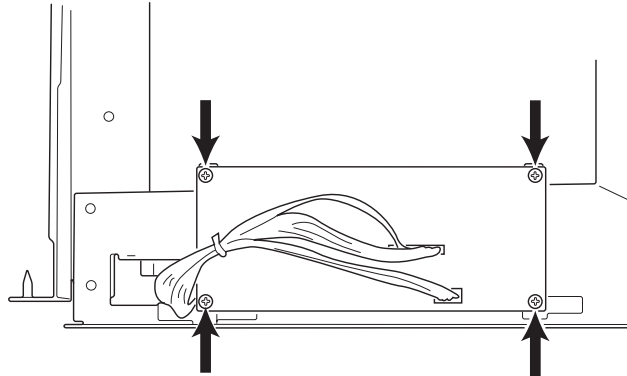

2. Remove the two screws from the duplex connector, and remove the connector.

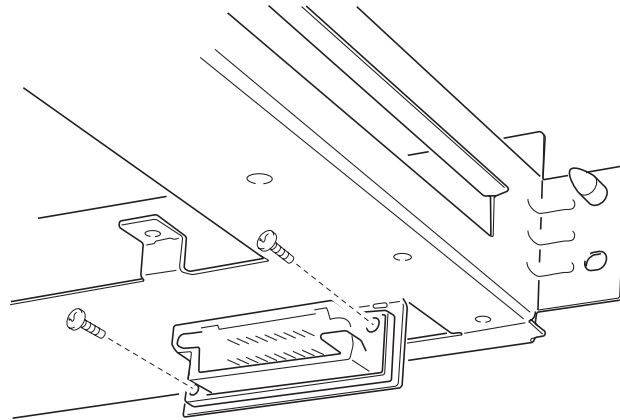

## ***Duplex timing belt removal***

1. Remove the three C-clips from the three timing gears, and remove the timing belts.
2. Remove the knob screw, and remove the timing belt.



### ***Duplex pressure roller and solenoid removal***

Remove the two screws securing the pressure roller solenoid assembly.

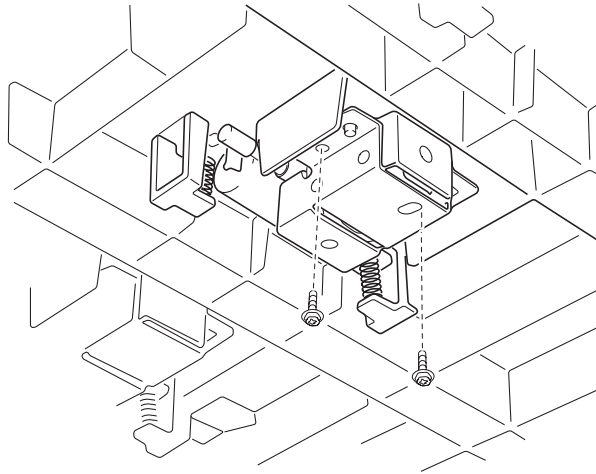

### ***Duplex feed roller and solenoid removal***

1. Remove the two screws securing the feed roll solenoid assembly.

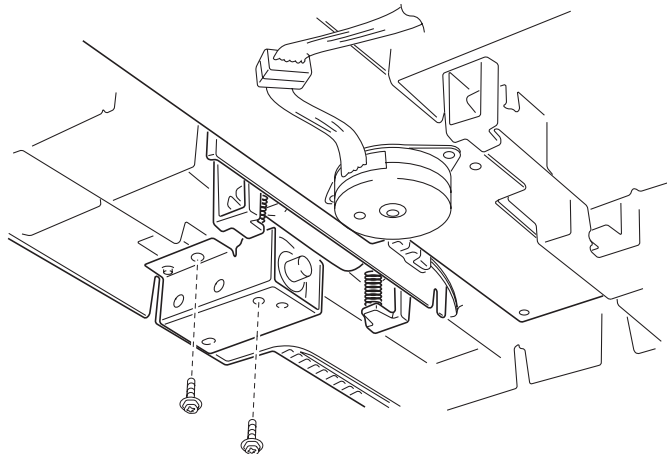

2. Remove the pressure roller and springs.
3. Remove the feed roller and springs.

## ***Duplex side fence motor assembly/side fence removal***

- 1.** Remove the three screws, and remove the side fence motor assembly.

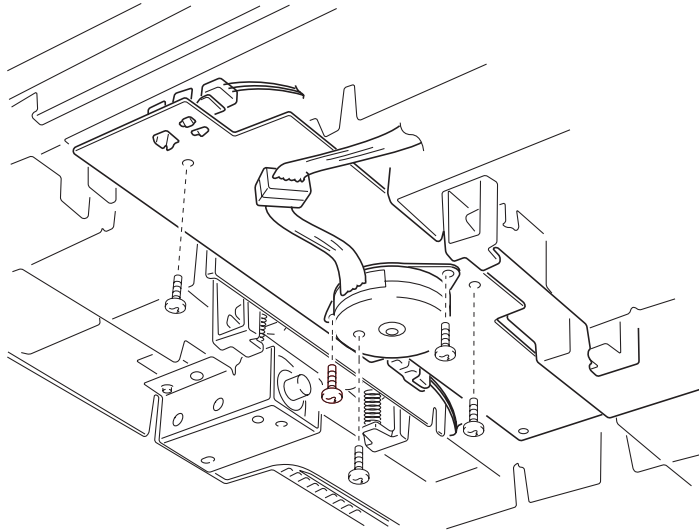

- 2.** Remove the front and rear side fences.  
**Note:** When installing, spread the front and rear side fences to the sides, and install.

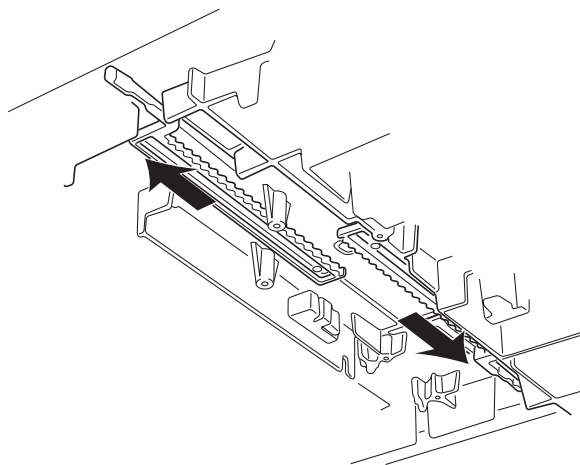

## ***Duplex paper carrying motor removal***

- 1.** Remove the gear cover.
- 2.** Remove the screws from the duplex paper carrying motor, and remove the motor.

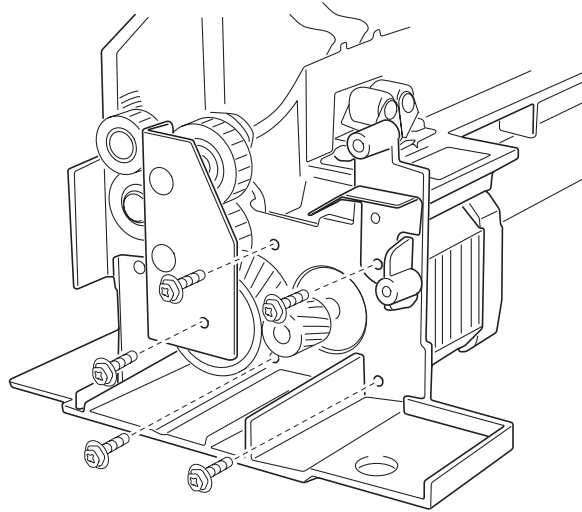

---

## High-capacity feeder (HCF) removals

### *HCF covers removal*

1. Remove the two screws from the drive cover, and remove the cover.
2. Remove the front cover.
3. Remove the two screws from the right cover, and remove the cover.
4. Remove the top cover.
5. Remove the rear cover.
6. Remove the four screws from the transfer cover, and remove the cover.

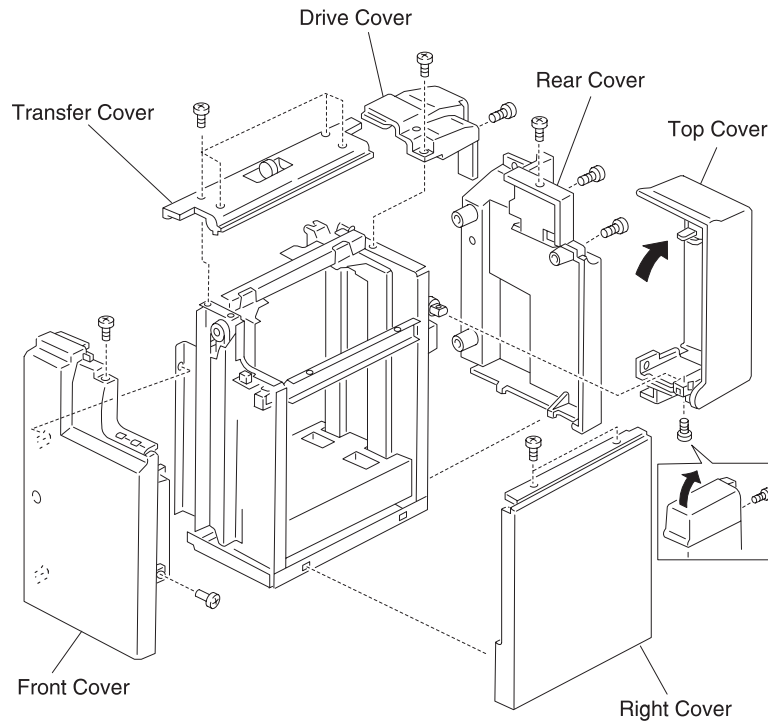

### ***HCF call roller, paper feed roller, reverse roller removal***

1. Open the top cover on the tray.
2. Remove the two screws from the transfer cover, and remove the cover.
3. Remove the retaining rings on the rollers, and remove the rollers.

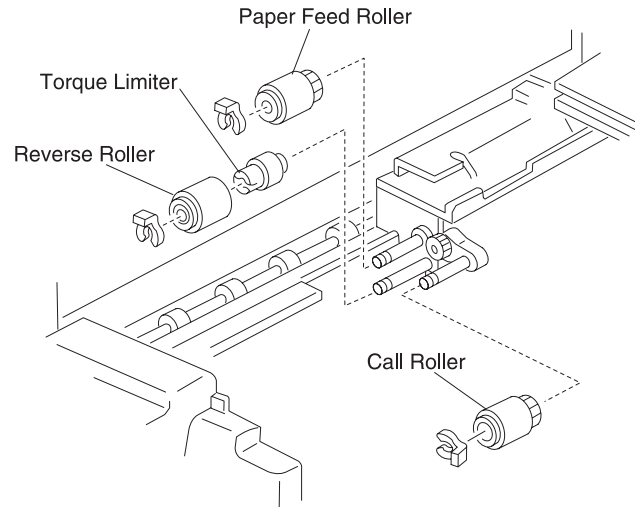

### ***HCF pickup solenoid removal***

1. Remove the four screws from the transfer cover, and remove the cover.
2. Remove the two screws from the drive cover, and remove the cover.
3. Remove the screw from the clamp plate, and remove the plate.
4. Remove the connector and the two screws from the pickup solenoid, and remove the solenoid.

Clamp Plate (Clamp; Paper Feed; Front and Rear)

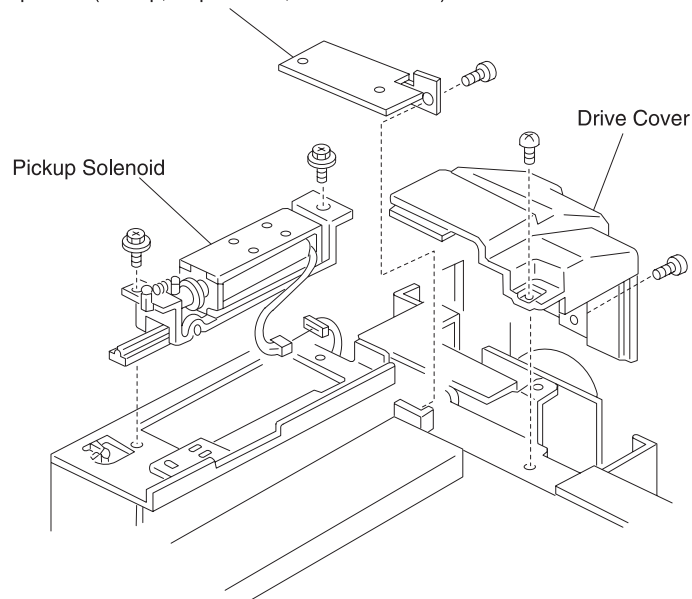

## HCF paper end sensor removal

### HCF paper size sensors (1, 2) removal

1. Cover the paper level sensor with your hand, and press the down button. The tray moves down. Lower the tray until the down sensor turns on.
2. Remove the front cover and transfer cover.
3. Remove the two screws on the front and rear sides of the side fence.
4. Mark the locking position of the side fence locking stay.
5. Remove the two screws on the side fence locking stay.
6. Remove the screw and connector from paper end sensor, and remove the sensor.
7. Remove the screw and connector from the clamp plane, and remove the paper size sensors 1 and 2.

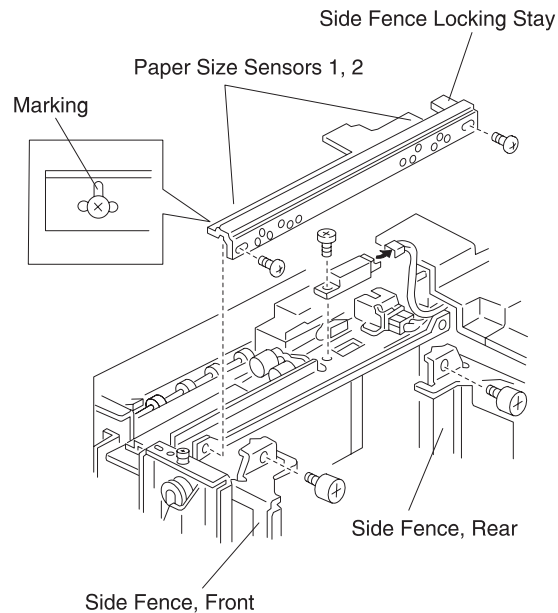

#### Notes:

- To prevent damage to the stay, hold the stay when removing the sensors.
- Be sure the side registration is not shifted, which may occur with the dismantling and mounting of the locking stay. If it is shifted, relocate the stay toward the front or rear to adjust.

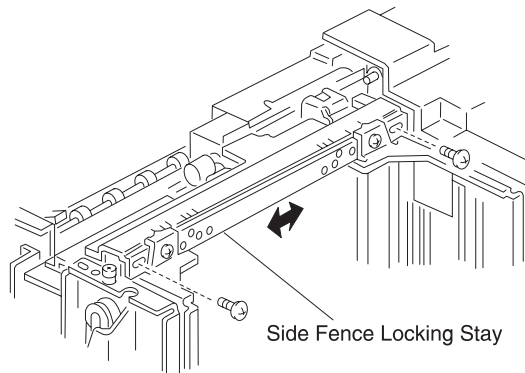

8. Remove the top cover switches.

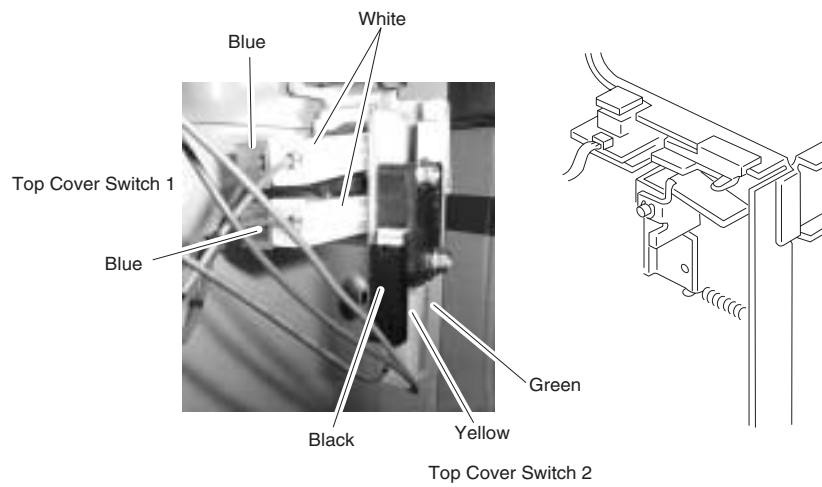

### ***HCF tray motor removal***

1. Remove the rear cover and the drive cover.
2. Remove the two screws of the tray motor, and remove the motor.

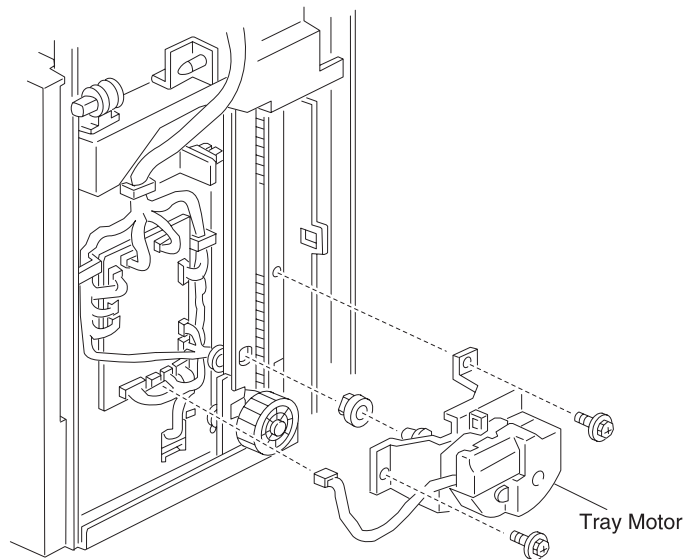

### ***HCF paper level sensor removal***

1. Remove the four screws from the transfer cover, and remove the cover.
2. Remove the two screws from the sensor, and remove the cover.
3. Remove the connector and screw from paper level sensor, and remove the sensor.

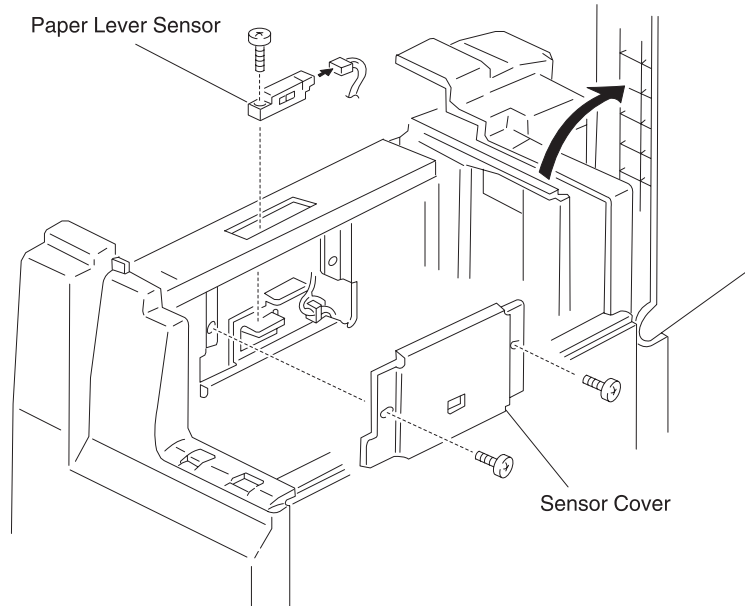

### ***HCF power supply removal***

1. Move the paper tray upward.
2. Disconnect the power cord.
3. Remove the front cover.
4. Remove the two screws from the power supply cover, and remove the cover.
5. Remove the four screws from the power supply unit, and remove the unit.
6. Remove the two screws from the DC-DC converter, and remove the converter.

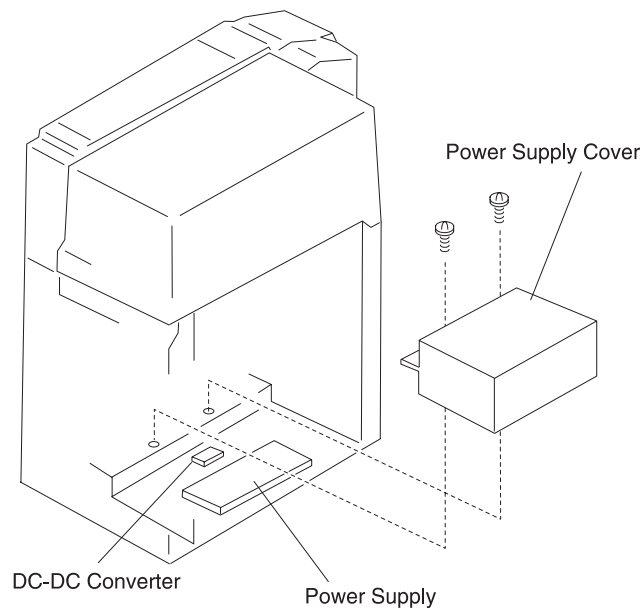



---

## Finisher removals

**Note:** Check finisher alignment when moving or servicing the finisher. After moving or servicing the finisher, print some test pages to the finisher to ensure the vertical and horizontal alignment is correct. If the finisher is not properly aligned, refer to **“Aligning the finisher and printer” on page 3-59** for alignment instructions.

### External covers removals

1. Remove the finisher trays.

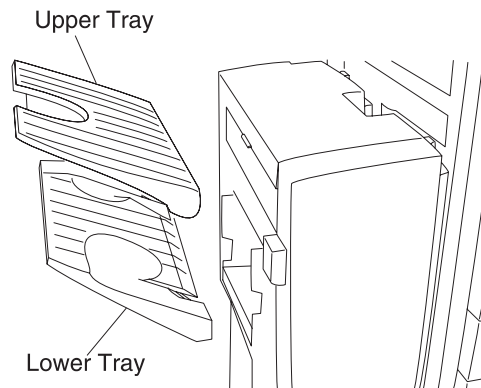

2. Remove the two screws from the front cover, and remove the cover.

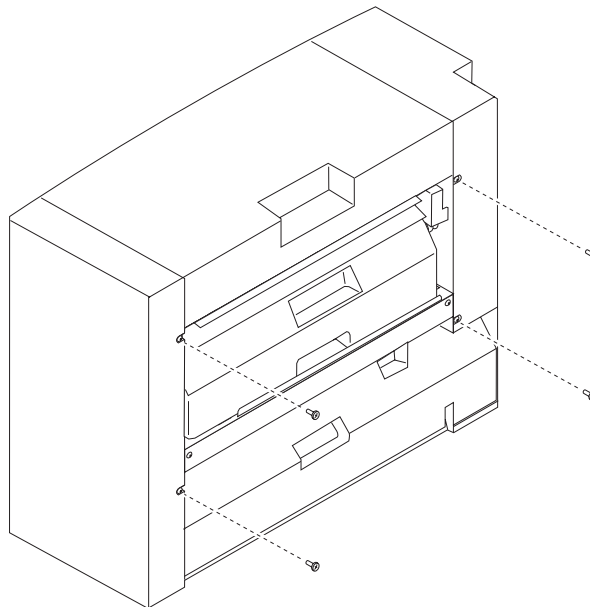

3. Remove the two screws from the rear cover, and remove the cover.

4. Remove the two screws from the top cover, and remove the cover.

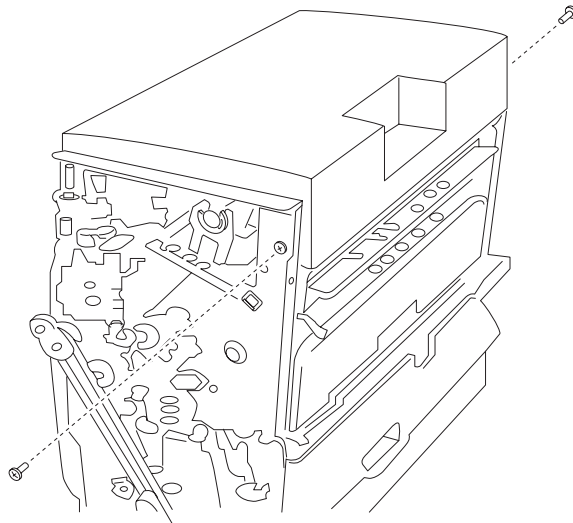

### ***Finisher control board removal***

1. Remove the external covers.
2. Disconnect all of the associated connectors.
3. Remove the four finisher control board mounting screws, and remove the board.

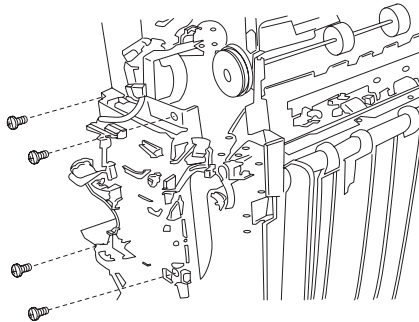

## ***Elevator motor removal***

1. Disconnect the elevator motor connector.
2. Remove the two elevator motor bracket screws from the bracket.

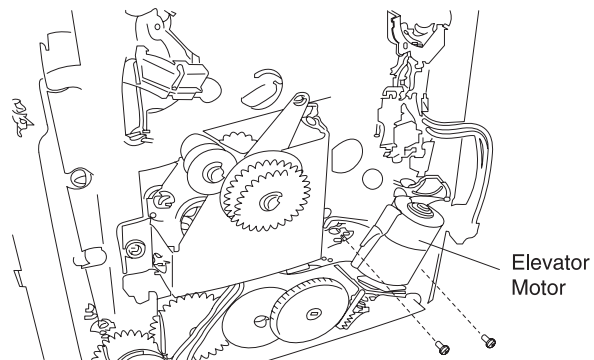

3. Remove the elevator motor assembly.

## ***Feed motor assembly removal***

1. Remove the finisher control board mounting bracket.
2. Loosen the tension bracket mounting screw.

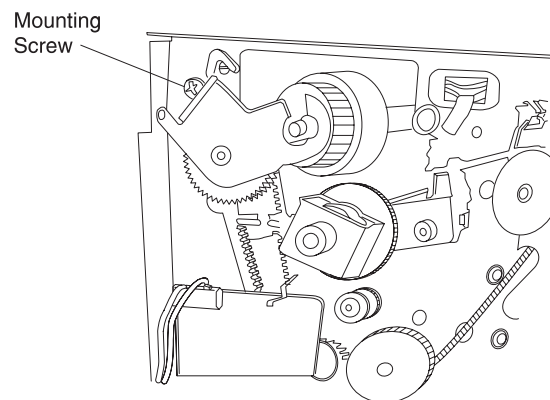

3. Disconnect the feed motor connector.
4. Remove the three screws and connector from the feed motor mounting bracket, and remove the feed motor assembly.
5. Remove the feed motor pulley.

## Hole punch removal

1. Remove the external covers.
2. Remove the hole punch unit cables.
3. Remove the tension spring.
4. Remove the screw and E-ring from the tension bracket, and remove the bracket.

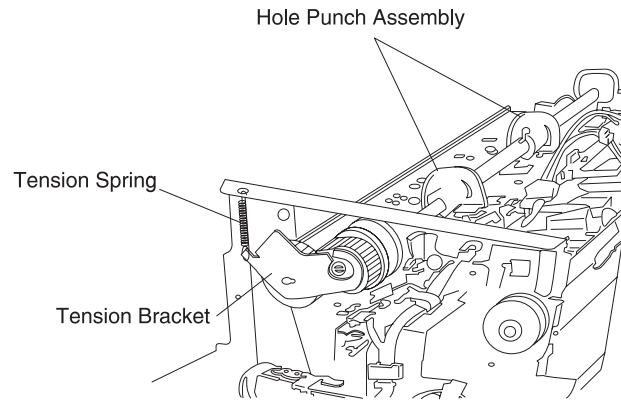

**Note:** When installing the tension bracket, use the left side screw hole for the three hole punch unit and the right side screw hole for the four hole punch unit.

5. Remove the two hole punch unit screws, and remove the unit.

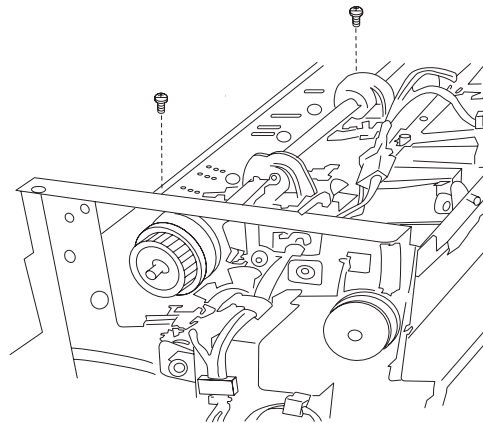

### ***Inverter paper exit discharge brush removal***

1. Remove the external covers.
2. Remove the finisher control board.
3. Remove the upper left panel.
4. Remove the two discharge brush screws, and remove the brush.

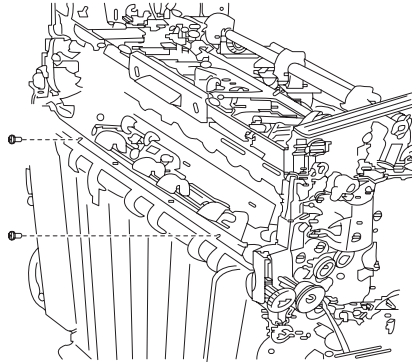

### ***Inverter paper exit roller removal***

1. Remove the front and rear external covers.
2. Remove the four lower left panel screws, and remove the panel.

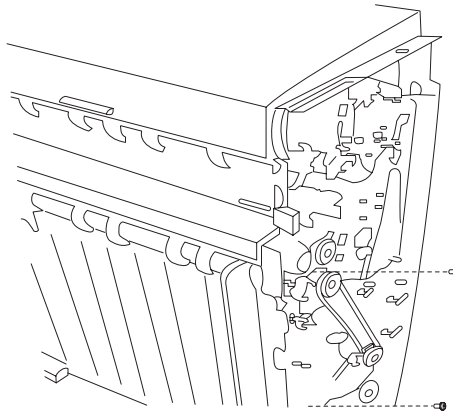

3. Disconnect the harness connect from the lower left panel.
4. Remove the inverter paper exit roller bushing.

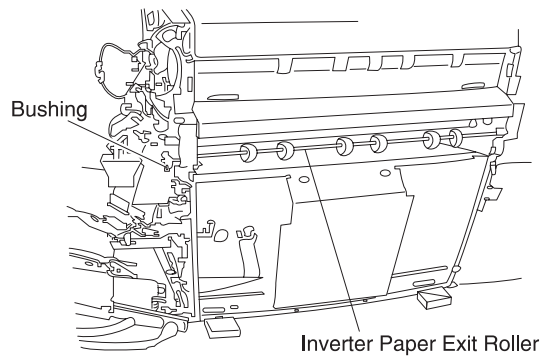

5. Remove the inverter idle gear.
6. Remove the inverter drive gear and bushing.

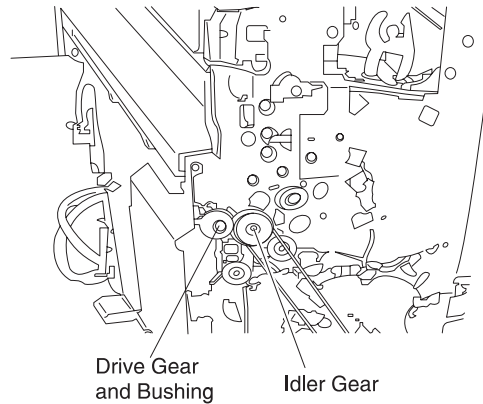

7. Remove the inverter paper exit roller.

### ***Jogging unit removal***

1. Remove the dust box.
2. Remove the two screws, and remove the cover.

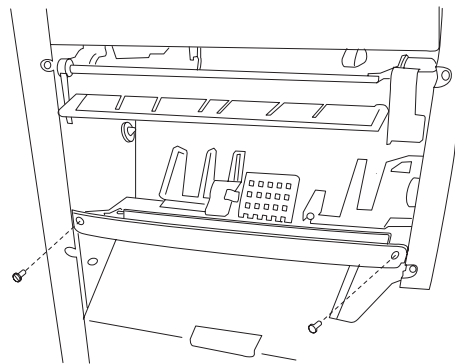

3. Disconnect the jogging motor connector.
4. Disconnect the jogging home position sensor connector.

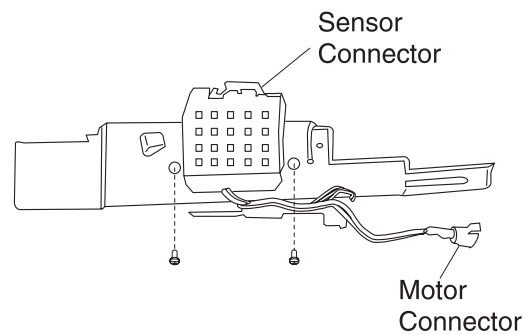

5. Remove the jogging unit.

## Path select gate removal

1. Remove the external covers.
2. Remove the two screws from the top cover, and remove the cover.
3. Remove the gate solenoid with mounting bracket.
4. Remove the straight paper exit sensor connector.
5. Remove the upper guide plate for the straight paper exit.
6. Remove the two screws and two springs for the upper guide plate.

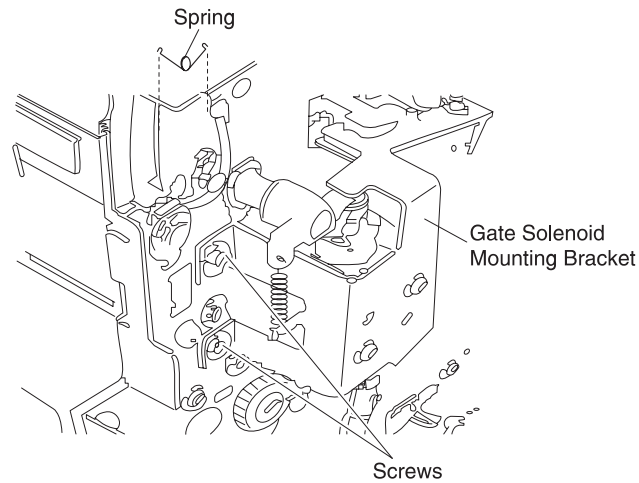

7. Remove the path select gate.

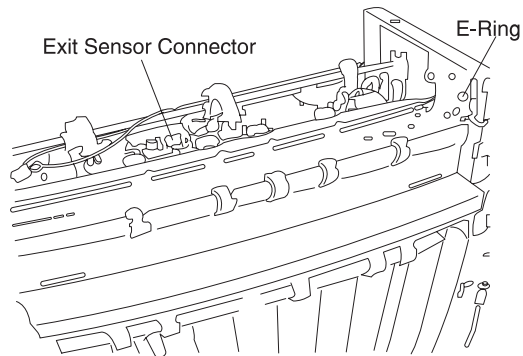

**Note:** Adjust the solenoid bracket mounting position so that the gate arm is contacting the solenoid.

## ***Patting roller removal***

1. Remove the front and rear covers.
2. Remove the finisher control board mounting bracket.

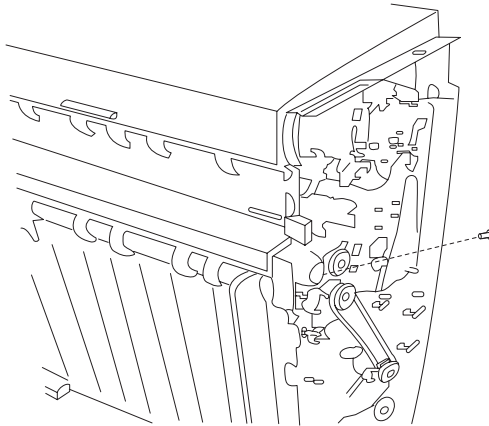

3. Remove the two screws from the upper left panel, and remove the panel.

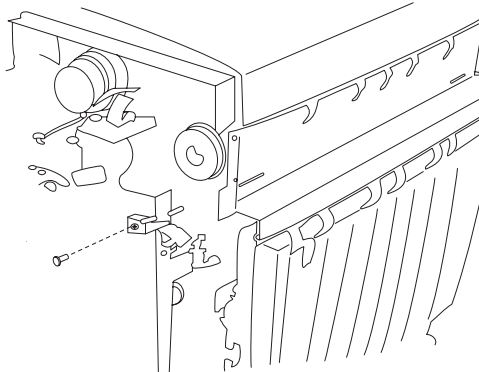

4. Disconnect the sensor connector.
5. Remove the sensor harness from the harness clamp.
6. Remove the four upper guide plate screws from the inverter paper exit, and remove the plate.

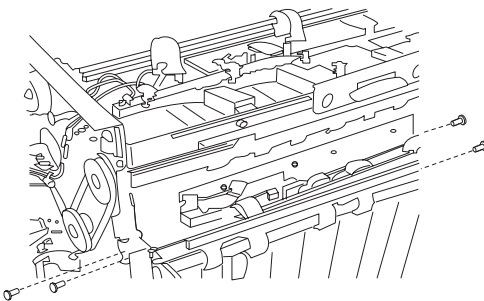

7. Remove the four screws from the inverter guide plate, and remove the plate.



- 8.** Remove the tension springs. Use the upper hole when installing the spring.

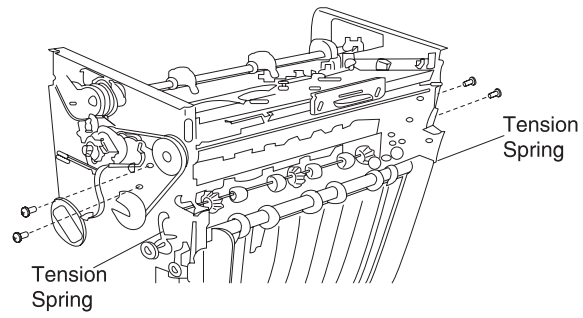

- 9.** Remove the gear and bushing.

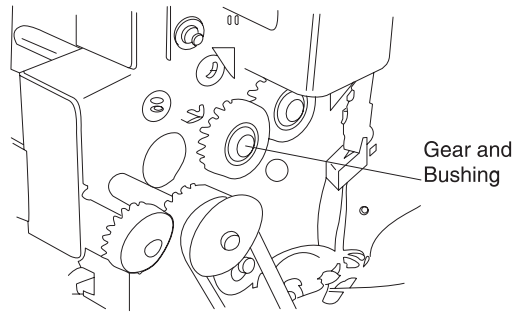

- 10.** Remove the patting roller.

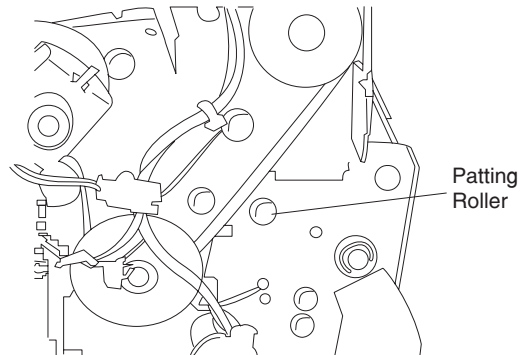

## ***Power supply removal***

1. Unplug the power cord from the printer.
2. Remove the external covers.
3. Remove the lower left panel.
4. Remove the cable connector for the left panel.
5. Remove the four lower guide support plate screws, and remove the plate.

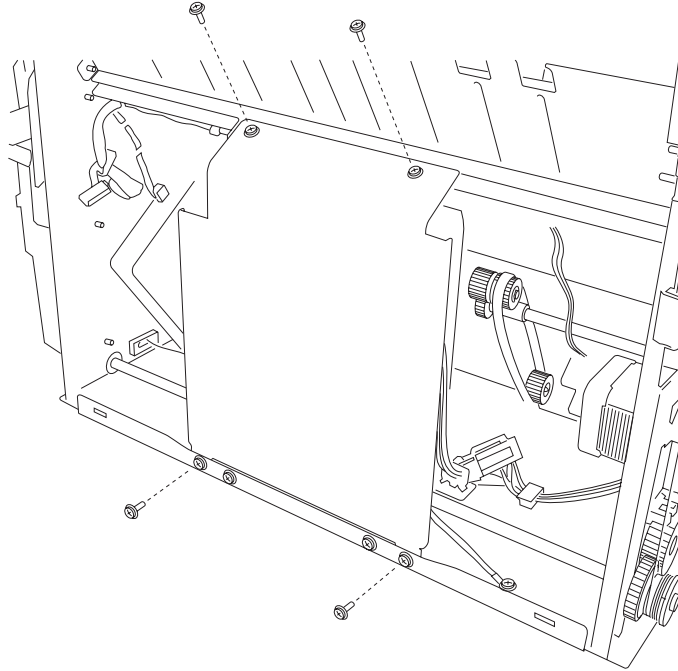

6. Remove the two power supply screws.

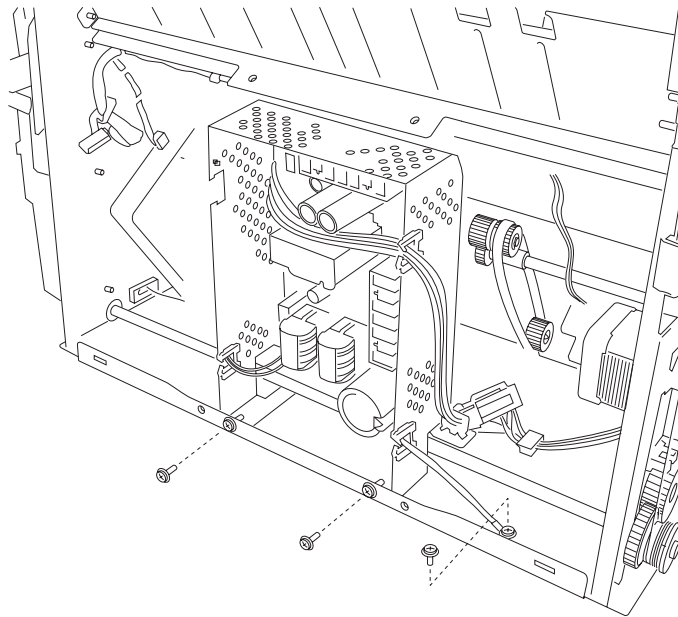

7. Remove the screw from the ground wire.
8. Disconnect the power supply connector, and remove the power supply.

## **Registration roller removal**

1. Remove the hole punch unit.
2. Remove the registration roller clutch.
3. Remove the registration roller bushing.
4. Remove the registration roller.

## **Registration roller clutch removal**

1. Remove the harness from the clamp.
2. Remove the three control board mounting bracket screws, and remove the bracket.

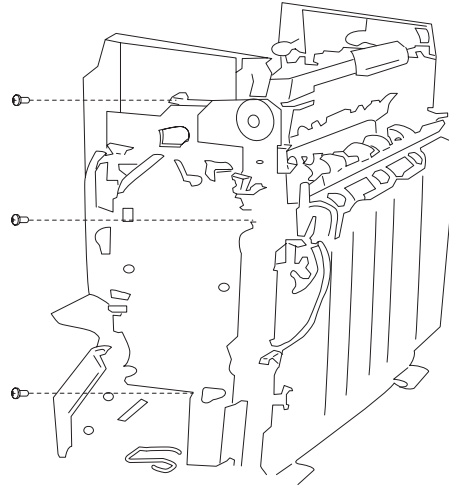

3. Remove the registration roller clutch set screw.

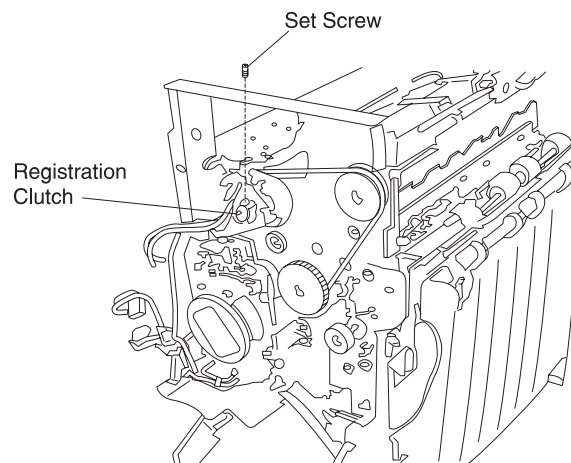

4. Remove the registration roller clutch connector.
5. Remove the registration roller clutch.

## ***Stack area discharge brush removal***

1. Remove the dust box.
2. Remove the stack area discharge brushes.

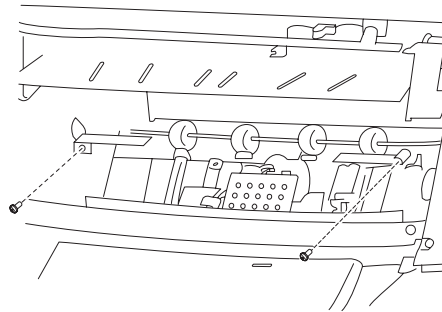

## ***Staple unit removal***

1. Remove the staple unit connector.

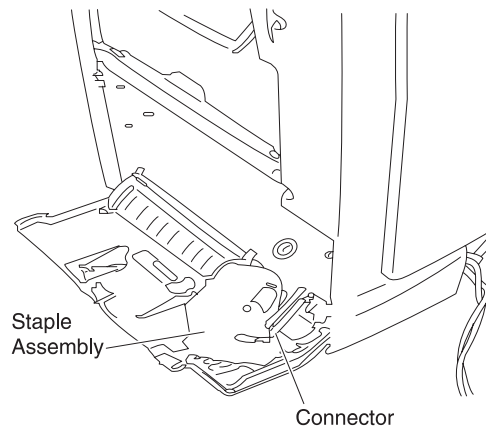

2. Pull outward on the staple cover, and remove the staple unit.

### ***Straight paper exit discharge brush removal***

1. Remove the external covers.
2. Remove the two screws from the top cover, and remove the cover.
3. Remove the two lever screws, and remove the lever.
4. Remove the two discharge brush screws, and remove the brush.

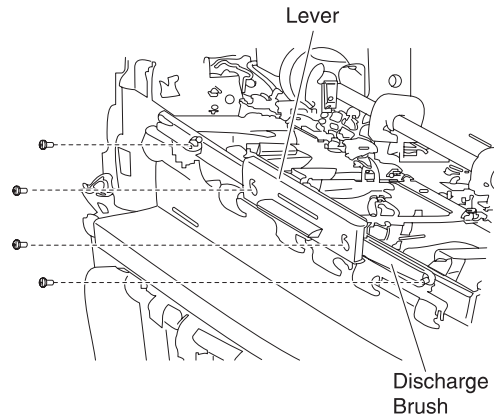

### ***Straight paper exit roller removal***

1. Remove the external covers.
2. Remove the finisher control board.
3. Remove the upper left panel.
4. Remove the front straight paper exit roller bushing.

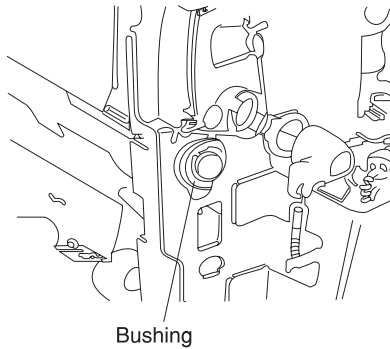

5. Remove the belt and pulley.

6. Remove the rear straight paper exit roller E-ring and bushing.

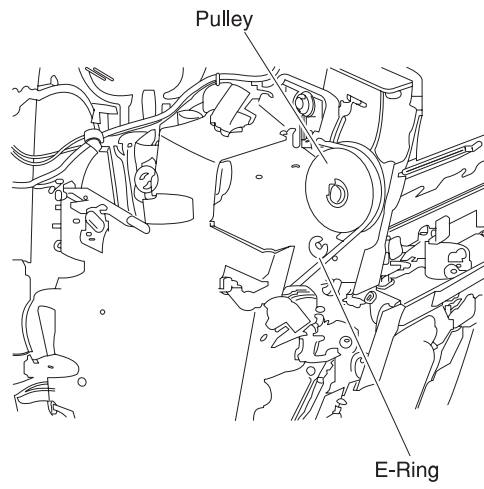

7. Remove the straight paper exit roller.

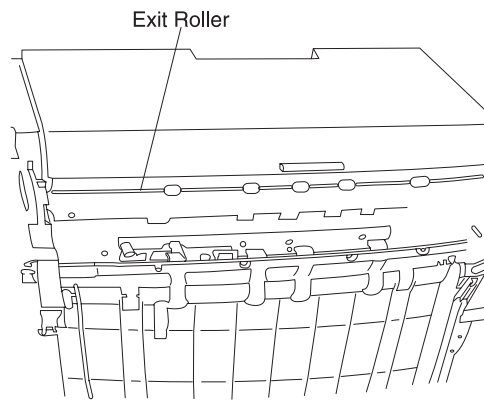

## Timing belts 1 and 2 removal

1. Remove the finisher control board mounting bracket.
2. Remove the feed motor mounting bracket.
3. Remove the tension bracket mounting screw.

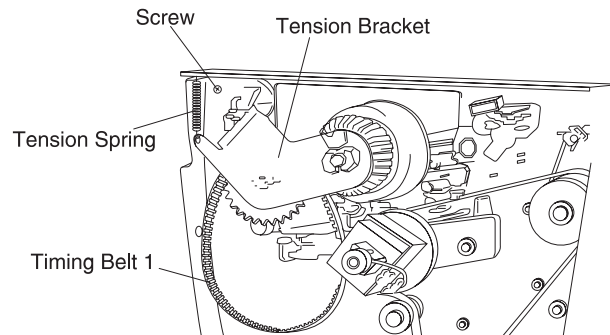

4. Remove the tension spring.
5. Remove the timing belt 1.
6. Loosen the tension bracket mounting screw for timing belt 2.

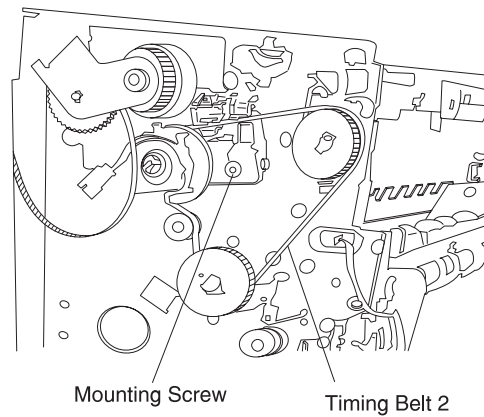

7. Remove the timing belt 2.

## Tractor belt removal

1. Remove the external covers.
2. Remove the lower left panel.
3. Remove the cable connector of the left panel.
4. Remove the belt motor unit.
5. Remove the four lower guide support plate screws for the invert paper exit.

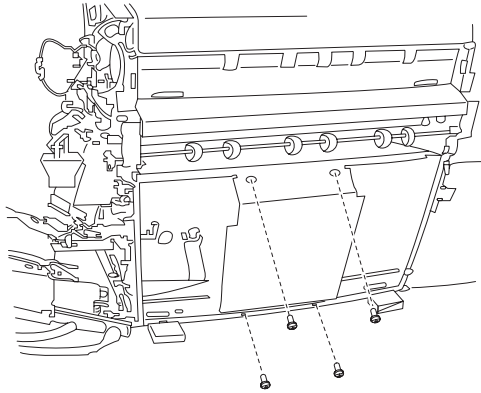

6. Remove the tension spring from the shaft.

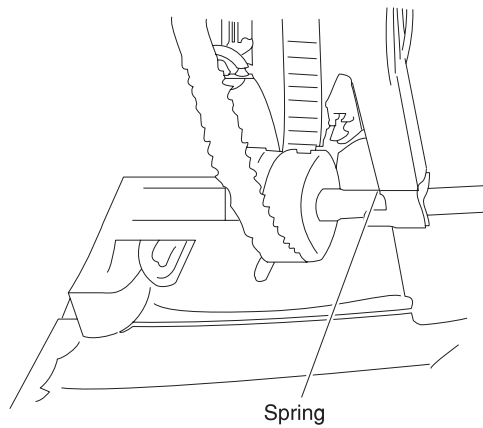

7. Remove the paper jam removal knob.

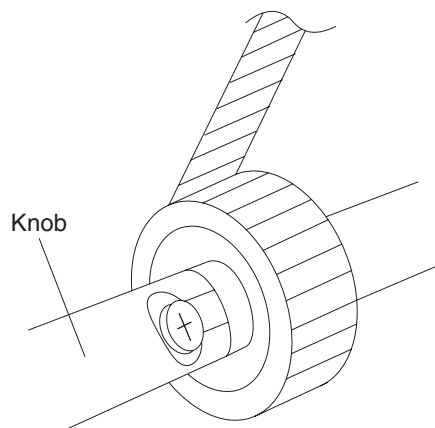



8. Remove the tractor belts.

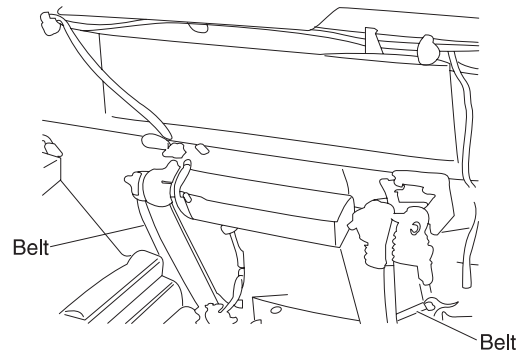

**Note:** Install the belt so that the belt tooth just under the plastic hook aligns with the hook on the other belt.

### ***Tractor drive motor assembly removal***

1. Remove the outer covers.
2. Remove the drive belt.

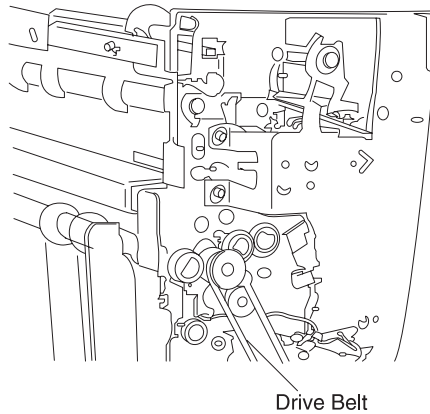

3. Remove the three screws, and disconnect the connector from the tractor drive motor assembly.

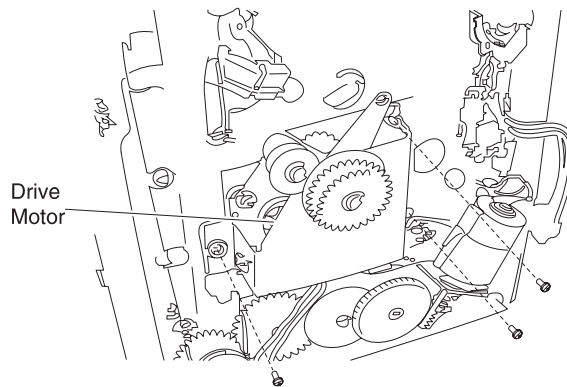

4. Remove the tractor drive motor assembly.



## 5. Locations

### Covers diagram

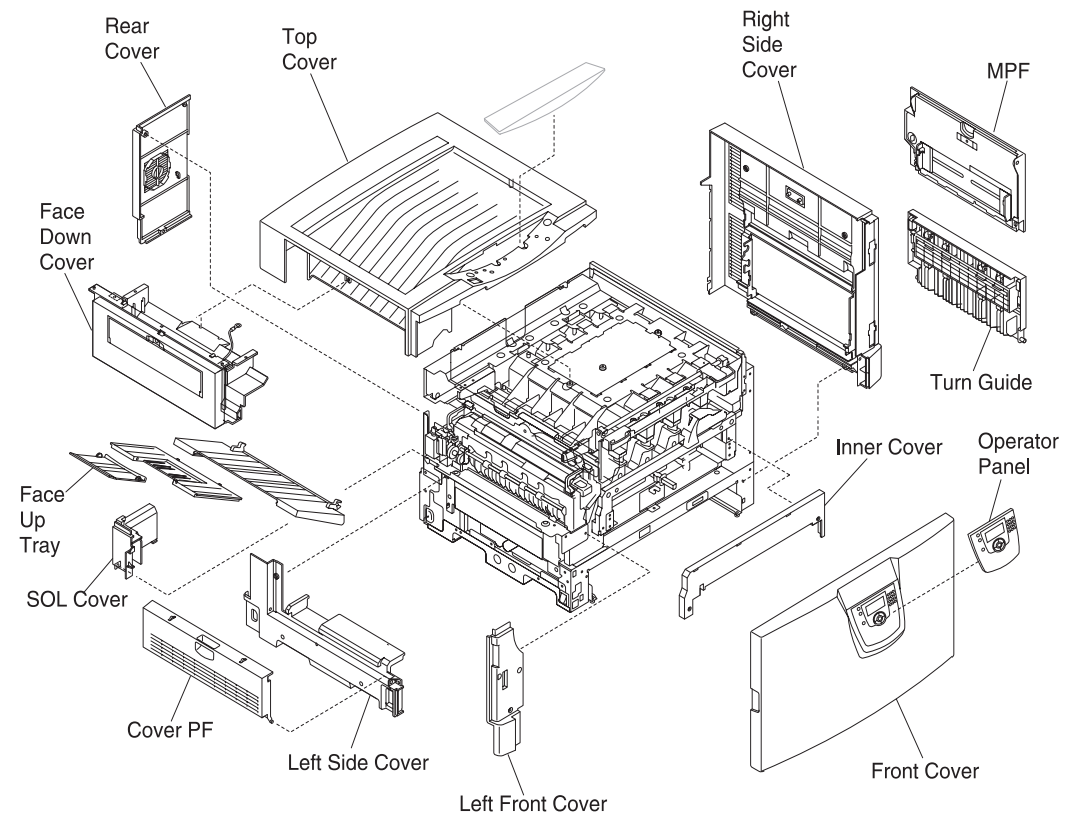

## Major parts diagram

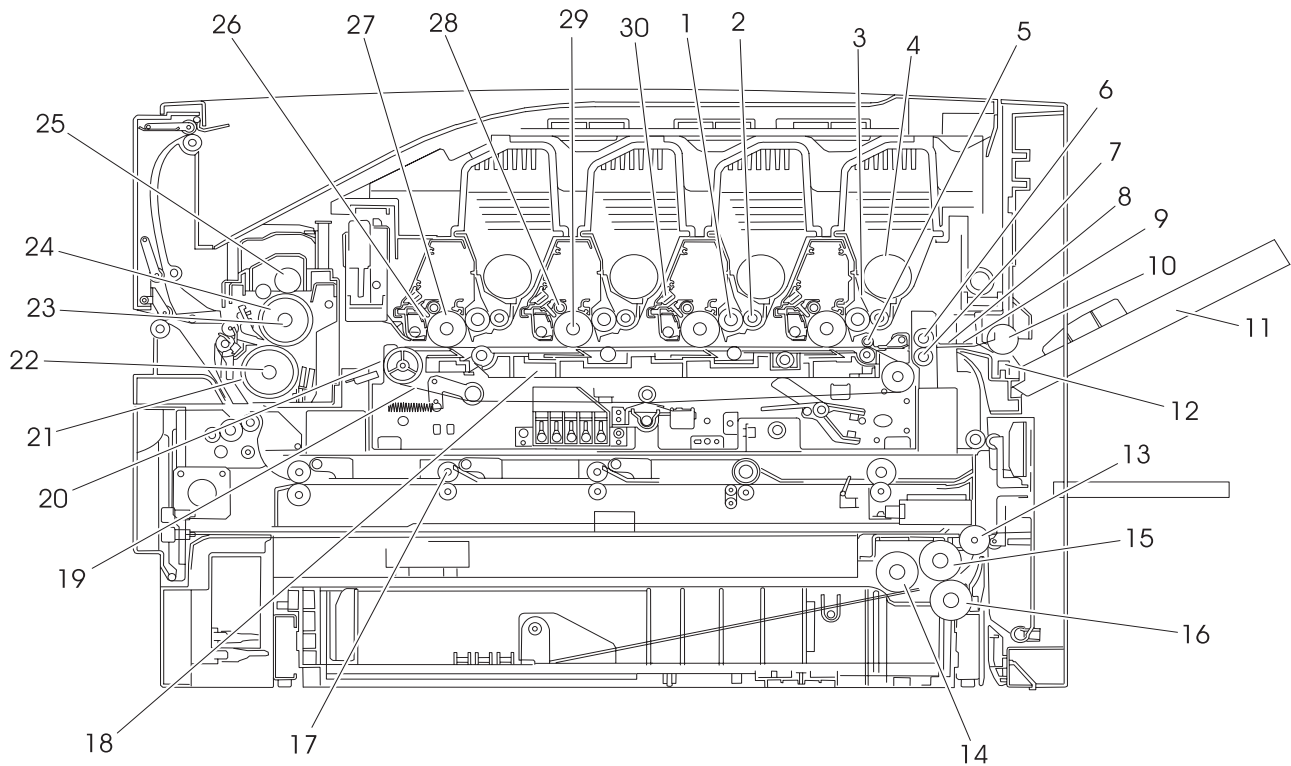

Number	Part	Number	Part
1	Development roll	16	Paper feed roll separator
2	Supply roll	17	Duplex unit
3	Doctor blade	18	Transfer sheet
4	Agitator	19	Transfer belt
5	Absorption roll	20	Belt drive roller
6	Registration roll upper	21	Paper delivery detection lever
7	Registration roll lower	22	Press roller
8	Registration sensor	23	Heater
9	Registration detector lever	24	Fuser roller
10	MPF roll	25	Oil coating roller
11	MPF unit	26	Cleaning blade
12	Fanning pad	27	Photodeveloper
13	Relay roll	28	Charge roll
14	Paper feed roll pickup	29	LED head
15	Paper feed roll feeder	30	Erase Lamp

**Sensor and switch locations**

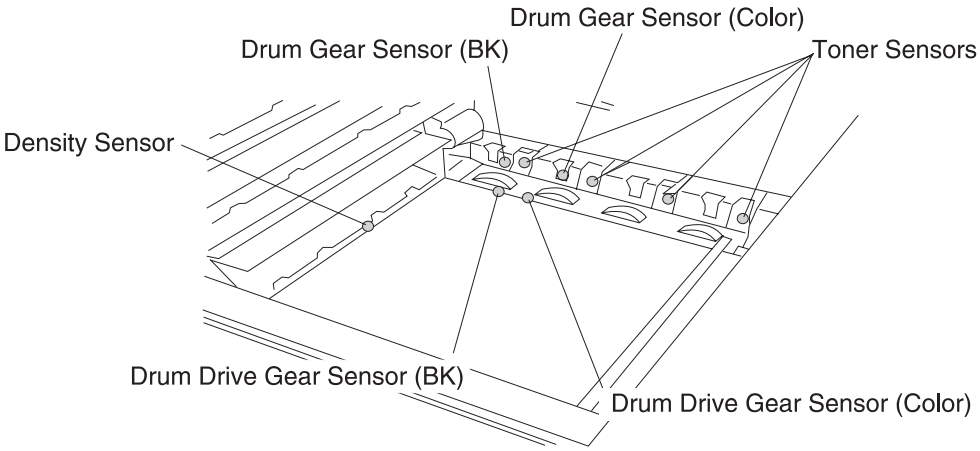
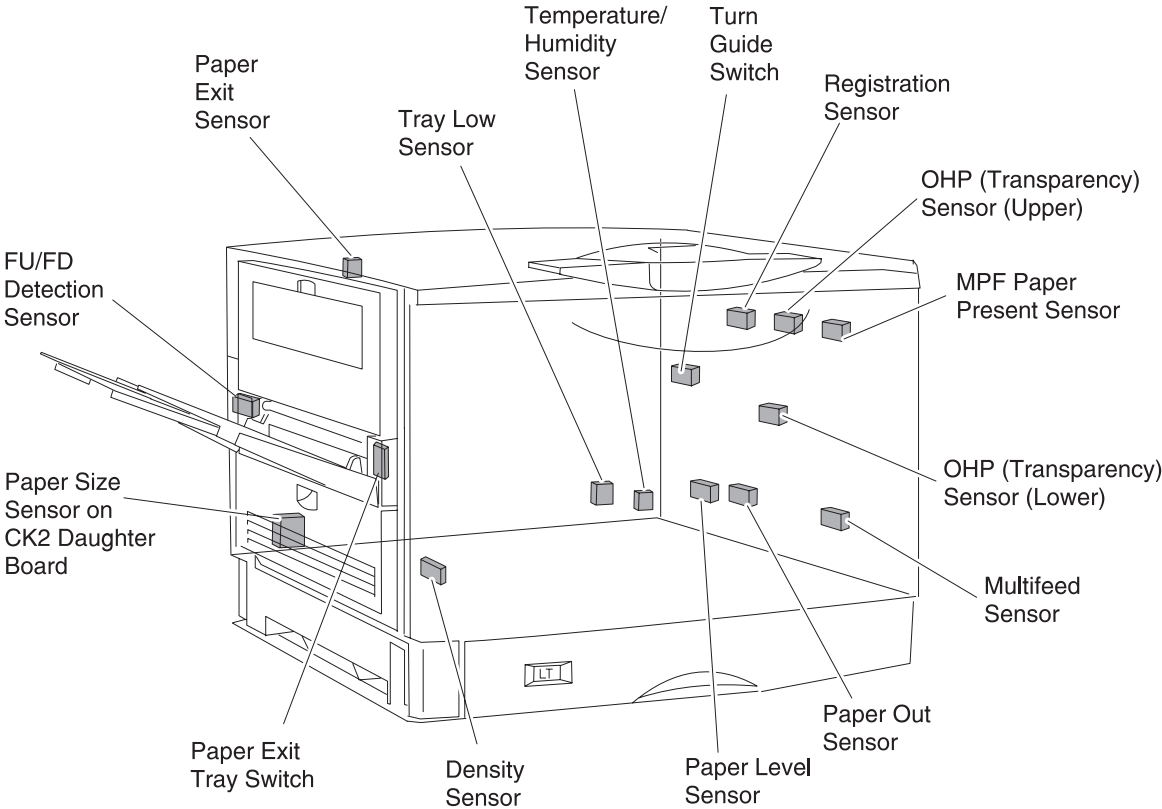

## Component locations

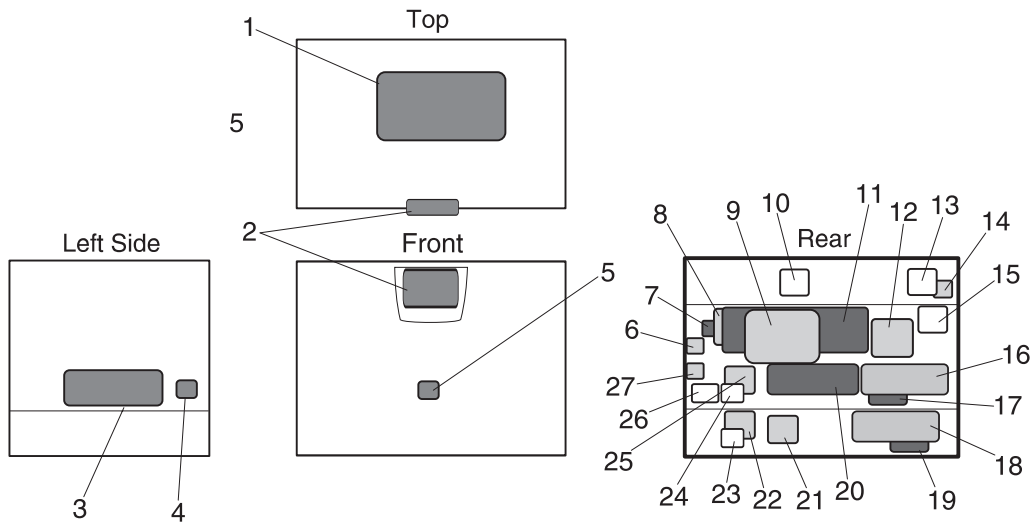

Number	Component	Number	Component
1	Printhead controller board	15	Main unit fan
2	Operator panel	16	Power supply 2
3	Motor driver board	17	CK2 daughter board
4	Power switch	18	Expansion paper feed controller
5	Sensor board	19	Paper size detector board (expansion paper feed option)
6	MPF clutch	20	Power supply 1
7	Registration clutch	21	Drive motor (extended paper feeder option)
8	CK1 daughter board	22	Paper lift motor (expansion paper feed option)
9	Printer controller board	23	Paper volume detection sensor (expansion paper feed option)
10	LED fan	24	Tray 1 low sensor
11	High voltage unit (HVU)	25	Paper lift motor
12	Drive motor	26	Temperature/humidity sensor board
13	Fuser fan	27	Relay clutch
14	Paper exit motor		

**Printer controller board**

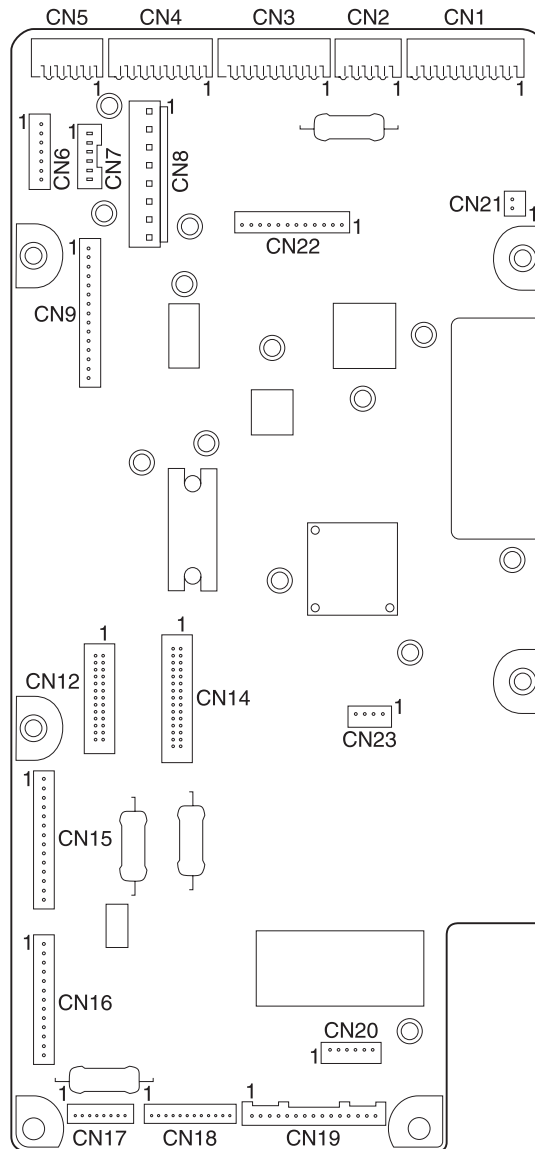

## Printer controller board connectors

The connectors are listed in numerical order. Note the orientation of the printer controller board diagram.

Board connectors in this table are attached to the board and cable connectors are made up of wires of various numbers and colors. Vertical connectors list wire colors top to bottom. Horizontal connectors list wire colors left to right.

### Print controller board connectors

Conn #	Orientation	Board connector color	Cable connector color	# Wires	Wire color	Connector
CN1	Vertical	Tan	White	16	<ul style="list-style-type: none"> <li>• 4 blue</li> <li>• 4 red</li> <li>• 4 black</li> <li>• 4 yellow</li> </ul>	Toner sensor assembly
CN2	Vertical	Tan	White	8	<ul style="list-style-type: none"> <li>• 4 black</li> <li>• 4 yellow</li> </ul>	Toner drum sensor assembly
CN3	Vertical	Tan	Tan	15	<ul style="list-style-type: none"> <li>• 15 green</li> </ul>	CK1 connector 1
CN4	Vertical	Tan	Tan	14	<ul style="list-style-type: none"> <li>• 14 green</li> </ul>	CK1 connector 2
CN5	Vertical	Tan	Tan	9	<ul style="list-style-type: none"> <li>• 9 green</li> </ul>	CK1 connector 3
CN6	Horizontal	White	White	7	<ul style="list-style-type: none"> <li>• 3 yellow</li> <li>• 1 brown</li> <li>• 1 blue</li> <li>• 1 gray</li> <li>• 1 white</li> </ul>	Expansion feeder connector
CN7	Horizontal	White	White	6	<ul style="list-style-type: none"> <li>• 1 white</li> <li>• 1 gray</li> <li>• 1 red</li> <li>• 1 orange</li> <li>• 1 purple</li> <li>• 1 black</li> </ul>	LVPS 2
CN8	Horizontal	White	White	8	<ul style="list-style-type: none"> <li>• 2 yellow</li> <li>• 4 black</li> <li>• 2 red</li> </ul>	LVPS 2
CN9	Horizontal	White	White	15	<ul style="list-style-type: none"> <li>• 1 brown</li> <li>• 1 blue</li> <li>• 1 gray</li> <li>• 1 white</li> <li>• 1 yellow</li> <li>• 1 brown</li> <li>• 1 blue</li> <li>• 1 gray</li> <li>• 1 white</li> <li>• 1 brown</li> <li>• 1 blue</li> <li>• 2 red</li> <li>• 1 black</li> <li>• 1 yellow</li> </ul>	HVPS
CN12	Horizontal	Tan	White	26	<ul style="list-style-type: none"> <li>• 1 white</li> <li>• 15 green</li> </ul>	RIP card
CN14	Horizontal	Tan	White	30	<ul style="list-style-type: none"> <li>• 1 blue</li> <li>• 29 white</li> </ul>	Printhead
CN15	Horizontal	White	White	14	<ul style="list-style-type: none"> <li>• 1 white</li> <li>• 13 blue</li> </ul>	Sensor board



**Print controller board connectors (continued)**

Conn #	Orientation	Board connector color	Cable connector color	# Wires	Wire color	Connector
CN16	Horizontal	White	White	13	<ul style="list-style-type: none"> <li>• Brown</li> <li>• Red</li> <li>• Orange</li> <li>• Yellow</li> <li>• Blue</li> <li>• Purple</li> <li>• Gray</li> <li>• White</li> <li>• Brown</li> <li>• Red</li> <li>• Orange</li> <li>• Yellow</li> <li>• Blue</li> <li>•</li> </ul>	Duplex unit
CN17	Vertical	Tan	Tan	8	• 8 green	CK2 connector 1
CN18	Vertical	Tan	Tan	12	• 12 green	CK2 connector 2
CN19	Vertical	White	White	15	<ul style="list-style-type: none"> <li>• 4 gray</li> <li>• 1 black</li> <li>• 1 white</li> <li>• 1 red</li> <li>• 2 gray</li> <li>• 6 white</li> </ul>	Fuser
CN20	Vertical	White	White	6	• 6 black	Gear phase sensor
CN21	Horizontal	White	White	2	<ul style="list-style-type: none"> <li>• White</li> <li>• Black</li> </ul>	RFID antenna
CN22	Vertical	White	White	12	<ul style="list-style-type: none"> <li>• 1 yellow</li> <li>• 11 white</li> </ul>	High Cap feeder
CN23	Vertical	White				DRG

**Printhead controller board**

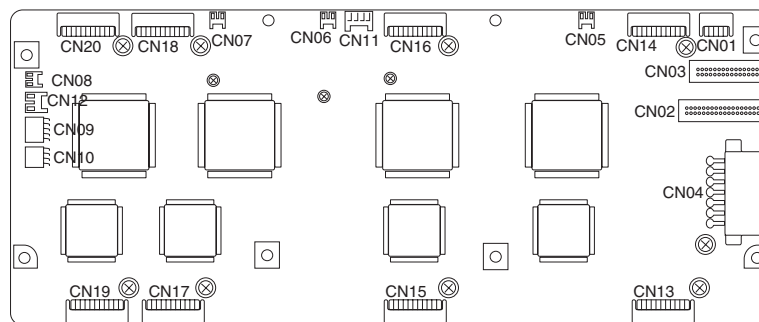

## Printhead controller board connectors

Conn #	Orientation	Board connector color	Cable connector color	# Wires	Wire color	Connector
CN01		Tan	White	8	<ul style="list-style-type: none"> <li>• 2 green</li> <li>• 2 blue</li> <li>• 2 red</li> <li>• 2 yellow</li> </ul>	RIP board
CN02		Tan	White	36	<ul style="list-style-type: none"> <li>• 35 blue</li> <li>• 1 white</li> </ul>	RIP board
CN03		Tan	White	30	<ul style="list-style-type: none"> <li>• 29 white</li> <li>• 1 blue</li> </ul>	Printer controller
CN04		Clear	Clear	14	<ul style="list-style-type: none"> <li>• 2 purple</li> <li>• 5 yellow</li> <li>• 7 black</li> </ul>	Power supply2
CN05		Red	Green	2	<ul style="list-style-type: none"> <li>• 2 red</li> </ul>	M LED eraser
CN06		Blue	Green	2	<ul style="list-style-type: none"> <li>• 2 blue</li> </ul>	C LED eraser
CN07		Yellow	Green	2	<ul style="list-style-type: none"> <li>• 2 black</li> </ul>	Y LED eraser
CN08		Black	Green	2	<ul style="list-style-type: none"> <li>• 2 black</li> </ul>	K LED eraser
CN09		White	White	4	<ul style="list-style-type: none"> <li>• Yellow</li> <li>• Orange</li> <li>• Brown</li> <li>• Black</li> </ul>	PEX motor
CN10		White	White	3	<ul style="list-style-type: none"> <li>• 3 brown</li> </ul>	Face down
CN11		White	White	3	<ul style="list-style-type: none"> <li>• Black</li> <li>• Yellow</li> <li>• Red</li> </ul>	LED fan
CN12		White	White	3	<ul style="list-style-type: none"> <li>• Black</li> <li>• Yellow</li> <li>• Red</li> </ul>	Fuser fan
CN13		White		40	<ul style="list-style-type: none"> <li>• 40 white ribbon</li> </ul>	M LED front
CN14		White		40	<ul style="list-style-type: none"> <li>• 40 white ribbon</li> </ul>	M LED rear
CN15		White		40	<ul style="list-style-type: none"> <li>• 40 white ribbon</li> </ul>	C LED front
CN16		White		40	<ul style="list-style-type: none"> <li>• 40 white ribbon</li> </ul>	C LED rear
CN17		White		40	<ul style="list-style-type: none"> <li>• 40 white ribbon</li> </ul>	Y LED front
CN18		White		40	<ul style="list-style-type: none"> <li>• 40 white ribbon</li> </ul>	Y LED rear
CN19		White		40	<ul style="list-style-type: none"> <li>• 40 white ribbon</li> </ul>	K LED front
CN20		White		40	<ul style="list-style-type: none"> <li>• 40 white ribbon</li> </ul>	K LED rear

## CK1 board connectors

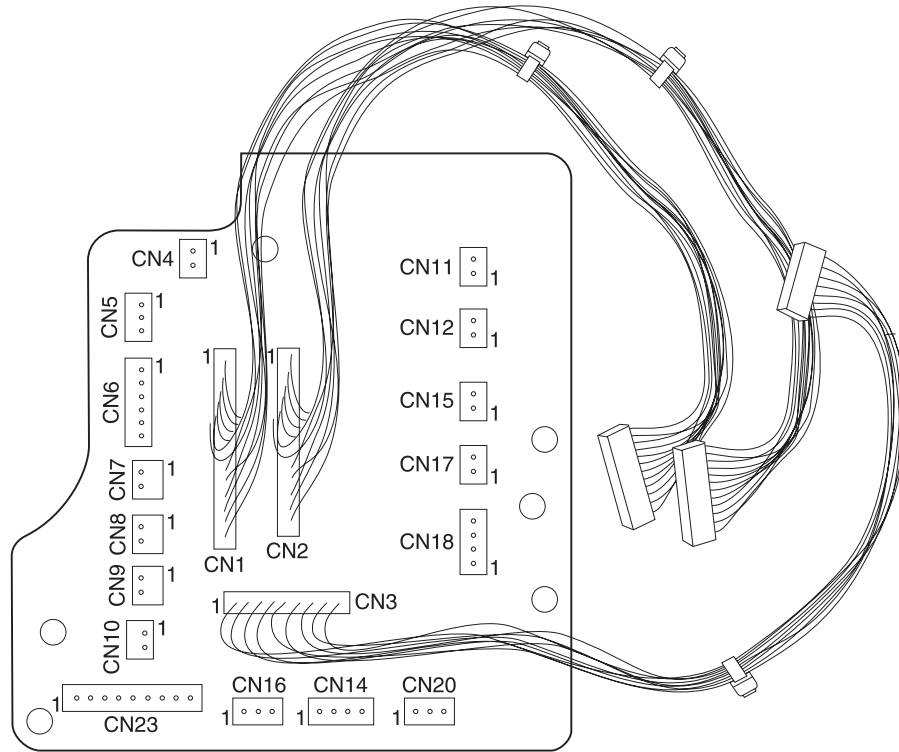

Conn #	Orientation	Board connector color	Cable connector color	# Wires	Wire color	Connector
CN4	Vertical	Magenta	Red	2	• 2 red	Lower OHP
CN5	Vertical	Green	Green	3	• 3 green	Upper OHP
CN6	Vertical	White	White	6	• 3 white • 3 black	Registration sensor
CN7	Vertical	White	White	2	• 2 white	Registration clutch
CN8	Vertical	Yellow	Yellow	2	• 2 yellow	MPF clutch
CN9	Vertical	Blue	Blue	2	• 2 blue	Relay clutch
CN10	Vertical	Brown	Brown	2	• 2 brown	Turn guide door closed sensor
CN11	Vertical	Orange	Orange	2	• 2 white	Belt up/down clutch
CN12	Vertical	White		2	• 2 black	Carrying clutch
CN14	Horizontal	Black			• 4 black	Multifeed sensor
CN15	Vertical	Green	White	2	• 2 white	Tray lift motor
CN16	Horizontal	White	White	3	• 3 gray	Paper edge detect sensor
CN17	Vertical	Pink	Pink	2	• 2 blue	Paper feed clutch
CN18	Vertical	White	White	4	• Blue • Black • Brown • Yellow	Humidity sensor
CN20	Horizontal	Magenta	Red	3	• 3 red	Paper level sensor
CN23	Horizontal	White	White	9	• 9 gray	Paperfeed sensor

## CK2 board connectors

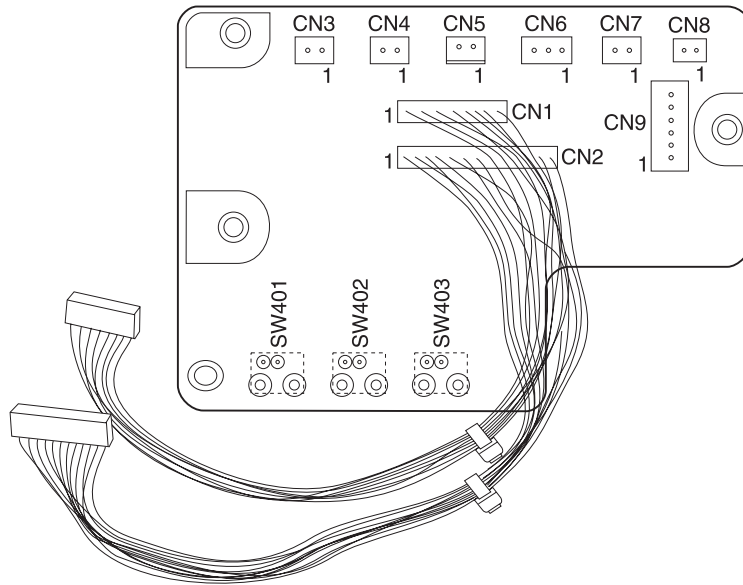

Conn #	Orientation	Board connector color	Cable connector color	# Wires	Wire color	Connector
CN1	Horizontal	Tan	Tan	8	• 8 green	Controller board
CN2	Horizontal	Tan	Tan	12	• 12 green	Controller board
CN3	Horizontal	Magenta	Red	2	• 2 red	Duplex
CN4	Horizontal	Green	Green	2	• 2 green	Face up
CN5	Horizontal	White	White	3	• 3 gray	Paper exit
CN6	Horizontal	White	White	3	• 1 black • 1 red • 1 yellow	Motor fan
CN7	Horizontal	Yellow	Yellow	2	• 2 blue	Face U/D solenoid
CN8	Horizontal	White		2		Flicker 230 V only
CN9	Vertical	Blue	Blue	6	• Yellow • Black • White • Gray • Blue • Brown	Motor drive

## RIP board

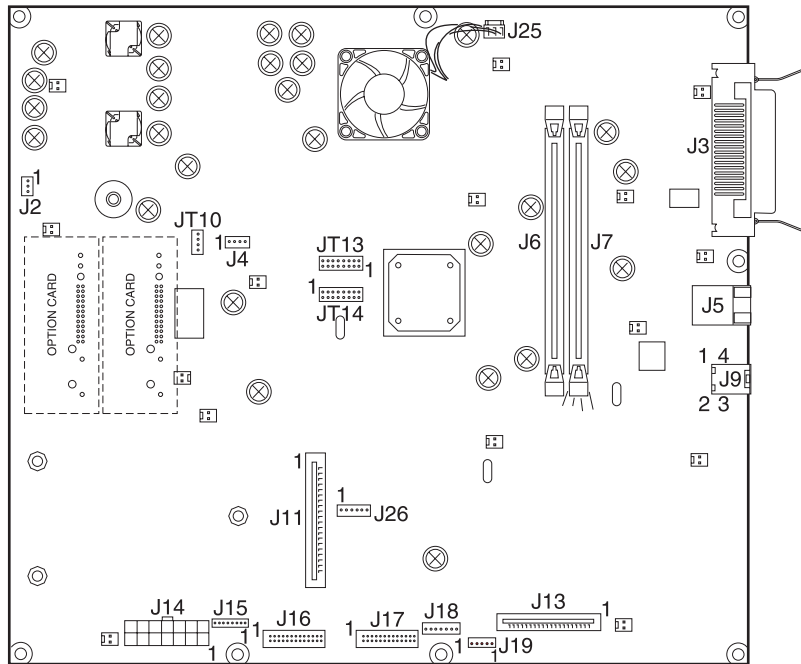

## RIP board connectors

Connection	# Wires	Wire colors	Connects to
J2	3	Black, red, yellow	Rip box fan
J3			Parallel port
J5			Ethernet port
J6			Memory
J7			Memory
J9	7		USB port
J14	14	3 yellow, 1 brown, 3 purple, 7 black	LVPS 2
J15	8	Green, 2 blue, 2 red, 2 yellow	Printhead controller
J16	36	35 blue, 1 white	Printhead controller
J17	26	25 green, 1 white	Printer controller
J18	7	Green, white, brown, white, blue, white, orange	Operator panel
J25	3	Red, white, black	CPU fan
J26	5	Red, white, green, black, silver	Operator panel USB connector

**LVPS 1 board connectors**

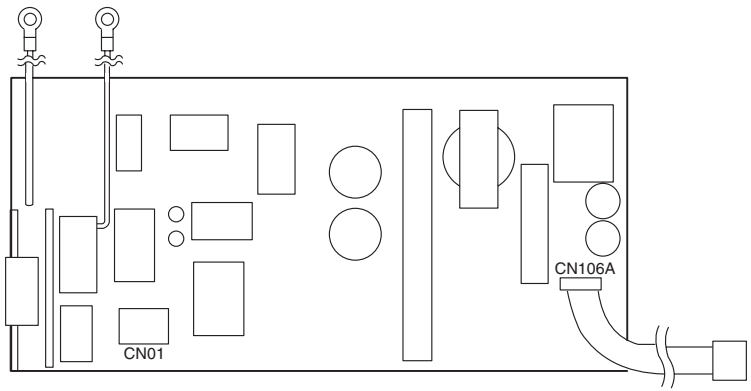

Conn #	Orientation	Board connector color	Cable connector color	# Wires	Wire color	Connector
CN01		White	White	4	<ul style="list-style-type: none"> <li>• Red</li> <li>• White</li> <li>• Blue</li> <li>• Black</li> </ul>	Main switch
CN04A		White	White	2	<ul style="list-style-type: none"> <li>• Black</li> <li>• White</li> </ul>	LVPS 2
CN106 A		White	White	5	<ul style="list-style-type: none"> <li>• 5 black</li> </ul>	LVPS 2

## LVPS 2 board connectors

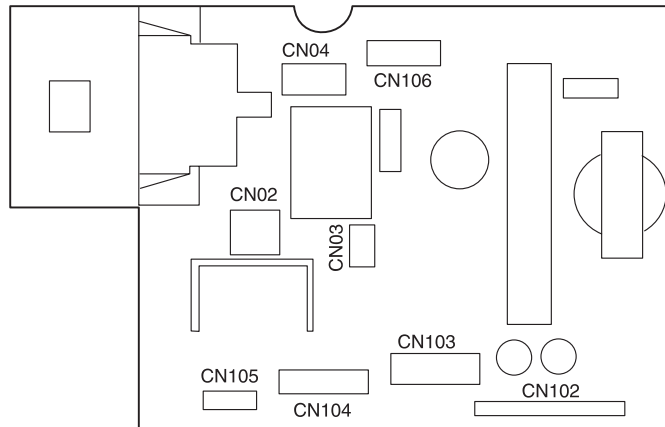

Conn #	Orientation	Board connector color	Cable connector color	# Wires	Wire color	Connector
CN02	Horizontal	White	White	3	<ul style="list-style-type: none"> <li>• Red</li> <li>• White</li> <li>• Black</li> </ul>	Fuser
CN03	Horizontal	White	White	2	<ul style="list-style-type: none"> <li>• Black</li> <li>• White</li> </ul>	Motor drive board
CN104	Horizontal	White	White	8	<ul style="list-style-type: none"> <li>• 2 yellow</li> <li>• 4 black</li> <li>• 2 red</li> </ul>	Printer controller
CN105	Horizontal	White	White	6	<ul style="list-style-type: none"> <li>• Gray</li> <li>• White</li> <li>• Red</li> <li>• Purple</li> <li>• Orange</li> <li>• Black</li> </ul>	Printer controller
CN102	Horizontal	White	White	14	<ul style="list-style-type: none"> <li>• 3 purple</li> <li>• 3 yellow</li> <li>• 1 brown</li> <li>• 7 black</li> </ul>	RIP board
CN103	Horizontal	Clear	Clear	14	<ul style="list-style-type: none"> <li>• 2 purple</li> <li>• 5 yellow</li> <li>• 7 black</li> </ul>	Printhead controller
CN04	Horizontal	White	White	2	<ul style="list-style-type: none"> <li>• Black</li> <li>• White</li> </ul>	LVPS 1
CN106	Horizontal	White	White	5	<ul style="list-style-type: none"> <li>• 5 black</li> </ul>	LVPS 1

## High voltage power supply board

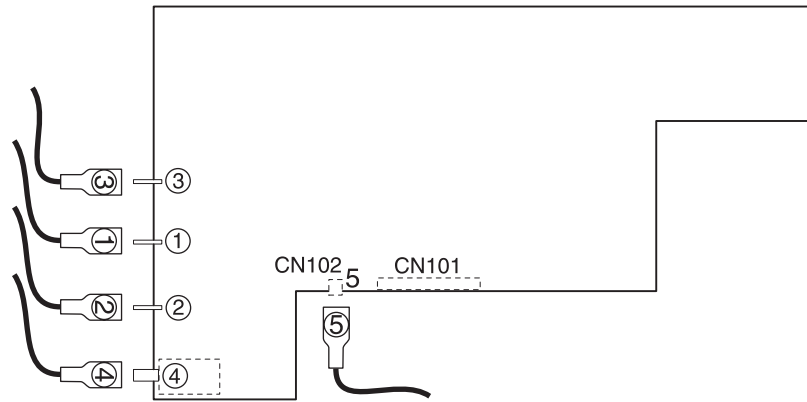

## Sensor board connectors

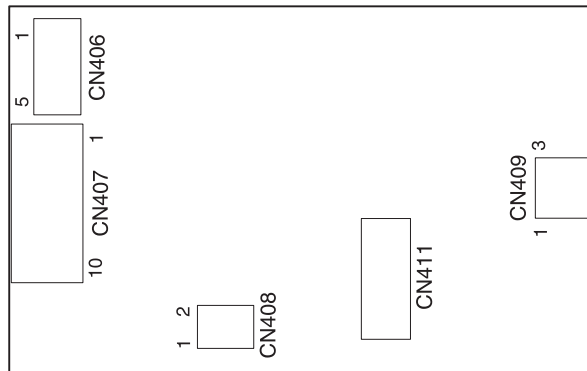

Conn #	Orientation	Board connector color	Cable connector color	# Wires	Wire color	Connector
CN406		White	White	5	<ul style="list-style-type: none"> <li>• Brown</li> <li>• Blue</li> <li>• Black</li> </ul>	Density sensor
CN407		White	White	14	<ul style="list-style-type: none"> <li>• 1 white</li> <li>• 13 blue</li> </ul>	Printer controller
CN409		White	White	3	<ul style="list-style-type: none"> <li>• Black</li> <li>• White</li> <li>• Yellow</li> </ul>	Belt up/down sensor
CN411		White	White	6	<ul style="list-style-type: none"> <li>• Grey</li> <li>• Purple</li> <li>• Green</li> <li>• Orange</li> <li>• Blue</li> <li>• Red</li> </ul>	Belt



## Expansion paper feeder controller board

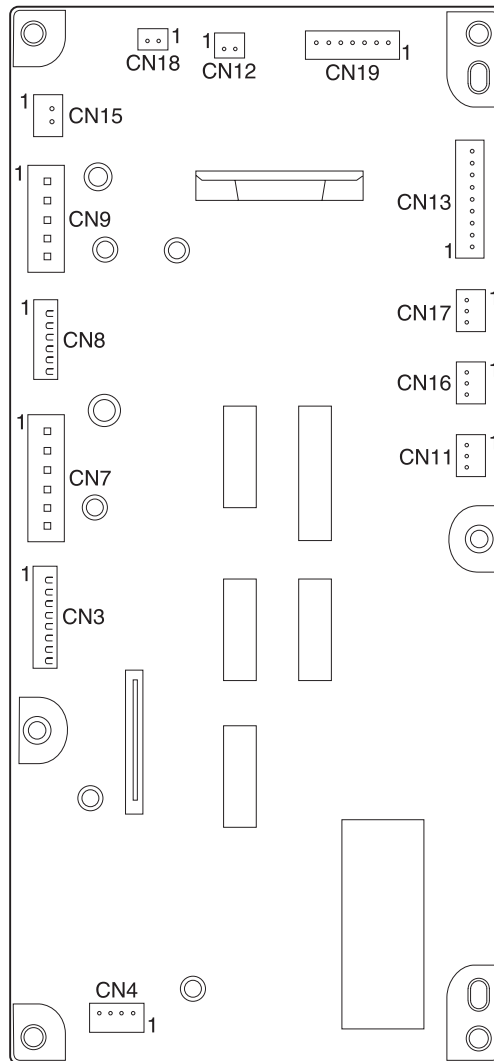

## Duplex unit controller board

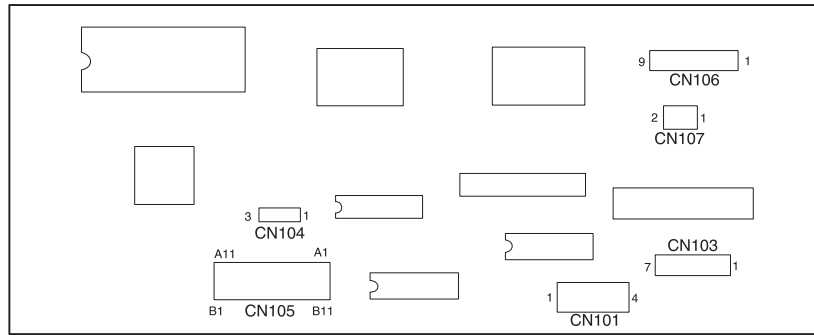

## Motor drive board connectors

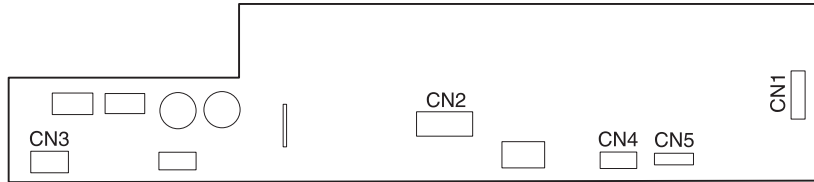

Conn #	Orientation	Board connector color	Cable connector color	# Wires	Wire color	Connector
CN2	Horizontal	White	White	3	<ul style="list-style-type: none"> <li>• White</li> <li>• Black</li> <li>• Red</li> </ul>	Motor
CN4	Horizontal	White	White	5	<ul style="list-style-type: none"> <li>• White</li> <li>• Yellow</li> <li>• Blue</li> <li>• Black</li> <li>• Red</li> </ul>	Motor
CN5	Horizontal	White	White	3	<ul style="list-style-type: none"> <li>• White</li> <li>• Black</li> <li>• Red</li> </ul>	Motor
CN1	Vertical	White	White	6	<ul style="list-style-type: none"> <li>• Brown</li> <li>• Blue</li> <li>• Gray</li> <li>• White</li> <li>• Black</li> <li>• Yellow</li> </ul>	CK2 daughter board
CN3	Horizontal	White	White	2	<ul style="list-style-type: none"> <li>• Black</li> <li>• White</li> </ul>	LVPS 2

**Size sensor board**

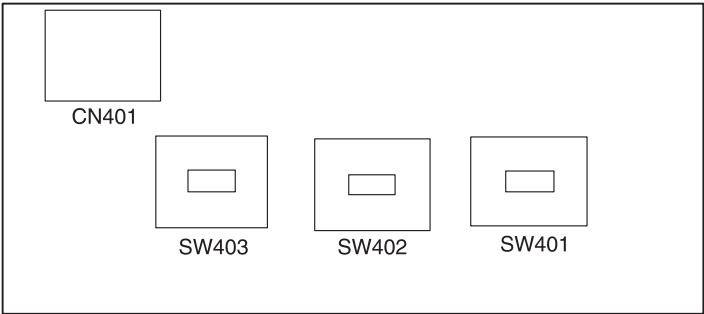

## Paper feed actuators

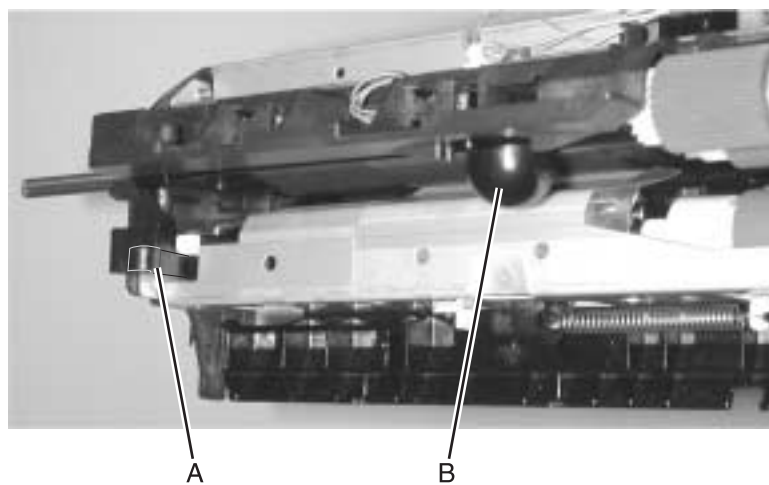

A	Paper tray present actuator
B	Paper out actuator

## Paper feed roller clutch



## High-capacity feeder (HCF)

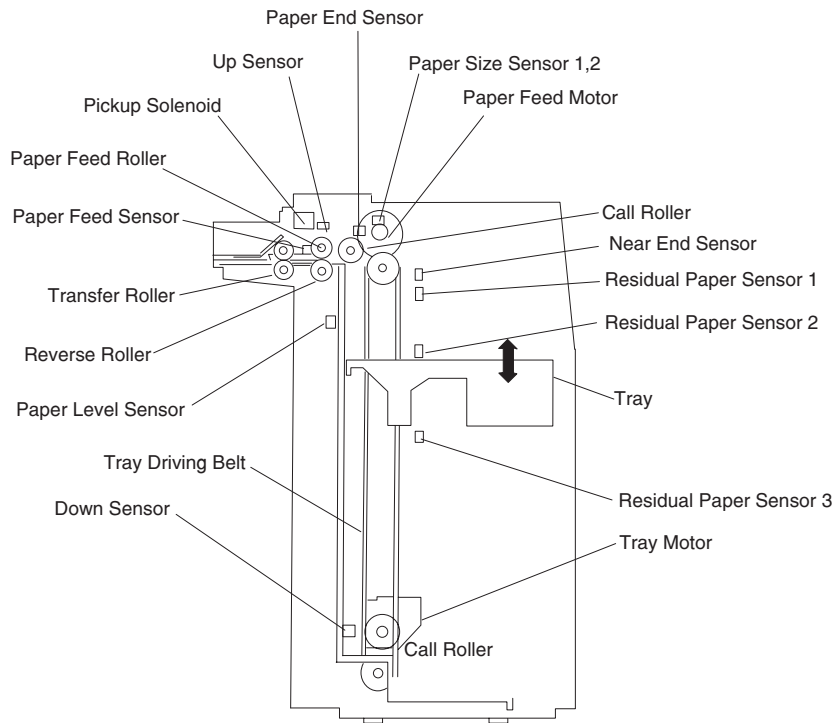

## High-capacity paper feed configuration

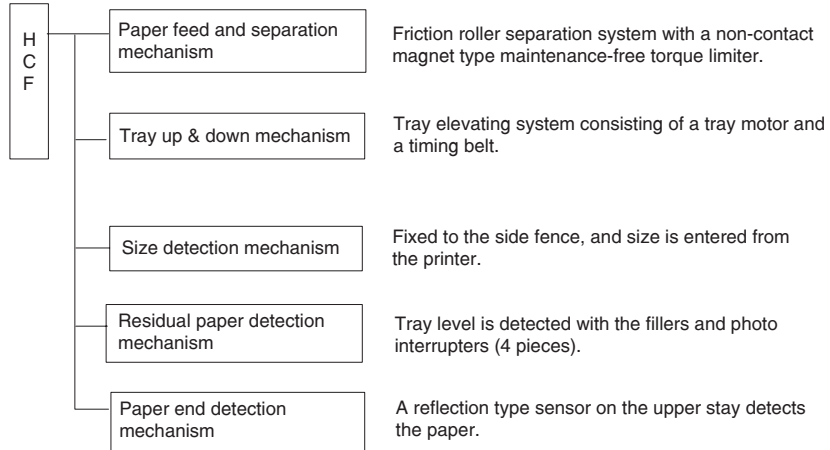

## Electrical parts layout

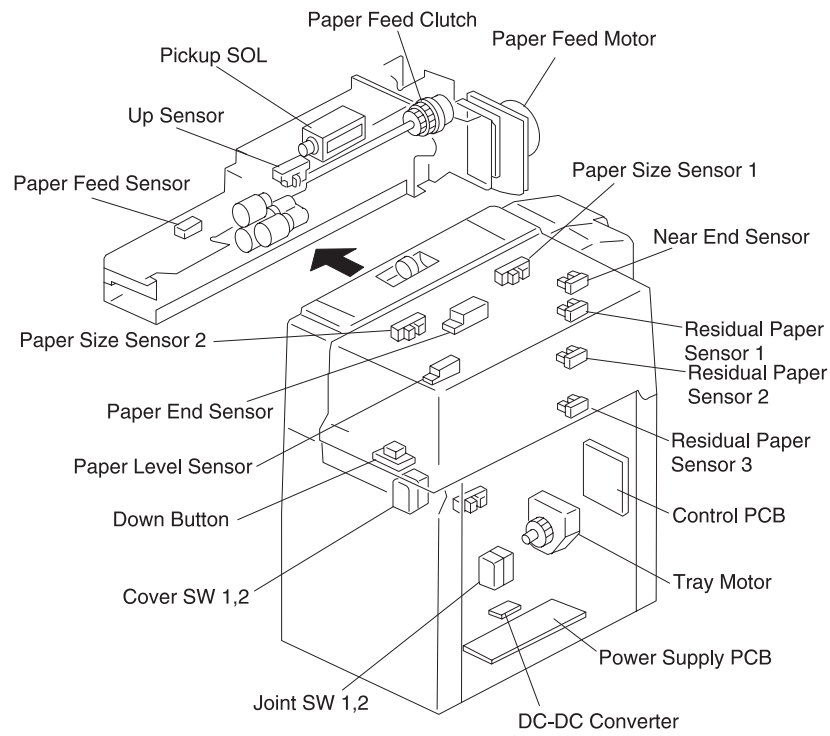

## Driving parts layout

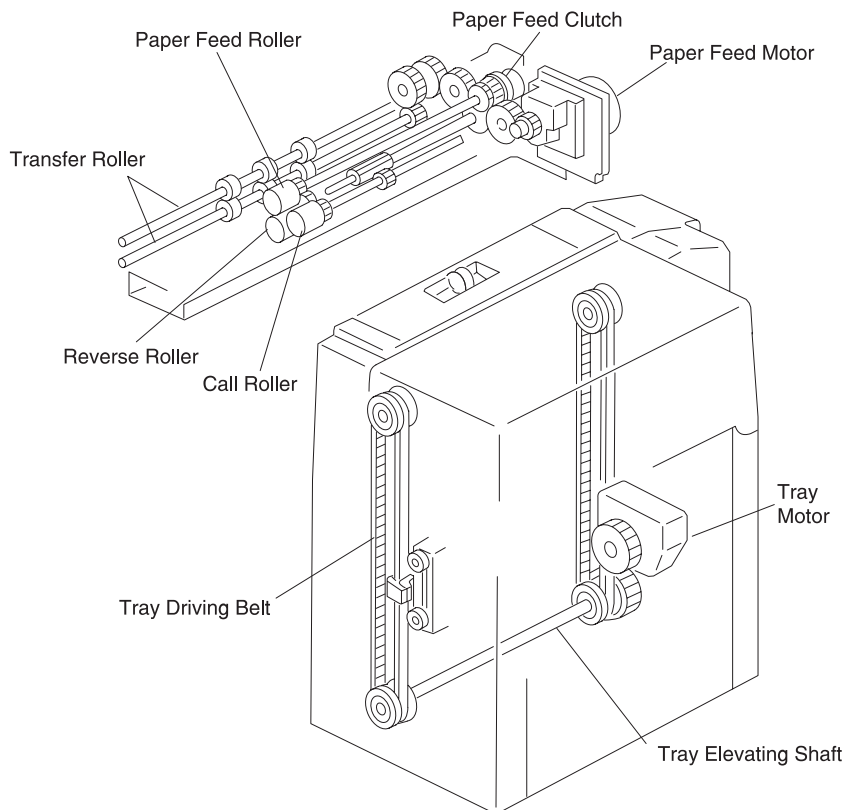

## Finisher locations

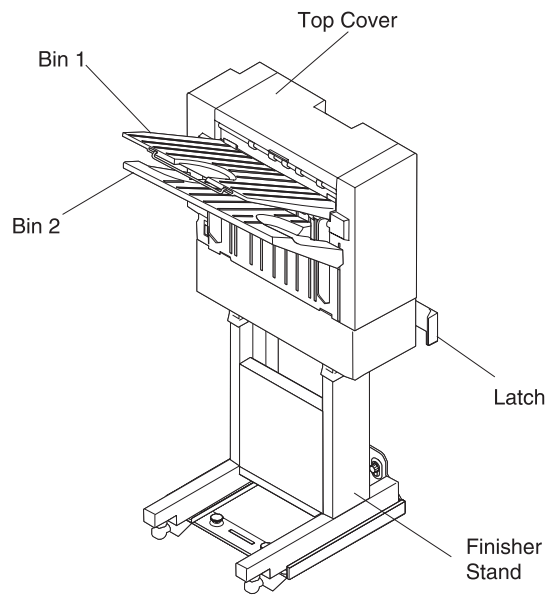
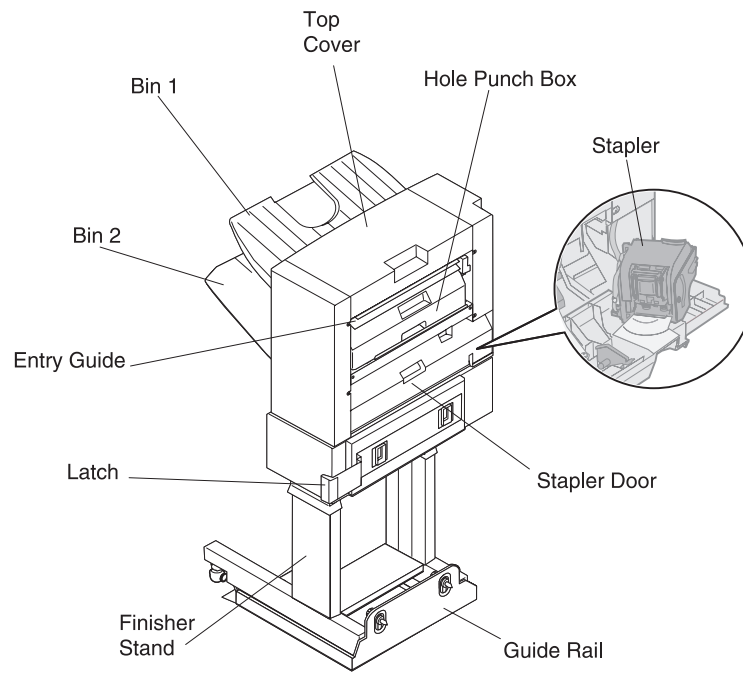

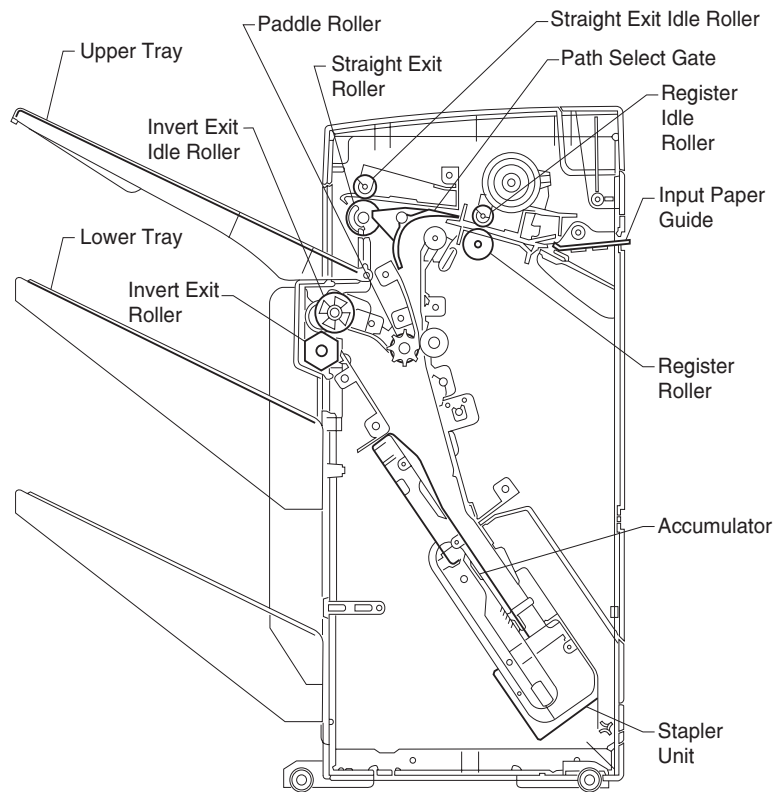

Sensor, Switch	Purpose
Paper input path sensor	Detects paper input from printer
Paper registration sensor	Trigger for punching
Paper exit sensor (face up bin)	Confirming paper path
Tractor home position sensor	Finds home position for driving belt
Paper full sensor A	Detecting paper full on tray 2
Paper detecting sensor	Detects paper for stapling
Staple home position sensor	Finds home position for stapling
No staple sensor	Detects staple empty
Finisher set switch	Detects connection with printer
Staple cartridge set switch	Detects staple cartridge open
Punch box detect sensor	Detects punch box
Invert path sensor	Detects invert paper jam
Paper exit sensor (face down bin)	Confirming paper path
Elevator upper limit sensor	Detecting face down bin
Elevator lower limit sensor	Detecting face down bin
Jogging home position sensor	Jogging home position for driving bar
Paper upper level sensor B	Detecting paper upper level



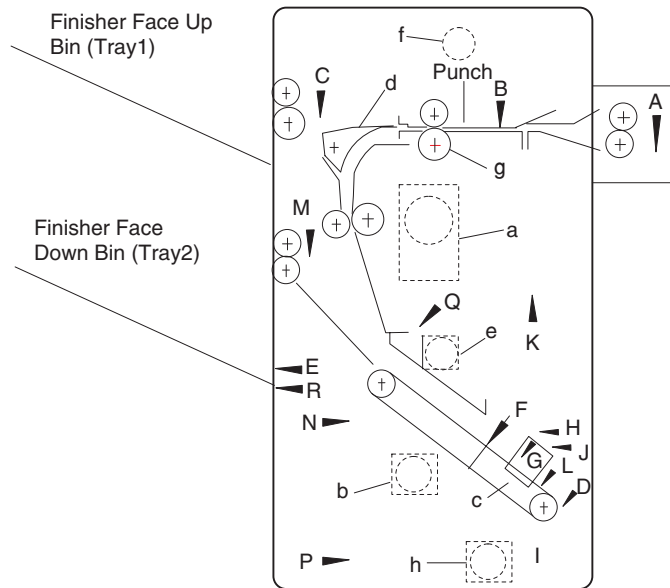

Motor, Solenoid, Clutch	Purpose
Paper feed motor	Paper feeding and inverting
Tractor drive motor	Tractor drive for paper feeding
Staple motor	Stapling
Path select solenoid	Path changing
Paper jogging motor	Jogging of paper
Punch clutch	Punching
Registration clutch	Paper registration/feeding
Elevator motor	Face down bin movement

## Finisher electrical parts

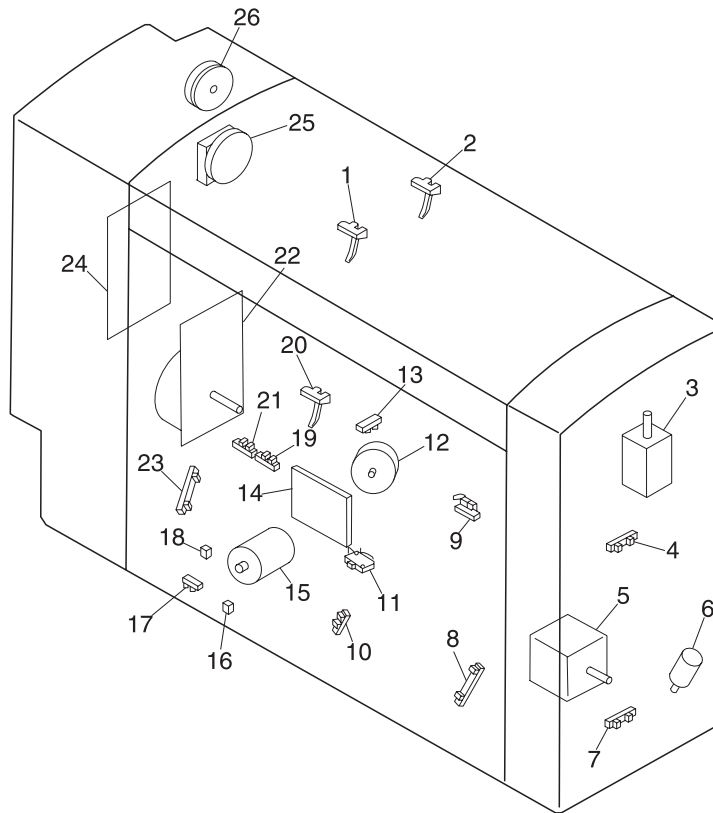

Number	Part name	Number	Part name
1	Paper exit sensor (upper tray)	14	Power supply PWBA
2	Paper register sensor	15	Staple motor
3	Path select solenoid	16	Staple existence sensor
4	Elevator upper limit Sensor	17	Staple home position sensor
5	Tractor drive motor	18	Staple cartridge set switch
6	Elevator motor	19	Paper upper level sensor B
7	Elevator lower limit sensor	20	Paper exit sensor (lower tray)
8	Invert path sensor	21	Paper full sensor A
9	Punch box detect sensor	22	Paper feed motor
10	Belt home position sensor	23	Paper detecting sensor
11	Finisher set switch	24	Finisher control board
12	Paper jogging motor	25	Registration clutch
13	Jogging home position sensor	26	Punch clutch

## 6. Preventive maintenance

### Maintenance kit

When nearing the end-of-life of the fuser or transfer belt, the following message appears, indicating that it's time to replace the fuser unit and/or transfer belt unit:

#### **80 Belt Life Warning** and/or **80 Fuser Life Warning**

Routine replacement of these parts ensures peak printer performance and helps prevent print quality problems and paper feed problems resulting from worn parts. The parts are in the maintenance kits listed.

Maintenance kit P/N	Unit	Printer power supply
40X1251	Transfer Belt	115 V–230 V
56P2650	Fuser	115 V
56P2651	Fuser	230 V

The status message appears until the appropriate part(s) is replaced.

### Paper path maintenance

A paper path maintenance kit can be used when a machine is experiencing misfeeds and jams after 200,000 pages. The order number for this kit is 40X1109. The kit is composed of the following parts:

56P9683	Carrying roller
40X1154	Registration frame
40X1077	Pickup roll
40X1078	Paper feed roll
40X1079	Separator roll
40X1064	FD paper exit roller

In addition to the paper path maintenance kit, the relay roller (40X1108) and turn guide rollers (40X1072) can be ordered.

When replacing the face down exit roller, lubricate the ends of the roller shaft with a small amount of Nyogel 744 (part number 40X0179).

## Periodic maintenance

This table lists the parts to be periodically cleaned by the servicer.

Part name		Method
Paper feed unit	<ul style="list-style-type: none"><li>• Pick roller</li><li>• Separator roller</li><li>• Paper feed roller</li><li>• MPF roll</li></ul>	Remove any dust or dirt, and wipe the surface lightly with a dry cloth. If it is still dirty, clean with a soft cloth and alcohol.
Registration unit	Registration roller, upper and lower	Remove any dust or dirt, and wipe the surface lightly with a dry cloth. If it is still dirty, clean with a soft cloth and alcohol.
Charge/exposure unit	LED head	Remove any dust or dirt, and wipe the surface lightly with a dry cloth. If it is still dirty, clean with a soft cloth and alcohol.
Transfer unit	Transfer belt	Remove any dust or dirt, and wipe the surface lightly with a dry cloth. If it is still dirty, clean with a soft cloth and alcohol.
Fuser unit	Heat rollers	Clean with a soft cloth, silicon oil, or alcohol.
Outer covers		Use a synthetic detergent and a damp cloth.

## Lubricants and cleaners

Lubricating	Cleaning
<ul style="list-style-type: none"><li>• Oil– #10: Apply between gears and shafts.</li><li>• Grease– # 23: Apply to gears.</li></ul>	Alcohol or isopropyl on plastic, rubber, and external parts.

## 7. Parts catalog

---

### How to use this parts catalog

The following legend is used in the parts catalog:

Asm- Index	Part number	Units/ mach	Description
---------------	----------------	----------------	-------------

- **Asm-index:** identifies the assembly and the item in the diagram. For example, 3-1 indicates assembly 3 and the item number 1.
- **Part number:** identifies the unique number that identifies this FRU.
- **Units/mach:** refers to the number of units actually used in the machine or product.
- **NS:** (Not shown) in the Asm-Index column indicates that the part is procurable, but is not pictured in the illustration.
- **PP:** (Parts Packet) in the parts description column indicates that the part is contained in a parts packet.

## Assembly 1: Covers 1

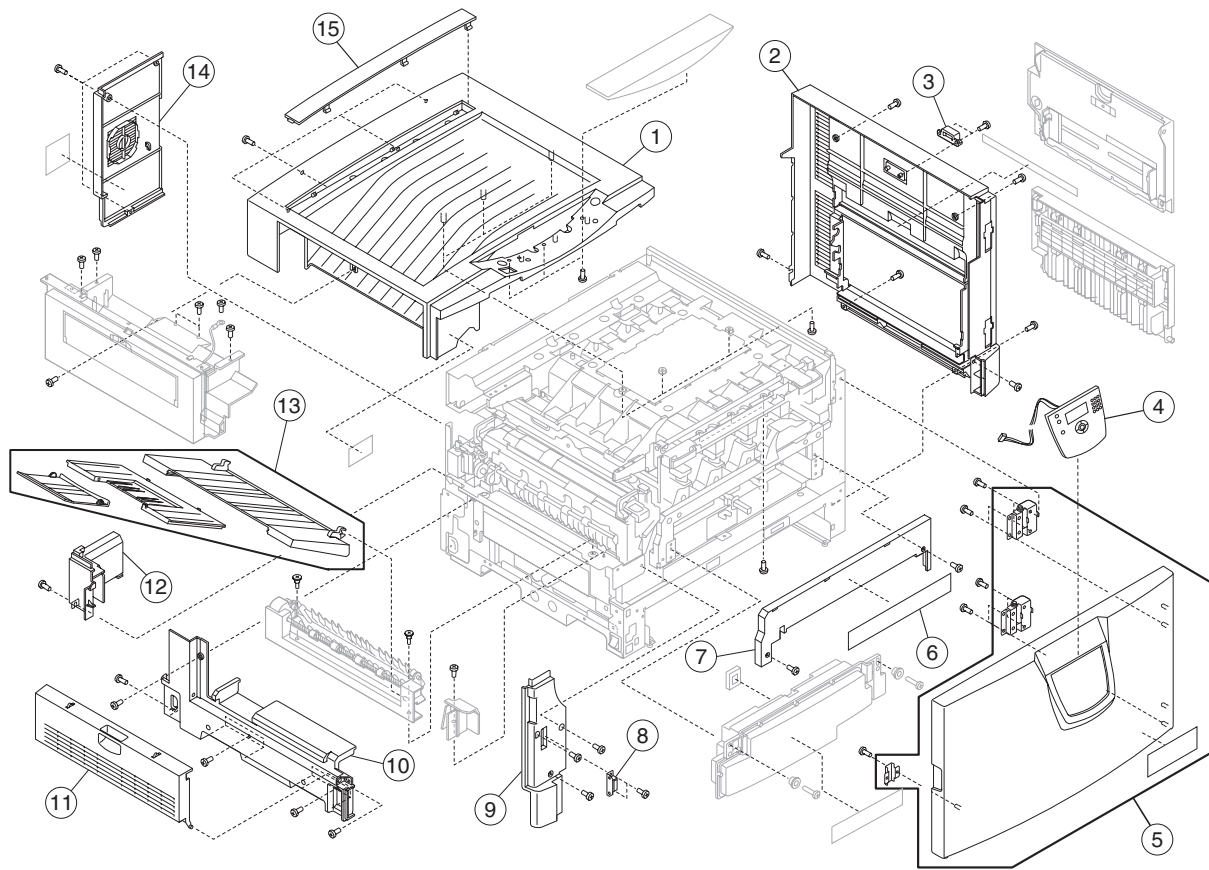

## Assembly 1: Covers 1

Index	P/N	Units	Description
1-4	40X1131	1	Cover, top
1-2	40X1124	1	Cover assembly, right side
1-3	40X1139	1	Magnet, right side latch
1-4	40X1259	1	Operator panel
1-5	40X1123	1	Cover assembly, front
1-6	56P9545	1	Label, operator panel
1-7	40X1132	1	Cover, waste toner bottle
1-8	40X1140	1	Magnet, front cover latch
1-9	40X1129	1	Cover, left front
1-40	40X1126	1	Cover, left side
1-41	40X1127	1	Cover, paper feed
1-42	40X1125	1	Cover, solenoid
1-43	40X1122	1	Tray assembly, exit
1-44	40X1128	1	Cover, rear
1-45	40X1130	1	Cover, adjustment
NS	40X1516		Label, MPT
NS	40X1262		Parts packet

## Assembly 2: Covers 2

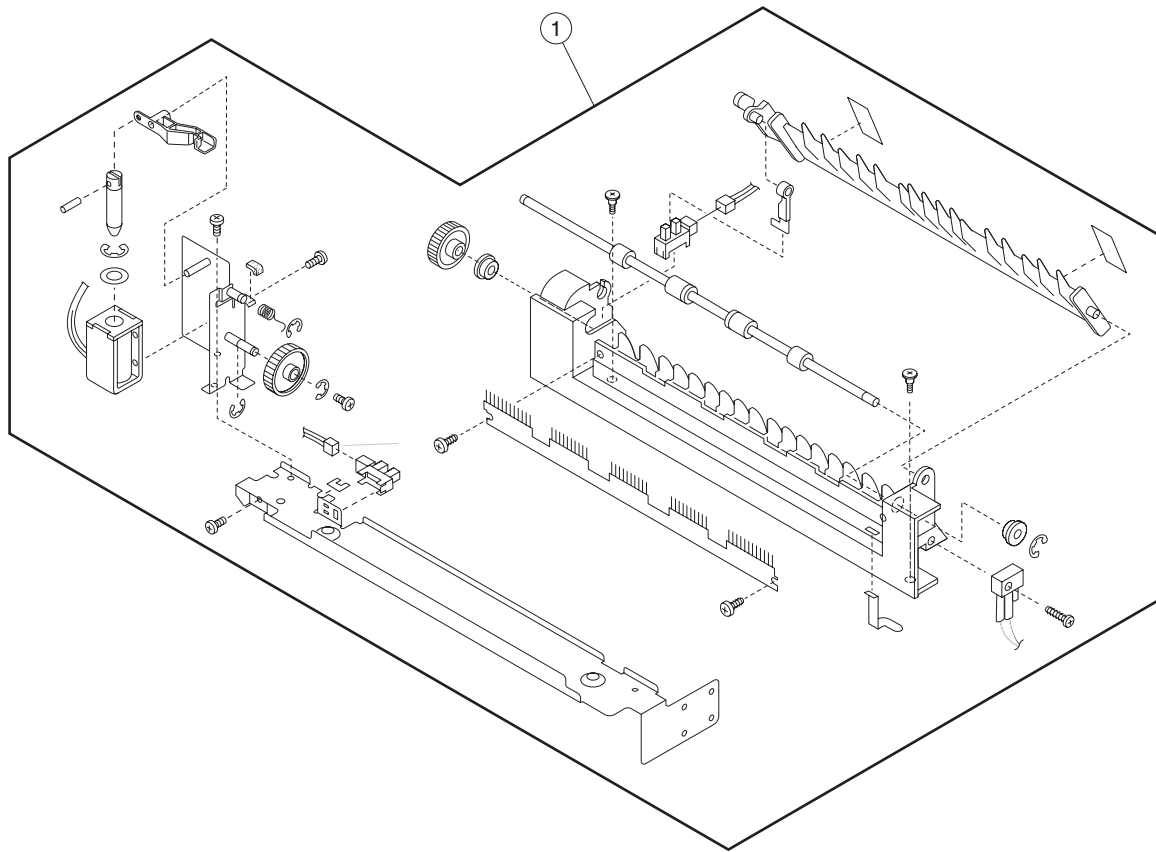

Index	P/N	Units	Description
2 —1	40X1026	1	Exit assembly, face up



## Assembly 3: Covers 3

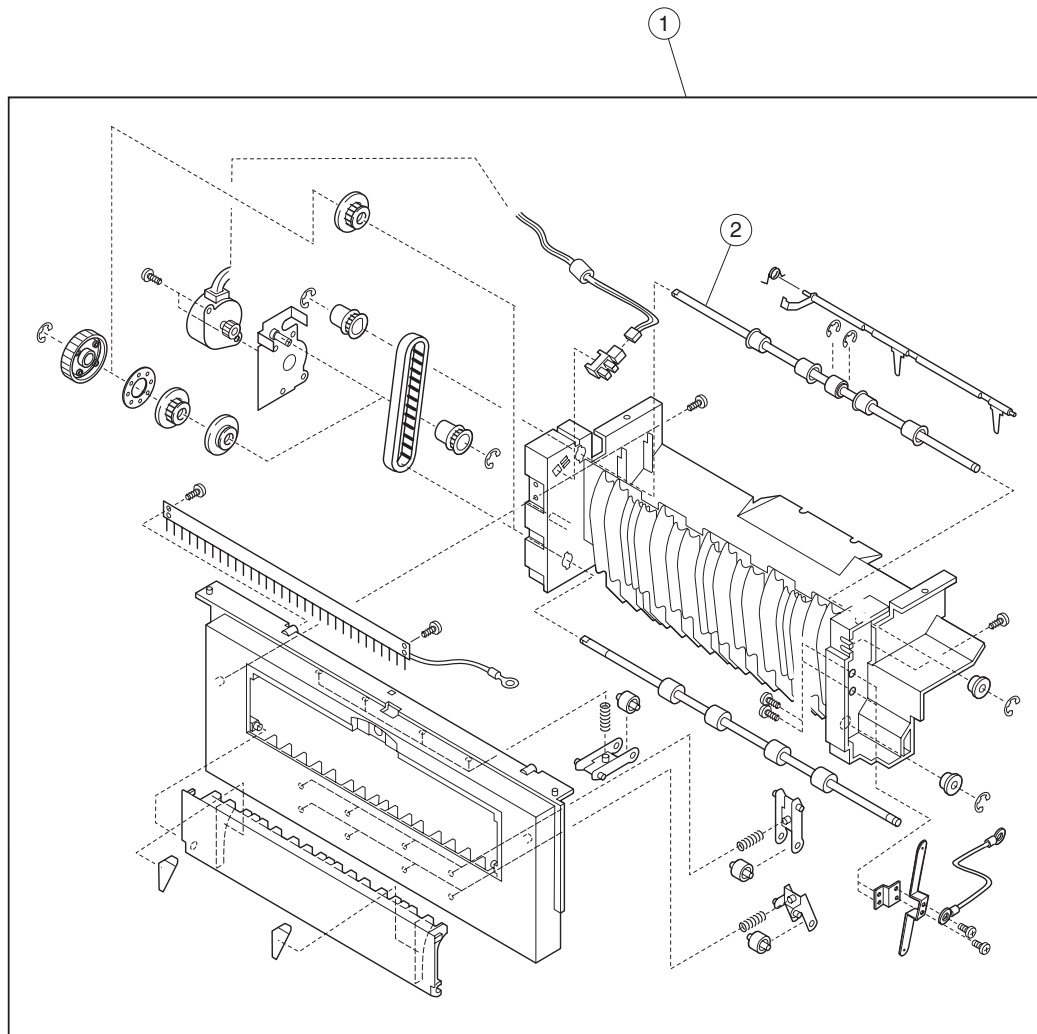

Index	P/N	Units	Description
3 —1	40X1027	1	Guide assembly, face-down
3 —2	40X1064	1	Exit roller, face-down

# Assembly 4: Covers 4

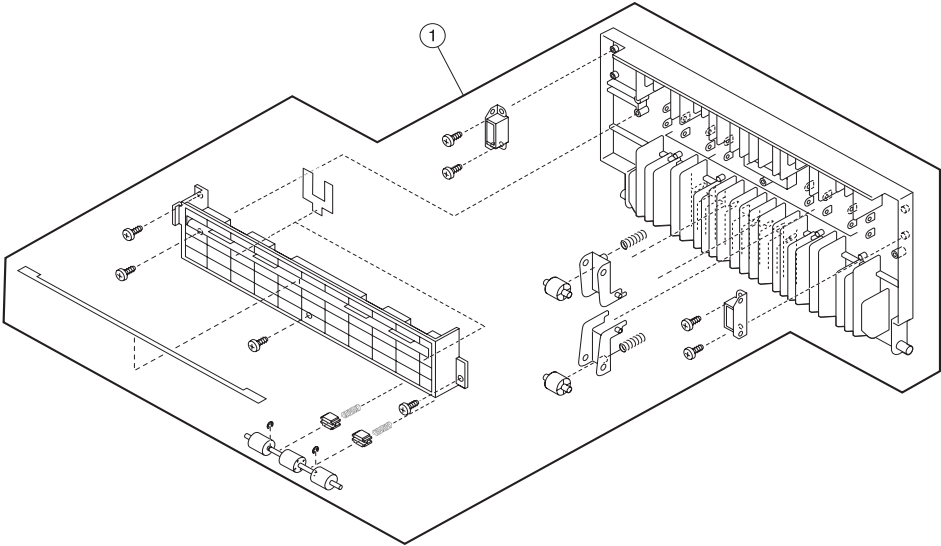

Index	P/N	Units	Description
4 —1	40X1242	1	Guide assembly, turn

## Assembly 5: Covers 5

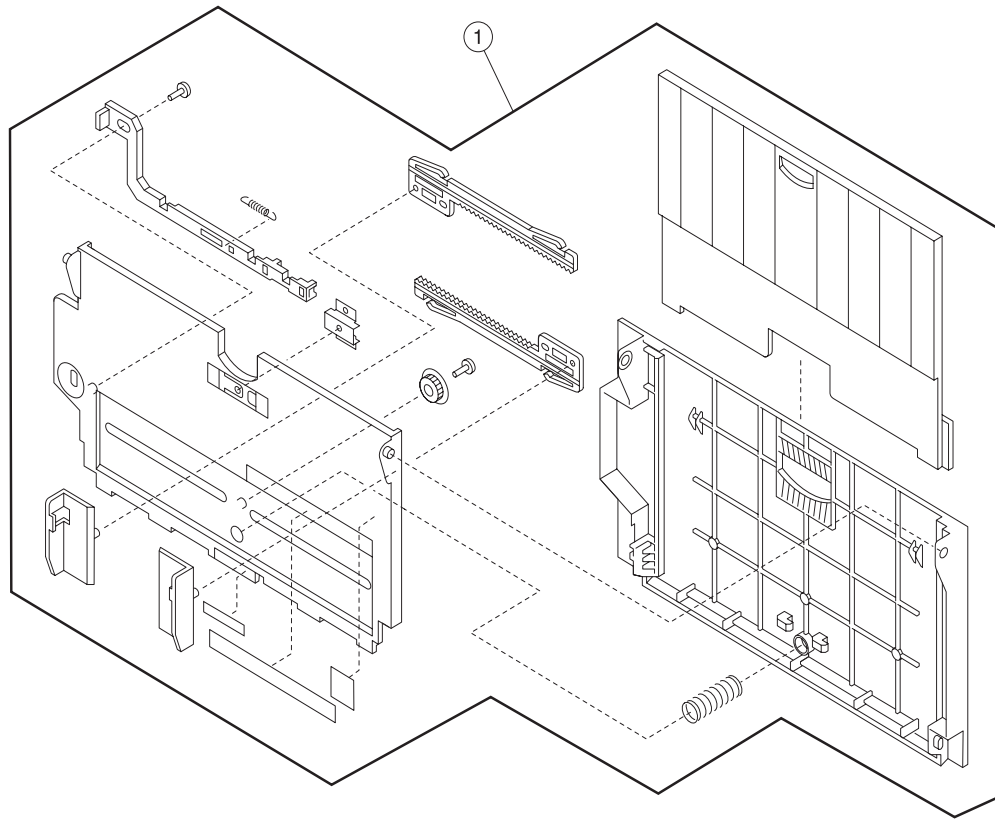

Index	P/N	Units	Description
5 —1	40X1135	1	Feeder assembly, multipurpose

# Assembly 6: Upper unit

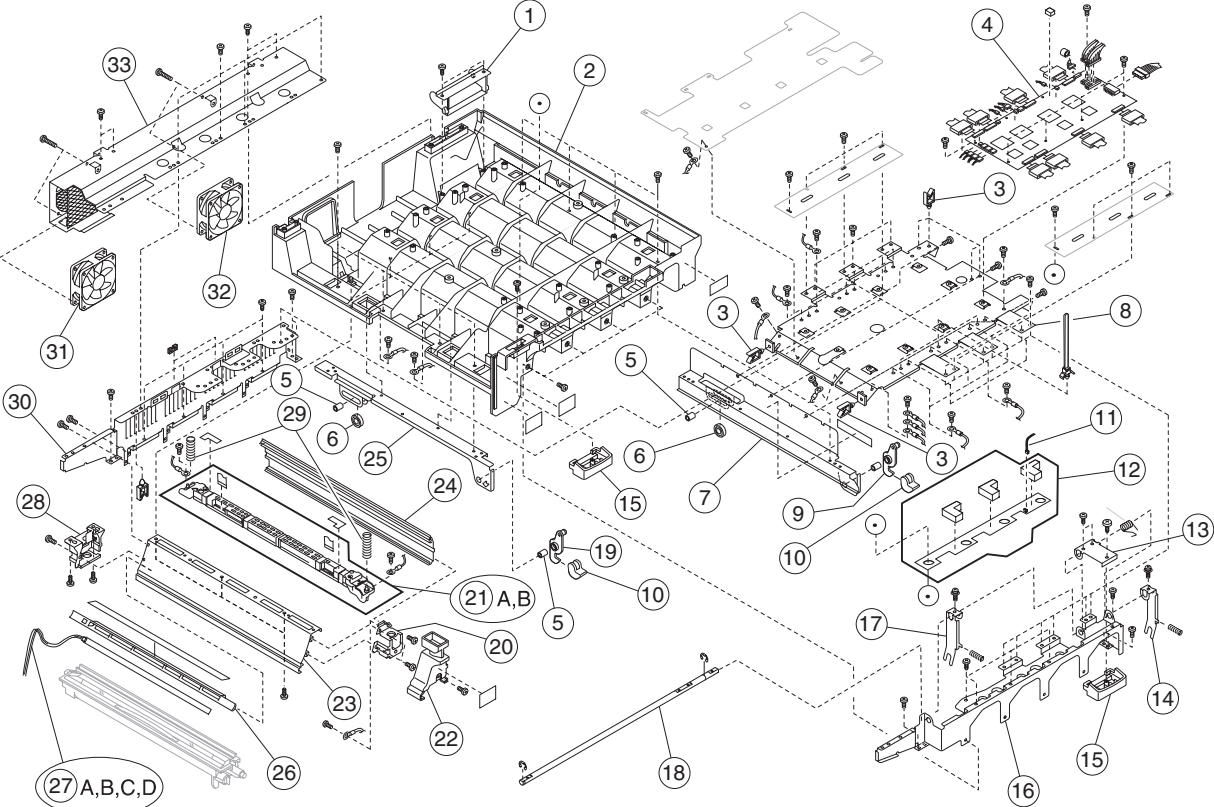

## Assembly 6: Upper unit

Index	P/N	Units	Description
6-4	56P9632	1	Shroud, cable
6-2	56P9591	1	Frame, upper
6-3	56P9638	4	Holder, cable
6-4	56P3980	1	Board, printhead controller
6-5	56P9628	2	Pivot, color link
6-6	56P9627	2	Bearing, roller
6-7	56P9624	1	Link, frame
6-8	40X1149	1	Frame, printhead controller
6-9	56P9625	1	Hook, right link
6-10	56P9626	2	Cover, hook
6-11	40X1118	1	Cable, RFID
6-12	40X1117	1	Assembly, RFID
6-13	40X1145	1	Hook, middle
6-14	40X1147	1	Hook, right
6-15	40X1257	1	Handle, up opening
6-16	40X1143	1	Bracket, front upper
6-17	40X1146	1	Hook, left
6-18	40X1144	1	Rod, interlocking
6-19	56P9630	1	Hook, left link
6-20	40X1142	4	Holder, front hsp
6-21A	56P3981	1	Assembly, LED printhead (K)
6-21B	56P3982	3	Assembly, LED printhead (C)
6-22	56P9611	4	Holder, front printhead
6-23	56P9592	4	Rail, left side
6-24	56P9610	4	Rail, right side
6-25	56P9629	1	Link, frame
6-26	56P9594	4	Cover, eraser
6-27A	40X1028	1	Lamp, M erase
6-27B	40X1029	1	Lamp, C erase
6-27C	40X1030	1	Lamp, Y erase
6-27D	40X1031	1	Lamp, K erase
6-28	56P9593	4	Holder, rear printhead
6-29	56P9609	8	Spring, printhead
6-30	40X1148	1	Bracket, rear upper
6-31	40X1032	1	Fan, upper right
6-32	40X1033	1	Fan, upper left
6-33	56P9621	1	Bracket, fan holder
NS	56P9993	4	Shield, light (used on p/n 56P9594)
NS	40X1263		Parts packet

# Assembly 7: Paper feed

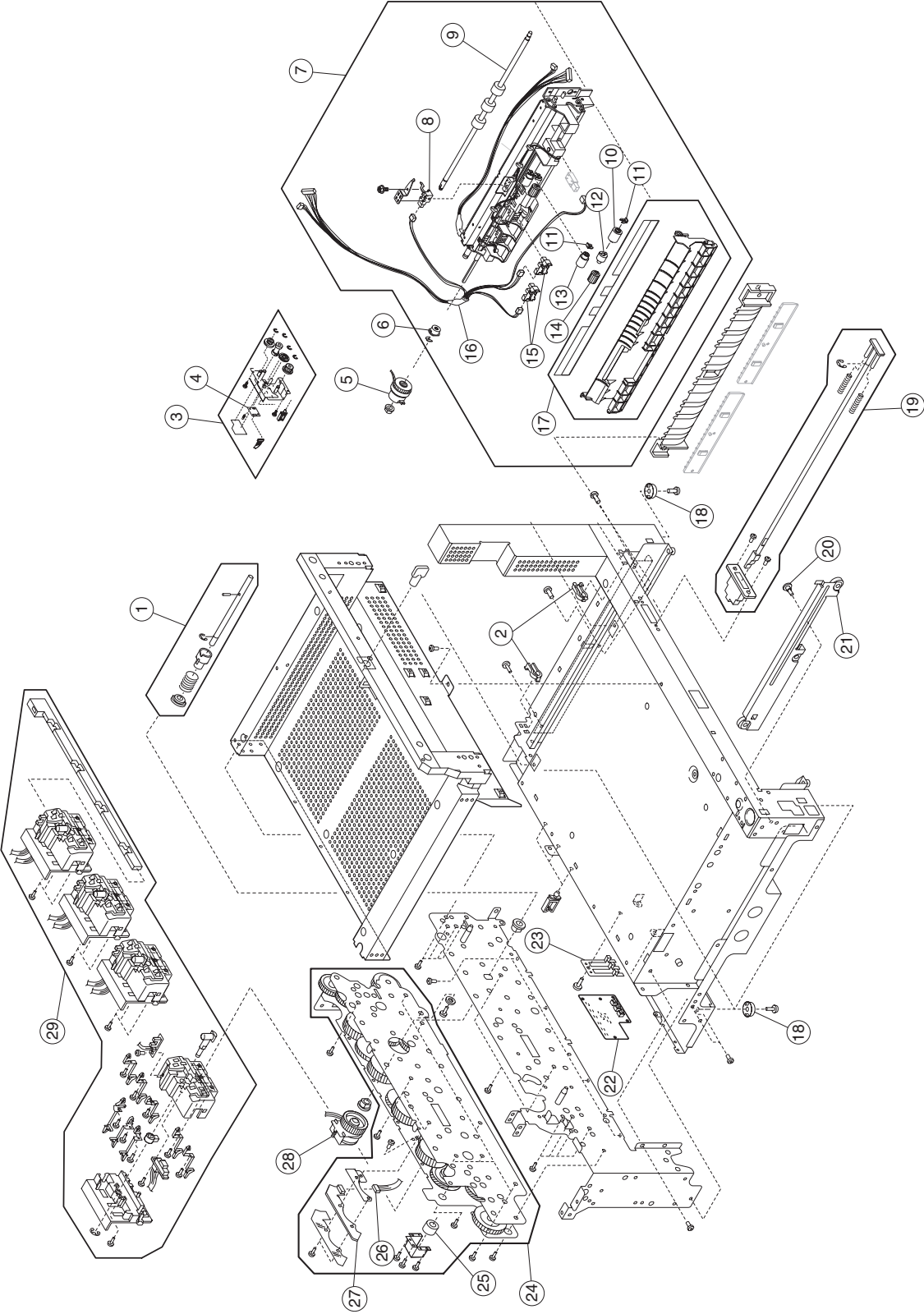

## Assembly 7: Paper feed

Index	P/N	Units	Description
7—1	40X1119	1	Shaft, changing
7—2	40X1103	2	Bushing, turn guide
7—3	40X1112	1	Assembly, drive link
7—4	40X1247	1	Sensor, humidity (not included in 7-3)
7—5	40X1082	1	Clutch, paper feed
7—6	40X1081	1	Clutch, roller 6 x 10 x 14
7—7	40X1075	1	Assembly, paper-feed base
7—8	40X1107	1	Sensor, relay
7—9	40X1108	1	Roller, relay
7—10	40X1079	1	Roller, separator
7—11	40X1106	1	Clip, paper-feed shaft
7—12	40X1080	1	Clutch, friction (torque limiter)
7—13	40X1078	1	Roller, paper feed
7—14	40X1077	1	Roller, pickup
7—15	40X1173	2	Interrupt, photo
7—16	40X1098	1	Cable asm, paper-feed type 1
7—17	40X1076	1	Plate, guide rocking
7—18	56P9503	4	Foot, rubber
7—19	56P9641	1	Actuator, front cover open switch
7—20	56P9524	1	Screw, slide rail
7—21	40X1034	1	Rail, base left side
7—22	40X1083	1	Board, CK2 daughter board/sensor
7—23	56P9521	1	Lever, size sense
7—24	56P2666	1	Unit, drive 120V
7—24	56P2667	1	Unit, drive 230V
7—25	40X1150	1	Clutch, drive unit
7—26	56P9644	1	Cable asm, drive unit sensor
7—27	56P9645	1	Sensor, drive unit
7—28	40X1037	1	Clutch, belt up/down
7—29	56P2668	1	Frame, sub
NS	40X1264	-	Parts packet (See <b>“Parts packets” on page 7-58</b> for contents)

# Assembly 8: Base 2

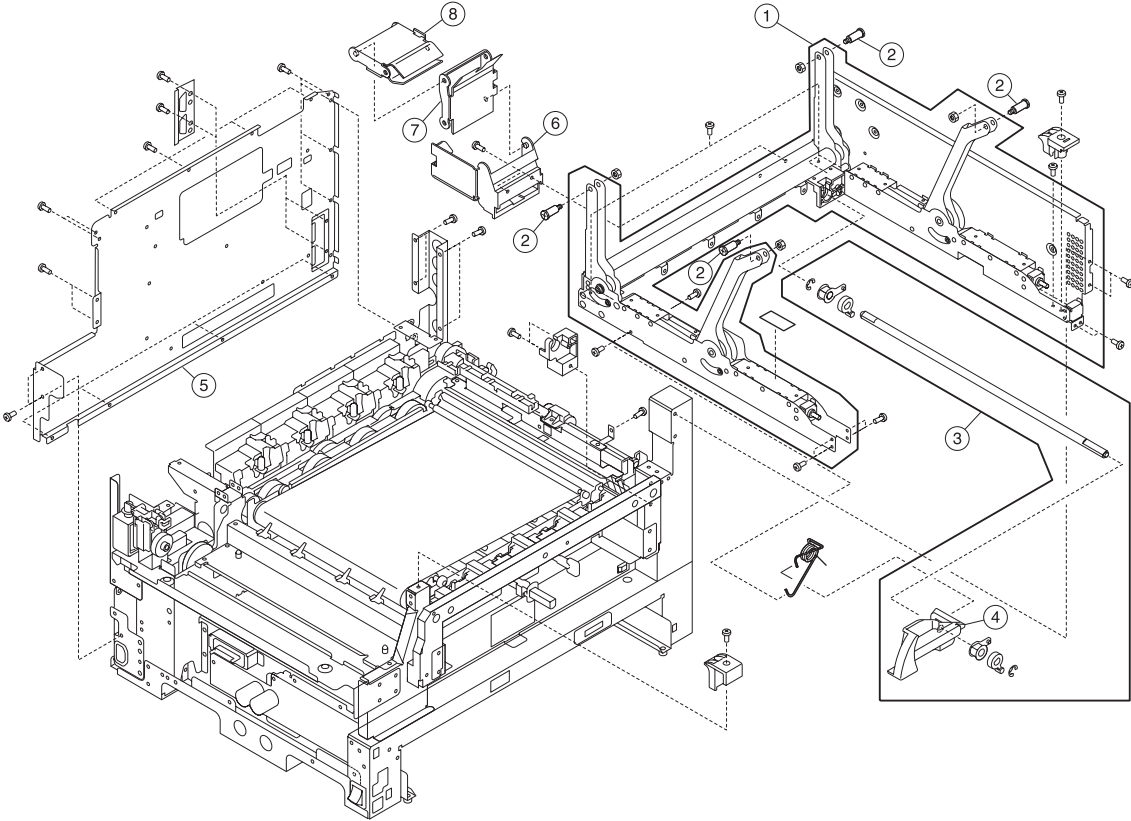



## Assembly 8: Base 2

Index	P/N	Units	Description
8 —1	40X1207	1	Support assembly, upper unit
8 —2	56P9667	4	Pin, upper unit support
8 —3	40X1208	1	Handle assembly, lock
8 —4	56P9669	1	Handle, lock
8 —5	40X1151	1	Cover, electronic
8 —6	56P9670	1	Shroud, cable
8 —7	56P9672	1	Guide, cable
8 —8	56P9671	1	Guide, cable
NS	40X1265	1	Parts packet

# Assembly 9: Base 3

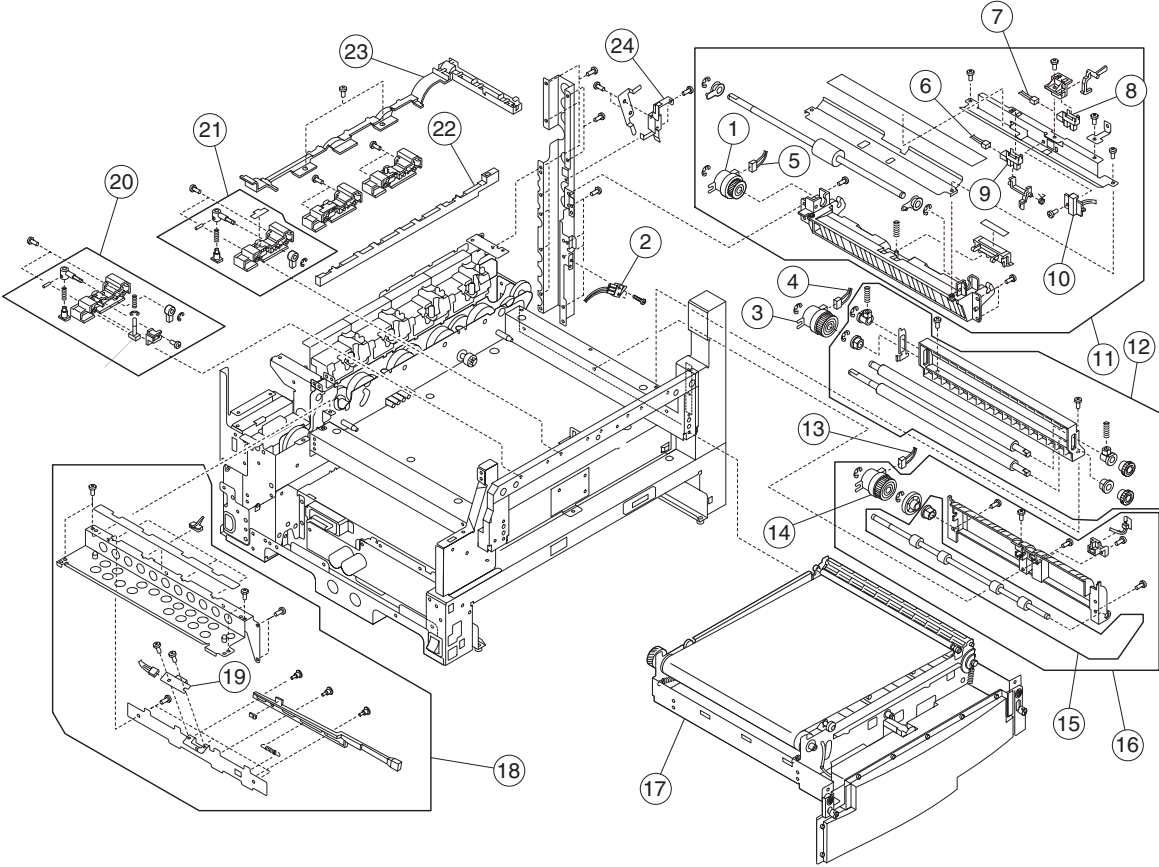

## Assembly 9: Base 3

Index	P/N	Units	Description
9—1	40X1067	1	Clutch, MPF
9—2	40X1085	1	Switch, turn guide
9—3	40X1040	1	Clutch, registration
9—4	40X1113	1	Cable, registration clutch
9—5	40X1116	1	Cable, MPF clutch
9—6	40X1115	1	Cable, registration sensor
9—7	40X1115	1	Cable, registration sensor
9—8	40X1137	1	Photo interruptor
9—9	40X1136	1	Photo interruptor
9—10	56P2671	1	Sensor, upper OHP
9—11	56P2669	1	Frame assembly, MPF
9—12	40X1154	1	Frame assembly, registration
9—13	40X1114	1	Cable, carrying clutch
9—14	40X1040	1	Clutch, registration (used on carrying frame)
9—15	56P9683	1	Roller assembly, carrying
9—16	40X1025	1	Frame assembly, carrying
9—17	40X1041	1	Unit, transfer belt
9—18	40X1209	1	Guide assembly, fuser entry
9—19	40X1152	1	Sensor, density
9—20	40X1155	2	Frame assembly, F1 sub
9—21	56P9685	2	Frame assembly, F2 sub
9—22	56P9686	1	Rod, lock
9—23	56P9687	1	Cover, gear
9—24	40X1156	1	Stopper, clutch
NS	56P9697	1	Bushing
NS	40X1266		Parts packet

# Assembly 10: Electrical A

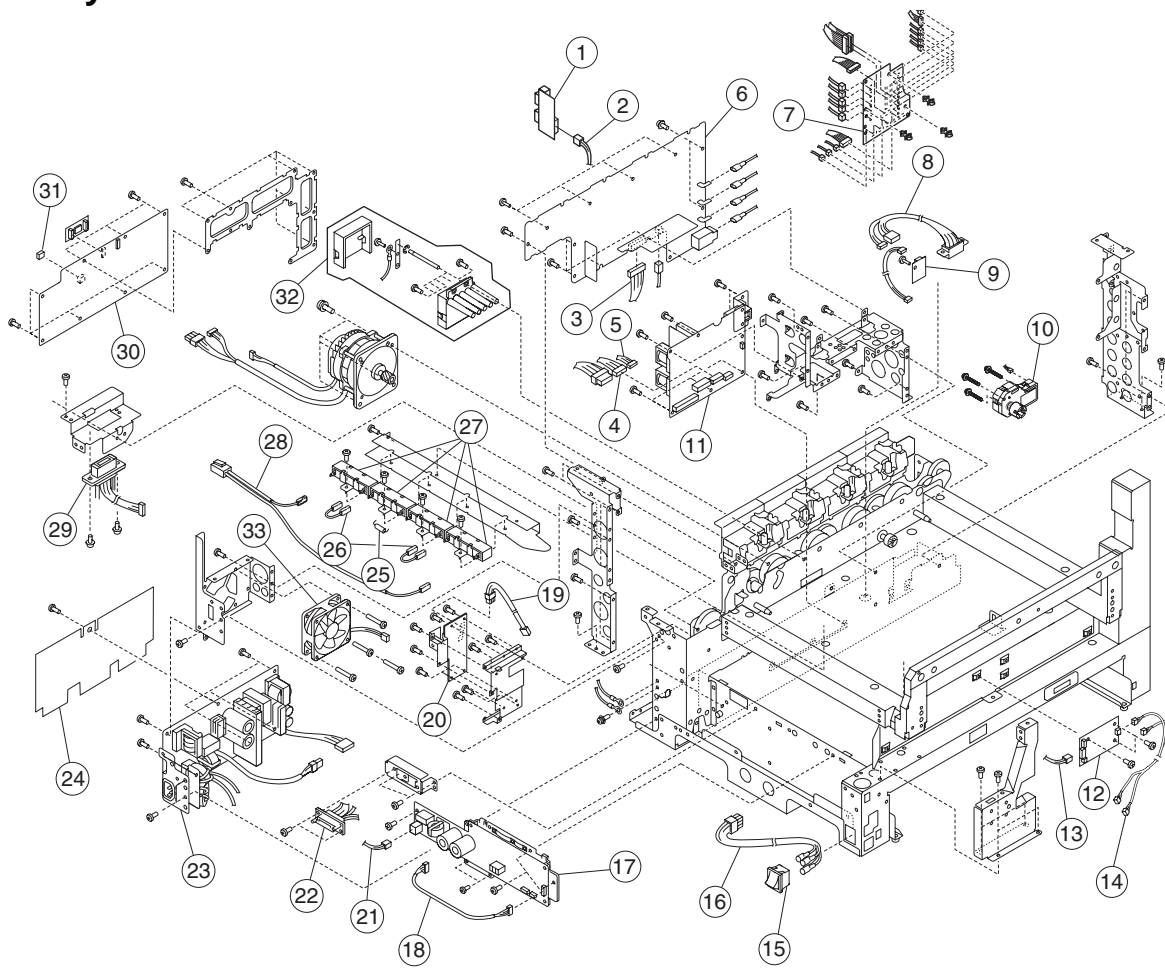

## Assembly 10: Electrical A

Index	P/N	Units	Description
10 —1	40X1101	1	Asm, HCF/FIN D-Sub
10 —2	40X1102	1	Cable asm, finisher
10 —3	56P9715	1	Cable asm, HVU
10 —4	56P9727	1	Cable asm, printer controller power 2
10 —5	40X1053	1	Cable asm, printer controller power 1
10 —6	56P3983	1	Supply, high voltage
10 —7	40X1084	1	Card, CK1 Daughter
10 —8	40X1042	1	Cable asm, feeder
10 —9	40X1247	1	Sensor, humidity
10 —10	40X1097	1	Motor, paper tray lift
10 —11	56P3986	1	Supply, 120V power 2
10 —11	56P3987	1	Supply, 230V power 2
10 —12	40X1043	1	Board, sensor
10 —13	40X1044	1	Cable asm, sensor board
10 —14	40X1120	1	Cable, belt relay
10 —15	40X1158	1	Switch, power
10 —16	40X1157	1	Cable, power switch
10 —17	56P2652	1	Board, 120V motor driver
10 —17	56P2653	1	Board, 230V motor driver
10 —18	40X1055	1	Cable asm, MIF
10 —19	40X1205	1	Cable asm, conditioning printer controller
10 —20	56P3988	1	Card, conditioning (230V only)
10 —21	56P9747	1	Cable, motor driver power
10 —22	56P2670	1	Cable asm, duplex connector
10 —23	56P3984	1	Supply, 120V power 1
10 —23	56P3985	1	Supply, 230V power 1
10 —24	56P9737	1	Sheet, insulation
10 —25	56P9943	1	Fuse, thermal (230V only)
10 —26	56P9738	1	Cable, conditioning joint (230V only)
10 —27	56P9741	1	Resistor, conditioning (230V only)
10 —28	56P9740	1	Cable, conditioning resistor (230V only)
10 —29	40X1049	1	Cable, fuser drawer
10 —29	40X1050	1	Cable, fuser drawer (230V only)
10 —30	56P2654	1	Board, printer controller
10 —31	56P9729	1	EEPROM, printer controller
10 —32	40X1052	1	Belt, power supply
10 —33	40X1047	1	Fan, power supply
NS	40X0269		Cord (8ft right angle) , US, Canada, ET AL
NS	40X0270		Cord (8ft 15A straight), Japan
NS	40X0286		Cord (6ft straight), England, France, Germany, Spain, Belgium
NS	40X0272		Cord (8ft right angle), Argentina, Paraguay, Uruguay
NS	40X0273		Cord (8ft straight), Italy
NS	40X0274		Cord (6ft straight), Switzerland
NS	40X0271		Cord (8ft straight ), UK

## Assembly 10 (continued): Electrical A

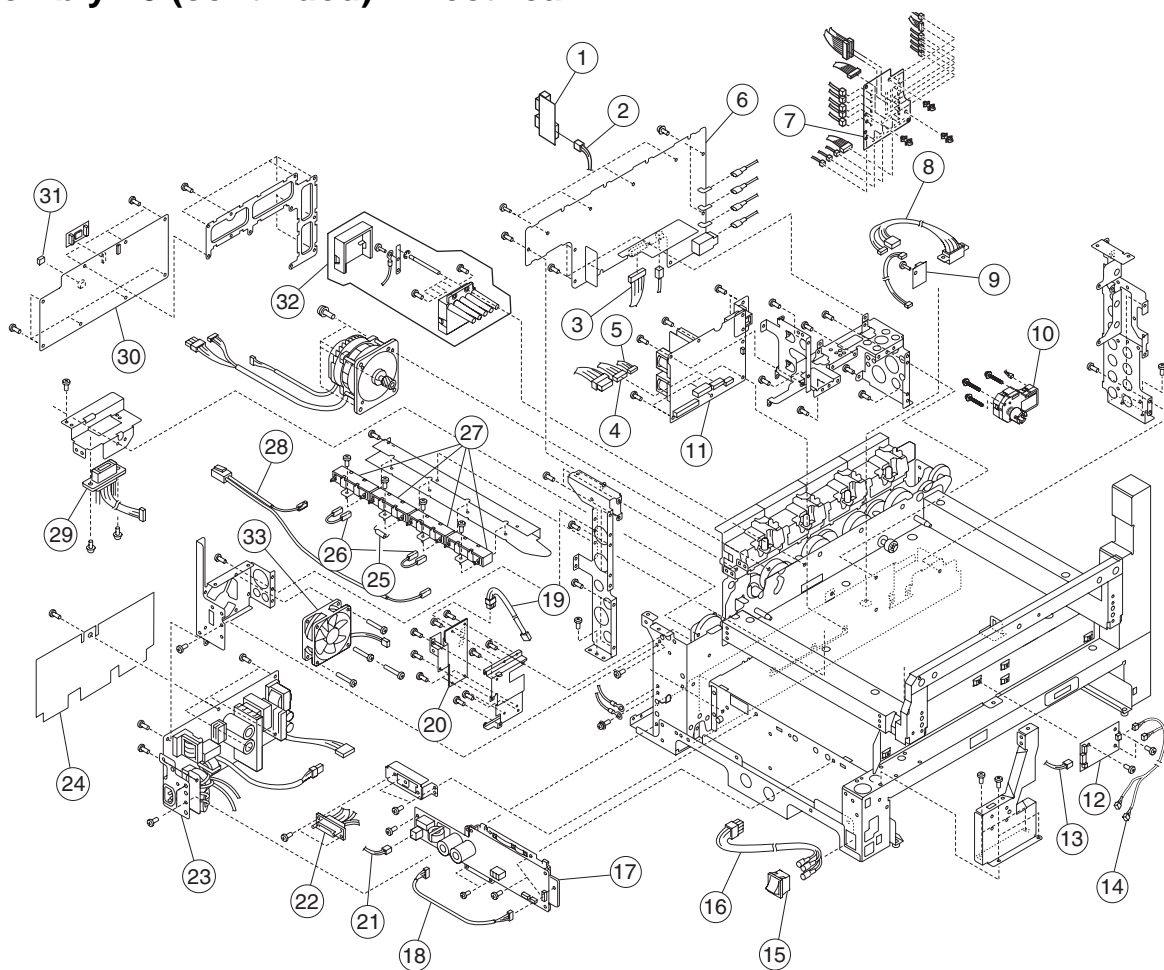

## Assembly 10 (continued): Electrical A

Index	P/N	Units	Description
NS	40X0275		Cord (6ft straight), Israel
NS	40X0276		Cord (6ft straight), South Africa
NS	40X0277		Cord (6ft high amp straight), Brazil (HV, LV)
NS	40X0278		Cord (HV 6ft straight), Austria, Russia
NS	40X0279		Cord (6ft straight), Denmark, Finland, Norway, Sweden
NS	40X0280		Cord (10A 3 cond. 6ft straight) , Korea
NS	40X0281		Cord (13A 3 cond. 6ft straight), Taiwan
NS	40X0282		Cord (1.77M straight), People's Republic of China
NS	40X0296		Cord (6ft straight), Australia
NS	40X1104		Interuptor, photo (paper low sensor)
NS	40X1267		Parts packet
NS	56P9964		Transformer (Japan Only)

# Assembly 11: Electrical B

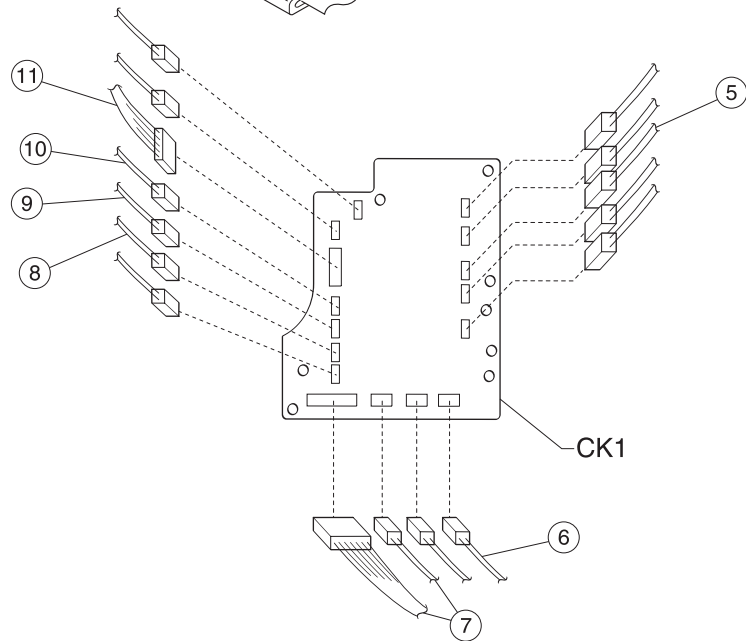
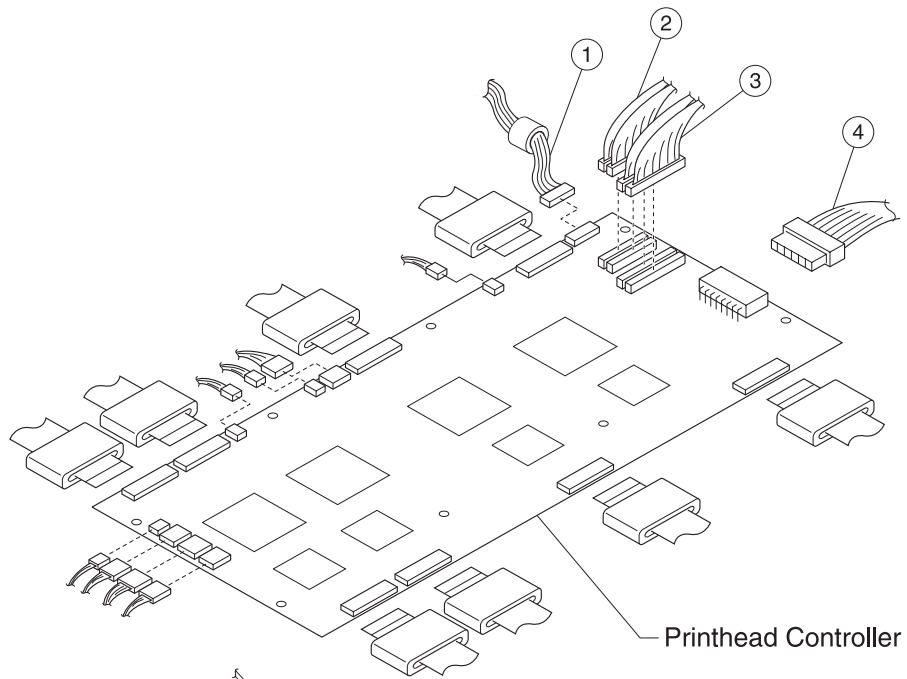



## Assembly 11: Electrical B

Index	P/N	Units	Description
11-4	40X1068	1	Cable assembly, 8 pin PH controller
2	40X1074	1	Cable assembly, 30 pin RIP harness
3	40X1073	1	Cable assembly, 36 pin RIP harness
4	56P9720	1	Cable assembly, printhead controller power
5	40X1099	1	Cable assembly, paper tray lift motor
6	40X1100	1	Cable assembly, cassette bottom sensor
7	40X1098	1	Cable assembly, paper feed type 1
8	40X1114	1	Cable assembly, carrying clutch
9	40X1116	1	Cable assembly, MPF clutch
10	40X1113	1	Cable assembly, registration clutch
11	40X1115	1	Cable assembly, registration sensor
NS	40X1267	1	Parts packet

## Assembly 12: RIP board

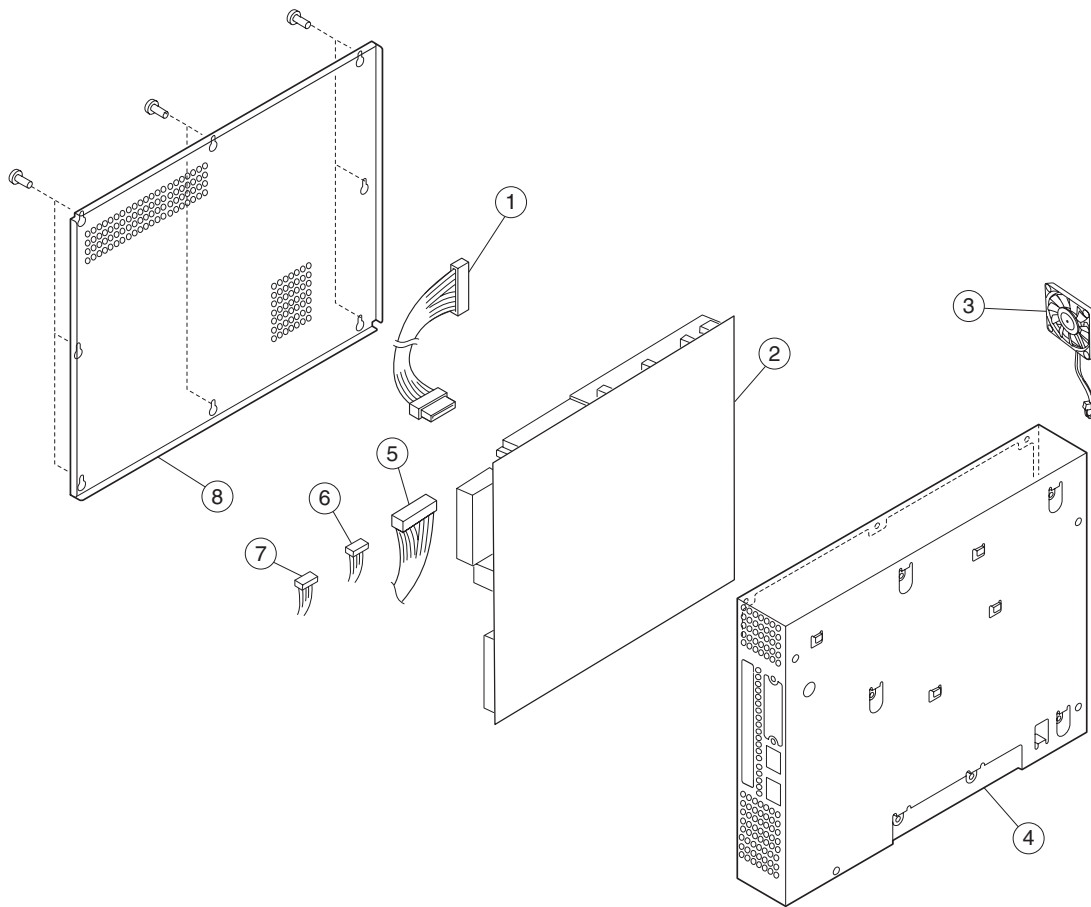

Index	P/N	Units	Description
12-4	56P9749	1	Cable assembly, power RIP
2	40X1248	1	Card assembly, RIP
3	40X1520	1	Fan, RIP box
4	40X1165	1	Box, RIP
5	40X1054	1	Cable assembly, 26 pin RIP printer controller
6	40X1255	1	Cable, USB
7	40X1256	1	Cable, operator panel
8	40X1166	1	Cover, RIP box
NS	40X1268	1	Parts packet

## Assembly 13: Fuser unit

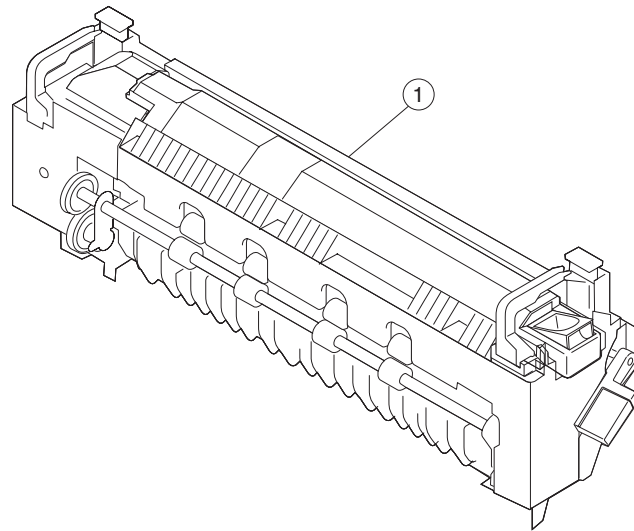

Index	P/N	Units	Description
12-4	56P2655	1	Fuser, 120V
1	56P2656	1	Fuser, 230V

# Assembly 14: Cassette

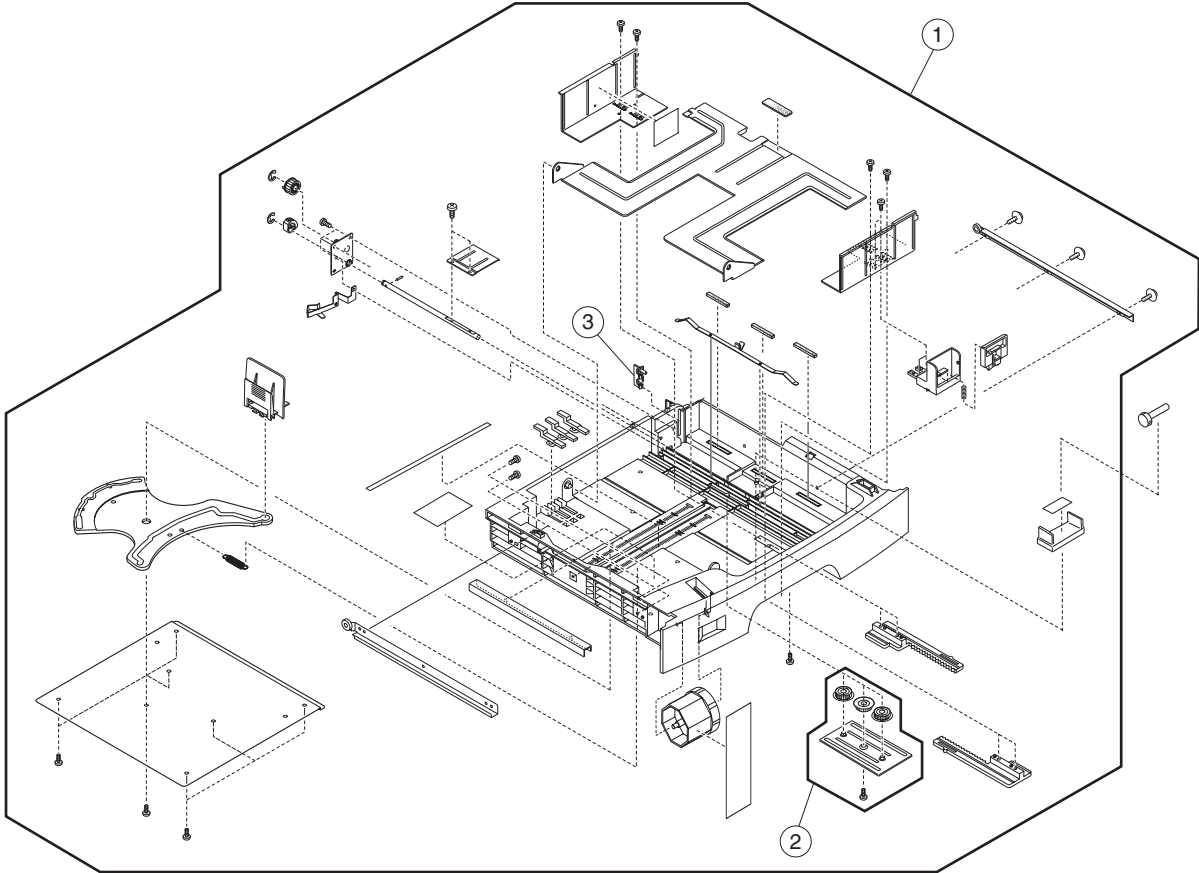

## Assembly 14: Cassette P/N 13N1778

Index	P/N	Units	Description
14-4	40X1058	1	Cassette, paper feed
2	40X1501	1	Kit, rack guard holder
3	40X1105	1	Flag, bottom sense

# Assembly 15: Expansion feeder 1

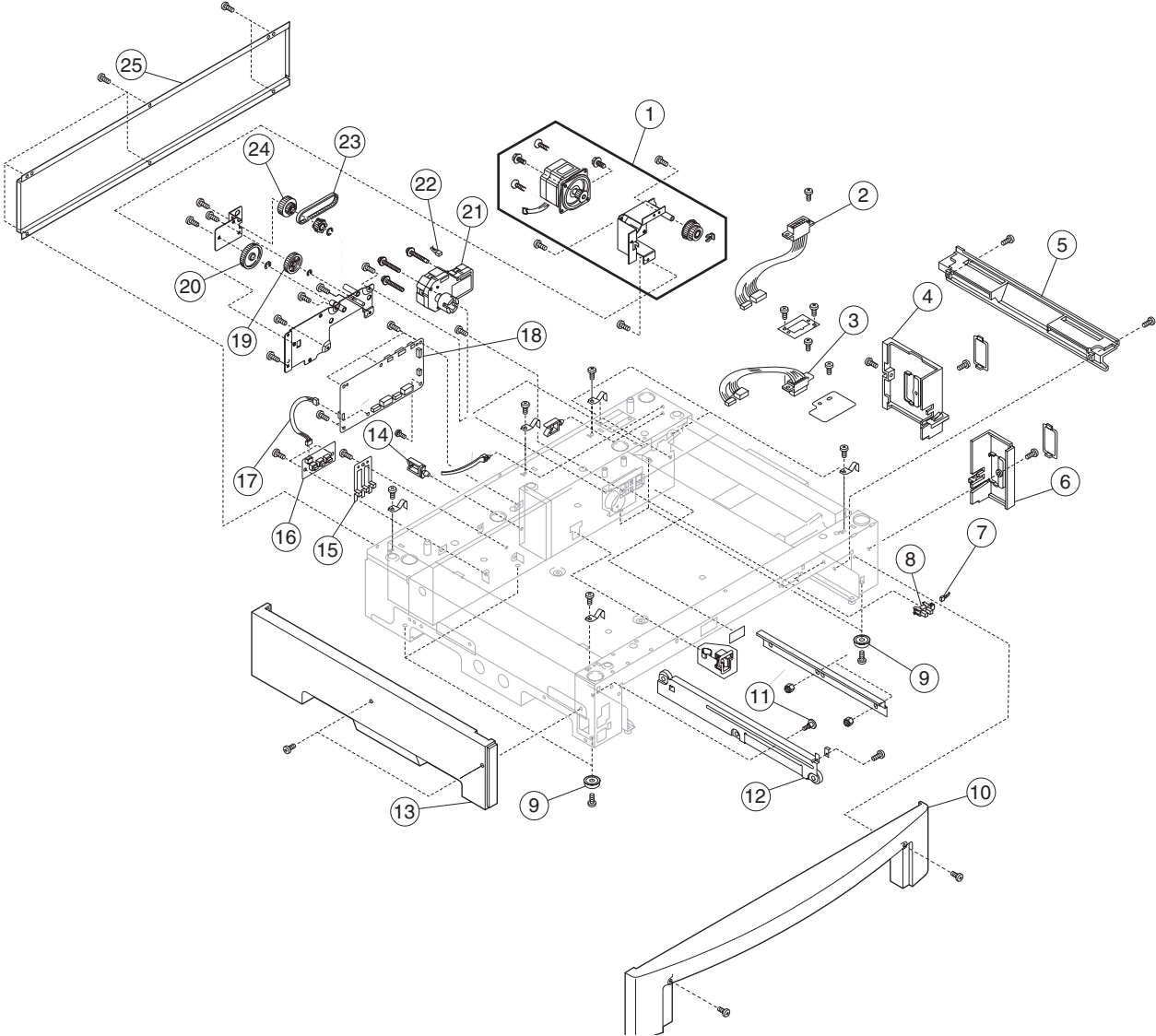

## Assembly 15: Expansion feeder 1

Index	P/N	Units	Description
	56P4024	—	Assembly, expansion feeder
15-4	40X1090	1	Motor asm, stepping
2	56P9777	1	Cable asm, upper optional drawer
3	56P9778	1	Cable asm, lower optional drawer
4	40X1204	1	Cover, right side C
5	40X1203	1	Cover, right side B
6	40X1202	1	Cover, right side A
7	40X1091	1	Cable asm, expansion paper level
8	40X1173	1	Interrupt, photo
9	56P9503	4	Foot, rubber
10	40X1200	1	Cover, front feed
11	56P9524	1	Screw, slide rail
12	40X1034	1	Rail, base left side
13	40X1201	1	Cover, left side
14	11G0199	2	Guide, wire
15	56P9521	1	Lever, size sense
16	56P9522	1	Card, size sense
17	56P9775	1	Cable asm, size sense
18	56P2657	1	Board, expansion feeder controller
19	40X1096	1	Gear, Z30
20	40X1093	1	Gear, IDS 38
21	40X1097	1	Motor, paper tray lift
22	40X1092	1	Cable asm, expansion lift motor
23	40X1095	1	Belt, timing S3M:177
24	40X1246	1	Gear, Z28:20T
25	40X1167	1	Cover, rear
NS	11G0399	4	Plate, ground
NS	40X1094	1	Pulley, timing 20t
NS	40X1269	1	Parts packet

# Assembly 16: Expansion feeder 2

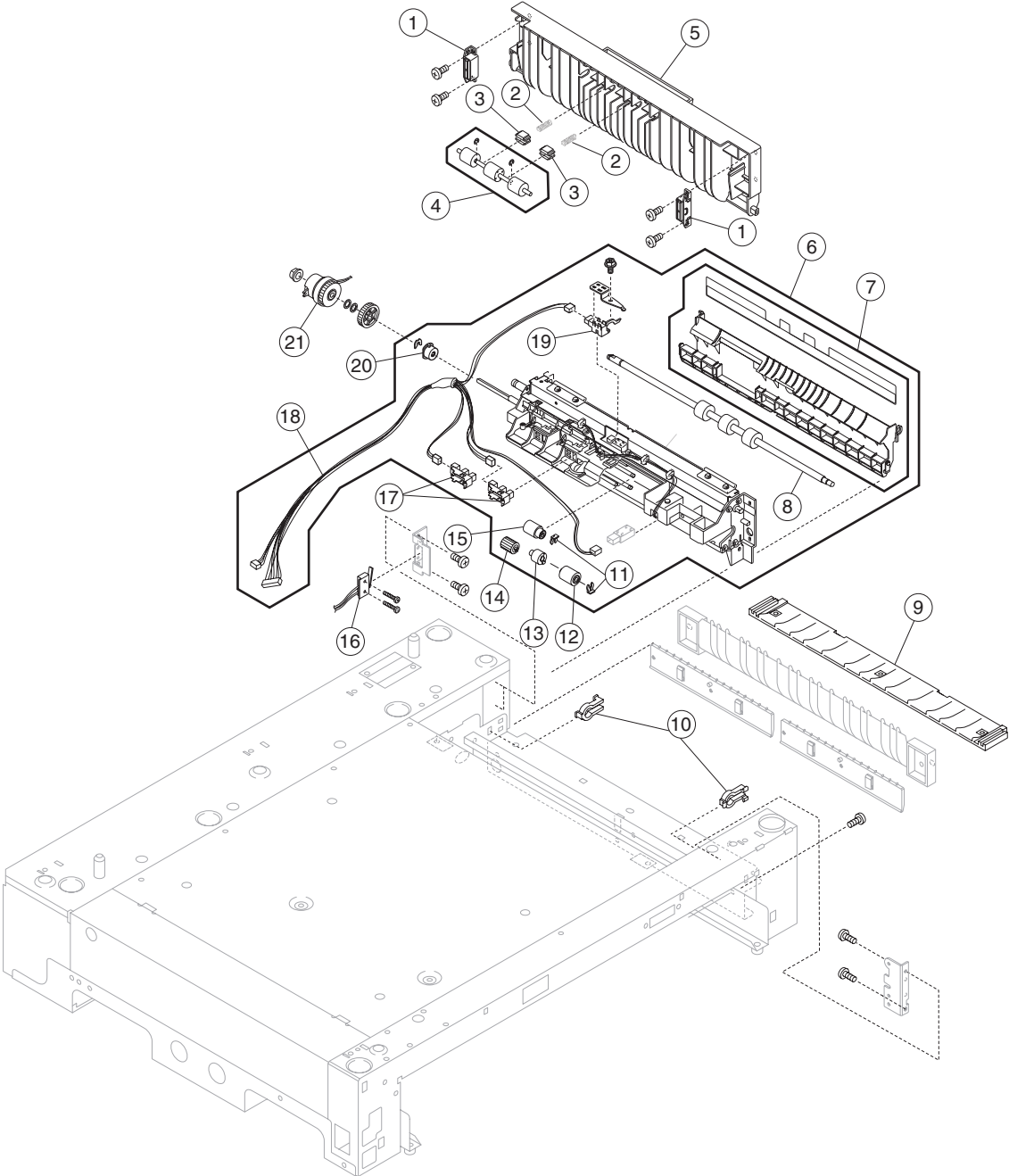



## Assembly 16: Expansion feeder 2

Index	P/N	Units	Description
16-4	40X1140	2	Magnet, front cover latch
2	40X1071	2	Spring, paper carry 2
3	40X1070	2	Bushing, pressure
4	40X1072	1	Roller, follow up
5	40X1069	1	Guide assembly, expansion turn guide
6	40X1086	2	Assembly, paper feed expansion
7	40X1076	1	Plate, guide rocking
8	40X1111	1	Roller, relay expansion feed
9	56P9788	1	Guide, HCPF
10	40X1103	1	Bushing, turn guide
11	40X1106	2	Clip, paper feed shaft
12	40X1079	2	Roller, separator
13	40X1080	1	Clutch, friction
14	40X1077	1	Roller, pickup
15	40X1078	1	Roller, paper feed
16	40X1088	1	Assembly, turn guide switch option
17	40X1173	1	Interrupt, photo
18	40X1089	1	Cable asm, paper feed type 2
19	40X1107	1	Sensor, relay
20	40X1081	1	Clutch, roller 6 x 10 x 14
21	40X1087	1	Clutch, paper feed
NS	40X1270		Parts packet

## Assembly 17: Duplex unit 1

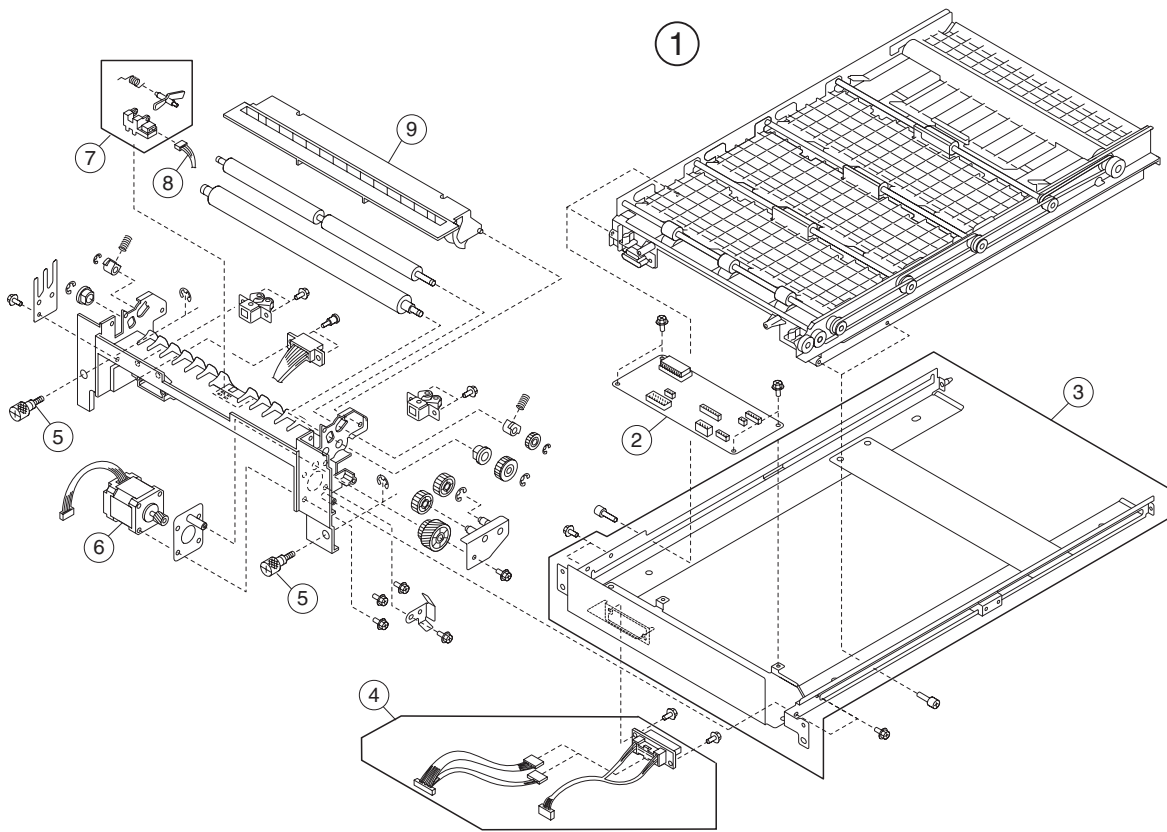

## Assembly 18: Duplex Unit 1 P/N 13N1783

Index	P/N	Units	Description
18-4	56P4023	1	Duplex assembly
2	40X1060	1	Board, duplex interface
3	40X1168	1	Frame, duplex
4	56P3990	1	Cable assembly, duplex connection
5	40X1169	2	Screw, duplex mounting
6	56P3989	1	Motor, duplex stepping
7	40X1171	1	Interrupter, photo
8	56P9806	1	Cable assembly, paper detection
9	56P9994	1	Plate, duplex guide
NS	56P9807	1	Cable assembly, duplex interface
NS	40X1271		Parts packet

## Assembly 19: Duplex unit 2

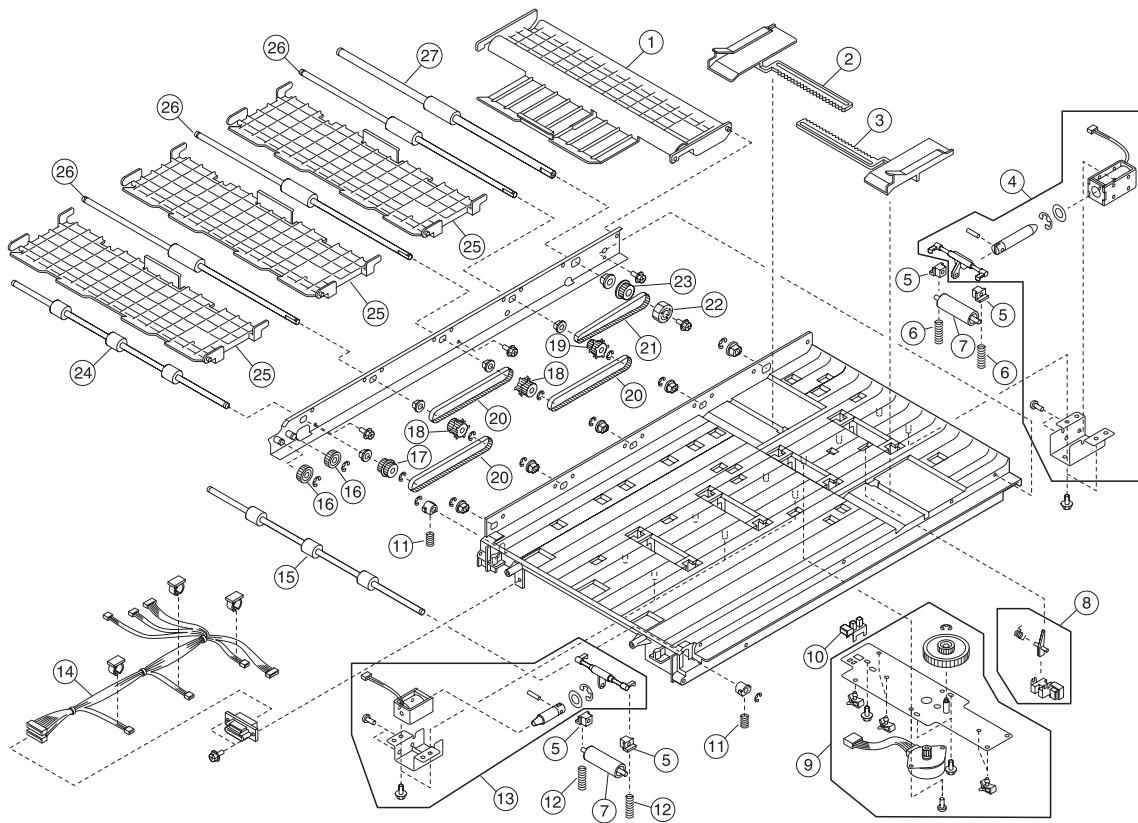

## Assembly 19: Duplex unit 2

Index	P/N	Units	Description
19-4	56P9825	1	Plate, paper re-feed drawer
2	56P9827	1	Guide, rear side
3	56P9826	1	Guide, front side
4	56P3992	1	Solenoid assembly, paper re-feed
5	56P9814	8	Bearing, release
6	56P9816	2	Spring, re-feed roller
7	56P9813	4	Roll, release
8	40X1171	1	Interrupter, photo
9	56P9828	1	Motor assembly, paper guide
10	40X1173	1	Interrupter, photo
11	56P9526	2	Spring, feed roller
12	56P9815	6	Spring, reed roller
13	56P3991	3	Solenoid assembly, feed roller
14	56P3993	1	Cable assembly, duplex drawer
15	40X1175	1	Roller, follow-up feed
16	56P9527	2	Gear, idler
17	56P9817	1	Gear, carrying roller
18	56P9818	2	Pulley, carrying roller timing
19	56P9819	1	Pulley, feed roller
20	56P9822	3	Belt, timing
21	56P9823	1	Belt, timing
22	56P9821	1	Knob, paper re-feed
23	56P9820	1	Pulley, re-feed roller
24	40X1174	1	Roller, drive feed
25	56P9824	3	Plate, paper carrying drawer
26	40X1176	3	Roller, middle feed
27	40X1177	1	Roller, re-feed
NS	40X1271	1	Parts packet

# Assembly 20: High-capacity feeder 1

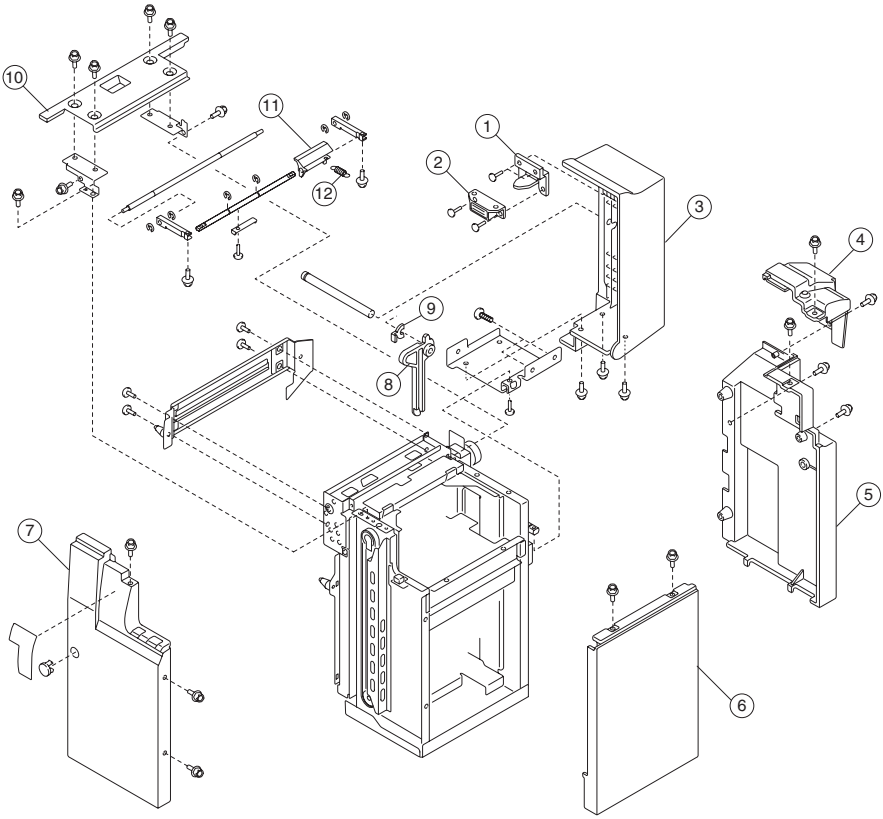

## Assembly 20: High-capacity feeder 1 P/N 13N1781

Index	P/N	Units	Description
20-4	56P9838	1	Catch, door
2	56P9835	1	Magnet, latch
3	56P9837	1	Cover, upper
4	56P9834	1	Cover, upper rear
5	56P9843	1	Cover, lower rear
6	56P9839	1	Cover, right
7	56P9833	1	Cover, front
8	56P9836	1	Fence, end
9	56P9940	1	Ring, snap
10	56P9841	1	Cover assembly, upper
11	56P9840	1	Lever, vertical transport
12	56P9842	1	Spring, tension
NS	56P9958	1	Parts packet

# Assembly 21: High-capacity feeder 2

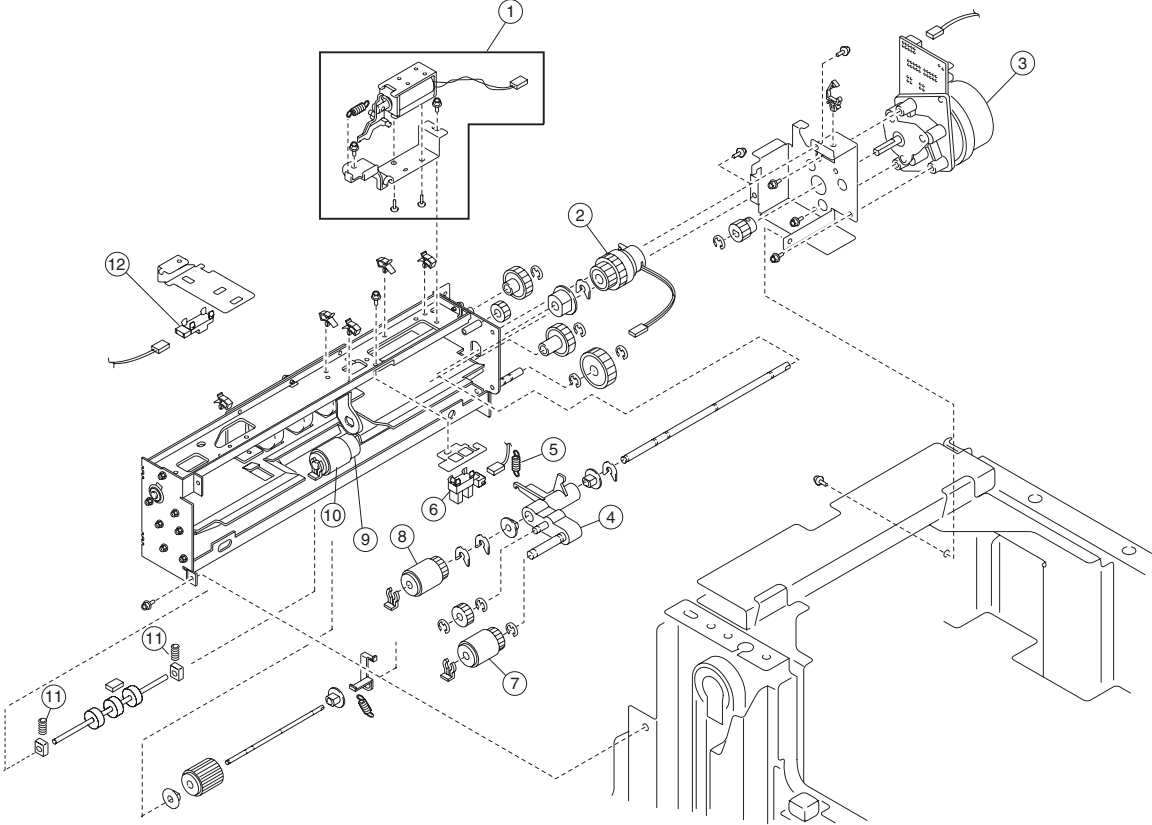



## Assembly 21: High-capacity feeder 3

Index	P/N	Units	Description
21-4	56P9846	1	Solenoid assembly, paper pickup
2	56P9848	1	Clutch, paper feed
3	56P9844	1	Motor assembly, transport
4	56P9941	1	Arm, pick-up
5	56P9501	1	Spring, pressure
6	56P9528	1	Interrupter, photo
7	56P9849	1	Roller, manual feed pickup
8	56P9850	1	Roller, manual feed
9	56P9852	1	Limitter, torque
10	56P9851	1	Roller, manual feed separate
11	56P9847	2	Spring, compression
12	56P9845	1	Sensor assembly, paper feed
NS	56P9959	1	Parts packet

# Assembly 22: High-capacity feeder 3

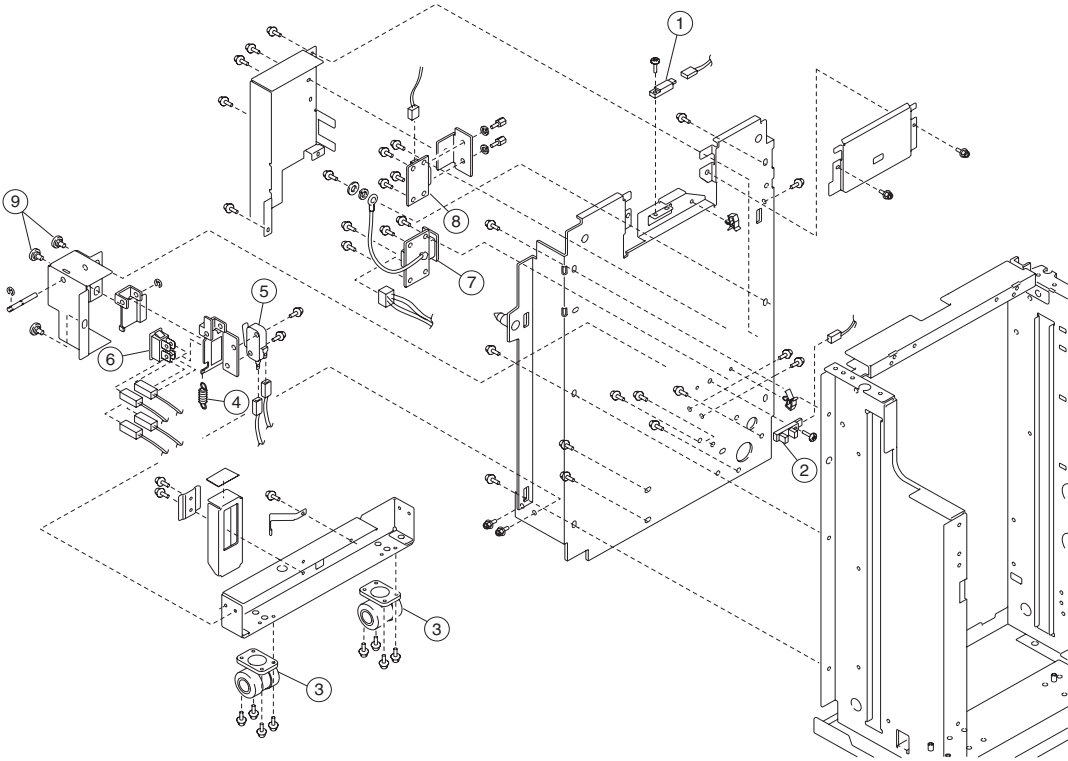

## Assembly 22: High-capacity feeder 3

Index	P/N	Units	Description
22-4	56P9854	1	Sensor assembly, photo
2	56P9855	1	Interrupter, photo
3	56P9529	4	Caster, HCF
4	56P9856	1	Spring, tension
5	56P9857	1	Switch, micro
6	56P9530	1	Switch, push
7	56P9859	1	Connector, inlet
8	56P9858	1	Connector, I/F
9	56P9853	3	Screw, shoulder
NS	56P9960	1	Parts packet

# Assembly 23: High-capacity feeder 4

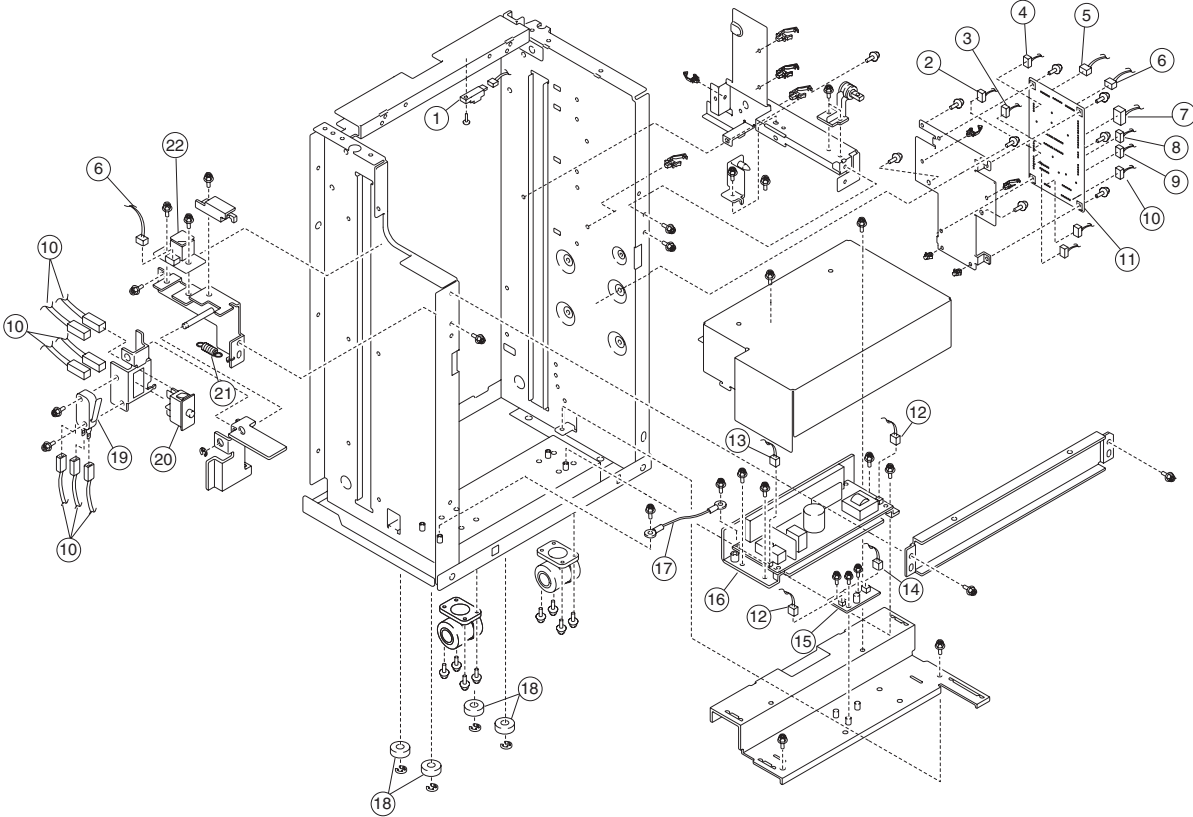

## Assembly 23: High-capacity feeder 4

Index	P/N	Units	Description
23-4	56P9541	1	Sensor, resistor
2	56P9875	1	Cable assembly, safety switch
3	56P9865	1	Cable assembly, HCF motor
4	56P9871	1	Cable assembly, I/F
5	56P9866	1	Cable assembly, paper feed sensor
6	56P9880	1	Cable, up/down switch
7	56P9879	1	Cable, paper volume
8	56P9878	1	Cable assembly, sensor
9	56P9877	1	Cable assembly, paper size sensor
10	56P9876	1	Cable assembly, lift motor
11	56P2658	1	Board, high-capacity feed
12	56P9873	1	Cable assembly, power supply out
13	56P9872	1	Cable assembly, power supply in
14	56P9874	1	Cable assembly, power supply
15	56P9870	1	Converter, DC/DC
16	56P4008	1	Power supply, HCF
17	56P9867	1	Cable assembly, drawer ground
18	56P9861	4	Roller, track
19	56P9864	1	Switch, micro
20	56P9530	1	Switch, push
21	56P9501	1	Spring, pressure pickup
22	56P9863	1	Switch, HCF push
NS	56P9961	1	Parts packet

# Assembly 24: High-capacity feeder 5

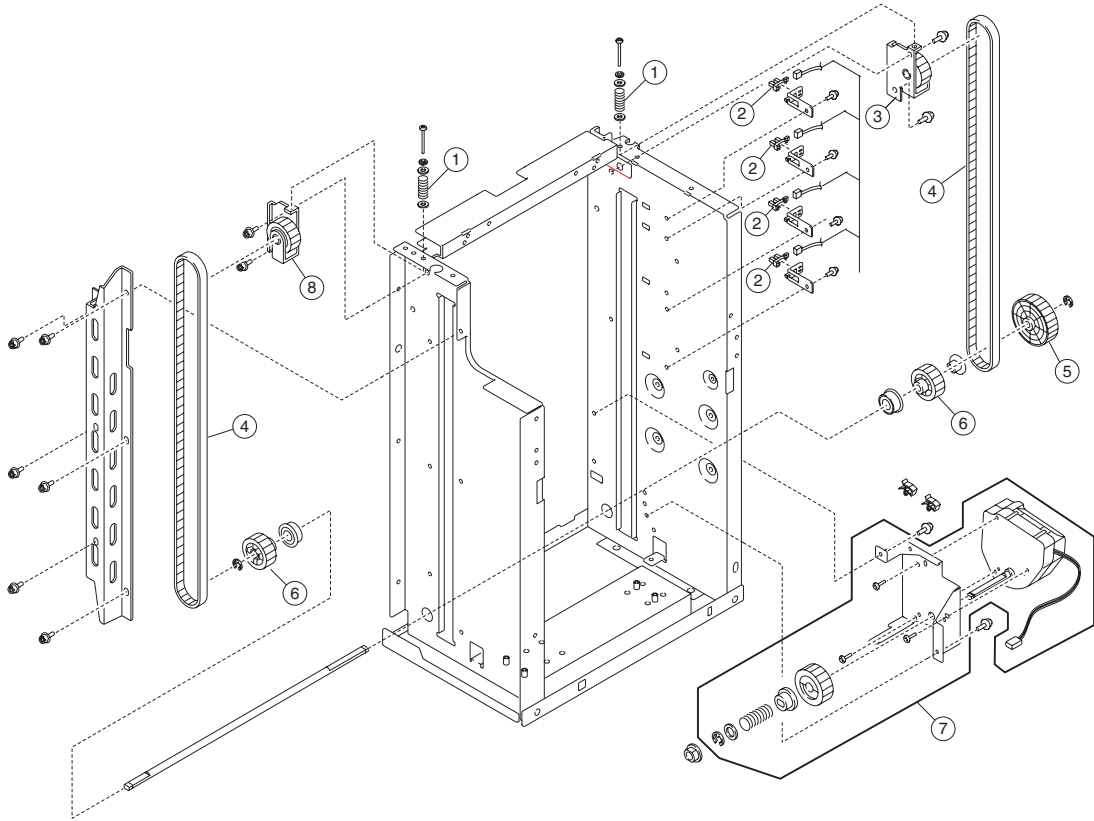

## Assembly 24: High-capacity feeder 5

Index	P/N	Units	Description
24-4	56P9883	2	Spring, pressure
2	56P9528	4	Interrupter, photo
3	56P9888	1	Bracket, rear idler
4	56P9884	2	Belt, timing
5	56P9886	1	Gear, drive
6	56P9885	2	Pulley, timing
7	56P9882	1	Motor, HCF DC
8	56P9887	1	Bracket, front idler
NS	56P9962	1	Parts packet

# Assembly 25: High-capacity feeder 6

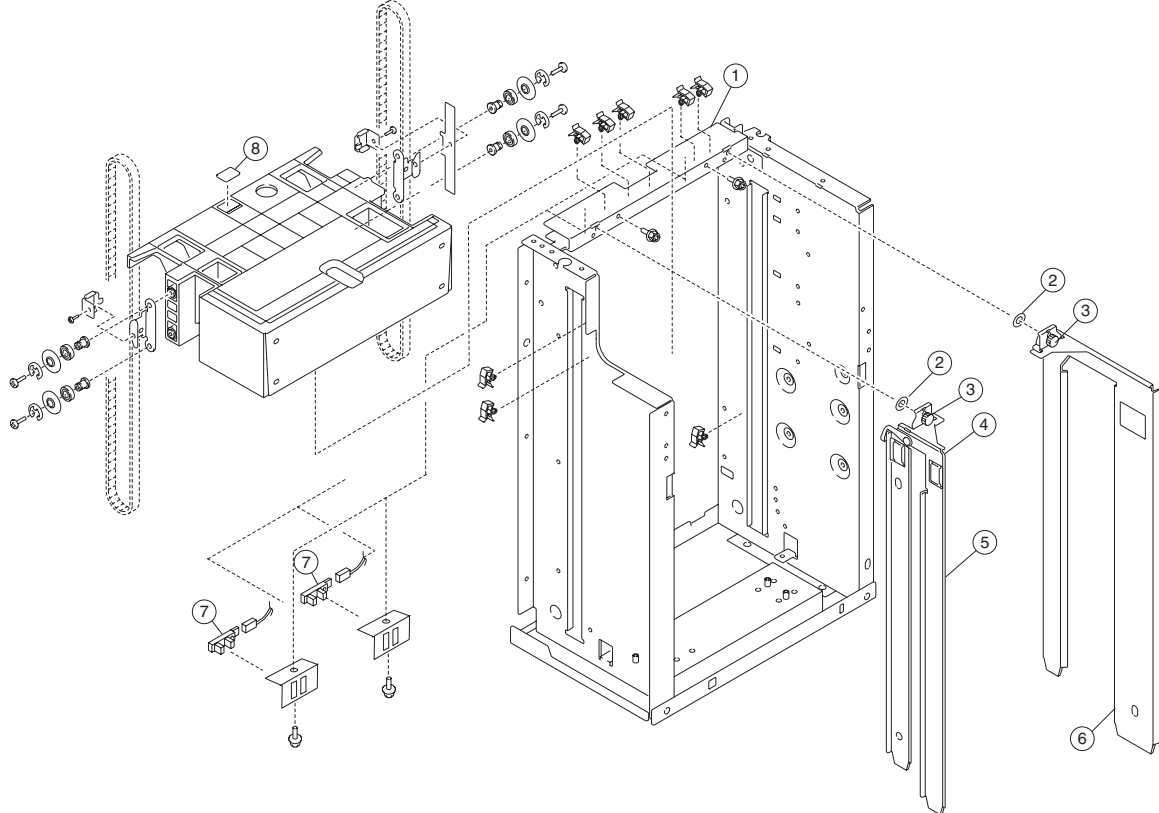



## Assembly 25: High-capacity feeder 6

Index	P/N	Units	Description
25-1	56P9892	1	Plate, upper side fence
2	56P9893	2	Knob, stopper
3	56P9891	2	Knob, tray
4	56P9890	2	Plate, paper adhesion
5	56P9915	1	Fence assembly, front side
6	56P9894	1	Fence assembly, rear side
7	56P9528	2	Interrupter, photo
8	56P9889	1	Pad, friction
NS	56P9963	1	Parts packet

# Assembly 26: Finisher covers

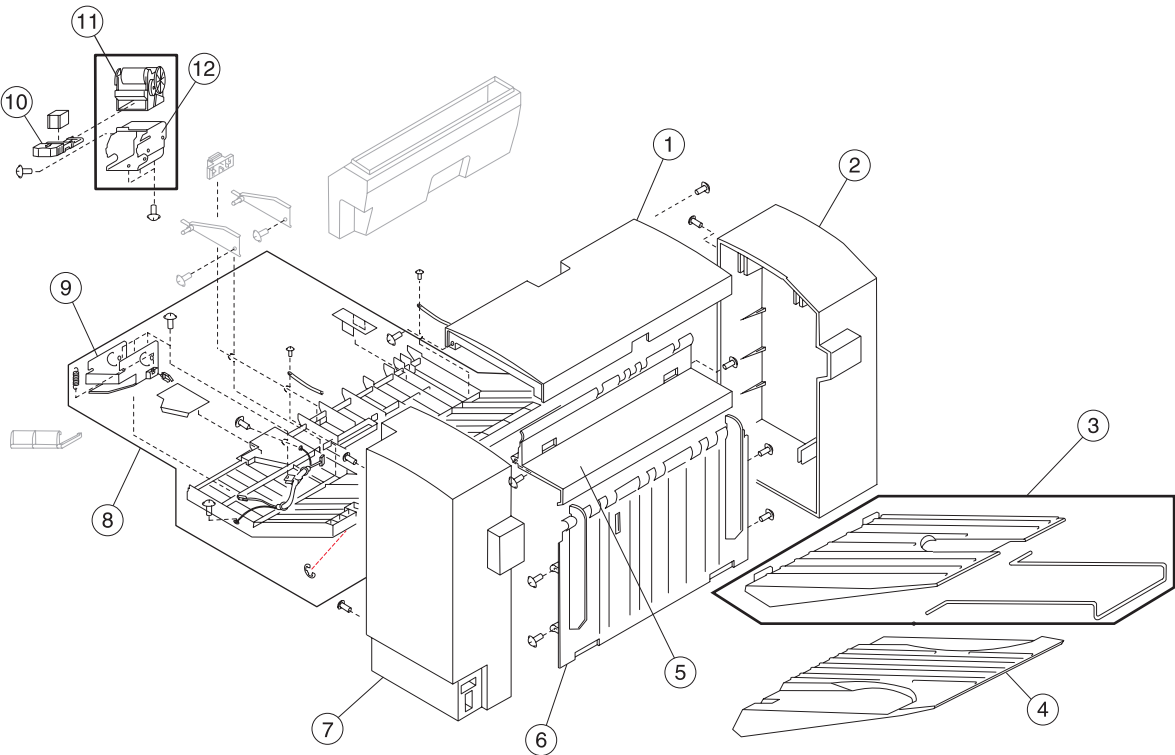

## Assembly 26: Finisher covers

Index	P/N	Units	Description
26-1	56P4064	1	Cover, top
2	56P4065	1	Cover, front
3	56P4067	1	Tray, upper
4	56P4068	1	Tray, lower
5	56P4062	1	Panel, left upper
6	40X1227	1	Assembly, lower left panel
7	56P4066	1	Cover, rear
8	56P4063	1	Assembly, staple cover
9	56P9365	1	Cover, staple A
10	56P9367	1	Cartridge, staple
11	56P9363	1	Stapler
12	56P9364	1	Cover, staple B

# Assembly 27: Finisher frame

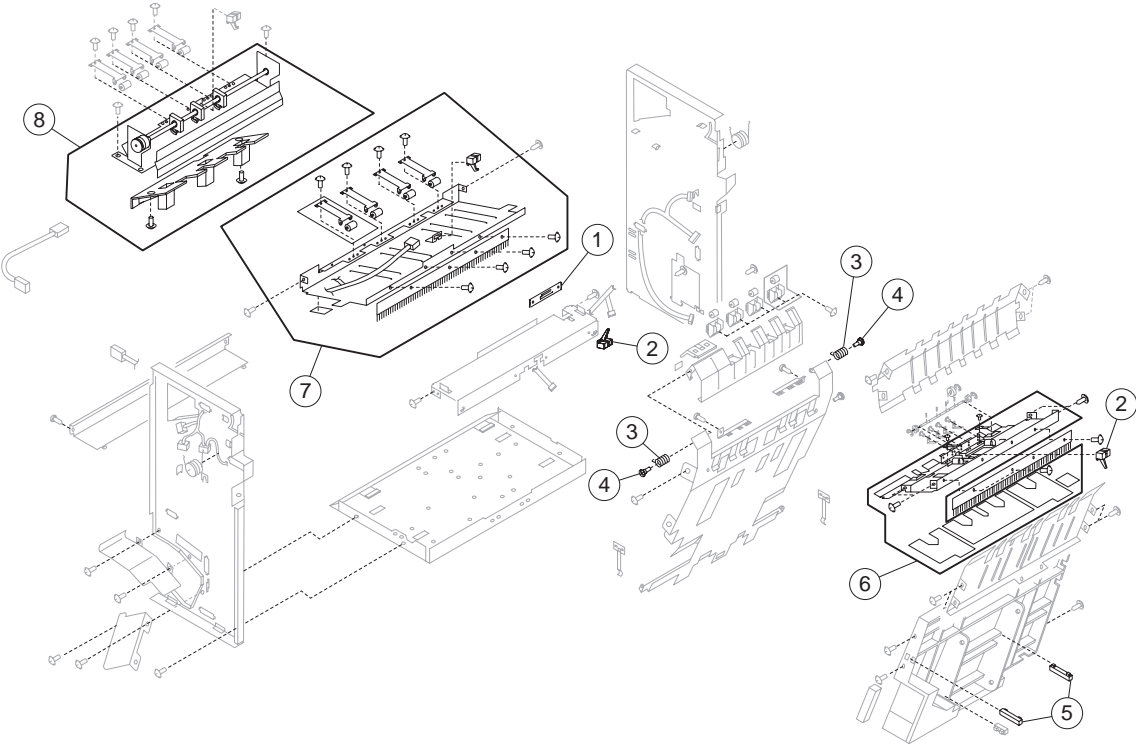

## Assembly 27: Finisher frame

Index	P/N	Units	Description
27-1	56P4069	1	Handle
2	56P9380	2	Sensor, photo
3	56P9386	2	Spring
4	56P9373	2	Screw, M4
5	56P9309	1	Assembly, exit guide inverter
6	56P9399	2	Sensor, photo
7	56P4364	1	Assembly, exit guide straight
8	56P9313	1	Unit, 3 hole punch (U.S. only)
8	56P9314	1	Unit, 4 hole punch (non U.S.)
NS	56P4072	1	Kit, punch speed up

# Assembly 28: Finisher feed 1

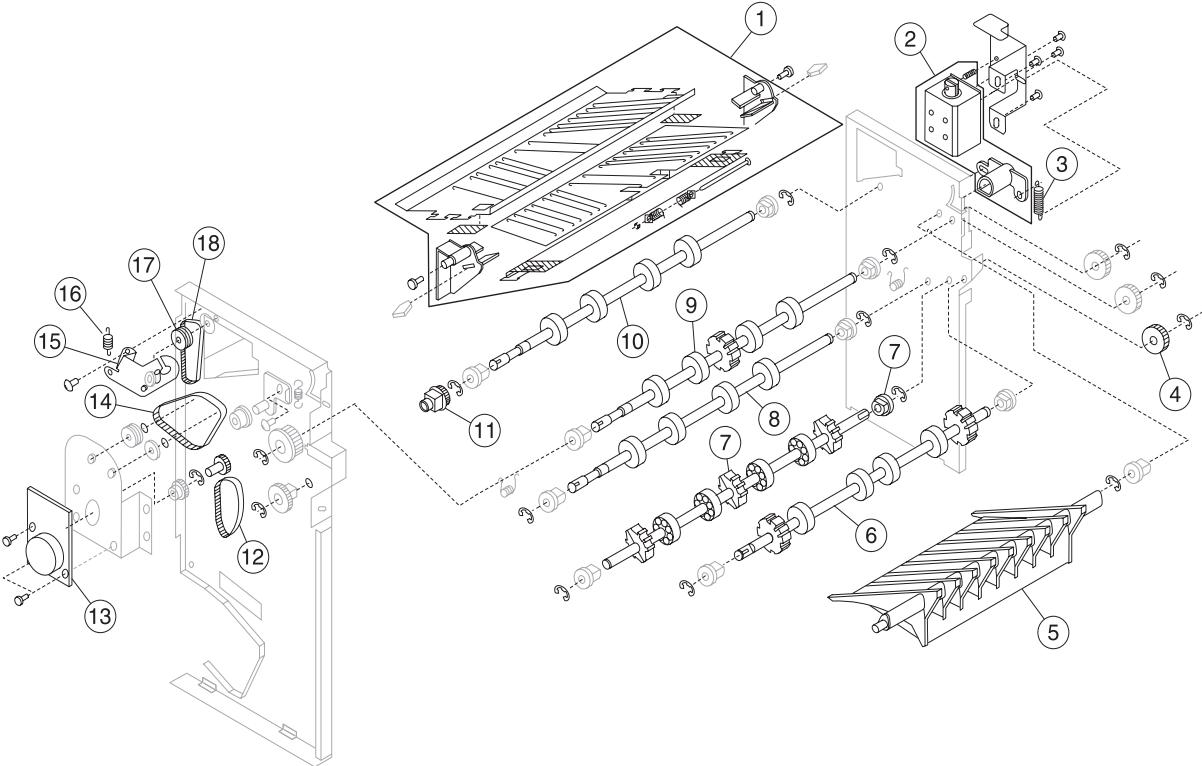

## Assembly 28: Finisher feed 1

Index	P/N	Units	Description
28-1	56P9395	1	Assembly, guide plate
2	56P9334	1	Assembly, solenoid
3	56P9396	1	Spring, H
4	56P9398	1	Gear, Z19
5	56P9310	1	Gate
6	56P9400	1	Roller
7	56P9361	1	Roller, patting
8	56P9401	2	Roller, I
9	56P9312	1	Roller, F
10	56P9405	1	Roller, G
11	56P9335	1	Clutch, registration
12	56P9407	1	Belt, timing 60S2M184
13	56P9341	1	Assembly, feed motor
14	56P9339	1	Belt, timing 60S2M334
15	56P4060	1	Assembly, punch drive
16	56P9318	1	Spring, B
17	56P4070	1	Pulley gear Z36/T24
18	56P4061	1	Belt

## Assembly 29: Finisher feed 2

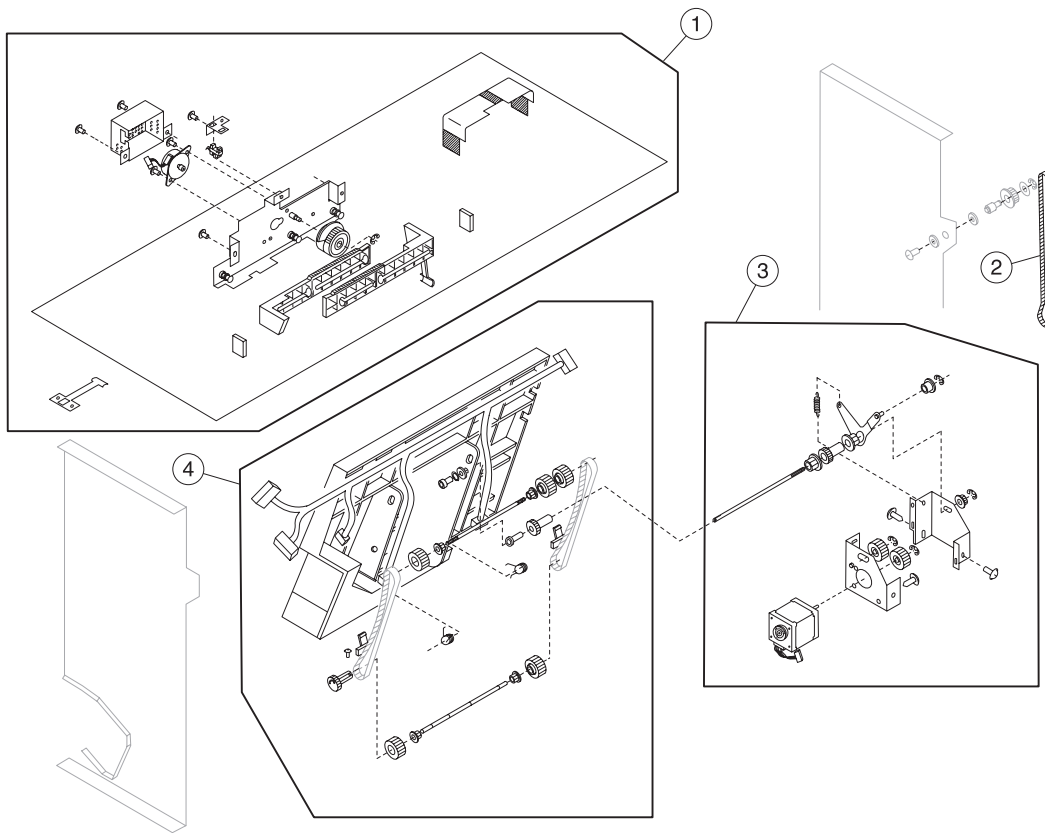

Index	P/N	Units	Description
29-1	56P9300	1	Assembly, jogging unit
2	56P9333	1	Belt, timing 60S3M408
3	56P9329	1	Assembly, tractor motor
4	56P9301	1	Assembly, guide stack



## Assembly 30: Finisher elevator

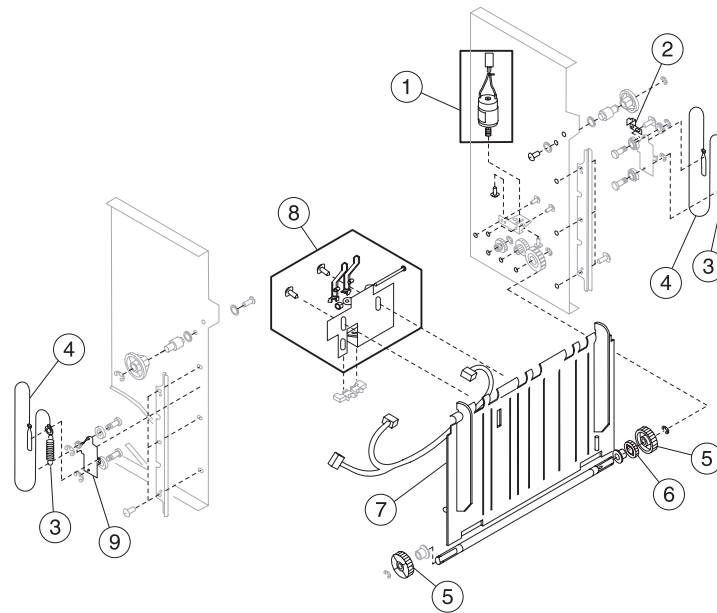

Index	P/N	Units	Description
30-1	56P9308	1	Assembly, elevator motor
2	56P9451	1	Shutter
3	56P9332	2	Spring, C
4	56P9331	2	Wire
5	56P9459	2	Drum, wire
6	56P9460	1	Gear, Z30
7	56P4073	1	Panel, lower left
8	56P9465	1	Assembly, sensor
9	56P9307	1	Assembly, hook rear

## Assembly 31: Finisher electronics

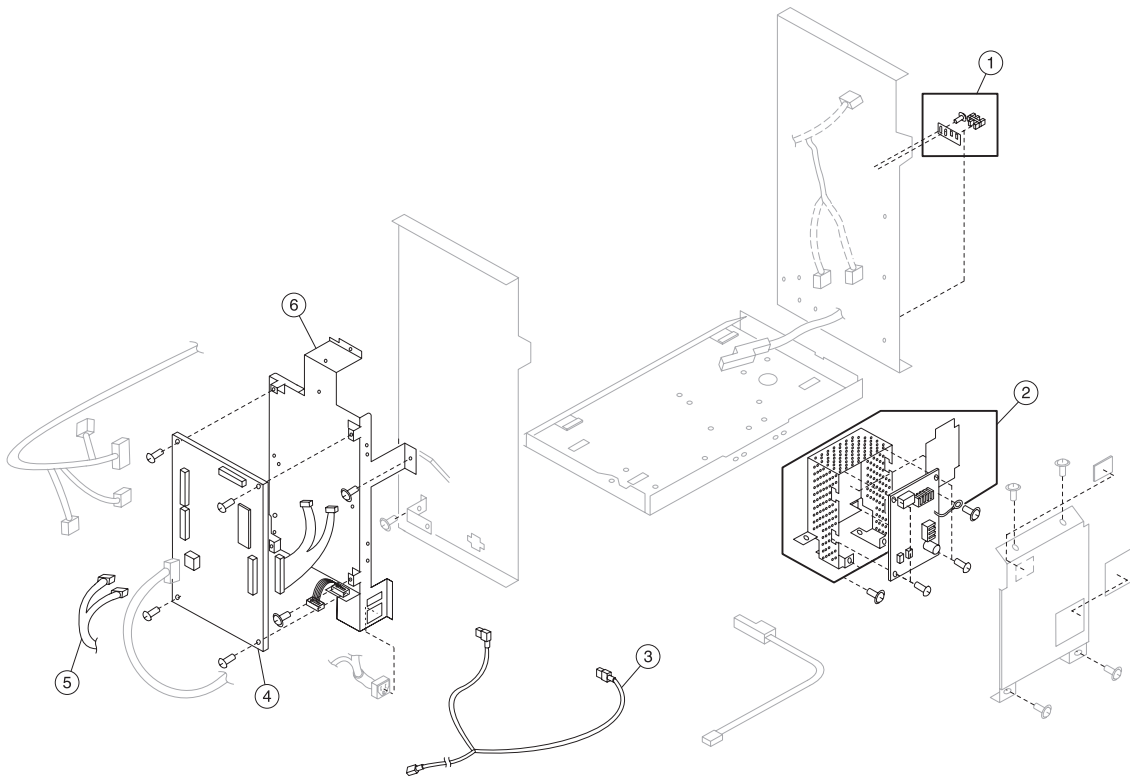

Index	P/N	Units	Description
31-1	56P9306	1	Assembly, upper limit sensor
2	56P9303	1	Supply, power
3	56P9358	1	Cord, Y power
3	56P9368	1	Cord, Y power (230 V only)
4	56P4365	1	Board, finisher control
5	56P9410	1	Cable
6	56P9420	1	Bracket, finisher control board
NS	56P9357	1	Cable, interface

## Assembly 32: Finisher docking 1

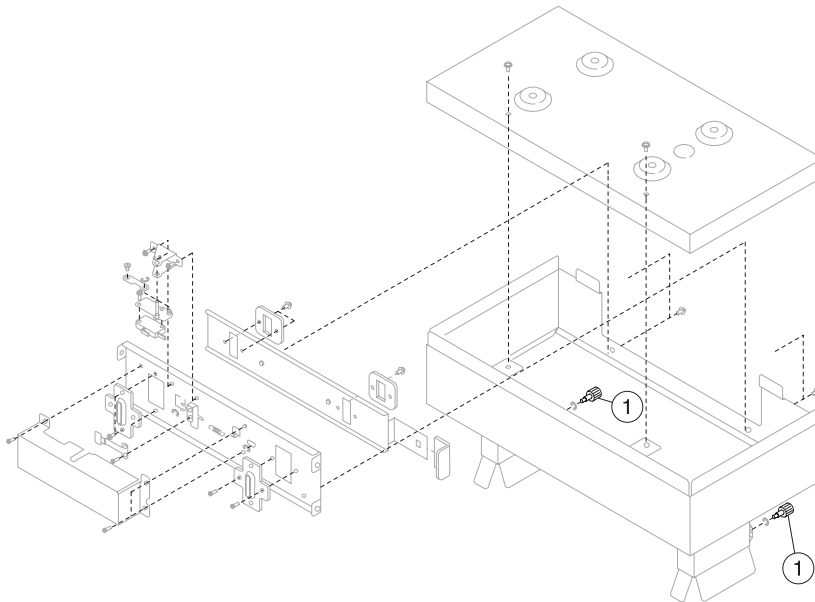

Index	P/N	Units	Description
32-1	56P9467	2	Screw, thumb

## Assembly 33: Finisher docking 2

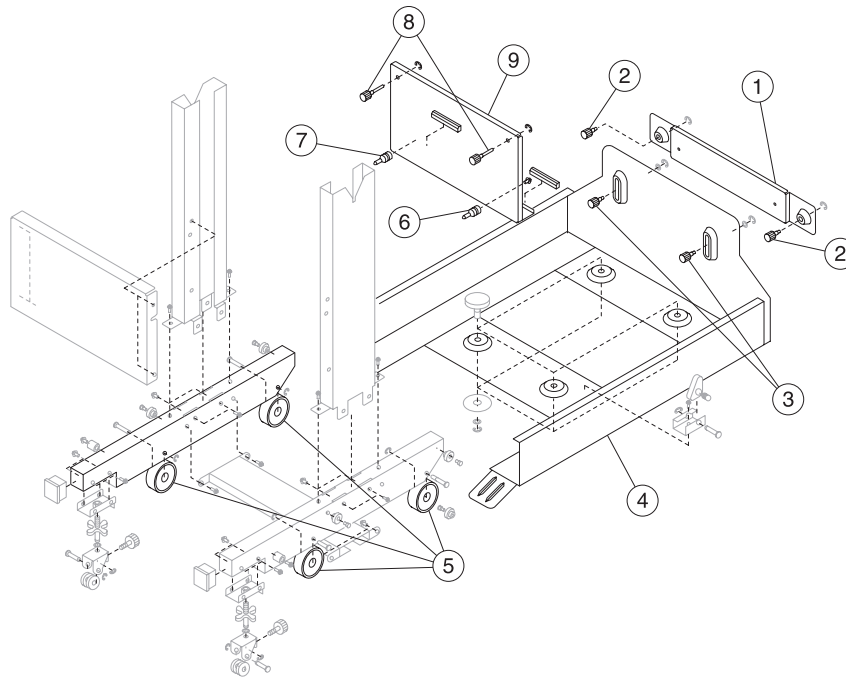

Index	P/N	Units	Description
33-1	40X1237	1	Bracket, rail
2	56P9472	2	Screw, lock
3	40X1238	1	Screw, rail
4	40X1239	1	Chassis, rail
5	56P9474	4	Roller
6	40X1241	1	Stud, lock-f
7	56P9473	1	Stud, lock
8	40X1240	1	Screw, lock
9	40X1254	1	Bracket, lock

## Assembly 34: Miscellaneous/options

Index	P/N	Units	Description
NS	40X1508	1	Card assembly, 128MB SDRAM memory
NS	40X1509	1	Card assembly, 256MB SDRAM memory
NS	40X1510	1	Card assembly, 512MB SDRAM memory
NS	40X1512	1	Kit, Japanese font
NS	40X1564	1	Card asm, 32 MB flash memory
NS	40X1565	1	Card asm, 64 MB flash memory
NS	40X1513	1	Kit, Simplified Chinese font
NS	40X1514	1	Kit, Traditional Chinese font
NS	40X1515	1	Kit, Korean font
NS	40X1503	1	Card, bar code
NS	40X1511	1	Kit, eST360CP net printer relocation
NS	40X1502	1	Card, IPDS
NS	40X1504	1	Card, Prescribe
NS	40X1505	1	Card, PrintCryption™
NS	40X1506	1	Card, forms
NS	40X1507	1	Card, forms (Double byte)
NS	56P9982	1	Drive assembly, hard file 20 gb (w/mounting kit)
NS	40X0290	1	Card, serial option
NS	40X0291	1	Card, parallel option
NS	40X1375	1	Adapter, MarkNet™ N8000 10/100
NS	40X1376	1	Adapter, MarkNet N8020 10/1000
NS	40X1377	1	Adapter, MarkNet N8030 Fiber
NS	40X1378	1	Adapter, MarkNet N8050 Americas
NS	40X1562	1	Adapter, MarkNet N8050 Europe
NS	40X1561	1	Antenna, external
NS	40X0179	1	Grease, Nyogel 744
NS	40X1109	1	Kit, paperpaphth maintainence
NS	56P9733	1	Cable, hi cap feeder interface

## Assembly 35: Parts packets

Index	P/N	Units	Description
NS	40X1262	1	<p>Parts packet, containing:</p> <ul style="list-style-type: none"> <li>• 5 Bind S-tight screws, 3x6, Zn-3R</li> <li>• 5 Bind S-tight screws, 3x15, Zn-3K</li> <li>• 5 Bind P-tight screws, 3x8, Zn-3K</li> <li>• 5 Bind P-tight screws, 3x10, Zn-3K</li> <li>• 5 Bind P-tight screws, 3x6, Zn-3K</li> <li>• 5 Bind P-tight screws, 3x8, Ni-3</li> <li>• 5 Bind screws, M3x6, Ni-3</li> </ul>
NS	40X1263	1	<p>Parts packet, including:</p> <ul style="list-style-type: none"> <li>• 5 Bind S-tight screws, 3x6, Zn-3R</li> <li>• 5 Bind P-tight screws, 3x8, Zn-3K</li> <li>• 5 Bind P-tight screws, 3x10, Zn-3K</li> <li>• 5 Bind screws, M3x4, Zn-3K</li> <li>• 5 Bind screws, M3x8, Zn-3K</li> <li>• 5 Bind screws, M3x6, Ni-3</li> <li>• 5 Screws with washers, M3x30, Zn-3K</li> <li>• 5 E-rings, ES-6, ACP</li> </ul>
NS	40X1264	1	<p>Parts packet, including:</p> <ul style="list-style-type: none"> <li>• 5 Bind S-tight screws, 3x6, Zn-3R</li> <li>• 5 Bind P-tight screws, 3x6, Zn-3K</li> <li>• 5 Bind P-tight screws, 3x8, Zn-3K</li> <li>• 5 Bind screws, M3x4, Zn-3K</li> <li>• 5 Bind screws, M3x6, Zn-3K</li> <li>• 5 Bind screws, M3x8, Zn-3K</li> <li>• 5 Pans with flange P-tight screws, 3x8, Zn-3K</li> <li>• 5 E-rings, ES-5, ACP</li> <li>• 5 E-rings, ES-6, ACP</li> <li>• 5 Spring pins, 2x10, ACP</li> </ul>
NS	40X1265	1	<p>Parts packet, including</p> <ul style="list-style-type: none"> <li>• 5 Bind S-tight screws, 3x6, Zn-3R</li> <li>• 5 Bind S-tight screws, 3x8, Zn-3R</li> <li>• 5 Bind P-tight screws, 3x8, Zn-3K</li> <li>• 5 E-rings, ES-4, ACP</li> </ul>

## Assembly 35: Parts packets (continued)

Index	P/N	Units	Description
NS	40X1266	1	Parts packet, including: <ul style="list-style-type: none"> <li>• 5 Bind S-tight screws, 3x6, Zn-3R</li> <li>• 5 Bind P-tight screws, 3x6, Zn-3K</li> <li>• 5 Bind P-tight screws, 3x8, Zn-3K</li> <li>• 5 E-rings, ES-3, ACP</li> <li>• 5 E-rings, ES-5, ACP</li> <li>• 5 E-rings, ES-6, ACP</li> <li>• 5 Spring pins, 2x10, ACP</li> <li>• 5 Bind screws, M3x8, Zn-3K</li> <li>• 5 Bind screws M2x8, Ni-3</li> </ul>
NS	40X1267	1	Parts packet, including: <ul style="list-style-type: none"> <li>• 5 Bind S-tight screws, 3x6, Zn-3R</li> <li>• 5 Bind S-tight screws, 3x8, Zn-3R</li> <li>• 5 Bind S-tight screws, 3x12, Zn-3R</li> <li>• 5 Bind P-tight screws, 3x8, Zn-3K</li> <li>• 5 Bind screws, M3x4, Zn-3K</li> <li>• 5 Bind screws, M3x6, Zn-3K</li> <li>• 5 Bind screws, M3x12, Zn-3K</li> <li>• 5 Pans with flange P-tight screws, 3x10, Zn-3K</li> <li>• 5 Screws with washers, M3x30, Zn-3K</li> <li>• 5 Screws with washers, M4x8, Zn-3K</li> <li>• 5 Screws with washers, M4x12, Zn-3K</li> <li>• 5 Screws with washers, M3x6, Ni-3(BS)</li> <li>• 5 Screws with washers, M4x8, Ni-3(BS)</li> <li>• 5 Screws with spring-washers, M3x8, Ni-3(BS)</li> <li>• 5 Screws with spring-washers, M4x8, Ni-3(BS)</li> <li>• 5 Natt with flange sereit, M3, Ni-3</li> <li>• 5 E-rings, ES-2.5, ACP</li> <li>• 5 Spring pins, 3x10, ACP</li> </ul>
NS	40X1268	1	Parts packet, including: <ul style="list-style-type: none"> <li>• 5 Bind S-tight screws, 3x6, Zn-3R</li> <li>• 5 Bind screws, M3x6, Zn-3K</li> <li>• 5 Bind screws, M3x10, Zn-3K</li> <li>• 5 Bind screws, M3x6, Ni-3</li> </ul>
NS	40X1269	1	Parts packet, including: <ul style="list-style-type: none"> <li>• 50 Bind S-tight screws, 3x6, Zn-3R</li> <li>• 50 Bind screws, M3x6, Zn-3K</li> <li>• 50 Bind screws, M3x8, Ni-3</li> <li>• 50 E-rings, ES-5, ACP</li> </ul>

## Assembly 35: Parts packets (continued)

Index	P/N	Units	Description
NS	40X1270	1	<p>Parts packet, including:</p> <ul style="list-style-type: none"> <li>• 5 Bind S-tight screws, 3x6, Zn-3R</li> <li>• 5 Bind S-tight screws, 3x8, Zn-3R</li> <li>• 5 Bind P-tight screws, 3x6, Zn-3K</li> <li>• 5 Bind P-tight screws, 3x8, Zn-3K</li> <li>• 5 Bind screws, M3x4, Zn-3K</li> <li>• 5 Bind screws, M3x6, Zn-3K</li> <li>• 5 E-rings, ES-5, ACP</li> <li>• 5 E-rings, ES-6, ACP</li> <li>• 5 Spring pins, 2x10, ACP</li> <li>• 5 Spring pins, 3x10, ACP</li> </ul>
NS	40X1271	1	<p>Parts packet, including:</p> <ul style="list-style-type: none"> <li>• 5 E-rings, ES-3, ACP</li> <li>• 5 E-rings, ES-4, ACP</li> <li>• 5 E-rings, ES-6, ACP</li> <li>• 5 R-screws, M3x6</li> <li>• 5 R-screws, M3x8</li> <li>• 5 R-screws, M4x6</li> <li>• 5 Pans S-tight screws, M3x6</li> <li>• 5 RP-tight screws, M3x8,</li> </ul>
NS	56P9958	1	<p>Parts packet, including:</p> <ul style="list-style-type: none"> <li>• 50 Bind S-tight screws, 3x6, Zn-3R</li> <li>• 50 Bind P-tight screws, 4x8, Zn-3R</li> <li>• 50 Pan screws, M4x6 Zn-3R</li> <li>• 50 Pan screws, M4x12, Zn-3R</li> <li>• 50 E-rings, ES-6, ACP</li> <li>• 50 RP-tight screws, M4x12</li> <li>• 50 RS-tight screws, M4x6</li> <li>• 50 RS-tight screws, M4x8</li> <li>• 50 RS-tight screws, M4x12</li> </ul>
NS	56P9959	1	<p>Parts packet, including:</p> <ul style="list-style-type: none"> <li>• 50 E-rings, ES-3, ACP</li> <li>• 50 E-rings, ES-4, ACP</li> <li>• 50 E-rings, ES-6, ACP</li> <li>• 50 RS-set screw cp, M3x3, Zn-3K</li> <li>• 50 RS-tight screws, M4x6</li> <li>• 50 RS-tight screws, M4x8</li> </ul>





















## Assembly 35: Parts packets (continued)

Index	P/N	Units	Description
NS	56P9960	1	Parts packet, including: <ul style="list-style-type: none"><li>• 50 Bind S-tight screws, 3x10, Zn-3R</li><li>• 50 E-rings, ES-4, ACP</li><li>• 50 RS-tight screws, M3x14</li><li>• 50 RS-tight screws, M4x6</li><li>• 50 RS-tight screws, M4x8</li><li>• 50 RS-tight round top screws, M3x6</li></ul>
NS	56P9961	1	Parts packet, including: <ul style="list-style-type: none"><li>• 50 E-rings, ES-4, ACP</li><li>• 50 RS-tight screws, M3x8</li><li>• 50 RS-tight screws, M3x14</li><li>• 50 RS-tight screws, M4x6</li><li>• 50 RS-tight screws, M4x8</li></ul>

## Assembly 35: Parts packets (continued)

Index	P/N	Units	Description
NS	56P9962	1	Parts packet, including: <ul style="list-style-type: none"><li>• 50 Screws with spring-washers, M4x30, Zn-3R</li><li>• 50 E-rings, ES-5, ACP</li><li>• 50 Plain washers, M4, Zn-3R</li><li>• 50 RS-tight screws, M4x6</li></ul>
NS	56P9963	1	Parts packet, including: <ul style="list-style-type: none"><li>• 50 Bind S-tight screws, 3x8, Zn-3R</li><li>• 50 Bind S-tight screws, 4x6, Zn-3R</li><li>• 50 Pan screws, M4x20, Zn-3R</li><li>• 50 E-rings, ES-6, ACP</li><li>• 50 RS-tight screws, M4x6</li><li>• 50 RS-tight round top screws, M4x6</li></ul>

## Assembly 36: Finisher parts packet P/N 56P9480

Pin		Retaining Ring -E Type	
Screw		Spring Pin	
Screw		Screw	
Tapping Screw		Spring Lock Washer	
Tapping Screw		Toothed Lock Washer	
Tapping Screw		Resin Ring	
Tapping Screw		Nut	
Set Screw		Tapping Screw	
Plain Washer		Tapping Screw	
		Screw	



# Index

## Numerics

1565 Emul Error Load Emul Option **2-37**  
200.yy Paper jam **2-42**  
249.yy Paper jam **2-42**  
24x.yy Paper jam **2-42**  
250.yy Paper jam **2-42**  
30 \> print unit missing **2-37**  
30 Coating roll missing **2-37**  
34 Incorrect Media **2-37**  
34 Short Paper **2-38**  
37 Insufficient memory for Flash Memory Defragment operation **2-38**  
37 Insufficient memory to collate job **2-38**  
37 Insufficient memory, some held jobs were lost **2-38**  
38 Memory Full **2-38**  
39 Page is too complex to print **2-38**  
40 Tray size sense error **2-39**  
41 Open bin 1 exit tray **2-39**  
51 Defective flash detected **2-39**  
52 Not enough free space in flash memory for resources **2-39**  
53 Unformatted flash detected **2-39**  
54 Network software error **2-39**  
54 Serial option error **2-39**  
54 Standard network software error **2-39**  
55 Unsupported flash option in slot **2-39**  
55 Unsupported option in slot **2-39**  
56 Parallel port disabled **2-40**  
56 Serial port disabled **2-40**  
56 Std. parallel port disabled **2-40**  
56 USB port disabled **2-40**  
57 Configuration change, some Held Jobs were lost **2-40**  
58 Input config error **2-40**  
58 Too many bins attached **2-40**  
58 Too many disks installed **2-40**  
58 Too many flash options installed **2-40**  
61 Defective disk **2-40**  
62 Disk full **2-40**  
63 Unformatted disk **2-41**  
64 Unsupported disk format **2-41**  
80 Belt life warning **2-41**  
80 Fuser life warning **2-41**  
80 Replace belt **2-41**  
80 Replace fuser **2-41**  
80 Scheduled maintenance **2-41**  
81 Engine code CRC failure **2-41**  
84 \> photo developer abnormal **2-41**  
84 Black photo developer life warning **2-41**  
84 Color photo developer life warning **2-41**  
84 Replace all photo developers **2-41**  
84 Replace black photo developer **2-41**  
84 Replace color photo developers **2-41**  
86 Abnormal coating roll **2-42**  
88 \> Toner is low **2-42**

88 OCR exhausted **2-42**  
88 Replace \> toner **2-42**

## A

Activating Menu Changes **2-30**  
adjustments  
    finisher hole punch alignment **3-69**  
    high-capacity paper feed timing belt **4-4**  
    procedures after replacement **4-4**  
All Photo Dev Life Warning **2-30**  
attendance messages **2-30**

## B

bin name Full **2-30**  
Black Low **2-30**  
Black Photo Dev Life Warning **2-30**  
Busy **2-30**

## C

Calibrating **2-30**  
Cancel not available **2-30**  
Cancelling Job **2-30**  
Change **2-30**  
Check tray connection **2-30**  
Clearing job accounting statistics **2-30**  
Close door **2-30**  
Close front door **2-30**  
Close side door **2-30**  
Close tray top cover **2-30**  
Color Photo Dev Life Warning **2-31**  
communication error  
    finisher **2-17**  
    printer/printhead controller board **2-17**  
configuration ID **1-20**  
connectivity **1-16**  
connectors  
    duplex unit controller board **5-16**  
    high voltage power supply board **5-14**  
    LVPS 2 board **5-13**  
    LVPS board **5-12**  
    motor drive board **5-16**  
    printer controller board **5-5**  
    printhead controller board **5-7**  
    RIP board **5-11**  
    sensor board **5-14**  
    size sensor board **5-17**  
Copies **2-31**

covers  
front left removal **4-8**  
left side removal **4-9**  
locations **5-1**  
parts catalog **7-2, 7-4, 7-5, 7-6, 7-7**  
rear removal **4-9**  
right side removal **4-10**  
RIP board removal **4-11**  
solenoid removal **4-9**  
top cover removal **4-6**  
Cyan Low **2-30**

## D

Defragmenting Flash **2-31**  
Delete **2-31**  
Delete all **2-31**  
Delete all confidential jobs **2-31**  
Deleting **2-31**  
development unit **3-24**  
diagnostic aids **3-1**  
diagnostic information **2-1**  
diagnostics  
image quality troubleshooting **2-63**  
maintenance analysis procedures (MAPS) **2-43**  
service checks **2-50**  
service error messages **2-5**  
symptom tables **2-3**  
DIP switch settings **3-43**  
Disabling DLEs **2-31**  
Disabling Menus **2-31**  
Disk corrupted **2-31**  
Disk Recovery x/5 yyy% **2-31**  
doors  
front door / operator panel removal **4-7**  
driving parts layout **5-20**  
duplex unit  
parts catalog **7-30, 7-32**  
removals **4-54**  
connector **4-53**  
feed roller and solenoid **4-55**  
paper carrying motor **4-57**  
side fence **4-56**  
side fence motor assembly **4-56**  
timing belt **4-54**  
theory of operation **3-32**

## E

electrical  
diagram **5-20**  
finisher diagram **5-24**  
finisher, parts catalog **7-54**  
high-capacity feeder diagram **5-20**  
parts catalog **7-16**  
Empty box M **2-31**  
Enabling Menus **2-31**  
Encrypting Disk yyy% **2-31**  
Engine Warming **2-31**  
Enter PIN **2-32**  
Enter PIN to lock **2-32**  
eraser removal **4-21**

error messages **2-5**  
Error printing from USB drive **2-32**  
Error reading USB drive **2-32**  
expansion feeder  
parts catalog **7-26, 7-28**  
theory of operation **3-32**

## F

fans  
main unit fan removal **4-25**  
upper fan removal **4-47**  
finisher  
adjusting wheels **3-64**  
aligning finisher and printer **3-59**  
aligning sides of finisher **3-62**  
aligning top of finisher **3-63**  
attaching cables **3-65**  
bins, attaching **3-58**  
docking plate and guide rail, attaching **3-52**  
electrical **5-24**  
electrical parts functions **3-45**  
elevator sequence **3-51**  
hole punch theory **3-48**  
installation **3-52**  
inverted paper path **3-47**  
jogging **3-49**  
lowering and raising **3-60**  
offsetting **3-49**  
parts catalog  
covers **7-46, 7-47**  
docking **7-55, 7-56**  
electronics **7-54**  
elevator **7-53**  
feed 1 **7-50, 7-51**  
feed 2 **7-52**  
frame **7-48, 7-49**  
removals  
control board **4-64**  
elevator motor **4-65**  
external covers **4-63**  
feed motor assembly **4-65**  
hole punch **4-66**  
inverter paper exit discharge brush **4-67**  
inverter paper exit roller **4-67**  
jogging unit **4-68**  
path select gate **4-69**  
power supply **4-72**  
registration roller **4-73**  
registration roller clutch **4-73**  
stack area discharge brush **4-74**  
staple unit **4-74**  
straight paper exit discharge brush **4-75**  
straight paper exit roller **4-75**  
timing belts 1 and 2 **4-77**  
tractor belt **4-78**  
tractor drive motor assembly **4-79**  
stand **3-54**  
stapling mechanism **3-50**  
straight paper path **3-46**  
theory of operation **3-44**

Flushing buffer **2-32**  
Formatting Disk **2-32**  
Formatting Disk yyy% **2-32**  
Formatting Flash **2-32**  
Fuser Life Warning **2-32**  
fuser unit  
    parts catalog **7-23**  
    removal **4-18**

## H

Handling ESD-sensitive parts **4-1**  
Hex Trace **2-32**  
high-capacity feeder  
    call roller removal **4-59**  
    covers removal **4-58**  
    diagram **5-19**  
    high-capacity paper feed timing belt adjustment **4-4**  
    paper end sensor removal **4-60**  
    paper feed configuration **5-19**  
    paper feed roller removal **4-59**  
    paper level sensor removal **4-62**  
    paper size sensors (1, 2) removal **4-60**  
    parts catalog **7-34, 7-36, 7-38, 7-40, 7-42, 7-43, 7-44, 7-45**  
    pickup solenoid removal **4-59**  
    power supply removal **4-62**  
    reverse roller removal **4-59**  
    theory **3-38**  
    tray motor removal **4-61**  
hole punch  
    adjustment **3-69**  
    removal **4-66**  
    theory of operation **3-48**  
Hole Punch Box Full **2-32**

## I

image quality troubleshooting **2-63**  
initial check **2-1**  
Insert hole punch box **2-32**  
Insert Staple Cartridge **2-32**  
Insert Tray \> **2-32**  
Install \> or Cancel Job **2-32**  
installation  
    environment **2-1**  
Insufficient memory to support Resource Save feature **2-38**  
Internal System Error Reload Bookmarks **2-32**  
Internal System Error, Reload Security Certificates **2-32**  
Invalid Engine Code **2-33**  
Invalid Network Code **2-33**  
Invalid PIN **2-33**

## L

LEDs  
    cleaning **2-64**  
Load **2-33**  
Load Manual **2-33**  
Load Staples **2-33**  
Load with **2-33**  
locations **5-1**  
    components **5-4**

covers **5-1**  
high capacity feeder **5-19**  
major parts **5-2**  
sensor and switches **5-3**  
lubricants **6-2**

## M

Magenta Low **2-30**  
Maintenance **2-33**  
maintenance  
    approach **1-19**  
    cleaning **1-19, 6-2**  
    dip switch specifications **3-43**  
    inspection **1-19**  
    lubricants **6-2**  
    periodic **6-2**  
    recommendations **1-20**  
maintenance analysis procedures (MAPS)  
    false 30 oil coating roll missing **2-44**  
    false 40 tray (x) size sensor error **2-46**  
    false 41 open bin 1 exit tray **2-46**  
    false 88 toner low/toner empty **2-45**  
    false close top door **2-43**  
    false close tray (x) top cover **2-43**  
    false print unit missing **2-45**  
    false side door open **2-43**  
    false tray (x) low/empty **2-44**  
    paper size **2-48**  
    unrecoverable check tray (x) or duplex connection **2-47**  
maintenance kit **6-1**  
menu overview **3-4**  
menu settings **3-3**  
Menus are Disabled **2-34**  
messages  
    printer messages **2-5**  
    service errors **2-5**  
models **1-1**  
multipurpose feeder  
    theory of operation **3-30**  
    tray removal **4-26**

## N

Network **2-34**  
No DRAM installed **2-34**  
No held jobs **2-34**  
No jobs found. **2-34**  
No jobs to cancel **2-34**  
No recognized file types **2-34**

## O

operator menu  
    disabled **3-3**  
options  
    parts catalog **7-57**

## P

- paper and media
  - guidelines **1-15**
  - paper checks **2-2**
  - print area **1-15**
  - printer capacity **1-13**
  - sizes **1-8**
  - specifications **1-7**
  - types **1-12**
  - weights **1-12**
- paper exit tray removal **4-12**
- paper feeding
  - multipurpose feeder **3-29**
  - paper jams **3-34**
  - theory **3-29**
  - weight of paper **3-33**
- paper jams **3-34**
- Parallel **2-34**
- part number **1-20**
- parts catalog
  - base **7-10, 7-12, 7-14**
  - cassette **7-24**
  - covers **7-2, 7-4, 7-5, 7-6, 7-7**
  - duplex unit **7-30, 7-32**
  - electrical **7-16**
  - expansion feeder **7-26, 7-28**
  - finisher
    - covers **7-46, 7-47**
    - docking **7-55, 7-56**
    - electronics **7-54**
    - elevator **7-53**
    - feed **7-50, 7-51, 7-52**
    - frame **7-48, 7-49**
  - finisher parts packet **7-63**
  - fuser unit **7-23**
  - high-capacity feeder **7-34, 7-36, 7-38, 7-40, 7-42, 7-43, 7-44, 7-45**
  - miscellaneous **7-57**
  - options **7-57**
  - parts packets **7-58**
  - RIP board **7-22**
  - upper unit **7-8**
- parts packets **7-58, 7-63**
- parts return **1-20**
- periodic maintenance **6-2**
- Port disabled Remove USB drive **2-34**
- POST **3-1**
- power and electrical specifications **1-17**
- Power Saver **2-34**
- power-on self-test sequence **3-1**
- preventive maintenance **6-1**
- print quality problems **2-63**
- printed circuit boards
  - inspection **4-2**
  - precautions **4-2**
  - replacement **4-2**
  - transportation and storage **4-2**
- Printer busy **2-34**
- printer controller board communication error **2-17**

- printer environment **1-18**
- Printer locked, enter PIN to unlock **2-34**
- printer messages **2-5**
- printhead
  - LED printhead removal **4-20**
- printhead controller board removal **4-38**
- Printing **2-34**
- Printing from USB drive **2-34**
- printing menu settings **3-3**
- Programming Disk **2-34**
- Programming Flash **2-34**
- Programming System Code **2-34**

## R

- Reading USB drive **2-34**
- Ready **2-35**
- Remote Management Active **2-35**
- removals
  - belt up/down clutch **4-12**
  - cassette guide **4-13**
  - connector, duplex unit **4-14**
  - covers
    - front left **4-8**
    - left side **4-9**
    - rear **4-9**
    - right side **4-10**
    - RIP board **4-11**
    - solenoid **4-9**
    - top **4-6**
  - density sensor **4-15**
  - drive gear unit sensor assembly **4-15**
  - duplex unit **4-54**
    - connector **4-53**
    - feed roller and solenoid **4-55**
    - paper carrying motor **4-57**
    - pressure roller and solenoid **4-55**
    - side fence motor assembly **4-56**
    - side fence removal **4-56**
    - timing belt **4-54**
  - duplex unit connector **4-14**
  - electronic box **4-16**
  - eraser **4-21**
  - face down guide assembly **4-32**
  - face up paper exit assembly **4-17**
  - finisher
    - control board **4-64**
    - elevator motor **4-65**
    - external covers **4-63**
    - feed motor assembly **4-65**
    - hole punch **4-66**
    - inverter paper exit discharge brush **4-67**
    - inverter paper exit roller **4-67**
    - jogging unit **4-68**
    - path select gate removal **4-69**
    - power supply **4-72**
    - registration roller **4-73**
    - registration roller clutch **4-73**
    - stack area discharge brush **4-74**
    - staple unit **4-74**
    - straight paper exit discharge brush **4-75**



- straight paper exit roller **4-75**
- timing belts 1 and 2 **4-77**
- tractor belt removal **4-78**
- tractor drive motor assembly **4-79**
- front cover open switch actuator **4-17**
- fuser **4-18**
- gear cover **4-19**
- high voltage power supply board **4-20**
- high-capacity feeder
  - call roller **4-59**
  - covers **4-58**
  - paper end sensor **4-60**
  - paper feed roller **4-59**
  - paper level sensor **4-62**
  - paper size sensors (1, 2) **4-60**
  - pickup solenoid **4-59**
  - power supply **4-62**
  - reverse roller **4-59**
  - tray motor **4-61**
- LED printhead **4-20**
- left slide rail **4-39**
- lock handle assembly **4-22**
- main drive unit **4-23**
- main unit fan **4-25**
- motor drive board **4-25**
- multipurpose feeder frame assembly **4-19**
- multipurpose feeder paper present sensor **4-25**
- multipurpose feeder tray **4-26**
- operator panel **4-7**
- paper carrying frame **4-29**
- paper exit tray **4-12**
- power supply 1 **4-35**
- power supply 2 **4-36**
- power switch **4-37**
- printer controller **4-37**
- printhead controller board **4-38**
- registration clutch **4-30**
- registration frame **4-30**
- registration sensor **4-30**
- RIP box **4-39**
- sensor board **4-40**
- sensor cleaner **4-15**
- separation fingers **4-15**
- stay arm **4-40**
- sub-frame **4-41**
- temperature/humidity sensor **4-42**
- top unit **4-43**
- transfer belt
  - normal removal **4-43**
  - turn guide cover sensor **4-47**
- upper fan **4-47**
- Remove all color supplies **2-35**
- Remove paper from all bins **2-35**
- Remove paper from bin **2-35**
- Remove paper from standard output bin **2-35**
- repair information
  - handling printed circuit boards **4-2**
  - service precautions **4-1**
- Replace All Color Photo Dev **2-35**

- Replace All Photo Dev **2-35**
- Replace Black **2-36**
- Replace Black and Oil Coating Roll **2-35**
- Replace Black Photo Dev **2-36**
- Replace Cyan **2-36**
- Replace Fuser **2-36**
- Replace Magenta **2-36**
- Replace oil coating roll **2-35**
- Replace Photo Dev **2-35**
- Replace Transfer Belt **2-36**
- Replace Yellow **2-36**
- Resetting Active Bin **2-36**
- Resetting Fuser Count **2-36**
- Resetting the Printer **2-36**
- Restore Held Jobs **2-36**
- Restoring Factory Defaults **2-36**
- Restoring Held Job xxx/yyy **2-36**

## S

- safety information **xvii**
- sensors
  - density **4-15**
  - drive gear unit **4-15**
  - finisher, functions **3-45**
  - high-capacity feeder paper end sensor removal **4-60**
  - high-capacity feeder paper level **4-62**
  - high-capacity feeder paper size sensors (1, 2) removal **4-60**
  - humidity **4-42**
  - locations **5-3**
  - multipurpose feeder paper present **4-25**
  - sensor board **4-40**
  - temperature **4-42**
  - turn guide cover **4-47**
- Serial \> **2-37**
- serial number **1-20**
- service checks **2-50**
  - drive 1 DC motor **2-50**
  - duplex **2-50**
  - expansion paper feed **2-52**
  - face down stacker full **2-52**
  - face up exit assembly **2-60**
  - high capacity feeder (HCF) **2-53**
  - marks on paper **2-55**
  - operator panel **2-55**
  - options **2-68**
  - paper carrying **2-56**
  - paper exit motor **2-50**
  - paper exit, face up exit assembly **2-60**
  - paper tray missing **2-60**
  - photodeveloper missing **2-61**
  - power supply **2-61**
  - serial port **2-68**
  - transfer belt up/down **2-62**
- service communication **2-17**

## service error

- 910 - drive motor error **2-9**
- 911 - paper exit motor error **2-9**
- 912 - high capacity feed motor error **2-10**
- 917 - RIP fan error **2-10**
- 918 - main unit fan error **2-10**
- 919 - power supply fan error **2-10**
- 920 - fuser error - fuser heater trouble **2-11**
- 923 - upper fuser thermistor open error **2-11**
- 924 - lower fuser thermistor open error **2-11**
- 925 - HVU error **2-12**
- 92x - toner sensor error **2-12**
- 930 - printhead error, yellow **2-13**
- 931 - printhead error, magenta **2-13**
- 932 - printhead error, yellow **2-14**
- 933 - printhead error, black **2-14**
- 934 - drum sensor, color **2-15**
- 935 - drum sensor, black **2-15**
- 936-9 - cassette error **2-15**
- 940 - high-capacity feed sensor error **2-16**
- 941 - high-capacity feed tray error **2-16**
- 942 - duplex error **2-16**
- 945 - engine flash error **2-16**
- 946 - printer/printhead controller board communication **2-17**
- 947 - finisher communication error **2-17**
- 948 - machine ID error **2-18**
- 949 - tray (x) communication error **2-18**
- 952 - NVRAM chip failure **2-19**
- 954 - NVRAM CRC failure **2-19**
- 955 - code CRC **2-19**
- 956 - processor failure **2-20**
- 957 - ASIC failure **2-20**
- 958 - NAND failure **2-20**
- 960 - RAM slot 1 bad **2-20**
- 961 - RAM slot 2 bad **2-20**
- 964 - emulation error **2-20**
- 970 - standard network error **2-20**
- 975 - unrecognizable network port **2-20**
- 976 - unrecoverable software error in network port **2-21**
- 978 - bad checksum **2-21**
- 979 - Flash parts failed **2-21**
- 980 - face up/down switching error **2-21**
- 981 - belt up/down sensor **2-22**
- 982 - sensor controller **2-23**
- 983 - black gear sensor **2-23**
- 984 - yellow gear sensor **2-23**
- 985 transfer belt thermistor **2-24**
- 986 - transparency (OHP) sensor **2-24**
- 993 - CPU **2-25**
- 994 - density sensor **2-26**
- 995 - finisher main feed motor **2-27**
- 996 - finisher jogging motor **2-27**
- 997 - finisher tractor motor **2-28**
- 999 - stapler motor **2-29**
- tray elevator motor **2-28**

service errors **2-5**

service precautions **4-1**

size detection **3-41**

Some held jobs were lost **2-37**

specifications

connectivity **1-16**

environment **1-18**

paper and media **1-7**

power and electrical **1-17**

technical **1-3**

Standard Bin Full **2-37**

Staples Empty **2-37**

Staples Low **2-37**

start **2-1**

sub-frame

removal **4-41**

Submitting selection **2-37**

switches, locations **5-3**

symptom table **2-3**

## T

technical specifications **1-3**

theory

belt unit **3-31**

belt up/down **3-31**

cleaning unit **3-28**

clearing paper jams **3-34**

configuration **3-24**

delivery **3-32**

development unit **3-24**

drive system **3-28**

duplex unit **3-32**

electrophotography **3-24**

electrophotography process **3-24**

expansion paper feeder **3-32**

fusing **3-26**

high capacity feeder (HCF) **3-38**

maintenance mode **3-43**

multipurpose feeding **3-30**

paper feeding **3-29**

paper feeding / fusing **3-28**

processes **3-24**

processes and configuration **3-24**

registration unit **3-30**

transfer unit **3-25**

tools **1-20**

transfer belt

removal **4-43**

Transfer Belt Life Warning **2-37**

Tray \> Empty **2-37**

Tray \> Low **2-37**

Tray \> Missing **2-37**

tray up/down mechanism **3-39**

troubleshooting **2-63**

## U

USB \> **2-37**

USB drive removed **2-37**

## V

View supplies **2-37**

## **W**

Waiting **2-37**  
weight, printer **1-3**

## **Y**

Yellow Low **2-30**



## Part number index

P/N	Description	Page
11G0199	Guide, wire	7-27
11G0399	Plate, ground	7-27
40X0179	Grease, Nyogel 744	7-57
40X0269	Cord, US, Canada, APG, LAD	7-17
40X0270	Cord, Japan	7-17
40X0271	Cord, UK	7-17
40X0272	Cord, Argentina, Paraguay, Uruguay	7-17
40X0273	Cord, Italy	7-17
40X0274	Cord, Switzerland	7-17
40X0275	Cord, Israel	7-19
40X0276	Cord, South Africa	7-19
40X0277	Cord, Brazil (HV, LV)	7-19
40X0278	Cord, Austria, Russia	7-19
40X0279	Cord, Denmark, Finland, Norway, Sweden	7-19
40X0280	Cord, Korea	7-19
40X0281	Cord, Taiwan	7-19
40X0282	Cord, People's Republic of China	7-19
40X0286	Cord, England, France, Germany, Spain, Belgium	7-17
40X0290	Card, serial option	7-57
40X0291	Card, parallel option	7-57
40X1025	Frame assembly, carrying	7-15
40X1026	Exit assembly, face up	7-4
40X1027	Guide assembly, face-down	7-5
40X1028	Lamp, M erase	7-9
40X1029	Lamp, C erase	7-9
40X1030	Lamp, Y erase	7-9
40X1031	Lamp, K erase	7-9
40X1032	Fan, upper right	7-9
40X1033	Fan, upper left	7-9
40X1034	Rail, base left side	7-11, 7-27
40X1037	Clutch, belt up/down	7-11
40X1040	Clutch, registration	7-15
40X1040	Clutch, registration (used on carrying frame)	7-15
40X1041	Unit, transfer belt	7-15
40X1042	Cable asm, feeder	7-17
40X1043	Board, sensor	7-17
40X1044	Cable asm, sensor board	7-17
40X1047	Fan, power supply	7-17
40X1049	Cable, fuser drawer	7-17
40X1050	Cable, fuser drawer (EMEA)	7-17
40X1052	Belt, power supply	7-17
40X1053	Cable asm, printer controller power 1	7-17
40X1054	Cable assembly, 26 pin RIP printer controller	7-22
40X1055	Cable asm, MIF	7-17
40X1058	Cassette, paper feed	7-25
40X1060	Board, duplex interface	7-31
40X1064	Exit roller, face-down	7-5
40X1067	Clutch, MPF	7-15
40X1068	Cable assembly, 8 pin PH controller	7-21
40X1069	Guide assembly, expansion turn guide	7-29
40X1070	Bushing, pressure	7-29
40X1071	Spring, paper carry 2	7-29
40X1072	Roller, follow up	7-29
40X1073	Cable assembly, 36 pin RIP harness	7-21

40X1074	Cable assembly, 30 pin RIP harness	7-21
40X1075	Assembly, paper-feed base	7-11
40X1076	Plate, guide rocking	7-11, 7-29
40X1077	Roller, pickup	7-11, 7-29
40X1078	Roller, paper feed	7-11, 7-29
40X1079	Roller, separator	7-11, 7-29
40X1080	Clutch, friction	7-11, 7-29
40X1081	Clutch, roller 6 x 10 x 14	7-11, 7-29
40X1082	Clutch, paper feed	7-11
40X1083	Board, CK2 daughter/sensor	7-11
40X1084	Card, CK1 daughter	7-17
40X1085	Switch, turn guide	7-15
40X1086	Assembly, paper feed expansion	7-29
40X1087	Clutch, paper feed	7-29
40X1088	Assembly, turn guide switch option	7-29
40X1089	Cable asm, paper feed type 2	7-29
40X1090	Motor asm, stepping	7-27
40X1091	Cable asm, expansion paper level	7-27
40X1092	Cable asm, exp lift motor	7-27
40X1093	Gear, IDS 38	7-27
40X1094	Pulley, timing	7-27
40X1095	Belt, timing S3M-177	7-27
40X1096	Gear, Z30	7-27
40X1097	Motor, paper tray lift	7-17, 7-27
40X1098	Cable asm, paper-feed type 1	7-11
40X1098	Cable assembly, paper feed type 1	7-21
40X1099	Cable assembly, 622 LFT guard	7-21
40X1100	Cable assembly, cassette bottom sensor	7-21
40X1101	Asm, HCF/FIN D-Sub	7-17
40X1102	Cable asm, finisher	7-17
40X1103	Bushing, turn guide	7-11, 7-29
40X1104	Interruptor, photo (paper low sensor)	7-19
40X1105	Flag, bottom sense	7-25
40X1106	Clip, paper feed shaft	7-29
40X1106	Clip, paper-feed shaft	7-11
40X1107	Sensor, relay	7-11, 7-29
40X1108	Roller, relay	7-11
40X1109	Kit, paperpath maint	7-57
40X1111	Roller, relay expansion feed	7-29
40X1112	Assembly, drive link	7-11
40X1113	Cable assembly, registration clutch	7-21
40X1113	Cable, registration clutch	7-15
40X1114	Cable assembly, carrying clutch	7-21
40X1114	Cable, carrying clutch	7-15
40X1115	Cable assembly, registration sensor	7-21
40X1115	Cable, registration sensor	7-15
40X1116	Cable assembly, MFP clutch	7-21
40X1116	Cable, MPF clutch	7-15
40X1117	Assembly, RFID	7-9
40X1118	Cable, RFID	7-9
40X1119	Shaft, changing	7-11
40X1120	Cable, belt relay	7-17
40X1122	Tray assembly, exit	7-3
40X1123	Cover assembly, front	7-3
40X1124	Cover assembly, right side	7-3
40X1125	Cover, solenoid	7-3
40X1126	Cover, left side	7-3
40X1127	Cover, paper feed	7-3
40X1128	Cover, rear	7-3

40X1129	Cover, left front	7-3
40X1130	Cover, adjustment	7-3
40X1131	Cover, top	7-3
40X1132	Cover, waste toner bottle	7-3
40X1135	Feeder assembly, multipurpose	7-7
40X1136	Photo interruptor	7-15
40X1137	Photo interruptor	7-15
40X1139	Magnet, right side latch	7-3
40X1140	Magnet, front cover latch	7-3, 7-29
40X1142	Holder, front hsp	7-9
40X1143	Bracket, front upper	7-9
40X1144	Rod, interlocking	7-9
40X1145	Hook, middle	7-9
40X1146	Hook, left	7-9
40X1147	Hook, right	7-9
40X1148	Bracket, rear upper	7-9
40X1149	Frame, printhead controller	7-9
40X1150	Clutch, drive unit	7-11
40X1151	Cover, electronic	7-13
40X1152	Sensor, density	7-15
40X1154	Frame assembly, registration	7-15
40X1155	Frame assembly, F1 sub	7-15
40X1156	Stopper, clutch	7-15
40X1157	Cable, power switch	7-17
40X1158	Switch, power	7-17
40X1165	Box, RIP	7-22
40X1166	Cover, RIP box	7-22
40X1167	Cover, rear	7-27
40X1168	Frame, duplex	7-31
40X1169	Screw, duplex mounting	7-31
40X1170	Motor, duplex stepping	7-31
40X1171	Interrupter, photo	7-31, 7-33
40X1173	Interrupt, photo	7-11, 7-27, 7-29
40X1173	Interrupter, photo	7-33
40X1174	Roller, drive feed	7-33
40X1175	Roller, follow-up feed	7-33
40X1176	Roller, middle feed	7-33
40X1177	Roller, re-feed	7-33
40X1200	Cover, front feed	7-27
40X1201	Cover, left side	7-27
40X1202	Cover, right side A	7-27
40X1203	Cover, right side B	7-27
40X1204	Cover, right side C	7-27
40X1205	Cable asm, conditioning printer controller	7-17
40X1207	Support assembly, upper unit	7-13
40X1208	Handle assembly, lock	7-13
40X1209	Guide assembly, fuser entry	7-15
40X1227	Assembly, lower left panel	7-47
40X1237	Bracket, rail	7-56
40X1238	Screw, rail	7-56
40X1239	Chassis, rail	7-56
40X1240	Screw, lock	7-56
40X1241	Stud, lock-f	7-56
40X1242	Guide assembly, turn	7-6
40X1246	Gear, Z28-20T	7-27
40X1247	Sensor, humidity (not included in 7-3)	7-11, 7-17
40X1248	Card assembly, RIP	7-22
40X1254	Bracket, lock	7-56
40X1255	Cable, USB	7-22

40X1256	Cable, operator panel	7-22
40X1257	Handle, up opening	7-9
40X1259	Operator panel	7-3
40X1262	Parts packet	7-3, 7-58
40X1263	Parts packet	7-9, 7-58
40X1264	Parts packet	7-11, 7-58
40X1265	Parts packet	7-13, 7-58
40X1266	Parts packet	7-15, 7-59
40X1267	Parts packet	7-19, 7-21, 7-59
40X1268	Parts packet	7-22, 7-59
40X1269	Parts packet	7-27, 7-59
40X1270	Parts packet	7-29, 7-60
40X1271	Parts packet	7-31, 7-33, 7-60
40X1375	Adapter, MarkNet N8000 10/100	7-57
40X1376	Adapter, MarkNet N8020 10/1000	7-57
40X1377	Adapter, MarkNet N8030 Fiber	7-57
40X1378	Adapter, MarkNet N8050 Americas	7-57
40X1501	Kit, rack guard holder	7-25
40X1502	Card, IPDS	7-57
40X1503	Card, bar code	7-57
40X1504	Card, Prescribe	7-57
40X1505	Card, PrintCrypton	7-57
40X1506	Card, forms	7-57
40X1507	Card, forms (Double byte)	7-57
40X1508	Card assembly, 128MB SDRAM memory	7-57
40X1509	Card assembly, 256MB SDRAM memory	7-57
40X1510	Card assembly, 512MB SDRAM memory	7-57
40X1511	Kit, eST360 CP net printer relocation	7-57
40X1512	Kit, Japanese font	7-57
40X1513	Kit, Simplified Chinese font	7-57
40X1514	Kit, Traditional Chinese font	7-57
40X1515	Kit, Korean font	7-57
40X1516	Label, MPT	7-3
40X1520	Fan, RIP box	7-22
40X1561	Antenna, external	7-57
40X1562	Adapter, MarkNet N8050 Europe	7-57
40X1564	Card asm, 32MB flash memory	7-57
40X1565	Card asm, 64MB flash memory	7-57
56P2652	Board, 120V motor drive	7-17
56P2653	Board, 230V motor drive	7-17
56P2654	Board, printer controller	7-17
56P2655	Fuser, 120V	7-23
56P2656	Fuser, 230V	7-23
56P2657	Board, expansion feeder controller	7-27
56P2658	Board, high capacity feed	7-41
56P2666	Unit, drive 120V	7-11
56P2667	Unit, drive 230V	7-11
56P2668	Frame, sub	7-11
56P2669	Frame assembly, MPF	7-15
56P2670	Cable asm, duplex connector	7-17
56P2671	Sensor, upper OHP	7-15
56P3980	Board, printhead controller	7-9
56P3981	Assembly, LED printhead (K)	7-9
56P3982	Assembly, LED printhead (C)	7-9
56P3983	Supply, high voltage	7-17
56P3984	Supply, 120V power 1	7-17
56P3985	Supply, 230V power 1	7-17
56P3986	Supply, 120V power 2	7-17
56P3987	Supply, 230V power 2	7-17



56P3988	Card, conditioning (EMEA) -----	7-17
56P3990	Cable assembly, duplex connection -----	7-31
56P3991	Solenoid assembly, feed roller -----	7-33
56P3992	Solenoid assembly, paper re-feed -----	7-33
56P3993	Cable assembly, duplex drawer -----	7-33
56P4008	Power supply, HCF -----	7-41
56P4023	Duplex assembly -----	7-31
56P4024	Assembly, expansion feeder -----	7-27
56P4060	Assembly, punch drive -----	7-51
56P4061	Belt -----	7-51
56P4062	Panel, left upper -----	7-47
56P4063	Assembly, staple cover -----	7-47
56P4064	Cover, top -----	7-47
56P4065	Cover, front -----	7-47
56P4066	Cover, rear -----	7-47
56P4067	Tray, upper -----	7-47
56P4068	Tray, lower -----	7-47
56P4069	Handle -----	7-49
56P4070	Pulley gear Z36/T24 -----	7-51
56P4072	Kit, punch speed up -----	7-49
56P4073	Panel, lower left -----	7-53
56P4364	Assembly, exit guide straight -----	7-49
56P4365	Board, finisher control -----	7-54
56P9300	Assembly, jogging unit -----	7-52
56P9301	Assembly, guide stack -----	7-52
56P9303	Supply, power -----	7-54
56P9306	Assembly, upper limit sensor -----	7-54
56P9307	Assembly, hook rear -----	7-53
56P9308	Assembly, elevator motor -----	7-53
56P9309	Assembly, exit guide inverter -----	7-49
56P9310	Gate -----	7-51
56P9312	Roller, F -----	7-51
56P9313	Unit, 3 hole punch (U.S. only) -----	7-49
56P9314	Unit, 4 hole punch (non U.S.) -----	7-49
56P9318	Spring, B -----	7-51
56P9329	Assembly, tractor motor -----	7-52
56P9331	Wire -----	7-53
56P9332	Spring, C -----	7-53
56P9333	Belt, timing (60S3M408) -----	7-52
56P9334	Assembly, solenoid -----	7-51
56P9335	Clutch, registration -----	7-51
56P9339	Belt, timing 60S2M334 -----	7-51
56P9341	Assembly, feed motor -----	7-51
56P9357	Cable, interface -----	7-54
56P9358	Cord, Y power -----	7-54
56P9361	Roller, patting -----	7-51
56P9363	Stapler -----	7-47
56P9364	Cover, staple B -----	7-47
56P9365	Cover, staple A -----	7-47
56P9367	Cartridge, staple -----	7-47
56P9368	Cord, Y power (230 V only) -----	7-54
56P9373	Screw, M4 -----	7-49
56P9380	Sensor, photo -----	7-49
56P9386	Spring -----	7-49
56P9395	Assembly, guide plate -----	7-51
56P9396	Spring, H -----	7-51
56P9398	Gear, Z19 -----	7-51
56P9399	Sensor, photo -----	7-49
56P9400	Roller -----	7-51

56P9401	Roller, I	7-51
56P9405	Roller, G	7-51
56P9407	Belt, timing 60S2M184	7-51
56P9410	Cable	7-54
56P9420	Bracket, finisher control board	7-54
56P9451	Shutter	7-53
56P9459	Drum, wire	7-53
56P9460	Gear, Z30	7-53
56P9465	Assembly, sensor	7-53
56P9467	Screw, thumb	7-55
56P9472	Screw, lock	7-56
56P9473	Stud, lock	7-56
56P9474	Roller	7-56
56P9480	Parts packet, finisher	7-63
56P9501	Spring, pressure	7-37
56P9501	Spring, pressure pickup	7-41
56P9503	Foot, rubber	7-11, 7-27
56P9521	Lever, size sense	7-11, 7-27
56P9522	Card, size sense	7-27
56P9524	Screw, slide rail	7-11, 7-27
56P9526	Spring, feed roller	7-33
56P9527	Gear, idler	7-33
56P9528	Interrupter, photo	7-37, 7-43, 7-45
56P9529	Caster, HCF	7-39
56P9530	Switch, push	7-39, 7-41
56P9541	Sensor, resistor	7-41
56P9545	Label, operator panel	7-3
56P9591	Frame, upper	7-9
56P9592	Rail, left side	7-9
56P9593	Holder, rear printhead	7-9
56P9594	Cover, eraser	7-9
56P9609	Spring, printhead	7-9
56P9610	Rail, right side	7-9
56P9611	Holder, front printhead	7-9
56P9621	Bracket, fan holder	7-9
56P9624	Link, frame	7-9
56P9625	Hook, right link	7-9
56P9626	Cover, hook	7-9
56P9627	Bearing, roller	7-9
56P9628	Pivot, color link	7-9
56P9629	Link, frame	7-9
56P9630	Hook, left link	7-9
56P9632	Shroud, cable	7-9
56P9638	Holder, cable	7-9
56P9641	Actuator, front cover open switch	7-11
56P9644	Cable asm, drive unit sensor	7-11
56P9645	Sensor, drive unit	7-11
56P9667	Pin, upper unit support	7-13
56P9669	Handle, lock	7-13
56P9670	Shroud, cable	7-13
56P9671	Guide, cable	7-13
56P9672	Guide, cable	7-13
56P9683	Roller assembly, carrying	7-15
56P9685	Frame assembly, F2 sub	7-15
56P9686	Rod, lock	7-15
56P9687	Cover, gear	7-15
56P9697	Bushing	7-15
56P9715	Cable asm, HVU	7-17
56P9720	Cable assembly, PH controller power	7-21

56P9727	Cable asm, printer controller power 2	7-17
56P9729	EEPROM, printer controller	7-17
56P9733	Cable, hi cap feeder interface	7-57
56P9737	Sheet, insulation	7-17
56P9738	Cable, conditioning joint	7-17
56P9740	Cable, conditioning resistor	7-17
56P9741	Resistor, conditioning (230V only)	7-17
56P9747	Cable, motor driver power	7-17
56P9749	Cable assembly, power RIP	7-22
56P9775	Cable asm, size sense	7-27
56P9777	Cable asm, upper optional drawer	7-27
56P9778	Cable asm, lower optional drawer	7-27
56P9788	Guide, HCPF	7-29
56P9806	Cable assembly, paper detection	7-31
56P9807	Cable assembly, duplex interface	7-31
56P9813	Roll, release	7-33
56P9814	Bearing, release	7-33
56P9815	Spring, reed roller	7-33
56P9816	Spring, re-feed roller	7-33
56P9817	Gear, carrying roller	7-33
56P9818	Pulley, carrying roller timing	7-33
56P9819	Pulley, feed roller	7-33
56P9820	Pulley, re-feed roller	7-33
56P9821	Knob, paper re-feed	7-33
56P9822	Belt, timing	7-33
56P9823	Belt, timing	7-33
56P9824	Plate, paper carrying drawer	7-33
56P9825	Plate, paper re-feed drawer	7-33
56P9826	Guide, front side	7-33
56P9827	Guide, rear side	7-33
56P9828	Motor assembly, paper guide	7-33
56P9833	Cover, front	7-35
56P9834	Cover, upper rear	7-35
56P9835	Magnet, latch	7-35
56P9836	Fence, end	7-35
56P9837	Cover, upper	7-35
56P9838	Catch, door	7-35
56P9839	Cover, right	7-35
56P9840	Lever, vertical transport	7-35
56P9841	Cover assembly, upper	7-35
56P9842	Spring, tension	7-35
56P9843	Cover, lower rear	7-35
56P9844	Motor assembly, transport	7-37
56P9845	Sensor assembly, paper feed	7-37
56P9846	Clutch, paper feed	7-37
56P9846	Solenoid assembly, paper pickup	7-37
56P9847	Spring, compression	7-37
56P9849	Roller, manual feed pickup	7-37
56P9850	Roller, manual feed	7-37
56P9851	Roller, manual feed separate	7-37
56P9852	Limiter, torque	7-37
56P9853	Screw, shoulder	7-39
56P9854	Sensor assembly, photo	7-39
56P9855	Interrupter, photo	7-39
56P9856	Spring, tension	7-39
56P9857	Switch, micro	7-39
56P9858	Connector, I/F	7-39
56P9859	Connector, inlet	7-39
56P9861	Roller, track	7-41

56P9863	Switch, HCF push	7-41
56P9864	Switch, micro	7-41
56P9865	Cable assembly, HCF motor	7-41
56P9866	Cable assembly, paper feed sensor	7-41
56P9867	Cable assembly, drawer ground	7-41
56P9870	Converter, DC/DC	7-41
56P9871	Cable assembly, I/F	7-41
56P9872	Cable assembly, power supply in	7-41
56P9873	Cable assembly, power supply out	7-41
56P9874	Cable assembly, power supply	7-41
56P9875	Cable assembly, safety switch	7-41
56P9876	Cable assembly, lift motor	7-41
56P9877	Cable assembly, paper size sensor	7-41
56P9878	Cable assembly, sensor	7-41
56P9879	Cable, paper volume	7-41
56P9880	Cable, up/down switch	7-41
56P9882	Motor, HCF DC	7-43
56P9883	Spring, pressure	7-43
56P9884	Belt, timing	7-43
56P9885	Pulley, timing	7-43
56P9886	Gear, drive	7-43
56P9887	Bracket, front idler	7-43
56P9888	Bracket, rear idler	7-43
56P9889	Pad, friction	7-45
56P9890	Plate, paper adhesion	7-45
56P9891	Knob, tray	7-45
56P9892	Plate, upper side fence	7-45
56P9893	Knob, stopper	7-45
56P9894	Fence assembly, rear side	7-45
56P9915	Fence assembly, front side	7-45
56P9940	Ring, snap	7-35
56P9941	Arm, pick-up	7-37
56P9943	Fuse, thermal	7-17
56P9958	Parts packet	7-35, 7-60
56P9959	Parts packet	7-37, 7-60
56P9960	Parts packet	7-39, 7-61
56P9961	Parts packet	7-41, 7-61
56P9962	Parts packet	7-43, 7-62
56P9963	Parts packet	7-45, 7-62
56P9964	Transformer (Japan only)	7-19
56P9982	Drive assembly, hard file 20 gb (w/mounting kit)	7-57
56P9993	Shield, light (used on p/n 56P9594)	7-9
56P9994	Plate, duplex guide	7-31

# Finisher Wiring Diagram

