

# TOSHIBA

# SERVICE MANUAL

## MULTIFUNCTIONAL DIGITAL SYSTEMS

# e-STUDIO2528A/3028A/ 3528A/4528A

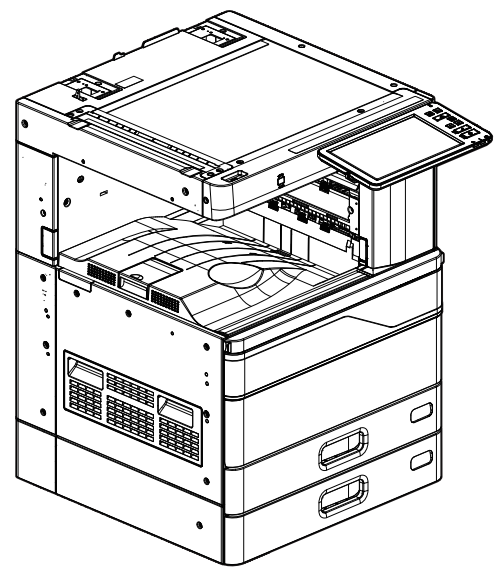

Model: DP-2528A/3028A/3528A/4528A  
Publish Date: December 2021  
File No. SME210007B0  
R210221X1102-TTEC  
Ver02 F 2023-02

## Trademarks

- Microsoft, Windows, Windows NT, and the brand names and product names of other Microsoft products are trademarks of Microsoft Corporation in the US and other countries.
- Apple, AppleTalk, Macintosh, Mac, Safari, and TrueType are trademarks of Apple Inc.
- Adobe<sup>®</sup>, Acrobat<sup>®</sup>, Acrobat Reader<sup>®</sup>, and PostScript<sup>®</sup> are trademarks or registered trademarks of Adobe Inc.
- Mozilla, Firefox and the Firefox logo are trademarks or registered trademarks of Mozilla Foundation in the U.S. and other countries.
- The official name of Windows<sup>®</sup> 10 is Microsoft Windows 10 Operating System.
- The official name of Windows<sup>®</sup> 11 is Microsoft Windows 11 Operating System.
- The official name of Windows Server<sup>®</sup> 2012 is Microsoft Windows Server 2012 Operating System.
- The official name of Windows Server<sup>®</sup> 2016 is Microsoft Windows Server 2016 Operating System.
- The official name of Windows Server<sup>®</sup> 2019 is Microsoft Windows Server 2019 Operating System.
- The official name of Windows Server<sup>®</sup> 2022 is Microsoft Windows Server 2022 Operating System.
- FLOIL<sup>®</sup> is a registered trademark of Kanto Kasei CO., Ltd.
- MOLYKOTE<sup>®</sup> is a registered trademark of DDP SPECIALTY ELECTRONIC MATERIALS US, INC..
- ALVANIA<sup>®</sup> is a registered trademark of Shell Brands International AG.
- VNC is a registered trademark of RealVNC Ltd. in the United States and other countries.
- e-STUDIO, e-BRIDGE, and TopAccess are trademarks of Toshiba Tec Corporation.
- Other company names and product names in this manual are the trademarks of their respective companies.

© 2021 - 2023 Toshiba Tec Corporation All rights reserved

Under the copyright laws, this manual cannot be reproduced in any form without prior written permission of Toshiba Tec Corporation.

# GENERAL PRECAUTIONS REGARDING THE SERVICE FOR THIS EQUIPMENT

**The installation and service shall be done by a qualified service technician.**

## 1. Transportation/Installation

- When transporting/installing the equipment, employ two persons and be sure to hold the positions as shown in the figure.  
The equipment is quite heavy, and weighs approximately 55 kg (121 lb.) (2528A/3028A) / approximately 57 kg (126 lb.) (3528A/4528A), therefore pay full attention when handling it.

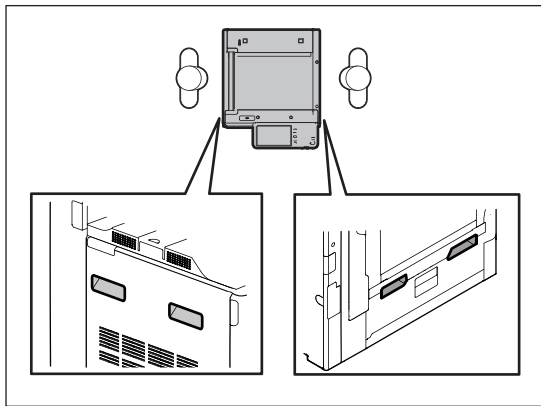

- Be sure not to hold the movable parts or units (e.g. the control panel, ADU or DF) when transporting the equipment.
- Be sure to use a dedicated outlet with AC 110 V / 13.2 A, 120 V / 12 A, 220-240 V 8 A for its power source.
- The equipment must be grounded for safety.
- Select a suitable place for installation. Avoid excessive heat, high humidity, dust, vibration and direct sunlight.
- Provide proper ventilation since the equipment emits a slight amount of ozone.
- To insure adequate working space for the copying operation, keep a minimum clearance of 30 cm (12") on the left, 80 cm (32") on the right and 10 cm (4") on the rear.
- The equipment shall be installed near the socket outlet and shall be easily accessible.
- Be sure to fix and plug in the power cable securely after the installation so that no one trips over it.
- When the equipment is used after the option is removed, be sure to install the parts or the covers which have been taken off so that the inside of the equipment is not exposed.
- Do not use an ozone generator near the MFP. Or, place any ozone generator as far away from the MFP as possible.
- Do not use an ultrasonic humidifier near the MFP.  
Components such as chlorinate and mineral will be atomized by an ultrasonic humidifier and they will adhere to electric parts in the MFP. This could cause malfunctions.
- Unpacking and installation of an MFP should be performed by following the Unpacking Instructions co-packed with it. After the installation is completed, be sure to check the operations and images.

- Do not lift the machine by the areas in the figure that are shaded when lifting it.

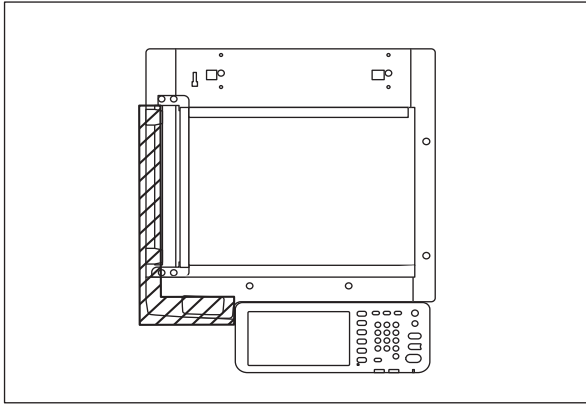

## 2. General Precautions at Service

- Be sure to turn the power OFF and unplug the power cable during service (except for the service should be done with the power turned ON).
- After the power cable is disconnected, an electric charge may remain in the boards of the equipment. Therefore, be sure to disconnect or connect the connectors when about 1 minute (e.g.: the time for taking off the rear cover) has passed after the power cable is disconnected.
- Generally, the fuse is embedded so that it would be on the live side. However, it could be on the neutral side depending on the type of the power plug to be used. Therefore, in order to disconnect and de-energize of the phase conductors, unplug the power plug.
- Unplug the power cable and clean the area around the prongs of the plug and socket outlet once a year or more. A fire may occur when dust lies on this area.
- When the parts are disassembled, reassembly is the reverse of disassembly unless otherwise noted in this manual or other related documents. Be careful not to install small parts such as screws, washers, pins, E-rings, star washers in the wrong places.
- Basically, the equipment should not be operated with any parts removed or disassembled.
- The PC board must be stored in an anti-electrostatic bag and handled carefully using an antistatic wristband since the ICs on it may be damaged due to static electricity.

**Caution: Before using the wristband, unplug the power cable of the equipment and make sure that there are no charged objects which are not insulated in the vicinity.**

- Avoid expose to laser beam during service. This equipment uses a laser diode. Be sure not to expose your eyes to the laser beam. Do not insert reflecting parts or tools such as a screwdriver on the laser beam path. Remove all reflecting metals such as watches, rings, etc. before starting service.
- Be sure not to touch high-temperature sections such as the exposure lamp, fuser unit, damp heater and areas around them.
- Be sure not to touch high-voltage sections such as the chargers, transfer roller, developer, high-voltage transformer, inverter for the LCD backlight and power supply unit. Especially, the board of these components should not be touched since the electric charge may remain in the capacitors, etc. on them even after the power is turned OFF.
- Make sure that the equipment will not operate before touching potentially dangerous places (e.g. rotating/operating sections such as gears, belts pulleys, fans and laser beam exit of the laser optical unit).
- Be careful when removing the covers since there might be the parts with very sharp edges underneath.
- When servicing the equipment with the power turned ON, be sure not to touch live sections and rotating/operating sections. Avoid exposing your eyes to laser beam.
- Use designated jigs and tools.
- Use recommended measuring instruments or equivalents.

- Return the equipment to the original state and check the operation when the service is finished.
- Be very careful to treat the touch panel gently and never hit it. Breaking the surface could cause malfunctions.
- Do not leave plastic bags where children can get at them. This may cause an accident such as suffocation if a child puts his/her head into a bag. Plastic bags of options or service parts must be brought back.
- There is a risk of an electric shock or fire resulting from the damage to the harness covering or conduction blockage. To avoid this, be sure to wire the harness in the same way as that before disassembling when the equipment is assembled/disassembled.

### **3. General operations**

- Check the procedures and perform as described in the Service Manual.
- Make sure you do not lose your balance.
- Avoid exposure to your skin and wear protective gloves as needed.

### **4. Important Service Parts for Safety**

The breaker, door switch, fuse, thermostat, thermofuse, thermistor, batteries, IC-RAMs including lithium batteries, etc. are particularly important for safety. Be sure to handle/install them properly. If these parts are short-circuited and their functions become ineffective, they may result in fatal accidents such as explosion or fire. Do not allow a short-circuit and do not use the parts not recommended by Toshiba Tec Corporation.

## 5. Cautionary Labels

During servicing, be sure to check the rating label and cautionary labels such as “Unplug the power cable during service”, “CAUTION. HOT”, “CAUTION. HIGH VOLTAGE”, “CAUTION. LASER BEAM”, etc. to see if there is any dirt on their surface and if they are properly stuck to the equipment.

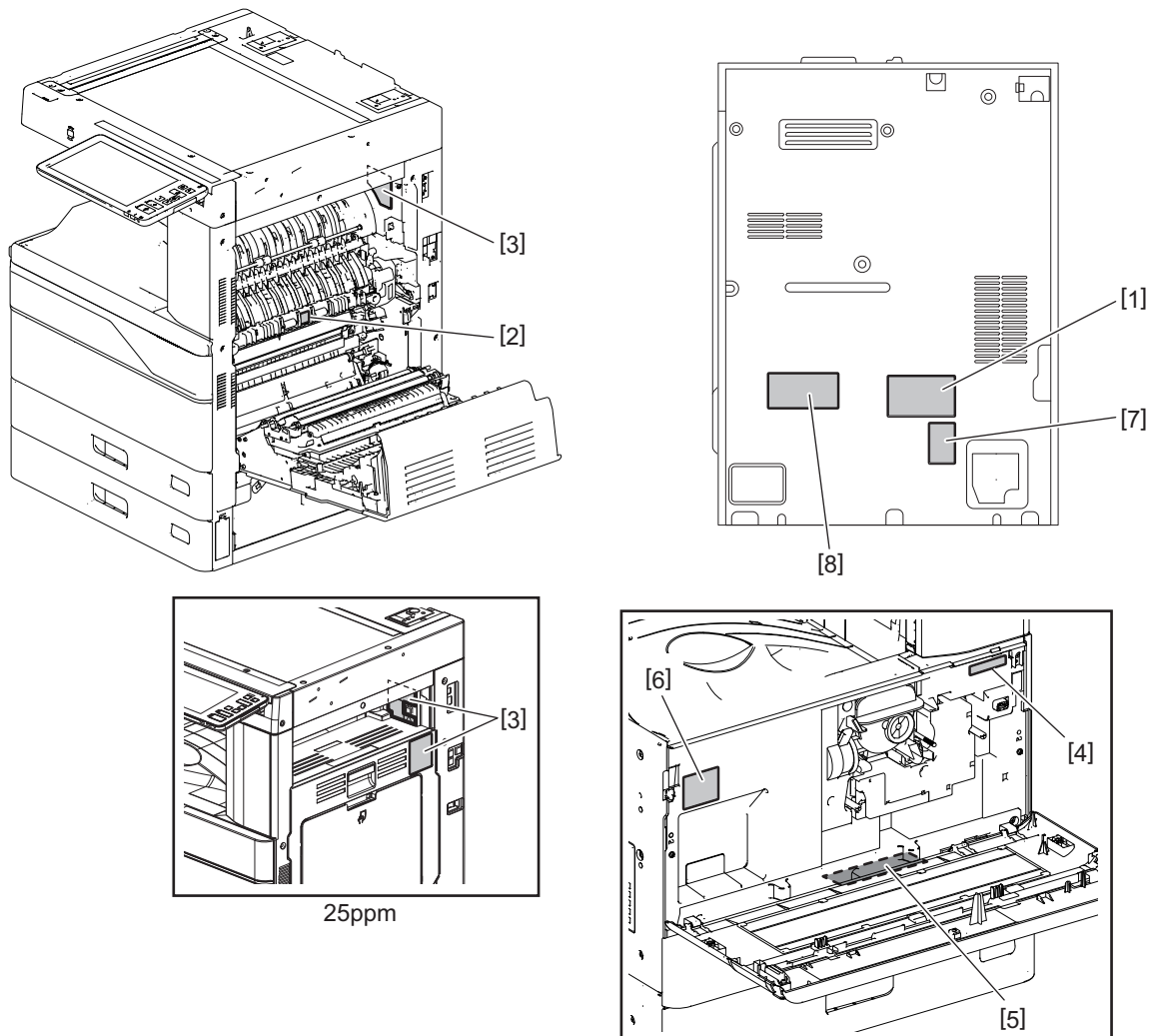

- [1] Rating label
- [2] Warning for high temperature area (fuser unit)
- [3] Warning for high temperature area (fuser unit)
- [4] Machine serial number label
- [5] Warning for high temperature area (damp heater)
- [6] Warning for laser
- [7] Warning for service
- [8] Warning for laser

## 6. Disposal of the Equipment, Supplies and Packing Materials

Regarding the recovery and disposal of the equipment, supplies, packing materials, follow the relevant local regulations or rules.

## 7. Batteries and IC RAMs including lithium batteries etc.

### CAUTION:

RISK OF EXPLOSION IF BATTERY IS REPLACED BY AN INCORRECT TYPE.

DISPOSE OF USED BATTERIES ACCORDING TO THE RELEVANT LOCAL REGULATIONS OR RULES.

## Precautions for Transporting Equipment Once Unpacked

### General Description

It is recommended to follow the procedure below when you transport equipment that has already been unpacked but has not been packed again. Note that the following procedure cannot guarantee the operation of the transported equipment.

### [A] Fixing the carriage

1. Perform the PM code: FS-03-261 (Scan motor ON Automatically stops at limit position) so that the carriage is moved to the fixing position.
2. Tighten the 2 screws to fix the carriage.

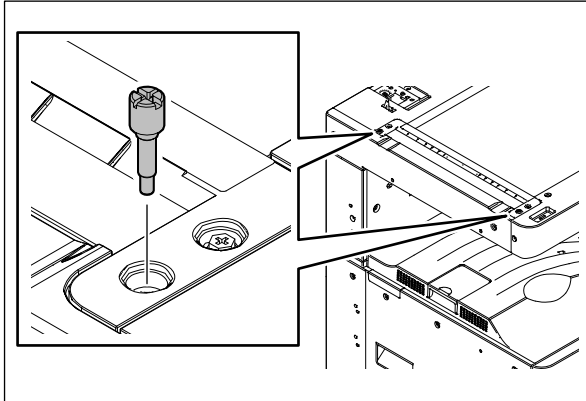

### [B] Attach the packing material (scanner supporting member)

1. Attach the packing material under the scanner (if it is still kept immediately after the setup).

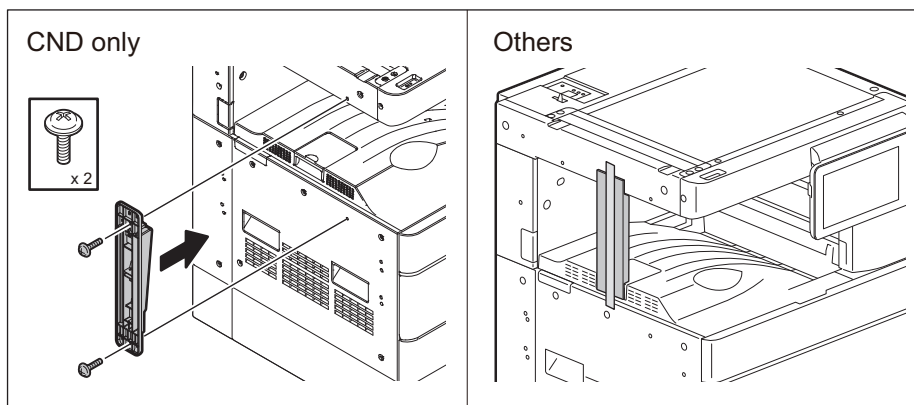

**[C] Attach the cushioning material**

When transporting the equipment with the DSDF installed, be sure to attach the cushioning material as below to prevent the cover in the scanner section from being scratched by the protrusion of the DSDF cover.

1. Fold the cushioning material (packing material) in two. (Utilize the packing material used in the scanner section, if available.) Place it on the upper surface of the scanner section so that it is covered.

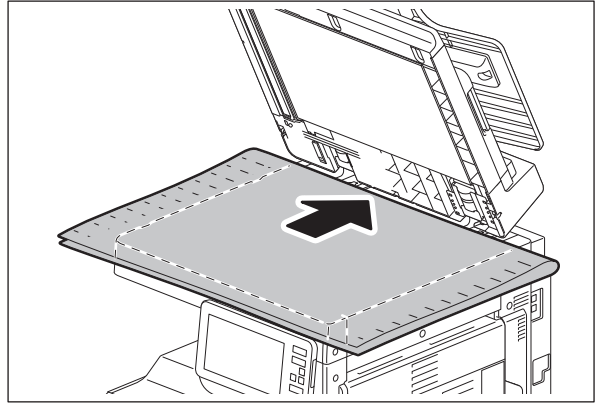
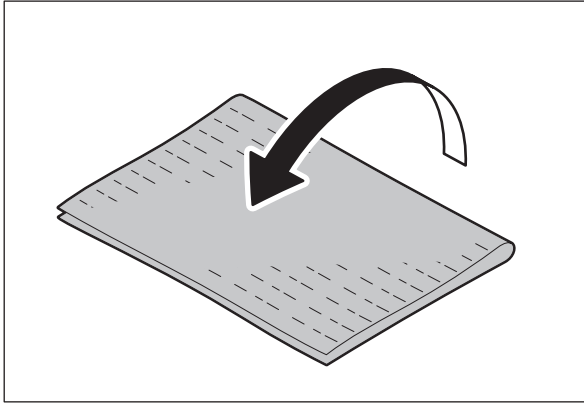

2. While paying attention to ensure that the cushioning material is not moved, slowly close the DSDF.

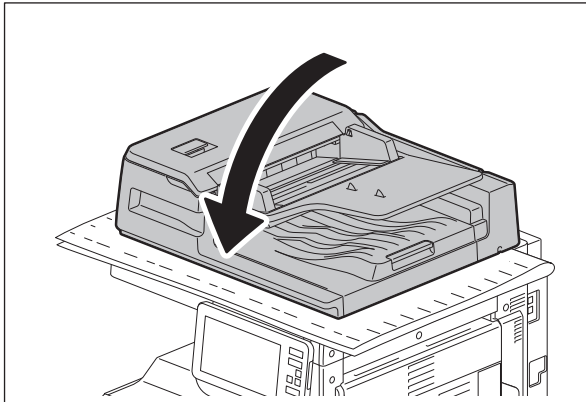



# ALLGEMEINE SICHERHEITSMASSNAHMEN IN BEZUG AUF DIE WARTUNG

**Die Installation und die Wartung sind von einem qualifizierten Service-Techniker durchzuführen.**

## 1. Transport/Installation

- Zum Transportieren/Installieren des Gerätes werden 2 Personen benötigt. Nur an den in der Abbildung gezeigten Stellen tragen.  
Das Gerät ist sehr schwer und wiegt etwa 55 kg (2528A/3028A) / etwa 57 kg (3528A/4528A); deshalb muss bei der Handhabung des Geräts besonders aufgepasst werden.

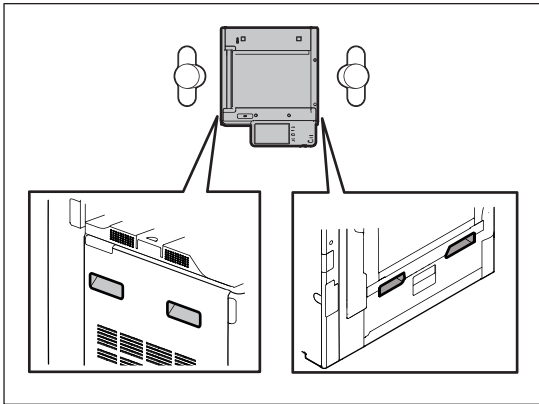

- Beim Transportieren des Geräts nicht an den beweglichen Teilen oder Einheiten (z.B. das Bedienungsfeld, die Duplexeinheit oder die automatische Dokumentenzuführung) halten.
- Eine spezielle Steckdose mit Stromversorgung von AC 110 V / 13.2 A, 120 V / 12 A, 220-240 V 8 A als Stromquelle verwenden.
- Das Gerät ist aus Sicherheitsgründen zu erden.
- Einen geeigneten Standort für die Installation wählen. Standorte mit zuviel Hitze, hoher Luftfeuchtigkeit, Staub, Vibrieren und direkter Sonneneinstrahlung sind zu vermeiden.
- Für ausreichende Belüftung sorgen, da das Gerät etwas Ozon abgibt.
- Um einen optimalen Kopierbetrieb zu gewährleisten, muss ein Abstand von mindestens 30 cm links, 80 cm rechts und 10 cm dahinter eingehalten werden.
- Das Gerät ist in der Nähe der Steckdose zu installieren; diese muss leicht zu erreichen sein.
- Nach der Installation muss das Netzkabel richtig hineingesteckt und befestigt werden, damit niemand darüber stolpern kann.
- Falls der Auspackungsstandort und der Installationsstandort des Geräts verschieden sind, die Bildqualitätsjustierung (automatische Gammajustierung) je nach der Temperatur und Luftfeuchtigkeit des Installationsstandorts und der Papiersorte, die verwendet wird, durchführen.
- Betreiben Sie keinen Ultraschall-Luftbefeuchter in der Nähe des MFP.  
Chlorat- und mineralhaltige Komponenten werden von einem Ultraschallbefeuchter zerstäubt und die Partikel können sich an den elektrischen Teilen innerhalb des MFP anlagern. Dies kann zu Fehlfunktionen führen.

## 2. Allgemeine Sicherheitsmassnahmen in bezug auf die Wartung

- Während der Wartung das Gerät ausschalten und das Netzkabel herausziehen (ausser Wartung, die bei einem eingeschalteten Gerät, durchgeführt werden muss).
- Das Netzkabel herausziehen und den Bereich um die Steckerpole und die Steckdose die Umgebung in der Nähe von den Steckerzacken und der Steckdose wenigstens einmal im Jahr reinigen. Wenn Staub sich in dieser Gegend ansammelt, kann dies ein Feuer verursachen.
- Die Sicherung ist normalerweise auf der stromführenden Phasenseite installiert. Je nach Art des verwendeten Steckers kann sie sich jedoch auch auf der Neutralseite befinden. Damit sichergestellt ist, dass der Phasenleiter stromlos ist, muss der Stromstecker gezogen werden.
- Wenn die Teile auseinandergenommen werden, wenn nicht anders in diesem Handbuch usw erklärt, ist das Zusammenbauen in umgekehrter Reihenfolge durchzuführen. Aufpassen, dass kleine Teile wie Schrauben, Dichtungsringe, Bolzen, E-Ringe, Stern-Dichtungsringe, Kabelbäume nicht an den verkehrten Stellen eingebaut werden.
- Grundsätzlich darf das Gerät mit entfernten oder auseinandergenommenen Teilen nicht in Betrieb genommen werden.
- Das PC-Board muss in einer Anti-elektrostatischen Hülle gelagert werden. Nur Mit einer Manschette bei Betätigung eines Armbandes anfassen, sonst könnte es sein, dass die integrierten Schaltkreise durch statische Elektrizität beschädigt werden.

**Vorsicht: Vor Benutzung der Manschette der Betätigung des Armbandes, das Netzkabel des Gerätes herausziehen und prüfen, dass es in der Nähe keine geladenen Gegenstände, die nicht isoliert sind, gibt.**

- Setzen Sie sich während der Wartungsarbeiten nicht dem Laserstrahl aus. Dieses Gerät ist mit einer Laserdiode ausgestattet. Es ist unbedingt zu vermeiden, direkt in den Laserstrahl zu blicken. Keine reflektierenden Teile oder Werkzeuge, wie z. B. Schraubendreher, in den Pfad des Laserstrahls halten. Vor den Wartungsarbeiten sämtliche reflektierenden Metallgegenstände, wie Uhren, Ringe usw., entfernen.
- Auf keinen Fall Hochtemperaturbereiche, wie die Belichtungslampe, die Fixiereinheit, die Heizquelle und die umliegenden Bereiche, berühren.
- Auf keinen Fall Hochspannungsbereiche, wie die Ladeeinheiten, die Transferwalze, die Entwicklereinheit, den Hochspannungstransformator, den Umrichter für die LCD-Hintergrundbeleuchtung und das Netzgerät, berühren. Insbesondere sollten die Platinen dieser Komponenten nicht berührt werden, da die Kondensatoren usw. auch nach dem Ausschalten des Geräts noch elektrisch geladen sein können.
- Vor dem Berühren potenziell gefährlicher Bereiche (z. B. drehbare oder betriebsrelevante Bereiche, wie Zahnräder, Riemen, Riemenscheiben, Lüfter und die Laseraustrittsöffnung der optischen Lasereinheit) sicherstellen, dass das Gerät sich nicht bedienen lässt.
- Beim Entfernen von Abdeckungen vorsichtig vorgehen, da sich darunter scharfkantige Komponenten befinden können.
- Bei Wartungsarbeiten am eingeschalteten Gerät dürfen keine unter Strom stehenden, drehbaren oder betriebsrelevanten Bereiche berührt werden. Nicht direkt in den Laserstrahl blicken.
- Ausschließlich vorgesehene Werkzeuge und Hilfsmittel verwenden.
- Empfohlene oder gleichwertige Messgeräte verwenden.
- Nach Abschluss der Wartungsarbeiten das Gerät in den ursprünglichen Zustand zurück versetzen und den einwandfreien Betrieb überprüfen.
- Das berührungsempfindliche Bedienungsfeld stets vorsichtig handhaben und keinen Stößen aussetzen. Wenn die Oberfläche beschädigt wird, kann dies zu Funktionsstörungen führen.
- Bewahren Sie Kunststofftüten kindersicher auf. Es besteht Erstickungsgefahr, wenn sich Kinder beim Spielen eine Kunststofftüte über den Kopf ziehen. Bitte nehmen Sie die Kunststofftüten von Optionen oder Serviceparts wieder zurück.
- Wenn der Schutzmantel eines Kabels oder die Steckerisolierung beschädigt werden, besteht Brandgefahr oder die Gefahr eines elektrischen Schlags. Um dies zu vermeiden, sollten Kabel in der gleichen Weise verlegt werden, wie sie vor der Demontage/dem Transport verlegt waren.

### 3. Allgemeine Sicherheitsmassnahmen

- Die Verfahren sind zu überprüfen und wie im Wartungshandbuch beschrieben durchzuführen.
- Vorsichtig, dass Sie nicht umfallen.
- Um Aussetzung zur Haut zu vermeiden, tragen Sie wenn nötig Schutzhandschuhe.

### 4. Sicherheitsrelevante Wartungsteile

- Der Leistungsschutzschalter, der Türschalter, die Sicherung, der Thermostat, die Thermosicherung, der Thermistor, der Akku, die IC-RAMs einschließlich der Lithiumakkus usw. sind besonders sicherheitsrelevant. Sie müssen unbedingt korrekt gehandhabt und installiert werden. Wenn diese Teile kurzgeschlossen und funktionsunfähig werden, kann dies zu schwerwiegenden Schäden, wie einer Explosion oder einer Explosion oder einem Abbrand, führen. Kurzschlüsse sind zu vermeiden, und es sind ausschließlich Teile zu verwenden, die von der Toshiba TEC Corporation empfohlen sind.

### 5. Warnetiketten

- Im Rahmen der Wartung unbedingt das Leistungsschild und die Etiketten mit Warnhinweisen überprüfen [z. B. „Unplug the power cable during service“ („Netz Kabel vor Beginn der Wartungsarbeiten abziehen“), „CAUTION. HOT“ („VORSICHT, HEISS“), „CAUTION. HIGH VOLTAGE“ („VORSICHT, HOCHSPANNUNG“), „CAUTION. LASER BEAM“ („VORSICHT, LASER“) usw.], um sicherzustellen, dass sie nicht verschmutzt sind und korrekt am Gerät angebracht sind.

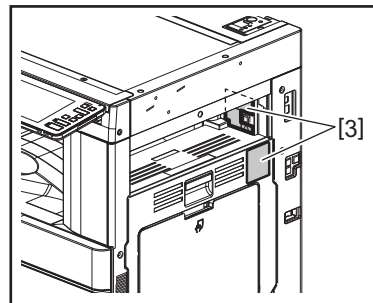
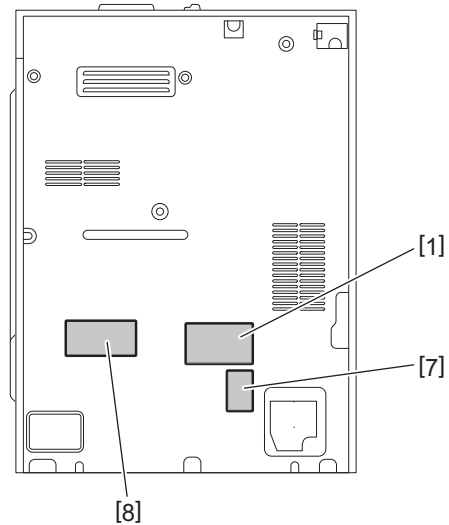
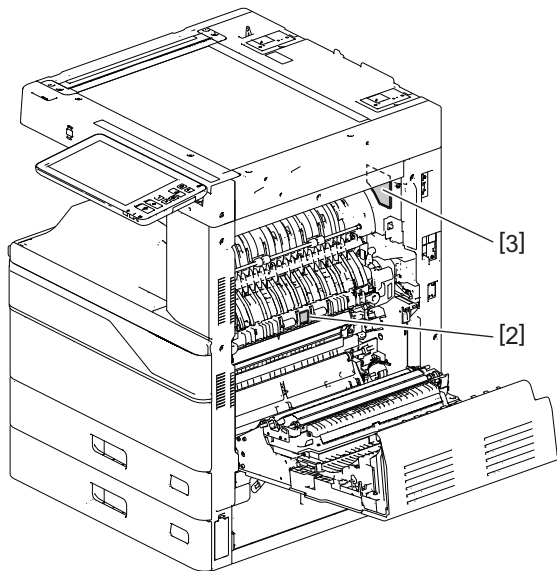

25ppm

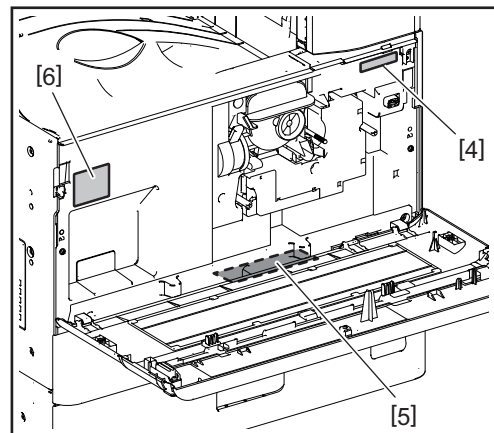

- [1] Erkennungsetikett
- [2] Warnung für Bereiche mit hohen Temperaturen
- [3] Warnung für Bereiche mit hohen Temperaturen
- [4] Produktionszahlsetikett
- [5] Warnung für Bereiche mit hohen Temperaturen

[6] Laser-Warnetikett

[7] Erklärungsetikett

[8] Laser-Warnetikett

#### **6. Entsorgung des Geräts, der Verbrauchs- und Verpackungsmaterialien**

- In Bezug auf die Entsorgung und Wiederverwertung des Geräts, der Verbrauchs- und Verpackungsmaterialien, sind die einschlägigen nationalen oder regionalen Vorschriften zu befolgen.

#### **7. Akkus und IC RAMs einschließlich Lithiumakkus etc.**

**VORSICHT:**

ES BESTEHT EXPLOSIONSGEFAHR; WENN DER AKKU DURCH DEN FALSCHEN TYP ERSETZT WIRD.

ENTSORGEN SIE GEBRAUCHTE AKKUS ENTSPRECHEND DER EINSCHLÄGIGEN REGIONALEN BESTIMMUNGEN UND VORSCHRIFTEN.

- **Laseremissionseinheit**

Diese Einheit besteht aus der Laserdiode, dem Fokussierungsobjektiv, der Blende und dem Zylinderobjektiv.

- Laserdiode

Diese Laserdiode zeichnet sich durch eine geringe Regeldifferenz, eine kleine Laservariation und einen niedrigen Schwellenstrom aus.

Die Blende der Laseremissionseinheit ist unter dem Fokussierobjektiv angeordnet, um die Form der Laserstrahlen in der primären und sekundären Scanrichtung festzulegen.

Die Laserdiode gibt Laserstrahlen als Reaktion auf die Signale der Laseremissionssteuerung (ein/aus) von der Lasertreiber-PC-Platine (LDR) aus. Die durch das Fokussierobjektiv geführten Laserstrahlen werden auf die Trommeloberfläche fokussiert.

- Vorsichtsmaßnahmen im Zusammenhang mit Lasern

Dieses Gerät enthält eine Laserdiode, die einen unsichtbaren Laserstrahl emittiert.

Da man diesen Laserstrahl nicht sehen kann, ist bei der Handhabung der Komponenten der optischen Lasereinheit, bei der Durchführung von Arbeiten und bei der Justierung des Laserstrahls äußerste Vorsicht geboten. Arbeiten dürfen niemals anhand anderer als den vorgeschriebenen Anleitungen durchgeführt werden; andernfalls kann es zu einer Schädigung Exposition durch Laserstrahlung kommen.

Die Lasereinheit ist vollständig mit einer Schutzabdeckung versiegelt. Solange ausschließlich die Arbeitsschritte der vorgeschriebenen Anleitungen durchgeführt werden, tritt der Laserstrahl nicht aus, und es besteht keine Gefahr, der Laserstrahlung ausgesetzt zu werden.

Das folgende Laser-Warnetikett ist an der Abdeckung vorne rechts angebracht.

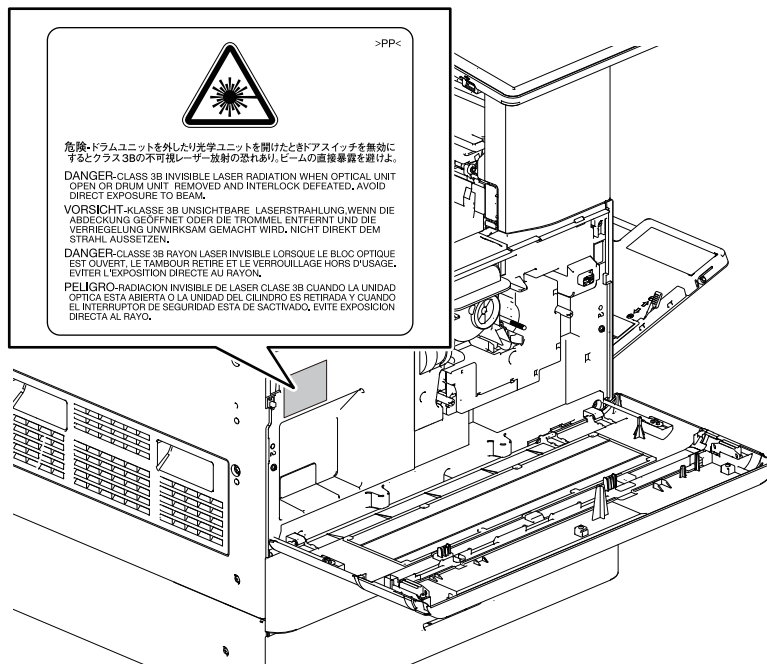

- **Warnhinweise:**

- Setzen Sie sich während der Wartungsarbeiten nicht dem Laserstrahl aus.  
Dieses Gerät ist mit einer Laserdiode ausgestattet. Es ist unbedingt zu vermeiden, direkt in den Laserstrahl zu blicken. Keine reflektierenden Teile oder Werkzeuge, wie z. B. Schraubendreher, in den Pfad des Laserstrahls halten. Vor den Wartungsarbeiten sämtliche reflektierenden Metallgegenstände, wie Uhren, Ringe usw., entfernen.
- Bei Wartungsarbeiten am eingeschalteten Gerät dürfen keine unter Strom stehenden, drehbaren oder betriebsrelevanten Bereiche berührt werden. Nicht direkt in den Laserstrahl blicken.
- Im Rahmen der Wartung unbedingt das Leistungsschild und die Etiketten mit Warnhinweisen überprüfen [z. B. „Unplug the power cable during service“ („Netzkabel vor Beginn der Wartungsarbeiten abziehen“), „CAUTION. HOT“ („VORSICHT, HEISS“), „CAUTION. HIGH VOLTAGE“ („VORSICHT, HOCHSPANNUNG“), „CAUTION. LASER BEAM“ („VORSICHT, LASER“) usw.], um sicherzustellen, dass sie nicht verschmutzt sind und korrekt am Gerät angebracht sind.

# CONTENTS

<b>1. DIFFERENCES BETWEEN MODELS .....</b>	<b>1-1</b>
<b>2. SPECIFICATIONS, ACCESSORIES, OPTIONS AND CONSUMABLES .....</b>	<b>2-1</b>
2.1 Specifications .....	2-1
2.1.1 General .....	2-1
2.1.2 Copy .....	2-4
2.1.3 Printing .....	2-11
2.1.4 Scan .....	2-11
2.1.5 Internet fax .....	2-12
2.1.6 Network fax (option) .....	2-12
2.2 Accessories .....	2-13
2.3 System List .....	2-14
2.4 Option List .....	2-16
2.5 Consumables .....	2-18
<b>3. OVERVIEW .....</b>	<b>3-1</b>
3.1 Sectional View .....	3-1
3.2 Electric Parts Layout .....	3-4
3.3 Symbols and Functions of Various Components .....	3-15
3.3.1 Motor and fan .....	3-15
3.3.2 Sensor and switch .....	3-16
3.3.3 Electromagnetic clutch .....	3-18
3.3.4 Solenoid .....	3-18
3.3.5 PC Board .....	3-18
3.3.6 Lamp and heater .....	3-19
3.3.7 Thermistor and thermostat .....	3-19
3.3.8 Transformer .....	3-20
3.3.9 Others .....	3-20
3.4 Copy Process .....	3-21
3.4.1 Overview of the copy process .....	3-21
3.5 Comparison with e-STUDIO2518A/3518A/4518A/5018A .....	3-22
3.6 General operation .....	3-24
3.6.1 Operation description .....	3-24
3.6.2 Detection of abnormality .....	3-27
3.6.3 Hibernation function .....	3-29
3.7 Control Panel .....	3-30
3.7.1 Overview .....	3-30
3.8 Scanning Section .....	3-31
3.8.1 Overview .....	3-31
3.8.2 Composition .....	3-32
3.8.3 Functions .....	3-33
3.8.4 Operation description .....	3-35
3.8.5 Process of original size detection .....	3-36
3.9 Data Writing Section .....	3-38
3.9.1 Overview .....	3-38
3.9.2 Laser precautions .....	3-39
3.10 Paper Feeding Section .....	3-40
3.10.1 Overview .....	3-40
3.10.2 Composition .....	3-41
3.10.3 Functions .....	3-42
3.10.4 Operation description .....	3-44
3.11 Driving Section .....	3-50
3.11.1 Overview .....	3-50
3.11.2 Functions .....	3-51
3.12 Drum Related Section .....	3-52
3.12.1 Overview .....	3-52

3.12.2	Composition .....	3-53
3.12.3	Functions .....	3-54
3.13	Developer Unit .....	3-57
3.13.1	Overview .....	3-57
3.13.2	Composition .....	3-58
3.13.3	Functions .....	3-59
3.13.4	Functions of the toner cartridge PC board (CTRG) .....	3-62
3.14	Fusing Section .....	3-65
3.14.1	Overview .....	3-65
3.14.2	Composition .....	3-66
3.14.3	Functions .....	3-66
3.14.4	Operation description .....	3-67
3.14.5	Heater control circuit .....	3-68
3.15	Paper Exit Section, Reverse Section .....	3-73
3.15.1	Overview .....	3-73
3.15.2	Functions .....	3-74
3.15.3	Paper exit motor, Reverse motor, Main motor .....	3-75
3.16	Automatic Duplexing Unit (ADU) .....	3-77
3.16.1	Overview .....	3-77
3.16.2	Composition .....	3-79
3.16.3	Functions .....	3-80
3.16.4	Operation description .....	3-81
3.16.5	Driving of the ADU .....	3-82
3.17	Power Supply Unit .....	3-83
3.17.1	Composition .....	3-83
3.17.2	Functions .....	3-83
3.17.3	Operation of output circuits .....	3-84
3.17.4	Output channel .....	3-86
3.17.5	Fuse .....	3-86
<b>4.</b>	<b>DISASSEMBLY AND REPLACEMENT .....</b>	<b>4-1</b>
4.1	Cover .....	4-1
4.1.1	Front cover .....	4-1
4.1.2	Left cover .....	4-1
4.1.3	Exit tray .....	4-2
4.1.4	Tray rear cover .....	4-2
4.1.5	Left top cover .....	4-3
4.1.6	Left rear cover .....	4-4
4.1.7	Paper exit back cover .....	4-4
4.1.8	Right top cover .....	4-5
4.1.9	Right front cover .....	4-5
4.1.10	Right rear cover .....	4-6
4.1.11	Front top cover .....	4-6
4.1.12	Control panel lower cover .....	4-7
4.1.13	Front right cover .....	4-8
4.1.14	Top rear cover .....	4-8
4.1.15	Rear cover .....	4-9
4.1.16	Front cover switch (SW21) .....	4-9
4.1.17	Front cover interlock switch (SW2) .....	4-10
4.2	Control Panel .....	4-11
4.2.1	Control panel unit .....	4-11
4.2.2	Key PC board, Button .....	4-14
4.2.3	Display PC board .....	4-15
4.3	Scanner Section .....	4-17
4.3.1	Original glass .....	4-17
4.3.2	Lens cover .....	4-22
4.3.3	Automatic original detection sensor-1 (S24) .....	4-22
4.3.4	Automatic original detection sensor-2 (S25) .....	4-23
4.3.5	Lens unit (CCD driving PC board) .....	4-23



4.3.6	Carriage home position sensor (S23)	4-25
4.3.7	Exposure lamp (EXP)	4-26
4.3.8	Scan motor (M1)	4-28
4.3.9	Platen sensor-1 (S21), Platen sensor-2 (S22)	4-29
4.3.10	Carriage-1	4-31
4.3.11	Carriage wire, Carriage-2	4-34
4.3.12	Scanner damp heater (DH1)	4-38
4.4	Data Writing Section	4-40
4.4.1	Laser optical unit	4-40
4.5	Paper feeding section	4-43
4.5.1	Bypass unit	4-43
4.5.2	Bypass unit paper feed roller	4-44
4.5.3	Bypass unit transport tray	4-46
4.5.4	Bypass unit separation roller holder	4-47
4.5.5	Bypass unit separation roller	4-48
4.5.6	Paper width detection PC board (SFBB)	4-49
4.5.7	Bypass tray paper sensor (S16)	4-50
4.5.8	ADU opening/closing switch (SW5)	4-53
4.5.9	Registration sensor (S19), 1st transport sensor (S43)	4-54
4.5.10	Paper dust holder	4-57
4.5.11	Registration roller (MFP side)	4-58
4.5.12	Registration roller (ADU side)	4-59
4.5.13	Jam access cover	4-60
4.5.14	Transport roller	4-61
4.5.15	Jam access cover opening/closing switch (SW20)	4-63
4.5.16	2nd transport sensor (S44)	4-64
4.5.17	1st drawer paper feed unit	4-65
4.5.18	1st drawer separation roller guide	4-66
4.5.19	2nd drawer paper feed unit	4-68
4.5.20	2nd drawer separation roller guide	4-69
4.5.21	1st drawer paper feed roller, Separation roller, Pickup roller	4-71
4.5.22	2nd drawer paper feed roller, Separation roller, Pickup roller	4-72
4.5.23	1st drawer detection switch (SW8)	4-75
4.5.24	2nd drawer detection switch (SW19)	4-76
4.5.25	1st drawer tray-up motor unit	4-77
4.5.26	2nd drawer tray-up motor unit	4-78
4.5.27	1st drawer tray-up motor (M15)	4-79
4.5.28	2nd drawer tray-up motor (M16)	4-80
4.5.29	1st drawer paper nearly empty sensor (S45)	4-81
4.5.30	2nd drawer paper nearly empty sensor (S46)	4-81
4.5.31	1st drawer paper empty sensor (S5), 1st drawer tray-up sensor (S31)	4-82
4.5.32	2nd drawer paper empty sensor (S34), 2nd drawer tray-up sensor (S35)	4-84
4.5.33	1st drawer paper width detection switch (SW6), 1st drawer paper length detection switch (SW7)	4-86
4.5.34	2nd drawer paper width detection switch (SW17), 2nd drawer paper length detection switch (SW18)	4-87
4.5.35	Transport clutch (H) (CLT5)	4-88
4.5.36	Transport clutch (L) (CLT6)	4-89
4.5.37	1st drawer paper feed clutch (CLT1)	4-90
4.5.38	2nd drawer paper feed clutch (CLT4)	4-91
4.5.39	Flywheel	4-92
4.5.40	Registration clutch (CLT7)	4-92
4.5.41	Paper feed drive unit	4-93
4.5.42	Paper feed drive gear	4-95
4.5.43	Drawer damp heater (DH4)	4-97
4.5.44	1st drawer soft-close unit (3528A/4528A)	4-99
4.5.45	2nd drawer soft-close unit (3528A/4528A)	4-99
4.5.46	Operation when replacing the soft-close unit for the first time	4-100

4.6	Driving Section .....	4-102
4.6.1	Main motor (M23) (3528A/4528A) .....	4-102
4.6.2	Main motor (M23) (2528A/3028A) .....	4-103
4.7	Drum Related Section .....	4-104
4.7.1	Process unit .....	4-104
4.7.2	Drum cleaner unit .....	4-105
4.7.3	Discharge LED .....	4-107
4.7.4	Main charger .....	4-108
4.7.5	Main charger grid .....	4-109
4.7.6	Main charger cleaner .....	4-109
4.7.7	Needle electrode .....	4-111
4.7.8	Drum .....	4-112
4.7.9	Drum cleaning blade .....	4-114
4.7.10	Drum separation finger .....	4-114
4.7.11	Recovery blade .....	4-115
4.7.12	Temperature/humidity sensor (S10) .....	4-116
4.7.13	Toner motor (K) (M11) .....	4-117
4.7.14	Process unit fan (F12) .....	4-118
4.8	Developer Unit .....	4-120
4.8.1	Developer unit .....	4-120
4.8.2	Discharging the developer material .....	4-122
4.8.3	Filling the developer material .....	4-123
4.8.4	Auto-toner sensor (S1) .....	4-124
4.8.5	Drum thermistor (THM3) .....	4-125
4.8.6	Guide roller, Developer sleeve .....	4-125
4.8.7	Mixer .....	4-130
4.8.8	Replacement procedure of the oil seal .....	4-133
4.9	Transfer Unit (TRU) .....	4-134
4.9.1	Transfer unit (TRU) .....	4-134
4.9.2	Suctioning fan (F3) .....	4-135
4.9.3	Transfer roller unit .....	4-136
4.9.4	Transfer roller .....	4-136
4.9.5	Separation needle .....	4-138
4.9.6	Ozone filter .....	4-139
4.10	Fusing Section .....	4-141
4.10.1	Fuser unit .....	4-141
4.10.2	Front side cover .....	4-143
4.10.3	Rear side cover .....	4-144
4.10.4	Heat roller cover .....	4-144
4.10.5	Paper entrance guide .....	4-145
4.10.6	Separation finger .....	4-146
4.10.7	Paper exit sensor (S13) .....	4-147
4.10.8	Fuser center thermostat (THM07), Fuser side thermostat (THM08) .....	4-149
4.10.9	Heat roller center thermistor (THM5), Heat roller side thermistor (THM6), Heat roller edge thermistor (THM7) .....	4-151
4.10.10	Center heater lamp (LAMP2), Side heater lamp (LAMP2), Sub heater lamp (LAMP3) .....	4-155
4.10.11	Pressure roller .....	4-158
4.10.12	Heat roller .....	4-160
4.11	Paper Exit Section, Reverse Section .....	4-162
4.11.1	Reverse unit (3528A/4528A) .....	4-162
4.11.2	Paper exit unit (3528A/4528A) .....	4-165
4.11.3	Paper exit unit (2528A/3028A) .....	4-165
4.11.4	Paper exit roller, Lower paper exit roller .....	4-166
4.11.5	Paper exit motor (M5) .....	4-168
4.11.6	Paper exit/reverse motor (M24) (3528A/4528A) .....	4-170
4.11.7	Reverse gate solenoid (SOL2) (3528A/4528A) .....	4-171
4.11.8	Upper paper exit roller (3528A/4528A) .....	4-173

4.11.9	Reverse roller (3528A/4528A)	4-175
4.12	Automatic Duplexing Unit (ADU)	4-176
4.12.1	Automatic duplexing unit (ADU)	4-176
4.12.2	Bypass tray paper feed clutch (CLT3)	4-178
4.12.3	ADU guide assembly (3528A/4528A)	4-180
4.12.4	ADU guide assembly (2528A/3028A)	4-182
4.12.5	ADU middle cover (3528A/4528A)	4-183
4.12.6	ADU middle cover (2528A/3028A)	4-185
4.12.7	ADU board (ADU) (3528A/4528A)	4-186
4.12.8	ADU board (ADU) (2528A/3028A)	4-187
4.12.9	ADU motor (M12) (3528A/4528A)	4-188
4.12.10	ADU motor (M12) (2528A/3028A)	4-189
4.12.11	ADU entrance sensor (S14)	4-190
4.12.12	ADU exit sensor (S15)	4-191
4.12.13	Transport roller (upper and lower)	4-191
4.12.14	Reverse sensor (S18) (3528A/4528A)	4-194
4.12.15	ADU interlock switch (SW3) (3528A/4528A)	4-194
4.12.16	ADU interlock switch (SW3) (2528A/3028A)	4-195
4.12.17	ADU fan (F13) (3528A/4528A)	4-196
4.13	Removal and Installation of Options	4-197
4.13.1	Dual Scan Document Feeder (DSDF)	4-197
4.13.2	Reversing Automatic Document Feeder (RADF)	4-202
4.13.3	Paper Feed Pedestal (PFP)	4-205
4.13.4	Large Capacity Feeder (LCF)	4-207
4.13.5	Bridge kit	4-211
4.13.6	Inner finisher	4-213
4.13.7	Saddle stitch finisher	4-216
4.13.8	Saddle stitch finisher (with Hole punch unit installed)	4-218
4.13.9	Finisher	4-220
4.13.10	Finisher (with Hole punch unit installed)	4-221
4.13.11	Job separator (2528A/3028A)	4-224
4.13.12	Job separator (3528A/4528A)	4-225
4.13.13	External Large Capacity Feeder (Ex-LCF)	4-227

<b>5.</b>	<b>SELF-DIAGNOSTIC MODE</b>	<b>5-1</b>
5.1	Overview	5-1
5.2	Description Rule for Each Menu and Mode	5-4
5.3	Service UI	5-7
5.3.1	Overview	5-7
5.3.2	Operation procedure	5-7
5.3.3	Starting the FS Menu from the normal mode	5-7
5.4	03 TEST MODE	5-8
5.4.1	Output check	5-8
5.4.2	Input check	5-8
5.5	04 TEST PRINT MODE	5-9
5.6	05 ADJUSTMENT MODE	5-9
5.6.1	TEST COPY	5-9
5.6.2	TEST PRINT	5-9
5.7	08 SETTING MODE	5-9
5.8	20 PM SUPPORT MODE	5-9
5.9	21 EPU REPLACE MODE	5-9
5.10	30 LIST PRINT MODE	5-10
5.10.1	List output table	5-10
5.10.2	Operation procedure	5-11
5.10.3	Samples of the output	5-11
5.11	FAX	5-33
5.11.1	11 FAX CLEAR MODE	5-33
5.11.2	12 FAX LIST PRINT MODE	5-34
5.11.3	13 FAX FUNCTION MODE	5-34

5.11.4	19 RAM EDIT MODE .....	5-34
5.12	35 DATA BACKUP/RESTORE MODE .....	5-35
5.13	36 CLONING .....	5-35
5.14	37 LICENSE MANAGEMENT .....	5-35
5.15	38 DEACTIVATE RELEASE MODE .....	5-35
5.16	01 Control Panel Check .....	5-36
5.16.1	Screen transition .....	5-36
5.16.2	Checking of the LCD back light and LEDs .....	5-37
5.16.3	Checking of the LCD display, hard keys and digital keys .....	5-37
5.16.4	Checking of the LCD touch sensor and USB storage device connection .....	5-38
5.17	73 Firmware Assist .....	5-39
5.17.1	Overview .....	5-39
5.17.2	Operation procedure .....	5-39
5.17.3	Functions .....	5-40
5.18	74 Storage Assist Mode .....	5-44
5.18.1	Overview .....	5-44
5.18.2	Operation procedure .....	5-44
5.18.3	Functions .....	5-44
5.19	75 File System Recovery .....	5-45
5.19.1	Overview .....	5-45
5.19.2	Operation procedure .....	5-45
5.19.3	Functions .....	5-45
5.20	76 SRAM Maintenance .....	5-48
5.20.1	Overview .....	5-48
5.20.2	Operation procedure .....	5-48
5.20.3	Functions .....	5-48
5.21	77 Detach Release .....	5-50
5.22	78 Option Storage Assist .....	5-50
5.23	TPM Restore .....	5-51
5.24	Batch Setting for Self-Diagnostic Codes .....	5-52
5.24.1	Overview .....	5-52
5.24.2	Setting files .....	5-52
5.24.3	Result files .....	5-52
5.24.4	Operation procedure .....	5-53

## **6. SETTING AND ADJUSTMENT ..... 6-1**

6.1	Image Related Adjustment .....	6-1
6.1.1	Image related adjustment .....	6-1
6.1.2	Auto-toner sensor adjustment .....	6-2
6.1.3	Alignment position adjustment .....	6-4
6.1.4	Image dimensional adjustment at the printing section .....	6-8
6.1.5	Image dimensional adjustment at the scanning section .....	6-16
6.1.6	Automatic gamma adjustment .....	6-24
6.1.7	Density unevenness correction .....	6-25
6.2	Image Related Adjustment (Overview) .....	6-27
6.2.1	List .....	6-27
6.2.2	Operation procedure .....	6-27
6.2.3	Scanning and paper feeding direction instruction patterns superposition function .....	6-28
6.3	Image Quality Adjustment (Copying Function) .....	6-29
6.3.1	Density adjustment .....	6-29
6.3.2	Gamma balance adjustment .....	6-29
6.3.3	Background adjustment .....	6-30
6.3.4	Blank page judgment threshold adjustment .....	6-30
6.3.5	Void amount adjustment for blank page judgment .....	6-30
6.3.6	Sharpness adjustment .....	6-31
6.3.7	Range correction adjustment .....	6-31
6.3.8	Smudged/faint text adjustment .....	6-31
6.3.9	Emission level adjustment .....	6-32

6.3.10	Background offset adjustment (DF) .....	6-32
6.3.11	Background offset adjustment on the back side of paper (DSDF).....	6-33
6.3.12	Drop out color adjustment.....	6-33
6.3.13	Scanning streak reduction .....	6-33
6.3.14	Background removal level adjustment.....	6-35
6.3.15	Low density text reproduction adjustment .....	6-35
6.4	Image Quality Adjustment (Printing Function).....	6-36
6.4.1	Gamma balance adjustment.....	6-36
6.4.2	Text density adjustment.....	6-37
6.4.3	Density upper limit value adjustment in toner saving mode.....	6-37
6.4.4	Sharpness adjustment .....	6-38
6.4.5	Thin line width lower limit adjustment .....	6-39
6.4.6	Background adjustment .....	6-39
6.4.7	Emission level adjustment .....	6-39
6.4.8	Graphic line density adjustment (1200 dpi) .....	6-40
6.4.9	Gradation reproduction switching for Text .....	6-40
6.4.10	Smudged text in black adjustment.....	6-40
6.4.11	Halftone setting.....	6-41
6.4.12	White void correction around the text .....	6-41
6.5	Image Quality Adjustment (Scanning Function).....	6-42
6.5.1	Gamma balance adjustment.....	6-42
6.5.2	RGB color balance adjustment .....	6-42
6.5.3	Density adjustment .....	6-43
6.5.4	Background adjustment .....	6-43
6.5.5	ACS judgment threshold.....	6-44
6.5.6	Void amount adjustment for ACS judgment.....	6-44
6.5.7	Blank page judgment threshold adjustment.....	6-44
6.5.8	Void amount adjustment for blank page judgment .....	6-44
6.5.9	Sharpness adjustment .....	6-45
6.5.10	Contrast adjustment.....	6-45
6.5.11	Black density fine adjustment .....	6-45
6.5.12	RGB conversion method selection .....	6-46
6.5.13	Saturation adjustment.....	6-46
6.5.14	SlimPDF capacity and image quality adjustment.....	6-46
6.5.15	Surrounding void amount adjustment .....	6-47
6.5.16	JPEG compression level adjustment .....	6-47
6.5.17	Scanning streak reduction .....	6-47
6.5.18	Background offset adjustment (DF).....	6-47
6.5.19	Background offset adjustment on the back side of paper (DSDF).....	6-47
6.5.20	Low density text reproduction process adjustment.....	6-48
6.6	Image Quality Adjustment (Fax Function).....	6-49
6.6.1	Density adjustment .....	6-49
6.6.2	Emission level adjustment .....	6-49
6.6.3	Background offset adjustment (DF).....	6-49
6.6.4	Background offset adjustment on the back side of paper (DSDF).....	6-49
6.7	Scanning Section .....	6-50
6.7.1	Carriage-1 position adjustment.....	6-50
6.7.2	Lens unit position adjustment .....	6-51
6.7.3	Belt tension adjustment of the scan motor.....	6-51
6.8	Data Writing Section .....	6-52
6.8.1	Image adjustment in the writing section.....	6-52
6.9	Paper Feeding Section.....	6-53
6.9.1	Adjustment of the clearance of the paper and side guide.....	6-53
6.9.2	Drawer separation roller pressure force adjustment.....	6-54
6.10	Developer Unit Adjustment .....	6-55
6.10.1	Auto-toner sensor adjustment.....	6-55
6.10.2	Doctor-to-sleeve gap adjustment.....	6-55
6.11	High-Voltage Transformer Adjustment.....	6-58

6.11.1	Adjustment .....	6-58
6.11.2	Precautions .....	6-64
6.12	Fusing Section .....	6-66
6.12.1	Thermostat gap adjustment .....	6-66
6.12.2	Height adjustment of the fuser unit guide rail .....	6-68
6.13	Control Panel Calibration .....	6-70
6.13.1	Overview .....	6-70
6.13.2	Operation procedure .....	6-70
<b>7.</b>	<b>PREVENTIVE MAINTENANCE (PM).....</b>	<b>7-1</b>
7.1	Overview .....	7-1
7.2	PM Display .....	7-1
7.2.1	Overview .....	7-1
7.2.2	PM display condition .....	7-1
7.2.3	PM display content .....	7-2
7.2.4	Counter clearing .....	7-2
7.3	PM Procedure .....	7-3
7.4	20 PM SUPPORT MODE.....	7-4
7.4.1	Overview .....	7-4
7.4.2	Operation flow.....	7-4
7.4.3	Operation screen .....	7-5
7.4.4	Access tree .....	7-8
7.5	Part Replacement Workflow.....	7-9
7.6	21 EPU REPLACE MODE .....	7-10
7.6.1	Overview .....	7-10
7.6.2	Operation flow.....	7-10
7.6.3	Counters to be cleared .....	7-12
7.6.4	Precautions .....	7-12
7.6.5	To allow the MFP to detect a recycled unit as a new one after replacement ..	7-13
7.7	Fuser Unit Status Detection Mode .....	7-14
7.7.1	Overview .....	7-14
7.7.2	Operation flow.....	7-14
7.7.3	Counters to be cleared .....	7-14
7.7.4	Precautions .....	7-14
7.8	Preventive Maintenance Checklist .....	7-15
7.8.1	Scanner .....	7-16
7.8.2	Laser optical unit.....	7-17
7.8.3	Paper feeding section .....	7-18
7.8.4	Bypass unit .....	7-19
7.8.5	Main charger.....	7-20
7.8.6	Drum unit .....	7-21
7.8.7	Developer Unit .....	7-23
7.8.8	Transfer unit.....	7-25
7.8.9	Fuser unit.....	7-27
7.8.10	Paper exit section, reverse section .....	7-29
7.8.11	Automatic Duplexing Unit .....	7-30
7.9	Machine Refreshing Checklist.....	7-31
7.10	Storage of Supplies and Replacement Parts .....	7-32
7.11	PM Kit.....	7-33
7.12	Maintenance Parts List.....	7-34
7.13	Grease List.....	7-36
<b>8.</b>	<b>ERROR CODE AND TROUBLESHOOTING .....</b>	<b>8-1</b>
8.1	Overview .....	8-1
8.1.1	If a problem continues even after performing all troubleshooting .....	8-2
8.1.2	Collection of debug logs with a USB storage device .....	8-3
8.1.3	Traceability label .....	8-5
8.1.4	Detach function .....	8-5
8.2	Error Code List .....	8-6

8.2.1	Paper misfeeding.....	8-6
8.2.2	Service call .....	8-14
8.2.3	Error in Internet fax and scanning functions .....	8-22
8.2.4	Printer function error .....	8-32
8.2.5	TopAccess related error, Communication error with external application .....	8-34
8.2.6	MFP access error .....	8-35
8.2.7	Maintenance error.....	8-39
8.2.8	Network error .....	8-53
8.2.9	Notification .....	8-57
8.2.10	FAX error .....	8-60
8.2.11	Error history .....	8-68
8.3	Analysis from Error Codes .....	8-70
8.3.1	Check item .....	8-70
8.3.2	Paper misfeeding (E series errors) .....	8-70
8.3.3	Service call (C series errors) .....	8-172
8.3.4	Service call (F series errors).....	8-216
8.3.5	Internet fax and scanning functions error .....	8-261
8.3.6	Printer function error .....	8-286
8.3.7	TopAccess related error, Communication error with external application .....	8-293
8.3.8	MFP access error .....	8-297
8.3.9	Maintenance error.....	8-301
8.3.10	Network error .....	8-322
8.3.11	FAX error .....	8-335
8.4	Other Errors .....	8-369
8.4.1	MFP operation disabled after the installation of option(s).....	8-369
8.4.2	Wireless LAN connection disabled .....	8-369
8.4.3	“Invalid Department Code” is displayed.....	8-369
8.4.4	“Install Fuser Unit” is displayed.....	8-369
8.4.5	Paper folded on the leading edge.....	8-369
8.4.6	Toner cartridge unrecognized.....	8-369
8.4.7	Ethernet disabled in half-duplex communication .....	8-370
8.4.8	The MFP does not start after the power has been turned ON.....	8-371
8.4.9	Countermeasure to sudden power failure.....	8-375
8.4.10	“Authentication Failed” displayed.....	8-377
8.4.11	Error code “M00” displayed while updating firmware.....	8-377
8.4.12	“Cover Open” remains displayed .....	8-377
8.4.13	“Fax line1 is out of order.” or “Fax line2 is out of order.” displayed .....	8-377
8.4.14	“Latch the developer unit” remains displayed .....	8-378
8.4.15	DSDF .....	8-378
8.4.16	Inner Finisher.....	8-379
8.4.17	The drawer is not automatically inserted .....	8-380
8.4.18	Troubleshooting for operation abnormality .....	8-380
8.4.19	The [ON/OFF] button does not work.....	8-380
8.5	Troubleshooting for the Image .....	8-381
8.5.1	Poor image density and gray balance .....	8-381
8.5.2	Background fogging.....	8-382
8.5.3	Moiré, lack of sharpness.....	8-384
8.5.4	Toner offset.....	8-385
8.5.5	Toner offset (shadow image) at the edges .....	8-387
8.5.6	Blurred image .....	8-388
8.5.7	Poor fusing.....	8-389
8.5.8	White copy .....	8-390
8.5.9	Solid copy .....	8-391
8.5.10	White banding and white void (in the feeding direction) .....	8-392
8.5.11	White banding (at right angles to the feeding direction) .....	8-394
8.5.12	Skew (slantwise copying) .....	8-395
8.5.13	Black banding (in the feeding direction).....	8-396
8.5.14	Black banding (at right angles to the feeding direction).....	8-398

8.5.15	White spots .....	8-399
8.5.16	Poor transfer .....	8-400
8.5.17	Uneven image density .....	8-401
8.5.18	Faded image (low density, abnormal gray balance) .....	8-402
8.5.19	Image dislocation in leading edge .....	8-404
8.5.20	Image jittering .....	8-405
8.5.21	Poor cleaning .....	8-406
8.5.22	Uneven light distribution .....	8-407
8.5.23	Blotched image .....	8-408
8.5.24	Black banding on image leading edge during scanning .....	8-409
8.5.25	Image distortion (dogleg image) .....	8-410
8.5.26	Image skewing on paper trailing edge .....	8-412
8.5.27	Shadow in copied or scanned images when using the DSDF .....	8-416
8.5.28	The exit paper surface feels rough like sand is adhering to it (carrier offset) .....	8-418
8.5.29	Scanned image abnormality .....	8-420
8.5.30	Drum pitch fogging.....	8-422
8.5.31	If an image-related problem continues after performing all troubleshooting ..	8-423
<b>9.</b>	<b>REPLACEMENT OF PC BOARDS, SSD .....</b>	<b>9-1</b>
9.1	Removal and Installation of PC Boards and SSD .....	9-1
9.1.1	SYS board cover.....	9-1
9.1.2	SYS board cooling fan (F1) .....	9-1
9.1.3	SSD .....	9-2
9.1.4	Optional HDD.....	9-2
9.1.5	Optional SSD .....	9-3
9.1.6	SYS board .....	9-3
9.1.7	SYS board case.....	9-6
9.1.8	LGC board .....	9-8
9.1.9	Switching regulator .....	9-10
9.1.10	High-voltage transformer (HVT).....	9-11
9.1.11	SRAM .....	9-12
9.1.12	Sub EEPROM.....	9-13
9.1.13	DAMP PC board .....	9-14
9.1.14	Power supply unit cooling fan (F8) .....	9-15
9.1.15	DSDF I/F board.....	9-15
9.2	Precautions, Procedures and Settings for Replacing PC Boards and Storage Device...	9-16
9.2.1	Precautions when replacing PC boards.....	9-16
9.2.2	Storage device fault diagnosis.....	9-17
9.2.3	Precautions and procedures when replacing the storage device .....	9-20
9.2.4	Precautions and procedures when replacing the SYS board .....	9-25
9.2.5	Precautions and procedure when replacing the SRAM .....	9-28
9.2.6	Procedures when replacing the LGC board.....	9-33
9.2.7	Procedures and settings when replacing the Sub EEPROM.....	9-34
9.2.8	Procedures and settings when replacing the lens unit .....	9-37
9.2.9	Firmware confirmation after the PC board/storage device replacement.....	9-37
9.2.10	License re-registration using the one-time dongle.....	9-38
9.3	Precautions when Disposing of the Storage Devices and PC Boards .....	9-40
9.3.1	Precautions when disposing of the storage devices .....	9-40
9.3.2	Precautions when disposing of the SYS board.....	9-40
9.3.3	Precautions when disposing of the SRAM.....	9-40
<b>10.</b>	<b>REMOTE SERVICE.....</b>	<b>10-1</b>
10.1	Auto Supply Order.....	10-1
10.1.1	Overview .....	10-1
10.1.2	Setting item .....	10-2
10.1.3	Setting procedure .....	10-4
10.1.4	Supply Order sheet format.....	10-13
10.2	Service Notification .....	10-15



10.2.1	Outline .....	10-15
10.2.2	Setting.....	10-15
10.2.3	Items to be notified .....	10-24
10.3	Remote Panel (VNC) .....	10-37
10.3.1	Overview .....	10-37
10.3.2	Setting.....	10-37
10.3.3	Operation .....	10-38
10.4	Remote Assistant Menu .....	10-39
10.4.1	Overview .....	10-39
10.4.2	Displaying of the [Remote Assistant Menu] icon .....	10-39
10.4.3	Logs Transmission.....	10-39
10.4.4	Remote Service .....	10-42
10.4.5	Remote Panel Operation .....	10-43
<b>11.</b>	<b>FIRMWARE UPDATING .....</b>	<b>11-1</b>
11.1	Overview .....	11-1
11.2	Firmware Updating with a USB Storage Device .....	11-2
11.2.1	Updating methods.....	11-2
11.2.2	File configuration of a USB storage device.....	11-3
11.2.3	Firmware type and data file for updating .....	11-4
11.2.4	Updating procedure .....	11-6
<b>12.</b>	<b>MANAGEMENT OF MFP INFORMATION.....</b>	<b>12-1</b>
12.1	Cloning (HS Menu).....	12-1
12.1.1	Overview .....	12-1
12.1.2	Precautions .....	12-1
12.1.3	Backup files .....	12-2
12.1.4	Cloning procedure .....	12-2
12.2	Cloning (FS Menu).....	12-4
12.2.1	Overview .....	12-4
12.2.2	Precautions .....	12-4
12.2.3	Clone file creation procedure .....	12-6
12.2.4	Clone file installation procedure.....	12-6
12.3	Backing Up and Restoring Data.....	12-7
12.3.1	Overview .....	12-7
12.3.2	Applicable data .....	12-7
12.3.3	Precautions .....	12-8
12.3.4	Backup file creation procedure .....	12-9
12.3.5	Restore procedure .....	12-10
12.3.6	Management of the backup function.....	12-11
12.4	TPM.....	12-13
12.4.1	Overview .....	12-13
12.4.2	Confirmation Method .....	12-13
12.4.3	Precautions for MFPs with TPM enabled .....	12-13
12.5	High Security Mode.....	12-14
12.5.1	Overview .....	12-14
12.5.2	Prior confirmation.....	12-14
12.5.3	Back up data in HDD .....	12-14
12.5.4	Procedure for entering the High Security mode.....	12-15
12.5.5	Restore user information and data in HDD .....	12-15
12.5.6	Precautions .....	12-16
12.6	Decommissioning.....	12-17
12.6.1	Overview .....	12-17
12.6.2	Function .....	12-17
12.6.3	Precautions .....	12-17
12.6.4	Procedures of decommissioning.....	12-17
<b>13.</b>	<b>WIRE HARNESS CONNECTION DIAGRAMS .....</b>	<b>13-1</b>
13.1	AC Wire Harness .....	13-1
13.2	DC Wire Harness / Electric Parts Layout .....	13-3

13.2.1	DC Wire Harness <2528A/3028A> .....	13-3
13.2.2	Electric Parts Layout <2528A/3028A> .....	13-4
13.2.3	DC Wire Harness <3528A/3528AG/4528A/4528AG> .....	13-5
13.2.4	Electric Parts Layout <3528A/3528AG/4528A/4528AG> .....	13-6
<b>14.</b>	<b>APPENDIX .....</b>	<b>14-1</b>
14.1	External Counters .....	14-1
14.1.1	Overview .....	14-1
14.1.2	Connector .....	14-1
14.1.3	Coin controller.....	14-1
14.1.4	Key copy counter .....	14-4
14.1.5	Precautions .....	14-5
14.2	Optional Storage Device .....	14-6
14.2.1	Overview .....	14-6
14.2.2	Disabling setting .....	14-6
14.2.3	Security setting .....	14-6
14.2.4	Precautions for disposal .....	14-6
14.2.5	Data overwriting function .....	14-6
14.3	Pixel Counter.....	14-7
14.3.1	Overview .....	14-7
14.4	NOTES FOR THE INSTALLATION OF A CARD READER.....	14-15
14.5	Usable USB storage device .....	14-15
14.6	License.....	14-16
14.6.1	Types and categories.....	14-16
14.6.2	How to activate the license.....	14-16
14.6.3	How to deactivate the license.....	14-20
14.6.4	How to delete the license.....	14-20
	<b>REVISION RECORD.....</b>	<b>1</b>

# 1. DIFFERENCES BETWEEN MODELS

This section describes the differences between the models and items which have been changed from the former ones.

	2528A 3028A	3528A 3528AG 4528A 4528AG	5528A 6528A
Main power switch	Not installed	Not installed	Not installed
Optical signal writing system	Laser (1-station)	Laser (1-station)	Laser (1-station and 4-beam)
Process unit	K only	K only	K only
	No compatibility with 5528A, 6528A	No compatibility with 5528A, 6528A	No compatibility with 2528A, 3028A, 3528A, 3528AG, 4528A, 4528AG
Drawer automatic pull-in mechanism	None	Addition of new mechanisms	Addition of new mechanisms
Bypass tray paper loading plate auto-up mechanism	None	None	Addition of new mechanisms
Maximum paper weight	256 g/m <sup>2</sup>	256 g/m <sup>2</sup>	300 g/m <sup>2</sup>
PFP, T-LCF, Ex-LCF transport system	Belt transportation	Belt transportation	Belt transportation
Reverse switching mechanism	Solenoid	Solenoid	Motor
Fusing heat source	Halogen lamp (2 pieces)	Halogen lamp (3 pieces)	IH
Main memory capacity	4 GB	4 GB (8 GB: 3528AG, 4528AG)	6 GB
Storage medium	SSD 128 GB	SSD 128 GB	SSD 128 GB
Motion sensor	None	None	None



## 2. SPECIFICATIONS, ACCESSORIES, OPTIONS AND CONSUMABLES

In this document, a model name is replaced with an alias as follows: Moreover, the availability of the model configurations depending on the destination is also described.

Model name	Alias	Availability								
		NAD	ARD	AUD	MJD	ASD	CND	CNS	TWD	JPD
e-STUDIO2528A	2528A	Yes	Yes	Yes	Yes	Yes	Yes	No	No	Yes
e-STUDIO3028A	3028A	Yes	No	No	Yes	Yes	Yes	No	Yes	No
e-STUDIO3528A	3528A	Yes	Yes	No	Yes	Yes	Yes	No	Yes	Yes
e-STUDIO3528AG	3528AG	No	No	No	No	No	No	Yes	No	No
e-STUDIO4528A	4528A	Yes	Yes	No	Yes	Yes	Yes	No	Yes	Yes
e-STUDIO4528AG	4528AG	No	No	No	No	No	No	Yes	No	No

- For details about the destination, see “destination” in the following reference.

 P. 2-1 “2.1.1 General”

### 2.1 Specifications

#### 2.1.1 General

Type	Desktop type Console type: when optional Paper Feed Pedestal (PFP) or optional Large Capacity Feeder (T-LCF) is installed.	
Original glass	Fixed	
Copy process	Indirect electrophotographic method (dry)	
Development system	2-component magnetic brush developing	
Fusing system	2528A, 3028A: Halogen lamp roller fusing method (2 pieces) 3528A, 3528AG, 4528A, 4528AG: Halogen lamp roller fusing method (3 pieces)	
Photoconductive type	OPC	
Original scanning sensor	CCD sensor	
Scanning light source	LED	
Resolution	Scanning	600 dpi x 600 dpi
	Writing	600 dpi x 600 dpi, 1-bit 2,400 dpi (equivalent) x 600 dpi (when smoothing processing is applied)
Gradation	256	
Paper feeding system	2 drawers and bypass tray 2 drawers, bypass tray and PFP with 2 drawers 2 drawers, bypass tray and T-LCF 2 drawers, bypass tray, PFP with 2 drawers and Ex-LCF (2.0K) 2 drawers, bypass tray, T-LCF and Ex-LCF (2.0K)	
Paper supply	Drawer, PFP, Envelope drawer	Stacking height: 60.5 mm • Plain: Approx. 550 sheets (80 g/m <sup>2</sup> , 21.3 lb. Bond) • Thick: Approx. 500 sheets (105 g/m <sup>2</sup> , 28 lb. Bond) Stacking height: 50 mm • Envelope: Approx. 60 sheets (applied to the Envelope Drawer only)

	Bypass tray	Stacking height: 11 mm <ul style="list-style-type: none"> <li>Plain: Approx. 100 sheets (80 g/m<sup>2</sup>, 21.3 lb. Bond)</li> <li>Thick: Approx. 80 sheets (105 g/m<sup>2</sup>, 28 lb. Bond)</li> <li>Envelope: Approx. 10 sheets</li> </ul>
	T-LCF	Stacking height: 110 mm x 2 <ul style="list-style-type: none"> <li>Plain: Approx. 2,000 sheets (80 g/m<sup>2</sup>, 21.3 lb. Bond)</li> <li>Thick: Approx. 1,660 sheets (105 g/m<sup>2</sup>, 28 lb. Bond)</li> </ul>
	Ex-LCF (2.0K)	Stacking height: 230 mm <ul style="list-style-type: none"> <li>Plain: Approx. 2,000 sheets (80 g/m<sup>2</sup>, 21.3 lb. Bond)</li> <li>Thick: Approx. 1,700 sheets (105 g/m<sup>2</sup>, 28 lb. Bond)</li> </ul>
Paper size	Drawer, PFP	A3, A4, A4-R, A5-R, B4, B5, B5-R, FOLIO. 8K, 16K, 16K-R, LD, LG, LT, LT-R, ST-R, COMPUTER, 13"LG, 8.5" x 8.5" Non-standard *1 *2: Paper size whose width is within 140 mm to 297 mm and length is 210 mm to 432 mm
	Bypass tray	A3, A4, A4-R, A5-R, B4, B5, B5-R, A6-R* <sup>6</sup> , Postcard* <sup>7</sup> , FOLIO, 8K, 16K, 16K-R, LD, LG, LT, LT-R, ST-R, COMPUTER, 13"LG, 8.5" x 8.5", Cho-3, You-4, DL, COM10, Monarch, KAKU-2 Non-standard *1 *2: Paper size whose width is within 100 mm to 297 mm and length is 148 mm to 432 mm
	T-LCF, Ex-LCF (2.0K)	A4, LT
	Envelope Drawer	A4-R, A5-R, B5-R, 16K-R, LG, LT-R, ST-R, 13" LG, COM10, Monarch, Cho-3, Cho-6, You-4, KAKU-2 Non-standard envelope: Paper size whose width is within 100 mm to 240 mm and length is 162 mm to 380 mm
Paper type	Drawer, PFP * <sup>3</sup> , T-LCF * <sup>3</sup> , Ex-LCF (2.0K) * <sup>3</sup>	Plain, Recycled paper, Thick, Thick 1, Thick 2, Thick 3
	Bypass tray	Plain, Recycled paper, Thick, Thick 1, Thick 2, Thick 3, Thin, Transparency, Postcard, Envelope, Label, Tab paper
	Envelope Drawer	Plain, Thick, Thick 1, Thick 2, Thick 3, Envelope
Paper weight	Drawer, PFP, T-LCF, Ex-LCF (2.0K)	60 g/m <sup>2</sup> to 256 g/m <sup>2</sup> (16 lb. Bond to 140 lb. Index)
	Bypass tray	Single-sheet feeding: 52 g/m <sup>2</sup> to 256 g/m <sup>2</sup> (14 lb. Bond to 140 lb. Index) Continuous feeding: 60 g/m <sup>2</sup> to 256 g/m <sup>2</sup> (16 lb. Bond to 140 lb. Index)
	Envelope Drawer	Plain, Thick, Thick 1: 60 g/m <sup>2</sup> to 256 g/m <sup>2</sup> (16 lb. Bond to 140 lb. Index) Envelope: 85 g/m <sup>2</sup> or below
Automatic Duplexing Unit	Paper refeeding/reversing system	Stackless, Switchback type
	Acceptable paper size	A3, A4, A4-R, A5-R, B4, B5, B5-R, FOLIO. 8K, 16K, 16K-R, LD, LG, LT, LT-R, ST-R, COMPUTER, 13"LG, 8.5" x 8.5"
	Acceptable paper weight	60 g/m <sup>2</sup> to 256 g/m <sup>2</sup> (16 lb. Bond to 140 lb. Index)
Toner supply system		Automatic toner density detection/supply Toner cartridge exchange type (Recovered toner supply mechanism available)
Density adjustment system		Magnetic auto-toner system (non-contact)
Total counter		Electronic counter displayed in 7-digit
Memory capacity	Main memory	4 GB (8 GB: 3528AG, 4528AG)
	Page memory	Included in the main memory
Standard storage device size (SSD)		128 GB
Registrable user account number		10,000
Registrable department code number		1,000

Warm-up time <sup>*4</sup>	Normal start-up: Approx. 20 sec. (stand-alone) (temperature: 20°C) Start-up without hibernation: Approx. 40 sec. (stand-alone) (temperature: 20°C)
Recovery from sleep <sup>*4</sup>	2528A, 3028A: Approx. 14 sec. 3528A, 3528AG, 4528A, 4528AG: Approx. 16 sec. (stand-alone) (temperature: 20°C)
Power source	AC 100 V (±10 %), 15 A (common for 50/60 Hz) AC 110 V (±10 %), 13.2 A (60 Hz) AC 120 V (±10 %), 12 A (common for 50/60 Hz) AC 220 V to 240 V (±10 %), 8A (common for 50/60Hz)
Power consumption <sup>*5</sup>	1.5 kW or less (100 V, 110 V, 120 V) 2.0 kW or less (220 V to 240 V)
Dimensions (MFP only)	585 (W) x 586 (D) x 787 (H) mm (when the tilt angle of the control panel is 90 degrees) 585 (W) x 720 (D) x 787 (H) mm (when the tilt angle of the control panel is 7 degrees) 
Weight	2528A, 3028A: Approx. 55 kg 3528A, 3528AG, 4528A, 4528AG: Approx. 57 kg
Destination	NAD: North America, Brazil ARD: Argentina AUD: Australia MJD: Europe ASD: Asia, Others CND, CNS: China TWD: Taiwan JPD: Japan

Fig. 2-1

\*1 Image deviation, image void, skewing, image tilting, corner folding or wrinkling may occur on non-standard size paper.  
 \*2 When printing is performed by using a printer driver, the available paper sizes may differ from the listed ones depending on the specifications of the printer driver.  
 \*3 Pre-punched paper is unacceptable.  
 \*4 This may vary depending on the quality maintenance behavior, such as the settings, conditions of use and toner refill.  
 \*5 Power for the options is supplied through the MFP.  
 \*6 JPD is not applicable.  
 \*7 For JPD only.

## 2.1.2 Copy

### [ 1 ] Copy specification

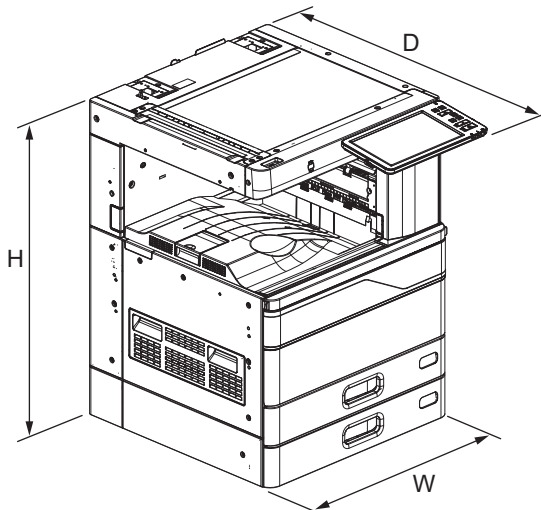
Storage capacity		Max. 1,000 sheets or until the memory is full
Original glass	Original scanning system	Flat surface scanning system (left rear corner used as guide to place an original)
	Original type	Sheets, Books
	Original size	Max. A3 or LD
Reversing Automatic Document Feeder (optional)	Original scanning system	Fixed scanning system by feeding the original (center used as guide to place originals)
	Original type	Plain paper, Recycled paper (The following types of paper are unacceptable.: duplicative draft, back carbon paper, bonded paper, stapled paper, high-transparency paper, photo, catalog, coated paper, etc.)
	Original size	A3, A4, A4-R, A5-R, B4, B5, B5-R, FOLIO, LD, LG, LT, LT-R, ST-R, COMPUTER
	Original paper weight *1	Simplex: 35 g/m <sup>2</sup> to 157 g/m <sup>2</sup> (9.3 lb. Bond to 41.8 lb. Bond) Duplex: 50 g/m <sup>2</sup> to 157 g/m <sup>2</sup> (13.3 lb. Bond to 41.8 lb. Bond)
	Original capacity	Stacking height: 16 mm, equivalent to 100 sheets of 80 g/m <sup>2</sup> (21.3 lb. Bond) plain paper
Dual Scan Document Feeder (optional)	Original scanning system	Fixed scanning system by feeding the original (center used as guide to place originals)
	Original type	Plain paper, Recycled paper (The following types of paper are unacceptable.: duplicative draft, back carbon paper, bonded paper, stapled paper, high-transparency paper, photo, catalog, coated paper, etc.)
	Original size	A3, A4, A4-R, A5-R, B4, B5, B5-R, FOLIO, LD, LG, LT, LT-R, ST-R, COMPUTER
	Original paper weight *1	35 g/m <sup>2</sup> to 209 g/m <sup>2</sup> (9.3 lb. Bond to 77.3 lb. Cover)
	Original capacity	Stacking height: 38 mm, equivalent to 300 sheets of 80 g/m <sup>2</sup> (21.3 lb. Bond) plain paper
Eliminated portion		Leading edge: 3.0 mm +2.0/-1.0 mm Trailing edge, Side edges: 2.0 mm ±2.0 mm
Multiple copying		Up to 999 sheets

\*1 Show-through will occur when a 2-sided thin-paper original such as 35 g/m<sup>2</sup> (9.3 lb. Bond) is scanned.

### [ 2 ] First copy time

2528A, 3028A	Approx. 4.3 sec.
3528A, 3528AG, 4528A, 4528AG	Approx. 3.6 sec.



### [ 3 ] Copy speed (sheets/min.)

#### [ 3-1 ] Plain, Thick

Plain: 60 g/m<sup>2</sup> to 80 g/m<sup>2</sup> (1.6 lbs. Bond to 21.3 lbs. Bond)

Thick: 81 g/m<sup>2</sup> to 105 g/m<sup>2</sup> (22 lb. Bond to 28 lb. Bond)

- “-” means “Not acceptable”.
- When originals are manually placed for single-sided, continuous copying
- When the RADF is used, the copy speed of the MFP is only possible under the following conditions:  
Original: A4 or LT (single-sided), Mode: APS selected, Automatic density not selected, Plain selected  
Reproduction ratio: 100%
- “Wait” may be displayed or the copy speed may decrease depending on the usage environment or print settings.

#### 2528A (Plain)

Paper supply Paper size	Drawer	Bypass tray		PFP	T-LCF, Ex-LCF (A4, LT only)
		Size specified	Size not specified		
A4, LT	25.3	25.3	16.8	25.3	25.3
B5, A5-R, ST-R, 8.5" x 8.5"					-
A4-R, B5-R, LT-R	23.3	23.3	16.8	23.3	-
B4, LG, FOLIO, COMPUTER	19.5	19.5	16.8	19.5	-
A3, LD	16.8	16.8	16.8	16.8	-

#### 3028A (Plain)

Paper supply Paper size	Drawer	Bypass tray		PFP	T-LCF, Ex-LCF (A4, LT only)
		Size specified	Size not specified		
A4, LT	30.3	30.3	16.8	30.3	30.3
B5, A5-R, ST-R, 8.5" x 8.5"					-
A4-R, B5-R, LT-R	23.3	23.3	16.8	23.3	-
B4, LG, FOLIO, COMPUTER	19.5	19.5	16.8	19.5	-
A3, LD	16.8	16.8	16.8	16.8	-

#### 3528A, 3528AG (Plain)

Paper supply Paper size	Drawer	Bypass tray		PFP	T-LCF, Ex-LCF (A4, LT only)
		Size specified	Size not specified		
A4, LT	35.3	35.3	25.4	35.3	35.3
B5, A5-R, ST-R, 8.5" x 8.5"					-
A4-R, B5-R, LT-R	35.0	35.0	25.4	35.0	-
B4, LG, FOLIO, COMPUTER	29.5	29.5	25.4	29.5	-
A3, LD	25.4	25.4	25.4	25.4	-

## 4528A, 4528AG (Plain)

Paper supply Paper size	Drawer	Bypass tray		PFP	T-LCF, Ex-LCF (A4, LT only)
		Size specified	Size not specified		
A4, LT	45.3	45.3	25.4	45.3	45.3
B5, A5-R, ST-R, 8.5" x 8.5"					-
A4-R, B5-R, LT-R	35.0	35.0	25.4	35.0	-
B4, LG, FOLIO, COMPUTER	29.5	29.5	25.4	29.5	-
A3, LD	25.4	25.4	25.4	25.4	-

## 2528A (Thick)

Paper supply Paper size	Drawer	Bypass tray		PFP	T-LCF, Ex-LCF (A4, LT only)
		Size specified	Size not specified		
A4, LT	25.3	25.3	16.4	25.3	25.3
B5, A5-R, ST-R, 8.5" x 8.5"					-
A4-R, B5-R, LT-R	22.5	22.5	16.4	22.5	-
B4, LG, FOLIO, COMPUTER	19.0	19.0	16.4	19.0	-
A3, LD	16.4	16.4	16.4	16.4	-

## 3028A (Thick)

Paper supply Paper size	Drawer	Bypass tray		PFP	T-LCF, Ex-LCF (A4, LT only)
		Size specified	Size not specified		
A4, LT	29.0	29.0	16.4	29.0	29.0
B5, A5-R, ST-R, 8.5" x 8.5"					-
A4-R, B5-R, LT-R	22.5	22.5	16.4	22.5	-
B4, LG, FOLIO, COMPUTER	19.0	19.0	16.4	19.0	-
A3, LD	16.4	16.4	16.4	16.4	-

## 3528A, 3528AG (Thick)

Paper supply Paper size	Drawer	Bypass tray		PFP	T-LCF, Ex-LCF (A4, LT only)
		Size specified	Size not specified		
A4, LT	35.3	35.3	24.8	35.3	35.3
B5, A5-R, ST-R, 8.5" x 8.5"					-
A4-R, B5-R, LT-R	33.9	33.9	24.8	33.9	-
B4, LG, FOLIO, COMPUTER	28.7	28.7	24.8	28.7	-
A3, LD	24.8	24.8	24.8	24.8	-

## 4528A, 4528AG (Thick)

Paper supply Paper size	Drawer	Bypass tray		PFP	T-LCF, Ex-LCF (A4, LT only)
		Size specified	Size not specified		
A4, LT	43.4	43.4	24.8	43.4	43.4
B5, A5-R, ST-R, 8.5" x 8.5"					-
A4-R, B5-R, LT-R	33.9	33.9	24.8	33.9	-
B4, LG, FOLIO, COMPUTER	28.7	28.7	24.8	28.7	-
A3, LD	24.8	24.8	24.8	24.8	-

**[ 3-2 ] Thick 1**Thick 1: 106 g/m<sup>2</sup> to 163 g/m<sup>2</sup> (90 lb. Index)

- “-” means “Not acceptable”.
- When originals are manually placed for single-sided, continuous copying

## 2528A

Paper supply Paper size	Drawer	Bypass tray		PFP	T-LCF, Ex-LCF (A4, LT only)
		Size specified	Size not specified		
A4, LT	25.3	25.3	16.0	25.3	-
B5, A5-R, ST-R, 8.5" x 8.5"					-
A4-R, B5-R, LT-R	22.5	22.5	16.0	22.5	-
B4, LG, FOLIO, COMPUTER	18.0	18.0	16.0	18.0	-
A3, LD	16.0	16.0	16.0	16.0	-

## 3028A

Paper supply Paper size	Drawer	Bypass tray		PFP	T-LCF, Ex-LCF (A4, LT only)
		Size specified	Size not specified		
A4, LT	29.0	29.0	16.0	29.0	-
B5, A5-R, ST-R, 8.5" x 8.5"					-
A4-R, B5-R, LT-R	22.5	22.5	16.0	22.5	-
B4, LG, FOLIO, COMPUTER	18.0	18.0	16.0	18.0	-
A3, LD	16.0	16.0	16.0	16.0	-

## 3528A, 3528AG

Paper supply Paper size	Drawer	Bypass tray		PFP	T-LCF, Ex-LCF (A4, LT only)
		Size specified	Size not specified		
A4, LT	35.3	35.3	20.0	35.3	-
B5, A5-R, ST-R, 8.5" x 8.5"					-
A4-R, B5-R, LT-R	29.0	29.0	20.0	29.0	-
B4, LG, FOLIO, COMPUTER	23.0	23.0	20.0	23.0	-
A3, LD	20.0	20.0	20.0	20.0	-

## 4528A, 4528AG

Paper supply Paper size	Drawer	Bypass tray		PFP	T-LCF, Ex-LCF (A4, LT only)
		Size specified	Size not specified		
A4, LT	40.0	40.0	20.0	40.0	-
B5, A5-R, ST-R, 8.5" x 8.5"					
A4-R, B5-R, LT-R	29.0	29.0	20.0	29.0	-
B4, LG, FOLIO, COMPUTER	23.0	23.0	20.0	23.0	-
A3, LD	20.0	20.0	20.0	20.0	-

**[ 3-3 ] Thick 2**Thick 2: 164 g/m<sup>2</sup> to 209 g/m<sup>2</sup> (110 lb. Index)

- “-” means “Not acceptable”.
- When originals are manually placed for single-sided, continuous copying

## 2528A

Paper supply Paper size	Drawer	Bypass tray		PFP	T-LCF, Ex-LCF (A4, LT only)
		Size specified	Size not specified		
A4, LT	25.0	25.0	14.0	25.0	-
B5, A5-R, ST-R, 8.5" x 8.5"					
A4-R, B5-R, LT-R	20.0	20.0	14.0	20.0	-
B4, LG, FOLIO, COMPUTER	16.0	16.0	14.0	16.0	-
A3, LD	14.0	14.0	14.0	14.0	-

## 3028A

Paper supply Paper size	Drawer	Bypass tray		PFP	T-LCF, Ex-LCF (A4, LT only)
		Size specified	Size not specified		
A4, LT	28.0	28.0	14.0	28.0	-
B5, A5-R, ST-R, 8.5" x 8.5"					
A4-R, B5-R, LT-R	20.0	20.0	14.0	20.0	-
B4, LG, FOLIO, COMPUTER	16.0	16.0	14.0	16.0	-
A3, LD	14.0	14.0	14.0	14.0	-

## 3528A, 3528AG, 4528A, 4528AG

Paper supply Paper size	Drawer	Bypass tray		PFP	T-LCF, Ex-LCF (A4, LT only)
		Size specified	Size not specified		
A4, LT	32.0	32.0	16.0	32.0	-
B5, A5-R, ST-R, 8.5" x 8.5"					
A4-R, B5-R, LT-R	23.0	23.0	16.0	23.0	-
B4, LG, FOLIO, COMPUTER	18.0	18.0	16.0	18.0	-
A3, LD	16.0	16.0	16.0	16.0	-

### [ 3-4 ] Thick 3

Thick 3: 210 g/m<sup>2</sup> to 256 g/m<sup>2</sup> (140 lb. Index)

Paper supply Paper size	Drawer	Bypass tray		PFP	T-LCF, Ex-LCF (A4, LT only)
		Size specified	Size not specified		
A4, LT	24.0	24.0	12.0	24.0	-
B5, A5-R, ST-R, 8.5" x 8.5"					
A4-R, B5-R, LT-R	17.0	17.0	12.0	17.0	-
B4, LG, FOLIO, COMPUTER	14.0	14.0	12.0	14.0	-
A3, LD	12.0	12.0	12.0	12.0	-

### [ 3-5 ] Envelope

Paper supply Paper size	Drawer	PFP
DL, Monarch, COM10, Cho-3, You-4, KAKU-2	10.0	10.0

### [ 4 ] System copy speed

Copy mode		Sec.	
		2528A	3028A
Single-sided originals	1 set	30.54	25.37
	3 sets	76.85	69.41
↓ Single-sided copies	5 sets	124.36	105.17
Single-sided originals	1 set	31.04	30.29
	3 sets	78.72	74.28
↓ Double-sided copies	5 sets	127.25	118.21
Double-sided originals	1 set	56.9	55.26
	3 sets	152.67	143.18
↓ Double-sided copies	5 sets	248.62	231.28
Double-sided originals	1 set	53.25	50.57
	3 sets	148.39	129.4
↓ Single-sided copies	5 sets	242.91	208.98

Copy mode		Sec.	
		3528A, 3528AG	4528A, 4528AG
Single-sided originals	1 set	22.2	19.27
	3 sets	56.32	45.76
↓ Single-sided copies	5 sets	90.32	72.06
Single-sided originals	1 set	23.79	21.7
	3 sets	57.74	48.71
↓ Double-sided copies	5 sets	92.25	74.98

Copy mode		Sec.	
		3528A, 3528AG	4528A, 4528AG
Double-sided originals ↓ Double-sided copies	1 set	52.48	52.7
	3 sets	120.4	105.76
	5 sets	185.45	158.8
Double-sided originals ↓ Single-sided copies	1 set	49.1	49.26
	3 sets	117.36	102.11
	5 sets	184.99	155.35

- The table shows the period of time when 10 sheets of an A4 or LT size original are set on the RADF and one of the copy modes above is selected.
- The period of time is from when the [START] button is pressed until “Ready” is displayed.
- When the following settings are specified: Automatic density, APS, AMS: OFF, Text/Photo: Selected  
Paper supply: Drawer 1, Sort: Selected
- No finisher, saddle stitch finisher and hole punch unit are installed.

## 2.1.3 Printing

Supported Page Description Language (RIP) (Printer driver)	PCL6, PostScript 3 (emulation)	
Supported Page Description Language (RIP) (MFP)	PCL6, PostScript 3 (emulation), XPS, PCL5e, PCL5c, PDF (emulation)	
Supported Client OS	Windows Server 2012, Windows 10, Windows Server 2016, Windows Server 2019, Windows 11, Windows Server 2022 Mac OS 10.12 or later Sun Solaris 11.2 HP-UX Version 11iv3 IBM AIX 7.x Fedora 21/22 Red Hat Enterprise Linux 5.x/6.x/7.x SuSE Linux Enterprise Server 11/12 Open SUSE 13.2/13.3 Ubuntu 14.04LTS/15.04 Debian 7/8 CUPS V1.1.15	
Resolution	600 dpi x 600 dpi, 1-bit All PDL 2,400 dpi (Equivalence) x 600 dpi (with smoothing) All PDL 1,200 dpi x 1,200 dpi, 2-bit (3,600 dpi (equivalent) x 1,200 dpi) PS only	
Eliminated portion	Leading edge, Trailing edge, Side edges: 4.2 mm ±2.0 mm	
Interface	Standard	Ethernet (1000BASE-T/100BASE-TX/10BASE-T), USB2.0 (High speed)
	Optional <sup>*1</sup>	Wireless LAN (IEEE802.11b/g/n, IEEE802.11a/n/ac) Bluetooth V4.2 (HCRP/BIP/OPP/FTP/HID)
Paper size	Bypass tray	Paper size whose width is within 100 mm to 297 mm and length is 148 mm to 432 mm

\*1 Equipped as the standard for JPD only

## 2.1.4 Scan

Scanning speed <sup>*1*2</sup>	RADF	100 dpi, 150 dpi, 200 dpi, 300 dpi: Simplex 73 spm or larger: 400 dpi: Simplex 62 spm or larger 600 dpi: Simplex 50 spm +7/-0.5 spm, Duplex 25 spm or larger
	DSDF	100 dpi, 150 dpi, 200 dpi, 300 dpi: Simplex 120 spm +14/-1 spm, Duplex 240 spm +28/-2 spm 400 dpi: Simplex 80 spm +16/-0.8 spm, Duplex 160 spm or larger 600 dpi: Simplex 70 spm +8/-0.6 spm, Duplex 120 spm or larger
Resolution	100, 150, 200, 300, 400, 600 dpi	
Scan mode	Black, Gray scale, Full color, ACS (Auto Color Selection)	
File format	JPEG, Multi/Single page TIFF, Multi/Single page PDF, Slim PDF, Multi/Single page XPS	

\*1 When single-sided A4/LT landscape originals are scanned continuously or scanning is completed

\*2 Common for Black, Gray scale, Full color

## 2.1.5 Internet fax

### [ 1 ] Transmission

Resolution	TX <dots/mm>	Standard (8 x 3.85) Fine (8 x 7.7)
Scanning	Original size	A3, A4, A4-R, A5, A5-R, B4, B5, B5-R, FOLIO, LD, LG, LT, LT-R, ST, ST-R, COMPUTER
	Speed	0.7 sec./page (A4) Max. 50 spm (ITU-T No.1, A4, 8 x 3.85, Text mode)
	Gray Scale	256 levels (error diffusion)
Address Book	Address Book	3,000 stations
	Group	Max. 200 stations
Transmission features	Broadcast transmission	Max. 400 destinations/job (A fax number and an e-mail address registered in the same job are available.)
	Message size limitation	Max. 100 MB
	Message division	Page by page

### [ 2 ] Reception







Reception format	TIFF-FX (Profile S, F, J)
------------------	---------------------------

## 2.1.6 Network fax (option)

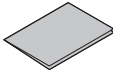
Compatible standards		Super G3, G3 (ITU-T.30) Internet Fax (Simple mode) (ITU-T.37)
TX Resolution	PSTN	Standard: 200 dpi x 100 dpi Fine: 200 dpi x 200 dpi Super Fine: 200 dpi x 400 dpi Ultra Fine: 400 dpi x 400 dpi
	Internet Fax	200 dpi x 200 dpi
Original size		A3, B4, A4, B5, A5, LT, LG, LD, ST, Folio, Computer
Mail box	User defined	Max. 300 boxes
Routed document format	Send to e-Filing	MMR
	Send to File (SMB)	Single TIFF, Multi-TIFF, Single PDF, Multi PDF
	Send to FTP	Single TIFF, Multi-TIFF, Single PDF, Multi PDF
	Send to E-mail	Single TIFF, Multi-TIFF, Single PDF, Multi PDF
	Send to I-Fax	TIFF-S
	Send to PSTN-Fax	MMR, MR, MH, JBIG

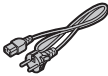

## 2.2 Accessories

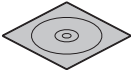
Name		Q'ty	Availability
Unpacking/Setup Instructions		1 set	For all destinations
Operator's Manuals • Safety Information: 1 • Quick Start Guide: 1		1 set	For all destinations
Power cable		1 pc.	For all destinations
Service information sheet		1 set	For all destinations
For our users		1 set	For all destinations
Rubber plug		2 pcs.	For all destinations
Developer material		1 set	ARD, AUD, ASD, CND, CNS, JPD
Right lower cover		1 pc.	For all destinations
Screw (M3 x 8)		1 pc.	For all destinations
DVD (Client Utilities / User Documentation DVD)		1 pc.	ARD, MJD, ASD, CND, CNS, TWD, JPD
Warranty sheet		1 pc.	NAD, CND, CNS
Toner		1 set	AUD, ASD, CND, CNS
Setup report		1 set	NAD
Accessories list		1 pc.	CND, CNS
CCC certificate		1 pc.	CND, CNS
Energy consumption sheet		1 pc.	CND, CNS
Ground wire		1 pc.	JPD
Ground wire fixing screw (M4 x 6)		1 pc.	JPD
Business card case		1 set	JPD
Warning sheet		1 pc.	JPD
Paper precaution sheet		1 pc.	JPD
Cleaning cloth		1 pc.	JPD
Cloth holder		1 pc.	JPD

### Notes:

Check that the above accessories are correctly co-packed at the time of unpacking.

## 2.3 System List

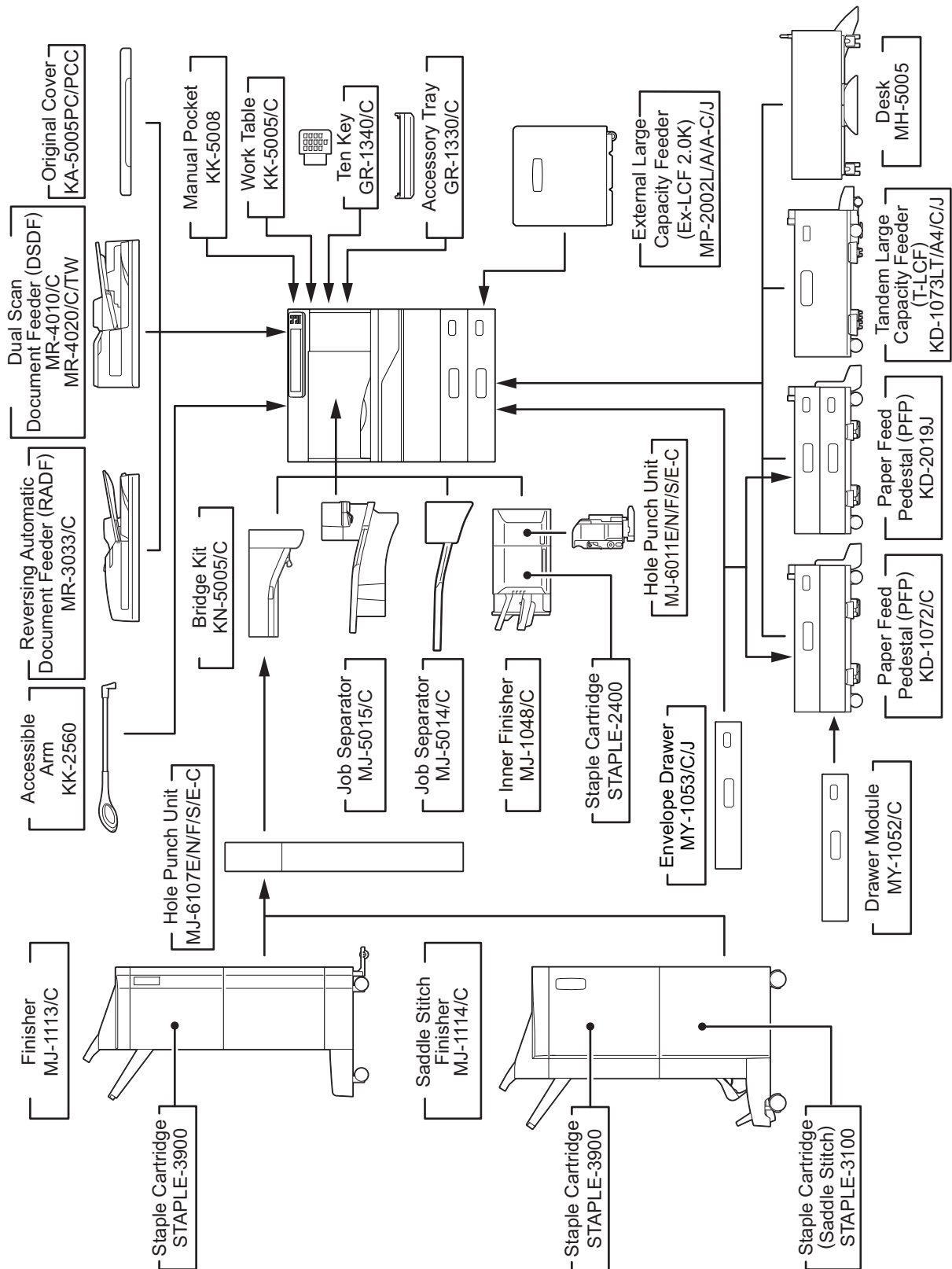

Fig. 2-2

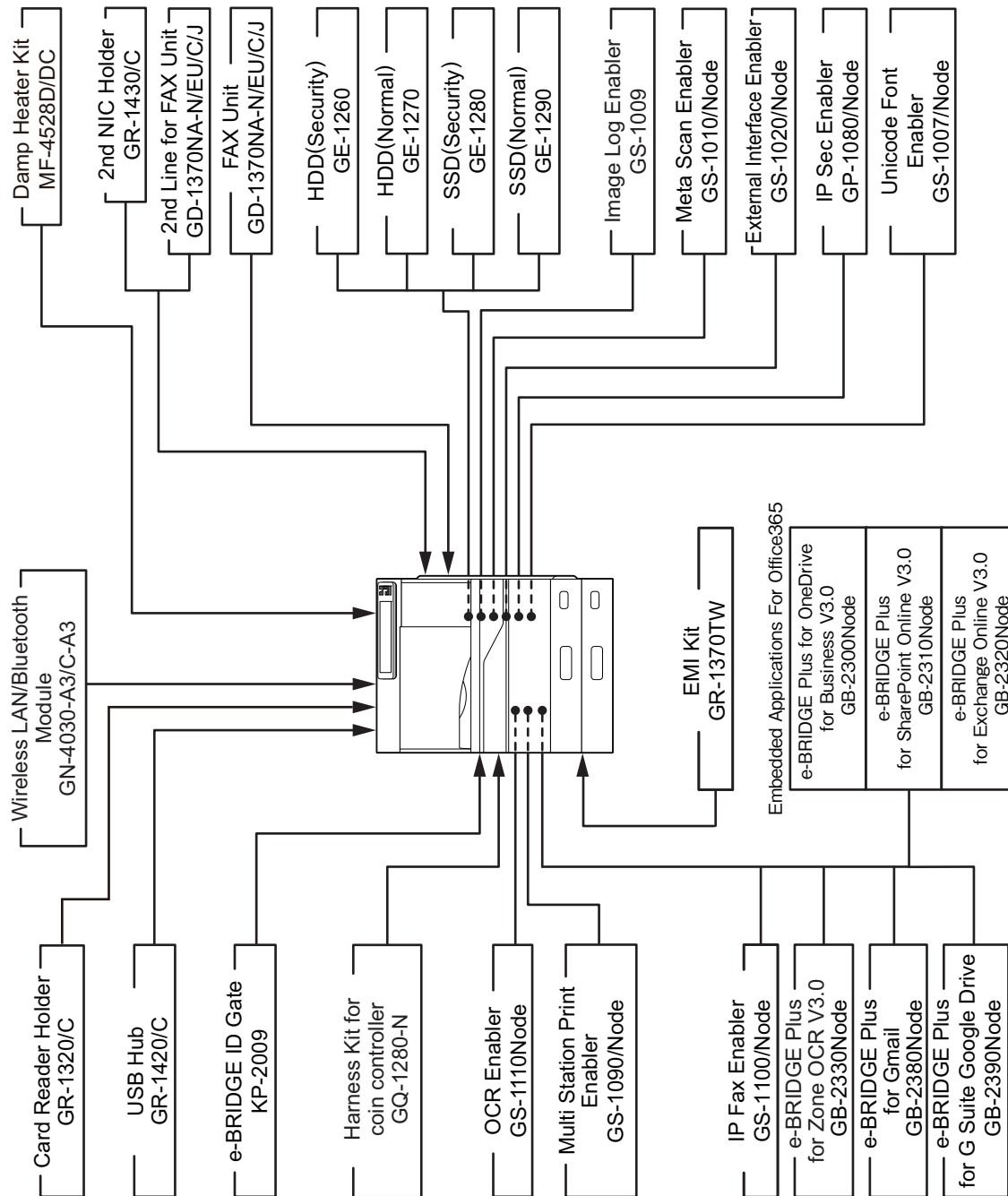

Fig. 2-3

**Notes:**

- The Bridge Kit (KN-5005) is necessary for installation of the Finisher (MJ-1113/C, MJ-1114/C).
- The Finisher (MJ-1113/C, MJ-1114/C) is necessary for installation of the Hole Punch Unit (MJ-6107E/N/F/S/E-C).
- The Inner Finisher (MJ-1048/C) is necessary for installation of the Hole Punch Unit (MJ-6011E/N/F/S/E-C).
- The PFP (KD-1072/C or KD-2019J) or the T-LCF (KD-1073LT/A4/C/J) is necessary for installation of the Ex-LCF (2.0K) (MP-2002L/A/A-C/J).
- Only either the 2nd NIC Holder (GR-1430/C) or the 2nd Line for the FAX Unit (GD-1370NA-N/EU/C/J) can be installed.

## 2.4 Option List

Option	Model name	Availability						
		NAD	ARD, AUD	MJD	ASD	CND, CNS	TWD	JPD
Reversing Automatic Document Feeder (RADF)	MR-3033/C	Yes	Yes	Yes	Yes	Yes	Yes	Yes
Dual Scan Document Feeder (DSDF)	MR-4010/C	Yes	Yes	Yes	Yes	Yes	No	Yes
	MR-4020/C/TW	Yes	Yes	Yes	Yes	Yes	Yes	Yes
Original Cover	KA-5005PC/PCC	Yes	Yes	Yes	Yes	Yes	Yes	Yes
Paper Feed Pedestal (PFP)	KD-1072/C	Yes	Yes	Yes	Yes	Yes	Yes	No
	KD-2019J	No	No	No	No	No	No	Yes
Drawer Module	MY-1052/C	Yes	Yes	Yes	Yes	Yes	Yes	No
Envelope Drawer	MY-1053/C/J	Yes	Yes	Yes	Yes	Yes	Yes	Yes
Large Capacity Feeder (T-LCF)	KD-1073LT/A4/C/J	Yes	Yes	Yes	Yes	Yes	Yes	Yes
External Large Capacity Feeder (2.0K) (Ex-LCF)	MP-2002L/A/A-C/J	Yes	Yes	Yes	Yes	Yes	Yes	Yes
Desk	MH-5005	No	Yes <sup>*1</sup>	Yes	No	No	No	Yes
Work Table	KK-5005/C	Yes	Yes	Yes	Yes	Yes	Yes	Yes
Operator's Manual Pocket	KK-5008	No	No	No	No	No	No	Yes
Accessible Arm	KK-2560	Yes	Yes	Yes	Yes	Yes	Yes	Yes
Bridge Kit	KN-5005/C	Yes	Yes	Yes	Yes	Yes	Yes	Yes
Finisher	MJ-1113/C	Yes	Yes	Yes	Yes	Yes	Yes	Yes
Saddle Stitch Finisher	MJ-1114/C	Yes	Yes	Yes	Yes	Yes	Yes	Yes
Hole Punch Unit (for MJ-1113/C, MJ-1114/C)	MJ-6107E/N/F/S/E-C	Yes	Yes	Yes	Yes	Yes	Yes	Yes
Inner Finisher	MJ-1048/C	Yes	Yes	Yes	Yes	Yes	Yes	Yes
Hole Punch Unit (for MJ-1048/C)	MJ-6011E/N/F/S/E-C	Yes	Yes	Yes	Yes	Yes	Yes	Yes
Staple Cartridge (staples for 50 sheets for MJ-1048/C)	STAPLE-2400	Yes	Yes	Yes	Yes	Yes	Yes	Yes
Staple Cartridge (for MJ-1114/C)	STAPLE-3100	Yes	Yes	Yes	Yes	Yes	Yes	Yes
Staple Cartridge (staples for 65 sheets for MJ-1113/C, MJ-1114/C)	STAPLE-3900	Yes	Yes	Yes	Yes	Yes	Yes	Yes
Job Separator (for 2528A, 3028A)	MJ-5014/C	Yes	Yes	Yes	Yes	Yes	Yes	Yes
Job Separator (for 3528A, 3528AG, 4528A, 4528AG)	MJ-5015/C	Yes	Yes	Yes	Yes	Yes	Yes	Yes
Damp Heater Kit	MF-4528D/DC	No	Yes	No	Std	Yes	Std	Std
FAX Unit (2nd Line for FAX Unit)	GD-1370NA-N/EU/C/J	Yes	Yes	Yes	Yes	Yes	Yes	Yes
Card Reader Holder	GR-1320/C	Yes	Yes	Yes	Yes	Yes	Yes	Yes
Accessory Tray	GR-1330/C	Yes	Yes	Yes	Yes	Yes	Yes	No
Panel Ten Key Option	GR-1340/C	Yes	Yes	Yes	Yes	Yes	Yes	Yes
EMI Kit	GR-1370TW	No	No	No	No	No	Yes	No
USB Hub Option	GR-1420/C	Yes	Yes	Yes	Yes	Yes	Yes	Yes
2nd NIC Holder	GR-1430/C	Yes	Yes	Yes	Yes	Yes	Yes	Yes
Wireless LAN / Bluetooth Module	GN-4030-A3/C-A3	Yes	Yes <sup>*1</sup>	Yes	Yes	Yes	No	Std
Harness kit for coin controller	GQ-1280-N	Yes	Yes	Yes	Yes	Yes	Yes	Yes
e-BRIDGE ID Gate	KP-2009	No	No	No	No	No	No	Yes
Security HDD option <sup>*2</sup>	GE-1260	Yes	Yes	Yes	Yes	No	Yes	Yes
HDD without Security option	GE-1270	No	No	No	No	Yes	No	No
Security SSD option	GE-1280	Yes	Yes	Yes	Yes	No	Yes	No
SSD without Security option	GE-1290	No	No	No	No	Yes	No	No
IPsec Enabler (License)	GP-1080/Node	Yes	Yes	Yes	Yes	No	Yes	Yes

Option	Model name	Availability						
		NAD	ARD, AUD	MJD	ASD	CND, CNS	TWD	JPD
Unicode Font enabler (license)	GS-1007/Node	Yes	Yes	Yes	Yes	Yes	Yes	Yes
Image Log Enabler	GS-1009	No	No	No	No	Yes	No	No
Meta scan enabler (license)	GS-1010/Node	Yes	Yes	Yes	Yes	Yes	Yes	Yes
External interface enabler (license)	GS-1020/Node	Std	Std	Std	Std	Std	Yes	Yes
Multi station print (license)	GS-1090/Node	Yes	Yes	Yes	Yes	Yes	Yes	Yes
IP Fax Enabler (license)	GS-1100/Node	Yes	Yes	Yes	Yes	Yes	Yes	Yes
OCR Enabler (license)	GS-1110Node	Std	Std	Std	Std	Std	Std	Yes
Embedded Applications For Office365 • e-BRIDGE Plus for OneDrive for Business V3.0 (Node)	GB-2300Node	Yes	Yes	Yes	Yes	No	Yes	Yes
Embedded Applications For Office365 • e-BRIDGE Plus for SharePoint Online V3.0 (Node)	GB-2310Node	Yes	Yes	Yes	Yes	No	Yes	Yes
Embedded Applications For Office365 • e-BRIDGE Plus for Exchange Online V3.0 (Node)	GB-2320Node	Yes	Yes	Yes	Yes	No	Yes	Yes
e-BRIDGE Plus for Zone OCR V3.0 (Node)	GB-2330Node	Yes	Yes	Yes	Yes	Yes	Yes	Yes
e-BRIDGE Plus for Gmail (Node)	GB-2380Node	Yes	Yes	Yes	Yes	No	Yes	Yes
e-BRIDGE Plus for G Suite Google Drive (Node)	GB-2390Node	Yes	Yes	Yes	Yes	No	Yes	Yes
Power Cable for UK	GE-1300	No	No	Yes	No	No	No	No



\*1 ARD is not applicable.

\*2 FIPS supported

**Remarks:**

- Letters of the alphabet added to the end of the model name mainly indicates the destination or region. For example, “C” indicates “China” and “J” indicates “Japan”. Moreover, “L” and “LT” indicate Letter series models, while “A” and “A4” indicate A4 series models.
- The options indicated with “Std” are equipped as the standard.

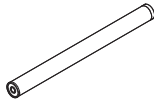
## 2.5 Consumables

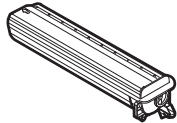
Drum 	PS-OD3028	JPD
	OD-3028	Other than JPD
Developer material 	PS-ZD3028	JPD
	D-3028	Other than JPD
Toner cartridge 	PS-ZT3028J(1)	JPD
	PS-ZT3028U(1)	NAD, ARD
	PS-ZT3028E(1)	MJD
	PS-ZT3028P(1)	AUD, ASD, TWD
	PS-ZT3028C(1) PS-ZT3028C(8) PS-ZT3028CM(1) PS-ZT3028CM(8)	CND, CNS

# 3. OVERVIEW

## 3.1 Sectional View

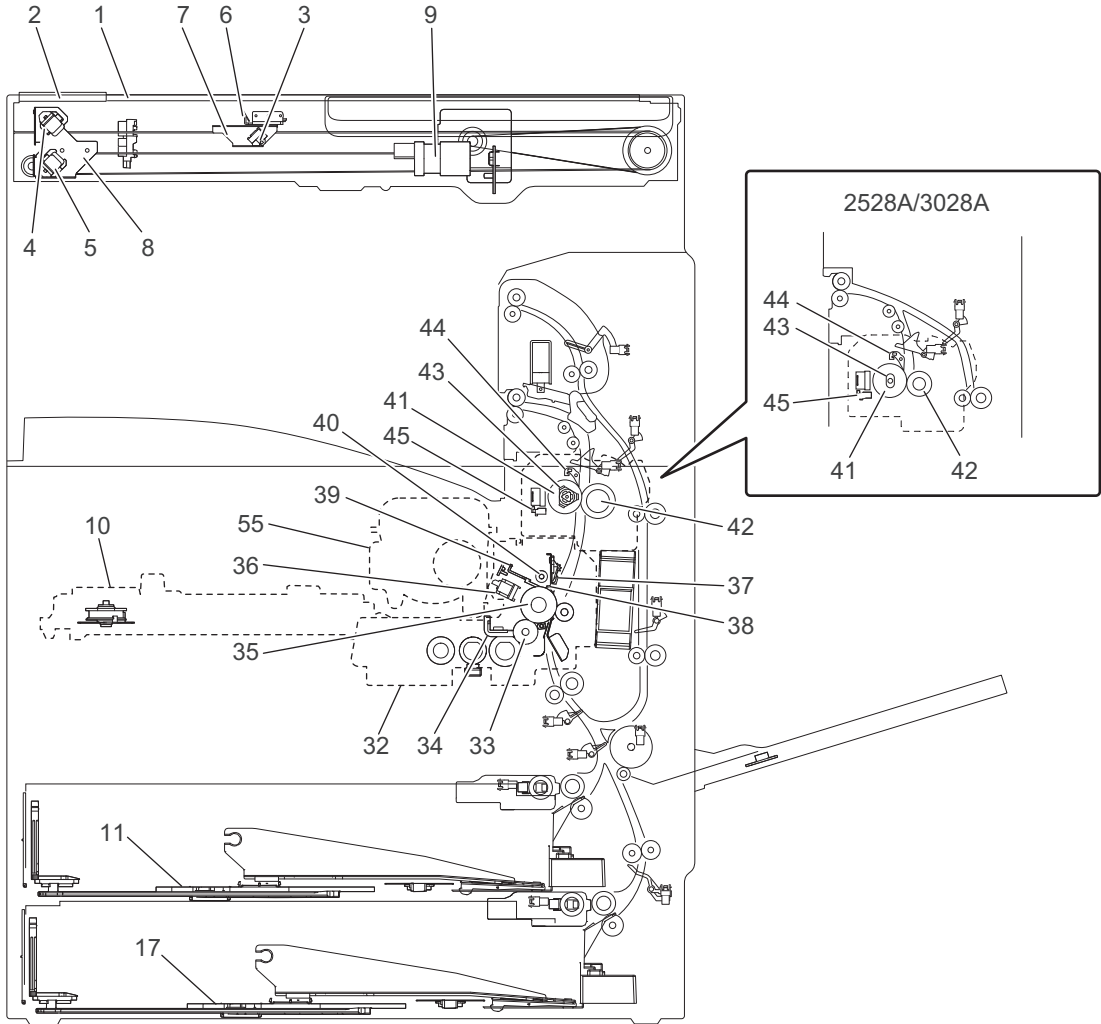

Fig. 3-1

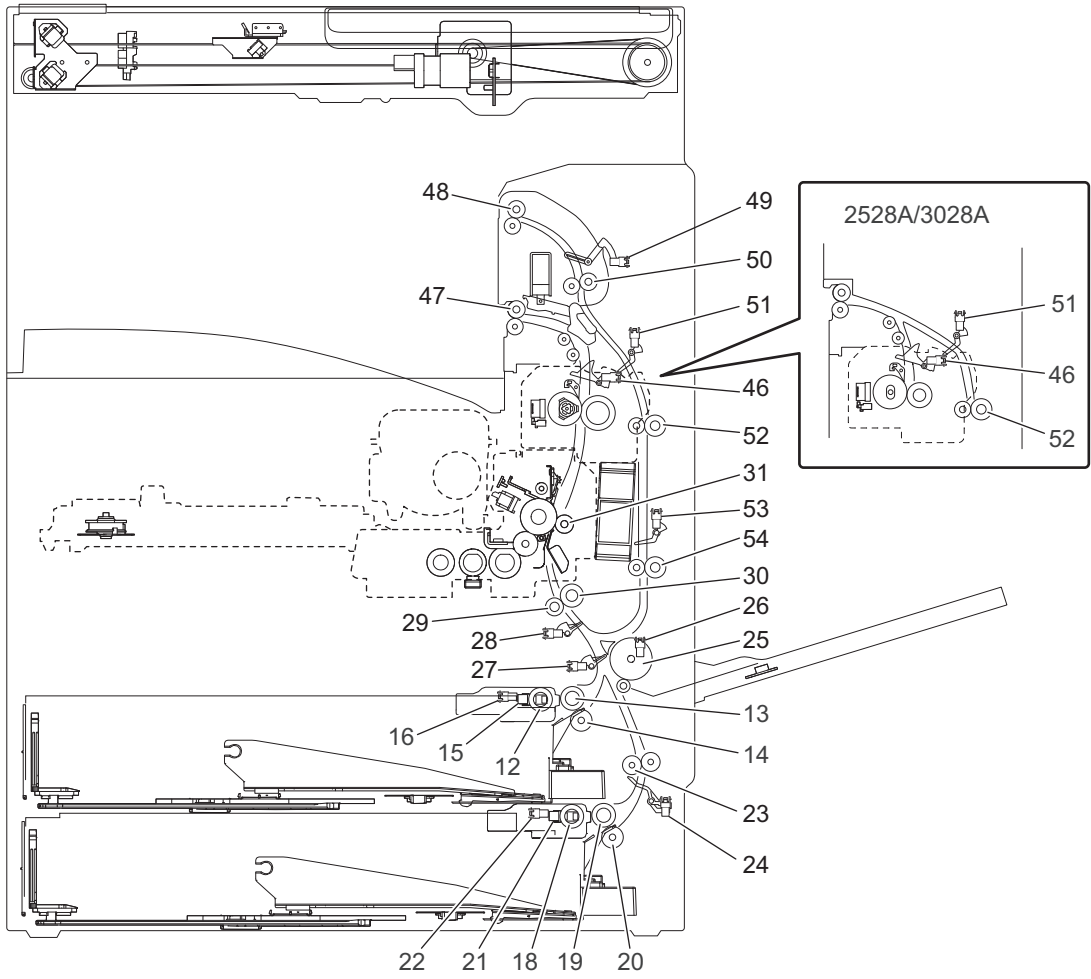

Fig. 3-2



1	Original glass	29	Registration roller (metal)
2	DF original glass	30	Registration roller (rubber)
3	Mirror-1	31	Transfer roller
4	Mirror-2	32	Developer unit
5	Mirror-3	33	Developer sleeve (Magnetic roller)
6	Reflector	34	Doctor blade
7	Carriage-1	35	Drum
8	Carriage-2	36	Main charger
9	Lens	37	Drum separation finger
10	Laser optical unit	38	Recovery blade
11	1st drawer	39	Drum cleaning blade
12	1st drawer paper feed roller	40	Toner recovery auger
13	1st drawer paper feed roller	41	Heat roller
14	1st drawer separation roller	42	Pressure roller
15	1st drawer tray-up sensor	43	Heater lamp
16	1st drawer paper empty sensor	44	Heat roller separation finger
17	2nd drawer	45	Heat roller center thermistor, Heat roller side thermistor, Heat roller edge thermistor
18	2nd drawer pickup roller	46	Paper exit sensor
19	2nd drawer paper feed roller	47	Paper exit roller (2528A/3028A), Lower paper exit roller (3528A/4528A)
20	2nd drawer separation roller	48	Upper paper exit roller
21	2nd drawer tray-up sensor	49	Reverse sensor
22	2nd drawer paper empty sensor	50	Reverse roller
23	Transport roller	51	ADU entrance sensor
24	2nd transport sensor	52	ADU upper transport roller
25	Bypass unit paper feed roller	53	ADU exit sensor
26	Bypass tray paper sensor	54	ADU lower transport roller
27	1st transport sensor	55	Toner cartridge
28	Registration sensor		

# 3.2 Electric Parts Layout

## [A] Scanner unit and control panel

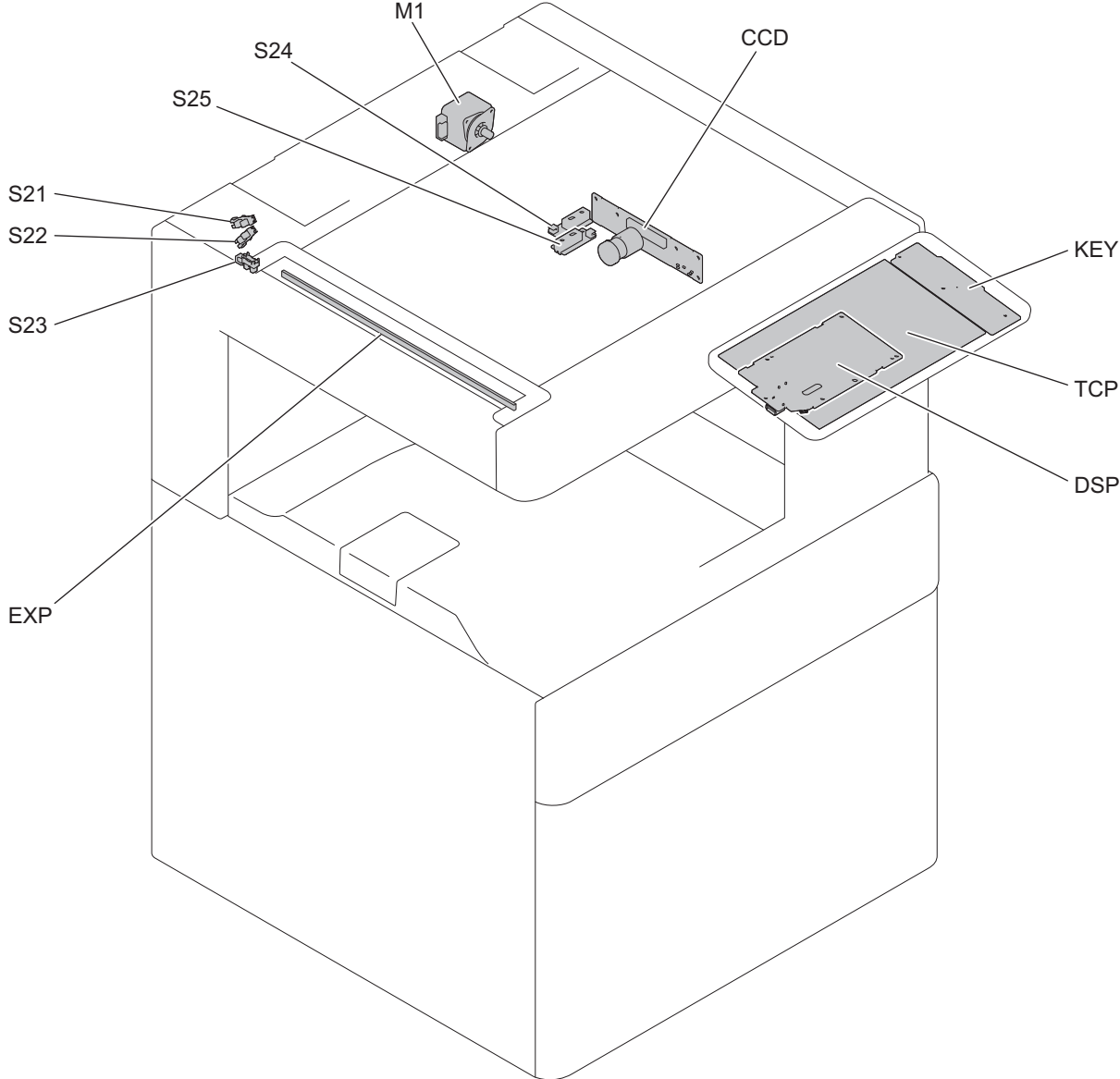

Fig. 3-3

[B] Toner cartridge section

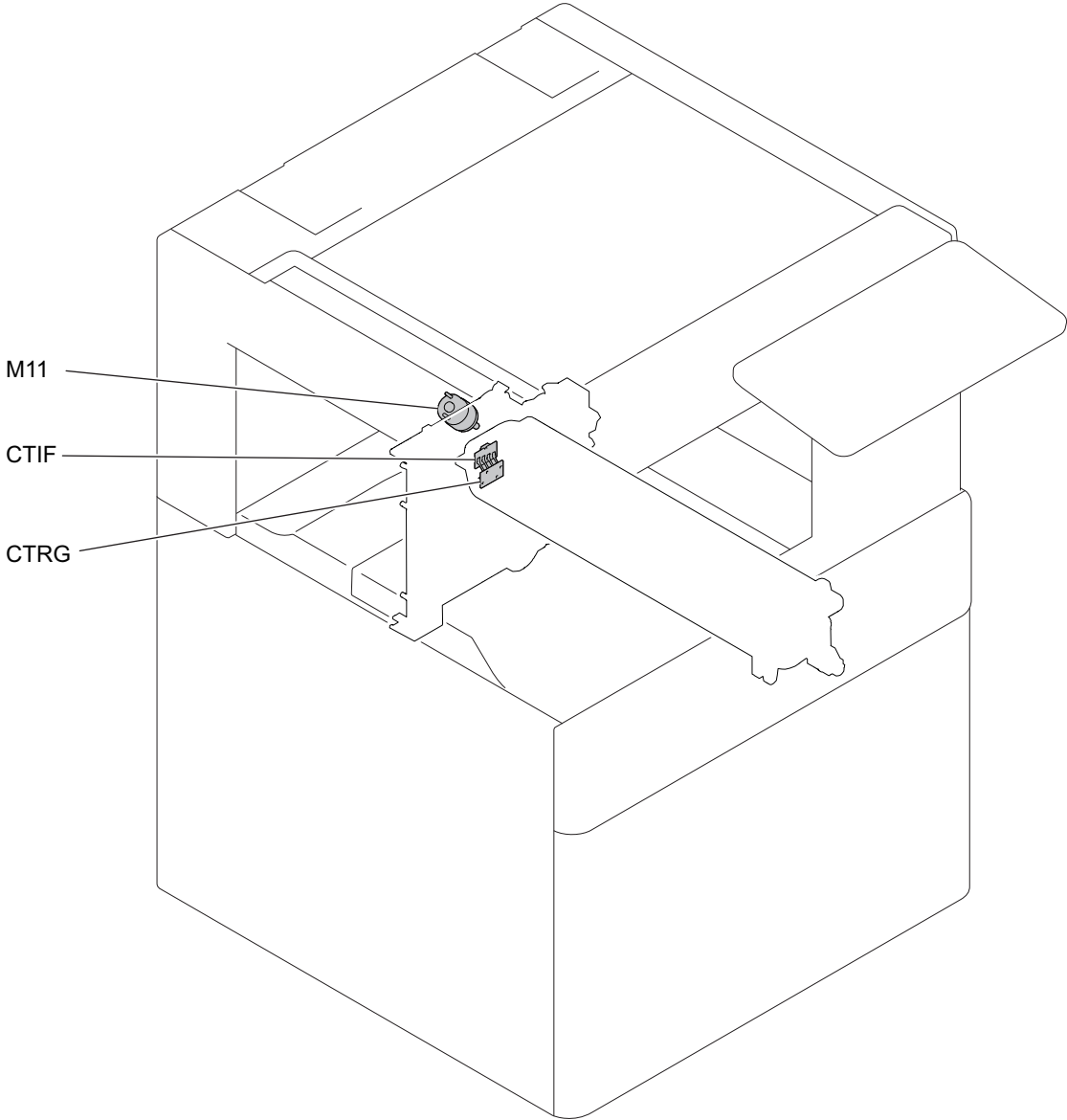

Fig. 3-4

[C] Developer unit section

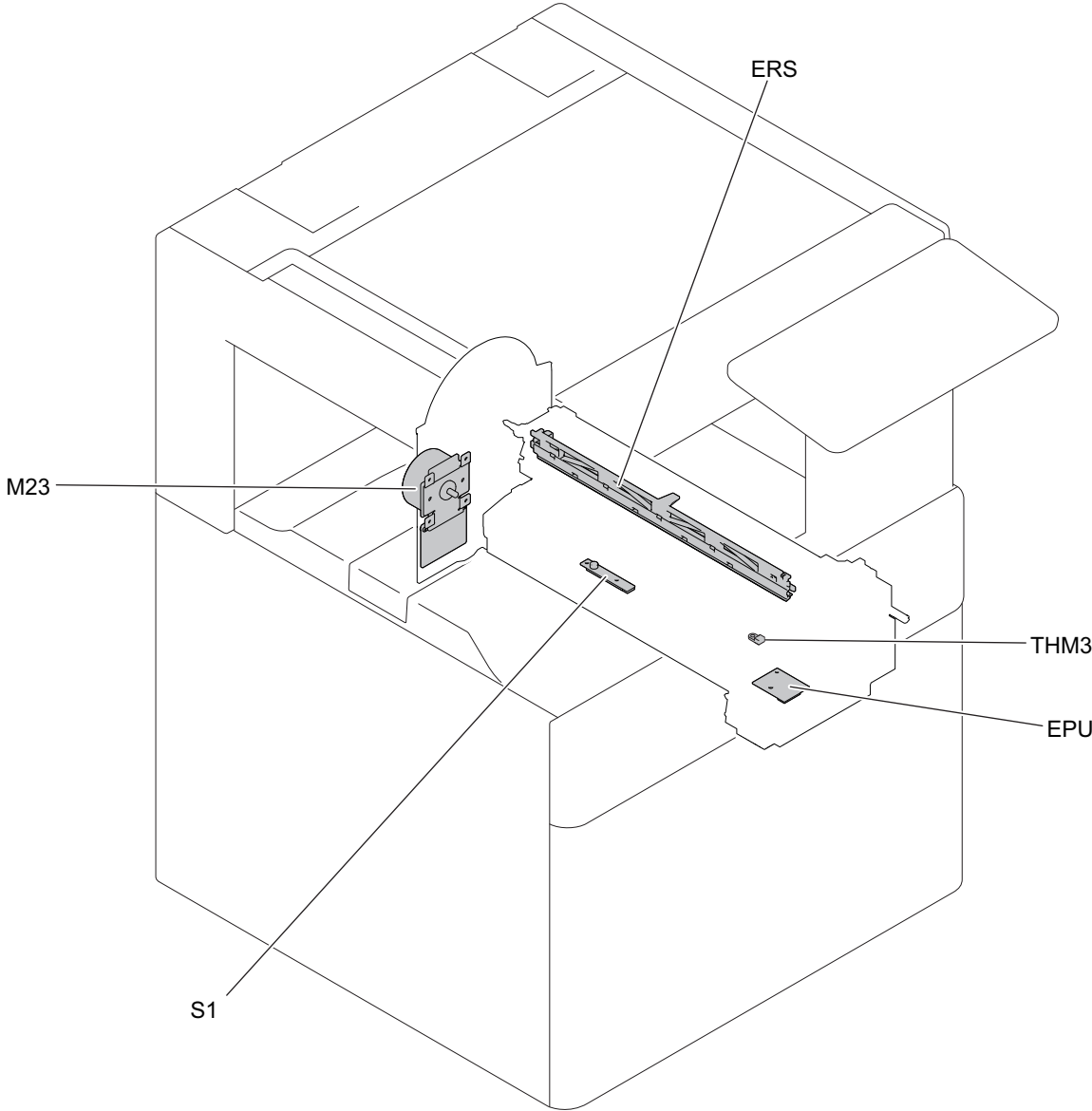

Fig. 3-5

[D] Data writing section

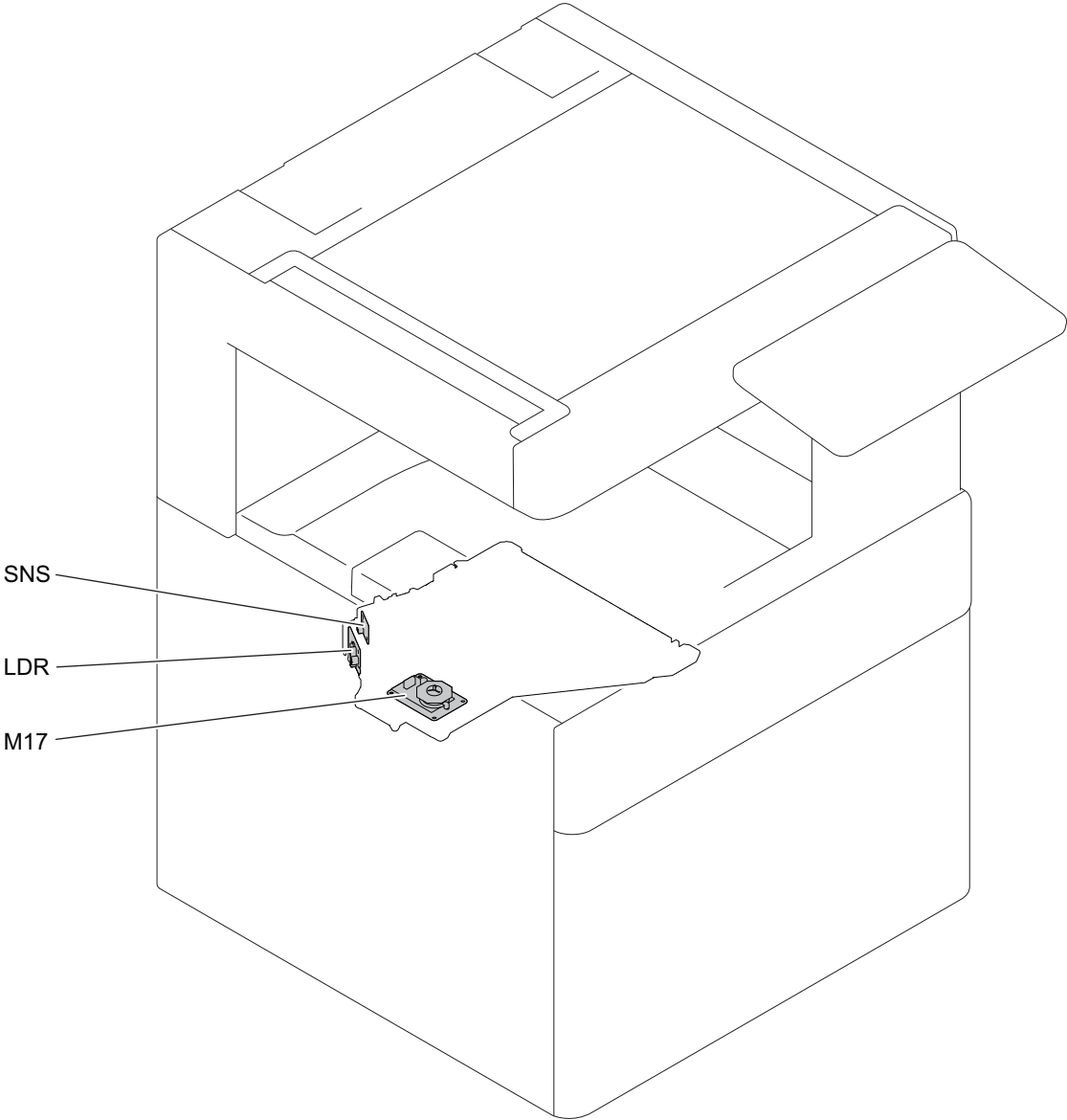
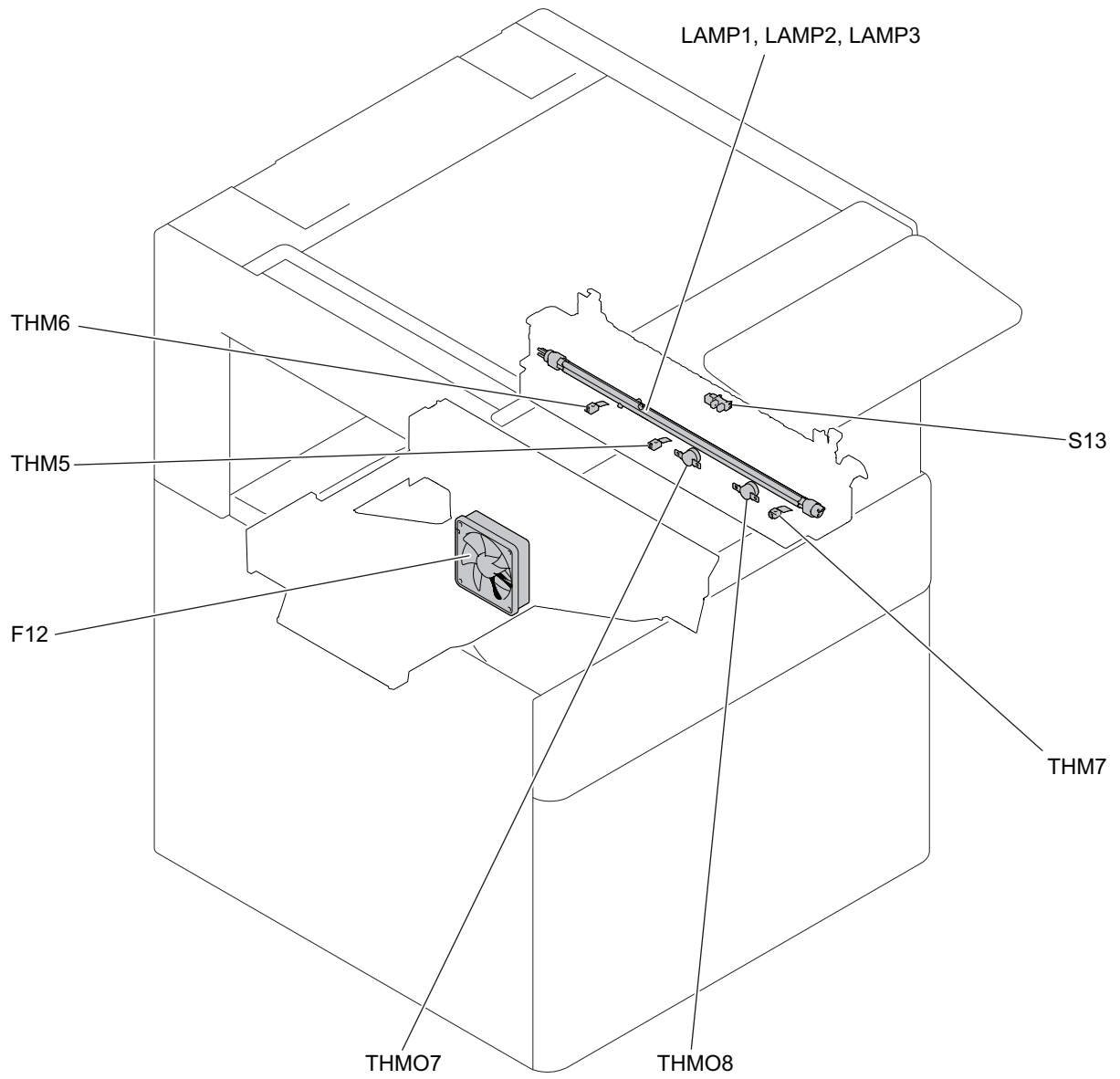

Fig. 3-6

**[E] Fuser unit**



**Fig. 3-7**

[F] Paper feeding section

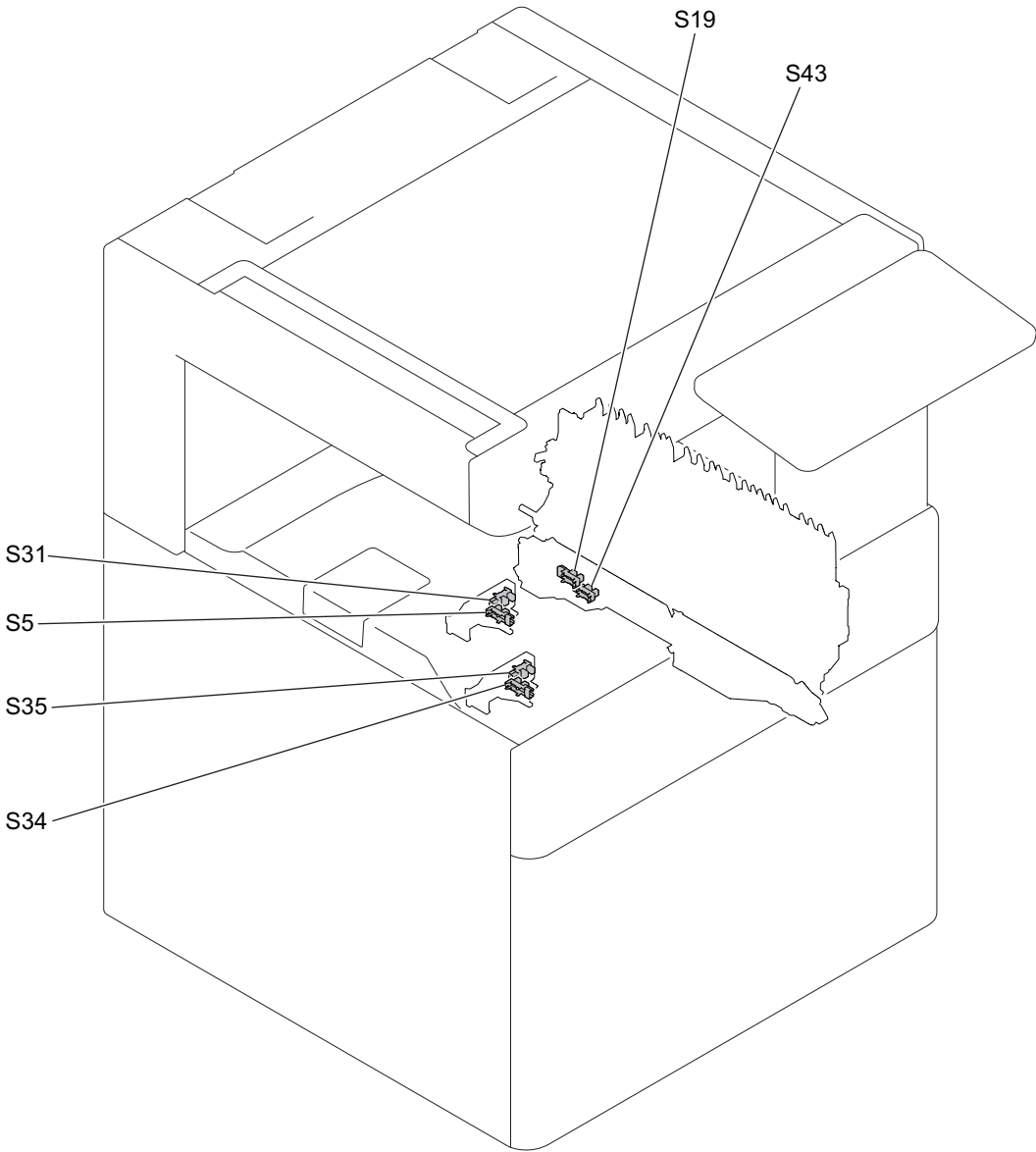

Fig. 3-8

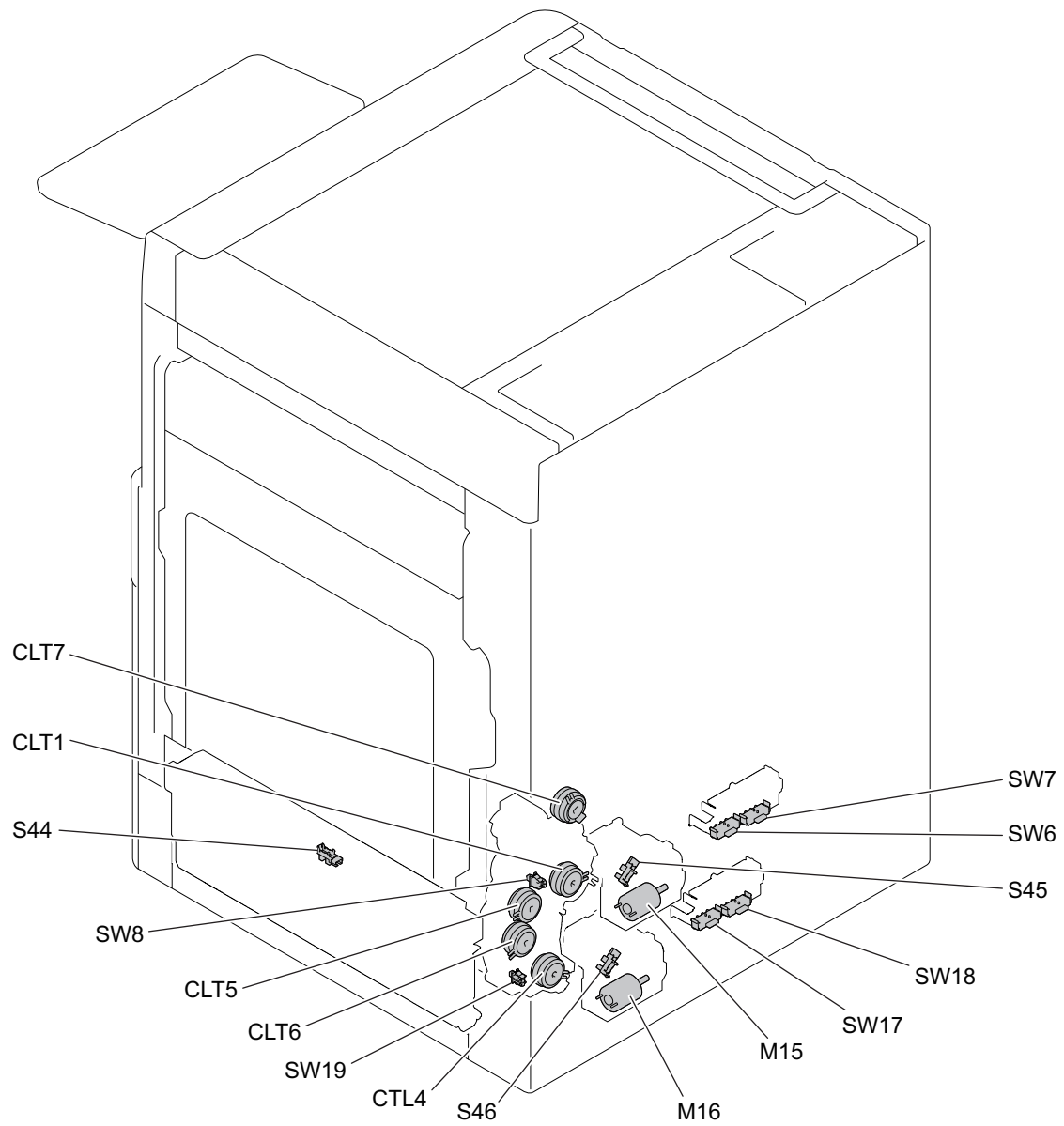

Fig. 3-9



[G] Automatic Duplexing Unit (ADU), bypass unit, paper exit/reverse unit  
2528A/3028A

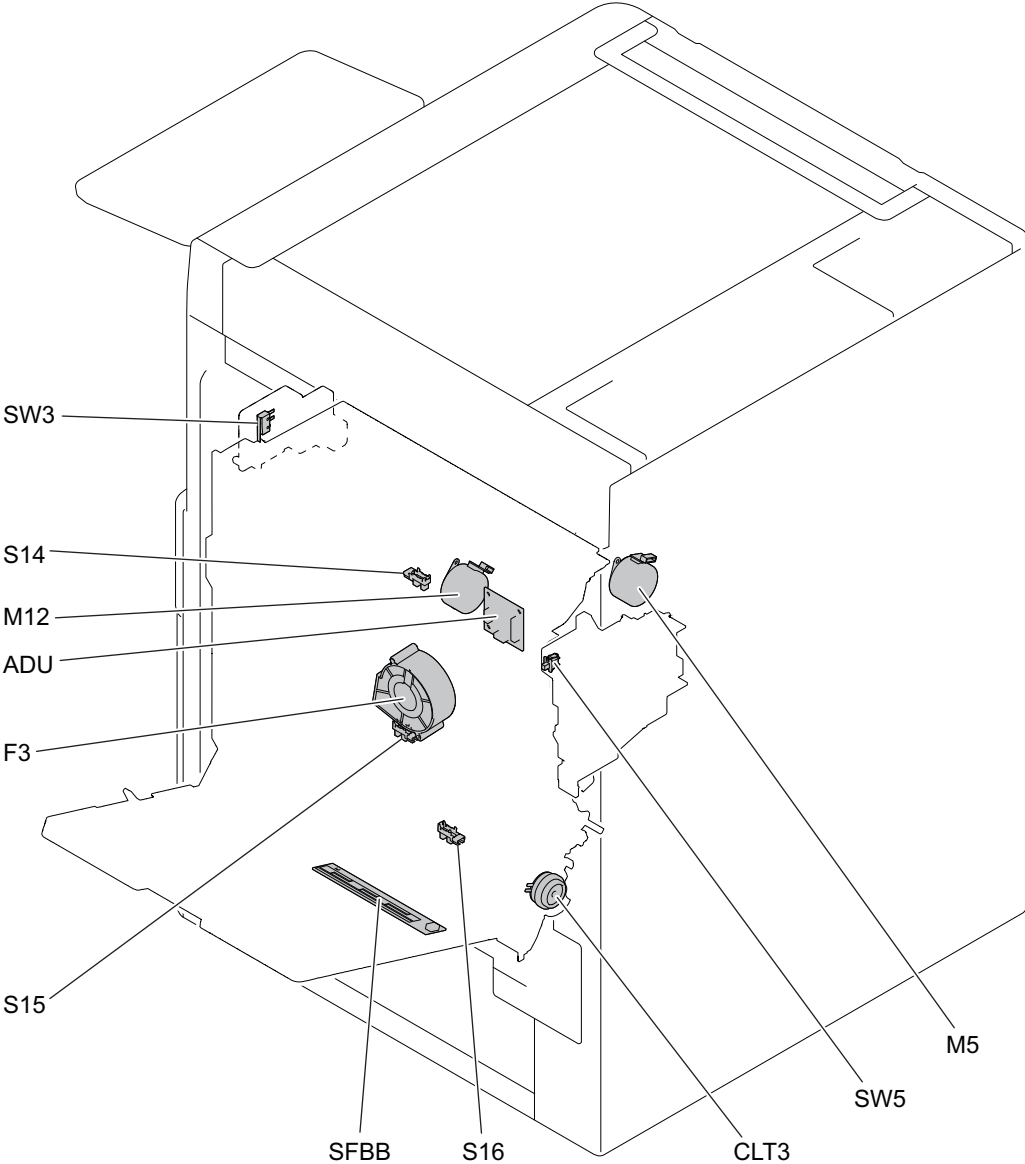

Fig. 3-10

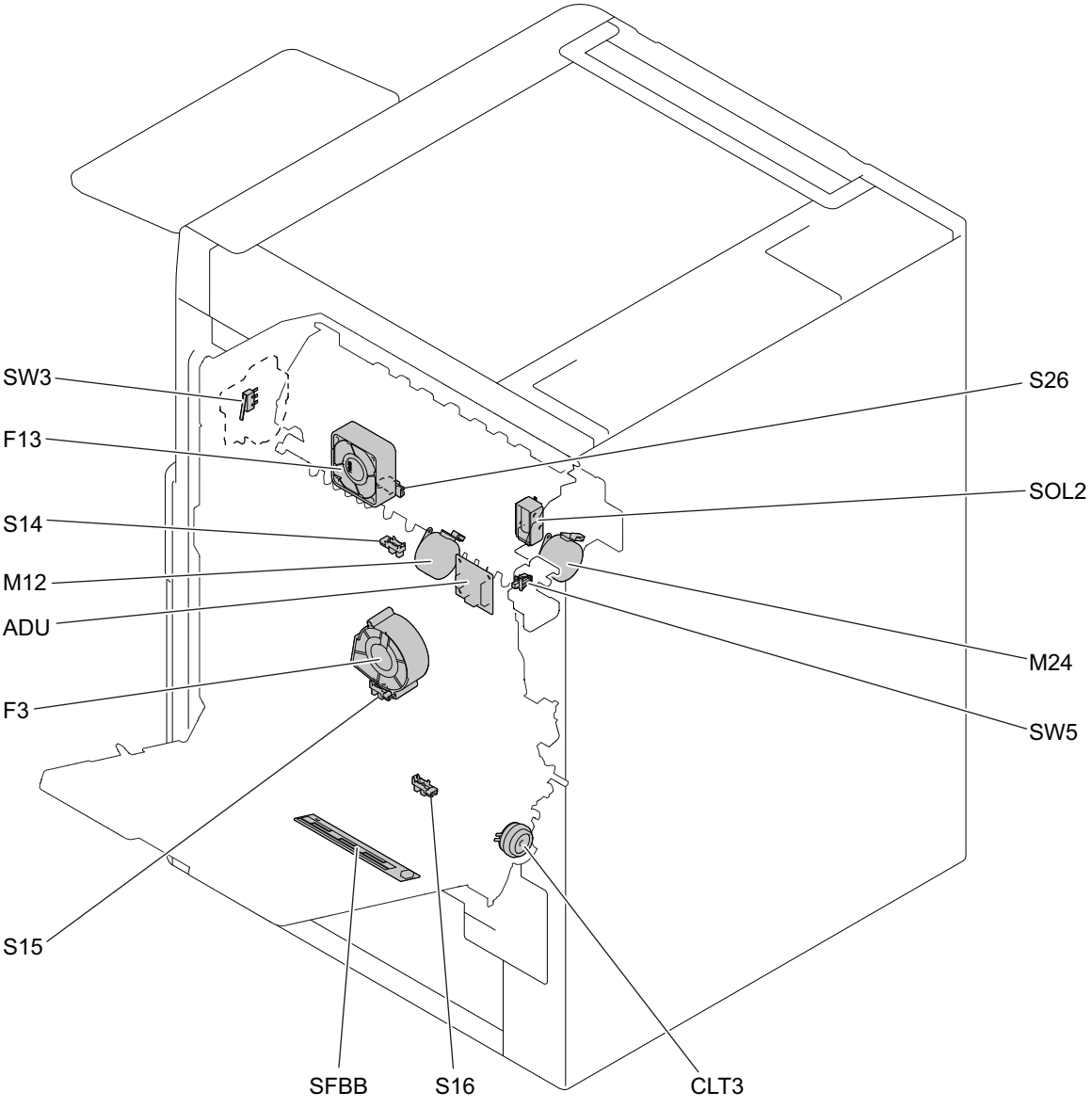

Fig. 3-11

[H] PC board, power supply, fan

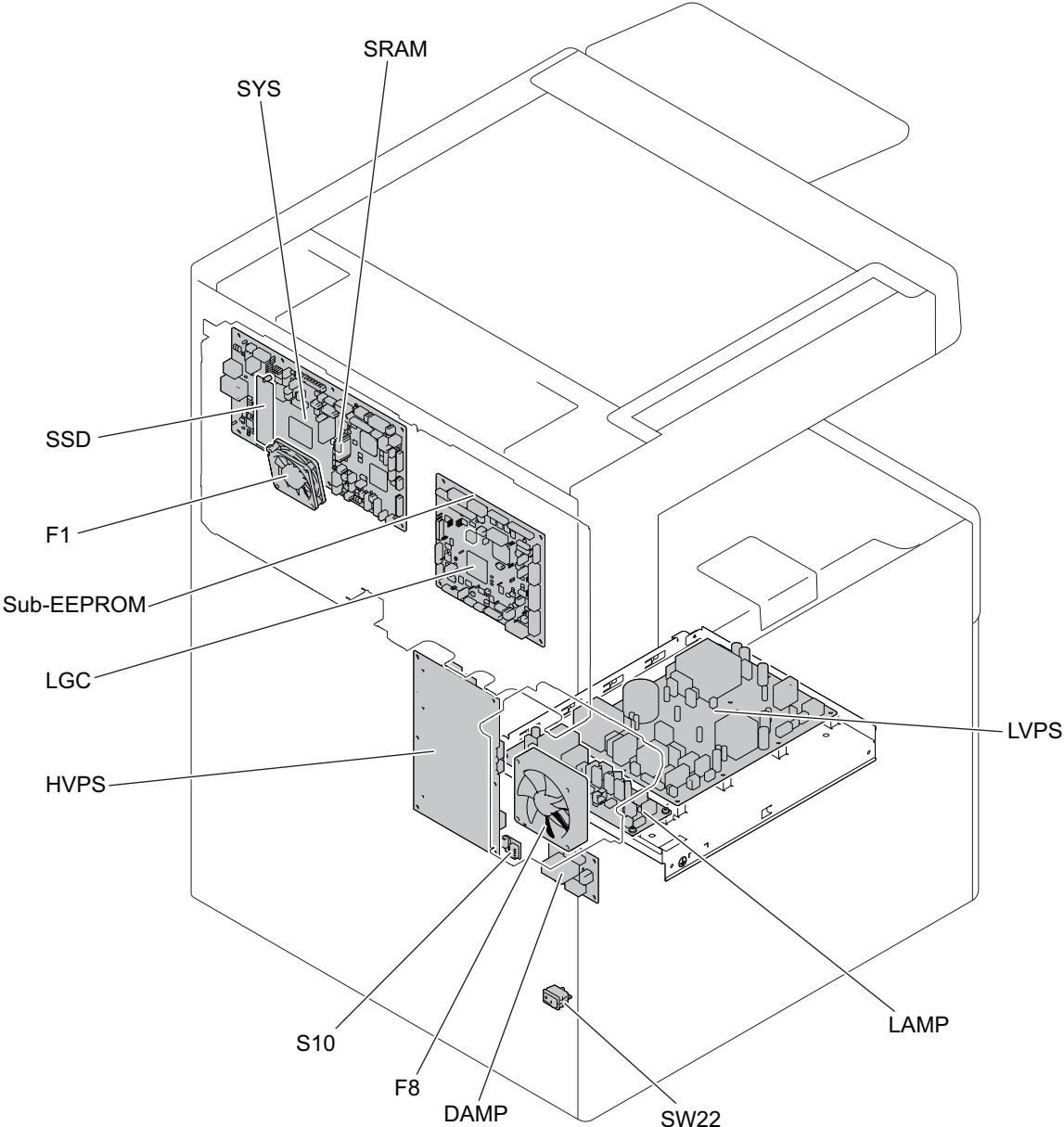

Fig. 3-12

[I] Cover switch and damp heater

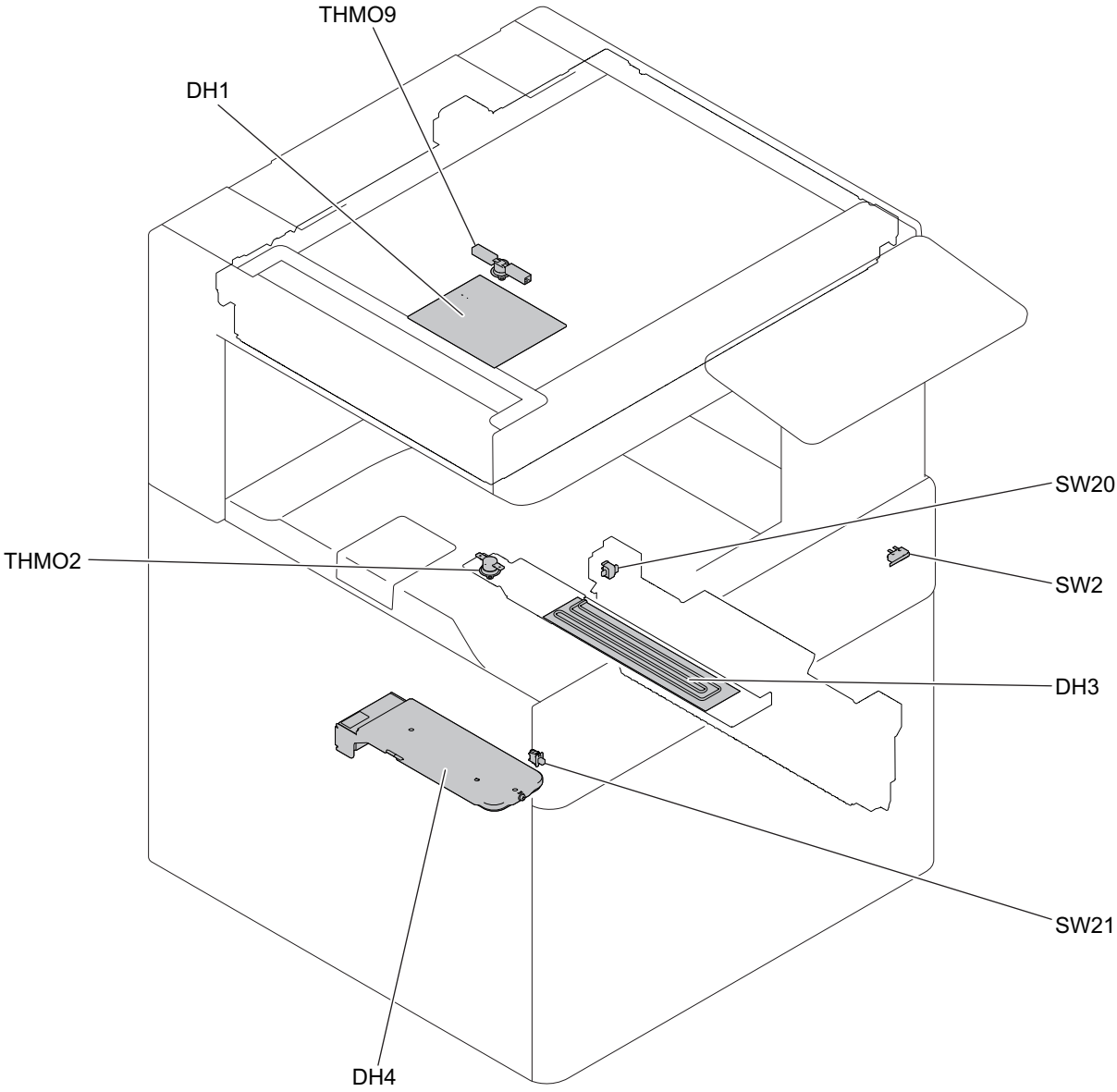

Fig. 3-13

### 3.3 Symbols and Functions of Various Components

The column "P-I" shows the page and item number in the parts list.

#### 3.3.1 Motor and fan

Symbol	Name	Function	Remarks	P-I
M1	Scan motor	Drives the carriages.	[A] Scanner unit and control panel Fig. 3-3	14-8
M5	Paper exit motor	Drives the paper exit roller. (2528A/3028A only)	[G] Automatic Duplexing Unit (ADU), bypass unit, paper exit/reverse unit Fig. 3-10	39-34
M11	Toner motor (K)	Charges the toner.	[B] Toner cartridge section Fig. 3-4	13-29
M12	ADU motor	Drives the ADU.	[G] Automatic Duplexing Unit (ADU), bypass unit, paper exit/reverse unit Fig. 3-10 Fig. 3-11	33-16
M15	1st drawer tray-up motor	Lifts up the tray in the 1st drawer.	[F] Paper feeding section Fig. 3-9	37-12
M16	2nd drawer tray-up motor	Lifts up the tray in the 2nd drawer.	[F] Paper feeding section Fig. 3-9	37-12
M17	Polygonal motor	Drives the polygonal mirror.	[D] Data writing section Fig. 3-6	10-1
M23	Main motor	Drives the drum, developer unit, fuser unit, registration roller, transport roller, paper feed roller and pickup roller. Drives the lower paper exit roller. (3528A/4528A)	[C] Developer unit section Fig. 3-5	13-21
M24	paper exit/reverse motor	Drives the reverse roller and upper paper exit roller. (3528A/4528A only)	[G] Automatic Duplexing Unit (ADU), bypass unit, paper exit/reverse unit Fig. 3-11	39-34
F1	SYS board cooling fan	Cools down the SYS board.	[H] PC board, power supply, fan Fig. 3-12	8-27
F3	Suctioning fan	Supports the separation process.	[G] Automatic Duplexing Unit (ADU), bypass unit, paper exit/reverse unit Fig. 3-10 Fig. 3-11	12-7
F8	Power supply unit cooling fan	Cools down the switching regulator.	[H] PC board, power supply, fan Fig. 3-12	4-27
F12	Process unit fan	Cools down the process unit.	[E] Fuser unit Fig. 3-7	4-14
F13	ADU fan	Cools down the paper exit section. (3528A/4528A only)	[G] Automatic Duplexing Unit (ADU), bypass unit, paper exit/reverse unit Fig. 3-11	34-25

### 3.3.2 Sensor and switch

Symbol	Name	Function	Remarks	P-I	
S1	Auto-toner sensor	Detects the toner density in the developer unit.	[C] Developer unit section	Fig. 3-5	27-20
S5	1st drawer paper empty sensor	Detects the paper loading level in the 1st drawer.	[F] Paper feeding section	Fig. 3-8	6-56
S10	Temperature/humidity sensor	Detects the temperature and humidity drawn into the MFP.	[H] PC board, power supply, fan	Fig. 3-12	4-16
S13	Paper exit sensor	Detects paper transportation at the paper exit section.	[E] Fuser unit	Fig. 3-7	32-25
S14	ADU entrance sensor	Detects the paper transportation at the entrance section of the ADU.	[G] Automatic Duplexing Unit (ADU), bypass unit, paper exit/reverse unit	Fig. 3-10 Fig. 3-11	33-19
S15	ADU exit sensor	Detects the paper transportation in the ADU.	[G] Automatic Duplexing Unit (ADU), bypass unit, paper exit/reverse unit	Fig. 3-10 Fig. 3-11	33-19
S16	Bypass tray paper sensor	Detects the paper loading level on the bypass tray.	[G] Automatic Duplexing Unit (ADU), bypass unit, paper exit/reverse unit	Fig. 3-10 Fig. 3-11	19-36
S19	Registration sensor	Detects the paper transportation at the registration roller section.	[F] Paper feeding section	Fig. 3-8	20-5
S21	Platen sensor-1	Detects the opening and closing status of the platen cover or DF.	[A] Scanner unit and control panel	Fig. 3-3	14-13
S22	Platen sensor-2	Detects the opening and closing status of the platen cover or DF.	[A] Scanner unit and control panel	Fig. 3-3	14-13
S23	Carriage home position sensor	Detects the home position of the carriage.	[A] Scanner unit and control panel	Fig. 3-3	11-5
S24	Automatic original detection sensor-1	Detects the original size.	[A] Scanner unit and control panel	Fig. 3-3	11-12
S25	Automatic original detection sensor-2	Detects the original size. (For LT)	[A] Scanner unit and control panel	Fig. 3-3	11-12B
S26	Reverse sensor	Detects transportation and misfeeding of paper at the paper exit/reverse section. (3528A/4528A only)	[G] Automatic Duplexing Unit (ADU), bypass unit, paper exit/reverse unit	Fig. 3-11	34-9
S31	1st drawer tray-up sensor	Detects the lift-up position of the tray in the 1st drawer.	[F] Paper feeding section	Fig. 3-8	6-56
S34	2nd drawer paper empty sensor	Detects the paper loading level in the 2nd drawer.	[F] Paper feeding section	Fig. 3-8	6-56
S35	2nd drawer tray-up sensor	Detects the lift-up position of the tray in the 2nd drawer.	[F] Paper feeding section	Fig. 3-8	6-56

Symbol	Name	Function	Remarks	P-I	
S43	1st transport sensor	Detects transportation and misfeeding of paper fed from the bypass tray, drawer and ADU.	[F] Paper feeding section	Fig. 3-8	20-5
S44	2nd transport sensor	Detects transportation and misfeeding of paper fed from the 2nd drawer, PFP and LCF.	[F] Paper feeding section	Fig. 3-9	20-5
S45	1st drawer paper nearly empty sensor	Detects the paper remaining level in the 1st drawer.	[F] Paper feeding section	Fig. 3-9	37-7
S46	2nd drawer paper nearly empty sensor	Detects the paper remaining level in the 2nd drawer.	[F] Paper feeding section	Fig. 3-9	37-7
SW2	Front cover interlock switch	Supplies and shuts off the AC power to the switching regulator (voltage-generating circuit interlocked with these covers) according to the opening and closing of the front cover. (Cover open: Shut off)	[I] Cover switch and damp heater	Fig. 3-13	5-41
SW3	ADU interlock switch	Supplies and shuts off the AC power to the switching regulator (voltage-generating circuit interlocked with these covers) according to the opening and closing of the ADU. (Cover open: Shut off)	[G] Automatic Duplexing Unit (ADU), bypass unit, paper exit/reverse unit	Fig. 3-10 Fig. 3-11	5-41
SW5	ADU opening/closing switch	Detects the opening and closing status of the ADU.	[G] Automatic Duplexing Unit (ADU), bypass unit, paper exit/reverse unit 2528A/3028A	Fig. 3-10	15-19
			[G] Automatic Duplexing Unit (ADU), bypass unit, paper exit/reverse unit 3528A/4528A	Fig. 3-11	7-6
SW6	1st drawer paper width detection switch	Detects the paper width in the 1st drawer.	[F] Paper feeding section	Fig. 3-9	37-16
SW7	1st drawer paper length detection switch	Detects the paper length in the 1st drawer.	[F] Paper feeding section	Fig. 3-9	37-16
SW8	1st drawer detection switch	Detects the 1st drawer.	[F] Paper feeding section	Fig. 3-9	6-54
SW17	2nd drawer paper width detection switch	Detects the paper width in the 2nd drawer.	[F] Paper feeding section	Fig. 3-9	37-16
SW18	2nd drawer paper length detection switch	Detects the paper length in the 2nd drawer.	[F] Paper feeding section	Fig. 3-9	37-16
SW19	2nd drawer detection switch	Detects the 2nd drawer.	[F] Paper feeding section	Fig. 3-9	6-54
SW20	Jam access cover opening/closing switch	Detects the opening and closing status of the jam access cover.	[I] Cover switch and damp heater	Fig. 3-13	20-27
SW21	Front cover switch	Detects the opening and closing status of the front cover.	[I] Cover switch and damp heater	Fig. 3-13	5-42

Symbol	Name	Function	Remarks	P-I	
SW22	Damp heater switch	Turns ON and OFF of the damp heater (JPD only)	[H] PC board, power supply, fan	Fig. 3-12	9-2

### 3.3.3 Electromagnetic clutch

Symbol	Name	Function	Remarks	P-I	
CLT1	1st drawer paper feed clutch	Drives the 1st drawer pickup roller.	[F] Paper feeding section	Fig. 3-9	38-10
CLT3	Bypass tray paper feed clutch	Driving the bypass unit paper feed roller	[G] Automatic Duplexing Unit (ADU), bypass unit, paper exit/reverse unit	Fig. 3-10 Fig. 3-11	19-13
CLT4	2nd drawer paper feed clutch	Drives the 2nd drawer pickup roller.	[F] Paper feeding section	Fig. 3-9	38-10
CLT5	Transport clutch (H)	Drives the transport roller (high speed).	[F] Paper feeding section	Fig. 3-9	38-10
CLT6	Transport clutch (L)	Drives the transport roller (low speed).	[F] Paper feeding section	Fig. 3-9	38-30
CLT7	Registration clutch	Drives the registration roller.	[F] Paper feeding section	Fig. 3-9	38-31

### 3.3.4 Solenoid

Symbol	Name	Function	Remarks	P-I	
SOL2	Reverse gate solenoid	Switches the transport path in the paper exit section. (3528A/4528A only)	[G] Automatic Duplexing Unit (ADU), bypass unit, paper exit/reverse unit	Fig. 3-11	39-30

### 3.3.5 PC Board

Symbol	Name	Function	Remarks	P-I	
CCD	CCD driving PC board (CCD board)	Controls the scanning of an original with a CCD.	[A] Scanner unit and control panel	Fig. 3-3	11-9
CTIF	Toner cartridge interface PC board (CTIF board)	Interface for detecting the toner cartridge (Detects the CTRG board.)	[B] Toner cartridge section	Fig. 3-4	6-60
CTRG	Toner cartridge PC board (CTRG board)	Maintains the information of the toner cartridge.	[B] Toner cartridge section	Fig. 3-4	-
DSP	Display PC board (DSP board)	Controls the whole control panel.	[A] Scanner unit and control panel	Fig. 3-3	3-16
EPU	EPU memory PC board (EPU board)	Judges whether the developer unit (EPU) is a new or used one. (For the service operation)	[C] Developer unit section	Fig. 3-5	27-40B
KEY	Key PC board (KEY board)	Controls the key switches and LEDs.	[A] Scanner unit and control panel	Fig. 3-3	3-12



Symbol	Name	Function	Remarks		P-I
LDR	Laser driving PC board (LDR board)	Drives the laser diode.	[D] Data writing section	Fig. 3-6	10-1
LGC	Logic PC board (LGC board)	Controls the print engine section.	[H] PC board, power supply, fan	Fig. 3-12	8-7
SFBB	Paper width detection PC board (SFB board)	Detects the paper width on the bypass tray.	[G] Automatic Duplexing Unit (ADU), bypass unit, paper exit/reverse unit	Fig. 3-10 Fig. 3-11	18-6
SNS	H-sync signal detection PC board (SNS board)	Detects the laser radiating position.	[D] Data writing section	Fig. 3-6	10-1
SYS	System PC board (SYS board)	Controls the whole system and image processing.	[H] PC board, power supply, fan	Fig. 3-12	8-29
ADU	ADU PC board (ADU board)	Drives the ADU motor.	[G] Automatic Duplexing Unit (ADU), bypass unit, paper exit/reverse unit	Fig. 3-10 Fig. 3-11	33-1

### 3.3.6 Lamp and heater

Symbol	Name	Function	Remarks		P-I
DH1	Drum damp heater	Prevents condensation of the drum. (JPD, ASD, TWD)	[I] Cover switch and damp heater	Fig. 3-13	5-20
DH3	Scanner damp heater	Prevents condensation of the carriage mirror. (JPD, ASD, TWD)	[I] Cover switch and damp heater	Fig. 3-13	11-17
DH4	Drawer damp heater	Prevents condensation inside the drawer. (JPD only)	[I] Cover switch and damp heater	Fig. 3-13	7-15
ERS	Discharge LED	Eliminates residual charge on the drum surface.	[C] Developer unit section	Fig. 3-5	26-32
EXP	Exposure lamp	Exposes an original. (LED lamp)	[A] Scanner unit and control panel	Fig. 3-3	22-3
LAMP1	Center heater lamp	Heats the center of the heat roller.	[E] Fuser unit	Fig. 3-7	30-8
LAMP2	Side heater lamp	Heats both edges of the heat roller.	[E] Fuser unit	Fig. 3-7	30-8
LAMP3	Sub heater lamp	Auxiliary heat of the heat roller. (3528A/4528A only)	[E] Fuser unit	Fig. 3-7	30-8

### 3.3.7 Thermistor and thermostat

Symbol	Name	Function	Remarks		P-I
THMO2	Drum damp heater thermostat	Prevents overheating of the drum damp heater. (Except for NAD, MJD)	[I] Cover switch and damp heater	Fig. 3-13	5-21
THMO7	Fuser center thermostat	Prevents overheating of the inside of the fuser unit.	[E] Fuser unit	Fig. 3-7	30-6

Symbol	Name	Function	Remarks	P-I	
THMO8	Fuser side thermostat	Prevents overheating of inside of the fuser unit.	[E] Fuser unit	Fig. 3-7	30-6
THMO9	Scanner damp heater thermostat	Controls the temperature of the scanner damp heater. (Except for NAD, MJD)	[I] Cover switch and damp heater	Fig. 3-13	11-17
THM3	Drum thermistor	Detects the surface temperature of the drum.	[C] Developer unit section	Fig. 3-5	27-22
THM5	Heat roller center thermistor	Detects the surface temperature of the center of the heat roller. (For controlling the temperature of the center heater lamp)	[E] Fuser unit	Fig. 3-7	31-4
THM6	Heat roller side thermistor	Detects the surface temperature of the rear of the heat roller. (For controlling the temperature of the side heater lamp)	[E] Fuser unit	Fig. 3-7	31-4
THM7	Heat roller edge thermistor	Detects the surface temperature of the rear edge of the heat roller. (For preventing overheating)	[E] Fuser unit	Fig. 3-7	31-4

### 3.3.8 Transformer

Symbol	Name	Function	Remarks	P-I	
HVPS	High-voltage transformer	Generates the high voltage and supplies it to the following sections. <ul style="list-style-type: none"> <li>• Main charger needle electrode</li> <li>• Main charger grid</li> <li>• Developer bias</li> <li>• Transfer bias</li> </ul>	[H] PC board, power supply, fan	Fig. 3-12	9-6

### 3.3.9 Others

Symbol	Name	Function	Remarks	P-I	
TCP	Touch panel	Displays and enters various kinds of information.	[A] Scanner unit and control panel	Fig. 3-3	3-1
SSD	SSD	Saves program data and image data.	[H] PC board, power supply, fan	Fig. 3-12	8-15
LVPS	Switching regulator	Generates the DC voltage and supplies it to each section of the MFP.	[H] PC board, power supply, fan	Fig. 3-12	9-5
LAMP	LAMP PC board	Controls the heater lamp	[H] PC board, power supply, fan	Fig. 3-12	9-16
DAMP	DAMP PC board	Supplies the power to each damp heater. (Except for NAD, MJD)	[H] PC board, power supply, fan	Fig. 3-12	9-11
SRAM	SRAM	Stores the programs, etc. used for the control by the SRAM on the SYS board.	[H] PC board, power supply, fan	Fig. 3-12	8-26
Sub-EEPROM	Electrically Erasable Programmable Read Only Memory	Stores the setting and adjustment values, etc. used for the control by the LGC board.	[H] PC board, power supply, fan	Fig. 3-12	8-23

## 3.4 Copy Process

### 3.4.1 Overview of the copy process

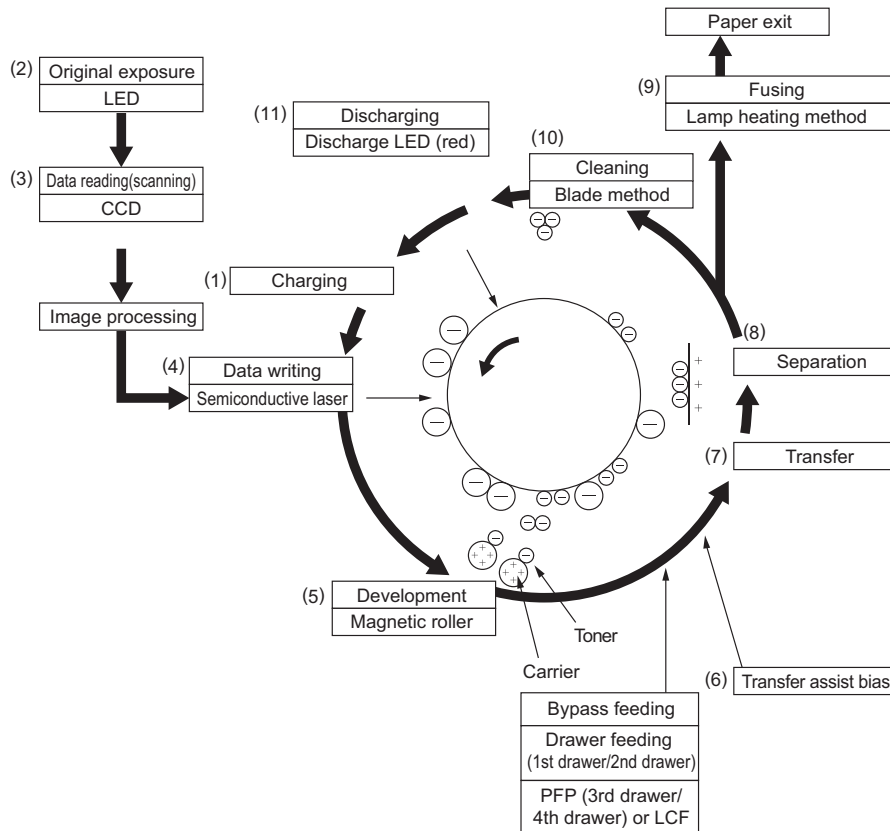

Fig. 3-14

- (1) Charging: Places a negative charge on the surface of the photoconductive drum.
- (2) Original exposure: Converts images on the original into optical signals.
- (3) Data reading: Converts optical signals into electrical ones.
- (4) Data writing: Converts the electrical signals into optical signals (by laser emission) and exposes the surface of the photoconductive drum.
- (5) Development: Allows the negatively-charged toner on the photoconductive drum to adhere and form a visible image.
- (6) Transfer assist bias: Improves transfer efficiency.
- (7) Transfer: Transfers the visible image on the photoconductive drum onto paper.
- (8) Separation: Separates paper with the toner image from the photoconductive drum.
- (9) Fusing: Fuses the toner image to the paper by applying heat and pressure.
- (10) Cleaning: Forcibly scrapes off the residual toner remaining on the photoconductive drum by means of the blade.
- (11) Discharging: Eliminates the residual negative charge from the surface of the photoconductive drum.

### 3.5 Comparison with e-STUDIO2518A/3518A/4518A/5018A

Process	e-STUDIO2518A/3518A/4518A/5018A		e-STUDIO2528A/3028A/3528A/4528A	
	e-STUDIO2518A	e-STUDIO3518A/ 4518A/5018A	e-STUDIO2528A/ 3028A	e-STUDIO3528A/ 4528A
1. Photoconductive drum	PS-OD-4530, OD-4530C (OPC ø30)	←	PS-OD3028, OD-3028 (OPC ø30)	←
• Sensitivity	Highly-sensitized/ durable drum	←	←	←
• Surface potential	Highly-sensitized/ durable drum -391 V (Adjustable)	←	←	←
2. Charging	Scorotron type (needle electrode)	←	←	←
• Grid voltage	-391 V (Adjustable output)	-429 V (Adjustable output)	←	←
3. Data writing				
• Light source	Semiconductor laser	←	←	←
• Light amount	-3.50 nJ/mm <sup>2</sup> (Adjustable output)	-3.75 nJ/mm <sup>2</sup> (Adjustable output)	-3.50 nJ/mm <sup>2</sup> (Adjustable output)	-3.75 nJ/mm <sup>2</sup> (Adjustable output)
4. Development				
• Magnetic roller	One magnetic roller	←	←	←
• Auto-toner	Magnetic permeability circuit method	←	←	←
• Toner supply	Cartridge replacement method	←	←	←
• Toner empty detection	Density detection method	←	←	←
• Toner	PS-ZT5018JS(1) PS-ZT5018U(1) PS-ZT5018C(1) PS-ZT5018C(8) PS-ZT5018T(1) PS-ZT5018E(1) PS-ZT5018P(1) PS-ZT5018CM(1) PS-ZT5018CM(8)	PS-ZT5018J(1) PS-ZT5018U(1) PS-ZT5018C(1) PS-ZT5018C(8) PS-ZT5018T(1) PS-ZT5018E(1) PS-ZT5018P(1) PS-ZT5018CM(1) PS-ZT5018CM(8)	PS-ZT3028J(1) PS-ZT3028U(1) PS-ZT3028E(1) PS-ZT3028P(1) PS-ZT3028C(1) PS-ZT3028C(8) PS-ZT3028CM(1) PS-ZT3028CM(8)	←
• Developer material	PS-ZD5070 D4530C	←	PS-ZD3028 D-3028	←
• Developer bias	DC -268 V (Adjustable output) AC 1100 V No reverse bias output	← ← ←	← ← ←	← ← ←
5. Transfer				
• Transfer method	Transfer roller method	←	←	←
• Transfer output	Adjustable output (constant current)	←	←	←
• Transfer assist bias	+475 V	←	←	←

Process	e-STUDIO2518A/3518A/4518A/5018A		e-STUDIO2528A/3028A/3528A/4528A	
	e-STUDIO2518A	e-STUDIO3518A/ 4518A/5018A	e-STUDIO2528A/ 3028A	e-STUDIO3528A/ 4528A
6. Separation				
• Separation method	Needle separation method	←	←	←
• Separation output	Adjustable output (constant current)	←	←	←
7. Discharging				
• Discharge LED	Exposure after cleaning	←	Exposure after cleaning	←
• Discharge LED	10 red LEDs	14 red LEDs	10 red LEDs	14 red LEDs
8. Cleaning Method				
•	Cleaning blade	←	←	←
• Recovered toner	Reuse (There is the recovered toner supply mechanism.)	←	←	←
9. Fusing				
• Method	Long-life heat roller method	←	←	←
	• Heat roller Thin roller coated with fluoroplastic (ø30)	←	←	←
	• Pressure roller PFA tube roller (ø22)	• Pressure roller PFA tube roller (ø30)	• Pressure roller PFA tube roller (ø22)	• Pressure roller PFA tube roller (ø30)
• Cleaning	None	←	←	←
• Heater	Heater lamp (6000 W x 2)	Heater lamp (6000 W x 2, 3000 W x 1)	Heater lamp (6000 W x 2)	Heater lamp (6000 W x 2, 3000 W x 1)
	ON/OFF control by the thermistor	←	←	←

## 3.6 General operation

### 3.6.1 Operation description

By using the copying function for the explanation purposes, the performance carried out from warming up to the ready status and the one by means of the operation are described.

#### [ 1 ] Warming-up

##### 1. Initialization

- The power is turned ON.
- The heater lamp is turned ON.
- “Wait Warming UP” is displayed.
- The fan motor is turned ON.
- Initialization of the scanning system starts.
- The carriage moves to its home position and stops.
- The carriage moves to the peak detection position.
- The exposure lamp (EXP) is turned ON.
- Peak detection (white color is detected by the shading correction plate)
- The exposure lamp (EXP) is turned OFF.
- “READY (WARMING UP)” is displayed.

##### 2. Pre-running operation

Pre-running operation is started when the temperature of the heat roller surface reaches a certain level.

- The main motor (M23) is turned ON.
- Heat roller rotation
- Drum rotation
- Initialization of the paper feeding system starts.
- Each drawer tray goes up.
- Pre-running operation stops after three seconds.

##### 3. When the temperature of the heat roller surface becomes sufficient for fusing,

- “READY” is displayed.

\*1 Color registration control and image quality control should be performed only at a change of environment or periodical performance timing.

#### [ 2 ] Ready (ready for copying)

- Buttons on the control panel are enabled.
- When no button is pressed for a certain period of time,  
Set number “1” and reproduction ratio “100%” are displayed. The MFP returns to the normal ready status.

### [ 3 ] Drawer feed copying by the [START] button (1st drawer paper feeding)

1. Press the [START] button.
  - “READY” changes to “COPYING”.
  - The exposure lamp (EXP) is turned ON.
  - The scan motor (M1) is turned ON. → The carriage-1 and -2 move forward.
  - The main motor (M23) and paper exit motor are turned ON.
  - The drum, fuser unit, developer unit and paper exit roller and lower paper exit roller are driven.
2. Paper feeding from the drawer
  - The main charger, developer bias and discharge LED are turned ON. Each fan is rotates at high speed. The 1st drawer paper feed clutch (CLT1) is turned ON.
  - The pickup roller and paper feed roller start to rotate.
  - The 1st transport sensor (S43) is turned ON.
  - Paper reaches the registration roller.
  - The registration sensor (S19) is turned ON and aligning is performed.
  - After a certain period of time, the paper feed clutch is turned OFF.
3. A certain period of time passed after the carriage operation
  - The registration clutch (CLT7) is turned ON. → Paper is transported to the transfer area.
  - The copy counter operates.
4. After a certain period of time, the transfer charger is turned ON.
5. Completion of scanning
  - The scan motor (M1) is turned OFF.
  - The exposure lamp (EXP) is turned OFF.
  - The registration clutch (CLT7) is turned OFF after the trailing edge of the paper has passed the registration roller.
  - “READY (PRINTING)” is displayed.
  - “WAIT” is displayed.
6. Paper exiting operation
  - The paper exit sensor (S13) detects the passing of the trailing edge of the paper.
  - The main charger, developer bias and discharge LED are turned OFF.
  - The polygonal motor (M17), main motor (M23) and paper exit motor are turned ON.
  - The drum, fuser unit and developer unit are stopped. Each fan returns to rotate at the normal rotation speed.
  - “READY” is displayed and the MFP enters into the ready mode.

#### **[ 4 ] Bypass feed copying**

1. Place A4 or LT paper on the bypass tray.
  - The bypass tray paper sensor (S16) is turned ON.
  - “Ready for bypass feeding” is displayed.
2. Press the [START] button.
  - “Ready for bypass feeding” changes to “COPYING”.
  - The exposure lamp (EXP) is turned ON.
  - The scan motor (M1) is turned ON. → The carriage-1 and -2 move forward.
  - The main motor (M23) and paper exit motor are turned ON.
  - The drum, fuser unit, developer unit and paper exit roller and lower paper exit roller are driven.
3. Paper feeding from the bypass tray
  - The main charger, developer bias and discharge LED are turned ON. Each fan is rotates at high speed.
  - The bypass tray paper feed clutch (CLT3) is turned ON.
  - The bypass unit paper feed roller starts rotating.
  - Aligning is performed.
  - Paper reaches the registration roller.
  - After a certain period of time, the bypass tray paper feed clutch (CLT3) is turned OFF.
4. Hereafter, operations (3) through (6) of “[3] Drawer feed copying by the [START] button (1st drawer paper feeding)” are repeated.

#### **[ 5 ] Interrupt copying**

1. Press [Interrupt].
  - The copying operation in progress is temporarily stopped and the carriage-1 and -2 return to the appropriate positions.
  - “Job interrupted job 1 saved” is displayed.
  - Automatic density and reproduction ratio 100% are set. The set number remains the same.
2. Select the desired copy condition
3. After interruption copying is finished:
  - The MFP returns to the status before the interruption by pressing [Interrupt].
4. Press the [START] button.
  - The copying operation before the interruption is resumed.



## 3.6.2 Detection of abnormality

When something abnormal has occurred in the MFP, symbols corresponding to the type of abnormality are displayed.

### [ 1 ] Types of abnormality

1. Abnormality which can be cleared even if the power is not turned off by the cover switch
  - (A) Add paper
  - (B) Abnormal paper feeding from the bypass tray
2. Abnormality which can be cleared if the power is turned off by the cover switch
  - (C) Misfeeding in the MFP
  - (D) Toner supply
  - (E) EPU not installed properly
3. Abnormality which can be cleared by performing the corresponding troubleshooting and rebooting the MFP
  - (G) Call for service

### [ 2 ] Description of abnormality

#### [ 2-1 ] Add paper

Instructions how to place more paper are displayed when there is no paper in the appropriate drawer or it is not installed in the MFP.

In this situation, the [START] button is disabled.

#### [ 2-2 ] Abnormality in drawers

When the power is turned ON or the drawer is inserted, the tray-up motor is turned ON, resulting in the lifting up of the tray in the drawer.

When the tray-up sensor is turned ON within a certain period of time, the tray-up motor stops. At this moment, it is judged that there is paper in the drawer if the paper empty sensor is turned ON. If the paper empty sensor is turned OFF, it is judged that there is no paper in the drawer.

If the tray-up sensor is not turned ON within a certain period of time, it is judged that an abnormality has occurred. As a result, "Paper Jam" is displayed regardless of the presence or absence of the paper.

#### [ 2-3 ] Abnormal paper feeding from the bypass tray

If the registration sensor is not turned ON within a certain period of time during paper feeding from the bypass tray or after the start of paper feeding from the bypass tray, it is judged that a paper misfeed has occurred.

#### [ 2-4 ] Misfeeding in the MFP

Detection of misfeeding of the leading edge of the paper by the paper exit sensor (S13):

When the registration clutch (CLT7) is turned ON but the paper exit sensor (S13) is not, even if a certain period of time has passed, it is judged that a paper misfeed (E010) has occurred and the operation has stopped as a result.

Detection of misfeeding of the trailing edge of the paper by the paper exit sensor (S13):

When the registration clutch (CLT7) is turned OFF but the paper exit sensor (S13) is not, even if a certain period of time has passed, it is judged that a paper misfeed (E020) has occurred and the operation has stopped as a result.

Other paper misfeeding:

- Immediately after the power is turned ON, if any one of all the sensors on the paper transport path detects paper (ON), it is judged that a paper misfeed (E030) has occurred.
- If the front cover is opened during copying, it is judged that a paper misfeed (E410) has occurred.

- If the registration sensor (S19) is not turned ON within a certain period of time after the leading edge of the paper has passed the transport roller, it is judged that a paper misfeed (E120, E200, E210, E300, E330, E3C0) has occurred.
- If the registration sensor (S19) is not turned ON within a certain period of time after the ADU motor (M12) is turned ON during paper feeding from the ADU, it is judged that a paper misfeed (E110) has occurred.
- If the ADU entrance sensor (S14) and ADU exit sensor (S15) do not detect the paper at a certain timing during paper transporting from the ADU, it is judged that a paper misfeed (E510, E520) has occurred.
- If the reverse sensor (S26) does not detect the paper at a certain timing during paper reversing, it is judged that a paper misfeed (E570, E580) has occurred. (3528A/4528A only)
- If the 1st transport sensor (S43), 2nd transport sensor (S44) and transport sensors in the PFP and LCF are not turned ON within a certain period of time after the paper feed clutch is turned ON during paper feeding from the MFP or the PFP, it is judged that a paper misfeed (E220, E310, E320, E340 to E360, E3D0, E3E0) has occurred. (A different error code appears depending on the paper source.)

### **[ 2-5 ] Toner supply**

When the toner density has become low, toner empty is detected. A message to advise that the toner be supplied is displayed and then the copying operation is disabled. In this case, replace the toner with a new one and then close the front cover. The toner supply operation is started. Then the copying operation is enabled again.

### **[ 2-6 ] EPU not installed properly**

When installation failure of the EPU has occurred, a message to indicate its installation abnormality is displayed. In such a case, reinstall the EPU and close the front cover to solve this problem.

### **[ 2-7 ] Call for service**

Check the error code displayed on the touch panel when “Call for service” appears and then deal with the abnormality in accordance with the error code table.

 P. 8-6 “8.2 Error Code List”

### 3.6.3 Hibernation function

A hibernation function is embedded in this MFP. This function allows the MFP to store the last status of the system in the SSD immediately before the power is turned OFF and to restart from this stored status at the next boot-up.

For the warming-up time, see the following reference.

 P. 2-1 “2.1.1 General”.

If hibernation is not performed when the power is turned OFF or the MFP boots up immediately after the settings, warming-up takes longer. This differs depending on the usage conditions; warming-up will take approx. 30 to 150 seconds.

The following are the conditions which necessitate a longer warming-up time.

- Rebooting from TopAccess
- At the first booting after a power failure
- At the first booting after a self-diagnostic code is changed in the Service UI
- When options or finishers are installed
- At the first booting after an option or a finisher is removed
- During the toner supply mode
- Operating while “READY (WARMING-UP)” is still on the touch panel
- At the first booting when the power is turned OFF during the network initialization
- At the first booting after the power is turned OFF in a procedure other than the correct one described in the Quick Start Guide.

## 3.7 Control Panel

### 3.7.1 Overview

The control panel consists of the touch panel, buttons and LEDs indicating the state of the MFP, including various modes.

Pictorial symbols and messages are displayed either by lighting or blinking to advise the user of the notification. When a paper misfeed or service call has occurred, the corresponding error code is also displayed.

The [ON/OFF] button on the control panel is usually used to turn the power ON and OFF. Press this button to turn the power of the MFP ON and OFF.

When the MFP is not shut down even if the [ON/OFF] button is pressed, hold it for a few seconds to forcibly shut the MFP down.

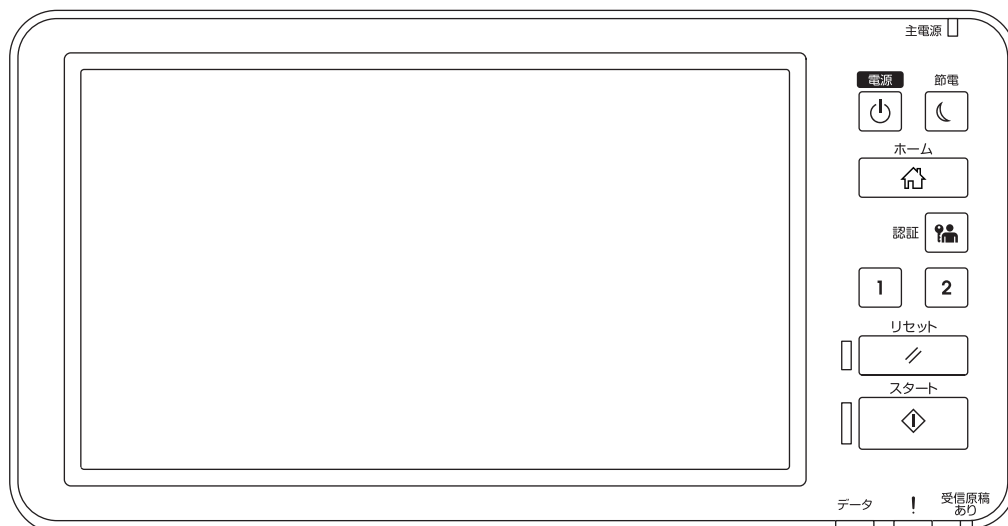

Fig. 3-15

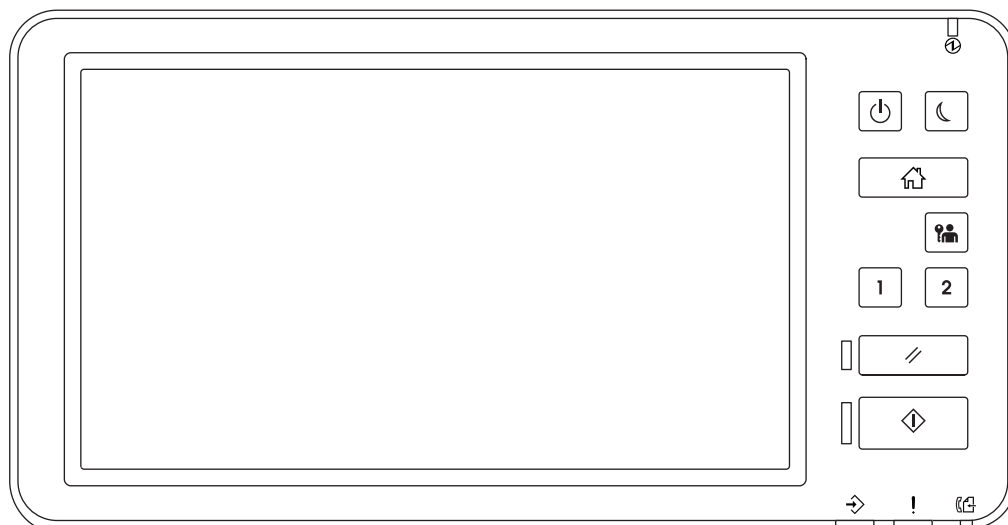

Fig. 3-16

Method: Color LCD with a touch panel

Touch panel: Resistance film type multi touch panel

Size: 10.1 inches

## 3.8 Scanning Section

### 3.8.1 Overview

In the scanning section of this MFP, the surface of an original is irradiated with a direct light and the reflected light is led through mirrors, a lens and a slit to the CCD. This CCD performs optical-to-electrical conversion to convert the optical image data into an electrical (analog) signal. This analog signal is converted to a digital signal, which then undertakes various corrective processes necessary for image formation. After that, arithmetic operation is performed on the digital signal, which is then transmitted to the data writing section.

In this MFP, a reduction-type 3-line CCD for color processing is used. How this CCD differs from black-and-white CCDs is that its devices are arranged in 3 lines and covered with color filters (Red, Green and Blue). The color separation is arranged by means of these filters.

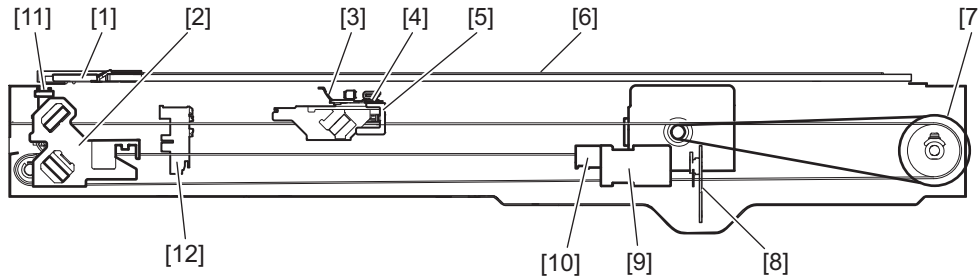

Fig. 3-17

- [1] ADF original glass
- [2] Carriage-2
- [3] Reflector
- [4] Exposure lamp
- [5] Carriage-1
- [6] Original glass
- [7] Drive pulley
- [8] CCD board
- [9] Lens
- [10] Automatic original detection sensor
- [11] Home position sensor
- [12] Platen sensor

### 3.8.2 Composition

Scanning Section		
Original glass	Original glass	
	ADF original glass	
Carriage-1	Exposure lamp (EXP)	
	Reflector	
	Mirror-1	
Carriage-2	Mirror-2	
	Mirror-3	
Lens unit	Lens	
	CCD driving PC board (CCD)	
Automatic original detection sensors (S24, S25*)		
Driving Section	Scan motor (M1)	<ul style="list-style-type: none"> <li>• 2-phase stepping motor</li> <li>• Drives the carriage-1 and carriage-2</li> </ul>
Others	Carriage home position sensor (S23)	
	Platen sensor-1 (S21)	
	Platen sensor-2 (S22)	

\* S25: other than JPD

### 3.8.3 Functions

The following shows the construction and purpose of the scanning system:

#### 1. Original glass

This is the glass for placing an original. The light from the exposure lamp (EXP) is irradiated to the original through this original glass. The ADF original glass is used when an original is read with the Automatic Document Feeder. The original is transported on the ADF original glass by the Automatic Document Feeder and the transported original is scanned under the ADF original glass by the carriage. The surface of the ADF original glass is coated so as not to be scratched by originals. Therefore, do not use such solvents as alcohol when cleaning the surface of the ADF original glass.

#### 2. Carriage-1

The carriage-1 consists of the exposure lamp (EXP), reflector, mirror-1, etc. The carriage-1 is driven by the scan motor (M1) and scans an original on the glass.

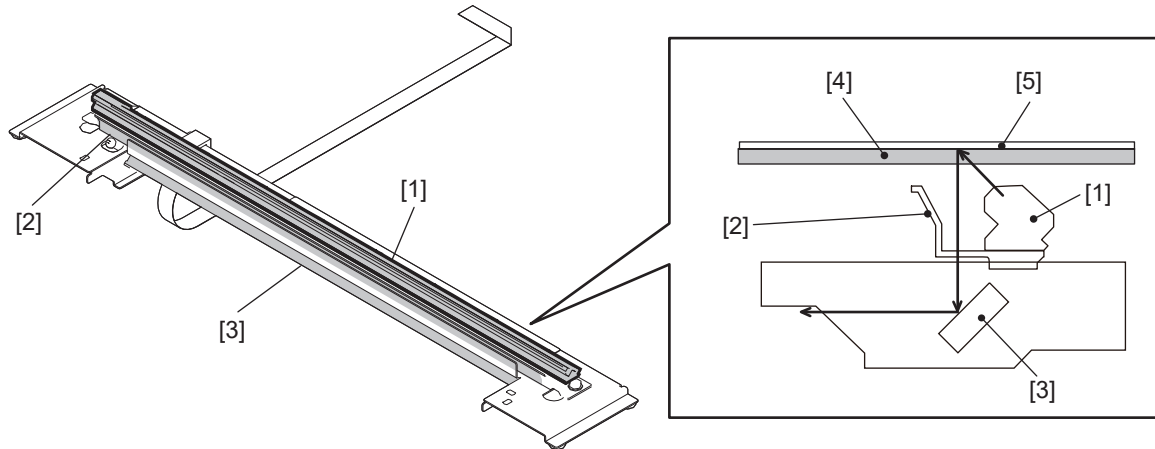

Fig. 3-18

- [1] Exposure lamp
- [2] Reflector
- [3] Mirror-1
- [4] Original glass
- [5] Original

- Exposure lamp (EXP)  
This lamp is the light source to irradiate the original on the glass. An LED lamp is used in this MFP.
- Reflector  
This is a plate to direct the light from efficiently the exposure lamp (EXP) to the surface of the original on the glass.
- Mirror-1  
This mirror directs the light reflected from the original to the mirror-2, which will be described later.

### 3. Carriage-2

The carriage-2 mainly consists of the mirror-2, mirror-3, etc. and directs the reflected light from the mirror-1 through the mirrors-2 and -3 to the lens.

This carriage is driven by the same scan motor (M1) as that for the carriage-1 at half the scanning speed of the carriage-1. (The scanning distance is also half that of the carriage-1.)

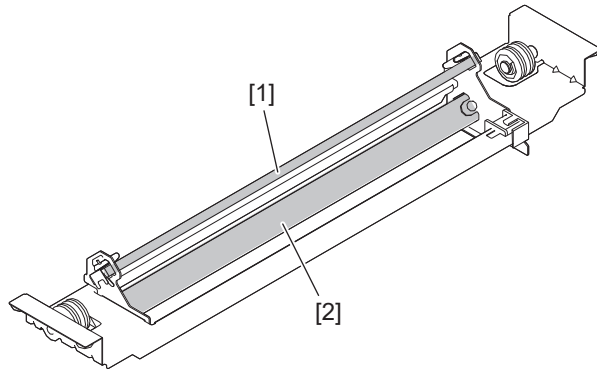

**Fig. 3-19**

[1] Mirror-2

[2] Mirror-3

### 4. Lens unit

The light reflected from the mirror-3 is led to the CCD placed at the focal point of the lens which is fixed in a position.

### 5. CCD driving PC board (CCD)

Processes such as signal amplification, signal integration and A/D conversion are applied on the electrical signal which was converted by the CCD.

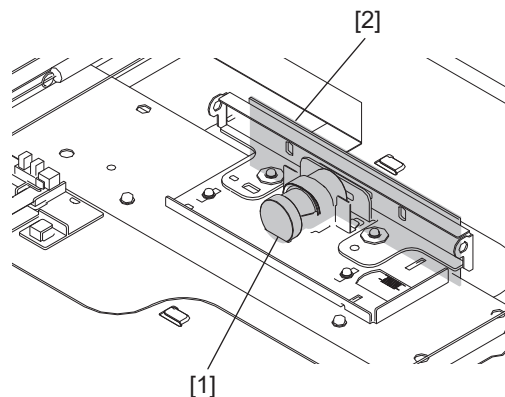

**Fig. 3-20**

[1] Lens unit

[2] CCD driving PC board

### 6. Automatic original detection sensors (S24, S25)

The size of the original placed on the glass is instantly detected using the automatic original detection sensors (S24, S25) fixed on the base frame without moving the carriage-1.



## 3.8.4 Operation description

### [ 1 ] Scanning operation

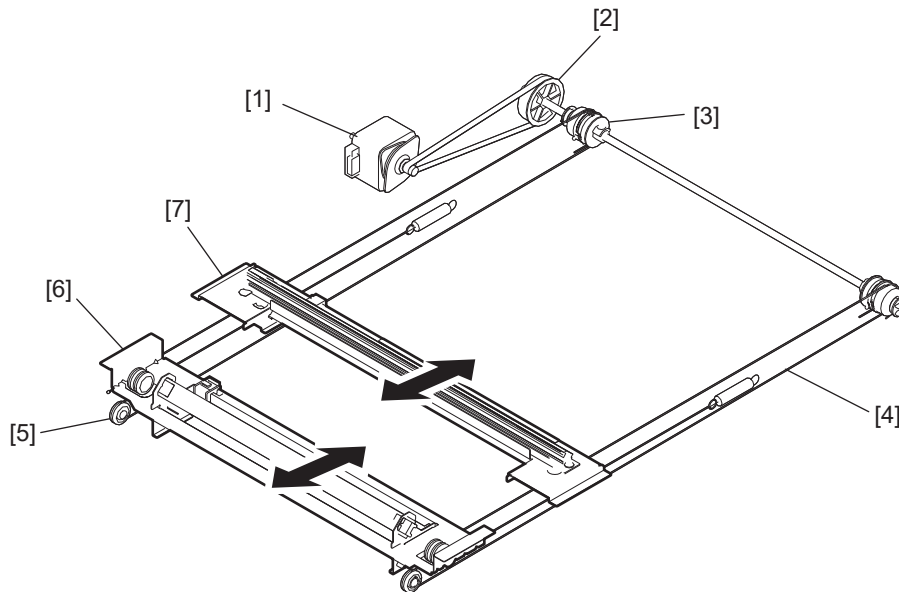

Fig. 3-21

- [1] Scan motor
- [2] Drive pulley
- [3] Wire pulley
- [4] Wire
- [5] Idler pulley
- [6] Carriage-2
- [7] Carriage-1

- Scanning of an original placed on the original glass  
The scan motor (M1) drives the carriages-1 and -2 through the timing belt and carriage wire. First, the scan motor drives the carriages-1 and -2 to their respective home positions. The home positions are detected when the carriage-1 passes the home position sensor (S23). When the [START] button is pressed, both carriages start to move and scan the original on the glass.
- Scanning of an original placed on the DF  
The carriage-1 stays at the shading position during shading correction and at the scanning position during scanning operation.
- Carriage speed  
The carriage speed of the original placed on the original glass in the color mode is the same as that in the black mode.

### 3.8.5 Process of original size detection

In this MFP, detection of the original sizes is performed with the combination of the CCD and automatic original detection sensors-1 and -2 (S24, S25).

The size in the primary scanning direction is detected by the CCD while that in the secondary scanning direction is detected by the sensors.

#### [ 1 ] Original size detection procedure

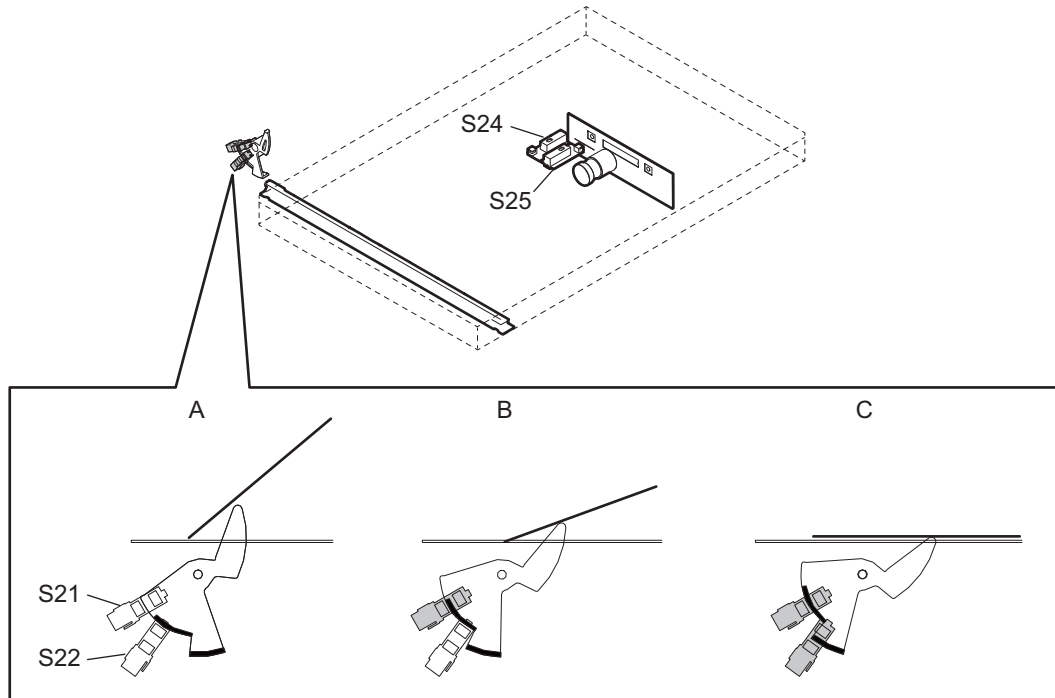

Fig. 3-22

A: Platen cover (or DF) fully opened

When the platen cover is fully opened, the original size is not detected.

B: Platen cover (or DF) opened by 25 degrees: Detected by the platen sensor-1 (S21)

When this status is detected, the exposure lamp of the scanner emits light and the presence/absence of the original in the secondary scanning direction and the paper size of the original in the primary scanning direction are detected by the automatic original detection sensor. (As for the LT series, two automatic original detection sensors are used.)

C: Platen cover (or DF) closed: Detected by the platen sensors-1 and -2 (S21, S22)

This status is detected by the platen sensors-1 and -2. The exposure lamp of the scanner emits light for a short time and the sensors detect the length of the original in the primary scanning direction again.

#### Remarks:

When the platen cover (or the DF) is fully closed or closed by 25 degrees or less, the exposure lamp emits light as follows.

Light emitted → OFF → light emitted → OFF → carriage moved

If the connectors are connected to the platen sensors-1 (S21) and -2 (S22) in reverse, the exposure lamp emits light as follows.

Light emitted → OFF → carriage moved → light emitted

When the following phenomena have occurred, the platen sensor-1 (S21) may be damaged. In such a case, check the sensors and the harnesses.

- The exposure lamp does not emit light even when the platen cover is opened by 25 degrees.
- The detected paper size of the original is not correct.

## [ 2 ] Detection points

The detection points in the primary and secondary scanning directions are as follows.

- **Sensor detection points (A4 and K Series)**

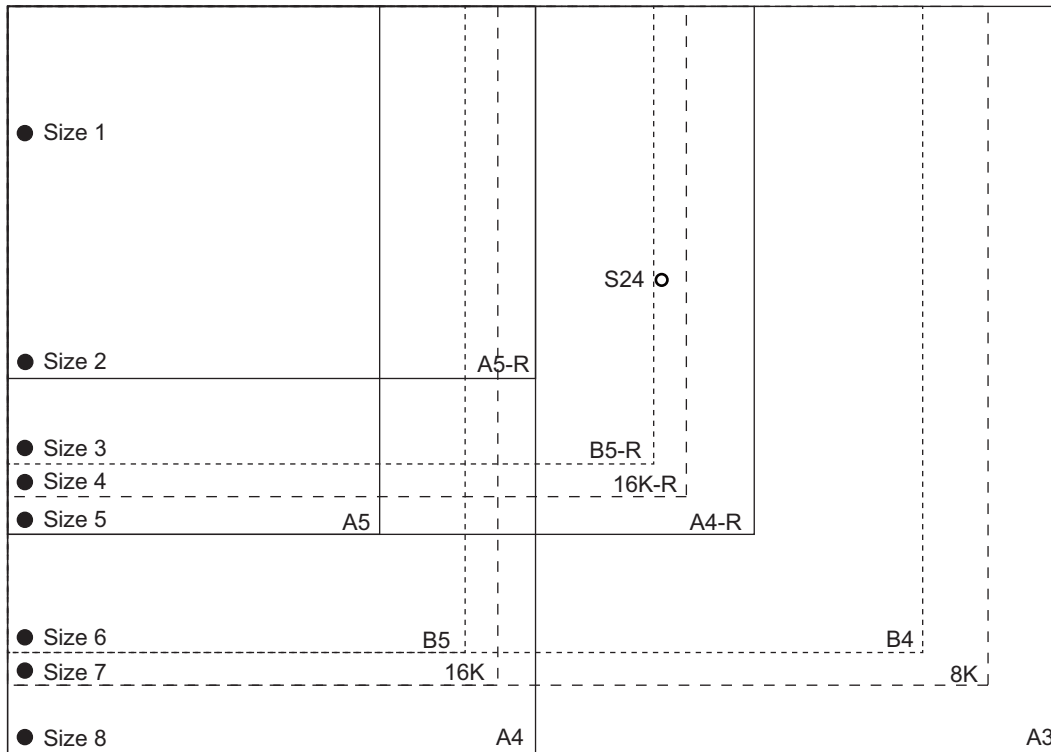

Fig. 3-23

- **Sensor detection points (LT Series)**

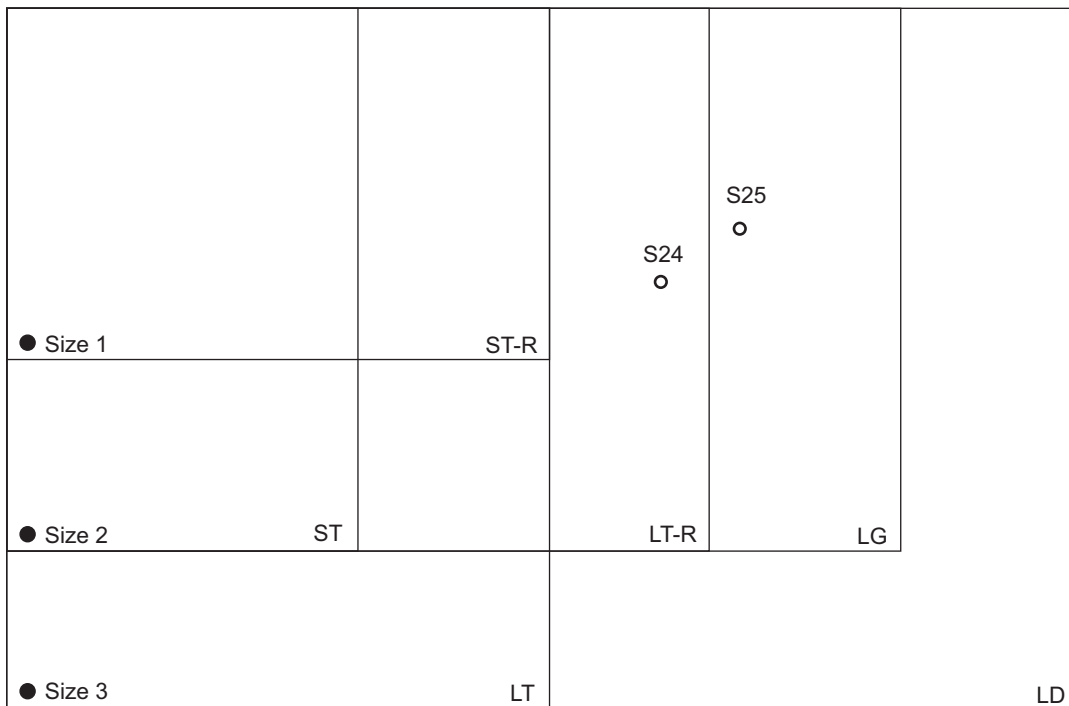

Fig. 3-24

## 3.9 Data Writing Section

### 3.9.1 Overview

In the data writing section, the laser optical unit radiates the laser beam onto the photoconductive drum in response to the digital image signals transmitted from the LGC board to create a latent image. The image signal is converted into the light emission signal of the laser diode on the laser driving PC board (LDR), then radiated on the photoconductive drum through optical elements such as cylinder lenses, polygonal mirror and f $\theta$  lens. The unit must not be disassembled in the field as they are very sensitive to dust and finely adjusted at the factory.

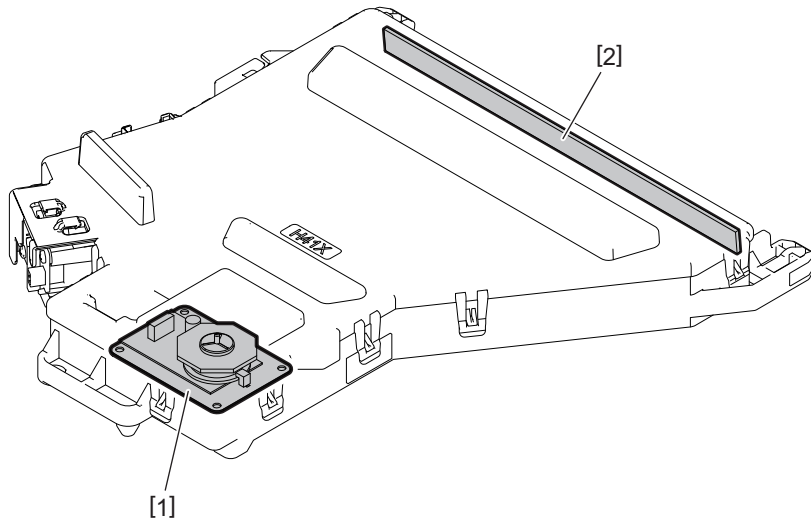

Fig. 3-25

[1] Polygonal motor

[2] Slit glass

## 3.9.2 Laser precautions

A laser diode is used for this MFP and radiates an invisible laser beam.

Since it is not visible, be extremely careful when handling the laser optical unit components, performing operations or adjusting the laser beam. Also, never perform the procedure with other than the specified manuals because you could be exposed to laser radiation.

The laser optical unit is completely sealed with a protective cover. As long as only the operations of specified manuals are performed, the laser beam does not leak and you are in no danger of being exposed to laser radiation.

The following cautionary label for the laser is attached to the inner cover and can be seen when you open the front laser cover.

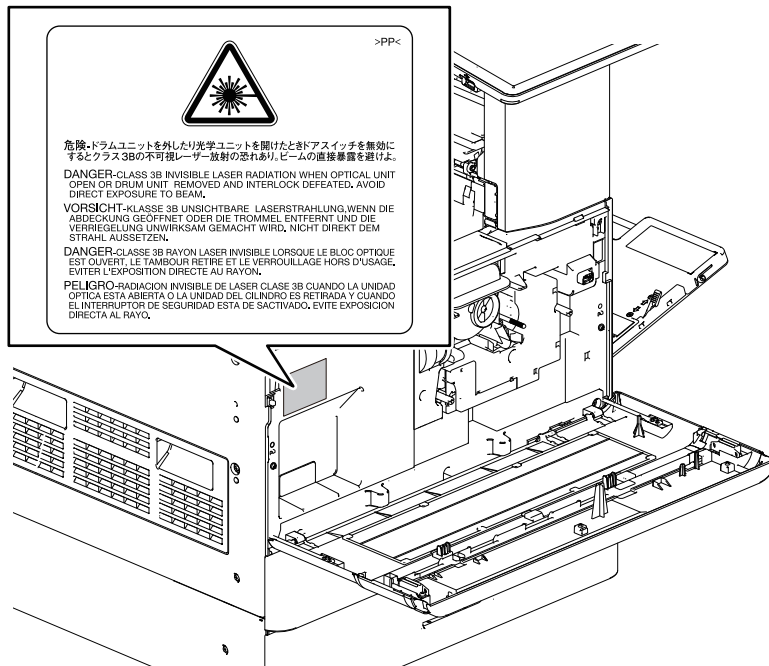

Fig. 3-26

### Notes:

- Avoid exposure to the laser beam during service. This MFP uses a laser diode. Be sure not to expose your eyes to the laser beam. Do not insert reflecting parts or tools such as screwdrivers into the laser beam path. Remove all reflecting metals such as watches, rings, etc. before starting service.
- When servicing the MFP with the power turned ON, be sure not to touch live sections and rotating/operating sections. Avoid exposing your eyes to the laser beam.
- During servicing, be sure to check the rating plate and cautionary labels such as “Unplug the power cable during service”, “CAUTION. HOT”, “CAUTION. HIGH VOLTAGE”, “CAUTION. LASER BEAM”, etc. to see if there is any dirt on their surface and if they are properly stuck to the MFP.

## 3.10 Paper Feeding Section

### 3.10.1 Overview

This chapter explains how the system works to pick up paper from the drawer or bypass tray and transport it to the transfer position.

The paper feeding section mainly consists of the pickup roller, paper feed roller, separation roller, transport roller, registration roller, bypass tray paper sensor (S16), drawer paper empty sensors (S5, S34), paper nearly empty sensors (S45, S46), registration sensor (S19) and the drive system for these components.

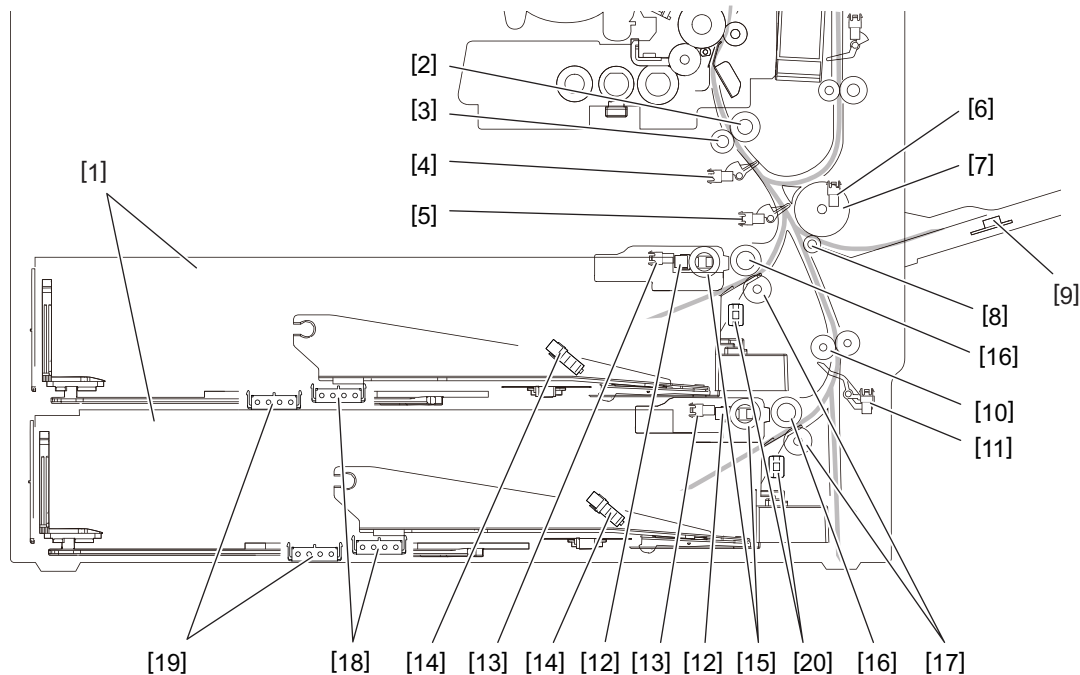

Fig. 3-27

- [1] Drawer
- [2] Registration roller (rubber)
- [3] Registration roller (metal)
- [4] Registration sensor
- [5] 1st transport sensor
- [6] Bypass tray paper sensor
- [7] Bypass unit paper feed roller
- [8] Bypass unit separation roller
- [9] Paper width detection PC board
- [10] Transport roller
- [11] 2nd transport sensor
- [12] Drawer tray-up sensor
- [13] Drawer paper empty sensor
- [14] Drawer paper nearly empty sensor
- [15] Drawer pickup roller
- [16] Drawer paper feed roller
- [17] Drawer separation roller
- [18] Drawer paper width detection switch
- [19] Drawer paper length detection switch
- [20] Drawer detection switch

### 3.10.2 Composition

Paper feeding section		
1st drawer paper feed unit, 2nd drawer paper feed unit	1st drawer pickup roller, 2nd drawer pickup roller	PM parts
	1st drawer paper feed roller, 2nd drawer paper feed roller	PM parts
	1st drawer separation roller, 2nd drawer separation roller	PM parts
	1st drawer paper nearly empty sensor, 2nd drawer paper nearly empty sensor	S45, S46
	1st drawer tray-up sensor, 2nd drawer tray-up sensor	S31, S35
	1st drawer paper empty sensor, 2nd drawer paper empty sensor	S5, S34
	1st drawer paper feed clutch, 2nd drawer paper feed clutch	CLT1, CLT4
Bypass unit	Bypass unit paper feed roller	PM parts
	Bypass unit separation pad	PM parts
	Bypass tray paper sensor	S16
	Bypass tray paper feed clutch	CLT3
	Paper width detection PC board	SFBB
Driving section, others	1st drawer tray-up motor, 2nd drawer tray-up motor	M15, M16
	Registration sensor	S19
	Registration roller (rubber)	
	Registration roller (metal)	
	1st transport sensor, 2nd transport sensor	S43, S44
	Transport roller	
	Registration clutch	CLT7
	Transport clutch (H)	CLT5
	Transport clutch (L)	CLT6
Jam access cover opening/closing switch	SW20	

### 3.10.3 Functions

1. Pickup roller  
This roller moves up and down to draw out a sheet of paper from the drawer and transport it to the paper feed roller.
2. Paper feed roller  
This roller transports the paper transported from the pickup roller to the registration roller.
3. Separation roller  
This roller is facing to the paper feed roller. When two or more sheets of paper are transported from the pickup roller, the load of the torque limiter (spring) of the separation roller is greater than the frictional force between the sheets. As the result, the separation roller is stopped and the lower sheet of paper is not transported any further. When only one sheet of paper is transported from the pickup roller, the separation roller is forced to rotate following the paper feed roller.
4. Transport roller  
This roller transports the paper transported from the 2nd drawer, PFP or LCF to the registration roller.
5. Registration roller  
Paper transported from each paper source is pushed against the registration roller (which is not being rotated) which aligns the leading edge of the paper. Then the registration roller rotates to transport the paper to the transfer unit.
6. Bypass unit paper feed roller  
This roller picks up and feeds paper from the bypass unit.
7. Bypass unit separation roller  
This roller is facing to the paper feed roller. When two or more sheets of paper are transported, the load of the torque limiter (spring) of the separation roller is greater than the frictional force between the sheets. As the result, the separation roller is stopped and the lower sheet of paper is not transported any further. When only one sheet of paper is transported, the separation roller is forced to rotate following the paper feed roller.
8. Bypass tray paper sensor (S16)  
This sensor detects that paper is set on the bypass tray. If paper is set on the bypass tray, bypass feeding always takes priority before drawer feeding.  
This sensor also detects whether paper has been transported from the bypass tray or not. In other words, whether the leading/trailing edge of paper has passed the bypass unit paper feed roller or not. This sensor is also utilized to detect the jams such as paper misfeeding in the bypass unit.
9. 1st drawer paper empty sensor (S5), 2nd drawer paper empty sensor (S34)  
This is a transmissive-type sensor which detects the availability of paper in the drawer by using an actuator. When there is no paper in the drawer, the actuator blocks the light path of the sensor, and the sensor detects that there is no paper.
10. 1st drawer paper nearly empty sensor (S45), 2nd drawer paper nearly empty sensor (S46)  
This is a transmissive-type sensor which detects the availability of paper in the drawer by using an actuator. When the remaining paper has become around 100 sheets, the actuator blocks the light path of the sensor to notify that the paper quantity is getting less.
11. Registration sensor (S19)  
This sensor detects that the leading edge of the paper has reached the registration roller and its trailing edge has passed this sensor.
12. 1st transport sensor (S43)  
This sensor detects whether paper from each paper source is being transported or not.



13. 2nd transport sensor (S44)

This sensor detects whether paper from the 2nd drawer and options (PFP, LCF) is being transported or not.

14. 1st drawer paper feed clutch (CLT1), 2nd drawer paper feed clutch (CLT4)

These clutches transmit the driving force from the main motor to drive the pickup roller.

15. Transport clutch (H) (CLT5)

This clutch transmits the driving force from the main motor to drive the transport roller at high speed.

16. Transport clutch (L) (CLT6)

This clutch transmits the driving force from the main motor to drive the transport roller at low speed.

17. Registration clutch (CLT7)

This clutch drives the registration roller.

18. Bypass tray paper feed clutch (CLT3)

This clutch drives the bypass unit paper feed roller. When this clutch is turned ON while the main motor is being rotated, paper on the bypass tray feeds and transports to the inside of the MFP.

### 3.10.4 Operation description

#### [ 1 ] Driving the rollers

The drive of the each motor in the paper feeding section is transmitted to the paper transport rollers as below.

- Main motor (M23)
  - This motor drives the 1st and 2nd drawer paper feed rollers through the 1st and 2nd drawer paper feed clutches (CLT1, CLT3)
  - Driving the bypass tray paper feed roller through the bypass tray paper feed clutch (CLT2)
  - Driving the transport roller through the transport clutches (H) and (L) (CLT5, CLT6)

#### [ 2 ] Picking up mechanism

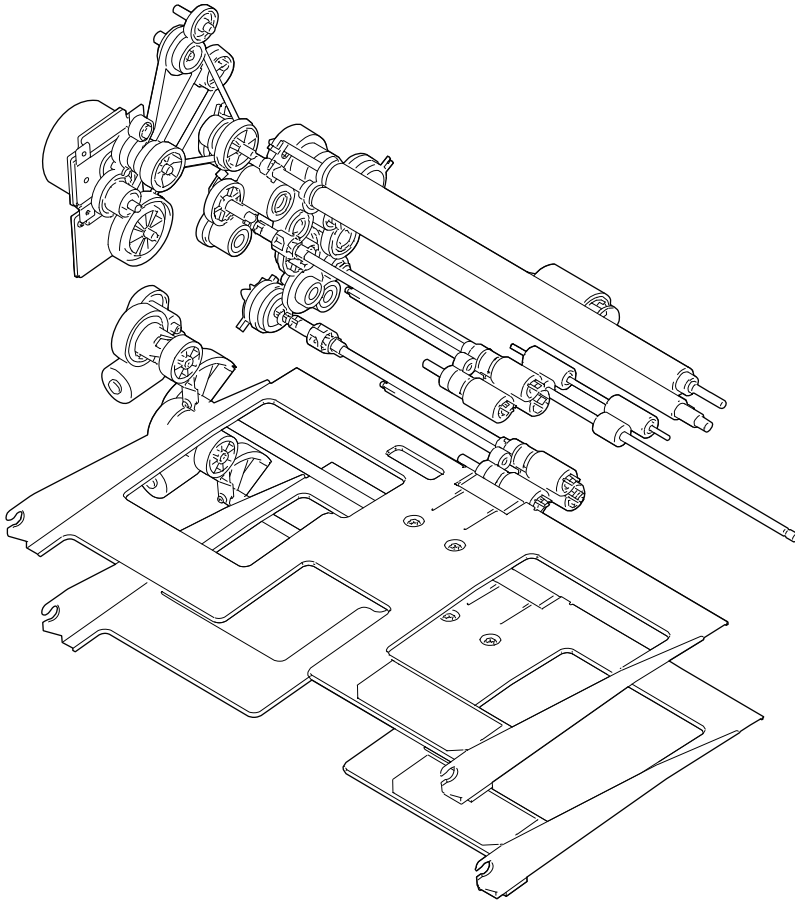

Fig. 3-28

When the drawer is inserted into the MFP, the drawer tray is raised by the tray-up motor and paper can be fed.

Paper is fed and transported by transmitting the driving force from the main motor to the pickup roller, paper feed roller and transport roller through the gears and clutches.

Paper is picked up by the movement of the paper feed clutch. When the paper feed clutch is turned ON, the pickup roller and paper feed roller rotate and the paper is picked up from the drawer.

The paper is separated by the separation roller.

### [ 3 ] Paper feeding mechanism

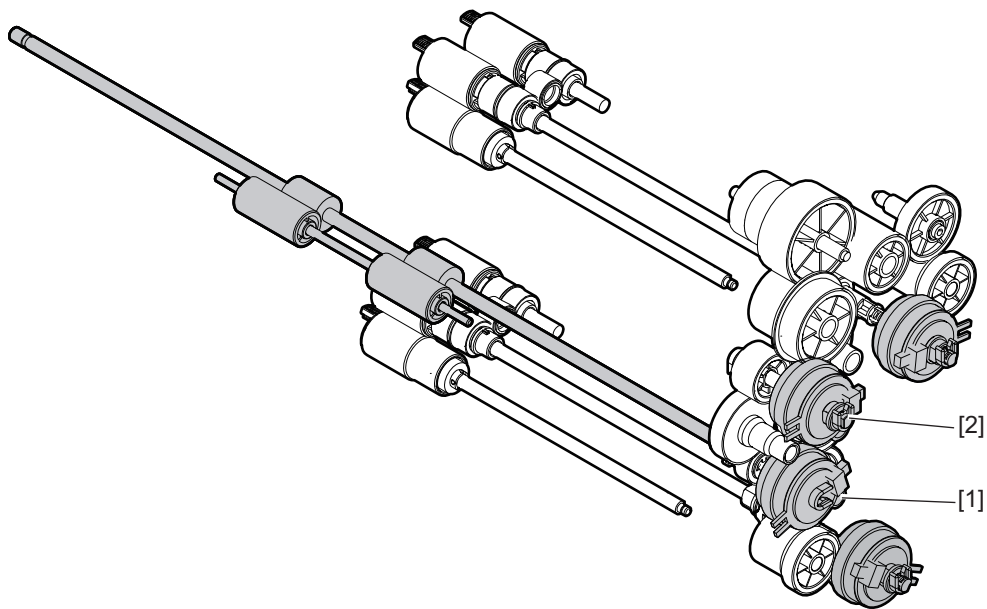

Fig. 3-29

- [1] Transport clutch (L)
- [2] Transport clutch (H)

The transport clutches (L) and (H) transmit the driving force from the main motor to the transport roller. When transporting paper, they are turned ON.

The transport clutch (L) is turned ON when low speed transportation is performed for printing. The transport clutch (High speed) is turned ON when high speed transportation is performed to transport the paper which has passed through the paper feed sensor to the registration position. High speed transportation is also performed when the paper is transported from the PFP to the registration position (When the PFP is connected).

#### [ 4 ] Driving the bypass unit paper feed roller

The driving force transmitted through the bypass tray paper feed clutch (CLT3) is transmitted to the bypass unit paper feed roller through the shaft. The roller is rotated by this driving force.

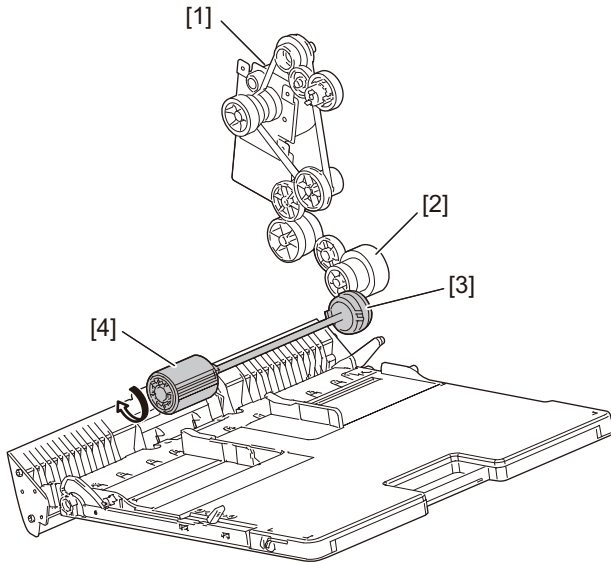

Fig. 3-30

- [1] Main motor
- [2] Gear
- [3] Bypass tray paper feed clutch
- [4] Bypass unit paper feed roller

#### [ 5 ] Paper separation

Paper separation is performed by means of the separation roller. The separation roller is pushed to the paper feed roller by the spring force.

When two or more sheets of paper are fed, since the friction between two sheets of paper is smaller than that between a sheet and the separation roller, the lower sheets are not transported any further while the uppermost one is transported by the paper feed roller.

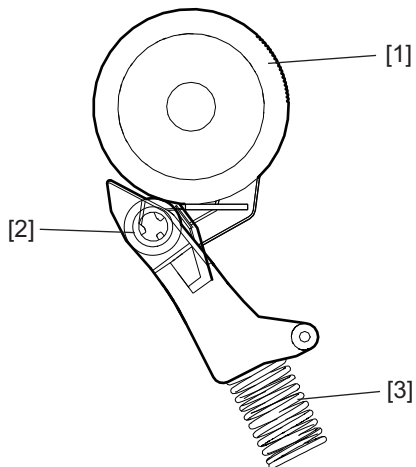

Fig. 3-31

- [1] Bypass unit paper feed roller
- [2] Separation roller
- [3] Spring

### [ 6 ] Paper size detection in the drawers

This MFP automatically detects the size of the paper placed in each drawer.

The end and side guides in each drawer are moved according to the paper size and a pusher moves together with those guides.

Then the protrusion of this pusher pushes each button of the drawer paper width detection switch and the drawer paper length detection switch.

Thus the paper size is detected with the combination of the pushing statuses of these sensors.

The drawer paper width detection switch detects the movement of the side guides while the drawer paper length detection switch detects that of the end guide.

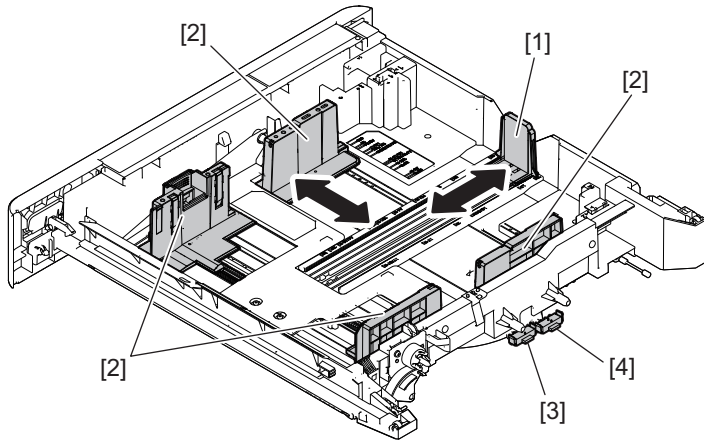

Fig. 3-32

The positions of the guides and the pusher in the cases of A3 and A4-R are shown below as examples

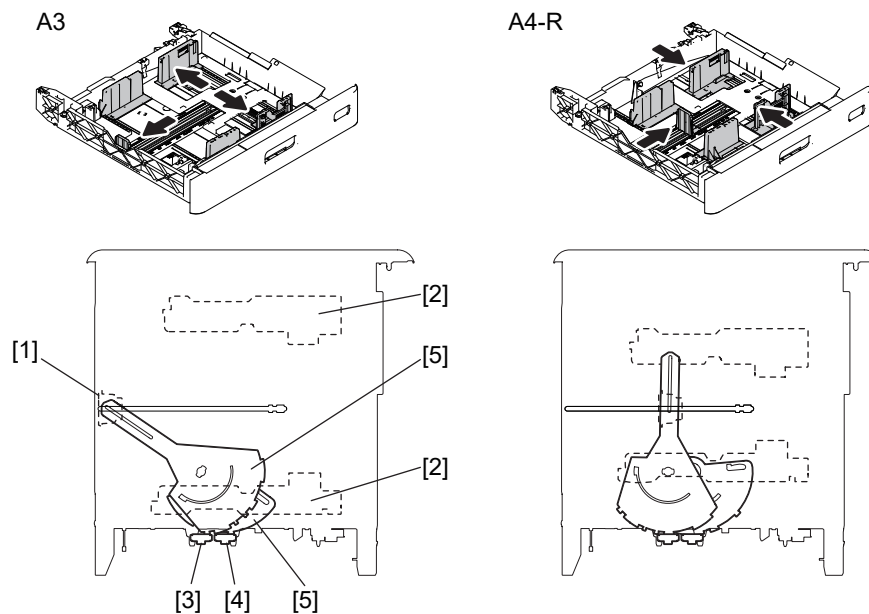

Fig. 3-33

- [1] End guide
- [2] Side guide
- [3] Drawer paper width detection switch
- [4] Drawer paper length detection switch
- [5] Pusher

**[ 7 ] Drawer soft-close mechanism (3528A/4528A only)**

When the drawer is inserted, it is slowly pulled in by means of the damper and soft-close unit installed in it.

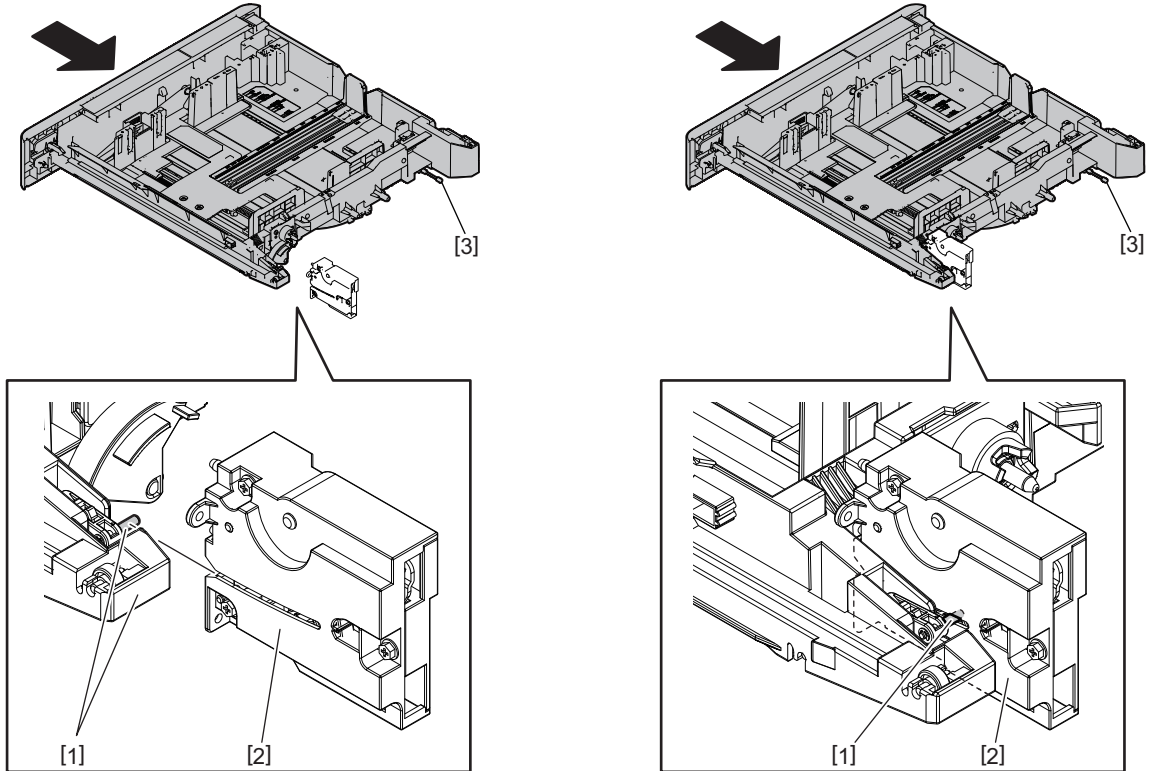

Fig. 3-34

- [1] Drawer
- [2] Soft-close unit
- [3] Damper

## [ 8 ] General operation

### [A] From power-ON to ready status

If either of the sensors on the transport path is ON (meaning there is paper on the transport path) when the MFP is turned ON, it is determined that a paper misfeed has occurred and no operation is enabled until the paper is removed.

### [B] Ready status

When a drawer is inserted or removed at ready status, to check the availability of paper.

### [C] Paper feeding from the bypass tray

- The bypass tray paper sensor detects paper on the bypass tray.
- The bypass tray paper feed clutch is turned ON and the bypass tray paper feed roller rotates to start paper feeding.
- The leading edge of the paper turns the registration sensor ON and the paper is aligned by the registration rollers.
- The bypass tray paper feed clutch is turned OFF and the bypass tray paper feed roller is stopped.
- The registration clutch is turned ON and the paper is transported to the transfer unit.

### [D] Paper feeding from the drawer

- 2nd drawer
  - The paper feed clutch and transport clutch (H) are turned ON and the pickup roller, paper feed roller and transport roller rotate to start paper feeding.
  - The leading edge of the paper turns the paper feed sensor ON and the paper feed clutch is turned OFF. (The pickup roller and paper feed roller stop rotating.)
  - The leading edge of the paper turns the registration sensor ON and the paper is aligned by the registration rollers.
  - The transport clutch (H) is turned OFF and the transport roller stops rotating.
  - The registration clutch and transport clutch (L) are turned ON and the paper is transported to the transfer unit.
- 1st drawer
  - The paper feed clutch is turned ON and the pickup roller and the paper feed roller rotate to start paper feeding.
  - The leading edge of the paper turns the registration sensor ON and the paper is aligned by the registration rollers.
  - The paper feed clutch is turned OFF and the pickup roller and the paper feed roller stop rotating.
  - The registration clutch is turned ON and the paper is transported to the transfer unit.

## [ 9 ] Drawer damp heater (JPD only)

The drawer damp heater is located at the middle of the 1st and 2nd drawers. It allows the prevention of an increase in the humidity by reducing the temperature alternation in the drawers.

The drawer damp heater can go into its operable status at any of the following points when the power cable of the MFP is connected and AC power is supplied.

- When the [ON/OFF] button on the control panel is turned OFF
- At the sleep mode
- At the super sleep mode

A heater whose maximum permissible power is 10.8 W is used in the drawer damp heater.

## [ 10 ] Envelope drawer

The envelope drawer is an option so that a standard envelope can be fed from the drawer. Different side walls compared to those for current drawers are adopted. These side walls are positioned by being aligned to the width of an envelope and they have the function of holding envelopes.

By using the drawer paper width detection switch and the drawer paper length detection switch, the level where the envelope drawer is installed is detected. Since the size of the paper in the envelope drawer is not detected automatically, it is necessary to set it manually.

## 3.11 Driving Section

### 3.11.1 Overview

The driving section drives the drum, developer unit, cleaner unit, fuser unit, transport roller, drawer paper feed roller, bypass unit paper feed roller and registration roller.

This section is driven by the rotation of the main motor (M23).

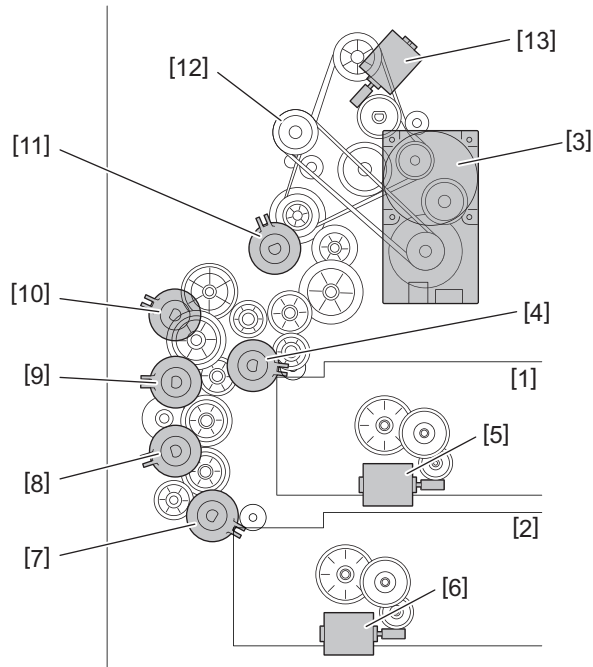

Fig. 3-35

- [1] 1st drawer
- [2] 2nd drawer
- [3] Main motor
- [4] 1st drawer paper feed clutch
- [5] 1st drawer tray-up motor
- [6] 2nd drawer tray-up motor
- [7] 2nd drawer paper feed clutch
- [8] Transport clutch (L)
- [9] Transport clutch (H)
- [10] Bypass tray paper feed clutch
- [11] Registration clutch
- [12] Drum
- [13] Toner motor (K)



### 3.11.2 Functions

1. Drum cleaner unit driving  
The drum is driven by transmitting the rotation of the main motor through the gears and the timing belt to the drum flange gear. Also the toner recovery auger is driven to transport the used toner to the developer unit.
2. Developer unit driving  
The developer unit is driven by transmitting the rotation of the main motor through the gears to the developer unit gears.
3. Fuser unit driving  
The fuser unit is driven by transmitting the rotation of the main motor through the gears and timing belt to the fuser unit gears.
4. Registration roller  
This drives the registration roller by transmitting the rotation of the main motor through the gears, timing belt and clutches.
5. Transport roller  
The transport roller is driven by transmitting the rotation of the main motor through the gears, timing belt and clutches.
6. Paper feed roller  
The drawer paper feed roller and bypass unit paper feed roller are driven by transmitting the rotation of the main motor through the gears and clutches.
7. Paper exiting options driving  
The Bridge Kit and Job Separator are driven by transmitting the rotation of the main motor through the gears and the timing belt to their gears.

## 3.12 Drum Related Section

### 3.12.1 Overview

The area around the drum, drum itself, image processing, their parts and control circuits are explained.

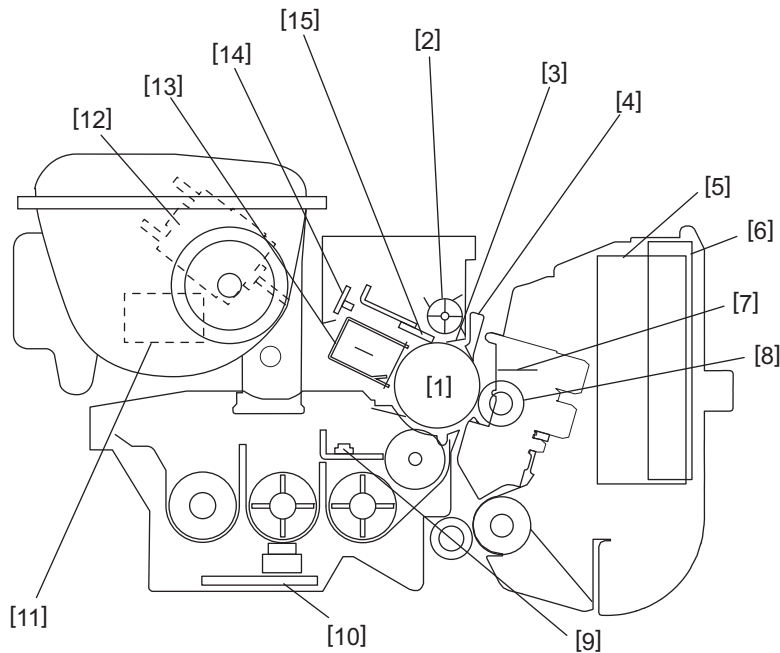

Fig. 3-36

- [1] Drum
- [2] Toner recovery auger
- [3] Recovery blade
- [4] Separation finger
- [5] Suctioning fan
- [6] Ozone filter
- [7] Separation needle
- [8] Transfer roller
- [9] Drum thermistor
- [10] EPU memory board
- [11] Toner cartridge interface PC board (CTIF board)
- [12] Toner motor (K)
- [13] Main charger
- [14] Discharge LED
- [15] Cleaning blade

### 3.12.2 Composition

Drum related section		
Drum cleaner unit	Drum	PM parts
	Main charger	PM parts
	Cleaner	
	Cleaning blade	PM parts
	Recovery blade	PM parts
	Needle electrode	PM parts
	Discharge LED	ERS
Transfer roller unit	Transfer roller	PM parts
	Separation needle	
Others	Drum thermistor	THM3
	High-voltage transformer	HVPS
	Suctioning fan	F3
	Process unit fan	F12
	Ozone filter	PM parts

### 3.12.3 Functions

1. Drum

A drum is made of a cylindrical aluminum base coated with a thin film of organic photoconductive substance.

A photoconductive object becomes insulative (high electrical resistance) when it is not exposed to light and becomes conductive (low electrical resistance) when it is exposed to light. This object is called a photoconductor.

2. Main charger

The main charger in this MFP consists of a metal rod with a U-shaped section, insulated blocks at both ends of the rod and a needle electrode attached between them.

When a high voltage is applied to the needle electrode, the air around it is charged (ionized). The ionized air then flows into the drum causing it to be charged. This phenomenon is called “corona discharge”. At the same time, a control bias is applied to the main charger grid to control the charging amount.

In a dark place, negative charge is evenly applied onto the drum surface by the corona discharge and the main charger grid.

In addition, a cleaner is installed to clean up the dust adhering to the needle electrode.

- Needle electrode

The needle electrode has aligned needles and their points perform the corona discharge. These points (electrodes) discharge toward the drum in one direction to realize more efficient discharging compared to a charger wire which discharges in a radial direction. Therefore, the needle electrode enables a reduction in the ozone amount.

The shape of the need electrode differs between 2528A/3028A and 3528A/4528A.

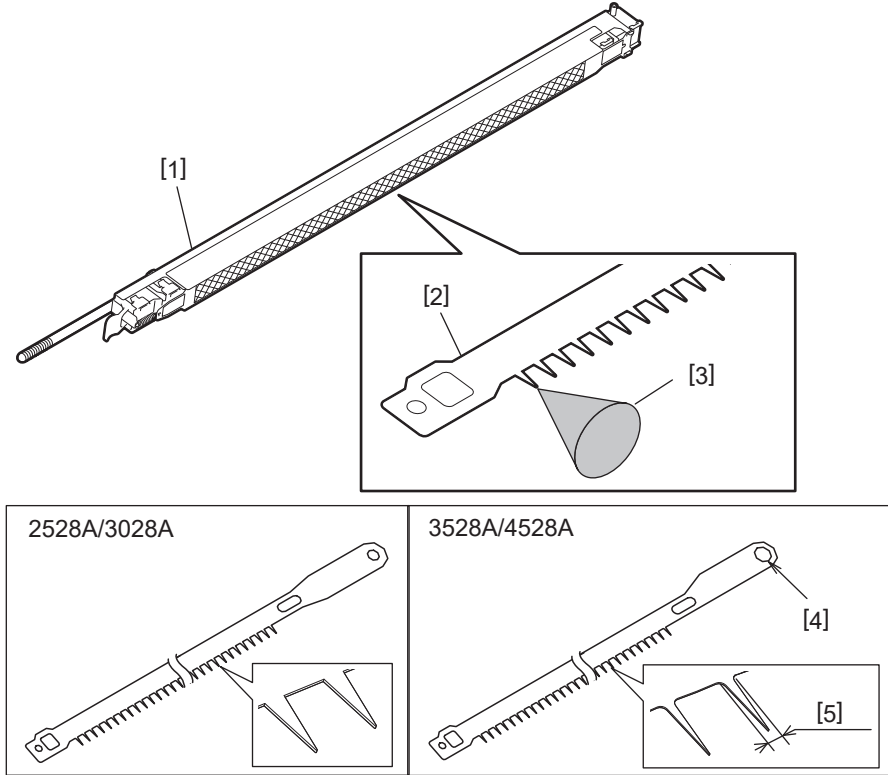

Fig. 3-37

- [1] Main charger
- [2] Needle electrode
- [3] Charging
- [4] Large
- [5] Thin

### 3. Drum cleaner

- Cleaning blade  
This blade is pressed against the drum surface and scrapes off the residual toner on the drum surface.
- Recovery blade  
This blade catches the toner scraped off by the cleaning blade.
- Toner recovery auger  
This auger carries the residual toner scraped off to the developer unit and reuses the toner.

### 4. Transfer roller unit

- Transfer assist bias  
Positive bias is applied to the registration roller, the pre-transfer guide and the fuser unit entrance guide so as to prevent the lowering of the transfer ability under high humidity environments.
- Transfer roller  
A transfer roller is used as the transfer charger for this MFP.  
With the transfer roller, dots are reproduced more clearly because the electric charge is concentrated on a contact point between the paper and the drum surface, and thus toner is less scattered at the time of transfer.
- Separation needle  
This needle requires a smaller capacity of the high-voltage transformer than the existing charger wire does.  
This needs to be cleaned with a brush at PM.

### 5. Discharge LED (ERS)

Discharge is a process to decrease or eliminate the electrical potential on the drum surface. The electrical resistance of the photosensitive layer is decreased by the light irradiation, and the residual charge on the drum surface is neutralized and eliminated. The electrical potential of the drum surface is fixed to a certain amount before the drum is charged. The number of the discharge LEDs for 2528A/3028A differs from that for 3528A/4528A because the discharging amount differs depending on the print speed. Therefore, be sure to install discharge LEDs in a correct model.  
2528A/3028A: 10 LEDs  
3528A/4528A: 14 LEDs

### 6. Drum thermistor (THM3)

The drum thermistor detects the drum surface temperature, and thus each rotation speed of the exhaust fan and internal cooling fan-1 is controlled when the MFP is in the ready status.

### 7. High-voltage transformer (HVPS)

This is a board to generate the output control voltage of the main charger, main charger grid, transfer charger, separation charger, developer bias and transfer assist bias.

### 8. Temperature/humidity sensor (S10)

This sensor and drum thermistor detect the temperature and humidity inside of the MFP since the drum, developer material and paper are affected by environmental elements such as the temperature or humidity. Thus the main charger grid, transfer/separation output, transfer assist bias, developer bias, laser output and auto-toner output are controlled to be at their optimum states.

### 9. Process unit fan (F12)

This fan cools down the inside of the MFP, drum cleaner and developer unit.

#### 10. Suctioning fan (F3)

This fan is equipped to cool down the inside of the MFP.

The air to exhaust includes the ozone generated by the corona discharge, and this ozone is removed by the ozone filter.

The exhaust fan also helps the paper separation by absorbing the paper to the post-transfer guide.

## 3.13 Developer Unit

### 3.13.1 Overview

The developer unit in this MFP has a recovered toner supply mechanism which recovers the recovered toner scraped off by the drum cleaning blade and recycles it. The developer unit is driven by the main motor to rotate the mixers and developer sleeve.

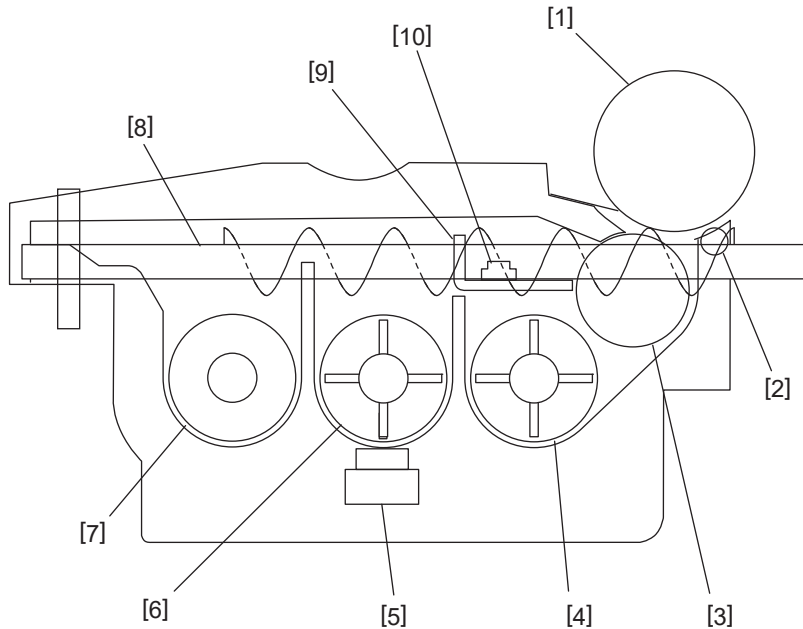

Fig. 3-38

- [1] Drum
- [2] Toner recovery roller (3528A/4528A only)
- [3] Developer sleeve
- [4] Mixer-1
- [5] Auto-toner sensor
- [6] Mixer-2
- [7] Mixer-3
- [8] Toner recycling auger
- [9] Doctor blade
- [10] Drum thermistor

### 3.13.2 Composition

Development unit	Developer material	PM parts
	Mixer-1, Mixer-2, Mixer-3	
	Developer sleeve (Magnetic roller)	
	Doctor blade	
	Auto-toner sensor	S1
	Drum thermistor	THM3
	EPU memory board	EPU
	Recovered toner supply mechanism (Toner recycling auger)	
Toner cartridge	Toner cartridge PC board	CTRG
	Toner cartridge interface PC board	CTIF
Toner motor (K)		M11



## 3.13.3 Functions

### [ 1 ] Overview

1. Toner cartridge drive unit, Toner cartridge installation detection mechanism (IC chip)  
The toner cartridge is filled with toner. The toner motor (K) drives the cartridge to supply the toner to the developer unit.  
The IC chip detects whether a toner cartridge is installed.
2. Development unit
  - Developer material  
The developer material consists of the carrier and toner.  
The carrier is an electrical conductive ferrite whose size is approx. 44  $\mu\text{m}$ . The toner is a resin particle whose size is approx. 8.5  $\mu\text{m}$ .  
Since the developer material deteriorates after a long time use, periodic replacements are needed.
  - Mixer-1, Mixer-2, Mixer-3  
The carrier and toner are rubbed against each other when the developer material is stirred. Then the carrier is positively charged (+) and the toner is negatively charged (-), and the toner is made to adhere to the drum surface by the electrostatic force.  
The mixer-3 is mounted exclusively to enable the recovered toner to be mixed in sufficient time.
  - Developer sleeve (Magnetic roller)  
These aluminum rollers have magnets inside. The developer material is pulled by these magnets to form a magnetic brush. The magnets are fixed at their position so only the sleeve rotates. By this rotation, the magnetic brush of the developer sleeve sweeps over the drum surface and thus development is performed.
  - Doctor blade  
The doctor blade controls the amount of the developer material from the developer sleeve so that the magnetic brush of the developer material can contact with the drum surface properly.
  - Auto-toner sensor (S1)  
To output a precise image, the proportion (toner density ratio) of the carrier and the toner in the developer material always needs to be constant. The magnetic permeability circuit in the auto-toner sensor detects the toner ratio in the developer material. This sensor drives the toner motor (K) to supply the toner from the toner cartridge.
  - Recovered toner supply mechanism  
The recovered toner transported from the drum cleaner is transported into the developer unit by the toner recycling auger on the front side of the developer unit. The driving force of the toner recycling auger is transmitted by the mixer-3.

## [ 2 ] Differences in the process unit

The process unit differs between 2528A/3028A and 3528A/4528A.

The differences are shown below.

Item	2528A/3028A	3528A/4528A
Toner recovery roller	Not installed	Installed
Gear, belt	For low speed	For high speed
Discharge LED	10 LEDs	14 LEDs
Needle electrode	For low speed	For high speed
Position of bracket hole (seen from the back side)	Bottom	Top

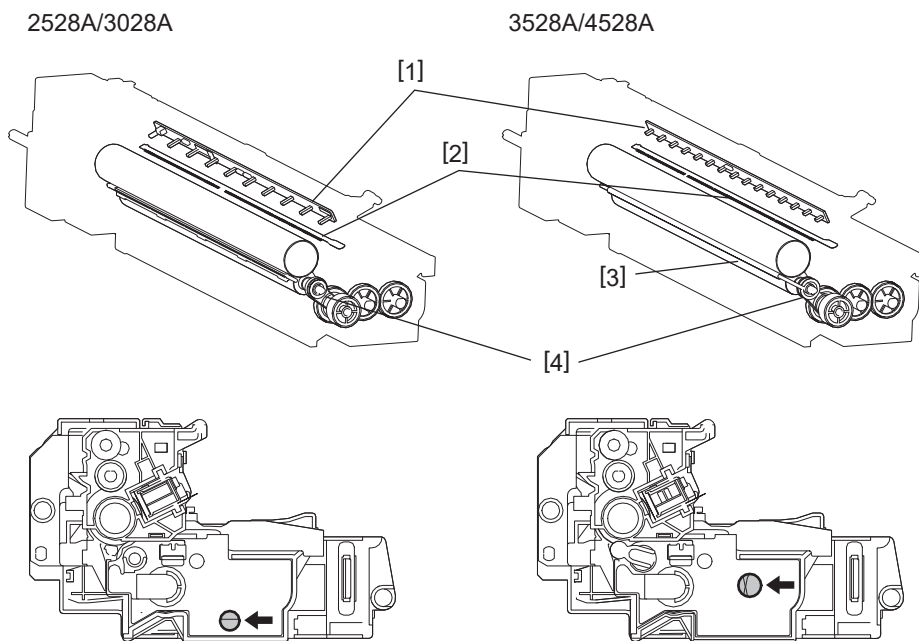

Fig. 3-39

- [1] Discharge LED
- [2] Needle electrode
- [3] Toner recovery roller
- [4] Gear, belt

### [ 3 ] Recovered toner supply mechanism

The toner scraped off by the drum cleaning blade is transported by the toner recovery auger and toner recycling auger to be recycled, and then returned to the developer unit. Then the recovered toner in the developer unit is mixed with developer material by the mixer-3. The mixer-3 is mounted exclusively to enable the recovered toner to be mixed in sufficient time.

On the other hand, the fresh toner transported into the developer unit from the toner cartridge is mixed by the mixer-2. Then the fresh toner and the recovered toner are mixed together and further transported to the mixer-1. They are further mixed and transported to the developer sleeve by the mixer-1.

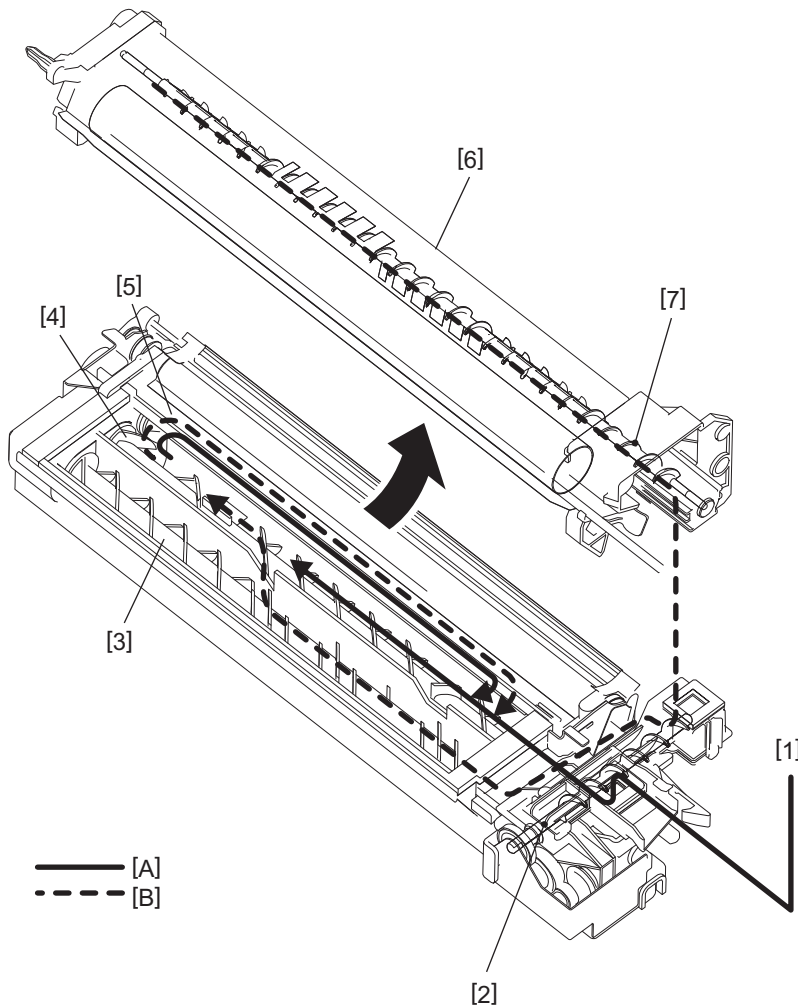

Fig. 3-40

- [A] Fresh toner
- [B] Recovered toner
- [1] toner cartridge
- [2] Toner recycling auger
- [3] Mixer-3
- [4] Mixer-2
- [5] Mixer-1
- [6] Drum cleaner
- [7] Toner recovery auger

### 3.13.4 Functions of the toner cartridge PC board (CTRG)

The toner cartridge PC board (CTRG) is equipped in the toner cartridge of this MFP. An IC chip is embedded in this board. Data such as the identification information for the recommended TOSHIBA toner cartridge, thresholds to determine if the cartridge is nearly empty, and controlling data for the image quality to be optimal according to the toner characteristics are written in this chip.

To measure the amount of toner remaining in the cartridge, when the value of the counter for the period of the toner cartridge rotation time is updated, this MFP writes the updated value into the toner cartridge PC board (CTRG).

These data written in the toner cartridge PC board (CTRG) enable the functions below and accordingly this MFP operates as shown below. Data reading is performed every time when the power is turned ON, the front cover is closed, a job is finished and the MFP has recovered from the sleep mode.

#### [ 1 ] Data read by the toner cartridge PC board (CTRG)

- Data to identify recommended TOSHIBA toner cartridges
- Thresholds to determine if the toner cartridge is nearly empty
- Value of the counter for the period of the toner cartridge rotation time
- Data for optimizing the image quality
- Threshold of toner remaining displays

#### [ 2 ] Function

- Toner cartridge check function  
This function checks whether the toner cartridge is inserted correctly or not, and whether the recommended toner cartridge is used or not.
- Toner remaining check function  
This function notifies the user of the near-empty status of the toner. Normally, "Toner is low" is displayed when the toner is running out and "Toner empty" when the toner cartridge becomes empty.
- Toner remaining check notification function  
Upon detecting the near-empty status of the toner, this function automatically notifies your service representative.
- Image optimization function  
This function controls the quality of images to be optimal according to the characteristics of the toner used.
- Toner remaining display function  
This function displays the remaining toner amount from 0% to 100%.

#### [ 3 ] Performance

A sign indicating that the toner cartridge is nearly empty appears in the following cases:

- The counter value for the toner cartridge rotation time has exceeded the threshold previously written in the toner cartridge PC board (CTRG). (Related code: FS-08-5155)
- The remaining amount of toner is equal to or less than the set amount (percentage or number of sheets). (Related codes: FS-08-5155, FS-08-5810, FS-08-5811)

When a used cartridge refilled with a new toner is used, a sign indicating that the toner cartridge is empty appears because information for determining the empty status has already been written in the toner cartridge PC board (CTRG).

When a non-recommended toner cartridge is used, "Toner not recognized" appears on the control panel, and then the MFP may stop normal operations. The toner remaining display function, the toner remaining check function, the automatic remote supply order to Toshiba service representatives and the image optimization function may also be disabled.

The self-diagnostic codes to adjust the timing for displaying the toner nearly-empty status are as follows.

- Toner near empty threshold setting (FS-08-5155)  
<Setting value>
  - 0: The period from the appearance of the toner nearly-empty indication to the actual complete consumption of the toner is set to long.
  - 1: Normal (Default)
  - 2: The period from the appearance of the toner nearly-empty indication to the actual complete consumption of the toner is set to short.
  - 4: Toner nearly-empty status threshold value (%)
  - 5: Toner nearly-empty status threshold value (Number of sheets)
- Toner near-empty status threshold value setting (%) (FS-08-5810)  
Use this code to specify the threshold value (unit: %) for displaying the toner nearly-empty status. This code is used when the value of FS-08-5155 is set to "4".
- Toner near-empty status threshold value setting (number of sheets) (FS-08-5811)  
Use this code to specify the threshold value (unit: number of sheets) for displaying the toner nearly-empty status. This code is used when the value of FS-08-5155 is set to "5".
- Fine adjustment of threshold value for displaying the toner remaining amount / toner nearly-empty (FS-08-5156)  
This code performs fine adjustment of the threshold value for displaying the toner remaining amount and toner nearly-empty.  
Display threshold value = Default threshold value x setting value/100 (Unit: %)

#### [ 4 ] Display adjustment of toner nearly-empty and toner empty

The toner empty indication appears when the auto-toner sensor in the developer unit detects the actual amount of toner in the developer unit has become low. The toner remaining amount is displayed by means of calculating it by counting the value of the counter for the period of the toner motor (K) rotation time. Then the toner nearly-empty indication appears when the calculated toner remaining amount has reached the specified value (the toner amount which can print approx. 1,000 sheets of paper when an image whose print ratio is 6% is printed with the A4 or LT equivalent paper size).

The relationship between the period of the toner motor (K) rotation time and the actual toner consumption amount varies depending on the printed images and usage conditions. Therefore, the displaying of the toner remaining amount can be adjusted by the codes shown below. However, it is recommended to handle the toner remaining amount as the reference since the printed images and usage conditions are always unstable and there will be variations in the systems.

1. Fine adjustment of the toner remaining amount display  
When the displayed toner remaining amount is decreased more quickly than that for the actual toner (when "1%" is being displayed for a long time), set a value in FS-08-5156 larger than the default one. When the displayed toner remaining amount is decreased more slowly than that for the actual toner (when the toner nearly-empty indication appears before "1%" is displayed), set a value in FS-08-5156 than smaller the default one.
2. Setting change of the period from the toner nearly-empty to the toner empty
  - Setting change of the period from the toner nearly-empty to the toner empty  
When the period is made longer, set "0" in FS-08-5155. When the period is made shorter, set "2" in FS-08-5155.
  - Setting change of the toner nearly-empty threshold value  
When the threshold value (default: printing approx. 1,000 sheets of paper is available when an image whose print ratio is 6% is printed with the A4 or LT equivalent paper size) used to designate toner nearly-empty is changed, perform the following setting change.

When the change is made by using the toner remaining amount (%), set “4” in FS-08-5155 and exchange the value of FS-08-5810. In order to designate the toner nearly-empty status while the toner remaining amount is greater than the default value, set a larger value in FS-08-5810. When the change is made by using the available remaining number of print sheets, set “5” in FS-08-5155 and exchange the value of FS-08-5811. In order to designate the toner nearly-empty status while the available remaining number of print sheets is greater than the default value (printing approx. 1,000 sheets of paper is available when an image whose print ratio is 6% is printed with the A4 or LT equivalent paper size), set a larger value in FS-08-5811.

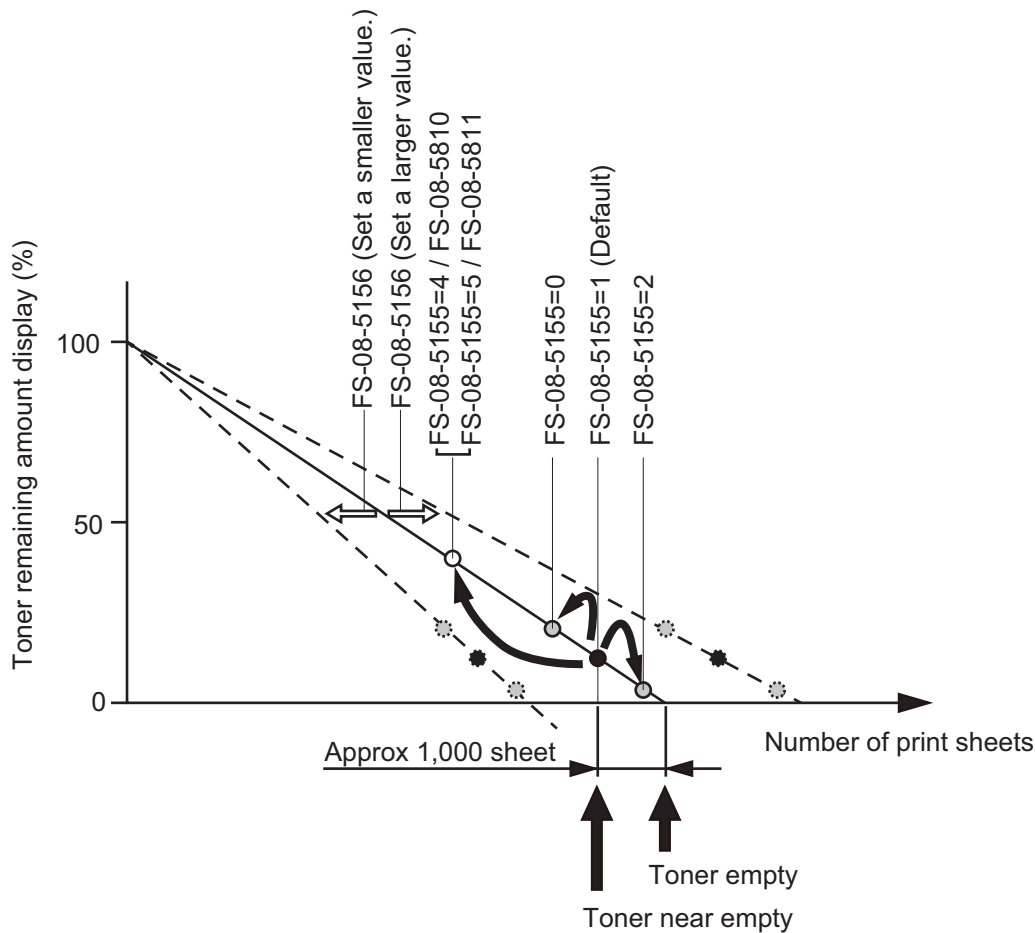

Fig. 3-41

**Notes:**

- Do not perform the change operations 1 (Fine adjustment of the toner remaining amount display) and 2 (Toner near-empty setting change) simultaneously. If the change is required by the combination of the operations 1 (Fine adjustment of the toner remaining amount display) and 2 (Toner near-empty setting change), only perform either of them first. Then change the setting for another one while checking the results.
- The values of the toner remaining amount and the number of print sheets are the reference. They will vary depending on the printed images and usage conditions.

## 3.14 Fusing Section

### 3.14.1 Overview

In the fusing section, toner is fused by applying heat and pressure to the transferred image on the transported paper. The paper is then transported to the paper exit section after the completion of fusing. The fuser unit consists of the heater lamp, heat roller, pressure roller, separation finger, thermistor, thermostat, etc.

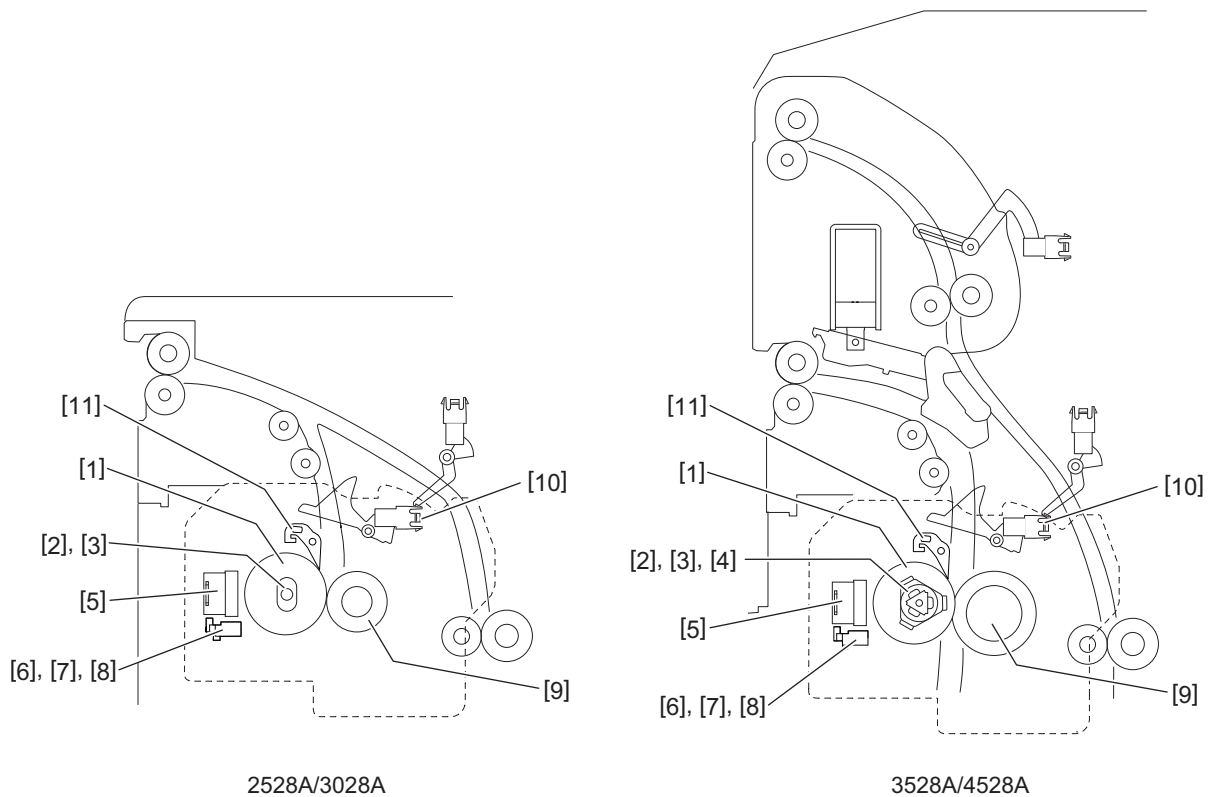

Fig. 3-42

- [1] Heat roller
- [2] Side heater lamp
- [3] Center heater lamp
- [4] Sub heater lamp
- [5] Fuser center thermostat, Fuser side thermostat
- [6] Heat roller edge thermistor
- [7] Heat roller center thermistor
- [8] Heat roller side thermistor
- [9] Pressure roller
- [10] Paper exit sensor
- [11] Heat roller separation finger

### 3.14.2 Composition

Item		2528A/3028A	3528A/4528A
Heat roller			
Center heater lamp	LAMP1 (600 W)	Maintenance required	Maintenance required
Side heater lamp	LAMP2 (600 W)	Maintenance required	Maintenance required
Sub heater lamp	LAMP3 (300 W)	None	Maintenance required
Heat roller center thermistor	THM5	Maintenance required	Maintenance required
Heat roller side thermistor	THM6	Maintenance required	Maintenance required
Heat roller edge thermistor	THM7	Maintenance required	Maintenance required
Fuser center thermostat	THMO7	Maintenance required	Maintenance required
Fuser side thermostat	THMO8	Maintenance required	Maintenance required
Pressure roller		ø22 mm	ø30 mm
Separation finger		Maintenance required	Maintenance required

### 3.14.3 Functions

#### 1. Center heater lamp (LAMP1), Side heater lamp (LAMP2), Sub heater lamp (LAMP3)

The heater lamps are halogen lamps used for applying heat to the heat roller. The fuser unit in this MFP has 3 heater lamps with each one having different functions. The 3 heater lamps, each having different functions are called the center heater lamp, the side heater lamp and the sub heater lamp. The center heater lamp has a coil wound up on its center and this part generates heat. The side heater lamp has coils wound up on its both ends and these parts generate heat. The sub heater lamp has a coil wound up in whole and generates heat to assist the center heater lamp and the side heater lamp.

For 2528A/3028A, the sub heater lamp is not installed.

The following is the output of each heater lamp.

Center heater lamp: 600 W

Side heater lamp: 600 W

Sub heater lamp: 300 W

#### 2. Heat roller

The heat roller applies heat onto the paper and is heated by the heater lamps installed inside of the heat roller. The heat from this roller fuses toner onto the paper. The heat roller in this MFP is a thin roller and the warming-up time is shortened.

#### 3. Pressure roller

The pressure roller is a sponge roller which assures the nip amount of the heat roller. The pressure from the spring presses the paper onto the heat roller to fuse the toner onto the paper efficiently. The pressure roller is an electrical conductive one, and to improve the transferability and prevent offset, a positive (+) bias is applied to the pressure roller and the entrance guide. A sponge roller with lower hardness is adopted for the pressure roller in this fuser unit to enable envelopes to pass through.

The outside diameter of the pressure roller is ø22 (mm) for 2528A/3028A and ø30 (mm) for 3528A/4528A.



4. Separation finger  
The separation fingers are installed, five above the pressure roller and five above the heat roller, in order to separate the paper, which has adhered to each roller.
5. Heat roller center thermistor (THM5), Heat roller side thermistor (THM6)  
These thermistors detect the temperature of the heat roller to maintain it in a certain temperature range between the lower limit causing poor fusing and the upper limit causing high temperature offsetting. When the temperature of the heat roller is lower than the preset temperature, it turns ON the power supply to the heater lamps, and when it is higher than the preset temperature, it cuts off the supply.  
The center thermistor detects the temperature of the center part of the heat roller. The side thermistor detects the temperature of one side of the heat roller and controls both sides.
6. Heat roller edge thermistor (THM7)  
This thermistor detects any temperature abnormality at both ends of the heat roller. This area may be overheated without heat absorption by the paper since it does not pass through this area. This thermistor is not related to the temperature control of the heat roller.
7. Fuser center thermostat (THMO7), Fuser side thermostat (THMO8)  
The thermostat cuts off the power supply to the heater lamps by opening itself if the heat roller becomes abnormally hot as a result of a problem such as a thermistor malfunction. The thermostat for this MFP is used to prevent an abnormal operation. When the thermostat detects any abnormality, it must be replaced as well as any other damaged parts in the fuser unit.
8. Paper exit sensor  
The paper exit sensor detects if the leading edge of the paper or the paper itself has passed through the fuser unit. This sensor is also used for the detection of a paper jam in the fuser unit and paper exit section.

### 3.14.4 Operation description

The heat roller is pressed with the spring force from the pressure roller side, and is rotated by the main motor drive. Then the paper transported to the fuser unit is held between the heat roller and pressure roller and the toner is fused on the paper by means of heat and pressure. After this, the separation fingers separate the paper from the heat roller or pressure roller. Then the paper is transported to the exit tray for paper exiting options through the paper exit roller and the lower paper exit roller. In addition, the heater lamps in the heat roller do not structurally rotate.

The 3 heater lamps, which having different functions are installed; the center heater lamp applies heat to the center part of the heat roller, the side heater lamp applies heat to both ends of the roller, and the sub heater lamp applies heat to the whole roller and assists the heater lamp and the side heater lamp. For 2528A/3028A, the sub heater lamp is not installed.

The thermistors control the temperature of the heat roller and detect temperature abnormalities. If the temperature becomes excessively high, the thermostat is opened to stop the power supply to the heater lamps.

### 3.14.5 Heater control circuit

#### [ 1 ] Composition

In this MFP, the surface temperature of the heat roller is controlled by turning ON and OFF 3 heater lamps (center, side and sub) which have different heat-generating positions with a command from the engine-CPU on the LGC board.

The surface temperature of the heat roller is detected by 3 thermistors (center, side and edge) and then the information of the temperature is transmitted to the engine-CPU and each control circuit. Based on the detected temperature, the engine-CPU transmits the control signal of the heater lamp to the control circuit (TRC: Triac) of each heater lamp on the switching regulator via the temperature control circuit. The power supply to the heat roller is thus controlled by driving the triac. The temperature control circuit detects the overheating of the heat roller. In case that the surface temperature of the heat roller has exceeded the specified temperature, the temperature control circuit turns the heater lamp OFF.

If the temperature control circuit does not function for some reason and the heat roller is abnormally overheated as the result, a relay OFF circuit transmits a relay OFF signal to turn off the relay, and to turn the power OFF forcibly. If the temperature control circuit does not function for some reason and the heat roller is abnormally overheated as the result, 2 thermostats (front and center ones in the fuser unit) shut off the power supply to the heater lamps to protect the MFP.

For 2528A/3028A, the sub heater lamp is not installed.

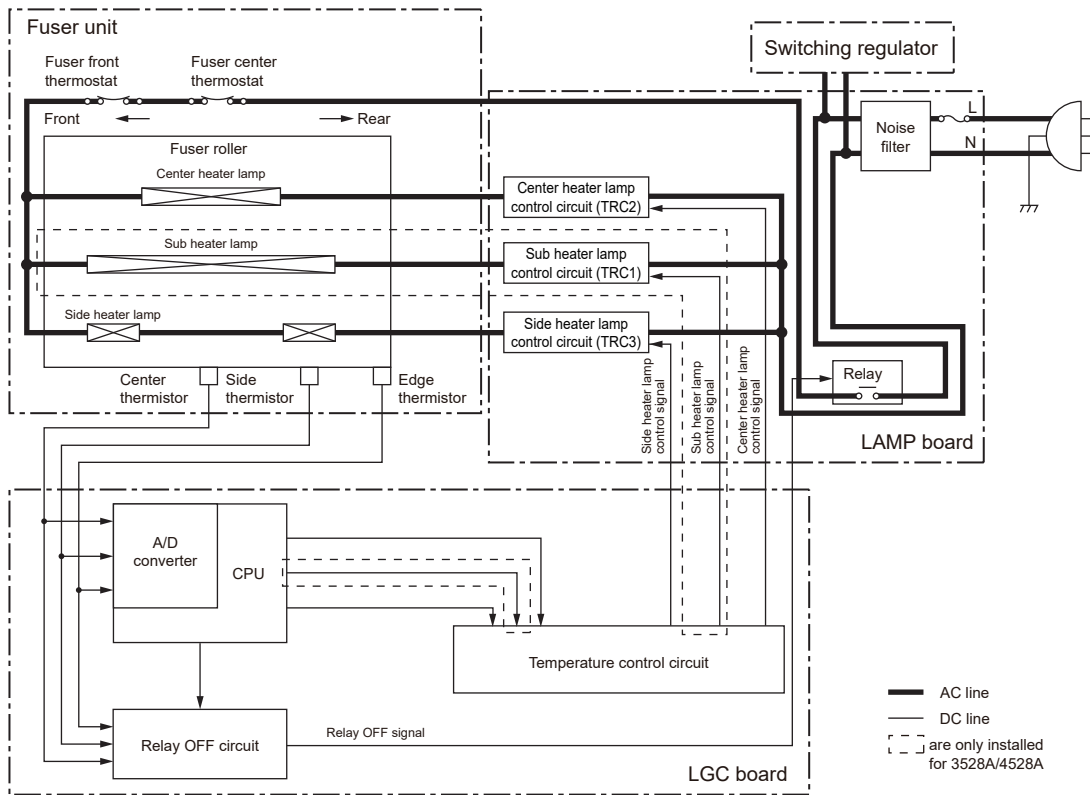

Fig. 3-43

## [ 2 ] Temperature detection section

### [ 2-1 ] Fuser unit error status counter control

- If any of the error codes [C411] to [C4B0] is displayed but the error is still not cleared and the heater lamp is not turned ON even after the thermistor, thermostat or heater lamps were repaired and the power was turned ON, check the value of FS-08-2002 (fuser unit error status counter) to clear it to "0".

**Important:**

If the value of FS-08-2002 (fuser unit error status counter) is abnormal, perform the troubleshooting for a C4B0 error.

- When the power was turned ON but the heater lamp is not turned ON and an error code [C411] or [C412] is displayed immediately, check the fuser unit error status counter to see whether the value is "2" or larger. If the value is "2" or larger, be sure to check the thermistor, thermostat and heater lamp and correct the relevant parts. Then clear the counter value to "0" and turn the power ON.
- When the thermistors detect overheating, the engine CPU determines an error code and the fuser unit error status counter value. Then to protect the fuser unit, each output (from the heater lamp, exposure lamp, control panel, motors and so on) is turned OFF and the power supply is turned OFF.

Error Code: C449

FS-08-2002 (Fuser unit error status counter): 9, 19, 21, 22, 23, 25, 27, 29, 45, 59, 60, 61, 63, 64, 65, 66, 67, 68

The thermistors continue detecting abnormal temperatures even after an error code and a counter value are determined. Even if the power is turned ON immediately, it is automatically turned OFF unless otherwise the surface temperature of the heat roller goes lower than the abnormal temperature detected. In this case, therefore, wait until the surface temperature of the heat roller becomes lower than the abnormal temperature detected. Then turn the power ON and check the counter value while waiting for the power is automatically turned OFF again. After confirming that it is a fuser unit abnormality, correct the subject part in the unit and clear the counter value of this code to "0" so that the MFP can be started up normally.

### [ 2-2 ] Temperature detection circuit

A thermistor is a device whose resistance varies according to the detected temperature. The ASIC detects voltages output from this device, and judges whether the operation of the fuser unit is normal or abnormal from the changes in voltages.

If any of the thermistors is broken, the control circuit judges that the surface temperature of the heat roller and pressure roller is extremely low and keeps turning the heater lamp ON. As a result, the surface temperature of the heat roller and pressure rises and this possibly activates a thermostat which is a safety protection device. To prevent this in advance, the ASIC detects whether each thermistor is broken or not.

Also, the control circuit constantly monitors the surface temperature of the heat roller to prevent it from excessive heating caused by abnormalities in circuits or thermistors. It automatically shuts OFF the power supply when the surface temperature exceeds the preset temperature.

### [ 2-3 ] Abnormality detection by the thermistors

The following table shows the conditions for judging the temperature abnormality of the heat roller and the detecting timing.

MFP operation status		Error code	Counter	Temperature judged			Detection timing
				Center thermistor	Side thermistor	Edge thermistor	
Power ON to Ready	At power ON	C449	9 Fixed	240°C or above	---	---	At power ON
				---	240°C or above	---	
				---	---	240°C or above	
			59 Fixed	Thermistor (HTERR signal: L)			
	Detecting 40°C	C449	19 Fixed	240°C or above	---	---	On usual
				---	240°C or above	---	
				---	---	240°C or above	
			60 Fixed	Thermistor (HTERR signal: L)			
		C411 *	1 Not fixed	40°C or below	40°C or below	---	Center 40°C Side 40°C
	C412	2 Fixed	40°C or below	40°C or below	---	Center 40°C Side 40°C	
	Detecting 100°C	C449	21 Fixed	240°C or above	---	---	On usual
				---	240°C or above	---	
---				---	240°C or above		
61 Fixed			Thermistor (HTERR signal: L)				
C443		3 Fixed	100°C or below	100°C or below	---	Center: 100°C Side: 100°C	
Detecting Ready temperature	C449	22 Fixed	240°C or above	---	---	On usual	
			---	240°C or above	---		
			---	---	240°C or above		
		63 Fixed	Thermistor (HTERR signal: L)				
	C452	62 Fixed	Ready temperature or above	100°C or below	---	Center: Ready temperature Side: Ready temperature	
			100°C or below	Ready temperature or above	---		
		5 Fixed	Ready temperature or above	---	---		
C445	5 Fixed	---	Ready temperature or above	---			

MFP operation status		Error code	Counter	Temperature judged			Detection timing	
				Center thermistor	Side thermistor	Edge thermistor		
During operation, At self-diagnostic mode	At Ready	C449	23 Fixed	240°C or above	---	---	On usual	
				---	240°C or above	---		
				---	---	240°C or above		
		C447	64 Fixed	Thermistor (HTERR signal: L)				On usual
		7 Fixed	40°C or below	---	---			
			---	40°C or below	---			
---	---	40°C or below	---					

MFP operation status		Error code	Counter	Temperature judged			Detection timing	
				Center thermistor	Side thermistor	Edge thermistor		
During operation, At self-diagnostic mode	During printing	C449	25 Fixed	240°C or above	---	---	On usual	
				---	240°C or above	---		
				---	---	240°C or above		
		65 Fixed	Thermistor (HTERR signal: L)					
		C447	8 Fixed	40°C or below	---	---		On usual
				---	40°C or below	---		
	---			---	40°C or below			
	C450	6 Fixed	The WAIT control according to low temperatures is 1 minute or more	---	---	On usual		
			---	The WAIT control according to low temperatures is 1 minute or more	---			
	At energy saving mode	C449	27 Fixed	240°C or above	---	---	On usual	
				---	240°C or above	---		
				---	---	240°C or above		
66 Fixed	Thermistor (HTERR signal: L)							
At paper misfeeding	C449	29 Fixed	240°C or above	---	---	On usual		
			---	240°C or above	---			
			---	---	240°C or above			
67 Fixed	Thermistor (HTERR signal: L)							
At self-diagnostic mode	C449	45 Fixed	240°C or above	---	---	On usual		
			---	240°C or above	---			
			---	---	240°C or above			
68 Fixed	Thermistor (HTERR signal: L)							

\* The shows that an error status has not yet been determined (= error status is detected only once).

## 3.15 Paper Exit Section, Reverse Section

### 3.15.1 Overview

For 2528A/3028A, a sheet of paper with the toner fused on is transported to the exit tray or Automatic Duplexing Unit (ADU) by switchbacking in the paper exit section.

For 3528A/4528A, a sheet of paper with the toner fused on is transported to the exit tray, but the lower exit roller does not switchback.

The reverse section is only installed for 3528A/4528A. The reverse section is a path only for switchbacking to the ADU to achieve the high-speed operation needed for duplex printing. The reverse section has the reverse gate which switches the transport path to the paper exit section or the reverse section. The reverse roller and upper exit roller switchbacks to transport the paper to the ADU.

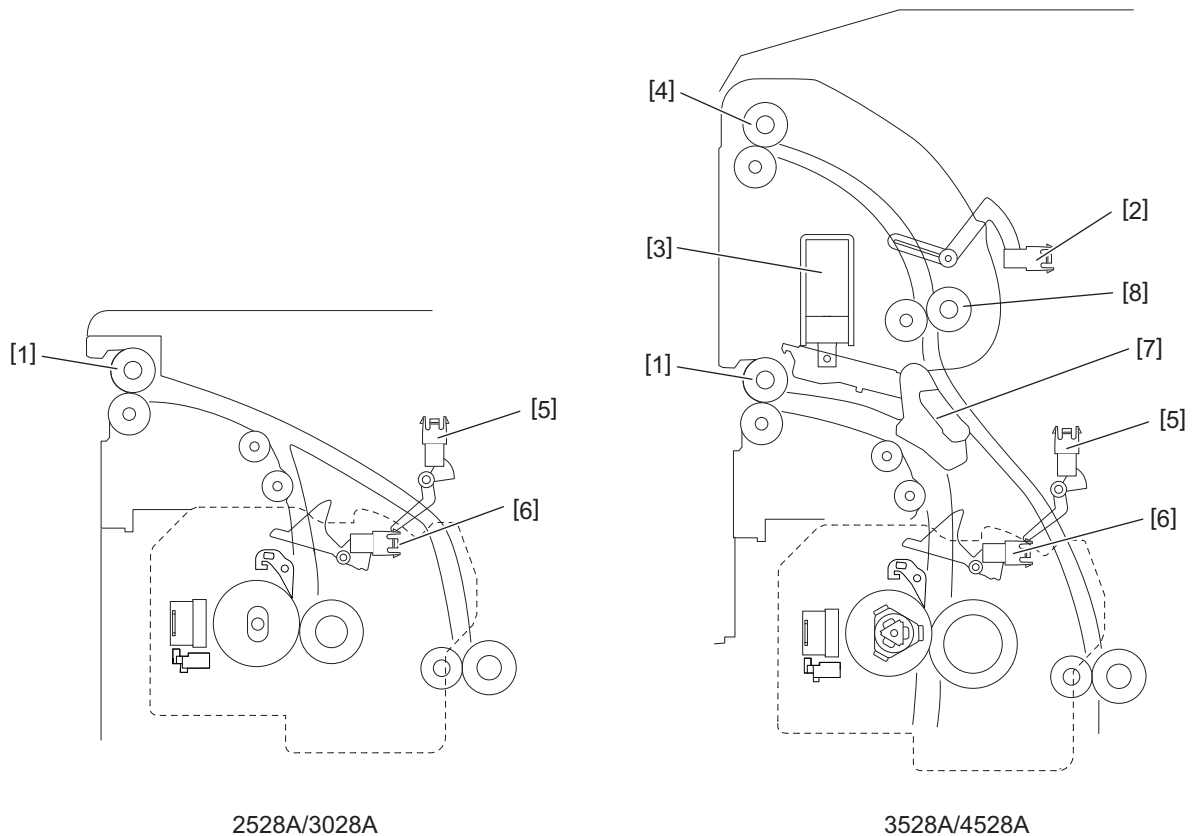

Fig. 3-44

- [1] Paper exit roller (2528A/3028A), Lower paper exit roller (3528A/4528A)
- [2] Reverse sensor
- [3] Reverse gate solenoid
- [4] Upper paper exit roller
- [5] ADU entrance sensor
- [6] Paper exit sensor
- [7] Reverse gate
- [8] Reverse roller

## Differences between 2528A/3028A and 3528A/4528A

Item	2528A/3028A	3528A/4528A
Reverse section (switchback mechanism) <ul style="list-style-type: none"> <li>• Reverse motor</li> <li>• Reverse sensor</li> <li>• Upper paper exit roller</li> <li>• Reverse roller</li> <li>• Reverse gate solenoid</li> <li>• Reverse gate</li> </ul>	None	Maintenance required

### 3.15.2 Functions

1. Paper exit motor (M5)  
The exit motor is a stepping motor which drives the paper exit roller (2528A/3028A). For 2528A/3028A, this motor rotates paper exit roller reversely to switchback when the paper is transported to the ADU.
2. Paper exit roller (2528A/3028A)  
The paper exit roller transports the paper from the fuser unit to exit tray. This roller is driven by the paper exit motor.  
For 2528A/3028A, this roller switchbacks to transport the paper to the ADU.
3. Lower paper exit roller (3528A/4528A)  
The lower paper exit roller transports the paper from the fuser unit to exit tray. This roller is driven by the main motor.
4. Reverse sensor (S26) (only installed for 3528A/4528A)  
The reverse sensor detects if the leading edge of the paper from the paper exit section has reached the reverse roller. This sensor is also used for the detection of a paper jam in the reverse section and the detection of the trailing edge of the reversed paper in duplex printing as well.
5. Paper exit/reverse motor (M24) (only installed for 3528A/4528A)  
The paper exit motor is a stepping motor which drives the reverse roller and upper paper exit roller. This motor rotates these rollers in normal and reverse to switchback when the paper is transported to the ADU.
6. Reverse roller, Upper paper exit roller (only installed for 3528A/4528A)  
The reverse roller and upper paper exit roller transport the paper from the paper exit section to the Job Separator (MJ-5015) or ADU. These rollers are driven by the paper exit motor.
7. Reverse gate solenoid (SOL2) (only installed for 3528A/4528A)  
The reverse gate solenoid drives the reverse gate to switch the paper transport path (paper exit section or reverse section).



### 3.15.3 Paper exit motor, Reverse motor, Main motor

#### 1. Paper exit motor

The figure shown below is the layout of the driving gears of the paper exit roller.

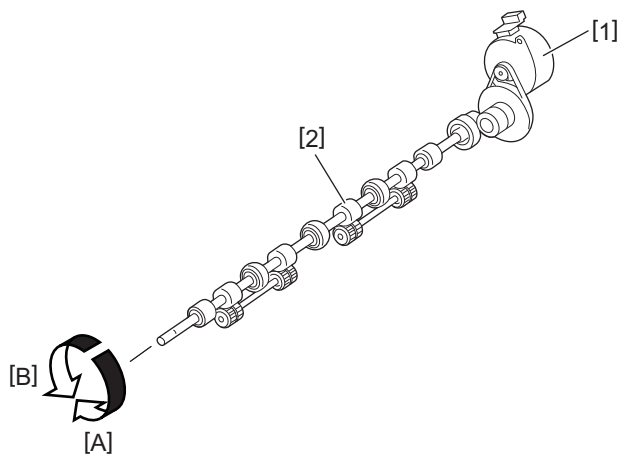

Fig. 3-45

- [1] Paper exit motor
- [2] Paper exit roller
- [A] Normal rotation
- [B] Reverse rotation

#### 2. Paper exit/reverse motor (only installed for 3528A/4528A)

The figure shown below is the layout of the driving gears of the reverse roller and upper paper exit roller.

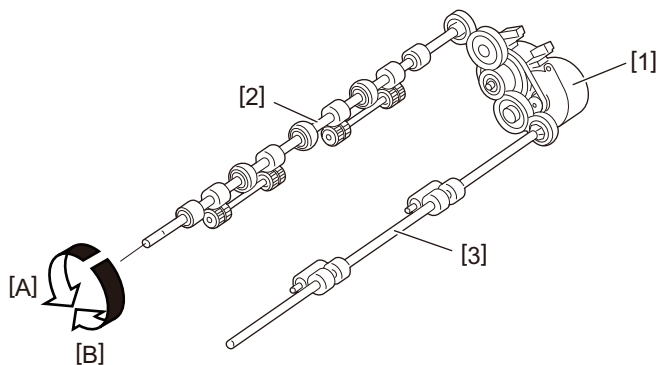
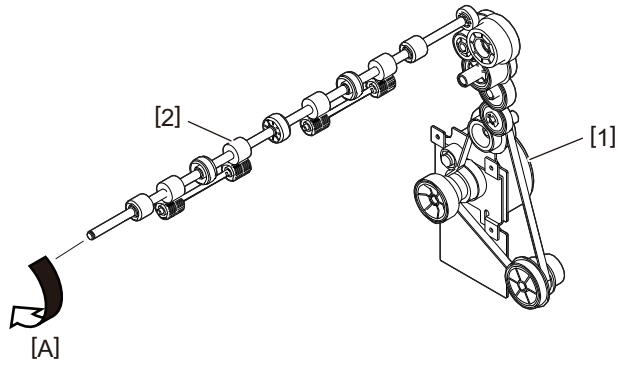

Fig. 3-46

- [1] Paper exit/reverse motor
- [2] Upper paper exit roller
- [3] Reverse roller
- [A] Normal rotation
- [B] Reverse rotation

### 3. Main motor

The figure shown below is the layout of the driving gears of the lower paper exit roller. (3528A/4528A only)



**Fig. 3-47**

[1] Main motor

[2] Lower paper exit roller

[A] Normal rotation

## 3.16 Automatic Duplexing Unit (ADU)

### 3.16.1 Overview

The Automatic Duplexing Unit (ADU) is a unit which automatically prints on both sides of paper. The ADU mainly consists of the transport rollers and their drive system, paper guide, ADU entrance sensor (S14) and ADU exit sensor (S15).

A switchback method using the paper exit roller is adopted for the ADU for 2528A/3028A. A sheet of paper is switchbacked at the paper exit roller right after the printing operation (fusing operation) on one side is completed. The reversed sheet is then transported to the registration section for the other side of the sheet to be printed.

A switchback method using the reverse section is adopted for the ADU for 3528A/4528A. A sheet of paper is switchbacked at the reverse section right after the printing operation (fusing operation) on one side is completed. The reversed sheet is then transported to the registration section for the other side of the sheet to be printed.

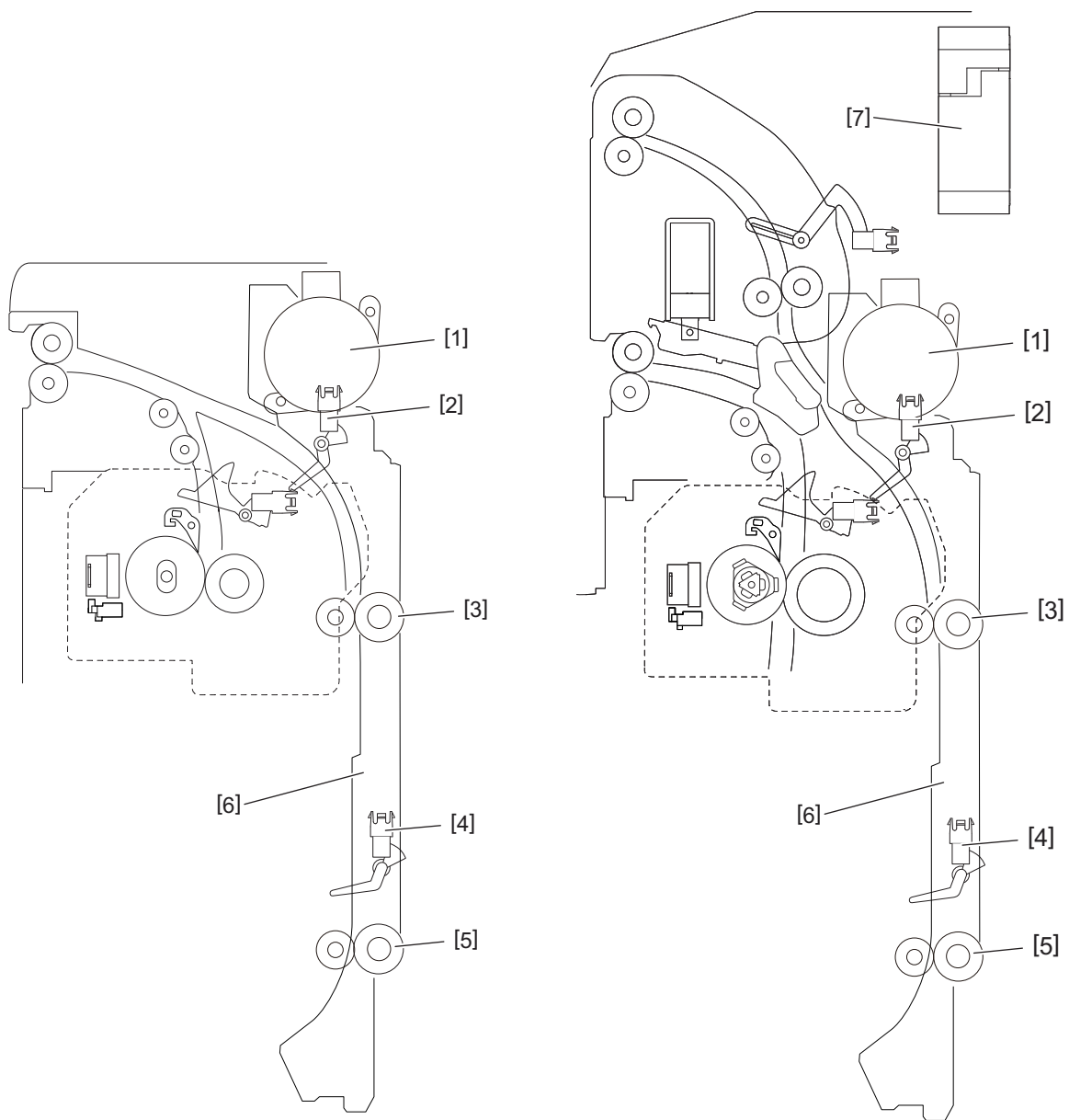

2528A/3028A

3528A/4528A

**Fig. 3-48**

- [1] ADU motor
- [2] ADU entrance sensor
- [3] Upper transport roller
- [4] ADU exit sensor
- [5] Lower transport roller
- [6] Paper guide
- [7] ADU fan (3528A/4528A only)

### 3.16.2 Composition

ADU motor	M12: Stepping motor
ADU entrance sensor	S14
ADU exit sensor	S15
Reverse sensor	S26
ADU driving PC board	ADU
Upper transport roller	
Lower transport roller	

### 3.16.3 Functions

1. ADU motor (M12)  
This motor drives the ADU upper transport roller and the ADU lower transport roller. This is installed to the rear frame of the MFP.
2. ADU entrance sensor (S14)  
This sensor detects the paper transported in the ADU.
3. ADU exit sensor (S15)  
This sensor detects the paper transported in the ADU.
4. ADU opening/closing switch (SW5)  
This switch detects the opening and closing status of the ADU.
5. Transport roller (upper and lower)  
These roller transport the paper inside the ADU.

### 3.16.4 Operation description

The printing of the back side (recording data of the back side of paper) is performed first by selecting duplex printing mode.

For 2528A/3028A, when the trailing edge of the paper has passed the paper exit gate, the paper is switched back by the paper exit roller and then is transported to the ADU. (The paper exit gate is switched by its own weight.) The switchbacked paper is transported with acceleration. When the ADU exit sensor detects the paper, the transportation decelerates.

The printing of the front side (recording data of the front side of paper) is performed at the registration section.

The paper passes through the paper exit gate again and is transported to the exit tray to complete duplex printing.

For 3528A/4528A, when the paper has passed the reverse sensor, the reverse gate solenoid switches the reverse gate, and the reverse roller and upper paper exit roller switchback to transport the paper into the ADU. The switchbacked paper is transported with acceleration. The transportation decelerates in front of the ADU exit sensor.

The printing of the front side (recording data of the front side of paper) is performed at the registration section.

The paper passes through the lower paper exit roller and is transported to the exit tray to complete duplex printing.

There are three methods of judging a paper jam: (1) whether the ADU entrance sensor is turned ON or not in a specified period of time after the switchback to the ADU started (E510). (2) whether the ADU exit sensor is turned ON or not in a specified period of time after the ADU entrance sensor is turned ON (E520). (3) whether the registration sensor is turned ON or not in a specified period of time after the paper feeding from the ADU to the MFP (E110).

If the ADU is opened during duplex printing, the ADU motor is stopped, namely, an E430 error (ADU open jam) occurs.

While paper is remaining in the ADU, the MFP is never stopped during printing by any interruption except a paper jam or a service call.

For the 2528A/3028A models, the duplex printing operation varies depending on the size of the paper, single-paper circulation and alternateness circulation.

### 3.16.5 Driving of the ADU

When the ADU motor (M12) rotates, the upper transport roller and lower transport roller are rotated via the gear and belts.

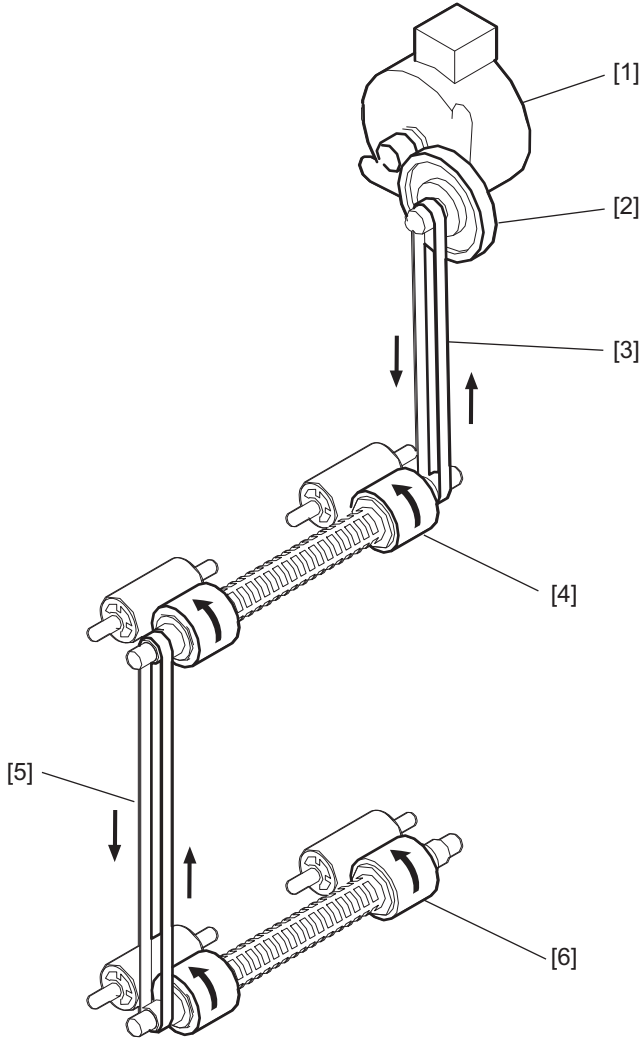

Fig. 3-49

- [1] ADU motor
- [2] Gear
- [3] Timing belt
- [4] Upper transport roller
- [5] Timing belt
- [6] Lower transport roller



## 3.17 Power Supply Unit

### 3.17.1 Composition

The power supply unit consists of AC filters, insulation-type DC output circuits, heater lamp control circuit and damp heater lamp control circuit.

### 3.17.2 Functions

The functions for each component in the power supply unit are as below.

1. AC filter  
Eliminates noise from the outside and prevents the noise generated by the MFP from leaking to the outside.
2. DC output circuits  
Converts AC voltage input from outside to DC voltage and supplies it to each electric part. The DC voltage is divided into the following two lines.
  - a. Power switch line:  
Power supply used in the entire MFP during the image forming process. Two kinds of voltage (+12 VA and +12 VS) are output when the power is turned ON.
  - b. Door switch line:  
Power supply used in the entire MFP during the image forming process, being supplied via the interlock switch.  
The voltage (+24 VD) is output only when the power is turned ON and the front cover and the ADU are closed.
3. Heater lamp control circuit  
TRC (triac) is driven by the heater control signals (HTR1ON, HTR2ON, HTRASTON) sent from the LGC board and the AC power is supplied to the center heater lamp, side heater lamp and sub heater lamp in the fuser unit.  
For 2528A/3028A, there is no HTRASTON signal since the sub heater lamp is not installed.
4. Damp heater power supply circuits (except for NAD, MJD)  
Outputs AC voltage input from outside to the DAMP PC board directly and supplies it to the damp heaters deployed in each section of the MFP.

### 3.17.3 Operation of output circuits

#### 1. Start-up operation of the MFP

Once the power cable of the MFP is plugged into an outlet, only +12 VS power is supplied to the power supply control circuits on the SYS board. When the power is turned ON by pressing the [ON/OFF] button on the control panel, the supplying of all the voltages is started. However, the voltage for the door switch line starts being supplied only when the front cover and ADU are closed.

#### 2. Stopping line output

When a power failure has occurred or the power cable is unplugged, the PWR-DN signal is output after the instantaneous outage insurance time elapses and then the supply of each voltage stops. If the voltage supply of the main line (+12 VA, +12 VS) stops earlier than the 24 V line does, it may cause damage to the electron device on each control circuit. To prevent this, the supply of these voltages stops after the PWR-DN signal is output and the minimum retaining time elapses.

#### 3. Output protection

Each output system includes an overcurrent and an overvoltage protection circuit (a fuse and an internal protection circuit). This is to prevent defects (damage or abnormal operation of the secondary circuit) which may be caused by an overcurrent due to a short circuit or an overvoltage due to a short circuit between different voltages. If the protection circuit is activated (except for a case in which the fuse is blown out), remove the causes such as the short circuit. Turn ON the power again to clear the overcurrent protection.

#### 4. Recovering from the super sleep mode (normal startup)

When the [Energy Saver] button on the control panel is pressed during the super sleep mode, its shifting or recovering signal (SYS-EN) is output from the SYS board and then voltage starts being supplied to all the lines, if no error was detected.

#### 5. Recovering from the super sleep mode (when receiving a packet)

When a packet from a network is received during the super sleep mode, it is shifted to the sleep mode.

When packets are received frequently, a control is performed to keep the sleep mode for a specified period. It will be cleared when the power is turned OFF and then back ON.

#### 6. Shifting to the super sleep mode (normal stopping)

When the [ENERGY SAVER] button on the control panel is pressed while the power is turned ON, a super sleep mode shifting/recovering signal (SYS-EN) is stopped after the initialization is finished and then all lines for the output voltage except +12 VS are closed.

In the following cases, the MFP does not shift into the super sleep mode.

- When the super sleep mode is set to be disabled on the control panel, TopAccess and with the code FS-08-8543.
- When the e-BRIDGE ID Gate (for JPD only), Overwrite Enabler, USB storage device, Fingerprint reader or 2ndNIC is installed.
- When the IPsec Enabler is installed and its function is set to be enabled.
- When the operation is being performed in the self-diagnosis mode. (Disabled until the power is turned OFF)
- When the VNC setting is set to be enabled.
- When the Wi-Fi Direct function is set to be enabled.
- When the Multi Station print function is set to be enabled.
- When the [Assume this MFP is the Primary Server] check box is selected in the [Home Setting] screen.
- When the license of the IP Fax is installed.
- When any of the recovery methods is selected in [Recovery Setting] of [Screen Control].
- When a background application is being started.
- The MFP is being operated on TopAccess (during the retaining of the session).

## 7. State of the power supply

- Power is not supplied.  
The power cable is unplugged from an outlet.
  
- Power OFF  
When the MFP is shut down, a DC voltage is supplied only to the circuits on the SYS board which are monitoring the [ON/OFF] button, but the MFP is not operable.
  
- Normal state (including the energy saving mode)  
The power is turned ON and a DC voltage is supplied to each board. When the cover of the MFP is closed, a 24 V DC voltage is supplied and the MFP enters into the ready or printing status.
  
- Sleep mode  
The 12 VS and 12 VA power are supplied to the SYS board which operates normally. No power is supplied to the LGC board. In addition, the DC power supply of 24 V series is not supplied either.
  
- Super sleep mode  
Only the 12 VS power is supplied to the SYS board, but the 12 VA power is not. The CPU on the SYS board stops operating and monitors a recovery event only. No power is supplied to the LGC board. In addition, the DC power supply of 24 V series is not supplied either.

### 3.17.4 Output channel

The following are output channels for the power switch line.

Power switch line

Connector	Pin No.	Voltage	Destination
CN511	1	+12 VA	SYS board
	2	+12 VA	SYS board
	6	+12 VS	SYS board

The following are output channels for the cover switch line.

Cover switch line

Connector	Pin No.	Voltage	Destination
CN514	5	+24 VD1	LGC board
	6	+24 VD2	LGC board
	7	+24 VD3	Scanner, DF
	8	+24 VD4	Finisher

### 3.17.5 Fuse

Secondary fuse:

Not installed

Primary fuse:

Part		Fuse	
Filter board	FIL	F1	
Switching regulator	PS	F1	

## 4. DISASSEMBLY AND REPLACEMENT

### 4.1 Cover

#### 4.1.1 Front cover

- (1) Open the front cover.
- (2) Loosen 2 screws. Release the hook and pull out the front cover [1] at an angle toward the low-front side.

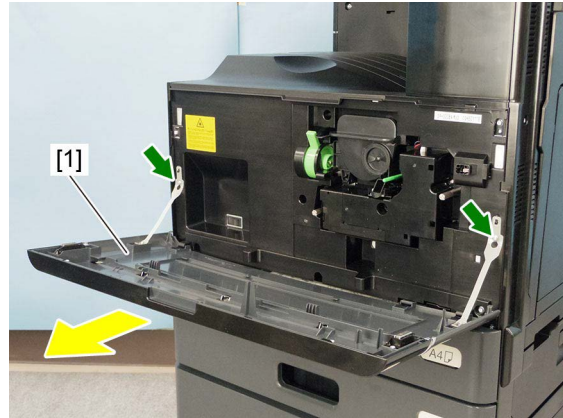

Fig. 4-1

#### 4.1.2 Left cover

- (1) Open the front cover and pull out the 1st drawer.
- (2) Remove 8 screws [2], [3]. Take off the left cover [1].  
[2] M4 x 8  
[3] M3 x 8

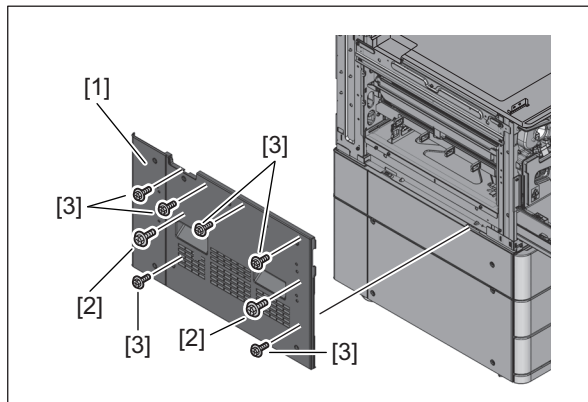

Fig. 4-2

### 4.1.3 Exit tray

- (1) Take off the left cover.  
📖 P. 4-1 "4.1.2 Left cover"
- (2) Take off the exit tray [1].

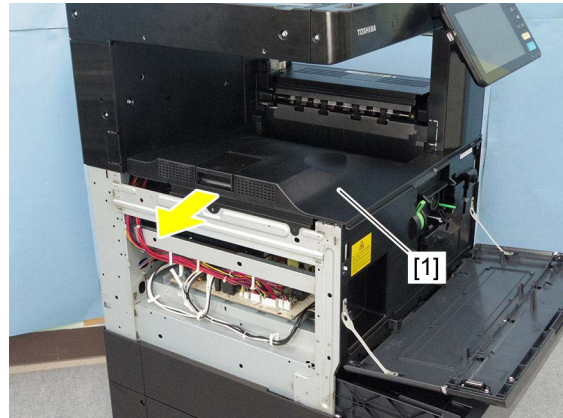

Fig. 4-3

### 4.1.4 Tray rear cover

- (1) Take off the exit tray.  
📖 P. 4-2 "4.1.3 Exit tray"
- (2) Take off the left rear cover.  
📖 P. 4-4 "4.1.6 Left rear cover"
- (3) Take off the paper exit back cover.  
📖 P. 4-4 "4.1.7 Paper exit back cover"
- (4) Remove 1 screw and take off the tray rear cover [1] by sliding it to the left.

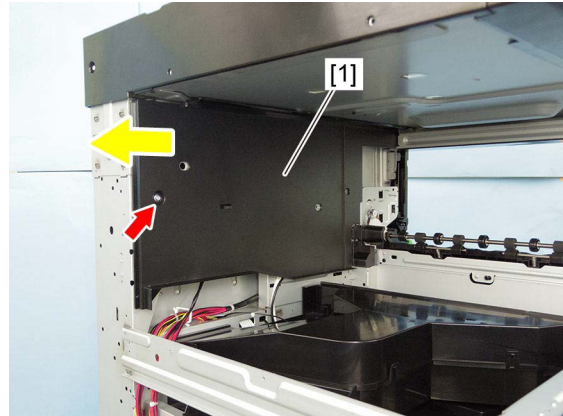

Fig. 4-4

**Notes:**

When installing, attach the latch [2] to the hole of the frame.

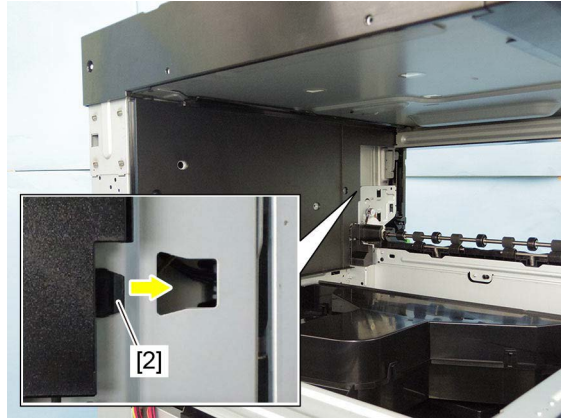

Fig. 4-5

### 4.1.5 Left top cover

(1) Remove 2 screws and take off the left top cover [1].

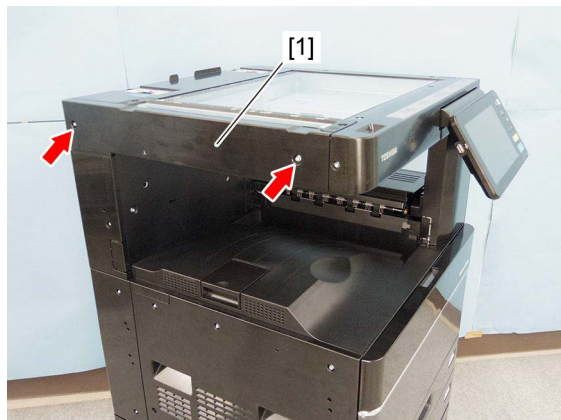

Fig. 4-6

### 4.1.6 Left rear cover

- (1) Take off the left top cover.  
📖 P. 4-3 "4.1.5 Left top cover"
- (2) Remove 1 screw [2] and take off the left rear cover [1] by lifting it up.

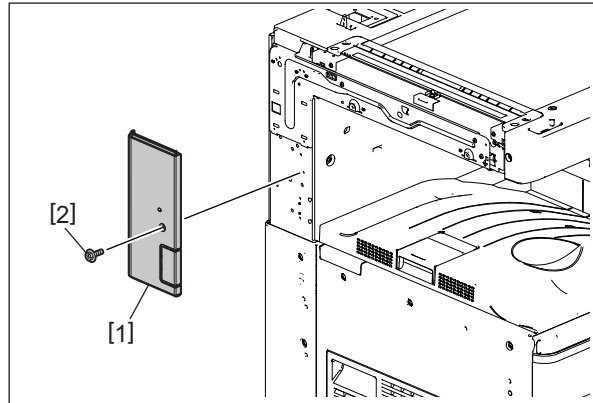

Fig. 4-7

### 4.1.7 Paper exit back cover

- (1) Open the ADU.
- (2) Remove 1 screw [2] and take off the paper exit back cover [1].

2528A/3028A

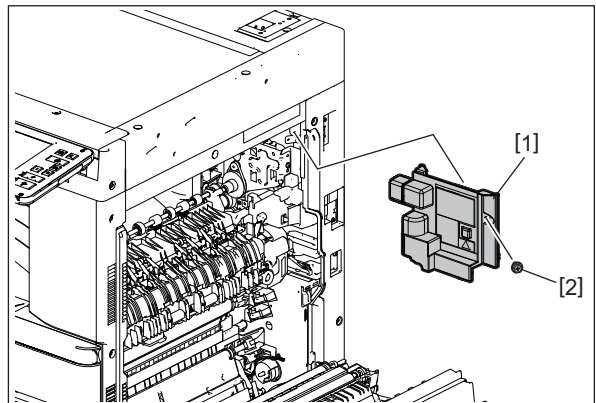

Fig. 4-8

3528A/4528A

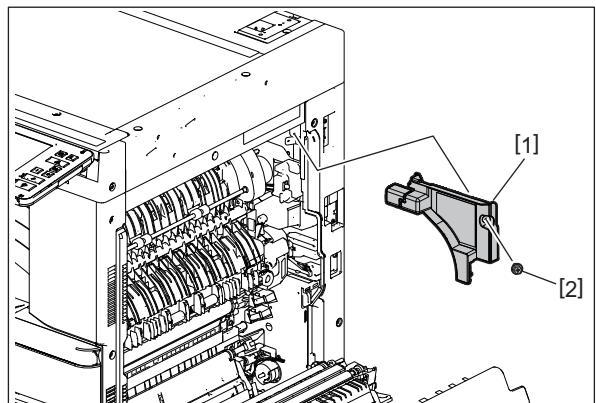

Fig. 4-9



### 4.1.8 Right top cover

- (1) Remove 3 screws and take off the right top cover [1] by lifting it up.

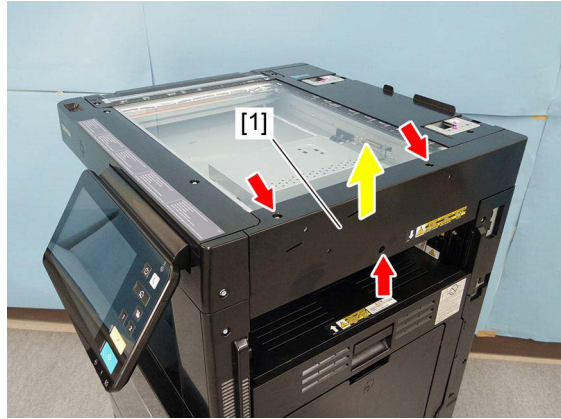

Fig. 4-10

### 4.1.9 Right front cover

- (1) Pull out the 1st and 2nd drawers.
- (2) Open the front cover.
- (3) Open the jam access cover.
- (4) Open the ADU.
- (5) Remove 2 screws and take off the right front cover [1] by lifting it up.

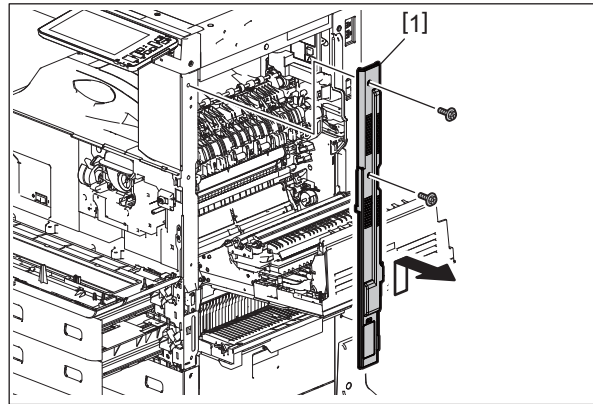

Fig. 4-11

### 4.1.10 Right rear cover

- (1) Open the jam access cover.
- (2) Take off the right top cover.  
P. 4-5 "4.1.8 Right top cover"
- (3) Open the ADU.
- (4) Remove 3 screws and take off the right rear cover [1].

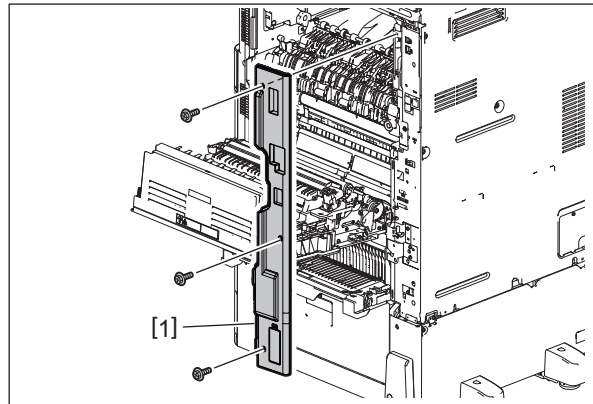

Fig. 4-12

### 4.1.11 Front top cover

- (1) Take off the right top cover.  
P. 4-5 "4.1.8 Right top cover"
- (2) Move the control panel to the position (rotated by 45 degrees) as indicated in the figure.

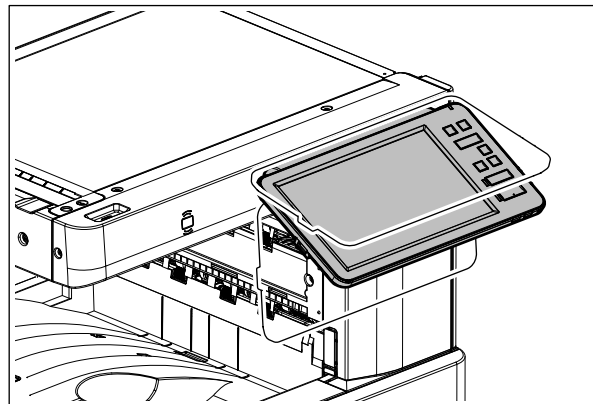

Fig. 4-13

- (3) Remove 2 caps.
- (4) Remove 3 screws and take off the front top cover [1] by sliding it to the left-hand side.

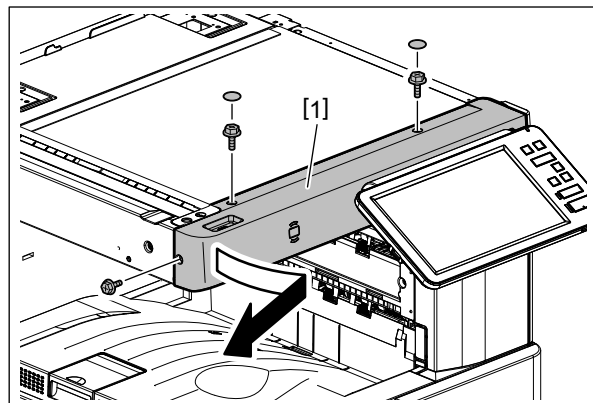

Fig. 4-14

## 4.1.12 Control panel lower cover

- (1) Make the control panel [1] level.

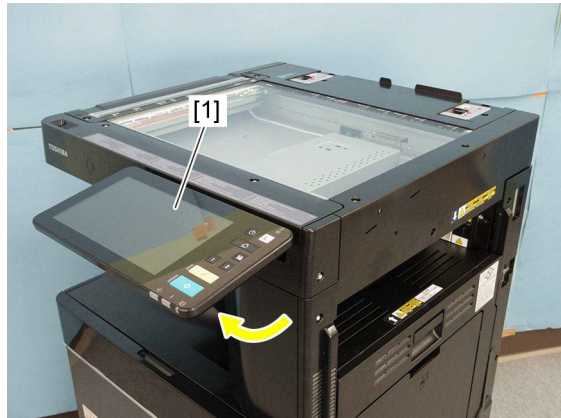

Fig. 4-15

- (2) Remove 2 screws and take off the control panel lower cover [2].

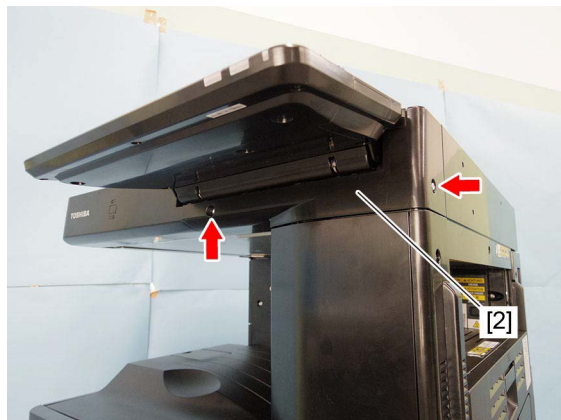

Fig. 4-16

### 4.1.13 Front right cover

- (1) Take off the control panel lower cover.  
📖 P. 4-7 “4.1.12 Control panel lower cover”
- (2) Open the front cover.
- (3) Remove 1 screw and take off the front right cover [1] by lifting it up.

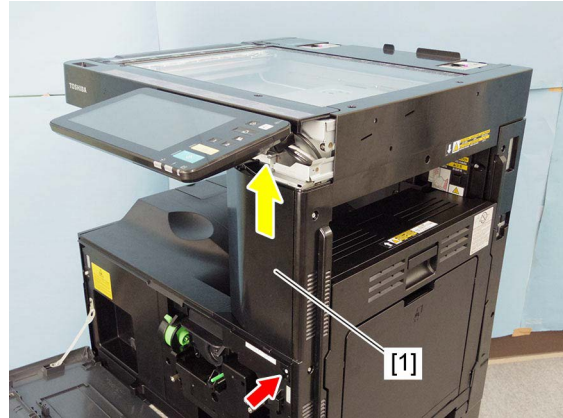

Fig. 4-17

### 4.1.14 Top rear cover

- (1) Take off the DSDF, RADF or platen cover.  
📖 P. 4-197 “4.13.1 Dual Scan Document Feeder (DSDF)”  
📖 P. 4-202 “4.13.2 Reversing Automatic Document Feeder (RADF)”
- (2) Take off the left top cover.  
📖 P. 4-3 “4.1.5 Left top cover”
- (3) Take off the right top cover.  
📖 P. 4-5 “4.1.8 Right top cover”
- (4) Remove 2 screws and take off the top rear cover [1].



Fig. 4-18

#### Notes:

When the platen cover is installed, remove 2 brackets.

### 4.1.15 Rear cover

- (1) Remove 6 screws and take off the rear cover [1] by lifting it up.

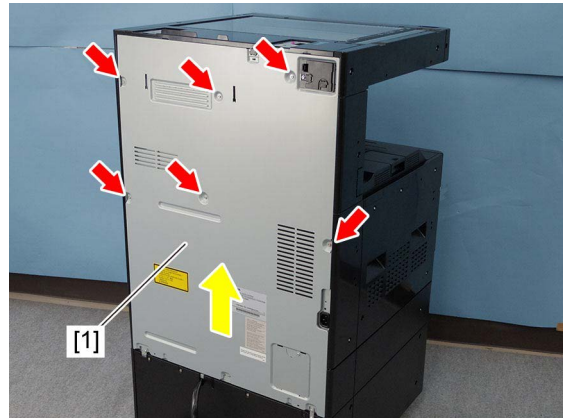



Fig. 4-19

### 4.1.16 Front cover switch (SW21)

- (1) Take off the exit tray.  
 P. 4-2 "4.1.3 Exit tray"
- (2) Disconnect 1 connector and take off the front cover switch [1].

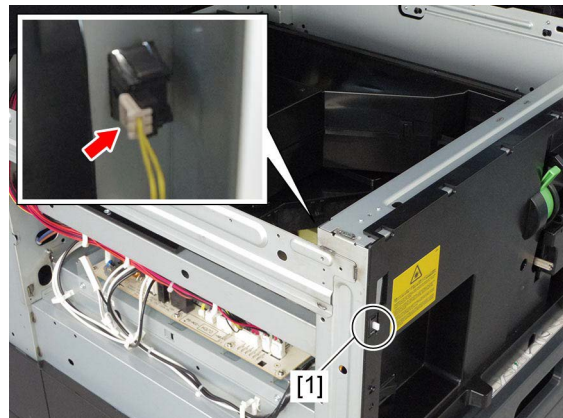

Fig. 4-20

## 4.1.17 Front cover interlock switch (SW2)

### Notes:

If the interlock switch is not installed appropriately, it may not work normally. If you carry out the maintenance of the MFP in such a situation, you could get an electric shock by touching live sections or be injured by touching moving sections. Therefore, to avoid this, be sure to perform correct handling and installation.

- (1) Take off the front cover.  
📖 P. 4-1 “4.1.1 Front cover”
- (2) Take off the exit tray.  
📖 P. 4-2 “4.1.3 Exit tray”
- (3) Take off the right front cover.  
📖 P. 4-5 “4.1.9 Right front cover”
- (4) Take off the front right cover.  
📖 P. 4-8 “4.1.13 Front right cover”
- (5) Take off the developer unit.  
📖 P. 4-120 “4.8.1 Developer unit”
- (6) Remove 5 screws and take off the inner cover [1].

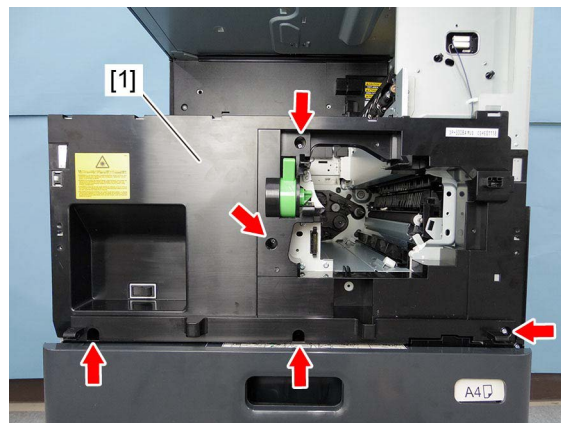

Fig. 4-21

- (7) Disconnect 2 connectors, remove 2 screws [2] and take off the front cover interlock switch [3].

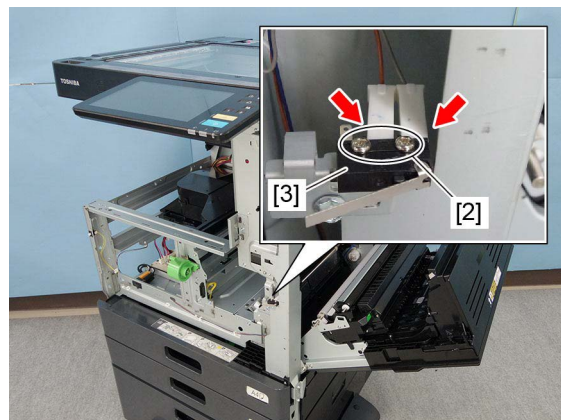



Fig. 4-22

## 4.2 Control Panel

### 4.2.1 Control panel unit

- (1) Take off the front top cover.  
 P. 4-6 “4.1.11 Front top cover”
- (2) Lower the control panel unit [1].

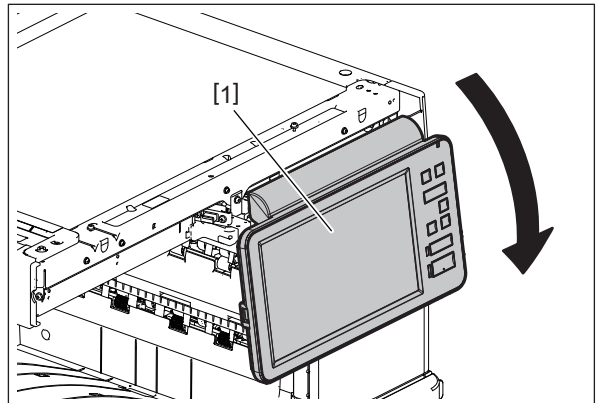

Fig. 4-23

- (3) Remove 2 screws [2] and take off the control panel unit [1] by sliding it.

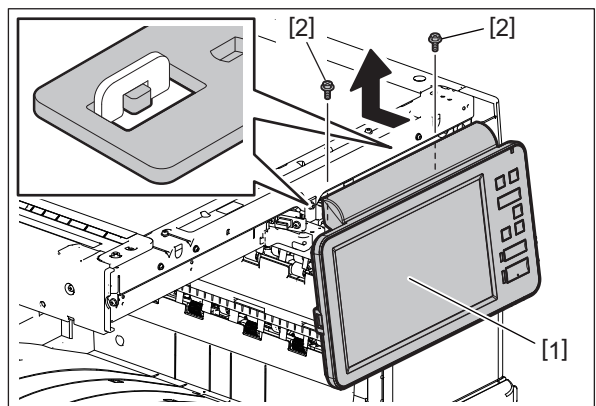

Fig. 4-24

- (4) Remove 4 screws [3].

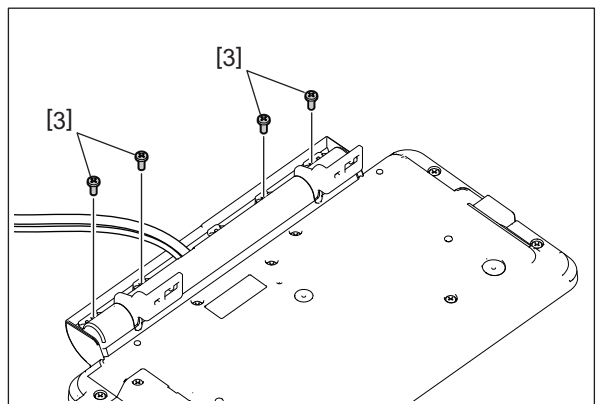

Fig. 4-25

(5) Raise 2 hinges [4] and take off the hinge cover [5].

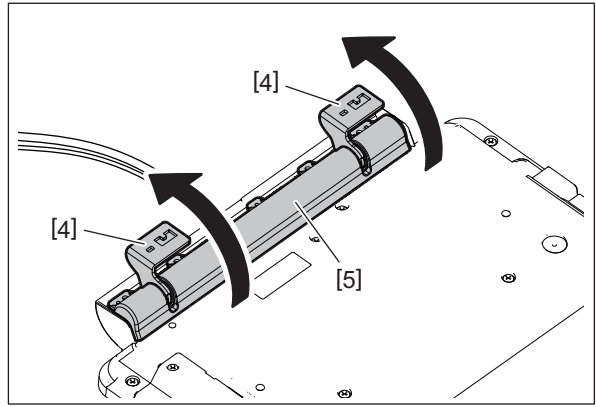

Fig. 4-26

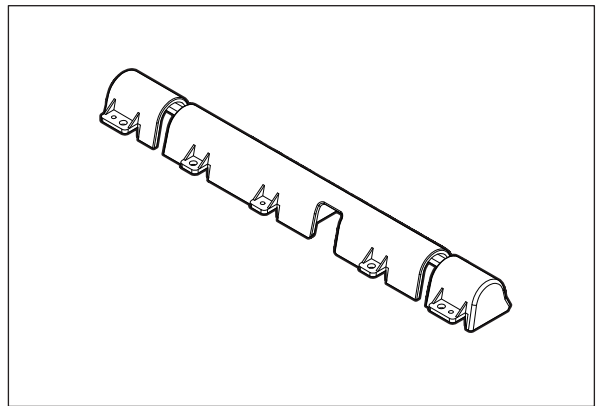

Fig. 4-27

(6) Remove 9 screws [6] and take off the cover [7].

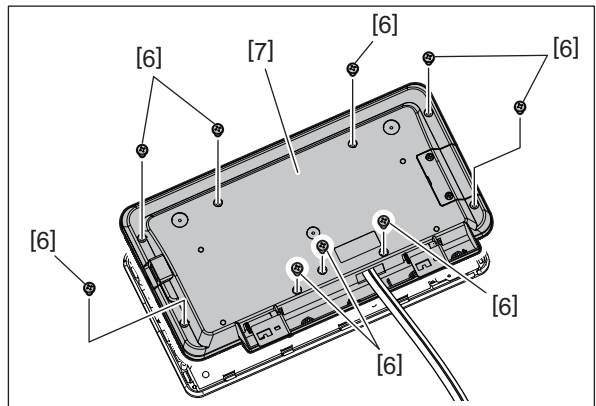

Fig. 4-28



- (7) Remove 1 screw [8]. Disconnect the connector [9] and remove the USB harness [10]. Disconnect 1 connector [11] and remove the signal harness [12].

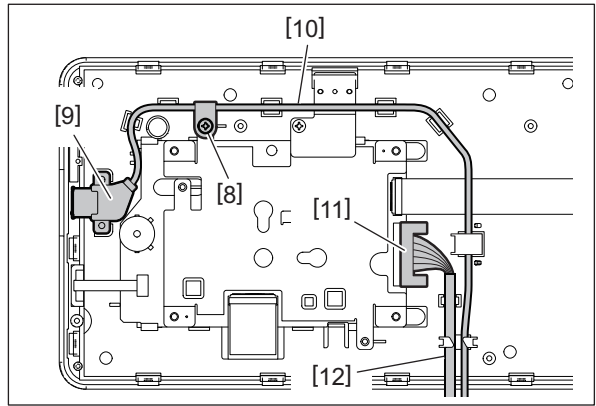

Fig. 4-29

**Notes:**

- When disconnecting the connector [11], release the lock in advance.

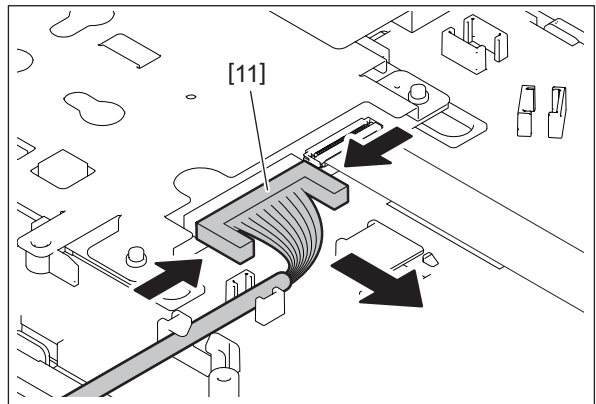

Fig. 4-30

- When installing the harness, pass it through 7 hooks [13].

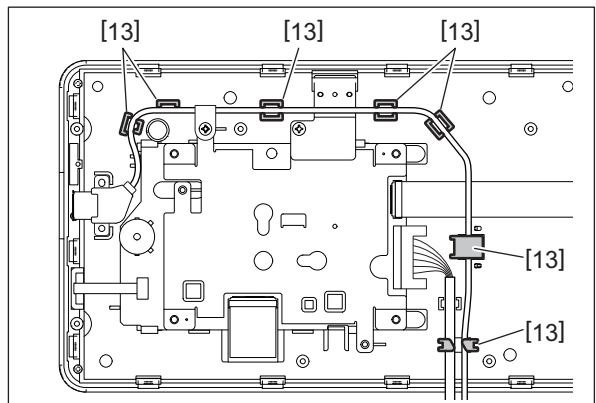

Fig. 4-31

## 4.2.2 Key PC board, Button

- (1) Take off the control panel unit.  
P. 4-11 "4.2.1 Control panel unit"
- (2) Release the flap [1] and remove 1 flat cable [2].  
Remove 1 screw [3] and take off the key PC board [4] and the sheet [5].

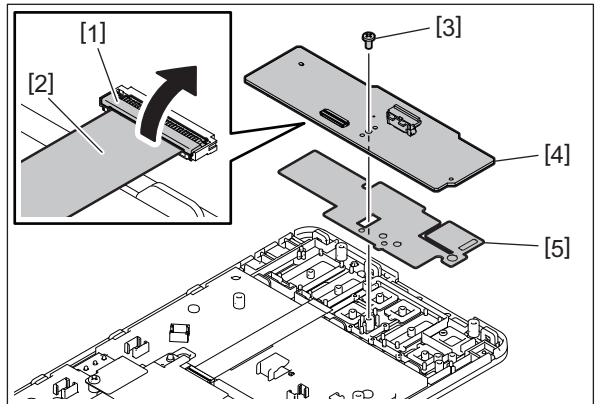

Fig. 4-32

- (3) Remove the buttons [6] through [11].

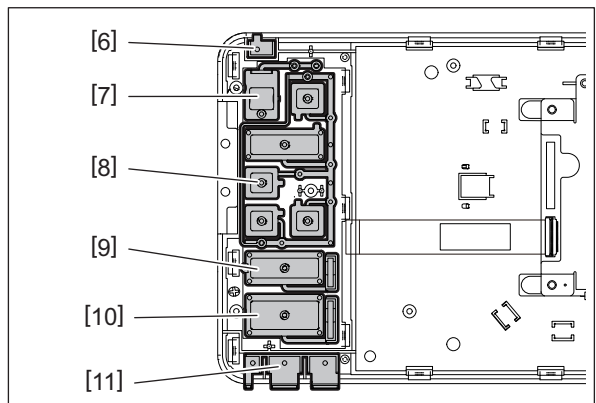

Fig. 4-33

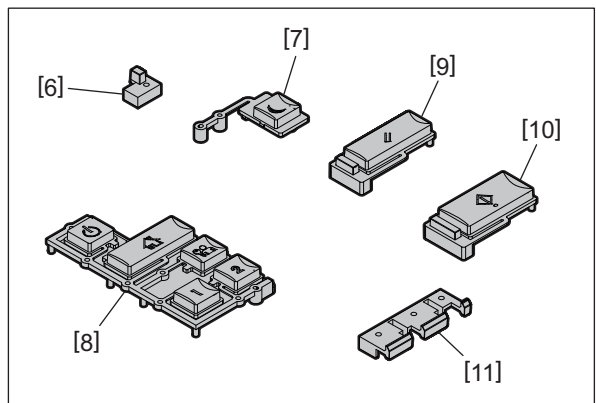

Fig. 4-34

### 4.2.3 Display PC board

- (1) Take off the control panel unit.  
P. 4-11 "4.2.1 Control panel unit"
- (2) Remove 1 screw [2] and take off the ground plate [1].

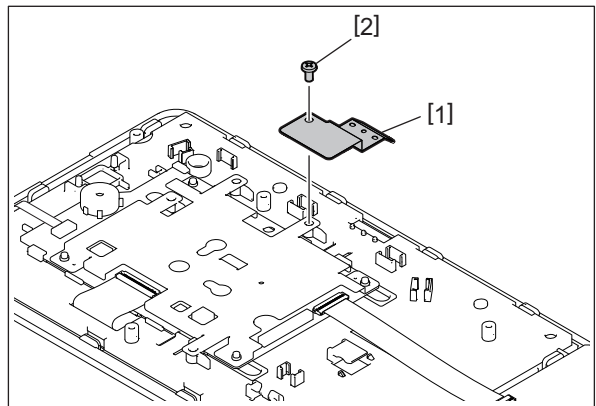

Fig. 4-35

- (3) Release the flap [3] and remove the flat cable [4].

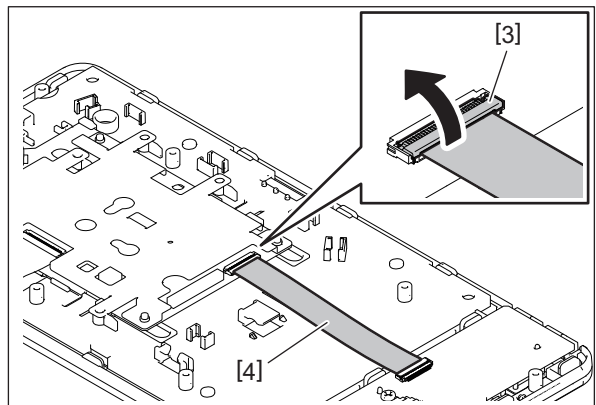

Fig. 4-36

- (4) Release the flap [5] and remove the flat cable [6].

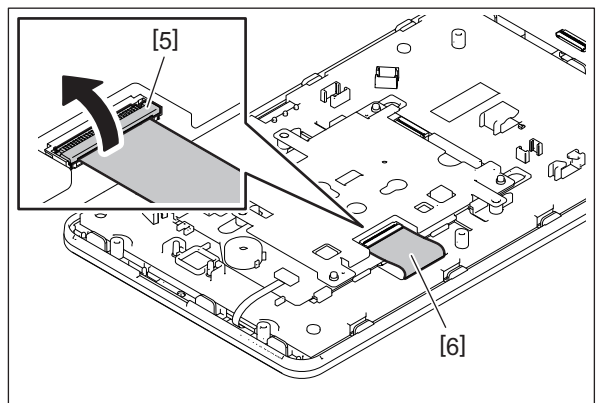

Fig. 4-37

- (5) Release the lock [7] and remove the flat cable [8].

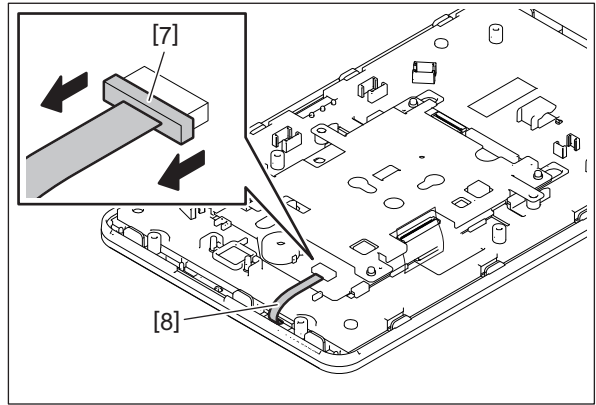

Fig. 4-38

- (6) Release 2 latches [9] and take off the display PC board [10] in the direction of the arrow.

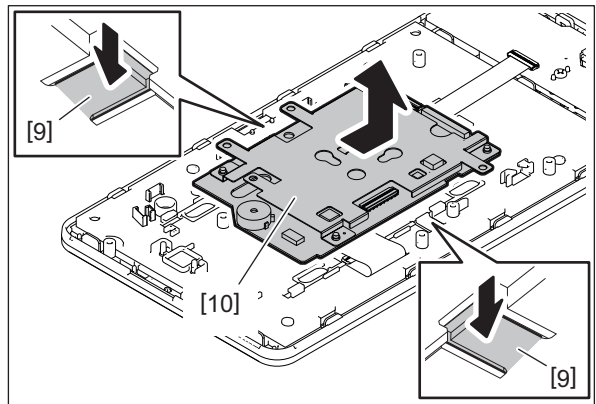

Fig. 4-39

**Notes:**

When the display PC board has been replaced, perform FS-08-9050 (panel calibration execution) before starting the MFP with the normal mode.

 P. 6-70 "6.13 Control Panel Calibration"

## 4.3 Scanner Section

### 4.3.1 Original glass

#### [A] Removal of the original glass and the ADF original glass

- (1) Take off the right top cover.  
📖 P. 4-5 “4.1.8 Right top cover”
- (2) Remove 2 screws [3] and take off the original glass [1] and the ADF original glass [2].

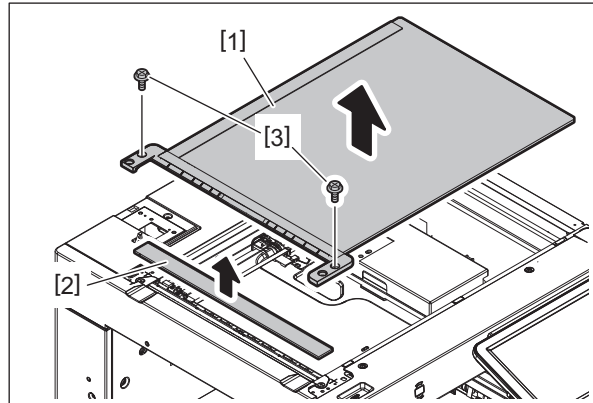

Fig. 4-40

#### [B] Installation of the original glass and the ADF original glass

- (1) While taking care not to crush the cushion at the edge of the ADF original glass [2], slide it to the left side and then install the original glass [1].
- (2) Secure the original glass with 2 screws [3].

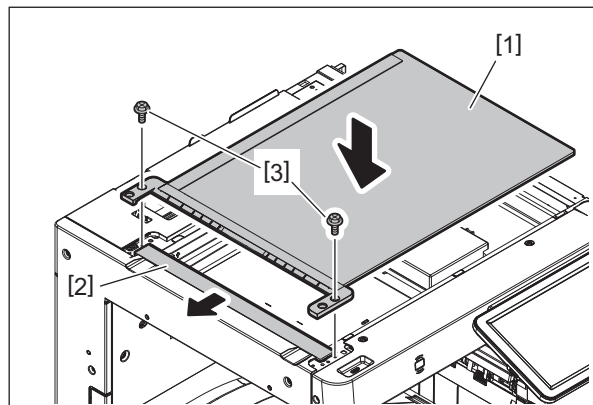

Fig. 4-41

#### Notes:

- Check that the ADF original glass [2] is securely inserted into the groove of the fixing part of the original glass [1].
- Securely insert 2 pins of the original glass [1] into the holes of the frame.

### [C] Replacement of the original glass and the ADF original glass

- (1) Take off the original glass and the ADF original glass.  
📖 P. 4-17 “[A] Removal of the original glass and the ADF original glass”
- (2) Remove 2 screws [2] and take off the left top cover [1].

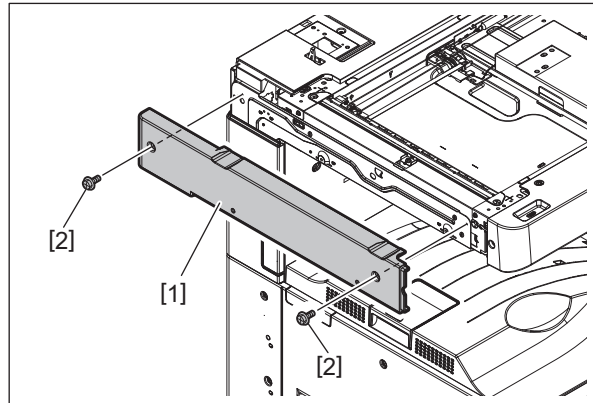

Fig. 4-42

- (3) Remove the film [3] and dispose of it.

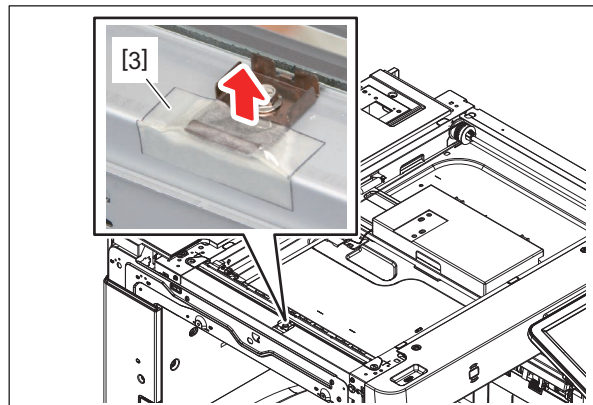

Fig. 4-43

- (4) Loosen 1 fixing screw [4] of the leaf spring. Slide the leaf spring [5] by 1 mm in the direction indicated by arrow [a] and tighten the fixing screw temporarily.

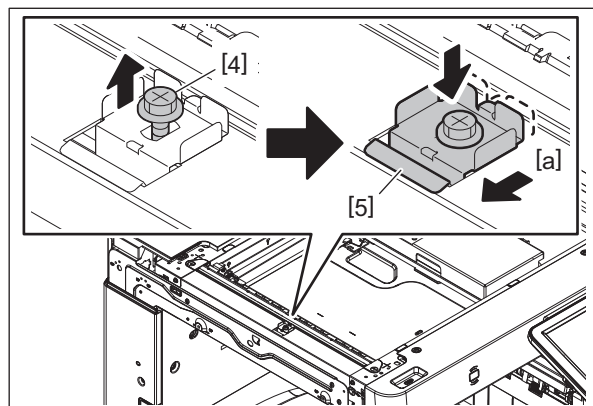

Fig. 4-44

- (5) Place a new ADF original glass [6] and set its position by aligning it to the mark-off lines.

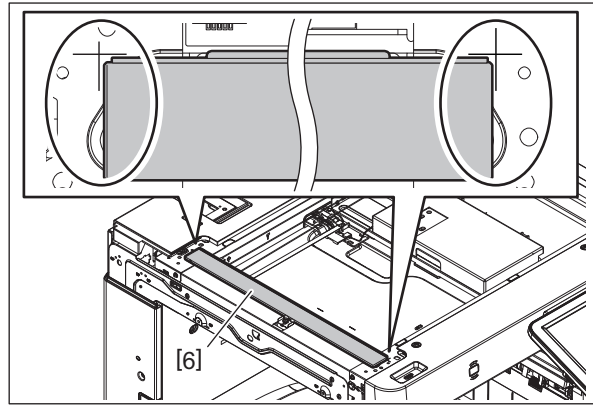

Fig. 4-45

- (6) Place a new original glass [7].

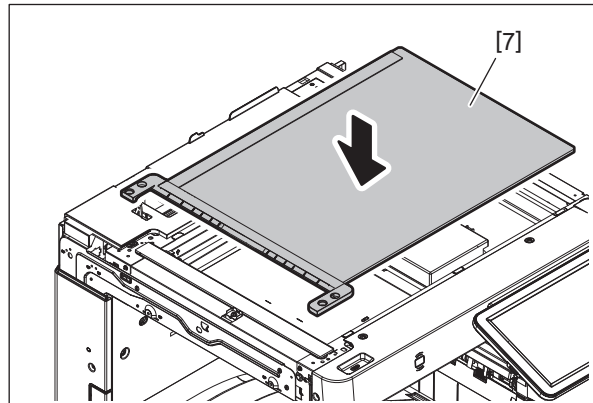

Fig. 4-46

**Notes:**

- Do not attach the screws of the original glass until step (10).
- While taking care not to crush the cushion at the edge of the ADF original glass, install the original glass.

- (7) Loosen 1 fixing screw [4] of the leaf spring. By means of the tension of the leaf spring [5], press the ADF original glass against the original glass. Tighten 1 fixing screw [4] of the leaf spring.

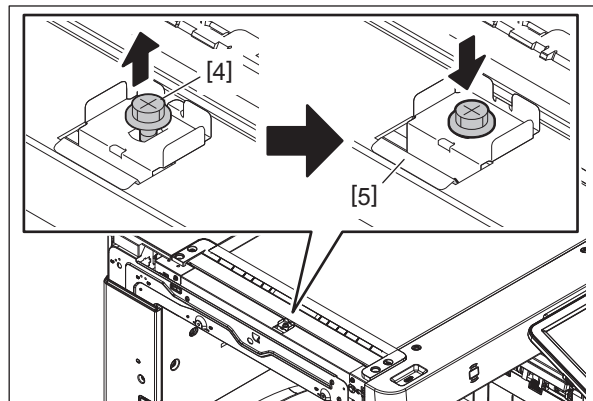

Fig. 4-47

(8) Attach a new film [8] to the scanner frame and the edge of the leaf spring [5].

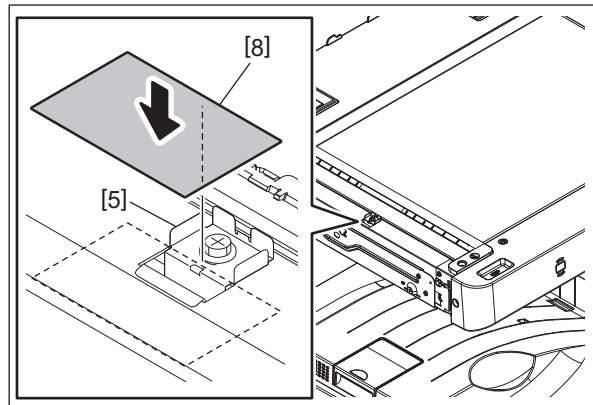

Fig. 4-48

**Notes:**

- Before attaching, use alcohol to clean the attachment surfaces and wait until they have dried.
- Be sure to align the film [8] to the leaf spring [5] as shown in the figure.
- Be sure to attach the film [8] securely to the leaf spring [5].

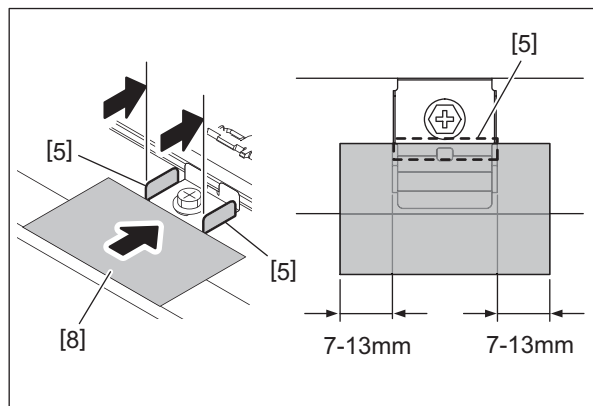

Fig. 4-49

(9) Fold the film [8] by aligning to the corner of the scanner frame and attach it. When the film is folded, lifting will be generated at the both edges on the folded portion. Therefore, in order to remove this lifting, pinch the folded portions of the film with your fingers so that its adhesive surfaces are stuck to each other.

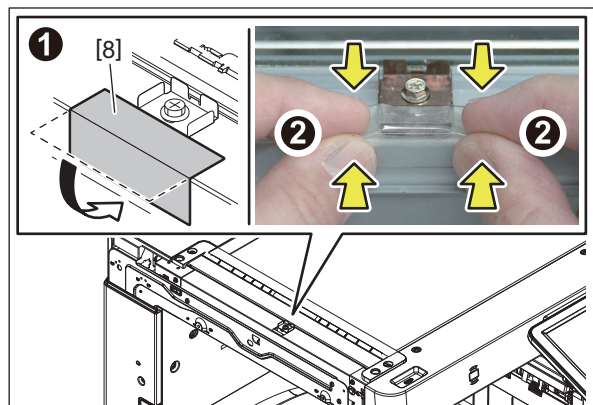

Fig. 4-50



**Notes:**

Confirm that the film is attached firmly.

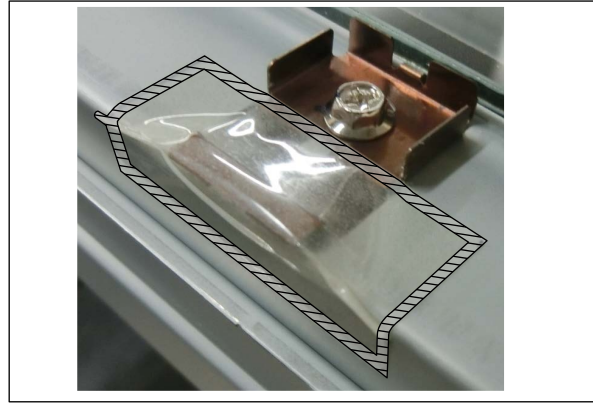

Fig. 4-51

(10) Secure the original glass [7] with 2 screws [9].

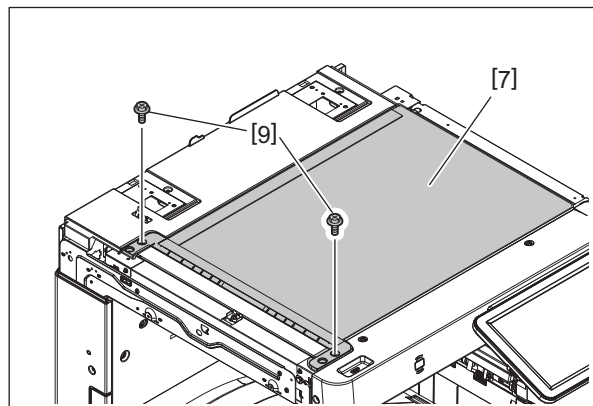

Fig. 4-52

(11) Secure the left top cover [1] with 2 screws [2].

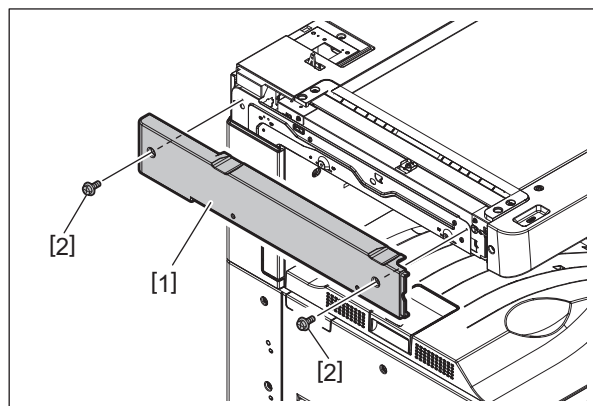



Fig. 4-53

### 4.3.2 Lens cover

- (1) Take off the original glass.  
 P. 4-17 "4.3.1 Original glass"
- (2) Remove 1 screw [2] and take off the lens cover [1] as shown in the figure.

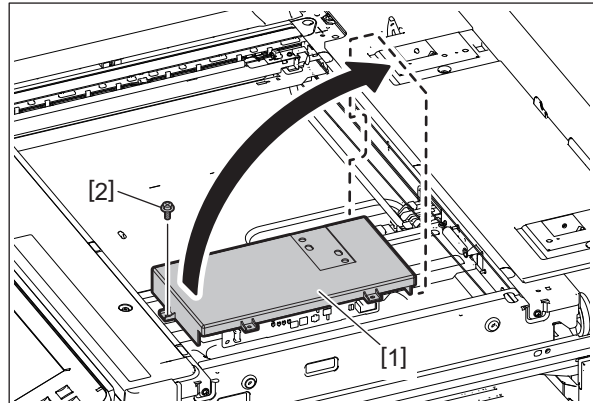



Fig. 4-54

### 4.3.3 Automatic original detection sensor-1 (S24)

- (1) Take off the lens cover.  
 P. 4-22 "4.3.2 Lens cover"
- (2) Remove 1 screw. Disconnect 1 connector [1] and take off the automatic original detection sensor-1 [2].

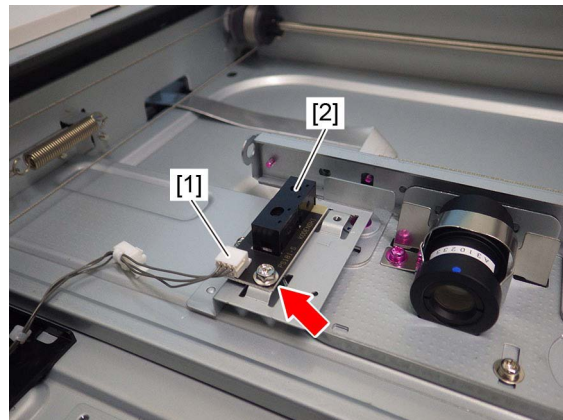

Fig. 4-55

#### 4.3.4 Automatic original detection sensor-2 (S25)

- (1) Take off the lens cover.  
P. 4-22 "4.3.2 Lens cover"
- (2) Remove 1 screw. Disconnect 1 connector [1] and take off the automatic original detection sensor-2 [2].

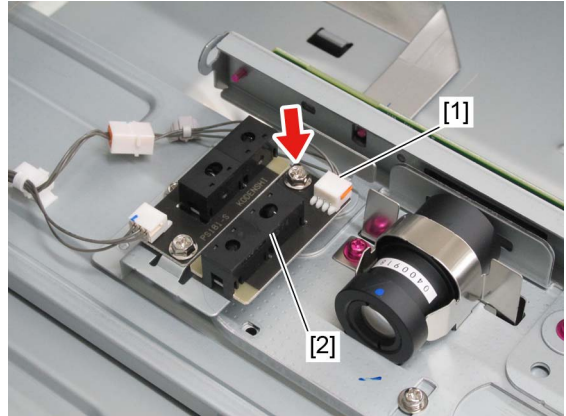

Fig. 4-56

#### 4.3.5 Lens unit (CCD driving PC board)

- (1) Take off the lens cover.  
P. 4-22 "4.3.2 Lens cover"
- (2) Remove 1 screw and take off the automatic original detection sensor bracket [1].

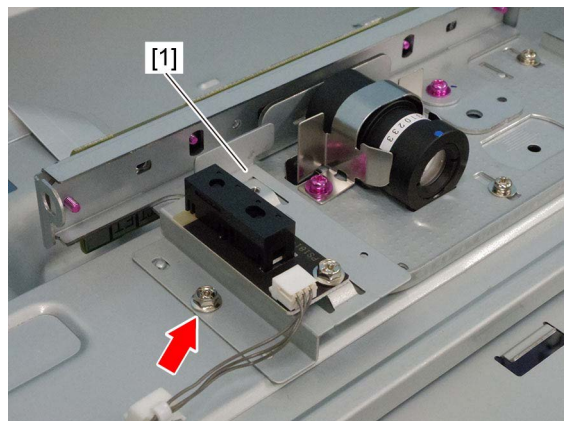

Fig. 4-57

- (3) Remove the HDMI cable [2].

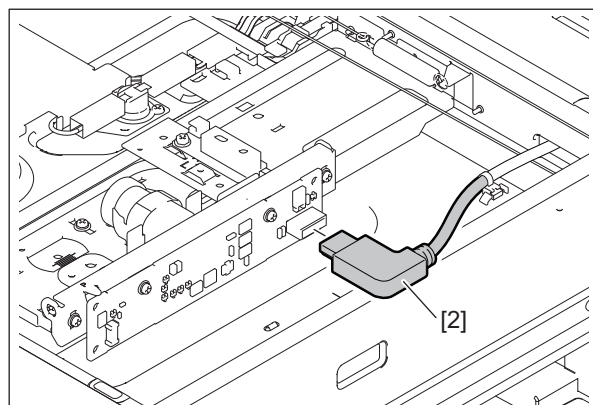

Fig. 4-58

(4) Remove 3 screws and take off the CCD lens unit [3].

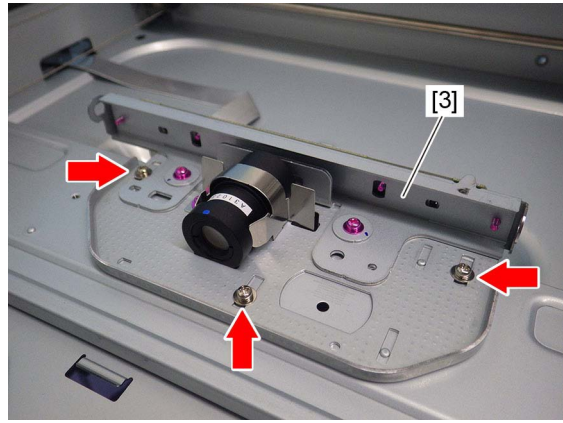

Fig. 4-59

**Notes:**

- The CCD lens unit is adjusted finely, so the re-adjustment or replacement of some parts are impossible in the field. The lens unit must be replaced on a unit basis.
- Handle the lens unit with care. Do not hold the adjustment unit or lens.
- Count the number of lines [4] and write it down for later reference before removing the CCD lens unit. When installing the CCD lens unit, the same number of lines needs to be visible.

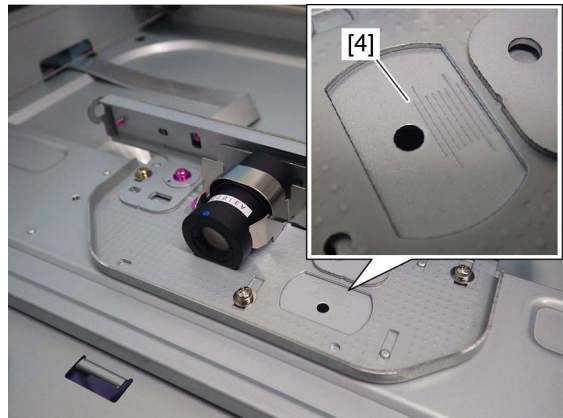

Fig. 4-60

- When replacing the CCD lens unit, do not touch the screws (7 places).

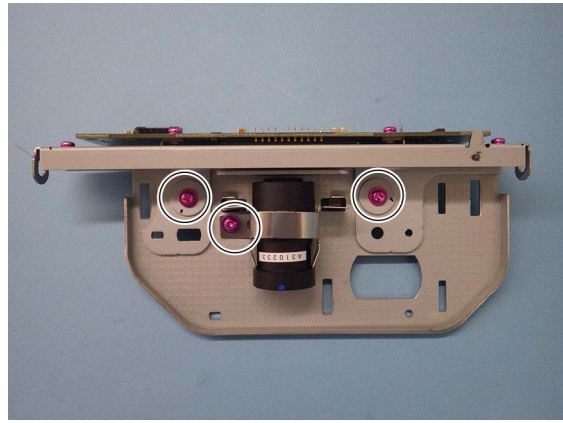

Fig. 4-61

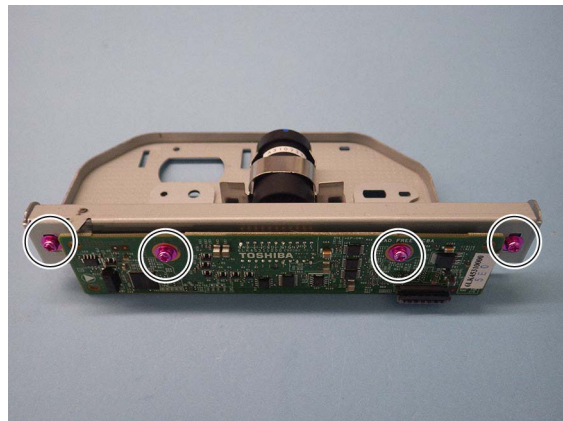

Fig. 4-62

#### 4.3.6 Carriage home position sensor (S23)

- (1) Take off the original glass.  
 P. 4-17 "4.3.1 Original glass"
- (2) Take off the top rear cover.  
 P. 4-8 "4.1.14 Top rear cover"
- (3) Remove 1 film [1] and disconnect the connector [2]. Release 3 latches and take off the carriage home position sensor [3].

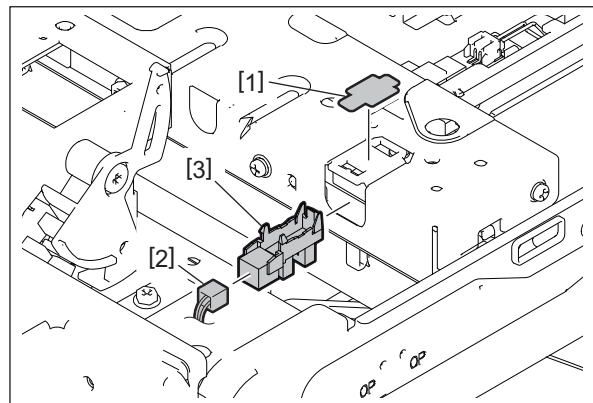

Fig. 4-63

### 4.3.7 Exposure lamp (EXP)

- (1) Take off the original glass and the front top cover.  
📖 P. 4-17 "4.3.1 Original glass"  
📖 P. 4-6 "4.1.11 Front top cover"
- (2) Move the carriage-1 [1] to a place where you can see the exposure lamp mounting screw [2] through the frame hole.

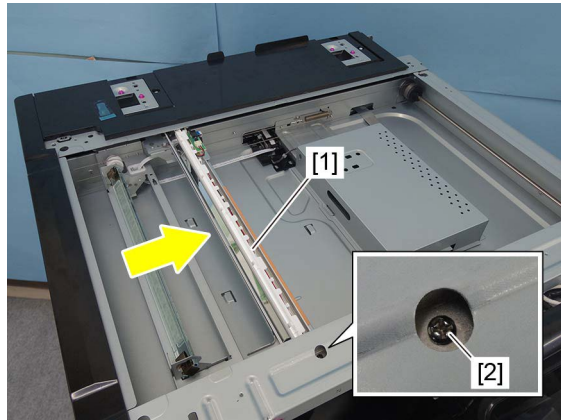

Fig. 4-64

**Notes:**

To move the carriage-1, manually rotate the drive pulley [3].

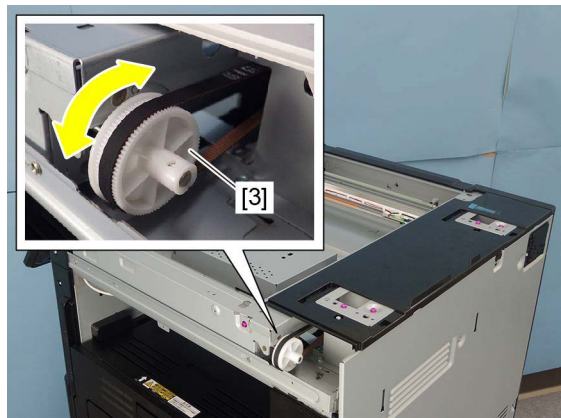

Fig. 4-65

- (3) Remove 1 screw [2].

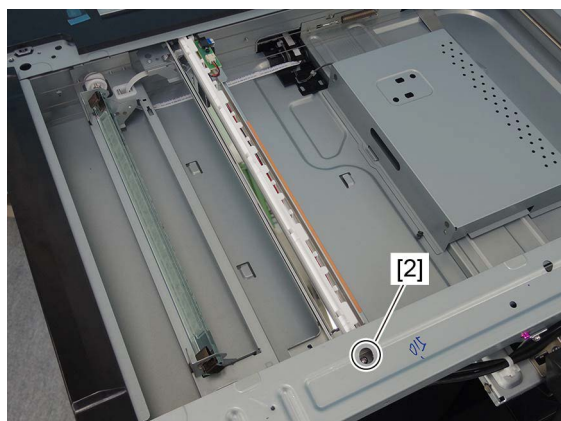

Fig. 4-66

- (4) Slide the front side of the exposure lamp [4] in the direction of the arrow and disconnect 1 connector [5]. Take off the exposure lamp [4] from the front side.

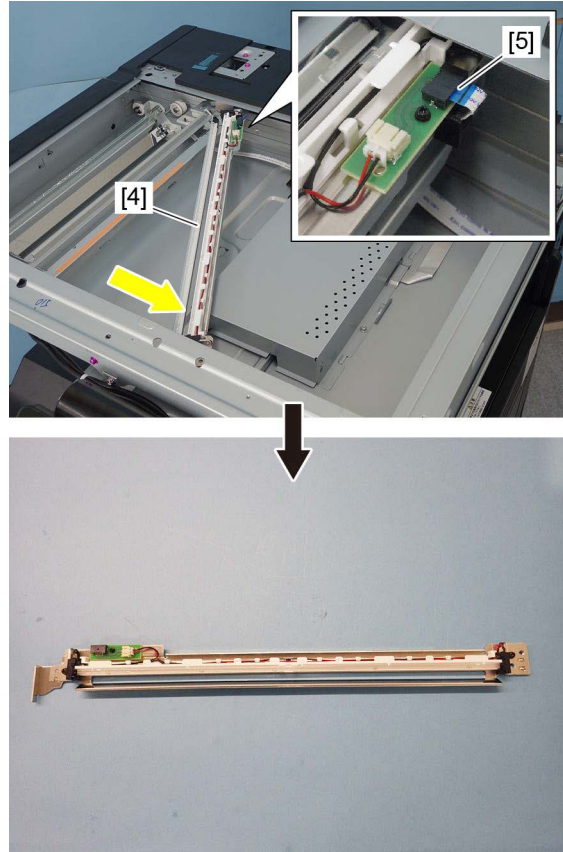

Fig. 4-67

**Notes:**

After replacing the exposure lamp, be sure to perform FS-05-3270.

### 4.3.8 Scan motor (M1)

- (1) Take off the top rear cover.  
📖 P. 4-8 "4.1.14 Top rear cover"
- (2) Take off the rear cover.  
📖 P. 4-9 "4.1.15 Rear cover"
- (3) Disconnect 1 connector.

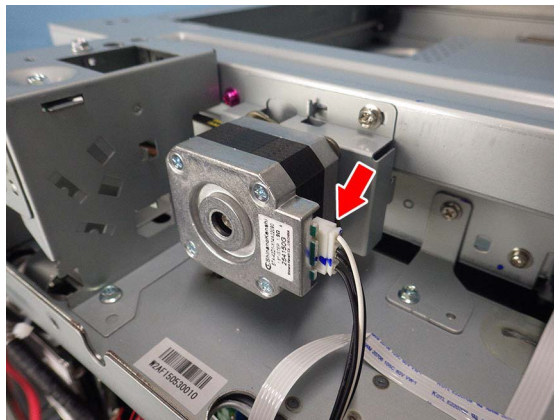

Fig. 4-68

- (4) Remove 2 screws and take off the scan motor assembly [1].

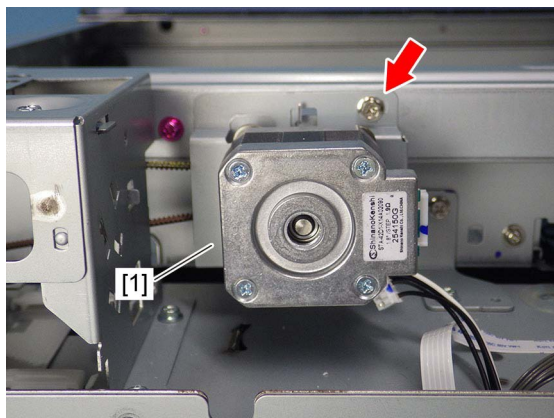

Fig. 4-69

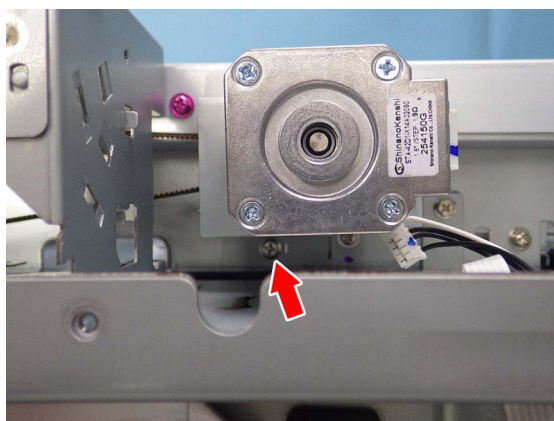

Fig. 4-70

#### Notes:

When installing the scan motor assembly, use the belt tension jig.

📖 P. 6-51 "6.7.3 Belt tension adjustment of the scan motor"



- (5) Remove 2 screws and take off the scan motor [2].

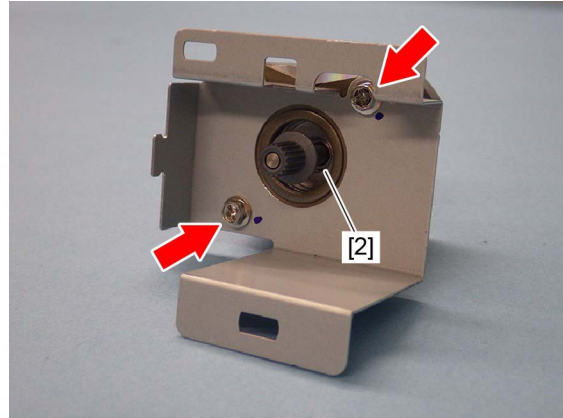

Fig. 4-71

#### 4.3.9 Platen sensor-1 (S21), Platen sensor-2 (S22)

- (1) Take off the top rear cover.  
P. 4-8 "4.1.14 Top rear cover"
- (2) Remove 4 screws [1] and 1 screw [2]. Take off the bracket unit [3].

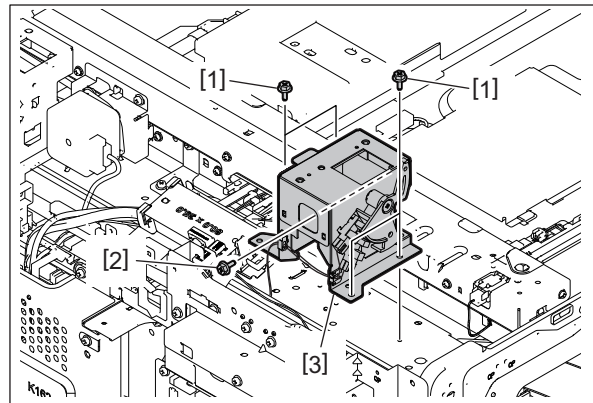

Fig. 4-72

- (3) Release the harness from 2 harness clamps [4] and disconnect 2 connectors [5].

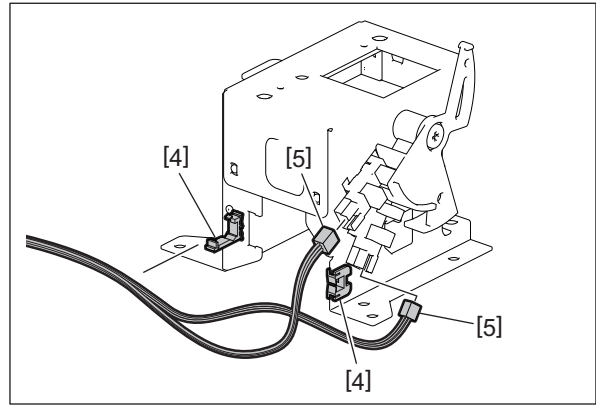

Fig. 4-73

**Notes:**

When installing, be careful not to connect each different connector.

- (4) Release each 3 latch and take off the platen sensor-1 [6] and platen sensor-2 [7].

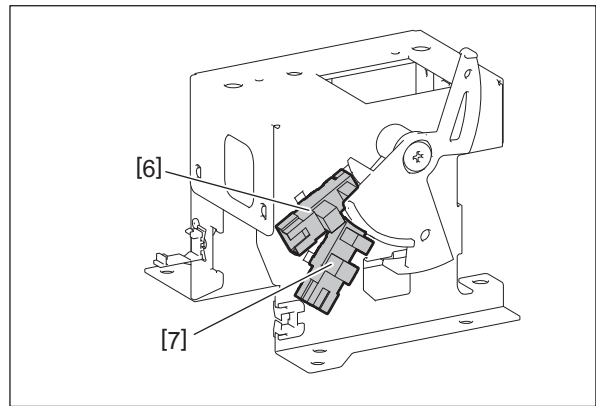

Fig. 4-74

### 4.3.10 Carriage-1

- (1) Take off the original glass.  
📖 P. 4-17 "4.3.1 Original glass"
- (2) Take off the front top cover and the top rear cover.  
📖 P. 4-6 "4.1.11 Front top cover"  
📖 P. 4-8 "4.1.14 Top rear cover"
- (3) Move the carriage-1 [1] to the leftmost side. Make sure that the screws on the carriage-1 are showing from the holes [2] of the frame.

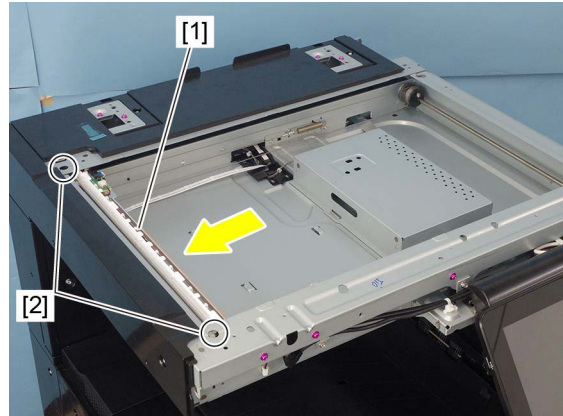

Fig. 4-75

#### Notes:

To move the carriage-1, manually rotate the drive pulley [3].

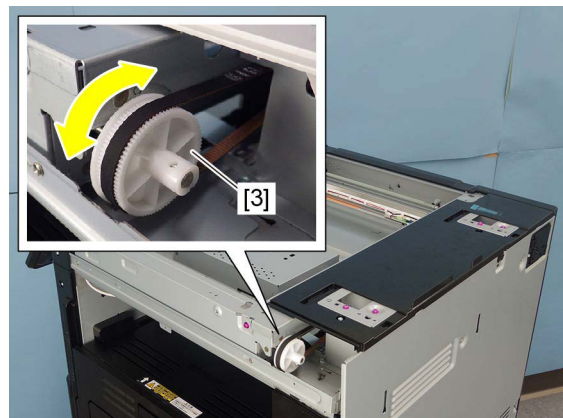

Fig. 4-76

- (4) Remove 2 screws from the holes [2] of the frame.

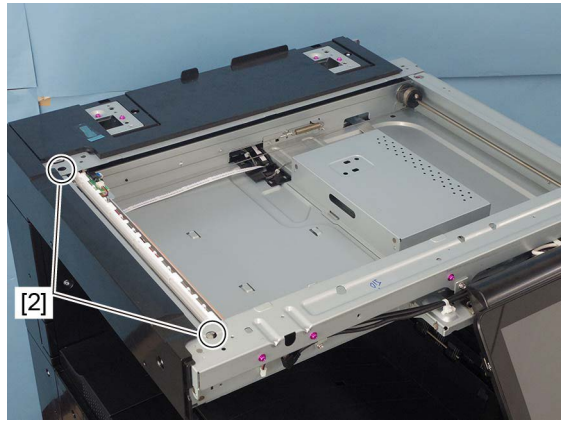

Fig. 4-77

- (5) Remove the flat cable [4] from the carriage-1 [1].  
(6) Release the flat cable [4] from the harness guide [5].

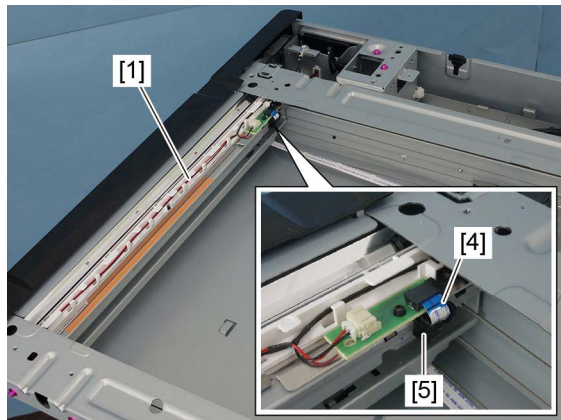

Fig. 4-78

- (7) Slide the front of the carriage-1 [1] in the direction of the arrow shown in the figure, while trying not to touch the mirror [6].

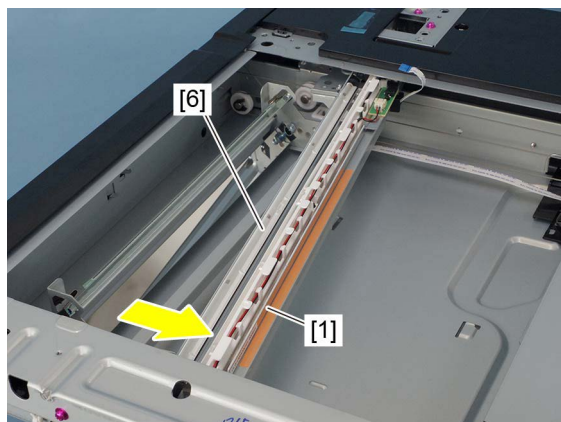

Fig. 4-79

**Notes:**

- When installing, attach the flat cable [4] to the harness guide [5].
- After installing, move the carriage-1 to the leftmost side and check the flat cable [4] for any twists.

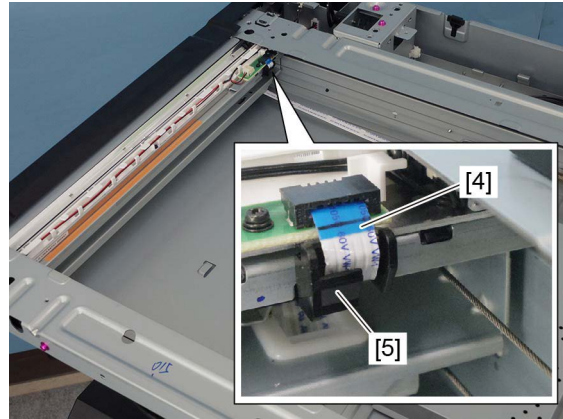

Fig. 4-80

- When installing the carriage-1, make sure that the wires [7] are placed on the front and rear notches [8] of the carriage-1 and fix them with screws.

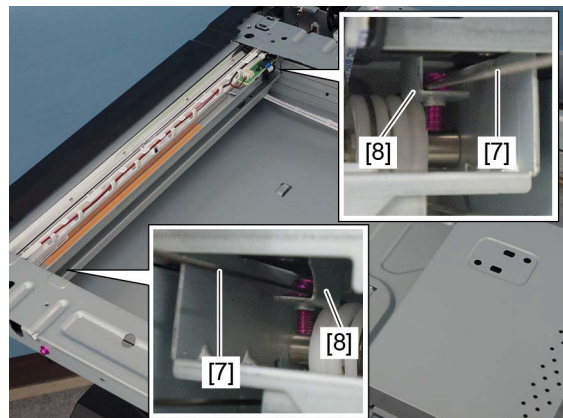

Fig. 4-81

### 4.3.11 Carriage wire, Carriage-2

**Notes:**

- When replacing the carriage wires with new ones, exchange those on the front and rear sides together.
- When the carriage wires are replaced with new ones, set the value of FS-08-6123 to "0".

**[A] Removing the carriage wire and carriage-2**

- (1) Remove the carriage-1.  
📖 P. 4-31 "4.3.10 Carriage-1"
- (2) Move the carriage-2 to the center.
- (3) Attach the wire holder jig [2] to the wire pulley [1] to prevent the wire from coming loose.

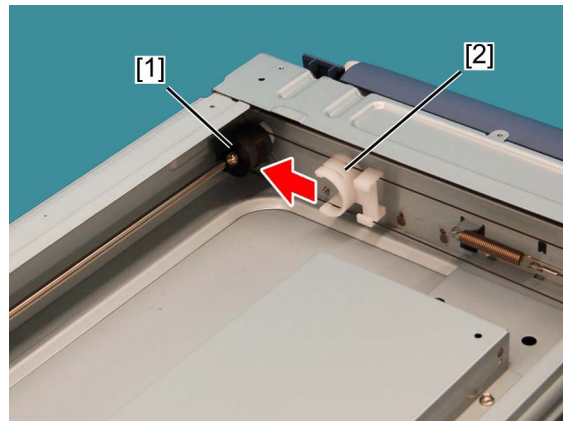

Fig. 4-82

**Notes:**

- When attaching the wire holder jig [2], make sure that the wire has not shifted or become loose.
- The wire should come out of the slot of the wire holder jig [2] and be passed under the jig arm [3].
- When installing the wire holder jig, be careful of its orientation.

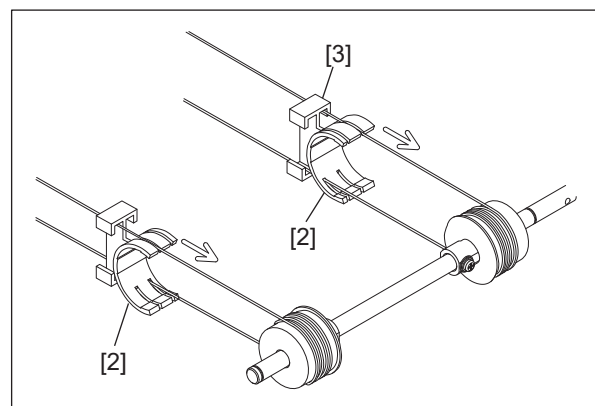

Fig. 4-83

- (4) Remove the tension springs [4] in the front and rear sides.
- (5) Remove the carriage wire [5].

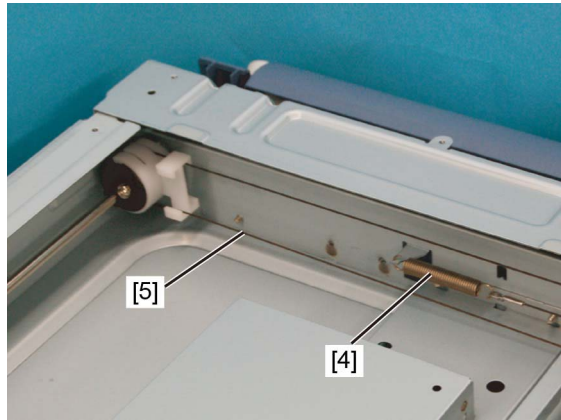

Fig. 4-84

- (6) Rotate the carriage-2 [6] in the direction shown in the figure, while trying not to touch the mirror. Then remove carriage-2 [6].

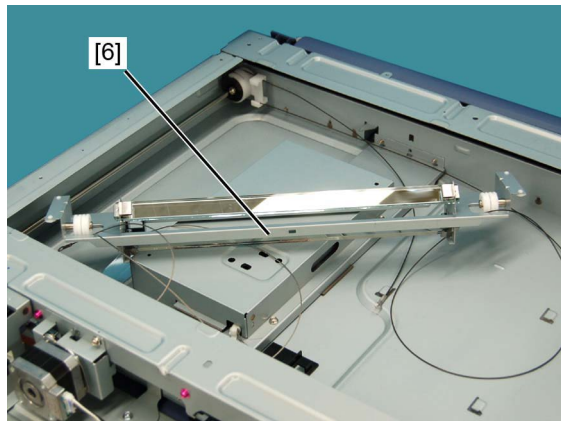

Fig. 4-85

**Notes:**

Replace the mirror-2 and -3 together with the carriage-2 [6]. Do not remove the mirror-2 and -3.

**[B] Installing the carriage wire**

(1) As shown in the figure, replace the carriage wire and install a new wire.

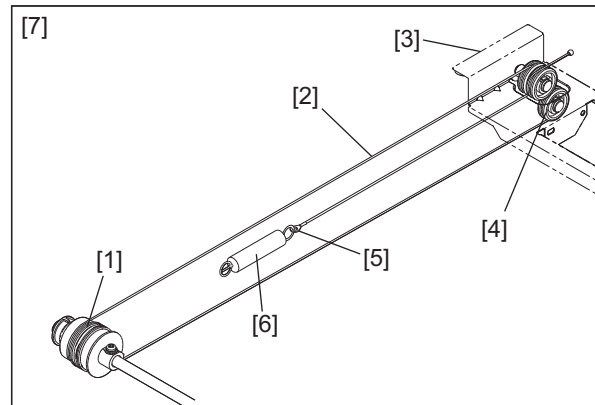

**Fig. 4-86**

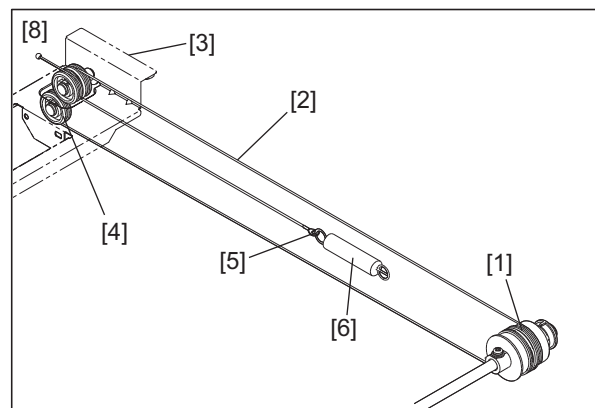

**Fig. 4-87**

- [1] Wire pulley
- [2] Carriage wire
- [3] Carriage-2
- [4] Idler pulley
- [5] Hook
- [6] Tension spring
- [7] Front side
- [8] Rear side

**Notes:**

Make sure that the tension applied to the wire is normal.



### [C] Winding on the wire pulley

- (1) Pull the  $\varnothing 3$  ball terminal [1] located at the center of the wire into a hole on the wire pulley. One end of the wire with the hook [2] attached comes to the outside.
- (2) Wind the wires around the wire pulleys of the front side [3] and rear side [4]. The number of turns to be wound are as follows: 3 toward the opposite side (outside) of the pulley boss [5], and 3 toward the pulley boss side (inside) [6].

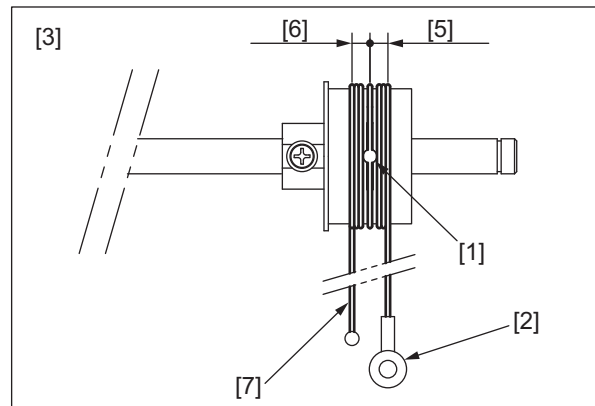

Fig. 4-88

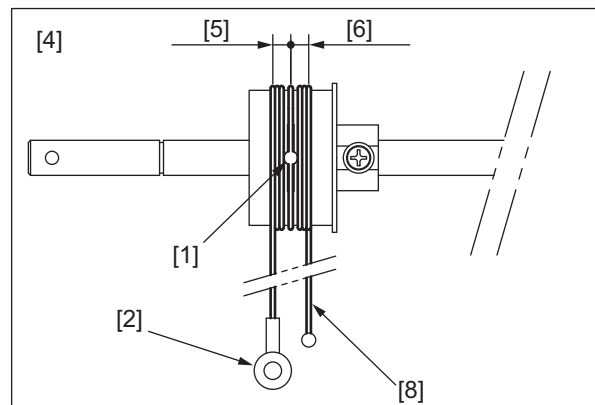

Fig. 4-89

- [7] Black  
[8] Sliver

#### Notes:

When winding the wire onto the pulley, be sure to note the following.

- Do not twist the wire.
- Wind the wires tightly so that they are in complete contact with the surface of the pulleys.
- Each turn should be pushed against the previously wound turn so that there is no space between them.

- (3) After winding the wires around the pulleys, attach the wire holder jigs to prevent the wire from coming loose.

**Notes:**

- When attaching the wire holder jig [9], make sure that the wire has not shifted or become loose.
- The wire should come out of the slot of the wire holder jig [9] and be passed under the jig arm [10].
- When installing the wire holder jig, be careful of its orientation.

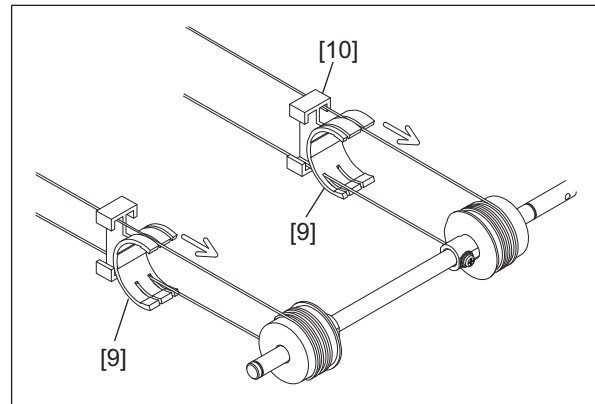

**Fig. 4-90**

### 4.3.12 Scanner damp heater (DH1)

- (1) Take off the top rear cover.  
 P. 4-8 “4.1.14 Top rear cover”
- (2) Take off the original glass.  
 P. 4-17 “4.3.1 Original glass”
- (3) Disconnect 1 connector [1].

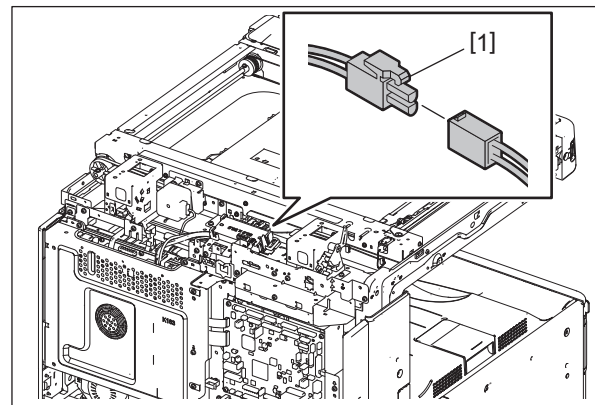

**Fig. 4-91**

(4) Release the lock and take off the scanner damp heater [2].

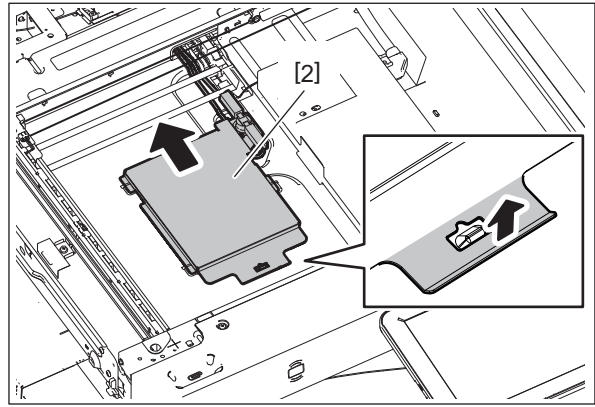

Fig. 4-92

**Notes:**

- Be sure that the fasten terminal is connected to the thermostat securely.
- Be sure that the thermostat is attached to the plate.

## 4.4 Data Writing Section

### 4.4.1 Laser optical unit

- (1) Take off the exit tray.  
P. 4-2 “4.1.3 Exit tray”
- (2) Disconnect 1 connector of the duct [1].



Fig. 4-93

- (3) Remove 1 screw and take off the duct [1].



Fig. 4-94

- (4) Remove the sponge [3] from the laser optical unit [2].

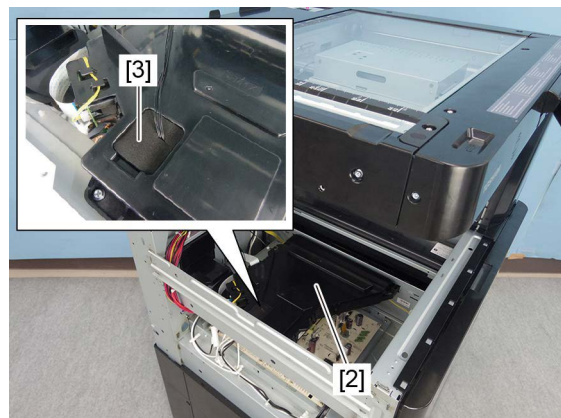

Fig. 4-95

- (5) Disconnect 1 connector [4].

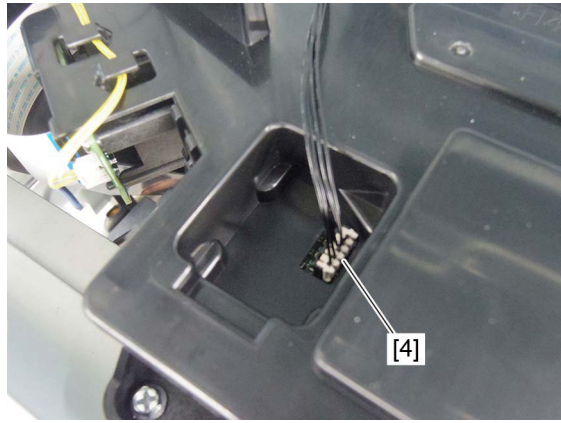

Fig. 4-96

- (6) Release the flat cable [6] from 1 harness guide [5].  
(7) Remove the flat cable [6] from the laser optical unit.

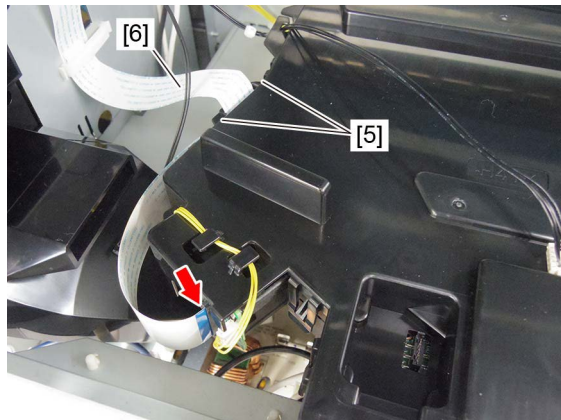

Fig. 4-97

- (8) Remove 1 screw and take off the laser optical unit [2].

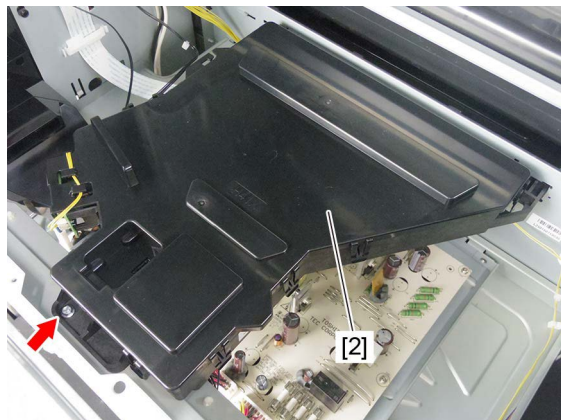
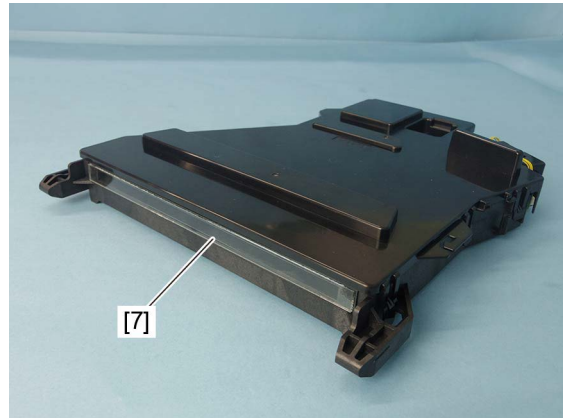

Fig. 4-98

**Notes:**

- Do not leave fingerprints or stain on the slit glass [7] of the laser optical unit.
- Pay close attention not to make an impact or vibration on the laser optical unit because it is a precise apparatus.
- Place the removed laser optical unit so as not to load on the polygonal motor.
- Do not disassemble the laser optical unit in the field because it is precisely adjusted and very sensitive to dust and stain.
- Hold the laser optical unit vertically. Do not press the top of the unit where the polygonal motor is installed with your hands or other things.



**Fig. 4-99**

## 4.5 Paper feeding section

### 4.5.1 Bypass unit

- (1) Take off the right front cover.  
📖 P. 4-5 “4.1.9 Right front cover”
- (2) Take off the right rear cover.  
📖 P. 4-6 “4.1.10 Right rear cover”
- (3) Remove 4 screws and take off the stay [1].

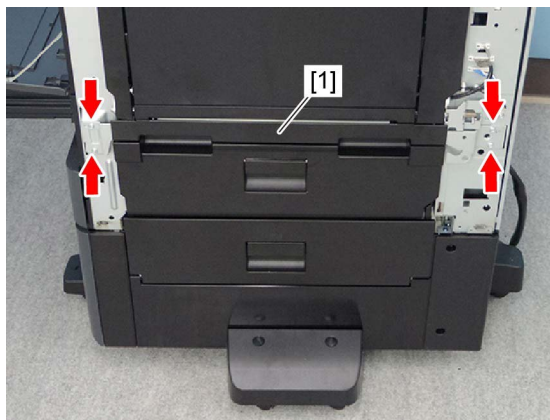

Fig. 4-100

- (4) To release the bypass unit [2], move the protrusions [3] at the front and rear sides of the bypass unit [2] to the wider space in the groove of the hinge stoppers [4].

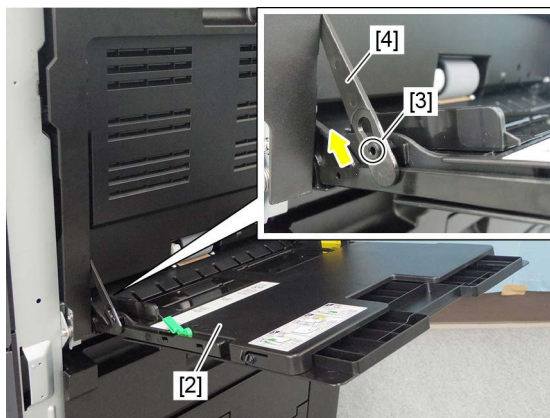

Fig. 4-101

- (5) Remove the arm [6] and paper holder release lever [7].

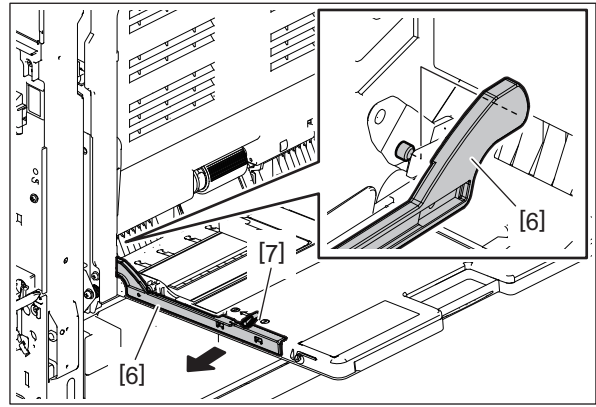

Fig. 4-102

- (6) Disconnect 1 connector and take off the bypass unit [2].

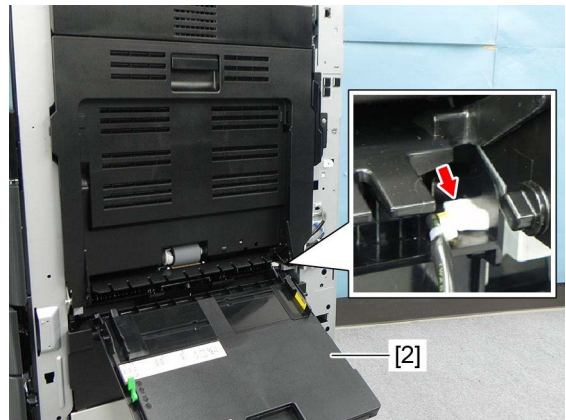

Fig. 4-103

#### 4.5.2 Bypass unit paper feed roller<sup>PM</sup>

- (1) Open the bypass tray [1].  
(2) Tilt the paper holder release lever [2] outward to release the pressure.



Fig. 4-104



- (3) Remove the stopper [4] from the bypass unit paper feed roller [3].

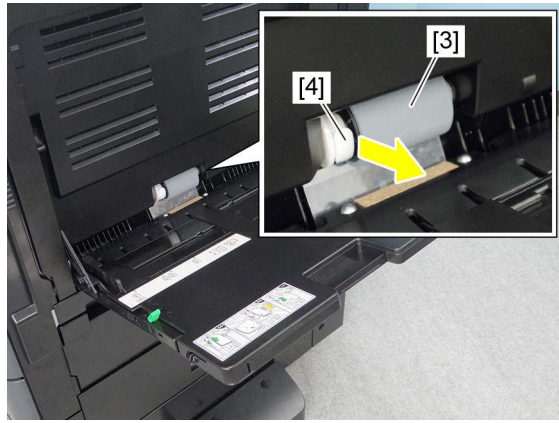

Fig. 4-105

- (4) Push the collar [5] toward the rear to release the lock.

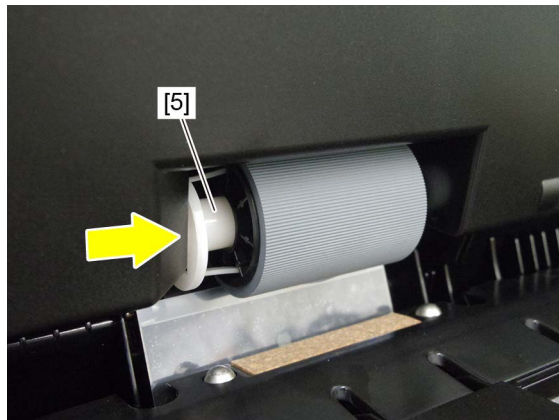

Fig. 4-106

- (5) Remove the bypass paper feed roller [3] while pulling it out.

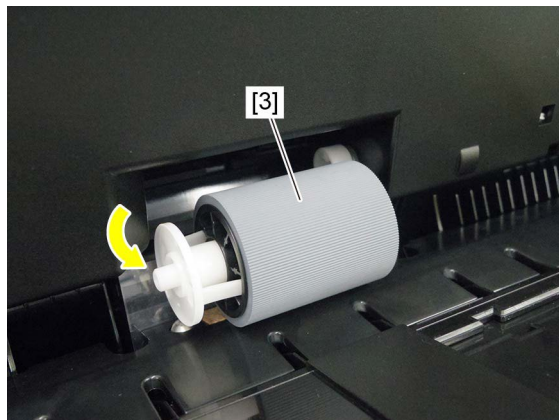

Fig. 4-107

- (6) Remove the collar [5] from the bypass unit paper feed roller [3].

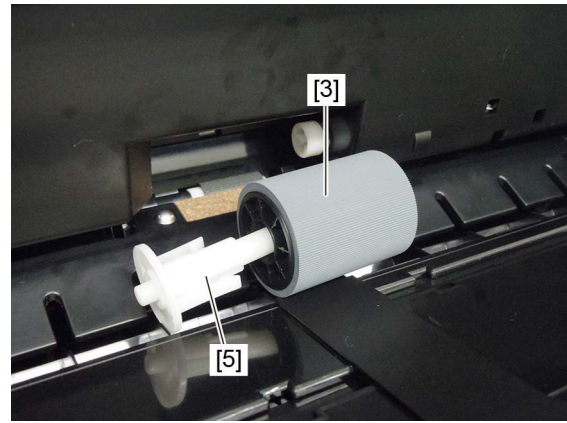

Fig. 4-108

**Notes:**

When installing, align the convex [6] of the roller [3] to the concave [7] of the MFP.

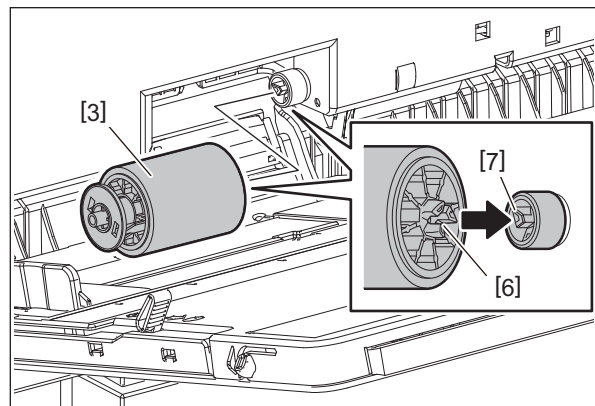

Fig. 4-109

### 4.5.3 Bypass unit transport tray

- (1) Take off the bypass unit.  
P. 4-43 "4.5.1 Bypass unit"
- (2) Take off the bypass unit paper feed roller.  
P. 4-44 "4.5.2 Bypass unit paper feed roller"
- (3) Take off the bypass unit transport tray [1].

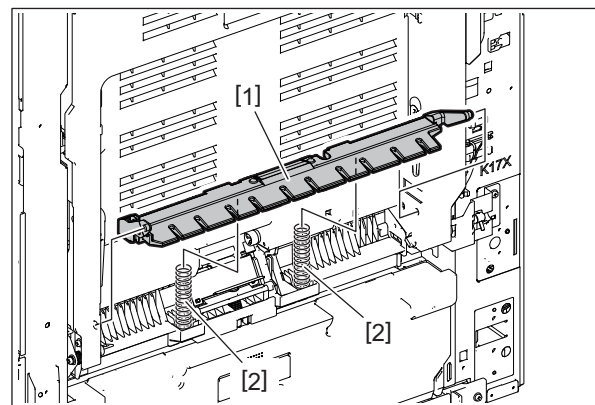

Fig. 4-110

**Notes:**

When installing, be sure that 2 springs [2] are attached securely.

#### 4.5.4 Bypass unit separation roller holder

- (1) Take off the bypass unit transport tray.  
☞ P. 4-46 "4.5.3 Bypass unit transport tray"
- (2) Push down the bypass unit separation roller holder [1] and release 2 latches [2].

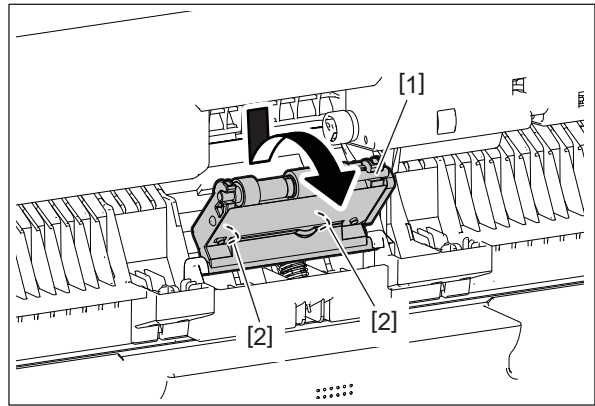

Fig. 4-111

- (3) Release the bypass unit separation roller holder [1] from the hook to take it off.

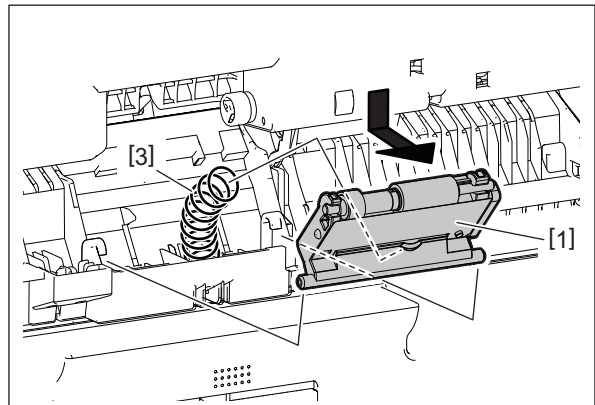



Fig. 4-112

**Notes:**

When installing, be sure that the spring [3] is attached securely.

### 4.5.5 Bypass unit separation roller

- (1) Take off the bypass unit separation roller holder.  
 P. 4-47 “4.5.4 Bypass unit separation roller holder”
- (2) Remove the bypass unit separation roller assembly [1].

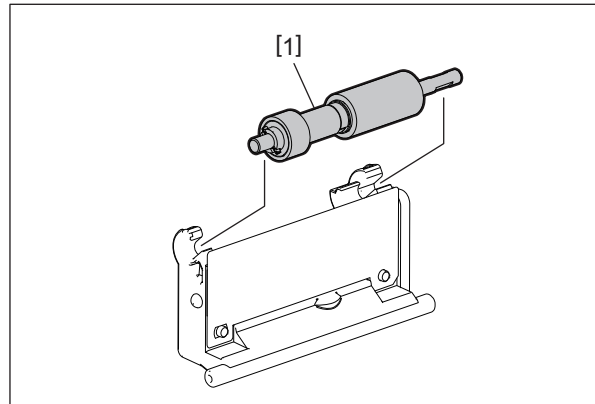

Fig. 4-113

- (3) Remove the bypass unit separation roller [2].

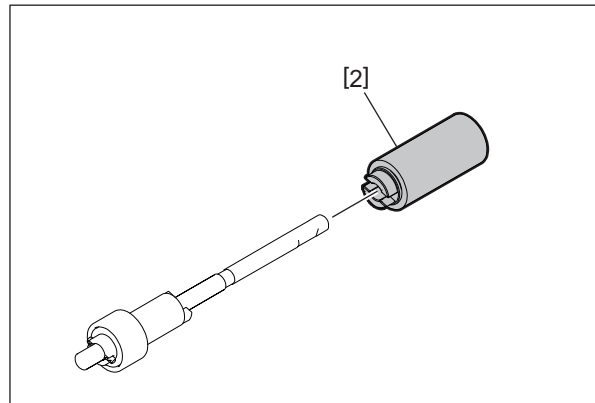

Fig. 4-114

#### Notes:

- When installing or removing, do not make the film deform.
- Handle the bypass separation roller with care so that no dirt, oils or stains adhere.
- Be careful not to drop the parts inside the MFP.
- When replacing the parts or performing refreshment, apply 1 rice-sized grain of white grease (Molykote HP-300) to the bearings [2] of the bypass separation roller.

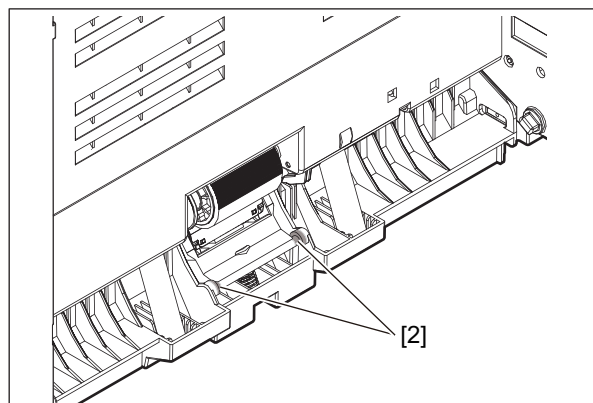

Fig. 4-115

## 4.5.6 Paper width detection PC board (SFBB)

- (1) Open the bypass tray [1] and pull out the slide tray [2].

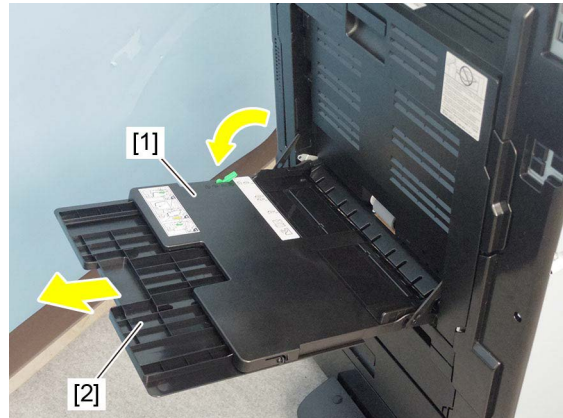

Fig. 4-116

- (2) Close the bypass tray. Remove 1 screw and take off the paper width detection PC board cover [3].

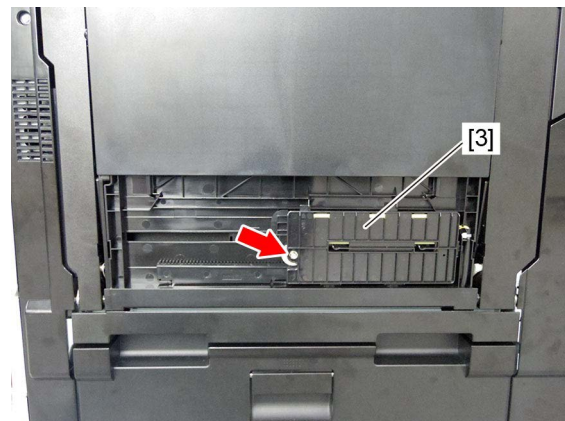

Fig. 4-117

### Notes:

When removing the paper width detection PC board cover [3], be careful not to drop the gear [4].

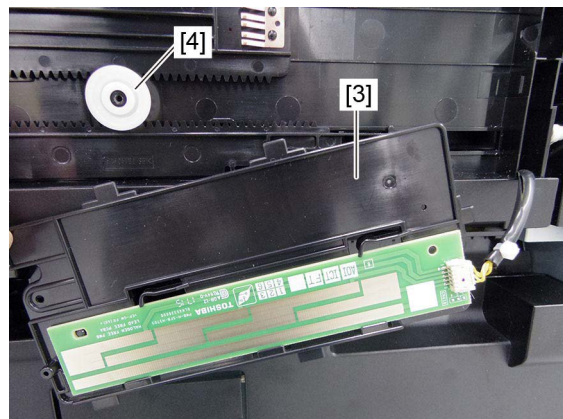

Fig. 4-118

- (3) Disconnect 1 connector and take off the paper width detection PC board [5].

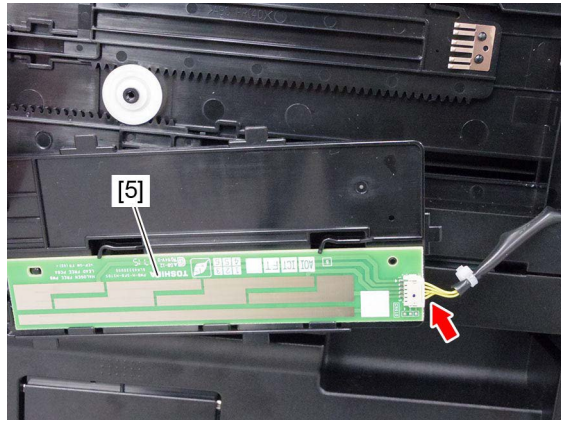

Fig. 4-119

#### 4.5.7 Bypass tray paper sensor (S16)

- (1) Remove the bypass tray paper feed clutch.  
📖 P. 4-178 “4.12.2 Bypass tray paper feed clutch (CLT3)”
- (2) Remove 2 screws from the ADU [1].

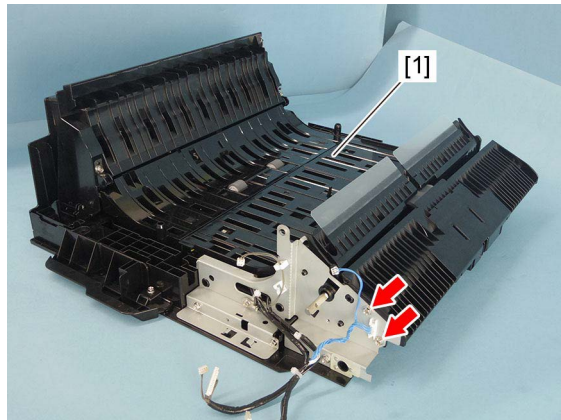

Fig. 4-120

(3) Disconnect 1 connector and take off the paper guide (lower) [2].

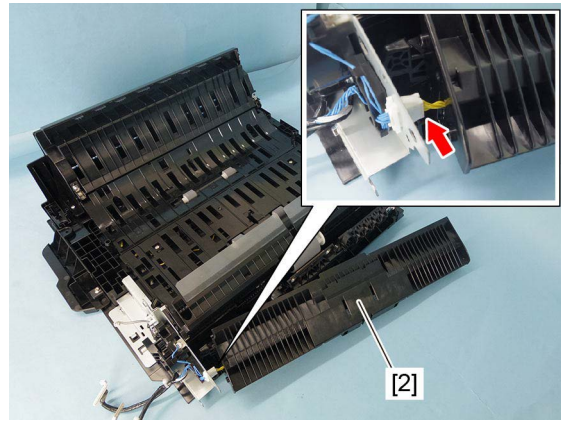

Fig. 4-121

(4) Remove 2 screws and take off the paper guide (middle) [3].

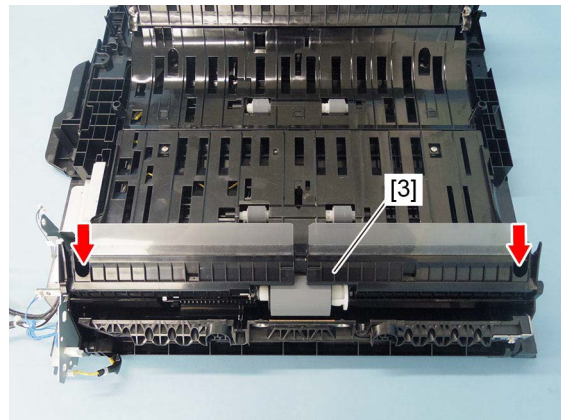

Fig. 4-122

(5) Remove the stopper [5] from the bypass unit paper feed roller [4].

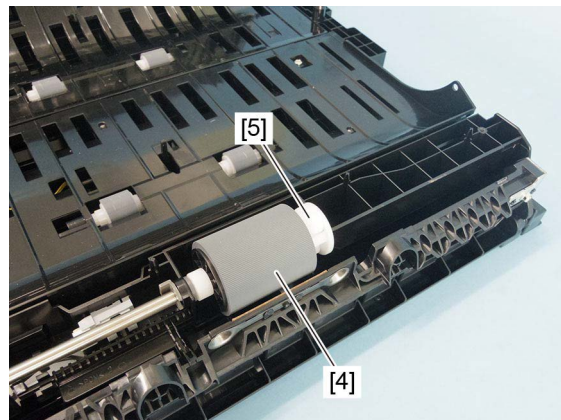

Fig. 4-123

- (6) Push the flange portion [6] into the inside and take off the bypass unit paper feed roller [4].

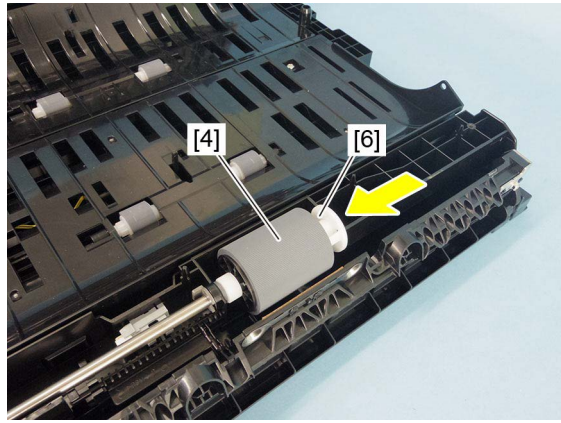

Fig. 4-124

- (7) Remove the clip [7]. Slide the shaft [8] toward the front side to take it off. Remove the collar [9].

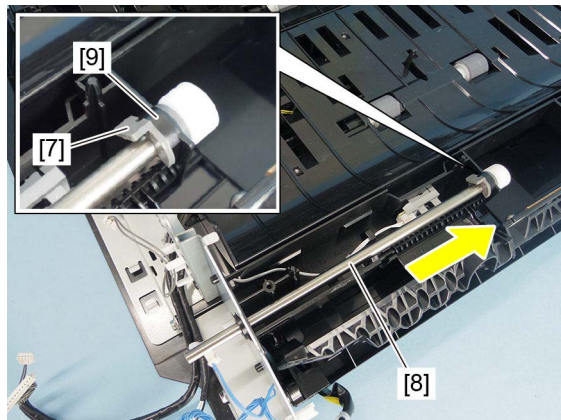

Fig. 4-125

- (8) Release the harness [10] from 2 harness guides.

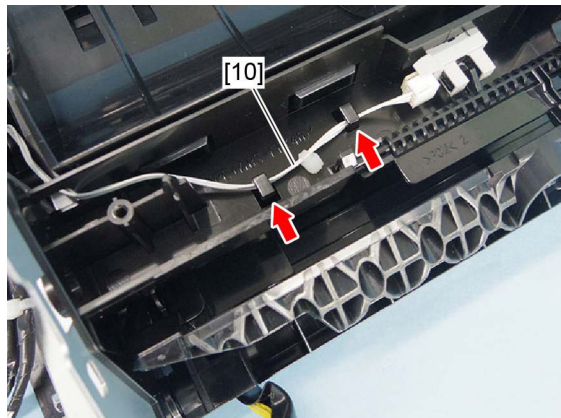

Fig. 4-126



- (9) Disconnect 1 connector [11].
- (10) Release the latch. Take off the bypass tray paper sensor [12] and the sensor arm [13].

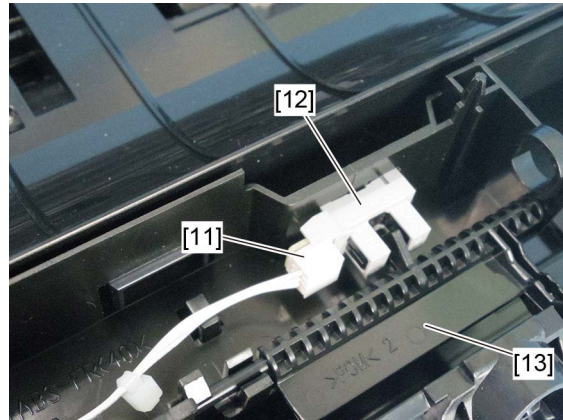

Fig. 4-127

#### 4.5.8 ADU opening/closing switch (SW5)

- (1) Open the ADU.
- (2) Release 2 latches.



Fig. 4-128

- (3) Pull out the ADU opening/closing switch [1]. Disconnect 1 connector and take off the ADU opening/closing switch [1].

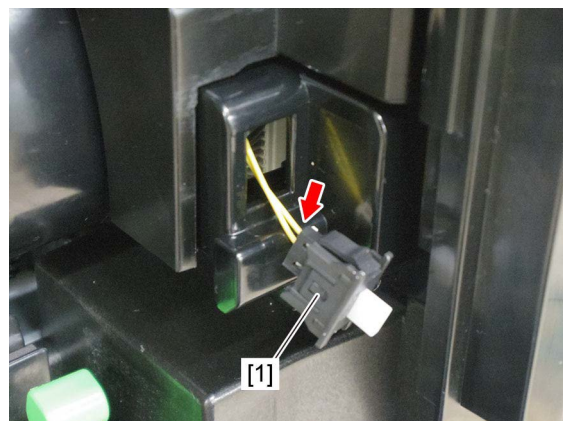

Fig. 4-129

### 4.5.9 Registration sensor (S19), 1st transport sensor (S43)

- (1) Take off the ADU.  
📖 P. 4-176 “4.12 Automatic Duplexing Unit (ADU)”
- (2) Take off the rear cover.  
📖 P. 4-9 “4.1.15 Rear cover”
- (3) Disconnect 1 connector [1].

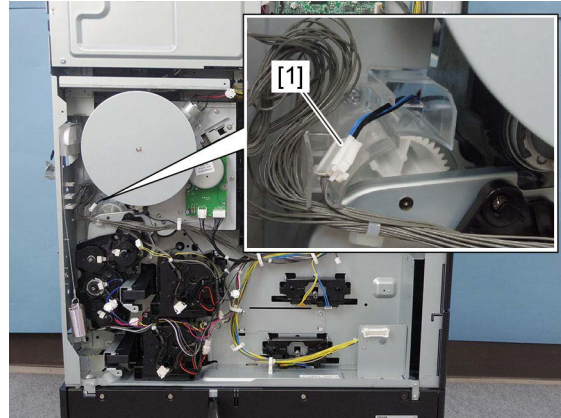

Fig. 4-130

- (4) Open the jam access cover [2].

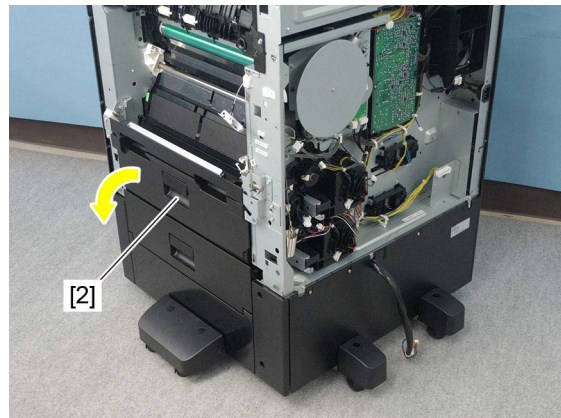

Fig. 4-131

- (5) Remove 4 screws and take off the stay [3].

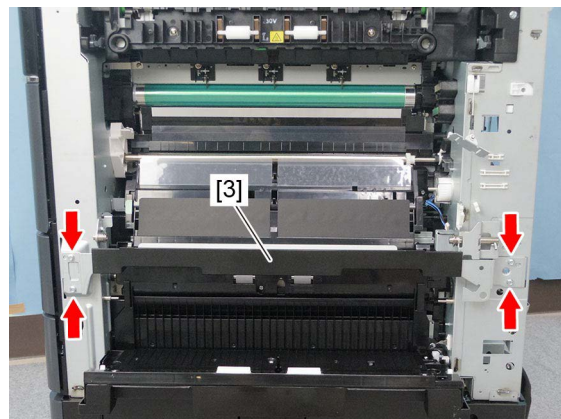

Fig. 4-132

(6) Remove 1 screw from the transport guide [4].

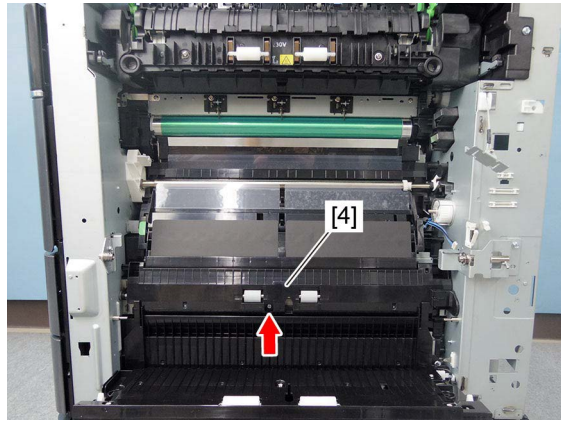

Fig. 4-133

(7) Release 2 latches [5]. Slide the transport guide [4] toward the front side and take it off by pulling it toward you.

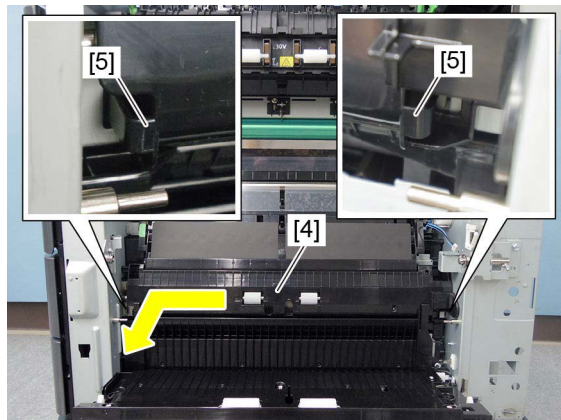

Fig. 4-134

(8) Remove 1 screw from the paper guide [6].

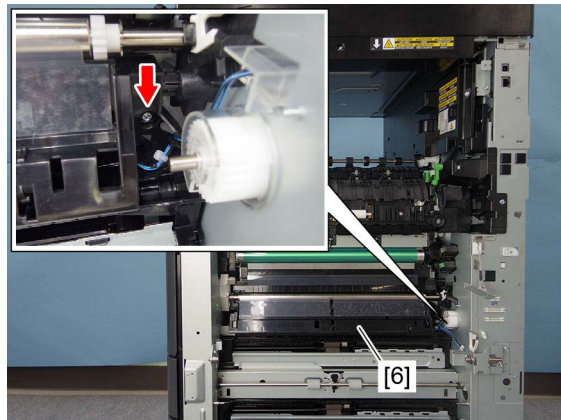

Fig. 4-135

(9) Take off the paper guide [6] by sliding it to the front side.

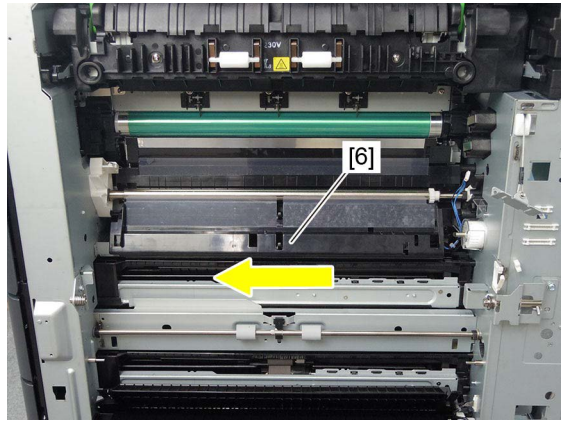

Fig. 4-136

(10) Release 2 latches and take off the sensor bracket [7].

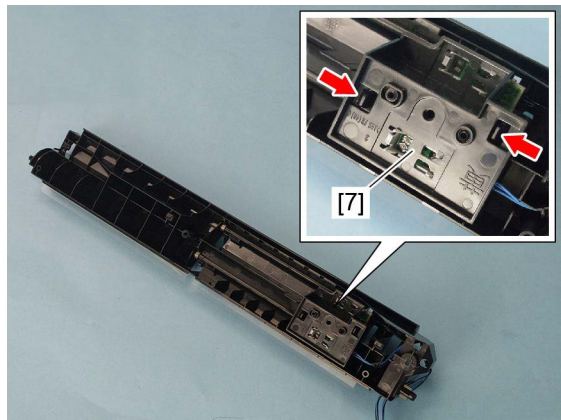

Fig. 4-137

(11) Disconnect 2 connectors. Take off the 1st transport sensor [8] and the registration sensor [9].

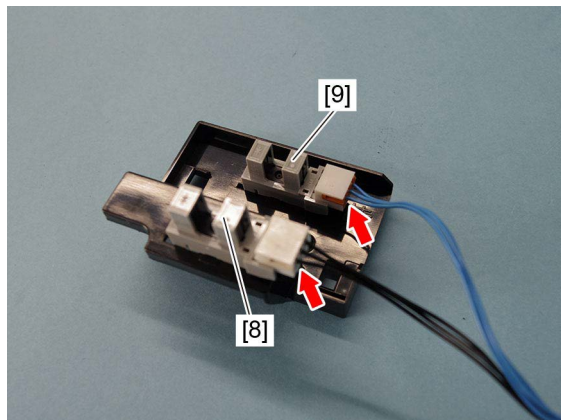

Fig. 4-138

**Notes:**

When connecting, be sure to connect the black wire harness to the 1st transport sensor [8] and the blue wire harness to the registration sensor [9].

## 4.5.10 Paper dust holder

- (1) Take off the process unit.  
P. 4-104 "4.7.1 Process unit"
- (2) Remove 1 screw and take off the paper dust holder [1] by sliding it in the direction of the arrow (A) and lift it up in the direction of the arrow (B).

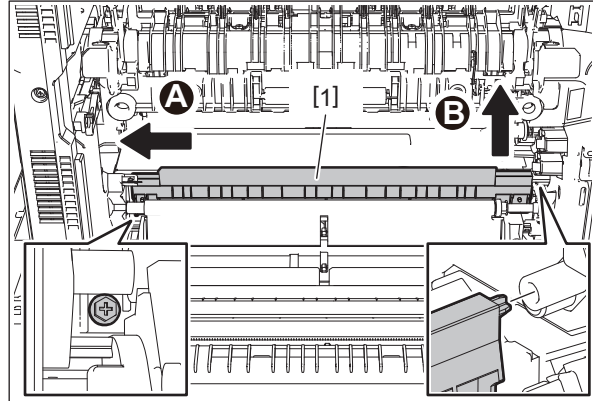

Fig. 4-139

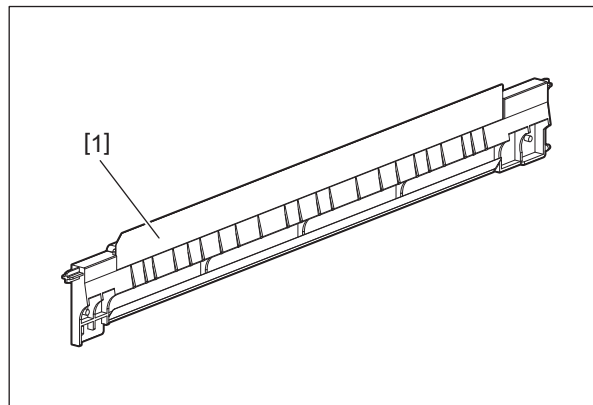

Fig. 4-140

### 4.5.11 Registration roller (MFP side)

- (1) Take off the registration clutch.  
P. 4-92 "4.5.40 Registration clutch (CLT7)"
- (2) Open the ADU.
- (3) Remove the clip [2] from the registration roller [1].

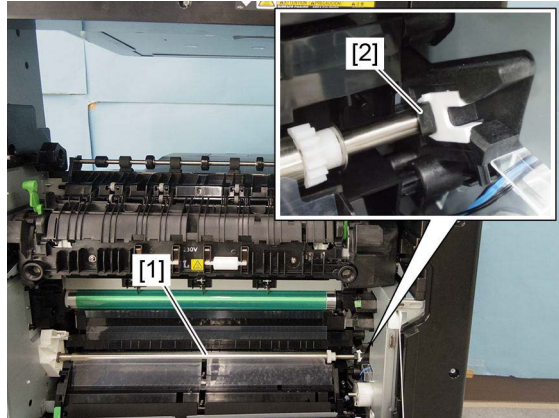

Fig. 4-141

- (4) Slide the registration roller [1] toward the rear side and remove 1 bushing [3] at the front side. Take off the registration roller [1].

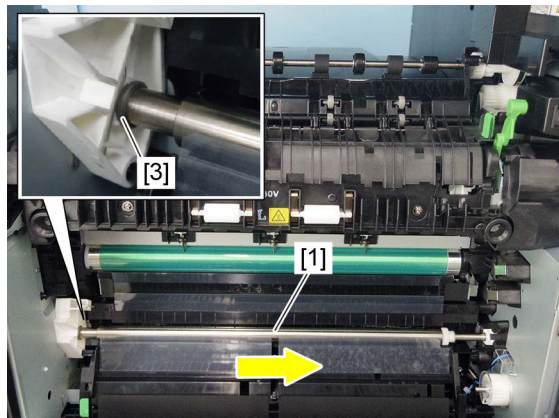

Fig. 4-142

- (5) Remove 1 stopper [4], 1 E-ring [5], 1 pin [6] and 1 gear [7] from the registration roller [1].

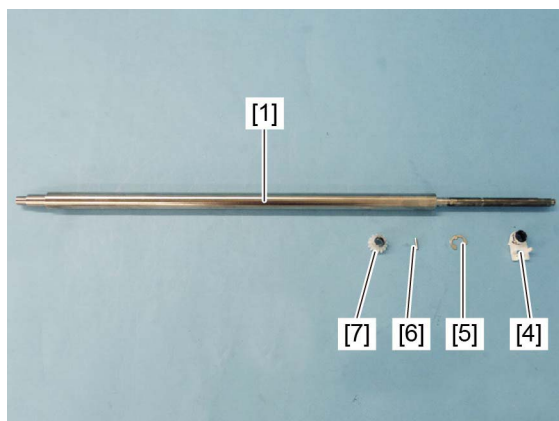

Fig. 4-143

## 4.5.12 Registration roller (ADU side)

- (1) Take off the transfer unit.  
P. 4-134 "4.9.1 Transfer unit (TRU)"
- (2) Remove 1 screw while holding the shaft [1] of the registration roller. Remove the bracket [2].

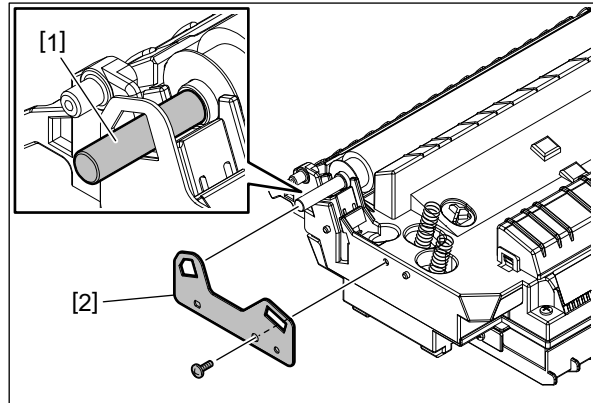

Fig. 4-144

- (3) Remove 1 screw while holding the shaft [3] of the registration roller. Remove the bracket [4].

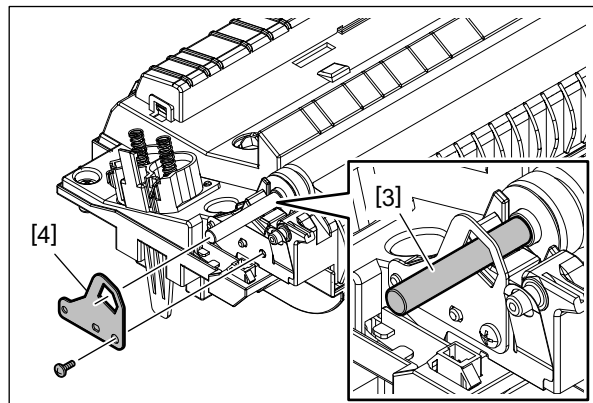

Fig. 4-145

- (4) Take off the registration roller [5].

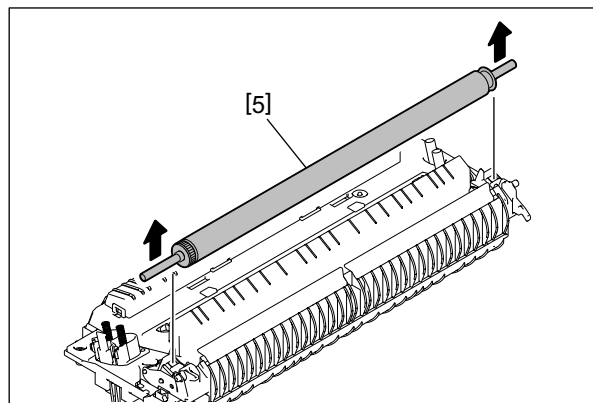

Fig. 4-146

- (5) Remove 2 washers [7], 1 E-ring [8], 1 gear [9] and 1 pin [6] from the registration roller [5].

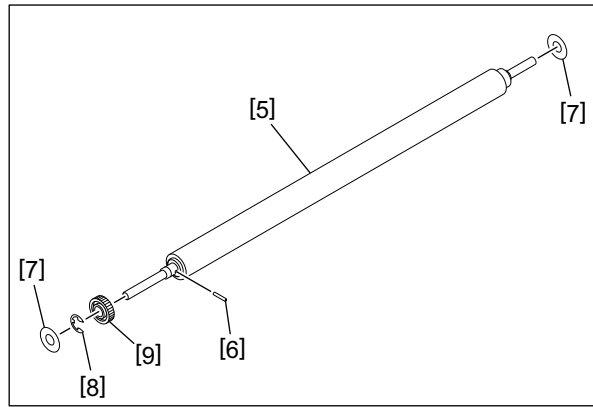

Fig. 4-147

### 4.5.13 Jam access cover

- (1) Open the jam access cover [1].

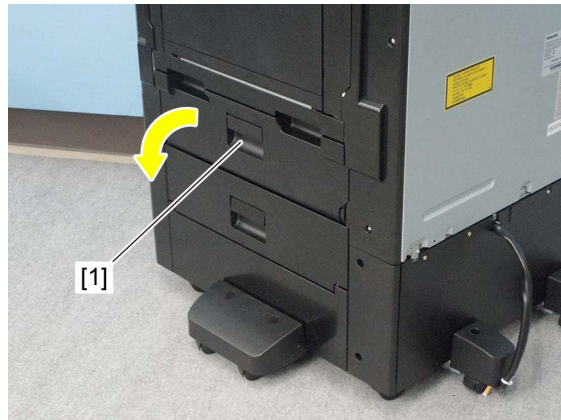

Fig. 4-148

- (2) Disconnect 1 connector [2]. Remove the stopper [3].



Fig. 4-149



- (3) While pressing the rear hinge [4] against the front side, remove the jam access cover [1] using the front hinge as a support.



Fig. 4-150

#### 4.5.14 Transport roller

- (1) Remove the transport clutch (L).  
P. 4-89 “4.5.36 Transport clutch (L) (CLT6)”
- (2) Take off the ADU.  
P. 4-176 “4.12.1 Automatic duplexing unit (ADU)”
- (3) Open the jam access cover [1].

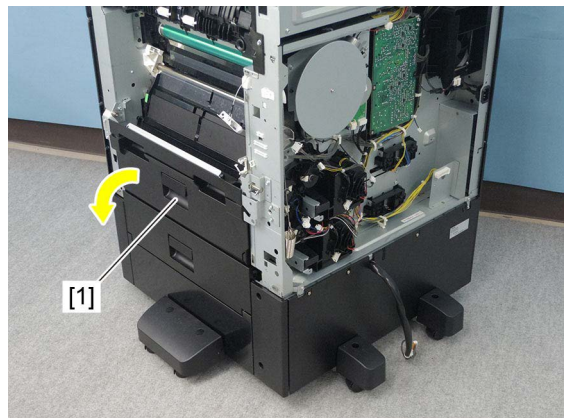

Fig. 4-151

- (4) Remove 4 screws and take off the stay [2].

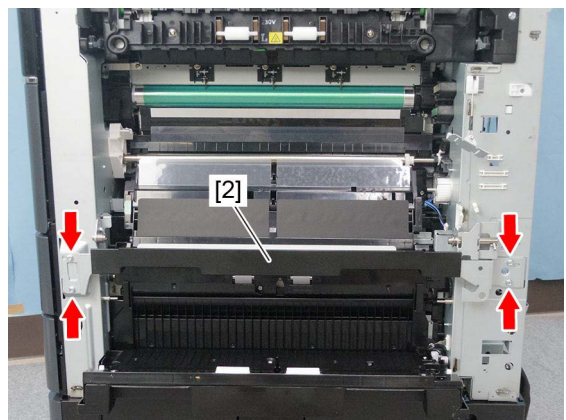

Fig. 4-152

(5) Remove 1 screw from the transport guide [3].

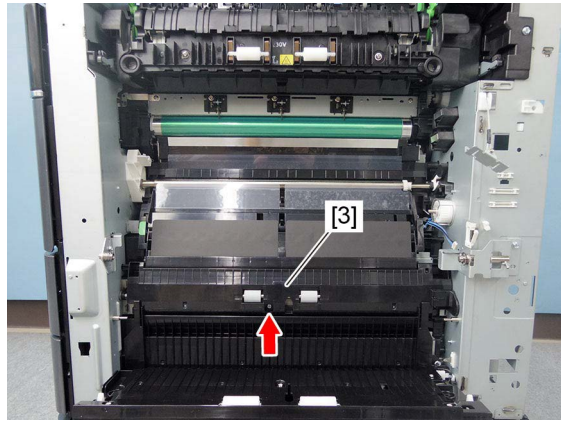

Fig. 4-153

(6) Release 2 latches [4]. Slide the transport guide [3] toward the front side and take it off by pulling it toward you.

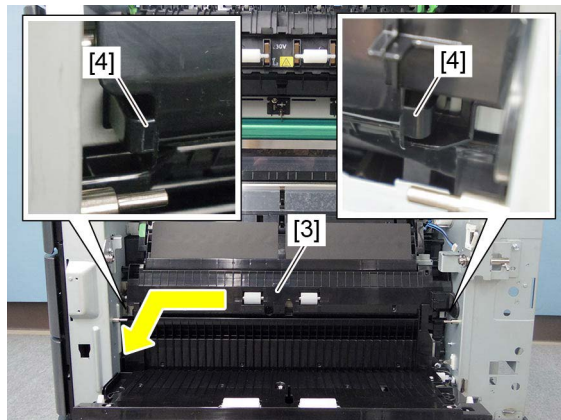

Fig. 4-154

(7) Remove the clip from the transport roller [5].

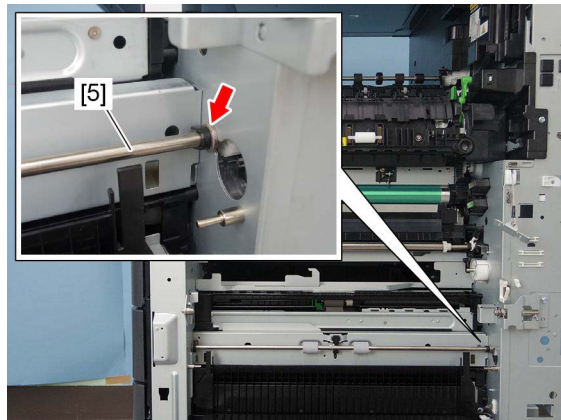

Fig. 4-155

- (8) Slide the bushing [6] to the front side and take off the transport roller [5].

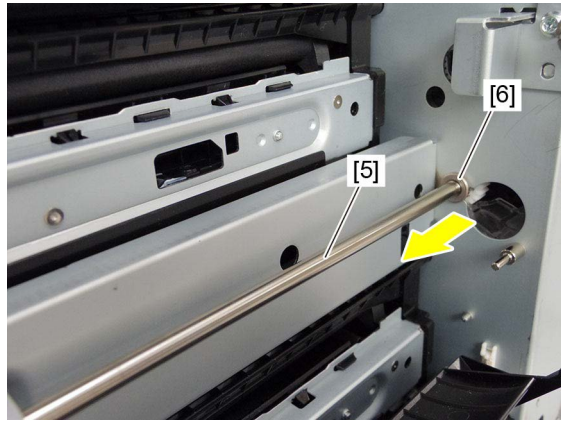

Fig. 4-156

- (9) Remove 2 bushings [7], 1 clip [8], 1 E-ring [9] and 1 gear [10].

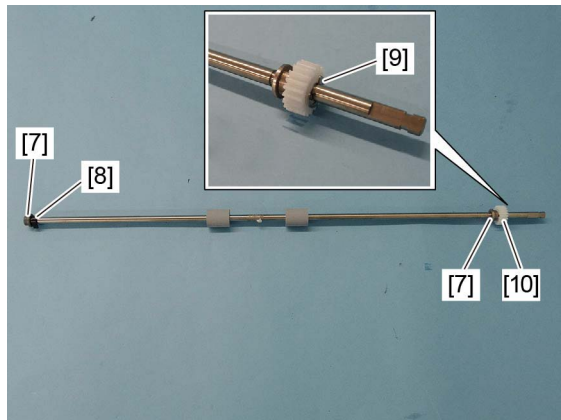

Fig. 4-157

#### 4.5.15 Jam access cover opening/closing switch (SW20)

- (1) Take off the jam access cover.  
P. 4-60 "4.5.13 Jam access cover"
- (2) Remove 4 screws. Release 3 latches [1] and take off the cover [2].

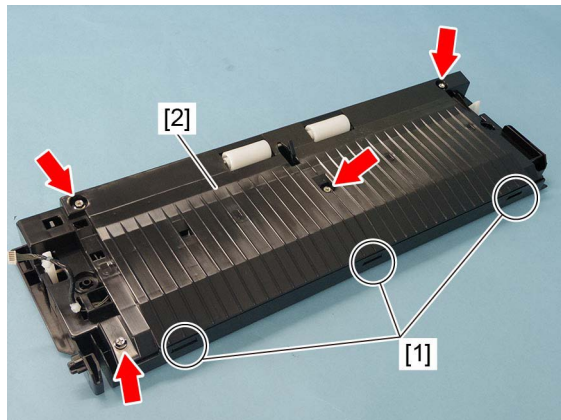

Fig. 4-158

- (3) Disconnect 1 connector [3]. Release the latch and take off the jam access cover opening/closing switch [4].

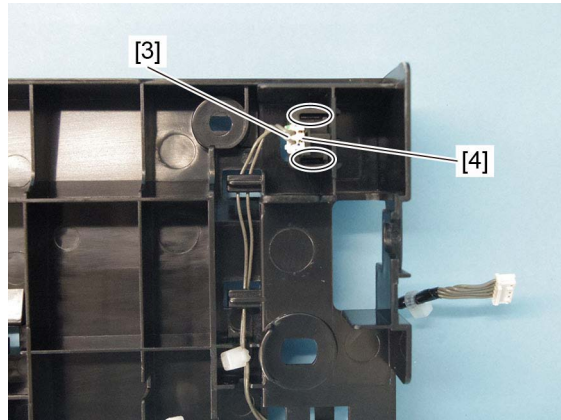

Fig. 4-159

#### 4.5.16 2nd transport sensor (S44)

- (1) Take off the jam access cover.  
P. 4-60 “4.5.13 Jam access cover”
- (2) Remove 4 screws. Release 3 latches [1] and take off the cover [2].

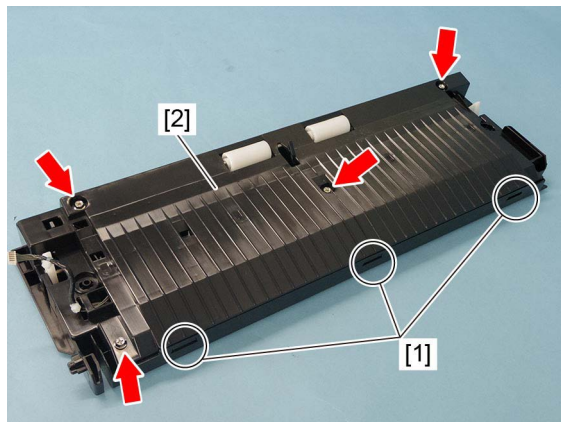

Fig. 4-160

- (3) Disconnect 1 connector [3], remove 2 screws and take off the cover [4].

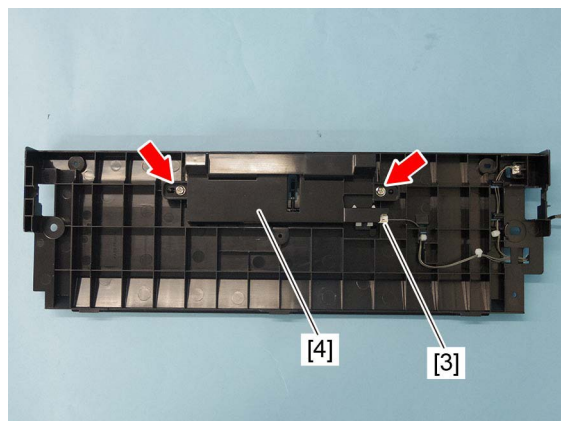

Fig. 4-161

- (4) Release the latch and take off the 2nd transport sensor [5].

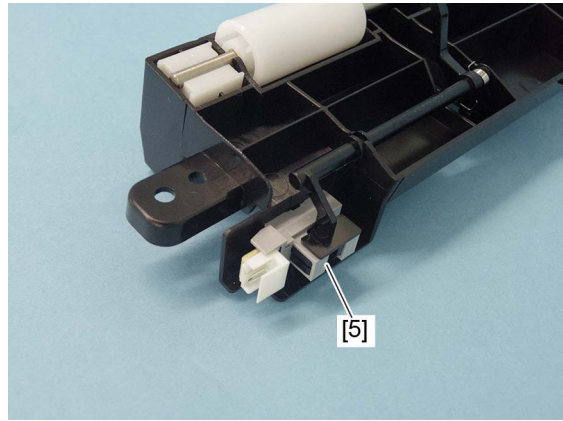



Fig. 4-162

### 4.5.17 1st drawer paper feed unit

- (1) Pull out the 1st drawer.
- (2) Take off the front cover.  
 P. 4-1 "4.1.1 Front cover"
- (3) Turn the lock lever [1] clockwise. Pull out the 1st drawer paper feed unit [2] toward you to remove it.

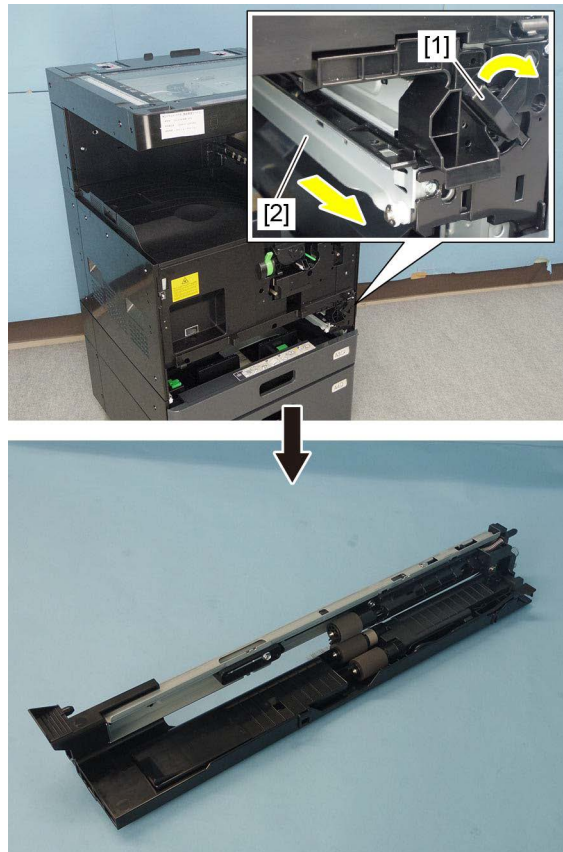

Fig. 4-163

**Notes:**

When installing, align the arrow of the 1st drawer paper feed unit to the guide before inserting.

#### 4.5.18 1st drawer separation roller guide

- (1) Take off the 1st drawer paper feed unit.  
P. 4-65 "4.5.17 1st drawer paper feed unit"
- (2) Remove 2 screws of the 1st drawer separation roller guide [1].

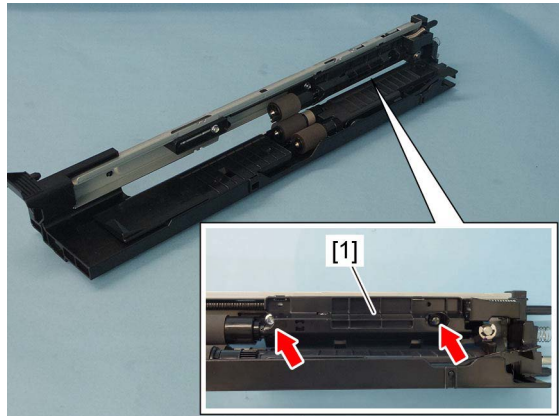

Fig. 4-164

- (3) Release 2 latches and take off the 1st drawer separation roller guide [1].

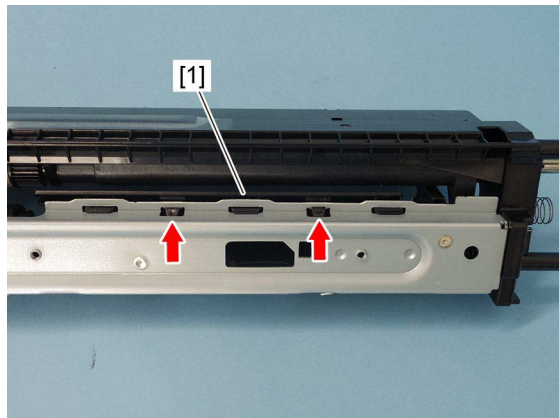

Fig. 4-165

- (4) Remove the E-ring and the shaft [2].

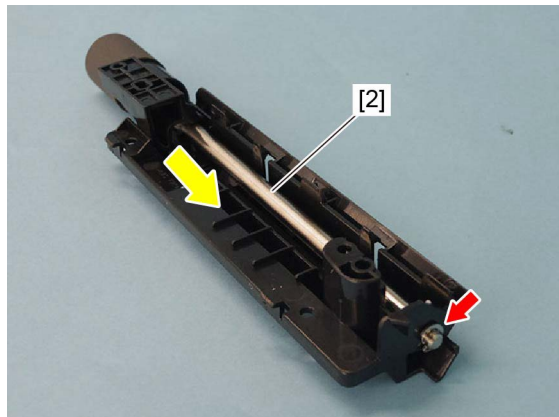

Fig. 4-166

(5) Take off the shaft cover [3].

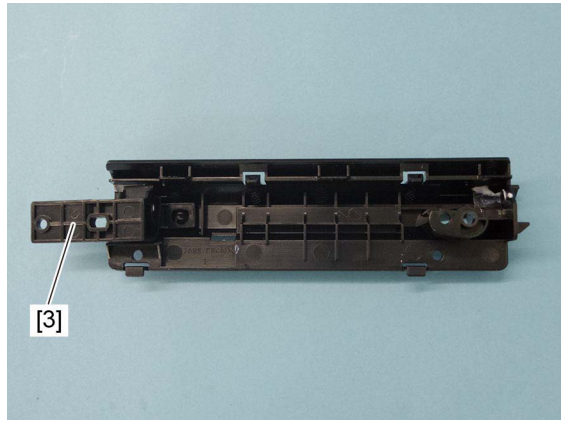

Fig. 4-167

**Notes:**

When replacing the parts or performing preventive maintenance, apply 1 rice-sized grain of white grease (Molykote HP-300) to the place [4] shown in the figure, and apply half a rice-sized grain of white grease (Molykote HP-300) to the 2 places [5] shown in the figure.

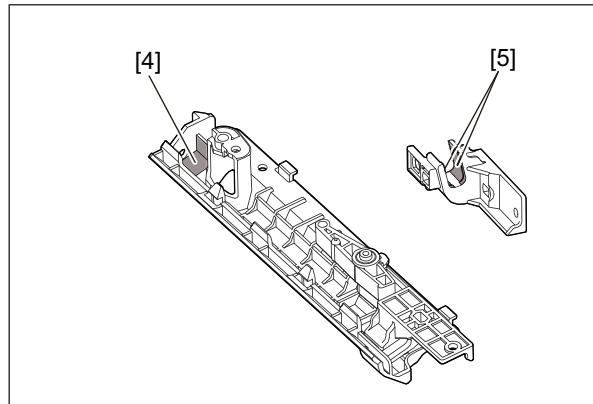

Fig. 4-168

## 4.5.19 2nd drawer paper feed unit

- (1) Pull out the 1st drawer.
- (2) Pull out the 2nd drawer.
- (3) Turn the lock lever [1] clockwise. Pull out the 2nd drawer paper feed unit [2] toward you to remove it.

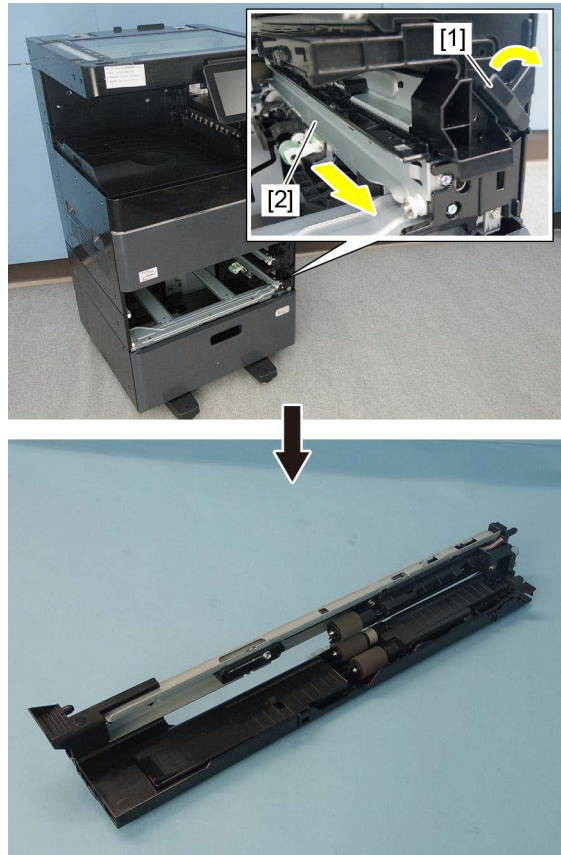

Fig. 4-169

### Notes:

When installing, align the arrow of the 2nd drawer paper feed unit to the guide before inserting.



## 4.5.20 2nd drawer separation roller guide

- (1) Take off the 2nd drawer paper feed unit.  
P. 4-68 "4.5.19 2nd drawer paper feed unit"
- (2) Remove 2 screws of the 2nd drawer separation roller guide [1].

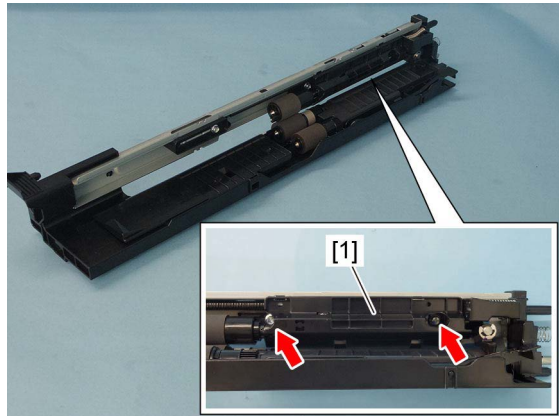

Fig. 4-170

- (3) Release 2 latches and take off the 2nd drawer separation roller guide [1].

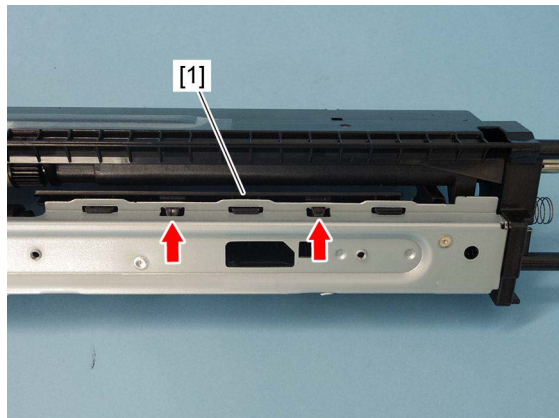

Fig. 4-171

- (4) Remove the E-ring and the shaft [2].

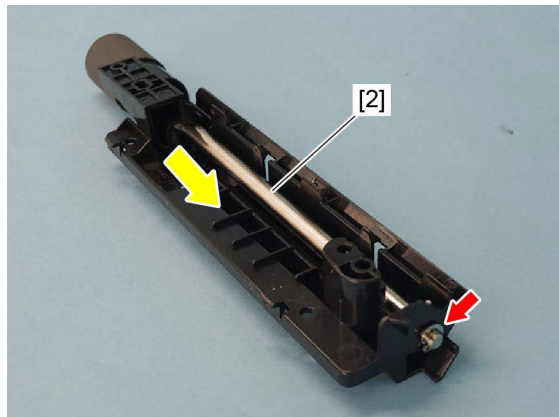

Fig. 4-172

(5) Take off the shaft cover [3].

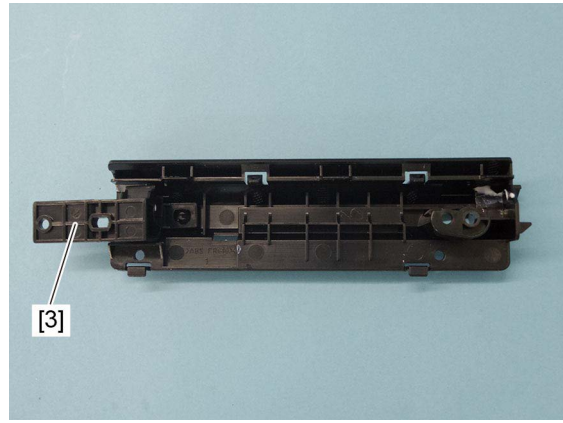

Fig. 4-173

**Notes:**

When replacing the parts or performing preventive maintenance, apply 1 rice-sized grain of white grease (Molykote HP-300) to the place [4] shown in the figure, and apply half a rice-sized grain of white grease (Molykote HP-300) to the 2 places [5] shown in the figure.

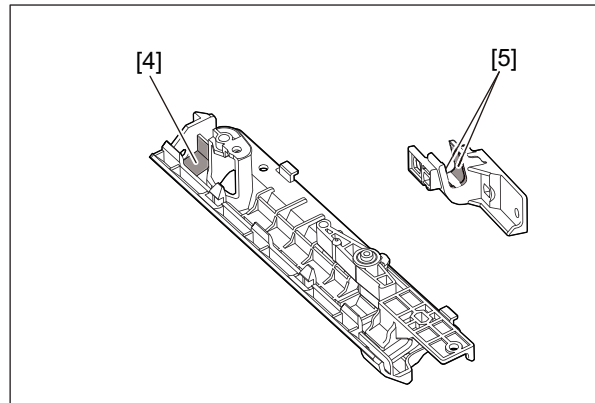

Fig. 4-174

## 4.5.21 1st drawer paper feed roller, Separation roller, Pickup roller<sup>EM</sup>

- (1) Take off the 1st drawer paper feed unit.  
P. 4-65 "4.5.17 1st drawer paper feed unit"
- (2) Slide the guide [1] to the front side.

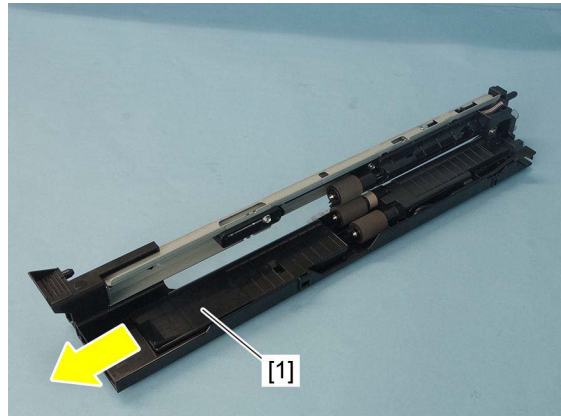

Fig. 4-175

- (3) Remove 1 clip [2] and take off the separation roller [3]. Remove 1 clip [4] and take off the paper feed roller [5]. Release the latch and take off the pickup roller [6].

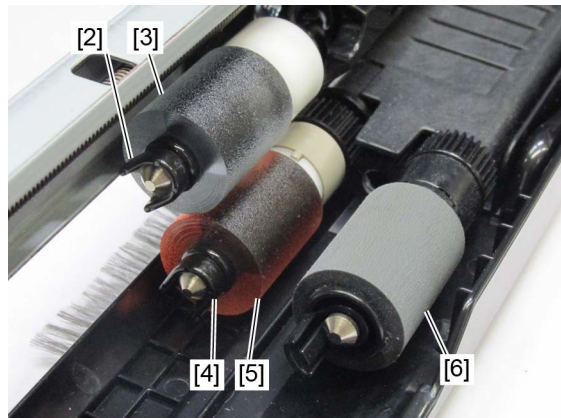

Fig. 4-176

Separation roller

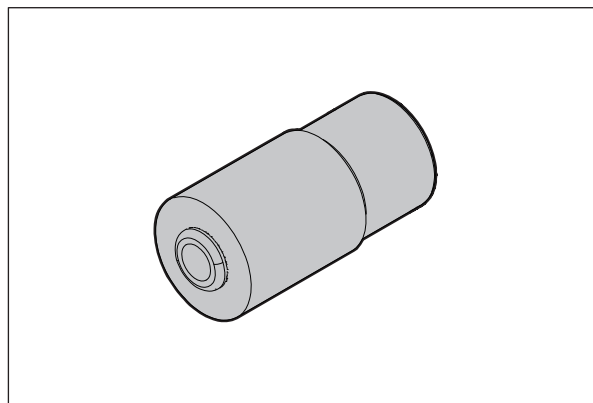

Fig. 4-177

Paper feed roller

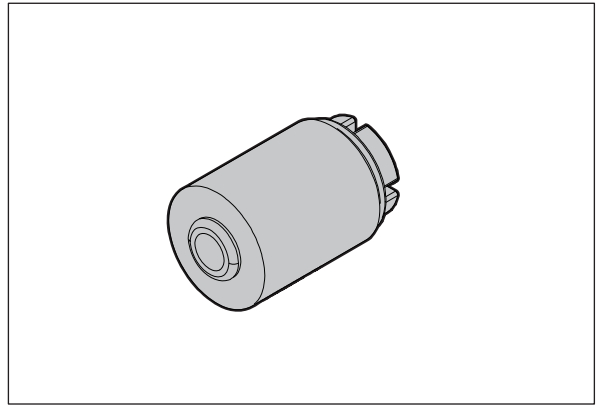

Fig. 4-178

Pickup roller

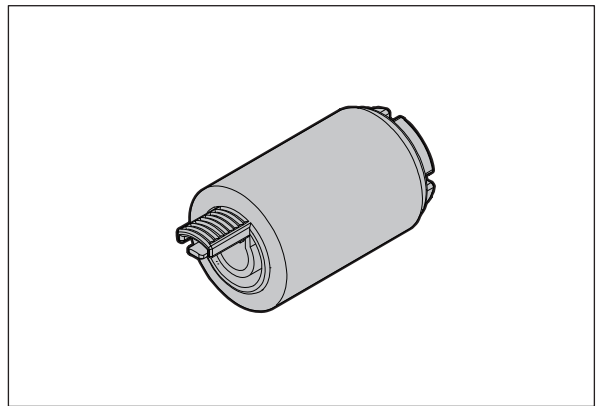



Fig. 4-179

#### 4.5.22 2nd drawer paper feed roller, Separation roller, Pickup roller

- (1) Take off the 2nd drawer paper feed unit.  
 P. 4-68 "4.5.19 2nd drawer paper feed unit"
- (2) Slide the guide [1] to the front side.

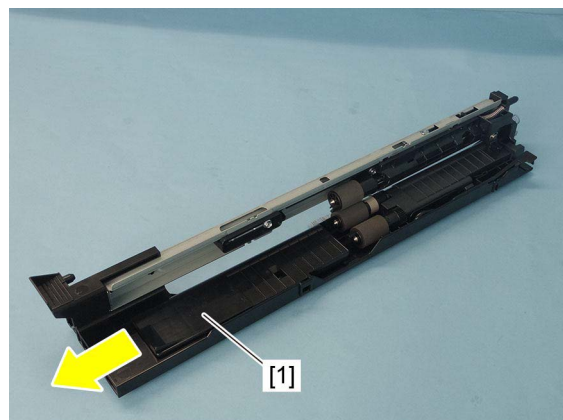

Fig. 4-180

- (3) Remove 1 clip [2] and take off the separation roller [3]. Remove 1 clip [4] and take off the paper feed roller [5]. Release the latch and take off the pickup roller [6].

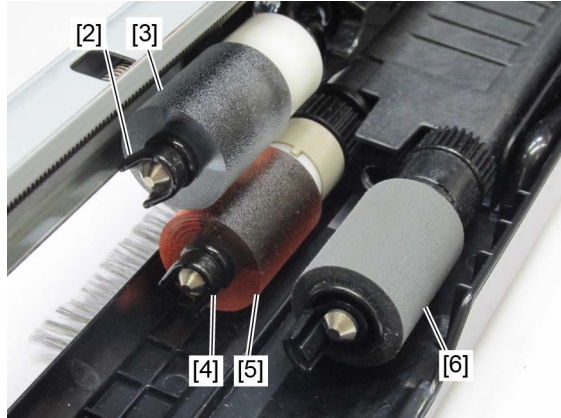

Fig. 4-181

Separation roller

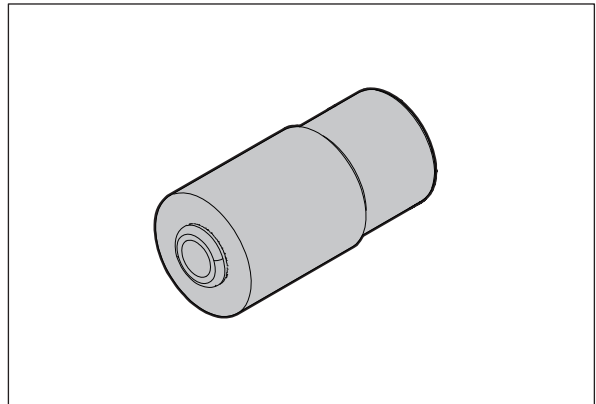

Fig. 4-182

Paper feed roller

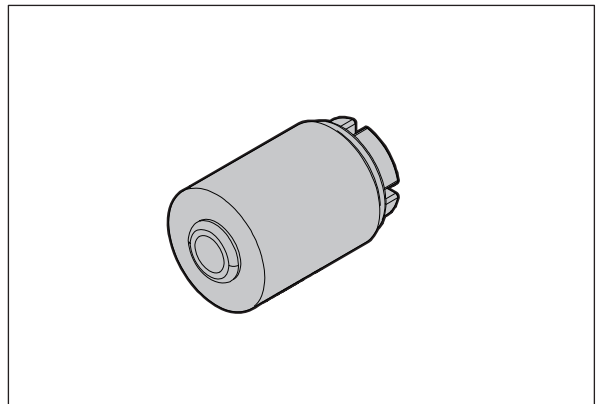
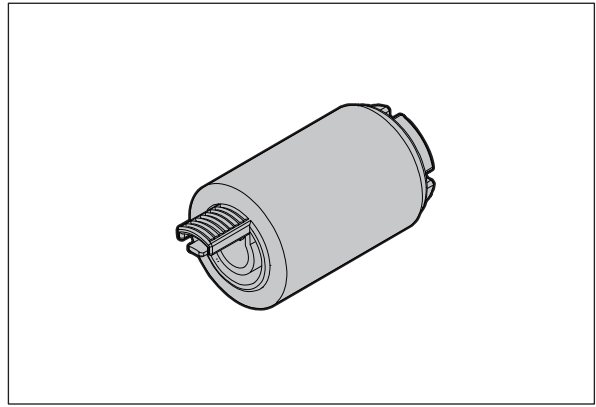

Fig. 4-183

Pickup roller



**Fig. 4-184**

### 4.5.23 1st drawer detection switch (SW8)

- (1) Take off the 1st drawer paper feed unit.  
📖 P. 4-65 "4.5.17 1st drawer paper feed unit"
- (2) Take off the 2nd drawer paper feed unit.  
📖 P. 4-68 "4.5.19 2nd drawer paper feed unit"
- (3) Take off the 1st drawer tray-up motor unit.  
📖 P. 4-77 "4.5.25 1st drawer tray-up motor unit"
- (4) Disconnect 1 connector [1] from the rear side and release 2 latches.

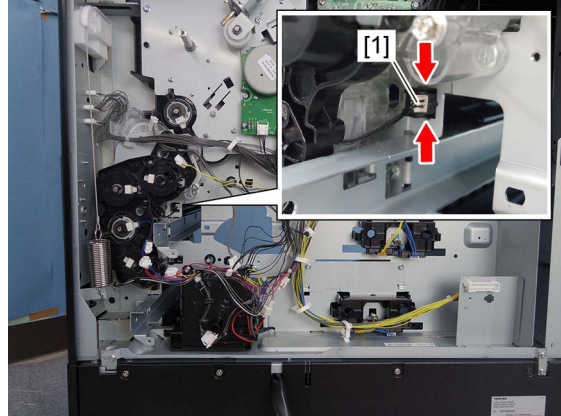

Fig. 4-185

- (5) Take off the 1st drawer detection switch [2] from the front side.

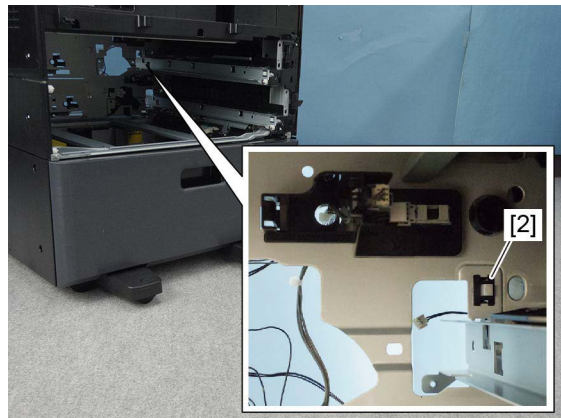

Fig. 4-186

#### 4.5.24 2nd drawer detection switch (SW19)

- (1) Take off the 1st drawer paper feed unit.  
📖 P. 4-65 “4.5.17 1st drawer paper feed unit”
- (2) Take off the 2nd drawer paper feed unit.  
📖 P. 4-68 “4.5.19 2nd drawer paper feed unit”
- (3) Take off the 2nd drawer tray-up motor unit.  
📖 P. 4-78 “4.5.26 2nd drawer tray-up motor unit”
- (4) Disconnect 1 connector [1] from the rear side and release 2 latches.

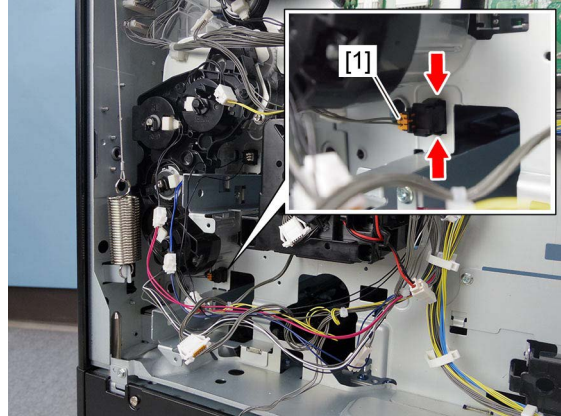

Fig. 4-187

- (5) Take off the 2nd drawer detection switch [2] from the front side.

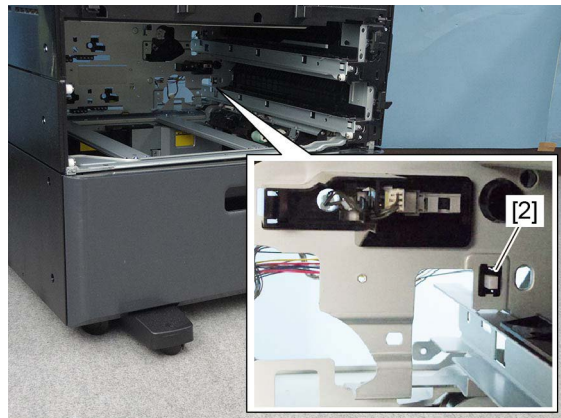



Fig. 4-188



## 4.5.25 1st drawer tray-up motor unit

- (1) Take off the rear cover.  
 P. 4-9 "4.1.15 Rear cover"
- (2) Disconnect 2 connectors [1]. Release the harness [2] from the harness clamp.

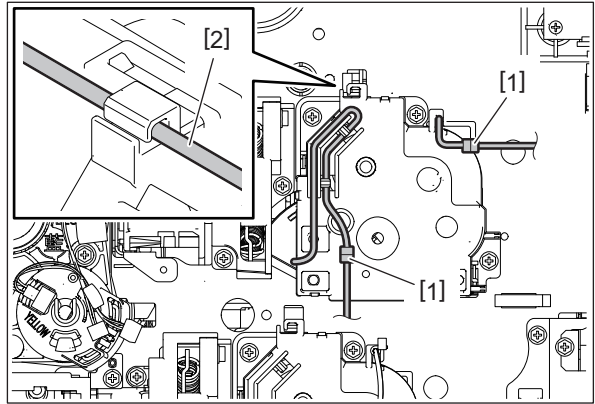

Fig. 4-189

- (3) Remove 3 screws [3] and take off the 1st drawer tray-up motor unit [4].

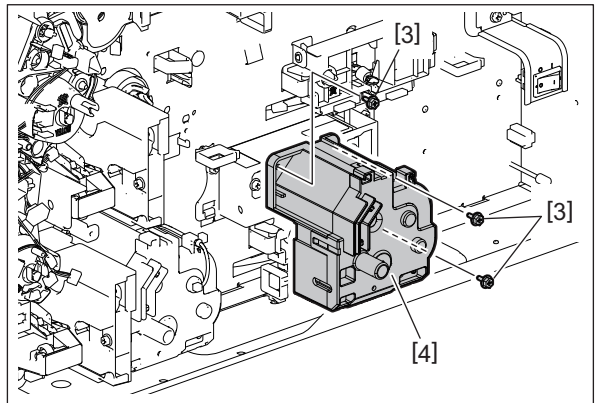

Fig. 4-190

## 4.5.26 2nd drawer tray-up motor unit

- (1) Take off the rear cover.  
📖 P. 4-9 "4.1.15 Rear cover"
- (2) Release 1 harness clamp [1] and disconnect 3 connectors [2]. Release the harness [3] from the harness clamp.

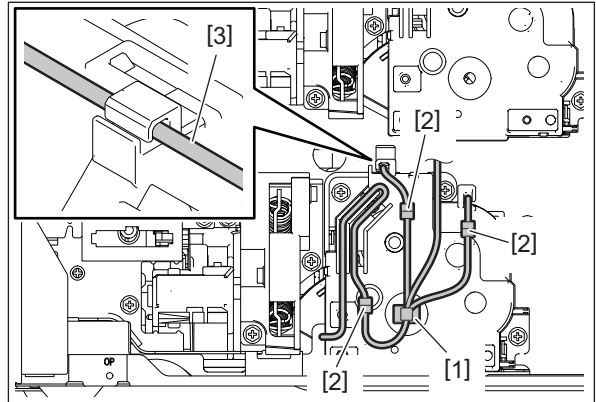

Fig. 4-191

- (3) Remove 3 screws [4] and take off the 2nd drawer tray-up motor unit [5].

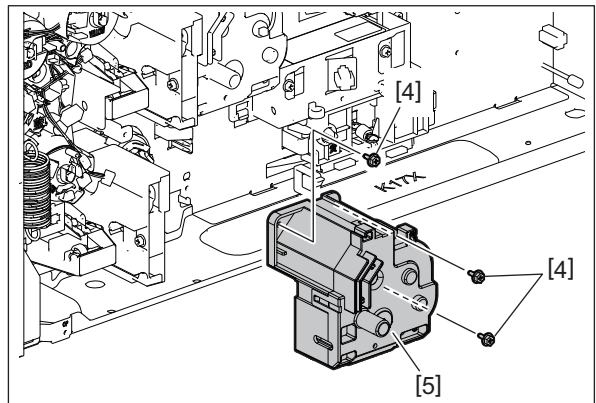

Fig. 4-192

## 4.5.27 1st drawer tray-up motor (M15)

- (1) Take off the 1st drawer tray-up motor unit.  
P. 4-77 "4.5.25 1st drawer tray-up motor unit"
- (2) Release the harnesses [1], [2] from the harness guide.

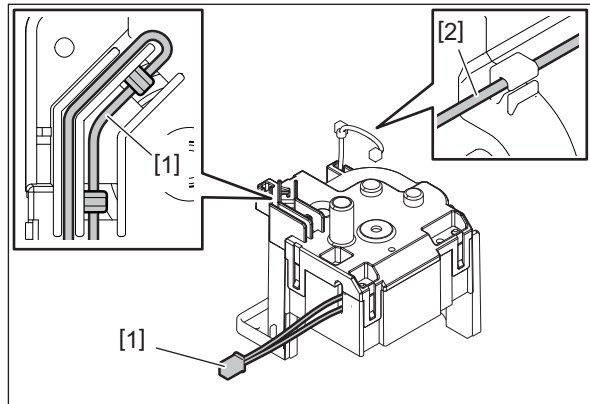

Fig. 4-193

- (3) Release 4 latches [3] and take off the cover [4].

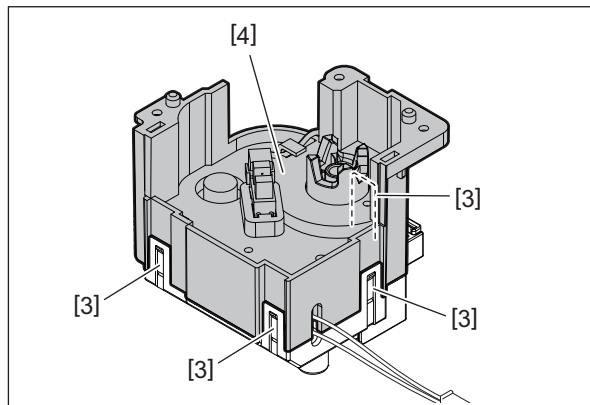

Fig. 4-194

- (4) Take off the 1st drawer tray-up motor [5].

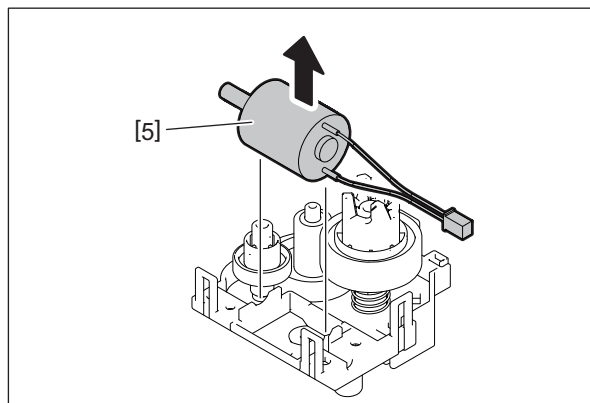

Fig. 4-195

## 4.5.28 2nd drawer tray-up motor (M16)

- (1) Take off the 2nd drawer tray-up motor unit.  
P. 4-78 "4.5.26 2nd drawer tray-up motor unit"
- (2) Release the harnesses [1], [2] from the harness guide.

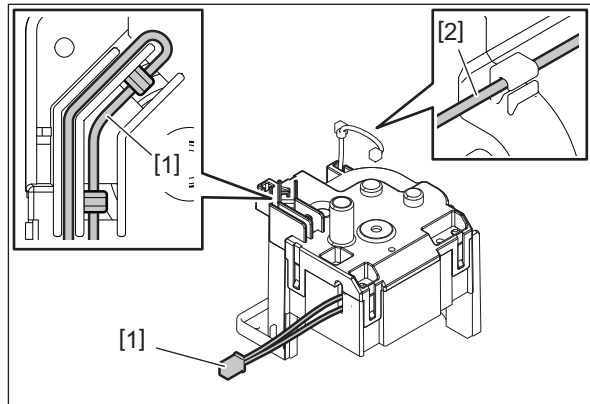

Fig. 4-196

- (3) Release 4 latches [3] and take off the cover [4].

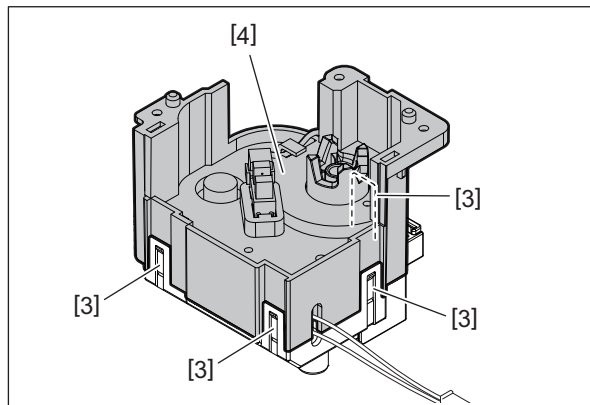

Fig. 4-197

- (4) Take off the 2nd drawer tray-up motor [5].

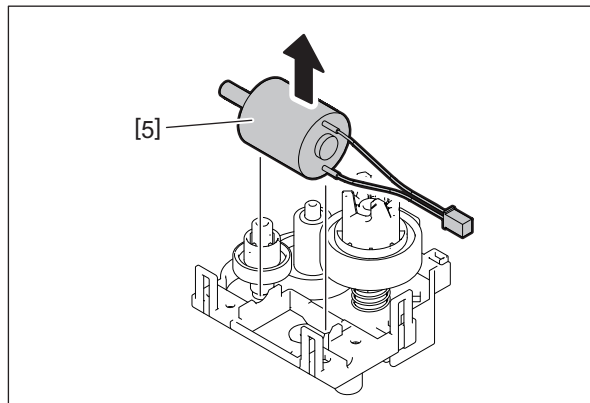

Fig. 4-198

#### 4.5.29 1st drawer paper nearly empty sensor (S45)

- (1) Remove the cover.  
P. 4-79 "4.5.27 1st drawer tray-up motor (M15)"
- (2) Disconnect the connector [1] and take off the 1st drawer paper nearly empty sensor [2].

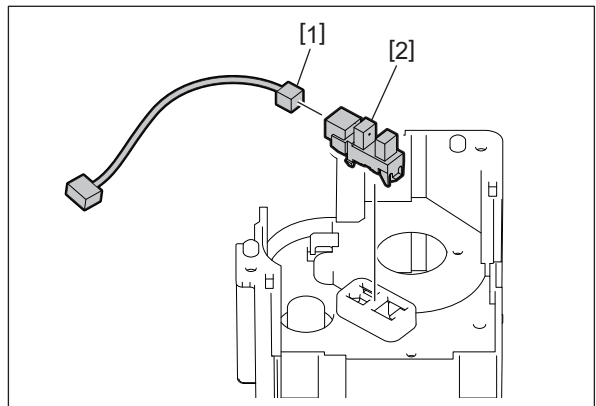

Fig. 4-199

#### 4.5.30 2nd drawer paper nearly empty sensor (S46)

- (1) Remove the cover.  
P. 4-80 "4.5.28 2nd drawer tray-up motor (M16)"
- (2) Disconnect the connector [1] and take off the 2nd drawer paper nearly empty sensor [2].

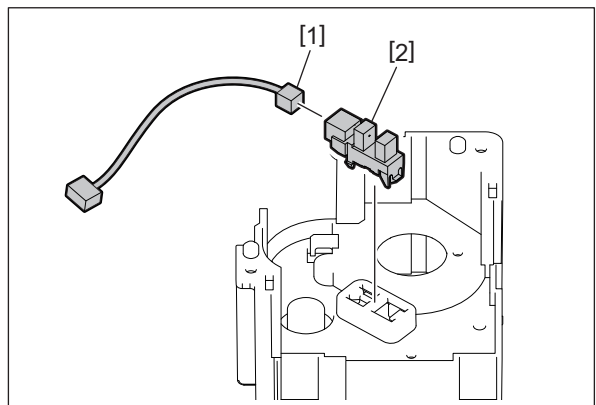

Fig. 4-200

### 4.5.31 1st drawer paper empty sensor (S5), 1st drawer tray-up sensor (S31)

- (1) Take off the 1st drawer paper feed unit.  
📖 P. 4-65 “4.5.17 1st drawer paper feed unit”
- (2) Take off the 2nd drawer paper feed unit.  
📖 P. 4-68 “4.5.19 2nd drawer paper feed unit”
- (3) Take off the 1st drawer tray-up motor unit.  
📖 P. 4-77 “4.5.25 1st drawer tray-up motor unit”
- (4) Release 1 latch.

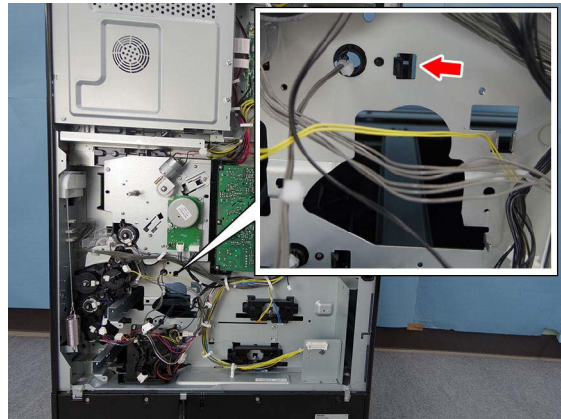

Fig. 4-201

- (5) Feed out the sensor holder [1] to the front side and take it off.

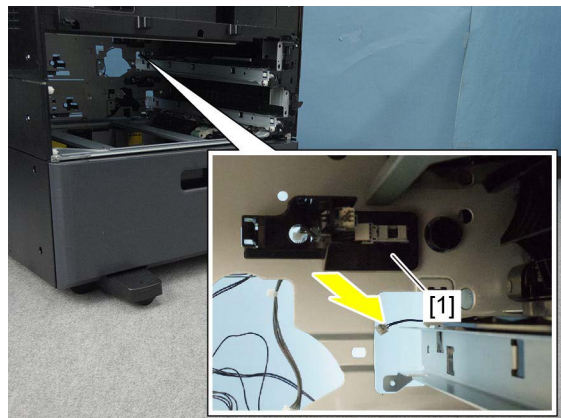

Fig. 4-202

**Notes:**

When installing, fix the sensor holder using its projection [2] and latch [3].

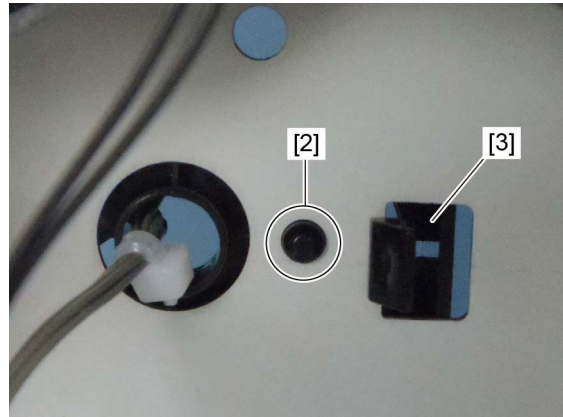

Fig. 4-203

- (6) Disconnect 2 connectors. Take off the 1st drawer paper empty sensor [4] and 1st drawer tray-up sensor [5].

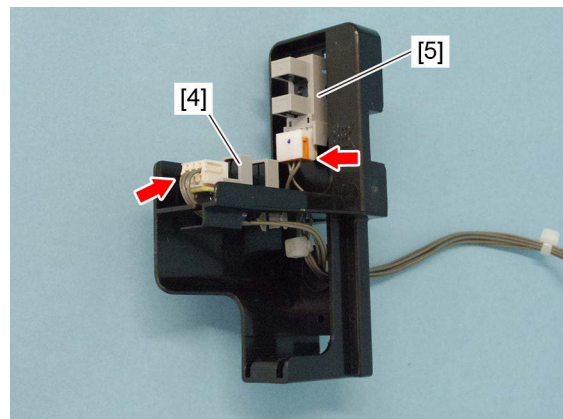

Fig. 4-204

**Notes:**

When connecting, be sure to connect the white connector to the 1st drawer paper empty sensor [4] and the yellow connector to the 1st drawer tray-up sensor [5].

### 4.5.32 2nd drawer paper empty sensor (S34), 2nd drawer tray-up sensor (S35)

- (1) Take off the 1st drawer paper feed unit.  
📖 P. 4-65 “4.5.17 1st drawer paper feed unit”
- (2) Take off the 2nd drawer paper feed unit.  
📖 P. 4-68 “4.5.19 2nd drawer paper feed unit”
- (3) Take off the 2nd drawer tray-up motor unit.  
📖 P. 4-78 “4.5.26 2nd drawer tray-up motor unit”
- (4) Release 1 latch.

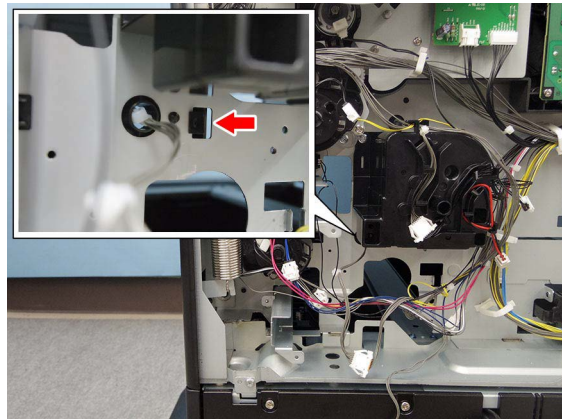

Fig. 4-205

- (5) Feed out the sensor holder [1] to the front side and take it off.

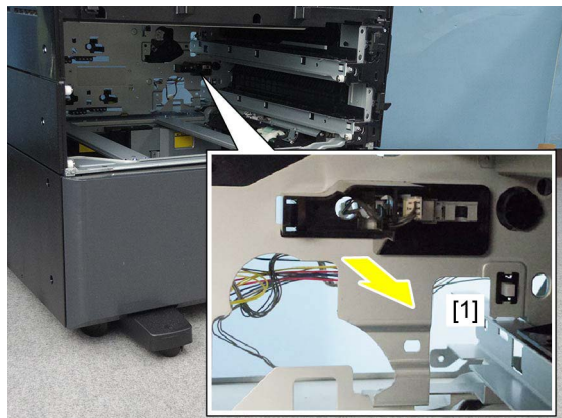

Fig. 4-206



**Notes:**

When installing, fix the sensor holder using its projection [2] and latch [3].

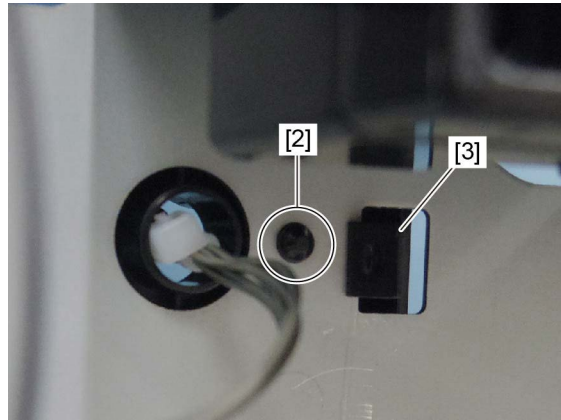

Fig. 4-207

- (6) Disconnect 2 connectors. Take off the 2nd drawer paper empty sensor [4] and 2nd drawer tray-up sensor [5].

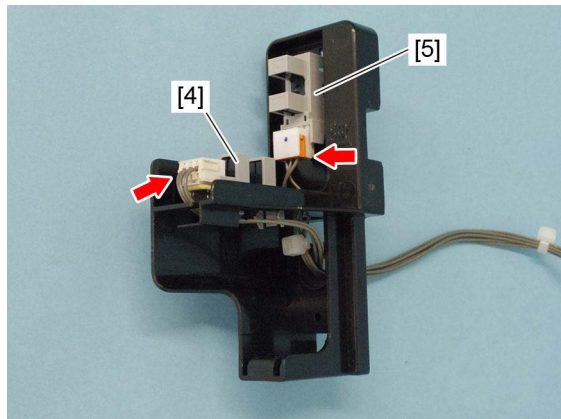

Fig. 4-208

**Notes:**

When connecting, be sure to connect the white connector to the 2nd drawer paper empty sensor [4] and the yellow connector to the 2nd drawer tray-up sensor [5].

### 4.5.33 1st drawer paper width detection switch (SW6), 1st drawer paper length detection switch (SW7)

- (1) Take off the rear cover.  
📖 P. 4-9 “4.1.15 Rear cover”
- (2) Remove 1 spring [1] and disconnect 2 connectors [2].

**Notes:**

When installing, connect the yellow harness connector [2] to the left side.

- (3) Release 2 latches and take off the switch holder [3].

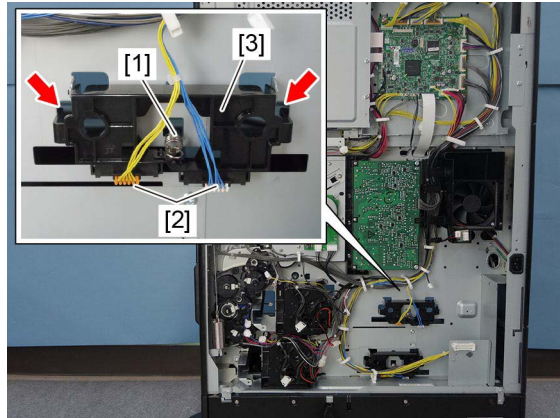

Fig. 4-209

- (4) Release 4 latches and take off the 1st drawer paper width detection switch [4] and 1st drawer paper length detection switch [5].

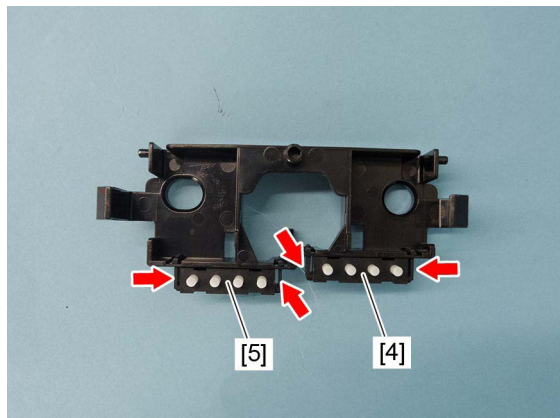

Fig. 4-210

#### 4.5.34 2nd drawer paper width detection switch (SW17), 2nd drawer paper length detection switch (SW18)

- (1) Take off the rear cover.  
📖 P. 4-9 “4.1.15 Rear cover”
- (2) Remove 1 spring [1] and disconnect 2 connectors [2].

**Notes:**

When installing, connect the yellow harness connector [2] to the left side.

- (3) Release 2 latches and take off the switch holder [3].

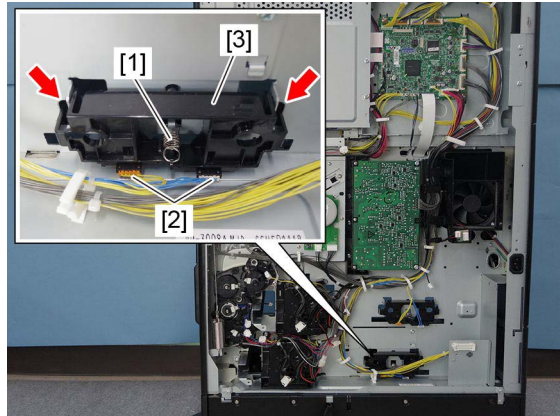

Fig. 4-211

- (4) Release 4 latches and take off the 2nd drawer paper width detection switch [4] and 2nd drawer paper length detection switch [5].

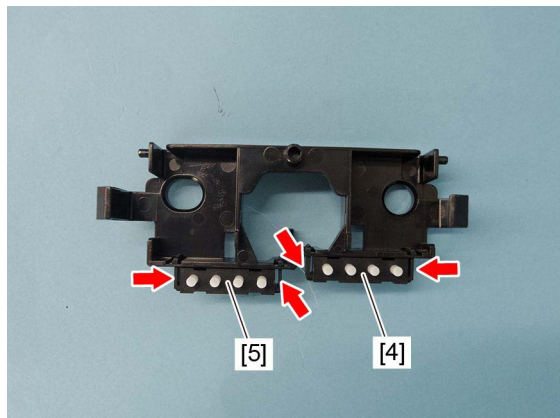

Fig. 4-212

### 4.5.35 Transport clutch (H) (CLT5)

- (1) Take off the rear cover.  
P. 4-9 "4.1.15 Rear cover"
- (2) Disconnect 3 connectors [1] and release the harness from 3 harness guides.

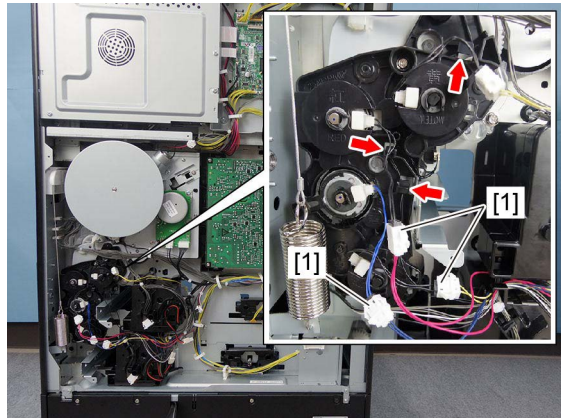

Fig. 4-213

- (3) Remove 3 clips.

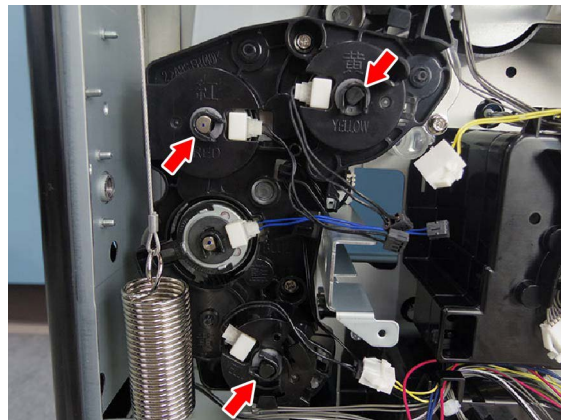

Fig. 4-214

- (4) Remove 3 bushings and 2 screws [2]. Take off the clutch cover [3].

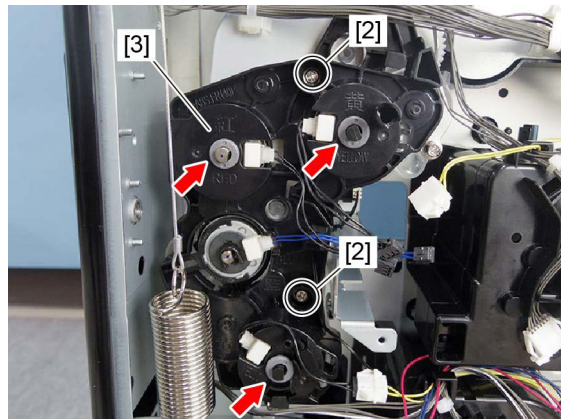

Fig. 4-215

- (5) Remove the transport clutch (H) [4].

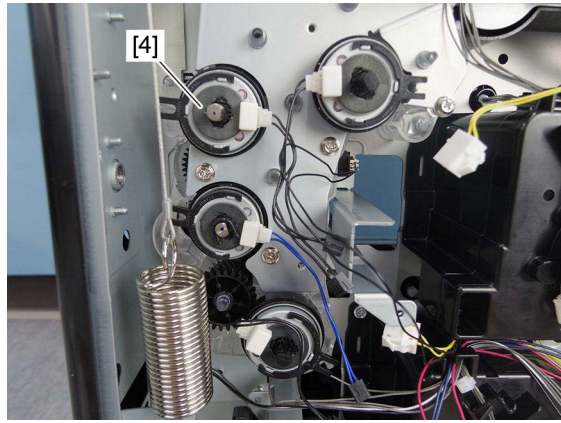

Fig. 4-216

**Notes:**

When installing, attach a rotation stopper.

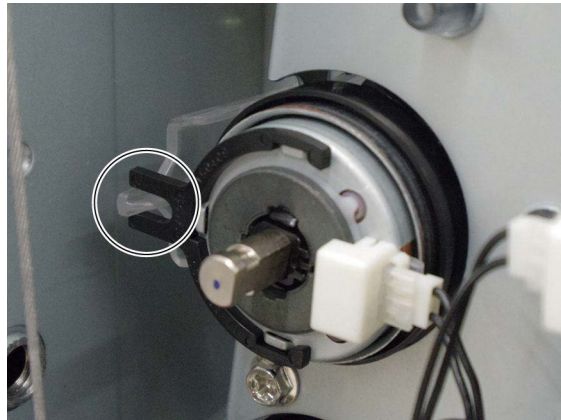

Fig. 4-217

### 4.5.36 Transport clutch (L) (CLT6)

- (1) Take off the rear cover.  
P. 4-9 "4.1.15 Rear cover"
- (2) Disconnect 1 connector [1]. Remove 1 clip and remove the transport clutch (L) [2].

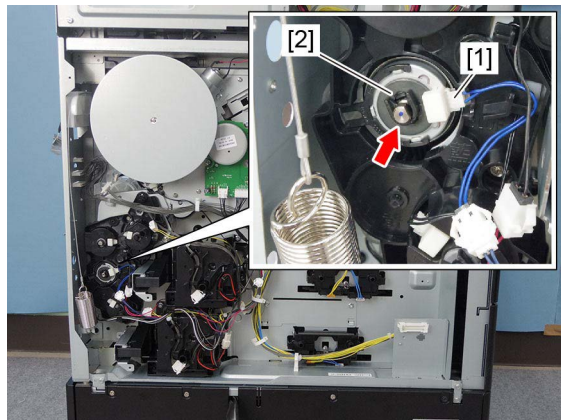

Fig. 4-218

**Notes:**

When installing, attach a rotation stopper to the clutch cover.

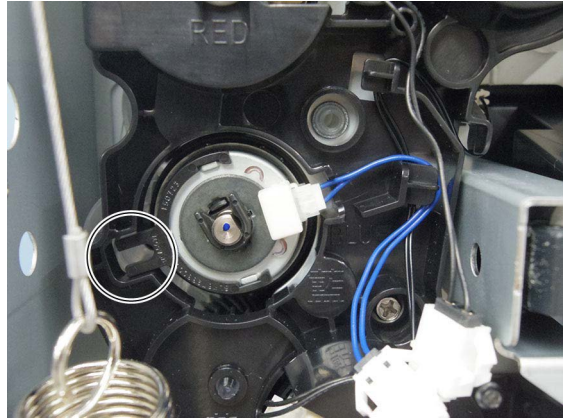

Fig. 4-219

### 4.5.37 1st drawer paper feed clutch (CLT1)

- (1) Take off the clutch cover.  
📖 P. 4-88 "4.5.35 Transport clutch (H) (CLT5)"
- (2) Take off the 2nd drawer paper feed clutch [1].

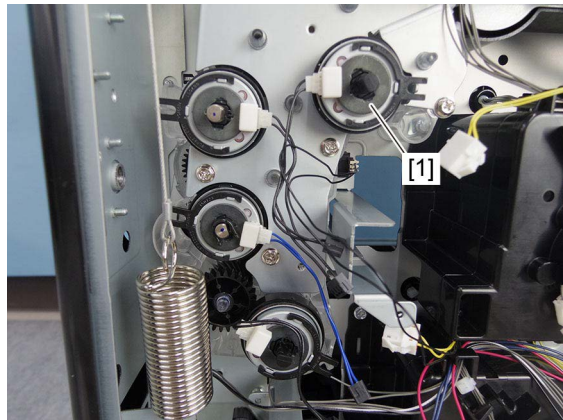

Fig. 4-220

**Notes:**

When installing, attach a rotation stopper.

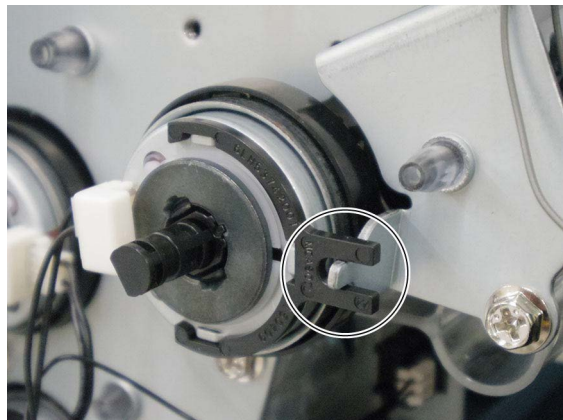



Fig. 4-221

### 4.5.38 2nd drawer paper feed clutch (CLT4)

- (1) Take off the clutch cover.  
 P. 4-88 "4.5.35 Transport clutch (H) (CLT5)"
- (2) Take off the 2nd drawer paper feed clutch [1].

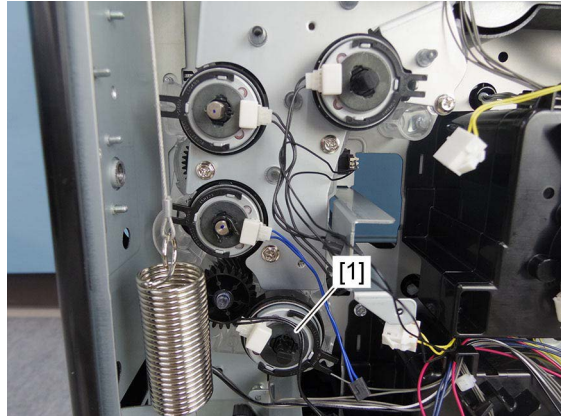

Fig. 4-222

**Notes:**

When installing, attach a rotation stopper.

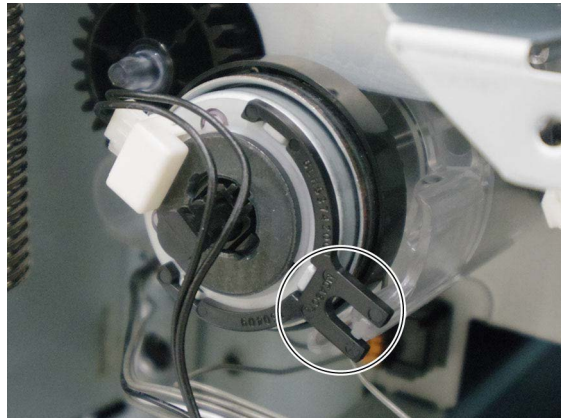

Fig. 4-223

### 4.5.39 Flywheel

- (1) Take off the rear cover.  
📖 P. 4-9 "4.1.15 Rear cover"
- (2) Remove 1 screw and the flywheel [1].



Fig. 4-224

### 4.5.40 Registration clutch (CLT7)

- (1) Remove the flywheel.  
📖 P. 4-92 "4.5.39 Flywheel"
- (2) Disconnect 1 connector [1], remove 1 clip and take off the registration clutch [2].

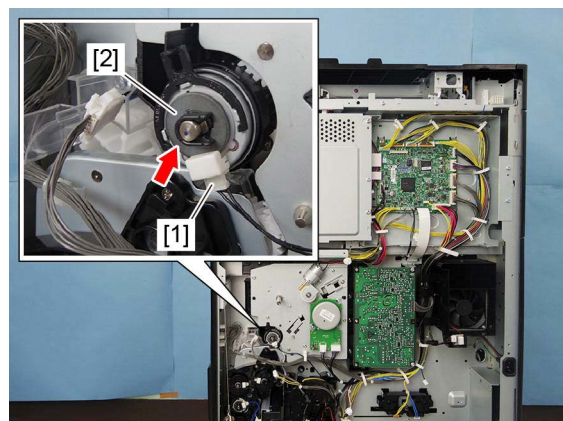

Fig. 4-225



**Notes:**

When installing, attach a rotation stopper.



Fig. 4-226

### 4.5.41 Paper feed drive unit

- (1) Remove the transport clutch (L).  
📖 P. 4-89 “4.5.36 Transport clutch (L) (CLT6)”
- (2) Disconnect 3 connectors.

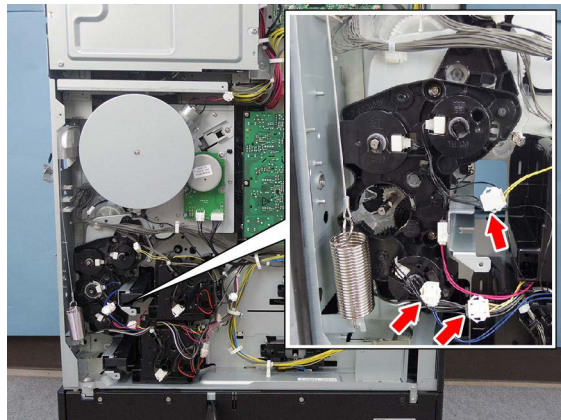

Fig. 4-227

- (3) Release 1 harness clamp [1] and disconnect 1 connector [2].
- (4) Release the harness from 2 harness guides.

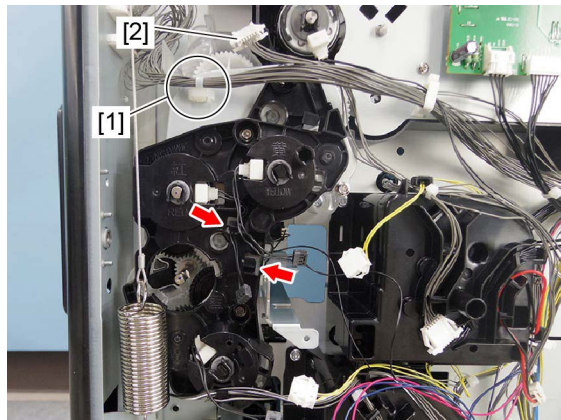

Fig. 4-228

(5) Remove the spring [3].

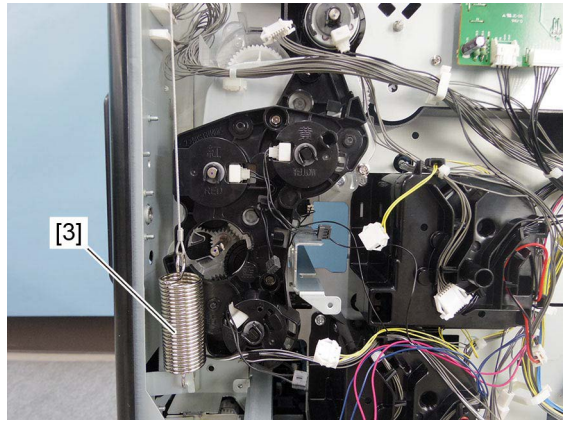

Fig. 4-229

(6) Remove 3 screws and take off the paper feed drive unit [4].

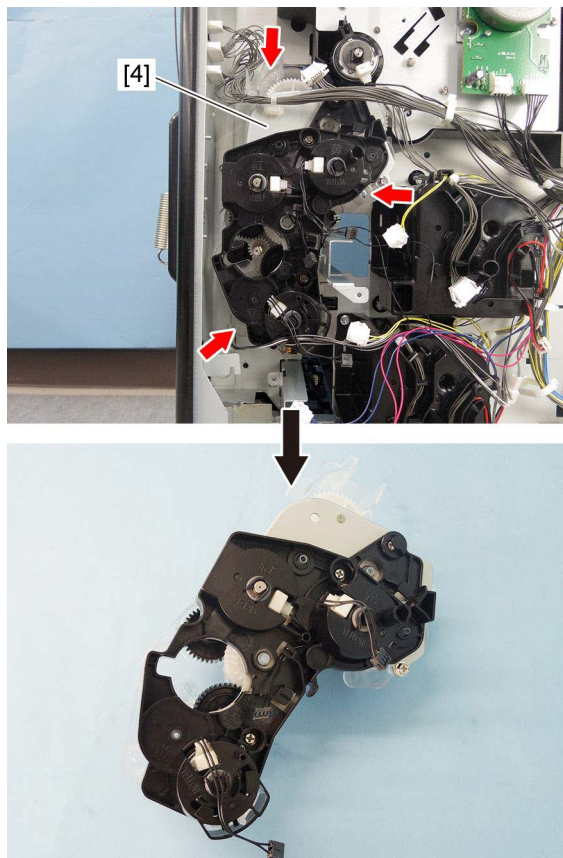

Fig. 4-230

**Notes:**

When replacing the gear, remove the clutch cover.

#### 4.5.42 Paper feed drive gear

- (1) Take off the paper feed drive unit.  
📖 P. 4-93 "4.5.41 Paper feed drive unit"
- (2) Remove 3 clips and 3 bushings [1].

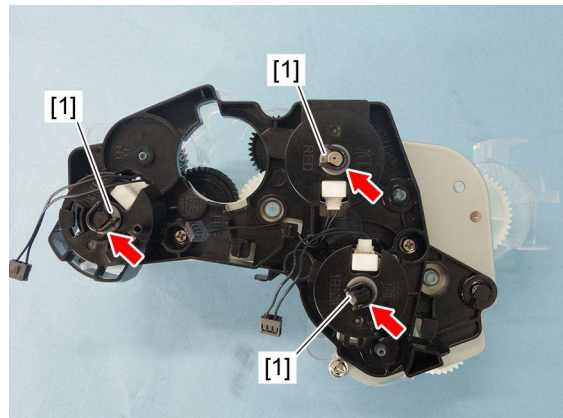

Fig. 4-231

- (3) Remove 2 screws and take off the clutch cover [2].

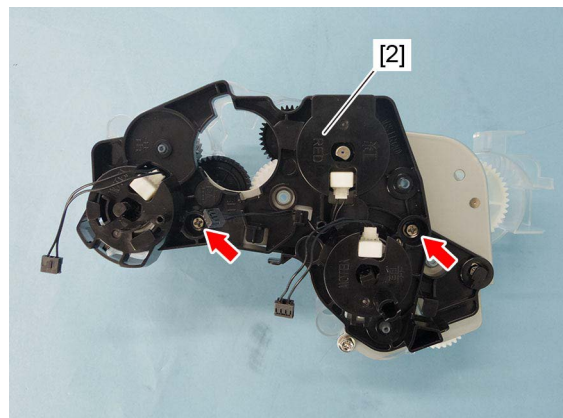

Fig. 4-232

- (4) Take off the 1st drawer paper feed clutch [3], 2nd drawer paper feed clutch [4] and transport clutch (H) [5].

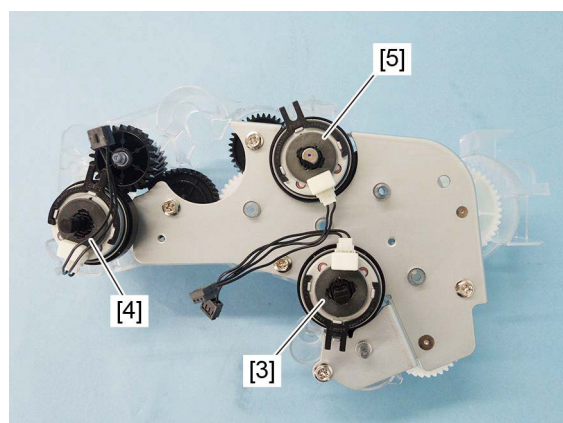

Fig. 4-233

**Notes:**

When installing, attach a rotation stopper.



Fig. 4-234

- (5) Remove 5 screws and take off the paper feed drive gear cover [6].

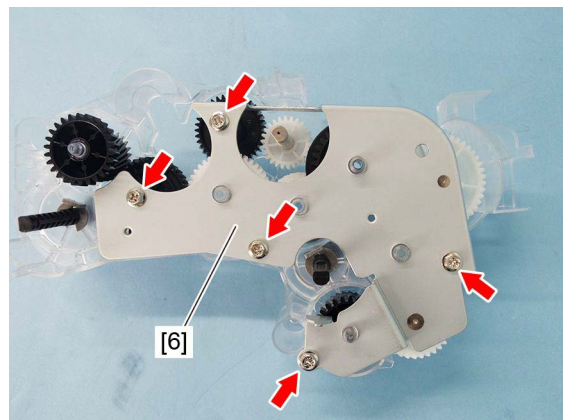

Fig. 4-235

**Notes:**

When replacing the parts or performing refreshment, apply 2 rice-sized grains of white grease (Molykote EM-30L) to the shaft [7].

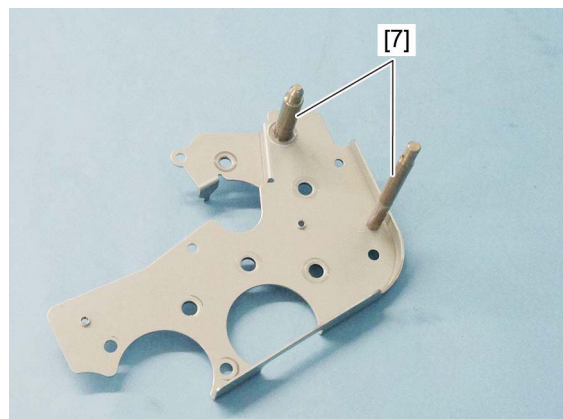

Fig. 4-236

- (6) Take off the paper feed drive gear.

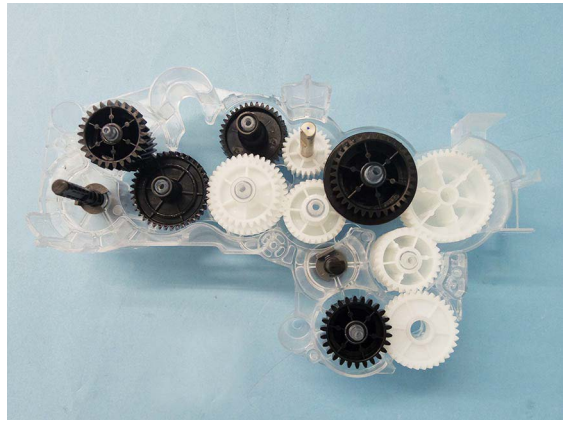

Fig. 4-237

#### 4.5.43 Drawer damp heater (DH4)

- (1) Take off the rear cover.  
P. 4-9 "4.1.15 Rear cover"
- (2) Pull out the 1st and 2nd drawers.
- (3) Remove 2 screws.

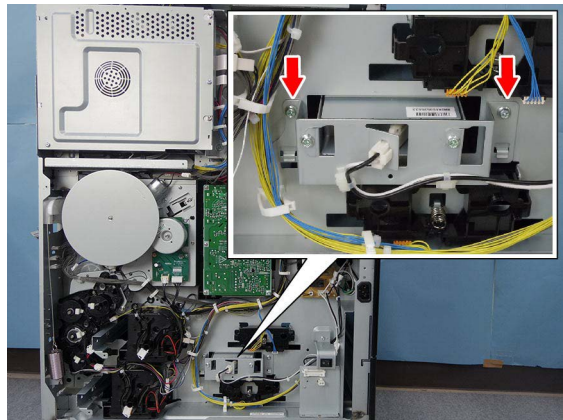

Fig. 4-238

- (4) Remove 2 screw and take off the bracket [1].

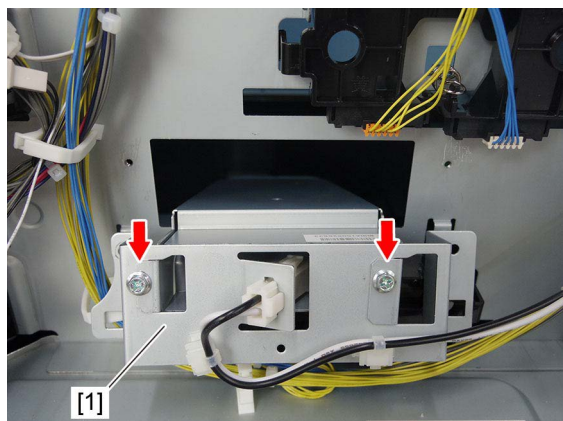

Fig. 4-239

- (5) Disconnect 1 connector and take off the drawer damp heater assembly [2].

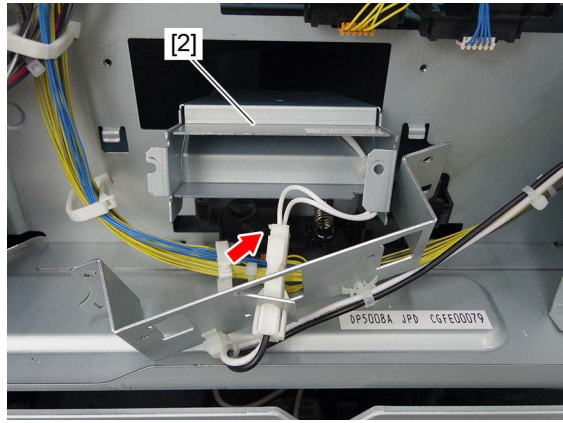

Fig. 4-240

- (6) Remove 1 screw and take off the cover [3] by sliding it in the direction of the arrow.

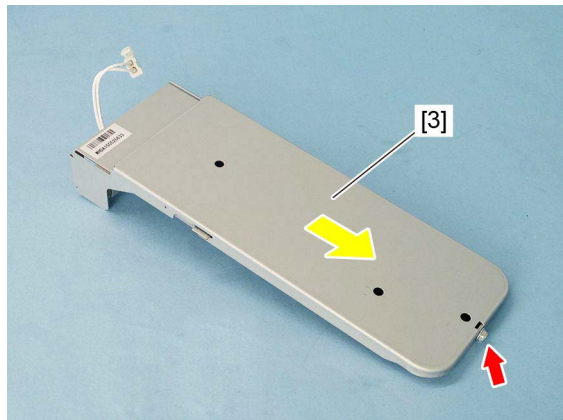

Fig. 4-241

- (7) Remove 1 screw and take off the drawer damp heater [4].

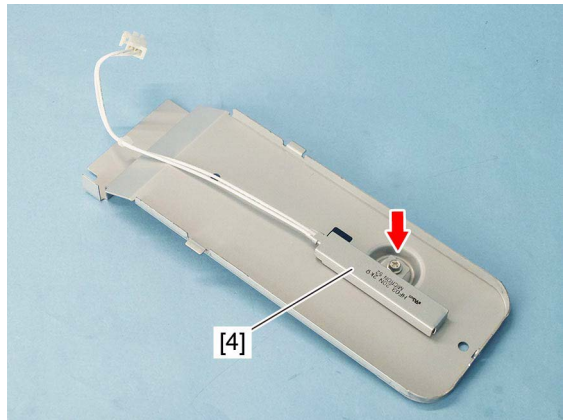

Fig. 4-242

#### 4.5.44 1st drawer soft-close unit (3528A/4528A)

- (1) Pull out the 1st drawer.
- (2) Take off the rear cover.  
📖 P. 4-9 “4.1.15 Rear cover”
- (3) Remove 3 screws [1] and take off the soft-close unit [2].

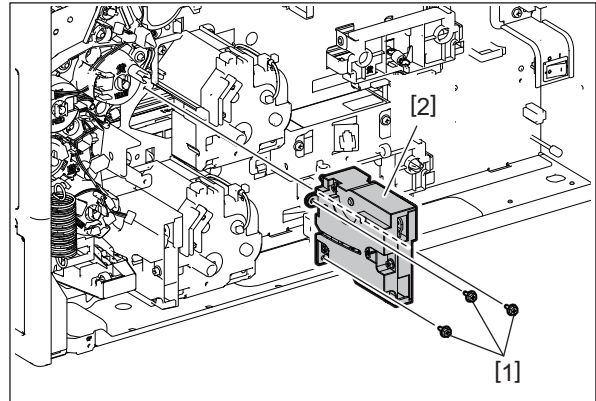

Fig. 4-243

#### Notes:

- Do not disassemble the soft-close units since a spring with a strong force is used and this will be dangerous.
- When the soft-close unit is replaced, perform the operation described in the following reference.  
📖 P. 4-100 “4.5.46 Operation when replacing the soft-close unit for the first time”

#### 4.5.45 2nd drawer soft-close unit (3528A/4528A)

- (1) Pull out the 2nd drawer.
- (2) Take off the rear cover.  
📖 P. 4-9 “4.1.15 Rear cover”
- (3) Remove 3 screws [1] and take off the soft-close unit [2].

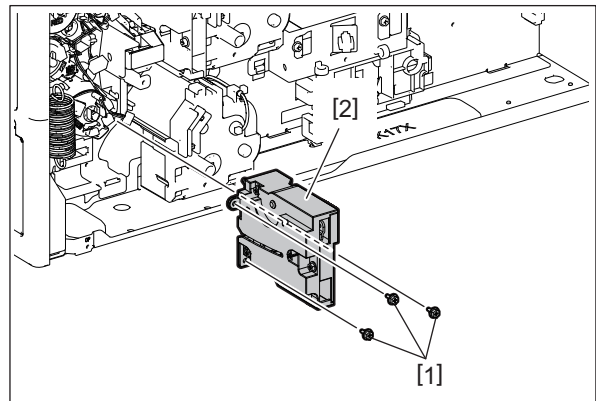

Fig. 4-244

#### Notes:

- Do not disassemble the soft-close units since a spring with a strong force is used and this will be dangerous.
- When the soft-close unit is replaced, perform the operation described in the following reference.  
📖 P. 4-100 “4.5.46 Operation when replacing the soft-close unit for the first time”

#### 4.5.46 Operation when replacing the soft-close unit for the first time

- (1) Take off the 1st drawer paper feed unit.  
📖 P. 4-65 "4.5.17 1st drawer paper feed unit"
- (2) Take off the 2nd drawer paper feed unit.  
📖 P. 4-68 "4.5.19 2nd drawer paper feed unit"
- (3) Remove 1 clip [1].

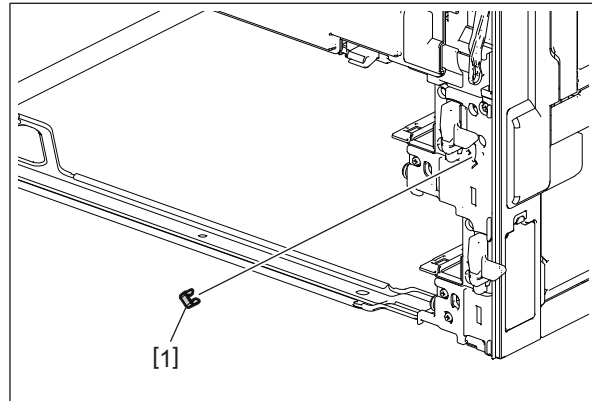

Fig. 4-245

- (4) Turn the lever counterclockwise. Remove the 1st drawer lever [2] and the 2nd drawer lever [3].

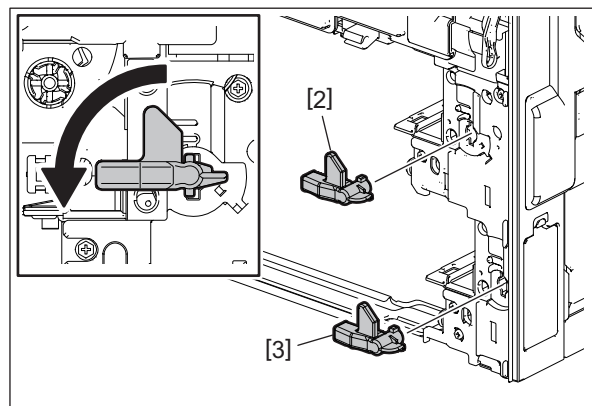

Fig. 4-246

- (5) Remove 2 screws and take off the cover [4].

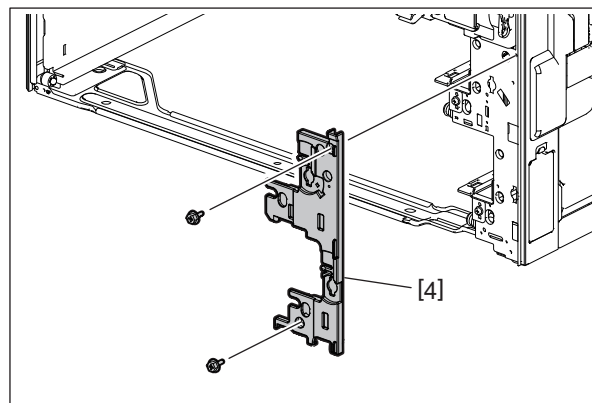

Fig. 4-247



- (6) Insert the drawer [5] or [6] with the soft-close unit replaced all the way in.  
Check if the drawer is automatically inserted by removing and then reinstalling it.

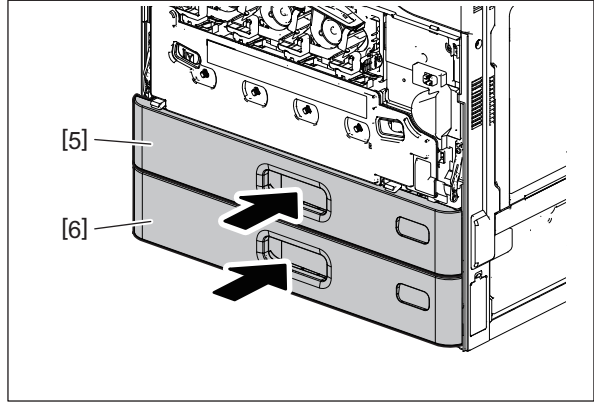



Fig. 4-248

## 4.6 Driving Section

### 4.6.1 Main motor (M23) (3528A/4528A)

- (1) Remove the flywheel.  
 P. 4-92 “4.5.39 Flywheel”
- (2) Disconnect 2 connectors.

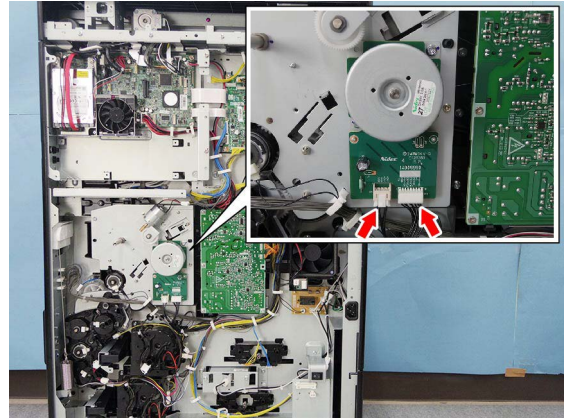

Fig. 4-249

- (3) Remove 2 screws and take off the main motor [1].

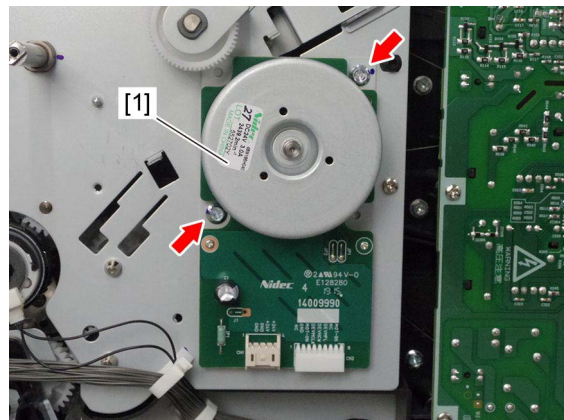



Fig. 4-250

## 4.6.2 Main motor (M23) (2528A/3028A)

- (1) Remove the flywheel.  
 P. 4-92 "4.5.39 Flywheel"
- (2) Disconnect 2 connectors.

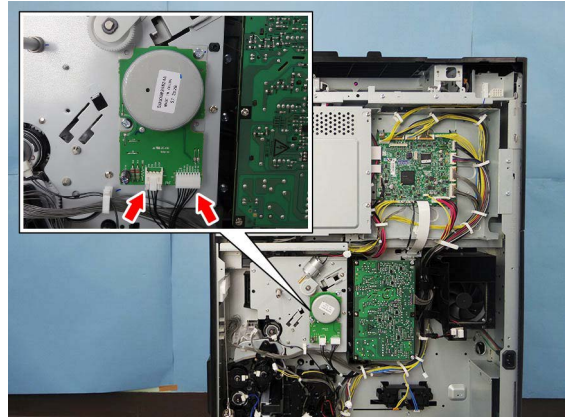

Fig. 4-251

- (3) Remove 2 screws and take off the main motor [1].

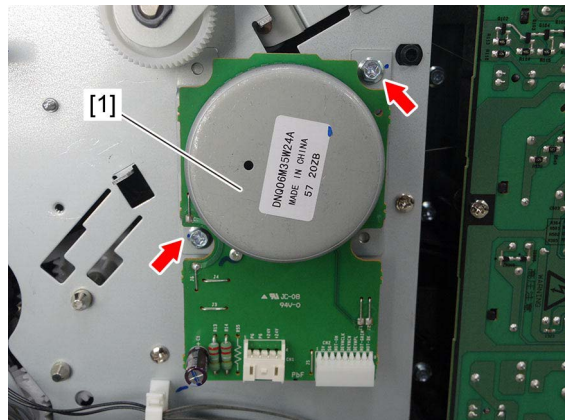

Fig. 4-252

## 4.7 Drum Related Section

### 4.7.1 Process unit

#### Notes:

Make sure to perform FS-05-2390 and then take off the process unit before the developer material is replaced.

- (1) Open the ADU.
- (2) Open the front cover.
- (3) Press down the lever [1] and take off the toner cartridge [2] by pulling it toward you.



Fig. 4-253

- (4) Loosen 2 screws and take off the process unit [3] by pulling it toward you.

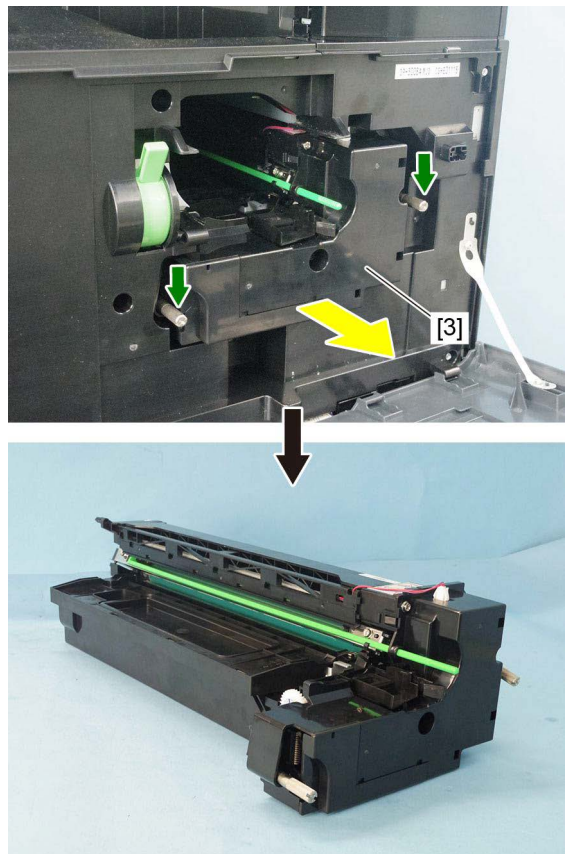

Fig. 4-254

## 4.7.2 Drum cleaner unit

- (1) Take off the process unit.  
P. 4-104 "4.7.1 Process unit"
- (2) Release 1 latch and take off the harness cover [1] by sliding it downward.

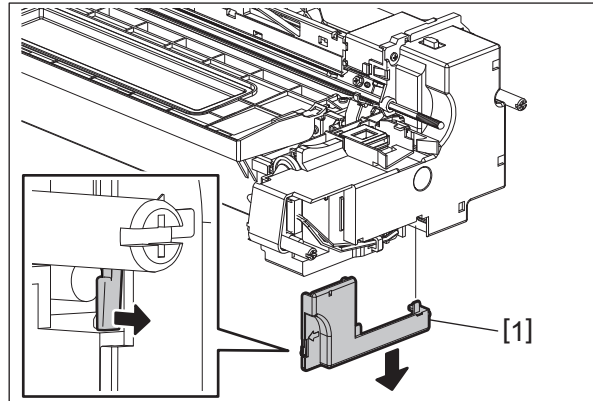

Fig. 4-255

- (3) Remove 1 screw and take off the plate [2].
- (4) Disconnect 1 connector.

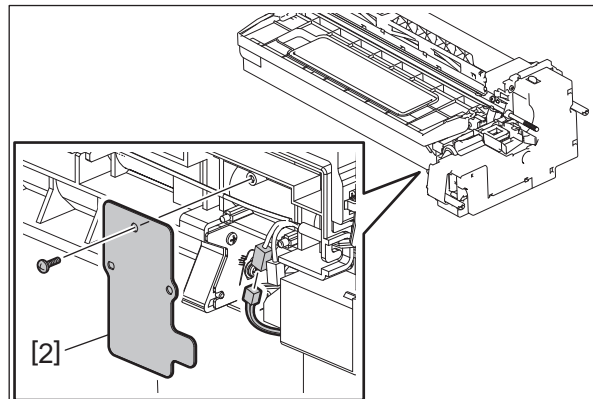

Fig. 4-256

- (5) Disconnect 2 connectors.

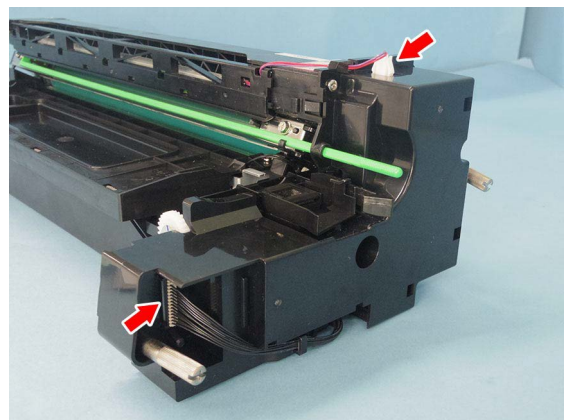

Fig. 4-257

- (6) Release the harness from 1 harness guide. Remove 2 screws. Release 1 latch and take off the process unit front cover [3].

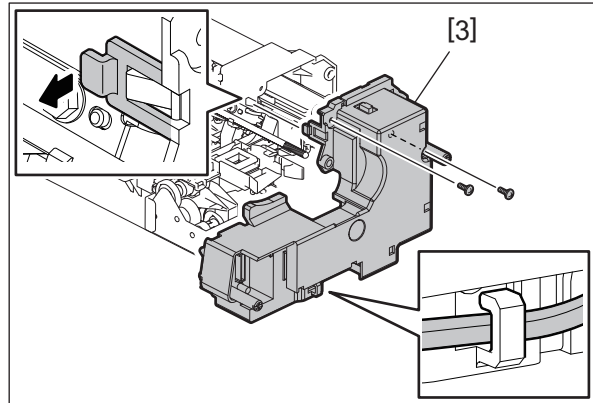

Fig. 4-258

- (7) Take off the drum cleaner unit [4] by lifting it up.

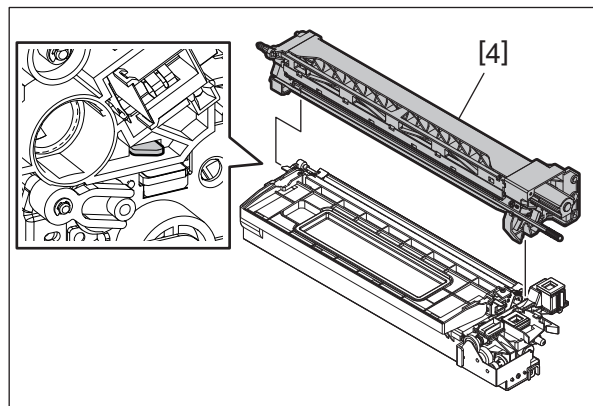

Fig. 4-259

**Notes:**

- When removing, be careful not to touch or scratch the drum surface.
- Do not deform the guide film [5] of the developer unit by touching this.

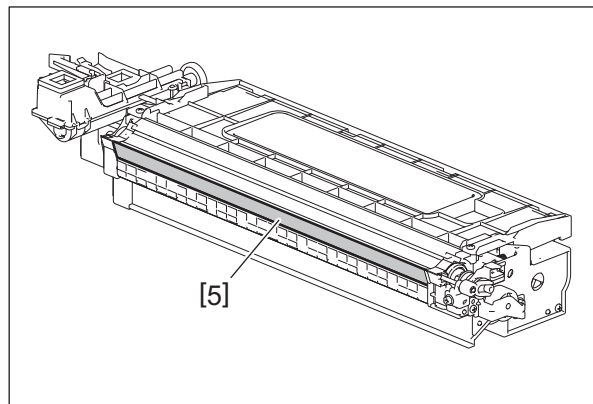

Fig. 4-260

### 4.7.3 Discharge LED

- (1) Take off the drum cleaner unit.  
📖 P. 4-105 "4.7.2 Drum cleaner unit"
- (2) Release 1 latch and take off the discharge LED unit [1].

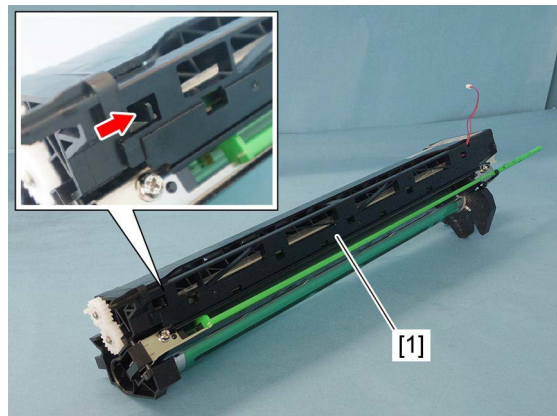

Fig. 4-261

**Notes:**

When removing, be careful not to touch or scratch the drum surface.

- (3) Release the harness [2] from 2 harness guides. Take off the discharge LED [3].

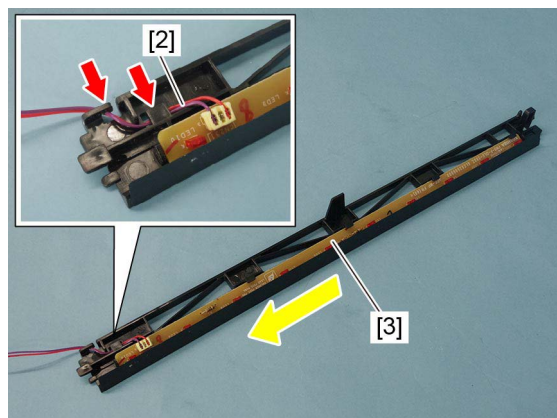

Fig. 4-262

**Notes:**

The number of the discharge LEDs differs between 2528A/3028A and 3528A/4528A. Therefore, do not install the LEDs in a wrong model.

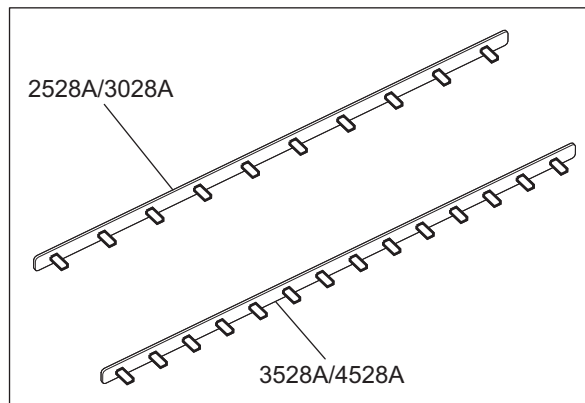

Fig. 4-263

#### 4.7.4 Main charger

- (1) Take off the discharge LED unit.  
P. 4-107 “4.7.3 Discharge LED”
- (2) Push the lever [1] and take off the main charger [2].

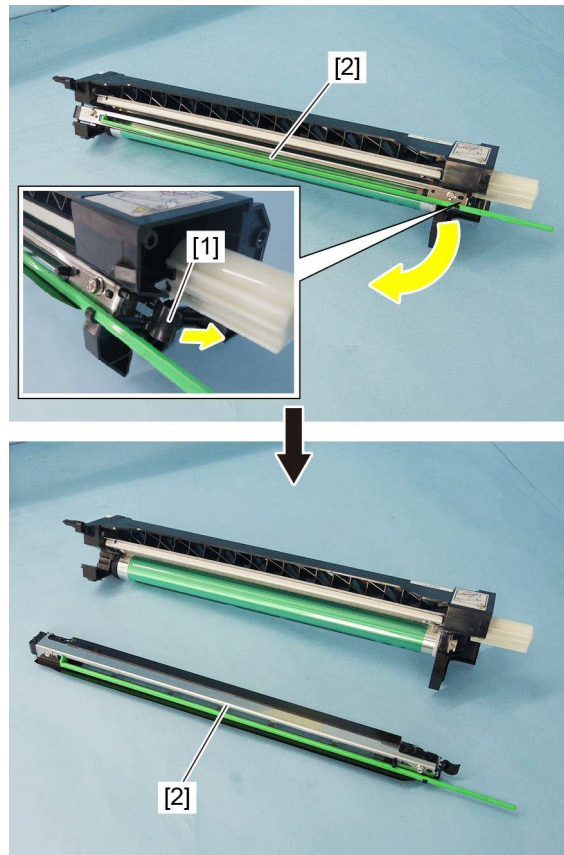

Fig. 4-264

#### Notes:

When removing, be careful not to touch or scratch the drum surface.



### 4.7.5 Main charger grid

- (1) Take off the main charger.  
P. 4-108 "4.7.4 Main charger"
- (2) Remove the spring [1] and take off the main charger grid [2].

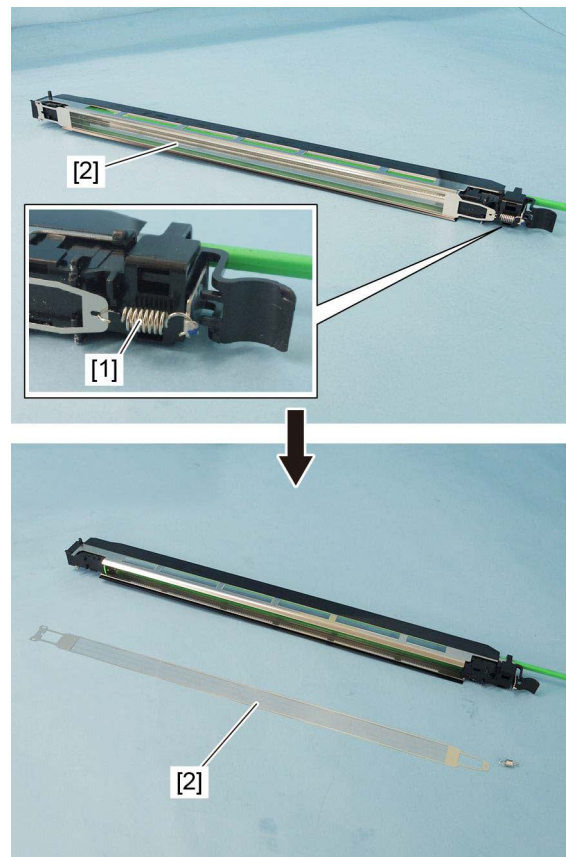

Fig. 4-265

#### Notes:

Do not touch the mesh area of the grid.

### 4.7.6 Main charger cleaner

- (1) Take off the main charger.  
P. 4-108 "4.7.4 Main charger"
- (2) Release the cleaner rod [1] from 2 hooks [2]. Then rotate the cleaner rod [1] by 90 degrees to take it off.

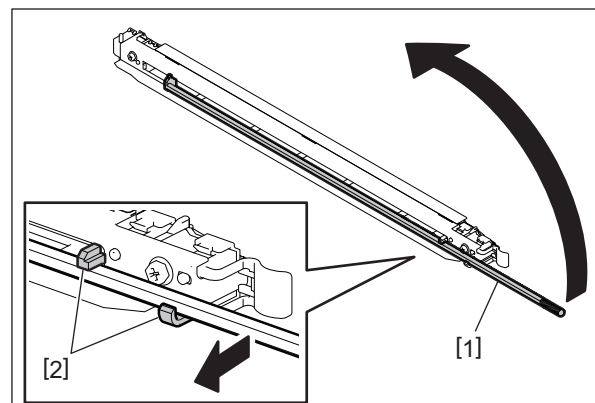

Fig. 4-266

- (3) Remove the main charger cleaner [2] from the cleaner rod [1].

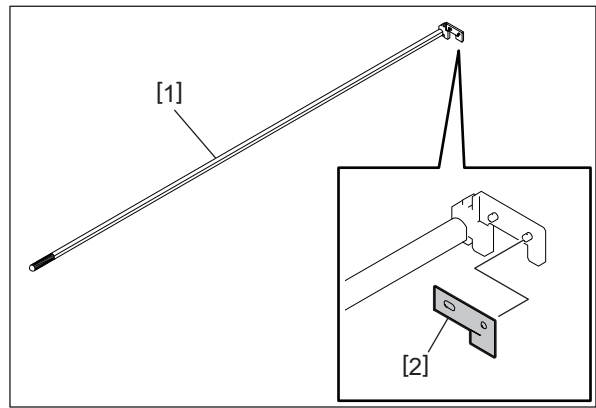

Fig. 4-267

**Notes: Be sure to attach the cleaner rod [1] to the correct position.**

- Attach the cleaner rod [1] so that it is above the needle electrode [3].

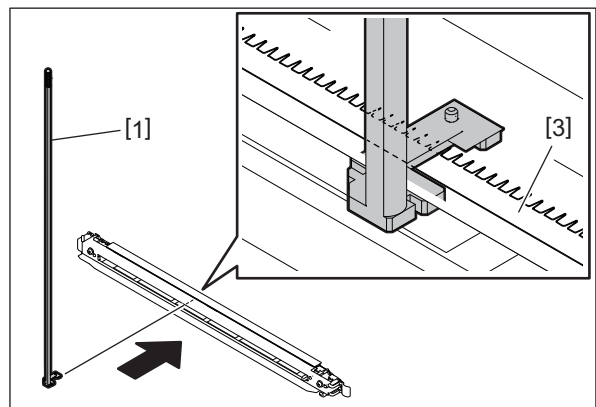

Fig. 4-268

- Tilt the cleaner rod [1] so that it is inserted into the groove [4] of the frame.

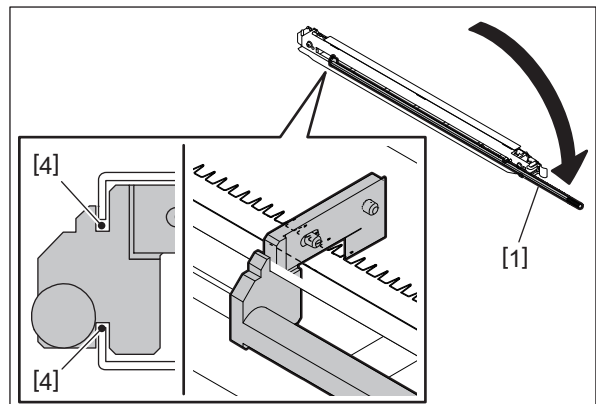



Fig. 4-269

### 4.7.7 Needle electrode

- (1) Take off the main charger grid.  
 P. 4-109 “4.7.5 Main charger grid”
- (2) Take off the main charger cleaner.  
 P. 4-109 “4.7.6 Main charger cleaner”
- (3) Release 4 latches and take off the terminal cover [1] at the front side.
- (4) Take off the terminal cover [2] at the rear side.

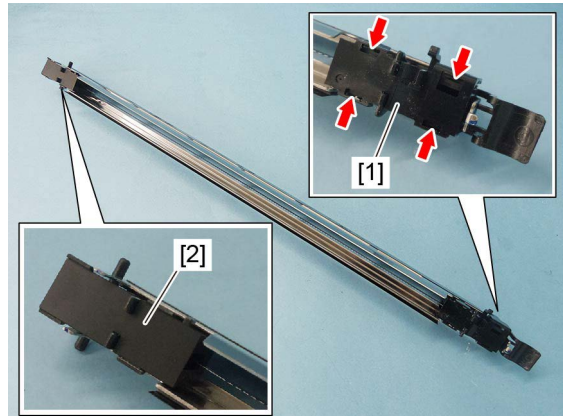

Fig. 4-270

- (5) Remove 1 terminal [3], 1 spring [4] and the needle electrode [5].

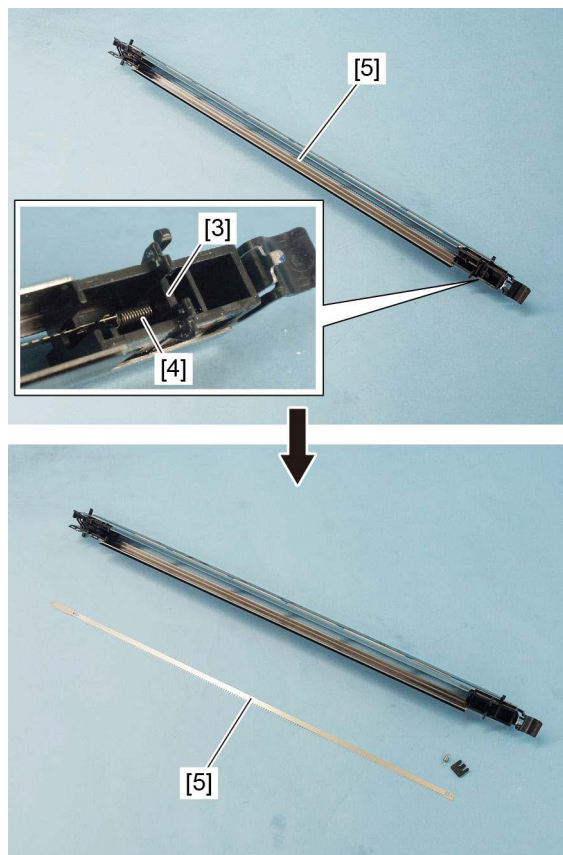
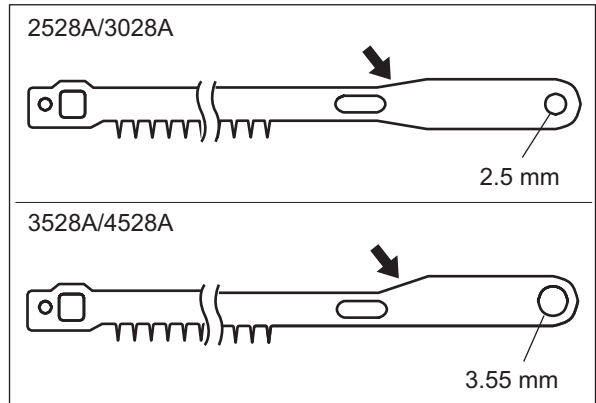

Fig. 4-271

**Notes:**

- Do not touch the needle electrode [5] directly with your bare hands.
- Make sure not to fold or bend the needle electrode [5].
- The form of the needle electrode [5] differs depending on the model as shown in the figure. Do not mix them when installing.



**Fig. 4-272**

### 4.7.8 Drum<sup>FM</sup>

- (1) Take off the main charger.  
📖 P. 4-108 “4.7.4 Main charger”
- (2) Rotate the lever [2] while pushing the latch [1]. Remove the lever [2] by pulling it toward you.

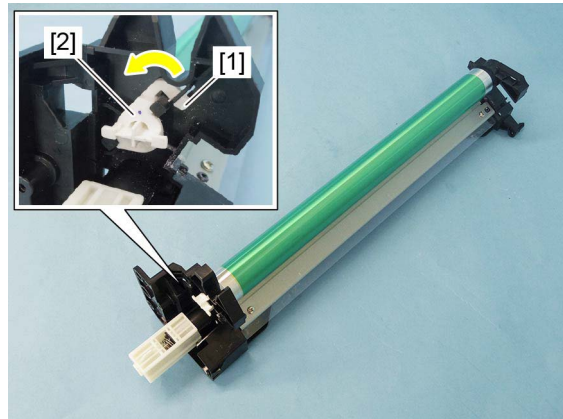

**Fig. 4-273**

(3) Take off the drum [3].

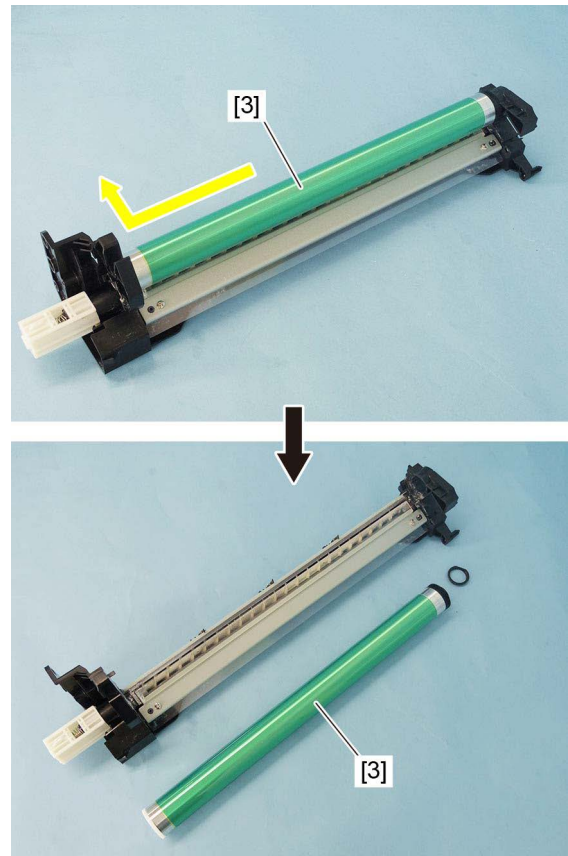



Fig. 4-274

**Notes:**

- Be careful not to touch, spit or scratch on the drum surface.
- Avoid a direct sunlight onto the drum. Move it to a dark place as soon as it is taken off.
- Be careful not to touch or scratch the edge of the drum cleaning blade.
- Be sure to apply patting powder (lubricant) to the entire surface of the drum when it is replaced or it is installed or removed from the cleaner.

### 4.7.9 Drum cleaning blade

- (1) Take off the drum.  
 P. 4-112 “4.7.8 Drum”
- (2) Remove 2 screws and take off the drum cleaning blade [1].

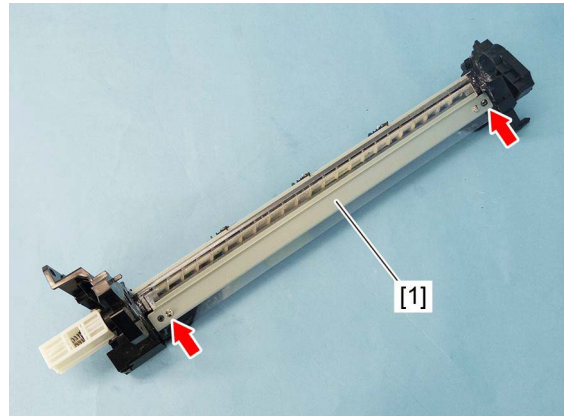



Fig. 4-275

#### Notes:

Be careful not to touch or scratch the edge of the drum cleaning blade [1].

### 4.7.10 Drum separation finger

- (1) Take off the drum.  
 P. 4-112 “4.7.8 Drum”
- (2) Remove 1 screw of each unit and take off 3 drum separation finger units [1].

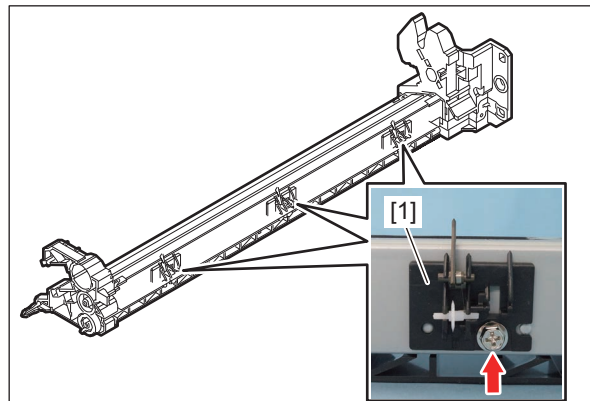

Fig. 4-276

#### Notes:

When replacing the drum separation fingers, make sure that the drum has been taken off first since the fingers may scratch the drum surface.

- (3) Remove the spring [2] and take off the drum separation finger [3].

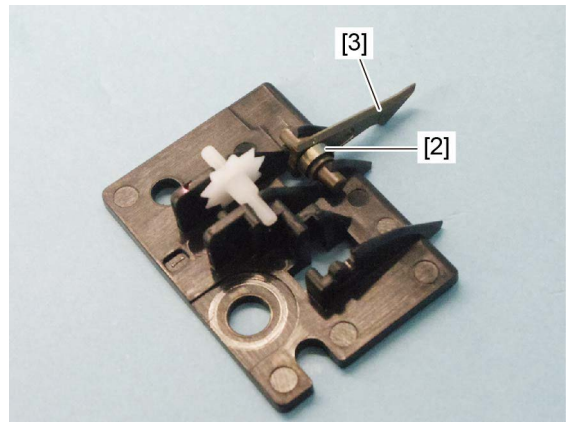



Fig. 4-277

**Notes:**

When the drum separation fingers have been replaced, check if the pressure movement is normal by moving them with your fingers.

### 4.7.11 Recovery blade

- (1) Take off the drum separation finger unit.  
 P. 4-114 “4.7.10 Drum separation finger”
- (2) Remove 2 screws and take off the recovery blade [1] with the bracket.

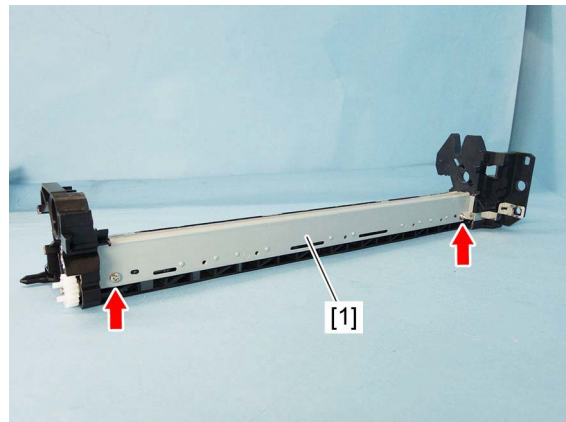

Fig. 4-278

**Notes:**

When cleaning the inside of the cleaner unit, be careful of the following in order not to damage the films [3] attached to the toner recovery auger [2]:

- Do not use an air blower for cleaning. (Use a vacuum cleaner.)
- When using a vacuum cleaner, be careful not to let its nozzle hit against the films.

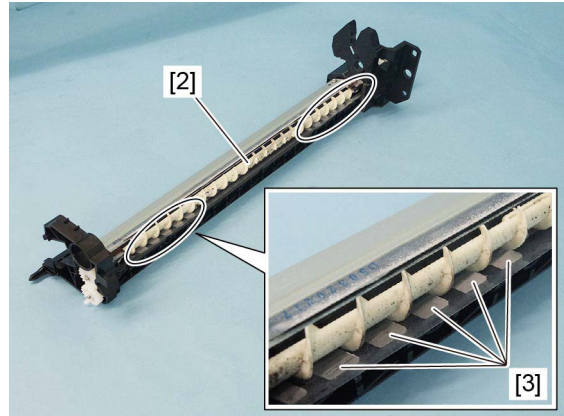

Fig. 4-279

- When rotating the toner recovery auger [2], rotate it only in the same direction as that for transporting toner.

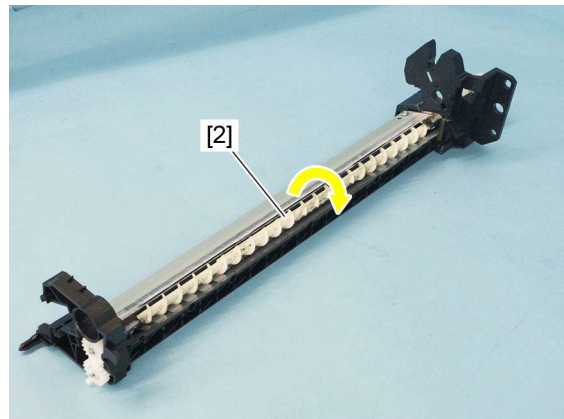

Fig. 4-280

### 4.7.12 Temperature/humidity sensor (S10)

- (1) Take off the rear cover.  
P. 4-9 “4.1.15 Rear cover”
- (2) Remove 1 screw and take off the temperature/humidity sensor [1].

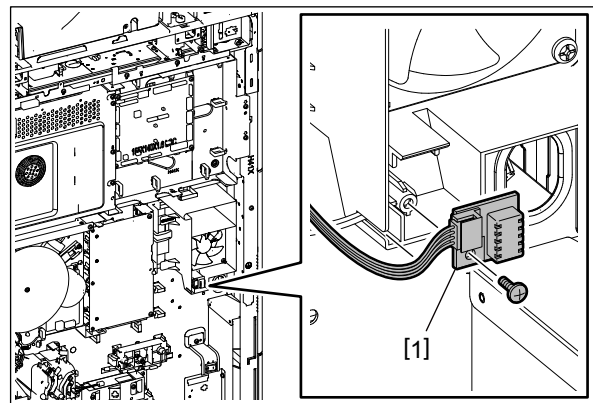

Fig. 4-281



- (3) Disconnect 1 connector from the temperature/humidity sensor [1].

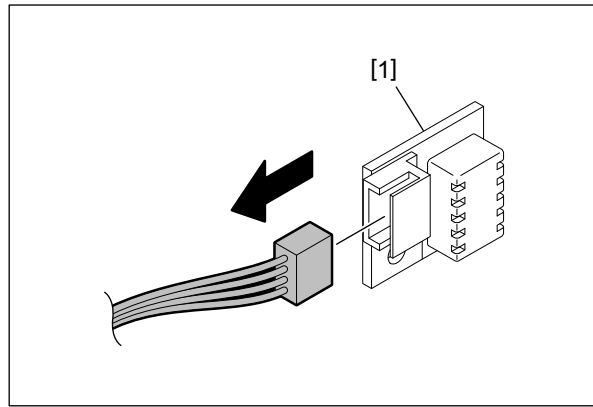

Fig. 4-282

### 4.7.13 Toner motor (K) (M11)

- (1) Remove the flywheel.  
P. 4-92 "4.5.39 Flywheel"
- (2) Disconnect 1 connector [1], remove 1 screw and take off the toner motor (K) [2] with the bracket.

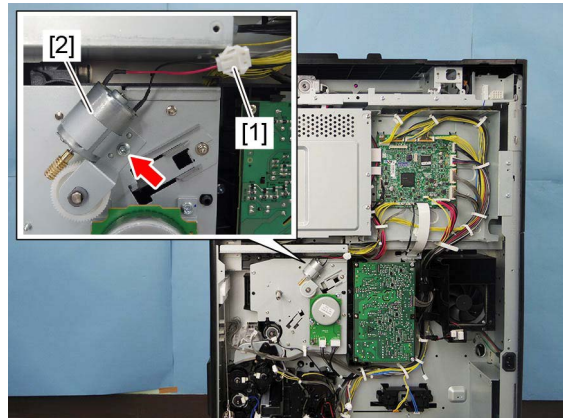

Fig. 4-283

- (3) Remove 2 screws and take off the toner motor (K) [2].

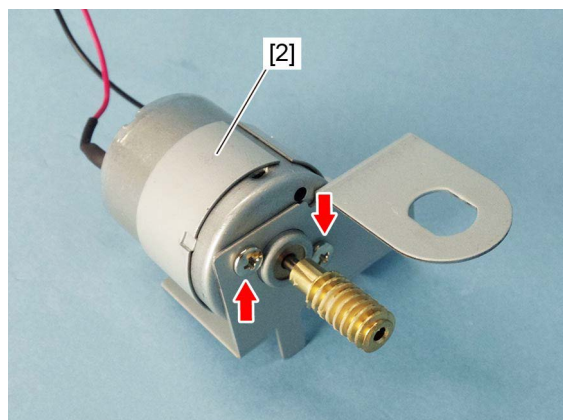

Fig. 4-284

#### Notes:

Pay attention to the size and length of the screws. If you use the wrong ones, the motor could be damaged.

#### 4.7.14 Process unit fan (F12)

- (1) Take off the exit tray.  
P. 4-2 "4.1.3 Exit tray"
- (2) Disconnect 1 connector of the duct [1].



Fig. 4-285

- (3) Remove 1 screw and take off the duct [1].



Fig. 4-286

- (4) Release 8 latches and take off the duct cover [2].

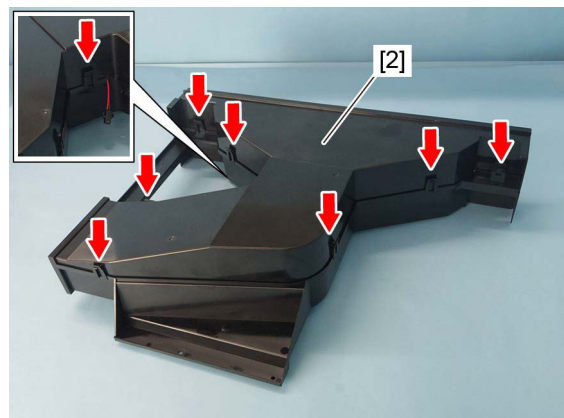

Fig. 4-287

(5) Take off the process unit fan [3] by lifting it up.

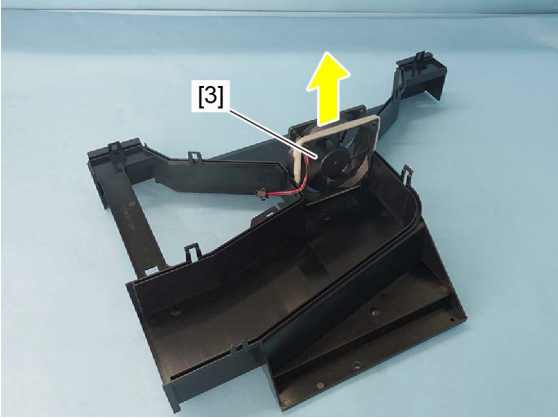



Fig. 4-288

## 4.8 Developer Unit

### 4.8.1 Developer unit

**Notes:**

Make sure to perform FS-05-2390 and then take off the process unit before the developer material is replaced.

- (1) Take off the process unit.  
 P. 4-104 "4.7.1 Process unit"
- (2) Release 1 latch and take off the harness cover [1] by sliding it downward.

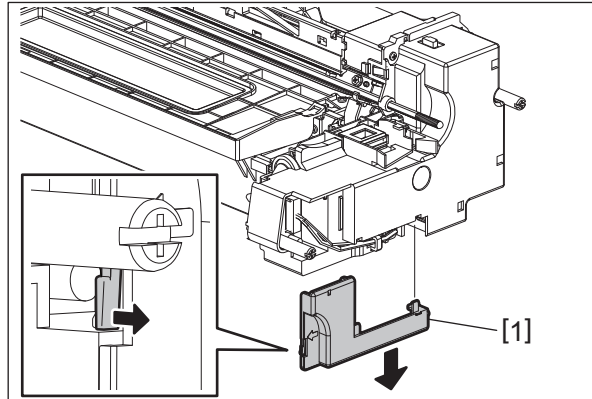

Fig. 4-289

- (3) Remove 1 screw and take off the plate [2].
- (4) Disconnect 1 connector.

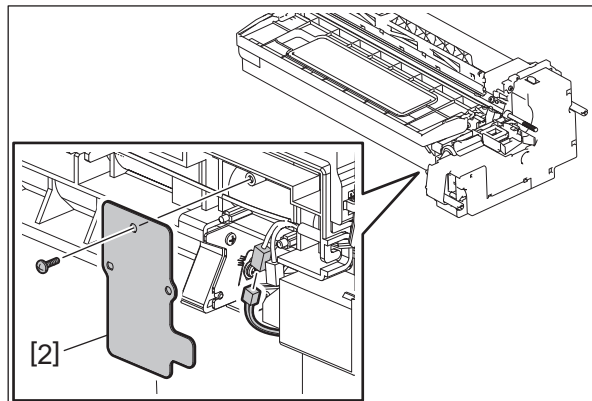

Fig. 4-290

- (5) Disconnect 2 connectors.

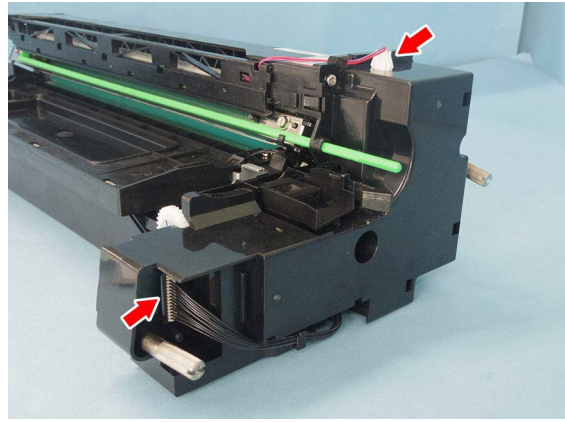

Fig. 4-291

- (6) Release the harness from 1 harness guide. Remove 2 screws. Release 1 latch and take off the process unit front cover [3].

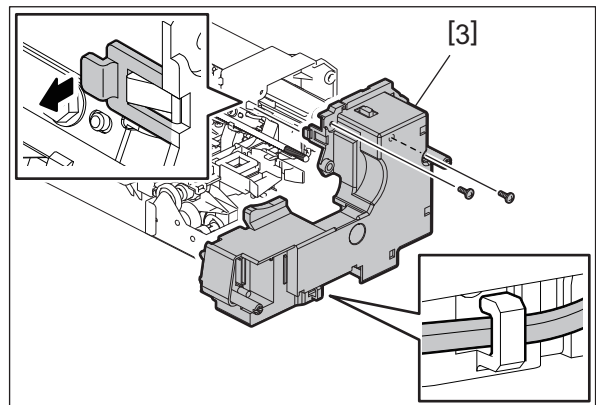

Fig. 4-292

- (7) Take off the drum cleaner unit [4] by lifting it up and separate it from the developer unit [5].

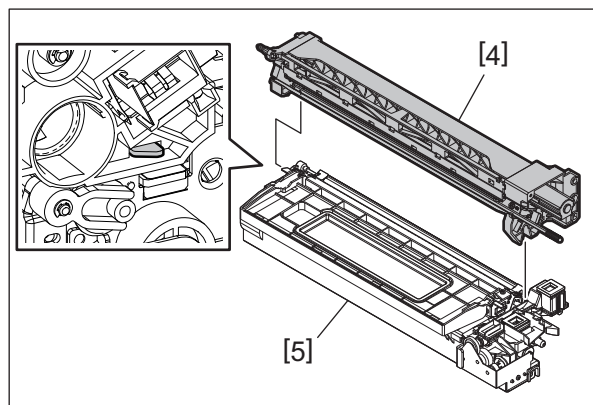

Fig. 4-293

**Notes:**

- When removing, be careful not to touch or scratch the drum surface.
- Do not deform the guide film [6] of the developer unit by touching this.

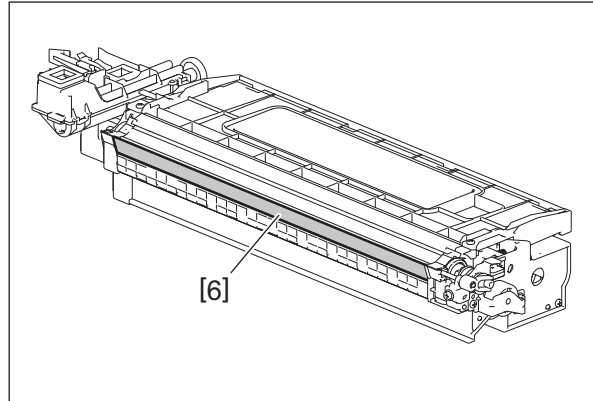

Fig. 4-294

## 4.8.2 Discharging the developer material

- (1) Take off the developer unit.  
📖 P. 4-120 “4.8.1 Developer unit”
- (2) Release the harness from 1 harness guide. Remove 2 screws and take off the developer unit upper cover [1] by sliding it in the direction of the arrow.

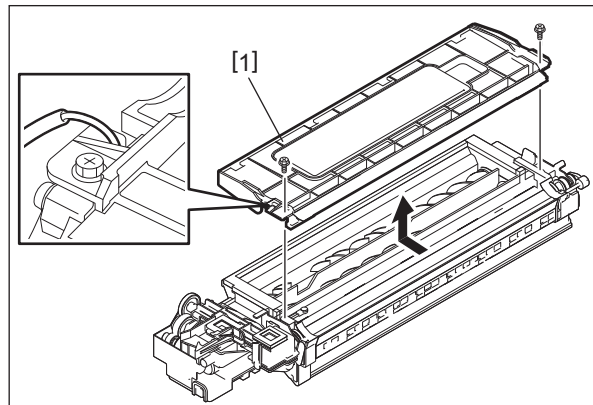

Fig. 4-295

**Notes:**

When installing the developer unit upper cover, make sure that the side seals [2] come between the developer unit upper cover [3] and rubber seal [4] on the cover.

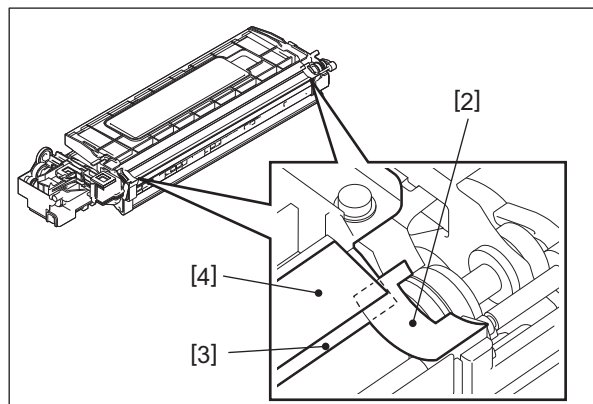

Fig. 4-296

- (3) Discharge the developer material from the rear side.

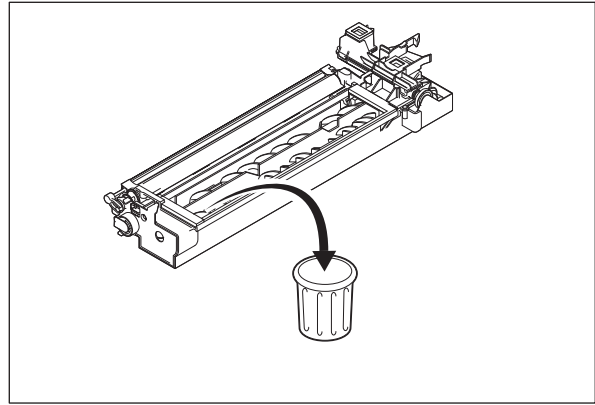

Fig. 4-297

**Notes:**

- When discharging the developer material, be careful not to let it drop on the gears of the developer unit.
- When cleaning the developer unit, never attempt to use solvent.

### 4.8.3 Filling the developer material

- (1) Remove the lid [1].
- (2) Shake the developer material bag and open it.
- (3) Rotate the gear on the rear side of the developer unit in the direction of the arrow while filling the developer unit with the developer material. Spread out the developer material over the developer sleeve.

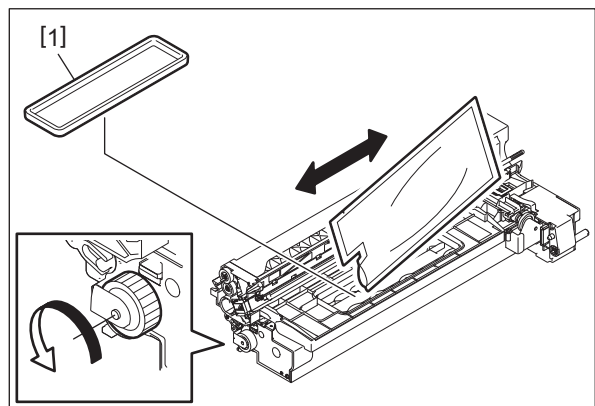



Fig. 4-298

#### 4.8.4 Auto-toner sensor (S1)

- (1) Discharge the developer material.  
 P. 4-122 "4.8.2 Discharging the developer material"
- (2) Place the developer unit upside down. Disconnect 1 connector [1].

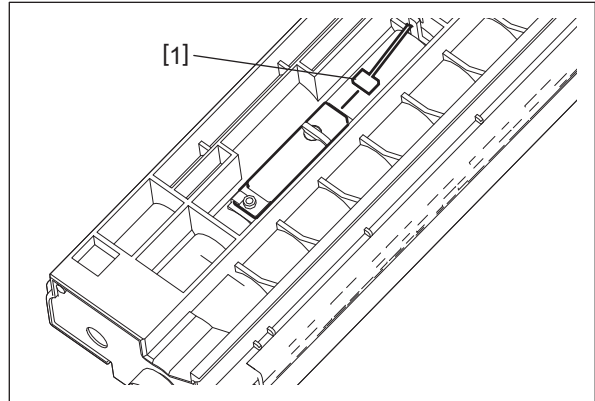

Fig. 4-299

- (3) Take off the auto-toner sensor [2] by rotating it.

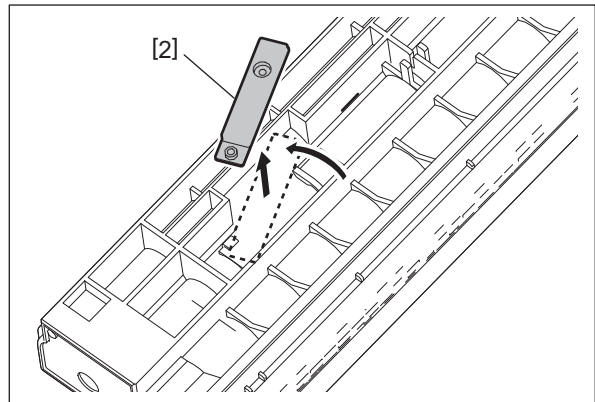

Fig. 4-300



### 4.8.5 Drum thermistor (THM3)

- (1) Discharge the developer material.  
📖 P. 4-122 “4.8.2 Discharging the developer material”
- (2) Disconnect 1 connector [1], remove 1 screw and take off the drum thermistor [2].

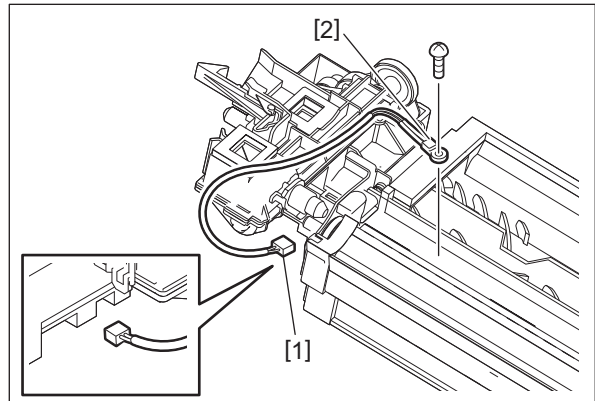

Fig. 4-301

### 4.8.6 Guide roller, Developer sleeve

- (1) Discharge the developer material.  
📖 P. 4-122 “4.8.2 Discharging the developer material”
- (2) Remove 2 screws and take off the recovered toner supply unit [1].

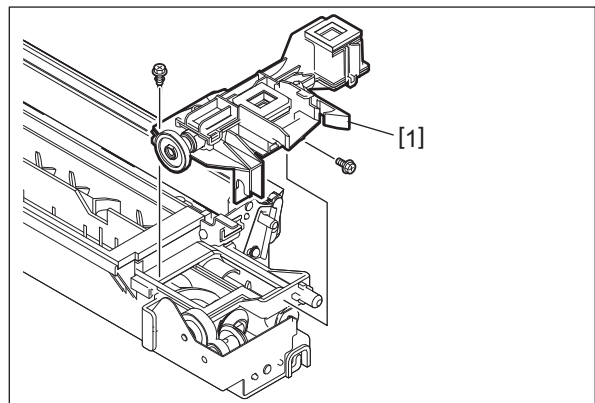

Fig. 4-302

- (3) Remove 1 screw and take off the recovered toner drive unit [2]. Remove 1 gear [3].

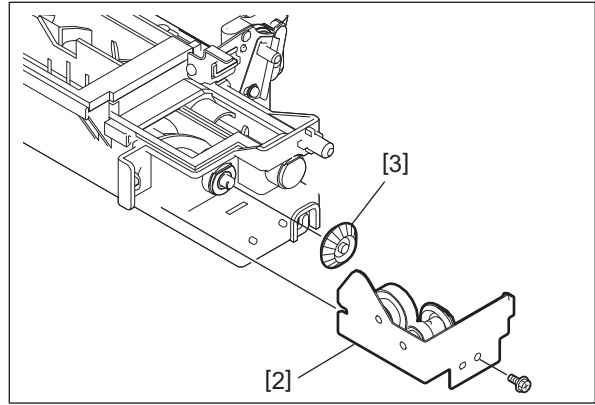

Fig. 4-303

- (4) Remove 2 leaf springs [4] fixing the doctor blade on both its ends.

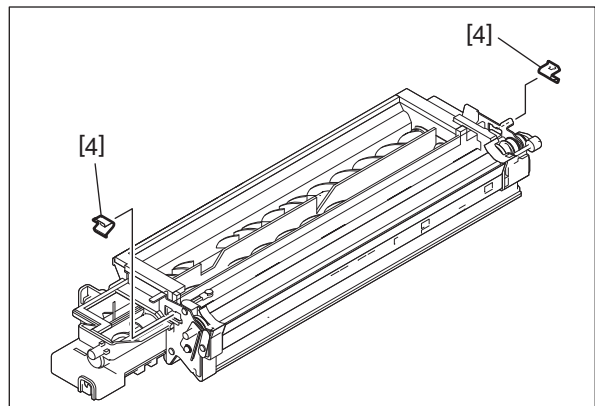

Fig. 4-304

- (5) Remove 2 screws [5] on both the ends of the doctor blade and remove 2 coil springs [6].

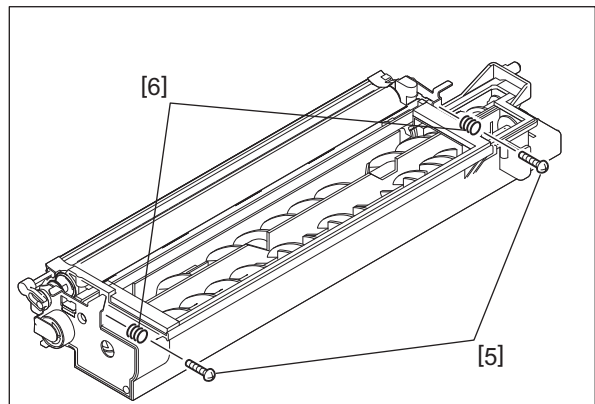

Fig. 4-305

**Notes:**

When the screws on both the ends of the doctor blade are removed, be sure to adjust the doctor sleeve gap ( $0.45 \pm 0.05$  mm) after assembling.

- (6) Remove 1 screw and 1 leaf spring [7].  
(3528A/4528A only)
- (7) Remove 1 screw and take off the pole position adjustment lever [8].

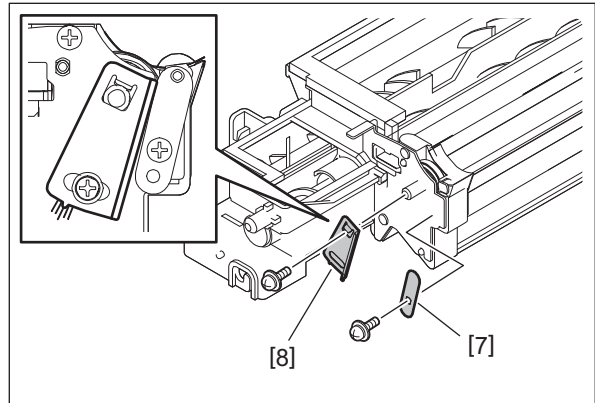

Fig. 4-306

**Notes:**

Before removing the pole position adjustment lever [8], record its scale position. (If necessary, add a marking.)

When the pole position adjustment lever [8] is reattached, align it to the recorded scale position.

- (8) Remove 2 screws and take off 1 bracket [9].

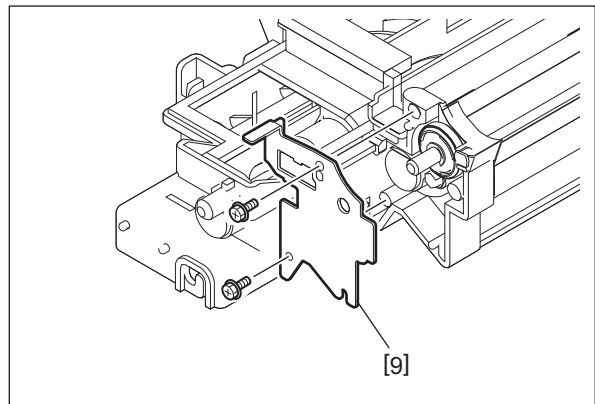

Fig. 4-307

- (9) Remove 1 E-ring [10] and the front side guide roller [11].

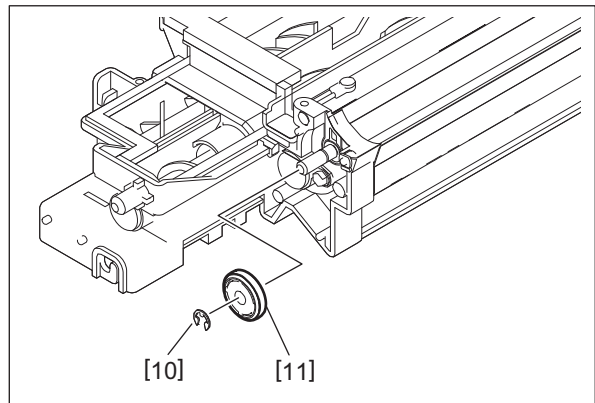

Fig. 4-308

(10) Remove 1 E-ring [12], 1 arm [13] and 1 cam [14].

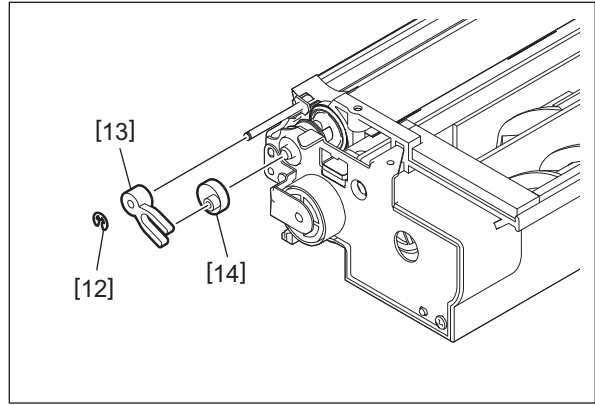

Fig. 4-309

(11) Remove 1 screw and 1 gear [15].

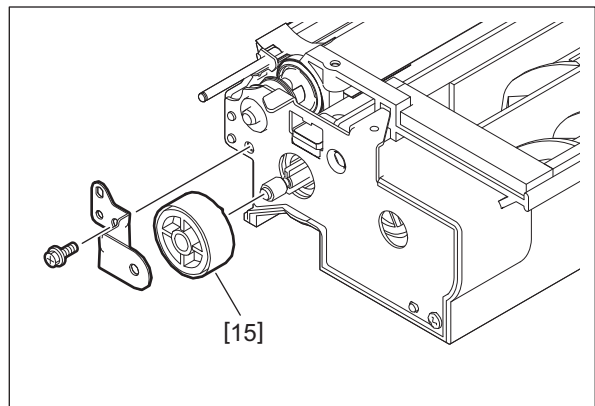

Fig. 4-310

(12) Remove 1 screw and take off 1 bracket [16] and 1 bearing [17].

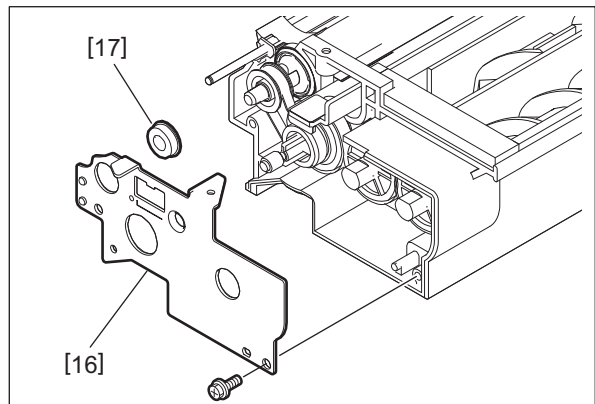

Fig. 4-311

(13) Remove 3 gears [18] and 1 timing belt [19].

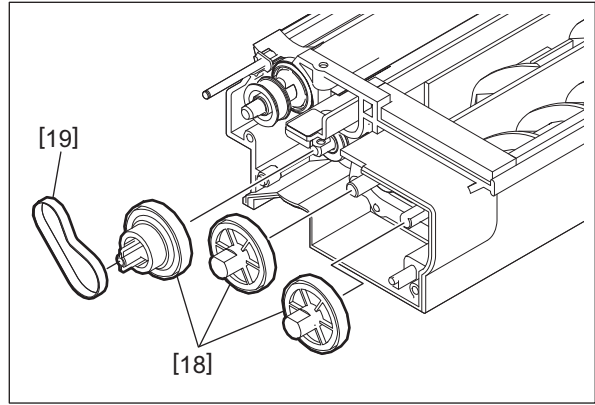

Fig. 4-312

(14) Remove 1 pulley [20] and 1 pin [21].  
(15) Remove the rear side guide roller [22].

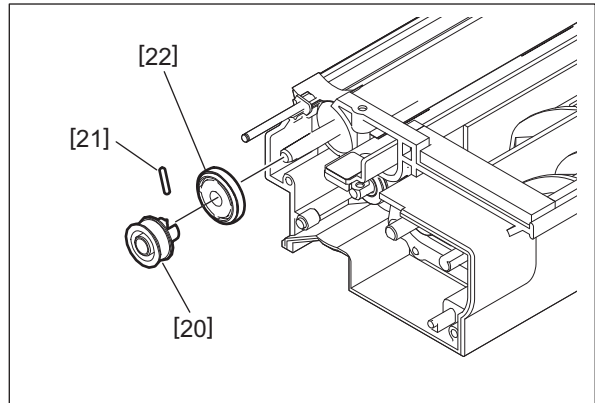

Fig. 4-313

(16) Remove the seal [23] on the front side. Remove 1 E-ring [24] and 1 bushing [25].

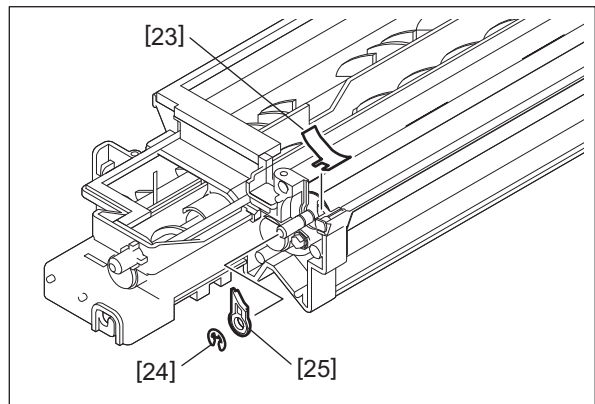

Fig. 4-314

(17) Take off the developer sleeve [26].

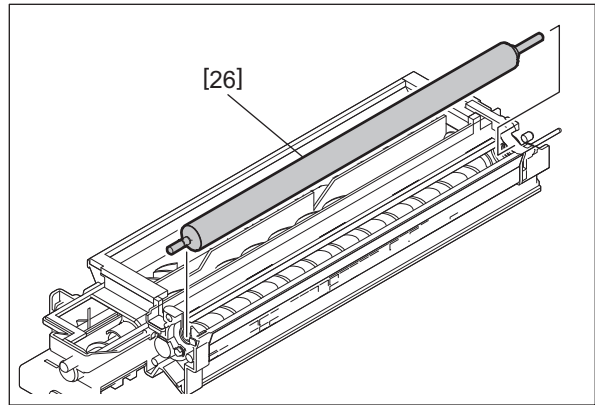

Fig. 4-315

### 4.8.7 Mixer

- (1) Take off the developer sleeve.  
📖 P. 4-125 “4.8.6 Guide roller, Developer sleeve”
- (2) Remove the doctor blade [1].

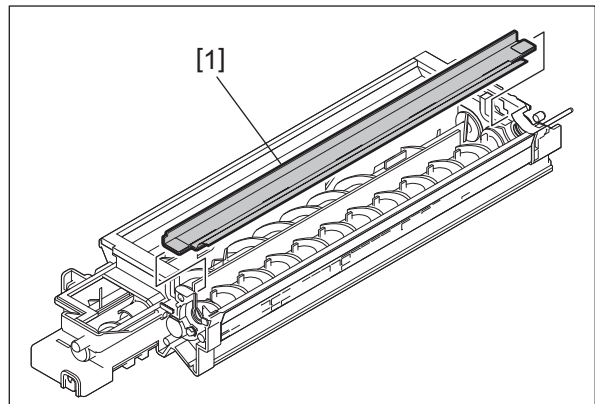

Fig. 4-316

- (3) Remove 2 screws and take off the holder [2].

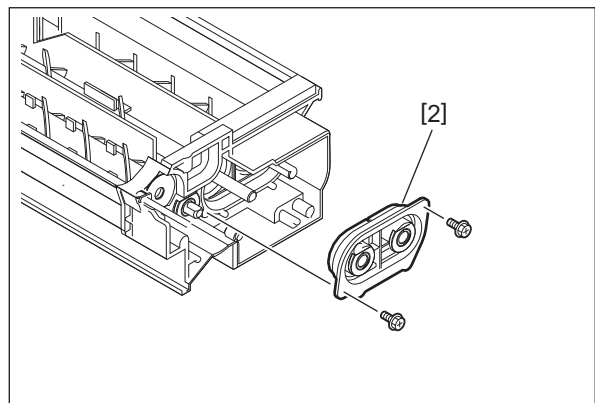

Fig. 4-317

- (4) Remove 2 bushings [3] and 2 oil seals [4] from the holder.  
📖 P. 4-133 "4.8.8 Replacement procedure of the oil seal"

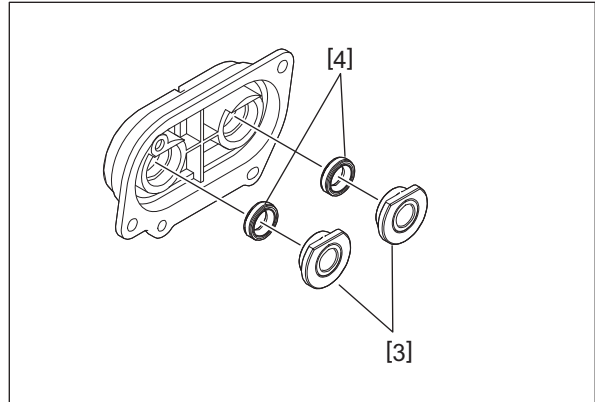

Fig. 4-318

- (5) Remove the mixer-2 [5] and mixer-3 [6].

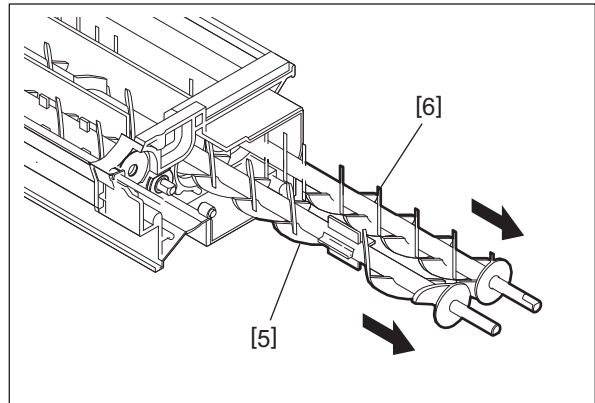

Fig. 4-319

- (6) Remove 2 bushings [7] and 2 oil seals [8] on the front side.  
📖 P. 4-133 "4.8.8 Replacement procedure of the oil seal"

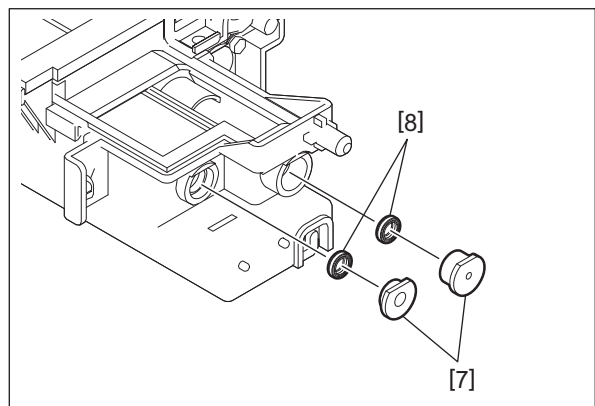

Fig. 4-320

- (7) Remove the end section [9] of the mixer-1.
- (8) Remove 1 bushing [10] and 1 oil seal [11].  
📖 P. 4-133 "4.8.8 Replacement procedure of the oil seal"

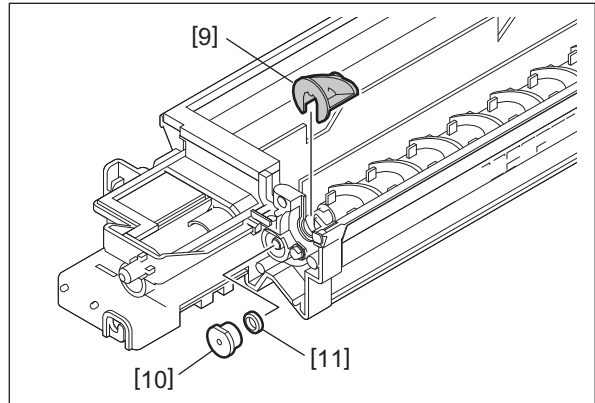

Fig. 4-321

- (9) Remove the mixer-1 [12].

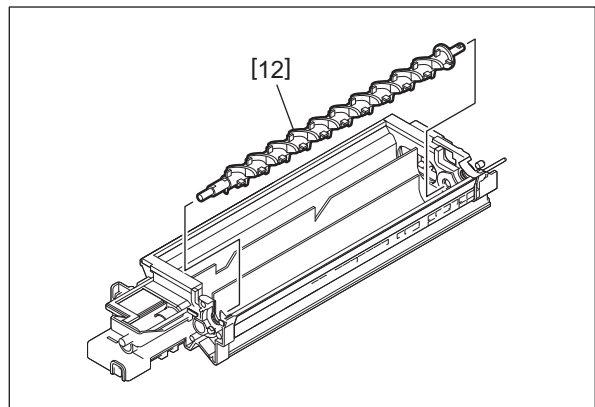

Fig. 4-322

- (10) Remove 1 bushing [13] and 1 oil seal [14] on the rear side.  
📖 P. 4-133 "4.8.8 Replacement procedure of the oil seal"

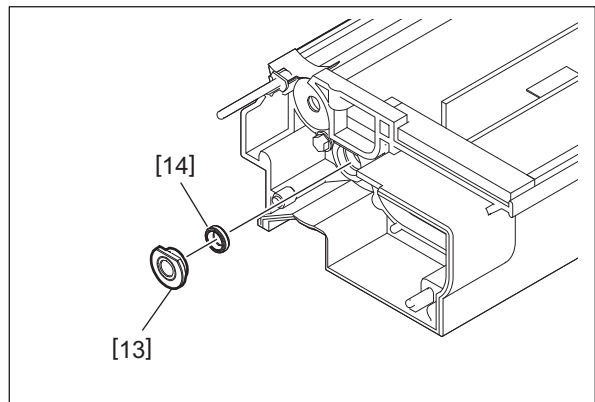

Fig. 4-323



### 4.8.8 Replacement procedure of the oil seal

- (1) Insert a fine screwdriver into the depression of the oil seal to take it out.
- (2) Push in a new oil seal parallel to the frame or bushing (shown figure).
- (3) Apply the grease (Alvania No.2; amount of 2 rice grains) on entire surface of the oil seal evenly.

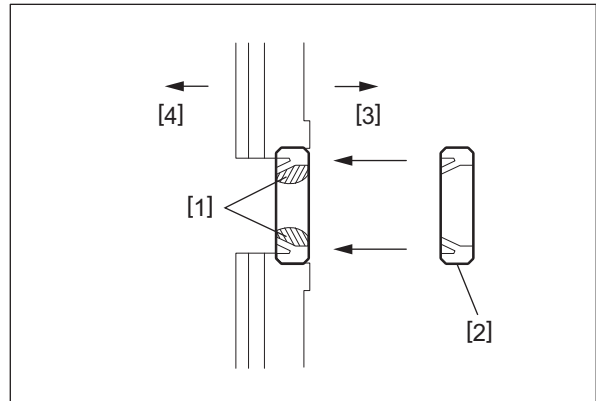

Fig. 4-324

- [1] Grease
- [2] Oil seal
- [3] Outside
- [4] Inside

**Notes:**

Wipe off the excessive grease.

## 4.9 Transfer Unit (TRU)

### 4.9.1 Transfer unit (TRU)

**Notes:**

When removing the transfer unit, take off the process unit and avoid a direct sunlight onto the drum.

- (1) Take off the ADU.  
 P. 4-176 "4.12.1 Automatic duplexing unit (ADU)"
- (2) Remove 4 screw and take off the bracket [1].

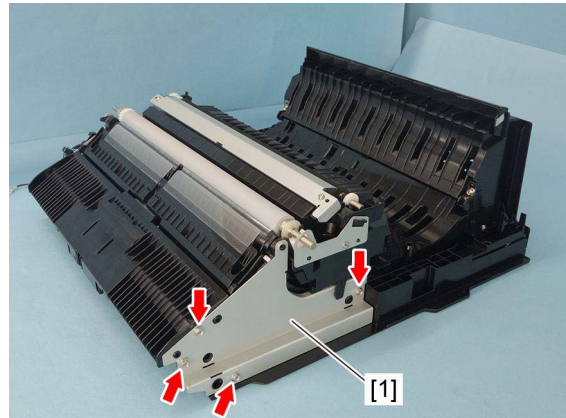

Fig. 4-325

- (3) Disconnect 1 connector and take off the transfer unit [2].

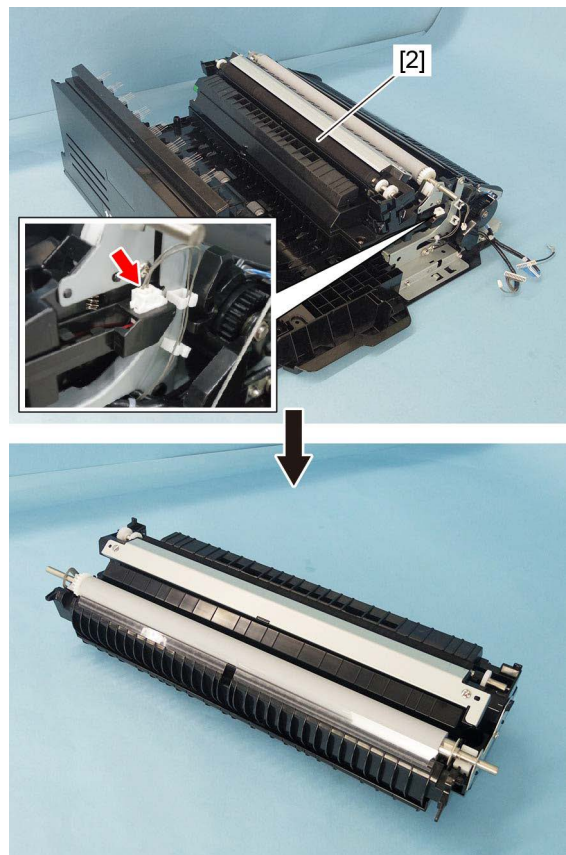

Fig. 4-326

## 4.9.2 Suctioning fan (F3)

- (1) Take off the transfer unit.  
P. 4-134 "4.9.1 Transfer unit (TRU)"
- (2) Remove 4 screws and take off the inner duct [1].

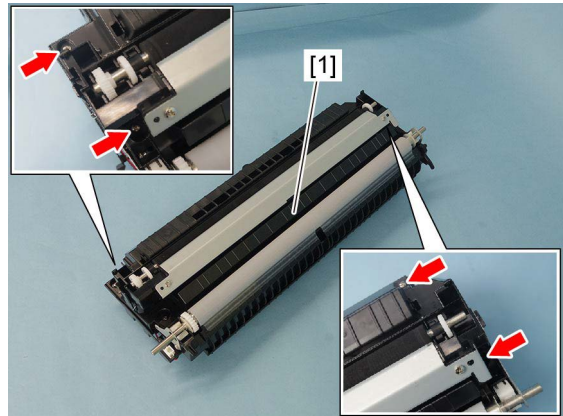

Fig. 4-327

- (3) Disconnect 1 connector [2].
- (4) Remove the double-sided adhesive tape and take off the suctioning fan [3].

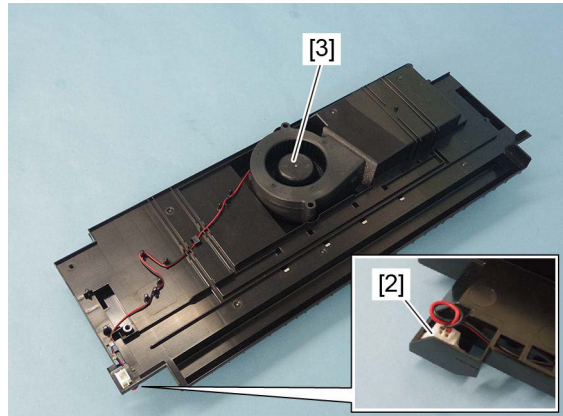

Fig. 4-328

### Notes:

When installing, pass the harness [4] through the harness guide as shown in the figure.

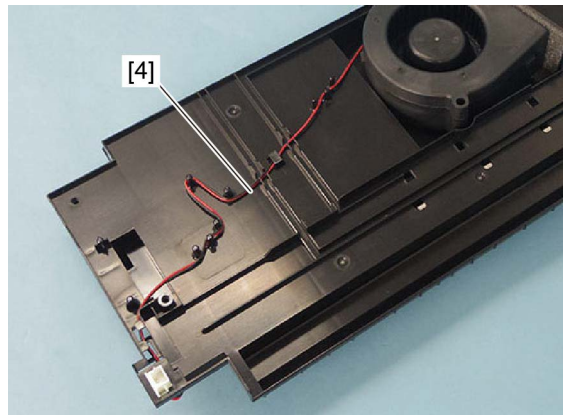

Fig. 4-329

### 4.9.3 Transfer roller unit

- (1) Open the ADU.
- (2) Release 1 hook on the rear side and take off the transfer roller unit [1].

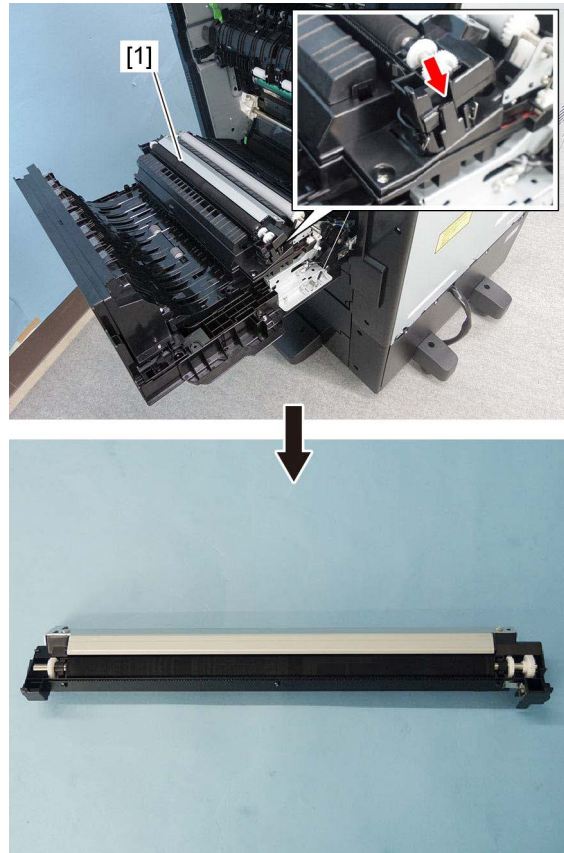

Fig. 4-330

### 4.9.4 Transfer roller<sup>PM</sup>

- (1) Take off the transfer roller unit.  
P. 4-136 "4.9.3 Transfer roller unit"
- (2) Release 4 latches of the transfer roller unit.

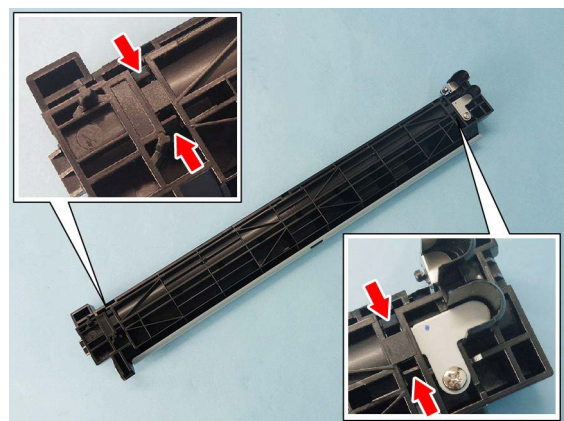

Fig. 4-331

(3) Take off the transfer roller [1].

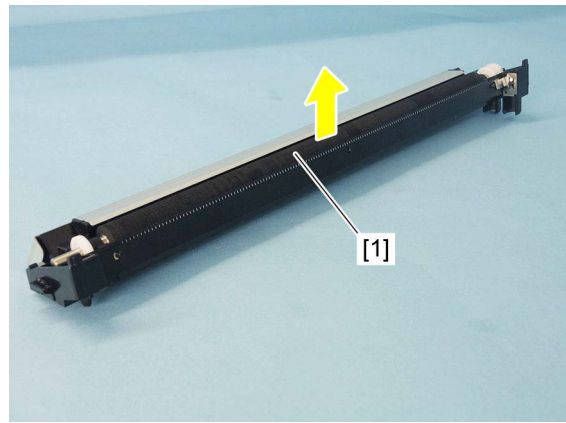

Fig. 4-332

(4) Remove 2 collars [2], 1 gear [3] and 2 stoppers [4] from the transport roller [1].

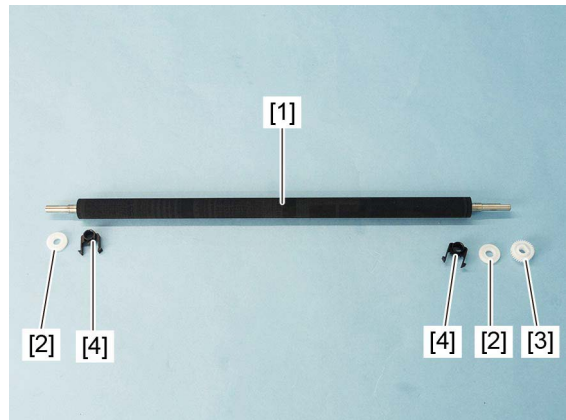



Fig. 4-333

**Notes:**

When installing the bushing and gear, pay attention to the orientation.

## 4.9.5 Separation needle

- (1) Take off the transfer roller unit.  
 P. 4-136 "4.9.3 Transfer roller unit"
- (2) Remove the double-sided adhesive tape and take off the cover [1].

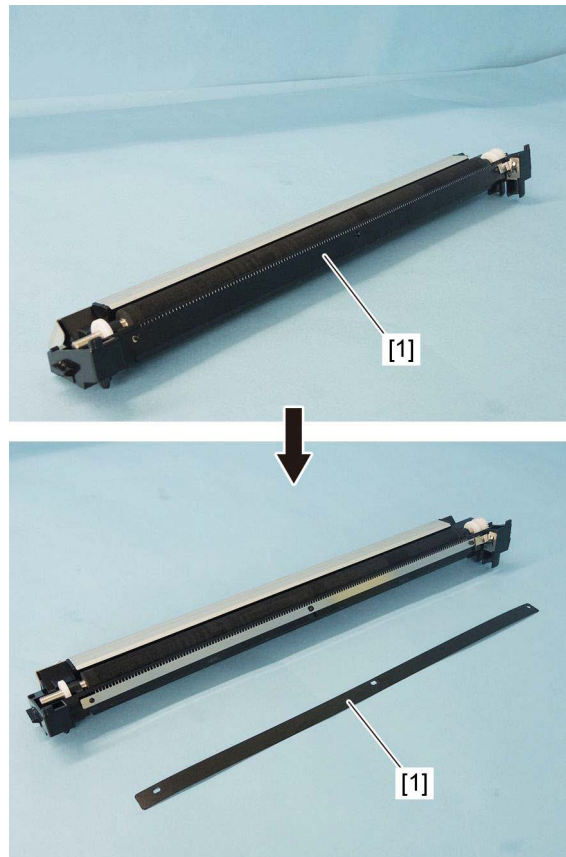

Fig. 4-334

### Notes:

When installing, insert the cover [1] into the lower side of the power supply plate [2].

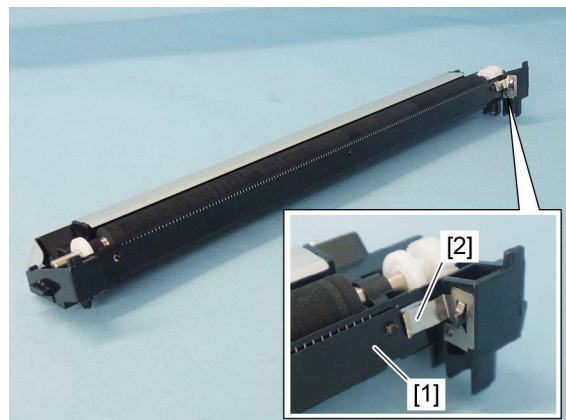

Fig. 4-335

- (3) Remove the separation needle [3] while being careful not to deform it.

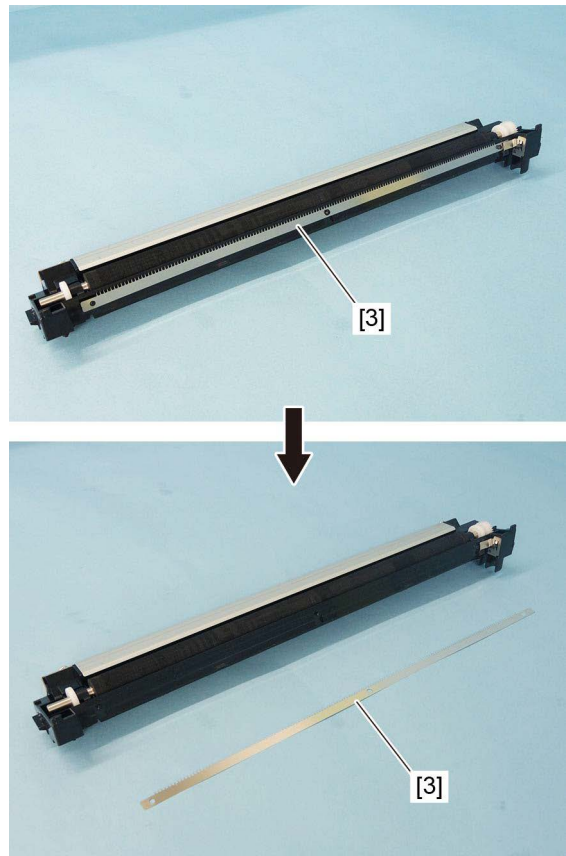

Fig. 4-336

#### 4.9.6 Ozone filter

- (1) Open the ADU.  
(2) Lift up the transfer unit [1].



Fig. 4-337

(3) Take off the cover [2] by sliding it toward you.

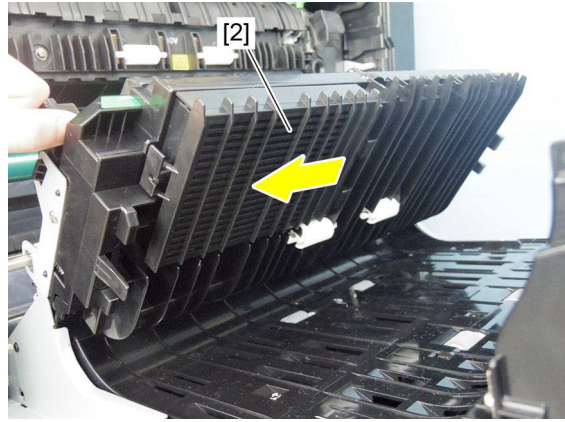

Fig. 4-338

(4) Remove the ozone filter [3].

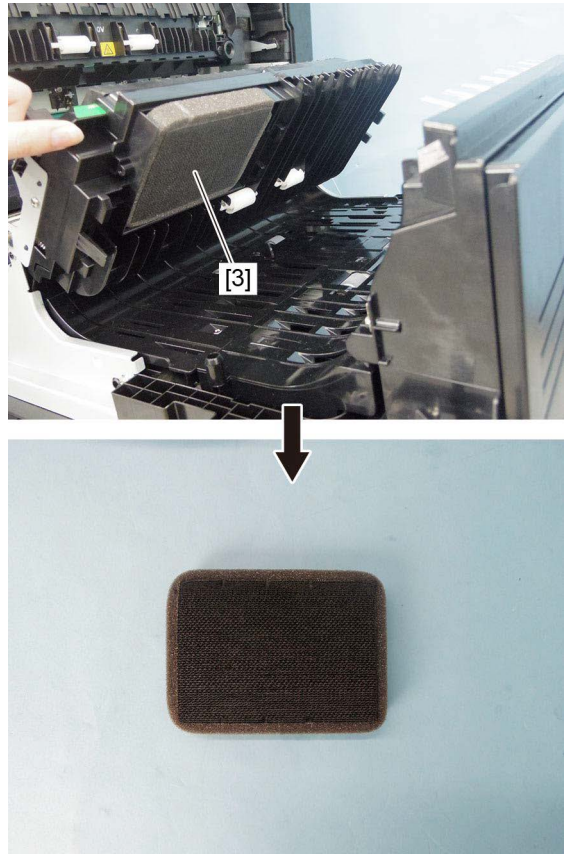

Fig. 4-339



## 4.10 Fusing Section

### 4.10.1 Fuser unit

**Notes:**

- Be sure that the temperature of the fuser unit has lowered enough before removing it. If the unit still heated should be removed, wear a pair of gloves before working.
- When the fuser unit is replaced with a new one, use the list output mode or 08 SETTING MODE to check that the value of the life counter related to the fusing has been cleared. In addition, be sure to carry out fuser thermistor correction.
- When disassembling the fuser unit or replacing any parts in it, be sure that the wire harness is correctly set, and also be careful not to get it caught between other parts.
- If the MFP is not going to be operated for a long time, attach the pressure release material (SPACER-PRS-INI) to avoid having pressure applied to the fuser unit.

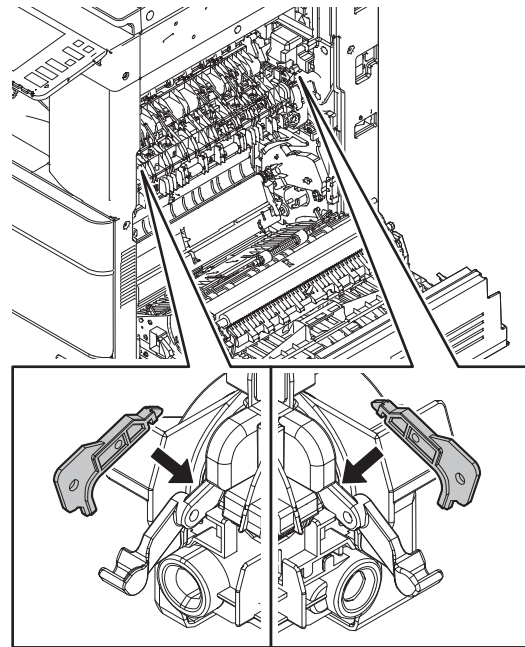

Fig. 4-340

- (1) Open the ADU.
- (2) Press down the lever [1]. Hold the handle [3] and take off the fuser unit [2].

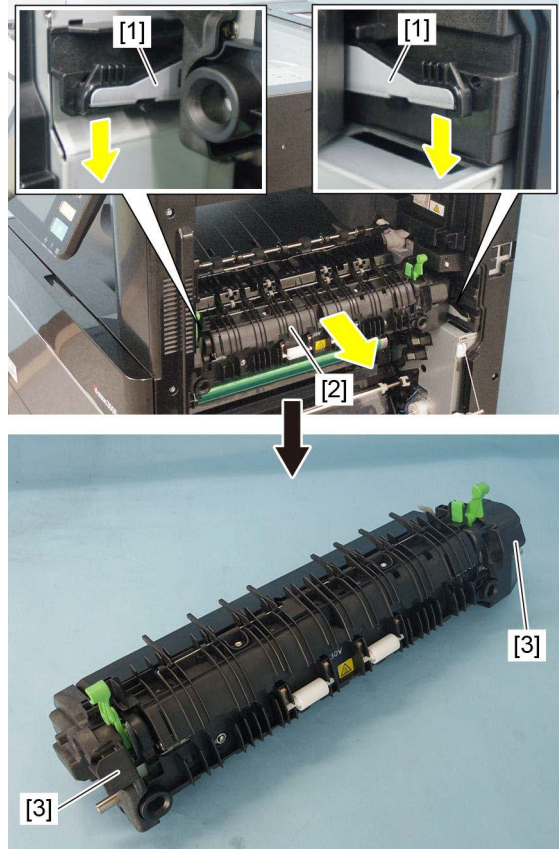

Fig. 4-341

**Notes:**

- The fuser unit is extremely hot. When removing the fuser unit, hold the handles [3] of the unit to avoid a direct touch on the unit.
- When installing the fuser unit, be sure to press it in until the lever goes up. If the lever goes down, the fuser unit has not been correctly installed.



Fig. 4-342



Fig. 4-343

- The fuser unit differs between 2528A/3028A and 3528A/4528A. For the identification, “H” is marked on the fuser unit for 3528A/4528A and “L” is marked on that for 2528A/3028A.

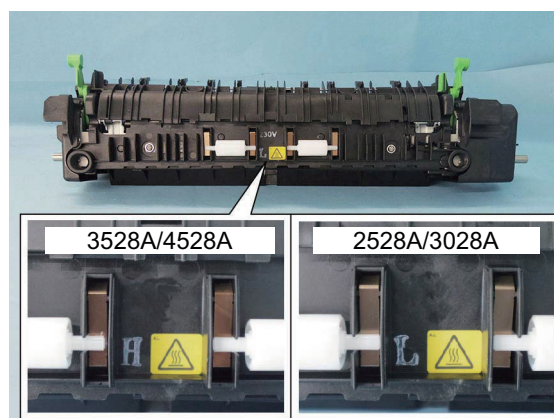

Fig. 4-344

#### 4.10.2 Front side cover

- Take off the fuser unit.  
 P. 4-141 “4.10.1 Fuser unit”
- Remove 2 screws and take off the front side cover [1].

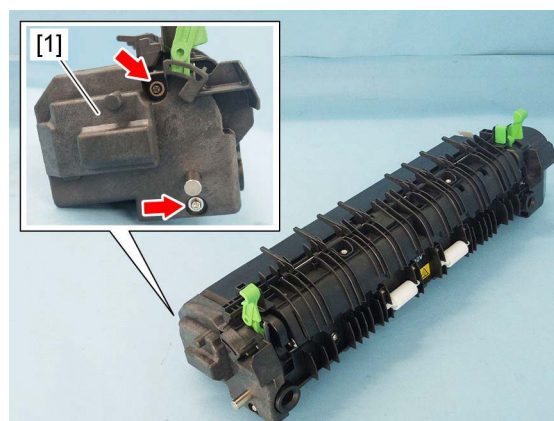

Fig. 4-345

**Notes:**

When installing the cover, put the harness into the harness guides so that it will not be pinched by the front side cover [1].

### 4.10.3 Rear side cover

- (1) Take off the fuser unit.  
P. 4-141 "4.10.1 Fuser unit"
- (2) Remove 2 screws and take off the rear side cover [1].

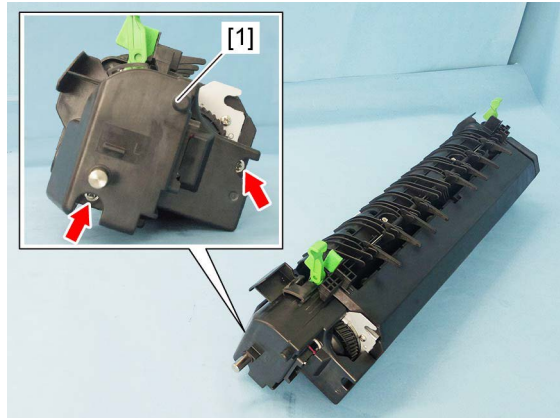

Fig. 4-346

**Notes:**

When installing the cover, put the harness into the harness guides so that it will not be pinched by the rear side cover [1].

### 4.10.4 Heat roller cover

- (1) Take off the fuser unit.  
P. 4-141 "4.10.1 Fuser unit"
- (2) Remove 2 screws and take off the heat roller cover [1].

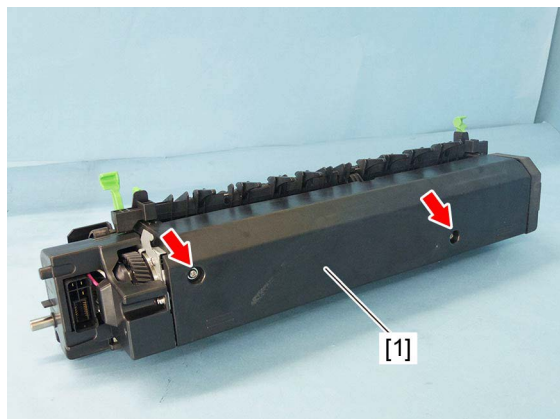

Fig. 4-347

## 4.10.5 Paper entrance guide

- (1) Take off the front side cover.  
📖 P. 4-143 "4.10.2 Front side cover"
- (2) Take off the rear side cover.  
📖 P. 4-144 "4.10.3 Rear side cover"
- (3) Remove 2 screws and take off the paper entrance guide [1].

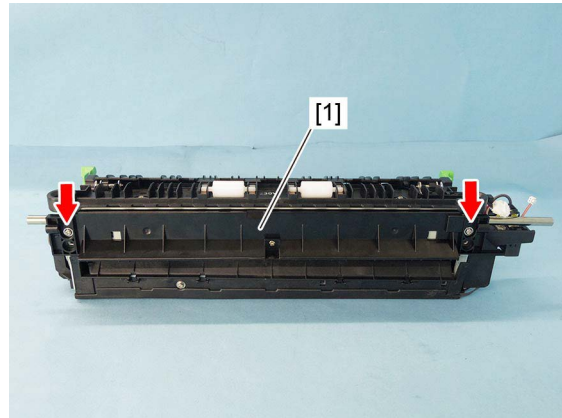

Fig. 4-348

- (4) Remove 1 screw and the brush [2].

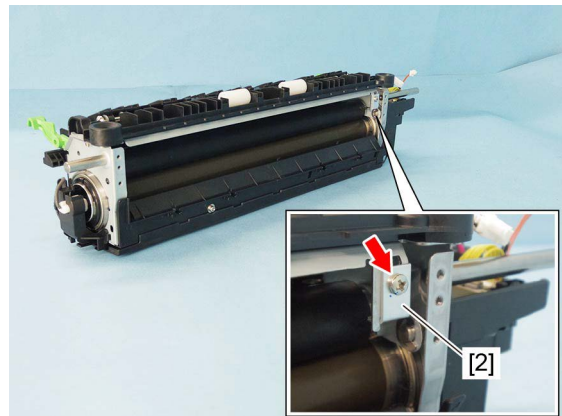

Fig. 4-349

## 4.10.6 Separation finger

- (1) Take off the front side cover.  
P. 4-143 “4.10.2 Front side cover”
- (2) Take off the rear side cover.  
P. 4-144 “4.10.3 Rear side cover”
- (3) Disconnect 1 connector [1], remove 2 screws and take off the pressure roller cover [2].

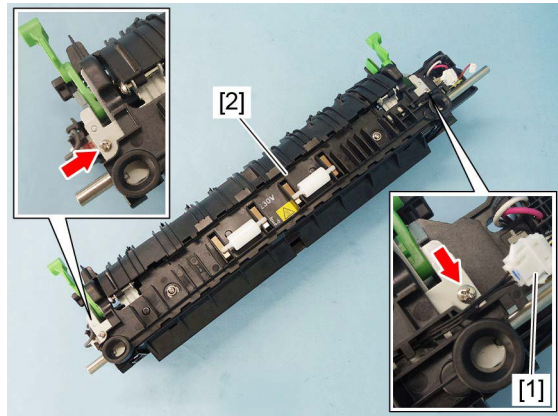

Fig. 4-350

- (4) Remove 3 screw and take off the cover [3].

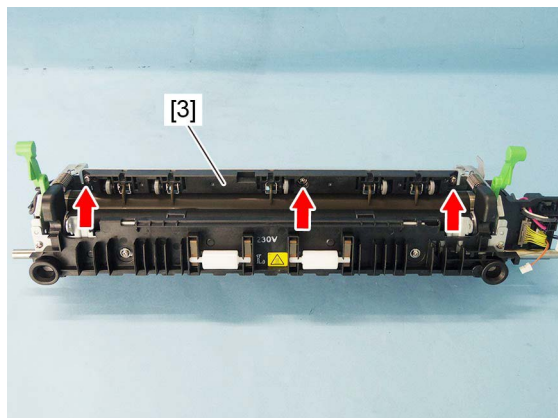

Fig. 4-351

- (5) Remove 5 springs [4] and take off 5 separation fingers [5].

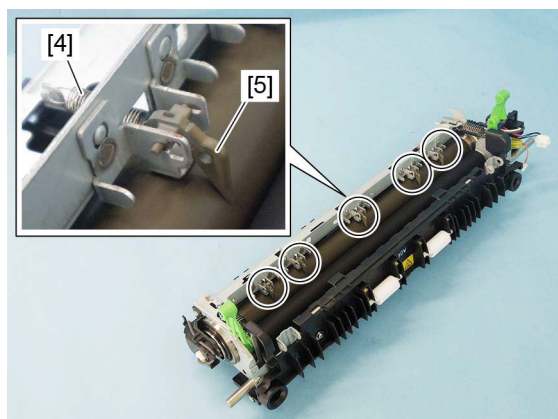

Fig. 4-352

**Notes:**

Remove the separation fingers in the following procedure.

1. Lift up a separation finger and slide it toward you.
2. Slide the separation finger to the front side and turn it to make it twist.
3. Remove the separation finger from the groove.

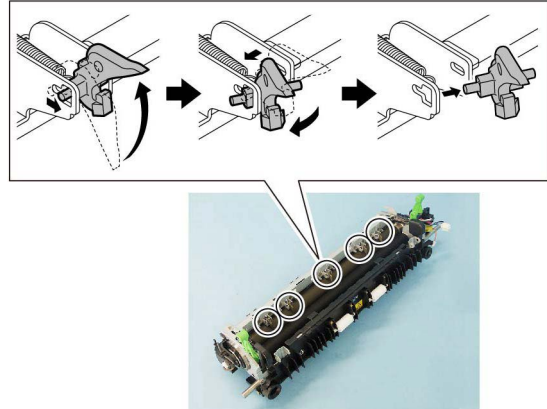

Fig. 4-353

### 4.10.7 Paper exit sensor (S13)

- (1) Take off the fuser unit.  
P. 4-141 "4.10.1 Fuser unit"
- (2) Tilt the pressure lever [1].
- (3) Remove 2 screws and open the pressure roller cover [2].

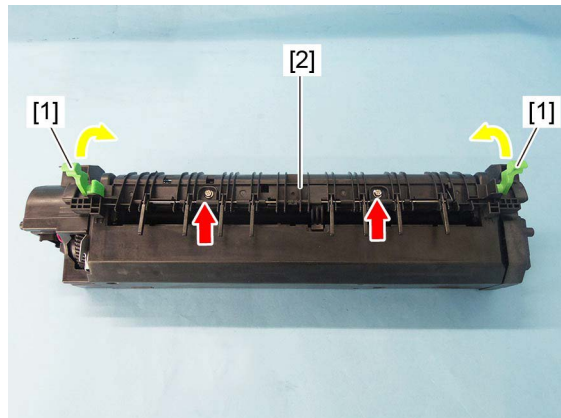

Fig. 4-354

- (4) Release 1 latch and take off the sensor cover [3].

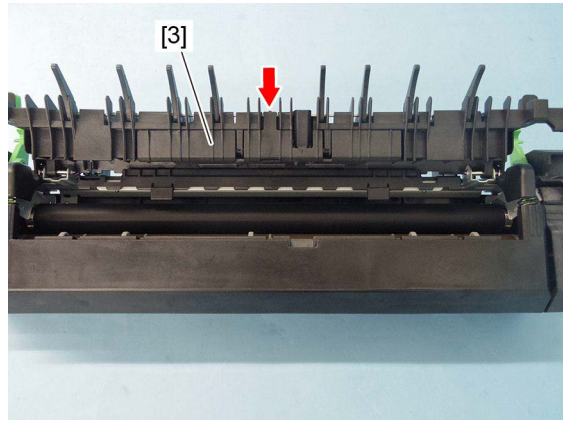

Fig. 4-355

- (5) Remove 1 actuator [4] and 1 spring [5].

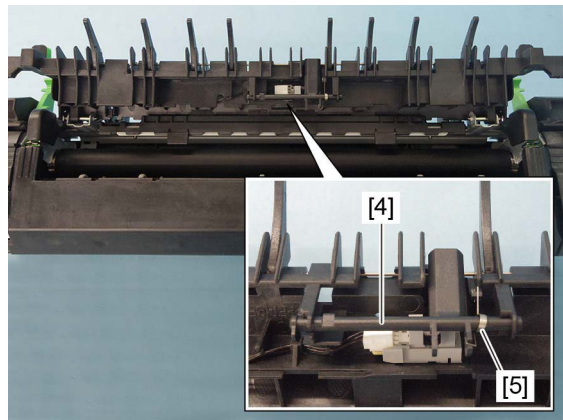

Fig. 4-356

- (6) Disconnect 1 connector [6].  
(7) Release the latch and take off the paper exit sensor [7].

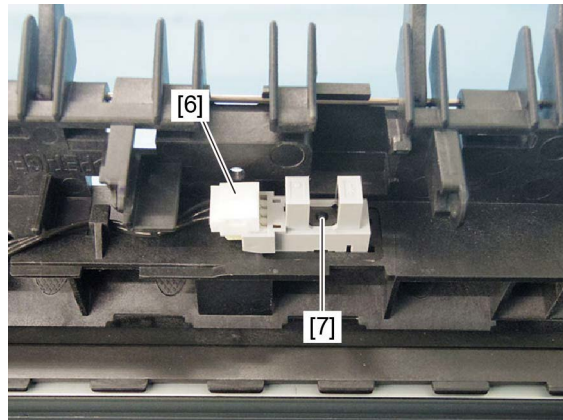

Fig. 4-357



#### 4.10.8 Fuser center thermostat (THMO7), Fuser side thermostat (THMO8)

- (1) Take off the heat roller cover.  
📖 P. 4-144 “4.10.4 Heat roller cover”
- (2) Remove 2 screws and the leaf spring [1].

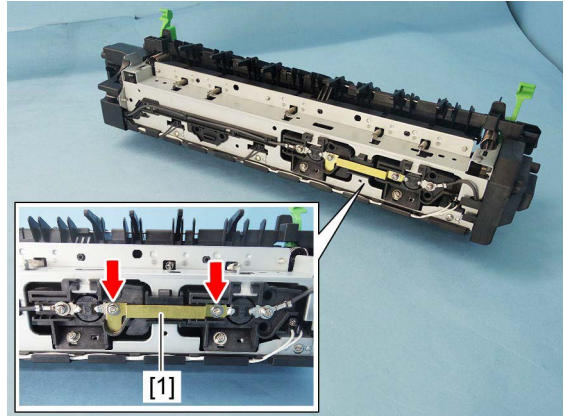

Fig. 4-358

- (3) Remove 2 screws and take off the fuser center thermostat [2] and fuser side thermostat [3].

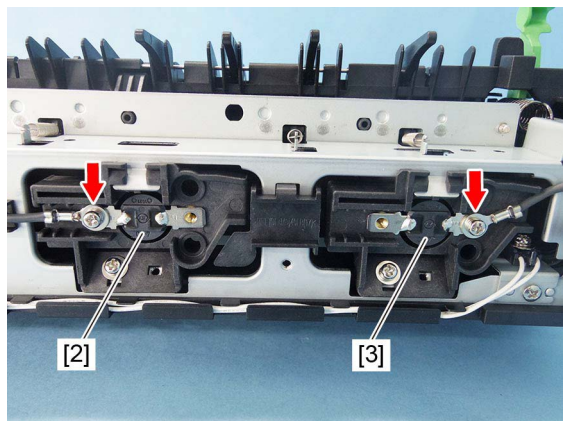
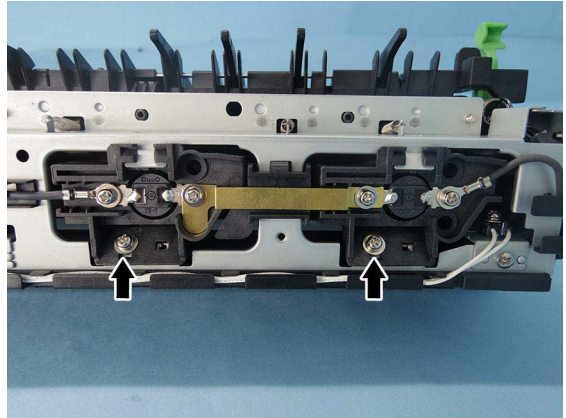

Fig. 4-359

**Notes:**

- If the thermostat is not installed appropriately when it is replaced or installed, it may not work normally. If you carry out the maintenance of the MFP in such a situation, they may result in fatal accidents such as explosion or fire. Therefore, to avoid this, be sure to perform correct handling and installation.
- When installing, check that the gap between the thermostat and the heat roller is within 1.6 to 2.1 mm. If the adjustment is necessary after checking, adjust the gap between thermostat (fuser center thermostat and fuser side thermostat) and fuser roller.  
📖 P. 6-66 “6.12.1 Thermostat gap adjustment”
- Do not loosen the screws with the white markings that is holding the thermostat.

**Fig. 4-360**

#### 4.10.9 Heat roller center thermistor (THM5), Heat roller side thermistor (THM6), Heat roller edge thermistor (THM7)

- (1) Take off the front side cover.  
📖 P. 4-143 “4.10.2 Front side cover”
- (2) Take off the rear side cover.  
📖 P. 4-144 “4.10.3 Rear side cover”
- (3) Take off the heat roller cover.  
📖 P. 4-144 “4.10.4 Heat roller cover”
- (4) Remove 2 screws and take off the rear lamp holder [1].

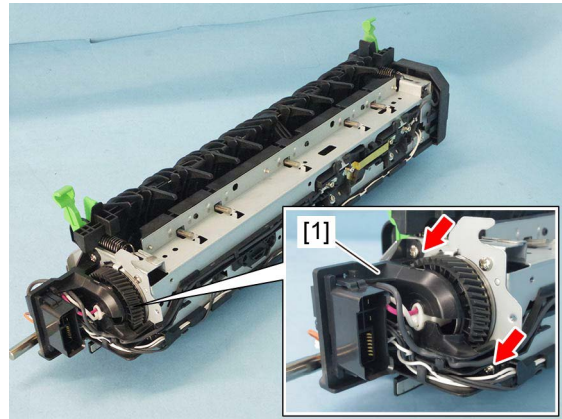

Fig. 4-361

- (5) Disconnect 3 connectors.

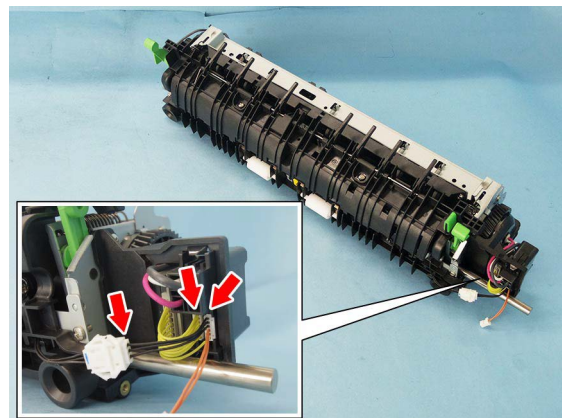

Fig. 4-362

(6) Release 2 latches and take off the connector bracket [2].

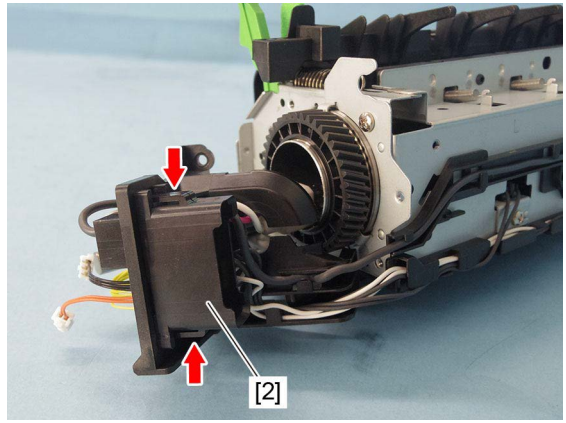

Fig. 4-363

(7) Disconnect 1 connector [3] and release the harness from 1 harness guide.

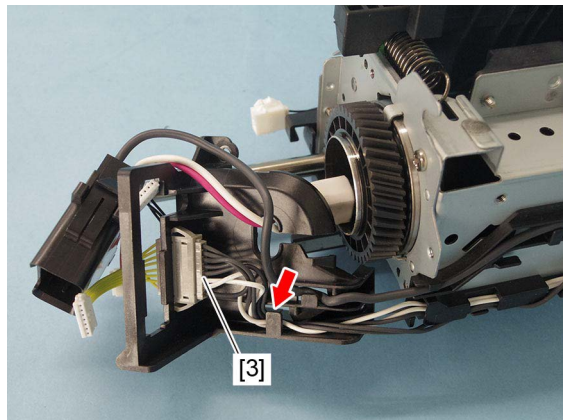

Fig. 4-364

(8) Release the harness from all the harness guides.

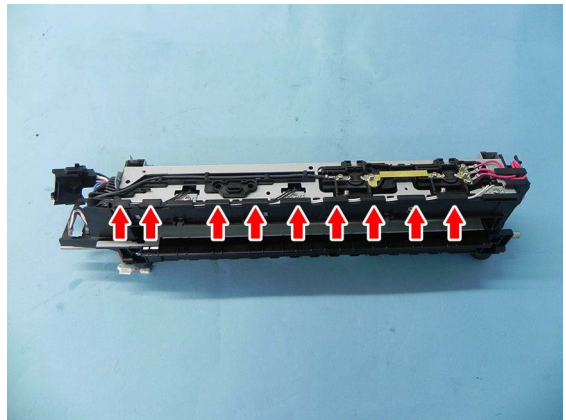

Fig. 4-365

- (9) Remove 3 screws and take off the heat roller center thermistor [4], heat roller side thermistor [5] and heat roller edge thermistor [6] with the bracket.

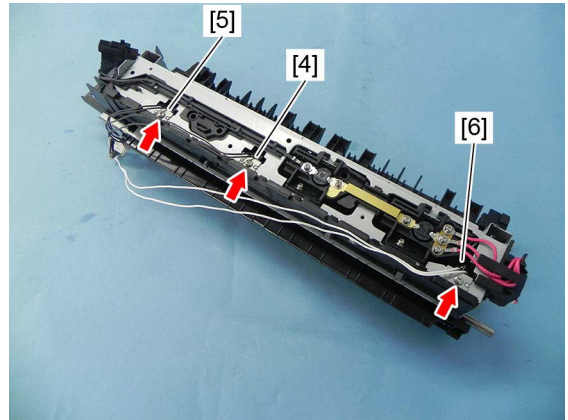

Fig. 4-366

- (10) Remove 3 screws and take off the heat roller center thermistor [4], heat roller side thermistor [5] and heat roller edge thermistor [6] from the bracket.

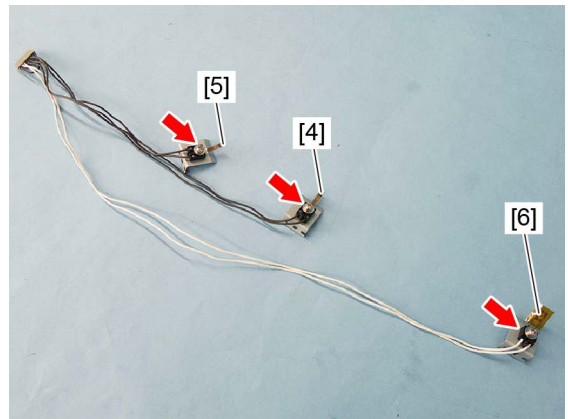

Fig. 4-367

**Notes:**

- When installing, be careful not to deform the thermistor.
- If the thermistor is not installed appropriately when it is replaced or installed, it may not work normally. If you carry out the maintenance of the MFP in such a situation, they may result in fatal accidents such as explosion or fire. Therefore, to avoid this, be sure to perform correct handling and installation.
- When installing, make sure that the heat roller center thermistor [5] and heat roller side thermistor [6] are in contact with the heat roller.



**Fig. 4-368**

- When installing, make sure that the heat roller edge thermistor [7] is in contact with the heat roller.



**Fig. 4-369**

## 4.10.10 Center heater lamp (LAMP2), Side heater lamp (LAMP2), Sub heater lamp (LAMP3)

### Notes:

For 2528A/3028A, a heater lamp with the center heater lamp (LAMP1) and side heater lamp (LAMP2) unified is installed.

For 3528A/4528A, a heater lamp with the center heater lamp (LAMP1), side heater lamp (LAMP2) and sub heater lamp (LAMP3) unified is installed.

- (1) Take off the front side cover.  
📖 P. 4-143 "4.10.2 Front side cover"
- (2) Take off the rear side cover.  
📖 P. 4-144 "4.10.3 Rear side cover"
- (3) Take off the heat roller cover.  
📖 P. 4-144 "4.10.4 Heat roller cover"
- (4) Remove 2 screws [1] and release the harness [2] from 4 harness guides.

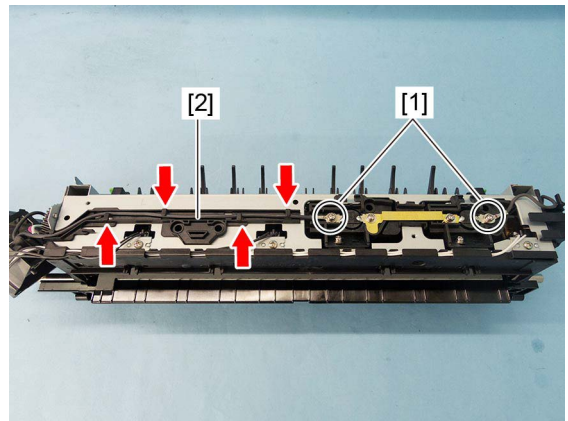

Fig. 4-370

- (5) Release the harness [3] from 3 harness guides. Remove 1 screw [4] and take off the front lamp holder [5].

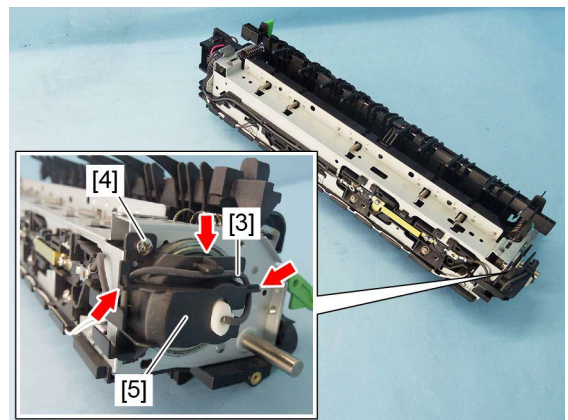

Fig. 4-371

(6) Disconnect 3 connectors.

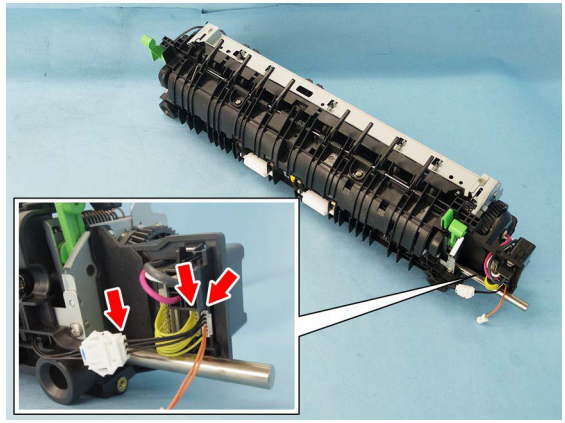

Fig. 4-372

(7) Release 2 latches and take off the connector bracket [6].

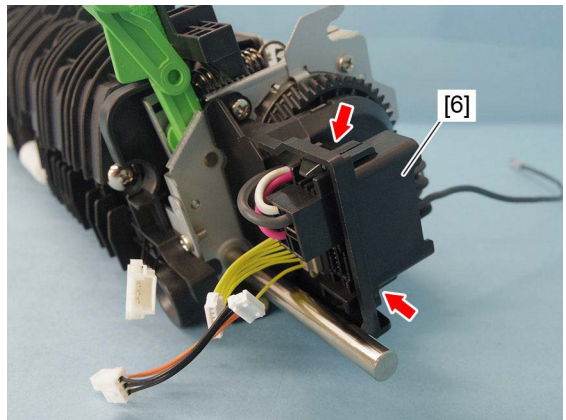

Fig. 4-373

(8) Remove 2 screws and take off the rear lamp holder [7].

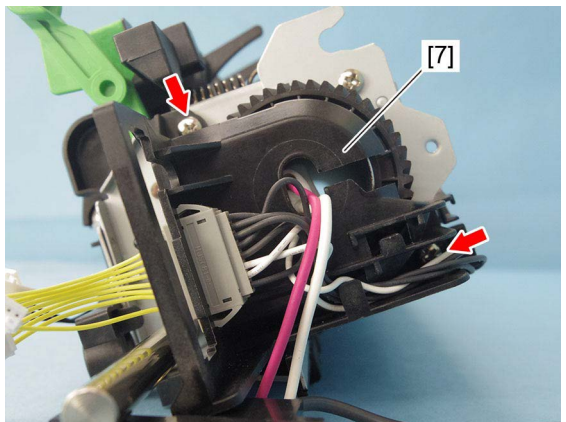

Fig. 4-374



(9) Take off the heater lamp [8] by pulling it to the rear side.

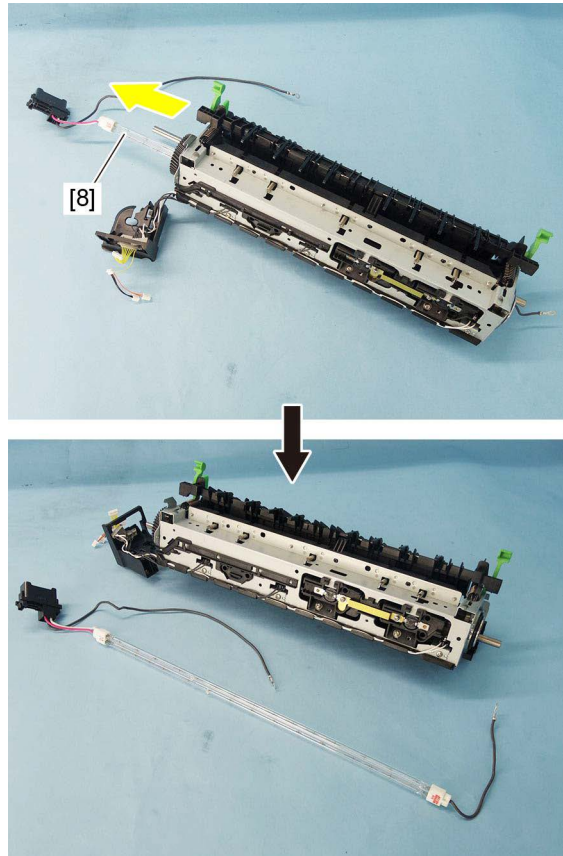

Fig. 4-375

**Notes:**

Do not touch the heater lamp directly with bare hands.

### 4.10.11 Pressure roller

- (1) Take off the front side cover.  
P. 4-143 "4.10.2 Front side cover"
- (2) Take off the rear side cover.  
P. 4-144 "4.10.3 Rear side cover"
- (3) Disconnect 1 connector [1]. Remove 2 screws and take off the pressure roller cover [2].

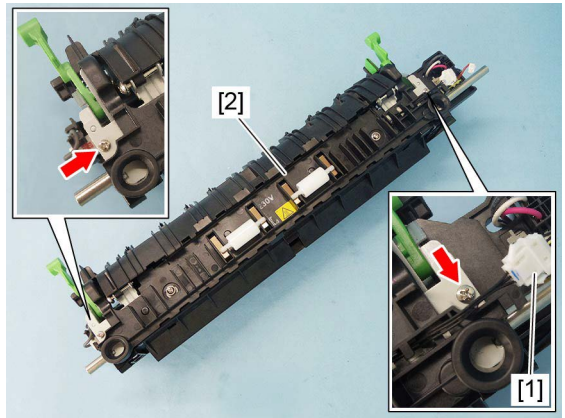

Fig. 4-376

- (4) Remove 2 springs [2].

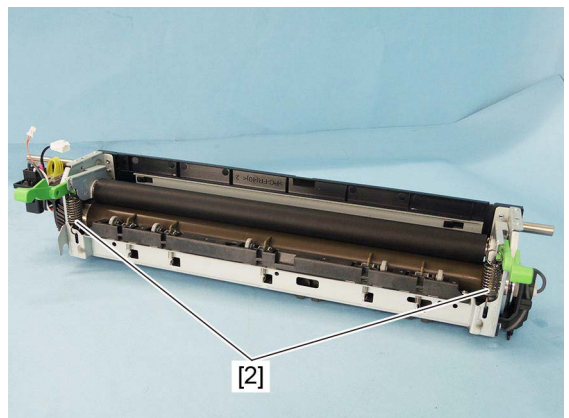

Fig. 4-377

- (5) Remove the pressure roller [4] by lifting up the pressure roller release lever [3].
- (6) Remove 2 levers [5].

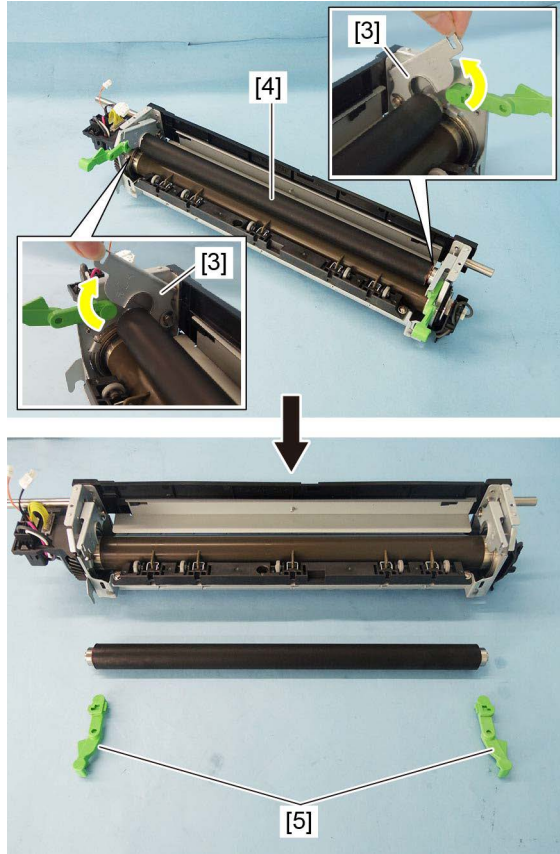

Fig. 4-378

### 4.10.12 Heat roller

- (1) Remove the separation finger.  
P. 4-146 “4.10.6 Separation finger”
- (2) Take off the paper entrance guide.  
P. 4-145 “4.10.5 Paper entrance guide”
- (3) Take off the pressure roller.  
P. 4-158 “4.10.11 Pressure roller”
- (4) Take off the heater lamp.  
P. 4-155 “4.10.10 Center heater lamp (LAMP2), Side heater lamp (LAMP2), Sub heater lamp (LAMP3)”
- (5) Remove 1 C-ring, 1 gear [1] and 1 collar [2] from the front side.

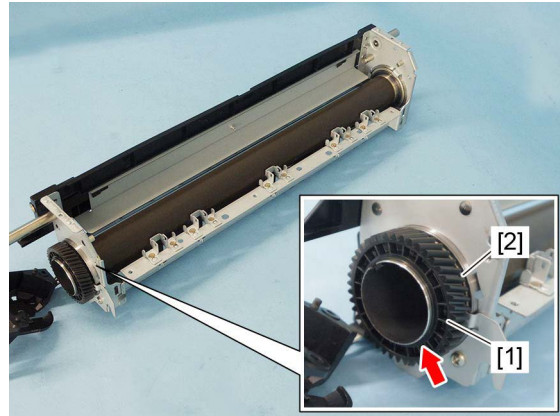

Fig. 4-379

- (6) Remove 1 C-ring, 1 washer [3] and 1 collar [4] from the rear side.

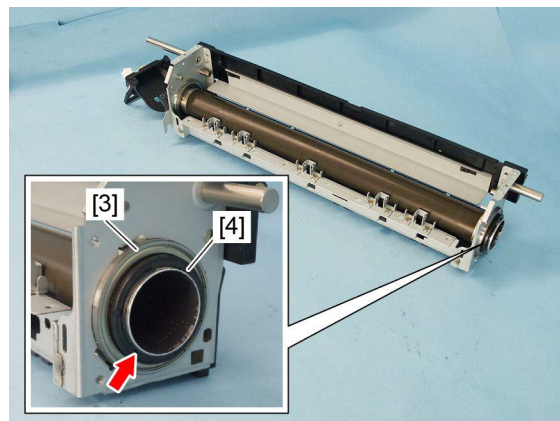

Fig. 4-380

(7) Remove 1 bearing [5]. Remove the heat roller [6] by pulling it to the front side.

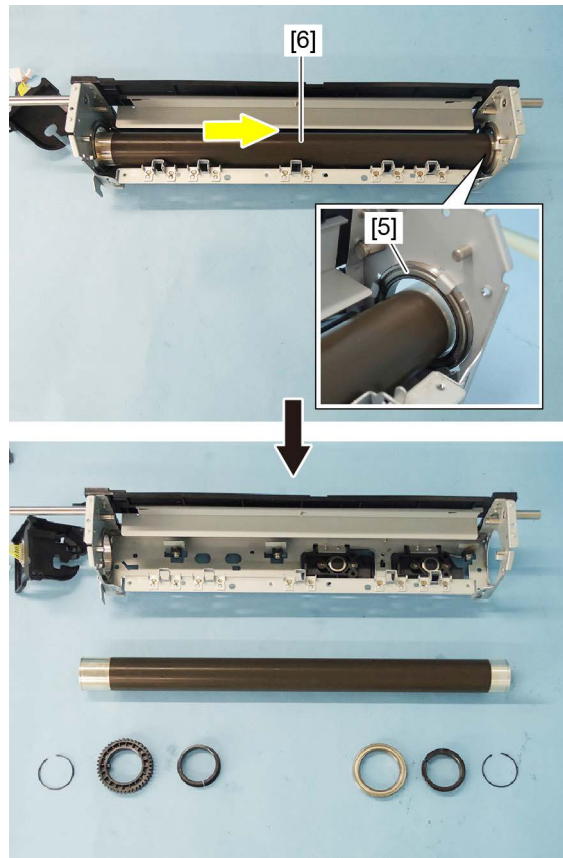

Fig. 4-381

**Notes:**

- Be sure not to scratch the heat roller.
- When removing and attaching the C-ring, be careful not to deform it by trying to widen it too much.

## 4.11 Paper Exit Section, Reverse Section

### 4.11.1 Reverse unit (3528A/4528A)

#### Notes:

Make a note of the installation position of the reverse unit and fixing screws in advance. Mark the position if needed. When reassembling, match the reverse unit with the previously marked position.

- (1) Take off the right rear cover.  
📖 P. 4-6 "4.1.10 Right rear cover"
- (2) Take off the paper exit back cover.  
📖 P. 4-4 "4.1.7 Paper exit back cover"
- (3) Remove 2 screws.

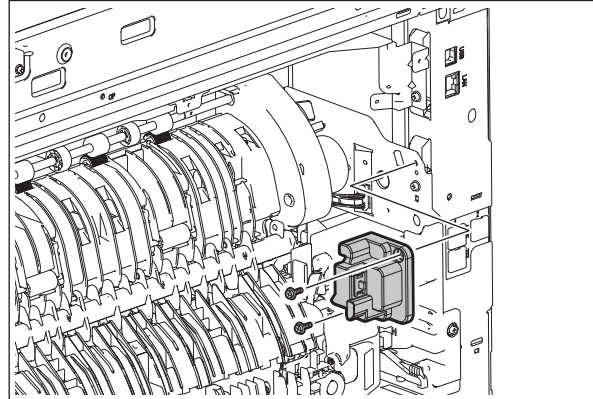

Fig. 4-382

- (4) Disconnect 1 connector [1] and take off the switch unit [2].

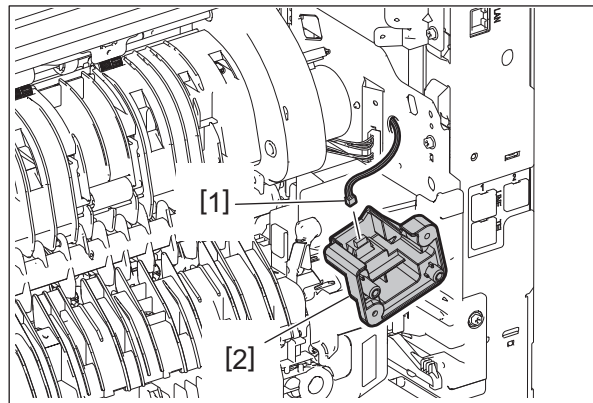

Fig. 4-383

- (5) Disconnect 1 connector [3] and remove 2 screws.

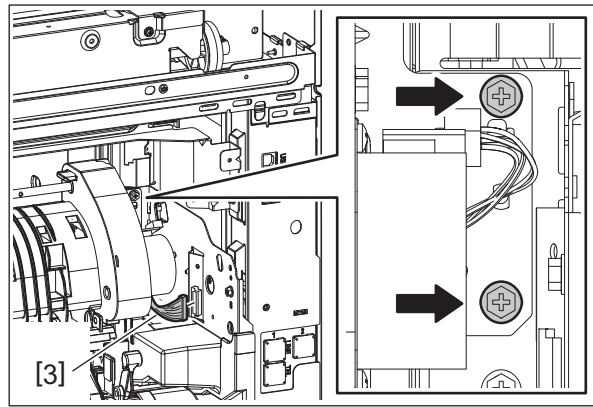

Fig. 4-384

- (6) Remove 1 screw.

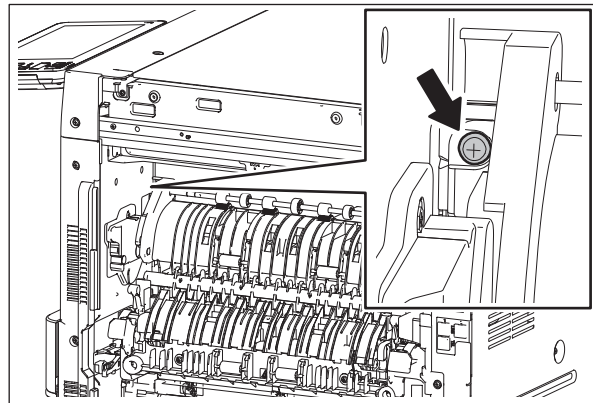

Fig. 4-385

**Notes:**

The attachment screw on the front side is a shoulder screw. When installing, exercise care not to confuse it with other kinds of screws.

- (7) Lift the rear side of the reverse unit [4] in the direction of the arrow [5] to release the rear side hook. Slide the reverse unit [4] toward the rear side [6] and release the front side insertion. Take off the reverse unit [4] by tilting it toward you [7].

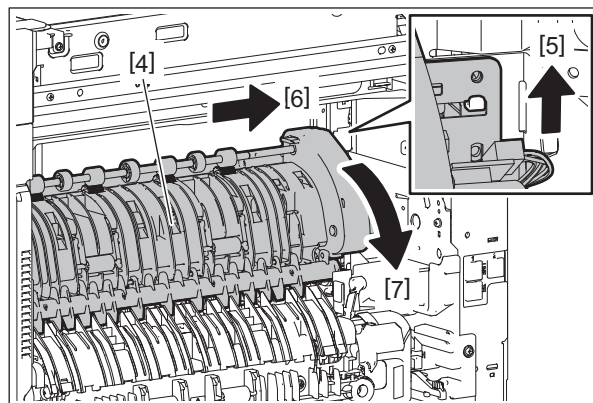
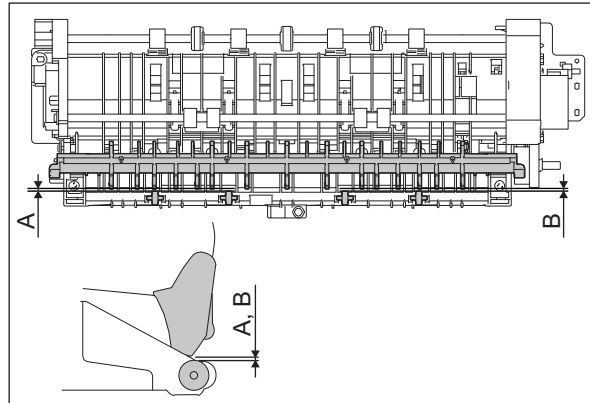

Fig. 4-386

**Notes:**

- Check that the gaps A and B (between the roller and the guide) are 0.8mm or over when the reverse unit is installed.
- To check the dimension of 0.8 mm, use a reverse unit gap confirmation jig with 0.8 mm.

**Fig. 4-387****Remarks:**

Gap adjustment procedure

1. Change the position of the screw D.
2. Loosen the screws C and E.
3. Adjust the gaps A and B to 0.8 mm or over.
4. Tighten the screws C, D and E.

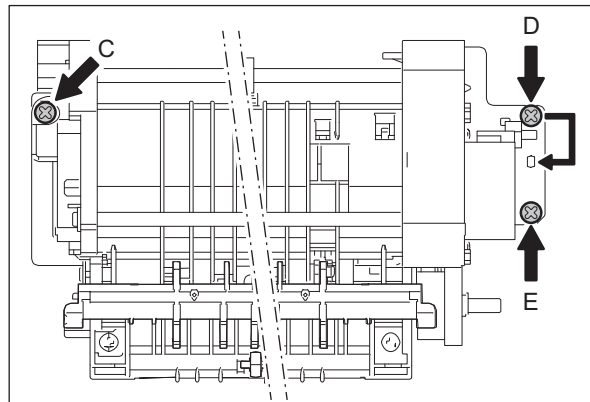
**Fig. 4-388**



## 4.11.2 Paper exit unit (3528A/4528A)

- (1) Take off the fuser unit.  
P. 4-141 "4.10.1 Fuser unit"
- (2) Take off the reverse unit.  
P. 4-162 "4.11.1 Reverse unit (3528A/4528A)"
- (3) Remove 1 screw [2] and 2 shoulder screws [3]. Take off the paper exit unit [1].

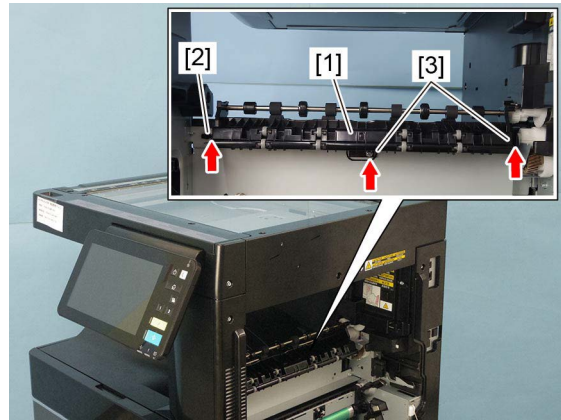

Fig. 4-389

## 4.11.3 Paper exit unit (2528A/3028A)

- (1) Take off the fuser unit.  
P. 4-141 "4.10.1 Fuser unit"
- (2) Remove 3 screws [2] and take off the paper exit unit [1].

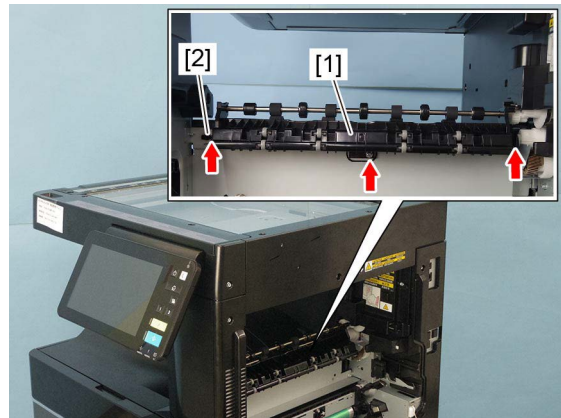

Fig. 4-390

#### 4.11.4 Paper exit roller, Lower paper exit roller

- (1) Take off the paper exit unit.  
P. 4-165 "4.11.2 Paper exit unit (3528A/4528A)"  
P. 4-165 "4.11.3 Paper exit unit (2528A/3028A)"
- (2) Remove 1 E-ring [1], 1 gear [2] and 1 bushing [3].

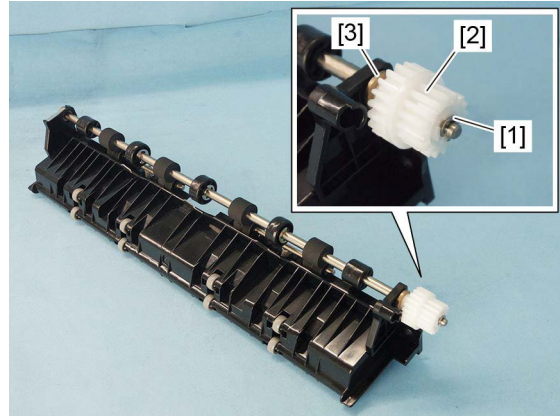

Fig. 4-391

- (3) Remove 1 E-ring [4] and 1 bushing [5].

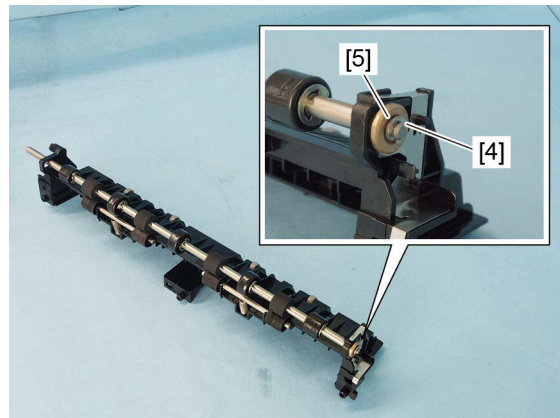

Fig. 4-392

- (4) Remove the paper exit roller and lower paper exit roller [6].

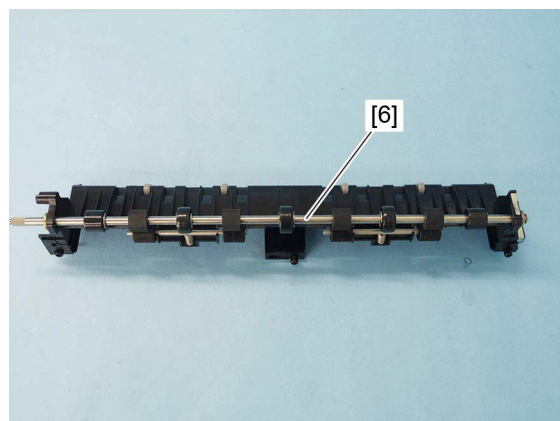

Fig. 4-393

(5) Take off the idling roller [7] and remove 2 springs [8].

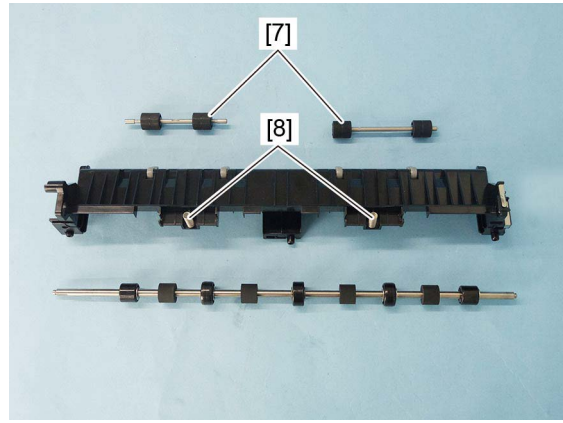

Fig. 4-394

**Notes:**

When replacing the idling roller or idling roller shaft, apply 1 rice sized grain of white grease (Molykote EM-30L) evenly around the 2 places [9] shown in the figure.

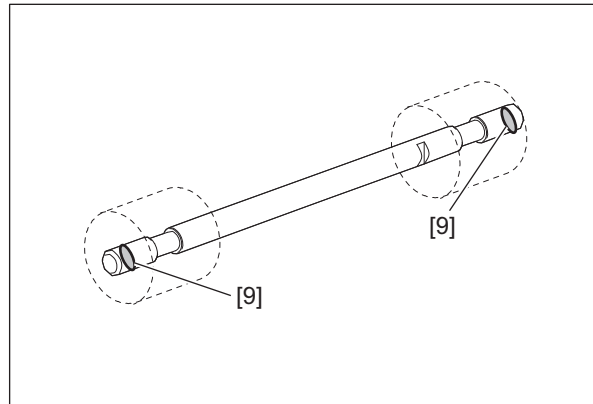

Fig. 4-395

### 4.11.5 Paper exit motor (M5)

- (1) Take off the right rear cover.  
📖 P. 4-6 “4.1.10 Right rear cover”
- (2) Take off the paper exit unit.  
📖 P. 4-165 “4.11.2 Paper exit unit (3528A/4528A)”
- (3) Take off the paper exit back cover.  
📖 P. 4-4 “4.1.7 Paper exit back cover”
- (4) Remove 1 screw and take off the paper exit motor assembly [1].

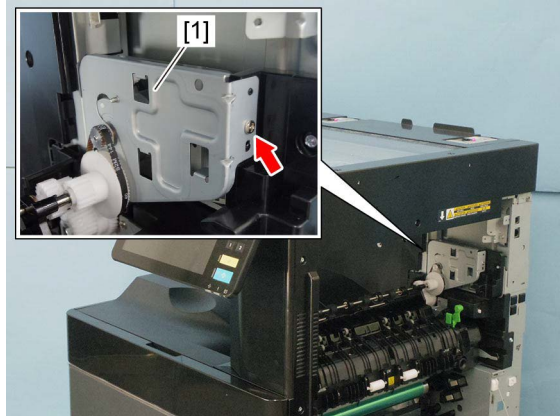

Fig. 4-396

- (5) Disconnect 1 connector from the paper exit motor assembly [1].

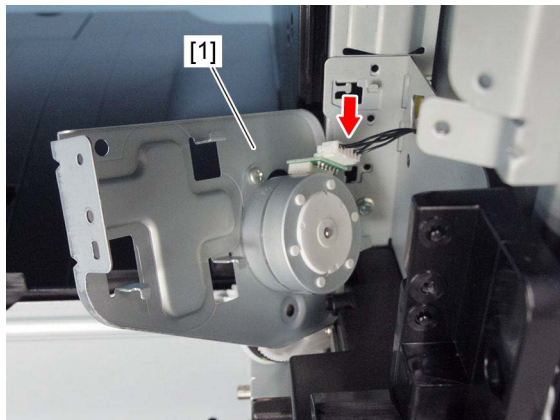

Fig. 4-397

(6) Remove the belt [2].

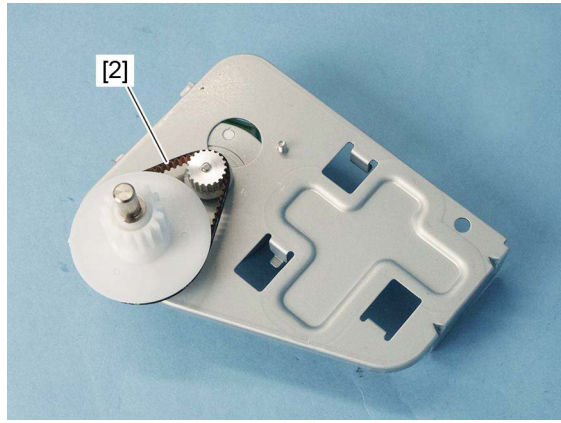

Fig. 4-398

(7) Remove 2 screws. Move the gear [3] to the big hole on the bracket and take off the paper exit motor [4].

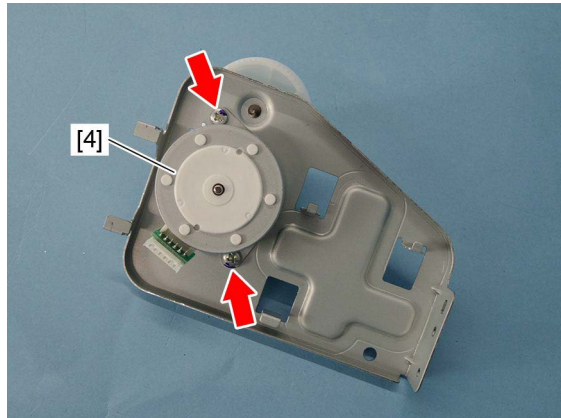

Fig. 4-399

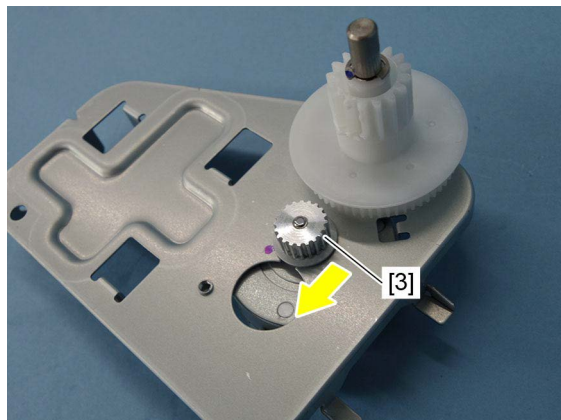

Fig. 4-400

#### 4.11.6 Paper exit/reverse motor (M24) (3528A/4528A)

- (1) Take off the reverse unit.  
P. 4-162 “4.11.1 Reverse unit (3528A/4528A)”
- (2) Disconnect 1 connector [1], remove 3 screws and take off the paper exit/reverse motor unit [2].

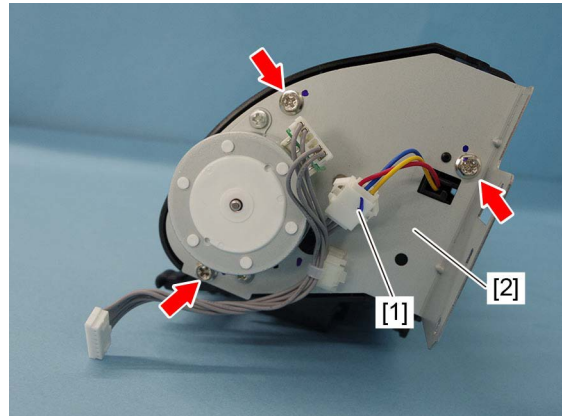

Fig. 4-401

#### Notes:

When installing, exercise care not to forget to attach the timing belt [3].

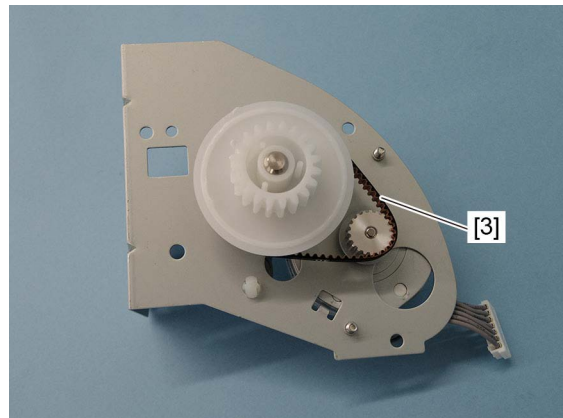

Fig. 4-402

- (3) Disconnect 1 connector [4], remove 2 screws and take off the paper exit/reverse motor [5].

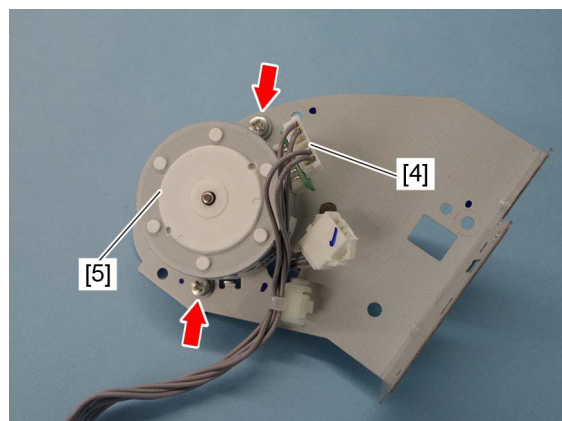

Fig. 4-403

### 4.11.7 Reverse gate solenoid (SOL2) (3528A/4528A)

- (1) Take off the paper exit/reverse motor unit.  
P. 4-170 "4.11.6 Paper exit/reverse motor (M24) (3528A/4528A)"
- (2) Remove 2 screws and take off the cover [1].

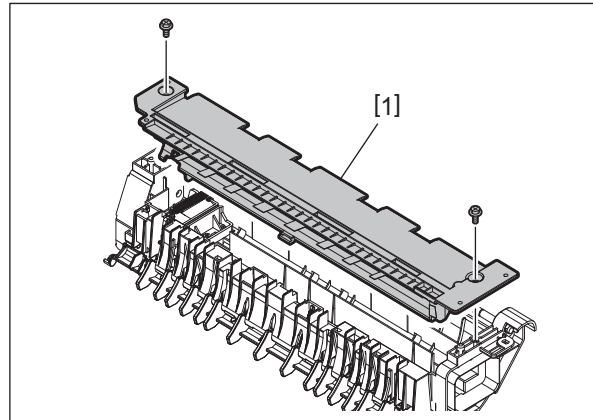

Fig. 4-404

- (3) Release the harness from the harness guide.
- (4) Remove 1 spring [2].

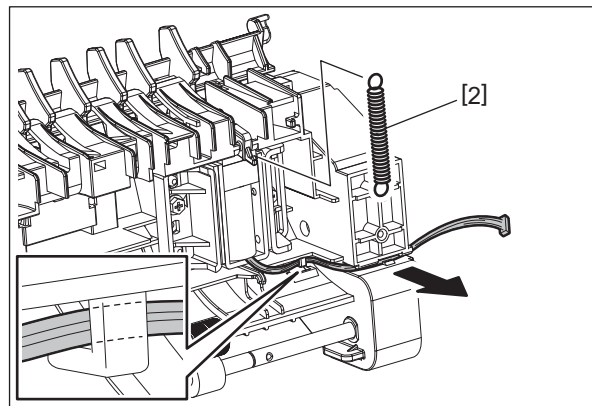

Fig. 4-405

- (5) Remove 2 screws.

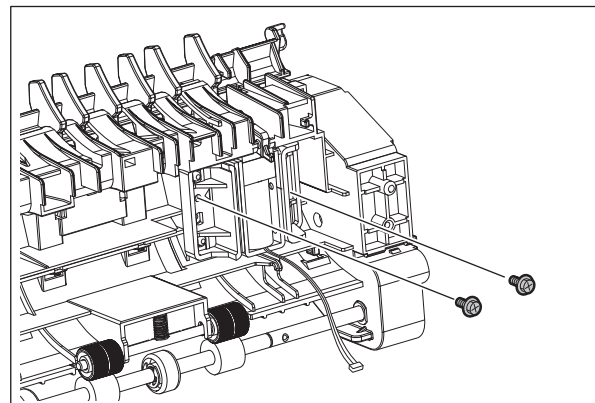

Fig. 4-406

- (6) Lift up the plunger [3] and take off the reverse gate solenoid [4] and 2 brackets [5] together.

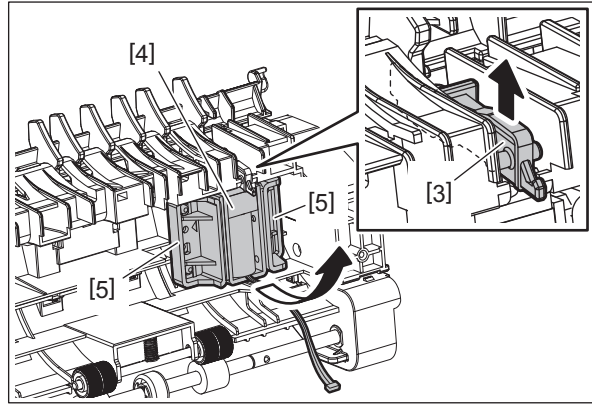

Fig. 4-407

- (7) Remove the plunger [3].

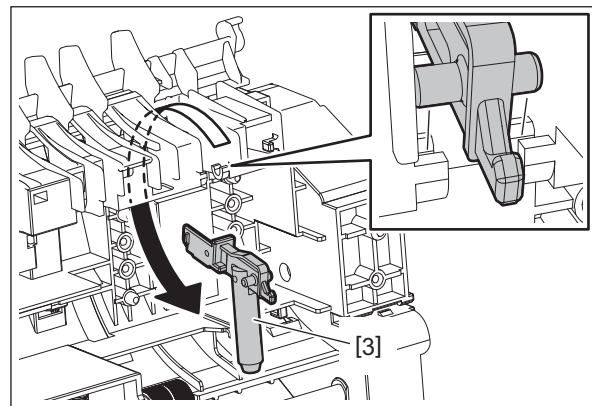

Fig. 4-408

**Notes:**

When installing, insert the plastic part at the edge of the plunger [3] into the groove of the reverse unit.



### 4.11.8 Upper paper exit roller (3528A/4528A)

- (1) Take off the paper exit/reverse motor unit.  
📖 P. 4-170 “4.11.6 Paper exit/reverse motor (M24) (3528A/4528A)”
- (2) Remove 2 screws and take off the cover [1].

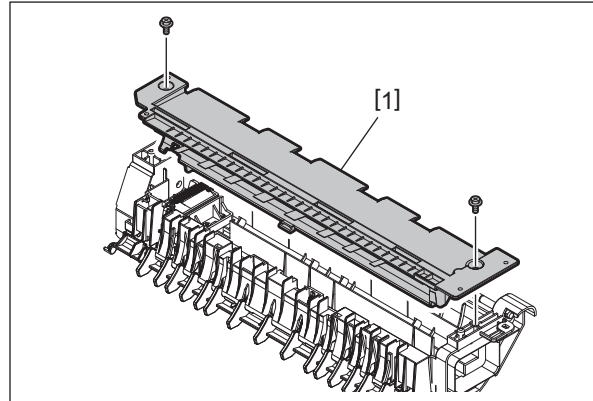

Fig. 4-409

- (3) Remove the 2 springs [2] applying pressure to the idling roller.

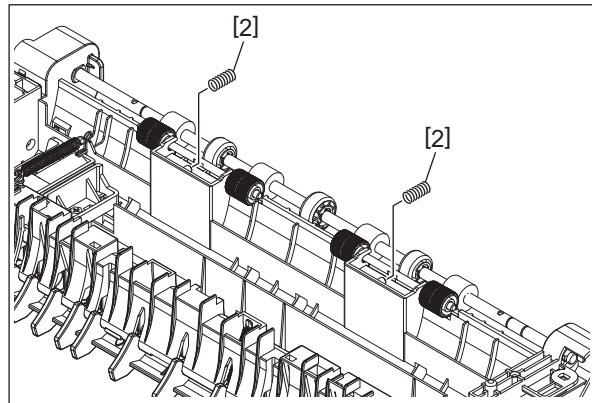

Fig. 4-410

- (4) Remove 1 gear [3], 1 clip [4], 1 bushing (metal) [5], 1 bushing (resin) [6] and take off the upper paper exit roller [7].

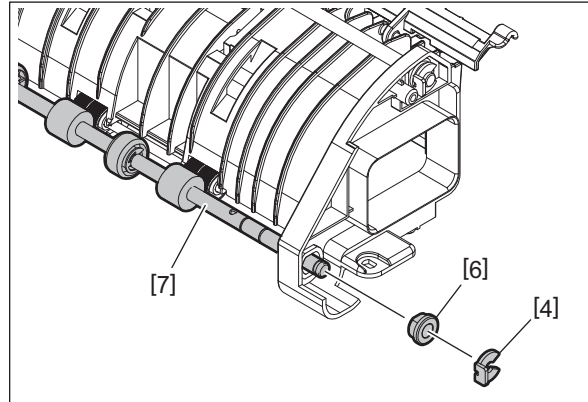

Fig. 4-411

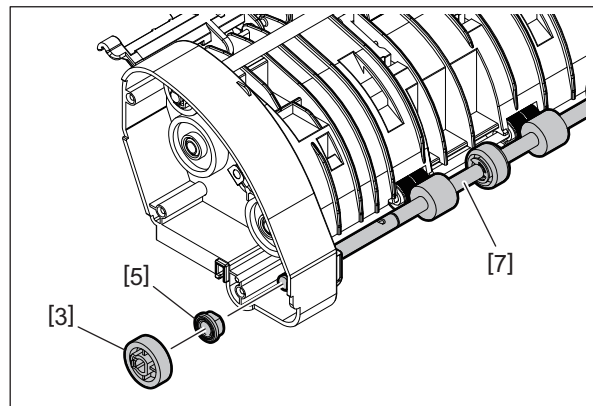

Fig. 4-412

**Notes:**

When replacing the idling roller or idling roller shaft, apply 1 rice sized grain of white grease (Molykote EM-30L) evenly around the 2 places [8] shown in the figure.

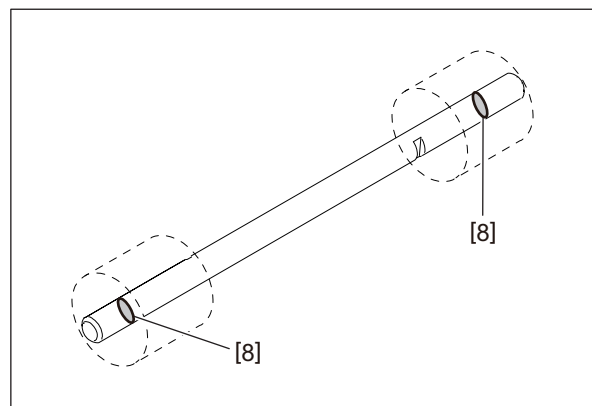

Fig. 4-413

### 4.11.9 Reverse roller (3528A/4528A)

- (1) Take off the paper exit/reverse motor unit.  
P. 4-170 "4.11.6 Paper exit/reverse motor (M24) (3528A/4528A)"
- (2) Remove 1 gear [1], 1 clip [2], 1 bushing (metal) [3], 1 bushing (resin) [5] and take off the reverse roller [4].

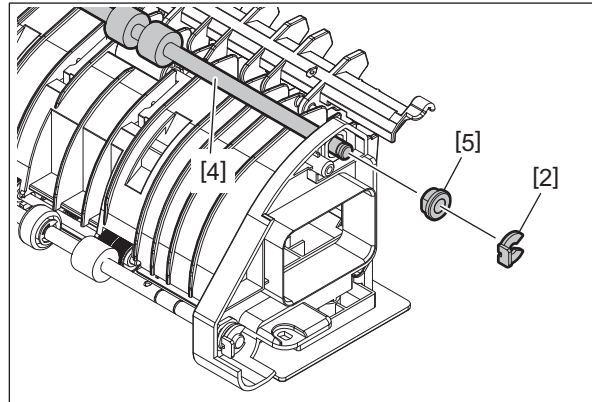

Fig. 4-414

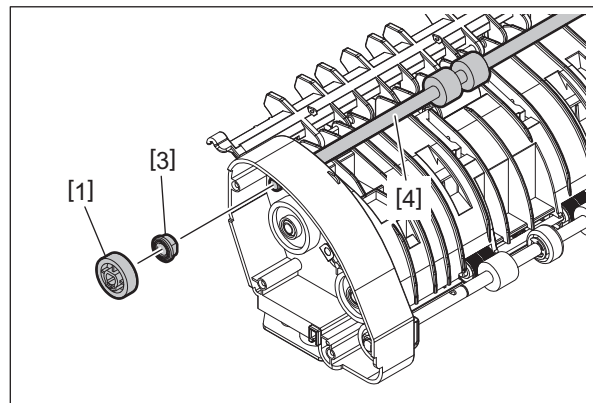

Fig. 4-415

## 4.12 Automatic Duplexing Unit (ADU)

### 4.12.1 Automatic duplexing unit (ADU)

- (1) Take off the right front cover.  
📖 P. 4-5 “4.1.9 Right front cover”
- (2) Take off the right rear cover.  
📖 P. 4-6 “4.1.10 Right rear cover”
- (3) Disconnect 3 connectors. Remove 1 screw [1] and take off the ground wire. Release the harness from 2 harness clamps [2].

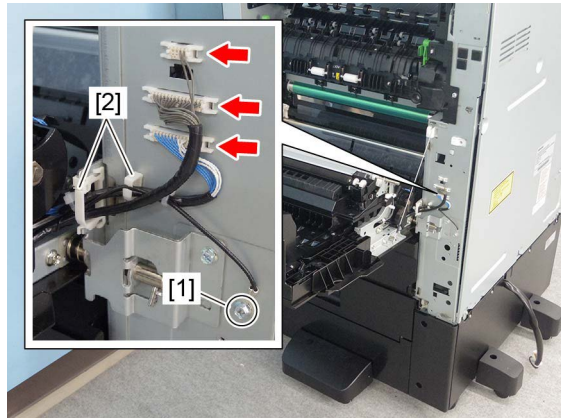

Fig. 4-416

- (4) Remove 1 screw and take off the wire end bracket [3] by sliding it in the direction of the arrow.

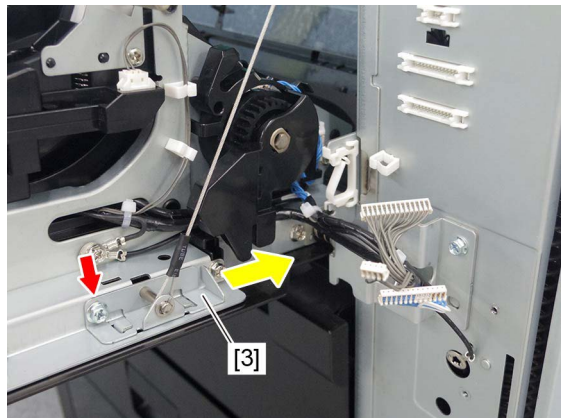

Fig. 4-417

- (5) Raise the rear hinge [4].

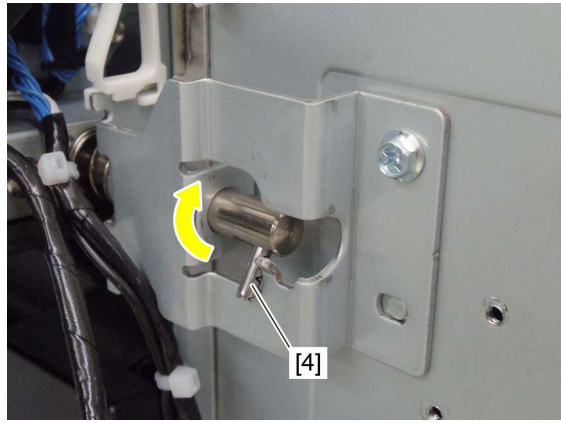

Fig. 4-418

**Notes:**

When installing, turn the rear hinge [4] downward.

- (6) Slide the rear hinge [4] to the rear side and pull it out from the ADU.

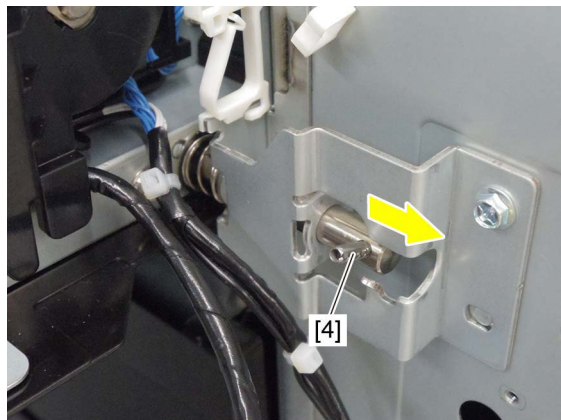

Fig. 4-419

- (7) Slightly lift up the ADU [5] and take it off by sliding it to the rear side.

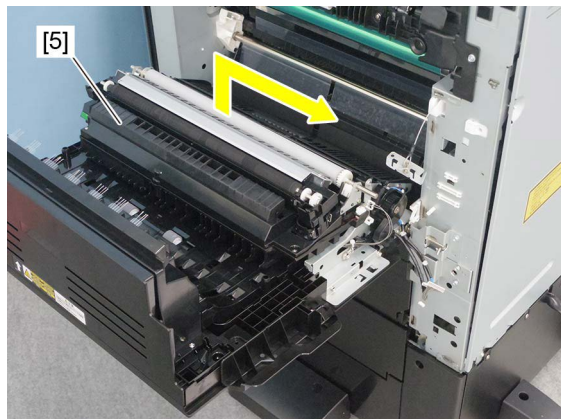

Fig. 4-420

**Notes:**

When installing the ADU, fit its boss [7] to the front hinge [6].

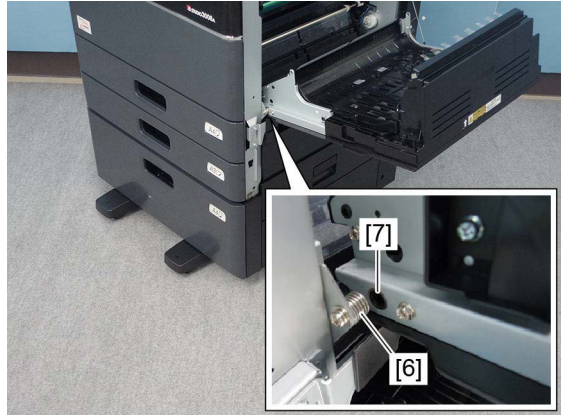

Fig. 4-421

### 4.12.2 Bypass tray paper feed clutch (CLT3)

- (1) Take off the ADU.  
P. 4-176 “4.12.1 Automatic duplexing unit (ADU)”
- (2) Release the harness [1] from 4 harness guides.

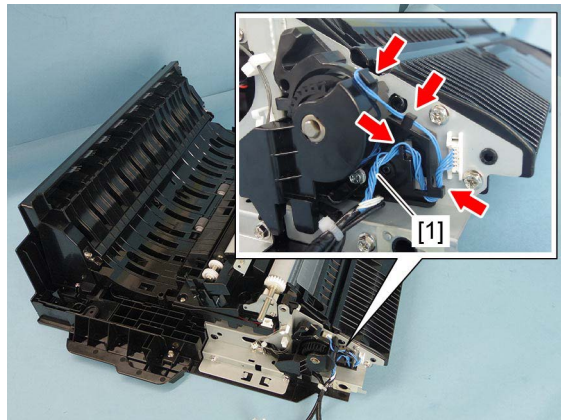

Fig. 4-422

- (3) Remove 1 screw and take off the clutch cover [2].

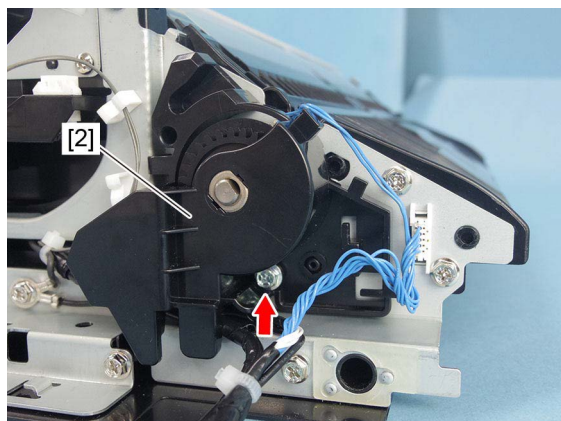

Fig. 4-423

- (4) Remove 1 bushing [3] and the leaf spring [4].

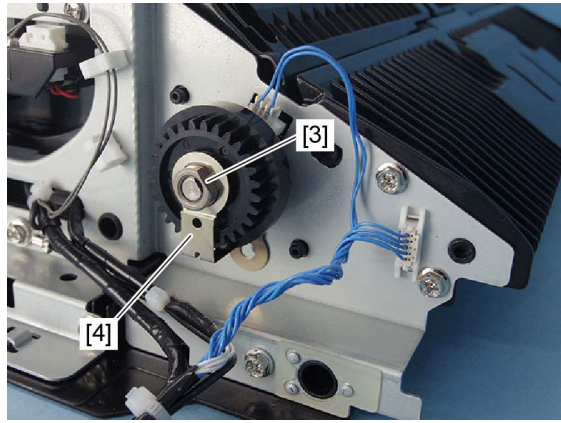

Fig. 4-424

- (5) Disconnect 1 connector and take off the bypass tray paper feed clutch [5].

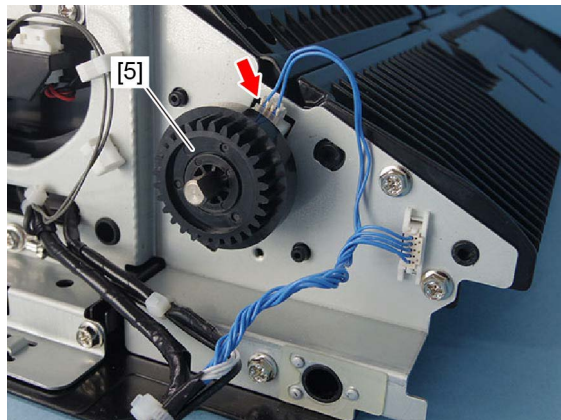

Fig. 4-425

**Notes:**

When installing, attach a rotation stopper [6] to the protrusion.

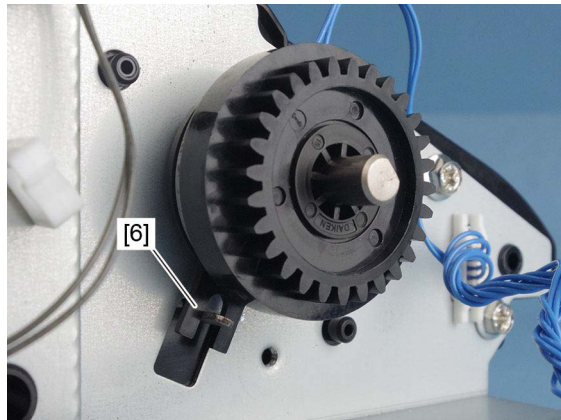

Fig. 4-426

### 4.12.3 ADU guide assembly (3528A/4528A)

- (1) Take off the transfer unit.  
P. 4-134 “4.9.1 Transfer unit (TRU)”
- (2) Remove the bypass tray paper feed clutch.  
P. 4-178 “4.12.2 Bypass tray paper feed clutch (CLT3)”
- (3) Remove 1 screw and take off the ground wire.



Fig. 4-427

- (4) Remove 2 screws and take off the cover [1].

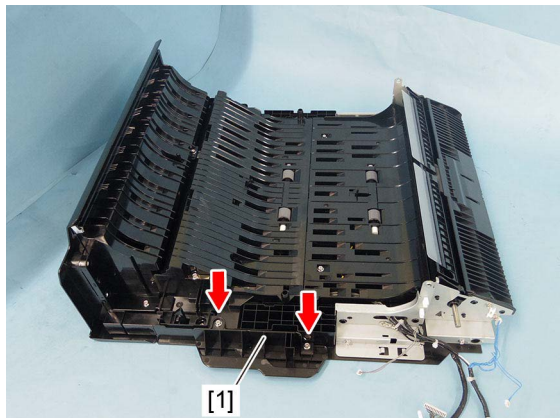

Fig. 4-428



(5) Remove 6 screws and take off the ADU guide assembly [2].

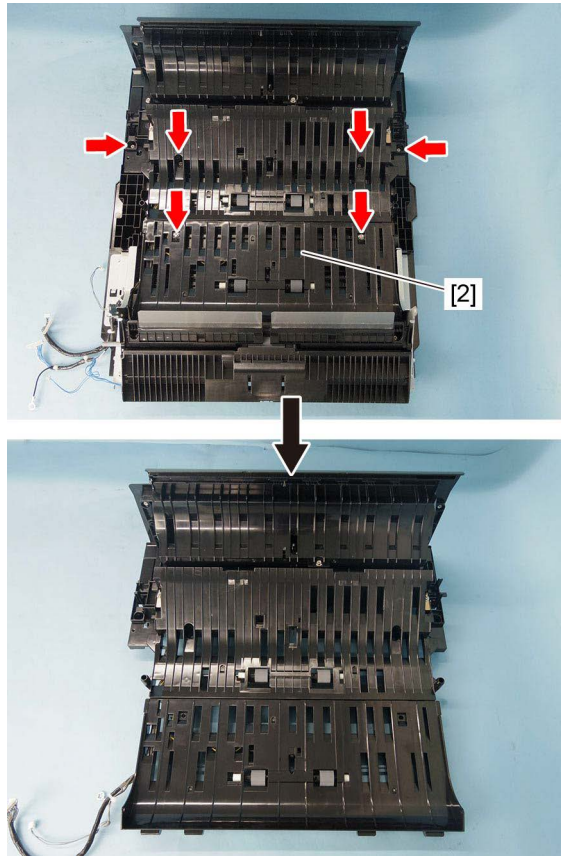

Fig. 4-429

#### 4.12.4 ADU guide assembly (2528A/3028A)

- (1) Take off the transfer unit.  
📖 P. 4-134 “4.9.1 Transfer unit (TRU)”
- (2) Remove the bypass tray paper feed clutch.  
📖 P. 4-178 “4.12.2 Bypass tray paper feed clutch (CLT3)”
- (3) Take off the ADU middle cover.  
📖 P. 4-185 “4.12.6 ADU middle cover (2528A/3028A)”
- (4) Remove 1 screw and take off the ground wire.

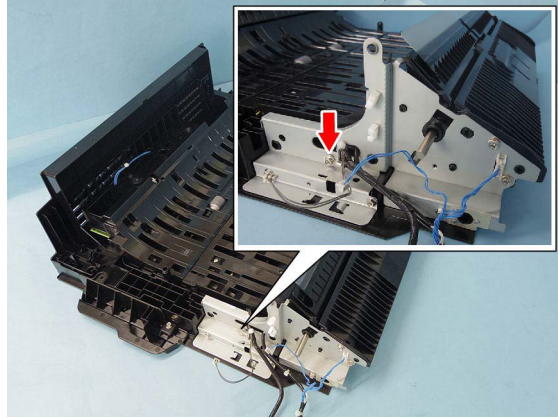

Fig. 4-430

- (5) Remove 4 screws and take off the ADU guide assembly [1].

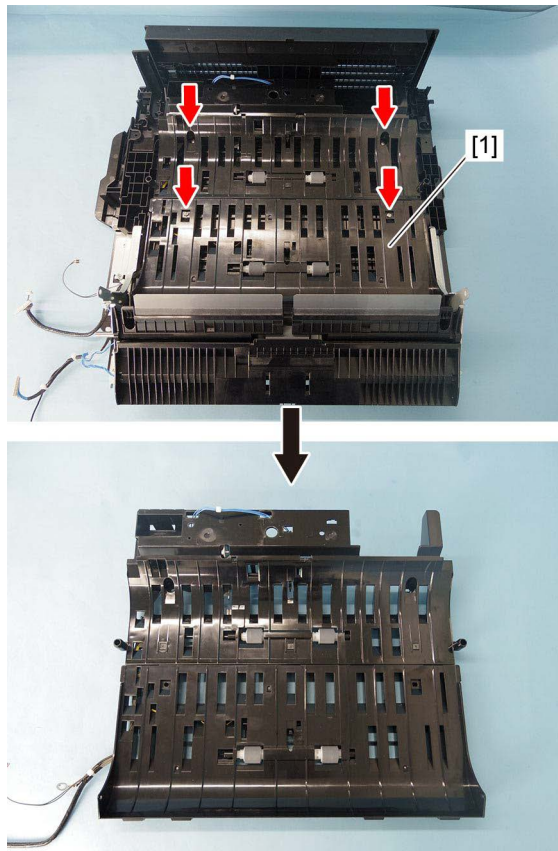

Fig. 4-431

#### 4.12.5 ADU middle cover (3528A/4528A)

- (1) Take off the ADU guide assembly.  
📖 P. 4-180 “4.12.3 ADU guide assembly (3528A/4528A)”
- (2) Remove 4 screws and take off the ADU upper cover [1].

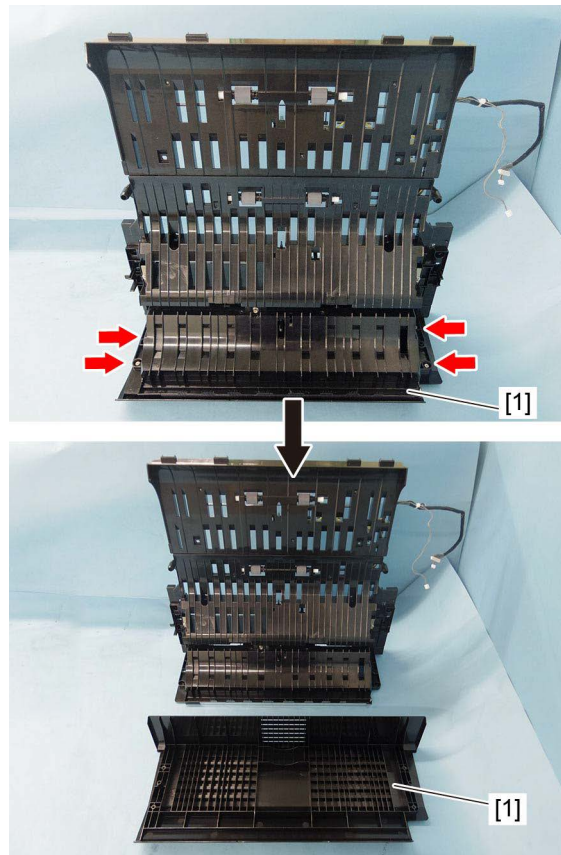

Fig. 4-432

- (3) Disconnect 2 connectors.

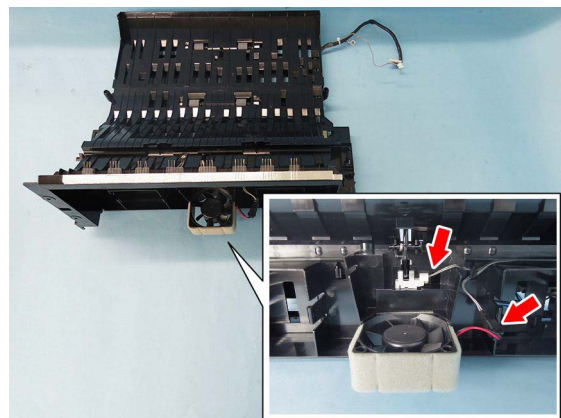

Fig. 4-433

(4) Release the harness [2] from 2 harness guides.

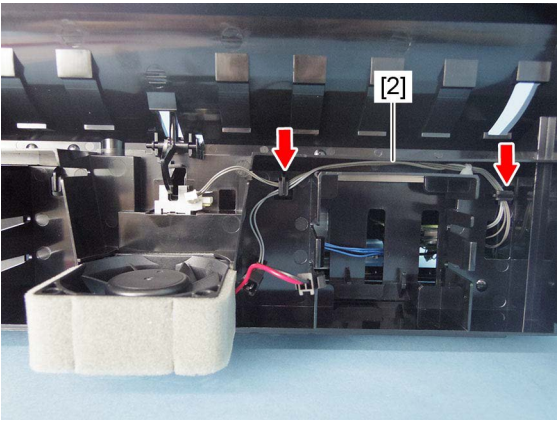

Fig. 4-434

(5) Remove 3 screws.

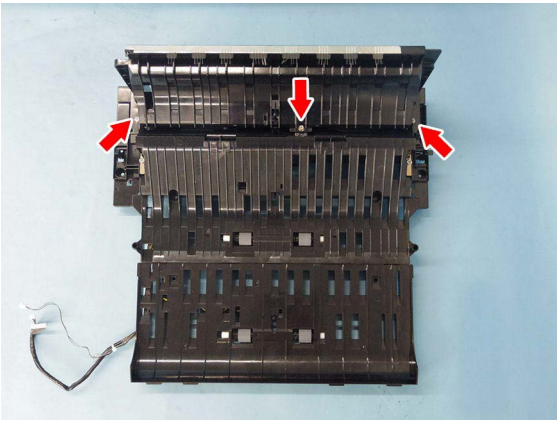

Fig. 4-435

- (6) Release 2 latches and take off the ADU middle cover [3].

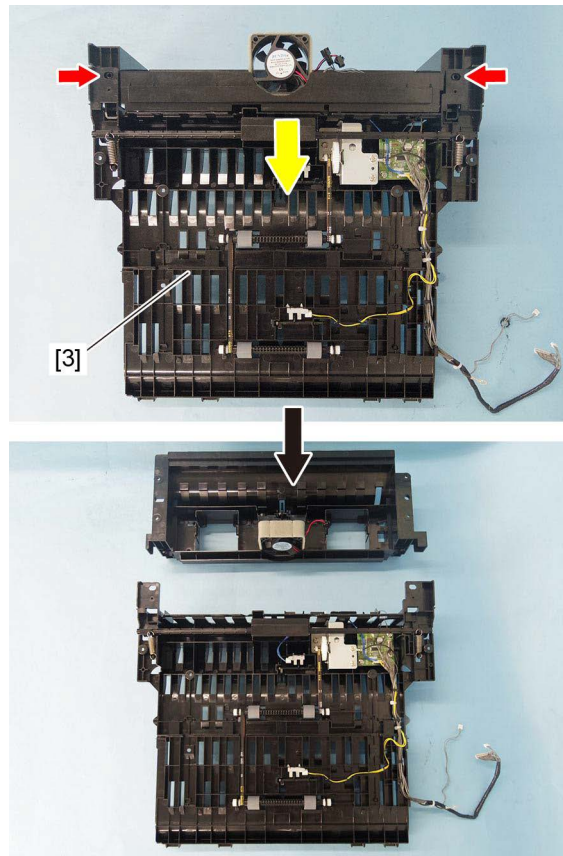

Fig. 4-436

#### 4.12.6 ADU middle cover (2528A/3028A)

- (1) Take off the ADU.  
P. 4-176 “4.12.1 Automatic duplexing unit (ADU)”
- (2) Remove 4 screws and take off the ADU middle cover [1].

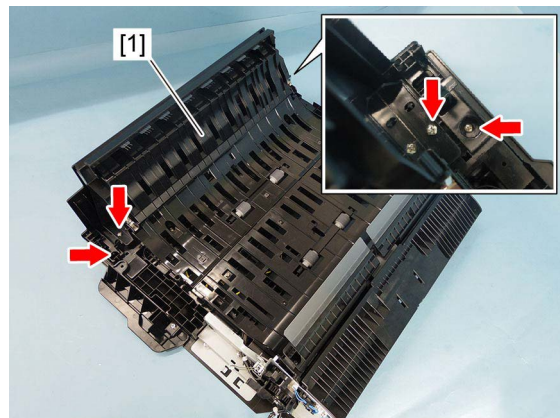



Fig. 4-437

### 4.12.7 ADU board (ADU) (3528A/4528A)

- (1) Take off the ADU guide assembly.  
 P. 4-180 “4.12.3 ADU guide assembly (3528A/4528A)”
- (2) Remove 2 springs and take off the ADU release lever [1].

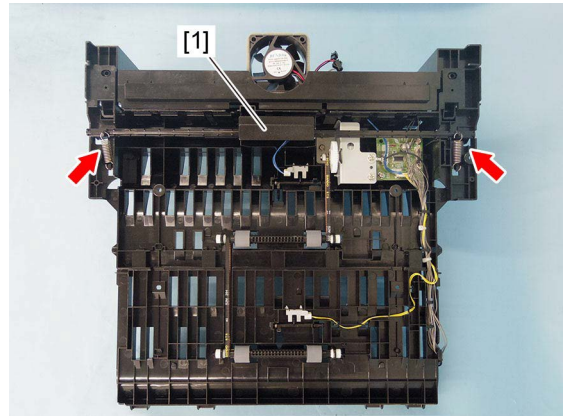

Fig. 4-438

- (3) Remove 1 screw and take off the ground wire.

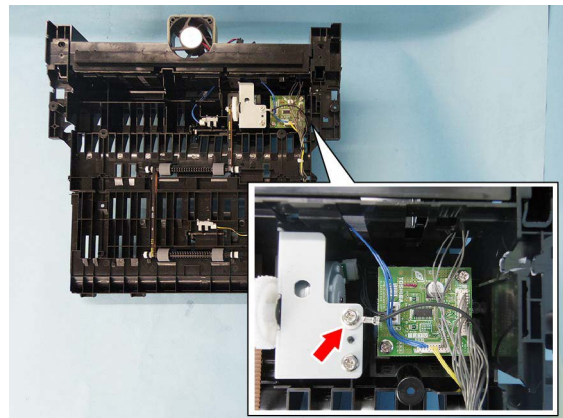

Fig. 4-439

- (4) Disconnect 3 connectors [2]. Remove 2 screws and take off the ADU board [3].

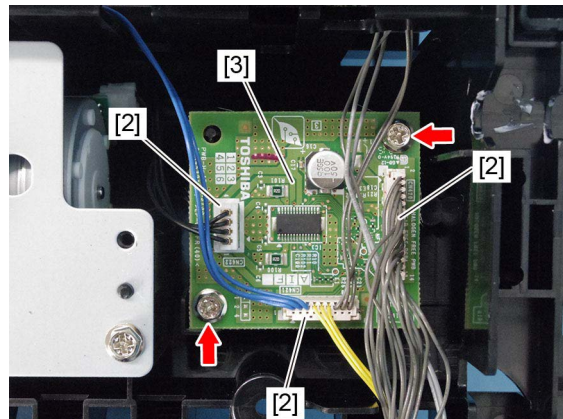



Fig. 4-440

#### 4.12.8 ADU board (ADU) (2528A/3028A)

- (1) Take off the ADU guide assembly.  
 P. 4-182 “4.12.4 ADU guide assembly (2528A/3028A)”
- (2) Remove 1 screw from the ADU guide assembly [1] and take off the ground wire.

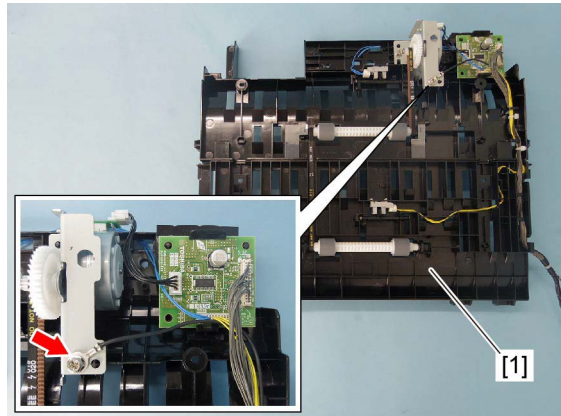

Fig. 4-441

- (3) Disconnect 3 connectors and take off the ADU board [2].

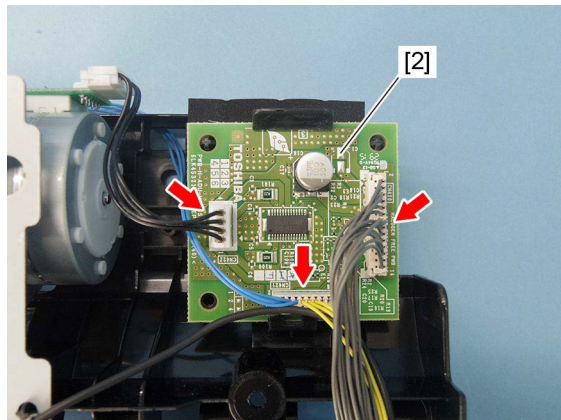



Fig. 4-442

### 4.12.9 ADU motor (M12) (3528A/4528A)

- (1) Take off the ADU guide assembly.  
 P. 4-180 “4.12.3 ADU guide assembly (3528A/4528A)”
- (2) Remove 2 springs and take off the ADU release lever [1].

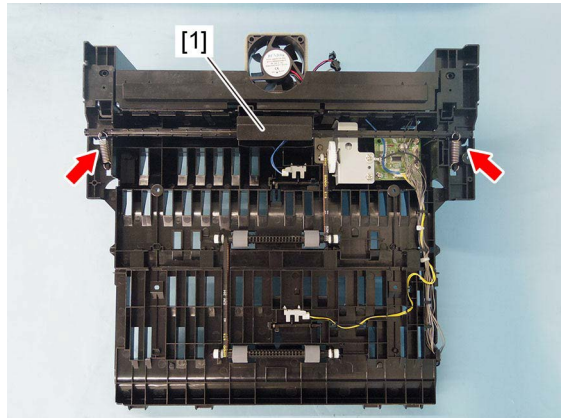

Fig. 4-443

- (3) Remove 1 screw [2] and take off the ground wire. Remove 2 screws.

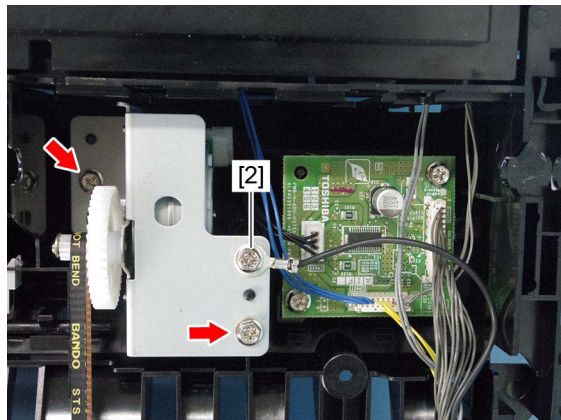

Fig. 4-444

- (4) Disconnect 1 connector and take off the ADU motor assembly [3].

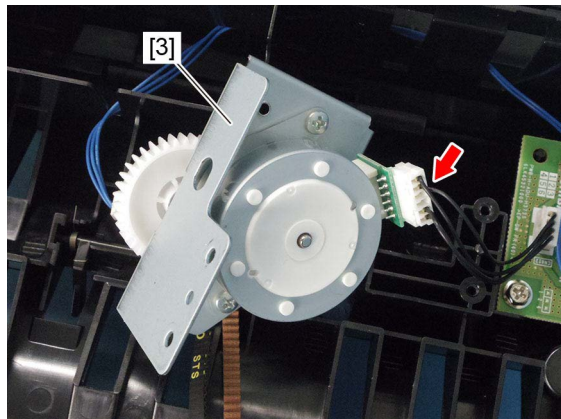

Fig. 4-445



- (5) Remove 2 screws and take off the ADU motor [4].

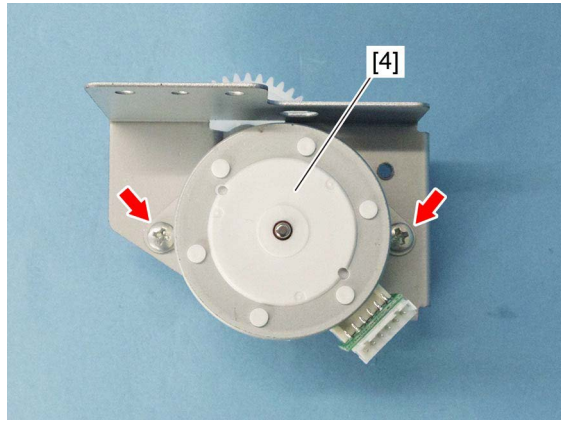

Fig. 4-446

#### 4.12.10 ADU motor (M12) (2528A/3028A)

- (1) Take off the ADU guide assembly.  
P. 4-182 "4.12.4 ADU guide assembly (2528A/3028A)"
- (2) Remove 2 screws from the ADU guide assembly [1].

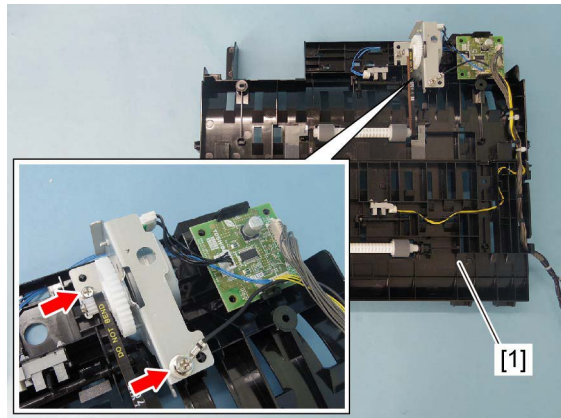

Fig. 4-447

- (3) Disconnect 1 connector and take off the ADU motor assembly [2].

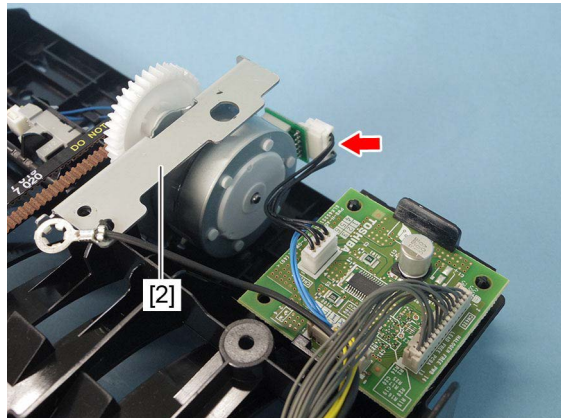

Fig. 4-448

- (4) Remove 2 screws and take off the ADU motor [3].

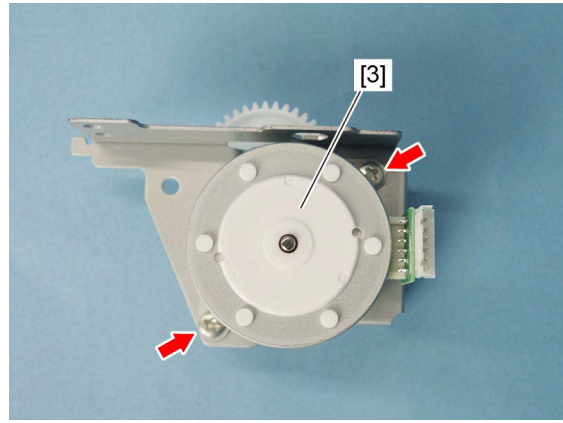

Fig. 4-449

#### 4.12.11 ADU entrance sensor (S14)

- (1) Take off the ADU guide assembly.  
P. 4-180 "4.12.3 ADU guide assembly (3528A/4528A)"  
P. 4-182 "4.12.4 ADU guide assembly (2528A/3028A)"
- (2) Disconnect 1 connectors [2] from the ADU guide assembly [1].
- (3) Release 2 latches and take off the ADU entrance sensor [3].

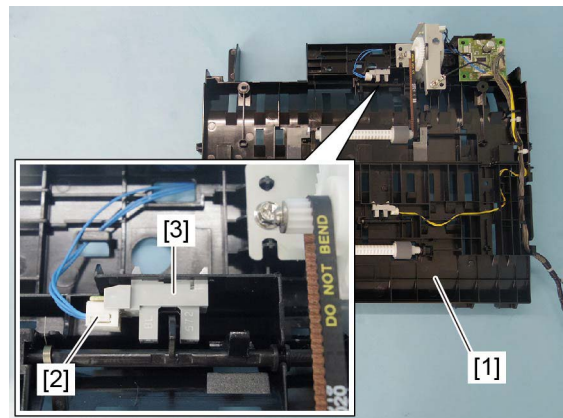

Fig. 4-450

### 4.12.12 ADU exit sensor (S15)

- (1) Take off the ADU guide assembly.  
    📖 P. 4-180 “4.12.3 ADU guide assembly (3528A/4528A)”  
    📖 P. 4-182 “4.12.4 ADU guide assembly (2528A/3028A)”
- (2) Disconnect 1 connector [2] from the ADU guide assembly [1].
- (3) Release 2 latches and take off the ADU exit sensor [3].

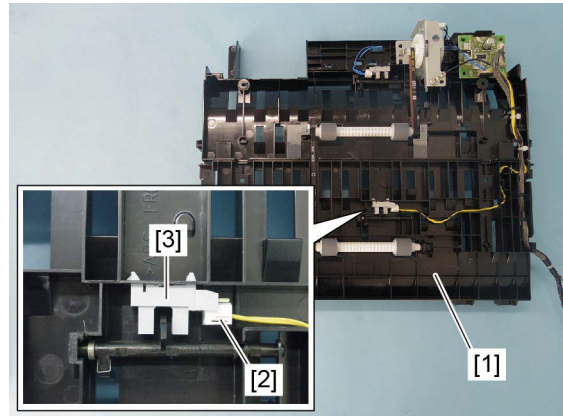

Fig. 4-451

### 4.12.13 Transport roller (upper and lower)

- (1) Take off the ADU guide assembly.  
    📖 P. 4-180 “4.12.3 ADU guide assembly (3528A/4528A)”  
    📖 P. 4-182 “4.12.4 ADU guide assembly (2528A/3028A)”
- (2) Bend the rib [2] of the ADU guide assembly [1] to remove the collar [3].

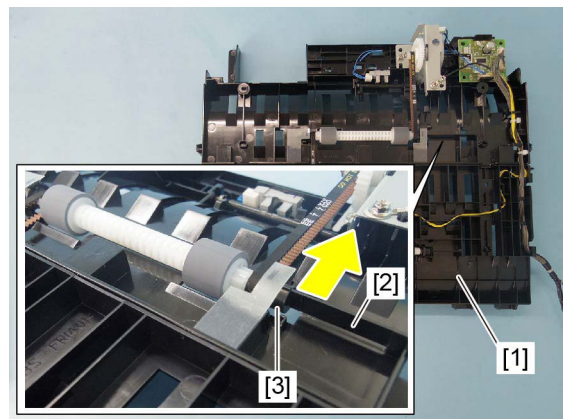

Fig. 4-452

(3) Remove the collar [4] and take off the upper transport roller [5].

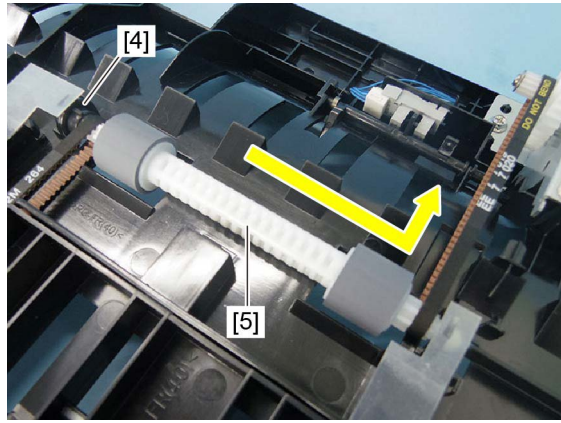

Fig. 4-453

(4) Bend the rib [6] to remove the collar [7].

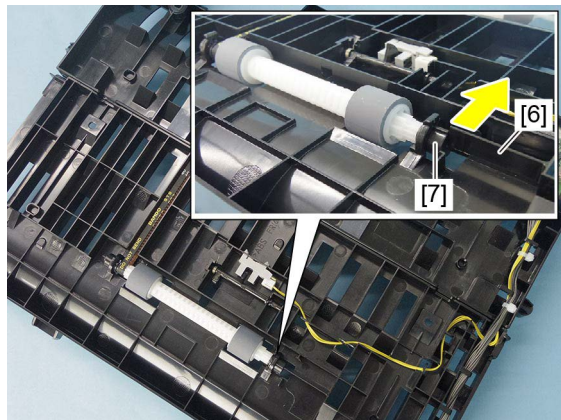

Fig. 4-454

(5) Remove the collar [8] and take off the lower transport roller [9].

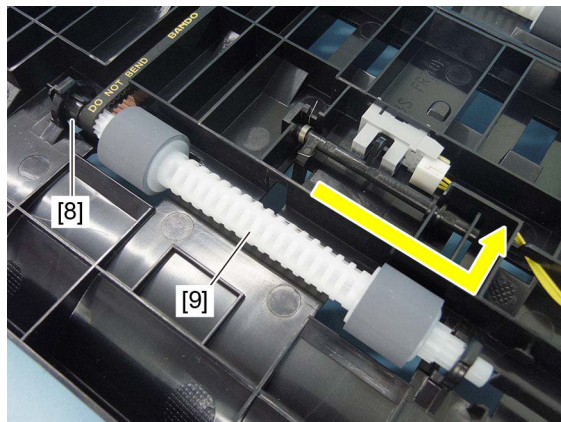

Fig. 4-455

**Notes:**

- Be sure to attach the belt [10] when carrying out installation.

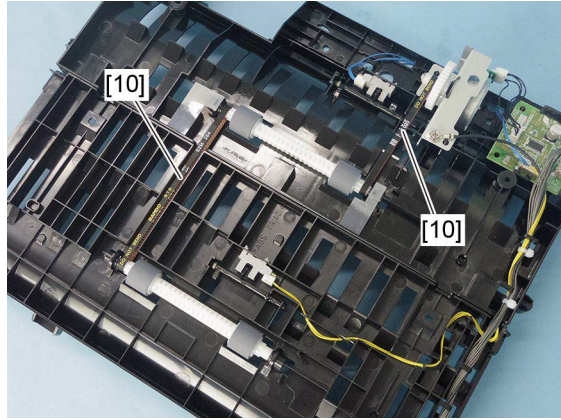

Fig. 4-456

- When replacing both the transport roller and the collar or performing machine refreshment, apply an appropriate amount of white grease (Molykote EM-30L) inside of the collar [11]. When applying grease, make sure that it is not running over. Grease might run out before the machine refreshment depending on frequency of use. In such a case, apply an appropriate amount of grease as necessary.

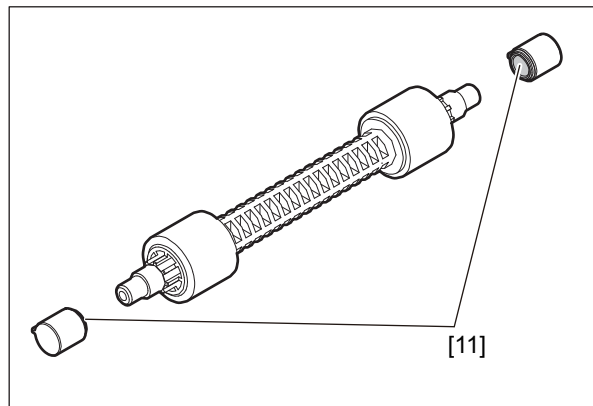



Fig. 4-457

#### 4.12.14 Reverse sensor (S18) (3528A/4528A)

- (1) Take off the ADU middle cover.  
 P. 4-183 “4.12.5 ADU middle cover (3528A/4528A)”
- (2) Release the latch and take off the reverse sensor [1].

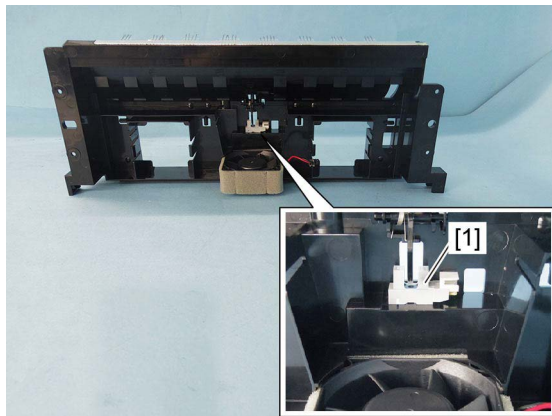



Fig. 4-458

#### 4.12.15 ADU interlock switch (SW3) (3528A/4528A)

**Notes:**

If the interlock switch is not installed appropriately, it may not work normally. If you carry out the maintenance of the MFP in such a situation, you could get an electric shock by touching live sections or be injured by touching moving sections. Therefore, to avoid this, be sure to perform correct handling and installation.

- (1) Take off the reverse unit.  
 P. 4-162 “4.11.1 Reverse unit (3528A/4528A)”
- (2) Remove 2 screws and take off the ADU interlock switch cover [1].

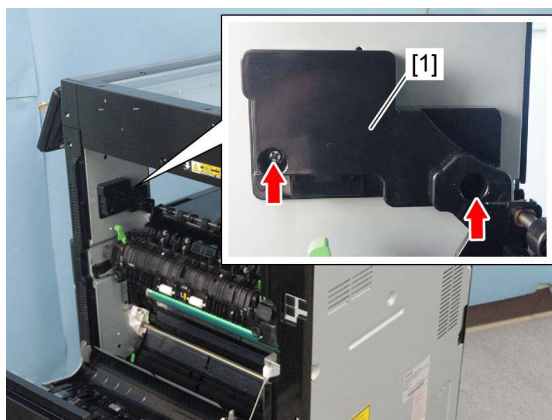

Fig. 4-459

- (3) Disconnect 2 connectors [2] from the rear side of the ADU interlock switch cover.
- (4) Release 2 latches [4]. Take off the ADU interlock switch [3].

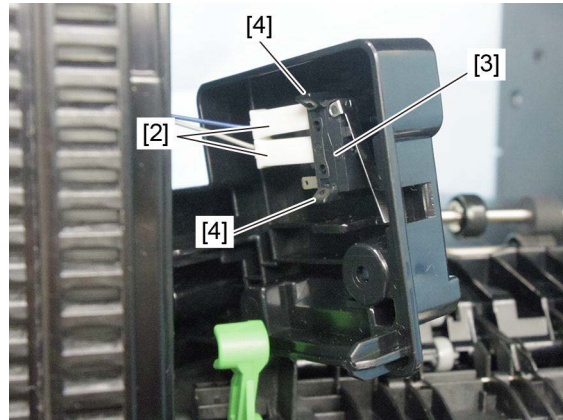

Fig. 4-460

#### 4.12.16 ADU interlock switch (SW3) (2528A/3028A)

**Notes:**

If the interlock switch is not installed appropriately, it may not work normally. If you carry out the maintenance of the MFP in such a situation, you could get an electric shock by touching live sections or be injured by touching moving sections. Therefore, to avoid this, be sure to perform correct handling and installation.

- (1) Open the ADU.
- (2) Remove 2 screws and take off the ADU interlock switch cover [1].

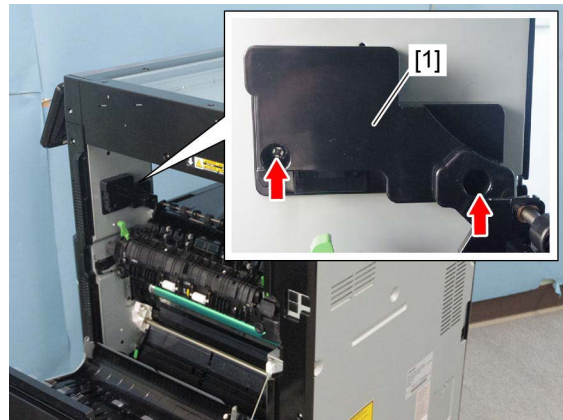

Fig. 4-461

- (3) Disconnect 2 connectors [2] from the rear side of the ADU interlock switch cover.
- (4) Release 2 latches [4]. Take off the ADU interlock switch [3].

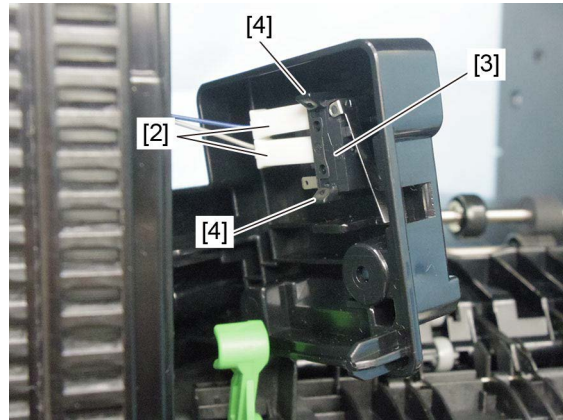

Fig. 4-462

#### 4.12.17 ADU fan (F13) (3528A/4528A)

- (1) Take off the ADU guide assembly.  
P. 4-180 “4.12.3 ADU guide assembly (3528A/4528A)”
- (2) Disconnect 1 connector and take off the ADU fan [1].

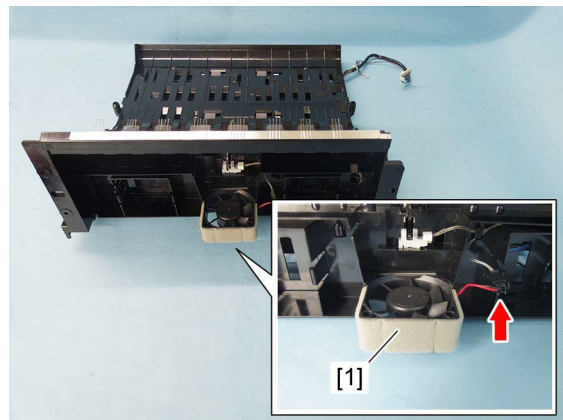

Fig. 4-463



## 4.13 Removal and Installation of Options

### Important:

Before installing or removing options, press the [ON/OFF] button on the control panel to shut down the MFP and disconnect the power cable from the outlet.

### 4.13.1 Dual Scan Document Feeder (DSDF)

- (1) Press the [ON/OFF] button on the control panel to shut down the MFP.
- (2) Remove the power cable.
- (3) Remove 1 screw and take off the connector cover [1].

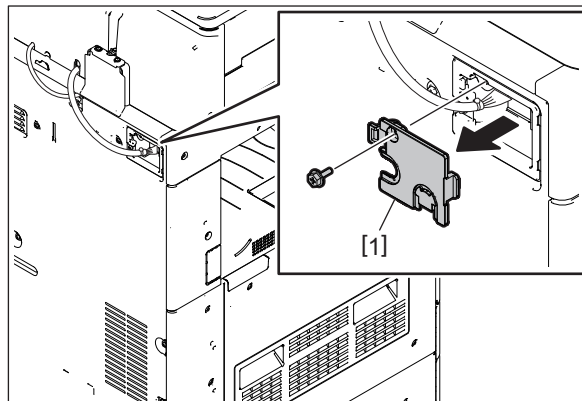

Fig. 4-464

- (4) Disconnect 1 connector [2].

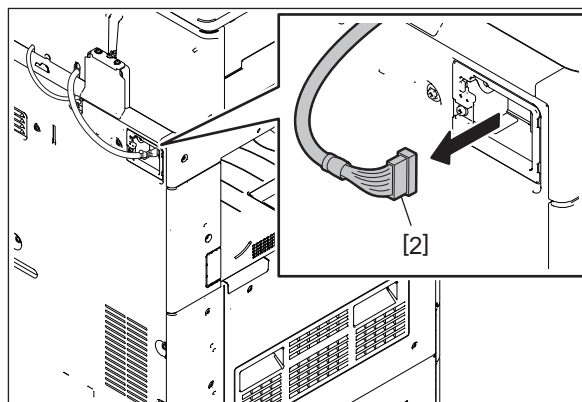

Fig. 4-465

- (5) Install the connector cover [1] and secure it with 1 screw.

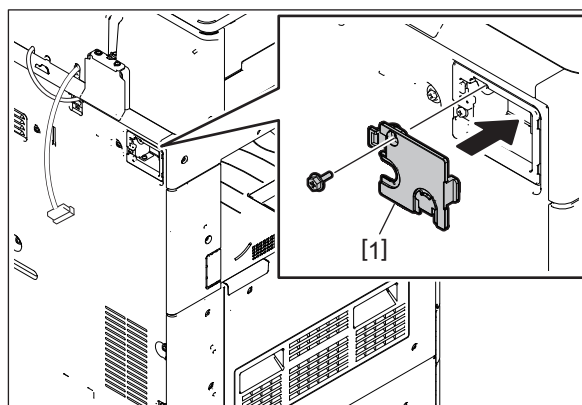

Fig. 4-466

- (6) Remove 1 screws [3] and take off the cover [4].

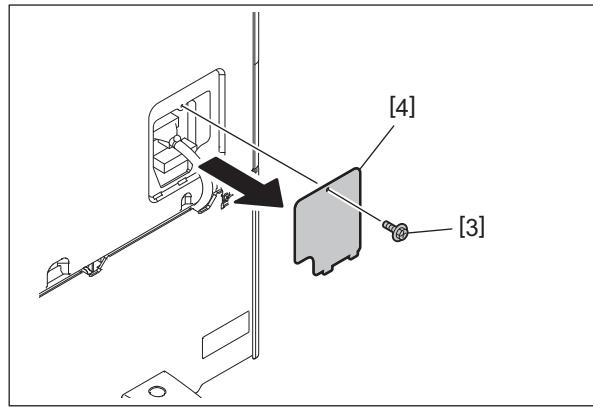

Fig. 4-467

- (7) Remove 1 screw [5] and take off the ground wire. Disconnect 1 connector [6] of the damp heater harness and 1 connector [7] of the signal harness.

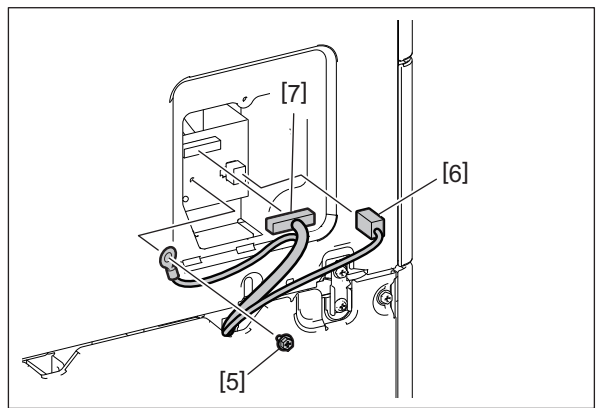

Fig. 4-468

- (8) Take off the rear cover.  
📖 P. 4-9 "4.1.15 Rear cover"

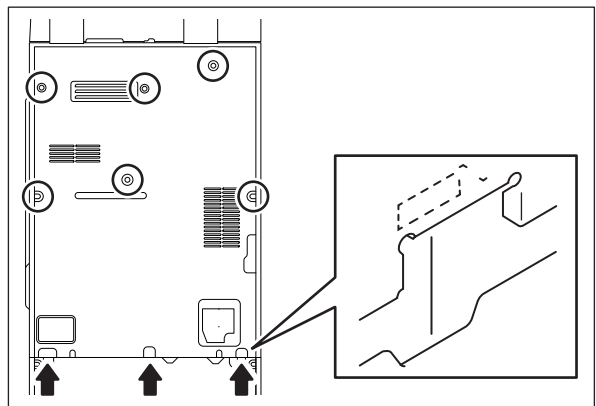

Fig. 4-469

- (9) Take off the SYS board cover.  
📖 P. 9-1 “9.1.1 SYS board cover”

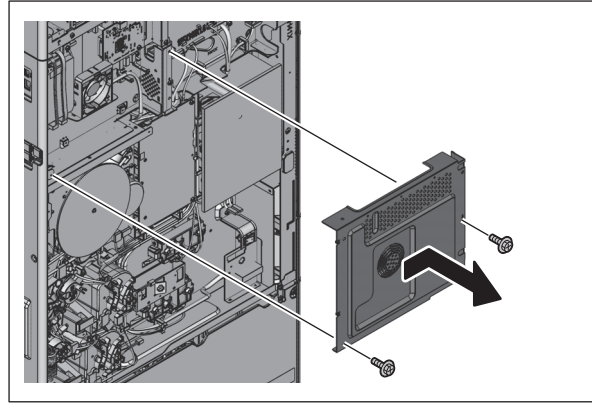

Fig. 4-470

- (10) Disconnect 1 connector [8].

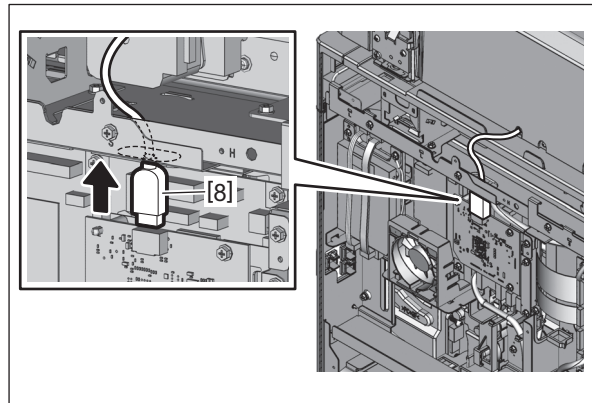

Fig. 4-471

- (11) Attach the SYS board.

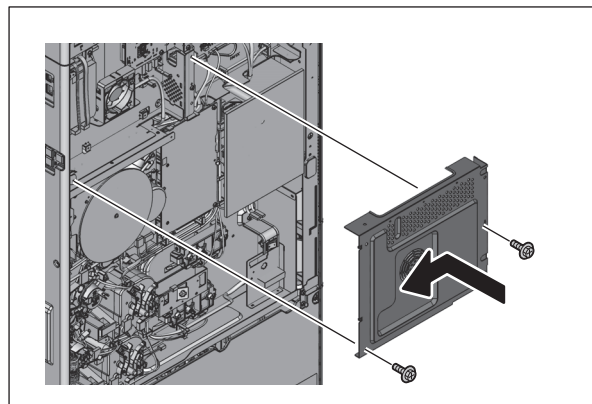

Fig. 4-472

(12) Install the rear cover.

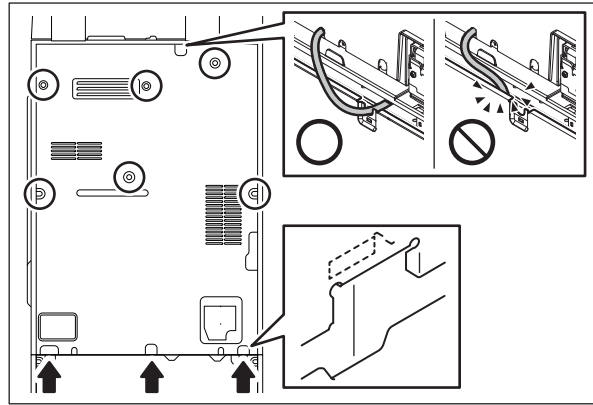

Fig. 4-473

(13) Connect 1 connector [6] of the damp heater harness and 1 connector [7] for the signal harness. Install the ground wire with 1 screw [5].

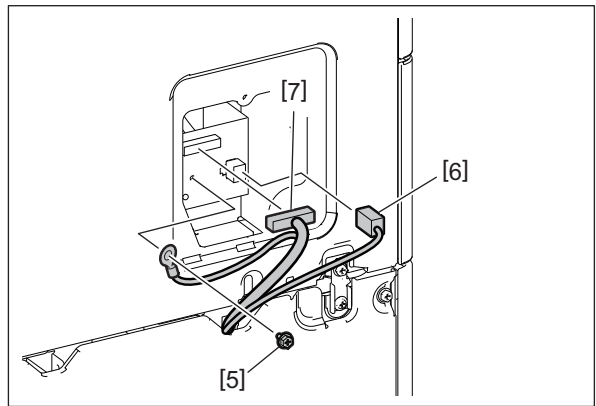

Fig. 4-474

(14) Install the cover [4] with 1 screw [3].

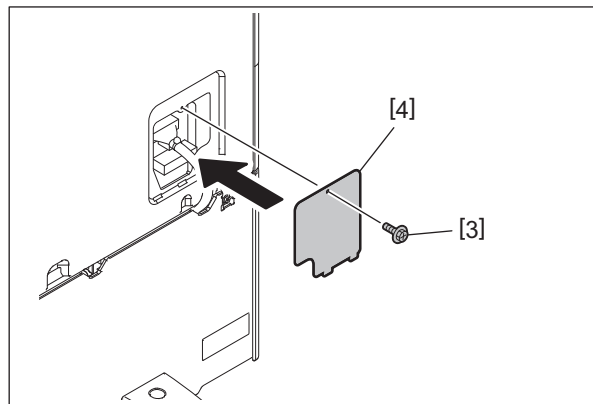

Fig. 4-475

(15) Remove 4 screws [9] and take off 2 brackets [10].

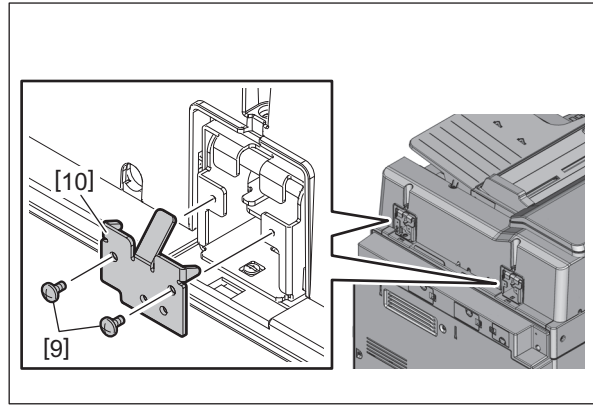

Fig. 4-476

(16) Remove 2 screws [11] and 1 washer [12].

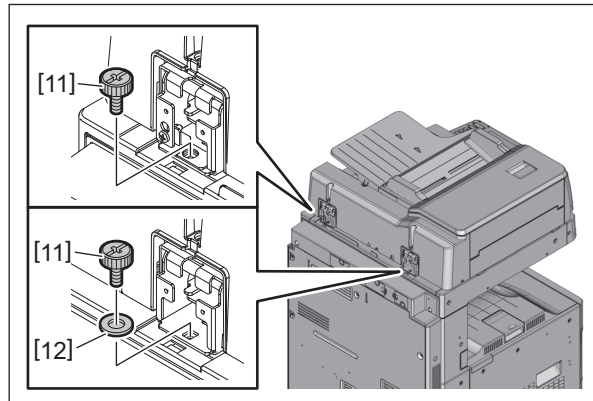

Fig. 4-477

(17) Open the DSDF and remove 2 screws [13].

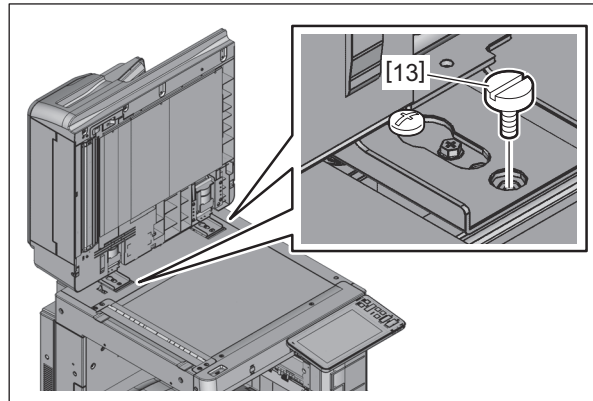

Fig. 4-478

(18) Take off the DSDF by sliding it toward the rear side.

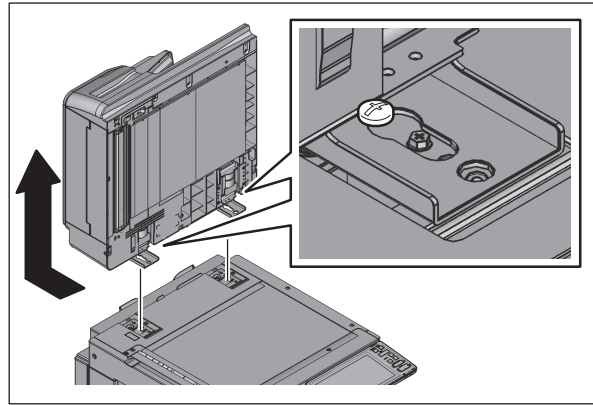

Fig. 4-479

#### 4.13.2 Reversing Automatic Document Feeder (RADF)

- (1) Press the [ON/OFF] button on the control panel to shut down the MFP.
- (2) Remove the power cable.
- (3) Remove 1 screw and take off the connector cover [1].

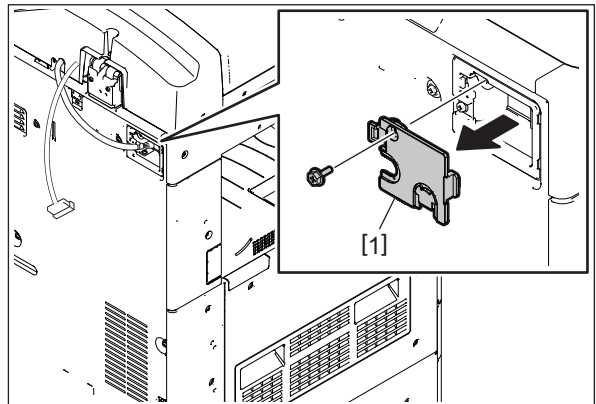

Fig. 4-480

- (4) Disconnect 1 connector [2].

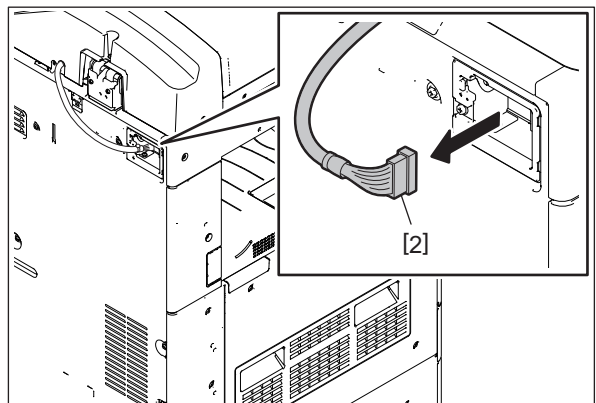

Fig. 4-481

(5) Install the connector cover [1] and secure it with 1 screw.

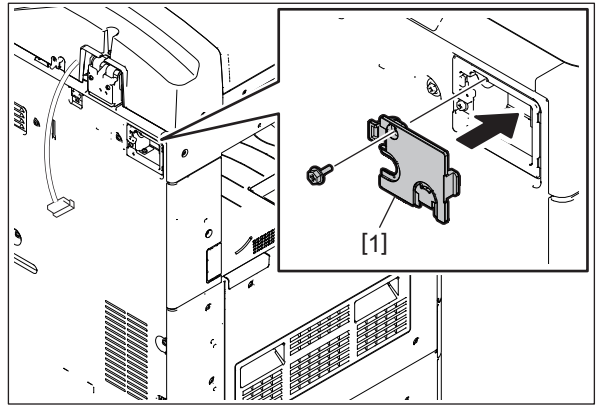

Fig. 4-482

(6) Remove 2 screws [3] and take off 1 bracket [4].

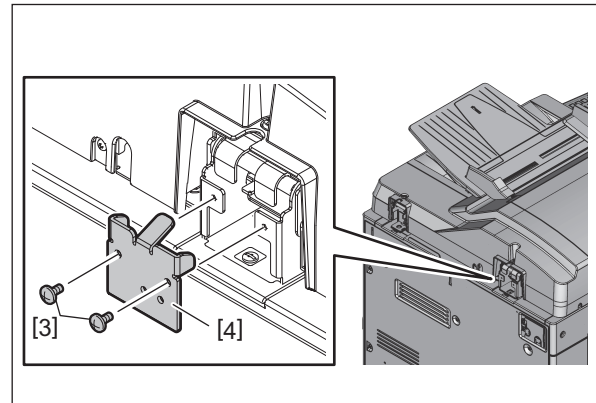

Fig. 4-483

(7) Take off the cover [5].

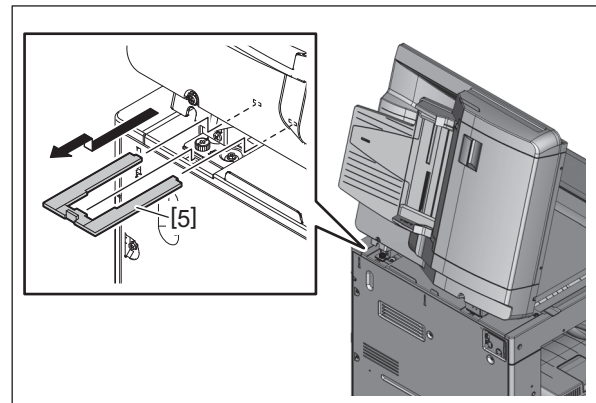

Fig. 4-484

(8) Remove 2 screws [6] and 1 washer [7].

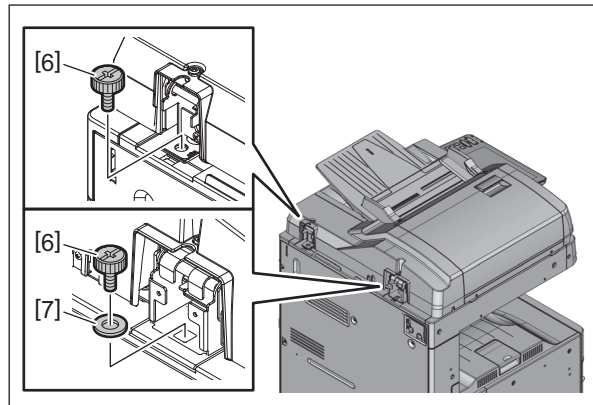

Fig. 4-485

(9) Open the RADF. Remove 2 screws [8].

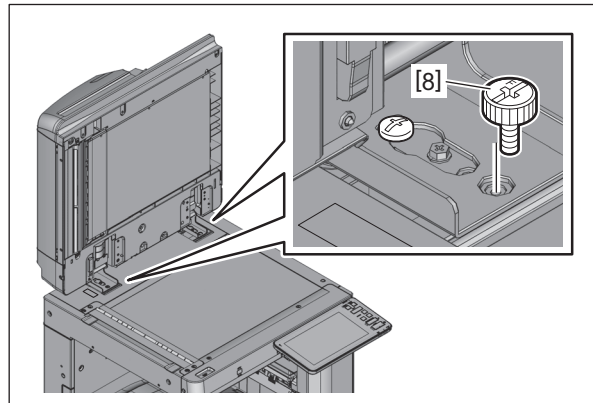

Fig. 4-486

(10) Take off the RADF by sliding it toward the rear side.

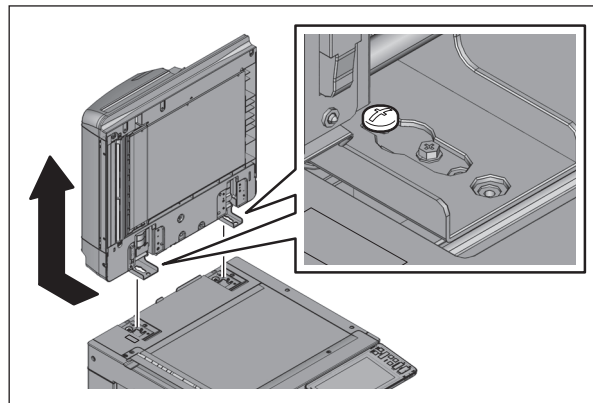

Fig. 4-487



### 4.13.3 Paper Feed Pedestal (PFP)

- (1) Press the [ON/OFF] button on the control panel to shut down the MFP.
- (2) Remove the power cable.
- (3) Remove 1 screw [1] and take off the cover [2].

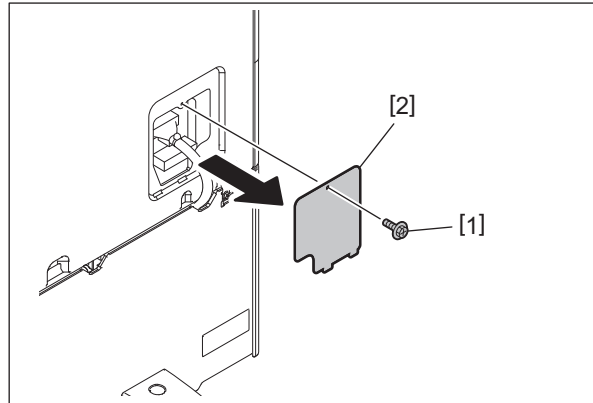

Fig. 4-488

- (4) Remove 1 screw [3] and take off the ground wire. Disconnect 1 connector [4].

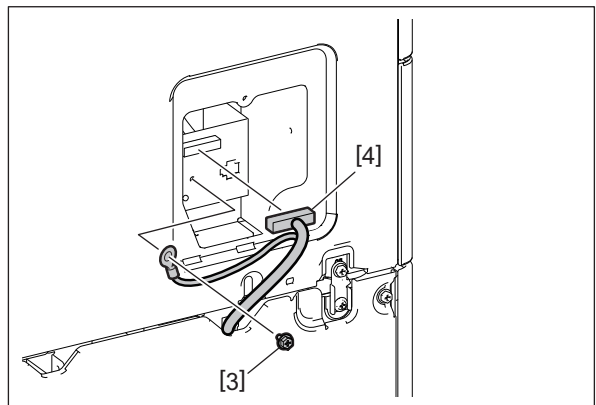

Fig. 4-489

- (5) Remove 2 screws [5] and take off 2 fixing brackets [6] on the rear side.

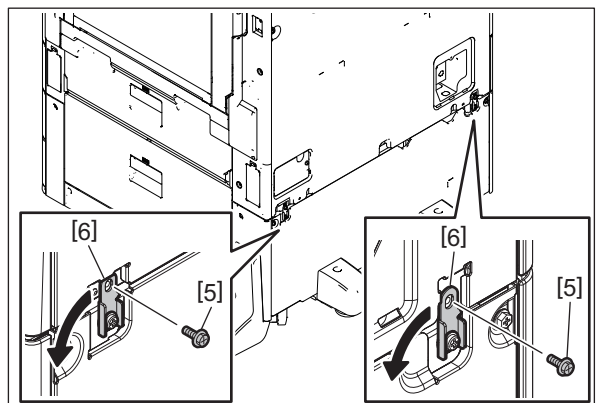

Fig. 4-490

(6) Install the cover [2] with 1 screw [1].

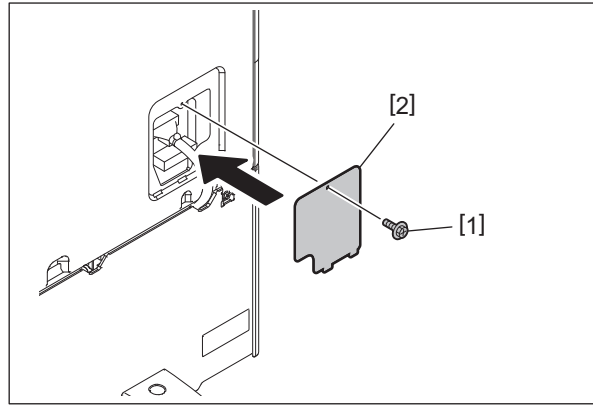

Fig. 4-491

(7) Pull out the drawer.

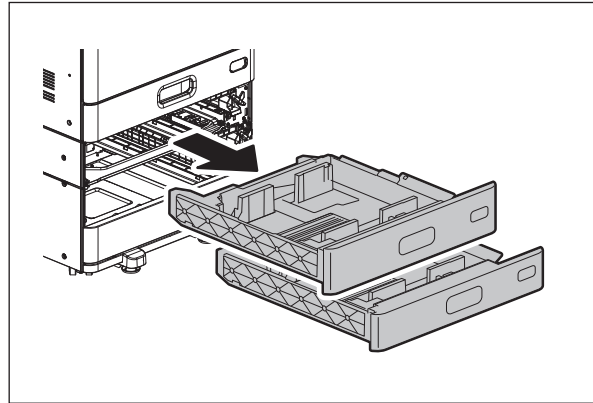

Fig. 4-492

(8) Remove 2 screws [7] and take off 2 fixing brackets [8] on the front side.

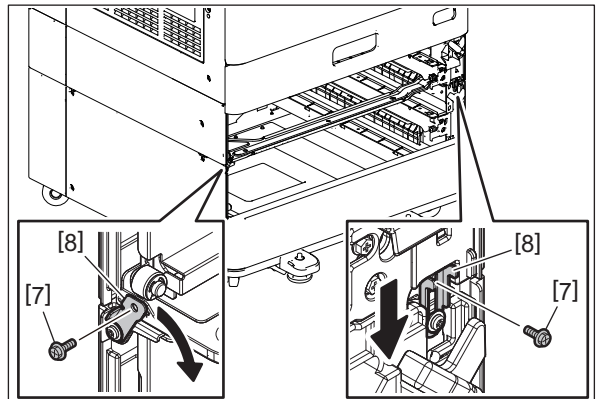

Fig. 4-493

(9) Install the drawer.

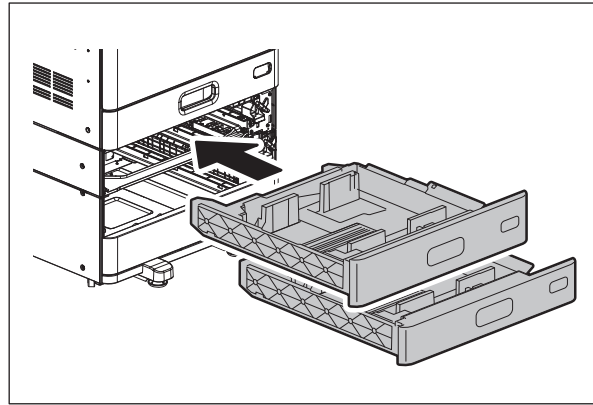

Fig. 4-494

(10) Lift the MFP up and remove the PFP.

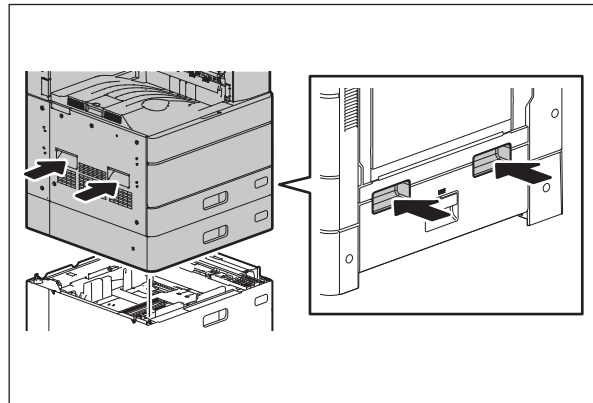

Fig. 4-495

#### 4.13.4 Large Capacity Feeder (LCF)

- (1) Press the [ON/OFF] button on the control panel to shut down the MFP.
- (2) Remove the power cable.
- (3) Remove 1 screw [1] and take off the cover [2].

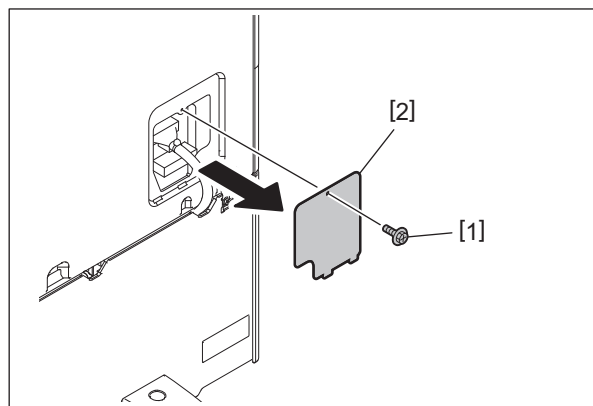

Fig. 4-496

- (4) Remove 1 screw [3] and take off the ground wire. Disconnect 1 connector [4] of the damp heater harness and 1 connector [5] of the signal harness.

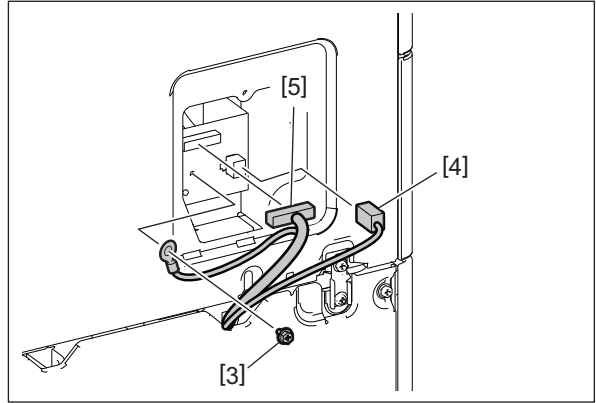

Fig. 4-497

- (5) Remove 2 screws [6] and take off 2 fixing brackets [7] on the rear side.

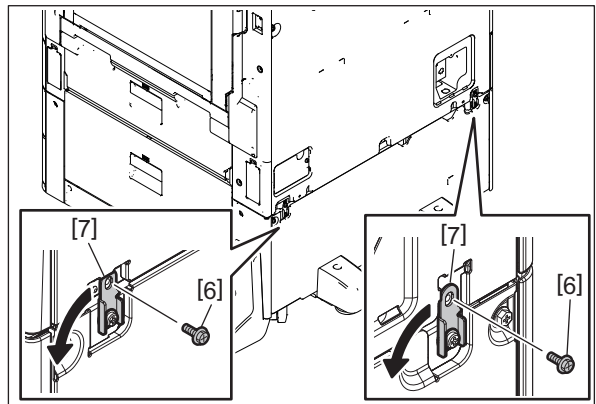

Fig. 4-498

- (6) Install the cover [2] with 1 screw [1].

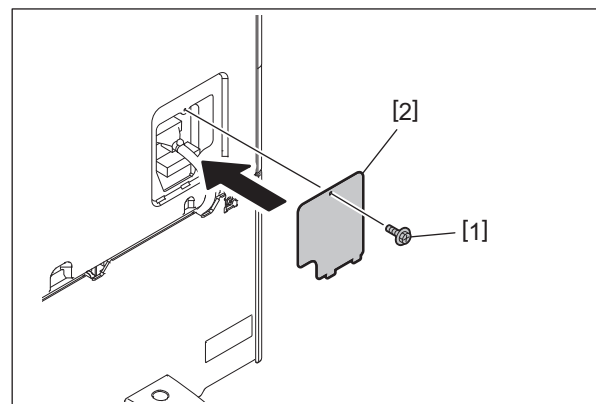

Fig. 4-499

(7) Pull out the drawer.

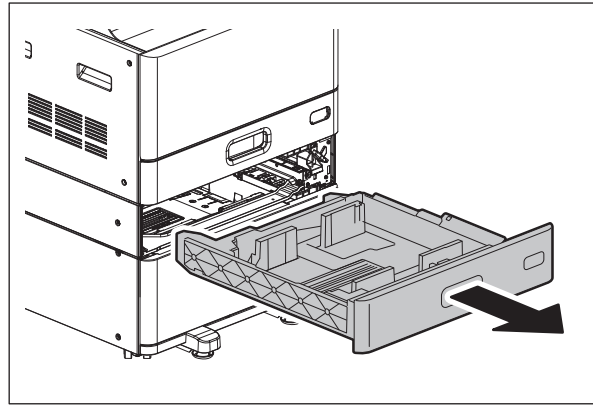

Fig. 4-500

(8) Pull out the LCF drawer.

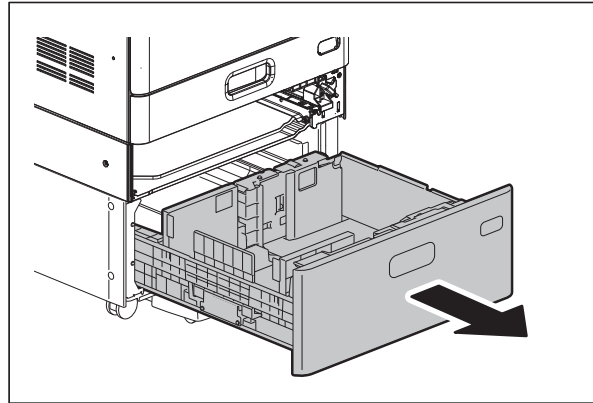

Fig. 4-501

(9) Install the right drawer.

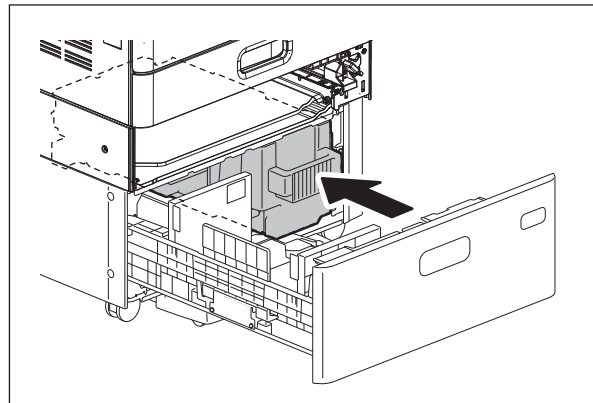

Fig. 4-502

(10) Remove 2 screws [8] and take off 2 fixing brackets [9] on the front side.

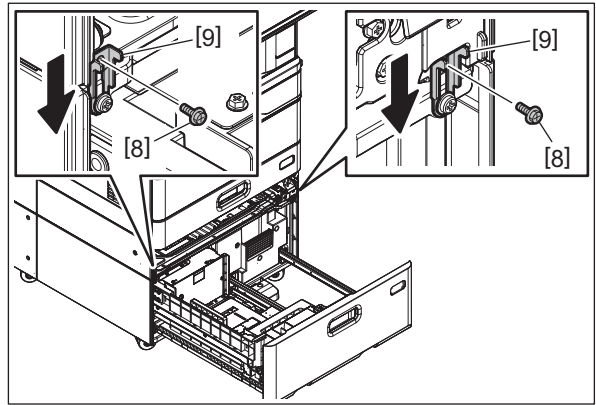

Fig. 4-503

(11) Install the LCF drawer.

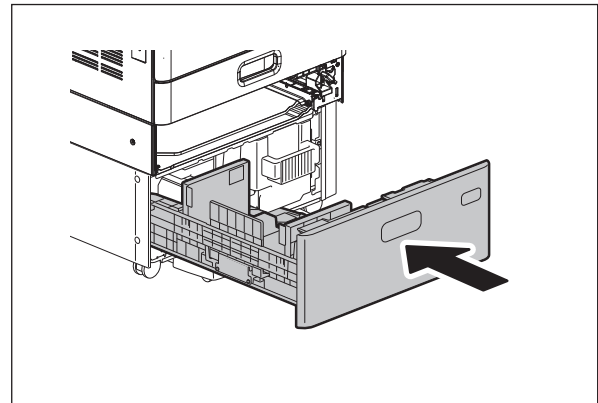

Fig. 4-504

(12) Install the drawer.

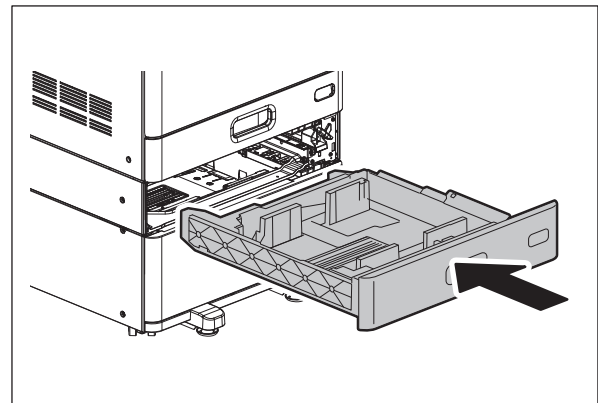

Fig. 4-505

(13) Lift the MFP up and remove the LCF.

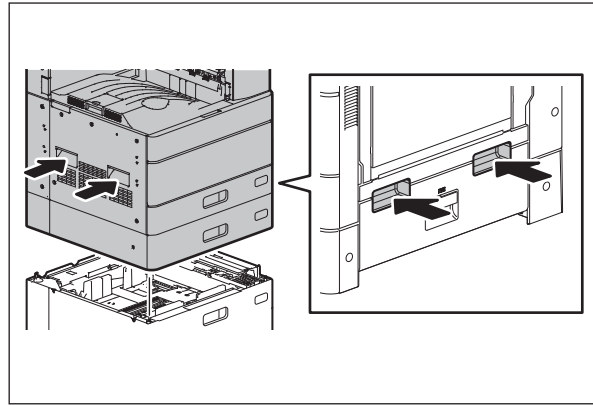

Fig. 4-506

### 4.13.5 Bridge kit

- (1) Press the [ON/OFF] button on the control panel to shut down the MFP.
- (2) Remove the power cable.
- (3) Take off the paper exit back cover.  
P. 4-4 "4.1.7 Paper exit back cover"
- (4) Disconnect 1 connector [1].

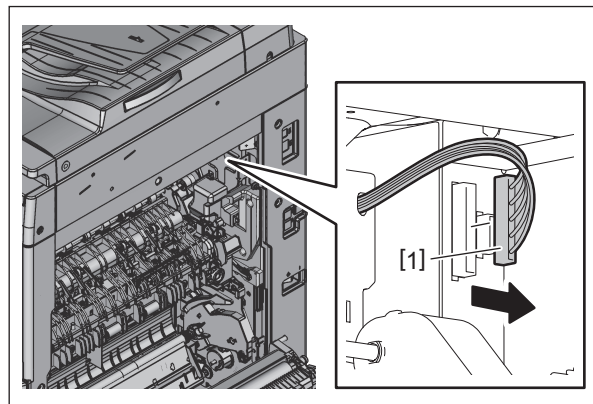

Fig. 4-507

- (5) Remove 1 screw [2] and take off the front cover [3] of the bridge kit.

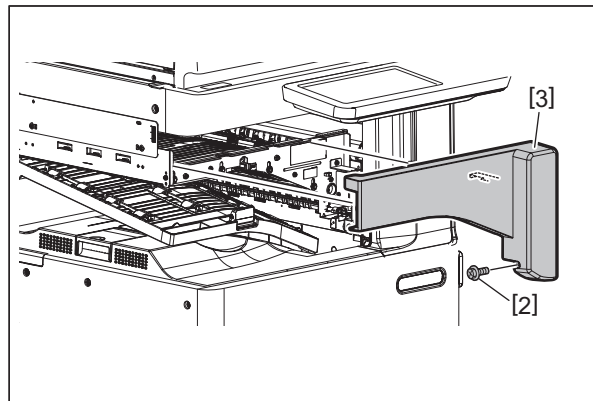

Fig. 4-508

(6) Remove 1 screw [4].

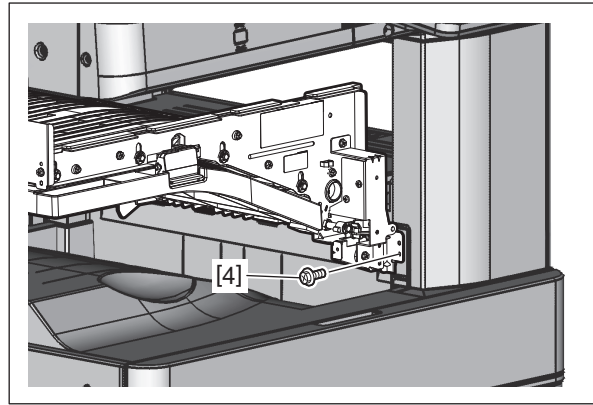

Fig. 4-509

(7) Remove 2 screws [5] and take off the fixing bracket [6].

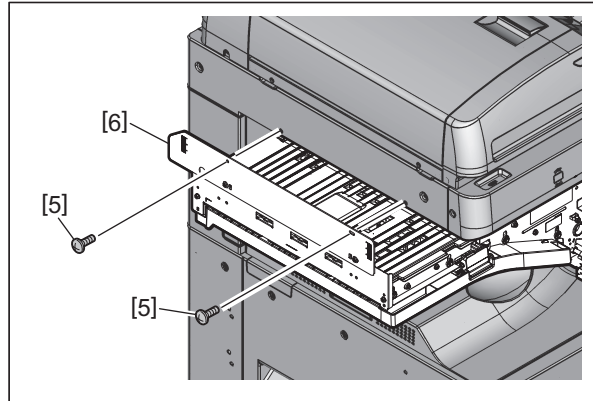

Fig. 4-510

(8) Lift the bridge kit up to pull out the hook. Pull the bridge kit toward the front side to take it off.

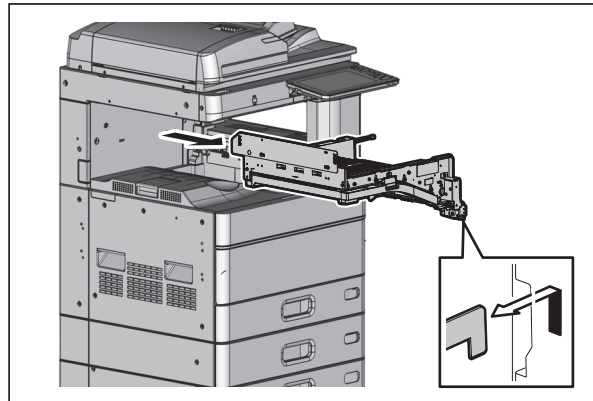

Fig. 4-511



### 4.13.6 Inner finisher

- (1) Press the [ON/OFF] button on the control panel to shut down the MFP.
- (2) Remove the power cable.
- (3) Remove 1 screw and take off the connector cover [1].

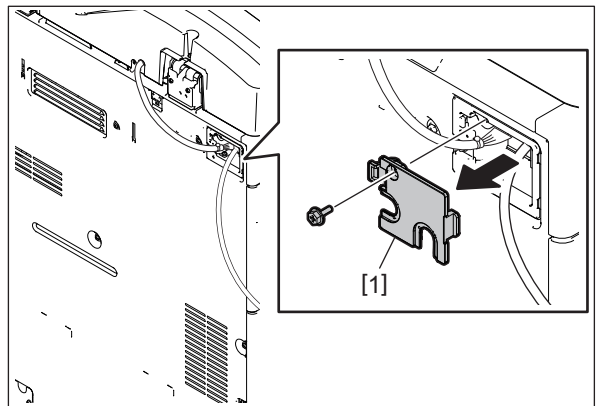

Fig. 4-512

- (4) Disconnect 1 connector [2].

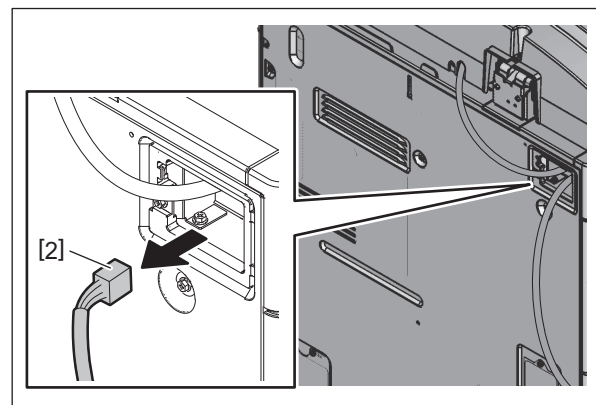

Fig. 4-513

- (5) Install the connector cover [1] and secure it with 1 screw.

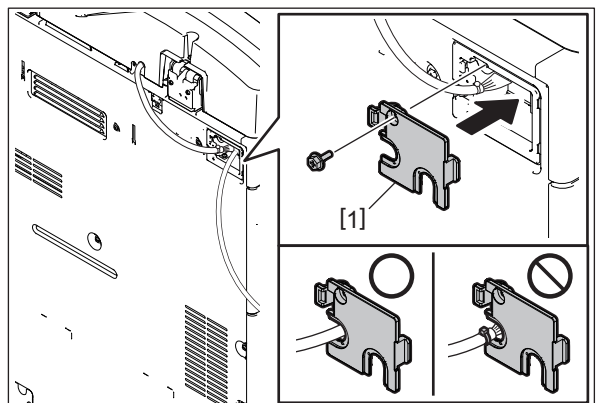

Fig. 4-514

(6) Open the cover [3] of the inner finisher.

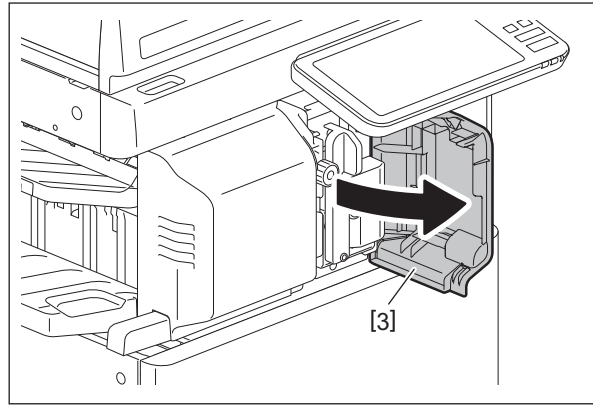

Fig. 4-515

(7) Press the button [4] to release the lock. Pull out the inner finisher [5].

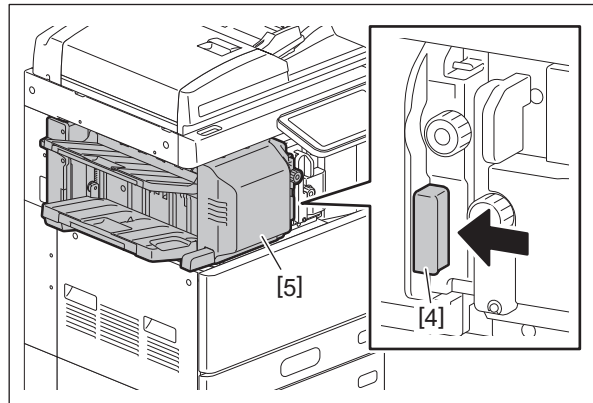

Fig. 4-516

(8) Remove 1 screw [6] and take off 1 bracket [7].

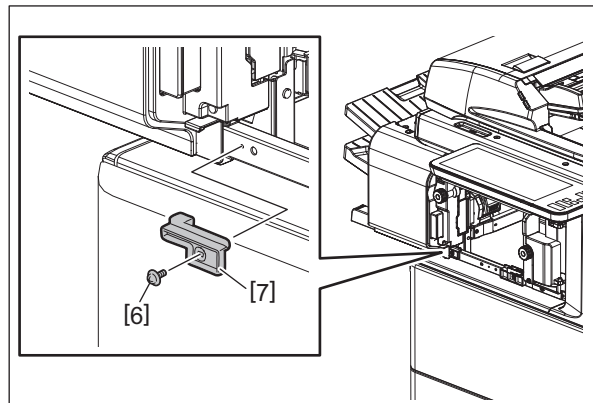

Fig. 4-517

(9) Slide the inner finisher to return it to the installation position temporarily.

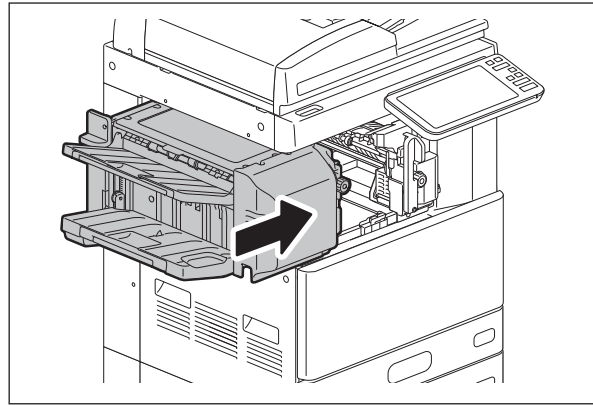

Fig. 4-518

(10) Remove 3 screws [8] and take off the cover [9].

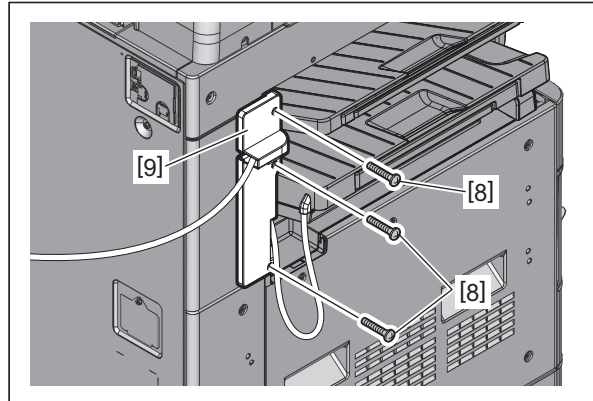

Fig. 4-519

(11) Remove 1 screw [10].

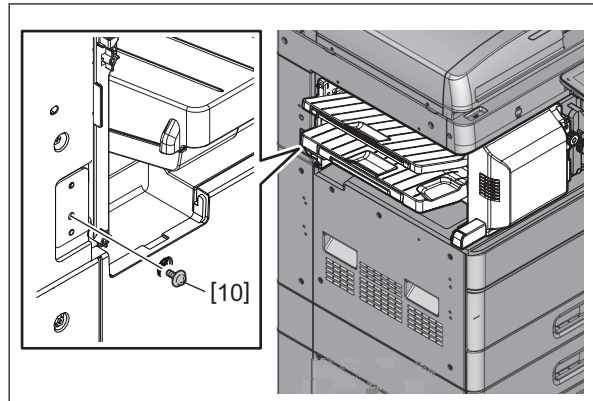

Fig. 4-520

(12) Take off the Finisher.

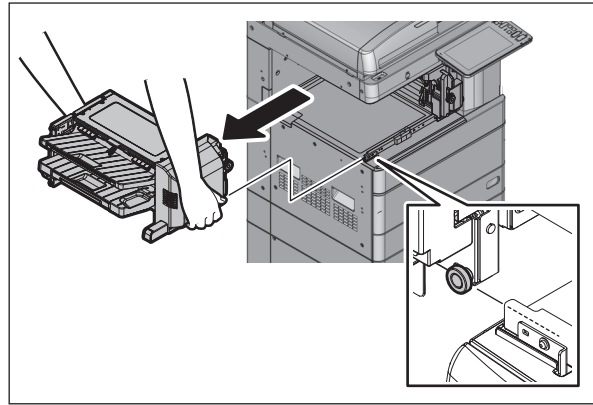

Fig. 4-521

#### 4.13.7 Saddle stitch finisher

- (1) Press the [ON/OFF] button on the control panel to shut down the MFP.
- (2) Remove the power cable.
- (3) Remove 1 screw and take off the connector cover [1].

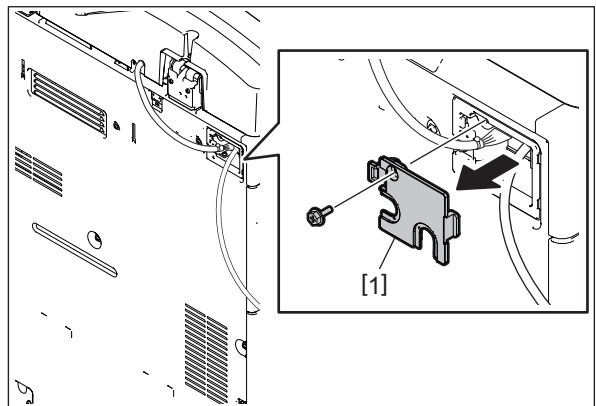

Fig. 4-522

- (4) Disconnect 1 connector [2].

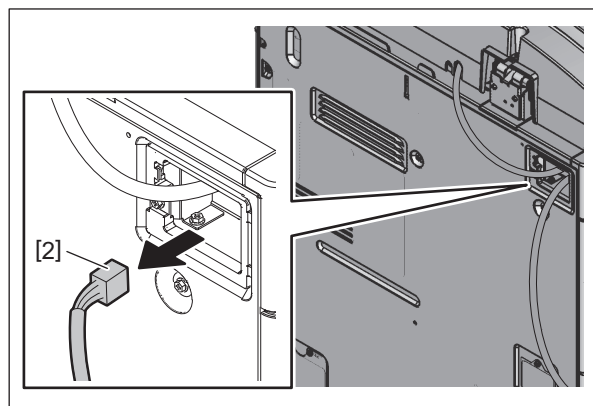

Fig. 4-523

- (5) Install the connector cover [1] and secure it with 1 screw.

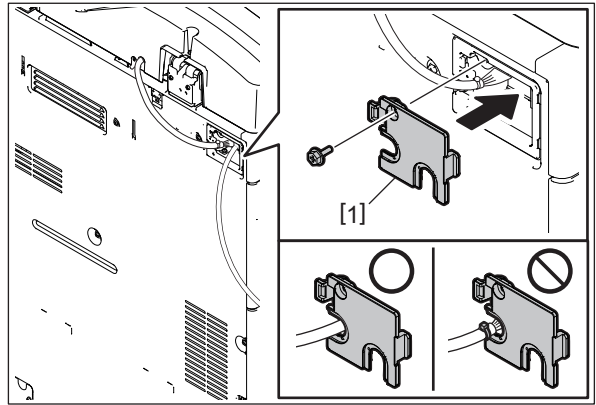

Fig. 4-524

- (6) Open the cover [3] of the saddle stitch finisher and remove 1 screw [4]. Pull out the lever [5].

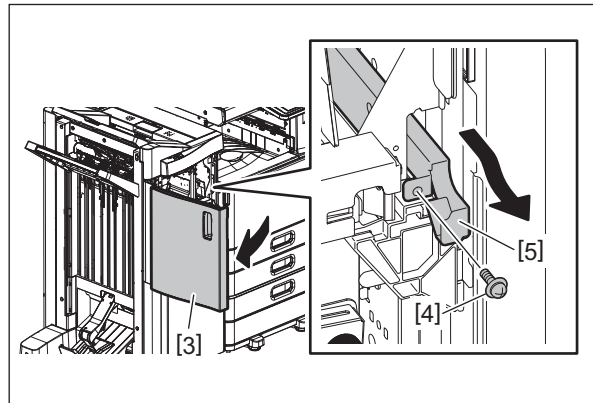

Fig. 4-525

- (7) Take off the saddle stitch finisher.

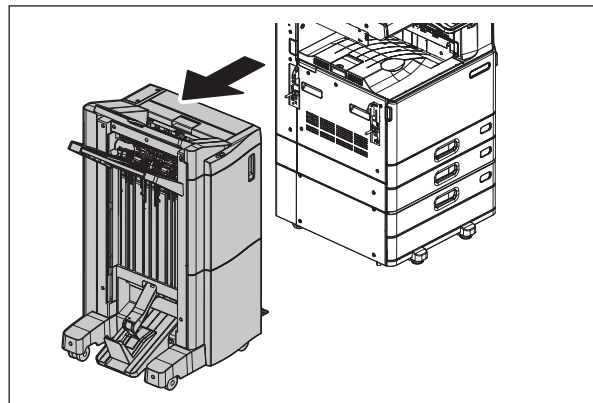

Fig. 4-526

### 4.13.8 Saddle stitch finisher (with Hole punch unit installed)

- (1) Press the [ON/OFF] button on the control panel to shut down the MFP.
- (2) Remove the power cable.
- (3) Remove 1 screw and take off the connector cover [1].

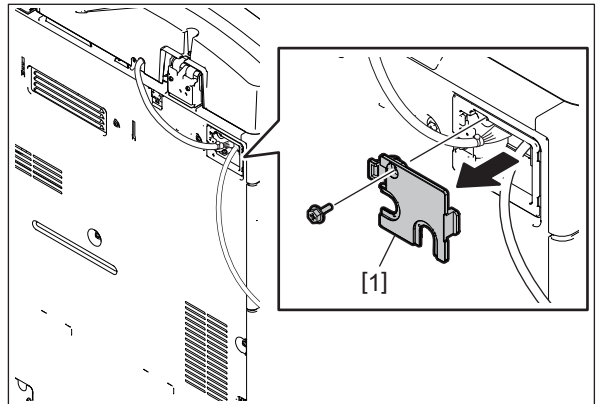

Fig. 4-527

- (4) Disconnect 1 connector [2].

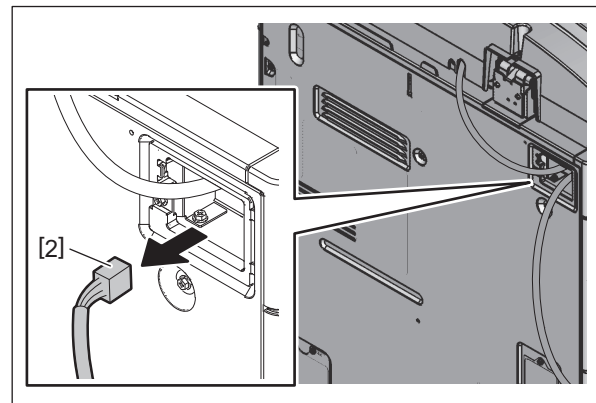

Fig. 4-528

- (5) Install the connector cover [1] and secure it with 1 screw.

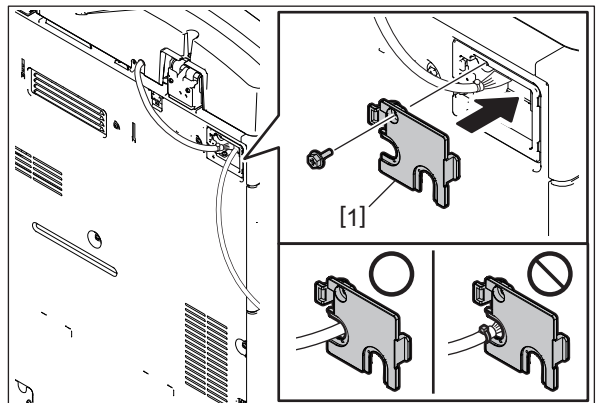

Fig. 4-529

(6) Take off the cover [3] of the hole punch unit lower side.

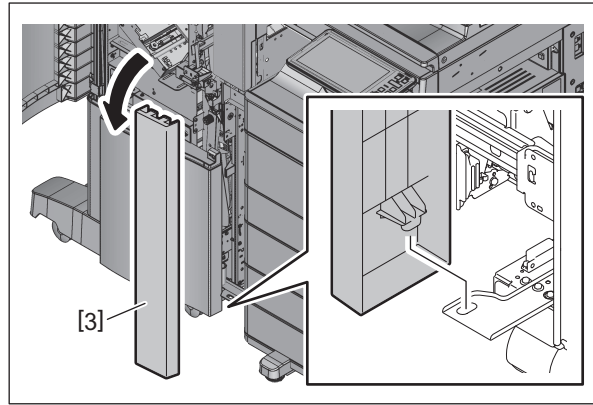

Fig. 4-530

(7) Open the cover [4] of the saddle stitch finisher and remove 1 screw [5]. Pull out the lever [6].

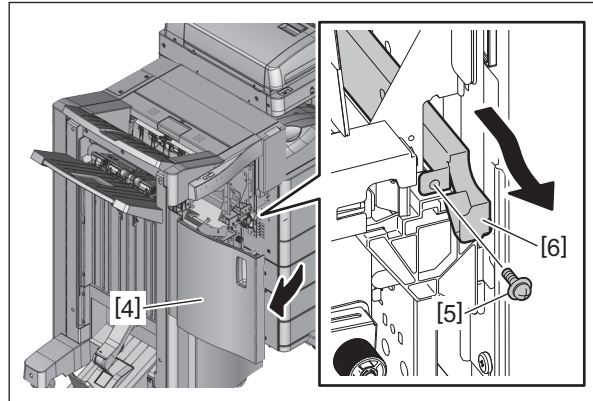

Fig. 4-531

(8) Take off the saddle stitch finisher.

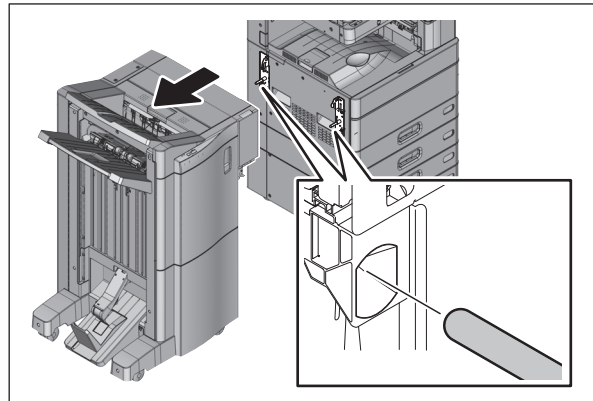

Fig. 4-532

**Notes:**

Be careful not to fell the saddle stitch finisher when it is moved.

### 4.13.9 Finisher

- (1) Press the [ON/OFF] button on the control panel to shut down the MFP.
- (2) Remove the power cable.
- (3) Remove 1 screw and take off the connector cover [1].

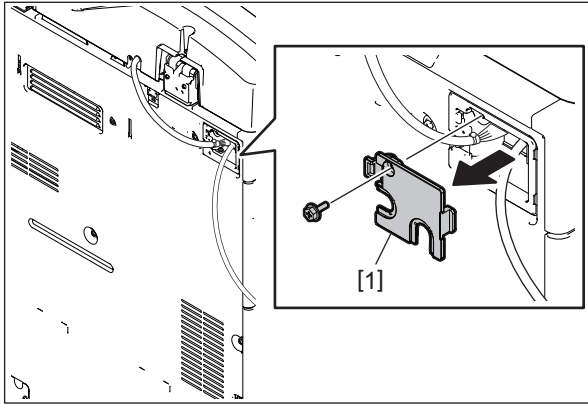

Fig. 4-533

- (4) Disconnect 1 connector [2].

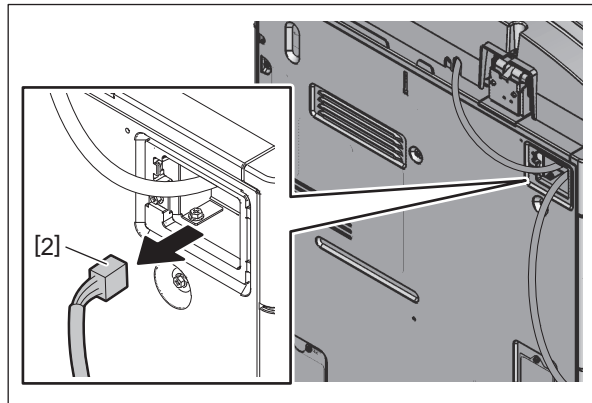

Fig. 4-534

- (5) Install the connector cover [1] and secure it with 1 screw.

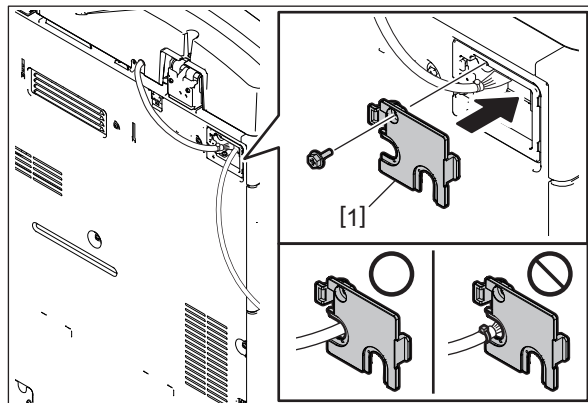

Fig. 4-535



- (6) Open the cover [3] of the Finisher and remove 1 screw [4]. Pull out the lever [5].

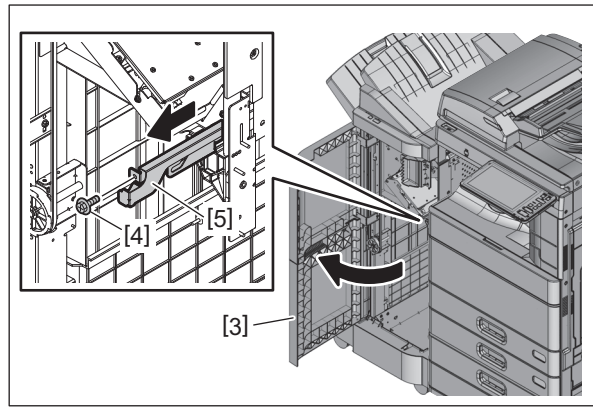

Fig. 4-536

- (7) Take off the Finisher.

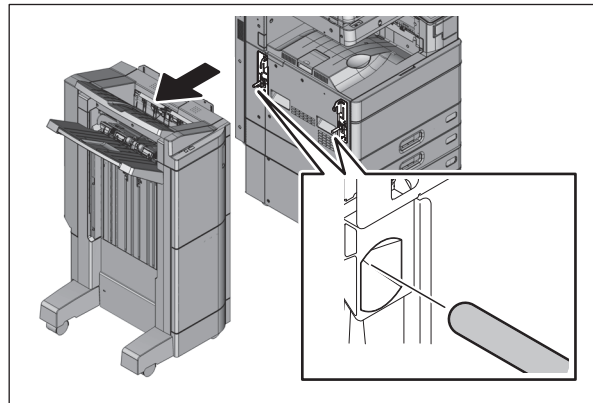

Fig. 4-537

#### 4.13.10 Finisher (with Hole punch unit installed)

- (1) Press the [ON/OFF] button on the control panel to shut down the MFP.
- (2) Remove the power cable.
- (3) Remove 1 screw and take off the connector cover [1].

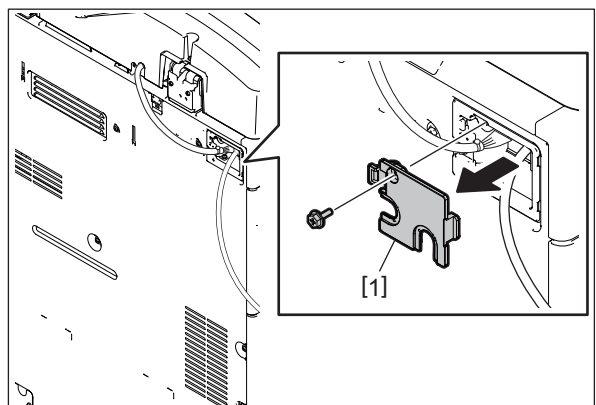

Fig. 4-538

(4) Disconnect 1 connector [2].

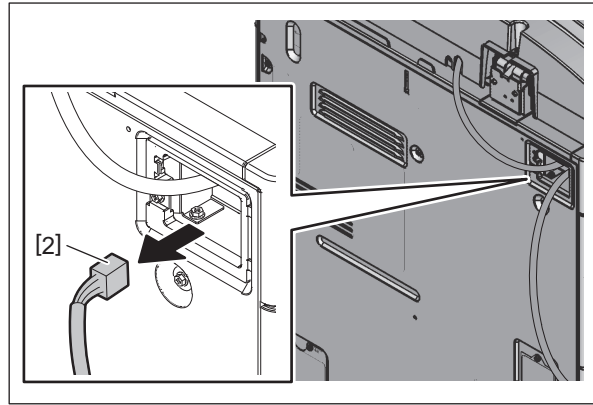

Fig. 4-539

(5) Install the connector cover [1] and secure it with 1 screw.

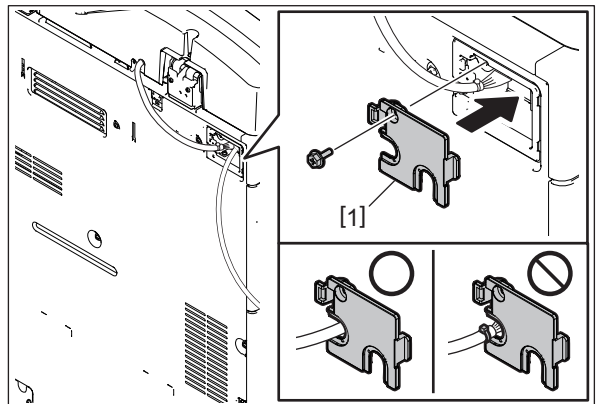

Fig. 4-540

(6) Take off the cover [3] of the hole punch unit lower side.

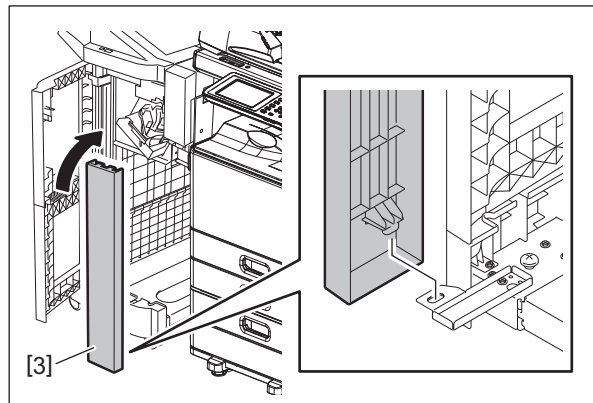

Fig. 4-541

- (7) Open the cover [4] of the Finisher and remove 1 screw [5]. Pull out the lever [6].

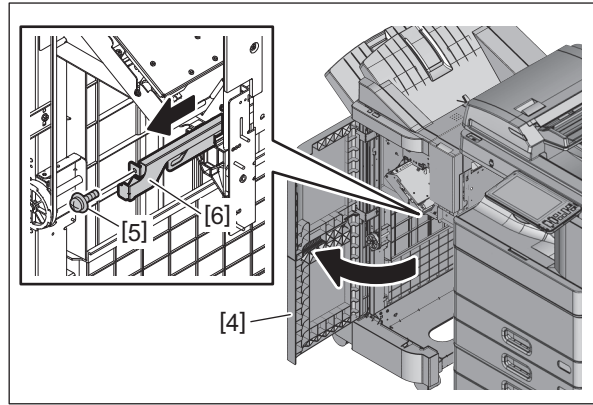

Fig. 4-542

- (8) Take off the Finisher.

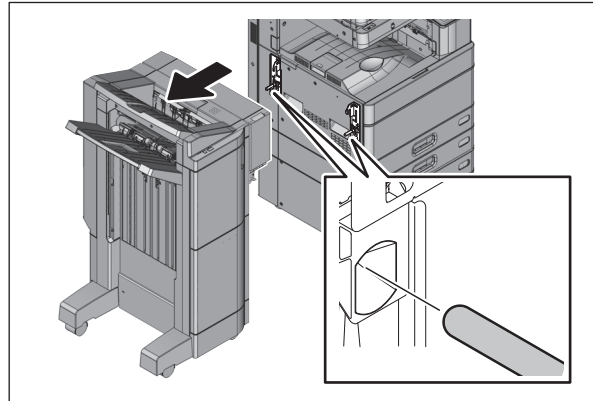

Fig. 4-543

**Notes:**

Be careful not to fell the Finisher when it is moved.

### 4.13.11 Job separator (2528A/3028A)

- (1) Press the [ON/OFF] button on the control panel to shut down the MFP.
- (2) Remove the power cable.
- (3) Take off the tray [1].

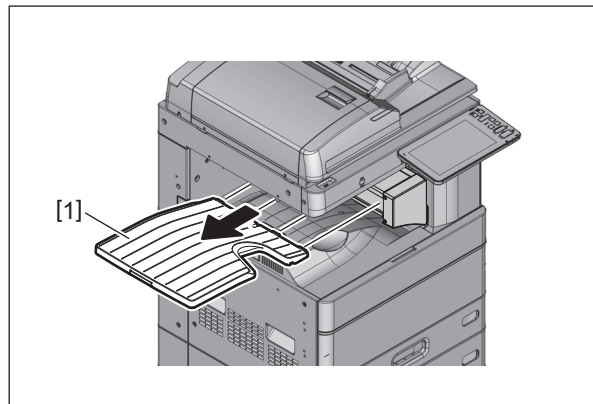

Fig. 4-544

- (4) Open the ADU. Remove 1 screw [2] and take off the paper exit back cover [3].

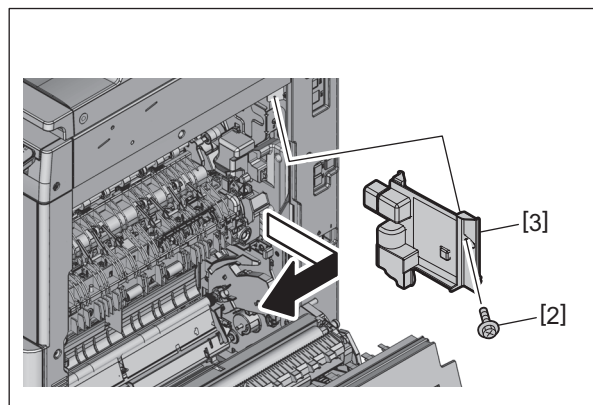

Fig. 4-545

- (5) Disconnect 2 connectors [4].

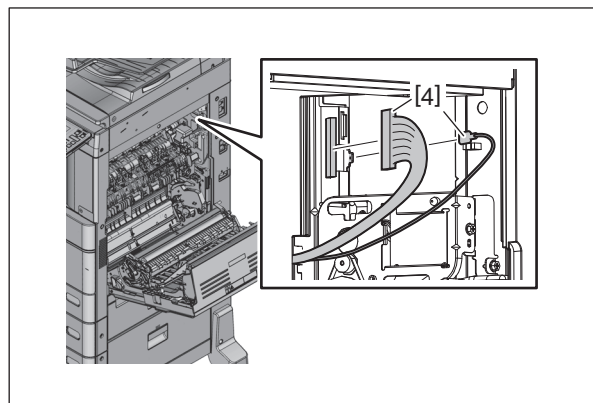

Fig. 4-546

- (6) Loosen 2 screws [5] and take off the front cover [6] of the job separator.

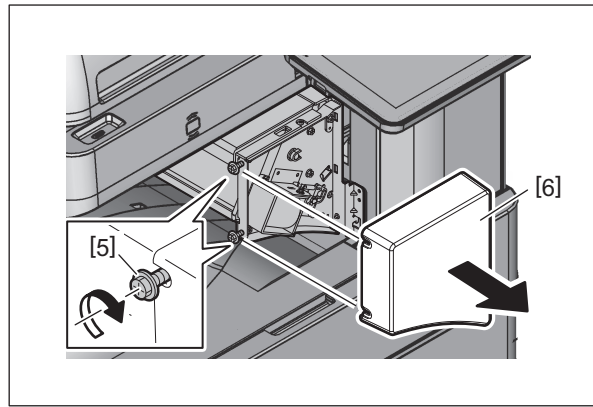

Fig. 4-547

- (7) Remove 1 screw [7]. Lift the inner tray [8] up to release the hook [9]. Pull the inner tray toward you to take it off.

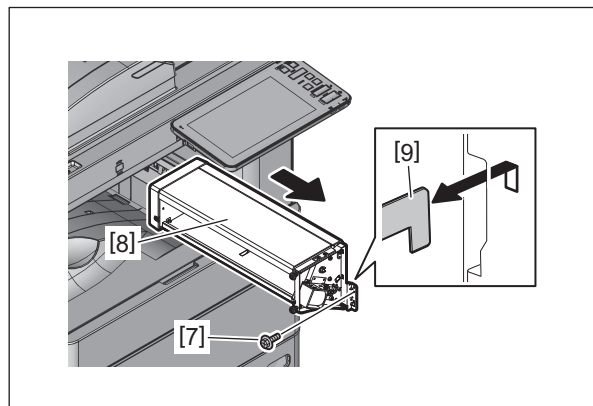

Fig. 4-548

#### 4.13.12 Job separator (3528A/4528A)

- (1) Press the [ON/OFF] button on the control panel to shut down the MFP.
- (2) Remove the power cable.
- (3) Take off the tray [1].

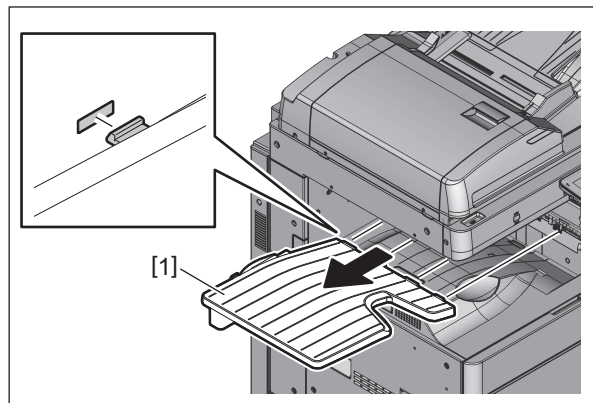

Fig. 4-549

(4) Open the ADU. Remove 1 screw [2] and take off the paper exit back cover [3].

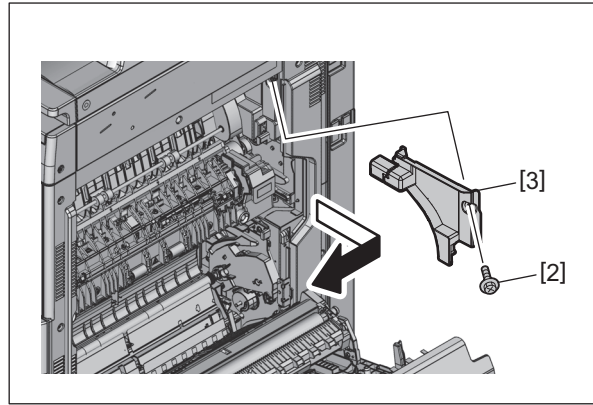

Fig. 4-550

(5) Disconnect 1 connectors [4].

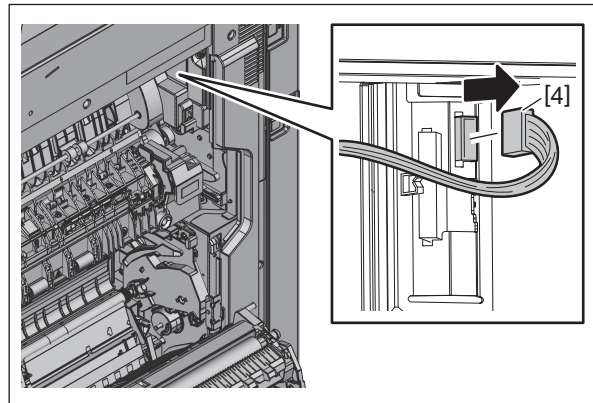

Fig. 4-551

(6) Remove 2 screws [5] and take off the job separator [6].

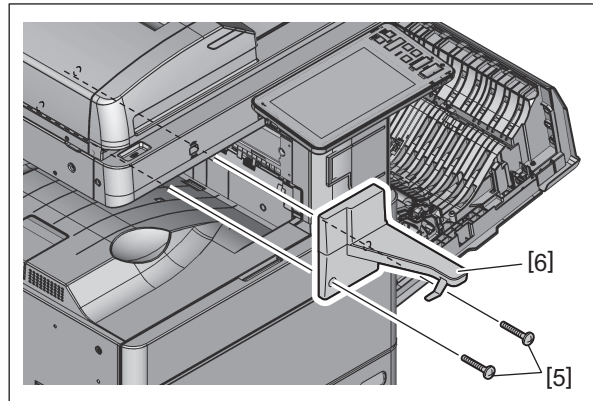

Fig. 4-552

### 4.13.13 External Large Capacity Feeder (Ex-LCF)

- (1) Press the [ON/OFF] button on the control panel to shut down the MFP.
- (2) Remove the power cable.
- (3) Pull out the Ex-LCF.

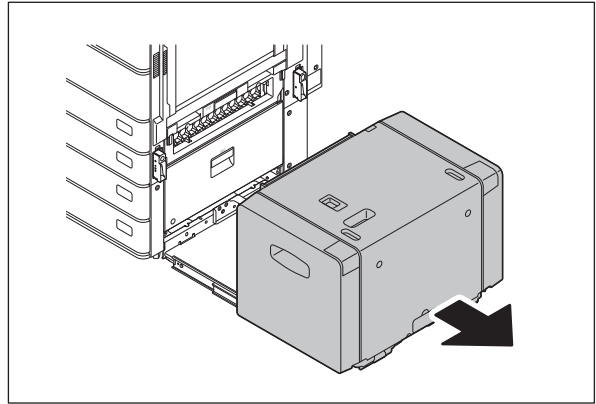

Fig. 4-553

- (4) Remove 1 screw [1] and take off the connector cover [2].

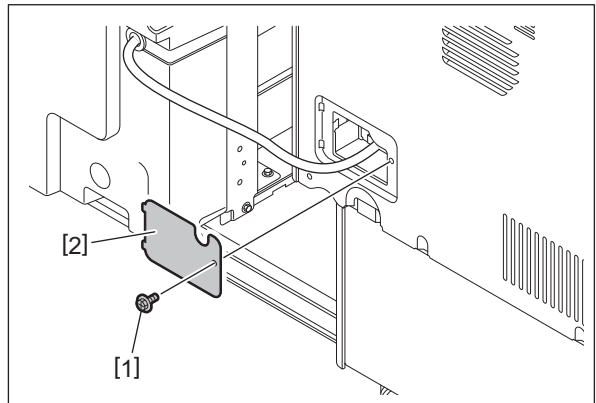

Fig. 4-554

- (5) Disconnect 1 connector [3].

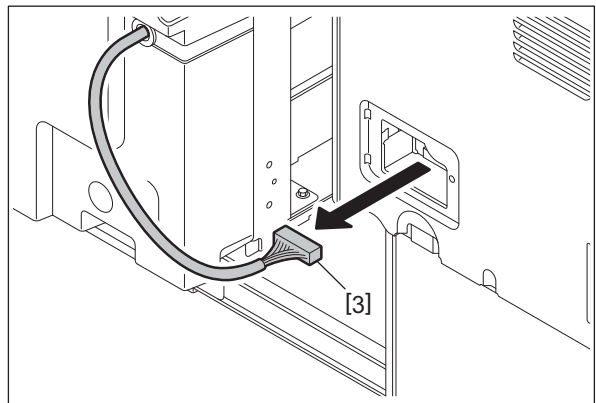

Fig. 4-555

(6) Install the cover [2] with 1 screw [1].

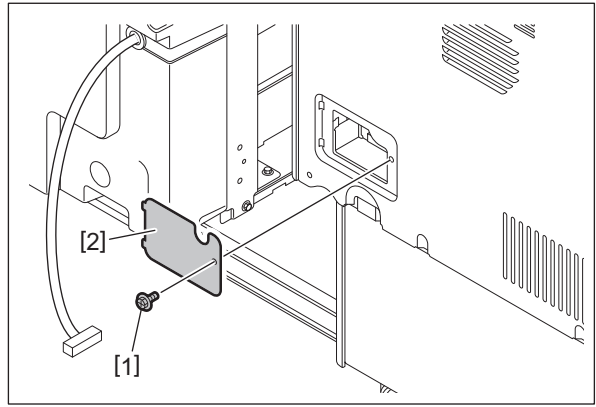

Fig. 4-556

(7) Remove 2 screws [4] on the rear side.

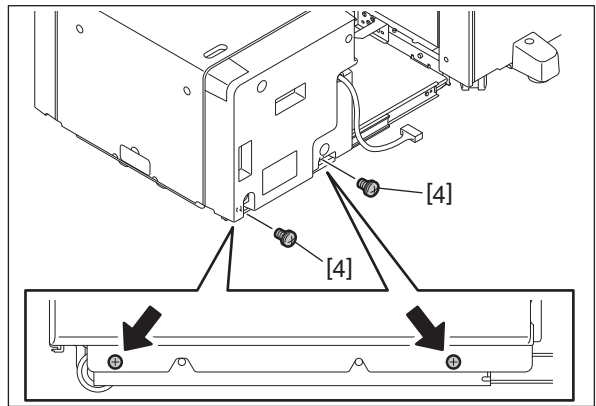

Fig. 4-557

(8) Remove 2 screws [5] on the front side.

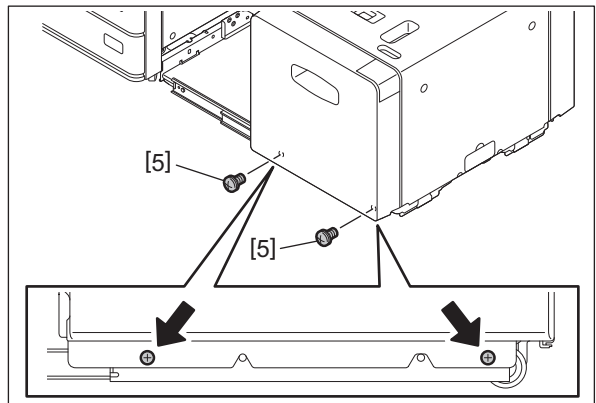

Fig. 4-558



(9) Remove the Ex-LCF.

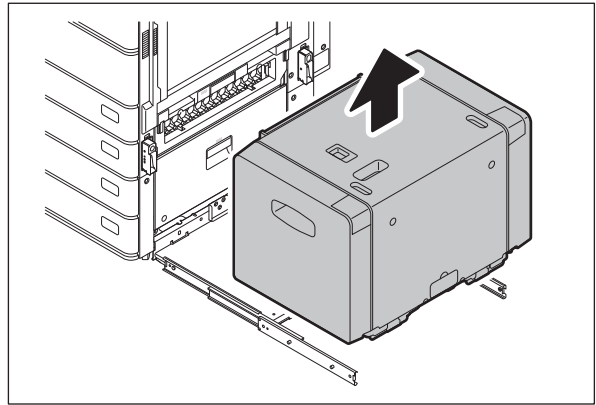

Fig. 4-559



## 5. SELF-DIAGNOSTIC MODE

### 5.1 Overview

This MFP consists of two servicing menus which have different start-up methods. Setting and adjustment can be performed by entering into a mode such as [05 ADJUSTMENT MODE] or [49 Firmware Update] from each menu.

- FS Menu

Mode		Contents
03 TEST MODE		Checks the status of the input/output signals.
04 TEST PRINT MODE		Outputs the test patterns.
05 ADJUSTMENT MODE		Adjusts various items.
08 SETTING MODE		Sets various items.
20 PM SUPPORT MODE		Clears each counter.
21 EPU REPLACE MODE		Uses when the EPU is replaced with one whose initial detection can be performed.
30 LIST PRINT MODE		Prints various lists or outputs them in a CSV format.
FAX	11 FAX CLEAR MODE	Sets the fax unit.
	12 FAX LIST PRINT MODE	The setting contents of the fax function can be output.
	13 FAX FUNCTION MODE	Sets the fax function.
	19 RAM EDIT MODE	Performs special adjustment and setting for the fax function. (This is not used generally.)
35 DATA BACKUP/RESTORE MODE		Backs up or restores data.
36 CLONING		Creates and installs clone files.
37 LICENSE MANAGEMENT		Manages the license of applications.
38 DEACTIVATE RELEASE MODE		Reconnects the detached device.

- HS Menu

Mode		Contents
01 Control Panel Check		Checks various contents regarding the LCD, LED, hard keys and digital keys on the control panel.
49 Firmware Update		Performs firmware update with a USB storage device.
59 SRAM Data Cloning		Backs up the SRAM data to a USB storage device.
73 Firmware Assist		Supports at the time of replacing the SYS board, SRAM and normal storage device. Clears error flags or SRAM. Performs safety deletion of the normal storage device and SRAM.
74 Storage Assist		Checks the type of the storage device connected and initializes it.
75 File System Recovery		Checks and recovers the file system of the connected storage. Initializes the normal storage device.
76 SRAM Maintenance		Recovers the MFP from particular errors such as F800 or F900.
77 Detach Release		Reconnects the detached device.
78 Option Storage Assist		Formats the optional storage device and deletes its settings.
TPM Restore		Restores TPM information.

**Remarks:**

Only the modes which are available for this MFP are displayed on each menu.

## [A] Starting each menu

Menu			Mode <sup>*1</sup>		Operation			
FS Menu [FUNCTION CLEAR] + [START] + [ON/OFF]	→	Enter a service password and press [OK].	→	03 TEST MODE	→	Refer to the SELF-DIAGNOSIS CODE.		
				04 TEST PRINT MODE	→	Refer to the SELF-DIAGNOSIS CODE.		
				05 ADJUSTMENT MODE	→	CLASSIC <sup>*2</sup>	→	Refer to the SELF-DIAGNOSIS CODE.
				08 SETTING MODE	→	CLASSIC <sup>*2</sup>	→	Refer to the SELF-DIAGNOSIS CODE.
				20 PM SUPPORT MODE	→			Ch 5.8
				21 EPU REPLACE MODE	→			Ch 7.6
				30 LIST PRINT MODE	→			Ch 5.10
				FAX • 11 FAX CLEAR MODE • 12 FAX LIST PRINT MODE • 13 FAX FUNCTION MODE • 19 RAM EDIT MODE <sup>*3</sup>	→			Refer to the SELF-DIAGNOSIS CODE.
				35 DATA BACKUP/RESTORE MODE	→			Ch 5.12
				36 CLONING	→			Ch 5.13
				37 LICENSE MANAGEMENT	→			Ch 5.14
				38 DEACTIVATE RELEASE MODE	→			Ch 5.15
HS Menu [HOME] + [START] + [ON/OFF]	→	Enter a service password and press [OK].	→	01 Control Panel Check	→	Ch 5.16		
				49 Firmware Update	→	Ch 11.2.4		
				59 SRAM Data Cloning	→	Ch 12.1.4		
				73 Firmware Assist	→	Ch 5.17		
				74 Storage Assist	→	Ch 5.18		
				75 File System Recovery	→	Ch 5.19		
				76 SRAM Maintenance	→	Ch 5.20		
				77 Detach Release	→	Ch 5.21		
78 Option Storage Assist	→	Ch 5.22						
TPM Restore <sup>*4</sup>	→	Enter a service password and press [OK].	→		Ch 5.23			

\*1 : FS Menu: Select the mode and press [Next]. HS Menu: Select the icon of the mode.

\*2 : Press [Classic] displayed at the upper right of the menu.

\*3 : This is not used generally.

\*4 : This function is displayed and becomes operable, only after the SYS board has been replaced.

## [B] Cancellation of the self-diagnostic mode

The modes, which can be entered from [FS Menu], can be canceled by the following methods.

- When [FS Menu] is displayed on the screen:  
Press [FS Menu] to return to the menu screen. Press [Normal].  
- The self-diagnostic mode finishes and the [HOME] screen appears. Rebooting/non-rebooting of the MFP will be performed depending on the mode worked and the code operated.
- When only [Return] is displayed on the screen:  
Press [Return] for several times until [FS Menu] is displayed on the screen. When [FS Menu] appears, press it.
- When neither [Return] nor [FS Menu] is not displayed on the screen:  
Press the [ON/OFF] button and perform the shut-down operation on the screen displayed.

To cancel the modes, which can be entered from [HS Menu], press the [ON/OFF] button for a few seconds to shut down the MFP.

## [C] State transition diagram of self-diagnostic modes

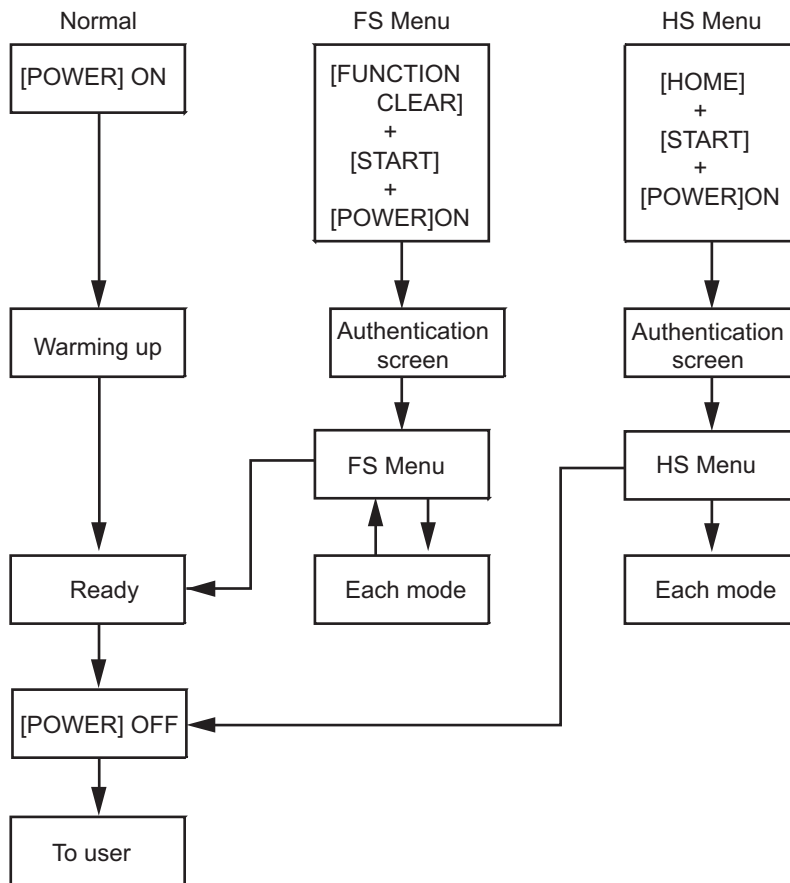

Fig.5-1

### Notes:

Be sure to cancel the self-diagnostic mode before customers start using the MFP.

## [D] Changing and setting of the service password

- (1) Press [XXX] on the FS Menu. The [XXX] screen appears.
- (2) Press [Service Password] to change or reset the service password.

## 5.2 Description Rule for Each Menu and Mode

The description of the self-diagnostic code complies with the rule below.

Example

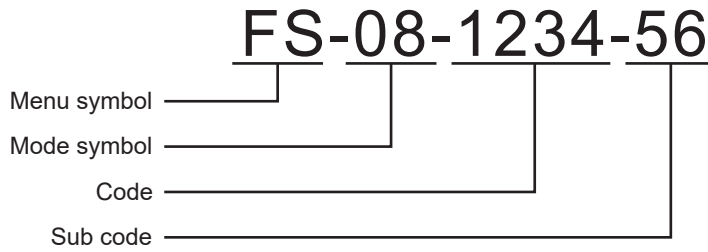

Fig.5-2

- (1) Menu symbol  
FS: FS Menu (Starting by pressing the [ON/OFF] button while pushing the [FUNCTION CLEAR] and [START] buttons simultaneously.)  
HS: HS Menu (Starting by pressing the [ON/OFF] button while pushing the [HOME] and [START] buttons simultaneously.)
- (2) Mode symbol  
The first two digits of each mode
- (3) Code  
Code number
- (4) Sub code  
This will only be given when a sub code exists.

### [A] FS Menu

#### [05 ADJUSTMENT MODE] and [08 SETTING MODE]:

"FS-05-1234-56" or "Perform FS-05-1234-56" is taken for explanation purposes.

- (1) Start the FS Menu by pressing the [ON/OFF] button while pushing the [FUNCTION CLEAR] and [START] buttons simultaneously.

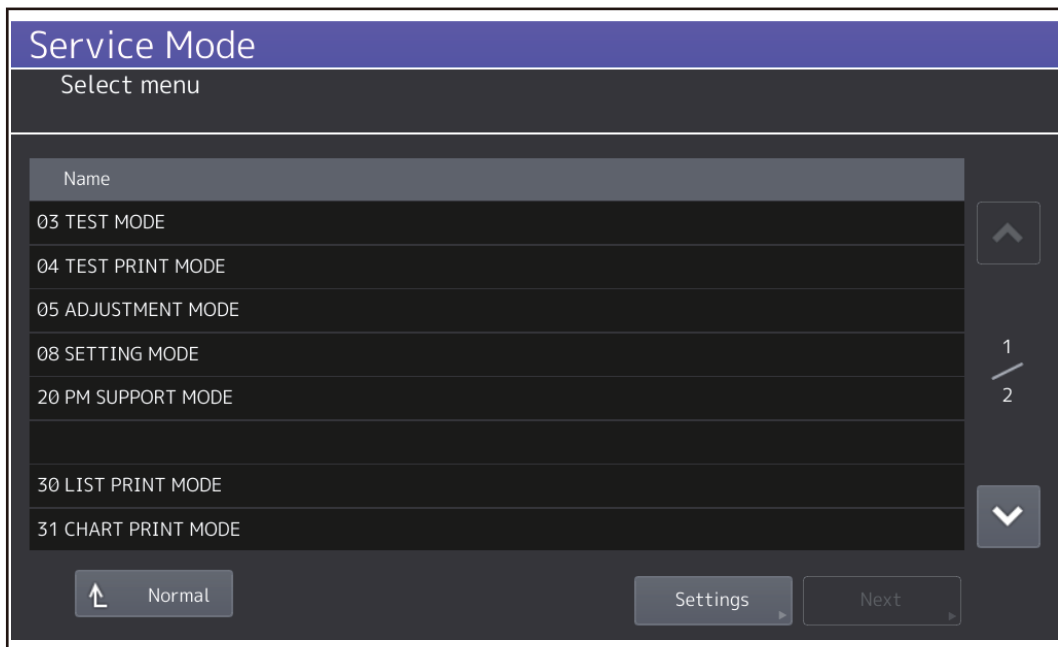

Fig.5-3

- (2) Select [05 ADJUSTMENT MODE] or [08 SETTING MODE] and press [Next].
- (3) Press [Classic] on the upper right of the menu to display the adjustment mode menu.

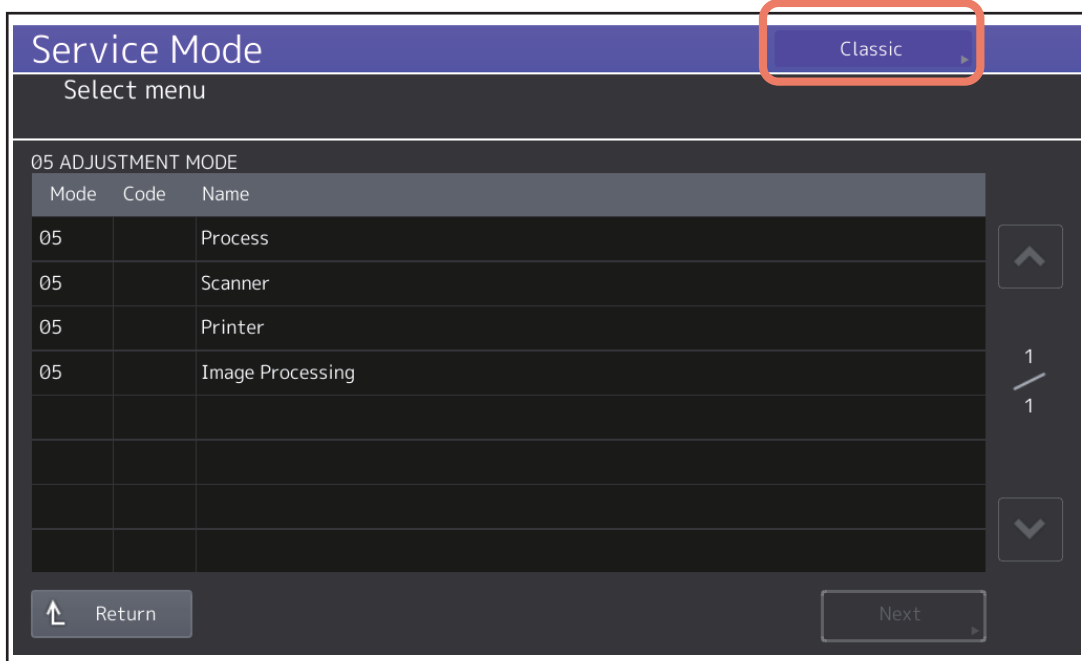

Fig.5-4

- (4) By using the digital keys displayed on the screen, enter [1], [2], [3], [4] and then press the [START] button. Enter the sub codes [5] and [6] and then press the [START] button.
- (5) Carry out the adjustment by following the instructions displayed on the screen or press the [START] button.

**[03 TEST MODE]:**

The key-pressing procedures for the modes, which are set by the combination of the [F1], [F2] and [F3] keys, are described as below.

[F1: ON]: Only F1 is turned ON.

[F1, 2: ON]: F1 and F2 are turned ON.

\* The number of the [F] key, which is turned ON, is depicted by dividing with “,” (commas) as above.

[F1, 2, 3: ON]: All of the [F] keys are turned ON.

[F: OFF]: All of the [F] keys are turned OFF.

e.g.:

[FS-03-F:OFF-9-A]: Turn OFF all of the [F] keys in the FS-03 mode, select [9] and then [A].

[FS-03-F1:ON-9-A]: Turn ON the [F1] key in the FS-03 mode, select [9] and then [A].

**[FAX]:**

In case of [FS-11], [FS-12] or [FS-13] is given in the explanations, select [FAX] in the [FS Menu] and then press [Next] to choose each mode.

## [B] HS Menu

- (1) Start the HS Menu by pressing the [ON/OFF] button while pushing the [HOME] and [START] buttons simultaneously.

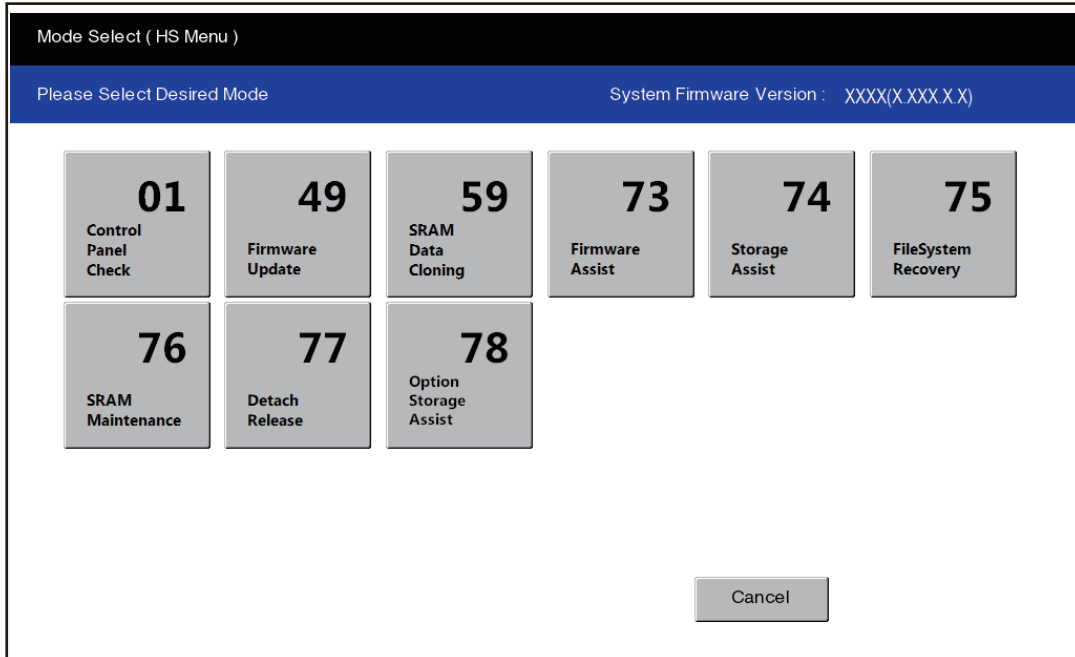

Fig.5-5

- (2) Press the icon to operate.
- (3) Follow the instructions displayed on the screen.

## [C] When the setting contents of the code are applied

The setting value is given at the end of the description by dividing with “:” (colons).

Example: [FS-08-8911:3]: “3” is set for FS-08-8911.



## 5.3 Service UI

### 5.3.1 Overview

Each mode of the self-diagnostic codes can be used by selecting the keyword of the screen in the Service UI.

The codes which are used frequently can be selected in the Service UI.

The Service UI can be used in the following modes in the FS Menu.

05 ADJUSTMENT MODE

08 SETTING MODE

#### Notes:

Not all codes can be used in the Service UI.

For the codes available with the Service UI, refer to the “Self-Diagnostic code list” (separate document).

### 5.3.2 Operation procedure

- (1) Start the FS Menu. Select the mode of the above Service UI and press [Next].
- (2) Select the item whose setting is to be changed and press [Next] until the code number is displayed.

The display shifts to the classic screen of the selected code.

### 5.3.3 Starting the FS Menu from the normal mode

If the gear icon is displayed on the USER FUNCTIONS menu of the normal mode, the FS Menu can be started.

- (1) Turn the power ON of the MFP.
- (2) Enter the service ID and service password if necessary.
- (3) Press [User Functions] on the HOME screen.
- (4) Press the gear icon on the upper left of the screen for at least 3 seconds.

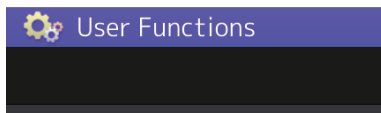

Fig.5-6

- (5) Enter the service password and press [OK].  
The FS Menu appears.  
In case the password has been forgotten, ask the administrator to reset the service password.

## 5.4 03 TEST MODE

### 5.4.1 Output check

The status of the output signal can be checked.

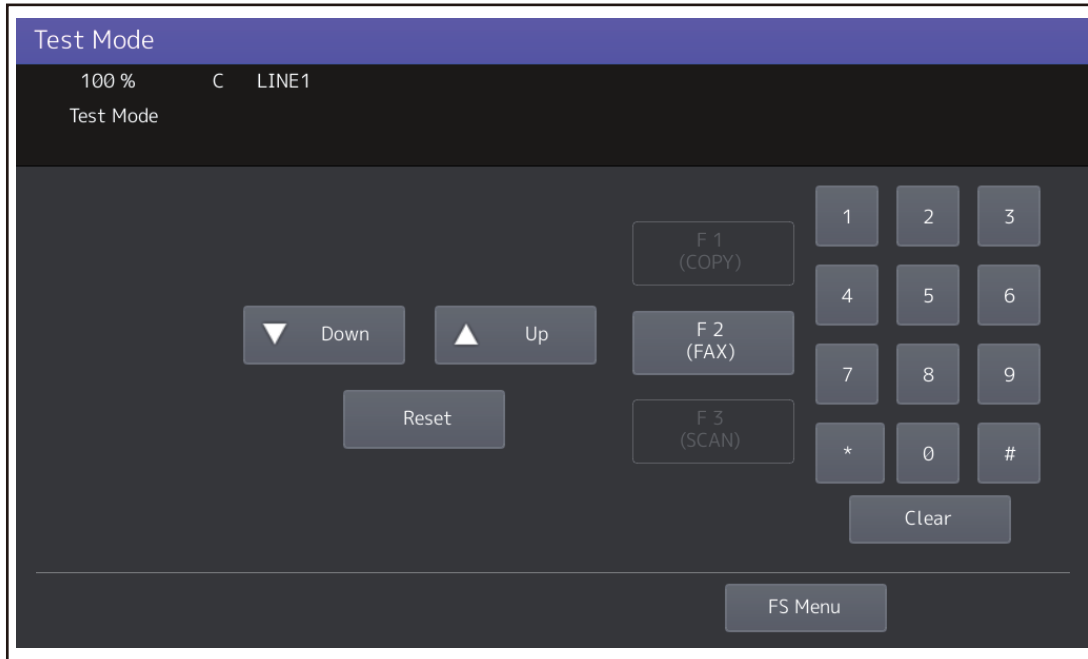

Fig.5-7

Operation procedure: Refer to the SELF-DIAGNOSIS CODE (separate document).

### 5.4.2 Input check

The status of each input signal can be checked by operating the [F1], [F2], [F3] and the digital keys.

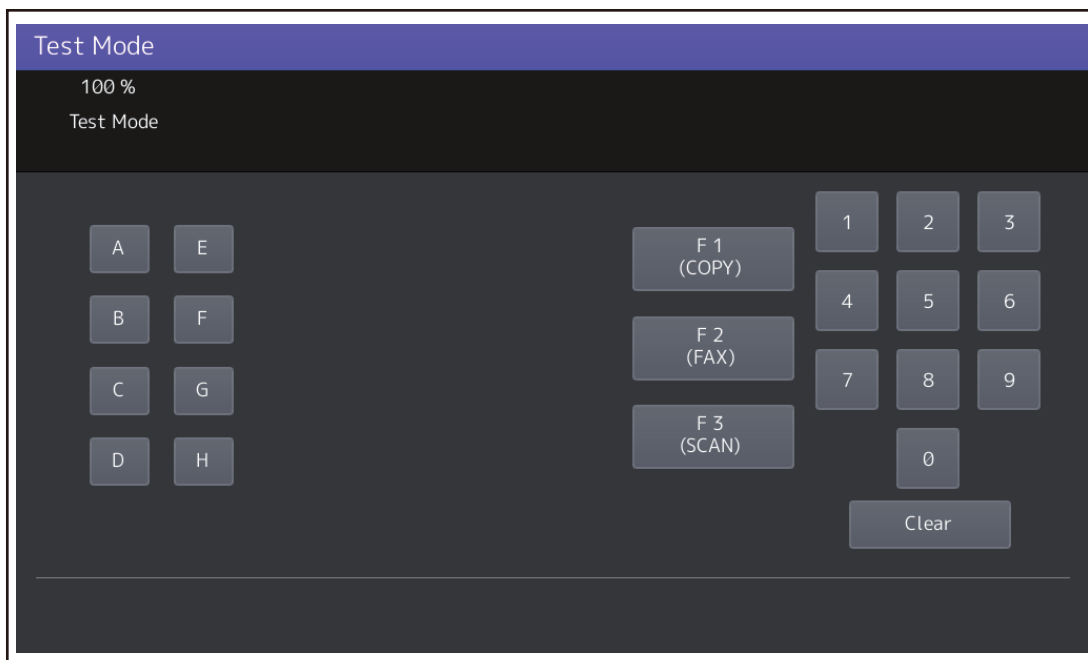

Fig.5-8

Operation procedure: Refer to the SELF-DIAGNOSIS CODE (separate document).

## 5.5 04 TEST PRINT MODE

The embedded test pattern can be printed out.

Operation procedure: Refer to the SELF-DIAGNOSIS CODE (separate document).

## 5.6 05 ADJUSTMENT MODE

Various test printings can be performed.

Operation procedure: Refer to the SELF-DIAGNOSIS CODE (separate document).

### 5.6.1 TEST COPY

One set of the test copy can be printed in the [Classic] mode standby screen in the [05 ADJUSTMENT MODE].

Operation procedure:

- (1) Press [TEST COPY] in the [Classic] Mode standby screen in the [05 ADJUSTMENT MODE].
- (2) Specify the drawer, original mode and density.  
Available items vary depending on the models.
- (3) Press the [START] button.

### 5.6.2 TEST PRINT

One sheet of the test print for various patterns can be printed out by entering a 1 to 3-digit code and pressing [TEST PRINT] in the [Classic] mode standby screen in [05 ADJUSTMENT MODE].

Operation procedure: Refer to the SELF-DIAGNOSIS CODE (separate document).

## 5.7 08 SETTING MODE

Various settings can be set.

Operation procedure: Refer to the SELF-DIAGNOSIS CODE (separate document).

## 5.8 20 PM SUPPORT MODE

 P. 7-4 “7.4 20 PM SUPPORT MODE”

Operation procedure:

[FS] → [20] → (Operation started) → Exit

## 5.9 21 EPU REPLACE MODE

 P. 7-10 “7.6 21 EPU REPLACE MODE”

## 5.10 30 LIST PRINT MODE

### 5.10.1 List output table

The following lists can be printed out in the list print mode.

Lists can be printed or saved in a USB storage device by outputting them into a CSV file format list.

List	Code		Output file name	Operation procedure
	Print	CSV		
Adjustment mode (05) data list	101	201	AJUSTMENT_LIST_sn_date.csv	1
Setting mode (08) data list	102	202	SETTING_LIST_sn_date.csv	1
PM support mode data list	103	203	PM_LIST_sn_date.csv	2
Pixel counter list (toner cartridge reference)	104	204	PIXEL_TONER_LIST_sn_date.csv	2
Pixel counter list (service technician reference)	105	205	PIXEL_SERVICE_LIST_sn_date.csv	2
Error history list (Max.: 1000)	106	206	ERROR_LOG_sn_date.csv	2
Error history list (Latest: 80)	107	-	-	2
Firmware update log (Max.: 200)	108	208	FW_UPGRAE_LOG_sn_date.csv	2
Paper sensor log <sup>*1</sup>	-	209	PAPER_SENSOR_LOG_sn_date.csv	2
Power ON/OFF log (Max.: 100)	110	210	POWER_ONOFF_LOG_sn_date.csv	2
Version list	111	211	VERSION_LIST_sn_date.csv	2
Engine firmware log <sup>*1</sup>	-	212	ENG_FW_LOG_sn_date.csv	2
Total counter list	114	214	TOTAL_COUNTER_LIST_sn_date.csv	2
DF Error history list <sup>*1</sup>	-	216	DF_ERROR_LOG_sn_date.csv	2
Misfeeding transport error log	-	217	MISFEEDING_TRANSPORT_ERROR_LOG_sn_date.csv	2
User operation log	-	218	FAX_OPERATION_LOG_sn_date.csv, SIMPLE_FAX_OPERATION_LOG_sn_date.csv	2
Setting change history	-	219	SETTING_CHANGE_HISTORY_sn_date.csv	2
DF Paper sensor log <sup>*1</sup>	-	220	DF_PAPER_SENSOR_LOG_sn_date.csv	2
(05) adjustment value difference	121	221	05DIFFERENCE_CODE_LIST_sn_date.csv	2
(08) setting value difference	122	222	08DIFFERENCE_CODE_LIST_sn_date.csv	2
Jog log / Message log	-	223	JOB_LOG_sn_date <sup>*2</sup> MESSAGE_LOG_sn_date <sup>*2</sup>	2
FAX function mode (13) data list	-	224	FAX_FUNCTION_LIST_sn_date.csv	2
Application list (Max.: 100)	125	225	APPLICATION_LIST_sn_date.csv	2
Life counter clear log	811	911	LIFE_COUNTER_CLEAR_LOG_sn_date.csv	2
Toner replacement log <sup>*1</sup>	-	912	TONER_REPLACE_LOG_sn_date.csv	2
Output all CSV files	-	300	CSV format files other than (05) adjustment value difference and (08) setting value difference	2

sn: Serial number of the MFP

date: File create date and time (YYYYMMDDHHMMSS)

\*1 : Output this only when instructed.

\*2 : Encryption file

## 5.10.2 Operation procedure

Lists can be printed by performing the code for printing. In addition, a CSV format file can be stored in a USB storage device by performing the code for csv outputting while it is inserted.

Operation procedure 1

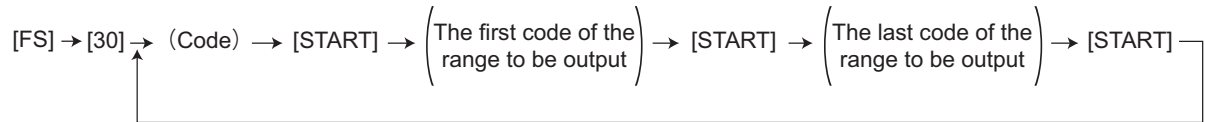

Fig.5-9

Operation procedure 2

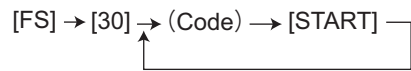

Fig.5-10

## 5.10.3 Samples of the output

Adjustment mode (05) data list

05 ADJUSTMENT MODE DATA LIST				S/N: xxxxxxxx		TOTAL: 9999999	
20xx-xx-xx xx:xx				TOSHIBA e-STUDIOxxx		DFTOTAL: 9999999	
CODE	DATA	CODE	DATA	CODE	DATA	CODE	DATA
2000	128	3860-0	88	4830	128	5920	128
.	.	.	.	.	.	.	.
.	.	.	.	.	.	.	.
.	.	.	.	.	.	.	.
.	.	.	.	.	.	.	.
.	.	.	.	.	.	.	.
.	.	.	.	.	.	.	.
.	.	.	.	.	.	.	.
.	.	.	.	.	.	.	.
.	.	.	.	.	.	.	.
.	.	.	.	.	.	.	.
.	.	.	.	.	.	.	.
.	.	.	.	.	.	.	.
.	.	.	.	.	.	.	.

Fig.5-11

Item	Contents
CODE	A self-diagnostic code is described. "XXXX-YY" is described when a sub code exists.
DATA	Value of the code

The selected setting codes and the current setting value for each code are output in a list.

### Remarks:

- Only the codes available to set or check are output.

- Codes whose setting value at the time of the output is not unnecessary are not output (e.g.: setting time of the MFP).

## Setting mode (08) data list

08 SETTING MODE DATA LIST		S/N: xxxxxxxx		TOTAL: 9999999			
20xx-xx-xx xx:xx		TOSHIBA e-STUDIOxxx		DF TOTAL: 9999999			
CODE	DATA	CODE	DATA	CODE	DATA	CODE	DATA
2010	2	2880	12	3040	0	3070-3	0
.	.	.	.	.	.	.	.
.	.	.	.	.	.	.	.
.	.	.	.	.	.	.	.
.	.	.	.	.	.	.	.
.	.	.	.	.	.	.	.
.	.	.	.	.	.	.	.
.	.	.	.	.	.	.	.
.	.	.	.	.	.	.	.
.	.	.	.	.	.	.	.
.	.	.	.	.	.	.	.
.	.	.	.	.	.	.	.
.	.	.	.	.	.	.	.

Fig.5-12

Item	Contents
CODE	A self-diagnostic code is described. "XXXX-YY" is described when a sub code exists.
DATA	Value of the code

The selected setting codes and the current setting value for each code are output in a list.

### Remarks:

- Only the codes available to set or check are output.
- Codes whose setting value at the time of the output is not unnecessary are not output (e.g.: setting time of the MFP).

## PM support mode data list

PM SUPPORT CODE LIST				
		S/N: xxxxxxxx	TOTAL:	9999999
		TOSHIBA e-STUDIOxxx	DF TOTAL:	9999999
20xx-xx-xx xx:xx				
UNIT	OUTPUT PAGES/ DEVELOP COUNTS	PM OUTPUT PAGE/ DEVELOP COUNTS	DRIVE COUNTS	PM DRIVE COUNTS
DRUM	2516	70000	11735	170000
DRUM BLADE	2516	70000	11735	170000
GRID	2516	70000	11735	170000
MAIN CHARGER NEEDLE	2516	70000	11735	170000
CHARGER CLEANING PAD	2516	70000	11735	170000
:	:	:	:	:
:	:	:	:	:

**Fig.5-13**

Item	Contents
UNIT	Unit name
OUTPUT PAGES/DEVELOP COUNTS	Number of output pages
PM OUTPUT PAGES/DEVELOP COUNTS	Number of recommended pages for replacement
DRIVE COUNTS	Drive time
PM DRIVE COUNTS	Recommended time for replacement

Sub unit information for 20 PM support mode is output.  
Use this list for confirming the PM units to be replaced at each PM.

### Remarks:

- When the recommended value has been exceeded, “\*” will be added to the number of output pages or drive time.
- See the following page for PM:  
 P. 7-1 “7. PREVENTIVE MAINTENANCE (PM)”



Pixel counter list (toner cartridge reference)

PIXEL COUNTER CODE LIST		S/N: xxxxxxxx	FIN S/N: xxxxxxxx	TOTAL: 9999999		
		TOSHIBA e-STUDIOxxx		DF TOTAL: 9999999		
20xx-xx-xx xx:xx						
TONERCARTRIDGE						
NO.	DATE		PPC	PRN	FAX	TOTAL
0	20xx-xx-xx	Print Count[LT/A4]	181	45	---	226
1	20xx-xx-xx	Average Pixel Count[%]	2.70	1.74	---	2.51
2	20xx-xx-xx	Latest Pixel Count[%]	6.15	0.39	---	0.39

Fig.5-14

Item	Contents
No.	Consecutive number
DATE	Date
PPC	Counter for copying
PRN	Counter for printing
FAX	Counter for fax
TOTAL	Total counter

Pixel counter data (toner cartridge reference) are output in a list.

**Remarks:**

See the following page for the pixel counter:

📖 P. 14-7 “14.3 Pixel Counter”

Pixel counter list (service technician reference)

PIXEL COUNTER CODE LIST		S/N: xxxxxxxx	FIN S/N: xxxxxxxx	TOTAL: 9999999		
		TOSHIBA e-STUDIOxxx		DF TOTAL: 9999999		
20xx-xx-xx xx:xx						
SERVICE ENGINEER						
NO.	DATE		PPC	PRN	FAX	TOTAL
0	20xx-xx-xx	Print Count[LT/A4]	181	45	---	226
1	20xx-xx-xx	Average Pixel Count[%]	2.70	1.74	---	2.51
2	20xx-xx-xx	Latest Pixel Count[%]	6.15	0.39	---	0.39

Fig.5-15

Item	Contents
No.	Consecutive number
DATE	Date
PPC	Counter for copying
PRN	Counter for printing
FAX	Counter for fax
TOTAL	Total counter

Pixel counter data (service technician reference) are output in a list.

**Remarks:**

See the following page for the pixel counter:

 P. 14-7 "14.3 Pixel Counter"

## Error history list

ERROR HISTORY LIST						
					S/N: xxxxxxxx	TOTAL: 9999999
					TOSHIBA e-STUDIOxxx	DF TOTAL: 9999999
20xx-xx-xx xx:xx						
CODE	COUNTER	DATE	TIME	ZOOM_XY	ABCD_EFHI_JLOP_QR	
F110	00000000	xxxx-xx-xx	xx:xx:xx	000 000	0000_0000_0000_00_0000000000	
F110	00000000	xxxx-xx-xx	xx:xx:xx	000 000	0000_0000_0000_00_0000000000	
F110	00000000	xxxx-xx-xx	xx:xx:xx	000 000	0000_0000_0000_00_0000000000	
F110	00000000	xxxx-xx-xx	xx:xx:xx	000 000	0000_0000_0000_00_0000000000	
F110	00000000	xxxx-xx-xx	xx:xx:xx	000 000	0000_0000_0000_00_0000000000	
EAD0	00000000	xxxx-xx-xx	xx:xx:xx	000 000	0000_0000_0000_00_0000000000	
E860	00000000	xxxx-xx-xx	xx:xx:xx	000 000	0000_0000_0000_00_0000000000	
E731	00000000	xxxx-xx-xx	xx:xx:xx	000 000	0000_0000_0000_00_0000000000	
E090	00000000	xxxx-xx-xx	xx:xx:xx	000 000	0000_0000_0000_00_0000000000	
E870	00000000	xxxx-xx-xx	xx:xx:xx	000 000	0000_0000_0000_00_0000000000	
E724	00000000	xxxx-xx-xx	xx:xx:xx	000 000	0000_0000_0000_00_0000000000	

**Fig.5-16**

The error history is output.

The maximum output numbers are as below.

- FS-30-106/206: 1000
- FS-30-107: 80

### Remarks:

- Only errors occurred under the normal mode and 30 list print mode are output.
- For the details of the error codes and items, refer to the following reference.
  - 📖 P. 8-6 “8.2 Error Code List”
  - 📖 P. 8-68 “8.2.11 Error history”

## Firmware update log

FW UPGRADE LOG												
										S/N: xxxxxxxx	TOTAL:	9999999
										TOSHIBA e-STUDIOxxx	DF TOTAL:	9999999
20xx-xx-xx xx:xx												
MANUFACTURE DATE 20xx-xx-xx												
UNPACKING DATE 20xx-xx-xx												
USER	ROM/VERSION	DATE	TOTAL	COPY(B)	COPY(2)	COPY(C)	PRINT(B)	PRINT(2)	PRINT(C)	LIST	FAX	STATUS
Service Txxxxxx>xxxx	20xx-xx-xx	20xx-xx-xx	99999999	99999999	99999999	99999999	99999999	99999999	99999999	99999999	99999999	OK
Service Txxxxxx>xxxx	20xx-xx-xx	20xx-xx-xx	99999999	99999999	99999999	99999999	99999999	99999999	99999999	99999999	99999999	OK
Service Txxxxxx>xxxx	20xx-xx-xx	20xx-xx-xx	99999999	99999999	99999999	99999999	99999999	99999999	99999999	99999999	99999999	OK
.	.	.	.	.	.	.	.	.	.	.	.	.
.	.	.	.	.	.	.	.	.	.	.	.	.
.	.	.	.	.	.	.	.	.	.	.	.	.
.	.	.	.	.	.	.	.	.	.	.	.	.
.	.	.	.	.	.	.	.	.	.	.	.	.
.	.	.	.	.	.	.	.	.	.	.	.	.

Fig.5-17

Item	Contents
USER	User who updated the firmware
ROM/VERSION	Firmware version
DATE	Firmware update date
TOTAL	Total counter data at firmware update
COPY(B)	Copy counter data (black) at firmware update
COPY(2)	Copy counter data (twin color) at firmware update
COPY(C)	Copy counter data (full color) at firmware update
PRINT(B)	Print counter data (black) at firmware update
PRINT(2)	Print counter data (twin color) at firmware update
PRINT(C)	Print counter data (full color) at firmware update
List	List print counter data at firmware update
FAX	Fax print counter data at firmware update
STATUS	Update result

Firmware update logs are output.

### Remarks:

- MANUFACTURE DATE: Manufacturing date, UNPACKING DATE: Unpacking date
- Lists are output only when the versions of ROMs updated with a USB storage device.

## Power ON/OFF log

POWER ON_OFF LOG							
		S/N: xxxxxxxx		TOTAL:		9999999	
		TOSHIBA e-STUDIOxxx		DF TOTAL:		9999999	
20xx-xx-xx xx:xx							
DATE	TIME	FUNCTION	TOTAL	DATE	TIME	FUNCTION	TOTAL
xxxx-xx-xx	xx:xx:xx	ON	99999999	xxxx-xx-xx	xx:xx:xx	ON	99999999
xxxx-xx-xx	xx:xx:xx	OFF	99999999	xxxx-xx-xx	xx:xx:xx	OFF	99999999
xxxx-xx-xx	xx:xx:xx	ON	99999999	xxxx-xx-xx	xx:xx:xx	ON	99999999
xxxx-xx-xx	xx:xx:xx	OFF	99999999	xxxx-xx-xx	xx:xx:xx	OFF	99999999
xxxx-xx-xx	xx:xx:xx	ON	99999999	xxxx-xx-xx	xx:xx:xx	RMT_OFF	99999999
xxxx-xx-xx	xx:xx:xx	OFF	99999999				
xxxx-xx-xx	xx:xx:xx	ON	99999999				
xxxx-xx-xx	xx:xx:xx	OFF	99999999				
xxxx-xx-xx	xx:xx:xx	RMT_OFF	99999999				
xxxx-xx-xx	xx:xx:xx	OFF	99999999				
.	.	.	.				
.	.	.	.				
.	.	.	.				

Fig.5-18

Item	Contents
DATE	Power ON/OFF date
TIME	Power ON/OFF time
FUNCTION	Power ON/OFF information (Power ON / Power OFF / Remote reset)
TOTAL	Total counter data at power ON/OFF

Power ON/OFF logs are output.

## Version list

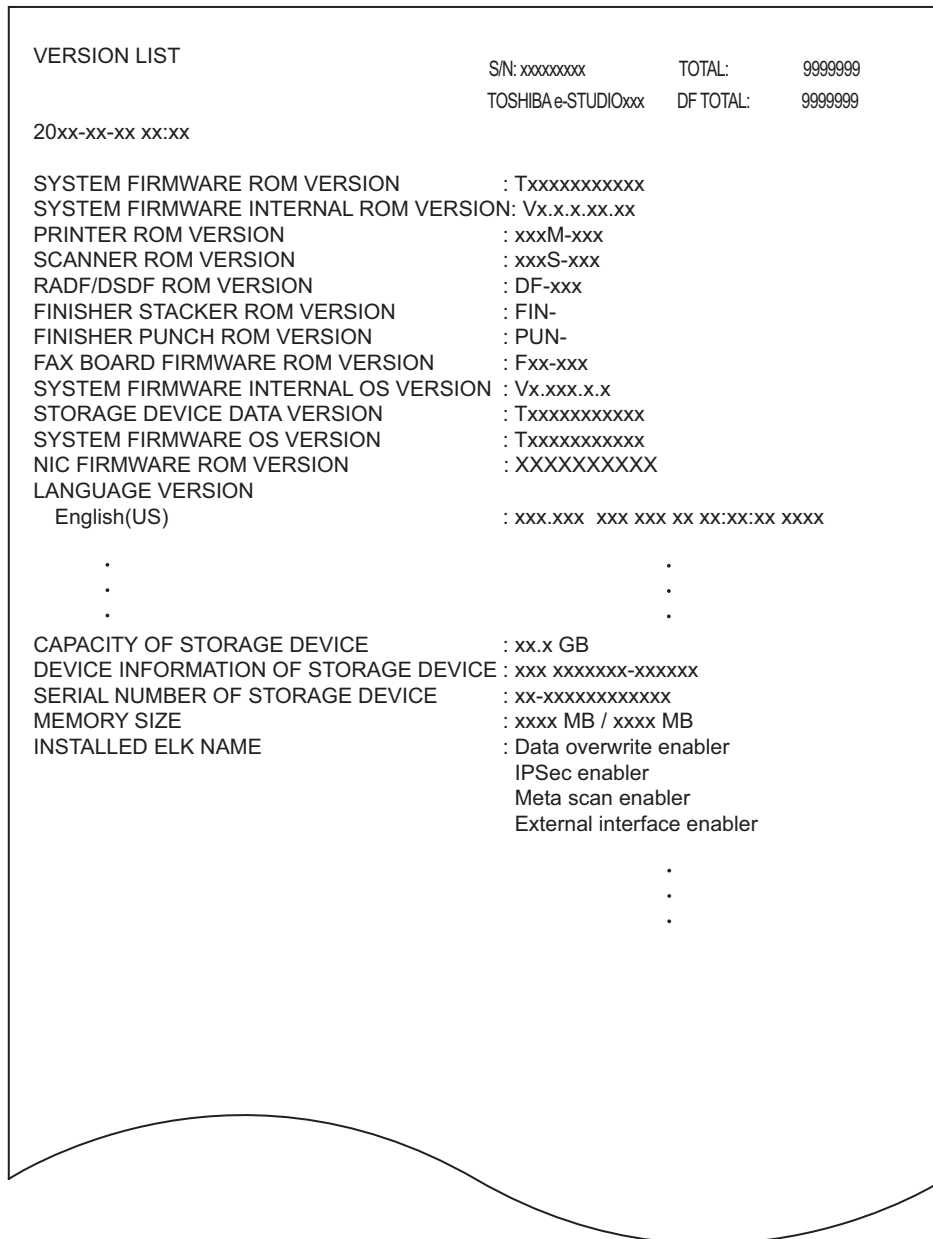

**Fig.5-19**

The versions of each firmware and language are output.

### Notes:

Some of the characters in the fonts that are used to print the version list are not supported. As a result, the language names under LANGUAGE VERSION may not be printed correctly when the version list is printed.

Total counter list

TOTAL COUNTER LIST	S/N: xxxxxxxx	FIN S/N: xxxxxxxx	TOTAL	: 9999999
20xx-xx-xx xx:xx	TOSHIBA e-STUDIOxxx		DF TOTAL	: 9999999

PRINT COUNTER					
	COPY	FAX	PRINTER	LIST	TOTAL
SMALL	xxxxxx	xxxxxx	xxxxxx	xxxxxx	xxxxxx
LARGE	xxxxxx	xxxxxx	xxxxxx	xxxxxx	xxxxxx
TOTAL	xxxxxx	xxxxxx	xxxxxx	xxxxxx	xxxxxx

CARIBRATION COUNTER : 0      DESTINY UNEVENNESS CORRECTION COUNTER : 0  
 OCR COUNTER : 0  
 SCAN COUNTER

TOTAL			
	FULL COLOR	BLACK	TOTAL
COPY	xxxxxx	xxxxxx	xxxxxx
FAX	xxxxxx	xxxxxx	xxxxxx
NETWORK	xxxxxx	xxxxxx	xxxxxx
TOTAL	xxxxxx	xxxxxx	xxxxxx

COPY			
	FULL COLOR	BLACK	TOTAL
SMALL	xxxxxx	xxxxxx	xxxxxx
LARGE	xxxxxx	xxxxxx	xxxxxx
TOTAL	xxxxxx	xxxxxx	xxxxxx

FAX			
	FULL COLOR	BLACK	TOTAL
SMALL	xxxxxx	xxxxxx	xxxxxx
LARGE	xxxxxx	xxxxxx	xxxxxx
TOTAL	xxxxxx	xxxxxx	xxxxxx

NETWORK			
	FULL COLOR	BLACK	TOTAL
SMALL	xxxxxx	xxxxxx	xxxxxx
LARGE	xxxxxx	xxxxxx	xxxxxx
TOTAL	xxxxxx	xxxxxx	xxxxxx

CALIBRATION COUNTER : 0

Fig.5-20

The total counter list is output.

**Remarks:**

When "1" (Enable) is set for FS-08-3667, a QR code is added to the total counter list.

Misfeeding transport error log

```

MISFEEDING TRANSPORT ERROR LOG, VERSION 1.0.0
20xx-xx-xx xx:xx
TOSHIBA e-STUDIOxxxx
Cxxxxxxxx
FIN S/N-xxxxxxxx
TOTAL,42737,691,5318,DF TOTAL,700
CODE,DATE-TIME,DATA
E120,2012-8-13,22:35:27,17,0,10,0,0,0,0,0,0,0,0,0,0,0,0,0,0,0,0,100,200,0,0
E013,2012-08-13 22:36:25,0,10,0,0,0,0,0,0,0,0,0,0,0,0,0,0,0,0,0,0,100,200,0,0,0,0,0,0,0,0
.      .
.      .
.      .
    
```

Fig.5-21

Item	Contents	Remarks
CODE	Error code	Code of the error which occurred
DATE	Occurrence date	Date that the error occurred
TIME	Occurrence time	Time that the error occurred
DATA	Self-diagnostic value	Self-diagnostic value which related to the occurred error

Paper feed transport error logs are output.

**Remarks:**

- Only the CSV format file output is performed.
- Maximum output number: 1000



## User operation log

```
FAX OPERATION LOG,VERSION 3.0.0
20xx-xx-xx xx:xx
TOSHIBA e-STUDIOxxxx
Cxxxxxxxx
FIN S/N-xxxxxxxx
TOTAL,42737,691,5318,DF TOTAL,700
DATE-TIME,FUNCTION,OPERATION,TARGET,PARAMETER
04/07 17:03:40014,SYSTEM,Display Legacy UI,USERFUNCTION
04/07 17:05:04741,SYSTEM,Display Legacy UI,USERFUNCTION
04/07 17:05:14410,COMMON,Input Edit Done,UserAuthentication_ChangePassword_OldPasswordBox,*****
.
.
```

**Fig.5-22**

```
SIMPLE FAX USER OPERATION LOG,VERSION 3.0.0
20xx-xx-xx xx:xx
TOSHIBA e-STUDIOxxxx
Cxxxxxxxx
FIN S/N-xxxxxxxx
TOTAL,42737,691,5318,DF TOTAL,700
DATE-TIME,FUNCTION,OPERATION,TARGET,PARAMETER
04/07 17:03:40014,SYSTEM,Display Legacy UI,USERFUNCTION
04/07 17:05:04741,SYSTEM,Display Legacy UI,USERFUNCTION
04/07 17:05:14410,COMMON,Input Edit Done,UserAuthentication_ChangePassword_OldPasswordBox,*****
.
.
```

**Fig.5-23**

Item	Contents	Remarks
DATE-TIME	Operation date and time	Date and time that users operated
FUNCTION	Function name	FAX or COMMON or SYSTEM or Simple FAX COMMON: Common popup OK, Cancel, etc. SYSTEM: Switching functions to Legacy
OPERATION	Operation information	Information operated by the user
TARGET	Operation information	Supplementary information operated by the user
PARAMETER	Operation information	Supplementary information operated by the user

User operation logs related to the fax function are output.

### Remarks:

- Only the CSV format file output is performed.
- Maximum output number: 1000
- User information, such as a password, direct entry prohibited setting, mailbox, are not recorded.

## Setting change history

```

SETTING CHANGE HISTORY,VERSION 3.0.0
20xx-xx-xx xx:xx
TOSHIBA e-STUDIOxxxx
Cxxxxxxxx
FIN S/N-xxxxxxxx
TOTAL,42737,691,5318,DF TOTAL,700
"Date Time","OperationApplication","userName","settingValue","settingXPath","DomainName"
"20XX-04-13T18:17:00","Other","","0","/Network/Services/IPF/enabled",""
"20XX-04-13T17:17:25","Panel","Service","8","Category-08/C-8942",""
"20XX-04-06T20:28:37","Panel","Admin","terminalIP","Controller/Settings/IPFax/xxxx/xxxx",""
"20XX-04-06T20:26:04","TopAccess","admin","Manual","Controller/Settings/xx/xx/xx/xx/xx",""
.
.
.

```

Fig.5-24

Item	Contents	Remarks
Date Time	Change date time	Date and time when the user changed the settings
OperationApplication	Change operation source	Where the setting change operation was performed (Panel / TopAccess / Other)
userName	Change username	The part where the setting change operation was performed (user name with Admin / Service / Admin authority)
settingValue	Value after change	Value after change operation
settingXPath	Setting name	Setting name of the changed operation (xpath notation)
DomainName	Domain name	

Setting change logs of users are output.

### Remarks:

- Only the CSV format file output is performed.
- Maximum output number: 1000
- Settings which are automatically altered in accordance with the changes made to others are not included.
- When changes have been made by means of the remote service, the use of this service is also recorded.
- When changes have been made by batch processing with cloning, only the execution of cloning is recorded. Changes made to each setting are not recorded.
- When changes have been made by batch processing with the self-diagnostic batch setting, only changes made to each setting are recorded. The execution of the self-diagnostic batch setting is not recorded.
- User data, Home data and Template data are not included.
- Values of the user information, such as a password and IP address, are replaced with “\*”.

(05) adjustment value difference

05 DIFFERENCE LIST			S/N: xxxxxxxx			TOTAL: 9999999		
xx-xx-xx xx:xx			TOSHIBA e-STUDIOxxxx			DF TOTAL: 9999999		
CODE	BACKUP	CURRENT	CODE	BACKUP	CURRENT			
* 2400	128	160						
.	.	.						
.	.	.						
.	.	.						
.	.	.						
.	.	.						
.	.	.						
.	.	.						
.	.	.						
.	.	.						
.	.	.						
.	.	.						
.	.	.						

Fig.5-25

Item	Contents
CODE	A self-diagnostic code is described. "XXXX-YY" is described when a sub code exists.
BACKUP	Backup value
CURRENT	Current value

The differences of [05 ADJUSTMENT MODE] between the values at the factory shipment and the current are output.

**Remarks:**

- "\*" is added to the left side of the code if there is a difference.
- "+" is added to the left side of the code whose BACKUP data do not exist.
- BACKUP data are created when an easy-setup is finished.
- Only the codes available to set or check are output.
- Codes whose setting value at the time of the output is not unnecessary are not output (e.g.: setting time of the MFP).

**Notes:**

- Back-up data of the factory default are automatically created when the automatic gamma adjustment of the easy set-up mode has been completed during the unpacking and setting up of the MFP. The back-up file will be retained even if the system firmware is upgraded. However, the file will be deleted when the standard storage device is formatted or replaced.
- When the easy set-up mode is restarted while a specified value such as 4 through 9 is set for FS-08-9022 (Production process management status for easy setup), the back-up file stored during unpacking and setting-up is deleted after the completion of the automatic gamma adjustment and a new one is created. The value as of then is stored in the created back-up file.
- When no back-up file exists

When FS-30-121 (122) is performed, the MFP returns to the ready state of the 30 LIST PRINT MODE without printing being performed. When FS-30-221 (222) is performed, the MFP returns to the ready state of the 30 LIST PRINT MODE and the error message “The file cannot be saved.” appears on the panel.

(08) setting value difference

08 DIFFERENCE LIST			S/N: xxxxxxxx	TOTAL:	9999999
xx-xx-xx xx:xx			TOSHIBA e-STUDIOxxxx	DF TOTAL:	9999999
CODE	BACKUP	CURRENT	CODE	BACKUP	CURRENT
* 2400	128	160			
.	.	.			
.	.	.			
.	.	.			
.	.	.			
.	.	.			
.	.	.			
.	.	.			
.	.	.			
.	.	.			
.	.	.			
.	.	.			

Fig.5-26

Item	Contents
CODE	A self-diagnostic code is described. "XXXX-YY" is described when a sub code exists.
BACKUP	Backup value
CURRENT	Current value

The differences of [08 SETTING MODE] between the values at the factory shipment and the current are output.

**Remarks:**

- "\*" is added to the left side of the code if there is a difference.
- "+" is added to the left side of the code whose BACKUP data do not exist.
- BACKUP data are created when an easy-setup is finished.
- Only the codes available to set or check are output.
- Codes whose setting value at the time of the output is not unnecessary are not output (e.g.: setting time of the MFP).

**Notes:**

- Back-up data of the factory default are automatically created when the automatic gamma adjustment of the easy set-up mode has been completed during the unpacking and setting up of the MFP. The back-up file will be retained even if the system firmware is upgraded. However, the file will be deleted when the standard storage device is formatted or replaced.
- When the easy set-up mode is restarted while a specified value such as 4 through 9 is set for FS-08-9022 (Production process management status for easy setup), the back-up file stored during unpacking and setting-up is deleted after the completion of the automatic gamma adjustment and a new one is created. The value as of then is stored in the created back-up file.
- When no back-up file exists

When FS-30-121 (122) is performed, the MFP returns to the ready state of the 30 LIST PRINT MODE without printing being performed. When FS-30-221 (222) is performed, the MFP returns to the ready state of the 30 LIST PRINT MODE and the error message “The file cannot be saved.” appears on the panel.

## FAX function mode (13) data list

```

13 FAX FUNCTION LIST FOR MAINTENANCE,VERSION x.x.x
20xx/xx/xx xx:xx:xx
TOSHIBA e-STUDIOxxxx
Cxxxxxxxx

TOTAL, 9999999, 9999999, 9999999, DF TOTAL, 9999999
CODE, SUB, DATA,
100, , 0
101, , 1
102, , 2
103, , 3
104, , 4
105, , 5
106, , 6
107, , 7
108, , 8
109, , 9
110, , 0
111, , 1
112, , 2

. .
. .
. .
. .
. .
. .

```

Fig.5-27

Item	Contents
CODE	Self-diagnostic code
SUB	Sub code (This will be blank if a sub code does not exist.)
DATA	Value of the code

The codes and the current setting value are output in a list.

### Remarks:

Only the codes available to set or check are output.

## Application list

APPLICATION LIST		S/N : Cxxxxxxx	TOTAL	: 2146
20xx-xx-xx xx:xx		TOSHIBA e-STUDIOxxxx	DF TOTAL	: 1213
APPLICATION				
NAME	APP ID/LOCALE	VERSION		
e-Bridge Plus for xxxx	xxxxxxx-xxxx-xxxx-xxxxxxxxxxxx	1.0.0		
	English(US)	1.2.1		
e-Bridge Plus for xxxxxxxxxxxxxxxxxxxxxxxx xx xxxxxxxx	xxxxxxx-xxxx-xxxx-xxxxxxxxxxxx	1.0.0		
	English(US)	1.2.2		
	English(GB)	1.1.1		
	Japanese	1.3.1		
.				
.				
APPLICATION LICENSE				
NAME	APP ID	INSTALL DATE		
e-Bridge Plus for xxxx	xxxxxxx-xxxx-xxxx-xxxxxxxxxxxx	20xx-xx-xxTxx:xx:xx		
e-Bridge Plus for xxxxxxxxxxxxxxxxxxxxxxxx xx xxxxxxxx	xxxxxxx-xxxx-xxxx-xxxxxxxxxxxx	20xx-xx-xxTxx:xx:xx		
.				
.				
UNIFIED LICENSE				
NAME	CERTIFICATE NUMBER	STATUS	DAYS	INSTALL DATE
e-Bridge Plus for xxxx	XXXXXXXXXX	ENABLE	xxxx	20xx-xx-xx
e-Bridge Plus for xxxxxxxxxxxxxxxxxxxxxxxx xx xxxxxxxx	XXXXXXXXXX	DISABLE	-	20xx-xx-xx
.				
.				

Fig.5-28

### Applications

Item	Contents
NAME	Application name
APP ID/LOCALE	Application ID or language
VERSION	Version of the application or language

### Application license

Item	Contents
NAME	Application name
APP ID	Application ID
INSTALL DATE	Installation date of the license

### UNIFIED license

Item	Contents
NAME	License name
CERTIFICATE NUMBER	License certificate ID
STATUS	License status (Enable or Disable)
DAYS	Valid period of the license
INSTALL DATE	Installation date of the license



Installed application and license information are output.

**Remarks:**

The maximum output numbers are as below.

Application: 30 (Up to 100 applications can be output by changing the setting value of FS-08-3798.)

Application license: 100

UNIFIED license: 100

# Life counter clear log

UNIT	DATE	TOTAL	OUTPUT PAGES	DRIVE COUNTS
Drum(K)	20xx-06-01	xxxxxx	xxxxxx	xxxxxxxx
	20xx-07-01	xxxxxx	xxxxxx	xxxxxxxx
	20xx-08-01	xxxxxx	xxxxxx	xxxxxxxx
	20xx-09-01	xxxxxx	xxxxxx	xxxxxxxx
	20xx-10-01	xxxxxx	xxxxxx	xxxxxxxx
Drum Blade (K)	20xx-06-01	xxxxxx	xxxxxx	xxxxxxxx
	20xx-07-01	xxxxxx	xxxxxx	xxxxxxxx
	20xx-08-01	xxxxxx	xxxxxx	xxxxxxxx
	20xx-09-01	xxxxxx	xxxxxx	xxxxxxxx
	20xx-10-01	xxxxxx	xxxxxx	xxxxxxxx
Grid (K)	20xx-06-01	xxxxxx	xxxxxx	xxxxxxxx
	20xx-07-01	xxxxxx	xxxxxx	xxxxxxxx
	20xx-08-01	xxxxxx	xxxxxx	xxxxxxxx
	20xx-09-01	xxxxxx	xxxxxx	xxxxxxxx
	20xx-10-01	xxxxxx	xxxxxx	xxxxxxxx
Main Charger Needle (K)	20xx-06-01	xxxxxx	xxxxxx	xxxxxxxx
	20xx-07-01	xxxxxx	xxxxxx	xxxxxxxx
	20xx-08-01	xxxxxx	xxxxxx	xxxxxxxx
	20xx-09-01	xxxxxx	xxxxxx	xxxxxxxx
	20xx-10-01	xxxxxx	xxxxxx	xxxxxxxx
Charger Cleaning Pad (K)	20xx-06-01	xxxxxx	xxxxxx	xxxxxxxx
	20xx-07-01	xxxxxx	xxxxxx	xxxxxxxx
	20xx-08-01	xxxxxx	xxxxxx	xxxxxxxx
	20xx-09-01	xxxxxx	xxxxxx	xxxxxxxx
	20xx-10-01	xxxxxx	xxxxxx	xxxxxxxx
Drum Gap Spacer (K)	20xx-06-01	xxxxxx	xxxxxx	xxxxxxxx
	20xx-07-01	xxxxxx	xxxxxx	xxxxxxxx
	20xx-08-01	xxxxxx	xxxxxx	xxxxxxxx
	20xx-09-01	xxxxxx	xxxxxx	xxxxxxxx
	20xx-10-01	xxxxxx	xxxxxx	xxxxxxxx
Pick Up Roller(1st CST.)	20xx-06-01	xxxxxx	xxxxxx	xxxxxxxx
	20xx-07-01	xxxxxx	xxxxxx	xxxxxxxx
	20xx-08-01	xxxxxx	xxxxxx	xxxxxxxx
	20xx-09-01	xxxxxx	xxxxxx	xxxxxxxx
	20xx-10-01	xxxxxx	xxxxxx	xxxxxxxx
Feed Roller(1st CST.)	20xx-06-01	xxxxxx	xxxxxx	xxxxxxxx
	20xx-07-01	xxxxxx	xxxxxx	xxxxxxxx
	20xx-08-01	xxxxxx	xxxxxx	xxxxxxxx
	20xx-09-01	xxxxxx	xxxxxx	xxxxxxxx
	20xx-10-01	xxxxxx	xxxxxx	xxxxxxxx
Sep Roller(1st CST.)	20xx-06-01	xxxxxx	xxxxxx	xxxxxxxx
	20xx-07-01	xxxxxx	xxxxxx	xxxxxxxx
	20xx-08-01	xxxxxx	xxxxxx	xxxxxxxx
	20xx-09-01	xxxxxx	xxxxxx	xxxxxxxx
	20xx-10-01	xxxxxx	xxxxxx	xxxxxxxx
Pick Up Roller(2nd CST.)	20xx-06-01	xxxxxx	xxxxxx	xxxxxxxx
	20xx-07-01	xxxxxx	xxxxxx	xxxxxxxx
	20xx-08-01	xxxxxx	xxxxxx	xxxxxxxx
	20xx-09-01	xxxxxx	xxxxxx	xxxxxxxx
	20xx-10-01	xxxxxx	xxxxxx	xxxxxxxx
Feed Roller(2nd CST.)	20xx-06-01	xxxxxx	xxxxxx	xxxxxxxx
	20xx-07-01	xxxxxx	xxxxxx	xxxxxxxx
	20xx-08-01	xxxxxx	xxxxxx	xxxxxxxx
	20xx-09-01	xxxxxx	xxxxxx	xxxxxxxx
	20xx-10-01	xxxxxx	xxxxxx	xxxxxxxx
Sep Roller(2nd CST.)	20xx-06-01	xxxxxx	xxxxxx	xxxxxxxx
	20xx-07-01	xxxxxx	xxxxxx	xxxxxxxx
	20xx-08-01	xxxxxx	xxxxxx	xxxxxxxx
	20xx-09-01	xxxxxx	xxxxxx	xxxxxxxx
	20xx-10-01	xxxxxx	xxxxxx	xxxxxxxx
.				
.				

Fig.5-29

Item	Contents
UNIT	Cleared unit name
DATE	Cleared date
TOTAL	Total counter at the time of clear
OUTPUT PAGES	Number of output pages of the unit at the time of clear
DRIVE COUNTS	Drive time of the unit at the time of clear

The clear history of the PM part counter is output.

**Remarks:**

Maximum output number: 200

## 5.11 FAX

Adjustment [Setup Fax] and setting of the fax function can be carried out.

Select [FAX] in the FS Menu and press [Next]. The following modes are displayed.

- 11 FAX CLEAR MODE
- 12 FAX LIST PRINT MODE
- 13 FAX FUNCTION MODE
- 19 RAM EDIT MODE

### Notes:

The data automatically received during the self-diagnostic mode are sometimes not printed.

Therefore, be sure to disconnect the modular cord from the line connector (LINE1, LINE2) of the MFP before starting the self-diagnostic mode. After the MFP is released from the self-diagnostic mode, reconnect the modular cord.

### 5.11.1 11 FAX CLEAR MODE

Select [FAX] in the FS Menu and press [Next]. Select [11 FAX CLEAR MODE] and press [Next]. [Setup Fax] and [Custom Initialize] are displayed.

#### [A] [Setup Fax]

The region of the fax can be set.

- (1) Press [Setup Fax].
- (2) Select the region and press [OK].

#### [B] [Custom Initialize]

Various fax memories can be initialized.

- Memory areas
  - User registration area (SRAM)
    - ID registration area
    - Home position
  - Image data area (storage device, SRAM)
    - Transmission file
    - Reception file
    - Image data file management area
    - Mailbox information
  - System setting area (NVRAM)
    - Settings in the [13 FAX FUNCTION MODE] areas 100 - 999
- Operation
  - (1) Press [Custom Initialize].
  - (2) Select the mode.
    - [Init Memory (Fax)], [Init Memory (IP Fax)]: Initializes the user registration area (SRAM) so that there are no data stored. Initializes the system setting area (NVRAM) so that its value is reset to the default setting.
    - [Clear Data]: Initializes the image data area (storage device, SRAM) so that there are no data stored.
    - [System Setup (Fax)], [System Setup (IP Fax)]: Initializes the system setting area (NVRAM) so that its value is reset to the default setting.

## 5.11.2 12 FAX LIST PRINT MODE

The setting contents of the fax function can be output.

- (1) Select [FAX] in the FS Menu and press [Next]. Select [12 FAX LIST PRINT MODE] and press [Next].
- (2) Select the list to output and press [Print].

The names of the lists in [12 FAX LIST PRINT MODE] are shown below.

Protocol trace list (Line 1)  
Protocol trace list (Line 2)  
Protocol trace list (IP Fax)  
Error count list (transmis./recept.) (Line 1)  
Error count list (transmis./recept.) (Line 2)  
Error count list (transmis./recept.) (IP Fax)  
ERROR COUNT LIST (IFAX)  
ERROR COUNT LIST (SCAN)  
Function List for Maintenance  
Memory dump list (system)  
Memory dump list (FAX/LINE1)  
Memory dump list (FAX/LINE2)  
SUPPLY ORDER LIST

## 5.11.3 13 FAX FUNCTION MODE

Various fax functions can be set.

Operation procedure: Refer to the SELF-DIAGNOSIS CODE (separate document).

## 5.11.4 19 RAM EDIT MODE

This is the mode for the special adjustments and settings. (This is not used generally.)

## 5.12 35 DATA BACKUP/RESTORE MODE

Backup files of the storage in the MFP can be saved (backed up) in a USB storage device or an external server and those saved backup files can be restored in the storage of the MFP.

- (1) Select [35 DATA BACKUP/RESTORE MODE] in the FS Menu and press [Next].  
[Data Backup] and [Data Restore] are displayed.
- (2) Select [Data Backup] or [Data Restore] and press [Next]. Press [USB Media].
- (3) Insert a USB storage device into the MFP and press [OK]. Backing up or restoring of the data starts.

### Remarks:

For details, see below.

 P. 12-7 “12.3 Backing Up and Restoring Data”

## 5.13 36 CLONING

A clone file including the setting information of this MFP and the user information can be created and clone files can be installed in this MFP.

For details, see below.

 P. 12-4 “12.2 Cloning (FS Menu)”

## 5.14 37 LICENSE MANAGEMENT

The application license can be registered or deleted.

For details, refer to the “License Management MANUAL” (separate document).

## 5.15 38 DEACTIVATE RELEASE MODE

Detached devices can be reconnected.

- (1) Press [Select] of the device to be reconnected.
- (2) Press [Execute].
- (3) Reboot the MFP.

### Notes:

This operation must be carried out after the repairing of the detached device has been finished.

### Remarks:

The same operation can be carried out with “77 Detach Release” of the HS Menu.

## 5.16 01 Control Panel Check

The following items can be checked.

- LCD back light illumination and brightness
- LCD display
- Hard keys performance
- LEDs illumination
- Digital keys performance
- LCD touch sensor
- USB storage device connection

### Notes:

To check the performance of the digital keys, connect the ten key option before starting this mode.

### 5.16.1 Screen transition

#### Notes:

It is not possible to return to the HS Menu from [01 Control Panel Check]. To quit [01 Control Panel Check], display the LCD back light check screen A and then press the [ON/OFF] button for a few seconds to shut down.

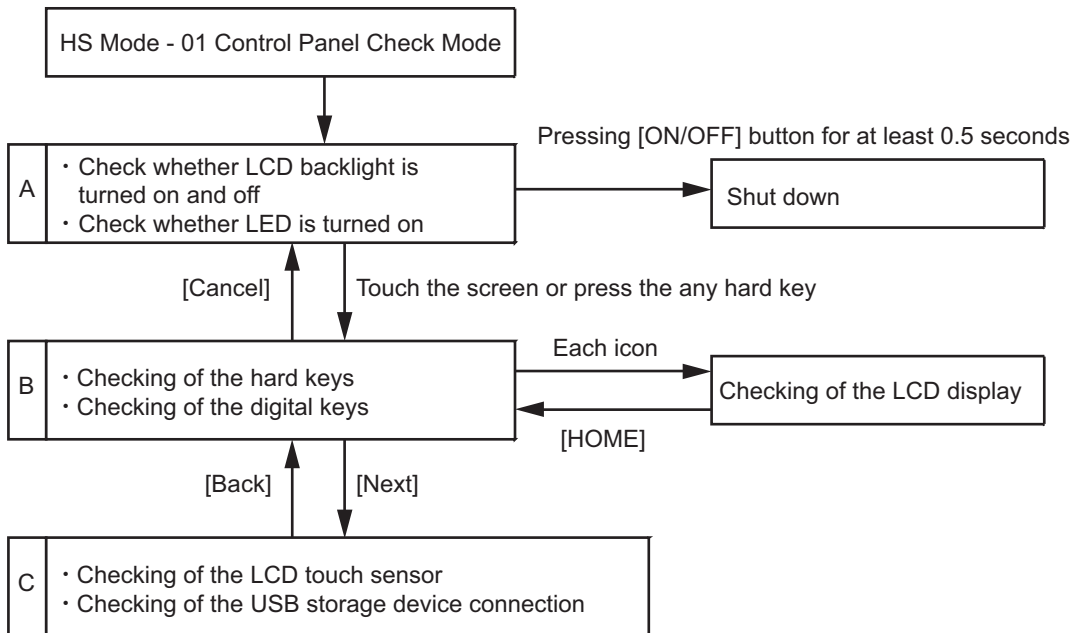

Fig.5-30

## 5.16.2 Checking of the LCD back light and LEDs

By pressing [01 Control Panel Check], the LCD back light blinks in 3-second intervals. Moreover, all LEDs are lit.

### Remarks:

By touching the screen or pressing any hard key, the screen is shifted to the hard key confirmation screen.

## 5.16.3 Checking of the LCD display, hard keys and digital keys

### [A] Checking of the LCD display

By pressing the icon on the touch panel, the LCD display (pictures 1 to 15) confirmation screen is displayed.

### Remarks:

The screen is returned to this one when the [HOME] button is pressed on each screen.

### [B] Checking of the hard keys

By pressing each hard key, a particular text is displayed and the lighting condition of the LED is changed. The following table shows each text and performance when the hard key is pressed.

Hard key	Text	Performance
POWER (pressing for at least 0.5 seconds)	MAIN POWER	The [MEMORY RX] LED is turned OFF.
ENERGY SAVER	ENERGY SAVER	The [ENERGY SAVER] LED is turned OFF.
ACCESS	ACCESS	The [PRINT DATA] LED is turned OFF.
HOME	HOME	The [!] LED is turned OFF.
Programmable key 1	P-1	The LCD back light is made darker by each pressing. (10 levels)
Programmable key 2	P-2	The LCD back light is made lighter by each pressing. (10 levels)
FUNCTION CLEAR	FUNCTION CLEAR	The [FUNCTION CLEAR] LED is turned OFF.
START	START	The [START] LED is turned OFF.

The text is displayed only while the key is being pressed. Each LED is turned OFF only while the key is being pressed.

### [C] Checking of the digital keys for the Ten Key option

By pressing each digital key, a particular text is displayed. The following table shows each text when the digital key is pressed.

Digital key	Text
1	OP-1
2	OP-2
3	OP-3
4	OP-4
5	OP-5
6	OP-6
7	OP-7
8	OP-8
9	OP-9
0	OP-0
*	OP-*
#	OP-#
C	OP-CLEAR

**Remarks:**

- By pressing the icon on the screen, the LCD display confirmation screen is displayed.
- By pressing [Next] in the LCD display, the screen is shifted to the LCD touch sensor and USB storage device confirmation screen.

### 5.16.4 Checking of the LCD touch sensor and USB storage device connection

The screen is shifted to the LCD touch sensor and USB storage device confirmation screen by pressing [Next].

**[A] Checking of the LCD touch sensor**

It can be checked whether the operations of swipe, pinch-out (enlargement) and pinch-in (reduction) are correctly detected on the screen. When the above operation is performed on the screen, an arrow which indicates the one detected by the touch sensor and a message are displayed.

Moreover, when any of [LH], [LL], [RH] or [RL] located on each corner of the screen is pressed, the calibration condition of the touched position can be checked.

**[B] Checking of the USB storage device connection**

It can be checked whether a USB storage device inserted into the USB port is connected properly. Install a USB storage device in the USB port and press the [START] button.

When a USB storage device is connected properly, [USB Connection Success] is displayed. If not, [USB Connection Failed] is displayed.

**Remarks:**

It is not possible to return to the HS Menu from [01 Control Panel Check]. To quit [01 Control Panel Check], display the LCD back light check screen and then press the [ON/OFF] button for a few seconds to shut down.



## 5.17 73 Firmware Assist

### 5.17.1 Overview

The following operations can be carried out; standard storage device and optional storage device partition, SRAM data initialization, standard storage device and SRAM data deletion, encryption key and license backing up and restoration.

The following table shows the functions in this mode.

Function	Contents
Clear Software Update Error Flag	Clears an update error flag.
Format Root Partition	Initializes data storage partition of the standard storage device.
Format Storage	Creates a partition in a standard storage device and optional storage device.
Key Backup/Restore	Backs up or restores the encryption key and license.
Erase Storage Securely	Erases data in a normal HDD securely.
Clear Service Tech Password	Initializes the service password.
Clear SRAM	Initializes SRAM data.
Erase SRAM Securely	Erases data in the SRAM securely.
Format Storage Without Key Generation	Creates a partition in a standard storage device without having to upgrade the key.
Storage Data Restore	Performs initializing, backup data restoring and firmware upgrading in a series in a standard storage device and an optional storage device.

### 5.17.2 Operation procedure

- (1) Press [73 Firmware Assist].
- (2) Press the icon to operate.

### 5.17.3 Functions

#### [A] Clear Software Update Error Flag

Even if the firmware downloading has been completed normally, the recovery mode may accidentally start up and an F600 error (service call) occurs when the power is turned ON again. In this case, clear the Update Error flags used in the download process with this function. (Normally, the flags are automatically cleared in the download process.)

Moreover, in the case of the recovery mode accidentally starting up after the replacement of the SRAM, the flags are cleared with this function.

#### [B] Format Root Partition

When a defect occurs on the UI data, etc. which are stored in the standard storage device, the partition with the stored UI data, etc. is initialized with this function.

Do not use this function since it is not normally necessary.

The system firmware must be installed after performing this function.

#### [C] Format Storage

After the standard storage device is replaced, when UI data are downloaded using a USB storage device, it is necessary to create a partition in the standard storage device of this MFP before downloading.

#### Notes:

- When this operation has been done, all data in the standard storage device and optional storage device are erased. Therefore, perform this only when a new standard storage device is installed.
- When this operation has been done, do not perform SRAM data initialization (Clear SRAM) before the normal startup.

#### [D] Key Backup/Restore

When the SRAM or the SYS board is replaced or initialized, the encryption key and license are erased. Therefore, they need to be backed up or restored with this function.

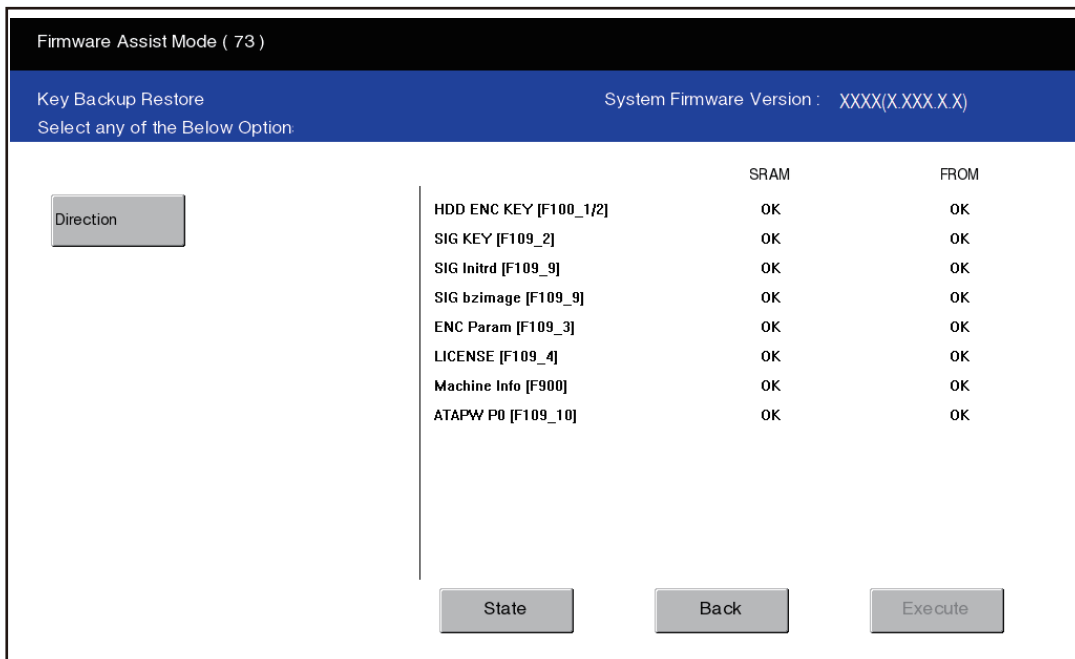

Fig.5-31

- (1) When “KeyBroken” or “KeyNull” is displayed on the FROM row, press [Direction] once and then [Execute].

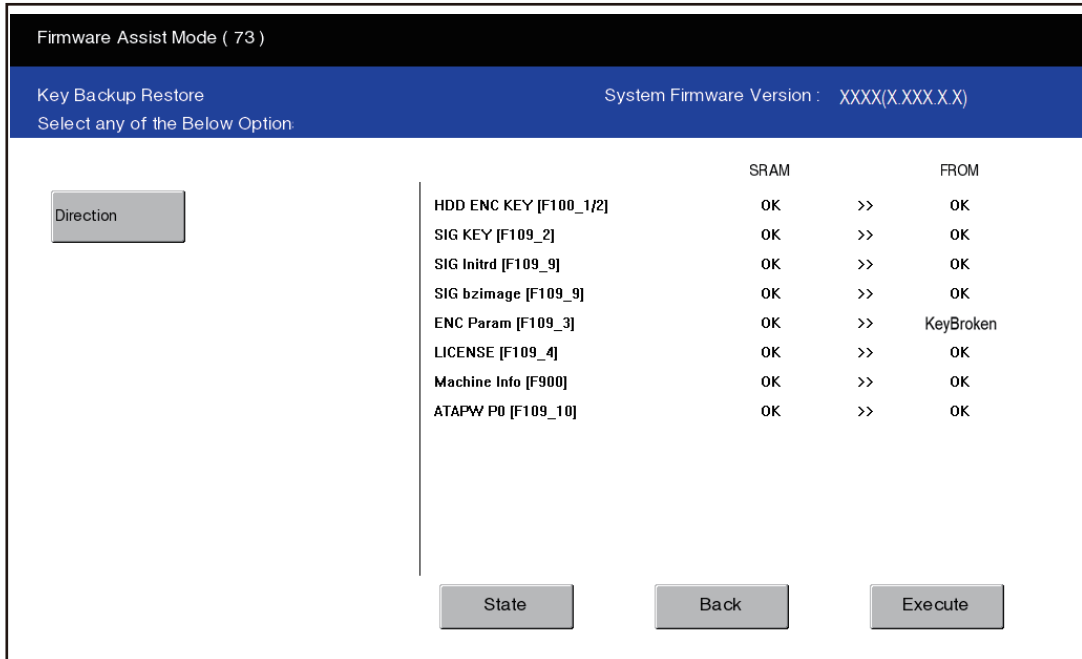

Fig.5-32

The encryption key and license of the SRAM are recovered in the FROM.

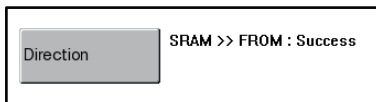

Fig.5-33

- (2) When “KeyBroken” or “KeyNull” is displayed on the SRAM row, press [Direction] twice and then [Execute].

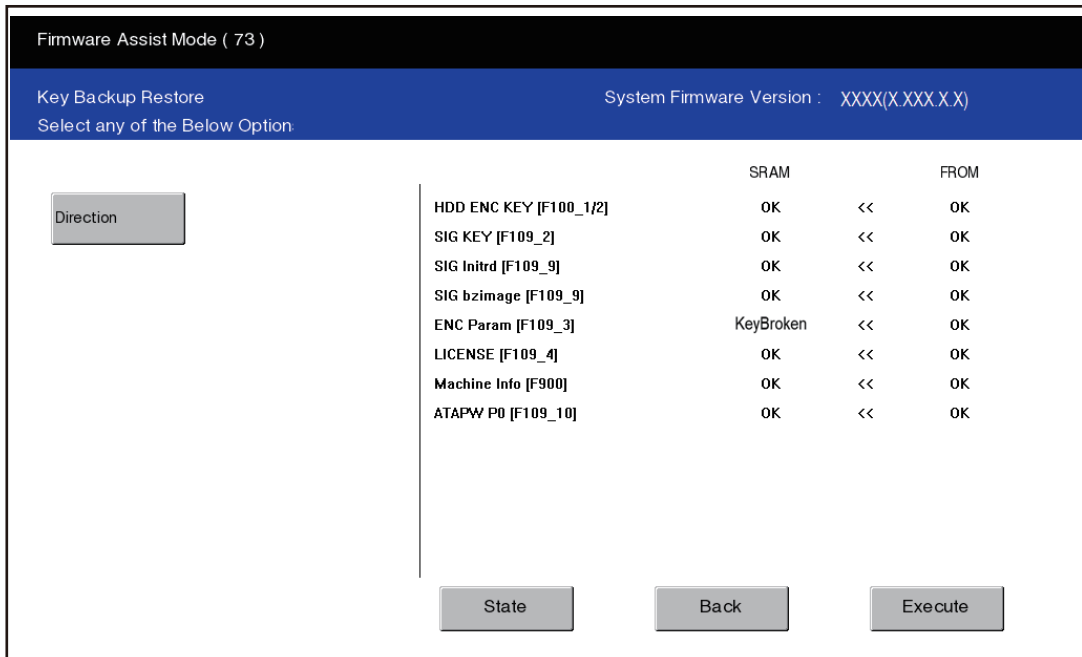

Fig.5-34

The encryption key and license of the FROM are backed up in the SRAM.

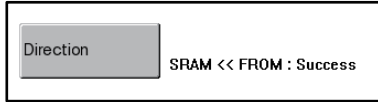

Fig.5-35

### [E] Erase Storage Securely

This function is used before a normal HDD is disposed of. This overwrites all the used areas on the HDD with the selected data and makes it unusable. After selecting this function, specify the level below to be overwritten. This setting is the overwriting method complying with DoD 5220.22-M.

LOW (Normally use this setting.)

This is the standard overwriting method.

“00-FF-Random-Verify” Once

MEDIUM

This overwriting method is more secure than LOW.

The erasing time is between LOW and HIGH.

“00-FF-Random” three times repeatedly -Verify

HIGH

This is the most secure overwriting method.

It takes the longest time to erase data.

“00-FF-Random” five times repeatedly -Verify

SIMPLE

This is the simple overwriting method.

It takes the shortest time to erase data.

Overwrite the Random data once

The reconfirmation screen is displayed when the icon is pressed. Press [OK]: Processing starts.  
Press [Back]: The screen returns to the previous one.

#### Notes:

When this operation has been done, do not perform SRAM data initialization (Clear SRAM) before the normal startup.

### [F] Clear Service Tech Password

This function is necessary after the standard storage device is replaced.

When the standard storage device is replaced, the service password is set as a blank in the new one. Therefore, the service password does not match the one saved in the SRAM. In this function, the service password is copied from the SRAM to a new standard storage device so that both service passwords become the same. The setting is reflected when the MFP is started up in the normal mode.

### [G] Clear SRAM

When the SRAM is replaced with a new one, abnormal values may be written in the new SRAM. In this case, SRAM data must be initialized with this function.

#### Notes:

- This function is required only when a new SRAM is installed.
- When this operation has been done, all data in the SRAM are erased. Therefore, perform this only when a new SRAM is installed.
- After this operation has been done, do not perform the initialization and formatting of the standard storage device before starting the MFP in the normal mode.

### [H] Erase SRAM Securely

This function is used before discarding the SRAM.

This overwrites all the used areas on the SRAM with the selected data and makes it unusable. Immediately after selecting this function, the processing starts.

## [I] Format Storage Without Key Generation

This creates a partition in a standard storage device without having to upgrade the key. When an optional storage device is installed, a partition is created in both a standard storage device and an optional storage device.

## [J] Storage Data Restore

This performs initializing, backup data restoring and firmware upgrading in a series in a standard storage device and an optional storage device.

### Notes:

- Perform this function only after the standard storage device or the optional storage device is replaced or when there will be no problem even if all the information in those devices is erased.
- Perform this function only when a USB storage device (\*), in which the backup data and the firmware standard package are stored, is prepared.
  - \* It is available even if these 2 files are stored in different USB storage devices separately.

- (1) Install the USB storage device with the back-up data stored in the MFP.
- (2) Perform this function.
  - Initialize the standard storage device and restore the back-up data.
  - If the firmware standard package is stored in this USB storage device, continuously upgrade the firmware.
  - If the firmware standard package is not stored in this USB storage device, an error appears. In such a case, install the USB storage device with the firmware standard package stored in the MFP and press [OK]. Firmware upgrading will start.
  - After upgrading is completed, reboot the MFP.

## 5.18 74 Storage Assist Mode

### 5.18.1 Overview

The type of the standard storage device and optional storage device can be checked and the condition of those devices can be returned to the one at the time of factory shipment.

74 Storage Assist function

- Checks the type of the storage device connected.
- Disposes of the connected storage device safely without any data leakage.
- Deletes image data when reusing a used storage device.

### 5.18.2 Operation procedure

- (1) Press [74 Storage Assist].  
The type of the storage connected is displayed.  
When a Secure HDD is mounted: Secure HDD  
When a Normal HDD is mounted: Normal HDD  
When an SSD is mounted: SSD
- (2) Press the icon to operate.

**Notes:**

- When “Normal HDD” is displayed, this function cannot be performed. In such a case, the following error message appears.  
“Operation Failed. Press SoftPower Key to Switch Off.”
- If the type of the storage device cannot be identified, “Unknown HDD” may appear.  
 P. 8-231 “ [F106\_1] Optional storage device error”

### 5.18.3 Functions

#### [A] Revert Factory Initial Status Storage

This function is used to dispose of the connected storage device as well as the MFP.

When this function is executed, all data in the storage device are deleted and it is reverted to its initial status at the factory shipment.

Data deletion requires only a few seconds. In order to make it usable again, the creation of the partition is necessary.

- (1) Press [Revert Factory Initial Status Storage].
- (2) Press [OK] to carry out the operation.  
When the operation is finished, the result appears on the screen.

**Notes:**

- If the MFP is started up in the normal mode under this condition, a service call (storage device mount error) will occur.
- After this has been performed, clearing of the storage device and reinstallation of applications are necessary.

## 5.19 75 File System Recovery

### 5.19.1 Overview

This is a mode to check if there is any damage to the file system and recover it if necessary. Use this mode only in the following cases.

- There is a possibility of damage to the file system.
- There is apparent damage to the file system, requiring recovery or initialization.

The following table shows the functions in this mode.

Function	Contents
Check F/S	Checks the file system.
Recovery F/S	Recovers the file system.
Initialize Storage	Initializes a partition in standard and optional storage devices.
Initialize DB	Initializes database (LDAP DB, log DB, language DB, AppMgmt DB, HomeScreen DB, JobHistory DB, AppLicense DB).
SMART Info	Displays the various information in standard and optional storage devices.
DISK Info	Displays the usage rate of each partition.
Storage Utility	Initializes log files.

### 5.19.2 Operation procedure

- (1) Press [75 File System Recovery].
- (2) Press the icon to operate.

**Notes:**

- Do not turn the power OFF after the processing has started (while the processing is being performed).
- After the processing is completed, a beep sounds 4 times and either “Completed” or “Failed” appears on the screen.

### 5.19.3 Functions

#### [A] Check F/S

In case that particular service calls occur or there is a possibility of damage to the file system, the status of each partition can be checked.

Explanation for each item

ALL: Checks all partitions.

/: Checks all root partition only.

Others: Checks each partition shown above.

**Remarks:**

More than one partition can be selected. (A check mark is displayed at the selected item.)

**Notes:**

If damage is found, recover or initialize the file system.

## **[B] Recovery F/S**

In case that an error occurs during the file system check, each partition can be recovered.

Explanation for each item

ALL: Recovers all partitions.

/: Recovers root partition only.

Others: Recovers displayed each partition.

### **Remarks:**

More than one partition can be selected. (A check mark is displayed at the selected item.)

### **Notes:**

If an error occurs during recovery, initialize the file system.

## **[C] Initialize Storage**

In case that an error occurs during the file system checking and the partition cannot be recovered with the recovery, each partition can be initialized.

It is recommended to export the user information such as the address book before performing this function.

Explanation for each item

ALL: Initializes partitions other than root one and creates initial files.

Others: Initializes each partition.

### **Remarks:**

More than one partition can be selected. (A check mark is displayed at the selected item.)

### **Notes:**

- Install the system software by performing HS-49 after initialization.
- If initialization is carried out by selecting [ALL], the log database is also initialized. Back up the data before initializing if necessary.
- If [ALL] is selected, do not perform SRAM data formatting (Clear SRAM) before the normal startup.

## **[D] Initialize DB**

In case that particular service calls occur or there is a possibility of damage to the database, each one can be initialized.

Explanation for each item

LDAP DB: Initializes address book data and the user information database.

Log DB(Log,Msg): Initializes the job log database and the message database.

Language DB: Initializes the language database.

AppMgmt DB: Initializes the application database.

HomeScreen DB: Initializes the home screen database.

JobHistory DB: Initializes the job history database.

AppLicense DB: Initializes the application license database.

ULM DB: Initializes the license manager database.

FingerPrint DB: Initializes the fingerprint database.



## **[E] SMART Info**

This function is used to display the various types of information of the storage connected. (Data equivalent to the setting contents of FS-08-9065 are displayed.)

The various types of information of the storage connected are displayed once this function is carried out. “---” is displayed for the items not supported.

### **Remarks:**

- NAV (Normalized Attribute Value): Indicates the value of the specified storage device condition as compared to the manufacturer's optimum value.
- Worst (Worst Ever Normalized Attribute Value): Indicates the worst value of NAV permitted by the manufacturer.

### **Notes:**

The values of NAV and Worst should be treated as a rough reference since their basis may differ depending on the specification of the storage device.

## **[F] DISK Info**

The usage rate of each partition can be checked.

When this function is executed, the usage rate of each partition is displayed.

## **[G] Storage Utility**

Log files for researching can be deleted. Since only a certain amount of log files for researching is usually stored in the work area of a storage device, the use of this mode is not necessary. In case the performance level of the MFP is lowered (e.g.: the response of the control panel becomes extremely slow), make use of this mode. This phenomenon may be resolved.

## 5.20 76 SRAM Maintenance

### 5.20.1 Overview

This is a mode in which you can clear particular errors such as F800 or F900.  
The processing contents of this mode are the same as those for [Clear SRAM] in [HS-73].

Functions of 76 SRAM Maintenance

- The serial number of this MFP can be set.
- An F800 error can be cleared.
- An F900 error can be cleared.

### 5.20.2 Operation procedure

- (1) Press [76 SRAM Maintenance].
- (2) Press the icon to operate.

#### Remarks:

- [Turn Line Mode ON] or [Turn Line Mode OFF] starts once each icon is pressed.
- When [Set Serial Number], [Reset Date and Time], [SRAM Re-Initialize] or [Clear SRAM] is pressed, the confirmation screen appears.

### 5.20.3 Functions

#### [A] Turn Line Mode ON

The MFP enters into the manufacturing mode.

#### [B] Turn Line Mode OFF

The MFP returns from the manufacturing mode.

#### [C] Set Serial Number

When replacing the SYS-SRAM, select this mode since it is necessary to set the serial number of the MFP in order to perform recovery by using SRAM backup data. Key in the serial number and press [OK]. Then the serial number is set in the SYS-SRAM.

- Clear SRAM first and then set the serial number in this mode.
- After setting, perform recovery by using SRAM backup data.  
 P. 12-2 “12.1.4 Cloning procedure”

#### [D] Reset Date and Time

Select this to clear an F800 error which occurred when the date and time were set as after the end of the year 2037 or when the actual end of the year 2037 has come.

- After executing this, start the MFP in the normal mode to reset the date and time.

#### [E] SRAM Re-Initialize

Clear an F900 error with this item, since it cannot be cleared if the SRAM and the SYS board are replaced together or when the SRAM is initialized with incorrect model information when it is replaced.

- After performing [Clear SRAM], carry out this function.
- Then perform initialization by following the replacement procedure of the SRAM.  
 P. 9-28 “9.2.5 Precautions and procedure when replacing the SRAM”

## **[F] Clear SRAM**

Select this to clear all SRAM data when replacing the SRAM.

- After replacing the SRAM, clear the SRAM data with this function.
- Then perform initialization by following the replacement procedure of the SRAM.  
 P. 9-28 “9.2.5 Precautions and procedure when replacing the SRAM”

### **Notes:**

After this operation has been done, do not perform the initialization and formatting of the standard storage device before starting the MFP in the normal mode.

## 5.21 77 Detach Release

Detached devices can be reconnected.

- (1) Press [Select] of the device to be reconnected.
- (2) Press [Execute].
- (3) Reboot the MFP.

**Notes:**

This operation must be carried out after the repairing of the detached device has been finished.

**Remarks:**

The same operation can be carried out with “38 DEACTIVATE RELEASE MODE” of the FS Menu.

## 5.22 78 Option Storage Assist

Formatting and disabling of the optional storage device can be done.

**[A] Format Option Storage**

When an optional storage device has become broken, the MFP will not be able to start. Therefore, format it by starting this function.

**[B] Disable Option Storage**

When an optional storage device has been removed, disable its setting by means of this function.

**Notes:**

The setting can be disabled only when the optional storage device is as below.

- SSD and normal HDD
- Security HDD to which “0” is set for 08-9717-1

**[C] Initialize Option Storage**

When an optional storage device does not work properly, perform this function. After the optional storage device is formatted, data in the standard storage device are moved to the optional storage device and it is initialized again.

**[D] Restore Option Storage Settings**

When an SRAM is replaced, the optional storage device settings are restored in it.

## 5.23 TPM Restore

Restores TPM information.

### Notes:

- This function is displayed and becomes operable, only after the SYS board has been replaced in an MFP in which TPM is enabled.
  - TPM information is important for users. Therefore, request users to enter a part of the information.
- (1) Install the USB storage device. (Operation by a user)
  - (2) Start the HS Menu.
  - (3) Press [TPM].

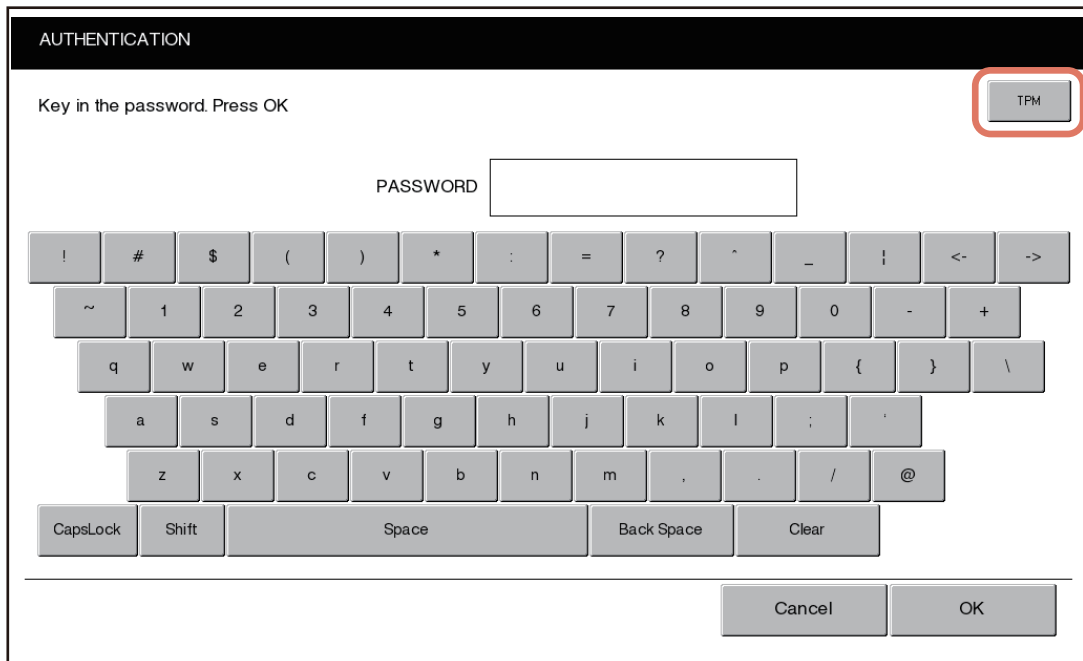

Fig.5-36

- (4) Enter the service password and press [OK].
- (5) Enter the password used when the TPM information has been backed up. (Operation by a user)
- (6) Press [Restore].
- (7) When "Operation Completed" appears, remove the USB storage device. (Operation by a user)
- (8) Turn the power OFF.

## 5.24 Batch Setting for Self-Diagnostic Codes

### 5.24.1 Overview

The encrypted setting files in which each setting value has been written can be stored in a USB storage device. Installing this USB storage device in the MFP and reading a setting file enables the batch setting for the self-diagnostic codes.

- After the batch setting is performed, a result file is stored in the USB storage device.

**Notes:**

This function is not available if an automatic execution script such as a log collection is stored in a USB storage device.

### 5.24.2 Setting files

An encrypted file in which the setting values for each code to be changed is written

File name: Apply a name by employing the usable characters for a FAT32 format (extension: diag).

**Notes:**

- A setting file has to be located in the 1st or 2nd layer of the root folder of a USB storage device.
- No other automatic execution script has to be located in the same layer in which a setting file is stored.
- Even if writing of the setting values has failed, the processing will not stop and writing into the setting file will continue to its end. After the processing has been completed, the result of the writing of all codes is stored in a result file and then a message indicating partial success will be displayed.

### 5.24.3 Result files

#### [ 1 ] Result files

A file in which success or failure of the replacement of the setting values for each code included in the setting files is written. A result file is stored in a USB storage device after this code is performed.

File name: DIG\_RESULT\_XXXX\_yymmddhhmmss.xml (XXXX: Serial No.)

File format: xml format

#### [ 2 ] Example

```
<Policy>
  <Data>
    <Category-05/>
    <Category-08>
      <Code>
        <MainCode>8724</MainCode>
        <RESULT>SUCCESS</RESULT>
      </Code>
      <Code>
        <MainCode>9240</MainCode>
        <RESULT>FAILED</RESULT>
      </Code>
      <Code>
        <MainCode>9264</MainCode>
        <SubCode>1</SubCode>
        <RESULT>UNSPECIFIED</RESULT>
      </Code>
    </Category-08>
```

```

    <Category-13/>
  </Data>
</Policy>
* SUCCESS: Update of values has succeeded.
* FAILED: Update of valued has failed.
* UNSPECIFIED: No codes written has existed. A value to be set is outside the assignable
  range.

```

**Notes:**

- The result files are saved in the root directory of the USB storage device.
- As for the codes whose values have been altered caused by the batch setting of another one, their items, such as the code number, the value changed and the success/failure of the change, are not described in a result file.
- In case an unavailable code for writing is included in the setting file, the processing will continue and then a message indicating partial success will be displayed after the setting of all codes has been completed. Unavailable codes for writing are displayed in the list by pressing [View]. [OK] is pressed on the screen of the message indicating partial success or the list screen, the display is returned to the BASIC screen.

### 5.24.4 Operation procedure

- (1) Enter into the Classic mode with [FS-08].
- (2) Install a USB storage device with setting files are stored in the MFP.
- (3) Key in [3673] and then press the [START] button.
- (4) Select a setting file.

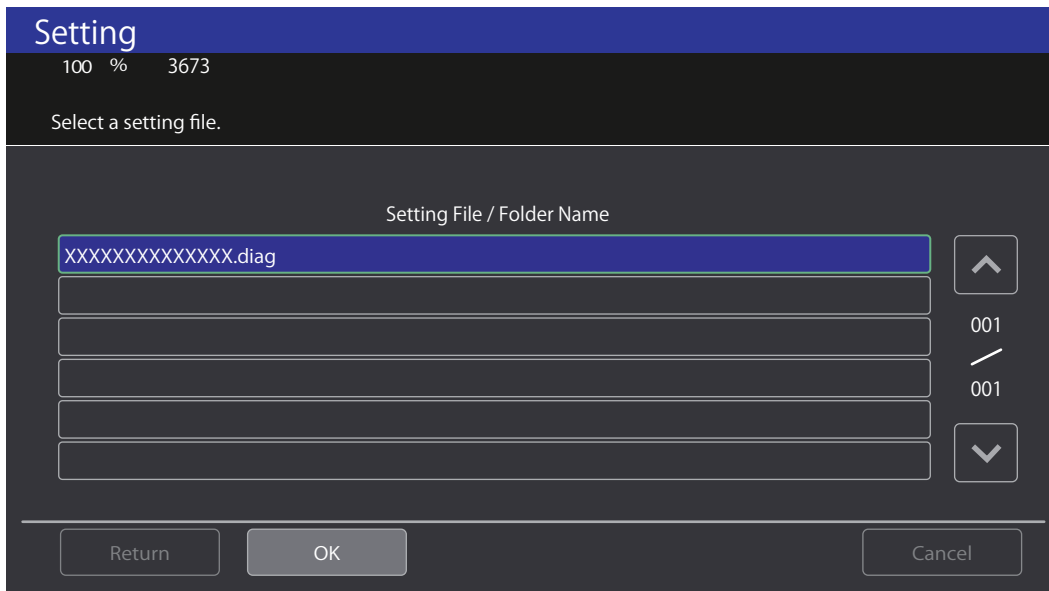

Fig.5-37

- (5) Press [OK].
- (6) Setting for all codes included in the setting file is completed, the BASIC screen of the 08 mode appears.
- (7) Remove the USB storage device.

**Remarks:**

- When the screen is shifted to the FS Menu using the gear icon on the [User Functions] screen, the status is moved to the normal mode after the USB batch setting is finished.
- If a code which requires rebooting is included in the setting file, a reboot promotion screen appears.





# 6. SETTING AND ADJUSTMENT

## 6.1 Image Related Adjustment

### 6.1.1 Image related adjustment

Perform image related adjustment in accordance with the following order.

**Notes:**

- When replacing components which have other specified instructions for adjustment, these are to be given priority.
- The adjustments connected with the dotted lines are not mandatory. However, if an adjustment is required, keep to the given the order.

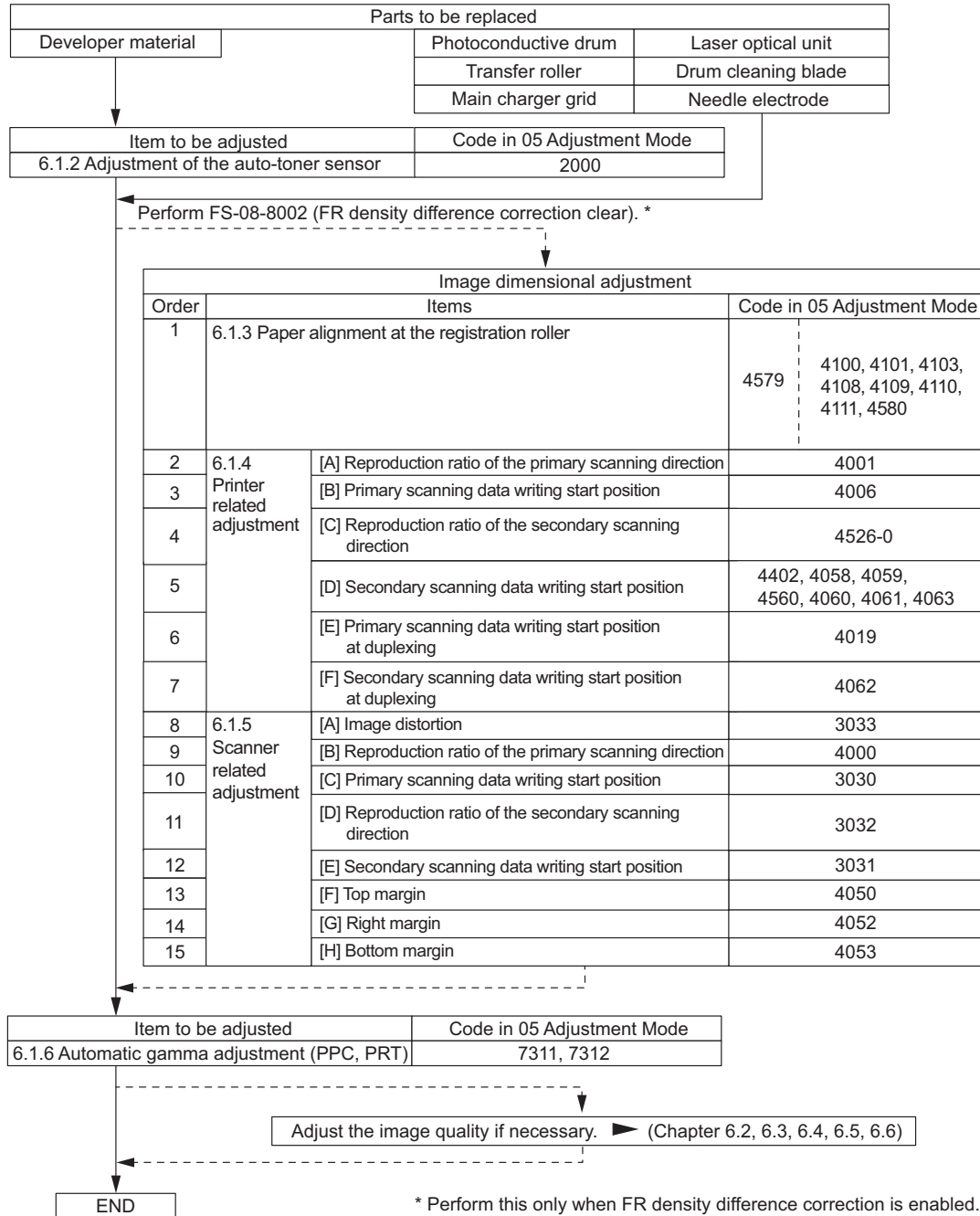

\* Perform this only when FR density difference correction is enabled.

**Fig.6-1**

## 6.1.2 Auto-toner sensor adjustment

When the developer material is replaced, adjust the auto-toner sensor by following the procedure below.

- (1) Install the process unit in the MFP.

**Notes:**

Do not install the toner cartridge.

- (2) Perform FS-05. The following message will be displayed.

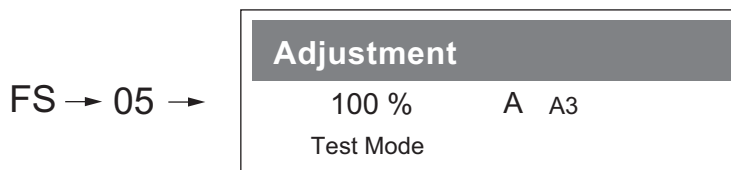

Fig.6-2

- (3) Key in the code and press the [START] button.  
Code: 2000

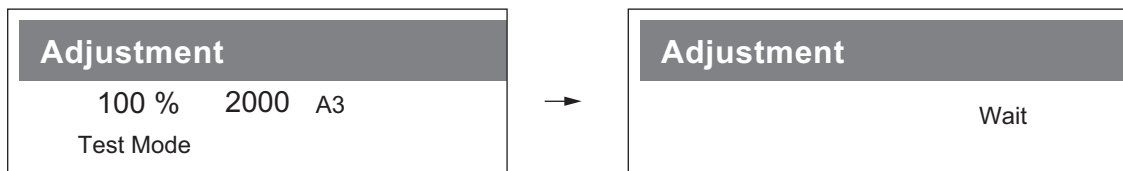

Fig.6-3

- (4) Approx. 2 minutes have passed, the value on the display automatically starts changing. Then the value becomes stable.

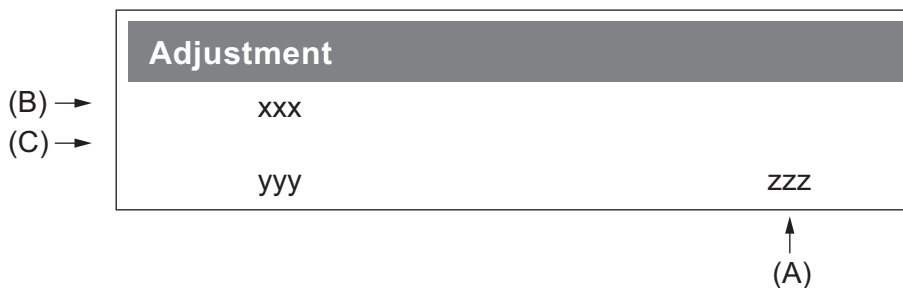

Fig.6-4

- (5) Check if the value B is within the range of 234 to 246.
- (6) If the value B is not within the range of 234 to 246, press the Up or Down button to adjust the value manually.

**Remarks:**

The relation between the button and the values A and B is as follows.

Button to be pressed	Value A	Value B
Up	Increased	Increased
Down	Decreased	Decreased

- (7) Press [OK] to store the adjustment result in the memory.  
The drum, developer unit, etc. are stopped and the following is displayed.

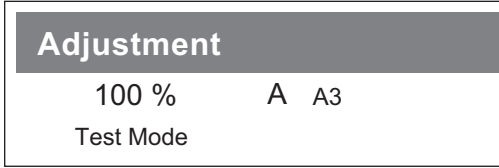

**Fig.6-5**

- (8) Turn the power OFF and install the toner cartridge.

## 6.1.3 Alignment position adjustment

### [A] Adjustment from the LCD

Paper alignment at the registration roller can be adjusted in the following procedure by performing FS-05-4579.

- (1) Select the drawer.

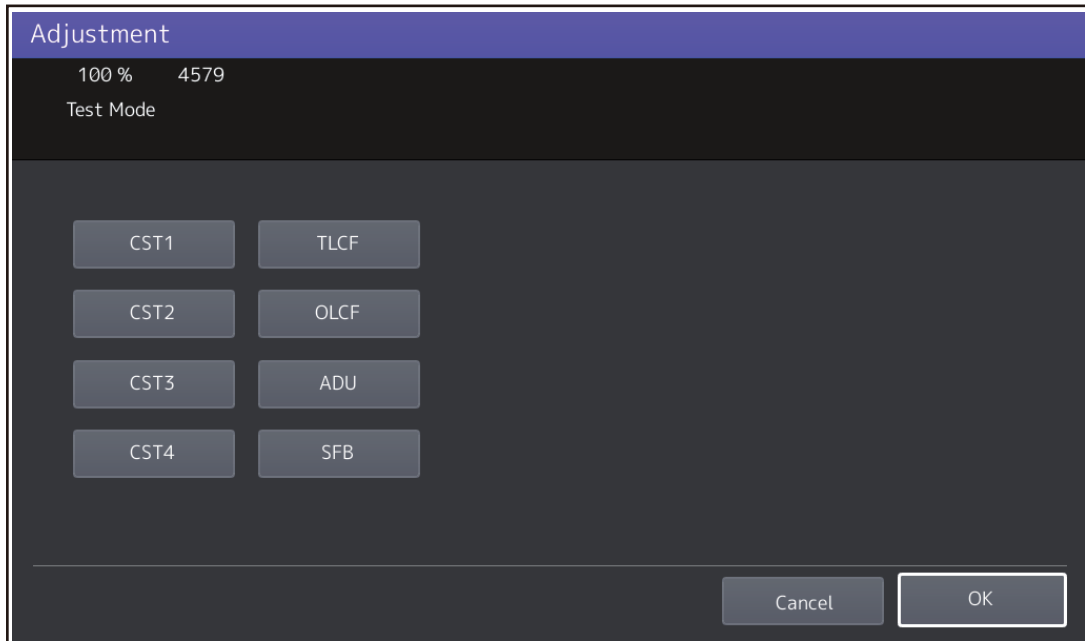

Fig.6-6

- (2) Select the paper size.

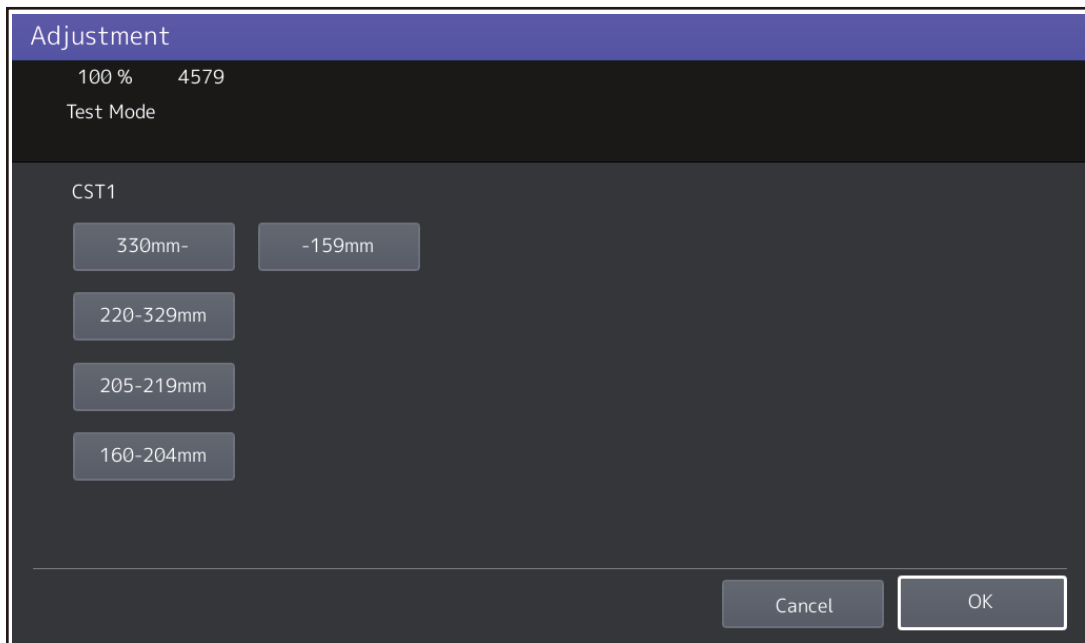

Fig.6-7

- (3) Select the paper type.

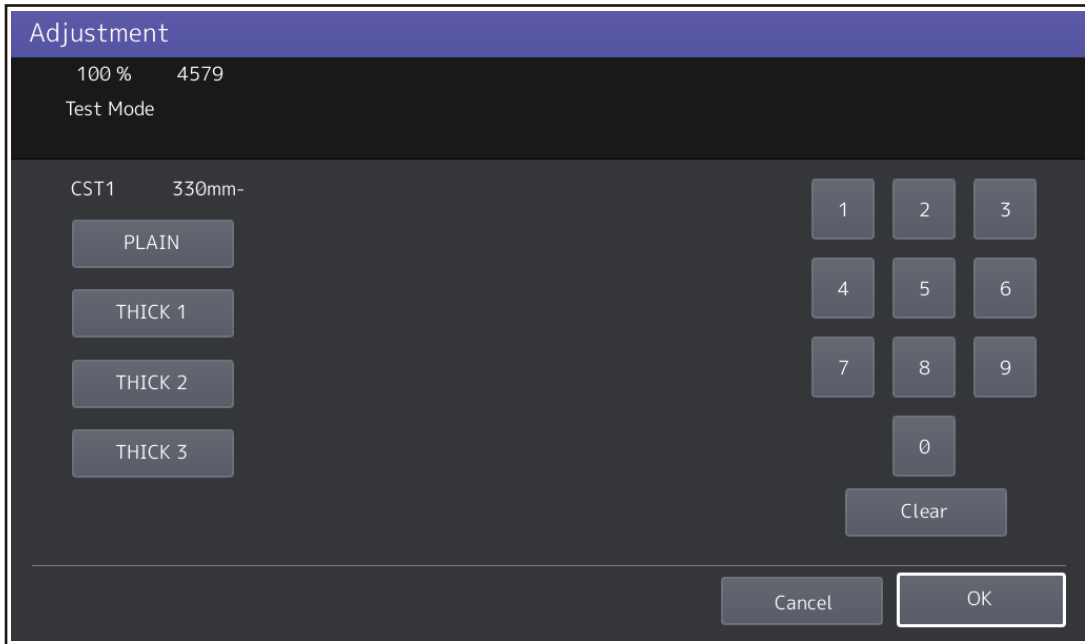

Fig.6-8

- (4) Key in the adjustment value.

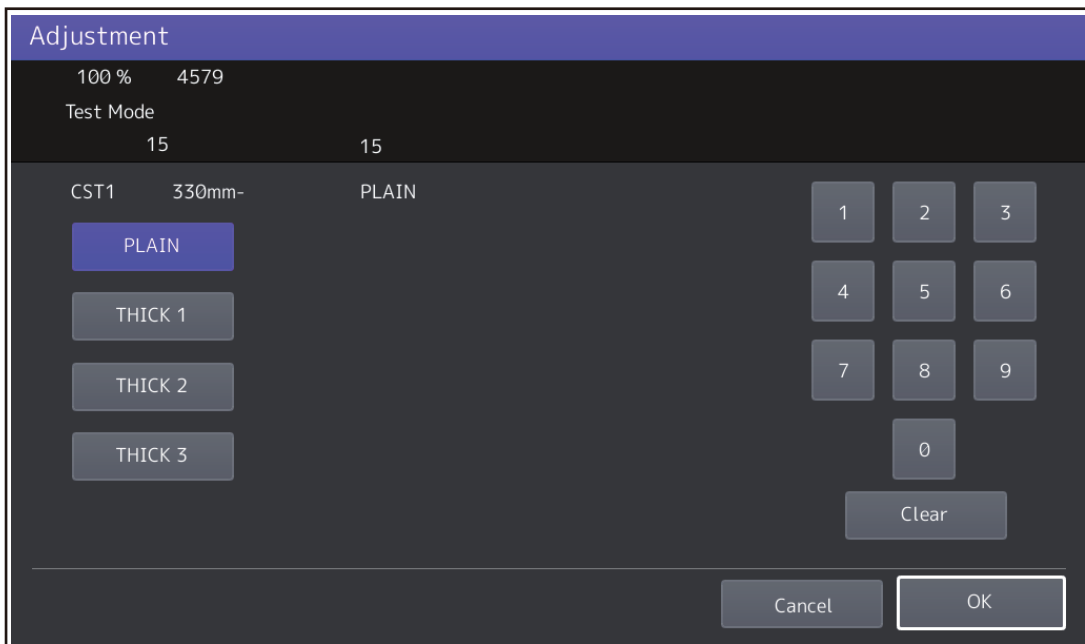

Fig.6-9

- (5) Press [OK] to finish the adjustment.  
Press the [FUNCTION CLEAR] button to return to the previous menu.

## [B] Adjustment by direct code entry

The alignment position can be adjusted by using the following codes in the 05 Adjustment Mode.

Drawer	Code	Sub code	(Select the paper size with the sub code.) Change amount per 1 step	Paper type*2
1st drawer (CST1)	4100	0, 1, 2, 3, 4*1	This may vary depending on the paper source, paper type and paper size. Refer to the SELF-DIAGNOSIS CODE (separate document).	Plain, Recycled, Thick
	4115			Thick 1, Thick 2, Thick 3
2nd drawer (CST2)	4101			Plain, Recycled, Thick
	4116			Thick 1, Thick 2, Thick 3, Envelope
3rd drawer (CST3)	4108			Plain, Recycled, Thick
	4117			Thick 1, Thick 2, Thick 3, Envelope
4th drawer (CST4)	4109			Plain, Recycled, Thick
	4118			Thick 1, Thick 2, Thick 3, Envelope
Bypass tray (SFB)	4103			Plain, Recycled, Thick, Thin
	4104			Thick 1
	4105			Thick 2
	4106			Thick 3
	4107			Transparency
	4185			Envelope
Automatic Duplexing Unit (ADU)	4110			Plain, Recycled, Thick
	4120			Thick 1, Thick 2, Thick 3
Large Capacity Feeder (T-LCF)	4111	-	Plain, Recycled, Thick	
	4119	0	Thick 1	
		1	Thick 2	
		2	Thick 3	
Large Capacity Feeder (Ex-LCF)	4580	-	Plain, Recycled, Thick	
	4581		Thick 1	
	4586		Thick 2	
	4592		Thick 3	

\*1 See the correspondence table for the paper size and the sub code.

\*2 See the correspondence table for the paper type and the paper weight.

### Correspondence table for the paper size and the sub code

Length in the secondary scanning direction	Sub code
330 mm or longer	0
220 mm to 329 mm	1
205 mm to 219 mm	2
160 mm to 204 mm	3
159 mm or shorter	4

### Correspondence table for the paper type and the paper weight

Paper type	Paper weight (g/m <sup>2</sup> )
Thin	52 to 59
Plain	60 to 80
Thick	81 to 105
Thick 1	106 to 163
Thick 2	164 to 209
Thick 3	210 to 256

- (1) Perform the test print according to the following procedure.  
<Procedure>

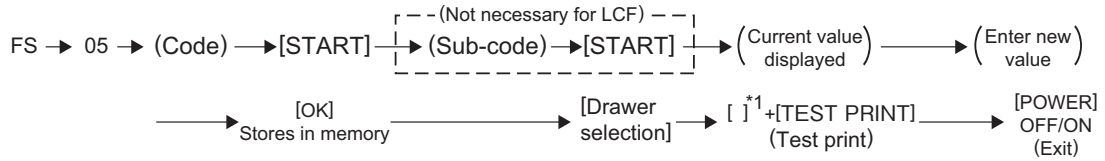

\*1

- 1: Simplex black grid pattern
- 3: Duplex black grid pattern

- (2) Check if any transfer void is occurring. If there is a transfer problem, try the values in descending order as “31” → “30” → “29”... until the transfer void disappears. At the same time, confirm if any paper misfeeding occurs. Also, when the aligning amount has been increased, this may increase the scraping noise caused by the paper and the film sheet as it is transported by the registration roller. If this scraping noise is annoying, try to decrease the value.

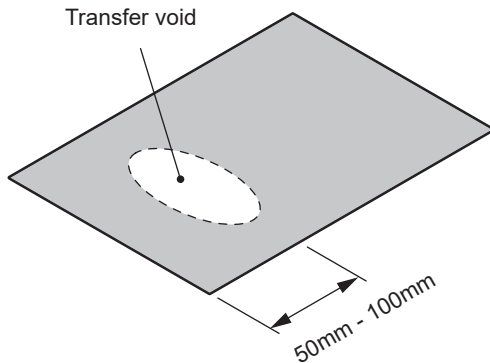

Fig.6-10

- (3) Perform the same procedure for all paper sources.

**Notes:**

When paper thinner than specified is used, paper misfeeding may occur frequently at the registration section. In this case, it is advisable to change (or reduce) the aligning amount. However, if the aligning amount is reduced too much, this may cause the shift of leading edge position. So, when adjusting the aligning amount, try to choose the appropriate amount while confirming the leading edge position is not shifted.

## 6.1.4 Image dimensional adjustment at the printing section

This adjustment is performed by using the chart output from the MFP. There are two ways of the image dimensional adjustment: Type 1 and Type 2.

- Type 1: Actual dimension adjustment method (Adjusts the image position and the ratio by measuring and checking the actual dimension of the images. The reference position of the image is the leading edge at the front.)

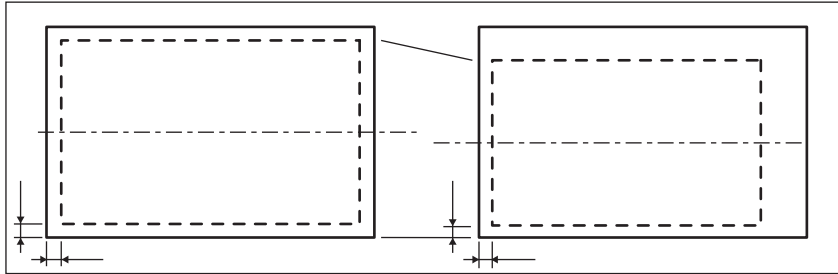

Fig.6-11

- Adjustment with a high degree of accuracy can be made.
  - The reference is given to the front side of the leading edge. Therefore, when the paper size is changed, the void around the paper tends to be altered accordingly.
- Type 2: Void even adjustment method (Adjusts the image position and the ratio by measuring and checking the void. The reference position of the image is the center of the paper.)

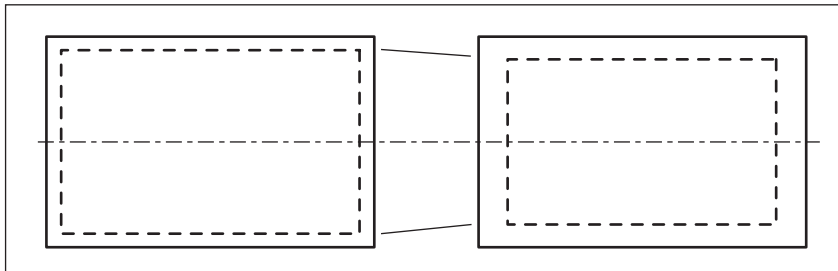

Fig.6-12

- The image position at the front and the back sides can make to be aligned easily.
- The void around the paper can make to be evenly aligned easily.

### Remarks:

The void correction of paper frequently used can be made easily by entering its actual dimension into FS-05-4922 and then performing FS-05-4920.

Use the appropriate chart corresponding to the adjustment instruction. After the image dimensional adjustment, perform FS-05-2742 (Enforced performing of image quality control (closed-loop)).

In addition, check that no gap has occurred in the following adjustments.

Scanning Section:  P. 6-16 "6.1.5 Image dimensional adjustment at the scanning section"



Type 1: Actual dimension adjustment method

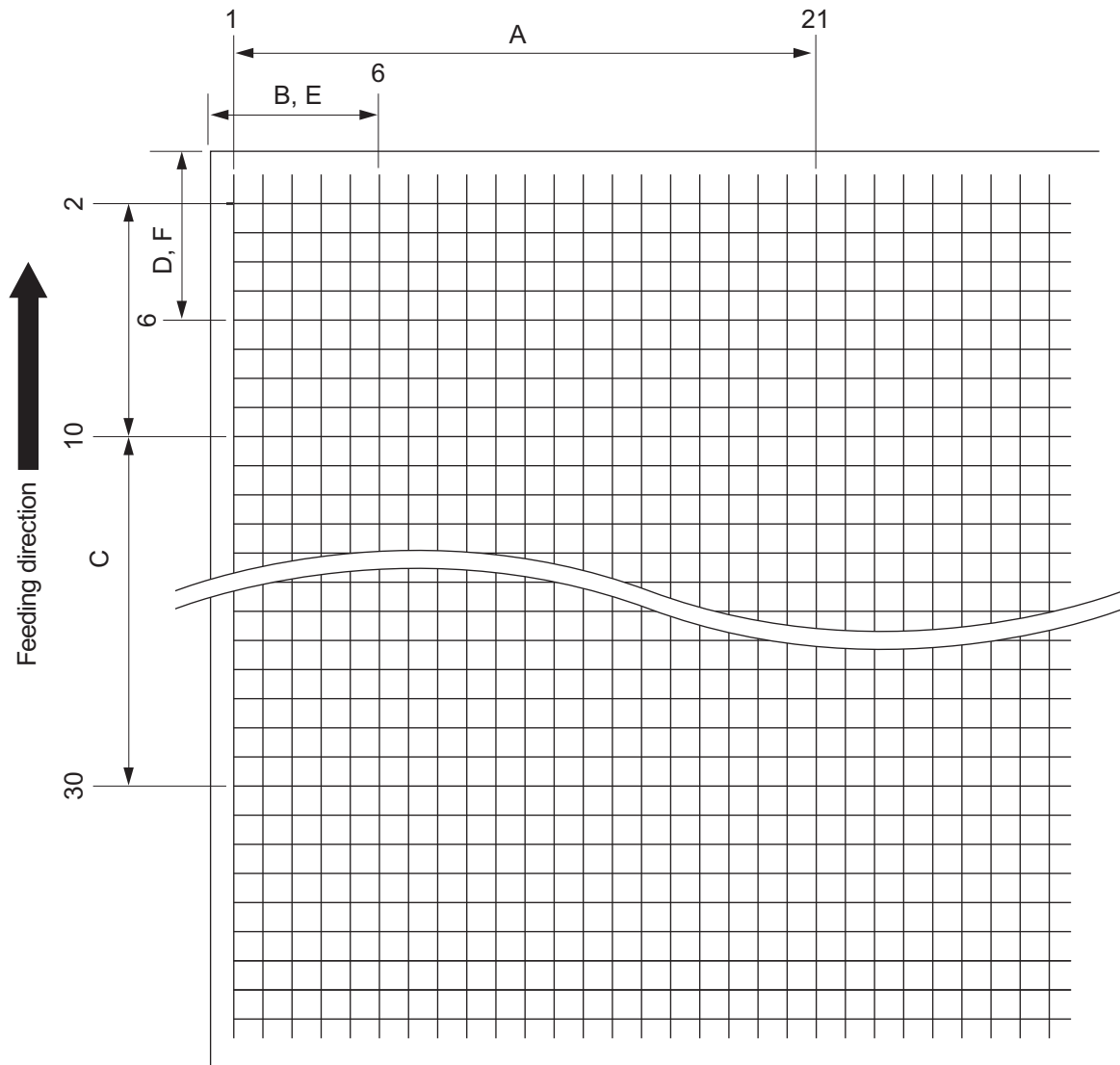

Fig.6-13 Grid pattern

	Adjustment acceptable range	Detail of adjustment	Chart
A	200 mm ± 0.5 mm	📖 P. 6-11 "[A] Reproduction ratio of the primary scanning direction"	05-1
B	52 mm ± 0.5 mm	📖 P. 6-11 "[B] Primary scanning direction data writing start position"	
C	200 mm ± 0.5 mm	📖 P. 6-12 "[C] Reproduction ratio of the secondary scanning direction"	
D	52 mm ± 0.5 mm	📖 P. 6-12 "[D] Secondary scanning direction data writing start position"	
E	52 mm ± 0.5 mm	📖 P. 6-13 "[E] Primary scanning direction data writing start position at duplexing"	05-3
F	52 mm ± 0.5 mm	📖 P. 6-13 "[F] Secondary scanning direction data writing start position at duplexing"	

**Notes:**

As for C, D and F, the measurement should be carried out by considering that there is a 1st line even if it is not actually printed.

Type 2: Void even adjustment method  
Simplex

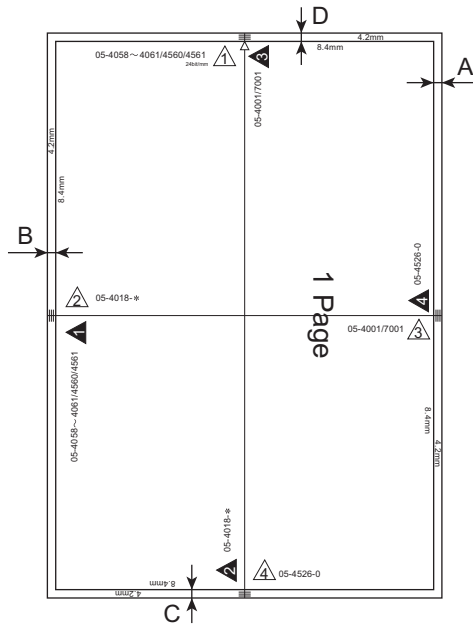

Duplex

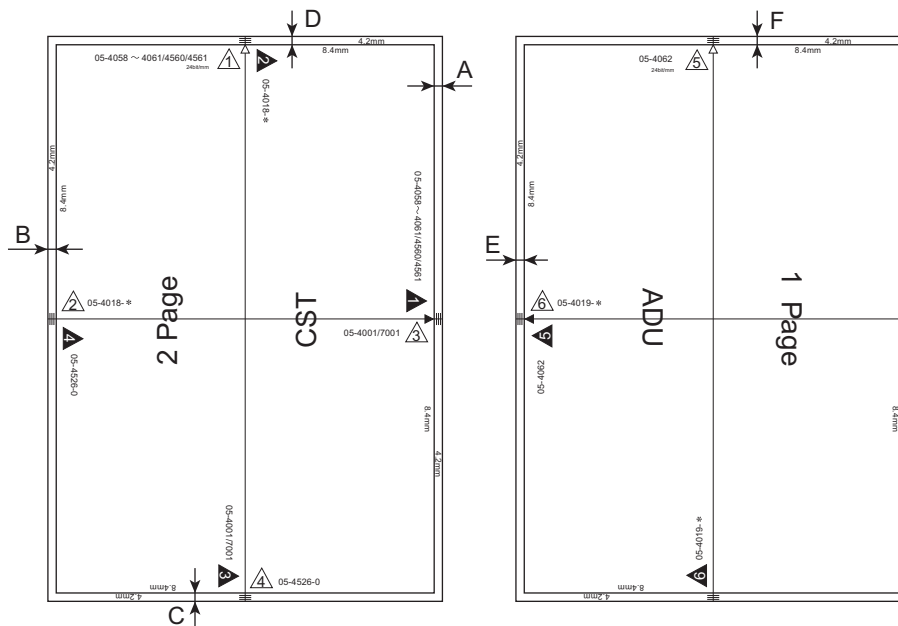

Fig.6-14

	Adjustment acceptable range	Detail of adjustment	Chart
A	4.2 mm ± 0.5 mm	📖 P. 6-11 “[A] Reproduction ratio of the primary scanning direction”	05-315
B	4.2 mm ± 0.5 mm	📖 P. 6-11 “[B] Primary scanning direction data writing start position”	
C	4.2 mm ± 0.5 mm	📖 P. 6-12 “[C] Reproduction ratio of the secondary scanning direction”	
D	4.2 mm ± 0.5 mm	📖 P. 6-12 “[D] Secondary scanning direction data writing start position”	
E	4.2 mm ± 0.5 mm	📖 P. 6-13 “[E] Primary scanning direction data writing start position at duplexing”	05-316
F	4.2 mm ± 0.5 mm	📖 P. 6-13 “[F] Secondary scanning direction data writing start position at duplexing”	

### [A] Reproduction ratio of the primary scanning direction

Paper source	Code	Acceptable value	Change amount per 1 step	Paper size	Chart
2nd drawer	05-4001	0 to 255	Approx. 0.10 mm	A3, LD	05-1 or 05-315

1. Print out the chart in the ready state of the Classic mode of FS-05.  
Perform FS-05-1 or FS-05-315 and then press [TEST PRINT].
2. Check that the distance A of the chart is within the acceptable range.  
FS-05-1: 200 mm  $\pm$  0.5 mm (Recommendation: 200 mm +0/-5 mm)  
FS-05-315: 4.2 mm  $\pm$  0.5 mm
3. If not, change the value of the code.  
The larger the adjustment value is, the longer the distance A becomes.
4. Output the chart again and measure the distance A.

### [B] Primary scanning direction data writing start position

Use the following code to adjust all paper sources at once.

Paper source	Code	Acceptable value	Change amount per 1 step	Paper size	Chart
2nd drawer	05-4006	0 to 255	Approx. 0.04 mm	A3, LD	05-1 or 05-315

Use the following code to adjust the paper sources individually.

Adjustment order	Paper source	Code	Sub code	Acceptable value	Change amount per 1 step	Paper size	Chart
1	1st drawer	05-4018	0	0 to 255	Approx. 0.04 mm	A3, LD	05-1 or 05-315
2	Bypass tray		5				
3	2nd drawer		1				
4	3rd drawer		2				
5	4th drawer		3				
6	T-LCF *		4				
7	Ex-LCF		6			A4, LT	

\* When the T-LCF is installed, adjustment of the 3rd and 4th drawers is unnecessary.

1. Print out the chart in the ready state of the Classic mode of FS-05.  
Perform FS-05-1 or FS-05-315 and then press [TEST PRINT].
2. Check that the distance B of the chart is within the acceptable range.  
FS-05-1: 52 mm  $\pm$  0.5 mm  
FS-05-315: 4.2 mm  $\pm$  0.5 mm
3. If not, change the value of the corresponding code.  
The larger the adjustment value is, the longer the distance B becomes.
4. Output the chart again and measure the distance B.

#### Notes:

- The adjustment result of FS-05-4006 is reflected to the control of each paper source. Therefore, perform adjustment for each paper source after FS-05-4006 has been carried out.
- If the setting value for each paper source has been changed, perform printing by selecting one whose value has been changed and check the images.

### [C] Reproduction ratio of the secondary scanning direction

Paper source	Code	Sub code	Acceptable value	Change amount per 1 step	Paper size	Chart
2nd drawer	05-4526	0	0 to 255	0.1%	A3, LD	05-1 or 05-315

1. Print out the chart in the ready state of the Classic mode of FS-05.  
Perform FS-05-98 or FS-05-315 and then press [TEST PRINT].
2. Check that the distance C of the chart is within the acceptable range.  
FS-05-1: 200 mm  $\pm$  0.5 mm (Recommendation: 200 mm +0/-5 mm)  
FS-05-315: 4.2 mm  $\pm$  0.5 mm
3. If not, change the value of the corresponding code.
  - The larger the adjustment value is, the longer the distance C becomes.
  - If the value has been changed, an image at the trailing edge may run off from the paper length or its density may become lighter. Therefore, perform adjustment while the image is being checked.
4. Output the chart again and measure the distance C.

#### Notes:

An image at the trailing edge may run off from the paper length or its density may become lighter. Therefore, perform adjustment while the image is being checked.

### [D] Secondary scanning direction data writing start position

Use the following code to adjust all paper sources at once.

Paper source	Code	Acceptable value	Change amount per 1 step	Paper size	Chart
2nd drawer	05-4402	0 to 200	Approx. 0.10 mm	A3, LD	05-1 or 05-315

Use the following code to adjust the paper sources individually.

Adjustment order	Paper source	Code	Acceptable value	Change amount per 1 step	Paper size	Chart
1	1st drawer	05-4058	0 to 100	Approx. 0.10 mm	A3, LD	05-98 or 05-315
2	2nd drawer	05-4059				
3	T-LCF *	05-4561				
4	3rd drawer	05-4060				
5	4th drawer	05-4560				
6	Bypass tray	05-4061				
7	Ex-LCF	05-4063				

\* When the T-LCF is installed, adjustment of the 3rd and 4th drawers is unnecessary.

1. Print out the chart in the ready state of the Classic mode of FS-05.  
Perform FS-05-1 or FS-05-315 and then press [TEST PRINT].
2. Check that the distance D of the chart is within the acceptable range.  
FS-05-1: 52 mm  $\pm$  0.5 mm  
FS-05-315: 4.2 mm  $\pm$  0.5 mm
3. If not, change the value of the corresponding code.  
The larger the adjustment value is, the longer the distance D becomes.
4. Output the chart again and measure the distance D.

#### Notes:

- The adjustment result of FS-05-4402 is reflected to the control of each paper source. Therefore, perform adjustment for each paper source after FS-05-4402 has been carried out.
- If the setting value for each paper source has been changed, perform printing by selecting one whose value has been changed and check the images.

**[E] Primary scanning direction data writing start position at duplexing**

Adjustment order	Paper source	Code	Sub code	Acceptable value	Change amount per 1 step	Paper size	Chart
1	2nd drawer	05-4019	0	0 to 255	Approx. 0.04 mm	Long size (330 mm or longer)	05-3 or 05-316
2			1			Short size (A4 or LT or shorter)	
			2			Middle size	

1. Print out the chart in the ready state of the Classic mode of FS-05. Perform FS-05-3 or FS-05-316 and then press [TEST PRINT].
2. Check that the distance E of the chart is within the acceptable range.  
FS-05-3: 52 mm ± 0.5 mm  
FS-05-316: 4.2 mm ± 0.5 mm
3. If not, change the value of the corresponding code.  
The larger the adjustment value is, the longer the distance E becomes.
4. Output the chart again and measure the distance E.

**Notes:**

- The adjustment result of FS-05-4006 has been reflected in FS-05-4019-0.
- The adjustment results of FS-05-4019-0 and FS-05-4006 are reflected to the control of each paper source. Therefore, perform adjustment for each paper size after FS-05-4006 and FS-05-4019-0 have been carried out.
- If the setting value for each paper size has been changed, perform printing by selecting one whose value has been changed and check the images.

**[F] Secondary scanning direction data writing start position at duplexing**

Paper source	Code	Acceptable value	Change amount per 1 step	Paper size	Chart
2nd drawer	05-4062	0 to 100	Approx. 0.10 mm	A3, LD	05-3 or 05-316

1. Print out the chart in the ready state of the Classic mode of FS-05. Perform FS-05-3 or FS-05-316 and then press [TEST PRINT].
2. Check that the distance F of the chart is within the acceptable range.  
FS-05-3: 52 mm ± 0.5 mm  
FS-05-316: 4.2 mm ± 0.5 mm
3. If not, change the value of the code.  
The larger the adjustment value is, the longer the distance F becomes.
4. Output the chart again and measure the distance F.

<Adjustment order summarize from A to F>

Measurement position	Code	Sub code	Paper source	Paper size	Type 1		Type 2		Change amount per 1 step
					Chart	Acceptable range (mm)	Chart	Acceptable range (mm)	
A	05-4001	-	2nd drawer	A3, LD	05-1	200 ± 0.5	05-315	4.2 ± 0.5	0.10 mm
B	05-4006	-	2nd drawer	A3, LD	05-1	52 ± 0.5	05-315	4.2 ± 0.5	0.04 mm
	05-4018	0	1st drawer	A3, LD	05-1	52 ± 0.5	05-315	4.2 ± 0.5	0.04 mm
		5	Bypass tray						
		1	2nd drawer						
		2	3rd drawer						
		3	4th drawer						
		4	T-LCF	A4, LT					
6	Ex-LCF	A4, LT							
C	05-4526	0	2nd drawer	A3, LD	05-1	200 ± 0.5	05-315	4.2 ± 0.5	0.1%
D	05-4402	-	2nd drawer	A3, LD	05-1	52 ± 0.5	05-315	4.2 ± 0.5	0.10 mm
	05-4058		1st drawer						
	05-4059		2nd drawer						
	05-4561		T-LCF	A4, LT					
	05-4060		3rd drawer	A3, LD					
	05-4560		4th drawer						
	05-4061		Bypass tray						
	05-4063		Ex-LCF	A4, LT					
E	05-4019	0	2nd drawer	Long size	05-3	52 ± 0.5	05-316	4.2 ± 0.5	0.04 mm
		1		Short size					
		2		Middle size					
F	05-4062	-	2nd drawer	A3, LD	05-3	52 ± 0.5	05-316	4.2 ± 0.5	0.10 mm

## [G] Print position adjustment (user)

A user can adjust the following items from the [User Functions] screen - [Admin] - [General] - [Print Position Adjustment].

Item to be adjusted	Drawer	Code	Sub code	Recommended value	Acceptable value	Default value	Operation procedure
Primary scanning direction	1st drawer (CST1)	05-4883	0	To move the image to the front side: Set a larger value. To move the image to the rear side: Set a smaller value. Approx. 0.5 mm per 1 step	0 to 255	128	05 Procedure 4
	2nd drawer (CST2)		1				
	3rd drawer (CST3)		2				
	4th drawer (CST4)		3				
	Large Capacity Feeder (T-LCF)		4				
	Bypass tray (SFB)		5				
	Large Capacity Feeder (Ex-LCF)		6				
	Automatic Duplexing Unit (ADU)		8				
Secondary scanning direction	1st drawer (CST1)	05-4884	0	To move the image to the trailing edge side: Set a larger value. To move the image to the leading edge side: Set a smaller value. Approx. 0.5 mm per 1 step			
	2nd drawer (CST2)		1				
	3rd drawer (CST3)		2				
	4th drawer (CST4)		3				
	Large Capacity Feeder (T-LCF)		4				
	Bypass tray (SFB)		5				
	Large Capacity Feeder (Ex-LCF)		6				
	Automatic Duplexing Unit (ADU)		8				

### Notes:

This adjustment is added to the that for [A] to [F].

## 6.1.5 Image dimensional adjustment at the scanning section

### [A] Image distortion

#### Notes:

- The specification of the distortion is 1mm to 200mm when a drawer equipped as standard is used, and is 3mm to 200mm when an optional drawer (PFU, PFP and LCF) is used.
- Do not perform this adjustment when the distortion is within the above value. If the adjustment has failed, fogging or a C260 error will occur.
- This adjustment is for the distortion in the scanning section. Therefore, do not use this to correct paper skew at paper feeding.
- When performing the adjustment, marginally rotate the screw by approximately one quarter while checking the image.

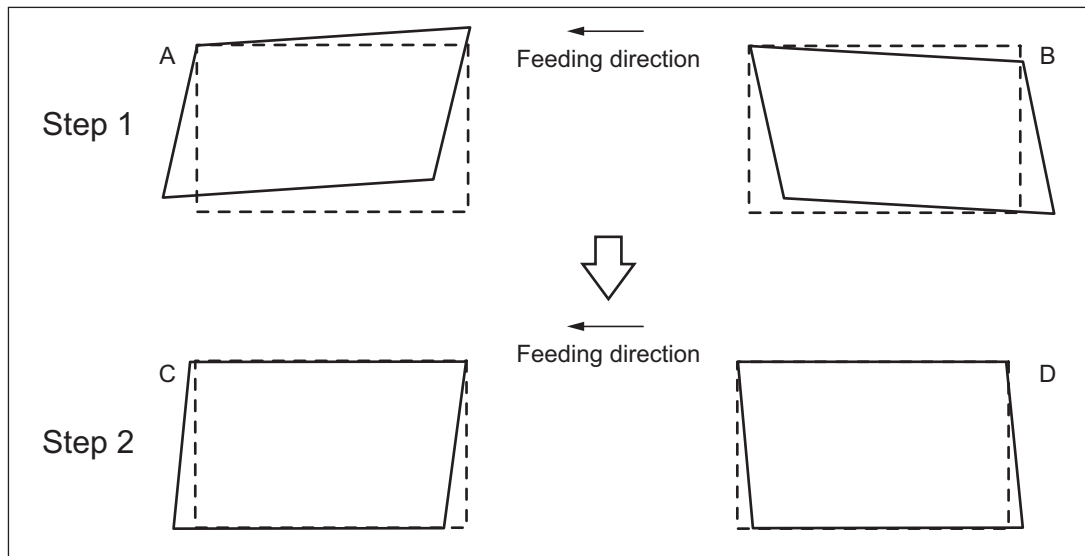

Fig.6-15

- (1) Perform FS-05.
- (2) Press [TEST COPY] → [START] button to make a copy of any image on a sheet of A3 or LD paper.
- (3) Key in [3033] and press the [START] to move the carriage to the adjustment position.
- (4) Make an adjustment in the order of step 1 and 2.

#### Step 1

In case of A:

Tighten the mirror-3 adjustment screw (Rear) [1]. (CW)

In case of B:

Loosen the mirror-3 adjustment screw (Rear) [1]. (CCW)

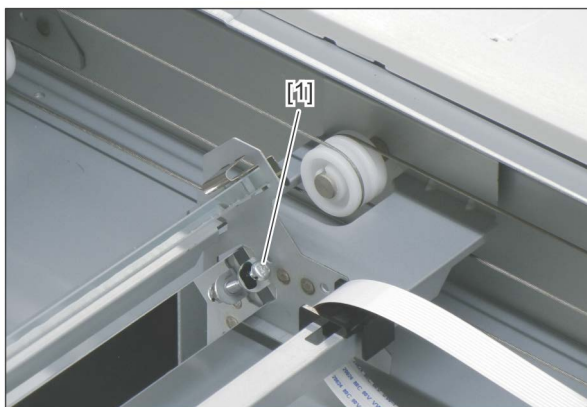

Fig.6-16



Step 2

In case of C:

Tighten the mirror-1 adjustment screw (Rear) [1]. (CW)

In case of D:

Loosen the mirror-1 adjustment screw (Rear) [1]. (CCW)

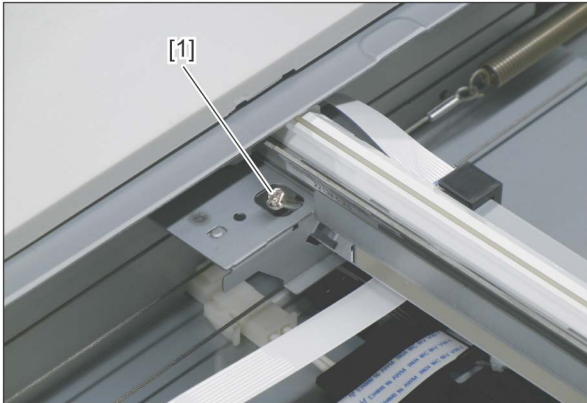

Fig.6-17

- (5) Apply the screw locking agents to the adjustment screws. (2 areas)  
Recommended screw lock agent  
Manufacturer: Three Bond  
Product name: 1401E

## [B] Reproduction ratio of the primary scanning direction

Paper source	Code	Acceptable value	Change amount per 1 step	Paper size	Original	Original Mode	Ratio
2nd drawer	05-4000	0 to 255	Approx. 0.10 mm	A3, LD	Scale	Text/Photo	100%

- (1) During the ready state of the Classic mode of FS-05, place the scale on the original glass and perform copying.
  - The scale should be placed on the rear to front direction.
  - Press [TEST COPY] and the [START] button.
- (2) Measure the distance B between 10 mm and 270 mm of the copied image by a scale and check that it is within the acceptable range.  
Acceptable range:  $260\text{mm} \pm 0.5 \text{ mm}$
- (3) If not, change the value of the code.  
The larger the adjustment value is, the longer the distance B becomes.
- (4) Output the test copy again and measure the distance B.

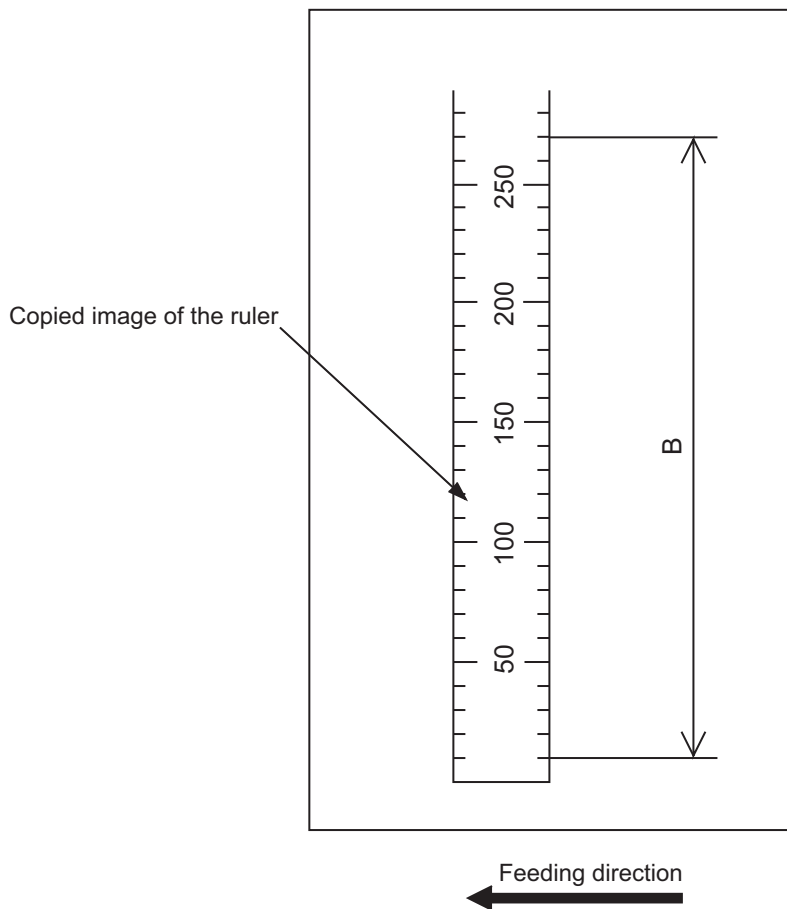

Fig.6-18

### [C] Primary scanning direction data image position

Paper source	Code	Acceptable value	Change amount per 1 step	Paper size	Original	Original Mode	Ratio
2nd drawer	05-3030	0 to 255	Approx. 0.04 mm	A3, LD	Scale	Text/Photo	100%

- (1) During the ready state of the Classic mode of FS-05, place the scale on the original glass and perform copying.
  - The scale should be placed while its front edge is aligned to the rear side and its side edge to the original scale at the paper exiting side.
  - Press [TEST COPY] and the [START] button.
- (2) Measure the distance C between the front side end of the copied image and the 10 mm line by a scale and check that it is within the acceptable range.  
Acceptable range:  $10\text{mm} \pm 0.5\text{ mm}$
- (3) If not, change the value of the code.  
The larger the adjustment value is, the longer the distance C becomes.
- (4) Output the test copy again and measure the distance C.

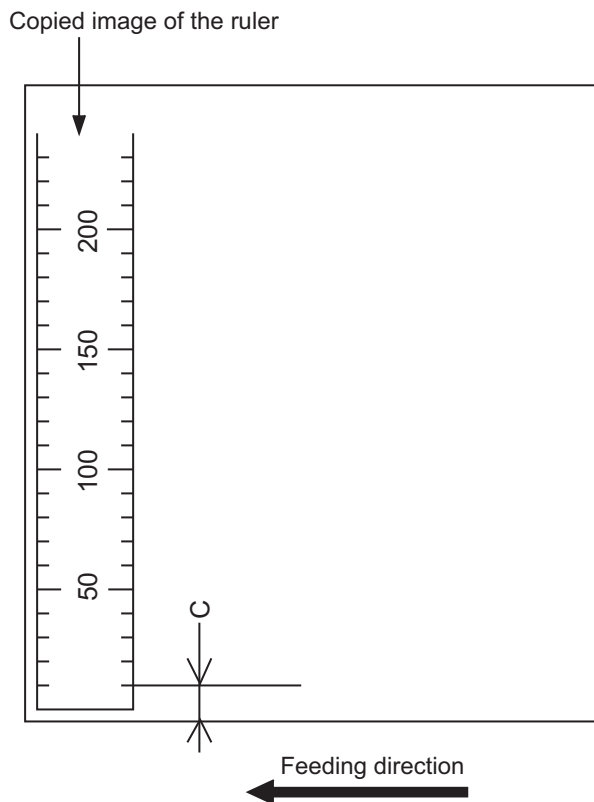
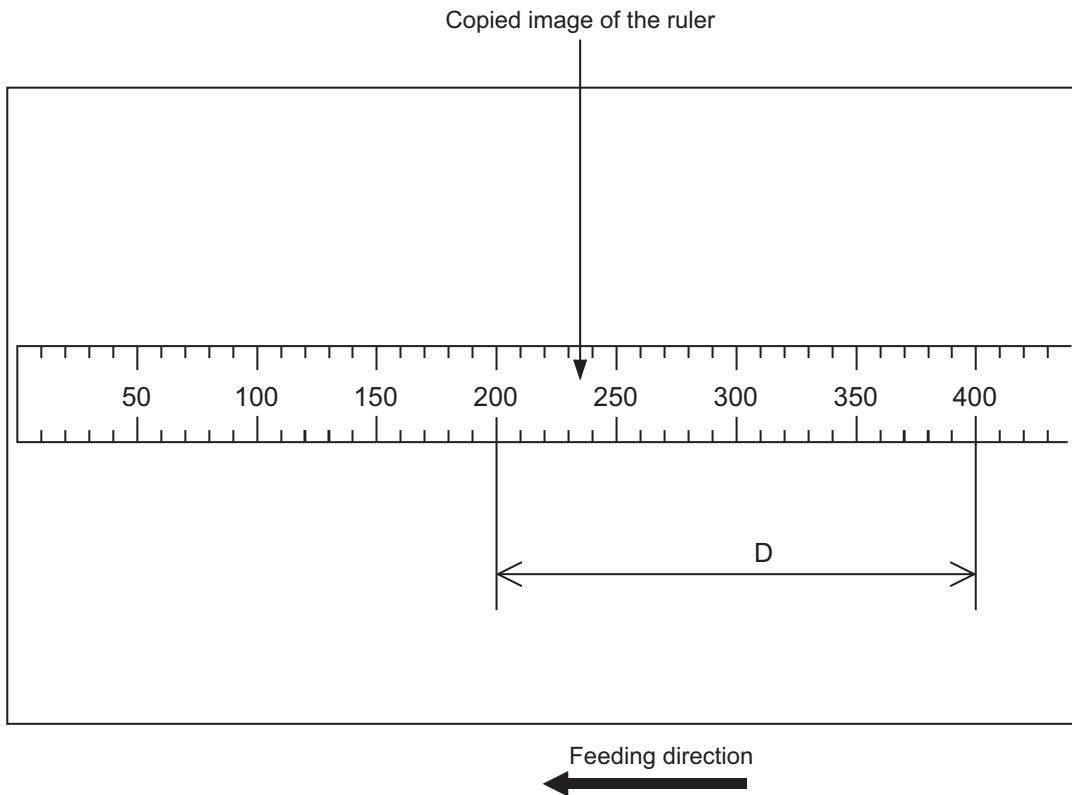

Fig.6-19

**[D] Reproduction ratio of the secondary scanning direction**

Paper source	Code	Acceptable value	Change amount per 1 step	Paper size	Original	Original Mode	Ratio
2nd drawer	05-3032	63 to 193	Approx. 0.018 %	A3, LD	Scale	Text/Photo	100%

- (1) During the ready state of the Classic mode of FS-05, place the scale on the original glass and perform copying.
  - The scale should be placed while its front edge is aligned to the original scale at the paper exiting side in the paper feeding to the paper exiting direction.
  - Press [TEST COPY] and the [START] button.
- (2) Measure the distance D between 200 mm and 400 mm of the copied image by a scale and check that it is within the acceptable range.  
Acceptable range: 200mm ± 0.5 mm
- (3) If not, change the value of the code.  
The larger the adjustment value is, the longer the distance D becomes.
- (4) Output the test copy again and measure the distance D.



**Fig.6-20**

### [E] Secondary scanning direction data image position

Paper source	Code	Acceptable value	Change amount per 1 step	Paper size	Original	Original Mode	Ratio
2nd drawer	05-3031	90 to 148	Approx. 0.08 mm	A3, LD	Scale	Text/Photo	100%

- (1) During the ready state of the Classic mode of FS-05, place the scale on the original glass and perform copying.
  - The scale should be placed while its front edge is aligned to the original scale at the paper exiting side in the paper feeding to paper exiting direction.
  - Press [TEST COPY] and the [START] button.
- (2) Measure the distance E between the leading edge of the copied image and the 10 mm line by a scale and check that it is within the acceptable range.  
Acceptable range:  $10\text{mm} \pm 0.5\text{ mm}$
- (3) If not, change the value of the code.  
The larger the adjustment value is, the longer the distance E becomes.
- (4) Output the test copy again and measure the distance E.

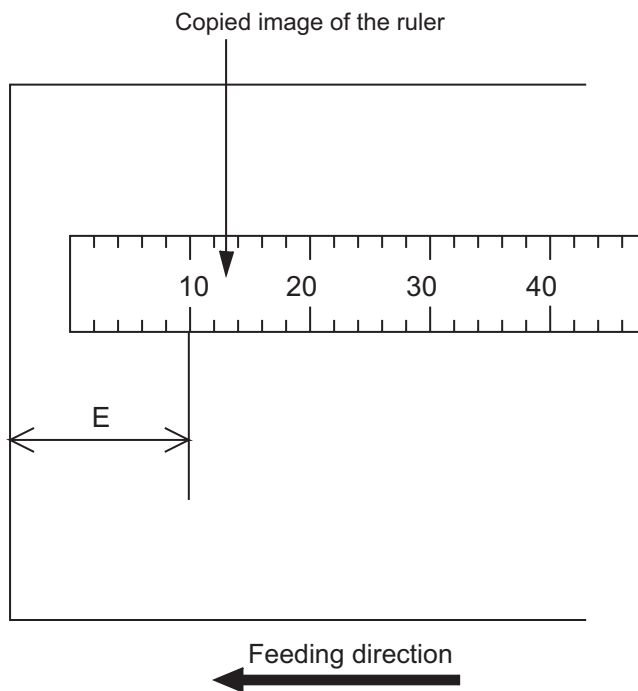
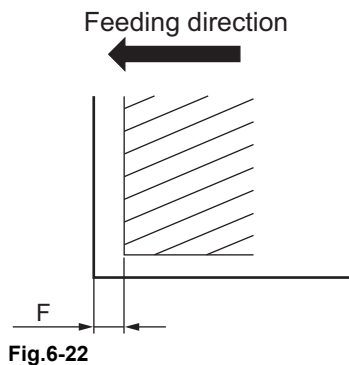

Fig.6-21

## [F] Top margin

Paper source	Code	Acceptable value	Change amount per 1 step	Paper size	Original	Original Mode	Ratio
2nd drawer	05-4050	0 to 255	Approx. 0.04 mm	A3, LD	Original cover or DF: Open	Text/Photo	100%

- (1) During the ready state of the Classic mode of FS-05, perform copying while the original cover or DF is kept open.  
Press [TEST COPY] and the [START] button.
- (2) Measure the margin F at the leading edge of the copied image by a scale and check that it is within the acceptable range.  
Acceptable range:  $4.2 \text{ mm} \pm 0.5 \text{ mm}$
- (3) If not, change the value of the code.  
The larger the adjustment value is, the wider the margin F becomes.
- (4) Output the test copy again and measure the margin F.



## [G] Right margin

Paper source	Code	Acceptable value	Change amount per 1 step	Paper size	Original	Original Mode	Ratio
2nd drawer	05-4052	0 to 255	Approx. 0.04 mm	A3, LD	Original cover or DF: Open	Text/Photo	100%

- (1) During the ready state of the Classic mode of FS-05, perform copying while the original cover or DF is kept open.  
Press [TEST COPY] and the [START] button.
- (2) Measure the margin G at the leading edge of the copied image by a scale and check that it is within the acceptable range.  
Acceptable range:  $4.2 \text{ mm} \pm 0.5 \text{ mm}$
- (3) If not, change the value of the code.  
The larger the adjustment value is, the wider the margin G becomes.
- (4) Output the test copy again and measure the margin G.

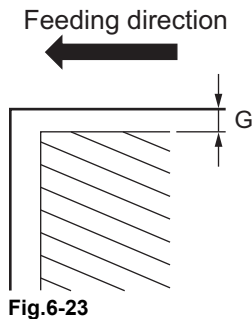

## [H] Bottom margin

Paper source	Code	Acceptable value	Change amount per 1 step	Paper size	Original	Original Mode	Ratio
2nd drawer	05-4053	0 to 255	Approx. 0.04 mm	A3, LD	Original cover or DF: Open	Text/Photo	100%

- (1) During the ready state of the Classic mode of FS-05, perform copying while the original cover or DF is kept open.  
Press [TEST COPY] and the [START] button.
- (2) Measure the margin H at the leading edge of the copied image by a scale and check that it is within the acceptable range.  
Acceptable range:  $4.2 \text{ mm} \pm 0.5 \text{ mm}$
- (3) If not, change the value of the code.  
The larger the adjustment value is, the wider the margin H becomes.
- (4) Output the test copy again and measure the margin H.

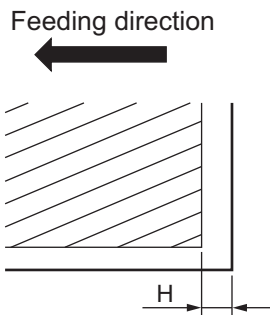

Fig.6-24

## 6.1.6 Automatic gamma adjustment

The density and gradation reproduction can be optimized. When parts are replaced or the gradation reproduction in the images is improper, perform this adjustment.

### Notes:

- When any of the following parts has been replaced, be sure to carry out this adjustment.
  - Photoconductive drum
  - Developer material
  - Laser optical unit
  - Transfer roller
  - Drum cleaning blade
  - Main charger grid
  - SRAM
  - Sub EEPROM
  - Standard storage device
- When the following operation is performed, be sure to carry out this adjustment.
  - Clearing of the standard storage device

### <Procedure>

- (1) Key in the code for chart printing in the ready state of the Classic mode of FS-05 to print out the chart for automatic gamma adjustment.  
Use A4 or LT size paper.
- (2) Place the chart printed out in step (1) on the original glass.  
When placing the chart, put its printed side down and align its side with 2 black squares to the reference at the left rear corner.
- (3) Key in the adjustment code and press the [START] button.

Function	Test print code	Adjustment code
Copying, Printing (600 dpi)	05-93	05-7311
Printing (1,200 dpi)	05-253	05-7312

- (4) Press [OK] to reflect the adjustment result.

### Remarks:

- To cancel the reflection of the adjustment result, press [Cancel].
- When "ADJUSTMENT ERROR" is shown, press [Cancel] to clear the error display and then perform the adjustment from step (2) again.



## 6.1.7 Density unevenness correction

The density difference at the front and rear can be corrected. Correction can be made automatically or manually.

### Remarks:

Automatic correction can be carried out through [Image Recovery] - [Density Unevenness Correction].

### Notes:

- When the automatic correction is carried out, the manual correction value is returned to the default one.
- When the manual correction is performed after the automatic correction, its result is added to the manual correction.
- For a printing job, this is effective only when "1" (Enabled) is set for 08-8124.
- This is effective for printing (600 dpi) only.

### [ 1 ] Automatic correction

- (1) Print a chart for the density difference correction at the front and rear with FS-05TP-291.
- (2) Place the chart printed out in step (1) on the original glass.  
When placing the chart, put its printed side down and align its side with 2 black squares to the reference at the left rear corner.
- (3) Perform FS-05-7329.

### Remarks:

- When "ADJUSTMENT ERROR" is shown, press [Cancel] to clear the error display. Then replace the chart correctly and perform the adjustment from step (2) again.
- The efficiency of the density unevenness correction can be adjusted by means of FS-05-8548. When a larger value is set, correction tends to be made.

### [ 2 ] Manual correction

Function	Item to be adjusted		Code	Sub code	Recommended value	Acceptable value	Default value	Operation procedure
Printing (600 dpi)	K (Black)	Area 1	8544	1, 2, 3, 4	To make the density darker: Set a larger value. To make the density lighter: Set a smaller value.	0 to 255	128	05 Procedure 4
		Area 2	8545					
		Area 3	8546					
		Area 4	8547					

The meaning of the sub code is as below.

Sub code	Density area to be adjusted
0	Low density
1	Medium density
2	High density

The details about the chart and area are shown as below.

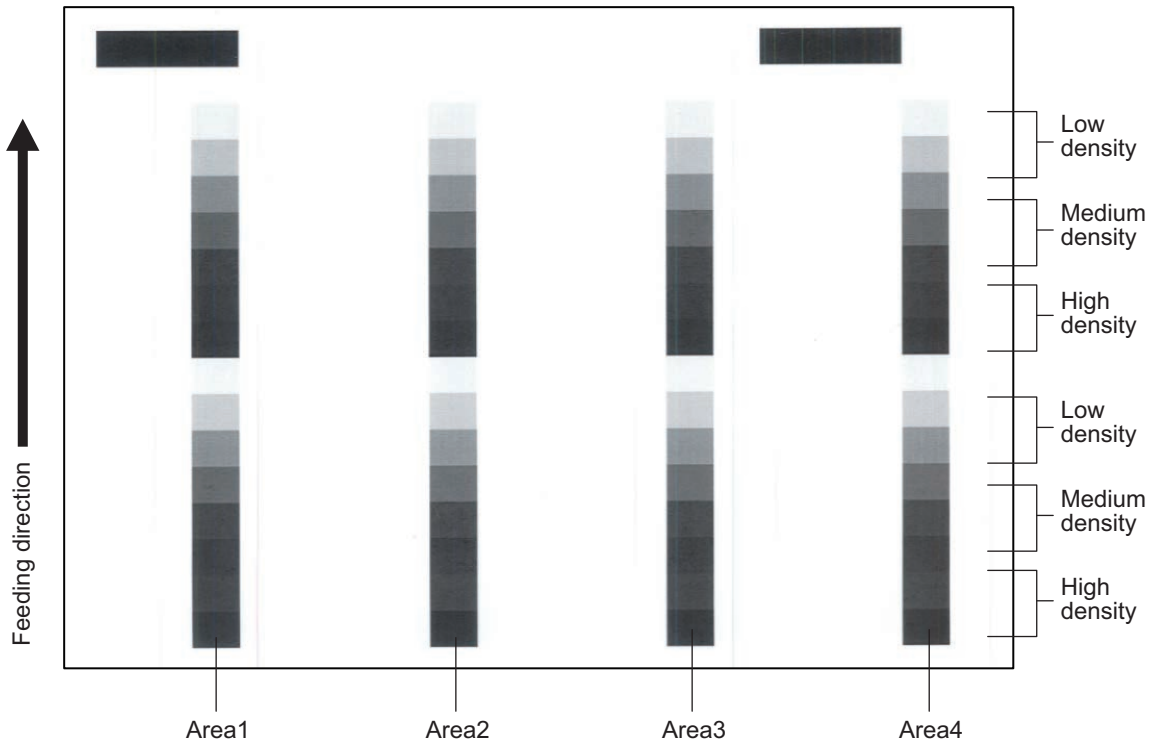

### [ 3 ] Correction clear

When FS-08-8002 is performed, the values for automatic and manual correction are returned to the default ones.

#### Remarks:

The gradation level reproducibility of gradation images can be switched by the following codes.

Color mode	Code	Sub code	Recommended value	Acceptable value	Default value	Operation procedure
Printer (600 dpi)	05-8092	0	0: Standard 1: Gradation priority	0 to 1	0	05 Procedure 4
		1			1	

The meaning of the sub code is as below.

Sub code	Explanation
0	When the FR density difference correction is disabled
1	When the FR density difference correction is enabled

#### Notes:

When any parts in the following units are replaced while FR density difference correction is enabled, perform FS-08-8002 (FR density difference correction clear).

- Data writing section
- Process unit (developer unit, cleaner)
- Transfer unit (TBU, TRU)
- Image quality control section
- Fusing section

## 6.2 Image Related Adjustment (Overview)

### 6.2.1 List

The following adjustment is applied to the image quality for various functions.

**Notes:**

When the adjustment has been carried out, check the image quality for all the functions to which the adjustment is applied.

Adjustment	Functions which can be adjusted			
	Copying	Printing	Scanning	Fax
6.3.4Blank page judgment threshold adjustment	Yes		Yes	
6.3.5Void amount adjustment for blank page judgment	Yes		Yes	
6.3.10Background offset adjustment (DF)	Yes		Yes*	Yes
6.3.11Background offset adjustment on the back side of paper (DSDF)	Yes		Yes*	Yes

\* Color adjustment is also possible.

### 6.2.2 Operation procedure

The operation procedure of the image quality adjustment is as follows.

#### [ 1 ] Operation procedure of the 05 Adjustment Mode

##### Procedure 1

- (1) Press [FS-05] > [Classic] to move to the code entry screen.
- (2) Key in the code and press the [START] button.
- (3) Key in the adjustment value and press [OK].
- (4) Perform test copy or test print if required.  
If the desired image density has not been attained, repeat steps (2) to (4).

##### Procedure 4

- (1) Press [FS-05] > [Classic] to move to the code entry screen.
- (2) Key in the code and press the [START] button.
- (3) Key in the sub code and press the [START] button.
- (4) Key in the adjustment value and press [OK].
- (5) Perform test copy or test print if required.  
If the desired image density has not been attained, repeat steps (2) to (5).

### 6.2.3 Scanning and paper feeding direction instruction patterns superposition function

Patterns to indicate the scanning direction during original scanning and the paper feeding direction during printing are synthesized on images of copying, printing, scanning and fax. This will be used to collect images for investigating the problems of an MFP.

Code	Recommended value	Acceptable value	Default value
05-7030	0: OFF 1: ON	0 to 1	0



**Notes:**

Be sure to return the value to “0” (default) when the investigation is finished.

The patterns and colors to be synthesized as information for original scanning are as below.

MFP performance	Pattern color
Black copying, black scanning, fax	Black
Gray Scale scanning	Gray

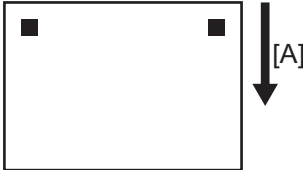

Scanned by placing an original on the original glass		[A] Carriage scanning direction
RADF: Front and back sides DSDF: Front side		[B] RADF or DSDF feeding direction
DSDF: Back side		[C] DSDF feeding direction

The patterns and colors to be synthesized as information for the paper feeding direction are as below.

MFP performance	Pattern color
Black copying, black printing, fax	Black

Outputted paper		[D] Paper feeding direction
-----------------	---	-----------------------------

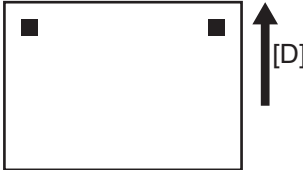
## 6.3 Image Quality Adjustment (Copying Function)

### 6.3.1 Density adjustment

The center value of the density can be adjusted.

If the setting value of the manual adjustment is changed, the density of the step of all indicators including the center value will be altered when an attempt is made to change the density manually on the [Basic] tab of the screen.

Item to be adjusted	Mode	Code	Recommended value	Acceptable value	Default value	Operation procedure
Automatic density	Text/Photo	05-7123	To make the density darker: Set a larger value. To make the density lighter: Set a smaller value.	0 to 255	128	05 Procedure 1
	Text	05-7124				
	Photo	05-7125				
	Custom	05-7137				
Manual density	Text/Photo	05-7114				
	Text	05-7115				
	Photo	05-7116				
	Custom	05-7134				
	Drop out color	05-7160				

#### Notes:

- Be sure to carry out this adjustment after performing the following one.  
 P. 6-24 “6.1.6 Automatic gamma adjustment”
- To check an image of Custom and Drop out color, use the one copied in the normal startup.
- The change of the setting value of the self-diagnostic code by 20 steps equivalents to that for 1 scale of the indicator.

### 6.3.2 Gamma balance adjustment

The density can be adjusted. The adjustment can be performed by selecting its density area from the following: low density, medium density and high density.

Mode	Code	Sub code	Recommended value	Acceptable value	Default value	Operation procedure
Text/Photo	05-7190	0, 1, 2	To make the density darker: Set a larger value. To make the density lighter: Set a smaller value.	0 to 255	128	05 Procedure 4
Text	05-7191					
Photo	05-7192					
Custom	05-7189					
Drop out color	05-7187					

The meaning of the sub code is as below.

Sub code	Density area to be adjusted
0	Low density
1	Medium density
2	High density

#### Notes:

- Be sure to carry out this adjustment after performing the following one.  
 P. 6-24 “6.1.6 Automatic gamma adjustment”
- To check an image of Custom and Drop out color, use the one copied in the normal startup.
- Change the setting value by 20 step while checking the image to set the most appropriate value.
- The density may be reversed with that for the adjoining density area depending on the setting value.

### 6.3.3 Background adjustment

The density of the background can be adjusted.

Mode	Code	Recommended value	Acceptable value	Default value	Operation procedure
Text/Photo	05-7100 05-7086*	To make the background darker: Set a larger value. To make the background lighter: Set a smaller value.	0 to 255	128	05 Procedure 1
Text	05-7101				
Photo	05-7102				
Custom	05-7106				
Drop out color	05-7107				

\* Manual density only

#### Notes:

- To check an image of Custom and Drop out color, use the one copied in the normal startup.
- The change of the setting value of the self-diagnostic code by 25 steps equivalents to that for 1 scale of the indicator.
- The setting value is the center value of [Background Adjustment] of the screen. Therefore, when the setting value is changed, all scales of the indicator are shifted by the value set in this setting accordingly.
- Change the setting value by 10 step while checking the image to set the most appropriate value.

### 6.3.4 Blank page judgment threshold adjustment

The threshold is adjusted for identification of whether the original set is a blank page or not.

Code	Recommended value	Acceptable value	Default value	Operation procedure
05-7618	To make the original tend to be judged as a blank page: Set a larger value. To make the original does not tend to be judged as a blank page: Set a smaller value.	0 to 255	128	05 Procedure 1

#### Notes:

Change the setting value by 15 steps while checking whether the original to be judged as blank is properly removed to set the most appropriate value.

### 6.3.5 Void amount adjustment for blank page judgment

The range of the image area to use blank page judgment of the original can be adjusted.

Code	Sub code	Recommended value	Acceptable value	Default value	Operation procedure
05-7616	0	To make the image area wider: Set a smaller value. To make the image area narrower: Set a larger value.	0 to 255	200	05 Procedure 4

#### Notes:

- 24 steps of the setting value are equivalent to approx. 1 mm image area.
- If too a smaller value is set, stains at the edges of an original may be judged as images. Due to this, the desired judgment may not be obtained.

### 6.3.6 Sharpness adjustment

The sharpness of images can be adjusted to make it softer or sharper. The adjustment can be made for each original mode.

Mode	Code	Recommended value	Acceptable value	Default value	Operation procedure
Text/Photo	05-7056	To make the image softer or to make moiré inconspicuous: Set a smaller value. To make the image sharper or to make thin lines clearer: Set a larger value.	0 to 255	128	05 Procedure 1
Text	05-7057				
Photo	05-7058				
Custom	05-7249				
Drop out color	05-7062				

**Notes:**

- To check an image of Custom and Drop out color, use the one copied in the normal startup.
- The change of the setting value of the self-diagnostic code by 25 steps equivalents to that for 1 scale of the indicator.
- The setting value is the center value of [Sharpness] of the screen. Therefore, when the setting value is changed, all scales of the indicator is shifted by the value set in this setting accordingly.
- The larger the value is, the more moiré tends to occur.

### 6.3.7 Range correction adjustment

The background peak value used for the range correction can be set to fixing or varying.

Item to be adjusted	Original mode	Code	Recommended value	Acceptable value	Default value	Operation procedure
Manual density	Text/Photo	05-7286	-	0 to 1	0	05 Procedure 1
	Text	05-7287		0: Background peak - Fixed	1	
	Custom	05-7237		1: Background peak - Varied	0	

**Notes:**

- To check an image of Custom, use the one copied in the normal startup.
- When “0” (Background peak - Fixed) is set: A certain level of the density can be removed regardless of the background of the original Uneven density in images will not occur.
- When “1” (Background peak - Varied) is set: The background will be removed corresponding to the background level of the original. The removal level of the background may not become even depending on the design of the original.

### 6.3.8 Smudged/faint text adjustment

The smudged or faint text can be adjusted.

Original mode	Code	Recommended value	Acceptable value	Default value	Operation procedure
Text/Photo	05-7097	To make the text and thin lines thicker: Set a smaller value. To make the text and thin lines thinner: Set a larger value.	0 to 4	2	05 Procedure 1
Text	05-7098				
Custom	05-7252				

**Remarks:**

- To check an image of Custom, use the one copied in the normal startup.
- Change the setting value by 1 step while checking the image to set the most appropriate value.

### 6.3.9 Emission level adjustment

The emission level can be set. The density can be adjusted by changing the dot size.

Original mode	Code	Sub code	Recommended value	Acceptable value	Default value	Operation procedure
Text/Photo	05-7218	0	To make the density darker: Set a larger value. To make the density lighter: Set a smaller value.	0 to 255	0	05 Procedure 4
		1			63	
		2			127	
		3			191	
		4			255	
Text	05-7219	0				
		1			63	
		2			127	
		3			191	
		4			255	
Photo	05-7220	0			0	
		1			63	
		2			127	
		3			191	
		4			255	

#### Notes:

- The setting of the sub code 4 is the most influential one to the density.
- Change the setting value by 8 step while checking the image to set the most appropriate value.
- The value of the sub code should be entered so that the value of the order becomes  $0 < 1 < 2 < 3 < 4$ .

### 6.3.10 Background offset adjustment (DF)

The reproduction ratio of the background in DF scanning can be adjusted. The adjustment value is applied to both the front and back sides.

Color mode	Code	Recommended value	Acceptable value	Default value	Operation procedure
Full color	05-7026	To make the background darker: Set a larger value.	0 to 255	128	05 Procedure 1
Black	05-7025	To make the background lighter: Set a smaller value.			

#### Notes:

- Change the setting value by 20 step while checking the image to set the most appropriate value.
- The adjustment results for the Black mode is applied to the image quality for copying, scanning (Black, Gray scale) and fax.
- The adjustment results for the Full Color mode is applied to the image quality only for scanning (Full color).



### 6.3.11 Background offset adjustment on the back side of paper (DSDF)

The reproduction ratio of the background on the back side of paper in DSDF scanning can be adjusted. The adjustment value is applied to the back side only.

Color mode	Code	Recommended value	Acceptable value	Default value	Operation procedure
Full color	05-7024	To make the background darker: Set a larger value. To make the background lighter: Set a smaller value.	0 to 255	128	05 Procedure 1
Black	05-7023				

#### Notes:

- Change the setting value by 20 step while checking the image to set the most appropriate value.
- The adjustment results for the Black mode is applied to the image quality for copying, scanning (Black, Gray scale) and fax.
- The adjustment results for the Full Color mode is applied to the image quality only for scanning (Full color).

### 6.3.12 Drop out color adjustment

The drop out level of a gray-like color during the drop out color mode can be adjusted.

Code	Recommended value	Acceptable value	Default value	Operation procedure
05-7066	To make the gray-like color tend to be dropped out: Set a larger value. To make the gray-like color does not tend to be dropped out: Set a smaller value.	20 to 80	50	05 Procedure 1

#### Notes:

- Be sure to carry out this adjustment after performing the following one.  
 P. 6-24 "6.1.6 Automatic gamma adjustment"
- Changing by "10" of the setting value is equivalent to 1 step of the slide bar on the LCD.
- To check an image of Drop out color, use the one copied in the normal startup.

### 6.3.13 Scanning streak reduction

The effectiveness of the ADF noise reduction function can be adjusted for each original mode.

Original mode	Code	Recommended value	Acceptable value	Default value	Operation procedure
Text/Photo	05-7151	To increase the effectiveness: Set a smaller value. To decrease the effectiveness: Set a larger value.	0 to 200	100	05 Procedure 1
Text	05-7152				
Photo	05-7153				
Custom	05-7150				

#### Notes:

- When "0" is set, the ADF noise reduction function will be invalid.
- To check an image of Custom, use the one copied in the normal startup.
- This is effective only when "1" is set for 08-7102.

Streaks generated on images during the scanning of an original can be reduced. The reduction level can be set for using the DF or the original glass, respectively.

When the DF is used for scanning, detection is performed for every scanned page to reduce streaks.

When the original glass is used for scanning, refer to the result of the automatic streak detection on it to reduce streaks.

Code	Item to be adjusted	Recommended value	Acceptable value	Default value	Operation procedure
08-7103	Streak correction enable/disable setting	0: Disabled 1: Enabled	0 to 1	0	05 Procedure 1
08-7104	Streak correction level setting (scanning by placing an original on the original glass)	Correction level 0: Low 1: Medium 2: High	0 to 2		
08-7105	Streak correction level setting (DF scanning)	Correction level 0: Low 1: Medium 2: High	0 to 2		

Code	Item to be adjusted	Operation procedure
08-7103	Streak detection execution	05 Procedure 1*

\* Perform this by placing an A4 or LT blank sheet of paper on the original glass.

**Notes:**

- To reduce streaks when the original glass is used for scanning, be sure to perform FS-05-7619.
- When streaks have not appeared on images due to the original glass being cleaned, perform FS-08-7108 and clear the detection result of FS-05-7619.
- The adjustment results is applied to the image quality for copying and scanning.

The correction level intensity of the scanning streak reduction level setting can be adjusted.  
When RADF is installed

Item to be adjusted	Code	Sub code	Recommended value	Acceptable value	Default value	Operation procedure
When scanning by placing an original on the original glass	05-7623	0	To make the streak correction intensity higher: Set a larger value.	0 to 255	0	05 Procedure 4
When using the DF for scanning		1	To make the streak correction intensity lower: Set a smaller value.			

When DSDF is installed

Item to be adjusted	Code	Sub code	Recommended value	Acceptable value	Default value	Operation procedure
When scanning by placing an original on the original glass	05-7623	0	To make the streak correction intensity higher: Set a larger value.	0 to 255	0	05 Procedure 4
When using the DF for scanning (front side)		1	To make the streak correction intensity lower: Set a smaller value.			
When using the DF for scanning (back side)		2				

**Notes:**

- When a larger value is set, the images around the streaks may be corrupted.
- This is effective only when "0" is set for 08-7102.
- When "1" is set for FS-08-7102, streak correction will be executed when only the DF is used for scanning.

### 6.3.14 Background removal level adjustment

The effectiveness of the removal can be adjusted for each original mode in the black mode and auto density.

Color mode	Original mode	Code	Recommended value	Acceptable value	Default value	Operation procedure
Black	Text/Photo	05-7032	To decrease the effectiveness of background removal: Set a larger value. To increase the effectiveness of background removal: Set a smaller value.	0 to 255	128	05 Procedure 1
	Text	05-7033				
	Photo	05-7034				
	Custom	05-7036				

**Notes:**

Do not apply this adjustment to a certain original and paper since this setting is reflected to all types of originals.

### 6.3.15 Low density text reproduction adjustment

The way of removing the background can be switched to a more effective one in order to reproduce a low density text for each original mode in the black mode and auto density.

Color mode	Original mode	Code	Recommended value	Acceptable value	Default value	Operation procedure
Black	Text/Photo	05-7238	0: Factory setting value (Default) 1: Disabled 2: Enabled	0 to 2	0	05 Procedure 1
	Text	05-7239				
	Photo	05-7240				
	Custom	05-7242				

**Notes:**

When the value is set to “1”, the density of the images may become lighter in its entirety. In such a case, increase the setting value of the density adjustment by approx. 20.

 P. 6-29 “6.3.1 Density adjustment”

## 6.4 Image Quality Adjustment (Printing Function)

### 6.4.1 Gamma balance adjustment

The density of the printing can be adjusted. The adjustment can be performed for each printer driver and resolution by selecting its density area from the following: low density, medium density and high density.

PDL, Resolution	Halftone	Item to be adjusted	Code	Sub code	Recommended value	Acceptable value	Default value	Operation procedure
PS 600 dpi	Smooth	All	05-7315	0, 1, 2	To make the density darker: Set a larger value. To make the density lighter: Set a smaller value.	0 to 255	128	05 Procedure 4
	Detail	All	05-7316					
	Auto	Text	05-7360					
		Graphic	05-7361					
PS 1200 dpi	Smooth	All	05-7309					
	Detail	All	05-7310					
	Auto	Text	05-7357					
		Graphic	05-7358					
PCL 600 dpi	Smooth	All	05-7317					
	Detail	All	05-7318					
	Auto	Text	05-7363					
		Graphic	05-7364					
		Image	05-7365					

The meaning of the sub code is as below.

Sub code	Density area to be adjusted
0	Low density
1	Medium density
2	High density

#### Notes:

- Be sure to carry out this adjustment after performing the following one.  
 P. 6-24 “6.1.6 Automatic gamma adjustment”
- The range of the effectiveness varies depending on the halftone setting.
- Change the setting value by 10 step while checking the image to set the most appropriate value.
- For Mac, adjust the PS drivers.
- The density may be reversed with that for the adjoining density area depending on the setting value.

<Density area range (lower, medium and high density)>

The color from the 1st to the 7th stage (low density), from the 8th to the 11th stage (medium density) and from the 12th to the 13th stage (high density) in “Patch chart for gamma adjustment ([94] [TEST PRINT])” can be used as a guide for the range of the density area (low density, medium density, high density) influenced by the change of the adjustment value.

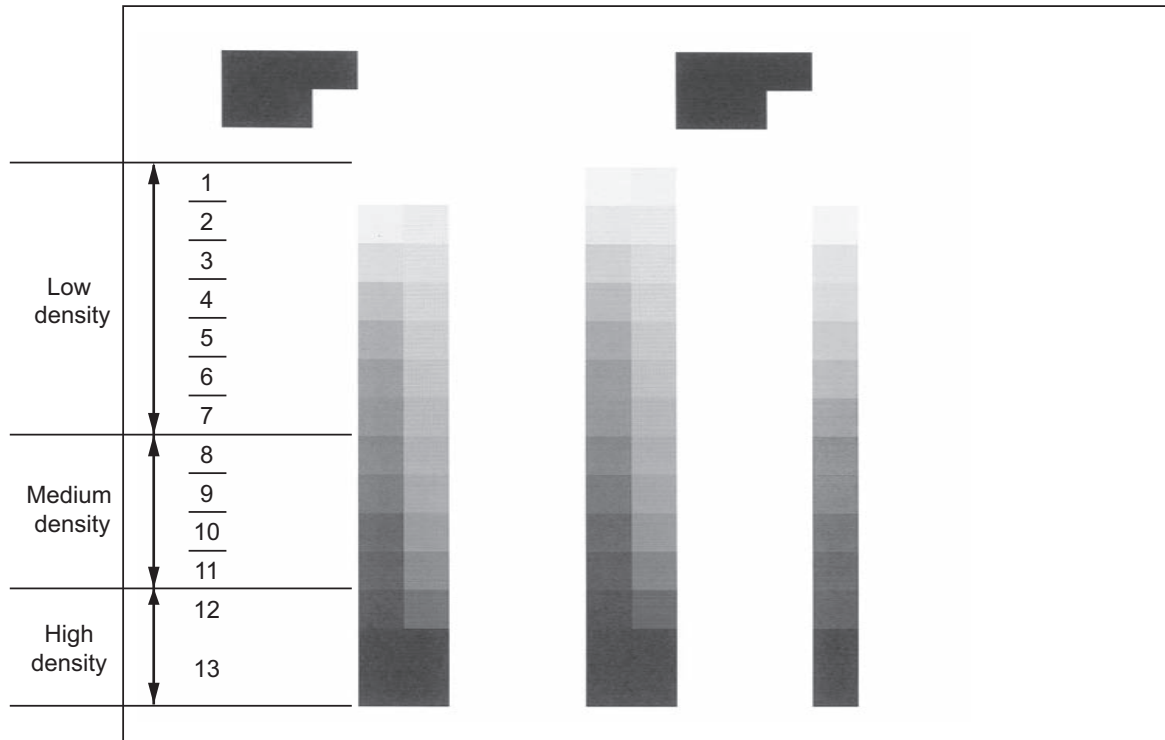

Fig.6-25

## 6.4.2 Text density adjustment

The density of characters can be adjusted.

Color mode	PDL	Code	Sub code	Recommended value	Acceptable value	Default value	Operation procedure
Black	PS	05-7340	-	To make the characters darker: Set a larger value. To make the characters lighter: Set a smaller value.	0 to 8	0	05 Procedure 1
	PCL	05-7341					

\* 600 dpi only

## 6.4.3 Density upper limit value adjustment in toner saving mode

The upper limit value of the density when “Toner Saving Mode” is selected in the [Custom] tab of the printer driver can be adjusted.

Resolution	PDL	Code	Sub code	Recommended value	Acceptable value	Default value	Operation procedure
600 dpi	PS	05-7307	0	To make the density darker: Set a larger value. To make the density lighter: Set a smaller value.	0 to 255	176	05 Procedure 4
	PCL		1				
1200 dpi	PS	05-7302	-				05 Procedure 1

## 6.4.4 Sharpness adjustment

The sharpness of the boundary of text and lines can be adjusted.

### [ 1 ] Sharpness adjustment

Color mode	Original type	Code	Sub code	Recommended value	Acceptable value	Default value	Operation procedure
Black*1	-	05-8118	0, 1, 2	To make the image softer or to make moiré inconspicuous: Set a smaller value. To make the image sharper or to make thin lines clearer: Set a larger value.	0 to 255	128, 128, 128	05 Procedure 4
e-Filing (Black)	-	05-8107	-			128	05 Procedure 1

The meaning of the sub code is as below.

Sub code	Item to be adjusted
0	Text
1	Graphic
2	Image

\*1: The meaning of the sub code when “1” is set in 05-7322 is as below.

Sub code	Item to be adjusted
0	Text
1	Graphic / Thin text
2	Image

#### Notes:

- 25 steps of the setting value are equivalent to 1 step of the sharpness adjustment on the printer driver.
- Change the setting value by 10 steps while checking the image to set the most appropriate value.
- When “0” is set, the image quality will not be changed even if the sharpness is adjusted on the printer driver.

### [ 2 ] Prevention setting of white voids resulting from the sharpness adjustment

Color mode	Code	Sub code	Recommended value	Acceptable value	Default value	Operation procedure
Black	05-8114	0, 1, 2	Prevents white voids resulting from the sharpness adjustment. 0: Disabled 1: Enabled	0 to 1	0	05 Procedure 4

The meaning of the sub code is as below.

Sub code	Item to be adjusted
0	Text
1	Graphics
2	Image

## 6.4.5 Thin line width lower limit adjustment

The thickness of the thin lines can be adjusted.

Resolution	Code	Recommended value	Acceptable value	Default value	Operation procedure
600 dpi	05-8240	To make the thin lines thicker: Set a larger value. To make the thin lines thinner: Set a smaller value.	1 to 9	2	05 Procedure 1
1200 dpi	05-8241				

### Notes:

This adjustment will be effective when the [Distinguish Thin Lines] check box is selected.

## 6.4.6 Background adjustment

The density of the background can be adjusted.

Resolution	Halftone	Code	Sub code	Recommended value	Acceptable value	Default value	Operation procedure
600 dpi	Auto / Smooth	05-8012	0, 1	To make the background darker: Set a larger value. To make the background lighter: Set a smaller value.	0 to 255	128	05 Procedure 4
	Detail	05-8015					05 Procedure 1
1200 dpi	Auto / Smooth	05-8018	-				
	Detail	05-8019					

### Notes:

The change of the setting value of the self-diagnostic code by 25 steps equivalents to that for 1 scale of the indicator.

The meaning of the sub code is as below.

Sub code	Item to be adjusted
0	PS
1	PCL

## 6.4.7 Emission level adjustment

The emission level when the following jobs are printed can be set.

- e-Filing

The density can be adjusted by changing the dot size.

Original mode	Code	Sub code	Recommended value	Acceptable value	Default value	Operation procedure
e-Filing	05-7356	0	To make the density darker: Set a larger value.	0 to 255	0	05 Procedure 4
		1			63	
		2	To make the density lighter: Set a smaller value.		127	
		3			191	
		4			255	

### Notes:

- The setting of the sub code 4 is the most influential one to the density.
- Change the setting value by 8 step while checking the image to set the most appropriate value.
- The value of the sub code should be entered so that the value of the order becomes  $0 < 1 < 2 < 3 < 4$ .
- This will not be applied to the images printed by the printer driver.

## 6.4.8 Graphic line density adjustment (1200 dpi)

The density of fine lines and characters can be adjusted. Moreover, the range to which the density adjustment is applied can be arranged.

### [ 1 ] Adjusting the density

Resolution	Code	Sub code	Recommended value	Acceptable value	Default value	Operation procedure
1200 dpi	05-8242	0	To make the density darker: Set a larger value. To make the density lighter: Set a smaller value.	0 to 5	3	05 Procedure 4

### [ 2 ] Arranging the application range of the density adjustment

Resolution	Item to be adjusted	Code	Sub code	Recommended value	Acceptable value	Default value	Operation procedure
1200 dpi	Lower limit value	05-8243	0	When a lower limit is decreased, lines with lighter colors will be adjusted. When an upper limit is increased, lines with darker colors will be adjusted.	0 to 255	1 200	05 Procedure 4
	Upper limit value		1				

#### Notes:

Set the values of the upper and lower limit properly making sure that they are not set in reverse.

## 6.4.9 Gradation reproduction switching for Text

The gradation reproduction method of Text can be switched.

Resolution	PDL	Code	Sub code	Recommended value	Acceptable value	Default value	Operation procedure
600 dpi	PS	05-7386	0		0 to 1 0: Text reproduction priority (Text with medium density will be darker.) 1: Gradation reproduction priority (Text with medium density will be lighter.)	0	05 Procedure 4
	PCL		1				
1200 dpi	PS	05-7387	-				05 Procedure 1

## 6.4.10 Smudged text in black adjustment

Smudged black text and thin lines can be adjusted.

Resolution	PDL	Code	Recommended value	Acceptable value	Default value	Operation procedure
600 dpi	PS	05-7325	To make the black text and thin lines thicker: Set a smaller value. To make the black text and thin lines thinner: Set a larger value.	0 to 9	2	05 Procedure 1
	PCL	05-7326			5	
1200 dpi	PS	05-7305		0 to 9	5	



## 6.4.11 Halftone setting

When [Auto] is selected in [Halftone] of the printer driver, the type of the halftone to be applied to each object can be changed.

Resolution	Item to be adjusted	Code	Sub code	Recommended value	Acceptable value	Default value	Operation procedure
600 dpi	Text	05-7382	0	-	1 to 2 1: Detail 2: High definition	1	05 Procedure 4
	Graphic		1			0	
	Image		2			0	
1200 dpi	Text	05-7383	0	-	0 to 1 0: Smooth 1: Detail	1	05 Procedure 4
	Graphic		1			0	
	Image		2			0	

### Notes:

When this adjustment is carried out, perform the following adjustment.

 P. 6-24 “6.1.6 Automatic gamma adjustment”

## 6.4.12 White void correction around the text

White voids around the text whose color is the same as that for the background can be corrected.

Color mode	Resolution	PDL	Code	Sub code	Meaning of the sub code	Recommended value	Acceptable value	Default value	Operation procedure
Black	600 dpi	PS	05-8204	0	-	0: OFF When a larger value is set, white voids around the text can be suppressed.	0 to 5	0	05 Procedure 1
		PCL		1	-				
	1200 dpi	PS	05-7378	0	-				
		PCL		1	-				

### Notes:

When a larger value is set, the area around the text will be darker. Therefore, set the appropriate value while checking the images.

When the white void correction is performed for images formed by K toner only, the object to be applied can be selected.

Color mode	Resolution	PDL	Code	Sub code	Recommended value	Acceptable value	Default value	Operation procedure
Black	600 dpi	PS	05-8206	0	0: Graphic only 1: Image only 2: Applied to both Graphic and Image	0 to 2	0	05 Procedure 4
		PCL		1				

## 6.5 Image Quality Adjustment (Scanning Function)

### 6.5.1 Gamma balance adjustment

The density of the Black and Gray scale can be adjusted. The adjustment can be performed by selecting its density area from the following: low density, medium density and high density.

Color mode	Original mode	Code	Sub code	Recommended value	Acceptable value	Default value	Operation procedure
Black	Text/Photo	05-7485	0, 1, 2	To make the density darker: Set a larger value. To make the density lighter: Set a smaller value.	0 to 255	128	05 Procedure 4
	Photo	05-7487					
	Custom	05-7480					
Gray scale	-	05-7488					

The meaning of the sub code is as below.

Sub code	Item to be adjusted
0	Low density
1	Medium density
2	High density

#### Notes:

Change the setting value by 20 step while checking the image to set the most appropriate value.

### 6.5.2 RGB color balance adjustment

The color balance of the color scanning can be adjusted.

Color mode	Original mode	Code	Sub code	Recommended value	Acceptable value	Default value	Operation procedure
Full color	Text/Photo	05-8425	0, 1, 2	To make the applicable color a higher level: Set a larger value. To make the applicable color a lower level: Set a smaller value.	0 to 255	128	05 Procedure 4
	Text	05-8426					
	Photo	05-8427					
	Custom	05-8428					

The meaning of the sub code is as below.

Sub code	Item to be adjusted
0	Red
1	Green
2	Blue

#### Notes:

The change of the setting value of the self-diagnostic code by 25 steps equivalents to that for 1 scale of the indicator.

### 6.5.3 Density adjustment

The center value of the density can be adjusted.

If the setting value of the manual adjustment is changed, the density of the step of all indicators including the center value will be altered when [Auto] is selected in Exposure on the [Scan Setting] screen.

Color mode	Item to be adjusted	Original mode	Code	Recommended value	Acceptable value	Default value	Operation procedure
Full color	Manual density	Text/Photo	05-8339	To make the density darker: Set a larger value. To make the density lighter: Set a smaller value.	0 to 255	128	05 Procedure 1
		Text	05-8340				
		Photo	05-8341				
		Custom	05-8380				
	Automatic density	Text/Photo	05-8342				
		Text	05-8343				
		Photo	05-8344				
		Custom	05-8381				
Gray scale	Manual density	-	05-7447				
	Automatic density		05-7459				
Black	Manual density	Text/Photo	05-7444				
		Text	05-7445				
		Photo	05-7446				
		Custom	05-7475				
	Automatic density	Text/Photo	05-7456				
		Text	05-7457				
		Photo	05-7458				
		Custom	05-7478				
Drop out color			05-7443				

#### Notes:

The change of the setting value of the self-diagnostic code by 20 steps equivalents to that for 1 scale of the indicator.

### 6.5.4 Background adjustment

The density of the background can be adjusted.

Color mode	Original mode	Code	Recommended value	Acceptable value	Default value	Operation procedure
Full color	Text/Photo	05-8309	To make the background darker: Set a larger value. To make the background lighter: Set a smaller value.	0 to 255	128	05 Procedure 1
	Text	05-8310				
	Photo	05-8311				
	Custom	05-8370				
Gray scale	-	05-7439				
Black	Text/Photo	05-7436				
	Text	05-7437				
	Photo	05-7438				
	Custom	05-7441				
Drop out color		05-7442				

#### Notes:

- The change of the setting value of the self-diagnostic code by 25 steps equivalents to that for 1 scale of the indicator.
- The setting value is the center value of [Background Adjustment] of the [Scan Setting] screen. Therefore, when the setting value is changed, all scales of the indicator is shifted by the value set in this setting accordingly.
- Change the setting value by 10 step while checking the image to set the most appropriate value.

## 6.5.5 ACS judgment threshold

The threshold to judge whether the original is color or black can be adjusted when Auto Color is selected.

Item to be adjusted	Code	Recommended value	Acceptable value	Default value	Operation procedure
ACS	05-7630	To make the image area wider: Set a smaller value. To make the image area narrower: Set a larger value.	0 to 255	70	05 Procedure 4

### Notes:

Change the setting value by 20 step while checking the image to set the most appropriate value.

## 6.5.6 Void amount adjustment for ACS judgment

The range of the image area to use the color or black judgment of the original can be adjusted when Auto Color is selected.

Item to be adjusted	Code	Sub code	Recommended value	Acceptable value	Default value	Operation procedure
ACS	05-7616	1	To make the image area wider: Set a smaller value. To make the image area narrower: Set a larger value.	0 to 255	70	05 Procedure 4

### Notes:

- 24 steps of the setting value are equivalent to approx. 1 mm image area.
- If too a smaller value is set, stains at the edges of an original may be judged as images. Due to this, the desired judgment may not be obtained.

## 6.5.7 Blank page judgment threshold adjustment

The threshold is adjusted for identification of whether the original set is a blank page or not. For the adjustment method, see the following reference.

 P. 6-30 “6.3.4 Blank page judgment threshold adjustment”

## 6.5.8 Void amount adjustment for blank page judgment

The range of the image area to use blank page judgment of the original can be adjusted. For the adjustment method, see the following reference.

 P. 6-30 “6.3.5 Void amount adjustment for blank page judgment”

## 6.5.9 Sharpness adjustment

The sharpness of the boundary of text and lines can be adjusted.

Color mode	Original mode	Code	Recommended value	Acceptable value	Default value	Operation procedure
Black	Text/Photo	05-7430	To make the image softer or to make moiré inconspicuous: Set a smaller value. To make the image sharper or to make thin lines clearer: Set a larger value.	0 to 255	200	05 Procedure 4
	Text	05-7431				
	Photo	05-7432				
	Custom	05-7470				
Full color	Text/Photo	05-8354				
	Text	05-8335				
	Photo	05-8336				
	Custom	05-8375				
Gray scale	-	05-7433				

### Notes:

- The change of the setting value of the self-diagnostic code by 25 steps equivalents to that for 1 scale of the indicator.
- The setting value is the center value of [Sharpness] of the [Scan Setting] screen. Therefore, when the setting value is changed, all scales of the indicator is shifted by the value set in this setting accordingly.
- Change the setting value by 10 step while checking the image to set the most appropriate value.

## 6.5.10 Contrast adjustment

The contrast in color scanning can be adjusted.

Color mode	Original mode	Code	Recommended value	Acceptable value	Default value	Operation procedure
Full color	Text/Photo	05-8419	To make the contrast higher: Set a larger value. To make the contrast lower: Set a smaller value.	0 to 255	128	05 Procedure 1
	Text	05-8420				
	Photo	05-8421				
	Custom	05-8422				

### Notes:

The change of the setting value of the self-diagnostic code by 25 steps equivalents to that for 1 scale of the indicator.

## 6.5.11 Black density fine adjustment

Black in color scanning can be adjusted so that it will be close to the color of an original.

Color mode	Original mode	Code	Recommended value	Acceptable value	Default value	Operation procedure
Full color	Text/Photo	05-8314	To make black darker: Set a larger value. To make black lighter: Set a smaller value.	0 to 4	1	05 Procedure 1
	Text	05-8315			0	
	Photo	05-8316				
	Custom	05-8371				

### Notes:

Be careful not to let the value be too large since the gradation is reproduced worse in the darker side.

## 6.5.12 RGB conversion method selection

The color space conversion method in color scanning can be adjusted.

Color mode	Original mode	Code	Recommended value	Acceptable value	Default value	Operation procedure
Full color	Text/Photo	05-8319	-	0: sRGB 1: AppleRGB 2: ROMMRGB 3: AdobeRGB	0	05 Procedure 1
	Text	05-8320				
	Photo	05-8321				
	Custom	05-8372				

## 6.5.13 Saturation adjustment

The saturation in color scanning can be adjusted.

Color mode	Original mode	Code	Recommended value	Acceptable value	Default value	Operation procedure
Full color	Text/Photo	05-8324	To make the saturation higher: Set a larger value. To make the saturation lower: Set a smaller value.	0 to 255	128	05 Procedure 1
	Text	05-8325				
	Photo	05-8326				
	Custom	05-8373				

## 6.5.14 SlimPDF capacity and image quality adjustment

The file size and the image quality can be adjusted by changing the compression ratio and resolution for areas other than text (such as a background) in SlimPDF.

The sharpness of the background can also be adjusted.

Item to be adjusted	Code	Recommended value	Acceptable value	Default value	Operation procedure
Compression ratio	05-9104	To improve the image quality: Set a larger value. (The file size will become larger.) To reduce the file size: Set a smaller value. (The image quality will become worse. (Noise will be increased in outlines and the boundary of white and other colors.))	0 to 10	5	05 Procedure 1
Sharpness	05-9105	To make the outline and boundary clearer: Set a larger value. (Noise will be enhanced or moiré may occur.) To make the outline and boundary softer: Set a smaller value. (Images may be blurred.)			
Resolution	05-9107	0: 75 dpi, 1: 100 dpi, 2: 150 dpi, 3: 200 dpi To improve the image quality: Set a larger value. (The file size will become larger.) To reduce the file size: Set a smaller value. (The image quality will become worse. (Some characters will become hard to read and the boundary of photos will be blurred.))	0 to 3	1	

### Notes:

- Change the setting value of 05-9104 and 05-9105 by 2 steps while checking the image in order to set the most appropriate value.
- When “5” is set in 05-9105, the sharpness will not be adjusted.
- Performing the adjustment by combining 05-9104 and 05-9107 can obtain good balance in the image quality and file size.  
e.g.: Set 2 or a larger value in 05-9107 to improve the image quality and set 4 or a smaller value in 05- 9104 to reduce the file size.

## 6.5.15 Surrounding void amount adjustment

The void amount around the scanned image during selecting [Auto Detected] can be adjusted. Perform this adjustment to remove shadows of the original generated around images.

Paper size	Size detection	Code	Recommended value	Acceptable value	Default value	Operation procedure
Standard	-	05-7489	To increase the void amount: Set a larger value. To decrease the void amount: Set a smaller value.	0 to 255	0	05 Procedure 1
Custom size	Size selection	05-7490			0	
	Auto	05-7491			0	

### Notes:

When the setting value of the self-diagnostic code is changed by 24 steps, the void amount will be altered by approx. 1 mm accordingly.

## 6.5.16 JPEG compression level adjustment

The compression ratio for saving the scanned images in the JPEG format can be adjusted.

Color mode	Code	Sub code	Meaning of the sub code	Recommended value	Acceptable value	Default value	Operation procedure
Full color	05-8304	0	High	To increase the compression ratio: Set a smaller value. To decrease the compression ratio: Set a larger value.	0 to 255	128	05 Procedure 4
		1	Mid				
		2	Low				

### Notes:

The larger the value is, the greater the file size but the higher the image quality becomes.

## 6.5.17 Scanning streak reduction

Streaks generated on images during the scanning of an original can be reduced. The reduction level can be set for using the DF or the original glass, respectively.

When the DF is used for scanning, detection is performed for every scanned page to reduce streaks.

When the original glass is used for scanning, refer to the result of the automatic streak detection on it to reduce streaks.

For the adjustment method, see the following reference.

 P. 6-33 "6.3.13 Scanning streak reduction"

## 6.5.18 Background offset adjustment (DF)

The reproduction ratio of the background in DF scanning can be adjusted. The adjustment value is applied to both the front and back sides.

For the adjustment method, see the following reference.

 P. 6-32 "6.3.10 Background offset adjustment (DF)"

## 6.5.19 Background offset adjustment on the back side of paper (DSDF)

The reproduction ratio of the background on the back side of paper in DSDF scanning can be adjusted. The adjustment value is applied to the back side only.

For the adjustment method, see the following reference.

 P. 6-33 "6.3.11 Background offset adjustment on the back side of paper (DSDF)"

## 6.5.20 Low density text reproduction process adjustment

The way of removing the background to create a priority for reducing a low density text can be set in the black mode and auto density.

This setting can be made for each original mode.

Color mode	Original mode	Code	Recommended value	Acceptable value	Default value	Operation procedure
Black	Text/Photo	05-7408	0: Factory setting value 1: Disabled 2: Enabled	0 to 2	0	05 Procedure 1
	Text	05-7409				
	Photo	05-7410				
	Gray Scale	05-7411				
	Custom	05-7412				

### Notes:

When the value is set to “2”, the density of the images may become darker in its entirety. In such a case, decrease the setting value of the density adjustment by approx. 20.

 P. 6-43 “6.5.3 Density adjustment”



## 6.6 Image Quality Adjustment (Fax Function)

### 6.6.1 Density adjustment

The center value of the density can be adjusted.

If the setting value of the manual adjustment is changed, the density of the step of all indicators including the center value will be altered when [Auto] is selected in Exposure on the [Option] screen.

Item to be adjusted	Original mode	Code	Recommended value	Acceptable value	Default value	Operation procedure
Manual density	Text/Photo	05-7533	To make the density darker: Set a larger value. To make the density lighter: Set a smaller value.	0 to 255	128	05 Procedure 1
	Text	05-7534				
	Photo	05-7535				
Automatic density	Text/Photo	05-7542				
	Photo	05-7543				

#### Notes:

The change of the setting value of the self-diagnostic code by 20 steps equivalents to that for 1 scale of the indicator.

### 6.6.2 Emission level adjustment

The emission level in the fax function can be set. The density can be adjusted by changing the dot size.

Code	Sub code	Recommended value	Acceptable value	Default value	Operation procedure
05-7595	0	To make the density darker: Set a larger value. To make the density lighter: Set a smaller value.	0 to 255	0	05 Procedure 4
	1			63	
	2			127	
	3			191	
	4			255	

#### Notes:

- The setting of the sub code 4 is the most influential one to the density.
- Change the setting value by 8 step while checking the image to set the most appropriate value.
- The value of the sub code should be entered so that the value of the order becomes  $0 < 1 < 2 < 3 < 4$ .

### 6.6.3 Background offset adjustment (DF)

The reproduction ratio of the background in DF scanning can be adjusted. The adjustment value is applied to both the front and back sides.

For the adjustment method, see the following reference.

📖 P. 6-32 “6.3.10 Background offset adjustment (DF)”

### 6.6.4 Background offset adjustment on the back side of paper (DSDF)

The reproduction ratio of the background on the back side of paper in DSDF scanning can be adjusted. The adjustment value is applied to the back side only.

For the adjustment method, see the following reference.

📖 P. 6-33 “6.3.11 Background offset adjustment on the back side of paper (DSDF)”

## 6.7 Scanning Section

### 6.7.1 Carriage-1 position adjustment

- (1) Take off the RADF or DSDF.  
📖 P. 4-197 “4.13.1 Dual Scan Document Feeder (DSDF)”  
📖 P. 4-202 “4.13.2 Reversing Automatic Document Feeder (RADF)”
- (2) Take off the right top cover.  
📖 P. 4-5 “4.1.8 Right top cover”
- (3) Take off the original glass.  
📖 P. 4-17 “4.3.1 Original glass”
- (4) Take off the left top cover.  
📖 P. 4-3 “4.1.5 Left top cover”
- (5) Move the carriage-1 [1] toward the paper exiting side.

**Notes:**

Rotate the drive pulley to move the carriage.

- (6) Loosen the 2 fixing screws of the wire. Tighten the screws by aligning the sections [5] and [6] of the carriage-1 with the inside of the exit side frame [2].

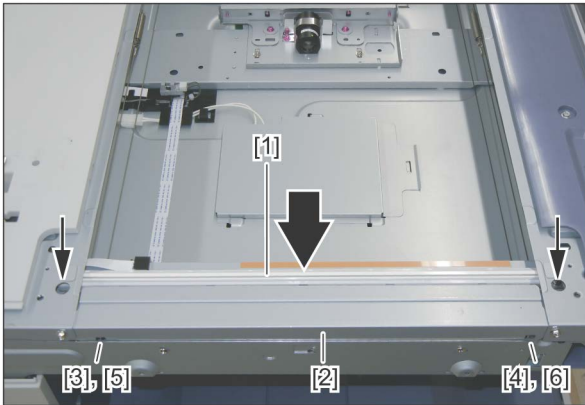

Fig.6-26

**Notes:**

Confirm that they are aligned properly through the windows [3] and [4] of the paper exiting side frame [2].

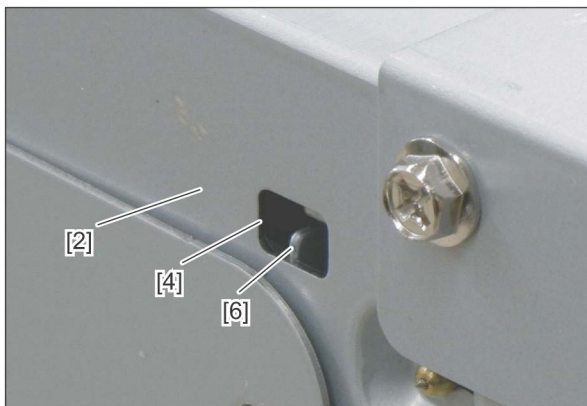

Fig.6-27

## 6.7.2 Lens unit position adjustment

Count the number of lines and write it down for later reference before removing the lens unit. When installing the lens unit, the same number of lines needs to be visible.

📖 P. 4-23 “4.3.5 Lens unit (CCD driving PC board)”

## 6.7.3 Belt tension adjustment of the scan motor

- (1) Take off the rear cover.  
📖 P. 4-9 “4.1.15 Rear cover”
- (2) Hook the belt tension jig [1] to the motor bracket [2] and hook section of the frame [3].
- (3) Loosen the screws [4], [5].
- (4) The scan motor [6] is pulled by the belt tension jig [1]. When it is stopped, tighten the screws in order of [4] and [5].
- (5) Remove the belt tension jig [1].

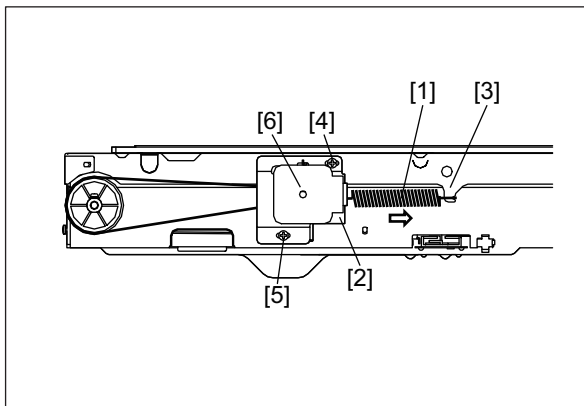





Fig.6-28

## 6.8 Data Writing Section

### 6.8.1 Image adjustment in the writing section

Refer to the following pages for details.

-  P. 6-11 “[B] Primary scanning direction data writing start position”
-  P. 6-12 “[D] Secondary scanning direction data writing start position”
-  P. 6-13 “[E] Primary scanning direction data writing start position at duplexing”

## 6.9 Paper Feeding Section

### 6.9.1 Adjustment of the clearance of the paper and side guide

If the clearance between the paper and the side guide is too wide, it can be adjusted to between 0 and 1 mm using the following procedure.

- (1) Take off the drawer from the MFP.
- (2) Move the side guide [1] and loosen 1 screw.

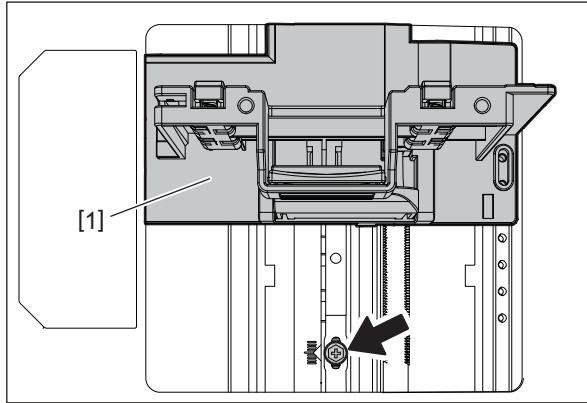

Fig.6-29

- (3) Move the side guide lock adjustment piece [2] to the front and tighten the screw.

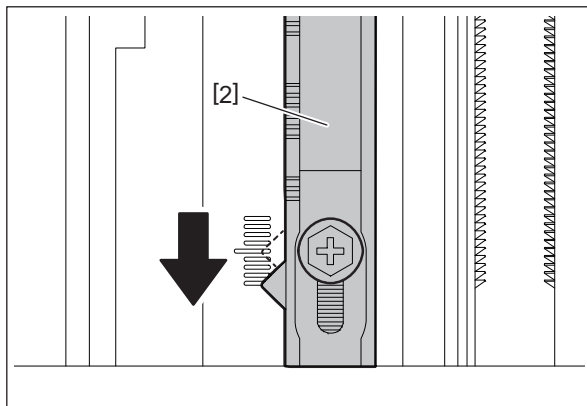

Fig.6-30

## 6.9.2 Drawer separation roller pressure force adjustment

If abnormal paper feeding or multiple paper feeding has occurred frequently before the preventive maintenance time of the separation roller, this may be improved by adjusting the pressure force of the separation roller.

### Notes:

- Before performing this adjustment, take a memo of the pre-adjustment setting position.
- By performing the adjustment, the occurrence of abnormal paper feeding or multiple paper feeding will increase. If necessary, give sufficient explanation to the users.
- Perform the adjustment carefully depending on the paper.

(1) Remove the paper feed unit.

📖 P. 4-65 “4.5.17 1st drawer paper feed unit”

📖 P. 4-68 “4.5.19 2nd drawer paper feed unit”

(2) Remove 1 screw and then attach it temporarily into the oblong hole next to it.

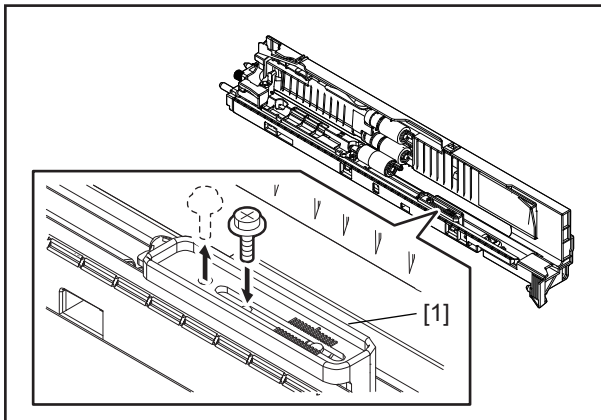

Fig.6-31

### Notes:

Make a mark for the installation position of the holder [1] in advance.

(3) Move the holder [1] and perform the adjustment as below.

- To solve multiple paper feeding: Move the holder [1] to the rear side (A). (Abnormal paper feeding tends to occur.)
- To solve abnormal paper feeding: Move the holder [1] to the front side (B). (Multiple feeding tends to occur.)

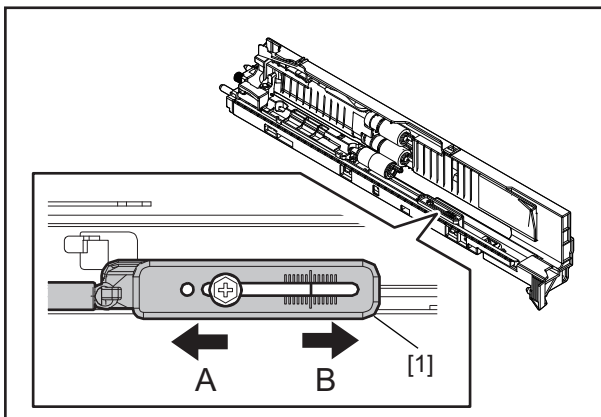

Fig.6-32

### Notes:

The recommended moving distance of the holder [1] is within 1 or 2 scale marks.

## 6.10 Developer Unit Adjustment

### 6.10.1 Auto-toner sensor adjustment

When the developer material is replaced, adjust the auto-toner sensor.

📖 P. 6-2 “6.1.2 Auto-toner sensor adjustment”

### 6.10.2 Doctor-to-sleeve gap adjustment

- (1) Perform FS-05-2390.
- (2) Take off the process unit from the MFP.
- (3) Take off the developer unit from the process unit.
- (4) Remove 2 screws and take off the developer unit upper cover [1] and discharge the developer material.

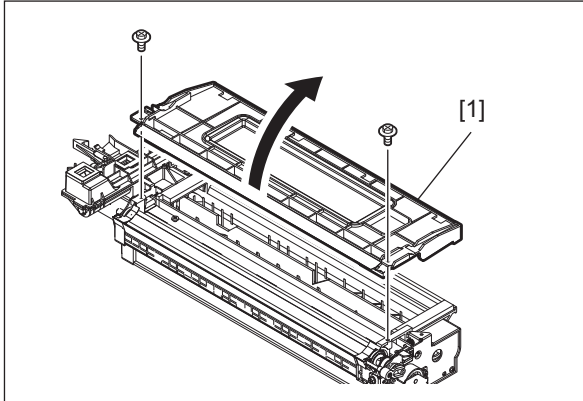

Fig.6-33

#### Notes:

Discharge the developer material from the rear side, being careful not to let it be scattered on the gear.

- (5) Turn the adjustment screw [2] to widen the gap so that the jig can be inserted in it. (Turning the screw clockwise widens the gap)

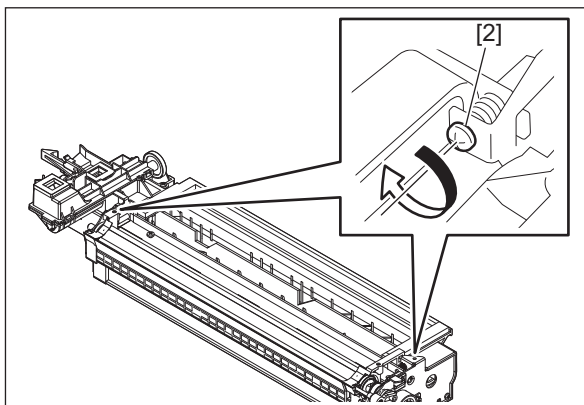

Fig.6-34

- (6) Insert the gauge with the thickness “0.45” of the doctor sleeve jig [4] into the gap between the developer sleeve and doctor blade after lifting up the toner scattering prevention sheet [3]. Adjust the screws [2] with the doctor blade to push the doctor sleeve jig lightly.

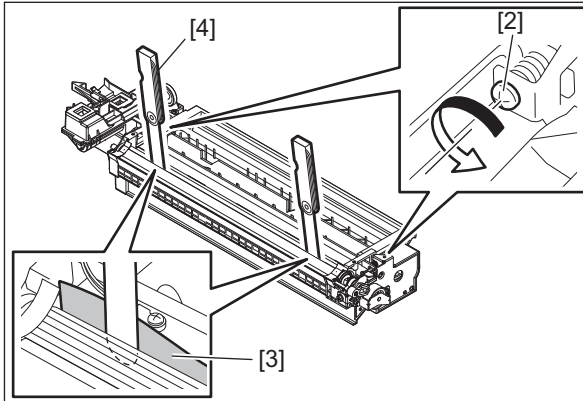

Fig.6-35

- (7) Insert the gauge “0.40” of the doctor sleeve jig [4] into the gap between the developer sleeve [5] and doctor blade. Confirm that the jig moves smoothly to the front and rear side, and the gauge “0.50” cannot be inserted into the gap.

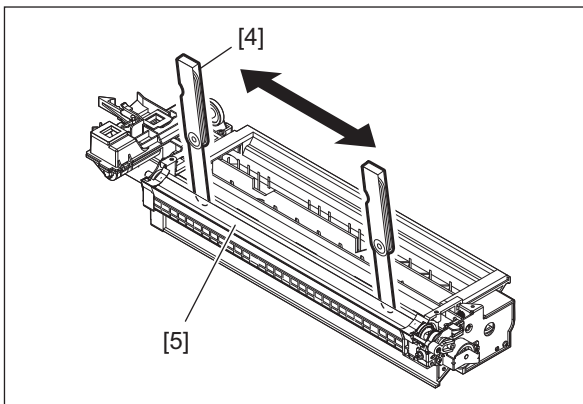

Fig.6-36

- (8) Confirm that the side seals [6] are attached to the toner scattering prevention sheet [3].

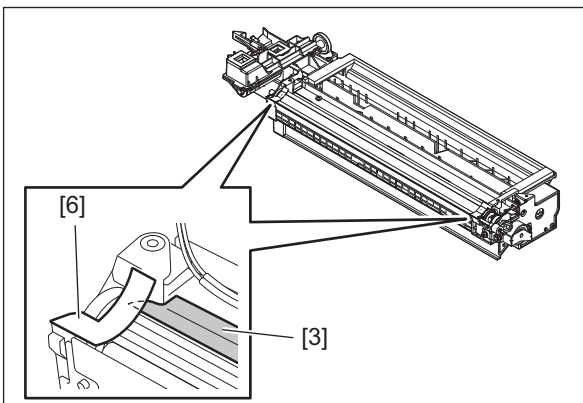

Fig.6-37



(9) Attach the developer unit upper cover [1] and tighten 2 screws.

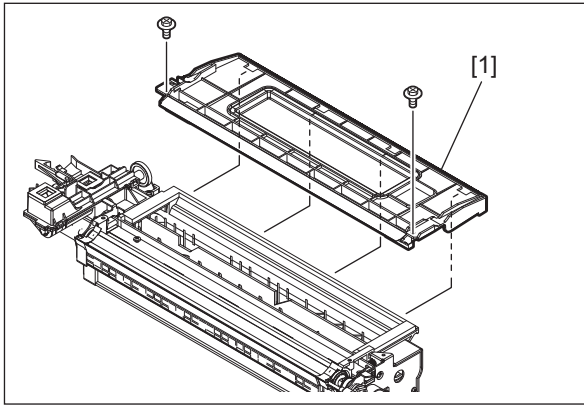

Fig.6-38

**Notes:**

- When the developer material is replaced, adjust the auto-toner sensor.  
📖 P. 6-2 “6.1.2 Auto-toner sensor adjustment”
- When installing the developer unit upper cover, make sure that the side seals [6] come between the developer unit upper cover [1] and rubber seal [7] on the cover.

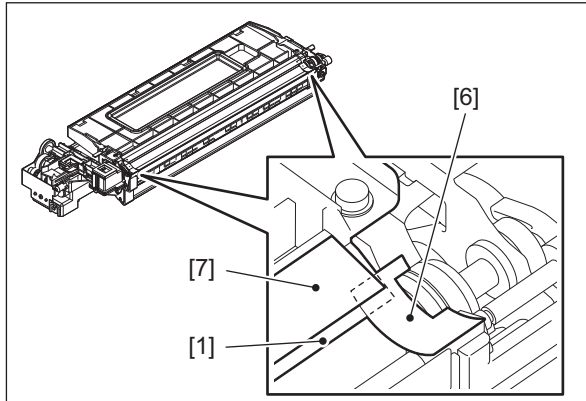

Fig.6-39

## 6.11 High-Voltage Transformer Adjustment

When replacing the high-voltage transformer, be sure to check each output adjustment of the main charger bias, developer bias, transfer bias, transfer cleaning bias (positive), transfer cleaning bias (negative) and separation bias.

### 6.11.1 Adjustment

#### [ 1 ] Preparation

Item		Developer bias	Main charger bias	Transfer bias Transfer cleaning bias (positive) Transfer cleaning bias (negative)	Separation bias
Process unit		Take off the process unit from the MFP and attach the high-voltage transformer jig.			
High-voltage transformer jig		Attach the high-voltage transformer jig to the process unit. Connect the green cable of the high-voltage transformer jig to ground on the MFP frame. P. 6-59 "[A] Installation of the high-voltage transformer jig"			
Digital tester	(+) terminal	Connect with the black cable (thick line) of the high-voltage transformer jig.	Connect with the red cable (thick line) of the high-voltage transformer jig.	Connect with the red cable (thin line) of the high-voltage transformer jig.	Connect with the gray cable of the high-voltage transformer jig.
	(-) terminal	Connect with the black cable (thin line) of the high-voltage transformer jig.			
	Function switch	DC			
	Full-scale (range)	1000 V		200 $\mu$ A	
	Remarks	Use a digital tester with an input resistance of 10 M $\Omega$ (RMS value) or higher.			
How to turn ON the power		Attach the door switch jig and start with the adjustment mode [05] while the front cover opened.			
Reference		P. 6-61 "[B] Connection for developer bias adjustment"	P. 6-61 "[C] Connection for main charger adjustment"	P. 6-62 "[D] Connection the transfer bias, transfer cleaning bias (positive) and transfer cleaning bias (negative) adjustment"	P. 6-62 "[E] Connection for separation charger adjustment"

### [A] Installation of the high-voltage transformer jig

The high-voltage transformer jig is composed of 2 cables and 1 adapter with a harness. Attach them to the process unit as shown in the figure.

- Black cable (thick line): Use the screw for the jig. (M3x8)
- Red cable (thick line): Use the screw for the process unit.
- Adapter: Use the screw for the process unit.

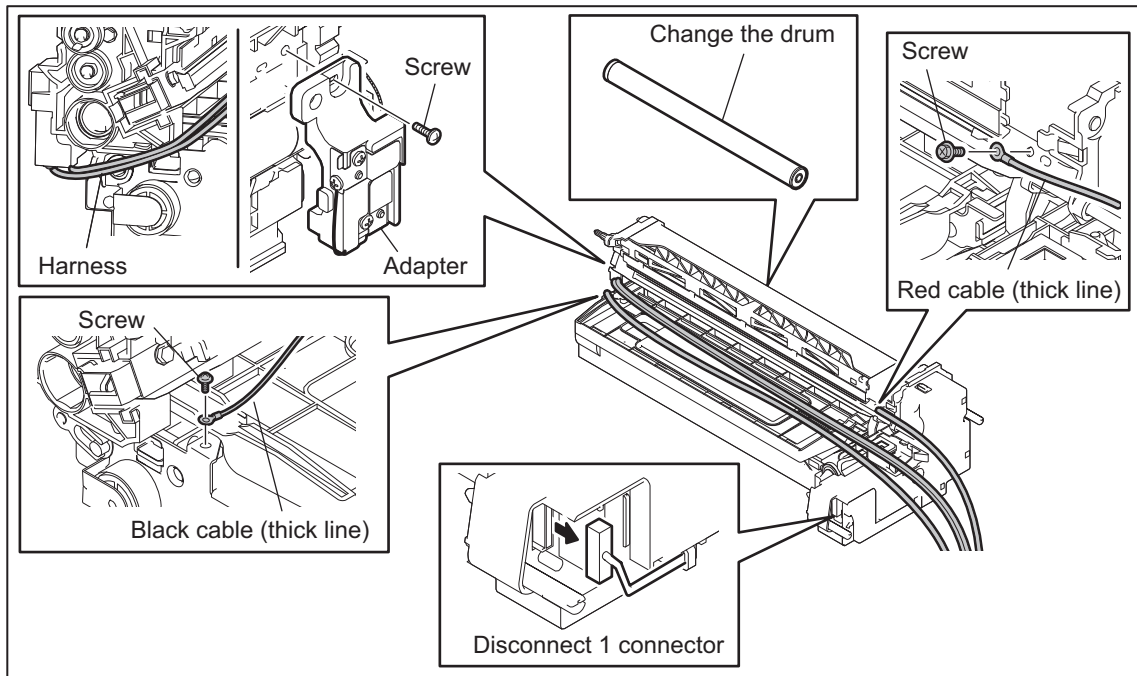

Fig.6-40

#### Notes:

- Confirm that the ground wire of the MFP is installed firmly.
- The adjustment may damage the drum. Therefore be sure to replace the drum with the one that you brought (or the one for measurement) before starting the adjustment.

- (1) Open the ADU.
- (2) Open the front cover and take off the toner cartridge.
- (3) Loosen 2 screws and take off the process unit [1].

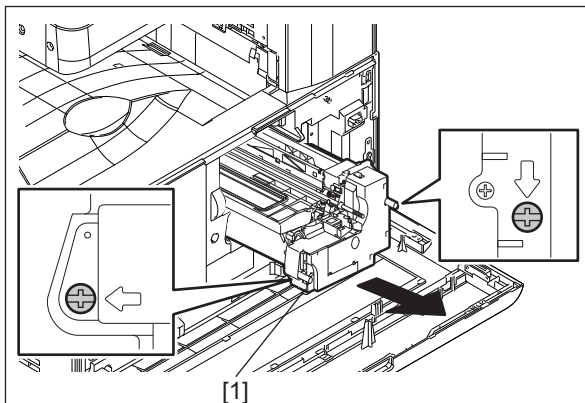

Fig.6-41

- (4) Install the high-voltage transformer jig [1] and fix it with 2 screws.

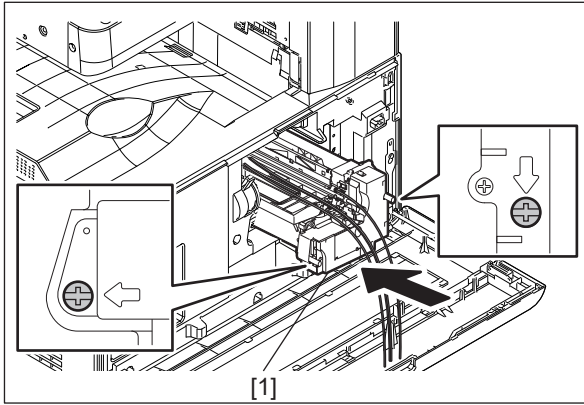

Fig.6-42

**Notes:**

Be careful not to let the harness be caught.

- (5) Fix the green cable [2] of the high-voltage transformer jig to the frame of the MFP.

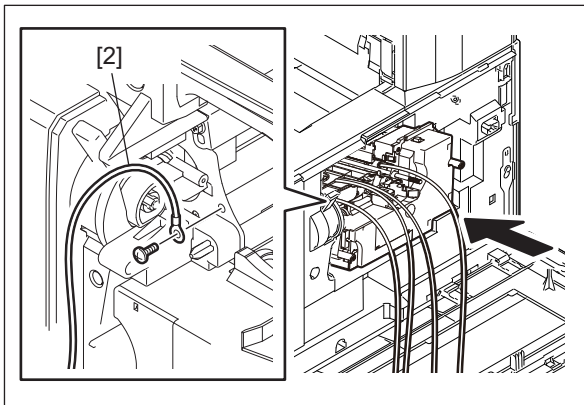

Fig.6-43

- (6) Install the door switch jig [3].  
(7) Take off the transfer roller unit.  
(8) Close the ADU.

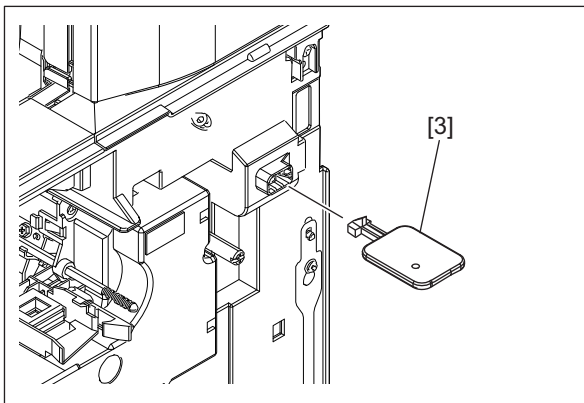

Fig.6-44

**[B] Connection for developer bias adjustment**

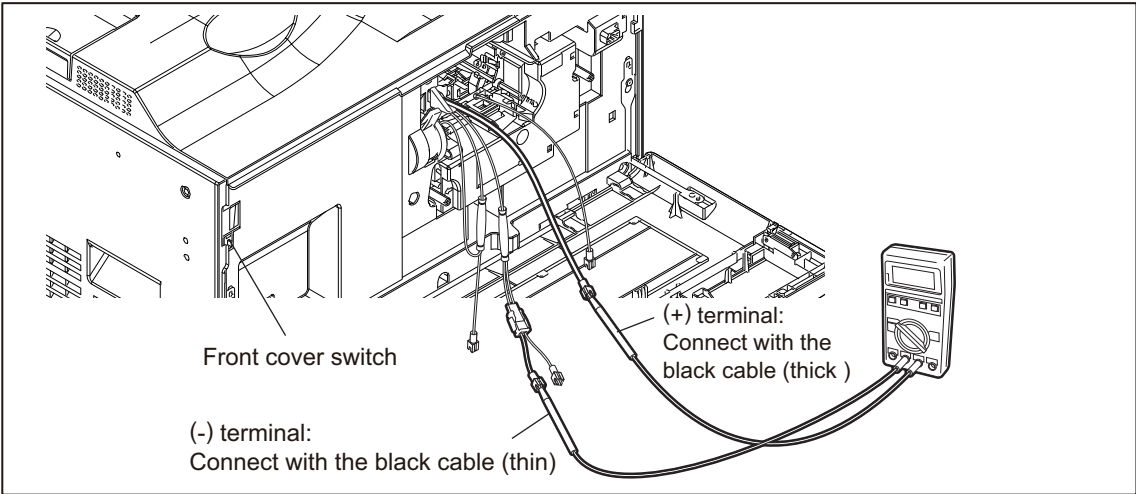

Fig.6-45

**[C] Connection for main charger adjustment**

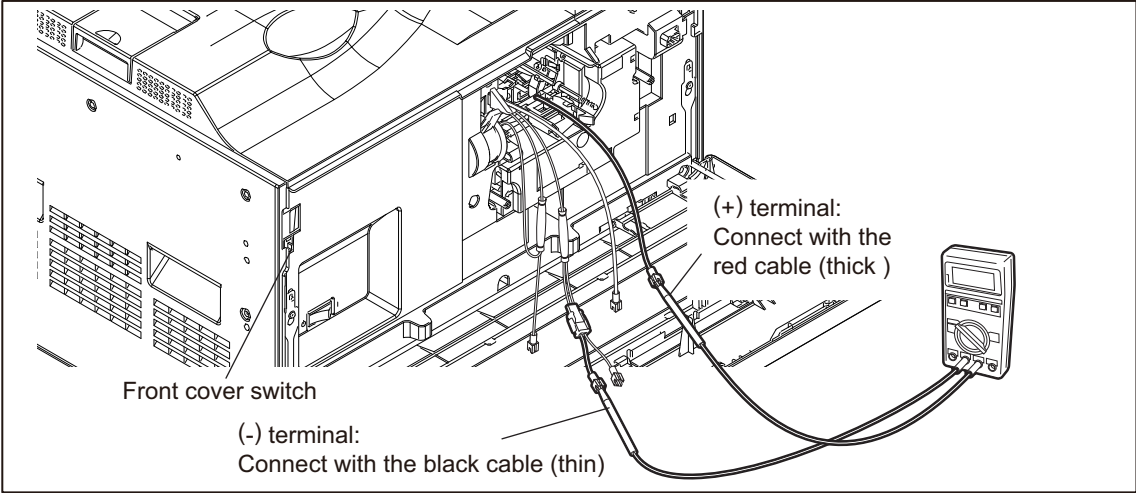
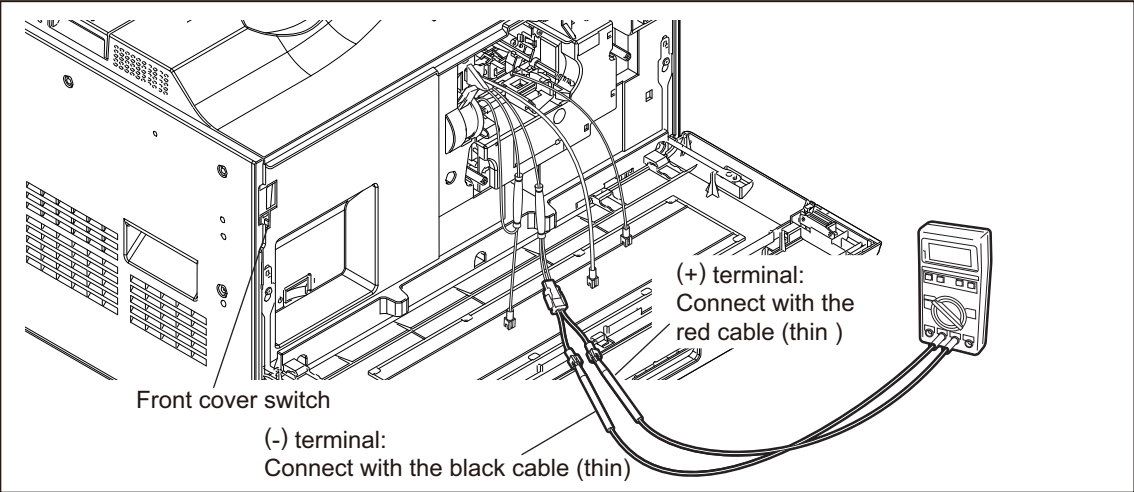

Fig.6-46

**[D] Connection the transfer bias, transfer cleaning bias (positive) and transfer cleaning bias (negative) adjustment**



**Fig.6-47**

**[E] Connection for separation charger adjustment**

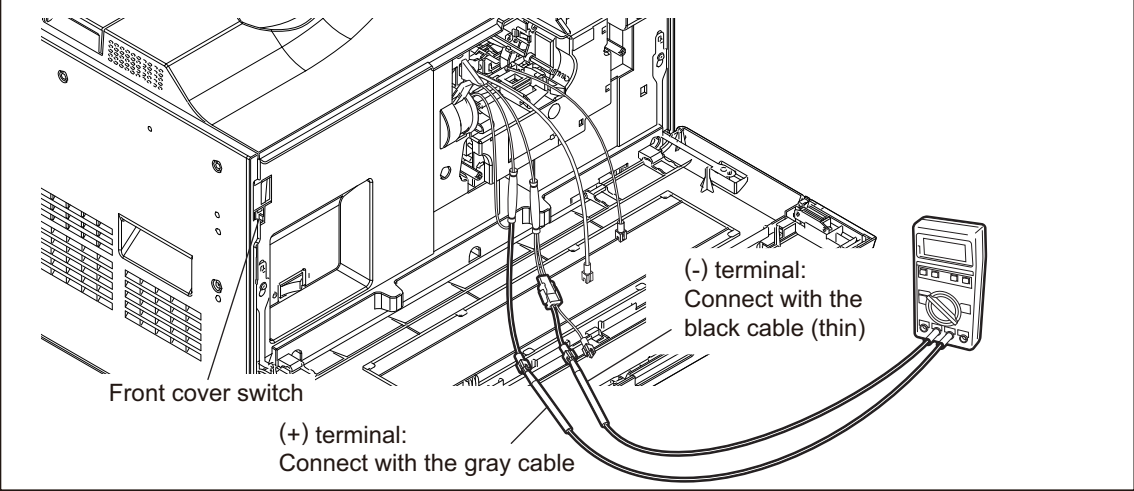

**Fig.6-48**

## [ 2 ] Operation procedure

### Notes:

When adjusting output of high-voltage transformer, make sure to use the high-voltage transformer jig.

Connect the digital testers as described in “[1] Preparation”, and follow the procedure below to adjust the output from the main charger, developer bias charger, transfer charger and separation charger.

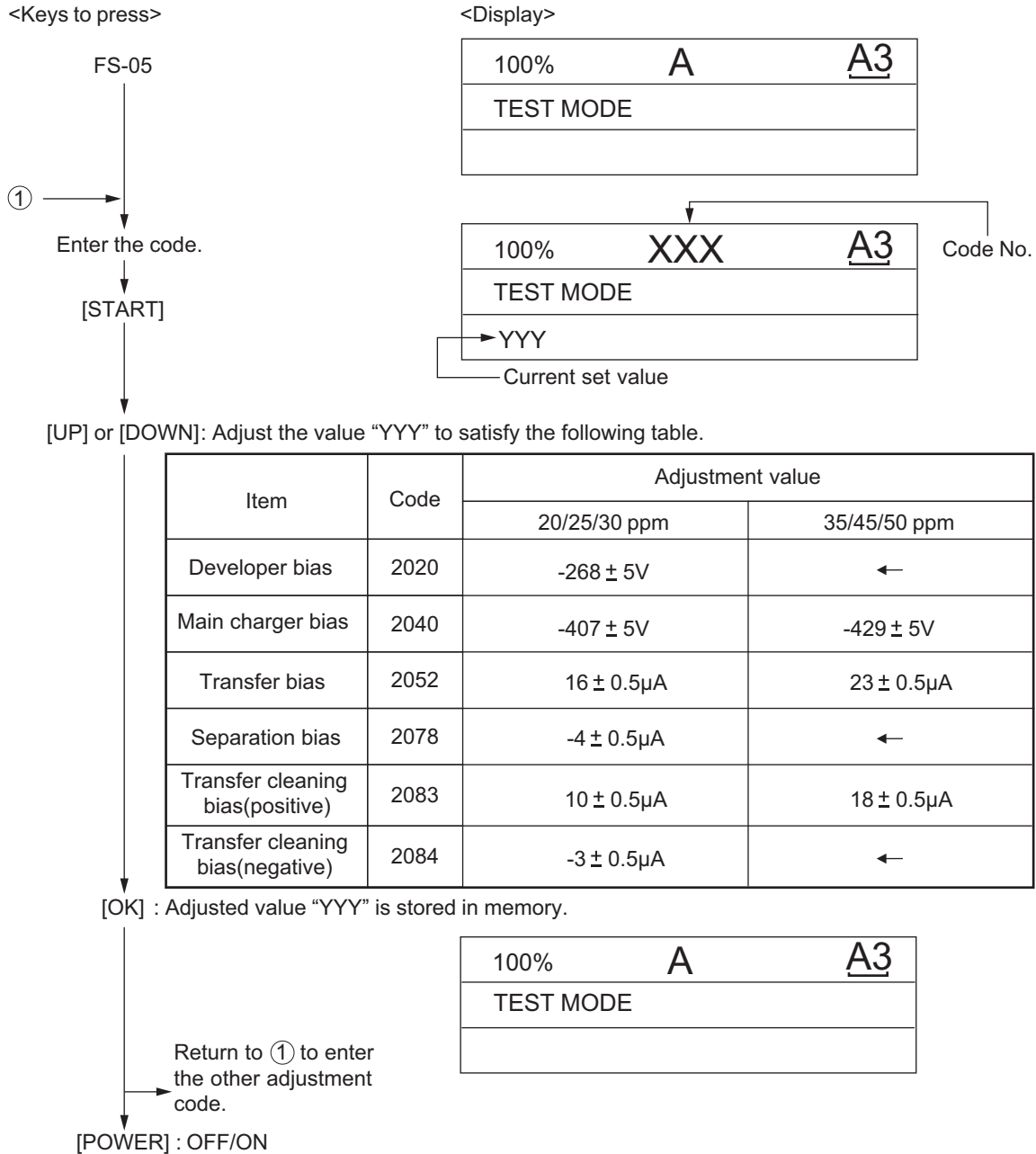

Fig.6-49

## 6.11.2 Precautions

### [ 1 ] Developer bias

#### Precautions for adjustment

Adjust the developer bias if fogging occurs over the entire image even though the main charger grid voltage and toner density are appropriate. However, the following may occur if the developer bias is lowered too much:

- Image contrast becomes low.
- The carrier in the developer material adheres to the photoconductive drum, causing scratches around the cleaner.
- Image is patchy or blurred.

### [ 2 ] Transfer

#### Items to be checked before adjustment

Blotched image or poor transfer can be also caused by matters other than defective adjustment of transfer output. Check the following items before adjusting the transfer charger. If there is no problem, adjust the output of the transfer.

- The transfer roller unit, transfer roller and power supply spring are properly installed. There is any foreign matter or damage on the transfer roller surface. The transfer guide is deformed.
- The process unit is properly installed. The developer magnetic brush is in contact with the drum. The process unit is worked correctly. The toner density is low.
- The copy paper is fed straight. The copy paper is abnormally moist.
- The rotation of the registration roller is normal.
- The separation output is different from the set value.
- The developer bias value is an appropriate one.

#### Precautions for adjustment

##### When blotched images appear:

If blotched images appear in halftone areas, lower the transfer output value. Note that transfer performance becomes low if the transfer output value is lowered too much.

##### When poor transfer occurs:

Increase the transfer output value under the following conditions. Note that blotched images appear if the transfer output value is increased too much.

- Poor transfer occurs although the transfer roller unit, transfer roller and power supply spring are properly installed and no abnormality exists on the appearance of the transfer roller.
- Thick paper has been frequently used.



## [ 3 ] Separation

### Items to be checked before adjustment

Poor paper separation from the drum can be also caused by matters other than defective adjustment of the separation output. Check the following items before making an adjustment. If there is no problem, adjust the output of the transfer.

- The erasing needle and the power supply bracket are dirty or dislocated.
- The mode is selected properly according to the paper weight.
- The process unit is properly installed. The developer magnetic brush is in contact with the drum.  
The process unit is worked correctly. The toner density is low.
- The copy paper is fed straight. The copy paper is abnormally moist.
- The rotation of the registration roller is normal.
- The output of the main charger is normal.
- The developer bias value is an appropriate one.
- The transfer output is different from the set value.
- The separation finger is in contact with the drum surface.

### Precautions for adjustment

#### When poor paper separation occurs:

Increase the separation output value under the following conditions. Note that poor transfer occurs if the separation output value is too high.

- Poor separation occurs even though the separation needle is not dirty.
- Thin paper has been frequently used.

#### **When poor transfer occurs:**

Decrease the separation output value when poor transfer occurs. Note that the separation performance becomes low if the separation output value is decreased too much.

## 6.12 Fusing Section

### 6.12.1 Thermostat gap adjustment

Perform this adjustment when the following parts are replaced or disassembled.

- Heat roller
- Center thermostat
- Side thermostat

Jig to be used: Non-contact thermistor/thermostat gap jig (Thick side)

#### Notes:

- Wait until the fuser unit is completely cooled down, and then start the adjustment.
- Place the fuser unit on a flat surface.
- Make sure that the pressure roller is pressed.
- Be careful not to damage the fuser roller and jig.

#### <Adjustment procedure>

- (1) Take off the fuser unit.  
📖 P. 4-141 “4.10.1 Fuser unit”
- (2) Take off the front side cover, rear side cover and heat roller cover.  
📖 P. 4-143 “4.10.2 Front side cover”  
📖 P. 4-144 “4.10.3 Rear side cover”  
📖 P. 4-144 “4.10.4 Heat roller cover”
- (3) Take off 1 heat roller separation finger located on the side thermostat [1]. Remove 1 coil spring [2].  
📖 P. 4-146 “4.10.6 Separation finger”

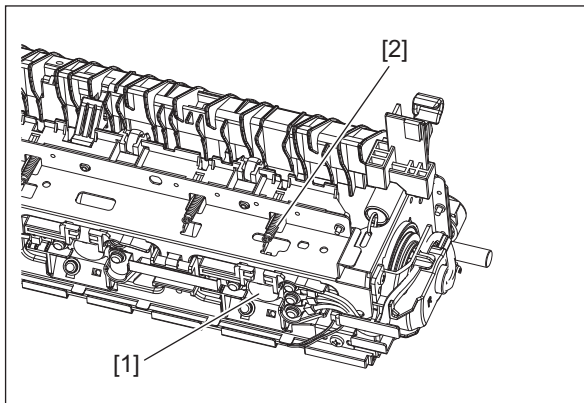

Fig.6-50

- (4) Insert the jig [5] between the side thermostat [1] and the fuser roller [4] through the window [3] in which the side thermostat [1] can be seen. Then confirm that the portion of the jig coming out of the window falls within the specified range of the scales.

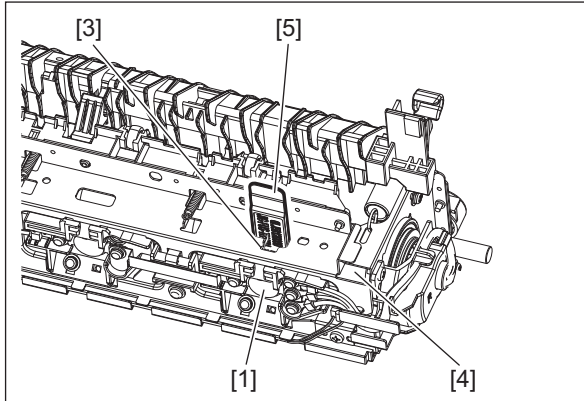

Fig.6-51

**Notes:**

The jig should be inserted under its own weight.

- (5) If the gap is not at the specified value, remove 1 screw of the side thermostat and screw it in the adjustment hole [6]. Then adjust the gap and tighten the screw. Repeat the confirmation of step (5) until the portion falls within the specified range.

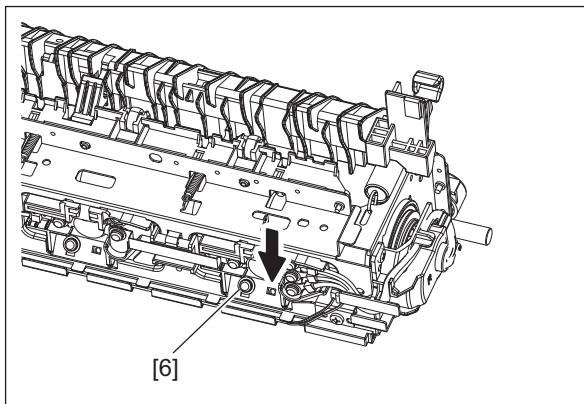

Fig.6-52

- (6) Check the gap between the center thermostat [7] and the fuser roller as in the same manner. Adjust it if needed.

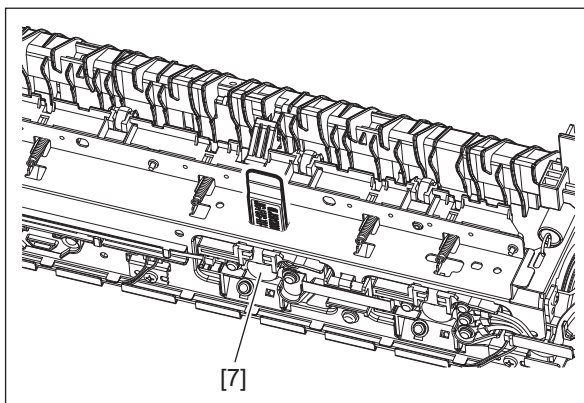

Fig.6-53

### 6.12.2 Height adjustment of the fuser unit guide rail

- (1) Loosen 2 screws [1] on the fuser unit guide rail (front) [4]. Remove 1 screw [2]. Change its position to the adjustment hole [3].

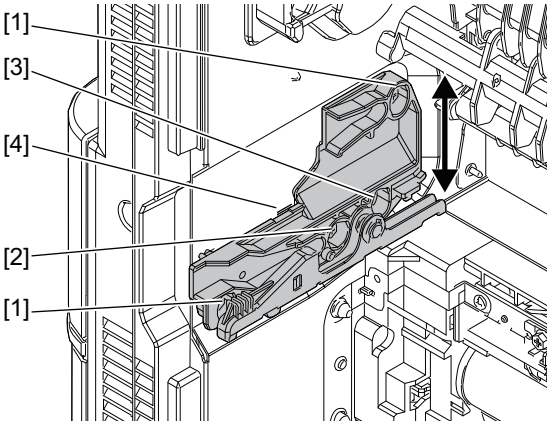

Fig.6-54

- (2) Move the fuser unit guide rail (front) upward or downward.

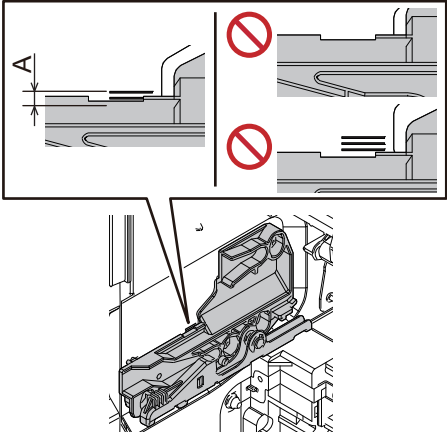

Fig.6-55

**Notes:**

Adjustment of the installation position of the fuser unit should be within the upper 1st line and lower 1st line from the center. (Within the range “A” shown in the figure)

(3) Tighten 1 screw on the adjustment hole [3] and 2 screws [1] on the fuser unit guide rail (front).

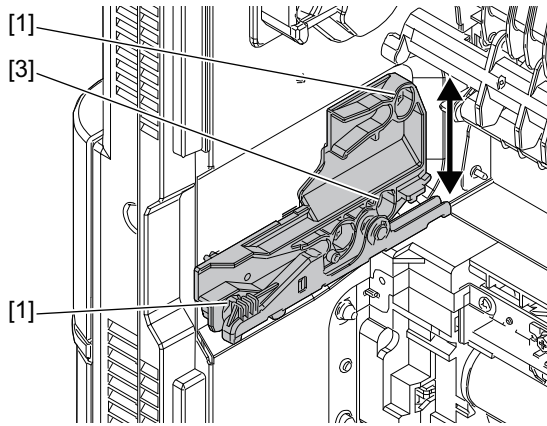

Fig.6-56

A: To make the length in the secondary scanning direction longer, move the fuser unit guide rail [1] upward.  
B: To make the length in the secondary scanning direction shorter, move the fuser unit guide rail [1] downward.

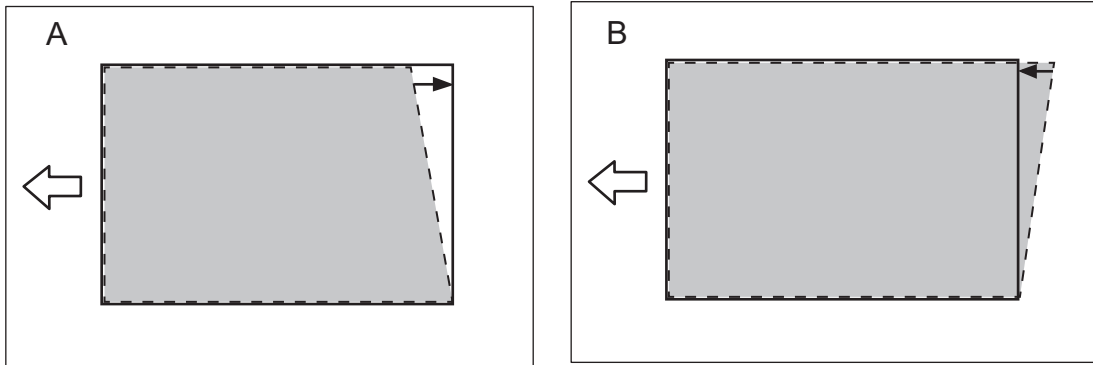

Fig.6-57

## 6.13 Control Panel Calibration

### 6.13.1 Overview

Perform this adjustment when the position touched on the touch panel sometimes cannot be detected properly, such as a touch-and-response position mismatch or a slow response due to disassembling and replacing of the control panel or its temporary change.

**Remarks:**

If the control panel is replaced in a unit base, performing this function is not necessary.

### 6.13.2 Operation procedure

- (1) Perform FS-08-9050.  
The calibration screen appears and a plus mark is displayed on the upper left of the screen.
- (2) Touch the center of the plus mark in the following order.  
The plus mark is displayed in the order of [2] > [3] > [4], when it is touched and recognized.

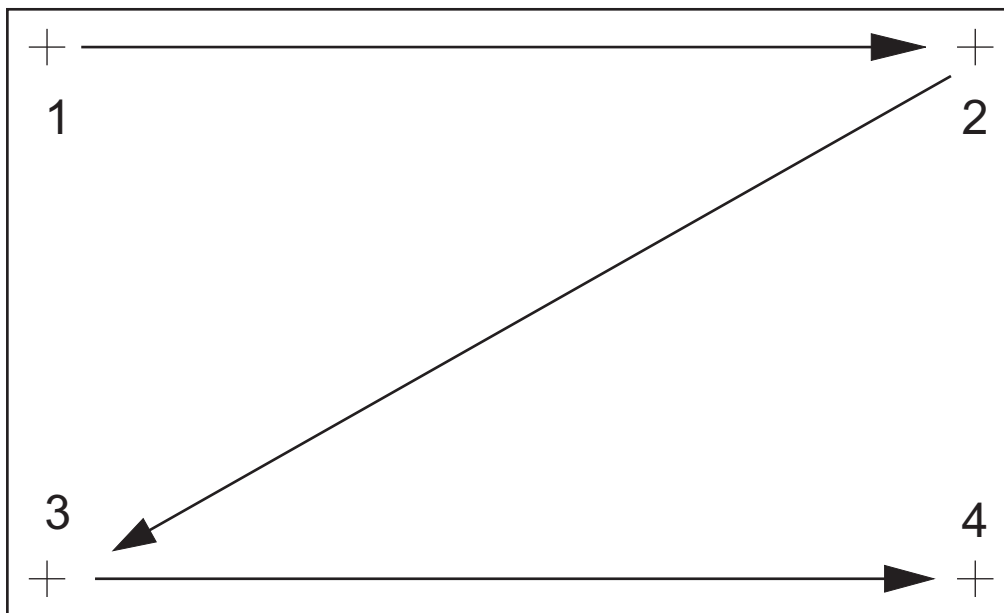

Fig.6-58

**Notes:**

- It is recommended to touch the plus mark using a touch pen with a fine tip.
- Calibration is performed at the touched position. Therefore, touch the mark properly.

- (3) When circle marks are displayed, keep touching the center of the marks with your fingers in the following order.  
After a few seconds have passed, the next circle marks are displayed.

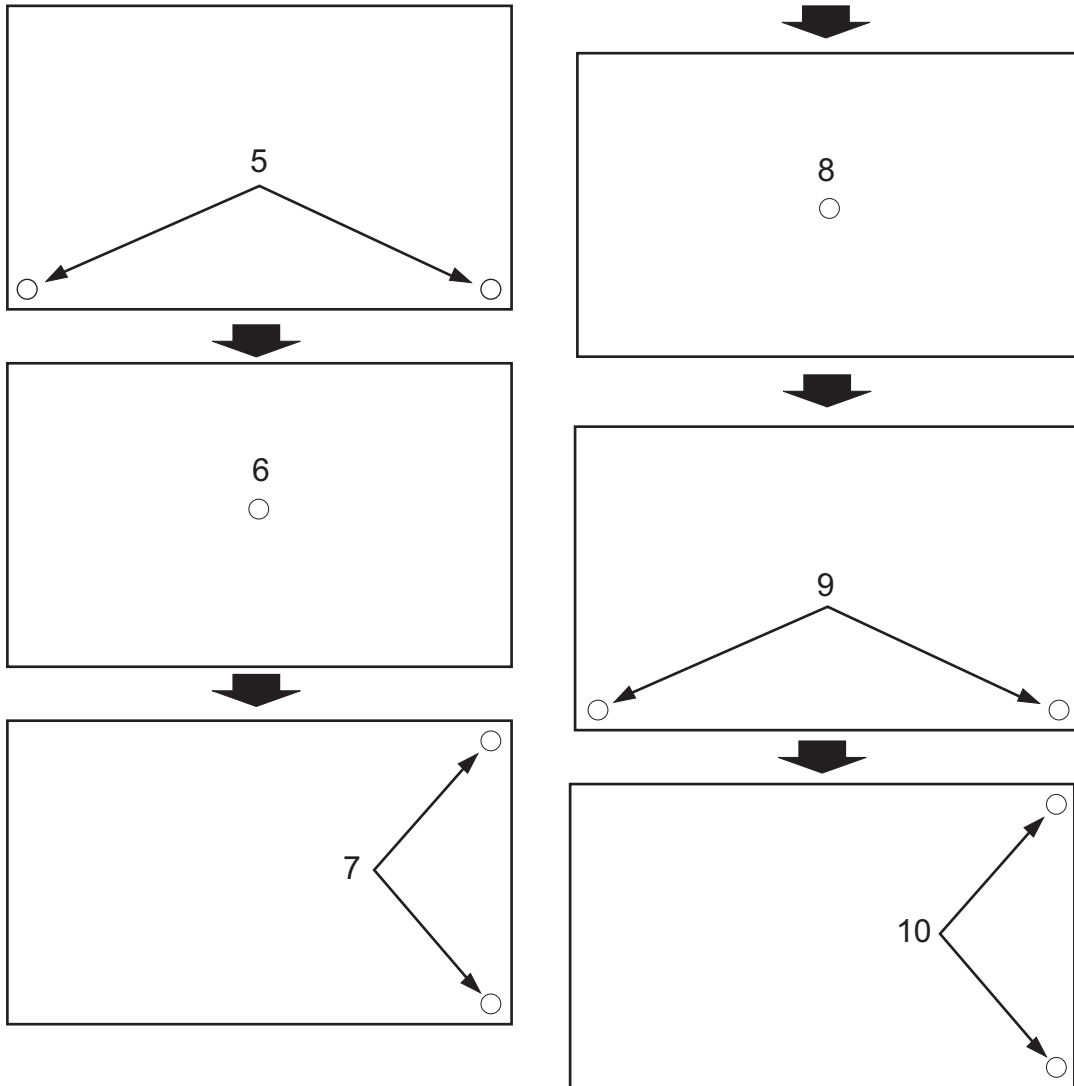

Fig.6-59

**Notes:**

- When two circle marks are displayed, touch them simultaneously.
- Calibration is performed at the touched position. Therefore, touch the mark properly.

(4) After all the marks are touched, the following screen appears and then calibration is completed.

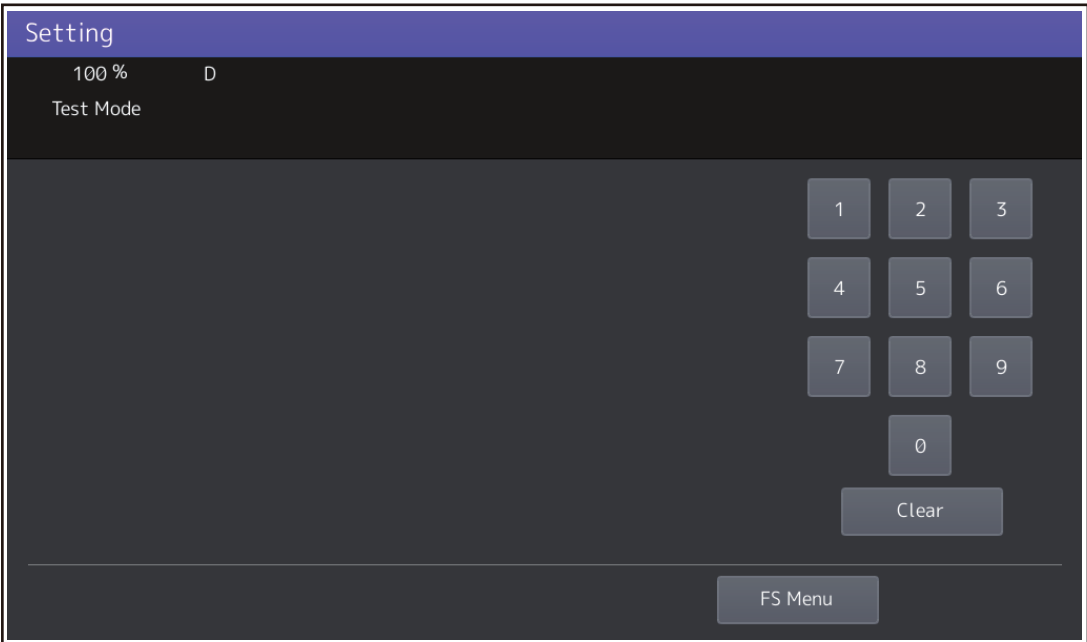

Fig.6-60



## 7. PREVENTIVE MAINTENANCE (PM)

### 7.1 Overview

The purpose of preventive maintenance (PM) is to maintain the quality level of this MFP by periodically inspecting, cleaning and replacing the parts whose replacement timing has come. There are PM kits packaged for each unit or a group of parts with the same replacement number of output pages, allowing you to carry out efficient parts replacement.

### 7.2 PM Display

#### 7.2.1 Overview

The maintenance timing for the PM parts of the process unit, such as the drum and the developer material, and those for other units varies depending on the use conditions by users. Therefore, this MFP shows the appropriate maintenance timing of each part on the LCD of the control panel.

“[Process unit (K)]” described below indicates the photoconductive drum or the drum unit including the photoconductive drum. “[Developer material (K)]” indicates the developer material or the developer unit including the developer material. “[PM parts other the process unit]” indicates the heat roller or the fuser unit including the heat roller.

#### 7.2.2 PM display condition

The conditions of the PM display consist of the codes of the 08 SETTING MODE for the “setting value treated as a threshold of the PM display”, “counter indicating the current number of prints and driving time” and “setting value which determines the display conditions”.

The PM timing is displayed when the counter exceeds the setting value according to the display condition based on the “setting value which determines the display conditions”.

- Setting value treated as a threshold of the PM display
  - FS-08-6190: PM counter setting value [Process unit (K)]
  - FS-08-6191: PM time counter setting value [Process unit (K)]
  - FS-08-5554: PM counter setting value [Developer material (K)]
  - FS-08-5555: PM time counter setting value [Developer material (K)]
  - FS-08-5562: PM counter setting value [PM parts other the process unit]
  - FS-08-5563: PM time counter setting value [PM parts other the process unit]

**Notes:**

When “0” is set as the setting value, the PM timing is not displayed.

- Counter indicating the current number of the prints and driving time
  - FS-08-6194: PM counter current value [Process unit (K)]
  - FS-08-6195: PM time counter current value [Process unit (K)]
  - FS-08-5568: PM counter current value [Developer material (K)]
  - FS-08-5569: PM time counter current value [Developer material (K)]
  - FS-08-5576: PM counter current value [PM parts other the process unit]
  - FS-08-5577: PM time counter current value [PM parts other the process unit]
- Setting value which determines the display conditions
  - FS-08-6198: PM switching of output pages/driving counts [Process unit (K)]
  - FS-08-5581: PM switching of output pages/driving counts [Developer material (K)]
  - FS-08-5585: PM switching of output pages/driving counts [PM parts other the process unit]

### 7.2.3 PM display content

When the counter value exceeds the setting value, the MFP notifies you that the maintenance time has arrived by displaying the message “Time for periodic maintenance \*\*\*\*” on the LCD screen. “\*\*\*\*” in the message is a 4-digit hexadecimal number code. This number is allocated in the following manner, therefore the parts needing maintenance can be identified.

PM parts for the process unit (K): 0008

Developer material (K): 0080

PM parts other than the process unit: 0100

If multiple parts have reached the maintenance time, the sum of the corresponding code values listed above is displayed in hexadecimal numbers.

For example, if the PM parts other than the process unit (K), developer material (K) and process unit reach the maintenance time, the 4-digit hexadecimal number code will be “0188” in hexadecimal numbers:  $0008+0080+0100=0188$ .

### 7.2.4 Counter clearing

The counter indicating “current number of prints and driving time” used for the PM display function is cleared by entering “0” in it or resetting it in the 20 PM SUPPORT MODE.

#### Notes:

Even if “0” is entered in the PM management setting value of the 08 SETTING MODE, the corresponding counter for the PM display is not reset. Be sure to clear the counter in the 20 PM SUPPORT MODE when the maintenance is finished.

The reset condition of each counter is as follows:

- FS-08-6194: PM counter current value [Process unit (K)]
- FS-08-6195: PM time counter current value [Process unit (K)]  
When the current value of “Cleaner/Drum” on the main screen or “Drum” on the sub-screen in the 20 PM support mode is cleared, the counter is reset.
- FS-08-5568: PM counter current value [Developer material (K)]
- FS-08-5569: PM time counter current value [Developer material (K)]  
When the current value of “Development Unit” on the main screen or “Black Developer” on the sub-screen in the 20 PM support mode is cleared, the counter is reset.
- FS-08-5576: PM counter current value [PM parts other the process unit]
- FS-08-5577: PM time counter current value [PM parts other the process unit]
- FS-08-6225: Thick paper 1 number of output pages counter current value
- FS-08-6226: Thick paper 2 number of output pages counter current value
- FS-08-6227: Thick paper 3 number of output pages counter current value
- FS-08-6228: OHP number of output pages counter current value
- FS-08-6244: Tab paper number of output pages counter current value
- FS-08-6247: Envelope number of output pages counter current value  
When the current value of “Fuser” on the main screen or “Fuser roller” on the sub-screen in the 20 PM support mode is cleared, the counter is reset.

#### Notes:

When 21 EPU replace mode is performed, the following counters are reset.

FS-08-6194: PM count current value

FS-08-6195: PM time counter current value

FS-08-5568: Developer material PM counter current value

FS-08-5569: Developer material PM time counter current value

## 7.3 PM Procedure

### (1) Preparation

Ask the user about the current conditions of the MFP and note them down.

Before starting maintenance, make some sample copies and store them.

See the replacement record and check the parts to be replaced in the 20 PM SUPPORT MODE or 30 LIST PRINT MODE.

- 20 PM SUPPORT MODE (FS-20)
- 30 LIST PRINT MODE (FS-30-103)

UNIT	OUTPUT PAGES DEVELOP COUNTS	PM OUTPUT PAGES DEVELOP COUNTS	DRIVE COUNTS	PM DRIVE COUNTS
DRUM	1957	1957	10870	170000
DRUM BLADE	1957	1957	10870	170000
GRID	1957	1957	10870	170000
NEEDLE ELECTRODE	1957	1957	10870	170000
SEPARATION FINGER (DRUM)	1077	1077	3766	170000
RECOVERY BLADE	1077	1077	3766	170000
DEVELOPER	1077	1077	3766	170000
TRANSFER ROLLER	1077	1077	3766	170000
OZONE FILTER	1077	1077	3766	170000
FUSER ROLLER	1077	1077	9547	170000
PRESS ROLLER	1077	1077	9547	170000
SEPARATION FINGER (FUSER)	1077	1077	9547	170000
PICK UP ROLLER (1st CST.)	1077	1077	9547	170000
FEED ROLLER (1st CST.)	1077	1077	9547	170000
SEP ROLLER (1st CST.)	1077	1077	9547	170000
PICK UP ROLLER (2nd CST.)	1077	1077	9547	170000

Fig. 7-1

Be sure to turn OFF the power and unplug the power cable from the outlet.

### (2) Maintenance

Perform cleaning, lubrication and part replacement in accordance with the preventive maintenance checklist.

### (3) Confirmation

After finishing the maintenance, make some copies to confirm that the MFP works properly.

## 7.4 20 PM SUPPORT MODE

### 7.4.1 Overview

This MFP has the 20 PM SUPPORT MODE which enables you to confirm the use status of each part (the number of output pages or developed pages, and drive counts) requiring periodic replacement and also the replacement record, as well as clearing counter values efficiently. This record can also be printed out in the 30 LIST PRINT MODE.

### 7.4.2 Operation flow

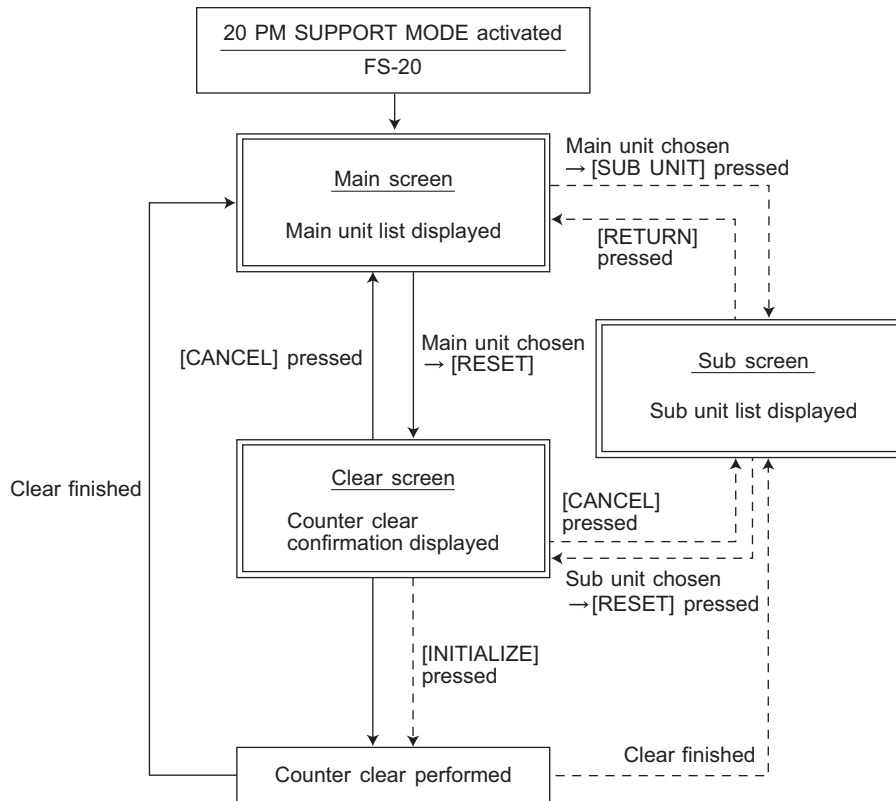

Fig. 7-2

- The authentication screen appears. Press [OK]. (Enter the password, if one has been set.)
- The screen goes back to the main screen when the counter clear is performed after moving from the main screen. The screen goes back to the sub screen when the counter clear is performed after moving from the sub screen. The screen goes back in the same manner when [Cancel] is pressed.

### 7.4.3 Operation screen

The description of the display (including the function of each button) on the LCD screen is shown below.

#### [ 1 ] Main screen

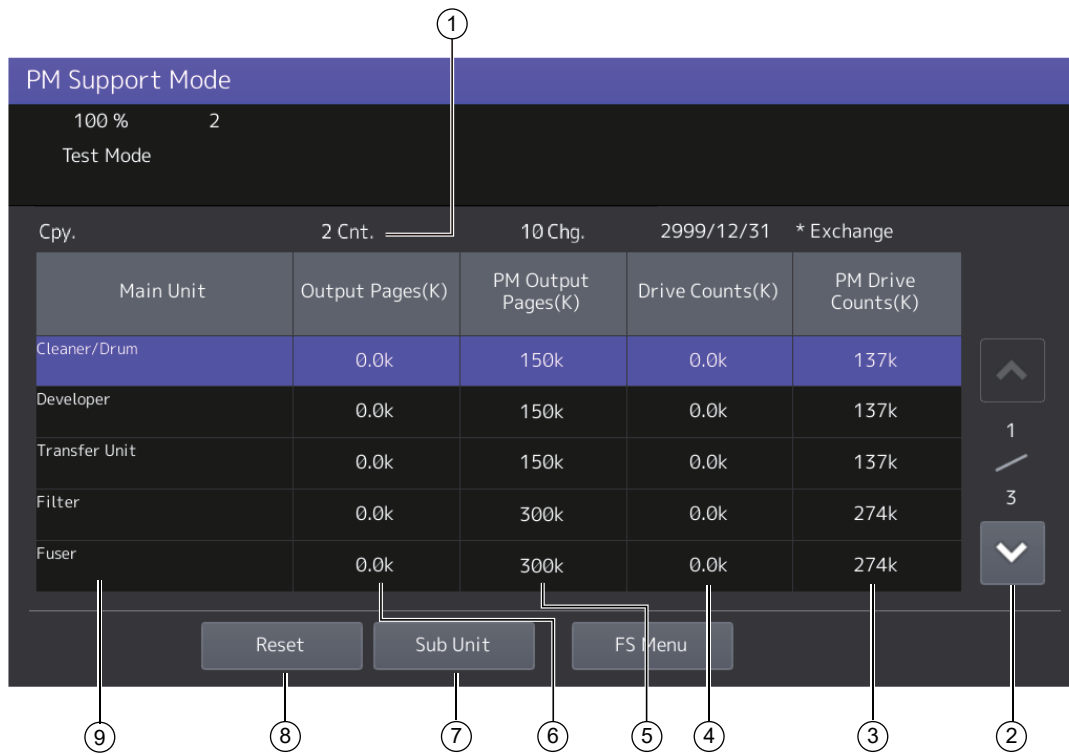

Fig. 7-3

1. The number of printed/developed pages (Page/D.cnt), drive counts (Cnt.) and previous replacement date (Chg.) for a selected unit are displayed. If the replacement date for the sub unit is different, information is not displayed. Therefore, press [Sub Unit] to move to the sub screen to see each information.
2. Select this to move to the next or previous page.
3. The standard value of the drive counts to replace the units (parts) is displayed.
4. The current value of the drive counts is displayed.  
 “\*” is displayed next to the current value when the number of the drive counts has exceeded its PM standard value.
5. The standard value of the printed/developed pages to replace the units (parts) is displayed.
6. The current value of the printed/developed pages is displayed.  
 When there are differences among the sub units (parts), “\_” is displayed and “Check Sub Unit” is displayed at the top.  
 “\*” is displayed next to the current value when the number of the printed/developed pages has exceeded its PM standard value.
7. Select this to move to the sub screen of the selected unit.
8. Select this to move to the clear screen to clear the selected unit counters 4 and 6.  
 All sub unit (part) counters belonging to that unit are also included.  
 When the unit is not selected, all counters are cleared.
9. The main unit name is displayed.

#### Notes:

- “-” is always displayed at the drive counts section for the DF and paper feeding system.
- The paper source differs depending on the structure of options. However, “0.0K” is displayed at the print count field and the reference value is displayed at the print count reference value field for the paper source even if it is not installed.

## [ 2 ] Sub screen

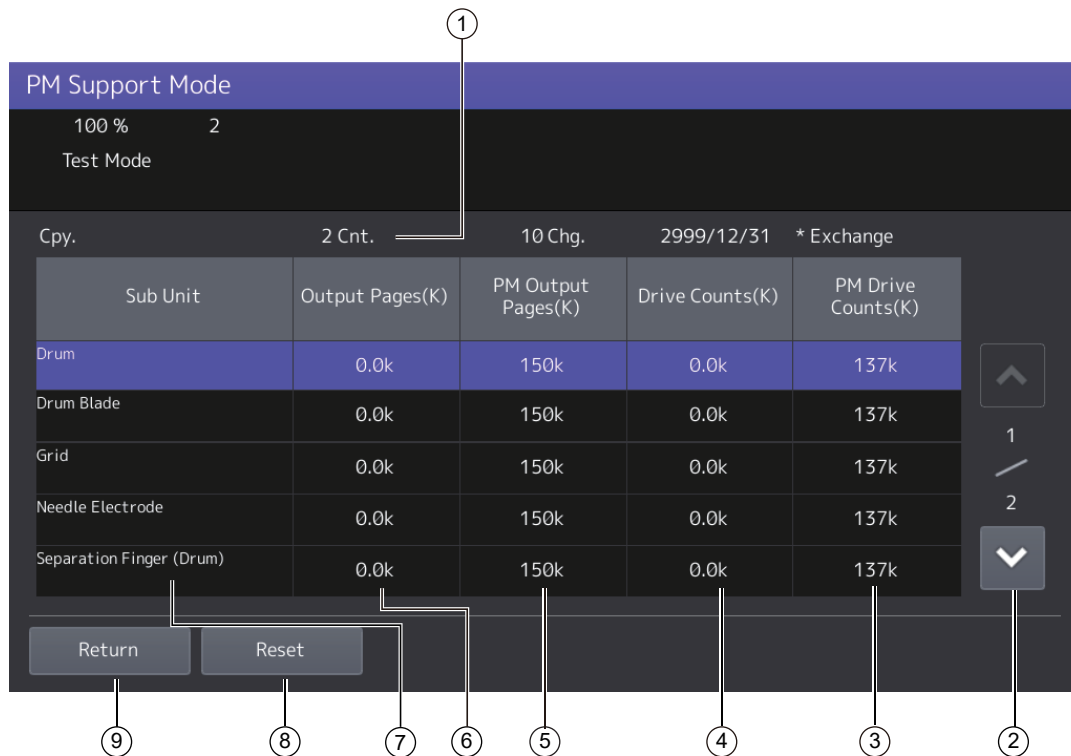

Fig. 7-4

1. The number of printed/developed pages, drive counts and previous replacement date for a selected sub units (parts) are displayed.
2. Select this to move to the next or previous page.
3. The standard value of the drive counts to replace the sub units (parts) is displayed.
4. The current value of the drive counts is displayed.  
 “\*” is displayed next to the current value when the number of the drive counts has exceeded its PM standard value.
5. The standard value of the printed/developed pages to replace the sub units (parts) is displayed.
6. The current value of the printed/developed pages is displayed.  
 “\*” is displayed next to the current value when the number of the printed/developed pages has exceeded its PM standard value.
7. The sub unit name is displayed.
8. Select this to move to the clear screen to clear the selected sub unit counters.
9. Select this to return to the main screen.

### [ 3 ] Clear screen

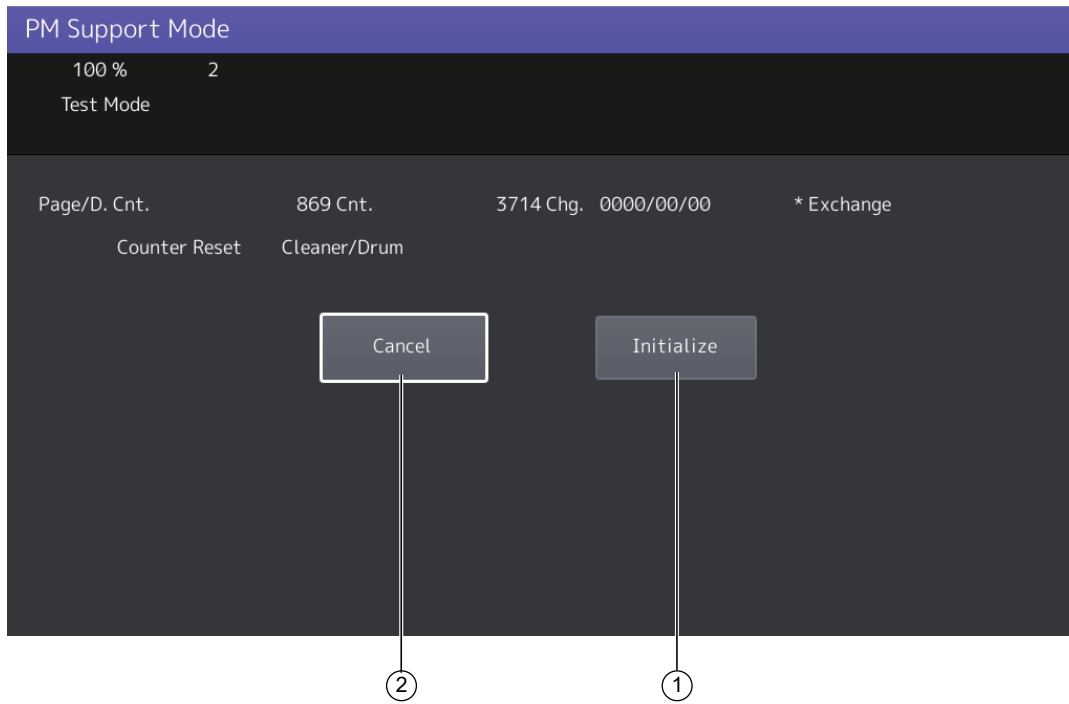

Fig. 7-5

1. Select this to clear the number of printed/developed pages and drive counts and to update the previous replacement date.
2. Select this to return to the main or sub screen without having clear the counter.

## 7.4.4 Access tree

The relationship between the main unit and the sub unit is as below.

### Notes:

Some parts in this manual are described with different names on the LCD. In this case, the name in this manual is indicated in square brackets [ ].

Main screen	Sub screen
Cleaner/Drum [Drum unit]	Drum [Drum] Drum Blade [Drum cleaning blade] Grid [Main charger grid] Needle electrode [Needle electrode] Separation finger (Drum) [Separation finger for drum] Recovery blade [Recovery blade]
Filter [Ozone filter]	-
Developer [Developer unit]	Developer [Developer]
Transfer unit [Transfer unit]	Transfer roller [Transfer roller]
Fuser [Fuser unit]	Fuser roller [Heat roller] Press roller [Pressure roller] Separation finger (Fuser) [Separation finger for pressure roller]
1st CST. [Upper drawer]	Pick Up Roller (1st CST.) [Pick-up roller] Feed Roller (1st CST.) [Feed roller] Sep Roller (1st CST.) [Separation roller]
2nd CST. [Upper drawer]	Pick Up Roller (2nd CST.) [Pick-up roller] Feed Roller (2nd CST.) [Feed roller] Sep Roller (2nd CST.) [Separation roller]
SFB [Bypass unit]	Feed Roller(SFB) [Feed roller] Sep Pad (SFB) [Separation pad]
DF [Document feeder]	Pick Up Roller (DF) [Pick-up roller] Feed Roller (DF) Sep Roller (DF)
LCF [T-LCF]	Pick Up Roller (LCF) [Pick-up roller] Feed Roller (LCF) Sep Roller (LCF)
3rd CST. [Upper drawer] [PFP upper drawer]	Pick Up Roller (3rd CST.) [Pick-up roller] Feed Roller (3rd CST.) Sep Roller (3rd CST.)
4th CST. [PFP lower drawer]	Pick Up Roller (4th CST.) [Pick-up roller] Feed Roller (4th CST.) Sep Roller (4th CST.)
O-LCF [Ex-LCF]	Pick Up Roller (O-LCF) Feed Roller (O-LCF) Sep Roller (O-LCF) [Separation roller]

### Notes:

- When the counter value of any of the pickup roller, paper feed roller and separation roller in each unit is cleared, the value of the feeding retry counter is also reset simultaneously.
- When [Clear] is pressed after selecting the paper feed unit in the main screen, the value of the feeding retry counter is also reset simultaneously.

Feeding retry counter:

- 1st drawer: Reset the feeding retry counter (FS-08-6230)
- 2nd drawer: Reset the feeding retry counter (FS-08-6231)
- PFP upper drawer: Reset the feeding retry counter (FS-08-6232)
- PFP lower drawer: Reset the feeding retry counter (FS-08-6233)
- Bypass unit: Reset the feeding retry counter (FS-08-6234)
- T-LCF: Reset the feeding retry counter (FS-08-6235)
- Ex-LCF: Reset the feeding retry counter (FS-08-6242)



## 7.5 Part Replacement Workflow

The replacement timing of parts differs depending on the user's conditions of use. Therefore, it is necessary to consider not only the number of printed/developed pages but also the drive time counts when deciding the timing for parts replacement. Even if the number of printed/developed pages has reached the level of replacement, for instance, the part may still be usable if its drive time counts do not reach the specified amount. On the other hand, the part may need replacement even if the number of printed/developed pages has not reached the level of replacement if its driving time exceeds the specified drive time counts. The replacement timing of some parts, such as the paper feed roller, is greatly dependent on the number of output pages rather than the drive time counts. The following workflow diagram shows how to judge the timing of replacement with the number of printed/developed pages.

### E.g.: When the number of printed/developed pages has reached the specified one

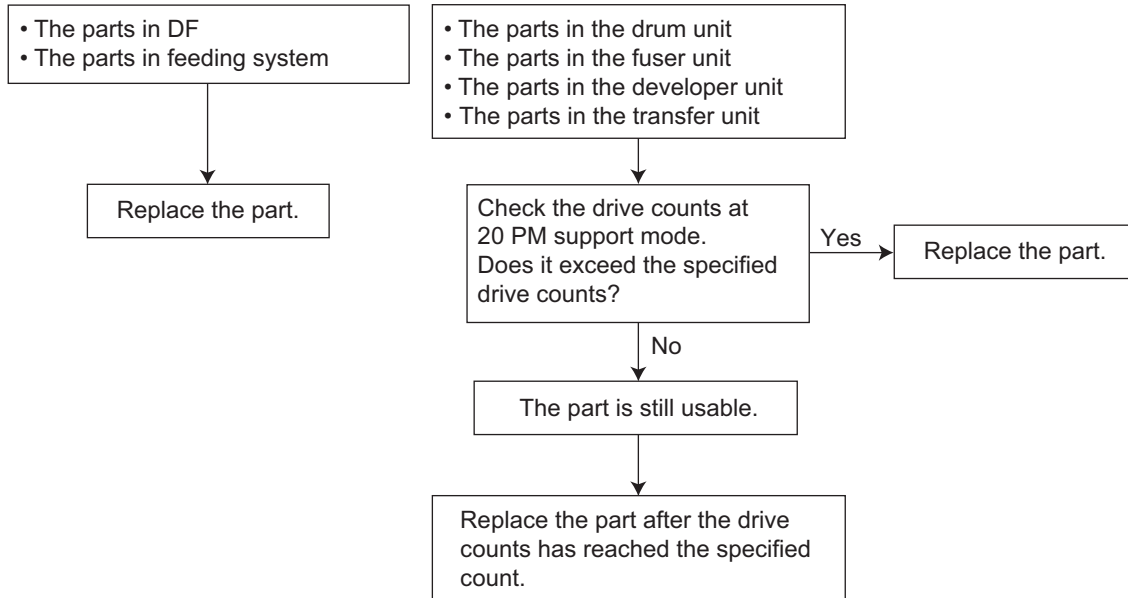

Fig. 7-6

### E.g.: When an image failure occurred before the number of printed/developed pages has reached the specified one

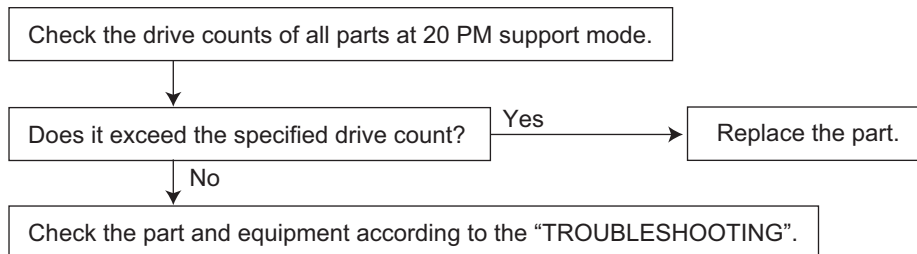

Fig. 7-7

## 7.6 21 EPU REPLACE MODE

### 7.6.1 Overview

As this model complies with the ERU (Easy Replacement Unit) rule, the EPUs (drum unit, developer unit) of this MFP can be removed or reinstalled easily.

When each EPU is replaced with a new unit at PM, the IC chip in the EPU board installed at the bottom of the developer unit detects whether a new or an old unit is installed. When the IC chip memory judges that the installed unit is a new one, the series of operations required at the replacement (counter reset for supply items in the EPU, auto-toner sensor initial adjustment and automatic gamma adjustment) is smoothly performed.

#### Notes:

If only the supply items in the EPU at PM are to be replaced, perform the life counter reset for each supply item; if developer material is to be replaced, perform the auto-toner sensor adjustment and the automatic gamma adjustment in the 20 PM Support Mode as described in this chapter.

### 7.6.2 Operation flow

The following is the operation flow.

#### Preparation

A4 or LT size papers need to be loaded in the drawer for automatic gamma adjustment. Before performing the 21 EPU replacement mode, load the A4 or LT size papers into the drawer and set the drawer paper size.

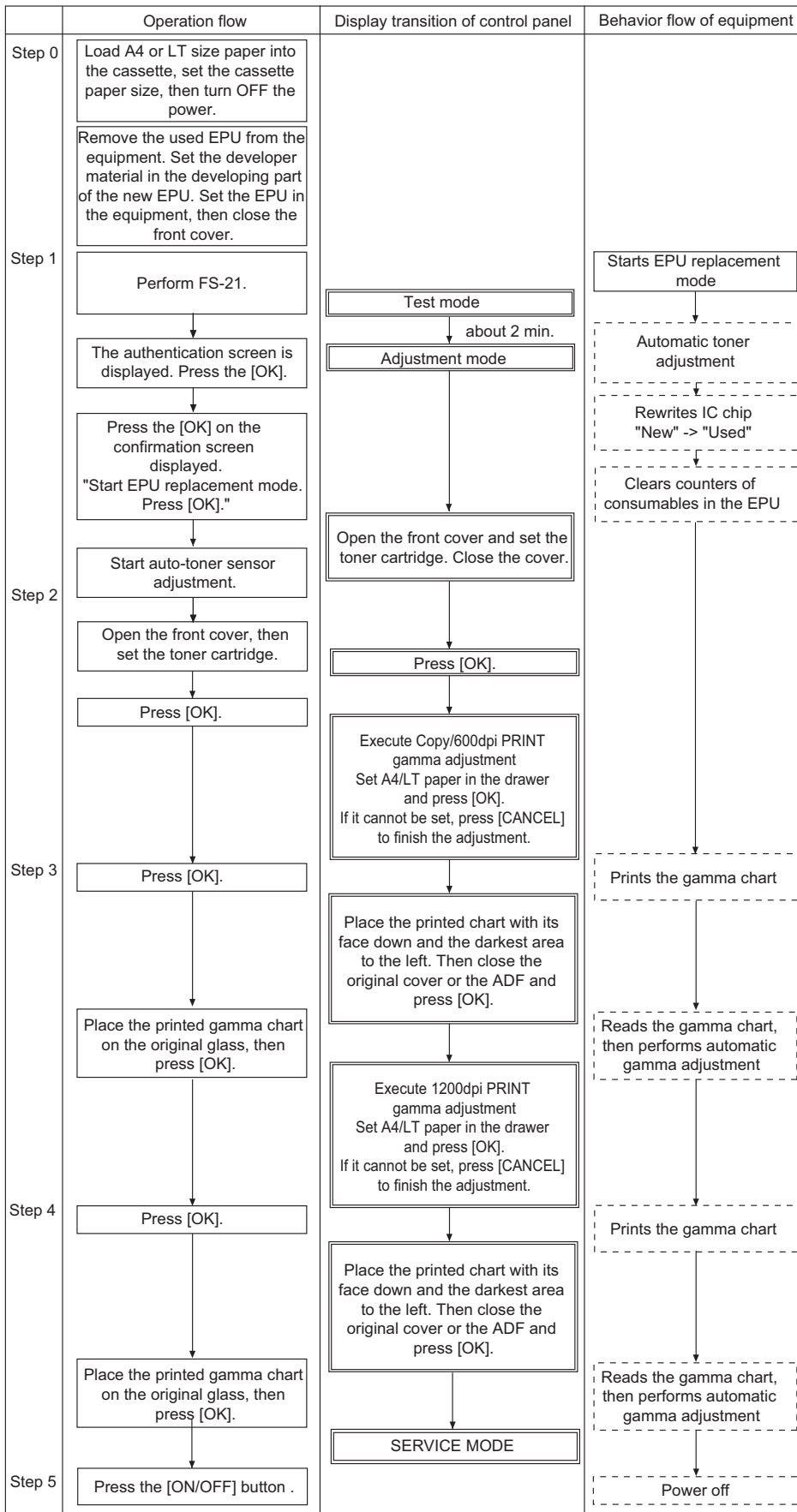

Fig. 7-8

### 7.6.3 Counters to be cleared

- FS-08-6250: Drum counter
- FS-08-6258: Drum cleaning blade counter
- FS-08-6274: Main charger grid counter
- FS-08-6282: Needle electrode counter
- FS-08-6272: Drum separation finger counter
- FS-08-6436: Recovery blade counter
- FS-08-6300: Developer material counter
- FS-08-6194: PM count current value
- FS-08-6195: PM time counter current value
- FS-08-5568: Developer material PM counter current value
- FS-08-5569: Developer material PM time counter current value

### 7.6.4 Precautions

- When the power is turned ON in the normal mode or during warming-up in the normal mode, the error code C3D1 appears after a new EPU unit (with new IC chip data) is installed. This indicates that the installed EPU unit has not been set up. Turn the power OFF and then perform FS-21. Then the MFP enters the EPU replacing mode.
- After Performing FS-21, the error code C3D2 appears after an old EPU unit (with old IC chip data) is installed. This is for preventing the MFP from detecting that the installed unit is a new one and performing wrong operations such as supply item counter reset. In this case, turn the power OFF and then back ON in the normal mode. The MFP returns to its normal operations.
- If IC chip information is not written as “used IC chip” in step 1, an error (C3D0) is displayed. If it occurs, perform the maintenance of each part according to the Troubleshooting.
- If you press [CANCEL] in step 3, the 21 EPU replacement mode ends without automatic gamma adjustment being performed.
- If [Adjustment error Press [OK] to perform the adjustment again or [CANCEL] to finish it.] is displayed in step 4, this means that the automatic gamma adjustment has failed. Check that the original is placed on the original glass in the correct direction, and press [OK] to start the adjustment again. If you press [CANCEL], the adjustment is canceled and the 21 EPU replacement mode ends.
- If automatic gamma adjustment is not performed in the 21 EPU replacement mode, the default gamma slope angle is used. To obtain optimal image quality, perform the adjustment according to the procedure in the “Automatic gamma adjustment” in the chapter of “Image Quality Adjustment”.
- If the 21 EPU replacement mode does not function, check that the value of FS-08-4556 (Detection setting of new or old EPU) is set to “1” (Enabled). If this value is set to “0” (Disabled), the EPU replacement mode does not function.

## 7.6.5 To allow the MFP to detect a recycled unit as a new one after replacement

To recycle an old EPU after replacement and also let the MFP detect that it is a new one, the supply items in the EPU and the IC chip data in the EPU board must be replaced.

In this case, the EPU board itself must be replaced with a new one (service part).

However, the EPU board is not installed in the EPU co-packed with the MFP. Therefore, in order to recycle it, it is necessary to install the EPU board which is supplied as a service part. Install the EPU board by the following order: Remove the sheet (PLATE-HLDR-HRNS-DEV). -> Attach the harnesses (HRNS-ATS-471, HRNS-EPU-471) supplied as a service part. -> Install the EPU board.

If the EPUs are replaced in the 20 PM support mode instead of the 21 EPU replacement mode noted in this chapter, the replacement or installation of the EPU board is not necessary.

Information in the IC chip can be confirmed with FS-08-4555-0 (Information check of new or old EPU memory). The display of [0xff00(NEW)] indicates a new IC chip while [0x00ff(OLD)] indicates a used one. A hexadecimal value ending with “-” indicates that invalid data have been entered.

## 7.7 Fuser Unit Status Detection Mode

### 7.7.1 Overview

As this model complies with the ERU provisions (Easy Replacement Unit), the fuser unit can be removed or reinstalled without any problem.

The fuse (service part) for detection of a new fuser unit can be installed in the unit. The circuit determining the fuser unit status judges whether the fuser unit is new or used by detecting the status of the fuse. In addition, when the circuit detects that a new fuser unit is connected, it supplies current to blow out the fuse to clear the fuser-related life counters.

#### Notes:

If only the supply parts in the fuser unit are to be replaced at PM, perform life counter clearing for each one in the PM support mode as described in this chapter.

### 7.7.2 Operation flow

- (1) When replacing supply parts or the fuser unit at PM, install a new fuse in it.

#### Notes:

If a fuser unit with an installed fuse is selected, replace that the fuse with a new one because it will have been blown out.

- (2) Install the fuser unit in the MFP.
- (3) Turn the power ON. If the fuser unit is then judged determined to be new, the fuser-related life counters are automatically cleared.

### 7.7.3 Counters to be cleared

- FS-08-6346: Heat roller center
- FS-08-6350: Pressure roller counter
- FS-08-6368: Heat roller separation finger counter
- FS-08-6225: Thick paper 1 number of output pages counter
- FS-08-6226: Thick paper 2 number of output pages counter
- FS-08-6227: Thick paper 3 number of output pages counter
- FS-08-6228: OHP number of output pages counter
- FS-08-6247: Envelope number of output pages counter
- FS-08-6244: Tab paper number of output pages counter

### 7.7.4 Precautions

- When the counters are not cleared, though the fuser unit is new, check that the value of the code FS-08-4549 is set at "0". If the value is "1", change it to "0", turn the power OFF and then back ON. Then check the counter values again  
FS-08-4549 (Detection setting of new or old fuser unit) 0: Enabled, 1: Disabled
- When the fuse is not blown out, though the fuser unit is new, a C4C0 error occurs. In this case, replace the fuse and turn the power OFF and then back ON, or remove the fuse and clear the counters in the PM support mode.

## 7.8 Preventive Maintenance Checklist

The following shows the items to be checked for each unit during the preventive maintenance.

Symbols and values used in the checklist

Item	Explanation
Cleaning	A: Clean with alcohol B: Clean with a soft pad, cloth or vacuum cleaner
Lubrication/Coating	L: Launa 40 W1: White grease (Molykote EM-30L) W2: White grease (Molykote HP-300) AV: Alvania No. 2 FL: FLOIL (GE-334C) C: Coating material (SANKOL CFD-409M) CG: Conductive grease (KS-660)
Replacement	Value: Replacement cycle R1: Replacement R3: Replace if deformed or damaged
Operation check	Yes: After cleaning or replacement, confirm there is no problem.

### Notes:

Perform cleaning and lubricating in the following timing. Lubricate the replacement parts according to the replacement cycle.

Model name	Print count
2528A	Every 100,000 sheets
3028A	Every 120,000 sheets
3528A	Every 125,000 sheets
4528A	Every 150,000 sheets

The replacement cycle of the parts in the feeding section equals to the number of sheets fed from each paper source.

Be careful not to put oil on the rollers, belts and belt pulleys when lubricating.

“P-I” represents the page item in “e-STUDIO2528A/3028A/3528A/4528A Service Parts List”.

## 7.8.1 Scanner

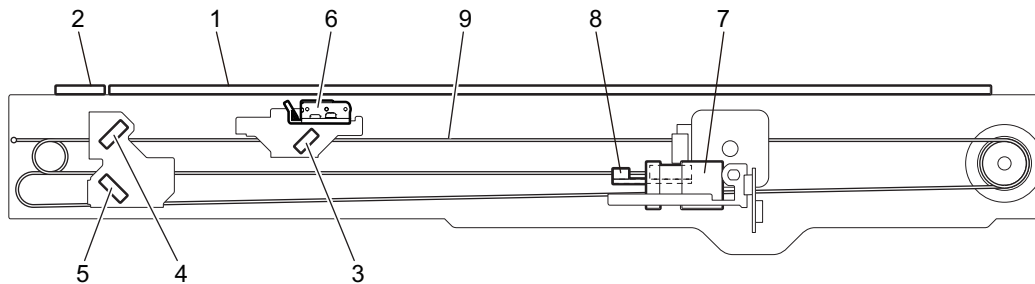

Fig. 7-9

### PM timing

Model name	(x 1,000 sheets)
2528A	100
3028A	120
3528A	125
4528A	150

Item		Cleaning, etc.		Replacement		Operation check	P-I
		Cleaning	Lubrication/Coating	Sheets	Drive counts		
1	Original glass	B or A					21-2
2	DF original glass	B					21-3
3	Mirror-1	B					22-1
4	Mirror-2	B					23-1
5	Mirror-3	B					23-1
6	Reflector	B					22-1
7	Lens	B					11-9
8	Automatic original detection sensor	B				Yes	11-12
9	Slide sheet (front, rear)	B					-

#### 1: Original glass, 2: DF original glass

Clean both sides of the original glass and DF original glass. Also clean the film attached to the DF original glass in order to wipe off any dirt or paper dust.

Make sure that there is no dust on the mirrors-1, -2, -3 and lens after cleaning. Then install the original glass and DF original glass.

#### Notes:

Make sure that there is no fingerprints or oil staining on the glass surface underneath the original scale since it is the reading part of the shading correction plate.

Do not use such solvents as alcohol when cleaning the surface of the DF original glass because it is coated.

Moreover, when cleaning the original glass with alcohol, do so only for the stained areas because fog may appear.



## 7.8.2 Laser optical unit

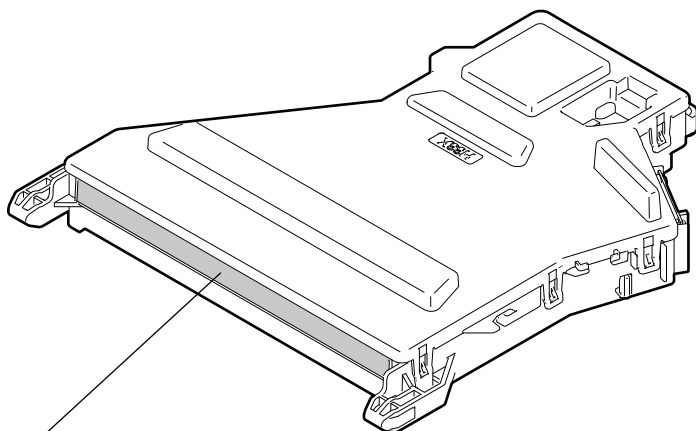

1

Fig. 7-10

### PM timing

Model name	(x 1,000 sheets)
2528A	100
3028A	120
3528A	125
4528A	150

Item		Cleaning, etc.		Replacement		Operation check	P-I
		Cleaning	Lubrication/Coating	Sheets	Drive counts		
1	Slit glass	B					10-1

## 7.8.3 Paper feeding section

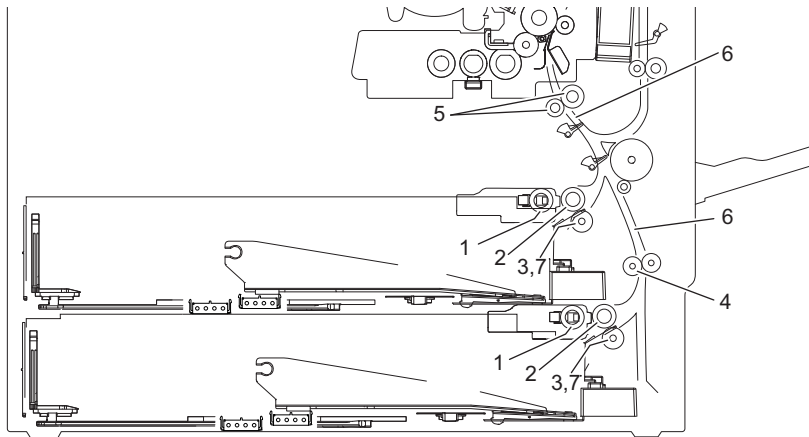

Fig. 7-11

### PM timing

Model name	(x 1,000 sheets)
2528A	100
3028A	120
3528A	125
4528A	150

Item	Cleaning, etc.		Replacement		Operation check	P-I
	Cleaning	Lubrication/Coating	Sheets	Drive counts		
1 Pickup roller			80			16-29
2 Paper feed roller			80			16-43
3 Separation roller		AV, W2	80			16-30
4 Transport roller	A		R3			16-35
5 Registration roller	A	W1, FL	R3			12-17, 20-3
6 Paper guide	B					-
7 Separation roller guide		W2				16-19

### 5: Registration roller

Apply grease [3] to the 2 contact points (at the front and rear) of the registration roller (rubber) [1] and the bushing [2] in the following manner. Bushing at the front side (white): 2-rice sized grains of Molykote (EM-30L) Bushing at the rear side (black): 2-rice sized grains of FLOIL (GE-344C)

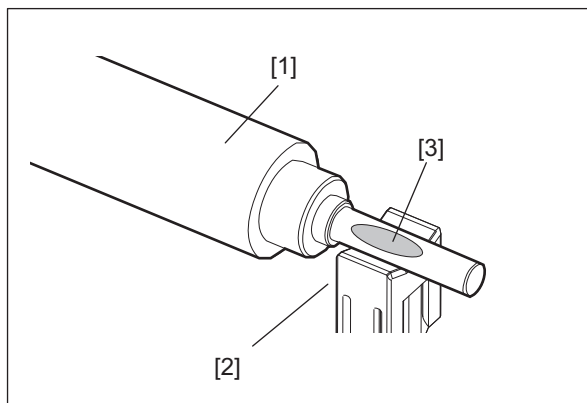

Fig. 7-12

## 7.8.4 Bypass unit

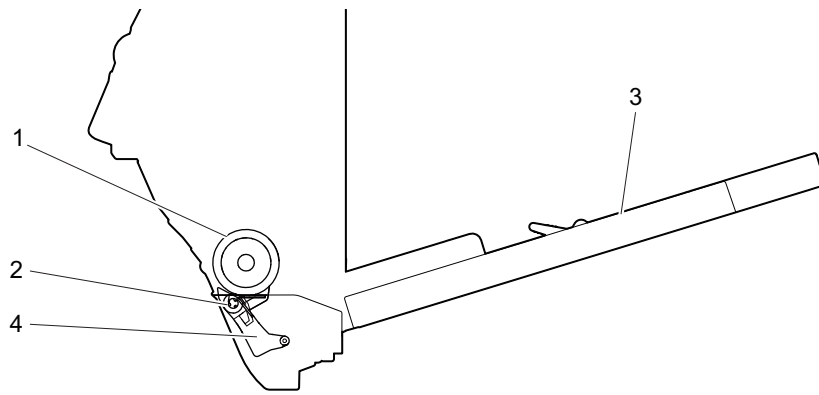

Fig. 7-13

### PM timing

Model name	(x 1,000 sheets)
2528A	100
3028A	120
3528A	125
4528A	150

Item		Cleaning, etc.		Replacement		Operation check	P-I
		Cleaning	Lubrication/Coating	Sheets	Drive counts		
1	Bypass unit paper feed roller			80			19-19
2	Bypass unit separation roller			80			19-37
3	Bypass tray	B					18-2, 18-13
4	Bypass unit separation roller holder		W2				19-24

1:

When replacing the roller, clean the inner diameter of the bushing.

## 7.8.5 Main charger

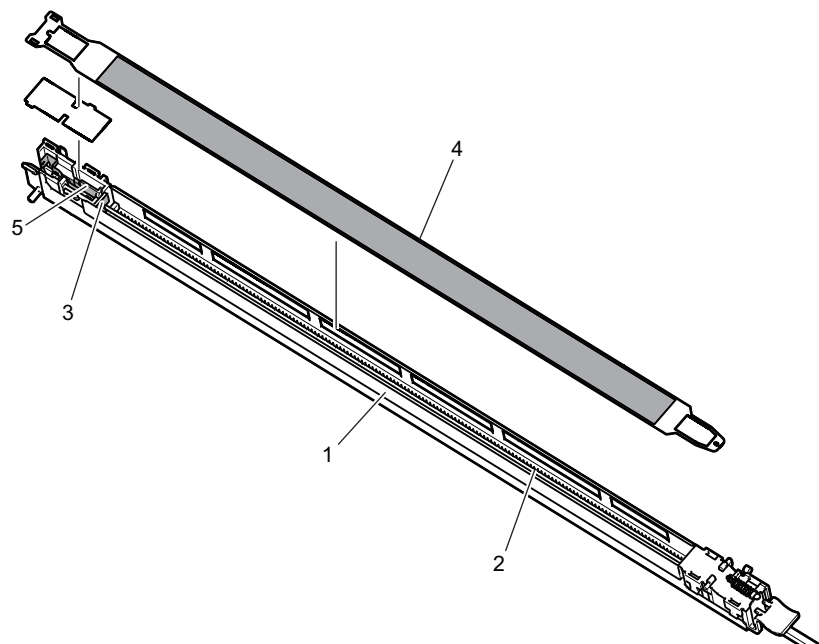

Fig. 7-14

### PM timing

Model name	(x 1,000 sheets)
2528A	100
3028A	120
3528A	125
4528A	150

Item	Cleaning, etc.		Replace	Operatio	P-I
	Cleani	Lubricatio	ment		
	ng	n/Coating	Sheets	n check	
1	Main charger case	B			24-16
2	Needle electrode		R1		24-6
3	Main charger cleaner		R3	Yes	24-14
4	Main charger grid		R1		24-11
5	Terminal point	B			24-5

#### 1: Main charger case

Clean the main charger case with a cloth soaked in water and squeezed tightly, and then wipe them with a dry cloth.

#### 2: Needle electrode

Clean the needle electrode only with the main charger cleaner.

Replace the needle electrode with a new one if it is damaged regardless of the number of output pages which have been made.

#### Notes:

Do not touch the needle electrode directly with your bare hands when replacing it.

## 7.8.6 Drum unit

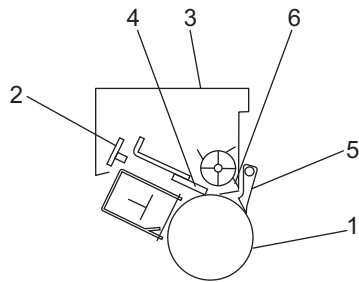

Fig. 7-15

### PM timing

Model name	(x 1,000 sheets)
2528A	100
3028A	120
3528A	125
4528A	150

Item		Cleaning, etc.		Replace ment	Operatio n check	P-I
		Cleani ng	Lubricatio n/Coating	Sheets		
1	Drum			R1		-
2	Discharge LED	B				26-32
3	Cleaner unit (whole)	B				-
4	Drum cleaning blade			R1		26-8
5	Drum separation finger			R1		26-12
6	Recovery blade			R1		26-10

### 1: Drum

- **Handling precautions**  
If fingerprints or oil adhere to the surface of the drum, its properties may degrade, affecting the quality of the copy image. So, wear gloves to avoid touching the drum surface with your bare hands. Be sure to handle the drum carefully when installing and removing it so as not to damage the drum surface.
- Be sure to apply “patting powder” (lubricant) to the entire surface of the drum (including both ends of the drum where OPC is not coated) when replacing the drum.  
Application of patting powder is for reducing the friction between the drum and cleaning blade. If the application of patting powder is neglected, the drum and cleaning blade may be damaged.
- **Clearing the drum counter**  
When the drum has been replaced with a new one, the drum counter must be cleared to 0 (zero). This clearing can be performed in 20 PM SUPPORT MODE.  
Drum (K): FS-08-6250-0, 3, 6, 7
- **Storage location of drums**  
The drum should be stored in a dark place where the ambient temperature is between 10°C to 35°C (no condensation). Be sure to avoid places where drums may be subjected to high humidity, chemicals and/or their fumes.  
Do not place the drum in a location where it is exposed to direct sunlight or high intensity light such as near a window. Otherwise the drum will fatigue, and will not produce sufficient image density immediately after being installed in the MFP.
- **Cleaning**

At periodic maintenance calls, wipe the entire surface of the drum clean using the designated cleaning cotton. Note that there is no need to clean the surface of the new drum unless there is a problem. Use sufficiently thick cleaning cotton (dry soft pad) so as not to scratch the drum surface inadvertently with your fingertips or nails. Also, remove your rings and wristwatch before starting cleaning work to prevent accidental damage to the drum. Do not use alcohol, selenium refresher and other organic solvents or silicon oil as they will have an adverse effect on the drum.

- Scratches on drum surface  
If the surface is scratched in such a way that the aluminum substrate is exposed, no copy image will be produced on this area. In addition, the cleaning blade will be damaged so replacement with a new drum will be necessary.
- Collecting used drums  
Regarding the recovery and disposal of used drums, follow the relevant local regulations or rules.

### 3: Cleaner unit (whole)

When cleaning the inside of the cleaner unit, remove the cleaning blade and recovery blade. Use a vacuum cleaner so as not to damage the film attached to the toner recovery auger. When using a vacuum cleaner, be careful not to hit the nozzle of the vacuum cleaner to the film. When rotating the toner recovery auger, rotate it only in the same direction as that for transporting toner.

### 4: Drum cleaning blade

- Handling precautions  
Pay attention to the following points as the cleaning blade life is determined by the condition of its edge. Replace the cleaning blade with new ones if poor images are copied due to the damaged blade regardless of the number of output pages which have been made.
  - Do not allow hard objects to hit or rub against blade edge.
  - Do not rub the edge with a cloth or soft pad.
  - Do not leave oil (or fingerprints, etc.) on the edges.
  - Do not apply solvents such as paint thinner to the blade.
  - Do not allow paper fibers or dirt to contact the edge.
  - Do not place near a heat source.
- Cleaning  
Clean the blade edge with a cloth moistened with water and squeezed lightly. Since the edge of the blade is vulnerable and can be easily damaged by factors such as the adherence of paper dust.

### 5: Drum separation finger

The paper misfeeding may be caused if the tip of the separation finger is deformed. If there is any problem with it, replace the finger with a new one regardless of the number of output pages which have been made. If any mark which was made by the finger appears on the printed image, clean the tip of the finger.

#### Notes:

- Wipe the tip of the finger lightly with a dry cloth trying not to deform it. Do not leave the lint on the tip.
- Apply patting powder to the tip of the fingers and drum surface after replacing or cleaning them to reduce the load on the drum surface by the finger.

### 6: Recovery blade

Clean the surface of the recovery blade with a soft pad or cloth, if dirt cannot be removed with a vacuum cleaner. If the edge of recovery blade is damaged, replace the blade regardless of the number of output pages.

#### Notes:

Never use water or alcohol for cleaning the recovery blade.

## 7.8.7 Developer Unit

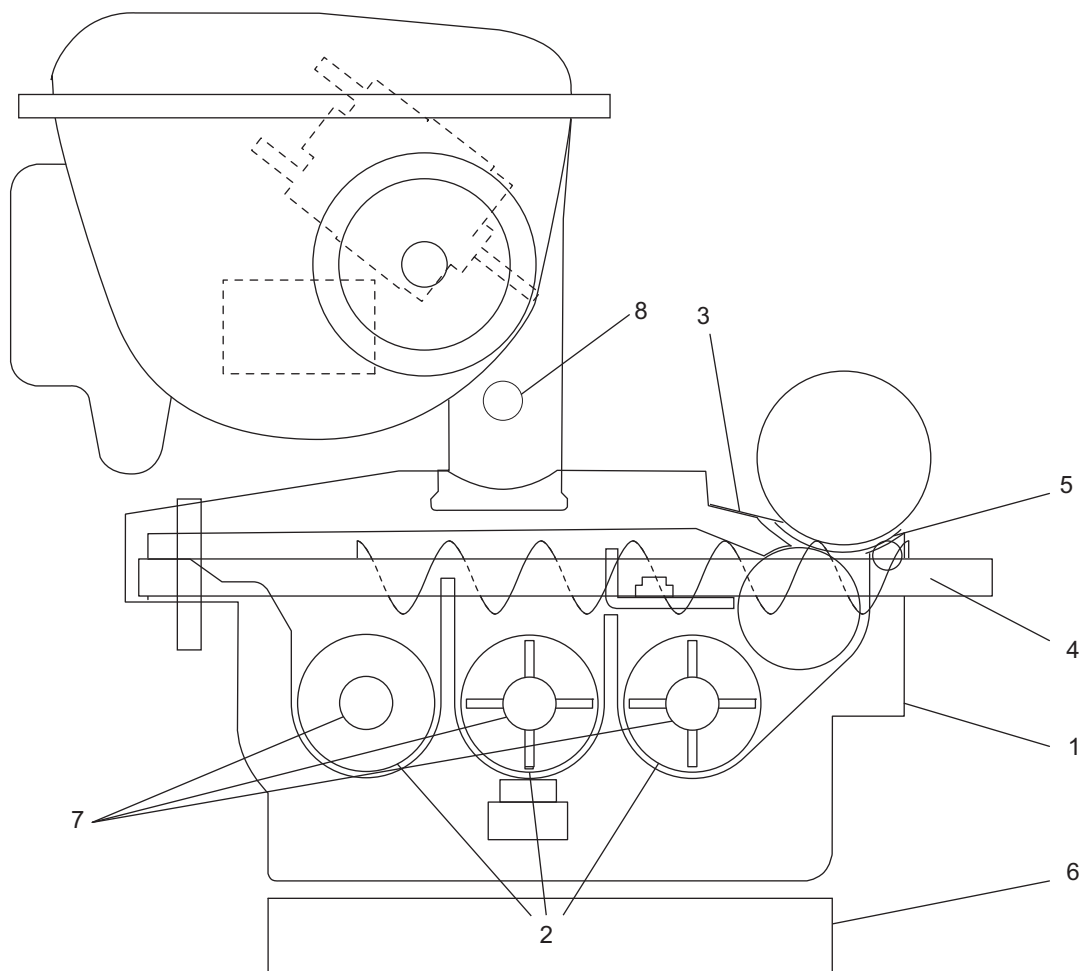

Fig. 7-16

### PM timing

Model name	(x 1,000 sheets)
2528A	100
3028A	120
3528A	125
4528A	150

Item		Cleaning, etc.		Replace-ment	Operatio-n check	P-I
		Cleani-ng	Lubricatio-n/Coating	Sheets		
1	Developer unit (whole)	B				-
2	Developer material			R1		-
3	Front seal (unified with the developer unit upper cover)	B		R3		27-32
4	Guide roller	B				27-26, 27-37
5	Side seal (front, rear)	B		R3		27-30, 27-31
6	Developer unit lower stay	B				-
7	Oil seal (6 pcs.)		AV	R3		28-11, 28-12
8	Toner cartridge drive gear shaft		W1			6-28

1. Developer unit (whole)

Do not use alcohol for cleaning the developer unit.

2: Developer material

After replacing the developer material, be sure to perform the auto-toner adjustment.

📖 P. 6-2 “6.1.2 Auto-toner sensor adjustment”

7: Oil seal

Total 6 pieces of the oil seals are located on both shafts of each mixer.

During replacement, coat the oil seal with grease (Alvanian No.2).

- (1) Push in a new oil seal [2] parallel to the mounting hole section of the developer frame [1] or outside of the holder.

**Notes:**

Pay attention to the direction in which the oil seal is attached.

- (2) Apply an even coat of grease [3] to the inside of the oil seal.

**Notes:**

- Amount: 2 rice-sized grains
- Wipe off any grease the exudes from the inside.

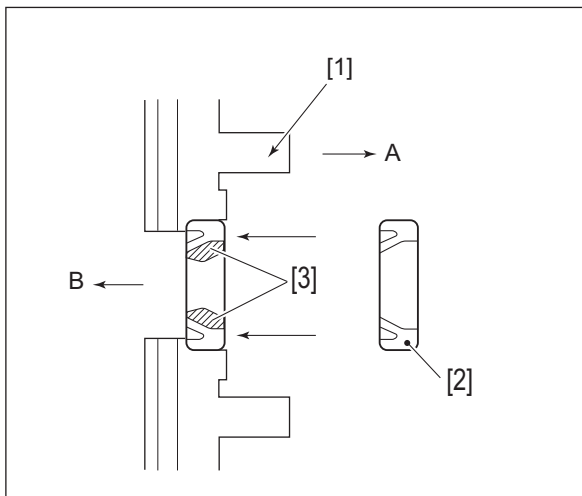

Fig. 7-17

- When the mixer is removed, clean its both edges with a dry cloth.
- In order to prevent damage to the oil seal, rotate the mixer when its both edges are inserted into the oil seals.



## 7.8.8 Transfer unit

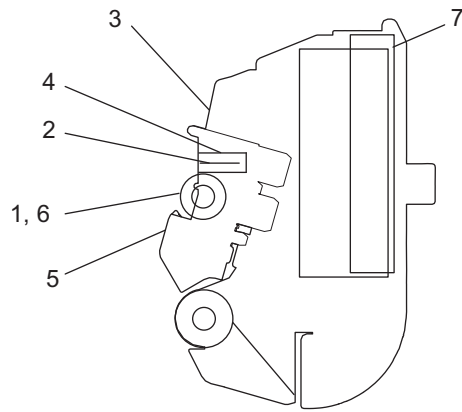

Fig. 7-18

### PM timing

Model name	(x 1,000 sheets)
2528A	100
3028A	120
3528A	125
4528A	150

Item		Cleaning, etc.		Replacement	Operation check	P-I
		Cleaning	Lubrication/Coating	Sheets		
1	Transfer roller			R1		25-5
2	Separation needle	B		R3		25-11
3	Transfer guide	B				25-2
4	Separation cover	B				-
5	Pre-transfer guide	B				25-14
6	Transfer roller gear	B				25-9
7	Ozone filter			R1(200/ 240/250/ 300)		12-14

#### 1: Transfer roller

- Replacement  
If there is damage on the roller, replace it even if the replacement time has not come.
- Handling precautions
  - Wear gloves to avoid touching the drum surface with your bare hands.
  - Do not allow oil or fingerprints to come in contact with the surface.
  - Do not allow hard objects to hit or rub against blade edge.
  - Do not allow paper fibers or dirt to contact the surface.
  - Do not apply solvents such as paint thinner to the blade.
  - Do not place near a heat source.
- Cleaning  
If bits of thread or similar adhere to the surface, remove them with gloves or a pair of tweezers. Be careful that the roller surface is not damaged by the points of the tweezers.

## 2: Separation needle

When cleaning the separation needle, be careful not to bend the needlepoint or leave lint on the needlepoint. If removing the dust is difficult, use brush to remove it.

## 3: Transfer guide

If there is paper dust in the whole transfer unit including the transfer guide, wipe them with a dry cloth. If the transfer guide is removed, clean the wall inside the unit.

## 7.8.9 Fuser unit

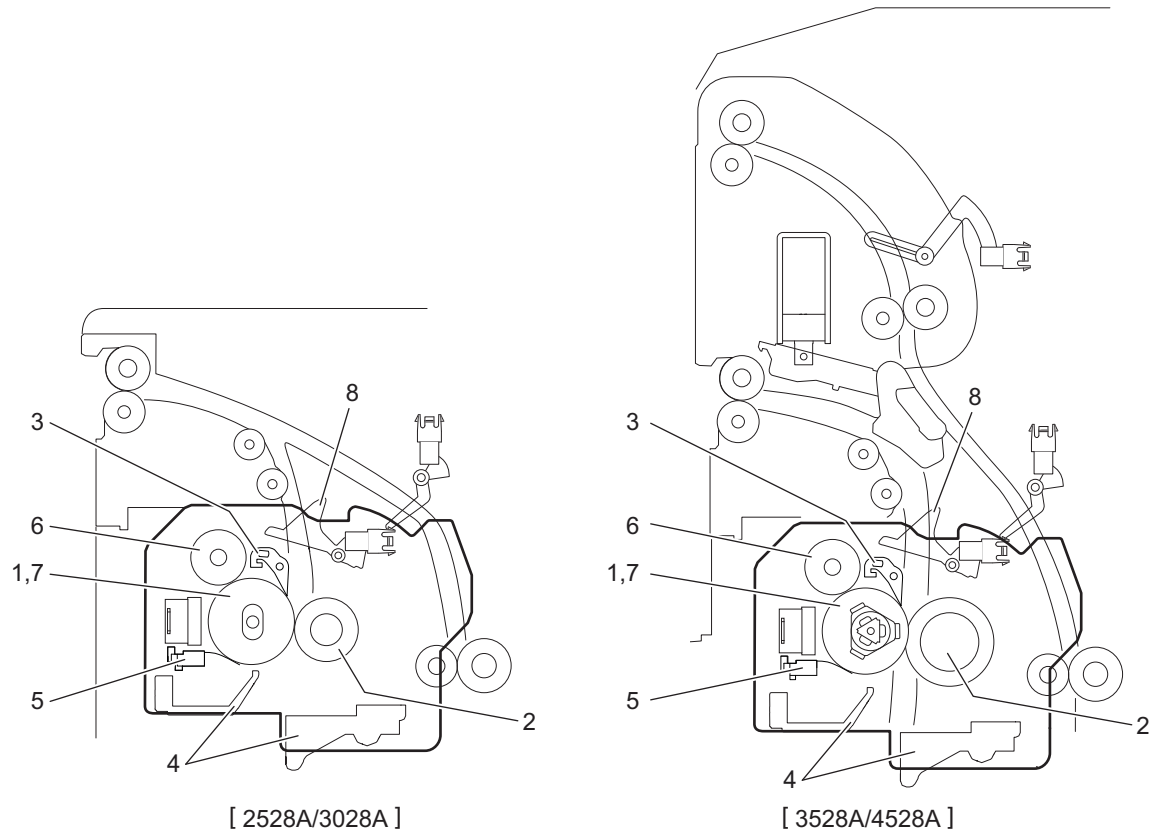

Fig. 7-19

### PM timing

Model name	(x 1,000 sheets)
2528A	100
3028A	120
3528A	125
4528A	150

Item		Cleaning, etc.		Replacement Sheets	Operation check	P-I
		Cleani ng	Lubricatio n/Coating			
1	Heat roller	A		R1(200/ 240/250/ 300)		31-15
2	Pressure roller	A		R1(200/ 240/250/ 300)		31-20
3	Heat roller separation finger	A		R1(200/ 240/250/ 300)		31-26
4	Fuser unit entrance guide	A				30-11, 31-12
5	Thermistor (3 pcs.)	A		R3		31-4
6	Drive gear (tooth face and shaft)		W2	R3		15-11, 15-15
7	Heat roller gear			R3		31-17
8	Paper exit sensor actuator	A				32-24

1, 2: Heat roller, Pressure roller

- Handling precautions  
Do not leave oil (or fingerprints, etc.) on the rollers.
- Cleaning  
Be sure to clean the surface with a soft cloth.  
Be careful not to deform or damage the rollers, possibly resulting in poor cleaning.

**Notes:**

Do not apply silicon oil.

3: Heat roller separation finger

The paper jam may be caused if the tip of the finger is damaged or deformed, or a dirt image caused by the finger occurs.

If there is any problem with it, replace the finger with a new one regardless of the number of output pages which have been made.

Do not damage the tip of the finger during the cleaning.

The finger may be damaged if the toner adhering to the tip of it is scraped off forcibly. Replace the finger if the toner is sticking to it heavily.

5: Thermistor

Clean the thermistor with alcohol if the toner or dirt is sticking to it when the heat roller is replaced.

Do not deform or damage the thermistor during the cleaning.

Replace the thermistor with a new one if it is damaged or deformed regardless of degree.

8: Paper exit sensor actuator

If toner has adhered, wipe it off with alcohol.

## 7.8.10 Paper exit section, reverse section

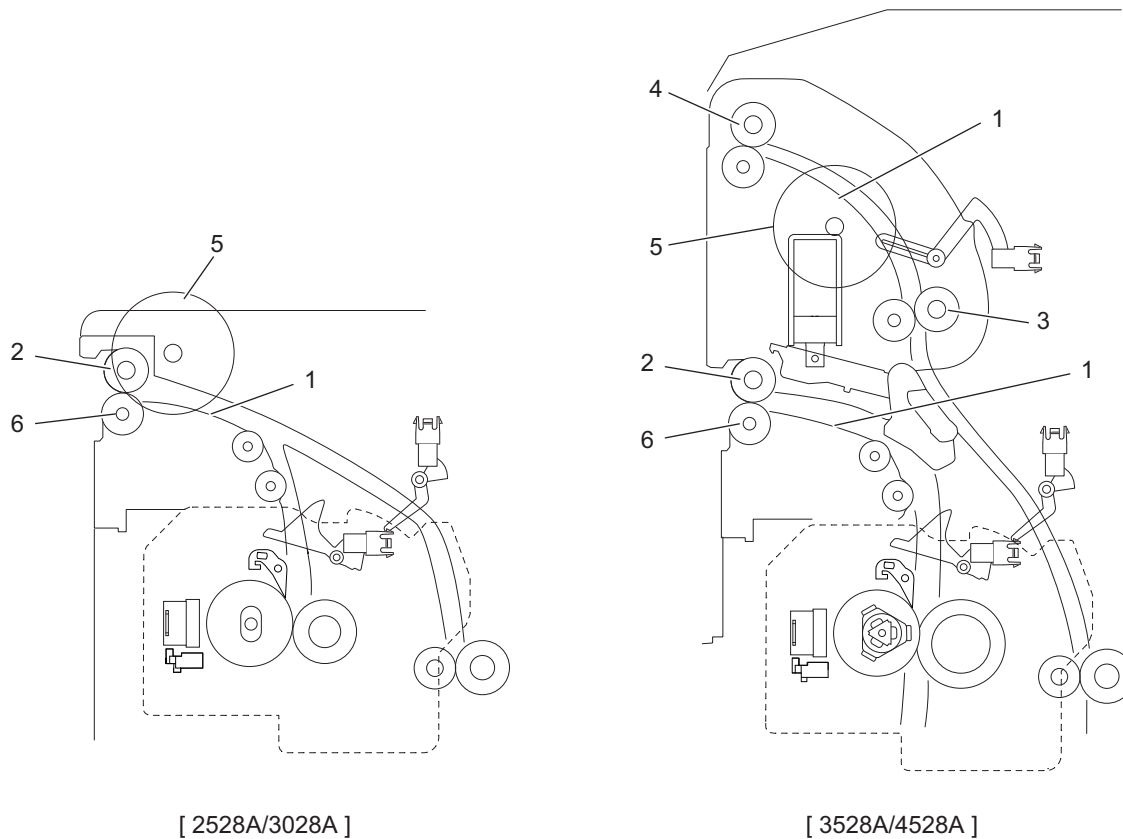

Fig. 7-20

### PM timing

Model name	(x 1,000 sheets)
2528A	100
3028A	120
3528A	125
4528A	150

Item		Cleaning, etc.		Replacement Sheets	Operation check	P-I
		Cleani ng	Lubricatio n/Coating			
1	Paper exit/reverse guide	A				39-8
	Paper exit/reverse guide (upper) (3028A/3528A/4528A)	A				39-20
2	Paper exit roller	A		R3		39-11
	Lower paper exit roller (3028A/ 3528A/4528A)	A		R3		39-11
3	Reverse roller	A		R3		31-32
4	Upper paper exit roller	A		R3		39-31
5	Drive gear		W1			39-24, 39-47
6	Conductive bushing		CG			39-40

2, 3, 4: Paper exit roller, Lower paper exit roller, Reverse roller, Upper paper exit roller  
Clean the pinch rollers facing the above rollers with alcohol at the same time as them.

## 7.8.11 Automatic Duplexing Unit

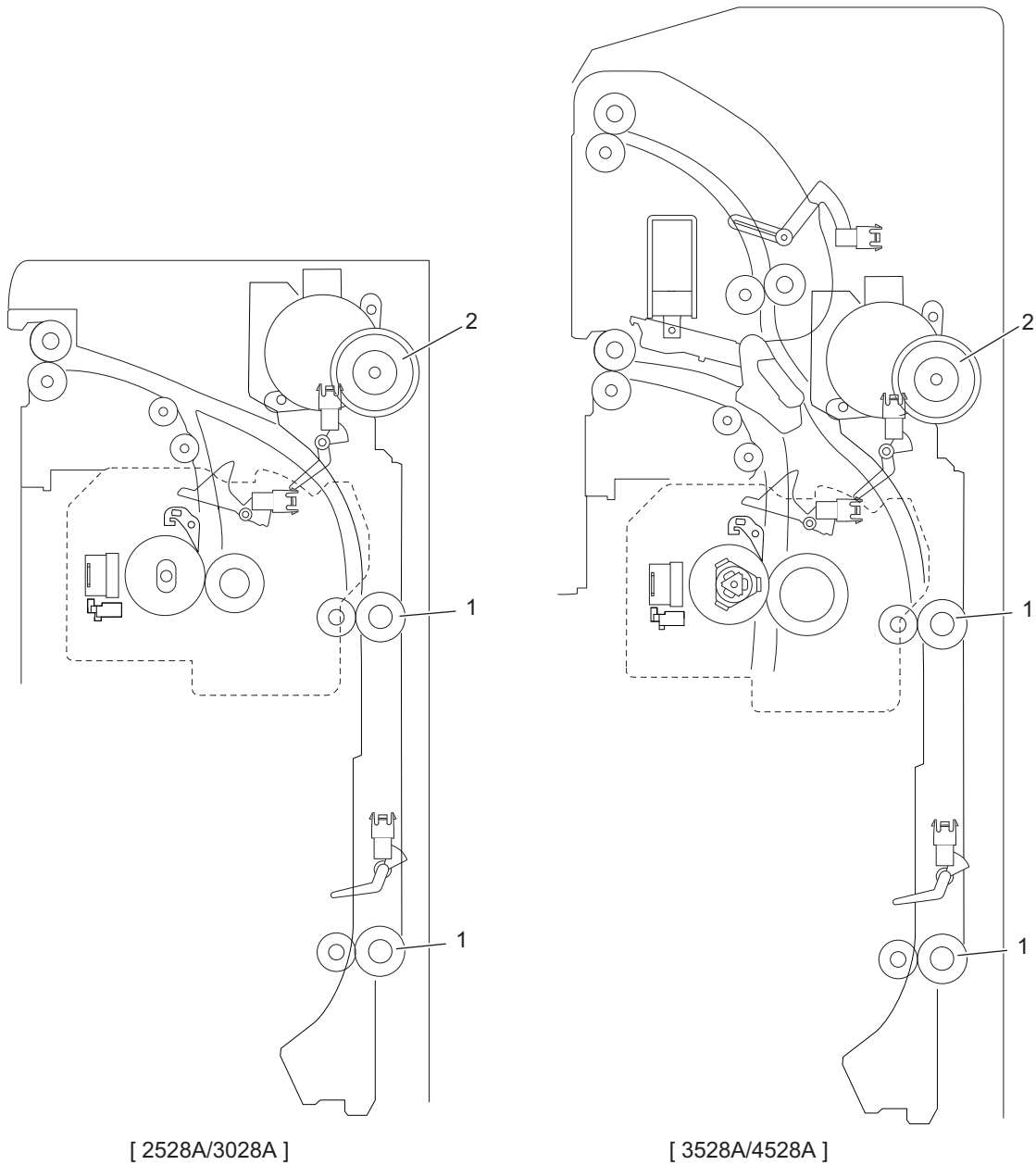

Fig. 7-21

Model name	(x 1,000 sheets)
2528A	100
3028A	120
3528A	125
4528A	150

Item	Cleaning, etc.		Replacement Sheets	Operation check	P-I
	Cleaning	Lubrication/Coating			
1	Transport roller (upper and lower)	A	R3		33-10
2	Drive gear		W1		33-14

1: Transport roller (upper and lower)

Clean the pinch rollers facing the above rollers with alcohol at the same time as them.

## 7.9 Machine Refreshing Checklist

The check items for each unit at the machine refreshment are shown below.

Symbols and values used in the checklist

Item	Explanation
Cleaning	A: Clean with alcohol B: Clean with a soft pad, cloth or vacuum cleaner
Lubrication/Coating	W1: White grease (Molykote EM-30L) W2: White grease (Molykote HP-300) R4: Lubrication recommended. If the parts are not lubricated at the machine refreshing interval, inspect their lubrication status at the subsequent PM.
Replacement	R1: Replacement R2: For preventive maintenance, check if the parts are damaged and replace them as required. If the parts are not replaced at the machine refreshing interval, inspect them at the subsequent PM. R3: Replace if deformed or damaged If the parts are not replaced at the machine refreshing interval, inspect them at the subsequent PM.

### Notes:

Perform machine refreshment in the following timing.

Model name	Print count
2528A	500,000 sheets
3028A	600,000 sheets
3528A	625,000 sheets
4528A	750,000 sheets

- When performing machine refreshment, check the items in the preventive maintenance checklist in addition to the items in the machine refreshing checklist.
- Be careful not to put oil on the rollers, belts and belt pulleys when lubricating.
- “P-I” represents the page item in “e-STUDIO2528A/3028A/3528A/4528A Service Parts List”.

Item	Cleaning	Lubrication/Coating	Replacement	P-I
- Drum drive unit		W1 (R4)		-
- Paper feed drive unit		W1 (R4)		-
- Developer drive unit		W1 (R4)		-
- Fuser unit driving section		W1 (R4)		-

## 7.10 Storage of Supplies and Replacement Parts

Precautions for storing supplies and replacement parts are shown below.

1. Toner, Developer material  
Toner and developer should be stored in a place where the ambient temperature is between 10°C to 35°C (no condensation), and should also be protected against direct sunlight during transportation.
2. Photoconductive drum  
Photoconductive drum should be stored in a dark place where the ambient temperature is between 10°C to 35°C (no condensation) Avoid places where the rollers and belts may be subjected to high humidity, chemicals and/or their fumes.  
Do not place the drum in a location where it is exposed to direct sunlight or high intensity light such as near a window. Otherwise the drum will fatigue, and will not produce sufficient image density immediately after being installed in the MFP.
3. Drum cleaning blade  
Drum cleaning blade and transfer belt cleaning blade should be stored in a flat place where the ambient temperature is between 10°C to 35°C, putting it in horizontal. Avoid places where the rollers and belts may be subjected to high humidity, chemicals and/or their fumes.
4. Heat roller, Pressure roller  
Avoid places where the rollers and belts may be subjected to high humidity, chemicals and/or their fumes.
5. Paper  
Avoid storing copy paper in places where it may be subjected to high humidity. After a package is opened, be sure to place and store it in a storage bag.  
When using thick paper whose weight is 157 g/m<sup>2</sup> or more, select that which is being stored in a place where the temperature is 19 to 25°C and the RH is 45 to 70%.
6. Transfer roller  
Photoconductive drum should be stored in a dark place where the ambient temperature is between 10°C to 35°C (no condensation) Avoid places where the rollers and belts may be subjected to high humidity, chemicals and/or their fumes.



## 7.11 PM Kit

A PM kit is a package for each unit of replacement parts requiring PM.

Kit name	Component	Q'ty	P-I
DEV-KIT-5008A	Drum cleaning blade	1	26-8
	Recovery blade	1	26-10
	Drum separation finger	3	26-12
	Main charger grid	1	24-11
	Needle electrode	2	24-6
	Transfer roller	1	25-5
	Developer material	1	-
FR-KIT-5008A *1	Heat roller	1	31-15
	Pressure roller	1	31-20B
	Heat roller separation finger	5	31-26
	Ozone filter	1	12-14
FR-KIT-3008A *2	Heat roller	1	31-15
	Pressure roller	1	31-20A
	Heat roller separation finger	5	31-26
	Ozone filter	1	12-14
ROL-KIT-FC30-U (1st drawer, 2nd drawer, PFP)	Pickup roller	1	16-29 (1st/2nd) 5-26 (PFP)
	Paper feed roller	1	16-43 (1st/2nd) 5-36 (PFP)
	Separation roller	1	16-30 (1st/2nd) 5-30 (PFP)
ROL-KIT-KD-1073 (T-LCF)	Pickup roller	1	5-27
	Paper feed roller	1	5-27
	Separation roller	1	5-8
DF-KIT-3031 (RADF)	Pickup roller	1	5-13
	Paper feed roller	1	5-13
	Separation roller	1	4-10
	Registration roller front sheet	2 1	4-38 4-39
KIT-ROL-MR-4010 (DSDF)	DSDF pickup roller	1	1-18
	DSDF paper feed roller	1	1-14
	DSDF separation roller	1	5-21
ROL-KIT-MP-2002 (External Large Capacity Feeder)	Pickup roller	1	4-18
	Paper feed roller	1	4-9
	Separation roller	1	4-37

\*1 : For 3528A/4528A

\*2 : For 2528A3028A/

## 7.12 Maintenance Parts List

The parts used for the maintenance of this MFP are as follows.

No.	Name	Purpose	P-I
1	Door-switch jig	Locking the door switch.	101-1
2	Cleaning brush	Cleaning inside of the MFP	101-2
3	Doctor sleeve jig	Measuring the gap between the developer sleeve and the doctor blade	101-3
4	Wire holder jig	Fixing the wire at the assembly of the carriage wire	101-5
5	Belt tension jig	Adjusting the belt tension at the installation of the scan motor	101-6
6	High-voltage transformer jig	Adjusting the high-voltage transformer	101-7
7	Drum bag	Storing the drum	102-21
8	Patting powder	For the photoconductive drum	101-17
9	Color test chart (TCC-2)	Test chart for A4/LD	101-22
10	Color test chart (TCC-3)	Test chart for A3/LD	101-23
11	Fuser unit fuse	For the fuser unit	30-23
12	Thermostat gap adjustment jig	Adjusting the gap of the fuser unit thermostat	101-9
13	Reverse unit gap confirmation jig	Checking the gap when the reverse unit is installed	101-24

\* "P-I" represents the page item in "e-STUDIO2528A/3028A/3528A/4528A Service Parts List".

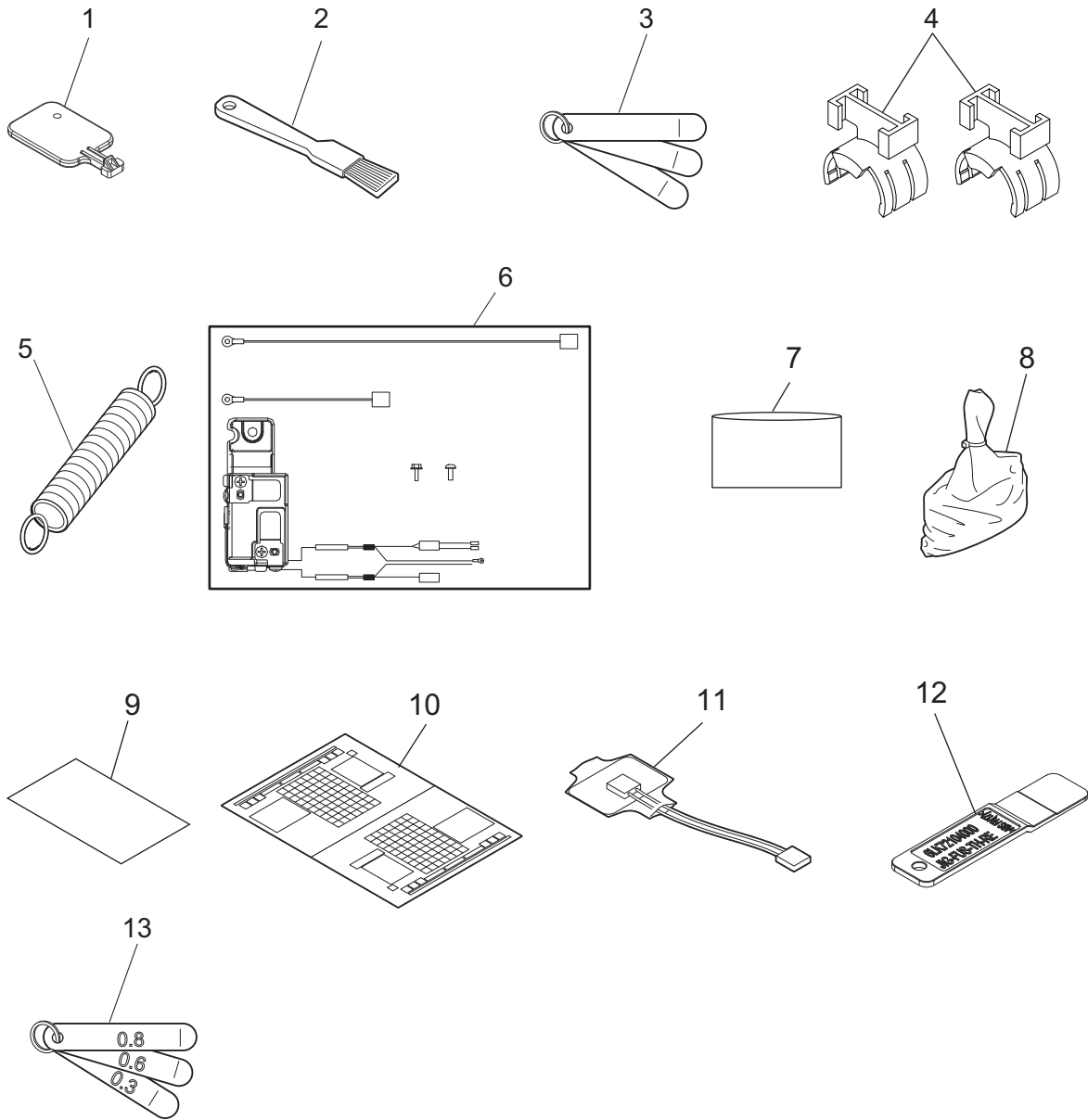

Fig. 7-22

## 7.13 Grease List

The grease used for the maintenance of this MFP is as follows.

Symbol	Name	Type	Color	Volume	Container	P-I
W1	White grease (Molykote EM-30L)	Grease	White	100 g	Tube	101-14
W2	White grease (Molykote HP-300)	Heat-resisting grease	White	10 g	Bottle	101-12
AV	Alvania No. 2	Grease	Amber	100 g	Tube	101-13
FL	FLOIL (GE-334C)	Conductive grease	Black	20 g	Bottle	101-15

"P-I" represents the page item in "e-STUDIO2528A/3028A/3528A/4528A Service Parts List".

## 8. ERROR CODE AND TROUBLESHOOTING

### 8.1 Overview

This chapter explains the procedures for solving troubles occurring in the MFP.

When a trouble occurs, check if an error code is displayed on the LCD screen of the control panel first. If displayed, refer to “8.2Error Code List” to figure out the classification and contents of the error, and then refer to “8.3Analysis from Error Codes” to remove its cause.

When no error is displayed but the MFP does not operate properly or images are not printed properly, refer to “8.4Other Errors” or “8.5Troubleshooting for the Image” to remove its cause.

When troubles have occurred in the MFP, various causes can be considered. Check the items below first.

- Is there any problem with the power cable or an outlet?  
Check that the power cable is inserted securely. If it is almost removed or not inserted securely, power voltage may become unstable, causing a trouble in the MFP.
- Are the connectors connected securely?  
Reconnect them securely. Even if they are apparently inserted, there may be a contact failure. Carefully check if the connection is secured especially after the disassembly or replacement of parts.
- Are there any abnormalities in the setting value of the self-diagnostic code?  
If an abnormal value has been entered in the self-diagnostic code related to the problem, an operation failure may occur. If an abnormal value has been entered in the self-diagnostic code related to the image quality adjustment, defective images may occur. Therefore, check that the proper value has been entered in the self-diagnostic code.
- Are there any similar cases?  
Check if there have been any similar problems in the troubleshooting in the Service Manual. If there are similar cases, refer to their troubleshooting.

#### Notes:

If an unusual odor is detected or if smoke or fire comes out of the MFP, immediately unplug the power cable.

Even in the cases other than the above, fully observe safety precautions.

If any PC board or HDD shall be replaced, refer to “9.2Precautions, Procedures and Settings for Replacing PC Boards and Storage Device”.

### 8.1.1 If a problem continues even after performing all troubleshooting

If a problem continues even after performing all troubleshooting and technical tips, report the problem to the appropriate Toshiba service center along with the following information. This information will help the service center understand your problem and take quick action to find the solution.

1. Serial number
  2. List Print (Refer to the appropriate Service Manual for the detailed procedure to obtain a List Print.)
    - A. Enter the value given below to obtain a List Print by CSV file.  
FS-30-300: All CSV files
    - B. Enter the value given below to obtain a List Print by printing it out.  
FS-30-101: 05 ADJUSTMENT MODE  
FS-30-102: 08 SETTING MODE  
FS-30-104: Pixel counter data (Toner cartridge standard)  
FS-30-106: Error history (Max.: 1,000 cases)  
FS-30-108: Firmware update log (Max.: 200 cases)  
FS-30-110: Power on/off log (Max.: 100 cases)
  3. For image-related problems, refer to the reference below.
    - 📖 P. 8-423 “8.5.31 If an image-related problem continues after performing all troubleshooting”  
If a problem nevertheless continues to persist, collect image samples with the problem areas and the feeding direction marked first. Then provide information about the type, size, and weight of the paper along with a copy of the print data and spool file causing the problem.  
A marking for the feeding direction can be added by the operation of the reference below.
    - 📖 P. 6-28 “6.2.3 Scanning and paper feeding direction instruction patterns superposition function”
  4. For abnormal acoustic noise, describe the situation in as much detail as possible.
  5. For hardware-related problems, provide photos of any broken parts, misfed paper, etc. In case of paper misfeeding, include the type of paper and its manufacturer.
  6. For software-related problems, provide list prints, TopAccess Logs and the detailed procedure needed to duplicate the problem.
- \* This is the minimum information required to report a complaint. Any further information will be a help to find out the cause of the problem.
- \* Follow the directions of the service center if they request additional information as each issue is unique to some degree.

## 8.1.2 Collection of debug logs with a USB storage device

### [ 1 ] Overview

The purpose of collecting the debug logs is to acquire the necessary information to analyze problems which have occurred while the MFP is being operated, by following the procedure below. (Only the problems whose investigation seem to be required)

In such a case, you can collect the debug logs by inserting a USB storage device containing the dedicated script file into the MFP. Even if the power has to be turned OFF and then back ON after a problem occurs, the debug logs will be saved in the MFP (up to 3 logs). If the debug logs have already been saved in the MFP, they also can be collected.

The following information is included in the USB debug logs.

Internal operation, Job history, storage device and memory usage status, etc. Personal/Corporate information (address book) not included

When the debug logs are collected, also do so for the following information since it may be difficult to investigate only using the debug log.

- List print mode [FS-30-300: All CSV files]
  - Job logs below in TopAccess > [Logs] > [Export Logs]
    - Print Job Log Export
    - Fax Transmission Journal Export
    - Fax Reception Journal Export
    - Scan Log Export
    - Message Log Export
    - Problem occurrence timeAlternatively, the time when the user called if it is difficult to work out when it occurred
  - Status of when you collected the debug log
- As in the example below, check the status to know if the problem occurred at the debug log collection or how the user recovered it.
- E.g.: You checked the problem and connected a USB storage device to the MFP.
- E.g.: No problem occurred when an attempt to collect the debug log was made; however, the log may have been collected since the user did turn OFF the power when the problem occurred.

### [ 2 ] Collection procedure

1. Precautions
  - When collecting a log, be sure to obtain consent from the user in advance.
  - Be sure to get the dedicated script file from the service center.
2. About USB storage devices

Be sure to format the USB storage device with FAT32 beforehand. (Recommend size: 2 GB or more)
3. Advance preparation of collection

Store the dedicated script file to the root directory of the USB storage device.
4. Collection procedure
  - (1) Insert the USB storage device with the dedicated script file stored into the MFP while the power is ON.
    - After the USB storage device is inserted into the MFP, the screen will change.
  - (2) Select [Basic Debug Logs], [All Debug Logs] or [9S-300CSV Print Job List] and then press the [START] button.
    - [9S-300CSV Print Job List] can be selected together with [Basic Debug Logs]. In addition, [9S-300CSV Print Job List] can also be selected together with [All Debug Logs].
    - The log collection of [All Debug Logs] will start automatically if no operation is made for 30 seconds after the screen has been changed.
    - The LED of the MFP starts blinking when the log collection has begun.
    - The panel display will be changed during the log collection depending on the conditions of the MFP. However, the log collection will continue as long as the LED is blinking.

- (3) When the log collection is finished, the beeping sound is heard. After the beeping sound has stopped, remove the USB storage device.
- The MFP will reboot automatically in 10 seconds after a beeping sound.
  - If this has not been done automatically after 30 seconds have passed, reboot the MFP manually.

**Notes:**

Do not remove the USB storage device while the LED in the MFP is blinking.

If the LED does not start blinking after the USB storage device is inserted and a few minutes have passed, attempt the procedure from step (1) again.

If there is no beeping sound after the LED starts blinking (about 20 minutes), attempt the procedure from step (1) again.

If the USB storage device is inserted when the MFP is not ready, the debug logs cannot be collected.

5. Collected debug logs

- When the collection of the debug logs is completed, the compressed file of the collected logs is stored in the root directory of the USB storage device.

File name:

XXXX.YYYYMMDDHHmmSS (for [Basic Debug Logs], [All Debug Logs])

XXXX.YYYYMMDDHHmmSS.Defunct (for [All Debug Logs])

XXXX.YYYYMMDDHHmmSS.PowerOff (for [All Debug Logs])

XXXX.YYYYMMDDHHmmSS\_9S300 (for [9S-300CSV Print Job List])

XXXX.YYYYMMDDHHmmSS\_JobList (for [9S-300CSV Print Job List])

XXXX.YYYYMMDDHHmmSS.USBLog (for [Basic Debug Logs], [All Debug Logs], [9S-300CSV Print Job List])

md5sum.txt (for [Basic Debug Logs], [All Debug Logs], [9S-300CSV Print Job List])

(XXXX= Serial number of the MFP, YYYY= year, MM= month, DD= day, HH= hour, mm= minute, SS= second)

- After the debug logs have been collected, be sure to send them to the service center together with a report.



### 8.1.3 Traceability label

A traceability label with a management No. at the manufacturing printed is attached to some units. If a problem occurs in a unit, report it to the appropriate service center along with the traceability label information to help them to understand it.

#### [ 1 ] Management No.

A management number consists of 13 digits with letters of the alphabet and numbers. The following shows the meaning of each block.

- From the 1st to 4th digits: Classification
- From the 5th to 10th digits: Production date
- From the 11th to 13th digits: Sequential numbers

Classification				Production date						Sequential numbers			
1	2	3	4	5	6	7	8	9	10	11	12	13	(digits)
1	2	3	4	1	2	3	4	5	6	1	2	3	

#### [ 2 ] Applicable units

A traceability label is attached to the following units.

No.	Unit	Remarks
1	LSU	
2	Process unit	
3	Fuser unit	
4	Scanner	
5	ADU	

### 8.1.4 Detach function

When the ADF or finishers break down, a service call will occur and the MFP goes into an inoperable condition.

In such a case, you can make the MFP operable by electrically detaching the broken-down ADF or finishers. This function is called “detach”.

This function is carried out by having a user press [Detach] when a service call has occurred.

This function is released by setting the following self-diagnostic code after the broken-down ADF or finishers are repaired.

FS-08-9722: Deactivate Cancel

## 8.2 Error Code List

The following error codes are displayed at the upper right of the screen when the “CLEAR PAPER” or “CALL SERVICE” symbol is blinking.

### Remarks:

Elision character of the “Error code display media”

Panel: Control panel

JLog: JobLog (TopAccess Print Log - Scan Log)

ML: Message Log (TopAccess Message Log)

Noti: Notification

CSV: CSV output (List print)

Y: Yes

2nd: An error status has been detected twice (= error code has been determined)

5th: An error status has been detected five times (= error code has been determined)

### 8.2.1 Paper misfeeding

Code	Message	Error code display media				
		Panel	JL	ML	Noti	CSV
[E010] Paper not reaching the paper exit sensor jam	Paper Ejection Misfeed - Please Clear Paper Path.	-	-	Y	Y	Y
[E020] Paper stopping at the paper exit sensor jam	Paper Ejection Misfeed - Please Clear Paper Path.	-	-	Y	Y	Y
[E030] Power-ON jam	Paper Misfeed in Printer - Please Clear Paper Path.	-	-	Y	Y	Y
[E061] Incorrect paper size setting for the 1st drawer jam	Paper Misfeed in Printer - Please Clear Paper Path.	-	-	Y	Y	Y
[E062] Incorrect paper size setting for the 2nd drawer jam	Paper Misfeed in Printer - Please Clear Paper Path.	-	-	Y	Y	Y
[E063] Incorrect paper size setting for the 3rd drawer jam	Paper Misfeed in Printer - Please Clear Paper Path.	-	-	Y	Y	Y
[E064] Incorrect paper size setting for the 4th drawer jam	Paper Misfeed in Printer - Please Clear Paper Path.	-	-	Y	Y	Y
[E065] Incorrect paper size setting for the bypass tray jam	Paper Misfeed in Printer - Please Clear Paper Path.	-	-	Y	Y	Y
[E090] Image data delay jam	Paper Misfeed in Printer - Please Clear Paper Path.	-	-	Y	Y	Y
[E0A0] Image transport ready time-out jam	Paper Misfeed in Printer - Please Clear Paper Path.	-	-	Y	Y	Y
[E110] ADU paper misfeed jam	Paper Insertion Misfeed - Please Clear Paper Path.	-	-	Y	Y	Y
[E120] Bypass tray paper misfeed jam	Paper Insertion Misfeed - Please Clear Paper Path.	-	-	Y	Y	Y
[E130] 1st drawer paper misfeed jam	Paper Insertion Misfeed - Please Clear Paper Path.	-	-	Y	Y	Y
[E140] 2nd drawer paper misfeed jam	Paper Insertion Misfeed - Please Clear Paper Path.	-	-	Y	Y	Y
[E150] 3rd drawer paper misfeed jam	Paper Insertion Misfeed - Please Clear Paper Path.	-	-	Y	Y	Y
[E160] 4th drawer paper misfeed jam	Paper Insertion Misfeed - Please Clear Paper Path.	-	-	Y	Y	Y
[E180] Ex-LCF paper misfeed jam	Paper Insertion Misfeed - Please Clear Paper Path.	-	-	Y	Y	Y
[E190] T-LCF paper misfeed jam	Paper Insertion Misfeed - Please Clear Paper Path.	-	-	Y	Y	Y
[E200] 1st drawer paper transport jam	Paper Misfeed in Printer - Please Clear Paper Path.	-	-	Y	Y	Y

Code	Message	Error code display media				
		Panl	JL	ML	Noti	CSV
[E210] 2nd drawer paper transport jam	Paper Misfeed in Printer - Please Clear Paper Path.	-	-	Y	Y	Y
[E220] 2nd drawer paper transport jam	Paper Misfeed in Printer - Please Clear Paper Path.	-	-	Y	Y	Y
[E260] Ex-LCF paper transport jam	Paper Misfeed in Printer - Please Clear Paper Path.	-	-	Y	Y	Y
[E270] Bypass tray paper transport jam	Paper Insertion Misfeed - Please Clear Paper Path.	-	-	Y	Y	Y
[E2C0] Ex-LCF paper transport jam	Paper Misfeed in Printer - Please Clear Paper Path.	-	-	Y	Y	Y
[E2D0] Ex-LCF paper transport jam	Paper Misfeed in Printer - Please Clear Paper Path.	-	-	Y	Y	Y
[E300] 3rd drawer paper transport jam	Paper Misfeed in Printer - Please Clear Paper Path.	-	-	Y	Y	Y
[E310] 3rd drawer paper transport jam	Paper Misfeed in Printer - Please Clear Paper Path.	-	-	Y	Y	Y
[E320] 3rd drawer paper transport jam	Paper Misfeed in Printer - Please Clear Paper Path.	-	-	Y	Y	Y
[E330] 4th drawer paper transport jam	Paper Misfeed in Printer - Please Clear Paper Path.	-	-	Y	Y	Y
[E340] 4th drawer paper transport jam	Paper Misfeed in Printer - Please Clear Paper Path.	-	-	Y	Y	Y
[E350] 4th drawer paper transport jam	Paper Misfeed in Printer - Please Clear Paper Path.	-	-	Y	Y	Y
[E360] 4th drawer paper transport jam	Paper Misfeed in Printer - Please Clear Paper Path.	-	-	Y	Y	Y
[E3C0] T-LCF paper transport jam	Paper Misfeed in Printer - Please Clear Paper Path.	-	-	Y	Y	Y
[E3D0] T-LCF paper transport jam	Paper Misfeed in Printer - Please Clear Paper Path.	-	-	Y	Y	Y
[E3E0] T-LCF paper transport jam	Paper Misfeed in Printer - Please Clear Paper Path.	-	-	Y	Y	Y
[E410] Front cover open jam	Paper Misfeed in Printer - Please Clear Paper Path.	-	-	Y	Y	Y
[E420] PFP side cover open jam	Paper Misfeed in Printer - Please Clear Paper Path.	-	-	Y	Y	Y
[E430] ADU open jam	Paper Misfeed in Printer - Please Clear Paper Path.	-	-	Y	Y	Y
[E440] Jam access cover open jam	Paper Misfeed in Printer - Please Clear Paper Path.	-	-	Y	Y	Y
[E450] T-LCF jam access cover open jam	Paper Misfeed in Printer - Please Clear Paper Path.	-	-	Y	Y	Y
[E480] Bridge kit open jam	Paper Misfeed in Printer - Please Clear Paper Path.	-	-	Y	Y	Y
[E490] Job separator open jam	Paper Misfeed in Printer - Please Clear Paper Path.	Y	-	Y	Y	Y
[E510] Paper not reaching the ADU jam	Paper Misfeed in Automatic Duplexing Unit - Please Clear Paper Path.	-	-	Y	Y	Y
[E520] Paper stopping in the ADU jam	Paper Misfeed in Automatic Duplexing Unit - Please Clear Paper Path.	-	-	Y	Y	Y
[E550] Paper remaining jam on the transport path	Paper Misfeed in Printer - Please Clear Paper Path.	-	-	Y	Y	Y
[E551] Paper remaining jam on the transport path (after a service call has occurred)	[Error] Paper Misfeed in the engine. Please clear paper path	-	-	Y	Y	Y

Code	Message	Error code display media				
		Panl	JL	ML	Noti	CSV
[E552] Paper remaining jam on the transport path (when the cover is closed)	[Error] Paper Misfeed in the engine. Please clear paper path	-	-	Y	Y	Y
[E570] Paper not reaching the reverse sensor jam	Paper Misfeed in Printer - Please Clear Paper Path.	-	-	Y	Y	Y
[E580] Paper stopping at the reverse sensor jam	Paper Misfeed in Printer - Please Clear Paper Path.	-	-	Y	Y	Y
[E701] Original picking up error	The original could not be transported properly. Check the condition of the original and set it again.	-	-	Y	Y	Y
[E702] Original picking up error	The original could not be transported properly. Check the condition of the original and set it again.	-	-	Y	Y	Y
[E703] DSDF multiple feeding jam	Paper Misfeed in Automatic Document Feeder - Please Clear Paper Path.	-	-	Y	-	Y
[E712] Original not reaching the DSDF registration sensor jam	Paper Misfeed in Automatic Document Feeder - Please Clear Paper Path.	-	-	Y	-	Y
[E712] Original not reaching the RADF original registration sensor jam		-	-	Y	-	Y
[E714] Paper feed signal reception jam in DSDF	Paper Misfeed in Automatic Document Feeder - Please Clear Paper Path.	-	-	Y	-	Y
[E714] Paper feed signal reception jam in RADF		-	-	Y	-	Y
[E717] Original not reaching the DSDF original feed sensor jam	Paper Misfeed in Automatic Document Feeder - Please Clear Paper Path.	-	-	Y	-	Y
[E718] Original setting jam, original tray lift abnormality	Paper Misfeed in Automatic Document Feeder - Please Clear Paper Path.	-	-	Y	-	Y
[E721] Original not reaching the DSDF read-in sensor-1 jam	Paper Misfeed in Automatic Document Feeder - Please Clear Paper Path.	-	-	Y	-	Y
[E721] Original not reaching the RADF read sensor jam		-	-	Y	-	Y
[E722] Original not reaching the DSDF original exit sensor jam	Paper Misfeed in Automatic Document Feeder - Please Clear Paper Path.	-	-	Y	-	Y
[E722] Original not reaching the RADF original exit/reverse sensor jam (during scanning)		-	-	Y	-	Y
[E724] Original stopping at the DSDF registration sensor jam	Paper Misfeed in Automatic Document Feeder - Please Clear Paper Path.	-	-	Y	-	Y
[E724] Original stopping at the RADF registration sensor jam		-	-	Y	-	Y
[E725] Original stopping at the DSDF read-in sensor-1 jam	Paper Misfeed in Automatic Document Feeder - Please Clear Paper Path.	-	-	Y	-	Y
[E725] Original stopping at the RADF read sensor jam		-	-	Y	-	Y
[E726] DSDF transport or paper exit signal reception jam	Paper Misfeed in Automatic Document Feeder - Please Clear Paper Path.	-	-	Y	-	Y
[E726] RADF transport or paper exit signal reception jam		-	-	Y	-	Y
[E727] Original not reaching the DSDF read-in sensor-2 jam	Paper Misfeed in Automatic Document Feeder - Please Clear Paper Path.	-	-	Y	-	Y
[E729] Original stopping at the DSDF read-in sensor-2 jam	Paper Misfeed in Automatic Document Feeder - Please Clear Paper Path.	-	-	Y	-	Y

Code	Message	Error code display media				
		Panl	JL	ML	Noti	CSV
[E731] Original stopping at the DSDF original exit sensor jam	Paper Misfeed in Automatic Document Feeder - Please Clear Paper Path.	-	-	Y	-	Y
[E731] Original stopping at the RADF original exit/reverse sensor jam		-	-	Y	-	Y
[E747] Original not reaching the RADF read sensor jam (at the reversal operation)	Paper Misfeed in Automatic Document Feeder - Please Clear Paper Path.	-	-	Y	-	Y
[E748] Original not reaching the RADF read sensor jam	Paper Misfeed in Automatic Document Feeder - Please Clear Paper Path.	-	-	Y	-	Y
[E762] Original remaining at the DSDF registration sensor jam	Paper Misfeed in Automatic Document Feeder - Please Clear Paper Path.	-	-	Y	-	Y
[E762] Original remaining at the RADF original registration sensor jam		-	-	Y	-	Y
[E769] Original remaining at the DSDF original feed sensor jam	Paper Misfeed in Automatic Document Feeder - Please Clear Paper Path.	-	-	Y	-	Y
[E769] Original remaining at the RADF original length detection sensor jam		-	-	Y	-	Y
[E770] Original remaining at the DSDF original width detection sensor-1 jam	Paper Misfeed in Automatic Document Feeder - Please Clear Paper Path.	-	-	Y	-	Y
[E770] Original remaining at the RADF original width detection sensor-1 jam		-	-	Y	-	Y
[E771] Original remaining at the DSDF original width detection sensor-2 jam	Paper Misfeed in Automatic Document Feeder - Please Clear Paper Path.	-	-	Y	-	Y
[E771] Original remaining at the RADF original width detection sensor-2 jam		-	-	Y	-	Y
[E774] Original remaining at the DSDF read-in sensor-1 jam	Paper Misfeed in Automatic Document Feeder - Please Clear Paper Path.	-	-	Y	-	Y
[E775] Original remaining at the DSDF read-in sensor-2 jam	Paper Misfeed in Automatic Document Feeder - Please Clear Paper Path.	-	-	Y	-	Y
[E777] Original remaining at the DSDF original exit sensor jam	Paper Misfeed in Automatic Document Feeder - Please Clear Paper Path.	-	-	Y	-	Y
[E777] Original remaining at the RADF original exit/reverse sensor jam		-	-	Y	-	Y
[E860] DSDF original jam access cover open jam, DSDF shading sheet HP sensor abnormality	Paper Misfeed in Automatic Document Feeder - Please Clear Paper Path.	-	-	Y	-	Y
[E860] RADF jam access cover open jam		-	-	Y	-	Y
[E870] DSDF open jam	Paper Misfeed in Automatic Document Feeder - Please Clear Paper Path.	-	-	Y	-	Y
[E870] RADF open jam		-	-	Y	-	Y
[E910] Paper not reaching the bridge kit transport sensor-1 jam	Paper Misfeed in Printer - Please Clear Paper Path.	Y	-	Y	Y	Y
[E920] Paper stopping at the bridge kit transport sensor-1 jam	Paper Misfeed in Printer - Please Clear Paper Path.	Y	-	Y	Y	Y
[E930] Paper not reaching the bridge kit transport sensor-2 jam	Paper Misfeed in Printer - Please Clear Paper Path.	Y	-	Y	Y	Y
[E940] Paper stopping at the bridge kit transport sensor-2 jam	Paper Misfeed in Printer - Please Clear Paper Path.	Y	-	Y	Y	Y
[E950] Paper not reaching the job separator transport sensor jam	Paper Misfeed in Printer - Please Clear Paper Path.	Y	-	Y	Y	Y
[E951] Paper stopping at the job separator transport sensor jam	Paper Misfeed in Printer - Please Clear Paper Path.	Y	-	Y	Y	Y
[E9F0] Punching jam (Inner Finisher)	Hole Punch Unit Misfeed in Finisher - Please Clear Hole Punch.	Y	-	Y	Y	Y

Code	Message	Error code display media				
		Panl	JL	ML	Noti	CSV
[E9F0] Punching jam (Finisher, Saddle Stitch Finisher)	Hole Punch Unit Misfeed in Finisher - Please Clear Hole Punch.	Y	-	Y	Y	Y
[EA10] Paper transport delay jam (Inner Finisher)	Paper Misfeed in Finisher - Please Clear Paper Path.	Y	-	Y	Y	Y
[EA10] Paper transport delay jam (Finisher, Saddle Stitch Finisher)		Y	-	Y	Y	Y
[EA20] Paper transport stop jam (Inner Finisher)	Paper Misfeed in Finisher - Please Clear Paper Path.	Y	-	Y	Y	Y
[EA20] Paper transport stop jam (Finisher, Saddle Stitch Finisher)		Y	-	Y	Y	Y
[EA21] Paper size error jam (Transport sensor) (Finisher, Saddle Stitch Finisher)	Paper Misfeed in Finisher - Please Clear Paper Path.	Y	-	Y	Y	Y
[EA22] Paper size error jam (Paper position sensor) (Finisher, Saddle Stitch Finisher)	Paper Misfeed in Finisher - Please Clear Paper Path.	-	-	Y	Y	Y
[EA23] Paper transport stop jam (Finisher, Saddle Stitch Finisher)	Paper Misfeed in Finisher - Please Clear Paper Path.	-	-	Y	Y	Y
[EA24] Paper transport delay jam (Finisher, Saddle Stitch Finisher)	Paper Misfeed in Finisher - Please Clear Paper Path.	-	-	Y	Y	Y
[EA25] Paper transport delay jam after the paper stack has exited (Inner Finisher)	Paper Misfeed in Finisher - Please Clear Paper Path.	-	-	Y	Y	Y
[EA25] Paper transport delay jam after the paper stack has exited (Finisher, Saddle Stitch Finisher)		-	-	Y	Y	Y
[EA26] Paper transport stop jam due to a stop signal from the MFP (Inner Finisher)	Paper Misfeed in Finisher - Please Clear Paper Path.	-	-	Y	Y	Y
[EA26] Paper transport stop jam due to a stop signal from the MFP (Finisher, Saddle Stitch Finisher)		-	-	Y	Y	Y
[EA27] Paper transport stop jam (Finisher, Saddle Stitch Finisher)	Paper Misfeed in Finisher - Please Clear Paper Path.	-	-	Y	Y	Y
[EA28] Paper transport stop jam due to an assist guide plate operation delay (Finisher, Saddle Stitch Finisher)	Paper Misfeed in Finisher - Please Clear Paper Path.	-	-	Y	Y	Y
[EA29] Paper transport stop jam due to a stack transport operation delay (Finisher, Saddle Stitch Finisher)	Paper Misfeed in Finisher - Please Clear Paper Path.	-	-	Y	Y	Y
[EA2A] Paper transport jam between the entrance path and the middle path sensors (Inner Finisher)	Paper Misfeed in Finisher - Please Clear Paper Path.	-	-	Y	Y	Y
[EA2B] Paper transport jam at the middle path sensor (Inner Finisher)	Paper Misfeed in Finisher - Please Clear Paper Path.	-	-	Y	Y	Y
[EA2C] Paper transport jam between the entrance path and the sub-path sensors (Inner Finisher)	Paper Misfeed in Finisher - Please Clear Paper Path.	-	-	Y	Y	Y
[EA2D] Paper transport jam at the sub-path sensor (Inner Finisher)	Paper Misfeed in Finisher - Please Clear Paper Path.	-	-	Y	Y	Y
[EA2E] Paper transport jam at the sub-path sensor (Inner Finisher)	Paper Misfeed in Finisher - Please Clear Paper Path.	-	-	Y	Y	Y
[EA31] Paper transport jam at the sub-path sensor (Inner Finisher)	Paper Misfeed in Finisher - Please Clear Paper Path.	Y	-	Y	Y	Y
[EA31] Transport path paper remaining jam (Finisher, Saddle Stitch Finisher)		Y	-	Y	Y	Y
[EA32] Exit paper remaining jam (Inner Finisher)	Paper Misfeed in Finisher - Please Clear Paper Path.	Y	-	Y	Y	Y
[EA32] Exit paper remaining jam (Finisher, Saddle Stitch Finisher)		Y	-	Y	Y	Y

Code	Message	Error code display media				
		Panl	JL	ML	Noti	CSV
[EA40] Cover open jam (Inner Finisher)	Paper Misfeed in Finisher - Please Clear Paper Path.	Y	-	Y	Y	Y
[EA40] Stationary tray open jam (Finisher, Saddle Stitch Finisher)		Y	-	Y	Y	Y
[EA41] Front top cover open jam (Finisher, Saddle Stitch Finisher)	Paper Misfeed in Finisher - Please Clear Paper Path.	Y	-	Y	Y	Y
[EA42] Hole punch: front cover open jam (Finisher, Saddle Stitch Finisher)	Paper Misfeed in Finisher - Please Clear Paper Path.	Y	-	Y	Y	Y
[EA50] Stapling jam (Inner Finisher)	Staple Jam in Finisher - Please Clear Staple.	Y	-	Y	Y	Y
[EA50] Stapling jam (Finisher, Saddle Stitch Finisher)		Y	-	Y	Y	Y
[EA60] Early arrival jam (Inner Finisher)	Paper Misfeed in Finisher - Please Clear Paper Path.	Y	-	Y	Y	Y
[EA60] Paper early arrival jam (Finisher, Saddle Stitch Finisher)		Y	-	Y	Y	Y
[EA70] Stack exit belt home position error (Finisher, Saddle Stitch Finisher)	Paper Misfeed in Finisher - Please Clear Paper Path.	Y	-	Y	Y	Y
[EA90] Cover open jam (Saddle Stitch Finisher)	Paper Misfeed in Finisher - Please Clear Paper Path.	Y	-	Y	Y	Y
[EAA0] Paper remaining jam in the saddle stitch unit (Saddle Stitch Finisher)	Paper Misfeed in Finisher - Please Clear Paper Path.	Y	-	Y	Y	Y
[EAB0] Paper transport jam in the saddle stitch unit (Saddle Stitch Finisher)	Paper Misfeed in Finisher - Please Clear Paper Path.	Y	-	Y	Y	Y
[EAB1] Paper size error jam (Saddle Stitch Finisher)	Paper Misfeed in Finisher - Please Clear Paper Path.	Y	-	Y	Y	Y
[EAD0] Print end command time-out error	Paper Misfeed in Printer - Please Clear Paper Path.	-	-	Y	Y	Y
[EAE0] Finisher receiving time-out jam	Paper Misfeed in Printer - Please Clear Paper Path.	-	-	Y	Y	Y
[EAE1] Finisher receiving time-out jam (1)	Paper Misfeed in Printer - Please Clear Paper Path.	-	-	Y	Y	Y
[EAE2] Finisher receiving time-out jam (2)	Paper Misfeed in Printer - Please Clear Paper Path.	-	-	Y	Y	Y
[EAE3] Finisher receiving time-out jam (3)	Paper Misfeed in Printer - Please Clear Paper Path.	-	-	Y	Y	Y
[EAE4] Finisher receiving time-out jam (4)	Paper Misfeed in Printer - Please Clear Paper Path.	-	-	Y	Y	Y
[EAE5] Finisher receiving time-out jam (5)	Paper Misfeed in Printer - Please Clear Paper Path.	-	-	Y	Y	Y
[EAE6] Finisher receiving time-out jam (6)	Paper Misfeed in Printer - Please Clear Paper Path.	-	-	Y	Y	Y
[EAE7] Finisher receiving time-out jam (7)	Paper Misfeed in Printer - Please Clear Paper Path.	-	-	Y	Y	Y
[EAE8] Finisher receiving time-out jam (8)	Paper Misfeed in Printer - Please Clear Paper Path.	-	-	Y	Y	Y
[EAE9] Finisher receiving time-out jam (9)	Paper Misfeed in Printer - Please Clear Paper Path.	-	-	Y	Y	Y
[EAEA] Finisher receiving time-out jam (10)	Paper Misfeed in Printer - Please Clear Paper Path.	-	-	Y	Y	Y
[EAEB] Finisher receiving time-out jam (11)	Paper Misfeed in Printer - Please Clear Paper Path.	-	-	Y	Y	Y
[EAEC] Finisher receiving time-out jam (12)	Paper Misfeed in Printer - Please Clear Paper Path.	-	-	Y	Y	Y
[EAED] Finisher receiving time-out jam (13)	Paper Misfeed in Printer - Please Clear Paper Path.	-	-	Y	Y	Y
[EAEF] Finisher receiving time-out jam (15)	Paper Misfeed in Printer - Please Clear Paper Path.	-	-	Y	Y	Y

Code	Message	Error code display media				
		Panl	JL	ML	Noti	CSV
[EAF1] Stack exit roller home position sensor detection abnormality (Inner Finisher)	Paper Misfeed in Finisher - Please Clear Paper Path.	Y	-	Y	Y	Y
[EAF2] Stapler unit sliding home position sensor detection abnormality (Inner Finisher)	Paper Misfeed in Finisher - Please Clear Paper Path.	Y	-	Y	Y	Y
[EAFA] Catching motor home position sensor detection abnormality	Paper Misfeed in Finisher - Please Clear Paper Path.	Y	-	Y	Y	Y
[EAFB] Stapler movement abnormality (Finisher, Saddle Stitch Finisher)	Paper Misfeed in Finisher - Please Clear Paper Path.	Y	-	Y	Y	Y
[EAFC] Movable tray height abnormality (Finisher, Saddle Stitch Finisher)	Paper Misfeed in Finisher - Please Clear Paper Path.	Y	-	Y	Y	Y
[EAFD] Movable tray movement abnormality (Finisher, Saddle Stitch Finisher)	Paper Misfeed in Finisher - Please Clear Paper Path.	Y	-	Y	Y	Y
[EAFE] Assist guide cam position abnormality (Finisher, Saddle Stitch Finisher)	Paper Misfeed in Finisher - Please Clear Paper Path.	Y	-	Y	Y	Y
[EB30] Ready time-out jam	Paper Misfeed in Printer - Please Clear Paper Path.	-	-	Y	Y	Y
[EB50] Paper remaining on the transport path jam due to multiple feeding	Paper Misfeed in Printer - Please Clear Paper Path.	-	-	Y	Y	Y
[EB60] Paper remaining on the transport path jam due to multiple feeding	Paper Misfeed in Printer - Please Clear Paper Path.	-	-	Y	Y	Y
[ED10] Hole punch: Skew adjustment motor home position detection abnormality (Finisher, Saddle Stitch Finisher)	Paper Misfeed in Finisher - Please Clear Paper Path.	Y	-	Y	Y	Y
[ED11] Hole punch: Sideways deviation adjustment motor home position detection abnormality (Finisher, Saddle Stitch Finisher)	Paper Misfeed in Finisher - Please Clear Paper Path.	Y	-	Y	Y	Y
[ED13] Front alignment plate home position abnormality (Finisher, Saddle Stitch Finisher)	Paper Misfeed in Finisher - Please Clear Paper Path.	Y	-	Y	Y	Y
[ED14] Rear alignment plate home position abnormality (Finisher, Saddle Stitch Finisher)	Paper Misfeed in Finisher - Please Clear Paper Path.	Y	-	Y	Y	Y
[ED15] Paddle home position abnormality (Finisher, Saddle Stitch Finisher)	Paper Misfeed in Finisher - Please Clear Paper Path.	Y	-	Y	Y	Y
[ED16] Buffer tray home position abnormality (Finisher, Saddle Stitch Finisher)	Paper Misfeed in Finisher - Please Clear Paper Path.	Y	-	Y	Y	Y
[EF10] Saddle stitch setting of unsupported paper (Saddle Stitch Finisher)	Paper Misfeed in Finisher - Please Clear Paper Path.	Y	-	Y	Y	Y
[EF11] Front saddle stitch stapling jam (Saddle Stitch Finisher)	Paper Misfeed in Finisher - Please Clear Paper Path.	Y	-	Y	Y	Y
[EF12] Rear saddle stitch stapling jam (Saddle Stitch Finisher)	Paper Misfeed in Finisher - Please Clear Paper Path.	Y	-	Y	Y	Y
[EF13] Saddle stitch paper holding home position abnormality (Saddle Stitch Finisher)	Paper Misfeed in Finisher - Please Clear Paper Path.	Y	-	Y	Y	Y
[EF14] Saddle stitch paper ejection jam (Saddle Stitch Finisher)	Paper Misfeed in Finisher - Please Clear Paper Path.	Y	-	Y	Y	Y
[EF15] Saddle stitch side alignment plate home position sensor abnormality (Saddle Stitch Finisher)	Paper Misfeed in Finisher - Please Clear Paper Path.	Y	-	Y	Y	Y
[EF16] Saddle stitch stacker motor home position abnormality (Saddle Stitch Finisher)	Paper Misfeed in Finisher - Please Clear Paper Path.	Y	-	Y	Y	Y



Code	Message	Error code display media				
		Panl	JL	ML	Noti	CSV
[EF17] Saddle stitch folding blade home position abnormality (Saddle Stitch Finisher)	Paper Misfeed in Finisher - Please Clear Paper Path.	Y	-	Y	Y	Y
[EF18] Saddle stitch additional folding roller home position abnormality (Saddle Stitch Finisher)	Paper Misfeed in Finisher - Please Clear Paper Path.	Y	-	Y	Y	Y
[EF19] Saddle stitch paper folding jam (Saddle Stitch Finisher)	Paper Misfeed in Finisher - Please Clear Paper Path.	Y	-	Y	Y	Y
[EF20] Saddle stitch stacker jam (Saddle Stitch Finisher)	Paper Misfeed in Finisher - Please Clear Paper Path.	-	-	Y	Y	Y
[EF21] Hole punch: Paper leading edge skew detection abnormality (Finisher, Saddle Stitch Finisher)	Paper Misfeed in Finisher - Please Clear Paper Path.	-	-	Y	Y	Y
[EF22] Hole punch: Paper leading edge detection abnormality (Finisher, Saddle Stitch Finisher)	Paper Misfeed in Finisher - Please Clear Paper Path.	-	-	Y	Y	Y
[EF23] Hole punch: Paper position alignment abnormality (Finisher, Saddle Stitch Finisher)	Paper Misfeed in Finisher - Please Clear Paper Path.	-	-	Y	Y	Y
[EF24] Hole punch: Paper trailing edge skew detection abnormality (Finisher, Saddle Stitch Finisher)	Paper Misfeed in Finisher - Please Clear Paper Path.	-	-	Y	Y	Y
[EF25] Hole punch: Paper trailing edge detection abnormality (Finisher, Saddle Stitch Finisher)	Paper Misfeed in Finisher - Please Clear Paper Path.	-	-	Y	Y	Y
[EF27] Hole punch: Paper edge detection abnormality 1 (Finisher, Saddle Stitch Finisher)	Paper Misfeed in Finisher - Please Clear Paper Path.	-	-	Y	Y	Y
[EF28] Hole punch: Paper edge detection abnormality 2 (Finisher, Saddle Stitch Finisher)	Paper Misfeed in Finisher - Please Clear Paper Path.	-	-	Y	Y	Y
[EF29] Hole punch: Required performance abnormality (Finisher, Saddle Stitch Finisher)	Paper Misfeed in Finisher - Please Clear Paper Path.	-	-	Y	Y	Y

## 8.2.2 Service call

Code	Message	Error code display media				
		Panl	JL	ML	Noti	CSV
[C010] Main motor abnormality	Main Motor Error - Please Contact Service Technician.	2nd	-	Y	Y	Y
[C040] PFP motor abnormality	Printer Input Error.	Y	-	Y	Y	Y
[C130] 1st drawer tray abnormality	Printer Input Error.	Y	-	Y	Y	Y
[C140] 2nd drawer tray abnormality	Printer Input Error.	Y	-	Y	Y	Y
[C150] 3rd drawer tray abnormality	Printer Input Error.	Y	-	Y	Y	Y
[C160] 4th drawer tray abnormality	Printer Input Error.	Y	-	Y	Y	Y
[C180] T-LCF tray abnormality	Printer Input Error.	Y	-	Y	Y	Y
[C1A0] T-LCF end fence abnormality	Printer Input Error.	Y	-	Y	Y	Y
[C1B0] T-LCF transport motor abnormality	Printer Input Error.	Y	-	Y	Y	Y
[C1C0] Ex-LCF tray motor abnormality (2.0K Ex-LCF)	Printer Input Error.	Y	-	Y	Y	Y
[C1F0] Ex-LCF transport motor abnormality (2.0K Ex-LCF)	Printer Input Error.	Y	-	Y	Y	Y
[C252] EEPROM communication error	Fatal Error - Please Contact Service Technician.	2nd	-	Y	Y	Y
[C253] EEPROM reading error	Fatal Error - Please Contact Service Technician.	2nd	-	Y	Y	Y
[C254] ASIC communication error	Fatal Error - Please Contact Service Technician.	2nd	-	Y	Y	Y
[C260] Peak detection error	Fatal Error - Please Contact Service Technician.	2nd	-	Y	Y	Y
[C262] Communication error	Fatal Error - Please Contact Service Technician.	2nd	-	Y	Y	Y
[C270] Carriage home position sensor not turning OFF within a specified period of time, Downloading firmware with an incorrect model	Fatal Error - Please Contact Service Technician.	Y	-	Y	Y	Y
[C280] Carriage home position sensor not turned ON within a specified period of time	Fatal Error - Please Contact Service Technician.	Y	-	Y	Y	Y
[C290] Scanner fuse blowout	Fatal Error - Please Contact Service Technician.	2nd	-	Y	Y	Y
[C3D0] EPU memory writing abnormality	Fatal Error - Please Contact Service Technician.	2nd	-	Y	Y	Y
[C3D1] EPU memory new detection abnormality	Fatal Error - Please Contact Service Technician.	2nd	-	Y	Y	Y
[C3D2] EPU memory old detection abnormality	Fatal Error - Please Contact Service Technician.	2nd	-	Y	Y	Y
[C411] Thermistor or heater abnormality at power-ON	Fatal Error - Please Contact Service Technician.	Y	-	Y	Y	Y
[C412] Thermistor or heater abnormality at power-ON	Fatal Error - Please Contact Service Technician.	Y	-	Y	Y	Y
[C443] Fusing temperature abnormality (low temperature WAIT control abnormality at printing status)	Fatal Error - Please Contact Service Technician.	Y	-	Y	Y	Y
[C445] Fusing temperature abnormality (pre-running end temperature abnormality)	Fatal Error - Please Contact Service Technician.	Y	-	Y	Y	Y
[C447] Fusing temperature abnormality (temperature abnormality at ready status and during printing)	Fatal Error - Please Contact Service Technician.	Y	-	Y	Y	Y
[C449] Fusing temperature abnormality (high temperature abnormality)	Fatal Error - Please Contact Service Technician.	Y	-	Y	Y	Y
[C450] Heater abnormality	Fatal Error - Please Contact Service Technician.	Y	-	Y	Y	Y

Code	Message	Error code display media				
		Panl	JL	ML	Noti	CSV
[C452] Heater lamp abnormality	Fatal Error - Please Contact Service Technician.	Y	-	Y	Y	Y
[C4B0] Status counter abnormality	Fatal Error - Please Contact Service Technician.	Y	-	Y	Y	Y
[C4C0] Fuser unit old-new detection fuse abnormality	Fatal Error - Please Contact Service Technician.	2nd	-	Y	Y	Y
[C550] Communication error between the scanner and the DF	Fatal Error - Please Contact Service Technician.	5th	-	Y	Y	Y
[C550] Communication error between the scanner and the DF						
[C551] DF model detection abnormality	Fatal Error - Please Contact Service Technician.	Y	-	Y	Y	Y
[C552] DF abnormality	Fatal Error - Please Contact Service Technician.	5th	-	Y	Y	Y
[C553] DSDf-CCD module peak detection abnormality	Fatal Error - Please Contact Service Technician.	5th	-	Y	Y	Y
[C554] AFE communication error	Fatal Error - Please Contact Service Technician.	5th	-	Y	Y	Y
[C558] EERPOM communication error (back side)	Fatal Error - Please Contact Service Technician.	5th	-	Y	Y	Y
[C559] ASIC communication error (back side)	Fatal Error - Please Contact Service Technician.	5th	-	Y	Y	Y
[C55A] Multiple feeding detection sensor connection abnormality	Fatal Error - Please Contact Service Technician.	5th	-	Y	Y	Y
[C55B] Multiple feeding detection sensor abnormality	Fatal Error - Please Contact Service Technician.	5th	-	Y	Y	Y
[C580] Communication error between the LGC board and the Finisher	Printer Output Error.	5th	-	Y	Y	Y
[C5A0] EEPROM communication abnormality (LGC board)	Fatal Error - Please Contact Service Technician.	Y	-	Y	Y	Y
[C5A1] EEPROM data abnormality (LGC board)	Fatal Error - Please Contact Service Technician.	Y	-	Y	Y	Y
[C5A8] Sub-EEPROM communication abnormality	Fatal Error - Please Contact Service Technician.	Y	-	Y	Y	Y
[C5A9] Sub-EEPROM data abnormality	Fatal Error - Please Contact Service Technician.	Y	-	Y	Y	Y
[C730] DSDf EEPROM writing abnormality	Automatic Document Feeder Error - Please Contact Service Technician.	2nd	-	Y	Y	Y
[C7B0] Initialization performance abnormality	Automatic Document Feeder Error - Please Contact Service Technician.	5th	-	Y	Y	Y
[C8C0] DSDf read-in sensor-1 automatic adjustment abnormality	Automatic Document Feeder Error - Please Contact Service Technician.	2nd	-	Y	Y	Y
[C8E0] DF communication protocol abnormality	Automatic Document Feeder Error - Please Contact Service Technician.	5th	-	Y	Y	Y
[C911] CTIF board access abnormality (K)	Failed to access to the toner IC chip.	-	-	Y	Y	Y
[C916] Sub-CPU abnormality	Fatal Error - Please Contact Service Technician.	2nd	-	Y	Y	Y
[C940] Engine-CPU abnormality	Fatal Error - Please Contact Service Technician.	2nd	-	Y	Y	Y
[C970] High-voltage transformer leakage abnormality	Fatal Error - Please Contact Service Technician.	2nd	-	Y	Y	Y

Code	Message	Error code display media				
		Panl	JL	ML	Noti	CSV
[CA10] Polygonal motor abnormality	Fatal Error - Please Contact Service Technician.	2nd	-	Y	Y	Y
[CA20] H-Sync detection error	Fatal Error - Please Contact Service Technician.	2nd	-	Y	Y	Y
[CB00] Finisher communication error (Inner Finisher, Finisher, Saddle Stitch Finisher)	Fatal Error - Please Contact Service Technician.	5th	-	Y	Y	Y
[CB10] Entrance motor abnormality (Finisher, Saddle Stitch Finisher)	Printer Output Error.	2nd	-	Y	Y	Y
[CB11] Buffer tray guide motor abnormality (Finisher, Saddle Stitch Finisher)	Fatal Error - Please Contact Service Technician.	5th	-	Y	Y	Y
[CB14] Assist guide cam position abnormality (Finisher, Saddle Stitch Finisher)	Fatal Error - Please Contact Service Technician.	2nd	-	Y	Y	Y
[CB15] Catching motor abnormality (Finisher, Saddle Stitch Finisher)	Fatal Error - Please Contact Service Technician.	5th	-	Y	Y	Y
[CB30] Movable tray shift motor abnormality (Inner Finisher)	Printer Output Error.	2nd	-	Y	Y	Y
[CB30] Movable tray shift motor abnormality (Finisher, Saddle Stitch Finisher)						
[CB31] Movable tray movement abnormality (Finisher, Saddle Stitch Finisher)	Fatal Error - Please Contact Service Technician.	2nd	-	Y	Y	Y
[CB40] Rear alignment plate home position sensor detection abnormality (Inner Finisher)	Printer Output Error.	5th	-	Y	Y	Y
[CB40] Front alignment motor abnormality (Finisher, Saddle Stitch Finisher)						
[CB50] Stapler home position abnormality (Inner Finisher)	Printer Output Error.	5th	-	Y	Y	Y
[CB50] Stapler home position abnormality (Finisher, Saddle Stitch Finisher)						
[CB51] Stapler movement home position abnormality (Inner Finisher)	Fatal Error - Please Contact Service Technician.	2nd	-	Y	Y	Y
[CB51] Stapler movement home position abnormality (Finisher, Saddle Stitch Finisher)						
[CB60] Stapler unit shift motor abnormality (Finisher, Saddle Stitch Finisher)	Printer Output Error.	5th	-	Y	Y	Y
[CB80] Finisher backup RAM data abnormality (Inner Finisher)	Printer Output Error.	2nd	-	Y	Y	Y
[CB80] Finisher backup RAM data abnormality (Finisher, Saddle Stitch Finisher)						
[CB81] Finisher Flash ROM data abnormality (Finisher, Saddle Stitch Finisher)	Fatal Error - Please Contact Service Technician.	2nd	-	Y	Y	Y
[CB82] Finisher main program error (Finisher, Saddle Stitch Finisher)	Fatal Error - Please Contact Service Technician.	2nd	-	Y	Y	Y
[CB84] Hole punch: Punch main program error (Finisher, Saddle Stitch Finisher)	Fatal Error - Please Contact Service Technician.	2nd	-	Y	Y	Y
[CB93] Saddle additional folding motor abnormality (Saddle Stitch Finisher)	Fatal Error - Please Contact Service Technician.	2nd	-	Y	Y	Y

Code	Message	Error code display media				
		Panl	JL	ML	Noti	CSV
[CB94] Saddle transport motor abnormality (Saddle Stitch Finisher)	Fatal Error - Please Contact Service Technician.	5th	-	Y	Y	Y
[CB95] Stacker motor abnormality (Saddle Stitch Finisher)	Fatal Error - Please Contact Service Technician.	5th	-	Y	Y	Y
[CBA0] Front saddle stapler home position abnormality (Saddle Stitch Finisher)	Fatal Error - Please Contact Service Technician.	5th	-	Y	Y	Y
[CBB0] Rear saddle stapler home position abnormality (Saddle Stitch Finisher)	Fatal Error - Please Contact Service Technician.	5th	-	Y	Y	Y
[CBC0] Saddle stitch side alignment motor abnormality (Saddle Stitch Finisher)	Fatal Error - Please Contact Service Technician.	5th	-	Y	Y	Y
[CBE0] Saddle stitch folding motor abnormality (Saddle Stitch Finisher)	Fatal Error - Please Contact Service Technician.	5th	-	Y	Y	Y
[CC02] Stack exit roller nip releasing home position detection abnormality (Inner Finisher)	Fatal Error - Please Contact Service Technician.	2nd	-	Y	Y	Y
[CC20] Communication error between the finisher control PC board and the saddle control PC board	Fatal Error - Please Contact Service Technician.	2nd	-	Y	Y	Y
[CC30] Stack transport motor abnormality (Finisher, Saddle Stitch Finisher)	Fatal Error - Please Contact Service Technician.	5th	-	Y	Y	Y
[CC31] Transport motor abnormality (Finisher, Saddle Stitch Finisher)	Fatal Error - Please Contact Service Technician.	2nd	-	Y	Y	Y
[CC41] Assist guide cam home position abnormality (Finisher, Saddle Stitch Finisher)	Fatal Error - Please Contact Service Technician.	2nd	-	Y	Y	Y
[CC51] Punch sliding motor abnormality (Inner Finisher)	Fatal Error - Please Contact Service Technician.	2nd	-	Y	Y	Y
[CC51] Hole punch: Transport motor abnormality (Finisher, Saddle Stitch Finisher)						
[CC52] Hole punch: Skew adjustment motor abnormality (Finisher, Saddle Stitch Finisher)	Fatal Error - Please Contact Service Technician.	5th	-	Y	Y	Y
[CC54] Hole punch: Paper detection sensors (Inner Finisher)	Fatal Error - Please Contact Service Technician.	2nd	-	Y	Y	Y
[CC60] Hole punch: Punch motor abnormality (Inner Finisher)	Fatal Error - Please Contact Service Technician.	2nd	-	Y	Y	Y
[CC61] Hole punch: Punch motor home position abnormality (Inner Finisher)	Fatal Error - Please Contact Service Technician.	5th	-	Y	Y	Y
[CC61] Hole punch: Punch motor home position detection abnormality (Finisher, Saddle Stitch Finisher)						
[CC71] Hole punch: Punch ROM abnormality (Finisher, Saddle Stitch Finisher)	Fatal Error - Please Contact Service Technician.	Y	-	Y	Y	Y
[CC72] Hole punch: Punch RAM data abnormality (Finisher, Saddle Stitch Finisher)	Fatal Error - Please Contact Service Technician.	Y	-	Y	Y	Y
[CC73] Hole punch: Punch device power supply abnormality (Finisher, Saddle Stitch Finisher)	Fatal Error - Please Contact Service Technician.	Y	-	Y	Y	Y
[CC74] Hole punch: Punch transport pulse abnormality (Finisher, Saddle Stitch Finisher)	Fatal Error - Please Contact Service Technician.	Y	-	Y	Y	Y

Code	Message	Error code display media				
		Panl	JL	ML	Noti	CSV
[CC80] Front alignment plate home position sensor detection abnormality (Inner Finisher)	Fatal Error - Please Contact Service Technician.	2nd	-	Y	Y	Y
[CC80] Rear alignment motor abnormality (Finisher, Saddle Stitch Finisher)						
[CC93] Knurled roller shift solenoid abnormality (Inner Finisher)	Fatal Error - Please Contact Service Technician.	2nd	-	Y	Y	Y
[CC94] Fan motor abnormality (Inner Finisher)	Fatal Error - Please Contact Service Technician.	2nd	-	Y	Y	Y
[CDE0] Paddle motor abnormality (Finisher, Saddle Stitch Finisher)	Printer Output Error.	5th	-	Y	Y	Y
[CE00] Communication error between the finisher control PC board and the hole punch control PC board (Finisher, Saddle Stitch Finisher)	Fatal Error - Please Contact Service Technician.	5th	-	Y	Y	Y
[CE50] Temperature/humidity sensor abnormality	Fatal Error - Please Contact Service Technician.	2nd	-	Y	Y	Y
[CE90] Drum thermistor abnormality	Fatal Error - Please Contact Service Technician.	2nd	-	Y	Y	Y
[CF10] Communication module writing abnormality (Finisher, Saddle Stitch Finisher)	Printer Output Error.	2nd	-	Y	Y	Y
[F070] Communication error between the system-CPU and the engine-CPU	Fatal Error - Please Contact Service Technician.	5th	-	Y	Y	Y
[F071] Communication initialization error between the system-CPU and the engine-CPU	-	2nd	-	Y	Y	-
[F074] Communication error between the system-CPU and the engine-CPU	Fatal Error - Please Contact Service Technician.	2nd	-	Y	Y	-
[F090] SRAM error on the SYS board	Fatal Error - Please Contact Service Technician.	Y	-	Y	Y	-
[F100_0] Storage device initialization error	Fatal Error - Please Contact Service Technician.	Y	-	Y	Y	-
[F100_1] Storage device initialization error	Fatal Error - Please Contact Service Technician.	Y	-	Y	Y	-
[F100_2] Storage device initialization error	Fatal Error - Please Contact Service Technician.	Y	-	Y	Y	-
[F100_3] Serial number value error	Fatal Error - Please Contact Service Technician.	Y	-	Y	Y	-
[F100_4] Hash check error of encryption partition key	Fatal Error - Please Contact Service Technician.	Y	-	Y	Y	-
[F101_0] Optional storage device installation error	Fatal Error - Please Contact Service Technician.	Y	-	Y	Y	-
[F101_1] Optional storage device root partition mount error (formatting failure)	Fatal Error - Please Contact Service Technician.	Y	-	Y	Y	-
[F101_2] Optional storage device partition mount error	Fatal Error - Please Contact Service Technician.	Y	-	Y	Y	-
[F101_3] Optional storage device partition mount error	Fatal Error - Please Contact Service Technician.	Y	-	Y	Y	-
[F101_4] Optional storage device partition mount error	Fatal Error - Please Contact Service Technician.	-	-	-	-	-
[F101_5] Partition mount error	Fatal Error - Please Contact Service Technician.	-	-	-	-	-
[F101_6] Partition mount error	Fatal Error - Please Contact Service Technician.	-	-	-	-	-
[F101_7] Partition mount error	Fatal Error - Please Contact Service Technician.	-	-	-	-	-

Code	Message	Error code display media				
		Panl	JL	ML	Noti	CSV
[F101_8] Partition mount error	Fatal Error - Please Contact Service Technician.	-	-	-	-	-
[F101_9] Partition mount error	Fatal Error - Please Contact Service Technician.	-	-	-	-	-
[F101_10] Partition mount error	Fatal Error - Please Contact Service Technician.	-	-	-	-	-
[F101_11] Partition mount error	Fatal Error - Please Contact Service Technician.	-	-	-	-	-
[F101_12] Optional storage device mount error	Fatal Error - Please Contact Service Technician.	-	-	-	-	-
[F101_13] Error due to damage to file	Fatal Error - Please Contact Service Technician.	-	-	-	-	-
[F101_14] Partition mount error	Fatal Error - Please Contact Service Technician.	-	-	-	-	-
[F102] Storage device start error	Fatal Error - Please Contact Service Technician.	Y	-	Y	Y	-
[F103] Storage device transfer time-out error	Fatal Error - Please Contact Service Technician.	5th	-	Y	Y	-
[F104] Storage device data error	Fatal Error - Please Contact Service Technician.	5th	-	Y	Y	-
[F105] Other errors for the storage device	Fatal Error - Please Contact Service Technician.	5th	-	Y	Y	-
[F106_0] Optional storage device error	-	2nd	-	-	-	-
[F106_1] Optional storage device error	-	2nd	-	-	-	-
[F106_2] Optional storage device error	-	2nd	-	-	-	-
[F106_3] Optional storage device error	-	2nd	-	-	-	-
[F106_4] Optional storage device error	-	2nd	-	-	-	-
[F106_5] Optional storage device error	-	2nd	-	-	-	-
[F106_6] Optional storage device error	-	2nd	-	-	-	-
[F106_7] Optional storage device error	-	2nd	-	-	-	-
[F106_8] Optional storage device error	-	2nd	-	-	-	-
[F106_10] Optional storage device error	-	2nd	-	-	-	-
[F106_11] License damage	-	2nd	-	-	-	-
[F106_12] License damage	-	2nd	-	-	-	-
[F106_UNDEF] Optional storage device error	-	2nd	-	-	-	-
[F107] File system error	-	2nd	-	-	-	-
[F109_0] Key consistency error	-	Y	-	-	-	-
[F109_1] Key consistency error	-	Y	-	-	-	-
[F109_2] Key consistency error	-	Y	-	-	-	-
[F109_3] Key consistency error	-	Y	-	-	-	-
[F109_4] Key consistency error	-	Y	-	-	-	-
[F109_5] Key consistency error	-	Y	-	-	-	-
[F109_6] Key consistency error	-	Y	-	-	-	-
[F109_7] Key consistency error	-	Y	-	-	-	-
[F110] Communication error between the system-CPU and the scanner-CPU	Fatal Error - Please Contact Service Technician.	5th	-	Y	Y	Y
[F111] Scanner-CPU response error	Fatal Error - Please Contact Service Technician.	5th	-	Y	Y	Y
[F115] S-VDEN ON signal time-out error	Fatal Error - Please Contact Service Technician.	2nd	-	Y	Y	Y
[F116] S-VDEN OFF signal time-out error	Fatal Error - Please Contact Service Technician.	2nd	-	Y	Y	Y
[F117] S-VDEN ON (back side) signal time-out error	Fatal Error - Please Contact Service Technician.	2nd	-	Y	Y	Y

Code	Message	Error code display media				
		Panl	JL	ML	Noti	CSV
[F118] S-VDEN OFF (back side) signal time-out error	Fatal Error - Please Contact Service Technician.	2nd	-	Y	Y	Y
[F119] Scanner abnormality detection	Fatal Error - Please Contact Service Technician.	5th	-	Y	Y	Y
[F11A] Scanner communication error	Fatal Error - Please Contact Service Technician.	2nd	-	Y	Y	Y
[F11B] Communication error between the DSDF-CCD module and the SYS board	Fatal Error - Please Contact Service Technician.	2nd	-	Y	Y	Y
[F120] Database error	Fatal Error - Please Contact Service Technician.	Y	-	Y	Y	-
[F121] User Information management database error	User Management DB corrupted.	2nd	-	Y	Y	-
[F122] Message/job log management database error	Log Management DB corrupted.	Y	-	Y	Y	-
[F124] Application management database error	AppManagement DB corrupted.	Y	-	Y	Y	-
[F125] Home screen database error	HomeScreen DB corrupted.	Y	-	Y	Y	-
[F126] Job history database error	JobHistory DB corrupted.	Y	-	Y	Y	-
[F127] Application license management database error	AppLicense DB corrupted.	Y	-	Y	Y	-
[F128] License manager database error	LMDB ERROR	-	-	Y	Y	-
[F130] Invalid MAC address	-	2nd	-	-	-	-
[F131] Filtering setting file damage error	Fatal Error - Please Contact Service Technician.	Y	-	Y	Y	-
[F141_0] Standard storage device installation error	-	Y	-	-	-	-
[F141_1] Standard storage device root partition mount error (formatting failure)	-	Y	-	-	-	-
[F141_2] Standard storage device partition mount error	-	Y	-	-	-	-
[F141_3] Standard storage device partition mount error	-	Y	-	-	-	-
[F141_4] Standard storage device partition mount error	-	Y	-	-	-	-
[F141_5] Partition mount error	-	Y	-	-	-	-
[F141_6] Partition mount error	-	Y	-	-	-	-
[F141_7] Partition mount error	-	Y	-	-	-	-
[F141_8] Partition mount error	-	Y	-	-	-	-
[F141_9] Partition mount error	-	Y	-	-	-	-
[F141_10] Partition mount error	-	Y	-	-	-	-
[F141_11] Partition mount error	-	Y	-	-	-	-
[F141_12] Standard storage device mount error	-	Y	-	-	-	-
[F141_13] Error due to damage to file	-	Y	-	-	-	-
[F141_14] Partition mount error	-	Y	-	-	-	-
[F150] Power failure during the manufacturing mode	-	Y	-	Y	Y	-
[F200] Data Overwrite Enabler disabled	Fatal Error - Please Contact Service Technician.	Y	-	Y	Y	-
[F350] SYS board abnormality	Fatal Error - Please Contact Service Technician.	Y	-	Y	Y	Y
[F351] SYS board abnormality	Fatal Error - Please Contact Service Technician.	Y	-	Y	Y	Y
[F400] SYS board cooling fan abnormality	Fatal Error - Please Contact Service Technician.	Y	-	Y	Y	-



Code	Message	Error code display media				
		Panl	JL	ML	Noti	CSV
[F410] Power abnormality	Fatal Error - Please Contact Service Technician.	2nd	-	Y	Y	Y
[F510] Application start error	-	5th	-	-	-	-
[F520] Operating system start error	-	Y	-	-	-	-
[F521] Integrity check error	-	Y	-	-	-	-
[F523] Security check error at the startup	-	Y	-	-	-	-
[F525] Invalid file execution error	-	Y	-	-	-	-
[F526] Anti-malware function error	-	Y	-	-	-	-
[F550] Encryption partition error	Fatal Error - Please Contact Service Technician.	-	-	Y	Y	-
[F600] Firmware update error	-	Y	-			-
[F700] Overwrite error	Fatal Error - Please Contact Service Technician.	-	-	Y	Y	-
[F800] Date error	-	Y	-	-	-	-
[F900] MFP information consistency error	-	Y	-	-	-	-
[F901] Communication error	-	Y	-	-	-	-

## 8.2.3 Error in Internet fax and scanning functions

### 1. Internet fax related error

Code	Message	Error code display media				
		Panl	JL	ML	Noti	CSV
[1C10] System access abnormality	Illegal Job status	-	Y	-	Y	-
[1C11] Insufficient memory	Not enough memory	-	Y	-	Y	-
[1C12] Message reception error	Illegal Job status	-	Y	-	Y	-
[1C13] Message transmission error	Illegal Job status	-	Y	-	Y	-
[1C14] Invalid parameter	Invalid parameter specified	-	Y	-	Y	-
[1C15] Exceeding file capacity	Message size exceeded limit or maximum size	-	Y	-	Y	-
[1C30] Directory creation failure	Failed to create directory	-	Y	-	Y	-
[1C31] File creation failure	Failed to create file	-	Y	-	Y	-
[1C32] File deletion failure	Failed to delete file	-	Y	-	Y	-
[1C33] File access failure	Failed to create file	-	Y	-	Y	-
[1C40] Image conversion abnormality	Failed to convert image file format	-	Y	-	Y	-
[1C60] Storage device full during processing	Failed To Process your Job. Insufficient Storage space.	-	Y	-	Y	-
[1C61] Address book reading failure	Failed to read AddressBook	-	Y	-	Y	-
[1C63] Terminal IP address unset	Invalid Domain Address	-	Y	-	Y	-
[1C64] Terminal mail address unset	Invalid Domain Address	-	Y	-	Y	-
[1C65] SMTP mail address unset	Failed to connect to SMTP server	-	Y	-	Y	-
[1C66] Server time-out error	Failed to connect to SMTP server	-	Y	-	Y	-
[1C69] SMTP server connection error	Failed to connect to SMTP server	-	Y	-	Y	-
[1C6B] Terminal mail address error	Invalid address specified in To: field	-	Y	-	Y	-
[1C6C] Destination mail address error	Invalid address specified in To: field	-	Y	-	Y	-
[1C6D] System error	NIC system error	-	Y	-	Y	-
[1C70] SMTP client OFF	SMTP service is not available	-	Y	-	Y	-
[1C71] SMTP authentication error	Failed SMTP Authentication	-	Y	-	Y	-
[1C72] POP before SMTP error	POP Before SMTP Authentication Failed	-	Y	-	Y	-
[1CC0] Job canceling	Job canceled	-	Y	-	Y	-
[1CC1] Power failure	Power failure occurred	-	Y	-	Y	-

## 2. RFC related error

Code	Message	Error code display media				
		Panl	JL	ML	Noti	CSV
[2500] HOST NAME error (RFC: 500), Destination mail address error (RFC: 500), Terminal mail address error (RFC: 500)	Syntax error, command unrecognized	-	Y	-	Y	-
[2501] HOST NAME error (RFC: 501), Destination mail address error (RFC: 501), Terminal mail address error (RFC: 501)	Syntax error in parameters or arguments	-	Y	-	Y	-
[2503] Destination mail address error (RFC: 503)	Bad sequence of commands	-	Y	-	Y	-
[2504] HOST NAME error (RFC: 504)	Command parameter not implemented	-	Y	-	Y	-
[2550] Destination mail address error (RFC: 550)	Mailbox unavailable	-	Y	-	Y	-
[2551] Destination mail address error (RFC: 551)	User not local	-	Y	-	Y	-
[2552] Terminal/destination mail address error (RFC: 552)	Insufficient system storage	-	Y	-	Y	-
[2553] Destination mail address error (RFC: 553)	Mailbox name not allowed	-	Y	-	Y	-

### 3. Remote scanning related error

Code	Message	Error code display media				
		Panl	JL	ML	Noti	CSV
[2A00] Successful completion (BoxInTA)	Successfully stored document	-	Y	-	-	-
[2A20] System management module resource acquiring failure	Failed to acquire resource	-	Y	-	-	-
[2A31] WS Scan disabled	WS Scan function is not available	-	Y	-	-	-
[2A40] System error	NIC system error	-	Y	-	-	-
[2A50] Job canceling	Job canceled	-	Y	-	-	-
[2A51] Power failure	Power failure occurred	-	Y	-	-	-
[2A60] WS Scan user authentication failure	Authentication for WS Scan failed	-	Y	-	-	-
[2A70] RemoteScan privilege check error	Insufficient permission to execute RemoteScan	-	-	Y	-	-
[2A71] WS Scan privilege check error	Insufficient permission to execute WS Scan	-	Y	-	-	-
[2A72] e-Filing data access privilege check error (Scan Utility)	Insufficient permission to access e-Filing box using scan utility	-	-	Y	-	-
[2A73] Address book operation privilege check error	Insufficient permission to execute Addressbook Export/Import operation	-	-	Y	-	-
[2AD0] e-Filing data backing up	Backup operation of e-Filing data from Backup/ Restore Utility is done	-	-	Y	-	-
[2AD1] e-Filing data restoring	Restore operation of e-Filing data from Backup/ Restore Utility is done	-	-	Y	-	-
[2AD2] e-Filing data archiving	Archive operation of e-Filing data is done	-	-	Y	-	-
[2AD3] e-Filing data restoring	Restore operation of e-Filing data is done	-	-	Y	-	-
[2AD4] e-Filing data downloading (Scan Utility)	Download e-Filing data by scan utility	-	-	Y	-	-

#### 4. e-Filing related error

Code	Message	Error code display media				
		PanI	JL	ML	Noti	CSV
[2B00] Doc saving successful (BoxIn)	Successfully stored document	-	Y	-	Y	-
[2B01] Successful completion (BoxPrnTA)	Successfully sent document to print queue	-	Y	-	-	-
[2B11] Job status abnormality	Job status failed	-	Y	-	Y	-
[2B20] File library function error	Failed to access file	-	Y	-	Y	-
[2B30] Insufficient storage device space in BOX partition	Insufficient Storage Device space.	-	Y	-	Y	-
[2B31] Status of the specified e-Filing or folder is undefined or being created or deleted	Failed to access Electronic Filing	-	Y	-	Y	-
[2B50] Image library error	Failed to process image	-	Y	-	Y	-
[2B51] List library error	Failed to print images from the document box	-	Y	-	Y	-
[2B71] There are documents which will expire in a few days	Document(s) expire(s) in a few days	-	-	Y	Y	-
[2B80] Storage device space in /BOX partition is nearly full (90%)	Storage Device space for Electronic Filing nearly full.	-	-	Y	Y	-
[2B90] Insufficient memory capacity	Insufficient Memory	-	Y	-	Y	-
[2BA0] Invalid Box password	Invalid Box password specified	-	Y	-	Y	-
[2BA1] The specified paper size, color mode or resolution is not available.	Failed to process image.	-	Y	-	Y	-
[2BB0] Job canceling	Job canceled	-	Y	-	Y	-
[2BB1] Power failure	Power failure occurred	-	Y	-	Y	-
[2BC0] Fatal failure occurred	NIC system error	-	Y	-	Y	-
[2BD0] Power failure during restoring of e-Filing	Power failure occurred during e-Filing restore.	-	-	Y	Y	-
[2BD1] e-Filing is initialized.	e-Filing Box Storage is initialized.	-	-	Y	Y	-
[2BE0] Machine parameter reading error	Failed to get machine parameter	-	Y	-	Y	-
[2BF0] Exceeding the maximum number of pages	Maximum number of pages has been exceeded (list Maximum)	-	Y	-	Y	-
[2BF1] Exceeding the maximum number of documents	Maximum number of documents has been exceeded (list Maximum)	-	Y	-	Y	-
[2BF2] Exceeding the maximum number of folders	Maximum number of folders has been exceeded (list Maximum)	-	Y	-	Y	-

## 5. E-mail related error

Code	Message	Error code display media				
		Panl	JL	ML	Noti	CSV
[2C00] Communication successful completion	Sent scanned image(s) by email	-	Y	-	Y	-
[2C01] Notification transmission successful completion	Sent scanned image(s) by email	-	Y	-	Y	-
[2C02] Transferring completion (E-mail reception)	Sent scanned image(s) by email	-	Y	-	Y	-
[2C04] Notification transmission successful completion	Service information was sent by E-mail	-	Y	-	Y	-
[2C10] System access abnormality	Illegal Job status	-	Y	-	Y	-
[2C11] Insufficient memory	Not enough memory	-	Y	-	Y	-
[2C12] Message reception error	Illegal Job status	-	Y	-	Y	-
[2C13] Message transmission error	Illegal Job status	-	Y	-	Y	-
[2C14] Invalid parameter	Invalid parameter specified	-	Y	-	Y	-
[2C15] Exceeding file capacity	Message size exceeded limit or maximum size	-	Y	-	Y	-
[2C20] System management module access abnormality	Illegal Job status	-	Y	-	Y	-
[2C21] Job control module access abnormality	Illegal Job status	-	Y	-	Y	-
[2C22] Job control module access abnormality	Illegal Job status	-	Y	-	Y	-
[2C30] Directory creation failure	Failed to create directory	-	Y	-	Y	-
[2C31] File creation failure	Failed to create file	-	Y	-	Y	-
[2C32] File deletion failure	Failed to delete file	-	Y	-	Y	-
[2C33] File access failure	Failed to create file	-	Y	-	Y	-
[2C40] Image conversion abnormality	Failed to convert image file format	-	Y	-	Y	-
[2C43] Encryption error	Encryption error. Failed to create file	-	Y	-	Y	-
[2C44] Encryption PDF enforced mode error	Creating the image file was not permitted	-	Y	-	Y	-
[2C45] Meta data creation error (ScanToEmail)	Failed in making meta data	-	Y	-	Y	-
[2C46] Creation of a signed PDF has failed. (An error due to the expiration date of a certificate): ScanToEmail	Creation of a signed PDF has failed since the certificate expired.	-	Y	-	Y	-
[2C47] Creation of a signed PDF has failed. (Version consistency between the signed PDF and certificates PDF): ScanToEmail	Version consistency between the signed PDF and certificates PDF	-	Y	-	Y	-
[2C50] Authentication failure at job execution	Insufficient permission to execute Scan job	-	Y	-	Y	-
[2C60] Storage device full during processing	Failed To Process your Job. Insufficient Storage space.	-	Y	-	Y	-
[2C61] Address book reading failure	Failed to read AddressBook	-	Y	-	Y	-
[2C62] Memory acquiring failure	Not enough memory	-	Y	-	Y	-
[2C63] Terminal IP address unset	Invalid Domain Address	-	Y	-	Y	-
[2C64] Terminal mail address unset	Invalid Domain Address	-	Y	-	Y	-
[2C65] SMTP mail address unset	Failed to connect to SMTP server	-	Y	-	Y	-
[2C66] Server time-out error	Failed to connect to SMTP server	-	Y	-	Y	-
[2C69] SMTP server connection error	Failed to connect to SMTP server	-	Y	-	Y	-

Code	Message	Error code display media				
		Panl	JL	ML	Noti	CSV
[2C6A] HOST NAME error (no RFC error)	Failed to send E-mail message	-	Y	-	Y	-
[2C6B] Terminal mail address error	Invalid address specified in From: field	-	Y	-	Y	-
[2C6C] Destination mail address error (no RFC error)	Invalid address specified in To: field	-	Y	-	Y	-
[2C70] SMTP client OFF	SMTP service is not available	-	Y	-	Y	-
[2C71] SMTP authentication error	Failed SMTP Authentication	-	Y	-	Y	-
[2C72] POP before SMTP error	POP Before SMTP Authentication Failed	-	Y	-	Y	-
[2CC0] Job canceling	Job canceled	-	Y	-	Y	-
[2CC1] Power failure	Power failure occurred	-	Y	-	Y	-

## 6. File sharing related error

Code	Message	Error code display media				
		Panl	JL	ML	Noti	CSV
[2D00] Successful completion (saving in a local directory)	Stored document in controller shared folder	-	Y	-	Y	-
[2D01] Successful completion (saving in Remote)	Stored document in network folder	-	Y	-	Y	-
[2D02] Successful completion (saving of a received FaxtoFile/&File in a local directory)	Stored document in controller shared folder	-	Y	-	Y	-
[2D03] Successful completion (saving of a received FaxtoFile/&File in Remote)	Stored document in network folder	-	Y	-	Y	-
[2D04] Successful completion (saving of a received EmailtoFile/&File in a local directory)	Stored document in controller shared folder	-	Y	-	Y	-
[2D05] Successful completion (saving of a received EmailtoFile/&File in Remote)	Stored document in network folder	-	Y	-	Y	-
[2D10] System access abnormality	Illegal Job status	-	Y	-	Y	-
[2D11] Insufficient memory	Not enough memory	-	Y	-	Y	-
[2D12] Message reception error	Illegal Job status	-	Y	-	Y	-
[2D13] Message transmission error	Illegal Job status	-	Y	-	Y	-
[2D14] Invalid parameter	Invalid parameter specified	-	Y	-	Y	-
[2D15] Exceeding the maximum size for file sharing	Document size exceeded limit or maximum size	-	Y	-	Y	-
[2D30] Directory creation failure	Failed to create directory	-	Y	-	Y	-
[2D31] File creation failure	Failed to create file	-	Y	-	Y	-
[2D32] File deletion failure	Failed to delete file	-	Y	-	Y	-
[2D33] File access failure	Failed to create file	-	Y	-	Y	-
[2D40] Image conversion abnormality	Failed to convert image file format	-	Y	-	Y	-
[2D43] Encryption error	Encryption error. Failed to create file	-	Y	-	Y	-
[2D44] Encryption PDF enforced mode error	Creating the image file was not permitted	-	-	-	Y	-
[2D45] Meta data creation error (ScanToFile)	Failed in making meta data	-	Y	-	Y	-
[2D46] Creation of a signed PDF has failed. (An error due to the expiration date of a certificate): ScanToFile	Creation of a signed PDF has failed since the certificate expired.	-	Y	-	Y	-
[2D47] Creation of a signed PDF has failed. (Version consistency between the signed PDF and certificates PDF): ScanToFile	Version consistency between the signed PDF and certificates PDF	-	Y	-	Y	-

Code	Message	Error code display media				
		Panl	JL	ML	Noti	CSV
[2D50] Authentication failure at job execution (A ScanToFile job is carried out while user authentication or department authentication has not been done.)	Insufficient permission to execute Scan job	-	Y	-	Y	-
[2D62] File server connection failure	Failed to connect to network destination. Check destination path	-	Y	-	Y	-
[2D63] Invalid network path	Specified network path is invalid. Check destination path	-	Y	-	Y	-
[2D64] Login failure	Logon to file server failed. Check username and password	-	Y	-	Y	-
[2D65] New document creation failure caused by an excess of documents in a folder	There are too many documents in folder. Failed in creating new document	-	Y	-	Y	-
[2D66] Storage capacity full failure during processing	Failed To Process your Job. Insufficient Storage space.	-	Y	-	Y	-
[2D67] FTP service not available	FTP service is not available	-	Y	-	Y	-
[2D68] File sharing service not available	File Sharing service is not available	-	Y	-	Y	-
[2D69] NetWare service not available	NetWare service is not available	-	Y	-	Y	-
[2DA0] Periodical deletion of scanned documents has been completed properly	Expired scan documents deleted from share folder.	-	-	Y	Y	-
[2DA1] Periodical deletion of transmitted fax documents has been completed properly.	Expired Sent Fax documents deleted from shared folder	-	-	Y	Y	-
[2DA2] Periodical deletion of received fax documents has been completed properly.	Expired Received Fax documents deleted from shared folder	-	-	Y	Y	-
[2DA3] Manual deletion of scanned documents has been completed properly.	Scanned documents in shared folder deleted upon user's request	-	-	Y	Y	-
[2DA4] Manual deletion of transmitted fax documents has been completed properly.	Sent Fax Documents in shared folder deleted upon user's request.	-	-	Y	Y	-
[2DA5] Manual deletion of received fax documents has been completed properly.	Received Fax Documents in shared folder deleted upon user's request.	-	-	Y	Y	-
[2DA6] File deletion failure	Failed to delete file	-	-	Y	Y	-
[2DA7] Resource acquiring failure	Failed to acquire resource	-	-	Y	Y	-
[2DC0] Job canceling	Job canceled	-	Y	-	Y	-
[2DC1] Power failure	Power failure occurred	-	Y	-	Y	-
[2E00] Successful completion (saving in a USB storage device)	Stored document in controller USB Media	-	Y	-	Y	-
[2E01] Successful completion (saving of a received FaxtoFile/&File in a USB storage device)	Stored document in controller USB Media	-	Y	-	Y	-
[2E02] Successful completion (saving of a received EmailtoFile/&File in a USB storage device)	Stored document in controller USB Media	-	Y	-	Y	-
[2E10] System access abnormality in ScanToUSB	Illegal Job status	-	Y	-	Y	-
[2E11] Insufficient memory capacity in ScanToUSB	Not enough memory	-	Y	-	Y	-
[2E12] Message reception error in ScanToUSB	Illegal Job status	-	Y	-	Y	-
[2E13] Message transmission error in ScanToUSB	Illegal Job status	-	Y	-	Y	-
[2E14] Parameter error in ScanToUSB	Invalid parameter specified	-	Y	-	Y	-



Code	Message	Error code display media				
		PanI	JL	ML	Noti	CSV
[2E15] Exceeding the maximum size for file sharing	Document size exceeded limit or maximum size	-	Y	-	Y	-
[2E30] Directory creation failure in ScanToUSB	Failed to create directory	-	Y	-	Y	-
[2E31] File creation failure in ScanToUSB	Failed to create file	-	Y	-	Y	-
[2E32] File deletion failure in ScanToUSB	Failed to delete file	-	Y	-	Y	-
[2E33] File access failure in ScanToUSB	Failed to create file	-	Y	-	Y	-
[2E40] Image conversion abnormality in ScanToUSB	Failed to convert image file format	-	Y	-	Y	-
[2E43] Encryption failure in ScanToUSB	Encryption error. Failed to create file	-	Y	-	Y	-
[2E44] Encryption PDF enforced mode error in ScanToUSB	Creating the image file was not permitted	-	-	-	Y	-
[2E45] Meta data creation error in USB storage device (ScanToFile)	Failed in making meta data	-	Y	-	Y	-
[2E46] Creation of a signed PDF has failed. (An error due to the expiration date of a certificate): ScanToUSB	Creation of a signed PDF has failed since the certificate expired.	-	Y	-	Y	-
[2E47] Creation of a signed PDF has failed. (Version consistency between the signed PDF and certificates PDF): ScanToUSB	Version consistency between the signed PDF and certificates PDF	-	Y	-	Y	-
[2E50] Authentication failure at job execution	Insufficient permission to execute Scan job	-	Y	-	Y	-
[2E65] File creation error due to insufficient USB folder capacity in ScanToUSB	There are too many documents in folder. Failed in creating new document	-	Y	-	Y	-
[2E66] Storage device full failure during ScanToUSB	Failed To Process your Job. Insufficient Storage space.	-	Y	-	Y	-
[2EC0] Job canceling	Job canceled	-	Y	-	Y	-
[2EC1] Power failure in ScanToUSB	Power failure occurred	-	Y	-	Y	-

## 7. E-mail reception related error

Code	Message	Error code display media				
		Panl	JL	ML	Noti	CSV
[3000] E-mail reception is completed properly	Received E-mail Job was successfully completed.	-	Y	-	Y	-
[3A10] E-mail MIME error	MIME Error has been detected in the received mail.	-	Y	-	Y	-
[3A20] E-mail analysis error	Analyze Error has been detected in the received mail.	-	Y	-	Y	-
[3A30] Partial mail time-out error	Whole partial mails were not reached by timeout.	-	Y	-	Y	-
[3A40] Partial mail related error	Partial Mail Error has been detected in the received mail.	-	Y	-	Y	-
[3A50] Insufficient storage device capacity error	Storage Device Full Error has occurred with this mail.	-	Y	-	Y	-
[3A70] Partial mail interruption error	Receiving partial mail was aborted since the partial mail setting has been changed to Disable.	-	Y	-	Y	-
[3A80] Partial mail reception setting OFF	Partial mail was received during the partial mail setting is disabled.	-	Y	-	Y	-
[3B10] E-mail format error	Format Error has been detected in the received mail.	-	Y	-	Y	-
[3B20] Content-Type error	Content-Type Error has been detected in the received mail.	-	Y	-	Y	-
[3B40] E-mail decode error	Decode Error has been detected in the received mail.	-	Y	-	Y	-
[3B50] Received mail data deletion	Received Email data was broken. It was deleted from mail server.	-	-	Y	Y	-
[3C10] TIFF analysis error	Tiff Analyze Error has been detected in the received mail.	-	Y	-	Y	-
[3C13] TIFF analysis error	Tiff Analyze Error has been detected in the received mail.	-	Y	-	Y	-
[3C20] TIFF compression error	Tiff Compression Error has been detected in the received mail.	-	Y	-	Y	-
[3C30] TIFF resolution error	Tiff Resolution Error has been detected in the received mail.	-	Y	-	Y	-
[3C40] TIFF paper size error	Tiff Paper Size Error has been detected in the received mail.	-	Y	-	Y	-
[3C50] Offramp destination error	Offramp Destination Error has been detected in the received mail.	-	Y	-	Y	-
[3C60] Offramp security error	Offramp Security Error has been detected in the received mail.	-	Y	-	Y	-
[3C70] Power failure	Power Failure has been occurred in E-mail receiving.	-	Y	-	Y	-
[3C90] Offramp fax transmission disable error	OffRamp Fax transmission disable error has been detected in the received mail.	-	Y	-	Y	-
[3D10] Destination address error	SMTP Destination Error has been detected in the received mail. This mail was deleted.	-	-	Y	Y	-
[3D20] Maximum number of offramp destination error	OffRamp Destination limitation Error has been detected in the received mail.	-	-	Y	Y	-

Code	Message	Error code display media				
		Panl	JL	ML	Noti	CSV
[3D30] No fax unit error	Fax unit Error has occurred because the OffRamp mail was received but it has no Fax unit.	-	-	Y	Y	-
[3E10] POP3 server connection error	POP3 Connection Error has occurred in the received mail.	-	-	Y	Y	-
[3E20] POP3 server connection time-out error	POP3 Connection Timeout Error has occurred in the received mail.	-	-	Y	Y	-
[3E30] POP3 login error	POP3 Login Error has occurred in the received mail.	-	-	Y	Y	-
[3E40] POP3 login type error	POP3 Login Error occurred in the received mail.	-	-	Y	Y	-
[3F10] File I/O error	File I/O Error has occurred in this mail. The mail cannot be received until File I/O is recovered.	-	-	Y	Y	-
[3F20] File I/O error	File I/O Error has occurred in this mail. The mail cannot be received until File I/O is recovered.	-	Y	-	Y	-

## 8.2.4 Printer function error

Following codes are displayed at the end of the user name on the print job log screen.

Code	Message	Error code display media				
		Panl	JL	ML	Noti	CSV
[4000] Successful completion	-	-	-	-	-	-
[4011] Print job cancellation	-	-	-	-	-	-
[4012] Automatic deletion of expired print jobs	-	-	-	-	-	-
[4021] Power failure at print job processing	-	-	-	-	-	-
[4031] Storage device full during print	-	-	-	-	-	-
[4032] Exceeding the upper limit of the registration number for the sharing jobs	-	-	-	-	-	-
[4033] Network setting error	-	-	-	-	-	-
[4041] User authentication error	-	-	-	-	-	-
[4042] Department authentication error	-	-	-	-	-	-
[4043] Project authentication error	-	-	-	-	-	-
[4045] Problem in LDAP server connection or LDAP server authorization settings	-	-	-	-	-	-
[4111] Quota over error (no quota in a department and user)	-	-	-	-	-	-
[4112] Quota over error (no quota in a user)	-	-	-	-	-	-
[4113] Quota over error (no quota in a department)	-	-	-	-	-	-
[4121] Job canceling due to external counter error	-	-	-	-	-	-
[4211] Printing data storing limitation error	-	-	-	-	-	-
[4212] e-Filing storing limitation error	-	-	-	-	-	-
[4213] File storing limitation error	-	-	-	-	-	-
[4214] Fax and internet fax transmission limitation error	-	-	-	-	-	-
[4221] Private-print-only error	-	-	-	-	-	-
[4222] Hold-print-only error	-	-	-	-	-	-
[4223] Private-print-only and Hold-print-only error	-	-	-	-	-	-
[4231] Hardcopy security printing error	-	-	-	-	-	-
[4231] Hardcopy security printing error	-	-	-	-	-	-
[4243] Sharing job - An error caused by not having a license	-	-	-	-	-	-
[4244] Sharing job - An error caused by function disabled	-	-	-	-	-	-
[4245] OCR functions not available	OCR function is not available.	-	-	-	Y	-
[4311] No privilege to perform a job	-	-	-	-	-	-
[4312] No privilege to store a file	-	-	-	-	-	-
[4313] No privilege for StoreToFile	-	-	-	-	-	-
[4314] No privilege for SendToFax and SendToFax	-	-	-	-	-	-
[4411] Image data creation failure	-	-	-	-	-	-
[4412] Decoding error	-	-	-	-	-	-
[4511] Connection timeout	Print failure due to connection timeout	Y	-	Y	-	-
[4521] Reaching the maximum number of connections	Cannot print due to connection limit	Y	-	Y	-	-

Code	Message	Error code display media				
		PanI	JL	ML	Noti	CSV
[4522] Exceeding the upper limit of the registration number of jobs during data reception	Registered print job number reached to limit during printing	Y	-	Y	-	-
[4523] Storage device full during data reception	Storage Device full occurred during printing	Y	-	Y	-	-
[4611] Font download failure (exceeding the maximum number of registrations)	-	-	-	-	-	-
[4612] Font download failure (Storage device full)	-	-	-	-	-	-
[4613] Font download failure (others)	-	-	-	-	-	-
[4621] Downloaded font deletion failure	-	-	-	-	-	-
[4721] Connection error of multi station print (Unavailable combination of the version)	Cannot connect MFP due to unexpected combination of Multi Station Print	-	-	Y	-	-
[4731] Multi Station print jobs have been removed. (An error has occurred in the job list.)	Multi Station Print job(s) have been deleted because an error occurred in the Job List	-	-	Y	-	-
[4F10] System abnormality	-	-	-	-	-	-
[4F11] RIP process error	-	-	-	-	-	-

## 8.2.5 TopAccess related error, Communication error with external application

Code	Message	Error code display media				
		Panl	JL	ML	Noti	CSV
[5110] Toner cartridge detection error	Toner not recognized. Please confirm it.	-	-	-	-	-
[5211] PM counter excess	-	-	-	Y	Y	-
[5212] Time for cleaning of the main charger	Open the front cover, and clean the slit glass and main charger.	-	-	Y	Y	-
[5310] Toner (K) empty	-	-	-	-	-	-
[5400] MFP registration success	Succeeded in MFP registration	-	-	Y	Y	-
[5401] Immediate connection execution to an eCC server	Immediate connection to Remote Maintenance Service has been executed.	-	-	Y	Y	-
[5410] MFP registration error	Remote maintenance service error	-	-	Y	Y	-
[5411] MFP registration lock error	Remote maintenance service error	-	-	Y	Y	-
[5412] Server busy error	Remote maintenance service error	-	-	Y	Y	-
[5413] Server error	Remote maintenance service error	-	-	Y	Y	-
[5414] Invalid device file	Remote maintenance service error	-	-	Y	Y	-
[5415] Communication error	Remote maintenance service error	-	-	Y	Y	-
[5416] Update failure of MFP setting file and system software	Remote maintenance service error	-	-	Y	Y	-
[5417] MFP setting file or system software is invalid.	Remote maintenance service error	-	-	Y	Y	-
[5419] File transmission to an eCC server failure	Remote maintenance service error	-	-	Y	Y	-
[5501] Communication data size exceeding error between the mobile and embedded applications	Request data or response data are too large.	-	-	Y	Y	-
[5502] Timeout error during the communication between the mobile and embedded applications	Timeout has occurred at the time of the communication between the mobile and embedded applications.	-	-	Y	Y	-
[5601] Proxy authentication failure	Failed to proxy authentication.	-	-	Y	Y	-
[5A10] End of the trial period	End of the trial period	-	-	Y	Y	-
[5BD0] Power failure during the database restoration	Power failure occurred during restore	-	-	Y	Y	-
[5C10] Fax unit installation error	FAX Unit is not attached.	-	-	Y	Y	-
[5C11] Network fax transmission error	Security error on Address Book.	-	-	Y	Y	-

## 8.2.6 MFP access error

Code	Message	Error code display media				
		Panl	JL	ML	Noti	CSV
[6000] User login success to an MFP	Successful user login	-	-	Y	Y	-
[6001] User login failure to an MFP	Failed user login	-	-	Y	Y	-
[6002] User logout success from an MFP: Manual logout	Successful user logout	-	-	Y	Y	-
[6003] User logout success from an MFP: Automatic logout	Successful user logout (Session Time Out)	-	-	Y	Y	-
[6004] Authentication success of a user box password	Successful User Box Authentication	-	-	Y	Y	-
[6005] Authentication failure of a user box password	Failed User Box Authentication	-	-	Y	Y	-
[6006] UserToken binding failure	User login information was broken	-	-	Y	Y	-
[6007] User login failure to an MFP	Failed user login	-	-	Y	Y	-
[6008] Connection failure to an external Role Base Access Control (LDAP) server	Failed to connect on External LDAP server for Role Base Access Control	-	-	Y	Y	-
[6009] User login failure to an MFP (during NIC initialization)	Failed user login (Authentication server connection error)	-	-	Y	Y	-
[600A] Department code not assigned to a user	Department code has not been assigned to the user	-	-	Y	Y	-
[600B] Password authentication of the Public Box has succeeded.	Successful Public Box Authentication	-	-	Y	Y	-
[600C] Password authentication of the Public Box has failed.	Failed Public Box Authentication	-	-	Y	Y	-
[6010] Home directory not found	Cannot find the Home Directory.	-	-	Y	Y	-
[6011] User automatic registration failure (due to an upper limit of the user registration number)	Failed to register the user by automatically (Maximum number of registered users)	-	-	Y	Y	-
[6013] Connection failure to an authentication server	Failed to connect on the authentication server	-	-	Y	Y	-
[6014] Inaccessible authentication server detection	Detected the authentication server that can not be connected	-	-	Y	Y	-
[6031] Setting error: CL code error	Illegal CL code.	-	-	Y	Y	-
[6032] Card abnormality: Validity date error	Illegal period.	-	-	Y	Y	-
[6033] Card abnormality: Flag information error (no room-entry data)	No entering record.	-	-	Y	Y	-
[6034] Card abnormality: Flag information error (card information error)	Illegal entering record.	-	-	Y	Y	-
[6035] Setting error: Flag information error (card information unset)	Illegal SSFC settings of MFP.	-	-	Y	Y	-
[6036] Setting error: Flag information error (information between an MFP and a card does not match)	Unmatched settings and card info.	-	-	Y	Y	-
[6037] Permission flag for use not available	You cannot be used.	-	-	Y	Y	-
[6040] Card authentication: Read error	Failed to read the card	-	-	Y	Y	-
[6041] Card authentication: Card related error	Card Authentication Failed because of Card Reading Error	-	-	Y	Y	-
[6042] Card authentication: Card setting error	Card Authentication Failed because of Setting Error	-	-	Y	Y	-
[6043] Card authentication failure (duplication of card information)	Card Authentication Failed because the card information was duplicated on the card server.	-	-	Y	Y	-

Code	Message	Error code display media				
		Panl	JL	ML	Noti	CSV
[6044] Card notification failure (Stage2)	Card Notification Communication Error	-	-	Y	Y	-
[6066] PIN authentication failure (duplication of a PIN code)	PIN Authentication Failed because the PIN code was duplicated on the PIN server.	-	-	Y	Y	-
[6070] Fingerprint authentication (User login success to an MFP)	Successful user login	-	-	Y	Y	-
[6071] Fingerprint authentication (User logout success from an MFP: manual logout)	Successful user logout	-	-	Y	Y	-
[6072] Fingerprint authentication (User logout success from an MFP: automatic logout)	Successful user logout (Session Time Out)	-	-	Y	Y	-
[6073] Fingerprint authentication (failure)	Failed Fingerprint Authentication	-	-	Y	Y	-
[6100] User account locking out	User account is locked	-	-	Y	Y	-
[6101] e-Filing locking out	Box is locked	-	-	Y	Y	-
[6102] User account is being locked out.	Failed to login because the user account had been locked out.	-	-	Y	Y	-
[6103] e-Filing is being locked out.	Failed to access Box because the Box had been locked out.	-	-	Y	Y	-
[6121] Automatic secure erase failure	Failed to Secure Erase	-	-	Y	Y	-
[6130] Synchronization with a time server has succeeded.	Successfully verified clock with Time Server	-	-	Y	Y	-
[6131] Synchronization failure with a time server	MFP fail to verify clock with Time Server	-	-	Y	Y	-
[6150] Print log database full	Print Log full (100% Used) Log OverWrite will be start Log OverWrite will be start	-	-	Y	Y	-
[6151] Print log database nearly full (95%)	Print Log near full (95% Used)	-	-	Y	Y	-
[6152] Print log database nearly full (90%)	Print Log near full (90% Used)	-	-	Y	Y	-
[6153] Print log database nearly full (80%)	Print Log near full (80% Used)	-	-	Y	Y	-
[6154] Print log database nearly full (70%)	Print Log near full (70% Used)	-	-	Y	Y	-
[6160] Scan log database full	Scan Log full (100% Used) Log OverWrite will be start	-	-	Y	Y	-
[6161] Scan log database nearly full (95%)	Scan Log near full (95% Used)	-	-	Y	Y	-
[6162] Scan log database nearly full (90%)	Scan Log near full (90% Used)	-	-	Y	Y	-
[6163] Scan log database nearly full (80%)	Scan Log near full (80% Used)	-	-	Y	Y	-
[6164] Scan log database nearly full (70%)	Scan Log near full (70% Used)	-	-	Y	Y	-
[6170] Fax transmission database full	FAX_Transmission Log full (100% Used) Log OverWrite will be start	-	-	Y	Y	-
[6171] Fax transmission database nearly full (95%)	FAX_Transmission Log near full (95% Used)	-	-	Y	Y	-
[6172] Fax transmission database nearly full (90%)	FAX_Transmission Log near full (90% Used)	-	-	Y	Y	-
[6173] Fax transmission database nearly full (80%)	FAX_Transmission Log near full (80% Used)	-	-	Y	Y	-
[6174] Fax transmission database nearly full (70%)	FAX_Transmission Log near full (70% Used)	-	-	Y	Y	-
[6180] Fax reception database full	FAX_Receive Log full (100% Used) Log OverWrite will be start	-	-	Y	Y	-
[6181] Fax reception database nearly full (95%)	FAX_Receive Log near full (95% Used)	-	-	Y	Y	-
[6182] Fax reception database nearly full (90%)	FAX_Receive Log near full (90% Used)	-	-	Y	Y	-



Code	Message	Error code display media				
		Panl	JL	ML	Noti	CSV
[6183] Fax reception database nearly full (80%)	FAX_Receive Log near full (80% Used)	-	-	Y	Y	-
[6184] Fax reception database nearly full (70%)	FAX_Receive Log near full (70% Used)	-	-	Y	Y	-
[6190] Message log database full	Message Log full (100% Used) Log OverWrite will be start	-	-	Y	Y	-
[6191] Message log database nearly full (95%)	Message Log near full (95% Used)	-	-	Y	Y	-
[6192] Message log database nearly full (90%)	Message Log near full (90% Used)	-	-	Y	Y	-
[6193] Message log database nearly full (80%)	Message Log near full (80% Used)	-	-	Y	Y	-
[6194] Message log database nearly full (70%)	Message Log near full (70% Used)	-	-	Y	Y	-
[61A0] Secure Receive ON mode	Secure Receive was enabled	-	-	Y	-	-
[61A1] Secure Receive OFF mode	Secure Receive was disabled	-	-	Y	-	-
[61C0] Application log database full	Application Log full (100% Used) Log OverWrite will be start	-	-	Y	Y	-
[61C1] Application log database nearly full (95%)	Application Log near full (95% Used)	-	-	Y	Y	-
[61C2] Application log database nearly full (90%)	Application Log near full (90% Used)	-	-	Y	Y	-
[61C3] Application log database nearly full (80%)	Application Log near full (80% Used)	-	-	Y	Y	-
[61C4] Application log database nearly full (70%)	Application Log near full (70% Used)	-	-	Y	Y	-
[61D0] Instruction to back up the storage device (SATA Port 0) (Backing up is required since the storage device may be malfunctioning.)	Please make a backup of Storage Device data.	Y	-	Y	Y	-
[61D1] Instruction to replace the storage device (SATA Port 0) (Replacing is required since the storage is on the verge of malfunctioning.)	Exchange of the Storage Device is required. Please contact service.	Y	-	Y	Y	-
[61D2] Instruction to back up the storage device (SATA Port 1) (Backing up is required since the storage device may be malfunctioning.)	Back up the storage device data	Y	-	Y	Y	-
[61D3] Instruction to replace the storage device (SATA Port 1) (Replacing is required since the storage is on the verge of malfunctioning.)	Replace the storage device (SATA Port 1)	Y	-	Y	Y	-
[6200] Security level change of an MFP by a service technician	Service Technician changed Security Level	-	-	Y	Y	-
[6220] Execution of the administrator setting wizard	-	-	-	-	-	-
[6221] Security settings change by an administrator	-	-	-	-	-	-
[6240] A user password is outside the security policy.	-	-	-	-	-	-
[6241] An e-Filing password is outside the security policy.	-	-	-	-	-	-
[6260] User information change	-	-	-	-	-	-
[6261] Role information change	-	-	-	-	-	-
[6262] Group role information change	-	-	-	-	-	-
[6280] Self-signed certification generation	-	-	-	-	-	-

Code	Message	Error code display media				
		PanI	JL	ML	Noti	CSV
[6281] Server certification generation	-	-	-	-	-	-
[6282] Certification addition failure	-	-	-	-	-	-
[6283] Encryption key generation	-	-	-	-	-	-

## 8.2.7 Maintenance error

Code	Message	Error code display media				
		Panl	JL	ML	Noti	CSV
[7100] System firmware installation success	Successfully updated Copier Firmware	-	Y	Y	-	-
[7101] System firmware installation failure	Failed to update Copier Firmware	-	Y	Y	-	-
[7102] Engine firmware installation success	Successfully updated Main ROM	-	-	Y	Y	-
[7103] Engine firmware installation failure	Failed to update Main ROM	-	-	Y	Y	-
[7104] Scanner firmware installation success	Successfully updated Scan ROM	-	-	Y	Y	-
[7105] Scanner firmware installation failure	Failed to update Scan ROM	-	-	Y	Y	-
[7108] Printer driver installation success	Successfully updated printer driver.	-	-	Y	Y	-
[7109] Printer driver installation failure	Failed to update printer driver.	-	-	Y	Y	-
[710A] Point and Print data installation success	Successfully updated printer driver.	-	-	Y	Y	-
[710B] Point and Print data installation failure	Failed to update printer driver.	-	-	Y	Y	-
[710E] Language pack installation success	Successfully installed language package	-	-	Y	Y	-
[710F] Language Pack installation failure	Failed to install language package	-	-	Y	Y	-
[7110] Patch installation success	Successfully installed patch	-	-	Y	Y	-
[7111] Patch installation failure	Failed to install patch	-	-	Y	Y	-
[7112] Plugin installation success	Successfully installed plugin	-	-	Y	Y	-
[7113] Plugin installation failure	Failed to install plugin	-	-	Y	Y	-
[7114] Storage device data installation success	Successfully updated Storage Device	-	-	Y	Y	-
[7115] Storage device data installation failure	Failed to update Storage Device	-	-	Y	Y	-
[7116] DF firmware installation success	Successfully updated DF ROM	-	-	Y	Y	-
[7117] DF firmware installation failure	Failed to update DF ROM	-	-	Y	Y	-
[711A] Electronic key clear	Cleared License Key	-	-	Y	Y	-
[711C] Electronic key returning success	Successfully removed License Key	-	-	Y	Y	-
[711D] License key returning failure	Failed to remove License Key	-	-	Y	Y	-
[711E] Electronic key installation success	Successfully installed License Key	-	-	Y	Y	-
[711F] License key installation failure	Failed to install License Key	-	-	Y	Y	-
[7120] Address book data import success	Successfully imported address book data	-	-	Y	Y	-
[7121] Address book data import failure	Failed to import address book data	-	-	Y	Y	-
[7124] MailBox data import success	Successfully imported Mailbox data	-	-	Y	Y	-
[7125] MailBox data import failure	Failed to import Mailbox data	-	-	Y	Y	-
[7126] Format file for meta scan import success	Successfully imported XML format file	-	-	Y	Y	-
[7127] Format file for meta scan import failure	Failed to import XML format file	-	-	Y	Y	-
[7128] User information import success	Successfully imported user information	-	-	Y	Y	-
[7129] User information import failure	Failed to import user information	-	-	Y	Y	-

Code	Message	Error code display media				
		Panl	JL	ML	Noti	CSV
[712A] Role information import success	Successfully imported role information	-	-	Y	Y	-
[712B] Role information import failure	Failed to import role information	-	-	Y	Y	-
[712C] Department data import success	Successfully imported department code	-	-	Y	Y	-
[712D] Department data import failure	Failed to import department code	-	-	Y	Y	-
[7130] Print Data Converter import success	Successfully imported print data converter	-	-	Y	Y	-
[7131] Print Data Converter import failure	Failed to import print data converter	-	-	Y	Y	-
[7132] Some user information import failure	Failed to import some user information	-	-	Y	Y	-
[7133] Some user information, role and group import failure	Failed to import some user information, roles and groups	-	-	Y	Y	-
[7134] Some department data import failure	Failed to import some department codes	-	-	Y	Y	-
[7136] EWB error screen file importing success	Successfully imported EWB error screen file	-	-	Y	Y	-
[7137] EWB error screen file importing failure	Failed to imported EWB error screen file	-	-	Y	Y	-
[7138] Certificate collection success from SCEP server	Successfully collected certificates from an SCEP server	-	-	Y	Y	-
[7139] Certificate collection failure from SCEP server	Failed to collect certificates from an SCEP server	-	-	Y	Y	-
[713A] Certificate import success	Successfully imported certificates	-	-	Y	Y	-
[713B] Certificates import failure	Failed to import certificates	-	-	Y	Y	-
[713C] User Combined data import success	Successfully imported user information, role and group	-	-	Y	Y	-
[713D] User Combined data import failure	Failed to import user information, role and group	-	-	Y	Y	-
[713E] Address book and mailbox data import success	Successfully imported address book and mailbox data	-	-	Y	Y	-
[713F] Address book and mailbox import failure	Failed to import address book and mailbox data	-	-	Y	Y	-
[7140] Address book data export success	Successfully exported address book data	-	-	Y	Y	-
[7141] Address book data export failure	Failed to export address book data	-	-	Y	Y	-
[7144] MailBox data export success	Successfully exported Mailbox data	-	-	Y	Y	-
[7145] MailBox data export failure	Failed to export Mailbox data	-	-	Y	Y	-
[7148] User information export success	Successfully exported user information	-	-	Y	Y	-
[7149] User information export failure	Failed to export user information	-	-	Y	Y	-
[714A] Role information export success	Successfully exported role information	-	-	Y	Y	-
[714B] Role information export failure	Failed to export role information	-	-	Y	Y	-
[714C] Department information export success	Successfully exported department code	-	-	Y	Y	-
[714D] Department information export failure	Failed to export department code	-	-	Y	Y	-
[714E] ICC Profile export success	Successfully exported ICC profile	-	-	Y	Y	-

Code	Message	Error code display media				
		Panl	JL	ML	Noti	CSV
[714F] ICC Profile export failure	Failed to export ICC profile	-	-	Y	Y	-
[7150] Log data export success	Successfully exported log data	-	-	Y	Y	-
[7151] Log data export failure	Failed to export log data	-	-	Y	Y	-
[7152] Log clear	Executed log clear	-	-	Y	Y	-
[7154] Log DB has been rebuilt automatically since it was damaged.	Rebuilt the Log DB by Log DB corruption	-	-	Y	Y	-
[7156] AppManagement DB has been rebuilt automatically since it was damaged.	Rebuilt the AppManagement DB due to AppManagement DB corruption.	-	-	Y	Y	-
[7157] HomeScreen DB has been rebuilt automatically since it was damaged.	Rebuilt the HomeScreen DB due to HomeScreen DB corruption.	-	-	Y	Y	-
[7158] JobHistory DB has been rebuilt automatically since it was damaged.	Rebuilt the JobHistory DB due to JobHistory DB corruption.	-	-	Y	Y	-
[7159] AppLicense DB has been rebuilt automatically since it was damaged.	Rebuilt the AppLicense DB by AppLicense DB corruption	-	-	Y	Y	-
[715A] Print Data Converter export success	Successfully exported print data converter	-	-	Y	Y	-
[715B] Print Data Converter export failure	Failed to export print data converter	-	-	Y	Y	-
[715C] User Combined data export success	Successfully exported user information, role and group	-	-	Y	Y	-
[715D] User Combined data export failure	Failed to export user information, role and group	-	-	Y	Y	-
[715E] Address book and mailbox data export success	Successfully exported address book and mailbox data	-	-	Y	Y	-
[715F] Address book and mailbox export failure	Failed to export address book and mailbox data	-	-	Y	Y	-
[7160] Addition in the address book	Added new destinations	-	-	Y	Y	-
[7162] Addition in e-Filing	Added new user boxes	-	-	Y	Y	-
[7163] Addition of department code	Added new department codes	-	-	Y	Y	-
[7165] Department counter clearing	Cleared Department Counter	-	-	Y	Y	-
[7166] Change in the address book	Edited address book	-	-	Y	Y	-
[7168] Change in e-Filing	Edit e-Filing	-	-	Y	Y	-
[7169] Change in the department code	Edited department code	-	-	Y	Y	-
[716C] Consistency processing of user department counter	Edited department code	-	-	Y	-	-
[7170] Deletion of destination	Deleted unnecessary destinations	-	-	Y	Y	-
[7172] Deletion of user box	Deleted unnecessary user boxes	-	-	Y	Y	-
[7173] Deletion of the department code	Deleted unnecessary department codes	-	-	Y	Y	-
[7174] Addition of new users	Added new users	-	-	Y	Y	-
[7175] Change in user information	Changed user information	-	-	Y	Y	-
[7176] Deletion of user	Deleted unnecessary users	-	-	Y	Y	-
[7177] Addition of new roles	Added new roles	-	-	Y	Y	-
[7178] Change in role information	Changed role information	-	-	Y	Y	-
[7179] Deletion of role	Deleted unnecessary roles	-	-	Y	Y	-
[717A] Addition of new groups	Added new groups	-	-	Y	Y	-
[717B] Change in group information	Changed group information	-	-	Y	Y	-
[717C] Deletion of group information	Deleted group information	-	-	Y	Y	-
[717D] Update of role/group assignment of users	Role/group assignment of users has been updated.	-	-	Y	Y	-

Code	Message	Error code display media				
		Panl	JL	ML	Noti	CSV
[717E] User's EWB information has been removed.	User's EWB information has been removed.	-	-	Y	Y	-
[7182] Change in device setting	Changed device settings	-	-	Y	Y	-
[7183] Change in network setting	Changed network settings	-	-	Y	Y	-
[7184] Change in security setting	Changed security settings	-	-	Y	Y	-
[7185] Change in authentication setting	Changed authentication settings	-	-	Y	Y	-
[7188] A user password is outside the security policy.	Failed to change the password due to the security policy	-	-	Y	Y	-
[7189] An e-Filing password is outside the security policy.	e-Filing Box password is not pursuant to Security Policy	-	-	Y	Y	-
[718A] The time set in the MFP has been changed.	Edited Date & Time Setting	-	-	Y	Y	-
[718B] Start of summer time	Started the Daylight Savings Time	-	-	Y	Y	-
[718C] End of summer time	Ended the Daylight Savings Time	-	-	Y	Y	-
[7190] DDNS public key file upload success	Successfully uploaded DDNS public key	-	-	Y	Y	-
[7191] DDNS public key file upload failure	Failed to upload DDNS public key	-	-	Y	Y	-
[7192] DDNS secret key file upload success	Successfully uploaded DDNS secret key	-	-	Y	Y	-
[7193] DDNS secret key file upload failure	Failed to upload DDNS secret key	-	-	Y	Y	-
[71A0] Self-signed certification generation	Selfsigned Certificate generated	-	-	Y	Y	-
[71A1] CA certification addition success	Successfully added CA certificates	-	-	Y	Y	-
[71A2] CA certificates addition failure	Failed to add CA certificates	-	-	Y	Y	-
[71A3] Encryption key generation	Cryptographic key generated	-	-	Y	Y	-
[71A4] Encryption key consistency check failure	Failed to consistency check for encryption key	-	-	Y	Y	-
[71A5] Device certification deletion success	Successfully deleted device certificates	-	-	Y	Y	-
[71A6] Device certificates deletion failure	Failed to delete device certificates	-	-	Y	Y	-
[71A7] CA certification deletion success	Successfully deleted CA certificates	-	-	Y	Y	-
[71A8] CA certificates deletion failure	Failed to delete CA certificates	-	-	Y	Y	-
[71A9] The validated date of the device certificates has expired.	The validated date of the device certificates has expired.	-	-	Y	Y	-
[71AA] Unknown error occurred during collection of certificates from an SCEP server	Unknown error occurred during collection of certificates from an SCEP server	-	-	Y	Y	-
[71AB] Timeout error occurred during collection of certificates from an SCEP server	Timeout error occurred during collection of certificates from an SCEP server	-	-	Y	Y	-
[71AC] File saving error occurred during collection of certificates from an SCEP server	File saving error occurred during collection of certificates from an SCEP server	-	-	Y	Y	-
[71AD] SCEP certificate collection error	Failed SCEP operation	-	-	Y	Y	-
[71B0] Software package file decryption failure	Failed to decrypt Software Package	-	-	Y	Y	-
[71B2] Laser firmware installation success	Successfully updated Laser ROM	-	-	Y	Y	-
[71B3] Laser firmware installation failure	Failed to update Laser ROM	-	-	Y	Y	-

Code	Message	Error code display media				
		Panl	JL	ML	Noti	CSV
[71B4] Finisher firmware installation success	Successfully updated Finisher ROM	-	-	Y	Y	-
[71B5] Finisher firmware installation failure	Failed to update Finisher ROM	-	-	Y	Y	-
[71B6] Saddle firmware installation success	Successfully updated Saddle ROM	-	-	Y	Y	-
[71B7] Saddle firmware installation failure	Failed to update Saddle ROM	-	-	Y	Y	-
[71B8] Punch firmware installation success	Successfully updated Punch ROM	-	-	Y	Y	-
[71B9] Punch firmware installation failure	Failed to update Punch ROM	-	-	Y	Y	-
[71BA] UI data installation success	Successfully updated UI Data	-	-	Y	-	-
[71BB] UI data installation failure	Failed to update UI Data	-	-	Y	-	-
[71BC] UI data recovery success	UI Data successfully rolled back	-	-	Y	-	-
[71BD] UI data recovery failure	Failed to rollback UI Data	-	-	Y	-	-
[71BE] UI data installation failure	Failed to update UI Data (non-permitted machine)	-	-	Y	-	-
[71BF] UI data installation failure	Failed to update UI Data (non-permitted model)	-	-	Y	-	-
[71C0] Integrity check by user request start	Integrity check by user request started	-	-	Y	Y	-
[71C0] Integrity check by user request end	No problems found in the integrity check by user request	-	-	Y	Y	-
[71C2] Integrity check by user request cancel	Integrity check cancelled by a user	-	-	Y	Y	-
[71C3] Integrity check at startup end	No problems found in the integrity check at startup	-	-	Y	Y	-
[71D0] Factory Default failure	Failed to restore Factory Default settings	-	-	Y	Y	-
[71E0] License abnormality due to damage on the license manager database	LMDB Recovery	-	-	Y	Y	-
[71F0] Clone file creation success	Successfully created clone file	-	-	Y	Y	-
[71F1] Clone file creation failure	Failed to create clone file	-	-	Y	Y	-
[71F2] Clone file import success	Successfully imported clone file	-	-	Y	Y	-
[71F3] Clone file import failure	Failed to import clone file	-	-	Y	Y	-
[71F4] Clone file decryption failure	Failed to decrypt clone file	-	-	Y	Y	-
[71F5] Clone file encryption failure	Failed to encrypt clone file	-	-	Y	Y	-
[7200] Image log saving success to an external server	Successful transfer of Image Log to the external server	-	-	Y	Y	-
[7201] Image log saving failure to an external server	Failed to transfer of Image Log to the external server	-	-	Y	Y	-
[7210] User management information synchronization success	Successful synchronization of User Management information	-	-	Y	Y	-
[7211] User management information synchronization failure	Failed to synchronize User Management information	-	-	Y	Y	-
[7212] User management information synchronization failure (incorrect setting)	Failed to synchronize User Management information (setting mistake)	-	-	Y	Y	-
[7213] Some user management information synchronization failure	Failed to synchronize User Management information for some secondary MFP	-	-	Y	Y	-
[7220] AddressBook delivery success	Successful synchronization of AddressBook	-	-	Y	Y	-
[7221] AddressBook delivery failure	Failed to synchronize Address Book	-	-	Y	Y	-

Code	Message	Error code display media				
		PanI	JL	ML	Noti	CSV
[7222] Some AddressBook delivery failure	Failed to synchronize AddressBook for some secondary MFP	-	-	Y	Y	-
[7230] Project creation	Added new Project Code	-	-	Y	Y	-
[7231] Project edition	Edited Project Code	-	-	Y	Y	-
[7232] Project deletion	Removed a Project Code	-	-	Y	Y	-
[7233] Project export success	Successfully exported Project Code	-	-	Y	Y	-
[7234] Project export failure	Failed to export Project Code	-	-	Y	Y	-
[7235] Exported project downloading	Download Project Code.	-	-	Y	Y	-
[7236] Project import success	Successfully imported Project Code	-	-	Y	Y	-
[7237] Project import failure	Failed to import Project Code	-	-	Y	Y	-
[7238] A part of projects import failure	Failed to import some Project Codes	-	-	Y	Y	-
[7240] Address book download	The address book has been downloaded.	-	-	Y	Y	-
[7242] Mailbox download operation	The mailbox has been downloaded.	-	-	Y	Y	-
[7244] User information download operation	The user information has been downloaded.	-	-	Y	Y	-
[7245] Role information download operation	The role information has been downloaded.	-	-	Y	Y	-
[7246] Department code download operation	The department code has been downloaded.	-	-	Y	Y	-
[7247] ICC profile download operation	The ICC profile has been downloaded.	-	-	Y	Y	-
[7248] Log download operation	The log has been downloaded.	-	-	Y	Y	-
[7249] User information, role and group download operation	The user information, role and group have been downloaded.	-	-	Y	Y	-
[724A] The address book and mailbox have been downloaded.	The address book and mailbox have been downloaded.	-	-	Y	Y	-
[7248] Clone file download operation	The clone file has been downloaded.	-	-	Y	Y	-
[724C] Print data converter download operation	The print data converter has been downloaded.	-	-	Y	Y	-
[7272] Fax firmware1 installation success	Successfully updated FAX FIRMWARE1	-	-	Y	Y	-
[7273] Fax firmware1 installation failure	Failed to update FAX FIRMWARE1	-	-	Y	Y	-
[7274] Fax firmware2 installation success	Successfully updated FAX FIRMWARE2	-	-	Y	Y	-
[7275] Fax firmware2 installation failure	Failed to update FAX FIRMWARE2	-	-	Y	Y	-
[7276] NIC firmware installation success	Successfully updated NIC FIRMWARE	-	-	Y	Y	-
[7277] NIC firmware installation failure	Failed to update NIC FIRMWARE	-	-	Y	Y	-
[7278] Monotype RIP Font installation success	Successfully installed Monotype RIP Font	-	-	Y	Y	-
[7279] Monotype RIP Font installation failure	Failed to install Monotype RIP Font	-	-	Y	Y	-
[7280] Data backup file storing success	Data Backup file storage was completed successfully	Y	-	Y	Y	-
[7281] Data backup file storing cancel	Data Backup file storage was cancelled	Y	-	Y	Y	-



Code	Message	Error code display media				
		PanI	JL	ML	Noti	CSV
[7282] Periodical data backing up has not been executed.	Regular Data Backup was not performed	Y	-	Y	Y	-
[7283] Data backup file storing failure (A USB storage device has not been inserted)	Data Backup file storage failed (USB media was not inserted)	Y	-	Y	Y	-
[7284] Data backup file storing failure (Storing of a file into a USB storage device has failed)	Data Backup file storage failed (Failed to save the file to USB media)	Y	-	Y	Y	-
[7285] Data backup file storing failure (Connection to an external server is not possible)	Data Backup file storage failed (Failed to connect to the external server)	Y	-	Y	Y	-
[7286] Data backup file storing failure (Storing of a file into an external server has failed)	Data Backup file storage failed (Failed to save the file to the external server)	Y	-	Y	Y	-
[7287] Data backup file storing failure	Data Backup file storage failed	Y	-	Y	Y	-
[7288] Data back-up file saving failure (Cloud storage certificates error)	Saving of the data back-up file has failed. (Cloud storage certificate error)	Y	-	Y	Y	-
[7289] Data back-up file saving failure (Cloud storage full)	Saving of the data back-up file has failed. (Cloud storage full error)	Y	-	Y	Y	-
[728A] Data back-up file saving failure (Server error)	Saving of the data back-up file has failed. (Server error)	Y	-	Y	Y	-
[728B] Data back-up file failure (Connection error: Invalid URL)	Saving of the data back-up file has failed. (Connection error: Invalid URL)	Y	-	Y	Y	-
[728C] Data back-up file saving failure (Connection error: Connection impossible)	Saving of the data back-up file has failed. (Connection error: Connection impossible)	Y	-	Y	Y	-
[728D] Data back-up file saving failure (Connection error: Invalid certificates)	Saving of the data back-up file has failed. (Connection error: Invalid certificate)	Y	-	Y	Y	-
[728E] Data back-up file saving failure (Connection error)	Saving of the data back-up file has failed. (Connection error)	Y	-	Y	Y	-
[7290] Data restoring success	Data Restore process was completed successfully	Y	-	Y	Y	-
[7291] Job cancel of data restore processing	Data Restore from USB media or the external server was cancelled	Y	-	Y	Y	-
[7292] Data restore processing failure (A USB storage device is not inserted)	Data Restore process failed (USB media was not inserted)	Y	-	Y	Y	-
[7293] Data restore processing failure (Connection to an external server is not possible)	Data Restore process failed (Failed to connect to the external server)	Y	-	Y	Y	-
[7294] Data restore processing failure (Obtaining a file from a USB storage device has failed)	Data Restore process failed (Failed to get the Data Backup file from USB media)	Y	-	Y	Y	-
[7295] Data restore processing failure (Obtaining a file from an external server has failed)	Data Restore process failed (Failed to get the Data Backup file from external server)	Y	-	Y	Y	-
[7296] Data restore processing failure (Data backup file is corrupted.)	Data Restore process failed (Data Backup file is corrupted)	Y	-	Y	Y	-
[7297] Data restore processing failure	Data Restore process failed	Y	-	Y	Y	-
[7298] Data restoration failure (Cloud server certificates error)	Data restoration has failed. (Cloud server certificates error)	Y	-	Y	Y	-
[7299] Data restoration failure (Back-up files do not exist in the cloud server.)	Data restoration has failed. (Back-up files not found in the cloud server.)	Y	-	Y	Y	-
[729A] Data restoration failure (Server error)	Data restoration has failed. (Server error)	Y	-	Y	Y	-

Code	Message	Error code display media				
		Panl	JL	ML	Noti	CSV
[729B] Data restoration failure (Connection error: Invalid URL)	Data restoration has failed. (Connection error: Invalid URL)	Y	-	Y	Y	-
[729C] Data restoration failure (Connection error: Connection impossible)	Data restoration has failed. (Connection error: Connection impossible)	Y	-	Y	Y	-
[729D] Data restoration failure (Connection error: Invalid certificates)	Data restoration has failed. (Connection error: Invalid certificates)	Y	-	Y	Y	-
[729E] Data restoration failure (Connection error)	Data restoration has failed. (Connection error)	Y	-	Y	Y	-
[729F] Data restoration failure (Inconsistency in the settings of the optional storage device)	Storage Device Restore process failed (Optional storage setting inconsistency)	Y	-	Y	Y	-
[72A0] Deletion of event notification destination information registered from an application	Notification events that were registered from an application were deleted.	-	-	Y	Y	-
[72B0] Enabling of TPM by means of the control panel or the self-diagnostic code has succeeded.	Succeeded to enable TPM	-	-	Y	Y	-
[72B1] Enabling of TPM by means of the control panel or the self-diagnostic code has failed.	Failed to enable TPM	-	-	Y	Y	-
[72B2] Disabling of TPM by means of the control panel or the self-diagnostic code has succeeded.	Succeeded to disable TPM	-	-	Y	Y	-
[72B3] Disabling of TPM by means of the control panel or the self-diagnostic code has failed.	Failed to disable TPM	-	-	Y	Y	-
[72B4] Backup of the TPM key has succeeded.	Succeeded to backup TPM key	-	-	Y	Y	-
[72B5] TPM key backup failure	Failed to backup TPM key	-	-	Y	Y	-
[72B6] Restoration of the TPM key has succeeded.	Succeeded to restore TPM key	-	-	Y	Y	-
[72B7] TPM key restoration failure	Failed to restore TPM key	-	-	Y	Y	-
[72B8] Consistency confirmation of the public key has succeeded. (At the startup of the MFP when TPM and secure startup are enabled)	Succeeded to consistency check for public key	-	-	Y	Y	-
[72C0] Fingerprint registration has succeeded.	Succeeded fingerprint registration	-	-	Y	Y	-
[72C1] Fingerprint registration failure	Failed fingerprint registration	-	-	Y	Y	-
[72C2] Fingerprint registration failure (fingerprint duplication)	This has failed since the same fingerprint has already been registered.	-	-	Y	Y	-
[72C3] Fingerprint deletion has succeeded.	Succeeded fingerprint deletion	-	-	Y	Y	-
[72C4] The deletion of a fingerprint has failed due to an internal error (standard storage device malfunction, database damage or hardware error).	Failed fingerprint deletion	-	-	Y	Y	-
[72C5] Deletion of all fingerprints has succeeded.	Succeeded all fingerprints deletion	-	-	Y	Y	-
[72C6] The deletion of all the registered fingerprints has failed due to an internal error (standard storage device malfunction, database damage or hardware error).	Failed all fingerprints deletion	-	-	Y	Y	-
[72C7] Connection of the fingerprint reader has been completed.	A fingerprint reader connected	-	-	Y	Y	-
[72C8] Connection of the fingerprint reader has been disconnected.	A fingerprint reader disconnected	-	-	Y	Y	-

Code	Message	Error code display media				
		Panl	JL	ML	Noti	CSV
[72C9] Fingerprint DB has been damaged.	Fingerprint DB has been damaged.	-	-	Y	Y	-
[72CA] Recovery of the fingerprint DB has been completed.	Fingerprint DB has been recovered.	-	-	Y	Y	-
[72CB] Fingerprint template has been damaged.	Fingerprint template has been damaged.	-	-	Y	Y	-
[72CC] Fingerprint reading has failed.	Fingerprint reading has failed.	-	-	Y	Y	-
[72D0] UI data installation failure	Failed to update UI Data (compatibility check error)	-	-	Y	-	-
[72D1] System firmware installation failure	Failed to update Copier Firmware (compatibility check error)	-	-	Y	Y	-
[72D2] Upgrading of the plug-in for printer drivers has succeeded.	Successfully updated plugin of printer driver.	-	-	Y	Y	-
[72D3] Upgrading of the plug-in for printer drivers has failed.	Failed to update plugin of printer driver.	-	-	Y	Y	-
[72D4] Deletion of the plug-in for printer drivers has succeeded.	Successfully deleted plugin of printer driver.	-	-	Y	Y	-
[72D5] Deletion of the plug-in for printer drivers has failed.	Failed to delete plugin of printer driver.	-	-	Y	Y	-
[72D6] UI data installation failure	Failed to update UI Data (License check error)	-	-	Y	Y	-
[72E0] Transition of template data to the home screen has succeeded.	Successfully transited template data to the home screen	-	-	Y	Y	-
[72E1] Template data to the home screen transition failure	Failed to transit template data to the home screen	-	-	Y	Y	-
[72E2] A part of the template data has not been transferred to the home screen.	Failed to transit some template data to the home screen	-	-	Y	Y	-
[72F0] Execution of the remote command has succeeded.	Execution of the remote command has succeeded.	-	-	Y	-	-
[72F1] Execution permission of the remote command has not been assigned to an administrator.	Execution permission of the remote command has not been assigned to an administrator.	-	-	Y	-	-
[72F2] Remote command execution is not available since jobs or another service are being operated.	Remote command execution is not available since jobs or another service are being operated.	-	-	Y	-	-
[72F3] Remote command file decryption failure	Decryption of the remote command file has failed.	-	-	Y	-	-
[72F4] Remote command verification failure	Verification of the remote command file has failed.	-	-	Y	-	-
[72F5] Compatibility error of the file format of the remote command	No compatibility in the file format of the remote command	-	-	Y	-	-
[72F6] Remote command execution failure	Failed to execute the remote command	-	-	Y	-	-
[72F7] Execution of a part of remote command has failed.	Failed to execute a part of the remote command	-	-	Y	-	-
[72F8] The power of the MFP has been turned OFF while the remote command was being operated.	The power of the MFP has been turned OFF while the remote command was being operated.	-	-	Y	-	-
[7300] An application has been installed.	Successfully installed Application	-	-	Y	Y	-
[7301] Application installation failure	Failed to install Application	-	-	Y	Y	-
[7302] An application has been uninstalled.	Successfully uninstalled Application	-	-	Y	Y	-
[7303] Uninstallation of an application has failed.	Failed to uninstall Application	-	-	Y	Y	-

Code	Message	Error code display media				
		PanI	JL	ML	Noti	CSV
[7304] An application has been updated.	An application has been updated.	-	-	Y	Y	-
[7305] Updating of an application has failed.	Failed to update Application	-	-	Y	Y	-
[7306] Deletion of all the applications has succeeded.	Application removal completed	-	-	Y	Y	-
[7307] Deletion of all the applications has failed.	Failed to completely delete application.	-	-	Y	Y	-
[7308] Applications have automatically stopped.	Automatically stopped the application.	-	-	Y	Y	-
[7309] Applications have automatically started.	Automatically started the application.	-	-	Y	Y	-
[7311] Start of an application has failed.	Failed to start Application	-	-	Y	Y	-
[7313] An application has ended abnormally.	Application was terminated abnormally	-	-	Y	Y	-
[7315] App start duplicated error	App start duplicated error. Please retry later.	-	-	Y	Y	-
[7316] Invalid application license	Application license is invalid.	-	-	Y	Y	-
[7320] The license of an application is enabled	Application license was activated.	-	-	Y	Y	-
[7321] Enabling of the license for an application has failed.	Failed to activation of application license	-	-	Y	Y	-
[7322] The license of an application has been disabled.	Application license was inactivated.	-	-	Y	Y	-
[7323] Disabling of the license for an application has failed.	Failed to inactivation of application license	-	-	Y	Y	-
[7324] Installation of the application license has succeeded.	Installed the application license.	-	-	Y	Y	-
[7325] Installation of the application license has failed.	Failed to install the application license.	-	-	Y	Y	-
[7326] Application license has been uninstalled.	Application license uninstalled.	-	-	Y	Y	-
[7327] Uninstallation of the application license has failed.	Failed to uninstall the application license.	-	-	Y	Y	-
[7328] Deletion of all the application licenses has succeeded.	Application license removal completed	-	-	Y	Y	-
[7329] Deletion of all the application licenses has failed.	Failed to completely delete application license.	-	-	Y	Y	-
[7330] The validated date of the license for an application will nearly have expired.	The expiration date of the license of the application approaches.	-	-	Y	Y	-
[7331] The validity date of the license for an application has expired.	The time limit of the application license expired.	-	-	Y	Y	-
[7332] Application installation error	Failed to install Application. Please update the Application.	-	-	Y	Y	-
[7333] Application start error	Failed to start Application. Please update the Application.	-	-	Y	Y	-
[7334] Installation of the application localization data has succeeded.	Successfully installed Application Localization.	-	-	Y	Y	-
[7335] Installation of the application localization data has failed.	Failed to install Application Localization.	-	-	Y	Y	-
[7336] Application install error	Application install error. The application is not supported for this MFP.	-	-	Y	Y	-

Code	Message	Error code display media				
		Panl	JL	ML	Noti	CSV
[7337] Automatic addition of application icons has failed since the Home screen to which they are automatically added had already become full	Failed to add application button automatically.	-	-	Y	Y	-
[7338] Application installation error (The application does not exist or is being operated.)	Failed to install Application. The application does not exist or is being operated	-	-	Y	Y	-
[7339] Application installation error (The use of the embedded application is not allowed.)	Failed to install Application. The use of the embedded application is not allowed.	-	-	Y	Y	-
[7340] Application installation error (The framework version of the MFP is old.)	Failed to install Application. The framework version of the MFP is old.	-	-	Y	Y	-
[7341] Application installation error (The version of the application is old.)	Failed to install Application. The version of the application is old.	-	-	Y	Y	-
[7342] Application installation error (Other jobs exist.)	Failed to install Application. Other jobs exist.	-	-	Y	Y	-
[7343] Application installation error (The control panel is being used or another service is being operated.)	Failed to install Application. The panel is being operated or other jobs are being running.	-	-	Y	Y	-
[7344] Installation or updating of the application has failed since files or folders could not be created.	Failed to install Application. Access to a file or folder failed.	-	-	Y	Y	-
[7345] Installation or updating of the application has failed since not enough space is remaining in a file storage device.	Failed to install Application. Not enough space has remained in a file storage.	-	-	Y	Y	-
[7346] Installation or updating of the application has failed since no execution privilege has been assigned (while the user authentication is enabled).	Failed to install Application. No execution privilege	-	-	Y	Y	-
[7347] Installation or updating of the application has failed since the file does not exist.	Failed to install Application. No files exist	-	-	Y	Y	-
[7348] Installation or updating of the application has failed since the application package is invalid.	Failed to install Application. Application package is invalid.	-	-	Y	Y	-
[7349] Installation or updating of the application has failed since the signature of the application package is invalid.	Failed to install Application. Application package signature is invalid.	-	-	Y	Y	-
[7350] Installation or updating of the application has failed since the application package to be installed is not supported by the MFP.	Failed to install Application. Application does not operate in this MFP.	-	-	Y	Y	-
[7351] Application installation error (The registration number has exceeded the maximum.)	Failed to install Application. The registration numbers exceeded the upper limit.	-	-	Y	Y	-
[7352] Installation or updating of the application has failed since the required operation is not supported.	Failed to install Application. The required operation is not supported.	-	-	Y	Y	-
[7353] Application uninstallation error (The application does not exist or is being operated.)	Application uninstall error. The application does not exist or is being operated	-	-	Y	Y	-
[7354] Application uninstallation error (Other jobs exist.)	Application uninstall error. Other jobs exist.	-	-	Y	Y	-
[7355] Application uninstallation error (The control panel is being used or another service is being operated.)	Application uninstall error. The panel is being operated or other jobs are being running.	-	-	Y	Y	-

Code	Message	Error code display media				
		Panl	JL	ML	Noti	CSV
[7356] Uninstallation of the application has failed since no execution privilege has been assigned (while the user authentication is enabled).	Application uninstall error. No execution privilege	-	-	Y	Y	-
[7357] Application rollback has succeeded.	Succeeded to rollback applications	-	-	Y	Y	-
[7358] Application rollback has failed.	Failed to rollback applications	-	-	Y	Y	-
[7359] Application rollback error (The application does not exist or is being operated)	Application rollback error The application does not exist or is being operated	-	-	Y	Y	-
[7360] Application rollback error (Other jobs exist.)	Application rollback error Other jobs exist.	-	-	Y	Y	-
[7361] Application rollback error (The control panel is being used or another service is being operated.)	Application rollback error The panel is being operated or other jobs are being running.	-	-	Y	Y	-
[7362] Application rollback has failed since no execution privilege has been assigned.	Application rollback error No execution privilege	-	-	Y	Y	-
[7400] License activation success (Online)	License Activation Success(Online)	-	-	Y	Y	-
[7401] License activation success (Offline)	License Activation Success(Offline)	-	-	Y	Y	-
[7402] License activation failure (Online)	License Activation failed	-	-	Y	Y	-
[7403] License activation failure (network timeout)	License Activation failed, NW timeout	-	-	Y	Y	-
[7404] License activation failure (network error)	License Activation failed, NW error	-	-	Y	Y	-
[7410] License deactivation success (Online)	License Deactivate Success(Online)	-	-	Y	Y	-
[7411] License deletion success (Offline)	License Deactivate Success(Offline)	-	-	Y	Y	-
[7412] License deactivation failure (Online)	License Deactivation failed	-	-	Y	Y	-
[7423] License deactivation failure (network timeout)	License Deactivation failed, NW timeout	-	-	Y	Y	-
[7424] License deactivation failure (network error)	License Deactivation failed, NW error	-	-	Y	Y	-
[7430] Serial number mismatching	License Activation failed, Invalid serial number	-	-	Y	Y	-
[7431] Subnet mismatching	License Activation failed, Invalid subnet	-	-	Y	Y	-
[7432] Domain mismatching	License Activation failed, Invalid Domain	-	-	Y	Y	-
[7433] Invalid license certificates ID	License Activation failed (Invalid input)	-	-	Y	Y	Y
[7434] License duplicating installation	License Activation failed (Same license)	-	-	Y	Y	Y
[7435] Unsupported license activation	License Activation failed (unsupported license)	-	-	Y	Y	Y
[7440] Signature mismatching	License file Signature mismatch error	-	-	Y	Y	-
[7441] End of the trial period	Trial License expired	-	-	Y	Y	-
[7442] End of the valid period	License period expired	-	-	Y	Y	-
[7444] No license exists	License Not Found	-	-	Y	Y	-
[7445] Full of the license	License Full	-	-	Y	Y	-
[7470] Creation of the debug log has succeeded.	Succeeded to create debug log	-	-	Y	-	-
[7471] Debug log creation failure	Failed to create debug log	-	-	Y	-	-

Code	Message	Error code display media				
		Panel	JL	ML	Noti	CSV
[7472] Transmission of the debug log to the remote maintenance service has succeeded.	Succeeded to transmit the debug log to the remote maintenance service	-	-	Y	-	-
[7473] Debug log to the remote maintenance service transmission failure	Failed to transmit the debug log to the remote maintenance service	-	-	Y	-	-
[7474] Transmission of the debug log by an e-mail has succeeded.	Succeeded to transmit the debug log by an e-mail	-	-	Y	-	-
[7475] Debug log by an e-mail transmission failure	Failed to transmit the debug log by an e-mail	-	-	Y	-	-
[7476] Obtaining of the print data has succeeded.	Succeeded to obtain print data	-	-	Y	-	-
[7477] Print data collection failure	Failed to obtain print data	-	-	Y	-	-
[7478] Transmission of the print data to the remote maintenance service has succeeded.	Succeeded to transmit the print data to the remote maintenance service	-	-	Y	-	-
[7479] Print data to the remote maintenance service transmission failure	Failed to transmit the print data to the remote maintenance service	-	-	Y	-	-
[747A] Transmission of the print data by an e-mail has succeeded.	Succeeded to transmit the print data by an e-mail	-	-	Y	-	-
[747B] Print data by an e-mail transmission failure	Failed to transmit the print data by an e-mail	-	-	Y	-	-
[747C] Print data by an e-mail transmission failure (Data size exceeding error)	Failed to transmit the print data by an e-mail (exceeding the maximum size)	-	-	Y	-	-
[747D] Obtaining of the network capture has succeeded.	Succeeded to obtain the network capture	-	-	Y	-	-
[747E] Network capture collection failure	Failed to obtain the network capture	-	-	Y	-	-
[747F] Transmission of the network capture to the remote maintenance service has succeeded.	Succeeded to transmit the network capture to the remote maintenance service	-	-	Y	-	-
[7480] Network capture to the remote maintenance service transmission failure	Failed to transmit the network capture to the remote maintenance service	-	-	Y	-	-
[7481] Transmission of the network capture by an e-mail has succeeded.	Succeeded to transmit the network capture by an e-mail	-	-	Y	-	-
[7482] Network capture by an e-mail transmission failure	Failed to transmit the network capture to the remote maintenance service	-	-	Y	-	-
[7483] Network capture by an e-mail transmission failure (Data size exceeding error)	Failed to transmit the network capture to the remote maintenance service (exceeding the maximum size)	-	-	Y	-	-
[7484] Deletion of the log data has succeeded.	Succeeded to delete the log data	-	-	Y	-	-
[7485] Log data deletion failure	Failed to delete the log data	-	-	Y	-	-
[7486] The log level has been changed.	Log level changed	-	-	Y	-	-
[7487] The log level has been set to the default.	The log level set to the default	-	-	Y	-	-
[7488] Debug logs have been properly saved in a USB storage device.	Debug log was stored to USB.	-	-	Y	-	-
[7489] Debug logs saving failure	Failed to store the debug log to USB.	-	-	Y	-	-
[7490] Remote Panel Operation (Cloud hub) connection start	Remote panel connection started	-	-	Y	-	-

Code	Message	Error code display media				
		Panl	JL	ML	Noti	CSV
[7491] Remote Panel Operation (Cloud hub) connection error: authentication error	Remote panel connection failed (authentication error)	-	-	Y	-	-
[7492] Remote Panel Operation (Cloud hub) connection error: network error	Remote panel connection failed (network error)	-	-	Y	-	-
[7493] Remote Panel Operation (Cloud hub) connection end	Remote panel connection ended	-	-	Y	-	-
[74A0] Anti-malware setting change	Edited Antimalware setting.	-	-	Y	-	-
[74A1] Updating of the firmware of the card reader has succeeded.	Successfully updated Firmware	-	-	Y	-	-
[74A2] Updating of the firmware of the card reader has failed.	Failed to update Firmware	-	-	Y	-	-
[74A3] The card reader has not been installed. Alternatively, the firmware of the installed card reader cannot be updated.	Card reader is not connected, or Card reader used cannot be updated with firmware	-	-	Y	-	-
[74A4] The specified file cannot be used for updating the firmware.	File is not a firmware update.	-	-	Y	-	-
[74A5] There are no files in the specified folder.	No firmware update file	-	-	Y	-	-



## 8.2.8 Network error

Code	Message	Error code display media				
		Panl	JL	ML	Noti	CSV
[8000] IPv4 address conflict	Static address of IPv4 was duplicated.	-	-	Y	Y	-
[8011] IPv6 link local address conflict	Link Local address of IPv6 was duplicated.	-	-	Y	Y	-
[8012] IPv6 manual address conflict	Manual address of IPv6 was duplicated.	-	-	Y	Y	-
[8013] IPv6 stateless address conflict	Stateless address of IPv6 was duplicated.	-	-	Y	Y	-
[8014] IPv6 stateful address conflict	Stateful address of IPv6 was duplicated.	-	-	Y	Y	-
[8021] Authentication success	-	-	-	-	-	-
[8022] 802.1X authentication failure	Authentication Failure	-	-	Y	-	-
[8023] Connection failure to an authentication server and a switch	Can not contact Authentication Server/Switch	-	-	Y	-	-
[8024] Certificates verification failure	Certificate verification Failure	-	-	Y	-	-
[8031] IPsec error for IKEv1 certification failure	No IKE proposal chosen	-	-	Y	Y	-
[8032] IPsec error for wrong proposal selection	IKE Certificate Authentication failed	-	-	Y	Y	-
[8033] IPsec error for shared key authentication failure	IKE Pre-shared key Authentication failed	-	-	Y	Y	-
[8034] IPsec error for invalid certificates upload	Invalid Certificate	-	-	Y	Y	-
[8035] IPsec error for non-supported certificates	Certificate Type unsupported	-	-	Y	Y	-
[8036] IPsec error for invalid certificates of authentication	Invalid Certificate	-	-	Y	Y	-
[8037] IPsec error for certificates disable	Certificate unavailable	-	-	Y	Y	-
[8038] IPsec error for SA non-existing	No ISAKMP SA established	-	-	Y	Y	-
[8039] IPsec error for invalid signature for certification	Invalid Signature	-	-	Y	Y	-
[803A] IPsec error for wrong selection of proposal	No IKEv2 proposal chosen	-	-	Y	Y	-
[803B] IPsec error for IKEv2 certification failure	IKEv2 Certificate Authentication failed	-	-	Y	Y	-
[803C] IKEv2 error for IKEv2 if secret key authentication failed	IKEv2 Secret key Authentication failed	-	-	Y	Y	-
[803D] IPsec error if peer does not support IKEv2 and falling back to IKEv1	Falling Back to IKEv1	-	-	Y	Y	-
[803E] IPsec error if ISAKMP SA is uncreated or destroyed due to some uncertain conditions	ISAKMP SA unusable (deleted)	-	-	Y	Y	-
[803F] IPsec error for IKEv2 if crypto operation failed	Crypto operation failed	-	-	Y	Y	-
[8040] IPsec error for IKEv2 if key info is invalid	Invalid key information	-	-	Y	Y	-
[8041] IPsec error for IKEv2 if CA is not trusted	CA not trusted	-	-	Y	Y	-
[8042] IPsec error for authentication method inconsistency	Authentication Method mismatch	-	-	Y	Y	-
[8043] IPsec error for version inconsistency	IKE Version mismatch	-	-	Y	Y	-
[8044] IPsec error for encapsulation inconsistency	Encapsulation mode mismatch	-	-	Y	Y	-

Code	Message	Error code display media				
		Panl	JL	ML	Noti	CSV
[8045] IPsec error for peer IP inconsistency	Peer IP Address mismatch	-	-	Y	Y	-
[8046] IPsec error for local IP inconsistency	Local IP Address mismatch	-	-	Y	Y	-
[8047] IPsec error for local ID inconsistency	Local ID mismatch	-	-	Y	Y	-
[8048] IPsec error for remote ID inconsistency	Remote ID mismatch	-	-	Y	Y	-
[8049] IPsec error for remote IP inconsistency	IPsec Remote IP mismatch	-	-	Y	Y	-
[804A] IPsec error for IKEv2 timeout	IKEv1/IKEv2 Timed out	-	-	Y	Y	-
[804B] IPsec error for invalid of ID manual key	Invalid manual key data	-	-	Y	Y	-
[8061] Update error for secure primary DDNS	Secure Update to Primary DDNS failed.	-	-	Y	Y	-
[8062] Update error for secure secondary DDNS	Secure Update to Secondary DDNS failed.	-	-	Y	Y	-
[8063] Update error for IPv6 secure primary DDNS	Secure Update to Primary IPv6 DDNS failed.	-	-	Y	Y	-
[8064] Update error for IPv6 secure secondary DDNS	Secure Update to Secondary IPv6 DDNS failed	-	-	Y	Y	-
[8065] Update error for IPv6 primary DDNS	IPv6 Update to Primary DDNS failed.	-	-	Y	Y	-
[8066] Update error for IPv6 secondary DDNS	IPv6 Update to Secondary DDNS failed.	-	-	Y	Y	-
[8067] Update error for IPv4 primary DDNS	IPv4 Update to Primary DDNS failed.	-	-	Y	Y	-
[8068] Update error for IPv4 secondary DDNS	IPv4 Update to Secondary DDNS failed.	-	-	Y	Y	-
[8069] Message displayed when the key file for SIG(0) or TSIG is invalid	Invalid TSIG/SIG(0) Key file uploaded	-	-	Y	Y	-
[80B1] Bluetooth connection failure	Bluetooth Disconnected	-	-	Y	Y	-
[80B2] Bluetooth print error	Bluetooth Print error	-	-	Y	Y	-
[80B3] Bluetooth fatal error	Bluetooth Fatal error	-	-	Y	Y	-
[80B4] Bluetooth storage nearly full	Bluetooth Storage Near Full	-	-	Y	Y	-
[80B5] Bluetooth storage full	Bluetooth Storage Full	-	-	Y	Y	-
[80C0] TLS session establishment failure (invalid message)	Failed to establish the TLS session (unexpected message)	-	-	Y	Y	-
[80C1] TLS session establishment failure (invalid MAC data)	Failed to establish the TLS session (bad record mac)	-	-	Y	Y	-
[80C2] TLS session establishment failure (decoding failure)	Failed to establish the TLS session (decryption failed)	-	-	Y	Y	-
[80C3] TLS session establishment failure (recording length abnormality)	Failed to establish the TLS session (record overflow)	-	-	Y	Y	-
[80C4] TLS session establishment failure (data decompression failure)	Failed to establish the TLS session (decompression failure)	-	-	Y	Y	-
[80C5] TLS session establishment failure (handshake failure)	Failed to establish the TLS session (handshake failure)	-	-	Y	Y	-
[80C6] TLS session establishment failure (certificate abnormality)	Failed to establish the TLS session (bad certificate)	-	-	Y	Y	-
[80C7] TLS session establishment failure (non-support certificate)	Failed to establish the TLS session (unsupported certificate)	-	-	Y	Y	-
[80C8] TLS session establishment failure (invalid certificate)	Failed to establish the TLS session (certificate revoked)	-	-	Y	Y	-

Code	Message	Error code display media				
		Panl	JL	ML	Noti	CSV
[80C9] TLS session establishment failure (certificate with validity date expired)	Failed to establish the TLS session (certificate expired)	-	-	Y	Y	-
[80CA] TLS session establishment failure (certificate process error)	Failed to establish the TLS session (certificate unknown)	-	-	Y	Y	-
[80CB] TLS session establishment failure (invalid parameter)	Failed to establish the TLS session (illegal parameter)	-	-	Y	Y	-
[80CC] TLS session establishment failure (unknown CA certificate)	Failed to establish the TLS session (unknown ca)	-	-	Y	Y	-
[80CD] TLS session establishment failure (access rejection)	Failed to establish the TLS session (access denied)	-	-	Y	Y	-
[80CE] TLS session establishment failure (decoding error)	Failed to establish the TLS session (decode error)	-	-	Y	Y	-
[80CF] TLS session establishment failure (decryption error)	Failed to establish the TLS session (decrypt error)	-	-	Y	Y	-
[80D0] TLS session establishment failure (export restrictions)	Failed to establish the TLS session (export restriction)	-	-	Y	Y	-
[80D1] TLS session establishment failure (non-support protocol version)	Failed to establish the TLS session (protocol version)	-	-	Y	Y	-
[80D2] TLS session establishment failure (internal error)	Failed to establish the TLS session (internal error)	-	-	Y	Y	-
[80D3] TLS session establishment failure (cancellation by a user)	Failed to establish the TLS session (user canceled)	-	-	Y	Y	-
[80D4] TLS session establishment failure (invalid renegotiation)	Failed to establish the TLS session (no renegotiation)	-	-	Y	Y	-
[80F0] LDAP DB damage detection	LDAP DB damage detected	-	-	Y	-	-
[8101] Wireless connection in the Access point failure	Wireless association with Access point failure	-	-	Y	-	-
[8102] Connection failure of MFP to the Access point with a specified SSID	MFP not able to contact the Access point with the specified SSID	-	-	Y	-	-
[8103] Wireless certificate verification failure	Wireless Certificate verification failure	-	-	Y	-	-
[8104] Wireless LAN / Bluetooth module hardware error	Wireless module Error	-	-	Y	-	-
[8106] The number of connection sessions of Wi-Fi Direct has reached the maximum.	Wi-Fi Direct Session MAX	-	-	Y	-	-
[8121] Domain: Authentication failure	Domain - General Failure during Authentication	-	-	Y	Y	-
[8122] Domain: Invalid user name or password	Domain - Invalid Username or Password	-	-	Y	Y	-
[8123] Domain: Invalid server	Domain - Server not present in Network	-	-	Y	Y	-
[8124] Domain: Invalid user account	Domain - User account is disabled on Server	-	-	Y	Y	-
[8125] Domain: Expired user account	Domain - User account has expired and cannot be used for logon	-	-	Y	Y	-
[8126] Domain: Locked user account	Domain - User account is locked and cannot be used for logon	-	-	Y	Y	-
[8127] Domain: Invalid log-in time	Domain - Invalid logon hours for the User	-	-	Y	Y	-
[8128] Active directory domain: Clock skew error	Active Directory Domain - Clock Skew error due to difference in Time between Server and MFP	-	-	Y	Y	-

Code	Message	Error code display media				
		Panl	JL	ML	Noti	CSV
[8129] Active directory domain: Expired Kerberos ticket	Active Directory Domain - Kerberos Ticket has expired and cannot be used for Authentication	-	-	Y	Y	-
[812A] Active directory domain: Kerberos ticket authentication failure	Active Directory Domain - Verification of the Ticket has failed	-	-	Y	Y	-
[812B] Active directory domain: Invalid realm name	Active Directory Domain-The Domain specified could not be found	-	-	Y	Y	-
[8200] The IPv4 address has conflicted. (Secondary interface)	Static address of IPv4 was duplicated. (secondary)	-	-	Y	Y	-
[8211] The IPv6 link local address has conflicted. (Secondary interface)	Link Local address of IPv6 was duplicated. (secondary)	-	-	Y	Y	-
[8212] The IPv6 manual address has conflicted. (Secondary interface)	Manual address of IPv6 was duplicated. (secondary)	-	-	Y	Y	-
[8213] The IPv6 stateless address has conflicted. (Secondary interface)	Stateless address of IPv6 was duplicated. (secondary)	-	-	Y	Y	-
[8214] The IPv6 stateful address has conflicted. (Secondary interface)	Stateful address of IPv6 was duplicated. (secondary)	-	-	Y	Y	-

## 8.2.9 Notification

Code	Message	Error code display media				
		Panl	JL	ML	Noti	CSV
[D101] Paper presence/absence in the LCF	Paper Empty in Large Capacity Feeder - Please Add Paper.	-	-	Y	Y	-
[D102] Paper presence/absence in the SFB	-	-	-	-	-	-
[D103] Paper presence/absence in the 1st drawer	Paper Empty in Drawer 1 - Please Add Paper.	-	-	Y	Y	-
[D104] Paper presence/absence in the 2nd drawer	Paper Empty in Drawer 2 - Please Add Paper.	-	-	Y	Y	-
[D105] Paper presence/absence in the PFP1	Paper Empty in Drawer 3 - Please Add Paper.	-	-	Y	Y	-
[D106] Paper presence/absence in the PFP2	Paper Empty in Drawer 4 - Please Add Paper.	-	-	Y	Y	-
[D201] Front cover	Front Cover Open - Please Close Cover.	-	-	Y	Y	-
[D202] Paper feed cover of the MFP	Paper Feeding Cover Open - Please Close Cover.	-	-	Y	Y	-
[D204] T-LCF cover (taking off of the LCF (large capacitor feeder))	Lower Side Cover Open - Please Close Cover.	-	-	Y	Y	-
[D205] Paper feed cover of the PFP (side cover)	Lower Side Cover Open - Please Close Cover.	-	-	Y	Y	-
[D206] ADU cover / unit	Automatic Duplexing Unit Cover Open - Please Close Cover.	-	-	Y	Y	-
[D207] Bridge kit transport cover	Relay Unit Cover Open - Please Close Cover.	-	-	Y	Y	-
[D209] Finisher joint has come off	Finisher Joint Cover Open - Please Close Cover.	-	-	Y	Y	-
[D20A] Finisher door	Finisher Door Open - Please Close Door.	-	-	Y	Y	-
[D20E] Saddle stitch stapler connection	Lower Tray Delivery Cover Open - Please Close Cover	-	-	Y	Y	-
[D20F] Front cover of the punch unit	Punch Unit Front Cover Open - Please Close Cover.	-	-	Y	Y	-
[D211] Job separator cover	Job Separator Cover Open - Please Close Cover.	-	-	Y	Y	-
[D217] Top cover of the Finisher	Finisher Door Open - Please Close Door.	-	-	Y	Y	-
[D301] Toner (K) empty	Black Toner Empty - Please Refill.	-	-	Y	Y	-
[D302] Toner (C) empty	Cyan Toner Empty - Please Refill.	-	-	Y	Y	-
[D303] Toner (M) empty	Magenta Toner Empty - Please Refill.	-	-	Y	Y	-
[D304] Toner (Y) empty	Yellow Toner Empty - Please Refill.	-	-	Y	Y	-
[D30F] Waste toner box full	Waste Toner Box Full - Please Replace.	-	-	Y	Y	-
[D311] Non-genuine toner (K)	-	-	-	-	-	-
[D312] Non-genuine toner (C)	-	-	-	-	-	-
[D313] Non-genuine toner (M)	-	-	-	-	-	-
[D314] Non-genuine toner (Y)	-	-	-	-	-	-
[D321] Toner (K) nearly empty	-	Y	-	-	-	-
[D322] Toner (C) nearly empty	-	Y	-	-	-	-
[D323] Toner (M) nearly empty	-	Y	-	-	-	-
[D324] Toner (Y) nearly empty	-	Y	-	-	-	-

Code	Message	Error code display media				
		Panl	JL	ML	Noti	CSV
[D32E] Waste toner box nearly full	-	-	-	-	Y	-
[D341] Cartridge (K) empty	Black Toner Empty - Please Refill.	-	-	Y	-	-
[D342] Cartridge (C) empty	Cyan Toner Empty - Please Refill.	-	-	Y	-	-
[D343] Cartridge (M) empty	Magenta Toner Empty - Please Refill.	-	-	Y	-	-
[D344] Cartridge (Y) empty	Yellow Toner Empty - Please Refill.	-	-	Y	-	-
[D361] Fuser unit replacement completion	New unit was installed	-	-	Y	-	-
[D362] EPU (K) replacement completion	New unit was installed	-	-	Y	-	-
[D363] EPU (C) replacement completion	New unit was installed	-	-	Y	-	-
[D364] EPU (M) replacement completion	New unit was installed	-	-	Y	-	-
[D365] EPU (Y) replacement completion	New unit was installed	-	-	Y	-	-
[D366] EPU2 (K) replacement completion	New unit was installed	-	-	Y	-	-
[D367] EPU2 (C) replacement completion	New unit was installed	-	-	Y	-	-
[D368] EPU2 (M) replacement completion	New unit was installed	-	-	Y	-	-
[D369] EPU2 (Y) replacement completion	New unit was installed	-	-	Y	-	-
[D401] 1st drawer	Close Drawer 1	-	-	Y	Y	-
[D402] 2nd drawer	Close Drawer 2	-	-	Y	Y	-
[D403] 3rd drawer	Close Drawer 3	-	-	Y	Y	-
[D404] 4th drawer	Close Drawer 4	-	-	Y	Y	-
[D405] Paper supply door of the T-LCF	Close large capacity feeder (LCF)	-	-	Y	Y	-
[D407] Paper supply door of the T-LCF (left side)	Close large capacity feeder (LCF)	-	-	Y	Y	-
[D711] 2nd drawer installation and removal	Add/Remove Drawer 2	-	-	Y	Y	-
[D712] 3rd drawer installation and removal	Add/Remove Drawer 3	-	-	Y	Y	-
[D713] 4th drawer installation and removal	Add/Remove Drawer 4	-	-	Y	Y	-
[D718] LCF installation and removal	Add/Remove Large Capacity Feeder	-	-	Y	Y	-
[D730] Finisher installation and removal	Add/Remove Finisher	-	-	Y	Y	-
[D731] Saddle stitch unit installation and removal	Add/Remove Saddle Finisher	-	-	Y	Y	-
[D732] Hole punch unit installation and removal	Add/Remove Hole Punch Unit	-	-	Y	Y	-
[D750] ADU installation and removal	Add/Remove Automatic Duplexing Unit	-	-	Y	Y	-
[D751] Bridge kit installation and removal	Add/Remove Relay Unit	-	-	Y	Y	-
[D770] ADF installation and removal	Add/Remove Automatic Document Feeder	-	-	Y	Y	-
[D7B0] FAX Unit line 1 installation and removal	Add/Remove Fax Unit(Line1)	-	-	Y	Y	-
[D7B1] FAX Unit line 2 installation and removal	Add/Remove Fax Unit(Line2)	-	-	Y	Y	-
[D7E0] Coin controller installation and removal	Add/Remove Coin Controller	-	-	Y	Y	-
[D7E1] Key copy counter installation and removal	Add/Remove Key Copy Counter	-	-	Y	Y	-
[D800] Shutdown	The machine was shut down	-	-	Y	Y	-
[D801] Power ON	Turned on the power	-	-	Y	Y	-
[D802] Shifting into the energy saving mode	Gone into the energy save mode	-	-	Y	Y	-
[D803] Shifting into the sleep mode	Gone into the sleep mode	-	-	Y	-	-

Code	Message	Error code display media				
		PanI	JL	ML	Noti	CSV
[D804] Reboot execution	The machine was rebooted	-	-	Y	Y	-
[D805] Silent reboot	-	-	-	-	-	-
[D806] Rebooting for recovering from an internal error (service call)	Rebooted to address internal errors.	Y	-	Y	-	-

## 8.2.10 FAX error

Code	Message	Error code display media				
		Panl	JL	ML	Noti	CSV
[0000] • Fax - The fax transmission has succeeded. - The fax reception has succeeded. • IP Fax - The IP Fax transmission has succeeded. - The IP Fax reception has succeeded.	<ul style="list-style-type: none"> <li>Your Send Fax job is successfully completed</li> <li>Your Received Fax job is successfully completed</li> <li>Your Send IP Fax job is successfully completed</li> <li>Your Received IP Fax job is successfully completed</li> </ul>	-	-	-	Y	-
[0012] Original jam	<ul style="list-style-type: none"> <li>Failed to process your send Fax job</li> <li>Failed to process your received Fax job</li> </ul>	-	-	-	Y	-
[0013] Cover is open	<ul style="list-style-type: none"> <li>Failed to process your send Fax job</li> <li>Failed to process your received Fax job</li> </ul>	-	-	-	Y	-
[0020] Power failure	<ul style="list-style-type: none"> <li>Failed to process your send Fax job</li> <li>Failed to process your received Fax job</li> <li>Failed to process your send IP Fax job</li> <li>Failed to process your received IP Fax job</li> </ul>	-	-	-	Y	-
[0030] Recording paper jam	<ul style="list-style-type: none"> <li>Your Fax job is canceled</li> <li>Your received Fax job is canceled</li> </ul>	-	-	-	Y	-
[0033] Polling error	<ul style="list-style-type: none"> <li>Failed to process your send Fax job</li> <li>Failed to process your received Fax job</li> </ul>	-	-	-	Y	-
[0040] Modem communication error	<ul style="list-style-type: none"> <li>Failed to process your send Fax job</li> <li>Failed to process your received Fax job</li> </ul>	-	-	-	Y	-
[0042] Memory full	<ul style="list-style-type: none"> <li>Failed to process your received Fax job</li> <li>Failed to process your received IP Fax job</li> </ul>	-	-	-	Y	-
[0050] Line is busy	<ul style="list-style-type: none"> <li>Failed to process your send Fax job</li> <li>Failed to process your send IP Fax job</li> </ul>	-	-	-	Y	-
[0051] No cable connected for fax line	Failed to process your send Fax job	Y	-	-	Y	-
[0052] T1 time-out	<ul style="list-style-type: none"> <li>Failed to process your send Fax job</li> <li>Failed to process your received Fax job</li> <li>Failed to process your send IP Fax job</li> <li>Failed to process your received IP Fax job</li> </ul>	-	-	-	Y	-
[00B0] Initial signal not detected	<ul style="list-style-type: none"> <li>Failed to process your send Fax job</li> <li>Failed to process your received Fax job</li> </ul>	-	-	-	Y	-



Code	Message	Error code display media				
		PanI	JL	ML	Noti	CSV
[00B1] Terminal constants not compatible	<ul style="list-style-type: none"> <li>Failed to process your send Fax job</li> <li>Failed to process your received Fax job</li> <li>Failed to process your send IP Fax job</li> <li>Failed to process your received IP Fax job</li> </ul>	-	-	-	Y	-
[00B2] DCN reception (Phase B)	<ul style="list-style-type: none"> <li>Failed to process your send Fax job</li> <li>Failed to process your received Fax job</li> <li>Failed to process your send IP Fax job</li> <li>Failed to process your received IP Fax job</li> </ul>	-	-	-	Y	-
[00B3] DCS / DTC not detected	<ul style="list-style-type: none"> <li>Failed to process your send Fax job</li> <li>Failed to process your received Fax job</li> <li>Failed to process your send IP Fax job</li> <li>Failed to process your received IP Fax job</li> </ul>	-	-	-	Y	-
[00B4] Training error	<ul style="list-style-type: none"> <li>Failed to process your send Fax job</li> <li>Failed to process your received Fax job</li> <li>Failed to process your send IP Fax job</li> <li>Failed to process your received IP Fax job</li> </ul>	-	-	-	Y	-
[00B5] CFR not detected	<ul style="list-style-type: none"> <li>Failed to process your send Fax job</li> <li>Failed to process your received Fax job</li> <li>Failed to process your send IP Fax job</li> <li>Failed to process your received IP Fax job</li> </ul>	-	-	-	Y	-
[00B6] No response made to CTC	<ul style="list-style-type: none"> <li>Failed to process your send Fax job</li> <li>Failed to process your received Fax job</li> <li>Failed to process your send IP Fax job</li> <li>Failed to process your received IP Fax job</li> </ul>	-	-	-	Y	-
[00B7] Phase B cannot be completed	<ul style="list-style-type: none"> <li>Failed to process your send Fax job</li> <li>Failed to process your received Fax job</li> <li>Failed to process your send IP Fax job</li> <li>Failed to process your received IP Fax job</li> </ul>	-	-	-	Y	-
[00C0] Image signal carrier not detected	<ul style="list-style-type: none"> <li>Failed to process your send Fax job</li> <li>Failed to process your received Fax job</li> <li>Failed to process your send IP Fax job</li> <li>Failed to process your received IP Fax job</li> </ul>	-	-	-	Y	-

Code	Message	Error code display media				
		PanI	JL	ML	Noti	CSV
[00C1] High-speed signal not detected	<ul style="list-style-type: none"> <li>Failed to process your send Fax job</li> <li>Failed to process your received Fax job</li> <li>Failed to process your send IP Fax job</li> <li>Failed to process your received IP Fax job</li> </ul>	-	-	-	Y	-
[00C2] Image signal carrier disconnected	<ul style="list-style-type: none"> <li>Failed to process your send Fax job</li> <li>Failed to process your received Fax job</li> <li>Failed to process your send IP Fax job</li> <li>Failed to process your received IP Fax job</li> </ul>	-	-	-	Y	-
[00C4] EOL time-out	<ul style="list-style-type: none"> <li>Failed to process your send Fax job</li> <li>Failed to process your received Fax job</li> <li>Failed to process your send IP Fax job</li> <li>Failed to process your received IP Fax job</li> </ul>	-	-	-	Y	-
[00C5] Excess length of data received	<ul style="list-style-type: none"> <li>Failed to process your send Fax job</li> <li>Failed to process your received Fax job</li> <li>Failed to process your send IP Fax job</li> <li>Failed to process your received IP Fax job</li> </ul>	-	-	-	Y	-
[00C6] Image code conversion error	<ul style="list-style-type: none"> <li>Failed to process your send Fax job</li> <li>Failed to process your received Fax job</li> <li>Failed to process your send IP Fax job</li> <li>Failed to process your received IP Fax job</li> </ul>	-	-	-	Y	-
[00C7] Phase C cannot be completed	<ul style="list-style-type: none"> <li>Failed to process your send Fax job</li> <li>Failed to process your received Fax job</li> <li>Failed to process your send IP Fax job</li> <li>Failed to process your received IP Fax job</li> </ul>	-	-	-	Y	-
[00C8] Transmitted image was not made in time	Failed to process your send IP Fax job	-	-	-	Y	-
[00D0] Post message not detected	<ul style="list-style-type: none"> <li>Failed to process your send Fax job</li> <li>Failed to process your received Fax job</li> <li>Failed to process your send IP Fax job</li> <li>Failed to process your received IP Fax job</li> </ul>	-	-	-	Y	-

Code	Message	Error code display media				
		Panl	JL	ML	Noti	CSV
[00D1] DCN reception	<ul style="list-style-type: none"> <li>Failed to process your send Fax job</li> <li>Failed to process your received Fax job</li> <li>Failed to process your send IP Fax job</li> <li>Failed to process your received IP Fax job</li> </ul>	-	-	-	Y	-
[00D2] Poor image quality	<ul style="list-style-type: none"> <li>Failed to process your send Fax job</li> <li>Failed to process your received Fax job</li> <li>Failed to process your send IP Fax job</li> <li>Failed to process your received IP Fax job</li> </ul>	-	-	-	Y	-
[00D3] No response made to EOR	<ul style="list-style-type: none"> <li>Failed to process your send Fax job</li> <li>Failed to process your received Fax job</li> <li>Failed to process your send IP Fax job</li> <li>Failed to process your received IP Fax job</li> </ul>	-	-	-	Y	-
[00D4] No response made to RR	<ul style="list-style-type: none"> <li>Failed to process your send Fax job</li> <li>Failed to process your received Fax job</li> <li>Failed to process your send IP Fax job</li> <li>Failed to process your received IP Fax job</li> </ul>	-	-	-	Y	-
[00D5] T5 time-out	<ul style="list-style-type: none"> <li>Failed to process your send Fax job</li> <li>Failed to process your received Fax job</li> <li>Failed to process your send IP Fax job</li> <li>Failed to process your received IP Fax job</li> </ul>	-	-	-	Y	-
[00D6] ERR returned to EOR	<ul style="list-style-type: none"> <li>Failed to process your send Fax job</li> <li>Failed to process your received Fax job</li> <li>Failed to process your send IP Fax job</li> <li>Failed to process your received IP Fax job</li> </ul>	-	-	-	Y	-
[00D7] Line disconnected by transmission of EOR	<ul style="list-style-type: none"> <li>Failed to process your send Fax job</li> <li>Failed to process your received Fax job</li> <li>Failed to process your send IP Fax job</li> <li>Failed to process your received IP Fax job</li> </ul>	-	-	-	Y	-
[00D8] Time-out between FCD frame	<ul style="list-style-type: none"> <li>Failed to process your send Fax job</li> <li>Failed to process your received Fax job</li> <li>Failed to process your send IP Fax job</li> <li>Failed to process your received IP Fax job</li> </ul>	-	-	-	Y	-

Code	Message	Error code display media				
		Panl	JL	ML	Noti	CSV
[00DA] MCF not returned	<ul style="list-style-type: none"> <li>Failed to process your send Fax job</li> <li>Failed to process your received Fax job</li> <li>Failed to process your send IP Fax job</li> <li>Failed to process your received IP Fax job</li> </ul>	-	-	-	Y	-
[00E8] Storage device error	<ul style="list-style-type: none"> <li>Failed to process your send Fax job</li> <li>Failed to process your received Fax job</li> <li>Failed to process your send IP Fax job</li> <li>Failed to process your received IP Fax job</li> </ul>	-	-	-	Y	-
[00F0] Software trouble	<ul style="list-style-type: none"> <li>Failed to process your send Fax job</li> <li>Failed to process your received Fax job</li> <li>Failed to process your send IP Fax job</li> <li>Failed to process your received IP Fax job</li> </ul>	-	-	-	Y	-
[00F1] Hardware noise	<ul style="list-style-type: none"> <li>Failed to process your send Fax job</li> <li>Failed to process your received Fax job</li> </ul>	-	-	-	Y	-
[00F4] Software trouble (Fax unit)	<ul style="list-style-type: none"> <li>Failed to process your send Fax job</li> <li>Failed to process your received Fax job</li> </ul>	-	-	-	Y	-
[0100] Registration success	Registration to SIP server Success.	-	-	Y	Y	-
[0101] Response Time-out (Registration)	Registration to SIP server failed.	-	-	Y	Y	-
[0102] Response Time-out (Invite)	IP Fax response timeout error	-	-	-	Y	-
[0103] "Multiple Choices" reception	Registration to SIP server failed.	Y	-	Y	Y	-
[0104] "Moved Permanently" reception	Registration to SIP server failed.	Y	-	Y	Y	-
[0105] "Moved Temporarily" reception	Registration to SIP server failed.	Y	-	Y	Y	-
[0106] "Use Proxy" reception	Registration to SIP server failed.	Y	-	Y	Y	-
[0107] "Alternative Service" reception	Registration to SIP server failed.	Y	-	Y	Y	-
[0109] "Bad Request" reception	Registration to SIP server failed.	Y	-	Y	Y	-
[010A] "Unauthorized" reception	Registration to SIP server failed.	Y	-	Y	Y	-
[010B] "Payment Required" reception	Registration to SIP server failed.	Y	-	Y	Y	-
[010C] "Forbidden" reception	Registration to SIP server failed.	Y	-	Y	Y	-
[010D] "Not Found" reception	Registration to SIP server failed.	Y	-	Y	Y	-
[010E] "Method Not Allowed" reception	Registration to SIP server failed.	Y	-	Y	Y	-
[010F] "Not Acceptable" reception	Registration to SIP server failed.	Y	-	Y	Y	-
[0110] "Proxy Authentication Required" reception	Registration to SIP server failed.	Y	-	Y	Y	-
[0111] "Request Timeout" reception	Registration to SIP server failed.	Y	-	Y	Y	-
[0113] "Gone" reception	Registration to SIP server failed.	Y	-	Y	Y	-
[0115] "Precondition Failed" reception	Registration to SIP server failed.	Y	-	Y	Y	-
[0116] "Request Entity Too Large" reception	Registration to SIP server failed.	Y	-	Y	Y	-
[0117] "Request-URI Too Long" reception	Registration to SIP server failed.	Y	-	Y	Y	-
[0118] "Unsupported Media Type" reception	Registration to SIP server failed.	Y	-	Y	Y	-

Code	Message	Error code display media				
		Panl	JL	ML	Noti	CSV
[0119] "Unsupported URI Scheme" reception	Registration to SIP server failed.	Y	-	Y	Y	-
[011A] "Unknown Resource-Priority" reception	Registration to SIP server failed.	Y	-	Y	Y	-
[011B] "Bad Extension" reception	Registration to SIP server failed.	Y	-	Y	Y	-
[011C] "Extension Required" reception	Registration to SIP server failed.	Y	-	Y	Y	-
[011D] "Session Timer Too Small" reception	Registration to SIP server failed.	Y	-	Y	Y	-
[011E] "Interval Too Brief" reception	Registration to SIP server failed.	Y	-	Y	Y	-
[011F] "Anonymity disallowed" reception	Registration to SIP server failed.	Y	-	Y	Y	-
[0120] "Temporarily Unavailable" reception	Registration to SIP server failed.	Y	-	Y	Y	-
[0121] "Call/Transaction Does Not Exist" reception	Registration to SIP server failed.	Y	-	Y	Y	-
[0122] "Loop Detected" reception	Registration to SIP server failed.	Y	-	Y	Y	-
[0123] "Too Many Hops" reception	Registration to SIP server failed.	Y	-	Y	Y	-
[0124] "Address Incomplete" reception	Registration to SIP server failed.	Y	-	Y	Y	-
[0125] "Ambiguous" reception	Registration to SIP server failed.	Y	-	Y	Y	-
[0126] "Busy Here" reception	Registration to SIP server failed.	Y	-	Y	Y	-
[0127] "Request Terminated" reception	Registration to SIP server failed.	Y	-	Y	Y	-
[0128] "Not acceptable here" reception	Registration to SIP server failed.	Y	-	Y	Y	-
[0129] "Bad Event" reception	Registration to SIP server failed.	Y	-	Y	Y	-
[012A] "Request Updated" reception	Registration to SIP server failed.	Y	-	Y	Y	-
[012B] "Request Pending" reception	Registration to SIP server failed.	Y	-	Y	Y	-
[012C] "Undecipherable" reception	Registration to SIP server failed.	Y	-	Y	Y	-
[012D] "Security Agreement Required" reception	Registration to SIP server failed.	Y	-	Y	Y	-
[012E] "Internal Server Error" reception	Registration to SIP server failed.	Y	-	Y	Y	-
[012F] "Not Implemented" reception	Registration to SIP server failed.	Y	-	Y	Y	-
[0130] "Bad Gateway" reception	Registration to SIP server failed.	Y	-	Y	Y	-
[0131] "Service Unavailable" reception	(Panl) Due to IP line traffic,It may take time to send. (ML) Transmission takes time because IP line is crowded.	Y	-	Y	Y	-
[0132] "Gateway Time-out" reception	Registration to SIP server failed.	Y	-	Y	Y	-
[0133] "Version Not Supported" reception	Registration to SIP server failed.	Y	-	Y	Y	-
[0134] "Message Too Large" reception	Registration to SIP server failed.	Y	-	Y	Y	-
[0135] "Precondition Failure" reception	Registration to SIP server failed.	Y	-	Y	Y	-
[0136] "Busy Everywhere" reception	Registration to SIP server failed.	Y	-	Y	Y	-
[0137] "Decline" reception	Registration to SIP server failed.	Y	-	Y	Y	-
[0138] "Does Not Exist Anywhere" reception	Registration to SIP server failed.	Y	-	Y	Y	-
[0139] "Not Acceptable" reception	Registration to SIP server failed.	Y	-	Y	Y	-
[013D] Other errors	Registration to SIP server failed.	Y	-	Y	Y	-
[013E] Other errors	IP Fax communication error	-	-	-	Y	-
[0140] Startup failure	(Panl) Reboot machine due to IP Fax initializing error. (ML) Failed to start IP Fax.	Y	-	Y	Y	-
[0141] Job interruption due to setting change	JOB interruption due to setting change occurred	-	-	-	Y	-
[0142] Recipient entry error	IP Fax communication error	-	-	-	Y	-
[0143] SIP server is unavailable	IP Fax communication error	-	-	-	Y	-
[0144] Under congestion	IP Fax communication error	-	-	-	Y	-
[0150] Disconnected by other side's device	IP Fax communication error	-	-	-	Y	-

Code	Message	Error code display media				
		Panl	JL	ML	Noti	CSV
[0200] The IP Fax transmission has been completed.	Your Send IP Fax job is successfully completed	-	-	-	Y	-
[0300] "Multiple Choices" reception	IP Fax communication error	-	-	-	Y	-
[0301] "Moved Permanently" reception	IP Fax communication error	-	-	-	Y	-
[0302] "Moved Temporarily" reception	IP Fax communication error	-	-	-	Y	-
[0305] "Use Proxy" reception	IP Fax communication error	-	-	-	Y	-
[0380] "Alternative Service" reception	IP Fax communication error	-	-	-	Y	-
[0400] "Bad Request" reception	IP Fax communication error	-	-	-	Y	-
[0401] "Unauthorized" reception	IP Fax communication error	-	-	-	Y	-
[0402] "Payment Required" reception	IP Fax communication error	-	-	-	Y	-
[0403] "Forbidden" reception	IP Fax communication error	-	-	-	Y	-
[0404] "Not Found" reception	IP Fax communication error	-	-	-	Y	-
[0405] "Method Not Allowed" reception	IP Fax communication error	-	-	-	Y	-
[0406] "Not Acceptable" reception	IP Fax communication error	-	-	-	Y	-
[0407] "Proxy Authentication Required" reception	IP Fax communication error	-	-	-	Y	-
[0408] "Request Timeout" reception	IP Fax communication error	-	-	-	Y	-
[0410] "Gone" reception	IP Fax communication error	-	-	-	Y	-
[0412] "Precondition Failed" reception	IP Fax communication error	-	-	-	Y	-
[0413] "Request Entity Too Large" reception	IP Fax communication error	-	-	-	Y	-
[0414] "Request-URI Too Long" reception	IP Fax communication error	-	-	-	Y	-
[0415] "Unsupported Media Type" reception	IP Fax communication error	-	-	-	Y	-
[0416] "Unsupported URI Scheme" reception	IP Fax communication error	-	-	-	Y	-
[0417] "Unknown Resource-Priority" reception	IP Fax communication error	-	-	-	Y	-
[0420] "Bad Extension" reception	IP Fax communication error	-	-	-	Y	-
[0421] "Extension Required" reception	IP Fax communication error	-	-	-	Y	-
[0422] "Session Timer Too Small" reception	IP Fax communication error	-	-	-	Y	-
[0423] "Interval Too Brief" reception	IP Fax communication error	-	-	-	Y	-
[0433] "Anonymity disallowed" reception	IP Fax communication error	-	-	-	Y	-
[0480] "Temporarily Unavailable" reception	IP Fax communication error	-	-	-	Y	-
[0481] "Call/Transaction Does Not Exist" reception	IP Fax communication error	-	-	-	Y	-
[0482] "Loop Detected" reception	IP Fax communication error	-	-	-	Y	-
[0483] "Too Many Hops" reception	IP Fax communication error	-	-	-	Y	-
[0484] "Address Incomplete" reception	IP Fax communication error	-	-	-	Y	-
[0485] "Ambiguous" reception	IP Fax communication error	-	-	-	Y	-
[0486] "Busy Here" reception	IP Fax communication error	-	-	-	Y	-
[0487] "Request Terminated" reception	IP Fax communication error	-	-	-	Y	-
[0488] "Not acceptable here" reception	IP Fax communication error	-	-	-	Y	-
[0489] "Bad Event" reception	IP Fax communication error	-	-	-	Y	-
[0490] "Request Updated" reception	IP Fax communication error	-	-	-	Y	-
[0491] "Request Pending" reception	IP Fax communication error	-	-	-	Y	-
[0493] "Undecipherable" reception	IP Fax communication error	-	-	-	Y	-
[0494] "Security Agreement Required" reception	IP Fax communication error	-	-	-	Y	-
[0500] "Internal Server Error" reception	IP Fax communication error	-	-	-	Y	-
[0501] "Not Implemented" reception	IP Fax communication error	-	-	-	Y	-

Code	Message	Error code display media				
		Panl	JL	ML	Noti	CSV
[0502] "Bad Gateway" reception	IP Fax communication error	-	-	-	Y	-
[0503] "Service Unavailable" reception	(Panl) Due to IP line traffic,It may take time to send. (ML) Transmission takes time because IP line is crowded.	Y	-	-	Y	-
[0504] "Gateway Time-out" reception	IP Fax communication error	-	-	-	Y	-
[0505] "Version Not Supported" reception	IP Fax communication error	-	-	-	Y	-
[0513] "Message Too Large" reception	IP Fax communication error	-	-	-	Y	-
[0580] "Precondition Failure" reception	IP Fax communication error	-	-	-	Y	-
[0600] "Busy Everywhere" reception	IP Fax communication error	-	-	-	Y	-
[0603] "Decline" reception	IP Fax communication error	-	-	-	Y	-
[0604] "Does Not Exist Anywhere" reception	IP Fax communication error	-	-	-	Y	-
[0606] "Not Acceptable" reception	IP Fax communication error	-	-	-	Y	-
[4246] IP Fax license is not installed	IP Fax license is not installed	-	-	Y	-	-
[DA01] Fax unit line 1 malfunction	(Panl) Fax line1 is out of order. Reboot the machine. (ML) FAX Unit Line1 is broken. Please Contact Service Technician.	Y	-	Y	-	-
[DA02] Fax unit line 2 malfunction	(Panl) Fax line2 is out of order. Reboot the machine. (ML) FAX Unit Line2 is broken. Please Contact Service Technician.	Y	-	Y	-	-

## 8.2.11 Error history

In the setting mode (FS-08-9703), the latest twenty groups of error data will be displayed.

Display  
example

EA10	01234567	2021-07-11 17:05:32	064	064	2362_1000_0000_0 _XXXXXXXXXX
Error code	Total counter	YYYY-MM-DD HH:MM:SS	MMM	NNN	ABCD_EFHI_JLOP_Q_R
4 digits	8 digits	14 digits	3 digits	3 digits	23 digits

A	Paper source
	0: Not selected, 1: Bypass tray, 2: LCF, 3: 1st drawer, 4: 2nd drawer, 5: PFP upper drawer 6: PFP lower drawer 7: Optional LCF, 8: Unused
B	Paper size code
	0: A5/ST, 1: A5-R, 2: ST-R, 3: LT, 4: A4, 5: B5-R, 6: LT-R, 7: A4-R, 8: OTHER/UNIV, 9: B5, A: FOLIO/COMP, B: LG, C: B4, D: LD, E: A3, F: 13"LG, G: Unused, H: A6-R, I: Postcard, J: 8.5"SQ, K: Unused, L: Unused, M: 8K, N: 16K-R, O: 16K, P: Envelope COM10, Q: Envelope DL, R: Envelope Monarch, S: Envelope CHO-3, T: Envelope YOU-4, U to Z: Not used, a: Envelope KAKU-2
C	Sort mode, staple mode
	0: Non-sort/Non-staple, 1: Group, 2: Sort, 7: Front staple 8: Double staple, 9: Rear staple, A: Saddle stitch, B: Center fold, C: Top Left, D: Top Right, E: Top Center, F: Left Center
D	ADF mode
	0: Not used, 1: Single (SADF), 2: Continuous
E	APS/AMS mode
	0: Not selected, 1: APS, 2: AMS
F	Duplex mode
	<b>Copying:</b> 0: Single-sided/Single-sided, 1: Book, 2: Double-sided/Single-sided, 4: Double-sided/Duplex copying, 8: Single-sided/Duplex copying <b>Printing:</b> 0: Single-sided, 8: Double-sided <b>Fax:</b> 0: Single-sided, 8: Double-sided <b>e-Filing:</b> 0: Single-sided, 8: Double-sided <b>List printing:</b> 0: Single-sided -
H	Image shift
	0: Unused, 1: Book, 2: Left, 3: Right, 4: Top, 5: Bottom, 6: Book + Top, 7: Book + Bottom, 8: Left + Top, 9: Left + Bottom, A: Right + Top, B: Right + Bottom
I	Editing
	0: Unused, 1: Masking, 2: Trimming, 3: Mirror image, 4: Unused, 5: NEG/POS
J	Edge erase, Dual-page
	0: Unused, 1: Edge erase, 2: Dual-page, 3: Edge erase & Dual-page
K	Not used
L	Function
	0: Unused, 1: Copying, 2: Fax/Internet fax transmission, 3: Fax/Internet fax/E-mail reception printing, 4: Not used, 5: Printing/List print, 6: Scan/E-mail transmission
MMM	Primary scanning reproduction ratio (display in hexadecimal)
	(M x 256) + (M x 16)+M



NNN	Secondary scanning reproduction ratio (display in hexadecimal)
	$(N \times 256) + (N \times 16) + N$
O	Color mode
	0: Auto color (Scan), 1: Full color (Scan), 2: Black, 3: Unused, 4: Unused, 5: Gray scale (Scan), 6: Unused, 7: Unused
P	Media type
	0: Plain paper, 1: Thick 1, 2: Thick 2, 3: Thick 3, 4: Unused, 5: Unused, 6: Unused, 7: Recycled paper, 8: Unused, 9: Unused, A: Thin paper, B: OHP film, C: Thick 1/ reverse, D: Thick 2/ reverse, E: Thick 3/ reverse, F: Unused, G: Unused, H: Unused, I: Envelope, J: Tab paper, K: Plain paper/ reverse, L: Recycled paper/ reverse, M: Thin paper/ reverse, N: Unused, O: Unused, P: Envelope/ reverse, Q: Thick, R: Thick/ reverse, S to Z: Not specified, a: User type 1, b: User type 2, c: User type 3, d: User type 4, e: User type 5, f: User type 6, g: User type 7, h: User type 8, i: User type 9, j: User type 10
Q	RADF size mixed
	0: Not used, 1: Mixed, 2: Not mixed
R	Workflow ID: 10-digit ID

## 8.3 Analysis from Error Codes

### 8.3.1 Check item

Check item	Description
Sensor check	<ul style="list-style-type: none"> <li>Check the sensors in the test mode.</li> <li>Check that there is no dust on the sensors.</li> <li>Check that the actuator is correctly operated.</li> </ul>
Connector check	<ul style="list-style-type: none"> <li>Check if the connectors are disconnected.</li> <li>Check that the pins are not deformed and do not come off.</li> <li>Disconnect and reconnect the connector. Even if the connector is not apparently disconnected, it may be connected too loosely. Therefore, check carefully that it is secure.</li> </ul>
Harness check	<ul style="list-style-type: none"> <li>Check if the harness is open circuited.</li> <li>Check if the harness is caught.</li> </ul>
Motor check	<ul style="list-style-type: none"> <li>Check the motors in the test mode.</li> <li>Check if there is any abnormality in the driving section.</li> <li>Check that there is no abnormality in the roller.</li> </ul>
PC board check	<ul style="list-style-type: none"> <li>Check that the boards are short circuited or open circuited.</li> <li>Check that the PC boards are installed properly.</li> <li>Check that the boards are not deformed due to a forcible installation.</li> </ul>

### 8.3.2 Paper misfeeding (E series errors)

#### [E010] Paper not reaching the paper exit sensor jam

Classification	Error content
Paper exit jam	The paper which has passed through the fuser unit does not reach the paper exit sensor.

Check item	Measures
Drawer	<ul style="list-style-type: none"> <li>Check if the paper is damaged or if it has been folded.</li> <li>Check the side guide in the drawer to confirm whether there is a reason for paper skewing in it.</li> </ul>
Paper exit unit	<ul style="list-style-type: none"> <li>Check that the paper exit unit is installed properly.</li> <li>Replace the paper exit unit.</li> </ul>
Fuser unit	<ul style="list-style-type: none"> <li>Check that the pressure release screw of the pressure roller is securely tightened and pressure is properly applied.</li> <li>Check if toner has adhered to the fuser entrance guide. If needed, clean it.</li> <li>Check if the separation finger is dirty. If so, clean it.</li> <li>Check if separation fingers or springs have come off. If so, correct this.</li> <li>Replace the separation finger.</li> </ul>
Paper exit sensor	<ul style="list-style-type: none"> <li>Sensor check Input check: FS-03-[ALL]OFF/[9]/[C]</li> <li>Actuator check</li> <li>Connector check</li> <li>Harness check</li> <li>Replace the sensor.</li> </ul>
LGC board	<ul style="list-style-type: none"> <li>PC board check</li> <li>Connector check (CN308, CN318)</li> <li>Harness check</li> <li>Replace the PC board.</li> </ul>
Leading edge margin	<ul style="list-style-type: none"> <li>Check that the image position and margin are adjusted properly.</li> <li>Widen the margin if needed.</li> </ul>
Aligning amount	<p>Confirm that the value of the paper alignment is appropriate. Adjust the aligning amount if needed.</p> <p><b>Remarks:</b> If the paper alignment is too small, a skew, an image dislocation in the feeding direction or an error such as E010 may occur. If the paper alignment is too large, a paper-folding noise or actual paper folding may occur during paper feeding.</p>
Registration roller	Check the condition of the roller. If it has deteriorated, replace it.

Check item	Measures
Registration clutch	<ul style="list-style-type: none"> <li>• Check that the registration clutch is working. Output check: FS-03-108, 158</li> <li>• Connector check</li> <li>• Harness check</li> <li>• Replace the registration clutch.</li> </ul>

Parts to be replaced	Remarks
Separation finger in the fuser unit	
Transfer belt	
Paper exit unit	
Paper exit sensor	
LGC board	
Registration roller	
Registration clutch	

### [E020] Paper stopping at the paper exit sensor jam

Classification	Error content
Paper exit jam	The trailing edge of the paper does not pass through the paper exit sensor after its leading edge has reached this sensor.

Check item	Measures
Drawer	<ul style="list-style-type: none"> <li>• Check if the paper is damaged or if it has been folded.</li> <li>• Check the side guide in the drawer to confirm whether there is a reason for paper skewing in it.</li> </ul>
Paper exit unit	<ul style="list-style-type: none"> <li>• Check that the paper exit unit is installed properly.</li> <li>• Replace the paper exit unit.</li> </ul>
Paper exit gate, reverse gate	Check if toner has adhered to the paper exit gate and reverse gate or if they are just dirty. If needed, clean them.
Fuser unit	<ul style="list-style-type: none"> <li>• Check that the pressure release screw of the pressure roller is securely tightened and pressure is properly applied.</li> <li>• Check if the separation finger is dirty. If so, clean it.</li> <li>• Check if separation fingers or springs have come off. If so, correct this.</li> <li>• Replace the separation finger.</li> <li>• Check if toner has adhered to the fuser entrance guide. If needed, clean it.</li> </ul>
Paper exit sensor	<ul style="list-style-type: none"> <li>• Sensor check Input check: FS-03-[ALL]OFF/[9]/[C]</li> <li>• Actuator check</li> <li>• Connector check</li> <li>• Harness check</li> <li>• Replace the sensor.</li> </ul>
LGC board	<ul style="list-style-type: none"> <li>• PC board check</li> <li>• Connector check (CN308, CN318)</li> <li>• Harness check</li> <li>• Replace the PC board.</li> </ul>
Leading edge margin	<ul style="list-style-type: none"> <li>• Check that the image position and margin are adjusted properly.</li> <li>• Widen the margin if needed.</li> </ul>
Reverse gate solenoid	<ul style="list-style-type: none"> <li>• Solenoid check Output check: FS-03-222, 03-223</li> <li>• Connector check</li> <li>• Harness check</li> </ul>
Registration roller	Check the condition of the roller. If it has deteriorated, replace it.
Registration clutch	<ul style="list-style-type: none"> <li>• Check that the registration clutch is working. Output check: FS-03-108, 158</li> <li>• Connector check</li> <li>• Harness check</li> <li>• Replace the registration clutch.</li> </ul>

Parts to be replaced	Remarks
Paper exit unit	

Parts to be replaced	Remarks
Separation finger in the fuser unit	
Paper exit sensor	
LGC board	
Reverse gate motor	

### [E030] Power-ON jam

Classification	Error content
Other paper jam	There is paper on the paper transport path when the power is turned ON.

Check item	Measures
Paper	Check that there is paper where the paper misfeed sign is indicating on the screen.
Sensors in the paper misfeed area	Check the sensors mounted in the location in question by referring to the table below. Registration section <ul style="list-style-type: none"> <li>Registration sensor</li> <li>1st transport sensor</li> </ul> Paper exit section <ul style="list-style-type: none"> <li>Paper exit sensor</li> </ul> ADU section <ul style="list-style-type: none"> <li>ADU entrance sensor</li> <li>ADU exit sensor</li> </ul> Bypass unit section <ul style="list-style-type: none"> <li>2nd transport sensor</li> </ul> LCF section <ul style="list-style-type: none"> <li>LCF transport sensor</li> </ul> PFP section <ul style="list-style-type: none"> <li>3rd drawer paper feed sensor</li> <li>4th drawer paper feed sensor</li> </ul> Bridge kit section <ul style="list-style-type: none"> <li>Bridge kit transport sensor-1</li> <li>Bridge kit transport sensor-2</li> </ul> Finisher section <ul style="list-style-type: none"> <li>Sensor (Finisher)</li> </ul> JSP section <ul style="list-style-type: none"> <li>JSP transport sensor</li> </ul>
1st transport sensor	<ul style="list-style-type: none"> <li>Sensor check</li> <li>Input check: FS-03-[ALL]OFF/[9]/[F]</li> <li>Actuator check</li> <li>Connector check</li> <li>Harness check</li> <li>Replace the sensor.</li> </ul>
Transport sensor	<ul style="list-style-type: none"> <li>Sensor check</li> <li>Input check: FS-03-[ALL]OFF/[9]/[B]</li> <li>Actuator check</li> <li>Connector check</li> <li>Harness check</li> <li>Replace the sensor.</li> </ul>
Paper exit sensor	<ul style="list-style-type: none"> <li>Sensor check</li> <li>Input check: FS-03-[ALL]OFF/[9]/[C]</li> <li>Actuator check</li> <li>Connector check</li> <li>Harness check</li> <li>Replace the sensor.</li> </ul>
ADU entrance sensor	<ul style="list-style-type: none"> <li>Sensor check</li> <li>Input check: FS-03-[ALL]OFF/[9]/[G]</li> <li>Actuator check</li> <li>Connector check</li> <li>Harness check</li> <li>Replace the sensor.</li> </ul>

Check item	Measures
ADU exit sensor	<ul style="list-style-type: none"> <li>• Sensor check Input check: FS-03-[ALL]OFF/[9]/[H]</li> <li>• Actuator check</li> <li>• Connector check</li> <li>• Harness check</li> <li>• Replace the sensor.</li> </ul>
2nd transport sensor	<ul style="list-style-type: none"> <li>• Sensor check Input check: FS-03-[F2]ON/[4]/[D]</li> <li>• Actuator check</li> <li>• Connector check</li> <li>• Harness check</li> <li>• Replace the sensor.</li> </ul>
T-LCF transport sensor	<ul style="list-style-type: none"> <li>• Sensor check Input check: FS-03-[F1]ON/[9]/[F]</li> <li>• Actuator check</li> <li>• Connector check</li> <li>• Harness check</li> <li>• Replace the sensor.</li> </ul>
3rd drawer paper feed sensor	<ul style="list-style-type: none"> <li>• Sensor check Input check: FS-03-[F2]ON/[0]/[C]</li> <li>• Actuator check</li> <li>• Connector check</li> <li>• Harness check</li> <li>• Replace the sensor.</li> </ul>
4th drawer paper feed sensor	<ul style="list-style-type: none"> <li>• Sensor check Input check: FS-03-[F2]ON/[0]/[D]</li> <li>• Actuator check</li> <li>• Connector check</li> <li>• Harness check</li> <li>• Replace the sensor.</li> </ul>
Bridge kit transport sensor-1	<ul style="list-style-type: none"> <li>• Sensor check Input check: FS-03-[ALL]OFF/[0]/[A]</li> <li>• Actuator check</li> <li>• Connector check</li> <li>• Harness check</li> <li>• Replace the sensor.</li> </ul>
Bridge kit transport sensor-2	<ul style="list-style-type: none"> <li>• Sensor check Input check: FS-03-[ALL]OFF/[0]/[B]</li> <li>• Actuator check</li> <li>• Connector check</li> <li>• Harness check</li> <li>• Replace the sensor.</li> </ul>
Sensor (Finisher)	<ul style="list-style-type: none"> <li>• Sensor check</li> <li>• Actuator check</li> <li>• Connector check</li> <li>• Harness check</li> <li>• Replace the sensor.</li> </ul>
JSP transport sensor	<ul style="list-style-type: none"> <li>• Sensor check Input check: FS-03-[ALL]OFF/[0]/[A]</li> <li>• Actuator check</li> <li>• Connector check</li> <li>• Harness check</li> <li>• Replace the sensor.</li> </ul>
LGC board	<ul style="list-style-type: none"> <li>• PC board check</li> <li>• Connector check</li> <li>• Harness check</li> <li>• Replace the PC board.</li> </ul> <p><b>Notes:</b> Check the boards of the ADU, PFP and LCF depending on the location of the sensors in the paper misfeed area.</p>

Parts to be replaced	Remarks
Sensors in the paper misfeed area	
LGC board	

**[E061] Incorrect paper size setting for the 1st drawer jam****[E062] Incorrect paper size setting for the 2nd drawer jam****[E063] Incorrect paper size setting for the 3rd drawer jam****[E064] Incorrect paper size setting for the 4th drawer jam****[E065] Incorrect paper size setting for the bypass tray jam**

Classification	Error content
Other paper jam	<ul style="list-style-type: none"> <li>The size of the paper in the drawer differs from the size setting of the MFP.</li> <li>The size of the paper in the bypass tray differs from the size setting of the MFP.</li> </ul>

Check item	Measures
Setting	<ul style="list-style-type: none"> <li>If any paper remains in the MFP, drawer or bypass tray, remove it.</li> <li>Match the paper size of the setting and the one in the drawer or the bypass tray.</li> </ul>
1st drawer paper width detection switch	<ul style="list-style-type: none"> <li>Switch check</li> <li>Input check: FS-03-[ALL]OFF/[1]/[A]-[D]</li> <li>Actuator check</li> <li>Connector check</li> <li>Harness check</li> <li>Replace the switch.</li> </ul>
1st drawer paper length detection switch	<ul style="list-style-type: none"> <li>Switch check</li> <li>Input check: FS-03-[ALL]OFF/[1]/[E]-[H]</li> <li>Actuator check</li> <li>Connector check</li> <li>Harness check</li> <li>Replace the switch.</li> </ul>
2nd drawer paper width detection switch	<ul style="list-style-type: none"> <li>Switch check</li> <li>Input check: FS-03-[F2]ON/[9]/[A]-[D]</li> <li>Actuator check</li> <li>Connector check</li> <li>Harness check</li> <li>Replace the switch.</li> </ul>
2nd drawer paper length detection switch	<ul style="list-style-type: none"> <li>Switch check</li> <li>Input check: FS-03-[F2]ON/[9]/[E]-[H]</li> <li>Actuator check</li> <li>Connector check</li> <li>Harness check</li> <li>Replace the switch.</li> </ul>
3rd drawer paper width detection switch	<ul style="list-style-type: none"> <li>Switch check</li> <li>Input check: FS-03-[F1]ON/[6]/[A]-[D]</li> <li>Actuator check</li> <li>Connector check</li> <li>Harness check</li> <li>Replace the switch.</li> </ul>
3rd drawer paper length detection switch	<ul style="list-style-type: none"> <li>Switch check</li> <li>Input check: FS-03-[F1]ON/[6]/[E]-[H]</li> <li>Actuator check</li> <li>Connector check</li> <li>Harness check</li> <li>Replace the switch.</li> </ul>
4th drawer paper width detection switch	<ul style="list-style-type: none"> <li>Switch check</li> <li>Input check: FS-03-[F1]ON/[7]/[A]-[D]</li> <li>Actuator check</li> <li>Connector check</li> <li>Harness check</li> <li>Replace the switch.</li> </ul>
4th drawer paper length detection switch	<ul style="list-style-type: none"> <li>Switch check</li> <li>Input check: FS-03-[F1]ON/[7]/[E]-[H]</li> <li>Actuator check</li> <li>Connector check</li> <li>Harness check</li> <li>Replace the switch.</li> </ul>

Check item	Measures
SFB board	<ul style="list-style-type: none"> <li>PC board check</li> <li>Connector check</li> <li>Harness check</li> <li>Replace the PC board.</li> </ul>
LGC board	<ul style="list-style-type: none"> <li>PC board check</li> <li>Connector check (CN321, CN317)</li> <li>Harness check</li> <li>Replace the PC board.</li> </ul>

Parts to be replaced	Remarks
1st drawer paper width detection switch	
1st drawer paper length detection switch	
2nd drawer paper width detection switch	
2nd drawer paper length detection switch	
3rd drawer paper width detection switch	
3rd drawer paper length detection switch	
4th drawer paper width detection switch	
4th drawer paper length detection switch	
SFB board	
LGC board	

### [E090] Image data delay jam

Classification	Error content
Other paper jam	The image data to be printed cannot be prepared.

Check item	Measures
Transport path	Remove any paper remaining in front of the registration sensor.
Power source	Check if the error is cleared by turning the power OFF and then back ON.
SYS board	<ul style="list-style-type: none"> <li>PC board check</li> <li>Connector check (SYS board - LGC board)</li> <li>Harness check (SYS board - LGC board)</li> <li>Replace the PC board.</li> </ul>
LGC board	<ul style="list-style-type: none"> <li>PC board check</li> <li>Connector check (SYS board - LGC board)</li> <li>Harness check (SYS board - LGC board)</li> <li>Replace the PC board.</li> </ul>
Storage device	Check the connector of the HDD or the SSD.

Parts to be replaced	Remarks
SYS board	
LGC board	
Storage device	
Harness	Connecting for the SYS board and LGC board

**[E0A0] Image transport ready time-out jam**

Classification	Error content
Other paper jam	The image data to be printed cannot be sent.

Check item	Measures
SYS board	<ul style="list-style-type: none"> <li>• PC board check</li> <li>• Connector check (SYS board - LGC board)</li> <li>• Harness check (SYS board - LGC board)</li> <li>• Replace the PC board.</li> </ul>
LGC board	<ul style="list-style-type: none"> <li>• PC board check</li> <li>• Connector check (SYS board - LGC board)</li> <li>• Harness check (SYS board - LGC board)</li> <li>• Replace the PC board.</li> </ul>

Parts to be replaced	Remarks
SYS board	
LGC board	
Harness	Connecting for the SYS board and LGC board

**[E110] ADU paper misfeed jam**

Classification	Error content
Paper misfeeding	Paper which has passed through the ADU does not reach the registration sensor during duplex printing.

Check item	Measures
Registration guide	Check the registration guide. If there is an abnormality, replace it.
Registration sensor	<ul style="list-style-type: none"> <li>• Sensor check Input check: FS-03-[ALL]OFF/[9]/[A]</li> <li>• Actuator check</li> <li>• Connector check</li> <li>• Harness check</li> <li>• Replace the sensor.</li> </ul>
LGC board	<ul style="list-style-type: none"> <li>• PC board check</li> <li>• Connector check (CN321, CN318)</li> <li>• Harness check</li> <li>• Replace the PC board.</li> </ul>
ADU board	<ul style="list-style-type: none"> <li>• PC board check</li> <li>• Connector check (CN420, CN421)</li> <li>• Harness check</li> <li>• Replace the PC board.</li> </ul>
ADU motor	<ul style="list-style-type: none"> <li>• Check that the motor is working. Output check: FS-03-115, 165</li> <li>• Connector check</li> <li>• Harness check</li> <li>• Replace the motor.</li> </ul>
Roller (ADU)	Check the condition of the roller. If it has deteriorated, replace it.

Parts to be replaced	Remarks
Registration sensor	
LGC board	
ADU board	
ADU motor	
Roller (ADU)	



### [E120] Bypass tray paper misfeed jam

Classification	Error content
Paper misfeeding	Paper fed from the bypass tray does not reach the bypass tray paper feed sensor.

Check item	Measures
Bypass tray	<ul style="list-style-type: none"> <li>Check if the paper is damaged or if it has been folded.</li> <li>Check the side guide in the bypass tray to confirm whether there is a cause of paper skewing in it.</li> </ul>
Rollers	<ul style="list-style-type: none"> <li>Check if the bypass unit paper feed roller and bypass unit separation roller are installed properly.</li> <li>Check the condition of the roller. If it has deteriorated, replace it.</li> </ul>
Bypass tray paper feed clutch	<ul style="list-style-type: none"> <li>Check that the clutch is working. Output check: FS-03-204</li> <li>Connector check</li> <li>Harness check</li> <li>Replace the clutch.</li> </ul>
1st transport sensor	<ul style="list-style-type: none"> <li>Sensor check Input check: FS-03-[ALL]OFF/[9]/[B]</li> <li>Actuator check</li> <li>Connector check</li> <li>Harness check</li> <li>Replace the sensor.</li> </ul>
LGC board	<ul style="list-style-type: none"> <li>PC board check</li> <li>Connector check (CN318, CN321)</li> <li>Harness check</li> <li>Replace the PC board.</li> </ul>

Parts to be replaced	Remarks
Bypass unit paper feed roller	
Bypass unit separation roller	
Bypass tray paper feed clutch	
1st transport sensor	
LGC board	

### [E130] 1st drawer paper misfeed jam

Classification	Error content
Paper misfeeding	Paper fed from the 1st drawer does not reach the 1st drawer paper feed sensor.

Check item	Measures
Drawer	<ul style="list-style-type: none"> <li>Check if the paper is damaged or if it has been folded.</li> <li>Check the side guide in the drawer to confirm whether there is a reason for paper skewing in it.</li> <li>Check that the paper stack height is within the specified range.</li> </ul>
Roller (1st drawer)	Check the condition of the paper feed roller, separation roller and pickup roller. If they have deteriorated, replace them.
1st transport sensor	<ul style="list-style-type: none"> <li>Sensor check Input check: FS-03-[ALL]OFF/[9]/[B]</li> <li>Actuator check</li> <li>Connector check</li> <li>Harness check</li> <li>Replace the sensor.</li> </ul>
1st drawer paper empty sensor	<ul style="list-style-type: none"> <li>Sensor check Input check: FS-03-[ALL]OFF/[0]/[G]</li> <li>Actuator check</li> <li>Connector check</li> <li>Harness check</li> <li>Replace the sensor.</li> </ul>

Check item	Measures
1st drawer paper feed clutch	<ul style="list-style-type: none"> <li>• Check that the clutch is working. Output check: FS-03-201</li> <li>• Connector check</li> <li>• Harness check</li> <li>• Replace the clutch.</li> </ul>
LGC board	<ul style="list-style-type: none"> <li>• PC board check</li> <li>• Connector check (CN316, CN318)</li> <li>• Harness check</li> <li>• Replace the PC board.</li> </ul>

Parts to be replaced	Remarks
1st transport sensor	
1st drawer paper empty sensor	
1st drawer paper feed clutch	
LGC board	
1st drawer paper feed roller	
1st drawer separation roller	
1st drawer paper feed roller	

### [E140] 2nd drawer paper misfeed jam

Classification	Error content
Paper misfeeding	Paper fed from the 2nd drawer does not reach the 2nd drawer paper feed sensor.

Check item	Measures
Drawer	<ul style="list-style-type: none"> <li>• Check if the paper is damaged or if it has been folded.</li> <li>• Check the side guide in the drawer to confirm whether there is a reason for paper skewing in it.</li> <li>• Check that the paper stack height is within the specified range.</li> </ul>
2nd drawer paper feed sensor	<ul style="list-style-type: none"> <li>• Sensor check Input check: FS-03-[F2]ON/[4]/[D]</li> <li>• Actuator check</li> <li>• Connector check</li> <li>• Harness check</li> <li>• Replace the sensor.</li> </ul>
2nd drawer paper empty sensor	<ul style="list-style-type: none"> <li>• Sensor check Input check: FS-03-[F2]ON/[4]/[G]</li> <li>• Actuator check</li> <li>• Connector check</li> <li>• Harness check</li> <li>• Replace the sensor.</li> </ul>
2nd drawer paper feed clutch	<ul style="list-style-type: none"> <li>• Check that the clutch is working. Output check: FS-03-202</li> <li>• Connector check</li> <li>• Harness check</li> <li>• Replace the clutch.</li> </ul>
Roller (2nd drawer)	Check the condition of the paper feed roller, separation roller and pickup roller. If they have deteriorated, replace them.
LGC board	<ul style="list-style-type: none"> <li>• PC board check</li> <li>• Connector check (CN316, CN318)</li> <li>• Harness check</li> <li>• Replace the PC board.</li> </ul>

Parts to be replaced	Remarks
2nd drawer paper feed sensor	
2nd drawer paper empty sensor	
LGC board	
2nd drawer paper feed clutch	
2nd drawer paper feed roller	

Parts to be replaced	Remarks
2nd drawer separation roller	
2nd drawer pickup roller	

### [E150] 3rd drawer paper misfeed jam

Classification	Error content
Paper misfeeding	Paper fed from the 3rd drawer does not reach the 3rd drawer paper feed sensor.

Check item	Measures
Drawer	<ul style="list-style-type: none"> <li>Check if the paper is damaged or if it has been folded.</li> <li>Check the side guide in the drawer to confirm whether there is a reason for paper skewing in it.</li> <li>Check that the paper stack height is within the specified range.</li> </ul>
3rd drawer paper feed sensor	<ul style="list-style-type: none"> <li>Sensor check Input check: FS-03-[F2]ON/[0]/[C]</li> <li>Actuator check</li> <li>Connector check</li> <li>Harness check</li> <li>Replace the sensor.</li> </ul>
3rd drawer paper empty sensor	<ul style="list-style-type: none"> <li>Sensor check Input check: FS-03-[F1]ON/[5]/[C]</li> <li>Actuator check</li> <li>Connector check</li> <li>Harness check</li> <li>Replace the sensor.</li> </ul>
3rd drawer paper feed clutch	<ul style="list-style-type: none"> <li>Check that the clutch is working. Output check: FS-03-226</li> <li>Connector check</li> <li>Harness check</li> <li>Replace the clutch.</li> </ul>
Roller (3rd drawer)	Check the condition of the paper feed roller, separation roller and pickup roller. If they have deteriorated, replace them.
PFP board	<ul style="list-style-type: none"> <li>PC board check</li> <li>Connector check (CN1004, CN1002)</li> <li>Harness check</li> </ul>
LGC board	<ul style="list-style-type: none"> <li>PC board check</li> <li>Connector check</li> <li>Harness check</li> <li>Replace the PC board.</li> </ul>

Parts to be replaced	Remarks
3rd drawer paper feed sensor	
3rd drawer paper empty sensor	
3rd drawer paper feed clutch	
PFP board	
LGC board	
3rd drawer paper feed roller	
3rd drawer separation roller	
3rd drawer pickup roller	

### [E160] 4th drawer paper misfeed jam

Classification	Error content
Paper misfeeding	Paper fed from the 4th drawer does not reach the 4th drawer paper feed sensor.

Check item	Measures
Drawer	<ul style="list-style-type: none"> <li>• Check if the paper is damaged or if it has been folded.</li> <li>• Check the side guide in the drawer to confirm whether there is a reason for paper skewing in it.</li> <li>• Check that the paper stack height is within the specified range.</li> </ul>
4th drawer paper feed sensor	<ul style="list-style-type: none"> <li>• Sensor check Input check: FS-03-[F2]ON/[0]/[D]</li> <li>• Actuator check</li> <li>• Connector check</li> <li>• Harness check</li> <li>• Replace the sensor.</li> </ul>
4th drawer paper empty sensor	<ul style="list-style-type: none"> <li>• Sensor check Input check: FS-03-[F1]ON/[5]/[G]</li> <li>• Actuator check</li> <li>• Connector check</li> <li>• Harness check</li> <li>• Replace the sensor.</li> </ul>
4th drawer paper feed clutch	<ul style="list-style-type: none"> <li>• Check that the clutch is working. Output check: FS-03-228</li> <li>• Connector check</li> <li>• Harness check</li> <li>• Replace the clutch.</li> </ul>
Roller (4th drawer)	Check the condition of the paper feed roller, separation roller and pickup roller. If they have deteriorated, replace them.
PFP board	<ul style="list-style-type: none"> <li>• PC board check</li> <li>• Connector check (CN1004, CN1006)</li> <li>• Harness check</li> </ul>
LGC board	<ul style="list-style-type: none"> <li>• PC board check</li> <li>• Connector check</li> <li>• Harness check</li> <li>• Replace the PC board.</li> </ul>

Parts to be replaced	Remarks
4th drawer paper feed sensor	
4th drawer paper empty sensor	
4th drawer paper feed clutch	
PFP board	
LGC board	
4th drawer paper feed roller	
4th drawer separation roller	
4th drawer pickup roller	

### [E180] Ex-LCF paper misfeed jam

Classification	Error content
Paper misfeeding	Paper fed from the Ex-LCF does not reach the Ex-LCF paper feed sensor.

Check item	Measures
Ex-LCF paper feed sensor	<ul style="list-style-type: none"> <li>• Sensor check Input check: FS-03-[F3]ON/[3]/[D]</li> <li>• Actuator check</li> <li>• Connector check</li> <li>• Harness check</li> <li>• Replace the sensor.</li> </ul>
Ex-LCF paper feed motor	<ul style="list-style-type: none"> <li>• Check that the motor is working. Output check: FS-03-147, 197</li> <li>• Connector check</li> <li>• Harness check</li> <li>• Replace the motor.</li> </ul>

Check item	Measures
Ex-LCF paper feed clutch	<ul style="list-style-type: none"> <li>• Check that the clutch is working. Output check: FS-03-453</li> <li>• Connector check</li> <li>• Harness check</li> <li>• Replace the clutch.</li> </ul>
Roller (Ex-LCF drawer)	Check the condition of the paper feed roller, separation roller and pickup roller. If they have deteriorated, replace them.
Ex-LCF board	<ul style="list-style-type: none"> <li>• PC board check</li> <li>• Connector check (CN850, CN854)</li> <li>• Harness check</li> </ul>
LGC board	<ul style="list-style-type: none"> <li>• PC board check</li> <li>• Connector check (CN326)</li> <li>• Harness check</li> <li>• Replace the PC board.</li> </ul>

Parts to be replaced	Remarks
Ex-LCF paper feed sensor	
Ex-LCF paper feed motor	
Ex-LCF paper feed clutch	
Ex-LCF board	
LGC board	
Ex-LCF paper feed roller	
Ex-LCF separation roller	
Ex-LCF pickup roller	

### [E190] T-LCF paper misfeed jam

Classification	Error content
Paper misfeeding	Paper fed from the T-LCF does not reach the T-LCF transport sensor.

Check item	Measures
T-LCF paper feed sensor	<ul style="list-style-type: none"> <li>• Sensor check Input check: FS-03-[F1]ON/[9]/[F]</li> <li>• Actuator check</li> <li>• Connector check</li> <li>• Harness check</li> <li>• Replace the sensor.</li> </ul>
T-LCF paper feed clutch	<ul style="list-style-type: none"> <li>• Check that the clutch is working. Output check: FS-03-209</li> <li>• Connector check</li> <li>• Harness check</li> <li>• Replace the clutch.</li> </ul>
Roller (T-LCF drawer)	Check the condition of the paper feed roller, separation roller and pickup roller. If they have deteriorated, replace them.
T-LCF board	<ul style="list-style-type: none"> <li>• PC board check</li> <li>• Connector check (CN1010, CN1011)</li> <li>• Harness check</li> </ul>
LGC board	<ul style="list-style-type: none"> <li>• PC board check</li> <li>• Connector check</li> <li>• Harness check</li> <li>• Replace the PC board.</li> </ul>

Parts to be replaced	Remarks
T-LCF paper feed sensor	
T-LCF paper feed clutch	
T-LCF board	
LGC board	
T-LCF paper feed roller	
T-LCF separation roller	

Parts to be replaced	Remarks
T-LCF pickup roller	

### [E200] 1st drawer paper transport jam

Classification	Error content
Paper transport jam	Paper does not reach the registration sensor.

Check item	Measures
Drawer	<ul style="list-style-type: none"> <li>• Check if the paper is damaged or if it has been folded.</li> <li>• Check the side guide in the drawer to confirm whether there is a reason for paper skewing in it.</li> <li>• Check that the paper stack height is within the specified range.</li> </ul>
1st transport sensor	<ul style="list-style-type: none"> <li>• Sensor check Input check: FS-03-[ALL]OFF/[9]/[B]</li> <li>• Actuator check</li> <li>• Connector check</li> <li>• Harness check</li> <li>• Replace the sensor.</li> </ul>
Registration sensor	<ul style="list-style-type: none"> <li>• Sensor check Input check: FS-03-[ALL]OFF/[9]/[A]</li> <li>• Actuator check</li> <li>• Connector check</li> <li>• Harness check</li> <li>• Replace the sensor.</li> </ul>
1st drawer paper feed clutch	<ul style="list-style-type: none"> <li>• Check that the clutch is working. Output check: FS-03-201</li> <li>• Connector check</li> <li>• Harness check</li> <li>• Replace the clutch.</li> </ul>
Roller (1st drawer)	Check the condition of the paper feed roller, separation roller and pickup roller. If they have deteriorated, replace them.
LGC board	<ul style="list-style-type: none"> <li>• PC board check</li> <li>• Connector check (CN316, CN318)</li> <li>• Harness check</li> <li>• Replace the PC board.</li> </ul>

Parts to be replaced	Remarks
1st transport sensor	
Registration sensor	
1st drawer paper feed clutch	
LGC board	
1st drawer paper feed roller	
1st drawer separation roller	
1st drawer paper feed roller	

### [E210] 2nd drawer paper transport jam

### [E300] 3rd drawer paper transport jam

### [E330] 4th drawer paper transport jam

### [E3C0] T-LCF paper transport jam

Classification	Error content
Paper transport jam	Paper does not reach the registration sensor.

Check item	Measures
Drawer	<ul style="list-style-type: none"> <li>• Check if the paper is damaged or if it has been folded.</li> <li>• Check the side guide in the drawer to confirm whether there is a reason for paper skewing in it.</li> <li>• Check that the paper stack height is within the specified range.</li> </ul>

Check item	Measures
1st transport sensor	<ul style="list-style-type: none"> <li>• Sensor check Input check: FS-03-[ALL]OFF/[9]/[B]</li> <li>• Actuator check</li> <li>• Connector check</li> <li>• Harness check</li> <li>• Replace the sensor.</li> </ul>
Registration sensor	<ul style="list-style-type: none"> <li>• Sensor check Input check: FS-03-[ALL]OFF/[9]/[A]</li> <li>• Actuator check</li> <li>• Connector check</li> <li>• Harness check</li> <li>• Replace the sensor.</li> </ul>
2nd drawer paper feed clutch	<ul style="list-style-type: none"> <li>• Check that the clutch is working. Output check: FS-03-202</li> <li>• Connector check</li> <li>• Harness check</li> <li>• Replace the clutch.</li> </ul>
Transport clutch (H)	<ul style="list-style-type: none"> <li>• Check that the clutch is working. Output check: FS-03-230</li> <li>• Connector check</li> <li>• Harness check</li> <li>• Replace the clutch.</li> </ul>
Transport clutch (L)	<ul style="list-style-type: none"> <li>• Check that the clutch is working. Output check: FS-03-233</li> <li>• Connector check</li> <li>• Harness check</li> <li>• Replace the clutch.</li> </ul>
Roller (each paper source)	Check the condition of the paper feed roller, separation roller and pickup roller. If they have deteriorated, replace them.
LGC board	<ul style="list-style-type: none"> <li>• PC board check</li> <li>• Connector check (CN316, CN318)</li> <li>• Harness check</li> <li>• Replace the PC board.</li> </ul>

Parts to be replaced	Remarks
1st transport sensor	
Registration sensor	
2nd drawer paper feed clutch	
Transport clutch (H)	
Transport clutch (L)	
LGC board	
Paper feed roller	
Separation roller	
Pickup roller	

**[E220] 2nd drawer paper transport jam****[E310] 3rd drawer paper transport jam****[E340] 4th drawer paper transport jam****[E3D0] T-LCF paper transport jam**

Classification	Error content
Paper transport jam	Paper does not reach the transport sensor.

Check item	Measures
Drawer	<ul style="list-style-type: none"> <li>• Check if the paper is damaged or if it has been folded.</li> <li>• Check the side guide in the drawer to confirm whether there is a reason for paper skewing in it.</li> <li>• Check that the paper stack height is within the specified range.</li> </ul>

Check item	Measures
1st transport sensor	<ul style="list-style-type: none"> <li>• Sensor check Input check: FS-03-[ALL]OFF/[9]/[B]</li> <li>• Actuator check</li> <li>• Connector check</li> <li>• Harness check</li> <li>• Replace the sensor.</li> </ul>
Transport clutch (H)	<ul style="list-style-type: none"> <li>• Check that the clutch is working. Output check: FS-03-230</li> <li>• Connector check</li> <li>• Harness check</li> <li>• Replace the clutch.</li> </ul>
Transport clutch (L)	<ul style="list-style-type: none"> <li>• Check that the clutch is working. Output check: FS-03-233</li> <li>• Connector check</li> <li>• Harness check</li> <li>• Replace the clutch.</li> </ul>
Roller (each paper source)	Check the condition of the paper feed roller, separation roller and pickup roller. If they have deteriorated, replace them.
LGC board	<ul style="list-style-type: none"> <li>• PC board check</li> <li>• Connector check (CN318)</li> <li>• Harness check</li> <li>• Replace the PC board.</li> </ul>

Parts to be replaced	Remarks
1st transport sensor	
Transport clutch (H)	
Transport clutch (L)	
LGC board	
Paper feed roller	
Separation roller	
Pickup roller	



### [E260] Ex-LCF paper transport jam

Classification	Error content
Paper transport jam	Paper fed from the Ex-LCF does not reach the registration sensor.
Check item	Measures
Registration sensor	<ul style="list-style-type: none"> <li>• Sensor check Input check: FS-03-[ALL]OFF/[9]/[A]</li> <li>• Actuator check</li> <li>• Connector check</li> <li>• Harness check</li> <li>• Replace the sensor.</li> </ul>
Transport clutch (H)	<ul style="list-style-type: none"> <li>• Check that the clutch is working. Output check: FS-03-230</li> <li>• Connector check</li> <li>• Harness check</li> <li>• Replace the clutch.</li> </ul>
Transport clutch (L)	<ul style="list-style-type: none"> <li>• Check that the clutch is working. Output check: FS-03-233</li> <li>• Connector check</li> <li>• Harness check</li> <li>• Replace the clutch.</li> </ul>
Roller (Ex-LCF)	Check the condition of the paper feed roller, separation roller and pickup roller. If they have deteriorated, replace them.
LGC board	<ul style="list-style-type: none"> <li>• PC board check</li> <li>• Connector check (CN318, CN326)</li> <li>• Harness check</li> <li>• Replace the PC board.</li> </ul>
Ex-LCF board	<ul style="list-style-type: none"> <li>• PC board check</li> <li>• Connector check (CN850, CN856)</li> <li>• Harness check</li> <li>• Replace the PC board.</li> </ul>
Ex-LCF transport clutch	<ul style="list-style-type: none"> <li>• Check that the clutch is working. Output check: FS-03-454</li> <li>• Connector check</li> <li>• Harness check</li> <li>• Replace the clutch.</li> </ul>

Parts to be replaced	Remarks
Registration sensor	
Transport clutch (H)	
Transport clutch (L)	
LGC board	
Ex-LCF board	
Ex-LCF paper feed roller	
Ex-LCF separation roller	
Ex-LCF pickup roller	
Ex-LCF transport clutch	

### [E270] Bypass tray paper transport jam

Classification	Error content
Paper transport jam	Paper does not reach the registration sensor.
Check item	Measures
Bypass tray	<ul style="list-style-type: none"> <li>• Check if the paper is damaged or if it has been folded.</li> <li>• Check the side guide to confirm whether there is a reason for paper skewing in it.</li> <li>• Check that the paper stack height is within the specified range.</li> </ul>

Check item	Measures
1st transport sensor	<ul style="list-style-type: none"> <li>• Sensor check Input check: FS-03-[ALL]OFF/[9]/[B]</li> <li>• Actuator check</li> <li>• Connector check</li> <li>• Harness check</li> <li>• Replace the sensor.</li> </ul>
Registration sensor	<ul style="list-style-type: none"> <li>• Sensor check Input check: FS-03-[ALL]OFF/[9]/[A]</li> <li>• Actuator check</li> <li>• Connector check</li> <li>• Harness check</li> <li>• Replace the sensor.</li> </ul>
Bypass tray paper feed clutch	<ul style="list-style-type: none"> <li>• Check that the clutch is working. Output check: FS-03-204</li> <li>• Connector check</li> <li>• Harness check</li> <li>• Replace the clutch.</li> </ul>
Roller (bypass tray)	Check the condition of the paper feed roller, separation roller and pickup roller. If they have deteriorated, replace them.
LGC board	<ul style="list-style-type: none"> <li>• PC board check</li> <li>• Connector check (CN318, CN321)</li> <li>• Harness check</li> <li>• Replace the PC board.</li> </ul>

Parts to be replaced	Remarks
1st transport sensor	
Registration sensor	
Bypass tray paper feed clutch	
LGC board	
Bypass unit paper feed roller	
Bypass unit separation roller	
Bypass tray pickup roller	

### [E2C0] Ex-LCF paper transport jam

Classification	Error content
Paper transport jam	Paper fed from the Ex-LCF does not reach the registration sensor.

Check item	Measures
1st transport sensor	<ul style="list-style-type: none"> <li>• Sensor check Input check: FS-03-[ALL]OFF/[9]/[B]</li> <li>• Actuator check</li> <li>• Connector check</li> <li>• Harness check</li> <li>• Replace the sensor.</li> </ul>
Registration sensor	<ul style="list-style-type: none"> <li>• Sensor check Input check: FS-03-[ALL]OFF/[9]/[A]</li> <li>• Actuator check</li> <li>• Connector check</li> <li>• Harness check</li> <li>• Replace the sensor.</li> </ul>
Transport clutch (H)	<ul style="list-style-type: none"> <li>• Check that the clutch is working. Output check: FS-03-230</li> <li>• Connector check</li> <li>• Harness check</li> <li>• Replace the clutch.</li> </ul>
Transport clutch (L)	<ul style="list-style-type: none"> <li>• Check that the clutch is working. Output check: FS-03-233</li> <li>• Connector check</li> <li>• Harness check</li> <li>• Replace the clutch.</li> </ul>

Check item	Measures
Roller (Ex-LCF)	Check the condition of the paper feed roller, separation roller and pickup roller. If they have deteriorated, replace them.
LGC board	<ul style="list-style-type: none"> <li>PC board check</li> <li>Connector check (CN318, CN326)</li> <li>Harness check</li> <li>Replace the PC board.</li> </ul>
Ex-LCF board	<ul style="list-style-type: none"> <li>PC board check</li> <li>Connector check (CN850, CN856)</li> <li>Harness check</li> <li>Replace the PC board.</li> </ul>
Ex-LCF transport clutch	<ul style="list-style-type: none"> <li>Check that the clutch is working. Output check: FS-03-454</li> <li>Connector check</li> <li>Harness check</li> <li>Replace the clutch.</li> </ul>

Parts to be replaced	Remarks
1st transport sensor	
Registration sensor	
Transport clutch (H)	
Transport clutch (L)	
LGC board	
Ex-LCF board	
Ex-LCF paper feed roller	
Ex-LCF separation roller	
Ex-LCF pickup roller	
Ex-LCF transport clutch	

### [E2D0] Ex-LCF paper transport jam

Classification	Error content
Paper transport jam	Paper fed from the Ex-LCF does not reach the 2nd drawer paper feed sensor.

Check item	Measures
2nd transport sensor	<ul style="list-style-type: none"> <li>Sensor check Input check: FS-03-[F2]ON/[4]/[D]</li> <li>Actuator check</li> <li>Connector check</li> <li>Harness check</li> <li>Replace the sensor.</li> </ul>
Ex-LCF transport clutch	<ul style="list-style-type: none"> <li>Check that the clutch is working. Output check: FS-03-454</li> <li>Connector check</li> <li>Harness check</li> <li>Replace the clutch.</li> </ul>
Roller (Ex-LCF)	Check the condition of the paper feed roller, separation roller and pickup roller. If they have deteriorated, replace them.
Ex-LCF board	<ul style="list-style-type: none"> <li>PC board check</li> <li>Connector check (CN850, CN856)</li> <li>Harness check</li> <li>Replace the PC board.</li> </ul>
LGC board	<ul style="list-style-type: none"> <li>PC board check</li> <li>Connector check (CN318, CN326)</li> <li>Harness check</li> <li>Replace the PC board.</li> </ul>

Parts to be replaced	Remarks
2nd drawer paper feed sensor	
Ex-LCF transport clutch	

Parts to be replaced	Remarks
Ex-LCF board	
LGC board	
Ex-LCF paper feed roller	
Ex-LCF separation roller	
Ex-LCF pickup roller	

**[E320] 3rd drawer paper transport jam**

**[E350] 4th drawer paper transport jam**

**[E3E0] T-LCF paper transport jam**

Classification	Error content
Paper transport jam	Paper does not reach the 2nd transport sensor.

Check item	Measures
2nd transport sensor	<ul style="list-style-type: none"> <li>• Sensor check Input check: FS-03-[F2]ON/[4]/[D]</li> <li>• Actuator check</li> <li>• Connector check</li> <li>• Harness check</li> <li>• Replace the sensor.</li> </ul>
PFP transport clutch	<ul style="list-style-type: none"> <li>• Check that the clutch is working. Output check: FS-03-225</li> <li>• Connector check</li> <li>• Harness check</li> <li>• Replace the clutch.</li> </ul>
T-LCF paper feed clutch	<ul style="list-style-type: none"> <li>• Check that the clutch is working. Output check: FS-03-209</li> <li>• Connector check</li> <li>• Harness check</li> <li>• Replace the clutch.</li> </ul>
Roller (each paper source)	Check the condition of the paper feed roller, separation roller and pickup roller. If they have deteriorated, replace them.
LGC board	<ul style="list-style-type: none"> <li>• PC board check</li> <li>• Connector check (CN318)</li> <li>• Harness check</li> <li>• Replace the PC board.</li> </ul>
PFP board	<ul style="list-style-type: none"> <li>• PC board check</li> <li>• Connector check</li> <li>• Harness check</li> </ul>
T-LCF board	<ul style="list-style-type: none"> <li>• PC board check</li> <li>• Connector check</li> <li>• Harness check</li> </ul>

Parts to be replaced	Remarks
2nd transport sensor	
PFP transport clutch	
T-LCF paper feed clutch	
LGC board	
Paper feed roller	
Separation roller	
Pickup roller	

**[E360] 4th drawer paper transport jam**

Classification	Error content
Paper transport jam	Paper does not reach the 3rd drawer paper feed sensor.

Check item	Measures
3rd drawer paper feed sensor	<ul style="list-style-type: none"> <li>• Sensor check Input check: FS-03-[F2]ON/[0]/[C]</li> <li>• Actuator check</li> <li>• Connector check</li> <li>• Harness check</li> <li>• Replace the sensor.</li> </ul>
PFP transport clutch	<ul style="list-style-type: none"> <li>• Check that the clutch is working. Output check: FS-03-225</li> <li>• Connector check</li> <li>• Harness check</li> <li>• Replace the clutch.</li> </ul>
Roller (each paper source)	Check the condition of the paper feed roller, separation roller and pickup roller. If they have deteriorated, replace them.
LGC board	<ul style="list-style-type: none"> <li>• PC board check</li> <li>• Connector check</li> <li>• Harness check</li> <li>• Replace the PC board.</li> </ul>
PFP board	<ul style="list-style-type: none"> <li>• PC board check</li> <li>• Connector check</li> <li>• Harness check</li> <li>• Replace the PC board.</li> </ul>

Parts to be replaced	Remarks
3rd drawer paper feed sensor	
PFP transport clutch	
LGC board	
PFP board	
4th drawer paper feed roller	
4th drawer separation roller	
4th drawer pickup roller	

### [E410] Front cover open jam

Classification	Error content
Cover open jam	The front cover has become open during printing.

Check item	Measures
Switching regulator	<ul style="list-style-type: none"> <li>• Check that the 24 V power supply is working. Input check: FS-03-[ALL]OFF/[7]/[D]</li> <li>• PC board check</li> <li>• Connector check (CN513, CN514)</li> <li>• Harness check</li> <li>• Fuse check</li> <li>• Replace the switching regulator.</li> </ul>
Front cover interlock switch	<ul style="list-style-type: none"> <li>• Switch check Input check: FS-03-[ALL]OFF/[7]/[D]</li> <li>• Connector check</li> <li>• Harness check</li> <li>• Replace the switch.</li> </ul>
LGC board	<ul style="list-style-type: none"> <li>• PC board check</li> <li>• Connector check (CN301)</li> <li>• Harness check</li> <li>• Replace the PC board.</li> </ul>
Front cover switch	<ul style="list-style-type: none"> <li>• Switch check Input check: FS-03-[ALL]OFF/[7]/[C]</li> <li>• Connector check (CN319)</li> <li>• Harness check</li> <li>• Replace the sensor.</li> </ul>
Front cover	Check if the cover is installed properly.

Parts to be replaced	Remarks
Switching regulator	
LGC board	
High-voltage transformer	
Front cover switch	

#### [E420] PFP side cover open jam

Classification	Error content
Cover open jam	The PFP side cover has become open during printing.

Check item	Measures
Side cover opening/closing switch	<ul style="list-style-type: none"> <li>Switch check Input check: FS-03-[F2]ON/[0]/[A]</li> <li>Connector check</li> <li>Harness check</li> <li>Replace the switch.</li> </ul>
PFP board	<ul style="list-style-type: none"> <li>PC board check</li> <li>Connector check (CN1001, CN1004)</li> <li>Harness check</li> <li>Replace the PC board.</li> </ul>
LGC board	<ul style="list-style-type: none"> <li>PC board check</li> <li>Connector check (CN315)</li> <li>Harness check</li> <li>Replace the PC board.</li> </ul>
Switching regulator	<ul style="list-style-type: none"> <li>Check that the 24 V power supply is working. Input check: FS-03-[ALL]OFF/[7]/[D]</li> <li>PC board check</li> <li>Connector check (CN513, CN514)</li> <li>Harness check</li> <li>Fuse check</li> <li>Replace the switching regulator.</li> </ul>

Parts to be replaced	Remarks
Side cover opening/closing switch	
PFP board	
LGC board	
Switching regulator	

#### [E430] ADU open jam

Classification	Error content
Cover open jam	The ADU has become open during printing.

Check item	Measures
ADU opening/closing switch	<ul style="list-style-type: none"> <li>Switch check Input check: FS-03-[ALL]OFF/[7]/[A]</li> <li>Connector check</li> <li>Harness check</li> <li>Replace the switch.</li> </ul>
LGC board	<ul style="list-style-type: none"> <li>PC board check</li> <li>Connector check (CN311)</li> <li>Harness check</li> <li>Replace the PC board.</li> </ul>
ADU interlock switch	<ul style="list-style-type: none"> <li>Switch check Input check: FS-03-[ALL]OFF/[7]/[D]</li> <li>Connector check</li> <li>Harness check</li> <li>Replace the switch.</li> </ul>

Check item	Measures
Switching regulator	<ul style="list-style-type: none"> <li>• Check that the 24 V power supply is working. Input check: FS-03-[ALL]OFF/[7]/[D]</li> <li>• PC board check</li> <li>• Connector check (CN513, CN514)</li> <li>• Harness check</li> <li>• Replace the switching regulator.</li> </ul>

Parts to be replaced	Remarks
ADU opening/closing switch	
LGC board	
ADU interlock switch	
Switching regulator	

**[E440] Jam access cover open jam**

Classification	Error content
Cover open jam	The jam access cover has become open during printing.

Check item	Measures
Jam access cover opening/closing switch	<ul style="list-style-type: none"> <li>• Switch check Input check: FS-03-[F2]ON/[4]/[A]</li> <li>• Connector check (CN318)</li> <li>• Harness check</li> <li>• Replace the switch.</li> </ul>
LGC board	<ul style="list-style-type: none"> <li>• PC board check</li> <li>• Connector check (CN318)</li> <li>• Harness check</li> <li>• Replace the PC board.</li> </ul>
Switching regulator	<ul style="list-style-type: none"> <li>• Check that the 24 V power supply is working. Input check: FS-03-[ALL]OFF/[7]/[D]</li> <li>• PC board check</li> <li>• Connector check (CN513, CN514)</li> <li>• Harness check</li> <li>• Replace the switching regulator.</li> </ul>

Parts to be replaced	Remarks
Jam access cover opening/closing switch	
LGC board	
Switching regulator	

**[E450] T-LCF jam access cover open jam**

Classification	Error content
Cover open jam	The T-LCF jam access cover has become open during printing.

Check item	Measures
T-LCF jam access cover opening/closing switch	<ul style="list-style-type: none"> <li>• Switch check Input check: FS-03-[F1]ON/[9]/[A]</li> <li>• Connector check</li> <li>• Harness check</li> <li>• Replace the switch.</li> </ul>
T-LCF board	<ul style="list-style-type: none"> <li>• PC board check</li> <li>• Connector check (CN1011)</li> <li>• Harness check</li> <li>• Replace the PC board.</li> </ul>
LGC board	<ul style="list-style-type: none"> <li>• PC board check</li> <li>• Connector check</li> <li>• Harness check</li> <li>• Replace the PC board.</li> </ul>

Parts to be replaced	Remarks
T-LCF jam access cover opening/closing switch	
T-LCF board	
LGC board	

#### [E480] Bridge kit open jam

Classification	Error content
Cover open jam	The bridge kit has become open during printing.

Check item	Measures
Bridge kit opening/closing detection sensor	<ul style="list-style-type: none"> <li>• Sensor check Input check: FS-03-[ALL]OFF/[7]/[B]</li> <li>• Actuator check</li> <li>• Connector check</li> <li>• Harness check</li> <li>• Replace the sensor.</li> </ul>
LGC board	<ul style="list-style-type: none"> <li>• PC board check</li> <li>• Connector check (CN311)</li> <li>• Harness check</li> <li>• Replace the PC board.</li> </ul>

Parts to be replaced	Remarks
Bridge kit opening/closing detection sensor	
LGC board	

#### [E490] Job separator open jam

Classification	Error content
Cover open jam	The JSP cover has become open during printing.

Check item	Measures
JSP cover switch	<ul style="list-style-type: none"> <li>• Switch check Input check: FS-03-[ALL]OFF/[7]/[B]</li> <li>• Connector check</li> <li>• Harness check</li> <li>• Replace the switch.</li> </ul>
LGC board	<ul style="list-style-type: none"> <li>• PC board check</li> <li>• Connector check (CN311)</li> <li>• Harness check</li> <li>• Replace the PC board.</li> </ul>

Parts to be replaced	Remarks
JSP cover switch	
LGC board	



## [E510] Paper not reaching the ADU jam

Classification	Error content
Paper transport jam	Paper does not reach the ADU entrance sensor after it has been switchbacked in the paper exit section.

Check item	Measures
Drawer	<ul style="list-style-type: none"> <li>• Check if the paper is damaged or if it has been folded.</li> <li>• Check the side guide in the drawer to confirm whether there is a reason for paper skewing in it.</li> </ul>
Paper exit gate, reverse gate	Check if toner has adhered to the paper exit gate and reverse gate or if they are just dirty. If needed, clean them.
Fuser unit	<ul style="list-style-type: none"> <li>• Check if separation fingers or springs have come off. If so, correct this.</li> <li>• Replace the separation finger.</li> </ul>
ADU entrance sensor	<ul style="list-style-type: none"> <li>• Sensor check Input check: FS-03-[ALL]OFF/[9]/[G]</li> <li>• Actuator check</li> <li>• Connector check</li> <li>• Harness check</li> <li>• Replace the sensor.</li> </ul>
Paper exit motor (2528A, 3028A)	<ul style="list-style-type: none"> <li>• Check that the motor is working. Output check: FS-03-121, 171</li> <li>• Connector check</li> <li>• Harness check</li> <li>• Replace the motor.</li> </ul>
Paper exit/reverse motor (3528A, 4528A)	<ul style="list-style-type: none"> <li>• Check that the motor is working. Output check: FS-03-121, 171</li> <li>• Connector check</li> <li>• Harness check</li> <li>• Replace the motor.</li> </ul>
ADU board	<ul style="list-style-type: none"> <li>• PC board check</li> <li>• Connector check (CN420, CN421)</li> <li>• Harness check</li> <li>• Replace the PC board.</li> </ul>
LGC board	<ul style="list-style-type: none"> <li>• PC board check</li> <li>• Connector check (CN321)</li> <li>• Harness check</li> <li>• Replace the PC board.</li> </ul>

Parts to be replaced	Remarks
Separation finger in the fuser unit	
ADU entrance sensor	
Paper exit motor (2528A, 3028A)	
Paper exit/reverse motor (3528A, 4528A)	
ADU board	
LGC board	

**[E520] Paper stopping in the ADU jam**

Classification	Error content
Paper transport jam	Paper which has passed through the ADU entrance sensor does not reach the ADU exit sensor.

Check item	Measures
ADU exit sensor	<ul style="list-style-type: none"> <li>• Sensor check Input check: FS-03-[ALL]OFF/[9]/[H]</li> <li>• Actuator check</li> <li>• Connector check</li> <li>• Harness check</li> <li>• Replace the sensor.</li> </ul>
ADU motor	<ul style="list-style-type: none"> <li>• Check that the motor is working. Output check: FS-03-110, 160</li> <li>• Connector check</li> <li>• Harness check</li> <li>• Replace the motor.</li> </ul>
ADU board	<ul style="list-style-type: none"> <li>• PC board check</li> <li>• Connector check (CN420, CN421)</li> <li>• Harness check</li> <li>• Replace the PC board.</li> </ul>
LGC board	<ul style="list-style-type: none"> <li>• PC board check</li> <li>• Connector check (CN321)</li> <li>• Harness check</li> <li>• Replace the PC board.</li> </ul>

Parts to be replaced	Remarks
ADU exit sensor	
ADU motor	
ADU board	
LGC board	

## [E550] Paper remaining jam on the transport path

Classification	Error content
Other paper jam	Paper is detected on the transport path when printing has been finished.
Check item	Measures
Paper	Check that there is paper where the paper misfeed sign is indicating on the screen.
Roller (each paper source)	Check the condition of the paper feed roller, separation roller and pickup roller. If they have deteriorated, replace them.
Sensors in the paper misfeed area	Check the sensors mounted in the location in question by referring to the table below. Registration section <ul style="list-style-type: none"> <li>Registration sensor</li> <li>1st transport sensor</li> </ul> Paper exit section <ul style="list-style-type: none"> <li>Paper exit sensor</li> </ul> ADU section <ul style="list-style-type: none"> <li>ADU entrance sensor</li> <li>ADU exit sensor</li> </ul> Bypass unit section <ul style="list-style-type: none"> <li>2nd transport sensor</li> </ul> LCF section <ul style="list-style-type: none"> <li>LCF transport sensor</li> </ul> PFP section <ul style="list-style-type: none"> <li>3rd drawer paper feed sensor</li> <li>4th drawer paper feed sensor</li> </ul> Bridge kit section <ul style="list-style-type: none"> <li>Bridge kit transport sensor-1</li> <li>Bridge kit transport sensor-2</li> </ul> Finisher section <ul style="list-style-type: none"> <li>Sensor (Finisher)</li> </ul> JSP section <ul style="list-style-type: none"> <li>JSP transport sensor</li> </ul>
Registration sensor	<ul style="list-style-type: none"> <li>Sensor check Input check: FS-03-[ALL]OFF/[9]/[A]</li> <li>Actuator check</li> <li>Connector check</li> <li>Harness check</li> <li>Replace the sensor.</li> </ul>
1st transport sensor	<ul style="list-style-type: none"> <li>Sensor check Input check: FS-03-[ALL]OFF/[9]/[B]</li> <li>Actuator check</li> <li>Connector check</li> <li>Harness check</li> <li>Replace the sensor.</li> </ul>
Paper exit sensor	<ul style="list-style-type: none"> <li>Sensor check Input check: FS-03-[ALL]OFF/[9]/[C]</li> <li>Actuator check</li> <li>Connector check</li> <li>Harness check</li> <li>Replace the sensor.</li> </ul>
ADU entrance sensor	<ul style="list-style-type: none"> <li>Sensor check Input check: FS-03-[ALL]OFF/[9]/[G]</li> <li>Actuator check</li> <li>Connector check</li> <li>Harness check</li> <li>Replace the sensor.</li> </ul>
ADU exit sensor	<ul style="list-style-type: none"> <li>Sensor check Input check: FS-03-[ALL]OFF/[9]/[H]</li> <li>Actuator check</li> <li>Connector check</li> <li>Harness check</li> <li>Replace the sensor.</li> </ul>

Check item	Measures
2nd transport sensor	<ul style="list-style-type: none"> <li>• Sensor check Input check: FS-03-[F2]ON/[4]/[D]</li> <li>• Actuator check</li> <li>• Connector check</li> <li>• Harness check</li> <li>• Replace the sensor.</li> </ul>
T-LCF transport sensor	<ul style="list-style-type: none"> <li>• Sensor check Input check: FS-03-[F1]ON/[9]/[F]</li> <li>• Actuator check</li> <li>• Connector check</li> <li>• Harness check</li> <li>• Replace the sensor.</li> </ul>
3rd drawer paper feed sensor	<ul style="list-style-type: none"> <li>• Sensor check Input check: FS-03-[F2]ON/[0]/[C]</li> <li>• Actuator check</li> <li>• Connector check</li> <li>• Harness check</li> <li>• Replace the sensor.</li> </ul>
4th drawer paper feed sensor	<ul style="list-style-type: none"> <li>• Sensor check Input check: FS-03-[F2]ON/[0]/[D]</li> <li>• Actuator check</li> <li>• Connector check</li> <li>• Harness check</li> <li>• Replace the sensor.</li> </ul>
Bridge kit transport sensor-1	<ul style="list-style-type: none"> <li>• Sensor check Input check: FS-03-[ALL]OFF/[0]/[A]</li> <li>• Actuator check</li> <li>• Connector check</li> <li>• Harness check</li> <li>• Replace the sensor.</li> </ul>
Bridge kit transport sensor-2	<ul style="list-style-type: none"> <li>• Sensor check Input check: FS-03-[ALL]OFF/[0]/[B]</li> <li>• Actuator check</li> <li>• Connector check</li> <li>• Harness check</li> <li>• Replace the sensor.</li> </ul>
Sensor (Finisher)	<ul style="list-style-type: none"> <li>• Sensor check</li> <li>• Actuator check</li> <li>• Connector check</li> <li>• Harness check</li> <li>• Replace the sensor.</li> </ul>
JSP transport sensor	<ul style="list-style-type: none"> <li>• Sensor check Input check: FS-03-[ALL]OFF/[0]/[A]</li> <li>• Actuator check</li> <li>• Connector check</li> <li>• Harness check</li> <li>• Replace the sensor.</li> </ul>
LGC board	<ul style="list-style-type: none"> <li>• PC board check</li> <li>• Connector check</li> <li>• Harness check</li> <li>• Replace the PC board.</li> </ul> <p><b>Notes:</b> Check the boards of the ADU, PFP and LCF depending on the location of the sensors in the paper misfeed area.</p>

Parts to be replaced	Remarks
Sensors in the paper misfeed area	
LGC board	ADU board, PFP board, LCF board

**[E551] Paper remaining jam on the transport path (after a service call has occurred)****[E552] Paper remaining jam on the transport path (when the cover is closed)**

Classification	Error content
Other paper jam	<ul style="list-style-type: none"> <li>Paper is detected on the transport path after a service call has occurred.</li> <li>Paper is detected on the transport path after the cover has been closed.</li> </ul>

Check item	Measures
Paper	Check that there is paper where the paper misfeed sign is indicating on the screen.
Roller (each paper source)	Check the condition of the paper feed roller, separation roller and pickup roller. If they have deteriorated, replace them.
Sensors in the paper misfeed area	<p>Check the sensors mounted in the location in question by referring to the table below.</p> <p>Registration section</p> <ul style="list-style-type: none"> <li>Registration sensor</li> <li>1st transport sensor</li> </ul> <p>Paper exit section</p> <ul style="list-style-type: none"> <li>Paper exit sensor</li> </ul> <p>ADU section</p> <ul style="list-style-type: none"> <li>ADU entrance sensor</li> <li>ADU exit sensor</li> </ul> <p>Bypass unit section</p> <ul style="list-style-type: none"> <li>2nd transport sensor</li> </ul> <p>LCF section</p> <ul style="list-style-type: none"> <li>LCF transport sensor</li> </ul> <p>PFP section</p> <ul style="list-style-type: none"> <li>3rd drawer paper feed sensor</li> <li>4th drawer paper feed sensor</li> </ul> <p>Bridge kit section</p> <ul style="list-style-type: none"> <li>Bridge kit transport sensor-1</li> <li>Bridge kit transport sensor-2</li> </ul> <p>Finisher section</p> <ul style="list-style-type: none"> <li>Sensor (Finisher)</li> </ul> <p>JSP section</p> <ul style="list-style-type: none"> <li>JSP transport sensor</li> </ul>
Registration sensor	<ul style="list-style-type: none"> <li>Sensor check</li> <li>Input check: FS-03-[ALL]OFF/[9]/[A]</li> <li>Actuator check</li> <li>Connector check</li> <li>Harness check</li> <li>Replace the sensor.</li> </ul>
1st transport sensor	<ul style="list-style-type: none"> <li>Sensor check</li> <li>Input check: FS-03-[ALL]OFF/[9]/[B]</li> <li>Actuator check</li> <li>Connector check</li> <li>Harness check</li> <li>Replace the sensor.</li> </ul>
Paper exit sensor	<ul style="list-style-type: none"> <li>Sensor check</li> <li>Input check: FS-03-[ALL]OFF/[9]/[C]</li> <li>Actuator check</li> <li>Connector check</li> <li>Harness check</li> <li>Replace the sensor.</li> </ul>
ADU entrance sensor	<ul style="list-style-type: none"> <li>Sensor check</li> <li>Input check: FS-03-[ALL]OFF/[9]/[G]</li> <li>Actuator check</li> <li>Connector check</li> <li>Harness check</li> <li>Replace the sensor.</li> </ul>
ADU exit sensor	<ul style="list-style-type: none"> <li>Sensor check</li> <li>Input check: FS-03-[ALL]OFF/[9]/[H]</li> <li>Actuator check</li> <li>Connector check</li> <li>Harness check</li> <li>Replace the sensor.</li> </ul>

Check item	Measures
2nd transport sensor	<ul style="list-style-type: none"> <li>• Sensor check Input check: FS-03-[F2]ON/[4]/[D]</li> <li>• Actuator check</li> <li>• Connector check</li> <li>• Harness check</li> <li>• Replace the sensor.</li> </ul>
T-LCF transport sensor	<ul style="list-style-type: none"> <li>• Sensor check Input check: FS-03-[F1]ON/[9]/[F]</li> <li>• Actuator check</li> <li>• Connector check</li> <li>• Harness check</li> <li>• Replace the sensor.</li> </ul>
3rd drawer paper feed sensor	<ul style="list-style-type: none"> <li>• Sensor check Input check: FS-03-[F2]ON/[0]/[C]</li> <li>• Actuator check</li> <li>• Connector check</li> <li>• Harness check</li> <li>• Replace the sensor.</li> </ul>
4th drawer paper feed sensor	<ul style="list-style-type: none"> <li>• Sensor check Input check: FS-03-[F2]ON/[0]/[D]</li> <li>• Actuator check</li> <li>• Connector check</li> <li>• Harness check</li> <li>• Replace the sensor.</li> </ul>
Bridge kit transport sensor-1	<ul style="list-style-type: none"> <li>• Sensor check Input check: FS-03-[ALL]OFF/[0]/[A]</li> <li>• Actuator check</li> <li>• Connector check</li> <li>• Harness check</li> <li>• Replace the sensor.</li> </ul>
Bridge kit transport sensor-2	<ul style="list-style-type: none"> <li>• Sensor check Input check: FS-03-[ALL]OFF/[0]/[B]</li> <li>• Actuator check</li> <li>• Connector check</li> <li>• Harness check</li> <li>• Replace the sensor.</li> </ul>
Sensor (Finisher)	<ul style="list-style-type: none"> <li>• Sensor check</li> <li>• Actuator check</li> <li>• Connector check</li> <li>• Harness check</li> <li>• Replace the sensor.</li> </ul>
JSP transport sensor	<ul style="list-style-type: none"> <li>• Sensor check Input check: FS-03-[ALL]OFF/[0]/[A]</li> <li>• Actuator check</li> <li>• Connector check</li> <li>• Harness check</li> <li>• Replace the sensor.</li> </ul>
LGC board	<ul style="list-style-type: none"> <li>• PC board check</li> <li>• Connector check</li> <li>• Harness check</li> <li>• Replace the PC board.</li> </ul> <p><b>Notes:</b> Check the boards of the ADU, PFP and LCF depending on the location of the sensors in the paper misfeed area.</p>

Parts to be replaced	Remarks
Sensors in the paper misfeed area	
LGC board	ADU board, PFP board, LCF board

## [E570] Paper not reaching the reverse sensor jam

Classification	Error content
Paper transport jam	Paper which has passed through the paper exit sensor does not reach the reverse sensor. (3528A, 4528A only)

Check item	Measures
Reverse sensor	<ul style="list-style-type: none"> <li>• Sensor check Input check: FS-03-[ALL]OFF/[9]/[D]</li> <li>• Actuator check</li> <li>• Connector check</li> <li>• Harness check</li> <li>• Replace the sensor.</li> </ul>
Paper exit/reverse motor	<ul style="list-style-type: none"> <li>• Check that the motor is working. Output check: FS-03-121, 171</li> <li>• Connector check</li> <li>• Harness check</li> <li>• Replace the motor.</li> </ul>
Reverse gate solenoid	<ul style="list-style-type: none"> <li>• Solenoid check Output check: FS-03-222, 03-223</li> <li>• Connector check</li> <li>• Harness check</li> </ul>
Reverse gate	<ul style="list-style-type: none"> <li>• Check if the parts are installed properly.</li> <li>• Check if the parts are damaged or deformed.</li> <li>• Check if a load is applied to the parts or if there is an abnormality in their performance.</li> </ul>
Reverse roller	Check the condition of the roller. If it has deteriorated, replace it.
Reverse unit	Check if the reverse unit installed properly. If not, correct this.
Fuser unit	Check if the fuser unit is installed properly. If not, correct this.
LGC board	<ul style="list-style-type: none"> <li>• PC board check</li> <li>• Connector check (CN321, CN307)</li> <li>• Harness check</li> <li>• Replace the PC board.</li> </ul>

Parts to be replaced	Remarks
Reverse sensor	
Paper exit/reverse motor	
Reverse roller	
Reverse unit	
Fuser unit	
LGC board	

### [E580] Paper stopping at the reverse sensor jam

Classification	Error content
Paper transport jam	The trailing edge of the paper does not pass through the reverse sensor after its leading edge has reached this sensor. (3528A, 4528A only)

Check item	Measures
Reverse sensor	<ul style="list-style-type: none"> <li>• Sensor check Input check: FS-03-[ALL]OFF/[9]/[D]</li> <li>• Actuator check</li> <li>• Connector check</li> <li>• Harness check</li> <li>• Replace the sensor.</li> </ul>
Paper exit/reverse motor	<ul style="list-style-type: none"> <li>• Check that the motor is working. Output check: FS-03-121, 171</li> <li>• Connector check</li> <li>• Harness check</li> <li>• Replace the motor.</li> </ul>
Reverse gate solenoid	<ul style="list-style-type: none"> <li>• Solenoid check Output check: FS-03-222, 223</li> <li>• Connector check</li> <li>• Harness check</li> </ul>
Reverse gate	<ul style="list-style-type: none"> <li>• Check if the parts are installed properly.</li> <li>• Check if the parts are damaged or deformed.</li> <li>• Check if a load is applied to the parts or if there is an abnormality in their performance.</li> </ul>
Reverse roller	Check the condition of the roller. If it has deteriorated, replace it.
Upper paper exit roller	Check the condition of the roller. If it has deteriorated, replace it.
Reverse unit	Check if the reverse unit installed properly. If not, correct this.
Fuser unit	Check if the fuser unit is installed properly. If not, correct this.
LGC board	<ul style="list-style-type: none"> <li>• PC board check</li> <li>• Connector check (CN307, CN321)</li> <li>• Harness check</li> <li>• Replace the PC board.</li> </ul>

Parts to be replaced	Remarks
Reverse sensor	
Paper exit/reverse motor	
Reverse gate	
Reverse roller	
Upper paper exit roller	
Reverse unit	
Fuser unit	
LGC board	

### [E703] DSDF multiple feeding jam

Classification	Error content
DSDF jam	Multiple feeding of originals has occurred.

Check item	Measures
Multiple feeding detection sensor (transmission side)	<ul style="list-style-type: none"> <li>• Sensor check</li> <li>• Connector check</li> <li>• Harness check</li> <li>• Replace the sensor.</li> </ul>
Multiple feeding detection sensor (reception side)	<ul style="list-style-type: none"> <li>• Sensor check</li> <li>• Connector check</li> <li>• Harness check</li> <li>• Replace the sensor.</li> </ul>



Check item	Measures
DSDF multiple feeding relay board	<ul style="list-style-type: none"> <li>PC board check</li> <li>Connector check</li> <li>Harness check</li> <li>Replace the PC board.</li> </ul>
DSDF control PC board	<ul style="list-style-type: none"> <li>PC board check</li> <li>Connector check</li> <li>Harness check</li> <li>Replace the PC board.</li> </ul>

Parts to be replaced	Remarks
Multiple feeding detection sensor (transmission side)	
Multiple feeding detection sensor (reception side)	
DSDF multiple feeding relay board	
DSDF control PC board	

### [E712] Original not reaching the DSDF registration sensor jam

Classification	Error content
DSDF jam	The original fed from the original tray does not reach the DSDF registration sensor.

Check item	Measures
Original	Flatten and reload an original if it is abnormally curled or is folded.
DSDF pickup roller DSDF original feed roller DSDF separation roller	Check the condition of the roller. If it has been stained, clean it. If it has deteriorated, replace it.
DSDF registration sensor	<ul style="list-style-type: none"> <li>Sensor check Input check: FS-03-[F2]ON/[7]/[H]</li> <li>Actuator check</li> <li>Connector check (J975, J950, CN74)</li> <li>Harness check</li> <li>Replace the sensor.</li> </ul>
DSDF control PC board	<ul style="list-style-type: none"> <li>PC board check</li> <li>Connector check (CN74)</li> <li>Harness check</li> <li>Replace the PC board.</li> </ul>

Parts to be replaced	Remarks
DSDF pickup roller	
DSDF original feed roller	
DSDF separation roller	
DSDF registration sensor	
DSDF control PC board	

### [E712] Original not reaching the RADF original registration sensor jam

Classification	Error content
RADF jam	The original fed from the original tray does not reach the original registration sensor.

Check item	Measures
Original	Flatten and reload an original if it is abnormally curled or is folded.
Pickup roller Paper feed roller Separation roller	Check the condition of the roller. If it has been stained, clean it. If it has deteriorated, replace it.

Check item	Measures
Original registration sensor	<ul style="list-style-type: none"> <li>• Sensor check Input check: FS-03-[F2]ON/[7]/[H]</li> <li>• Actuator check</li> <li>• Connector check (CN74, J88, J86)</li> <li>• Harness check</li> <li>• Replace the sensor.</li> </ul>
RADF board	<ul style="list-style-type: none"> <li>• PC board check</li> <li>• Connector check (CN74)</li> <li>• Harness check</li> <li>• Replace the PC board.</li> </ul>

Parts to be replaced	Remarks
Pickup roller	
Paper feed roller	
Separation roller	
Original registration sensor	
RADF board	

#### [E714] Paper feed signal reception jam in DSDF

Classification	Error content
DSDF jam	The DSDF has received the paper feed signal from the MFP even though there is no original on the original tray.

Check item	Measures
Reproducibility	Release the misfeeding and reattempt copying or scanning.
DSDF original empty sensor	<ul style="list-style-type: none"> <li>• Sensor check Input check: FS-03-[F2]ON/[7]/[B]</li> <li>• Actuator check</li> <li>• Connector check (CN75)</li> <li>• Harness check</li> <li>• Replace the sensor.</li> </ul>
DSDF control PC board	<ul style="list-style-type: none"> <li>• PC board check</li> <li>• Connector check (CN75)</li> <li>• Harness check</li> <li>• Replace the PC board.</li> </ul>

Parts to be replaced	Remarks
DSDF original empty sensor	
DSDF control PC board	

#### [E714] Paper feed signal reception jam in RADF

Classification	Error content
RADF jam	The RADF has received the paper feed signal from the MFP even though there is no original on the original tray.

Check item	Measures
Reproducibility	Release the misfeeding and reattempt copying or scanning.
Original empty sensor	<ul style="list-style-type: none"> <li>• Sensor check Input check: FS-03-[F2]ON/[7]/[B]</li> <li>• Actuator check</li> <li>• Connector check (CN75, J92, J96)</li> <li>• Harness check</li> <li>• Replace the sensor.</li> </ul>
RADF board	<ul style="list-style-type: none"> <li>• PC board check</li> <li>• Connector check (CN75)</li> <li>• Harness check</li> <li>• Replace the PC board.</li> </ul>

Parts to be replaced	Remarks
Original empty sensor	

Parts to be replaced	Remarks
RADF board	

**[E717] Original not reaching the DSDF original feed sensor jam**

Classification	Error content
DSDF jam	The original does not reach the DSDF original feed sensor even though original feeding has started.

Check item	Measures
DSDF original feed sensor	<ul style="list-style-type: none"> <li>• Sensor check Input check: FS-03-[F2]ON/[8]/[E]</li> <li>• Actuator check</li> <li>• Connector check (J974, J950, CN74)</li> <li>• Harness check</li> <li>• Replace the sensor.</li> </ul>
DSDF original feed motor	<ul style="list-style-type: none"> <li>• Check that the motor is working. Output check: FS-03-281</li> <li>• Connector check (J990, CN77)</li> <li>• Harness check</li> <li>• Replace the motor.</li> </ul>
DSDF control PC board	<ul style="list-style-type: none"> <li>• PC board check</li> <li>• Connector check (CN74, CN77)</li> <li>• Harness check</li> <li>• Replace the PC board.</li> </ul>

Parts to be replaced	Remarks
DSDF original feed sensor	
DSDF original feed motor	
DSDF control PC board	

**[E718] Original setting jam, original tray lift abnormality**

Classification	Error content
DSDF jam	<ul style="list-style-type: none"> <li>• The original tray lift has been driven to raise itself and the DSDF tray lift upper limit sensor has not been turned ON within a specified time.</li> <li>• The original tray lift has been driven to lower itself and the DSDF tray lift lower limit sensor has not been turned ON within a specified time.</li> </ul>

Check item	Measures
During original feeding or the initial operation, when an original is pulled out after being placed	
Malfunction	Check whether an operation to apply a load to the original tray has been performed while it is being raised or lowered. Check that there is no foreign matter in the original tray lifting section. If the cause of this problem is any of the above, take an appropriate measure, open and then close the cover to release the problem. If the cause of this problem is other than the above, take the following measure.
When the original tray lift is being rising (When this problem has occurred after the original placing or during original transporting)	
DSDF tray lift upper limit sensor	There will be an abnormality in the DSDF tray lift upper limit sensor when an error occurs while the tray is being raised. <ul style="list-style-type: none"> <li>• Sensor check Input check: FS-03-[F2]ON/[6]/[E]</li> <li>• Actuator check</li> <li>• Connector check</li> <li>• Harness check</li> <li>• Replace the sensor.</li> </ul>
When the original tray lift is being lowering (When this problem has occurred if an original is pulled out during the initial operation or the operation itself)	

Check item	Measures
DSDF tray lift lower limit sensor	There will be an abnormality in the DSDF tray lift lower limit sensor when an error occurs while the tray is being lowered. <ul style="list-style-type: none"> <li>• Sensor check Input check: FS-03-[F2]ON/[6]/[F]</li> <li>• Actuator check</li> <li>• Connector check</li> <li>• Harness check</li> <li>• Replace the sensor.</li> </ul>
When the original tray lift does not work (not being raised and lowered)	
DSDF tray-up clutch	There will be an abnormality in the DSDF tray-up clutch if it does not work. <ul style="list-style-type: none"> <li>• Check that the clutch is working.</li> <li>• Connector check</li> <li>• Harness check</li> <li>• Replace the clutch.</li> </ul>
DSDF separation motor	There will be an abnormality in the DSDF separation motor if it does not work. <ul style="list-style-type: none"> <li>• Check that the motor is working. Output check: FS-03-291, 292</li> <li>• Connector check</li> <li>• Harness check</li> <li>• Replace the motor.</li> </ul>
All	
DSDF control PC board	Check that there is no abnormality on the DSDF control PC board when operation failure has occurred in the DSDF tray lift upper limit sensor, DSDF tray lift lower limit sensor, DSDF tray-up clutch or DSDF separation motor. If there is any abnormality, replace it.

Parts to be replaced	Remarks
DSDF tray lift upper limit sensor	
DSDF tray lift lower limit sensor	
DSDF tray-up clutch	
DSDF separation motor	
DSDF control PC board	

### [E721] Original not reaching the DSDF read-in sensor-1 jam

Classification	Error content
DSDF jam	The original passed through the DSDF registration sensor does not reach the DSDF read-in sensor-1.

Check item	Measures
DSDF registration roller Pre-read roller	Check the condition of the roller. If it has been stained, clean it. If it has deteriorated, replace it.
DSDF read-in sensor-1	<ul style="list-style-type: none"> <li>• Sensor check Input check: FS-03-[F2]ON/[7]/[G]</li> <li>• Connector check (J983, J956, CN75)</li> <li>• Harness check</li> <li>• Replace the sensor.</li> </ul>
Aligning amount	Perform FS-05-3040 (Alignment position adjustment).
DSDF read motor	<ul style="list-style-type: none"> <li>• Check that the motor is working. Output check: FS-03-282</li> <li>• Connector check (J992, CN79)</li> <li>• Harness check</li> <li>• Replace the motor.</li> </ul>
DSDF registration motor	<ul style="list-style-type: none"> <li>• Check that the motor is working. Output check: FS-03-283</li> <li>• Connector check (J982, CN79)</li> <li>• Harness check</li> <li>• Replace the motor.</li> </ul>

Check item	Measures
DSDF control PC board	<ul style="list-style-type: none"> <li>• PC board check</li> <li>• Connector check (CN75, CN79)</li> <li>• Harness check</li> <li>• Replace the PC board.</li> </ul>

Parts to be replaced	Remarks
DSDF registration roller	
Pre-read roller	
DSDF read-in sensor-1	
DSDF read motor	
DSDF registration motor	
DSDF control PC board	

### [E721] Original not reaching the RADF read sensor jam

Classification	Error content
RADF jam	The original passed through the registration sensor (when scanning the front side) or the reverse sensor (when scanning the back side) does not reach the read sensor.

Check item	Measures
Registration roller Read roller	Check the condition of the roller. If it has been stained, clean it. If it has deteriorated, replace it.
Read sensor	<ul style="list-style-type: none"> <li>• Sensor check Input check: FS-03-[F2]ON/[7]/[G]</li> <li>• Actuator check</li> <li>• Connector check (CN75, J94)</li> <li>• Harness check</li> <li>• Replace the sensor.</li> </ul>
RADF board	<ul style="list-style-type: none"> <li>• PC board check</li> <li>• Connector check (CN75)</li> <li>• Harness check</li> <li>• Replace the PC board.</li> </ul>

Parts to be replaced	Remarks
Registration roller	
Read roller	
Read sensor	
RADF board	

**[E722] Original not reaching the DSDF original exit sensor jam**

Classification	Error content
DSDF jam	The original passed through the DSDF read-in sensor-2 does not reach the DSDF original exit sensor.

Check item	Measures
Post-read roller-2	Check the condition of the roller. If it has been stained, clean it. If it has deteriorated, replace it.
DSDF original exit sensor	<ul style="list-style-type: none"> <li>• Sensor check Input check: FS-03-[F2]ON/[7]/[E]</li> <li>• Actuator check</li> <li>• Connector check (J985, J957, CN75)</li> <li>• Harness check</li> <li>• Replace the sensor.</li> </ul>
DSDF control PC board	<ul style="list-style-type: none"> <li>• PC board check</li> <li>• Connector check (CN75)</li> <li>• Harness check</li> <li>• Replace the PC board.</li> </ul>

Parts to be replaced	Remarks
Post-read roller-2	
DSDF original exit sensor	
DSDF control PC board	

**[E722] Original not reaching the RADF original exit/reverse sensor jam (during scanning)**

Classification	Error content
RADF jam	The original passed through the read sensor does not reach the RADF original exit/reverse sensor while it is transported from the scanning section to the exit section.

Check item	Measures
Read roller	Check the condition of the roller. If it has been stained, clean it. If it has deteriorated, replace it.
Original exit/reverse sensor	<ul style="list-style-type: none"> <li>• Sensor check Input check: FS-03-[F2]ON/[7]/[E]</li> <li>• Actuator check</li> <li>• Connector check (CN75, J93)</li> <li>• Harness check</li> <li>• Replace the sensor.</li> </ul>
RADF board	<ul style="list-style-type: none"> <li>• PC board check</li> <li>• Connector check (CN75)</li> <li>• Harness check</li> <li>• Replace the PC board.</li> </ul>

Parts to be replaced	Remarks
Read roller	
Original exit/reverse sensor	
RADF board	

**[E724] Original stopping at the DSDF registration sensor jam**

Classification	Error content
DSDF jam	The trailing edge of the original does not pass through the DSDF registration sensor after its leading edge has passed through this sensor.

Check item	Measures
DSDF registration roller	Check the condition of the roller. If it has been stained, clean it. If it has deteriorated, replace it.

Check item	Measures
DSDF registration sensor	<ul style="list-style-type: none"> <li>• Sensor check Input check: FS-03-[F2]ON/[7]/[H]</li> <li>• Actuator check</li> <li>• Connector check (J975, J950, CN74)</li> <li>• Harness check</li> <li>• Replace the sensor.</li> </ul>
DSDF tray original length sensor-1 DSDF tray original length sensor-2 DSDF tray original width sensor-1 DSDF tray original width sensor-2	<ul style="list-style-type: none"> <li>• Sensor check Input check for the DSDF tray original width sensor-1 and -2: FS-03-[F2]ON/[8]/[F], FS-03-[F2]ON/[8]/[G] Input check for the DSDF tray original length sensor-1 and -2: FS-03-[F2]ON/[8]/[D], FS-03-[F2]ON/[7]/[A]</li> <li>• Actuator check</li> <li>• Connector check (J970, J971, CN76)</li> <li>• Harness check</li> <li>• Replace the sensor.</li> </ul>
DSDF control PC board	<ul style="list-style-type: none"> <li>• PC board check</li> <li>• Connector check (CN75)</li> <li>• Harness check</li> <li>• Replace the PC board.</li> </ul>

Parts to be replaced	Remarks
DSDF registration roller	
DSDF registration sensor	
DSDF tray original length sensor-1	
DSDF tray original length sensor-2	
DSDF tray original width sensor-1	
DSDF tray original width sensor-2	
DSDF control PC board	

#### [E724] Original stopping at the RADF registration sensor jam

Classification	Error content
RADF jam	The trailing edge of the original does not pass through the registration sensor after its leading edge has passed through this sensor.

Check item	Measures
Registration roller	Check the condition of the roller. If it has been stained, clean it. If it has deteriorated, replace it.
Original registration sensor	<ul style="list-style-type: none"> <li>• Sensor check Input check: FS-03-[F2]ON/[7]/[H]</li> <li>• Actuator check</li> <li>• Connector check (CN74, J88, J86)</li> <li>• Harness check</li> <li>• Replace the sensor.</li> </ul>
Original width detection sensor-1	<ul style="list-style-type: none"> <li>• Sensor check Input check: FS-03-[F2]ON/[8]/[F]</li> <li>• Actuator check</li> <li>• Connector check (CN74, J86, J89)</li> <li>• Harness check</li> <li>• Replace the sensor.</li> </ul>
Original width detection sensor-2	<ul style="list-style-type: none"> <li>• Sensor check Input check: FS-03-[F2]ON/[8]/[G]</li> <li>• Actuator check</li> <li>• Connector check (CN74, J86, J90)</li> <li>• Harness check</li> <li>• Replace the sensor.</li> </ul>
RADF board	<ul style="list-style-type: none"> <li>• PC board check</li> <li>• Connector check (CN74)</li> <li>• Harness check</li> <li>• Replace the PC board.</li> </ul>

Parts to be replaced	Remarks
Registration roller	
Original registration sensor	
Original width detection sensor-1	
Original width detection sensor-2	
RADF board	

### [E725] Original stopping at the DSDF read-in sensor-1 jam

Classification	Error content
DSDF jam	The trailing edge of the original does not pass through the DSDF read-in sensor-2 after its leading edge has passed through this sensor.

Check item	Measures
Post-read roller-1	Check the condition of the roller. If it has been stained, clean it. If it has deteriorated, replace it.
DSDF read-in sensor-1	<ul style="list-style-type: none"> <li>• Sensor check Input check: FS-03-[F2]ON/[7]/[G]</li> <li>• Perform DSDF read-in sensor-1 automatic adjustment.</li> <li>• Connector check (J983, J956, CN75)</li> <li>• Harness check</li> <li>• Replace the sensor.</li> </ul>
DSDF control PC board	<ul style="list-style-type: none"> <li>• PC board check</li> <li>• Connector check</li> <li>• Harness check</li> <li>• Replace the PC board.</li> </ul>

Parts to be replaced	Remarks
Post-read roller-1	
DSDF read-in sensor-1	
DSDF control PC board	

### [E725] Original stopping at the RADF read sensor jam

Classification	Error content
RADF jam	The trailing edge of the original does not pass through the read sensor after its leading edge has reached this sensor.

Check item	Measures
Post-read roller-1	Check the condition of the roller. If it has been stained, clean it. If it has deteriorated, replace it.
Read sensor	<ul style="list-style-type: none"> <li>• Sensor check Input check: FS-03-[F2]ON/[7]/[G]</li> <li>• Connector check (CN75, J94)</li> <li>• Harness check</li> <li>• Replace the sensor.</li> </ul>
Original intermediate transport sensor	<ul style="list-style-type: none"> <li>• Sensor check Input check: FS-03-[F2]ON/[7]/[F]</li> <li>• Connector check (CN75, J95)</li> <li>• Harness check</li> <li>• Replace the sensor.</li> </ul>
RADF board	<ul style="list-style-type: none"> <li>• PC board check</li> <li>• Connector check (CN75)</li> <li>• Harness check</li> <li>• Replace the PC board.</li> </ul>

Parts to be replaced	Remarks
Post-read roller-1	
Read sensor	
Original intermediate transport sensor	



Parts to be replaced	Remarks
RADF board	

### [E726] DSDF transport or paper exit signal reception jam

Classification	Error content
DSDF jam	A transport or paper exit signal has been received even if no original is in the DSDF.

Check item	Measures
Reproducibility	Turn the power OFF and then back ON to check the occurrence.
DSDF control PC board	<ul style="list-style-type: none"> <li>• PC board check</li> <li>• Connector check</li> <li>• Harness check</li> <li>• Replace the PC board.</li> </ul>
SYS board	<ul style="list-style-type: none"> <li>• PC board check</li> <li>• Connector check</li> <li>• Harness check</li> <li>• Replace the PC board.</li> </ul>
Switching regulator	<ul style="list-style-type: none"> <li>• Check that the 24 V power supply is working.</li> <li>• Check that the 5 V power supply is working.</li> <li>• PC board check</li> <li>• Connector check</li> <li>• Harness check</li> <li>• Fuse check</li> <li>• Replace the switching regulator.</li> </ul>

Parts to be replaced	Remarks
DSDF control PC board	
SYS board	
Switching regulator	

### [E726] RADF transport or paper exit signal reception jam

Classification	Error content
RADF jam	A transport or paper exit signal has been received even if no original is in the RADF.

Check item	Measures
Reproducibility	Turn the power OFF and then back ON to check the occurrence.
RADF control PC board	<ul style="list-style-type: none"> <li>• PC board check</li> <li>• Connector check</li> <li>• Harness check</li> <li>• Replace the PC board.</li> </ul>
SYS board	<ul style="list-style-type: none"> <li>• PC board check</li> <li>• Connector check</li> <li>• Harness check</li> <li>• Replace the PC board.</li> </ul>
Switching regulator	<ul style="list-style-type: none"> <li>• Check that the 24 V power supply is working.</li> <li>• Check that the 5 V power supply is working.</li> <li>• PC board check</li> <li>• Connector check</li> <li>• Harness check</li> <li>• Fuse check</li> <li>• Replace the switching regulator.</li> </ul>

Parts to be replaced	Remarks
RADF control PC board	
SYS board	
Switching regulator	

**[E727] Original not reaching the DSDF read-in sensor-2 jam**

Classification	Error content
DSDF jam	The original passed through the DSDF read-in sensor-1 does not reach the DSDF read-in sensor-2.

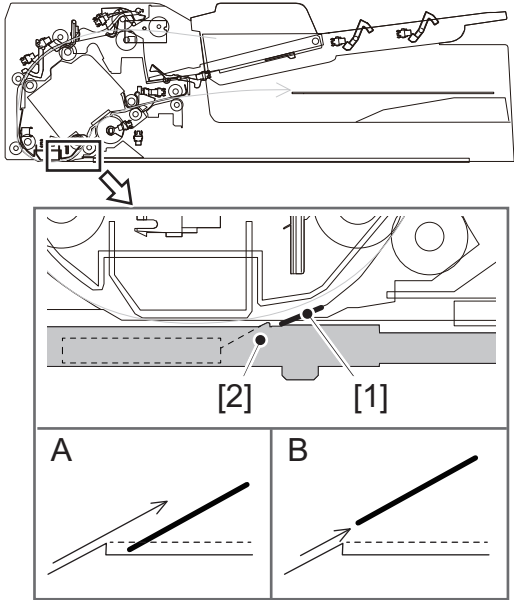
Check item	Measures
Film [1]	<p>If an original has stopped at the transparent film [1], turn on the exposure lamp (output check: FS-03-267) and confirm the position between the film [1] and the upper edge of the slope [2].</p>  <p><b>Fig.8-1</b></p> <p>State A (throughout the whole of the transparent film): OK (Go to the next step.)            State B: Perform the height adjustment.            Replace the film if the position between it and the upper edge of the slope cannot be adjusted as shown above [A].</p>
Post-read roller-1	Check the condition of the roller. If it has been stained, clean it. If it has deteriorated, replace it.
Installation	Check that the DSDF is installed properly.
DSDF read-in sensor-2	<ul style="list-style-type: none"> <li>• Sensor check Input check: FS-03-[F2]ON/[6]/[D]</li> <li>• Connector check (J984, J956, CN75)</li> <li>• Harness check</li> <li>• Replace the sensor.</li> </ul>
DSDF control PC board	<ul style="list-style-type: none"> <li>• PC board check</li> <li>• Connector check (CN75)</li> <li>• Harness check</li> <li>• Replace the PC board.</li> </ul>

Parts to be replaced	Remarks
Post-read roller-1	
DSDF read-in sensor-2	
DSDF control PC board	

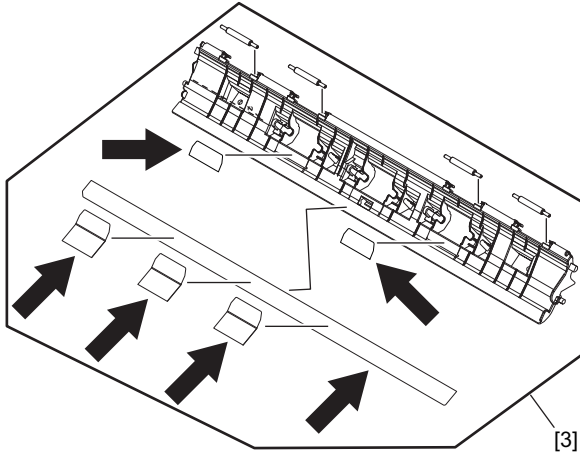
Parts to be replaced	Remarks
Film	Replace all the films or the guide [3].  Fig.8-2

### [E729] Original stopping at the DSDF read-in sensor-2 jam

Classification	Error content
DSDF jam	The trailing edge of the original does not pass through the DSDF read-in sensor-2 after its leading edge has passed through this sensor.

Check item	Measures
DSDF pre-read roller-2	Check the condition of the roller. If it has been stained, clean it. If it has deteriorated, replace it.
DSDF read-in sensor-2	<ul style="list-style-type: none"> <li>• Sensor check</li> <li>Input check: FS-03-[F2]ON/[6]/[D]</li> <li>• Connector check (J984, J956, CN75)</li> <li>• Harness check</li> <li>• Replace the sensor.</li> </ul>
DSDF original exit motor	<ul style="list-style-type: none"> <li>• Check that the motor is working.</li> <li>Output check: FS-03-284</li> <li>• Connector check (J991, CN77)</li> <li>• Harness check</li> <li>• Replace the motor.</li> </ul>
DSDF control PC board	<ul style="list-style-type: none"> <li>• PC board check</li> <li>• Connector check (CN75)</li> <li>• Harness check</li> <li>• Replace the PC board.</li> </ul>

Parts to be replaced	Remarks
DSDF pre-read roller-2	
DSDF read-in sensor-2	
DSDF original exit motor	
DSDF control PC board	

### [E731] Original stopping at the DSDF original exit sensor jam

Classification	Error content
DSDF jam	The trailing edge of the original does not pass through the DSDF original exit sensor after its leading edge has passed through this sensor.

Check item	Measures
DSDF original exit roller	Check the condition of the roller. If it has been stained, clean it. If it has deteriorated, replace it.
Original exit section	Check that there is no original or foreign matter in the transport path. If there is any, remove it.

Check item	Measures
DSDF original exit sensor	<ul style="list-style-type: none"> <li>• Sensor check Input check: FS-03-[F2]ON/[7]/[E]</li> <li>• Actuator check</li> <li>• Connector check (J985, J957, CN75)</li> <li>• Harness check</li> <li>• Replace the sensor.</li> </ul>
DSDF control PC board	<ul style="list-style-type: none"> <li>• PC board check</li> <li>• Connector check (CN75)</li> <li>• Harness check</li> <li>• Replace the PC board.</li> </ul>

Parts to be replaced	Remarks
DSDF original exit roller	
DSDF original exit sensor	
DSDF control PC board	

### [E731] Original stopping at the RADF original exit/reverse sensor jam

Classification	Error content
RADF jam	The trailing edge of the original does not pass through the original exit/reverse sensor after its leading edge has reached this sensor.

Check item	Measures
Paper exit roller	Check the condition of the roller. If it has been stained, clean it. If it has deteriorated, replace it.
Original exit section	Check that there is no original or foreign matter in the transport path. If there is any, remove it.
Original exit/reverse sensor	<ul style="list-style-type: none"> <li>• Sensor check Input check: FS-03-[F2]ON/[7]/[E]</li> <li>• Actuator check</li> <li>• Connector check (J93, CN75)</li> <li>• Harness check</li> <li>• Replace the sensor.</li> </ul>
RADF board	<ul style="list-style-type: none"> <li>• PC board check</li> <li>• Connector check (CN75)</li> <li>• Harness check</li> <li>• Replace the PC board.</li> </ul>

Parts to be replaced	Remarks
Paper exit roller	
Original exit/reverse sensor	
RADF board	

### [E747] Original not reaching the RADF read sensor jam (at the reversal operation)

### [E748] Original not reaching the RADF read sensor jam

Classification	Error content
RADF jam	The original does not reach the RADF read sensor.

Check item	Measures
RADF intermediate transport roller	Check the condition of the roller. If it has been stained, clean it. If it has deteriorated, replace it.
RADF reverse registration roller	Check the condition of the roller. If it has been stained, clean it. If it has deteriorated, replace it.
RADF original exit/reverse roller	Check the condition of the roller. If it has been stained, clean it. If it has deteriorated, replace it.

Check item	Measures
Read sensor	<ul style="list-style-type: none"> <li>• Sensor check Input check: FS-03-[F2]ON/[7]/[G]</li> <li>• Actuator check</li> <li>• Connector check (CN75, J94)</li> <li>• Harness check</li> <li>• Replace the sensor.</li> </ul>
RADF read motor	<ul style="list-style-type: none"> <li>• Check that the motor is working. Output check: FS-03-283</li> <li>• Connector check (J65, CN77)</li> <li>• Harness check</li> <li>• Replace the motor.</li> </ul>
RADF original exit/reverse motor	<ul style="list-style-type: none"> <li>• Check that the motor is working. Output check: FS-03-284</li> <li>• Connector check</li> <li>• Harness check (CN78)</li> <li>• Replace the motor.</li> </ul>

Parts to be replaced	Remarks
RADF intermediate transport roller	
RADF reverse registration roller	
RADF original exit/reverse roller	
Read sensor	
RADF read motor	
RADF original exit/reverse motor	

#### [E762] Original remaining at the DSDF registration sensor jam

Classification	Error content
DSDF jam	The DSDF registration sensor remains turned ON.

Check item	Measures
Original exit section	Check that there is no original or foreign matter in the transport path. If there is any, remove it.
DSDF registration sensor	<ul style="list-style-type: none"> <li>• Sensor check Input check: FS-03-[F2]ON/[7]/[H]</li> <li>• Actuator check</li> <li>• Connector check (J975, J950, CN74)</li> <li>• Harness check</li> <li>• Replace the sensor.</li> </ul>
DSDF control PC board	<ul style="list-style-type: none"> <li>• PC board check</li> <li>• Connector check (CN74)</li> <li>• Harness check</li> <li>• Replace the PC board.</li> </ul>

Parts to be replaced	Remarks
DSDF registration sensor	
DSDF control PC board	

#### [E762] Original remaining at the RADF original registration sensor jam

Classification	Error content
RADF jam	The RADF original registration sensor remains turned ON.

Check item	Measures
Original exit section	Check that there is no original or foreign matter in the transport path. If there is any, remove it.
RADF original registration sensor	<ul style="list-style-type: none"> <li>• Sensor check</li> <li>• Actuator check</li> <li>• Connector check</li> <li>• Harness check</li> <li>• Replace the sensor.</li> </ul>

Check item	Measures
RADF board	<ul style="list-style-type: none"> <li>• PC board check</li> <li>• Connector check</li> <li>• Harness check</li> <li>• Replace the PC board.</li> </ul>
Parts to be replaced	Remarks
RADF original registration sensor	
RADF board	

### [E769] Original remaining at the DSDF original feed sensor jam

Classification	Error content
DSDF jam	The DSDF original feed sensor remains turned ON.

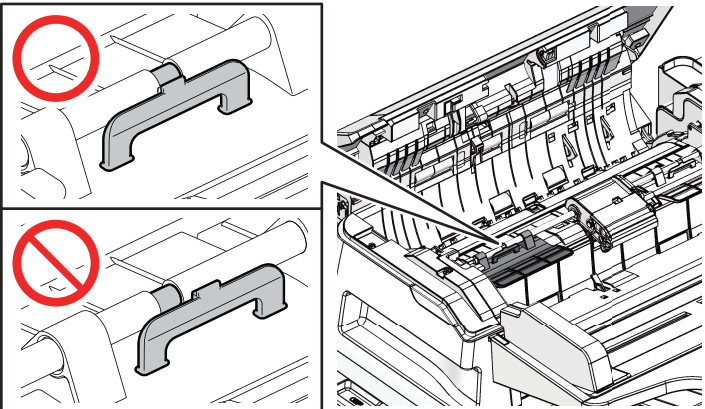
Check item	Measures
Corner folding prevention guide	<ul style="list-style-type: none"> <li>• Check if the guide is installed properly.</li> <li>• If its latch has come off from the shaft groove, slide the guide to reinstall it.</li> <li>• Connector check (J975, J950, CN74)</li> <li>• Replace the corner folding protective guide if it is damaged.</li> </ul>  <p><b>Fig.8-3</b></p>
DSDF original feed sensor	<ul style="list-style-type: none"> <li>• Sensor check Input check: FS-03-[F2]ON/[8]/[E]</li> <li>• Actuator check</li> <li>• Connector check (J974, J950, CN74)</li> <li>• Harness check</li> <li>• Replace the sensor.</li> </ul>
DSDF control PC board	<ul style="list-style-type: none"> <li>• PC board check</li> <li>• Connector check (CN74)</li> <li>• Harness check</li> <li>• Replace the PC board.</li> </ul>

Parts to be replaced	Remarks
Corner folding prevention guide	
DSDF original feed sensor	
DSDF control PC board	

**[E769] Original remaining at the RADF original length detection sensor jam**

Classification	Error content
RADF jam	The RADF original length detection sensor remains turned ON.
Check item	Measures
RADF original length detection sensor	<ul style="list-style-type: none"> <li>• Sensor check</li> <li>• Actuator check</li> <li>• Connector check</li> <li>• Harness check</li> <li>• Replace the sensor.</li> </ul>
RADF board	<ul style="list-style-type: none"> <li>• PC board check</li> <li>• Connector check</li> <li>• Harness check</li> <li>• Replace the PC board.</li> </ul>
Parts to be replaced	Remarks
RADF original length detection sensor	
RADF board	

**[E770] Original remaining at the DSDF original width detection sensor-1 jam**

Classification	Error content
DSDF jam	The DSDF original width detection sensor-1 remains turned ON.
Check item	Measures
DSDF original width detection sensor-1	<ul style="list-style-type: none"> <li>• Sensor check Input check: FS-03-[F2]ON/[8]/[F]</li> <li>• Actuator check</li> <li>• Connector check (J972, J950, CN75)</li> <li>• Harness check</li> <li>• Replace the sensor.</li> </ul>
DSDF control PC board	<ul style="list-style-type: none"> <li>• PC board check</li> <li>• Connector check (CN74)</li> <li>• Harness check</li> <li>• Replace the PC board.</li> </ul>
Parts to be replaced	Remarks
DSDF original width detection sensor-1	
DSDF control PC board	

**[E770] Original remaining at the RADF original width detection sensor-1 jam**

Classification	Error content
RADF jam	The RADF original width detection sensor-1 remains turned ON.
Check item	Measures
RADF original width detection sensor-1	<ul style="list-style-type: none"> <li>• Sensor check</li> <li>• Actuator check</li> <li>• Connector check</li> <li>• Harness check</li> <li>• Replace the sensor.</li> </ul>
RADF board	<ul style="list-style-type: none"> <li>• PC board check</li> <li>• Connector check</li> <li>• Harness check</li> <li>• Replace the PC board.</li> </ul>
Parts to be replaced	Remarks
RADF original width detection sensor-1	
RADF board	

**[E771] Original remaining at the DSDF original width detection sensor-2 jam**

Classification	Error content
DSDF jam	The DSDF original width detection sensor-2 remains turned ON.

Check item	Measures
DSDF original width detection sensor-2	<ul style="list-style-type: none"> <li>• Sensor check Input check: FS-03-[F2]ON/[8]/[G]</li> <li>• Connector check (J973, J950, CN75)</li> <li>• Harness check</li> <li>• Replace the sensor.</li> </ul>
DSDF control PC board	<ul style="list-style-type: none"> <li>• PC board check</li> <li>• Connector check (CN74)</li> <li>• Harness check</li> <li>• Replace the PC board.</li> </ul>

Parts to be replaced	Remarks
DSDF original width detection sensor-2	
DSDF control PC board	

**[E771] Original remaining at the RADF original width detection sensor-2 jam**

Classification	Error content
RADF jam	The RADF original width detection sensor-2 remains turned ON.

Check item	Measures
RADF original exit/reverse roller	Check the condition of the roller. If it has been stained, clean it. If it has deteriorated, replace it.
RADF original width detection sensor-2	<ul style="list-style-type: none"> <li>• Sensor check</li> <li>• Actuator check</li> <li>• Connector check</li> <li>• Harness check</li> <li>• Replace the sensor.</li> </ul>
RADF board	<ul style="list-style-type: none"> <li>• PC board check</li> <li>• Connector check</li> <li>• Harness check</li> <li>• Replace the PC board.</li> </ul>

Parts to be replaced	Remarks
RADF original exit/reverse roller	
RADF original width detection sensor-2	
RADF board	

**[E774] Original remaining at the DSDF read-in sensor-1 jam**

Classification	Error content
DSDF jam	The DSDF read-in sensor-1 remains turned ON.

Check item	Measures
DSDF read-in sensor-1	<ul style="list-style-type: none"> <li>• Sensor check Input check: FS-03-[F2]ON/[7]/[G]</li> <li>• Actuator check</li> <li>• Connector check (J983, J956, CN75)</li> <li>• Harness check</li> <li>• Replace the sensor.</li> </ul>
DSDF control PC board	<ul style="list-style-type: none"> <li>• PC board check</li> <li>• Connector check (CN74)</li> <li>• Harness check</li> <li>• Replace the PC board.</li> </ul>

Parts to be replaced	Remarks
DSDF read-in sensor-1	



Parts to be replaced	Remarks
DSDf control PC board	

#### [E775] Original remaining at the DSDf read-in sensor-2 jam

Classification	Error content
DSDf jam	The DSDf read-in sensor-2 remains turned ON.

Check item	Measures
Pre-read roller-2	Check the condition of the roller. If it has been stained, clean it. If it has deteriorated, replace it.
DSDf read-in sensor-2	<ul style="list-style-type: none"> <li>• Sensor check Input check: FS-03-[F2]ON/[6]/[D]</li> <li>• Connector check (J984, J956, CN75)</li> <li>• Harness check</li> <li>• Replace the sensor.</li> </ul>
DSDf control PC board	<ul style="list-style-type: none"> <li>• PC board check</li> <li>• Connector check (CN74)</li> <li>• Harness check</li> <li>• Replace the PC board.</li> </ul>

Parts to be replaced	Remarks
Pre-read roller-2	
DSDf read-in sensor-2	
DSDf control PC board	

#### [E777] Original remaining at the DSDf original exit sensor jam

Classification	Error content
DSDf jam	The DSDf original exit sensor remains turned ON.

Check item	Measures
DSDf original exit roller	Check the condition of the roller. If it has been stained, clean it. If it has deteriorated, replace it.
DSDf original exit sensor	<ul style="list-style-type: none"> <li>• Sensor check Input check: FS-03-[F2]ON/[7]/[E]</li> <li>• Actuator check</li> <li>• Connector check (J985, J957, CN75)</li> <li>• Harness check</li> <li>• Replace the sensor.</li> </ul>
DSDf control PC board	<ul style="list-style-type: none"> <li>• PC board check</li> <li>• Connector check (CN74)</li> <li>• Harness check</li> <li>• Replace the PC board.</li> </ul>

Parts to be replaced	Remarks
DSDf original exit roller	
DSDf original exit sensor	
DSDf control PC board	

#### [E777] Original remaining at the RADf original exit/reverse sensor jam

Classification	Error content
RADF jam	The RADf original exit/reverse sensor remains turned ON.

Check item	Measures
RADF original exit/reverse roller	Check the condition of the roller. If it has been stained, clean it. If it has deteriorated, replace it.

Check item	Measures
RADF original exit/reverse sensor	<ul style="list-style-type: none"> <li>• Sensor check</li> <li>• Actuator check</li> <li>• Connector check</li> <li>• Harness check</li> <li>• Replace the sensor.</li> </ul>
RADF board	<ul style="list-style-type: none"> <li>• PC board check</li> <li>• Connector check</li> <li>• Harness check</li> <li>• Replace the PC board.</li> </ul>

Parts to be replaced	Remarks
RADF original exit/reverse roller	
RADF original exit/reverse sensor	
RADF board	

### [E860] DSDF original jam access cover open jam, DSDF shading sheet HP sensor abnormality

Classification	Error content
DSDF jam	<p>The DSDF original jam access cover has become open during DSDF operation. The paper exit motor has been driven and the DSDF shading sheet HP sensor has not been turned ON within a specified time.</p> <p>Details: If this problem has occurred at the start of a duplex copying or scanning job or at the end of a copying or scanning job, the cover may have opened as a result.</p> <p>The home position detection is carried out by the DSDF shading sheet HP sensor when the cover or the DSDF is closed, the power is turned ON, during the initial operation or at the end of a job. This home position detection checks that the DSDF shading sheet HP sensor is turned ON within a specified time after the DSDF exit motor has started driving. If the home position cannot be detected when the cover or the DSDF is closed or the power is turned ON, a cover open error will be displayed. If the home position cannot be detected during the initial operation or at the end of a job, a DSDF shading sheet HP sensor abnormality will occur and this error code will be displayed.</p>

Check item	Measures
When paper misfeeding has occurred at the start or end of the original transportation	
DSDF lower cover	Check that the cover is closed appropriately.
DSDF lower cover opening/closing detection sensor	<ul style="list-style-type: none"> <li>• Sensor check Input check: FS-03-[F2]ON/[6]/[C]</li> <li>• Actuator check</li> <li>• Connector check (J980, J953, CN75)</li> <li>• Harness check</li> <li>• Replace the sensor.</li> </ul>
DSDF lower cover interlock switch	<ul style="list-style-type: none"> <li>• Check that the switch is working properly.</li> <li>• Connector check</li> <li>• Harness check</li> <li>• Replace the switch.</li> </ul>
DSDF original exit motor	<ul style="list-style-type: none"> <li>• Check that the motor is working. If yes, check the DSDF shading sheet HP sensor. Output check: FS-03-284</li> <li>• Connector check (J991, CN77)</li> <li>• Harness check</li> <li>• Replace the motor.</li> </ul>
DSDF shading sheet HP sensor	<ul style="list-style-type: none"> <li>• Sensor check Input check: FS-03-[F2]ON/[6]/[A]</li> <li>• Actuator check</li> <li>• Connector check (CN75)</li> <li>• Harness check</li> <li>• Replace the sensor.</li> </ul>

Check item	Measures
DSDf control PC board	<ul style="list-style-type: none"> <li>PC board check</li> <li>Connector check (CN74)</li> <li>Harness check</li> <li>Replace the PC board.</li> </ul>
When paper misfeeding has occurred during original transportation	
DSDf upper cover DSDf lower cover Front cover (MFP)	Check that the cover is closed appropriately.
DSDf upper cover opening/ closing detection sensor	<ul style="list-style-type: none"> <li>Sensor check Input check: FS-03-[F2]ON/[7]/[C]</li> <li>Actuator check</li> <li>Connector check (J981, J954, CN75)</li> <li>Harness check</li> <li>Replace the sensor.</li> </ul>
DSDf upper cover interlock switch	<ul style="list-style-type: none"> <li>Check that the switch is working properly.</li> <li>Connector check</li> <li>Harness check</li> <li>Replace the switch.</li> </ul>
DSDf lower cover opening/ closing detection sensor	<ul style="list-style-type: none"> <li>Sensor check Input check: FS-03-[F2]ON/[6]/[C]</li> <li>Actuator check</li> <li>Connector check (J980, J953, CN75)</li> <li>Harness check</li> <li>Replace the sensor.</li> </ul>
DSDf lower cover interlock switch	<ul style="list-style-type: none"> <li>Check that the switch is working properly.</li> <li>Connector check</li> <li>Harness check</li> <li>Replace the switch.</li> </ul>
DSDf original exit motor	<ul style="list-style-type: none"> <li>Check that the motor is working. If yes, check the DSDf shading sheet HP sensor. Output check: FS-03-284</li> <li>Connector check (J991, CN77)</li> <li>Harness check</li> <li>Replace the motor.</li> </ul>
DSDf shading sheet HP sensor	<ul style="list-style-type: none"> <li>Sensor check Input check: FS-03-[F2]ON/[6]/[A]</li> <li>Actuator check</li> <li>Connector check (CN75)</li> <li>Harness check</li> <li>Replace the sensor.</li> </ul>
DSDf control PC board	<ul style="list-style-type: none"> <li>PC board check</li> <li>Connector check (CN74)</li> <li>Harness check</li> <li>Replace the PC board.</li> </ul>

Parts to be replaced	Remarks
DSDf lower cover opening/closing detection sensor	
DSDf lower cover interlock switch	
DSDf original exit motor	
DSDf shading sheet HP sensor	
DSDf control PC board	
DSDf upper cover opening/ closing detection sensor	
DSDf upper cover interlock switch	

**[E860] RADF jam access cover open jam**

Classification	Error content
RADF jam	The RADF jam access cover has become open during RADF operation.

Check item	Measures
RADF jam access cover	Check that the cover is closed appropriately.
RADF jam access cover sensor	<ul style="list-style-type: none"> <li>• Sensor check Input check: FS-03-[F2]ON/[7]/[C]</li> <li>• Actuator check</li> <li>• Connector check (CN75, J92, J97)</li> <li>• Harness check</li> <li>• Replace the sensor.</li> </ul>
RADF board	<ul style="list-style-type: none"> <li>• PC board check</li> <li>• Connector check (CN75)</li> <li>• Harness check</li> <li>• Replace the PC board.</li> </ul>

Parts to be replaced	Remarks
RADF jam access cover sensor	
DSD control PC board	

**[E870] DSD open jam****[E870] RADF open jam**

Classification	Error content
DSD jam	The DSD has become open during DSD operation.
RADF jam	The RADF has become open during RADF operation.

Check item	Measures
Platen sensor-1	<ul style="list-style-type: none"> <li>• Sensor check Input check: FS-03-[F2]ON/[5]/[C]</li> <li>• Actuator check</li> <li>• Connector check (CN121)</li> <li>• Harness check</li> <li>• Replace the sensor.</li> </ul>
Platen sensor-2	<ul style="list-style-type: none"> <li>• Sensor check Input check: FS-03-[F2]ON/[5]/[G]</li> <li>• Actuator check</li> <li>• Connector check (CN121)</li> <li>• Harness check</li> <li>• Replace the sensor.</li> </ul>
RADF control PC board, DSD control PC board	<ul style="list-style-type: none"> <li>• PC board check</li> <li>• Connector check</li> <li>• Harness check</li> <li>• Replace the PC board.</li> </ul>

Parts to be replaced	Remarks
Platen sensor-1	
Platen sensor-2	
RADF control PC board, DSD control PC board	

**[E910] Paper not reaching the bridge kit transport sensor-1 jam**

Classification	Error content
Bridge kit jam	Paper which has passed through the paper exit sensor does not reach the bridge kit transport sensor-1 and bridge kit path entrance sensor.

Check item	Measures
Drawer	<ul style="list-style-type: none"> <li>• Check if the paper is damaged or if it has been folded.</li> <li>• Check the side guide in the drawer to confirm whether there is a reason for paper skewing in it.</li> </ul>

Check item	Measures
Bridge Kit	<ul style="list-style-type: none"> <li>• Check if there are any scratches on the rib in the gate section of the bridge kit. Replace it if needed.</li> <li>• Check if the guide of the bridge kit is deformed. Replace it if needed.</li> </ul>
Bridge kit transport sensor-1	<ul style="list-style-type: none"> <li>• Sensor check Input check: FS-03-[ALL]OFF/[0]/[A]</li> <li>• Actuator check</li> <li>• Connector check (CN346)</li> <li>• Harness check</li> <li>• Replace the sensor.</li> </ul>
Bridge kit gate solenoid	<ul style="list-style-type: none"> <li>• Solenoid check Output check: FS-03-232</li> <li>• Connector check (CN343)</li> <li>• Harness check</li> <li>• Replace the solenoid.</li> </ul>
LGC board	<ul style="list-style-type: none"> <li>• PC board check</li> <li>• Connector check (CN311)</li> <li>• Harness check</li> <li>• Replace the PC board.</li> </ul>
Leading edge margin	<ul style="list-style-type: none"> <li>• Check that the image position and margin are adjusted properly.</li> <li>• Widen the margin if needed.</li> </ul>

Parts to be replaced	Remarks
Bridge Kit	
Bridge kit transport sensor-1	
Bridge kit gate solenoid	
LGC board	

### [E920] Paper stopping at the bridge kit transport sensor-1 jam

Classification	Error content
Cover open jam	The trailing edge of the paper does not pass through the bridge kit transport sensor-1 after its leading edge has reached this sensor.

Check item	Measures
Drawer	<ul style="list-style-type: none"> <li>• Check if the paper is damaged or if it has been folded.</li> <li>• Check the side guide in the drawer to confirm whether there is a reason for paper skewing in it.</li> </ul>
Finisher	Check if paper misfeeding has occurred in the finisher. If paper misfeeding has occurred, take the appropriate action.
Bridge Kit	<ul style="list-style-type: none"> <li>• Check if there are any scratches on the rib in the gate section of the bridge kit. Replace it if needed.</li> <li>• Check if the guide of the bridge kit is deformed. Replace it if needed.</li> <li>• Check if the film on the bridge kit exit is deformed. Correct it if needed.</li> </ul>
Bridge kit transport sensor-1	<ul style="list-style-type: none"> <li>• Sensor check Input check: FS-03-[ALL]OFF/[0]/[A]</li> <li>• Actuator check</li> <li>• Connector check (CN346)</li> <li>• Harness check</li> <li>• Replace the sensor.</li> </ul>
Bridge kit gate solenoid	<ul style="list-style-type: none"> <li>• Solenoid check Output check: FS-03-232</li> <li>• Connector check (CN343)</li> <li>• Harness check</li> <li>• Replace the solenoid.</li> </ul>
Bridge kit transport roller	<ul style="list-style-type: none"> <li>• Check that the transport roller of the bridge kit is worked when the main motor rotates. Output check: FS-03-111, 116</li> <li>• Check the drive section of the MFP and the bridge kit.</li> <li>• Check the condition of the paper exit roller of the MFP and the rollers and pressure spring of the bridge kit. If they have been stained, clean them. Replace it if it is worn out.</li> </ul>

Check item	Measures
LGC board	<ul style="list-style-type: none"> <li>PC board check</li> <li>Connector check (CN311)</li> <li>Harness check</li> <li>Replace the PC board.</li> </ul>
Leading edge margin	<ul style="list-style-type: none"> <li>Check that the image position and margin are adjusted properly.</li> <li>Widen the margin if needed.</li> </ul>

Parts to be replaced	Remarks
Bridge Kit	
Bridge kit transport sensor-1	
Bridge kit gate solenoid	
Bridge kit transport roller	
LGC board	

### [E930] Paper not reaching the bridge kit transport sensor-2 jam

Classification	Error content
Bridge kit jam	The leading edge of the paper does not reach the bridge kit transport sensor-2 after it has reached the bridge kit transport sensor-1.

Check item	Measures
Bridge Kit	<ul style="list-style-type: none"> <li>Check if there are any scratches on the rib in the gate section of the bridge kit. Replace it if needed.</li> <li>Check if the guide of the bridge kit is deformed. Replace it if needed.</li> </ul>
Bridge kit transport sensor-2	<ul style="list-style-type: none"> <li>Sensor check</li> <li>Input check: FS-03-[ALL]OFF/[0]/[B]</li> <li>Actuator check</li> <li>Connector check (CN307, J607, J802)</li> <li>Harness check</li> <li>Replace the sensor.</li> </ul>
Bridge kit transport roller	<ul style="list-style-type: none"> <li>Check that the transport roller of the bridge kit is worked when the main motor rotates.</li> <li>Output check: FS-03-111, 116</li> <li>Check the drive section of the MFP and the bridge kit.</li> <li>Check the condition of the paper exit roller of the MFP and the rollers and pressure spring of the bridge kit. If they have been stained, clean them. Replace it if it is worn out.</li> </ul>
LGC board	<ul style="list-style-type: none"> <li>PC board check</li> <li>Connector check (CN311)</li> <li>Harness check</li> <li>Replace the PC board.</li> </ul>

Parts to be replaced	Remarks
Bridge Kit	
Bridge kit transport sensor-2	
Bridge kit transport roller	
LGC board	

### [E940] Paper stopping at the bridge kit transport sensor-2 jam

Classification	Error content
Bridge kit jam	The trailing edge of the paper does not pass through the bridge kit transport sensor-2 after its leading edge has reached this sensor.

Check item	Measures
Bridge Kit	<ul style="list-style-type: none"> <li>Check if there are any scratches on the rib in the gate section of the bridge kit. Replace it if needed.</li> <li>Check if the guide of the bridge kit is deformed. Replace it if needed.</li> </ul>

Check item	Measures
Bridge kit transport sensor-2	<ul style="list-style-type: none"> <li>• Sensor check Input check: FS-03-[ALL]OFF/[0]/[B]</li> <li>• Actuator check</li> <li>• Connector check (CN307, J607, J802)</li> <li>• Harness check</li> <li>• Replace the sensor.</li> </ul>
Bridge kit transport roller	<ul style="list-style-type: none"> <li>• Check that the transport roller of the bridge kit is worked when the main motor rotates. Output check: FS-03-111, 116</li> <li>• Check the drive section of the MFP and the bridge kit.</li> <li>• Check the condition of the paper exit roller of the MFP and the rollers and pressure spring of the bridge kit. If they have been stained, clean them. Replace it if it is worn out.</li> </ul>

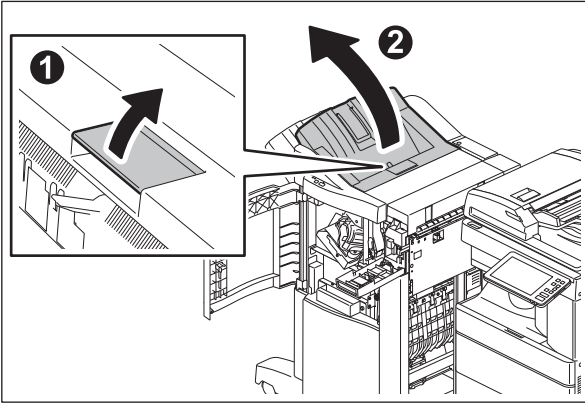
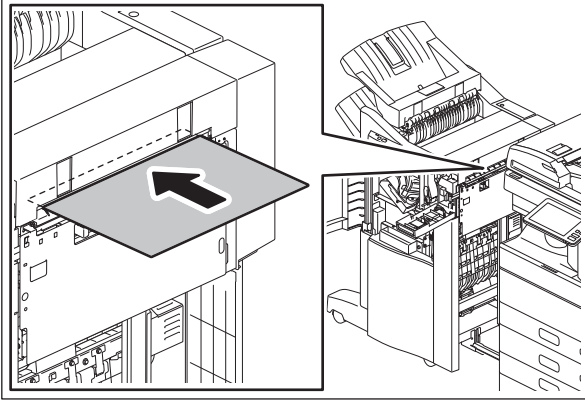
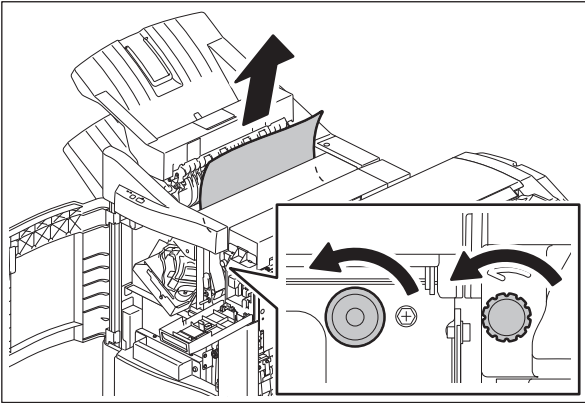
Check item	Measures
<p>Hole punch unit (when paper misfeeding has occurred immediately after unpacking and installing)</p>	<p>Correct the film in the hole punch unit since it may be deformed.</p> <ol style="list-style-type: none"> <li>1. Separate the Finisher with the Hole Punch Unit installed from the MFP.</li> <li>2. Open the stationary tray of the Finisher.</li> </ol>  <p><b>Fig.8-4</b></p> <ol style="list-style-type: none"> <li>3. Insert one sheet of A4/LT-size thick paper into the paper transport inlet of the Hole Punch Unit.</li> </ol>  <p><b>Fig.8-5</b></p> <p><b>Remarks:</b></p> <p>Use the thick paper of A4-LT size and 216g/m<sup>2</sup> (80 lb. Bond) or equivalent.</p> <ol style="list-style-type: none"> <li>4. Open the front cover of the Finisher. Turn the 2 knobs simultaneously. Send the thick paper by turning the knobs in the direction of the arrow to remove it.</li> </ol>  <p><b>Fig.8-6</b></p>



Check item	Measures
LGC board	<ul style="list-style-type: none"> <li>• PC board check</li> <li>• Connector check (CN311)</li> <li>• Harness check</li> <li>• Replace the PC board.</li> </ul>

Parts to be replaced	Remarks
Bridge Kit	
Bridge kit transport sensor-2	
Bridge kit transport roller	
LGC board	

### [E950] Paper not reaching the job separator transport sensor jam

### [E951] Paper stopping at the job separator transport sensor jam

Classification	Error content
Job separator jam	Paper which has passed through the paper exit sensor does not reach the JSP transport sensor.
	The trailing edge of the paper does not pass through the JSP transport sensor after its leading edge has reached this sensor.

Check item	Measures
Job separator	Check if the guide of the job separator is deformed. Replace it if needed.
JSP transport sensor	<ul style="list-style-type: none"> <li>• Sensor check Input check: FS-03-[ALL]OFF/[0]/[A]</li> <li>• Actuator check</li> <li>• Connector check (CN260, CN262)</li> <li>• Harness check</li> <li>• Replace the sensor.</li> </ul>
JSP board	<ul style="list-style-type: none"> <li>• PC board check</li> <li>• Connector check (CN260, CN262)</li> <li>• Harness check</li> <li>• Replace the PC board.</li> </ul>
LGC board	<ul style="list-style-type: none"> <li>• PC board check</li> <li>• Connector check (CN311)</li> <li>• Harness check</li> <li>• Replace the PC board.</li> </ul>

Parts to be replaced	Remarks
Job separator	
JSP transport sensor	
JSP board	
LGC board	

### [E9F0] Punching jam (Inner Finisher)

Classification	Error content
Job separator jam	Punching is not performed properly.

Check item	Measures
Punch sliding motor	Check the motor winding to confirm that the current flows in it. If not, replace the motor.
Punch sliding unit home position sensor	<ul style="list-style-type: none"> <li>• Actuator check</li> <li>• Connector check</li> <li>• Harness check</li> <li>• Measure the voltage of TP26 on the hole punch control PC board. Then check if the measured voltage is 1 V or lower when not shielded and within the range of 5 V <math>\pm</math>5% when shielded. If the voltage does not fall within the mentioned range, replace the sensor.</li> </ul>

Check item	Measures
Paper detection sensors (light-receiving and light-emitting)	Measure the voltage of 8-pin of CN6 on the hole punch control PC board. Then check if the measured voltage is 3.0 V or higher when not shielded and 1.2 V or lower when shielded. If the voltage does not fall within the mentioned range, replace the board at the light-receiving or light-emitting side.
Hole punch control PC board	<ul style="list-style-type: none"> <li>Check that the current flows between the connector terminals. If not, replace the cables. (Punch control PC board: CN3, CN4, CN5, CN6, CN7)</li> <li>If the error still persists after replacing the motor, the sensor and the connector, exchange the hole punch control PC board.</li> </ul>
Finisher control PC board	<ul style="list-style-type: none"> <li>PC board check</li> <li>Connector check</li> <li>Harness check</li> <li>Replace the PC board.</li> </ul>

Parts to be replaced	Remarks
Punch sliding motor	
Punch sliding unit home position sensor	
Paper detection sensors (light-receiving and light-emitting)	
Hole punch control PC board	
Finisher control PC board	

#### [E9F0] Punching jam (Finisher, Saddle Stitch Finisher)

Classification	Error content
Finisher jam Saddle stitch finisher jam	Punching is not performed properly.

Check item	Measures
Punch motor (M3)	<ul style="list-style-type: none"> <li>Check that the motor is working.</li> <li>Connector check</li> <li>Harness check</li> <li>Replace the motor.</li> </ul>
Punch HP sensor (S4)	<ul style="list-style-type: none"> <li>Sensor check</li> <li>Actuator check</li> <li>Connector check</li> <li>Harness check</li> <li>Replace the sensor.</li> </ul>
Punch sensor (S5)	<ul style="list-style-type: none"> <li>Sensor check</li> <li>Actuator check</li> <li>Connector check</li> <li>Harness check</li> <li>Replace the sensor.</li> </ul>
Hole punch control PC board (HP)	<ul style="list-style-type: none"> <li>PC board check</li> <li>Connector check</li> <li>Harness check</li> <li>Replace the PC board.</li> </ul>
Finisher control PC board	<ul style="list-style-type: none"> <li>PC board check</li> <li>Connector check</li> <li>Harness check</li> <li>Replace the PC board.</li> </ul>

Parts to be replaced	Remarks
Punch motor (M3)	
Punch HP sensor (S4)	
Punch sensor (S5)	
Hole punch control PC board (HP)	
Finisher control PC board	

**[EA10] Paper transport delay jam (Inner Finisher)**

Classification	Error content
Inner finisher jam	1st transport motor (M8) abnormality and 2nd transport motor (M4) abnormality

Check item	Measures
1st transport motor (M8)	<ul style="list-style-type: none"> <li>Check the motor winding to confirm that the current flows in it. If not, replace the motor.</li> <li>Check that the current flows between the connector terminals. If not, replace the cables. (CN22)</li> </ul>
2nd transport motor (M4)	<ul style="list-style-type: none"> <li>Check the motor winding to confirm that the current flows in it. If not, replace the motor.</li> <li>Check that the current flows between the connector terminals. If not, replace the cables. (CN14)</li> </ul>
Finisher control PC board (FIN)	<ul style="list-style-type: none"> <li>PC board check</li> <li>Connector check (CN22, CN14)</li> <li>Harness check</li> <li>Replace the PC board.</li> </ul>

Parts to be replaced	Remarks
1st transport motor (M8)	
2nd transport motor (M4)	
Finisher control PC board (FIN)	

**[EA10] Paper transport delay jam (Finisher, Saddle Stitch Finisher)**

Classification	Error content
Finisher jam Saddle stitch finisher jam	Paper transport delay jam

Check item	Measures
Paper feed sensor (S22)	<ul style="list-style-type: none"> <li>Sensor check</li> <li>Actuator check</li> <li>Connector check (CN1)</li> <li>Harness check</li> <li>Replace the sensor.</li> </ul>
Transport path switching solenoid (SOL5)	<ul style="list-style-type: none"> <li>Solenoid check While the solenoid is turned ON or OFF, if the gap between the surface of the transport guide and the upper surface of the tip of the flap is not within the proper value (OFF: 1.5 to 2.1 mm, ON: 2.3 to 2.9 mm), adjust this.</li> <li>Connector check (CN1)</li> <li>Harness check</li> </ul>
Entrance motor (M1)	<ul style="list-style-type: none"> <li>Check that the motor is working.</li> <li>Connector check (CN17)</li> <li>Harness check</li> <li>Replace the motor.</li> </ul>
Finisher control PC board (FIN)	<ul style="list-style-type: none"> <li>PC board check</li> <li>Connector check (CN1, CN17)</li> <li>Harness check</li> <li>Replace the PC board.</li> </ul>

Parts to be replaced	Remarks
Paper feed sensor (S22)	
Entrance motor (M1)	
Finisher control PC board (FIN)	

**[EA20] Paper transport stop jam (Inner Finisher)**

Classification	Error content
Inner finisher jam	1st transport motor (M8) abnormality and 2nd transport motor (M4) abnormality

Check item	Measures
1st transport motor (M8)	<ul style="list-style-type: none"> <li>Check the motor winding to confirm that the current flows in it. If not, replace the motor.</li> <li>Check that the current flows between the connector terminals. If not, replace the cables. (CN22)</li> </ul>
2nd transport motor (M4)	<ul style="list-style-type: none"> <li>Check the motor winding to confirm that the current flows in it. If not, replace the motor.</li> <li>Check that the current flows between the connector terminals. If not, replace the cables. (CN14)</li> </ul>
Finisher control PC board (FIN)	<ul style="list-style-type: none"> <li>PC board check</li> <li>Connector check (CN22, CN14)</li> <li>Harness check</li> <li>Replace the PC board.</li> </ul>

Parts to be replaced	Remarks
1st transport motor (M8)	
2nd transport motor (M4)	
Finisher control PC board (FIN)	

**[EA20] Paper transport stop jam (Finisher, Saddle Stitch Finisher)**

Classification	Error content
Finisher jam Saddle stitch finisher jam	Paper transport delay jam

Check item	Measures
Entrance sensor (S1)	<ul style="list-style-type: none"> <li>Sensor check</li> <li>Actuator check</li> <li>Connector check</li> <li>Harness check</li> <li>Replace the sensor.</li> </ul>
Finisher control PC board (FIN)	<ul style="list-style-type: none"> <li>PC board check</li> <li>Connector check (CN8)</li> <li>Harness check</li> <li>Replace the PC board.</li> </ul>
Assist guide	Check if there is any abnormality in the adjustment (height) of the guide.

Parts to be replaced	Remarks
Entrance sensor (S1)	
Finisher control PC board (FIN)	

**[EA21] Paper size error jam (Transport sensor) (Finisher, Saddle Stitch Finisher)**

Classification	Error content
Finisher jam Saddle stitch finisher jam	The transport sensor on the finisher transport path detects that the paper is shorter than the acceptable size.

Check item	Measures
Paper	Use the paper specified in the specifications if a one shorter than the acceptable size is utilized.
Entrance sensor (S1)	<ul style="list-style-type: none"> <li>Sensor check</li> <li>Actuator check</li> <li>Connector check</li> <li>Harness check</li> <li>Replace the sensor.</li> </ul>

Check item	Measures
Transport sensor (S2)	<ul style="list-style-type: none"> <li>• Sensor check</li> <li>• Actuator check</li> <li>• Connector check</li> <li>• Harness check</li> <li>• Replace the sensor.</li> </ul>
Finisher control PC board (FIN)	<ul style="list-style-type: none"> <li>• PC board check</li> <li>• Connector check (CN8)</li> <li>• Harness check</li> <li>• Replace the PC board.</li> </ul>

Parts to be replaced	Remarks
Entrance sensor (S1)	
Transport sensor (S2)	
Finisher control PC board (FIN)	

### [EA22] Paper size error jam (Paper position sensor) (Finisher, Saddle Stitch Finisher)

Classification	Error content
Finisher jam Saddle stitch finisher jam	The paper position sensor of the Hole Punch Unit detects that the paper is shorter than the acceptable size.

Check item	Measures
Paper	Use the paper specified in the specifications if a one shorter than the acceptable size is utilized.
Paper position sensor (S6-1, S6-2) (Hole punch unit)	<ul style="list-style-type: none"> <li>• Clean the sensor and around it to remove the paper dust.</li> <li>• Sensor check</li> <li>• Connector check (CN1, CN2)</li> <li>• Harness check</li> <li>• Replace the sensor.</li> </ul>
Finisher control PC board (FIN)	<ul style="list-style-type: none"> <li>• PC board check</li> <li>• Connector check (CN8)</li> <li>• Harness check</li> <li>• Replace the PC board.</li> </ul>
Hole punch control PC board (HP)	<ul style="list-style-type: none"> <li>• PC board check</li> <li>• Connector check (CN1, CN2)</li> <li>• Harness check</li> <li>• Replace the PC board.</li> </ul>

Parts to be replaced	Remarks
Paper position sensor (S6-1, S6-2) (Hole punch unit)	
Finisher control PC board (FIN)	
Hole punch control PC board (HP)	

### [EA23] Paper transport stop jam (Finisher, Saddle Stitch Finisher)

Classification	Error content
Finisher jam Saddle stitch finisher jam	The trailing edge of the paper does not pass through the transport sensor after its leading edge has passed through this sensor on the finisher transport path.

Check item	Measures
Paper	Use the paper specified in the specifications if a one shorter than the acceptable size is utilized.
Transport sensor (S2)	<ul style="list-style-type: none"> <li>• Sensor check</li> <li>• Actuator check</li> <li>• Connector check</li> <li>• Harness check</li> <li>• Replace the sensor.</li> </ul>

Check item	Measures
Finisher control PC board (FIN)	<ul style="list-style-type: none"> <li>• PC board check</li> <li>• Connector check (CN8)</li> <li>• Harness check</li> <li>• Replace the PC board.</li> </ul>

Parts to be replaced	Remarks
Transport sensor (S2)	
Finisher control PC board (FIN)	

#### [EA24] Paper transport delay jam (Finisher, Saddle Stitch Finisher)

Classification	Error content
Finisher jam Saddle stitch finisher jam	The leading edge of the paper does not reach the transport sensor after it has passed through the entrance sensor on the finisher transport path.

Check item	Measures
Pinch roller arm	Check the position of the pinch roller arm. If it is down, correct its mechanism.
Transport path switching solenoid (SOL5)	<ul style="list-style-type: none"> <li>• Solenoid check While the solenoid is turned ON or OFF, if the gap between the surface of the transport guide and the upper surface of the tip of the flap is not within the proper value (OFF: 1.5 to 2.1 mm, ON: 2.3 to 2.9 mm), adjust this.</li> <li>• Connector check (CN1)</li> <li>• Harness check</li> </ul>
Entrance sensor (S1)	<ul style="list-style-type: none"> <li>• Sensor check</li> <li>• Actuator check</li> <li>• Connector check (CN8)</li> <li>• Harness check</li> <li>• Replace the sensor.</li> </ul>
Transport sensor (S2)	<ul style="list-style-type: none"> <li>• Sensor check</li> <li>• Actuator check</li> <li>• Connector check (CN8)</li> <li>• Harness check</li> <li>• Replace the sensor.</li> </ul>
Entrance motor (M1)	<ul style="list-style-type: none"> <li>• Check that the motor is working.</li> <li>• Connector check (CN17)</li> <li>• Harness check</li> <li>• Replace the sensor.</li> </ul>
Finisher control PC board (FIN)	<ul style="list-style-type: none"> <li>• PC board check</li> <li>• Connector check (CN1, CN8, CN17)</li> <li>• Harness check</li> <li>• Replace the PC board.</li> </ul>

Parts to be replaced	Remarks
Entrance sensor (S1)	
Transport sensor (S2)	
Entrance motor (M1)	
Finisher control PC board (FIN)	

#### [EA25] Paper transport delay jam after the paper stack has exited (Inner Finisher)

Classification	Error content
Inner finisher jam	Stack exit motor (M5) abnormality

Check item	Measures
Stack exit motor (M5)	<ul style="list-style-type: none"> <li>• Check the motor winding to confirm that the current flows in it. If not, replace the motor.</li> <li>• Check that the current flows between the connector terminals. If not, replace the cables. (CN14)</li> </ul>

Check item	Measures
Finisher control PC board (FIN)	<ul style="list-style-type: none"> <li>PC board check</li> <li>Connector check (CN1, CN8, CN17)</li> <li>Harness check</li> <li>Replace the PC board.</li> </ul>
Parts to be replaced	Remarks
Stack exit motor (M5)	
Finisher control PC board (FIN)	

### [EA25] Paper transport delay jam after the paper stack has exited (Finisher, Saddle Stitch Finisher)

Classification	Error content
Finisher jam Saddle stitch finisher jam	The finishing tray paper detection sensor detects the paper after the exiting of a stack of the paper is completed.

Check item	Measures
Transport sensor (S2)	<ul style="list-style-type: none"> <li>Sensor check</li> <li>Actuator check</li> <li>Connector check (CN8)</li> <li>Harness check</li> <li>Replace the sensor.</li> </ul>
Finisher control PC board (FIN)	<ul style="list-style-type: none"> <li>PC board check</li> <li>Connector check (CN25)</li> <li>Harness check</li> <li>Replace the PC board.</li> </ul>

Parts to be replaced	Remarks
Transport sensor (S2)	
Finisher control PC board (FIN)	

### [EA26] Paper transport stop jam due to a stop signal from the MFP (Inner Finisher)

Classification	Error content
Inner finisher jam	A command to stop the MFP operation is received while paper is being transported.

Check item	Measures
Finisher	<ul style="list-style-type: none"> <li>Check if the harness between the MFP and the finisher controller PC board (FIN) is disconnected or open circuited.</li> <li>Check if the pattern on the finisher controller PC board (FIN) is open circuited or short circuited.</li> <li>Update the finisher firmware.</li> <li>Replace the finisher control PC board (FIN).</li> </ul>
LGC board	<ul style="list-style-type: none"> <li>Check if the harness between the Finisher and the LGC board is disconnected or open circuited.</li> <li>Connector check (CN314)</li> <li>Check if the pattern on the LGC board is open circuited or short circuited.</li> <li>Replace the LGC board.</li> </ul>

Parts to be replaced	Remarks
Finisher control PC board (FIN)	
LGC board	

**[EA26] Paper transport stop jam due to a stop signal from the MFP (Finisher, Saddle Stitch Finisher)**

Classification	Error content
Finisher jam Saddle stitch finisher jam	A command to stop the MFP operation is received while paper is being transported.

Check item	Measures
Finisher	<ul style="list-style-type: none"> <li>• Check if the harness between the MFP and the finisher controller PC board (FIN) is disconnected or open circuited.</li> <li>• Check if the pattern on the finisher controller PC board (FIN) is open circuited or short circuited.</li> <li>• Update the finisher firmware.</li> <li>• Replace the finisher control PC board (FIN).</li> </ul>
LGC board	<ul style="list-style-type: none"> <li>• Check if the harness between the Finisher and the LGC board is disconnected or open circuited.</li> <li>• Connector check (CN314)</li> <li>• Check if the pattern on the LGC board is open circuited or short circuited.</li> <li>• Replace the LGC board.</li> </ul>

Parts to be replaced	Remarks
Finisher control PC board (FIN)	
LGC board	

**[EA27] Paper transport stop jam (Finisher, Saddle Stitch Finisher)**

Classification	Error content
Finisher jam Saddle stitch finisher jam	The entrance sensor is turned ON in a slower timing than that specified.

Check item	Measures
Entrance sensor (S1)	<ul style="list-style-type: none"> <li>• Sensor check</li> <li>• Actuator check</li> <li>• Connector check (CN8)</li> <li>• Harness check</li> <li>• Replace the sensor.</li> </ul>
Finisher control PC board (FIN)	<ul style="list-style-type: none"> <li>• PC board check</li> <li>• Connector check (CN8)</li> <li>• Harness check</li> <li>• Replace the PC board.</li> </ul>

Parts to be replaced	Remarks
Entrance sensor (S1)	
Finisher control PC board (FIN)	

**[EA28] Paper transport stop jam due to an assist guide plate operation delay (Finisher, Saddle Stitch Finisher)**

Classification	Error content
Finisher jam Saddle stitch finisher jam	An attempt to start the assist guide plate operation for dropping the paper on the finishing tray is made, but the previous assist guide plate operation has not yet been finished.

Check item	Measures
Assist guide	<ul style="list-style-type: none"> <li>• Check if there is any abnormality in the installation of the guide.</li> <li>• Check if there is any mechanical problem.</li> <li>• If there is any, correct it.</li> </ul>
Assist guide motor (M10)	<ul style="list-style-type: none"> <li>• Check that the motor is working.</li> <li>• Connector check (CN10)</li> <li>• Harness check</li> <li>• Replace the motor.</li> </ul>



Check item	Measures
Finisher control PC board (FIN)	<ul style="list-style-type: none"> <li>PC board check</li> <li>Connector check (CN10)</li> <li>Harness check</li> <li>Replace the PC board.</li> </ul>

Parts to be replaced	Remarks
Assist guide motor (M10)	
Finisher control PC board (FIN)	

### [EA29] Paper transport stop jam due to a stack transport operation delay (Finisher, Saddle Stitch Finisher)

Classification	Error content
Finisher jam Saddle stitch finisher jam	An attempt to drop a stack of the paper on the finishing tray by extending the buffer tray is made, but the previous stack has not yet exited.

Check item	Measures
Buffer tray guide	<ul style="list-style-type: none"> <li>Check if there is any abnormality in the installation of the guide.</li> <li>Check if there is any mechanical problem.</li> <li>If there is any, correct it.</li> </ul>
Buffer tray guide motor (M2)	<ul style="list-style-type: none"> <li>Check that the motor is working.</li> <li>Connector check (CN10)</li> <li>Harness check</li> <li>Replace the motor.</li> </ul>
Finisher control PC board (FIN)	<ul style="list-style-type: none"> <li>PC board check</li> <li>Connector check (CN10)</li> <li>Harness check</li> <li>Replace the PC board.</li> </ul>

Parts to be replaced	Remarks
Buffer tray guide motor (M2)	
Finisher control PC board (FIN)	

### [EA2A] Paper transport jam between the entrance path and the middle path sensors (Inner Finisher)

Classification	Error content
Inner finisher jam	The leading edge of the paper does not reach the middle path sensor after it has passed through the entrance sensor on the finisher transport path.

Check item	Measures
1st transport motor (M8)	<ul style="list-style-type: none"> <li>Check the motor winding to confirm that the current flows in it. If not, replace the motor.</li> <li>Check that the current flows between the connector terminals. If not, replace the cables. (CN22)</li> </ul>
2nd transport motor (M4)	<ul style="list-style-type: none"> <li>Check the motor winding to confirm that the current flows in it. If not, replace the motor.</li> <li>Check that the current flows between the connector terminals. If not, replace the cables. (CN14)</li> </ul>
Entrance path sensor (S19)	<ul style="list-style-type: none"> <li>Actuator check</li> <li>Connector check (CN22)</li> <li>Harness check</li> <li>Measure the voltage of TP86 on the finisher control PC board (FIN). Then check that the measured voltage is 1 V or lower when not shielded and within the range of 3.3 V <math>\pm</math>5% when shielded. If the voltage does not fall within the mentioned range, replace the sensor.</li> </ul>
Middle path sensor (S7)	<ul style="list-style-type: none"> <li>Actuator check</li> <li>Connector check (CN6)</li> <li>Harness check</li> <li>Measure the voltage of TP84 on the finisher control PC board (FIN). Then check that the measured voltage is 1 V or lower when not shielded and within the range of 3.3 V <math>\pm</math>5% when shielded. If the voltage does not fall within the mentioned range, replace the sensor.</li> </ul>

Check item	Measures
Finisher control PC board (FIN)	<ul style="list-style-type: none"> <li>PC board check</li> <li>Connector check (CN6, CN14, CN22)</li> <li>Harness check</li> <li>Replace the PC board.</li> </ul>

Parts to be replaced	Remarks
1st transport motor (M8)	
2nd transport motor (M4)	
Entrance path sensor (S19)	
Middle path sensor (S7)	
Finisher control PC board (FIN)	

### [EA2B] Paper transport jam at the middle path sensor (Inner Finisher)

Classification	Error content
Inner finisher jam	Paper remains at the middle path sensor for a longer period than specified while being transported on the finisher transport path.

Check item	Measures
2nd transport motor (M4)	<ul style="list-style-type: none"> <li>Check the motor winding to confirm that the current flows in it. If not, replace the motor.</li> <li>Check that the current flows between the connector terminals. If not, replace the cables. (CN14)</li> </ul>
Entrance path sensor (S19)	<ul style="list-style-type: none"> <li>Actuator check</li> <li>Connector check (CN22)</li> <li>Harness check</li> <li>Measure the voltage of TP86 on the finisher control PC board (FIN). Then check that the measured voltage is 1 V or lower when not shielded and within the range of 3.3 V <math>\pm</math>5% when shielded. If the voltage does not fall within the mentioned range, replace the sensor.</li> </ul>
Middle path sensor (S7)	<ul style="list-style-type: none"> <li>Actuator check</li> <li>Connector check (CN6)</li> <li>Harness check</li> <li>Measure the voltage of TP84 on the finisher control PC board (FIN). Then check that the measured voltage is 1 V or lower when not shielded and within the range of 3.3 V <math>\pm</math>5% when shielded. If the voltage does not fall within the mentioned range, replace the sensor.</li> </ul>
Finisher control PC board (FIN)	<ul style="list-style-type: none"> <li>PC board check</li> <li>Connector check (CN6, CN14, CN22)</li> <li>Harness check</li> <li>Replace the PC board.</li> </ul>

Parts to be replaced	Remarks
2nd transport motor (M4)	
Entrance path sensor (S19)	
Middle path sensor (S7)	
Finisher control PC board (FIN)	

### [EA2C] Paper transport jam between the entrance path and the sub-path sensors (Inner Finisher)

Classification	Error content
Inner finisher jam	The leading edge of the paper does not reach the sub-path sensor after it has passed through the entrance sensor on the finisher transport path.

Check item	Measures
1st transport motor (M8)	<ul style="list-style-type: none"> <li>Check the motor winding to confirm that the current flows in it. If not, replace the motor.</li> <li>Check that the current flows between the connector terminals. If not, replace the cables. (CN22)</li> </ul>

Check item	Measures
2nd transport motor (M4)	<ul style="list-style-type: none"> <li>Check the motor winding to confirm that the current flows in it. If not, replace the motor.</li> <li>Check that the current flows between the connector terminals. If not, replace the cables. (CN14)</li> </ul>
Entrance path sensor (S19)	<ul style="list-style-type: none"> <li>Actuator check</li> <li>Connector check (CN22)</li> <li>Harness check</li> <li>Measure the voltage of TP86 on the finisher control PC board (FIN). Then check that the measured voltage is 1 V or lower when not shielded and within the range of 3.3 V <math>\pm</math>5% when shielded. If the voltage does not fall within the mentioned range, replace the sensor.</li> </ul>
Sub-path sensor (S8)	<ul style="list-style-type: none"> <li>Actuator check</li> <li>Connector check (CN6)</li> <li>Harness check</li> <li>Measure the voltage of TP85 on the finisher control PC board (FIN). Then check that the measured voltage is 1 V or lower when not shielded and within the range of 3.3 V <math>\pm</math>5 % when shielded. If the voltage does not fall within the mentioned range, replace the sensor.</li> </ul>
Stationary tray full detection sensor (S11)	<ul style="list-style-type: none"> <li>Actuator check</li> <li>Connector check (CN10)</li> <li>Harness check</li> <li>Measure the voltage of TP26 on the finisher control PC board (FIN). Then check that the measured voltage is 1 V or lower when not shielded and within the range of 3.3 V <math>\pm</math>5% when shielded. If the voltage does not fall within the mentioned range, replace the sensor.</li> </ul>
Finisher control PC board (FIN)	<ul style="list-style-type: none"> <li>PC board check</li> <li>Connector check (CN6, CN10, CN14, CN22)</li> <li>Harness check</li> <li>Replace the PC board.</li> </ul>

Parts to be replaced	Remarks
1st transport motor (M8)	
2nd transport motor (M4)	
Entrance path sensor (S19)	
Sub-path sensor (S8)	
Stationary tray full detection sensor (S11)	
Finisher control PC board (FIN)	

### [EA2D] Paper transport jam at the sub-path sensor (Inner Finisher)

Classification	Error content
Inner finisher jam	Paper remains at the sub-path sensor for a longer period than specified while being transported on the finisher transport path.

Check item	Measures
2nd transport motor (M4)	<ul style="list-style-type: none"> <li>Check the motor winding to confirm that the current flows in it. If not, replace the motor.</li> <li>Check that the current flows between the connector terminals. If not, replace the cables. (CN14)</li> </ul>
Entrance path sensor (S19)	<ul style="list-style-type: none"> <li>Actuator check</li> <li>Connector check (CN22)</li> <li>Harness check</li> <li>Measure the voltage of TP86 on the finisher control PC board (FIN). Then check that the measured voltage is 1 V or lower when not shielded and within the range of 3.3 V <math>\pm</math>5% when shielded. If the voltage does not fall within the mentioned range, replace the sensor.</li> </ul>

Check item	Measures
Sub-path sensor (S8)	<ul style="list-style-type: none"> <li>Actuator check</li> <li>Connector check (CN6)</li> <li>Harness check</li> <li>Measure the voltage of TP85 on the finisher control PC board (FIN). Then check that the measured voltage is 1 V or lower when not shielded and within the range of 3.3 V <math>\pm</math>5 % when shielded. If the voltage does not fall within the mentioned range, replace the sensor.</li> </ul>
Stationary tray full detection sensor (S11)	<ul style="list-style-type: none"> <li>Actuator check</li> <li>Connector check (CN10)</li> <li>Harness check</li> <li>Measure the voltage of TP26 on the finisher control PC board (FIN). Then check that the measured voltage is 1 V or lower when not shielded and within the range of 3.3 V <math>\pm</math>5% when shielded. If the voltage does not fall within the mentioned range, replace the sensor.</li> </ul>
Finisher control PC board (FIN)	<ul style="list-style-type: none"> <li>PC board check</li> <li>Connector check (CN6, CN10, CN14, CN22)</li> <li>Harness check</li> <li>Replace the PC board.</li> </ul>

Parts to be replaced	Remarks
2nd transport motor (M4)	
Entrance path sensor (S19)	
Sub-path sensor (S8)	
Stationary tray full detection sensor (S11)	
Finisher control PC board (FIN)	

#### [EA2E] Paper transport jam at the sub-path sensor (Inner Finisher)

Classification	Error content
Inner finisher jam	Paper is detected in the sub-path sensor when the power is turned ON or the cover is closed.

Check item	Measures
Entrance path sensor (S19)	<ul style="list-style-type: none"> <li>Actuator check</li> <li>Connector check (CN22)</li> <li>Harness check</li> <li>Measure the voltage of TP86 on the finisher control PC board (FIN). Then check that the measured voltage is 1 V or lower when not shielded and within the range of 3.3 V <math>\pm</math>5% when shielded. If the voltage does not fall within the mentioned range, replace the sensor.</li> </ul>
Sub-path sensor (S8)	<ul style="list-style-type: none"> <li>Actuator check</li> <li>Connector check (CN6)</li> <li>Harness check</li> <li>Measure the voltage of TP85 on the finisher control PC board (FIN). Then check that the measured voltage is 1 V or lower when not shielded and within the range of 3.3 V <math>\pm</math>5 % when shielded. If the voltage does not fall within the mentioned range, replace the sensor.</li> </ul>
Stationary tray full detection sensor (S11)	<ul style="list-style-type: none"> <li>Actuator check</li> <li>Connector check (CN10)</li> <li>Harness check</li> <li>Measure the voltage of TP26 on the finisher control PC board (FIN). Then check that the measured voltage is 1 V or lower when not shielded and within the range of 3.3 V <math>\pm</math>5% when shielded. If the voltage does not fall within the mentioned range, replace the sensor.</li> </ul>
Finisher control PC board (FIN)	<ul style="list-style-type: none"> <li>PC board check</li> <li>Connector check (CN6, CN10, CN22)</li> <li>Harness check</li> <li>Replace the PC board.</li> </ul>

Parts to be replaced	Remarks
Entrance path sensor (S19)	
Sub-path sensor (S8)	

Parts to be replaced	Remarks
Stationary tray full detection sensor (S11)	
Finisher control PC board (FIN)	

### [EA31] Paper transport jam at the sub-path sensor (Inner Finisher)

Classification	Error content
Inner finisher jam	Paper is detected in the entrance path sensor or the middle path sensor when the power is turned ON or the cover is closed.

Check item	Measures
Entrance path sensor (S19)	<ul style="list-style-type: none"> <li>Actuator check</li> <li>Connector check (CN22)</li> <li>Harness check</li> <li>Measure the voltage of TP86 on the finisher control PC board (FIN). Then check that the measured voltage is 1 V or lower when not shielded and within the range of 3.3 V <math>\pm</math>5% when shielded. If the voltage does not fall within the mentioned range, replace the sensor.</li> </ul>
Middle path sensor (S7)	<ul style="list-style-type: none"> <li>Actuator check</li> <li>Connector check (CN6)</li> <li>Harness check</li> <li>Measure the voltage of TP84 on the finisher control PC board (FIN). Then check that the measured voltage is 1 V or lower when not shielded and within the range of 3.3 V <math>\pm</math>5% when shielded. If the voltage does not fall within the mentioned range, replace the sensor.</li> </ul>
Sub-path sensor (S8)	<ul style="list-style-type: none"> <li>Actuator check</li> <li>Connector check (CN6)</li> <li>Harness check</li> <li>Measure the voltage of TP85 on the finisher control PC board (FIN). Then check that the measured voltage is 1 V or lower when not shielded and within the range of 3.3 V <math>\pm</math>5% when shielded. If the voltage does not fall within the mentioned range, replace the sensor.</li> </ul>
Finisher control PC board (FIN)	<ul style="list-style-type: none"> <li>PC board check</li> <li>Connector check (CN6, CN22)</li> <li>Harness check</li> <li>Replace the PC board.</li> </ul>

Parts to be replaced	Remarks
Entrance path sensor (S19)	
Middle path sensor (S7)	
Sub-path sensor (S8)	
Finisher control PC board (FIN)	

### [EA31] Transport path paper remaining jam (Finisher, Saddle Stitch Finisher)

Classification	Error content
Finisher jam Saddle stitch finisher jam	An attempt to drop a stack of the paper on the finishing tray by extending the buffer tray is made, but the previous stack has not yet exited.

Check item	Measures
Entrance sensor (S1)	<ul style="list-style-type: none"> <li>Sensor check</li> <li>Actuator check</li> <li>Connector check (CN8)</li> <li>Harness check</li> <li>Replace the sensor.</li> </ul>
Paper feed sensor (S22)	<ul style="list-style-type: none"> <li>Sensor check</li> <li>Actuator check</li> <li>Connector check (CN1)</li> <li>Harness check</li> <li>Replace the sensor.</li> </ul>

Check item	Measures
Paper position sensor (S6-1, S6-2) (Hole punch unit)	<ul style="list-style-type: none"> <li>• Clean the sensor and around it to remove the paper dust.</li> <li>• Sensor check</li> <li>• Connector check (CN1, CN2)</li> <li>• Harness check</li> <li>• Replace the sensor.</li> </ul>
Transport sensor (S2)	<ul style="list-style-type: none"> <li>• Sensor check</li> <li>• Actuator check</li> <li>• Connector check (CN8)</li> <li>• Harness check</li> <li>• Replace the sensor.</li> </ul>
Finisher control PC board (FIN)	<ul style="list-style-type: none"> <li>• PC board check</li> <li>• Connector check (CN1, CN8)</li> <li>• Harness check</li> <li>• Replace the PC board.</li> </ul>
Hole punch control PC board (HP)	<ul style="list-style-type: none"> <li>• PC board check</li> <li>• Connector check (CN1, CN2)</li> <li>• Harness check</li> <li>• Replace the PC board.</li> </ul>

Parts to be replaced	Remarks
Entrance sensor (S1)	
Paper feed sensor (S22)	
Paper position sensor (S6-1, S6-2) (Hole punch unit)	
Transport sensor (S2)	
Finisher control PC board (FIN)	
Hole punch control PC board (HP)	

### [EA32] Exit paper remaining jam (Inner Finisher)

Classification	Error content
Inner finisher jam	Paper is detected in the finishing tray sensor when the power is turned ON.

Check item	Measures
Finishing tray sensor (S4)	<ul style="list-style-type: none"> <li>• Actuator check</li> <li>• Connector check (CN5)</li> <li>• Harness check</li> <li>• Measure the voltage of TP14 on the finisher control PC board (FIN). Then check that the measured voltage is 1 V or lower when not shielded and within the range of 3.3 V <math>\pm</math>5% when shielded. If the voltage does not fall within the mentioned range, replace the sensor.</li> </ul>
Finisher control PC board (FIN)	<ul style="list-style-type: none"> <li>• PC board check</li> <li>• Connector check (CN5)</li> <li>• Harness check</li> <li>• Replace the PC board.</li> </ul>

Parts to be replaced	Remarks
Finishing tray sensor (S4)	
Finisher control PC board (FIN)	

### [EA32] Exit paper remaining jam (Finisher, Saddle Stitch Finisher)

Classification	Error content
Finisher jam Saddle stitch finisher jam	Paper is detected in the finishing tray paper sensor when the power is turned ON.

Check item	Measures
Finishing tray paper detection sensor (S12)	<ul style="list-style-type: none"> <li>• Sensor check</li> <li>• Actuator check</li> <li>• Connector check (CN25)</li> <li>• Harness check</li> <li>• Replace the sensor.</li> </ul>

Check item	Measures
Finisher control PC board (FIN)	<ul style="list-style-type: none"> <li>• PC board check</li> <li>• Connector check (CN25)</li> <li>• Harness check</li> <li>• Replace the PC board.</li> </ul>

Parts to be replaced	Remarks
Finishing tray paper detection sensor (S12)	
Finisher control PC board (FIN)	

#### [EA40] Cover open jam (Inner Finisher)

Classification	Error content
Inner finisher jam	The cover of the finisher has become open during the operation.

Check item	Measures
Sub-path sensor (S12)	<ul style="list-style-type: none"> <li>• Actuator check</li> <li>• Connector check (CN10)</li> <li>• Harness check</li> <li>• Measure the voltage of TP12 on the finisher control PC board (FIN). Then check that the measured voltage is 1 V or lower when not shielded and within the range of 3.3 V <math>\pm</math>5% when shielded. If the voltage does not fall within the mentioned range, replace the sensor.</li> </ul>
Front cover switch (SW1)	<ul style="list-style-type: none"> <li>• Actuator check</li> <li>• Connector check (CN13)</li> <li>• Harness check</li> <li>• Measure the voltage of TP77 on the finisher control PC board (FIN). Then check that the measured voltage is 1 V or lower when not shielded and within the range of 3.3 V <math>\pm</math>5% when shielded. If the voltage does not fall within the mentioned range, replace the switch.</li> </ul>
Finisher control PC board (FIN)	<ul style="list-style-type: none"> <li>• PC board check</li> <li>• Connector check (CN10, CN13)</li> <li>• Harness check</li> <li>• Replace the PC board.</li> </ul>

Parts to be replaced	Remarks
Sub-path sensor (S12)	
Front cover switch (SW1)	
Finisher control PC board (FIN)	

#### [EA40] Stationary tray open jam (Finisher, Saddle Stitch Finisher)

Classification	Error content
Finisher jam Saddle stitch finisher jam	<ul style="list-style-type: none"> <li>• The cover of the finisher has become open during the operation.</li> <li>• The stationary tray of the finisher has become open during the operation.</li> <li>• The 24 V voltage cannot be detected on the finisher control PC board.</li> </ul>

Check item	Measures
Stationary tray	<ul style="list-style-type: none"> <li>• Check if there is any abnormality in the cover.</li> <li>• Close the cover if it is opened.</li> <li>• Replace the cover.</li> </ul>
Stationary tray opening/closing switch (SW2)	<ul style="list-style-type: none"> <li>• Switch check</li> <li>• Actuator check</li> <li>• Connector check (CN14)</li> <li>• Harness check</li> <li>• Replace the switch.</li> </ul>
Front cover opening/closing switch (SW1)	<ul style="list-style-type: none"> <li>• Switch check</li> <li>• Actuator check</li> <li>• Connector check (CN14)</li> <li>• Harness check</li> <li>• Replace the switch.</li> </ul>

Check item	Measures
Finisher connection cable	<ul style="list-style-type: none"> <li>• Check if there is any abnormality in the cable.</li> <li>• Connector check</li> </ul>
Connection cable	<ul style="list-style-type: none"> <li>• Check if there is any abnormality in the cable.</li> <li>• Connector check</li> </ul>
Finisher control PC board (FIN)	<ul style="list-style-type: none"> <li>• PC board check</li> <li>• Connector check (CN14)</li> <li>• Harness check</li> <li>• Replace the PC board.</li> </ul>
Saddle control PC board (SDL)	<ul style="list-style-type: none"> <li>• PC board check</li> <li>• Connector check (CN6)</li> <li>• Harness check</li> <li>• Replace the PC board.</li> </ul>
Hole punch control PC board (HP)	<ul style="list-style-type: none"> <li>• PC board check</li> <li>• Connector check (CN4)</li> <li>• Harness check</li> <li>• Replace the PC board.</li> </ul>

Parts to be replaced	Remarks
Front top cover	
Stationary tray opening/closing switch (SW2)	
Front cover opening/closing switch (SW1)	
Finisher control PC board (FIN)	
Saddle control PC board (SDL)	
Hole punch control PC board (HP)	

#### [EA41] Front top cover open jam (Finisher, Saddle Stitch Finisher)

Classification	Error content
Finisher jam Saddle stitch finisher jam	The front top cover of the finisher has become open during the operation.

Check item	Measures
Front top cover	<ul style="list-style-type: none"> <li>• Check if there is any abnormality in the cover.</li> <li>• Close the cover if it is opened.</li> <li>• Check if the cover locking bracket is damaged.</li> <li>• Replace the cover locking bracket.</li> </ul>
Front cover opening/closing switch (SW1)	<ul style="list-style-type: none"> <li>• Switch check</li> <li>• Actuator check</li> <li>• Connector check (CN14)</li> <li>• Harness check</li> <li>• Replace the switch.</li> </ul>
Finisher control PC board (FIN)	<ul style="list-style-type: none"> <li>• PC board check</li> <li>• Connector check (CN14)</li> <li>• Harness check</li> <li>• Replace the PC board.</li> </ul>

Parts to be replaced	Remarks
Cover locking bracket	
Front cover opening/closing switch (SW1)	
Finisher control PC board (FIN)	



### [EA42] Hole punch: front cover open jam (Finisher, Saddle Stitch Finisher)

Classification	Error content
Hole punch unit jam	The front cover of the hole punch unit has become open during the operation.

Check item	Measures
Front cover	<ul style="list-style-type: none"> <li>• Check if there is any abnormality in the cover.</li> <li>• Close the cover if it is opened.</li> <li>• Replace the cover.</li> </ul>
Front cover opening/closing sensor (S1)	<ul style="list-style-type: none"> <li>• Sensor check</li> <li>• Actuator check</li> <li>• Connector check</li> <li>• Harness check</li> <li>• Replace the sensor.</li> </ul>
Hole punch control PC board (HP)	<ul style="list-style-type: none"> <li>• PC board check</li> <li>• Connector check (CN10)</li> <li>• Harness check</li> <li>• Replace the PC board.</li> </ul>

Parts to be replaced	Remarks
Front cover	
Front cover opening/closing sensor (S1)	
Hole punch control PC board (HP)	

### [EA50] Stapling jam (Inner Finisher)

Classification	Error content
Inner finisher jam	Stapling is not correctly done.

Check item	Measures
Stapling start position sensor (S17)	<ul style="list-style-type: none"> <li>• Actuator check</li> <li>• Connector check (CN17)</li> <li>• Harness check</li> <li>• Measure the voltage of TP23 on the finisher control PC board (FIN). Then check that the measured voltage is 1 V or lower when not shielded and within the range of 3.3 V <math>\pm</math>5% when shielded. If the voltage does not fall within the mentioned range, replace the stapler unit.</li> </ul>
Staple empty sensor (S18)	<ul style="list-style-type: none"> <li>• Actuator check</li> <li>• Connector check (CN17)</li> <li>• Harness check</li> <li>• Measure the voltage of TP24 on the finisher control PC board (FIN). Then check that the measured voltage is 1 V or lower when not shielded and within the range of 3.3 V <math>\pm</math>5% when shielded. If the voltage does not fall within the mentioned range, replace the stapler unit.</li> </ul>
Finisher control PC board (FIN)	<ul style="list-style-type: none"> <li>• PC board check</li> <li>• Connector check (CN17)</li> <li>• Harness check</li> <li>• Replace the PC board.</li> </ul>

Parts to be replaced	Remarks
Stapler unit	
Finisher control PC board (FIN)	

**[EA50] Stapling jam (Finisher, Saddle Stitch Finisher)**

Classification	Error content
Finisher jam Saddle stitch finisher jam	Stapling is not correctly done.

Check item	Measures
Stapler	<ul style="list-style-type: none"> <li>• Take off the staple cartridge and remove the staple sheet slid from the staple case.</li> <li>• If the actuator of the stapler safety sensor (S11) does not move smoothly, remove its clip from the side and then reattach it.</li> <li>• Connector check (CN2)</li> <li>• Harness check</li> <li>• Replace the stapler.</li> </ul>
Finisher control PC board (FIN)	<ul style="list-style-type: none"> <li>• PC board check</li> <li>• Connector check (CN2)</li> <li>• Harness check</li> <li>• Replace the PC board.</li> </ul>
Belt	<p>Check if the belt tension of the stapler unit is loosened. If it is loosened, perform the adjustment according to the following procedure.</p> <ol style="list-style-type: none"> <li>1. Before adjusting the belt tension, make a mark for the initial position.</li> <li>2. Loosen the screw of the belt pulley metal plate.</li> <li>3. Move the pulley to the front side by 0.5 to 1.0 mm from the marked position and then tighten the screw.</li> </ol>

Parts to be replaced	Remarks
Stapler	
Finisher control PC board (FIN)	

**[EA60] Early arrival jam (Inner Finisher)**

Classification	Error content
Inner finisher jam	Paper has arrived at the finisher from the MFP too early.

Check item	Measures
Entrance path sensor (S19)	<ul style="list-style-type: none"> <li>• Actuator check</li> <li>• Connector check (CN22)</li> <li>• Harness check</li> <li>• Measure the voltage of TP86 on the finisher control PC board (FIN). Then check that the measured voltage is 1V or lower when not shielded and within the range of 3.3 V <math>\pm</math>5% when shielded. If the voltage does not fall within the mentioned range, replace the sensor.</li> </ul>
Finisher control PC board (FIN)	<ul style="list-style-type: none"> <li>• PC board check</li> <li>• Connector check (CN22)</li> <li>• Harness check</li> <li>• Replace the PC board.</li> </ul>

Parts to be replaced	Remarks
Stapler	
Finisher control PC board (FIN)	

**[EA60] Paper early arrival jam (Finisher, Saddle Stitch Finisher)**

Classification	Error content
Finisher jam Saddle stitch finisher jam	Paper has arrived at the finisher from the MFP too early.

Check item	Measures
Paper feed sensor (S22)	<ul style="list-style-type: none"> <li>• Sensor check</li> <li>• Actuator check</li> <li>• Connector check (CN1)</li> <li>• Harness check</li> <li>• Replace the sensor.</li> </ul>

Check item	Measures
Finisher control PC board (FIN)	<ul style="list-style-type: none"> <li>PC board check</li> <li>Connector check (CN1)</li> <li>Harness check</li> <li>Replace the PC board.</li> </ul>

Parts to be replaced	Remarks
Paper feed sensor (S22)	
Finisher control PC board (FIN)	

#### [EA70] Stack exit belt home position error (Finisher, Saddle Stitch Finisher)

Classification	Error content
Finisher jam Saddle stitch finisher jam	The stack exit belt is not at its home position.

Check item	Measures
Paper feed sensor (S22)	<ul style="list-style-type: none"> <li>Sensor check</li> <li>Actuator check</li> <li>Connector check (CN1)</li> <li>Harness check</li> <li>Replace the sensor.</li> </ul>
Finisher control PC board (FIN)	<ul style="list-style-type: none"> <li>PC board check</li> <li>Connector check (CN1)</li> <li>Harness check</li> <li>Replace the PC board.</li> </ul>

Parts to be replaced	Remarks
Paper feed sensor (S22)	
Finisher control PC board (FIN)	

#### [EA90] Cover open jam (Saddle Stitch Finisher)

Classification	Error content
Saddle stitch finisher jam	The saddle stitch unit has become open during the operation.

Check item	Measures
Saddle stitch unit	Close the saddle stitch unit if it is open.
Saddle stitch unit opening/closing switch (SW5)	<ul style="list-style-type: none"> <li>Switch check</li> <li>Actuator check</li> <li>Connector check (CN26)</li> <li>Harness check</li> <li>Replace the switch.</li> </ul>

Parts to be replaced	Remarks
Saddle stitch unit opening/closing switch (SW5)	

#### [EAA0] Paper remaining jam in the saddle stitch unit (Saddle Stitch Finisher)

Classification	Error content
Saddle stitch finisher jam	Paper is detected in the saddle stitch unit when the power is turned ON.

Check item	Measures
Saddle stitch unit	Close the saddle stitch unit if it is open.
Junction box sensor (S26)	<ul style="list-style-type: none"> <li>Sensor check</li> <li>Actuator check</li> <li>Connector check (CN1)</li> <li>Harness check</li> <li>Replace the sensor.</li> </ul>

Check item	Measures
Transport path-2 sensor (S27)	<ul style="list-style-type: none"> <li>• Sensor check</li> <li>• Actuator check</li> <li>• Connector check (CN3)</li> <li>• Harness check</li> <li>• Replace the sensor.</li> </ul>
Transport path-3 sensor (S28)	<ul style="list-style-type: none"> <li>• Sensor check</li> <li>• Actuator check</li> <li>• Connector check (CN3)</li> <li>• Harness check</li> <li>• Replace the sensor.</li> </ul>
Eject roller sensor (S29)	<ul style="list-style-type: none"> <li>• Sensor check</li> <li>• Actuator check</li> <li>• Connector check (CN3)</li> <li>• Harness check</li> <li>• Replace the sensor.</li> </ul>
Finisher control PC board (FIN)	<ul style="list-style-type: none"> <li>• PC board check</li> <li>• Connector check (CN21, CN1)</li> <li>• Harness check</li> <li>• Replace the PC board.</li> </ul>
Saddle control PC board (SDL)	<ul style="list-style-type: none"> <li>• PC board check</li> <li>• Connector check (CN3, CN6)</li> <li>• Harness check</li> <li>• Replace the PC board.</li> </ul>

Parts to be replaced	Remarks
Junction box sensor (S26)	
Transport path-2 sensor (S27)	
Transport path-3 sensor (S28)	
Eject roller sensor (S29)	
Finisher control PC board (FIN)	
Saddle control PC board (SDL)	

### [EAB0] Paper transport jam in the saddle stitch unit (Saddle Stitch Finisher)

Classification	Error content
Saddle stitch finisher jam	Paper is detected in the saddle stitch unit when the power is turned ON.

Check item	Measures
Paper	If any paper remains in the finisher, remove it.
Transport roller	<ul style="list-style-type: none"> <li>• Check if there is any abnormality in the rotation of the roller.</li> <li>• Check if there is any mechanical problem.</li> <li>• If there is any, correct it.</li> </ul>
Paper feed sensor (S22)	<ul style="list-style-type: none"> <li>• Sensor check</li> <li>• Actuator check</li> <li>• Connector check (CN1)</li> <li>• Harness check</li> <li>• Replace the sensor.</li> </ul>
Junction box sensor (S26)	<ul style="list-style-type: none"> <li>• Sensor check</li> <li>• Actuator check</li> <li>• Connector check (CN1)</li> <li>• Harness check</li> <li>• Replace the sensor.</li> </ul>
Transport path-2 sensor (S27)	<ul style="list-style-type: none"> <li>• Sensor check</li> <li>• Actuator check</li> <li>• Connector check (CN3)</li> <li>• Harness check</li> <li>• Replace the sensor.</li> </ul>
Transport path-3 sensor (S28)	<ul style="list-style-type: none"> <li>• Sensor check</li> <li>• Actuator check</li> <li>• Connector check (CN3)</li> <li>• Harness check</li> <li>• Replace the sensor.</li> </ul>

Check item	Measures
Eject roller sensor (S29)	<ul style="list-style-type: none"> <li>• Sensor check</li> <li>• Actuator check</li> <li>• Connector check (CN3)</li> <li>• Harness check</li> <li>• Replace the sensor.</li> </ul>
Saddle transport motor (M16)	<ul style="list-style-type: none"> <li>• Check that the motor is working.</li> <li>• Connector check (CN5)</li> <li>• Harness check</li> <li>• Replace the motor.</li> </ul>
Transport path switching solenoid (SOL5)	<ul style="list-style-type: none"> <li>• Solenoid check While the solenoid is turned ON or OFF, if the gap between the surface of the transport guide and the upper surface of the tip of the flap is not within the proper value (OFF: 1.5 to 2.1 mm, ON: 2.3 to 2.9 mm), adjust this.</li> <li>• Connector check (CN17)</li> <li>• Harness check</li> </ul>
Entrance motor (M1)	<ul style="list-style-type: none"> <li>• Check that the motor is working.</li> <li>• Connector check (CN1)</li> <li>• Harness check</li> <li>• Replace the motor.</li> </ul>
Finisher control PC board (FIN)	<ul style="list-style-type: none"> <li>• PC board check</li> <li>• Connector check</li> <li>• Harness check</li> <li>• Replace the PC board.</li> </ul>
Saddle control PC board (SDL)	<ul style="list-style-type: none"> <li>• PC board check</li> <li>• Connector check</li> <li>• Harness check</li> <li>• Replace the PC board.</li> </ul>

Parts to be replaced	Remarks
Paper feed sensor (S22)	
Junction box sensor (S26)	
Transport path-2 sensor (S27)	
Transport path-3 sensor (S28)	
Eject roller sensor (S29)	
Saddle transport motor (M16)	
Entrance motor (M1)	
Finisher control PC board (FIN)	
Saddle control PC board (SDL)	

### [EAB1] Paper size error jam (Saddle Stitch Finisher)

Classification	Error content
Saddle stitch finisher jam	Paper is shorter than the acceptable paper size.

Check item	Measures
Paper	Use the paper specified in the specifications if a one shorter than the acceptable size is utilized.
Paper feed sensor (S22)	<ul style="list-style-type: none"> <li>• Sensor check</li> <li>• Actuator check</li> <li>• Connector check (CN1)</li> <li>• Harness check</li> <li>• Replace the sensor.</li> </ul>
Junction box sensor (S26)	<ul style="list-style-type: none"> <li>• Sensor check</li> <li>• Actuator check</li> <li>• Connector check (CN1)</li> <li>• Harness check</li> <li>• Replace the sensor.</li> </ul>

Check item	Measures
Transport path-2 sensor (S27)	<ul style="list-style-type: none"> <li>• Sensor check</li> <li>• Actuator check</li> <li>• Connector check (CN3)</li> <li>• Harness check</li> <li>• Replace the sensor.</li> </ul>
Transport path-3 sensor (S28)	<ul style="list-style-type: none"> <li>• Sensor check</li> <li>• Actuator check</li> <li>• Connector check (CN3)</li> <li>• Harness check</li> <li>• Replace the sensor.</li> </ul>
Eject roller sensor (S29)	<ul style="list-style-type: none"> <li>• Sensor check</li> <li>• Actuator check</li> <li>• Connector check (CN3)</li> <li>• Harness check</li> <li>• Replace the sensor.</li> </ul>
Finisher control PC board (FIN)	<ul style="list-style-type: none"> <li>• PC board check</li> <li>• Connector check</li> <li>• Harness check</li> <li>• Replace the PC board.</li> </ul>
Saddle control PC board (SDL)	<ul style="list-style-type: none"> <li>• PC board check</li> <li>• Connector check</li> <li>• Harness check</li> <li>• Replace the PC board.</li> </ul>

Parts to be replaced	Remarks
Paper feed sensor (S22)	
Junction box sensor (S26)	
Transport path-2 sensor (S27)	
Transport path-3 sensor (S28)	
Eject roller sensor (S29)	
Finisher control PC board (FIN)	
Saddle control PC board (SDL)	

#### [EAD0] Print end command time-out error

Classification	Error content
Inner finisher jam Finisher jam Saddle stitch finisher jam	Printing has not been finished normally because of a communication error between the SYS board and the LGC board at the end of printing.

Check item	Measures
Reproducibility	Turn the power OFF and then back ON to check the occurrence.
SYS board	<ul style="list-style-type: none"> <li>• PC board check</li> <li>• Connector check (CN132)</li> <li>• Harness (flat cable) check</li> <li>• Replace the PC board.</li> </ul>
LGC board	<ul style="list-style-type: none"> <li>• PC board check</li> <li>• Connector check (CN309)</li> <li>• Harness (flat cable) check</li> <li>• Replace the PC board.</li> </ul>

Parts to be replaced	Remarks
SYS board	
LGC board	

- [EAE0] Finisher receiving time-out jam  
[EAE1] Finisher receiving time-out jam (1)  
[EAE2] Finisher receiving time-out jam (2)  
[EAE3] Finisher receiving time-out jam (3)  
[EAE4] Finisher receiving time-out jam (4)  
[EAE5] Finisher receiving time-out jam (5)  
[EAE6] Finisher receiving time-out jam (6)  
[EAE7] Finisher receiving time-out jam (7)  
[EAE8] Finisher receiving time-out jam (8)  
[EAE9] Finisher receiving time-out jam (9)  
[EAEA] Finisher receiving time-out jam (10)  
[EAEB] Finisher receiving time-out jam (11)  
[EAEC] Finisher receiving time-out jam (12)  
[EAED] Finisher receiving time-out jam (13)  
[EAEF] Finisher receiving time-out jam (15)

Classification	Error content
Finisher jam Saddle stitch finisher jam	<ul style="list-style-type: none"> <li>• Finisher adjustment value writing abnormality</li> <li>• Finisher ON/OFF abnormality</li> <li>• Stack of paper enforced exiting abnormality</li> <li>• Stack of paper enforced exiting abnormality (Saddle stitch unit)</li> <li>• Mechanical initialize abnormality</li> <li>• Finisher response abnormality</li> <li>• Stack of paper exiting status abnormality</li> <li>• Stapling status abnormality</li> <li>• Saddle stitch folding status abnormality</li> <li>• Cancellation abnormality</li> <li>• Finisher communication abnormality</li> <li>• Finisher reception data abnormality</li> <li>• Finisher transmission data abnormality</li> <li>• Sensor passing notification abnormality</li> <li>• Finisher paper exiting end abnormality</li> </ul>

Check item	Measures
Reproducibility	Turn the power OFF and then back ON to check the occurrence.
Finisher	<ul style="list-style-type: none"> <li>• PC board check</li> <li>• Connector check</li> <li>• Harness check</li> <li>• Replace the PC board.</li> </ul>
LGC board	<ul style="list-style-type: none"> <li>• Check if the finisher works properly.</li> <li>• Check if the 24 V voltage is being supplied to the finisher.</li> <li>• Check if there is any abnormality in the interface connector between the finisher and the LGC board.</li> <li>• Check if the harness between the finisher and the LGC board is scratched or open circuited.</li> </ul>

#### [EAF1] Stack exit roller home position sensor detection abnormality (Inner Finisher)

Classification	Error content
Inner finisher jam	The detection of the home position of the stack exit roller lift motor ends abnormally.

Check item	Measures
Stack exit roller shift motor (M6)	<ul style="list-style-type: none"> <li>• Check the motor winding to confirm that the current flows in it. If not, replace the motor.</li> <li>• Check that the current flows between the connector terminals. If not, replace the cables. (CN14)</li> </ul>
Stack exit roller home position sensor (S13)	<ul style="list-style-type: none"> <li>• Sensor check</li> <li>• Actuator check</li> <li>• Connector check (CN10)</li> <li>• Harness check</li> <li>• Replace the sensor.</li> </ul>

Check item	Measures
Finisher control PC board (FIN)	<ul style="list-style-type: none"> <li>PC board check</li> <li>Connector check (CN10, CN14)</li> <li>Harness check</li> <li>Replace the PC board.</li> </ul>

Parts to be replaced	Remarks
Stack exit roller shift motor (M6)	
Stack exit roller home position sensor (S13)	
Finisher control PC board (FIN)	

## [EAF2] Stapler unit sliding home position sensor detection abnormality (Inner Finisher)

Classification	Error content
Inner finisher jam	The detection of the home position of the stapler unit sliding motor ends abnormally.

Check item	Measures
Stapler unit sliding motor (M7) defect	<ul style="list-style-type: none"> <li>Check the motor winding to confirm that the current flows in it. If not, replace the motor.</li> <li>Check that the current flows between the connector terminals. If not, replace the cables. (CN18)</li> </ul>
Stapler unit sliding home position sensor (S3) defect	<ul style="list-style-type: none"> <li>Actuator check</li> <li>Connector check (CN3)</li> <li>Harness check</li> <li>Measure the voltage of TP18 on the finisher control PC board (FIN). Then check that the measured voltage is 1 V or lower when not shielded and within the range of 3.3 V <math>\pm</math>5% when shielded. If the voltage does not fall within the mentioned range, replace the sensor.</li> </ul>
Finisher control PC board (FIN)	<ul style="list-style-type: none"> <li>PC board check</li> <li>Connector check (CN3, CN18)</li> <li>Harness check</li> <li>Replace the PC board.</li> </ul>

Parts to be replaced	Remarks
Stapler unit sliding motor (M7) defect	
Stapler unit sliding home position sensor (S3) defect	
Finisher control PC board (FIN)	

## [EAFA] Catching motor home position sensor detection abnormality

Classification	Error content
Finisher jam Saddle stitch finisher jam	The detection of the home position of the catching motor ends abnormally.

Check item	Measures
Catching motor (M21)	<ul style="list-style-type: none"> <li>Check that the motor is working.</li> <li>Connector check (CN17)</li> <li>Harness check</li> <li>Replace the motor.</li> </ul>
Catching motor home position sensor (S52)	<ul style="list-style-type: none"> <li>Sensor check</li> <li>Actuator check</li> <li>Connector check (CN17)</li> <li>Harness check</li> <li>Replace the sensor.</li> </ul>
Finisher control PC board (FIN)	<ul style="list-style-type: none"> <li>PC board check</li> <li>Connector check (CN17)</li> <li>Harness check</li> <li>Replace the PC board.</li> </ul>



Parts to be replaced	Remarks
Catching motor (M21)	
Catching motor home position sensor (S52)	
Finisher control PC board (FIN)	

**[EAFB] Stapler movement abnormality (Finisher, Saddle Stitch Finisher)**

**[CB51] Stapler movement home position abnormality (Finisher, Saddle Stitch Finisher)**

Classification	Error content
[EAFB] Finisher jam Saddle stitch finisher jam [CB51] Finisher service call Saddle stitch finisher service call	The stapler is not at its home position.

Check item	Measures
Stapler	<ul style="list-style-type: none"> <li>• Check if there is any abnormality in the installation of the stapler.</li> <li>• Check if there is any mechanical problem.</li> <li>• If there is any, correct it.</li> </ul>
Stapler unit home position sensor (S10)	<ul style="list-style-type: none"> <li>• Sensor check</li> <li>• Actuator check</li> <li>• Connector check (CN27)</li> <li>• Harness check</li> <li>• Replace the sensor.</li> </ul>
Stapler unit shift motor (M9)	<ul style="list-style-type: none"> <li>• Check that the motor is working.</li> <li>• Connector check (CN15)</li> <li>• Harness check</li> <li>• Replace the motor.</li> </ul>

Parts to be replaced	Remarks
Stapler unit home position sensor (S10)	
Stapler unit shift motor (M9)	

**[EAFC] Movable tray height abnormality (Finisher, Saddle Stitch Finisher)**

**[CB30] Movable tray shift motor abnormality (Finisher, Saddle Stitch Finisher)**

Classification	Error content
[EAFC] Finisher jam Saddle stitch finisher jam [CB30] Finisher service call Saddle stitch finisher service call	The movable tray shift motor or the movable tray does not work normally.

Check item	Measures
Movable tray	<ul style="list-style-type: none"> <li>• Check if there is any abnormality in the installation of the tray.</li> <li>• Check if there is any mechanical problem.</li> <li>• If there is any, correct it.</li> </ul>
Movable tray shift motor (M12)	<ul style="list-style-type: none"> <li>• Check that the motor is working.</li> <li>• Connector check (CN19)</li> <li>• Harness check</li> <li>• Replace the motor.</li> </ul>
Movable tray position sensors A, B, C (S13, S14, S15)	<ul style="list-style-type: none"> <li>• Sensor check</li> <li>• Actuator check</li> <li>• Connector check (CN20)</li> <li>• Harness check</li> <li>• Replace the sensor.</li> </ul>

Parts to be replaced	Remarks
Movable tray shift motor (M12)	
Movable tray position sensors A, B, C (S13, S14, S15)	

**[EAFD] Movable tray movement abnormality (Finisher, Saddle Stitch Finisher)**  
**[CB31] Movable tray movement abnormality (Finisher, Saddle Stitch Finisher)**

Classification	Error content
[EAFD] Finisher jam Saddle stitch finisher jam [CB31] Finisher service call Saddle stitch finisher service call	The actuator of the movable tray stack height detection sensor does not move smoothly.

Check item	Measures
Movable tray stack height detection sensor (S16)	<ul style="list-style-type: none"> <li>• Sensor check</li> <li>• Actuator check</li> <li>• Connector check (CN22)</li> <li>• Harness check</li> <li>• Replace the sensor.</li> </ul>
Movable tray position sensors A, B, C (S13, S14, S15)	<ul style="list-style-type: none"> <li>• Sensor check</li> <li>• Actuator check</li> <li>• Connector check (CN20)</li> <li>• Harness check</li> <li>• Replace the sensor.</li> </ul>

Parts to be replaced	Remarks
Movable tray stack height detection sensor (S16)	
Movable tray position sensors A, B, C (S13, S14, S15)	

**[EAFE] Assist guide cam position abnormality (Finisher, Saddle Stitch Finisher)**  
**[CB14] Assist guide cam position abnormality (Finisher, Saddle Stitch Finisher)**

Classification	Error content
[EAFE] Finisher jam Saddle stitch finisher jam [CB14] Finisher service call Saddle stitch finisher service call	The assist guide cam or the assist guide motor does not work normally.

Check item	Measures
Assist guide cam	<ul style="list-style-type: none"> <li>• Check if there is any abnormality in the installation of the cam.</li> <li>• Check if there is any mechanical problem by rotating it.</li> <li>• If there is any, correct it.</li> </ul>
Assist guide motor (M10)	<ul style="list-style-type: none"> <li>• Check that the motor is working.</li> <li>• Connector check (CN10)</li> <li>• Harness check</li> <li>• Replace the motor.</li> </ul>
Finisher control PC board (FIN)	<ul style="list-style-type: none"> <li>• PC board check</li> <li>• Connector check (CN10)</li> <li>• Harness check</li> <li>• Replace the PC board.</li> </ul>

Parts to be replaced	Remarks
Assist guide motor (M10)	
Finisher control PC board (FIN)	

**[EB30] Ready time-out jam**

Classification	Error content
Inner finisher jam Finisher jam Saddle stitch finisher jam	The operation could not be continued properly when the paper has been transported from the MFP to the finisher due to a communication abnormality between them.

Check item	Measures
Reproducibility	Turn the power OFF and then back ON to check the occurrence.

Check item	Measures
Finisher	<ul style="list-style-type: none"> <li>• Check if the finisher works properly.</li> <li>• Check if there is any abnormality in the interface connector between the finisher and the LGC board.</li> <li>• Check if the harness between the finisher and the LGC board is scratched or open circuited.</li> <li>• Update the finisher firmware to the latest one.</li> </ul>

### [EB50] Paper remaining on the transport path jam due to multiple feeding

Classification	Error content
Other paper jam	The multiple feeding of preceding paper caused the misfeeding of upcoming paper.

Check item	Measures
1st transport sensor	<ul style="list-style-type: none"> <li>• Sensor check Input check: FS-03-[ALL]OFF/[9]/[B]</li> <li>• Actuator check</li> <li>• Connector check (CN318)</li> <li>• Harness check</li> <li>• Replace the sensor.</li> </ul>
Registration sensor	<ul style="list-style-type: none"> <li>• Sensor check Input check: FS-03-[ALL]OFF/[9]/[A]</li> <li>• Actuator check</li> <li>• Connector check (CN318)</li> <li>• Harness check</li> <li>• Replace the sensor.</li> </ul>
LGC board	<ul style="list-style-type: none"> <li>• PC board check</li> <li>• Connector check Bypass tray: CN321 1st drawer: CN317, CN316 2nd drawer: CN317, CN316 PFP, LCF: CN315</li> <li>• Harness check</li> <li>• Replace the PC board.</li> </ul>
Bypass tray paper feed clutch	<ul style="list-style-type: none"> <li>• Check that the clutch is working. Output check: FS-03-204</li> <li>• Connector check (CN321)</li> <li>• Harness check</li> <li>• Replace the clutch.</li> </ul>
1st drawer paper feed clutch	<ul style="list-style-type: none"> <li>• Check that the clutch is working. Output check: FS-03-201</li> <li>• Connector check (CN316)</li> <li>• Harness check</li> <li>• Replace the clutch.</li> </ul>
2nd drawer paper feed clutch	<ul style="list-style-type: none"> <li>• Check that the clutch is working. Output check: FS-03-202</li> <li>• Connector check (CN316)</li> <li>• Harness check</li> <li>• Replace the clutch.</li> </ul>
Transport clutch (H)	<ul style="list-style-type: none"> <li>• Check that the clutch is working. Output check: FS-03-230</li> <li>• Connector check (CN318)</li> <li>• Harness check</li> <li>• Replace the clutch.</li> </ul>
Transport clutch (L)	<ul style="list-style-type: none"> <li>• Check that the clutch is working. Output check: FS-03-233</li> <li>• Connector check (CN318)</li> <li>• Harness check</li> <li>• Replace the clutch.</li> </ul>

Check item	Measures
2nd transport sensor	<ul style="list-style-type: none"> <li>• Sensor check Input check: FS-03-[F2]ON/[4]/[D]</li> <li>• Actuator check</li> <li>• Connector check (CN318)</li> <li>• Harness check</li> <li>• Replace the sensor.</li> </ul>

Parts to be replaced	Remarks
1st transport sensor	
Registration sensor	
LGC board	
Bypass tray paper feed clutch	
1st drawer paper feed clutch	
2nd drawer paper feed clutch	
Transport clutch (H)	
Transport clutch (L)	
2nd transport sensor	

### [EB60] Paper remaining on the transport path jam due to multiple feeding

Classification	Error content
Other paper jam	The multiple feeding of preceding paper caused the misfeeding of upcoming paper.

Check item	Measures
Registration sensor	<ul style="list-style-type: none"> <li>• Sensor check Input check: FS-03-[ALL]OFF/[9]/[A]</li> <li>• Actuator check</li> <li>• Connector check (CN318)</li> <li>• Harness check</li> <li>• Replace the sensor.</li> </ul>
LGC board	<ul style="list-style-type: none"> <li>• PC board check</li> <li>• Connector check Bypass tray: CN321 1st drawer: CN317, CN316 2nd drawer: CN317, CN316 PFP, LCF: CN315</li> <li>• Harness check</li> <li>• Replace the PC board.</li> </ul>
Registration clutch	<ul style="list-style-type: none"> <li>• Check that the registration clutch is working. Output check: FS-03-108, 158</li> <li>• Connector check</li> <li>• Harness check</li> <li>• Replace the registration clutch.</li> </ul>
Drive section, rollers	Check the drive sections, gears and rollers. If they are worn out, deformed or have deteriorated, replace them.

Parts to be replaced	Remarks
Registration sensor	
LGC board	
Registration clutch	

**[ED10] Hole punch: Skew adjustment motor home position detection abnormality (Finisher, Saddle Stitch Finisher)**

Classification	Error content
Hole punch unit jam	The home position of the skew adjustment motor cannot be detected.

Check item	Measures
Skew adjustment mechanism	<ul style="list-style-type: none"> <li>• Check if there is any abnormality in the movement of the skew adjustment motor.</li> <li>• Check if there is any mechanical problem by moving it.</li> <li>• If there is any, correct it.</li> </ul>
Skew adjustment motor (M1)	<ul style="list-style-type: none"> <li>• Check that the motor is working.</li> <li>• Connector check (CN10)</li> <li>• Harness check</li> <li>• Replace the motor.</li> </ul>
Skew HP sensor (S2)	<ul style="list-style-type: none"> <li>• Sensor check</li> <li>• Actuator check</li> <li>• Connector check (CN10)</li> <li>• Harness check</li> <li>• Replace the sensor.</li> </ul>
Hole punch control PC board (HP)	<ul style="list-style-type: none"> <li>• PC board check</li> <li>• Connector check (CN10)</li> <li>• Harness check</li> <li>• Replace the PC board.</li> </ul>

Parts to be replaced	Remarks
Skew adjustment motor (M1)	
Skew HP sensor (S2)	
Hole punch control PC board (HP)	

**[ED11] Hole punch: Sideways deviation adjustment motor home position detection abnormality (Finisher, Saddle Stitch Finisher)**

Classification	Error content
Hole punch unit jam	The home position of the sideways deviation adjustment motor cannot be detected.

Check item	Measures
Sideways deviation adjustment mechanism	<ul style="list-style-type: none"> <li>• Check if there is any abnormality in the movement of the sideways deviation adjustment motor.</li> <li>• Check if there is any mechanical problem by moving it.</li> <li>• If there is any, correct it.</li> </ul>
Sideways deviation adjustment motor (M2)	<ul style="list-style-type: none"> <li>• Check that the motor is working.</li> <li>• Connector check (CN9)</li> <li>• Harness check</li> <li>• Replace the motor.</li> </ul>
Sideways deviation HP sensor (S3)	<ul style="list-style-type: none"> <li>• Sensor check</li> <li>• Actuator check</li> <li>• Connector check (CN8)</li> <li>• Harness check</li> <li>• Replace the sensor.</li> </ul>
Hole punch control PC board (HP)	<ul style="list-style-type: none"> <li>• PC board check</li> <li>• Connector check (CN8, CN9)</li> <li>• Harness check</li> <li>• Replace the PC board.</li> </ul>

Parts to be replaced	Remarks
Sideways deviation adjustment motor (M2)	
Sideways deviation HP sensor (S3)	
Hole punch control PC board (HP)	

**[ED13] Front alignment plate home position abnormality (Finisher, Saddle Stitch Finisher)**

Classification	Error content
Finisher jam Saddle stitch finisher jam	The home position of the front alignment plate cannot be detected.

Check item	Measures
Front alignment plate	<ul style="list-style-type: none"> <li>• Check if there is any abnormality in the movement of the front alignment plate.</li> <li>• Check if there is any mechanical problem by moving it.</li> <li>• If there is any, correct it.</li> </ul>
Front alignment plate home position sensor (S7)	<ul style="list-style-type: none"> <li>• Sensor check</li> <li>• Actuator check</li> <li>• Connector check (CN25)</li> <li>• Harness check</li> <li>• Replace the sensor.</li> </ul>
Front alignment motor (M5)	<ul style="list-style-type: none"> <li>• Check that the motor is working.</li> <li>• Connector check (CN18)</li> <li>• Harness check</li> <li>• Replace the motor.</li> </ul>
Finisher control PC board (FIN)	<ul style="list-style-type: none"> <li>• PC board check</li> <li>• Connector check (CN18, CN25)</li> <li>• Harness check</li> <li>• Replace the PC board.</li> </ul>

Parts to be replaced	Remarks
Front alignment plate home position sensor (S7)	
Front alignment motor (M5)	
Finisher control PC board (FIN)	

**[ED14] Rear alignment plate home position abnormality (Finisher, Saddle Stitch Finisher)**

Classification	Error content
Finisher jam Saddle stitch finisher jam	The home position of the rear alignment plate cannot be detected.

Check item	Measures
Rear alignment plate	<ul style="list-style-type: none"> <li>• Check if there is any abnormality in the movement of the rear alignment plate.</li> <li>• Check if there is any mechanical problem by moving it.</li> <li>• If there is any, correct it.</li> </ul>
Rear alignment plate home position sensor (S8)	<ul style="list-style-type: none"> <li>• Sensor check</li> <li>• Actuator check</li> <li>• Connector check (CN25)</li> <li>• Harness check</li> <li>• Replace the sensor.</li> </ul>
Rear alignment motor (M6)	<ul style="list-style-type: none"> <li>• Check that the motor is working.</li> <li>• Connector check (CN18)</li> <li>• Harness check</li> <li>• Replace the motor.</li> </ul>
Finisher control PC board (FIN)	<ul style="list-style-type: none"> <li>• PC board check</li> <li>• Connector check (CN18, CN25)</li> <li>• Harness check</li> <li>• Replace the PC board.</li> </ul>

Parts to be replaced	Remarks
Rear alignment plate home position sensor (S8)	
Rear alignment motor (M6)	
Finisher control PC board (FIN)	

### [ED15] Paddle home position abnormality (Finisher, Saddle Stitch Finisher)

Classification	Error content
Finisher jam Saddle stitch finisher jam	The home position of the paddle cannot be detected.

Check item	Measures
Paddle	<ul style="list-style-type: none"> <li>Check if there is any abnormality in the movement of the paddle.</li> <li>Check if there is any mechanical problem by rotating it.</li> <li>If there is any, correct it.</li> </ul>
Paddle home position sensor (S3)	<ul style="list-style-type: none"> <li>Sensor check</li> <li>Actuator check</li> <li>Connector check (CN15)</li> <li>Harness check</li> <li>Replace the sensor.</li> </ul>
Paddle motor (M3)	<ul style="list-style-type: none"> <li>Check that the motor is working.</li> <li>Connector check (CN16)</li> <li>Harness check</li> <li>Replace the motor.</li> </ul>
Finisher control PC board (FIN)	<ul style="list-style-type: none"> <li>PC board check</li> <li>Connector check (CN15, CN16)</li> <li>Harness check</li> <li>Replace the PC board.</li> </ul>

Parts to be replaced	Remarks
Paddle home position sensor (S3)	
Paddle motor (M3)	
Finisher control PC board (FIN)	

### [ED16] Buffer tray home position abnormality (Finisher, Saddle Stitch Finisher)

Classification	Error content
Finisher jam Saddle stitch finisher jam	The home position of the buffer tray cannot be detected.

Check item	Measures
Buffer tray guide	<ul style="list-style-type: none"> <li>Check if there is any abnormality in the movement of the buffer tray guide.</li> <li>Check if there is any mechanical problem by opening and closing it.</li> <li>If there is any, correct it.</li> </ul>
Buffer tray home position sensor (S5)	<ul style="list-style-type: none"> <li>Sensor check</li> <li>Actuator check</li> <li>Connector check (CN11)</li> <li>Harness check</li> <li>Replace the sensor.</li> </ul>
Assist guide motor (M10)	<ul style="list-style-type: none"> <li>Check that the motor is working.</li> <li>Connector check (CN10)</li> <li>Harness check</li> <li>Replace the motor.</li> </ul>
Buffer tray guide motor (M2)	<ul style="list-style-type: none"> <li>Check that the motor is working.</li> <li>Connector check (CN10)</li> <li>Harness check</li> <li>Replace the motor.</li> </ul>
Finisher control PC board (FIN)	<ul style="list-style-type: none"> <li>PC board check</li> <li>Connector check (CN10)</li> <li>Harness check</li> <li>Replace the PC board.</li> </ul>

Parts to be replaced	Remarks
Buffer tray home position sensor (S5)	
Assist guide motor (M10)	
Buffer tray guide motor (M2)	

Parts to be replaced	Remarks
Finisher control PC board (FIN)	

### [EF10] Saddle stitch setting of unsupported paper (Saddle Stitch Finisher)

Classification	Error content
Saddle stitch finisher jam	Unsupported paper size, type and an excess number of pages for stapling are selected.

Check item	Measures
Paper	Check the paper size, type and number of pages for stapling. Change the settings to the supported ones.

### [EF11] Front saddle stitch stapling jam (Saddle Stitch Finisher)

Classification	Error content
Saddle stitch finisher jam	Front stapling is not correctly done.

Check item	Measures
Paper	Use the paper specified in the specifications if a type outside of the range is selected.
Staple cartridge of the saddle stitch (front side)	Remove the staple sheet slid from the staple case.
Front saddle stitch stapler drive unit	<ul style="list-style-type: none"> <li>• Check if there is any abnormality in the movement of the drive unit.</li> <li>• Check if there is any mechanical problem by moving it.</li> <li>• If there is any, correct it.</li> <li>• Connector check</li> <li>• Harness check</li> </ul>
Saddle control PC board (SDL)	<ul style="list-style-type: none"> <li>• PC board check</li> <li>• Connector check (CN2)</li> <li>• Harness check</li> <li>• Replace the PC board.</li> </ul>

Parts to be replaced	Remarks
Saddle control PC board (SDL)	

### [EF12] Rear saddle stitch stapling jam (Saddle Stitch Finisher)

Classification	Error content
Saddle stitch finisher jam	Rear stapling is not correctly done.

Check item	Measures
Paper	Use the paper specified in the specifications if a type outside of the range is selected.
Staple cartridge of the saddle stitch (rear side)	Remove the staple sheet slid from the staple case.
Rear saddle stitch stapler drive unit	<ul style="list-style-type: none"> <li>• Check if there is any abnormality in the movement of the drive unit.</li> <li>• Check if there is any mechanical problem by moving it.</li> <li>• If there is any, correct it.</li> <li>• Connector check</li> <li>• Harness check</li> </ul>
Saddle control PC board (SDL)	<ul style="list-style-type: none"> <li>• PC board check</li> <li>• Connector check (CN1)</li> <li>• Harness check</li> <li>• Replace the PC board.</li> </ul>

Parts to be replaced	Remarks
Saddle control PC board (SDL)	



### [EF13] Saddle stitch paper holding home position abnormality (Saddle Stitch Finisher)

Classification	Error content
Saddle stitch finisher jam	The home position of the paper holding cannot be detected.

Check item	Measures
Paper holding cam	<ul style="list-style-type: none"> <li>• Check if there is any abnormality in the movement of the cam.</li> <li>• Check if there is any mechanical problem by rotating it.</li> <li>• If there is any, correct it.</li> </ul>
Paper holding home position sensor (S38)	<ul style="list-style-type: none"> <li>• Sensor check</li> <li>• Actuator check</li> <li>• Connector check (CN5)</li> <li>• Harness check</li> <li>• Replace the sensor.</li> </ul>
Paper holding clutch (CLT4)	<ul style="list-style-type: none"> <li>• Check that the clutch is working.</li> <li>• Connector check (CN5)</li> <li>• Harness check</li> <li>• Replace the clutch.</li> </ul>
Saddle transport motor (M16)	<ul style="list-style-type: none"> <li>• Check that the motor is working.</li> <li>• Connector check (CN5)</li> <li>• Harness check</li> <li>• Replace the motor.</li> </ul>
Saddle control PC board (SDL)	<ul style="list-style-type: none"> <li>• PC board check</li> <li>• Connector check (CN5)</li> <li>• Harness check</li> <li>• Replace the PC board.</li> </ul>

Parts to be replaced	Remarks
Paper holding home position sensor (S38)	
Paper holding clutch (CLT4)	
Saddle transport motor (M16)	
Saddle control PC board (SDL)	

### [EF14] Saddle stitch paper ejection jam (Saddle Stitch Finisher)

Classification	Error content
Saddle stitch finisher jam	Paper ejection is not completed within a fixed time.

Check item	Measures
Ejection sensor (S31)	<ul style="list-style-type: none"> <li>• Sensor check</li> <li>• Actuator check</li> <li>• Connector check (CN7)</li> <li>• Harness check</li> <li>• Replace the sensor.</li> </ul>
Saddle control PC board (SDL)	<ul style="list-style-type: none"> <li>• PC board check</li> <li>• Connector check (CN6, CN7)</li> <li>• Harness check</li> <li>• Replace the PC board.</li> </ul>
Finisher control PC board (FIN)	<ul style="list-style-type: none"> <li>• PC board check</li> <li>• Connector check (CN21)</li> <li>• Harness check</li> <li>• Replace the PC board.</li> </ul>

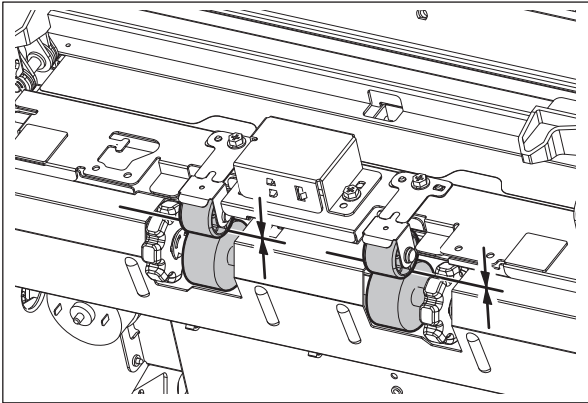
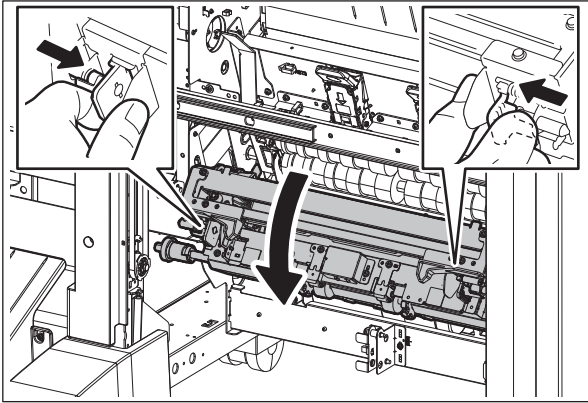
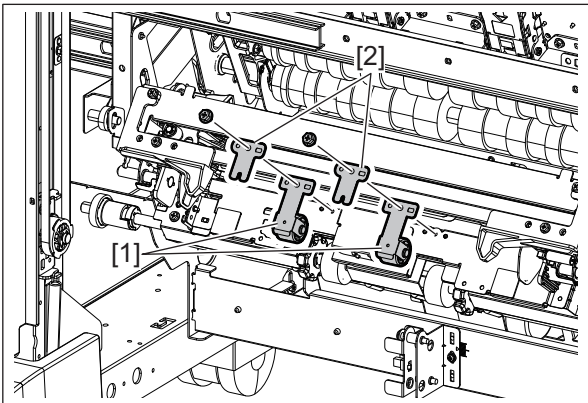
Check item	Measures
<p>Leaf springs and the assist leaf springs of the transport pinch roller (for the saddle)</p>	<ul style="list-style-type: none"> <li>Check if there is any gap between the ejection roller (for the saddle) and the ejection pinch roller (for the saddle). If there is, replace the leaf springs and the assist leaf springs of the ejection pinch roller (for the saddle).</li> </ul>  <p><b>Fig.8-7</b></p> <ul style="list-style-type: none"> <li>Check if the leaf springs [1] and the assist leaf springs [2] of the ejection pinch roller (for the saddle) are deformed. In order to confirm that there is no warpage or deformation on the leaf springs and the assist leaf springs of the ejection pinch roller (for the saddle), remove them and put them on a flat place. If they are warped or deformed, replace them.</li> <li>For the removal procedure of the leaf springs [1] and the assist leaf springs [2], refer to the following figures.</li> </ul>  <p><b>Fig.8-8</b></p>  <p><b>Fig.8-9</b></p>

Check item	Measures
<p>Leaf springs and the assist leaf springs of the transport pinch roller (for the saddle)</p>	<div data-bbox="611 157 1201 561" style="border: 1px solid black; padding: 10px; margin-bottom: 10px;"> </div> <p data-bbox="587 583 671 608"><b>Fig.8-10</b></p> <p data-bbox="627 644 703 670"><b>Notes:</b></p> <p data-bbox="663 672 1390 753">In order to confirm that there is no warpage or deformation on the leaf springs and the assist leaf springs of the ejection pinch roller (for the saddle), remove them and put them on a flat place.</p> <div data-bbox="611 780 1201 1185" style="border: 1px solid black; padding: 10px; margin-bottom: 10px;"> </div> <p data-bbox="587 1206 671 1232"><b>Fig.8-11</b></p> <div data-bbox="611 1293 1201 1698" style="border: 1px solid black; padding: 10px;"> </div> <p data-bbox="587 1719 671 1744"><b>Fig.8-12</b></p>

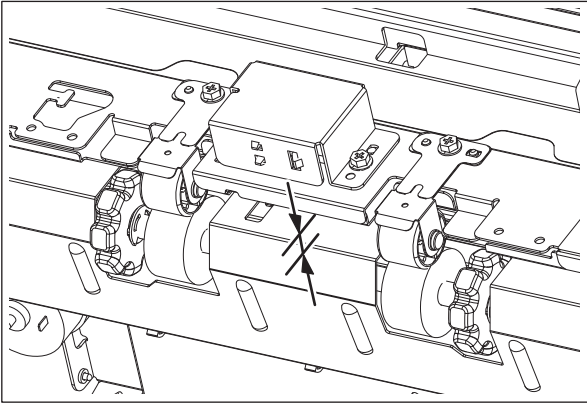
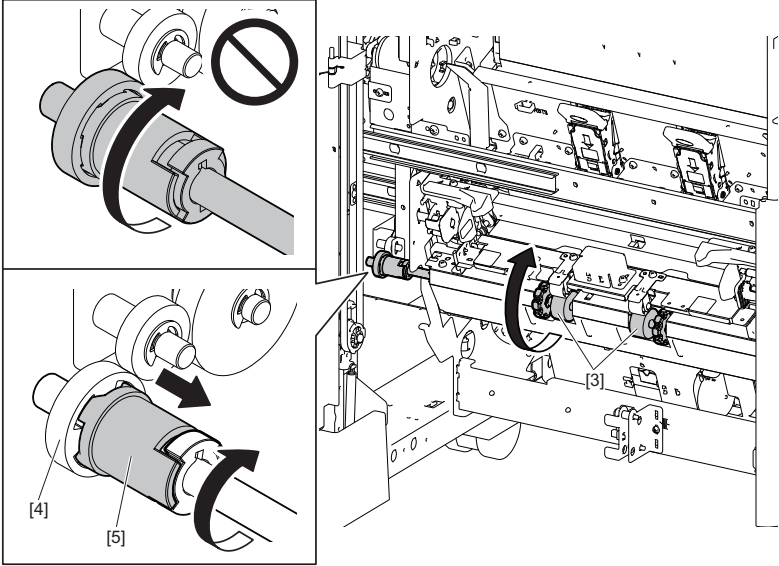
Check item	Measures
Lower ejection guide	<p>Check that the gap of the lower ejection guide is 15 mm or below. If the gap is larger than 15 mm, check the attachment condition or replace the lower ejection guide.</p>  <p><b>Fig.8-13</b></p>
Ejection roller (for the saddle)	<ul style="list-style-type: none"> <li>Check the engagement status of the gear [4] by rotating the ejection roller [3] (for the saddle) in the direction of the arrow (opposite direction of the exiting).  When not good: The gear [4] rotates without having been engaged. (The ratchet [5] does not rotate.)  When OK: The ratchet [5] rotates while sliding, but the gear [4] is stopped. (The gear [4] is engaged.)</li> </ul>  <p><b>Fig.8-14</b></p>

Check item	Measures
Ejection roller (for the saddle)	<ul style="list-style-type: none"> <li data-bbox="587 136 1390 242">In the case of “not good”, replace the bracket [7] at the idle gear [6] side. When replacing, check the position where the pre-change bracket [7] is attached and add its marking in order to install the post-change one in the same place.</li> </ul> <p data-bbox="587 697 671 725"><b>Fig.8-15</b></p> <p data-bbox="624 755 1129 783">Follow the figures below to remove the bracket.</p> <p data-bbox="587 1240 671 1268"><b>Fig.8-16</b></p> <p data-bbox="587 1753 671 1781"><b>Fig.8-17</b></p>

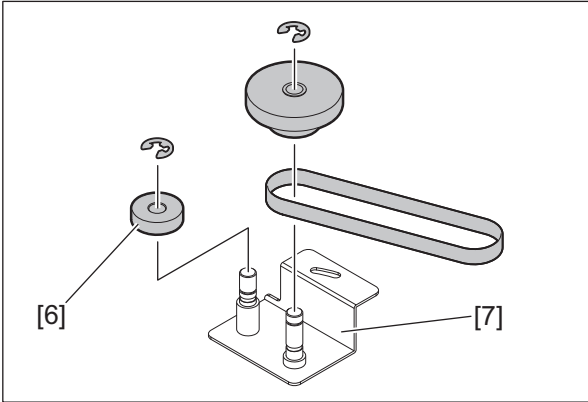
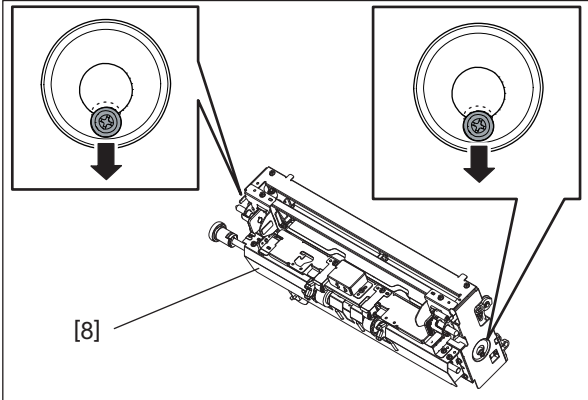
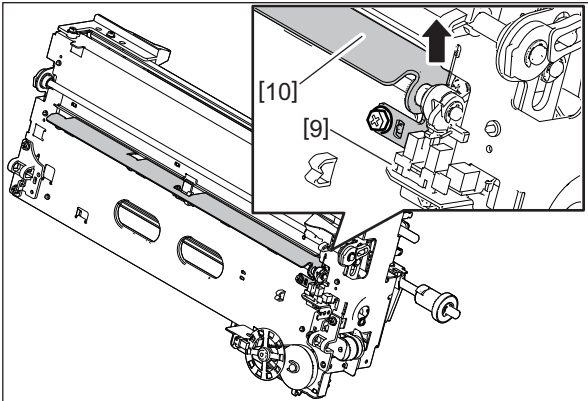
Check item	Measures
Ejection roller (for the saddle)	 <p><b>Fig.8-18</b></p>
Additional folding unit	<ul style="list-style-type: none"> <li>• Correct the misalignment of the shaft of the additional folding unit [8]. Move the screws in the direction of the arrow and secure them. (both the front and rear)</li> </ul>  <p><b>Fig.8-19</b></p> <ul style="list-style-type: none"> <li>• Replace the following parts. <ul style="list-style-type: none"> <li>- BRIR-ROD-EX-F-SDL-F5330</li> <li>- PLT-BURR-ROD-EX-F-SDL</li> <li>- ASYS-PLT3-FILM3-EFS</li> <li>- FILM4-EFS</li> </ul> </li> <li>• Check if there is a disconnection of the connector, incorrect installation or breakage of the ejection transport sensor (S41) [9]. If there is, reinstall the sensor correctly or replace it. Move the bracket [10] in the direction of the arrow and secure it with the screw.</li> </ul>  <p><b>Fig.8-20</b></p>

Parts to be replaced	Remarks
Ejection sensor (S31)	
Saddle control PC board (SDL)	
Finisher control PC board (FIN)	
Lower ejection guide	

### [EF15] Saddle stitch side alignment plate home position sensor abnormality (Saddle Stitch Finisher)

Classification	Error content
Saddle stitch finisher jam	The home position of the jog cannot be detected.

Check item	Measures
Jog	<ul style="list-style-type: none"> <li>Check if there is any abnormality in the movement of the jog.</li> <li>Check if there is any mechanical problem by moving it.</li> <li>If there is any, correct it.</li> </ul>
Side alignment plate home position sensor (S36)	<ul style="list-style-type: none"> <li>Sensor check</li> <li>Actuator check</li> <li>Connector check (CN4)</li> <li>Harness check</li> <li>Replace the sensor.</li> </ul>
Side alignment motor (M15)	<ul style="list-style-type: none"> <li>Check that the motor is working.</li> <li>Connector check (CN4)</li> <li>Harness check</li> <li>Replace the motor.</li> </ul>
Saddle control PC board (SDL)	<ul style="list-style-type: none"> <li>PC board check</li> <li>Connector check (CN4)</li> <li>Harness check</li> <li>Replace the PC board.</li> </ul>

Parts to be replaced	Remarks
Side alignment plate home position sensor (S36)	
Side alignment motor (M15)	
Saddle control PC board (SDL)	

### [EF16] Saddle stitch stacker motor home position abnormality (Saddle Stitch Finisher)

Classification	Error content
Saddle stitch finisher jam	The home position of the stacker carrier cannot be detected.

Check item	Measures
Stacker carrier	<ul style="list-style-type: none"> <li>Check if there is any abnormality in the movement of the stacker carrier.</li> <li>Check if there is any mechanical problem by moving it.</li> <li>If there is any, correct it.</li> </ul>
Stacker home position sensor (S33)	<ul style="list-style-type: none"> <li>Sensor check</li> <li>Actuator check</li> <li>Connector check (CN8)</li> <li>Harness check</li> <li>Replace the sensor.</li> </ul>
Stacker motor (M14)	<ul style="list-style-type: none"> <li>Check that the motor is working.</li> <li>Connector check (CN8)</li> <li>Harness check</li> <li>Replace the motor.</li> </ul>
Saddle control PC board (SDL)	<ul style="list-style-type: none"> <li>PC board check</li> <li>Connector check (CN8)</li> <li>Harness check</li> <li>Replace the PC board.</li> </ul>

Parts to be replaced	Remarks
Stacker home position sensor (S33)	

Parts to be replaced	Remarks
Stacker motor (M14)	
Saddle control PC board (SDL)	

### [EF17] Saddle stitch folding blade home position abnormality (Saddle Stitch Finisher)

Classification	Error content
Saddle stitch finisher jam	The home position of the folding blade cam cannot be detected.

Check item	Measures
Folding blade cam	<ul style="list-style-type: none"> <li>• Check if there is any abnormality in the movement of the folding blade cam.</li> <li>• Check if there is any mechanical problem by moving it.</li> <li>• If there is any, correct it.</li> </ul>
Folding blade home position sensor (S35)	<ul style="list-style-type: none"> <li>• Sensor check</li> <li>• Actuator check</li> <li>• Connector check (CN12)</li> <li>• Harness check</li> <li>• Replace the sensor.</li> </ul>
Folding motor (M17)	<ul style="list-style-type: none"> <li>• Check that the motor is working.</li> <li>• Connector check (CN9)</li> <li>• Harness check</li> <li>• Replace the motor.</li> </ul>
Folding blade clutch (CLT3)	<ul style="list-style-type: none"> <li>• Check that the clutch is working.</li> <li>• Connector check (CN13)</li> <li>• Harness check</li> <li>• Replace the clutch.</li> </ul>
Saddle control PC board (SDL)	<ul style="list-style-type: none"> <li>• PC board check</li> <li>• Connector check (CN9, CN12, CN13)</li> <li>• Harness check</li> <li>• Replace the PC board.</li> </ul>

Parts to be replaced	Remarks
Folding blade home position sensor (S35)	
Folding motor (M17)	
Folding blade clutch (CLT3)	
Saddle control PC board (SDL)	

### [EF18] Saddle stitch additional folding roller home position abnormality (Saddle Stitch Finisher)

Classification	Error content
Saddle stitch finisher jam	The home position of the additional folding roller cannot be detected.

Check item	Measures
Additional folding carrier	<ul style="list-style-type: none"> <li>• Check if there is any abnormality in the movement of the additional folding carrier.</li> <li>• Check if there is any mechanical problem by moving it.</li> <li>• If there is any, correct it.</li> </ul>
Additional folding home position sensor (S39)	<ul style="list-style-type: none"> <li>• Sensor check</li> <li>• Actuator check</li> <li>• Connector check (CN7)</li> <li>• Harness check</li> <li>• Replace the sensor.</li> </ul>
Additional folding motor encoder sensor (S42)	<ul style="list-style-type: none"> <li>• Sensor check</li> <li>• Actuator check</li> <li>• Connector check (CN7)</li> <li>• Harness check</li> <li>• Replace the sensor.</li> </ul>
Additional folding motor (M20)	<ul style="list-style-type: none"> <li>• Check that the motor is working.</li> <li>• Connector check (CN10)</li> <li>• Harness check</li> <li>• Replace the motor.</li> </ul>



Check item	Measures
Saddle control PC board (SDL)	<ul style="list-style-type: none"> <li>• PC board check</li> <li>• Connector check (CN7, CN10)</li> <li>• Harness check</li> <li>• Replace the PC board.</li> </ul>

Parts to be replaced	Remarks
Additional folding home position sensor (S39)	
Additional folding motor encoder sensor (S42)	
Additional folding motor (M20)	
Saddle control PC board (SDL)	

### [EF19] Saddle stitch paper folding jam (Saddle Stitch Finisher)

Classification	Error content
Saddle stitch finisher jam	Fold processed paper cannot be transported to the additional folding roller.

Check item	Measures
Paper	Use the paper specified in the specifications if a type outside of the range is selected.
Ejection transport sensor (S41)	<ul style="list-style-type: none"> <li>• Sensor check</li> <li>• Actuator check</li> <li>• Connector check (CN7)</li> <li>• Harness check</li> <li>• Replace the sensor.</li> </ul>
Saddle control PC board (SDL)	<ul style="list-style-type: none"> <li>• PC board check</li> <li>• Connector check (CN6, CN7)</li> <li>• Harness check</li> <li>• Replace the PC board.</li> </ul>
Finisher control PC board (FIN)	<ul style="list-style-type: none"> <li>• PC board check</li> <li>• Connector check (CN21)</li> <li>• Harness check</li> <li>• Replace the PC board.</li> </ul>

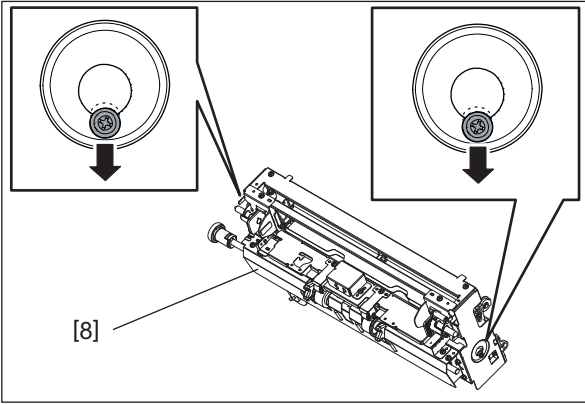
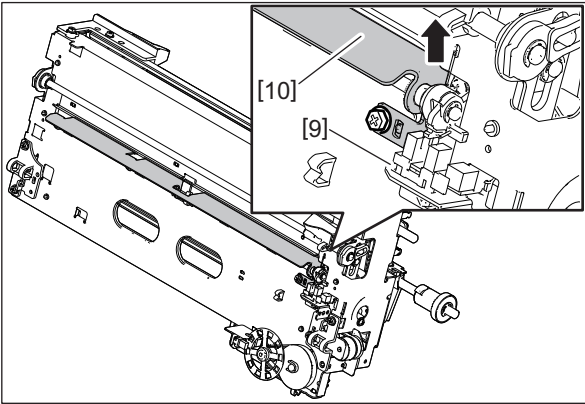
Check item	Measures
Additional folding unit	<ul style="list-style-type: none"> <li>Correct the misalignment of the shaft of the additional folding unit [8]. Move the screws in the direction of the arrow and secure them. (both the front and rear)</li> </ul>  <p><b>Fig.8-21</b></p> <ul style="list-style-type: none"> <li>Replace the following parts. <ul style="list-style-type: none"> <li>BRIR-ROD-EX-F-SDL-F5330</li> <li>PLT-BURR-ROD-EX-F-SDL</li> <li>ASYS-PLT3-FILM3-EFS</li> <li>FILM4-EFS</li> </ul> </li> <li>Check if there is a disconnection of the connector, incorrect installation or breakage of the ejection transport sensor (S41) [9]. If there is, reinstall the sensor correctly or replace it. Move the bracket [10] in the direction of the arrow and secure it with the screw.</li> </ul>  <p><b>Fig.8-22</b></p>

Parts to be replaced	Remarks
Ejection transport sensor (S41)	
Saddle control PC board (SDL)	
Finisher control PC board (FIN)	

### [EF20] Saddle stitch stacker jam (Saddle Stitch Finisher)

Classification	Error content
Saddle stitch finisher jam	Transported paper cannot be detected in the stacker paper detection sensor.

Check item	Measures
Paper	Use the paper specified in the specifications if a type outside of the range is selected.

Check item	Measures
Stacker paper detection sensor (S30)	<ul style="list-style-type: none"> <li>• Sensor check</li> <li>• Actuator check</li> <li>• Connector check (CN3)</li> <li>• Harness check</li> <li>• Replace the sensor.</li> </ul>
Saddle control PC board (SDL)	<ul style="list-style-type: none"> <li>• PC board check</li> <li>• Connector check (CN3, CN6)</li> <li>• Harness check</li> <li>• Replace the PC board.</li> </ul>
Finisher control PC board (FIN)	<ul style="list-style-type: none"> <li>• PC board check</li> <li>• Connector check (CN21)</li> <li>• Harness check</li> <li>• Replace the PC board.</li> </ul>

Parts to be replaced	Remarks
Stacker paper detection sensor (S30)	
Saddle control PC board (SDL)	
Finisher control PC board (FIN)	

### [EF21] Hole punch: Paper leading edge skew detection abnormality (Finisher, Saddle Stitch Finisher)

Classification	Error content
Hole punch unit jam	One of the two skew sensors cannot detect paper within a specified time.

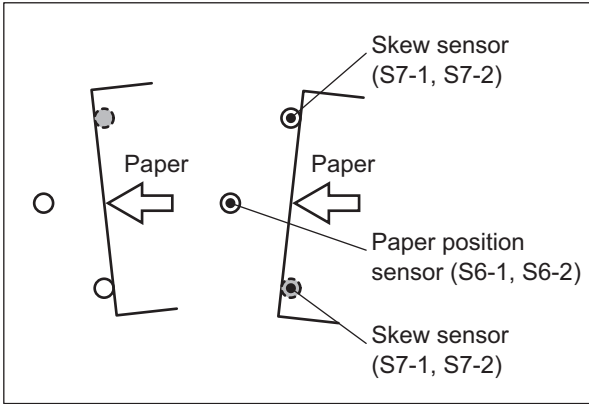
Check item	Measures
Paper	<p>When the paper is stopped at the position in the figure, perform troubleshooting for the paper folding.</p>  <p><b>Fig.8-23</b></p>
Skew sensors (S7-1, S7-2)	<ul style="list-style-type: none"> <li>• Sensor check</li> <li>• Connector check (CN6, CN7)</li> <li>• Harness check</li> <li>• Replace the sensor.</li> </ul>
Hole punch control PC board (HP)	<ul style="list-style-type: none"> <li>• PC board check</li> <li>• Connector check (CN4, CN6, CN7)</li> <li>• Harness check</li> <li>• Replace the PC board.</li> </ul>

Parts to be replaced	Remarks
Skew sensors (S7-1, S7-2)	
Hole punch control PC board (HP)	

**[EF22] Hole punch: Paper leading edge detection abnormality (Finisher, Saddle Stitch Finisher)**

Classification	Error content
Hole punch unit jam	The leading edge of the paper cannot be detected within a specified time after its skewing was detected.

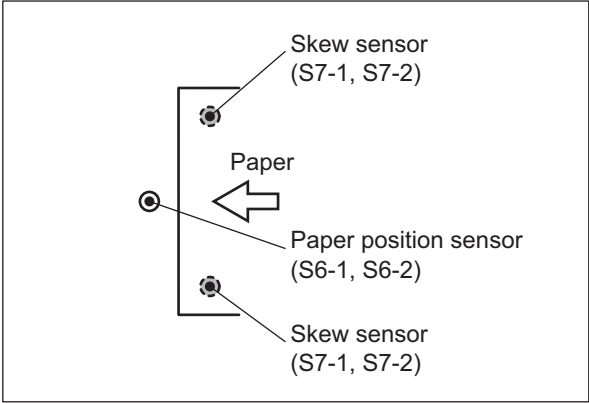
Check item	Measures
Paper	<p>When the paper is stopped at the position in the figure, perform troubleshooting for the paper folding.</p>  <p><b>Fig.8-24</b></p>
Paper position sensors (S6-1, S6-2)	<ul style="list-style-type: none"> <li>• Sensor check</li> <li>• Connector check (CN1, CN2)</li> <li>• Harness check</li> <li>• Replace the sensor.</li> </ul>
Hole punch control PC board (HP)	<ul style="list-style-type: none"> <li>• PC board check</li> <li>• Connector check (CN1, CN2, CN4)</li> <li>• Harness check</li> <li>• Replace the PC board.</li> </ul>

Parts to be replaced	Remarks
Paper position sensors (S6-1, S6-2)	
Hole punch control PC board (HP)	

**[EF23] Hole punch: Paper position alignment abnormality (Finisher, Saddle Stitch Finisher)**

Classification	Error content
Hole punch unit jam	The position of the paper cannot be detected by the sideways deviation mechanism.

Check item	Measures
Sideways deviation adjustment motor (M2)	<ul style="list-style-type: none"> <li>• Check that the motor is working.</li> <li>• Connector check (CN9)</li> <li>• Harness check</li> <li>• Replace the motor.</li> </ul>
Sideways deviation HP sensor (S3)	<ul style="list-style-type: none"> <li>• Sensor check</li> <li>• Actuator check</li> <li>• Connector check (CN8)</li> <li>• Harness check</li> <li>• Replace the sensor.</li> </ul>
Paper position sensors (S6-1, S6-2)	<ul style="list-style-type: none"> <li>• Sensor check</li> <li>• Connector check (CN1, CN2)</li> <li>• Harness check</li> <li>• Replace the sensor.</li> </ul>
Hole punch control PC board (HP)	<ul style="list-style-type: none"> <li>• PC board check</li> <li>• Connector check (CN1, CN2, CN4, CN8, CN9)</li> <li>• Harness check</li> <li>• Replace the PC board.</li> </ul>

Parts to be replaced	Remarks
Sideways deviation adjustment motor (M2)	
Sideways deviation HP sensor (S3)	
Paper position sensors (S6-1, S6-2)	
Hole punch control PC board (HP)	

**[EF24] Hole punch: Paper trailing edge skew detection abnormality (Finisher, Saddle Stitch Finisher)**

Classification	Error content
Hole punch unit jam	One of the two skew sensors cannot detect paper within a specified time.

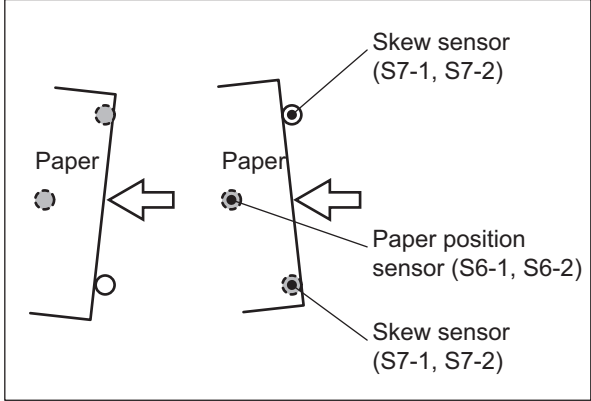
Check item	Measures
Paper	<p>When the paper is stopped at the position in the figure, perform troubleshooting for the paper folding.</p>  <p><b>Fig.8-25</b></p>
Skew sensors (S7-1, S7-2)	<ul style="list-style-type: none"> <li>• Sensor check</li> <li>• Connector check (CN6, CN7)</li> <li>• Harness check</li> <li>• Replace the sensor.</li> </ul>
Hole punch control PC board (HP)	<ul style="list-style-type: none"> <li>• PC board check</li> <li>• Connector check (CN4, CN6, CN7)</li> <li>• Harness check</li> <li>• Replace the PC board.</li> </ul>

Parts to be replaced	Remarks
Skew sensors (S7-1, S7-2)	
Hole punch control PC board (HP)	

**[EF25] Hole punch: Paper trailing edge detection abnormality (Finisher, Saddle Stitch Finisher)**

Classification	Error content
Hole punch unit jam	The trailing edge of the paper cannot be detected within a specified time after its skewing was detected.

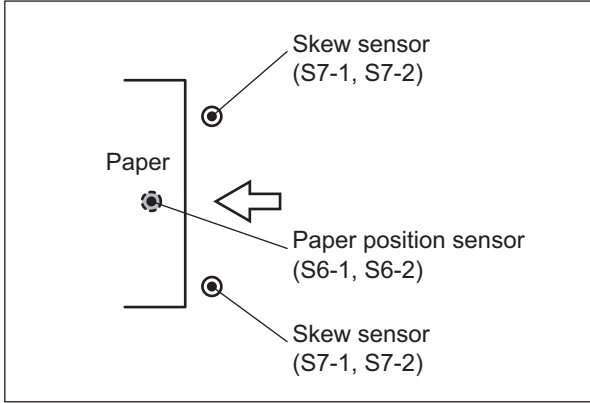
Check item	Measures
Paper	<ul style="list-style-type: none"> <li>When the paper is stopped at the position in the figure, perform troubleshooting for the paper folding.</li> </ul>  <p><b>Fig.8-26</b></p> <ul style="list-style-type: none"> <li>If paper dusts or punch wastes are adhering on the paper position sensors (S6-1, S6-2), remove them.</li> </ul>
Paper position sensors (S6-1, S6-2)	<ul style="list-style-type: none"> <li>Sensor check</li> <li>Connector check (CN1, CN2)</li> <li>Harness check</li> <li>Replace the sensor.</li> </ul>
Hole punch control PC board (HP)	<ul style="list-style-type: none"> <li>PC board check</li> <li>Connector check (CN1, CN2, CN4)</li> <li>Harness check</li> <li>Replace the PC board.</li> </ul>

Parts to be replaced	Remarks
Paper position sensors (S6-1, S6-2)	
Hole punch control PC board (HP)	

**[EF27] Hole punch: Paper edge detection abnormality 1 (Finisher, Saddle Stitch Finisher)**

Classification	Error content
Hole punch unit jam	The leading edge of the paper is detected before the paper leading edge skew detection.

Check item	Measures
Skew sensors (S7-1, S7-2)	<ul style="list-style-type: none"> <li>Sensor check</li> <li>Connector check (CN6, CN7)</li> <li>Harness check</li> <li>Replace the sensor.</li> </ul>
Hole punch control PC board (HP)	<ul style="list-style-type: none"> <li>PC board check</li> <li>Connector check (CN4, CN6, CN7)</li> <li>Harness check</li> <li>Replace the PC board.</li> </ul>

Parts to be replaced	Remarks
Skew sensors (S7-1, S7-2)	
Hole punch control PC board (HP)	

**[EF28] Hole punch: Paper edge detection abnormality 2 (Finisher, Saddle Stitch Finisher)**

Classification	Error content
Hole punch unit jam	The trailing edge of the paper is detected before the paper trailing edge skew detection.

Check item	Measures
Skew sensors (S7-1, S7-2)	<ul style="list-style-type: none"> <li>• Sensor check</li> <li>• Connector check (CN6, CN7)</li> <li>• Harness check</li> <li>• Replace the sensor.</li> </ul>
Hole punch control PC board (HP)	<ul style="list-style-type: none"> <li>• PC board check</li> <li>• Connector check (CN4, CN6, CN7)</li> <li>• Harness check</li> <li>• Replace the PC board.</li> </ul>

Parts to be replaced	Remarks
Skew sensors (S7-1, S7-2)	
Hole punch control PC board (HP)	

**[EF29] Hole punch: Required performance abnormality (Finisher, Saddle Stitch Finisher)**

Classification	Error content
Hole punch unit jam	A performance which is required cannot be executed.

Check item	Measures
Setting	Check if the conditions of the paper size, paper weight and paper type are appropriate for hole punching. If not, change the setting.
Hole punch control PC board (HP)	<ul style="list-style-type: none"> <li>• PC board check</li> <li>• Connector check (CN6, CN14)</li> <li>• Harness check</li> <li>• Replace the PC board.</li> </ul>

Parts to be replaced	Remarks
-	

### 8.3.3 Service call (C series errors)

#### [C010] Main motor abnormality

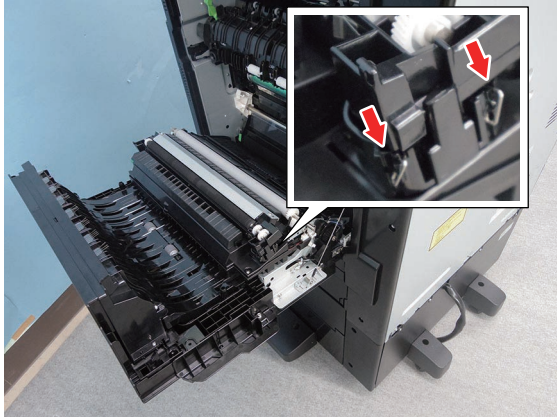
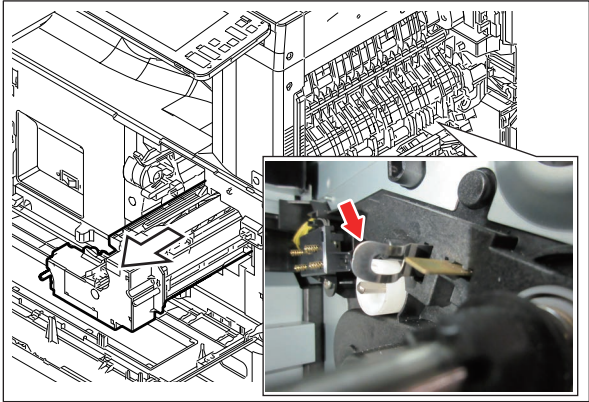
Classification	Error content
Motor abnormality	The main motor does not work normally.
Check item	Measures
Main motor	<ul style="list-style-type: none"> <li>• Check that the motor is working. Output check: FS-03-101, 151</li> <li>• Connector check (CN308)</li> <li>• Harness check</li> <li>• Replace the motor.</li> </ul>
LGC board	<ul style="list-style-type: none"> <li>• PC board check</li> <li>• Connector check (CN308)</li> <li>• Harness check</li> <li>• Replace the PC board.</li> </ul>
Spring of the high-voltage supply	<ul style="list-style-type: none"> <li>• If the power supply spring for the transferring and separation is removed, attach it correctly.</li> </ul>  <p><b>Fig.8-27</b></p> <ul style="list-style-type: none"> <li>• If the power supply spring for the main charger is deformed, replace it.</li> </ul>  <p><b>Fig.8-28</b></p>
Process unit	Turn the gear of the process unit manually. If not, replace the process unit.
Fuser unit	Release the pressure lever and turn the gear of the fuser unit manually. If not, replace the fuser unit.
Parts to be replaced	Remarks
Main motor	
LGC board	
Spring of the high-voltage supply	



Parts to be replaced	Remarks
Process unit	
Fuser unit	

#### [C040] PFP motor abnormality

Classification	Error content
Motor abnormality	The PFP motor does not work normally.

Check item	Measures
PFP motor	<ul style="list-style-type: none"> <li>Check that the motor is working. Output check: FS-03-109, 159</li> <li>Connector check</li> <li>Harness check</li> <li>Replace the motor.</li> </ul>
LGC board	<ul style="list-style-type: none"> <li>PC board check</li> <li>Connector check (CN315)</li> <li>Harness check</li> <li>Replace the PC board.</li> </ul>
PFP board	<ul style="list-style-type: none"> <li>PC board check</li> <li>Connector check</li> <li>Harness check</li> <li>Replace the PC board.</li> </ul>

Parts to be replaced	Remarks
PFP motor	
LGC board	
PFP board	

#### [C130] 1st drawer tray abnormality

Classification	Error content
Motor abnormality	The 1st drawer tray-up motor or the 1st drawer tray does not work normally.

Check item	Measures
1st drawer tray-up motor	<ul style="list-style-type: none"> <li>Check that the motor is working. Output check: FS-03-242</li> <li>Connector check (CN318)</li> <li>Harness check</li> <li>Replace the motor.</li> </ul>
1st drawer tray-up sensor	<ul style="list-style-type: none"> <li>Sensor check Input check: FS-03-[ALL]OFF/[0]/[E]</li> <li>Actuator check</li> <li>Connector check (CN316)</li> <li>Harness check</li> <li>Replace the sensor.</li> </ul>
LGC board	<ul style="list-style-type: none"> <li>PC board check</li> <li>Connector check (CN316, CN318)</li> <li>Harness check</li> <li>Replace the PC board.</li> </ul>

Parts to be replaced	Remarks
1st drawer tray-up motor	
1st drawer tray-up sensor	
LGC board	

**[C140] 2nd drawer tray abnormality**

Classification	Error content
Motor abnormality	The 2nd drawer tray-up motor or the 2nd drawer tray does not work normally.

Check item	Measures
2nd drawer tray-up motor	<ul style="list-style-type: none"> <li>• Check that the motor is working. Output check: FS-03-243</li> <li>• Connector check (CN318)</li> <li>• Harness check</li> <li>• Replace the motor.</li> </ul>
2nd drawer tray-up sensor	<ul style="list-style-type: none"> <li>• Sensor check Input check: FS-03-[F2]ON/[4]/[E]</li> <li>• Actuator check</li> <li>• Connector check (CN316)</li> <li>• Harness check</li> <li>• Replace the sensor.</li> </ul>
LGC board	<ul style="list-style-type: none"> <li>• PC board check</li> <li>• Connector check (CN316, CN318)</li> <li>• Harness check</li> <li>• Replace the PC board.</li> </ul>

Parts to be replaced	Remarks
2nd drawer tray-up motor	
2nd drawer tray-up sensor	
LGC board	

**[C150] 3rd drawer tray abnormality**

Classification	Error content
Motor abnormality	The 3rd drawer tray-up motor or the 3rd drawer tray does not work normally.

Check item	Measures
3rd drawer tray-up motor	<ul style="list-style-type: none"> <li>• Check that the motor is working. Output check: FS-03-278</li> <li>• Connector check</li> <li>• Harness check</li> <li>• Replace the motor.</li> </ul>
3rd drawer tray-up sensor	<ul style="list-style-type: none"> <li>• Sensor check Input check: FS-03-[F1]ON/[5]/[A]</li> <li>• Actuator check</li> <li>• Connector check</li> <li>• Harness check</li> <li>• Replace the sensor.</li> </ul>
LGC board	<ul style="list-style-type: none"> <li>• PC board check</li> <li>• Connector check (CN315)</li> <li>• Harness check</li> <li>• Replace the PC board.</li> </ul>
PFP board	<ul style="list-style-type: none"> <li>• PC board check</li> <li>• Connector check</li> <li>• Harness check</li> <li>• Replace the PC board.</li> </ul>

Parts to be replaced	Remarks
3rd drawer tray-up motor	
3rd drawer tray-up sensor	
LGC board	
PFP board	

**[C160] 4th drawer tray abnormality**

Classification	Error content
Motor abnormality	The 4th drawer tray-up motor or the 4th drawer tray does not work normally.

Check item	Measures
4th drawer tray-up motor	<ul style="list-style-type: none"> <li>• Check that the motor is working. Output check: FS-03-280</li> <li>• Connector check</li> <li>• Harness check</li> <li>• Replace the motor.</li> </ul>
4th drawer tray-up sensor	<ul style="list-style-type: none"> <li>• Sensor check Input check: FS-03-[F1]ON/[5]/[E]</li> <li>• Actuator check</li> <li>• Connector check</li> <li>• Harness check</li> <li>• Replace the sensor.</li> </ul>
LGC board	<ul style="list-style-type: none"> <li>• PC board check</li> <li>• Connector check (CN315)</li> <li>• Harness check</li> <li>• Replace the PC board.</li> </ul>
PFP board	<ul style="list-style-type: none"> <li>• PC board check</li> <li>• Connector check</li> <li>• Harness check</li> <li>• Replace the PC board.</li> </ul>

Parts to be replaced	Remarks
4th drawer tray-up motor	
4th drawer tray-up sensor	
LGC board	
PFP board	

**[C180] T-LCF tray abnormality**

Classification	Error content
Motor abnormality	The T-LCF tray-up motor or the T-LCF tray does not work normally.

Check item	Measures
T-LCF tray-up motor	<ul style="list-style-type: none"> <li>• Check that the motor is working. Output check: FS-03-271</li> <li>• Connector check</li> <li>• Harness check</li> <li>• Replace the motor.</li> </ul>
T-LCF tray-up sensor	<ul style="list-style-type: none"> <li>• Sensor check Input check: FS-03-[F1]ON/[8]/[A]</li> <li>• Actuator check</li> <li>• Connector check</li> <li>• Harness check</li> <li>• Replace the sensor.</li> </ul>
T-LCF paper feeding side bottom sensor	<ul style="list-style-type: none"> <li>• Sensor check Input check: FS-03-[F1]ON/[8]/[E]</li> <li>• Actuator check</li> <li>• Connector check</li> <li>• Harness check</li> <li>• Replace the sensor.</li> </ul>
LGC board	<ul style="list-style-type: none"> <li>• PC board check</li> <li>• Connector check (CN315)</li> <li>• Harness check</li> <li>• Replace the PC board.</li> </ul>
T-LCF board	<ul style="list-style-type: none"> <li>• PC board check</li> <li>• Connector check</li> <li>• Harness check</li> <li>• Replace the PC board.</li> </ul>

Parts to be replaced	Remarks
T-LCF tray-up motor	
T-LCF tray-up sensor	
T-LCF paper feeding side bottom sensor	
LGC board	
T-LCF board	

### [C1A0] T-LCF end fence abnormality

Classification	Error content
Motor abnormality	The T-LCF end fence motor or the T-LCF end fence does not work normally.

Check item	Measures
T-LCF end fence motor	<ul style="list-style-type: none"> <li>Check that the motor is working. Output check: FS-03-207</li> <li>Connector check</li> <li>Harness check</li> <li>Replace the motor.</li> </ul>
T-LCF end fence home position sensor	<ul style="list-style-type: none"> <li>Sensor check Input check: FS-03-[F1]ON/[8]/[H]</li> <li>Actuator check</li> <li>Connector check</li> <li>Harness check</li> <li>Replace the sensor.</li> </ul>
T-LCF end fence stop position sensor	<ul style="list-style-type: none"> <li>Sensor check Input check: FS-03-[F1]ON/[8]/[G]</li> <li>Actuator check</li> <li>Connector check</li> <li>Harness check</li> <li>Replace the sensor.</li> </ul>
LGC board	<ul style="list-style-type: none"> <li>PC board check</li> <li>Connector check (CN315)</li> <li>Harness check</li> <li>Replace the PC board.</li> </ul>
T-LCF board	<ul style="list-style-type: none"> <li>PC board check</li> <li>Connector check</li> <li>Harness check</li> <li>Replace the PC board.</li> </ul>

Parts to be replaced	Remarks
T-LCF end fence motor	
T-LCF end fence home position sensor	
T-LCF end fence stop position sensor	
LGC board	
T-LCF board	

### [C1B0] T-LCF transport motor abnormality

Classification	Error content
Motor abnormality	The T-LCF transport motor does not work normally.

Check item	Measures
T-LCF transport motor	<ul style="list-style-type: none"> <li>Check that the motor is working. Output check: FS-03-122, 172</li> <li>Connector check</li> <li>Harness check</li> <li>Replace the motor.</li> </ul>

Check item	Measures
LGC board	<ul style="list-style-type: none"> <li>• PC board check</li> <li>• Connector check (CN315)</li> <li>• Harness check</li> <li>• Replace the PC board.</li> </ul>
T-LCF board	<ul style="list-style-type: none"> <li>• PC board check</li> <li>• Connector check</li> <li>• Harness check</li> <li>• Replace the PC board.</li> </ul>

Parts to be replaced	Remarks
T-LCF transport motor	
LGC board	
T-LCF board	

### [C1C0] Ex-LCF tray motor abnormality (2.0K Ex-LCF)

Classification	Error content
Motor abnormality	The Ex-LCF motor does not work normally.

Check item	Measures
Ex-LCF tray motor	<ul style="list-style-type: none"> <li>• Check that the motor is working. Output check: FS-03-452</li> <li>• Connector check</li> <li>• Harness check</li> <li>• Replace the motor.</li> </ul>
Ex-LCF tray-up sensor	<ul style="list-style-type: none"> <li>• Sensor check Input check: FS-03-[F3]ON/[3]/[H]</li> <li>• Actuator check</li> <li>• Connector check</li> <li>• Harness check</li> <li>• Replace the sensor.</li> </ul>
Ex-LCF tray bottom sensor	<ul style="list-style-type: none"> <li>• Sensor check Input check: FS-03-[F3]ON/[3]/[G]</li> <li>• Actuator check</li> <li>• Connector check</li> <li>• Harness check</li> <li>• Replace the sensor.</li> </ul>
LGC board	<ul style="list-style-type: none"> <li>• PC board check</li> <li>• Connector check (CN326)</li> <li>• Harness check</li> <li>• Replace the PC board.</li> </ul>
Ex-LCF board	<ul style="list-style-type: none"> <li>• PC board check</li> <li>• Connector check</li> <li>• Harness check</li> <li>• Replace the PC board.</li> </ul>

Parts to be replaced	Remarks
Ex-LCF tray motor	
Ex-LCF tray-up sensor	
Ex-LCF tray bottom sensor	
LGC board	
Ex-LCF board	

**[C1F0] Ex-LCF transport motor abnormality (2.0K Ex-LCF)**

Classification	Error content
Motor abnormality	The Ex-LCF transport motor does not work normally.

Check item	Measures
Ex-LCF transport motor	<ul style="list-style-type: none"> <li>• Check that the motor is working. Output check: FS-03-147</li> <li>• Connector check</li> <li>• Harness check</li> <li>• Replace the motor.</li> </ul>
LGC board	<ul style="list-style-type: none"> <li>• PC board check</li> <li>• Connector check (CN323)</li> <li>• Harness check</li> <li>• Replace the PC board.</li> </ul>
Ex-LCF board	<ul style="list-style-type: none"> <li>• PC board check</li> <li>• Connector check</li> <li>• Harness check</li> <li>• Replace the PC board.</li> </ul>

Parts to be replaced	Remarks
Ex-LCF transport motor	
LGC board	
Ex-LCF board	

**[C252] EEPROM communication error****[C253] EEPROM reading error**

Classification	Error content
Scanner abnormality	EEPROM communication error EEPROM reading error (The MFP will be rebooted at the first time the error occurs.)

Check item	Measures
Reproducibility	Turn the power OFF and then back ON to check the occurrence.
Harness	<ul style="list-style-type: none"> <li>- Check if the connectors between the SYS board and the CCD board are connected properly.</li> <li>- If there is any abnormality in the harness and connectors between connectors.</li> </ul>
CCD board	<ul style="list-style-type: none"> <li>- PC board check</li> <li>- Connector check</li> <li>- Harness check</li> <li>- Replace the PC board.</li> </ul>
SYS board	<ul style="list-style-type: none"> <li>- PC board check</li> <li>- Replace the PC board.</li> </ul>

Parts to be replaced	Remarks
Harness	
CCD board	
SYS board	

### [C260] Peak detection error

Classification	Error content
Scanner abnormality	Lighting of the exposure lamp (white reference) is not detected when the power is turned ON.

Check item	Measures
Exposure lamp	<ul style="list-style-type: none"> <li>Check if the exposure lamp lights. Output check: FS-03-267</li> <li>Connector check (CN123)</li> <li>Harness check Check if the wiring of the harness is proper.</li> <li>Replace the exposure lamp if it does not light.</li> </ul>
Shading plate	Check if there is any scratch or stain on the shading plate.
Carriage	<ul style="list-style-type: none"> <li>Move the carriage to the left stopping point to check whether it is tilted.</li> <li>Check if the wire fixing screw is loosened.</li> <li>Check if the carriage works normally. Check if the movement of the carriage is unstable due to disengagement of the carriage roller.</li> </ul>
Mirror	<ul style="list-style-type: none"> <li>Check if the mirror is tilted.</li> <li>Check that the lens is reflected in the mirror looking at the carriage-1 from the upper position.</li> <li>Check if the mirror is secured by the leaf spring.</li> </ul>
CCD board, lens unit	<ul style="list-style-type: none"> <li>Check if the lens unit is installed properly. (Check if the lens unit is tilted or the screw is securely tightened.)</li> <li>Connector check (CN120)</li> <li>Harness check</li> </ul>
SYS board	<ul style="list-style-type: none"> <li>PC board check</li> <li>Connector check (CN120, CN123)</li> <li>Harness check</li> <li>Replace the PC board.</li> </ul>

Parts to be replaced	Remarks
Exposure lamp	
Shading plate	
Carriage-1, carriage-2	
CCD board, lens unit	
SYS board	

### [C262] Communication error

Classification	Error content
Scanner abnormality	Communication error between the CCD board and the SYS board

Check item	Measures
RADF, DSDF	<p>Turn the power OFF and disconnect the harness between the RADF or DSDF and the MFP from the SYS board. Then check if the error is reproduced under this situation.</p> <p>If the error is not reproduced, perform the following measures.</p> <ol style="list-style-type: none"> <li>Check if the connectors between the RADF or DSDF and the MFP are connected properly. (CN122)</li> <li>If there is any abnormality in the harness and connectors, replace them.</li> <li>Check if there is any abnormality in the appearance of the parts mounted on the RADF control PC board or the DSDF control PC board.</li> <li>Replace the RADF control PC board or the DSDF control PC board.</li> </ol> <p>If the error is reproduced, perform the following measures</p>
Harness	<ul style="list-style-type: none"> <li>Check if the connectors are connected properly. (CN120, CN001)</li> <li>If there is any abnormality in the harness and connectors between the SYS board and the CCD board, replace the harness and connectors.</li> </ul>

Check item	Measures
CCD board	<ul style="list-style-type: none"> <li>PC board check</li> <li>Connector check (CN001)</li> <li>Harness check</li> <li>Replace the PC board.</li> </ul>
SYS board	<ul style="list-style-type: none"> <li>PC board check</li> <li>Connector check (CN120)</li> <li>Harness check</li> <li>Replace the PC board.</li> </ul>

Parts to be replaced	Remarks
RADF control PC board, DSDF control PC board	
Harness	
CCD board	
SYS board	

**[C270] Carriage home position sensor not turning OFF within a specified period of time, Downloading firmware with an incorrect model**

Classification	Error content
Scanner abnormality	<ul style="list-style-type: none"> <li>The carriage does not shift from its home position within a specified time.</li> <li>Downloading firmware with an incorrect model</li> </ul>

Check item	Measures
Carriage locking	Check if the carriage locking screw for packaging is attached.
CCD board	<ul style="list-style-type: none"> <li>PC board check</li> <li>Connector check (CN001, CN120)</li> <li>Harness check</li> <li>Replace the PC board.</li> </ul>
Firmware	If the model of the downloaded firmware is incorrect, a C270 error occurs. If the exposure lamp blinks twice, download the correct firmware.
Carriage home position sensor	<ul style="list-style-type: none"> <li>Sensor check</li> <li>Input check: FS-03-[F2]ON/[6]/[H]</li> <li>Actuator check</li> <li>Connector check (CN121)</li> <li>Harness check</li> <li>Replace the sensor.</li> </ul>
SYS board	<ul style="list-style-type: none"> <li>PC board check</li> <li>Connector check (CN120)</li> <li>Harness check</li> <li>Replace the PC board.</li> </ul>
Scan motor	<ul style="list-style-type: none"> <li>Check that the motor is working.</li> <li>Output check: FS-03-261</li> <li>Connector check (CN124)</li> <li>Harness check</li> <li>Motor check</li> <li>Replace the motor.</li> </ul>
Setting	Initialize the SRAM.

Parts to be replaced	Remarks
CCD board	
Carriage home position sensor	
SYS board	
Scan motor	



### [C280] Carriage home position sensor not turned ON within a specified period of time

Classification	Error content
Scanner abnormality	The carriage home position sensor is not turned ON within a specified period of time.

Check item	Measures
Carriage locking	Check if the carriage locking screw for packaging is attached.
CCD board	<ul style="list-style-type: none"> <li>• PC board check</li> <li>• Connector check (CN120)</li> <li>• Harness check</li> <li>• Replace the PC board.</li> </ul>
Carriage home position sensor	<ul style="list-style-type: none"> <li>• Sensor check Input check: FS-03-[F2]ON/[6]/[H]</li> <li>• Actuator check</li> <li>• Connector check (CN121)</li> <li>• Harness check</li> <li>• Replace the sensor.</li> </ul>
SYS board	<ul style="list-style-type: none"> <li>• PC board check</li> <li>• Connector check (CN121, CN124)</li> <li>• Harness check</li> <li>• Replace the PC board.</li> </ul>
Scan motor	<ul style="list-style-type: none"> <li>• Check that the motor is working. Output check: FS-03-261</li> <li>• Connector check (CN124)</li> <li>• Harness check</li> <li>• Motor check</li> <li>• Replace the motor.</li> </ul>

Parts to be replaced	Remarks
CCD board	
Carriage home position sensor	
SYS board	
Scan motor	

### [C290] Scanner fuse blowout

Classification	Error content
Scanner abnormality	The scanning system does not operate due to a blowout of the fuse.

Check item	Measures
SYS board	<ul style="list-style-type: none"> <li>• PC board check</li> <li>• Connector check</li> <li>• Harness check</li> <li>• Replace the PC board.</li> </ul>
LVPS	<ul style="list-style-type: none"> <li>• PC board check</li> <li>• Connector check (CN514)</li> <li>• Harness check</li> <li>• Replace the PC board.</li> <li>• Check if the fuse is open circuited.</li> </ul>

Parts to be replaced	Remarks
SYS board	
LVPS	

**[C3D0] EPU memory writing abnormality**

Classification	Error content
Process related abnormality	Writing of the memory on the EPU board has failed.
Check item	Measures
Process unit	<ul style="list-style-type: none"> <li>• Check if the process unit is installed properly.</li> <li>• Connector check</li> <li>• Harness check</li> </ul>
EPU board	<ul style="list-style-type: none"> <li>• PC board check</li> <li>• Connector check</li> <li>• Harness check</li> <li>• Replace the PC board.</li> </ul>
LGC board	<ul style="list-style-type: none"> <li>• PC board check</li> <li>• Connector check (CN319)</li> <li>• Harness check</li> <li>• Replace the PC board.</li> </ul>
Parts to be replaced	Remarks
EPU board	
LGC board	

**[C3D1] EPU memory new detection abnormality**

Classification	Error content
Process related abnormality	The process unit has been identified as a new one in the normal startup.
Check item	Measures
Process unit	<ul style="list-style-type: none"> <li>• If the process unit has been replaced before the startup, turn off the power of the MFP and perform 21 EPU REPLACE MODE.</li> <li>• If the process unit has not been replaced, check the following items. <ul style="list-style-type: none"> <li>- Check if the process unit is installed properly.</li> <li>- Connector check</li> <li>- Harness check</li> </ul> </li> </ul>
EPU board	<ul style="list-style-type: none"> <li>• PC board check</li> <li>• Connector check</li> <li>• Harness check</li> <li>• Replace the PC board.</li> </ul>
LGC board	<ul style="list-style-type: none"> <li>• PC board check</li> <li>• Connector check (CN319)</li> <li>• Harness check</li> <li>• Replace the PC board.</li> </ul>
Parts to be replaced	Remarks
EPU board	
LGC board	

**[C3D2] EPU memory old detection abnormality**

Classification	Error content
Process related abnormality	The process unit is not identified as a new one during 21 EPU REPLACE MODE.
Check item	Measures
Process unit	<p>Check if the process unit is a new one. If yes, check the following items.</p> <ul style="list-style-type: none"> <li>• Check if the process unit is installed properly.</li> <li>• Connector check</li> <li>• Harness check</li> </ul>

Check item	Measures
EPU board	<ul style="list-style-type: none"> <li>PC board check</li> <li>Connector check</li> <li>Harness check</li> <li>Replace the PC board.</li> </ul>
LGC board	<ul style="list-style-type: none"> <li>PC board check</li> <li>Connector check (CN319)</li> <li>Harness check</li> <li>Replace the PC board.</li> </ul>

Parts to be replaced	Remarks
EPU board	
LGC board	

### [C411] Thermistor or heater abnormality at power-ON

### [C412] Thermistor or heater abnormality at power-ON

Classification	Error content
Fuser unit abnormality	<ul style="list-style-type: none"> <li>An abnormality of the thermistor is detected when the power is turned ON.</li> <li>The temperature of the heat roller does not rise within a specified period of time after the power is turned ON.</li> </ul>

Check item	Measures
Power voltage	Check if the power voltage is normal. (The voltage during the operation is $\pm 10\%$ of the rated voltage.)
Thermistor	<ul style="list-style-type: none"> <li>Check if each thermistor is installed properly.</li> <li>Harness check</li> <li>Connector check</li> </ul>
Fuser unit	<ul style="list-style-type: none"> <li>Check if the fuser unit is installed properly.</li> <li>Check if the drawer connector is damaged or there is a defect in its connection.</li> <li>Check if the heater lamp is open circuited.</li> <li>Check if the terminal of the heater lamp is attached securely.</li> <li>Check if each thermostat is blown.</li> </ul>
Switching regulator	<ul style="list-style-type: none"> <li>PC board check</li> <li>Connector check (CN501, CN513)</li> <li>Harness check</li> <li>Replace the PC board.</li> </ul>
LGC board	<ul style="list-style-type: none"> <li>PC board check</li> <li>Connector check (CN302, CN308)</li> <li>Harness check</li> <li>Replace the PC board.</li> </ul>
LAMP board	<ul style="list-style-type: none"> <li>PC board check</li> <li>Connector check (CN549 to 552, CN554, CN557)</li> <li>Harness check</li> <li>Replace the PC board.</li> </ul>
ADU interlock switch	<ul style="list-style-type: none"> <li>Switch check Input check: FS-03-[ALL]OFF/[7]/[D]</li> <li>Connector check</li> <li>Harness check</li> <li>Replace the switch.</li> </ul>
Clearing of the status counter	<p>After the measures have been taken, perform the following items.</p> <ol style="list-style-type: none"> <li>Perform FS-08-2002.</li> <li>Change the displayed status counter value to "0".</li> <li>By turning the power OFF and then back ON, check that the MFP will enter into the ready state.</li> </ol>

Parts to be replaced	Remarks
Thermistor	
Switching regulator	
LGC board	
LAMP board	

Parts to be replaced	Remarks
ADU interlock switch	

**[C443] Fusing temperature abnormality (low temperature WAIT control abnormality at printing status)**

**[C445] Fusing temperature abnormality (pre-running end temperature abnormality)**

**[C447] Fusing temperature abnormality (temperature abnormality at ready status and during printing)**

**[C449] Fusing temperature abnormality (high temperature abnormality)**

**[C450] Heater abnormality**

**[C452] Heater lamp abnormality**

Classification	Error content
Fuser unit abnormality	<ul style="list-style-type: none"> <li>An abnormality of the thermistor is detected.</li> <li>The temperature of the heat roller does not rise within a specified period of time.</li> <li>The temperature of the heat roller has exceeded the range.</li> </ul>

Check item	Measures
Power voltage	Check if the power voltage is normal. (The voltage during the operation is $\pm 10\%$ of the rated voltage.)
Thermistor	<ul style="list-style-type: none"> <li>Check if each thermistor is installed properly.</li> <li>Harness check</li> <li>Connector check</li> </ul>
Fuser unit	<ul style="list-style-type: none"> <li>Check if the fuser unit is installed properly.</li> <li>Check if the drawer connector is damaged or there is a defect in its connection.</li> <li>Check if the heater lamp is open circuited.</li> <li>Check if the terminal of the heater lamp is attached securely.</li> <li>Check if each thermostat is blown.</li> </ul>
Switching regulator	<ul style="list-style-type: none"> <li>PC board check</li> <li>Connector check (CN501, CN513)</li> <li>Harness check</li> <li>Replace the PC board.</li> </ul>
LGC board	<ul style="list-style-type: none"> <li>PC board check</li> <li>Connector check (CN302, CN308)</li> <li>Harness check</li> <li>Replace the PC board.</li> </ul>
LAMP board	<ul style="list-style-type: none"> <li>PC board check</li> <li>Connector check (CN549 to 552, CN554, CN557)</li> <li>Harness check</li> <li>Replace the PC board.</li> </ul>
ADU interlock switch	<ul style="list-style-type: none"> <li>Switch check</li> <li>Input check: FS-03-[ALL]OFF/[7]/[D]</li> <li>Connector check</li> <li>Harness check</li> <li>Replace the switch.</li> </ul>
Clearing of the status counter	<p>After the measures have been taken, perform the following items.</p> <ol style="list-style-type: none"> <li>Perform FS-08-2002.</li> <li>Change the displayed status counter value to "0".</li> <li>By turning the power OFF and then back ON, check that the MFP will enter into the ready state.</li> </ol>

Parts to be replaced	Remarks
Fuser unit	
Switching regulator	
LGC board	
LAMP board	
ADU interlock switch	

### [C4B0] Status counter abnormality

Classification	Error content
Fuser unit abnormality	An abnormal value is entered in the status counter.
Check item	Measures
LGC board	<ul style="list-style-type: none"> <li>PC board check</li> <li>Harness check</li> <li>Replace the PC board.</li> </ul>
EEPROM	Check if the EEPROM is mounted properly.
Clearing of the status counter	After the measures have been taken, perform the following items. <ol style="list-style-type: none"> <li>Perform FS-08-2002.</li> <li>Change the displayed status counter value to "0".</li> <li>By turning the power OFF and then back ON, check that the MFP will enter into the ready state.</li> </ol>
Parts to be replaced	Remarks
LGC board	

### [C4C0] Fuser unit old-new detection fuse abnormality

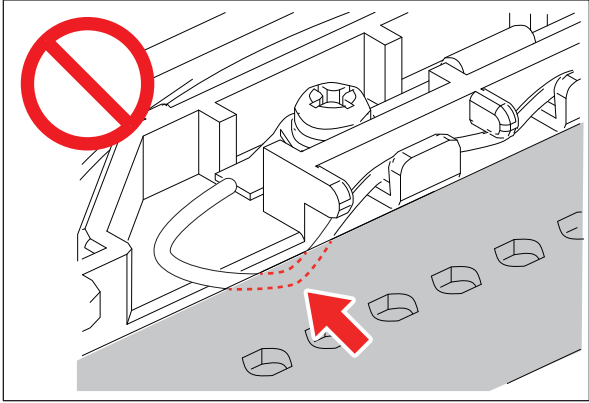
Classification	Error content
Fuser unit abnormality	Fuser unit old-new detection fuse abnormality
Check item	Measures
Fuser unit	<ul style="list-style-type: none"> <li>Check if the fuser unit is installed properly.</li> <li>Check if the drawer connector is damaged or there is a defect in its connection.</li> <li>Connector check (CN308)</li> <li>Check if the harness of the fuser unit old-new detection fuse is caught, open circuited or short circuited.</li> </ul>  <p><b>Fig.8-29</b></p>
LGC board	<ul style="list-style-type: none"> <li>PC board check</li> <li>Connector check (CN308)</li> <li>Harness check</li> <li>Replace the PC board.</li> </ul>
Parts to be replaced	Remarks
Fuser unit	
LGC board	

**[C550] Communication error between the scanner and the DF**

Classification	Error content
DSDF abnormality	Communication cannot be made properly between the scanner and the DF.

Check item	Measures
HDMI cable	Check that the HDMI cable is connected properly.
DSDF I/F board	<ul style="list-style-type: none"> <li>• PC board check</li> <li>• Connector check (CN89)</li> <li>• Harness check</li> <li>• Replace the PC board.</li> </ul>
DSDF board	<ul style="list-style-type: none"> <li>• PC board check</li> <li>• Connector check (CN71)</li> <li>• Harness check</li> <li>• Replace the PC board.</li> </ul>
SYS board	<ul style="list-style-type: none"> <li>• PC board check</li> <li>• Connector check (CN122, CN129)</li> <li>• Harness check</li> <li>• Replace the PC board.</li> </ul>

Parts to be replaced	Remarks
HDMI cable	
DSDF I/F board	
DSDF board	
SYS board	

**[C550] Communication error between the scanner and the DF**

Classification	Error content
RADF abnormality	Communication cannot be made properly between the scanner and the DF.

Check item	Measures
RADF board	<ul style="list-style-type: none"> <li>• PC board check</li> <li>• Connector check (CN71)</li> <li>• Harness check</li> <li>• Replace the PC board.</li> </ul>
SYS board	<ul style="list-style-type: none"> <li>• PC board check</li> <li>• Connector check (CN122, CN129)</li> <li>• Harness check</li> <li>• Replace the PC board.</li> </ul>

Parts to be replaced	Remarks
RADF board	
SYS board	

**[C551] DF model detection abnormality**

Classification	Error content
DSDF or RADF abnormality	An incorrect DF is installed in the MFP.

Check item	Measures
DSDF, RADF	<ul style="list-style-type: none"> <li>• Check if the installed DSDF or RADF is an option exclusively set for the model.</li> <li>• Replace the DSDF or RADF with the one exclusively set for the model.</li> </ul>
DSDF I/F board	<ul style="list-style-type: none"> <li>• PC board check</li> <li>• Connector check (CN129)</li> <li>• Harness check</li> <li>• Replace the PC board.</li> </ul>

Check item	Measures
SYS board	<ul style="list-style-type: none"> <li>PC board check</li> <li>Connector check (CN122)</li> <li>Harness check</li> <li>Replace the PC board.</li> </ul>

Parts to be replaced	Remarks
DSDf, RADf	
DSDf I/F board	
SYS board	

### [C552] DF abnormality

Classification	Error content
DSDf or RADf abnormality	DF abnormality

Check item	Measures
DSDf control PC board	<ul style="list-style-type: none"> <li>PC board check</li> <li>Connector check (CN71)</li> <li>Harness check</li> <li>Replace the PC board.</li> </ul>
RADf control PC board	<ul style="list-style-type: none"> <li>PC board check</li> <li>Connector check (CN71)</li> <li>Harness check</li> <li>Replace the PC board.</li> </ul>
Firmware	<ul style="list-style-type: none"> <li>Reinstall the DSDf firmware.</li> <li>Reinstall the RADf firmware.</li> </ul>

Parts to be replaced	Remarks
DSDf control PC board	
RADf control PC board	

### [C553] DSDf-CCD module peak detection abnormality

Classification	Error content
DSDf abnormality	<ul style="list-style-type: none"> <li>The light source of the DSDf-CCD module does not light.</li> <li>There is a detection error of the light source.</li> </ul>

Check item	Measures
HDMI cable	Check that the HDMI cable is connected properly. (CN129)
DSDf I/F board	<ul style="list-style-type: none"> <li>PC board check</li> <li>Connector check (CN89)</li> <li>Harness check</li> <li>Replace the PC board.</li> </ul>
DSDf control PC board	<ul style="list-style-type: none"> <li>PC board check</li> <li>Connector check (CN71)</li> <li>Harness check</li> <li>Replace the PC board.</li> </ul>
SYS board	<ul style="list-style-type: none"> <li>PC board check</li> <li>Connector check (CN122, CN129)</li> <li>Harness check</li> <li>Replace the PC board.</li> </ul>
Switching regulator	<ul style="list-style-type: none"> <li>PC board check</li> <li>Connector check (CN511)</li> <li>Harness check</li> <li>Replace the PC board.</li> </ul>
DSDf original exit motor	<ul style="list-style-type: none"> <li>Check that the motor is working. Output check: FS-03-284, FS-03-285</li> <li>Connector check</li> <li>Harness check</li> <li>Replace the motor.</li> </ul>

Check item	Measures
DSDF-CCD module	<ul style="list-style-type: none"> <li>Check if the connectors of the DSDF-CCD module are connected properly.</li> <li>Check if there is any abnormality in the DSDF-CCD module.</li> </ul>

Parts to be replaced	Remarks
DSDF I/F board	
DSDF control PC board	
SYS board	
DSDF original exit motor	
DSDF-CCD module	

#### [C554] AFE communication error

Classification	Error content
DSDF abnormality	Communication error between the DSDF-CCD module and the SYS board (This error is determined when the problem is not solved even if the MFP is rebooted by the specified number of times.)

Check item	Measures
HDMI cable	Check that the HDMI cable is connected properly.
Flat cable	Check that the flat cable is connected properly.
DSDF I/F board	<ul style="list-style-type: none"> <li>PC board check</li> <li>Connector check (CN89)</li> <li>Harness check</li> <li>Replace the PC board.</li> </ul>
DSDF relay PC board	<ul style="list-style-type: none"> <li>PC board check</li> <li>Connector check (CN129)</li> <li>Harness check</li> <li>Replace the PC board.</li> </ul>
DSDF-CCD module	<ul style="list-style-type: none"> <li>Check if the connectors of the DSDF-CCD module are connected properly.</li> <li>Check if there is any abnormality in the DSDF-CCD module.</li> </ul>
SYS board	<ul style="list-style-type: none"> <li>PC board check</li> <li>Connector check (CN129)</li> <li>Harness check</li> <li>Replace the PC board.</li> </ul>

Parts to be replaced	Remarks
DSDF I/F board	
SYS board	
DSDF relay PC board	
DSDF-CCD module	
HDMI cable	
Flat cable	

#### [C558] EERPOM communication error (back side)

Classification	Error content
DSDF abnormality	Communication error between the DSDF-CCD module and the SYS board (The MFP will be rebooted at the first time the error occurs.)

Check item	Measures
HDMI cable	Check that the HDMI cable is connected properly.
Flat cable	Check that the flat cable is connected properly.
DSDF I/F board	<ul style="list-style-type: none"> <li>PC board check</li> <li>Connector check (CN89)</li> <li>Harness check</li> <li>Replace the PC board.</li> </ul>



Check item	Measures
DSDF relay PC board	<ul style="list-style-type: none"> <li>PC board check</li> <li>Connector check (CN129)</li> <li>Harness check</li> <li>Replace the PC board.</li> </ul>
DSDF-CCD module	<ul style="list-style-type: none"> <li>Check if the connectors of the DSDF-CCD module are connected properly.</li> <li>Check if there is any abnormality in the DSDF-CCD module.</li> </ul>
SYS board	<ul style="list-style-type: none"> <li>PC board check</li> <li>Connector check (CN129)</li> <li>Harness check</li> <li>Replace the PC board.</li> </ul>

Parts to be replaced	Remarks
DSDF I/F board	
SYS board	
DSDF relay PC board	
DSDF-CCD module	
HDMI cable	
Flat cable	

### [C559] ASIC communication error (back side)

Classification	Error content
DSDF abnormality	Communication error between the DSDF I/F board and the SYS board (The MFP will be rebooted at the first time the error occurs.)

Check item	Measures
DSDF I/F board	<ul style="list-style-type: none"> <li>PC board check</li> <li>Connector check (CN89)</li> <li>Harness check</li> <li>Replace the PC board.</li> </ul>
SYS board	<ul style="list-style-type: none"> <li>PC board check</li> <li>Connector check</li> <li>Harness check</li> <li>Replace the PC board.</li> </ul>

Parts to be replaced	Remarks
DSDF I/F board	
SYS board	

### [C55A] Multiple feeding detection sensor connection abnormality

Classification	Error content
DSDF abnormality	A signal from the multiple feeding detection sensor cannot be detected.

Check item	Measures
Multiple feeding detection sensor	<ul style="list-style-type: none"> <li>Check if the sensor is installed properly.</li> <li>Connector check</li> <li>Harness check</li> <li>Replace the sensor.</li> </ul>
DSDF control PC board	<ul style="list-style-type: none"> <li>PC board check</li> <li>Connector check</li> <li>Harness check</li> <li>Replace the PC board.</li> </ul>

Parts to be replaced	Remarks
Multiple feeding detection sensor	
DSDF control PC board	

**[C55B] Multiple feeding detection sensor abnormality**

Classification	Error content
DSDF abnormality	A malfunction of the sensor is detected. A signal from the multiple feeding detection sensor cannot be received properly.

Check item	Measures
Multiple feeding detection sensor	<ul style="list-style-type: none"> <li>• Sensor check</li> <li>• Connector check</li> <li>• Harness check</li> <li>• Replace the sensor.</li> </ul>
DSDF control PC board	<ul style="list-style-type: none"> <li>• PC board check</li> <li>• Connector check</li> <li>• Harness check</li> <li>• Replace the PC board.</li> </ul>

Parts to be replaced	Remarks
Multiple feeding detection sensor	
DSDF control PC board	

**[C580] Communication error between the LGC board and the Finisher**

Classification	Error content
Finisher abnormality	A communication error has occurred between the LGC board and the Finisher.

Check item	Measures
Finisher	<ul style="list-style-type: none"> <li>• Check if the installed Finisher is an option exclusively set for the model.</li> <li>• Replace the Finisher with the one exclusively set for the model.</li> </ul>
LGC board	<ul style="list-style-type: none"> <li>• PC board check</li> <li>• Connector check (CN314)</li> <li>• Harness check</li> <li>• Replace the PC board.</li> </ul>
Finisher control PC board	<ul style="list-style-type: none"> <li>• PC board check</li> <li>• Connector check (CN3, CN13)</li> <li>• Harness check</li> <li>• Replace the PC board.</li> </ul>

Parts to be replaced	Remarks
LGC board	
Finisher control PC board	

**[C5A0] EEPROM communication abnormality (LGC board)**

Classification	Error content
EEPROM abnormality	There is no response from the EEPROM.

Check item	Measures
EEPROM	Check the EEPROM.
LGC board	<ul style="list-style-type: none"> <li>• PC board check</li> <li>• Socket check</li> <li>• Replace the PC board.</li> </ul>

Parts to be replaced	Remarks
EEPROM	
LGC board	

**[C5A1] EEPROM data abnormality (LGC board)**

Classification	Error content
EEPROM abnormality	An abnormality has occurred in the EEPROM data.
Check item	Measures
EEPROM	Check the EEPROM.
LGC board	<ul style="list-style-type: none"> <li>PC board check</li> <li>Socket check</li> <li>Replace the PC board.</li> </ul>
Reproducibility	Reboot the MFP to check that the error does not occur. If it changes to another code, follow its troubleshooting procedure.
EEPROM data	<ol style="list-style-type: none"> <li>Perform FS-08-4871.</li> <li>Reboot the MFP to check that the error does not occur. If it changes to another code, follow its troubleshooting procedure.</li> </ol>
Parts to be replaced	Remarks
EEPROM	
LGC board	

**[C5A8] Sub-EEPROM communication abnormality**

Classification	Error content
EEPROM abnormality	There is no response from the sub-EEPROM.
Check item	Measures
Sub-EEPROM	Check the sub-EEPROM.
LGC board	<ul style="list-style-type: none"> <li>PC board check</li> <li>Socket check</li> <li>Replace the PC board.</li> </ul>
Parts to be replaced	Remarks
Sub-EEPROM	
LGC board	

**[C5A9] Sub-EEPROM data abnormality**

Classification	Error content
EEPROM abnormality	An abnormality has occurred in the sub-EEPROM data.
Check item	Measures
Sub-EEPROM	Check the sub-EEPROM.
LGC board	<ul style="list-style-type: none"> <li>PC board check</li> <li>Socket check</li> <li>Replace the PC board.</li> </ul>
Reproducibility	Reboot the MFP to check that the error does not occur. If it changes to another code, follow its troubleshooting procedure.
Sub-EEPROM data	<ol style="list-style-type: none"> <li>Perform FS-08-4870.</li> <li>Reboot the MFP to check that the error does not occur. If it changes to another code, follow its troubleshooting procedure.</li> </ol>
Parts to be replaced	Remarks
Sub-EEPROM	
LGC board	

**[C730] DSDF EEPROM writing abnormality**

Classification	Error content
DSDF abnormality	An abnormality has occurred while the data are being written in the EEPROM of the DSDF.
Check item	Measures
Adjustment	Perform DSDF read-in sensor-1 automatic adjustment.
DSDF control PC board	<ul style="list-style-type: none"> <li>• PC board check</li> <li>• Connector check (CN122)</li> <li>• Harness check</li> <li>• Replace the PC board.</li> </ul>
Parts to be replaced	Remarks
DSDF control PC board	

**[C7B0] Initialization performance abnormality**

Classification	Error content
DSDF abnormality	The initialization is not completed within the specified time.
Check item	Measures
Reproducibility	Turn the power OFF and then back ON to check the occurrence.
DSDF shading sheet	Clean the DSDF shading sheet.
SYS board	<ul style="list-style-type: none"> <li>• PC board check</li> <li>• Connector check (CN122)</li> <li>• Harness check</li> <li>• Replace the PC board.</li> </ul>
Parts to be replaced	Remarks
DSDF shading sheet	
SYS board	

**[C8C0] DSDF read-in sensor-1 automatic adjustment abnormality**

Classification	Error content
DSDF abnormality	An adjustment value becomes outside the specified one during DSDF read-in sensor-1 automatic adjustment.
Check item	Measures
DSDF read-in sensor-1	<ul style="list-style-type: none"> <li>• Sensor check</li> <li>• Connector check</li> <li>• Harness check</li> <li>• Perform DSDF read-in sensor-1 adjustment manually.</li> <li>• Replace the sensor.</li> </ul>
DSDF control PC board	<ul style="list-style-type: none"> <li>• PC board check</li> <li>• Connector check</li> <li>• Harness check</li> <li>• Replace the PC board.</li> </ul>
Parts to be replaced	Remarks
DSDF read-in sensor-1	
DSDF control PC board	

**[C8E0] DF communication protocol abnormality**

Classification	Error content
DSDF or RADF abnormality	System stop is required due to the control abnormality.
Check item	Measures
Reproducibility	Turn the power OFF and then back ON to check the occurrence.

Check item	Measures
DSDF control PC board, RADF control PC board	<ul style="list-style-type: none"> <li>PC board check</li> <li>Connector check (CN71)</li> <li>Harness check</li> <li>Replace the PC board.</li> </ul>
SYS board	<ul style="list-style-type: none"> <li>PC board check</li> <li>Connector check (CN122)</li> <li>Harness check</li> <li>Replace the PC board.</li> </ul>

Parts to be replaced	Remarks
DSDF control PC board, RADF control PC board	
SYS board	

### [C911] CTIF board access abnormality (K)

Classification	Error content
Circuit related service call	Abnormal access to the toner cartridge IC chip

Check item	Measures
Reproducibility	Open and then close the front cover to check if "Non-genuine toner cartridge" is displayed. When this is displayed, use a genuine toner cartridge.
Toner cartridge	<ul style="list-style-type: none"> <li>Check the symptom by removing and then reinstalling the toner cartridge (K).</li> <li>Check if the CTRG board properly contact the toner cartridge (K).</li> <li>Wipe the contact point with a soft cloth if it is stained.</li> </ul> <p><b>Notes:</b> Avoid directly touching the contact point with your hands.</p>
CTIF board	<ul style="list-style-type: none"> <li>Check if there is any abnormality in the installation of the PC board.</li> <li>Connector check (CN231)</li> <li>Harness check</li> <li>Check if the springs for the contact point for the toner cartridge (K) is deformed.</li> <li>Gently push the spring for the contact point to check that it has returned.</li> </ul> <p><b>Notes:</b> If the spring is pushed strongly, it may be deformed.</p> <ul style="list-style-type: none"> <li>Replace the PC board.</li> </ul>
LGC board	<ul style="list-style-type: none"> <li>PC board check</li> <li>Connector check (CN325)</li> <li>Harness check</li> <li>Replace the PC board.</li> </ul>
Setting	When the error is cleared, set "0" (normal) to the following self-diagnostic codes. K: FS-08-4689-3

Parts to be replaced	Remarks
Toner cartridge	
LGC board	
CTIF board	

### [C916] Sub-CPU abnormality

Classification	Error content
Circuit related service call	An abnormality has occurred during the access to the sub-CPU.

Check item	Measures
Reproducibility	Turn the power OFF and then back ON to check the occurrence.

Check item	Measures
LGC board	<ul style="list-style-type: none"> <li>PC board check</li> <li>Replace the PC board.</li> </ul>
Parts to be replaced	Remarks
LGC board	

#### [C940] Engine-CPU abnormality

Classification	Error content
Circuit related service call	An abnormality has occurred in the engine-CPU.
Check item	Measures
Reproducibility	Turn the power OFF and then back ON to check the occurrence.
Firmware	<ul style="list-style-type: none"> <li>Check if the combination of the version for all the firmware items installed in the MFP is appropriate.</li> <li>Reinstall the engine firmware.</li> </ul>
LGC board	<ul style="list-style-type: none"> <li>PC board check</li> <li>Replace the PC board.</li> </ul>
Parts to be replaced	Remarks
LGC board	

#### [C970] High-voltage transformer leakage abnormality

Classification	Error content
Circuit related service call	Leakage from the main charger has been detected.
Check item	Measures
EPU	<ul style="list-style-type: none"> <li>Check if all the EPUs are installed properly.</li> <li>Press the EPU securely until a click sound is heard.</li> </ul>
Main charger	<ul style="list-style-type: none"> <li>Check if the main charger is installed properly.</li> <li>Check if there is any abnormality such as damage, deformation foreign matter adhering to the main charger grid.</li> <li>Check if there is any abnormality such as damage, deformation foreign matter adhering to the needle electrode.</li> </ul>
Spring of the high-voltage supply contact point	<ul style="list-style-type: none"> <li>Check if the spring of the high-voltage supply contact point is deformed.</li> <li>If so, correct or replace it.</li> </ul>
High-voltage transformer	<ul style="list-style-type: none"> <li>PC board check</li> <li>Connector check</li> <li>Harness check</li> <li>Replace the PC board.</li> </ul>
Separation needle	<ul style="list-style-type: none"> <li>Check if it is installed properly.</li> <li>Check if there is any abnormality such as damage, deformation foreign matter adhering to it.</li> </ul>
Transfer roller	<ul style="list-style-type: none"> <li>Check if it is installed properly.</li> <li>Check if there is any abnormality such as damage, deformation foreign matter adhering to it.</li> </ul>
Parts to be replaced	Remarks
Main charger	
Spring of the high-voltage supply contact point	
High-voltage transformer	
Separation needle	
Transfer roller	

### [CA10] Polygonal motor abnormality

Classification	Error content
Writing related service call	The polygonal motor does not work normally.
Check item	Measures
Polygonal motor	<ul style="list-style-type: none"> <li>Check that the motor is working. Output check: FS-03-[ALL]OFF/[5]/[B]</li> <li>Connector check (CN304)</li> <li>Harness check (between the laser optical unit and LGC board)</li> <li>Replace the laser optical unit.</li> </ul>
LGC board	<ul style="list-style-type: none"> <li>PC board check</li> <li>Connector check (CN306)</li> <li>Harness check</li> <li>Replace the PC board.</li> </ul>
Parts to be replaced	Remarks
Laser optical unit	
LGC board	

### [CA20] H-Sync detection error

Classification	Error content
Writing related service call	The laser beams cannot be detected by the H-sync detection PC board.
Check item	Measures
Laser optical unit	<ul style="list-style-type: none"> <li>Connector check (CN201, CN204)</li> <li>Harness check</li> <li>Replace the laser optical unit.</li> </ul> <p><b>Notes:</b> Even if the flat cable is not apparently disconnected, it may be connected too loosely. Therefore, check carefully and connect it securely.</p>
LGC board	<ul style="list-style-type: none"> <li>PC board check</li> <li>Connector check (CN304)</li> <li>Harness check</li> <li>Replace the PC board.</li> </ul> <p><b>Notes:</b> Even if the flat cable is not apparently disconnected, it may be connected too loosely. Therefore, check carefully and connect it securely.</p>
Parts to be replaced	Remarks
Laser optical unit	
LGC board	

### [CB00] Finisher communication error (Inner Finisher, Finisher, Saddle Stitch Finisher)

Classification	Error content
Inner finisher service call Finisher service call Saddle stitch finisher service call	A communication error has occurred between the MFP and the Finisher.
Check item	Measures
Finisher	<ul style="list-style-type: none"> <li>Check if the harness between the MFP and the Finisher is disconnected or open circuited.</li> <li>Check if the finisher control PC board is open circuited or short circuited.</li> <li>Update the finisher firmware.</li> <li>Replace the finisher control PC board.</li> </ul>

Check item	Measures
LGC board	<ul style="list-style-type: none"> <li>• PC board check</li> <li>• Connector check (CN314)</li> <li>• Harness check</li> <li>• Replace the PC board.</li> </ul>

Parts to be replaced	Remarks
Finisher control PC board	
LGC board	

### [CB10] Entrance motor abnormality (Finisher, Saddle Stitch Finisher)

Classification	Error content
Finisher service call Saddle stitch finisher service call	The entrance motor or the entrance roller does not work normally.

Check item	Measures
Entrance roller	Check the condition of the roller. If it has been stained, clean it. If it has deteriorated, replace it.
Entrance motor	<ul style="list-style-type: none"> <li>• Check that the motor is working.</li> <li>• Connector check</li> <li>• Harness check</li> <li>• Replace the motor.</li> </ul>
Finisher control PC board	<ul style="list-style-type: none"> <li>• PC board check</li> <li>• Connector check (CN17)</li> <li>• Harness check</li> <li>• Replace the PC board.</li> </ul>

Parts to be replaced	Remarks
Entrance roller	
Entrance motor	
Finisher control PC board	

### [CB11] Buffer tray guide motor abnormality (Finisher, Saddle Stitch Finisher)

Classification	Error content
Finisher service call Saddle stitch finisher service call	<ul style="list-style-type: none"> <li>• The buffer tray guide motor or the buffer tray guide does not work normally.</li> <li>• A CB11 error will occur if an ED16 error has occurred three times in succession or it has occurred during the initialization.</li> </ul>

Check item	Measures
Buffer tray guide	While the buffer roller is being raised, open and then close the buffer tray guide. If there is any mechanical problem, correct it.
Buffer tray guide motor	<ul style="list-style-type: none"> <li>• Check that the motor is working.</li> <li>• Connector check</li> <li>• Harness check</li> <li>• Replace the motor.</li> </ul>
Finisher control PC board	<ul style="list-style-type: none"> <li>• PC board check</li> <li>• Connector check (CN10)</li> <li>• Harness check</li> <li>• Replace the PC board.</li> </ul>

Parts to be replaced	Remarks
Buffer tray guide	
Buffer tray guide motor	
Finisher control PC board	



### [CB15] Catching motor abnormality (Finisher, Saddle Stitch Finisher)

Classification	Error content
Finisher service call Saddle stitch finisher service call	The catching motor does not work normally.

Check item	Measures
Catching motor	<ul style="list-style-type: none"> <li>• Check that the motor is working.</li> <li>• Connector check</li> <li>• Harness check</li> <li>• Replace the motor.</li> </ul>
Finisher control PC board	<ul style="list-style-type: none"> <li>• PC board check</li> <li>• Connector check (CN17)</li> <li>• Harness check</li> <li>• Replace the PC board.</li> </ul>

Parts to be replaced	Remarks
Catching motor	
Finisher control PC board	

### [CB30] Movable tray shift motor abnormality (Inner Finisher)

Classification	Error content
Inner finisher service call	The movable tray shift motor or the movable tray does not work normally.

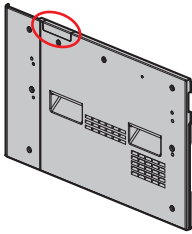
Check item	Measures
Movable tray	<ul style="list-style-type: none"> <li>• Check if there is any abnormality in the operation of the movable tray.</li> <li>• Check if there is any obstacle or any abnormality under the movable tray.</li> <li>• Remove them at the time of unpacking. Check if the left small cover of the MFP is removed.</li> </ul>  <p><b>Fig.8-30</b></p>
Movable tray shift motor	<ul style="list-style-type: none"> <li>• Check that the motor is working.</li> <li>• Connector check</li> <li>• Harness check</li> <li>• Check the coil to confirm that the current flows in it.</li> <li>• Replace the motor.</li> </ul>
Movable tray lower limit sensor	<ul style="list-style-type: none"> <li>• Sensor check</li> <li>• Actuator check</li> <li>• Connector check</li> <li>• Harness check</li> <li>• Measure the voltage of TP17 on the finisher control PC board. Then check that the measured voltage is 1 V or lower when not shielded and within the range of 3.3 V ± 5% when shielded.</li> <li>• Replace the sensor.</li> </ul>
Stack top detection solenoid	<ul style="list-style-type: none"> <li>• Solenoid check</li> <li>• Connector check</li> <li>• Harness check</li> <li>• Check the coil to confirm that the current flows in it.</li> <li>• Replace the solenoid.</li> </ul>

Check item	Measures
Stack top detection sensor-1	<ul style="list-style-type: none"> <li>• Sensor check</li> <li>• Actuator check</li> <li>• Connector check</li> <li>• Harness check</li> <li>• Measure the voltage of TP11 on the finisher control PC board. Then check that the measured voltage is 1 V or lower when not shielded and within the range of 3.3 V <math>\pm</math>5% when shielded.</li> <li>• Replace the sensor.</li> </ul>
Stack top detection sensor-2	<ul style="list-style-type: none"> <li>• Sensor check</li> <li>• Actuator check</li> <li>• Connector check</li> <li>• Harness check</li> <li>• Measure the voltage of TP20 on the finisher control PC board. Then check that the measured voltage is 1 V or lower when not shielded and within the range of 3.3 V <math>\pm</math>5% when shielded.</li> <li>• Replace the sensor.</li> </ul>
Finisher control PC board	<ul style="list-style-type: none"> <li>• PC board check</li> <li>• Connector check</li> <li>• Harness check</li> <li>• Replace the PC board.</li> </ul>

Parts to be replaced	Remarks
Movable tray shift motor	
Movable tray lower limit sensor	
Stack top detection solenoid	
Stack top detection sensor-1	
Stack top detection sensor-2	
Finisher control PC board	

#### [CB40] Rear alignment plate home position sensor detection abnormality (Inner Finisher)

Classification	Error content
Inner finisher service call	<ul style="list-style-type: none"> <li>• The rear alignment motor or the rear alignment plate does not work normally.</li> <li>• A CB40 error will occur if an ED13 error has occurred three times in succession.</li> </ul>

Check item	Measures
Rear alignment motor (M3)	<ul style="list-style-type: none"> <li>• Check that the motor is working.</li> <li>• Connector check (CN5)</li> <li>• Harness check</li> <li>• Check the coil to confirm that the current flows in it.</li> <li>• Replace the motor.</li> </ul>
Rear alignment plate home position sensor (S6)	<ul style="list-style-type: none"> <li>• Actuator check</li> <li>• Connector check (CN22)</li> <li>• Harness check</li> <li>• Measure the voltage of TP16 on the finisher control PC board (FIN). Then check that the measured voltage is 1 V or lower when not shielded and within the range of 3.3 V <math>\pm</math>5% when shielded. If the voltage does not fall within the mentioned range, replace the sensor.</li> </ul>
Finisher control PC board (FIN)	<ul style="list-style-type: none"> <li>• PC board check</li> <li>• Connector check (CN5, CN12)</li> <li>• Harness check</li> <li>• Replace the PC board.</li> </ul>

Parts to be replaced	Remarks
Rear alignment motor (M3)	
Rear alignment plate home position sensor (S6)	
Finisher control PC board (FIN)	

### [CB40] Front alignment motor abnormality (Finisher, Saddle Stitch Finisher)

Classification	Error content
Finisher service call Saddle stitch finisher service call	<ul style="list-style-type: none"> <li>The front alignment motor or the front alignment plate does not work normally.</li> <li>A CB40 error will occur if an ED13 error has occurred three times in succession.</li> </ul>

Check item	Measures
Front alignment plate	<ul style="list-style-type: none"> <li>Check if there is any abnormality in the installation of the front alignment plate.</li> <li>Check if there is any mechanical problem by moving it.</li> <li>If there is any, correct it.</li> </ul>
Front alignment motor (M5)	<ul style="list-style-type: none"> <li>Check that the motor is working.</li> <li>Connector check</li> <li>Harness check</li> <li>Replace the motor.</li> </ul>
Finisher control PC board	<ul style="list-style-type: none"> <li>PC board check</li> <li>Connector check (CN18)</li> <li>Harness check</li> <li>Replace the PC board.</li> </ul>

Parts to be replaced	Remarks
Front alignment plate	
Front alignment motor (M5)	
Finisher control PC board	

### [CB50] Stapler home position abnormality (Inner Finisher)

Classification	Error content
Inner finisher service call	<ul style="list-style-type: none"> <li>The staple unit clinching home position sensor does not work normally.</li> <li>A CB50 error will occur if an EA50 error has occurred three times in succession.</li> </ul>

Check item	Measures
Stapler motor (M10)	<ul style="list-style-type: none"> <li>Check that the motor is working.</li> <li>Connector check</li> <li>Harness check</li> <li>Check the coil to confirm that the current flows in it.</li> <li>Replace the motor.</li> </ul>
Staple unit clinching home position sensor (S16)	<ul style="list-style-type: none"> <li>Actuator check</li> <li>Connector check</li> <li>Harness check</li> <li>Measure the voltage of CN16 on the finisher control PC board (FIN). Then check that the measured voltage is 1 V or lower when not shielded and within the range of 3.3 V <math>\pm</math>5% when shielded. If the voltage does not fall within the mentioned range, replace the stapler unit.</li> </ul>
Staple unit improper clinching prevention sensor (S15)	<ul style="list-style-type: none"> <li>Actuator check</li> <li>Connector check</li> <li>Harness check</li> <li>Measure the voltage of TP25 on the finisher control PC board (FIN). Then check that the measured voltage is 1 V or lower when not shielded and within the range of 3.3 V <math>\pm</math>5% when shielded. If the voltage does not fall within the mentioned range, replace the sensor.</li> </ul>
Finisher control PC board (FIN)	<ul style="list-style-type: none"> <li>PC board check</li> <li>Connector check (CN16, CN17)</li> <li>Harness check</li> <li>Replace the PC board.</li> </ul>

Parts to be replaced	Remarks
Stapler motor (M10)	

Parts to be replaced	Remarks
Staple unit clinching home position sensor (S16)	
Staple unit improper clinching prevention sensor (S15)	
Finisher control PC board (FIN)	

#### [CB50] Stapler home position abnormality (Finisher, Saddle Stitch Finisher)

Classification	Error content
Finisher service call Saddle stitch finisher service call	<ul style="list-style-type: none"> <li>The stapler unit home position sensor does not work normally.</li> <li>A CB50 error will occur if an EA50 error has occurred three times in succession.</li> </ul>

Check item	Measures
Stapler unit	<ul style="list-style-type: none"> <li>Connector check</li> <li>Harness check</li> </ul>
Finisher control PC board	<ul style="list-style-type: none"> <li>PC board check</li> <li>Connector check</li> <li>Harness check</li> <li>Replace the PC board.</li> </ul>

Parts to be replaced	Remarks
Stapler unit	
Finisher control PC board	

#### [CB51] Stapler movement home position abnormality (Inner Finisher)

Classification	Error content
Inner finisher service call	The stapler unit is not at its home position.

Check item	Measures
Stapler unit sliding motor (M7)	<ul style="list-style-type: none"> <li>Check that the motor is working.</li> <li>Connector check (CN3)</li> <li>Harness check</li> <li>Check the coil to confirm that the current flows in it.</li> <li>Replace the motor.</li> </ul>
Stapler unit sliding home position sensor (S3)	<ul style="list-style-type: none"> <li>Actuator check</li> <li>Connector check (CN16)</li> <li>Harness check</li> <li>Measure the voltage of TP18 on the finisher control PC board (FIN). Then check that the measured voltage is 1 V or lower when not shielded and within the range of 3.3 V <math>\pm</math>5% when shielded. If the voltage does not fall within the mentioned range, replace the sensor.</li> </ul>
Finisher control PC board (FIN)	<ul style="list-style-type: none"> <li>PC board check</li> <li>Connector check (CN3, CN18)</li> <li>Harness check</li> <li>Replace the PC board.</li> </ul>

Parts to be replaced	Remarks
Stapler unit sliding motor (M7)	
Stapler unit sliding home position sensor (S3)	
Finisher control PC board (FIN)	

**[CB60] Stapler unit shift motor abnormality (Finisher, Saddle Stitch Finisher)**

Classification	Error content
Finisher service call Saddle stitch finisher service call	The stapler unit shift motor or the stapler unit does not work normally.

Check item	Measures
Stapler unit	<ul style="list-style-type: none"> <li>• Connector check</li> <li>• Harness check</li> </ul>
Stapler unit shift motor (M9)	<ul style="list-style-type: none"> <li>• Check that the motor is working.</li> <li>• Connector check</li> <li>• Harness check</li> <li>• Replace the motor.</li> </ul>
Finisher control PC board	<ul style="list-style-type: none"> <li>• PC board check</li> <li>• Connector check (CN18)</li> <li>• Harness check</li> <li>• Replace the PC board.</li> </ul>

Parts to be replaced	Remarks
Stapler unit	
Stapler unit shift motor (M9)	
Finisher control PC board	

**[CB80] Finisher backup RAM data abnormality (Inner Finisher)**

Classification	Error content
Inner finisher service call	An abnormality of the checksum value of the finisher control PC board is detected when the power is turned ON.

Check item	Measures
Reproducibility	Turn the power OFF and then back ON to check the occurrence.
Finisher control PC board (FIN)	<ul style="list-style-type: none"> <li>• PC board check</li> <li>• Connector check</li> <li>• Harness check</li> <li>• Replace the PC board.</li> </ul>

Parts to be replaced	Remarks
Finisher control PC board (FIN)	

**[CB80] Finisher backup RAM data abnormality (Finisher, Saddle Stitch Finisher)**

Classification	Error content
Finisher service call Saddle stitch finisher service call	An abnormality of the checksum value of the finisher control PC board is detected when the power is turned ON.

Check item	Measures
Reproducibility	Turn the power OFF and then back ON to check the occurrence.
Finisher control PC board (FIN)	<ul style="list-style-type: none"> <li>• PC board check</li> <li>• Connector check</li> <li>• Harness check</li> <li>• Replace the PC board.</li> </ul>

Parts to be replaced	Remarks
Finisher control PC board (FIN)	

**[CB81] Finisher Flash ROM data abnormality (Finisher, Saddle Stitch Finisher)**

Classification	Error content
Finisher service call Saddle stitch finisher service call	An abnormality of the checksum value of the finisher control PC board is detected when the power is turned ON.

Check item	Measures
Reproducibility	Turn the power OFF and then back ON to check the occurrence.

Check item	Measures
Finisher control PC board (FIN)	<ul style="list-style-type: none"> <li>PC board check</li> <li>Connector check</li> <li>Harness check</li> <li>Replace the PC board.</li> </ul>

Parts to be replaced	Remarks
Finisher control PC board (FIN)	

### [CB82] Finisher main program error (Finisher, Saddle Stitch Finisher)

Classification	Error content
Finisher service call Saddle stitch finisher service call	Finisher main program error

Check item	Measures
Reproducibility	Turn the power OFF and then back ON to check the occurrence.
Firmware	Reinstall the finisher firmware.
Finisher control PC board (FIN)	<ul style="list-style-type: none"> <li>PC board check</li> <li>Connector check</li> <li>Harness check</li> <li>Replace the PC board.</li> </ul>

Parts to be replaced	Remarks
Finisher control PC board (FIN)	

### [CB84] Hole punch: Punch main program error (Finisher, Saddle Stitch Finisher)

Classification	Error content
Hole punch unit service call	Punch main program error

Check item	Measures
Reproducibility	Turn the power OFF and then back ON to check the occurrence.
Firmware	Reinstall the punch firmware.
Hole punch control PC board (PNC)	<ul style="list-style-type: none"> <li>PC board check</li> <li>Connector check</li> <li>Harness check</li> <li>Replace the PC board.</li> </ul>

Parts to be replaced	Remarks
Hole punch control PC board (PNC)	

### [CB93] Saddle additional folding motor abnormality (Saddle Stitch Finisher)

Classification	Error content
Saddle stitch finisher service call	<ul style="list-style-type: none"> <li>An abnormal interruption of the encoder pulse of the additional folding motor or its operation abnormality has occurred.</li> <li>A CB93 error will occur if an EF18 error has occurred three times in succession.</li> </ul>

Check item	Measures
Additional folding carrier	<ul style="list-style-type: none"> <li>Check if there is any abnormality in the installation of the additional folding carrier.</li> <li>Check if there is any mechanical problem by moving it.</li> <li>If there is any, correct it.</li> </ul>
Additional folding motor (M20)	<ul style="list-style-type: none"> <li>Check that the motor is working.</li> <li>Connector check</li> <li>Harness check</li> <li>Replace the motor.</li> </ul>
Saddle control PC board (SDL)	<ul style="list-style-type: none"> <li>PC board check</li> <li>Connector check (CN10)</li> <li>Harness check</li> <li>Replace the PC board.</li> </ul>

Parts to be replaced	Remarks
Additional folding carrier	
Additional folding motor (M20)	
Saddle control PC board (SDL)	

#### [CB94] Saddle transport motor abnormality (Saddle Stitch Finisher)

Classification	Error content
Saddle stitch finisher service call	<ul style="list-style-type: none"> <li>An abnormal interruption of the saddle transport motor or its operation abnormality has occurred.</li> <li>An abnormality has occurred in the paper holding mechanism or the path switching solenoid.</li> <li>A CB94 error will occur if an EAB0 or EF13 error has occurred three times in succession.</li> </ul>

Check item	Measures
Saddle transport roller	<ul style="list-style-type: none"> <li>Check if there is any abnormality in the installation of the saddle transport roller.</li> <li>Check if there is any mechanical problem by moving it.</li> <li>If there is any, correct it.</li> </ul>
Saddle transport motor (M16)	<ul style="list-style-type: none"> <li>Check that the motor is working.</li> <li>Connector check</li> <li>Harness check</li> <li>Replace the motor.</li> </ul>
Saddle control PC board (SDL)	<ul style="list-style-type: none"> <li>PC board check</li> <li>Connector check (CN5)</li> <li>Harness check</li> <li>Replace the PC board.</li> </ul>

Parts to be replaced	Remarks
Saddle transport roller	
Saddle transport motor (M16)	
Saddle control PC board (SDL)	

#### [CB95] Stacker motor abnormality (Saddle Stitch Finisher)

Classification	Error content
Saddle stitch finisher service call	<ul style="list-style-type: none"> <li>An abnormal interruption of the stacker motor or its operation abnormality has occurred.</li> <li>A CB95 error will occur if an EF16 error has occurred three times in succession.</li> </ul>

Check item	Measures
Stacker carrier	<ul style="list-style-type: none"> <li>Check if there is any abnormality in the installation of the stacker carrier.</li> <li>Check if there is any mechanical problem by moving it.</li> <li>If there is any, correct it.</li> </ul>
Stacker motor (M14)	<ul style="list-style-type: none"> <li>Check that the motor is working.</li> <li>Connector check</li> <li>Harness check</li> <li>Replace the motor.</li> </ul>
Saddle control PC board (SDL)	<ul style="list-style-type: none"> <li>PC board check</li> <li>Connector check (CN8)</li> <li>Harness check</li> <li>Replace the PC board.</li> </ul>

Parts to be replaced	Remarks
Stacker carrier	
Stacker motor (M14)	
Saddle control PC board (SDL)	

**[CBA0] Front saddle stapler home position abnormality (Saddle Stitch Finisher)**

Classification	Error content
Saddle stitch finisher service call	The detection of the home position of the stapler ends abnormally.
Check item	Measures
Front saddle stapler clinch unit	<ul style="list-style-type: none"> <li>Connector check</li> <li>Harness check</li> <li>Replace the unit.</li> </ul>
Saddle control PC board (SDL)	<ul style="list-style-type: none"> <li>PC board check</li> <li>Connector check (CN2)</li> <li>Harness check</li> <li>Replace the PC board.</li> </ul>
Parts to be replaced	Remarks
Front saddle stapler clinch unit	
Saddle control PC board (SDL)	

**[CBB0] Rear saddle stapler home position abnormality (Saddle Stitch Finisher)**

Classification	Error content
Saddle stitch finisher service call	The detection of the home position of the stapler ends abnormally.
Check item	Measures
Rear saddle stapler clinch unit	<ul style="list-style-type: none"> <li>Connector check</li> <li>Harness check</li> <li>Replace the unit.</li> </ul>
Saddle control PC board (SDL)	<ul style="list-style-type: none"> <li>PC board check</li> <li>Connector check (CN1)</li> <li>Harness check</li> <li>Replace the PC board.</li> </ul>
Parts to be replaced	Remarks
Rear saddle stapler clinch unit	
Saddle control PC board (SDL)	

**[CBC0] Saddle stitch side alignment motor abnormality (Saddle Stitch Finisher)**

Classification	Error content
Saddle stitch finisher service call	<ul style="list-style-type: none"> <li>The side alignment motor or the alignment plate jog does not work normally.</li> <li>A CBC0 error will occur if an EF15 error has occurred three times in succession.</li> </ul>
Check item	Measures
Jog	<ul style="list-style-type: none"> <li>Check if there is any abnormality in the movement of the jog.</li> <li>Check if there is any mechanical problem by moving it.</li> <li>If there is any, correct it.</li> </ul>
Side alignment motor (M15)	<ul style="list-style-type: none"> <li>Check that the motor is working.</li> <li>Connector check (CN4)</li> <li>Harness check</li> <li>Replace the motor.</li> </ul>
Saddle control PC board (SDL)	<ul style="list-style-type: none"> <li>PC board check</li> <li>Connector check (CN4)</li> <li>Harness check</li> <li>Replace the PC board.</li> </ul>
Parts to be replaced	Remarks
Side alignment motor (M15)	
Saddle control PC board (SDL)	



### [CBE0] Saddle stitch folding motor abnormality (Saddle Stitch Finisher)

Classification	Error content
Saddle stitch finisher service call	<ul style="list-style-type: none"> <li>An abnormal interruption of the encoder pulse of the folding motor or its operation abnormality has occurred.</li> <li>A CBE0 error will occur if an EF17 error has occurred three times in succession.</li> </ul>

Check item	Measures
Folding motor encoder sensor (S34)	<ul style="list-style-type: none"> <li>Sensor check</li> <li>Encoder check</li> <li>Connector check (CN13)</li> <li>Harness check</li> <li>Replace the sensor.</li> </ul>
Folding motor (M17)	<ul style="list-style-type: none"> <li>Check that the motor is working.</li> <li>Connector check (CN9)</li> <li>Harness check</li> <li>Replace the motor.</li> </ul>
Saddle control PC board (SDL)	<ul style="list-style-type: none"> <li>PC board check</li> <li>Connector check (CN9, CN13)</li> <li>Harness check</li> <li>Replace the PC board.</li> </ul>

Parts to be replaced	Remarks
Folding motor encoder sensor (S34)	
Folding motor (M17)	
Saddle control PC board (SDL)	

### [CC02] Stack exit roller nip releasing home position detection abnormality (Inner Finisher)

Classification	Error content
Inner finisher service call	The detection of the home position of the stack exit roller nip releasing has ended abnormally.

Check item	Measures
Stack exit roller shift motor (M6)	<ul style="list-style-type: none"> <li>Check the motor winding to confirm that the current flows in it. If not, replace the motor.</li> <li>Check that the current flows between the connector terminals. If not, replace the cables. (CN14)</li> </ul>
Stack exit roller home position sensor (S13)	<ul style="list-style-type: none"> <li>Sensor check</li> <li>Actuator check</li> <li>Connector check (CN10)</li> <li>Harness check</li> <li>Replace the sensor.</li> </ul>
Finisher control PC board (FIN)	<ul style="list-style-type: none"> <li>PC board check</li> <li>Connector check (CN10, CN14)</li> <li>Harness check</li> <li>Replace the PC board.</li> </ul>

Parts to be replaced	Remarks
Stack exit roller shift motor (M6)	
Stack exit roller home position sensor (S13)	
Finisher control PC board (FIN)	

### [CC20] Communication error between the finisher control PC board and the saddle control PC board

Classification	Error content
Saddle stitch finisher service call	A communication error has occurred between the finisher control PC board and the saddle control PC board.

Check item	Measures
Finisher control PC board (FIN)	<ul style="list-style-type: none"> <li>PC board check</li> <li>Connector check (CN21)</li> <li>Harness check</li> <li>Replace the PC board.</li> </ul>
Saddle control PC board (SDL)	<ul style="list-style-type: none"> <li>PC board check</li> <li>Connector check (CN6)</li> <li>Harness check</li> <li>Replace the PC board.</li> </ul>
Firmware	Reinstall the finisher firmware.

Parts to be replaced	Remarks
Finisher control PC board (FIN)	
Saddle control PC board (SDL)	

### [CC30] Stack transport motor abnormality (Finisher, Saddle Stitch Finisher)

Classification	Error content
Finisher service call Saddle stitch finisher service call	<ul style="list-style-type: none"> <li>The stack transport motor or the stack transport belt does not work normally.</li> <li>A CC30 error will occur if an EA70 error has occurred three times in succession.</li> </ul>

Check item	Measures
Stack transport belt	<ul style="list-style-type: none"> <li>Check if there is any abnormality in the movement of the transport belt.</li> <li>Check if there is any mechanical problem by moving it.</li> <li>If there is any, correct it.</li> </ul>
Stack transport motor (M8)	<ul style="list-style-type: none"> <li>Check that the motor is working.</li> <li>Connector check</li> <li>Harness check</li> <li>Replace the motor.</li> </ul>
Finisher control PC board (FIN)	<ul style="list-style-type: none"> <li>PC board check</li> <li>Connector check (CN18)</li> <li>Harness check</li> <li>Replace the PC board.</li> </ul>

Parts to be replaced	Remarks
Stack transport belt	
Stack transport motor (M8)	
Finisher control PC board (FIN)	

### [CC31] Transport motor abnormality (Finisher, Saddle Stitch Finisher)

Classification	Error content
Finisher service call Saddle stitch finisher service call	The transport motor, the stack transport roller-1 or -2 does not work normally.

Check item	Measures
Stack transport roller-1, stack transport roller-2	<ul style="list-style-type: none"> <li>Check if there is any abnormality in the rotation of the roller.</li> <li>Check if there is any mechanical problem by moving it.</li> <li>If there is any, correct it.</li> </ul>
Transport motor (M7)	<ul style="list-style-type: none"> <li>Check that the motor is working.</li> <li>Connector check</li> <li>Harness check</li> <li>Replace the motor.</li> </ul>

Check item	Measures
Finisher control PC board (FIN)	<ul style="list-style-type: none"> <li>PC board check</li> <li>Connector check (CN15)</li> <li>Harness check</li> <li>Replace the PC board.</li> </ul>

Parts to be replaced	Remarks
Stack transport roller-1, stack transport roller-2	
Transport motor (M7)	
Finisher control PC board (FIN)	

#### [CC41] Assist guide cam home position abnormality (Finisher, Saddle Stitch Finisher)

Classification	Error content
Finisher service call Saddle stitch finisher service call	The home position of the assist guide cam cannot be detected.

Check item	Measures
Assist guide cam	<ul style="list-style-type: none"> <li>Check if there is any abnormality in the movement of the assist guide cam.</li> <li>Check if there is any mechanical problem by moving it.</li> <li>If there is any, correct it.</li> </ul>
Assist guide home position sensor (S6)	<ul style="list-style-type: none"> <li>Sensor check</li> <li>Actuator check</li> <li>Connector check</li> <li>Harness check</li> <li>Replace the sensor.</li> </ul>
Finisher control PC board (FIN)	<ul style="list-style-type: none"> <li>PC board check</li> <li>Connector check (CN11)</li> <li>Harness check</li> <li>Replace the PC board.</li> </ul>

Parts to be replaced	Remarks
Assist guide cam	
Assist guide home position sensor (S6)	
Finisher control PC board (FIN)	

#### [CC51] Punch sliding motor abnormality (Inner Finisher)

Classification	Error content
Inner finisher service call	The punch sliding unit does not work normally.

Check item	Measures
Punch sliding motor (M12)	Check the motor winding to confirm that the current flows in it. If not, replace the motor.
Punch sliding unit home position sensor (S23)	<ul style="list-style-type: none"> <li>Actuator check</li> <li>Connector check</li> <li>Harness check</li> <li>Measure the voltage of TP26 on the hole punch control PC board. Then check if the measured voltage is 1 V or lower when not shielded and within the range of 5 V <math>\pm</math>5% when shielded. If the voltage does not fall within the mentioned range, replace the sensor.</li> </ul>
Hole punch control PC board (HP)	<ul style="list-style-type: none"> <li>Check that the current flows between the connector terminals. If not, replace the cables. (Hole punch control PC board: CN3, CN4, CN5, CN6, CN7)</li> <li>If the error still persists after replacing the motor, the sensor and the connector, exchange the hole punch control PC board.</li> </ul>
Finisher control PC board (FIN)	<ul style="list-style-type: none"> <li>PC board check</li> <li>Connector check</li> <li>Harness check</li> <li>Replace the PC board.</li> </ul>

Parts to be replaced	Remarks
Punch sliding motor (M12)	
Punch sliding unit home position sensor (S23)	
Hole punch control PC board (HP)	
Finisher control PC board (FIN)	

### [CC51] Hole punch: Transport motor abnormality (Finisher, Saddle Stitch Finisher)

Classification	Error content
Hole punch unit service call	<ul style="list-style-type: none"> <li>The sideways deviation adjustment motor or the punch unit does not work normally.</li> <li>A CC51 error will occur if an ED11 error has occurred three times in succession or it has occurred during the initialization.</li> </ul>

Check item	Measures
Sideways deviation HP sensor (S3)	<ul style="list-style-type: none"> <li>Sensor check</li> <li>Actuator check</li> <li>Connector check (CN8)</li> <li>Harness check</li> <li>Replace the sensor.</li> </ul>
Sideways deviation adjustment motor (M2)	<ul style="list-style-type: none"> <li>Check that the motor is working.</li> <li>Connector check (CN9)</li> <li>Harness check</li> <li>Replace the motor.</li> </ul>
Hole punch control PC board (HP)	<ul style="list-style-type: none"> <li>PC board check</li> <li>Connector check (CN8, CN9)</li> <li>Harness check</li> <li>Replace the PC board.</li> </ul>

Parts to be replaced	Remarks
Sideways deviation HP sensor (S3)	
Sideways deviation adjustment motor (M2)	
Hole punch control PC board (HP)	

### [CC52] Hole punch: Skew adjustment motor abnormality (Finisher, Saddle Stitch Finisher)

Classification	Error content
Hole punch unit service call	<ul style="list-style-type: none"> <li>The skew adjustment motor or the punch unit does not work normally.</li> <li>A CC52 error will occur if an ED10 error has occurred three times in succession or it has occurred during the initialization.</li> </ul>

Check item	Measures
Skew HP sensor (S2)	<ul style="list-style-type: none"> <li>Sensor check</li> <li>Actuator check</li> <li>Connector check (CN10)</li> <li>Harness check</li> <li>Replace the sensor.</li> </ul>
Skew adjustment motor (M1)	<ul style="list-style-type: none"> <li>Check that the motor is working.</li> <li>Connector check (CN10)</li> <li>Harness check</li> <li>Replace the motor.</li> </ul>
Hole punch control PC board (HP)	<ul style="list-style-type: none"> <li>PC board check</li> <li>Connector check (CN10)</li> <li>Harness check</li> <li>Replace the PC board.</li> </ul>

Parts to be replaced	Remarks
Skew HP sensor (S2)	
Skew adjustment motor (M1)	

Parts to be replaced	Remarks
Hole punch control PC board (HP)	

#### [CC54] Hole punch: Paper detection sensors (Inner Finisher)

Classification	Error content
Inner finisher service call	The adjustment of the paper detection sensors has failed.

Check item	Measures
Paper detection sensors (S24, S25)	<ul style="list-style-type: none"> <li>• Actuator check</li> <li>• Connector check</li> <li>• Harness check</li> <li>• Measure the voltage CN6.8pin on the hole punch control PC board. Then check if the measured voltage is 3.0 V or higher when not shielded and 1.2 V or lower when shielded. If the voltage does not fall within the mentioned range, replace the board at the light-receiving or light-emitting side.</li> </ul>
Hole punch control PC board (HP)	<ul style="list-style-type: none"> <li>• PC board check</li> <li>• Connector check</li> <li>• Harness check</li> <li>• Replace the PC board.</li> </ul>

Parts to be replaced	Remarks
Paper detection sensors (S24, S25)	
Skew adjustment motor (M1)	
Hole punch control PC board (HP)	

#### [CC60] Hole punch: Punch motor abnormality (Inner Finisher)

#### [CC61] Hole punch: Punch motor home position abnormality (Inner Finisher)

Classification	Error content
Inner finisher service call	The punch motor or the punch unit does not work normally.
	<ul style="list-style-type: none"> <li>• The detection of the home position of the punch motor has ended abnormally.</li> <li>• A CC61 error will occur if an E9F0 error has occurred three times in succession or it has occurred during the initialization.</li> </ul>

Check item	Measures
Punch motor (M11)	Check the coil to confirm that the current flows in it. If not, replace it.
Punch rear shaft home position sensor (S22)	<ul style="list-style-type: none"> <li>• Actuator check</li> <li>• Connector check</li> <li>• Harness check</li> <li>• Measure the voltage of TP25 on the hole punch control PC board. Then check if the measured voltage is 1 V or lower when not shielded and within the range of 5 V <math>\pm</math>5% when shielded. If the voltage does not fall within the mentioned range, replace the sensor.</li> </ul>
Punch shaft home position sensor (S26)	<ul style="list-style-type: none"> <li>• Actuator check</li> <li>• Connector check</li> <li>• Harness check</li> <li>• Measure the voltage of TP24 on the hole punch control PC board. Then check if the measured voltage is 1 V or lower when not shielded and within the range of 5 V <math>\pm</math>5% when shielded. If the voltage does not fall within the mentioned range, replace the sensor.</li> </ul>
Punch motor clock sensor (S20)	<ul style="list-style-type: none"> <li>• Actuator check</li> <li>• Connector check</li> <li>• Harness check</li> <li>• Measure the voltage of TP27 on the hole punch control PC board. Then check if the measured voltage is 1 V or lower when not shielded and within the range of 5 V <math>\pm</math>5% when shielded. If the voltage does not fall within the mentioned range, replace the sensor.</li> </ul>

Check item	Measures
Hole punch control PC board (HP)	<ul style="list-style-type: none"> <li>• PC board check</li> <li>• Connector check (CN2, CN5, CN6, CN7, CN8)</li> <li>• Harness check</li> <li>• Replace the PC board.</li> </ul>

Parts to be replaced	Remarks
Punch motor (M11)	
Punch rear shaft home position sensor (S22)	
Punch shaft home position sensor (S26)	
Punch motor clock sensor (S20)	
Hole punch control PC board (HP)	

**[CC61] Hole punch: Punch motor home position detection abnormality (Finisher, Saddle Stitch Finisher)**

Classification	Error content
Hole punch unit service call	<ul style="list-style-type: none"> <li>• The punch motor or the punch unit does not work normally.</li> <li>• A CC61 error will occur if an E9F0 error has occurred three times in succession or it has occurred during the initialization.</li> </ul>

Check item	Measures
Punch motor (M3)	<ul style="list-style-type: none"> <li>• Check that the motor is working.</li> <li>• Connector check</li> <li>• Harness check</li> <li>• Replace the motor.</li> </ul>
Punch HP sensor (S4)	<ul style="list-style-type: none"> <li>• Sensor check</li> <li>• Actuator check</li> <li>• Connector check</li> <li>• Harness check</li> <li>• Replace the sensor.</li> </ul>
Hole punch control PC board (HP)	<ul style="list-style-type: none"> <li>• PC board check</li> <li>• Connector check (CN3, CN4, CN5)</li> <li>• Harness check</li> <li>• Replace the PC board.</li> </ul>
Finisher control PC board	<ul style="list-style-type: none"> <li>• PC board check</li> <li>• Connector check (CN7)</li> <li>• Harness check</li> <li>• Replace the PC board.</li> </ul>

Parts to be replaced	Remarks
Punch motor (M3)	
Punch HP sensor (S4)	
Hole punch control PC board (HP)	
Finisher control PC board	

**[CC71] Hole punch: Punch ROM abnormality (Finisher, Saddle Stitch Finisher)**

Classification	Error content
Hole punch unit service call	An abnormality of the checksum value of the hole punch control PC board is detected when the power is turned ON.

Check item	Measures
Reproducibility	Turn the power OFF and then back ON to check the occurrence.
Hole punch control PC board (HP)	<ul style="list-style-type: none"> <li>• PC board check</li> <li>• Connector check</li> <li>• Harness check</li> <li>• Replace the PC board.</li> </ul>
Finisher control PC board (FIN)	<ul style="list-style-type: none"> <li>• PC board check</li> <li>• Connector check</li> <li>• Harness check</li> <li>• Replace the PC board.</li> </ul>

Parts to be replaced	Remarks
Hole punch control PC board (HP)	
Finisher control PC board (FIN)	

**[CC72] Hole punch: Punch RAM data abnormality (Finisher, Saddle Stitch Finisher)**

Classification	Error content
Hole punch unit service call	An abnormality of the checksum value of the finisher control PC board is detected when the power is turned ON.

Check item	Measures
Reproducibility	Turn the power OFF and then back ON to check the occurrence.
Hole punch control PC board (HP)	<ul style="list-style-type: none"> <li>• PC board check</li> <li>• Connector check</li> <li>• Harness check</li> <li>• Replace the PC board.</li> </ul>
Finisher control PC board (FIN)	<ul style="list-style-type: none"> <li>• PC board check</li> <li>• Connector check</li> <li>• Harness check</li> <li>• Replace the PC board.</li> </ul>

Parts to be replaced	Remarks
Hole punch control PC board (HP)	
Finisher control PC board (FIN)	

**[CC73] Hole punch: Punch device power supply abnormality (Finisher, Saddle Stitch Finisher)****[CC74] Hole punch: Punch transport pulse abnormality (Finisher, Saddle Stitch Finisher)**

Classification	Error content
Hole punch unit service call	The punch motor or the punch unit does not work normally.

Check item	Measures
Reproducibility	Turn the power OFF and then back ON to check the occurrence.
Firmware	Reinstall the finisher firmware.
Hole punch control PC board (HP)	<ul style="list-style-type: none"> <li>• PC board check</li> <li>• Connector check</li> <li>• Harness check</li> <li>• Replace the PC board.</li> </ul>

Parts to be replaced	Remarks
Hole punch control PC board (HP)	

### [CC80] Front alignment plate home position sensor detection abnormality (Inner Finisher)

Classification	Error content
Inner finisher service call	The front alignment motor or the front alignment plate does not work normally.

Check item	Measures
Front alignment motor (M2)	<ul style="list-style-type: none"> <li>• Check that the motor is working.</li> <li>• Connector check</li> <li>• Harness check</li> <li>• Check the coil to confirm that the current flows in it.</li> <li>• Replace the motor.</li> </ul>
Front alignment plate home position sensor (S5)	<ul style="list-style-type: none"> <li>• Actuator check</li> <li>• Connector check</li> <li>• Harness check</li> <li>• Measure the voltage of TP15 on the finisher control PC board. Then check that the measured voltage is 1 V or lower when not shielded and within the range of 3.3 V <math>\pm</math>5% when shielded. If the voltage does not fall within the mentioned range, replace the sensor.</li> </ul>
Finisher control PC board (FIN)	<ul style="list-style-type: none"> <li>• PC board check</li> <li>• Connector check (CN5, CN12)</li> <li>• Harness check</li> <li>• Replace the PC board.</li> </ul>

Parts to be replaced	Remarks
Front alignment motor (M2)	
Front alignment plate home position sensor (S5)	
Finisher control PC board (FIN)	

### [CC80] Rear alignment motor abnormality (Finisher, Saddle Stitch Finisher)

Classification	Error content
Finisher service call Saddle stitch finisher service call	<ul style="list-style-type: none"> <li>• The rear alignment motor or the rear alignment plate does not work normally.</li> <li>• A CC80 error will occur if an ED14 error has occurred three times in succession.</li> </ul>

Check item	Measures
Rear alignment plate	<ul style="list-style-type: none"> <li>• Check if there is any abnormality in the installation of the rear alignment plate.</li> <li>• Check if there is any mechanical problem by moving it.</li> <li>• If there is any, correct it.</li> </ul>
Rear alignment motor (M6)	<ul style="list-style-type: none"> <li>• Check that the motor is working.</li> <li>• Connector check</li> <li>• Harness check</li> <li>• Replace the motor.</li> </ul>
Finisher control PC board (FIN)	<ul style="list-style-type: none"> <li>• PC board check</li> <li>• Connector check (CN18)</li> <li>• Harness check</li> <li>• Replace the PC board.</li> </ul>

Parts to be replaced	Remarks
Rear alignment plate	
Rear alignment motor (M6)	
Finisher control PC board (FIN)	



### [CC93] Knurled roller shift solenoid abnormality (Inner Finisher)

Classification	Error content
Inner finisher service call	An abnormality has occurred in the knurled roller shift solenoid.
Check item	Measures
Knurled roller shift solenoid (SOL3)	<ul style="list-style-type: none"> <li>• Solenoid check</li> <li>• Connector check</li> <li>• Harness check</li> <li>• Check the coil to confirm that the current flows in it.</li> <li>• Replace the solenoid.</li> </ul>
2nd transport motor (M4)	<ul style="list-style-type: none"> <li>• Check the motor winding to confirm that the current flows in it. If not, replace the motor.</li> <li>• Check that the current flows between the connector terminals. If not, replace the cables. (CN14)</li> </ul>
Knurled roller home position sensor (S10)	<ul style="list-style-type: none"> <li>• Sensor check</li> <li>• Actuator check</li> <li>• Connector check</li> <li>• Harness check</li> <li>• Replace the sensor.</li> </ul>
Finisher control PC board (FIN)	<ul style="list-style-type: none"> <li>• PC board check</li> <li>• Connector check (CN22, CN14)</li> <li>• Harness check</li> <li>• Replace the PC board.</li> </ul>
Gear	<p>Check the gear of the transport unit in the finishing section. When assembling the gear, align its rib to the protrusion as shown in the figure.</p> 

Fig.8-31

Parts to be replaced	Remarks
Knurled roller shift solenoid (SOL3)	
2nd transport motor (M4)	
Knurled roller home position sensor (S10)	
Finisher control PC board (FIN)	

### [CC94] Fan motor abnormality (Inner Finisher)

Classification	Error content
Inner finisher service call	An abnormality has occurred in the fan motor.
Check item	Measures
Fan motor (M9)	<ul style="list-style-type: none"> <li>• Check the motor winding to confirm that the current flows in it. If not, replace the motor.</li> </ul>
Finisher control PC board (FIN)	<ul style="list-style-type: none"> <li>• PC board check</li> <li>• Connector check</li> <li>• Harness check</li> <li>• Replace the PC board.</li> </ul>

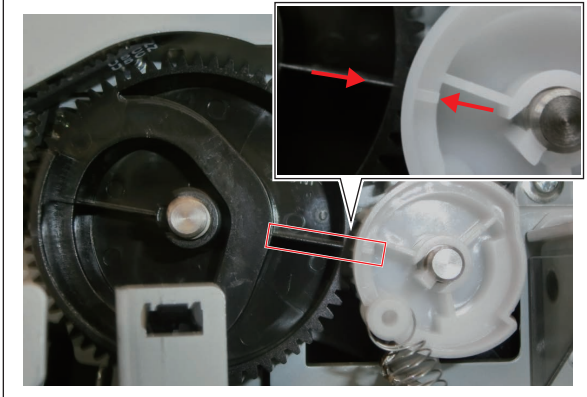
Parts to be replaced	Remarks
Fan motor (M9)	
Finisher control PC board (FIN)	

### [CDE0] Paddle motor abnormality (Finisher, Saddle Stitch Finisher)

Classification	Error content
Finisher service call Saddle stitch finisher service call	<ul style="list-style-type: none"> <li>The paddle motor or the paddle does not work normally.</li> <li>A CDE0 error will occur if an ED15 error has occurred three times in succession.</li> </ul>

Check item	Measures
Paddle	<ul style="list-style-type: none"> <li>Check if there is any abnormality in the movement of the paddle.</li> <li>Check if there is any mechanical problem by moving it.</li> <li>If there is any, correct it.</li> </ul>
Paddle motor (M3)	<ul style="list-style-type: none"> <li>Check that the motor is working.</li> <li>Connector check (CN16)</li> <li>Harness check</li> <li>Replace the motor.</li> </ul>
Finisher control PC board (FIN)	<ul style="list-style-type: none"> <li>PC board check</li> <li>Connector check (CN16)</li> <li>Harness check</li> <li>Replace the PC board.</li> </ul>

Parts to be replaced	Remarks
Paddle	
Paddle motor (M3)	
Finisher control PC board (FIN)	

### [CE00] Communication error between the finisher control PC board and the hole punch control PC board (Finisher, Saddle Stitch Finisher)

Classification	Error content
Finisher service call Saddle stitch finisher service call	A communication error has occurred between the finisher control PC board and the hole punch control PC board.

Check item	Measures
Finisher control PC board (FIN)	<ul style="list-style-type: none"> <li>PC board check</li> <li>Connector check (CN7)</li> <li>Harness check</li> <li>Replace the PC board.</li> </ul>
Hole punch control PC board (HP)	<ul style="list-style-type: none"> <li>PC board check</li> <li>Connector check (CN4)</li> <li>Harness check</li> <li>Replace the PC board.</li> </ul>
Firmware	<ul style="list-style-type: none"> <li>Reinstall the finisher firmware.</li> <li>Reinstall the hole punch unit firmware.</li> </ul>

Parts to be replaced	Remarks
Finisher control PC board (FIN)	
Hole punch control PC board (HP)	

### [CE50] Temperature/humidity sensor abnormality

Classification	Error content
Copy process related service call	The output value of the temperature/humidity sensor is out of the specified range.

Check item	Measures
Temperature/humidity sensor	<ul style="list-style-type: none"> <li>• Sensor check</li> <li>• Connector check</li> <li>• Harness check</li> <li>• Replace the sensor.</li> </ul>
LGC board	<ul style="list-style-type: none"> <li>• PC board check</li> <li>• Connector check (CN320)</li> <li>• Harness check</li> <li>• Replace the PC board.</li> </ul>

Parts to be replaced	Remarks
Temperature/humidity sensor	
LGC board	

### [CE90] Drum thermistor abnormality

Classification	Error content
Copy process related service call	The output value of the drum thermistor is out of the specified range.

Check item	Measures
Drum thermistor	<ul style="list-style-type: none"> <li>• Thermistor check</li> <li>Input check: FS-03-[F1]ON/[3]</li> <li>• Connector check (CN319)</li> <li>• Harness check</li> <li>• Replace the sensor.</li> </ul>
LGC board	<ul style="list-style-type: none"> <li>• PC board check</li> <li>• Connector check (CN319)</li> <li>• Harness check</li> <li>• Replace the PC board.</li> </ul>
Developer unit	Check if there is any abnormality in the connector and the harness of the developer unit.

Parts to be replaced	Remarks
Drum thermistor	
LGC board	

### [CF10] Communication module writing abnormality (Finisher, Saddle Stitch Finisher)

Classification	Error content
Finisher service call Saddle stitch finisher service call	An abnormality to write into the communication module has occurred.

Check item	Measures
Finisher	Check if the harness between the MFP and the Finisher is disconnected or open circuited.
Finisher control PC board (FIN)	<ul style="list-style-type: none"> <li>• PC board check</li> <li>• Connector check (CN3, CN13)</li> <li>• Harness check</li> <li>• Replace the PC board.</li> </ul>
LGC board	<ul style="list-style-type: none"> <li>• PC board check</li> <li>• Connector check (CN314)</li> <li>• Harness check</li> <li>• Replace the PC board.</li> </ul>
Firmware	Reinstall the finisher firmware.

Parts to be replaced	Remarks
Finisher control PC board (FIN)	
LGC board	

### 8.3.4 Service call (F series errors)

#### [F070] Communication error between the system-CPU and the engine-CPU

Classification	Error content
Communication related service call	A communication error has occurred between the system-CPU and the engine-CPU.

Check item	Measures
Reproducibility	Turn the power OFF and then back ON. Then check if the error code changes to another one. If it changes to another code, follow its troubleshooting procedure.
Firmware	<ul style="list-style-type: none"> <li>Check the version of the system firmware on the SYS board.</li> <li>Check the version of the engine firmware on the LGC board.</li> </ul>
SYS board	<ul style="list-style-type: none"> <li>PC board check</li> <li>Connector check (SYS board - LGC board)</li> <li>Harness check (SYS board - LGC board)</li> <li>Replace the PC board.</li> </ul>
LGC board	<ul style="list-style-type: none"> <li>PC board check</li> <li>Connector check (SYS board - LGC board)</li> <li>Harness check (SYS board - LGC board)</li> <li>Replace the PC board.</li> </ul>
Switching regulator	<ul style="list-style-type: none"> <li>PC board check</li> <li>Connector check (switching regulator - LGC board)</li> <li>Harness check (switching regulator - LGC board)</li> <li>Replace the PC board.</li> </ul>

Parts to be replaced	Remarks
SYS board	
LGC board	
Switching regulator	

#### [F071] Communication initialization error between the system-CPU and the engine-CPU

Classification	Error content
Communication related service call	A communication initialization error has occurred between the system-CPU and the engine-CPU.

Check item	Measures
Firmware	<ul style="list-style-type: none"> <li>Check the version of the system firmware on the SYS board.</li> <li>Check the version of the engine firmware on the LGC board.</li> </ul>
SYS board	<ul style="list-style-type: none"> <li>PC board check</li> <li>Connector check (SYS board - LGC board)</li> <li>Harness check (SYS board - LGC board)</li> <li>Replace the PC board.</li> </ul>
LGC board	<ul style="list-style-type: none"> <li>PC board check</li> <li>Connector check (SYS board - LGC board)</li> <li>Harness check (SYS board - LGC board)</li> <li>Replace the PC board.</li> </ul>
Switching regulator	<ul style="list-style-type: none"> <li>PC board check</li> <li>Connector check (switching regulator - LGC board)</li> <li>Harness check (switching regulator - LGC board)</li> <li>Replace the PC board.</li> </ul>
LGC board	Check that the LED2 on the LGC board is lit. If not, replace the LGC board.

Parts to be replaced	Remarks
SYS board	
LGC board	
Switching regulator	

### [F074] Communication error between the system-CPU and the engine-CPU

Classification	Error content
Communication related service call	There is no response for the engine-CPU.

Check item	Measures
Reproducibility	Turn the power OFF and then back ON. Then check if the error code changes to another one. If it changes to another code, follow its troubleshooting procedure.
Firmware	<ul style="list-style-type: none"> <li>Check the version of the system firmware on the SYS board.</li> <li>Check the version of the engine firmware on the LGC board.</li> </ul>
SYS board	<ul style="list-style-type: none"> <li>PC board check</li> <li>Connector check (SYS board - LGC board)</li> <li>Harness check (SYS board - LGC board)</li> <li>Replace the PC board.</li> </ul>
LGC board	<ul style="list-style-type: none"> <li>PC board check</li> <li>Connector check (SYS board - LGC board)</li> <li>Harness check (SYS board - LGC board)</li> <li>Replace the PC board.</li> </ul>
Switching regulator	<ul style="list-style-type: none"> <li>PC board check</li> <li>Connector check (switching regulator - LGC board)</li> <li>Harness check (switching regulator - LGC board)</li> <li>Replace the PC board.</li> </ul>
LGC board	Check that the LED2 on the LGC board is lit. If not, replace the LGC board.

Parts to be replaced	Remarks
SYS board	
LGC board	
Switching regulator	

### [F090] SRAM error on the SYS board

Classification	Error content
System related service call	Initialization error of the SRAM on the SYS board.

Check item	Measures
SRAM	<ul style="list-style-type: none"> <li>Check if the SRAM is installed properly.</li> <li>By following the procedure below, initialize the SRAM to check that it should be restored. <ol style="list-style-type: none"> <li>Shut down the MFP.</li> <li>Perform FS-08.</li> <li>Press [CLASSIC].</li> <li>When "SRAM REQUIRES INITIALIZATION" is displayed on the LCD screen, check the destination and then press the [START] button. If the destination is not correct, enter the correct one and then press the [START] button.</li> <li>After the confirmation message is displayed on the LCD screen, press [INITIALIZE]. (SRAM initialization starts.)</li> <li>Enter the serial number of the MFP correctly. (FS-08-9601)</li> <li>Initialize the NIC information. (FS-08-9083)</li> <li>Shut down the MFP.</li> <li>Perform FS-05.</li> <li>Press [CLASSIC].</li> <li>Perform FS-05-3203 and FS-05-3240 (Data transfer of characteristic value of scanner).</li> <li>By using the [4] [TEST PRINT] test pattern, perform FS-05-7869 (Automatic gamma adjustment (PPC)).</li> <li>By using the [70] [TEST PRINT] test pattern, perform FS-05-8008 and FS-05-8009 (Automatic gamma adjustment (PRT)).</li> <li>Reboot the MFP.</li> </ol> </li> <li>If the error still persists, replace the SRAM.</li> </ul>

Check item	Measures
SYS board	<ul style="list-style-type: none"> <li>• PC board check</li> <li>• Connector check</li> <li>• Harness check</li> <li>• Replace the PC board.</li> </ul>

Parts to be replaced	Remarks
SRAM	
SYS board	

### [F100\_0] Storage device initialization error

Classification	Error content
System related service call	The key data operation has failed.

Check item	Measures
SRAM	<ul style="list-style-type: none"> <li>• Check if the SRAM is installed properly.</li> <li>• By following the procedure below, initialize the SRAM to check that it should be restored. <ol style="list-style-type: none"> <li>1. Shut down the MFP.</li> <li>2. Perform FS-08.</li> <li>3. Press [CLASSIC].</li> <li>4. When "SRAM REQUIRES INITIALIZATION" is displayed on the LCD screen, check the destination and then press the [START] button. If the destination is not correct, enter the correct one and then press the [START] button.</li> <li>5. After the confirmation message is displayed on the LCD screen, press [INITIALIZE]. (SRAM initialization starts.)</li> <li>6. Enter the serial number of the MFP correctly. (FS-08-9601)</li> <li>7. Initialize the NIC information. (FS-08-9083)</li> <li>8. Shut down the MFP.</li> <li>9. Perform FS-05.</li> <li>10. Press [CLASSIC].</li> <li>11. Perform FS-05-3203 and FS-05-3240 (Data transfer of characteristic value of scanner).</li> <li>12. By using the [4] [TEST PRINT] test pattern, perform FS-05-7869 (Automatic gamma adjustment (PPC)).</li> <li>13. By using the [70] [TEST PRINT] test pattern, perform FS-05-8008 and FS-05-8009 (Automatic gamma adjustment (PRT)).</li> <li>14. Reboot the MFP. <ul style="list-style-type: none"> <li>• If the error still persists, replace the SRAM.</li> </ul> </li> </ol> </li> </ul>
SYS board	<ul style="list-style-type: none"> <li>• PC board check</li> <li>• Connector check</li> <li>• Harness check</li> <li>• Replace the PC board.</li> </ul>

Parts to be replaced	Remarks
SRAM	
SYS board	

### [F100\_1] Storage device initialization error

Classification	Error content
System related service call	Encryption key data of either the SRAM or the SYS board are damaged.

Check item	Measures
Encryption key status	Perform HS-73 Firmware Assist mode > Key Backup/Restore and check the displayed message. Take the appropriate countermeasures shown below according to the error and messages displayed in the "SRAM" and "FROM" fields.
"SRAM" field: OK "FROM" field: AccessFailed	Replace the SYS board.

Check item	Measures
“SRAM” field: OK “FROM” field: KeyNull	Recover the encryption key on the SYS board. 📖 P. 9-26 “[C] Restore Encryption Key and License”
“SRAM” field: OK “FROM” field: KeyBroken	
“SRAM” field: AccessFailed “FROM” field: OK	Replace the SRAM. (Backup data not used)
“SRAM” field: KeyNull “FROM” field: OK	Recover the encryption key on the SRAM by means of backup. 📖 P. 9-31 “[H] Backup encryption key and license (FROM > SRAM)”
“SRAM” field: KeyBroken “FROM” field: OK	
“SRAM” field: KeyMismatch “FROM” field: KeyMismatch	<ul style="list-style-type: none"> <li>The error occurs when the SYS board is replaced: Recover the encryption key on the SYS board. 📖 P. 9-26 “[C] Restore Encryption Key and License”</li> <li>The error occurs except when the SYS board is replaced: Replace the SRAM.</li> </ul>
Firmware	If the error still persists, reinstall the system firmware and the system software by the HS-49 Firmware Update mode.

Parts to be replaced	Remarks
SRAM	
SYS board	

### [F100\_2] Storage device initialization error

Classification	Error content
System related service call	Encryption key data of both the SRAM or the SYS board are damaged.

Check item	Measures
Encryption key status	Perform HS-73 Firmware Assist mode > Key Backup/Restore and check the displayed message. Take the appropriate countermeasures shown below according to the error and messages displayed in the “SRAM” and “FROM” fields.
“SRAM” field: * “FROM” field: AccessFailed	Replace the SYS board. <ul style="list-style-type: none"> <li>When there are backup data in a USB storage device: <ol style="list-style-type: none"> <li>Recover all the data on the SRAM by means of cloning. HS-59 SRAM Data Cloning &gt; Restore SRAM Data from USB</li> <li>Recover the encryption key and the license on the SYS board by means of restoring. 📖 P. 9-26 “[C] Restore Encryption Key and License”</li> </ol> </li> </ul>
“SRAM” field: AccessFailed “FROM” field: *	Replace the SRAM.
“SRAM” field: KeyNull / KeyBroken “FROM” field: KeyNull / KeyBroken	<ul style="list-style-type: none"> <li>When there are no backup data in a USB storage device: Reinstall the system software.</li> <li>When there are backup data in a USB storage device: <ol style="list-style-type: none"> <li>Recover all the data on the SRAM by means of cloning. HS-59 SRAM Data Cloning &gt; Restore SRAM Data from USB</li> <li>Recover the encryption key and the license on the SYS board by means of restoring. 📖 P. 9-26 “[C] Restore Encryption Key and License”</li> </ol> </li> </ul>
Firmware	If the error still persists, reinstall the system firmware and the system software by the HS-49 Firmware Update mode.

\* AccessFailed, KeyNull or KeyBroken

Parts to be replaced	Remarks
SRAM	
SYS board	

### [F100\_3] Serial number value error

Classification	Error content
System related service call	Only the first two characters of the serial number are entered. (The serial number is not completely entered.)

Check item	Measures
Serial number	<ul style="list-style-type: none"><li>Perform FS-08-9601 (Equipment number (serial number) display) to enter the serial number.</li><li>If an F100_3 error occurs at the FS Menu startup, select HS-76 SRAM Maintenance &gt; Set Serial Number and enter the serial number.</li></ul>

### [F100\_4] Hash check error of encryption partition key

Classification	Error content
System related service call	Hash check error of encryption partition key

Check item	Measures
SYS board	Replace the SYS board.

Parts to be replaced	Remarks
SYS board	

### [F101\_0] Optional storage device installation error

#### [F101\_1] Optional storage device root partition mount error (formatting failure)

#### [F101\_2] Optional storage device partition mount error

#### [F101\_3] Optional storage device partition mount error

Classification	Error content
System related service call	Sub code 0: The installation of the storage device cannot be detected. Sub code 1: The storage device cannot be installed due to damage to the areas in which the program is mainly stored. Sub codes 2, 3: The areas other than those described in the F101_1 and F101_4 to F101_10 errors are damaged.

Check item	Measures
1. SRAM	Check if the SRAM was used in another MFP.
2. Optional storage device	Turn the power of the MFP OFF and check the installation status of the optional storage device. <ul style="list-style-type: none"><li>Check if there is any abnormality in the connector and the harness.</li><li>Check if the connector pins are bent.</li><li>Check if the optional storage device was used in another MFP.</li></ul>
3. Key	If the error still persists even after step 2, perform this step. <ul style="list-style-type: none"><li>Perform HS-73 Firmware Assist &gt; Key Backup/Restore and check that each Key Status is "OK".</li><li>If not, recover the key. (Carry out SRAM to FROM copying or FROM to SRAM copying.)</li></ul>
4. Format	If the error still persists even after step 3, perform this step. Perform HS-73 Firmware Assist > Format Storage, and then install "System Software (HD data)" with HS-49 Firmware Update. <b>Notes:</b> The following contents will be deleted with this operation. <ul style="list-style-type: none"><li>Message Log</li><li>Job Log</li><li>Spool Data (Print, Email reception)</li><li>Template</li></ul>
5. Setting	If an F101_1 error has occurred while a security storage device is installed or if the error still persists even after step 4, perform the following item and reattempt step 4. <ul style="list-style-type: none"><li>HS-74 Storage Assist &gt; Revert Factory Initial Status Storage</li></ul>
6. Harness of the optional storage device	If the error still persists even after step 5, replace the harness of the optional storage device.
7. Optional storage device	If the error still persists even after step 6, replace the optional storage device.



Check item	Measures
8. SYS board	If the error still persists even after step 7, replace the SYS board.

Parts to be replaced	Remarks
Harness of the optional storage device	
Optional storage device	
SYS board	

**[F101\_4] Optional storage device partition mount error**

**[F101\_12] Optional storage device mount error**

Classification	Error content
System related service call	Sub code 4: The "/work" partition is damaged. Sub code 12: File link error in the "/work" partition.

Check item	Measures
1. SRAM	Check if the SRAM was used in another MFP.
2. Optional storage device	Turn the power of the MFP OFF and check the installation status of the optional storage device. <ul style="list-style-type: none"> <li>Check if there is any abnormality in the connector and the harness.</li> <li>Check if the connector pins are bent.</li> <li>Check if the optional storage device was used in another MFP.</li> </ul>
3. Key	If the error still persists even after step 2, perform this step. <ul style="list-style-type: none"> <li>Perform HS-73 Firmware Assist &gt; Key Backup/Restore and check that each Key Status is "OK".</li> <li>If not, recover the key. (Carry out SRAM to FROM copying or FROM to SRAM copying.)</li> </ul>
4. Recovery	If the error still persists even after step 3, perform HS-75 File System Recovery > Recovery F/S > /work and then reboot the MFP.
5. Initialization	If the error still persists even after step 4, perform HS-75 File System Recovery > Initialize Storage > /work and then reboot the MFP.
6. Format	If the error still persists even after step 5, perform this step. Perform HS-73 Firmware Assist > Format Storage, and then install "System Software (HD data)" with HS-49 Firmware Update. <p><b>Notes:</b></p> <ul style="list-style-type: none"> <li>The following contents will be deleted with this operation.</li> <li>Message Log</li> <li>Job Log</li> <li>Spool Data (Print, Email reception)</li> <li>Template</li> </ul>
7. Setting	If the error still persists even after step 6, perform the following and then reattempt step 6. <ul style="list-style-type: none"> <li>HS-74 Storage Assist &gt; Revert Factory Initial Status Storage</li> </ul>
8. Optional storage device	If the error still persists even after step 7, replace the optional storage device.
9. Harness of the optional storage device	If the error still persists even after step 8, replace the harness of the optional storage device.
10. SYS board	If the error still persists even after step 9, replace the SYS board.

Parts to be replaced	Remarks
Harness of the optional storage device	
Optional storage device	
SYS board	

## [F101\_5] Partition mount error

Classification	Error content
System related service call	Sub code 5: The "/registration" partition is damaged.

Check item	Measures
1. SRAM	Check if the SRAM was used in another MFP.
2. Optional storage device	Turn the power of the MFP OFF and check the installation status of the optional storage device. <ul style="list-style-type: none"> <li>• Check if there is any abnormality in the connector and the harness.</li> <li>• Check if the connector pins of the optional storage device are bent.</li> <li>• Check if the optional storage device was used in another MFP.</li> </ul>
3. Key	If the error still persists even after step 2, perform this step. <ul style="list-style-type: none"> <li>• Perform HS-73 Firmware Assist &gt; Key Backup/Restore and check that each Key Status is "OK".</li> <li>• If not, recover the key. (Carry out SRAM to FROM copying or FROM to SRAM copying.)</li> </ul>
4. Recovery	If the error still persists after step 3, perform HS-75 File System Recovery > Recovery F/S > /registration and reboot the MFP.
5. Initialization	If the error still persists even after step 4, perform HS-75 File System Recovery > Initialize Storage > /registration and then reboot the MFP.
6. Format	If the error still persists even after step 5, perform this step. Perform HS-73 Firmware Assist > Format Storage, and then install "System Software (HD data)" with HS-49 Firmware Update. <p><b>Notes:</b></p> <p>The following contents will be deleted with this operation.</p> <ul style="list-style-type: none"> <li>• Message Log</li> <li>• Job Log</li> <li>• Spool Data (Print, Email reception)</li> <li>• Template</li> </ul>
7. Setting	If the error still persists even after step 6, perform the following and then reattempt step 6. <ul style="list-style-type: none"> <li>• HS-74 Storage Assist &gt; Revert Factory Initial Status Storage</li> </ul>
8. Optional storage device	If the error still persists even after step 7, replace the optional storage device.
9. Harness of the optional storage device	If the error still persists even after step 8, replace the harness of the optional storage device.
10. SYS board	If the error still persists even after step 9, replace the SYS board.

Parts to be replaced	Remarks
Harness of the optional storage device	
Optional storage device	
SYS board	

## [F101\_6] Partition mount error

Classification	Error content
System related service call	Sub code 6: The "/backup" partition is damaged.

Check item	Measures
1. SRAM	Check if the SRAM was used in another MFP.
2. Optional storage device	Turn the power of the MFP OFF and check the installation status of the optional storage device. <ul style="list-style-type: none"> <li>• Check if there is any abnormality in the connector and the harness.</li> <li>• Check if the connector pins of the optional storage device are bent.</li> <li>• Check if the optional storage device was used in another MFP.</li> </ul>
3. Key	If the error still persists even after step 2, perform this step. <ul style="list-style-type: none"> <li>• Perform HS-73 Firmware Assist &gt; Key Backup/Restore and check that each Key Status is "OK".</li> <li>• If not, recover the key. (Carry out SRAM to FROM copying or FROM to SRAM copying.)</li> </ul>
4. Recovery	If the error still persists even after step 3, perform HS-75 File System Recovery > Recovery F/S > /backup and then reboot the MFP.
5. Initialization	If the error still persists even after step 4, perform HS-75 File System Recovery > Initialize Storage > /backup and then reboot the MFP.
6. Format	If the error still persists even after step 5, perform this step. Perform HS-73 Firmware Assist > Format Storage, and then install "System Software (HD data)" with HS-49 Firmware Update. <p><b>Notes:</b></p> <p>The following contents will be deleted with this operation.</p> <ul style="list-style-type: none"> <li>• Message Log</li> <li>• Job Log</li> <li>• Spool Data (Print, Email reception)</li> <li>• Template</li> </ul>
7. Setting	If the error still persists even after step 6, perform the following and then reattempt step 6. <ul style="list-style-type: none"> <li>• HS-74 Storage Assist &gt; Revert Factory Initial Status Storage</li> </ul>
8. Optional storage device	If the error still persists even after step 7, replace the optional storage device.
9. Harness of the optional storage device	If the error still persists even after step 8, replace the harness of the optional storage device.
10. SYS board	If the error still persists even after step 9, replace the SYS board.

Parts to be replaced	Remarks
Harness of the optional storage device	
Optional storage device	
SYS board	

## [F101\_7] Partition mount error

Classification	Error content
System related service call	Sub code 7: The "/imagedata" partition is damaged.

Check item	Measures
1. SRAM	Check if the SRAM was used in another MFP.
2. Optional storage device	Turn the power of the MFP OFF and check the installation status of the optional storage device. <ul style="list-style-type: none"> <li>• Check if there is any abnormality in the connector and the harness.</li> <li>• Check if the connector pins of the optional storage device are bent.</li> <li>• Check if the optional storage device was used in another MFP.</li> </ul>
3. Key	If the error still persists even after step 2, perform this step. <ul style="list-style-type: none"> <li>• Perform HS-73 Firmware Assist &gt; Key Backup/Restore and check that each Key Status is "OK".</li> <li>• If not, recover the key. (Carry out SRAM to FROM copying or FROM to SRAM copying.)</li> </ul>
4. Recovery	If the error still persists after step 3, perform HS-75 File System Recovery > Recovery F/S > /imagedata and reboot the MFP.
5. Initialization	If the error still persists even after step 4, perform HS-75 File System Recovery > Initialize Storage > /imagedata and then reboot the MFP.
6. Format	If the error still persists even after step 5, perform this step. Perform HS-73 Firmware Assist > Format Storage, and then install "System Software (HD data)" with HS-49 Firmware Update. <p><b>Notes:</b></p> <ul style="list-style-type: none"> <li>• The following contents will be deleted with this operation.</li> <li>• Message Log</li> <li>• Job Log</li> <li>• Spool Data (Print, Email reception)</li> <li>• Template</li> </ul>
7. Setting	If the error still persists even after step 6, perform the following and then reattempt step 6. <ul style="list-style-type: none"> <li>• HS-74 Storage Assist &gt; Revert Factory Initial Status Storage</li> </ul>
8. Optional storage device	If the error still persists even after step 7, replace the optional storage device.
9. Harness of the optional storage device	If the error still persists even after step 8, replace the harness of the optional storage device.
10. SYS board	If the error still persists even after step 9, replace the SYS board.

Parts to be replaced	Remarks
Harness of the optional storage device	
Optional storage device	
SYS board	

## [F101\_8] Partition mount error

Classification	Error content
System related service call	Sub code 8: The "/storage" partition is damaged.

Check item	Measures
1. SRAM	Check if the SRAM was used in another MFP.
2. Optional storage device	Turn the power of the MFP OFF and check the installation status of the optional storage device. <ul style="list-style-type: none"> <li>• Check if there is any abnormality in the connector and the harness.</li> <li>• Check if the connector pins of the optional storage device are bent.</li> <li>• Check if the optional storage device was used in another MFP.</li> </ul>
3. Key	If the error still persists even after step 2, perform this step. <ul style="list-style-type: none"> <li>• Perform HS-73 Firmware Assist &gt; Key Backup/Restore and check that each Key Status is "OK".</li> <li>• If not, recover the key. (Carry out SRAM to FROM copying or FROM to SRAM copying.)</li> </ul>
4. Recovery	If the error still persists even after step 3, perform HS-75 File System Recovery > Recovery F/S > /storage and then reboot the MFP.
5. Initialization	If the error still persists even after step 4, perform HS-75 File System Recovery > Initialize Storage > /storage and then reboot the MFP.
6. Format	If the error still persists even after step 5, perform this step. Perform HS-73 Firmware Assist > Format Storage, and then install "System Software (HD data)" with HS-49 Firmware Update. <p><b>Notes:</b></p> <p>The following contents will be deleted with this operation.</p> <ul style="list-style-type: none"> <li>• Message Log</li> <li>• Job Log</li> <li>• Spool Data (Print, Email reception)</li> <li>• Template</li> </ul>
7. Setting	If the error still persists even after step 6, perform the following and then reattempt step 6. <ul style="list-style-type: none"> <li>• HS-74 Storage Assist &gt; Revert Factory Initial Status Storage</li> </ul>
8. Optional storage device	If the error still persists even after step 7, replace the optional storage device.
9. Harness of the optional storage device	If the error still persists even after step 8, replace the harness of the optional storage device.
10. SYS board	If the error still persists even after step 9, replace the SYS board.

Parts to be replaced	Remarks
Harness of the optional storage device	
Optional storage device	
SYS board	

**[F101\_9] Partition mount error**

Classification	Error content
System related service call	Sub code 9: The "/encryption" partition is damaged.

Check item	Measures
1. SRAM	Check if the SRAM was used in another MFP.
2. Optional storage device	Turn the power of the MFP OFF and check the installation status of the optional storage device. <ul style="list-style-type: none"> <li>• Check if there is any abnormality in the connector and the harness.</li> <li>• Check if the connector pins of the optional storage device are bent.</li> <li>• Check if the optional storage device was used in another MFP.</li> </ul>
3. Key	If the error still persists even after step 2, perform this step. <ul style="list-style-type: none"> <li>• Perform HS-73 Firmware Assist &gt; Key Backup/Restore and check that each Key Status is "OK".</li> <li>• If not, recover the key. (Carry out SRAM to FROM copying or FROM to SRAM copying.)</li> </ul>
4. Recovery	If the error still persists after step 3, perform HS-75 File System Recovery > Recovery F/S > /encryption and reboot the MFP.
5. Initialization	If the error still persists even after step 4, perform HS-75 File System Recovery > Initialize Storage > /encryption and then reboot the MFP.
6. Format	If the error still persists even after step 5, perform this step. Perform HS-73 Firmware Assist > Format Storage, and then install "System Software (HD data)" with HS-49 Firmware Update. <p><b>Notes:</b></p> <p>The following contents will be deleted with this operation.</p> <ul style="list-style-type: none"> <li>• Message Log</li> <li>• Job Log</li> <li>• Spool Data (Print, Email reception)</li> <li>• Template</li> </ul>
7. Setting	If the error still persists even after step 6, perform the following and then reattempt step 6. <ul style="list-style-type: none"> <li>• HS-74 Storage Assist &gt; Revert Factory Initial Status Storage</li> </ul>
8. Optional storage device	If the error still persists even after step 7, replace the optional storage device.
9. Harness of the optional storage device	If the error still persists even after step 8, replace the harness of the optional storage device.
10. SYS board	If the error still persists even after step 9, replace the SYS board.

Parts to be replaced	Remarks
Harness of the optional storage device	
Optional storage device	
SYS board	

## [F101\_10] Partition mount error

Classification	Error content
System related service call	Sub code 10: The “/application” partition is damaged.

Check item	Measures
1. SRAM	Check if the SRAM was used in another MFP.
2. Optional storage device	Turn the power of the MFP OFF and check the installation status of the optional storage device. <ul style="list-style-type: none"> <li>• Check if there is any abnormality in the connector and the harness.</li> <li>• Check if the connector pins of the optional storage device are bent.</li> <li>• Check if the optional storage device was used in another MFP.</li> </ul>
3. Key	If the error still persists even after step 2, perform this step. <ul style="list-style-type: none"> <li>• Perform HS-73 Firmware Assist &gt; Key Backup/Restore and check that each Key Status is “OK”.</li> <li>• If not, recover the key. (Carry out SRAM to FROM copying or FROM to SRAM copying.)</li> </ul>
4. Recovery	If the error still persists after step 3, perform HS-75 File System Recovery > Recovery F/S > /application and reboot the MFP.
5. Initialization	If the error still persists even after step 4, perform HS-75 File System Recovery > Initialize Storage > /application and then reboot the MFP.
6. Format	If the error still persists even after step 5, perform this step. Perform HS-73 Firmware Assist > Format Storage, and then install “System Software (HD data)” with HS-49 Firmware Update. <p><b>Notes:</b></p> <p>The following contents will be deleted with this operation.</p> <ul style="list-style-type: none"> <li>• Message Log</li> <li>• Job Log</li> <li>• Spool Data (Print, Email reception)</li> <li>• Template</li> </ul>
7. Setting	If the error still persists even after step 6, perform the following and then reattempt step 6. <ul style="list-style-type: none"> <li>• HS-74 Storage Assist &gt; Revert Factory Initial Status Storage</li> </ul>
8. Optional storage device	If the error still persists even after step 7, replace the optional storage device.
9. Harness of the optional storage device	If the error still persists even after step 8, replace the harness of the optional storage device.
10. SYS board	If the error still persists even after step 9, replace the SYS board.

Parts to be replaced	Remarks
Harness of the optional storage device	
Optional storage device	
SYS board	

### [F101\_11] Partition mount error

Classification	Error content
System related service call	Sub code 11: The "/platform" partition is damaged.

Check item	Measures
1. SRAM	Check if the SRAM was used in another MFP.
2. Optional storage device	Turn the power of the MFP OFF and check the installation status of the optional storage device. <ul style="list-style-type: none"> <li>• Check if there is any abnormality in the connector and the harness.</li> <li>• Check if the connector pins of the optional storage device are bent.</li> <li>• Check if the optional storage device was used in another MFP.</li> </ul>
3. Format	If the error still persists even after step 2, perform this step. Perform HS-73 Firmware Assist > Format Storage, and then install "System Software (HD data)" with HS-49 Firmware Update.  <b>Notes:</b> The following contents will be deleted with this operation. <ul style="list-style-type: none"> <li>• Message Log</li> <li>• Job Log</li> <li>• Spool Data (Print, Email reception)</li> <li>• Template</li> </ul>
4. Setting	If the error still persists even after step 3, perform the following and then reattempt step 3. <ul style="list-style-type: none"> <li>• HS-74 Storage Assist &gt; Initialize Storage &gt; /application</li> </ul>
5. Optional storage device	If the error still persists even after step 4, replace the optional storage device.
6. Harness of the optional storage device	If the error still persists even after step 5, replace the harness of the optional storage device.
7. SYS board	If the error still persists even after step 6, replace the SYS board.

Parts to be replaced	Remarks
Harness of the optional storage device	
Optional storage device	
SYS board	

### [F101\_13] Error due to damage to file

Classification	Error content
System related service call	Sub code 13: A file in the "/imagedata" partition is damaged.

Check item	Measures
1. SRAM	Check if the SRAM was used in another MFP.
2. Optional storage device	Turn the power of the MFP OFF and check the installation status of the optional storage device. <ul style="list-style-type: none"> <li>• Check if there is any abnormality in the connector and the harness.</li> <li>• Check if the connector pins of the optional storage device are bent.</li> <li>• Check if the optional storage device was used in another MFP.</li> </ul>
3. Recovery	If the error still persists even after step 2, perform this step. <ul style="list-style-type: none"> <li>• Perform HS-75 File System Recovery &gt; Recovery F/S &gt; /imagedata and reboot the MFP.</li> </ul>
4. Format	If the error still persists even after step 3, perform this step. Perform HS-73 Firmware Assist > Format Storage, and then install "System Software (HD data)" with HS-49 Firmware Update.  <b>Notes:</b> The following contents will be deleted with this operation. <ul style="list-style-type: none"> <li>• Message Log</li> <li>• Job Log</li> <li>• Spool Data (Print, Email reception)</li> <li>• Template</li> </ul>
5. Setting	If the error still persists even after step 4, perform the following and then reattempt step 4. <ul style="list-style-type: none"> <li>• HS-74 Storage Assist &gt; Revert Factory Initial Status Storage</li> </ul>



Check item	Measures
6. Optional storage device	If the error still persists even after step 5, replace the optional storage device.
7. Harness of the optional storage device	If the error still persists even after step 6, replace the harness of the optional storage device.
8. SYS board	If the error still persists even after step 7, replace the SYS board.

Parts to be replaced	Remarks
Harness of the optional storage device	
Optional storage device	
SYS board	

### [F101\_14] Partition mount error

Classification	Error content
System related service call	Sub code 14: The optional storage device cannot be installed due to the damage to the “//rollback” partition.

Check item	Measures
1. Reproducibility	Reboot the MFP.
2. SRAM	Check if the SRAM was used in another MFP.
3. Optional storage device	Turn the power of the MFP OFF and check the installation status of the optional storage device. <ul style="list-style-type: none"> <li>• Check if there is any abnormality in the connector and the harness.</li> <li>• Check if the connector pins of the optional storage device are bent.</li> <li>• Check if the optional storage device was used in another MFP.</li> </ul>
4. Format	If the error still persists even after step 3, perform this step. Perform HS-73 Firmware Assist > Format Storage, and then install “System Software (HD data)” with HS-49 Firmware Update. <p><b>Notes:</b> The following contents will be deleted with this operation.</p> <ul style="list-style-type: none"> <li>• Message Log</li> <li>• Job Log</li> <li>• Spool Data (Print, Email reception)</li> <li>• Template</li> </ul>
5. Setting	If the error still persists even after step 4, perform the following and then reattempt step 4. <ul style="list-style-type: none"> <li>• HS-74 Storage Assist &gt; Revert Factory Initial Status Storage</li> </ul>
6. Optional storage device	If the error still persists even after step 5, replace the optional storage device.
7. Harness of the optional storage device	If the error still persists even after step 6, replace the harness of the optional storage device.
8. SYS board	If the error still persists even after step 7, replace the SYS board.

Parts to be replaced	Remarks
Harness of the optional storage device	
Optional storage device	
SYS board	

**[F102] Storage device start error****[F103] Storage device transfer time-out error****[F104] Storage device data error****[F105] Other errors for the storage device**

Classification	Error content
Storage device related service call	<ul style="list-style-type: none"> <li>• A storage device cannot become the "Ready" state.</li> <li>• Reading/writing cannot be performed within the specified period of time.</li> <li>• An abnormality is detected in data of storage device.</li> <li>• Another error has occurred in the storage device.</li> </ul>

Check item	Measures
Standard storage device	<ul style="list-style-type: none"> <li>• Standard storage device check</li> <li>• Connector check</li> </ul>
Optional storage device	<ul style="list-style-type: none"> <li>• Optional storage device check</li> <li>• Connector check</li> <li>• Harness check</li> </ul>

Parts to be replaced	Remarks
Standard storage device	
Harness of the optional storage device	
Optional storage device	
SYS board	

**[F106\_0] Optional storage device error**

Classification	Error content
Storage device related service call	<ul style="list-style-type: none"> <li>• The security HDD has been replaced with a normal HDD illegally.</li> <li>• The security SSD has been replaced with a normal SSD illegally.</li> </ul>

Check item	Measures
Storage device type	<p>Perform HS-74 Storage Assist and check the storage device type displayed on the Current Storage Type menu. If a normal type storage device is installed, replace it with the one that was there previously or a security type storage device. When a security type storage device is installed, go to the next step.</p> <p><b>Notes:</b> To replace with the original storage device, start the MFP in the normal mode and then reinstall the system software only if any abnormality occurs.</p>
Optional storage device	<ul style="list-style-type: none"> <li>• Optional storage device check</li> <li>• Connector check</li> <li>• Harness check</li> <li>• If the problem cannot be confirmed, perform the following items. <ol style="list-style-type: none"> <li>1. Perform HS-74 Storage Assist &gt; Revert Factory Initial Status Storage.</li> <li>2. Reinstall the system software.</li> </ol> </li> <li>• If the error still persists, replace the optional storage device.</li> </ul>
SYS board	Replace the SYS board.

Parts to be replaced	Remarks
Harness of the optional storage device	
Optional storage device	
SYS board	

### [F106\_1] Optional storage device error

Classification	Error content
Storage device related service call	Storage device type detection has failed.
Check item	Measures
Reproducibility	<ul style="list-style-type: none"> <li>Reboot the MFP.</li> <li>Reinstall the system software.</li> </ul>
Optional storage device	<ul style="list-style-type: none"> <li>Optional storage device check</li> <li>Connector check</li> <li>Harness check</li> <li>Perform HS-75 File System Recovery to check the file system and restore it. If HS-75 File System Recovery cannot be performed, replace the optional storage device.</li> <li>Perform HS-74 Storage Assist and check the storage device type displayed on the Current Storage Type menu. If "Unknown" is displayed, reinstall the system software.</li> <li>If the error still persists, replace the optional storage device.</li> </ul>
SYS board	Replace the SYS board.
Parts to be replaced	Remarks
Harness of the optional storage device	
Optional storage device	
SYS board	

### [F106\_2] Optional storage device error

Classification	Error content
Storage device related service call	Downloading of or consistency check for the encryption key has failed.
Check item	Measures
Key	<p>Check the status of HDD ENC KEY (encryption key) displayed in HS-73 Firmware Assist &gt; Key Backup/Restore. After confirming, shut down the MFP.</p> <ul style="list-style-type: none"> <li>When both the SRAM and FROM status are OK, reinstall the system firmware.</li> <li>In case either the SRAM or FROM status is other than OK, recover the encryption key.</li> <li>In case both the SRAM and FROM status fail, reinstall the system software.</li> </ul>
Optional storage device	<ul style="list-style-type: none"> <li>Replace the optional storage device.</li> <li>Replace the harness of the optional storage device.</li> </ul>
SYS board	Replace the SYS board.
Parts to be replaced	Remarks
Harness of the optional storage device	
Optional storage device	
SYS board	

**[F106\_3] Optional storage device error**

Classification	Error content
Storage device related service call	The generation of the authentication Admin Password has failed.

Check item	Measures
Format	<p>Perform HS-73 Firmware Assist &gt; Format Storage and then install "System Software (HD data)" with HS-49 Firmware Update. After confirming, shut down the MFP.</p> <p><b>Notes:</b> The following contents will be deleted with this operation.</p> <ul style="list-style-type: none"> <li>• Message Log</li> <li>• Job Log</li> <li>• Spool Data (Print, Email reception)</li> <li>• Template</li> </ul>
Optional storage device	<ul style="list-style-type: none"> <li>• Replace the optional storage device.</li> <li>• Replace the harness of the optional storage device.</li> </ul>
SYS board	Replace the SYS board.

Parts to be replaced	Remarks
Harness of the optional storage device	
Optional storage device	
SYS board	

**[F106\_4] Optional storage device error**

Classification	Error content
Storage device related service call	The generation of a random number for authentication data has failed.

Check item	Measures
Format	<p>Perform HS-73 Firmware Assist &gt; Format Storage and then install "System Software (HD data)" with HS-49 Firmware Update. After confirming, shut down the MFP.</p> <p><b>Notes:</b> The following contents will be deleted with this operation.</p> <ul style="list-style-type: none"> <li>• Message Log</li> <li>• Job Log</li> <li>• Spool Data (Print, Email reception)</li> <li>• Template</li> </ul>
Optional storage device	<ul style="list-style-type: none"> <li>• Replace the optional storage device.</li> <li>• Replace the harness of the optional storage device.</li> </ul>
SYS board	Replace the SYS board.

Parts to be replaced	Remarks
Harness of the optional storage device	
Optional storage device	
SYS board	

### [F106\_5] Optional storage device error

Classification	Error content
Storage device related service call	The transmission of authentication data has failed.
Check item	Measures
Format	<p>Perform HS-73 Firmware Assist &gt; Format Storage and then install "System Software (HD data)" with HS-49 Firmware Update. After confirming, shut down the MFP.</p> <p><b>Notes:</b> The following contents will be deleted with this operation.</p> <ul style="list-style-type: none"> <li>• Message Log</li> <li>• Job Log</li> <li>• Spool Data (Print, Email reception)</li> <li>• Template</li> </ul> <p><b>Remarks:</b> When this error has occurred after returning SRAM data for SRAM cloning, copy the Secure HDD key from the FROM to the SRAM.</p> <ol style="list-style-type: none"> <li>1. Perform HS-73 Firmware Assist &gt; Key Backup/Restore to check the key status.</li> <li>2. Press [Direction] twice. Check that the copying of the key from the FROM to the SRAM is selected.</li> <li>3. Press [Execute]. When the restoring of the key is completed, "Success" appears.</li> <li>4. After the operation is completed, shut down the MFP.</li> </ol>
Optional storage device	<ul style="list-style-type: none"> <li>• Replace the optional storage device.</li> <li>• Replace the harness of the optional storage device.</li> </ul>
SYS board	Replace the SYS board.

Parts to be replaced	Remarks
Harness of the optional storage device	
Optional storage device	
SYS board	

### [F106\_6] Optional storage device error

### [F106\_7] Optional storage device error

### [F106\_8] Optional storage device error

### [F106\_10] Optional storage device error

### [F106\_UNDEF] Optional storage device error

Classification	Error content
Storage device related service call	Error caused by reason other than F106_0 to 5

Check item	Measures
Format	<p>Perform HS-73 Firmware Assist &gt; Format Storage and then install "System Software (HD data)" with HS-49 Firmware Update. After confirming, shut down the MFP.</p> <p><b>Notes:</b> The following contents will be deleted with this operation.</p> <ul style="list-style-type: none"> <li>• Message Log</li> <li>• Job Log</li> <li>• Spool Data (Print, Email reception)</li> <li>• Template</li> </ul>
Optional storage device	<ul style="list-style-type: none"> <li>• Replace the optional storage device.</li> <li>• Replace the harness of the optional storage device.</li> </ul>
SYS board	Replace the SYS board.

Parts to be replaced	Remarks
Harness of the optional storage device	

Parts to be replaced	Remarks
Optional storage device	
SYS board	

### [F106\_11] License damage

Classification	Error content
License related service call	Both licenses saved in the storage device and the SRAM are damaged.

Check item	Measures
Backup data restoring	Restore the backup data with the latest status, including all the activated licenses.  <b>Remarks:</b> Applications with the trial license cannot be recovered from the backup data. If necessary, reinstall the applications.
License activation	If there are no backup data as above, reactivate all the licenses which have been activated in this MFP. If the functions have been activated by the export license file, import the license exported from the host unit of the MFP.
Optional storage device	<ul style="list-style-type: none"> <li>Replace the optional storage device.</li> <li>Replace the harness of the optional storage device.</li> </ul>
SRAM	Replace the SRAM.
SYS board	Replace the SYS board.

Parts to be replaced	Remarks
SRAM	
Harness of the optional storage device	
Optional storage device	
SYS board	

### [F106\_12] License damage

Classification	Error content
License related service call	The license registered in the SRAM is damaged.

Check item	Measures
Reproducibility	<ul style="list-style-type: none"> <li>Reboot the MFP.</li> <li>If the problem still persists, perform FS-08-9053 and reboot the MFP again.</li> </ul>
SRAM	Replace the SRAM.
SYS board	Replace the SYS board.

Parts to be replaced	Remarks
SRAM	
SYS board	

**[F107] File system error**

<b>Classification</b>	<b>Error content</b>
System related service call	File system error
Setting	Perform HS-73 Firmware Assist > Format Storage and then install "SYSTEM SOFTWARE(SD) COMMON" with the HS-49 Firmware Update. After confirming, shut down the MFP.  Note: The following contents will be deleted with this operation. <ul style="list-style-type: none"><li>• Message Log</li><li>• Job Log</li><li>• Spool Data (Print, Email reception)</li><li>• Template</li></ul>
Standard storage device	If the error still persists even after the above step is performed, replace the standard storage device. If the above step is cannot be performed, replace the standard storage device.
Optional storage device	If the error still persists even after the above step is performed, replace the optional storage device. Moreover, if the above step is cannot be performed, replace the optional storage device.

<b>Parts to be replaced</b>	<b>Remarks</b>
Standard storage device	
Optional storage device	
SYS board	

**[F109\_0] Key consistency error****[F109\_1] Key consistency error****[F109\_2] Key consistency error**

Classification	Error content
Key related service call	Sub code 0: Consistency of each key data item has failed due to damage in the consistency check module. Sub code 1: key data used for the SRAM encryption are damaged. Sub code 2: key data used for the SRAM encryption are damaged.

Check item	Measures
Reproducibility	Reboot the MFP.
Firmware	<ul style="list-style-type: none"> <li>Reinstall the system firmware.</li> <li>Reinstall the system software.</li> </ul>
SRAM	Replace the SRAM.
SYS board	Replace the SYS board.

Parts to be replaced	Remarks
SRAM	
SYS board	

**[F109\_3] Key consistency error**

Classification	Error content
System related service call	The parameter for storage device partition encryption is damaged.

Check item	Measures
Encryption key status	Perform HS-73 Firmware Assist mode > Key Backup/Restore and check the displayed message. Take the appropriate countermeasures shown below according to the error and messages displayed in the "SRAM" and "FROM" fields.
"SRAM" field: * "FROM" field: AccessFailed	Replace the SYS board. <ul style="list-style-type: none"> <li>When there are backup data in a USB storage device: <ol style="list-style-type: none"> <li>Recover all the data on the SRAM by means of cloning. HS-59 SRAM Data Cloning &gt; Restore SRAM Data from USB</li> <li>Recover the encryption key and the license on the SYS board by means of restoring.  P. 9-26 "[C] Restore Encryption Key and License"</li> </ol> </li> </ul>
"SRAM" field: AccessFailed "FROM" field: *	Replace the SRAM.
"SRAM" field: AccessFailed "FROM" field: OK	
"SRAM" field: OK "FROM" field: KeyNull / KeyBroken	Recover the encryption key on the SYS board. P. 9-26 "[C] Restore Encryption Key and License"
"SRAM" field: KeyNull / KeyBroken "FROM" field: OK	Recover the encryption key on the SRAM by means of backup. P. 9-31 "[H] Backup encryption key and license (FROM > SRAM)"
"SRAM" field: KeyNull / KeyBroken "FROM" field: KeyNull / KeyBroken	<ul style="list-style-type: none"> <li>When there are no backup data in a USB storage device: Reinstall the system software.</li> <li>When there are backup data in a USB storage device: <ol style="list-style-type: none"> <li>Recover all the data on the SRAM by means of cloning. HS-59 SRAM Data Cloning &gt; Restore SRAM Data from USB</li> <li>Recover the encryption key and the license on the SYS board by means of restoring.  P. 9-26 "[C] Restore Encryption Key and License"</li> </ol> </li> </ul>
Firmware	If the error still persists, reinstall the system firmware and the system software by the HS-49 Firmware Update mode.

\* AccessFailed or KeyMismatch



Parts to be replaced	Remarks
SRAM	
SYS board	

#### [F109\_4] Key consistency error

Classification	Error content
System related service call	The license data are damaged.

Check item	Measures
Encryption key status	Perform HS-73 Firmware Assist mode > Key Backup/Restore and check the displayed message. Take the appropriate countermeasures shown below according to the error and messages displayed in the "SRAM" and "FROM" fields.
"SRAM" field: * "FROM" field: AccessFailed	Replace the SYS board. <ul style="list-style-type: none"> <li>When there are backup data in a USB storage device: <ol style="list-style-type: none"> <li>Recover all the data on the SRAM by means of cloning. HS-59 SRAM Data Cloning &gt; Restore SRAM Data from USB</li> <li>Recover the encryption key and the license on the SYS board by means of restoring. P. 9-26 "[C] Restore Encryption Key and License"</li> </ol> </li> </ul>
"SRAM" field: AccessFailed "FROM" field: *	Replace the SRAM.
"SRAM" field: Keymismatch "FROM" field: Keymismatch	<ul style="list-style-type: none"> <li>When this error has occurred during replacing the SYS board, recover the license on it. (Restore the license from the SRAM to the FROM.)</li> <li>When this error has occurred except during replacement of the SYS board, recover the license of the SRAM. (Back up the license from the FROM to the SRAM.)</li> </ul>
Firmware	If the error still persists, reinstall the system firmware and the system software by the HS-49 Firmware Update mode.

\* AccessFailed or KeyMismatch

Parts to be replaced	Remarks
SRAM	
SYS board	

## [F109\_5] Key consistency error

Classification	Error content
Storage device related service call	The encryption key of the optional storage device is damaged.

Check item	Measures
Encryption key status	Perform HS-73 Firmware Assist mode > Key Backup/Restore and check the displayed message. Take the appropriate countermeasures shown below according to the error and messages displayed in the "SRAM" and "FROM" fields.
"SRAM" field: * "FROM" field: AccessFailed	Replace the SYS board. <ul style="list-style-type: none"> <li>When there are backup data in a USB storage device: <ol style="list-style-type: none"> <li>Recover all the data on the SRAM by means of cloning. HS-59 SRAM Data Cloning &gt; Restore SRAM Data from USB</li> <li>Recover the encryption key and the license on the SYS board by means of restoring.  P. 9-26 "[C] Restore Encryption Key and License"</li> </ol> </li> </ul>
"SRAM" field: AccessFailed "FROM" field: *	Replace the SRAM.
"SRAM" field: OK "FROM" field: KeyNull / KeyBroken	Recover the encryption key on the SYS board. P. 9-26 "[C] Restore Encryption Key and License"
"SRAM" field: KeyNull / KeyBroken "FROM" field: KeyNull / KeyBroken	<ul style="list-style-type: none"> <li>When there are no backup data in a USB storage device: Reinstall the system software.</li> <li>When there are backup data in a USB storage device: <ol style="list-style-type: none"> <li>Recover all the data on the SRAM by means of cloning. HS-59 SRAM Data Cloning &gt; Restore SRAM Data from USB</li> <li>Recover the encryption key and the license on the SYS board by means of restoring.  P. 9-26 "[C] Restore Encryption Key and License"</li> </ol> </li> </ul>
"SRAM" field: KeyMismatch "FROM" field: KeyMismatch	<ul style="list-style-type: none"> <li>The error occurs when the SYS board is replaced: Recover the encryption key on the SYS board by means of restoring. (Transfer the key from the SRAM to the FROM.)  P. 9-26 "[C] Restore Encryption Key and License"</li> <li>The error occurs except when the SYS board is replaced: Recover the encryption key on the SRAM by means of restoring. (Transfer the key from the FROM to the SRAM.)  P. 9-31 "[H] Backup encryption key and license (FROM &gt; SRAM)"</li> </ul>

\* AccessFailed or KeyMismatch

Parts to be replaced	Remarks
SRAM	
SYS board	

## [F109\_6] Key consistency error

Classification	Error content
Storage device related service call	The administrator password for the authentication of the optional storage device is damaged.

Check item	Measures
Encryption key status	Perform HS-73 Firmware Assist mode > Key Backup/Restore and check the displayed message. Take the appropriate countermeasures shown below according to the error and messages displayed in the "SRAM" and "FROM" fields.
"SRAM" field: * "FROM" field: AccessFailed	Replace the SYS board. <ul style="list-style-type: none"> <li>When there are backup data in a USB storage device: <ol style="list-style-type: none"> <li>Recover all the data on the SRAM by means of cloning. HS-59 SRAM Data Cloning &gt; Restore SRAM Data from USB</li> <li>Recover the encryption key and the license on the SYS board by means of restoring. P. 9-26 "[C] Restore Encryption Key and License"</li> </ol> </li> </ul>
"SRAM" field: AccessFailed "FROM" field: *	Replace the SRAM.
"SRAM" field: OK "FROM" field: KeyNull / KeyBroken	Recover the encryption key on the SYS board. P. 9-26 "[C] Restore Encryption Key and License"
"SRAM" field: KeyNull / KeyBroken "FROM" field: OK	Backup the encryption key of the SRAM. P. 9-31 "[H] Backup encryption key and license (FROM > SRAM)"
"SRAM" field: KeyNull / KeyBroken "FROM" field: KeyNull / KeyBroken	<ul style="list-style-type: none"> <li>When there are no backup data in a USB storage device: Reinstall the system software.</li> <li>When there are backup data in a USB storage device: <ol style="list-style-type: none"> <li>Recover all the data on the SRAM by means of cloning. HS-59 SRAM Data Cloning &gt; Restore SRAM Data from USB</li> <li>Recover the encryption key and the license on the SYS board by means of restoring. P. 9-26 "[C] Restore Encryption Key and License"</li> </ol> </li> </ul>
"SRAM" field: KeyMismatch "FROM" field: KeyMismatch	<ul style="list-style-type: none"> <li>The error occurs when the SYS board is replaced: Recover the encryption key on the SYS board by means of restoring. (Transfer the key from the SRAM to the FROM.) P. 9-26 "[C] Restore Encryption Key and License"</li> <li>The error occurs except when the SYS board is replaced: Recover the encryption key on the SRAM by means of restoring. (Transfer the key from the FROM to the SRAM.) P. 9-31 "[H] Backup encryption key and license (FROM &gt; SRAM)"</li> </ul>

\* AccessFailed or KeyMismatch

Parts to be replaced	Remarks
SRAM	
SYS board	

## [F109\_7] Key consistency error

Classification	Error content
Storage device related service call	Hash check of the optional storage device authentication key has failed.
Check item	Measures
Format	Perform HS-73 Firmware Assist mode > Key Backup/Restore and check the displayed message. Take the appropriate countermeasures shown below according to the error and messages displayed in the "SRAM" and "FROM" fields.
"SRAM" field: * "FROM" field: AccessFailed	Perform HS-73 Firmware Assist > Format Storage and then install "System Software (HD data)" with HS-49 Firmware Update. <b>Notes:</b> The following contents will be deleted with this operation. <ul style="list-style-type: none"> <li>• Message Log</li> <li>• Job Log</li> <li>• Spool Data (Print, Email reception)</li> <li>• Template</li> </ul>
SRAM	Replace the SRAM.
SYS board	Replace the SYS board.

Parts to be replaced	Remarks
SRAM	
SYS board	

## [F110] Communication error between the system-CPU and the scanner-CPU

### [F111] Scanner-CPU response error

Classification	Error content
Scanning system related service call	A communication error has occurred between the system-CPU and the scanner-CPU. There is no response from the scanner-CPU.
Check item	Measures
Reproducibility	Turn the power OFF and then back ON to check the occurrence.
Setting	<ul style="list-style-type: none"> <li>• Check if the value of FS-08-9000 (Destination setting of the MFP) is set correctly.</li> <li>• Perform FS-05--3203 (Data transfer of characteristic value of scanner).</li> </ul>
Firmware	Update the scanner firmware installed in the MFP.
CCD board	<ul style="list-style-type: none"> <li>• PC board check</li> <li>• Connector check (CN120)</li> <li>• Harness check</li> <li>• Replace the PC board.</li> </ul>
SYS board	<ul style="list-style-type: none"> <li>• PC board check</li> <li>• Connector check (CN120)</li> <li>• Harness check</li> <li>• Replace the PC board.</li> </ul>
LGC board	<ul style="list-style-type: none"> <li>• PC board check</li> <li>• Connector check (CN309)</li> <li>• Harness check</li> <li>• Replace the PC board.</li> </ul>
Parts to be replaced	Remarks
CCD board	
SYS board	
LGC board	

**[F115] S-VDEN ON signal time-out error****[F116] S-VDEN OFF signal time-out error**

Classification	Error content
Scanning system related service call	The scanning job has not finished normally.

Check item	Measures
Reproducibility	Turn the power OFF and then back ON to check the occurrence. If it changes to another code, follow its troubleshooting procedure.
Harness, connector	<ul style="list-style-type: none"> <li>Check if the joint connector (J12) between the RADF and the MFP is connected properly or there is any abnormality in it.</li> <li>Check if there is any abnormality in the harnesses between the SYS board and the joint connector, and between the joint connector and the RADF control PC board.</li> <li>If there is any abnormality such as scratches, open-circuit and catching on the harness or its pin is deformed, replace them.</li> </ul>
RADF control PC board	<ul style="list-style-type: none"> <li>PC board check</li> <li>Connector check (CN71)</li> <li>Harness check</li> <li>Replace the PC board.</li> </ul>
SYS board	<ul style="list-style-type: none"> <li>PC board check</li> <li>Connector check (CN122)</li> <li>Harness check</li> <li>Replace the PC board.</li> </ul>

Parts to be replaced	Remarks
Harness	
RADF control PC board	
SYS board	

**[F117] S-VDEN ON (back side) signal time-out error****[F118] S-VDEN OFF (back side) signal time-out error**

Classification	Error content
Scanning system related service call	The scanning job has not finished normally.

Check item	Measures
Reproducibility	Turn the power OFF and then back ON to check the occurrence. If it changes to another code, follow its troubleshooting procedure.
Harness, connector	<ul style="list-style-type: none"> <li>Check if the joint connector (J12) between the DSDF and the MFP is connected properly or there is any abnormality in it.</li> <li>Check if there is any abnormality in the harnesses between the SYS board and the joint connector, and between the joint connector and the DSDF control PC board.</li> <li>If there is any abnormality such as scratches, open-circuit and catching on the harness or its pin is deformed, replace them.</li> </ul>
DSDF control PC board	<ul style="list-style-type: none"> <li>PC board check</li> <li>Connector check (CN71)</li> <li>Harness check</li> <li>Replace the PC board.</li> </ul>
SYS board	<ul style="list-style-type: none"> <li>PC board check</li> <li>Connector check (CN122)</li> <li>Harness check</li> <li>Replace the PC board.</li> </ul>

Parts to be replaced	Remarks
Harness	
DSDF control PC board	
SYS board	

**[F119] Scanner abnormality detection**

Classification	Error content
Scanning system related service call	There is an abnormality in the connection between the scanner-CPU and the system-CPU
Check item	Measures
SYS board	<ul style="list-style-type: none"> <li>PC board check</li> <li>Replace the PC board.</li> </ul>
Parts to be replaced	Remarks
SYS board	

**[F11A] Scanner communication error**

Classification	Error content
Scanning system related service call	Communication error between the CCD board and the SYS board
Check item	Measures
Reproducibility	Turn the power OFF and then back ON. Then check if the error code changes to another one. If it changes to another code, follow its troubleshooting procedure.
Harness	<ul style="list-style-type: none"> <li>Check if there is an abnormality in the harness between the CCD board and the SYS board.</li> <li>Check if the harness is connected to the connector properly.</li> <li>If there is any abnormality such as scratches, open-circuit and catching on the harness or its pin is deformed, replace them.</li> </ul>
CCD board	<ul style="list-style-type: none"> <li>PC board check</li> <li>Connector check (CN001)</li> <li>Harness check</li> <li>Replace the PC board.</li> </ul>
SYS board	<ul style="list-style-type: none"> <li>PC board check</li> <li>Connector check (CN120)</li> <li>Harness check</li> <li>Replace the PC board.</li> </ul>
Parts to be replaced	Remarks
Harness	
CCD board	
SYS board	

**[F11B] Communication error between the DSDF-CCD module and the SYS board**

Classification	Error content
Scanning system related service call	Communication error between the DSDF-CCD module and the SYS board
Check item	Measures
Reproducibility	Turn the power OFF and then back ON. Then check if the error code changes to another one. If it changes to another code, follow its troubleshooting procedure.
SYS board	<ul style="list-style-type: none"> <li>PC board check</li> <li>Connector check (CN122)</li> <li>Harness check</li> <li>Replace the PC board.</li> </ul>

Check item	Measures
DSDF I/F board	<ul style="list-style-type: none"> <li>• Check if the DSDF I/F board is installed in the SYS board properly.</li> <li>• Check if there is any abnormality in the connector (CN89) of the DSDF I/F board.</li> <li>• Check if the connectors between the DSDF I/F board and the DSDF control PC board are disconnected or the harnesses are open circuited. Correct it if there is abnormality.</li> <li>• Check if there is any abnormality in the DSDF I/F board (IC6, IC9, IC204).</li> <li>• Replace the DSDF I/F board.</li> </ul>
DSDF control PC board	<ul style="list-style-type: none"> <li>• PC board check</li> <li>• Connector check</li> <li>• Harness check</li> <li>• Replace the PC board.</li> </ul>
HDMI cable	Check if the HDMI cables (CN78, CN90) are connected properly.
DSDF-CCD module	<ul style="list-style-type: none"> <li>• Check if the connectors of the DSDF-CCD module are connected properly.</li> <li>• Check if there is any abnormality in the DSDF-CCD module.</li> </ul>

Parts to be replaced	Remarks
Harness	
DSDF I/F board	
DSDF control PC board	
DSDF-CCD module	
SYS board	

#### [F120] Database error

Classification	Error content
System related service call	Database is not operating normally.

Check item	Measures
Database	<p>Check that no jobs are remaining. Then perform HS-75 File System Recovery &gt; Initialize DB &gt; LDAP DB and Log DB(Job,Msg) to rebuild the database.</p> <p><b>Notes:</b></p> <ul style="list-style-type: none"> <li>• If an attempt is made to rebuild the database with jobs remaining, delete them after completing.</li> <li>• When [Rebuilding all database] is performed, all data included in Log, User, Role, Group, Department and Address book information will be deleted. After rebuilding, data can be recovered by restoring those backed up in advance.</li> </ul>
Firmware	Reinstall the system software. HS-49 Firmware Update > System Software(HD data)
Standard storage device	<ul style="list-style-type: none"> <li>• Connector check</li> <li>• Replace the standard storage device.</li> </ul>
Optional storage device	<ul style="list-style-type: none"> <li>• Replace the optional storage device.</li> <li>• Replace the harness of the optional storage device.</li> </ul>

Parts to be replaced	Remarks
Standard storage device	
Optional storage device	

### [F121] User Information management database error

Classification	Error content
System related service call	Login after the startup with any mode has failed because the user management information database is damaged.

Check item	Measures
Database	<p>Check that no jobs are remaining. Then perform HS-75 File System Recovery &gt; Initialize DB &gt; LDAP DB to rebuild the database.</p> <p><b>Notes:</b></p> <ul style="list-style-type: none"> <li>• If an attempt is made to rebuild the database with jobs remaining, delete them after completing.</li> <li>• When [Rebuilding all database] is performed, all data included in Log, User, Role, Group, Department and Address book information will be deleted. After rebuilding, data can be recovered by restoring those backed up in advance.</li> </ul>
Firmware	Reinstall the system software. HS-49 Firmware Update > System Software(HD data)
Standard storage device	<ul style="list-style-type: none"> <li>• Connector check</li> <li>• Replace the standard storage device.</li> </ul>
Optional storage device	<ul style="list-style-type: none"> <li>• Replace the optional storage device.</li> <li>• Replace the harness of the optional storage device.</li> </ul>

Parts to be replaced	Remarks
Standard storage device	
Optional storage device	

### [F122] Message/job log management database error

Classification	Error content
System related service call	Login after the startup with any mode has failed because the log management information database is damaged.

Check item	Measures
Database	<p>Check that no jobs are remaining. Then perform HS-75 File System Recovery &gt; Initialize DB &gt; Log DB(Job,Msg) to rebuild the database.</p> <p><b>Notes:</b></p> <ul style="list-style-type: none"> <li>• If an attempt is made to rebuild the database with jobs remaining, delete them after completing.</li> <li>• When [Rebuilding all database] is performed, all data included in Log, User, Role, Group, Department and Address book information will be deleted. After rebuilding, data can be recovered by restoring those backed up in advance.</li> </ul>
Firmware	Reinstall the system software. HS-49 Firmware Update > System Software(HD data)
Standard storage device	<ul style="list-style-type: none"> <li>• Connector check</li> <li>• Replace the standard storage device.</li> </ul>
Optional storage device	<ul style="list-style-type: none"> <li>• Replace the optional storage device.</li> <li>• Replace the harness of the optional storage device.</li> </ul>

Parts to be replaced	Remarks
Standard storage device	
Optional storage device	



**[F124] Application management database error**

Classification	Error content
System related service call	The application management database is damaged.
Check item	Measures
Database	Perform HS-75 File System Recovery > Initialize DB > AppMgmt DB to delete the journal file.  <b>Notes:</b> All of the application information will be deleted.
Firmware	Reinstall the system software. HS-49 Firmware Update > System Software(HD data)
Standard storage device	<ul style="list-style-type: none"> <li>Connector check</li> <li>Replace the standard storage device.</li> </ul>
Optional storage device	<ul style="list-style-type: none"> <li>Replace the optional storage device.</li> <li>Replace the harness of the optional storage device.</li> </ul>
Parts to be replaced	Remarks
Standard storage device	
Optional storage device	

**[F125] Home screen database error**

Classification	Error content
System related service call	The home screen database is damaged.
Check item	Measures
Database	Perform HS-75 File System Recovery > Initialize DB > HomeScreen DB to delete the journal file.
Firmware	Reinstall the system software. HS-49 Firmware Update > System Software(HD data)
Standard storage device	<ul style="list-style-type: none"> <li>Connector check</li> <li>Replace the standard storage device.</li> </ul>
Optional storage device	<ul style="list-style-type: none"> <li>Replace the optional storage device.</li> <li>Replace the harness of the optional storage device.</li> </ul>
Parts to be replaced	Remarks
Standard storage device	
Optional storage device	

**[F126] Job history database error**

Classification	Error content
System related service call	The job history database is damaged.
Check item	Measures
Database	Perform HS-75 File System Recovery > Initialize DB > JobHistory DB to delete the journal file.
Firmware	Reinstall the system software. HS-49 Firmware Update > System Software(HD data)
Standard storage device	<ul style="list-style-type: none"> <li>Connector check</li> <li>Replace the standard storage device.</li> </ul>
Optional storage device	<ul style="list-style-type: none"> <li>Replace the optional storage device.</li> <li>Replace the harness of the optional storage device.</li> </ul>
Parts to be replaced	Remarks
Standard storage device	
Optional storage device	

**[F127] Application license management database error**

Classification	Error content
System related service call	The application license management database is damaged.

Check item	Measures
Database	Perform HS-75 File System Recovery > Initialize DB > AppLicense DB to delete the journal file.
Firmware	Reinstall the system software. HS-49 Firmware Update > System Software(HD data)
Standard storage device	<ul style="list-style-type: none"> <li>Connector check</li> <li>Replace the standard storage device.</li> </ul>
Optional storage device	<ul style="list-style-type: none"> <li>Replace the optional storage device.</li> <li>Replace the harness of the optional storage device.</li> </ul>

Parts to be replaced	Remarks
Standard storage device	
Optional storage device	

**[F128] License manager database error**

Classification	Error content
System related service call	The license manager database is damaged.

Check item	Measures
Reproducibility	Turn the power OFF and then back ON to check the occurrence. If the error code is changed to 71E0, follow its troubleshooting procedure.
Database	<ol style="list-style-type: none"> <li>Perform HS-75 File System Recovery &gt; Initialize DB &gt; ULM DB to delete the journal file.</li> <li>Reboot the MFP to check the occurrence. If the error code is changed to 71E0, follow its troubleshooting procedure.</li> </ol>
SRAM	Replace the SRAM.
Standard storage device	<ul style="list-style-type: none"> <li>Connector check</li> <li>Replace the standard storage device.</li> </ul>
Optional storage device	<ul style="list-style-type: none"> <li>Replace the optional storage device.</li> <li>Replace the harness of the optional storage device.</li> </ul>

Parts to be replaced	Remarks
Standard storage device	
Optional storage device	

**[F130] Invalid MAC address**

Classification	Error content
System related service call	This error will occur when the first 3 bytes of the MAC address is not "00", "80" or "91".

Check item	Measures
SYS board	Replace the PC board.

Parts to be replaced	Remarks
SYS board	

### [F131] Filtering setting file damage error

Classification	Error content
System related service call	The filtering function does not work properly due to the damage to the file for the filtering setting.

Check item	Measures
Format	<p>Perform HS-73 Firmware Assist &gt; Format Storage, and then install "System Software (HD data)" with HS-49 Firmware Update.</p> <p><b>Notes:</b> The following contents will be deleted with this operation.</p> <ul style="list-style-type: none"> <li>• Message Log</li> <li>• Job Log</li> <li>• Spool Data (Print, Email reception)</li> <li>• Template</li> </ul>

Parts to be replaced	Remarks
Standard storage device	
Optional storage device	

### [F141\_0] Standard storage device installation error

### [F141\_1] Standard storage device root partition mount error (formatting failure)

### [F141\_2] Standard storage device partition mount error

### [F141\_3] Standard storage device partition mount error

Classification	Error content
System related service call	<p>Sub code 0: The installation of the storage device cannot be detected.</p> <p>Sub code 1: The storage device cannot be installed due to damage to the areas in which the program is mainly stored.</p> <p>Sub codes 2, 3: The areas other than those described in the F101_1 and F101_4 to F101_10 errors are damaged.</p>

Check item	Measures
1. SRAM	Check if the SRAM was used in another MFP.
2. Standard storage device	<p>Turn the power of the MFP OFF and check the installation status of the standard storage device.</p> <ul style="list-style-type: none"> <li>• Check if there is any abnormality in the connector.</li> <li>• Check if the connector pins are bent.</li> <li>• Check if the standard storage device was used in another MFP.</li> </ul>
3. Key	<p>If the error still persists even after step 2, perform this step.</p> <ul style="list-style-type: none"> <li>• Perform HS-73 Firmware Assist &gt; Key Backup/Restore and check that each Key Status is "OK".</li> <li>• If not, recover the key. (Carry out SRAM to FROM copying or FROM to SRAM copying.)</li> </ul>
4. Format	<p>If the error still persists even after step 3, perform this step.</p> <p>Perform HS-73 Firmware Assist &gt; Format Storage, and then install "System Software (HD data)" with HS-49 Firmware Update.</p> <p><b>Notes:</b> The following contents will be deleted with this operation.</p> <ul style="list-style-type: none"> <li>• Message Log</li> <li>• Job Log</li> <li>• Spool Data (Print, Email reception)</li> <li>• Template</li> </ul>
5. Setting	<p>If an F101_1 error has occurred while a security storage device is installed or if the error still persists even after step 4, perform the following item and reattempt step 4.</p> <ul style="list-style-type: none"> <li>• HS-74 Storage Assist &gt; Revert Factory Initial Status Storage</li> </ul>
6. Standard storage device	If the error still persists even after step 5, replace the standard storage device.
7. SYS board	If the error still persists even after step 6, replace the SYS board.

Parts to be replaced	Remarks
Standard storage device	
SYS board	

**[F141\_4] Standard storage device partition mount error**

**[F141\_12] Standard storage device mount error**

Classification	Error content
System related service call	Sub code 4: The “/work” partition is damaged. Sub code 12: File link error in the “/work” partition.

Check item	Measures
1. SRAM	Check if the SRAM was used in another MFP.
2. Standard storage device	Turn the power of the MFP OFF and check the installation status of the standard storage device. <ul style="list-style-type: none"> <li>• Check if there is any abnormality in the connector.</li> <li>• Check if the connector pins are bent.</li> <li>• Check if the standard storage device was used in another MFP.</li> </ul>
3. Key	If the error still persists even after step 2, perform this step. <ul style="list-style-type: none"> <li>• Perform HS-73 Firmware Assist &gt; Key Backup/Restore and check that each Key Status is “OK”.</li> <li>• If not, recover the key. (Carry out SRAM to FROM copying or FROM to SRAM copying.)</li> </ul>
4. Recovery	If the error still persists even after step 3, perform HS-75 File System Recovery > Recovery F/S > /work and then reboot the MFP.
5. Initialization	If the error still persists even after step 4, perform HS-75 File System Recovery > Initialize Storage > /work and then reboot the MFP.
6. Format	If the error still persists even after step 5, perform this step. Perform HS-73 Firmware Assist > Format Storage and then install “System Software (HD data)” with HS-49 Firmware Update. <p><b>Notes:</b></p> <p>The following contents will be deleted with this operation.</p> <ul style="list-style-type: none"> <li>• Message Log</li> <li>• Job Log</li> <li>• Spool Data (Print, Email reception)</li> <li>• Template</li> </ul>
7. Setting	If the error still persists even after step 6, perform the following and then reattempt step 6. <ul style="list-style-type: none"> <li>• HS-74 Storage Assist &gt; Revert Factory Initial Status Storage</li> </ul>
8. Standard storage device	If the error still persists even after step 7, replace the standard storage device.
9. SYS board	If the error still persists even after step 8, replace the SYS board.

Parts to be replaced	Remarks
Standard storage device	
SYS board	

**[F141\_5] Partition mount error**

Classification	Error content
System related service call	Sub code 5: The "/registration" partition is damaged.

Check item	Measures
1. SRAM	Check if the SRAM was used in another MFP.
2. Standard storage device	Turn the power of the MFP OFF and check the installation status of the standard storage device. <ul style="list-style-type: none"> <li>• Check if there is any abnormality in the connector.</li> <li>• Check if the connector pins are bent.</li> <li>• Check if the standard storage device was used in another MFP.</li> </ul>
3. Key	If the error still persists even after step 2, perform this step. <ul style="list-style-type: none"> <li>• Perform HS-73 Firmware Assist &gt; Key Backup/Restore and check that each Key Status is "OK".</li> <li>• If not, recover the key. (Carry out SRAM to FROM copying or FROM to SRAM copying.)</li> </ul>
4. Recovery	If the error still persists after step 3, perform HS-75 File System Recovery > Recovery F/S > /registration and reboot the MFP.
5. Initialization	If the error still persists even after step 4, perform HS-75 File System Recovery > Initialize Storage > /registration and then reboot the MFP.
6. Format	If the error still persists even after step 5, perform this step. Perform HS-73 Firmware Assist > Format Storage and then install "System Software (HD data)" with HS-49 Firmware Update. <p><b>Notes:</b> The following contents will be deleted with this operation.</p> <ul style="list-style-type: none"> <li>• Message Log</li> <li>• Job Log</li> <li>• Spool Data (Print, Email reception)</li> <li>• Template</li> </ul>
7. Setting	If the error still persists even after step 6, perform the following and then reattempt step 6. <ul style="list-style-type: none"> <li>• HS-74 Storage Assist &gt; Revert Factory Initial Status Storage</li> </ul>
8. Standard storage device	If the error still persists even after step 7, replace the standard storage device.
9. SYS board	If the error still persists even after step 8, replace the SYS board.

Parts to be replaced	Remarks
Standard storage device	
SYS board	

## [F141\_6] Partition mount error

Classification	Error content
System related service call	Sub code 6: The "/backup" partition is damaged.

Check item	Measures
1. SRAM	Check if the SRAM was used in another MFP.
2. Standard storage device	Turn the power of the MFP OFF and check the installation status of the standard storage device. <ul style="list-style-type: none"> <li>• Check if there is any abnormality in the connector.</li> <li>• Check if the connector pins are bent.</li> <li>• Check if the standard storage device was used in another MFP.</li> </ul>
3. Key	If the error still persists even after step 2, perform this step. <ul style="list-style-type: none"> <li>• Perform HS-73 Firmware Assist &gt; Key Backup/Restore and check that each Key Status is "OK".</li> <li>• If not, recover the key. (Carry out SRAM to FROM copying or FROM to SRAM copying.)</li> </ul>
4. Recovery	If the error still persists even after step 3, perform HS-75 File System Recovery > Recovery F/S > /backup and then reboot the MFP.
5. Initialization	If the error still persists even after step 4, perform HS-75 File System Recovery > Initialize Storage > /backup and then reboot the MFP.
6. Format	If the error still persists even after step 5, perform this step. Perform HS-73 Firmware Assist > Format Storage and then install "System Software (HD data)" with HS-49 Firmware Update. <p><b>Notes:</b> The following contents will be deleted with this operation.</p> <ul style="list-style-type: none"> <li>• Message Log</li> <li>• Job Log</li> <li>• Spool Data (Print, Email reception)</li> <li>• Template</li> </ul>
7. Setting	If the error still persists even after step 6, perform the following and then reattempt step 6. <ul style="list-style-type: none"> <li>• HS-74 Storage Assist &gt; Revert Factory Initial Status Storage</li> </ul>
8. Standard storage device	If the error still persists even after step 7, replace the standard storage device.
9. SYS board	If the error still persists even after step 8, replace the SYS board.

Parts to be replaced	Remarks
Standard storage device	
SYS board	

## [F141\_7] Partition mount error

Classification	Error content
System related service call	Sub code 7: The "/imagedata" partition is damaged.

Check item	Measures
1. SRAM	Check if the SRAM was used in another MFP.
2. Standard storage device	Turn the power of the MFP OFF and check the installation status of the standard storage device. <ul style="list-style-type: none"> <li>• Check if there is any abnormality in the connector.</li> <li>• Check if the connector pins are bent.</li> <li>• Check if the standard storage device was used in another MFP.</li> </ul>
3. Key	If the error still persists even after step 2, perform this step. <ul style="list-style-type: none"> <li>• Perform HS-73 Firmware Assist &gt; Key Backup/Restore and check that each Key Status is "OK".</li> <li>• If not, recover the key. (Carry out SRAM to FROM copying or FROM to SRAM copying.)</li> </ul>
4. Recovery	If the error still persists after step 3, perform HS-75 File System Recovery > Recovery F/S > /imagedata and reboot the MFP.
5. Initialization	If the error still persists even after step 4, perform HS-75 File System Recovery > Initialize Storage > /imagedata and then reboot the MFP.
6. Format	If the error still persists even after step 5, perform this step. Perform HS-73 Firmware Assist > Format Storage and then install "System Software (HD data)" with HS-49 Firmware Update. <p><b>Notes:</b> The following contents will be deleted with this operation.</p> <ul style="list-style-type: none"> <li>• Message Log</li> <li>• Job Log</li> <li>• Spool Data (Print, Email reception)</li> <li>• Template</li> </ul>
7. Setting	If the error still persists even after step 6, perform the following and then reattempt step 6. <ul style="list-style-type: none"> <li>• HS-74 Storage Assist &gt; Revert Factory Initial Status Storage</li> </ul>
8. Standard storage device	If the error still persists even after step 7, replace the standard storage device.
9. SYS board	If the error still persists even after step 8, replace the SYS board.

Parts to be replaced	Remarks
Standard storage device	
SYS board	

## [F141\_8] Partition mount error

Classification	Error content
System related service call	Sub code 8: The "/storage" partition is damaged.

Check item	Measures
1. SRAM	Check if the SRAM was used in another MFP.
2. Standard storage device	Turn the power of the MFP OFF and check the installation status of the standard storage device. <ul style="list-style-type: none"> <li>• Check if there is any abnormality in the connector.</li> <li>• Check if the connector pins are bent.</li> <li>• Check if the standard storage device was used in another MFP.</li> </ul>
3. Key	If the error still persists even after step 2, perform this step. <ul style="list-style-type: none"> <li>• Perform HS-73 Firmware Assist &gt; Key Backup/Restore and check that each Key Status is "OK".</li> <li>• If not, recover the key. (Carry out SRAM to FROM copying or FROM to SRAM copying.)</li> </ul>
4. Recovery	If the error still persists even after step 3, perform HS-75 File System Recovery > Recovery F/S > /storage and then reboot the MFP.
5. Initialization	If the error still persists even after step 4, perform HS-75 File System Recovery > Initialize Storage > /storage and then reboot the MFP.
6. Format	If the error still persists even after step 5, perform this step. Perform HS-73 Firmware Assist > Format Storage and then install "System Software (HD data)" with HS-49 Firmware Update. <p><b>Notes:</b> The following contents will be deleted with this operation.</p> <ul style="list-style-type: none"> <li>• Message Log</li> <li>• Job Log</li> <li>• Spool Data (Print, Email reception)</li> <li>• Template</li> </ul>
7. Setting	If the error still persists even after step 6, perform the following and then reattempt step 6. <ul style="list-style-type: none"> <li>• HS-74 Storage Assist &gt; Revert Factory Initial Status Storage</li> </ul>
8. Standard storage device	If the error still persists even after step 7, replace the standard storage device.
9. SYS board	If the error still persists even after step 8, replace the SYS board.

Parts to be replaced	Remarks
Standard storage device	
SYS board	



## [F141\_9] Partition mount error

Classification	Error content
System related service call	Sub code 9: The "/encryption" partition is damaged.
Check item	Measures
1. SRAM	Check if the SRAM was used in another MFP.
2. Standard storage device	Turn the power of the MFP OFF and check the installation status of the standard storage device. <ul style="list-style-type: none"> <li>• Check if there is any abnormality in the connector.</li> <li>• Check if the connector pins are bent.</li> <li>• Check if the standard storage device was used in another MFP.</li> </ul>
3. Key	If the error still persists even after step 2, perform this step. <ul style="list-style-type: none"> <li>• Perform HS-73 Firmware Assist &gt; Key Backup/Restore and check that each Key Status is "OK".</li> <li>• If not, recover the key. (Carry out SRAM to FROM copying or FROM to SRAM copying.)</li> </ul>
4. Recovery	If the error still persists after step 3, perform HS-75 File System Recovery > Recovery F/S > /encryption and reboot the MFP.
5. Initialization	If the error still persists even after step 4, perform HS-75 File System Recovery > Initialize Storage > /encryption and then reboot the MFP.
6. Format	If the error still persists even after step 5, perform this step. Perform HS-73 Firmware Assist > Format Storage and then install "System Software (HD data)" with HS-49 Firmware Update. <p><b>Notes:</b> The following contents will be deleted with this operation.</p> <ul style="list-style-type: none"> <li>• Message Log</li> <li>• Job Log</li> <li>• Spool Data (Print, Email reception)</li> <li>• Template</li> </ul>
7. Setting	If the error still persists even after step 6, perform the following and then reattempt step 6. <ul style="list-style-type: none"> <li>• HS-74 Storage Assist &gt; Revert Factory Initial Status Storage</li> </ul>
8. Standard storage device	If the error still persists even after step 7, replace the standard storage device.
9. SYS board	If the error still persists even after step 8, replace the SYS board.
Parts to be replaced	Remarks
Standard storage device	
SYS board	

## [F141\_10] Partition mount error

Classification	Error content
System related service call	Sub code 10: The "/application" partition is damaged.

Check item	Measures
1. SRAM	Check if the SRAM was used in another MFP.
2. Standard storage device	Turn the power of the MFP OFF and check the installation status of the standard storage device. <ul style="list-style-type: none"> <li>• Check if there is any abnormality in the connector.</li> <li>• Check if the connector pins are bent.</li> <li>• Check if the standard storage device was used in another MFP.</li> </ul>
3. Key	If the error still persists even after step 2, perform this step. <ul style="list-style-type: none"> <li>• Perform HS-73 Firmware Assist &gt; Key Backup/Restore and check that each Key Status is "OK".</li> <li>• If not, recover the key. (Carry out SRAM to FROM copying or FROM to SRAM copying.)</li> </ul>
4. Recovery	If the error still persists after step 3, perform HS-75 File System Recovery > Recovery F/S > /application and reboot the MFP.
5. Initialization	If the error still persists even after step 4, perform HS-75 File System Recovery > Initialize Storage > /application and then reboot the MFP.
6. Format	If the error still persists even after step 5, perform this step. Perform HS-73 Firmware Assist > Format Storage and then install "System Software (HD data)" with HS-49 Firmware Update. <p><b>Notes:</b> The following contents will be deleted with this operation.</p> <ul style="list-style-type: none"> <li>• Message Log</li> <li>• Job Log</li> <li>• Spool Data (Print, Email reception)</li> <li>• Template</li> </ul>
7. Setting	If the error still persists even after step 6, perform the following and then reattempt step 6. <ul style="list-style-type: none"> <li>• HS-74 Storage Assist &gt; Revert Factory Initial Status Storage</li> </ul>
8. Standard storage device	If the error still persists even after step 7, replace the standard storage device.
9. SYS board	If the error still persists even after step 8, replace the SYS board.

Parts to be replaced	Remarks
Standard storage device	
SYS board	

### [F141\_11] Partition mount error

Classification	Error content
System related service call	Sub code 11: The "/platform" partition is damaged.

Check item	Measures
1. SRAM	Check if the SRAM was used in another MFP.
2. Standard storage device	Turn the power of the MFP OFF and check the installation status of the standard storage device. <ul style="list-style-type: none"> <li>• Check if there is any abnormality in the connector.</li> <li>• Check if the connector pins are bent.</li> <li>• Check if the standard storage device was used in another MFP.</li> </ul>
3. Format	If the error still persists even after step 2, perform this step. Perform HS-73 Firmware Assist > Format Storage and then install "System Software (HD data)" with HS-49 Firmware Update.  <b>Notes:</b> The following contents will be deleted with this operation. <ul style="list-style-type: none"> <li>• Message Log</li> <li>• Job Log</li> <li>• Spool Data (Print, Email reception)</li> <li>• Template</li> </ul>
4. Setting	If the error still persists even after step 3, perform the following and then reattempt step 3. <ul style="list-style-type: none"> <li>• HS-74 Storage Assist &gt; Initialize Storage &gt; /application</li> </ul>
5. Standard storage device	If the error still persists even after step 4, replace the standard storage device.
6. SYS board	If the error still persists even after step 5, replace the SYS board.

Parts to be replaced	Remarks
Standard storage device	
SYS board	

### [F141\_13] Error due to damage to file

Classification	Error content
System related service call	Sub code 13: A file in the "/imagedata" partition is damaged.

Check item	Measures
1. SRAM	Check if the SRAM was used in another MFP.
2. Standard storage device	Turn the power of the MFP OFF and check the installation status of the standard storage device. <ul style="list-style-type: none"> <li>• Check if there is any abnormality in the connector.</li> <li>• Check if the connector pins are bent.</li> <li>• Check if the standard storage device was used in another MFP.</li> </ul>
3. Recovery	If the error still persists even after step 2, perform this step. <ul style="list-style-type: none"> <li>• Perform HS-75 File System Recovery &gt; Recovery F/S &gt; /imagedata and reboot the MFP.</li> </ul>
4. Format	If the error still persists even after step 3, perform this step. Perform HS-73 Firmware Assist > Format Storage and then install "System Software (HD data)" with HS-49 Firmware Update.  <b>Notes:</b> The following contents will be deleted with this operation. <ul style="list-style-type: none"> <li>• Message Log</li> <li>• Job Log</li> <li>• Spool Data (Print, Email reception)</li> <li>• Template</li> </ul>
5. Setting	If the error still persists even after step 4, perform the following and then reattempt step 4. <ul style="list-style-type: none"> <li>• HS-74 Storage Assist &gt; Revert Factory Initial Status Storage</li> </ul>
6. Standard storage device	If the error still persists even after step 5, replace the standard storage device.

Check item	Measures
7. SYS board	If the error still persists even after step 6, replace the SYS board.
Parts to be replaced	Remarks
Standard storage device	
SYS board	

#### [F141\_14] Partition mount error

Classification	Error content
System related service call	Sub code 14: The standard storage device cannot be installed due to the damage to the “//rollback” partition.

Check item	Measures
1. Reproducibility	Reboot the MFP.
2. SRAM	Check if the SRAM was used in another MFP.
2. Standard storage device	Turn the power of the MFP OFF and check the installation status of the standard storage device. <ul style="list-style-type: none"> <li>• Check if there is any abnormality in the connector.</li> <li>• Check if the connector pins are bent.</li> <li>• Check if the standard storage device was used in another MFP.</li> </ul>
4. Format	If the error still persists even after step 3, perform this step. Perform HS-73 Firmware Assist > Format Storage and then install “System Software (HD data)” with HS-49 Firmware Update. <p><b>Notes:</b> The following contents will be deleted with this operation.</p> <ul style="list-style-type: none"> <li>• Message Log</li> <li>• Job Log</li> <li>• Spool Data (Print, Email reception)</li> <li>• Template</li> </ul>
5. Setting	If the error still persists even after step 4, perform the following and then reattempt step 4. <ul style="list-style-type: none"> <li>• HS-74 Storage Assist &gt; Revert Factory Initial Status Storage</li> </ul>
6. Standard storage device	If the error still persists even after step 5, replace the standard storage device.
7. SYS board	If the error still persists even after step 6, replace the SYS board.

Parts to be replaced	Remarks
Standard storage device	
SYS board	

**[F150] Power failure during the manufacturing mode**

Classification	Error content
System related service call	When a power failure occurred during the manufacturing mode, this error code appears at the next startup.

Check item	Measures
Reproducibility	Turn the power OFF and then back ON. Then check if the error code changes to another one. If it changes to another code, follow its troubleshooting procedure.
Setting	Set "0" in FS-08-9010. If it changes to another code, follow its troubleshooting procedure.

**[F200] Data Overwrite Enabler disabled**

Classification	Error content
System related service call	The data overwrite function has become disabled. <b>Remarks:</b> An F200 error will not occur in an MFP in which a data overwrite enabler is installed as the standard.

Check item	Measures
License	Set "1" in FS-08-9238 to enable the license.

**[F350] SYS board abnormality**

Classification	Error content
System related service call	SYS board abnormality

Check item	Measures
Firmware	<ul style="list-style-type: none"> <li>Check if the combination of the version for all the firmware items installed in the MFP is appropriate.</li> <li>Reinstall the firmware with the correct combination of the version.</li> </ul>
SYS board	<ul style="list-style-type: none"> <li>PC board check</li> <li>Connector check</li> <li>Harness check</li> <li>Replace the PC board.</li> </ul>

Parts to be replaced	Remarks
SYS board	

**[F351] SYS board abnormality**

Classification	Error content
System related service call	SYS board abnormality

Check item	Measures
Firmware	<ul style="list-style-type: none"> <li>Check if the combination of the version for the system firmware, system software and scanner firmware installed in the MFP is appropriate.</li> <li>Reinstall the firmware with the correct combination of the version.</li> </ul>
DSDf relay board	<ul style="list-style-type: none"> <li>PC board check</li> <li>Connector check (CN129)</li> <li>Harness check</li> <li>Replace the PC board.</li> </ul>
SYS board	<ul style="list-style-type: none"> <li>PC board check</li> <li>Connector check (CN129)</li> <li>Harness check</li> <li>Replace the PC board.</li> </ul>

Parts to be replaced	Remarks
DSDf relay board	
SYS board	

**[F400] SYS board cooling fan abnormality**

Classification	Error content
System related service call	There is an abnormality in the SYS board cooling fan.
Check item	Measures
SYS board cooling fan	Check if the SYS board cooling fan is rotating properly. Check if there is any foreign matter on the SYS board cooling fan.
SYS board	<ul style="list-style-type: none"> <li>• PC board check</li> <li>• Connector check (CN117)</li> <li>• Harness check</li> <li>• Replace the PC board.</li> </ul>
Parts to be replaced	Remarks
SYS board cooling fan	
SYS board	

**[F410] Power abnormality**

Classification	Error content
System related service call	The status of the LSI mounted on the SYS board has become an error due to a power abnormality. The MFP will be automatically rebooted at the first-time occurrence; however, the error history will not remain when rebooting is done automatically. This error code appears if an error has occurred continuously.
Check item	Measures
Power cable	<ul style="list-style-type: none"> <li>• Check if the power cable is inserted securely.</li> <li>• Check if there is any abnormality such as scratches in the power cable.</li> </ul>
User's site	<ul style="list-style-type: none"> <li>• Do not plug any cables for other devices in the outlet to which that for the MFP is connected.</li> <li>• The power cable co-packed with the MFP must be used.</li> <li>• The power cable must be used without employing any extension cables.</li> <li>• Be sure to use an outlet which is far from the one to which a device, such as an air conditioner or a printer, which uses a large amount of power is connected.</li> </ul>
Switching regulator	<ul style="list-style-type: none"> <li>• PC board check</li> <li>• Connector check (CN511)</li> <li>• Harness check</li> <li>• Replace the PC board.</li> </ul>
SYS board	<ul style="list-style-type: none"> <li>• PC board check</li> <li>• Connector check</li> <li>• Harness check</li> <li>• Replace the PC board.</li> </ul>
Parts to be replaced	Remarks
Switching regulator	
SYS board	

### [F510] Application start error

Classification	Error content
System related service call	Start of an application has failed.

Check item	Measures
Reproducibility	<ul style="list-style-type: none"><li>• Reboot the MFP.</li><li>• Reinstall the system software.</li></ul>
Format	Perform HS-73 Firmware Assist > Format Storage and then install "System Software (HD data)" with HS-49 Firmware Update.  <b>Notes:</b> The following contents will be deleted with this operation. <ul style="list-style-type: none"><li>• Message Log</li><li>• Job Log</li><li>• Spool Data (Print, Email reception)</li><li>• Template</li></ul>

### [F520] Operating system start error

Classification	Error content
System related service call	Start of an application has failed.

Check item	Measures
1. Reproducibility	<ul style="list-style-type: none"><li>• Reboot the MFP.</li><li>• Reinstall the system software.</li></ul>
2. Recovery	If the error still persists even after step 1, perform HS-75 File System Recovery > Check F/S. If there is a partition with an error, perform HS-75 File System Recovery > Recovery F/S and then reboot the MFP.
3. Initialization	If the error still persists even after step 2, perform HS-75 File System Recovery > Initialize Storage and then reboot the MFP.
4. Format	If the error still persists even after step 3, perform this step. Perform HS-73 Firmware Assist > Format Storage and then install "System Software (HD data)" with HS-49 Firmware Update.  <b>Notes:</b> The following contents will be deleted with this operation. <ul style="list-style-type: none"><li>• Message Log</li><li>• Job Log</li><li>• Spool Data (Print, Email reception)</li><li>• Template</li></ul>

### [F521] Integrity check error

Classification	Error content
System related service call	The program data authentication has failed.

Check item	Measures
Reproducibility	Turn the power OFF and then back ON to check the occurrence.
Firmware	Reinstall all the firmware items and applications which are already stored in the MFP. (System firmware, system software, applications, engine firmware, scanner firmware, fax firmware)

**[F523] Security check error at the startup**

Classification	Error content
System related service call	An abnormality has been detected during the security condition check at the startup.

Check item	Measures
Reproducibility	Turn the power OFF and then back ON to check the occurrence.
Firmware	Reinstall all the firmware items and applications which are already stored in the MFP. (System firmware, system software, applications, engine firmware, scanner firmware, fax firmware)

**[F525] Invalid file execution error**

Classification	Error content
System related service call	Execution of a possibly invalid file has been detected.

Check item	Measures
1. Reproducibility	Turn the power OFF and then back ON to check the occurrence.
2. Firmware	Reinstall all the firmware items and applications which are already stored in the MFP. (System firmware, system software, applications, engine firmware, scanner firmware, fax firmware)
3. Format	If the error still persists even after step 2, perform this step and then reattempt step 2. <ul style="list-style-type: none"> <li>HS-73 Firmware Assist &gt; Format Storage</li> </ul>

**[F526] Anti-malware function error**

Classification	Error content
System related service call	A problem has occurred in the anti-malware function. <ul style="list-style-type: none"> <li>Daemon cannot be started or is ended abnormally.</li> <li>The white list is broken.</li> </ul>

Check item	Measures
1. Reproducibility	Turn the power OFF and then back ON to check the occurrence.
2. Firmware	Reinstall all the firmware items and applications which are already stored in the MFP. (System firmware, system software, applications, engine firmware, scanner firmware, fax firmware)
3. Format	If the error still persists even after step 2, perform this step and then reattempt step 2. <ul style="list-style-type: none"> <li>HS-73 Firmware Assist &gt; Format Storage</li> </ul>

**[F550] Encryption partition error**

Classification	Error content
System related service call	Reading and writing of the encryption partition has failed.

Check item	Measures
Key	Perform HS-73 Firmware Assist mode > Key Backup/Restore and check the displayed message. Restore the encryption key according to the error and messages displayed in the "SRAM" and "FROM" fields.

**[F600] Firmware update error**

Classification	Error content
System related service call	Updating of the firmware has failed.

Check item	Measures
Setting	1. Perform HS-73 Firmware Assist > Clear Software Update Error Flag. 2. Reinstall the firmware in error on the F600 error screen.



**[F700] Overwrite error**

Classification	Error content
System related service call	An error has occurred during overwriting.
Check item	Measures
Reproducibility	Reboot the MFP.
Optional storage device	Replace the optional storage device.

**[F800] Date error**

Classification	Error content
System related service call	The year 2038 problem.
Check item	Measures
Setting	<ol style="list-style-type: none"> <li>1. Perform HS-76 SRAM clear mode &gt; Reset Date and Time.</li> <li>2. Request the administrator to set the date and time.</li> </ol>

**[F900] MFP information consistency error**

Classification	Error content
System related service call	The MFP information is damaged.
Check item	Measures
Reproducibility	Perform HS-76 SRAM Maintenance > SRAM Re-Initialize and reboot the MFP.
Optional storage device	<ol style="list-style-type: none"> <li>1. Perform HS-73 Firmware Assist &gt; Key Backup/Restore.</li> <li>2. Press [Key] twice. Check that the copying of the key from the FROM to the SRAM is selected.</li> <li>3. Press [Execute]. When the restoring of the key is completed, "Success" appears.</li> <li>4. After the operation is completed, shut down the MFP.</li> </ol>

**[F901] Communication error**

Classification	Error content
System related service call	<ul style="list-style-type: none"> <li>• The information of the LGC board is damaged.</li> <li>• An LGC board for another model with a different processing speed has been installed.</li> </ul>
Check item	Measures
Connection condition of connectors	Check if there is no problem in all the harnesses and connectors connected to the LGC board.
LGC board	<ul style="list-style-type: none"> <li>• Check if an LGC board appropriate for the model has been installed. The model of the MFP can be confirmed by the rating label attached to it. The model matching the LGC board can be checked by looking at the label color attached to it.</li> <li>• If an LGC board for a different model has been installed, replace it with the appropriate one.</li> </ul>
Parts to be replaced	Remarks
LGC board	

### 8.3.5 Internet fax and scanning functions error

**Notes:**

When storage device initialization is performed (HS-75 File System Recovery > Initialize Storage), all data in the shared folder, e-Filing, Address Book, template, etc. are erased. Be sure to back up these data before the initialization. Note that some of data cannot be backed up.

 P. 9-20 “9.2.3 Precautions and procedures when replacing the storage device”

#### [ 1 ] Internet fax related error

##### [1C10] System access abnormality

Classification	Error content
Internet fax related error	System access abnormality
Check item	Measures
Setting	Turn the power OFF and then back ON. Perform the job in error again. If the error still persists, check if the settings of SSL/TLS and the authentication are specified properly in the SMTP client setting. If the error nevertheless continues to persist, check if there are no jobs existing and then initialize the storage device.

##### [1C11] Insufficient memory

Classification	Error content
Internet fax related error	Insufficient memory
Check item	Measures
Setting	Perform the job in error again after the running jobs are completed if there are any. If the error still persists, turn the power OFF and then back ON and then perform the jobs again.

##### [1C12] Message reception error

##### [1C13] Message transmission error

Classification	Error content
Internet fax related error	[1C12] Message reception error [1C13] Message transmission error
Check item	Measures
Setting	Turn the power OFF and then back ON. Perform the job in error again.

##### [1C14] Invalid parameter

Classification	Error content
Internet fax related error	Invalid parameter
Check item	Measures
Setting	Form the template again if it is used. If the error still persists, turn the power OFF and then back ON and then perform the jobs again.

##### [1C15] Exceeding file capacity

Classification	Error content
Internet fax related error	Exceeding file capacity
Check item	Measures
Setting	Extend the “Maximum send to E-mail/IFAX size” or reduce the number of pages and perform the job again.

**[1C30] Directory creation failure****[1C31] File creation failure****[1C33] File access failure**

Classification	Error content
Internet fax related error	[1C30] Directory creation failure [1C31] File creation failure [1C33] File access failure
Check item	Measures
Setting	Check if the access privilege to the storage directory is writable. Check if the server or local disk has sufficient space in its disk capacity.
Parts to be replaced	Remarks
SYS board	

**[1C32] File deletion failure**

Classification	Error content
Internet fax related error	File deletion failure
Check item	Measures
Setting	Turn the power OFF and then back ON. Perform the job in error again. If the error nevertheless continues to persist, check if there are no jobs existing and then initialize the storage device (HS-75 File System Recovery > Initialize Storage).

**[1C40] Image conversion abnormality**

Classification	Error content
Internet fax related error	Image conversion abnormality
Check item	Measures
Setting	Turn the power OFF and then back ON. Perform the job in error again. Replace the SYS board and perform the job again.
Parts to be replaced	Remarks
SYS board	

**[1C60] Storage device full during processing**

Classification	Error content
Internet fax related error	Storage device full during processing
Check item	Measures
Setting	Delete the jobs in being set, in running or in HOLD, PRIVATE, PROOF or INVALID and the perform the job again. Reduce the number of pages of the job in error and then perform it again. Check if the server or local disk has sufficient space in its disk capacity.
Parts to be replaced	Remarks
SYS board	

**[1C61] Address book reading failure**

Classification	Error content
Internet fax related error	AddressBook reading failure
Check item	Measures
Setting	Turn the power OFF and then back ON. Perform the job in error again. Reset the data in the Address Book and perform the job again.

**[1C63] Terminal IP address unset**

Classification	Error content
Internet fax related error	Terminal IP address unset
Check item	Measures
Setting	Reset the Terminal ID address. Turn the power OFF and then back ON. Perform the job in error again.

**[1C64] Terminal mail address unset**

Classification	Error content
Internet fax related error	Terminal mail address unset
Check item	Measures
Setting	Reset the Terminal mail address. Turn the power OFF and then back ON. Perform the job in error again.

**[1C65] SMTP mail address unset**

Classification	Error content
Internet fax related error	SMTP mail address unset
Check item	Measures
Setting	Reset the SMTP address and perform the job. Turn the power OFF and then back ON. Perform the job in error again.

**[1C66] Server time-out error**

Classification	Error content
Internet fax related error	Server time-out error
Check item	Measures
Setting	Check if the SMTP server works properly.

**[1C69] SMTP server connection error**

Classification	Error content
Internet fax related error	SMTP server connection error
Check item	Measures
Setting	Reset the login name and password of the SMTP server and perform the job again. Check if the SMTP server works properly.

**[1C6B] Terminal mail address error**

Classification	Error content
Internet fax related error	Terminal mail address error
Check item	Measures
Setting	Check if the SMTP authentication method is correct. Check if an invalid character is included in the Terminal mail address. Select the correct SMTP authentication method, set the appropriate Terminal mail address by removing invalid characters and perform the job again.

**[1C6C] Destination mail address error**

Classification	Error content
Internet fax related error	Destination mail address error

Check item	Measures
Setting	Check if an invalid character is included in the Destination mail address. Set the appropriate Destination mail address by removing invalid characters and perform the job again.

#### [1C6D] System error

Classification	Error content
Internet fax related error	System error

Check item	Measures
Setting	Turn the power OFF and then back ON. Perform the job in error again. If the error still persists, replace the SYS board.

Parts to be replaced	Remarks
SYS board	

#### [1C70] SMTP client OFF

Classification	Error content
Internet fax related error	SMTP client OFF

Check item	Measures
Setting	Enable the SMTP setting and perform the job again.

#### [1C71] SMTP authentication error

Classification	Error content
Internet fax related error	SMTP authentication error

Check item	Measures
Setting	Check if the SMTP authentication method, login name and password are correct. Then perform the job again.

#### [1C72] POP before SMTP error

Classification	Error content
Internet fax related error	POP before SMTP error

Check item	Measures
Setting	Check if both the settings of POP before SMTP and POP3 are correct. Then perform the job again.

#### [1CC1] Power failure

Classification	Error content
Internet fax related error	Power failure

Check item	Measures
Setting	Check if the power cable is connected properly or is inserted securely. Check if the power voltage is unstable.

## [ 2 ] RFC related error

**[2500] HOST NAME error (RFC: 500), Destination mail address error (RFC: 500), Terminal mail address error (RFC: 500)**

**[2501] HOST NAME error (RFC: 501), Destination mail address error (RFC: 501), Terminal mail address error (RFC: 501)**

Classification	Error content
RFC related error	[2500] HOST NAME error (RFC: 500), Destination mail address error (RFC: 500), Terminal mail address error (RFC: 500) [2501] HOST NAME error (RFC: 501), Destination mail address error (RFC: 501), Terminal mail address error (RFC: 501)

Check item	Measures
Setting	Check if the Destination mail address and Destination mail address are correct. Check if the mail server works properly. Turn the power OFF and then back ON. Perform the job in error again.

**[2503] Destination mail address error (RFC: 503)**

**[2504] HOST NAME error (RFC: 504)**

**[2551] Destination mail address error (RFC: 551)**

Classification	Error content
RFC related error	[2503] Destination mail address error (RFC: 503) [2504] HOST NAME error (RFC: 504) [2551] Destination mail address error (RFC: 551)

Check item	Measures
Setting	Check if the mail server works properly. Turn the power OFF and then back ON. Perform the job in error again. If the error still persists, replace the SYS board.

Parts to be replaced	Remarks
SYS board	

**[2550] Destination mail address error (RFC: 550)**

Classification	Error content
RFC related error	Destination mail address error (RFC: 550)

Check item	Measures
Setting	Check the state of the mail box in the mail server.

**[2552] Terminal/destination mail address error (RFC: 552)**

Classification	Error content
RFC related error	Terminal / Destination mail address error (RFC: 552)

Check item	Measures
Setting	Confirm the capacity of the mail box in the mail server. Reattempt the transmission by selecting the text mode or selecting a lower resolution or dividing the original. Turn the power OFF and then back ON. Perform the job in error again.

**[2553] Destination mail address error (RFC: 553)**

Classification	Error content
RFC related error	Destination mail address error (RFC: 553)

Check item	Measures
Setting	Check if invalid characters are used in the mail box name in the mail server.

### [ 3 ] Remote scanning related error

#### [2A20] System management module resource acquiring failure

Classification	Error content
Remote scanning related error	System management module resource acquiring has failed.

Check item	Measures
Setting	Perform the job in error again. If the error still persists, turn the power OFF and then back ON and then perform the jobs again.

#### [2A31] WS Scan disabled

Classification	Error content
Remote scanning related error	A job is performed while WS Scan function is disabled.

Check item	Measures
Setting	Check if WS Scan function (Web Scanning Service) is disabled on TopAccess. If it is disabled, enable it. Or, check if the forcible encryption setting of the secure PDF is enabled.

#### [2A40] System error

Classification	Error content
Remote scanning related error	A system error has occurred.

Check item	Measures
Setting	Turn the power OFF and then back ON. Perform the job in error again.

#### [2A51] Power failure

Classification	Error content
Remote scanning related error	Power failure

Check item	Measures
Setting	<ul style="list-style-type: none"><li>• Check if the power cable is connected properly or is inserted securely.</li><li>• Check if the power voltage is unstable.</li></ul>

#### [2A60] WS Scan user authentication failure

Classification	Error content
Remote scanning related error	WS Scan for job authentication has failed.

Check item	Measures
Setting	<ul style="list-style-type: none"><li>• When "1" (TTEC's WIA driver) is set for FS-08-9749 and Windows Fax&amp;Scan is also used: Check if the user name used to log in Windows is registered as a user.</li><li>• When MFP panel or EWB Scan is used: Check if the login user name is registered as a user.</li></ul>

#### [2A70] RemoteScan privilege check error

Classification	Error content
Remote scanning related error	A job is performed by a user without Remote Scan privilege.

Check item	Measures
Setting	Check if the correct privilege is given to the user.

**[2A71] WS Scan privilege check error**

Classification	Error content
Remote scanning related error	A job is performed by a user without WS Scan privilege.
Check item	Measures
Setting	Check if the correct privilege is given to the user.

**[2A72] e-Filing data access privilege check error (Scan Utility)**

Classification	Error content
Remote scanning related error	A user without e-Filing data access privilege tried to use Scan utility.
Check item	Measures
Setting	Check if the correct privilege is given to the user.

**[2A73] Address book operation privilege check error**

Classification	Error content
Remote scanning related error	Address book operation privilege check error
Check item	Measures
Setting	A user who does not have the AddressbookRemoteAccess privilege has performed export or import of the address book. Check if the correct privilege is given to the user.

**[ 4 ] e-Filing related error**

**[2B11] Job status abnormality**

**[2B20] File library function error**

**[2B30] Insufficient storage device space in BOX partition**

**[2BC0] Fatal failure occurred**

Classification	Error content
e-Filing related error	[2B11] Job status abnormality [2B20] File library function error [2B30] Insufficient storage device space in BOX partition [2BC0] Fatal failure occurred

Check item	Measures
Setting	<ul style="list-style-type: none"> <li>Erase some data in e-Filing or the shared folder and then perform the job in error again (in case of a 2B30 error).</li> <li>Ask the administrator if the e-Filing function is disabled.</li> <li>Turn the power OFF and then back ON. Perform the job in error again.</li> <li>Check if there are no other running jobs and perform the storage device formatting (HS-75 File System Recovery &gt; Initialize Storage). If the recovery is still not completed, replace the SYS board.</li> </ul>

Parts to be replaced	Remarks
SYS board	

**[2B31] Status of the specified e-Filing or folder is undefined or being created or deleted**

Classification	Error content
e-Filing related error	Status of the specified e-Filing or folder is undefined or being created or deleted



Check item	Measures
Setting	<ul style="list-style-type: none"> <li>• Check if the specified e-Filing or folder exists.</li> <li>• Delete the specified e-Filing or folder.</li> <li>• Change the name of the folder to be created.</li> <li>• Perform the job in error again.</li> </ul>

### [2B50] Image library error

#### [2B90] Insufficient memory capacity

Classification	Error content
e-Filing related error	[2B50] Image library error [2B90] Insufficient memory capacity

Check item	Measures
Setting	<ul style="list-style-type: none"> <li>• Turn the power OFF and then back ON. Perform the job in error again. If the error still persists, replace the SYS board.</li> <li>• Delete the jobs in being set, in running or in HOLD, PRIVATE, PROOF or INVALID and then perform the job in error again.</li> </ul>

Parts to be replaced	Remarks
SYS board	

### [2B51] List library error

Classification	Error content
e-Filing related error	List library error

Check item	Measures
Setting	<p>Check if the Function list can be printed. If printing is possible, perform the job in error again. If printing is not possible, replace the SYS board. If it still cannot be printed, initialize the storage device (HS-75 &gt; Initialize Storage).</p>

Parts to be replaced	Remarks
SYS board	

### [2BA0] Invalid Box password

Classification	Error content
e-Filing related error	Invalid Box password

Check item	Measures
Setting	<ul style="list-style-type: none"> <li>• Check if the password is correct.</li> <li>• Reset the password.</li> <li>• If this error has occurred when data in e-Filing is printed, perform printing with the administrator password.</li> </ul>

### [2BA1] The specified paper size, color mode or resolution is not available.

Classification	Error content
e-Filing related error	Invalid paper size, color mode, resolution

Check item	Measures
Setting	The specified paper size, color mode or resolution is not available. Check the setting.

### [2BB1] Power failure

#### [2BD0] Power failure during restoring of e-Filing

Classification	Error content
e-Filing related error	[2BB1] Power failure [2BD0] Power failure during restoring of e-Filing

Check item	Measures
Setting	<ul style="list-style-type: none"> <li>• Check if the power cable is connected properly or is inserted securely.</li> <li>• Check if the power voltage is unstable.</li> </ul>

### [2BE0] Machine parameter reading error

Classification	Error content
e-Filing related error	Machine parameter reading error

Check item	Measures
Setting	Turn the power OFF and then back ON. Perform the job in error again.

### [2BF0] Exceeding the maximum number of pages

Classification	Error content
e-Filing related error	Exceeding the maximum number of pages

Check item	Measures
Setting	Reduce the number of pages of the job in error and then perform it again.

### [2BF1] Exceeding the maximum number of documents

Classification	Error content
e-Filing related error	Exceeding the maximum number of documents

Check item	Measures
Setting	Back up the documents in the box or folder to a client PC or delete them.

### [2BF2] Exceeding the maximum number of folders

Classification	Error content
e-Filing related error	Exceeding the maximum number of folders

Check item	Measures
Setting	Back up the folders in the box to a client PC or delete them.

## [ 5 ] E-mail related error

### [2C10] System access abnormality

Classification	Error content
E-mail related error	System access abnormality

Check item	Measures
Setting	Turn the power OFF and then back ON. Perform the job in error again. If the error still persists, check if the settings of SSL/TLS and the authentication are specified properly in the SMTP client setting. If the error nevertheless continues to persist, check if there are no jobs existing and then initialize the storage device.

### [2C11] Insufficient memory

Classification	Error content
E-mail related error	Insufficient memory

Check item	Measures
Setting	Perform the job in error again after the running jobs are completed if there are any. If the error still persists, turn the power OFF and then back ON and then perform the jobs again.

**[2C12] Message reception error****[2C13] Message transmission error**

Classification	Error content
E-mail related error	[2C12] Message reception error [2C13] Message transmission error
Check item	Measures
Setting	Turn the power OFF and then back ON. Perform the job in error again.

**[2C14] Invalid parameter**

Classification	Error content
E-mail related error	Invalid parameter
Check item	Measures
Setting	Form the template again if it is used. If the error still persists, turn the power OFF and then back ON and then perform the jobs again.

**[2C15] Exceeding file capacity**

Classification	Error content
E-mail related error	Exceeding file capacity
Check item	Measures
Setting	Extend the "Maximum send to E-mail/iFAX size" or reduce the number of pages and perform the job again.

**[2C20] System management module access abnormality****[2C21] Job control module access abnormality****[2C22] Job control module access abnormality**

Classification	Error content
E-mail related error	[2C20] System management module access abnormality [2C21] [2C22] Job control module access abnormality.
Check item	Measures
Setting	Turn the power OFF and then back ON. Perform the job in error again. Check if there are no other running jobs and perform the storage device formatting (HS-75 File System Recovery > Initialize Storage). If the recovery is still not completed, replace the SYS board.
Parts to be replaced	Remarks
SYS board	

**[2C30] Directory creation failure****[2C31] File creation failure****[2C33] File access failure**

Classification	Error content
E-mail related error	[2C30] Directory creation failure [2C31] File creation failure [2C33] File access failure
Check item	Measures
Setting	<ul style="list-style-type: none"> <li>Check if the access privilege to the storage directory is writable.</li> <li>Check if the server or local disk has sufficient space in its disk capacity.</li> </ul>

**[2C32] File deletion failure**

Classification	Error content
E-mail related error	File deletion failure
Check item	Measures
Setting	Turn the power OFF and then back ON. Perform the job in error again. If the error still occurs, first, check if there are no jobs existing and then perform the storage device formatting (HS-75 File System Recovery > Initialize Storage).

**[2C40] Image conversion abnormality****[2C62] Memory acquiring failure**

Classification	Error content
E-mail related error	[2C40] Image conversion abnormality [2C62] Memory acquiring failure
Check item	Measures
Setting	<ul style="list-style-type: none"> <li>• Turn the power OFF and then back ON. Perform the job in error again.</li> <li>• Replace the SYS board and perform the job again.</li> </ul>
Parts to be replaced	Remarks
SYS board	

**[2C43] Encryption error**

Classification	Error content
E-mail related error	Encryption error
Check item	Measures
Setting	Turn the power OFF and then back ON. Perform the job in error again.

**[2C44] Encryption PDF enforced mode error**

Classification	Error content
E-mail related error	Encryption PDF enforced mode error
Check item	Measures
Setting	Reset the encryption setting and perform the job in error again. If an image file without being encrypted needs to be created, ask the administrator.

**[2C45] Meta data creation error (ScanToEmail)**

Classification	Error content
E-mail related error	Creation of meta data failed when a user tried to perform meta scan for ScanToEmail.
Check item	Measures
Setting	Check the template settings and perform the job in error again. If the error still persists, turn the power OFF and then back ON and then perform the job in error again.

**[2C46] Creation of a signed PDF has failed. (An error due to the expiration date of a certificate): ScanToEmail**

Classification	Error content
E-mail related error	Creation of a signed PDF has failed since the certificate expired.
Check item	Measures
Setting	Register the certificate again from TopAccess or the control panel.

**[2C47] Creation of a signed PDF has failed. (Version consistency between the signed PDF and certificates PDF): ScanToEmail**

Classification	Error content
E-mail related error	Creation of a signed PDF has failed since the combination of the certificate data (signature algorithm, public key) and the PDF version is not supported.
Check item	Measures
Setting	Perform one of the following items. <ul style="list-style-type: none"> <li>• Make the PDF version to 1.7 by setting "4" in FS-08-3817.</li> <li>• Make the PDF/A file format setting to PDF/A2-b by means of TopAccess or by setting "1" in FS-08-9471.</li> <li>• From TopAccess, set SHA1 for the signature algorithm and RSA1024 for the public key of the certificate and then register it again.</li> </ul>

**[2C50] Authentication failure at job execution**

Classification	Error content
E-mail related error	Authentication failure at job execution
Check item	Measures
Setting	A ScanToEmail job is carried out while user authentication or department authentication has not been done. Retry the job after user authentication or department authentication has been done.

**[2C60] Storage device full during processing**

Classification	Error content
E-mail related error	Storage device full during processing
Check item	Measures
Setting	<ul style="list-style-type: none"> <li>• Delete the jobs in being set, in running or in HOLD, PRIVATE, PROOF or INVALID and the perform the job again.</li> <li>• Reduce the number of pages of the job in error and then perform it again.</li> <li>• Check if the server or local disk has sufficient space in its disk capacity.</li> </ul>

**[2C61] Address book reading failure**

Classification	Error content
E-mail related error	AddressBook reading failure
Check item	Measures
Setting	<ul style="list-style-type: none"> <li>• Turn the power OFF and then back ON. Perform the job in error again.</li> <li>• Reset the data in the Address Book and perform the job again.</li> </ul>

**[2C63] Terminal IP address unset**

Classification	Error content
E-mail related error	Terminal IP address unset
Check item	Measures
Setting	<ul style="list-style-type: none"> <li>• Reset the Terminal ID address.</li> <li>• Turn the power OFF and then back ON. Perform the job in error again.</li> </ul>

**[2C64] Terminal mail address unset**

Classification	Error content
E-mail related error	Terminal mail address unset
Check item	Measures
Setting	<ul style="list-style-type: none"> <li>• Reset the Terminal mail address.</li> <li>• Turn the power OFF and then back ON. Perform the job in error again.</li> </ul>

**[2C65] SMTP mail address unset**

Classification	Error content
E-mail related error	SMTP mail address unset
Check item	Measures
Setting	<ul style="list-style-type: none"> <li>Reset the SMTP address and perform the job.</li> <li>Turn the power OFF and then back ON. Perform the job in error again.</li> </ul>

**[2C66] Server time-out error**

Classification	Error content
E-mail related error	Server time-out error
Check item	Measures
Setting	Check if the SMTP server works properly.

**[2C69] SMTP server connection error**

Classification	Error content
E-mail related error	SMTP server connection error
Check item	Measures
Setting	<ul style="list-style-type: none"> <li>Reset the login name and password of the SMTP server and perform the job again.</li> <li>Check if the SMTP server works properly.</li> </ul>

**[2C6A] HOST NAME error (no RFC error)**

Classification	Error content
E-mail related error	HOST NAME error (no RFC error)
Check item	Measures
Setting	Check if an invalid character is included in the device name. Delete the invalid character and set the appropriate device name.

**[2C6B] Terminal mail address error**

Classification	Error content
E-mail related error	Terminal mail address error
Check item	Measures
Setting	Check if the SMTP authentication method is correct. Check if an invalid character is included in the Terminal mail address. Select the correct SMTP authentication method, set the appropriate Terminal mail address by removing invalid characters and perform the job again.

**[2C6C] Destination mail address error (no RFC error)**

Classification	Error content
E-mail related error	Destination mail address error (no RFC error)
Check item	Measures
Setting	Check if an invalid character is included in the Destination mail address. Set the appropriate Destination mail address by removing invalid characters and perform the job again.

**[2C70] SMTP client OFF**

Classification	Error content
E-mail related error	SMTP client OFF

Check item	Measures
Setting	Enable the SMTP setting and perform the job again.

### [2C71] SMTP authentication error

Classification	Error content
E-mail related error	SMTP authentication error

Check item	Measures
Setting	Check if the SMTP authentication method, login name and password are correct. Then perform the job again.

### [2C72] POP before SMTP error

Classification	Error content
E-mail related error	POP before SMTP error

Check item	Measures
Setting	Check if both the settings of POP before SMTP and POP3 are correct. Then perform the job again.

### [2CC1] Power failure

Classification	Error content
E-mail related error	Power failure

Check item	Measures
Setting	Check if the power cable is connected properly or is inserted securely. Check if the power voltage is unstable.

## [ 6 ] File sharing related error

### [2D10] System access abnormality

### [2D32] File deletion failure

### [2DA6] File deletion failure

### [2DA7] Resource acquiring failure

Classification	Error content
File sharing related error	[2D10] System access abnormality [2D32] [2DA6] File deletion failure [2DA7] Resource acquiring failure

Check item	Measures
Setting	<ul style="list-style-type: none"> <li>Delete some files in the shared folder by using Explorer because of automatic/manual file deletion failure (in case of [2DA6]).</li> <li>Turn the power OFF and then back ON. Perform the job in error again. If the error still occurs, first, check if there are no jobs existing and then perform the storage device formatting (HS-75 File System Recovery &gt; Initialize Storage).</li> </ul>

### [2D11] Insufficient memory

Classification	Error content
File sharing related error	Insufficient memory

Check item	Measures
Setting	Perform the job in error again after the running jobs are completed if there are any. If the error still persists, turn the power OFF and then back ON and then perform the jobs again.

**[2D12] Message reception error****[2D13] Message transmission error**

Classification	Error content
File sharing related error	[2D12] Message reception error [2D13] Message transmission error

Check item	Measures
Setting	Turn the power OFF and then back ON. Perform the job in error again.

**[2D14] Invalid parameter**

Classification	Error content
File sharing related error	Invalid parameter

Check item	Measures
Setting	Form the template again if it is used. If the error still persists, turn the power OFF and then back ON and then perform the jobs again.

**[2D15] Exceeding the maximum size for file sharing**

Classification	Error content
File sharing related error	Exceeding the maximum size for file sharing

Check item	Measures
Setting	Delete some documents in the folder and then perform the job in error again.

**[2D30] Directory creation failure****[2D31] File creation failure****[2D33] File access failure**

Classification	Error content
File sharing related error	[2D30] Directory creation failure [2D31] File creation failure [2D33] File access failure

Check item	Measures
Setting	<ul style="list-style-type: none"> <li>• Check if the access privilege to the storage directory is writable.</li> <li>• Check if the server or local disk has sufficient space in its disk capacity.</li> </ul>

**[2D40] Image conversion abnormality**

Classification	Error content
File sharing related error	Image conversion abnormality

Check item	Measures
Setting	<ul style="list-style-type: none"> <li>• Turn the power OFF and then back ON. Perform the job in error again.</li> <li>• Replace the SYS board and perform the job again.</li> </ul>

**[2D43] Encryption error**

Classification	Error content
File sharing related error	Encryption error

Check item	Measures
Setting	Turn the power OFF and then back ON. Perform the job in error again.

**[2D44] Encryption PDF enforced mode error**

Classification	Error content
File sharing related error	Encryption PDF enforced mode error



Check item	Measures
Setting	Reset the encryption setting and perform the job in error again. If an image file without being encrypted needs to be created, ask the administrator.

#### [2D45] Meta data creation error (ScanToFile)

Classification	Error content
File sharing related error	Creation of meta data failed when a user tried to perform meta scan for ScanToFile.

Check item	Measures
Setting	Check the template settings and perform the job in error again. If the error still persists, turn the power OFF and then back ON and then perform the job in error again.

#### [2D46] Creation of a signed PDF has failed. (An error due to the expiration date of a certificate): ScanToFile

Classification	Error content
E-mail related error	Creation of a signed PDF has failed since the certificate expired.

Check item	Measures
Setting	Register the certificate again from TopAccess or the control panel.

#### [2D47] Creation of a signed PDF has failed. (Version consistency between the signed PDF and certificates PDF): ScanToFile

Classification	Error content
E-mail related error	Creation of a signed PDF has failed since the combination of the certificate data (signature algorithm, public key) and the PDF version is not supported.

Check item	Measures
Setting	Perform one of the following items. <ul style="list-style-type: none"> <li>• Make the PDF version to 1.7 by setting "4" in FS-08-3817.</li> <li>• Make the PDF/A file format setting to PDF/A2-b by means of TopAccess or by setting "1" in FS-08-9471.</li> <li>• From TopAccess, set SHA1 for the signature algorithm and RSA1024 for the public key of the certificate and then register it again.</li> </ul>

#### [2D50] Authentication failure at job execution (A ScanToFile job is carried out while user authentication or department authentication has not been done.)

Classification	Error content
File sharing related error	Authentication failure at job execution (A ScanToFile job is carried out while user authentication or department authentication has not been done.)

Check item	Measures
Setting	Retry the job after user authentication or department authentication has been done.

#### [2D62] File server connection failure

Classification	Error content
File sharing related error	File server connection failure

Check item	Measures
Setting	<ul style="list-style-type: none"> <li>• Check the IP address and path of the server.</li> <li>• Check if the server works properly.</li> </ul>

**[2D63] Invalid network path**

Classification	Error content
File sharing related error	Invalid network path
Check item	Measures
Setting	Check the network path. If the network path is correct, turn the power OFF and then back ON and then perform the jobs again.

**[2D64] Login failure**

Classification	Error content
File sharing related error	Login failure
Check item	Measures
Setting	<ul style="list-style-type: none"> <li>Reset the login name and password and perform the job.</li> <li>Check if the account setting of the server is correct.</li> </ul>

**[2D65] New document creation failure caused by an excess of documents in a folder**

Classification	Error content
File sharing related error	New document creation failure caused by an excess of documents in a folder
Check item	Measures
Setting	Delete some documents in the folder.

**[2D66] Storage capacity full failure during processing**

Classification	Error content
File sharing related error	Storage capacity full failure during processing
Check item	Measures
Setting	<ul style="list-style-type: none"> <li>Delete the jobs in being set, in running or in HOLD, PRIVATE, PROOF or INVALID and the perform the job again.</li> <li>Reduce the number of pages of the job in error or select a lower resolution and then perform the job again.</li> <li>Check if the server or local disk has sufficient space in its disk capacity.</li> </ul>

**[2D67] FTP service not available**

Classification	Error content
File sharing related error	FTP service not available
Check item	Measures
Setting	Check if the setting of the FTP service is enabled.

**[2D68] File sharing service not available**

Classification	Error content
File sharing related error	File sharing service not available
Check item	Measures
Setting	Check if the setting of the SMB is enabled.

**[2D69] NetWare service not available**

Classification	Error content
File sharing related error	When a user tried to perform ScanToFile with NetWare protocol even though the NetWare setting is disabled, a message notifies the user that NetWare service is disabled.

Check item	Measures
Setting	Check if the setting of the NetWare is enabled.

### [2DC1] Power failure

Classification	Error content
File sharing related error	Power failure

Check item	Measures
Setting	Check if the power cable is connected properly or is inserted securely. Check if the power voltage is unstable.

### [2E10] System access abnormality in ScanToUSB

Classification	Error content
File sharing related error	Job status is invalid.

Check item	Measures
Setting	Turn the power OFF and then back ON. Perform the job in error again. If the error still occurs, first, check if there are no jobs existing and then perform the storage device formatting (HS-75 File System Recovery > Initialize Storage).

### [2E11] Insufficient memory capacity in ScanToUSB

Classification	Error content
File sharing related error	Insufficient memory capacity for USB storage device

Check item	Measures
Setting	Perform the job in error again after the running jobs are completed if there are any. If the error still persists, turn the power OFF and then back ON and then perform the jobs again.

### [2E12] Message reception error in ScanToUSB

### [2E13] Message transmission error in ScanToUSB

Classification	Error content
File sharing related error	Job status is invalid.

Check item	Measures
Setting	Turn the power OFF and then back ON. Perform the job in error again.

### [2E14] Parameter error in ScanToUSB

Classification	Error content
File sharing related error	The specified parameter is invalid.

Check item	Measures
Setting	Form the template again if it is used. If the error still persists, turn the power OFF and then back ON and then perform the jobs again.

### [2E15] Exceeding the maximum size for file sharing

Classification	Error content
File sharing related error	There are too many files in the folder. Creation of a new document has failed.

Check item	Measures
Setting	Delete some documents in the folder and then perform the job in error again.

**[2E30] Directory creation failure in ScanToUSB****[2E31] File creation failure in ScanToUSB**

Classification	Error content
File sharing related error	[2E30] Creation of a directory has failed. [2E31] Creation of a file has failed.
Check item	Measures
Setting	<ul style="list-style-type: none"> <li>• Check if the access privilege to the storage directory is writable.</li> <li>• Check if the server or local disk has sufficient space in its disk capacity.</li> </ul>

**[2E32] File deletion failure in ScanToUSB**

Classification	Error content
File sharing related error	Deletion of a file has failed.
Check item	Measures
Setting	Turn the power OFF and then back ON. Perform the job in error again. If the error still occurs, first, check if there are no jobs existing and then perform the storage device formatting (HS-75 File System Recovery > Initialize Storage).

**[2E33] File access failure in ScanToUSB**

Classification	Error content
File sharing related error	Creation of a file has failed.
Check item	Measures
Setting	<ul style="list-style-type: none"> <li>• Check if the access privilege to the storage directory is writable.</li> <li>• Check if the server or local disk has sufficient space in its disk capacity.</li> </ul>

**[2E40] Image conversion abnormality in ScanToUSB**

Classification	Error content
File sharing related error	Conversion of image file format has failed.
Check item	Measures
Setting	<ul style="list-style-type: none"> <li>• Turn the power OFF and then back ON. Perform the job in error again.</li> <li>• Replace the SYS board and perform the job again.</li> </ul>
Parts to be replaced	Remarks
SYS board	

**[2E43] Encryption failure in ScanToUSB**

Classification	Error content
File sharing related error	Creation of a file has failed due to PDF encryption error.
Check item	Measures
Setting	Turn the power OFF and then back ON. Perform the job in error again.

**[2E44] Encryption PDF enforced mode error in ScanToUSB**

Classification	Error content
File sharing related error	Creation of an image file is not permitted.
Check item	Measures
Setting	Reset the encryption setting and perform the job in error again. To create an image file not encrypted, consult your administrator.

**[2E45] Meta data creation error in USB storage device (ScanToFile)**

Classification	Error content
File sharing related error	Creation of meta data has failed.
Check item	Measures
Setting	Check the template settings and perform the job in error again. If the error still persists, turn the power OFF and then back ON and then perform the job in error again.

**[2E46] Creation of a signed PDF has failed. (An error due to the expiration date of a certificate): ScanToUSB**

Classification	Error content
E-mail related error	Creation of a signed PDF has failed since the certificate expired.
Check item	Measures
Setting	Register the certificate again from TopAccess or the control panel.

**[2E47] Creation of a signed PDF has failed. (Version consistency between the signed PDF and certificates PDF): ScanToUSB**

Classification	Error content
E-mail related error	Creation of a signed PDF has failed since the combination of the certificate data (signature algorithm, public key) and the PDF version is not supported.
Check item	Measures
Setting	Perform one of the following items. <ul style="list-style-type: none"> <li>• Make the PDF version to 1.7 by setting "4" in FS-08-3817.</li> <li>• Make the PDF/A file format setting to PDF/A2-b by means of TopAccess or by setting "1" in FS-08-9471.</li> <li>• From TopAccess, set SHA1 for the signature algorithm and RSA1024 for the public key of the certificate and then register it again.</li> </ul>

**[2E50] Authentication failure at job execution**

Classification	Error content
File sharing related error	A ScanToUSB job is carried out while user authentication or department authentication has not been done.
Check item	Measures
Setting	Retry the job after user authentication or department authentication has been done.

**[2E65] File creation error due to insufficient USB folder capacity in ScanToUSB**

Classification	Error content
File sharing related error	Creation of a new file failed because there were too many files in the USB folder.
Check item	Measures
Setting	Delete some documents in the folder.

**[2E66] Storage device full failure during ScanToUSB**

Classification	Error content
File sharing related error	Storage device full has occurred during processing.
Check item	Measures
Setting	<ul style="list-style-type: none"> <li>• Delete the jobs in being set, in running or in HOLD, PRIVATE, PROOF or INVALID and the perform the job again.</li> <li>• Reduce the number of pages of the job in error and then perform it again.</li> <li>• Check if there is enough space in the USB storage device.</li> </ul>

## [2EC1] Power failure in ScanToUSB

Classification	Error content
File sharing related error	A job was interrupted due to a power failure.

Check item	Measures
Setting	<ul style="list-style-type: none"><li>• Check if the power cable is connected properly or is inserted securely.</li><li>• Check if the power voltage is unstable.</li></ul>

## [ 7 ] E-mail reception related error

### [3A10] E-mail MIME error

Classification	Error content
E-mail reception related error	E-mail MIME error

Check item	Measures
Setting	The format of the e-mail is not supported by MIME1.0. Ask the sender to retransmit the e-mail in the format supported by MIME1.0.

### [3A20] E-mail analysis error

### [3B10] E-mail format error

### [3B40] E-mail decode error

Classification	Error content
E-mail reception related error	[3A20] E-mail analysis error [3B10] E-mail format error [3B40] E-mail decode error

Check item	Measures
Setting	E-mail data are damaged from the transmission to the reception. Ask the sender to retransmit the e-mail.

### [3A30] Partial mail time-out error

Classification	Error content
E-mail reception related error	Partial mail time-out error

Check item	Measures
Setting	A partial mail is not received in a specified period of time. Ask the sender to retransmit the e-mail. Or, set the time-out period of the partial mail longer.

### [3A40] Partial mail related error

Classification	Error content
E-mail reception related error	Partial mail related error

Check item	Measures
Setting	The format of the partial mail is not supported by this MFP. Ask the sender to recreate and retransmit the partial mail in an RFC2046 format.

### [3A50] Insufficient storage device capacity error

Classification	Error content
E-mail reception related error	Insufficient storage device capacity error

Check item	Measures
Setting	The storage device capacity is not sufficient for a temporary concentration of the jobs, etc. Ask the sender to retransmit after a certain period of time or divide the e-mail into more than one. Insufficient storage device capacity error also occurs when printing cannot be performed for reasons such as lack of printing paper. In this case, supply paper.

### [3A70] Partial mail interruption error

Classification	Error content
E-mail reception related error	Partial mail interruption error

Check item	Measures
Setting	The partial mail reception setting becomes OFF during its reception. Reset the partial mail reception setting ON and then ask the sender to retransmit the partial mail.

### [3A80] Partial mail reception setting OFF

Classification	Error content
E-mail reception related error	Partial mail reception setting OFF

Check item	Measures
Setting	Reset the partial mail reception setting ON and then ask the sender to retransmit the partial mail.

### [3B20] Content-Type error

Classification	Error content
E-mail reception related error	Content-Type error

Check item	Measures
Setting	The file format attached to the e-mail is not supported by this MFP (TIFF-FX/PDF/JPEG/XPS). Or the combination of the file formats attached to the e-mail is not available to be received together by this MFP. (The file format TIFF-FX cannot be received together with PDF, JPEG and XPS ones.) Request the sender to retransmit the file by modifying the file format which is supported by this MFP. Or request the sender to retransmit the e-mail by attaching only TIFF-FX format files or by attaching PDF, JPEG and XPS format files (a mixture of the formats is available).

### [3B50] Received mail data deletion

Classification	Error content
E-mail reception related error	Received mail data deletion

Check item	Measures
Setting	Received e-mail data have been deleted from a server as their reception process could not be carried out since they were broken. Check if the address of the e-mail sent immediately before the error is correct. Ask the sender to retransmit the deleted e-mail.

### [3C10] TIFF analysis error

### [3C13] TIFF analysis error

Classification	Error content
E-mail reception related error	TIFF analysis error

Check item	Measures
Setting	E-mail data are damaged from the transmission to the reception. Alternatively, the file format attached to the e-mail is not supported by this MFP. (Supported: TIFF-FX) Ask the sender to retransmit the e-mail.

### [3C20] TIFF compression error

Classification	Error content
E-mail reception related error	TIFF compression error

Check item	Measures
Setting	The compression method of the TIFF file is not acceptable for this MFP. (Acceptable: MH, MR, MMR, JBIG) Ask the sender to retransmit the file in the acceptable compression method.

### [3C30] TIFF resolution error

Classification	Error content
E-mail reception related error	TIFF resolution error

Check item	Measures
Setting	The resolution of the TIFF file is not acceptable for this MFP. (Acceptable: 200 x 100, 200 x 200, 200 x 400, 400 x 400, 300 x 300 or equivalent) Ask the sender to retransmit the file in the acceptable resolution.

### [3C40] TIFF paper size error

Classification	Error content
E-mail reception related error	TIFF paper size error

Check item	Measures
Setting	The paper size of the TIFF file is not acceptable for this MFP. (Acceptable: A4, B4, A3, B5, LT, LG, LD or ST) Ask the sender to retransmit the file in the acceptable paper size.

### [3C50] Offramp destination error

Classification	Error content
E-mail reception related error	Offramp destination error

Check item	Measures
Setting	The fax number of the offramp destination is incorrect. Ask the sender to correct the fax number of the offramp destination and retransmit it.

### [3C60] Offramp security error

Classification	Error content
E-mail reception related error	Offramp security error

Check item	Measures
Setting	The fax number of the offramp destination is not registered in the address book. Check the fax number of the offramp destination and contact the sender.

### [3C70] Power failure

Classification	Error content
E-mail reception related error	Power failure



Check item	Measures
Setting	Check if the job is recovered after turning power OFF and then back ON. Request the sender to retransmit the e-mail if the job is not recovered.

### [3C90] Offramp fax transmission disable error

Classification	Error content
E-mail reception related error	Offramp fax transmission disable error

Check item	Measures
Setting	This error is displayed when a fax or internet fax transmission limitation error has occurred during offramp gateway function. Enable the fax transmission features.

### [3D10] Destination address error

Classification	Error content
E-mail reception related error	Destination address error

Check item	Measures
Setting	Check if the setting of the server of DNS is correct. Correct if any of the setting is incorrect. When the setting is correct, ask the sender to confirm if the destination is correct.

### [3D20] Maximum number of offramp destination error

Classification	Error content
E-mail reception related error	Offramp destination limitation error

Check item	Measures
Setting	Inform the sender that the transferring of fax data over 40 is not supported.

### [3D30] No fax unit error

Classification	Error content
E-mail reception related error	No fax unit error

Check item	Measures
Setting	The fax board is not installed or there is any abnormality in the fax board. Check if the fax board is installed properly.

### [3E10] POP3 server connection error

Classification	Error content
E-mail reception related error	POP3 server connection error

Check item	Measures
Setting	Check if the IP address or the domain name of the POP3 server set for this MFP is correct. Or, check if the POP3 server to be connected works properly.

### [3E20] POP3 server connection time-out error

Classification	Error content
E-mail reception related error	POP3 server connection time-out error

Check item	Measures
Setting	Check if the POP3 server to be connected works properly. Check that the LAN cable is connected properly.

**[3E30] POP3 login error**

Classification	Error content
E-mail reception related error	POP3 login error
Check item	Measures
Setting	Check if the POP3 server login name and password set for this MFP are correct.

**[3E40] POP3 login type error**

Classification	Error content
E-mail reception related error	POP3 login type error
Check item	Measures
Setting	Check if the login type (Auto, POP3, APOP) to the POP3 server is correct.

**[3F10] File I/O error****[3F20] File I/O error**

Classification	Error content
E-mail reception related error	File I/O error
Check item	Measures
Setting	Mail data are not transferred to the storage device properly. Ask the sender to retransmit the e-mail. If the error still persists after the retransmission, replace the storage device.
Parts to be replaced	Remarks
Storage device	

## 8.3.6 Printer function error

### [4011] Print job cancellation

Classification	Error content
Printer function error	A print job (copy, list print, network print) has been deleted from the print job screen.

Check item	Measures
Setting	This message appears when deleting a job on the screen.

### [4012] Automatic deletion of expired print jobs

Classification	Error content
Printer function error	Print jobs which had expired since their retention time had passed, have been deleted automatically. (Print jobs such as Private, Hold, Proof, Invalid Department, Multi Station and jobs being skipped)

Check item	Measures
Setting	When this has been carried out, this error code is displayed on the Print Log.

### [4021] Power failure at print job processing

Classification	Error content
Printer function error	The power of the MFP is turned OFF during a print job (copy, list print, network print) process.

Check item	Measures
Setting	Check if the power cable is connected properly or is inserted securely. Check if the power voltage is unstable.

### [4031] Storage device full during print

Classification	Error content
Printer function error	A large amount of image data is saved in a storage device at private print or invalid network print.

Check item	Measures
Setting	Delete unnecessary private print jobs and invalid department print jobs and then perform printing again. Check if the server or local disk has sufficient space in its disk capacity.

### [4032] Exceeding the upper limit of the registration number for the sharing jobs

Classification	Error content
Printer function error	No more sharing jobs can be registered because its registration number as a personal or functional has reached the upper limit. (A specific error for the Serverless Location Free Print function)

Check item	Measures
Setting	Check that no unnecessary shared jobs yet to be printed are remaining. If there are such jobs, delete them.

### [4033] Network setting error

Classification	Error content
Printer function error	A sharing job cannot be registered since the applicable address has not been found from the list used for the Serverless Location Free Print function. (A specific error for the Serverless Location Free Print function)

Check item	Measures
Setting	The address applicable to this MFP has not been registered in the cooperating machine list. Add the address applicable to this MFP.

#### [4041] User authentication error

Classification	Error content
Printer function error	The user who intended to print a document is not registered as a user.

Check item	Measures
Setting	Perform the authentication or register as a user, and then perform printing again.

#### [4042] Department authentication error

Classification	Error content
Printer function error	The department whose code is specified for a print job is not registered.

Check item	Measures
Setting	Check department information registered in this MFP.

#### [4043] Project authentication error

Classification	Error content
Printer function error	The project whose code is specified for a print job is not registered.

Check item	Measures
Setting	Check project information registered in this MFP.

#### [4045] Problem in LDAP server connection or LDAP server authorization settings

Classification	Error content
Printer function error	Problem in LDAP server connection or LDAP server authorization settings

Check item	Measures
Setting	Ask the LDAP server administrator to confirm the LDAP server connection or the LDAP server authorization settings.

#### [4111] Quota over error (no quota in a department and user)

Classification	Error content
Printer function error	The number of the assigned pages set by the department and user management has reached 0.

Check item	Measures
Setting	Both the numbers of the assigned pages set by the department management and user management have reached 0 at the same time. Assign the number of the pages again or perform initialization.

#### [4112] Quota over error (no quota in a user)

Classification	Error content
Printer function error	The number of the assigned pages set by the user management has reached 0.

Check item	Measures
Setting	The number of the assigned pages set by the user management has reached 0. Assign the number of the pages again or perform initialization.

**[4113] Quota over error (no quota in a department)**

Classification	Error content
Printer function error	The number of the assigned pages set by the department management has reached 0.
Check item	Measures
Setting	The number of the assigned pages set by the department management has reached 0. Initialize the quota.

**[4121] Job canceling due to external counter error**

Classification	Error content
Printer function error	Job canceling due to external counter error
Check item	Measures
Setting	<ol style="list-style-type: none"> <li>Drop a coin and perform the print job in error again.</li> <li>Insert a key card and perform the print job in error again. Or, ask your administrator.</li> <li>Insert a key counter and perform the print job in error again.</li> <li>Release the Schedule Print setting and then perform the print job again.</li> </ol>

**[4211] Printing data storing limitation error**

Classification	Error content
Printer function error	Printing with its data being stored to the storage device temporarily (Proof print, Private print, Scheduled print, etc.) has been performed.
Check item	Measures
Setting	Select "Normal print", and then perform printing again.

**[4212] e-Filing storing limitation error**

Classification	Error content
Printer function error	Printing with its data being stored to the storage device (print and e-Filing, print to e-Filing, etc.) has been performed.
Check item	Measures
Setting	Select "Normal print", and then perform printing again.

**[4213] File storing limitation error**

Classification	Error content
Printer function error	The file storing function is disabled.
Check item	Measures
Setting	The file storing function is disabled. Check the setting of the MFP.

**[4214] Fax and internet fax transmission limitation error**

Classification	Error content
Printer function error	The fax and internet fax transmission functions or the network fax and internet fax functions are set to "disabled".
Check item	Measures
Setting	The fax and internet fax transmission functions or the network fax and internet fax functions are set to "disabled". Check the setting of the MFP.

**[4221] Private-print-only error**

Classification	Error content
Printer function error	Jobs other than Private print ones have been performed.
Check item	Measures
Setting	Email direct printing cannot be performed since Private printing is not selectable for it. Select "Private print", and then perform the printing again.

**[4222] Hold-print-only error**

Classification	Error content
Printer function error	Hold-print-only error
Check item	Measures
Setting	Email direct printing cannot be performed since Hold printing is not selectable for it.

**[4223] Private-print-only and Hold-print-only error**

Classification	Error content
Printer function error	Private-print-only and Hold-print-only error
Check item	Measures
Setting	Email direct printing cannot be performed since Private printing and Hold printing are not selectable for it.

**[4231] Hardcopy security printing error**

Classification	Error content
Printer function error	A hardcopy security printing job has been performed when the function is restricted.
Check item	Measures
Setting	Hardcopy security printing cannot be performed because the function is restricted in the self-diagnostic mode. Check the settings of the MFP.

**[4243] Sharing job - An error caused by not having a license**

Classification	Error content
Printer function error	Sharing job - An error caused by not having a license
Check item	Measures
Setting	Check if the license of the multi station print option is installed. If it is not, install it.

**[4244] Sharing job - An error caused by function disabled**

Classification	Error content
Printer function error	Sharing job - An error caused by function disabled
Check item	Measures
Setting	Check from TopAccess if the function of the multi station print option is disabled. If it is disabled, enable it.

**[4245] OCR functions not available**

Classification	Error content
Printer function error	OCR functions not available

Check item	Measures
Setting	Check if the OCR license or an extended memory is installed.

#### [4246] IP Fax license is not installed

Classification	Error content
Printer function error	The IP Fax function utilizing an NW-Fax driver cannot be used since the license of the IP Fax has not been installed.

Check item	Measures
Setting	Check that the license of the IP Fax has been installed correctly and reattempt the operation.

#### [4311] No privilege to perform a job

Classification	Error content
Printer function error	No privilege to perform a job

Check item	Measures
Setting	Confirm the administrator for the job authorization.

#### [4312] No privilege to store a file

Classification	Error content
Printer function error	No privilege to store a file

Check item	Measures
Setting	Ask the administrator about the privilege to store a file.

#### [4313] No privilege for StoreToFile

#### [4314] No privilege for SendToFax and SendToIFax

Classification	Error content
Printer function error	[4313] No privilege to StoreToFile is given. (e-Filing storage permission) [4314] No privilege for SendToFax and SendToIFax is given. (Fax / Internet Fax transmission permission)

Check item	Measures
Setting	Check the privilege given. Ask the administrator to add the necessary privilege.

#### [4411] Image data creation failure

Classification	Error content
Printer function error	Image data creation failure

Check item	Measures
Setting	The data or file to be printed may be broken. <ul style="list-style-type: none"> <li>• Network print: The print data are broken. Alternatively, they are invalid.</li> <li>• Direct print: The file is broken. Alternatively, the file format is not supported by this MFP.</li> </ul>

#### [4412] Decoding error

Classification	Error content
Printer function error	The PDF file is encrypted incorrectly or encrypted in a language not supported.

Check item	Measures
Setting	Printing using this function cannot be performed due to a decoding process error which occurs because the PDF file is encrypted incorrectly or encrypted in a language not supported.

**[4511] Connection timeout**

Classification	Error content
Printer function error	Time-out is detected when printing has failed since the print data sending was stopped during the communication with the client PC or the connection had not been disconnected from the PC.
Check item	Measures
Setting	Check that the Ethernet setting of the MFP is the same as that for the hub to which the MFP is being connected. Check that the Ethernet cable is connected properly.

**[4521] Reaching the maximum number of connections**

Classification	Error content
Printer function error	A job cannot be received since the MFP has reached the max. number of connections.
Check item	Measures
Setting	Perform printing again after a certain period of time. If this frequently occurs due to the network environment or the number of the client PCs, change the setting of the following self-diagnostic codes. • FS-08-3727, FS-08-3731, FS-08-3732, FS-08-3765, FS-08-9561

**[4522] Exceeding the upper limit of the registration number of jobs during data reception**

Classification	Error content
Printer function error	The reception of jobs is limited since the MFP has been in the nearly Workflow Full status.
Check item	Measures
Setting	Wait until the printing of the jobs which are being processed or are waiting is completed and then perform printing again. Delete unnecessary private print jobs and invalid department print jobs and then perform printing again.

**[4523] Storage device full during data reception**

Classification	Error content
Printer function error	The reception of jobs is limited since the MFP has been in the nearly storage device Full status.
Check item	Measures
Setting	Delete unnecessary private print jobs and invalid department print jobs and then perform printing again. Check if the server or local disk has sufficient space in its disk capacity.

**[4611] Font download failure (exceeding the maximum number of registrations)****[4612] Font download failure (Storage device full)**

Classification	Error content
Printer function error	[4611] A new font cannot be registered because the number of fonts registered in this MFP has already reached the limit. [4612] A new font cannot be registered because there is insufficient space in the font storage area of this MFP.
Check item	Measures
Setting	Delete one or more fonts already registered.

**[4613] Font download failure (others)**

Classification	Error content
Printer function error	A new font cannot be registered due to other abnormalities.



Check item	Measures
Setting	Reattempt the downloading. Recreate font data and reattempt the downloading.

#### [4621] Downloaded font deletion failure

Classification	Error content
Printer function error	The specified font cannot be deleted because it does not exist, it is undeletable or any another abnormality has occurred.

Check item	Measures
Setting	Check if the font to be deleted is registered in the MFP. Check if the font to be deleted is the one registered in the MFP beforehand.

#### [4721] Connection error of multi station print (Unavailable combination of the version)

Classification	Error content
Printer function error	Connection failure of Multi Station Print because of an unavailable ROM version combination.

Check item	Measures
Setting	Check the version of the MFP to connect and then update the version of the unconnectable MFP to become the same as that for the connected one.



#### [4731] Multi Station print jobs have been removed. (An error has occurred in the job list.)

Classification	Error content
Printer function error	Jobs have been removed since an error had occurred in the job list of Multi Station print.

Check item	Measures
Setting	Print the removed jobs again.

#### [4F10] System abnormality

Classification	Error content
Printer function error	Printing was not performed successfully due to other abnormalities.

Check item	Measures
Setting	<ol style="list-style-type: none"> <li>1. Perform the job in error again. If the error still persists, turn the power OFF and then back ON and then perform the jobs again.</li> <li>2. Collect the debug log with a USB storage device.   P. 8-3 "8.1.2 Collection of debug logs with a USB storage device"</li> <li>3. Initializes the storage device.  Refer to step 3 and later in  P. 9-20 "9.2.3 Precautions and procedures when replacing the storage device" in [E]Replace / Format storage device.</li> </ol>

#### [4F11] RIP process error

Classification	Error content
Printer function error	Printing was not performed successfully, since other abnormalities had occurred during RIP processing.

Check item	Measures
Setting	Perform the job in error again. If the error still persists, turn the power OFF and then back ON and then perform the jobs again.

## 8.3.7 TopAccess related error, Communication error with external application

### [5110] Toner cartridge detection error

Classification	Error content
TopAccess related error	Toner cartridge detection error
Check item	Measures
Toner cartridge	Refer to the troubleshooting for C911, C912, C913 and C914 errors.  P. 8-193 " [C911] CTIF board access abnormality (K)"

### [5212] Time for cleaning of the main charger

Classification	Error content
TopAccess related error	Appears when the time for main charger cleaning comes (at the output of approx. every 10,000 sheets).
Check item	Measures
Main charger	Clean the main charger.

### [5310] Toner (K) empty

Classification	Error content
TopAccess related error	The toner cartridge has become empty.
Check item	Measures
Toner cartridge	Replace the toner cartridge. If the error still persists after replacement, check if the toner cartridge interface PC board (CTIF board) or the toner cartridge PC board (CTRG board) is connected properly.

### [5410] MFP registration error

Classification	Error content
Communication error with external application	<ul style="list-style-type: none"> <li>The serial number of the MFP is not registered in the Remote maintenance service.</li> <li>The registration processing from the MFP to the Remote maintenance service has failed.</li> </ul>
Check item	Measures
Remote maintenance service setting	Contact the administrator of the Remote maintenance service to confirm that the serial number and model name of the MFP have been correctly imported to the Remote maintenance service. (Be sure the serial number of the MFP is CAPITALIZED.)

### [5411] MFP registration lock error

Classification	Error content
Communication error with external application	Data to send to the Remote maintenance service from the MFP have been damaged or incorrect authentication data have been sent.
Check item	Measures
Remote maintenance service setting	<ul style="list-style-type: none"> <li>Check that the local date and time are correctly set in the MFP. If not, enter the correct ones.</li> <li>If an error continues to be recorded for several days even though the date and time have been correctly set, contact the administrator of the Remote Maintenance service.</li> </ul>

**[5412] Server busy error**

Classification	Error content
Communication error with external application	The Remote maintenance service cannot handle the periodic communication from the MFP due to overloading.
Check item	Measures
None	<ul style="list-style-type: none"> <li>The MFP performs the periodic communication automatically. Therefore, check that no error will occur at the next periodic communication.</li> <li>If an error continues to be recorded for several days, contact the administrator of the Remote Maintenance service.</li> </ul>

**[5413] Server error**

Classification	Error content
Communication error with external application	<ul style="list-style-type: none"> <li>The server of the Remote maintenance service cannot make response to the MFP.</li> <li>A temporary power failure has occurred.</li> </ul>
Check item	Measures
Remote maintenance service setting	<ul style="list-style-type: none"> <li>Contact the administrator of the Remote maintenance service to confirm that the serial number and model name of the MFP have been correctly imported to the Remote maintenance service. (Be sure the serial number of the MFP is CAPITALIZED.)</li> <li>If an error continues to be recorded for several days, contact the administrator of the Remote Maintenance service.</li> </ul>

**[5414] Invalid device file**

Classification	Error content
Communication error with external application	A device file to send to the Remote maintenance service from the MFP has been damaged.
Check item	Measures
Communication environment	<ul style="list-style-type: none"> <li>The MFP performs the periodic communication automatically. Therefore, check that no error will occur at the next periodic communication.</li> <li>If an error continues to be recorded for several days, contact the administrator of the Remote Maintenance service.</li> </ul>

**[5415] Communication error**

Classification	Error content
Communication error with external application	The MFP cannot communicate the Remote maintenance service.
Check item	Measures
Setting	Check that there is no problem in the wiring connection between the MFP and the Remote maintenance service as well as in the connection and setting of network devices.

**[5416] Update failure of MFP setting file and system software**

Classification	Error content
Communication error with external application	<ul style="list-style-type: none"> <li>The setting files and the system software of the MFP cannot be updated because there is an ongoing job.</li> <li>There are too many printing and fax jobs which are ongoing.</li> </ul>
Check item	Measures
Communication environment	Have the customer clear pending jobs in the MFP job queues and retry the update by the Remote maintenance service.

**[5417] MFP setting file or system software is invalid.**

Classification	Error content
Communication error with external application	Upgrading has failed since the setting files of the MFP or the system software that has been downloaded from the Remote maintenance server has been incorrect or has been damaged.

Check item	Measures
Communication environment	Contact the administrator of the Remote maintenance service to check that the setting files of the MFP or the system software that has been downloaded is applicable to the model.

**[5419] File transmission to an eCC server failure**

Classification	Error content
Communication error with external application	A file transmitting to an eCC server is destroyed since its size has exceeded 200 MB.

Check item	Measures
Communication environment	Reduce the number of selected items and then perform it again.

**[5501] Communication data size exceeding error between the mobile and embedded applications**

Classification	Error content
Communication error	The communication data size between the mobile and embedded applications has exceeded 10 MB.

Check item	Measures
Communication environment	Make the communication data size between the mobile and embedded applications 10 MB or below.

**[5502] Timeout error during the communication between the mobile and embedded applications**

Classification	Error content
Communication error	Timeout has occurred at the time of the communication between the mobile and embedded applications.

Check item	Measures
Communication environment	Check if the embedded application to be communicated is operated properly.

**[5601] Proxy authentication failure**

Classification	Error content
Communication error	During communication, authentication has failed in the proxy server used for the communication setting for the obtaining of EWB, embedded applications and screen saver.

Check item	Measures
Communication environment	Check if the ID and password settings of the proxy server are correct.

**[5BD0] Power failure during the database restoration**

Classification	Error content
TopAccess related error	Power supply has been cut off during the restoration of the database sent from TopAccess.

Check item	Measures
Power supply related items	<ul style="list-style-type: none"> <li>• Check if the power cable is connected properly or is inserted securely.</li> <li>• Check if the power voltage is unstable.</li> <li>• Reattempt the restoration of the database (address book, templates, F-code (Mailbox), user information, etc.).</li> </ul>

**[5C10] Fax unit installation error**

<b>Classification</b>	<b>Error content</b>
TopAccess related error	Network Fax is disabled because no fax unit is installed.

<b>Check item</b>	<b>Measures</b>
Fax unit	<ul style="list-style-type: none"><li>• Check if the fax unit is installed.</li><li>• Check if there is any damage or abnormality on the fax board.</li><li>• Check if the connectors of the fax board are connected properly.</li></ul>

**[5C11] Network fax transmission error**

<b>Classification</b>	<b>Error content</b>
TopAccess related error	A Network Fax job has failed because the specified address is not registered in the AddressBook.

<b>Check item</b>	<b>Measures</b>
Setting	The address specified for the network fax has not been registered in the address book. Register it.

### 8.3.8 MFP access error

#### [6007] User login failure to an MFP

Classification	Error content
MFP access error	User authentication cannot be done because connection to the authentication server has failed.

Check item	Measures
Setting	Check the server operating status and confirm that the connection from the MFP has been made firmly.

#### [6008] Connection failure to an external Role Base Access Control (LDAP) server

Classification	Error content
MFP access error	User authentication cannot be done because connection to an external RBAC server has failed.

Check item	Measures
Setting	Check the server operating status and confirm that the connection from the MFP has been made firmly.

#### [6009] User login failure to an MFP (during NIC initialization)

Classification	Error content
MFP access error	Connection to an authentication server has failed since NIC initialization is being performed.

Check item	Measures
Setting	Perform user login after NIC initialization has been completed.

#### [600A] Department code not assigned to a user

Classification	Error content
MFP access error	Authentication has failed since the department code has not been assigned to the user.

Check item	Measures
Setting	Assign the department code to the user.

#### [6011] User automatic registration failure (due to an upper limit of the user registration number)

Classification	Error content
MFP access error	User automatic registration has failed since the user registration number has reached its upper limit.

Check item	Measures
Setting	Delete unnecessary registered users.

#### [6013] Connection failure to an authentication server

Classification	Error content
MFP access error	Connection to the authentication server has failed.

Check item	Measures
Setting	Check that the server settings registered from [TopAccess] > [Administration] > [Maintenance] > [Directory Service] are proper. When "Auto" is selected as the authentication method, this error may be output to the log depending on the environment.

**[6014] Inaccessible authentication server detection**

Classification	Error content
MFP access error	An inaccessible authentication server has been detected.
Check item	Measures
Setting	Check if the authentication server is down since there is an inaccessible authentication server. Access to the inaccessible server will be attempted again when the time set in FS-08-8788 has passed since the inaccessibility detection or when the MFP is turned OFF and then back ON.

**[6031] Setting error: CL code error**

Classification	Error content
MFP access error	A card cannot be used since its CL code does not match.
Check item	Measures
Setting	Use a valid card.

**[6032] Card abnormality: Validity date error**

Classification	Error content
MFP access error	A card cannot be used since its validity date has expired.
Check item	Measures
Setting	Use a card whose validity date has not expired.

**[6033] Card abnormality: Flag information error (no room-entry data)**

Classification	Error content
MFP access error	A card cannot be used since no room-entry data are recorded in it.
Check item	Measures
Setting	Use a valid card which has been used for entering the room.

**[6034] Card abnormality: Flag information error (card information error)**

Classification	Error content
MFP access error	A card cannot be used since the data required for its use are not set correctly.
Check item	Measures
Setting	Use a valid card.

**[6035] Setting error: Flag information error (card information unset)**

Classification	Error content
MFP access error	Necessary information in order to use a card is not set in the MFP.
Check item	Measures
Setting	Use a valid card or ask your administrator to register the information.

**[6036] Setting error: Flag information error (information between an MFP and a card does not match)**

Classification	Error content
MFP access error	A card cannot be used since its information and the value set in the MFP do not match.
Check item	Measures
Setting	Use a valid card or ask your administrator to register the information.

**[6037] Permission flag for use not available**

Classification	Error content
MFP access error	A card cannot be used since the privilege to use the device or MFP is not given.
Check item	Measures
Setting	Use a valid card or ask your administrator to give the privilege.

**[6040] Card authentication: Read error**

Classification	Error content
MFP access error	Card information could not be obtained correctly.
Check item	Measures
Setting	Reattempt card scanning. If the error persists even though the card scanning is attempted several times, the card information may be broken or the card reader may be damaged.

**[6041] Card authentication: Card related error**

Classification	Error content
MFP access error	Card information cannot be obtained correctly.
Check item	Measures
Setting	Reattempt scanning. If the error persists even though the card scanning is attempted several times, the card information may be broken or the card reader may be damaged.

**[6042] Card authentication: Card setting error**

Classification	Error content
MFP access error	The self-diagnostic code required for card authentication is not set in this MFP correctly.
Check item	Measures
Setting	Set the correct self-diagnostic code.

**[6073] Fingerprint authentication (failure)**

Classification	Error content
MFP access error	Authentication has failed since no fingerprint is registered or the authentication accuracy of the scanned fingerprint is low.
Check item	Measures
Setting	<ul style="list-style-type: none"> <li>• Place the finger again.</li> <li>• Carry out authentication using another finger already registered.</li> </ul> <p><b>Remarks:</b> In the following cases, the authentication accuracy becomes lowered and thus authentication becomes difficult.</p> <ul style="list-style-type: none"> <li>• The finger is stained or injured.</li> <li>• The fingerprint reader is stained.</li> <li>• The fingerprint cannot be distinguished since its minutiae are significantly low. In such a case, make the authentication accuracy low in the fingerprint authentication accuracy setting in TopAccess. This error may be avoidable.</li> </ul>

**[6101] e-Filing locking out**

Classification	Error content
MFP access error	The e-Filing became inaccessible because an incorrect password has been entered for the specified number of times.



Check item	Measures
Setting	Reattempt to access the e-Filing after a while. Ask the administrator.

#### [6102] User account is being locked out.

Classification	Error content
MFP access error	User login has failed because the user account is being locked out.

Check item	Measures
Setting	Log into TopAccess as an administrator and release the locked user account.

#### [6103] e-Filing is being locked out.

Classification	Error content
MFP access error	The e-Filing became inaccessible because an incorrect password has been entered for the specified number of times.

Check item	Measures
Setting	Reattempt to access the e-Filing after a while. For the locking period, as your administrator.

#### [6121] Automatic secure erase failure

Classification	Error content
MFP access error	Automatic secure erase has failed.

Check item	Measures
Setting	Data overwriting has failed due to some reasons. If the error still occurs after rebooting the MFP, study to reinstall the software or to replace the storage device using the following procedure: HS-73 Firmware Assist > Format Storage.

#### [6131] Synchronization failure with a time server

Classification	Error content
MFP access error	The MFP cannot be synchronized with the SNTP server.

Check item	Measures
Setting	Check if the SNTP server works properly. Check if the path to the SNTP server works properly. Check if the settings in TopAccess > [Administrator] > [Setup] > [General] > [SNTP Service] are correct.

### 8.3.9 Maintenance error

[7101] System firmware installation failure

[7103] Engine firmware installation failure

[7105] Scanner firmware installation failure

[7111] Patch installation failure

[7113] Plugin installation failure

[7115] Storage device data installation failure

[7117] DF firmware installation failure

Classification	Error content
Maintenance error	[7101] Installation of the system firmware has failed. [7103] Installation of the engine firmware has failed. [7105] Installation of the scanner firmware has failed. [7111] Installation of the patch has failed. [7113] Installation of the plugin has failed. [7115] Storage device data installation has failed. [7117] Installation of the DF firmware has failed. [7119] Installation of the PFC firmware has failed.

Check item	Measures
Setting	The software package file may have a problem or may be corrupted. Check the software package file and then reinstall it.

#### [7109] Printer driver installation failure

Classification	Error content
Maintenance error	Installation of the printer driver has failed.

Check item	Measures
Setting	The printer driver file may have a problem or may be corrupted. Check the package file and then upload it.

#### [710B] Point and Print data installation failure

Classification	Error content
Maintenance error	Installation of the Point and Print data has failed.

Check item	Measures
Setting	The Point and Print data file may have a problem or may be corrupted. Check the package file and then upload it.

#### [710F] Language Pack installation failure

Classification	Error content
Maintenance error	Installation of the Language Pack has failed.

Check item	Measures
Setting	The Language Pack file may have a problem or may be corrupted. Check the package file and then upload it.

#### [711D] License key returning failure

Classification	Error content
Maintenance error	Returning of the one-time dongle license to a USB storage device has failed.

Check item	Measures
Setting	Return the license to the USB storage device used for installing the license. Check if the USB storage device is installed properly. <b>Notes:</b> The GP-1080 IPsec Enabler cannot return to the USB storage device due to a license issue. The GP-1070 Overwrite Enabler cannot return to the USB device in the high security (08-8911: 3).

#### [711F] License key installation failure

Classification	Error content
Maintenance error	Installation of the one-time dongle license has failed.

Check item	Measures
Setting	Check if the USB storage device is installed properly.

#### [7121] Address book data import failure

Classification	Error content
Maintenance error	Importing of the address book data has failed.

Check item	Measures
Setting	Check if the proper files are used.

#### [7125] MailBox data import failure

Classification	Error content
Maintenance error	Importing of the mailbox data has failed.

Check item	Measures
Setting	Check if the proper files are used.

#### [7127] Format file for meta scan import failure

Classification	Error content
Maintenance error	Importing of the format file for meta scan has failed.

Check item	Measures
Setting	Check if the proper files are used.

#### [7129] User information import failure

Classification	Error content
Maintenance error	Importing of the user information has failed.

Check item	Measures
Setting	Check if the proper files are used.

#### [712B] Role information import failure

Classification	Error content
Maintenance error	Importing of the role information has failed.

Check item	Measures
Setting	Check if the proper files are used.

**[712D] Department data import failure**

Classification	Error content
Maintenance error	Importing of the department data has failed.
Check item	Measures
Setting	Check if the proper files are used.

**[7131] Print Data Converter import failure**

Classification	Error content
Maintenance error	Importing of the Print Data Converter has failed.
Check item	Measures
Setting	Check if the proper files are used.

**[7132] Some user information import failure**

Classification	Error content
Maintenance error	Importing of some user information has failed.
Check item	Measures
Setting	The registered number has exceeded the upper limit during importing or invalid information may be included in some data. Check if the proper files are used and the registered number.

**[7133] Some user information, role and group import failure**

Classification	Error content
Maintenance error	Importing of some user information, role and group has failed.
Check item	Measures
Setting	The registered number has exceeded the upper limit during importing or invalid information may be included in some data. Check if the proper files are used and the registered number.

**[7134] Some department data import failure**

Classification	Error content
Maintenance error	Importing of some department data has failed.
Check item	Measures
Setting	The registered number has exceeded the upper limit during importing or invalid information may be included in some data. Check if the proper files are used and the registered number.

**[7139] Certificate collection failure from SCEP server**

Classification	Error content
Maintenance error	Certificate collection from a SCEP server has failed.
Check item	Measures
Setting	Collect the settings of a SCEP server or in TopAccess Administration > Security > Certificate Management SCEP(Automatic).

**[713B] Certificates import failure**

Classification	Error content
Maintenance error	Importing of the certificates has failed.
Check item	Measures
Setting	The certificates may have a problem or may be corrupted. Check the certificates and reattempt this.

**[713D] User Combined data import failure**

Classification	Error content
Maintenance error	Importing of the User Combined data has failed.
Check item	Measures
Setting	Check if the proper files are used.

**[713F] Address book and mailbox import failure**

Classification	Error content
Maintenance error	Importing of the address book and mailbox has failed.
Check item	Measures
Setting	Check that the proper files are target to be imported.

**[7141] Address book data export failure**

Classification	Error content
Maintenance error	Exporting of the address book data has failed.
Check item	Measures
Setting	Check if enough space remains in the storage device and then reattempt the operation.

**[7145] MailBox data export failure**

Classification	Error content
Maintenance error	Exporting of the mailbox data has failed.
Check item	Measures
Setting	Check if enough space remains in the storage device and then reattempt the operation.

**[7149] User information export failure**

Classification	Error content
Maintenance error	Exporting of the user information has failed.
Check item	Measures
Setting	Check if enough space remains in the storage device and then reattempt the operation.

**[714B] Role information export failure**

Classification	Error content
Maintenance error	Exporting of the role information has failed.
Check item	Measures
Setting	Check if enough space remains in the storage device and then reattempt the operation.

**[714D] Department information export failure**

Classification	Error content
Maintenance error	Exporting of the department information has failed.
Check item	Measures
Setting	Check if enough space remains in the storage device and then reattempt the operation.

**[714F] ICC Profile export failure**

Classification	Error content
Maintenance error	Exporting of the ICC Profile has failed.
Check item	Measures
Setting	Check if enough space remains in the storage device and then reattempt the operation.

**[7151] Log data export failure**

Classification	Error content
Maintenance error	Exporting of the log data has failed.
Check item	Measures
Setting	Check if enough space remains in the storage device and then reattempt the operation.

**[715B] Print Data Converter export failure**

Classification	Error content
Maintenance error	Exporting of the Print Data Converter has failed.
Check item	Measures
Setting	Check if enough space remains in the storage device and then reattempt the operation.

**[715D] User Combined data export failure**

Classification	Error content
Maintenance error	Exporting of the User Combined data has failed.
Check item	Measures
Setting	Check if enough space remains in the storage device and then reattempt the operation.

**[715F] Address book and mailbox export failure**

Classification	Error content
Maintenance error	Exporting of the address book and mailbox has failed.
Check item	Measures
Setting	Check if enough space remains in the storage device and then reattempt the operation.

**[7191] DDNS public key file upload failure**

Classification	Error content
Maintenance error	Uploading of the DDNS public key file has failed.
Check item	Measures
Setting	The DDNS public key file may have a problem or may be corrupted. Check the file and then upload it.

**[7193] DDNS secret key file upload failure**

Classification	Error content
Maintenance error	Uploading of the DDNS secret key file has failed.
Check item	Measures
Setting	The DDNS secret key file may have a problem or may be corrupted. Check the file and then upload it.

**[71A2] CA certificates addition failure**

Classification	Error content
Maintenance error	Addition of the CA certificates has failed.
Check item	Measures
Setting	The CA certificates may have a problem or may be corrupted. Check the CA certificates and reattempt this.

**[71A4] Encryption key consistency check failure**

Classification	Error content
Maintenance error	Encryption key consistency check has failed.
Check item	Measures
Setting	Perform HS-73 Firmware Assist > [KeyBackup / Restore] to recover the encryption key.

**[71A6] Device certificates deletion failure**

Classification	Error content
Maintenance error	Deletion of the device certificates has failed.
Check item	Measures
Setting	Reboot the MFP and then reattempt this.

**[71A8] CA certificates deletion failure**

Classification	Error content
Maintenance error	Deletion of the CA certificates has failed.
Check item	Measures
Setting	Reboot the MFP and then reattempt this.

**[71AA] Unknown error occurred during collection of certificates from an SCEP server**

Classification	Error content
Maintenance error	Unknown error has occurred during collection of certificates from an SCEP server.
Check item	Measures
Setting	Collect the settings of a SCEP server or in TopAccess Administration > Security > Certificate Management SCEP(Automatic).

**[71AB] Timeout error occurred during collection of certificates from an SCEP server**

Classification	Error content
Maintenance error	A timeout error has occurred during collection of certificates from an SCEP server.
Check item	Measures
Setting	Collect the settings of a SCEP server or in TopAccess Administration > Security > Certificate Management SCEP(Automatic).

**[71AC] File saving error occurred during collection of certificates from an SCEP server**

Classification	Error content
Maintenance error	A file saving error has occurred during collection of certificates from an SCEP server.
Check item	Measures
Setting	Data overwriting has failed due to some reasons. If the error still occurs after rebooting the MFP, study to reinstall the software or to replace the storage device using the following procedure: HS-73 Firmware Assist > Format Storage.

**[71B0] Software package file decryption failure**

Classification	Error content
Maintenance error	Decryption of the software package file has failed.
Check item	Measures
Setting	The software package file may have a problem or may be corrupted. Check the software package file and then reinstall it.

**[71B5] Finisher firmware installation failure**

Classification	Error content
Maintenance error	Installation of the finisher firmware has failed.
Check item	Measures
Setting	Installation of the finisher firmware has failed. Reinstall the firmware.

**[71B7] Saddle firmware installation failure**

Classification	Error content
Maintenance error	Installation of the saddle firmware has failed.
Check item	Measures
Setting	Installation of the saddle firmware has failed. Reinstall the firmware.

**[71B9] Punch firmware installation failure**

Classification	Error content
Maintenance error	Installation of the punch firmware has failed.
Check item	Measures
Setting	Installation of the punch firmware has failed. Reinstall the firmware.

**[71D0] Factory Default failure**

Classification	Error content
Maintenance error	Factory default has failed.
Check item	Measures
Setting	Reboot the MFP and then reattempt this.



### [71E0] License abnormality due to damage on the license manager database

Classification	Error content
License management	A message which notifies that the license manager database is restored and the recovery of the license becomes possible

Check item	Measures
Backup data	Restore the backup data with the latest status, including all the activated licenses, are stored. <b>Remarks:</b> Applications with the trial license cannot be recovered from the backup data. If necessary, reinstall the applications.
License	<ul style="list-style-type: none"><li>• If there are no backup data as above, reactivate all the licenses which have been activated in this MFP.</li><li>• If the functions have been activated by the export license file, import the license exported from the host unit of the MFP.</li></ul>

### [71F1] Clone file creation failure

Classification	Error content
Maintenance error	Creation of the clone file has failed.

Check item	Measures
Setting	Check if enough space remains in the storage device and then reattempt the operation.

### [71F3] Clone file import failure

Classification	Error content
Maintenance error	Importing of the clone file has failed.

Check item	Measures
Setting	The file may be broken. Check the file and password. Then reattempt this.

### [71F4] Clone file decryption failure

Classification	Error content
Maintenance error	Decryption of the clone file has failed.

Check item	Measures
Setting	The file may be broken or the an incorrect password has been entered. Check the file and password. Then reattempt this.

### [71F5] Clone file encryption failure

Classification	Error content
Maintenance error	Encryption of the clone file has failed.

Check item	Measures
Setting	Reboot the MFP and then reattempt this.

### [7288] Data back-up file saving failure (Cloud storage certificates error)

Classification	Error content
Backing Up and Restoring Data	Saving of the data back-up file has failed due a cloud storage certificates error.

Check item	Measures
Setting	Contact your administrator of the remote maintenance and ask if the MFP has been recorded for service or if its serial number has been registered in a cloud server.

**[7289] Data back-up file saving failure (Cloud storage full)**

Classification	Error content
Backing Up and Restoring Data	Saving of the data back-up file has failed due to a cloud storage full.
Check item	Measures
Setting	Delete unnecessary data from the cloud server to secure enough space in the storage.

**[728A] Data back-up file saving failure (Server error)**

Classification	Error content
Backing Up and Restoring Data	Saving of the data back-up file has failed due to a server error.
Check item	Measures
Setting	Wait for a while and then reattempt it.

**[728B] Data back-up file failure (Connection error: Invalid URL)**

Classification	Error content
Backing Up and Restoring Data	Saving of the data back-up file has failed due to a connection error caused by an invalid URL.
Check item	Measures
Setting	Check if the URL of the server is correct.

**[728C] Data back-up file saving failure (Connection error: Connection impossible)**

Classification	Error content
Backing Up and Restoring Data	Saving of the data back-up file has failed due to an error in the connection to the cloud server.
Check item	Measures
Setting	Check that all the network settings necessary for the backing up of data are proper.

**[728D] Data back-up file saving failure (Connection error: Invalid certificates)**

Classification	Error content
Backing Up and Restoring Data	Saving of the data back-up file has failed due to connection error caused by an invalid SSL certificates.
Check item	Measures
Setting	Install a valid SSL certificates.

**[728E] Data back-up file saving failure (Connection error)**

Classification	Error content
Backing Up and Restoring Data	Saving of the data back-up file has failed due to a network error.
Check item	Measures
Setting	Wait for a while and then reattempt it.

**[7298] Data restoration failure (Cloud server certificates error)**

Classification	Error content
Backing Up and Restoring Data	Data restoration has failed due to a cloud server certificate error.
Check item	Measures
Setting	Contact your administrator of the remote maintenance and ask if the MFP has been recorded for service or if its serial number has been registered in a cloud server.

**[7299] Data restoration failure (Back-up files do not exist in the cloud server.)**

Classification	Error content
Backing Up and Restoring Data	Data restoration has failed since back-up files to perform the restoration operation do not exist in the cloud server.
Check item	Measures
Setting	Check if there are the necessary back-up files in the cloud server.

**[729A] Data restoration failure (Server error)**

Classification	Error content
Backing Up and Restoring Data	Data restoration has failed due to a server error.
Check item	Measures
Setting	Wait for a while and then reattempt it.

**[729B] Data restoration failure (Connection error: Invalid URL)**

Classification	Error content
Backing Up and Restoring Data	Data restoration has failed due to a connection error caused by an invalid URL.
Check item	Measures
Setting	Check if the URL of the server is correct.

**[729C] Data restoration failure (Connection error: Connection impossible)**

Classification	Error content
Backing Up and Restoring Data	Data restoration has failed due to an error in the connection to the cloud server.
Check item	Measures
Setting	Check that all the network settings necessary for data restoration are proper.

**[729D] Data restoration failure (Connection error: Invalid certificates)**

Classification	Error content
Backing Up and Restoring Data	Data restoration has failed due to connection error caused by an invalid SSL certificate.
Check item	Measures
Setting	Install a valid SSL certificates.

**[729E] Data restoration failure (Connection error)**

Classification	Error content
Backing Up and Restoring Data	Data restoration has failed due to a network error.
Check item	Measures
Setting	Wait for a while and then reattempt it.

**[729F] Data restoration failure (Consistency in the settings of the optional storage device)**

Classification	Error content
Backing Up and Restoring Data	Data restoration has failed since the settings of the optional storage device were changed.
Check item	Measures
Setting	

**[72B1] Enabling of TPM by means of the control panel or the self-diagnostic code has failed.**

Classification	Error content
Maintenance error	Enabling of TPM by means of the control panel or the self-diagnostic code has failed.
Check item	Measures
Setting	Enable the TPM again. If the error still persists, replace the SYS board.

**[72B3] Disabling of TPM by means of the control panel or the self-diagnostic code has failed.**

Classification	Error content
Maintenance error	Disabling of TPM by means of the control panel or the self-diagnostic code has failed.
Check item	Measures
Setting	Disable the TPM again. If the error still persists, replace the SYS board.

**[72B5] TPM key backup failure**

Classification	Error content
Maintenance error	Backup of the TPM key into a USB storage device has failed.
Check item	Measures
Setting	Check if the USB storage device is usable.

**[72B7] TPM key restoration failure**

Classification	Error content
Maintenance error	Restoration of the TPM key from a USB storage device has failed.
Check item	Measures
Setting	Check if a TPM key, which has been backed up correctly, is used.

**[72C1] Fingerprint registration failure**

Classification	Error content
Maintenance error	Fingerprint registration has failed.
Check item	Measures
Setting	<ul style="list-style-type: none"> <li>• Place the finger again.</li> <li>• Register the fingerprint using another finger.</li> </ul> <p><b>Remarks:</b></p> <p>In the following cases, registration of the fingerprint may fail.</p> <ul style="list-style-type: none"> <li>• The finger is stained or injured.</li> <li>• The fingerprint reader is stained.</li> <li>• If minutiae of the fingerprint of a registerer are significantly low, it cannot be distinguished and thus its registration will sometimes fail as a result. In such a case, make the authentication accuracy low in the fingerprint authentication accuracy setting in TopAccess. This error may be avoidable.</li> </ul>

**[72C2] Fingerprint registration failure (fingerprint duplication)**

Classification	Error content
Maintenance error	Fingerprint registration has failed due to the following reasons. <ul style="list-style-type: none"> <li>• The same fingerprint has already been registered.</li> <li>• A fingerprint having rarely similar characteristics has already been registered.</li> </ul>
Check item	Measures
Setting	<ul style="list-style-type: none"> <li>• Delete the fingerprint and register it again.</li> <li>• Register the fingerprint using another finger.</li> </ul>

**[72C9] Fingerprint DB has been damaged.**

Classification	Error content
Maintenance error	A fingerprint database stored in a standard storage device is corrupted.
Check item	Measures
Setting	The error log is recorded into TopAccess and the recovery is attempted automatically. (Up to 3 times)

**[72CB] Fingerprint template has been damaged.**

Classification	Error content
Maintenance error	A standard storage device is malfunctioning or a fingerprint template file (fingerprint registered file) is damaged.
Check item	Measures
Setting	Delete fingerprints (specific ones or all) and register them again.

**[72CC] Fingerprint reading has failed.**

Classification	Error content
Maintenance error	Fingerprint reading has failed.
Check item	Measures
Setting	Check that the fingerprint reader is connected properly.

**[72E1] Template data to the home screen transition failure**

Classification	Error content
Maintenance error	Transition of template data to the home screen has failed.
Check item	Measures
Setting	Check if the proper files are used.

**[72E2] A part of the template data has not been transferred to the home screen.**

Classification	Error content
Maintenance error	A part of the template data has not been transferred to the home screen due to the following reasons. <ul style="list-style-type: none"> <li>The number of the registrations has reached the maximum during data transferring.</li> <li>Invalid information has been included in some data.</li> </ul>
Check item	Measures
Setting	<ul style="list-style-type: none"> <li>Delete unnecessary templates from the registered ones.</li> <li>Check if the proper files are used.</li> </ul>

**[72F1] Execution permission of the remote command has not been assigned to an administrator.**

Classification	Error content
Maintenance error	Execution permission of the remote command has not been assigned to an administrator.
Check item	Measures
Setting	Ask your administrator to permit the remote command execution from TopAccess.

**[72F2] Remote command execution is not available since jobs or another service are being operated.**

Classification	Error content
Maintenance error	Remote command execution is not available since jobs or another service are being operated.

Check item	Measures
Setting	Execute the remote command again.

**[72F3] Remote command file decryption failure**

Classification	Error content
Maintenance error	Decryption of the remote command file has failed.

Check item	Measures
Setting	Encrypt the remote command file (JSON file) by using the password which is the same as that for FS-08-3552 (password for the remote command).

**[72F4] Remote command verification failure**

Classification	Error content
Maintenance error	Verification of the remote command file has failed.

Check item	Measures
Setting	Check if the format of the JSON file used when the remote command file is created.

**[72F5] Compatibility error of the file format of the remote command**

Classification	Error content
Maintenance error	Compatibility error of the file format of the remote command

Check item	Measures
Setting	An old schema of the remote command may be applied to the MFP. Upgrade the version of the ROM in the MFP.

**[72F6] Remote command execution failure**

Classification	Error content
Maintenance error	Execution of the remote command has failed.

Check item	Measures
Setting	Check if a non-existent value is written or obtaining is specified in the JSON file or self-diagnostic batch setting file which is used when the remote command file is created.

**[72F7] Execution of a part of remote command has failed.**

Classification	Error content
Maintenance error	Execution of a part of remote command has failed.

Check item	Measures
Setting	Check if a non-existent value is written or obtaining is specified in the JSON file or self-diagnostic batch setting file which is used when the remote command file is created.

**[72F8] The power of the MFP has been turned OFF while the remote command was being operated.**

Classification	Error content
Maintenance error	The power of the MFP has been turned OFF while the remote command was being operated.

Check item	Measures
Setting	Execute the remote command again.

**[7301] Application installation failure**

Classification	Error content
Maintenance error	Installation of the application has failed.

Check item	Measures
Does "The version of framework is old." appear during the application installation?	<ul style="list-style-type: none"> <li>• Update the system firmware.</li> <li>• After updating the system firmware, reinstall the application.</li> </ul>

**[7332] Application installation error**

Classification	Error content
Maintenance error	Application installation error

Check item	Measures
Setting	Installation of the application has failed. Update the application.

**[7333] Application start error**

Classification	Error content
Maintenance error	Application start error

Check item	Measures
Setting	Start of the installation has failed. Update the application.

**[7338] Application installation error (The application does not exist or is being operated.)**

Classification	Error content
Maintenance error	Installation or updating of the application has failed due to the following reasons. <ul style="list-style-type: none"> <li>• The application does not exist.</li> <li>• The application is being operated.</li> </ul>

Check item	Measures
Setting	Check if the application is being operated. If it is, quit it. After that, reattempt the installation.

**[7339] Application installation error (The use of the embedded application is not allowed.)**

Classification	Error content
Maintenance error	Installation or updating of the application has failed since the use of the embedded application is not allowed.

Check item	Measures
Setting	Enable the application setting. (Set "1" in FS-08-3698.)

**[7340] Application installation error (The framework version of the MFP is old.)**

Classification	Error content
Maintenance error	Installation or updating of the application has failed since the framework version of the MFP is old.

Check item	Measures
Setting	Install a SYS ROM with a new version.

**[7341] Application installation error (The version of the application is old.)**

Classification	Error content
Maintenance error	Installation or updating of the application has failed since the version of the application is old.

Check item	Measures
Setting	Install an application with a new version.

**[7342] Application installation error (Other jobs exist.)**

Classification	Error content
Maintenance error	Installation or updating of the application has failed since there are other jobs.

Check item	Measures
Setting	Check if the jobs are being operated. If they are, close them. After that, reattempt the installation.

**[7343] Application installation error (The control panel is being used or another service is being operated.)**

Classification	Error content
Maintenance error	Installation or updating of the application has failed due to the following reasons. <ul style="list-style-type: none"> <li>• The control panel is being used.</li> <li>• Other jobs are being operated.</li> </ul>

Check item	Measures
Setting	Check if another user is operating the MFP or is carrying out cloning.

**[7351] Application installation error (The registration number has exceeded the maximum.)**

Classification	Error content
Maintenance error	Installation or updating of the application has failed since the number of the registrations has exceeded the maximum.

Check item	Measures
Setting	Increase the maximum number of the installation of the application by means of FS-08-3798 or uninstall unnecessary applications.

**[7353] Application uninstallation error (The application does not exist or is being operated.)**

Classification	Error content
Maintenance error	Uninstallation of the application has failed due to the following reasons. <ul style="list-style-type: none"> <li>• The application does not exist.</li> <li>• The application is being operated.</li> </ul>

Check item	Measures
Setting	Check if the application is being operated. If it is, quit it. After that, reattempt the uninstallation.



**[7354] Application uninstallation error (Other jobs exist.)**

Classification	Error content
Maintenance error	Uninstallation of the application has failed since there are other jobs.
Check item	Measures
Setting	Check if the jobs are being operated. If they are, close them. After that, reattempt the uninstallation.

**[7355] Application uninstallation error (The control panel is being used or another service is being operated.)**

Classification	Error content
Maintenance error	Uninstallation of the application has failed due to the following reasons. <ul style="list-style-type: none"> <li>• The control panel is being used.</li> <li>• Other jobs are being operated.</li> </ul>
Check item	Measures
Setting	Check if another user is operating the MFP or is carrying out cloning.

**[7359] Application rollback error (The application does not exist or is being operated)**

Classification	Error content
Maintenance error	Application rollback has failed due to the following reasons. <ul style="list-style-type: none"> <li>• The application does not exist.</li> <li>• The application is being operated.</li> </ul>
Check item	Measures
Setting	Check if the application is being operated. If it is, quit it. After that, reattempt the rollback.

**[7360] Application rollback error (Other jobs exist.)**

Classification	Error content
Maintenance error	Application rollback has failed since there are other jobs.
Check item	Measures
Setting	Check if the jobs are being operated. If they are, close them. After that, reattempt the rollback.

**[7361] Application rollback error (The control panel is being used or another service is being operated.)**

Classification	Error content
Maintenance error	Application rollback has failed due to the following reasons. <ul style="list-style-type: none"> <li>• The control panel is being used.</li> <li>• Other jobs are being operated.</li> </ul>
Check item	Measures
Setting	Check if another user is operating the MFP or is carrying out cloning.

**[7402] License activation failure (Online)**

Classification	Error content
License management	License activation by means of [Online] has failed.
Check item	Measures
License	Ask the license provider whether the license is correct. If the license is not correct, ask the head office to issue the correct license authentication ID.

**[7403] License activation failure (network timeout)****[7404] License activation failure (network error)**

Classification	Error content
License management	License activation by means of [Online] has failed due to a network problem.

Check item	Measures
Network setting	<ul style="list-style-type: none"> <li>Check that the URL for the license server has not been changed. If the URL for the license server has been changed, enter the post-change URL into FS-08-3634 and then reattempt the activation.</li> <li>Ask a user (a network administrator) to check that the value entered in the following code is correct. FS-08-8693 to 8696</li> </ul>
Network environment	<p>Ask a user (a network administrator) to check whether the following settings are correct.</p> <ul style="list-style-type: none"> <li>The proxy is not filtered.</li> <li>The firewall is set properly.</li> </ul>
License server	<p>Ask the license provider that both servers are working. If they are not working, reattempt the activation after recovering.</p>

**[7412] License deactivation failure (Online)**

Classification	Error content
License management	License deactivation by means of [Online] has failed.

Check item	Measures
License server	Ask the license provider whether the license information exists in the server.

**[7423] License deactivation failure (network timeout)****[7424] License deactivation failure (network error)**

Classification	Error content
License management	License deactivation by means of [Online] has failed due to a network problem.

Check item	Measures
Network setting	<ul style="list-style-type: none"> <li>Check that the URL for the license server has not been changed. If the URL for the license server has been changed, enter the post-change URL into FS-08-3634 and then reattempt the activation.</li> <li>Ask a user (a network administrator) to check that the value entered in the following code is correct. FS-08-8693 to 8696</li> </ul>
Network environment	<p>Ask a user (a network administrator) to check whether the following settings are correct.</p> <ul style="list-style-type: none"> <li>The proxy is not filtered.</li> <li>The firewall is set properly.</li> </ul>
License server	<p>Ask the license provider that both servers are working. If they are not working, reattempt the deactivation after recovering.</p>

**[7430] Serial number mismatching**

Classification	Error content
License management	The serial number registered in the license does not match that for the activated MFP while the license has been activated by means of [Offline].

Check item	Measures
Serial number	<p>Check whether the serial number for the MFP matches the one included in the file name of the license file. If the serial number does not match, perform the activation in the MFP which has a serial number which is included in the file name of the license file.</p>

### [7431] Subnet mismatching

Classification	Error content
License management	The values of the 1st to 3rd octet registered in the license do not match those for the IP address of the MFP in which activation is being performed while the license has been activated by means of [Offline].

Check item	Measures
IP address	If this error has occurred during the activation in the host unit of the MFP, ask the license provider to rerelease the license with the correct information. If this error has occurred during the activation by means of the export license file, check that the values of the 1st to 3rd octet for the IP address of the MFP in which activation is being performed match those for the host unit.

### [7432] Domain mismatching

Classification	Error content
License management	The domain registered in the license does not match that for the MFP while the license has been activated by means of [Offline].

Check item	Measures
IP address	If this error has occurred during the activation in the host unit of the MFP, ask the license provider to rerelease the license with the correct domain. If this error has occurred during the activation by means of the export license file, check that the domain of the MFP in which activation is being performed matches that for the host unit.

### [7433] Invalid license certificates ID

Classification	Error content
License management	The license certificates ID format does not match.

Check item	Measures
License	<ul style="list-style-type: none"><li>• If the certificates ID was manually entered, check it. If it is incorrect, enter the correct one.</li><li>• If the certificates ID was selected from the file, check which is correct, the file or the certificate ID. If the file or the certificates file is incorrect, enter the correct one.</li></ul>

### [7434] License duplicating installation

Classification	Error content
License management	The license to be installed has already been installed.

Check item	Measures
License	<ul style="list-style-type: none"><li>• Check that the license to be installed is correct. If not, install the correct one.</li><li>• Check that the MFP in which the license is installed is correct. Check if the MFP is the one in which the license has already been installed.</li></ul>

### [7435] Unsupported license activation

Classification	Error content
License management	The license cannot be installed since it is not supported for the MFP.

Check item	Measures
License	Check that the MFP in which the license is installed is correct. Check if the MFP is supported.

**[7440] Signature mismatching**

Classification	Error content
License management	The license file is broken.
Check item	Measures
License server	Ask the license provider to rerelease the license.

**[7444] No license exists**

Classification	Error content
License management	License Not Found
Check item	Measures
-	Wait for a while and then reattempt the same operation. If this error has occurred repeatedly and the license is used continuously, deactivate or delete the license and then perform reactivation with the reusable license.

**[7445] Full of the license**

Classification	Error content
License management	Since the number of the licenses registered in this MFP has reached the maximum, new ones cannot be activated.
Check item	Measures
License	Deactivate or delete the licenses which are not being used.

**[7471] Debug log creation failure**

Classification	Error content
Debug log management	Creation of the debug log has failed.
Check item	Measures
Setting	Wait for a while and then reattempt it.

**[7473] Debug log to the remote maintenance service transmission failure**

Classification	Error content
Debug log management	Transmission of the debug log to the remote maintenance service has failed.
Check item	Measures
Setting	Check the setting for making the communication to the remote maintenance service and then reattempt it.

**[7475] Debug log by an e-mail transmission failure**

Classification	Error content
Debug log management	Transmission of the debug log by an e-mail has failed.
Check item	Measures
Setting	Check the settings of the e-mail address and the server and then reattempt it.

**[7477] Print data collection failure**

Classification	Error content
Debug log management	Obtaining of the print data has failed.
Check item	Measures
Setting	Wait for a while and then reattempt it.

**[7479] Print data to the remote maintenance service transmission failure**

Classification	Error content
Debug log management	Transmission of the print data to the remote maintenance service has failed.

Check item	Measures
Setting	Check the setting for making the communication to the remote maintenance service and then reattempt it.

**[747B] Print data by an e-mail transmission failure**

Classification	Error content
Debug log management	Transmission of the print data by an e-mail has failed.

Check item	Measures
Setting	Check the settings of the e-mail address and the server and then reattempt it.

**[747C] Print data by an e-mail transmission failure (Data size exceeding error)**

Classification	Error content
Debug log management	Transmission of an e-mail has failed since the size of the print data has exceeded the maximum.

Check item	Measures
Setting	Decrease the size of the print data to be transmitted to less than 30 MB and then reattempt it.

**[747E] Network capture collection failure**

Classification	Error content
Debug log management	Obtaining of the network capture has failed.

Check item	Measures
Setting	Wait for a while and then reattempt it.

**[7480] Network capture to the remote maintenance service transmission failure**

Classification	Error content
Debug log management	Transmission of the network capture to the remote maintenance service has failed.

Check item	Measures
Setting	Check the setting for making the communication to the remote maintenance service and then reattempt it.

**[7482] Network capture by an e-mail transmission failure**

Classification	Error content
Debug log management	Transmission of the network capture by an e-mail has failed.

Check item	Measures
Setting	Check the settings of the e-mail address and the server and then reattempt it.

**[7483] Network capture by an e-mail transmission failure (Data size exceeding error)**

Classification	Error content
Debug log management	Transmission of an e-mail has failed since the size of the network capture has exceeded the maximum.

Check item	Measures
Setting	Specify the setting so that the obtaining of the network capture time becomes shorter and then reattempt it.

#### [7485] Log data deletion failure

Classification	Error content
Debug log management	Deletion of the log data has failed.

Check item	Measures
Setting	Wait for a while and then reattempt it.

#### [7489] Debug logs saving failure

Classification	Error content
Debug log management	Saving of the debug logs has failed.

Check item	Measures
Setting	<ul style="list-style-type: none"> <li>• Check that there is enough space in the USB storage device.</li> <li>• Check that the USB storage device is properly connected in the MFP.</li> </ul>

#### [7491] Remote Panel Operation (Cloud hub) connection error: authentication error

Classification	Error content
Debug log management	Connection of the remote panel has failed due to an authentication error.

Check item	Measures
Setting	<ul style="list-style-type: none"> <li>• Check that the entered authentication code is correct.</li> <li>• Check that the authentication code has not expired.</li> </ul>

#### [7492] Remote Panel Operation (Cloud hub) connection error: network error

Classification	Error content
Debug log management	Connection of the remote panel has failed due to a network error.

Check item	Measures
Setting	Check that the network configuration of the MFP is correct. When a proxy server is used, check its configuration again.

## 8.3.10 Network error

### [8000] IPv4 address conflict

Classification	Error content
Network error	IPv4 address conflict

Check item	Measures
Setting	Check if the same IP address is used by another MFP.

### [8011] IPv6 link local address conflict

Classification	Error content
Network error	IPv6 link local address conflict

Check item	Measures
Setting	Check if the same IP address is used by another MFP.

### [8012] IPv6 manual address conflict

Classification	Error content
Network error	IPv6 manual address conflict

Check item	Measures
Setting	Check if the same IP address is used by another MFP.

### [8013] IPv6 stateless address conflict

Classification	Error content
Network error	IPv6 stateless address conflict

Check item	Measures
Setting	Check if the same IP address is used by another MFP.

### [8014] IPv6 stateful address conflict

Classification	Error content
Network error	IPv6 stateful address conflict

Check item	Measures
Setting	Check if the same IP address is used by another MFP.

### [8022] 802.1X authentication failure

Classification	Error content
Network error	802.1X authentication failure

Check item	Measures
Setting	Set the correct authentication information.

### [8023] Connection failure to an authentication server and a switch

Classification	Error content
Network error	Connection to an authentication server and a switch has failed.

Check item	Measures
Setting	Check the connectivity to the switch and server.

**[8024] Certificates verification failure**

Classification	Error content
Network error	Certificates verification has failed.
Check item	Measures
Setting	Install the correct certificates.

**[8031] IPsec error for IKEv1 certification failure**

Classification	Error content
Network error	IKEv1 certification has failed.
Check item	Measures
Setting	<ol style="list-style-type: none"> <li>CA and user certificate in both the MFP and remote peer - certificate timestamp and IPsec Certificate template should be valid.</li> <li>The CRL DP server name is mapped in the MFP's host table or DNS entry.</li> <li>Certificates against CRL</li> </ol>

**[8032] IPsec error for wrong proposal selection**

Classification	Error content
Network error	No IKEv1 Phase1 proposal chosen
Check item	Measures
Setting	Check the IKEv1 IPsec proposal parameters (like encryption/ authentication algorithms, DH group, authentication methods) in the MFP and peer machine.

**[8033] IPsec error for shared key authentication failure**

Classification	Error content
Network error	IKEv1 shared key authentication has failed.
Check item	Measures
Setting	IKE pre-shared key does not match. Check the PSK of the MFP and remote machine.

**[8034] IPsec error for invalid certificates upload**

Classification	Error content
Network error	IKEv1 invalid certificate.
Check item	Measures
Setting	Check the CA and user certificates of the MFP and peer machine.

**[8035] IPsec error for non-supported certificates**

Classification	Error content
Network error	IKEv1 certificates is not supported.
Check item	Measures
Setting	Check the user certificate type.



**[8036] IPsec error for invalid certificates of authentication**

Classification	Error content
Network error	IKEv1 invalid certificate.
Check item	Measures
Setting	Check the CA certificates of the MFP and peer machine.

**[8037] IPsec error for certificates disable**

Classification	Error content
Network error	There are no available certificates.
Check item	Measures
Setting	Certificates have been deleted from the certificate store. Upload the certificates again.

**[8038] IPsec error for SA non-existing**

Classification	Error content
Network error	No SA is established,
Check item	Measures
Setting	<p>Check the IKEv1 IPsec proposal parameters (like encryption/ authentication algorithms, DH group, authentication methods) in the MFP and peer machine.</p> <ol style="list-style-type: none"> <li>1. Check the CA and certificate of the MFP and remote peer. Check the date of the certificate and IPsec certificate template.</li> <li>2. The CRL DP server name is mapped in the MFP's host table or DNS entry.</li> <li>3. Certificates against CRL</li> </ol>

**[8039] IPsec error for invalid signature for certification**

Classification	Error content
Network error	Invalid signature
Check item	Measures
Setting	The signature payload (MAC or IV) does not match. Check the CA and user certificates of the MFP and peer machine.

**[803A] IPsec error for wrong selection of proposal**

Classification	Error content
Network error	No IKEv2 proposal is chosen.
Check item	Measures
Setting	Check the IKEv2 IPsec proposal parameters (like encryption/ authentication algorithms, DH group, authentication methods) in the MFP and peer machine.

**[803B] IPsec error for IKEv2 certification failure**

Classification	Error content
Network error	IKEv2 certification has failed.
Check item	Measures
Setting	<ol style="list-style-type: none"> <li>1. Check if the CA and user certificate in both the MFP and remote peer - certificate timestamp and IPsec Certificate template should be valid.</li> <li>2. The CRL DP server name is mapped in the MFP's host table or DNS entry.</li> <li>3. Certificates against CRL</li> </ol>

**[803C] IKEv2 error for IKEv2 if secret key authentication failed**

Classification	Error content
Network error	IKEv2 secret key authentication has failed.
Check item	Measures
Setting	IKEv2 pre-shared key does not match. Check the PSK of the MFP and peer machine.

**[803D] IPsec error if peer does not support IKEv2 and falling back to IKEv1**

Classification	Error content
Network error	Falling Back to IKEv1 has been performed.
Check item	Measures
Setting	The remote machine does not support IKEv2. Downgrade and use IKEv1.

**[803E] IPsec error if ISAKMP SA is uncreated or destroyed due to some uncertain conditions**

Classification	Error content
Network error	ISAKMP SA cannot be used.
Check item	Measures
Setting	Restart IPsec on peer and retry.

**[803F] IPsec error for IKEv2 if crypto operation failed**

Classification	Error content
Network error	Encryption in IKEv2 has failed.
Check item	Measures
Setting	If certificates are being used, upload the certificates again using a security service. Restart IPsec on the MFP.

**[8040] IPsec error for IKEv2 if key info is invalid**

Classification	Error content
Network error	Key information is invalid.
Check item	Measures
Setting	Check the IKE setting of the MFP and peer machine.

**[8041] IPsec error for IKEv2 if CA is not trusted**

Classification	Error content
Network error	Certificates have not been issued by a trusted authority.
Check item	Measures
Setting	Check the CA certificates of the MFP and peer machine. Check the timestamp of the CA certificate.

**[8042] IPsec error for authentication method inconsistency**

Classification	Error content
Network error	The authentication method does not match.
Check item	Measures
Setting	The IKE authentication type does not match. Check the certificate type of the MFP and peer machine.

**[8043] IPsec error for version inconsistency**

Classification	Error content
Network error	The IKE version does not match.
Check item	Measures
Setting	The IKE version does not match. Check the IKE version of the MFP and peer.

**[8044] IPsec error for encapsulation inconsistency**

Classification	Error content
Network error	Encapsulation does not match.
Check item	Measures
Setting	Check the IPsec mode (Transport, Tunnel) of the MFP and peer.

**[8045] IPsec error for peer IP inconsistency**

Classification	Error content
Network error	The IP address of the peer machine does not match.
Check item	Measures
Setting	The remote traffic selector does not match. Check the destination address and port in the IPsec filter.

**[8046] IPsec error for local IP inconsistency**

Classification	Error content
Network error	The OP address of the local machine does not match.
Check item	Measures
Setting	The local traffic selector does not match. Check the source address and port in the IPsec filter.

**[8047] IPsec error for local ID inconsistency**

Classification	Error content
Network error	The local ID does not match.
Check item	Measures
Setting	Check the user certificates of the MFP.

**[8048] IPsec error for remote ID inconsistency**

Classification	Error content
Network error	The remote ID does not match.
Check item	Measures
Setting	Check the user certificates of the peer machine.

**[8049] IPsec error for remote IP inconsistency**

Classification	Error content
Network error	The IPsec remote IP does not match.
Check item	Measures
Setting	The remote traffic selector does not match. Check the source address and port in the IPsec filter.

**[804A] IPsec error for IKEv2 timeout**

Classification	Error content
Network error	IKEv1 / IKEv2 timeout
Check item	Measures
Setting	Check the network connectivity between the MFP and peer machine. Select the flush connections option and retry.

**[804B] IPsec error for invalid of ID manual key**

Classification	Error content
Network error	The manual key is invalid.
Check item	Measures
Setting	Check the inbound and outbound keys (ESP encryption, authentication and AH authentication) of the MFP and remote PC.

**[8061] Update error for secure primary DDNS****[8062] Update error for secure secondary DDNS****[8063] Update error for IPv6 secure primary DDNS****[8064] Update error for IPv6 secure secondary DDNS****[8065] Update error for IPv6 primary DDNS****[8066] Update error for IPv6 secondary DDNS****[8067] Update error for IPv4 primary DDNS****[8068] Update error for IPv4 secondary DDNS**

Classification	Error content
Network error	[8061] Update error for secure primary DDNS [8062] Update error for secure secondary DDNS [8063] Update error for IPv6 secure primary DDNS [8064] Update error for IPv6 secure secondary DDNS [8065] Update error for IPv6 primary DDNS [8066] Update error for IPv6 secondary DDNS [8067] Update error for IPv4 primary DDNS [8068] Update error for IPv4 secondary DDNS
Check item	Measures
Setting	Check if there is any problem in the DNS or DDNS settings.

**[8069] Message displayed when the key file for SIG(0) or TSIG is invalid**

Classification	Error content
Network error	This message is displayed when the key file for SIG(0) or TSIG is invalid.
Check item	Measures
Setting	Verify the TSIG/SIG(0) key files used.

**[80B1] Bluetooth connection failure**

Classification	Error content
Network error	Bluetooth connection has failed.
Check item	Measures
Module connection status	Check if the wireless LAN or Bluetooth module is connected.

**[80C0] TLS session establishment failure (invalid message)**

Classification	Error content
Network error	An invalid message has been received.

Check item	Measures
Setting	<ul style="list-style-type: none"> <li>• Check the SSL/TLS settings of a connect-to server.</li> <li>• Check the SSL/TLS certificate installed in the MFP.</li> </ul>

#### [80C1] TLS session establishment failure (invalid MAC data)

Classification	Error content
Network error	Invalid MAC data have been received.

Check item	Measures
Setting	<ul style="list-style-type: none"> <li>• Check the SSL/TLS settings of a connect-to server.</li> <li>• Check the SSL/TLS certificate installed in the MFP.</li> </ul>

#### [80C2] TLS session establishment failure (decoding failure)

Classification	Error content
Network error	TLSCiphertext data structure has been encoded by an invalid method.

Check item	Measures
Setting	<ul style="list-style-type: none"> <li>• Check the SSL/TLS settings of a connect-to server.</li> <li>• Check the SSL/TLS certificate installed in the MFP.</li> </ul>

#### [80C3] TLS session establishment failure (recording length abnormality)

Classification	Error content
Network error	A TLSCiphertext record whose size is $2^{14}+2048$ bytes or more has been received. Alternatively, decoding to a TLSCompressed record whose size is $2^{14}+2048$ bytes or more has been carried out.

Check item	Measures
Setting	<ul style="list-style-type: none"> <li>• Check the SSL/TLS settings of a connect-to server.</li> <li>• Check the SSL/TLS certificate installed in the MFP.</li> </ul>

#### [80C4] TLS session establishment failure (data decompression failure)

Classification	Error content
Network error	Data (output) with an invalid expansion function have been received. (E.g.: Data with length exceeded)

Check item	Measures
Setting	<ul style="list-style-type: none"> <li>• Check the SSL/TLS settings of a connect-to server.</li> <li>• Check the SSL/TLS certificate installed in the MFP.</li> </ul>

#### [80C5] TLS session establishment failure (handshake failure)

Classification	Error content
Network error	A handshake_failure alert message has been received.

Check item	Measures
Setting	<ul style="list-style-type: none"> <li>• Check the SSL/TLS settings of a connect-to server.</li> <li>• Check the SSL/TLS certificate installed in the MFP.</li> </ul>

#### [80C6] TLS session establishment failure (certificate abnormality)

Classification	Error content
Network error	A certificate has been broken. Alternatively, a signature which cannot be verified properly has been included.

Check item	Measures
Setting	Check the SSL/TLS certificate installed in the MFP.

**[80C7] TLS session establishment failure (non-support certificate)**

Classification	Error content
Network error	The type of the certificate has not been supported.
Check item	Measures
Setting	Check the SSL/TLS certificate installed in the MFP.

**[80C8] TLS session establishment failure (invalid certificate)**

Classification	Error content
Network error	The certificate has been disabled by its signer.
Check item	Measures
Setting	Check the SSL/TLS certificate installed in the MFP.

**[80C9] TLS session establishment failure (certificate with validity date expired)**

Classification	Error content
Network error	The validity date of the certificate has expired.
Check item	Measures
Setting	Check the SSL/TLS certificate installed in the MFP.

**[80CA] TLS session establishment failure (certificate process error)**

Classification	Error content
Network error	Since a non-specified problem has occurred, the certification process has failed.
Check item	Measures
Setting	Check the SSL/TLS certificate installed in the MFP.

**[80CB] TLS session establishment failure (invalid parameter)**

Classification	Error content
Network error	The acceptable range of the field for handshake has been exceeded. Alternatively, an inconsistency between another field has occurred.
Check item	Measures
Setting	<ul style="list-style-type: none"> <li>• Check the SSL/TLS settings of a connect-to server.</li> <li>• Check the SSL/TLS certificate installed in the MFP.</li> </ul>

**[80CC] TLS session establishment failure (unknown CA certificate)**

Classification	Error content
Network error	A valid certificate chain or a part of the chain has been received; however, there is no CA certificate. Alternatively, a certificate could not be received since it does not match the already-known relied CA.
Check item	Measures
Setting	Check the SSL/TLS certificate installed in the MFP.

**[80CD] TLS session establishment failure (access rejection)**

Classification	Error content
Network error	Although a valid certificate has been received, a connect-to server has rejected the access when access control was applied.
Check item	Measures
Setting	Check the SSL/TLS settings of a connect-to server.

**[80CE] TLS session establishment failure (decoding error)**

Classification	Error content
Network error	A value in the field is outside of the range. Alternatively, a message could be decoded since its length was inappropriate.
Check item	Measures
Setting	<ul style="list-style-type: none"> <li>• Check the SSL/TLS settings of a connect-to server.</li> <li>• Check the SSL/TLS certificate installed in the MFP.</li> </ul>

**[80CF] TLS session establishment failure (decryption error)**

Classification	Error content
Network error	A handshake encryption process has failed.
Check item	Measures
Setting	<ul style="list-style-type: none"> <li>• Check the SSL/TLS settings of a connect-to server.</li> <li>• Check the SSL/TLS certificate installed in the MFP.</li> </ul>

**[80D0] TLS session establishment failure (export restrictions)**

Classification	Error content
Network error	A negotiation which does not comply with the export restrictions of the regulation has been detected.
Check item	Measures
Setting	<ul style="list-style-type: none"> <li>• Check the SSL/TLS settings of a connect-to server.</li> <li>• Check the SSL/TLS certificate installed in the MFP.</li> </ul>

**[80D1] TLS session establishment failure (non-support protocol version)**

Classification	Error content
Network error	Unsupported versions of the TLS protocol have been recognized.
Check item	Measures
Setting	<ul style="list-style-type: none"> <li>• Check that the communication with a client, server or external applications is made using the supported TLS protocol (only TLS1.2 available as of 2020) in the SSL/TLS settings.</li> <li>• Check the SSL/TLS certificate installed in the MFP.</li> </ul>

**[80D2] TLS session establishment failure (internal error)**

Classification	Error content
Network error	A process cannot be continued due to an internal error.
Check item	Measures
Setting	<ul style="list-style-type: none"> <li>• Check the SSL/TLS settings of a connect-to server.</li> <li>• Check the SSL/TLS certificate installed in the MFP.</li> </ul>

**[80D3] TLS session establishment failure (cancellation by a user)**

Classification	Error content
Network error	A handshake has been canceled for a reason other than a protocol error.
Check item	Measures
Setting	<ul style="list-style-type: none"> <li>• Check the SSL/TLS settings of a connect-to server.</li> <li>• Check the SSL/TLS certificate installed in the MFP.</li> </ul>

**[80D4] TLS session establishment failure (invalid renegotiation)**

Classification	Error content
Network error	The following items are improper: A client response to a HelloRequest message. A server response to a ClientHello message received after the first handshake. Renegotiation performed later.

Check item	Measures
Setting	<ul style="list-style-type: none"> <li>• Check the SSL/TLS settings of a connect-to server.</li> <li>• Check the SSL/TLS certificate installed in the MFP.</li> </ul>

#### [80F0] LDAP DB damage detection

Classification	Error content
Network error	LDAP DB damage has been detected.

Check item	Measures
Setting	<ul style="list-style-type: none"> <li>• Check the SSL/TLS settings of a connect-to server.</li> <li>• Check the SSL/TLS certificate installed in the MFP.</li> </ul>

#### [8101] Wireless connection in the Access point failure

Classification	Error content
Network error	Wireless connection in the Access point has failed.

Check item	Measures
Setting	Verify the credentials used for association with the access point.

#### [8102] Connection failure of MFP to the Access point with a specified SSID

Classification	Error content
Network error	Connection failure of MFP to the Access point with a specified SSID failure

Check item	Measures
Setting	Verify the access point name setting and mechanism used for association same as the access point setting.

#### [8103] Wireless certificate verification failure

Classification	Error content
Network error	Wireless certificate verification has failed.

Check item	Measures
Setting	Verify the certificate settings used for association.

#### [8104] Wireless LAN / Bluetooth module hardware error

Classification	Error content
Network error	Connection to access point has failed due to a wireless LAN or Bluetooth hardware error.

Check item	Measures
Wireless LAN/Bluetooth module	<ul style="list-style-type: none"> <li>• Check the connection of the wireless LAN/Bluetooth module.</li> <li>• Replace the wireless LAN/Bluetooth module.</li> </ul>

#### [8121] Domain: Authentication failure

Classification	Error content
Network error	An unknown domain authentication error has occurred when connecting to the domain controller.

Check item	Measures
Setting	Check the network settings of this MFP and connect to the domain controller again.



**[8122] Domain: Invalid user name or password**

Classification	Error content
Network error	The user name or password of the domain authentication is not valid and thus the user cannot log in.

Check item	Measures
Setting	Check if the user name or password of this MFP is entered correctly. Enter the user name or password by specifying the upper and lower case letters correctly.

**[8123] Domain: Invalid server**

Classification	Error content
Network error	The server cannot be detected at domain authentication.

Check item	Measures
Setting	Check if the server is down. Check the network settings of this MFP. If the name resolution is used, check the settings of the DNS and DDNS.

**[8124] Domain: Invalid user account**

Classification	Error content
Network error	The user account is invalid at domain authentication and thus the user cannot log in.

Check item	Measures
Setting	Check if the setting of the user account in [Active Directory User and Computer] is disabled.

**[8125] Domain: Expired user account**

Classification	Error content
Network error	The validity date of the user account has expired at domain authentication and thus the user cannot log in.

Check item	Measures
Setting	Check if the setting of the user account in [Active Directory User and Computer] has expired.

**[8126] Domain: Locked user account**

Classification	Error content
Network error	The user account has been locked at domain authentication and thus the user cannot log in.

Check item	Measures
Setting	Check the setting of the account lock-out on the server.

**[8127] Domain: Invalid log-in time**

Classification	Error content
Network error	The log-in time is invalid at domain authentication and thus the user cannot log in.

Check item	Measures
Setting	Check the log-in time setting of the user account in [Active Directory User and Computer].

**[8128] Active directory domain: Clock skew error**

Classification	Error content
Network error	The difference between the time set in the MFP and that set in the server is more than five minutes at domain authentication of the Active Directory and thus the user cannot log in.

Check item	Measures
Setting	Match the time of the MFP and domain controller. The use of an SNTP server is recommended if it exists in the network environment.

**[8129] Active directory domain: Expired Kerberos ticket**

Classification	Error content
Network error	A Kerberos ticket has expired at domain authentication of the Active Directory and thus the user cannot log in.

Check item	Measures
Setting	Check if the validity date of the Kerberos ticket on the Kerberos server has expired.

**[812A] Active directory domain: Kerberos ticket authentication failure**

Classification	Error content
Network error	The user cannot log in due to Kerberos ticket authentication failure of Active Directory domain authentication.

Check item	Measures
Setting	Check if the user name or password of this MFP is entered correctly. If the error still persists, ask your Windows Server administrator.

**[812B] Active directory domain: Invalid realm name**

Classification	Error content
Network error	The user cannot log in due to invalid realm name at Active Directory domain authentication.

Check item	Measures
Setting	Check if the realm name of the Active Directory server of this MFP is incorrect. If the error still persists, ask your Windows Server administrator.

**[8200] The IPv4 address has conflicted. (Secondary interface)**

Classification	Error content
Network error	The IPv4 address of the secondary interface has conflicted.

Check item	Measures
Setting	Check that the same IP address is not used in other terminals in the secondary network.

**[8211] The IPv6 link local address has conflicted. (Secondary interface)**

Classification	Error content
Network error	The IPv6 address of the secondary interface has conflicted.

Check item	Measures
Setting	Check that the same IP address is not used in other terminals in the secondary network.

**[8212] The IPv6 manual address has conflicted. (Secondary interface)**

<b>Classification</b>	<b>Error content</b>
Network error	The IPv6 manual address of the secondary interface has conflicted.

<b>Check item</b>	<b>Measures</b>
Setting	Check that the same IP address is not used in other terminals in the secondary network.

**[8213] The IPv6 stateless address has conflicted. (Secondary interface)**

<b>Classification</b>	<b>Error content</b>
Network error	The IPv6 stateless address of the secondary interface has conflicted.

<b>Check item</b>	<b>Measures</b>
Setting	Check that the same IP address is not used in other terminals in the secondary network.

**[8214] The IPv6 stateful address has conflicted. (Secondary interface)**

<b>Classification</b>	<b>Error content</b>
Network error	The IPv6 stateful address of the secondary interface has conflicted.

<b>Check item</b>	<b>Measures</b>
Setting	Check that the same IP address is not used in other terminals in the secondary network.

## 8.3.11 FAX error

### [0012] Original jam

Classification	Error content
Fax	The fax transmission has failed since an original was misfed in the DF while a fax job was being sent.
Check item	Measures
Setting	Remove the misfed original and reattempt the fax transmission.

### [0013] Cover is open

Classification	Error content
Fax	The fax transmission has failed since the cover of the MFP or options that process paper was opened.
Check item	Measures
Setting	Close the cover and reattempt the fax transmission.

### [0020] Power failure Transmission

Classification	Error content
Fax	The fax transmission has failed due to a power failure.
Check item	Measures
Setting	Reattempt the fax transmission.

### Reception

Classification	Error content
Fax	The fax reception has failed due to a power failure.
Check item	Measures
Setting	Reattempt the fax reception.

### Transmission

Classification	Error content
IP Fax	The IP Fax transmission has failed due to a power failure.
Check item	Measures
Setting	Reattempt the IP Fax transmission.

### Reception

Classification	Error content
IP Fax	The IP Fax reception has failed due to a power failure.
Check item	Measures
Setting	Reattempt the IP Fax reception.

### [0030] Recording paper jam

Classification	Error content
Fax	The fax transmission has been stopped due to the following reason. <ul style="list-style-type: none"><li>• Paper misfeeding occurred with another job.</li><li>• A Fax job was canceled.</li></ul>
Check item	Measures
Setting	In the case of paper misfeeding, remove it and reattempt the fax transmission.

### [0033] Polling error

Classification	Error content
Fax	The polling reception has failed due to the following reason. <ul style="list-style-type: none"><li>• A polling original was not set on the other side's device.</li><li>• The security setting between this MFP and the other side's device did not match.</li></ul>
Check item	Measures
Setting	Take the following action and reattempt the polling reception. <ul style="list-style-type: none"><li>• Ask to set the polling original on the other side's device.</li><li>• Make the security setting matched between this MFP and the other side's device.</li></ul>

### [0040] Modem communication error Transmission

Classification	Error content
Fax	The fax transmission has failed since the modem could not send the signal properly.
Check item	Measures
Setting	Reattempt the fax transmission.

### Reception

Classification	Error content
Fax	The fax reception has failed since the modem could not receive the signal properly.
Check item	Measures
Setting	Reattempt the fax reception.

### [0042] Memory full

Classification	Error content
Fax	The fax reception has been canceled since the capacity in a shortage device or an abnormality occurred in it while a fax job was being received. (Pages which are received successfully will be printed out.)
Check item	Measures
Setting	Take the following action and reattempt the fax reception. <ul style="list-style-type: none"><li>• In the case of a capacity in a storage device, free up the memory space.</li><li>• In the case of an abnormality, replace the storage device.</li></ul>

Classification	Error content
IP Fax	The IP Fax reception has been canceled since the capacity in a storage device or an abnormality occurred in it while an IP Fax job was being received. (Pages which are received successfully will be printed out.)

Check item	Measures
Setting	Take the following action and reattempt the IP Fax reception. <ul style="list-style-type: none"> <li>• In the case of a capacity in a storage device, free up the memory space.</li> <li>• In the case of an abnormality, replace the storage device.</li> </ul>

#### [0050] Line is busy

Classification	Error content
Fax	Since the line of the other side's device was busy, the fax transmission has failed even though the redialing was carried out by the maximum number of specified times.

Check item	Measures
Setting	Reattempt the fax transmission. Increase the number of redialing times if required.

#### [0051] No cable connected for fax line

Classification	Error content
Fax	The fax transmission has failed since no cable for the fax line was connected.

Check item	Measures
Setting	Connect a cable for the fax line and reattempt the fax transmission.

#### [0052] T1 time-out

Classification	Error content
Fax	The fax transmission has failed since NSF/DIS could not be detected. (Memory transmission)

Check item	Measures
Setting	Check that the other side's device is answering in the fax mode and reattempt the fax transmission.

Classification	Error content
IP Fax	The IP Fax transmission has failed since NSF/DIS could not be detected. (Memory transmission)

Check item	Measures
Setting	Check that the other side's device is answering in the fax mode and reattempt the fax transmission.

#### [00B0] Initial signal not detected

Classification	Error content
Fax	The fax transmission has failed since NSF/DIS could not be detected. (Direct transmission)

Check item	Measures
Setting	Check that the other side's device is answering in the fax mode and reattempt the fax transmission.

## [00B1] Terminal constants not compatible

### Transmission

Classification	Error content
Fax	The fax transmission has failed since the other side's device did not have the capability which was transferred by NSF/DIS on this MFP.

Check item	Measures
Setting	Check the capability of the other side's device and reattempt the fax transmission by using a receivable mode for it.

### Reception

Classification	Error content
Fax	The fax reception has failed since NSS/DCS, which was a capability other than the ones transferred by NSF/DIS on this MFP, was received.

Check item	Measures
Setting	Check the capability of this MFP and reattempt the fax reception by using a receivable mode for it.

### Transmission

Classification	Error content
IP Fax	The IP Fax transmission has failed since the other side's device did not have the capability which was transferred by NSF/DIS on this MFP.

Check item	Measures
Setting	Check the capability of the other side's device and reattempt the IP Fax transmission by using a receivable mode for it.

### Reception

Classification	Error content
IP Fax	The IP Fax job reception has failed since NSS/DCS, which was a capability other than the ones transferred by NSF/DIS on this MFP, was received.

Check item	Measures
Setting	Check the capability of this MFP and reattempt the IP Fax reception by using a receivable mode for it.

## [00B2] DCN reception (Phase B)

### Transmission

Classification	Error content
Fax	The fax transmission has failed since DCN was sent in Phase B.

Check item	Measures
Setting	Reattempt the fax transmission.

### Reception

Classification	Error content
Fax	The fax reception has failed since DCN was received in Phase B.

Check item	Measures
Setting	Reattempt the fax reception.

### Transmission

Classification	Error content
IP Fax	The IP Fax transmission has failed since DCN was sent in Phase B.

Check item	Measures
Setting	Reattempt the IP Fax transmission.

**Reception**

Classification	Error content
IP Fax	The IP Fax reception has failed since DCN was received in Phase B.
Check item	Measures
Setting	Reattempt the IP Fax reception.

**[00B3] DCS / DTC not detected**

Classification	Error content
Fax	The fax reception has failed since DCS/DTC could not be detected.
Check item	Measures
Setting	Reattempt the fax reception.

**Transmission**

Classification	Error content
IP Fax	The IP Fax transmission has failed since DCS/DTC could not be detected.
Check item	Measures
Setting	Reattempt the IP Fax transmission.

**Reception**

Classification	Error content
IP Fax	The IP Fax reception has failed since DCS/DTC could not be detected.
Check item	Measures
Setting	Reattempt the IP Fax reception.

**[00B4] Training error****Transmission**

Classification	Error content
Fax	This MFP has performed fall-back but the fax transmission has failed.
Check item	Measures
Setting	Adjust the attenuator and link equalizer of this MFP and the other side's device and reattempt the fax transmission.

**Reception**

Classification	Error content
Fax	The fax reception has failed since after receiving FTT, the receiver has received a timeout or DCN.
Check item	Measures
Setting	Adjust the attenuator and link equalizer of this MFP and the other side's device and reattempt the fax reception.

**Transmission**

Classification	Error content
IP Fax	This MFP has performed fall-back but the IP Fax transmission has failed.
Check item	Measures
Setting	Check the following items and reattempt the IP Fax transmission. <ul style="list-style-type: none"> <li>This MFP and the other side's device are connected to a network properly.</li> <li>If the other side's device is in the fax mode, its attenuator and link equalizer are adjusted properly.</li> </ul>



## Reception

Classification	Error content
IP Fax	The IP Fax reception has failed since after receiving FTT, the receiver has received a timeout or DCN.

Check item	Measures
Setting	Check the following items and reattempt the IP Fax reception. <ul style="list-style-type: none"><li>• This MFP and the other side's device are connected to a network properly.</li><li>• If the other side's device is in the fax mode, its attenuator and link equalizer are adjusted properly.</li></ul>

## [00B5] CFR not detected

Classification	Error content
Fax	The fax transmission has failed since a training signal has been sent out but CFR could not be detected.

Check item	Measures
Setting	Adjust the attenuator and link equalizer of this MFP and the other side's device and reattempt the fax transmission.

Classification	Error content
IP Fax	The IP Fax transmission has failed since a training signal has been sent out but CFR could not be detected.

Check item	Measures
Setting	Check the following items and reattempt the IP Fax transmission. <ul style="list-style-type: none"><li>• The network of this MFP is functioning properly.</li><li>• The IP Fax function of this MFP is set properly.</li><li>• If the other side's device is in the fax mode, its attenuator and link equalizer are adjusted properly.</li></ul>

## [00B6] No response made to CTC

Classification	Error content
Fax	The fax transmission has failed since no response was made to CTC.

Check item	Measures
Setting	Adjust the attenuator and link equalizer of this MFP and the other side's device and reattempt the fax transmission.

## Transmission

Classification	Error content
IP Fax	The IP Fax transmission has failed since no response was made to CTC.

Check item	Measures
Setting	Check the following items and reattempt the IP Fax transmission. <ul style="list-style-type: none"><li>• This MFP and the other side's device are connected to a network properly.</li><li>• If the other side's device is in the fax mode, its attenuator and link equalizer are adjusted properly.</li></ul>

## Reception

Classification	Error content
IP Fax	The IP Fax reception has failed since DCN was received.

Check item	Measures
Setting	Check the following items and reattempt the IP Fax reception. <ul style="list-style-type: none"> <li>This MFP and the other side's device are connected to a network properly.</li> <li>If the other side's device is in the fax mode, its attenuator and link equalizer are adjusted properly.</li> </ul>

### [00B7] Phase B cannot be completed

#### Transmission

Classification	Error content
Fax	The fax transmission has failed since a modem error or a sequence error in the fax unit occurred.

Check item	Measures
Setting	Reattempt the fax transmission. If the error persists, replace the fax unit.

#### Reception

Classification	Error content
Fax	The fax reception has failed since a modem error or a sequence error in the fax unit occurred.

Check item	Measures
Setting	Reattempt the fax reception. If the error persists, replace the fax unit.

#### Transmission

Classification	Error content
IP Fax	The IP Fax transmission has failed since an error occurred in the system.

Check item	Measures
Setting	Reboot this MFP and reattempt the IP Fax transmission.

#### Reception

Classification	Error content
IP Fax	The IP Fax reception has failed since an error occurred in the system.

Check item	Measures
Setting	Reboot this MFP and reattempt the IP Fax reception.

### [00C0] Image signal carrier not detected

Classification	Error content
Fax	The fax reception has failed since this MFP has failed to detect a carrier.

Check item	Measures
Setting	Adjust the attenuator and link equalizer of this MFP and the other side's device and reattempt the fax reception.

### [00C1] High-speed signal not detected

Classification	Error content
Fax	The fax reception has failed since this MFP has failed to detect a high-speed signal.

Check item	Measures
Setting	Adjust the attenuator and link equalizer of this MFP and the other side's device and reattempt the fax reception.

Classification	Error content
IP Fax	The IP Fax reception has failed since this MFP has failed to detect a high-speed signal.

Check item	Measures
Setting	<p>Check the following items and reattempt the IP Fax reception.</p> <ul style="list-style-type: none"> <li>• The network of this MFP and the other side's device is functioning properly.</li> <li>• The IP Fax function of this MFP is set properly.</li> <li>• If the other side's device is in the fax mode, its attenuator and link equalizer are adjusted properly.</li> </ul>

## [00C2] Image signal carrier disconnected

### Transmission

Classification	Error content
Fax	The fax transmission has failed since a carrier disconnection was detected after the image signal was picked up by the other side's device.

Check item	Measures
Setting	Reattempt the fax transmission.

### Reception

Classification	Error content
Fax	The fax reception has failed since a carrier disconnection was detected after the image signal was picked up by this MFP.

Check item	Measures
Setting	Reattempt the fax reception.

Classification	Error content
IP Fax	The IP Fax reception has failed since a carrier disconnection was detected after the image signal was picked up by this MFP.

Check item	Measures
Setting	Reattempt the IP Fax reception.

## [00C4] EOL time-out

Classification	Error content
Fax	The fax reception has failed since this MFP could not detect EOL or not decode with MMR.

Check item	Measures
Setting	Reattempt the fax reception.

## [00C5] Excess length of data received

Classification	Error content
Fax	The fax reception has failed due to the disconnection of the communication since the length of the received original exceeded 2 m.

Check item	Measures
Setting	Ask to make the length of the original 2 m or less and reattempt the fax reception.

Classification	Error content
IP Fax	The IP Fax reception has failed due to the disconnection of the communication since the length of the received original exceeded 2 m.

Check item	Measures
Setting	Ask to make the length of the original 2 m or less and reattempt the IP Fax reception.

#### [00C6] Image code conversion error

Classification	Error content
Fax	The fax reception has failed since the conversion of the received image went wrong.

Check item	Measures
Setting	Reattempt the fax reception.

Classification	Error content
IP Fax	The IP Fax reception has failed since the conversion of the received image went wrong.

Check item	Measures
Setting	Reattempt the IP Fax reception.

#### [00C7] Phase C cannot be completed Transmission

Classification	Error content
Fax	The fax transmission has failed since a modem error or a sequence error in the fax unit occurred.

Check item	Measures
Setting	Reattempt the fax transmission. If the error persists, replace the fax unit.

#### Reception

Classification	Error content
Fax	The fax reception has failed since a modem error or a sequence error in the fax unit occurred.

Check item	Measures
Setting	Reattempt the fax reception. If the error persists, replace the fax unit.

#### Transmission

Classification	Error content
IP Fax	The IP Fax transmission has failed since a system error or a sequence error occurred.

Check item	Measures
Setting	Reboot this MFP and reattempt the IP Fax transmission.

#### Reception

Classification	Error content
IP Fax	The IP Fax reception has failed since a system error or a sequence error occurred.

Check item	Measures
Setting	Reboot this MFP and reattempt the IP Fax reception.

**[00C8] Transmitted image was not made in time**

Classification	Error content
IP Fax	The IP Fax transmission has failed due to the disconnection of the communication from the other side's device since the notification of the transmitted image was not made in time.

Check item	Measures
Setting	Reattempt the IP Fax transmission.

**[00D0] Post message not detected  
Transmission**

Classification	Error content
Fax	The fax transmission has failed since this MFP could not detect an MCF, RTP, RTN, PIN or PIP or the other side's device could not detect MPS, EOM or EOP.

Check item	Measures
Setting	Reattempt the fax transmission.

**Reception**

Classification	Error content
Fax	The fax reception has failed since the other side's device could not detect an MCF, RTP, RTN, PIN or PIP or this MFP could not detect MPS, EOM or EOP.

Check item	Measures
Setting	Reattempt the fax reception.

**Transmission**

Classification	Error content
IP Fax	The IP Fax transmission has failed since this MFP could not detect an MCF, RTP, RTN, PIN or PIP fax or the other side's device could not detect MPS, EOM or EOP.

Check item	Measures
Setting	Reattempt the IP Fax transmission.

**Reception**

Classification	Error content
IP Fax	The IP Fax reception has failed since the other side's device could not detect an MCF, RTP, RTN, PIN or PIP fax or this MFP could not detect MPS, EOM or EOP.

Check item	Measures
Setting	Reattempt the IP Fax reception.

**[00D1] DCN reception**

Classification	Error content
Fax	The fax reception has failed since DCN was received.

Check item	Measures
Setting	Reattempt the fax reception.

**Transmission**

Classification	Error content
IP Fax	The IP Fax transmission has failed since DCN was received.

Check item	Measures
Setting	Reattempt the IP Fax transmission.

### Reception

Classification	Error content
IP Fax	The IP Fax reception has failed since DCN was received.

Check item	Measures
Setting	Reattempt the IP Fax reception.

### [00D2] Poor image quality Transmission

Classification	Error content
Fax	The fax transmission has failed since the quality of the received image was poor in the other side's device.

Check item	Measures
Setting	Reattempt the fax transmission.

### Reception

Classification	Error content
Fax	The fax reception has failed since the quality of the received image was poor.

Check item	Measures
Setting	Reattempt the fax reception.

### Transmission

Classification	Error content
IP Fax	The IP Fax transmission has failed since the quality of the received image was poor in the other side's device.

Check item	Measures
Setting	Check the following items and reattempt the IP Fax transmission. <ul style="list-style-type: none"> <li>The network of this MFP and the other side's device is functioning properly.</li> <li>The IP Fax function of this MFP is set properly.</li> </ul>

### Reception

Classification	Error content
IP Fax	The IP Fax reception has failed since the quality of the received image was poor.

Check item	Measures
Setting	Check the following items and reattempt the IP Fax reception. <ul style="list-style-type: none"> <li>The network of this MFP and the other side's device is functioning properly.</li> <li>The IP Fax function of this MFP is set properly.</li> </ul>

### [00D3] No response made to EOR

Classification	Error content
Fax	The fax transmission has failed since no response was made to EOR or DCN was received during ECM transmission.

Check item	Measures
Setting	Ask to adjust the attenuator and link equalizer of the other side's device and reattempt the fax transmission.

Classification	Error content
IP Fax	The fax transmission has failed since no response was made to EOR or DCN was received during ECM transmission.
Check item	Measures
Setting	Check the following items and reattempt the IP Fax transmission. <ul style="list-style-type: none"> <li>• The network of this MFP is functioning properly.</li> <li>• The IP Fax function of this MFP is set properly.</li> <li>• If the other side's device is in the fax mode, its attenuator and link equalizer are adjusted properly.</li> </ul>

#### [00D4] No response made to RR

Classification	Error content
Fax	The fax transmission has failed since no response was made to RR or DCN was received during ECM transmission.
Check item	Measures
Setting	Ask to adjust the attenuator and link equalizer of the other side's device and reattempt the fax transmission.

Classification	Error content
IP Fax	The fax transmission has failed since no response was made to RR or DCN was received during ECM transmission.
Check item	Measures
Setting	Check the following items and reattempt the IP Fax transmission. <ul style="list-style-type: none"> <li>• The network of this MFP is functioning properly.</li> <li>• The IP Fax function of this MFP is set properly.</li> <li>• If the other side's device is in the fax mode, its attenuator and link equalizer are adjusted properly.</li> </ul>

#### [00D5] T5 time-out

Classification	Error content
Fax	The fax transmission has failed since RNR-RR was repeated and the line was disconnected due to timeout during ECM transmission.
Check item	Measures
Setting	Reattempt the fax transmission. If the error persists, check whether the other side's device can output MCF or not.

#### [00D6] ERR returned to EOR

Classification	Error content
Fax	The fax reception has failed due to the bad condition of the communication.
Check item	Measures
Setting	Reattempt the fax reception.

Classification	Error content
IP Fax	The IP Fax reception has failed due to the bad condition of the communication.
Check item	Measures
Setting	Check the following items and reattempt the IP Fax reception. <ul style="list-style-type: none"> <li>• The network of this MFP and the other side's device is functioning properly.</li> <li>• The IP Fax function of this MFP is set properly.</li> </ul>

**[00D7] Line disconnected by transmission of EOR**

Classification	Error content
Fax	The fax transmission has failed since the line was disconnected after EOR was sent by this MFP during ECM transmission.

Check item	Measures
Setting	Adjust the attenuator and link equalizer of this MFP and reattempt the fax transmission.

Classification	Error content
IP Fax	The IP Fax transmission has failed since the line was disconnected after EOR was sent by this MFP during ECM transmission.

Check item	Measures
Setting	Check the following items and reattempt the IP Fax transmission. <ul style="list-style-type: none"> <li>The network of this MFP and the other side's device is functioning properly.</li> <li>The IP Fax function of this MFP is set properly.</li> </ul>

**[00D8] Time-out between FCD frame**

Classification	Error content
Fax	The fax reception has failed since a time-out occurred between the FCD frames.

Check item	Measures
Setting	Reattempt the fax reception.

**[00DA] MCF not returned**

Classification	Error content
Fax	The fax reception has failed since MCF could not be returned from this MFP.

Check item	Measures
Setting	Reattempt the fax reception.

Classification	Error content
IP Fax	The IP Fax reception has failed since MCF could not be returned from this MFP.

Check item	Measures
Setting	Reattempt the IP Fax reception.

**[00E8] Storage device error  
Transmission**

Classification	Error content
Fax	The fax transmission has failed due to a defective storage device.

Check item	Measures
Setting	Reattempt the fax transmission. If the error persists, replace the storage device.

**Reception**

Classification	Error content
Fax	The fax reception has failed due to a defective storage device.



Check item	Measures
Setting	Reattempt the fax reception. If the error persists, replace the storage device.

### Transmission

Classification	Error content
IP Fax	The IP Fax transmission has failed due to a defective storage device.

Check item	Measures
Setting	Reattempt the IP Fax transmission. If the error persists, replace the storage device.

### Reception

Classification	Error content
IP Fax	The IP Fax reception has failed due to a defective storage device.

Check item	Measures
Setting	Reattempt the IP Fax reception. If the error persists, replace the storage device.

## [00F0] Software trouble

### Transmission

Classification	Error content
Fax	The fax transmission has failed due to defective software.

Check item	Measures
Setting	Reinstall the fax firmware. If the error persists, replace the fax board.

### Reception

Classification	Error content
Fax	The fax reception has failed due to defective software.

Check item	Measures
Setting	Reinstall the fax firmware. If the error persists, replace the fax board.

### Transmission

Classification	Error content
IP Fax	The IP Fax transmission has failed due to defective software.

Check item	Measures
Setting	Check that the IP Fax function of this MFP is set properly. Reboot this MFP and reattempt the IP Fax transmission.

### Reception

Classification	Error content
IP Fax	The IP Fax reception has failed due to defective software.

Check item	Measures
Setting	Check that the IP Fax function of this MFP is set properly. Reboot this MFP and reattempt the IP Fax reception.

## [00F1] Hardware noise

### Transmission

Classification	Error content
Fax	The fax transmission has failed due to defective hardware.

Check item	Measures
Setting	<ul style="list-style-type: none"> <li>• Reboot this MFP and reattempt the fax transmission.</li> <li>• Reinstall the fax firmware.</li> <li>• If the error persists, replace the fax board.</li> </ul>

### Reception

Classification	Error content
Fax	The fax reception has failed due to defective hardware.

Check item	Measures
Setting	<ul style="list-style-type: none"> <li>• Reboot this MFP and reattempt the fax reception.</li> <li>• Reinstall the fax firmware.</li> <li>• If the error persists, replace the fax board.</li> </ul>

### [00F4] Software trouble (Fax unit)

#### Transmission

Classification	Error content
Fax	The fax transmission has failed due to defective software.

Check item	Measures
Setting	<ul style="list-style-type: none"> <li>• Reboot this MFP and reattempt the fax transmission.</li> <li>• Reinstall the fax firmware.</li> <li>• If the error persists, replace the fax board.</li> </ul>

### Reception

Classification	Error content
Fax	The fax reception has failed due to defective software.

Check item	Measures
Setting	<ul style="list-style-type: none"> <li>• Reboot this MFP and reattempt the fax reception.</li> <li>• Reinstall the fax firmware.</li> <li>• If the error persists, replace the fax board.</li> </ul>

### [0101] Response Time-out (Registration)

Classification	Error content
IP Fax	A time-out has occurred since there was no response from an SIP server. (Register)

Check item	Measures
Setting	Check the setting of the network or the SIP server.

### [0102] Response Time-out (Invite)

Classification	Error content
IP Fax	The IP Fax transmission has failed due to a time-out since there was no response from an SIP server. (Invite)

Check item	Measures
Setting	Reattempt the IP Fax transmission. If the error persists, check the network or the server setting and recipient information.

### [0103] “Multiple Choices” reception

Classification	Error content
IP Fax	The registration to an SIP server has failed due to an error. (Multiple Choices)

Check item	Measures
Setting	Check the setting of the network or the SIP server.

#### [0104] “Moved Permanently” reception

Classification	Error content
IP Fax	The registration to an SIP server has failed due to an error. (Moved Permanently)

Check item	Measures
Setting	Check the setting of the network or the SIP server.

#### [0105] “Moved Temporarily” reception

Classification	Error content
IP Fax	The registration to an SIP server has failed due to an error. (Moved Temporarily)

Check item	Measures
Setting	Check the setting of the network or the SIP server.

#### [0106] “Use Proxy” reception

Classification	Error content
IP Fax	The registration to an SIP server has failed due to an error. (Use Proxy)

Check item	Measures
Setting	Check the setting of the network or the SIP server.

#### [0107] “Alternative Service” reception

Classification	Error content
IP Fax	The registration to an SIP server has failed due to an error. (Alternative Service)

Check item	Measures
Setting	Check the setting of the network or the SIP server.

#### [0109] “Bad Request” reception

Classification	Error content
IP Fax	The registration to an SIP server has failed due to an error. (Bad Request)

Check item	Measures
Setting	Check the setting of the network or the SIP server.

#### [010A] “Unauthorized” reception

Classification	Error content
IP Fax	The registration to an SIP server has failed due to an error. (Unauthorized)

Check item	Measures
Setting	Check the setting of the network or the SIP server.

#### [010B] “Payment Required” reception

Classification	Error content
IP Fax	The registration to an SIP server has failed due to an error. (Payment Required)

Check item	Measures
Setting	Check the setting of the network or the SIP server.

#### [010C] “Forbidden” reception

Classification	Error content
IP Fax	The registration to an SIP server has failed due to an error. (Forbidden)

Check item	Measures
Setting	Check the setting of the network or the SIP server.

#### [010D] “Not Found” reception

Classification	Error content
IP Fax	The registration to an SIP server has failed due to an error. (Not Found)

Check item	Measures
Setting	Check the setting of the network or the SIP server.

#### [010E] “Method Not Allowed” reception

Classification	Error content
IP Fax	The registration to an SIP server has failed due to an error. (Method Not Allowed)

Check item	Measures
Setting	Check the setting of the network or the SIP server.

#### [010F] “Not Acceptable” reception

Classification	Error content
IP Fax	The registration to an SIP server has failed due to an error. (Not Acceptable)

Check item	Measures
Setting	Check the setting of the network or the SIP server.

#### [0110] “Proxy Authentication Required” reception

Classification	Error content
IP Fax	The registration to an SIP server has failed due to an error. (Proxy Authentication Required)

Check item	Measures
Setting	Check the setting of the network or the SIP server.

#### [0111] “Request Timeout” reception

Classification	Error content
IP Fax	The registration to an SIP server has failed due to an error. (Request Timeout)

Check item	Measures
Setting	Check the setting of the network or the SIP server.

#### [0113] “Gone” reception

Classification	Error content
IP Fax	The registration to an SIP server has failed due to an error. (Gone)

Check item	Measures
Setting	Check the setting of the network or the SIP server.

#### [0115] “Precondition Failed” reception

Classification	Error content
IP Fax	The registration to an SIP server has failed due to an error. (Precondition Failed)

Check item	Measures
Setting	Check the setting of the network or the SIP server.

#### [0116] “Request Entity Too Large” reception

Classification	Error content
IP Fax	The registration to an SIP server has failed due to an error. (Request Entity Too Large)

Check item	Measures
Setting	Check the setting of the network or the SIP server.

#### [0117] “Request-URI Too Long” reception

Classification	Error content
IP Fax	The registration to an SIP server has failed due to an error. (Request-URI Too Long)

Check item	Measures
Setting	Check the setting of the network or the SIP server.

#### [0118] “Unsupported Media Type” reception

Classification	Error content
IP Fax	The registration to an SIP server has failed due to an error. (Unsupported Media Type)

Check item	Measures
Setting	Check the setting of the network or the SIP server.

#### [0119] “Unsupported URI Scheme” reception

Classification	Error content
IP Fax	The registration to an SIP server has failed due to an error. (Unsupported URI Scheme)

Check item	Measures
Setting	Check the setting of the network or the SIP server.

#### [011A] “Unknown Resource-Priority” reception

Classification	Error content
IP Fax	The registration to an SIP server has failed due to an error. (Unknown Resource-Priority)

Check item	Measures
Setting	Check the setting of the network or the SIP server.

#### [011B] “Bad Extension” reception

Classification	Error content
IP Fax	The registration to an SIP server has failed due to an error. (Bad Extension)

Check item	Measures
Setting	Check the setting of the network or the SIP server.

#### [011C] “Extension Required” reception

Classification	Error content
IP Fax	The registration to an SIP server has failed due to an error. (Extension Required)

Check item	Measures
Setting	Check the setting of the network or the SIP server.

#### [011D] “Session Timer Too Small” reception

Classification	Error content
IP Fax	The registration to an SIP server has failed due to an error. (Session Timer Too Small)

Check item	Measures
Setting	Check the setting of the network or the SIP server.

#### [011E] “Interval Too Brief” reception

Classification	Error content
IP Fax	The registration to an SIP server has failed due to an error. (Interval Too Brief)

Check item	Measures
Setting	Check the setting of the network or the SIP server.

#### [011F] “Anonymity disallowed” reception

Classification	Error content
IP Fax	The registration to an SIP server has failed due to an error. (Anonymity disallowed)

Check item	Measures
Setting	Check the setting of the network or the SIP server.

#### [0120] “Temporarily Unavailable” reception

Classification	Error content
IP Fax	The registration to an SIP server has failed due to an error. (Temporarily Unavailable)

Check item	Measures
Setting	Check the setting of the network or the SIP server.

#### [0121] “Call/Transaction Does Not Exist” reception

Classification	Error content
IP Fax	The registration to an SIP server has failed due to an error. (Call/Transaction Does Not Exist)

Check item	Measures
Setting	Check the setting of the network or the SIP server.

#### [0122] “Loop Detected” reception

Classification	Error content
IP Fax	The registration to an SIP server has failed due to an error. (Loop Detected)

Check item	Measures
Setting	Check the setting of the network or the SIP server.

### [0123] “Too Many Hops” reception

Classification	Error content
IP Fax	The registration to an SIP server has failed due to an error. (Too Many Hops)

Check item	Measures
Setting	Check the setting of the network or the SIP server.

### [0124] “Address Incomplete” reception

Classification	Error content
IP Fax	The registration to an SIP server has failed due to an error. (Address Incomplete)

Check item	Measures
Setting	Check the setting of the network or the SIP server.

### [0125] “Ambiguous” reception

Classification	Error content
IP Fax	The registration to an SIP server has failed due to an error. (Ambiguous)

Check item	Measures
Setting	Check the setting of the network or the SIP server.

### [0126] “Busy Here” reception

Classification	Error content
IP Fax	The registration to an SIP server has failed due to an error. (Busy Here)

Check item	Measures
Setting	Check the setting of the network or the SIP server.

### [0127] “Request Terminated” reception

Classification	Error content
IP Fax	The registration to an SIP server has failed due to an error. (Request Terminated)

Check item	Measures
Setting	Check the setting of the network or the SIP server.

### [0128] “Not acceptable here” reception

Classification	Error content
IP Fax	The registration to an SIP server has failed due to an error. (Not acceptable here)

Check item	Measures
Setting	Check the setting of the network or the SIP server.

**[0129] “Bad Event” reception**

Classification	Error content
IP Fax	The registration to an SIP server has failed due to an error. (Bad Event)

Check item	Measures
Setting	Check the setting of the network or the SIP server.

**[012A] “Request Updated” reception**

Classification	Error content
IP Fax	The registration to an SIP server has failed due to an error. (Request Updated)

Check item	Measures
Setting	Check the setting of the network or the SIP server.

**[012B] “Request Pending” reception**

Classification	Error content
IP Fax	The registration to an SIP server has failed due to an error. (Request Pending)

Check item	Measures
Setting	Check the setting of the network or the SIP server.

**[012C] “Undecipherable” reception**

Classification	Error content
IP Fax	The registration to an SIP server has failed due to an error. (Undecipherable)

Check item	Measures
Setting	Check the setting of the network or the SIP server.

**[012D] “Security Agreement Required” reception**

Classification	Error content
IP Fax	The registration to an SIP server has failed due to an error. (Security Agreement Required)

Check item	Measures
Setting	Check the setting of the network or the SIP server.

**[012E] “Internal Server Error” reception**

Classification	Error content
IP Fax	The registration to an SIP server has failed due to an error. (Internal Server Error)

Check item	Measures
Setting	Check the setting of the network or the SIP server.



**[012F] “Not Implemented” reception**

Classification	Error content
IP Fax	The registration to an SIP server has failed due to an error. (Not Implemented)

Check item	Measures
Setting	Check the setting of the network or the SIP server.

**[0130] “Bad Gateway” reception**

Classification	Error content
IP Fax	The registration to an SIP server has failed due to an error. (Bad Gateway)

Check item	Measures
Setting	Check the setting of the network or the SIP server.

**[0131] “Service Unavailable” reception**

Classification	Error content
IP Fax	The IP Fax transmission took time since the IP line was busy.

Check item	Measures
Setting	Wait for a while and then reattempt the IP Fax transmission. If this still persists, check the setting of the SIP server.

**[0132] “Gateway Time-out” reception**

Classification	Error content
IP Fax	The registration to an SIP server has failed due to an error. (Gateway Time-out)

Check item	Measures
Setting	Check the setting of the network or the SIP server.

**[0133] “Version Not Supported” reception**

Classification	Error content
IP Fax	The registration to an SIP server has failed due to an error. (Version Not Supported)

Check item	Measures
Setting	Check the setting of the network or the SIP server.

**[0134] “Message Too Large” reception**

Classification	Error content
IP Fax	The registration to an SIP server has failed due to an error. (Message Too Large)

Check item	Measures
Setting	Check the setting of the network or the SIP server.

**[0135] “Precondition Failure” reception**

Classification	Error content
IP Fax	The registration to an SIP server has failed due to an error. (Precondition Failure)

Check item	Measures
Setting	Check the setting of the network or the SIP server.

**[0136] “Busy Everywhere” reception**

Classification	Error content
IP Fax	The registration to an SIP server has failed due to an error. (Busy Everywhere)

Check item	Measures
Setting	Check the setting of the network or the SIP server.

**[0137] “Decline” reception**

Classification	Error content
IP Fax	The registration to an SIP server has failed due to an error. (Decline)

Check item	Measures
Setting	Check the setting of the network or the SIP server.

**[0138] “Does Not Exist Anywhere” reception**

Classification	Error content
IP Fax	The registration to an SIP server has failed due to an error. (Does Not Exist Anywhere)

Check item	Measures
Setting	Check the setting of the network or the SIP server.

**[0139] “Not Acceptable” reception**

Classification	Error content
IP Fax	The registration to an SIP server has failed due to an error. (Not Acceptable)

Check item	Measures
Setting	Check the setting of the network or the SIP server.

**[013D] Other errors**

Classification	Error content
IP Fax	The registration to an SIP server has failed due to an error. (Other errors)

Check item	Measures
Setting	Check the setting of the network or the SIP server.

**[013E] Other errors**

Classification	Error content
IP Fax	The IP Fax transmission/reception has failed due to a communication error. (Other errors)

Check item	Measures
Setting	Check the setting of the network or the SIP server.

**[0140] Startup failure**

Classification	Error content
IP Fax	The starting of the IP Fax function has failed.

Check item	Measures
Setting	Reboot the MFP.

**[0141] Job interruption due to setting change**

Classification	Error content
IP Fax	The implementation of an IP Fax job has been stopped since the settings were changed.

Check item	Measures
Setting	Reattempt the IP Fax transmission/reception.

**[0142] Recipient entry error**

Classification	Error content
IP Fax	The IP Fax transmission has failed due to a communication error. (Recipient entry error)

Check item	Measures
Setting	Correct the recipient and reattempt the IP Fax transmission.

**[0143] SIP server is unavailable**

Classification	Error content
IP Fax	The IP Fax transmission/reception has failed due to a communication error. (SIP server unavailable)

Check item	Measures
Setting	Check the setting of the network or the SIP server.

**[0144] Under congestion**

Classification	Error content
IP Fax	The IP Fax transmission has failed due to a communication error. (Under congestion)

Check item	Measures
Setting	Wait for a while and then reattempt the IP Fax transmission.

**[0150] Disconnected by other side's device****Transmission**

Classification	Error content
IP Fax	The IP Fax transmission has failed due to a communication error. (Communication disconnection from the other side's device)

Check item	Measures
Setting	Wait for a while and then reattempt the IP Fax transmission.

**Reception**

Classification	Error content
IP Fax	The IP Fax reception has failed due to a communication error. (Communication disconnection from the other side's device)

Check item	Measures
Setting	Reattempt the IP Fax reception.

**[0300] "Multiple Choices" reception**

Classification	Error content
IP Fax	The IP Fax transmission/reception has failed due to a communication error. (Multiple Choices)

Check item	Measures
Setting	Check the setting of the network or the SIP server.

**[0301] "Moved Permanently" reception**

Classification	Error content
IP Fax	The IP Fax transmission/reception has failed due to a communication error. (Moved Permanently)

Check item	Measures
Setting	Check the setting of the network or the SIP server.

**[0302] "Moved Temporarily" reception**

Classification	Error content
IP Fax	The IP Fax transmission/reception has failed due to a communication error. (Moved Temporarily)

Check item	Measures
Setting	Check the setting of the network or the SIP server.

**[0305] "Use Proxy" reception**

Classification	Error content
IP Fax	The IP Fax transmission/reception has failed due to a communication error. (Use Proxy)

Check item	Measures
Setting	Check the setting of the network or the SIP server.

**[0380] “Alternative Service” reception**

Classification	Error content
IP Fax	The IP Fax transmission/reception has failed due to a communication error. (Alternative Service)
Check item	Measures
Setting	Check the setting of the network or the SIP server.

**[0400] “Bad Request” reception**

Classification	Error content
IP Fax	The IP Fax transmission/reception has failed due to a communication error. (Bad Request)
Check item	Measures
Setting	Wait for a while and then reattempt the IP Fax transmission.

**[0401] “Unauthorized” reception**

Classification	Error content
IP Fax	The IP Fax transmission/reception has failed due to a communication error. (Unauthorized)
Check item	Measures
Setting	Wait for a while and then reattempt the IP Fax transmission.

**[0402] “Payment Required” reception**

Classification	Error content
IP Fax	The IP Fax transmission/reception has failed due to a communication error. (Payment Required)
Check item	Measures
Setting	Wait for a while and then reattempt the IP Fax transmission.

**[0403] “Forbidden” reception**

Classification	Error content
IP Fax	The IP Fax transmission/reception has failed due to a communication error. (Forbidden)
Check item	Measures
Setting	Wait for a while and then reattempt the IP Fax transmission.

**[0404] “Not Found” reception**

Classification	Error content
IP Fax	The IP Fax transmission/reception has failed due to a communication error. (Not Found)
Check item	Measures
Setting	Wait for a while and then reattempt the IP Fax transmission.

**[0405] “Method Not Allowed” reception**

Classification	Error content
IP Fax	The IP Fax transmission/reception has failed due to a communication error. (Method Not Allowed)

Check item	Measures
Setting	Wait for a while and then reattempt the IP Fax transmission.

**[0406] “Not Acceptable” reception**

Classification	Error content
IP Fax	The IP Fax transmission/reception has failed due to a communication error. (Not Acceptable)

Check item	Measures
Setting	Wait for a while and then reattempt the IP Fax transmission.

**[0407] “Proxy Authentication Required” reception**

Classification	Error content
IP Fax	The IP Fax transmission/reception has failed due to a communication error. (Proxy Authentication Required)

Check item	Measures
Setting	Wait for a while and then reattempt the IP Fax transmission.

**[0408] “Request Timeout” reception**

Classification	Error content
IP Fax	The IP Fax transmission/reception has failed due to a communication error. (Request Timeout)

Check item	Measures
Setting	Wait for a while and then reattempt the IP Fax transmission.

**[0410] “Gone” reception**

Classification	Error content
IP Fax	The IP Fax transmission/reception has failed due to a communication error. (Gone)

Check item	Measures
Setting	Wait for a while and then reattempt the IP Fax transmission.

**[0412] “Precondition Failed” reception**

Classification	Error content
IP Fax	The IP Fax transmission/reception has failed due to a communication error. (Precondition Failed)

Check item	Measures
Setting	Wait for a while and then reattempt the IP Fax transmission.

**[0413] “Request Entity Too Large” reception**

Classification	Error content
IP Fax	The IP Fax transmission/reception has failed due to a communication error. (Request Entity Too Large)

Check item	Measures
Setting	Wait for a while and then reattempt the IP Fax transmission.

**[0414] “Request-URI Too Long” reception**

Classification	Error content
IP Fax	The IP Fax transmission/reception has failed due to a communication error. (Request-URI Too Long)

Check item	Measures
Setting	Wait for a while and then reattempt the IP Fax transmission.

**[0415] “Unsupported Media Type” reception**

Classification	Error content
IP Fax	The IP Fax transmission/reception has failed due to a communication error. (Unsupported Media Type)

Check item	Measures
Setting	Wait for a while and then reattempt the IP Fax transmission.

**[0416] “Unsupported URI Scheme” reception**

Classification	Error content
IP Fax	The IP Fax transmission/reception has failed due to a communication error. (Unsupported URI Scheme)

Check item	Measures
Setting	Wait for a while and then reattempt the IP Fax transmission.

**[0417] “Unknown Resource-Priority” reception**

Classification	Error content
IP Fax	The IP Fax transmission/reception has failed due to a communication error. (Unknown Resource-Priority)

Check item	Measures
Setting	Wait for a while and then reattempt the IP Fax transmission.

**[0420] “Bad Extension” reception**

Classification	Error content
IP Fax	The IP Fax transmission/reception has failed due to a communication error. (Bad Extension)

Check item	Measures
Setting	Wait for a while and then reattempt the IP Fax transmission.

**[0421] “Extension Required” reception**

Classification	Error content
IP Fax	The IP Fax transmission/reception has failed due to a communication error. (Extension Required)

Check item	Measures
Setting	Wait for a while and then reattempt the IP Fax transmission.

**[0422] “Session Timer Too Small” reception**

Classification	Error content
IP Fax	The IP Fax transmission/reception has failed due to a communication error. (Session Timer Too Small)

Check item	Measures
Setting	Wait for a while and then reattempt the IP Fax transmission.

**[0423] “Interval Too Brief” reception**

Classification	Error content
IP Fax	The IP Fax transmission/reception has failed due to a communication error. (Interval Too Brief)

Check item	Measures
Setting	Wait for a while and then reattempt the IP Fax transmission.

**[0433] “Anonymity disallowed” reception**

Classification	Error content
IP Fax	The IP Fax transmission/reception has failed due to a communication error. (Anonymity disallowed)

Check item	Measures
Setting	Wait for a while and then reattempt the IP Fax transmission.

**[0480] “Temporarily Unavailable” reception**

Classification	Error content
IP Fax	The IP Fax transmission/reception has failed due to a communication error. (Temporarily Unavailable)

Check item	Measures
Setting	Wait for a while and then reattempt the IP Fax transmission.

**[0481] “Call/Transaction Does Not Exist” reception**

Classification	Error content
IP Fax	The IP Fax transmission/reception has failed due to a communication error. (Call/Transaction Does Not Exist)

Check item	Measures
Setting	Wait for a while and then reattempt the IP Fax transmission.



**[0482] “Loop Detected” reception**

Classification	Error content
IP Fax	The IP Fax transmission/reception has failed due to a communication error. (Loop Detected)

Check item	Measures
Setting	Wait for a while and then reattempt the IP Fax transmission.

**[0483] “Too Many Hops” reception**

Classification	Error content
IP Fax	The IP Fax transmission/reception has failed due to a communication error. (Too Many Hops)

Check item	Measures
Setting	Wait for a while and then reattempt the IP Fax transmission.

**[0484] “Address Incomplete” reception**

Classification	Error content
IP Fax	The IP Fax transmission/reception has failed due to a communication error. (Address Incomplete)

Check item	Measures
Setting	Wait for a while and then reattempt the IP Fax transmission.

**[0485] “Ambiguous” reception**

Classification	Error content
IP Fax	The IP Fax transmission/reception has failed due to a communication error. (Ambiguous)

Check item	Measures
Setting	Wait for a while and then reattempt the IP Fax transmission.

**[0486] “Busy Here” reception**

Classification	Error content
IP Fax	The IP Fax transmission/reception has failed due to a communication error. (Busy Here)

Check item	Measures
Setting	Wait for a while and then reattempt the IP Fax transmission.

**[0487] “Request Terminated” reception**

Classification	Error content
IP Fax	The IP Fax transmission/reception has failed due to a communication error. (Request Terminated)

Check item	Measures
Setting	Wait for a while and then reattempt the IP Fax transmission.

**[0488] “Not acceptable here” reception**

Classification	Error content
IP Fax	The IP Fax transmission/reception has failed due to a communication error. (Not acceptable here)
Check item	Measures
Setting	Wait for a while and then reattempt the IP Fax transmission.

**[0489] “Bad Event” reception**

Classification	Error content
IP Fax	The IP Fax transmission/reception has failed due to a communication error. (Bad Event)
Check item	Measures
Setting	Wait for a while and then reattempt the IP Fax transmission.

**[0490] “Request Updated” reception**

Classification	Error content
IP Fax	The IP Fax transmission/reception has failed due to a communication error. (Request Updated)
Check item	Measures
Setting	Wait for a while and then reattempt the IP Fax transmission.

**[0491] “Request Pending” reception**

Classification	Error content
IP Fax	The IP Fax transmission/reception has failed due to a communication error. (Request Pending)
Check item	Measures
Setting	Wait for a while and then reattempt the IP Fax transmission.

**[0493] “Undecipherable” reception**

Classification	Error content
IP Fax	The IP Fax transmission/reception has failed due to a communication error. (Undecipherable)
Check item	Measures
Setting	Wait for a while and then reattempt the IP Fax transmission.

**[0494] “Security Agreement Required” reception**

Classification	Error content
IP Fax	The IP Fax transmission/reception has failed due to a communication error. (Security Agreement Required)
Check item	Measures
Setting	Wait for a while and then reattempt the IP Fax transmission.

**[0500] “Internal Server Error” reception**

Classification	Error content
IP Fax	The IP Fax transmission/reception has failed due to a communication error. (Internal Server Error)

Check item	Measures
Setting	Check the setting of the SIP server.

**[0501] “Not Implemented” reception**

Classification	Error content
IP Fax	The IP Fax transmission/reception has failed due to a communication error. (Not Implemented)

Check item	Measures
Setting	Check the setting of the SIP server.

**[0502] “Bad Gateway” reception**

Classification	Error content
IP Fax	The IP Fax transmission/reception has failed due to a communication error. (Bad Gateway)

Check item	Measures
Setting	Check the setting of the SIP server.

**[0503] “Service Unavailable” reception**

Classification	Error content
IP Fax	The IP Fax transmission/reception has failed due to a communication error. (Service Unavailable)

Check item	Measures
Setting	Wait for a while and then reattempt the IP Fax transmission.

**[0504] “Gateway Time-out” reception**

Classification	Error content
IP Fax	The IP Fax transmission/reception has failed due to a communication error. (Gateway Time-out)

Check item	Measures
Setting	Check the setting of the SIP server.

**[0505] “Version Not Supported” reception**

Classification	Error content
IP Fax	The IP Fax transmission/reception has failed due to a communication error. (Version Not Supported)

Check item	Measures
Setting	Check the setting of the SIP server.

**[0513] “Message Too Large” reception**

Classification	Error content
IP Fax	The IP Fax transmission/reception has failed due to a communication error. (Message Too Large)
Check item	Measures
Setting	Check the setting of the SIP server.

**[0580] “Precondition Failure” reception**

Classification	Error content
IP Fax	The IP Fax transmission/reception has failed due to a communication error. (Precondition Failure)
Check item	Measures
Setting	Check the setting of the SIP server.

**[0600] “Busy Everywhere” reception**

Classification	Error content
IP Fax	The IP Fax transmission/reception has failed due to a communication error. (Busy Everywhere)
Check item	Measures
Setting	Check the setting of the network or the SIP server.

**[0603] “Decline” reception**

Classification	Error content
IP Fax	The IP Fax transmission/reception has failed due to a communication error. (Decline)
Check item	Measures
Setting	Check the setting of the network or the SIP server.

**[0604] “Does Not Exist Anywhere” reception**

Classification	Error content
IP Fax	The IP Fax transmission/reception has failed due to a communication error. (Does Not Exist Anywhere)
Check item	Measures
Setting	Check the setting of the network or the SIP server.

**[0606] “Not Acceptable” reception**

Classification	Error content
IP Fax	The IP Fax transmission/reception has failed due to a communication error. (Not Acceptable)
Check item	Measures
Setting	Check the setting of the network or the SIP server.

**[4246] IP Fax license is not installed**

<b>Classification</b>	<b>Error content</b>
IP Fax	The license of the IP Fax has not been installed.

<b>Check item</b>	<b>Measures</b>
Setting	Check that the license of the IP Fax has been installed.

**[DA01] Fax unit line 1 malfunction**

<b>Classification</b>	<b>Error content</b>
Fax	The fax unit of line 1 has been damaged or an abnormality has occurred in the interface between the systems.

<b>Check item</b>	<b>Measures</b>
Setting	Reboot the MFP. If the error still persists, replace the fax unit of line 1.

**[DA02] Fax unit line 2 malfunction**

<b>Classification</b>	<b>Error content</b>
Fax	The fax unit of line 2 has been damaged or an abnormality has occurred in the interface between the systems.

<b>Check item</b>	<b>Measures</b>
Setting	Reboot the MFP. If the error still persists, replace the fax unit of line 2.

## 8.4 Other Errors

### 8.4.1 MFP operation disabled after the installation of option(s)

Check if the optional boards are installed properly.

### 8.4.2 Wireless LAN connection disabled

The connection state and settings of the Wireless LAN can be checked with [USER FUNCTIONS] > [ADMIN] > [WIRELESS LAN] > [SETTING CHECK].

For details, ask the administrator.

- “NIC INITIALIZING” does not disappear at the time of the power being turned ON and it disappears after 6 minutes with the NIC initializing time-out. In this case, the connection to the Wireless LAN does not succeed even though “NIC INITIALIZING” disappears.
- The connection to the Wireless LAN cannot be made if the access point to be connected is not found or the security settings are not correct.

### 8.4.3 “Invalid Department Code” is displayed

Log into TopAccess as an administrator, select [Authentication] on the [User Management] tab, and then check whether Department Setting is enabled or disabled.

Department Setting is enabled:

- Log into TopAccess as an administrator, select [Authentication] on the [User Management] tab, and then check User Management Setting.
- Check the setting of FS-08-3805 in the setting mode.

Department Setting is disabled:

- Log into TopAccess as an administrator, select [Authentication] on the [User Management] tab, and then check User Management Setting.

### 8.4.4 “Install Fuser Unit” is displayed

This message appears when the installation signal of the fuser unit cannot be detected by the LGC board.

When this message is displayed, check the following items.

- Check if the fuser unit is installed properly.
- Check if the drawer connector of the fuser unit is damaged or there is a defect in its connection.
- Disconnect the connector (CN308) and confirm that the current flows between the 1-pin and 7-pin. If not, check if the connector between the harnesses is disconnected or it is connected securely.
- Replace the LGC board.

### 8.4.5 Paper folded on the leading edge

If the leading edge of B4, B5 or B5-R paper is folded when it exits, check the following items.

- Check if the rear and side guides of the drawer or the side guides of the bypass tray correspond to the paper size.

### 8.4.6 Toner cartridge unrecognized

If the toner cartridge is not recognized, check the following items.

- Check that there is no access abnormality to the toner cartridge IC chip.
- Check the setting of FS-08-4689 in the setting mode. If the value is “1” to “5”, perform the troubleshooting in the following reference.

 P. 8-193 “ [C911] CTIF board access abnormality (K)”

## 8.4.7 Ethernet disabled in half-duplex communication

The Ethernet of this MFP does not support half-duplex communication.

When the port setting of the switch is fixed at half-duplex communication, use any of 10/100/1000 Mbps, full-duplex fixed communication mode or auto-negotiation function. In addition, select the setting of the MFP corresponding to that of the switch. ([ADMIN] > [NETWORK] > [ETHERNET])

Check the set communication speed as follows if required: [ADMIN] > [NETWORK] > [ETHERNET]

## 8.4.8 The MFP does not start after the power has been turned ON.

### [ 1 ] The LCD screen does not display after the power has been turned ON.

#### 1. Overview

When the lamps on the control panel do not light or error codes are not displayed on the screen after the power has been turned ON, perform this troubleshooting.

#### 2. Status LED, Power LED

After the power is turned ON, the status of the MFP from the startup until the end of system device initialization (the LCD screen works) is displayed by the status LED (8-bit) on the SYS board. When the MFP does not start or the LCD screen does not display after the power is turned ON, check this status LED on the SYS board in order to judge the corresponding troubleshooting. In addition to this, the power LED is lit when 12 VA power is being supplied to the SYS board.

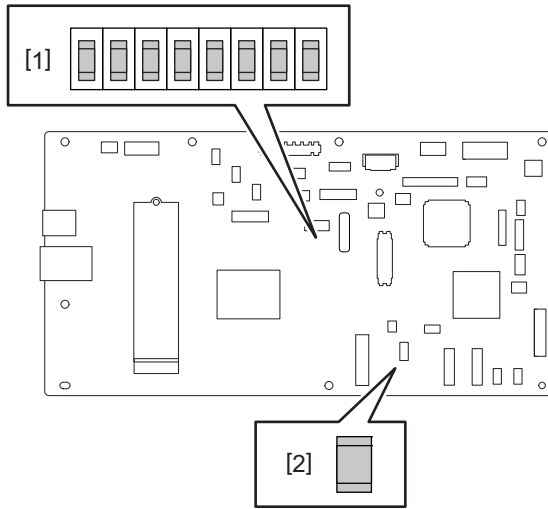

Fig.8-32

1	Status LED
2	Power LED

#### 3. Measures

When an error code is displayed, perform its troubleshooting.

If the LCD screen is turned OFF and an error code cannot be confirmed as a result, check the lighting condition of each LED and perform the troubleshooting according to the status below.



## Main power LED and energy saver LED on the control panel

LED	Lighting condition	SYS power LED	Troubleshooting
Main Power LED	ON	ON	<p>The control panel does not operate normally.</p> <ul style="list-style-type: none"> <li>• Check the connection of the harness (41-pin) of the control panel. Check if there is any abnormality in the harness.</li> <li>• Check if there is any abnormality in the parts of the control panel.</li> <li>• Download the system software again.</li> <li>• Check if there is any abnormality in the SYS board.</li> <li>• Replace the control panel.</li> <li>• Replace the SYS board.</li> </ul>
		OFF	<p>The 12 VA power is not supplied to the SYS board.</p> <ul style="list-style-type: none"> <li>• Check the connection of the power harness of the SYS board. Check if there is any abnormality in the harness.</li> <li>• Check if there is any abnormality in the switching regulator.</li> <li>• Check if there is any abnormality in the SYS board.</li> <li>• Replace the power harness of the SYS board.</li> <li>• Replace the switching regulator.</li> <li>• Replace the SYS board.</li> </ul> <p>The 12 VA power supply is stopped due to an overcurrent.</p> <ul style="list-style-type: none"> <li>• Turn the power OFF and open the front cover. While keeping this status, press the power button to check that the SYS power LED is turned ON.</li> </ul> <p>[If the SYS power LED is turned ON]</p> <ul style="list-style-type: none"> <li>• Check if there is any abnormality in all the harnesses with the 24 V power supplied.</li> <li>• Check if there is any abnormality in all the boards with the 24 V power supplied.</li> <li>• Replace all boards with the 24 V power supplied.</li> </ul> <p>[If the SYS power LED is not turned ON]</p> <ul style="list-style-type: none"> <li>• Check if there is any abnormality in all the harnesses with the 12 VA power supplied.</li> <li>• Check if there is any abnormality in all the boards with the 12 VA power supplied.</li> <li>• Replace all boards with the 12 VA power supplied.</li> </ul>
	OFF	ON	<p>The 5 VS power is not supplied to the control panel.</p> <ul style="list-style-type: none"> <li>• Check the connection of the harness of the control panel.</li> <li>• Check if there is any abnormality in the parts of the control panel.</li> </ul>
		OFF	<p>The power is not supplied to the SYS board.</p> <ul style="list-style-type: none"> <li>• Check the connection of the power supply harness of the SYS board.</li> <li>• Check if there is any abnormality in the switching regulator.</li> <li>• Check if there is no abnormality in the SYS board.</li> </ul>

LED	Lighting condition	SYS power LED	Troubleshooting
Energy saver LED	ON	-	-
	Blinking	-	When the energy saver LED is turned OFF after a certain time has passed: Initialization between the control panel and the SYS board is not completed. <ul style="list-style-type: none"> <li>• Check the connection of the harness of the control panel.</li> <li>• Check if there is any abnormality in the parts of the control panel.</li> <li>• SYS board abnormality (Check the lighting condition of the SYS power LED and SYS status LED and perform the measures described in the next table.)</li> </ul>
		-	When the energy saver LED blinks even if some times have passed: Initialization between the control panel and the SYS board is not completed. <ul style="list-style-type: none"> <li>• Check the connection of the harness of the control panel.</li> <li>• Check if there is any abnormality in the parts of the control panel.</li> <li>• SYS board abnormality (Check the lighting condition of the SYS power LED and SYS status LED and perform the measures described in the next table.)</li> </ul>
	OFF	ON	The 12 VA power is not supplied to the control panel. <ul style="list-style-type: none"> <li>• Check the connection of the harness of the control panel.</li> <li>• Check if there is any abnormality in the parts of the control panel.</li> </ul>

Power LED and Status LED on the SYS board

LED	Lighting condition	SYS board status	Troubleshooting
Power LED	OFF	Waiting for the power supply	Check the connection of the switching regulator harness and the power supply harness.

LED		Lighting condition	SYS board status	Troubleshooting
Status LED	Bit0	ON	Main memory abnormality	Replace the SYS board.
	Bit1	ON	IC abnormality	Replace the SYS board.
	Bit2	ON	Control panel communication error	<ul style="list-style-type: none"> <li>Check the connection of the harness of the control panel.</li> <li>Check if there is any abnormality in the parts of the control panel.</li> </ul>
	Bit3	ON	ASIC detection error	Replace the SYS board.
		Blinking	Initialization abnormality	Replace the SYS board.
	Bit4	ON	ASIC detection error	Replace the SYS board.
		Blinking	Initialization abnormality	Replace the SYS board.
	Bit5	ON	Network IC communication error	<ul style="list-style-type: none"> <li>When the error code is F130, follow its troubleshooting procedure.</li> <li>If the screen does not display, replace the SYS board.</li> </ul>
	Bit6	ON	OS lock	Reboot the MFP to check whether the problem is solved. If the problem reoccurs, download the system software again.
Bit7	ON	During the energy saving mode, Recovery error from the energy saving mode	Reboot the MFP to check whether the problem is reproduced. If the problem reoccurs, download the system software again.	

**Remarks:**

- If an error code appears, follow its troubleshooting procedure.
- When all the status LEDs are lit, replace the SYS board.



## 8.4.9 Countermeasure to sudden power failure

	Symptom	Check item	Measures
1	The [ENERGY SAVER] button is lit. The power supply is recovered by pressing the [ENERGY SAVER] button.	The mode is at the sleep mode.	Turn off the sleep mode setting. Alternatively, change the setting.
2	The power supply is recovered by pressing the [POWER] button.	The weekly timer has run.	<ul style="list-style-type: none"> <li>Turn off the setting of the weekly timer. Alternatively, change the setting.</li> <li>Check if the time is set correctly.</li> </ul>
3	The power supply is not recovered even if the [POWER] button is pressed.	The harness of the 12V or 24V power is short circuited. <ul style="list-style-type: none"> <li>Check if there is any abnormality, such as scratches or being caught on the harnesses of each board, and damage on the connector pins.</li> </ul>	<ul style="list-style-type: none"> <li>Replace the harness.</li> <li>Replace the switching regulator.</li> </ul>
4	The main power LED is not lit.	<ul style="list-style-type: none"> <li>Check if there is any abnormality in the power cable.</li> <li>Check if there is any abnormality such as scratches or being caught on the harnesses for the inlet or the power button.</li> <li>Check if the fuse (F1) for the switching regulator are cut.</li> <li>Check if the harness for the switching regulator is inserted properly.</li> </ul>	<ul style="list-style-type: none"> <li>Replace the power cable.</li> <li>Replace the harnesses for the inlet, power button and the switching regulator.</li> <li>Replace the switching regulator.</li> </ul>
5	The main power LED is lit.	Check the voltage of the power supply connectors (CN105, CN136) on the SYS board. <ul style="list-style-type: none"> <li>The voltage of CN105 1-pin is lower than 8 V and that for 4-pin is lower than 8.4 V.</li> <li>The voltage of CN136 4-pin is 0 V, that for CN105 1-pin is 10.8 V or more and that for CN105 4-pin is 0 V.</li> </ul>	Replace the switching regulator.
		Check the voltage of the power supply connectors (CN105, CN135) on the SYS board. <ul style="list-style-type: none"> <li>The voltage of CN105 1-pin is 8 V or more, that for CN105 4-pin is 8.4 V or more and that for CN135 4-pin is 8.4 V or more.</li> </ul>	Replace the SYS board.
6	Power supply failed at warming up. (The main power lamp is lit.)	Check if there is any abnormality in the fuser unit. <ul style="list-style-type: none"> <li>Check if there is any abnormality in the terminal of the connector.</li> <li>Check if there is any abnormality in the installation of the thermistor or no foreign matter adhering.</li> </ul>	<ul style="list-style-type: none"> <li>Repair the defective portions of the fuser unit.</li> <li>Replace the fuser unit.</li> </ul>
		Check if there is any abnormality in the LGC board. <ul style="list-style-type: none"> <li>Check if the connector of the LGC board is disconnected, is soldered on the board firmly or its pins are damaged.</li> </ul>	<ul style="list-style-type: none"> <li>Replace the harness.</li> <li>Replace the LGC board.</li> </ul>
		Check if there is any abnormality in the switching regulator.	Replace the switching regulator.

	Symptom	Check item	Measures
7	Power supply failed when the motor rotates. Power supply failed when the cover is closed.	Check if there is any abnormality in the motor. <ul style="list-style-type: none"> <li>Check if there is any abnormality which makes the motor disable to rotate.</li> <li>Check if there is any abnormality such as scratches or being caught on the harness of the motor.</li> </ul>	Release the problems or replace the motor and harness.
		Check if there is any abnormality in the options. <ul style="list-style-type: none"> <li>Check if the problem is released when disconnecting the option.</li> </ul>	Check if there is any abnormality in the disconnected option and release the problems.
8	Power supply failed when the ADU is opened and closed.	Check if there is any abnormality such as scratches or being caught on the harness for the ADU hinge.	Replace the harness.
9	Power supply failed when the DF is opened and closed.	<ul style="list-style-type: none"> <li>Check if there is any abnormality such as scratches or being caught on the harness for the DF and the scanner.</li> <li>Check if there is any abnormality such as scratches or being caught on the harness between the SYS board and the scanner. Check if there is any abnormality in the connector pins.</li> </ul>	Replace the harness.
10	The MFP is rebooted.	An error has occurred. (Depending on the error, the MFP will reboot at its first time and then a service call will happen at its second time.)	<ul style="list-style-type: none"> <li>Check the error code and solve the problem.</li> <li>Replace the SYS board.</li> </ul>

Parts to be replaced	Remarks
Power cable	
Switching regulator	
Fuser unit	
SYS board	
LGC board	
Harnesses	

## 8.4.10 “Authentication Failed” displayed

- Reset the service password.  
Reset the service password by accessing [USER FUNCTIONS] > [ADMIN] > [GENERAL] > [PASSWORD SETUP] > [RESET SERVICE PASSWORD].
- Initialize the SRAM.  
Refer to  P. 9-28 “9.2.5 Precautions and procedure when replacing the SRAM”, and perform “[D] Initialize SRAM system storage area” and following steps.
- Replace the SRAM.  
Refer to  P. 9-28 “9.2.5 Precautions and procedure when replacing the SRAM”, and replace the SRAM board.

## 8.4.11 Error code “M00” displayed while updating firmware

Check item	Measures
SYS board	<ul style="list-style-type: none"> <li>• Connector check (CN133, CN132)</li> <li>• Harness check</li> <li>• Open circuit or short circuit check</li> </ul>
LGC board	<ul style="list-style-type: none"> <li>• Connector check (CN330, CN329, CN314)</li> <li>• Harness check</li> <li>• Open circuit or short circuit check</li> </ul>
LVPS board	Connector check (CN512)

Parts to be replaced	Remarks
SYS board	
LGC board	
LVPS board	
Harness	

## 8.4.12 “Cover Open” remains displayed

Check item	Measures
Front cover	<ul style="list-style-type: none"> <li>• Check if the front cover is closed appropriately.</li> <li>• Check if the interlock switch (SW2) is working properly when the front cover is closed.</li> </ul>
Automatic Duplexing Unit	<ul style="list-style-type: none"> <li>• Check if the Automatic Duplexing Unit is closed appropriately.</li> <li>• Check if the interlock switch (SW3) is working properly when the Automatic Duplexing Unit is closed.</li> </ul>
LGC board	Replace the LGC board.
Switching regulator	Replace the switching regulator.

Parts to be replaced	Remarks
LGC board	
Switching regulator	

## 8.4.13 “Fax line1 is out of order.” or “Fax line2 is out of order.” displayed

1. Turn the power OFF and then back ON.
2. Replace the fax board.

## 8.4.14 “Latch the developer unit” remains displayed

After the power is turned ON, “Latch the developer unit” is displayed on the LCD screen. This display is not changed even if the developer unit is removed and then installed.

Step	Check item	Measures
1	Installation state of the developer unit	<ul style="list-style-type: none"> <li>Remove and install the developer unit. Close the front cover.</li> <li>Check if the drawer connector is connected securely or its pins are not deformed.</li> </ul>
2	Change in the display	Check if the display is changed when the power is turned OFF and then back ON. If an error indication is displayed, perform its troubleshooting in accordance with its procedure.
3	SYS board	<ul style="list-style-type: none"> <li>Connector check (CN132)</li> <li>Harness check</li> <li>Open circuit or short circuit check</li> </ul>
4	LGC board	<ul style="list-style-type: none"> <li>Connector check (CN310)</li> <li>Harness check</li> <li>Open circuit or short circuit check</li> </ul>
		<ul style="list-style-type: none"> <li>Connector check (CN319)</li> <li>Harness check</li> <li>Open circuit or short circuit check</li> </ul>
		<ul style="list-style-type: none"> <li>Connector check (CN313)</li> <li>Harness check</li> <li>Open circuit or short circuit check</li> </ul>
5	EPU board	<ul style="list-style-type: none"> <li>Connector check (CN451, CN453)</li> <li>Harness check</li> <li>Open circuit or short circuit check</li> </ul>
6	Flat cable	Check if there is any abnormality in the terminal of the flat cable between the SYS and LGC boards. Check if the flat cable is open circuited.
7	Harness	Check if there is a short circuit or open circuit in the harness (CN313) for connecting the LGC board and the developer unit whose display is not changed.

Parts to be replaced	Remarks
Flat cable	
SYS board	
LGC board	
EPU board	
Developer unit	

## 8.4.15 DSDF

### [ 1 ] Misdetection of the original size in the DSDF

Classification	Error content
DSDF	Original size misdetection

Check item	Measures
DSDF tray original length sensor-1	<ul style="list-style-type: none"> <li>Check that the sensor is working properly. (Input check: FS-03-[F2]ON/[7]/[A])</li> <li>Check that the actuator is working properly.</li> <li>Connector check (CN970, CN76)</li> <li>Harness check</li> <li>Check if the sheet attached to the sensor is warped.</li> <li>Replace the sensor.</li> </ul>

Check item	Measures
DSDF tray original length sensor-2	<ul style="list-style-type: none"> <li>Check that the sensor is working properly. (Input check: FS-03-[F2]ON/[8]/[D])</li> <li>Check that the actuator is working properly.</li> <li>Connector check (CN971, CN76)</li> <li>Harness check</li> <li>Check if the sheet attached to the sensor is warped.</li> <li>Replace the sensor.</li> </ul>
DSDF tray original width sensor	<ul style="list-style-type: none"> <li>Check that the sensor is working properly. (Input check: FS-03-[F2]ON/[8]/[A][B][C])</li> <li>Replace the sensor.</li> </ul>
Contact point leaf spring of the DSDF tray original width sensor	Replace the contact point leaf spring of the DSDF tray original width sensor.

Parts to be replaced	Remarks
DSDF tray original length sensor-1	
DSDF tray original length sensor-2	
DSDF tray original width sensor	
Contact point leaf spring of the DSDF tray original width sensor	

## 8.4.16 Inner Finisher

### [ 1 ] Movable tray full still persists even after the paper has been removed.

Classification	Error content
Finisher related alarm	The movable tray is full of paper.

Check item	Measures
Paper	Remove all of paper on the movable tray.
Movable tray lower limit sensor (S14)	Measure the voltage of TP17 on the finisher control PC board (FIN). Then check that the measured voltage is 1 V or lower when not shielded and within the range of 3.3 V $\pm$ 5% when shielded. If the voltage does not fall within the mentioned range, replace the sensor.
Movable tray paper exist sensor (S9)	Measure the voltage of TP8 on the finisher control PC board (FIN). Then check that the measured voltage is 1 V or lower when not shielded and within the range of 3.3 V $\pm$ 5% when shielded. If the voltage does not fall within the mentioned range, replace the sensor.
Cables and connectors	Check that the current flows between the connector terminals. If not, replace the cables. (Finisher control PC board (FIN): CN6)
Finisher control PC board (FIN)	If the error still persists after replacing the sensors and the connectors, exchange the finisher control PC board (FIN).

Parts to be replaced	Remarks
Movable tray lower limit sensor (S14)	
Movable tray paper exist sensor (S9)	
Finisher control PC board (FIN)	
Cables	



## 8.4.17 The drawer is not automatically inserted

### [ 1 ] 1st and 2nd drawers

- (1) Perform the operation described in the following reference.  
📖 P. 4-100 “4.5.46 Operation when replacing the soft-close unit for the first time”
- (2) Replace the soft-close unit.  
📖 P. 4-99 “4.5.44 1st drawer soft-close unit (3528A/4528A)”  
📖 P. 4-99 “4.5.45 2nd drawer soft-close unit (3528A/4528A)”

### [ 2 ] 3rd and 4th drawers

- (1) Perform the operation when replacing the soft-close unit for the first time.
  1. Remove 1 screw [1] and take off the paper feed cover [2] of the PFP.
  2. Insert the drawer with the soft-close unit replaced all the way in.
  3. Check if the drawer is automatically inserted by removing and then reinstalling it again.
- (2) Replace the soft-close unit.

## 8.4.18 Troubleshooting for operation abnormality

When a power failure has occurred, the storage device of the MFP will be damaged and thus a display or operation abnormality may occur. In such a case, recover the operation by performing the following items.

Check item	Measures
Storage device	Perform the following self-diagnostic code is to check if there is any abnormality in the storage device. If there is any abnormality, replace it. <ul style="list-style-type: none"><li>• Standard storage device: FS-08-9008-1</li><li>• Optional storage device: FS-08-9008-2</li></ul>
Firmware updating	Update the firmware to check that the problem is solved. <ul style="list-style-type: none"><li>• System firmware</li><li>• System software</li><li>• Engine firmware</li><li>• Scanner firmware</li></ul>
Storage device initialization	Initialize the storage device to check that the problem is solved. <b>Notes:</b> <ul style="list-style-type: none"><li>• Check the backup data in advance. Back up the data if you do not have them.</li><li>• After the initialization, reattempt the necessary settings.</li></ul>
Initialize SRAM	Initialize the SRAM to check that the problem is solved. <b>Notes:</b> <ul style="list-style-type: none"><li>• Check the backup data in advance. Back up the data if you do not have them.</li><li>• After the initialization, reattempt the necessary settings.</li></ul>

## 8.4.19 The [ON/OFF] button does not work

If the MFP cannot be shut down by pressing the [ON/OFF] button when an abnormality has occurred, perform the following steps.

- (1) Press the [ON/OFF] button for a few seconds to forcibly shut the MFP down.
- (2) If the forcible shutting down in Step (1) is not possible, disconnect the power plug from the outlet.

### Remarks:

- If the power plug has been disconnected from the outlet, check that the MFP is started normally the next time the power is turned ON.
- If an error has occurred when the MFP is started, follow its troubleshooting procedure.
- If any abnormality has occurred when the MFP is started, check the switching regulator. Replace the switching regulator if there is any abnormality in it.

## 8.5 Troubleshooting for the Image

### 8.5.1 Poor image density and gray balance

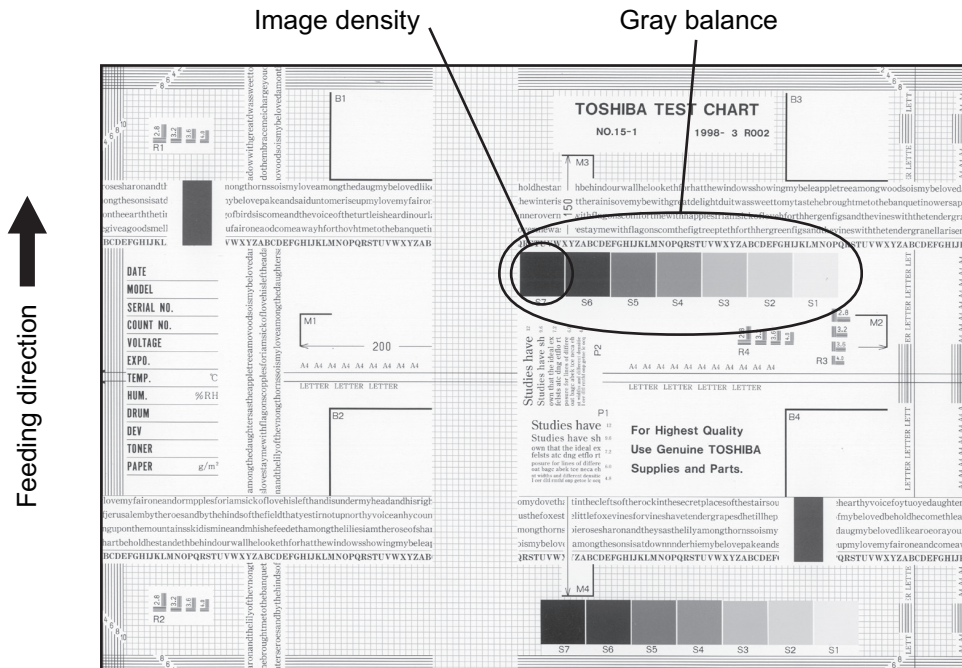

Fig.8-33

Cause/Section	Step	Check item	Measures
Density, gray balance	1	Check the image density and gray balance.	Perform the density adjustment.
Printing section	2	Check printed images of 04-114 (test print).	Go to step 4 if an abnormality occurs.
Scanner	3	Check if the original glass, mirrors or lens is dirty.	Clean them.
Printed images abnormality	4	Has any faded image (low density) occurred?	Perform the troubleshooting against the faded image.
	5	Has background fogging occurred?	Perform the troubleshooting against the background fogging.
	6	Has blotch image occurred?	Perform the troubleshooting against the blotch image.
	7	Has poor transfer occurred?	Perform the troubleshooting against the poor transfer.

## 8.5.2 Background fogging

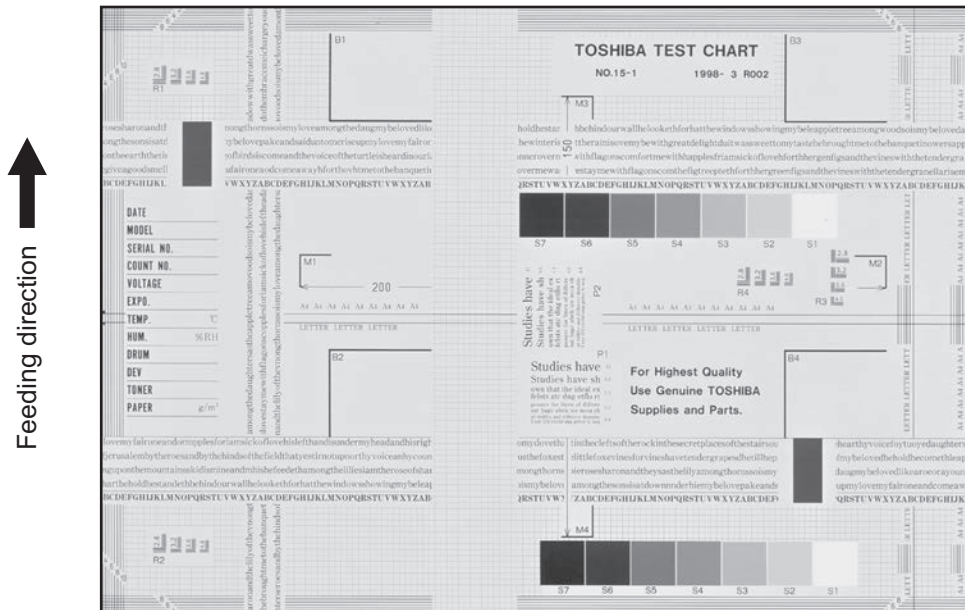

Fig.8-34

Cause/Section	Step	Check item	Measures
Adjustment	1	Perform the shading correction.	Perform FS-05-3218. If an error has occurred, reattempt it. If the error still persists, clean the original glass covering the shading correction plate and perform FS-05-3218 again.
Density reproduction	2	Poor density reproduction	Perform the density adjustment.
Background reproducibility	3	Poor background reproduction	Perform the background adjustment.
Printing section	4	Check printed images of 04-114 (test print).	Go to step 5 if an abnormality occurs.
Scanner	5	Check if the original glass, DF original glass, mirrors or lens is dirty.	Clean them.
Auto-toner	6	Does the auto-toner sensor work properly?	Check the performance of the auto-toner sensor and readjust it if necessary.
	7	Is the toner supply operating constantly?	Check the motor and circuits.
High-voltage transformer (Main charger bias, developer bias)	8	Is the high-voltage transformer output defective?	Adjust the output or replace the high-voltage transformer.
Developer unit	9	Is the contact between the drum and developer material proper?	Adjust the doctor-to-sleeve gap and pole position.
Developer material, toner, drum	10	Are the specified developer material, toner and drum used?	Use the specified developer material, toner and drum.
	11	Have the developer material and drum reached their PM life?	Replace the developer material and drum.
	12	Is the storage environment of the toner cartridge 35°C or less without dew?	Use the toner cartridge stored in the environment within specifications.

Cause/Section	Step	Check item	Measures
Drum cleaning blade	13	Is the cleaning carried out properly?	Check the pressure of the drum cleaning blade.
Toner dusting	14	Is the toner accumulated on the seals of the developer unit?	Remove the toner and clean the seals.

### 8.5.3 Moiré, lack of sharpness

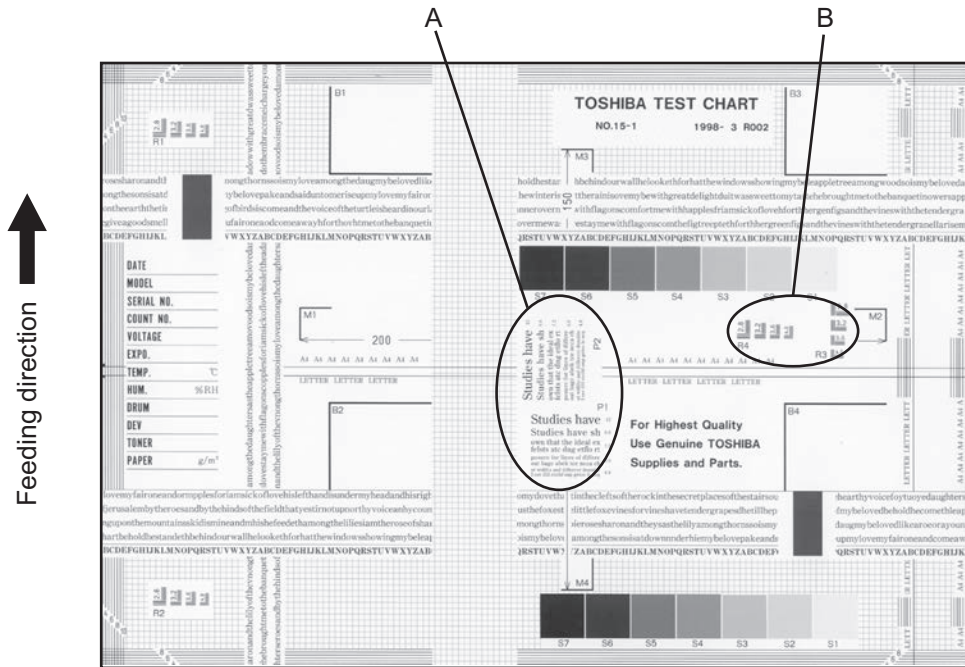

Fig.8-35

#### Moiré

Cause/Section	Step	Check item	Measures
Density reproduction	1	Poor density reproduction	Perform the density adjustment.
Parameter adjustment value	2	Check the image processing parameters.	Check the sharpness adjustment value.
Printing section	3	Check printed images of 04-114 (test print).	When defects occur, perform the corresponding troubleshooting procedures.

#### Lack of sharpness

Cause/Section	Step	Check item	Measures
Density reproduction	1	Poor density reproduction	Perform the density adjustment.
Parameter adjustment value	2	Check the image processing parameters.	Check the sharpness adjustment value.
Printing section	3	Check printed images of 04-114 (test print).	When defects occur, perform the corresponding troubleshooting procedures.
	4	Adjust the image processing parameters.	While checking the above encircled image A, increase sharpness by sharpness adjustment.

## 8.5.4 Toner offset

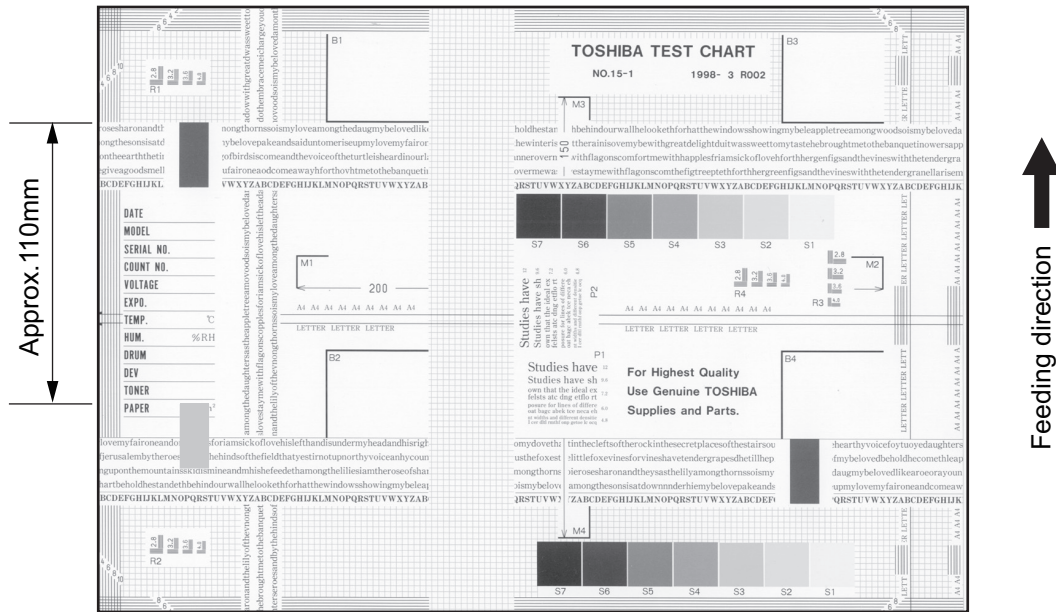

Fig.8-36

Toner offset: A shadow image appears approx. 110 mm behind the high density image.

Cause/Section	Step	Check item	Measures
Density	1	Is the density too high?	Perform the density adjustment.
Fuser unit	2	Is the pressure of the heat roller normal?	Check the pressure release parts and the pressure mechanism.
	3	Is the thermistor in the contact properly?	Contact the thermistor properly.
	4	Are there any scratches on the heat roller surface?	Replace the heat roller.
	5	Has the heat roller reached its PM life?	Replace the heat roller.
	6	Is the setting temperature of the heat roller normal?	Check the setting and correct it. (FS-08-2120, 2010, 2009, 2140, 2100, 2101, 5285 (35/45/50 ppm only))
	7	Check the conduction between the fuser unit entrance guide and the registration roller on the MFP side.	Check if the power supply metal plate of the fuser unit is installed properly.
	Paper	8	Is the paper mode proper?
9		Is the setting temperature of the heat roller of each paper mode normal?	Check the setting and correct it. (FS-08-2028, 2049, 2050, 2051, 2141, 2142, 2143, 2192, 2194, 2195) (FS-08-5328, 5329, 5330, 5331, 5332: 35/45/50 ppm only)
10		Is the non-recommended paper used?	Use the recommended paper.
Developer material	11	Is the specified developer material used?	Use the specified developer material and toner.

Cause/Section	Step	Check item	Measures
Scanner	12	Check if the original glass, mirrors, lens or shading correction plate position of the original glass is dirty.	Clean them.
Power source	13	Is the power supplied to heater lamp normally? Check if there is no abnormality in the switching regulator.	Replace the switching regulator.

## 8.5.5 Toner offset (shadow image) at the edges

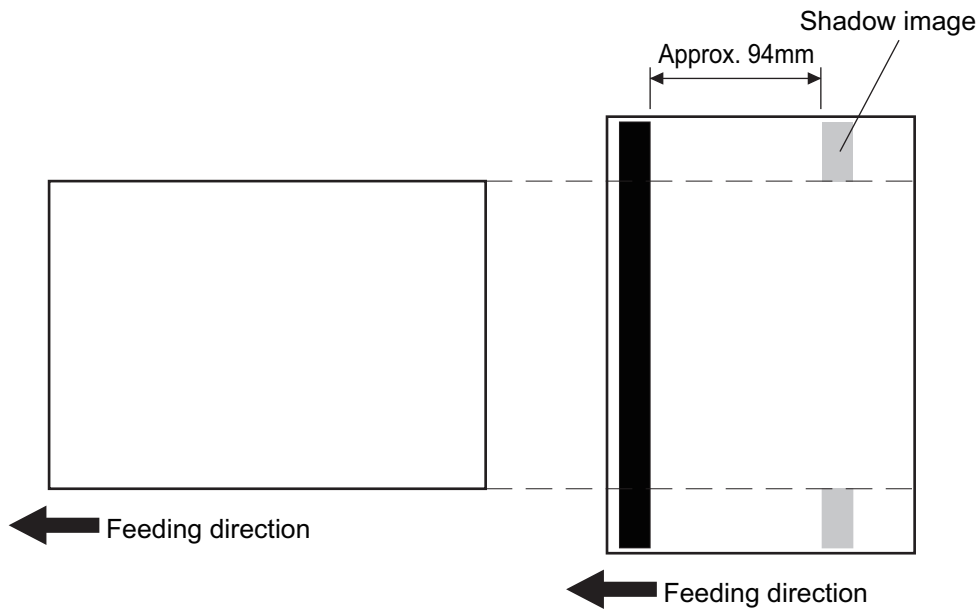

Fig.8-37

Toner offset (shadow image) sometimes appears at both edges of the paper when a wide-size sheet is printed following the continuous printing of narrow-size ones or rotate sort-printing. In such a case, change the setting of Wait between the printings of narrow-size and wide-size paper.

### Notes:

When the setting is changed, toner offset (shadow image) can be reduced; however, the performance (printing speed) will also be lowered accordingly. Therefore, the setting should only be changed depending on the occurrence frequency or corresponding to users' requests.

#### 1. Combined job

Code	Recommended setting value	Remarks
FS-08-5455	5	Wait is carried out with a small number of sheets.
FS-08-5456-0	45	Extend the wait time.
FS-08-5456-1	45	
FS-08-5456-2	45	

#### 2. To insert the Ready state between jobs

Code	Recommended setting value	Remarks
FS-08-2074	3	Extend the wait time.



## 8.5.6 Blurred image

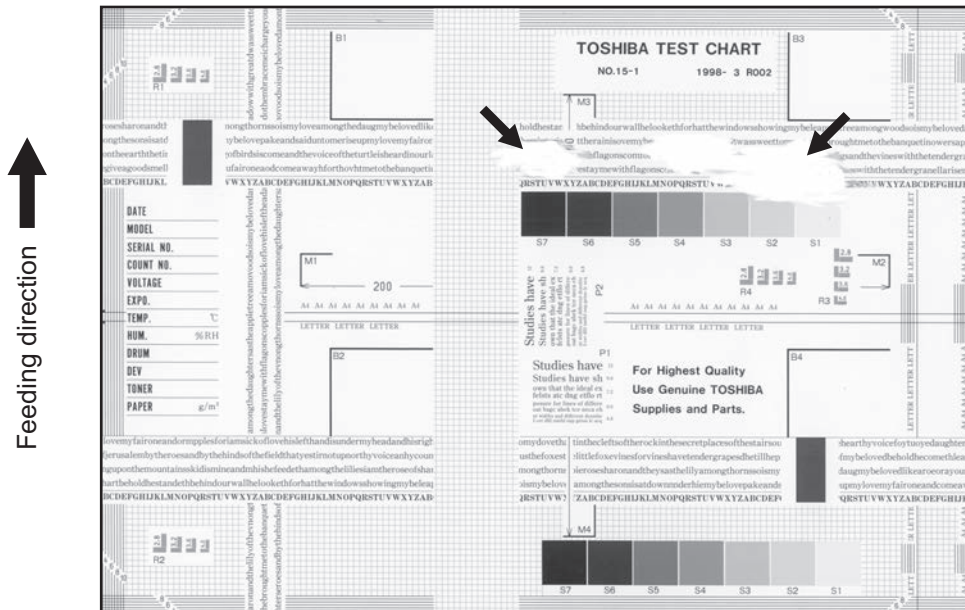

Fig.8-38

Cause/Section	Step	Check item	Measures
Paper	1	Is paper in the drawer or LCF damp?	Change the paper. Do not keep paper in a humid place.
Bedewing of scanner	2	Is the scanner bedewed?	Clean the scanner.
Drum	3	Is the drum bedewed or dirty?	Wipe the drum with a dry cloth. <b>Notes:</b> Do not use alcohol or other organic solvents or silicon oil as they will have an adverse effect on the drum.
Ozone exhaust	4	Does the ozone exhaust fan operate?	Check the connection of the connector. Replace the ozone exhaust fan.
	5	Is the ozone filter stained or damaged?	Replace the ozone filter.

## 8.5.7 Poor fusing

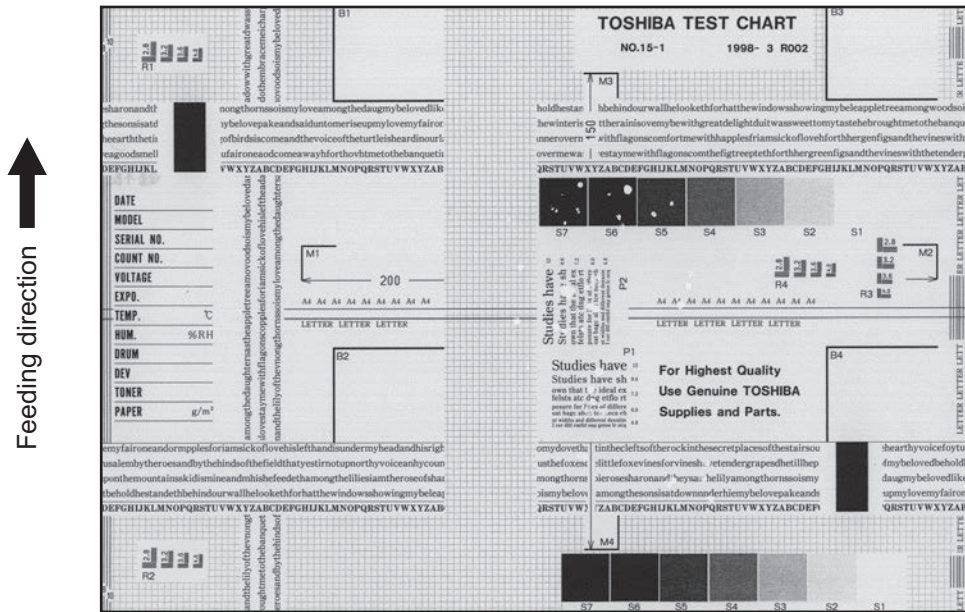

Fig.8-39

Cause/Section	Step	Check item	Measures
Heater electric power abnormality	1	Is the terminal contact normal?	Correct it.
	2	Is the heater short circuited or open circuited?	Replace the heater.
Insufficient pressure to the heat roller	3	Is the pressure spring working properly?	Check the pressure spring and correct it.
Heat roller temperature	4	Is the temperature of the heat roller normal?	Check the setting and correct it. FS-08-2120, 2010, 2009, 2140, 2100, 2101, 5285 (35/45/50 ppm only)
Developer material, toner	5	Are the specified developer material and toner used?	Use the specified developer material and toner.
Paper	6	Is paper in the drawer or LCF damp?	Do not keep paper in a humid place.
	7	Is the paper type corresponding to its mode?	Use the proper type of paper or select the proper mode.
	8	Is the setting temperature of the heat roller of each paper mode normal?	Check the setting and correct it. FS-08-2028, 2049, 2050, 2051, 2141, 2142, 2143, 2192, 2194, 2195 (FS-08-5328, 5329, 5330, 5331, 5332: 35/45/50 ppm only)
	9	Is the non-recommended paper used?	Use the recommended paper.
Power source	10	Is the power supplied to heater lamp normally? Check if there is no abnormality in the switching regulator.	Replace the switching regulator.

## 8.5.8 White copy



Fig.8-40

Cause/Section	Step	Check item	Measures
Transfer roller unit	1	Is the spring for supplying power of the transfer roller attached properly?	Check the spring for supplying power and set it correctly.
High-voltage transformer (Transfer bias, developer bias)	2	Is the high-voltage transformer output defective?	Adjust the output or replace the high-voltage transformer.
	3	Is the connector of the high-voltage harness securely connected? Is the harness open circuited?	Reconnect the connectors securely. Replace the high-voltage harness.
Developer unit	4	Is the developer unit installed securely?	Check the engagement of the gears of the developer unit and set them correctly.
	5	Does the developer sleeve and mixer rotate?	Check and correct the developer drive system.
	6	Is the developer material transported properly?	Remove foreign matters from the developer material if there are any.
	7	Is there any magnetic brush phase error?	Adjusts the developer pole position.
	8	Is the position of the doctor blade correct?	Adjust it with the doctor-sleeve-jig.
Drum	9	Does the drum rotate properly?	Check the drum drive system.
CCD board, SYS board, LGC board, harnesses	10	Are the connectors securely connected? Is any harness between the boards open circuited?	Reconnect the connectors securely. Replace the harness.

## 8.5.9 Solid copy



Fig.8-41

Cause/Section	Step	Check item	Measures
Exposure lamp	1	Does the exposure lamp light?	Check if the connector contacts with the exposure lamp terminal. Replace the defective lamp.
Scanner	2	Is there any foreign matter in the optical path?	Remove it.
Bedewing of scanner and drum	3	Is the scanner or drum bedewed?	Clean the mirrors, lens and drum. Keep the power cable plugged.
Main charger	4	Is the main charger installed securely?	Reinstall it securely.
	5	Is the needle electrode broken?	Replace the needle electrode.
High-voltage transformer (Main charger)	6	Is the high-voltage transformer output defective?	Adjust the output or replace the high-voltage transformer.
	7	Is the connector of the high-voltage harness securely connected? Is the harness open circuited?	Reconnect the connectors securely. Replace the high-voltage harness.
CCD board, SYS board, LGC board, harnesses	8	Are the connectors securely connected? Is any harness between the boards open circuited?	Reconnect the connectors securely. Replace the harness.

## 8.5.10 White banding and white void (in the feeding direction)

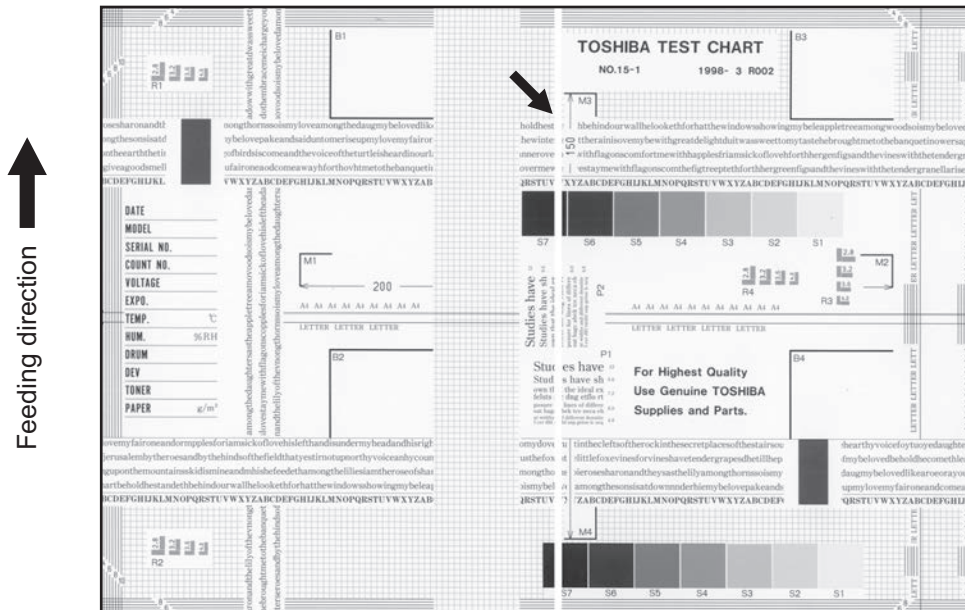

Fig.8-42

Cause/Section	Step	Check item	Measures
Laser optical unit	1	Is there any foreign matter or dirt in the slit glass?	Remove the foreign matter or stain.
Main charger grid	2	Is there any foreign matter on the main charger grid?	Remove the foreign matter.
Toner cartridge	3	Is the adhered foreign matter blocking the laser light path?	Remove the foreign matter.
Developer unit	4	Is the floated lid of the developer bottle blocking the laser light path?	Check the lid and place it properly
	5	Is the transport of the developer material poor?	Remove foreign matters from the developer material if there are any. *1)
	6	Is there a foreign matter or dew on the drum seal?	Remove the foreign matter or dew.
	7	Is the upper drum seal of the developer unit in contact with the drum?	Correct the position of the drum seal or replace it.
Drum	8	Is there a foreign matter on the drum surface?	Replace the drum. If there is a convex foreign matter adhering to the drum surface, it indicates that the blade edge at this area is worn out. In this case, replace both the drum and the drum cleaning blade.
Transport path	9	Does the toner image contact with any foreign matter before the paper enters the fusing section after the separation?	Remove the foreign matter.
Discharge LED	10	Has any of the discharge LEDs gone out?	Replace the discharge LED.

Cause/Section	Step	Check item	Measures
Scanner	11	Is there a foreign matter on the optical path?	Remove the foreign matter.
	12	Check if the original glass, mirrors, lens or shading correction plate position of the original glass is dirty.	Clean them.
Cleaner	13	Is there any foreign matter, which contacts the drum on the cleaner stay?	Remove the foreign matter.

\*1) Prescription for foreign matter in the doctor sleeve gap

- Pull the doctor blade in the direction of the arrow.
- Rotate the gear.
- Remove the foreign matter that has come out on the developer sleeve.

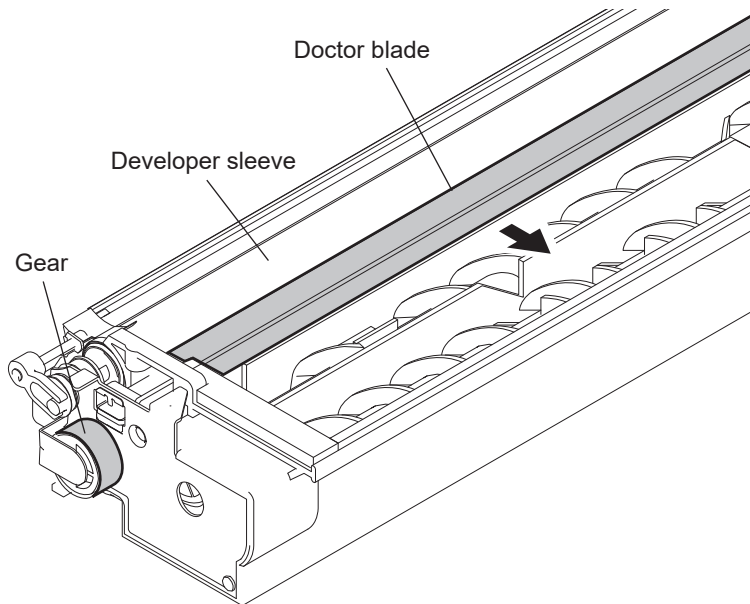

Fig.8-43

## 8.5.11 White banding (at right angles to the feeding direction)

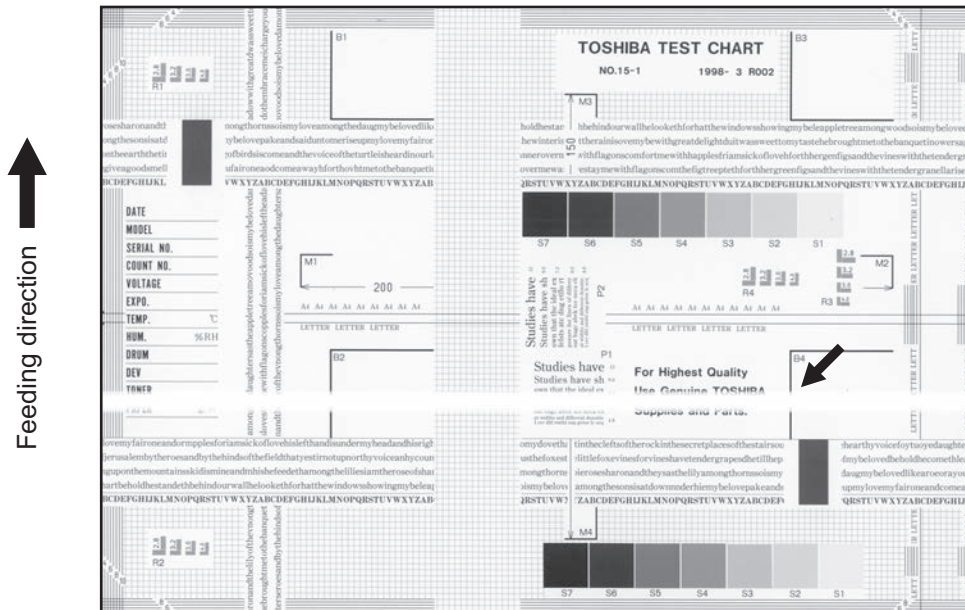

Fig.8-44

Cause/Section	Step	Check item	Measures
Main charger	1	Is there any foreign matter on the main charger?	Remove the foreign matter.
	2	Is the terminal contact normal?	Clean or adjust the terminals.
Drum	3	Are there any abnormalities on the drum surface?	Replace the drum.
Discharge LED	4	Is the discharge LED lit properly?	Replace the discharge LED or check the harness and the circuit.
Developer unit	5	Does the developer sleeve rotate properly? Are there any abnormalities on the developer sleeve surface?	Check the developer drive system or clean the developer sleeve surface.
Drive system	6	Does the drum or scanner synchronize correctly?	Check each drive system.
High-voltage transformer (Main charger bias, developer bias, transfer bias)	7	Is the high-voltage transformer output defective?	Adjust the output or replace the high-voltage transformer.
Transfer roller unit	8	Is there any foreign matter adhering to the transfer roller? Is there any abnormality in the appearance of the roller? Has the number of output pages exceeded the threshold for the life of the transfer roller?	Remove the foreign matter from the roller surface. Replace the roller if there is any abnormality in its appearance. Also replace the roller if the number of output pages has exceeded the threshold of its life.
Paper feeding section	9	Is the paper aligning amount proper?	Adjust the aligning amount.

## 8.5.12 Skew (slantwise copying)

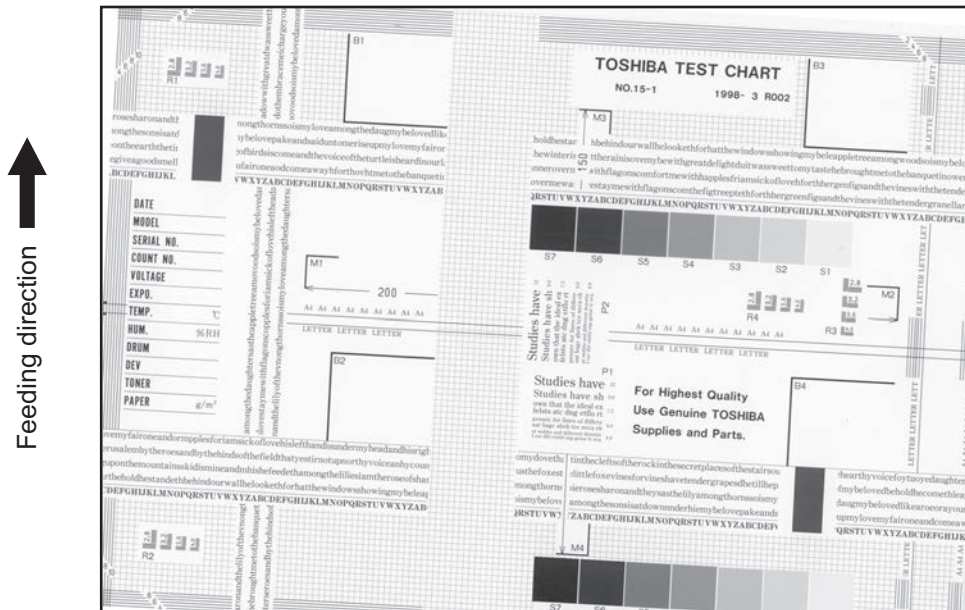

Fig.8-45

Cause/Section	Step	Check item	Measures
Setup condition (floor surface)	1	Check if the original glass is in the horizontal position.	Arrange the adjusters so that the original glass is in the horizontal position.
Drawer LCF	2	Is the drawer or LCF installed properly?	Reinstall the drawer or LCF properly.
	3	Is too much paper loaded in the drawer or LCF?	Reduce paper to 550 or fewer sheets in the drawer.  Reduce paper to 1,000 or fewer sheets in the feeding side tray and the standby side tray of LCF, respectively.
	4	Is the paper corner folded?	Change the paper direction and reinsert it.
	5	Are the side guides in the drawer or LCF set properly?	Adjust the position of the side guides.
	Paper feed roller	6	Is the surface of the paper feed roller dirty?
Rollers	7	Is each roller fixed to the shaft properly?	Check the E-rings, pins, clips and setscrews.
Registration roller	8	Is the spring of the registration roller removed?	Reattach the spring correctly. Clean the registration roller if it is dirty.
Pre-registration guide	9	Is the pre-registration guide installed properly?	Correct it.
Scanner	10	Is the carriage-1 tilted?	Adjust the carriage-1.
RADF, DSDf	11	Is the RADf or DSDf installed or adjusted properly?	Reinstall it. Readjust it.



## 8.5.13 Black banding (in the feeding direction)

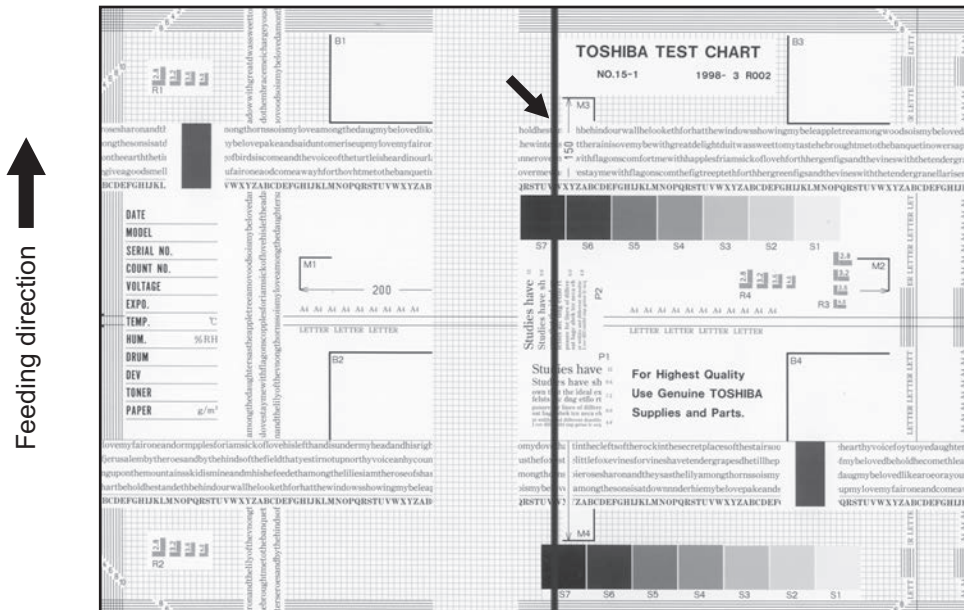

Fig.8-46

Cause/Section	Step	Check item	Measures
Scanner	1	Is there any foreign matter in the optical path?	Clean the slit, lens and mirrors.
	2	Is there dust or stain on the shading correction plate and the ADF original glass?	Clean them.
	3	Disconnect the harness from the connector of the CCD board. Check if there is any foreign matter on the terminals of the connector and the harness.	Clean the terminals of the connector and the harness with an air blower or a brush.
Main charger	4	Is there any foreign matter on the main charger grid?	Remove the foreign matter.
	5	Is the main charger grid dirty or deformed?	Clean or replace the main charger grid.
	6	Is there any foreign matter on the main charger?	Remove the foreign matter.
	7	Is the needle electrode dirty or deformed?	Clean or replace the needle electrode.
	8	Is there foreign matter inside the main charger case?	Remove the foreign matter.
	9	Is the inner surface of the main charger case dirty?	Clean its inside.
Cleaner	10	Is there paper dust sticking to the drum cleaning blade edge?	Clean or replace the drum cleaning blade.
	11	Is the drum cleaning blade working properly?	Check the pressure of the drum cleaning blade.
	12	Is toner recovery defective?	Clean the toner recovery auger section.
Paper dust holder	13	Check if paper dust is accumulated in the paper dust holder.	Take off the paper dust holder and clean it. (Remove the paper dust.)

Cause/Section	Step	Check item	Measures
Fuser unit	14	Is the heat roller surface dirty or damaged?	Clean or replace the heat roller.
	15	Is there any dirt on the thermistor?	Clean the thermistor.
Drum	16	Are there any scratches on the drum?	Replace the drum.
Laser optical unit	17	Is there any foreign matter or dirt in the slit glass?	Remove the foreign matter or stain.
SYS board	18	Disconnect the harness from the connector (between the SYS board and the CCD) of the SYS board. Check if there is any foreign matter on the terminals of the connector and the harness.	Clean the terminals of the connector and the harness with an air blower or a brush.

## 8.5.14 Black banding (at right angles to the feeding direction)

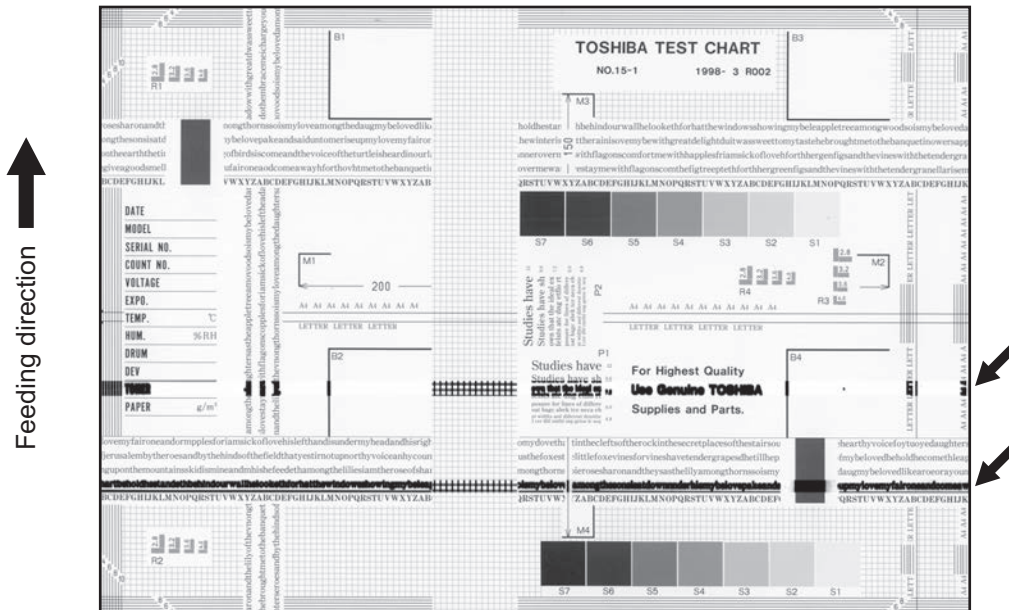

Fig.8-47

Cause/Section	Step	Check item	Measures
Main charger	1	Is the needle electrode dirty or deformed?	Clean or replace the needle electrode.
Fuser unit	2	Are the heat roller, separation finger and thermistor dirty?	Clean them.
High-voltage transformer (Main charger bias, developer bias, transfer bias)	3	Is the high-voltage transformer output defective?	Adjust the output or replace the high-voltage transformer.
Drum	4	Are there any deep scratches on the drum surface?	Replace the drum, especially if the scratches have reached the aluminum base.
	5	Are there any fine scratches (drum pitting) on the drum surface?	Check the contact of the cleaning blade and recovery blade and adjust it properly.
Scanner	6	Is there any foreign matter on the rail for the carriage?	Remove the foreign matter.

## 8.5.15 White spots



Fig.8-48

Cause/Section	Step	Check item	Measures
Developer unit Toner cartridge	1	Is the toner density of the developer material proper?	Check and correct the auto-toner sensor and toner supply operation. Check if the amount of the toner in the toner is sufficient.
	2	Is the doctor-sleeve gap proper?	Adjust the doctor-to-sleeve gap.
Developer material, toner, drum	3	Are the specified developer material, toner and drum used?	Use the specified developer material, toner and drum.
	4	Have the developer material and drum reached their PM life?	Replace the developer material and drum.
	5	Is the storage environment of the toner cartridge 35°C or less without dew?	Use the toner cartridge stored in the environment within specifications.
	6	Is there any dent on the drum surface?	Replace the drum.
	7	Is there any film forming on the drum surface?	Clean or replace the drum.
Main charger	8	Is there any foreign matter on the main charger?	Remove the foreign matter.
	9	Is the needle electrode dirty or deformed?	Clean or replace the needle electrode.
High-voltage transformer (Main charger bias, developer bias, transfer bias)	10	Is the high-voltage transformer output improper?	Adjust the output or replace the high-voltage transformer.

Cause/Section	Step	Check item	Measures
Transfer roller unit	11	Is there any foreign matter such as fiber in the paper transport area of the transfer roller unit and the separation needle?	Clean the transfer roller and the separation needle.
	12	Is there any foreign matter adhering to the transfer roller? Is there any abnormality in the appearance of the roller?	Clean the transfer roller and the separation needle.

### 8.5.16 Poor transfer

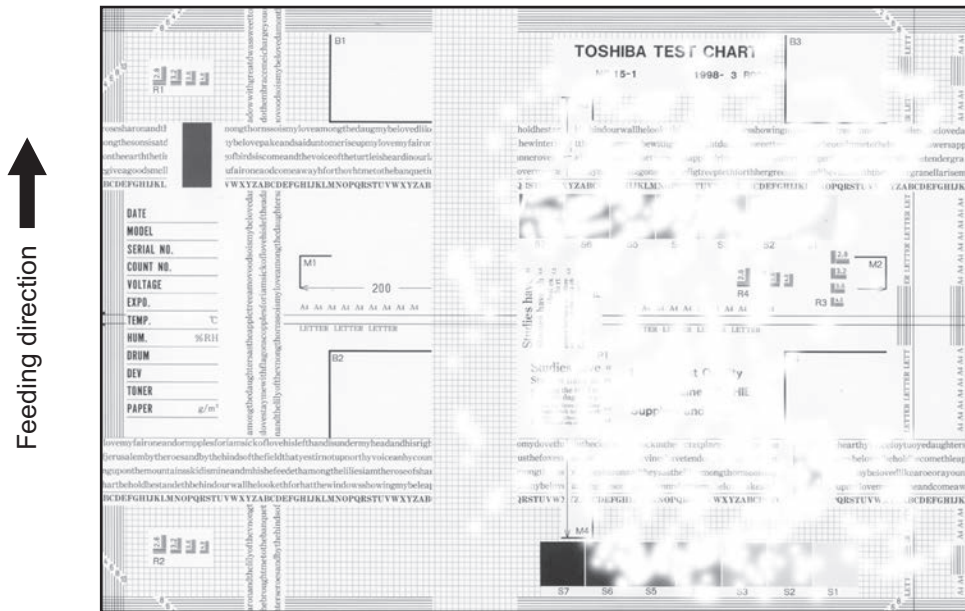

Fig.8-49

Cause/Section	Step	Check item	Measures
Paper	1	Is the paper in the drawer or LCF curled?	Reinsert paper with reverse side up or change paper.
	2	Is paper in the drawer or LCF damp?	Change the paper. Do not keep paper in a humid place.
	3	Is the paper type corresponding to its mode?	Select the correct paper mode.
	4	Is the non-recommended paper used?	Use the recommended paper.
Transfer roller unit	5	Is the transfer roller contacting with the drum? Are the charger pushing-spring and the transfer roller pressure spring installed properly?	Check and reinstall them correctly.
Registration roller	7	Is the registration roller malfunctioning?	Clean the roller if it is dirty. Reattach the spring if it has come off. Replace defective clutch-related parts. Readjust the rotation speed.
High-voltage transformer (transfer)	8	Is the high-voltage transformer output defective?	Adjust the output or replace the high-voltage transformer.

## 8.5.17 Uneven image density

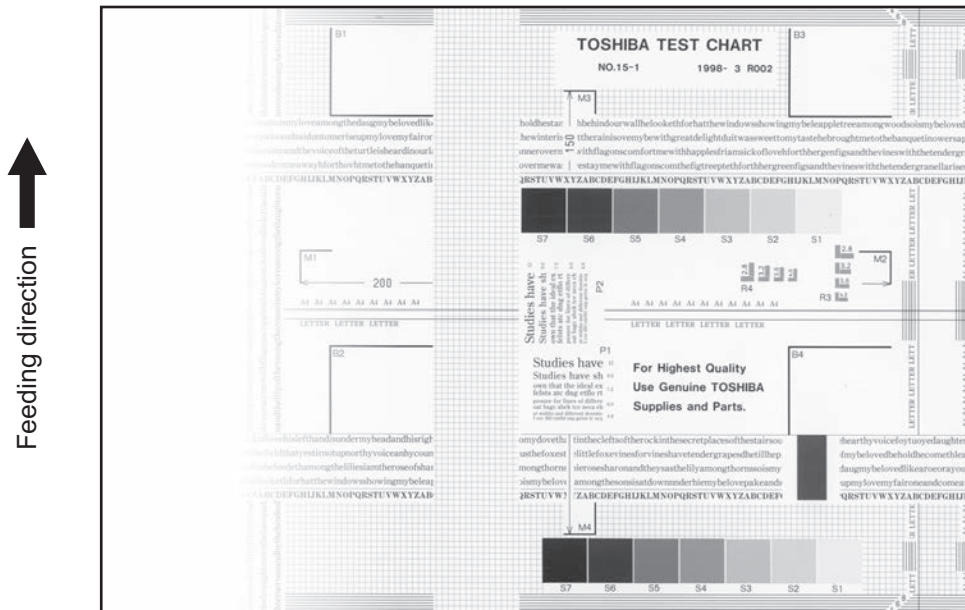

Fig.8-50

Cause/Section	Step	Check item	Measures
Main charger	1	Is the main charger dirty?	Clean the main charger or replace the needle electrode or the main charger grid.
Transfer roller unit	2	Is the transfer roller contacting with the drum? Are the charger pushing-spring and the transfer roller pressure spring installed properly?	Check and reinstall them correctly.
Laser optical unit	3	Is there any foreign matter or dirt in the slit glass?	Remove the foreign matter or stain.
Discharge LED	4	Are the connectors of discharge LED harness securely connected?	Reconnect the connectors securely.
	5	Is the discharge LED dirty?	Clean the discharge LED.
	6	Has any of the discharge LEDs gone out?	Replace the discharge LED.
Developer unit	7	Is the magnetic brush in proper contact with the drum?	Adjust the doctor-to-sleeve gap.
	8	Is the developer unit pressure spring applying properly?	Check the pressure mechanism.
	9	Is the transport of the developer material poor?	Remove foreign matters from the developer material if there are any.
Scanner	10	Is the original cover or RADF open?	Close the original cover or RADF.
	11	Check if the original glass, mirrors, lens or shading correction plate position of the original glass is dirty.	Clean them.

## 8.5.18 Faded image (low density, abnormal gray balance)

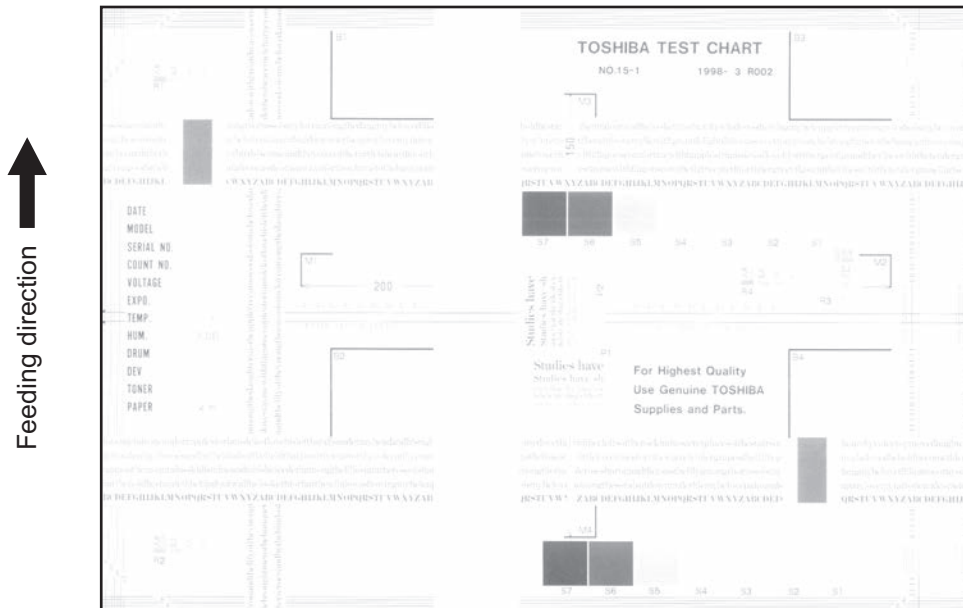

Fig.8-51

Cause/Section	Step	Check item	Measures
Toner empty	1	Is the "ADD TONER" symbol blinking?	Replace the toner cartridge.
Auto-toner circuit	2	Is there enough toner in the toner cartridge?	Check the auto-toner circuit function.
	3	Is the toner density of the developer material too low?	
Toner motor	4	Does the toner motor operate properly?	Check the toner motor and its drive circuits.
Toner cartridge	5	Is there any abnormality in the toner cartridge?	Replace the toner cartridge.
Developer material	6	Has the developer material reached its PM life?	Replace the developer material.
Developer unit	7	If the magnetic brush in proper contact with the drum?	Check the installation of the developer unit. Adjust the doctor-to-sleeve gap and pole position.
	8	Is the developer sleeve pressure spring applying properly?	Check the pressure mechanism.
Main charger	9	Is the main charger dirty?	Clean the main charger or replace the needle electrode or the main charger grid.
Drum	10	Is there any film forming on the drum surface?	Clean or replace the drum.
	11	Has the drum reached its PM life?	Replace the drum.
Transfer roller unit	12	Is the spring for supplying power of the transfer roller attached properly?	Check the spring for supplying power and set it correctly.

Cause/Section	Step	Check item	Measures
High-voltage transformer	13	Is the high-voltage transformer setting improper?	Adjust the high-voltage transformer output.
	14	Is the connector of the high-voltage harness securely connected? Is the harness open circuited?	Reconnect the connectors securely. Replace the high-voltage harness.
Discharge LED	15	Are the connectors of discharge LED harness securely connected?	Reconnect the connectors securely.



## 8.5.19 Image dislocation in leading edge

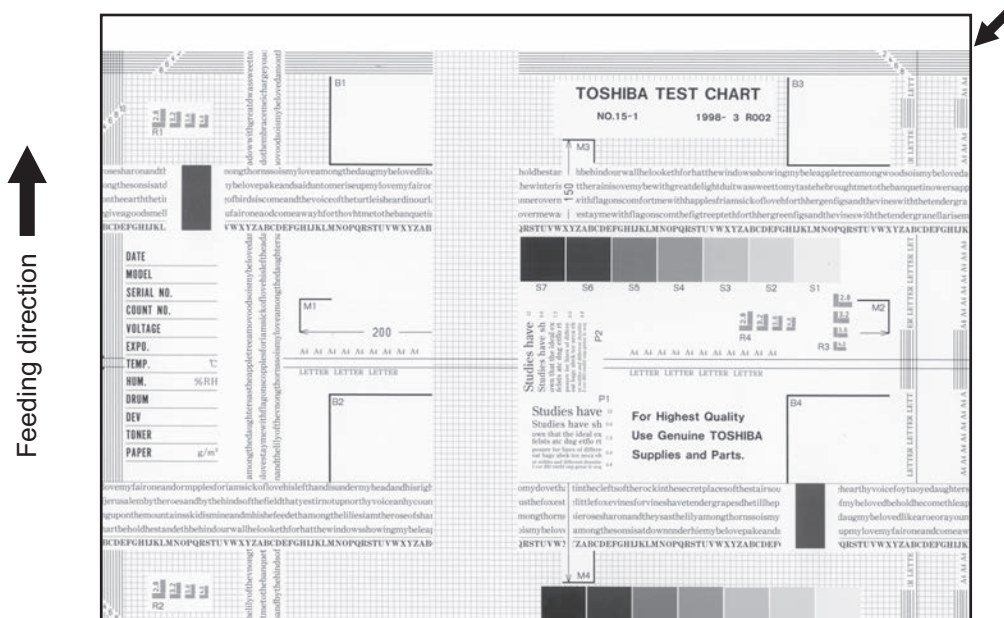

Fig.8-52

Cause/Section	Step	Check item	Measures
Adjustment error of scanner or printer section	1	Is the same dislocation on every copy?	Adjust the leading edge position using the Adjustment Mode.
Registration roller	2	Is the registration roller dirty or is the spring removed?	Clean the registration roller with alcohol. Reattach the spring correctly.
	3	Does the registration roller work properly?	Adjust or replace the registration roller if the gears are not engaged properly.
Paper feed clutch	4	Does the paper feed clutch work properly?	Check the circuit and the paper feed clutch and replace them if necessary.
Pre-registration guide	5	Is the pre-registration guide installed properly?	Correct it.

## 8.5.20 Image jittering

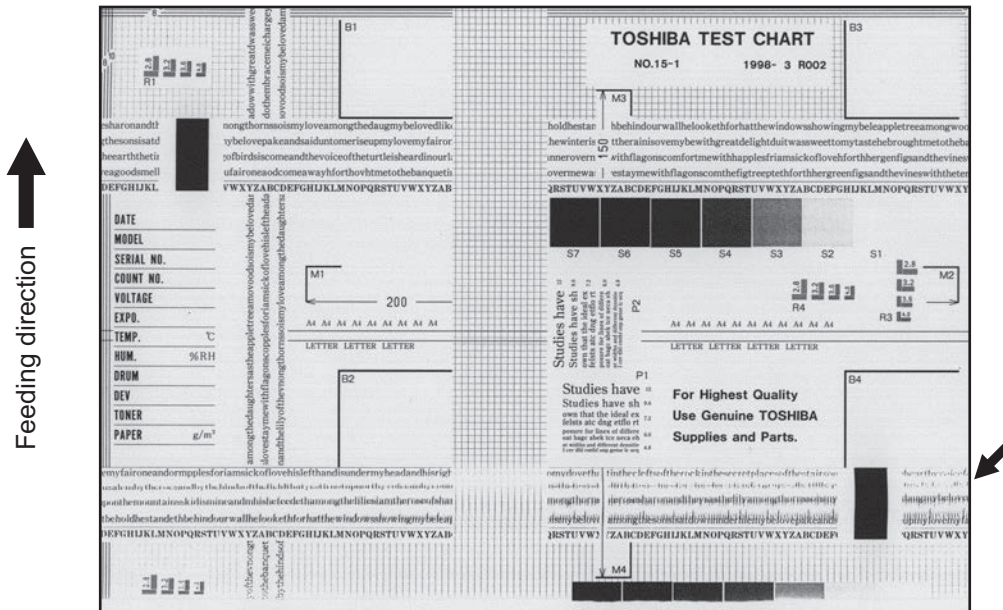

Fig.8-53

Cause/Section	Step	Check item	Measures
-	1	Is the toner image on the drum proper?	If proper, perform steps 2 to 4; otherwise, perform step 5 and after.
Registration roller	2	The rotation of the registration roller is normal.	Check the registration roller section and its springs.
Heat roller, Pressure roller	3	Are the heat roller and pressure roller rotating normally?	Check the heat roller section. Replace the heat roller or pressure roller if necessary.
Drum	4	Is there a large scratch on the drum?	Replace the drum.
Carriage operation	5	Is there any abnormality in the carriage feet?	Replace the carriage feet.
	6	Is the tension of the timing belt proper?	Adjust the tension.
	7	Is there any abnormality in the carriage drive system?	Check the carriage drive system.
Scanner	8	Are the mirrors installed properly?	Correct it.
Drum drive system	9	Are there any abnormalities in the drum drive system?	Check the drum drive system. Clean or replace the gears if they are dirty or there are scratches on them.

## 8.5.21 Poor cleaning

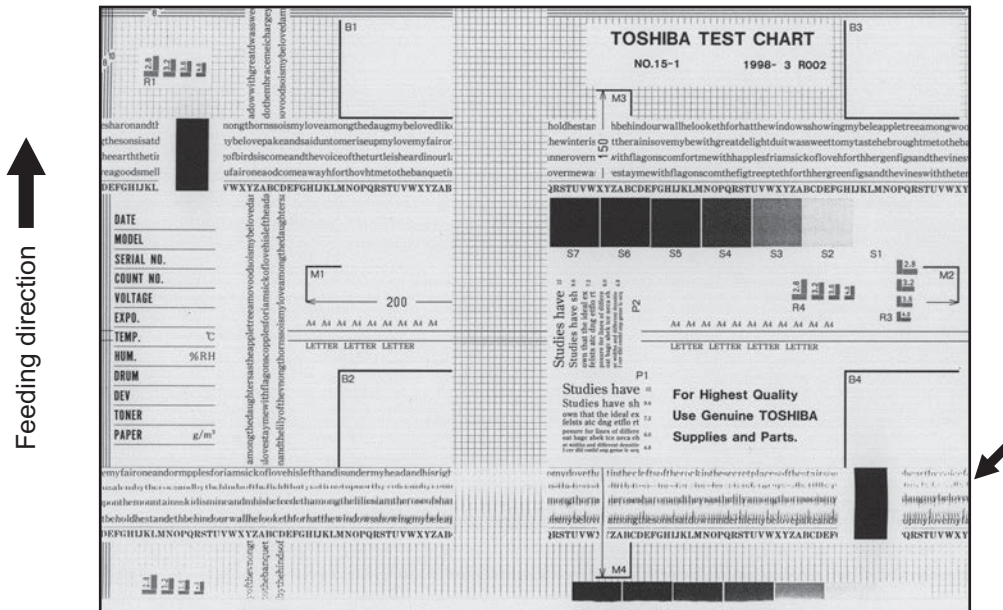

Fig.8-54

Cause/Section	Step	Check item	Measures
Developer material	1	Is the specified developer material used?	Use the specified developer material and toner.
Cleaner	2	Is the cleaning blade in proper contact with the drum?	Check the cleaning blade.
	3	Has the cleaning blade been turned up?	Replace the cleaning blade. Check the drum and replace it if necessary.
Paper dust holder	4	Check if paper dust is accumulated in the paper dust holder.	Take off the paper dust holder and clean it. (Remove the paper dust.)
Toner recovery auger	5	Is toner recovery defective?	Clean the toner recovery auger. Check the pressure of the cleaning blade. Check if the toner recovery auger is being rotated properly.
Fuser unit	6	Are there bubble-like scratches on the heat roller (94 mm pitch on the image)?	Replace the heat roller. Check and adjust the temperature control circuit.
	7	Has the heat roller reached its PM life?	Replace the heat roller.
	8	Is the pressure of the heat roller normal?	Check and adjust the pressure mechanism.
	9	Is the setting temperature of the heat roller normal?	Check the setting and correct it. FS-08-2009, 2010, 2100, 2101, 2120, 2140, 5285 (35/45/50 ppm only)

## 8.5.22 Uneven light distribution



Fig.8-55

Cause/Section	Step	Check item	Measures
Original glass	1	Is the original glass dirty?	Clean the original glass.
Main charger	2	Are the needle electrode, main charger grid and main charger case dirty?	Clean or replace them.
Discharge LED	3	Is the discharge LED dirty?	Clean the discharge LED.
	4	Has any of the discharge LEDs gone out?	Replace the discharge LED.
Scanner	5	Check if the reflector, exposure lamp, mirrors, lens or shading correction plate position of the original glass is dirty.	Clean them.
Exposure lamp	6	Is the exposure lamp tilted?	Adjust the installation position of the exposure lamp.
	7	Is the exposure lamp discolored or degraded?	Replace the exposure lamp.

## 8.5.23 Blotched image

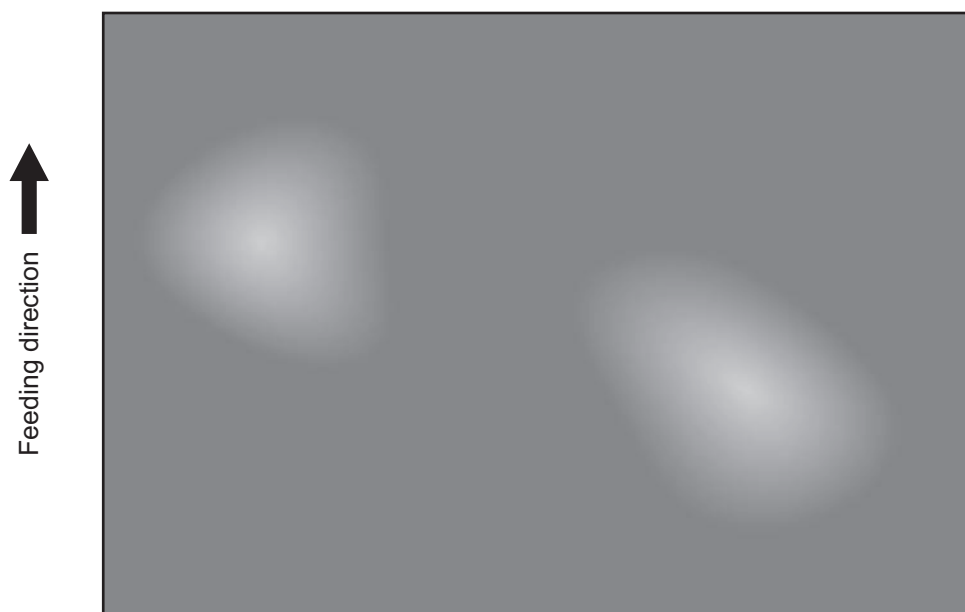

Fig.8-56

Cause/Section	Step	Check item	Measures
Paper	1	Is the paper type corresponding to its mode?	Check the paper type and mode.
	2	Is paper too dry?	Change the paper.
Transfer roller unit	3	Is the spring for supplying power of the transfer roller attached properly?	Check the spring for supplying power and set it correctly.
High-voltage transformer (transfer)	4	Is the high-voltage transformer output properly?	Adjust the output. Replace the high-voltage transformer if necessary.
Separation	5	Is the output from the separation charger too high?	Adjust the output from the separation charger.

## 8.5.24 Black banding on image leading edge during scanning

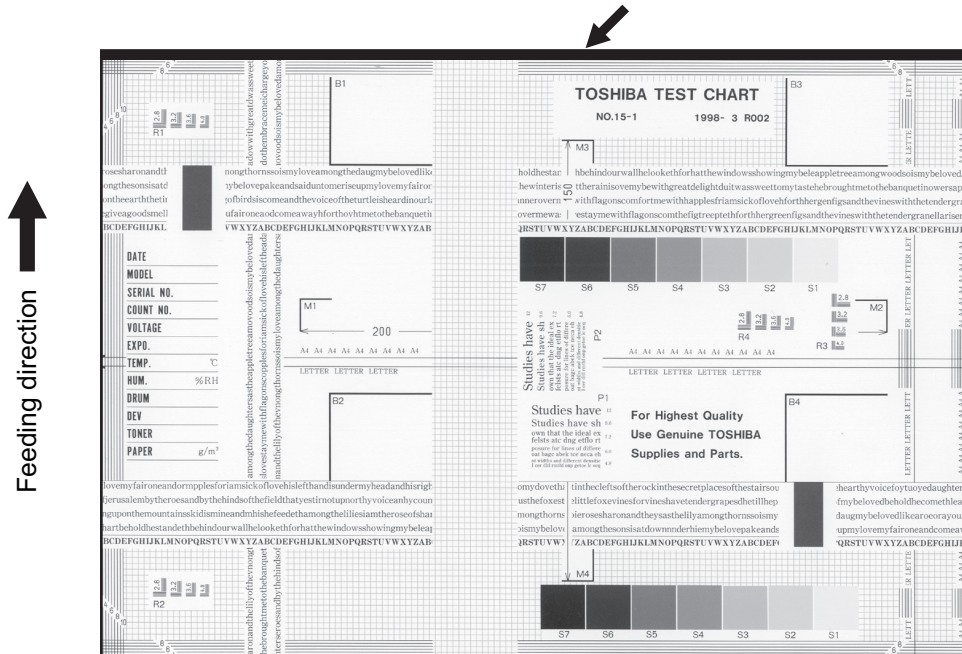

Fig.8-57

Cause/Section	Step	Check item	Measures
Scanner	1	Amount of surrounding void (network scanning)	Perform FS-05-7489 to adjust the amount of the surrounding void during network scanning.

8.5.25 Image distortion (dogleg image)

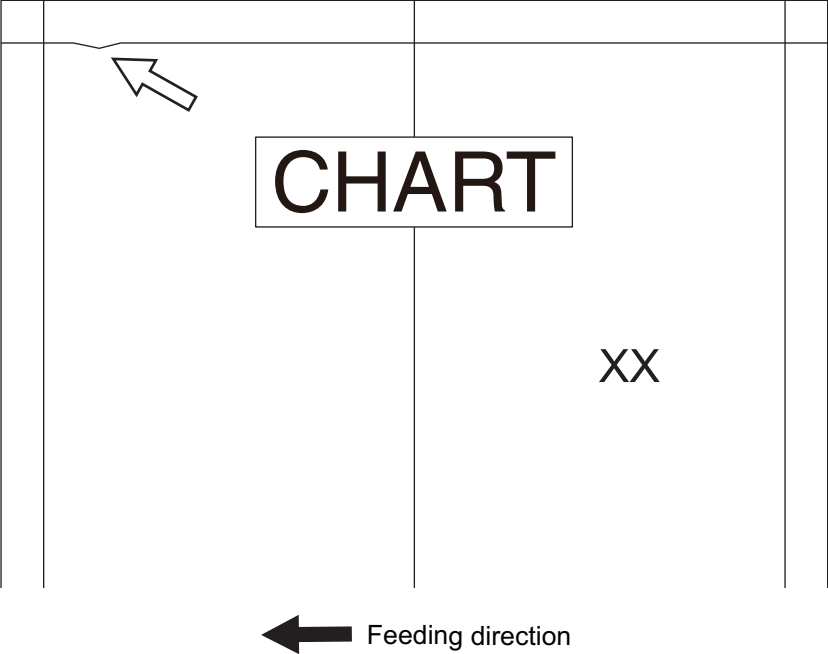

Fig.8-58

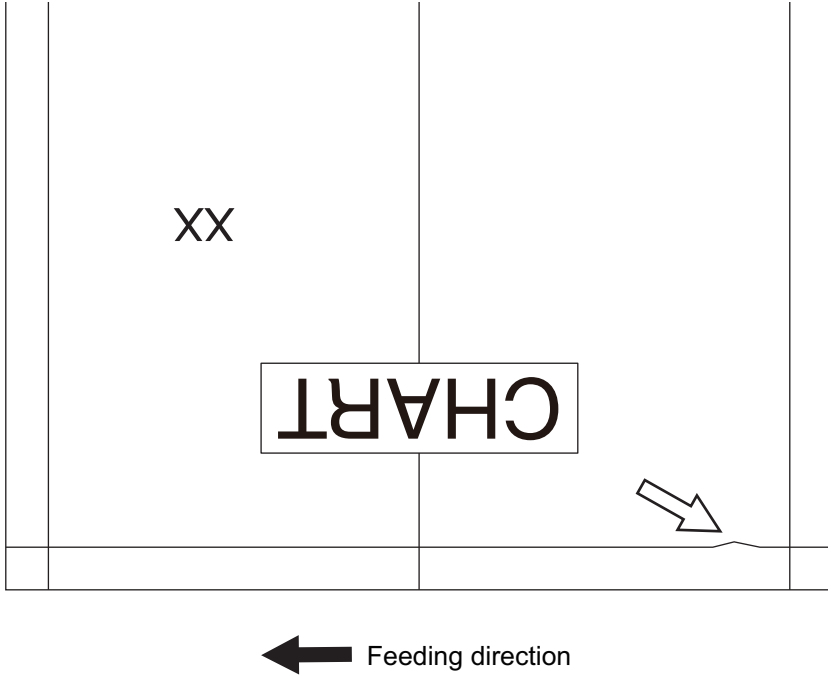

Fig.8-59

The image distortion (dogleg image) shown upper occur on the leading or trailing edge at the back side of the copied or scanned paper while the DSDF is used.

Cause/Section	Step	Check item	Measures
DSDF	1	Position adjustment, height adjustment	Check the installation condition of the DSDF and confirm that there are no abnormalities in the adjustment for its position and height.
	2	Skew adjustment	<p>Perform the adjustment of image tilting at the back side.</p> <p><b>Remarks:</b> The phenomenon tends to be reduced if the CCD module is moved in the "+" direction.</p> <p>Perform the adjustment of image tilting at the front side corresponding to the tilted amount of the back side.</p> <p><b>Notes:</b> When this adjustment is performed, the entire image may be tilted. Even if this adjustment is performed, a dogleg image will not be resolved completely.</p>



## 8.5.26 Image skewing on paper trailing edge

When a grid pattern is output, follow the procedure below if the image on the paper trailing edge is skewed by 1.0mm or more.

[A] The rear side in the secondary scanning direction is longer than the front side. (Front < Rear)

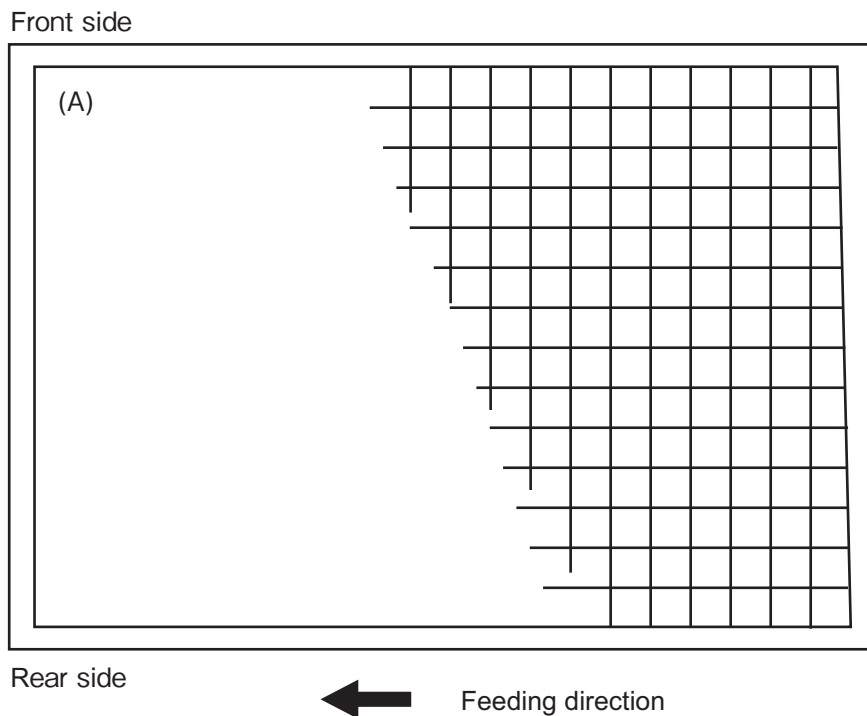
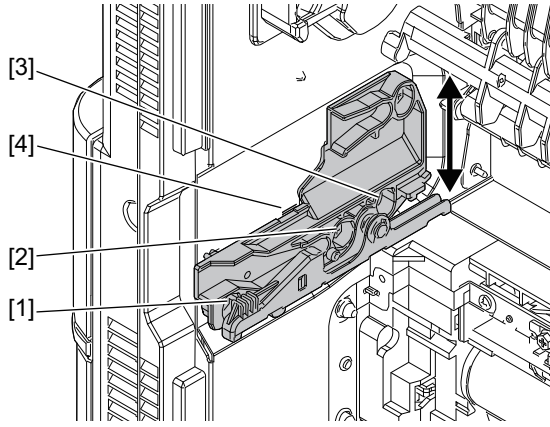

Fig.8-60

Cause/Section	Step	Check item	Measures
Fuser unit	1	Fuser unit guide rail	Adjust the fuser unit guide rail. (P. 8-413"Fig.8-61") <ol style="list-style-type: none"> <li>1. Take off the fuser unit.</li> <li>2. Loosen 1 screw [1] of the front guide rail in the fuser unit.</li> <li>3. Remove 1 screw [2] and attach it to the screw hole for adjustment [3].</li> <li>4. Move the fuser unit guide rail upward by 1mm.               <ul style="list-style-type: none"> <li>- Moving it by 1mm changes the screw in the trailing edge by 0.65mm.</li> <li>- There is a 1-mm scale on the part marked with [4].</li> </ul> </li> <li>5. Tighten 1 screw [1] of the front guide rail in the fuser unit.</li> <li>6. Install the fuser unit.               <ul style="list-style-type: none"> <li>- Check that the image on the paper trailing edge is skewed by 1 mm or less after the adjustment.</li> </ul> </li> </ol>



**Fig.8-61**

**Notes:**

Adjustment of the installation position of the fuser unit should be within the upper 1st line and lower 1st line from the center. (Within the range “A” shown in the figure)

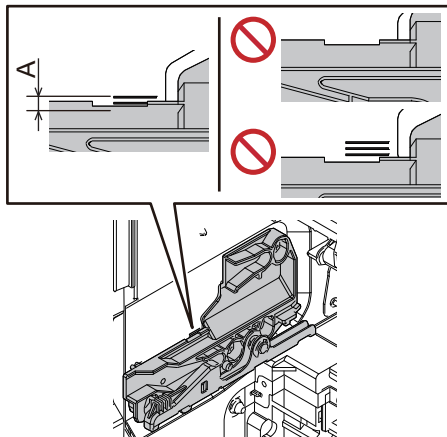

**Fig.8-62**

[B] The front side in the secondary scanning direction is longer than the rear side. (Front > Rear)

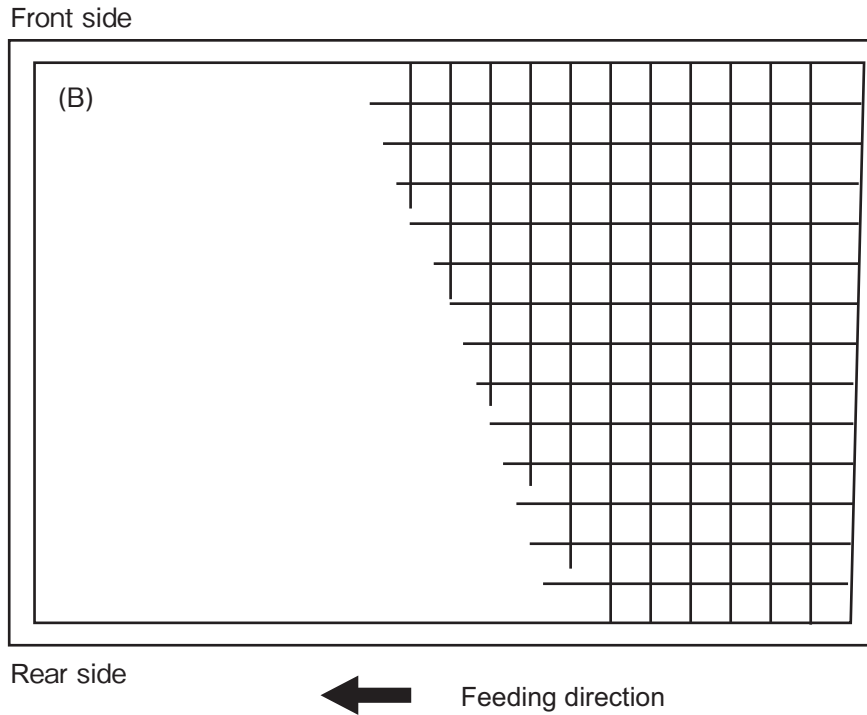

Fig.8-63

Cause/Section	Step	Check item	Measures
Fuser unit	1	Fuser unit guide rail	<p>Adjust the fuser unit guide rail.</p> <ol style="list-style-type: none"> <li>1. Take off the fuser unit.</li> <li>2. Loosen 1 screw [1] of the front guide rail in the fuser unit.</li> <li>3. Remove 1 screw [2] and attach it to the screw hole for adjustment [3].</li> <li>4. Move the fuser unit guide rail downward by 1mm. <ul style="list-style-type: none"> <li>- Moving it by 1mm changes the screw in the trailing edge by 0.65mm.</li> <li>- There is a 1-mm scale on the part marked with [4].</li> </ul> </li> <li>5. Tighten 1 screw [1] of the front guide rail in the fuser unit.</li> <li>6. Install the fuser unit. <ul style="list-style-type: none"> <li>- Check that the image on the paper trailing edge is skewed by 1 mm or less after the adjustment.</li> </ul> </li> </ol>

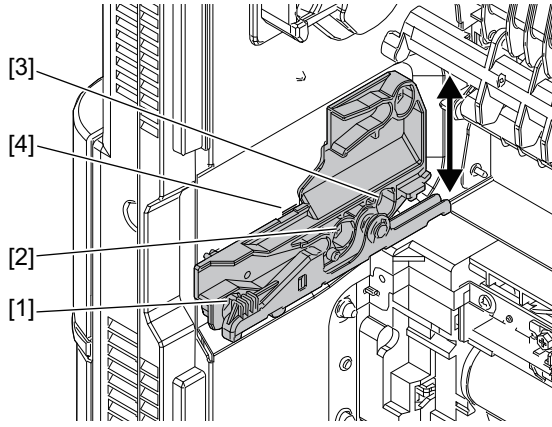
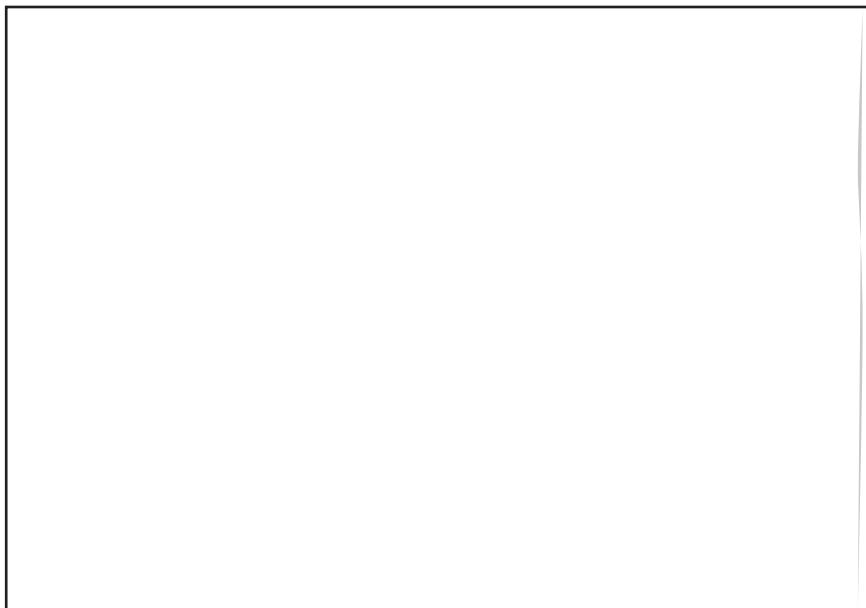

Fig.8-64

## 8.5.27 Shadow in copied or scanned images when using the DSDF



← Feeding direction

Fig.8-65

Cause/Section	Step	Check item	Measures	Remarks
Prior confirmation (MFP/DSDF adjustment condition check)	1	Check that the image dimensional adjustment of the MFP is performed properly.	If the adjustment is insufficient, perform the following items. 1. Image dimensional adjustment at the printing section 2. Image dimensional adjustment at the scanning section	If there is no problem in the adjustment condition, start the adjustment from step 3.
	2	Check that the image related adjustment of the DSDF is performed properly.	If the adjustment is insufficient, perform the following items. 1. Leading edge position adjustment 2. Sideways deviation adjustment 3. Reproduction ratio adjustment	

Cause/Section	Step	Check item	Measures	Remarks
Image related adjustment of the MFP and DSDF	3	Perform scanning from the DSDF and check whether a shadow or an image void has appeared at the leading or trailing edge in the feeding direction.	If any defects occur in images, perform the following items. <ol style="list-style-type: none"> <li>Image dimensional adjustment at the printing section (Secondary scanning data writing start position adjustment, Reproduction ratio of the secondary scanning direction adjustment)</li> <li>Image dimensional adjustment at the scanning section (Secondary scanning data writing start position adjustment)</li> <li>Image related adjustment of the DSDF (Adjustment of the leading edge position, Adjustment of the copy ratio)</li> </ol>	
	4	Perform scanning from the DSDF and check whether a shadow or an image void has appeared at the left or right edge in the feeding and vertical direction.	If any defects occur in images, perform the following items. <ol style="list-style-type: none"> <li>Image dimensional adjustment at the printing section (Primary scanning data writing start position adjustment)</li> <li>Image dimensional adjustment at the scanning section (Primary scanning data writing start position adjustment)</li> <li>Adjustment of DSDF sideways deviation</li> </ol>	
Copying	5	<ul style="list-style-type: none"> <li>Check whether a trailing edge shadow of an original has appeared at copying only.</li> <li>Check whether a trailing edge shadow of an original has appeared when copying is done by selecting a larger size of paper than that for an original or by reducing the size.</li> </ul>	If any defects occur in images, perform the following items. <ol style="list-style-type: none"> <li>Change the value of FS- 08-3075 (Allowing of trailing edge adjustment of scanning) to "1" (Allowed).</li> <li>Decrease the value of FS-05-3350 (Scan trailing edge adjustment for the front side) and FS-05-3351 (Scan trailing edge adjustment for the back side) from 50 until the trailing edge shadow of an original has disappeared.</li> </ol> <p><b>Remarks:</b> When the value is decreased by "1", the image will be cut (become shorter) by 0.3mm.</p> <p><b>Notes:</b> The level of the removal of a shadow will vary depending on the conditions of the original or the sensors.</p>	This adjustment is available only for the copying function. (This adjustment cannot be performed in the scanning function.)

## 8.5.28 The exit paper surface feels rough like sand is adhering to it (carrier offset)

Cause/Section	Step	Check item	Measures
Developer material, drum	1	Have the developer material and drum reached their PM life?	Replace the developer material and the drum.
Main charger	2	Is there any foreign matter on the main charger?	Clean or replace the main charger.
Developer unit	3	<ul style="list-style-type: none"> <li>Are the connectors of the auto-toner sensor connected properly? (CN319, J626, J627)</li> <li>Is the auto-toner sensor installed correctly?</li> </ul>	<ul style="list-style-type: none"> <li>Connect the connectors and perform auto-toner sensor adjustment.</li> <li>Install the auto-toner sensor correctly and perform auto-toner sensor adjustment.</li> </ul>
Discharge LED	4	<p>Are the discharge LEDs lit? Check this by the following procedure.</p> <ol style="list-style-type: none"> <li>Start the MFP with 03 TEST MODE.</li> <li>Open the front cover and install the door-switch jig.</li> <li>Perform 03-235 and 03-236 to check that the discharge LEDs for each color are lit.</li> </ol> <p><b>Notes:</b> Be sure to perform this in a short time.</p>	<ul style="list-style-type: none"> <li>If the discharge LEDs are not lit, check that the connectors are connected securely. (CN626, J452, J534, J553)</li> <li>Replace the discharge LED.</li> </ul>
Toner motor	5	<p>Are the toner motors working properly? Perform 03-102 to check if the toner motor is working properly.</p>	<ul style="list-style-type: none"> <li>Check if the connectors for each toner motor are connected securely. (CN325, CN444)</li> <li>If the toner motor harness is open circuited, replace it.</li> <li>Replace the toner motor.</li> <li>Replace the CTIF board.</li> <li>Replace the LGC board.</li> </ul>
High-voltage transformer	6	<ul style="list-style-type: none"> <li>Is there any abnormality in the high-voltage connection points (CH1, CH2, CH3) of the main charger bias and the developer bias?</li> <li>Check if the connectors of the high-voltage transformer are connected securely. (CN541, CN540 and each Faston terminal)</li> <li>Is there any abnormality in the contact point of the high-voltage transformer?</li> <li>Is the harness of the high-voltage transformer open circuited?</li> <li>Is there any abnormality in the high-voltage transformer?</li> </ul>	<ul style="list-style-type: none"> <li>Connect the connectors securely.</li> <li>If the harness is open circuited, replace it.</li> <li>Replace the high-voltage transformer.</li> </ul>
LGC board	7	<ul style="list-style-type: none"> <li>Check if the connectors of the LGC board are connected. (CN303, CN321)</li> <li>Is the harness of the LGC board open circuited?</li> <li>Is there any abnormality in the LGC board?</li> </ul>	<ul style="list-style-type: none"> <li>Connect the connectors securely.</li> <li>If the harness is open circuited, replace it.</li> <li>Replace the LGC board.</li> </ul>
Process unit (EPU)	8	Is there any abnormality in the process units (EPU)?	Replace the process unit (EPU) and perform auto-toner sensor adjustment.

### Notes:

The carrier may be adhering to each transport guide, each transfer roller and the fuser unit. Therefore, perform cleaning after this troubleshooting has been carried out.

Parts to be replaced	Remarks
Developer material	
Drum	
Main charger	
Discharge LED	

<b>Parts to be replaced</b>	<b>Remarks</b>
Toner motor	
Process unit (EPU)	Developer unit, Cleaner
High-voltage transformer	
LGC board	
Pressure roller	



## 8.5.29 Scanned image abnormality

When the following abnormality has appeared on images in the scanning and copying functions even if there is no abnormality in the output images in the printing function, there will be an abnormality in the scanner. In such a case, perform this countermeasure.

Example of abnormal images

- (1) The entire image has become lighter or darker.
- (2) The entire image has been colored.
- (3) The color of the image does not match that of the original.

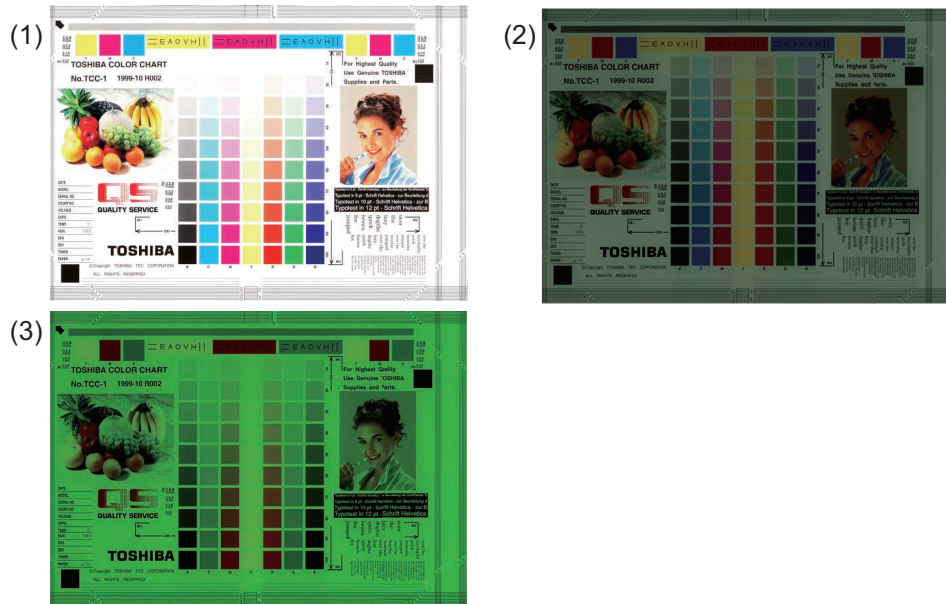

Fig.8-66

Abnormality in the scanner of the MFP

- When an abnormality in the images has occurred in scanning using the original glass
- When an abnormality in the images has occurred in scanning using the RADF
- When an abnormality in the images only on the front side has occurred in scanning using the DSDF

Cause/Section	Step	Check item	Measures
Connectors	1	Are the connectors securely connected?	<ul style="list-style-type: none"> <li>• Reconnect the connector (CN120) of the SYS board and then check the image.</li> <li>• Reconnect the connector (CN001) of the CCD board and then check the image.</li> </ul>
SYS board	2	Is there any abnormality in the SYS board?	<p>If this problem still persists even after step 1 was performed, replace the SYS board and then check the image. Do not perform FS-053-203 (Data transfer of characteristic value of the scanner) at this time.</p> <p>If the image condition has become better, finish this troubleshooting without carrying out FS-05-3203. (It is not necessary to continue to perform the subsequent steps.)</p>
CCD board	3	Is there any abnormality in the CCD board?	<p>If this problem still persists even after step 2 was performed, replace the CCD board. Do not perform FS-05-3209 (Data transfer of characteristic value) at this time. After replacing, check the image.</p> <p>If the image condition has become better, finish this troubleshooting without carrying out FS-05-3209. (It is not necessary to continue to perform the subsequent steps.)</p>

Cause/Section	Step	Check item	Measures
SRAM	4	Is there any abnormality in the SRAM data?	If this problem still persists even after step 3 was performed, return the CCD board to a removed one. Perform FS-05-3203 (Data transfer of characteristic value of the scanner) and check the image. If the image condition has become better, finish this troubleshooting.
CCD board, SRAM	5	Is there any abnormality in both the CCD board and the SRAM?	If this problem still persists even after step 4 was performed, replace the CCD board with the one used in step 3. Perform FS-05-3203 (Data transfer of characteristic value of the scanner) and check the image. If the image condition has become better, finish this troubleshooting.

#### Abnormality in the scanner (DSDf-CCD module) of the DSDf

- When an abnormality in the images only on the back side has occurred in scanning using the DSDf

Cause/Section	Step	Check item	Measures
Connectors	1	Are the connectors securely connected?	<ul style="list-style-type: none"> <li>Reinstall the DSDf I/F board and check the image.</li> <li>Reconnect the HDMI cable of the DSDf I/F board and check the image.</li> <li>Reconnect the connector (CN91) and the HDMI cable (CN78) of the DSDf control PC board and check the image.</li> </ul>
DSDf I/F board	2	Is there any abnormality in the DSDf I/F board?	If this problem still persists even after step 1 was performed, replace the DSDf I/F board and then check the image. If the image condition has become better, finish this troubleshooting.
SYS board	3	Is there any abnormality in the SYS board?	If this problem still persists even after step 2 was performed, replace the SYS board and then check the image. Do not perform FS-053-203 (Data transfer of characteristic value of the scanner) at this time. If the image condition has become better, finish this troubleshooting without carrying out FS-05-3203. (It is not necessary to continue to perform the subsequent steps.)
DSDf-CCD module	4	Is there any abnormality in the DSDf-CCD module?	If this problem still persists even after step 3 was performed, replace the DSDf-CCD module. Perform FS-05-3240 (Data transfer of characteristic value of the scanner) and check the image. If the image condition has become better, finish this troubleshooting.

## 8.5.30 Drum pitch fogging

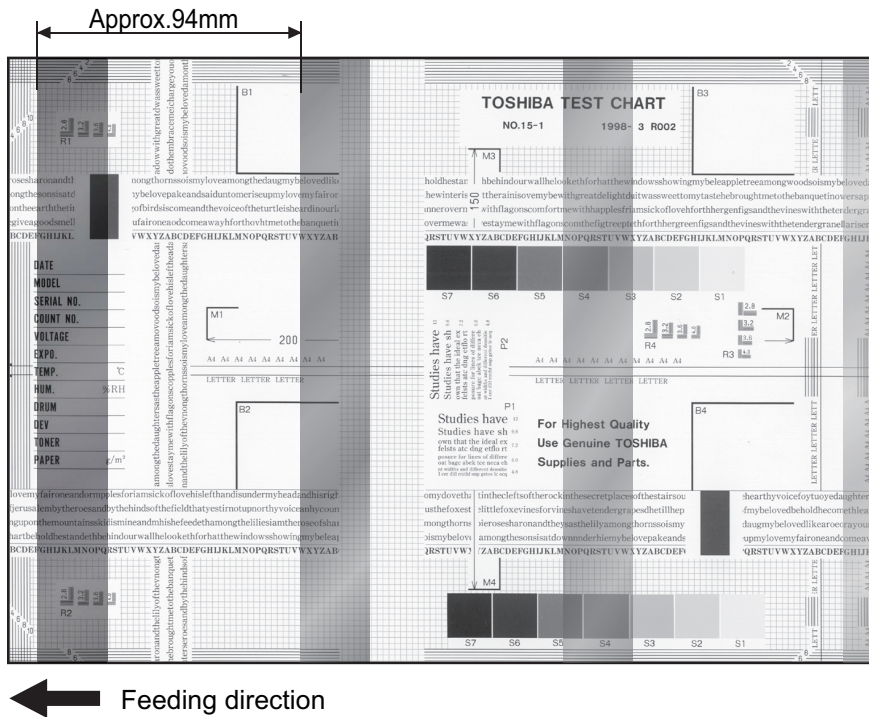

Fig.8-67

Cause/Section	Step	Check item	Measures
Image	1	Does fogging appear in at right angles to the paper feeding direction cyclically (approx. 94 mm pitch)?	Set "14" (30 sec.) in FS-08-2111-0 and FS-08-2111-1 as a guide. <b>Notes:</b> Once this adjustment has been performed, the warming-up time after power-ON and recovering from the sleep mode will become longer.

### 8.5.31 If an image-related problem continues after performing all troubleshooting

If an image-related problem continues even after performing all the troubleshooting, an abnormal value may have been entered in the self-diagnostic code. In such a case, attempt the initialization of the self-diagnostic code in accordance with the table below.

**Notes:**

- Perform the list print before the initialization.
- Initialization should be performed only for the function in which the image-related problem has occurred.
- The self-diagnostic code which will be initialized is related to the image adjustment. Therefore, only problems which have occurred during the image processing can be solved. If a cause of the problem is related to the hardware or other system issues, it will not be able to be solved even if the initialization of the self-diagnostic code is performed.

Function	Self-diagnostic code to be initialized	Precautions
Copying	FS-08-7000	After the initialization has been carried out, perform automatic gamma adjustment.
Printing	FS-08-7300	After the initialization has been carried out, perform automatic gamma adjustment (600 dpi and 1200 dpi).
Scanning	FS-08-7400	None
Fax	FS-08-7500	None



## 9. REPLACEMENT OF PC BOARDS, SSD

### 9.1 Removal and Installation of PC Boards and SSD

#### Notes:

When the PC board and SSD are replaced, check the notes in the following reference.

📖 P. 9-16 “9.2 Precautions, Procedures and Settings for Replacing PC Boards and Storage Device”

#### 9.1.1 SYS board cover

- (1) Take off the rear cover.  
📖 P. 4-9 “4.1.15 Rear cover”
- (2) Remove 1 screw [2] and take off the SYS board cover [1] by sliding it toward the right side.

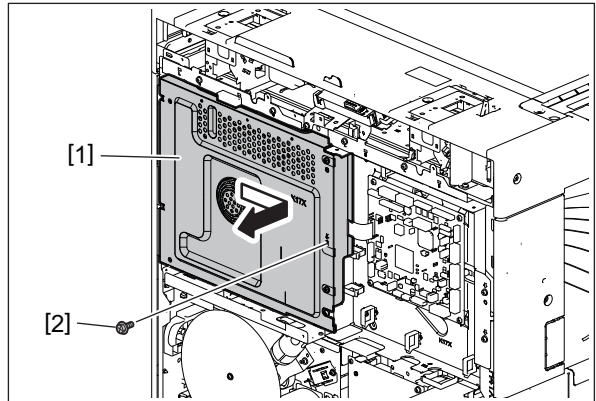

Fig. 9-1

#### 9.1.2 SYS board cooling fan (F1)

- (1) Take off the SYS board cover.  
📖 P. 9-1 “9.1.1 SYS board cover”
- (2) Disconnect 1 connector [1]. Lift up 2 latches of the SYS board cooling fan [2] and take it off by sliding it toward the rear side.

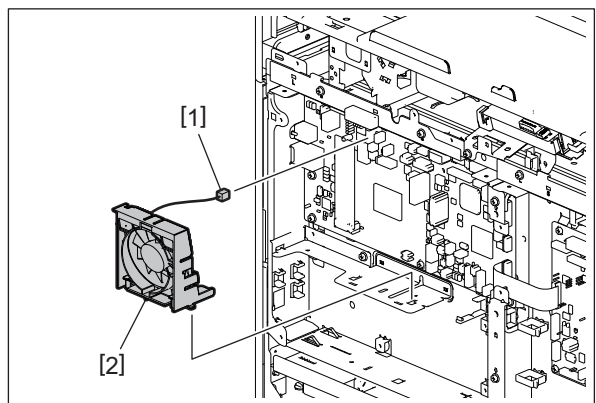

Fig. 9-2

### 9.1.3 SSD

- (1) Take off the SYS board cover.  
📖 P. 9-1 "9.1.1 SYS board cover"
- (2) Remove 1 screw [1] and take off the SSD [2].

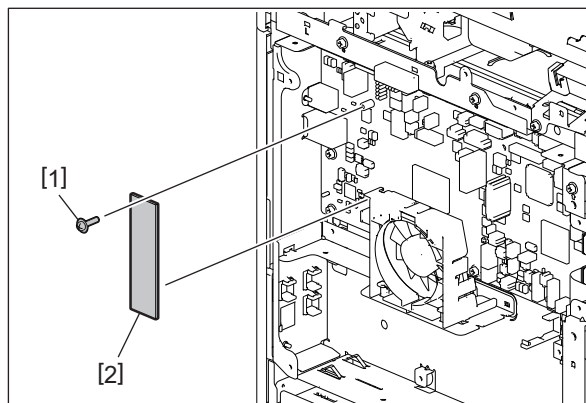

Fig. 9-3

### 9.1.4 Optional HDD

- (1) Take off the SYS board cover.  
📖 P. 9-1 "9.1.1 SYS board cover"
- (2) Disconnect 2 connectors connected to the SYS board. Remove 4 screws and take off the optional HDD [1].

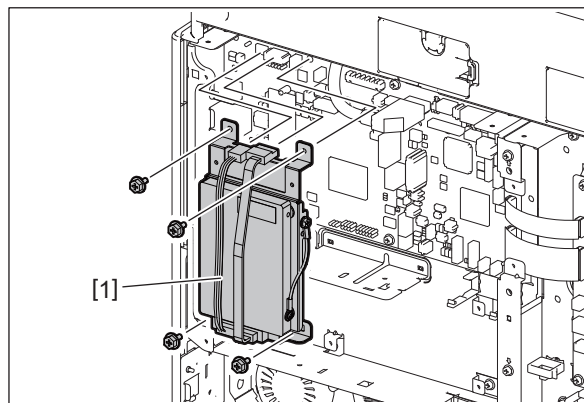

Fig. 9-4

### 9.1.5 Optional SSD

- (1) Take off the SYS board cover.  
📖 P. 9-1 “9.1.1 SYS board cover”
- (2) Disconnect 2 connectors connected to the SYS board. Remove 4 screws and take off the SSD [1].

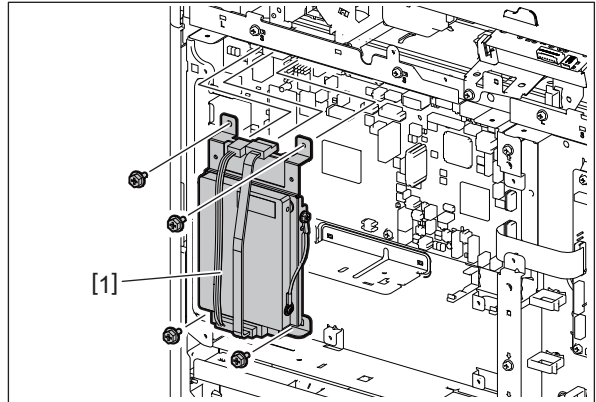

Fig. 9-5

### 9.1.6 SYS board

- (1) Take off the SYS board cover.  
📖 P. 9-1 “9.1.1 SYS board cover”
- (2) If the DSDF is installed, remove the DSDF I/F board.  
📖 P. 9-15 “9.1.15 DSDF I/F board”
- (3) Remove the SYS board cooling fan.  
📖 P. 9-1 “9.1.2 SYS board cooling fan (F1)”
- (4) Disconnect all connectors connected to the SYS board. Release the lock by raising the flap and remove 1 flat cable [1].

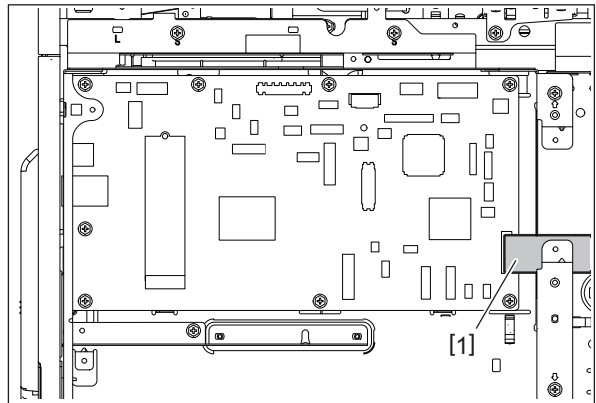

Fig. 9-6



**Notes:**

- When installing the harnesses, be sure to connect each USB harness correctly.  
CN112: Gray USB connector (Harness of the control panel)  
CN113: Black USB connector (Extension cable for the card reader)
- When removing the flat cable [1], release the lock in advance by raising the flap [2].  
When installing the flat cable [1], insert it and then lock it by tilting the flap [2].
- When connecting the flat cable [1] to the connector, do not push it in strongly.
- When installing the flat cable [1], be careful not to insert it at an angle.
- Do not apply pressure to or damage the edge of the flat cable [1].

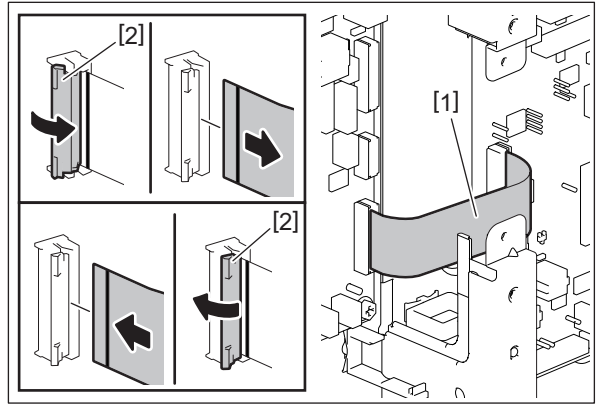

Fig. 9-7

- (5) Remove 1 screw [3].

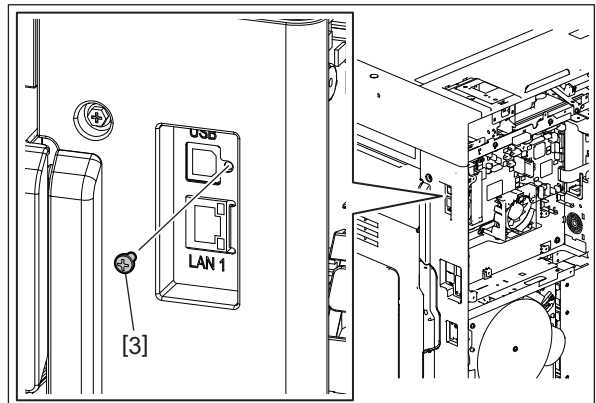

Fig. 9-8

- (6) Remove 8 screws and take off the SYS board [4].

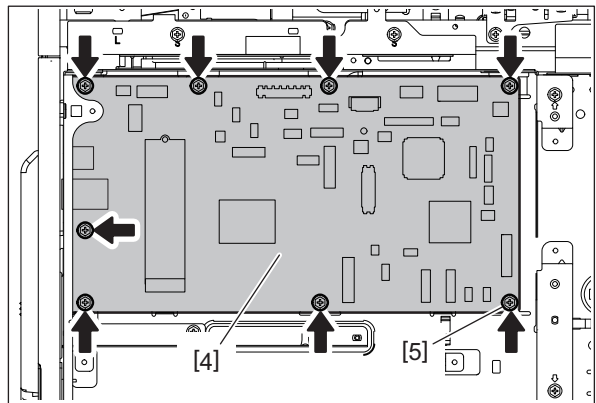
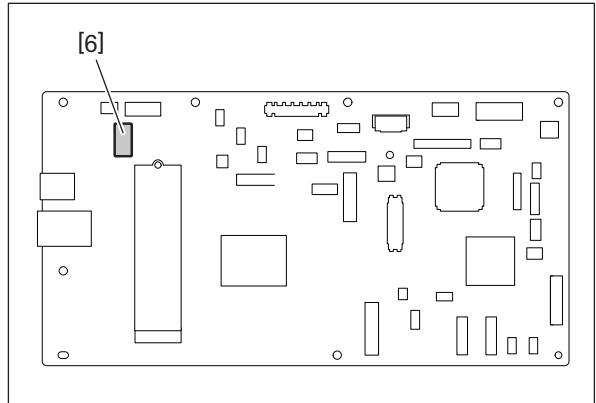

Fig. 9-9

**Notes:**

- When installing the SYS board, fasten the screw [5] at first.

- The SYS board to be installed differs depending on the MFP. Due to this, before replacing, be sure to check that the color of the identification label [6] on the SYS board in order to install the corresponding one in the MFP.  
2528A/3028A: Brown  
3528A/4528A (other than CNS/TWD): Red  
3528A/4528A (CNS): Green  
2528A/3028A (TWD): Indigo  
3528A/4528A (TWD): Yellow



**Fig. 9-10**

## 9.1.7 SYS board case

- (1) Take off the SYS board cover.  
 P. 9-1 "9.1.1 SYS board cover"
- (2) Disconnect 11 connectors connected to the SYS board. Release the lock by raising the flap and remove 2 flat cables [1].

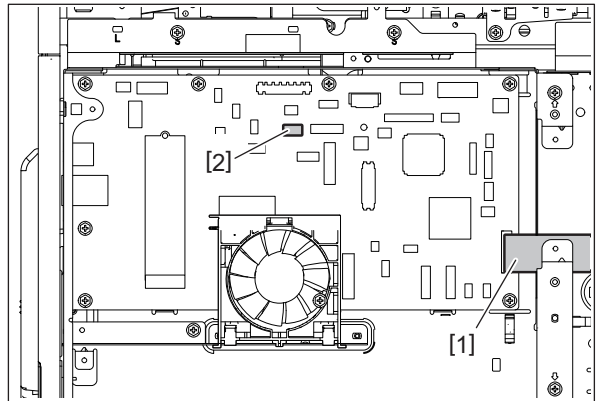

Fig. 9-11

### Notes:

- Do not disconnect 1 connector [2] connected to the SYS board cooling fan.
- When installing the harnesses, be sure to connect each USB harness correctly.  
CN112: Gray USB connector (Harness of the control panel)  
CN113: Black USB connector (Extension cable for the card reader)
- When removing the flat cable [1], release the lock in advance by raising the flap [3].  
When installing the flat cable [1], insert it and then lock it by tilting the flap [3].
- When connecting the flat cable [1] to the connector, do not push it in strongly.
- When installing the flat cable [1], be careful not to insert it at an angle.
- Do not apply pressure to or damage the edge of the flat cable [1].

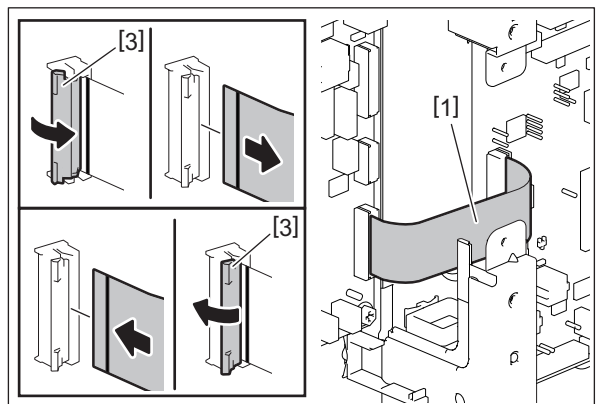

Fig. 9-12

- (3) Release the harness from the harness clamp [4]. Remove 7 screws and take off the SYS board case [5].

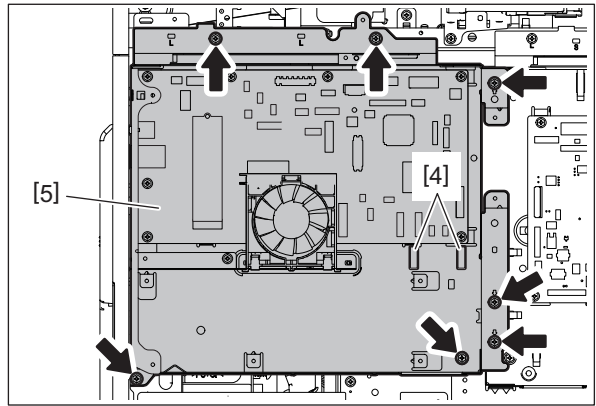



Fig. 9-13

**Notes:**

Hold the SYS board case to remove it.

### 9.1.8 LGC board

- (1) Take off the rear cover.  
 P. 4-9 "4.1.15 Rear cover"
- (2) Disconnect all connectors connected to the LGC board and remove the flat cable [1].

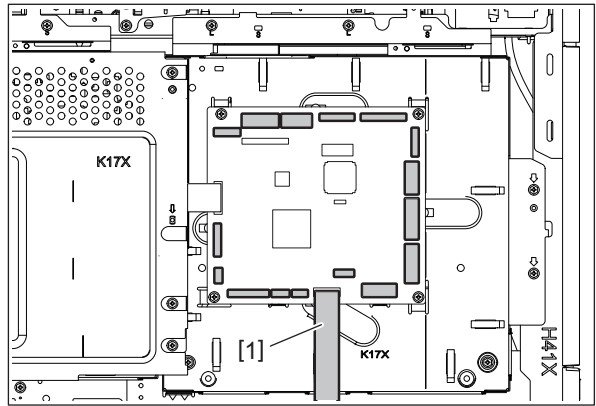

Fig. 9-14

- (3) Release the lock by raising the flap and remove 1 flat cable [2].

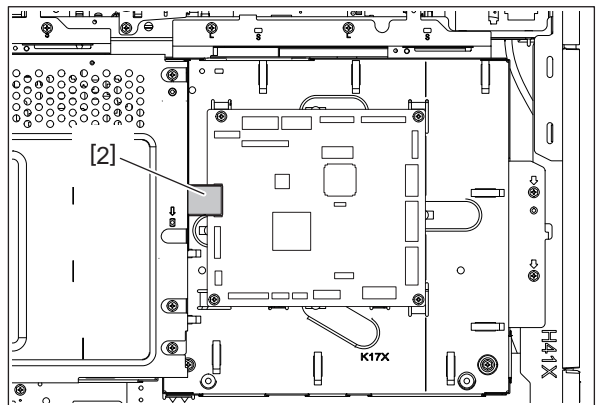
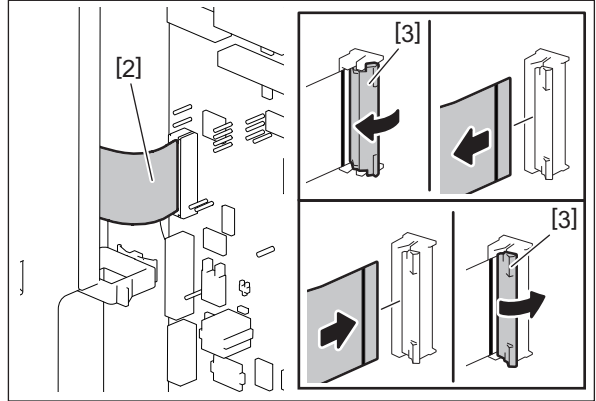

Fig. 9-15

**Notes:**

- When removing the flat cable [2], release the lock in advance by raising the flap [3].  
When installing the flat cable [2], insert it and then lock it by tilting the flap [3].



**Fig. 9-16**

- When connecting the flat cable [2] to the connector, do not push it in strongly.
- When installing the flat cable [2], be careful not to insert it at an angle.
- Do not apply pressure to or damage the edge of the flat cable [2].

(4) Remove 4 screws and take off the LGC board [4].

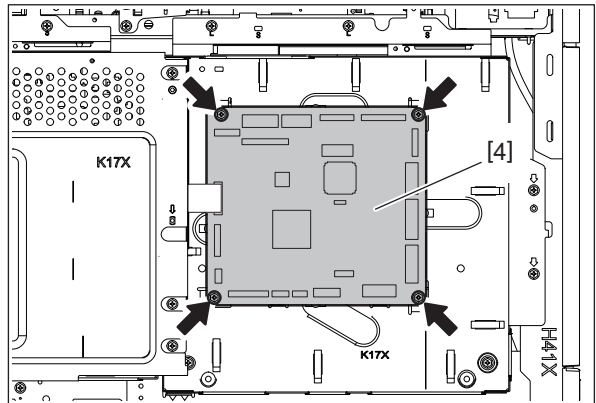

**Fig. 9-17**

**Notes:**

The LGC board to be installed differs depending on the models. Due to this, before replacing, be sure to check that the color of the identification label [5] on the LGC board in order to install the corresponding one of the model.

- 2528A: White
- 3028A: Pink
- 3528A: Blue
- 4528A: Yellow

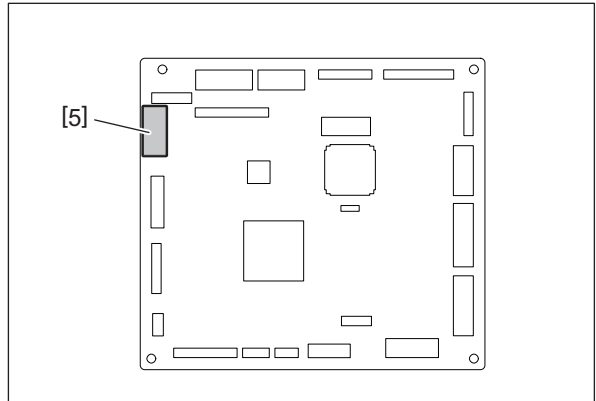

Fig. 9-18

### 9.1.9 Switching regulator

**Notes:**

- Be sure to unplug the power cable before starting this work.
- Electric charge may remain in the capacitors on the switching regulator even if the MFP is shut down and the plug is disconnected. Since there is a risk of an electric shock, pay full attention not to touch the board and mounted parts while handling the switching regulator.

- (1) Take off the left cover.  
📖 P. 4-1 “4.1.2 Left cover”
- (2) Release the harness from the harness clamp [1].
- (3) Remove 2 screws and slightly slide the switching regulator [2] toward you.

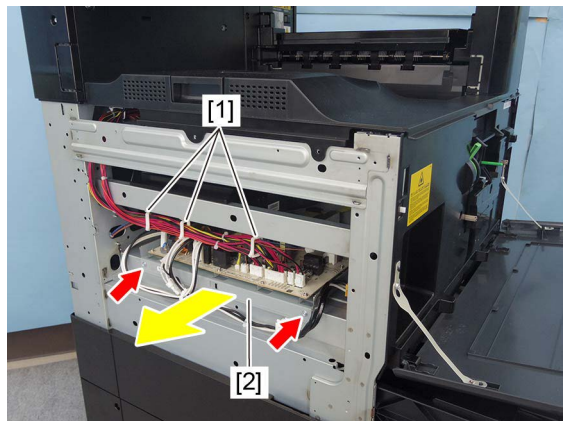

Fig. 9-19

- (4) Disconnect 11 connectors. Take off the switching regulator [2] by sliding it toward you.

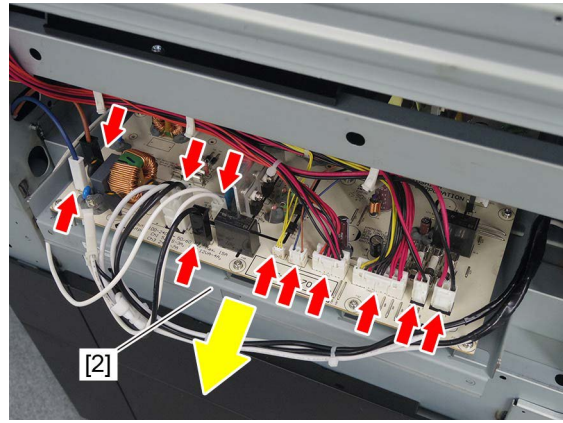

Fig. 9-20

### 9.1.10 High-voltage transformer (HVT)

**Notes:**

Be sure to unplug the power cable before starting this work.

- (1) Take off the rear cover.  
P. 4-9 “4.1.15 Rear cover”
- (2) Remove 5 screws.

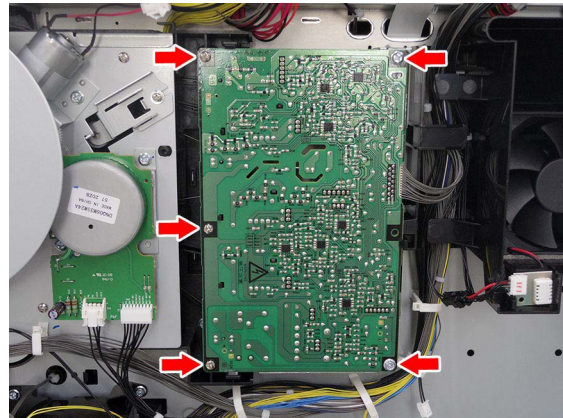

Fig. 9-21

- (3) Release 3 hooks and turn over the high-voltage transformer [1].

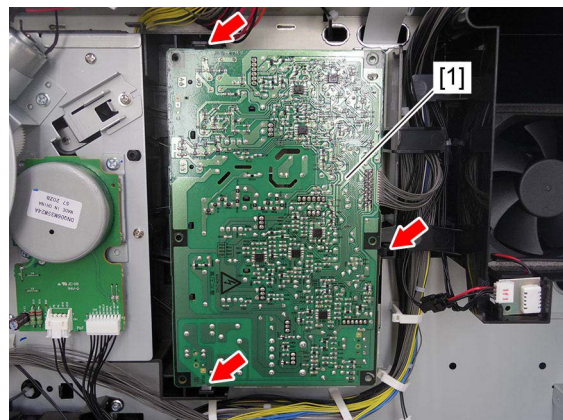

Fig. 9-22



- (4) Disconnect 1 connectors and take off the high-voltage transformer [1].

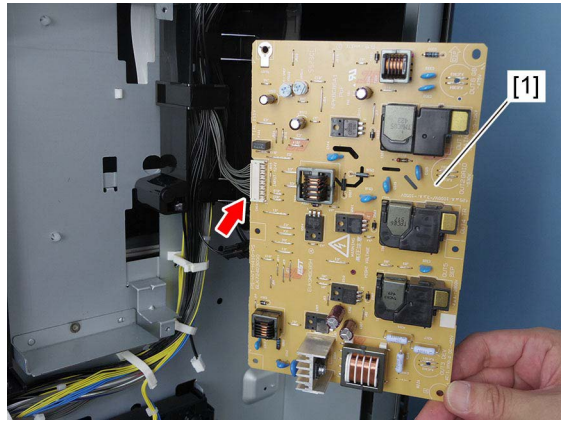

Fig. 9-23

### 9.1.11 SRAM

- (1) Take off the SYS board cover.  
P. 9-1 "9.1.1 SYS board cover"
- (2) Remove the SRAM [4] from the SYS board.

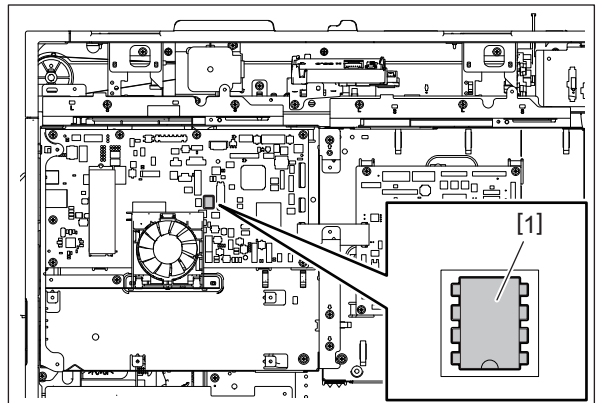

Fig. 9-24

**Notes:**

- Be careful not to damage the SRAM when removing it from the SYS board.
- When installing the SRAM, pay attention to the orientation. Install the SRAM with its concave portion down.

## 9.1.12 Sub EEPROM

- (1) Take off the rear cover.  
P. 4-9 "4.1.15 Rear cover"
- (2) Remove the Sub EEPROM [1] from the LGC board.

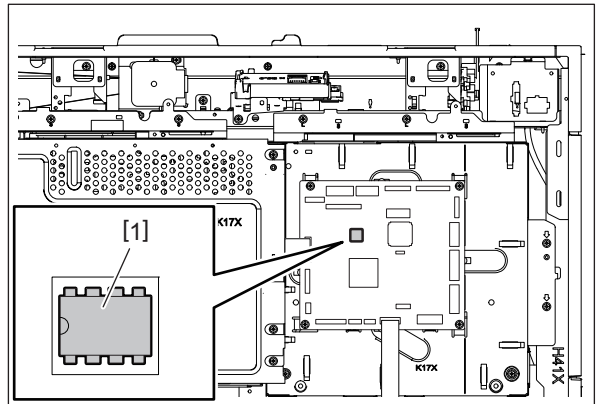

Fig. 9-25

### Notes:

- Be careful not to damage the Sub EEPROM when removing it from the LGC board.
- When installing the Sub EEPROM, pay attention to the orientation. Install the Sub EEPROM with its concave portion left.

### 9.1.13 DAMP PC board

#### Notes:

- Be sure to unplug the power cable before starting this work.
- If the DAMP PC board is not installed appropriately, a serious accident such as an electric shock may occur. Therefore, to avoid this, be sure to perform correct handling and installation.

- (1) Take off the rear cover.  
📖 P. 4-9 “4.1.15 Rear cover”
- (2) Disconnect 3 connectors.

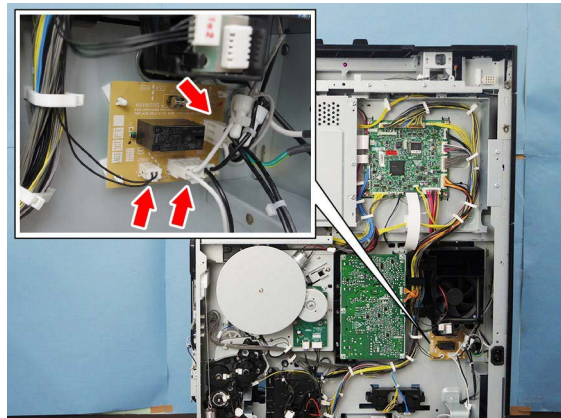

Fig. 9-26

- (3) Release 4 locking supports and remove the DAMP PC board [1].

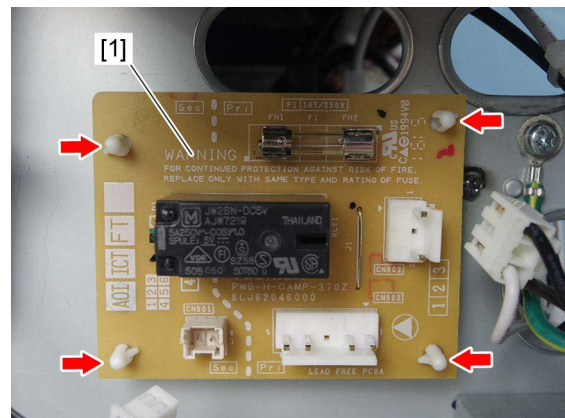

Fig. 9-27

### 9.1.14 Power supply unit cooling fan (F8)

- (1) Take off the rear cover.  
P. 4-9 “4.1.15 Rear cover”
- (2) Remove the temperature/humidity sensor.  
P. 4-116 “4.7.12 Temperature/humidity sensor (S10)”
- (3) Remove 2 screws. Disconnect 1 connector [3] and take off the power supply unit cooling fan [4],

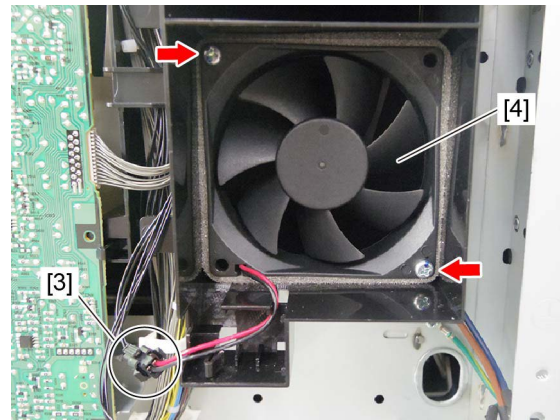

Fig. 9-28

### 9.1.15 DSDF I/F board

- (1) Take off the SYS board cover.  
P. 9-1 “9.1.1 SYS board cover”
- (2) Remove 2 screws. Release 1 locking support and take off the DSDF I/F board.

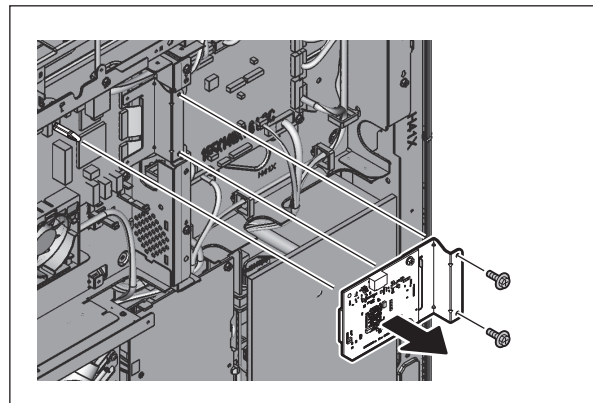







Fig. 9-29

## 9.2 Precautions, Procedures and Settings for Replacing PC Boards and Storage Device

### 9.2.1 Precautions when replacing PC boards

- The ID for each MFP is registered on the LGC board, the SYS board and Lens unit. So, if their replacement is required, be sure to replace only one board at a time. Do not replace the SYS board and the SRAM together.
- If both the LGC board and SYS board require replacement, replace them in the following procedure.
  1. First, replace one of the board to be replaced.
  2. Turn the power ON and confirm that “READY” is displayed.
  3. Turn the power OFF.
  4. Replace another board that requires replacement.
- When replacing the LGC board, remove the Sub EEPROM on the old board, and then attach it to the new board.  
 P. 9-20 “9.2.3 Precautions and procedures when replacing the storage device”
- When the storage device requires replacement, see the following reference.  
 P. 9-20 “9.2.3 Precautions and procedures when replacing the storage device”
- When the SYS board requires replacement, see the following reference.  
 P. 9-25 “9.2.4 Precautions and procedures when replacing the SYS board”
- When the lens unit requires replacement, see the following reference.  
 P. 9-37 “9.2.8 Procedures and settings when replacing the lens unit”
- When the SRAM requires replacement, see the following reference.  
 P. 9-28 “9.2.5 Precautions and procedure when replacing the SRAM”
- When the DSP board requires replacement, see the following reference.  
 P. 6-70 “6.13 Control Panel Calibration”

## 9.2.2 Storage device fault diagnosis

This enables the displaying of the storage device operation history, which is recorded in it, on the touch panel. Storage device failure can be diagnosed or predicted with the information displayed. The display method and items differ depending on the types of the storage device (SSD or HDD).

### [ 1 ] Standard storage device (SSD)

#### (1) Display

Perform HS-75 File System Recovery > [SMART Info] > [Standard storage]. The following screen is displayed.

ID	NAME	VALUE	NAV	Worst
01	Number of UNC Error	0	100	100
09	Power-on Hours Count	1017	100	100
0c	Power ON/OFF Cycles Count	287	100	100
a2	Spare Block Count(CE)	478	100	100
a8	SATA PHY Error Count	0	100	100
aa	Bad Block Count(Later)	0	100	100
ad	Erase Count(Ave)	15	100	100
c0	Unexpected Power Loss Count	10	100	100
c2	Temperature	41	59	56
da	CRC Error Count	0	100	100
e7	SSD Life Left	99	100	100
e9	NAND Write(GB)	1096	100	100
f1	Host Write(GB)	611	100	100
f6	Total Erase Count	123970	100	100

Model : PhisonPHSM128GFNTL-E-TE0040-S-SCRM133 ——— SSD model name  
 Serial : 128210305000164 ——— SSD serial number

Fig. 9-30

- Items supported differ depending on the storage device manufacturer.
- “---” is displayed on the VALUE, NAV and Worst columns if items are not supported.

#### (2) Usage

The combination of the values of ID=a2 and e7 is used to diagnose whether or not the SSD has a physical failure when it is suspected.

Result		Description	Diagnosis
ID	VALUE		
a2	5	The number of remaining spare blocks is small.	SSD replacement is recommended.
e7	0	The flash memory has reached the end of its life.	SSD replacement is recommended.

#### (3) ID=a2 and e7

ID	Name	Description	Remarks
a2	Spare Block Count(CE)	Number of remaining spare blocks	A faulty block will be replaced with a spare one.
e7	SSD Life Left	Flash memory life (%)	“100%” is indicated at the beginning of use. When it becomes “0%”, the flash memory has reached the end of its life.

(4) Description of each ID

ID	Name	Explanation
01	Number of UNC Error	Uncorrectable error numbers
05	SSD Status	SSD status (0: Normal, 1: Abnormal)
09	Power-on Hours Count	Power-on hours
0c	Power ON/OFF Cycles Count	Power ON/OFF times
a2	Spare Block Count(CE)	Number of remaining spare blocks (A faulty block will be replaced with a spare one.)
a8	SATA PHY Error Count	Error detection times in PHY (physical layer)
aa	Bad Block Count(Later)	Number of faulty blocks
ad	Erase Count(Ave)	Flash memory average erasure (P/E <sup>*</sup> ) times per block
c0	Unexpected Power Loss Count	Forcible power OFF times
c2	Temperature	SSD internal temperature
da	CRC Error Count	CRC error occurrence times
e7	SSD Life Left	Flash memory life (Unit: %) ("100%" is indicated at the beginning of use. When it becomes "0%", the flash memory has reached the end of its life.)
e9	NAND Write(GB)	Writing size to a flash memory (Unit: GB)
f1	Host Write(GB)	Writing size to an SSD controller (Unit: GB)
f2	Host Read(GB)	Reading size from an SSD controller (Unit: GB)
f6	Total Erase Count	Flash memory total erasure (P/E <sup>*</sup> ) times

\* P/E: program/erase

## [ 2 ] Optional storage device (HDD)

### (1) Display

Perform HS-75 File System Recovery > [SMART Info] > [Optional storage]. The following screen is displayed.

ID	NAME	VALUE	NAV	Worst
01	Read Error Rate	0	100	100
02	Throughput Performance	0	100	100
03	Spin Up Time	1308	100	100
04	Spin Start/Stop Count	92	100	100
05	Re-allocated Sector Count	0	100	100
06	Read Channel Margin	-----	---	---
07	Seek Error Rate	0	100	100
08	Seek Time Performance	0	100	100
09	Power-On Hours	75	100	100
0a	Spin Retry Count	0	101	100
0b	Calibration Retry Count	-----	---	---
0c	Power Cycle Count	71	100	100
bf	Shock Sense Count	0	100	100
c0	Power-Off Retract Count	0	100	100
c1	Load Cycle Count	1094	100	100
c2	Temperature	25	100	100
c3	ECC On the Fly Count	-----	---	---
c4	Re-allocation Event Count	0	100	100
c5	Current Pending Sector Count	0	100	100
c6	Off-Line Scan Unc Sector Count	0	100	100

Model : TOSHIBA MQ01ABU032BW — HDD model name  
 Serial : 58NBWVTST — HDD serial number

NextPage Back

Fig. 9-31

- Items supported differ depending on the storage device manufacturer.
- “---” is displayed on the VALUE, NAV and Worst columns if items are not supported.

### (2) Usage

The combination of the values of ID=05 and c5 is used to diagnose whether or not the HDD has a physical failure when its failure is suspected (service call F100 to F109 or F120 to F124 occurred).

Refer to the following pages for details about the fault diagnosis for the SSD.

📖 P. 9-17 “[ 1 ] Standard storage device (SSD)”

Result		Description	Diagnosis
ID	VALUE		
05	0	Low possibility of physical failure	HDD replacement is not required.
c5	0		
05	From 1 to 999	Defective sector has been reassigned and the storage device is recovered.	HDD replacement is not required.
c5	0		
05	Any value	High possibility of defective sector existence. (There will be a possibility of physical failure depending on the use of HDD.)	HDD replacement is recommended.
c5	1 or more		
05	Either one is at least 1000.	High possibility of physical failure	HDD replacement is recommended.
c5			
05	All values are displayed as “-----”.	High possibility of physical failure (An HDD connector, harness or SYS board may be one of the causes.)	HDD replacement is recommended.
c5			



(3) ID=05 and c5

ID	Name	Description	Remarks
05	Re-allocated Sector Count	Number of sectors reallocated	This value tends to increase at HDD failure.
c5	Current Pending Sector Count	Number of candidate sectors to be reallocated	This value tends to increase at HDD failure.

(4) Description of each ID

ID	Name	Explanation
01	Read Error Rate	Read error rate
02	Throughput Performance	Throughput performance
03	Spin Up Time	Spindle motor start-up time
04	Spin Start/Stop Count	Spindle motor start and stop times
05	Re-allocated Sector Count	Number of reallocation sectors
07	Seek Error Rate	Seek error rate
08	Seek Time Performance	Seek time performance
09	Power-On Hours	Power on hours (The unit varies depending on the manufacture: Minute or Hour.)
0a	Spin Retry Count	Spindle motor start-up retry times
0c	Power Cycle Count	Power ON/OFF times
c0	Power off Retract Count	Emergency unloading times
c1	Load Cycle Count	Loading/unloading times
c2	Temperature	HDD internal temperature
c3	ECC On the Fly Count	ECC On the Fly count
c4	Reallocation Event Count	Reallocation event times
c5	Current Pending Sector Count	Number of reallocation candidate sectors
c6	Off-Line Scan Uncorrectable Sector Count	Off-line scanning uncorrectable sector count
c7	Ultra DMA CRC Error Count (Rate)	Ultra DMA CRC error count
c8	Write Error Rate	Write error rate

**Notes:**

“Over-range” is displayed if the number of digits acquired from the HDD exceeds the maximum digits which can be displayed on the control panel; however, this does not indicate an error.

### 9.2.3 Precautions and procedures when replacing the storage device

The following optional storage devices can be installed in this MFP.

- Security HDD (GE-1360)
- Normal HDD (GE-1270: CND only)
- Security SSD (GE-1350, GE-1280)
- Normal SSD (GE-1290: CND only)

By the setting of FS-08-9717-1 (Optional storage device security setting), data in the optional storage device are protected and operated as below.

- When "0" (Normal) is set for FS-08-9717-1: Expands the image saving area.
- When "1" (Security) is set for FS-08-9717-1: Protects major user data (scanning data, address book) and expands the image saving area.
- When "2" (High security) is set for FS-08-9717-1: Protects all user data.

#### Notes:

- When the storage device is replaced, it is necessary to back up the data in it before replacing and to recover them after replacing.
- To maintain the security, ask users to perform the backup or restore for users' data and information in the storage device. The service technician can perform them only when users permit it.
- Some data in the storage device cannot be backed up and can be kept only on the paper.
- Do not replace the storage device and the SRAM together.
- When the storage device is replaced, do not perform SRAM data formatting (Clear SRAM) before the normal start-up.
- When the storage device is replaced, do not restore the back-up file before the normal start-up.

A procedure for replacing the storage device is shown below.

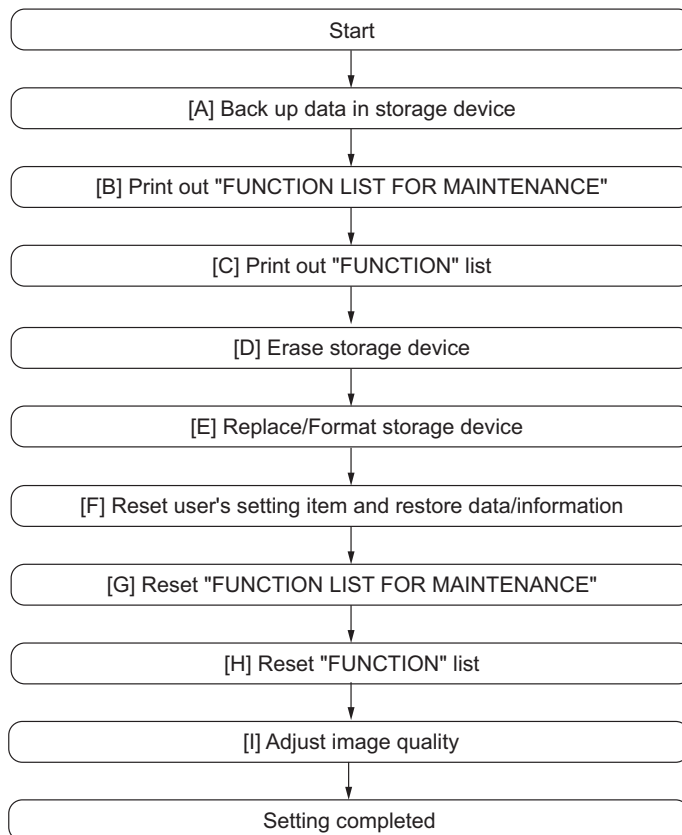

Fig. 9-32

## [A] Back up data in storage devices

Ask the user (administrator) to back up the data in the storage devices. Refer to the table below for the type of data, availability and method of backup.

Data type in storage devices	Availability	Backup method
Image data in e-Filing	Available	Archive them in "e-Filing" of TopAccess. As for the backup in Box data, all data (selectable by the box) can be backed up or restored in one go by using "e-Filing Backup/Restore Utility".
Mailbox information, Template registration information, Address book data, License	Available	Export them in the [Administration] tab - [Maintenance] - [Export] of TopAccess.
User information, Combined information (User information + Role + Group), LDAP Role, Department information, Project code	Available	Export them in the [Administration] tab - [Export/Import] - [Export] of TopAccess.
Log data (Print, Scan, FAX (Transmission, Reception))	Available	Export them in the "Administrator" menu of TopAccess. (Import cannot be performed.)
Data in the shared folder (Scanned data, Saved data of copy and FAX transmission)	Available	Copy them to the client computer via the network. (The data which have been copied to the client computer cannot be copied to the shared folder.)
Print waiting data (Copying data and FAX reception data that are waiting to be printed due to the paper run-out and jam, etc.)	Not available	Finish printing them after supplying paper or releasing the jam, etc. (The data cannot be left.)
Print job (Private print data, Schedule print data)	Not available	If any jobs are left, print them. (The data cannot be backed up.)
FAX saved data (Confidential / Bulletin board data)	Not available	Print them. (The data cannot be backed up.)
Registration data for FAX transmission (Delayed transmission / Recovery transmission)	Not available	The data cannot be backed up.

### Notes:

If the backing up of the license has failed, reissue it and install it in the MFP again.

 P. 14-16 "14.6 License"

## [B] Print out "FUNCTION LIST FOR MAINTENANCE"

- (1) Perform FS-12 (12 FAX LIST PRINT MODE).
- (2) Select "Function list for Maintenance" and then press [PRINT].

## [C] Print out "FUNCTION" list

- (1) Press [USER FUNCTIONS] on the [HOME] screen.
- (2) Enter the password in [Administrator] tab and press [OK].

### Notes:

Explain the procedure to the users (machine administrators) and ask them to enter their password.

- (3) Press [LIST/REPORT] and then [LIST].
- (4) Press [FUNCTION]. The "FUNCTION LIST" is printed out.

## **[D] Delete data in storage devices**

- (1) Perform HS-74 Storage Assist > [Revert Factory Initial Status Storage] and then press [OK].
- (2) Turn the power OFF.

## **[E] Replace / Format storage device**

### **Standard storage device**

- (1) Be sure to unplug the power cable before starting this work.
- (2) Replace the standard storage device.  
 P. 9-2 "9.1.3 SSD"
- (3) Creates a partition of the standard storage device.  
Perform HS-73 Firmware Assist > [Format Storage] and then press [OK].  
When "Operation Complete" is displayed on the LCD, creating of the partitions is completed.

#### **Remarks:**

When HS-73 Firmware Assist > [Storage Data Restore] is carried out instead of step (3), perform [Storage Data Restore] and then the following steps in [E].

(4) > (5) > (6) > (9) > (10) > (11) > (12)

In addition, skip [F] and perform the procedure from [G].

- (4) Turn the power OFF.
- (5) Initialize the service password.  
Perform HS-73 Firmware Assist > [Clear Service Tech Password] and then press [OK].  
When "Reset Complete" is displayed on the LCD, formatting of the service tech password is completed.
- (6) Turn the power OFF.
- (7) Update the system software using the USB storage device.  
 P. 11-2 "11.2 Firmware Updating with a USB Storage Device"
- (8) Turn the power OFF.
- (9) When the Fax Board (GD-1370) is installed, perform [CUSTOM INITIALIZE] > [INIT MEMORY(FAX)] and [CLEAR DATA] in the FS-11 FAX CLEAR MODE. Then turn the power OFF.
- (10) Check the system software version (FS-08-8952).  
Confirm the version displayed on the LCD, and then press [OK].
- (11) Initialize the NIC information (FS-08-9083).
- (12) Turn the power OFF.

#### **Notes:**

When replacing or formatting the standard storage device, the licenses installed in the MFP are removed. Therefore, it is necessary to restore those licenses after the replacement or formatting.

 P. 14-16 "14.6 License"

### Optional storage device

- (1) Creates a partition of the standard storage device.  
Perform HS-73 Firmware Assist > [Format Storage] and then press [OK].  
When "Operation Complete" is displayed on the LCD, creating of the partitions is completed.
- (2) Turn the power OFF.
- (3) Update the system software using the USB storage device.  
📖 P. 11-2 "11.2 Firmware Updating with a USB Storage Device"
- (4) Be sure to unplug the power cable before starting this work.
- (5) Replace the optional storage device.  
📖 P. 9-2 "9.1.4 Optional HDD"  
📖 P. 9-3 "9.1.5 Optional SSD"

#### Remarks:

Once the optional storage device is installed, its partition is created automatically.

- (6) Initialize the service password.  
Perform HS-73 Firmware Assist > [Clear Service Tech Password] and then press [OK].  
When "Reset Complete" is displayed on the LCD, formatting of the service tech password is completed.
- (7) Turn the power OFF.
- (8) When the Fax Board (GD-1370) is installed, perform [CUSTOM INITIALIZE] > [INIT MEMORY(FAX)] and [CLEAR DATA] in the FS-11 FAX CLEAR MODE. Then turn the power OFF.
- (9) Check the system software version (FS-08-8952).  
Confirm the version displayed on the LCD and then press [OK].
- (10) Initialize the NIC information (FS-08-9083).
- (11) Turn the power OFF.

### [F] Reset user's setting items and restore data/information

Ask the user (MFP administrator) to reset the user's setting items and to restore data or information. Refer to the following for the reset and restore.

Items to be reset and restored	Action
Printer driver	Upload them in the "Administrator" menu of TopAccess.
Mailbox information, Template registration information, Address book data, License	Import them in the [Administration] tab - [Maintenance] - [Import] of TopAccess.
User information, Combined information (User information + Role + Group), LDAP Role, Department information, Project code	Import them in the [Administration] tab - [Export/Import] - [Import] of TopAccess.
Image data in e-Filing	Upload them in the "e-Filing" of TopAccess.

**Notes:**

- When the SSL is enabled, perform the setting of the following items again with “Self-signed certificate” of TopAccess.
  - Country or Region Name
  - State or Province Name
  - Locality Name
  - Organization Name
  - Organizational Unit Name
  - Common Name
  - Email Address
- When the wireless LAN is used, recreate its setting. (Only when security with a certificate is used)
  - CA certificate (PEM)
  - CA certificate (DER)
- If the restoring of the licenses has failed while the storage data are backed up, reissue them and install them in the MFP again.  
 P. 14-16 “14.6 License”

**[G] Reset “FUNCTION LIST FOR MAINTENANCE”**

- (1) Print out the “FUNCTION LIST FOR MAINTENANCE” list before initializing the storage device.  
 P. 9-21 “[B] Print out “FUNCTION LIST FOR MAINTENANCE””
- (2) Perform FS-13 (13 FAX FUNCTION MODE).
- (3) Compare the lists which were printed before and after the initializing to check the setting items having the different setting values. Set the value which was set before the initializing.
- (4) Turn the power OFF.

**[H] Reset “FUNCTION” list**

Reset the fax function by referring to the “FUNCTION” list.

 P. 9-21 “[C] Print out “FUNCTION” list”

- (1) Press [USER FUNCTIONS] on the [HOME] screen.
- (2) Enter the password in [Administrator] tab and press [OK].

**Notes:**

Explain the procedure to the users (MFP administrators) and ask them to enter their password.

- (3) Press [FAX] and then [TERMINAL ID] to set each item.
- (4) Press [INITIAL SETUP] to set each item.

**[I] Adjust image quality**

- (1) Perform Automatic gamma adjustment.  
 P. 6-24 “6.1.6 Automatic gamma adjustment”
- (2) Turn the power OFF.

## 9.2.4 Precautions and procedures when replacing the SYS board

A procedure for SYS board replacement is shown below.

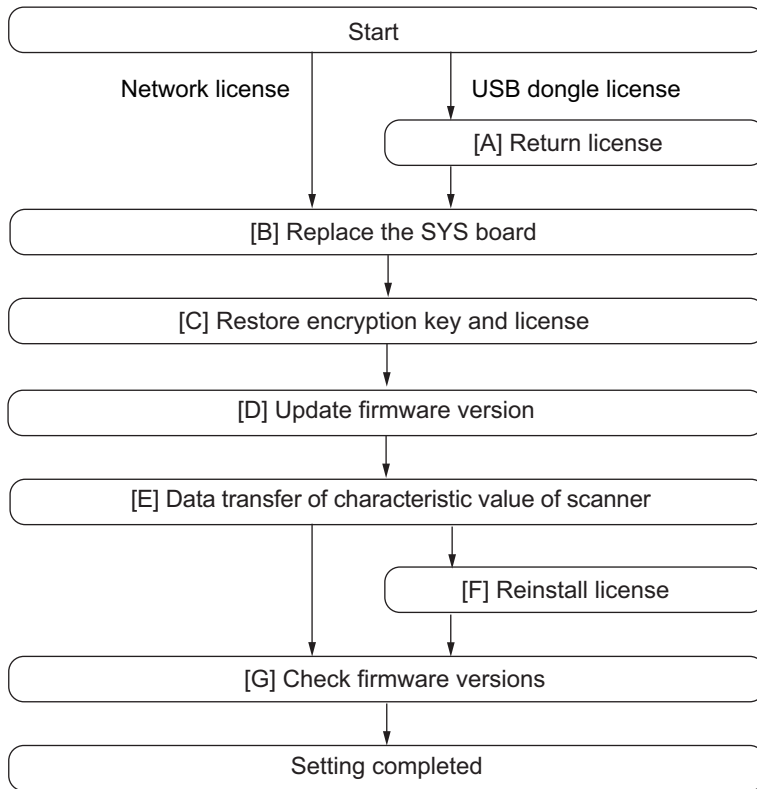

Fig. 9-33

### Notes:

- When the SYS board in the MFP with TPM enabled is replaced, the restoring operation of TPM is necessary.
  - P. 5-51 “5.23 TPM Restore”
- It is required to perform storage device initialization in the MFP with the High Security Mode enabled. Therefore, perform the following items which are carried out at the storage device replacement in advance.
  - P. 9-21 “[A] Back up data in storage devices”
  - P. 9-21 “[B] Print out “FUNCTION LIST FOR MAINTENANCE””
  - P. 9-21 “[C] Print out “FUNCTION” list”

### [A] Return License

#### Notes:

- If the 08 Setting Mode is not started up, “[A] Return License” can be omitted. In that case, reinstall the license with “[1] Re-registration when the board is replaced” if it is cleared since “[H] Reinstallation of License” cannot be performed.
- When the security mode is set to High Security, specify the security mode level to “1” (Low level) for FS-08-8911 and then reboot the MFP.

- (1) Perform FS-08-3840.
- (2) Select the license to be returned, and then press [REMOVE].
- (3) Install the one-time dongle, which you used for uploading the selected license, in the MFP and then press [OK].

- (4) The Remove screen is displayed, then press [YES].  
If this screen is not displayed, check whether the one-time dongle is installed in the MFP properly.
- (5) After 10 to 40 seconds passes, the screen for notifying the success of performance is displayed. Then press [OK].  
If this screen is not displayed or the screen for notifying the failure of performance is displayed, quit this operation by pressing [NO] or [CLOSE].  
Then, check whether the one-time dongle, which you used for uploading the selected license, is installed in the MFP.
- (6) Check that the returned license is not displayed on the screen.

**Remarks:**

If there are any other licenses to be returned, repeat from step (2).

If there is no more licenses to be returned, press [CLOSE] and then turn the power OFF.

**[B] Replace the SYS board**

**Notes:**

Before replacing the SYS board, perform the following procedure.

 P. 9-16 “9.2.1 Precautions when replacing PC boards”

- (1) Be sure to unplug the power cable before starting this work.
- (2) Replace the SYS board.
- (3) Install the SRAM in the new SYS board (from the old SYS board).
- (4) Install the standard SSD in the new SYS board (from the old SYS board).

**[C] Restore Encryption Key and License**

- (1) Perform HS-73 Firmware Assist.
- (2) Press [Key Backup/Restore].
- (3) Press [Direction], and then press [Execute].
- (4) Wait until the restoring of the encryption key and license is completed. “Success” is displayed. Confirm that “OK” is indicated in all of the FROM column and then reboot the MFP.

**For MFP with the High Security Mode enabled**

Continue by performing the following steps.

1. Create the partitions on the storage device.  
Perform HS-73 Firmware Assist > [Format Storage] and then press [OK].  
When “Operation Complete” is displayed on the LCD, creating of the partitions is completed.
2. Turn the power OFF.
3. Initialize the service password.  
Perform HS-73 Firmware Assist > [Clear Service Tech Password] and then press [OK].  
When “Reset Complete” is displayed on the LCD, formatting of the service tech password is completed.
4. Turn the power OFF.
5. Update the system software using the USB storage device.
6. Turn the power OFF.
7. When the Fax Board (GD-1370) is installed, perform [CUSTOM INITIALIZE] > [INIT MEMORY(FAX)] and [CLEAR DATA] in the FS-11 FAX CLEAR MODE. Then turn the power OFF.



8. Check the system software version (FS-08-8952).  
Confirm the version displayed on the LCD and then press [OK].
9. Initialize the NIC information (FS-08-9083).
10. Turn the power OFF.
11. Perform the following procedure.  
📖 P. 12-13 “12.4.3 Precautions for MFPs with TPM enabled”

#### **[D] Update firmware version**

- (1) Update the version of the system firmware using the USB storage device.  
📖 P. 11-2 “11.2 Firmware Updating with a USB Storage Device”

#### **[E] Data transfer of characteristic value of scanner**

- (1) Perform FS-05-3203.
- (2) Turn the power OFF.

#### **[F] Reinstall license**

If the license was returned in “[A] Return License”, reinstall it with the following procedure.

📖 P. 9-25 “[A] Return License”

- (1) Perform FS-08-3840.
- (2) Press [INSTALL].
- (3) Install the one-time dongle in the MFP (the one which you used for returning the selected license before replacing the MFP). Then press [OK].
- (4) Select the license to be installed, and then press [INSTALL].
- (5) The screen for notifying that the installation will be started is displayed. Then press [YES].
- (6) After 10 to 40 seconds passes, the screen for notifying the success of performance is displayed. Then press [OK]. If the screen for notifying a failure of the performance is displayed, quit this operation by pressing [NO].  
Then check that the one-time dongle is installed properly in the MFP.
- (7) Check that the installed license is displayed on the license list.

#### **Remarks:**

- If there are any other licenses to be installed, repeat from step (2).
- If there are no other licenses to be installed, press [CLOSE] and then turn the power OFF.

#### **[G] Check firmware versions**

- System firmware version (FS-08-9930)
- Scanner firmware version (FS-08-9902)

#### **Notes:**

If the security mode is changed from High Security to Low Security in the step “[A] Return License”, set the value of FS-08-8911 to “3” (High Security).

## 9.2.5 Precautions and procedure when replacing the SRAM

### Notes:

- Do not replace the storage device and the SRAM together.
- Be careful not to damage the board when replacing the SRAM.
- When the SRAM is replaced, do not perform the initialization of the standard storage device before starting the MFP in the normal mode.
- When disposing of the SRAM, see the following reference.  
📖 P. 9-40 “9.3.3 Precautions when disposing of the SRAM”

A procedure for replacing the SRAM is shown below.

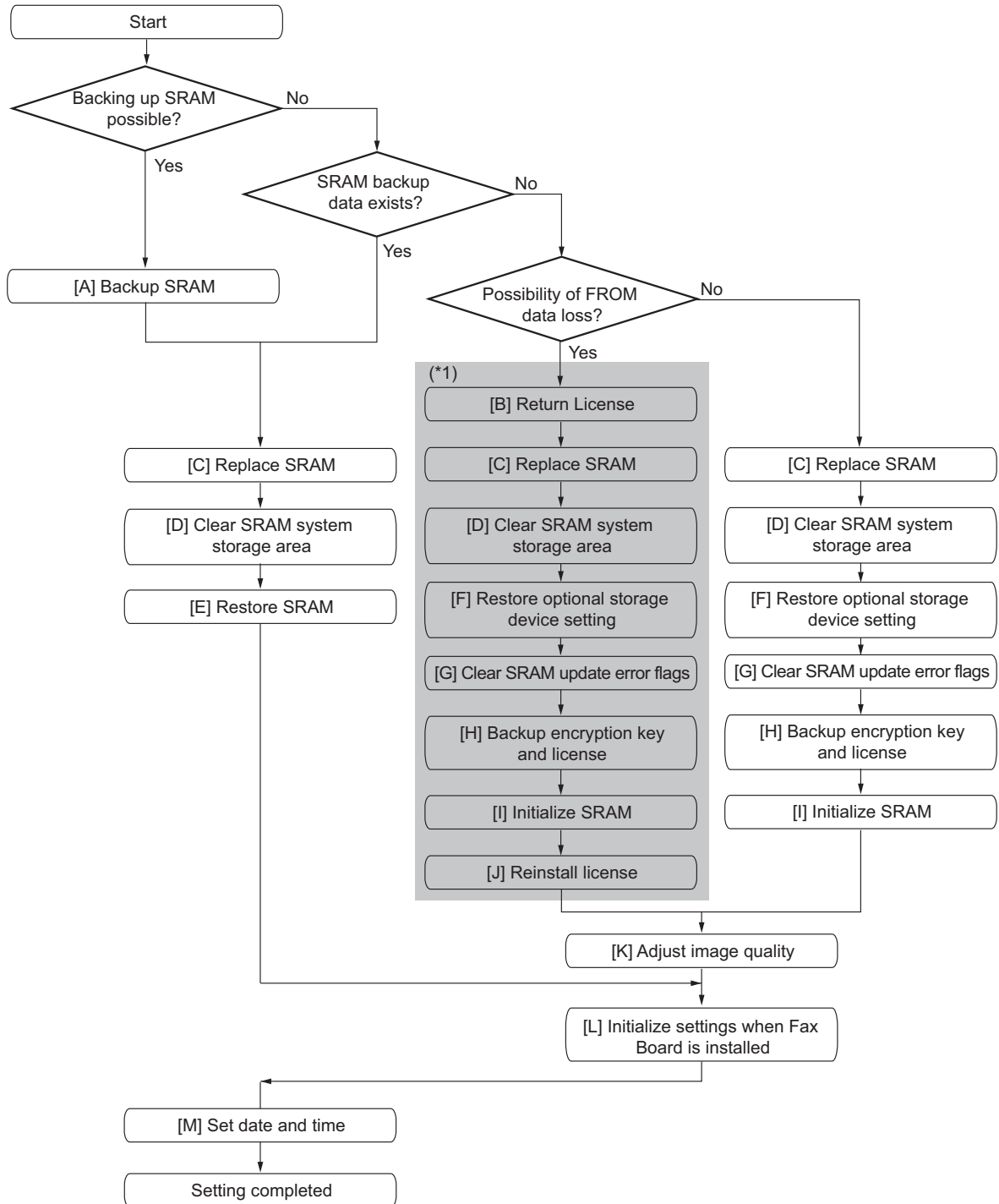

Fig. 9-34

**Notes:**

Use the flow (\*1) when securely returning and reinstalling the license. Returning and reinstalling the license is required when it has been lost. The examples are as below.

e.g. 1: When SRAM data are overwritten on the FROM mistakenly due to an incorrect operation during the backup of the license



e.g. 2: When the SYS board (SRAM) is damaged or the license data in the FROM are broken

**[A] Backup SRAM**

Perform a backup before replacing the SRAM.

 P. 12-2 “[A] Backup procedure”

**Notes:**

- If “[A] Backup SRAM” fails, proceed to the following procedure.  
 P. 9-29 “[B] Return License”
- If “[A] Backup SRAM” succeeds, proceed to the following procedure.  
 P. 9-29 “[C] Replace SRAM”

**[B] Return License****Notes:**

When the security mode is set to High Security, specify the security mode level to “1” (Low level) for FS-08-8911 and then reboot the MFP.

- (1) Perform FS-08-3840.
- (2) Select the license to be returned, and then press [REMOVE].
- (3) Install the one-time dongle, which you used for uploading the selected license, in the MFP and then press [OK].
- (4) The Remove screen is displayed. Press [YES].  
If this screen is not displayed, check whether the one-time dongle is installed in the MFP properly.
- (5) After 10 to 40 seconds passes, the screen for notifying the success of performance is displayed. Then press [OK].  
If this screen is not displayed or the screen for notifying the failure of performance is displayed, quit this operation by pressing [NO] or [CLOSE].  
Then, check whether the one-time dongle, which you used for uploading the selected license, is installed in the MFP.
- (6) Check that the returned license is not displayed on the screen.

**Remarks:**

If there are any other licenses to be returned, repeat from step (2).

If there is no more licenses to be returned, press [CLOSE] and then turn the power OFF.

**[C] Replace SRAM**

- (1) Be sure to unplug the power cable before starting this work.
- (2) Replace the SRAM.  
 P. 9-12 “9.1.11 SRAM”

**[D] Clear SRAM system storage area**

- (1) Perform HS-76 SRAM Maintenance.  
The authentication screen appears. Press [OK]. (Entry of a password is unnecessary.)
- (2) When “SRAM Clear Mode” appears on the LCD, press the [Clear SRAM].
- (3) When “SRAM Format Completed” is displayed on the LCD, initializing is completed.
- (4) Turn the power OFF.

**[E] Restore SRAM**

- (1) Perform HS-76 SRAM Maintenance.
- (2) When “SRAM Clear Mode” appears on the LCD screen, press [Set Serial Number].
- (3) Key in the serial number printed on the label attached to the rear cover of the MFP and then press [OK].
- (4) “Set Serial Number was completed.” is displayed.
- (5) Turn the power OFF.
- (6) If there are SRAM backup data, perform restoring.  
 P. 12-2 “[B] Restore procedure”
- (7) Turn the power OFF after the restoring of SRAM is completed.

**Remarks:**

When the restoration is completed successfully, proceed to the following procedure.  
 P. 9-32 “[L] Initialize settings when FAX Board (GD-1370) is installed”

**[F] Restore optional storage device setting**

When an optional storage device is installed, restore the setting in accordance with the procedure below.

- (1) Perform HS-78 Restore Option Storage Settings.
- (2) When “Restore Optional Storage Settings” is displayed on the LCD, press [Restore to SRAM].
- (3) When “Confirmation Screen” is displayed on the LCD, press [OK].
- (4) When “Completed” is displayed on the LCD, restoration is completed.
- (5) Turn the power OFF.

**[G] Clear SRAM Update Error Flag**

- (1) Perform HS-73 Firmware Assist.
- (2) Press [Clear Software Update Error Flag].
- (3) When “Operation Complete” is displayed on the LCD, clearing the flag is completed.
- (4) Turn the power OFF.

**[H] Backup encryption key and license (FROM > SRAM)**

- (1) Perform HS-73 Firmware Assist.
- (2) Press [Key Backup/Restore].
- (3) Press [Direction] twice and then [Execute].
- (4) Wait until the backup of the encryption key and license is completed. "Success" is displayed. Confirm that "OK" is indicated in all of the SRAM column and then reboot the MFP.
- (5) Turn the power OFF.

**[I] Initialize SRAM**

- (1) Perform FS-08.
- (2) Initialize the SRAM.  
When "SRAM REQUIRES INITIALIZATION" is displayed on the LCD, check the destination and then press the [START] button. If the destination is not correct, key in the correct one and then press the [START] button.  
After the confirmation message is displayed, press [OK].
- (3) Perform FS-08-9030 (initialization at the software version upgrade).
- (4) Initialize the NIC information (FS-08-9083).
- (5) Enter the serial number (FS-08-9601).  
Key in the serial number on the label attached to the rear cover of the MFP and then press [OK].
- (6) Turn the power OFF.

**[J] Reinstall license**

If the license was returned in "[B] Return License", reinstall it with the following procedure.

 P. 9-29 "[B] Return License"

- (1) Perform FS-08-3840.
- (2) Press [INSTALL].
- (3) Install the one-time dongle in the MFP (the one which you used for returning the selected license before replacing the MFP). Then press [OK].
- (4) Select the license to be installed, and then press [INSTALL].
- (5) The screen for notifying that the installation will be started is displayed. Then press [YES].
- (6) After 10 to 40 seconds passes, the screen for notifying the success of performance is displayed. Then press [OK]. If the screen for notifying a failure of the performance is displayed, quit this operation by pressing [NO].  
Then check that the one-time dongle is installed properly in the MFP.
- (7) Check that the installed license is displayed on the license list.

**Remarks:**

- If there are any other licenses to be installed, repeat from step (2).
- If there are no other licenses to be installed, press [CLOSE] and then turn the power OFF.

**[K] Adjust image quality**

- (1) Perform FS-05-3203 (Data transfer of characteristic value of scanner).
- (2) Perform Automatic gamma adjustment.  
 P. 6-24 “6.1.6 Automatic gamma adjustment”
- (3) Turn the power OFF.

**[L] Initialize settings when FAX Board (GD-1370) is installed**

- (1) Reinstall the FAX Board (GD-1370).
- (2) Set the destination of FAX (FS-08-9001).
- (3) Turn the power OFF.
- (4) Perform FS-11 > CUSTOM INITIALIZE > INIT MEMORY(FAX).
- (5) Turn the power OFF and then back ON.
- (6) Set the dial type according to these buttons: [HOME] > [USER FUNCTIONS] > [ADMIN] > [FAX] > [INITIAL SETUP]

**[M] Set date and time**

Set the date and time according to these buttons. [HOME] > [USER FUNCTIONS] > [ADMIN] > [GENERAL] > [CLOCK] > [DATE/TIME]

## 9.2.6 Procedures when replacing the LGC board

Be sure to follow the procedure below when replacing the LGC board.

- (1) Perform FS-08-4870 to back up the data in the Main EEPROM to the Sub EEPROM.
- (2) Turn the power OFF and unplug the power cable.
- (3) Remove the LGC board.  
 P. 9-8 "9.1.8 LGC board"
- (4) Remove the Sub EEPROM from the LGC board.
- (5) Install the removed Sub EEPROM in the new LGC board.
- (6) Attach the new LGC board to the MFP.
- (7) Perform FS-08-4871 to back up the data in the Sub EEPROM to the Main EEPROM.

### Remarks:

- After the LGC board is replaced, update the version of the engine firmware to the latest one.
- Moving to FS-08 after replacing the LGC board enables the recovering of the licenses.

## 9.2.7 Procedures and settings when replacing the Sub EEPROM

### Notes:

Be careful not to damage the Sub EEPROM when replacing it.

A procedure for replacing the Sub EEPROM is shown below.

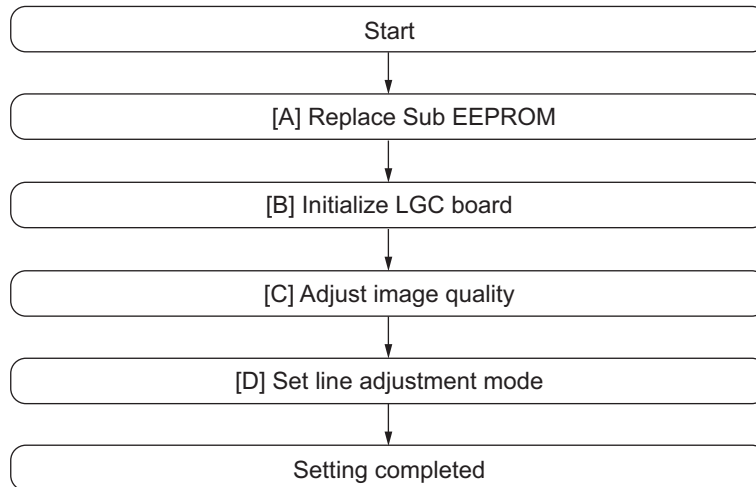

Fig. 9-35

### [A] Replacing the Sub EEPROM

- (1) Turn the power OFF and unplug the power cable.
- (2) Remove the Sub EEPROM from the LGC board.
- (3) Attach the new Sub EEPROM to the LGC board.
- (4) Perform FS-08-4870 to back up the data in the Main EEPROM to the Sub EEPROM.
- (5) If the problem still persists, replace the LGC board and perform the steps in [B].

#### Remarks:

After the LGC board is replaced, update the version of the engine firmware to the latest one.

### [B] Initialize LGC board

- (1) Open the front cover, and check the destination printed on the white tape stuck on the MFP.
- (2) Perform FS-08-9060 (Destination display at SRAM initialization).



- (3) Check whether the displayed destination (see the below figure) of the LGC-SRAM is the same as the one in step (1).

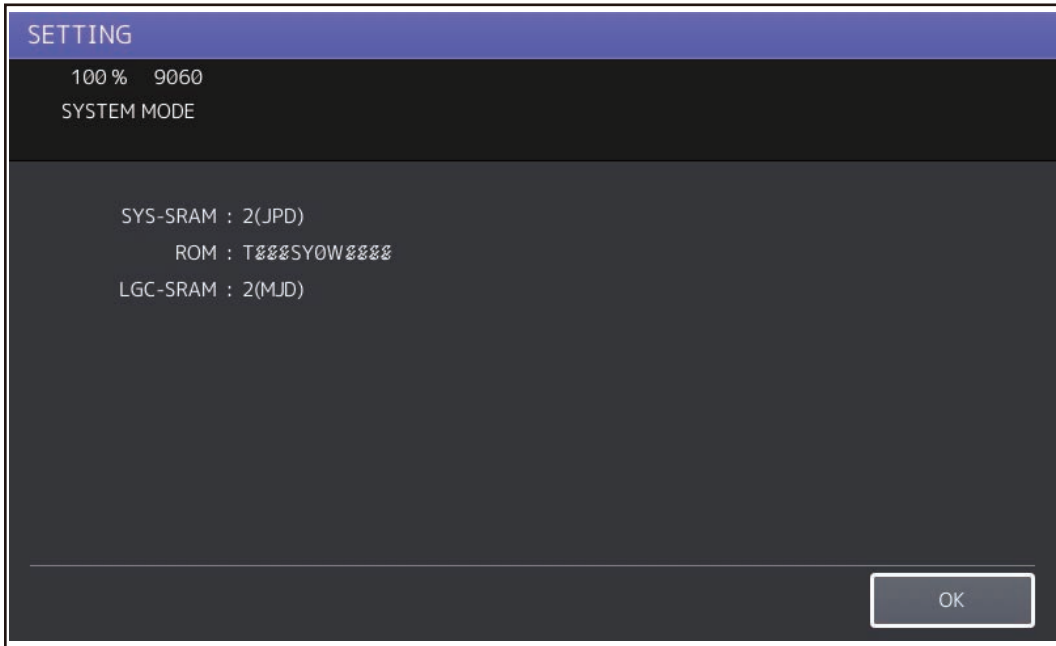

Fig. 9-36

**Remarks:**

If the destinations are different, initialize the LGC-SRAM with reference to the following procedure. Even if the destinations are the same, initialize the LGC-SRAM if required.  
📖 P. 9-28 "9.2.5 Precautions and procedure when replacing the SRAM"

- (4) Perform FS-08-9090 (Printer all clear).
- (5) Press [INITIALIZE] to perform the initialization of the Main EEPROM.

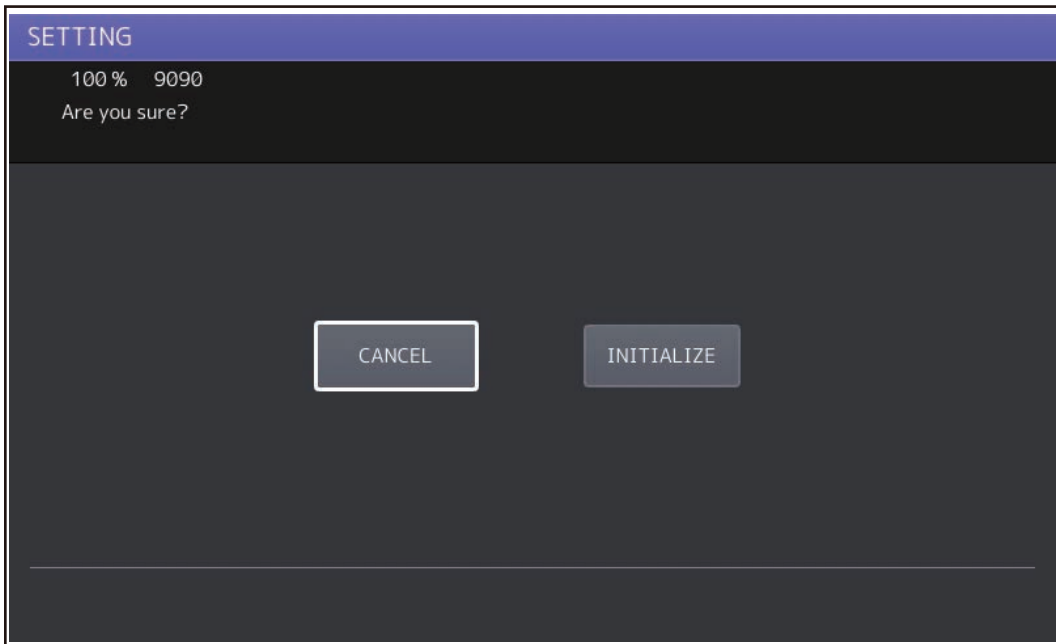

Fig. 9-37

- (6) Perform FS-08-9060 to display the destination at SRAM initialization. Check whether the destination of the one given on the attached label to the MFP and the LGC-SRAM and SYS-RAM is the same.

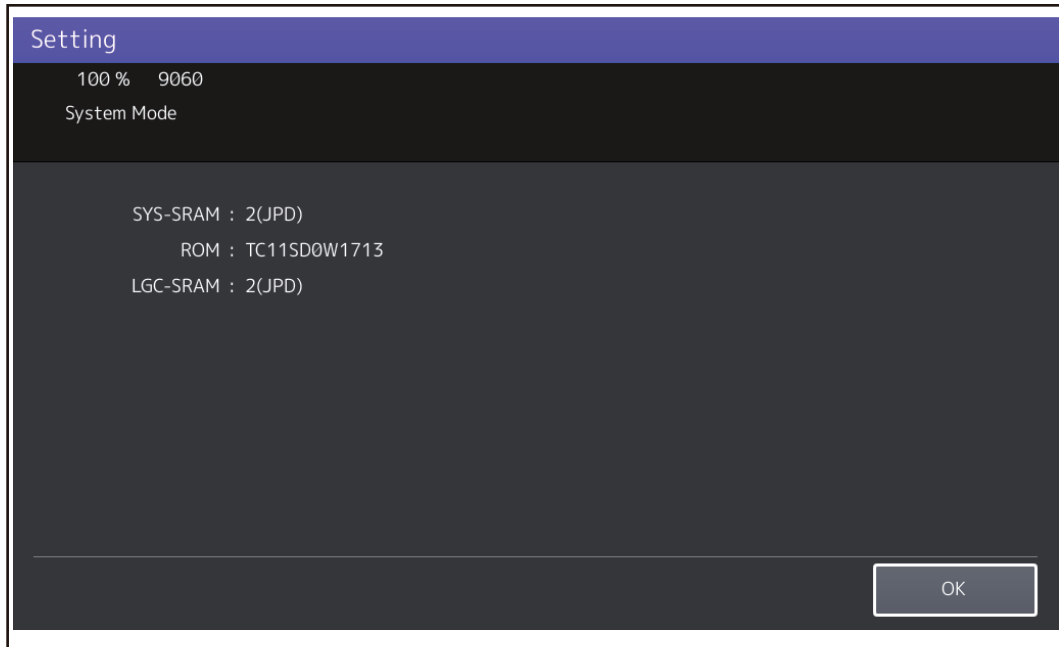

Fig. 9-38

**Remarks:**

If an error occurs during the initialization of the LGC board and the initialization fails, error messages are displayed on the touch panel. The error messages and the corresponding troubleshooting methods are shown below.

Error message	Countermeasure
UNDEFINED MODEL	There may be any abnormality in the LGC board. Replace the LGC board by following the reference below. 📖 P. 9-8 "9.1.8 LGC board"
UNDEFINED VERSION	There may be an abnormality in the EEPROM. Recheck the destination of the LGC-SRAM. Replace the Sub EEPROM by following the reference below. 📖 P. 9-36 "[A] Replacing the Sub EEPROM"
VERIFY ERROR	Check the installation of the Sub EEPROM.

## 9.2.8 Procedures and settings when replacing the lens unit

When replacing the lens unit, follow the procedure below.

- (1) Confirm that the power is turned OFF.
- (2) Replace the lens unit.  
📖 P. 4-23 “4.3.5 Lens unit (CCD driving PC board)”
- (3) Perform FS-05-3209 (Data transfer of characteristic value of scanner / SYS board > Lens unit).
- (4) Perform FS-05-3218 (Shading correction plate Automatic dust detection adjustment).
- (5) Turn the power OFF.

## 9.2.9 Firmware confirmation after the PC board/storage device replacement

After replacing the PC board/storage device, check the firmware version in the 08 Setting Mode and confirm if the firmware combination is correct,

Firmware	Code
System software	9900
System firmware	9930
Engine Firmware	9901
Scanner firmware	9902
NIC firmware	9990
RADF/DSDF firmware	9903
Finisher firmware	9904
Hole punch firmware	9944
Fax board firmware (Line 1)	9905
Fax board firmware (Line 2)	9969

The installed ROM versions and the registered optional Electronic License Keys can be confirmed in the list print mode following the procedure below.

- (1) Perform FS-30-111 to print out VERSION LIST.  
It is recommended to keep this list for future reinstallation such as the replacement of the SYS board.
- (2) Shut down the MFP.

## 9.2.10 License re-registration using the one-time dongle

### [ 1 ] Re-registration when the board is replaced

The license registered using the one-time dongle can be re-registered only in the same MFP. When the SYS board or SRAM is replaced, follow the procedures for re-registration given below.

- (1) Perform FS-08-3840.
- (2) Press [INSTALL].
- (3) Install the one-time dongle in the MFP (the one which you used for registering the selected license) and then press [OK].
- (4) Select the license to be installed, and then press [INSTALL].
- (5) The screen for notifying that the installation will be started is displayed. Then press [YES].
- (6) After 10 to 40 seconds have passed, the screen for notifying the success of the performance is displayed. Then press [OK]. If the screen for notifying a failure of the performance is displayed, quit this operation by pressing [NO]. Then check that the one-time dongle is installed properly in the MFP.
- (7) Check that the installed license is displayed on the license list.

#### Remarks:

If there are any other licenses to be installed, repeat from step (2).

If there are no other licenses to be installed, press [CLOSE] and then turn the power OFF.

#### Notes:

This procedure is available only with the one-time dongle used for the previous registration, since the model information registered in it is utilized. Use the same one-time dongle and the MFP when registering the license.

### [ 2 ] Re-registration when the MFP is replaced due to malfunction

When the MFP has to be replaced due to a malfunction, return the license registered in the MFP to the one-time dongle and register it to the new MFP following the procedure below.

#### Notes:

It is not possible to re-register the license for the IPsec Enabler (GP-1080) into other MFP.

- (1) Perform FS-08-3840.
- (2) Select the license to be returned, and then press [REMOVE].
- (3) Install the one-time dongle, which you used for uploading the selected license, in the MFP and then press [OK].
- (4) The Remove screen is displayed, then press [YES].  
If this screen is not displayed, check whether the one-time dongle is installed in the MFP properly.
- (5) After 10 to 40 seconds have passed, the screen for notifying the success of the performance is displayed. Then press [OK].  
If the screen for notifying a failure of the performance is displayed, quit this operation by pressing [NO].  
Then, check whether the one-time dongle, which you used for uploading the selected license, is installed in the MFP.

- (6) Check that the returned license is not displayed on the screen.

**Remarks:**

If there are any other licenses to be returned, repeat from step (2). If there is no more licenses to be returned, press [CLOSE] and then turn the power OFF.

- (7) Replace the MFP.
- (8) Perform FS-08-3840.
- (9) Press [INSTALL].
- (10) Install the one-time dongle in the MFP (the one which you used for returning the selected license before replacing the MFP). Then press [OK].
- (11) Select the license to be installed, and then press [INSTALL].
- (12) The screen for notifying that the installation will be started is displayed. Then press [YES].
- (13) After 10 to 40 seconds have passed, the screen for notifying the success of the performance is displayed. Then press [OK].  
If the screen for notifying a failure of the performance is displayed, quit this operation by pressing [NO].  
Then check that the one-time dongle is installed properly in the MFP.
- (14) Check that the installed license is displayed on the license list.

**Remarks:**

If there are any other licenses to be installed, repeat from step (9).

If there are no other licenses to be installed, press [CLOSE] and then turn the power OFF.

## 9.3 Precautions when Disposing of the Storage Devices and PC Boards

### 9.3.1 Precautions when disposing of the storage devices

#### [ 1 ] Standard storage device

When disposing of the standard storage device, perform the following operation.

HS-74 Storage Assist > [Revert Factory Initial Status Storage] > [Standard storage]

#### [ 2 ] Security HDD / security SSD / normal SSD (optional)

When disposing of any of the security HDD, the security SSD or the normal SSD, perform the following operation.

HS-74 Storage Assist > [Revert Factory Initial Status Storage] > [Optional storage]

#### [ 3 ] Optional normal HDD

When disposing of the optional normal HDD, perform the following setting

HS-73 Firmware Assist > [Erase Storage Securely]: Normal HDD securely erasing

This setting is the overwriting method complying with DoD 5220.22-M.

1. LOW: This is the normal overwriting method. (This setting is used normally.)  
"00-FF-Random-Verify" Once
2. MEDIUM: This overwriting method is more secure than LOW. The erasing time is between LOW and HIGH.  
"00-FF-Random" three times repeatedly -Verify
3. HIGH: This is the most secure overwriting method. It takes the longest time to erase data.  
"00-FF-Random" five times repeatedly -Verify
4. SIMPLE: This is the simple overwriting method. It takes the shortest time to erase data.  
Overwrite the Random data once

#### Remarks:

The approximate time for securely erasing a normal HDD (320GB) is as follows (referential values).

Erase type	Erase time
LOW	Approximately 4.25 hours
MEDIUM	Approximately 11 hours
HIGH	Approximately 17.25 hours
SIMPLE	Approximately 2.25 hours

### 9.3.2 Precautions when disposing of the SYS board

When disposing of the SYS board, data clearing is not required since important data, such as user information, etc. are stored in the SRAM.

### 9.3.3 Precautions when disposing of the SRAM

When disposing of the SRAM, perform HS-73 Firmware Assist > [Erase SRAM Securely] (SRAM securely erasing) for security reasons.

#### Notes:

If this is performed, the MFP cannot be started up.

## 10. REMOTE SERVICE

This chapter explains details of the functions so that service engineers can perform service more effectively.

### 10.1 Auto Supply Order

#### 10.1.1 Overview

This function automatically orders the toner cartridge.

(1) Order method

The following two methods are available to place an order.

- Fax  
Installation of a fax board is required.  
If no fax board is installed, this function is set to Off.
- E-mail (by attaching a TIFF image)

(2) Order timing

The auto supply order is sent as indicated in the following steps.

- Toner cartridge
  1. Toner empty occurs.
  2. The toner cartridge is replaced.
  3. The toner empty counter is incremented when the total number of prints or the pixel counter value exceeds the threshold set in the following self-diagnostic code.

Code	Setting item	Contents
FS-08-6506	Toner empty determination counter	Selects the counter to determine toner empty. 0: Output pages 1: Pixel counter
FS-08-6507	Threshold setting for toner empty determination (output pages)	Sets the number of output pages to determine toner empty. This setting is valid when "0" is set for FS-08-6506.
FS-08-6508	Threshold setting for toner empty determination (pixel counter)	Sets the number of the pixel counter value to determine toner empty. This setting is valid when "1" is set for FS-08-6506.

e.g.:

When "0" is set for FS-08-6506 and "50" is set for FS-08-6507, the toner empty counter is incremented when 50 sheets are printed after the toner cartridge has been replaced.

4. When the accumulated number of toner empty times reaches the set condition, an order is placed automatically.

(3) When placing an order has failed

If some problems occur and the order cannot be placed after being registered as a job, refer to the standard countermeasure for a fax or e-mail transmission failure.

## 10.1.2 Setting item

To enable the Auto Supply Order function, the following settings are required.

### Notes:

When selecting e-mail to place an order, it is required that the sending and the receiving of e-mails are available. Confirm the details with the administrator.

#### (1) Self-diagnostic setting (08 SETTING MODE)

As the default setting, the Auto Supply Order setting menu is not displayed on the HOME SCREEN.

Changing the setting is required to display the menu with FS-08-9783.

0: Valid (Fax, Internet fax)

1: Valid (Fax, Internet fax, HTTP\*)

2: Invalid (Default)

When the value is changed from "2" (default) to "0", the Auto Supply Order setting menu is displayed.

\* HTTP has not been supported yet.

#### (2) Touch panel setting

Each item is set from the Auto Supply Order menu on the HOME SCREEN.

Entering the password and customer information is required because the setting is made from the Admin menu. Setting it with the administrator is a must.

### Basic setting

[Admin] > [Service] > [Supply Order Setup] > [Order Information]

Auto Supply Order	Order method Selects from [Fax], [Mail] or [HTTP]. *1
Fax Number	Fax number of a supplier *2
E-mail	E-mail address of a supplier *3
Customer	Customer information
Name	
Tel Number	
E-mail	
Address	
Supplier	Supplier information
Name	
Address	
Service Engineer	Service engineer information
Number	
Name	
Tel Number	
E-mail	

\*1 HTTP has not been supported yet.

\*2 The Fax Number of the supplier must be entered when an order is made by means of a fax.

\*3 The e-mail address of the supplier must be entered when an order is made by means of an e-mail.



Detailed setting for the order

[Admin] > [Service] > [Supply Order Setup] > [Toner Ordering]

***** TONER ORDER	Order information (Toner cartridge)
Part Number	Part number to be ordered
Condition	Number of conditions *1
Quantity	Quantity to be ordered
Auto Order	ON/OFF setting of order for each part

\*1 The order is placed when the number of replacement reaches the number specified for Condition.

Fax Number of this MFP (common information)

[Admin] > [Fax] > [Terminal ID]

ID Name	ID name of this MFP
Fax Number	Fax number of this MFP

E-mail information of this MFP (common information)

[Admin] > [E-mail]

From Address	E-mail address of this MFP *1
From Name	E-mail user name of this MFP

\*1 When sending an e-mail, the validity of the address is checked. If the address is invalid, it is not sent.

(3) Outputting of the setting list of Auto Supply Order

1. Perform FS-12 (12 FAX LIST PRINT MODE).
2. Select "SUPPLY ORDER LIST" and then press [Print].

### 10.1.3 Setting procedure

- (1) Perform FS-08-9783 and set the setting value to "0".
- (2) Turn the power OFF and then back ON.
- (3) Press [User Functions] on the HOME SCREEN.
- (4) Press [Admin] tab.  
When the Administrator Password has been set, the Administrator Password menu is displayed.

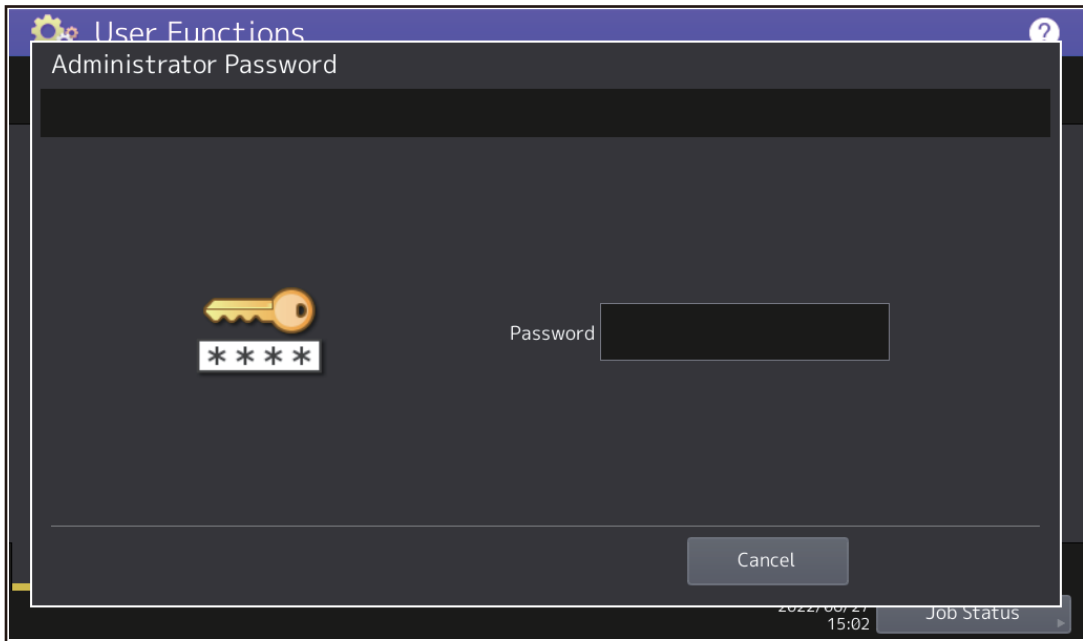

Fig.10-1

- (5) The keyboard appears upon your touching the entry box for a password. Enter the administrator password and then press [OK] or [Close].  
Confirm the password to the administrator.

(6) Press [Service] in the [Admin] tab.



Fig.10-2

(7) The Service screen is displayed.

(8) Press [Supply Order Setup].

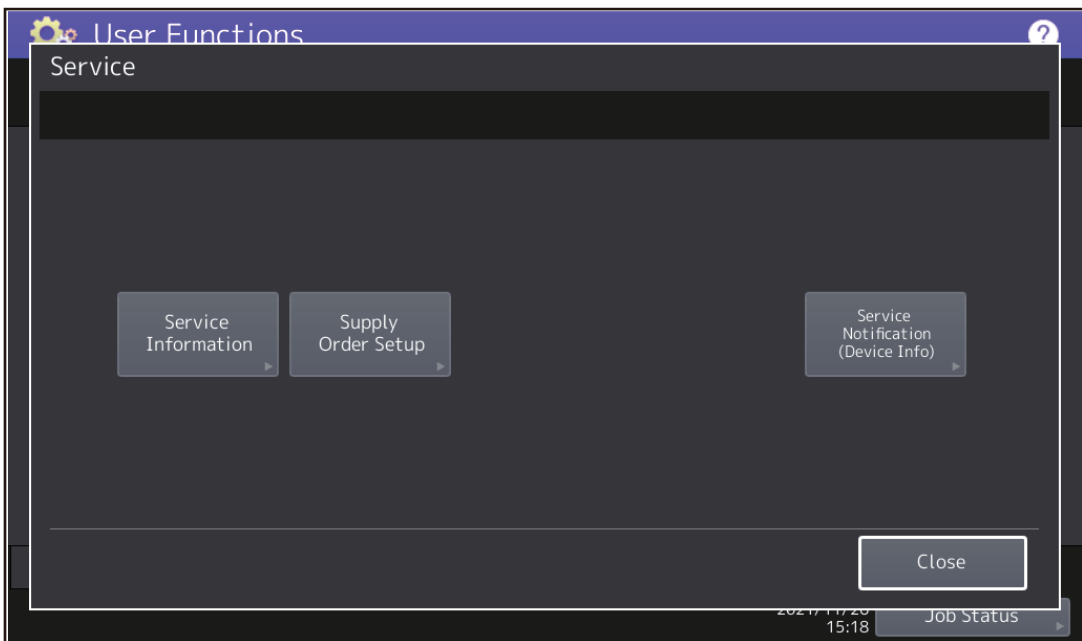

Fig.10-3

(9) Press [Order Information].

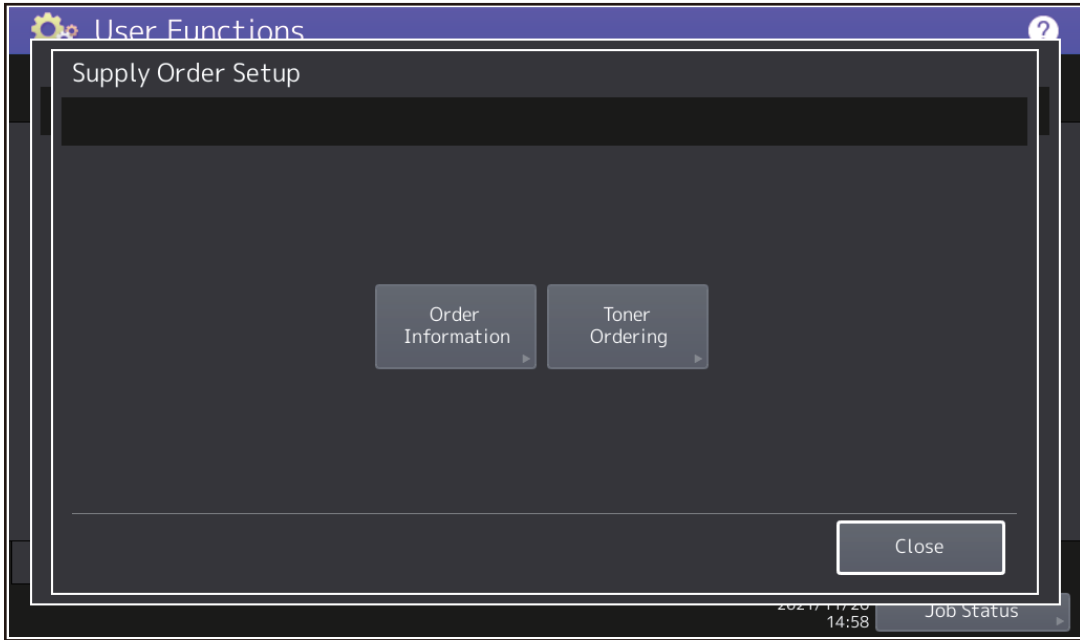

Fig.10-4

(10) The Order Information menu is displayed.

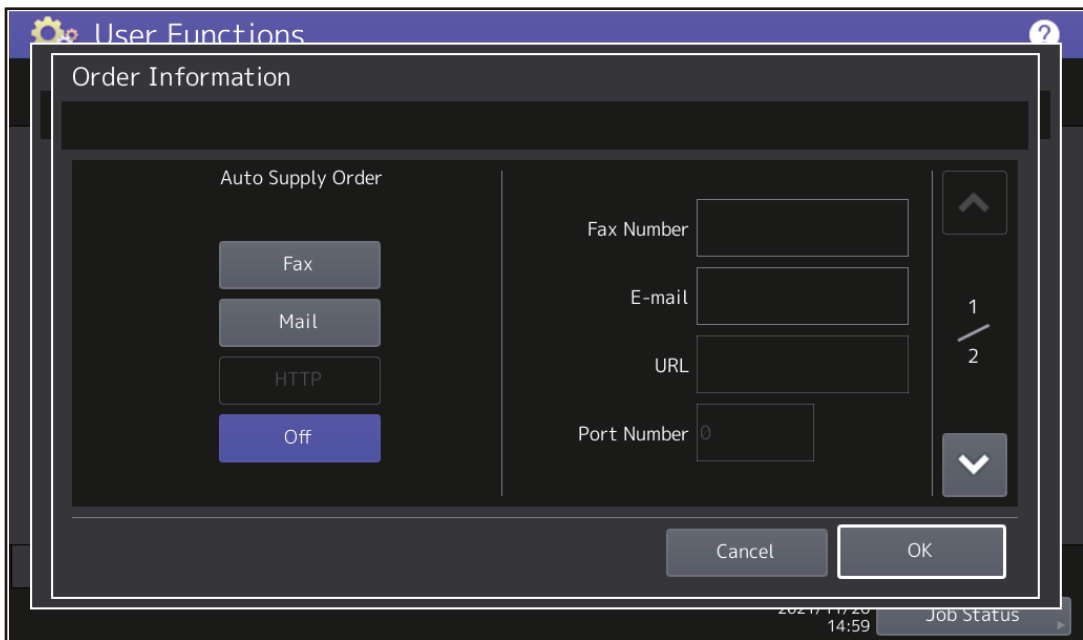

Fig.10-5

(11) Press the buttons on the screen of Order Information to set the required item.

[Fax], [Mail], [Off]	Selects [Fax] or [Mail] for the transmitting method of the order. (HTTP has not been supported yet.) [Off]: Turns off the Auto Supply Order function.
[Fax Number]	Enters the fax number of the supplier. (This must be entered when an order is transmitted by means of a fax.)
[E-mail]	Enters the e-mail address of the supplier. (This must be entered when an order is transmitted by means of an e-mail.)

(12) Press the scroll button.

(13) The Supplier screen is displayed.

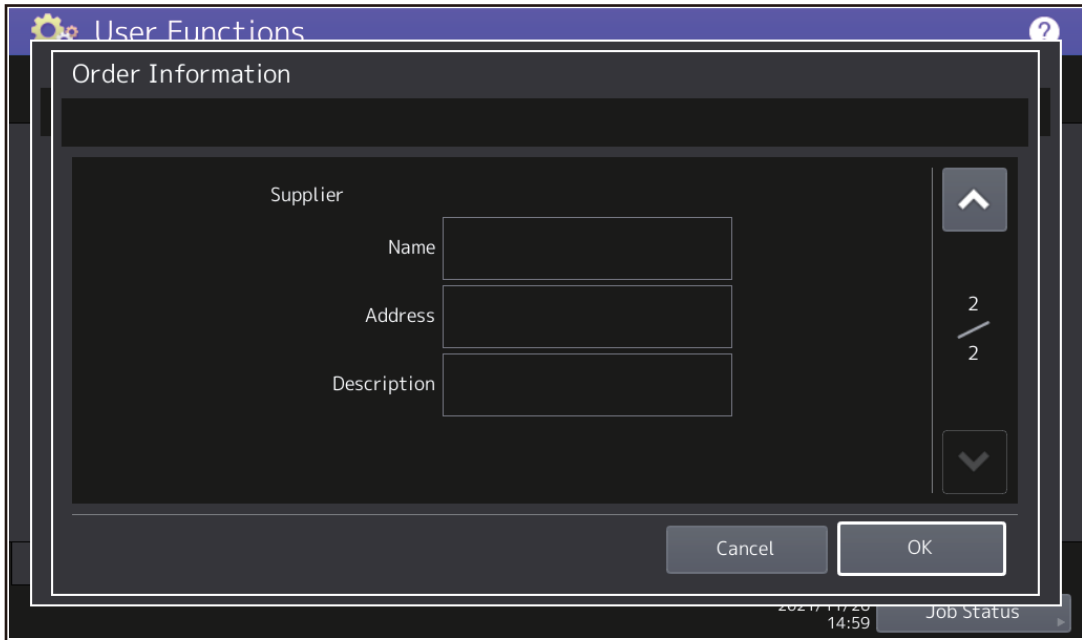

Fig.10-6

(14) Press the buttons of the screen of Supplier to set the required item.

[Name]	Enters the supplier name.
[Address]	Enters the address of the supplier.
[Description]	Enters the remarks if necessary.

(15) Press [OK].

Press [OK] to register the entered information and then the screen returns to the Service screen.  
Press [Cancel] to cancel the entered information and then the screen returns to the Service screen.

(16) The Service screen is displayed.



Fig.10-7

(17) Press [Service Information].

(18) The Service Information screen is displayed.

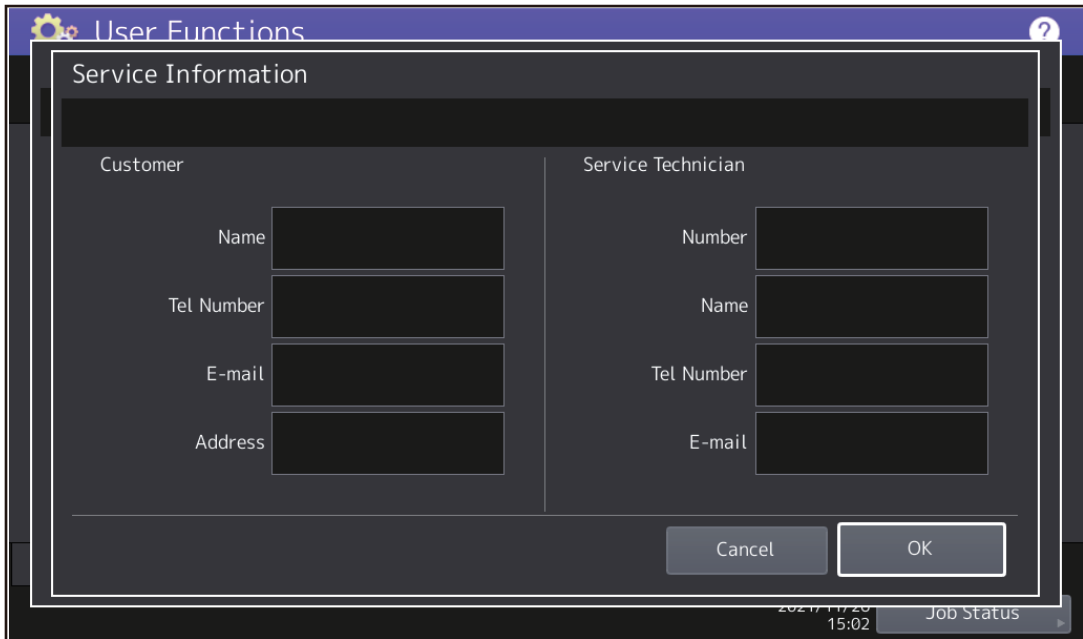

Fig.10-8

(19) Press the buttons of the screen of Service Information to set the required item.

<b>Customer</b>	
[Name]	Enters the name of the customer.
[Tel Number]	Enters the telephone number of the customer.
[E-mail]	Enters the e-mail address of the customer.
[Address]	Enters the address of the customer.

<b>Service Technician</b>	
[Number]	Enters the number of the service engineer.
[Name]	Enters the name of the service engineer.
[Tel Number]	Enters the telephone number of the service engineer.
[E-mail]	Enters the e-mail address of the service engineer.

(20) Press [OK] to register and complete the order information setting.

(21) The screen returns to the Service menu.

(22) Press [Supply Order Setup].

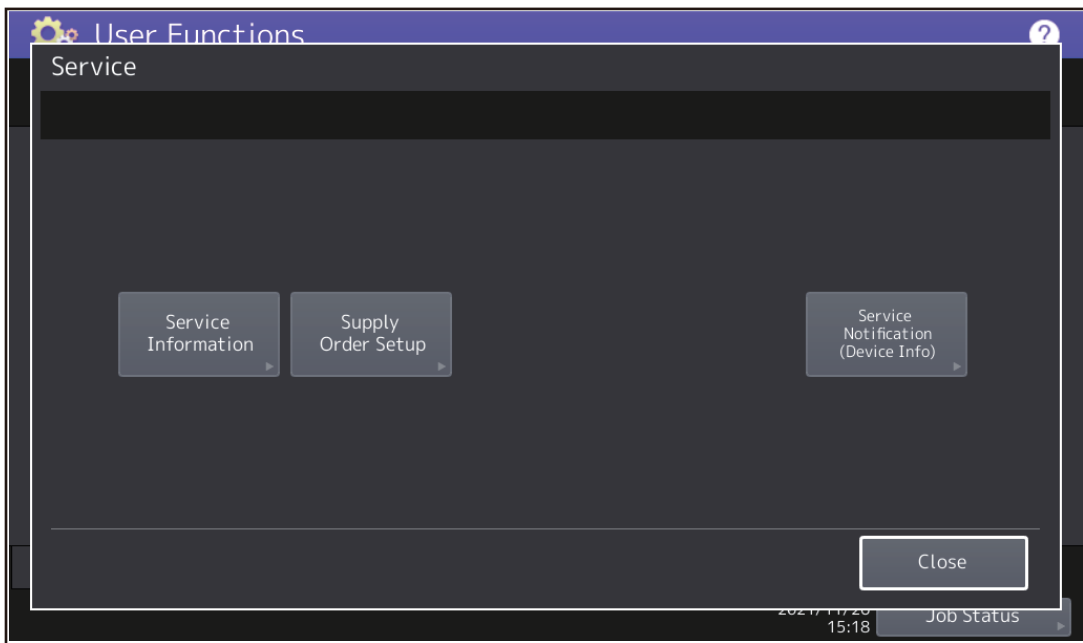

Fig.10-9

(23) Press [Toner Ordering].

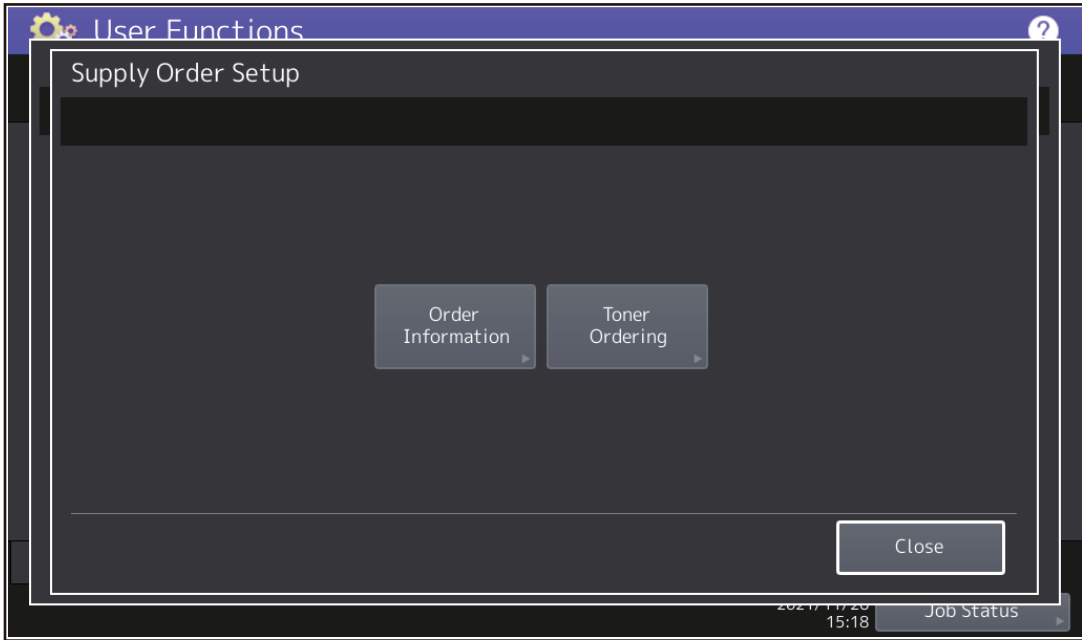

Fig.10-10

(24) Select the part to be ordered. (Press [Toner].)

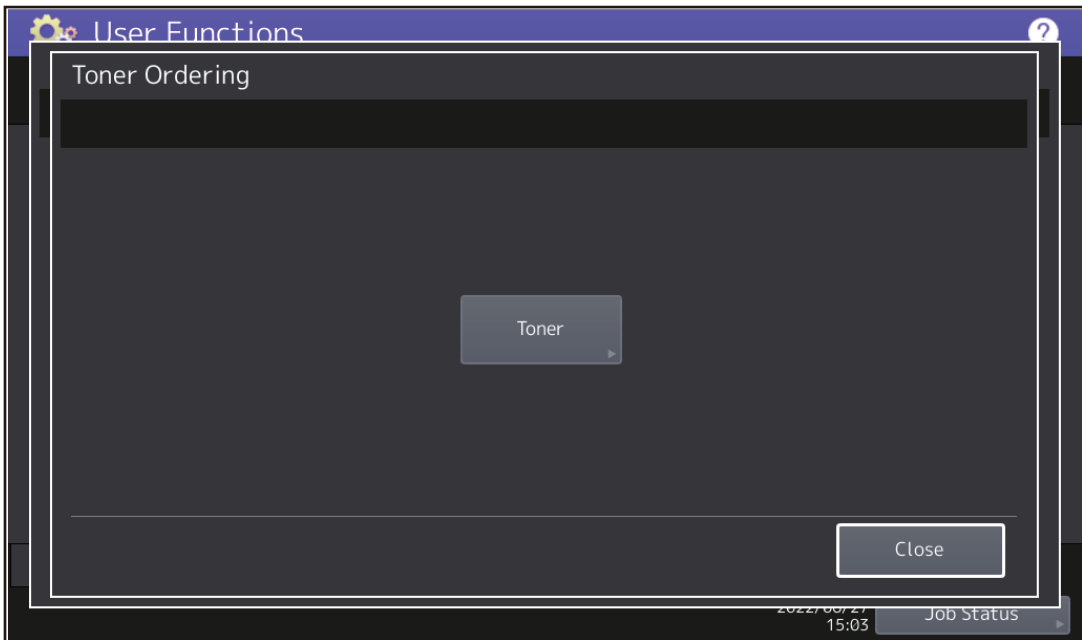

Fig.10-11



(25) Input the Order Information of the toner cartridge.

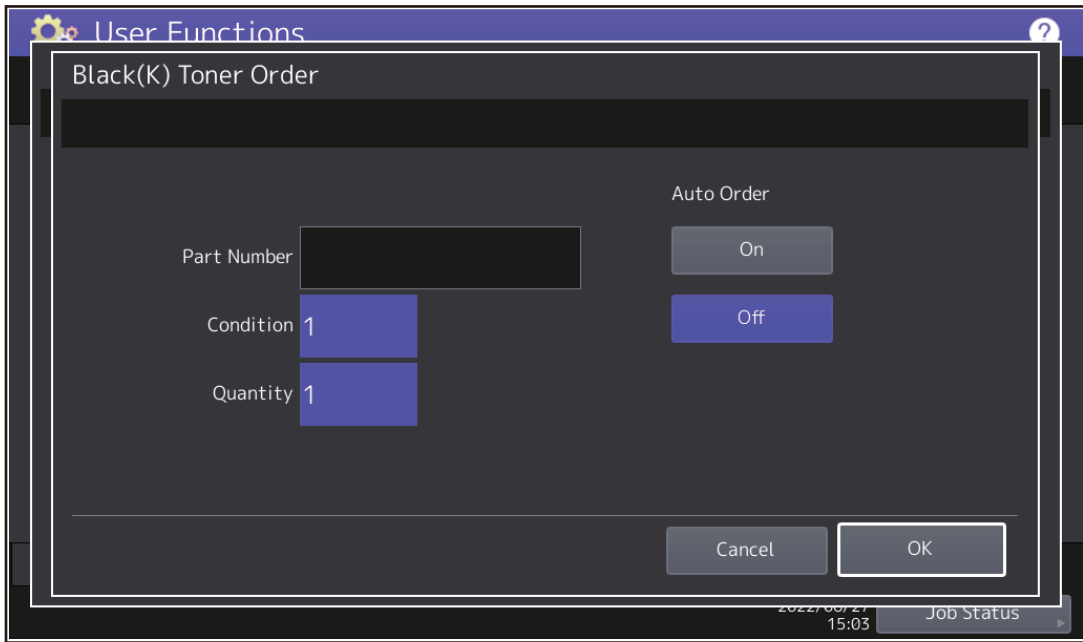

Fig.10-12

[Part Number]	Toner cartridge number
[Condition]	The order is placed when the accumulated number of toner empty times reaches the value set in here.
[Quantity]	Quantity to be ordered
[Auto Order]	Selects whether each part is ordered automatically or not. [On]: Automatically ordered, [Off]: Not ordered automatically

(26) Press [OK] to register the Order Information.

**Notes:**

Auto Supply Order setting is also available from the following 08 SETTING MODE.

Setting Item	code	Contents
The transmitting way of order [Fax], [Mail], [Off]	FS-08-9750	0: Ordered by FAX 1: Ordered by E-mail 2: Ordered by HTTP *1 3: OFF
SUPPLIER [Fax Number]	FS-08-9751	Maximum 32 digits
SUPPLIER [E-mail]	FS-08-9752	Maximum 192 letters
CUSTOMER [Name]	FS-08-9756	Maximum 50 letters
CUSTOMER [Tel Number]	FS-08-9757	Maximum 32 letters
CUSTOMER [E-mail]	FS-08-9758	Maximum 192 letters
CUSTOMER [Address]	FS-08-9759	Maximum 100 letters
SUPPLIER [Name]	FS-08-9764	Maximum 50 letters
SUPPLIER [Address]	FS-08-9765	Maximum 100 letters
SERVICE ENGINEER [Number]	FS-08-9760	Maximum 5 digits
SERVICE ENGINEER [Name]	FS-08-9761	Maximum 50 letters
SERVICE ENGINEER [Tel Number]	FS-08-9762	Maximum 32 digits
SERVICE ENGINEER [E-mail]	FS-08-9763	Maximum 192 letters
Remarks [Description]	FS-08-9766	Maximum 128 letters
TONER [Part Number]	FS-08-9776	Maximum 20 digits
TONER [Condition]	FS-08-9778	1-99
TONER [Quantity]	FS-08-9777	1-99

\*1 HTTP has not been supported yet.



(2) Result list

```

SUPPLY ORDER FORM
CONFIRMATION
ORDER SUCCESSFUL

DATE & TIME :99-99-'99 99:99
CUSTOMER NAME :XXXXXXXXXXXXXXXXXXXXXXXXXXXXXXXXXXXX
CUSTOMER ADDRESS :XXXXXXXXXXXXXXXXXXXXXXXXXXXXXXXXXXXXXXXXXXXX
CUSTOMER TEL NUMBER :XXXXXXXXXXXXXXXXXXXXXXXXXXXXXXXXXXXXXXXXXXXX
CUSTOMER E-MAIL ADDRESS :XXXXXXXXXXXXXXXXXXXXXXXXXXXXXXXXXXXXXXXXXXXX
SERVICE TECHNICIAN NUMBER :XXXXXXXXXXXXXXXXXXXXXXXXXXXXXXXXXXXXXXXXXXXX
SERVICE TECHNICIAN NAME :XXXXXXXXXXXXXXXXXXXXXXXXXXXXXXXXXXXXXXXXXXXX
SERVICE TECHNICIAN TEL NUMBER :XXXXXXXXXXXXXXXXXXXXXXXXXXXXXXXXXXXXXXXXXXXX
SERVICE TECHNICIAN E-MAIL :XXXXXXXXXXXXXXXXXXXXXXXXXXXXXXXXXXXXXXXXXXXX
SUPPLIER NAME :XXXXXXXXXXXXXXXXXXXXXXXXXXXXXXXXXXXXXXXXXXXX
SUPPLIER ADDRESS :XXXXXXXXXXXXXXXXXXXXXXXXXXXXXXXXXXXXXXXXXXXX

-----
TONER CARTRIDGE : PART NUMBER QUANTITY
XXXXXXXXXXXX 99 (*1)
-----
DESCRIPTION AREA .....
.....

DEVICE DESCRIPTION :XXXXXXXXXXXXXXXXXXXXXXXXXXXX
SERIAL NUMBER :XXXXXXXXXXXXXXXXXXXXXXXXXXXX
DEVICE FAX NUMBER :XXXXXXXXXXXXXXXXXXXXXXXXXXXX
DEVICE E-MAIL ADDRESS :XXXXXXXXXXXXXXXXXXXXXXXXXXXX

PRINT COUNTER TOTAL BLACK FULL COLOR
0 0 -----
SCAN COUNTER 0 0 0

TONER INFORMATION

BLACK REMAINING QUANTITY (%) : 00000059
    
```



Fig.10-14

\*1 Part not to be ordered is not output. (Less space between the lines)

## 10.2 Service Notification

### 10.2.1 Outline

This function automatically notifies the status of the MFP to the service engineer by fax or e-mail. The following 5 are the items to be notified.

- **Total Counter Transmit**  
When this function is effective, it notifies each counter information periodically (on the set date and time every month).
- **Service Call Transmit (E-mail only)**  
When this function is effective, it notifies the corresponding error code and such at a service call error.
- **PM Counter Transmit**  
When this function is effective, it notifies that the PM timing has come when the present PM count has reached to its setting value, or the present PM driving count has reached to its setting value.
- **Toner near-empty notification**  
If this function is effective, it notifies each counter information and toner cartridge information when toner near-empty occurs.
- **Storage device alert notification**  
When this function is effective, it notifies an alert for backing up or replacing it.  
 P. 12-11 “12.3.6 Management of the backup function”
- **Deactivation notification**  
When this function is effective, it notifies that the deactivation has been performed (e-mail only).  
 P. 8-5 “8.1.4 Detach function”

### 10.2.2 Setting

#### Notes:

When using this function, it is required that sending and receiving fax or e-mail are available.  
Confirm the details to the administrator.

#### [ 1 ] Preparation

If the menu display of this function is disabled (not displayed), set it to be enabled (displayed) with the following code.

FS-08-9604: Display set of the [Service Notification] button

0: Not displayed

1: Displayed

## [ 2 ] Setting procedure

- (1) Press [User Functions] on the HOME SCREEN and select the [Admin] tab. Then, enter the password and press [OK].  
Confirm the password to the administrator.

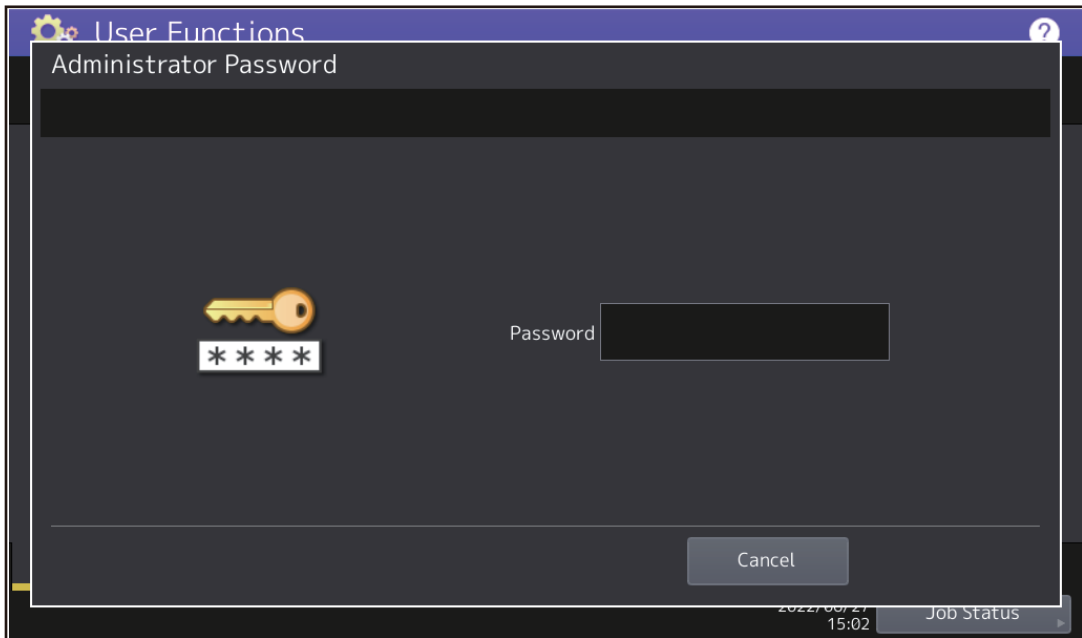

Fig.10-15

- (2) Press [Service].

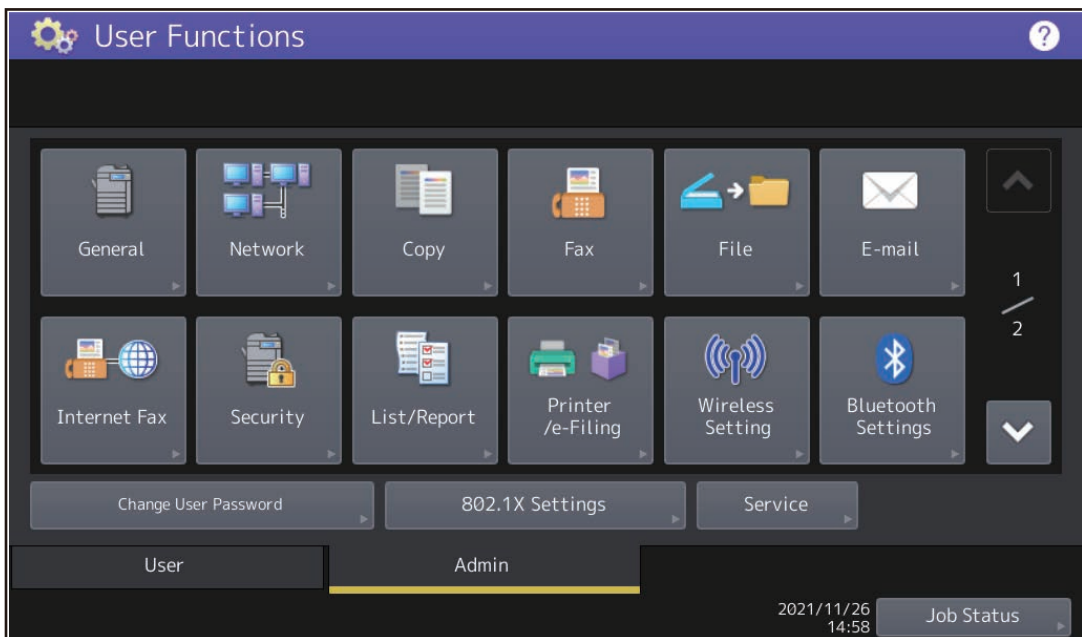

Fig.10-16

(3) Press [Service Notification].



Fig.10-17

(4) Press [E-Mail] or [Fax].  
When [Off] is pressed, all functions related Service Notification become ineffective.

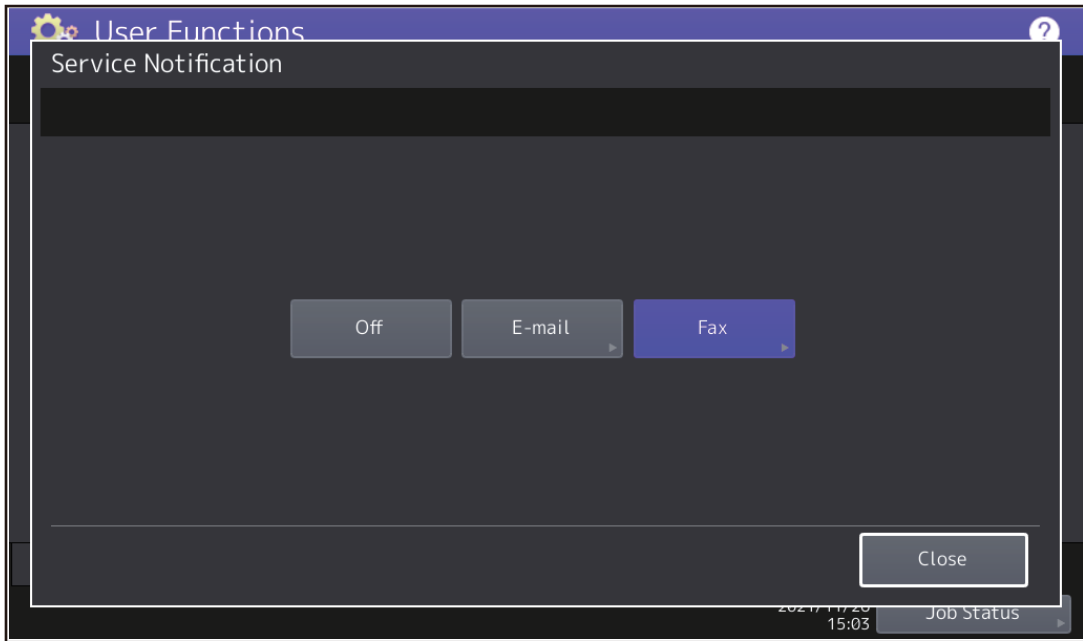

Fig.10-18

- (5) Enter the E-mail address or Fax Number of the destination and press [OK]. A maximum of 3 addresses can be set. (The keyboard appears upon your touching the entry box for an e-mail address.)

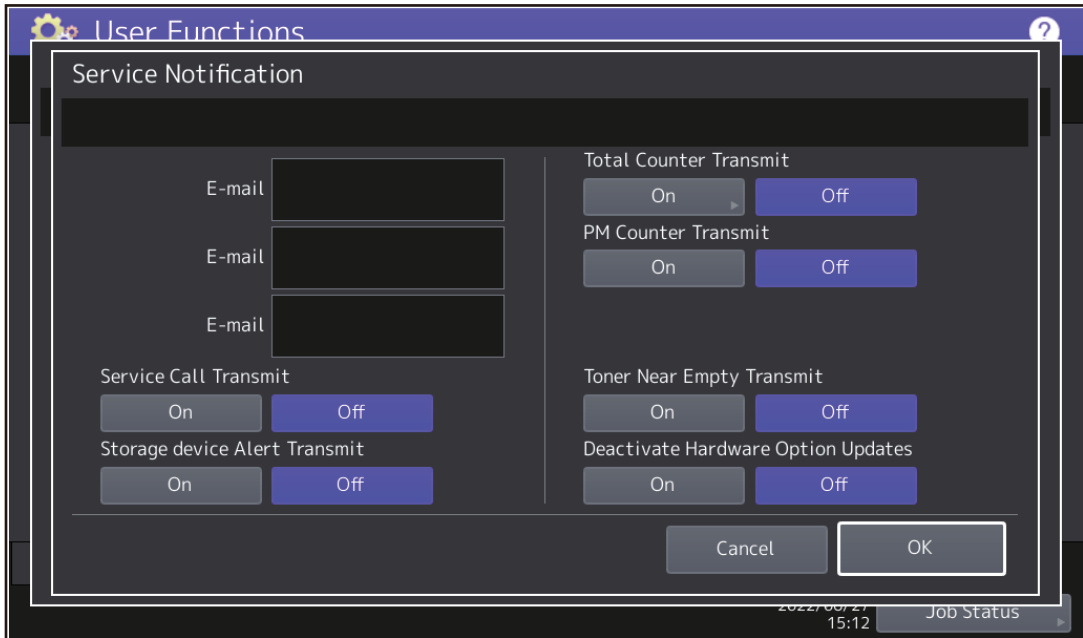

Fig.10-19

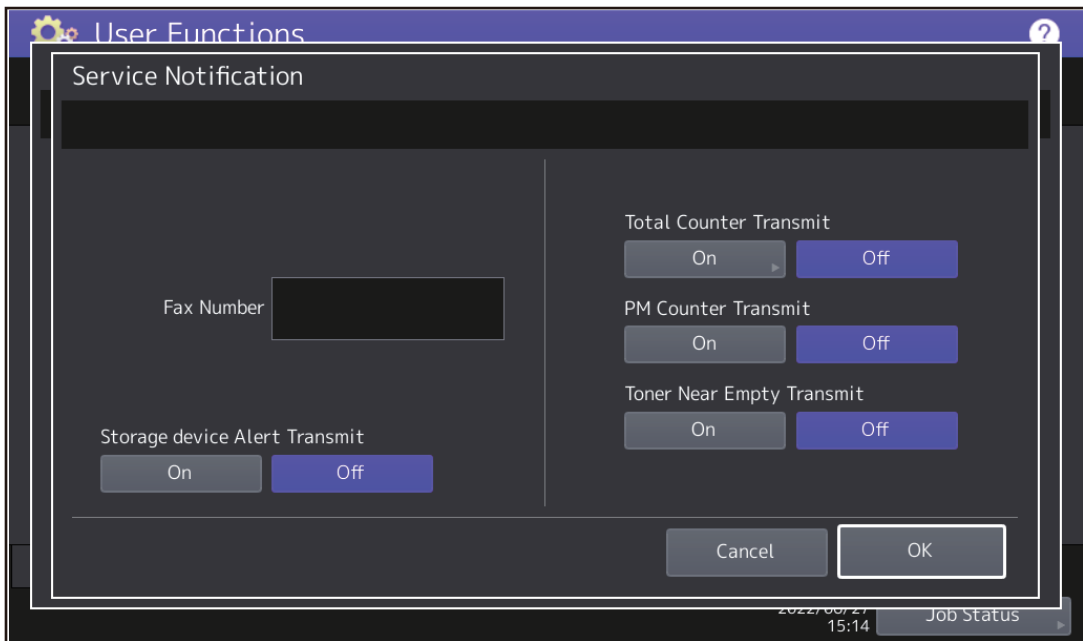

Fig.10-20



- (6) Press [On] to notify or [Off] not to notify each item for E-mail and Fax.  
When Total Count Transmit is set to On, the screen to set the notification date is displayed.  
Then set the notification date with the following procedure.  
The following 3 items can be specified for the date setting.
- Day of the week (More than one day can be selected.)
  - Notify Date 1
  - Notify Date 2

#### **Day of the week ([Sun] to [Sat])**

Pressing [Sun] to [Sat] of the desired day makes transmission on every specified day. More than one day can be selected.

This does not affect the settings of Notify Date 1 and Notify Date 2.

You can send the Total Counter immediately without the above settings by pressing [Send Now].

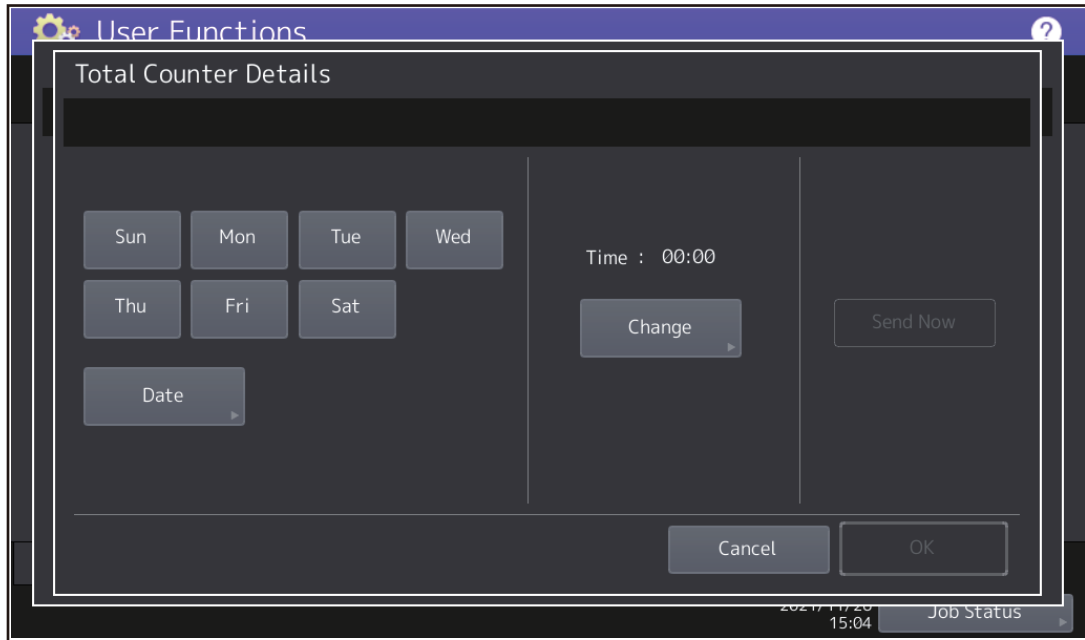

Fig.10-21

#### **Notify Date 1 and Notify Date 2 ([Date])**

Pressing [Date] sets up to 2 dates on which you want to send data.

This is not affected by the specified day of the week.

Enter the date (acceptable values: 0 to 31) in Notify Date 1 or Notify Date 2 and press [OK].

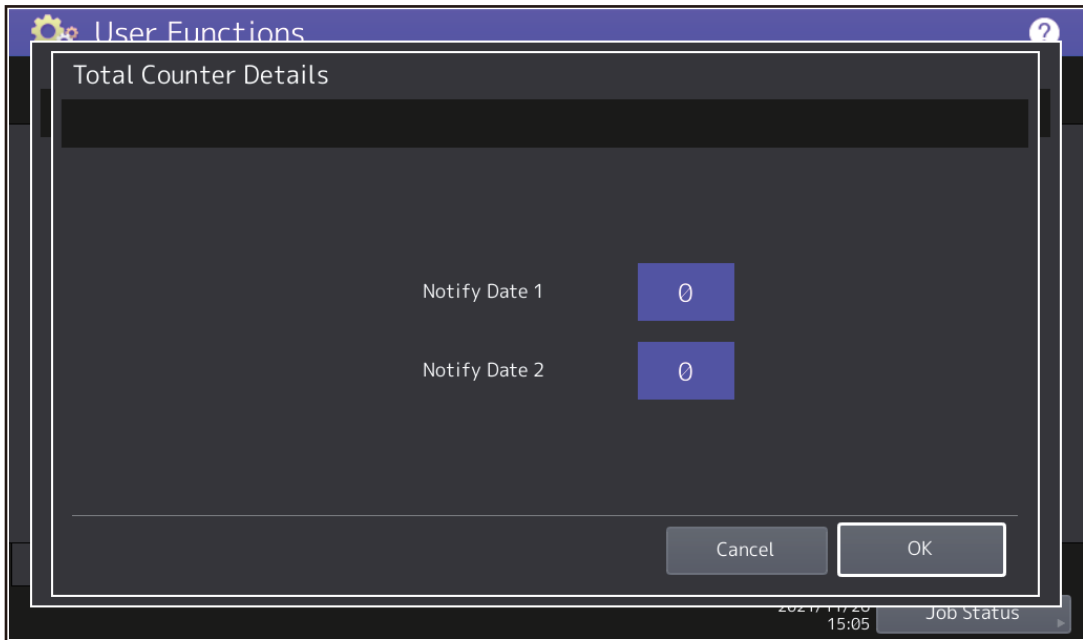

Fig.10-22

### Time setting ([Change])

Pressing [Change] sets the time at which you want to send data.

This is the time when data are sent with Day of the week, Notify Date 1 and Notify Date 2.

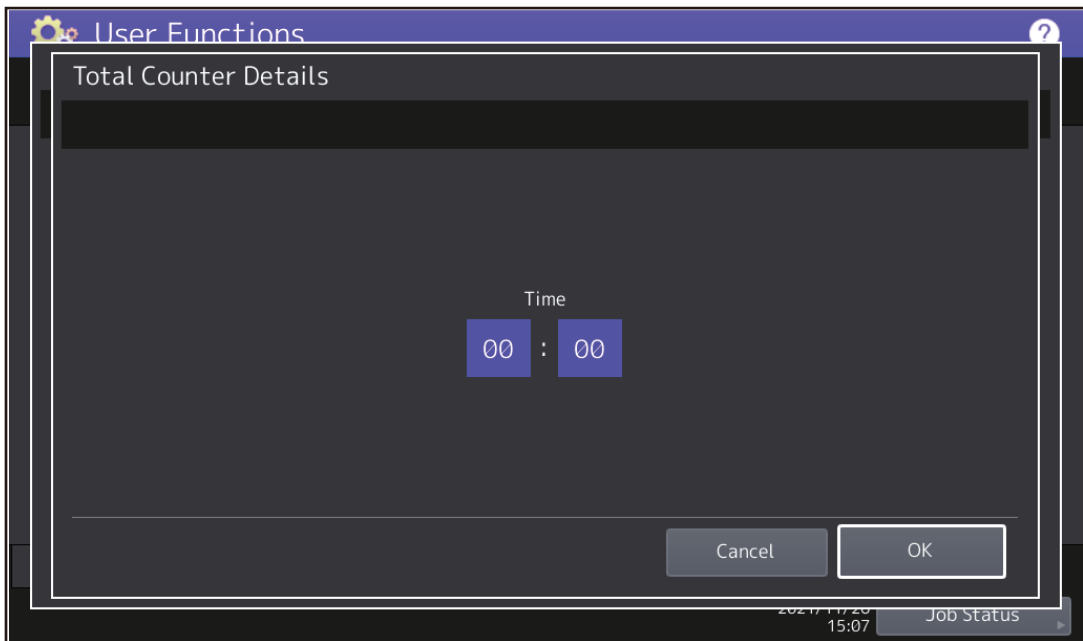

Fig.10-23

The digital keys appear by touching the value displayed in Time. Set “Time” in the left-hand column and “Minute” in the right-hand column. (Acceptable value: 00:00 to 23:59)

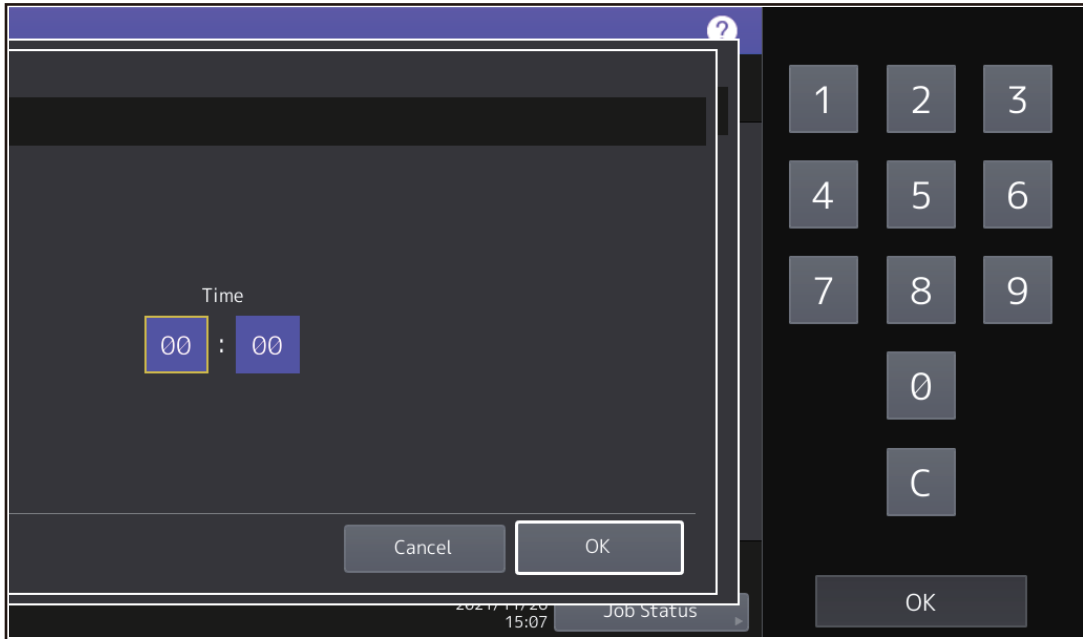

Fig.10-24

(7) After all the settings are completed, press [OK].

**Notes:**

- Service Notification setting is also available from the following 08 SETTING MODE.
- Set the value “1” or “2” for FS-08-9793. Then set the items (self-diagnostic code) which you want to transmit to On.
- Register the e-mail address or Fax Number of the supplier and set the date and time for the transmission.
- Set the value “1” for the self-diagnostic code whose items should be described in the service notification.

Item	code	Contents
Service Notification setting	FS-08-9793	0: Invalid, 1: Valid (E-mail), 2: Valid (Fax)
E-mail address 1	FS-08-9794	Maximum 192 letters
E-mail address 2	FS-08-9607	Maximum 192 letters
E-mail address 3	FS-08-9608	Maximum 192 letters
Fax number	FS-08-9784	Maximum 32 digits
Total Counter Transmit setting	FS-08-9795	0: OFF (Invalid), 1: ON (Valid)
Total counter transmission date setting	FS-08-9796	0 to 31
Total counter transmission date setting(2)	FS-08-9880	0 to 31
Day of total counter data transmission	FS-08-9881	1 byte 00000000(0)-01111111(127) From the 2nd bit - Sunday, Monday, Tuesday, Wednesday, Thursday, Friday, Saturday
Total counter transmission interval setting (Hour/Minute/Minute)	FS-08-9606	00:00-23:59 (Hour/Minute/Minute)
Service Call Transmit setting	FS-08-9605	0: OFF (Invalid), 1: ON (Valid)
PM Counter Transmit setting	FS-08-9797	0: OFF (Invalid), 1: ON (Valid)
Toner near empty Transmit setting	FS-08-8538	0: OFF (Invalid), 1: ON (Valid)

- (8) The screen returns to the Service menu.
- (9) Press [Service Notification (Device Info)].



Fig.10-25

- (10) Press [On] or [Off] on the Service Notification (Device Info) menu.  
When [Off] is pressed, all functions related Service Notification (Device Info) become ineffective.

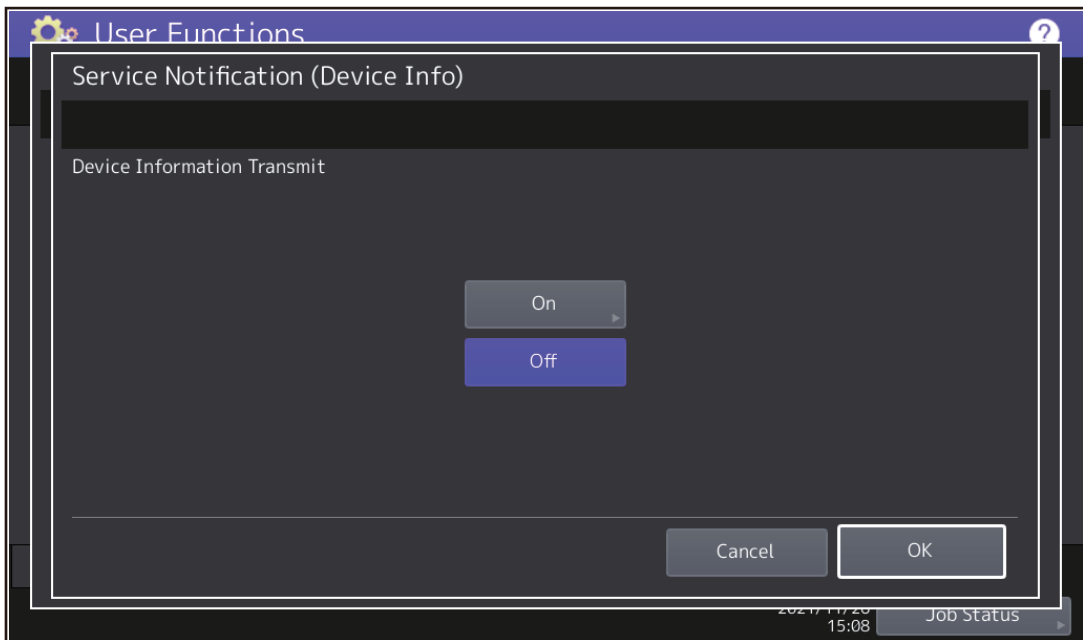
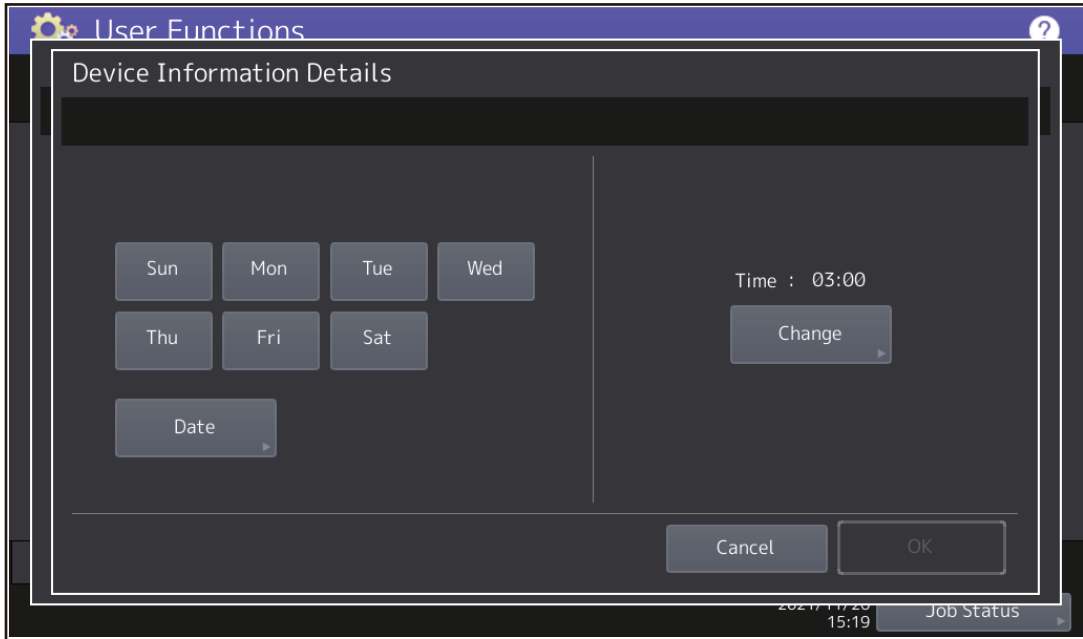

Fig.10-26

- (11) When Service Notification (Device Info) is set to On, the menu to set the notification date is displayed. Then set the notification date with the following procedure.



**Fig.10-27**

The following items for the machine information notification can be set as well as that for the total counter transmit.

- Day of the week (More than one day can be selected.)
- Notify Date 1
- Notify Date 2

After all the settings are completed, press [OK].

### 10.2.3 Items to be notified

The items to be notified are shown below.

#### [ 1 ] Total Counter Transmit / PM Counter Transmit by E-mail

Subject: COUNTER NOTIFICATION

(In case of the PM Counter Transmit, it is shown as "PERIODICAL MAINTENANCE NOTIFICATION".)

Date	: 04/26/20XX 12:34	
Machine Model	: TOSHIBA e-STUDIOXXX	
SerialNumber	: 1234567890	
Total Counter	: 00004787	
Supplier:		
Name	: SUPPLIER_NAME	
Fax Number	: 1122334455	
E-Mail	: Supplier_emailaddress@cccc.xxx	
Address	: SUPPLIER_ADDRESS	
Customer:		
Name	: CUSTOMER_NAME	
Tel Number	: 1234567890	
E-Mail	: customer_emailaddress@dddd.xxx	
Address	: CUSTOMER_ADDRESS	
Service Technician:		
Number	: svc12	
Name	: xxxxxxxxxxxx	
Tel Number	: 0987654321	
E-Mail	: svc@toshibatec.co.jp	
ChargeCounterFormat:		
LargeSizeChargeCount	1	
LargeSizeChargePaperDefinition	1	
PMCounterFormat:		
LargeSizePMCount	1	
LargeSizePMPaperDefinition	0	
Charge Counter:	Large	Small
<Print Counter>		
Black	-----	
Copy	00000000	00000000
Print	00000000	00000000
List	00000000	00000000
FAX	00000000	00000000
<Scan Counter>		
Full Color	-----	
Net Scan	00000000	00000000
Black	-----	
Copy Scan	00000000	00000000
FAX Scan	00000000	00000000
Net Scan	00000000	00000000
<FAX Counter>		
Transmit	00000000	00000000
Receive	00000000	00000000

(\*1)

Fig.10-28

Periodical Maintenance Counter:			
	Pages	Drive Counts	
-----			
K-EPU			
Setting	00000000	00000000	
Current	00000000	00000000	
-----			
K-Dev			
Setting	00000000	00000000	
Current	00000000	00000000	
-----			
Others			
Setting	00000000	00000000	
Current	00000000	00000000	
-----			
Printer Error History:			
Date	Time	ErrorCode	Counter
04/13/20XX	16:44	F110	00000000
04/12/20XX	22:28	F110	00000000
04/12/20XX	22:23	F110	00000000
03/15/20XX	22:23	F110	00000000
02/25/20XX	11:12	F110	00000000
-----			
Toner Cartridge Information:			
Color Code	Black		
Toner Near-Empty Counter			
Setting	00000000		
Color Code	00000000		
Toner Near-Empty Sensed	1		
Point Of Destination	JPD		
Used History			
Developer Counter	00000056		
Developer Driving Time	00000057		
Drum Driving Time	00000058		
-----			
Toner	Remaining Quantity (%)		
Black	00000000		

Fig.10-29

- \*1 When "1" set for FS-08-3667, a QR code will be added.
- \*2 The latest 20 errors are displayed.

[ 2 ] Total Counter Transmit / PM Counter Transmit by FAX

Sheet 1

COUNTER NOTIFICATION (*1)		SUCCESSFUL TX NOTICE (or TX FAILURE NOTICE)
DATE		: XX/04/14 13:47
MACHINE MODEL		: TOSHIBA e-STUDIOXXXX
SERIAL NUMBER		: 1234567890
TOTAL COUNTER		: 00004787
CUSTOMER NAME		: CUSTOMER_NAME
CUSTOMER ADDRESS		: CUSTOMER_ADDRESS
CUSTOMER TEL NUMBER		: 1234567890
CUSTOMER E-MAIL ADDRESS		: customer_emailaddress@ddd.xxx
SERVICE TECHNICIAN NUMBER		: svc12
SERVICE TECHNICIAN NAME		: xxxxxxxxxxxx
SERVICE TECHNICIAN TEL NUMBER		: 0987654321
SERVICE TECHNICIAN E-MAIL		: svc@toshibatec.co.jp
SUPPLIER NAME		: SUPPLIER_NAME
SUPPLIER ADDRESS		: SUPPLIER_ADDRESS
SUPPLIER FAX NUMBER		: 5544332211
SUPPLIER E-MAIL		: supplier_emailaddress@cccc.xxx

Fig.10-30

COUNTER NOTIFICATION (*1)							
CHARGE COUNTER FORMAT				PM COUNTER FORMAT			
LARGE SIZE CHARGE COUNT	:	1		LARGE SIZE PM COUNT	:	1	
LARGE SIZE CHARGE PAPER DEFINITION	:	1		LARGE SIZE PM PAPER DEFINITION	:	0	
CHARGE COUNTER							
PRINT COUNTER			SCAN COUNTER				
BLACK	LARGE	SMALL	FULL COLOR	LARGE	SMALL		
COPY	00000000	00000000	NET SCAN	00000000	00000000		
PRINT	00000000	00000000	BLACK	LARGE	SMALL		
LIST	00000000	00000000	COPY SCAN	00000000	00000000		
FAX	00000000	00000000	FAX SCAN	00000000	00000000		
FAX COUNTER			NET SCAN	00000000	00000000		
	LARGE	SMALL					
TRANSMIT	00000000	00000000					
RECEIVE	00000000	00000000					
PERIODICAL MAINTENANCE COUNTER							
SETTING VALUE (K-EPU PAGES)	:	00000000	SETTING VALUE (K-DEV DRIVE COUNTS)	:	00000000		
CURRENT VALUE (K-EPU PAGES)	:	00000000	CURRENT VALUE (K-DEV DRIVE COUNTS)	:	00000000		
SETTING VALUE (K-EPU DRIVE COUNTS)	:	00000000	SETTING VALUE (OTHERS PAGES)	:	00000000		
CURRENT VALUE (K-EPU DRIVE COUNTS)	:	00000000	CURRENT VALUE (OTHERS PAGES)	:	00000000		
SETTING VALUE (K-DEV PAGES)	:	00000000	SETTING VALUE (OTHERS DRIVE COUNTS)	:	00000000		
CURRENT VALUE (K-DEV PAGES)	:	00000000	CURRENT VALUE (OTHERS DRIVE COUNTS)	:	00000000		
PRINTER ERROR HISTORY							
DATE	TIME	ERROR CODE	COUNTER	DATE	TIME	ERROR CODE	COUNTER
XX/04/13	16:44	F110	00000000	XX/04/13	16:44	F110	00000000
XX/04/12	22:28	F110	00000000	XX/04/13	16:44	F110	00000000
XX/04/12	22:23	F110	00000000	XX/04/13	16:44	F110	00000000
XX/03/15	22:23	F110	00000000	XX/04/13	16:44	F110	00000000
XX/02/25	11:12	F110	00000000	XX/04/13	16:44	F110	00000000
TONER INFORMATION							
BLACK REMAINING QUANTITY (%)	:	00000059					

Fig.10-31

\*1 In case of the PM Counter Transmit, the title is replaced to “PERIODICAL MAINTENANCE NOTIFICATION”.

\*2 The latest 20 errors are displayed.



### [ 3 ] Toner near-empty notification by e-mail

Subject: Toner Near-Empty Notification

```
Date : 04/26/20XX 12:34
Machine Model : TOSHIBA e-STUDIOXXX
SerialNumber : 1234567890
Total Counter : 00004787

Supplier:
Name : SUPPLIER_NAME
Fax Number : 1122334455
E-Mail : Supplier_emailaddress@cccc.xxx
Address : SUPPLIER_ADDRESS

Customer:
Name : CUSTOMER_NAME
Tel Number : 1234567890
E-Mail : customer_emailaddress@dddd.xxx
Address : CUSTOMER_ADDRESS

Service Technician:
Number : svc12
Name : xxxxxxxxxxxx
Tel Number : 0987654321
E-Mail : svc@toshibatec.co.jp

ChargeCounterFormat:
LargeSizeChargeCount 1
LargeSizeChargePaperDefinition 1

PMCounterFormat:
LargeSizePMCount 1
LargeSizePMPaperDefinition 0

Charge Counter:
      Large      Small
<Print Counter>
Black -----
Copy      00000000  00000000
Print     00000000  00000000
List      00000000  00000000
FAX       00000000  00000000

<Scan Counter>
Full Color -----
Net Scan  00000000  00000000
Black -----
Copy Scan 00000000  00000000
FAX Scan  00000000  00000000
Net Scan  00000000  00000000

<FAX Counter>
Transmit  00000000  00000000
Receive   00000000  00000000
```

Fig.10-32

Periodical Maintenance Counter:			
	Pages	Drive Counts	
K-EPU			
Setting	00000000	00000000	
Current	00000000	00000000	
K-EPU			
Setting	00000000	00000000	
Current	00000000	00000000	
Others			
Setting	00000000	00000000	
Current	00000000	00000000	
Printer Error History:			
Date	Time	ErrorCode	Counter
04/13/20XX	16:44	F110	00000000
04/12/20XX	22:28	F110	00000000
04/12/20XX	22:23	F110	00000000
03/15/20XX	22:23	F110	00000000
02/25/20XX	11:12	F110	00000000
] (*1)			
Toner Cartridge Information:			
Toner Near-Empty Counter			
Setting		00000000	
Current		00000000	
Toner Near-Empty Sensed		1	
Point Of Destination		0	
Used History			
Developer Counter		00000000	
Developer Driving Time		00000000	
Drum Driving Time		00000000	
Toner Information:			
Toner			
-----			
Black		00000000	

**Fig.10-33**

\*1 The latest 20 errors are displayed.

## [ 4 ] Toner near-empty notification by FAX

### Sheet 1

TONER NEAR-EMPTY NOTIFICATION	
DATE	: XX/04/14 13:47
MACHINE MODEL	: TOSHIBA e-STUDIOXXXX
SERIAL NUMBER	: 1234567890
TOTAL COUNTER	: 00004787
CUSTOMER NAME	: CUSTOMER_NAME
CUSTOMER ADDRESS	: CUSTOMER_ADDRESS
CUSTOMER TEL NUMBER	: 1234567890
CUSTOMER E-MAIL ADDRESS	: customer_emailaddress@ddd.xxx
SERVICE TECHNICIAN NUMBER	: svc12
SERVICE TECHNICIAN NAME	: xxxxxxxxxxxx
SERVICE TECHNICIAN TEL NUMBER	: 0987654321
SERVICE TECHNICIAN E-MAIL	: svc@toshibatec.co.jp
SUPPLIER NAME	: SUPPLIER_NAME
SUPPLIER ADDRESS	: SUPPLIER_ADDRESS
SUPPLIER FAX NUMBER	: 5544332211
SUPPLIER E-MAIL	: supplier_emailaddress@cccc.xxx

Fig.10-34

COUNTER NOTIFICATION							
CHARGE COUNTER FORMAT				PM COUNTER FORMAT			
LARGE SIZE CHARGE COUNT	:	1		LARGE SIZE PM COUNT	:	1	
LARGE SIZE CHARGE PAPER DEFINITION	:	1		LARGE SIZE PM PAPER DEFINITION	:	0	
CHARGE COUNTER							
PRINT COUNTER			SCAN COUNTER				
BLACK	LARGE	SMALL	FULL COLOR	LARGE	SMALL		
COPY	00000000	00000000	NET SCAN	00000000	00000000		
PRINT	00000000	00000000	BLACK	LARGE	SMALL		
LIST	00000000	00000000	COPY SCAN	00000000	00000000		
FAX	00000000	00000000	FAX SCAN	00000000	00000000		
FAX COUNTER			NET SCAN	00000000	00000000		
TRANSMIT	LARGE	SMALL					
RECEIVE	00000000	00000000					
PERIODICAL MAINTENANCE COUNTER							
SETTING VALUE (K-EPU PAGES)	:	00000000	SETTING VALUE (K-DEV DRIVE COUNTS)	:	00000000		
CURRENT VALUE (K-EPU PAGES)	:	00000000	CURRENT VALUE (K-DEV DRIVE COUNTS)	:	00000000		
SETTING VALUE (K-EPU DRIVE COUNTS)	:	00000000	SETTING VALUE (OTHERS PAGES)	:	00000000		
CURRENT VALUE (K-EPU DRIVE COUNTS)	:	00000000	CURRENT VALUE (OTHERS PAGES)	:	00000000		
SETTING VALUE (K-DEV PAGES)	:	00000000	SETTING VALUE (OTHERS DRIVE COUNTS)	:	00000000		
CURRENT VALUE (K-DEV PAGES)	:	00000000	CURRENT VALUE (OTHERS DRIVE COUNTS)	:	00000000		
PRINTER ERROR HISTORY							
DATE	TIME	ERROR CODE	COUNTER	DATE	TIME	ERROR CODE	COUNTER
XX/04/13	16:44	F110	00000000	XX/04/13	16:44	F110	00000000
XX/04/12	22:28	F110	00000000	XX/04/13	16:44	F110	00000000
XX/04/12	22:23	F110	00000000	XX/04/13	16:44	F110	00000000
XX/03/15	22:23	F110	00000000	XX/04/13	16:44	F110	00000000
XX/02/25	11:12	F110	00000000	XX/04/13	16:44	F110	00000000

(\*1)

Fig.10-35

COUNTER NOTIFICATION							
PRINTER ERROR HISTORY							
DATE	TIME	ERROR CODE	COUNTER	DATE	TIME	ERROR CODE	COUNTER
XX/04/13	16:44	F110	00000000	XX/04/13	16:44	F110	00000000
XX/04/12	22:28	F110	00000000	XX/04/13	16:44	F110	00000000
XX/04/12	22:23	F110	00000000	XX/04/13	16:44	F110	00000000
XX/03/15	22:23	F110	00000000	XX/04/13	16:44	F110	00000000
XX/02/25	11:12	F110	00000000	XX/04/13	16:44	F110	00000000

(\*1)

Toner Cartridge Information:

Toner Near-Empty Counter Setting	00000000
Toner Near-Empty Counter Current	00000000
Toner Near-Empty Sensed	1
Point Of Destination	JPD
Used History	
Developer Counter	00000000
Developer Driving Time	00000000
Drum Driving Time	00000000

Fig.10-36

\*1 The latest 20 errors are displayed.

**[ 5 ] Service Call Transmit**  
 Subject: Service Call Notification

Date: 04/14/20XX 13:47  
 Machine Name: e-STUDIOXXX SerialNumber:1234567890

Function: Print  
 Severity: Error  
 ErrorCode: XXXX  
 Message:  
 XXX

Supplier:  
 Name : SUPPLIER\_NAME  
 Tel Number : 1122334455  
 E-Mail : supplier\_emailaddress@cccc.xxx  
 Address : SUPPLIER\_ADDRESS

Customer:  
 Name : CUSTOMER\_NAME  
 Tel Number : 1234567890  
 E-Mail : customer\_emailaddress@dddd.xxx  
 Address : CUSTOMER\_ADDRESS

Service Technician:  
 Number : svc12  
 Name : xxxxxxxxxxxx  
 Tel Number : 0987654321  
 E-Mail : svc@toshibatec.co.jp

Printer Error History:

Date	Time	ErrorCode	Counter
04/13/20XX	16:44	F110	
04/12/20XX	22:28	F110	
04/12/20XX	22:23	F110	
03/15/20XX	22:23	F110	
02/25/20XX	11:12	F110	

Toner Information

Toner	Remaining Quantity(%)
Black	00000000

(\*)

(\*)

**Fig.10-37**

\*1 The values are fixed as; Function: Print, Severity: Error.

\*2 The latest 20 errors are displayed.

## [ 6 ] Storage device alert notification by E-mail

Subject: STORAGE DEVICE ALERT NOTIFICATION

For the SATA Port0: SSD and Port1: HDD

Date	: 99-99-'99 99:99
Machine Model	: TOSHIBA e-STUDIOxxxx
Serial Number	: 1234567890
F/W Ver.	: XXXXXXXXXXXXXXXX
Total Counter	: 00000000
Supplier:	
Name	: XXXXXXXXXXXXXXXXXXXXXXXXXXXXXXXXXXXX
Tel Number	: XXXXXXXXXXXXXXXXXXXXXXXXXXXXXXXXXXXX
E-Mail	: XXXXXXXXXXXXXXXXXXXXXXXXXXXXXXXXXXXX
Address	: XXXXXXXXXXXXXXXXXXXXXXXXXXXXXXXXXXXX
Customer:	
Name	: XXXXXXXXXXXXXXXXXXXXXXXXXXXXXXXXXXXX
Tel Number	: XXXXXXXXXXXXXXXXXXXXXXXXXXXXXXXXXXXX
E-Mail	: XXXXXXXXXXXXXXXXXXXXXXXXXXXXXXXXXXXX
Address	: XXXXXXXXXXXXXXXXXXXXXXXXXXXXXXXXXXXX
Service Technician:	
Number	: XXXXXXXXXXXXXXXXXXXXXXXXXXXXXXXXXXXX
Name	: XXXXXXXXXXXXXXXXXXXXXXXXXXXXXXXXXXXX
Tel Number	: XXXXXXXXXXXXXXXXXXXXXXXXXXXXXXXXXXXX
E-Mail	: XXXXXXXXXXXXXXXXXXXXXXXXXXXXXXXXXXXX
Storage Model Number (Port0)	: XXXXXXXXXXXXXXXXXXXXXXXX
Storage Serial Number (Port0)	: XXXXXXXXXXXXXXXXXXXXXXXX
SMART Information (Port0)	
Uncorrectable Error Count	: XXXXXXXXXXXXXXXXXXXXXXXX
Power-On hours Count	: XXXXXXXXXXXXXXXXXXXXXXXX
Drive Power Cycle Count	: XXXXXXXXXXXXXXXXXXXXXXXX
Spare Block Count	: XXXXXXXXXXXXXXXXXXXXXXXX
Later Bad Block Count	: XXXXXXXXXXXXXXXXXXXXXXXX
Max Erase Cunt	: XXXXXXXXXXXXXXXXXXXXXXXX
Avg Erase Count	: XXXXXXXXXXXXXXXXXXXXXXXX
Unexpected Power Loss Count	: XXXXXXXXXXXXXXXXXXXXXXXX
Temperature(Minimum)	: XXXXXXXXXXXXXXXXXXXXXXXX
Temperature(Maximum)	: XXXXXXXXXXXXXXXXXXXXXXXX
CRC Error Count	: XXXXXXXXXXXXXXXXXXXXXXXX
SSD Life Left	: XXXXXXXXXXXXXXXXXXXXXXXX
NAND write(GB)	: XXXXXXXXXXXXXXXXXXXXXXXX
Host write(GB)	: XXXXXXXXXXXXXXXXXXXXXXXX
Total Erase Count	: XXXXXXXXXXXXXXXXXXXXXXXX
Storage Model Number (Port1)	: TOSHIBAXXXXXXXXXXXXXXXXXXXXX
Storage Serial Number (Port1)	: XXXXXXXXXXXXXXXXXXXXXXXX
SMART Information (Port1)	
Start/Stop Count	: 0
Reallocated Sector Count	: 0
Power-On hours count	: 0
Drive Power Cycle Count	: 0
Shock Sense Count	: 0
Power-Off Retract Count	: 0
Load Cycle Count	: 0
Temperature(Minimum)	: 0
Temperature(Maximum)	: 0
Reallocated Sector Event	: 0
Current Pending Sector Count	: 0
CRC Error Count	: 0
Loaded Hours	: 0
STORAGE CHECK RESULT : Data backup and exchange of the storage device (SATA Port 1) are required. (*1)	

Fig.10-38

\*1 Results of execution of FS-08-9008. For details, see the following reference.

 P. 12-11 “12.3.6 Management of the backup function”

# [ 7 ] HDD alert notification by Fax

Sheet 1

```
STORAGE DEVICE ALERT NOTIFICATION

DATE : 99-99-'99 99:99
MACHINE MODEL : TOSHIBA e-STUDIOxxxx
SERIAL NUMBER :1234567890
TOTAL COUNTER : 00000000
CUSTOMER NAME : XXXXXXXXXXXXXXXXXXXXXXXXXXXXXXXXXXXX
CUSTOMER ADDRESS : XXXXXXXXXXXXXXXXXXXXXXXXXXXXXXXXXXXX
CUSTOMER TEL NUMBER : XXXXXXXXXXXXXXXXXXXXXXXXXXXXXXXXXXXX
CUSTOMER E-MAIL ADDRESS : XXXXXXXXXXXXXXXXXXXXXXXXXXXXXXXXXXXX
SERVICE TECHNICIAN NUMBER : XXXXXXXXXXXXXXXXXXXXXXXXXXXXXXXXXXXX
SERVICE TECHNICIAN NAME : XXXXXXXXXXXXXXXXXXXXXXXXXXXXXXXXXXXX
SERVICE TECHNICIAN TEL NUMBER : XXXXXXXXXXXXXXXXXXXXXXXXXXXXXXXXXXXX
SERVICE TECHNICIAN E-MAIL : XXXXXXXXXXXXXXXXXXXXXXXXXXXXXXXXXXXX
SUPPLIER NAME : XXXXXXXXXXXXXXXXXXXXXXXXXXXXXXXXXXXX
SUPPLIER ADDRESS : XXXXXXXXXXXXXXXXXXXXXXXXXXXXXXXXXXXX
SUPPLIER FAX NUMBER : XXXXXXXXXXXXXXXXXXXXXXXXXXXXXXXXXXXX
SUPPLIER E-MAIL ADDRESS : XXXXXXXXXXXXXXXXXXXXXXXXXXXXXXXXXXXX
```

Fig.10-39



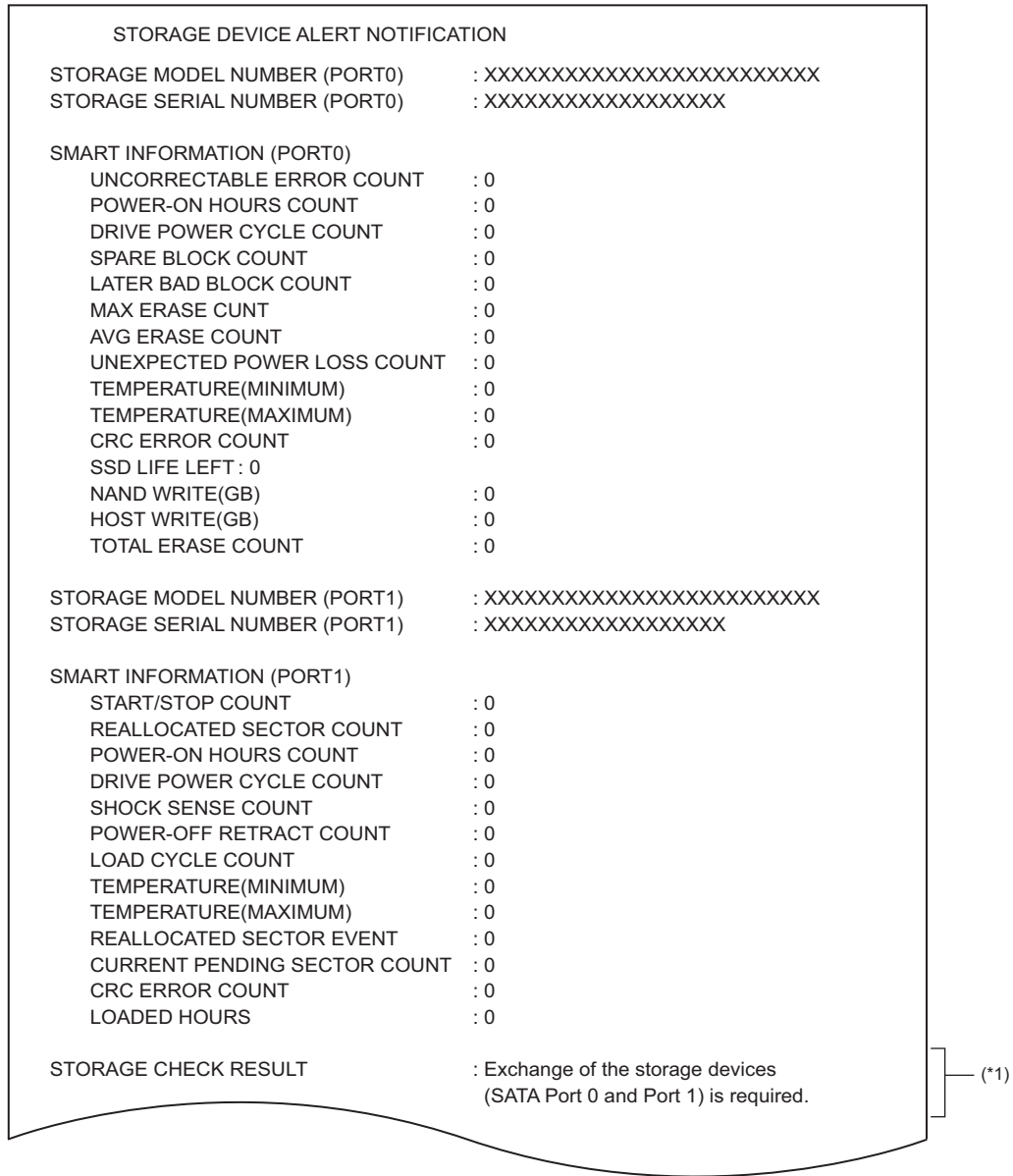

**Fig.10-40**

\*1 Results of execution of FS-08-9008. For details, see the following reference.

P. 12-11 “12.3.6 Management of the backup function”

## [ 8 ] Deactivation notification by e-mail

Subject: DEACTIVATE NOTIFICATION

Date : 04/14/20XX 15:26  
Machine Name: e-STUDIOxxxx SerialNumber:1234567890

Function : DF Deactivate  
Severity : Warning  
ErrorCode : DB01  
Message  
Document Feeder was deactivated.

Supplier:  
Name : SUPPLIER\_NAME  
Tel Number : 1122334455  
E-Mail : supplier\_emailaddress@cccc.xxx  
Address : SUPPLIER\_ADDRESS

Customer:  
Name : CUSTOMER\_NAME  
Tel Number : 1234567890  
E-Mail : customer\_emailaddress@dddd.xxx  
Address : CUSTOMER\_ADDRESS

Service Technician:  
Number : svc12  
Name : xxxxxxxxxxxx  
Tel Number : 0987654321  
E-Mail : svc@toshibatec.co.jp

Printer Error History:

Date	Time	ErrorCode	Counter
04/13/20XX	16:44	EAD0	01234567
04/12/20XX	22:28	EAD0	01234567
04/12/20XX	22:23	EAD0	01234567
03/15/20XX	22:23	EAD0	01234567
02/25/20XX	11:12	EAD0	01234567

Toner Information

Toner	Remaining Quantity(%)
Black	00000000

(\*1)

(\*2)

Fig.10-41

\*1 Display example when the DF is deactivated. An error code and message are shown.

\*2 The latest 20 errors are displayed.

## 10.3 Remote Panel (VNC)

### 10.3.1 Overview

By using the Remote Panel (VNC: Virtual Network Computing) function, the control panel of MFP\* which is located in a remote place can be operated by a client computer or tablet.

\* MFP whose IP address can be confirmed from a client computer or tablet to be operated

#### Notes:

- Be sure to obtain permission from the user beforehand to enable and use this function.
- If the user approval can be obtained, ask that the MFP be operated with this function enabled.
- The VNC client software needs to be installed in a client computer or tablet in order for you to perform the VNC connection with the MFP. (Recommended VNC client software: "UltraVNC")

The following items become operable in the VNC function.

- All the operations which are available on the control panel (operations of icons in the touch panel and hard keys)
- Shifting to the FS Menu from the normal mode
- Browsing and setting self-diagnostic codes in the FS Menu

#### Notes:

The pinch operation on the touch panel, [ON/OFF] button operation, LED lamp performance and Ten Key (option) operation are not supported.

### 10.3.2 Setting

#### [ 1 ] MFP setting

Set this function from TopAccess or [08 SETTING MODE].

#### [A] Setting from TopAccess

Access from TopAccess > [Administration] > [Setup] > [Network] and specify the items in VNC Setting as below.

Item name	Setting
Enable VNC Function	Select [Enable].
Old Password	Enter the old password for the VNC function.
New Password	Enter a new password for the VNC function.
Retype Password	Retype the new password for the VNC function.
Enable SSL/TLS	Select [Disable].

#### [B] Setting from [08 SETTING MODE]

Code	Contents	Setting
FS-08-8794	VNC connection of control panel	Set "1" (Allowed to connect).
FS-08-8559	Password at VNC connection	Enter a password for the VNC function.
FS-08-8699	SSL function setting	Set "0" (Disabled).

#### Notes:

- Be sure to change the default password at the time of the first setting.
- To use "UltraVNC" for the VNC client software, set [Disable] in the [Enable SSL/TLS] option.
- To perform the VNC function by selecting [Enable] for the [Enable SSL/TLS] option, use a VNC client software which supports SSL/TLS.
- Specify a password with six or more and eight or less alphanumeric letters.
- When the "Enable" is selected for Enable VNC Function (FS-08-8794: 1), the MFP cannot shift to the Super Sleep mode.

## [ 2 ] Setting a client computer or tablet

Install the VNC client software.

### 10.3.3 Operation

#### [ 1 ] VNC connection between the MFP and a client computer or tablet

- (1) Start the VNC client software in the client computer or tablet.
- (2) Enter the IP address of the MFP to connect in the VNC Server field and press [Connect].

**Remarks:**

Select "Auto" for Quick Options.

- (3) Enter the password for the VNC connection and press [Log On].  
The control panel of the connected MFP is displayed.

**Notes:**

Only one client computer or tablet can be connected to one MFP.

#### [ 2 ] Operation of the MFP on the remote panel

The MFP can be operated by mouse clicking the button or icon on the control panel displayed on the client computer or tablet.

**Notes:**

- The pinch operation on the touch panel, [ON/OFF] button operation, LED lamp performance and Ten Key (option) operation are not supported.
- Operation on the control panel of the MFP is possible even during the VNC connection.
- The MFP does not shift to the Energy Saving mode or Sleep mode during the VNC connection.

#### [ 3 ] Shifting to the FS Menu

- (1) Press the [Gear] icon with the mouse for at least 3 seconds.
- (2) Enter the service password on the login screen and press [OK].

**Important:**

Be sure to shift the MFP to the normal mode before quitting the VNC connection.

**Notes:**

- While the MFP is shifting to the FS Menu, jobs such as network printing, fax, internet fax and remote scanning are not accepted.
- If the MFP is rebooted when it is returned from the FS Menu to the normal mode, the VNC connection is disconnected. To continue the operation, perform the VNC connection again.

## 10.4 Remote Assistant Menu

### 10.4.1 Overview

By utilizing the Remote Assistant Menu, even if a service engineer does not actually visit the user's site, the necessary information to solve problems can be obtained because this makes it possible to operate the screen of the MFP. The following functions are available for the Remote Assistant Menu.

- Logs Transmission
- Remote Service
- Remote Panel Operation

### 10.4.2 Displaying of the [Remote Assistant Menu] icon

The Remote Assistant Menu is operated by a user. Therefore, it is necessary to have the [Remote Assistant Menu] icon displayed on the HOME SCREEN in accordance with the following procedure.

- (1) Enable more than one functions contained in the Remote Assistant Menu.

**Remarks:**

For details, see the following reference.

 P. 10-39 "10.4.3 Logs Transmission"

 P. 10-42 "10.4.4 Remote Service"

 P. 10-43 "10.4.5 Remote Panel Operation"

- (2) From the HOME SCREEN, select the setting icon and then press [Button Contents] > [Register From Function List] > [Remote Assistant Menu].

### 10.4.3 Logs Transmission

The following functions are available for Logs Transmission.

- Investigation Logs Transmission
- Print Data Transmission
- Network Capture Transmission
- Delete All Logs

#### [ 1 ] Setting and functions

Code	Contents	Setting	Investigation Logs Transmission	Print Data Transmission	Network Capture Transmission	Delete All logs
FS-08-9579	Logs transmission enable/disable setting	Set "1" (Enabled). *1	Yes	Yes	Yes	Yes
FS-08-9630	Logs transmission authentication setting	1: Enabled(Default) Entry of the authentication code is required. 0: Disabled Entry of the authentication code is not required. Please obtain user approval before changing to this setting.	Yes	Yes	Yes	Yes
FS-08-9609	Logs transmission e-mail address	Set an e-mail address.	Yes	Yes	Yes	
FS-08-9653	DF Error history list Message log description setting	Set "1" (Enabled).	Yes			

Code	Contents	Setting	Investigation Logs Transmission	Print Data Transmission	Network Capture Transmission	Delete All logs
FS-08-9657	Debug logs level change by administrator	0: Prohibited (Default) 1: Permitted of changing the debug logs level by an administrator. Please change to this setting if necessary.	Yes			
FS-08-8942	Debug logs level setting	This can be changed when "1" (Permitted) is set for FS-08-9657. The default value is "2" (Normal). Change the value to "0" (High) if required.*2	Yes			
FS-08-8761-1	Upper limit setting of print data saving number	30: Default 0 to 100: Acceptable value If a value over 100 needs to be set, select "0" (No limitation).		Yes		

\*1 All functions in Logs Transmission become available.

\*2 When "0" (High) is set for FS-08-8942, the performance may be lowered.

## [ 2 ] Investigation Logs Transmission

### [ 2-1 ] Overview

This is a function to record the information related to errors and problems of the MFP and send or save them with the specified method.

### [ 2-2 ] Operation

- (1) From the HOME SCREEN, press [Remote Assistant Menu] > [Logs Transmission] > [Investigation Logs Transmission].
- (2) Select [Transmission Method].
  - [Send to Remote Maintenance Service]: Transmits via eCC (e-BRIDGE CloudConnect).
  - [Send by E-mail]: Transmits via e-mail.
  - [Store to the machine]: Stores in a storage device in the MFP.
  - [Store to USB]: Stores in the USB storage device connected to the MFP.
- (3) Press [Execute].

#### Remarks:

- Press the button to start creating (recording) investigation logs.
- The MFP cannot be operated during investigation logs creation and storing to the USB storage device.
- When the creation has succeeded, a pop-up menu to confirm the transmission of the data is displayed.
- After the logs are created, the MFP is automatically rebooted regardless of the succession or failure of the creation.
- The investigation logs stored in storage device in the MFP can be obtained from eBX\_eBN\_Service Util Tool.
- If the investigation logs have already existed in the storage device in the MFP, they will be removed before new investigation logs creation is started.
- When the size of the investigation logs to transmit to eCC exceeds 100 MB, they will be divided automatically.
- When the size of the investigation logs transmitted via e-mail exceeds 30 MB, only parts of them will be sent.

## [ 3 ] Print Data Transmission

### [ 3-1 ] Overview

This is a function to record the printing related information of the MFP and send or save them.

### [ 3-2 ] Operation

- (1) From the HOME SCREEN, press [Remote Assistant Menu] > [Logs Transmission] > [Print Data Transmission] > [Print Data Setting]. Select [Enable] and press [Save].
- (2) Select [Transmission Method].
  - [Send to Remote Maintenance Service]: Transmits via eCC.
  - [Send by E-mail]: Transmits via e-mail.
  - [Store to the machine]: Stores in a storage device in the MFP.
  - [Store to USB]: Stores in the USB storage device connected to the MFP.
- (3) From [Print Data Setting], select [Disable] and press [Save].

#### Remarks:

- When [Disable] is selected in [Print Data Setting], obtaining of the print data is finished.
- When the power is turned OFF during print data obtaining, those already obtained are removed. However, they will not be removed by the shutdown operation.
- When the size of the print data to transmit to eCC exceeds 100 MB, the data will be transmitted that divided in small sizes.
- When the size of the print data transmitted by an e-mail exceeds 30 MB, a transmission error will occur.

## [ 4 ] Network Capture Transmission

### [ 4-1 ] Overview

This is a function to record all incoming and outgoing network activity from the MFP; and transmits the logs via selected method.

### [ 4-2 ] Operation

- (1) From the HOME SCREEN, press [Remote Assistant Menu] > [Logs Transmission] > [Network Capture Transmission].
- (2) Specify [Taken time for Network Capture(Hour)].
- (3) Select [Transmission Method].
  - [Send to Remote Maintenance Service]: Transmits via eCC\*.
  - [Send by E-mail]: Transmits via e-mail.
  - [Store to the machine]: Stores in a storage device in the MFP.

\* Version R4.25 or later
- (4) Press [Start].

#### Remarks:

- When the size of the network capture data transmitted by an e-mail exceeds 30 MB, a transmission error may occur.
- Pressing [Start] begins the recording of the network capture.
- After the recording has been started, press [Close] so that the MFP can be used as usual.
- After the time specified in (2) has passed, the recording finishes automatically and network capture is sent by the selected transmission method.
- If the size of the network capture data reaches 2 GB, the recording finishes automatically even if it is before the specified time, and the network capture is sent.
- When the size of the network capture data to transmit to eCC exceeds 100 MB, they will be divided automatically.
- By pressing the following buttons, the network capture can also be interrupted.
  - [Break off (Don't Send)]: Interrupts the network capture and discards data at that time.
  - [Break off (Send)]: Interrupts the network capture and transmits data at that time by the selected transmission method.

## [ 5 ] Delete All Logs

### [ 5-1 ] Overview

This is a function to delete all files created during logs transmission.

### [ 5-2 ] Operation

- (1) From the HOME SCREEN, press [Remote Assistant Menu] > [Logs Transmission] > [Delete All Logs].
- (2) After the confirmation message is displayed, press [Yes].

#### Remarks:

Log files are always overwritten. Therefore, it is generally not necessary to execute [Delete All Logs] function.

## 10.4.4 Remote Service

### [ 1 ] Overview

When the remote management of the MFP is performed by means of eCC, updating of the firmware version and changing of the settings in the MFP are carried out periodically (once a day) or at the time of rebooting the MFP. Using the Remote Service function can immediately reflect any updates or setting changes to the MFP, and thus the time to solve the problem can be shortened.

### [ 2 ] Setting

Code	Description	Setting
FS-08-3820	e-BRIDGE CloudConnect enable/disable setting	Set "1" (Enabled).
FS-08-3821	Remote Service authentication setting	1: Enabled (Default) Entry of the authentication code is required. 0: Disabled Entry of the authentication code is not required. Please obtain user approval before changing to this setting.

### [ 3 ] Operation

- (1) From the HOME SCREEN, press [Remote Assistant Menu] > [Remote Service].
- (2) After the confirmation message is displayed, press [Yes].

#### Remarks:

- During the connecting of e-BRIDGE CloudConnect, the operation of other functions becomes impossible.
- When the connecting of eCC is finished, the MFP will reboot.
- When this operation has been completed successfully, "Communication success" is displayed on the HOME SCREEN.
- If an error has occurred, check the message log of TopAccess and take an appropriate measure.



## 10.4.5 Remote Panel Operation

### [ 1 ] Overview

This is a function to operate the screen of the MFP in a separate location via the cloud. By utilizing this function, maintenance service can be carried out and the necessary information to solve problems can be obtained even if a service engineer does not actually visit the user's site. This function can be used even if the MFP is not connected to eCC.

### [ 2 ] Setting

- (1) Set the remote panel (VNC).  
📖 P. 10-37 "[ 1 ] MFP setting"
- (2) Set the Remote Panel Operation function.

Code	Description	Setting
FS-08-9467-0	Remote Panel Operation (eRA <sup>*</sup> ) enable/disable setting	Set "1" (Enabled).
FS-08-9467-1	Remote Panel Operation (eRA <sup>*</sup> ) authentication setting	0: Enabled (Default) Entry of the authentication code is required. 1: Disabled Entry of the authentication code is not required. Please obtain user approval before changing to this setting.
FS-08-9468	Remote Panel Operation (eRA <sup>*</sup> ) Relay server URL	<a href="https://ap.era.toshiba-solutions.com/v1/device_connection_request">https://ap.era.toshiba-solutions.com/v1/device_connection_request</a> Change it if needed.

\* eRA: e-Bridge Remote Assist

#### Notes:

The setting in the following menu may be required. [Administration] > [Application] > [Settings] > [Proxy setting]  
This setting will also be reflected to [Host Name] and [Port No.] in [Administration] > [Application] > [Settings] > [Proxy setting].

### [ 3 ] Operation

- (1) From the HOME SCREEN, press [Remote Assistant Menu] > [Remote Panel Operation].
- (2) Key in an authentication code and press [Connect].

#### Remarks:

The connection with the eRA server is automatically disconnected in one hour. When the connection is disconnected, perform the steps from (1) again.



# 11. FIRMWARE UPDATING

## 11.1 Overview

When you want to update the firmware to the latest one or the MFP becomes inoperable due to some defect in the firmware, updating can be performed by using a firmware package stored in the USB storage device.

### Notes:

- Written firmware varies depending on the kinds of the boards provided as service parts. For updating, only the minimum firmware is installed in the system PC board, logic PC board and fax board. The latest version of the firmware at the time of delivery is written on the RADF PC board, DSDF PC board and finisher PC board. When any of above boards is replaced with a new one in the field, check the other firmware version used and then update with a corresponding suitable version.
- “Can’t fetch Ver” is displayed in the Installed Version field when the version of the installed firmware cannot be acquired properly. For example, if [HS-49 Firmware Update] is carried out without your performing the normal startup after updating, this message will appear for some firmware.

## 11.2 Firmware Updating with a USB Storage Device

The software and firmware can be updated by means of a USB storage device in which an update package is stored.

For the data file for each firmware, refer to the following tables.

### Notes:

When performing the update, use the latest firmware package.

### 11.2.1 Updating methods

There are two types of updating methods by using a USB storage device; normal update and patch update. The firmware packages are provided in a compressed file (.zip) corresponding to the updating methods.

Updating method	Package/file name	Explanation
Normal update	TS20ALL0Wxxxx.zip <sup>*1</sup> or TS20ALL0Wxxxx_2020AC2525AC2528A.zip <sup>*2</sup>	Updates the version by using a package storing all files related to the firmware updating.
Patch update	TS20ALLPWxxxx.zip or TS20ALLPWxxxx_2020AC2525AC2528A.zip <sup>*2</sup>	Updates the version by using a package storing the firmware whose correction is required. This method is applied to the system firmware and system software only.

\*1: The files for the following models have been stored.

- 2020AC/2520AC
- 2525AC/3025AC/3525AC/4525AC/5525AC/6525AC
- 2528A/3028A/3528A/4528A/5528A/6528A
- 6526AC/6527AC/7527AC
- 6529A/7529A/9029A

\*2: The files for the following models have been stored.

- 2020AC/2520AC
- 2525AC/3025AC/3525AC/4525AC/5525AC/6525AC
- 2528A/3028A/3528A/4528A/5528A/6528A

### Remarks:

- These firmware packages are provided in common for multiple models.
- “xxxx” indicates the version.

## 11.2.2 File configuration of a USB storage device

Store the firmware package for updating in the root of the USB storage device. The configuration of each package is as below.

### [A] Normal update

e.g.: Configuration file for TS20ALL0Wxxxx.zip

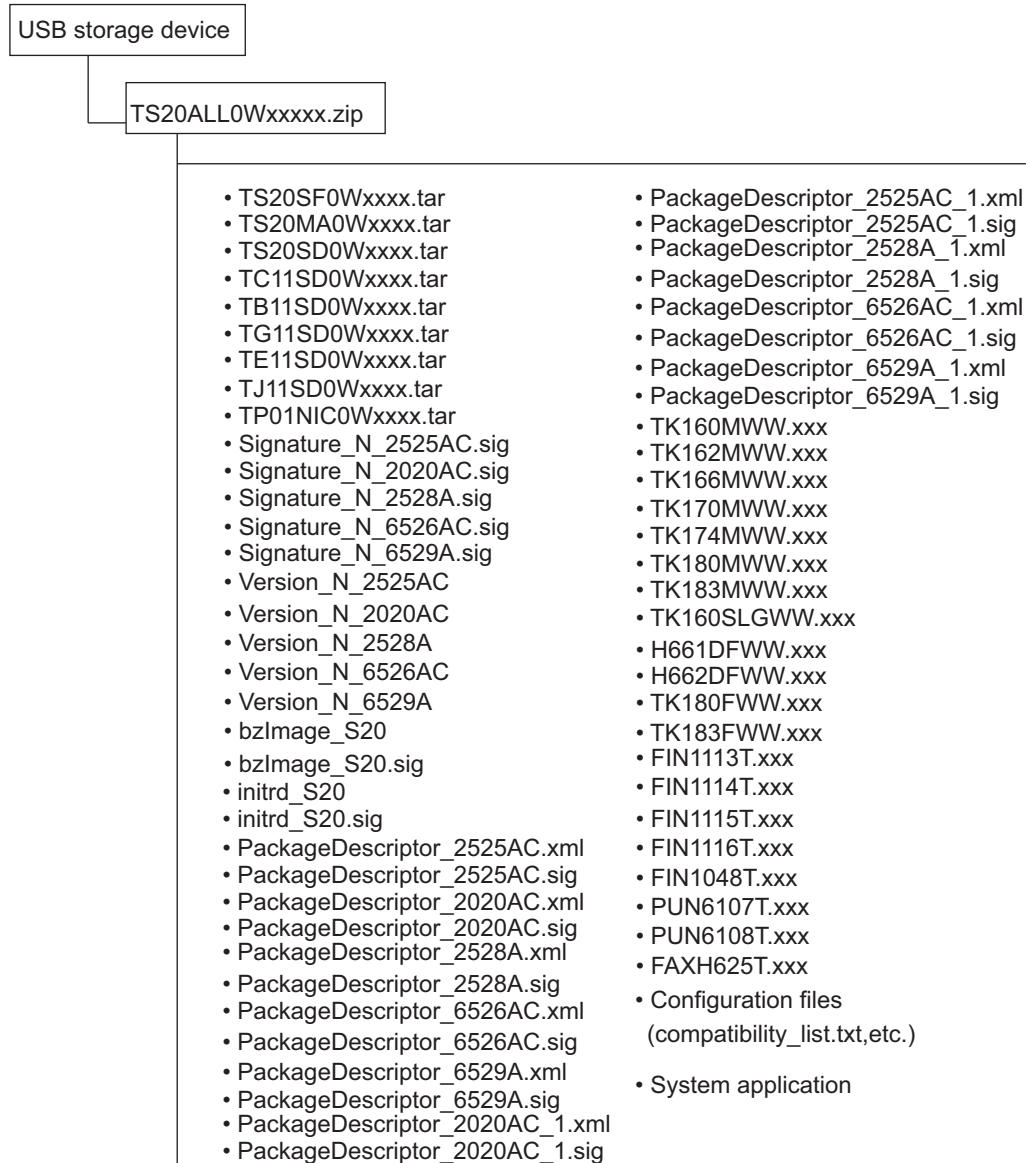

Fig.11-1

## [B] Patch update



Fig.11-2

### Notes:

Since the date and time set in the MFP are recorded in the firmware update log, make sure that they are correct before updating the firmware.

### Important:

- For details about the specification of a USB storage device available for updating the firmware, refer to the following reference.  
 P. 14-15 “14.5 Usable USB storage device”
- Do not update the firmware by any storage device other than a flash memory (such as a USB connection type memory card reader, CD/DVD drive or hard disk), since it is never guaranteed.

## 11.2.3 Firmware type and data file for updating

During the firmware updating, the model of the MFP and the installation status of options are automatically judged and only the corresponding software is displayed.

### [A] Normal update

#### MFP

Firmware type	Stored	Data file name	Display
System firmware (Common for models)	System PC board (SYS board)	TS20SF0Wxxxx.tar	SYSTEM FIRMWARE (OS)
System software (Common for models)	SSD	TS20MA0Wxxxx.tar	SYSTEM SOFTWARE (MA)
System software (Common for models)	SSD	TS20SD0Wxxxx.tar	SYSTEM SOFTWARE (SD) COMMON
System software (Model specific)	SSD	TG11SD0Wxxxx.tar	SYSTEM SOFTWARE (SD) SPECIFIC
Engine Firmware (Model specific)	Logic PC board (LGC board)	TK170MWW.xxx	ENGINE FIRMWARE
Scanner firmware (Common for models)	System PC board (SYS board)	TK160SLGWW.xxx	SCANNER FIRMWARE
NIC firmware (Common for models)	System PC board (SYS board)	TP01NIC0Wxxxx.tar	NIC FIRMWARE

### Remarks:

“xxxx” or “xxx” indicates the version.

### Options

Firmware type	Stored	Data file name	Display
RADF firmware	DLG board (MR-3033)	H662DFWW.xxx	RADF FIRMWARE
DSDf firmware	DLG board (MR-4010/4020)	H661DFWW.xxx	DSDf FIRMWARE
Finisher firmware (MJ-1113)	Finisher PC board	FIN1113T.xxx	FINISHER FIRMWARE

Firmware type	Stored	Data file name	Display
Finisher firmware (MJ-1114)	Finisher PC board	FIN1114T.xxx	FINISHER FIRMWARE
Finisher firmware (MJ-1048)	Finisher PC board	FIN1048T.xxx	FINISHER FIRMWARE
Hole punch firmware (MJ-6107)	Hole punch PC board	PUN6107T.xxx	PUNCH FIRMWARE
FAX firmware (GD-1370)	System PC board (SYS board)	FAXH625T.xxx	FAX FIRMWARE1, FAX FIRMWARE2

**Remarks:**

- “xxx” indicates the version.
- Only the firmware for the options installing in the MFP is displayed.

**[B] Patch update**

Firmware type	Stored	Data file name	Display
System firmware (Common for models)	System PC board (SYS board)	TS20SFPWxxxx.tar	SYSTEM FIRMWARE (OS)
System software (Common for models)	SSD	TS20MAPWxxxx.tar	SYSTEM SOFTWARE (MA)
System software (Common for models)	SSD	TS20SDPWxxxx.tar	SYSTEM SOFTWARE (SD) COMMON
System software (Model specific)	SSD	TG11SDPWxxxx.tar	SYSTEM SOFTWARE (SD) SPECIFIC
NIC firmware (Common for models)	System PC board (SYS board)	TP01NIC0Wxxxx.tar	NIC FIRMWARE

**Remarks:**

“xxxx” indicates the version.

## 11.2.4 Updating procedure

### Important:

Never shut down the MFP during the update. Otherwise, firmware data and the following option data (if installed) could be damaged and may not be able to be operated properly.

- Meta Scan Enabler: GS-1010/1010Node
- External Interface Enabler: GS-1020/1020Node
- IPsec Enabler: GP-1080/1080Node
- OCR Enabler: GS-1110Node
- Multi Station Print Enabler: GS-1090/1090Node

### [ 1 ] Firmware version update

- (1) Connect the USB storage device to the PC and write the data file.  
Store the data file for updating in the root of the USB storage device.
- (2) Press the [ON/OFF] button to shut down the MFP.
- (3) Connect the USB storage device [1] to the USB port [2].

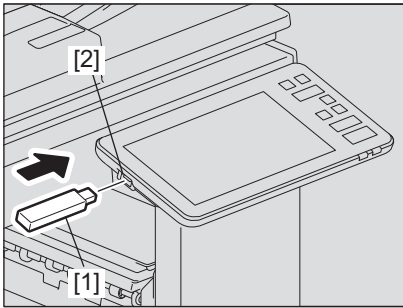

Fig.11-3

- (4) Start the HS Menu.



(5) Press [49 Firmware Update].

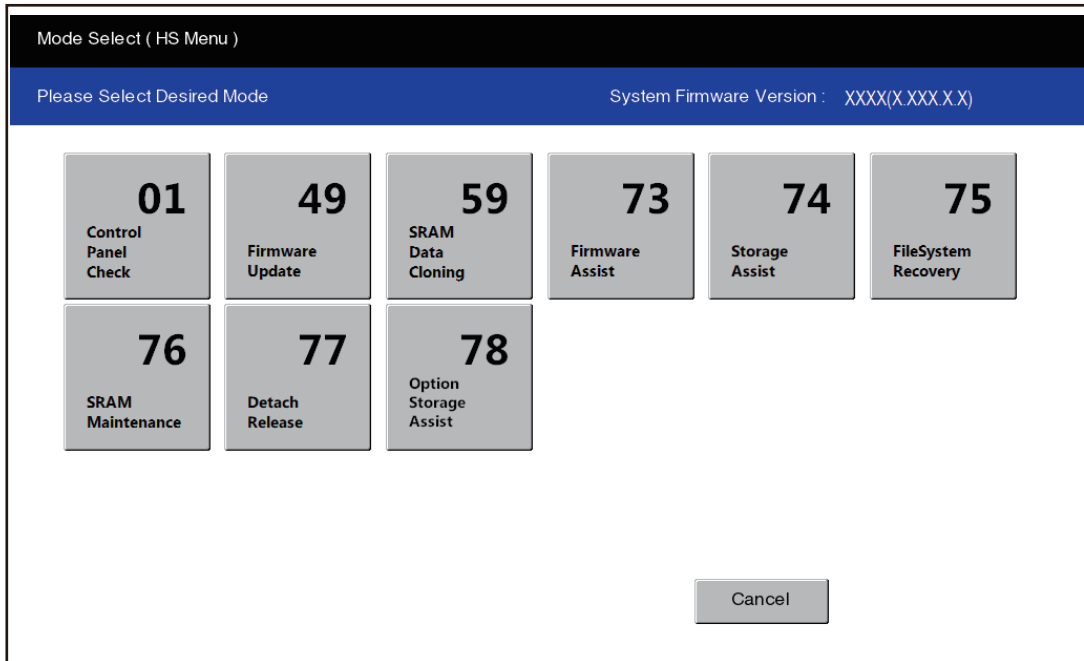

Fig.11-4

The firmware package stored in the USB storage device is displayed.

(6) Select the target firmware package and press [OK].

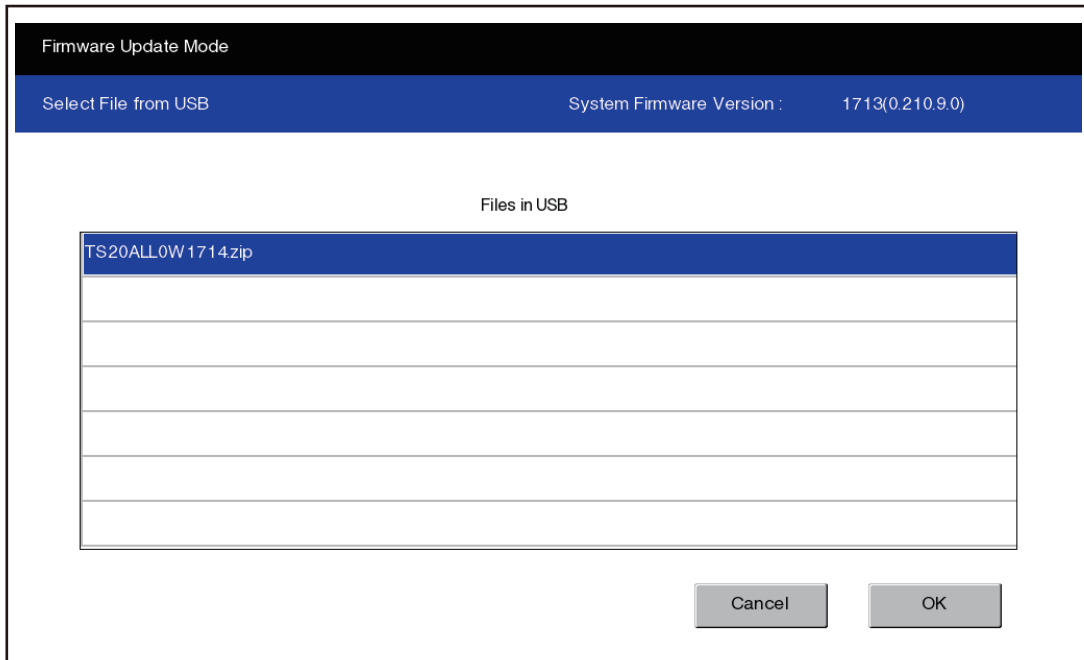

Fig.11-5

The selection screen of the update items is displayed.

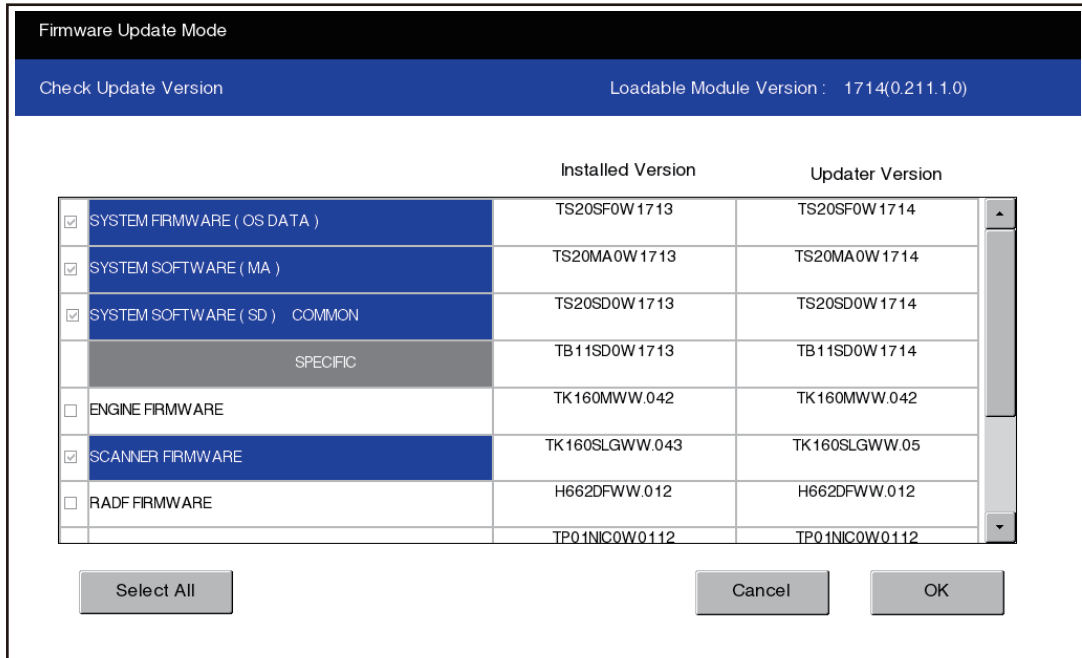

Fig.11-6

**Notes:**

- The model of the MFP and the installation status of options are automatically judged and only the corresponding software is displayed.
- If there is such in the update file, firmware with a later version than the current one is being selected to be updated.

**[A] Normal update**

Item	File name ("xxx" or "xxxx" indicates the version.)	Remarks
SYSTEM FIRMWARE (OS)	TS20SF0Wxxxx.tar	Common data for models
SYSTEM SOFTWARE (MA)	TS20MA0Wxxxx.tar	Common data for models
SYSTEM SOFTWARE (SD) COMMON*	TS20SD0Wxxxx.tar	Common data for models
SYSTEM SOFTWARE (SD) SPECIFIC*	TG11SD0Wxxxx.tar	Model specific data
ENGINE FIRMWARE	TK170MWW.xxx	Model specific data
SCANNER FIRMWARE	TK160SLGWW.xxx	Common data for models
RADF FIRMWARE	H662DFWW.xxx	When MR-3033 installed
DSDL FIRMWARE	H661DFWW.xxx	When MR-4010 or MR-4020 installed
FAX FIRMWARE1. FAX FIRMWARE2	FAXH625T.xxx	When GD-1370 installed
FINISHER FIRMWARE	FIN1113T.xxx	When MJ-1113 installed
	FIN1114T.xxx	When MJ-1114 installed
	FIN1048T.xxx	When MJ-1048 installed
PUNCH FIRMWARE	PUN6107T.xxx	When MJ-6107 installed

\* SYSTEM SOFTWARE (SD) COMMON and SYSTEM SOFTWARE (SD) SPECIFIC cannot be selected separately. If updating is carried out by selecting either of them, the MFP may not be able to be operated properly.

**[B] Patch update**

Item	File name (“xxxx” indicates the version.)	Remarks
SYSTEM FIRMWARE (OS)	TS20SFPWxxxx.tar	Common data for models
SYSTEM SOFTWARE (MA)	TS20MAPWxxxx.tar	Common data for models
SYSTEM SOFTWARE (SD) COMMON	TS20SDPWxxxx.tar	Common data for models
SYSTEM SOFTWARE (SD) SPECIFIC	TG11SDPWxxxx.tar	Model specific data

- If the USB storage device is not recognized properly, “USB device Not detected” is displayed. In this case, disconnect the USB storage device and connect it again within 3 minutes, or shut down the MFP and connect the device properly. Then repeat the procedure from step (5).
- If any of the error messages below is displayed, confirm if the data file in the USB storage device is correct. Then repeat the procedure from step (5).

Error number	Message	Cause
01	Model specific update program XXXXXXXXXXXX is not stored.	No update file of this MFP exists in the USB storage device.

(7) Select the item to be updated.

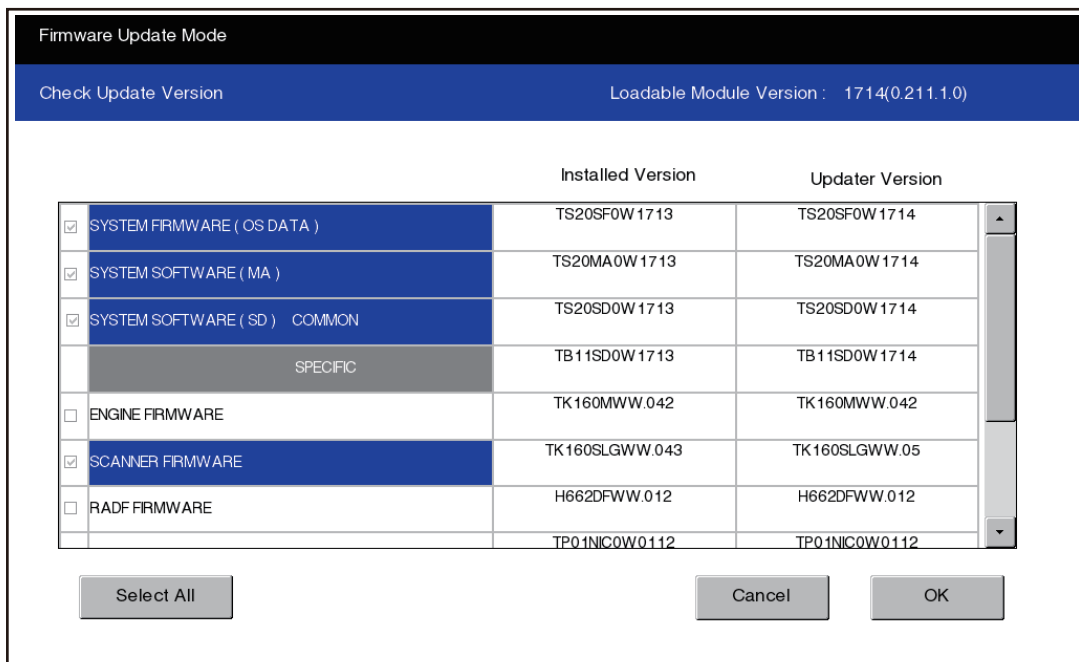

Fig.11-7

The item selected is highlighted and a check is marked at its left side. The selection is released by pressing the item once again.

Item	Remarks
SYSTEM FIRMWARE (OS)	Updating the system firmware.
SYSTEM SOFTWARE (MA)	Updating the system firmware (MA).
SYSTEM SOFTWARE (SD) COMMON	Updating the system software (SD).
SYSTEM SOFTWARE (SD) SPECIFIC	
ENGINE FIRMWARE	Updating the engine firmware.
SCANNER FIRMWARE	Updating the scanner firmware.
RADF FIRMWARE	Updating the RADF firmware.
DSD FIRMWARE	Updating the DSD F firmware.

Item	Remarks
FAX FIRMWARE	Updating the FAX firmware.
FINISHER FIRMWARE	Updating the finisher firmware.
PUNCH FIRMWARE	Updating the hole punch firmware.

(8) Press [OK].

Updating starts and the processing status is displayed on the screen.

Status display during updating	Status display when updating is completed
SYSTEM FIRMWARE (OS) update in progress	SYSTEM FIRMWARE (OS) Completed
SYSTEM SOFTWARE (MA) update in progress	SYSTEM SOFTWARE (MA) Completed
SYSTEM SOFTWARE (SD) update in progress	SYSTEM SOFTWARE (SD) Completed
ENGINE FIRMWARE update in progress	ENGINE FIRMWARE Completed
SCANNER FIRMWARE update in progress	SCANNER FIRMWARE Completed
RADF FIRMWARE update in progress	RADF FIRMWARE Completed
DSD FIRMWARE update in progress	DSD FIRMWARE Completed
FAX FIRMWARE update in progress	FAX FIRMWARE Completed
FINISHER FIRMWARE update in progress	FINISHER FIRMWARE Completed
PUNCH FIRMWARE update in progress	PUNCH FIRMWARE Completed

(9) When updating is completed properly, the following message is displayed at the bottom of the screen.

Normal update: Update successfully completed Restart the MFP

Patch update: Patch Update Successfully Restart the MFP

**Notes:**

- Troubleshooting when “Customized UI version is not compatible!” is displayed  
In the MFP with the customized UI installed, when its version is not compatible with that for the SSD DATA to be installed, “Customized UI version is not compatible!” is displayed and the updating will fail. To continue the updating, perform FS-08-3512 (Customized UI uninstallation).
- Troubleshooting when “Update Failed” is displayed
  - Even though an update fails, do not turn the power OFF until other updates are finished.
  - “Update Failed.” is displayed at the bottom of the screen when the updating is not completed properly. “Failed” appears next to the failed item on the status display. If “Update Failed” appears at the bottom of the screen, shut down the MFP and then check the following items. After confirming and clearing the problems, restart updating from the beginning.  
Does the USB storage device meet the conditions to be used for updating?  
Is the data file written properly in the USB storage device?  
Is the USB storage device installed properly?  
Do the USB storage device and MFP operate properly?  
When an H05 error occurs and it does not clear after the USB storage device is checked, replace the SYS board.
  - The integrity check system is automatically operated before firmware updating. During this operation, “Verifying Signature...” and “Progress: \*\*%” are displayed on the screen. When the check is completed properly, no message for notifying the success will appear and the firmware updating will start. If it fails, “Invalid Signature” and “Copy Data with >valid signature in USB” will be shown. In that case, firmware updating cannot be performed, so shut down the MFP and disconnect the USB storage device. Check that there is no abnormality in the firmware data and reperform updating.
  - When a system firmware or system software update error occurs, “Update Failed” or “Failed” appears on the screen and the error number appears next to the message. For details of each error, refer to the following tables.

System firmware update error	
Error number	Error content
O01	FROM writing failed
O02	FROM verification error
O03	File operation error
O06	Device error
O07	Signature check error
O08	No signature error

System software update error	
Error number	Error content
H01	File creation error
H02	File decompression error (Out of free disk space on the storage device at file extraction)
H03	Partition mount error
H04	Other errors
H05	Signature check error
H06	No signature error
H07	Storage device full error
H08	RIP font installation error

- When an engine firmware, scanner firmware, RADF/DSDF firmware, hole punch firmware, finisher firmware or FAX firmware error occurs, "Update Failed" or "Failed" appears on the screen and the error number appears next to the message. For details of each error, refer to the following tables.

Engine firmware update error		
Error number	Error message	Error content
M01	Request Timeout	Request timeout
M02	Communication timeout (When the download is written)	Communication timeout (When the download is written.)
M03	Communication timeout (When the download is finished)	Communication timeout (When the download is finished.)
M04	Downloading request was denied. (When the download is requested)	Downloading request was denied. (when the download is requested.)
M05	Deletion error (When the download is written)	Deletion error (When the download is written.)
M06	Writing error (When the download is written)	Writing error (When the download is written.)
M07	Checksum error (When the download is finished)	Checksum error (When the download is finished.)
M08	Reception status code abnormality (When the download is requested)	Reception status code abnormality (when the download is requested.)
M09	Reception status code abnormality (When the download is written)	Reception status code abnormality (When the download is written.)
M10	Reception status code abnormality (When the download is finished)	Reception status code abnormality (When the download is finished.)
M11	Version downgrade abnormality (When download request is initiated)	Version downgrade abnormality (When the download is started.)
M12	File decompression error (System)	File decompression error (System)
M13	File decompression error (ROM data)	File decompression error (ROM error)
M00	Other error	Other errors

Scanner firmware update error		
Error number	Error message	Error content
S01	Communication timeout (When the download is requested)	Communication timeout (when the download is requested.)
S02	Communication timeout (When the download is written)	Communication timeout (When the download is written.)
S03	Communication timeout (When the download is finished)	Communication timeout (When the download is finished.)
S05	Deletion error (When the download is written)	Deletion error (When the download is written.)
S06	Writing error (When the download is written)	Writing error (When the download is written.)
S08	Reception status code abnormality (When the download is requested)	Reception status code abnormality (when the download is requested.)
S09	Reception status code abnormality (When the download is written)	Reception status code abnormality (When the download is written.)
S10	Reception status code abnormality (When the download is finished)	Reception status code abnormality (When the download is finished.)
S11	Scanner not connected (When the download is finished)	Scanner not installed (When the download is finished.)
S12	Scanner download error (When the download is requested)	Scanner download error (when the download is requested.)
S00	Other error	Other errors

RADF/DADF firmware update error		
Error number	Error message	Error content
R01	Communication timeout (When the download is requested)	Communication timeout (when the download is requested.)
R02	Communication timeout (When the download is written)	Communication timeout (When the download is written.)
R03	Communication timeout (When the download is finished)	Communication timeout (When the download is finished.)
R05	Deletion error (When the download is written)	Deletion error (When the download is written.)
R06	Writing error (When the download is written)	Writing error (When the download is written.)
R08	Reception status code abnormality (When the download is requested)	Reception status code abnormality (when the download is requested.)
R09	Reception status code abnormality (When the download is written)	Reception status code abnormality (When the download is written.)
R10	Reception status code abnormality (When the download is finished)	Reception status code abnormality (When the download is finished.)
R11	ADF not connected	RADF/DADF not installed
R12	ADF download error	Invalid firmware data
R13	RADF version error	Invalid firmware data
R14	RADF version downgrade Error	Firmware data downgrade error
R00	Other error	Other errors

Hole punch firmware update error		
Error number	Error message	Error content
U01	Communication timeout (When the download is requested)	Communication timeout (when the download is requested.)
U02	Communication timeout (When the download is written)	Communication timeout (When the download is written.)
U03	Communication timeout (When the download is finished)	Communication timeout (When the download is finished.)

Hole punch firmware update error		
Error number	Error message	Error content
U04	Downloading request was denied. (When the download is requested)	Downloading request was denied. (when the download is requested.)
U05	Deletion error (When the download is written)	Deletion error (When the download is written.)
U06	Writing error (When the download is written)	Writing error (When the download is written.)
U07	Checksum error (When the download is finished)	Checksum error (When the download is finished.)
U08	Reception status code abnormality (When the download is requested)	Reception status code abnormality (when the download is requested.)
U09	Reception status code abnormality (When the download is written)	Reception status code abnormality (When the download is written.)
U10	Reception status code abnormality (When the download is finished)	Reception status code abnormality (When the download is finished.)
U00	Other error	Other errors

Finisher firmware update error		
Error number	Error message	Error content
F01	Time out (When the download is requested)	Communication timeout (when the download is requested.)
F02	Time out (When the download is written)	Communication timeout (When the download is written.)
F03	Time out (When the download is finished)	Communication timeout (When the download is finished.)
F04	Reception failed (When the download is requested)	Downloading request was denied. (when the download is requested.)
F05	Deletion error (When the download is written)	Deletion error (When the download is written.)
F06	Writing error (When the download is written)	Writing error (When the download is written.)
F07	Checksum error (When the download is finished)	Checksum error (When the download is finished.)
F08	Reception status code abnormality (When the download is requested)	Reception status code abnormality (when the download is requested.)
F09	Reception status code abnormality (When the download is written)	Reception status code abnormality (When the download is written.)
F10	Reception status code abnormality (When the download is finished)	Reception status code abnormality (When the download is finished.)
F00	Other error	Other errors

FAX firmware update error		
Error number	Error message	Error content
FX01	Communication Timeout (when the download is requested)	Communication timeout (when the download is requested.)
FX02	Communication Timeout (when data is downloaded)	Communication timeout (When the download is finished.)
FX03	Download request Failed	Downloading request was denied. (when the download is requested.)
FX04	Received failure during download request	Reception error (when the download is requested.)
FX05	Received failure during data download	Reception error (At the time of downloading)
FX06	File decompression error	File decompression error
FX07	Other Errors	Other errors

(10) Check that [Automatic Initialization] is displayed and then remove the USB storage device.

(11) Press [Automatic Initialization].

The MFP is rebooted and the initialization of the updating data is carried out.

## [ 2 ] Confirmation of Update Results

After updating is completed, check each data version in the 08 Setting Mode to confirm that the data have been overwritten properly.

Firmware	Code
System software	9900
System firmware	9930
Engine Firmware	9901
Scanner firmware	9902
RADF/DSDF firmware	9903
Finisher firmware	9904
Hole punch firmware	9944
Fax firmware (Line 1)	9905
Fax firmware (Line 2)	9969



## 12. MANAGEMENT OF MFP INFORMATION

### 12.1 Cloning (HS Menu)

#### 12.1.1 Overview

By using [59 SRAM Data Cloning] in the HS Menu, the SRAM data can be backed up into a USB storage device and such data can be restored into the MFP.

This function backs up or restores the data of the same MFP (same serial number), and is performed when the SRAM is replaced.

#### Notes:

The SYS board and SRAM should never be replaced together.

#### 12.1.2 Precautions

- When the standard storage device is initialized or replaced, back up the SRAM data afterwards.
- It is assumed that data cloning is to be performed when an MFP or any options are installed. If the address book has been registered, do not perform restoring. Otherwise, registered or set data are lost.
- For details about the specification of a USB storage device available for cloning, refer to the following reference.  
 P. 14-15 “14.5 Usable USB storage device”
- Cloning (HS Menu) with any storage devices other than a flash memory (e.g.: USB-connectible memory card reader, CD/DVD drive, hard disk) will never be guaranteed. Therefore, never use them for this operation.
- Be sure to unplug the LAN cable and fax line before data are backed up / restored. Also, do not open the DF, cover, drawer etc. during the cloning (HS Menu).
- Data can be backed up or restored between the MFPs only with the same model and version. If the version is different, update the firmware and back up / restore data in the same version.
- Restore data to an MFP which has the same options as when the data are backed up.
- Delete the backed up files in the USB storage device after the cloning.

### 12.1.3 Backup files

The following files are saved in the root directory of the USB storage device by backing up.

File name	Remarks
Modelname_MFPSerialNo_yyyy-MM-dd_hh-mm	E.g.: When backup was performed at 13:59 on October 1st, 20xx Txxx_CUK911379_20xx-10-01_13-59

### 12.1.4 Cloning procedure

#### [A] Backup procedure

- (1) Press the [ON/OFF] button to shut down the MFP.
- (2) Connect the USB storage device to the USB port.
- (3) Perform HS-59 -> [Backup SRAM Data to USB].

**Notes:**

When "Operation Failed" is displayed, turn the power OFF and then reattempt the steps from (1).

- (4) Enter the password and press [OK].

**Remarks:**

Maximum 15 characters

This password will be used when the backed-up clone data are restored in the MFP.

- (5) "Backup successfully done" is displayed on the LCD when the backup has been properly completed.
- (6) Turn the power OFF.

#### [B] Restore procedure

- (1) Press the [ON/OFF] button to shut down the MFP.
- (2) Connect the USB storage device to the USB port.
- (3) Perform HS-59 -> [Restore SRAM Data from USB].
- (4) Enter the password which has been set in (4) of [A] and press [OK].
- (5) Enter the serial number of the MFP and press [OK].

**Notes:**

Use the serial number given on the label attached to the rear cover for the entry.

- (6) "Restore successfully done Restart the MFP" is displayed on the LCD when the restoring has been properly completed.
- (7) Turn the power OFF.

**Notes:**

- When a back-up file is restored, do not perform the initialization or formatting of the standard storage device before the normal startup.
- When the back-up files, which were created before the standard storage device has been initialized or replaced, are restored, do so also for ADIKey.

 P. 9-26 "[C] Restore Encryption Key and License"

### [C] Confirmation of the error

“Operation Failed” is displayed on the lower left part of the LCD when the data have not been properly backed up or restored.

Moreover, details of the error are displayed under the above message.

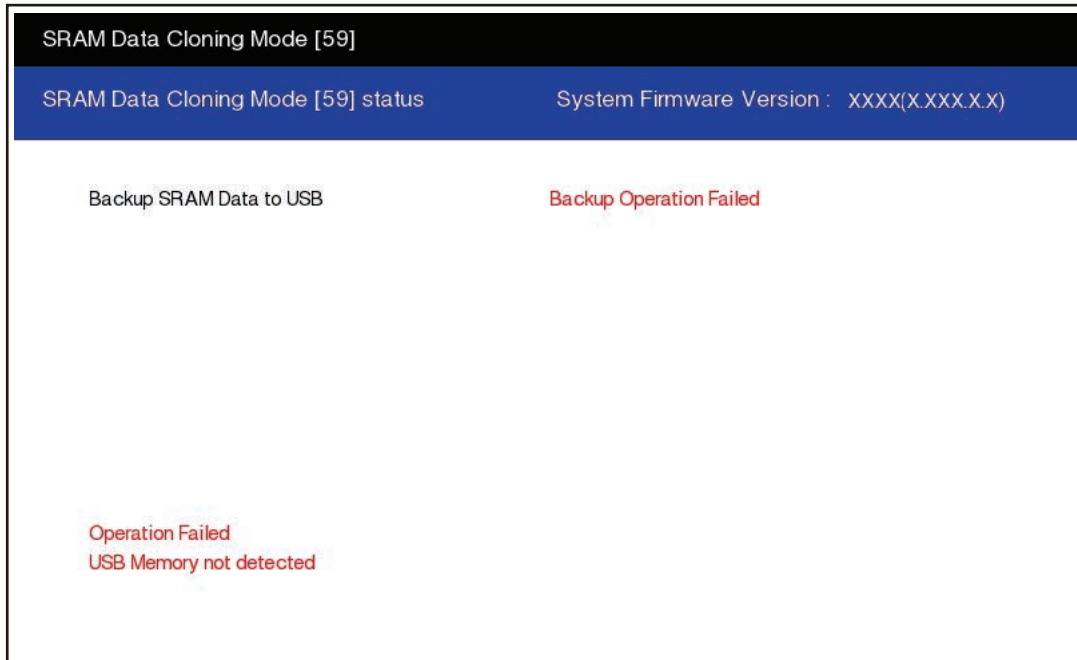

Fig.12-1

In this case, turn the power OFF and then check the following items.

After confirming and solving the problem, back up / restore the data again from the beginning.

- Does the USB storage device meet the conditions being used for this cloning?
- Is the updated program file written on the USB storage device properly?
- Is the USB storage device installed properly?
- Do the USB storage device and the MFP operate properly?

Backup	
Display content	Error content
USB device not detected	The USB storage device has not been installed.
SRAM Device Not Connected	The SRAM has not been installed.
Backup not created	Creation of the back-up file of data of the SRAM has failed.
Encryption Failed	An encryption of the back-up file has failed.
Password Not Appended to Backup	Addition of the encryption password has failed.
MFP Serial Number Not Set	Acquisition of the MFP serial number has failed.

Restore	
Display content	Error content
USB device not detected	The USB storage device has not been installed.
SRAM Device Not Connected	The SRAM has not been installed.
Invalid Backup File	The SYS board has not been recognized.
No Backup File Exists	No back-up file has existed in the USB storage device.
Invalid password	An incorrect password has been entered.
Decryption Failed	Decoding of the back-up file has failed.
Invalid MFP Serial Number: xxxxxxxx	An incorrect serial number has been entered.
MFP Serial Number Not Set	Acquisition of the MFP serial number has failed.
Backup File Corrupted	A back-up file has been damaged.

## 12.2 Cloning (FS Menu)

### 12.2.1 Overview

By using [36 Cloning] in the FS Menu, the MFP settings or user data can be stored into a USB storage device as clone data. Also, a clone file created by another MFP can be installed to the MFP in order to make it have the same conditions as the one which created the clone file.

### 12.2.2 Precautions

- A clone file created by the following MFPs can be installed in this MFP.
  - e-STUDIO6526AC/6527AC/7527AC
  - e-STUDIO6529A/7529A/9029A
  - e-STUDIO2525AC/3025AC/3525AC/4525AC/5525AC/6525AC
  - e-STUDIO2020AC/2520AC
  - e-STUDIO5528A/6528A
  - e-STUDIO2528A/2528A/3528A/4528A
  - e-STUDIO330AC/400AC
  - e-STUDIO2010AC/2510AC
  - e-STUDIO2015NC/2515AC/3015AC/3515AC/4515AC/5015AC
  - e-STUDIO5516AC/6516AC/7516AC
  - e-STUDIO2018A/2518A/3018A/3518A/4518A/5018A
  - e-STUDIO5518A/6518A/7518A/8518A
  - e-STUDIO2000AC/2500AC
  - e-STUDIO2505AC/3005AC/3505AC/4505AC/5005AC
  - e-STUDIO5506AC/6506AC/7506AC
  - e-STUDIO2008A/2508A/3008A/3508A/4508A/5008A
  - e-STUDIO5508A/6508A/7508A/8508A
  - e-STUDIO3508LP/4508LP/5008LP, Loops LP35/LP45/LP50
  - e-STUDIO2050C/2550C
  - e-STUDIO2555C/3055C/3555C/4555C/5055C
  - e-STUDIO2555CSE/3055CSE/3555CSE/4555CSE/5055CSE
  - e-STUDIO5560C/6560C/6570C
  - e-STUDIO207L/257/307/357/457/507
  - e-STUDIO557/657/757/857
  - e-STUDIO307LP, Loops LP301
  - e-STUDIO287CS/347CS/407CS
  - e-STUDIO287CSL/347CSL
  - e-STUDIO477S/527S
  - e-STUDIO477SL
  - e-STUDIO2040C/2540C/3040C/3540C/4540C
  - e-STUDIO5540C/6540C/6550C
  - e-STUDIO206L/256/306/356/456/506
  - e-STUDIO256SE/306SE/356SE/456SE/506SE
  - e-STUDIO556/656/756/856
  - e-STUDIO556SE/656SE/756SE/856SE
  - e-STUDIO306LP, Loops LP30
- When a clone file created by this MFP is installed in another one, confirm the installation ability by referring to the Service Manual for the target model.
- When a clone file created by another unit of the MFP is installed in this one, settings and information about the functions which are not supported by this MFP will be disregarded.
- When cloning of user information is carried out by means of this function, ask your users to change the setting to [Enable] of [User Information Cloning] from [Administration] - [Setup] - [General settings] - [Device Information] via TopAccess.
- When cloning of the administrator password is carried out by means of this function, ask your users to change the setting to [Enable] of [Administrator's Password Cloning] from [Administration] - [Setup] - [General settings] - [Device Information] via TopAccess

- For details about the specification of a USB storage device available for cloning, refer to the following reference.  
📖 P. 14-15 “14.5 Usable USB storage device”
- Delete a clone file stored in the USB storage device after the cloning.
- Precautions for passwords
  - When a clone file is created through [Administration] by using TopAccess or the control panel, the service password is cloned.  
For example, when cloning is performed with a clone file where the service password is blank, the cloned service password is also blank.
  - During cloning in the FS Menu, operation varies whether the setting of [User Information Cloning] from [Administration] - [Setup] - [General settings] - [Device Information] via TopAccess is [Enabled] or [Disabled].  
Disabled (default): The service password is not cloned.  
Enabled: The service password is cloned.

### 12.2.3 Clone file creation procedure

- (1) Press [36 CLONING] in the FS Menu.
- (2) Press [Create Clone File].
- (3) Select the categories to be included in the clone file.

**Notes:**

- If the following categories cannot be selected, ask your users to change the setting to [Enable] of [User Information Cloning] from [Administration] - [Setup] - [General settings] - [Device Information] via TopAccess.
  - User Management
  - Address Book
  - Address Book + Template + Mailboxes
- If Administrator's Password cannot be selected, ask your users to change the setting to [Enable] of [Administrator's Password Cloning] from [Administration] - [Setup] - [General settings] - [Device Information] via TopAccess.

- (4) Press [Save].
- (5) Enter a file name. Set a password if necessary.  
Once a password has been set, its entry is required when this clone file is installed in the MFP.
- (6) Press [Save].  
The clone file is stored by a file name with the extension ".enc" applied.

**Notes:**

Be sure to disconnect the USB storage device after the completion screen is displayed.

### 12.2.4 Clone file installation procedure

- (1) Press [36 CLONING] in the FS Menu.
- (2) Press [Install Clone File].
- (3) Connect the USB storage device with the stored clone file and press [OK].
- (4) Select the clone file to be installed.  
Enter the password if one has been set.
- (5) Press [Install].

**Notes:**

Be sure to disconnect the USB storage device after the completion screen is displayed.

## 12.3 Backing Up and Restoring Data

### 12.3.1 Overview

By using [35 DATA BACKUP/RESTORE MODE] in the FS Menu, the MFP settings or user data stored in the storage devices and SRAM can be backed up. They also can be restored into an MFP from which the back-up files were created.

### 12.3.2 Applicable data

Category name	Contents	Remarks
MFP setting	Code setting values in [05 ADJUSTMENT MODE] or [08 SETTING MODE]	Codes whose [Backup] column in the self-diagnostic code list is [Yes]
	Gamma automatic adjustment data, LDAP roll mapping data, certificate files, language packs, client software (printer driver, univ.zip/ps3.zip/InstallClient1.exe), print data converters, ICC profiles, card reader settings, meta data XML format, print fonts, logs (jobs, messages, applications), job history data	
User Management	Users (including user counters), groups, roles, allocation, department codes (including department counters), templates, address books, project codes, EWB history data, home settings data	
Mailboxes	Mailbox data	User permission is required*
Application (including licenses)	Application data (including license data)	
e-Filing	Document data in e-Filing	User permission is required*

\* These can be backed up if they are checked in TopAccess - [Administration] - [Maintenance] - [Data Backup Function] - [Target of Data Backup].

### 12.3.3 Precautions

- Back-up data can be restored into an MFP from which back-up files were created.  
Back-up data cannot be restored into an MFP from which the back-up files were created, if the configuration of the optional storage device differs from the one at the time of file creation.
- Although this function can be performed from the FS Menu and the User Function mode, there are restrictions on the storage location of backup files and restoration source when the FS Menu is used.

Function	Backup file storage location/restoration source	
	External server	USB storage device
FS-[35 DATA BACKUP/RESTORE MODE]	No	Yes
User Function mode	Yes	Yes

- Unique information such as the name of fax terminal or NetBIOS are not backed up.
- If periodic backup starts after backup has already been started from the control panel, or if you try to start backup when periodic backup is being performed, the latter back up will be canceled.
- When NW printer jobs or fax jobs are received during backup operation, jobs will successfully be received but not be printed out. These jobs will be printed out after the completion of backup.
- Backup files are encrypted and then stored into USB storage devices or external servers. Encryption is performed with an MFP-unique key and thus backup files cannot be restored to other MFP.
- The data backup function (FS-08-8679) cannot be enabled in the MFP with the High Security mode ON.
- For details about the specification of a USB storage device available for backup, refer to the following reference.  
 P. 14-15 “14.5 Usable USB storage device”
- The approximate time for data backup/restore is as follows (referential values):  
 When the backup file is 10 GB,  
 Backup (USB storage device): Approximately 36 minutes + backup file creation time  
 Backup (external server): Approximately 10 minutes + backup file creation time  
 Restore (USB storage device): Approximately 9 minutes + time for restoring to the MFP  
 Restore (external server): Approximately 24 minutes + time for restoring to the MFP
  - When applications and e-Filing are selected, backup or restore may take more 1 hour or more depending on the data volume stored in the MFP.
  - The total data volume of e-Filing and Mailbox is 30 GB or more, backup may fail.



### 12.3.4 Backup file creation procedure

- (1) Select [35 DATA BACKUP/RESTORE MODE] in the FS Menu.
- (2) Select [Data Backup].
- (3) Select [USB Media].
- (4) Connect the USB storage device and press [OK].

**Remarks:**

If backup files exist in the USB storage device, the file path, firmware version, and backup date are displayed.

- (5) Select [Backup].
- (6) Select [OK] to start backup.

**Notes:**

- During backup operation, you cannot move to another screen. (All hardware keys are unavailable.)
- Select [Cancel] to cancel the current process.
- When an error occurs, the error screen is displayed. For the details of the error, refer to the following.  
📖 P. 8-1 “8. ERROR CODE AND TROUBLESHOOTING”
- Note the following factors, which may cause an error while storing backup files into the USB storage device.
  - No USB storage device is inserted.
  - Storing files into the USB storage device has failed due to capacity shortage or writing permission.
- Backup files are stored in a folder (serial number) in the USB storage device.
- The name of the file where backup files are stored is as follows:  
(Serial number)\_HddBackupData.enc
- Be sure to disconnect the USB storage device after the completion screen is displayed.

## 12.3.5 Restore procedure

### Notes:

- Make sure that the backup file is created by the MFP you are restoring.
- Confirm that the configuration of the optional storage device of the MFP to make the restoration remains the same as when the backup was performed.

(1) Select [35 DATA BACKUP/RESTORE MODE] in the FS Menu.

(2) Press [Data Restore].

(3) Select [USB Media].

(4) Connect the USB storage device and press [OK].

### Remarks:

- If backup files exist in the USB storage device, the file path, firmware version, and backup date are displayed.
- When an error occurs, the error screen is displayed.

(5) Press [Restore].

(6) Select [OK] to start backup.

### Notes:

- During backup operation, you cannot move to another screen. (All hardware keys are unavailable.)
- Select [Cancel] to cancel the current process.
- When an error occurs, the error screen is displayed. For the details of the error, refer to the following.  
 P. 8-1 "8. ERROR CODE AND TROUBLESHOOTING"

(7) When the progress bar reaches 100%, the MFP automatically reboots in the special mode. When processes are done in the special mode, "Complete" is displayed and the MFP reboots.

### Notes:

When processes have failed, "Failed" is displayed. In that case, shut down the MFP by pressing [Shutdown] on the screen and then turn ON the MFP.

## 12.3.6 Management of the backup function

When the standard storage device and the optional storage device are damaged, not only the MFP stops operation, but also the data in those storages may be lost. To prevent this, the following actions are recommended.

- Periodically back up the data in the storage devices.
- Utilize the Storage device Alert function (to issue a warning when storage devices have deteriorated and replacement is required).

Backup can be set or performed by the user from TopAccess or the User Function mode.

- Backup

Setting	FS Menu	User operation
Enabling/disabling the backup function	08-8679	TopAccess - [Administration] - [Maintenance] - [Data Backup Function]
External server setting	08-8680, 08-8682 to 08-8687	
Automatic data backup cycle	08-8681-0 to 3	
Target of Data Backup	08-8688-0 to 1, 3 to 5	
Perform data backup	[35 DATA BACKUP/RESTORE MODE] <sup>*1</sup>	User Function mode <sup>*2</sup>
Restore		

\*1 : Only the USB storage device can be used.

\*2 : Displayed on the screen only when 08-8679 is enabled (when the data backup function is enabled in TopAccess).

### Notes:

- Periodic backup is not performed when a job is being performed. Periodic backup is automatically performed after the completion of the job.
  - When the MFP is in the energy saving mode/sleep mode, periodic backup is performed after the MFP has returned from the energy saving mode/sleep mode.
  - When the MFP is in the super sleep mode, periodic backup is performed after the MFP has returned from the super sleep mode. The MFP enters the super sleep mode after the completion of backup.
  - When the MFP is OFF on the date specified for periodic backup, such periodic backup is skipped.
  - Backup is canceled when [Cancel] is pressed during backup.
- Storage device Alert function

Setting	Contents	FS Menu	Service Notification
S.M.A.R.T self test	Execution setting of the self-testing  <b>Remarks:</b> The applicable storage device for this test is an HDD only.	08-9006-0 to 3	-
Judgment results	Judgment results of the storage status	08-9008-0 to 2	-
Warning indication	Settings for warnings to be displayed for the user based on the judgment results	08-9009-0 to 1	-
Equipment information notification	Settings for whether the service technician is notified with an alert when it is judged that replacement of storage devices is required	08-9046	Yes

**Notes:**

- When the S.M.A.R.T self test is being performed, “Storage device self test is processing” is displayed.
- The S.M.A.R.T self test is performed only when the MFP is ON at the specified time and also not in the super sleep mode.
- When it is the time for fixed time reboot, the fixed time reboot is prioritized.
- The state of storage devices is checked every 6 hours. When conditions are met, a message to request data backup in storage devices or replacement of storage devices is displayed on the panel.
- When the periodic backup function is enabled, no message to request backup is displayed.
- When backup is performed with the backup function once or more, no message to request backup is displayed.
- The indication is cleared when the system firmware version up is performed.

## 12.4 TPM

### 12.4.1 Overview

This is a function to encrypt authentication information and encryption keys in the standard storage device and optional storage device and store them by means of TPM (Trusted Platform Module). The security level against property loss can be enhanced by enabling TPM.

#### Remarks:

- This function is disabled at the time of factory shipment.
- Users can set to enable or disable with the User Function mode and service technicians can do so by means of the self-diagnostic code.
- When this function has been enabled, a signature check is carried out at the startup.

### 12.4.2 Confirmation Method

Press [COUNTER] on the touch panel. If the TPM icon is displayed at the top right of the screen, TPM is in operation.



Fig.12-2

### 12.4.3 Precautions for MFPs with TPM enabled

When the SYS board in an MFP with TPM enabled is replaced, a USB storage device, in which a password for this function is enabled and TPM information is stored, is necessary.

## 12.5 High Security Mode

### 12.5.1 Overview

The High Security mode is a security mode complying with CC certification which is suitable for HCD-PP. When entering the High Security mode, be sure to perform preparation and follow the entering procedure.

### 12.5.2 Prior confirmation

- Confirm that the administrator for the MFP is authorized and ask him/her to observe the installation.
- Make sure that the security HDD (GE-1260) is installed to the MFP since it is required to enter the High Security mode complying with HCD-PP.

**Notes:**

When the security HDD (GE-1260) is installed, an icon of the FIPS hard disk is displayed on the counter screen.

- To avoid physical security problems, such as hardware removal or inappropriate disassembly at the installation site, take all necessary measures, such as checking who enters and leaves the site.

### 12.5.3 Back up data in HDD

Ask the user (administrator) to back up the data in the storage devices. Backup methods and applicable data are as follows.

Backup method	Operation	Applicable data
Export information.	Export required information in TopAccess - [Administration] - [Maintenance] - [Export].	"Address Book", "F Code", "Template"
Export information.	Export required information in TopAccess - [User Management] - [Export/Import] - [Export].	"User Information", "LDAP Role", "Department Information", "Project Code"
Archive and download documents.	1. Archive document by selecting them in TopAccess - [e-Filing]. 2. Download archived documents.	e-Filing data
Copy files.	Copy files from Share Folder to another PC.	Data stored in the share folder of the MFP such as Scan to file or Copy and file
Export log data.	Create export files of the target data in TopAccess - [Logs] - [Export Logs].	All items
Print out the function list.	Print out [Function] in [Home] - [User Functions] - [Admin] - [List/Report] - [List].	System related settings and user information
Print out Function List for Maintenance.*	Print out [Function List for Maintenance] in FS-FAX-[12 Fax List Print Mode].	Fax related settings and user information
Take notes.	Take notes of information in TopAccess - [Administration].	Information in TopAccess - [Administration]

\* Only the service technician can operate.

**Notes:**

- Log into the MFP or TopAccess as the Administrator.
- Print out and hand over the following data to the user since they cannot be backed up.
  - Print waiting data (Copying data and Fax reception data that are waiting to be printed due to the paper run-out and jam, etc.)
  - Print job (Private print data, Schedule print data)
  - Fax saved data (Confidential or Bulletin board data)
- Inform the user that the following data cannot be backed up.
  - Registration data for Fax transmission (Delayed transmission or Recovery transmission)
- Compatibility of cloning data is lost between the High Security mode and the normal mode; therefore, cloning data cannot be imported.
- The data backup function is not available in the MFP with the High Security mode ON.

**12.5.4 Procedure for entering the High Security mode**

- (1) Set "1" (Enabled) in FS-08-9717-0 (Advanced storage connection setting).
- (2) Set "2" (High security) in FS-08-9717-1 (Advanced storage security setting).
- (3) Set "3" (High level) in FS-08-8911 (Security mode (level) setting).
- (4) Reboot the MFP.
- (5) Change the administrator password.

**Notes:**

- Explain the procedure to the users (MFP administrators) and ask them to enter their password.
  - For the administrator password, this should comply with the high security mode password policy.
- (6) Check that the MFP is shifted to the High Security mode by means of the following display.
    - A key-shaped icon appears at the bottom of the touch panel.
    - The version name of the installed system ROM (SYS V3.0) is displayed at the top right of the counter menu.

CPU Name	SYS Version
Intel Atom E3930 1.3GHz	SYS V3.0

- (7) Reset the user data backed up in advance.

**12.5.5 Restore user information and data in HDD**

Ask the user (administrator) to restore user information and data in the storage devices. Restoration methods and applicable data are as follows.

Restoration method	Operation	Applicable data
Print out the function list.	<ol style="list-style-type: none"> <li>1. Print out [Function] in [Home] - [User Functions] - [Admin] - [List/Report] - [List].</li> <li>2. Comparing it with the list printed out before entering the High Security mode, restore those with a different value and reenter user information.</li> </ol>	System related settings and user information
Print out Function List for Maintenance.*	<ol style="list-style-type: none"> <li>1. Print out [Function List for Maintenance] in FS-FAX-[12 Fax List Print Mode].</li> <li>2. Comparing it with the list printed out before entering the High Security mode, restore those with a different value and reenter user information.</li> </ol>	Fax related settings and user information

Restoration method	Operation	Applicable data
Reset or reenter.	Reenter the information you have taken notes of in TopAccess - [Administration].	Information in TopAccess - [Administration]
Import information.	Import required information in TopAccess - [Administration] - [Maintenance] - [Import].	"Address Book", "F Code", "Template"
Import information.	Import required information in TopAccess - [User Management] - [Export/Import] - [Import].	"User Information", "LDAP Role", "Department Information", "Project Code"
Upload archived documents.	Upload archived documents in TopAccess - [e-Filing].	e-Filing data

\* Only the service technician can operate.

#### Notes:

Log into the MFP or TopAccess as the Administrator.

## 12.5.6 Precautions

- In the High Security mode, an integrity check system is operated at every reboot. If F521 (integrity check error) is displayed, take the necessary measures following the troubleshooting procedure.
- When a self-diagnostic mode is started in the High Security mode, an authentication screen appears. Enter the default user name and password of the service.
- If a password change screen appears, reset the password according to the rules below.
  - It must not be the same as the user name or not include the user name.
  - It must be a combination of letters of the alphabet, numbers and symbols.
  - It must be 8 characters or more for the administrator password and 6 characters or more for the service password. (Maximum 64 characters)
  - The same character must not be repeated 4 times within the new password.
  - The old and the new passwords must not be the same.
- When the MFP is shifted to the High Security mode, the contents for some codes will be changed as below.
  - The default value is changed.
  - The settings cannot be changed.
  - Some setting values cannot be selected.
 For details, refer to the "Self-diagnostic code list" (separate document).
- The HDD is initialized (and the saved user data are deleted) when the MFP returns to the normal mode from the High Security mode. Be sure to back up user data before having it do so.
- In the above case, the password is not reset. The password setting can be changed with the code FS-08-8919.
- After the MFP enters the High Security mode, ask the administrator for the MFP to select [Full] and perform the Integrity check manually.



## 12.6 Decommissioning

### 12.6.1 Overview

Decommissioning is a function to perform a batch processing of deleting user data, initializing settings, etc. This function is used at the removal of the MFP.

### 12.6.2 Function

With decommissioning, a batch processing of deleting user data, initializing settings, etc. can be performed.

There are two ways for decommissioning; one is performed from the control panel on the MFP and the other is performed by remote operation using the remote maintenance service. In this manual, the way used for decommissioning from the control panel on the MFP is explained.

### 12.6.3 Precautions

- Deleted data and formatted setting values subject to decommissioning cannot be returned to the original values.
- The MFP cannot be operated after performing decommissioning.

#### Remarks:

- The firmware update log and the power ON/OFF log are not deleted.
- Installed licenses and system applications are not deleted.
- The data of the NIC Config List and the Function List which the remote maintenance service obtains are formatted.

### 12.6.4 Procedures of decommissioning

#### [ 1 ] Performing of decommissioning

- (1) Confirm that no paper jams and errors have occurred and the MFP is not being operated.
- (2) Perform FS-08-8615.
- (3) Press [Execution].

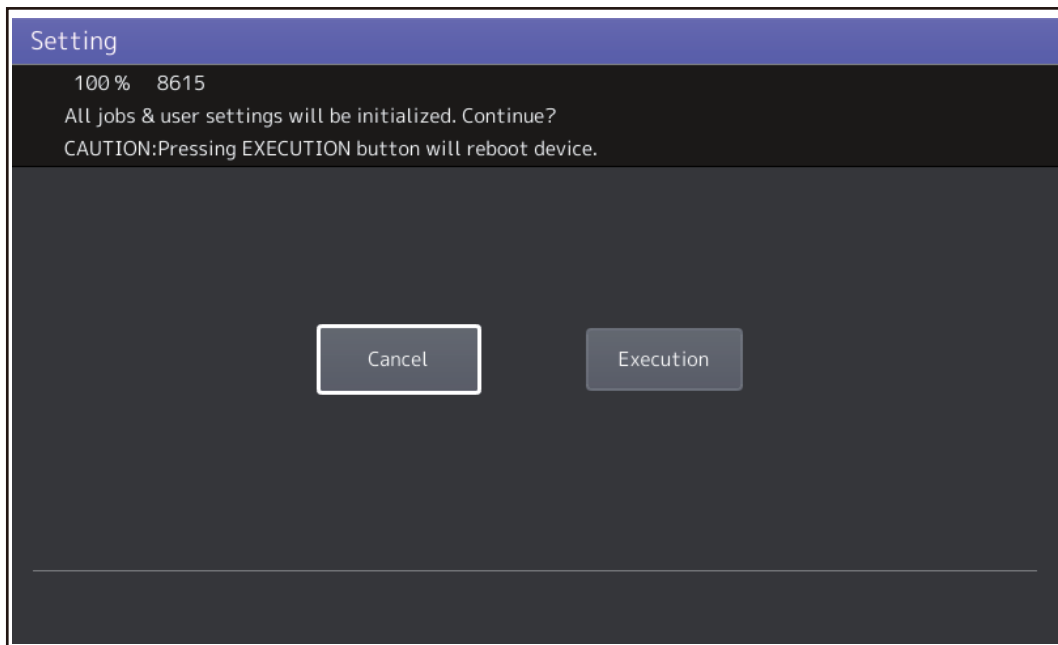

Fig.12-3

The MFP is rebooted. After rebooting, the MFP enters the decommissioning mode and starts processing.

The MFP carries out the following items while performing decommissioning.

- Stopping the network function
- Prohibiting job reception and job execution
- Deleting pending jobs
- Performing system initialization
- Deleting users information, etc.

(4) When the processing is completed, “Success” or “Failed” is displayed.

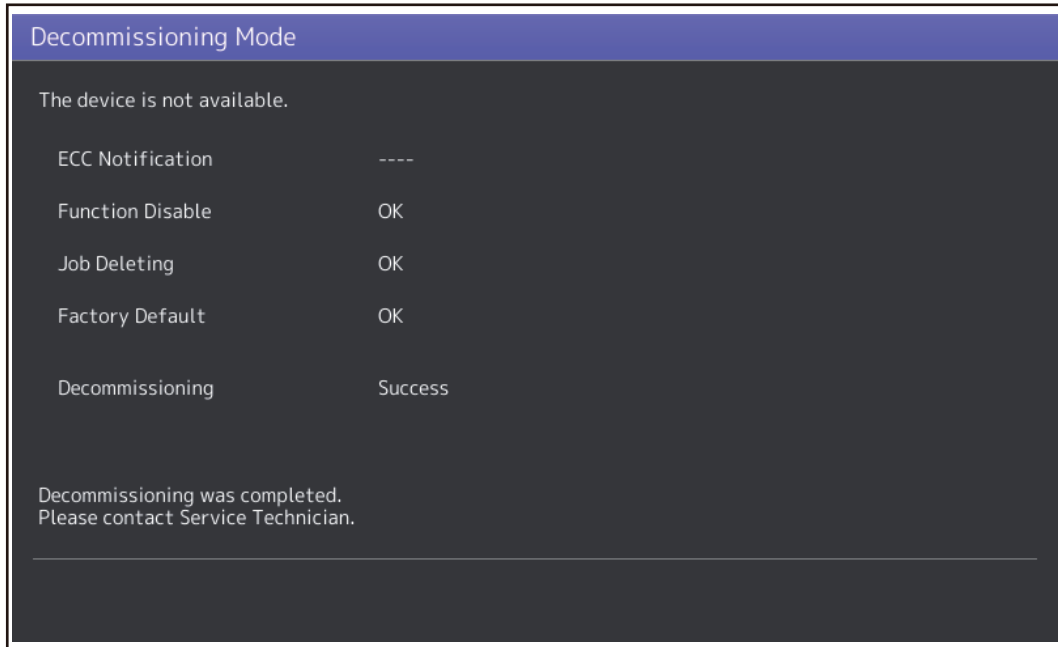

Fig.12-4

**Notes:**

When “Failed” is displayed, manually delete or format the data.

(5) After the processing is completed, the MFP is kept in the decommissioning mode state.

**Remarks:**

The MFP will keep retaining the decommissioning mode until it is canceled.

While the decommissioning mode is retained, the processing result keeps being displayed and receiving and executing of jobs are stopped. Only the [ON/OFF] button is available.

(6) To cancel the decommissioning mode, perform the procedure of [2].

**[ 2 ] Cancellation of decommissioning**

(1) Perform FS-08-8616.

(2) Press [Execution].

The MFP is rebooted. The MFP enters the normal mode after rebooting.

**Remarks:**

**If the decommissioning mode cannot be canceled even though the procedure of [2] has been carried out, perform the following steps.**

1. Perform HS-49 Firmware Update.
2. Install the system software.
3. The MFP is rebooted. Confirm that the state of the MFP is changed to the normal mode.

# 13. WIRE HARNESS CONNECTION DIAGRAMS

## 13.1 AC Wire Harness

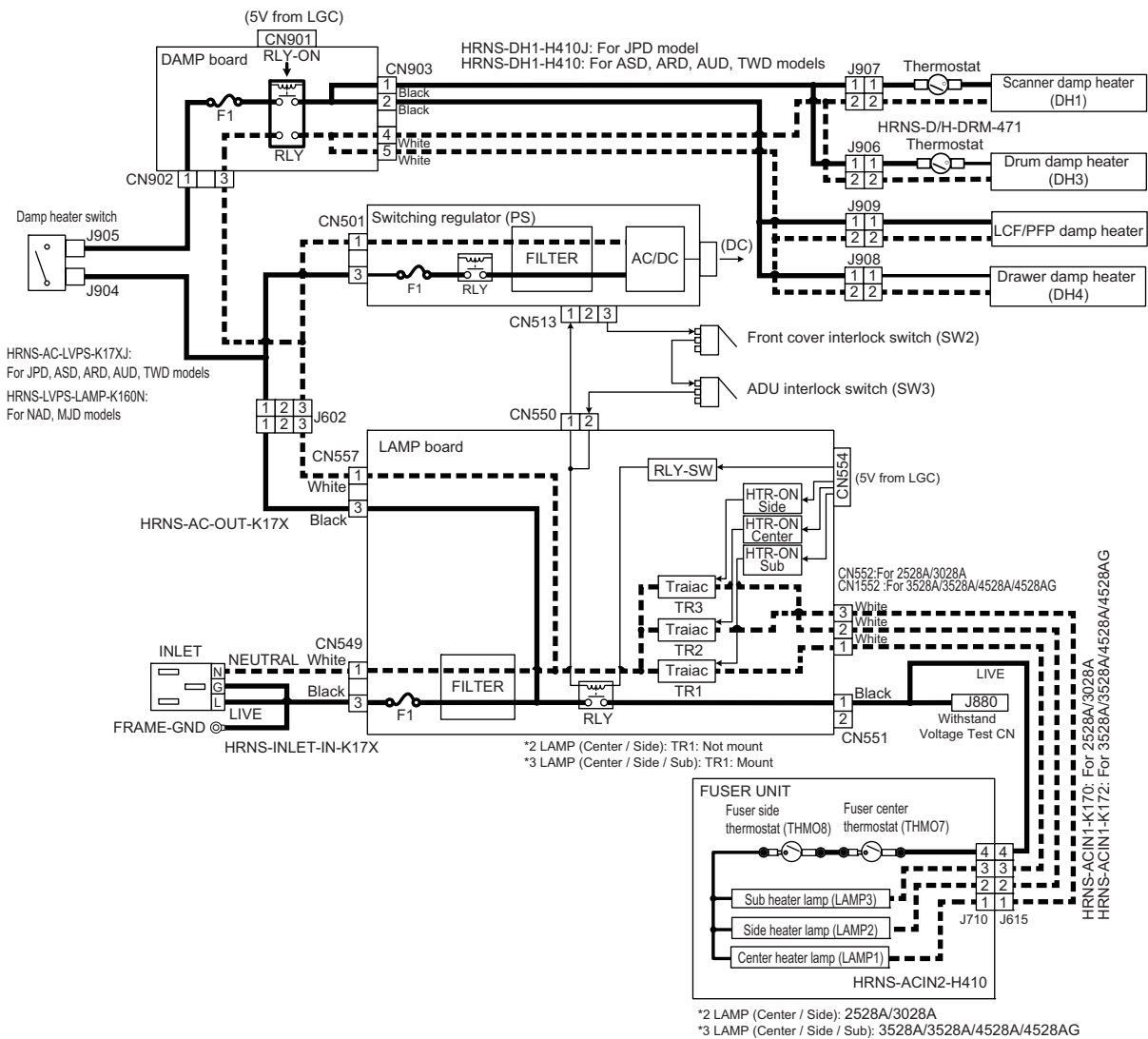

Fig.13-1

**Notes:**

- Front cover interlock switch (SW2) and ADU interlock switch (SW3) are the interlock switches with 12V DC.
- When the front cover interlock switch (SW2) or ADU interlock switch (SW3) is turned OFF, 24VD output will stop.



13.2.1 DC Wire Harness <2528A/3028A>

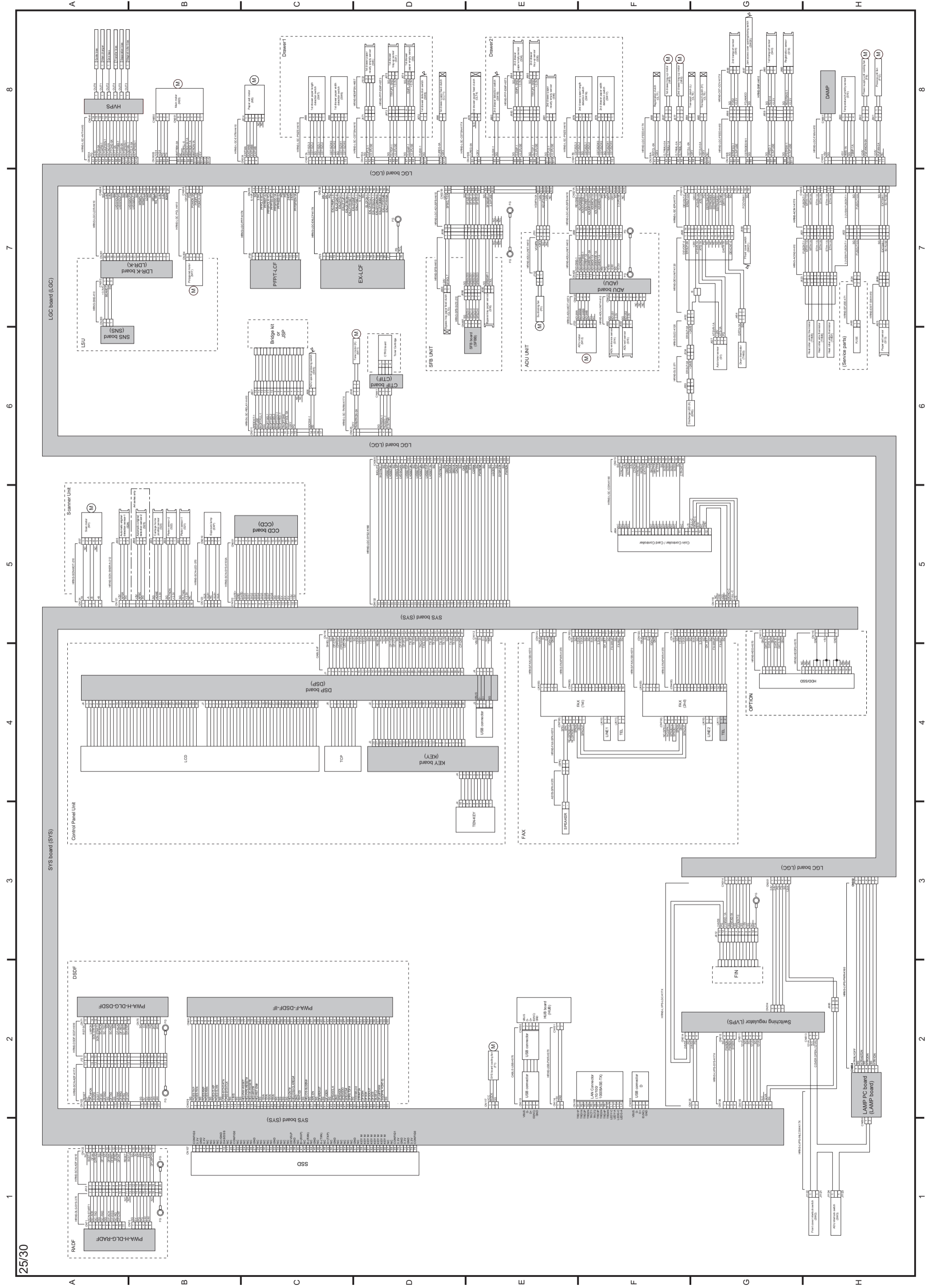

### 13.2.2 Electric Parts Layout <2528A/3028A>

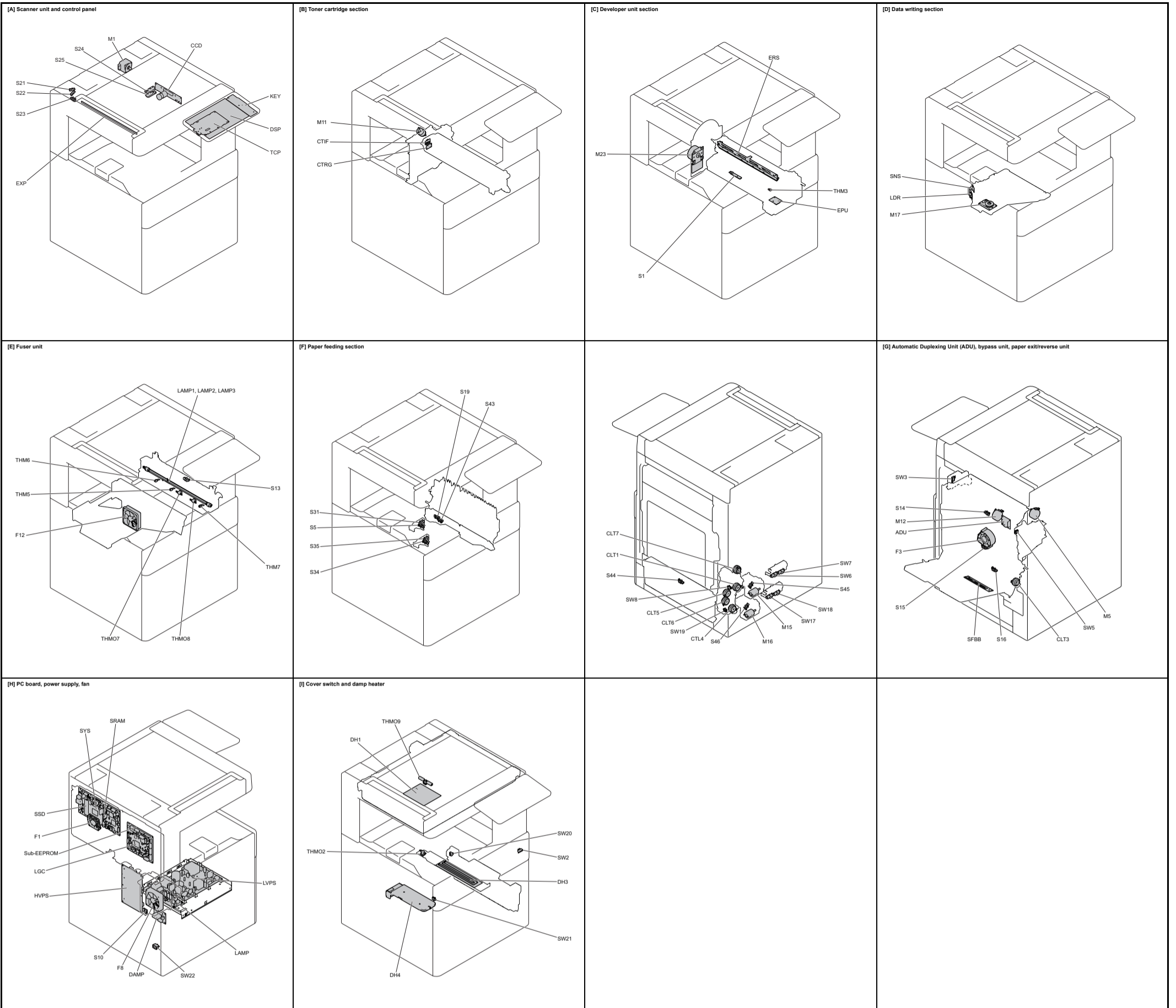

Symbol	Name	Figure	Wire harness location
M1	Scan motor	[A]	5-A
M5	Paper exit motor	[G]	8-C
M11	Toner motor (K)	[B]	6-D
M12	ADU motor	[G]	6-F
M15	1st drawer tray-up motor	[F]	8-F
M16	2nd drawer tray-up motor	[F]	8-F
M17	Polygonal motor	[D]	7-B
M23	Main motor	[C]	8-B
F1	SYS board cooling fan	[H]	2-E
F3	Suctioning fan	[G]	7-E
F8	Power supply unit cooling fan	[H]	8-H
F12	Process unit fan	[E]	8-H

Symbol	Name	Figure	Wire harness location
S1	Auto-toner sensor	[C]	8-G
S5	1st drawer paper empty sensor	[F]	8-D
S10	Temperature/humidity sensor	[H]	8-H
S13	Paper exit sensor	[E]	6-H
S14	ADU entrance sensor	[G]	6-F
S15	ADU exit sensor	[G]	6-F
S16	Bypass tray paper sensor	[G]	7-E
S19	Registration sensor	[F]	8-G
S21	Platen sensor-1	[A]	5-B
S22	Platen sensor-2	[A]	5-B
S23	Carriage home position sensor	[A]	5-B
S24	Automatic original detection sensor-1	[A]	5-A
S25	Automatic original detection sensor-2	[A]	5-B
S31	1st drawer tray-up sensor	[F]	8-D
S34	2nd drawer paper empty sensor	[F]	8-E
S35	2nd drawer tray-up sensor	[F]	8-E
S43	1st transport sensor	[F]	8-G
S44	2nd transport sensor	[F]	8-G
S45	1st drawer paper nearly empty sensor	[F]	8-D
S46	2nd drawer paper nearly empty sensor	[F]	8-E
SW2	Front cover interlock switch	[I]	AC Wire Harness
SW3	ADU interlock switch	[G]	AC Wire Harness
SW5	ADU opening/closing switch	[G]	6-C
SW6	1st drawer paper width detection switch	[F]	8-C
SW7	1st drawer paper length detection switch	[F]	8-C
SW8	1st drawer detection switch	[F]	8-D
SW17	2nd drawer paper width detection switch	[F]	8-F
SW18	2nd drawer paper length detection switch	[F]	8-F
SW19	2nd drawer detection switch	[F]	8-E
SW20	Jam access cover opening/closing switch	[I]	8-G
SW21	Front cover switch	[I]	7-G
SW22	Damp heater switch	[H]	-

Symbol	Name	Figure	Wire harness location
CLT1	1st drawer paper feed clutch	[F]	8-D
CLT3	Bypass tray paper feed clutch	[G]	7-D
CLT4	2nd drawer paper feed clutch	[F]	8-E
CLT5	Transport clutch (H)	[F]	8-G
CLT6	Transport clutch (L)	[F]	8-F
CLT7	Registration clutch	[F]	8-F

Symbol	Name	Figure	Wire harness location
CCD	CCD driving PC board (CCD board)	[A]	5-B
CTIF	Toner cartridge interface PC board (CTIF board)	[B]	6-D
CTRG	Toner cartridge PC board (CTRG board)	[B]	6-D
DSP	Display PC board (DSP board)	[A]	4-C
EPU	EPU memory PC board (EPU board)	[C]	-
KEY	Key PC board (KEY board)	[A]	4-C
LDR	Laser driving PC board (LDR board)	[D]	7-B
LGC	Logic PC board (LGC board)	[H]	6-D
SFBB	Paper width detection PC board (SFBB board)	[G]	6-E
SNS	H-sync signal detection PC board (SNS board)	[D]	6-A
SYS	System PC board (SYS board)	[H]	5-D
ADU	ADU PC board (ADU board)	[G]	7-F

Symbol	Name	Figure	Wire harness location
DH1	Drum damp heater	[I]	AC Wire Harness
DH3	Scanner damp heater	[I]	AC Wire Harness
DH4	Drawer damp heater	[I]	AC Wire Harness
ERS	Discharge LED	[C]	AC Wire Harness
EXP	Exposure lamp	[A]	5-B
LAMP1	Center heater lamp	[E]	AC Wire Harness
LAMP2	Side heater lamp	[E]	AC Wire Harness
LAMP3	Sub heater lamp	[E]	AC Wire Harness

Symbol	Name	Figure	Wire harness location
THM02	Drum damp heater thermostat	[I]	AC Wire Harness
THM07	Fuser center thermostat	[E]	AC Wire Harness
THM08	Fuser side thermostat	[E]	AC Wire Harness
THM09	Scanner damp heater thermostat	[I]	AC Wire Harness
THM3	Drum thermistor	[C]	6-G
THM5	Heat roller center thermistor	[E]	6-H
THM6	Heat roller side thermistor	[E]	6-H
THM7	Heat roller edge thermistor	[E]	6-H

Symbol	Name	Figure	Wire harness location
HVT	High-voltage transformer	[H]	8-A

Symbol	Name	Figure	Wire harness location
TCP	Touch panel	[A]	4-C
SSD	SSD	[H]	1-C
LVP5	Switching regulator	[H]	2-G
LAMP	LAMP PC board	[H]	2-H
DAMP	DAMP PC board	[H]	8-H
SRAM	SRAM	[H]	-
Sub-EEPROM	Electrically Erasable Programmable Read Only Memory	[H]	-

13.2.3 DC Wire Harness <3528A/3528AG/4528A/4528AG>

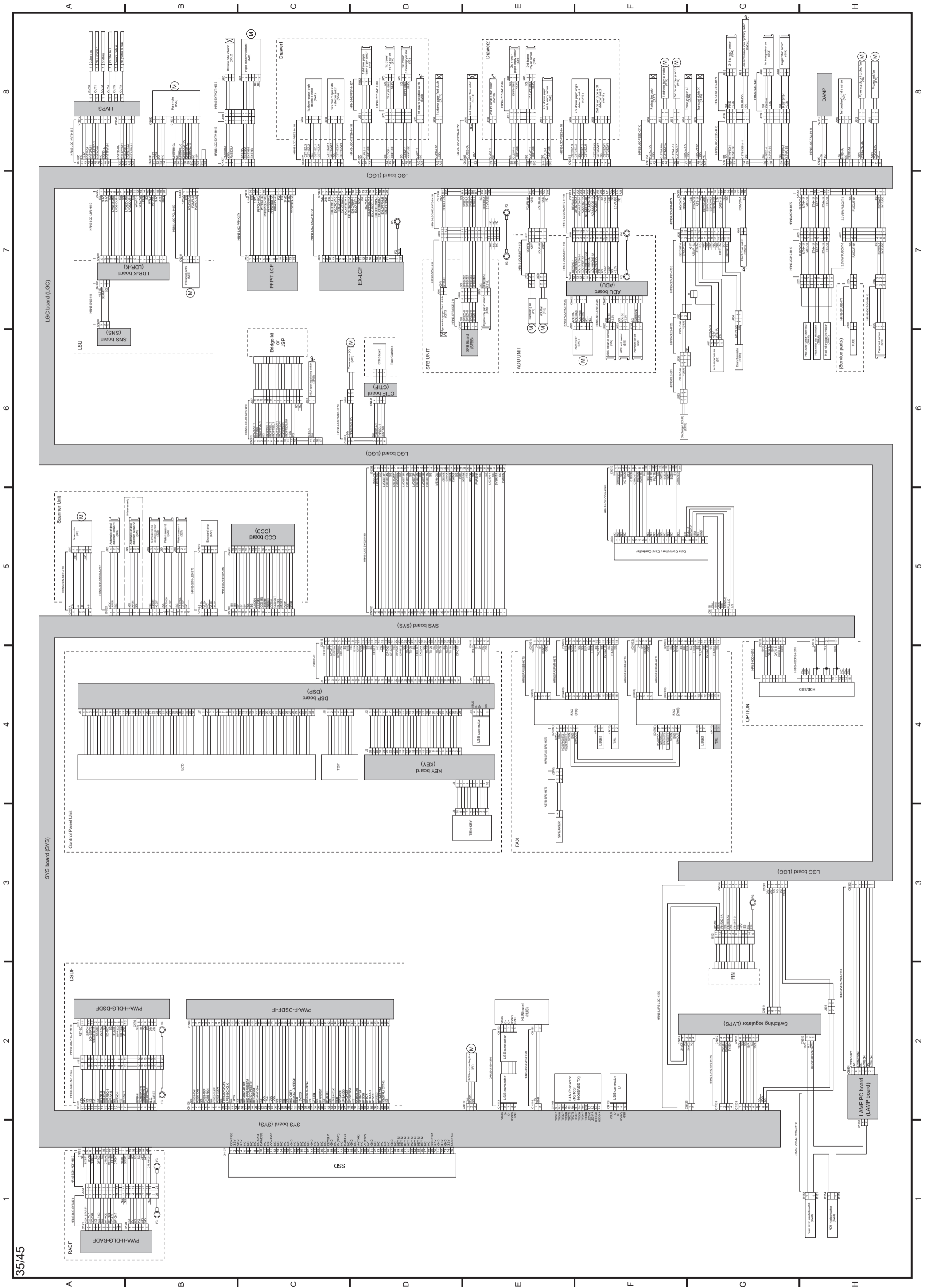

### 13.2.4 Electric Parts Layout <3528A/3528AG/4528A/4528AG>

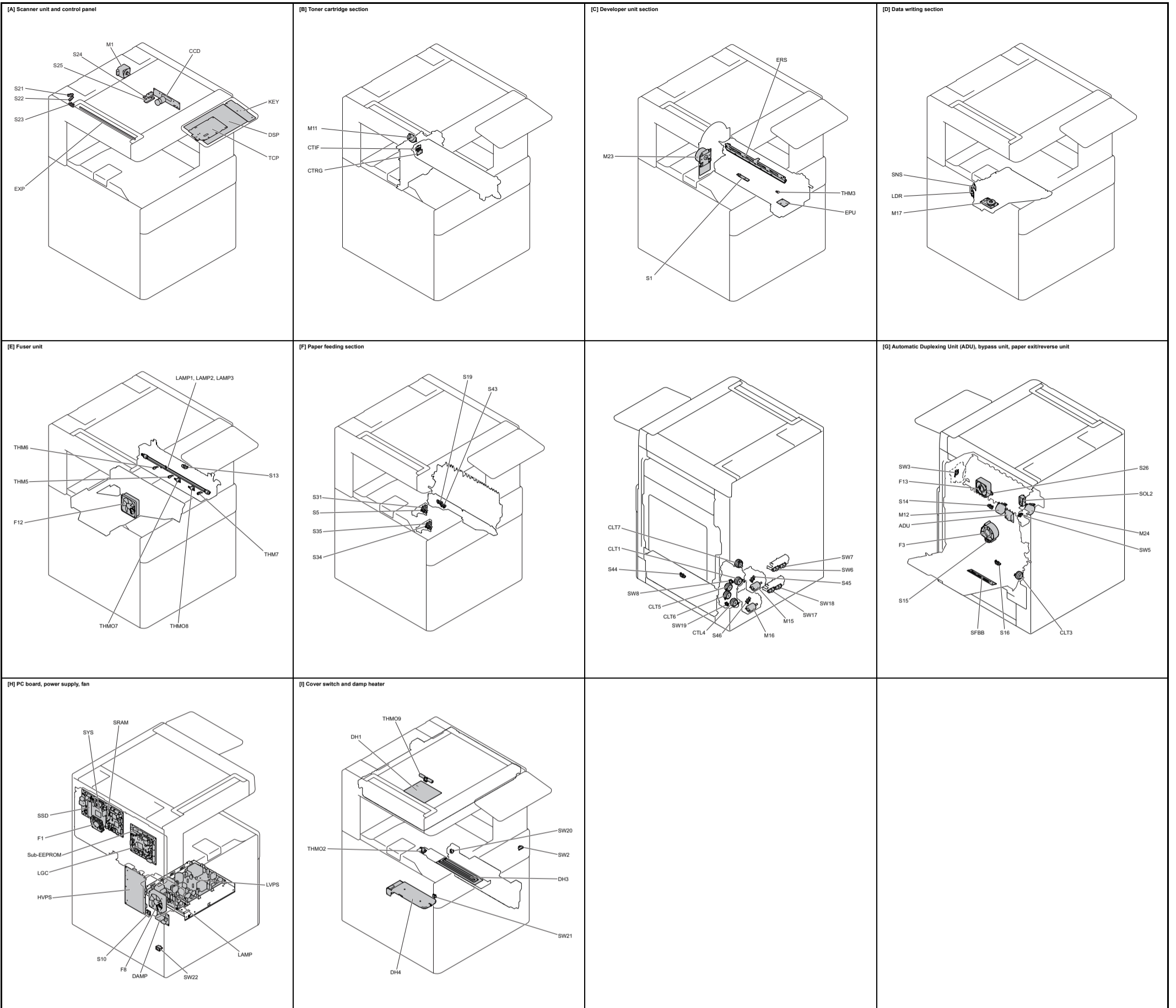

Symbol	Name	Figure	Wire harness location
M1	Scan motor	[A]	5-A
M11	Toner motor (K)	[B]	6-D
M12	ADU motor	[G]	6-F
M15	1st drawer tray-up motor	[F]	8-F
M16	2nd drawer tray-up motor	[F]	8-F
M17	Polygonal motor	[D]	7-B
M23	Main motor	[C]	8-B
M24	paper exitreverse motor	[G]	8-C
F1	SYS board cooling fan	[H]	2-E
F3	Suctioning fan	[G]	7-E
F8	Power supply unit cooling fan	[H]	8-H
F12	Process unit fan	[E]	8-H
F13	ADU fan	[G]	7-E

Symbol	Name	Figure	Wire harness location
S1	Auto-toner sensor	[C]	5-C
S5	1st drawer paper empty sensor	[F]	8-D
S10	Temperature/humidity sensor	[H]	8-H
S13	Paper exit sensor	[E]	6-H
S14	ADU entrance sensor	[G]	6-F
S15	ADU exit sensor	[G]	6-F
S16	Bypass tray paper sensor	[G]	7-E
S19	Registration sensor	[F]	8-G
S21	Platen sensor-1	[A]	5-B
S22	Platen sensor-2	[A]	5-B
S23	Carriage home position sensor	[A]	5-B
S24	Automatic original detection sensor-1	[A]	5-A
S25	Automatic original detection sensor-2	[A]	5-B
S26	Reverse sensor	[G]	6-F
S31	1st drawer tray-up sensor	[F]	8-D
S34	2nd drawer paper empty sensor	[F]	8-E
S35	2nd drawer tray-up sensor	[F]	8-E
S43	1st transport sensor	[F]	8-G
S44	2nd transport sensor	[F]	8-G
S45	1st drawer paper nearly empty sensor	[F]	8-D
S46	2nd drawer paper nearly empty sensor	[F]	8-E
SW2	Front cover interlock switch	[I]	AC Wire Harness
SW3	ADU interlock switch	[G]	AC Wire Harness
SW5	ADU opening/closing switch	[G]	6-C
SW6	1st drawer paper width detection switch	[F]	8-C
SW7	1st drawer paper length detection switch	[F]	8-C
SW8	1st drawer detection switch	[F]	8-D
SW17	2nd drawer paper width detection switch	[F]	8-F
SW18	2nd drawer paper length detection switch	[F]	8-F
SW19	2nd drawer detection switch	[F]	8-E
SW20	Jam access cover opening/closing switch	[I]	8-G
SW21	Front cover switch	[I]	7-G
SW22	Damp heater switch	[H]	-

Symbol	Name	Figure	Wire harness location
CLT1	1st drawer paper feed clutch	[F]	8-D
CLT3	Bypass tray paper feed clutch	[G]	7-D
CLT4	2nd drawer paper feed clutch	[F]	8-E
CLT5	Transport clutch (H)	[F]	8-G
CLT6	Transport clutch (L)	[F]	8-F
CLT7	Registration clutch	[F]	8-F

Symbol	Name	Figure	Wire harness location
SOL2	Reverse gate solenoid	[G]	8-B

Symbol	Name	Figure	Wire harness location
CCD	CCD driving PC board (CCD board)	[A]	5-B
CTIF	Toner cartridge interface PC board (CTIF board)	[B]	6-D
CTRG	Toner cartridge PC board (CTRG board)	[B]	6-D
DSP	Display PC board (DSP board)	[A]	4-C
EPU	EPU memory PC board (EPU board)	[C]	-
KEY	Key PC board (KEY board)	[A]	4-C
LDR	Laser driving PC board (LDR board)	[D]	7-B
LGC	Logic PC board (LGC board)	[H]	6-D
SFBB	Paper width detection PC board (SFB board)	[G]	6-E
SNS	H-sync signal detection PC board (SNS board)	[D]	6-A
SYS	System PC board (SYS board)	[H]	5-D
ADU	ADU PC board (ADU board)	[G]	7-F

Symbol	Name	Figure	Wire harness location
DH1	Drum damp heater	[I]	AC Wire Harness
DH3	Scanner damp heater	[I]	AC Wire Harness
DH4	Drawer damp heater	[I]	AC Wire Harness
ERS	Discharge LED	[C]	AC Wire Harness
EXP	Exposure lamp	[A]	5-B
LAMP1	Center heater lamp	[E]	AC Wire Harness
LAMP2	Side heater lamp	[E]	AC Wire Harness
LAMP3	Sub heater lamp	[E]	AC Wire Harness

Symbol	Name	Figure	Wire harness location
THM02	Drum damp heater thermostat	[I]	AC Wire Harness
THM07	Fuser center thermostat	[E]	AC Wire Harness
THM08	Fuser side thermostat	[E]	AC Wire Harness
THM09	Scanner damp heater thermostat	[I]	AC Wire Harness
THM3	Drum thermistor	[C]	6-G
THM5	Heat roller center thermistor	[E]	6-H
THM6	Heat roller side thermistor	[E]	6-H
THM7	Heat roller edge thermistor	[E]	6-H

Symbol	Name	Figure	Wire harness location
HVT	High-voltage transformer	[H]	8-A

Symbol	Name	Figure	Wire harness location
TCP	Touch panel	[A]	4-C
SSD	SSD	[H]	1-C
LVPS	Switching regulator	[H]	2-G
LAMP	LAMP PC board	[H]	2-H
DAMP	DAMP PC board	[H]	8-H
SRAM	SRAM	[H]	-
Sub-EEPROM	Electrically Erasable Programmable Read Only Memory	[H]	-



## 14. APPENDIX

### 14.1 External Counters

#### 14.1.1 Overview

This chapter describes the interface between external counters, such as a coin controller and key copy counter.

#### 14.1.2 Connector

- LGC board connector: CN313 (B20B-CZHK-B-1(LF)(SN)(V): manufactured by JST)
- SYS board connector: CN118 (B7B-PH-SM4): manufactured by JST)

#### 14.1.3 Coin controller

##### [ 1 ] Setting

1. Set "1" or "5" in FS-08-9016.
2. Harness kit: GQ-1280-N

##### [ 2 ] Pin layout

###### Notes:

Do not connect inductive loads, such as a mechanical counter or a relay coil, to CTRON.

###### 1. LGC board

Pin No.	I/O	Signal name	Function	Voltage level	Remarks
1 to 4	-	-	-	-	Connection prohibited
5	Power	+24V	24 V line	DC24 V +10/-5 %	
6	Out	CTRON	Total counter On signal	Open collector	L: On IO (Max): 500 mA
7	In	CTRCNT	Copy permission signal	L = 0 V, H = DC3.3 V	L: Allowed *1
8	Out	MCRUN	Ready to copy signal	Open collector	L: Operating IO (Max): 40 mA
9	Out	EXTCTR	Paper exit sensor On signal	Open collector	L: On IO (Max): 40 mA
10 to 18	-	-	-	-	Connection prohibited
19	Power	+5VL	5 V line	DC5.1 V	At the sleep mode: Off
20	-	-	-	-	Connection prohibited

\*1 When the coin controller outputs the CTRCNT signal, the controller should be driven by means of an open collector or open drain to prevent the inflow of current to the MFP.

## 2. SYS board side

Pin No.	I/O	Signal name	Function	Voltage level	Remarks
1	Out	LARGE/ SMALL	Paper size signal	Open collector	L: Large size IO (Max): 20 mA
2	-	-	-	-	Connection prohibited
3	-	-	-	-	Connection prohibited
4	-	-	-	-	Connection prohibited
5	-	-	-	-	Connection prohibited
6	GND	SG	Signal Ground	0 V	
7	-	-	-	-	Connection prohibited

### [ 3 ] Details of the signals

#### 1. CTRON signal (output signal)

The CTRON signal is synchronized with an electronic counter of the MFP and it becomes “Low” when one sheet of paper is counted up. This signal is output from the LGC board.



Fig.14-1

#### 2. CTRCNT signal (input signal)

The CTRCNT signal enables the acceptance of copies when the coin controller is connected, and copies can be accepted with “Low”. In case of “High”, “Set Key Counter” appears and copies cannot be made.

#### 3. MCRUN signal (output signal)

The MCRUN signal is changed to “Low” during copying. It becomes “Low” at 30 ms or more before the CTRON signal is turned ON, and “High” at 50 ms or more after the EXTCTR signal goes OFF. However, if copying is interrupted due to forced toner supply or similar, this signal is “High” until copying is made possible again.

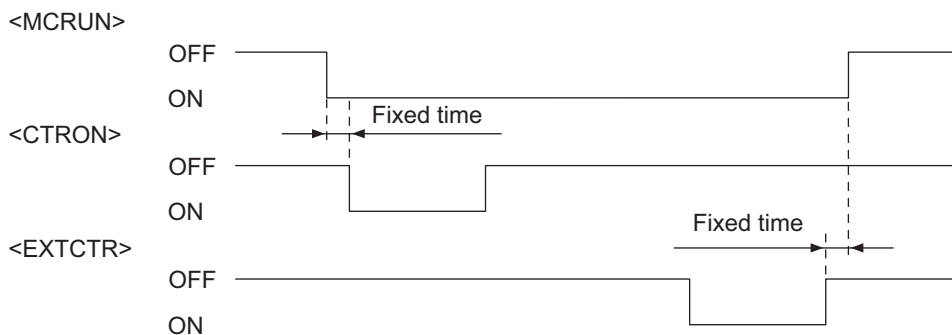

Fig.14-2

#### 4. EXTCTR signal (output signal)

The EXTCTR signal is synchronized with “Exit sensor ON” and becomes “Low” (ON) for 200 ms. The coin controller counts the number of times with this signal. This is the signal only for the coin controller.

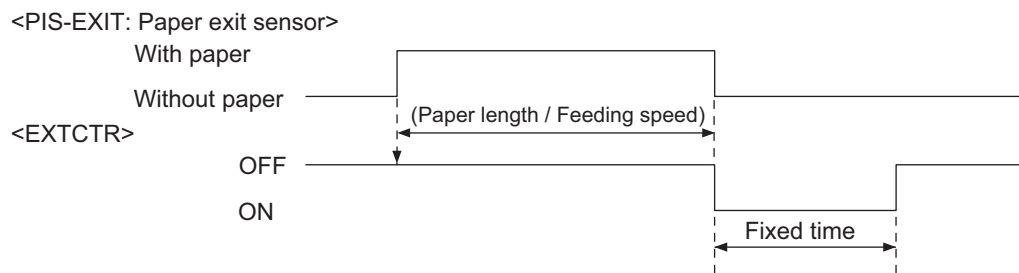

Fig.14-3

#### 5. LARGE/SMALL signal (output signal)

When large-size paper, such as A3, A3 wide or LD, is selected for the paper size is not specified in the manual feeding, it outputs “Low” in real time. In other cases, it outputs “High”. The setting change for large size paper is performed with F/W. This is the signal only for the coin controller.

### [ 4 ] Harness (GQ-1280-N)

PC boards	Connector	Pin No.	Signal name	Pin No.	Connector
SYS board (CN118)	Connector-2	1	LARGE/SMALL	7	Connector-3 (Coin controller)
		2	-	-	
		3	-	-	
		4	-	-	
		5	-	-	
		6	SG	12	
		7	-	-	
LGC board (CN313)	Connector-1	1	-	-	
		2	-	-	
		3	-	-	
		4	-	-	
		5	+24V	1	
		6	CTRON	2	
		7	CTRCNT	3	
		8	MCRUN	4	
		9	EXTCTR	5	
		10	PG	6	
		11	-	-	
		12	-	-	
		13	-	-	
14	-	-			
15	-	-			
16	-	-			
17	-	-			
18	-	-			
19	+5VL	11			
20	-	-			

## 14.1.4 Key copy counter

### [ 1 ] Setting

1. Set "3" in FS-08-9016.
2. Harness kit: -

### [ 2 ] Pin layout

#### Notes:

Use 24 V supplied from the MFP as power for the output signals (KCTRON) from the transistor.

1. LGC board

Pin No.	I/O	Signal name	Function	Voltage level	Remarks
1	GND	SG	Signal Ground	0 V	
2	In	CTRCNT	Copy permission signal	L = 0 V, H = DC3.3 V	L: Allowed *1
3	Power	+24V	24 V line	DC24 V +10/-5 %	
4	Out	KCTRON	Mechanical counter On signal	Open collector	L: On IO (Max): 500 mA
5 to 20	-	-	-	-	Connection prohibited

\*1 When the coin controller outputs the CTRCNT signal, the controller should be driven by means of an open collector or open drain to prevent the inflow of current to the MFP.

2. SYS board side

Do not connect the SYS board.

### [ 3 ] Details of the signals

1. CTRCNT signal (input signal)

The CTRCNT signal enables the acceptance of copies when the key counter is connected, and copies can be accepted with "Low". In case of "High", "Set Key Counter" appears and copies cannot be made.

2. KCTRON signal (output signal)

These signals are synchronized with the electronic counter of the MFP and they become "Low" when the counter is turned ON. They are the signals for driving a mechanical counter, and output from the LGC board.

They can drive inductive loads, such as a solenoid, using 24V supplied from the MFP. The interval between when they are turned ON and when this happens next must be at least 100 ms.

"Single count" or "Double count" can be switched according to the paper size by setting "1" or "2" for FS-08-6010.

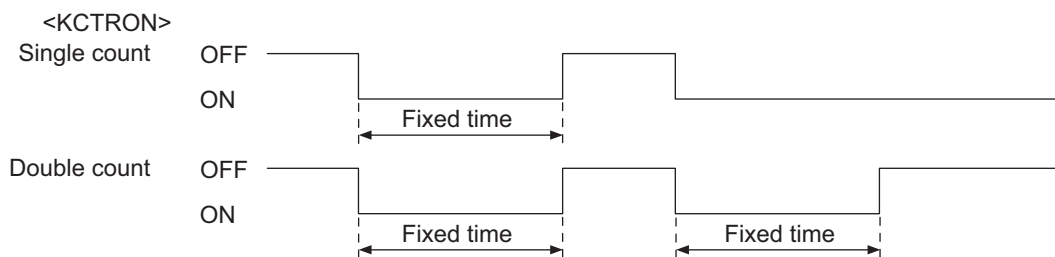

Fig.14-4

## 14.1.5 Precautions

### [ 1 ] Setting code

Each signal will be enabled by configuring the setting code FS-08-9016 (Counter installed externally).

FS-08-9016

- 0: No external counter (default)
- 1: Coin controller
- 3: Key copy counter
- 5: Coin controller supporting mixed-size

### [ 2 ] Setting value change and restrictions when using the coin controller

FS-08-9016 (Counter installed externally): Set to "1" (Coin controller) or "5" (Coin controller supporting mixed-size).

#### Notes:

- Mixed-size jobs will be supported by setting to "5". The switching process of the size signal is carried out for each page.
- Be sure to make the following charge settings appropriately according to the usage.
  - FS-08-9017 (Setting for counter installed externally): To charge only when copies are made, set to "1".
  - FS-08-6011 (Definition setting of large sized paper): To make only A3 and LD be specified for the large size, set to "0". To make B4, LG, FOLIO, COMP as well as A3 and LD be specified for the large size, set to "1".

### [ 3 ] Installation of external counters

It is not allowed to install more than one external counter (key copy counter and coin controller) at the same time.

### [ 4 ] Setting value change and restrictions when using the key counter

The key copy counter used for current models is not supported in this MFP, but the circuit for driving the counter has been mounted. The mechanical counter can be used by setting as below. However, the harness for connecting it has not been provided as an option.

#### 1. Setting value

FS-08-9016 (Counter installed externally): Set to "3" (Key copy counter).

FS-08-9017 (Setting for counter installed externally): It should be charged precisely according to the usage.

E.g.: To charge only when copies are made, set to "1".

FS-08-6011 (Definition setting of large sized paper): To make only A3 and LD be specified for the large size, set to "0". To make B4, LG, FOLIO, COMP as well as A3 and LD be specified for the large size, set to "1".

### [ 5 ] Restrictions when using the external counter

The Job Skip function will be disabled when an external counter is installed (when a value other than "0" is set for FS-08-9016).

Therefore, if printing is attempted while a counter or a coin controller is used, all jobs stored in the storage may be printed.

### [ 6 ] Restrictions for e-Filing

When an external counter has been installed (a value other than "0" is set for FS-08-9016), documents can be saved in e-Filing and files can be saved in a shared folder. However, printing of documents saved in e-Filing is not possible.

#### Notes:

This will become possible by setting the value "1" (Allowed) for FS-08-8670 (e-Filing print setting when key counter/totalizer is installed) when the value "3" (Key copy counter) is set for FS-08-9016.

## 14.2 Optional Storage Device

### 14.2.1 Overview

The security setting and operation method of the optional storage device is explained.

### 14.2.2 Disabling setting

When the installed optional storage device is in the following condition, it can be disabled. Since the optional storage device can be disabled temporarily when it has malfunctioned, an MFP can be used without your stopping it.

#### [ 1 ] Condition

- SSD or normal HDD
- Security HDD to which “0” is set for FS-08-9717-1

#### [ 2 ] Setting procedure

Perform one of the following items.

- Set “0” for FS-08-9717-0 (Connection setting).
- Set to disable from 78 Option Storage Assist > Disable Option Storage.

#### Notes:

After the optional storage device has been disabled, perform HS-73 Firmware Assist > Format Storage and then install “System Software (HD data)” with HS-49 Firmware Update.

### 14.2.3 Security setting

FS-08-9717-1 (Security setting) is available for the security HDD.

#### Notes:

- Set the value suiting the MFP operation.
- When the High Security Mode is enabled, set “2” for FS-08-9717-1.
- When “1” or “2” has been set for FS-08-9717-1, the value cannot be changed to “0”.
- When “1” or “2” has been set for FS-08-9717-1, the MFP cannot be operated without having an optional storage device.
- When the value of FS-08-9717-1 is changed from “2” to “1”, perform HS-73 Firmware Assist > Format Storage and then install “System Software (HD data)” with HS-49 Firmware Update.

### 14.2.4 Precautions for disposal

The disposal process differs depending on the type of the optional storage device.

Storage type	Disposal process
Security HDD	HS-78-Format Option Storage
Normal HDD	HS-73-Erase Storage Securely
SSD	-

### 14.2.5 Data overwriting function

To enable the data overwriting function, set “1” (Enabled) in FS-08-9238.

#### Notes:

- This is available only when an HDD is installed.
- For some models, “1” (Enabled) is set at the time of factory shipment.

## 14.3 Pixel Counter

### 14.3.1 Overview

#### [ 1 ] Overview

The pixel counter is a function that counts the number of dots emitted by writing the light source and converting it into the print ratio (%) per standard paper size. This “Print ratio (%) per standard paper size” is called the Pixel count (%).

This function enables you to know how each user uses the MFP and to understand the tendency of the toner consumption (number of pages output per cartridge).

However, since some of the factors in “2” below are not taken into account by the pixel counter, its accuracy sometimes does not match the actual toner consumption.

#### [ 2 ] Factors affecting toner consumption

The standard number of pages output per cartridge shows the average number of pages output under the condition that the data of the print ratio 5% is printed on the standard paper size (A4 or LT) under normal temperature and humidity.

However, users do not always print under the above conditions. As for the type of original, copy/print mode and environment, each user has a different tendency, and as a result, the number of pages output per cartridge will vary.

The major factors affecting toner consumption are as follows:

- Original / Data coverage
- Original / Data density
- Original / Print mode
- Density setting
- Print pattern (Character image such as text consuming more toner than solid images even though they may have the same density.)
- Number of pages per job (More toner is required when printing in the non-continuous running mode.)
- Number of the times of image quality control
- Paper (type, size and feeding direction)
- Environmental conditions (temperature, humidity)
- Others (In addition to the above, there are other factors that may influence the toner consumption. These include variations between individual products, life of consumables, bias voltage, drum surface potential, etc.)

The general relations between the first 4 factors and toner consumption per page output in the copying function are as follows:

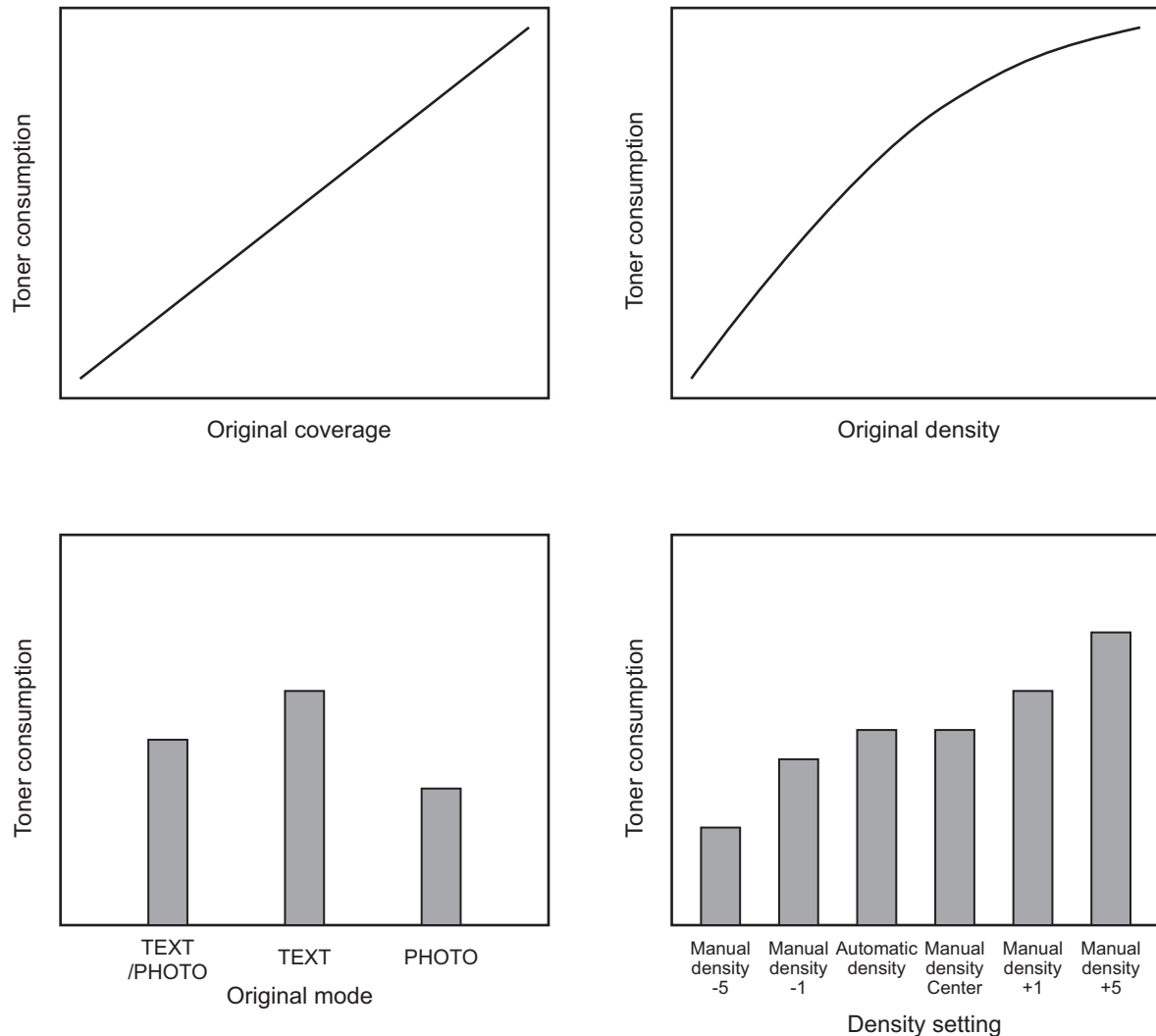

Fig.14-5 Factors affecting toner consumption and the tendency

### [ 3 ] Details of the pixel counter

- Toner cartridge reference and service technician reference  
The pixel counter function in this MFP has 2 references, the toner cartridge reference and the service technician reference.

#### **Toner cartridge reference**

This is a system that accumulates data between the installation of a new toner cartridge and the next installation.

The installation of a new toner cartridge is judged when the total number of the pixel count or pages output after the detection of toner cartridge empty has exceeded the threshold.

The threshold to be used is selectable in FS-08-6506 between the pixel count and pages output (0: Output pages, 1: Pixel counter). The threshold of pixel count is set in FS-08-6508 and that of pages output is set in FS-08-6507.

When a new toner cartridge is judged as installed, the data related with the previous cartridge is cleared and replaced with the data after the installation of the new cartridge.

Clearing of the counter of the toner cartridge reference is performed in FS-08-6503.



### Service technician reference

This is a system that accumulates data between the service technician clearing the service technician reference counter and the subsequent clearing of the same counter. Clearing of the counter of the service technician reference is performed in FS-08-6502.

- Print count (number of output pages)  
The number of pages output shown at the pixel counter is counted after all paper sizes have been converted to the standard paper size (A4/LT).  
Printing on other than the standard size paper is converted by the paper area ratio.  
The examples of conversion are as follows. The standard paper size is set in FS-08-6500.

#### E.g.:

When printing on A4/LT size: Counts the number of pages output as the print count

When printing on A3/LD size: Counts the number of pages output multiplied by 2 as the print count (Area ratio to A4/LT: 200%)

When printing on B4 size: Counts the number of pages output multiplied by 1.49 as the print count (Area ratio to A4: 149%)

When printing on LG size: Counts the number of pages output multiplied by 1.27 as the print count (Area ratio to LT: 127%)

- Pixel count (%)  
The pixel count (%) shows the ratio of the emitting pixels of the writing light source to all pixels on standard-size paper.  
The examples of pixel count are as follows.

#### Notes:

In the following examples, 'solid copy' is considered to be 100%. But since the image has 4 margins, it never actually becomes 100%.

#### E.g.:

Printing 5 pages on A4/LT size with solid copy (writing light source emit to all pixels)  
Pixel count: 100%, Print count: 5

Printing 5 pages on A4/LT size with blank copy (writing light source never emit)  
Pixel count: 0%, Print count: 5

Printing 2 pages on A4/LT size with solid copy (writing light source emit to all pixels), Printing 2 pages on A4/LT size with blank copy (writing light source never emit)  
Pixel count: 50%, Print count: 4

Printing 3 pages on A4/LT size with 6% of writing light source emission, Printing 1 page on A4/LT size with 2% of writing light source emission  
Pixel count: 5%, Print count: 4

Printing 2 pages on A3/LD size with solid copy (writing light source emit to all pixels)  
Pixel count: 100%, Print count: 4

Printing 2 pages on A3/LD size with 6% of writing light source emission  
Pixel count: 6%, Print count: 4

- Average pixel count (%) and latest pixel count (%)  
There are 2 types of the value calculated as the pixel count: the average pixel count (%) and the latest pixel count (%).

**Average pixel count (%)**

The average value of all pixel count data after each reference data is cleared is calculated and displayed.

**Latest pixel count (%)**

The value is displayed for printing just before the pixel counter is confirmed.

- Type of calculated data  
Since this MFP is multifunctional, the data of the pixel count are calculated for each function.

The following list is the information that can be confirmed by LCD screen. But actually, more information can be confirmed by FS-08.

 P. 14-14 “• Display in the FS-08 SETTING MODE”

**Type of calculated data**

	Toner cartridge reference	Service technician reference
Copying function	Yes	Yes
Printing function	Yes	Yes
Fax function	Yes	Yes
Total	Yes	Yes

- Setting related with the pixel counter function

**Standard paper size setting**

The standard paper size (A4 or LT) to be converted into the pixel count is selected (FS-08-6500).

**Pixel counter display setting**

Whether or not to display the pixel counter on the LCD screen is selected (FS-08-6504).

**Display reference setting**

The reference when the pixel counter is displayed on the LCD screen (toner cartridge reference or service technician reference) is selected (FS-08-6505).

**Toner empty determination counter**

This is the counter to determine the replacement of a new toner cartridge after toner empty is detected.

After toner empty is detected by the auto-toner sensor, this counter checks whether it is detected one more time while the specified number of the pixel count or pages output is counted.

When toner empty detection fails, it can be presumed that a new toner cartridge has been installed.

**Pixel counter clearing**

There are 3 types for the pixel count clear as follows:

FS-08-6501: All information related to the pixel count is cleared.

FS-08-6502: All information related to the service technician reference pixel count is cleared.

FS-08-6503: All information related to the toner cartridge reference pixel count is cleared.

#### [ 4 ] Relationship between the pixel count and toner consumption

If a user prints out the image with large coverage or high density, this may cause the pixel count to have a large value. Moreover, the setting in which the toner consumption becomes high in the original mode or the density setting may cause it as well.

In this case, the replacement cycle of the toner cartridge is faster than for the standard number of pages output. Therefore, this trend needs to be understood as regards the service.

The relationship between the pixel count and the number of pages output per cartridge is as follows:

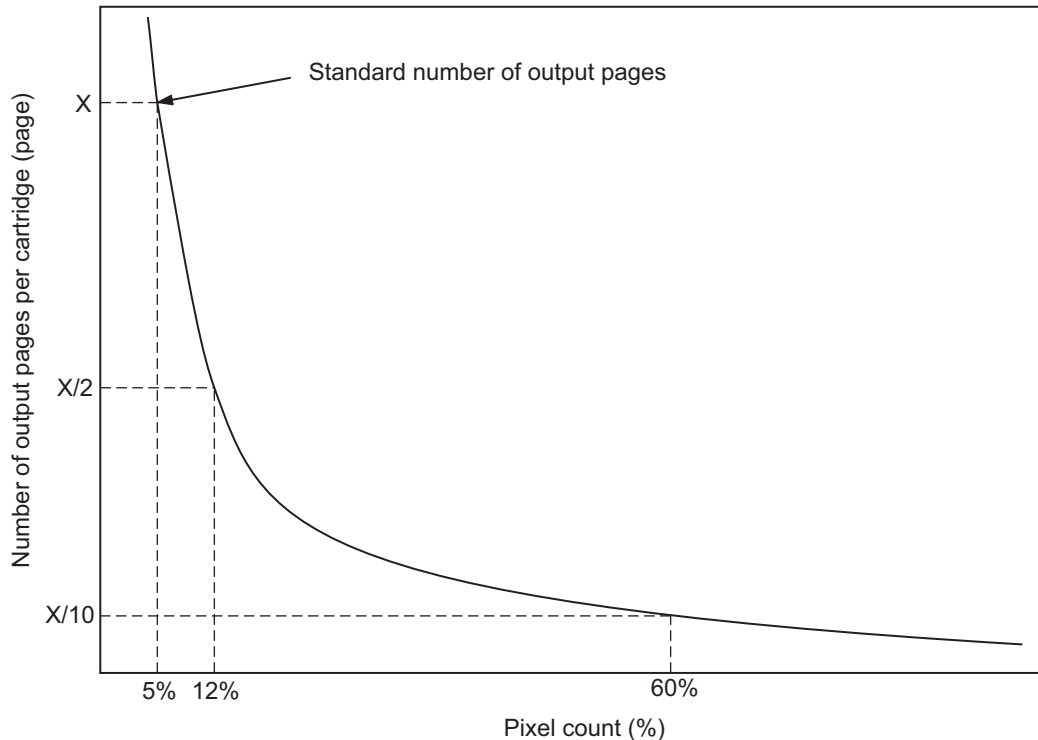

Fig.14-6 Pixel count and number of pages output per cartridge

#### [ 5 ] Pixel counter confirmation

- Display on the LCD screen

Whether or not to display the pixel counter on the LCD screen is selected (0: Displayed, 1: Not displayed) in the setting mode (FS-08-6504). In addition, whether or not to display it at the service technician reference or toner cartridge reference is selected (0: Service technician reference, 1: Toner cartridge reference) in FS-08-6505.

The following screen is displayed when the buttons, [Counter] and [Pixel Counter], are pressed in this order after "Displayed" is selected with the code above and the power is turned ON as usual. (The displayed buttons depend on the setting of FS-08-6505.)

The following screen is displayed when "1" (Toner cartridge reference) is selected for FS-08-6505.

	Copy	Printer	Total
Print Count [LT/A4]	0	352	352
Average Pixel Count [%]	0	1.96	1.96
Latest Pixel Count [%]	0	1.24	1.24

Fig.14-7 Information screen of toner cartridge reference

The following screen is displayed when "0" (Service technician reference) is selected for FS-08-6505.

	Copy	Printer	Total
Print Count [LT/A4]	0	352	352
Average Pixel Count [%]	0	2.40	2.40
Latest Pixel Count [%]	0	2.18	2.18

Fig.14-8 Information screen of service technician reference

- Data list printing  
 The data for the pixel counter can be printed in FS-30 LIST PRINT MODE.  
 FS-30-104: The data of the toner cartridge reference is printed.  
 FS-30-105: The data of service technician reference is printed.

PIXEL COUNTER CODE LIST						
		S/N: xxxxxxxx	FIN S/N: xxxxxxxx		TOTAL: 9999999	
		TOSHIBA e-STUDIOxxx			DF TOTAL: 9999999	
20xx-xx-xx xx:xx						
TONERCARTRIDGE						
NO.	DATE	COLOR	PPC	PRN	FAX	TOTAL
0	20xx-xx-xx	Print Count[LT/A4]	181	45	---	226
1	20xx-xx-xx	Average Pixel Count[%]	2.70	1.74	---	2.51
2	20xx-xx-xx	Latest Pixel Count[%]	6.15	0.39	---	0.39

**Fig.14-9 Data list of toner cartridge reference**

PIXEL COUNTER CODE LIST						
		S/N: xxxxxxxx	FIN S/N: xxxxxxxx		TOTAL: 9999999	
		TOSHIBA e-STUDIOxxx			DF TOTAL: 9999999	
20xx-xx-xx xx:xx						
SERVICEMAN						
NO.	DATE	COLOR	PPC	PRN	FAX	TOTAL
0	20xx-xx-xx	Print Count[LT/A4]	181	45	---	226
1	20xx-xx-xx	Average Pixel Count[%]	2.70	1.74	---	2.51
2	20xx-xx-xx	Latest Pixel Count[%]	6.15	0.39	---	0.39

**Fig.14-10 Data list of service technician reference**

- Display in the FS-08 SETTING MODE  
Information of the pixel count can be also checked in 08 SETTING MODE.

**Print count, pixel count**

Pixel count code table

		Toner cartridge reference	Service technician reference
Copying function	Print count (page)	6563	6558
	Average pixel count (%)	6623	6602
	Latest pixel count (%)	6724	6616
Printing function	Print count (page)	6565	6560
	Average pixel count (%)	6629	6603
	Latest pixel count (%)	6725	6617
Fax function	Print count (page)	6566	6561
	Average pixel count (%)	6635	6604
	Latest pixel count (%)	6644	6618
Total	Average pixel count (%)	6634	6605

**Other information**

Toner cartridge replacement counter

The toner cartridge replacement count is displayed.

FS-08-6576

Toner cartridge reference count started date

The toner cartridge reference count started date is displayed.

FS-08-6522

Service technician reference count cleared date

The service technician reference count cleared date is displayed.

The date when FS-08-6502 was performed is stored.

FS-08-6510

Toner cartridge reference count cleared date

The toner cartridge reference count cleared date is displayed.

The date when FS-08-6503 was performed is stored.

FS-08-6514

## 14.4 NOTES FOR THE INSTALLATION OF A CARD READER

- (1) The card reader to use in this equipment needs to satisfy all of the following conditions. However, the operation cannot be guaranteed even if all of these conditions are satisfied.
  1. Complying with the USB HID class and satisfying the following class codes
    - Class code: 0x03
    - Sub Class code: 0x00
    - Protocol code: 0x01
  2. An interface descriptor for the USB HID class needs to be single. (A card reader which consists of multiple HID classes, such as card reader and keyboard functions, cannot be used.)
  3. The USB VID/PID of the card reader has been registered in this equipment. For details about the registration of VID/PID, ask your service contact center.
- (2) When any problems concerning to a card reader have occurred, ask your service contact center to confirm whether the card reader satisfies the above conditions or not.

## 14.5 Usable USB storage device

The USB storage device for the maintenance operation of the MFP must meet the following conditions.

- A combination USB storage device with a flash memory (to be connected directly to the USB port)
- The capacity is 1 GB or more. A USB storage device with 2 GB or more is recommended.
- A USB storage device compliant with the following specifications established by USB-IF (USB Implementers Forum)
  - Class number: 8 (=08h) (Mass-storage class)
  - Sub-class number: 6 (=06h) (SCSI transfer command set)
  - Protocol number: 80 (=50h) (Bulk-only)
- A USB storage device compliant with USB2.0.
- When a USB storage device compliant with USB 3.0 is used, the MFP will be operated equivalent to USB 2.0 (HighSpeed(480Mbps)).
- The USB format type should be FAT32 or exFAT.
- A USB storage device formatted with exFAT can only be used at the time of the HS mode only.
- When a file whose size is 2 GB or larger is saved in a USB storage device, the USB format type should be exFAT.

### Remarks:

A USB storage device which has been confirmed in advance to be operable in the MFP should be used.

## 14.6 License

### 14.6.1 Types and categories

There are following types and categories in the licenses.

Type	Description	Category	Description
Node	This can be used only for one unit of the equipment.	Indefinite	There is no limitation in the use term.
		Term	The functions can be used for a certain period of time. The time when the license has been activated becomes the start date.
		Trial	The functions are activated temporarily for the trial use before purchasing the applications with the trial license.
Subnet	This can be used in multiple units of the equipment whose 1st to 3rd octets of the IP address are the same.	-	-
Domain	This can be used in multiple units of the equipment with the same domain.	-	-

### 14.6.2 How to activate the license

The activation method and the operation procedure differ depending on the network environment of the equipment and the license type. Be sure to perform the operation properly in accordance with these.

Activation method	Necessary information	Remarks
[Online]	License authentication ID	* Text file
[Offline]	License file	zip file

\* A multiple number of license authentication IDs can be contained in one text file.

#### [ 1 ] [Online]

When the equipment can make an outside communication via a network, the license can be activated by selecting [Online].

Necessary information: License authentication ID

Be sure to store license authentication IDs with a text format in a USB storage device.

#### Remarks:

- Apply an arbitrary name to the file.
- Store the file in the root of a USB storage device.
- When a multiple number of license authentication IDs is stored in one text file, insert line feeds for each ID.

(1) In order to activate the license by [Online], perform the following network settings.

Code	Content
FS-08-3634 *1	License server URL setting
FS-08-8693 *2	IP address of the license activation proxy server
FS-08-8694 *2	Port number of the license activation proxy server
FS-08-8695 *2	Login user name to connect to the license activation proxy server
FS-08-8696 *2	Password to connect to the license activation proxy server

\*1 Obtain this information from the license provider. Use the default URL in principle.

\*2 Obtain this information from the user or the network administrator.

(2) Press [Activate] on the License Management screen. The License Activation screen appears.

(3) Press [Online] on the License Activation screen.



- (4) Press [USB]. Insert a USB storage device with license authentication ID files stored into the equipment.

**Remarks:**

If license authentication IDs are entered by using a keyboard, press the text box without inserting a USB storage device. After the license authentication ID is entered, press [OK] and go to step (10).

- (5) Press [OK]. The Select a file screen appears and all the license authentication ID files in the USB storage device are displayed.
- (6) Select the license authentication ID file in which the license authentication ID to be activated is included. Press [OK].
- (7) The Select a License Certificate Number screen appears. All the license authentication IDs included in the selected file are displayed.
- (8) Select the license authentication ID to be activated and press [Set].
- (9) Confirm that the correct license authentication ID is entered in the text box and press [OK].
- (10) The confirmation screen appears. Press [Yes].
- (11) The screen indicating under processing appears. After a few minutes have passed, the confirmation screen indicating the success of the authentication appears. Press [OK].
- (12) Confirm that the activated license is displayed in the License Management screen.

## [ 2 ] [Offline]

When the equipment cannot make an outside communication via a network, the license can be activated by selecting [Offline].

Necessary information: In case of the license file: "LIC\_xxxx\_yyyy.zip"

xxxx: A different value appears depending on the license.

yyyy: Serial No. of the equipment

**Remarks:**

- Store the license file in the root of a USB storage device.
- Activation can be carried out only in the equipment with the same serial No. as that for the license file.
- Check that the date and time of the equipment is correct.
- The subnet license can be activated only in equipment in which a network connection has been made by means of the specified IP address. - The domain license can be activated only in the equipment to which a connection to the specified domain has been made.

- (1) Press [Activate] on the License Management screen. The License Activation screen appears.
- (2) Press [Offline] on the License Activation screen.
- (3) Insert a USB storage device with the license authentication ID files stored into the equipment.
- (4) Press [OK]. The Select a file screen appears and all the license files in the USB storage device are displayed.
- (5) Select the license file in which the license to be activated is included. Press [OK].
- (6) The confirmation screen appears. Press [Yes].
- (7) The confirmation screen indicating the success of the processing appears. Press [OK].

- (8) Confirm that the activated license is displayed in the License Management screen.

### [ 3 ] Activation of the Subnet License and the Domain License in the 2nd or Later Unit of the Equipment

For the subnet license and the domain license, it is required to activate the license in several units of the equipment. The equipment in which the license has been activated by means of the license authentication ID or the license file will be the host unit. By using an export license file exported from this host unit, activate the license of other units of the equipment in which required conditions are satisfied.

- (1) On the License Management screen of the host unit, press [Details] of the license file to be exported.
- (2) Press [Export] in the License Details screen.

**Remarks:**

- [Export] is displayed on the screen only for the Subnet license and the Domain license.
- In case of the export license file: "LIC\_xxxx\_Export.zip"  
xxxx: A different value appears depending on the license.

- (3) Insert a USB storage device to store the license file into the equipment and press [OK].
- (4) The confirmation screen appears. Press [Yes].
- (5) The confirmation screen indicating the success of the processing appears. Press [OK] and remove the USB storage device.
- (6) Insert the USB storage device with the export license file stored into another unit of the equipment in which the required conditions are satisfied. Activate the license.

**Remarks:**

- The export license file can be used in several units of the equipment.
- The activation procedure is the same as that for [Offline].

#### [ 4 ] Activation after Replacing or Formatting the Standard Storage Device

After the standard storage device has been replaced or formatted, the licenses will go into an incomplete status.

In such a case, after replacing or formatting the standard storage device, it is necessary to restore the backup data with the latest status, including all the activated licenses.

Normal

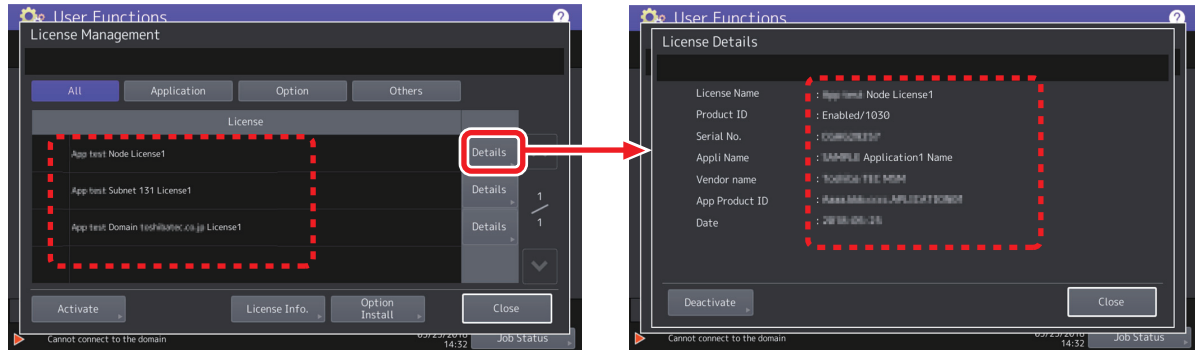

Fig.14-11

After the standard storage device replaced

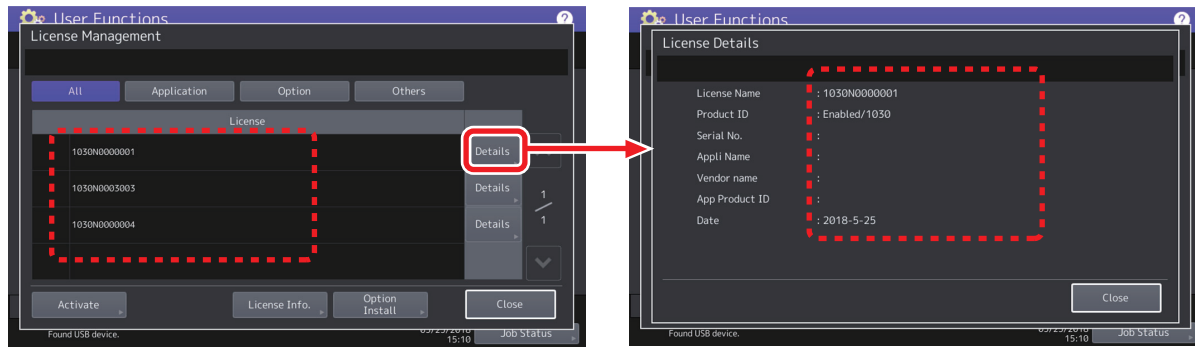

Fig.14-12

- Restore the latest backup data including all the activated licenses.
- If there are no backup data as above, reactivate all the licenses which have been activated in this equipment.  
P. 14-16 “14.6.2 How to activate the license”
- If the functions have been activated by the export license file, import the license exported from the host unit of the equipment.  
P. 14-18 “[ 3 ] Activation of the Subnet License and the Domain License in the 2nd or Later Unit of the Equipment”

#### Remarks:

- Applications with the trial license cannot be recovered from the backup data. If necessary, reinstall the applications.
- The out-of-order period caused by the breakage of the equipment is included in the day count for the term license.

### 14.6.3 How to deactivate the license

A license whose type is the indefinite node license can be deactivated. The deactivation method and the operation procedure differ depending on the network environment of the equipment. Be sure to perform the operation properly in accordance with this.

- (1) Press [Details] of the license to be deleted on the License Management screen.
- (2) Press [Deactivate] on the License Details screen.
- (3) Press [Online] or [Offline].

**Remarks:**

- For the equipment which can make an outside communication, press [Online] to deactivate the license.
- When the license is deactivated by means of the use of [Offline], send a disable certificate file (\*) of the license to the license provider.
- \* A file stored in a USB storage device when the license is deactivated.  
“LIC\_Deact\_xxxx\_yyyy.zip”  
xxxx: A different value appears depending on the license.  
yyyy: Serial No. of the equipment

- (4) The confirmation screen appears. Press [Yes].
- (5) Press [Details] of the license file which has been deactivated on the License Management screen. The License Details screen appears. Check that “Disabled” is indicated in Product ID.

### 14.6.4 How to delete the license

Licenses whose type are the subnet license and the domain license can be deleted. However, do not perform the deletion of these licenses in principle. If the deletion of the licenses is required for some reason, do so not only in the host unit but also in all other units in which the licenses have been activated by means of an export license file.

# REVISION RECORD

## Ver02d

Ver02d <2024/03/14>	
Page	Contents
8-239	Added content: F109_8, F109_9, F109_10
8-239a	Added content: F109_11
8-239b	Added content: F109_12
9-16 to 9-39	Modified content in section 9.2
14-16	Added section 14.6 License

## Ver02c

Ver02c <2023/10/05>	
Page	Contents
9-17 to 9-17a	Added SSD fault diagnosis
7-33	Added content to Section 7.11 PM Kit

## Ver02b

Ver02b <2023/06/12>	
Page	Contents
8-256	Added Remark to F200 Error Troubleshooting
9-16	Added item to 9.2.1 Precautions when replacing PC boards
8-178	Added content to C353 error Troubleshooting
3-18	Corrected 3.3.3 Electromagnetic clutch
12-14 to 12-16	Added content to 12.5 High Security Mode

## Ver02a

Ver02a <2023/5/12>	
Page	Contents
8-234a	Added F107 error troubleshooting

## Ver02

Ver02 <2023/2/17>	
Page	Contents
Trademarks	The description for the trademarks has been updated.
2-2	The mistakes have been corrected.
2-3	The mistakes have been corrected.
2-11	The mistakes have been corrected.
2-12	The mistakes have been corrected.
3-27	The mistake of description of power switch have been corrected.
3-30	The description of the power switch has been added.
5-39	The mistakes have been corrected.
5-40	The mistakes have been corrected.
5-42	The mistakes have been corrected.
5-43	The mistakes have been corrected. The description has been updated.
5-50	The mistakes have been corrected. The description has been updated.
8-8	The error codes of RADF have been added.
8-10	The mistake of the error description for EA21 and EA22 have been corrected.
8-14	The error item (C254) has been added.
8-15	The error items (C558 and C559) have been added.
8-21	The error items (F525 and F526) have been added.
8-33	The error item (4F11) has been added.

8-52	The error items (74A1 to 74A5) have been added.
8-112	The procedure of the troubleshooting for E747/E748 have been added.
8-113	The procedure of the troubleshooting for E762 have been added.
8-115	The procedure of the troubleshooting for E769/E770 have been added.
8-116	The procedure of the troubleshooting for E771 have been added.
8-117	The procedure of the troubleshooting for E777 have been added.
8-128	The description of the EA21 troubleshooting have been changed.
8-129	The description of the EA22 troubleshooting have been changed.
8-178	The procedure of the troubleshooting for C254 have been added.
8-188	The procedure of the troubleshooting for C554/C558 have been added.
8-189	The procedure of the troubleshooting for C559 have been added.
8-259	The procedure of the troubleshooting for F525/F526 have been added.
8-292	The procedure of the troubleshooting for 4F11 have been added.
8-380	The troubleshooting for “The [ON/OFF] button does not work” have been added.
-26	The mistakes have been corrected.
9-28	The mistakes have been corrected.
9-30	The procedure has been added.
9-39	The note has been changed. The description of the HDD erase time has been added.
10-37	The mistakes have been corrected.
11-2	The description of the firmware update has been changed.
11-4	The mistakes have been corrected.
11-5	The mistakes have been corrected.
12-4	The model names have been updated.
12-11	The maintenance code has been corrected.

## Ver01

Ver01 <2022/08/19>	
Page	Contents
2-1	Information for the TWD model has been added.
2-3	Information for the TWD model has been added. The mistake has been corrected.
2-13 to 18	An information for the TWD model has been added.
3-13, 3-20	The mistake has been corrected.
3-19	An information for the TWD model has been added.
6-24, 6-32, 6-39, 6-47, 6-49	The mistake has been corrected.
8-3	The mistake has been corrected.
9-2	The illustration has been changed.
9-5	An information for the TWD model has been added.
9-13, 9-34, 9-28, 9-30	The mistake has been corrected.
10-37	The mistake has been corrected.
11-4, 11-6, 12-1, 12-4, 12-8	The contents have been changed.
12-15, 12-16	The mistake has been corrected.
13-1, 13-4, 13-6	An information for the TWD model has been added.
14-15	The contents have been changed.

## Ver00

Ver00 <2021/12/22>	
Page	Contents
	Initial release

**TOSHIBA**

**Toshiba Tec Corporation**

1-11-1, OSAKI, SHINAGAWA-KU, TOKYO, 141-8562, JAPAN